

K i n e t i c

A r c h i t e c t u r e :

the spatial

organization of

daily mobility

within a

Public Bathhouse

The copyright of this thesis vests in the author. No quotation from it or information derived from it is to be published without full acknowledgement of the source. The thesis is to be used for private study or non-commercial research purposes only.

Published by the University of Cape Town (UCT) in terms of the non-exclusive license granted to UCT by the author.

Kinetic Architecture —
the spatial organization of daily mobility within a Public Bathhouse

Design Research Project APG5058S

Submitted in partial fulfillment of the requirements for the degree
Master of Architecture (Professional),

by
Hermias Cornelius de Vries

at
University of Cape Town; School of Architecture, Planning & Geomatics

October 2011

Study leaders: Jo Noero & Francis Carter





Abstract

Theories & principles of human movement are investigated to see whether the choreography of daily routine [motion] can produce architectural form. The architectural project manifests itself as the reevaluation of 'the place' of movement, or rather, to do battle against 'the non-place', and brings forth a combination of landmark, infrastructure and place of gathering around the program of a public bathhouse within a South African urban context. The proposal provides ablution and infrastructure to a public transport interchange (the non-place) precinct within Cape Town CBD, in order to initiate new social organizations of intermodal urban space & to reframe existing organizations. This is done through examining the choreography of motion [that is set up by the intermodal infrastructure at Cape Town's Train Station] between simultaneous movement systems & sequences and how this can lead to a hybrid architecture where machine, human & nature can ultimately work together.

The architectural exploration aims to enrich the ritual of cleansing by introducing the act of bathing to the public urban environment. Challenges associated with the typology is addressed through integration with surroundings, ensuring the potential of social life centered around a fundamental human act. The goal therefore lies in a celebration of ritual & routine as derived from context, not the imposition of an ancient typology, or an irrelevant program.

table of

C o n t e n t s

chapter **00.** page **08.**
List of figures

chapter **01.** page **11.**
Theoretical discourse
+ Kinetic Architecture: the spatial organization of daily mobility

chapter **02.** page **31.**
Context - Site
+ Reasoning behind the chosen site
+ Context History: From Past to Present - Railway Infrastructure
+ Site Analysis

chapter **03.** page **45.**
Program
+ Defining the public bathhouse & the necessity for cleansing
+ A brief history of public bathing – Rituals of Bathing
+ Programmatic distribution

chapter **04.** page **61.**
Design Development
- Standard practice
- Movement exercises

chapter **05.** page **79.**
Technical research
+ The flow of water - Service Infrastructure
+ The flow of concrete - Building Structure

chapter **06.** page **107.**
List of references

chapter **07.** page **111.**
Conclusion [Addendum]
+ Final Plans & sections
+ Explanatory diagrams
+ Model

- Fig 1** - Arnheim Pavilion, The Netherlands, 1966, Aldo van Eyck - [Fleming, 2005]
- Fig 2** - Bauhaus building in Dessau Germany, by Walter Gropius (1926) - [Droste, 2006]
- Fig 3** - Diagrams showing Approach towards a building - [Ching, 1996]
- Fig 4** - Diagrams showing Entrance into a building - [Ching, 1996]
- Fig 5** - Diagrams showing the Configuration of the Path - [Ching, 1996]
- Fig 6** - Diagrams showing the Path-Space Relationship - [Ching, 1996]
- Fig 7** - Diagrams showing the Form of the Circulation space - [Ching, 1996]
- Fig 8** - The watercolour painting by Paul Klee - [Bacon, 1967]
- Fig 9** - Diagrams based on Paul Klee's work on movement systems. - [Bacon, 1967]
- Fig 10** - Film strip - 'motion picture' - Author
- Fig 11** - Plan of Parc de La Vilette - [Rattenbury, 2004]
- Fig 12** - Parc La Vilette Sequences - [Barzilay, Hayward, Lombard-Valentino, 1984]
- Fig 13** - Movement Notation - [Feireiss, 1994]
- Fig 14** - Marcel Duchamp's Nude Descending A Staircase (1912) - [Marien, Fleming, 2005]
- Fig 15** - Les Femmes d'Alger by Pablo Picasso (1906-1907) - [Marien, Fleming, 2005]
- Fig 16** - 'Unique Forms of Continuity' by Umberto Boccioni's (1913) - [http://www.artsology.com/motion_in_art.php]
- Fig 17** - Photo by Harold Edgerton (1938) - [http://www.artsology.com/motion_in_art.php]
- Fig 18** - Jackson Pollock's painting Blue Poles (1953) - [Marien, Fleming, 2005]
- Fig 19** - Rem Koolhaas (OMA), Circulation Diagram - [Gausa, Guallart, Muller, Soriano, Porras, Morales, 2003]
- Fig 20** - Existing & new movement diagrams of Philadelphia, Louis Khan (1952-1953) -
- Fig 21** - Villa Savoye by Le Corbusier, Poissy, East of Paris (1929) - [Ching, 1996]
- Fig 22** - The Carpenter Centre for the Visual Arts at Harvard University by Le Corbusier, Cambridge, Massachusetts (1961-1964) - [Ching, 1996]
- Fig 23** - The Guggenheim by Frank Lloyd Wright, New York (1959) - [Marien, Fleming, 2005]
- Fig 24** - Manhattan Transcripts by Bernard Tschumi (1976-1981) - Excerpt from Episode 1: The Park - [Kipnis, c2001]
- Fig 25** - Manhattan Transcripts - Excerpt from Episode 2: The Street (Border Crossing) - [Kipnis, c2001]
- Fig 26** - Manhattan Transcripts - Excerpt from Episode 3: The Tower (The Fall) - [Kipnis, c2001]
- Fig 27** - Manhattan Transcripts - Excerpt from Episode 4: The Block - [Kipnis, c2001]
- Fig 28** - Movement Diagram for the Mercedes Benz Museum - [http://www.unstudio.com/nl/unstudio/projects]
- Fig 29** - Model (Final & floor sections) of the Mercedes Benz Museum - [http://www.unstudio.com/nl/unstudio/projects]
- Fig 30** - Mercedes Benz Museum by UN Studio, Stuttgart, Germany (2006) - [http://www.unstudio.com/nl/unstudio/projects]
- Fig 31** - Living Sequence translated into the mobius loop - [Gausa, Guallart, Muller, Soriano, Porras, Morales, 2003]
- Fig 32** - Plan of the Mobius house - [Gausa, Guallart, Muller, Soriano, Porras, Morales, 2003]
- Fig 33** - Mobius House by UN Studio, Netherlands (1996) - [http://www.unstudio.com/nl/unstudio/projects]
- Fig 34** - Bifurcation Sequence illustrated in images - [Kubo, 2004.]
- Fig 35** - The no-return Diagram - [Kubo, 2004.]
- Fig 36** - Movement Diagram becomes the form of the building - [Kubo, 2004.]
- Fig 37** - International Port Terminal in Yokohama by Foreign Office Architects (1996-2002) - [Kubo, 2004.]
- Fig 38** - Location of site relative to the world, South Africa & Cape Town - [Google Earth, 2011]
- Fig 39** - Diagram showing the site relative to surrounding "event" buildings. The platform also connects these various event spaces. - [Author]
- Fig 40** - Conceptual thinking of site as a threshold 'in-between' space. - [Author]
- Fig 41** - Diagram showing site relative to surrounding existing public movement systems which relies on the raised platform for access & linkage. - [Author]
- Fig 42** - Diagram showing the extent of the existing raised platform above the train station with primary access points. - [Author]
- Fig 43** - Diagram showing transformation of land reclamation & change in different train stations over the years - [Drawing by Author; Photos from The National Library; Maps from Chief Directorate Surveys & Mapping]
- Fig 44** - Site analysis according to Bernard Tschumi - SPACE, EVENT & MOVEMENT. - [Author]
- Fig 45** - Graphic on an old Roman Pot used for bathing - [Yegül, 1992]
- Fig 46** - Graphic on an old Roman Pot used for bathing - [Yegül, 1992]
- Fig 47** - Diagram showing the most common Roman Bath types & their sequences - [Author]
- Fig 48** - Drawing illustrating the hypocaust system to heat the baths, floors - [Yegül, 1992]
- Fig 49** - The Baths of Caracalla in Rome - [Yegül, 1992]
- Fig 50** - Typical floor layout of a Japanese Sento - [Author]
- Fig 51** - Typical layout of a Turkish Bath - [http://www.turkishbath.net/history.htm Retrieved April 2011]
- Fig 52** - Turkish Baths - Euston Road, London - [Allsop, 1890]
- Fig 53** - Diagram showing the most common sequence in a bathhouse - [Author]
- Fig 54** - Vals Baths, by Peter Zumthor, Exterior courtyard - [Zumthor, 2007]
- Fig 55** - Mansell Road bathhouse, Durban - Exterior view, section & plan - [Low, 1995-5]
- Fig 56** - Diagram of conceptual thinking behind arrangement of the programs - [Author]
- Fig 57** - Preliminary sequence sketches for the program - [Author]
- Fig 58** - Scripting the journey through simultaneous movement systems - [Author]
- Fig 59** - Movement bifurcation sequence diagram - [Author]
- Fig 60** - Existing standards set up by the INPUT & OUTPUT of the train movement system. - [Author]
- Fig 61** - Plan & section of preliminary water circulation in building. - [Author]
- Fig 62** - Diagrammatic representation of water circulation forming a closed system. - [Author]
- Fig 63** - A typical Bathroom sequence - always returning to the change room, before continuing with the journey. - [Author]
- Fig 64** - Primary movement routes through the site: four primary entry points leading one to the centre of the site for the choice of male OR female. - [Author]
- Fig 65** - Diagram showing the primary elements of the building: Non-place (site); Public Surface, Private Surface & the Supporting Structural Grid. - [Author]
- Fig 66** - Plan of the Public Surface at the top. - [Author]
- Fig 67** - Plan of the Bathing level (bottom level). - [Author]
- Fig 68** - Diagram of the service cores & route in & around the building. - [Author]
- Fig 69** - Sketches of movement through the changing rooms towards the different bathing spaces. [Author]
- Fig 70** - Cross section with baths at the bottom and the public floor on top. - [Author]
- Fig 71** - Section along the train tracks with primary bathing courtyard, showers on both ends & public floor on top. - [Author]
- Fig 72** - Weaving of the elements into a harmonious whole to become a building filled with rich spatial experiences. - [Author]
- Fig 73** - A selection of models where the building roof becomes the public 'movement surface' together with a 'spatial loop' showing the primary bathing circulation under the public roof. - [Author]
- Fig 74** - Placement of spaces within the figure '8' spatial loop. - [Author]
- Fig 75** - Simultaneous movement routes shaping the building & site. - [Author]
- Fig 76** - Bathing level. - [Author]
- Fig 77** - Public Floor Level. - [Author]
- Fig 78** - Rhythm set up by the INPUT OUTPUT sequence of the trains. - [Author]
- Fig 79** - Structural grid on the platforms. - [Author]
- Fig 80** - Carving movement through the 'SOLID' EVENT spaces. - [Author]
- Fig 81** - Conceptual diagram of the primary circulation cutting through the Solid event & the Transparent Connecting bridges; with the planar threshold walls separating the spaces. [Author]
- Fig 82** - Diagram of the crossing-points the primary link & the secondary filters create. This 'decision-making' space creates bifurcations in the journey and an important crossing point of all paths/journeys/movement systems. - [Author]
- Fig 83** - Shifting the transparent linking spaces along the tracks & solid event spaces to shape the building. - [Author]
- Fig 84** - Three-dimensional & material quality of the SOLID private bathing spaces connected with TRANSPARENT change room bridges. - [Author]
- Fig 85** - Dividing the site into equal parts of movement, space & event. - [Author]
- Fig 86** - Connecting the two entrances of each bathroom (male | female) with a direct pathway physically, but in-direct visually. - [Author]
- Fig 87** - Existing rhythm of the Input-Output of the train which sets up the construction method and spatial layout of the solid & void bands of the building. - [Author]
- Fig 88** - Configuration of the different connector spaces [change rooms] within the bathhouse: from the surface cleaners closest at the edges | entrances of the building towards the private deep & physical cleansers at the centre of the building - [Author]
- Fig 89** - Configuration of the event spaces servicing the connector spaces within each bathhouse: from two public outer bands towards two private inner bands. - [Author]
- Fig 90** - Configuration of the movement through the site and bathhouses. - [Author]
- Fig 91** - Design development of the plans - [Author]
- Fig 92** - Explanatory cross section showing direct & indirect circulation & visual links between the solid & transparent spaces. - [Author]
- Fig 93** - Sequence of different movement patterns in & around the building - [Author]
- Fig 94** - Design development of the solid event spaces & the transparent spaces. - [Author]
- Fig 95** - Different spatial experiences - [Author]
- Fig 96** - Design development of the plans. - [Author]
- Fig 97** - Design development of the cross section - [Author]
- Fig 98** - Conceptual diagram of solids & voids with the primary Male & Female movement through the building - [Author]
- Fig 99** - Stormwater channeled into the atlantic ocean. - [Von Zeil, 2009]
- Fig 100** - Stormwater channeled into the atlantic ocean. - [Von Zeil, 2009]
- Fig 101** - Ground floor plan, first floor plan & North West elevation showing storage tanks & water reticulation network. - [Leonardi, 2009]
- Fig 102** - Grey water reticulation diagram - [Leonardi, 2009]
- Fig 103** - Photos of Harmonia 57 with vegetation & water reticulation on exterior of the building [Leonardi, 2009]
- Fig 104** - Elevation of Pompidou Centre with services located on exterior facade. - [Sudjic, 1994]
- Fig 105** - Photo of exterior services on facade of Pompidou Centre - [Sudjic, 1994]
- Fig 106** - Relationship between served (yellow) & service spaces (blue). - [Powell, 2006]
- Fig 107** - Prefabricated toilet cubicles being installed. - [Powell, 2006]
- Fig 108** - Exterior view of Lloyd's of London showing sculptural quality of the service infrastructure. - [Powell, 2006]
- Fig 109** - Floor plan showing water channels on the floor & light channels in the ceiling. - [Zumthor, 2007]
- Fig 110** - Photo of interior bath - [Zumthor, 2007]
- Fig 111** - First floor plan: BATHS - [Zumthor, 2007]

- Fig 112 - Longitudinal & cross sections through building showing services installed below the baths. - [Zumthor, 2007]
- Fig 113 - Ground floor plan: SERVICES - [Zumthor, 2007]
- Fig 114 - Waterproofing detail - [Zumthor, 2007]
- Fig 115 - Typical closed circulation water system. - [Author]
- Fig 116 - Diagram showing the Run-off & greywater cycle. - [Author]
- Fig 117 - Standard Abeco water tanks. - [http://www.abecotanks.co.za]
- Fig 118 - Heat pump diagram - [http://www.itsolar.co.za]
- Fig 119 - Evacuated tube solar water heaters - components. - [http://www.itsolar.co.za]
- Fig 120 - Pool Reticulation Diagram - [Author]
- Fig 121 - Basement level showing primary service corridors for all water services & A/C units; together with all service rooms: laundry, storage, mechanical room & offices. - [Author]
- Fig 122 - Level 2 showing the return path of the water back into the building. - [Author]
- Fig 123 - Construction of the existing Cape Town train station and raised platform. - [National Library]
- Fig 124 - Section view of the Structural Concept for the bathhouse. - [Author]
- Fig 125 - Appearance of the smooth & light precast concrete elements v/s the dark & rough cast-in-place concrete elements. - [Author]
- Fig 126 - Cast-in-place concrete 'threshold planes': primary structural support for whole building. [Author]
- Fig 127 - Diagram study of the precast prestressed concrete framed structure suspended in-between the solid threshold planes. - [Author]
- Fig 128 - Precast prestressed concrete components - floor & roof beams, stairs, wall cladding, floor panels. - [Author]
- Fig 129 - Exploded diagram illustrating the primary components of the 'transparent' roof structure suspended between the solid threshold planes. - [Author]
- Fig 130 - Cross Section of roof structure illustrating attachment to solid threshold concrete wall. [Author]
- Fig 131 - Roof vents - [Author]
- Fig 132 - Premanufactured motorized roof louvre system with translucent panels for the light to filter through the roof even when the louvres are closed. - [Author]
- Fig 133 - Exploded diagram illustrating the primary components of the 'transparent' floor structure suspended between the solid threshold planes. - [Author]
- Fig 134 - Cross Section of floor structure illustrating attachment to solid threshold concrete wall. Also shows the suspended floor of the shower circulation space. - [Author]
- Fig 135 - Detail section of the floor lights inserted in-between the hollow-core slabs with lighting fixture installed below. - [Author]
- Fig 136 - 3-Dimensional view of the steel & glass floor light box. - [Author]
- Fig 137 - Exploded diagram illustrating the primary components of the 'transparent' facade structure suspended between the floor & roof beams.
- Fig 138 - Cross section and plan view of the transparent facade edge of the building.

University of Cape Town

chapter 01.
Theoretical discourse

Kinetic Architecture: the spatial organization of daily mobility

Introduction

"Architecture exists, like cinema, in the dimension of time and movement. One conceives and reads a building in terms of sequences. To erect a building is to predict and seek effects of contrast and linkage through which one passes... In the continuous shot | sequence that a building is, the architect works with cuts and edits, framings and openings." Jean Nouvel [Rattenbury, 1994:35]

The first thing I learnt when I first started studying architecture, is that architecture is an artform consisting of space; and the space composed not from two or three dimensions, but from four dimensions. The fourth dimension being time itself. Architecture is the only art where all these dimensions can be sculpted & manipulated into forms which ultimately becomes a building - where one can walk through and experience it in the time the user so chooses. Architecture is thus not just some 'thing' to look at, but it must be experienced by moving through the spaces.

Ideas about movement were fundamental for Modernist architecture of the early twentieth century and are ubiquitous in contemporary theory and practice. The shifting theoretical terrain in which bodily movement is made sense of has continuously produced different understandings of architectural possibilities. For example, where in much early Modernism, and in present conventional practice, movement is often articulated in terms of technical, functional circulation (Le Corbusier's Carpenter Centre for the Visual Arts at Harvard University) and narrativised aesthetic experience (Tschumi's Parc de La Vilette), other recent practices adopt more ambivalent approaches. In this context, examining changing conceptions and structuring of bodily movement within architecture provides a design strategy with endless possibilities.

According to the Oxford American Dictionary the word 'kinetic' means something that is dependent on movement for its effect. Kinetic architecture is thus not an architecture | architectural elements that move, but rather a type of architecture that requires the movement of the body through the space, for it to be fully experienced & understood as a whole.

The research explores firstly the open question of what movement is. This is explored to get a better understanding & background of how people understand & explain movement. Theorists such as Edmund Bacon, Christian Norberg-Schulz, Francis D.K Ching and Paul Klee are relevant here. In analyzing 'movement' I became aware of specifically three aspects:

- a) The notion that movement can be classified as the in-between space;
- b) The sequential act delivered by movement; &
- c) Notation of movement.

The questions I asked myself were:

Is there an alternative tradition, an alternative paradigm of space or at least the theoretical possibility of defining space through movement alone? How do I design a system of circulation without presupposing points to be connected? Can physical movement translate into form & ultimately into architecture? Can theories about movement translate into architecture?

This notion of the body and the eye was taken further by the cubists. What Cubism tried to achieve is reevaluating the plane and seeking multiple points of view towards a single object, as Picasso's *Les Femmes d'Alger* shows. The conception of space-time is most frankly manifested in the Bauhaus building in Dessau in 1926. [Figure 2] Walter Gropius, the prominent founder of Bauhaus, achieved the two fundamentals of this conception: multiplicity of points of reference and simultaneity. To grasp various spaces from one point of view, or with other words, to need various points of views in order to grasp the whole structure is the basic characteristic of this new space conception.

01

What is

MOVEMENT,

in time, through space?

According to the Oxford American Dictionary, 'movement' is an act of changing physical location or position or of having this change. One realizes that it is a physical act performed either by the body or the eye. The 'body' moves from here to there to do this & that. The 'eye' explores what is happening here and when.

According to Kenneth Warriner there are two typologies of movement:

1. **space of the body - 'space-in-the-making'** – movement through space; to enter & experience, space-making actions;
 2. **space of the eye - 'ready-made-space'** – seeing space from a distance or observing space. [Frances Bronet & John Schumacher, 1999 - 97-109]
- The space of the eye is already there, at once before us, always waiting for our bodily actions, whereas the space of the body is perpetually in-the-making through those very same actions: you go here, then there. Only for ready-made space can all places exist at the same moment, because they are already grasped at a distance by the eye (the simultaneity of places in the space of the eye).

space-in-the-making, places are realized only through movement of the body, not the eye: we are on our feet, ready to move and make contact with another body, which we do not already grasp at a distance. Warriner introduces the phrase "two movement topologies" in the process of applying these two hypotheses to Van Eyck's Sonsbeek Sculpture Pavilion in Arnheim. [Figure 1] Warriner describes a tension between body and eye in the Pavilion. The eyes are led, for example, through and beyond the immediate confines of the tight channels of space, whereas the body is caught up in these 'streets', in a close and guarded attention that is periodically released into really free movement at the end of each 'street' as it opens into the clearing.

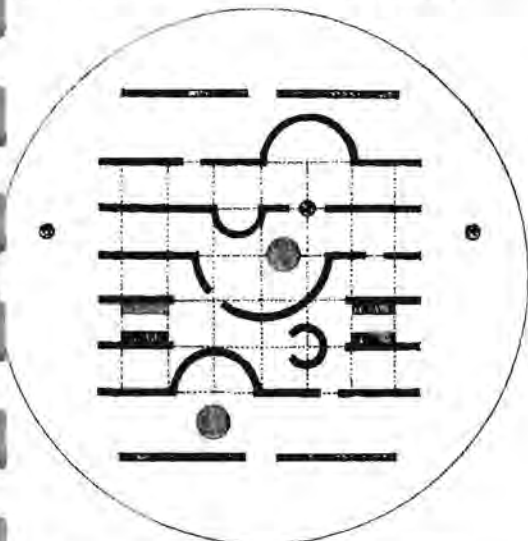

Figure 1: Arnheim Pavilion, The Netherlands, 1966, Aldo van Eyck.

While experiencing space with one's senses from different view points, the mind builds an image of the environment. A child first constructs a world out of similarities, then connects the recognized things with particular places to construct space. The mind then needs to tell the body when one is where & why, to try and orientate the body in space. Norberg-Schulz states that proximity, continuity, and enclosure are the basic **schemata of orientation**, that is, the constituent elements of what he calls 'existential space'. [Christian Norberg-Schulz, 1971 - 18-24]

According to Schulz, the organizational schemata is:

1. Centre & Place (Proximity)

The places are goals/foci where we experience the meaningful events of our existence, but they are also points of departure from which we orient ourselves & take possession of the environment.

e.g. home[centre] - station[in-between] - work[centre]

2. Direction & Path (Continuity)

Above, below, in front, behind, right, left: rooted in man's constitution & in his relationship to the gravitational field. First of all, the vertical axis can be considered the sacred dimension of space, a path towards a reality which may be higher/lower than daily life; or a path that conquers gravity. On the other hand, all horizontal directions are equal & form a plane of infinite extension.

The path, Norberg-Schulz writes: "is a direction to be followed towards a goal, but during the journey events happen & the path is also experienced as having a character of its own. What happens along the way is added to tension created by the goal to be reached & the point of departure left behind." [Norberg-Schulz, 1971 - 22] Deviations from the straight/preferred path are to either obtain something [positive deviation] or evade something [negative deviation]. Movement along a path thus requires the mind to constantly make decisions on whether to accept or reject the bifurcations in the path. This aspect of a path is determined by its relation to places. It either leads towards a goal, away from a point of departure, or it forms a ring around the place.

3. Area & Domain (Enclosure)

Domain is a relatively 'unstructured ground' on which places & paths appear as more pronounced 'figures'. It has a unifying function; it 'fills out' the image & makes it coherent. It can be defined as the particular activity of humans in the area influenced by physical, functional, social & cultural factors.



Figure 2: Bauhaus building in Dessau Germany, by Walter Gropius (1926)

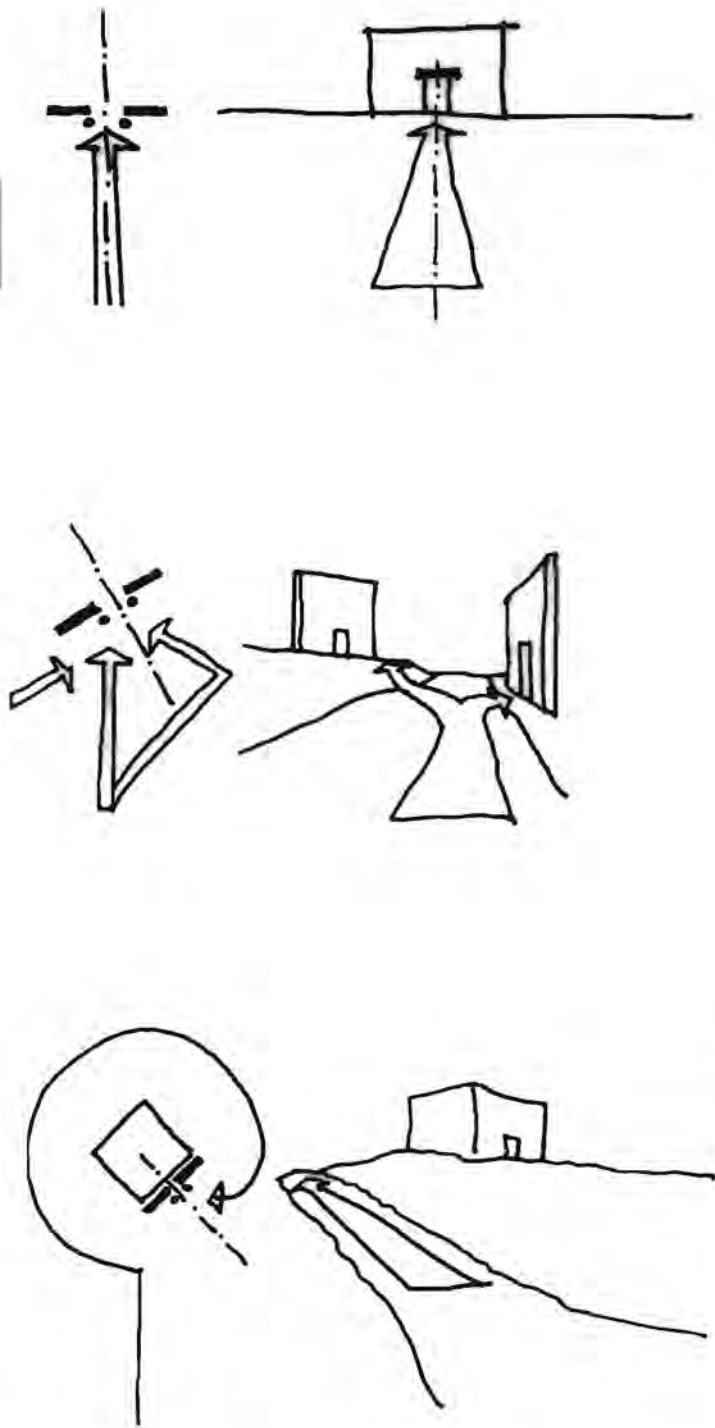

Figure 3: Diagrams showing Approach towards a building, drawings by author, adapted from DK Ching.

Now that the body can move around freely, orientate itself in space & experience it fully with all the senses, it is ready to experience architecture. The path of our movement can be conceived as the perceptual thread that links the spaces of a building, or any series of interior or exterior spaces, together. Since we move in TIME, through a SEQUENCE of SPACE, we experience a space in relation to where we've been & where we anticipate going. DK Ching categorizes movement/circulation of a building into five branches: [Ching, 1996 - 229]

1. Approach

Prior to passing into the interior of a building, we approach its entrance along a path. This counts as the first phase of the circulation system during which we are prepared to experience, see & use the spaces within a building. Approaching a building can be done from different angles, e.g. frontal, oblique or spiraling around the building.

2. Entrance

Entering a building or a defined field of interior/exterior space, involves the act of penetrating a vertical plane that distinguishes on space from another & separates here from there; moving from inside to outside.

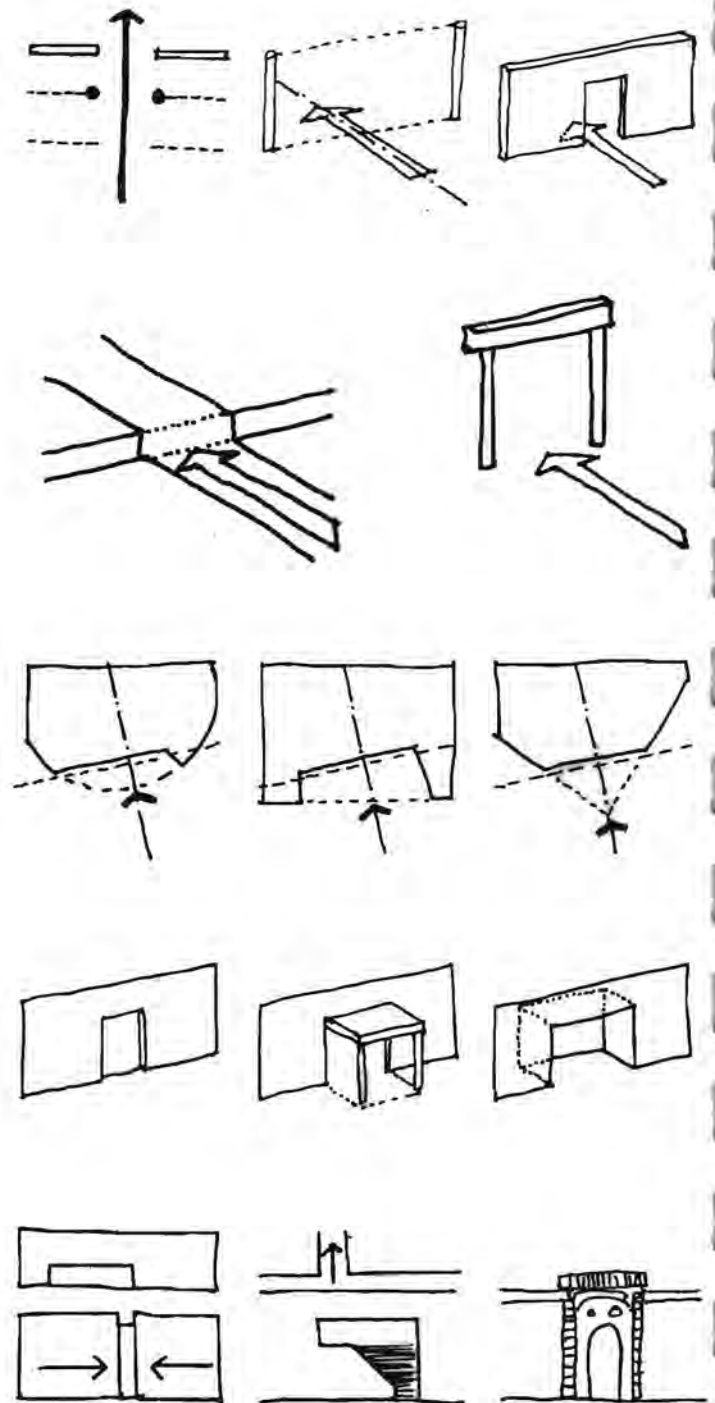

Figure 4: Diagrams showing Entrance into a building, drawings by author, adapted from DK Ching.

3. Configuration of the path

All paths of movement, whether of people, cars, goods, or services, are linear in nature. All paths have a starting point, from which we are taken through a sequence of spaces to our destination. The intersection of paths is always a point of decision making for the person approaching it. The continuity & scale of each path at an intersection can help us distinguish between major routes leading to major spaces & secondary paths leading to lesser spaces. Once we are able to map out in our minds the circulation routes, our orientation within the building & our understanding of its spatial layout will be made clear. Path can be linear, radial, spiral, grid, network or a composite.

4. Path-space relationships

Paths may be related to the spaces they link in the following ways: they may pass by spaces, pass through spaces, or terminate in a space.

5. Form of the circulation space

Spaces for movement form an integral part of any building organization & occupy a significant amount of the volume of a building. If considered as functional linking devices, then circulation paths would be endless,

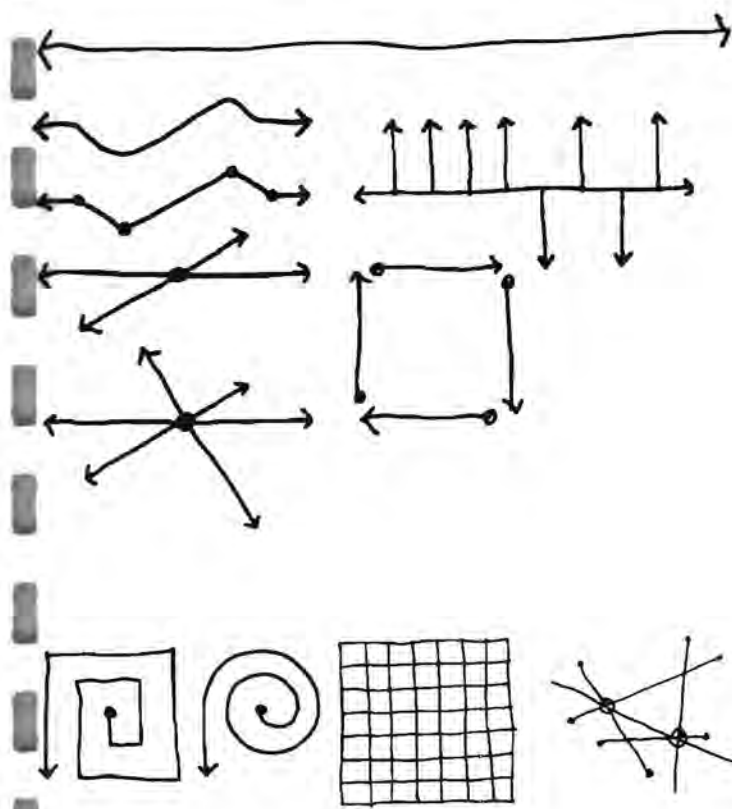
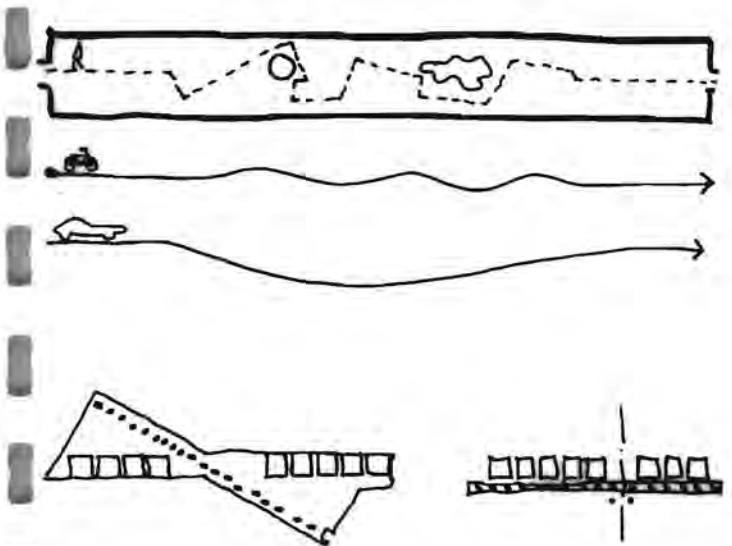

Figure 5: Diagrams showing the Configuration of the Path, drawings by author, adapted from DK Ching.

corridor-like spaces. The form & scale of a circulation space should accommodate the movement of people as they promenade, pause, rest, or take in a view along a path. The path can be enclosed, open on one side or open on both sides – depending on the program.

Through applying these five 'branches of movement' to the actual movement of the body through a building, one can start to understand the way architects need to think about movement through a building. Movement is not left over space in a building after the main hall has been designed. The movement/circulation space can become the so called 'starting block' for the design to take shape around it. This is where designing with movement becomes exciting. When moving through the spaces of a building (from the approach all the way to the exit again) the designer can start manipulating the actual movement of the user.

This is where the architect becomes the composer of a music piece, manipulating the architecture to function as a building according to the program, but also making it rich experience for the user. Ways in which one can manipulate the movement of the user:

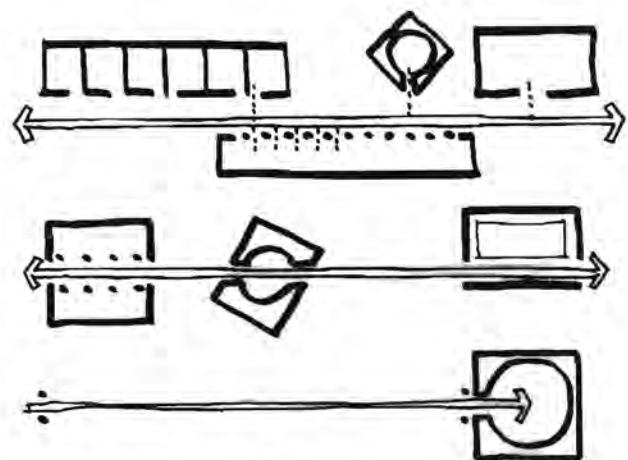

Figure 6: Diagrams showing the Path-Space Relationship, drawings by author, adapted from DK Ching.

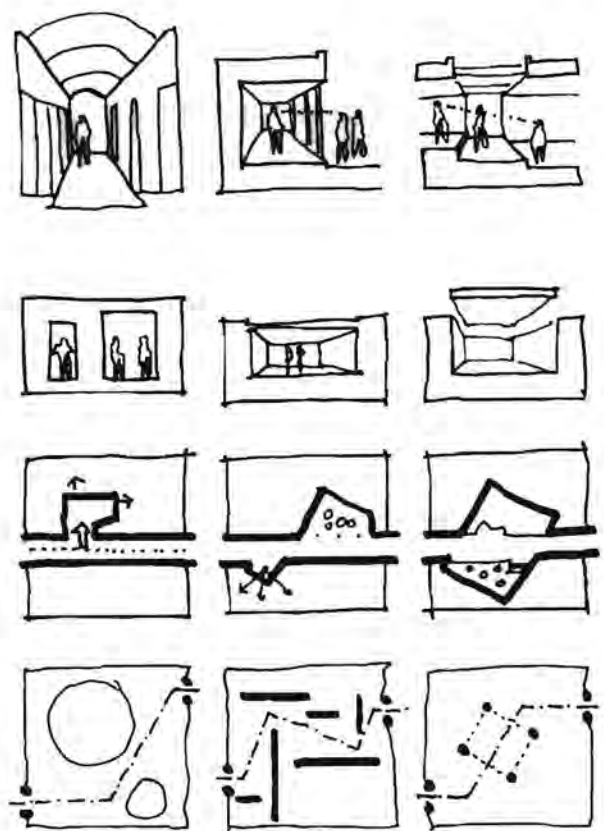

Figure 7: Diagrams showing the Form of the Circulation space, drawings by author, adapted from DK Ching.

1. Rhythm:
Rhythm occurs as a result of the change in temporal space between one movement and the next movement. It can also be defined as the regular repeated pattern of movement or the recurring sequence of events. Rhythm creates scale in a building or even in a façade. It can be seen as a repetition device to organize forms & spaces in the building through e.g. structural elements. Rhythm may also be interrupted to announce an important moment in the design, like an entrance way.

2. Time:
Time is defined as the indefinite continued progress of existence & events in the past, present & future. Time is needed to experience space in different ways: be it temporary structures or a permanent architectural installation; day or night, light or dark; summer or winter. All these aspects derived from time become design elements in the movement of the body, in time, through the building. Architecture's relationship to time is typically posed in terms of the representation of motion. The representation of time and motion in architecture has been a persistent theme throughout its history. It was Siegfried Giedeon's Mechanization Takes Command and Space, Time, and Architecture

that established these themes as the primary concern of Twentieth Century architectural theory and design. Yet, despite the experiments of the early Modernists, architecture remains as the last discipline dedicated to statics.

3. Continuity:

Related to both rhythm and time, continuity explains events in time. It may be unbroken or constant existence or operation of something over a period of time. Edmund Bacon on Continuity of experiences:

"The role of the design in the city should be to create a harmonious environment for each individual – from the moment he rises in the morning until he retires at night. Movement through space creates a continuity of experiences derived from the nature & form of the spaces through which the movement occurs. This gives the key to the concept of a movement system as a dominant organizing force in architectural design. If one can establish a track through space that becomes the actual path of movement of large numbers of people, or participants, and can design the area adjacent to it to produce a continuous flow of harmonic experience as one moves over that track in space, successful designs in cities will be created. In other words, to the extent that the designer can project himself into the mind & feelings of the participator & so perceive his design as it is to be experienced by those for whom it was created, to that extent will the design achieve its original purpose. It is thus not just the destination, but the journey itself along a route is as important as the departure/arrival nodes." [Bacon, 1967 - 34]

4. Speed:

Speed is the rate at which you are moving. It may be fast, medium or slow, but all depends on the mode of transport, and the state/urgency of the user. One can start to design with speed by looking at the two extremes:

- + when moving FAST: makes the same space feel longer | bigger, so the detail intake level of the user is low. This also creates a space where the interaction of the user with the environment is very low. One's reaction time is also slower | longer that will create longer, more curvaceous bends.
- + when moving SLOW: makes the same space feel smaller, so the detail intake level of the user is high. This creates a space where the interaction of the user with the environment is very high. One's reaction time is also more rapid/short in time, which will create sharp bends & twists.

In looking at all these aspects of movement, one comes to the conclusion that movement is dependant upon a multitude of elements for it to 'function' properly. The aimless movement of a person in space without any senses is nothing more than a cellphone without signal on a deserted island – useless. In the end, movement cannot be looked at in isolation. It has to function with a multitude of different **simultaneous movement systems & simultaneous continuities**. Looking at the city from an urban point of view, Edmund Bacon states that:

"One must see the continuity of space experience in terms of a series of movement systems based on different rates of speed and different modes of movement, each of those interrelated with the others & each contributing its part to the total living experience in the city. There will be a sequence of simultaneous experiences for people who move about the city in automobiles, on highways and local streets, in busses & on railroads. The designer is also concerned with the impressions gained at the moment of transfer from a vehicle to the ground, & movement on foot to one or another destination in the city. It is possible to conceive the essential form of these simultaneous movement systems in three dimensions in space as an abstract design, from which the design structure of the project begins to emerge."

This principle can be applied to smaller scale projects as well, where the designer creates simultaneous movement systems of people, goods, water, etc. all linked into one. Norbert Schulz's 'existential space' consists of several overlapping & inter-penetrating systems which interact with each other in such a complex totality, that ambiguity & conflicts are bound to happen. [Norberg-Schulz, 1971 - 32] It is this ambiguity & conflict that creates spaces where chance meetings between people may occur. Without this element, a room just stays a room, and a movement route stays just that. These systems must intersect and join at various points.

The concept of simultaneous movement systems can better be understood by looking at some of Paul Klee's diagrams & writings on movement systems. Klee says:

"As we look at a tree we see in its basic design a form which is capable of growth & which is a direct physical expression of a series of basic movement systems. The seed of the tree contains the initial impulse for growth, a directive which results in a series of tubes possessing a common quality: unity of direction or parallelism, and, in relation to the environment in which they are located, a purposeful vertical direction. The trunk of the tree, which establishes the path of movement of thousands of tubes, diverging in the branches & delivering the chemicals necessary for growth to the leaves, can be likened to a city's movement systems. Water acts as the vehicle to propel the chemicals to the leaves, and in turn it evaporates into the air. The point of change from water to vapor is the place where the flowers and fruit develop. So in cities the points of connection between systems should be places of special emphasis and design enrichment." [Bacon, 1978 - 128]

The diagrams based on Paul Klee's work illustrate the flow of lines of energy along the veins & sub-veins radiating outward from the stem of the leaf, & from them, the outward flow of the flesh of the leaf. This flow of energy expires in space, the points of expiration determining the form of the leaf. With the tree itself, a more complex expression of precisely the same principle is manifest: the form is determined by the location of expiration of the energy of growth in relation to the point where the seed was planted in the earth. The Klee watercolour adds another dimension to the structural movement of energy within the city: the creation of fields of quality at the points of convergence of movement systems. Since the veins of a leaf or the branches of a tree are comparable to the channels of movement of people & goods within a city, we see the parallel between organic structural forms and the city movement system, their sequential effect on the sensibilities of the people who move over them, and the resulting effect on the appearance and character of the city adjacent to them. In this painting we see that it is the movement systems which determine the shape of the fields of influence. These vary in intensity with the degree of movement, overlapping one another as they radiate outward.

Movement, in time, through space, is thus a multi-faceted action of the human body in and around architecture. But can it be seen as a design generator, rather than left-over, second-hand space?

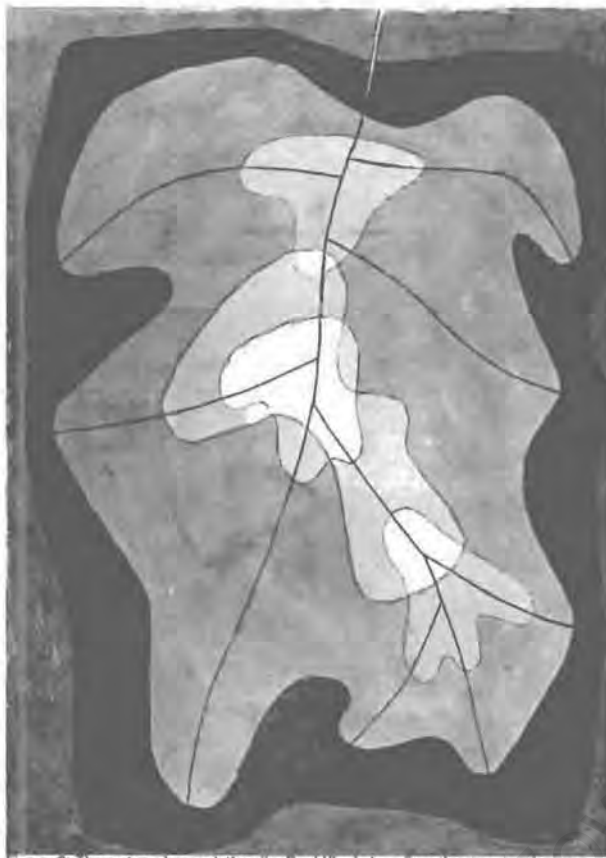
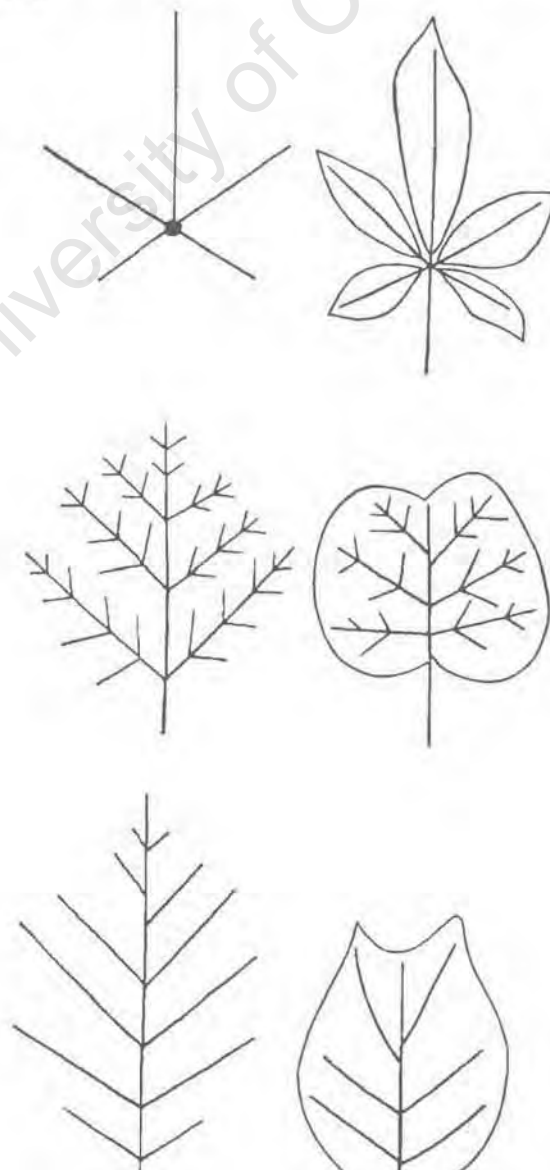

Figure 8: The watercolour painting (by Paul Klee) describes the structural movement of energy within the city – the creation of fields of quality at the points of convergence of movement systems

Figure 9: Diagrams based on Paul Klee's work on movement systems. The diagrams illustrate the flow of lines of energy along the veins & sub-veins radiating outward from the stem of the leaf, and from them, the outward flow of the flesh of the leaf. This flow of energy expires in space, the points of expiration determining the form of the leaf.



Circulation space in a building is usually conceived as the 'in-between' space in a building. It doesn't belong to the space you entering into or to the space you are exiting out of. It is seen as space to take you from one place to the next – a connector of sorts. To be out of place is not to be in another place but somewhere in between. A 'non-place' is what Marc Auge terms the interstitial location between here & there. Non-places are detached from any localization or social networks and tend to be anonymous. [Auge, 1995.] Mobility is concerned with how one occupies the duration between places. In the void of travel, the passenger 'kills time' & finds himself in a spatial threshold, and this threshold is formed by the mode of transport. It is then ironic when Tschumi speaks of the circulation space as the place where everything happens:

"... most of the culture of the school is not happening in the classroom. It's not happening in the seminar room. At Columbia it's on the steps, on the staircase, on the landings where people smoke forbidden cigarettes. It happens just exactly in these residual spaces. So I thought that if I design a school of architecture, why not design residual space and place some of these major activities (in other words, in this case, the places of meeting, the bar, the auditorium, the exhibition space) within that space?" [Tschumi – Jerusalem Seminar in Architecture]

He continues in saying:

"Architecture does not begin with the predictable layout of the seats, and not only the skin and the large-scale envelope, but in the in-between space, in the interstices between the two envelopes. The space of the in-between, that heterogeneous space, that space that had been defined and that space that was going to be the space of movement." [Tschumi – Jerusalem Seminar in Architecture]

The space of movement can function as different elements in a building, depending on the program & context. Going back to Klee's analogy of the flow of energy, one can say that the movement space acts as an exchange of energies between spaces. The movement space functions as a:

+ CONNECTOR:

the means to establish a direct physical connection between spaces.

+ BARRIER:

a separating element between spaces that need not be connected.

+ FILTER:

the means to make connection indirect. A filter is something that passes through a device to remove unwanted material. The movement space as a filter gives the user a choice to stop | extend the journey or turn left | right & by doing this it filters the users into different specific directions.

+ SWITCH:

connect at will; a means to regulate the connector. Here the movement pattern can be altered with adding movable devices in the directed path.

The IN [-] BETWEEN

An exhibition, 'First International Architecture Biennale Rotterdam Mobility, A Room with a View', held in 2003, focused on the importance of mobility routes not only being traffic space but also public space, space in which to be (a fact seemed to have escaped the attention of policy makers). It called for a different way of looking at how mobility is embedded in everyday life. One part of the exhibition focused on new urban planning principles in looking at the route as a place where stuff happens: what one sees and does while moving through the urban fabric.

Therefore, even if the movement space is the in-between space, it still functions as a place with an event. A simple bench in a circulation space creates a whole different dynamic for that space – it makes a place out of the non-place.

Furthermore, one can see from the analysis by Ching that movement through space is like telling a story – first approach, then enter inside, then walk through, then exit... Spatial sequences imply movement of the observer. The path of our movement can be concealed as the perceptual thread that links the spaces of a building, or any series of interior and exterior spaces together. Ching argues that all paths have a starting point from which there is movement through a sequence of spaces to the destination [2007: 264]. Being an architect one gets the chance to design this sequence of events the user will experience in a building. Experiential architecture is about that path unfolding through movement.

Movement is not goal orientated. Sequence is a particular order in which related events, movements, or things follow each other. [American Oxford dictionary] It defines a discontinuous (and not always linear) succession of individual events that are linked, not necessarily formally but by means of infrastructure, & separated rhythmically by variable intervals of time & longer & shorter intercidences. It is thus not just the act of connecting the one space with the other where nothing happens along the route. It is all about the story the architect want to tell. The question one must ask oneself in designing in this frame of mind is how & why & when & where does this happen here & there... this is where memory comes in...

Memory is what makes us aware of time & the sequence of events in the architecture. In the film "Memento" the lead character Leonard (Guy Pearce) has lost his ability to remember. Every day he has to establish with the help of tattoos and notes, where he is, when it is and where he is going. In fact, the film illustrates the power of memory when he distorts his past to "manipulate his future self" to commit an unmotivated murder.

Without memory it would be impossible to experience architecture. Without memory we cannot determine our place in the world. It is through memory that we can understand the moving image – we remember the preceding frames, and our minds can follow the trajectory of movement.

"They establish a memory of the preceding frame, of the course of events. Their final meaning is cumulative; it does not depend merely on a single frame (such as a façade), but on a succession of frames or spaces". [Tschumi, *The Manhattan Transcripts*, 1994]

A film is often called a "movie" or a "motion picture", since the narrative is conveyed through a rapid succession of images giving the illusion of continuous movement. The architecture of Bernard Tschumi is inspired by cinematic terms and techniques. Tschumi is only one example of an architect working with this sequence of events unfolding and writing a 'script' for the user.

"There is no architecture without the movement of bodies in space, no architecture without program, without activities and without event." [Tschumi, *The Manhattan Transcripts*, 1994]

This, in a sense, is the theme of Tschumi's architecture - passing time in space. The form of notation done in *The Manhattan Transcripts*, which was developed to a large degree into space, movement and event, or as Tschumi calls it, SEM – is what gives the meaning to architecture for Tschumi. Architectural sequences, according to Tschumi is:

1. Transformational Sequence

Internal, a device for working. Like layers of trace paper in an iterative design process. This process may be based in intuition and habit; or it may be based on precise transformative rules. There are closed sequences with predictable ends and there are open sequences without closure.

2. Spatial Sequence

Constant throughout history. They are endless in their morphological variation. They have a planned path with fixed halting points. They vary in scale and complexity. They are productions of geometry. Spatial and transformational sequences rarely intersect.

3. Programmatic Sequence

Incidents super-imposed on spatial sequences. Collections of events strung along collections of spaces. They are social and cultural. Is there ever a causal link between spatial and programmatic sequences?

he SEQUENTIAL

Tschumi's Parc de la Villette in Paris (1982) is an urban park designed with consideration of the temporal quality of space, and the spatial quality of time derived from movement. The Cinematic Promenade is regarded as a film strip composed of a montage of sequences and frames. Successive frames of individual gardens represent the image track, and connecting pedestrian walkways represent the sound track. Tschumi argues that a cinegram is created by the rapid succession of frames, and therefore exists as a superimposition of independent parts. The relationship between the independent frames and the whole is essential in the understanding of the film, and the sequence of events becomes important. As one can see in the competition drawings for the park in figure 11, one starts to understand the notion of movement as a sequential way of form-making. The design panels are laid out like story boards describing different spatial sequences by walking through the park. The approach behind La Vilette suggests meeting points, anchoring points where fragments of dislocated reality can be apprehended – deconstruction. [Tschumi, 1994 - 179]

As years went by, the multiple interpretations that multiple architects gave to deconstruction became more multiple than deconstruction's theory of multiple readings could ever have hoped. For one architect it had to do with dissimulation, for another, with fragmentation; for yet another, with displacement. Again, to quote Nietzsche: "There are no facts, only an infinity of interpretations." And very soon, maybe due to the fact that many architects shared the same dislike for the *geborgenheit* of the "historical postmodernists" and the same fascination for the early twentieth century avantgarde, deconstructivism was born - and immediately called a "style" - precisely what these architects had been trying to avoid. Any interest in post-structuralist thought and deconstruction stemmed from the fact that they challenged the idea of a single unified set of images, the idea of certainty, and of course, the idea of an identifiable language.

Deconstructivism (Deconstructivist Architecture 1988, by MOMA) allows any conflicts between incompatible planning factors to remain unresolved and relieves the architect of responsibility for imposing a synthesis that would compromise the honest expression of those factors. The resulting building may therefore defy conventions of rational order in structural assembly and spatial organization for the sake of honoring the disorderly truth imposed by competing factors in the environment. Thus, it involves designing buildings in such a way that the user must negotiate his/her way around, in, and through a building on the basis of a series of experiential decisions, without knowing a predetermined path. Maybe this is the primary reason Tschumi used the deconstructionist theory of Jacques Derrida – to deconstruct a building is to force the user to move around in order to 'understand' the architecture.

Looking at this example, one realizes that the movement space itself is not a 'non-place', but a in-between space filled with multiple design possibilities ready to be designed & explained through the sequential mapping of the user through space. But can this sequential mapping of the user become physical form? Can it become a building, architecture? And if so, how do architects notate movement?

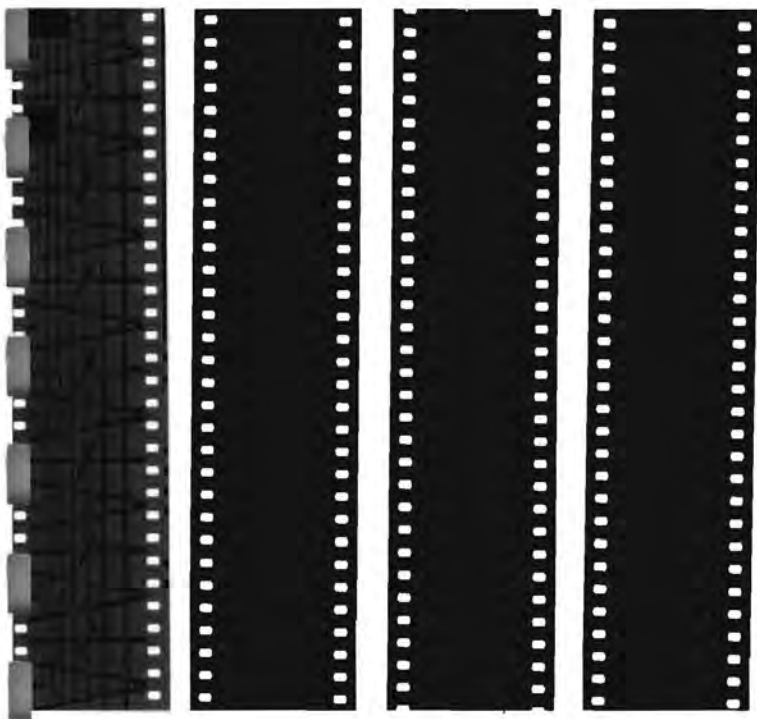

Figure 10: 'Motion Picture' filmstrip, by author

Sequence 1: Ourcq Canal, covered Galerie, Promenade cinématique, Folie Astronomique, folie des Enfants, circles of trees.

Sequence 2: Along the Ourcq Canal the covered East-West Galerie with a jogging path on the roof (the Pododrome).

Sequence 3: Isolated Folie with access ramp.

Sequence 4: north-South covered Galerie along the Great Hall, and the folie de la Gastronomie.

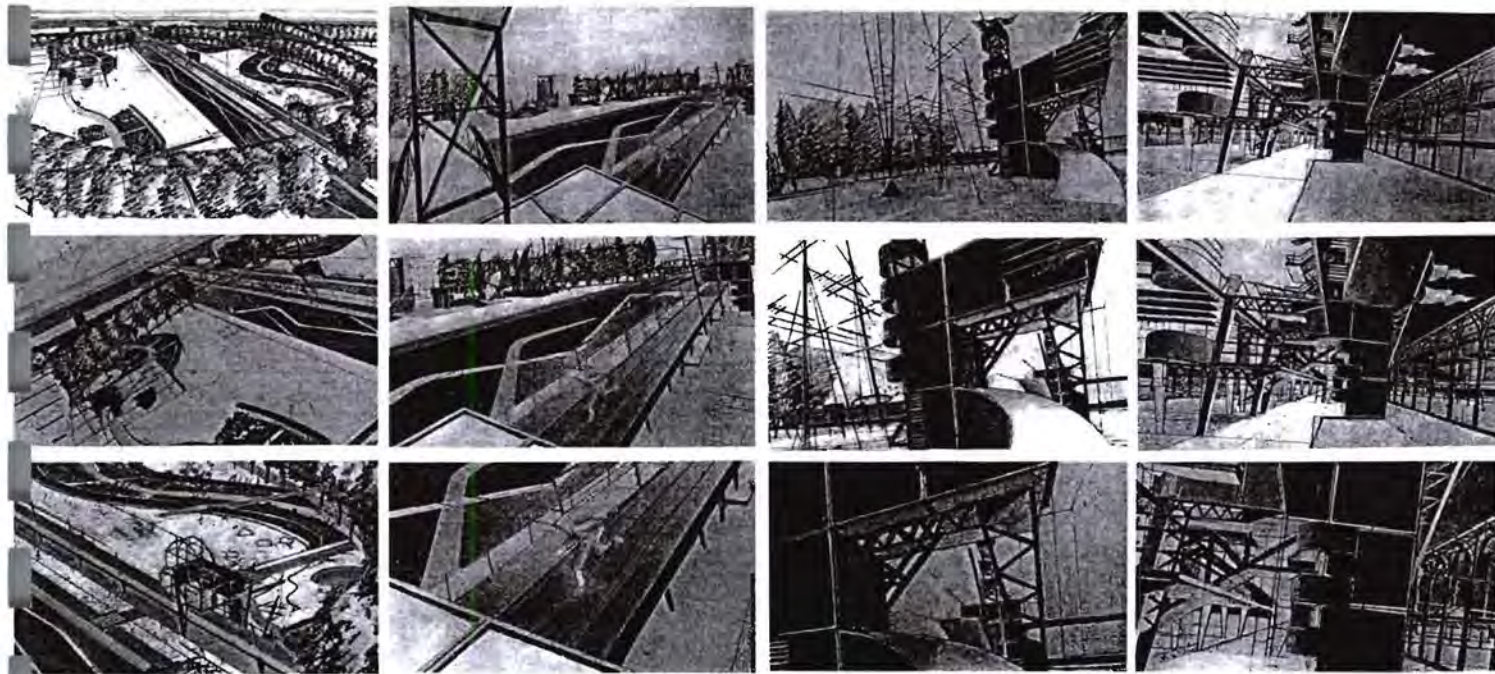

Figure 11 Storyboard for Parc de La Vilette

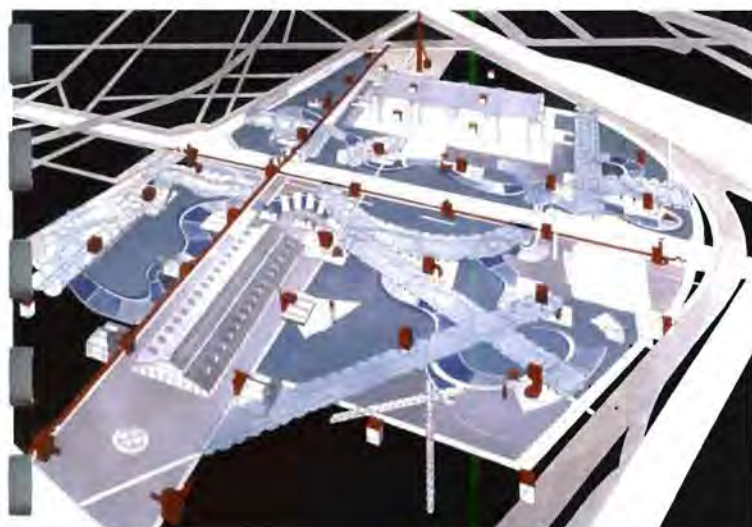

Figure 12: Plan of Parc de La Vilette



Figure 14: Marcel Duchamp's 'Nude Descending A Staircase' (1912)



Figure 15: 'Les Femmes d'Alger' (O.J.) by Pablo Picasso (1906-1907)



Figure 16: 'Unique Forms of Continuity in Space' by Umberto Boccioni's (1913)



Figure 17: Photo by Harold Edgerton (1938)

SOLIDifying movement

How does one capture movement on paper, in sculpture, in architecture? Existing tools of design focuses on static snapshot state of things – models, drawings etc. & rarely makes any mention of the factor of time – they seem to illustrate the 'perfect' moment in time. Notation in time is used in science, dance, music, animation & film for choreographic layout, score, storyboards, etc. It uses the creative skills of observation, selection & interpretation, so as to analyse the movement of bodies in space, and then laying it down on paper. Architecture could benefit from the study of time notation in other disciplines so as to develop principles & techniques for the use & representation of time in design. See figure 13.

Figure 13: Movement Notations

Movement of viscous fluid behind a stationary cilinder

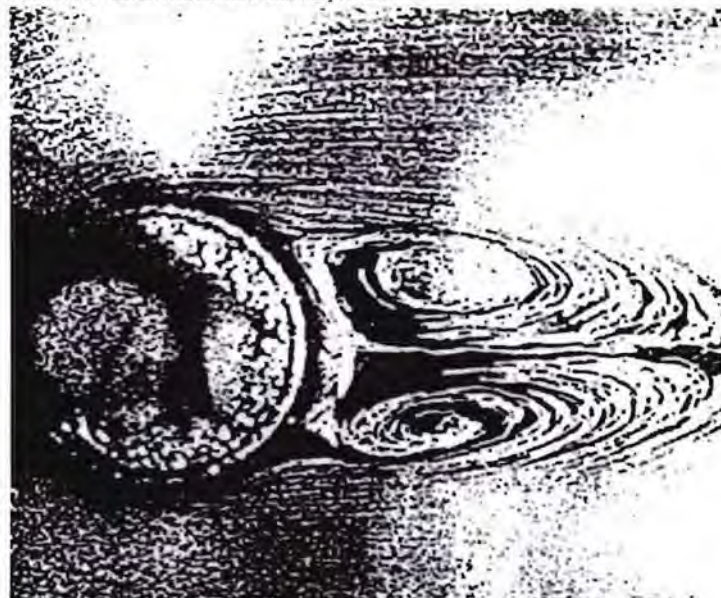

Kinetic Architecture – the spatial organization of daily mobility within a Public Bathhouse

Liquid flow behind an obstacle





Figure 18: Jackson Pollock's painting Blue Poles (1953)

Painting and photography allow the artist to capture a moment in time. That moment is frozen ... or is it? Numerous artists have attempted to depict motion and to show movement over time: [http://www.artsology.com/motion_in_art.php]

- In Marcel Duchamp's *Nude Descending A Staircase* from 1912, the person is painted as if there were multiple depictions of the same person going down the stairs; the viewer can see each step being taken. [figure 14]

- *Les Femmes d'Alger (O. J. Version O)* (produced by Pablo Picasso between 1906-1907) – the synthesis of different viewpoints into a single optical experience. Picasso's extraordinary decision to compress what normally occurs in time & through space, magnified the existence of both space & time as autonomous artistic and, ultimately, architectural concepts. (also known as cubist simultaneity) [figure 15]

Umberto Boccioni's sculpture, titled *Unique Forms of Continuity in Space* from 1913, also shows a person in motion. The sculptor's aim was to illustrate the interaction of a moving object with the space that surrounds it. [figure 16]

Motion from a dance choreography - G. Balanchine

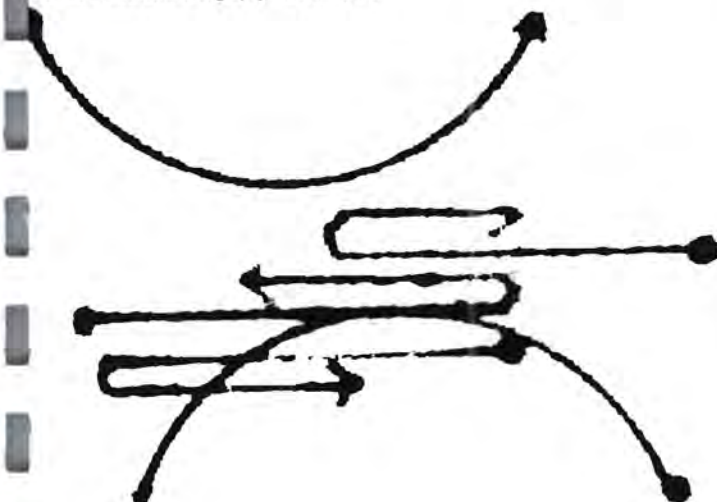

- In this photograph from 1938, one can see Harold Edgerton's technique of using multiple flashes during the process of taking the picture, which allowed the camera to capture high-speed motion. Here we see the golf club during the full range of its swinging motion. [figure 17]

- Jackson Pollock's painting *Blue Poles* from 1953 is an abstract painting whose imagery is the result of motion - the motion of Pollock taking his paintbrush and flicking paint across the canvas. To some extent Pollock realized that the journey toward making a work of art was as important as the work of art itself. Artists realized that Jackson Pollock's process - placing unstretched raw canvas on the floor where it could be attacked from all four sides using artistic and industrial materials; dripping and throwing linear skeins of paint; drawing, staining, and brushing; using imagery and non-imagery - essentially blasted artmaking beyond any prior boundary. Pollock made conscious motions to get the effects he desired. (also known as abstract expressionism) [figure 18]

Music notation - H. Pousseur

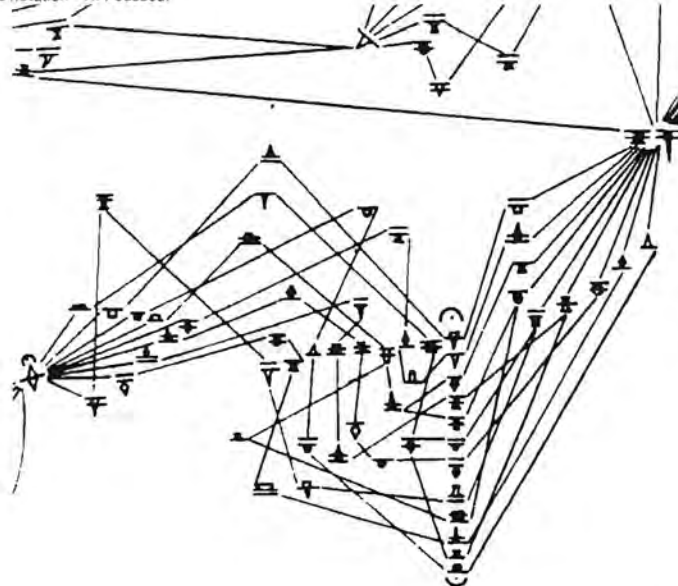

In contradiction towards these views, Eisenstein writes: "Painting has remained incapable of fixing the total representation of a phenomenon in its full visual multi-dimensionality. Only the film camera has solved the problem of doing this on a flat surface, but its un- doubted ancestor in this capability is — architecture..." [Bois, 1989]

Can architecture then be seen as the ultimate three- dimensional notation system?

Architects usually start out drawing diagrams. The diagram can be seen as a map or cartography of movements. As a medium, the diagram plays a dual role. It is a manner of notation (analysis, of recognition & of reflection) but also a machine of action (generative, synthetic & productive). This projective condition alludes to the operative nature of the diagram as an abstract machine — as Gilles Deleuze calls it — in turn capable of spurring and channeling processes & actions. The diagram thus becomes the essential bit of action. A synthesis of evolutionary forces, vectors and possible events.

"It can never be free of value or meaning (...) while it explains relationships in an architectural object, it is not isomorphic with it. (...) unlike traditional forms of representation, the diagram as a generator is a mediator between a palpable object, a real building, and what can be called architecture's interiority." [Eisenman, 1999 - 27]

What follows is some examples of how architects try to make sense of movement notation & ultimately making form.

Khan's movement diagrams of Philadelphia (1952-1953) was a way to plan the traffic movement. The great thing about the graphics is their ability to show intensity as well. Khan understood not just to draw the movement, but overlay it with more information than first meets the eye. [figure 20]

Le Corbusier develops the seemingly unproblematic idea of an architecture of movement, best exemplified by his classic icon of modernity: the **Villa Savoye (1929)** in Paris, one of the few built experiments in modern "space-time". Within his Oeuvre Complete, edited by Le Corbusier himself, the photographic sequence through the interior of the villa is inconspicuously subtitled "promenade architecturale". The building is inspired by Le Corbusier's five points of architecture. Pilotis allowed the building to be lifted and make circulation free. The free facade allowed him to frame periaptic views of the landscape. In the publication *Vers une Architecture* he refers to the Acropolis, as illustrated by Choisy and Eisenstein. Le Corbusier is aware of the movement of the viewer and the resultant change of view. The ramp is an important circulation element in his design, the architectural promenade that ultimately leads to the roof terrace. From here a exterior window frames another important view. [figure 21]

The Carpenter Centre for the Visual Arts at Harvard University, Cambridge, Massachusetts, 1961-1964

The modernist dream of movement in continuity, or a new kind of movement. Le Corbusier wrote: "a stair separates...a ramp connects." At this building the ramp traces the mobile section drawn by the observer in motion. Its path moves the spectator through the building, opens interior up to exterior, and connects the building to the life of the campus.

The ramp penetrates the building, slipping in between its parts, making visible the openness of the structure. One does not enter the building so much as pass through it. The ramp conditions the entire spatial organization: the ramp allows the observer to enter the building as the eye enters a painting, at the centre of its spatial field, as apposed to the hierarchical stacking of a classical façade. [figure 22]

Frank Lloyd Wright – The Guggenheim, New York (1959)

The movement through the building commences once one enters the elevator and ascend to the top floor. Thereafter the movement is a slow spiraling descending ramp on which artworks are displayed.

This movement through the building proved to be very unpopular to museum curators who have complained about the difficulty of exhibiting artwork on a sloped floor and curved wall. The movement pattern on the interior is transferred to the exterior façade with visible thick bands. [figure 23]

Kinetic Architecture — the spatial organization of daily mobility within a Public Bathhouse

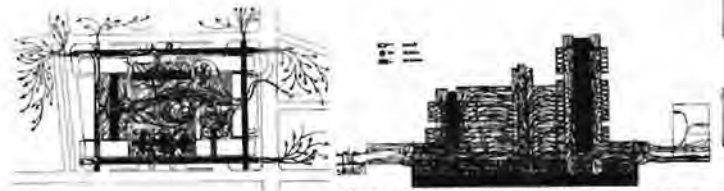

Figure 19: Rem Koolhaas (OMA), Circulation Diagram



Figure 20: Existing & new movement diagrams of Philadelphia, Louis Khan (1952-1953)



Figure 21: Villa Savoye by Le Corbusier, Poissy, East of Paris (1929)

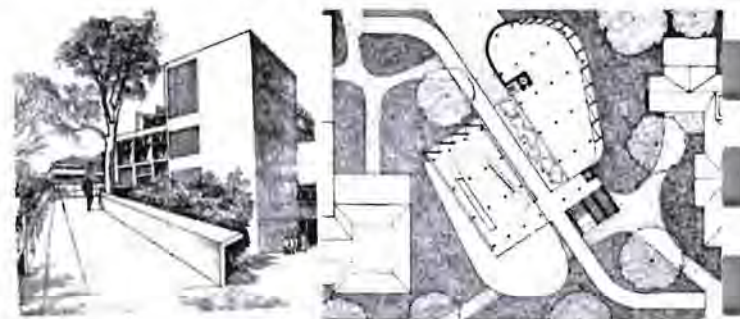

Figure 22: The Carpenter Centre for the Visual Arts at Harvard University by Le Corbusier, Cambridge, Massachusetts (1961-1964)



Figure 23: The Guggenheim by Frank Lloyd Wright, New York (1959)

Bernard Tschumi – Manhattan Transcripts (1976-1981)

Figures 30-33)

"If the spatial sequence implies the movement of the observer, then such movement can be objectively mapped & formalized – sequentially. Movement notation: an extension from the drawn conventions of choreography, it attempts to eliminate the preconceived meanings given to particular actions in order to concentrate on their spatial effects: the movement of bodies in space (dancers, footballers, acrobats). The final meaning of any sequence is dependant on the relation space/event/ movement." [Tschumi, c1994 - 162]

The Manhattan Transcripts (figures 24-26) is a series of drawings coordinated by Bernard Tschumi to illustrate an architectural representation of reality. In this representation a relationship is established between space, movement and events. "The Park" (figure 24) consists of a series of photographs and drawings illustrating the account of a murder. Photographs direct action, plans reveal the architectural manifestation, and diagrams indicate the movements of the main protagonists. The attitudes, plans, notations and movements are linked and together they define the architectural space of the park. Tschumi states that "in their individual state objects, movements & events are simply discontinuous. Only when they unite do they establish an instant of continuity".

The relationship between objects, movements and events formulates the architectural experience. These form three levels to which the element of time is introduced in the form of moments, intervals and sequences. In order to gain the complete experience the succession of one frame after another is necessary. "The Transcripts are thus not self-contained images. They establish a memory of the preceding frames, of the course of events, their final meaning is cumulative; it does not depend on a single frame but on a succession of frames and spaces" [Tschumi, 1994:11]. Similarly, movement through a building should be experienced as a sequence of events stimulating a sequence of experiences.

Influenced by poststructuralist texts as much as by the different techniques of film montage, the Transcripts were only introducing, in a theoretical manner, what is to be applied at La Vilette." [Tschumi, c1994 - 182]

"The Manhattan Transcripts, is to deconstruct architectural norms in order to reconstruct architecture along different axes; to indicate that space, movement, & event are inevitably part of a minimal definition of architecture, and that the contemporary disjunction between use, form & social values suggests an interchangeable relation between object, movement & action. In this manner, the program becomes an integral part of architecture, and each element of this program becomes an element of permutation akin to solid elements." [Tschumi, c1994 - 186]

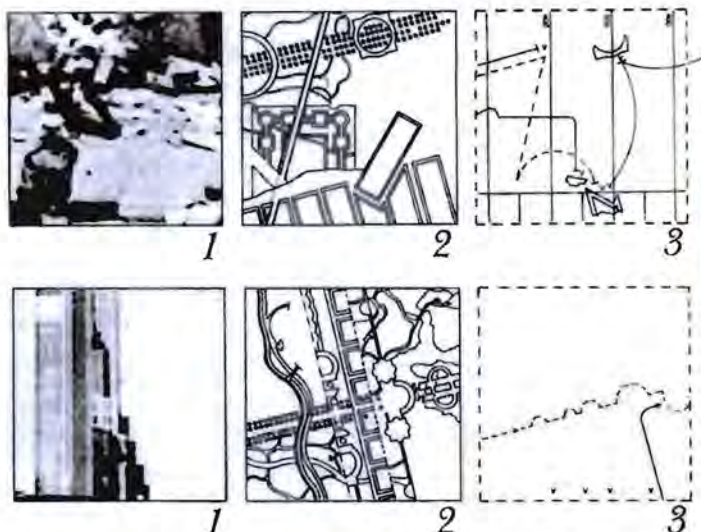

Figure 24: Manhattan Transcripts by Bernard Tschumi (1976-1981) – Excerpt from Episode 1: The Park

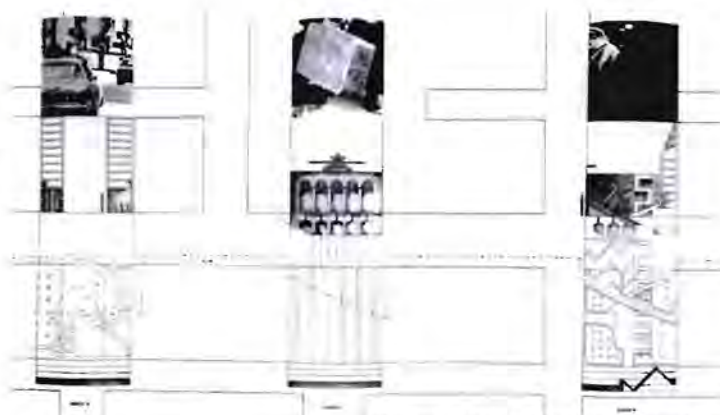

Figure 25: Manhattan Transcripts - Excerpt from Episode 2: The Street (Border Crossing)

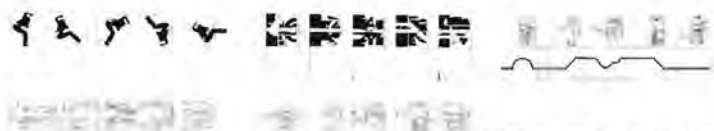

Figure 26: Manhattan Transcripts - Excerpt from Episode 3: The Tower (The Fall)

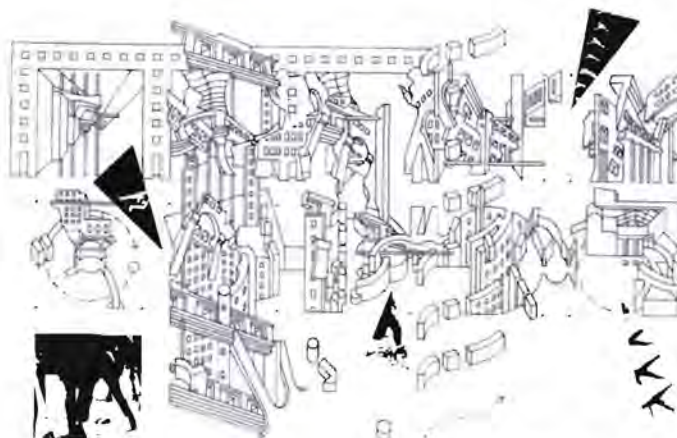

Figure 27: Manhattan Transcripts - Excerpt from Episode 4: The Block

Another architectural practice, UN Studio, looks at an architecture of systems, taking arbitrary movement diagrams & making them form a building focused on materials & scale.

MERCEDES- BENZ MUSEUM, STUTTGARD, GERMANY

Architects: UN Studio Date: 2006 [figures 28-30]

In this building, the architects use the double helix, of which lines never cross, as concept. The helix was interpreted into architecture by creating two ramps spiraling around each other, but never connecting. The exhibits are placed along the ramp and users spiral up with the one ramp, down with the other. The double helix concept allows users to have two experiences of the same building, depending on which route they take. This means that two groups of users can exist independent of each other. The routes in the precedent studies are designed not to cross. However, during the theory investigation process, it was established that, when lines cross, intensities are created at intersections. At the intensities an opportunity is given for dialogue between user groups and allows them to change direction from one route to another. A rhizome is formed, where all routes are connected to each other.



Figure 28: Movement Diagram for the Mercedes Benz Museum

MOBIUS HOUSE, AMSTERDAM, THE NETHERLANDS

Architects: UN Studio Date: 1996 [figures 31-33]

With this precedent, the design process is generated by an analysis of the uses to be accommodated, and how these uses can be connected to each other with a spatial loop – the mobius strip. The architects use the mobius strip to accommodate various strands of movement into one building. The mobius strip consists of lines that never cross but surfaces that interact. Spatially this can be interpreted as facilities being the points of interaction and not the paths.

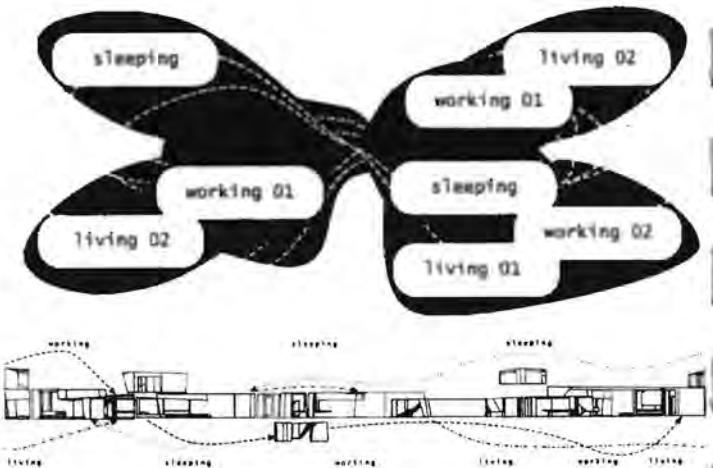

Figure 31: Living Sequence translated into the mobius loop

International Port Terminal in Yokohama

Architects: Foreign Office Architects (1996- 2002) [figures 34-37]

The project started from the possibility of generating organization from a circulation pattern, as a development of the idea of hybridization between a shed (a more or less undetermined container) and a ground. The circulation pattern was an attempt to move forward from similar approaches already developed during the 70's, where circulation was organized & then 'architecture' deployed on the circulation diagram, but in a more consistent manner in which circulation can literally shape space. According to the architects, a transportation building usually works as an INPUT-OUTPUT device, with very clear orientation: DEPARTURES & ARRIVALS.

They were interested in exploring the possibility of a transportation infrastructure that could operate less as a gate, as a limit, & more as a field of movements with no structural orientation. Their first move was to set the circulation diagram as a structure of interlaced loops that allowed for multiple return paths. The connection between the circulation paths was always set as a bifurcation, so that rather than setting the program as a series of adjacent spaces with more or less determined limits, they articulated them in the continuity of a branched sequence along the circulation system. The design team called this the 'no-return-diagram' & this was the first attempt to give the building a particular spatial performance.



Figure 34: Bifurcation Sequence illustrated in images

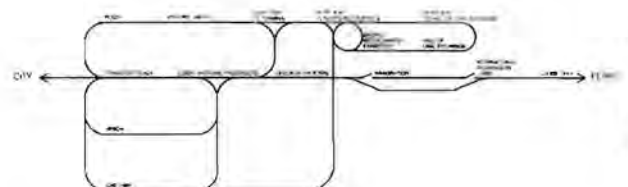

Figure 35: The no-return Diagram



Figure 29: Model (Final & floor sections) of the Mercedes Benz Museum



Figure 30: Mercedes Benz Museum by UN Studio, Stuttgart, Germany (2006)

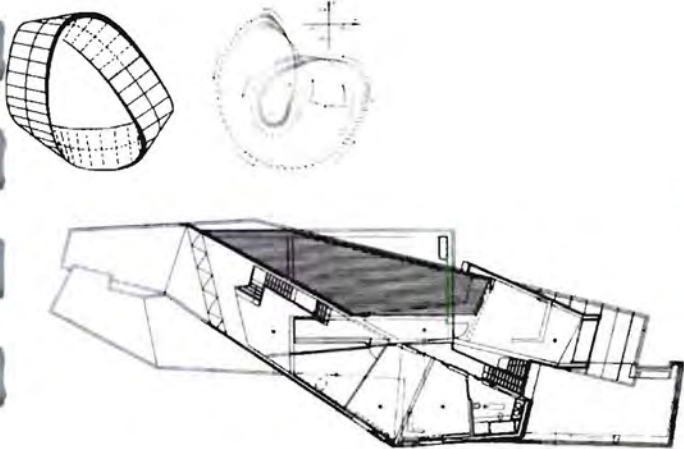

Figure 32: Plan of the Mobius house



Figure 33: Mobius House by UN Studio, Netherlands (1996)

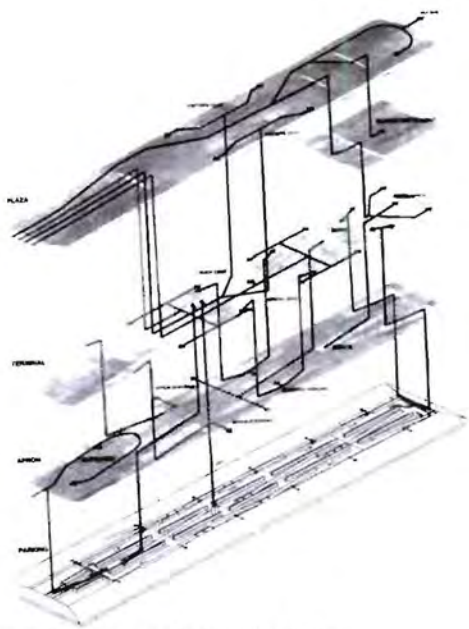

Figure 36: Movement Diagram becomes the form of the building

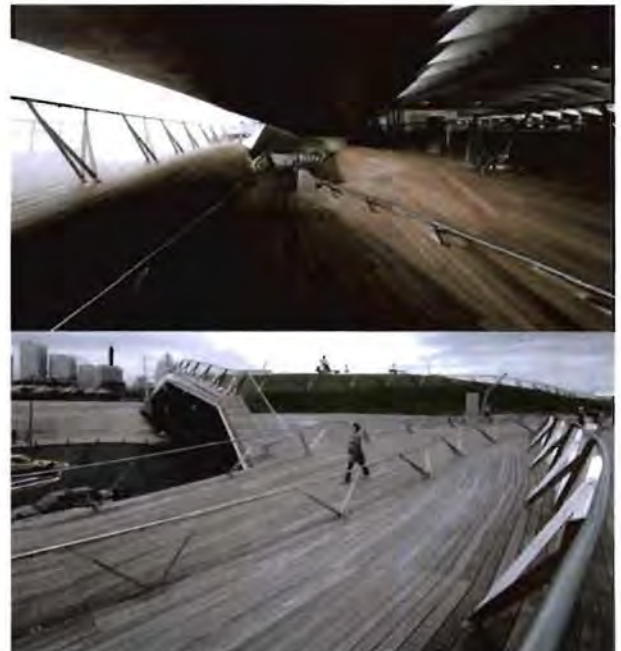

Figure 37: International Port Terminal in Yokohama by Foreign Office Architects (1996-2002)

Conclusion

As Henri Lefebvre has proposed, the realities of space as produced in practice perhaps always involve relationships among physical & sensual perceptions, mental or intellectual conceptions, and lived & imaginative experiences of what space is or might be. [Lefebvre; 1991] Ben van Berkel appears to understand this when he points out, for example, that architecture is more than language, more than thought, more than style, and more than programmatic elaboration. He asserts that physical movements in space are fundamental to the ways we are able to perceive architecture, and notes that the construction of place is predicated upon the bringing together of thoughts & perceptions. [Van Berkel & Bos; 1993]

Architecture is not about the conditions of design, but about the design of conditions that will dislocate the most traditional and regressive aspects of our society and simultaneously reorganize these elements in the most liberating way, where our experience becomes the experience of events organized and strategized through architecture. The movement of the human thus creates a path where his/her vectors again become the walls that are then transformed into the negative and this becomes the space – the spatial loop of movement. The theoretical possibility of defining space through movement alone, I think, is possible... to an extent. Analyzing movement on its own brings one to a dead end where it is exactly that – just movement. But movement has lots of interdependent auxiliary aspects to which an architect can respond in order to create spaces that speaks of: tempo, time, rhythm, sequences, seasons, memory, direction, journey, scenes, event - and this is where the poetics of movement comes in. So, its almost as if one must design with a 'movement + ...' perspective in mind. Whatever follows after movement (in the 'movement + ... equation) is up to the designer.

If one represents an architectural reality in a dynamic way, it will influence the way one designs. One perspective (movement alone) cannot stand in for the whole design. Architecture must evolve from the Renaissance architect where space is explored from a multitude of angles ("movement + ..." perspective). The journey must be scripted like a scriptwriter for a movie. The actor never just moves, he moves fast between the high buildings with an angry look in his eye while climbing the scaffolding with a broken leg and a gun in his left hand. When Greg Lynn says: "Architectural form is typically conceived as a modulating frame through which a mobile eye moves," [Greg Lynn, 1999] one can come to the conclusion that architecture demands movement, through space & time.

Can physical movement translate into form & ultimately into architecture? Bacon thinks, "Scientific thought in recent years has continuously led us further into the realization of the dominance of space & movement and to the notion that matter is really the product of movement in space." [Bacon, 1967 - p34]

Form-follows-function was first popularized by architect Louis Sullivan and Nicolas Cisneros at the beginning of the 20th century. May we say that form-follows-movement?

I truly believe that the choreography of movement creates wonderful pieces of architecture.

University of Cape Town

University of Cape Town

chapter 02.
Context - Site

University of Cape Town



South Africa
Western Cape



Cape Town City Bowl



Cape Town **Intermodal Interchange:** Raised Platform

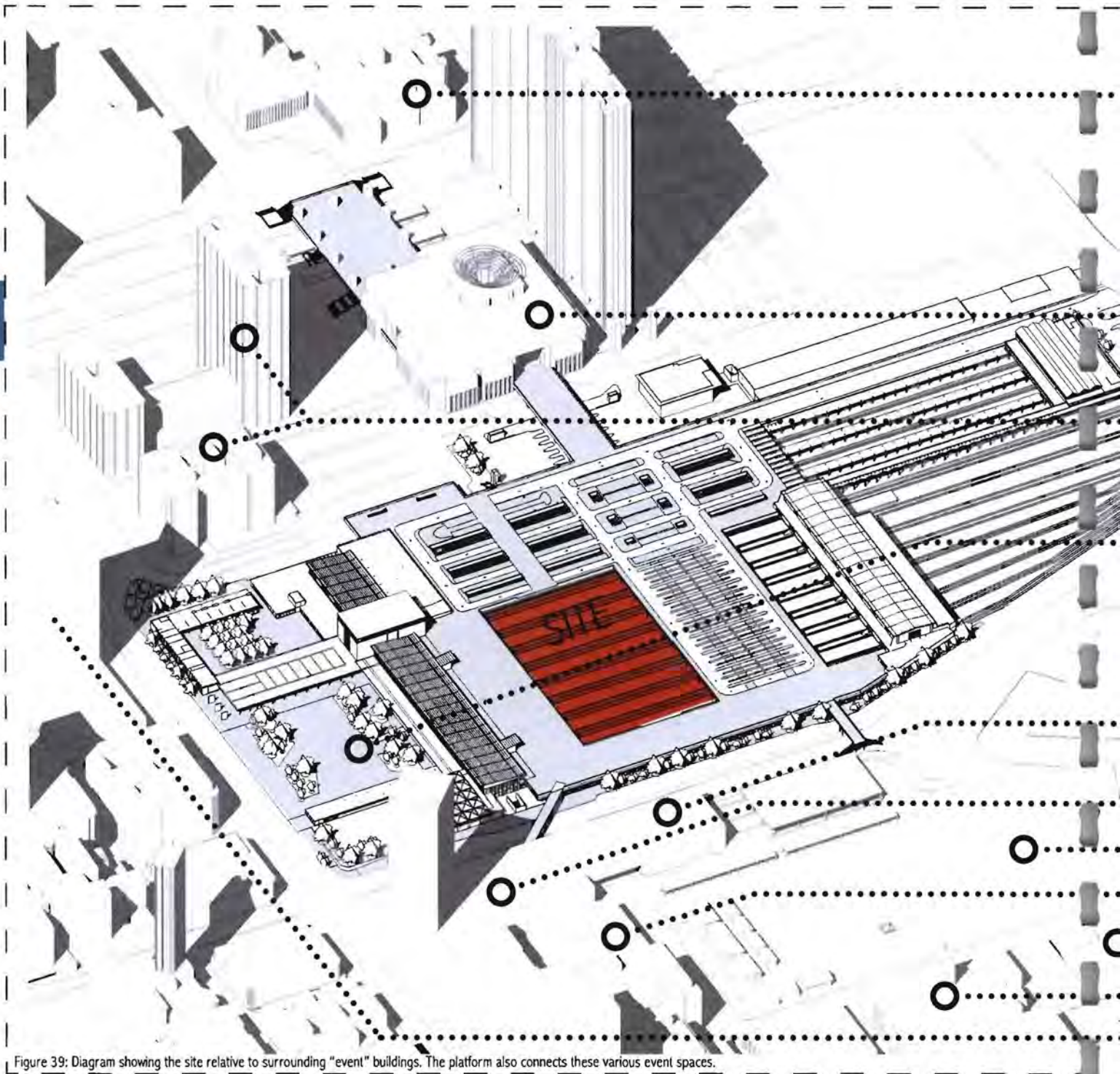

Figure 39: Diagram showing the site relative to surrounding "event" buildings. The platform also connects these various event spaces.

Reasoning behind the chosen site

Having done the research on movement [chapter 1] I decided that the principles & knowledge gained from the research must inform my decisions on choosing a site and program for the intended building & thesis project. The research led me more & more towards working at intermodal spaces. An intermodal space is an intersection of two/more modes or nodal lines and is, thus, a potential interchange. Some modes/nodes are materialised in space as railway stations, airports, network hubs, and ultimately, cities. It can also be described as the space where ones mode of transport changes. Having looked at various transport interchange sites in Cape Town CBD, I decided to focus my attention on the main Cape Town Train Station.

Kinetic Architecture – the spatial organization of daily mobility within a Public Bathhouse

The **Cape Town transport interchange** deals with some of the principles discussed on movement in the previous chapter:

A]

A transport interchange is in itself an **'in-between'** space. The transition point, where human becomes one with the machine (train, bus, car or taxi) and his feet are exchanged for moving wheels, is the place where all these people find themselves every day, changing from one mode of transport to the next. They commute far distances between house & work, township/suburb & town, squatter & citizen, here & there. The people using the public transport thus inhabit the 'in-between' state of being on the move between spaces – not being at the office or at home - but in-between. The Cape Town station together with the BRT station, taxi's and Golden Arrow bus station act as a portal to the city for a large community of commuters. In anthropological terms, Marc Auge has defined **'non-places'** as places resulting from new conditions of living and which are 'the real measure of our time'. Transit points, temporary abodes, dense network of means of transport which are also inhabited spaces' are among other non-places, characterized by "solitary individuality", 'the fleeting, the temporary & the

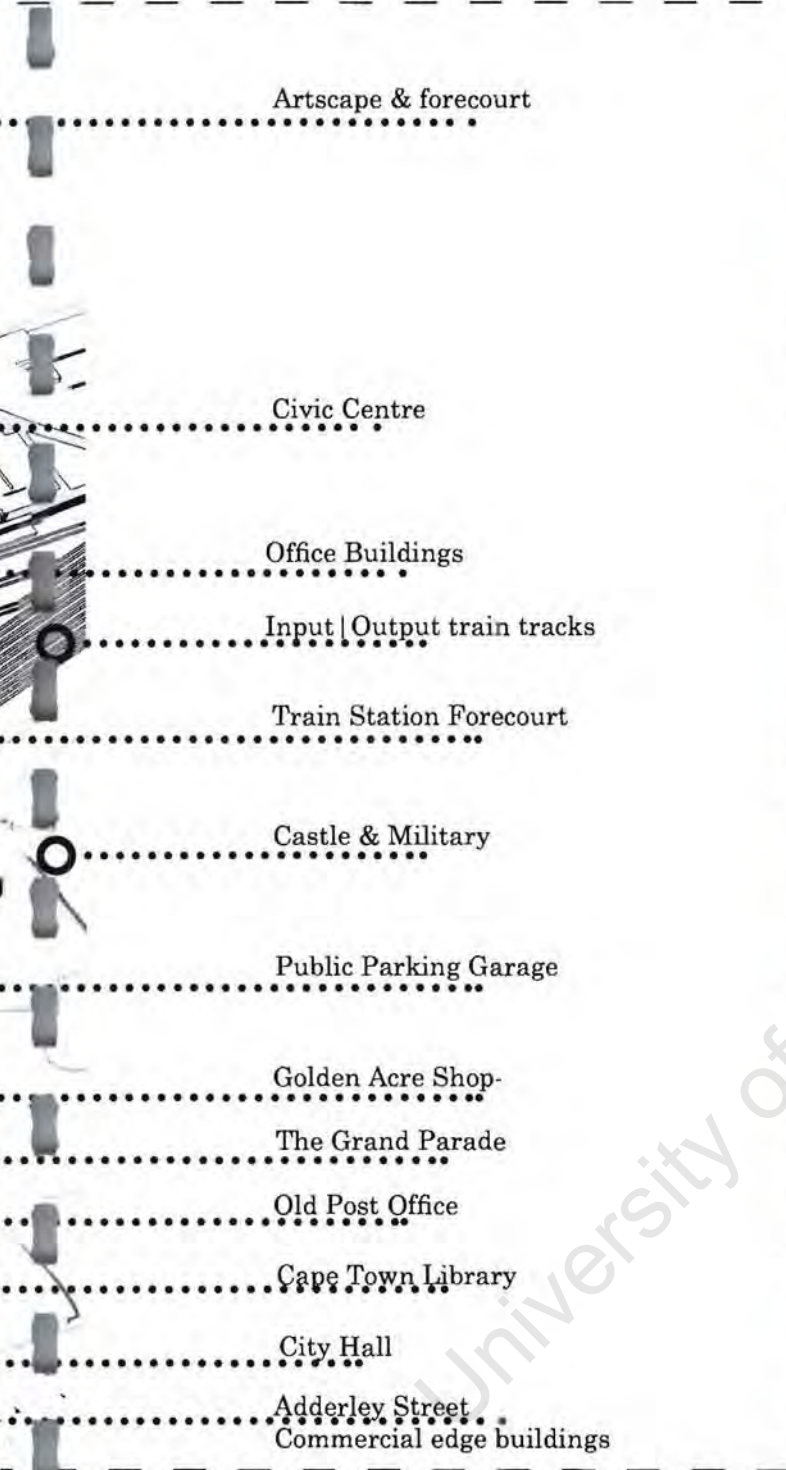

ephemeral', while maintaining some of the qualities of place: 'the invention of the everyday and the arts of doing', so subtly analysed by Michel de Certeau. [M. Auge, *Non-Places: introduction to an anthropology of supermodernity*; London, Verso, 1992; p78-79]

Pass through space, in-between space, intermodal space, transit space, threshold space, input-output – this is essentially the spatial framework of the spaces in the station. It is the constant routine: arrival – in-between – departure – journey – arrival – in-between – departure which drives the shape & form of these spaces.

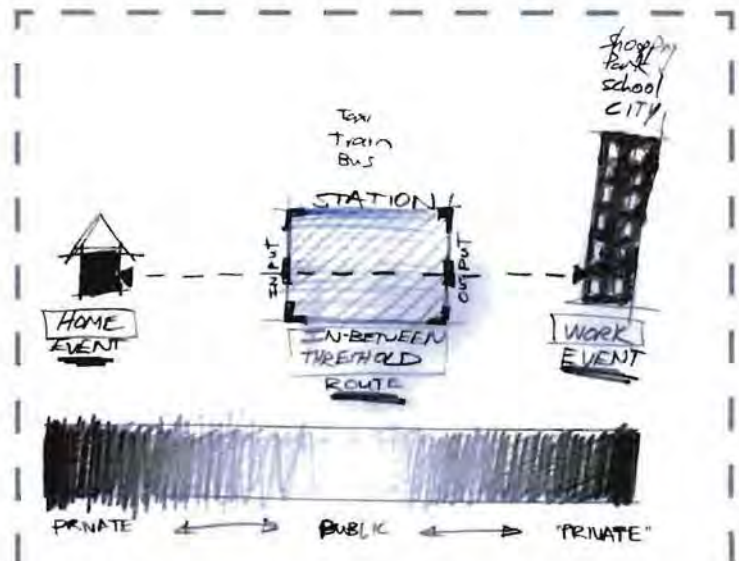

Figure 40: Conceptual thinking of site as a threshold 'in-between' space.

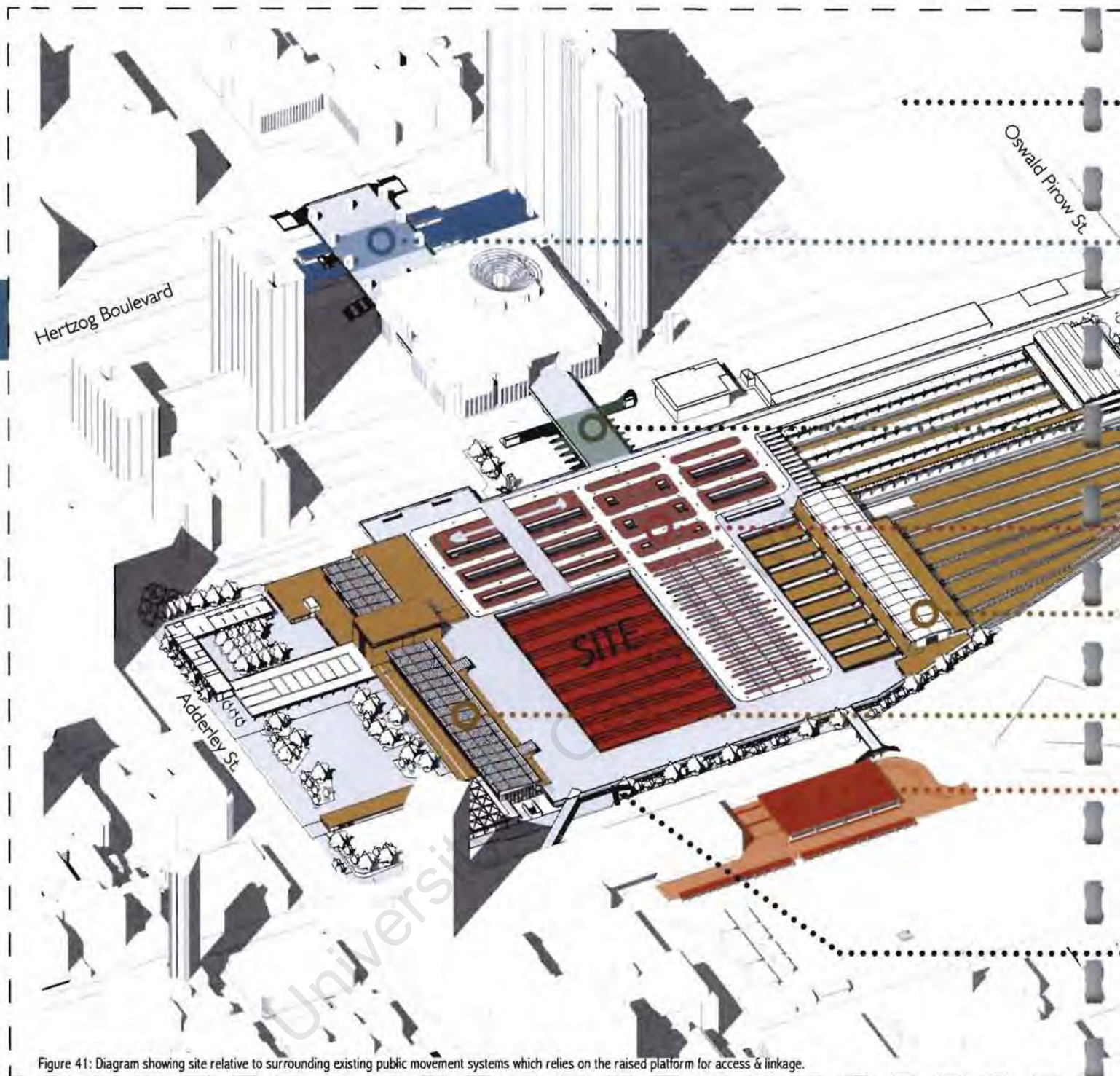

Figure 41: Diagram showing site relative to surrounding existing public movement systems which relies on the raised platform for access & linkage.

B]

Various connected **movement systems** each with their own speeds & rhythms. A system by definition comprises a set of parts or elements which work together to form an integrated whole. [Oxford American Dictionary] The parts or elements of the "in-between" space or the intermodal space comprise, on the one hand, the nodal generators & the attractors of activity – that is, the rail & the bus terminals & bus stops, parking garages & lots etc; and on the other hand there are the pedestrian flows which constitute the human elements of the system. Thus, it is important to study the behaviour patterns of the pedestrian in that space AND to look at the patterns of the transport mode.

Existing public transport movement systems connected to the station are:
Air

The 'My Citi Bus' connects the airport with the platform via an IRT station on Hertzog Boulevard (Airport Link).

Rail

The Shosholoz Meyl is the passenger rail operations of Spoornet and operates two long-distance passenger rail services from Cape Town: a daily service to and from Johannesburg weekly service to and from Durban. Cape Town is also one terminus of the luxury tourist-oriented Blue Train as well as the five-star Rovos Rail.

Metrarail operates a commuter rail service in Cape Town and the surrounding area. The Metrorail network consists of 96 stations throughout the suburbs and outskirts of Cape Town. Cape Metrorail runs the suburban network of trains, consisting of 5 routes, which serve 4 defined areas:

South (including the Cape Flats and the Simon's Town line via Wynberg, Newlands, Claremont and Rondebosch),
Ikapa (Cape Town and city destinations),

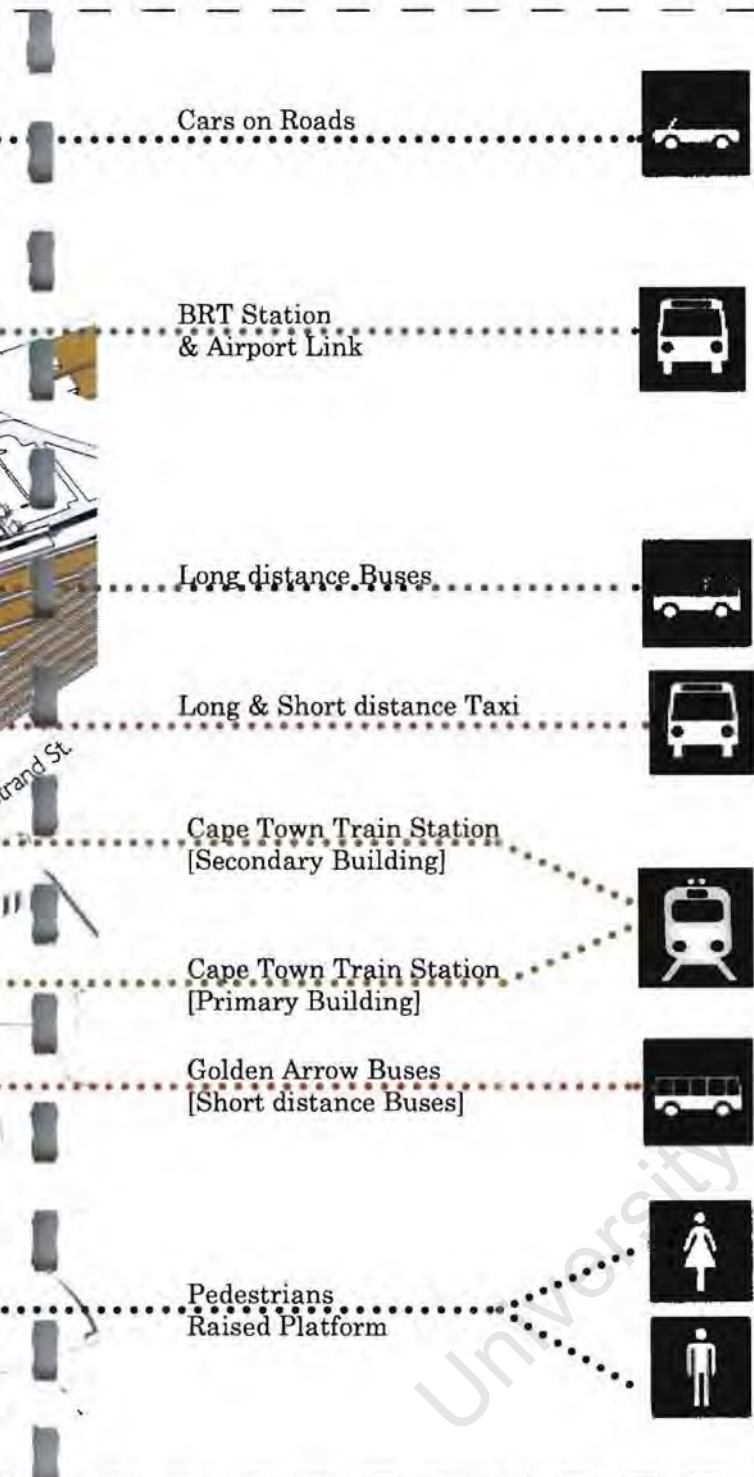

Central (including Langa and Khayelitsha)
North (including Bellville, Wellington, Stellenbosch and Strand).
Trains generally run from Cape Town station daily 4.30 am to 7.30 pm depending on the route travelled.

Road

The N2, also known as the Eastern Boulevard, as it enters the City Bowl becomes Strand street and borders the station on the south side. Also Adderley street on the north.

Local Buses

Golden Arrow Bus Services (situated on strand street) operates scheduled bus services throughout the Cape Town metropolitan area. Buses run daily roughly from 6.00 am to 8.00 pm (depending on the route), with a restricted service at the weekend.

Long-Distance Buses

Several companies run long-distance bus services from Cape Town to the other cities in South Africa, which is located below the raised platform deck as one enters the Civic Centre.

Integrated Rapid Transit

Cape Town has embarked on Phase 1 of the IRT system. Phase 1 will include a West Coast Service, Inner City Service and Airport Link. The station is located on Herzog boulevard which is connected to the station by the raised platform.

Minibus Taxis

Cape Town taxi rank is located above the train station on the raised platform.

Pedestrians

People from all over Cape Town use the station at different times of day for various reasons - children going to school & home, people going to work at various places in the CBD etc.

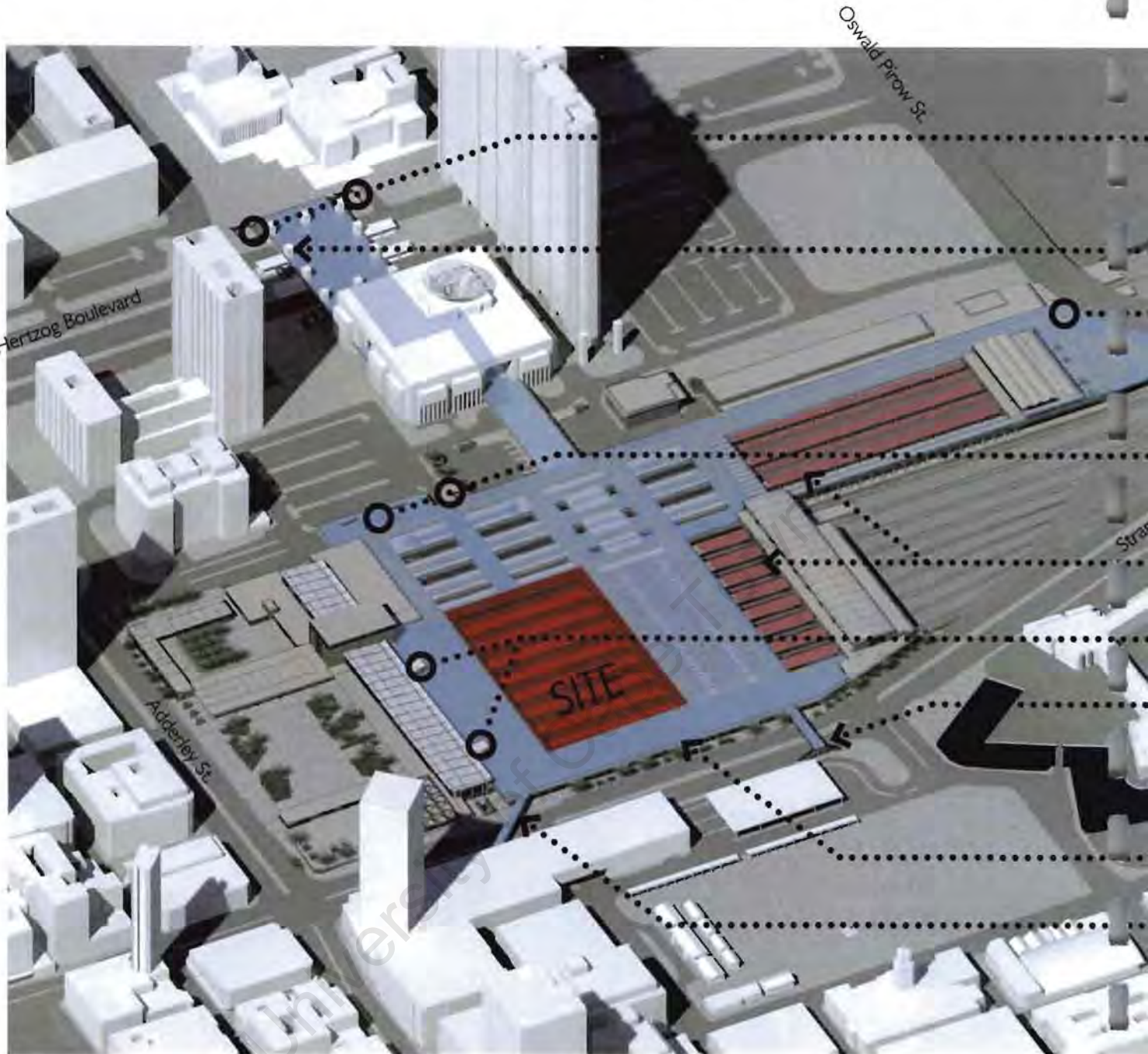

Figure 42: Diagram showing the extent of the existing raised platform above the train station with primary access points.

The site I have chosen for the building is located on top of the raised platform above the train station. This was also informed by the movement principles:

A) Link/Bridge component

The raised platform stretches from Strand street towards Hertzog Boulevard connecting various public spaces together: the Grand Parade & City Hall, Golden Arrow bus station, Golden Acre shopping mall, Train Station, Taxi stations, long distance bus station, Civic Centre, Primary BRT Station and the Artscape Theatre complex. The platform thus acts as a link connecting all these components together but it also bridges the gap over the 'non-place'/in-between space. This bridging act has made room for the intermodal interchange to shift its focus from a 'non-place' filled with only an input-output movement system to becoming a 'place' where events happen. The 'in-between' journey of the people between work & home, or school and home is thus intercepted with events along the way. The transport interchange then functions as a 'destination place', and not just a 'connector place'. It functions not only as a movement route, but also as an event space.

B) Infrastructure Barrier

The site is located inside a gap/hole left open in the platform above the railway lines. It is a piece of transport infrastructure that has disconnected places from one another, creating undesirable edge conditions & territorial islands on the platform with no social cohesion. Traders & pedestrians are squashed onto a one meter sidewalk while taxis rush past you with only a few millimetres to spare. It functions primarily as a non-place where people move through, with no recreation areas. Interchange architecture is capable of multiplying links & interconnections between the user & his/her various cultural environments; between the place & the city. But these human- & machine links have to function in a harmonious whole without creating infrastructural barriers. The machine-space must enrich the human-space, rather than live in isolation. The world can no longer afford to regard mobility and urban infrastructure as a purely technical problem: it has become a social, cultural and ethical question. Already in the 1930's Frank Lloyd Wright noticed: "the machine is at work busy moulding as well as destroying human character". [F L Wright, 1932; p. 7]

Staircase access from Artscape

Staircase Access from BRT Station

Only Vehicle access for taxis & deliveries

Staircase & lift from outside Train Station

Other 'wholes' in platform ..

Staircase & Elevator from
inside Train Station

Staircase & Bridge access from Golden Arrow
Bus Station & the Grand Parade

Raised Platform

Skybridge above Strand
Street



Can the no man's land that envelops the existing infrastructure be transformed into a space with an identity? Can we find additional uses for the 'gap' in the platform? Can bridges be turned into architecture and architecture into bridges?

Thus, the station & site functions as a place of interchange & intersection; it bridges the 'in-between' movement space while at the same time being of the 'non-place'; it lies at the crossroads of various movement systems - & architecture lies at the crossroads of modal connectivity.

'space of the body' & 'space of the eye'

According to Kenneth Warriner there are two typologies of movement (chapter 1):

1. space of the body - 'space-in-the-making'
2. space of the eye - 'ready-made-space'.

The raised platform separates the view of the pedestrian into two systems, namely above & below the platform. The train users below the platform will only be able to perceive the intended building (inside the gap) from below with their eyes (space of the eye) and will not be able to experience the space until moving out and onto the platform. The intended building thus requires movement of the user from a 'ready-made-space' towards a 'space-in-the-making'.

Land Reclam



1926



1944

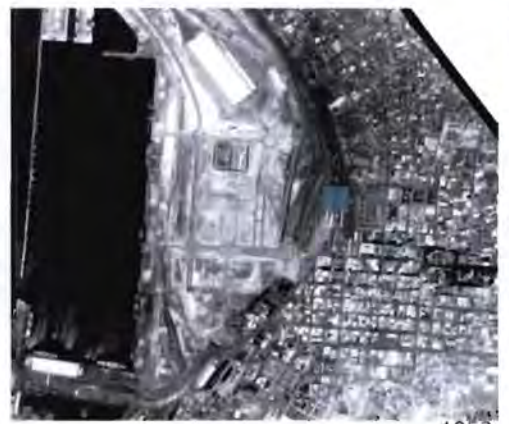

1953

Context History From past to present - railway infrastructure



Cape Town Railway Station:

1875



1884



1925





1968

1977

2001

02

Cape Town itself has gone through many changes over the years – from a fortified and stop-over port town in the 1700's, to an industrialised booming town in the 1800's & 1900's, to a modernist engineered city in the twentieth century. Finally, we find ourselves today in a multifaceted city shaped by all these elements over time – for good or bad.

The first ever public transport mode in Cape Town was the 8 miles an hour horse-drawn omnibus which began in 1836 when roads were improved in the surrounding areas. The Cape Town Railway & Dock Company built the first stretch of line to Eerste River in 1862, but the original train station was only built in 1878 designed by A.W. Ackermann, symbolizing Cape Town's importance as Africa's most Southern rail terminus.

In 1892 The Metropolitan and Suburban Railway Company constructed a line to Seapoint & the city's Tramway Company was reborn in 1894 with the first electric tram running in 1896 up Adderley street. Railways transformed Cape Town's customary excursions. Between 1862 & 1890 the railway extended to Bellville, Stellenbosch, Wynberg, Muizenberg, Kalk Bay and Simon's Town, making places accessible for more people connecting different parts of social life – sport, recreational gardens, theatres, beaches, gambling places, etc.

Moving towards a modern Cape Town, between 1919 & 1945 the town was transformed into an industrial city particularly with the development of the docks, electricity & motor cars. This period was also known as the 2nd transport revolution of Cape Town. The last tram ran from Adderley Street to Seapoint in 1939 and made way for the motor vehicle. Motor traffic added a new hazard to the streets but also created new jobs in the city: from salesmen to repair shops.

During the second World War the docks, then closed to the public, were again greatly enlarged. In 1937 a Dutch company (Hollandse Aanneming Maatskappij) was given the contract for reclaiming two square kilometres of land. The pier was demolished in 1940 to make way for the major reclamation scheme which isolated the city from its waterfront but provided it with a modern harbour. The venture was a joint effort by the South African Railways & Harbours (SAR&H) administration and the city council. This scheme also swept away the original Roggebaai Harbour to make way for a new bigger Duncan Dock in 1943. E.E. Beaudouin was Cape Town's planning advisor and the mastermind behind the Foreshore Reclamation. Sweeping vistas & wide boulevards would replace much of District Six and other areas to give way for a 'monumental approach' into the city. [Worden, Van Heyningen & Bickford-Smith. (1999), p.150-151]

There was a difference of opinion to the location of the new railway station

between the railway & the municipality, but in the end the government decided that it should remain in the current position but decked over, "thus meeting the City Council's requirements for unity of design, town-planning efficiency & adequate provision for traffic facilities & control." [Ibid, words printed in the Cape Times, 28-02-1945 p.152] According to this statement, one can see that the planning mindset of the time was completely focussed on mechanical social engineering.

From focussing on the human & pedestrian in the past, to planning public buildings to respond to vehicular control. The Railway Station & Deck (as we know it today) was completed and the deck was considered the link between the old city & the new city.

Current proposals for the future regarding the station:

The Culembourg Development Proposal by Piet Louw (architect, urban designer & city planner) in association with David Dewar (city & regional planner) in October 2003, develops an overall framework for the area which includes some proposals for the foreshore & the train station. The framework seeks to reduce the barrier effect between the city and the sea caused by the highways & the harbour development. The proposal also recognises that the city and main public transport interchange are becoming increasingly eccentric in relation to the greater metropolitan area as the city develops further out towards the north, east & south. With this project the main idea is to reposition the main transport interchange at the Salt River Circle (sinking all railway lines below ground) and creating a 'special place' between the existing station and the new one.

The City of Cape Town has published a Spatial Development Plan (draft for comment) for the Table Bay area in August 2009 that shows future plans for the city, especially transport & port related issues.

Currently the train station also includes a bus & taxi station together with some informal street stalls on the roof. The city is currently busy with a scheme – "Intersite: Cape Town Station Revitalisation 2030" – proposed by Makeka Design Laboratory to upgrade this area. The proposal consists of four neighbourhoods / precincts, which include: mixed use; technological research; government services and health & lifestyle. These precincts are connected with green spaces and an underground railway station with dispersed entry levels. [Cape Town Station Revitalisation 2030; Makeka Design Laboratory; April 2010]

Figure 43: Diagram showing transformation of land reclamation & change in different train stations over the years



1950

1961

1968

2000

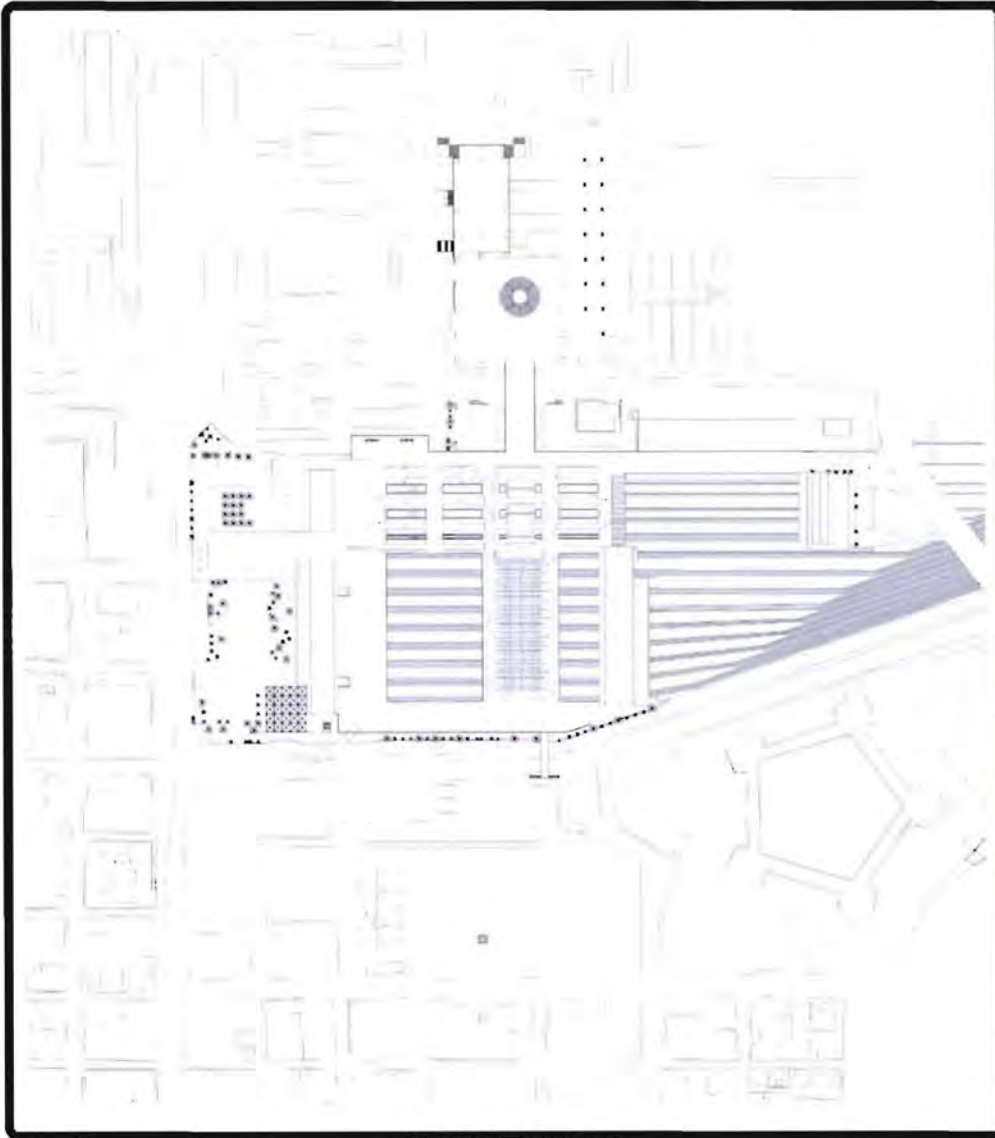

SPACE



EVENT

Figure 44: Site analysis according to Bernard Tschumi - SPACE [spatial framework represented by a plan]; EVENT [photograph collage of current event conditions] & MOVEMENT [existing primary pedestrian movement patterns].

Site Analysis

Mapping daily mobility across the site

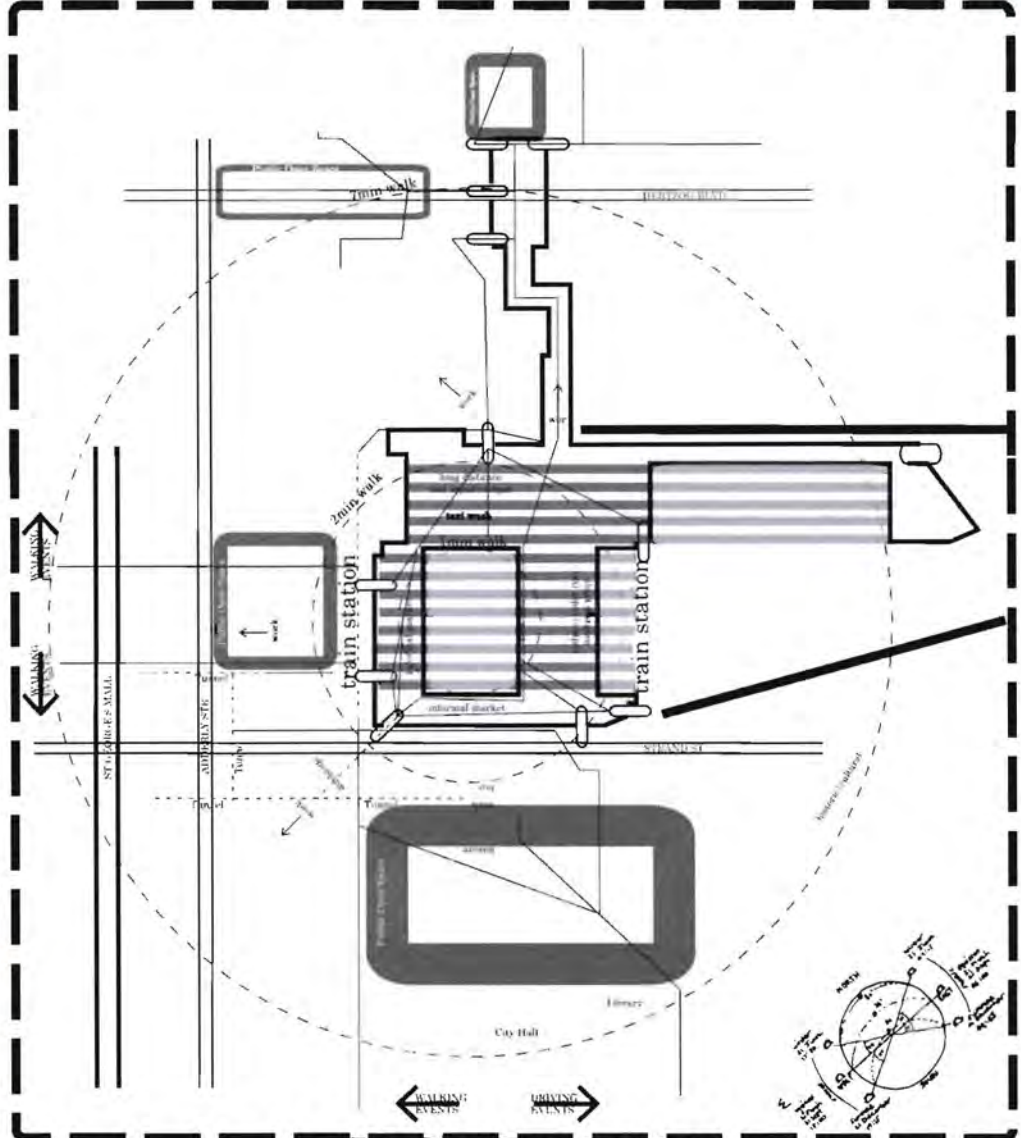
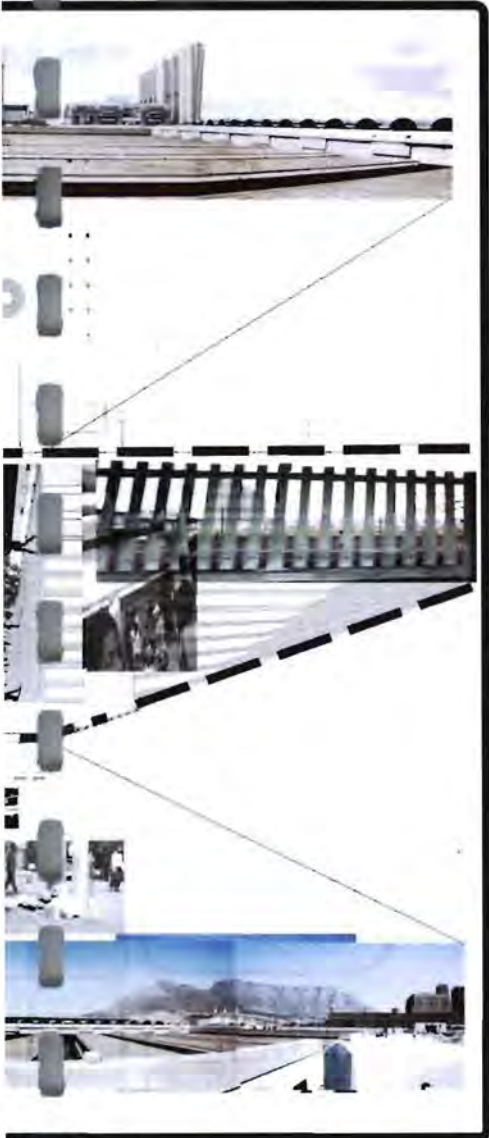

MOVEMENT

University of Cape Town

University of Cape Town

How to define the public bathhouse & the necessity for cleansing

"Public spaces are produced by the people who connect, disconnect, flow through & transect them, and by the people who play, laugh, cry & interact in them – in other words they are spaces of desire & effect. Encounters constitute the very spaces within which they are enacted; encounters bring a place into being. In this sense we can think of urban encounters as choreography. Public spaces are performed as well as being spaces of performance." [Watson; 2006 – 80]



Figure 45: Graphic on an old Roman Pot used for bathing

Secondly, the nodal interchange is filled with thousands of people everyday establishing a **threshold space** – in between work & live during the week & between leisure and live during weekends. It is a 'journey non-place' without an actual event. Thus, the bathhouse provides a 'place' or an event space for the public who inhabits the 'in-between' state everyday (workers) & occasionally (travellers). The public using the intermodal interchange are thus not just moving through the station as a path, but also going towards it as an end destination with an event.

Thirdly, a bathhouse on the platform will **connect**: the daily worker from Khayalitsha on the train or taxi to the daily worker from town in the Civic centre or the occasional traveller from the BRT station to the daily traveller on the Golden arrow bus. An estimated 500 000 people commute to the Cape Town station everyday by rail, bus & taxi. (info from MetroRail) Included in these estimates is the proposed bus rapid transit system. The site provides the opportunity for the project to facilitate a connection between commuters, vendors, the homeless, visitors, and residents on the level field of partaking in a ritual of basic human need. Through appropriate location and design of the public bathhouse, communities that engage with and use the station & surrounding public transport, could find common ground and mutual support.

The majority of dwellings located in rural or informal areas do not have access to running water. Within these communities, access to water, especially water for bathing, is still limited, not because they are poor, but because the infrastructure provided by the city council is not sufficient for the amount of users. There are 759,767 formal households, of which 87.4% have a flush or chemical toilet & even less have access to basic running water to bath. A communal tap, or tap on site, is commonly the primary source of water (Statistics South Africa, 2007:39). This service situation defines the primary user of the proposed bathhouse as commuters travelling to the city. The bathhouse is thus centrally located at the main Cape Town train station in the CBD. The ownership and funding structure together with the possible transfer thereof, should acknowledge the local conditions. The city is busy with a ticketing system where the user has a prepaid travel card to use on any public transport system, be it train or BRT bus. Tickets for the bathhouse could be included in the train-/taxi-/bus ticket or weekly or monthly tickets could be bought at the entrance. Ultimately, the public bathhouse should integrate ritual with the environment through the architectural experience.

Fourthly, individual perceptions of space & time are changing, causing new forms of mobility to emerge. Average commuting distances are increasing because the old classical pattern whereby people work and live in the same town has ceased to be true. Travel patterns have become more complex because people occupy their time more & more diversely – a person will take advantage of an outing to carry out various parts of his/her occupational program, combining several goals, such as work, school, shopping etc. alternating between transportation modes depending on the destination, time of day & end goal. **Cross-programming** is thus essential for this intermodal node, because a train station on its own creates physical & metaphysical barriers with less social cohesion. Ultimately, transport solutions should include mixed-use developments, bringing working & living closer together – closing the 'in-between' state of the intermodal interchange.

The focus of an intermodal interchange should be on the organization of movement & space, not just on movement. Thus, the future focus needs to be the integration of land use & transport strategies & the relationship between connecting places while at the same time creating locations – **nodes of diverse social activity**.

Public ablution buildings often become neglected, vandalized and generally dangerous environments. This common scenario arises from the tendency to isolate ablution buildings from the public, not celebrating their public potential. The aim of this proposal is to address this situation through a public place of dignity and social potential centered on the enrichment and celebration of the necessary ritual of cleansing. Considering a public building as a reflection of its users implies experiential quality as a means of integrating a personal ritual with its environment. A public place available to daily travelers, offering a space where people could easily mix together and thus potentially breaking down class barriers.

The primary questions I was asking myself in choosing an intended program for the site were:

- What happens in the intermodal space between man and machine?
- In what mode of transport must man be to perform activity?
- Is activity related to either of transport modes or is it an "in-between" separate activity?
- What are the in-between barriers?
- How long do they use the space?
- Who uses the intermodal space?
- Why do they use it?
- Where are they going?
- What will happen to daily users if in-between space changes into something different?
- How do we reinstate the in-between space for all humans & reduce the harsh edges created by machine and man?

Together with these questions posed by the site, was my interest in a building that requires a certain sequential act through the spaces within it. This interest developed through the knowledge gained from the research on movement in chapter one. It is made clear through the statement by Jean Nouvel:

"Architecture exists, like cinema, in the dimension of time and movement. One conceives and reads a building in terms of sequences. To erect a building is to predict and seek effects of contrast and linkage through which one passes... In the continuous shot | sequence that a building is, the architect works with cuts and edits, framings and openings."

The perfect program that answers the questions above and fits within the site and my interests in sequence, is a public bathhouse. The South African bathhouse could be defined as a service facility within an environment where densities of potential users who share the communal need for ablution, is identified. A bathhouse in the urban context of South Africa should embody a democratic attitude of accessibility, thereby informing the architectural program.

Why a bathhouse on the train station?

Firstly, a bathhouse has a **specific sequence** through which one needs to move from being dry to wet; from being dirty to being clean or from being cold to being hot. The intended building is thus shaped and formed by different movement systems acting on the site (input-output sequence from the taxi's and trains) and from the inherent movement because of the building program (bathing).

Rituals of Bathing

A brief history of public bathing

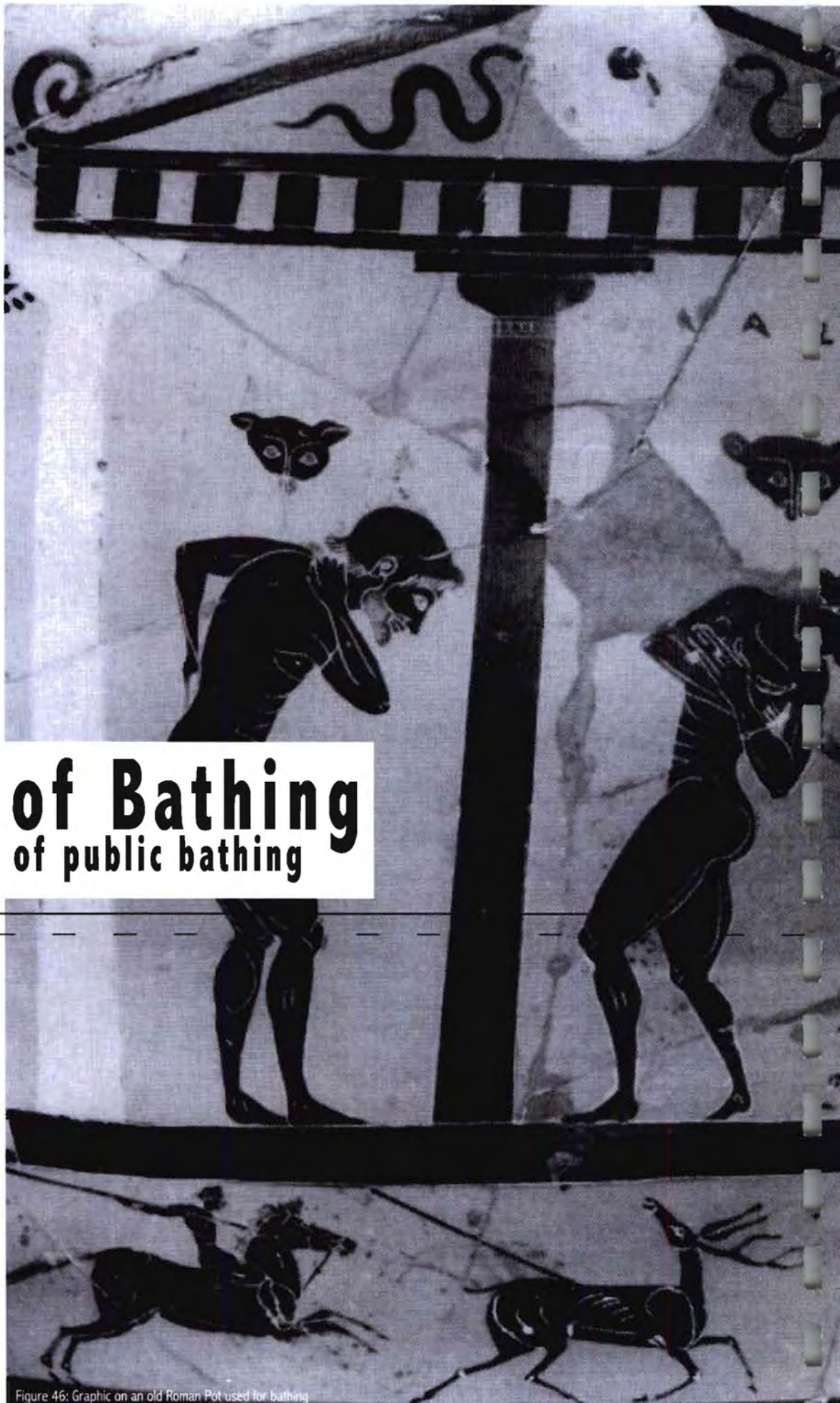

Figure 46: Graphic on an old Roman Pot used for bathing

The bathhouse as an architectural typology has a rich and established history. A contemporary investigation of this typology requires a clarification of relevant terms and concepts, ensuring that the project is undertaken within the appropriate context. Crucial to this undertaking is an appropriate definition of the term 'public bathhouse', as it forms a base for interpretation of the investigation. Although I have done a detailed research of the different types of bathhouses, I will not include a detailed written explanation of each because it is not my primary aim. Rather, I am interested in the sequences of the different spaces within each type of bathhouse & the type of spaces and programs that accompanied them. Also, a model of superimposing contemporary advantages onto the ideals of a classic bathhouse is investigated, aiming to avoid the imposition of an alien, ancient or inappropriate intervention.

Public baths originated from a communal need for cleanliness (in times or places) where fine grain infrastructure is not available to all, be it through a lack of technology, availability of resources or prejudice. The term public may confuse some people, as some types of public baths are restricted depending on membership, gender, religious affiliation, or other reasons. As societies have changed, public baths have been replaced as private bathing facilities became more commonly available. Public baths have also become incorporated into the social system as meeting places. Communities therefore gather at places of communal bathing where a central facility is able to serve a large population efficiently [Showerman, 1931: 357]. Antiquity has taken what is, to us, a basic & prosaic function & elevated it to the level of a cultural & recreational act, a civic institution for which there is no real counterpart in modern Western civilization.

Public baths appear at a variety of times and places throughout the world. Examples being the Turkish hamman, Japanese onsen or sentō, Finnish sauna, Russian banya and Roman thermae. [see figure] Each one developed through either cultural, religious or basic human need. The Roman thermae as a classic precedent embodies the closest relation to this dissertation, where government involvement, democratic access and servicing potential relates to the proposed urban context of the investigation. It is not the built form that is important, but the way their bathhouses allowed the public to interact publicly in a very private domain. The main reasons being the ability for the public to gather inside large halls at various moments while going through the bathing sequence and the different programs attached to the bathhouse. In many ways, baths were the ancient Roman equivalent of community centers. Because the bathing process took so long, conversation was necessary. Many Romans would use the baths as a place to invite their friends to dinner parties, and many politicians would go to the baths to convince fellow Romans to join their causes. Only the very wealthy could afford entertainment in their own homes, so ordinary people looked beyond their homes for recreation. The imperial baths provided far more than hot, cold, & tepid swimming pools. They also offered dressing rooms, gymnasiums, restaurants, bars, & shady walks. In addition, guests could attend plays, witness athletic contests, listen to public lectures, read in one of the libraries, or stroll about the galleries or gardens where paintings or statues were exhibited. The baths were, in short, the people's palaces. They were also the sites where much ancient statuary were displayed. [Fleming, 101]

The bathing customs of the Sento temple, a public Japanese bathhouse, have remained largely unchanged over the centuries and bear resemblance, in some respects, to documented ancient Roman practices. Like the Romans, the Japanese bathe communally in hot water; nudity is an accepted facet of the public bathing process; and the bath, despite its deep religious roots & associations, has evolved into a sensual, rather than a spiritual, experience. Traditionally these bath houses have been quite utilitarian, with one large room separating the sexes by a tall barrier, and on both sides, usually a minimum of lined up faucets and a single large bath for the already washed bathers to sit in among others.



THERMAE

Roman baths - the people's palaces

EXAMPLE

- + Aquae Sulis in Bath, England.
- + Baths of Caracalla, Italy, 212-216 CE.

SPATIAL RELATIONSHIP

- + a portico with entrance from the street
- + an exercise yard (palaestra)
- + an undressing room (apodyterium)
- + a cold room with plunge-bath (frigidarium)
- + a warm room (tepidarium)
- + a hot room (caldarium)
- + and a hot, dry steam bath (laconicum or sudatorium)

SPECIALITY

- + game rooms
- + gardens
- + libraries
- + theatres
- + galleries
- + restaurants
- + swimming pools

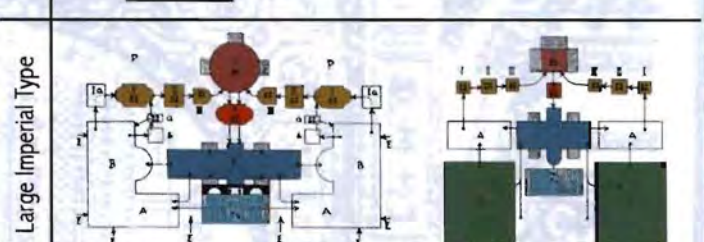
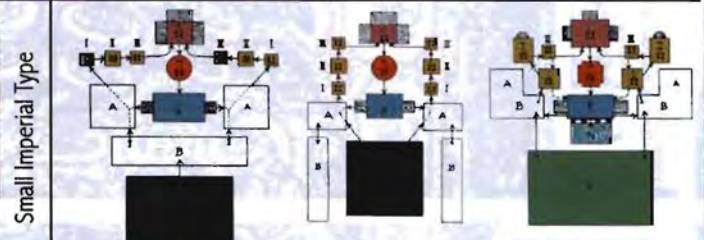
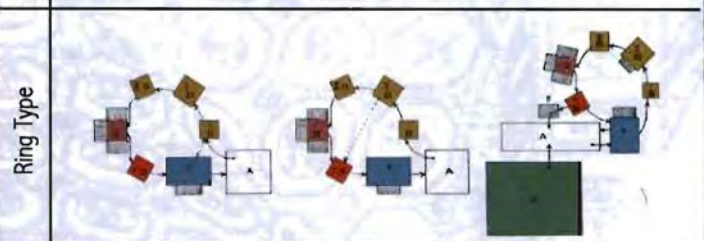
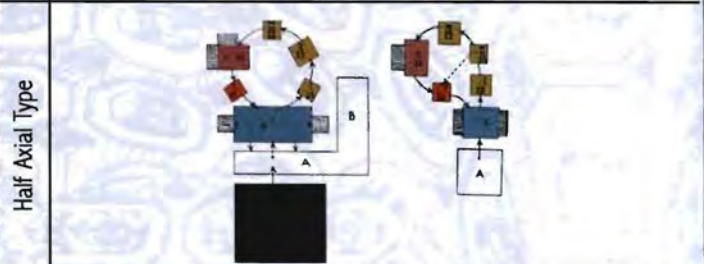
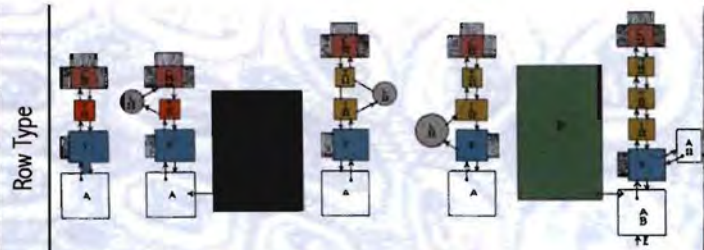

figure 47: Diagram showing the most common Roman Bath types & their sequences

figure 48: Drawing illustrating the hypocauste system to heat the baths, floors & walls.

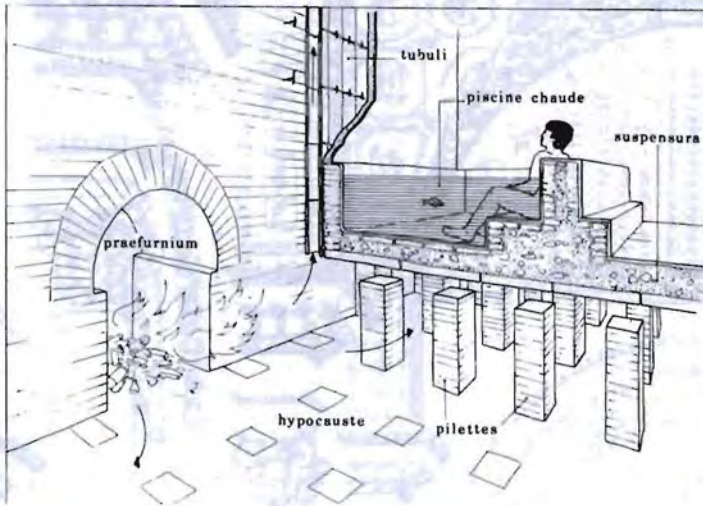

figure 49: The Baths of Caracalla in Rome, Italy were Roman public baths, built in Rome between AD 212 and 216, during the reign of the Emperor Caracalla. The bath building was 228 meters long, 116 meters wide and 38.5 meters estimated height, and could hold an estimated 1,600 bathers.

SENTO | ONSEN
Japanese baths

EXAMPLE

- + Spa LaQua at the Tokyo Dome City
- + Oedo Onsen Monogatari (Big Edo Hot Spring Story) in Odaiba, Tokyo.

SPATIAL RELATIONSHIP

- + a single large bath for the already washed bathers to sit in among others.
- + Entrance area with bandai
- + Changing room
- + Japanese garden with a pond
- + Bathing area
- + washing stations
- + bathtubs
- + Sauna with cold bath outside (optional)
- + Boiler room (kamaba)

SPECIALITY

- + Buddhist culture - spiritual bathing (at first - now leisure activity)
- + daily baths in sexually mixed groups
- + with one large room separating the sexes by a tall barrier,
- + Gyozei, to bathe in a shallow wooden tub.
- + Scale: small
- + Japanese landscape mosaic mural

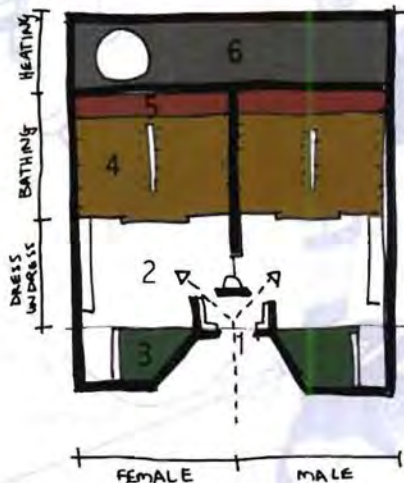

1. Entrance area with bandai
2. Changing room
3. Japanese garden
4. washing stations (lined up faucets)
5. bathtubs
6. Boiler room (kamaba)

figure 50: Typical floor layout of a Japanese Sento

HAMAN
Turkish baths

EXAMPLE

- + Çemberlitas Hamam in Istanbul, built in 1584.
- + Hamam Omerye - Cyprus
- + Rudas Baths, Király Baths & Racz Thermal Bath - Budapest

SPATIAL RELATIONSHIP

- + central courtyard or 'Camekan'
- + Separate dressing room: Apodyterium
- + Sudorific chambers: sweating rooms
- + First hot room: tepidarium - washing up with water
- + Second hot room: calidarium - steam & massages
- + Third hot room: laconicum
- + Washing room: lavatorium (optional separate)
- + Cooling room: Frigidarium - relax & snack

SPECIALITY

- + annexes to mosques
- + sexes separate by time of day | separate quarters
- + traditional entertainment (e.g. dancing, food, ceremonies, before weddings, high-holidays, celebrating newborns, beauty trips)
- + tellak - the masseurs in the baths
- + once a week (not daily)
- + no exercise yard (palaestra)

Original Type in Turkey



figure 51: Typical layout of a Turkish Bath

Type in England

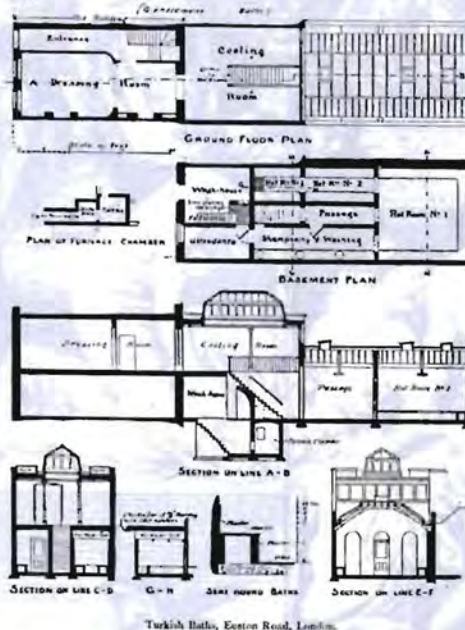

figure 52: Turkish Baths - Euston Road, London

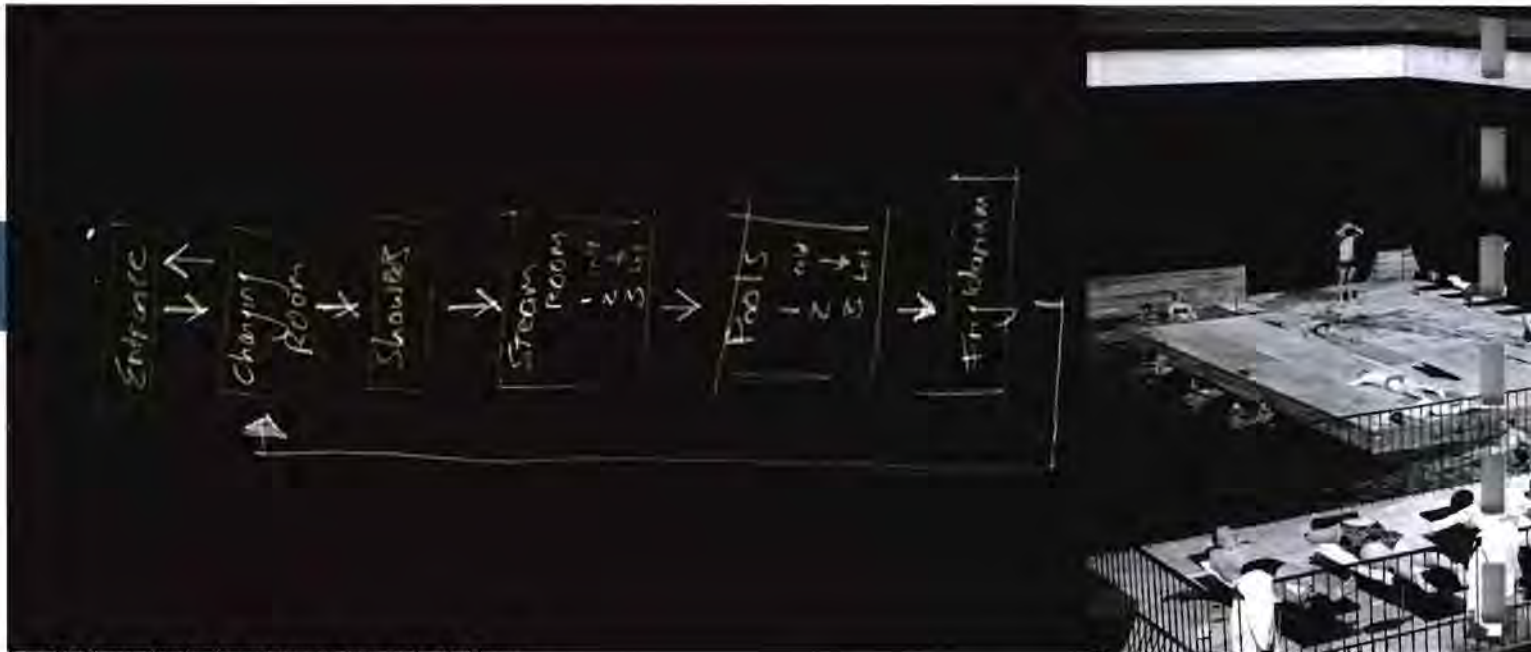

figure 53: Diagram showing the most common sequence in a bathhouse

figure 54: Vals Baths, by Peter Zumthor
Exterior courtyard

The Finnish sauna is a substantial part of Finnish culture - an average of one per household. For Finnish people the sauna is a place to relax in with friends and family, and a place for physical and mental relaxation as well. Finns think of saunas not as a luxury, but as a necessity.

One reason the sauna culture has always flourished in Finland has been because of the versatility of the sauna. When people were moving the first thing they did was built a sauna. You could live in it, make food in the stove, take care of your personal hygiene and most importantly, give birth in an almost sterile environment.

All the different types of bathhouses have their own specific sequence, but the most common thread/sequence can be described as:

Upon entrance into the bathhouse, the patron would first enter a changing room in which they would undress themselves. The patron would then go through showers to cleanse him/herself. After the cleansing it is up to the patron whether he/she wants to participate in the other different baths and hotrooms. The patron will then go through two or three hot steam rooms [sweating rooms or sudorific chambers] with showers/cold water to splash themselves. After this

they would go through two or three water pools ranging from cold to very hot water. Usually the sequence ends at the frigidarium (cold-room) and then the changeroom again.

It is crucial to note the shift in the nature and perception of the public bathhouse since the Modern era. Coinciding with the improvement of service delivery to private dwellings, the role of the public bathhouse changed. Considering the contemporary example, the thermal baths at Vals by Peter Zumthor (1996), proves the case in point. Relevant to its affluent context, the bath serves as a recreational and profitable addition to a hotel complex. [figure] Whether this building is to be considered a true public bathhouse is questionable, as it provides to a limited range of clients whilst physical, necessary cleaning of oneself is not the primary goal of a visit. Formally the baths at Vals can be defined as a private spa, rather than a public bathhouse. A public bathhouse has origins in providing a necessary service, as thermae embody. While access to thermae was available and encouraged to all citizens, the baths at Vals is considered to embody a character of exclusion rather than inclusion.



Figure 55: Mansell Road bathhouse, Durban - Exterior view, section & plan

Typically this same phenomenon of exclusion appears in the case of wellness centres, spa's or gym facilities, where access is granted on the basis of membership or entry fees. Although these facilities aren't strictly bathhouses, the nature of the shift away from providing a basic service is evident. In contrast, the Roman *thermae* were accessible, subsidised and functional baths, with exercise and wellness facilities attached over time. The contemporary examples of exercise facilities do not provide the necessary service of cleansing as their primary goal.

A South African precedent of public ablution & bathing is the Long Street Baths which was built in 1908 and renovated by Ken Duncan in 1990. (*The Argus*, Monday, 6 August 1990) The baths are open from 7am-10pm daily with activities such as swimming, coaching, waterpolo, underwater hockey, synchronized swimming, swimming lessons, Turkish bath (sauna) followed by a dip in icy waters (lunge pool) & slipper baths (ordinary bath/showers). Mostly, this bathhouse is primarily used for sporting activities, and not for basic cleansing needs.

The work of Rodney Harber is investigated as another contemporary South African precedent of public ablution and bathing. (figure) In essence the core of a public bathhouse provides a service to an area that does not have basic ablution facilities. Expanding on the basic need, Mansell Road bathhouse deliberately includes and anticipates for a layer of commercial activity, thereby expanding the program and providing opportunity to vendors, realizing a true public bathhouse. The bathhouse includes ablution facilities, accommodation and opportunity for formal and informal trade (Low, 2005:5). The inclusion of commercial activity as a part of public ablution facilities addresses issues of security within an urban setting. By providing passive surveillance through the permanent presence of shopkeepers and clients, a form of community policing is introduced. The result is a commercial niche, specifically relevant to the users of a bathhouse. This public bathhouse encourages opportunity and variety, enriching the bathing ritual and confirming the building as a public bathhouse.

**EXPERIENCED
SPACE**

space
IN-THE-MAKING

direct links
[foot]



PRIVATE ACT



**PERCEIVED
SPACE**

READY-MADE
space

indirect links
[eyes]

PUBLIC ACT



Scripting the Journey



PUBLIC PROGRAMS



BATHING

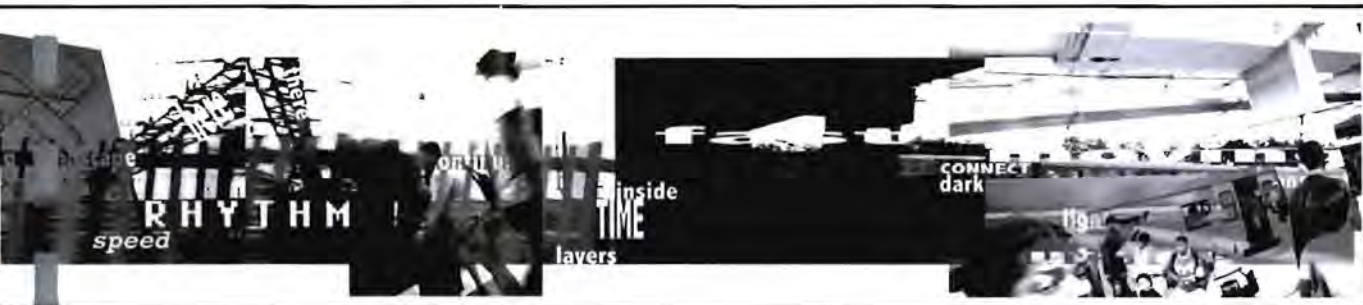

TRANSPORT

figure 56: Diagram of conceptual thinking behind arrangement of the programs

exhibition, 'First International Architecture Biennale Rotterdam Mobility, A room with a View', held in 2003, focused on the importance of mobility routes not only being traffic space but also public space, space in which to be (a fact seemed to have escaped the attention of policy makers). It called for a different way of looking at how mobility is embedded in everyday life. One part of the exhibition focused on new urban planning principles in looking at the route as a place where stuff happens: what one sees and does while moving through the urban fabric. The 'chapters' were called:

- + 'From here to there' includes projects that focus on the use, layout or organization of movement from A to B, the route.
 - + 'Alongside the route' Projects that function immediately adjacent to this route are classified under the category
 - + 'Panorama from the route' - the area experienced from the route.
 - + 'Transfers, stopovers?' covers those projects focusing on junctions, where routes cross each other and where a program has been added.
- Therefore, even if the movement space is the in-between space, it still functions as a place with an event. A simple bench in a circulation space creates a whole different dynamic for that space – it makes a place out of the non-place.

According to Kenneth Warriner there are two typologies of movement (chapter 1):

1. space of the body - 'space-in-the-making'
2. space of the eye - 'ready-made-space'.

The raised platform separates the view of the pedestrian into two systems, namely above & below the platform. The train users below the platform will only be able to perceive the intended building (inside the gap) from below with their eyes (space of the eye) and will not be able to experience the space until moving out and onto the platform. [because of security reasons the bathhouse is not accessed from the train loading platforms] The intended building thus requires movement of the user from a 'ready-made-space' towards a 'space-in-the-making'. Above the raised platform the pedestrians then have the option of experiencing the different event | programmed spaces.

[see figure 56]

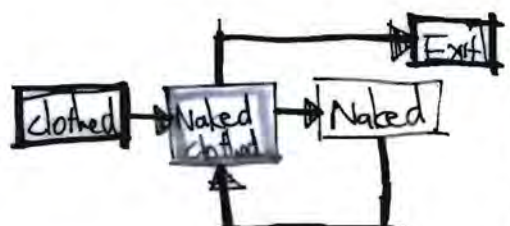
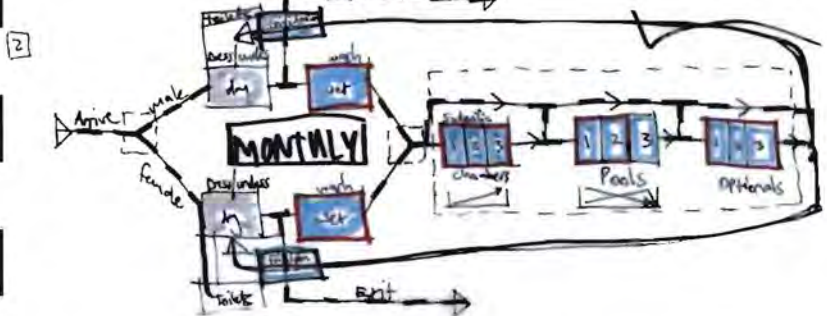
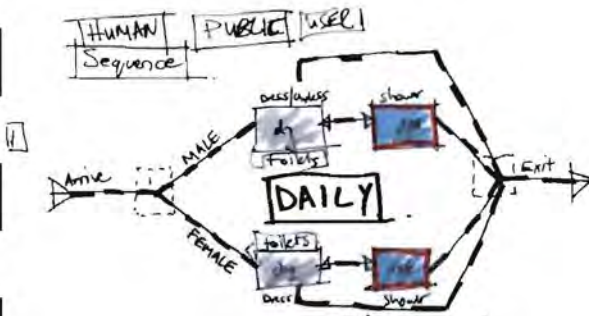
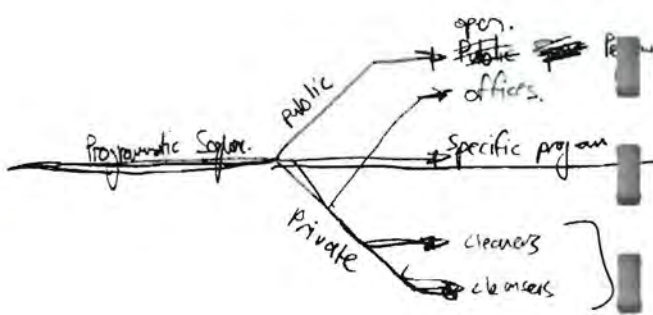
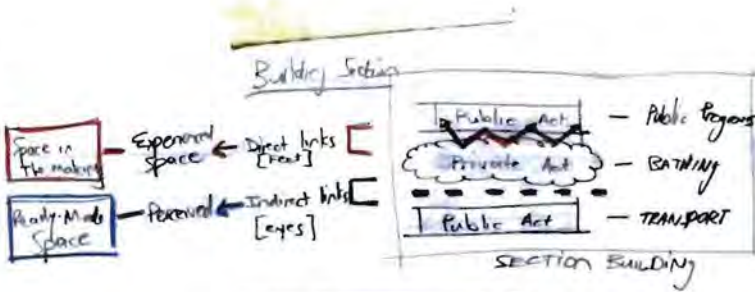

use are

- surface cleaners - people passing through the intermodal space on a daily basis and use the bathhouse for a quick shower or bath before or after work | school;
- physical cleansers - people using primarily the 25m pool for exercise and then a quick shower;
- deep cleansers - people using everything the bathhouse has to offer for a longer period of time (pools, showers, garden courtyards, steam rooms etc)

As the site is located on top of the train station (non-place), the proposal is that the space surrounding the building be opened as a public plaza in order to give continuity to this sequence of public spaces [PROGRAM-MATIC & INPUT | OUTPUT SEQUENCE]. The constant servicing of the building is seen as its own movement system and becomes an aesthetic of the building - visible at all times. [SERVICING SEQUENCE]

Furthermore, unlike a linear methodology of spatializing the given program, the approach is to feed a variety of information and conditions into the design process, allowing the resulting feedback to be continuously incorporated into the design development. If one would draw a diagram showing the bifurcation sequence of arriving at the site with the bathhouse in it, it would look like figure 59. Each bifurcation represents a decision that needs to be made by the user/pedestrian where to go or what to do next.

The m [fig] sho ent sy It is set up to see how the movement systems & spaces differ from one another according to speed, time, rhythm, continuity, possible crossing nodes and thresholds. The building consists of primarily four movement systems:

1. programmatic sequence [cross | open program - secondary space]
2. bathing sequence [fixed program - primary space]
3. servicing sequence &
4. existing train & taxi input | output sequence.

Each system is analyzed to see the shape, scale & texture it will produce in the space & to see what are the spatial requirements needed for each movement system.

The design of the bathhouse concentrates on issues such as the need to accommodate 'passengers' of varying volume & frequency with public & civic events, & the interaction of travelers with the public. As a result, the flow of people - from arriving, ticket allocation, waiting, bathing, drying, clothing, departure - is uniquely integrated with interconnected public spaces. There requirements are to provide both bathing facilities for the everyday surface cleanser, deep cleanser & swimmer in one building [BATHING SEQUENCE].

the d roce- ooking he d move- sys- tems within and surrounding the bathhouse. Edmund Bacon states that: "One must see the continuity of space experience in terms of a series of movement systems based on different rates of speed and different modes of movement, each of those interrelated with the others & each contributing its part to the total living experience in the city....It is possible to conceive the essential form of these simultaneous movement systems in three dimensions in space as an abstract design, from which the design structure of the project begins to emerge."

Norbert Schulz's 'existential space' consists of several overlapping & inter-penetrating systems which interact with each other in such a complex totality, that ambiguity & conflicts are bound to happen. [Norberg-Schulz, 1971 - 32]

It is this ambiguity & conflict that creates spaces where chance meetings between people may occur. Without this element, a room just stays a room, and a movement route stays just that. These systems must intersect and join at various points for a rich experience. All these movement systems shape the building in the end.

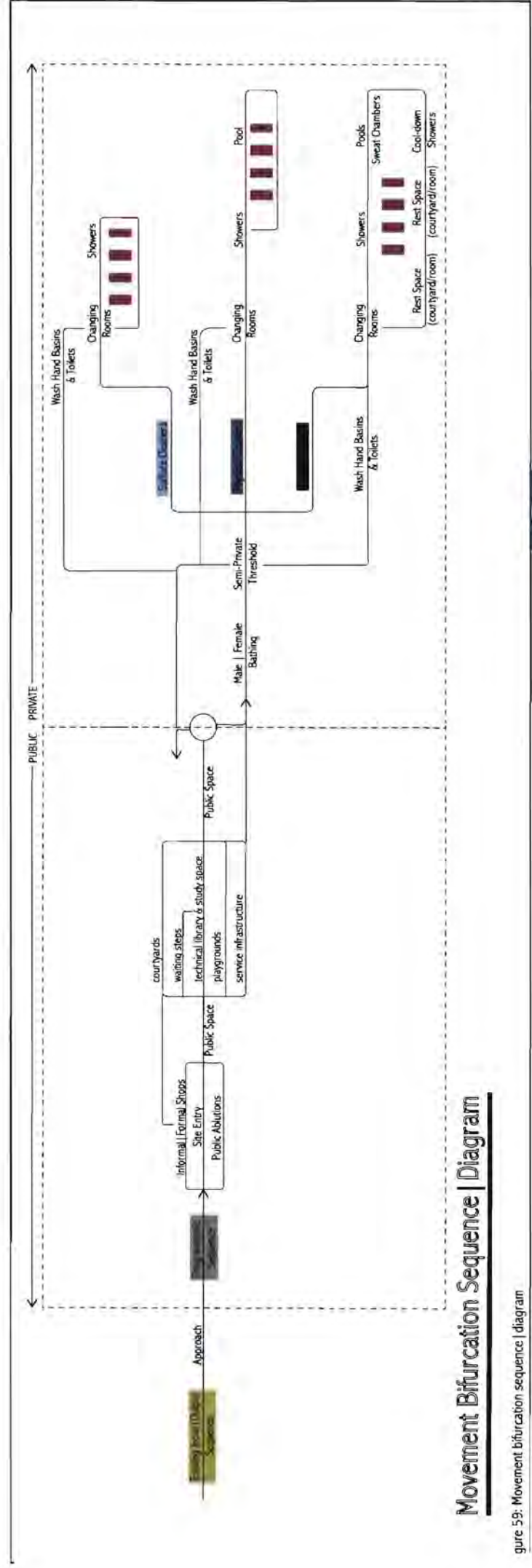

Movement Bifurcation Sequence | Diagram

University of Cape Town

University of Cape Town

chapter 04.
Design Development

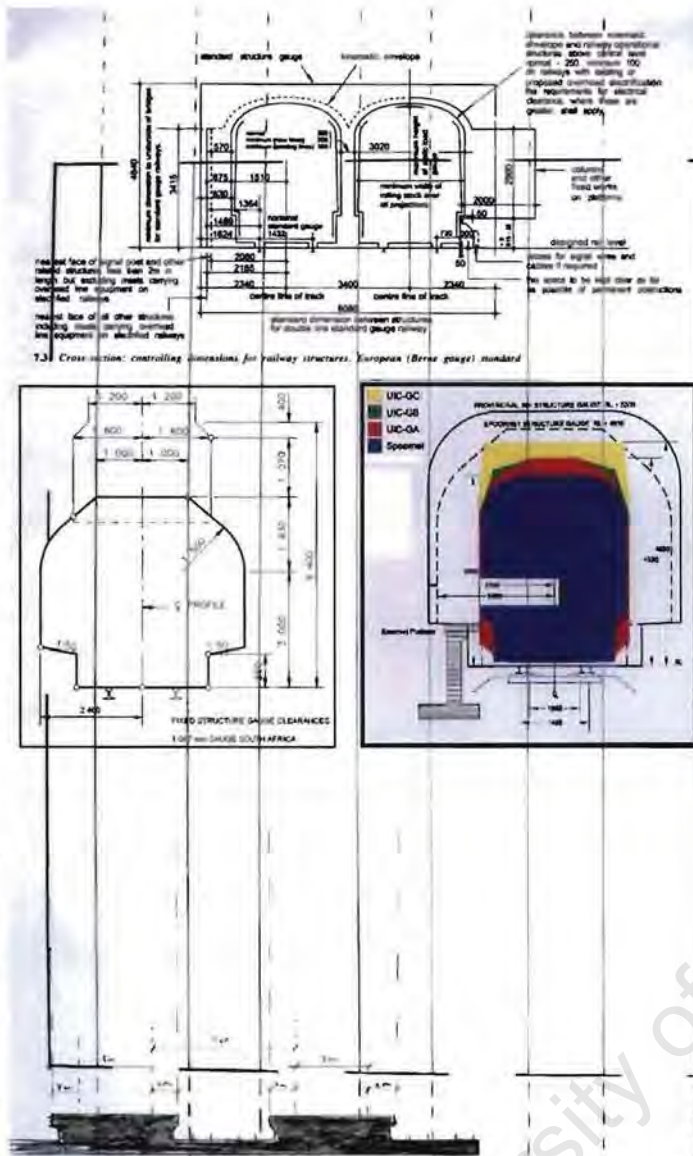
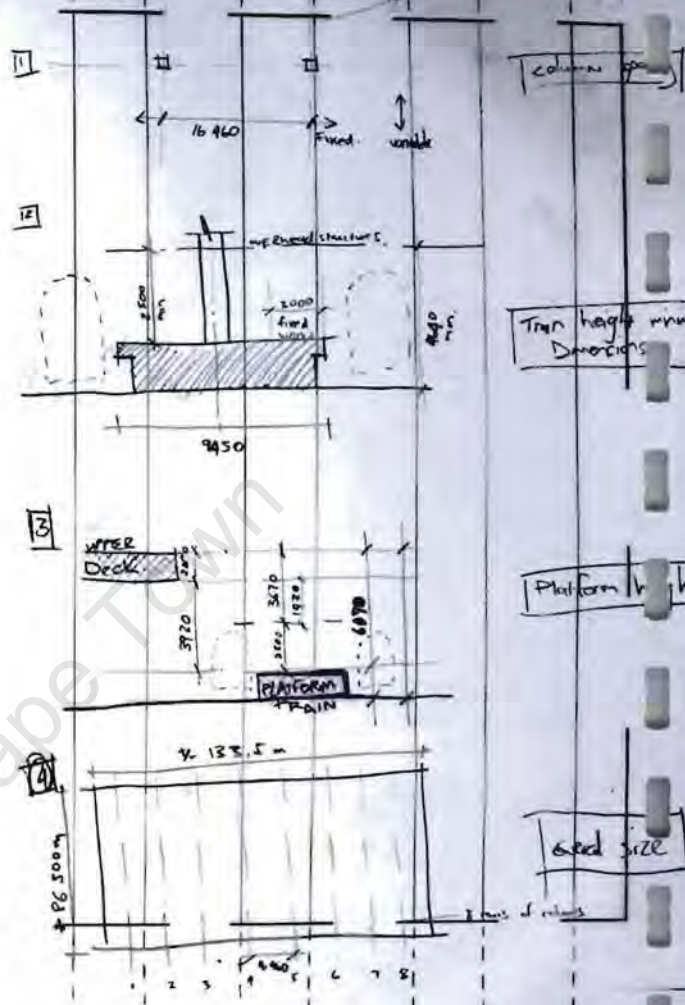

figure 60: Existing standards set up by the INPUT & OUTPUT of the train movement system

Structural Constraints.



Standard practice

The design process started with getting to know all the standard practices of the simultaneous movement systems. These systems need to become the so called 'starting block' for the design to take shape around it. Edmond Bacon states: "It is possible to conceive the essential form of these simultaneous movement systems in three dimensions in space as an abstract design, from which the design structure of the project begins to emerge." In knowing the standards of the systems one can start to design with it - either keeping it the same or changing it into new possibilities. The aim is for all the movement systems to work together in a harmonious whole, while still being a rich experience for the user groups.

1. INPUT-OUTPUT SYSTEM [fig 60]

The movement of the trains below set up a very definite grid of PLATFORM v/s TRAIN TRACKS. This sets up a column grid of 16,460m c/c across the site on the platforms. The other option is a column grid of 5.5m over the platforms & then an 11m span across the train tracks. This arrangement comes from the limit set out by the train standards: the closest any fixed element can be from the edge of the platform is 2m.

The minimum height above the platforms for any fixed structure is 2.5m and

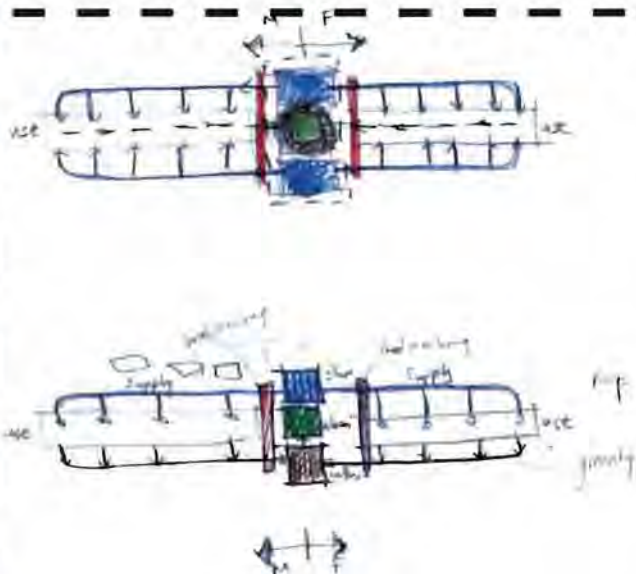

Figure 61: Plan & section of preliminary water circulation in building

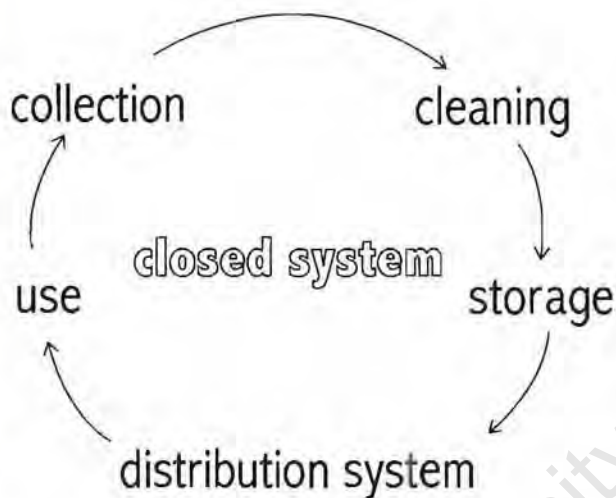

Figure 62: Diagrammatic representation of water circulation forming a closed system



Figure 63: A typical Bathhouse sequence - always returning to the change room, before continuing with the journey

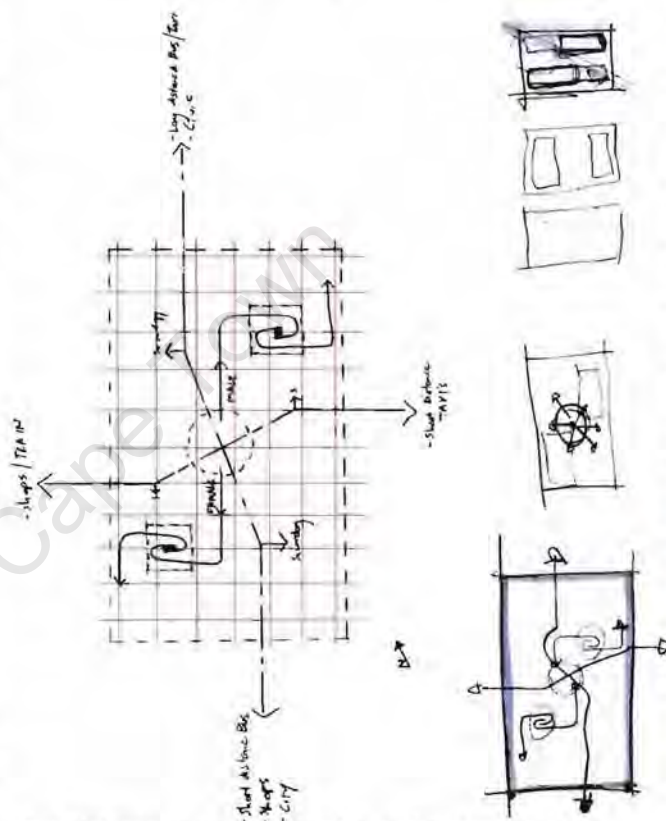

Figure 64: Primary movement routes through the site: four primary entry points leading one to the centre of the site for the choice of male OR female.

ove the train tracks it is 4650m. This arrangement of heights allows a floor to be inserted above the train platform section where the roof is level with the existing public raised platform above. A floor above the train tracks section produces a roof of 1.5m above the existing raised platform. This creates a new level for the public concourse platform above.

WATER SERVICE SYSTEM [fig 61 & 62]

The water service & reticulation system is fully explained in chapter five, but the basic circulation path is a closed system:

USE - COLLECTION - CLEANING - STORAGE - DISTRIBUTION

Figure 61 shows a plan and section view of the basic path of the water, where the water is USED at the bottom of the building; COLLECTED & CLEANED at one central point; HEATED & STORED on top of the building & then DISTRIBUTED down into the building again.

BATHING SEQUENCE [fig 53 on page 52 & fig 63]

Figure 63 shows a typical bathhouse sequence if one follows the 'Deep

Cleansing' route. The bathhouse user always returns to the changeroom before going to the next event/action, and thus the change room became quite an important aspect from the start of the designing phase.

4. PROGRAMMATIC SEQUENCE [fig 64]

The people filtering into the site from the different intermodal spaces (taxi, train, bus etc) has different programmatic options to choose from once they have entered the site - the primary option being MALE or FEMALE bathhouse. From here they decide to go to a different intermodal space, shops or public toilets....

It was important from the start to create a mix of slow- & quick-, direct- & indirect- pathways through the site connecting the various programs on and around the site with the primary entrance points at the centre of each side of the site.

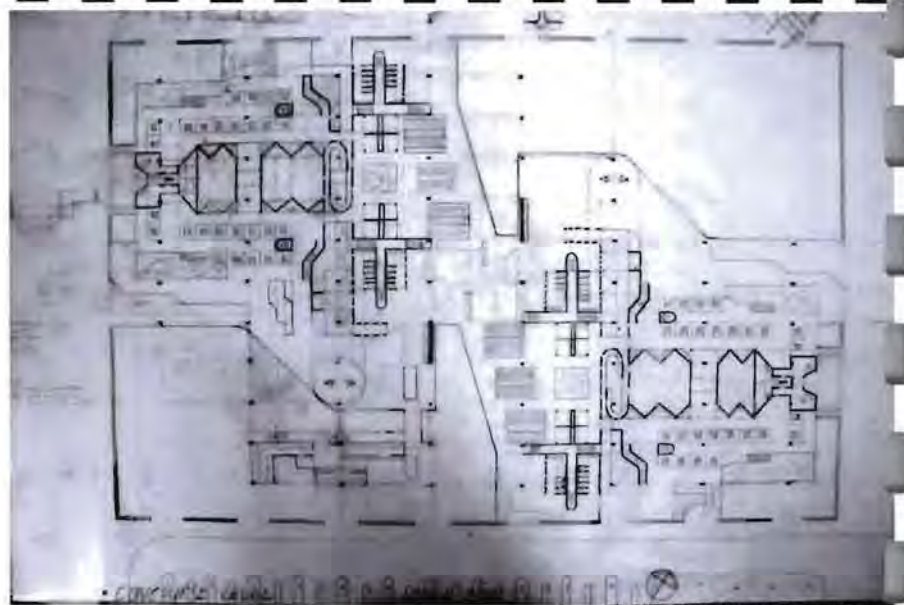
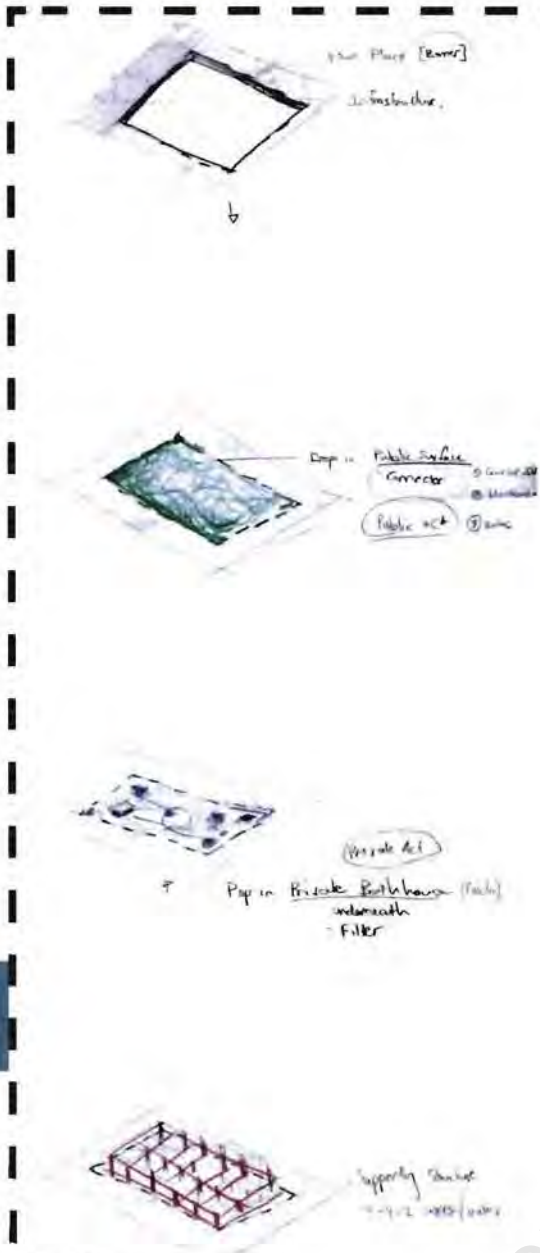

figure 66: Plan of the Public Surface at the top.

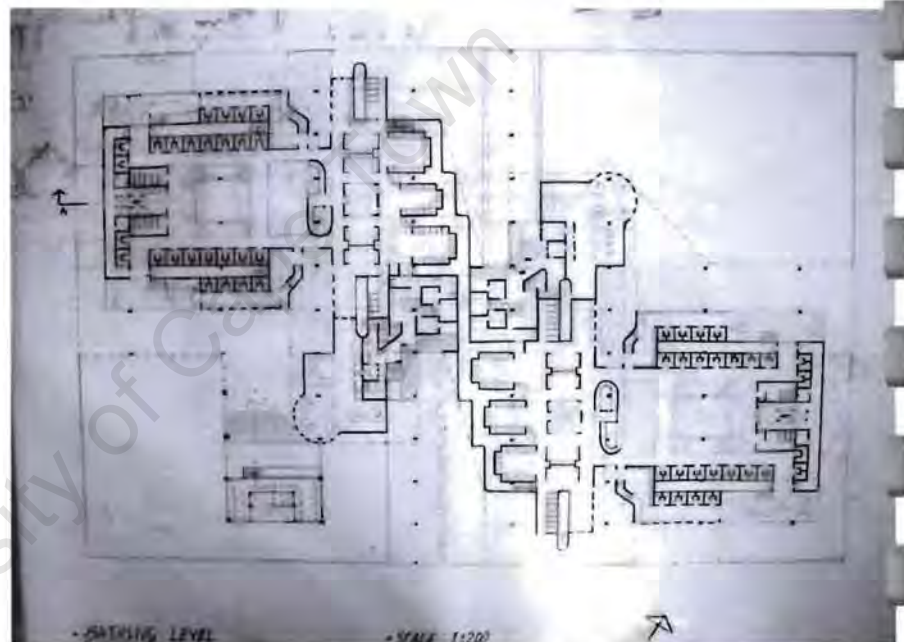

figure 67: Plan of the Bathing level (bottom level).

figure 65: Diagram showing the primary elements of the building: Non-place (site); Public Surface; Private Surface & the Supporting Structural Grid.

Movement exercises

The first sketches all started with a diagram [fig 65] showing the overall idea of the development of the site: starting with the 'non-place' within the intermodal interchange and filling it with events and functional spaces for the people on their way to work | school | home to go to. The public surface [fig 66] at the top thus needs to act as a connecting surface over which the people move. The roof of the bathhouse thus becomes the public floor with all the bathing facilities suspended on one level between the train tracks & the upper public deck. The primary ordering element for the bathhouse was the 'closed circular service route' enveloping the private bathing spaces. [fig 68] Wrapping the service cores around the building 'protects' the private bathing act inside from the public act outside and all the service elements and water reticulation becomes an aesthetic on the outside of the building. The building is visible from all sides and from the bottom and thus it was essential to 'close' the bathing spaces with a 'breathable' service corridor without closing the building off completely. I decided from the start that the bathhouse will function as two separate buildings (male & female) mirrored along the long axis of the site. South Africa is not a culture which had bathhouses throughout the centuries, and we are thus not used to the customs of mixed sex bathing. The bathing complex must look like one building, but function as two separate ones.

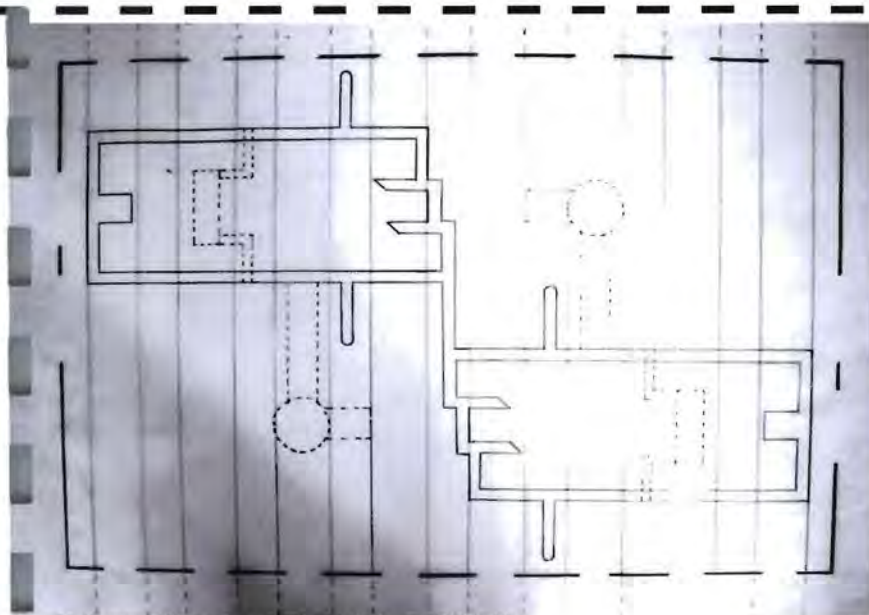

figure 68: Diagram of the service cores & route in & around the building.

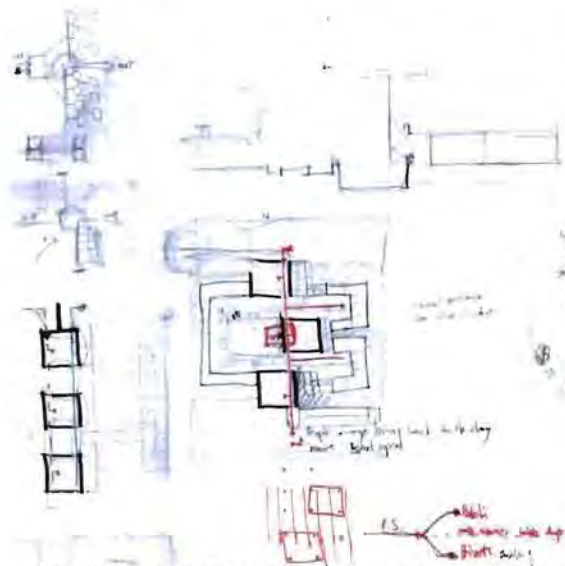

figure 69. Sketches of movement through the changing rooms towards the different bathing spaces.



figure 70: Cross section with baths at the bottom and the public floor on top.



figure 71: Section along the train tracks with primary bathing courtyard, showers on both ends & public floor on top.

04

The journey takes one from various bridge spaces on the public surface passing public toilets & formal | informal shops towards a long ramped threshold space down into the building. The bridge spaces change into event room spaces on the inside with pass-by movement routes. The various change rooms are placed around a central roofed courtyard with shower isles leading off them. The heated pools & steam rooms are placed at the centre of the site. The structure of the building is completely precast concrete elements slotted into place. The column grid used was the 16m centre of platform to centre of platform and it tied in with the existing column grid in the other direction. The sections above show the red pronounced precast elements which forms a matrix which the user 'tracks' his movement. Precast concrete skylights have a double function of bringing light into the bathhouse and becoming usable surfaces on the public floor e.g. chairs, grass mounds, informal shops etc.

The bathhouse sequence with the service cores as an entity worked on its own, and the structural grid as an entity also worked on its own, but not together. It was as if the bathhouse was designed without taking into account the grid imposed by the trains. Also, the bathing sequence is very monotonous being on one level with no real difference or progress in the experience of the spaces.

I was constantly trying to weave the different elements into a harmonious whole...



figure 72: Weaving of the elements into a harmonious whole to become a building filled with rich spatial experiences.

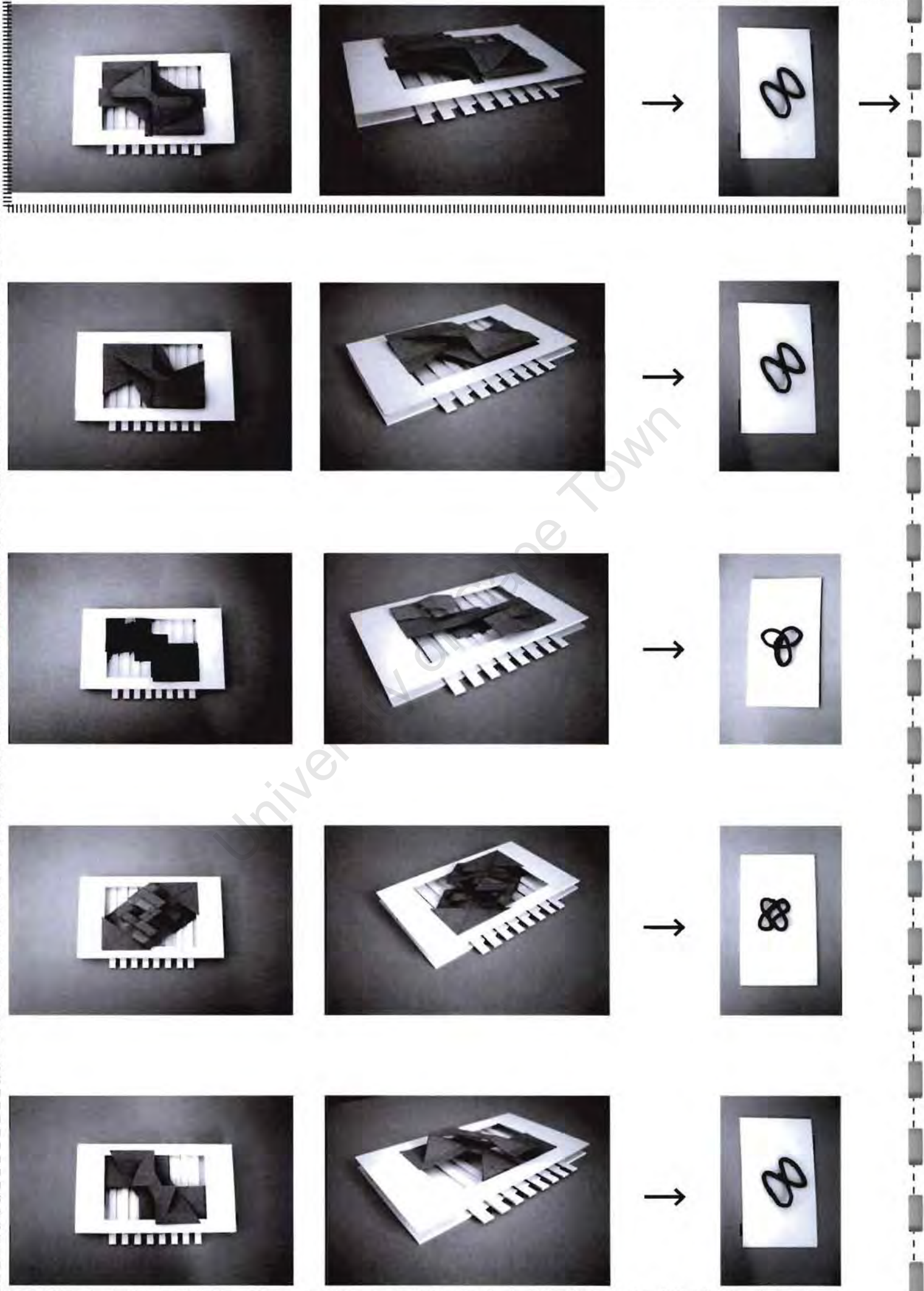

figure 73: A selection of models where the building roof becomes the public 'movement surface'; together with a 'spatial loop' showing the primary bathing circulation under the public roof.

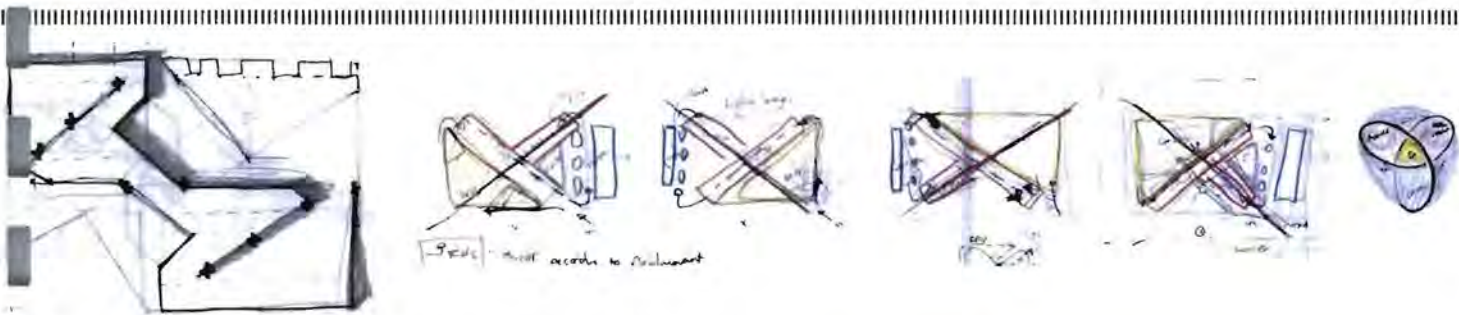

Figure 74: Placement of spaces within the figure '8' spatial loop.

Decided to design the public floor as a 'ramped movement surface' to cover the non-place, much like the theories developed by Foreign Office Architects [p26-27]. This surface gets sculpted to form a direct & fast route through the building at the level of the existing raised platform; & a meandering slow route over the building. The bathhouse is then inserted underneath the public sculpted surface.

Figure 73 shows a selection of models exploring with different surfaces. Spatial loops (becoming the bathing circulation) is then inserted underneath the surface.

Chose one model and designed a quick diagrammatic building incorporating the simultaneous movement systems. [fig 74-77] The public floor (roof of the building) becomes the connecting device filled with informal shops, open courtyards, vegetation and green spaces.

The figure '8' used for the spatial loop becomes the circulation route for the bathers inside the bathhouse. Dry and wet areas are separated with the wet water spaces all located at the centre of the site for easy maintenance & shorter pipe lengths. A central circulation core becomes the secondary returning route for bathers and the primary structural support for the building. The structural grid remained the same (16m c/c) but the geometry of the building made it very difficult for a standardised precast concrete system. The construction method was changed to cast-in-place concrete.

The figure '8' spatial loop used for bathing worked well with the deep cleansers who need to go through the whole sequence, but didn't work with the surface cleaners who need to get in & out fast. A bathing sequence requires a to and fro movement between the change room and the toilets; or pools, or showers and not a continuous closed journey, like a gallery or a museum. The spatial loop (fig'8') and the public surface each had its own requirements in terms of levels, and then to fit it into the existing levels & heights of the raised podium above the train tracks became nearly impossible. I went through every possible sequence & route but every time the routes became too complicated where one first has to go up to go down or one would reach a dead end because the levels did not match up. Every right move I made with one movement system created unresolvable problems with the next system.

So again, the conceptual diagram [fig 75] works well on its own & with the service system of the building, but it didn't fit in with the existing conditions regarding heights & grids. The connecting sculpted public floor also works well on its own, but not with the train grid & fixed geometry. Although I learnt a lot from these exercises (sculpting movement surfaces into sculptural elements and creating space with the same element) the building still wasn't of the site - it was an added surface which could have been added on any site (over train tracks or on soil). The surface couldn't incorporate the INPUT-OUTPUT sequence of the trains and the spatial loop figure '8' couldn't incorporate all the bathing requirements - SURFACE, PHYSICAL & DEEP cleansing.

Designing with different movement systems, one system always gets pronounced where the others are then filled-in around a 'primary' one. Is it possible for all systems to be equally supportive in shaping the building?

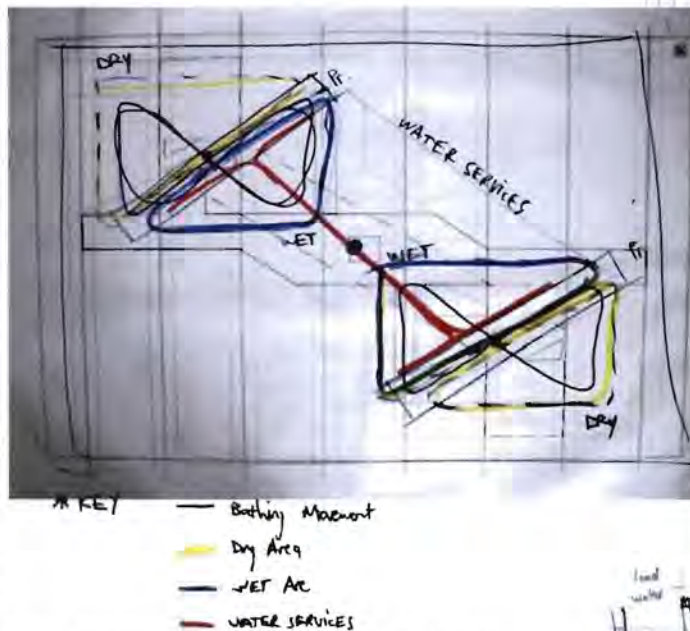

Figure 75: Simultaneous movement routes shaping the building & site.

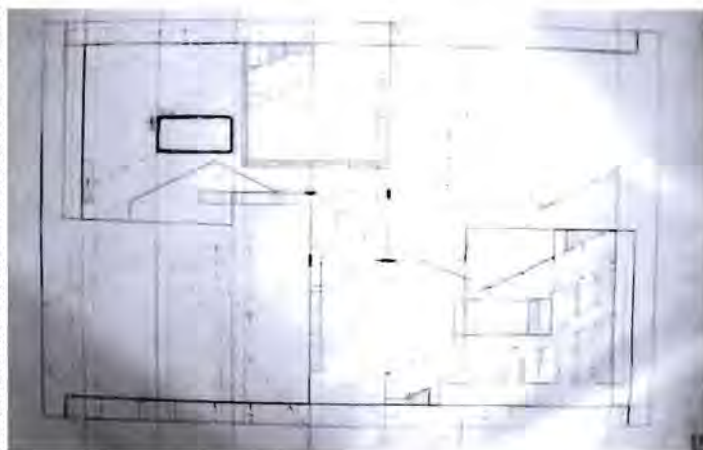

Figure 76: Bathing level

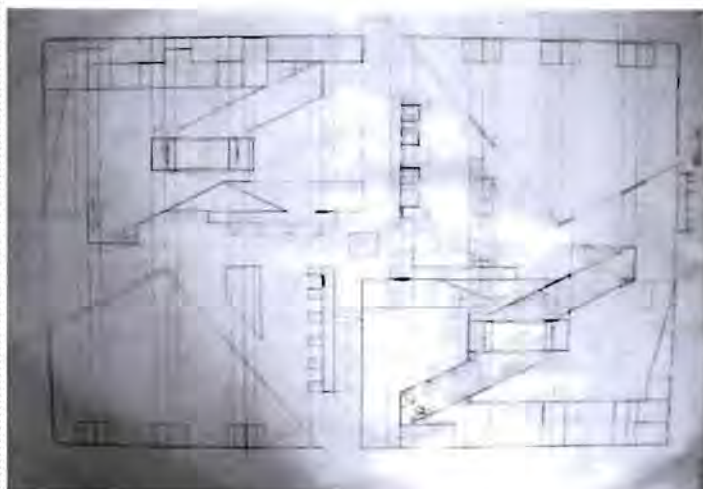

Figure 77: Public Floor Level



figure 78: Rhythm set up by the INPUT OUTPUT sequence of the trains.



figure 79: Structural grid on the platforms

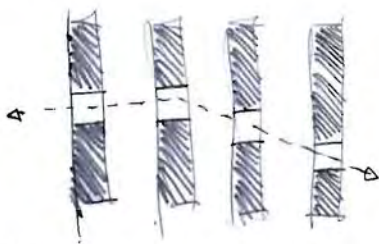

figure 80: Carving movement through the 'SOLID' EVENT spaces

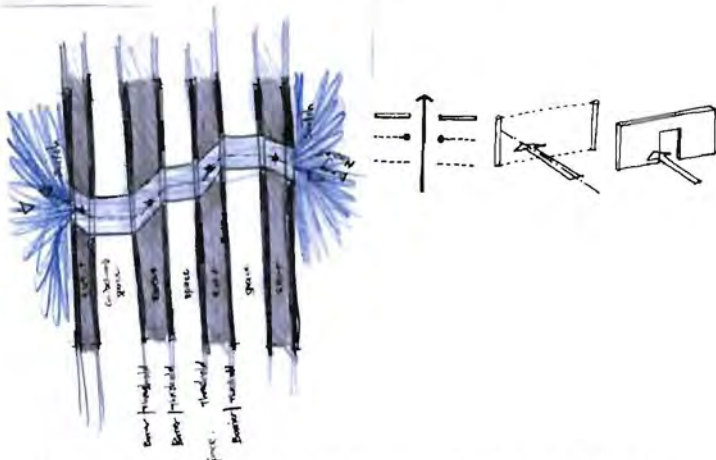
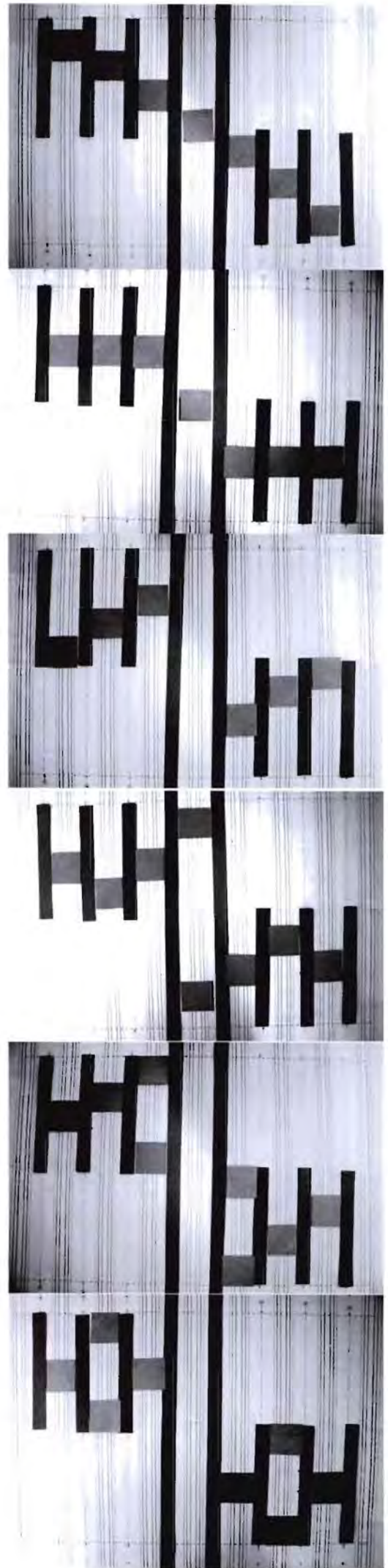

figure 81: Conceptual diagram of the primary circulation cutting through the Solid event & the Transparent Connecting bridges; with the planar threshold walls separating the spaces.



figure 82: Diagram of the crossing-points the primary link & the secondary filters create. This 'decision-making' space creates bifurcations in the journey and an important crossing point of all paths/journeys/movement systems.



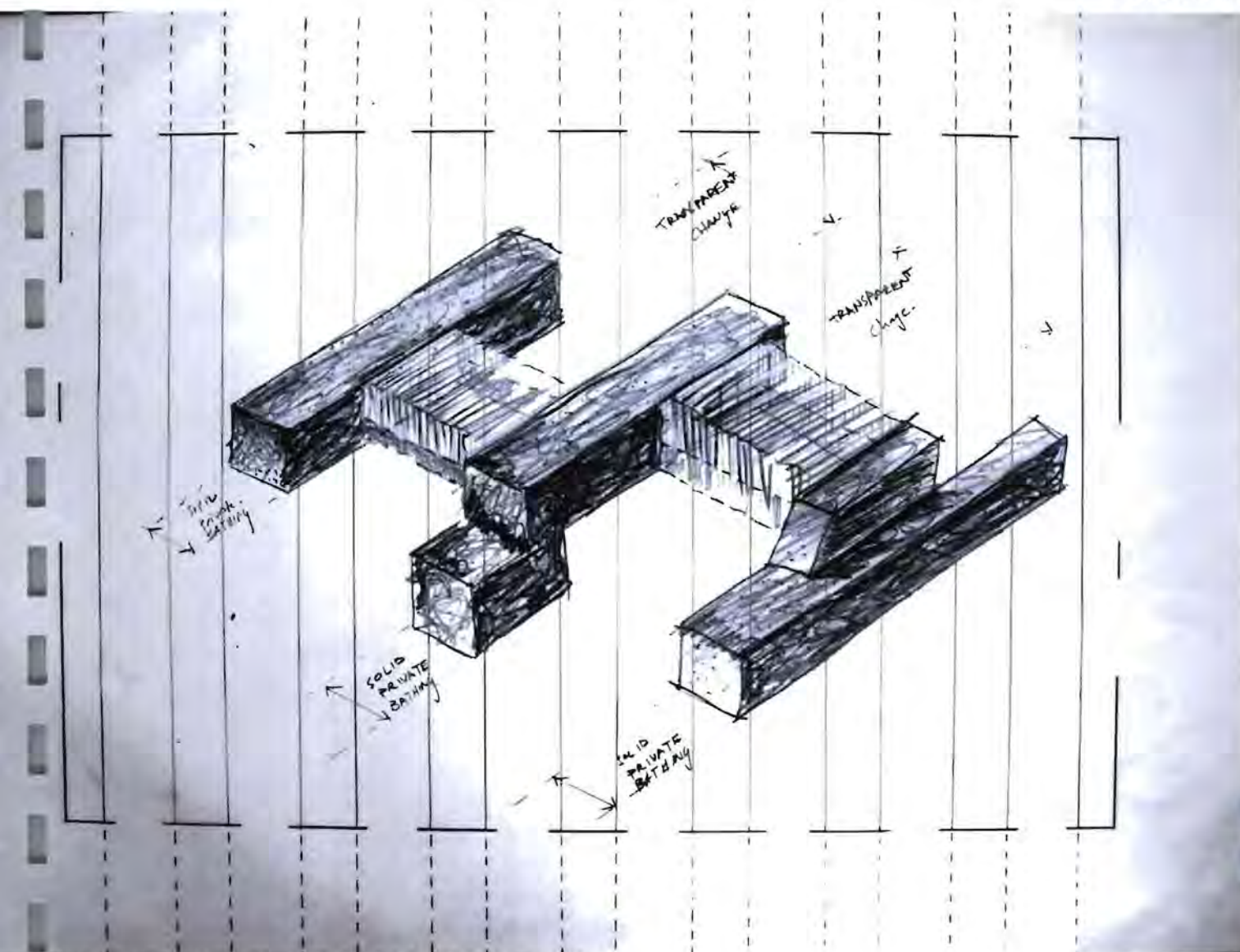

figure 84: Three-dimensional & material quality of the SOLID private bathing spaces connected with TRANSPARENT change room bridges.

The previous exercises was a way for me to work through all the possibilities & limitations of each movement system, functioning on its own, and together with the others. It helped me get to know what is possible with the site and the existing structures. The knowledge learnt is now taken further & combined into a few conceptual diagrams and sketches which has been developed into a final building. [please note: refer to final drawings as well while reading the following passages. They are attached in the addendum Chapter 7 called Conclusion]

The structural column grid was changed from the usual centre to centre of platform, to a new grid still complying to the 'Metrorail' train standards. The new grid has its columns/walls placed 2m from the edge of the platform creating a 5.5m span for the Solid event spaces directly above the platforms, and an 11m span for the transparent bridges directly above the train tracks. [fig 79] The spacing of the columns/walls along the platform can be changed to suit the building above. The columns were changed into 'threshold planes' which are concrete walls only perforated to allow for movement through the different spaces. The wall is thickened where needed to carry the loads. [see Chapter 5]

This new grid arrangement creates a rhythm across the site which is created by the INPUT OUTPUT sequence of the trains. and. The site is thus occupied by a 'broken' | deconstructed building consisting of 5m wide SOLID "private" EVENT bands, & 11m wide TRANSPARENT semi-public | public SPACE above the tracks, only connected by MOVEMENT of the user through the site & the building to piece it together & understand it as a whole. The relationship between the independant parts & the whole is essential in the understanding of the building, & the sequence of events becomes important - linking these solids &

figure 83: Shifting the transparent linking spaces along the tracks & solid event spaces to shape the building, searching for equilibrium & rhythm: PUBLIC V/S PRIVATE; OPEN V/S CLOSED; SOLID V/S TRANSPARENT.

voids together.

This rhythm which is created by the solid & transparent spaces lets one know consciously when one is moving through the building: it is constant THRESHOLD PLANES being crossed and makes one aware of the journey - moving from light to dark; or from being seen to being safe and invisible... This concept is taken through to the materiality & construction methods as well (explained in chapter 5), but in short, the solid spaces are dark, rough water-washed cast-in-place concrete which forms the supporting structure for the light, smooth precast concrete infill bridges in-between. This idea of having two separate construction methods creates a strong rhythm across the site - dark v/s light; smooth v/s rough; solid v/s transparent & expresses the structural nature of concrete. It is thus a combination between the previous exercises where the rigid, precise & long spanning capability of the precast concrete is used within the void transparent spaces & the rough, fluid sculptural quality & shorter span ratios of cast-in-place concrete are used within the solid event spaces.

The solid spaces are then filled in with all the 'event spaces', becoming the 'wet' areas in the building where one goes to to have a shower, toilet, wash ones face, cleanse oneself in the steam rooms etc. [fig 89] The user has the feeling of being safe within this solid mass to be naked within the train station. The transparent space bridges are the change rooms which becomes the 'social bridges' of the bathhouse. [fig 88] The materials and construction method of these spaces are to be as light as possible. This creates the feeling of being in-between the solid masses; in-between being naked & clothed; in-between dry & wet; in-between being visible & invisible; in-between public & private; in-between train station & bathhouse. It is the same principle of movement where one is not at home or at work but in-between, still on the move...on the way to be cleansed....being within the 'changing' threshold space.

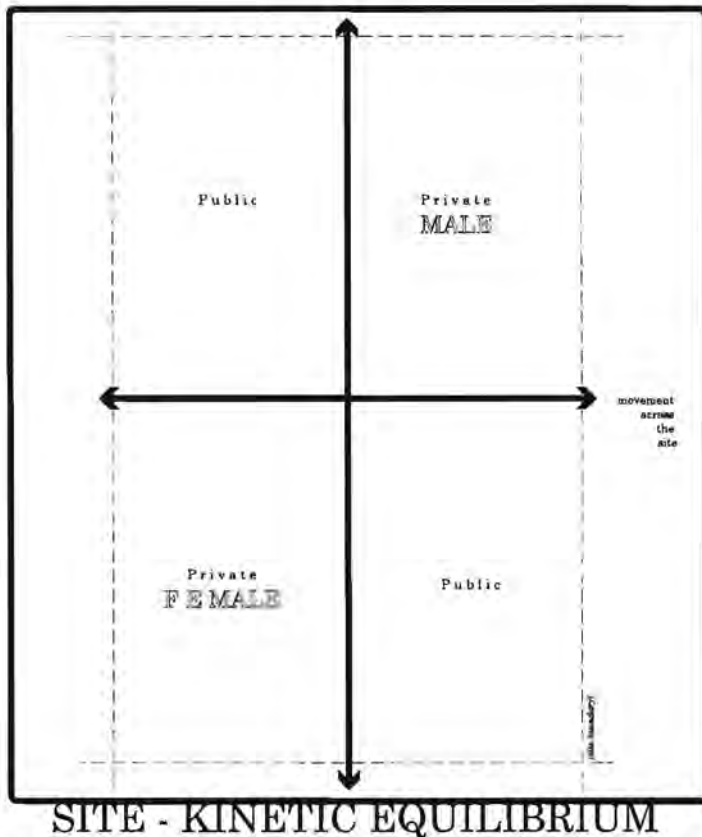

figure 85: Deviding the site into equal parts of movement, space & event.

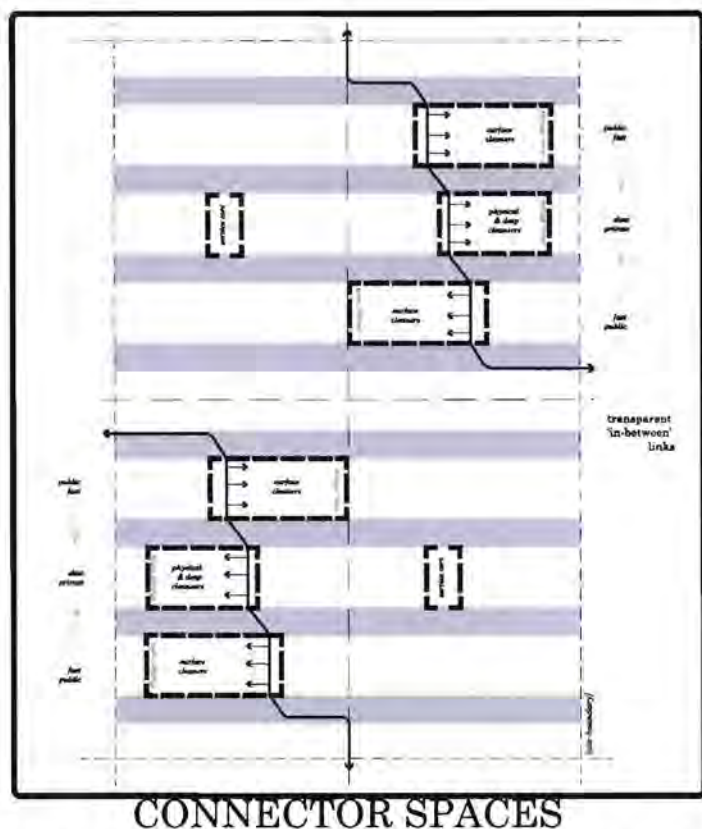

figure 88: Configuration of the different connector spaces [change rooms] within the bathhouse: from the surface cleaners closest at the edges | entrances of the building towards the private deep & physical cleansers at the centre of the building

Figure 88 shows the configuration of the different connector spaces [change rooms] within the bathhouse: from the surface cleaners closest at the edges | entrances of the building towards the private deep & physical cleansers' change room at the centre of the building; with the pass-by circulation route connecting them. The surface cleaners' change rooms on the edges are directly connected to showers, baths, toilets & wash hand basins in the solid event spaces on either side of them, but the surface cleaners' change room is not connected to the spaces directly. The user must take the 'longer journey onto the main circulation path towards the crossing point & make a decision where to go. The surface cleaner's change rooms each have two shower isles on both sides [descending from existing level] and one toilet room isle ascending on the interior edge of the space. The deep cleansers only have 'on-route' showers in the event spaces on the way towards their specific activity - swimming or bathing or steaming.

The floor levels of the various spaces [solid v/s transparent spaces] are offset at 1.5m with the two surface cleaner's change rooms at the same level as the existing raised platform [entrance level]. [see fig 92] This configuration of levels makes it possible for spaces to be directly connected visually throughout the building with sight lines going over ramps & staircases. It also enhances the feeling of the user being at more than one place at a time, or in-between spaces: being in the change room but also part of the activities happening in the toilet- & shower spaces. The surface cleaners thus only ascend | descend half a level to get to the showers | toilets directly from the change room. The deep & physical cleansers' change room is surrounded by service corridors on both sides and the walls are pulled back to enhance the feeling of floating in-between train tracks and sky, services & lockers - with no direct linkage into the event spaces.

This configuration of levels, services, event spaces and circulation paths all work together for a quick | direct surface cleaner's sequence and a longer, slower | indirect deep & physical cleanser's sequence and also with the easily to & fro movement between the event spaces & the change rooms.

Figure 89 shows the configuration of the event spaces servicing the connector spaces within each bathhouse. It was a long process to get the right configuration of spaces within the solid spaces. They had to correspond to the specific type of change room and the specific journey | sequence being undertaken (being for the surface cleaners or the deep- & physical cleansers) & incorporate the servicing sequence within them as well. The service corridors are located on the sides of the solid bands [see figure 90: white dashed lines & figure 92]. The fact that the surface cleaners' change rooms had to be directly connected to the toilets & showers shifted the service corridors towards the 'outside' face in the event band. In this position, the service corridors wraps around the private bathing spaces making them invisible from the train platforms and other areas. The service corridor acts as the in-between threshold space between public & private; naked & clothed; wet & dry. The configuration of the spaces within the 5.5m wide strips are allocated in each bathhouse from two public outer bands towards two private inner bands. [fig 89] Giving the two outer bands over to the public realm enhances the spaces around it - being the taxi stations & shops. It also creates a public activity at the centre of the site - not having any 'dead' spaces where people can create trouble. Figure 92 shows the allocations of spaces in the cross section where the activity level increases from 'daily life cleansing' at the bottom towards a 'higher than daily life cleansing' at the very top of the building. The vertical axis can be considered the sacred dimension of space, a path towards a reality which may be higher/lower than daily life. Again, this configuration enhances the quick & slower sequences of the different bathers within the building.

The light quality changes as one moves through the different solids & voids to enhance the threshold experience of the different user groups. The 'transparent bridges' [change rooms] are constructed from precast- prestressed concrete elements with linear floor light shafts & transparent roof louvres [explained in chapter 5] - all to give a transparent lighting scheme within the space. The light filters in from all sides; through window strips on the outer edges, floor strips below & roof strips above to enhance the transparent in-between experience. As one moves inside the solid event spaces the light

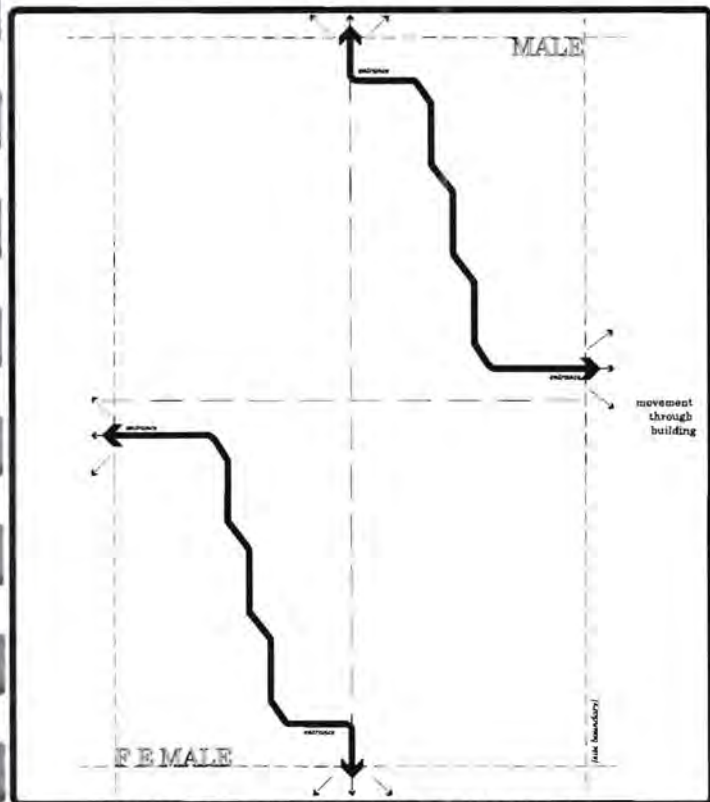

BATHING EQUILIBRIUM

figure 86: Connecting the two entrances of each bathhouse [male | female] with a direct pathway physically, but in-direct visually.

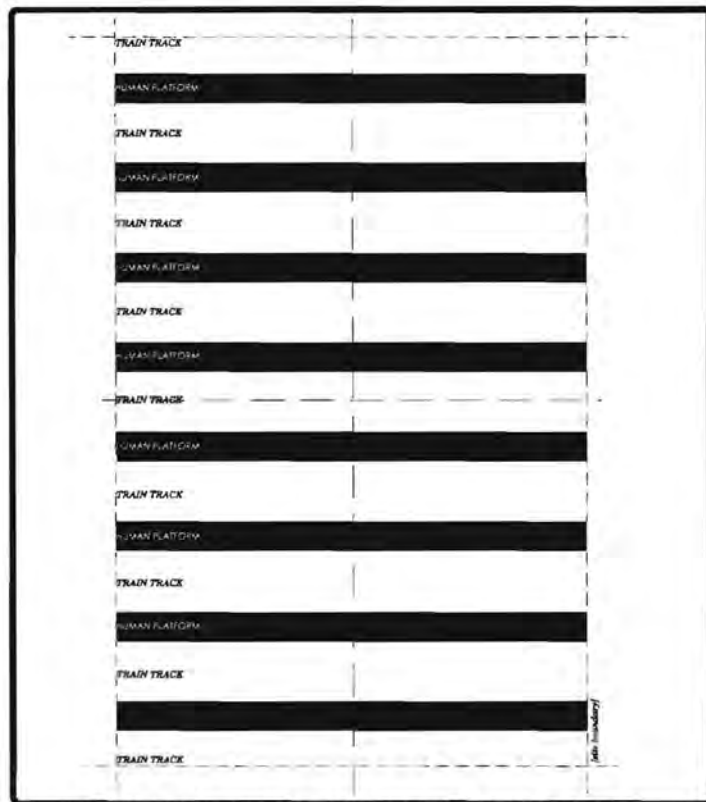

MOVEMENT GRID BY TRAIN

figure 87: Existing rhythm of the Input-Output of the train which sets up the construction method and spatial layout of the solid & void bands of the building.

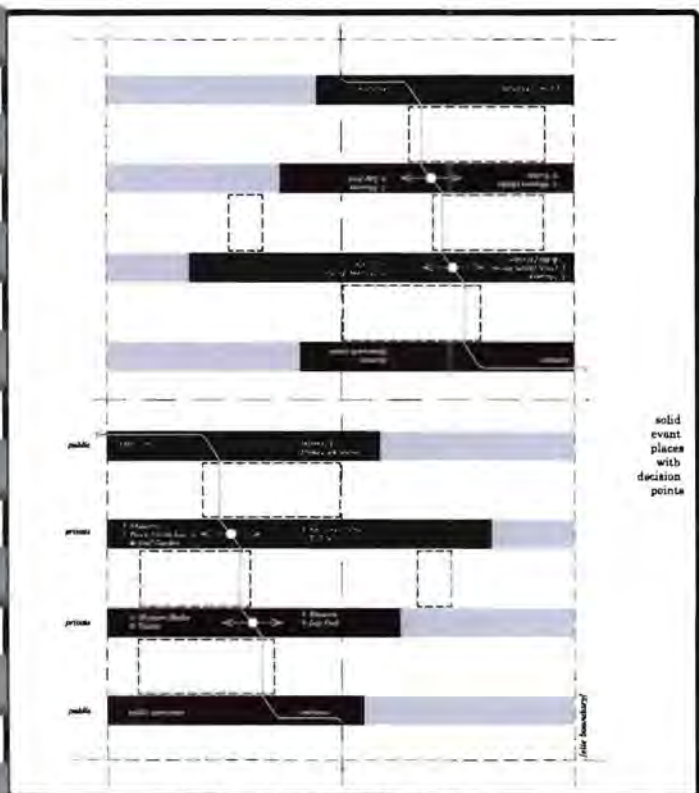

EVENT SPACES

figure 89: Configuration of the event spaces servicing the connector spaces within each bathhouse: from two public outer bands towards two private inner bands.

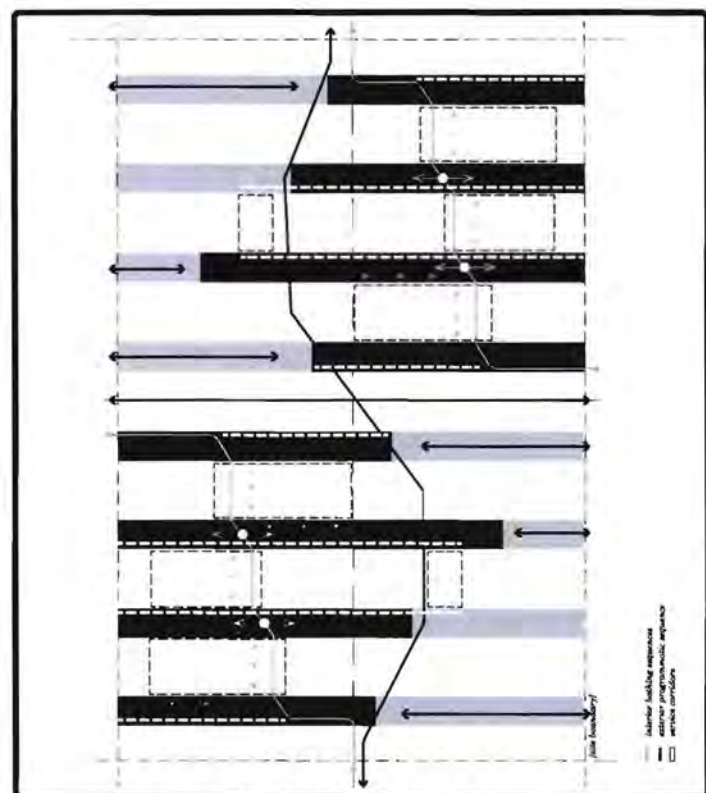

MOVEMENT

figure 90: Configuration of the movement through the site and bathhouses: primary routes being directly connected, but visually indirectly to create a meander | journey through the site | building; secondary routes are direct links originating at the crossing points with the primary route - creating a space of 'decision-making' on the movement route.

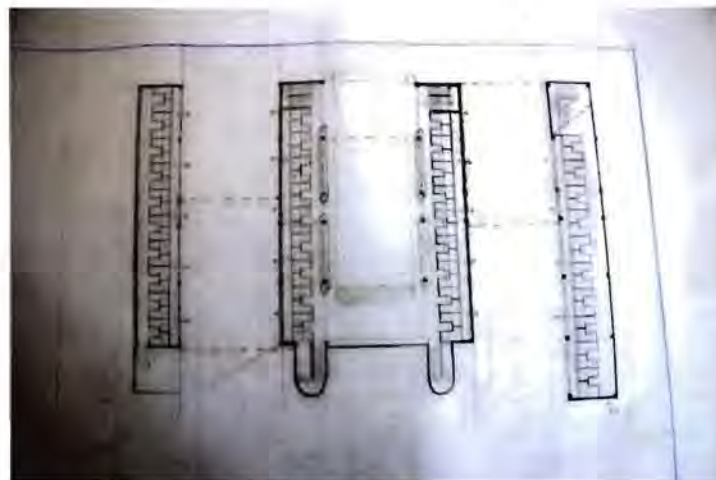
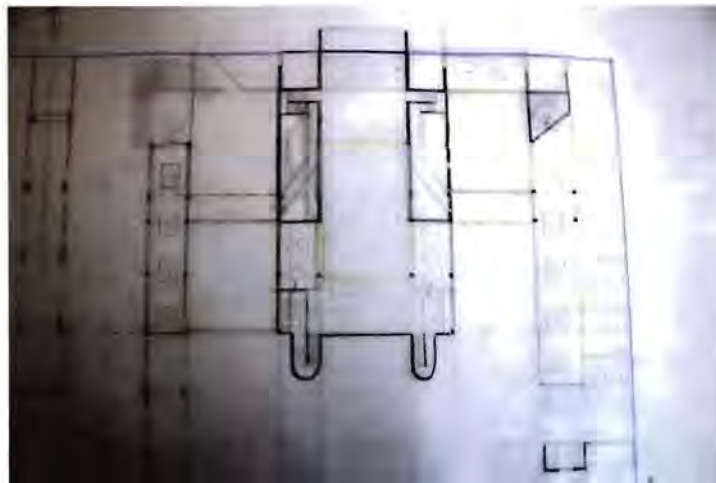
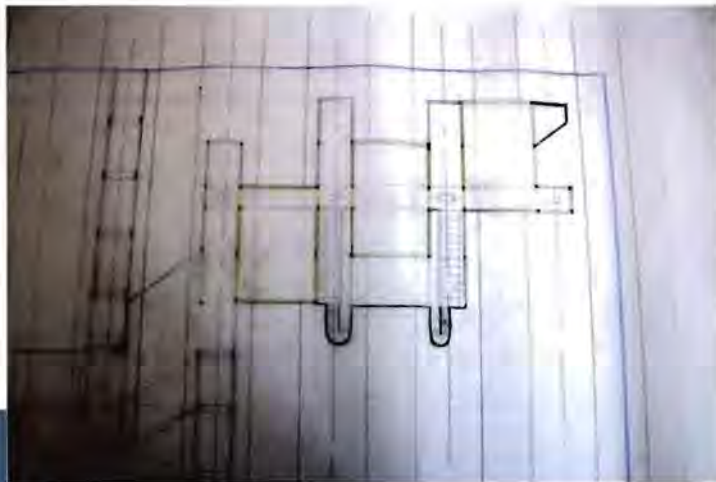
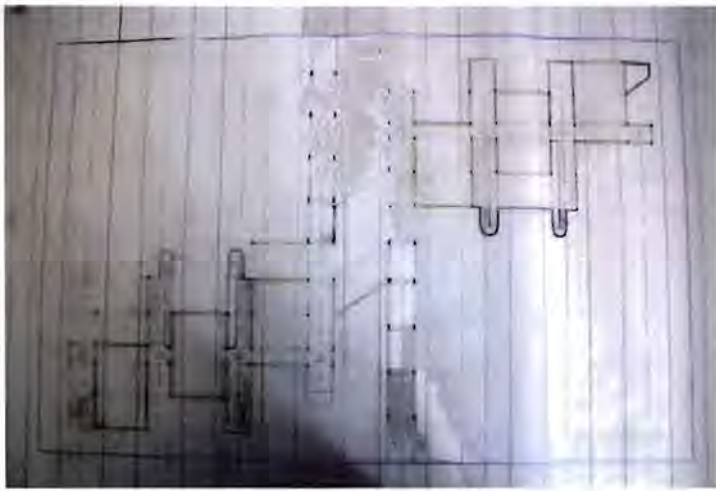

figure 91: Design development of the plans
Kinetic Architecture – the spatial organization of daily mobility within a Public Bathhouse

quality changes from coming from every direction to only focussed sharp lights. This is achieved through linear concrete skylights in the roof of these spaces. The skylights are precast concrete elements bringing light down into the private realm below & functions as seats | tables above in the public realm. The threshold planes [edge walls between the the solid event spaces & the transparent change rooms] are only perforated to allow for movement through the building & also contains narrow linear perforations to allow for views into change room spaces or out of the building., just as Jean Nouvel states:

“Architecture exists, like cinema, in the dimension of time and movement. One conceives and reads a building in terms of sequences. To erect a building is to predict and seek effects of contrast and linkage through which one passes... In the continuous shot | sequence that a building is, the architect works with cuts and edits, framings and openings.”

The primary movement route through each bathhouse [male | female] is a line that connects the two opposite entrances of the bathhouse at the centre of the sides of the site. [fig 86, 88-90] Physically it is a direct link, but visually it is indirect: the pathway changes direction at each intersection with an event space. This creates a decision-making-space | bifurcation at the crossing point with the secondary routes. These crossing points become quite pronounced throughout the building as it is also the primary entrance route for the clean hot & cold water into the building. The pathway cuts through the change rooms as pass-by spaces. These bifurcation zones are the crossing of all the routes/sequences/journeys within the building [pools, showers, toilets, etc] and they become the points from which one orients oneself. At the intensities an opportunity is given for dialogue between user groups and allows them to change direction from one route to another. A rhizome is formed, where all routes are connected to each other.

The curving of this primary circulation route through the building also increases curiosity of the user - wanting to find out what is around the next corner. It is thus not a direct straight link where everything can be seen at once [ready-made-space], but a staggered curving link where the user has to move through the spaces in order to experience it [space-in-the-making]. The secondary circulation spaces in the event spaces are interrupted by holes in the floor to allow for light to penetrate into the shower spaces below & to visually connect the spaces. These circulation paths lead one to certain events within the event solid with normal flat floor, being a short threshold [toilets & hand was basins] or ramps being the longer threshold [pools & steam rooms]. The movement inside the building thus changes from being free & open [inside the change room spaces] to confined & linear movement inside the solid event spaces.

Figure 90 also shows the configuration of the movement through the site surrounding the bathhouses: primary routes being directly connected, but visually indirectly to create a meander | journey through the site. The two bathhouses [male & female] are mirrored along the central axis of the site with the solid bands of the buildings extending at different lengths in order for the viewer not to see directly through the site, but experience it as he/she moves along the meandering pathway. The solid bands from the building continue to create a floor at the existing level of the raised platform to create continuous public floor strips that also covers & protects the train passengers on the train platforms below from rain. These solid strips also continue past the existing site boundary to become formal & informal shops on the existing deck/platform. The void spaces in-between these solid strips [above the railway tracks] are filled in only at certain intervals with precast concrete 'bridges' to connect & complete the pathways for the people to walk across the site. These bridges are filled in with strips of vegetation & trees providing solar shade & visual barrier for the change rooms' glass & concrete facade. There are also precast concrete benches & tables which could be used by the general public passing through or become an informal shop. These infill spaces become social bridges/rooms/courtyards for children, taxi drivers, working class or travellers to hang-out and rest, do homework while waiting for someone, eating lunch etc. They are also filled with holes to enhance the 'transparent' experience of them from down below. The existing primary connecting routes from the different spaces on the upper deck [sky bridge from the Golden Acre; the steel bridge from the Grand Parade; the two entrances from the train station] are incorporated into the new

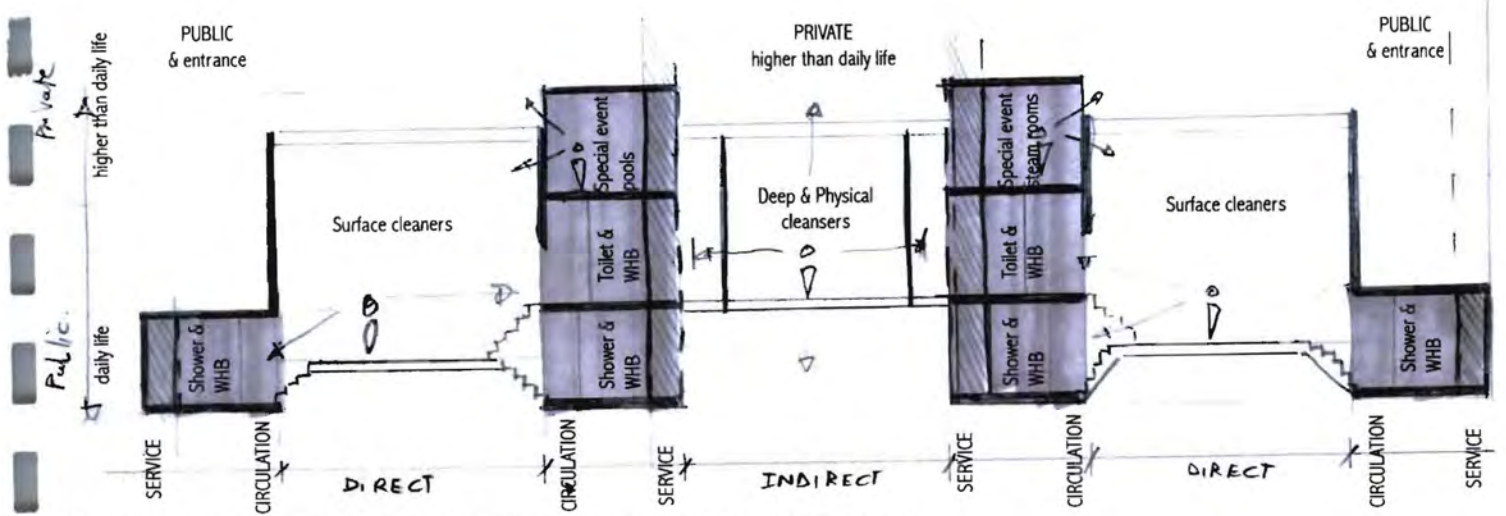

figure 92: Explanatory cross section showing direct & indirect circulation & visual links between the solid & transparent spaces.

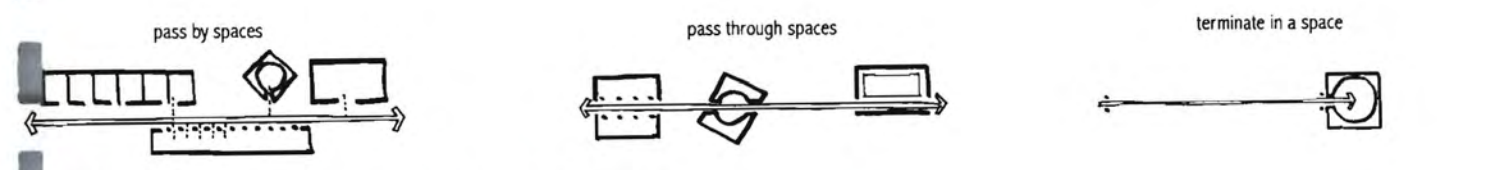

Figure 93: Sequence of different movement patterns in & around the building

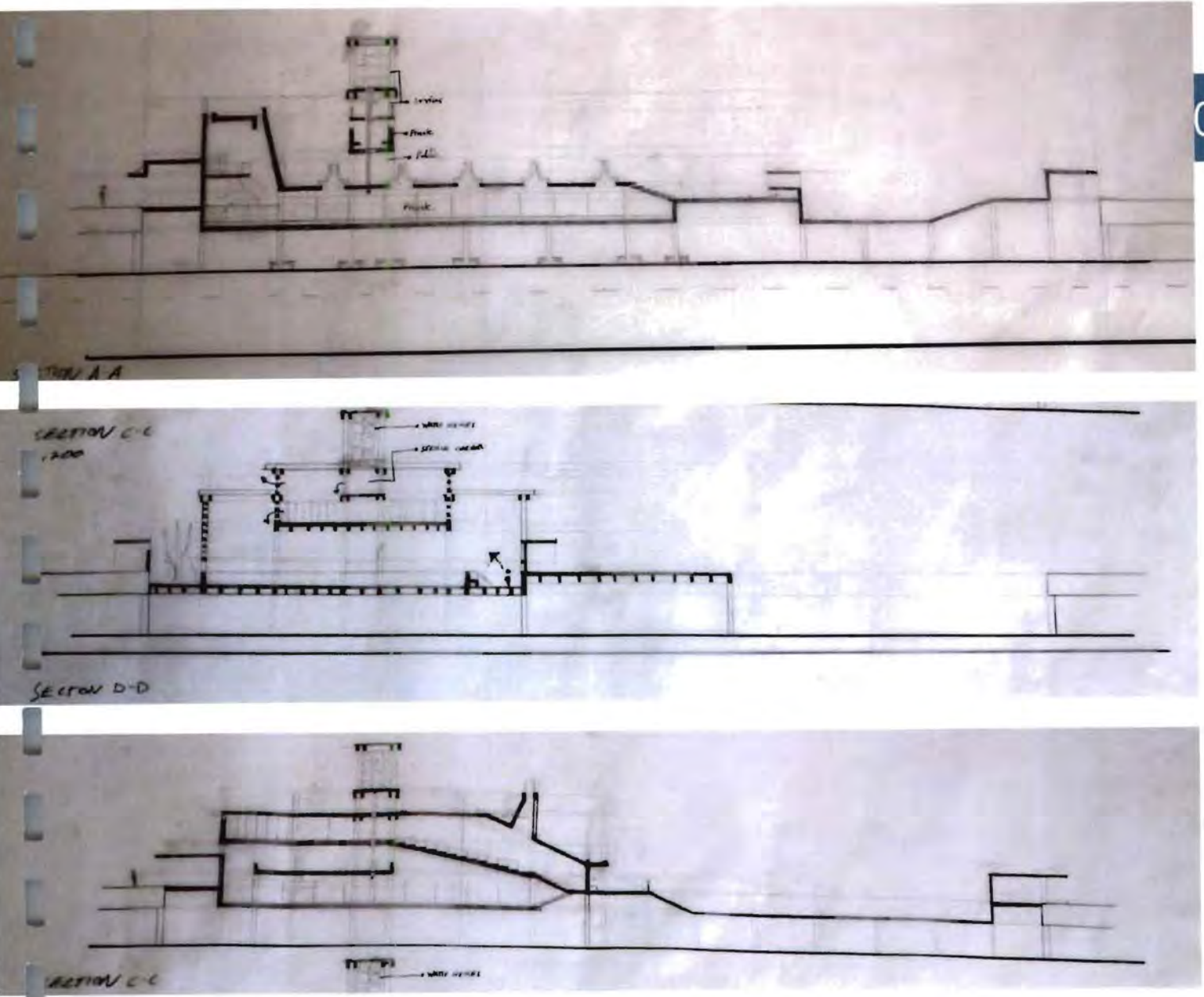

figure 94: Design development of the solid event spaces & the transparent spaces.



figure 95: Different spatial experiences

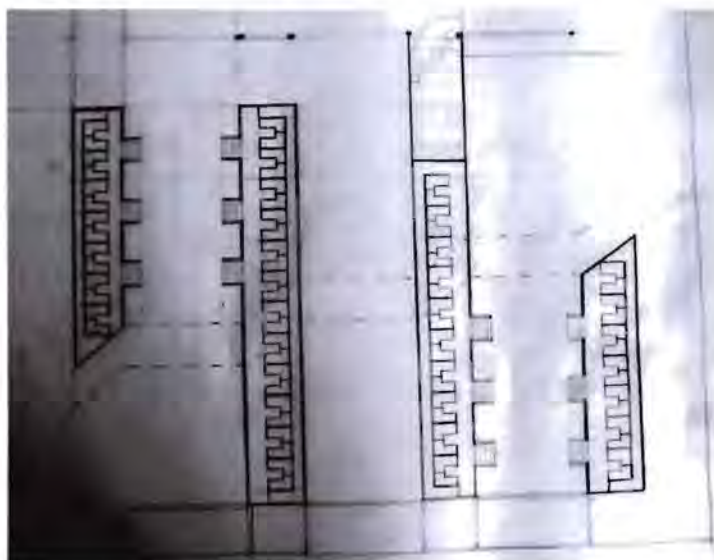
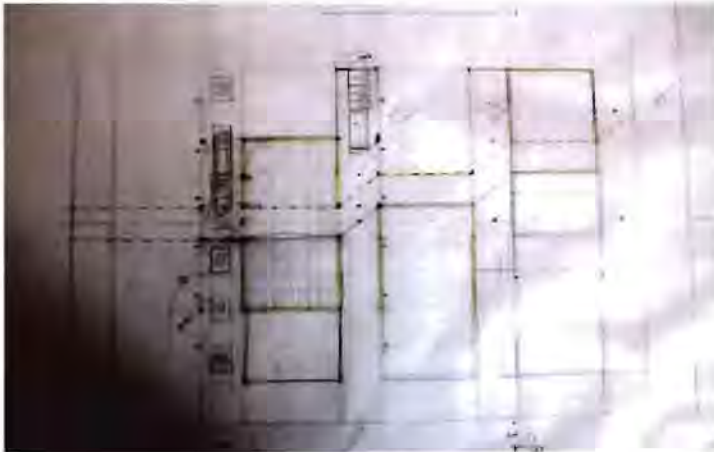

figure 96: Design development of the plans.

design with new public open courtyards at their entrances together with a courtyard at the main south entrance of the site. These spaces are surrounded by new formal & informal shops configured and placed to tie in with the solid & transparent bands of the bathhouse. The surface material of the bathhouse [smooth & rough concrete pavers with precast concrete floor slabs] is continued throughout the upper deck to give a uniform appearance to the whole site & have a continuation of the rhythmic experience while walking through the new & old spaces of the upper deck.

The deep & physical cleansers take the ramp up 1.5m above the entrance level to their change room located at the centre of the building. Attached to the change room is also an exterior courtyard with trees & seats. They are not directly connected to any showers or toilet facilities. They have to continue on the longer journey through all the thresholds the building has to offer. Half of the two solid bands are filled with the toilet facilities, and the other half sections are used for the location of the showers & ramps to get to the lap pool or steam rooms.

The one solid ramp [passing showers on the way] takes one to the first floor where the relaxation pools & steam rooms are. The ramp leads one up towards the crossing point where one has to decide between the pools or the steam rooms. The fire & ice pool are located at the centre of the warm pool and can only be reached by going through the warm pool first. The fire & ice pools are contained inside two cavernous boxes placed directly opposite one another, in order for the user to switch between the two. The skylights in these spaces filters light through a 200mm gap down onto the dark rough textured concrete walls. The skylights follow the path of the walls to lead on deeper into the space. The roof height gets higher the deeper one explores the pool spaces with a big light shaft at the end shining onto submerged concrete benches.

To get to the steam rooms one has to cross the transparent threshold space again. One passes another crossing point where one must decide between steam rooms or an exterior roof garden. The steam rooms are placed in a 'zipper' formation where one can't see through the space but one must take the journey for it to reveal what is behind the next enclave. The steam room becomes hotter as one moves deeper into the 'zipper'. Cold cool down showers are located between each enclave. Light shines through narrow slits above the wide benches down onto the rough textured walls. Linear windows are cut into the walls to reveal the surface cleaner's change room at the bottom & the sky at the top. This enhances the experience of the user still being part & in-between all the other user's sequences within the building.

The other solid ramp at the opposite end takes on to the lap pool. The physical cleansers pass the showers on the way down towards the pool. The 25m lap pool is located at the centre of the building and becomes a spectator sport with clear glass facades towards the exterior & interior. The tiles of the swimming pool are taken up the concrete wall to enhance the experience of the user being INSIDE a pool space - even if he/she is not swimming in the pool itself. Directly behind the tiled surface are the red | blue open service corridors which surrounds the space. This enhances the feeling of the user being inside a pool but also inside the service sequence of the building - being in-between & apart of all the different sequences of the building at once.

The building functions thus as lots of separate deconstructed buildings, each with its own event spaces & enveloping thresholds, with movement connecting them all together. These separated spaces are organized according to daily routine and finally shaped by all the simultaneous movement sequences.

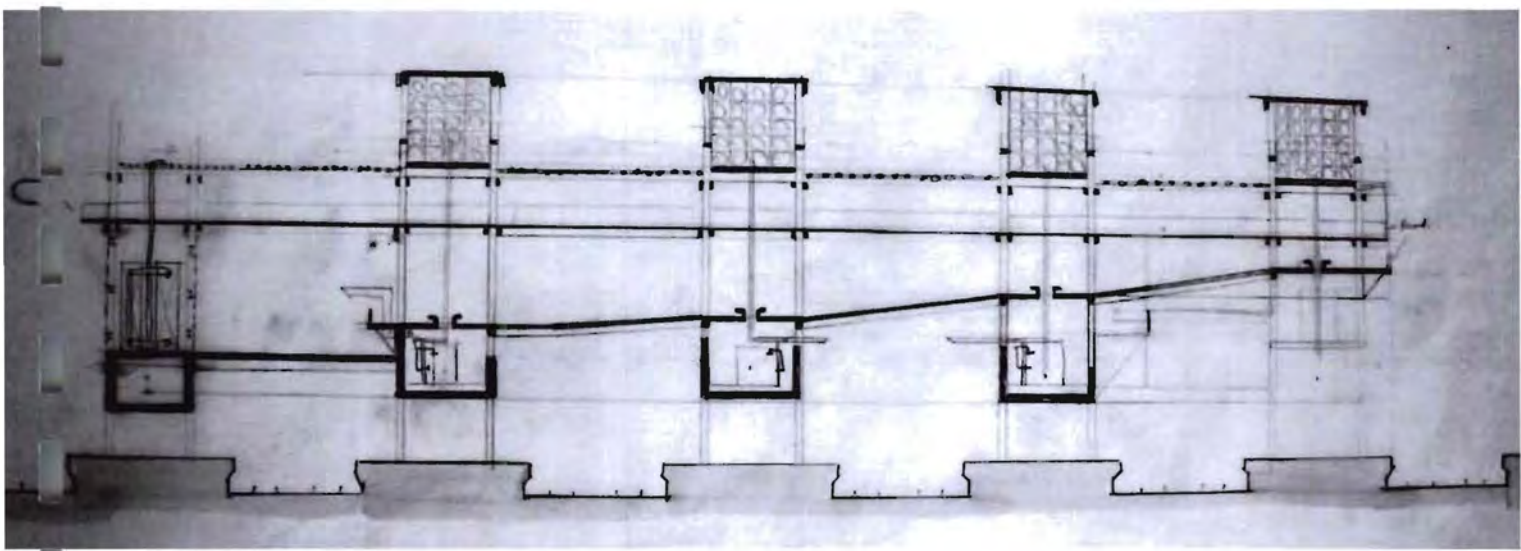
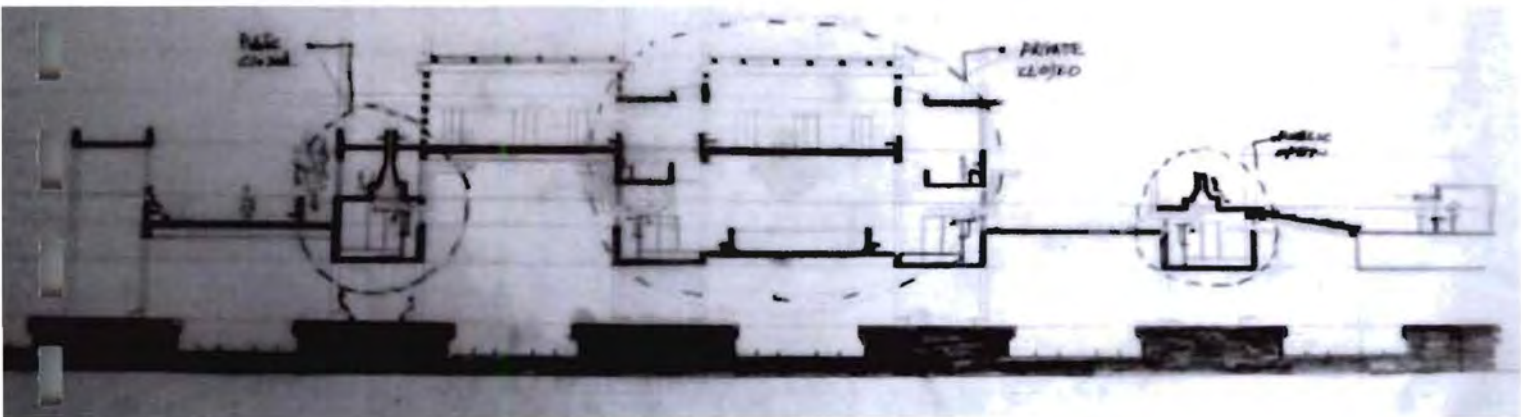
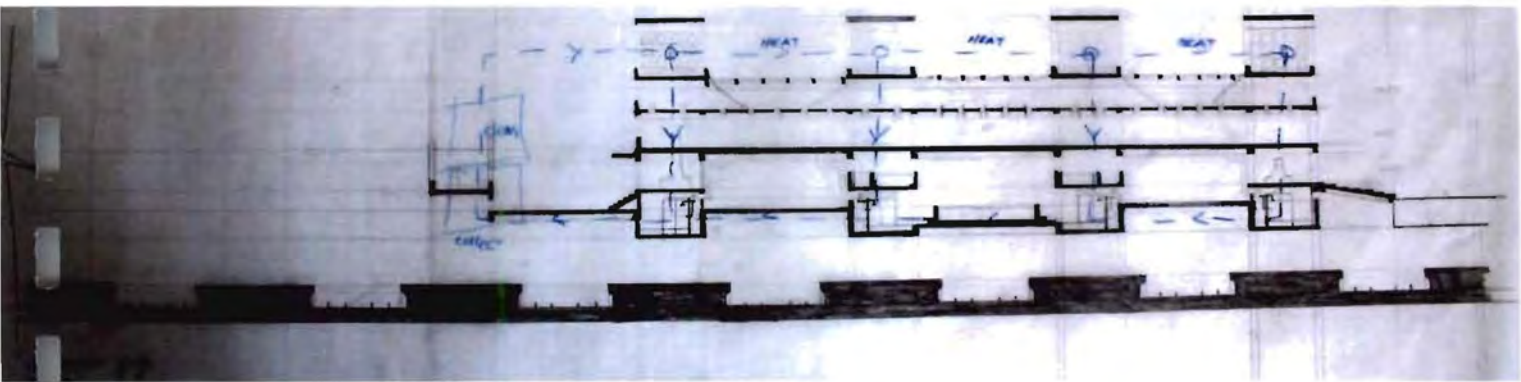

04

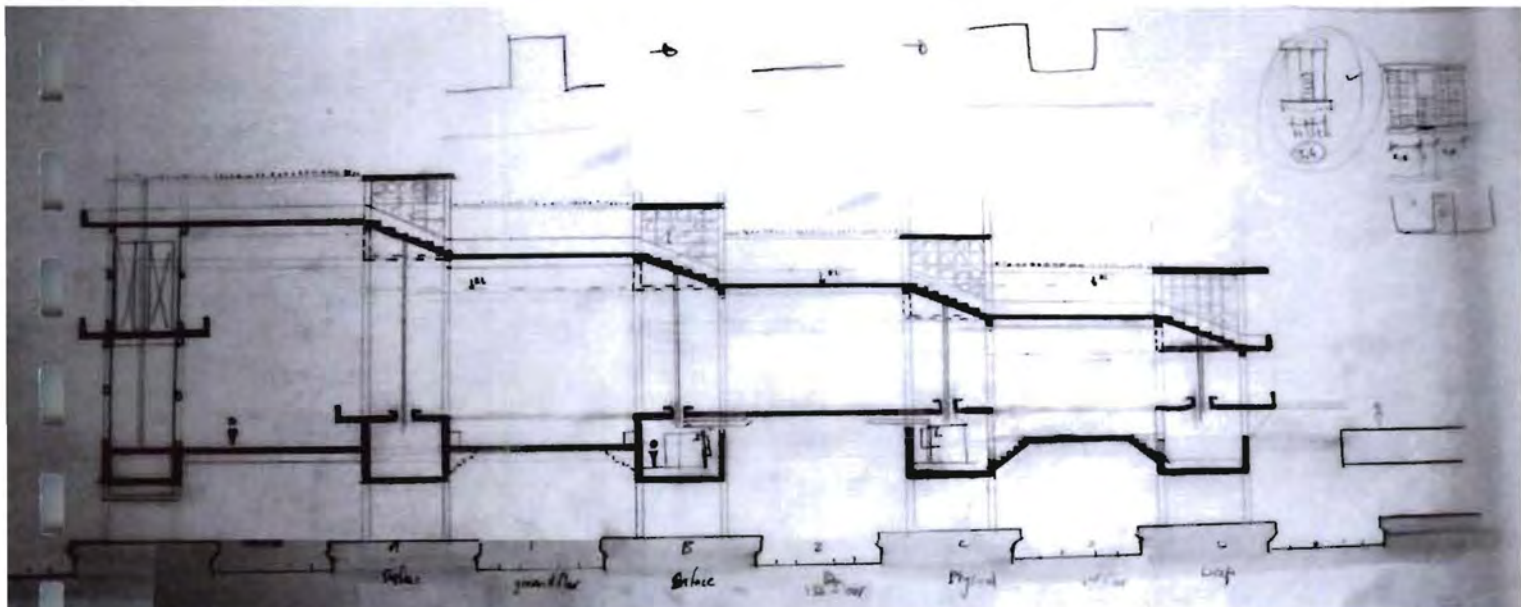
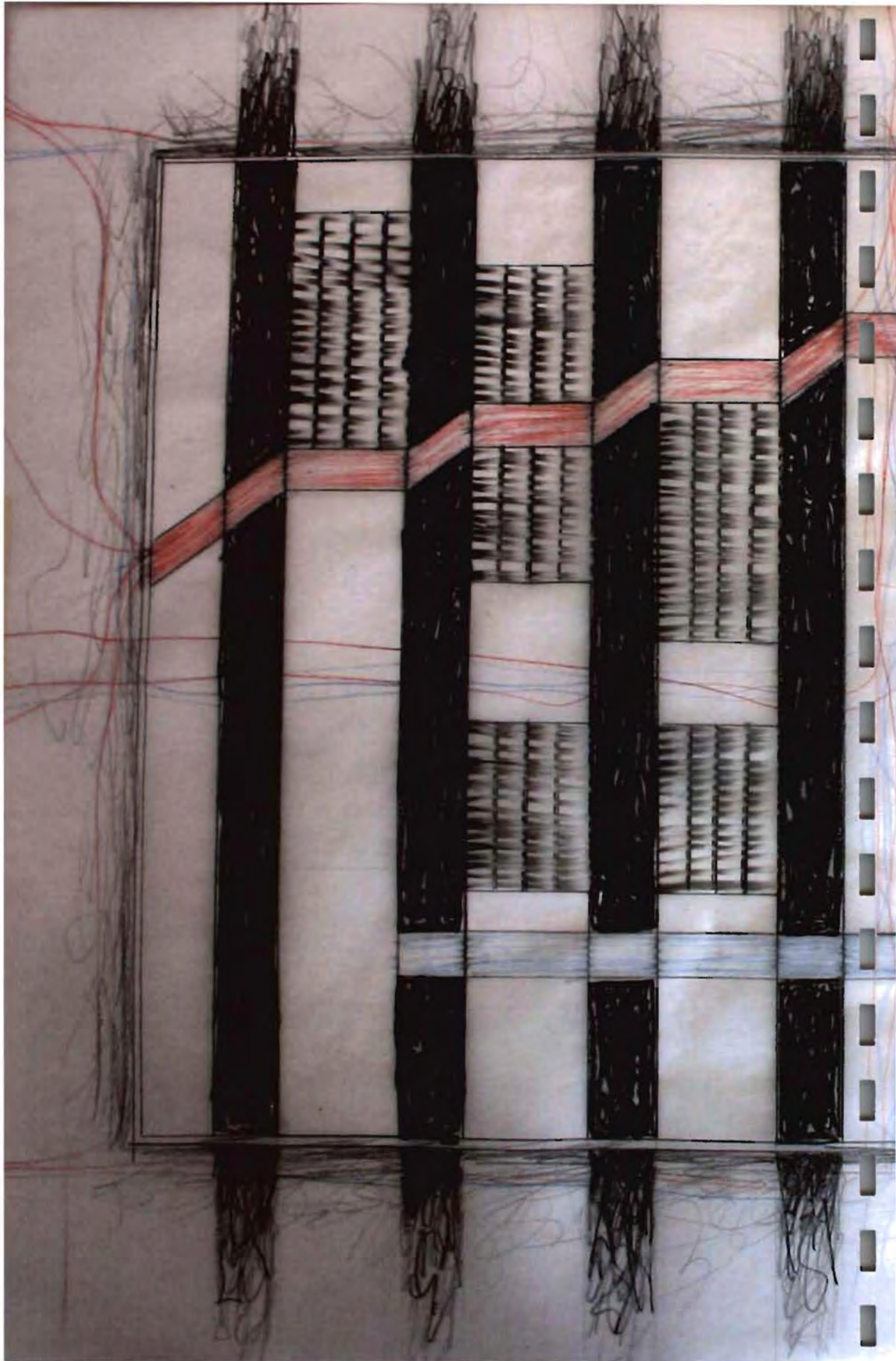

Figure 97: Design development of the cross section



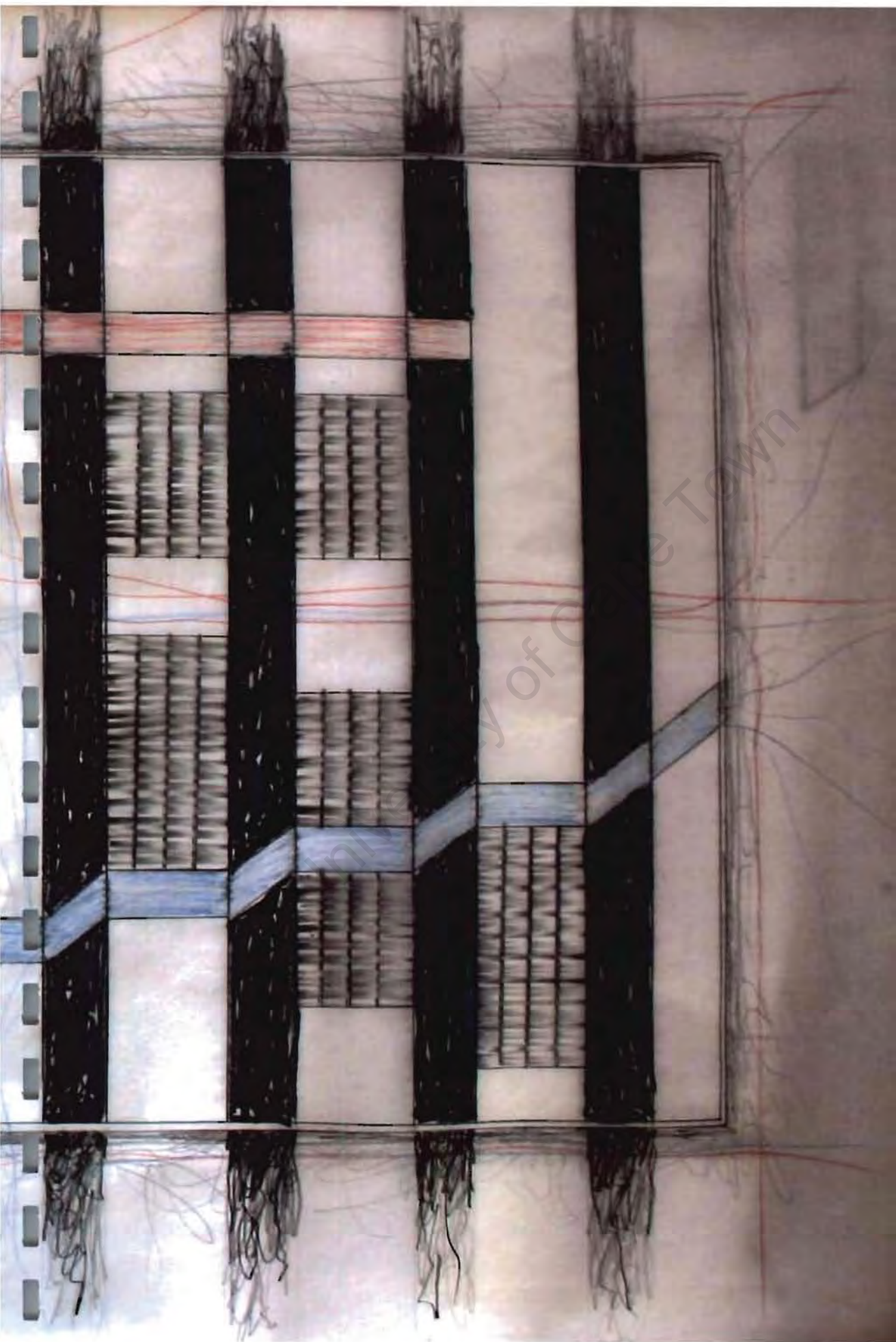

figure 98: Conceptual diagram of solids & voids with the primary Male & Female movement through the site & buildings.

University of Cape Town

University of Cape Town

chapter 05.

Technical Research & Development

The flow of water - Service Infrastructure

'Once contained, water gives life, by providing something to drink, by washing wounds, by becoming the focal point of our activities. Within the realm of the man-made environment, water removes itself from the speculative and becomes both sensual and economic. It becomes a representative and structuring element. It can become one of four things: a point, a line, a pool or an edge. As such it becomes a point of gathering, a source of power, a place of culture and reflection or a place of limits and imagination. These are the four fundamental characteristics water takes in architecture.' [Betsky, 1995:9]

Clean water is becoming an increasingly scarce commodity. Buildings should aim to develop systems to minimize the consumption and pollution of this resource. Careful design is used to develop rainwater harvesting, plumbing and ecological sanitation systems that enable buildings to be self-reliant for their water needs and avoid polluting water.

Water control has always been the primary element in construction: either to keep it out or to keep it in. Throughout the history of mankind people have used different ways in controlling water either by channeling or storing. One example is the Roman aqueduct. The Roman development of the arch led to the building of the great aqueducts for which were used to transport great amounts of water over vast miles of land. Once the water had reached the destination, it was kept into a storage tank where it would be distributed by pipes to different locations at the city. The most notable of these aqueducts were the Aqua Appia, the first Roman aqueduct, and the Aqua Claudia, built by the emperor Claudius and would remain one of the largest in the city. Roman developments in water and public hygiene were remarkable, particularly given their day and age, with innovations in public and private baths and latrines, under-floor heating in the form of the hypocaust and piped water. Though the Romans were not the first to have a mass water system, the Greeks had water pumps in the cities, their system is important because it was the first where water was available to everyone on such a mass scale. One example is the Palace of Knossos, Crete, 1500BC: a drainage system with stone channels and terracotta pipes to discard rainwater from roofs. Houses had simple closets flushable with water. It was only when the Italian Renaissance reinvented the aqueduct that the idea of water related to buildings appeared again in Europe in the context of landscaped garden design such as water jets, sprays and cascading waterfalls at the grand villas of the day. The industrial revolution brought about the first major development in water supply and drainage. Traps with water seals were patented in 1782. The first water closets appeared at the end of the 18th century. Separate soilwater discharge was the beginning of the modern water flushed sewer system. From here on, the water system developed into the system we know today, with separate underground pipes for sewage and stormwater.

Urban buildings receive potable water under pressure from a metered connection provided by a local authority. Presently, Cape Town's water goes into the stormwater system and out to sea, as the main water supply is piped from the Steenbras, Wemmershoek and Tierwaterskloof dams. This is not sustainable. The water flowing from Table Mountain into the city bowl area was channeled into open 'grachts' alongside the roads. But these 'grachts' were a source of problems, drunken sailors fell into them, the water was polluted by the rubbish dumped into them. So in 1771 Cape Town was furnished with proper sewers in the form of 'rioeulen' (drainage pipes). From 1838 to 1901 the grachts were slowly being covered/refurbished by brick sewers. The main river of the city bowl has its source at the top of Platteklip Gorge on Table Mountain, the Platteklip Stream. It drains the Northern slopes of the Table Mountain & remains a

perennial river. It is canalized in part, and disappears into a stormwater channel of the urban fabric in the foothill zone, channeled down towards the Castle, before spilling out into the Atlantic Ocean. The other primary water source flows from the main spring at the foot of Table Mountain, through the Company Gardens, down Adderley, Heerengracht and then the ocean. The water channeled is said to be flowing at a rate between 20-40l/s, wasted into the ocean. It is proposed that one of these channels are used for the provision of water for the bathhouse. This means that clean potable water that would have been wasted into the sea, is now used productively.

Over half of the bathhouse consists of servicing infrastructure. Usually the service systems are hidden in basements or under suspended ceilings, but when these systems are exposed it becomes an aesthetic of the building and this needs to be designed with great care. It is this fact that has led me to the intense research of the intended systems that will be used in the building, especially the water infrastructure. These infrastructure systems are usually left up to the different engineers to specify and design. It is with good reason that engineers are responsible for their part of the building but it is also good for the architect to know about these systems to properly design with them, so that in the end, the service infrastructure can be made an aesthetic of the building. The placing of pipes is a matter requiring in all baths great care & forethought. We must abandon the idea that pipes can be stowed away anywhere and anyhow. Every pipe should be in such a position as best facilitates inspection & repair; but also facilitate in making it a rich spatial experience. Therefore, the following precedent studies include projects dealing with water reticulation strategies regarding pools or run-off water from roofs, and also shows us that infrastructure is not to be hidden.



Figure 99 & 100: Clean stormwater from Table Mountain channeled into the Atlantic Ocean. It is proposed that one of these channels are used for the provision of water for the bathhouse.

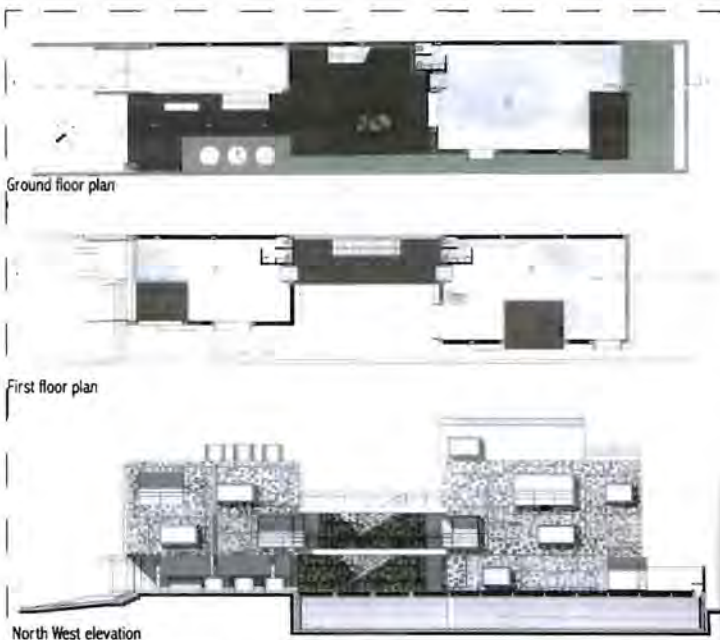

Figure 101: Ground floor plan, first floor plan & North West elevation showing storage tanks & water reticulation network.

Precedent study

Harmonia 57, Sao Paulo, Brazil, 2008

Triptyque Architecture

Figure 102: Grey water reticulation diagram

- 1 - rain water collector
- 2 - green roof
- 3 - natural filters
- 4 - reservoir
- 5 - water well
- 6 - soil draining
- 7 - water pumps
- 8 - industrial filter
- 9 - reservoir

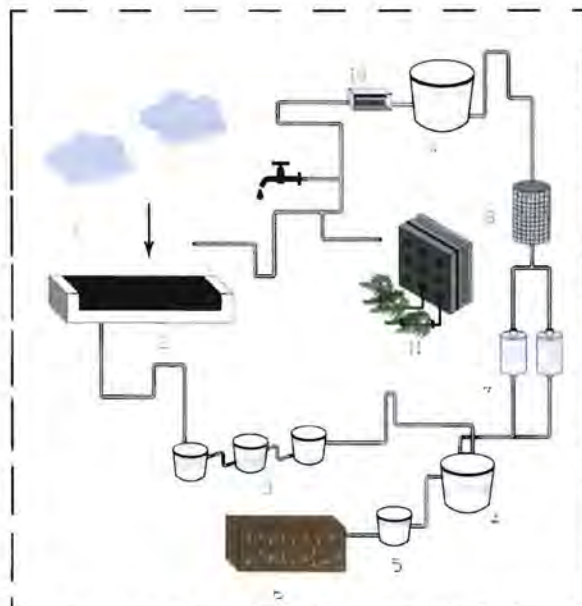

Normally technical systems with an ecological functionality are invisible, as they largely exist to regulate. Recently we are beginning to see in the experimental work of architects such as R&Sie & EcoLogic Studio serious attempts to bring together the notion of structure, natural systems & growth, and function. Harmonia 57 is a three story building of six artist's studios. The first impression is of a skin of vegetation dominating thick concrete walls. Made of a porous mix of cement, vermiculitis and sand, the concrete's enlarged pores were made with a small mould, to accommodate the different plant species. Their varied mass is watered by a system of external piping. Triptyque were keen to generate an efficient ecosystem for water and plants. A system of yellow painted water pipes across the exterior, with electric pumps, a water treatment system and rooftop tank, conspicuously serves the whole structure, rather like the human body's arterial network. On the façade there are sprinklers with nebulisers on pipelines, and over the green roof irrigation sprays which emit a humid mist, giving the building an intriguing character. The time and frequency of irrigation is electronically programmed, with a sensor disconnecting the irrigation program when rain is detected, while motor pump enables the periodic emission of liquid fertilizer.

This system works in tandem with the green roof which generates fresh air & moisture and provides good thermal conditions inside the building, avoiding the need for air conditioning. The roof is made up of a layer of expanded clay, metal clean brush, wood, plastic & earth, which serve as an initial water filtration. Rain water is collected here and is stored in three ground wells, and pumped into boxes positioned higher up to supply the building's needs, as well as used to maintain a high level of groundwater to help restore the local hydrological cycle.

This flexible, resilient system has been much admired, although it does not actually use solar panels for financial reasons, and some dislike the pipes themselves for being an 'anti-design' statement and wish they could be more aesthetically appealing. The architects explain it as instead of being a greenhouse, the ecosystem is woven around the façade as if it is the dominant structure – as if the construction was inside out. The architects feel the building is a low-tech, primitive 'body/machine'. While the pipes are visible, the structure itself is hidden behind the greenery, but not to be picturesque but to "put the building's degeneration and aging in an aesthetic process – a beautiful/ugly/living mix". Triptyque like to quote the French artist Dominique Gonzales-Foerster's definition of a tropical identity as 'something organic, intense, sensorial, vegetal, pulsating, immature, out of controle'. The architects explored the dichotomy of the concept of organic versus artificial, but through a functional rather than a merely metaphorical resolution of the two. It can be considered a robust ecosystem symbolizing urban growth through the interconnection of natural & artificial elements. [Leonardi, 2009 – 105]

Figure 103: Photo of Harmonia 57 with vegetation & water reticulation on exterior of the building.



They describe the Pompidou Centre as "a flexible container, and a dynamic communications machine made from prefabricated parts to attract as wide a public as possible by cutting across traditional institutional limits; a people's centre, a university of the street." [Sudjic, 1994 – 56]

The tubular-frame steel façade with its escalator tube slashing diagonally up and across, the services wall with colour-coded exposed plumbing on the rue Renard.

The fire authorities had a major impact on both the form of the building (overall height to be lowered) and the materials used. The hollow steel columns are filled with water to serve as a fire protection system. The rest of the steel work is carefully wrapped in fireproof blankets, which in turn are hidden inside steel sleeves.

Figure 104: Elevation of Pompidou Centre with services located

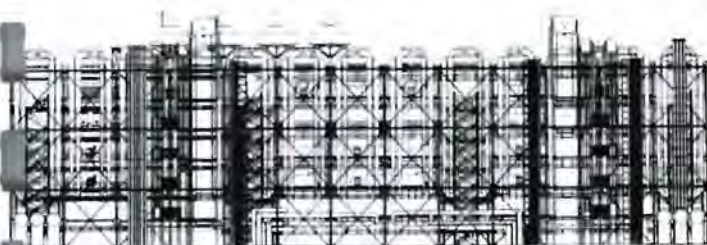

Precedent study

Pompidou Centre, Paris France, 1970-77

Richard Rogers & Renzo Piano

Figure 105: Photo of exterior services on facade of Pompidou Centre



"Turning the plan inside out by placing service cores outside the main envelope offers two principle benefits – freeing the building of all internal obstructions, & making lifts and servicing systems more accessible for maintenance & future upgrades without disturbance to occupants." John Young [Powell, 2006 – 82]

The essence of Roger's design was an arrangement to allow for any foreseeable growth or shrinkage to be accommodated over the coming years. It called for a 'flexible' building where services are easily accessed and changed. Also to maximize the usable space in the building, all the services were banished to the perimeter of the building. Servicing includes a high degree of air conditioning reflecting the large population, intensive use of computers & the need to exclude noise. The six service towers are located at the corners of the building which gives it a highly articulated presence, and a measure of Roger's predilection for Louis Khan's concept of served and servant spaces. These towers contain the lifts, services, washrooms & escape stairs. The prefabricated steel toilet capsules were craned into position. This accelerated construction & ensured a high degree of finish.

Roger's original scheme for the structure, developed with the engineers at Ove Arup and Partners who also worked on the Hong Kong & Shanghai Bank, was a tubular steel system, which would have been fire-proofed by the simple expedient of filling it with water. In the event it would have taken too long to secure the statutory approvals, so a refined concrete structure was adopted instead. The beautifully made concrete stand in contrast to the steel-faced towers. Rogers describes the building as a piece of machinery, a flexible kits of moving parts that is continually changing. "The key to this juxtaposition of parts is the legibility of the role of each technological component which is functionally stressed to the full," he says. "Thus one may recognize in each part its process of manufacture, erection, maintenance and finally demolition; the how, why and what of the building. Each single element is isolated and used to give order. Nothing is hidden, everything is expressed. The legibility of the parts gives the building scale, grain and shadow". [Sudjic, 1994 – 74]

Precedent study

Lloyd's of London, London UK, 1978-86

Richard Rogers

Figure 106: Relationship between served (yellow) & service spaces (blue).

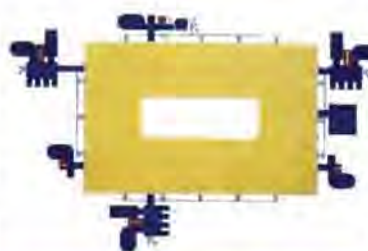
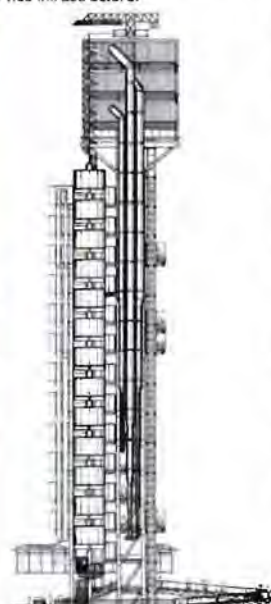

Figure 107: Prefabricated toilet cubicles being installed.



Figure 108: Exterior view of Lloyd's of London showing sculptural quality of the service infrastructure.



05

The water treatment plant is located beneath the baths. Spring water is channeled to the fresh water reservoir. A small amount of this fresh water is constantly being pumped into the individual pools by the circulation system: flowing in through brass outlets at calf level, flowing out through the overflow gutleys at the edge of the pools & in the top step, it is channeled via temporary storage reservoirs to the quartz sand filter system. To get rid of bacteriological contaminants ozone is added to the running water, this is done in two stages, before & after filtration. Ozone is the expensive version of water treatment and disinfection, but that is its only disadvantage. It is an instable molecule of three oxygen atoms, at normal temperature it is gaseous with a clearly bluish hue. In contaminated water it splits: one of the oxygen atoms not only oxidizes & destroys metals but bacteria, viruses, & organic impurities as well. At the same time the other two oxygen atoms become a normal oxygen molecule, as a by-product this oxygen enriches the water and the surrounding air. Ozone is also odorless – that is another advantage it has over chlorine. The used water flows into the wastewater reservoir beneath the outside pool, where it is stripped of valuable heat to be used for the heating system, before it is filtered and released into the nearby river. The baths are completely emptied and cleaned once a week. After the emptying & cleaning procedures the pools are refilled with water from the fresh water reservoir located beneath the indoor pool.

Figure 109: Floor plan showing water channels on the floor & light channels in the ceiling.

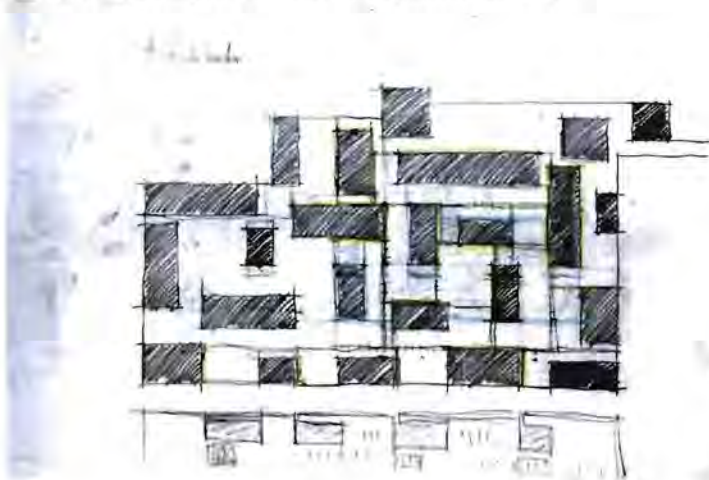

Precedent study
Therme Vals, Vals Switzerland,
Peter Zumthor

Similarly, the technical solutions, pool- & floor waterproofing, pool overflows, sluicing-channels, heating, air conditioning, thermal insulation & expansion joints – have been designed to reinforce the monolithic, homogenous presence of the structure as a whole:

- they either fit the pattern of layering & joining stone masses (e.g. water overflows, sluicing-channels, vertical expansion joints), or
- are incorporated within the composite construction of stone & concrete (e.g. waterproofing, thermal insulation, horizontal expansion joints)

These expansion joints allow for the expansion of various building parts due to temperature changes & horizontal & vertical movement. Illumination joints along the ceiling, and water joints along the floor: some expansion joints along the floor accept water, but not all the floor joints conduct water, some are lined with bitumen; all ceiling joints, by contrast, are illumination joints.

Sketches depicting the movement of water and light throughout the building.

When the visitors leave the artificially lit cavern system of the entrance, pass through the darkly clad changing rooms, and step onto a raised band of rock to see, for the first time, as bathers now, the continuous space of the bathing floor lying before them. And when they climb down into the landscape of blocks & wander through the different interconnected opening & closing spaces, they become aware that the blocks have doors in them, each with containing a special hollowed-out space requiring intimacy / private space, or benefit from it (e.g. sweat stone, shower stone, massage block, drinking fountain stone, rest space, fire bath, flower bath, cold bath, sounding stone). Traditional therapies (medicinal baths, mud treatments, massages & physiotherapy) are offered in blocks on the lower floor. It is thus two types of spaces: the meandering,



Figure 110: Photo of interior bath

Kinetic Architecture – the spatial organization of daily mobility within a Public Bathhouse

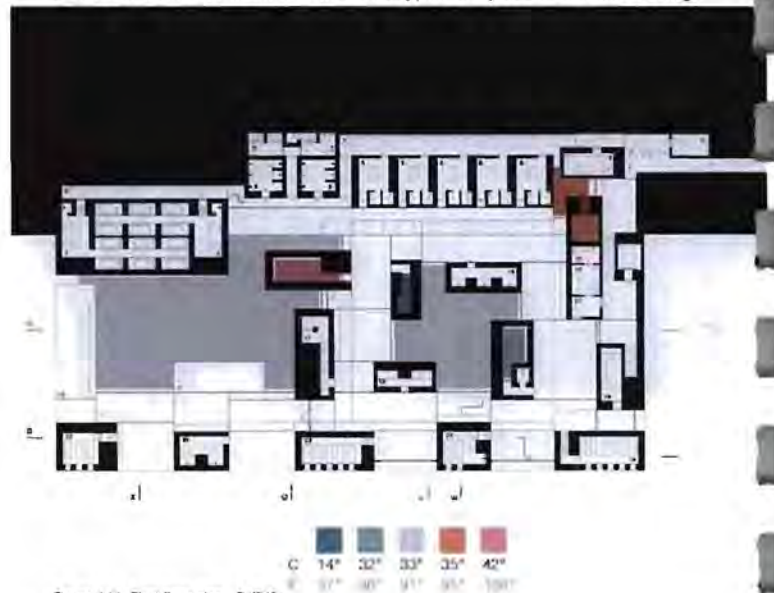

Figure 111: First floor plan - BATHS

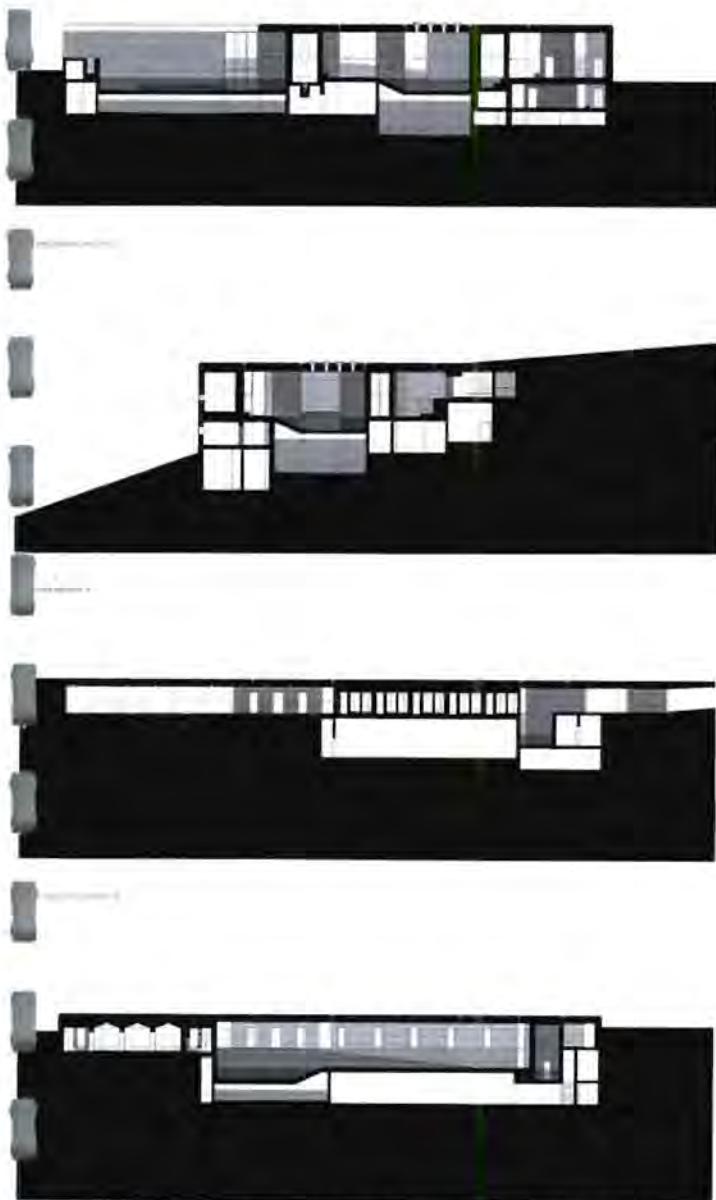

Figure 112: Longitudinal & cross sections through building showing services installed below the baths.

interconnected space between the blocks & the introverted rooms within the blocks themselves.

Waterproofing

Two different systems were used to protect the building from groundwater and rainwater, to avoid uncontrolled overflow in the pools & gullies, and to waterproof the stone floors in the bathing areas. So-called rigid waterproofing consists of waterproof concrete or bonded masonry. It is achieved by reinforcing the concrete sufficiently to prevent cracks. However, a certain amount of humidity still seeps through. And since possible leaks cant be ruled out entirely, this method can only be used if the back of the wall that is exposed to water on the inside is unobstructed to allow observation & maintenance at all times, & if it does not have to satisfy any aesthetic requirements. The floor slabs of the building, the underground services of the baths as well as the pools & water reservoirs are all insulated in this way. All those parts of the building that had to be waterproof but which maintenance could not access freely from the back or from below were sealed with a so-called liquid membrane, a seamless synthetic coating that is applied like a coat of paint: the floor of the areas in front of the showers and around the pools on the bathing level.

The detail drawing (figure 30) shows the comparatively simple construction of rigid insulation in one of the baths and the considerably more complicated construction for the lateral application of liquid membrane around the indoor pool. The numbers, each assigned to one component of the building, show the 11 steps involved from pouring the first wall of concrete in the basement to laying the stone floor around the indoor bath. First the small concrete base (5) must be poured, the floor sealant (7) must be wrapped up the side of the base, and a wall of five stones constructed in front of it (8). Only then can construction of the compound masonry begin, in this case, the double-front construction in which concrete is poured into the space between the two walls of stacked stone (9). The example is telling: the integration of waterproofing, insulation and expansion joints in the stone mass of the building required a high level of complexity in the invention of customized construction and work procedures. The building looks simple. The complexity is hidden in the mass.

- laundry store
- 41 - cleaner's storeroom
- 42 - toilets
- 43 - storeroom
- plant access
- plant stairs, sub-floor
- flower bath equipment
- 47 - chemicals
- 48 - lift machinery room
- electricity plant
- 50 - water treatment
- 51 - main sanitation plant
- 52 - air-conditioning plant
- 53 - carbonic acid
- 54 - fire bath plant
- 55 - ozone treatment
- 56 - secondary sanitation plant
- 57 - freshwater tank
- 58 - wastewater tank



Figure 113: Ground floor plan - SERVICES

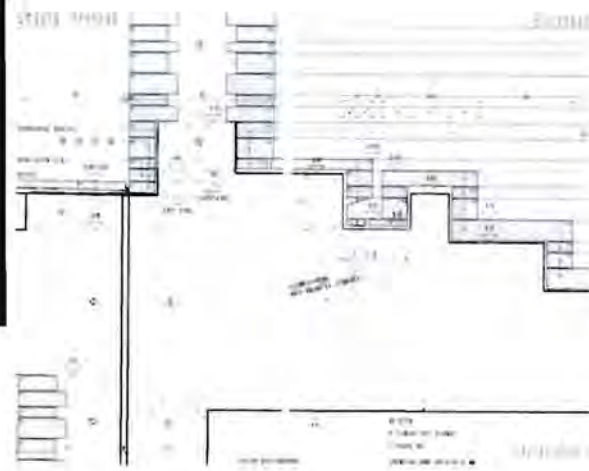

Figure 114: Waterproofing detail

Water Management within the bathhouse

Water management plays a crucial role in ensuring the feasibility of the bathhouse facility. A potentially large amount of water is used within the building, implying that an efficient method of water harvesting, use and re-use is proposed. The concept of sustainable construction has its origin in the era of the 1970's. During these years there was a major movement towards energy conservation, energy efficiency & alternate energy resources prompted by the oil crises, which occurred during this time. More recently, global concern about the shortage of water has caused architects to attentively address the notion of water conscious design.

The water used in the bathhouse consists primarily of three systems:

- RUN-OFF CYCLE: EXTERIOR CIRCULATION** - [figure]
the water runoff & vegetation sequence;
- GREYWATER CYCLE: INTERIOR CIRCULATION** - [figure]
the circulation of water servicing the building i.t.o the bathing sequence & daily usage (toilets, cleaning);
- POOL CYCLE:** [figure]
the circulation of water servicing the building i.t.o the pools.

These three systems are separated primarily because of the different filtration strategies, water quality and water temperatures that are needed for the intended end uses.

The existing stormwater from the Platteklip stream will be the primary source of water, augmented by rainwater and groundwater harvesting. On-site greywater treatment will clean and re-use the water; potable water will have municipal water as source. The primary method of water heating will be solar, using vacuum tube solar water heaters installed on the roof. The intent is to provide an efficient, not necessarily self-sufficient system. All sanitary fittings are water efficient, vandal resistant and operated through IR sensors. All hot water pipes and storage tanks are insulated to prevent heat-loss.

In the end it has all got to do with the servicing strategy, particularly the relationship between service and serviced areas, as Louis Khan would say. Once the one system works with the other in a harmonious whole, then architecture will speak a tone of completeness. The two must complement each other to create a space interwoven with the movement of water (infrastructure) and the movement of people in between it.

The following pages explain the different water systems through the use of diagrams and text together with calculations done for the bathhouse - total water supply, water demand, total amount of solar water heaters needed etc.



Figure 115: Typical closed circulation water system

A) RUN-OFF CYCLE: Exterior Water Circulation

[explanation of diagram & water calculations]

+ Precipitation [A1]

Cape Town's rainfall season is primarily in the winter months (April-August). The annual rainfall for Cape town is 515mm which is quite high compared to e.g. Pretoria, which is 160mm rainfall per annum. [www.weathersa.co.za]

+ Rainwater collectors: run-off roofs & surfaces [A2]

Additional care may be needed here to avoid contamination from sediment and oil and fuel spills from vehicles. This is addressed through proprietary filter and oil traps as well as permeable paving systems. Permeable paving combined with sub-base layers is used to enable rainwater to be absorbed into the ground and reduce runoff from the site; & to filter and store rainwater.

[Rainwater harvesting Calculation on page 91]

+ Natural Sand Filters [A3]

A combination of coarse & fine sand filters are used in order to trap particles. Recommended filtration is 1 ton sand per 100,000 liters water. Oil traps are also used to rid the water from oil spilled from the vehicles. Seeing that the whole site of the building is elevated and on top of a large concrete platform, all drainage from the vegetation will also be filtered through natural layers of soil & granular infill. (see 'vegetation drainage')

+ Storage tank [A4]

The storage tank itself is made of metal Abeco storage tanks manufactured locally. The fresh water supply storage tank will receive water from three sources: municipal water supply (which acts as backup & comes from the Platteklip stream), harvested rainwater from roofs & harvested rainwater from the site (plants & surfaces).

+ Pump [A5]

The pump mechanism is specified by the engineer after the amount of total water needed is calculated. The pump, together with the filters are in the pump room, easily accessed for maintenance.

+ Vegetation & sprinkler system [A6]

Planting should be carefully specified to avoid large requirements for water. Indigenous planting and dry climate plants as aloes and succulents with low water requirements may not need irrigation at all. Clustering plants with different water requirements can also reduce water consumption as irrigation is minimized.

Irrigation system consists of PVC pipes with standpipes & sprinklers @ 12m centres.

+ Vegetation draining [A7]

The structure consists of:

- vegetation
- 150-350mm thick sandy topsoil
- Geotextile separation layer
- 100mm thick drainage layer of 20mm stone
- Irrigation system: PVC pipes with standpipes & sprinklers @ 12m centres
- [Optional - 2nd screed layer]
- Waterproof membrane
- Screed to fall (min 1:70)
- Reinforced concrete

Excess water not used by vegetation will then drain through these layers that act as a natural filter.

The water is then fed back through the filters into the fresh water supply tank for re-use.

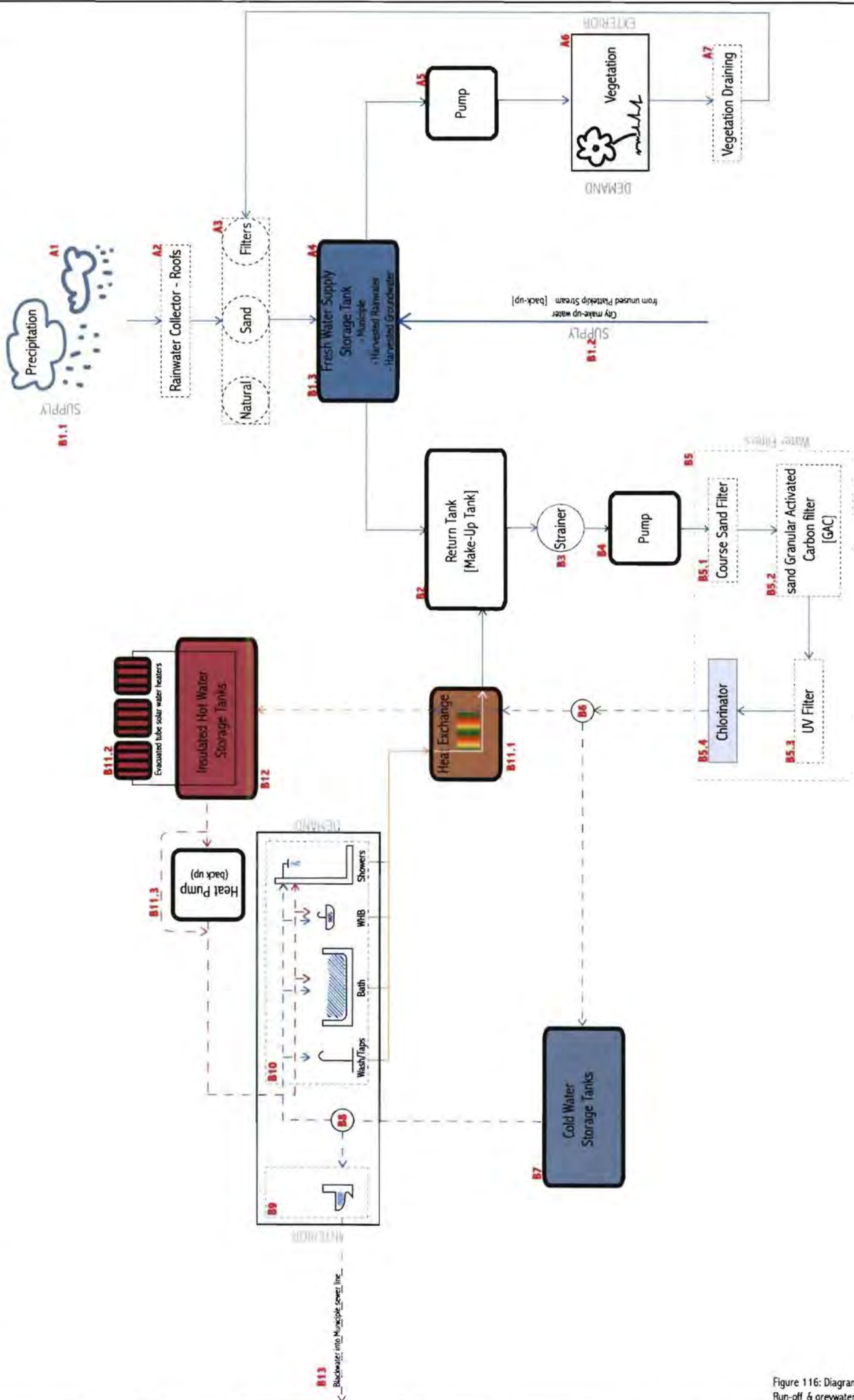

Figure 116: Diagram showing the Run-off & greywater cycle.

B) GREYWATER CYCLE: Interior Water Circulation

[explanation of diagram & water calculations]

Interior Water Circulation

+ SUPPLY [B1]

The potential rainwater harvesting capacity of a roof and site is calculated by multiplying the area of the roof by the annual rainfall. Whatever the amount of water needed that is not supplied by the rainwater & surface run-off, is topped up with municipal water.

Amount supplied by site & roof run-off = 1 429 898 litres per annum (male/female)

+ Return tank [B2]

The return tank is used to mix the used greywater with fresh water before it is filtered and returned into the cycle. The freshwater is supplied from the fresh water supply tank.

+ Strainer [B3]

A strainer is used to free the greywater of hair and big particles before it enters the pump in order not to damage the pump.

+ Pump [B4]

All filters use pumps and operate under pressure. Pumps required specified by the engineer after the total amount of water needed is calculated.

+ Water filters [B5]

A combination of filters are used to address the cleaning of greywater based on the requirements of program, these include (in order):

1. A coarse sand filter [B5.1]: trap large particles. Recommended filtration is 1 ton sand per 100,000 liters water.
2. A sand-granular activated carbon (GAC) filter [B5.2]: removes soap and organic material from the water as soap bound to organics, in turn bind to the porous carbon granules.
3. An ultraviolet (UV) filter [B5.3]: neutralizes any pathogens that passed through the carbon filter.
4. A chlorinator [B5.4]: serves the purpose of ensuring the long term cleanliness of water in the event of storage. Chlorination is the process of adding the element chlorine to water as a method of water purification to make it fit for human consumption as drinking water. Water which has been treated with chlorine is effective in preventing the spread of waterborne disease.

+ CYCLE SPLITS INTO COLD & HOT WATER [B6]

HOT

The filtered cold water is heated primarily by two systems, together with a back-up system in place. The primary heating is done through a heat exchanger, then passed onto the solar water heaters. (water needs to be heated from 17°C to 60°C) If this is not sufficient, the water passes through a heat pump as a back-up heater before it is used in the showers & baths. The water can bypass the heat pump if necessary.

+ Heat exchange [B11.1]

A heat exchange is employed to increase the efficiency of the system, made of a highly conductive metal, fluids of differing temperatures exchange heat as they flow through the unit simultaneously. Warm water returning from the showers exchanges its heat with cold water on its way to solar water heaters. The water never mixes, only heat is exchanged.

The solar thermal system consists of the solar collectors, a controller and hot water storage tanks. I have chosen the active indirect or closed loop system which uses a heat exchanger that separates the potable water from the heated fluid, known as the "heat-transfer fluid" (HTF), that circulates through the collector and storage tank.

The two most common HTFs are water and an antifreeze/water mix that typically uses non-toxic propylene glycol. After being heated in the panels, the HTF travels to the heat exchanger/storage tank, where its heat is transferred to the potable water.

Though slightly more expensive, indirect systems offer freeze protection and typically offer overheat protection as well.

Active systems (pumped systems) use one or more pumps to circulate water and/or heating fluid in the system.

+ Evacuated tube solar water heaters [B11.2]

Evacuated tube collectors are more expensive than flat panel collectors; however, they are also significantly more effective. Evacuated-tube solar panels can produce water at 120°C. Unfortunately, all evacuated tubes are imported from China and no local manufacturing capabilities currently exist.

Evacuated tube collectors (ETC) are a way in which heat loss to the environment, inherent in flat plates, has been reduced. Since heat loss due to convection cannot cross a vacuum, it forms an efficient isolation mechanism to keep heat inside the collector pipes. Kinetic Architecture – the spatial organization of daily mobility within a Public Bathroom

Since two flat sheets of glass are normally not strong enough to withstand a vacuum, the vacuum is rather created between two concentric tubes. Each Vacuum tube consists of two transparent borosilicate glass tubes. The outer tube is manufactured according to SABS standards. The inner tube is coated with a special selective coating, which has excellent solar heat absorption and minimal heat reflection properties. The air between the tubes is removed to form a vacuum, which eliminates conductive and convective heat loss, enabling the tubes to absorb the energy from the sun's infrared rays which can pass through the clouds. Wind and low temperatures have less of an effect on the performance of the vacuum tubes compared to flat plate collectors due to the insulating properties of the vacuum. The tubes passively track the sun's heat all day. The shape of the tubes provides superior absorption as the tube is round, the sun's rays are always striking the tube's surface at right angles, minimizing reflection (Sun Africa, 2009:2-3). Evacuated tube collectors provide a more constant output throughout the year and they are frost resistant. The life expectancy is also longer on the evacuated tube collectors, than on the flat plate collectors.

Panel Dimensions & Output power (yearly average kWh/day for Cape Town:

2020mm x 1006mm x 150mm (12 tubes) - 4.8kWh/day

2020mm x 1486mm x 150mm (18 tubes) - 7.2kWh/day

2020mm x 1966mm x 150mm (24 tubes) - 9.6kWh/day

2020mm x 2446mm x 150mm (30 tubes) - 12kWh/day

The collectors are placed at an angle of 40° relative to the horizon, facing North, maximizing solar exposure year round. Although the heat output of the solar collector is reduced on overcast days it will still be able to provide heating. (latitude angle of the site: plus 5-10° - South Africa lies between 22° and 35° latitude. Ideal tilt angle range would be 27°-45°). Approximately 25-30% of the sun's energy actually gets through the clouds.

+ Hot water storage tanks [B12]

The solar collector, located on the roof, collects the sun's energy and transfers the heat to the storage tank. The storage tank allows the hot water to be stored until it is used. The water storage tanks chosen is Abeco. All their steel components are hot dip galvanized to internationally accepted standards. Due to their modular design Abeco tanks offer a great number of advantages.

- Safe hygienic water storage
- Unaffected by ultra violet or light penetration
- Rugged and simple design
- Easy and quick to install
- Reduced project lead time from initialization to completion
- Apart from cold water applications Abeco Tanks are also supplied for:
 - Hot water
 - Fuels
 - Effluent
 - Corrosive Liquids

The tanks come with the following standard accessories:

- Caged external access ladder
- Internal access ladder
- Hinged lockable manhole
- Float and pointer type water level indicator
- Screened ventilator

[<http://www.abecotanks.co.za>]

There is virtually no limit to the capacity that can be accommodated but the tank depth is limited to 4 panels (4.88m) for standard tanks and 5 panels (6.1m) in special applications. Panel sizes are 1220x1220mm. Three standard thicknesses are produced: 3mm, 4.5mm & 6mm, depending on the water pressure.

The storage system really works well: it is modular so can fit any design and also all the loads are taken care of by internal bracing members designed by the supplying engineers.

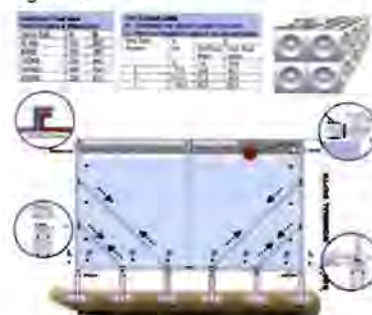

Figure 117: Standard Abeco water tanks



CALCULATIONS FOR WATER USAGE AT THE BATHHOUSE

calculations apply for one half of the facility and is applied twice [male & female]

Heat pump (back-up) [B11.3]

A heat pump works like an air conditioner in reverse. It uses a relatively small amount of electricity to extract heat from the ambient air surrounding it, enabling it to heat the refrigerant which is then compressed causing it to get even hotter. This is then run through a heat exchanger where this energy is drawn off to heat the water and then the refrigerant is allowed to expand again, thus cooling it down and enabling it again to absorb heat from the surrounding air. So, electricity is only used to run a fan & a compressor and the heat is provided indirectly by the sun. This system is up to four times more efficient than conventional geysers, & results in a 75% savings on electricity consumption.

The main advantages of a heat pump are the ability to work day and night, rain or shine. A solar system will only save you more money than a heat pump but only if the system has much more capacity than the demand and also depending on the usage pattern.

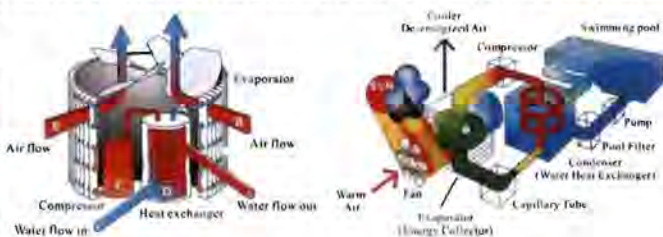

Figure 118: Heat pump diagram

Taps | baths | whb | showers [B10]

Wash hand basin taps

Large quantities of water can be wasted when taps are left running. This is often the case in wash hand basin taps. To reduce wastage the following measures are taken:
 - Flow rates: Taps with flow rates of under 6L/minute is specified. Where flow rates are higher than this, constrictors and aerators are used to reduce flow rates.
 - Usage: The length of usage is controlled through metering and demand taps or taps fitted with proximity sensors.

Showers

The specification of showerhead and controls can support efficiency in the following ways:
 - Flow rate: between 5-10L/minute are specified for showers.

The water is then drained back to the freshwater make-up tank. Before it goes to the make-up tank it is passed through the heat exchanger to rid the water of its heat.

LD

Cold water storage tank [B7]

Cold water stored in an Abeco tank.

COLD CYCLE SPLITS INTO TWO: [B8]

Taps | baths | whb | showers [B10]

The water is then drained back to the freshwater make-up tank for re-use.

Toilets [B9]

Toilets are very large users of water and there are means to reduce the amount of water used. Dual-flush toilets specified have low water requirements. Consumption does not exceed 4.5L for 1/2 flush and 9L for full flush.

Municipal sewage system [B13]

Blackwater from the toilet is fed into the municipal sewer system.



Figure 119: Evacuated tube solar water heaters - components

Annual Supply from roof & site runoff

Male/Female:

Total Roof Area = 1975m²

Total Site Area left over = 1110m²

Total Area (site+roof) = 3085m²

Annual rainfall for Cape Town: 515mm

Annual rainfall harvesting capacity = (annual rainfall) x (total area) x (90% efficiency)
 = (515) x (3085) x (90%)
 = 1 429 898 liters

Water consumption - DEMAND

Water consumption in the building is calculated by multiplying the quantity of water used by different water consuming devices in the building by the number of times these are used. After this calculation is done, the total amount of storage tanks can be calculated.

Showers: 90 @ 40 litre per use (10 min)
 = 3600 litre per hour @ 6 uses/hr
 = 21600 litre/hr
 21,6 m³/hr storage capacity required

Baths: 10 (1m x 1,2m x 1,2m)
 = 14,4 m³ @ 1 change/hr
 = 14,4m³/hr storage capacity required

Wash Hand Basins: 81 @ 3 litres per use @ 6 uses/hr
 = 1458 litres/hr
 1,458m³/hr storage capacity required

Toilets: 44 @ 9 litres per use @ 6 uses/hr
 = 2376 litres/hr
 2,376m³/hr storage capacity required

Total water use = [showers]21,6 + [baths]14,4 + [whb]1,458 + [toilets]2,376
 = 39,834 m³/hr (peak loads, all showers running a full hour)

Two tanks per water use (hot & cold) implies that while one is drained, the other is filled with water returning from the filters and heaters. The total storage capacity needed for hot & cold water is thus 80m³/hr (seperately). There are four water storage towers on top of the roof of the building supplying the branch of water services directly under it. Each tower holds 20m³ of hot and 20m³ of cold water (80m³ / 4 towers = 20m³). Each tower consist of four tanks: 2 hot (10m³ each) & 2 cold (10m³ each). So, while the one is drained, the other is filled with clean filtered water.

The returning water tank is located at the main service & filtration room and holds 40m³. The sixth tower (also 40m³) is used to store water returning from pipes and showers when the facility is not in full use and store water drained from the roof and site.

Modular Abeco water storage tanks employed measure 1,728 m³ per module @ 24 modules per tower = 41,472 m³ per tower.

05

C) Water (re)Cycle in the pool

[explanation of diagram & water calculations]

The pool water reticulation system basically consist of 5 aspects:

+ **Pool hydraulics:** to ensure effective distribution of disinfectant throughout the pool and removal of contaminated water.

+ **Treatment trough disinfection and filtration:** to remove particulates, pollutants and microorganisms.

+ **Addition of fresh water at frequent intervals:** to dilute substances that cannot be removed from the water by treatment. Dilution limits the build-up of pollutants from bathers (e.g. constituents of sweat and urine), disinfection by-products and various other dissolved chemicals. Pool operators should replace pool water as a regular part of their water treatment regime. As a general rule, the addition of fresh water to disinfected pools should not be less than 30 litres per bather.

+ **Cleaning:** to remove biofilms from surfaces, sediments from the pool floor and particulates adsorbed to filter materials.

+ **Adequate ventilation**

Some of the components used to treat or heat the water in the pool system is the same as in the greywater reticulation system. Thus, the components will be named but not discussed again.

Please refer to diagram.

[C1 & C2] Fresh water supply & Make-Up | Balance tank

Coagulation, filtration and disinfection will not remove all pollutants. Swimming pool design should enable the dilution of pool water with fresh water. Fresh water is supplied from the municipal water system. Dilution limits the build-up of pollutants from bathers (e.g. constituents of sweat and urine), of by-products of disinfection and of various other dissolved chemicals.

C3. Filtration & Disinfection

Disinfectants are added in order to inactivate pathogens and other nuisance microorganisms. Some disinfectants, such as ozone and UV, kill or inactivate microorganisms as the water undergoes treatment, but there is no lasting disinfectant effect or 'residual' that reaches the pool and continues to act upon chemicals and microorganisms in the water. Thus, where these types of disinfection are used, a chlorine- or bromine-type disinfectant is also employed to provide continued disinfection. The use of bromine-based disinfectants is generally not practical for outdoor pools and spas because the bromine residual is depleted rapidly in sunlight.

C3.1. Strainer

The strainer protects the pumps from clogging & damage from hair, lint, pins, and other foreign material. Consists of a catchment with a removable strainer made of non-corrosive material through which the water is pumped.

C3.2. Coagulants

Coagulants (e.g. polyaluminium chloride) is used to enhance the removal of dissolved, colloidal or suspended material. These work by bringing the material out of solution or suspension as solids and then dumping the solids together to produce a floc. The floc is then trapped during filtration.

C3.3. Chlorinator (chemical process)

A chlorinator serves the purpose of ensuring the long term cleanliness of water. Water which has been treated with chlorine is effective in preventing the spread of waterborne disease.

Without getting to technical Salt Water Chlorinators work by using electrolysis to release chlorine gas from the salt in the water. Mill run salt is added to the pool water to achieve a saturation of approximately 3200 parts per million. This is about the same amount of salt found in a human tear. The salt water is then passed through a chlorinator cell that is plumbed into the equipment after the heater. The cell is electronically charged and releases the chlorine gas from the salt. The chlorine gas is mixed with the water to create liquid chlorine and is then delivered back to the pool.

With Salt Water Chlorinators chloramines are less of an issue. Since the systems are constantly producing fresh chlorine, there is always enough free chlorine to kill off the chloramines. For this reason swimming pools using these systems will have little or no chlorine smell and leave swimmers skin much smoother. (http://www.h2opoolproducts.com/article_info.php?articles_id=1)

C3.4. Natural Sand Filters

There are a number of types of filter available, and the choice of filter is based on several factors, including:

+ the quality of the source water;

+ the amount of filter area available and number of filters (pools benefit greatly from the increased flexibility and safeguards of having more than one filter)

+ filtration rate: typically, the higher the filtration rate, the lower the filtration efficiency.

C3.5. UV Filter (chemical process)

An ultraviolet (UV) filter neutralizes any pathogens that passed through the carbon filter. Ozone and UV radiation purify the pool water as it passes through the plant room, and neither leaves residual disinfectant in the water. They are, therefore, used in conjunction with conventional chlorine based disinfectants.

C4. Pump

An electrically operated water pump is the prime motivator in recirculating the water from the pool. Water is forced through the filter and then returned to the pool. Commercial and public pool pumps usually run 24 hours a day for the entire operating season of the pool.

Pool pumps typically are "self priming": so they may be positioned above the mean water level of the pool yet still start up and function after a timed rest period. Pumps that do not "self prime" are termed "flooded suction" and must be gravity fed by the pump by being located below the mean level of the pool water.

Turnover ratio – the number of times the water is circulated in 24 hours effects the size of the treatment system. A turnover ratio of at least 4 is desirable per day – that is 6 hours per circulation. (World Health Organization, 2006 - 23)

C5. Ph correction

The pH should be maintained between 7.2 and 7.8 for chlorine disinfectants. (p. 95)

Heating Water [C6.1; C6.2; C6.3; C7]

Swimming pools need only be heated a few degrees above ambient (to 25-30°C), as apposed to hot water required in the bathrooms (60-65°C). Evacuated tubes in an indirect configuration do not have pool water pumped through them, they are used in conjunction with a heat exchanger that transfers the heat to pool water. This causes less corrosion. The water is passed through a heat pump if necessary. A simple rule-of-thumb for the required panel area needed is 50% of the pool's surface area. This is for areas where pools are used in the summer season only, not year 'round. Adding solar collectors to a conventional outdoor pool, in a cold climate, can typically extend the pool's comfortable usage by some months or more if an insulating pool cover is also used.

C8. Treated water entering the pool

Return water inlets must be at least 300mm below water surface to prevent loss of disinfectant; and placed at 6m centres around the pool.

(Table – p.91)

C9. Top- & Bottom off-take

Treated water must get to all parts of the pool, and polluted water must be removed – especially from areas most used and most polluted by bathers. It is recommended that 75–80% be taken from the surface (where the pollution is greatest – surface water off-take), with the remainder taken from the bottom of the pool (bottom off-take)[C9]. The bottom returns allow the removal of grit and improved circulation within the pool. (p.91) An overflow channel is a gutter that surrounds the pool, covered by a removable grille. Surface water flows over the edge of the pool and runs by gravity to the filtration plant. Overflow channels allow faster turnover of the surface water than is possible with simple weir skimmers, which is why they are commonly found in public pools.

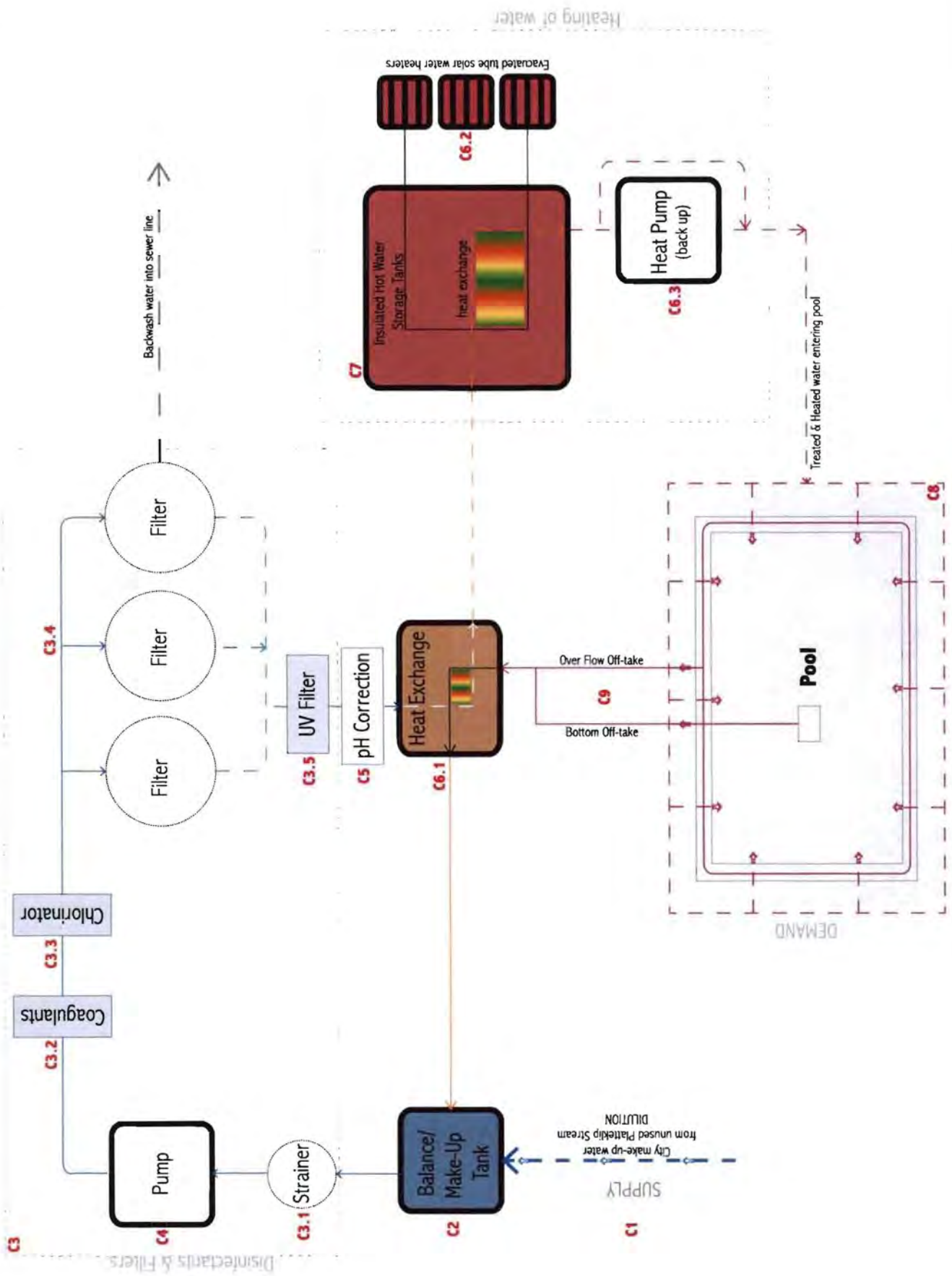

Figure 120: Pool Reticulation Diagram

Service Movement Diagrams of Female Bathhouse

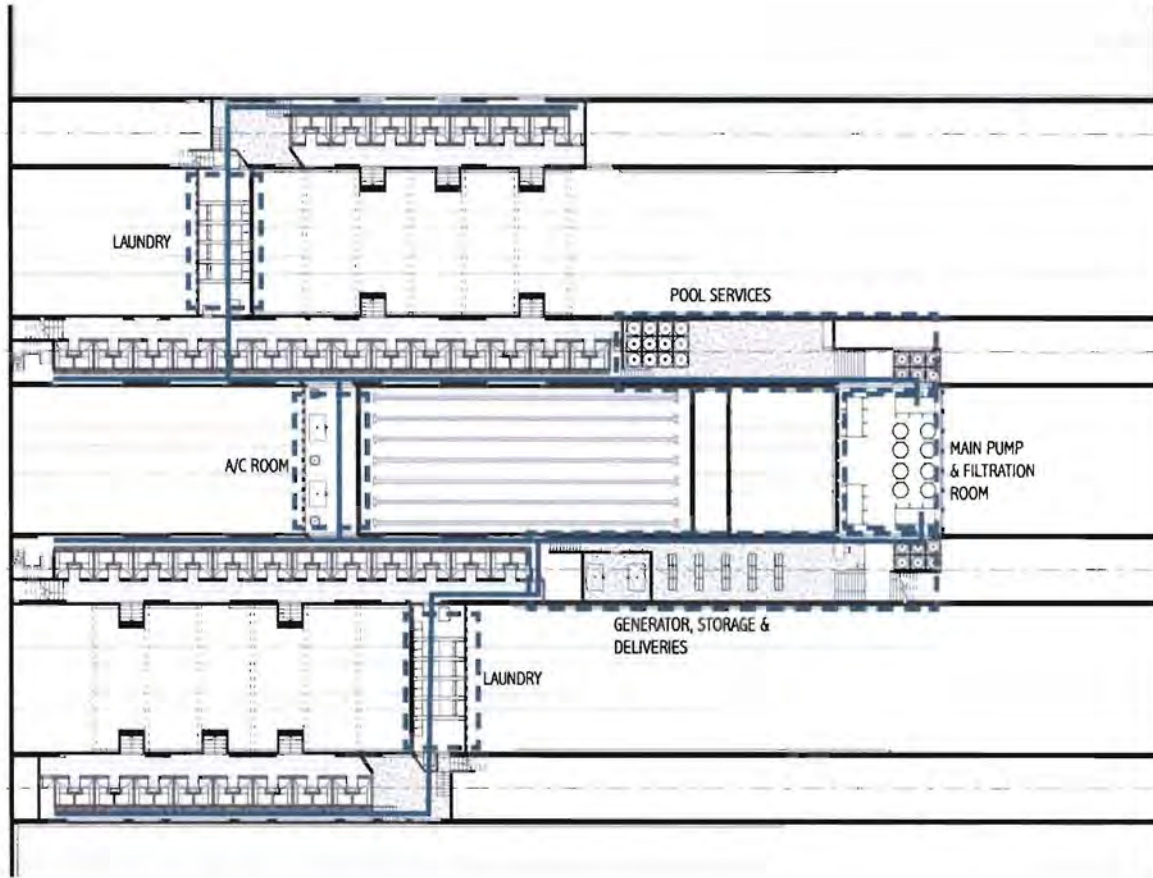

Figure 121: Basement level showing primary service corridors for all water services & A/C units; together with all service rooms: laundry, storage, mechanical room & offices.

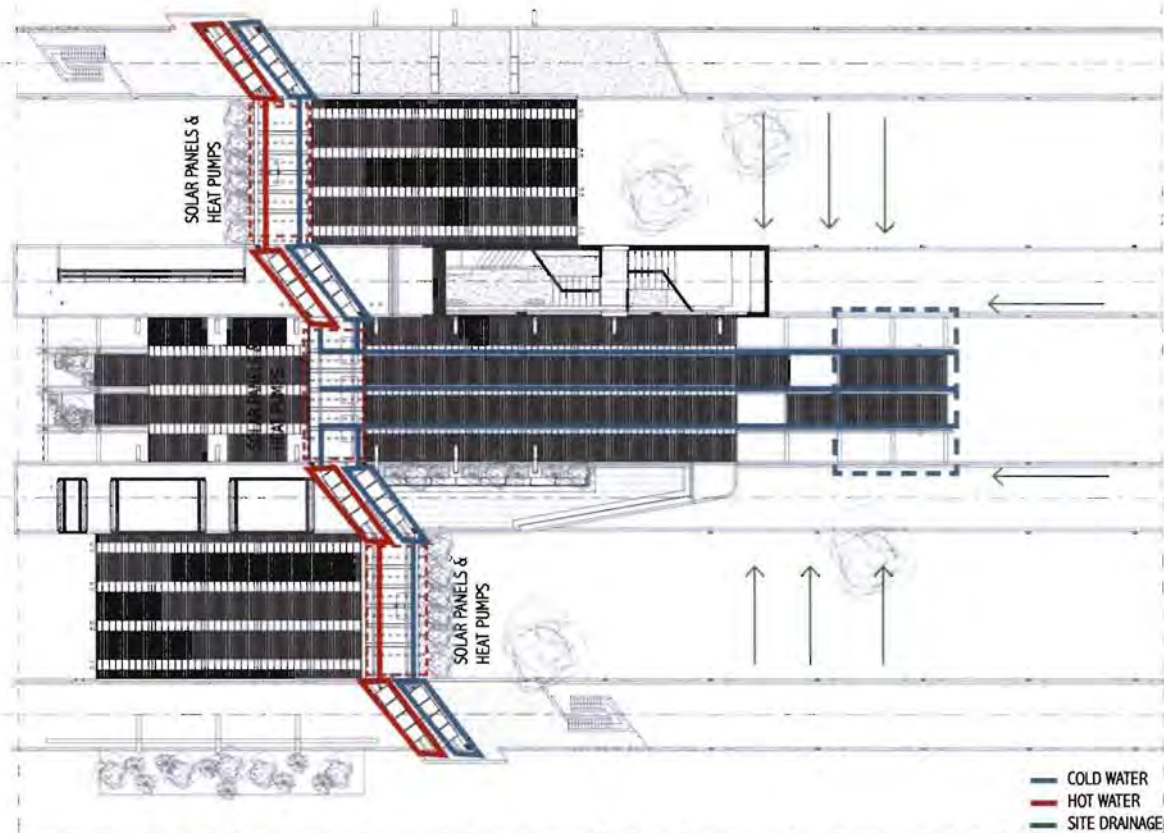

Figure 122: Level 2 showing the return path of the water back into the building. Four water towers located on the crossing points of all the movement systems with the service heating bridges connecting them. Water is heated through the solar panels [heatpumps as backup located on the bridges in-between] stored in the towers, and redistributed down into the building through the crossing point & into the service corridors.

Service sequence

Servicing of the building refers to the systems and methods employed to manage the functional requirements of the program. These include ventilation, thermal comfort and climate control, water management, drainage, and circulation of people and goods. The intent is to use the service areas as shelter for the private nature of the program wrapping around the private shower spaces. This configuration also allows the services to become an aesthetic of the building's skin. The concrete load bearing wall is perforated allowing all service corridors to be exposed & visible. The interior 'shower wall' becomes the weather skin of the building [only in the service corridors].

All the service pipes, walls, floors, glass louvres etc. are colour coded according to the sex: MALE = BLUE & FEMALE = RED. As one approaches the site the red & blue service elements immediately tells one which building is male & female. These colours also highlight the primary SERVICE SEQUENCE within the building & thus becomes an aesthetic of the building as one can almost track the path of the water through the building just by looking at the building from a distance.

Figure 121 & 122 shows the path of the water in one bathhouse together with the service corridors & service spaces. The main filtration & pump service room is placed 'outside' the building to make the process visible to the public. The roof of this space is raked seating that also becomes the spectator seats for the lap pool. The water gets pumped up & over the extended roof and runs on top of the precast concrete footings for the roof vents. The water is taken towards a long service pathway above the building which contains all the heating (solar & heat pumps) & storage towers. The solar panels are placed as a roof membrane [pergola] over the bridging spaces between the storage towers, with the heatpumps directly below. Four water towers are located on the crossing points of all the movement systems on the solid cast-in-place load bearing walls. The water continues down into the building through the crossing point & into the service corridors from where it is distributed to all toilets, showers, baths etc. One can see in figure 121 a typical layout of the branched service corridors. All used water is taken back to the main filtration room. The basement floor is completely waterproofed with a PVC suspended floor system. All water reticulation into the shower cubicles takes place under the suspended floor & against the back of the service wall. The ground- & first floor of the service corridors are painted metal floors consisting of I-Beams & expanded metal bolted in place between the concrete walls.

Water Drainage

All water from the roof & site is drained towards the 'solid bands' [where the service corridors are located] and taken to a make-up tank at the main filtration room. The water from the solid concrete roofs are drained through fullbore roof outlets and into the service corridors.

The water from the 'transparent' sections is drained through painted steel gutters [integrated within the roof louvres] & downpipes [leading down the precast concrete wall cladding] into a gutter leading towards the service corridors.

Water from the infill bridges around the site drains through the permeable concrete paving onto waterproofed screed to fall towards the solid bands. The water is then taken towards the storage tank with pipes running alongside the concrete threshold walls.

Thermal Comfort & Climate control

The Cape Peninsula has a Subtropical Mediterranean climate (Koppen Csb), with mild, wet winters, and dry and very warm summers. Cape Town can be considered to fall under the "Temperate climatic zone". This entails to:

- use medium to high mass exposed structure
- maximize natural ventilation in Summer, & minimize it in Winter
- shade in summer, but use solar gain in winter
- use east-west orientation & passive solar gain
- use light to medium exterior colours

The thermal mass of the building is used as a method of regulating thermal conditions inside the building. Heavy mass elements are able to absorb heat and re-radiate it into a building at a later time. Concrete provides good thermal mass (Green building council of Australia, 2005:40). A strategy to ventilate the mass that gathered heat during the day at nighttime during summer is investigated. This ensures that the heat of the day only reaches the interior at night, ventilating rids the structure of this heat. During winter months the mass is encouraged to retain its heat by not ventilating the structure at night. Again a mixed mode strategy is employed, all the solid bands [water areas], are mechanically maintained, aided by the passive mechanisms. A centralized air-conditioning unit distributes conditioned air into through the service corridors & into the primary water areas where it is then extracted by vents through the roof. The transparent bridge spaces in-between are ventilated using louvre windows at the bottom of the room & louvre vents in the roof. In the case of the louvred roof being closed, ventilation is still accommodated for in the roof construction. Operable glazing sections as part of the shelter construction allows for a measure of control over ventilation conditions.

Taking precedent from ancient baths, the system of raised floors is retained at the primary showers & steam rooms. Service corridors are open to the exterior so these spaces are naturally ventilated. The raised floor aids in water drainage | reticulation and allows for warm air from service areas to be pumped into the cavity, heating the space above.

The flow of concrete - Building Structure

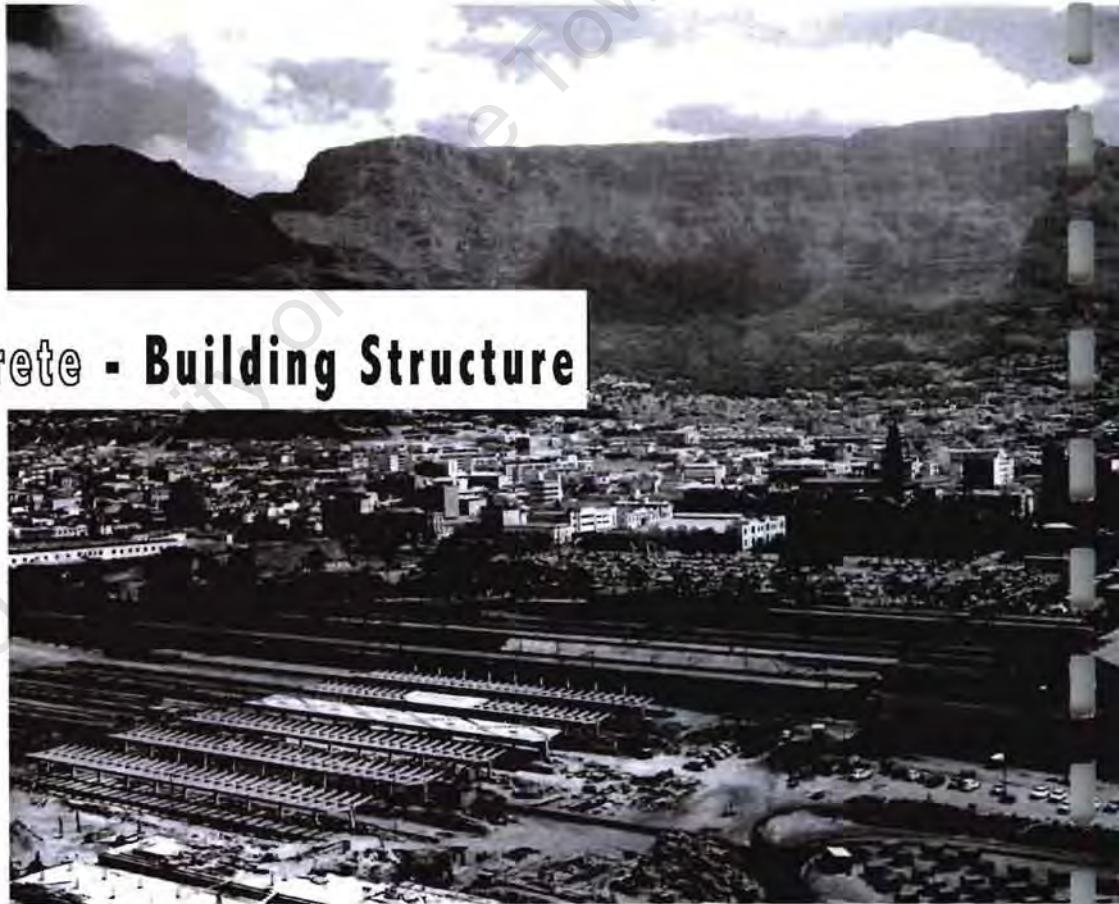

Figure 123: Construction of the existing Cape Town train station and raised platform.

contextual response

Some of the earliest uses of concrete as a building material & most innovative applications of concrete aesthetics – bold, curvilinear forms, vaults, and domes started with bath buildings. Not only were the baths an effective testing ground for new ideas, but because of their position between purely utilitarian structures & the more conservative, traditional forms of religious & public buildings (such as temples & Basilicas), they were instrumental in bringing wide spread acceptance of new ideas & revolutionary style into the realm of architecture proper. [Yegul, 1992 – 2]

The site and almost 90% of all the buildings surrounding the site were built in the 1960's and every building is built with concrete where it also becomes the final finish of the buildings. The train station itself is built out of precast concrete units used for roof beams, floor tiles and wall cladding. I decided to continue this tradition and build the bathhouse from the same material. The bathhouse thus has a monolithic appearance growing out of the existing raised platform. The building is sculpted & shaped by the movement routes around & within it. Also, I knew from the beginning that constructing the bathhouse on top of a working railway structure is quite difficult. Thus, precast elements would have to suffice to help with the speed and all other construction processes.

The structural system employed to realize the design is intended to act as a fundamental part of the experience. The structure directly results in the building, acting as structure and shelter simultaneously. Understood as a weaving of modular, precast and prestressed concrete structural components, together with cast-in-place concrete - a three-dimensional matrix of interrelated parts combine to form the building.

The railway grid immediately proposed a set grid for the structure: railway - platform - railway - platform - railway - platform. The span across the railway tracks from centre of platform to centre of platform is 16.5 meters, while the spacing along the platform could be varied. This was a very difficult grid to work with and delivered too complex structural connections with large spans. The only way this grid could work is if one closes the site with a podium deck and then building a building on top of that, which is denying the true nature of the site. I wanted to design a building that is shaped by the movement of the railway and speaks of being true to the context and site.

With this in mind the two systems (railway space & the platform space) are completely separated in terms of construction method: [see figure 124]

Platform Space

The platform space is the only space where the construction team will be able to move around. This gave rise to the structure, on the platform space, to be built primarily of cast-in-place concrete. It has a span/column grid of 5.5m over the platform for the people boarding the train to walk under. These structures on the 'platform spaces' act as the supporting structure (and foundation) for the precast concrete spanning elements spanning over the railway. This space forms the 'SOLID' pieces of the building with a very rough concrete texture.

2. Railway track Space

The railway space acts as the 'infill' for the building: after all the 'platform spaces' have been constructed, the smooth precast prestressed concrete elements for the railway space spanning 11m over the tracks are 'filled in'. These spaces form the 'TRANSPARENT' pieces of the building.

This method of construction makes the whole process a lot easier dealing with the closing of platforms & train schedules. The 'platform spaces' are built first, one by one, closing only one platform at a time. The train station can thus still function while busy constructing the building. The difference in finishing of the concrete (rough retarded platform space) creates a stark contrast between the two systems. This makes the building more contextual and shows that there are two different movements below the building: human v/s machine/train.

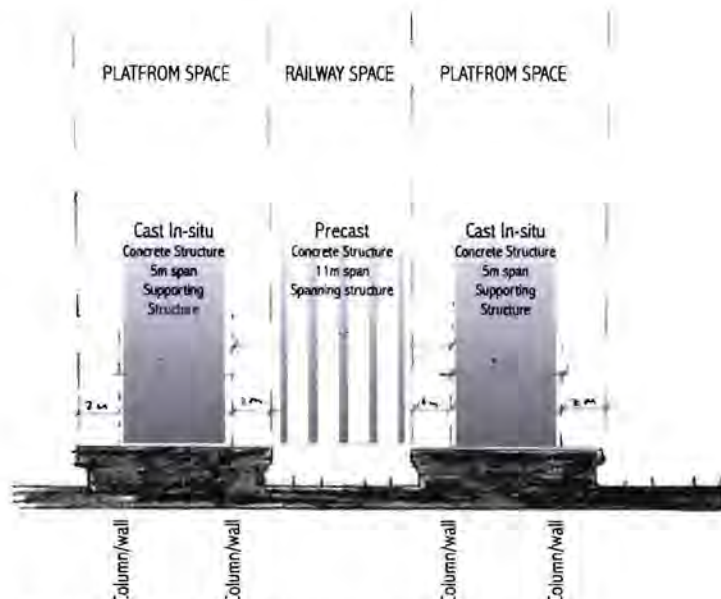

Figure 124: Section view of the Structural Concept for the bathhouse.

General advantages in using concrete:

Concrete is durable and robust, intended to resist any physical abuse to which the building might be subject to, which requires little or no maintenance.

Concrete resists weathering, while maintaining structural integrity, vital when considering the presence of moisture implied by the program.

Precast's speed of erection and its ability to be cast and erected in all kinds of weather aid the entire construction team.

Architectural concrete is non-combustible with inherent fire-resistant capability, creating a safe envelope that helps protect personnel, equipment and the building itself. It also eliminates the need and cost of additional fireproofing measures, except on structural-steel frames.

In addition, the inherent sound attenuation properties due to concrete's mass provide an economical acoustical barrier to exterior or interior noise penetration.

Concrete is an environmentally sound material. It is produced from natural materials. No toxic substances are produced in its production or use. Also, the production energy consumption of the concrete is quite small.

The thermal mass of concrete saves energy year-round by reducing temperature swings. Concrete's high albedo (or ratio of light reflected) has the added quality of reflecting heat as well as light, thus reducing the "heat island" effect and higher temperatures endemic to urban areas.

Each construction system will now be explained separately together with each one's relevant construction details.

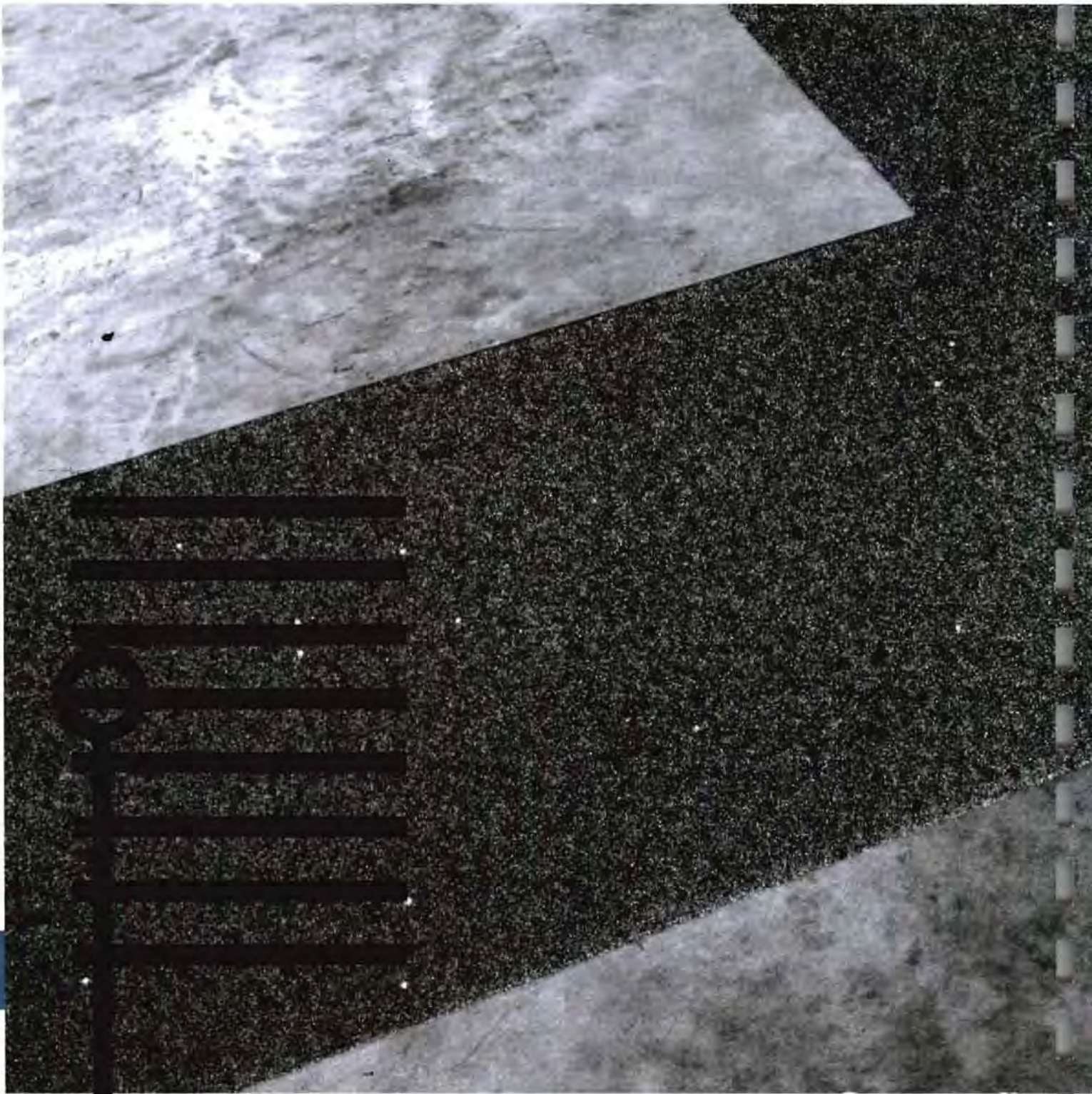

Cast In-Situ Concrete

The cast-in-situ concrete elements are placed directly on the existing train platforms & they make up the structural support structure for every element in the design. They manifest as a series of 'threshold planes' along the length of the platforms. Two planes per platform are placed 2m from the edge of the platform to create a 5.5m wide band. The planes are filled in with the event spaces [all water functions] & then perforated to allow for movement through the different spaces.

The threshold planes are 200mm thick solid cast-in-situ concrete walls with triangular thickenings [total: 400mm thick] to carry the loads. The regular span at the bottom along the platform between the 'columns' is 8m.

Previously normal columns were the primary structure, but combining the wall & column into one structural element enhances the experience of the user walking THROUGH THRESHOLD PLANES. It functions as a wall, column, balustrade, connection & separation element.

WALLS

The walls are contrasted against the smooth precast concrete structures by treating the surface on both sides. Retarded and water-washed textures are achieved by using nonabrasive means to fully expose the natural color and brightness of coarse aggregate. Chemical retarders work by delaying the hardening of the cement surface paste over selected time periods and to selected depths, which is followed by water washing and brushing. Water-washed textures simply use high-pressure water and brushes to remove surface paste prior to the hardening of the paste. Water washing, unlike retarded finishing, has a propensity for dislodging the coarse aggregate, which may require reseeded for a uniform surface texture. A dark aggregate is used also to enhance the contrast.

Figure 125: Appearance of the smooth & light precast concrete elements v/s the dark & rough cast-in-place concrete elements

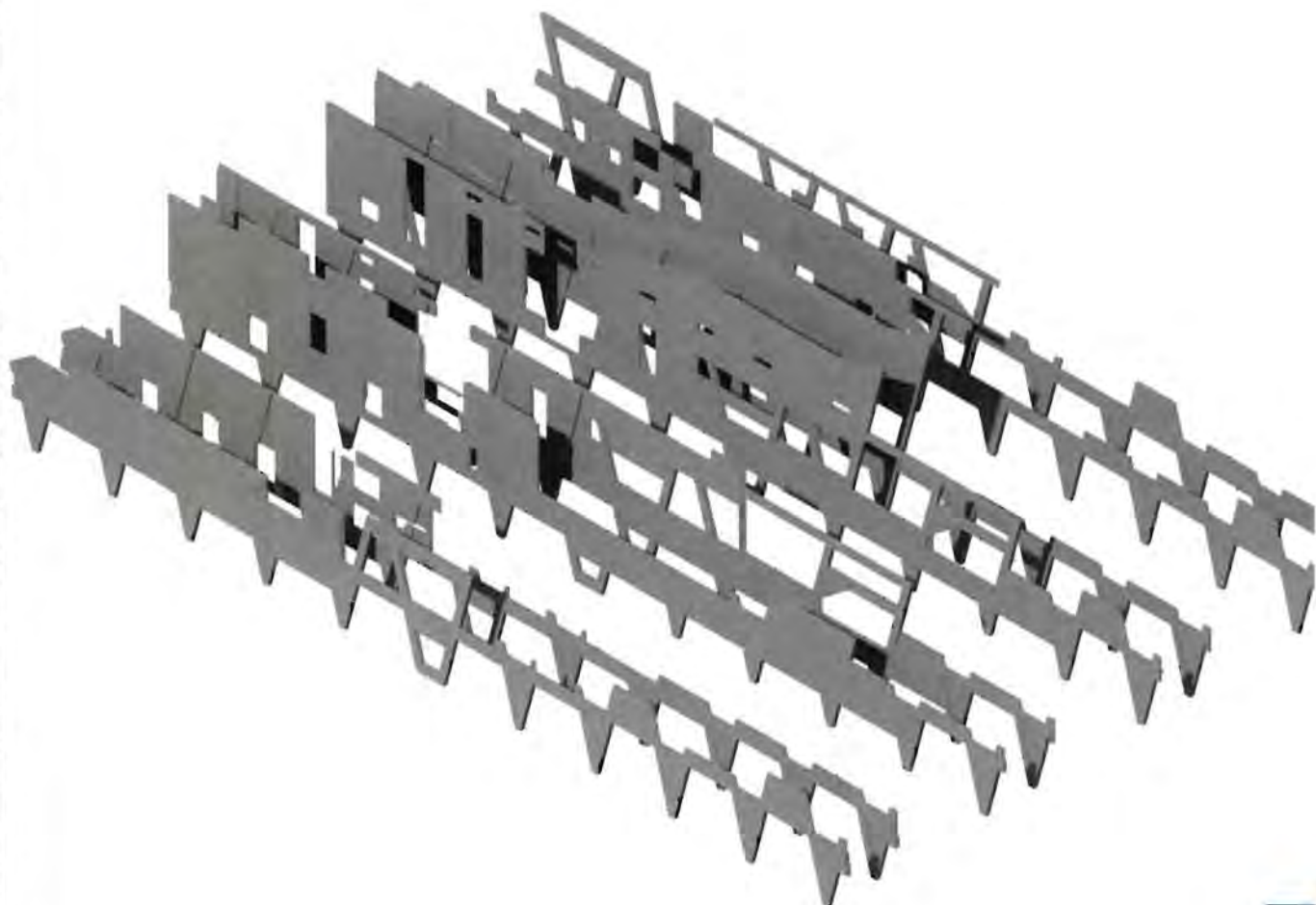
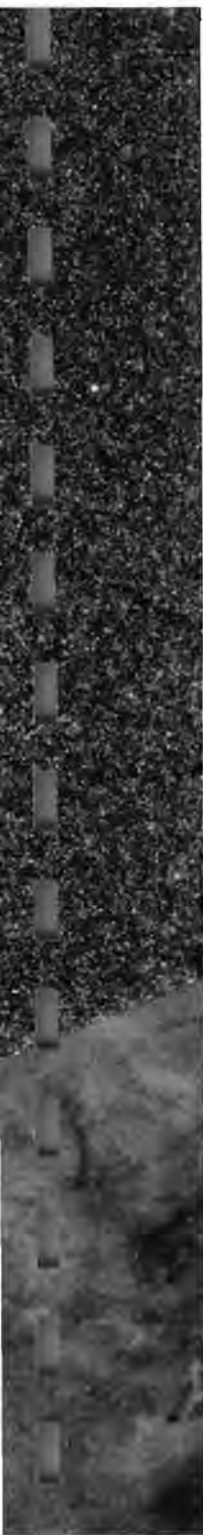

FLOORS & ROOFS

The screeded & tinted floors in the solid bands also resemble this rough finish but to a lesser extent. The suspended floor in the shower isles & steam rooms are covered with 50mm thick precast concrete tiles - also with same finish.

The pools are constructed with concrete & waterproofed with dark tinted Toughflex according to pool manufacturer's specifications.

The flat concrete roofs are made watertight with a screeded finish to fall [min1:70] to fullbore outlets & a waterproofing membrane is laid over the-screed. The roof is then covered with aggregate to protect the waterproofing.

The skylights are constructed of sculptural precast concrete elements covered with glass skylights. The skylight frame is a steel tophat section with the glass held with structural silicon. The tophat section provides a lip for fixing the glass and an air space between the glass & the concrete stale air to escape.

PERFORATIONS

Windows in the threshold planes are linear elements spaced close together. The window frame is a wide steel flat wrapping around the opening as wide as the thickness of the wall. This is cast in place & thus functions as the shuttering for the opening as well. The 6mm thick safety glass is held in place with structural silicon against an equal angle. The glass is flush with the outside skin of the wall.

Figure 126: Cast-in-place concrete 'threshold planes': primary structural support for whole building.

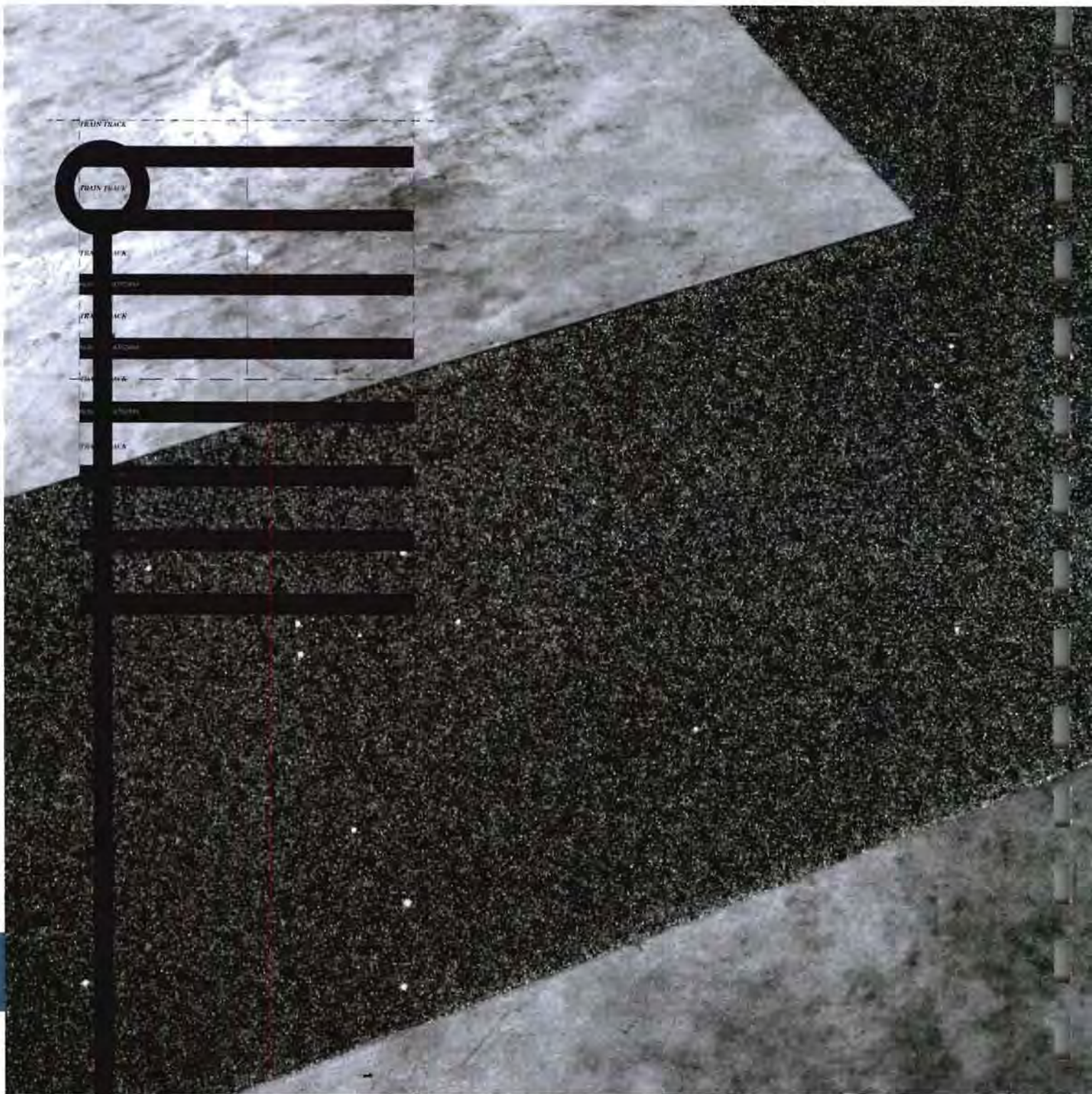

Precast Prestressed Concrete

Precast concrete consists of concrete (a mixture of cement, water, aggregates and admixtures) that is cast into a specific shape at a location other than its in-service position. The concrete is placed into a form, typically wood or steel, and cured before being stripped from the form, usually the following day. These components are then transported to the construction site for erection into place.

Precast prestressed concrete components are reinforced with either conventional reinforcing bars, strands with high tensile strength, or a combination of both. The strands are pretensioned in the form before the concrete is poured. Once the concrete has cured to a specific strength, the strands are cut (detensioned). As the strands, having bonded to the concrete, attempt to regain their original untensioned length, they bond to the concrete and apply a compressive force.

Architectural precast concrete units are produced under strict, factory-controlled conditions to ensure a high quality product in the desired shapes,

Kinetic Architecture – the spatial organization of daily mobility within a Public Bathhouse

colors and textures along with close tolerances. The intent is to establish a local industry and skills and production.

- Cleaning moulds
- Pretensioning, laying of reinforcing steel
- Concreting, vibrating, compacting
- Finishing
- Curing
- Prestressing by detensioning the moulds
- Cutting of protruding prestressing steel
- Demoulding and storage.

The intent is to expand the social potential of the bathhouse by capitalizing on the construction process.

The precast elements are cast in steel shuttering for a smooth final finish.

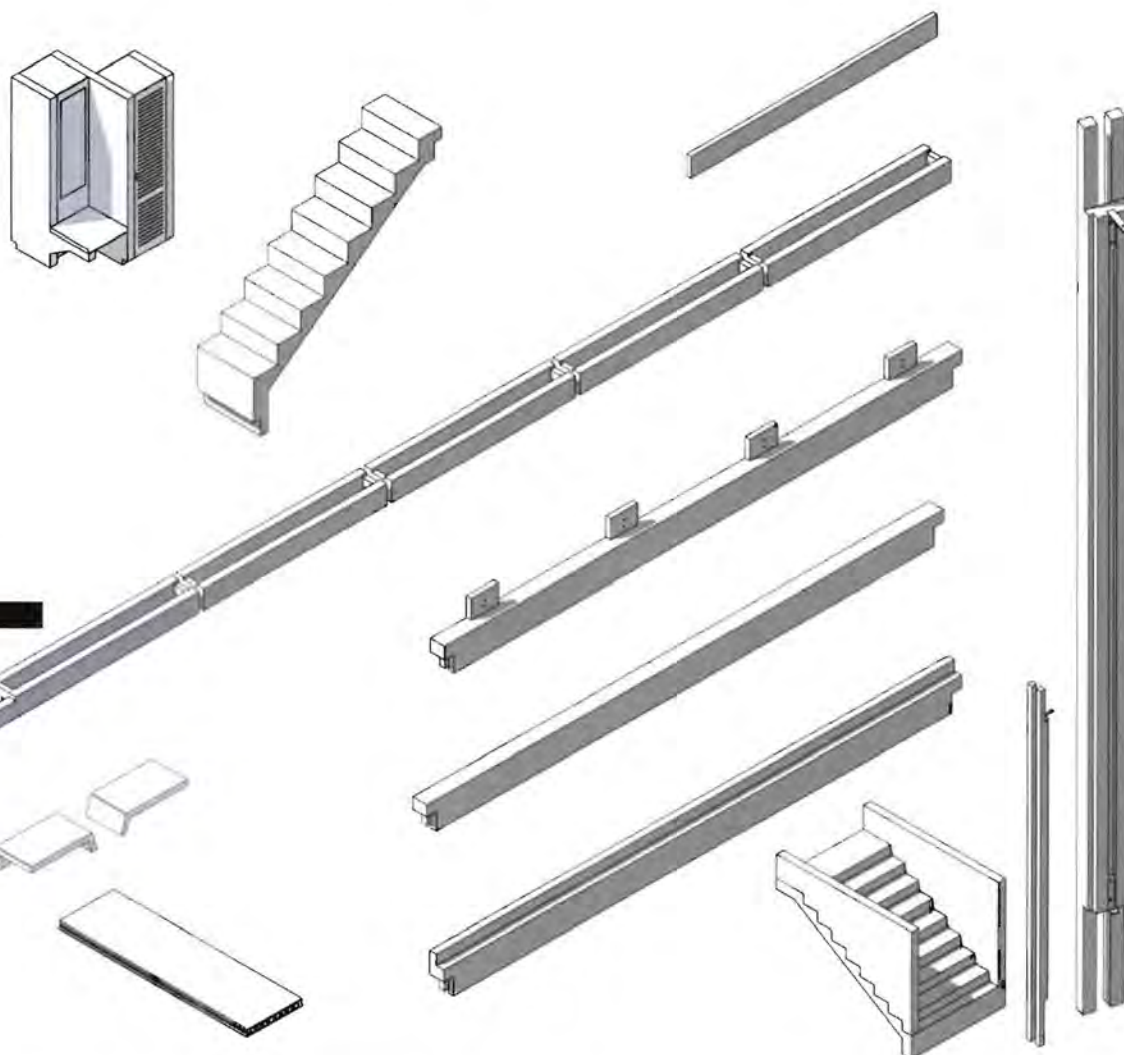
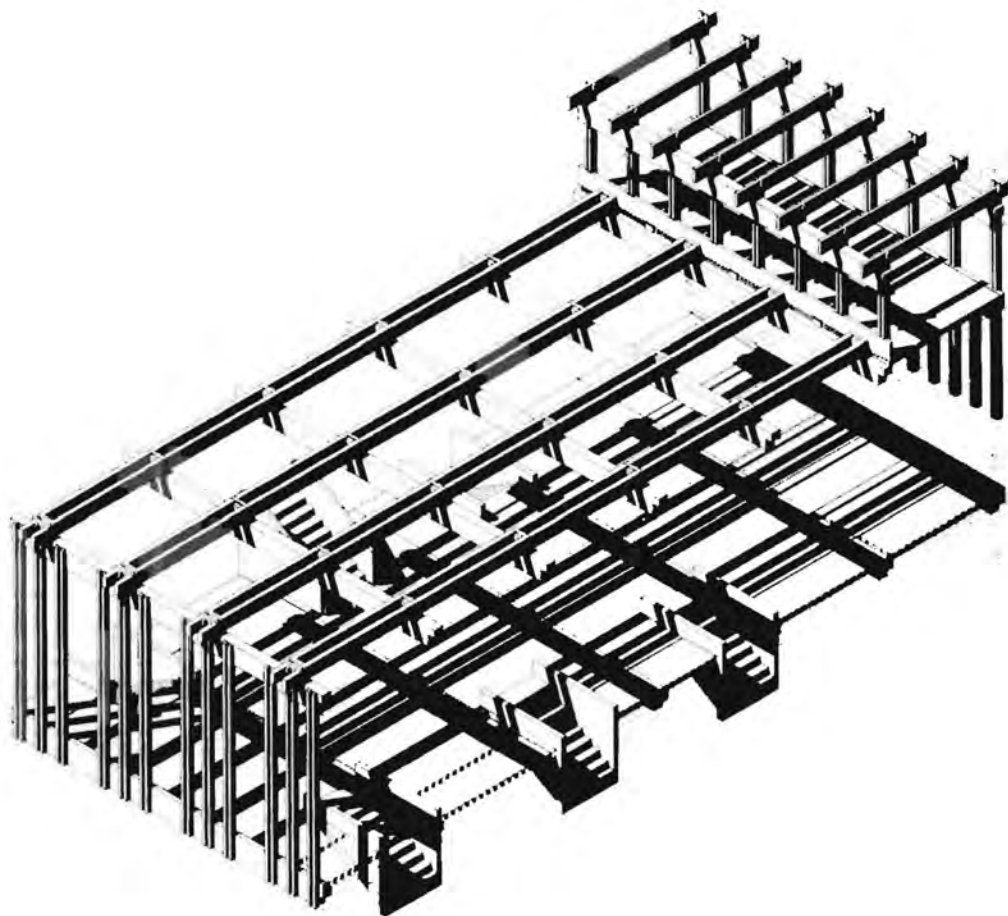

05

Figure 127: Diagram study of the precast prestressed concrete framed structure suspended in-between the solid threshold planes

Figure 128: Precast prestressed concrete components - floor & roof beams, stairs, wall cladding, floor panels.

'Transparent' Roof Construction

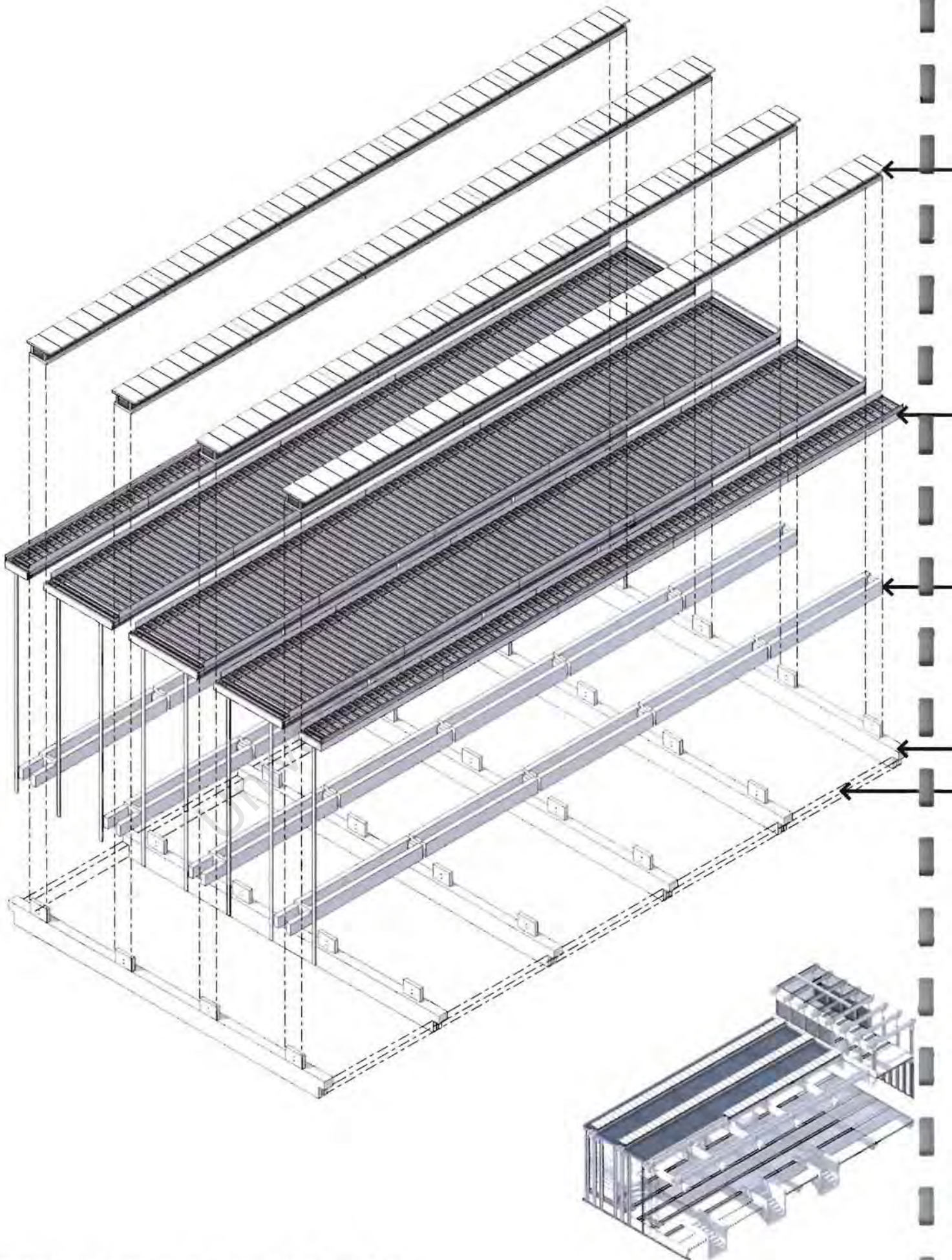

Figure 129: Exploded diagram illustrating the primary components of the 'transparent' roof structure suspended between the solid threshold planes.

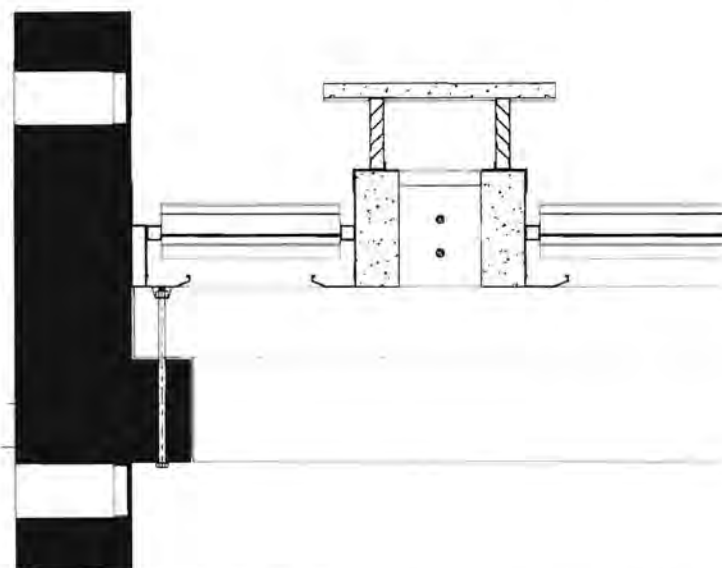
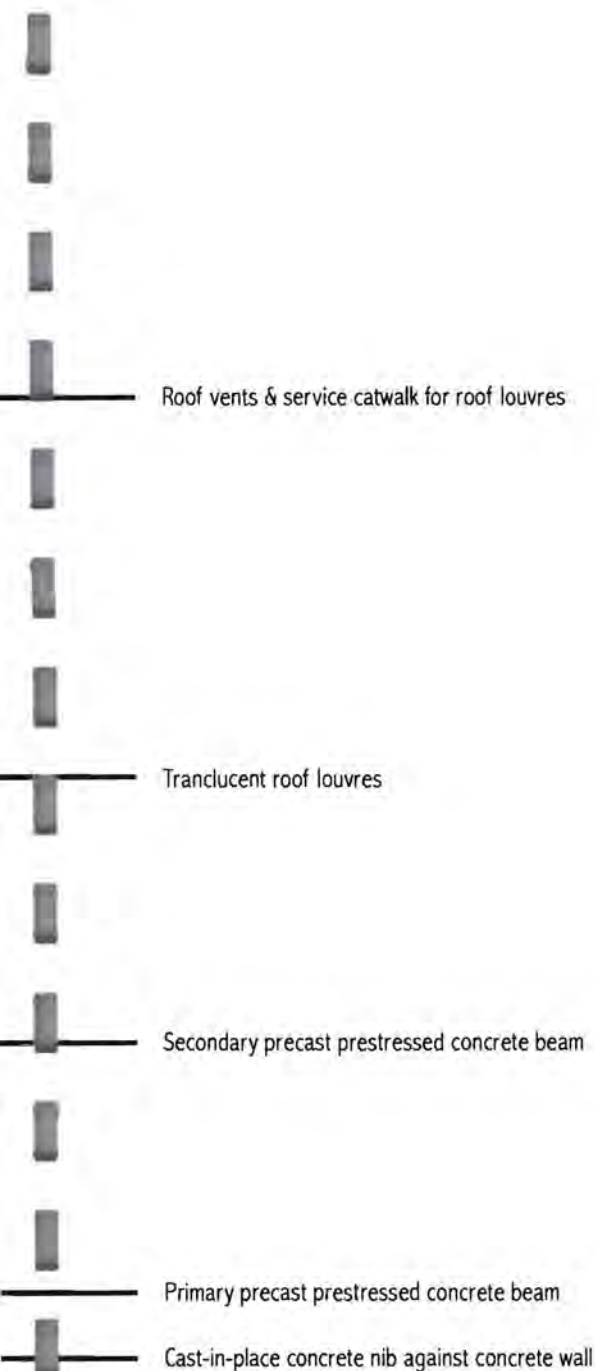

Figure 130: Cross Section of roof structure illustrating attachment to solid threshold concrete wall.

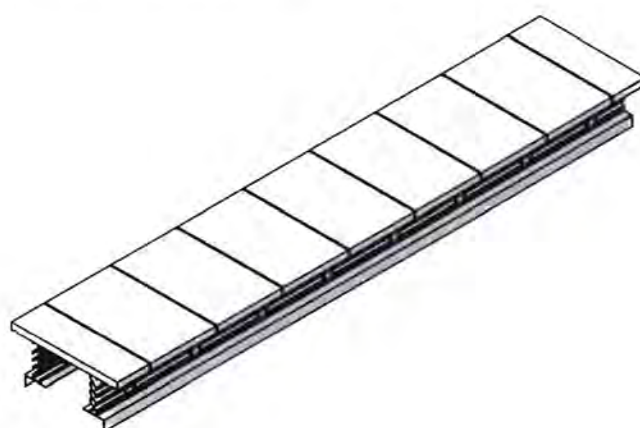

Figure 131: Roof vents

The primary precast prestressed concrete beams rest on top of a neoprene bearing pad on a cast-in-place concrete nib against the concrete wall. A uPVC grouting tube is cast into the nib. A galvanized steel rod is inserted and fixed with cement grout inside the cavity. The secondary beams are fixed to the cast-in-place steel upstand nibs on top of the primary beam with steel rods & cement grout. A premanufactured aluminium opening louvre roof system is proposed between the secondary beams. The louvres close and interlock, creating a weatherproof roof. When closed, a translucent UV treated Naturelite panel in the louvre admits light through. The louvres have a 180 degree range of motion, managed through a hidden motorized pivot system, this motor can be connected to a sun and rain sensor and be fully automated (LouvreTec, 2009:9). The lightweight aluminium louvres resist heat gain, while shading or exposing the concrete mass from and to the sun. The louvres are integrated with its own aluminium gutter system attached to a aluminium subframe. This in turn is fixed to the concrete beams with expansion bolts & metal flashing is applied. The roof vents are constructed of a painted steel frame with aluminium louvres inserted into the frame. The steel frame covers the concrete beam and functions as flashing/waterproofing element as well. Rectangular steel posts welded to the steel frame at intervals carry the precast concrete tiles. The roof vents function as service catwalk for the roof louvres & to accommodate natural ventilation when the roof louvres are closed.



Figure 132: Premanufactured motorized roof louvre system with translucent panels for the light to filter through the roof even when the louvres are closed.

'Transparent' Floor Construction

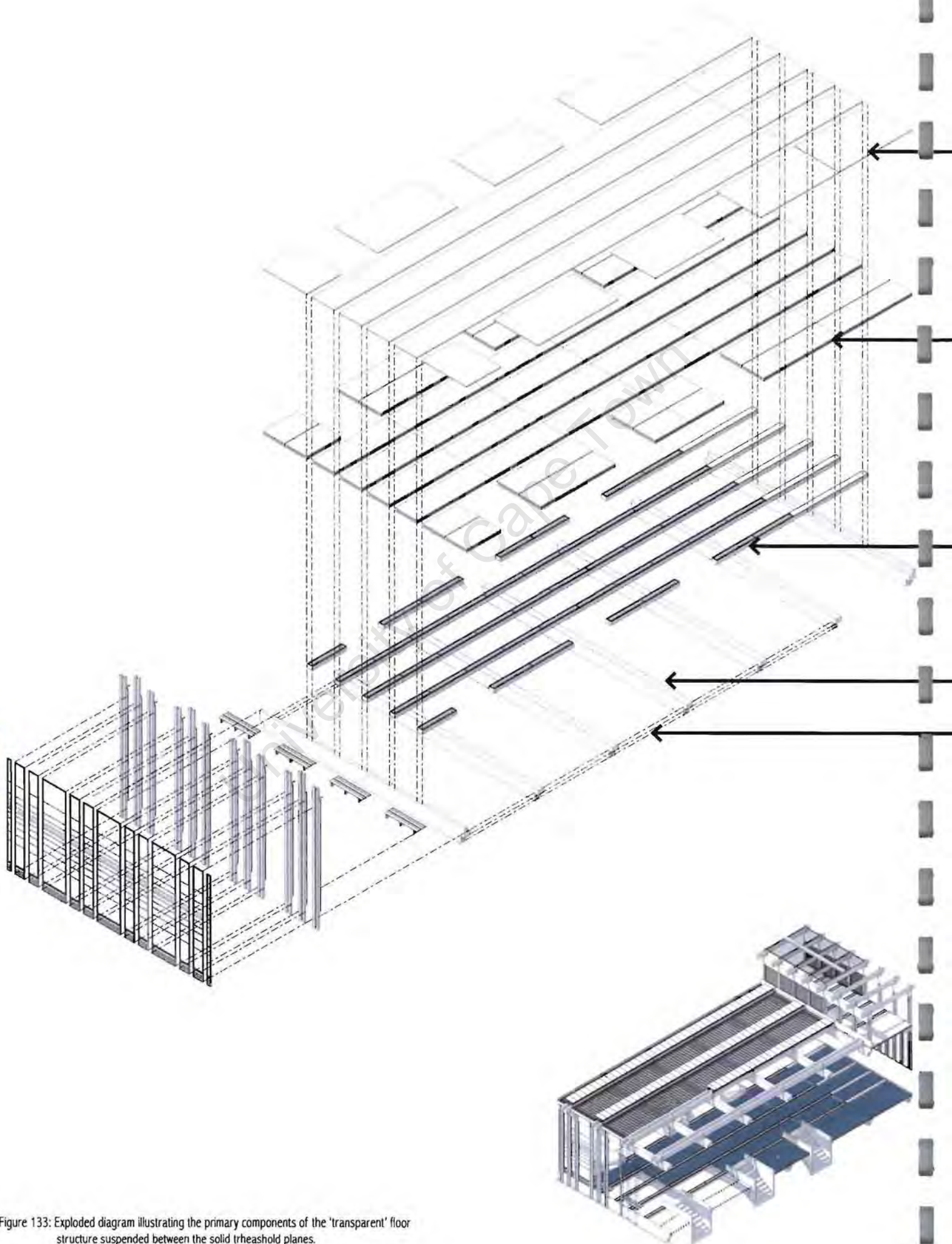
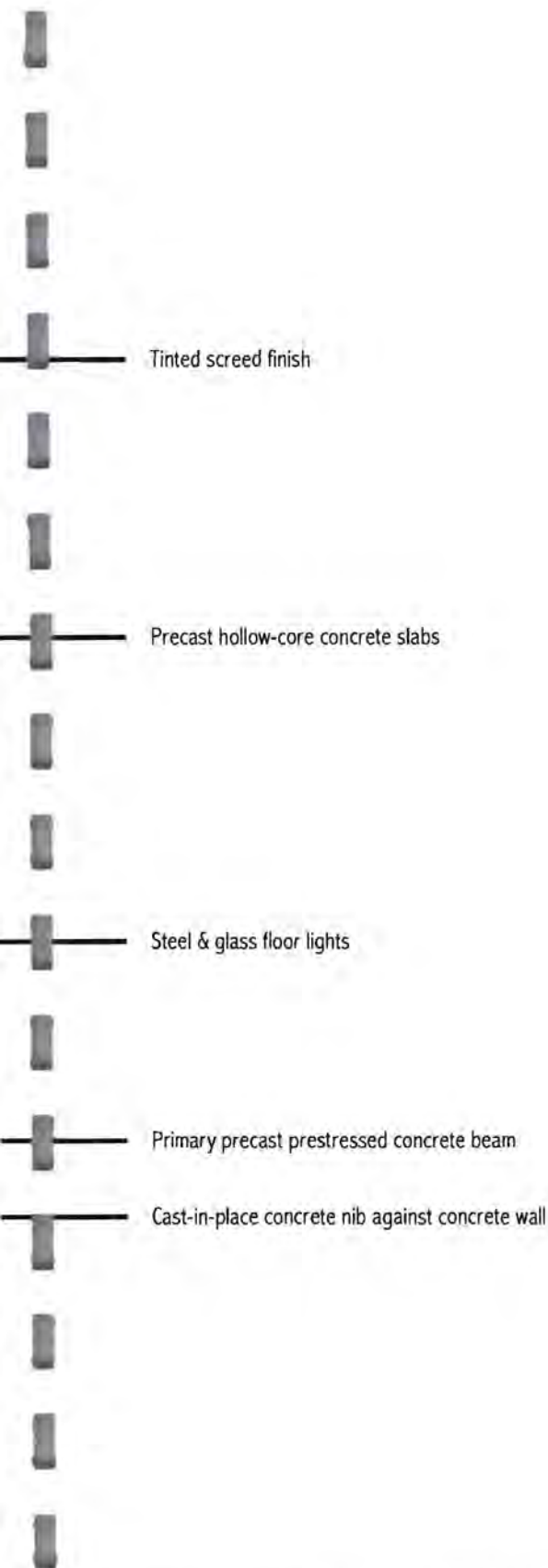

Figure 133: Exploded diagram illustrating the primary components of the 'transparent' floor structure suspended between the solid threshold planes.



The primary precast prestressed concrete beams rest on top of a neoprene bearing pad on a cast-in-place concrete nib against the concrete wall. A uPVC grouting tube is cast into the nib. A galvanized steel rod is inserted and fixed with cement grout inside the cavity. Beams are placed at 4m intervals. Blue/red painted steel & opaque glass floor lights are fixed on top of the concrete beams with expansion bolts. The 10mm thick safety glass is fixed with structural silicon & dome head bolts onto a steel angle welded to the steel box frame. A light fitting is also installed below the floor - this creates linear transparent shining lines on the floor viewed from the top & linear light fixtures for the train tracks from the bottom. Precast hollow-core concrete slabs are placed between the floor lights on the floor beams [4m x 1.2m sections]. A final tinted screed finish is applied to the floor.

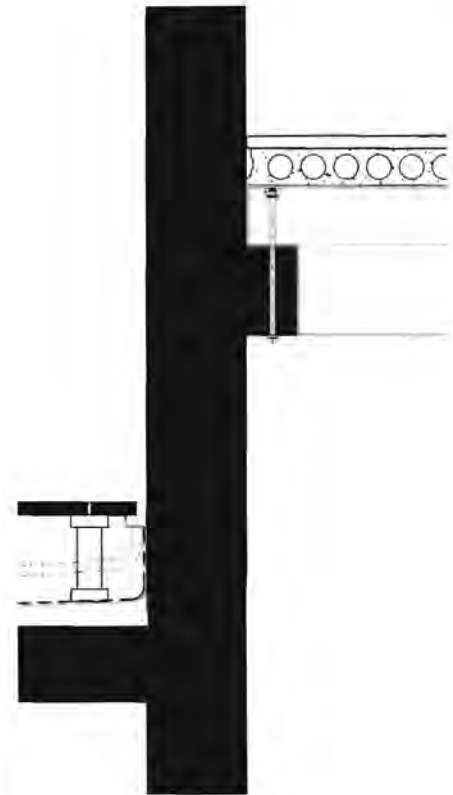

Figure 134: Cross Section of floor structure illustrating attachment to solid threshold concrete wall. Also shows the suspended floor of the shower circulation space.

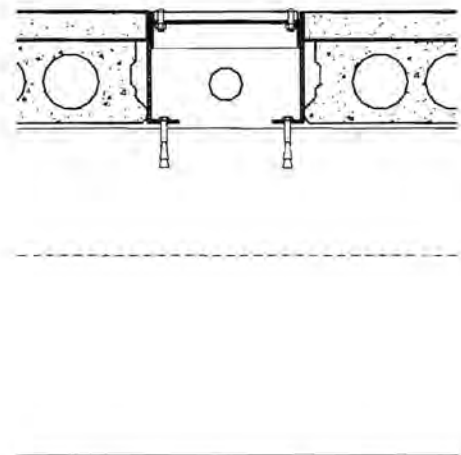

Figure 135: Detail section of the floor lights inserted in-between the hollow-core slabs with lighting fixture installed below

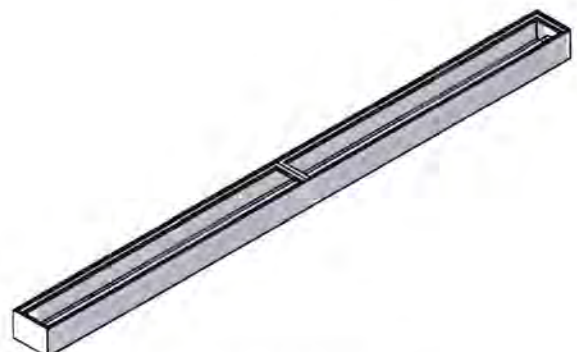
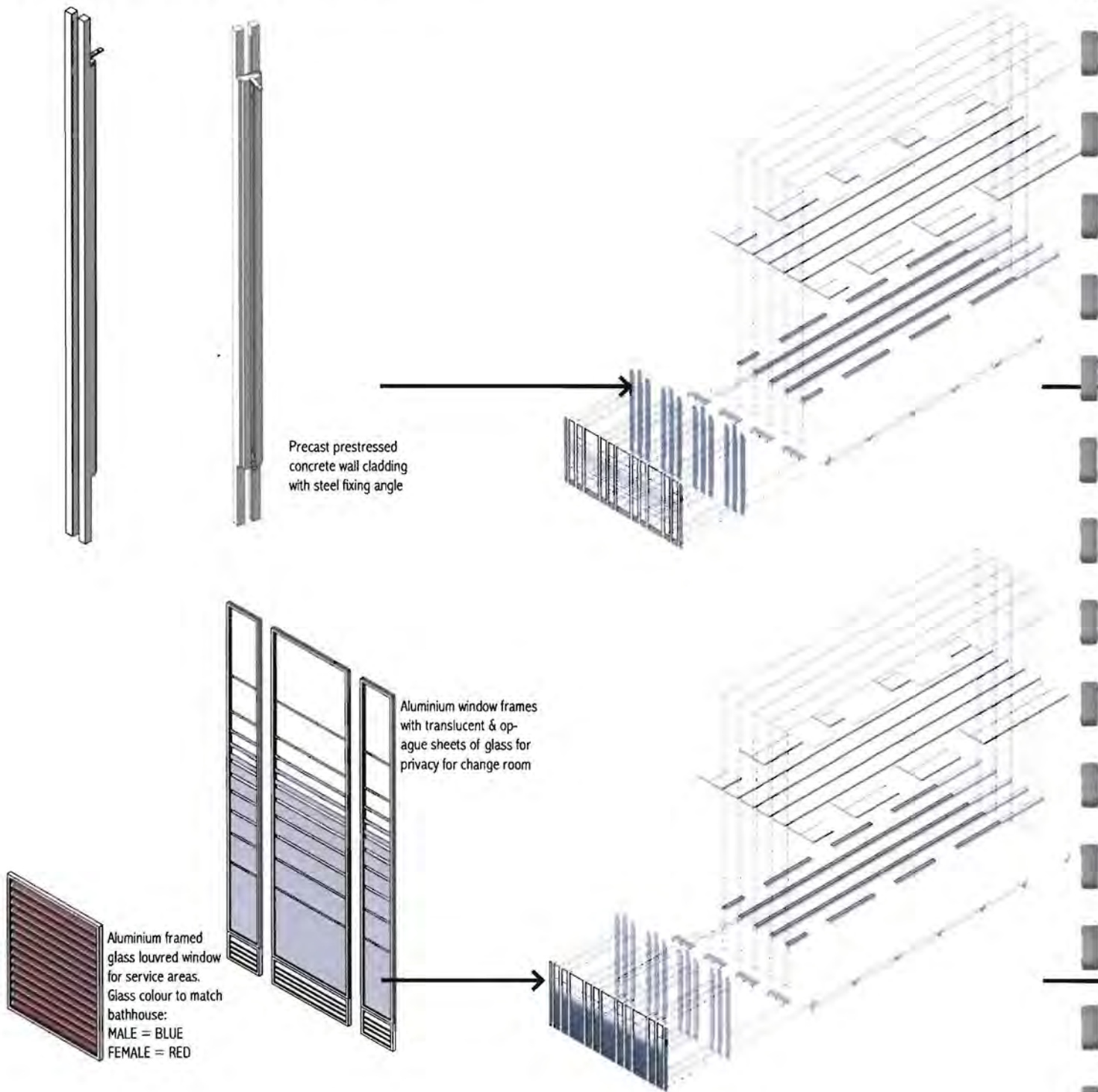

Figure 136: 3-Dimensional view of the steel & glass floor light box.

'Transparent' Facade Construction



The precast prestressed concrete wall cladding is fixed in place between the top & bottom precast beam of the facade. It rests on top of a neoprene bearing pad and is fixed at the top & bottom of the beams with a steel angle plate & expansion bolts. These wall cladding elements are shaped to receive the red | blue painted steel downpipes from the louvre roof above. The two aluminium window frames on either side also fits into recesses. The column also receives a steel & timber bench & is fixed to the centre recess of the column with expansion bolts. The cladding elements are extended past the bottom & top concrete beam in order to enhance the vertical 'transparent' lines of the bridge section of the building.

Aluminium framed glass louvred windows are installed at the top service walkway on top of the building. The glass louvres are coloured to match the male | female bathhouse: MALE = BLUE; FEMALE = RED. This creates a continuous red | blue band across the top of the building revealing the service sequence of the building to the users.

The aluminium window frames installed between the concrete wall cladding columns are fixed with bands of translucent & opaque sheets of glass for privacy for change room. The bands start of completely opaque at the bottom up to a height of 1.5m and then becomes completely transparent at the top. The bottom of the linear windows are fixed with aluminium louvres for natural ventilation to sweep through the space & exit through the vents | louvres of the roof.

Figure 137: Exploded diagram illustrating the primary components of the 'transparent' facade structure suspended between the floor & roof beams.

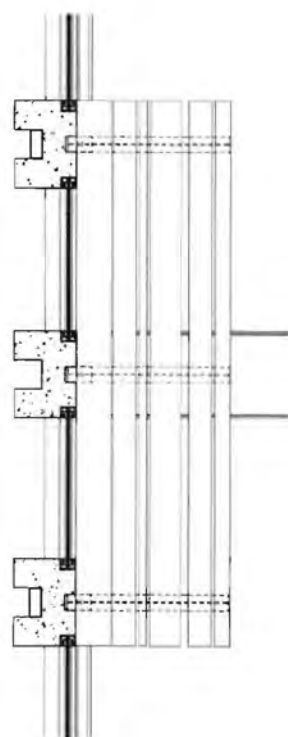
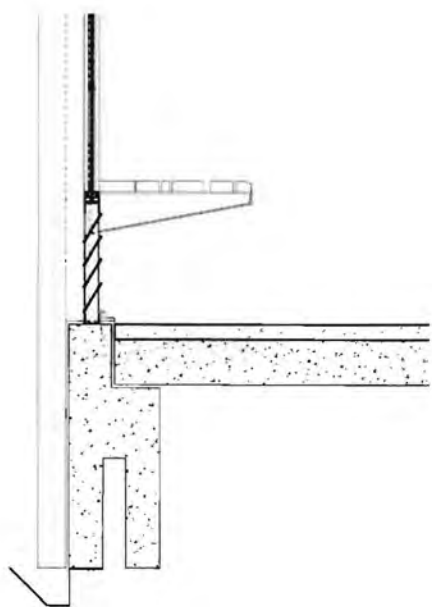
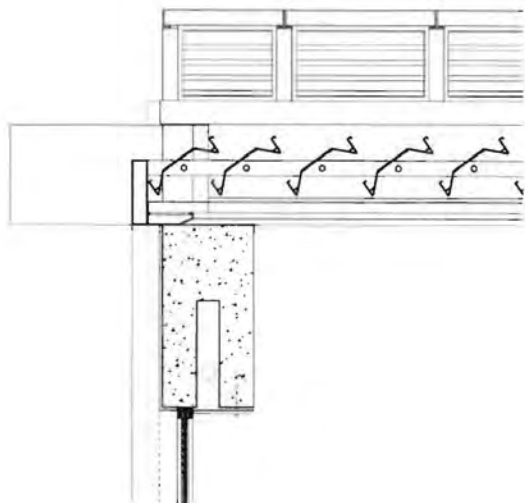
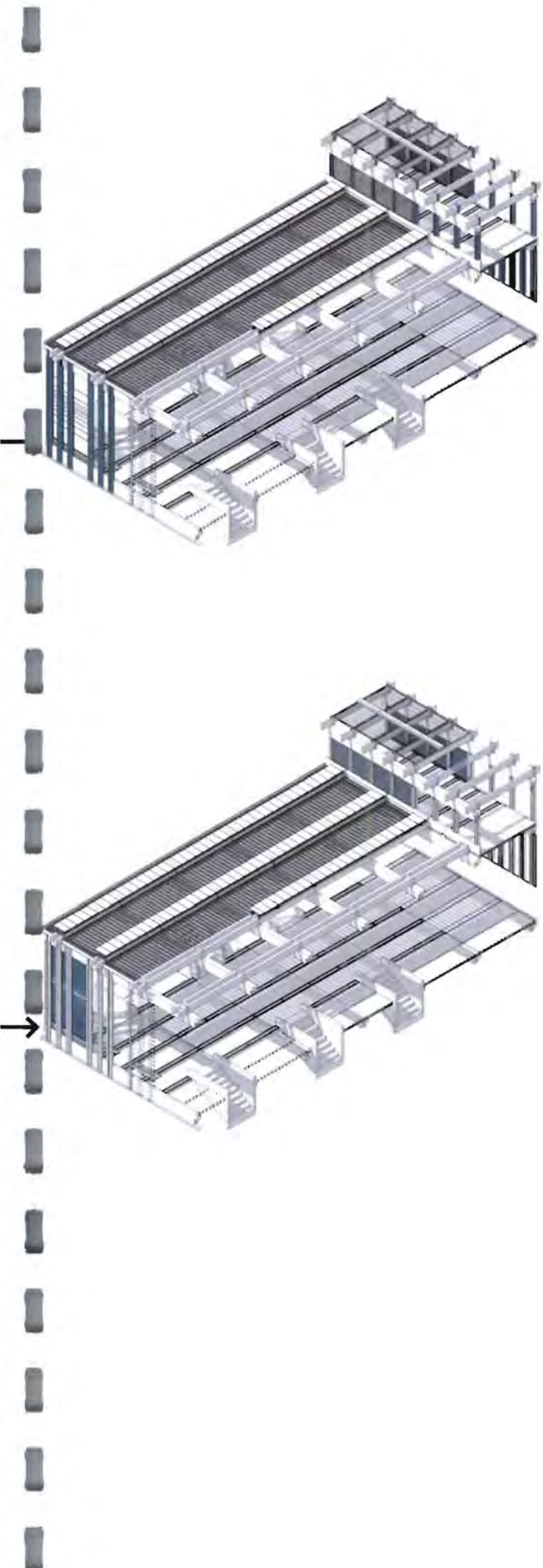

Figure 138: Cross section and plan view of the transparent facade edge of the building.

University of Cape Town



University of Cape Town

chapter 06.

List of references

Books/Journals:

- Kubo, M (ed); Ferre, A (ed); FOA. (2003) *Phylogenesis – FOA's Ark*, London: Actar.
- Kipnis, J; preface by Terence Riley. (c2001) *Perfect acts of achitecture*; New York : Museum of Modern Art ; Columbus : Wexner Center for the Arts ; New York : Distributed by Harry N. Abrams.
- Tschumi, Bernard. (c1994) *Architecture and disjunction*, Cambridge, Mass : MIT Press.
- Marianne Barzilay, Catherine Hayward, Lucette Lombard-Valentino; (1984) *L'invention du parc : Parc de la Villette, Paris : concours international competition*, Graphite Editions/E.P.P.V, Paris.
- Feireiss K (ed). (1994) *Ben Van Berkel: Mobile Forces*, Ernst & Sohn; Berlin.
- Christian Norberg-Schulz. (1971) *Existence, Space & Architecture*, (New Concepts of Architecture; Littlehampton Book Services Ltd; First Edition / First Printing edition.
- Francis D.K. Ching. (1996) *Architecture: Form, Space & Order*, 2nd Edition; John Wiley & Sons Inc.
- Krystallia Kamvasinou. (2010) *Notation Timelines & the Aesthetics of Disappearance*, *The journal of Architecture*, Vol. 15 No.4.
- Lynn, Greg. (c1999) *Animate Form*, New York : Princeton Architectural Press.
- Mark Wigley (1993) *The Architecture of Deconstruction*, M.I.T. Press.
- Patrik Schumacher. (1996) *The Architecture of Movement*, Published In: ARCH+ 134/135, *Wohnen zur Disposition*, Dezember 1996 German: Architektur der Bewegung.
- Gausa M, Guallart V, Muller W, Soriano F, Porras F, Morales J. (2003) *The Metapolis Dictionary of Advanced Architecture – city, technology & society in the information age*, Actar Publishers, Barcelona.
- Bronet F, Schumacher J. (1999) *Design in Movement: The Prospects of Interdisciplinary Design*, *Journal of Architectural Education* November 1999; ACSA, Inc.; p. 97-109
- Rattenbury K, Bevan R, Long K. (2004) *Architects Today*, Laurence King Publishing Ltd, UK.
- Bacon, Edmond. (1967) *Design of Cities*, Thames & Hudson, London. (revised edition)
- Leyda, J. (1963) *Film Form – Sergei Eisenstein*, Dennis Dobson Ltd. London.
- Droste, M. (2006) *Bauhaus – Bauhaus Archive 1919-1933*, Taschen; Published by the Bauhaus-Archive Museum fur Gestaltung.
- Marien M.W, Fleming W. (2005) *Fleming's Arts & Ideas*, Tenth Edition; Thomson Wadsworth, USA.
- Lefebvre, Henri. (2004) *Rhythmanalysis : space, time and everyday life / Henri Lefebvre ; translated by Stuart Elden and Gerald Moore ; with an introduction by Stuart Elden*. New York ; London : Continuum.
- Diller, E., Scofidio, R. (2002), *Blur: the making of nothing*; Harry N. Abrams.
- Sudjic, D. (1994). *The architecture of Richard Rogers*; Fourth Estate & Word-search Ltd, London.
- Powell, Kenneth. (1994), Richard Rogers; Artemis London Limited, London.
- Powell, Kenneth. (2006), Richard Rogers – *Architecture of the future*; Birkhauser, Switzerland.
- Nassimbeni, Lorenzo. *Sustainable construction : an investigation into rainwater harvesting, water recycling and water saving in buildings, their technology and construction methods*, UCT Built Environment Library Technical Library.
- Violet, Pierre-Louis. (2007), *Water engineering in ancient civilizations : 5,000 years of history / Pierre-Louis Violet ; translated into English by Forrest M. Holly, Jr*; Madrid : International Association of Hydraulic Engineering and Research.
- Hicks, T.G. (ed). (c2006), *Handbook of mechanical engineering calculations*, New York : McGraw-Hill.
- Leonardi, N (ed). (2009) *The Plan – Architectural & Technologies in detail*, Volume 35 July/August 2009, The Art & Architecture editions CENTAURO srl, Italy; pages: 102-112.
- Von Zeil, Caron. (2009). *CAMISSA: the place of sweet waters*, MLA, UCT.
- Gibbert, J. (2009), *Green Building Handbook for South Africa*. CSIR Built Environment: City of Tswane
- Napier, A. (2000), *Enviro-Friendly Methods in small building design for South Africa*, Published by the Author.
- Zumthor, P. (2007) *Peter Zumthor: Therme Vals*; Verlag Scheidegger & Spiess AG, Zurich.
- Allsop, Robert Owen. (1890) *The Turkish bath : its design and construction : with chapters on the adaption of the bath to the private house, the institution, and the training stable*; London : Spon,
- Watson, Sophie. (2006) *City publics : the (dis)enchantments of urban encounters*; London : Routledge
- DeLaine, Janet. (1997) *The baths of Caracalla : a study in the design, construction, and economics of large-scale building projects in imperial Rome*; Portsmouth, R.I. : Journal of Roman Archaeology
- Cape Town (South Africa). City Engineer's Dept. Town Planning Branch. (1984) *Greening the city : plan & programme for swimming baths : analysis of comments received and proposed modifications to the plan and programme / City Engineer's Department, Town Planning Branch*. Cape Town
- Neil Leach, ed. (1997) *Rethinking Architecture: a reader in Cultural theory*, London, Routledge,
- Don Pinnock, Ideology and Urban planning: Blueprints of a garrison town, in Wilmot G. James & Mary Simons, Eds. *The Angry Divide: Social and economic history of the Western Cape*. (Cape Town, David Philip, 1989)
- Frank Lloyd Wright. (1932) *The Disappearing City*, William Farquhar Payson, New York,
- Honikman, A.H. (1966) *Cape Town: City of Good Hope*; Howard B. Timmins Publishers; Cape Town;
- Pama, C. (1975) *Regency Cape Town*; Tafelberg Publishers, Cape Town
- Ryan, R. (1981) *A city that changed its face*; McKerrow Atkins Publishers, Cape Town

John Rennie. (1978) *The Buildings of Central Cape Town, 1978, Volume One*. Cape Town, Cape Provincial Institute of Architects,

Ngel Worden, Elizabeth van Heyningen, & Vivian Bickford-Smith. (1998) *Cape Town – The making of a City*. Cape Town: David Phillip Publishers (Pty) Ltd,

Ngel Worden, Elizabeth van Heyningen, & Vivian Bickford-Smith. (1999) *Cape Town – In the Twentieth Century*. Cape Town: David Phillip Publishers (Pty) Ltd.

Awkes, D. (2008) *The Environmental Imagination: Technics and poetics of the architectural environment*, Routledge Taylor & Francis Group, London.

Jacobs, Jane. (1961) *The Death and Life of Great American Cities*. Random House, New York.

Yegül, Fikret K. (1992) *Baths and bathing in classical antiquity / Fikret Yegül*. New York, N.Y : Architectural History Foundation Cambridge, Mass : MIT Press

Patsky, A. Take me to the water, dipping into the history of water in architecture. *Architectural design*. Vol 65 no 1-2 January- February 1995. P 9-15

Showerman, G. (1931) *Rome and the Romans: A survey and interpretation*. New York, the Macmillan co.

Waterproofing Association (South Africa): *Manual / Waterproofing Association South Africa = Handboek / Waterdigtings Assosiasie Suid Afrika; Edenglen (South Africa) : The Association, 1986*

Perkins, Phillip H. (1976) *Concrete structures : repair, waterproofing and protection*; London : Applied Science,

Low, I (ed). "Baragwanath Transport Facility & Trader Market." *Digest of South African Architecture 2008, Volume 13*. pages 22-25.

Ludwig Hansen. "Integrating Marginalised Urban Users – accommodating street traders and taxis." *Journal of the South African Institute of Architects*. November/December 2008. Pages 44-49.

"Cities for People." *Proceedings of a seminar held at the Mount Nelson Hotel the 2nd October 1975, The treasurer - South African Institute of Town & Regional Planners, 1975.*

Department of Transport. (2009) *National Transport Master Plan 2050: Rail Usage Study Report; Report Number RL/2/08-2009*

Scheme Design Proposals:

Wekka Design Laboratory. *Cape Town Station Revitalisation 2030*; April 2010

City of Cape Town. *Spatial Development Plan: Table Bay*. August 2009

David Dewar & Piet Louw. *A Broader Foreshore Urban Design Framework for the City of Cape Town*. October 2003

Cape Town Partnership. "Cape Town Central City: Into the Future".

Web:

Exhibition on mobility – First International Architecture Biennale in Rotterdam: 'Mobility: A Room with a View' (2003). Retrieved April 2011, from IABR: www.2003.iabr.nl

Motion in Art. Retrieved March 2011, from Artsology: http://www.artsology.com/motion_in_art.php

Lukez, P. (1999). *The frame & beyond: mediating Film & Architecture*. Retrieved April 2011, from Lukez: www.lukez.com/teaching/fall1999studio_description.html

Bois, Y (1989). Sergei M. Eisenstein, Montage & Architecture (CA.1938). In *assemblage 10* December 1989 pg.111-131. Retrieved March 2011, <http://www.cosmopista.files.wordpress.com>

Solar collector, Retrieved May 2011, from wikimedia: <http://upload.wikimedia.org/wikipedia/commons/0/02/IndirectSystem-Schematics2.jpg>

Solar Information, Retrieved May 2011, from ITS Solar: <http://www.itsolar.co.za/index.php>

Water tanks, Retrieved May 2011, from Abeco Tanks: <http://www.abecotanks.co.za>

Salt water chlorinators for pools, Retrieved May 2011, from Wikipedia: http://en.wikipedia.org/wiki/Salt_water_chlorination

Table for climate data for Cape Town, Retrieved April 2011, from Weather SA: www.weathersa.co.za

(2006). *Guidelines for safe recreational water environments. Volume 2, Swimming pools and similar environments*, © World Health Organization Library Cataloguing-in-Publication Data; Retrieved April 2011, from WHO: www.who.int

(1976). *Swimming Pools: safety & disease control through Proper Design and Operation*, HHS Publications Retrieved April 2011, from Centers for Disease Control & Prevention: <http://www.cdc.gov/healthywater/swimming/>

Statistics South Africa. 2007. *General household survey*. Cape Town. Statistics South Africa.

Vitrex. 2009. *Stile*. Retrieved June 2011: <http://www.vitrex.co.za/stile.htm>

http://www.capetown.gov.za/en/EnvironmentalResourceManagement/publications/Documents/Biodiv_fact_sheet_suppl_Endemic_spp_list_2010-03.pdf

<http://www.turkishbath.net/history.htm> Retrieved April 2011

<http://www.istanbultouristichotels.com/turkishbaths.htm> - drawing - Retrieved May 2011

<http://cyberbohemia.com/Pages/russianbaniahistory.htm> Retrieved May 2011

University of Cape Town

University of Cape Town

Included after examination

University of Cape Town

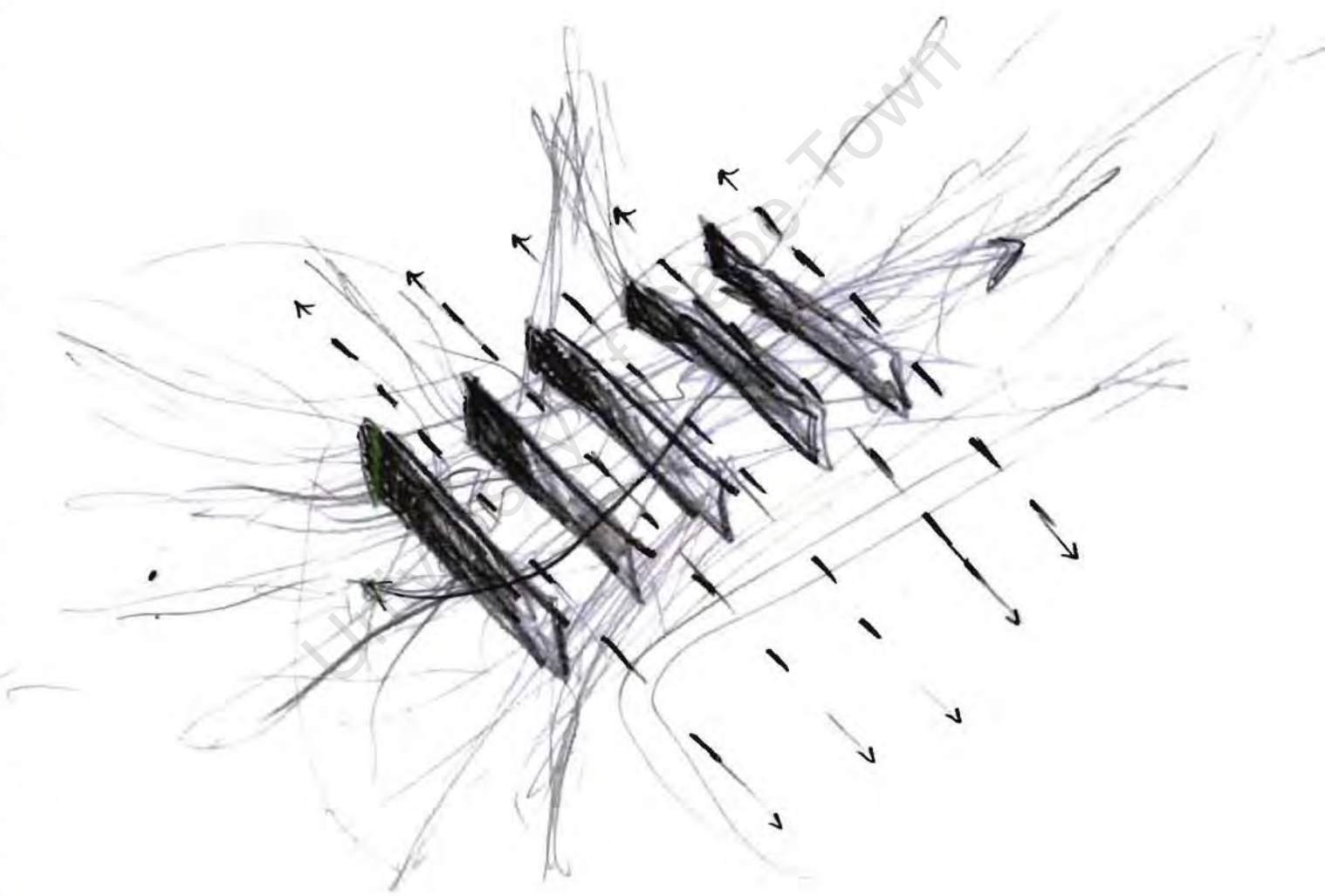

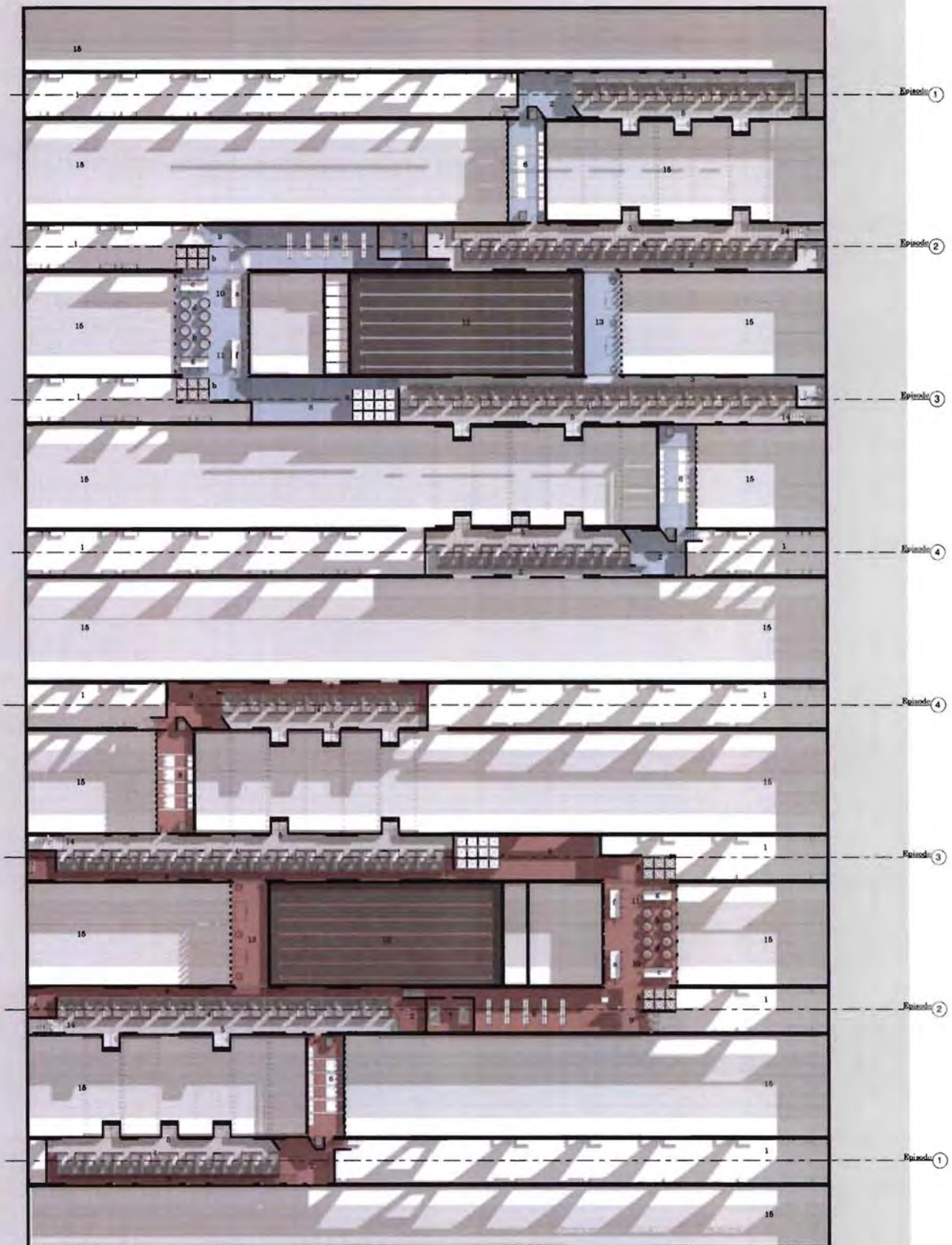

LEVEL -1

- 1 Train Platform with seats below
- 2 Service Office
- 3 Service Corridor
- 4 Showers/Baths with shared wash hand basin
- 5 Circulation

- 6 Laundry
- 7 Built-Up Generator
- 8 Storage & Service Office
- 9 Service & Delivery Entrance

- 10 Grey Water Service:
 - a) heat exchanger
 - b) make-up tank
 - c) strainer & pump
 - d) filter

- 11 Swimming Pool Service:
 - a) make-up tank
 - b) heat exchanger
 - c) strainer & pump
 - d) filter

- 12 25m Swimming Pool
- 13 A/C room
- 14 Emergency Exit
- 15 Train Tracks Below



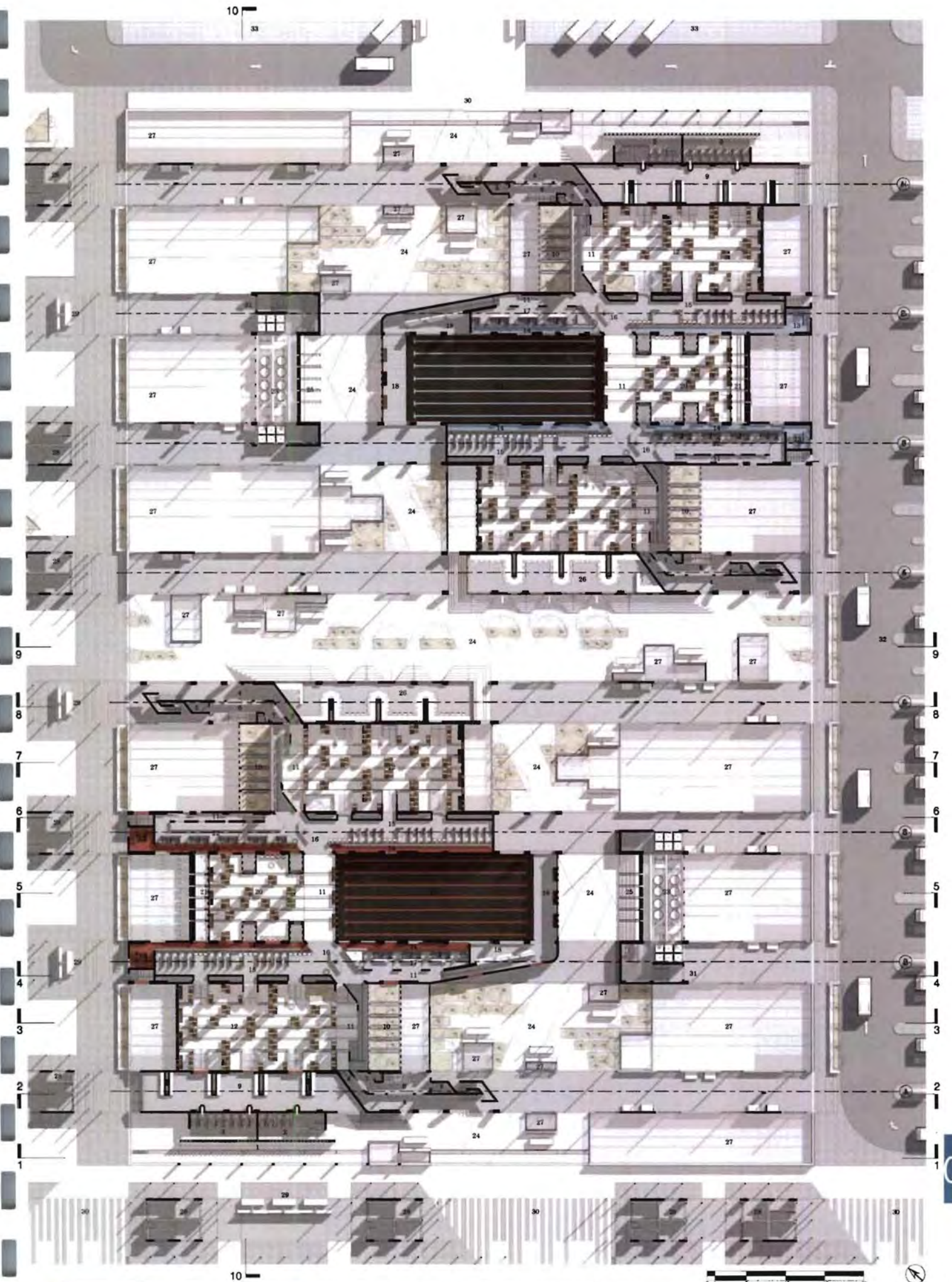

LEVEL 0
Existing Conceptual Level

- | | | | | | |
|---------------------------------|---|---|--|---|--|
| 1. Public wash basins | 10. Roof garden | 13. Toilet & Wash Hand Basins | 20. Physical & Deep Cleaners' Change Room & lockers | 25. Exterior seating & viewing steps | 30. Open Storage / Existing Courtyards |
| 2. Public Male Toilet | 11. Circulation space | 14. Water pipes Entrance Point to Roof with suit & drinking water | 21. Seating steps towards Exterior Courtyard & garden | 26. Public computer facilities | 31. Service & Delivery Kiosks |
| 3. Public Female Toilet | 12. Surface Cleaners change rooms & lockers | 15. Showers (primarily for physical cleaners - swimmers) | 22. Showers (primarily for Deep cleaners) | 27. Open viewing hole towards truss below | 32. Malibus Taxi Station |
| 4. Public Delta Extractor Siper | 13. Service Circulation | 16. Pool existing | 23. Water Filtration, Storage & Pump rooms | 28. Parcel shops | 33. Taxi Waiting area |
| 5. Office | 14. Service Corridor | 17. 35m Swimming pool | 24. Exterior (left) Events space - garden courtyards & seating (informal shops | 29. Internal shop / public bench | |

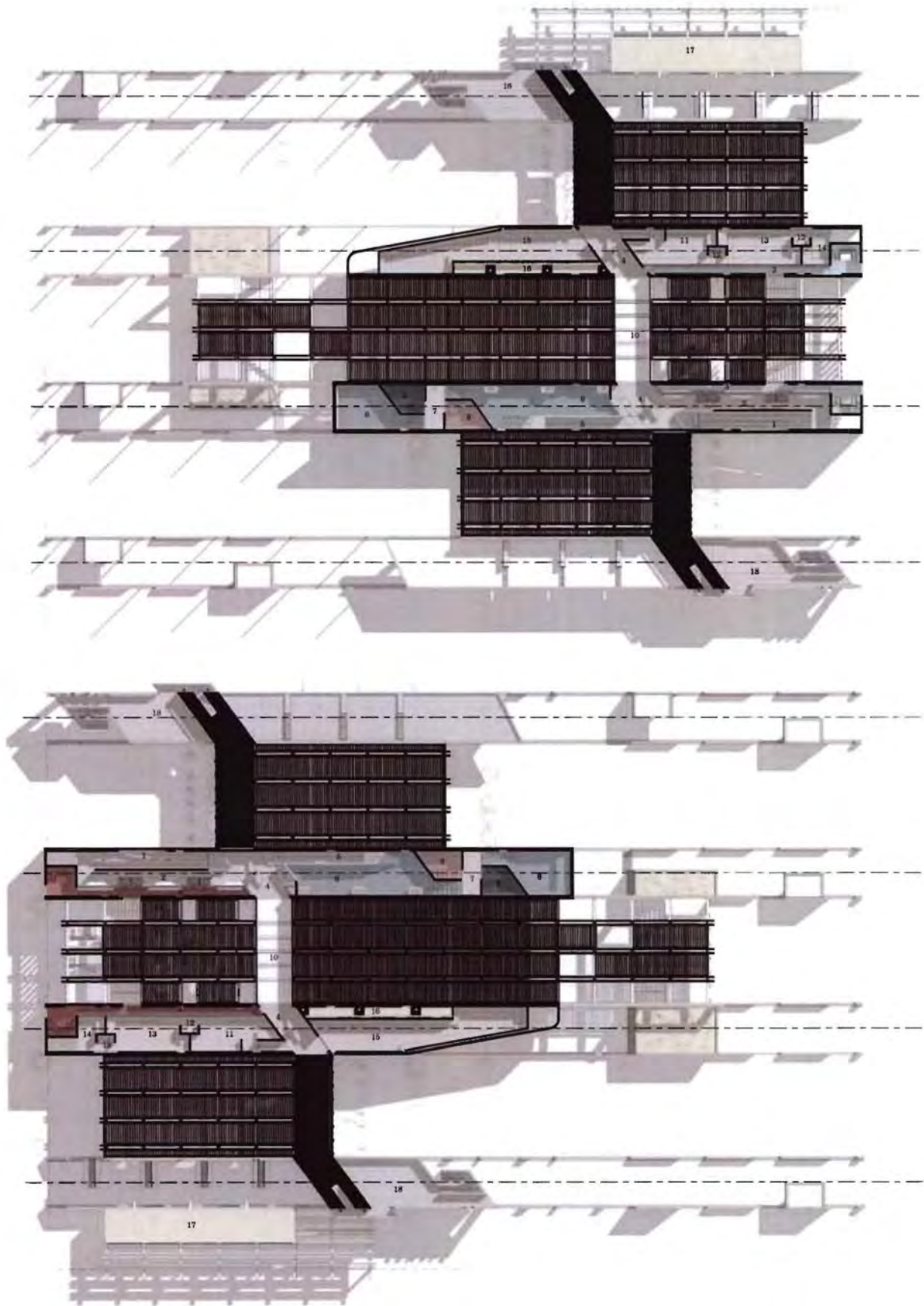

LEVEL 1

- 1. Circulation
- 2. Showers & suite
- 3. Service Corridor
- 4. Water Flow Entry Point: Hot & drinking water
- 6. Ramp & level hangars

- 6. Warm Bath (30 °C)
- 7. Circulation bridge with services below
- 8. Ice Bath (14 °C)
- 9. Hot Bath (42 °C)
- 10. Threshold space

- 11. Sweating Chamber 1
- 12. Cool Down Shower
- 13. Sweating Chamber 2
- 14. Sweating Chamber 3
- 15. Exterior garden courtyard with water

- 16. Plaster & A/C Extractors
- 17. Roof Garden
- 18. Service Circulation towards water using elements



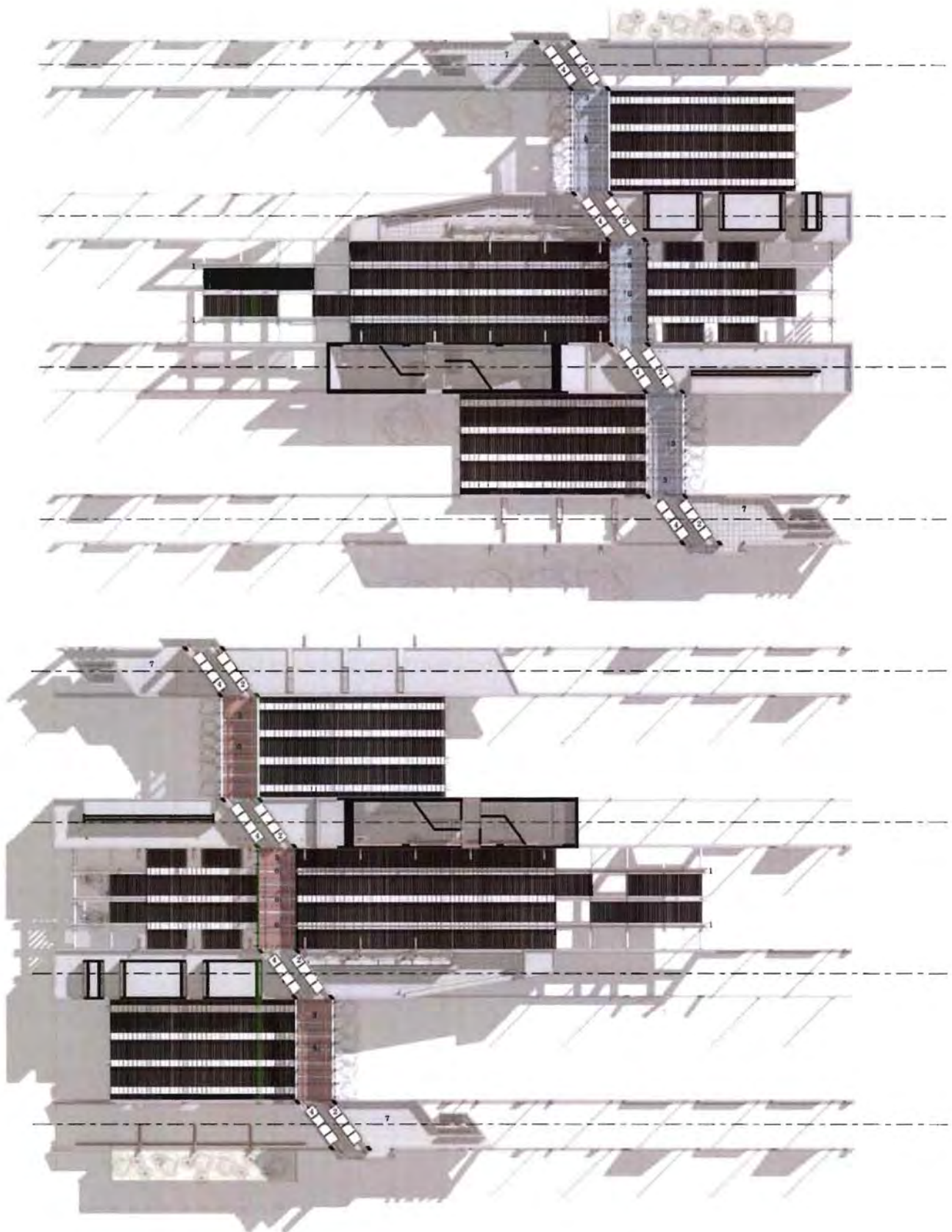

LEVEL 2
+ 7.00

- 1. Water pipes from Elvers below along roof beam towards heating system
- 2. Cold Water Storage
- 3. Solar Panels above
- 4. Hot Water Storage
- 5. Back-up Heat pumps
- 6. Fluid water Heat pumps
- 7. Service circulation towards water heating system



07

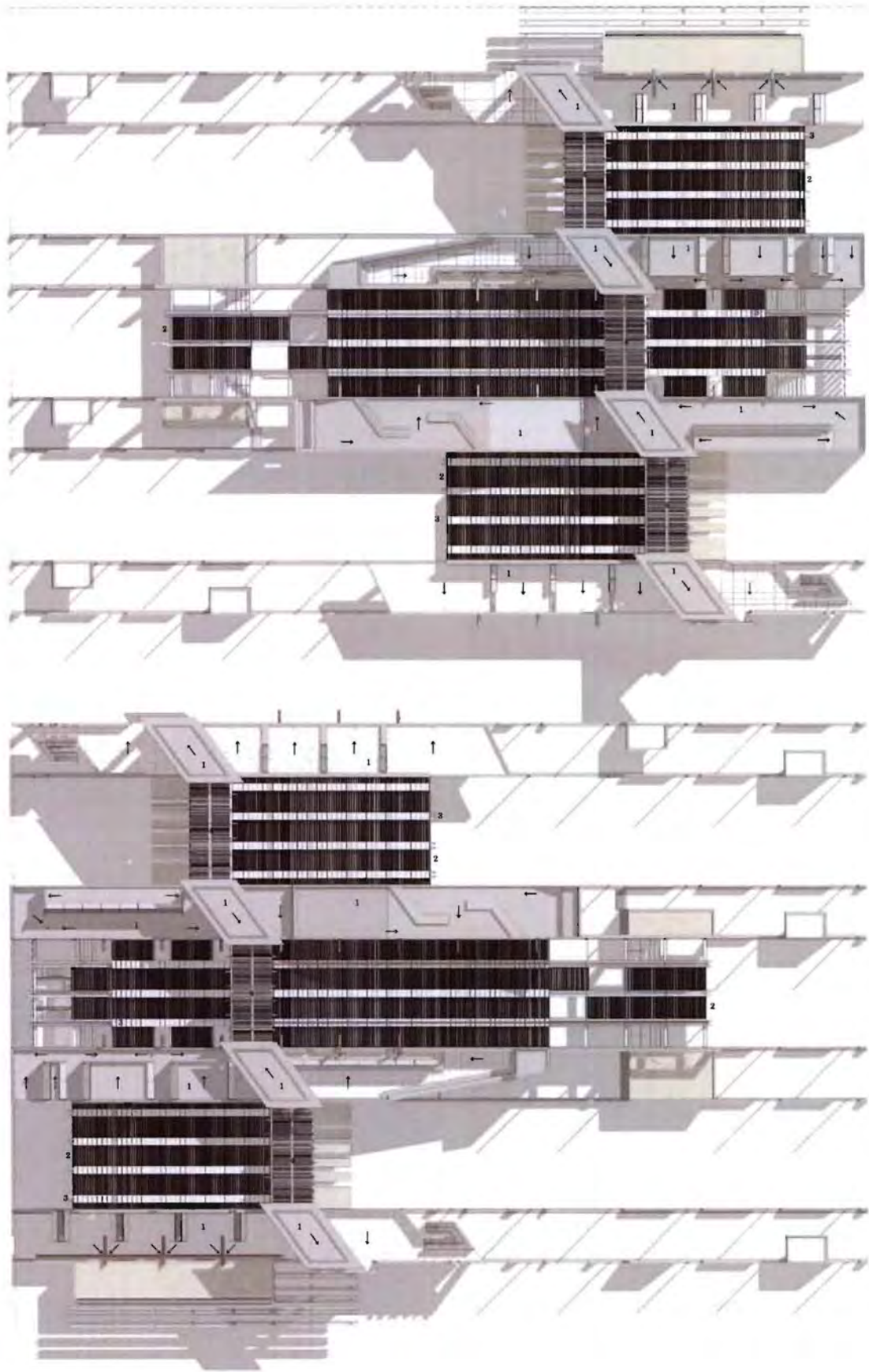

ROOF

- Water fall (1:70 min) towards gutter outlet
- 1. Cast-in-situ concrete roof with waterproofing & screed to fall
- 2. Translucent insulated sloped roof sections
- 3. Precast concrete slabs for roof voids & louvre maintenance
- 4. Solar panels



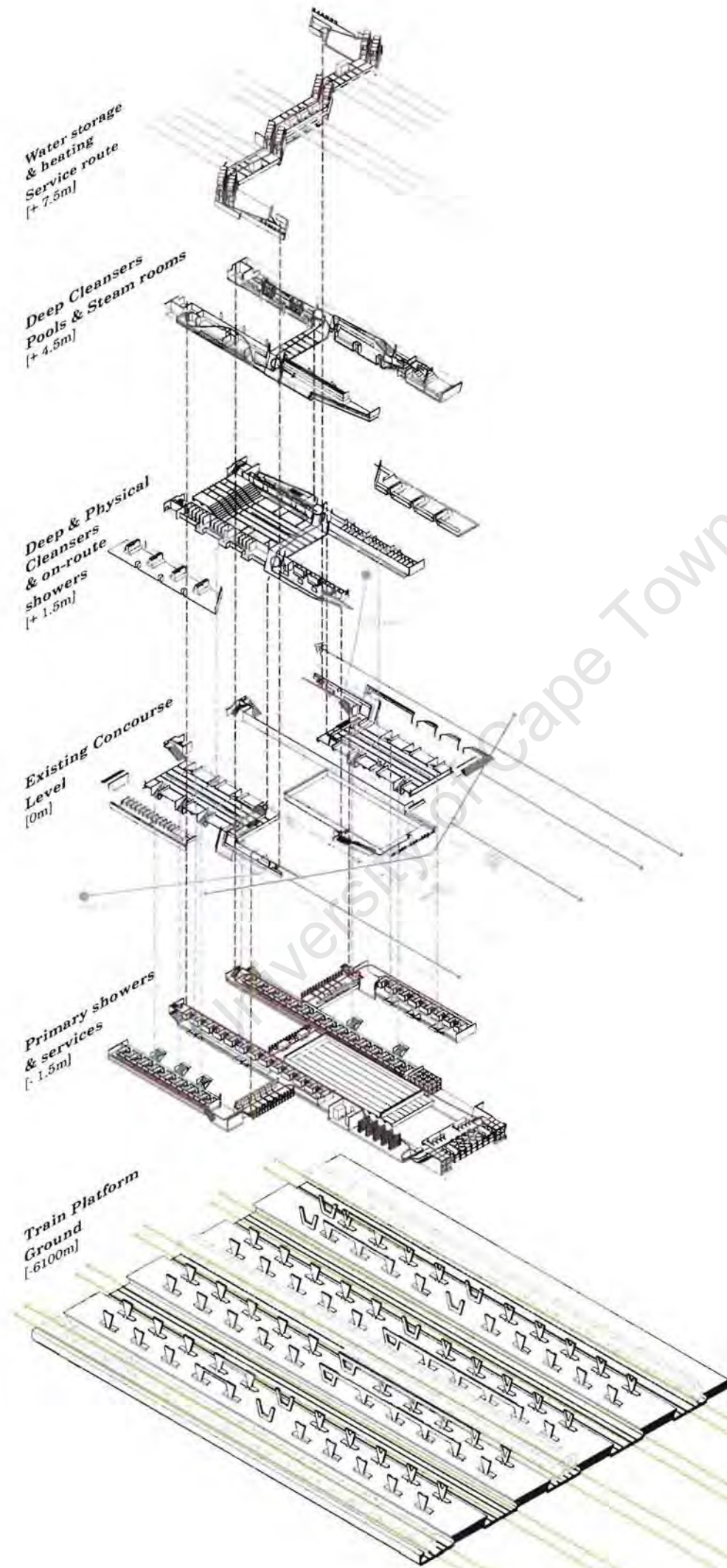

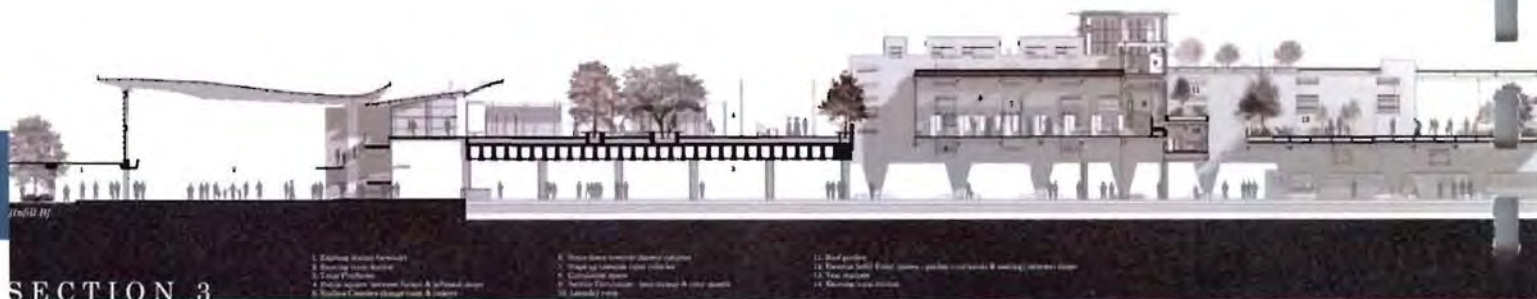

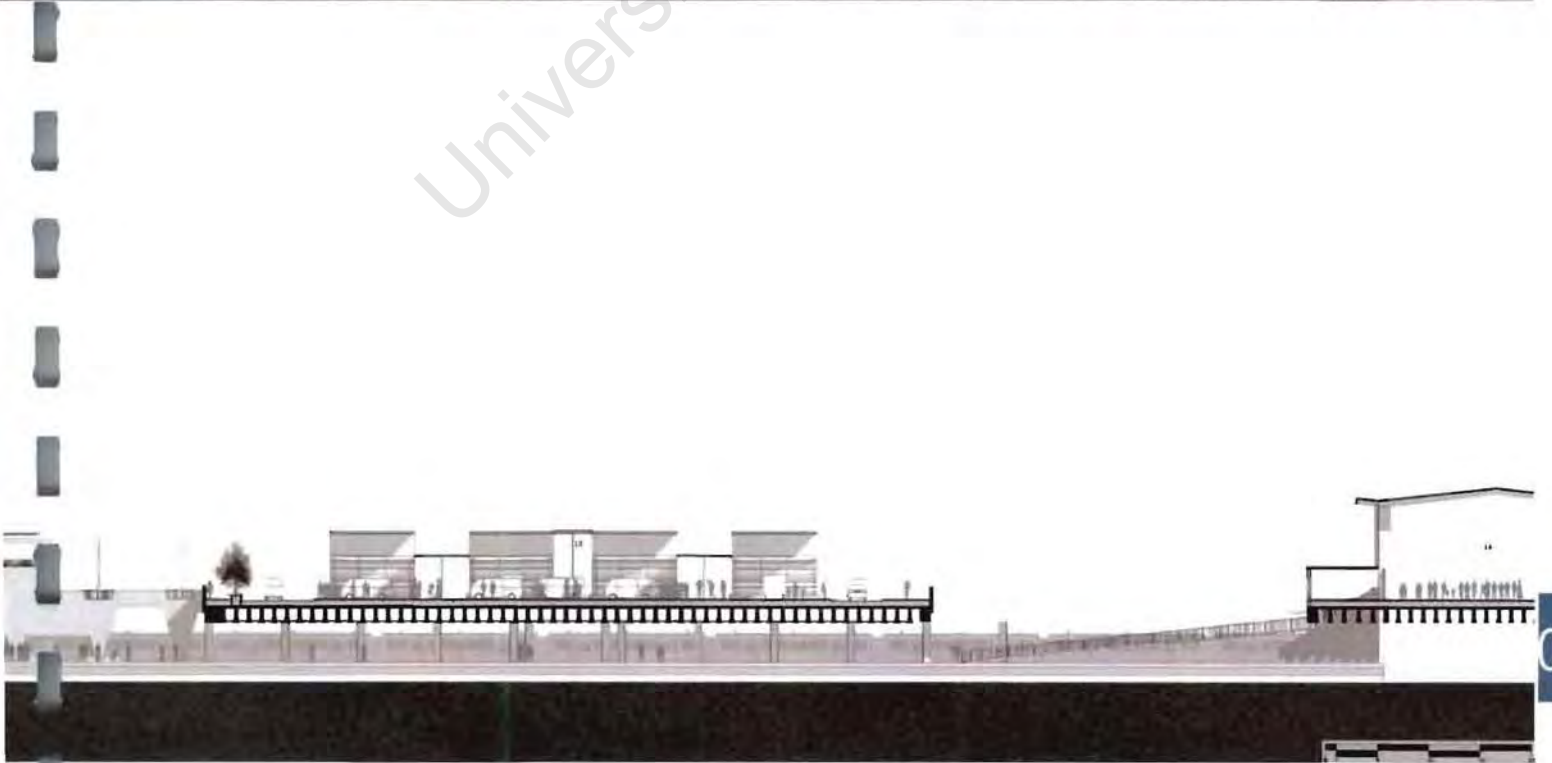
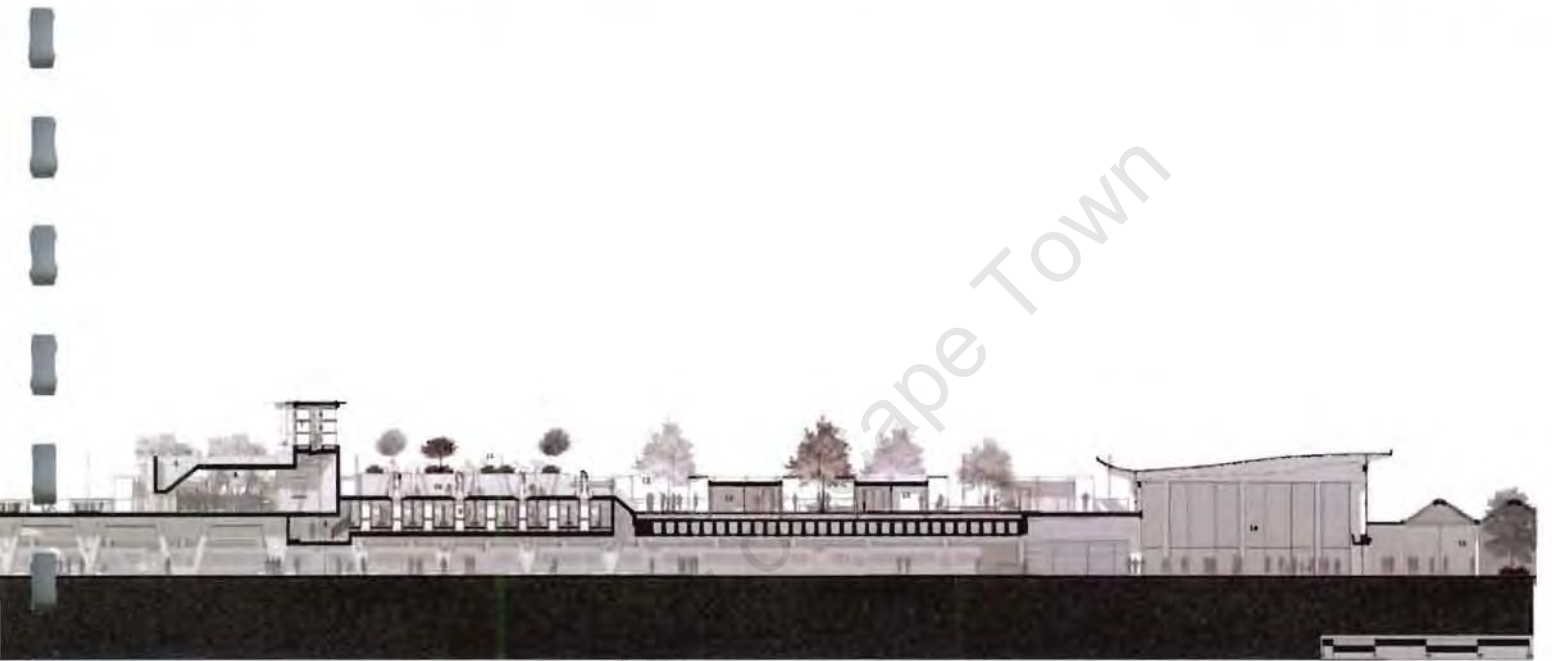
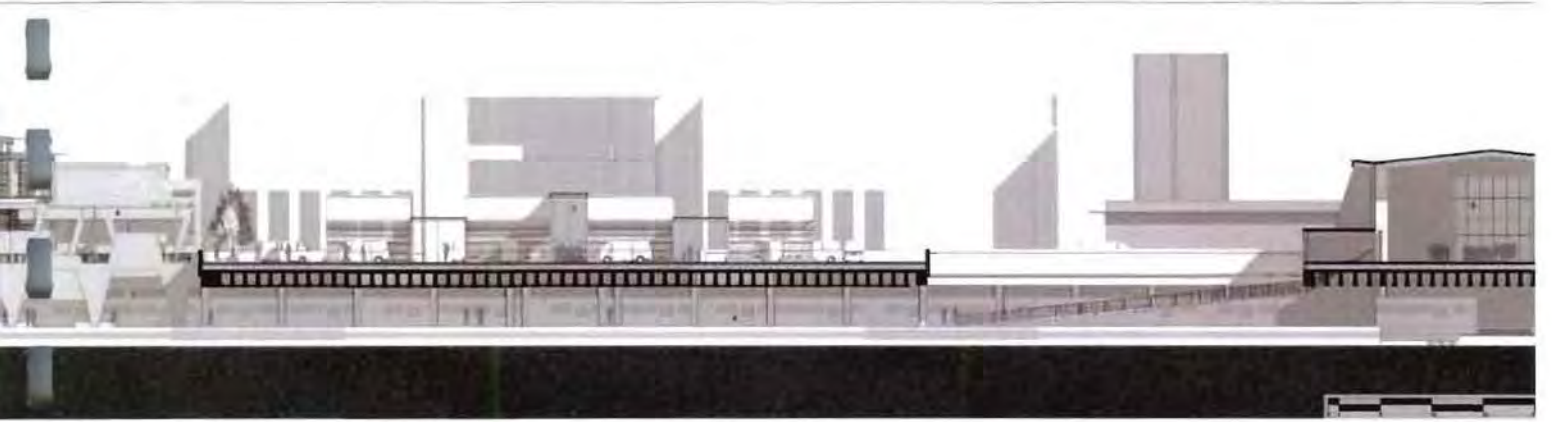

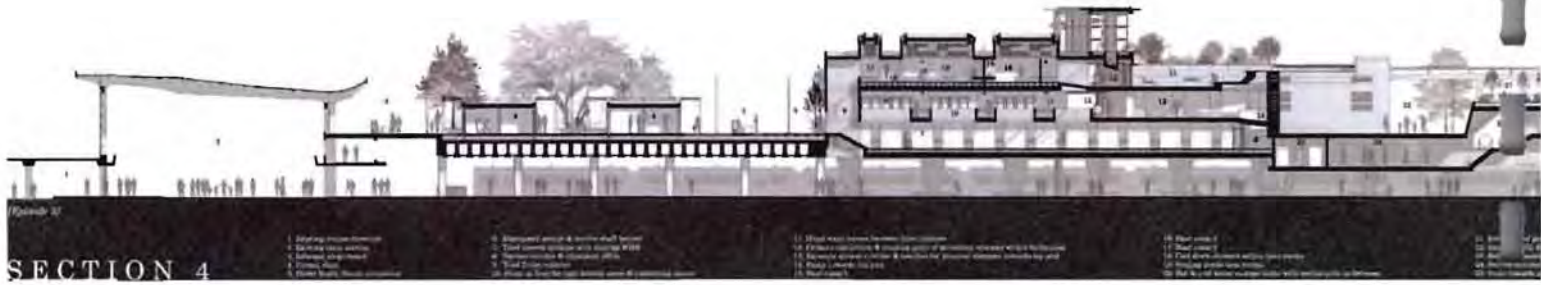

- SECTION 4
- 1. Existing structure
 - 2. Existing structure
 - 3. Existing structure
 - 4. Existing structure
 - 5. Existing structure
 - 6. Existing structure
 - 7. Existing structure
 - 8. Existing structure
 - 9. Existing structure
 - 10. Existing structure
 - 11. Existing structure
 - 12. Existing structure
 - 13. Existing structure
 - 14. Existing structure
 - 15. Existing structure
 - 16. Existing structure
 - 17. Existing structure
 - 18. Existing structure
 - 19. Existing structure
 - 20. Existing structure
 - 21. Existing structure
 - 22. Existing structure
 - 23. Existing structure
 - 24. Existing structure
 - 25. Existing structure
 - 26. Existing structure
 - 27. Existing structure
 - 28. Existing structure
 - 29. Existing structure
 - 30. Existing structure

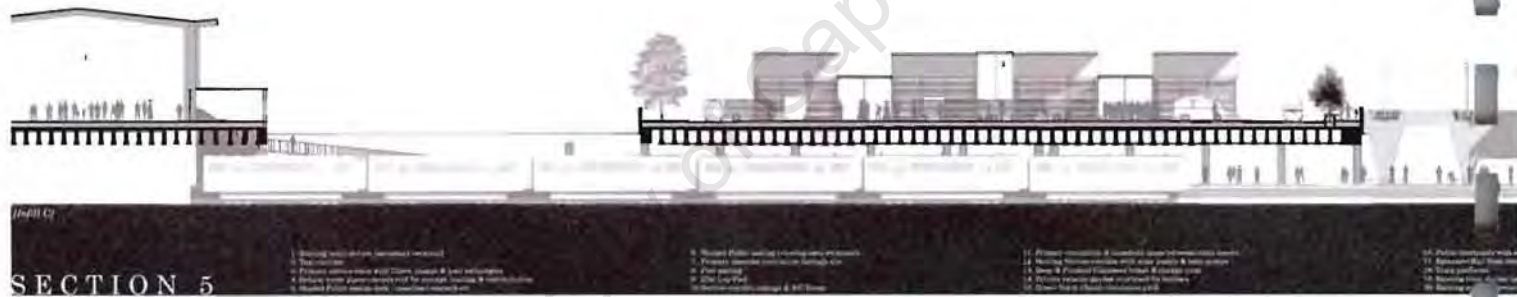

- SECTION 5
- 1. Existing structure
 - 2. Existing structure
 - 3. Existing structure
 - 4. Existing structure
 - 5. Existing structure
 - 6. Existing structure
 - 7. Existing structure
 - 8. Existing structure
 - 9. Existing structure
 - 10. Existing structure
 - 11. Existing structure
 - 12. Existing structure
 - 13. Existing structure
 - 14. Existing structure
 - 15. Existing structure
 - 16. Existing structure
 - 17. Existing structure
 - 18. Existing structure
 - 19. Existing structure
 - 20. Existing structure
 - 21. Existing structure
 - 22. Existing structure
 - 23. Existing structure
 - 24. Existing structure
 - 25. Existing structure
 - 26. Existing structure
 - 27. Existing structure
 - 28. Existing structure
 - 29. Existing structure
 - 30. Existing structure



- SECTION 6
- 1. Existing structure
 - 2. Existing structure
 - 3. Existing structure
 - 4. Existing structure
 - 5. Existing structure
 - 6. Existing structure
 - 7. Existing structure
 - 8. Existing structure
 - 9. Existing structure
 - 10. Existing structure
 - 11. Existing structure
 - 12. Existing structure
 - 13. Existing structure
 - 14. Existing structure
 - 15. Existing structure
 - 16. Existing structure
 - 17. Existing structure
 - 18. Existing structure
 - 19. Existing structure
 - 20. Existing structure
 - 21. Existing structure
 - 22. Existing structure
 - 23. Existing structure
 - 24. Existing structure
 - 25. Existing structure
 - 26. Existing structure
 - 27. Existing structure
 - 28. Existing structure
 - 29. Existing structure
 - 30. Existing structure

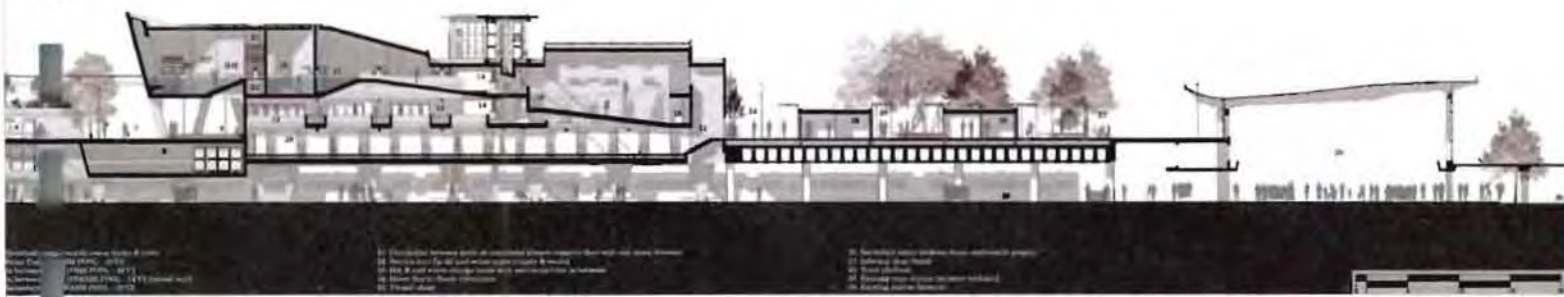

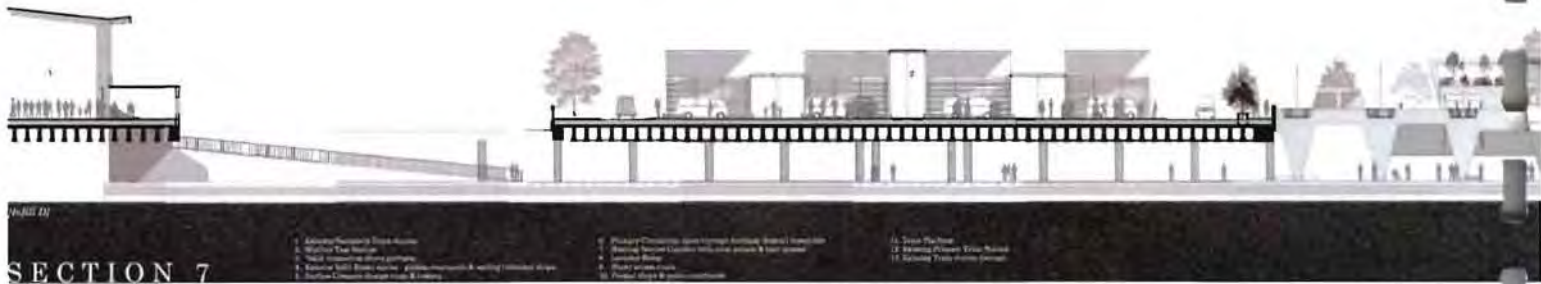

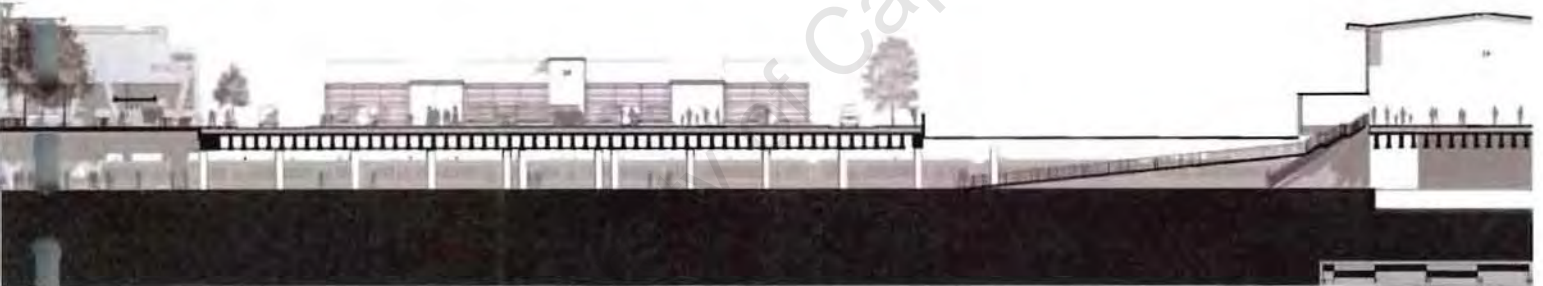
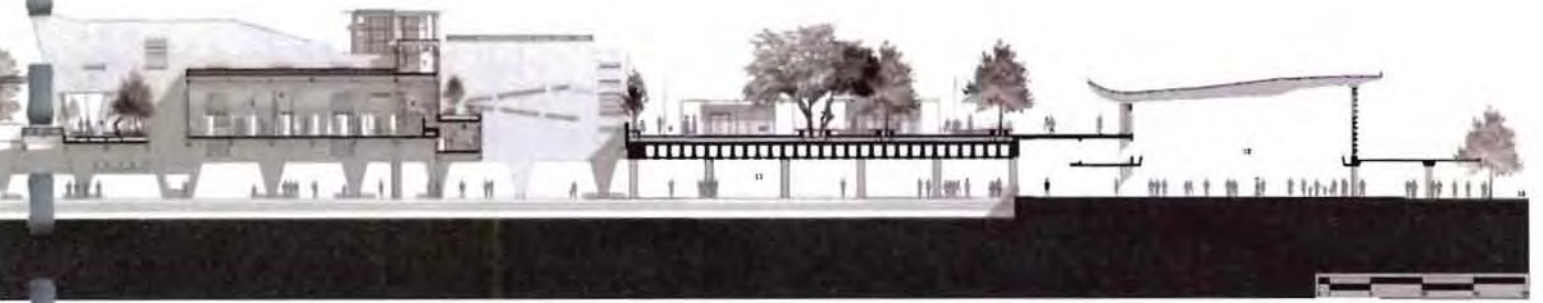

University of Cape Town



SECTION 10

- 1. Long concrete slab structure
- 2. Slab structure with concrete
- 3. Slab structure with concrete
- 4. Slab structure with concrete
- 5. Slab structure with concrete
- 6. Slab structure with concrete
- 7. Slab structure with concrete
- 8. Slab structure with concrete
- 9. Slab structure with concrete
- 10. Slab structure with concrete
- 11. Slab structure with concrete
- 12. Slab structure with concrete
- 13. Slab structure with concrete
- 14. Slab structure with concrete
- 15. Slab structure with concrete
- 16. Slab structure with concrete
- 17. Slab structure with concrete
- 18. Slab structure with concrete
- 19. Slab structure with concrete
- 20. Slab structure with concrete



[Infill & Episodes]

SECTION 10

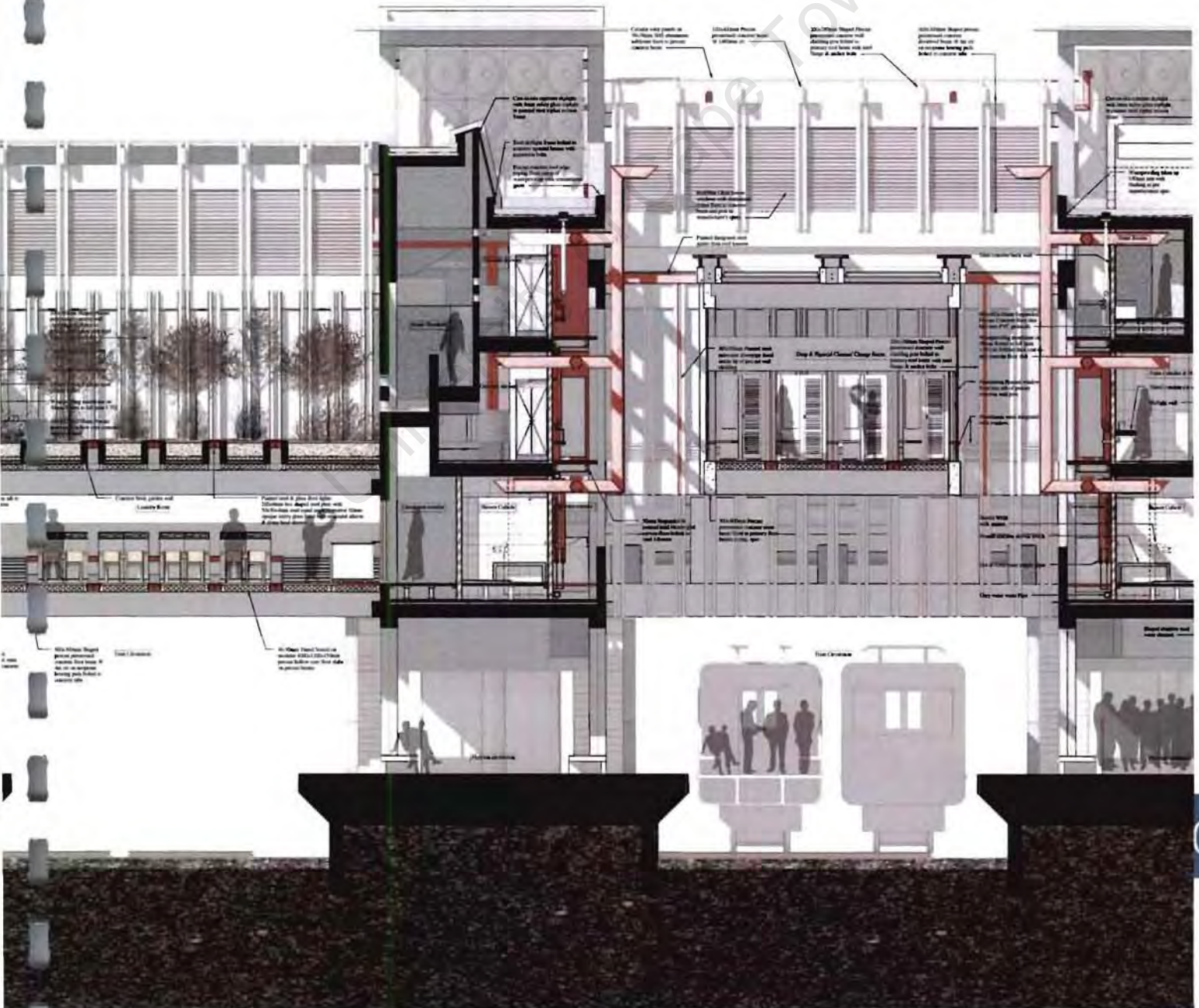
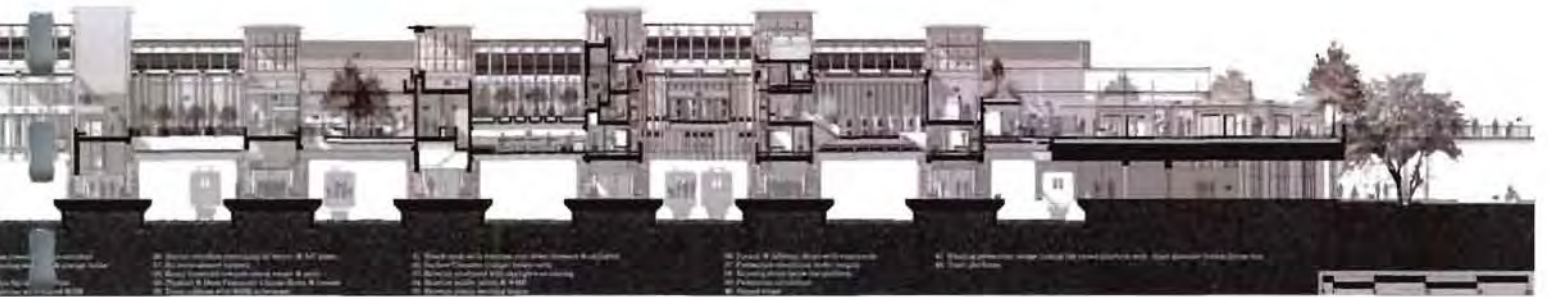



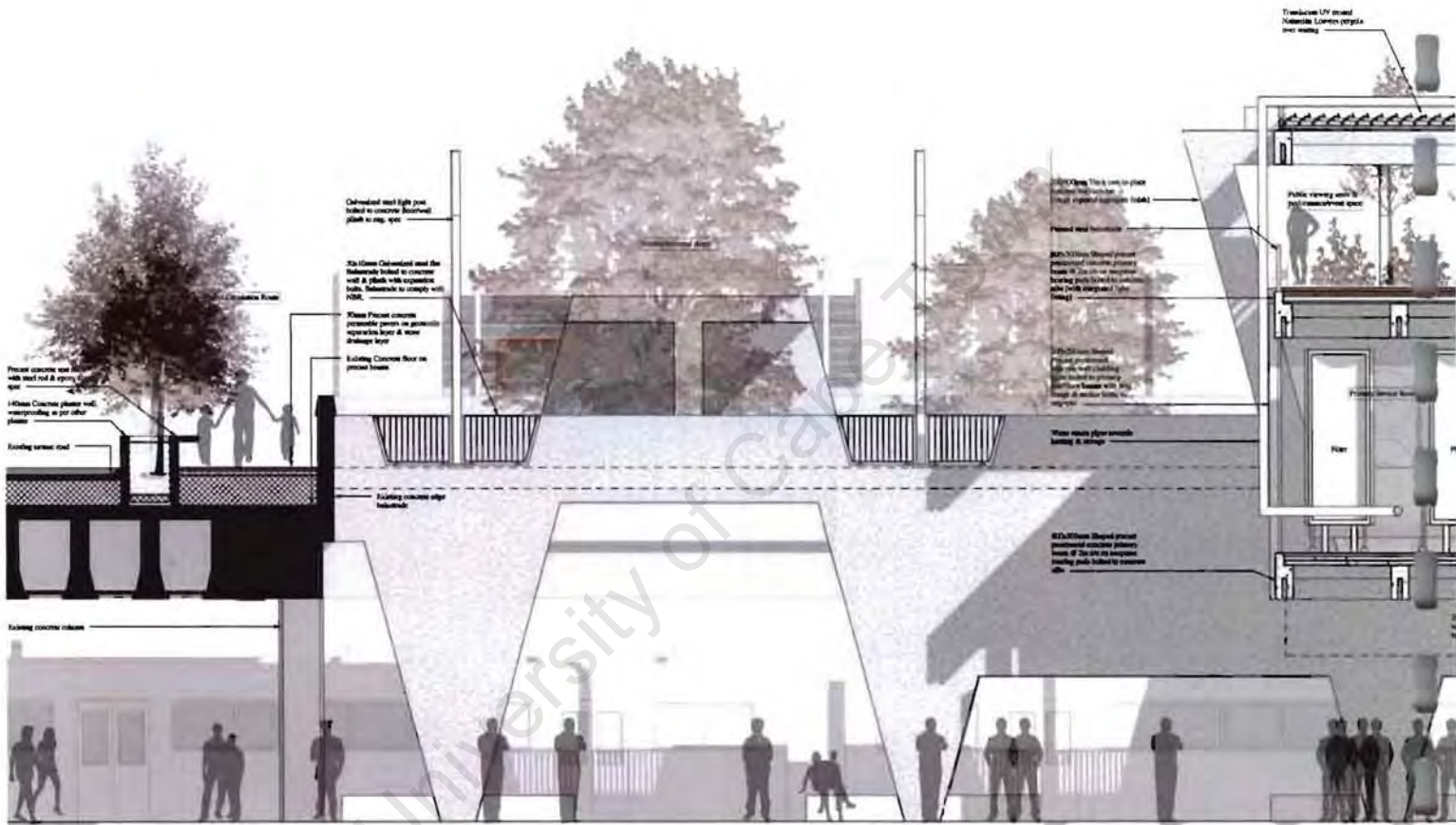

[Infill C]

SECTION 5

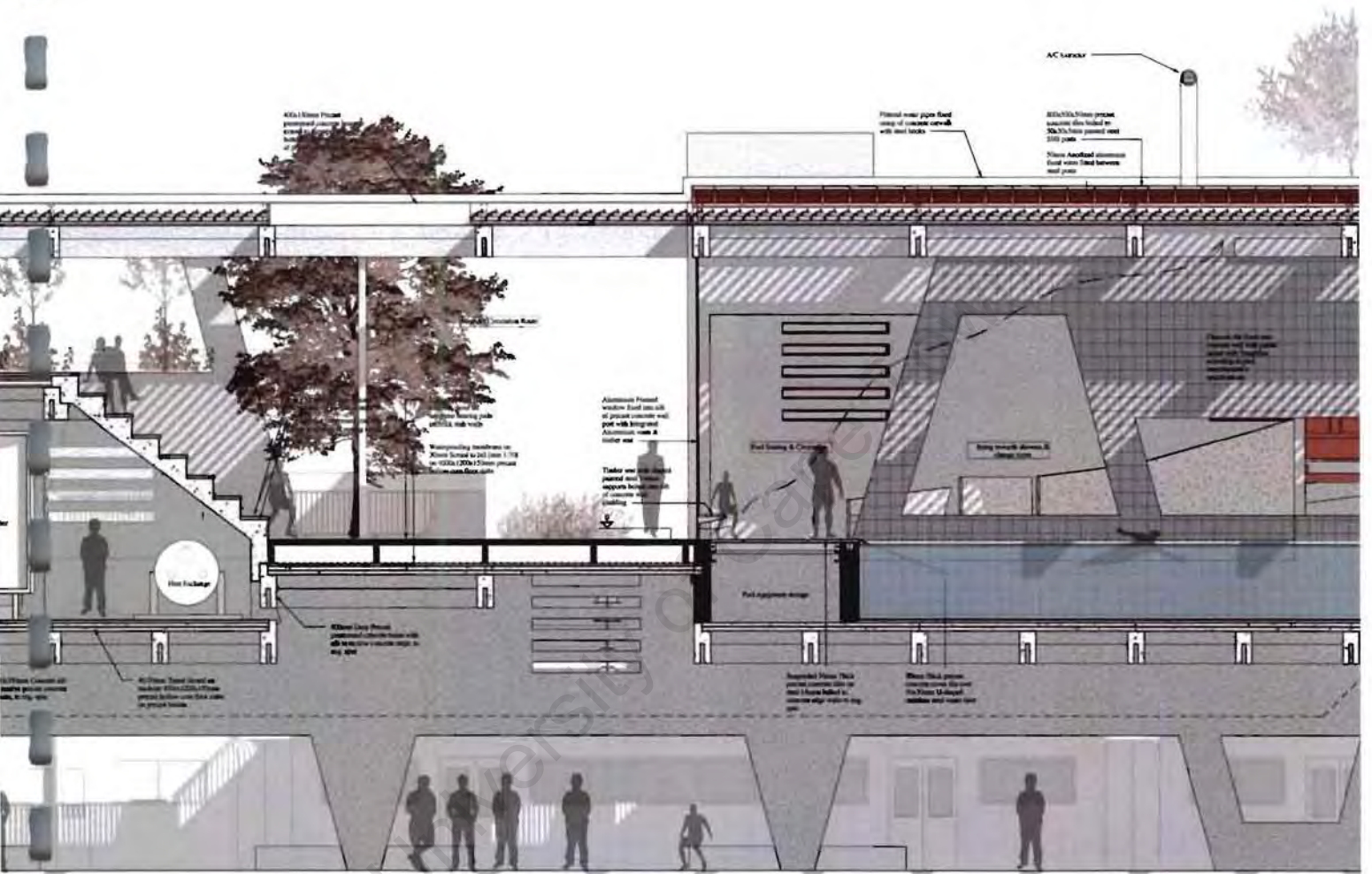

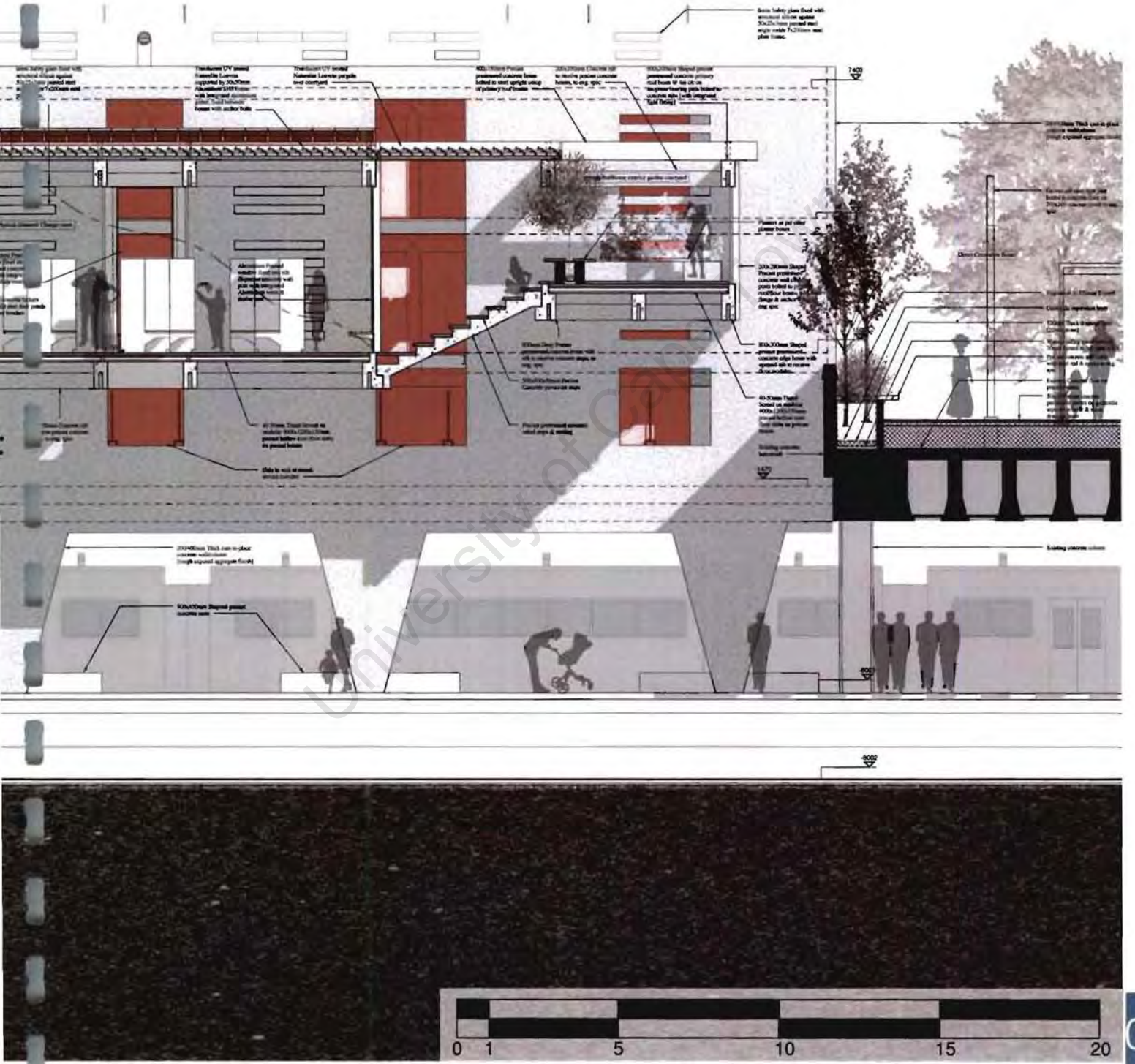

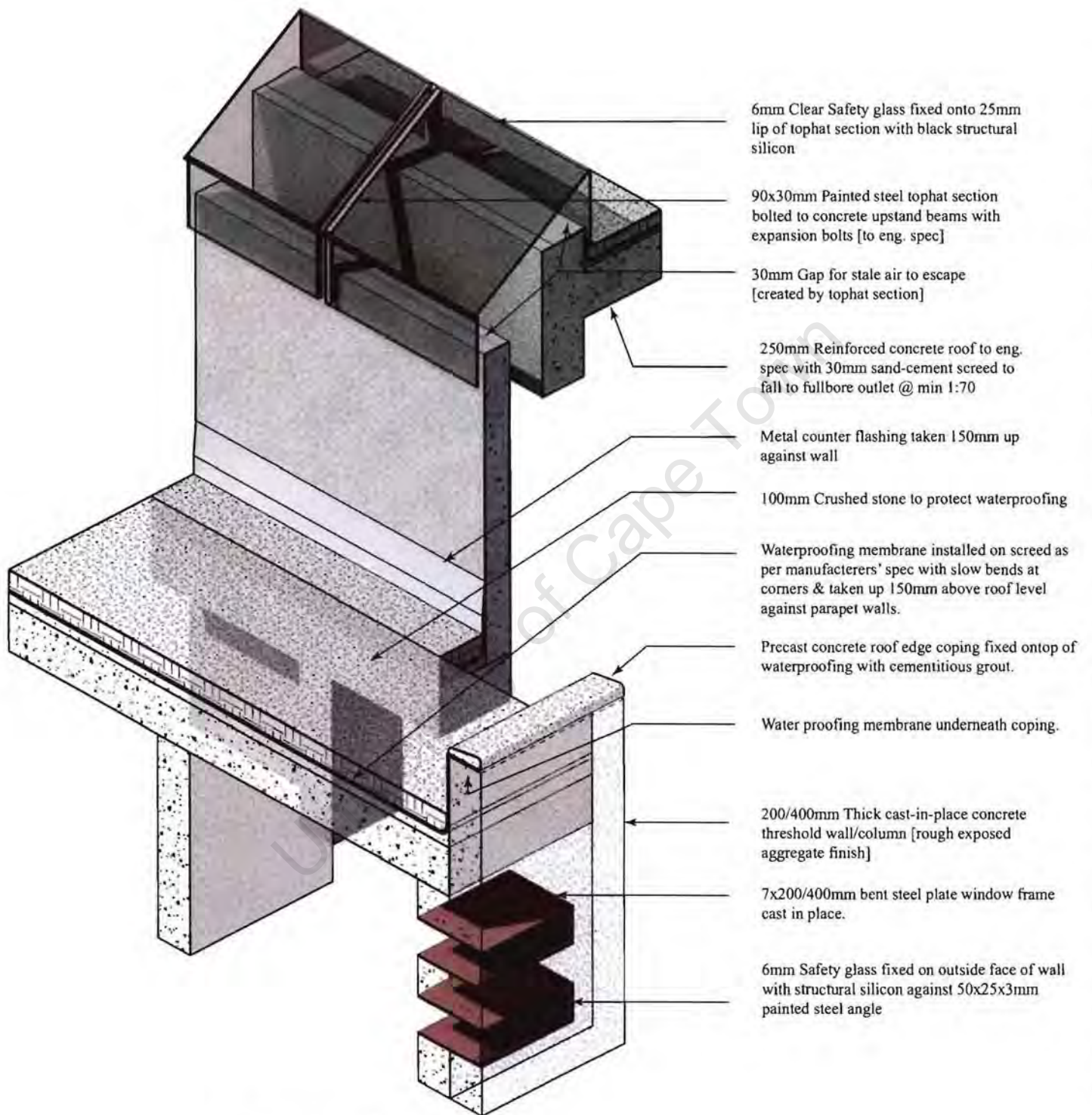

*3D drawing of primary
'SOLID' components
[NTS]*

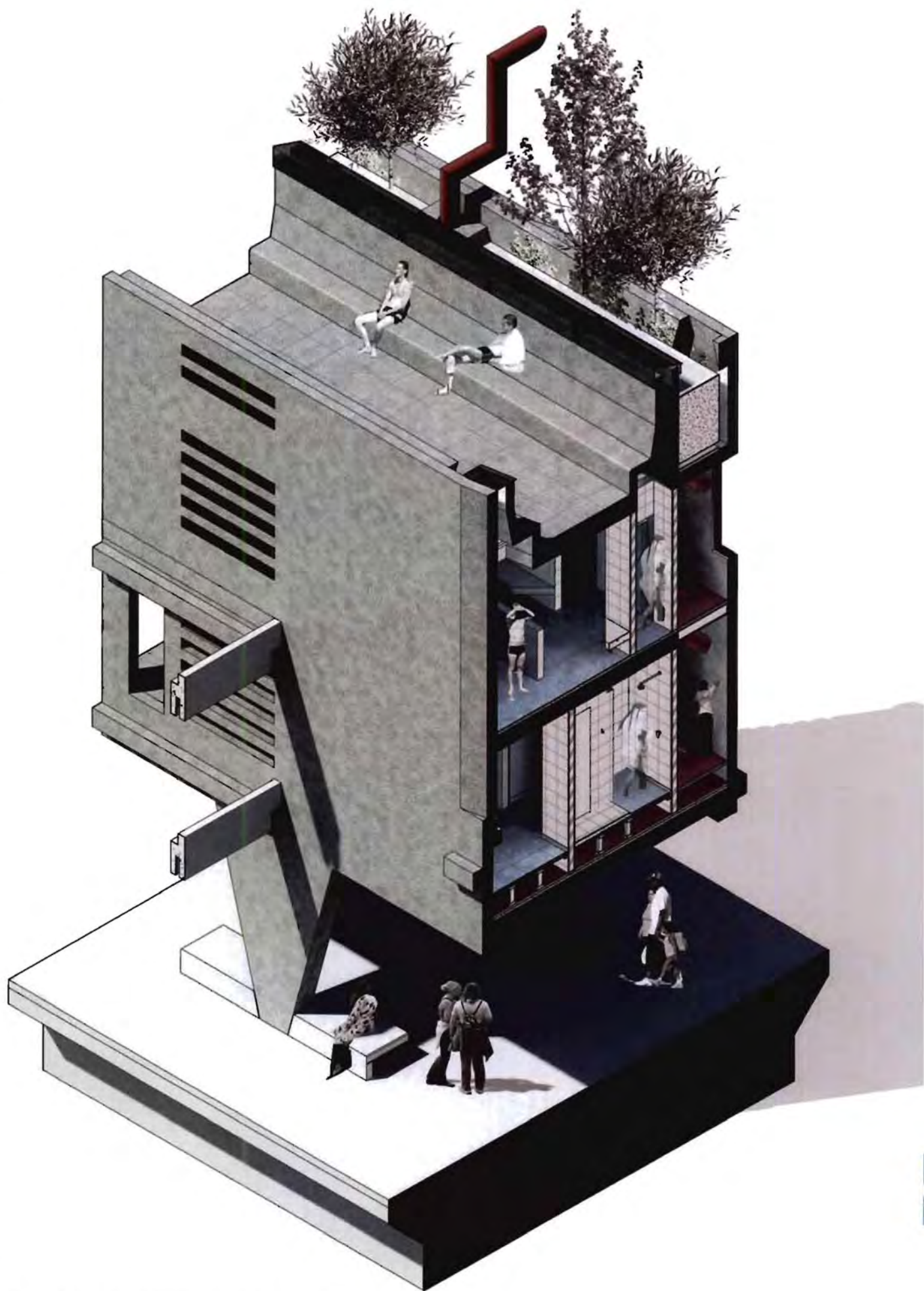

*3D drawing of 'SOLID' event spaces
above the train platforms
[NTS]*

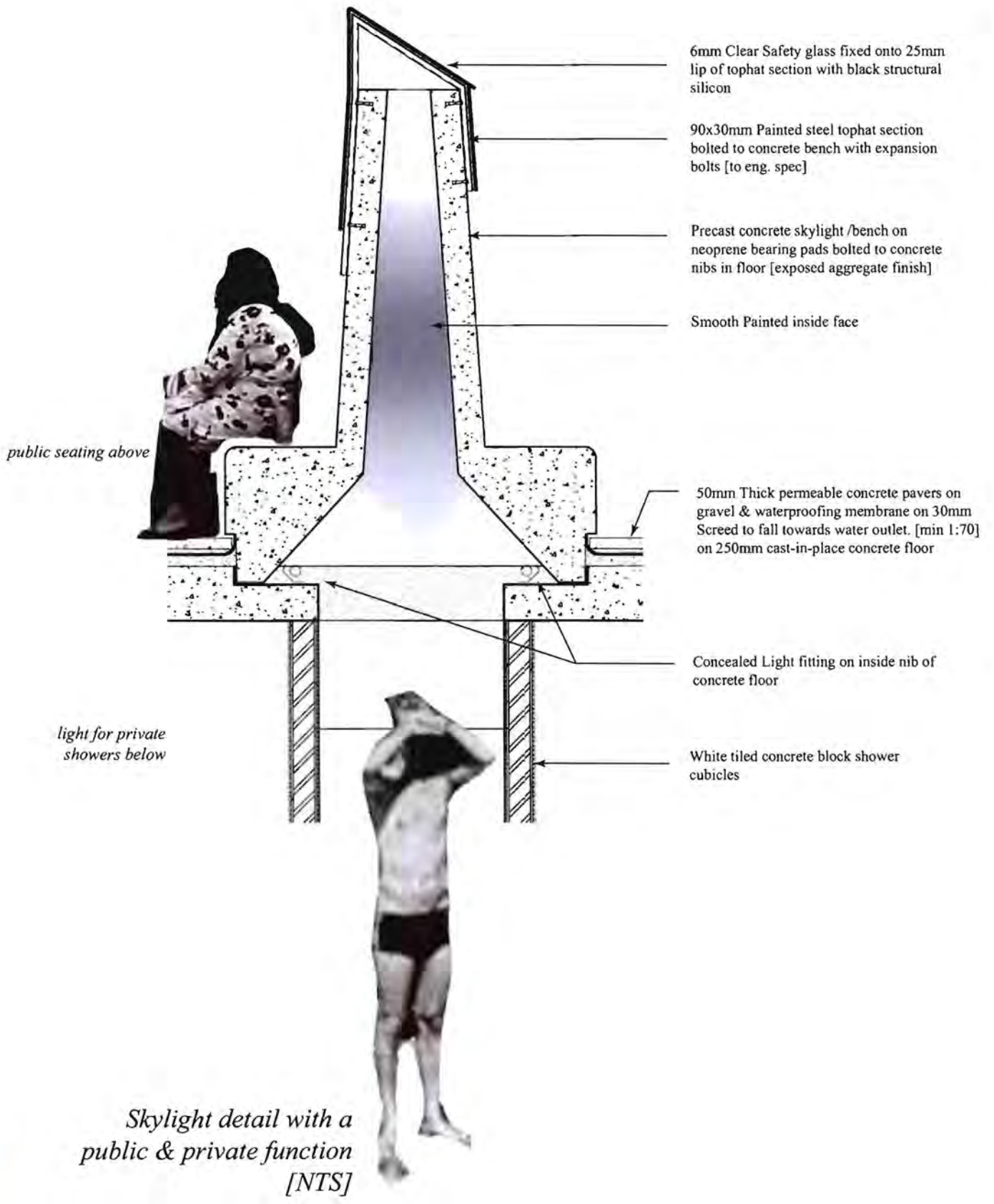

Infill landscaping detail
[NTS]

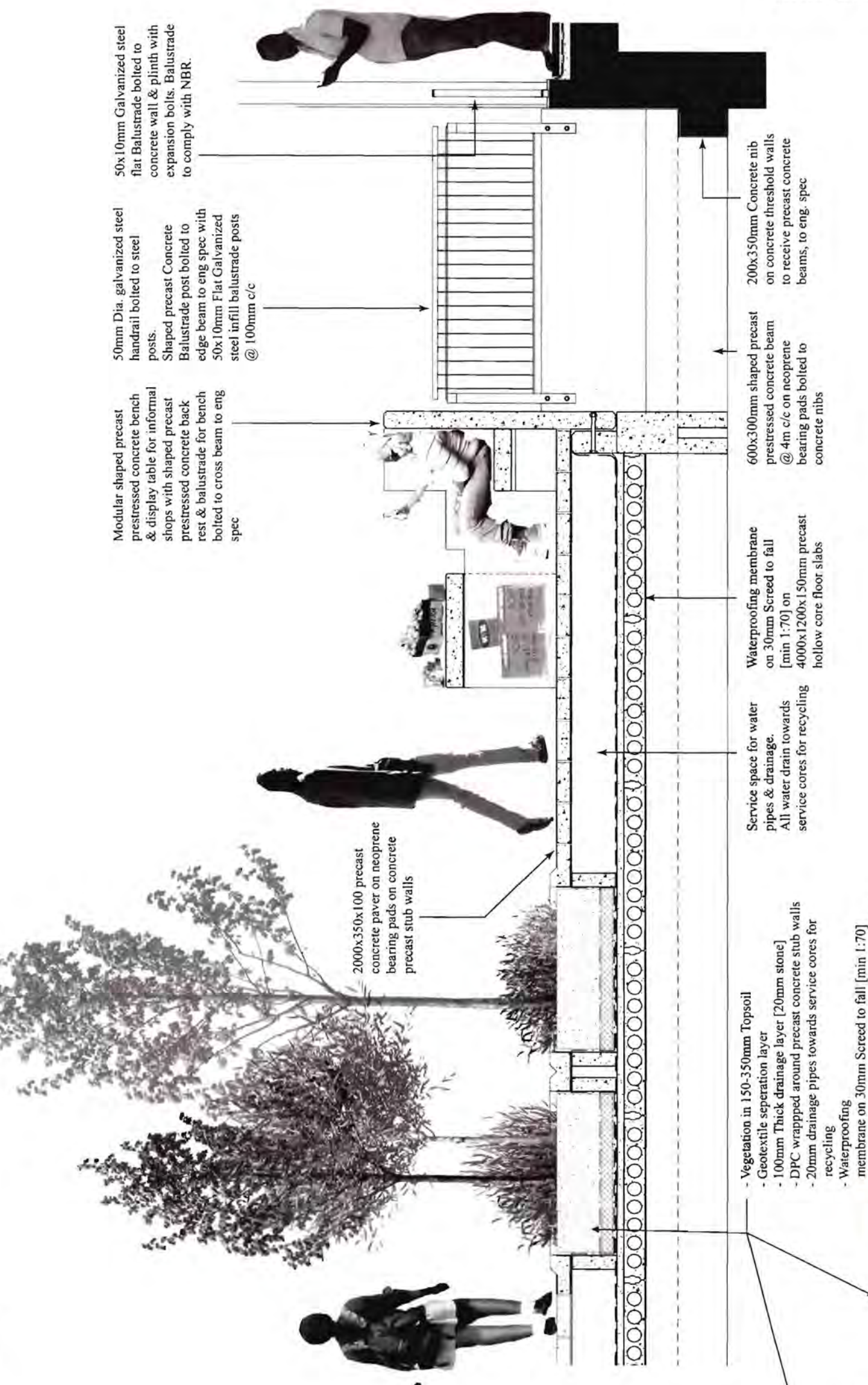

50x10mm Galvanized steel flat Balustrade bolted to concrete wall & plinth with expansion bolts. Balustrade to comply with NBR.

50mm Dia. galvanized steel handrail bolted to steel posts.
Shaped precast Concrete Balustrade post bolted to edge beam to eng spec with 50x10mm Flat Galvanized steel infill balustrade posts @ 100mm c/c

Modular shaped precast prestressed concrete bench & display table for informal shops with shaped precast prestressed concrete back rest & balustrade for bench bolted to cross beam to eng spec

2000x350x100 precast concrete paver on neoprene bearing pads on concrete precast stub walls

200x350mm Concrete nib on concrete threshold walls to receive precast concrete beams, to eng. spec

600x300mm shaped precast prestressed concrete beam @ 4m c/c on neoprene bearing pads bolted to concrete nibs

Waterproofing membrane on 30mm Screed to fall [min 1:70] on 4000x1200x150mm precast hollow core floor slabs

Service space for water pipes & drainage. All water drain towards service cores for recycling

- Vegetation in 150-350mm Topsoil
- Geotextile separation layer
- 100mm Thick drainage layer [20mm stone]
- DPC wrapped around precast concrete stub walls
- 20mm drainage pipes towards service cores for recycling
- Waterproofing membrane on 30mm Screed to fall [min 1:70]
- 4000x1200x150mm Precast prestressed hollow core

'Transparent' Roof

Roof vents & service catwalk for roof louvres:

- 800x500x50mm precast concrete tiles bolted onto 50x50x3mm painted steel SHS pedestals with a bent steel z-frame
- Anodized Aluminium fixed louvres fixed between steel pedestals

- Translucent premanufactured aluminium opening louvre roof system with translucent UV treated Naturelite panel managed through a hidden motorized pivot system
- Integrated aluminium gutter attached to aluminium subframe
- Aluminium subframe fixed to concrete beams with expansion bolts & metal flashing applied

Secondary precast prestressed concrete beam fixed to the steel upstand nibs on top of the primary beam with steel rods & cement grout.

- Primary precast prestressed concrete beam resting on top of a neoprene bearing pad on a cast-in-place concrete nib against the concrete wall.
- Galvanized steel plate cast into beam for craning purposes & receiving secondary beam

200x350mm Cast-in-place concrete nib against concrete wall with uPVC grouting tubes to receive primary beams & galvanized steel fixing rods

'Transparent' Floor

40-50mm Leveling smooth tinted screed finish

4000x1200x150mm modular Precast hollow-core concrete slabs

Steel & glass floor lights:

- 200x5mm Painted steel sheet shaped to form a light box and fixed to concrete beams with expansion bolts.
- A painted steel subframe of 50x50x3mm equal angle to receive 10mm thick opaque safety glass fixed with structural silicon & dome head bolts.
- Tube Lights fitted inside light box.

11000x700x400mm Primary precast prestressed concrete beams spaced @ 4m c/c resting on top of a neoprene bearing pad on a cast-in-place concrete nib against the concrete wall

250x350mm Cast-in-place concrete nib against concrete wall with uPVC grouting tubes to receive primary beams & galvanized steel fixing rods

'Transparent' Facade

The facade cladding receives a steel & timber bench & is fixed to the centre recess of the column with shaped galvanized steel brace & expansion bolts.

200x280mm Shaped Precast prestressed concrete wall cladding rests on top of a neoprene bearing pad & bolted to primary roof & floor beam with steel flange & expansion bolts. Shaped with 50x100 & 38x50mm recesses to receive the red | blue painted steel downpipes & aluminium window frames

Aluminium window frames fixed to manufacturers' spec with 6mm thick safety translucent & opaque sheets of glass for privacy for change room. Bottom of the linear windows are fixed with aluminium louvres for natural ventilation to sweep through the space & exit through the vents | louvres in the roof.



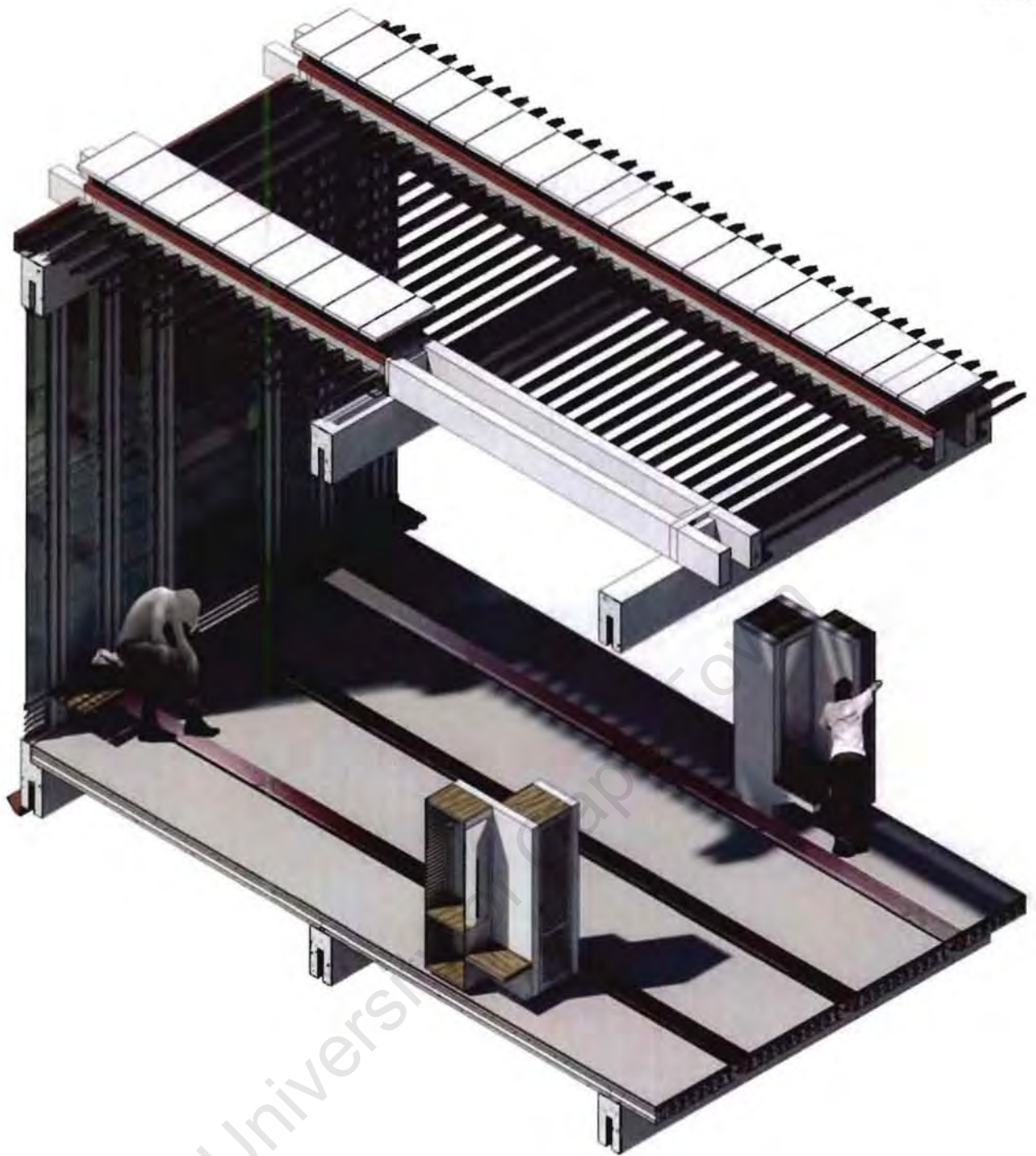

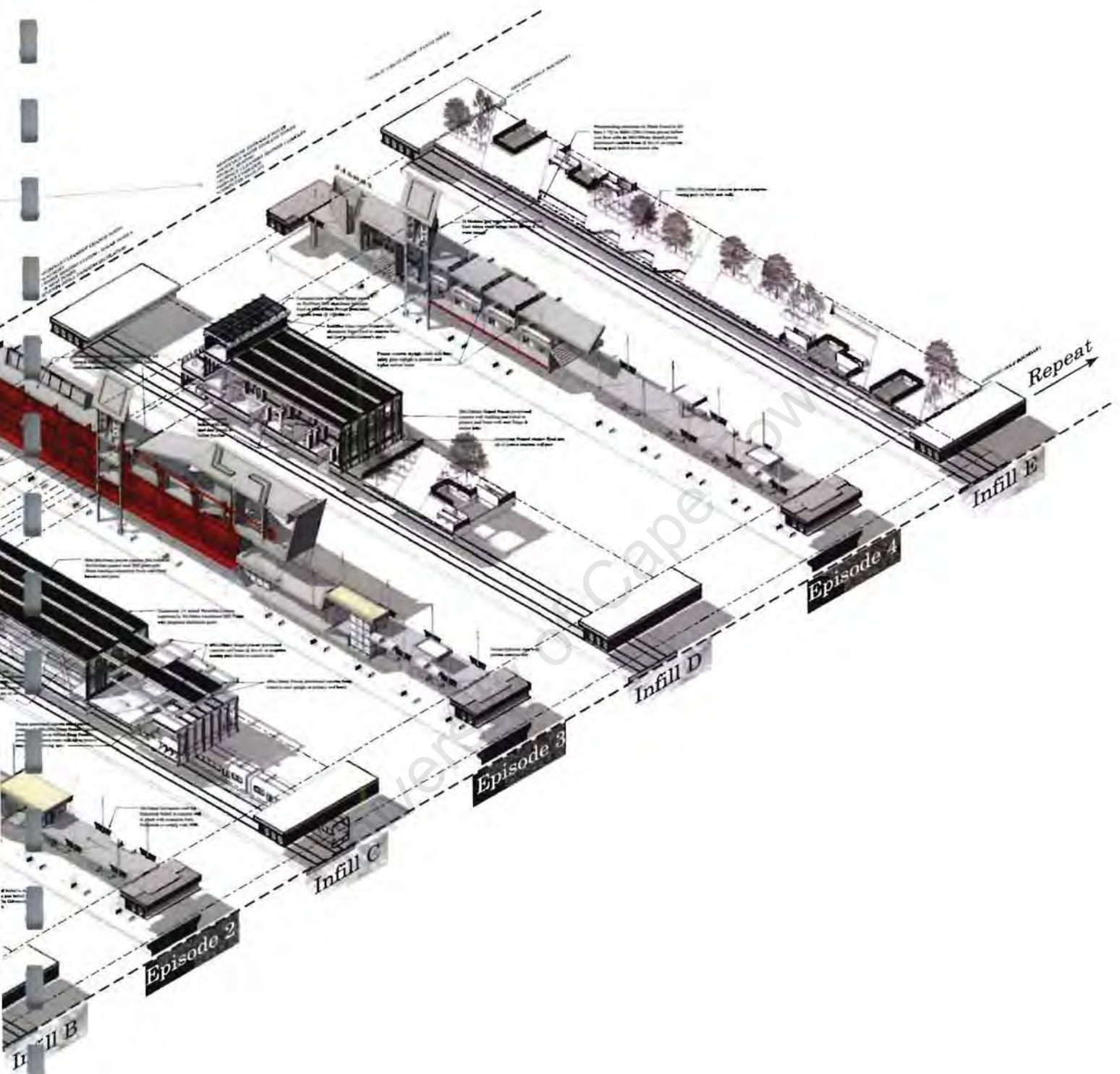

Exploded 3D drawing of 'SOLID Episodes' & 'TRANSPARENT Infill' spaces [NTS]



1. Arriving at the intermodal interchange - Existing train INPUT | OUTPUT Sequence

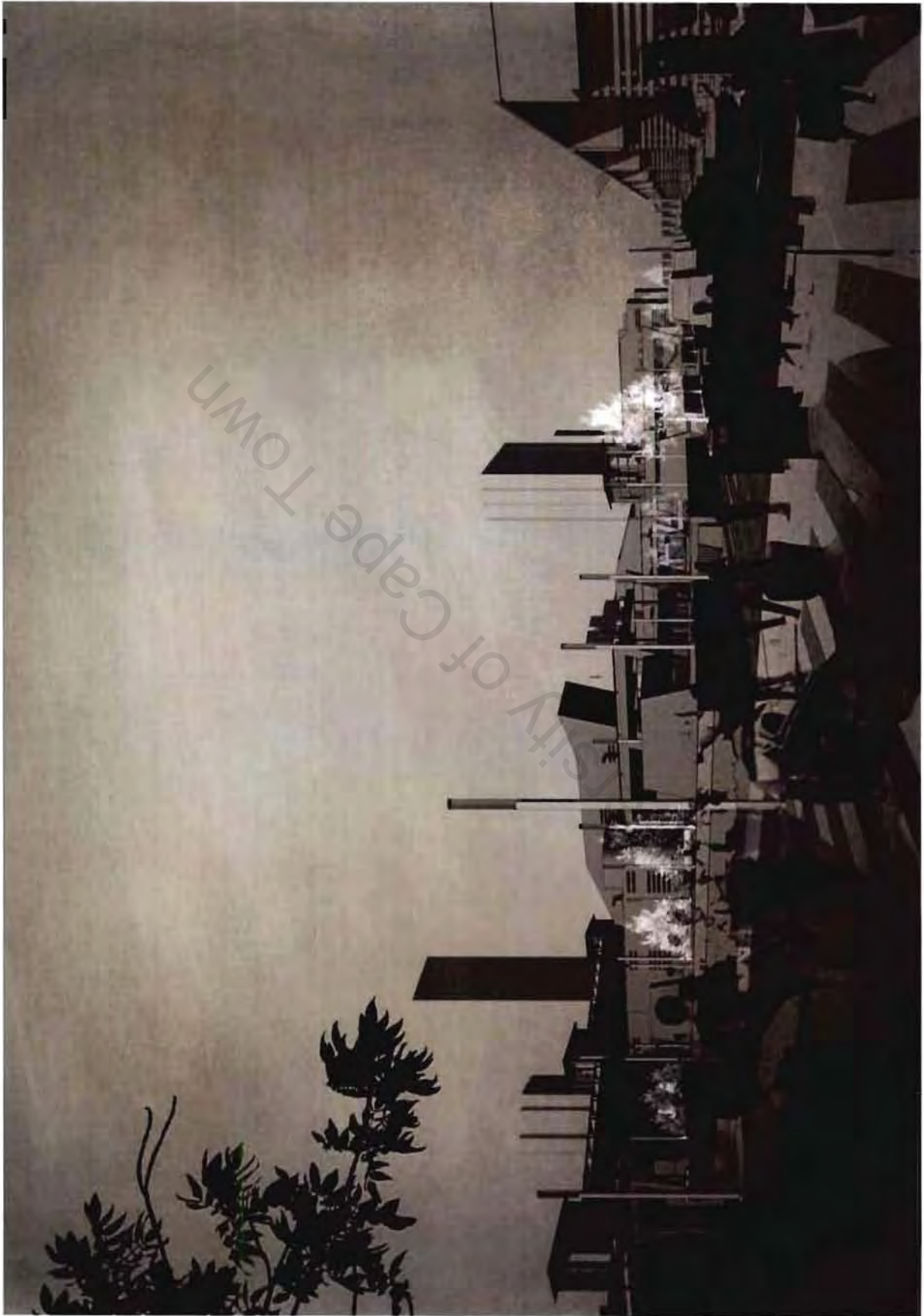

2. Approaching the place of events - Programmatic Sequence

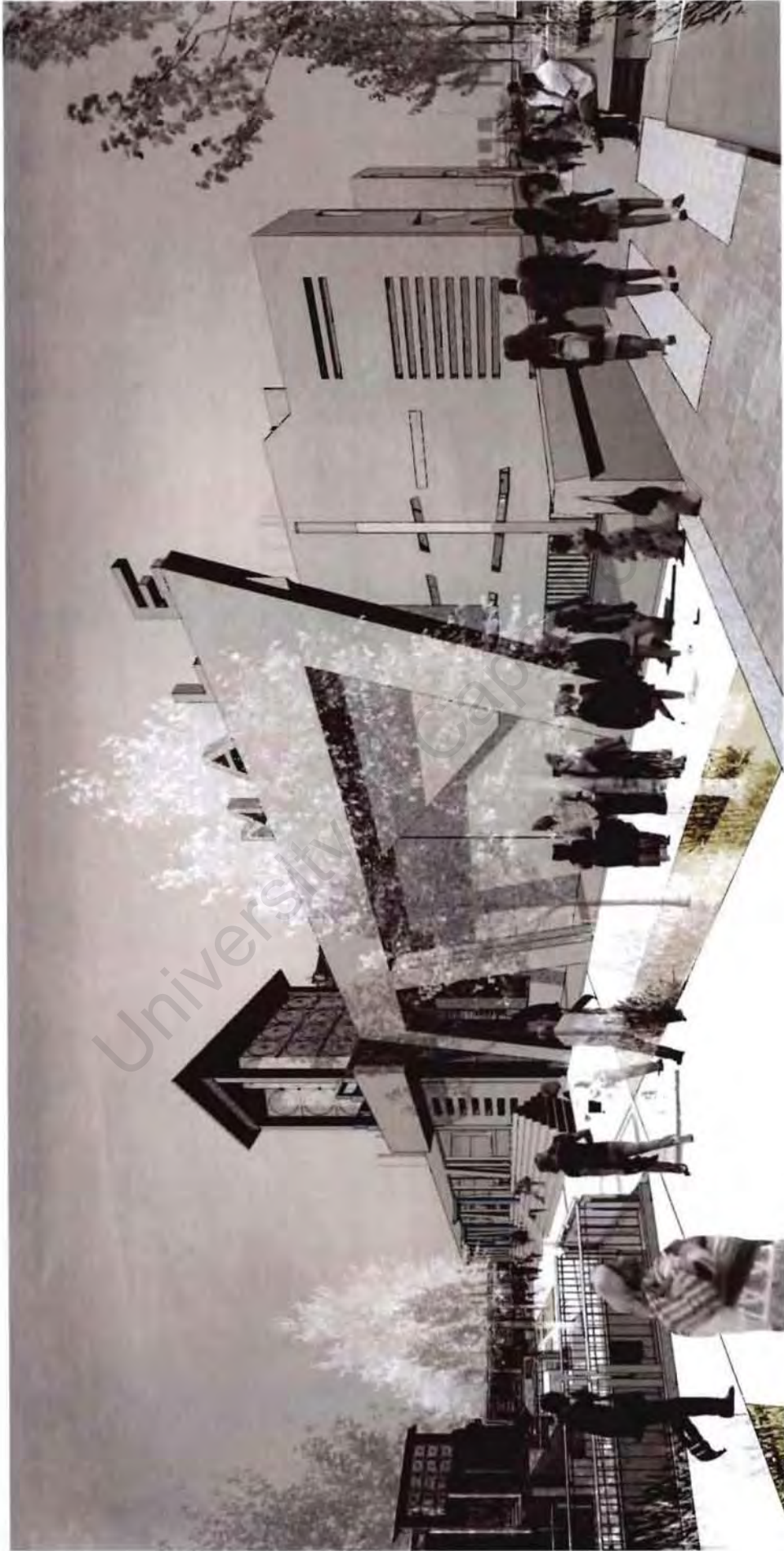

3. Entrance to Bathhouse - Bathing Sequence

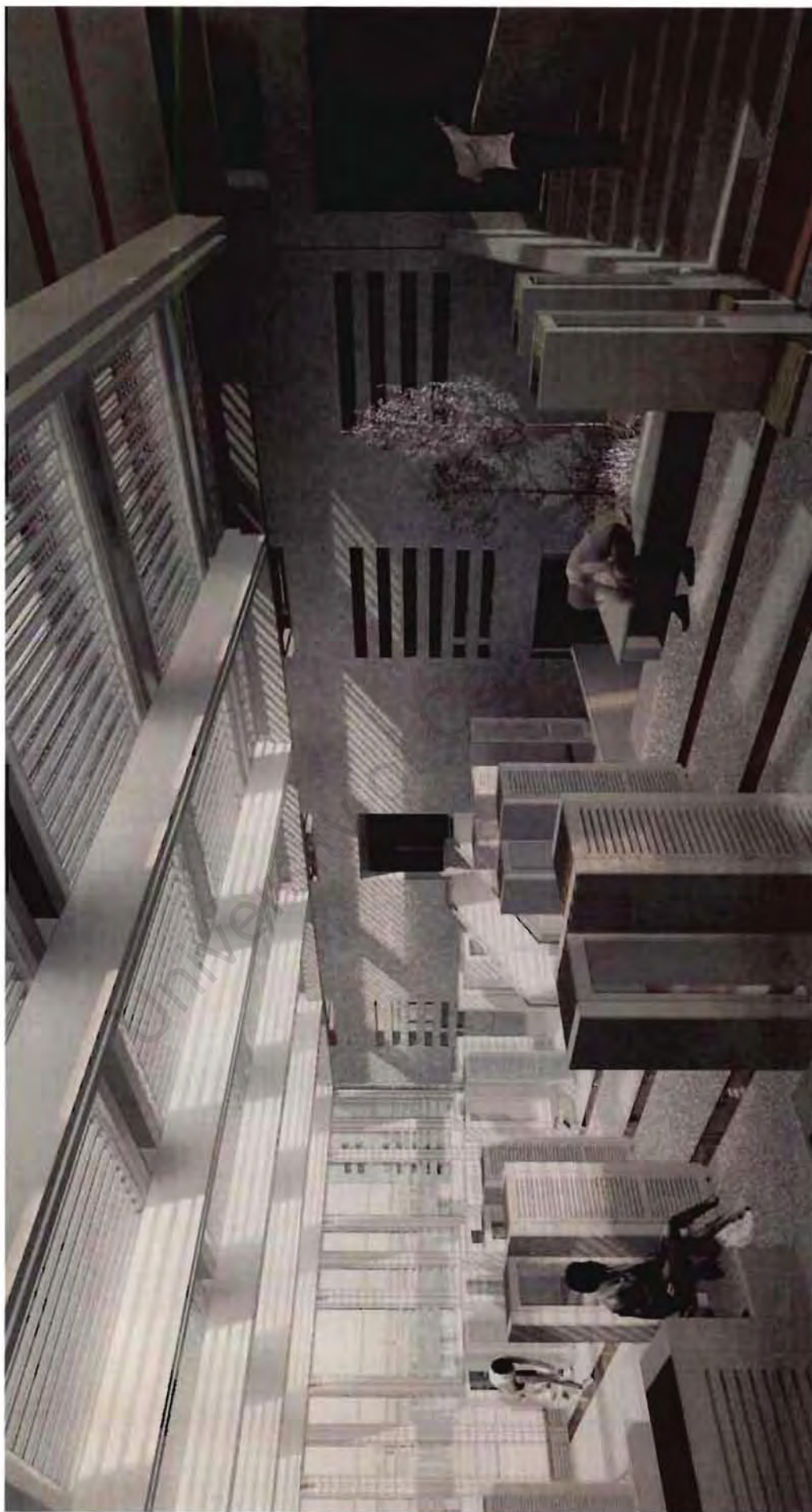

4. Infill threshold change room - Surface Cleansers



5. Shower cubicle - Surface Cleansers

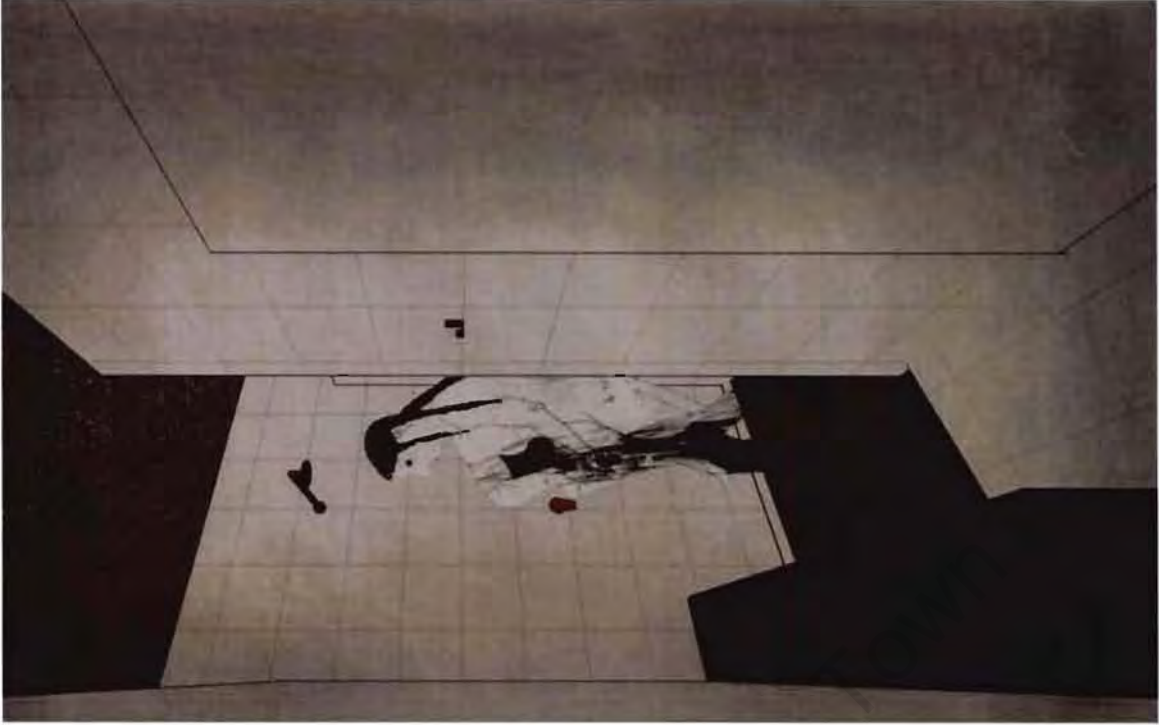

6. Shower cubicle - Surface Cleansers



7. Crossing node between all sequences - All Cleansers & Service Sequence



8. On-route showers & 25m Lap pool - Physical Cleansers between Service Sequence

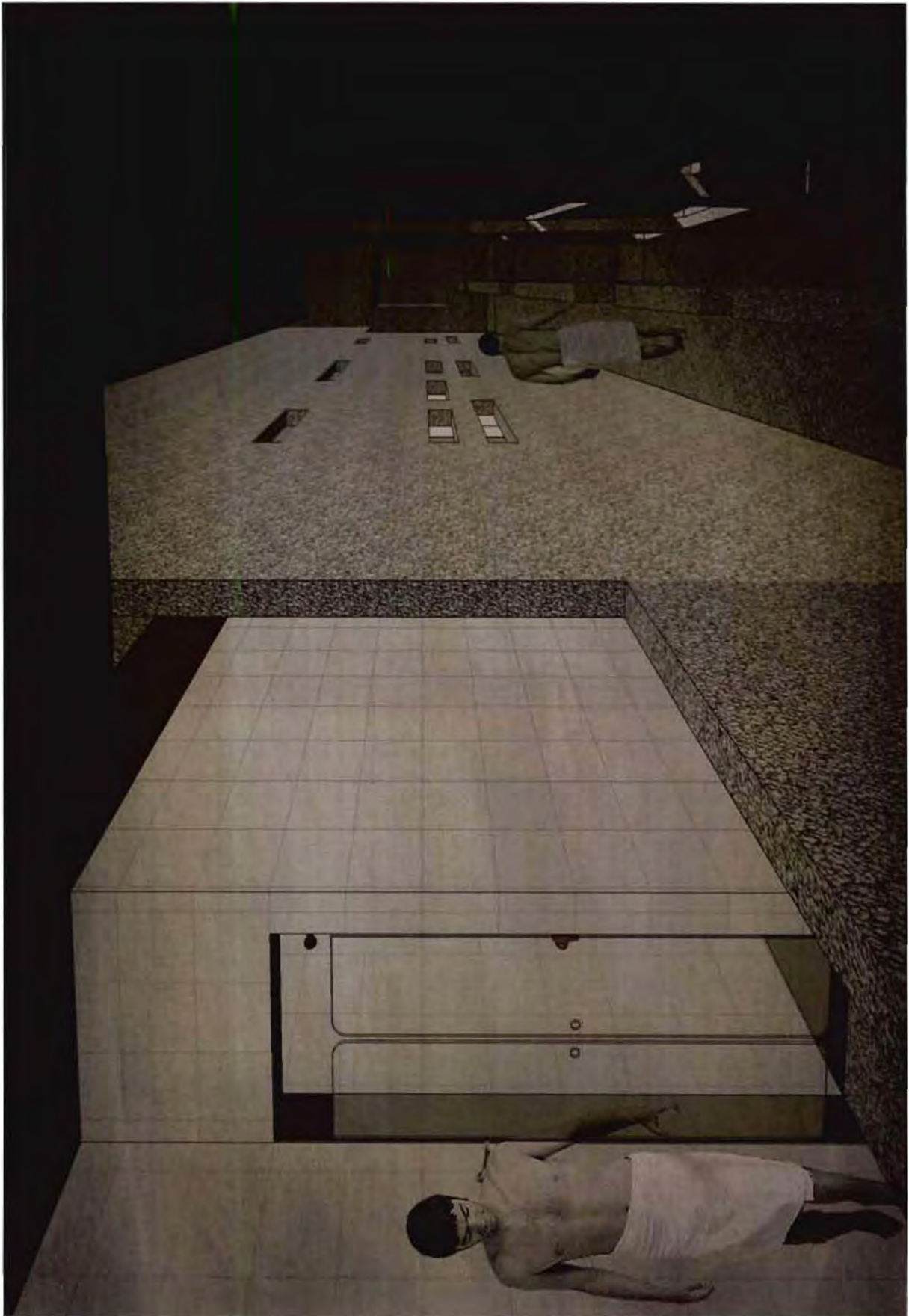

9. On-route showers threshold ramp - Deep Cleansers

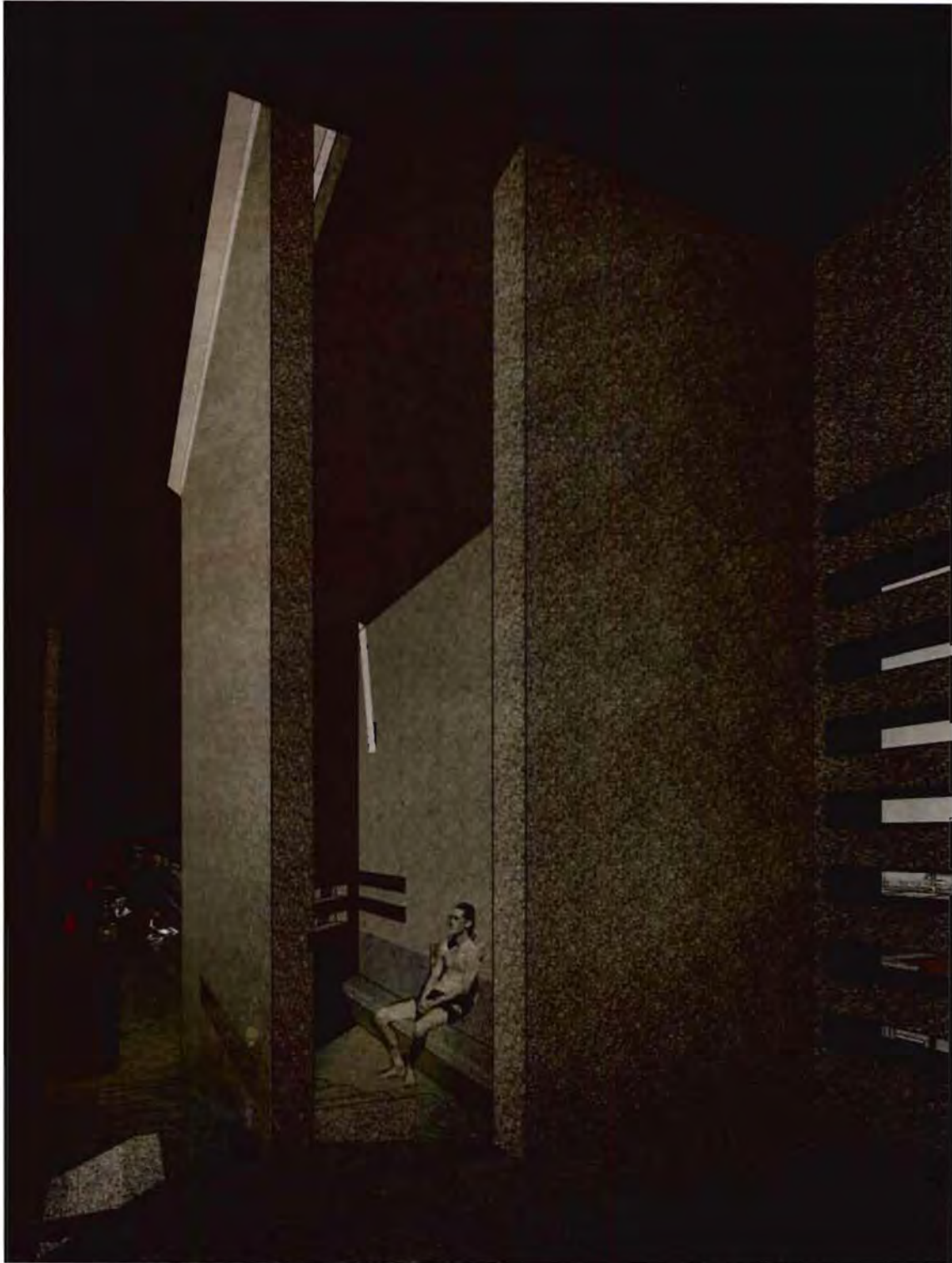

10. Fire & Ice Baths - Deep Cleansers

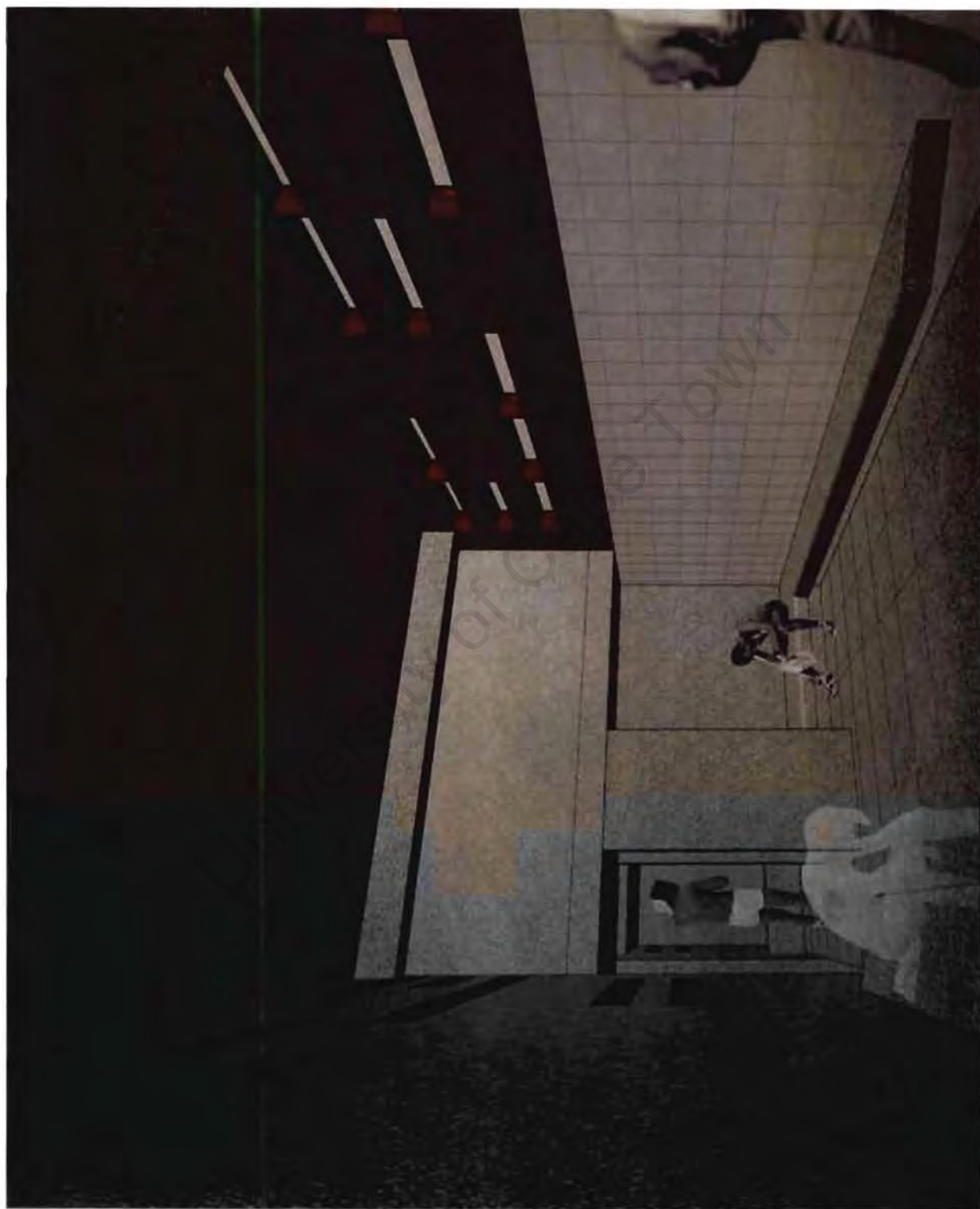

11. Steam Rooms - Deep Cleansers



12. Private Roof Garden - Deep Cleansers



07

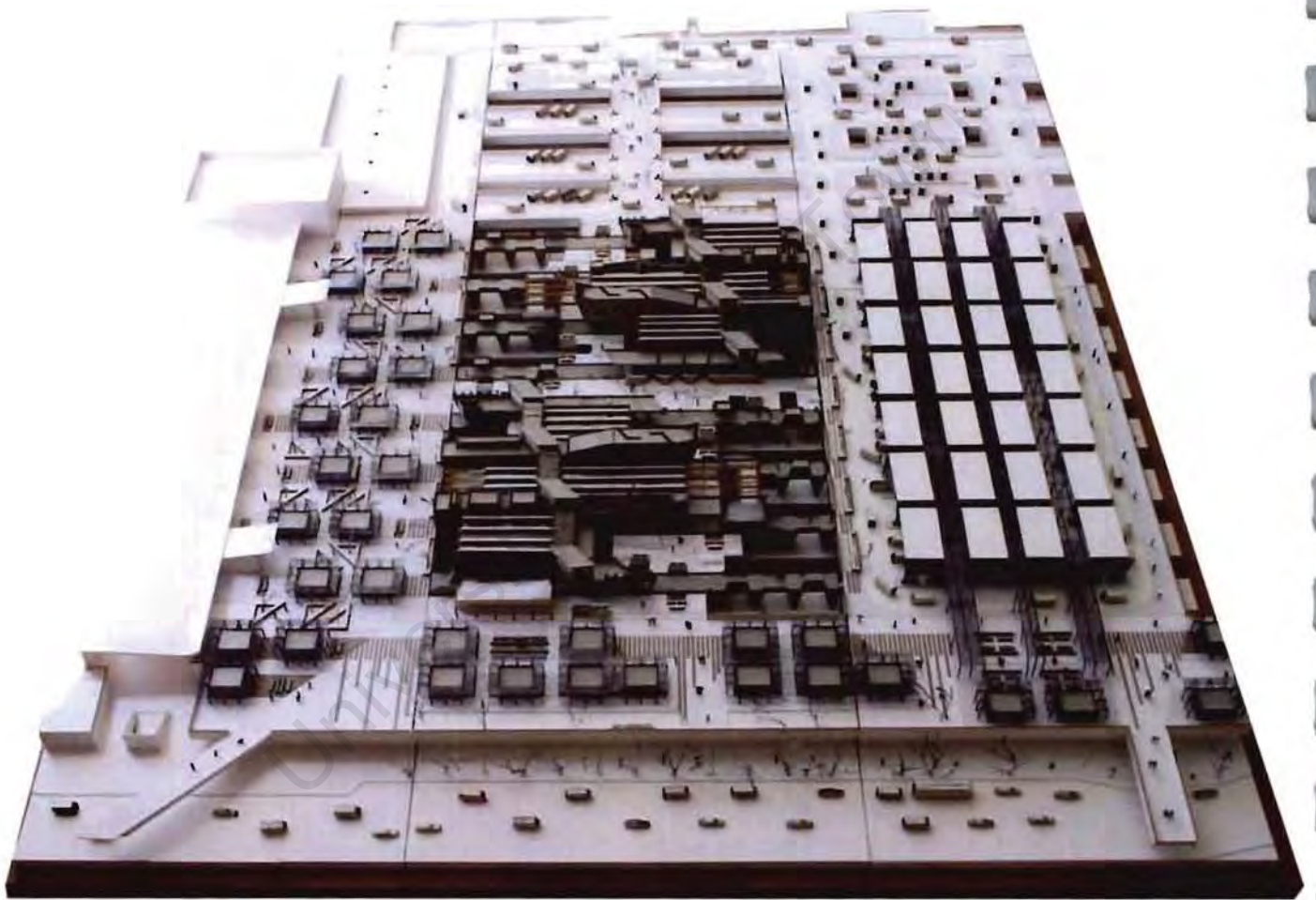

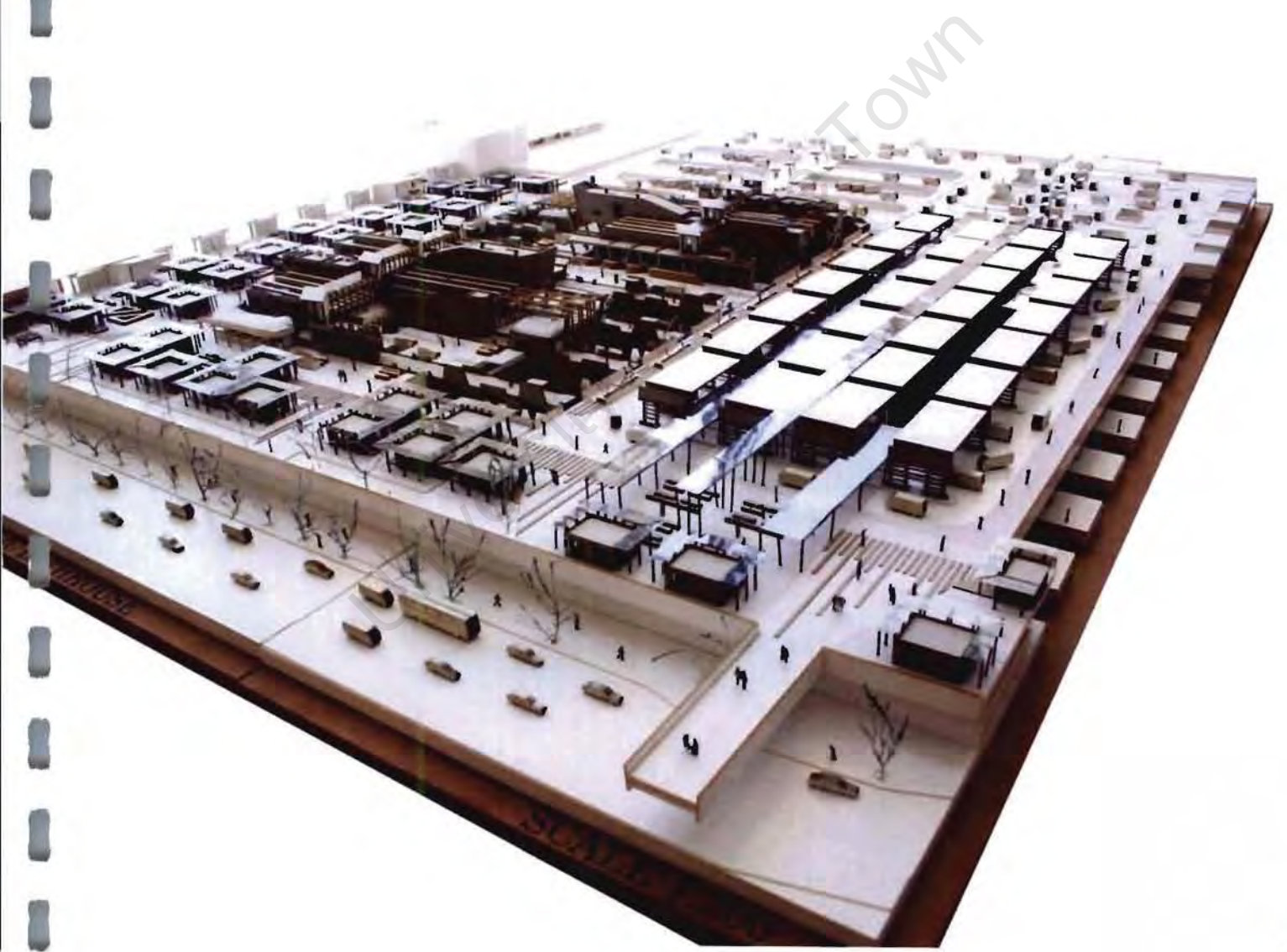

07

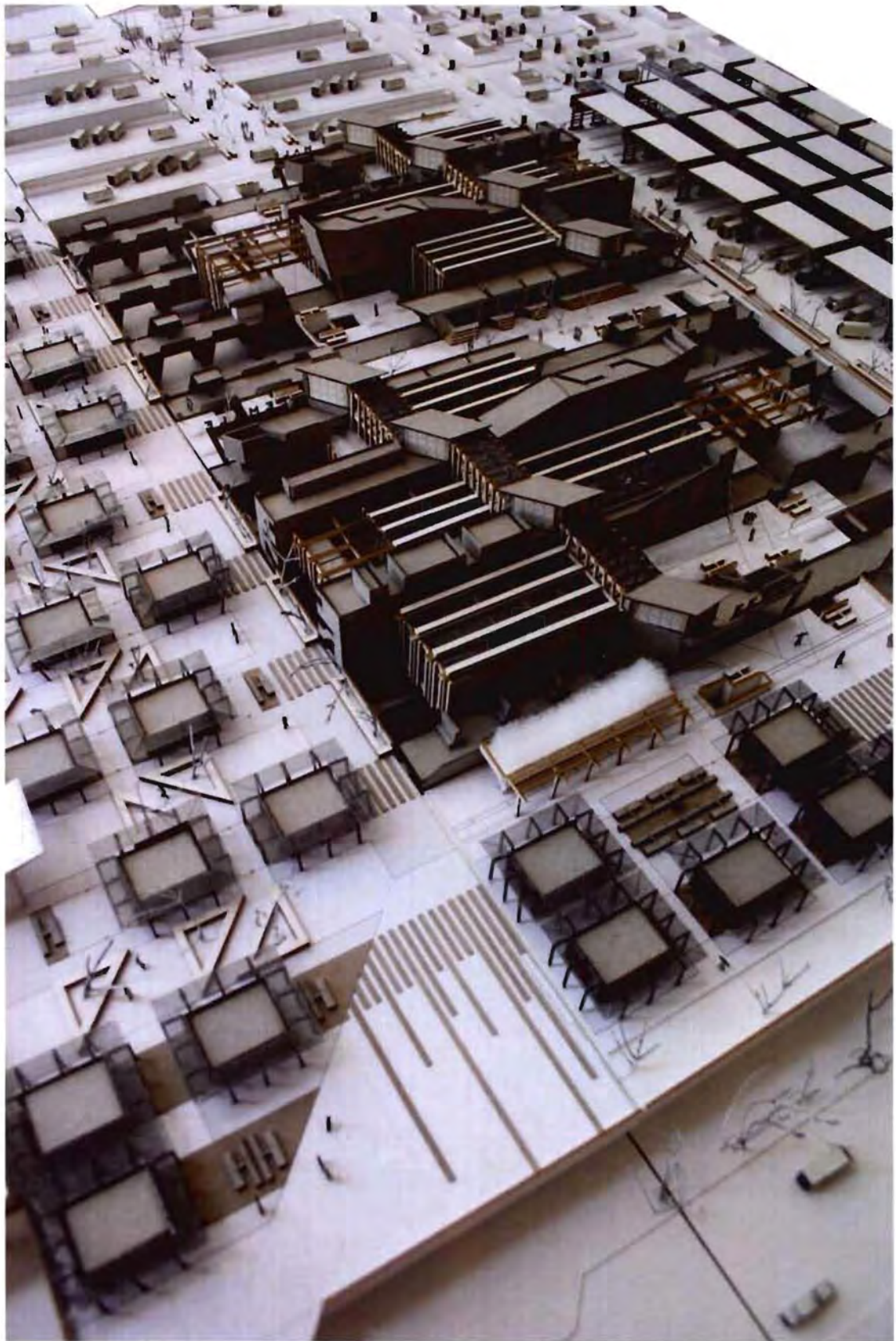

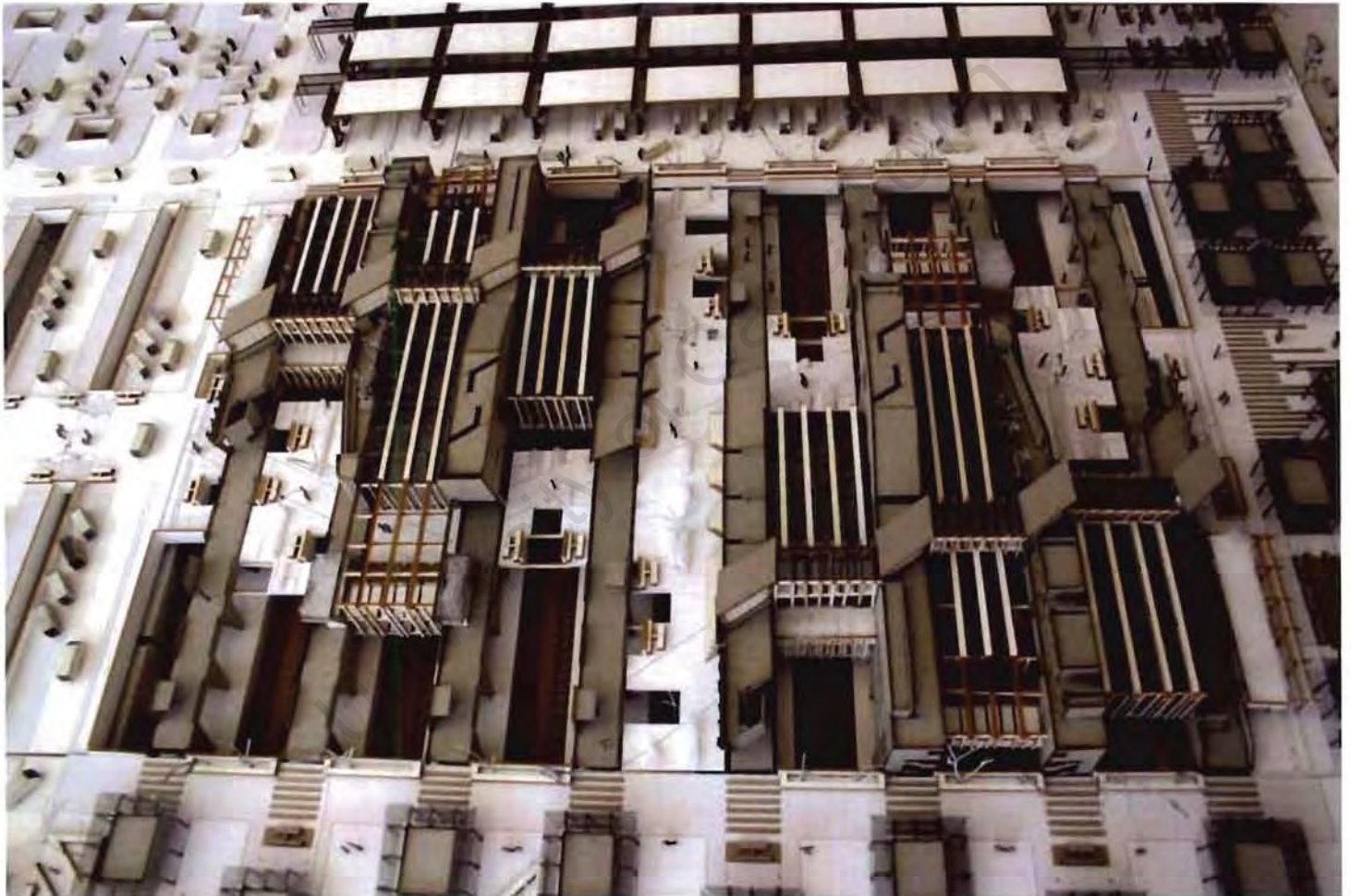

Kinetic Architecture

the spatial organization of daily mobility within a Public Bathhouse

Submitted in partial fulfilment of the requirements for the degree
Master of Architecture (Professional),

by
Hermias Cornelius de Vries

at

University of Cape Town; School of Architecture, Planning & Geomatics