

Considering the effect of pulp chemistry during flotation on froth stability

Nanji Ruth Sheni

A thesis submitted to the faculty of Engineering and the Built Environment,
University of Cape Town in fulfilment of the requirements for the degree of
Master of Science in Engineering

June 2016

The copyright of this thesis vests in the author. No quotation from it or information derived from it is to be published without full acknowledgement of the source. The thesis is to be used for private study or non-commercial research purposes only.

Published by the University of Cape Town (UCT) in terms of the non-exclusive license granted to UCT by the author.

Declaration

I know the meaning of plagiarism and declare that all the work in the document, save for that which is properly acknowledged, is my own. This thesis/dissertation has been submitted to the Turnitin module (or equivalent similarity and originality checking software) and I confirm that my supervisor has seen my report and any concerns revealed by such have been resolved with my supervisor.

Signed by candidate

Nanji Ruth Sheni

Acknowledgements

I would first like to thank God who has given me the ability to will and to do His good pleasure. I would like to acknowledge and express my deepest gratitude to the following people without whom this thesis would not be possible:

- My supervisors, Dr Kirsten Corin and Mrs Jenny Wiese, who have patiently borne with me through all the highs and lows of this period and have been great supports, advisors and friends.
- Prof Cyril O'Connor who has brought insight and enthusiasm into this project.
- The CMR laboratory staff, especially Mrs Shireen Govender and Mr Kenneth Maseko, who have always helped me and been a pleasure to work with.
- My dad, Prof DDD Sheni, and mum, Dr JEN Sheni, who have supported and challenged me to be better every step of the way.
- My brothers, Joshua and Dauda Sheni, who still find my work inspiring.
- My friends and extended family, with special mention to Nana, Onyinye, Melvin, Thobile, Rose, Andre, Cornell and Ellah Peek, Margreth and Eddie, who always gave me a reason to smile and kept me motivated.

Synopsis

On an industrial scale the need for improved flotation performance is of high importance in the current economic climate. Studies have shown that the pulp phase chemistry has a strong effect on the froth phase and therefore it is necessary to investigate how the manipulation of pulp chemistry factors can improve flotation performance. Research into the manipulation of this chemistry is well underway and factors including the pulp potential (Eh), pH, dissolved oxygen (DO) and ionic strength (IS) govern the pulp chemistry. This study aims to investigate how the manipulation of these factors affects the froth stability, bubble size and entrainment of the froth phase through Platinum Group Metal (PGM) flotation.

In this study the Eh, pH, DO and IS were successfully manipulated to investigate their effects on froth stability and water recovery in 2-phase, as well as their effect on water and solids recovery, entrainment and the grades and recoveries of valuable minerals (copper, nickel, platinum and palladium) in 3-phase in the absence and presence of depressant at high dosages; 500 g/t Carboxymethyl Cellulose (CMC). Stability column tests were used to determine froth stability as a function of the dynamic stability factor (Barbian *et al.*, 2005) and batch flotation tests were used to obtain the total water and solids recovered, the grades and recoveries of the valuable minerals as well as to determine entrainment. Further tests were performed to investigate the effect of changing the pH on the Eh in a 3-phase system in which all the other pulp factors were kept constant. The effect of changing the pulp factors on the froth bubble size was investigated by capturing side view images of the froth obtained in a batch flotation cell as each pulp factor was changed.

This study has shown that careful control of the pulp chemistry, namely increasing IS, increasing pH, decreasing DO and decreasing Eh, resulted in improved froth stability. The Eh was found to be inversely proportional to the pH. This study has further shown that increased water recoveries and reduced bubble size in the froth were observed at 5 IS as compared to 1 IS due to the froth stabilising nature of the pulp at 5 IS. Operating at high Eh (500-730 mV) was observed to be detrimental to valuable mineral grades and recoveries and promotes entrainment. This kind of knowledge contribution may be key in improving flotation performance and increasing the grades and recoveries of valuable minerals obtained in South Africa's PGM mining industry.













Abbreviations

| | |
|--|------------------------------------|
| Ag | Silver |
| Ag/AgCl | Silver/silver chloride |
| As | Arsenide |
| BIC | Bushveld Igneous Complex |
| BMS | Base metal sulfide |
| Ca | Calcium |
| Ca(NO ₃) ₂ ·4H ₂ O | Calcium nitrate 4-hydrate |
| CaCl ₂ | Calcium chloride |
| °C | Degrees centigrade |
| CCC | Critical coalescence concentration |
| CMC | Carboxymethyl cellulose |
| CMR | Centre for Minerals Research |
| DO | Dissolved oxygen |
| DTP | Dithiophosphate |
| Eh | Pulp/RedOx potential |
| g | grams |
| g/mol | grams per mol |
| g/t | grams per ton |
| Hg | Mercury |
| Hg/Hg ₂ Cl ₂ | Calomel |
| IS | Ionic strength |
| L/min | Litres per minute |
| Mg | Magnesium |
| MgSO ₄ ·7H ₂ O | Magnesium sulfate heptahydrate |
| Mg(NO ₃) ₂ ·6H ₂ O | Magnesium nitrate |
| MIBC | Methyl Isobutyl Carbinol |
| min | Minute(s) |
| MnO ₂ | Manganese dioxide |
| mm | Milcalcium oxidetres |

















| | |
|---------------------------------|-----------------------------------|
| mV | Millivolts |
| NaCl | Sodium chloride |
| Na ₂ CO ₃ | Sodium carbonate |
| NFG | Naturally floatable gangue |
| PAX | Potassium amyl xanthate |
| Pd | Palladium |
| PGM | Platinum group metal |
| PGE | Platinum group element |
| ppm | Parts per million |
| Pt | Platinum |
| rpm | Revolutions per minute |
| S | Sulphide |
| SEX | Sodium ethyl xanthate |
| SIBX | Sodium isobutyl xanthate |
| STP | Standard temperature and pressure |
| Te | Telluride |
| UCT | University of Cape Town |
| UG2 | Upper Group Chromite No. 2 |
| µm | Micron(s) |
| X ₂ | Dixanthogen |
| XRD | X-ray Diffraction |
| XRF | X-ray Fluorescence |
| XPS | X-ray photoelectron spectroscopy |

Graphical Key

2-Phase Key

| Symbol | Test | Condition |
|---|---------|-----------------------|
|  | Test 1 | 1 IS pH9 DO8 Eh(-50) |
|  | Test 2 | 1 IS pH11 DO8 Eh(-90) |
|  | Test 3 | 1 IS pH11 DO8 Eh430 |
|  | Test 4 | 5 IS pH9 DO8 Eh90 |
|  | Test 5 | 5 IS pH11 DO8 Eh(-90) |
|  | Test 6 | 5 IS pH11 DO8 Eh500 |
|  | Test 7 | 1 IS pH9 DO0 Eh40 |
|  | Test 8 | 1 IS pH11 DO0 Eh(-60) |
|  | Test 9 | 1 IS pH11 DO0 Eh370 |
|  | Test 10 | 5 IS pH9 DO0 Eh30 |
|  | Test 11 | 5 IS pH11 DO0 Eh(-70) |
|  | Test 12 | 5 IS pH11 DO0 Eh570 |

3-Phase Key

| Symbol | Test | Condition |
|---|---------|------------------------------|
|  | Test 13 | 1 IS, pH 9, DO 8, Eh (-70) |
|  | Test 14 | 1 IS, pH 11, DO 8, Eh (-100) |
|  | Test 15 | 1 IS, pH 9, DO 8, Eh 730 |
|  | Test 16 | 5 IS, pH 9, DO 8, Eh (-80) |
|  | Test 17 | 5 IS, pH 11, DO 8, Eh (-120) |
|  | Test 18 | 5 IS, pH 9, DO 8, Eh 730 |
|  | Test 19 | 5 IS, pH 11, DO 8, Eh 660 |
|  | Test 20 | 1 IS, pH 11, DO 8, Eh 500 |
|  | Test 21 | 1 IS, pH 9, DO 0, Eh 50 |
|  | Test 22 | 1 IS, pH 11, DO 0, Eh (-20) |
|  | Test 23 | 1 IS, pH 9, DO 0, Eh 700 |
|  | Test 24 | 1 IS, pH 11, DO 0, Eh 500 |
|  | Test 25 | 5 IS, pH 9, DO 0, Eh (-40) |
|  | Test 26 | 5 IS, pH 11, DO 0, Eh (-90) |
|  | Test 27 | 5 IS, pH 9, DO 0, Eh 720 |
|  | Test 28 | 5 IS, pH 11, DO 0, Eh 650 |

Model Equations Coded Factors:

A = IS, B = pH, C = DO, D = Eh

Table of Contents

| | |
|--|-----|
| Declaration..... | i |
| Acknowledgements..... | ii |
| Synopsis..... | iii |
| Abbreviations..... | iv |
| Graphical Key..... | vi |
| 2-Phase Key..... | vi |
| 3-Phase Key..... | vi |
| Model Equations Coded Factors:..... | vi |
| Table of Contents..... | vii |
| List of Figures..... | x |
| List of Tables..... | xiv |
| 1 Introduction..... | 1 |
| 1.1 Background..... | 1 |
| 1.2 Scope..... | 3 |
| 2 Literature Review..... | 5 |
| 2.1 Froth Flotation..... | 5 |
| 2.1.1 2-Phase Flotation..... | 6 |
| 2.1.2 Flotation Reagents..... | 6 |
| 2.1.3 PGM Flotation..... | 9 |
| 2.2 The Pulp Phase..... | 9 |
| 2.2.1 The Pulp Potential (Eh)..... | 9 |
| 2.2.2 pH..... | 11 |
| 2.2.3 Eh-pH Diagrams..... | 13 |
| 2.2.4 Dissolved oxygen (DO)..... | 15 |
| 2.2.5 Ionic Strength (IS)..... | 17 |
| 2.3 The Froth Phase..... | 19 |
| 2.3.1 Froth Stability Calculation..... | 20 |
| 2.3.2 Flotation of Fine Particles..... | 21 |
| 2.3.3 Entrainment..... | 21 |
| 2.4 The Bushveld Igneous Complex..... | 23 |
| 2.4.1 The Platreef..... | 25 |

| | | |
|-------|---|----|
| 3 | Research Objectives | 27 |
| 3.1 | Objectives..... | 27 |
| 3.2 | Hypotheses..... | 27 |
| 3.3 | Key Questions..... | 27 |
| 4 | Experimental Details..... | 28 |
| 4.1 | Ore Preparation..... | 28 |
| 4.2 | Water..... | 29 |
| 4.3 | Reagents..... | 29 |
| 4.4 | Stability Column Tests | 30 |
| 4.5 | Batch Flotation Tests..... | 31 |
| 4.5.1 | Factorial Design and Experimental Conditions Obtained | 32 |
| 4.5.2 | Batch Flotation Procedure | 34 |
| 4.6 | Depressant Tests | 36 |
| 4.6.1 | Gangue Recovery and Entrainment..... | 36 |
| 4.7 | Data Analysis | 37 |
| 4.8 | Testing the Effect of pH on Eh..... | 37 |
| 4.9 | Bubble Size Comparison..... | 37 |
| 4.10 | Assays | 38 |
| 5 | Results..... | 39 |
| 5.1 | 2-Phase Tests..... | 39 |
| 5.1.1 | 2-Phase Stability Column Tests..... | 39 |
| 5.1.2 | 2-Phase Batch Tests | 40 |
| 5.2 | 3-Phase Tests..... | 43 |
| 5.2.1 | Water and Solids Recovery | 43 |
| 5.2.2 | Water Recovery 3D Surface Plots | 48 |
| 5.2.3 | Solids Recovery 3D Surface Plots..... | 52 |
| 5.2.4 | Valuable Mineral Recovery-Water Recovery..... | 58 |
| 5.2.5 | Valuable Mineral Grade and Recovery Curves | 60 |
| 5.2.6 | Copper and Nickel Recovery Grid and Model Equations..... | 63 |
| 5.3 | Depressant Tests | 65 |
| 5.3.1 | Stability Column Depressant Tests | 65 |
| 5.3.2 | Batch Depressant Tests..... | 66 |

| | | |
|-------|--|-----|
| 5.3.3 | Gangue Recovery and Entrainment | 71 |
| 5.4 | The Effect of Changing pH on Eh | 75 |
| 5.4.1 | Test Conditions | 75 |
| 5.4.2 | Results | 75 |
| 5.5 | The Effect of Pulp Conditions on Bubble Size | 76 |
| 5.5.1 | Test Conditions | 76 |
| 5.5.2 | Results | 76 |
| 5.6 | Key Findings..... | 80 |
| 6 | Discussion | 81 |
| 6.1 | The Effect of Pulp Factors on Froth Stability..... | 81 |
| 6.2 | The Effect of Pulp Factors on Valuable Mineral Grade and Recoveries | 85 |
| 6.3 | The Effect of Pulp Factors on Entrainment | 91 |
| 6.4 | The Effect of Pulp Factors on Bubble Size in the Froth Phase | 92 |
| 6.5 | The Effect of Eh Modifiers..... | 93 |
| 7 | Conclusions..... | 95 |
| 7.1 | Improved flotation outcomes can be achieved with careful control of flotation pulp chemistry as this chemistry will determine both the stability of the froth phase as well as the ability of the valuable minerals to reach the froth phase. | 95 |
| 7.2 | Eh can be manipulated by careful control of pH during the flotation process as Eh is simply an indicator of other chemical factors within the system..... | 96 |
| 7.3 | Increased ionic strength of process water lowers the likelihood of bubble coalescence, therefore, smaller bubbles will be present in the froth phase and this will result in higher water recoveries and more entrained material entering the concentrate. | |
| | 96 | |
| 8 | Recommendations..... | 97 |
| 9 | References | 98 |
| 10 | Appendix A..... | 106 |
| 10.1 | 2-Phase Batch Flotation Data..... | 106 |
| 10.2 | 3-Phase Batch Flotation Data..... | 107 |
| 10.3 | Valuable Mineral Grade and Recovery Data | 109 |
| 10.4 | Depressant Batch Flotation Data | 110 |
| 10.5 | Stability Column Data..... | 110 |
| 10.6 | Entrainment Data | 111 |

| | | |
|--------|--|-----|
| 10.7 | pH Eh Experimental Data | 114 |
| 10.8 | Conductivity Experiments | 114 |
| 11 | Appendix B | 117 |
| 11.1 | 2-Phase Water Recovery 3D Surface Plots..... | 117 |
| 11.2 | 3-Phase Solids Recovery 3D Surface Plots | 119 |
| 11.3 | Grade and Recovery Curves | 119 |
| 11.4 | Mineral Recovery-Water Recovery Results..... | 120 |
| 11.4.1 | 3-Phase Copper and Nickel Recovery 3D Surface Plots..... | 120 |
| 11.5 | Depressant Results..... | 124 |

List of Figures

| | | |
|-------------|---|----|
| Figure 1-1: | Scope of experimental plan | 4 |
| Figure 2-1: | Schematic of a flotation cell and process (adapted from 911 Metallurgist, 2015).5 | |
| Figure 2-2: | Alkyl xanthate general molecular structure (Castelyn, 2012) | 7 |
| Figure 2-3: | Molecular structure of CMC (Ingenito <i>et al.</i> , 2013) | 8 |
| Figure 2-4: | Molecular structure of guar gum (Chaplin, 2015)..... | 9 |
| Figure 2-5: | Eh-pH diagrams of the system Pt-O-H. $\Sigma Pt = 10 - 10$, 298.15 K, 10^5 Pa (Takeno, 2005) | 14 |
| Figure 2-6: | Eh-pH diagram for the butyl xanthate/oxygen system and the observed lower (E^L) and upper (E^U) limiting flotation potential of galena and chalcopyrite at which flotation recovery is greater than 50% (BX ⁻ : 2×10^{-5} mol/L) (adapted from Hu <i>et al.</i> , 2009) | 14 |
| Figure 2-7: | A Geological plan view map of the Bushveld Complex (O'Connor and Shackleton, 2013) | 24 |
| Figure 2-8: | Stratigraphic column showing layers of the Bushveld Complex. UG-1=Upper Group Chromite No.1, UG-2=Upper Group Chromite No.2. (Schouwstra, 2000) | 25 |
| Figure 4-1: | Milling curves for 1 kg batch float and 2 kg column float | 28 |
| Figure 4-2: | Stability column with agitator and rotameter, indicating slurry and froth phase. | 31 |
| Figure 4-3: | Picture of UCT Leeds 3 L laboratory batch flotation cell | 35 |
| Figure 4-4: | Pictures of HANNA meter and Eh probe, and TPS meter and DO and pH probes | 36 |
| Figure 5-1: | 2-Phase froth stability results for differing Eh, DO, pH and IS values. Error bars represent standard error. | 40 |

Figure 5-2: Cumulative water recovered as a function of time for 2-phase tests at all conditions. The dashed lines represent DO 0 and the solid lines DO 8 conditions. The Eh was increased by NaClO addition. Error bars represent standard error.41

Figure 5-3: Final water recovery for batch flotation tests conducted at differing Eh, DO, pH and IS values in 2-phase. The Eh was increased by NaClO addition. Error bars represent standard error.42

Figure 5-4: 3D surface plot of the interaction between pH and Eh in relation to water recovery in a 2-phase system43

Figure 5-5: Water recovered as a function of time for 3-phase flotation tests. The Eh was increased by NaClO addition. Error bars represent standard error.44

Figure 5-6: Solids recovered as a function of time for 3-phase flotation tests. The Eh was increased by NaClO addition. Error bars represent standard error.45

Figure 5-7: Solids recovered versus water recovered over time for 3-phase flotation tests. The Eh was increased by NaClO addition. Error bars represent standard error.45

Figure 5-8: Solids recovered versus water recovered over time for 3-phase flotation tests at DO 8. The Eh was increased by NaClO addition. Error bars represent standard error.46

Figure 5-9: Solids recovered versus water recovered over time for 3-phase flotation tests at DO 0. The Eh was increased by NaClO addition. Error bars represent standard error.46

Figure 5-10: Final water recovery for batch flotation tests conducted at differing Eh, DO, pH and IS values in 3-phase. The Eh was increased by NaClO addition. Error bars represent standard error.47

Figure 5-11: Final solids recovery for batch flotation tests conducted at differing Eh, DO, pH and IS values in 3-phase. The Eh was increased by NaClO addition. Error bars represent standard error.48

Figure 5-12: 3D surface plot of the interaction between pH and IS in relation to water recovery in a 3-phase system, where Eh and DO are kept constant at 300 mV and 4 ppm, respectively.49

Figure 5-13: 3D surface plot of the interaction between pH and Eh in relation to water recovery in a 3-phase system, where IS and DO are kept constant at 3 IS and 4 ppm, respectively.49

Figure 5-14: 3D surface plot of the interaction between pH and DO in relation to water recovery in a 3-phase system where IS and Eh are kept constant at 3 IS and 300 mV, respectively.50

Figure 5-15: 3D surface plot of the interaction between IS and Eh in relation to water recovery in a 3-phase system where DO and pH are kept constant at 4 ppm and pH 10, respectively.51

Figure 5-16: 3D surface plot of the interaction between IS and DO in relation to water recovery in a 3-phase system where Eh and pH are kept constant at 300 mV and pH 10, respectively.51

Figure 5-17: 3D surface plot of the interaction between Eh and DO in relation to water recovery in a 3-phase system where IS and pH are kept constant at 3 IS and pH 10, respectively.....52

Figure 5-18: 3D surface plot of the interaction between pH and IS in relation to solids recovery in a 3-phase system where Eh and DO are kept constant at 300 mV and 4 ppm, respectively.....53

Figure 5-19: 3D surface plot of the interaction between pH and Eh in relation to solids recovery in a 3-phase system where IS and DO are kept constant at 3 IS and 4 ppm, respectively.....53

Figure 5-20: 3D surface plot of the interaction between IS and Eh in relation to solids recovery in a 3-phase system where DO and pH are kept constant at 4 ppm and pH 10, respectively.....54

Figure 5-21: 3D surface plot of the interaction between Eh and DO in relation to solids recovery in a 3-phase system where IS and pH are kept constant at 3 IS and pH 10, respectively.....55

Figure 5-22: Summary grids of 2-phase and 3-phase effects of IS, pH, DO and Eh on water and, in 3-phase, solids recovery, as well as the factors' effects on one another. The dark red symbolises the strongest positive contributors and the dark blue the strong negative contributors. The white is a neutral interaction and no contribution.56

Figure 5-23: Copper recovery as a function of water recovery at different conditions. The Eh was increased by NaClO addition.58

Figure 5-24: Nickel recovery as a function of water recovery at different conditions. The Eh was increased by NaClO addition.59

Figure 5-25: Platinum recovery as a function of water recovery at different conditions. The Eh was increased by NaClO addition.59

Figure 5-26: Palladium recovery as a function of water recovery at different conditions. The Eh was increased by NaClO addition.60

Figure 5-27: Copper grade as a function of copper recovery at different conditions. The Eh was increased by NaClO addition.61

Figure 5-28: Nickel grade as a function of nickel recovery at different conditions. The Eh was increased by NaClO addition.....61

Figure 5-29: Platinum grade as a function of platinum recovery at different conditions. The Eh was increased by NaClO addition.62

Figure 5-30: Palladium grade as a function of palladium recovery at different conditions. The Eh was increased by NaClO addition.63

Figure 5-31: Summary grid of the effects of IS, pH, DO and Eh on copper and nickel recovery, as well as the factors' effects on one another. The dark red symbolises the strongest positive contributors and the dark blue the strong negative contributors. The white is a neutral interaction and no contribution.64

| | |
|--|-----|
| Figure 5-32: 3-Phase froth stability results for differing Eh, DO, pH and IS values with and without depressant. The Eh was increased by NaClO addition. Error bars represent standard error. | 66 |
| Figure 5-33: Final 3-phase water recovery for batch flotation tests conducted at differing Eh, DO, pH and IS values in the absence and presence of depressant. The Eh was increased by NaClO addition. Error bars represent standard error..... | 67 |
| Figure 5-34: Final 3-phase solids recovery for batch flotation tests conducted at differing Eh, DO, pH and IS values in the absence and presence of depressant. The Eh was increased by NaClO addition. Error bars represent standard error..... | 68 |
| Figure 5-35: Copper grade as a function of copper recovery at different conditions in the presence of depressant. The Eh was increased by NaClO addition. | 69 |
| Figure 5-36: Nickel grade as a function of nickel recovery at different conditions in the presence of depressant. The Eh was increased by NaClO addition. | 69 |
| Figure 5-37: Platinum grade as a function of Platinum recovery at different conditions in the presence of depressant. The Eh was increased by NaClO addition. | 70 |
| Figure 5-38: Palladium grade as a function of palladium recovery at different conditions in the presence of depressant. The Eh was increased by NaClO addition. | 70 |
| Figure 5-39: Total Entrained Gangue as a function of water recovery at different conditions at 500 g/t CMC. The Eh was increased by NaClO addition. The text boxes indicate the entrainment factor for each curve. | 71 |
| Figure 5-40: Naturally Floating Gangue (NFG) as a function of water recovery at different conditions in the absence of depressant. The Eh was increased by NaClO addition..... | 72 |
| Figure 5-41: Entrained gangue recovered as a function of water recovery at different conditions in the absence of depressant. The Eh was increased by NaClO addition..... | 73 |
| Figure 5-42: Total solids and entrained gangue recovered as a function of water recovery at different conditions in the absence of depressant for each. The Eh was increased by NaClO addition..... | 74 |
| Figure 5-43: The response of changing pH on Eh in a 1 IS and DO 8 batch flotation system. Error bars represent standard error. | 76 |
| Figure 5-44: Comparison of bubble sizes observed at the Test 13 (1 IS) and 5 IS where pH, DO and Eh remained constant..... | 77 |
| Figure 5-45: Comparison of bubble sizes observed at the Test 13 (pH 9) and pH 11 where IS, DO and Eh remained constant..... | 78 |
| Figure 5-46: Comparison of bubble sizes observed at the Test 13 (DO 8) and DO 0 where IS, pH and Eh remained constant | 79 |
| Figure 5-47: Comparison of bubble sizes observed at the Test 13 (Low Eh) and High Eh where IS, pH and DO remained constant. The Eh was increased by NaClO addition. | 80 |
| Figure 6-1: Pourbaix diagrams of copper, nickel, platinum and palladium at STP (Takeno, 2005) | 90 |
| Figure 10-1: The effect of different conditions on conductivity..... | 115 |

| | |
|--|-----|
| Figure 11-1: 3D surface plot of the interaction between pH and IS in relation to water recovery in a 2-phase system | 117 |
| Figure 11-2: 3D surface plot of the interaction between pH and DO in relation to water recovery in a 2-phase system | 117 |
| Figure 11-3: 3D surface plot of the interaction between DO and Eh in relation to water recovery in a 2-phase system | 118 |
| Figure 11-4: 3D surface plot of the interaction between IS and Eh in relation to water recovery in a 2-phase system | 118 |
| Figure 11-5: 3D surface plot of the interaction between IS and DO in relation to solids recovery in a 3-phase system | 119 |
| Figure 11-6: Grade-Recovery curves for sulfur at different conditions..... | 119 |
| Figure 11-7: Recovery versus water curves for sulfur at different conditions | 120 |
| Figure 11-8: 3D surface plot of the interaction between IS and Eh in relation to copper recovery | 120 |
| Figure 11-9: 3D surface plot of the interaction between pH and Eh in relation to copper recovery | 121 |
| Figure 11-10: 3D surface plot of the interaction between Eh and DO in relation to copper recovery | 121 |
| Figure 11-11: 3D surface plot of the interaction between IS and Eh in relation to nickel recovery | 122 |
| Figure 11-12: 3D surface plot of the interaction between pH and Eh in relation to nickel recovery | 122 |
| Figure 11-13: 3D surface plot of the interaction between Eh and DO in relation to nickel recovery | 123 |
| Figure 11-14: 3D surface plot of the interaction between pH and DO in relation to copper recovery | 123 |
| Figure 11-15: Grade-Recovery curves for sulfur at different conditions and a high depressant dosage..... | 124 |

List of Tables

| | |
|--|----|
| Table 2-1: Table of pH modifier depression effects on pyrite, sphalerite and calcium oxide at pH 12 using butyl xanthate collector (adapted from Hu <i>et al.</i> , 2009)..... | 12 |
| Table 2-2: Table of the different influences of pH modifiers on the electrode potential at pH 12 after 50 min on pyrite, sphalerite and galena (adapted from Hu <i>et al.</i> , 2009)..... | 13 |
| Table 2-3: Some observations of the effect of DO on the effects of pH in the flotation of chalcopyrite..... | 16 |
| Table 2-4: α and β ion assignments of plant water salts | 18 |

| | |
|---|----|
| Table 2-5: The percentage of the platinum, palladium and other elements in the Merensky, UG2 and Platreef (Dunne, 2011)..... | 26 |
| Table 2-6: Bulk mineralogy and platinum distribution across the Platreef, Merensky and UG2 reef (Adapted from Shamaila and O'Connor, 2008) | 26 |
| Table 4-1: Table of plant water salts in grams per litre | 29 |
| Table 4-2: Table of reagent suite | 29 |
| Table 4-3: Table of pulp factor lower and higher levels | 32 |
| Table 4-4: 2-Phase Test Graphical Key | 33 |
| Table 4-5: 3-Phase Test Graphical Key | 34 |
| Table 5-1: Summary table of dynamic stability factor obtained, water recovered, solids recovered, NFG and entrained gangue obtained at each condition | 74 |
| Table 5-2: Amount of NFG and entrained gangue obtained at constant a water recovery of 1500 g at in the absence of depressant for each test condition | 75 |
| Table 5-3: Key findings of pulp factor effects on water and solids recovery, valuable mineral grade and recovery, froth stability and bubble size | 80 |

1 Introduction

1.1 Background

The platinum mining industry has recently been negatively impacted by the global drop in the price of platinum group metals as well as by the strikes in the mines, specifically in South Africa. For this reason, it is becoming more important to improve flotation performance across the plants in South Africa. The country contains 95.5 % of the world's known platinum reserves and produced about 72.0 % of the world's platinum in 2013. However, this fell to about 68.0 % in 2014 and has been predicted to fall even further due to the unrest experienced in its mines (U.S. Department of the Interior, 2015). It is, therefore, necessary to find new ways to increase the grades and recoveries of platinum and platinum group metals (PGMs) in order to keep South Africa as a world competitor.

One key step in doing this is to improve the mineral beneficiation process which is made up of comminution, flotation, smelting and refining. Flotation is the main focus of this thesis. It makes use of chemical reagents to render the desired minerals hydrophobic and therefore recoverable (Kawatra and Eisele, 2001). The flotation cell is divided into two main sections, the froth phase and the pulp phase, with the two sections meeting at the pulp-froth interphase. The pulp phase chemistry has significant effects on the froth phase. This chemistry is quite complex and is comprised of factors such as the pulp potential (Eh), pH, dissolved oxygen (DO) and ionic strength (IS) not to mention reagents. Each of these pulp factors has a significant effect on the overall flotation performance of the system. This has therefore led to research into the effects of Eh, pH, DO and IS on the flotation performance of PGM ores. However, the effects of these factors on the flotation performance and the combined manipulation of these factors within the pulp is still unknown. Knowledge concerning the full extent to which these factors affect the flotation performance is currently limited and this research, therefore, aims to expand on this knowledge and investigate these effects further. These pulp factors are expounded on below.

The Eh is the redox potential of the pulp. It has an upper and lower limit which varies with the solution or pulp in question. The Eh can be used to determine whether or not the

reagent attachment to the mineral will take place as it can determine the condition of the mineral surface (Hu *et al.*, 2009).

Eh-pH diagrams are used to illustrate equilibrium relationships between dissolved and solid species. They provide the regions for various minerals in which improved flotation is possible when pH is varied. These regions include lower limits of potential at which collectorless flotation begins and upper limits at which it ceases for each mineral (Hu *et al.*, 2009). The Eh can be manipulated using pH and DO (Kuopanportti *et al.*, 1997) and chemical means. The Eh is affected by the purity of the solution in which it is measured, the type of electrode used and the history of the indicator electrodes (Chander, 2003). Eh measurements are best made at the solid-liquid interface within the pulp as this potential has the greatest influence on mineral flotation (Hu *et al.*, 2009). The Eh measured in this study was the mixed potential for the system.

Dissolved oxygen (DO) within the pulp relates to the oxidation of the mineral surface. Oxygen is necessary for electrochemical reactions on the mineral surface. The oxidation of sulphide minerals results in the production of oxygen-sulphur species which exchange with the collector ion to form the metal collector salt. Depending on the mineral being floated, the presence of oxygen may result in the formation of dixanthogen and other species essential for hydrophobicity. Pulp potential, pH and time have significant effects on these oxidation products. The higher the pulp potential, the higher the oxidation rate of sulphide minerals. XPS and polarised curve results have found the order of oxidation of certain sulphide minerals to be: pyrrhotite > pyrite > chalcopyrite > sphalerite > galena (Hu *et al.*, 2009).

Ionic strength (IS) refers to the ions present in the water used to form the pulp. An increase in IS has been found to increase froth stability and the entrainment of gangue minerals. IS also affects the effectiveness of the gangue depressant used (Corin *et al.*, 2010).

The froth phase is where valuable minerals are collected into the concentrate for further upgrading. Froth stability can be defined as the froth's ability to resist bubbles bursting and bubble coalescence (Farrokhpay, 2011). The stability of the froth greatly impacts the grade and recovery of valuable minerals in flotation. It is influenced by the presence of particles, particle size and hydrophobicity (Johansson and Pugh, 1992), reagents and operating factors

such as the aeration rate, water quality and gas dispersion (Farrokhpay, 2011). Water recovery is a good indicator of froth stability as an increase in water recovery tends to correspond to a stable froth (Wiese and Harris, 2012).

This research aims to investigate how varying these pulp factors will affect the froth phase through the flotation of a Platreef ore body. The effects on the froth phase that were observed were froth stability, bubble size within the froth, entrainment and the grades and recoveries of the valuable minerals.

1.2 Scope

This research focused mainly on the manipulation of the Eh, pH, IS and DO. The Eh was changed either using the pH and DO or chemical means. The froth phase effects that were monitored were froth stability, entrainment and the grades and recoveries of the valuable minerals. The equipment used was a laboratory batch flotation cell and a stability column. 2-phase, 3-phase and high depressant tests were performed in both sets of equipment in order to achieve the research objectives. A standard reagent suite was used and Platreef was chosen. Design Expert 9 (Stat-Ease Inc, 2014), statistical analysis software, was used to analyse the data collected from the batch cell and error bars were used to indicate the standard error of the data.

This study was limited to monitoring water recovery as a measure of froth stability and kinetics were not considered. The monitoring of the pulp factors was limited to the batch and stability column cells and did not include the milling environment. Figure 1-1 shows the experimental plan for the batch cell and stability column.

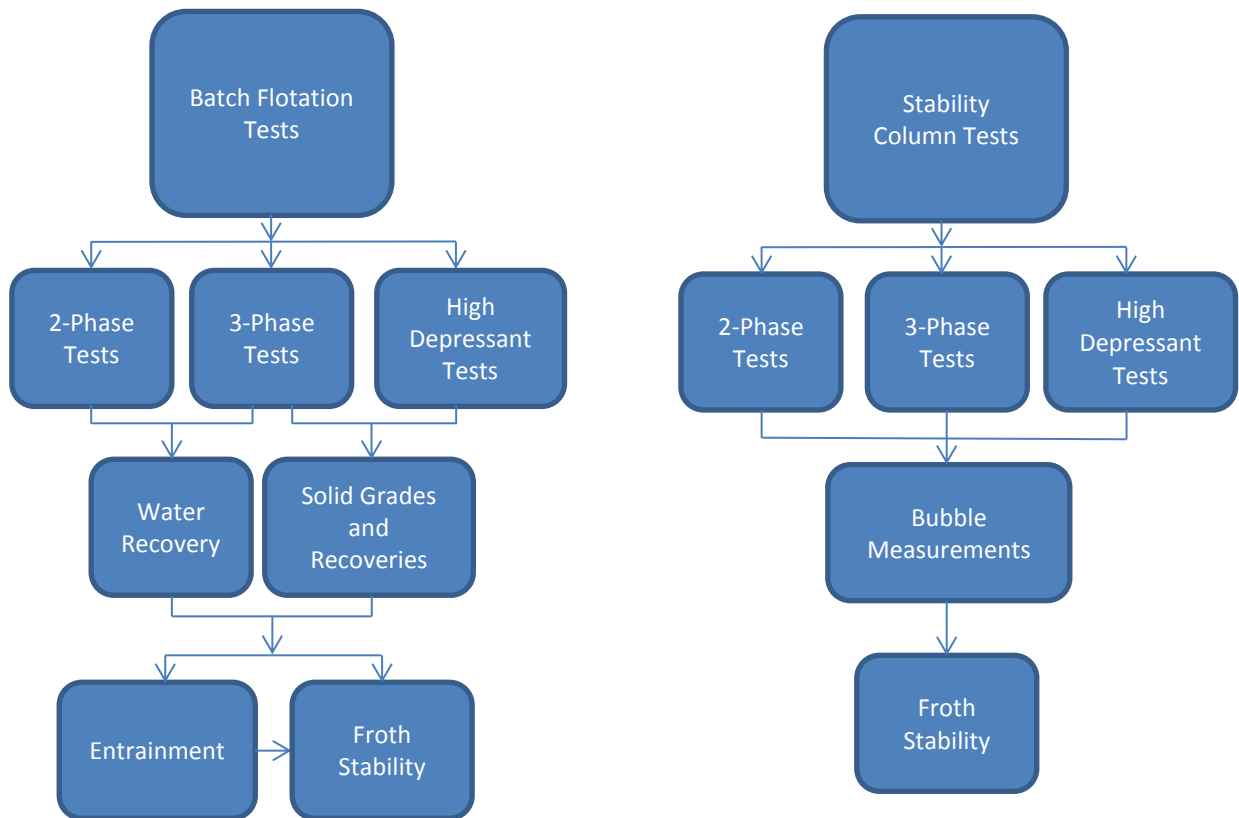

Figure 1-1: Scope of experimental plan

2 Literature Review

2.1 Froth Flotation

Kawatra and Eisele (2001) defined froth flotation as “a highly versatile method for physically separating particles based on differences in the ability of air bubbles to selectively adhere to specific mineral surfaces in a mineral-water slurry.” The selectivity of the air bubbles to the mineral surfaces is dependent on the hydrophobicity of the mineral being floated. Reagents are used to manipulate the chemistry of the minerals in the slurry so that the desired minerals are rendered hydrophobic and the undesired gangue minerals hydrophilic (Kawatra and Eisele, 2001).

A schematic of the Barker flotation cell and a continuous flotation process is shown in Figure 2-1. The batch flotation procedure would differ in that there would be no feed stream flowing into the cell during flotation and the tailings would be collected after the flotation procedure is complete. During batch flotation a slurry is placed in the flotation cell and the chemical reagents are added to the pulp and allowed to condition for a period of time with the agitator switched on. Once the pulp has been conditioned, the air supply is opened and the process of hydrophobic particle attachment to air bubbles and transport to the froth from the pulp occurs and the froth is scraped into the concentrate launder. Once all the concentrates are collected, the air supply is switched off and the tailings are collected. 2-phase froth flotation can also be performed in this cell.

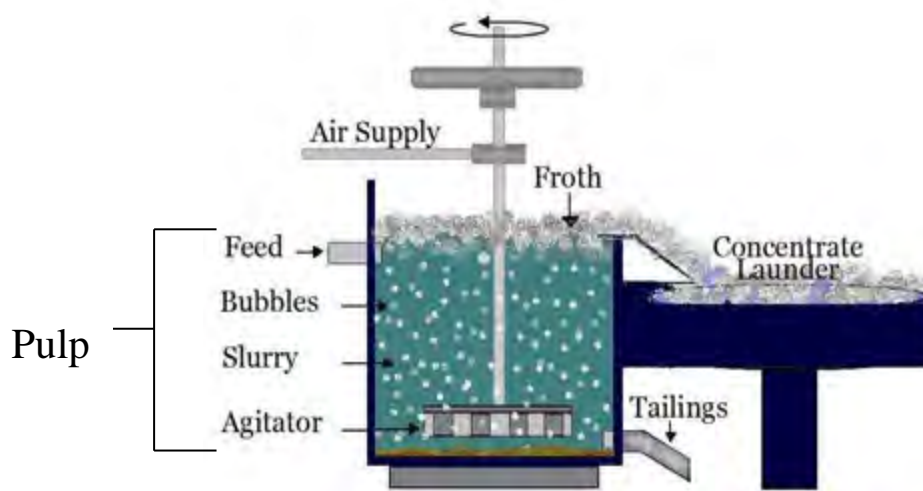

Figure 2-1: Schematic of a flotation cell and process (adapted from 911 Metallurgist, 2015)

2.1.1 2-Phase Flotation

2-phase flotation is the process in which only the gas and liquid phases are considered. Within the 2-phase system, the effects on the froth phase of IS, pH and other chemical factors can be more clearly seen, with specific reference to their effect on the water recovery and froth stability. In 2-phase flotation, it has been seen that more stable froths were found at increased ionic strengths due to decreased bubble size (Manono, 2010). However, froth stability will still be affected by solid particles and the results of froth stability in a 2-phase system are not always transferable to a 3-phase system. Manono *et al.* (2012) found that the increased IS was linked to the increased froth stability when solids were present.

2.1.2 Flotation Reagents

The reagents used in the process of flotation are classified as frothers, collectors, activators, depressants and pH regulators. Although not the focus of this study a description of each reagent group follows:

2.1.2.1 Frothers

Frothers are used to stabilise the froth layer in order to make sure that the air bubbles remain intact long enough to be removed from the slurry along with the attached hydrophobic minerals. The most commonly used frothers are poly glycol ethers and alcohols such as Methyl Isobutyl Carbinol (MIBC).

Frothers are an essential addition to the pulp for the formation of a sustainable froth, as pure liquids are not able to form such froths (Manev and Nguyen, 2005). Some frothers disperse gas and cause a decrease in the bubble size due to a decrease in surface tension (Drzymala, 2007). Frothers reduce the surface tension of the liquid through its heteropolar molecular nature. This results in a preferential adsorption of its molecules at the air-water interface. This adsorption is what promotes the liquid film's resistance to local thinning when drainage occurs (Simulescu *et al.*, 2008). Frothers interact with collectors (Laskowski, 2004) and the arrangement of the molecules at the interface allows for the hydrophobic group to be in the air whilst the hydrophilic group remains in the water (Harris, 1982).

Frothers provide factors that increase the rate of flotation by increasing the chance of particle-bubble contact. These factors are: an increase in the air dispersion within the

flotation cell, an increase in the total surface area of the bubbles due to a decrease in their size, a reduction in the coalescence of bubbles within the pulp, and a decrease in the rate of bubbles rising to the surface (Harris, 1982). Frothers are also used to control the liquid film behaviour of the froth by reducing the thinning of the films that occur during drainage. The adsorption of the frother into the pulp affects the changes in the liquid properties that control how the liquid film can withstand changes in the size and shape of the bubbles proceeding to the froth (Manev and Nguyen, 2005).

2.1.2.2 Collectors

The purpose of the collectors is to adsorb onto the mineral's surface forming a non-polar hydrophobic hydrocarbon film. This increases the ability of the mineral surface to adhere to the air bubbles. Collectors bond to the mineral surface through either chemisorption or physisorption. During chemisorption, a chemical bond is created between the collector and the mineral surface and also permanently alters the mineral's surface chemistry. During physisorption, the collector is held onto the surface by physical forces. Xanthates are the commonly used collectors however new chemistries such as dithiophosphates and thianocarbamates are also being used. The general molecular structure of an alkyl xanthate is shown in Figure 2-2.

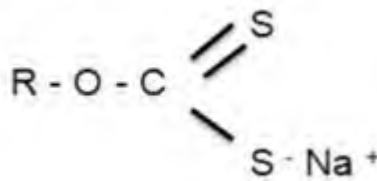

Figure 2-2: Alkyl xanthate general molecular structure (Castelyn, 2012)

2.1.2.3 Activators

Activators are chemical modifiers used in flotation that aid in collector adsorption. Activators adsorb onto the mineral surface and in so doing promote collector attachment on mineral surfaces that would not normally allow for collector attachment (Kawatra and Eisele, 2001). One of the most commonly used activators in PGM flotation is copper sulphate (Cu_2SO_4). CuSO_4 can act by adsorption and also by atom replacement as with ZnS

(sphalerite) where Zn goes into solution and Cu can become part of the surface lattice structure, however this is pH dependent.

2.1.2.4 Depressants

Depressants are chemical modifiers that influence collector attachment to minerals. Depressants are used to prevent collector adsorption onto undesired mineral surfaces and thereby render the undesired mineral hydrophilic (Kawatra and Eisele, 2001) and improve flotation selectivity. Depressants may also adsorb onto the undesired mineral to render it hydrophilic. These modifiers may be organic or inorganic. Organic depressants include sulfhydryl acetic acid and polyacrylamide polymers, and inorganic depressants include lime and sodium sulphide (Hu *et al.*, 2009). Carboxymethyl cellulose (CMC) and guar gum depressants form part of the anionic polymers in the family of organic depressants. CMC and guar gum are commonly used in the depression of gangue minerals during copper-nickel sulphide and PGM flotation, and especially in the depression of talc (PERUMIN 32: Convencion Minera, 2015). The molecular structures for CMC and guar gum are shown in Figure 2-3 and Figure 2-4.

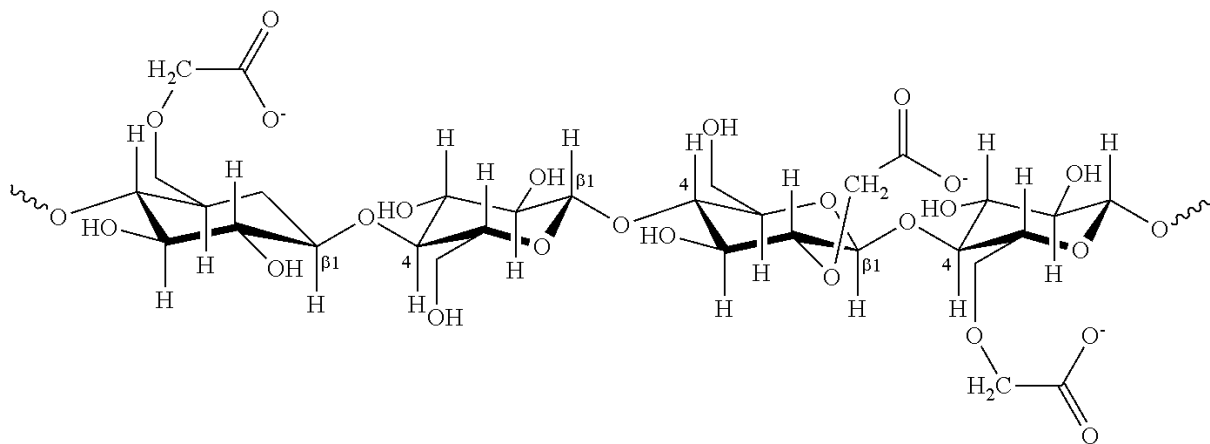

Figure 2-3: Molecular structure of CMC (Ingenito *et al.*, 2013)

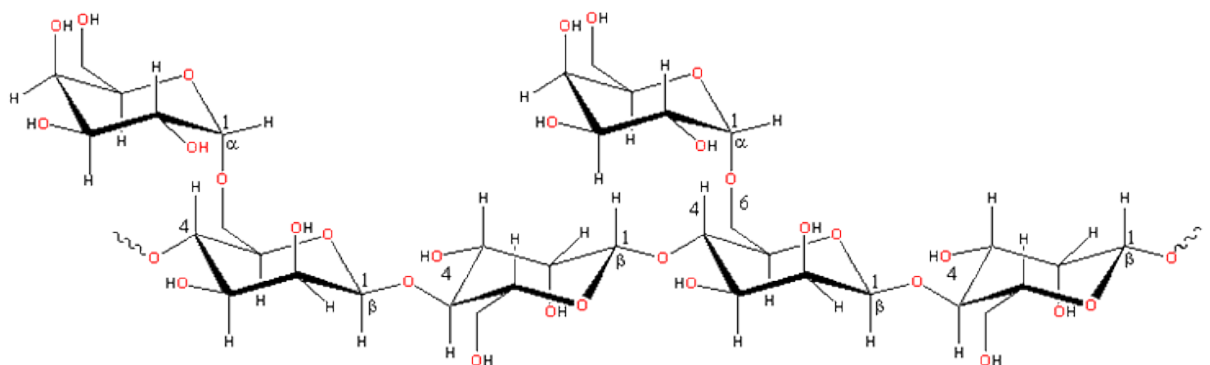

Figure 2-4: Molecular structure of guar gum (Chaplin, 2015)

2.1.2.5 pH Regulators

pH regulators are used to manipulate the pH. Surface chemistry of minerals may be dependent on pH since, generally, minerals have a positive surface charge in acidic conditions and a negative charge when in alkaline conditions (Kawatra and Eisele, 2001). Examples of pH regulators are sodium hydroxide (NaOH), sulphuric acid (H₂SO₄) and Lime (CaO).

2.1.3 PGM Flotation

The conventional conditions for floating PGM ores are at pH 9 and 25 °C. Thiol collectors, such as xanthates, and poly glycol ether frothers are the reagents typically used. In the UCT laboratory batch flotation process, PGM ores are usually floated for 20 minutes with concentrates collected at 2, 6, 12 and 20 minutes.

2.2 The Pulp Phase

The pulp phase is the phase within which most of the chemical interactions of flotation take place. During the flotation process, the mineral surface is oxidised (anodic process) and oxygen is reduced (cathodic process). This process affects the interactions of the mineral with the collector and subsequently the flotation performance. The cathodic process is necessary for the electrochemical reactions on the sulphide surface. This process occurs differently for each mineral (Hu *et al.*, 2009).

During flotation, particles move from the pulp to the froth phase through first colliding with the bubbles, followed by attachment and then detachment in the concentrate (Bloom and Heindel, 2003; Duan *et al.*, 2003; Dai *et al.*, 1998). Factors that affect these chemical interactions include Eh, pH, IS and DO.

2.2.1 The Pulp Potential (Eh)

The Eh is the pulp potential, also known as the redox potential, and is “a measure of the tendency of a solution to be oxidising or reducing” (Hu *et al.*, 2009). It allows for correlations to be drawn with the flotation performance. Eh aids in predicting the regions of optimal flotation and estimating the surface conditions of sulphide minerals (Goktepe, 2002). There is an upper and lower limit of pulp potential at different pH values. The lower limit of the

pulp potential is where the sulphide mineral's flotation begins. The upper limit is where the flotation ceases (Hu *et al.*, 2009).

For many decades pulp potential has been used to control the flotation process. Kuopanportti *et al* (1997), found that Eh can be used to predict the rate of xanthate adsorption and the flotation behaviour of chalcopyrite and pyrite because as Eh increases the adsorption rate increases. This could, therefore, extend to other sulphide minerals.

Factors that affect pulp potential include: the grinding conditions such as purging with oxygen or nitrogen, the grinding media which could increase or reduce the galvanic interactions observed, collector addition during grinding, DO levels, the pH within the mill and other modifying agents (Corin *et al.*, 2013; Chander, 2003).

Eh increases with a decrease in pH as seen by Equation 2-1 and Equation 2-2 in which an the half reaction for hydrogen (the concentration of which determines the increase in pH) has an Eh of 0 V and the half reaction for the hydroxide (a decrease in pH) results in increasing the Eh to 0.4 V.



Eh also increases with an increase in DO. It is more strongly dependent on DO than on pH. The effects of DO on Eh are more significant at low pH values and the control of Eh with DO requires the manipulation of nitrogen and oxygen flows through the flotation cell (Kuopanportti *et al*, 1997).

2.2.1.1 Eh Electrodes

In measuring these potentials, the type of electrode used affects the pulp potentials obtained. Mineral electrodes, noble metal electrodes and ion selective electrodes are used to measure the Eh of solutions or slurries (Chander, 2003). It is, therefore, best to use an electrode made from the target mineral, when using a mineral electrode, because the relevant Eh is found at the mineral/solution interface (Hu *et al.*, 2009). A platinum electrode can be used, when using a noble metal electrode, as it is highly corrosion resistant (Goktepe, 2002). Pretreatment of the electrodes can be performed chemically, electrochemically and mechanically (Chander, 2003).

Noble metal electrodes are the most commonly used electrodes with platinum and gold being the most frequently used in this set. The reference electrode used is either the calomel ($\text{Hg}/\text{Hg}_2\text{Cl}_2$) or silver/silver chloride (Ag/AgCl). To convert the results obtained from these electrodes to a hydrogen scale, 0.2415 V or 0.2223 V are added to the results obtained on a hydrogen scale for the calomel and silver chloride electrode, respectively (Chander, 2003). If more than one redox couple is present in the system, the mixed potential is the potential the electrodes will measure.

Platinum electrodes have been found to yield different potential readings based on the oxygen content of the pulp or solution (Natarajan and Iwasaki, 1972; Rand and Woods, 1984; Gebhardt and Shedd, 1988). The sensitivity of platinum electrodes to DO in solution led to the conclusion that there exists a high affinity of oxygen to platinum (Gebhardt and Shedd, 1988). However, when it is necessary to reduce the effects of oxygen, gold Eh electrodes are recommended due to their reduced sensitivity to oxygen (Chander, 2003). For the purpose of this research, a platinum electrode was used as it is more readily available.

2.2.2 pH

pH may enhance collector attachment to the mineral surface. Changing the pH of the system can chemically alter the surface chemistry of the minerals in the slurry by changing the surface charges. In acidic conditions, most minerals will have a positive charge and in alkaline conditions, a negative charge (Kawatra and Eisele, 2001).

Collector groups respond differently to changes in pH. A decrease in pH causes an increase in the attachment of sulfhydryl collectors such as xanthates, for example, with pyrite and chalcopyrite, the lower the pH the greater the rate of xanthate adsorption (Kuopanportti *et al.*, 1997). In tests performed by Kuopanportti *et al.* (1997), as pH increased, with an increase in DO concentration at each pH, the fastest adsorption of xanthate occurred at the lowest pH measured (pH 6) and the highest DO concentration. However, as the pH changes, different sulphides experience collector attachment and varied degrees of hydrophobicity (Kawatra and Eisele, 2001). Changing the pH can result in changes in the pulp potential upper and lower limits for minerals (Hu *et al.*, 2009).

2.2.2.1 pH Modifiers

pH modifiers in sulphide flotation include sodium hydroxide, sodium sulphide, calcium oxide, potassium hydroxide, sodium carbonate and potassium carbonate. The recovery or depression of sulphide and other minerals within the slurry is dependent on the pH modifier and the collector. In the monitoring of the collectorless flotation of chalcopyrite, Hu *et al.* (2009) found that depending on the pH modifier used, the upper pH limit for depression was different; decreasing with an increase in pH in the modifier order of sodium hydroxide, calcium oxide and sodium sulphide. Concerning the flotation of pyrite, sphalerite and galena and butyl xanthate as a collector at pH 12, Table 2-1 shows the influence of different pH modifiers (Hu *et al.*, 2009).

Table 2-1: Table of pH modifier depression effects on pyrite, sphalerite and calcium oxide at pH 12 using butyl xanthate collector (adapted from Hu *et al.*, 2009)

| Sulphide Mineral | pH Modifier | Effect |
|------------------|-------------|------------------------------------|
| Pyrite | NaOH or CaO | Complete depression |
| Sphalerite | CaO | Effective depression |
| Galena | NaOH or CaO | Maintains good flotation response. |

Overall, calcium oxide was stronger than sodium hydroxide in depressing all three sulphide minerals and may be the most effective for use in lead-zinc-iron sulphide ore separation (Hu *et al.*, 2009).

The pH modifiers work so differently that even if they are each used to reach the same pH value, their effect on a mineral electrode and subsequently the electrode potential may be vastly different. Table 2-2 summarises some of these effects (Hu *et al.*, 2009).

Table 2-2: Table of the different influences of pH modifiers on the electrode potential at pH 12 after 50 min on pyrite, sphalerite and galena (adapted from Hu *et al.*, 2009)

| Sulphide Mineral | pH Adjustment by NaOH | pH Adjustment by CaO |
|------------------|--|---|
| | Rapid Increase in Electrode Potential after 50 min | Slight Increase in Electrode Potential after 50 min |
| Pyrite | 70 mV to 110 mV | 60 mV to 75 mV |
| Sphalerite | -12 mV to 10 mV | -12 mV to -8 mV |
| Galena | -30 mV to -10 mV | -40 mV to -36 mV |

Sodium hydroxide, therefore, has a larger and more rapid effect on the observed potential increase. Sodium hydroxide was the pH modifier used in this research.

2.2.2.2 pH and Froth Stability

Changes in the pH of the system can significantly affect the froth. Farrokhpay and Zanin (2012) found that decreasing the pH from 11 to 4, increased the froth height as well as the froth half-life, and therefore increased the froth stability. This may be as a result of an increase in water recovery rather than because of an effect on the bubble size of the froth as Tucker *et al.*, (1994) found that pH has no significant effect on bubble size.

2.2.3 Eh-pH Diagrams

Eh-pH diagrams, more commonly known as Pourbaix diagrams, are electrochemical phase diagrams that compare reaction thermodynamic equilibriums with experimental flotation potential in order to determine the flotation behaviour of hydrophobic species within Eh-pH ranges in a collector-mineral-water system (Hu *et al.*, 2009). These diagrams relate the dominant aqueous species of an element or mineral to the stable solid phase of that species within a range of Eh and pH as well as provide further detail into the surface chemistry of minerals (Takeno, 2005). Examples of Eh-pH diagrams are shown in Figure 2-5 (for an element) and Figure 2-6 (for a mineral system). Figure 2-6 represents a real world example.

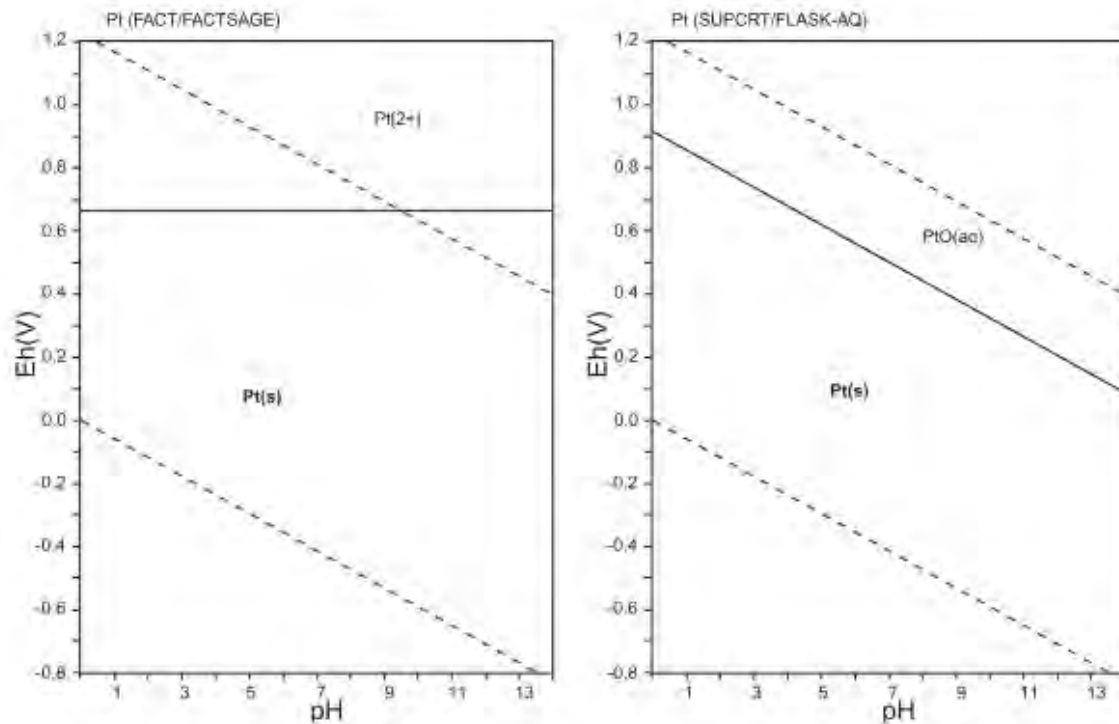

Figure 2-5: Eh-pH diagrams of the system Pt-O-H. $\Sigma\text{Pt} = 10^{-10}$, 298.15 K, 10^5 Pa (Takeno, 2005)

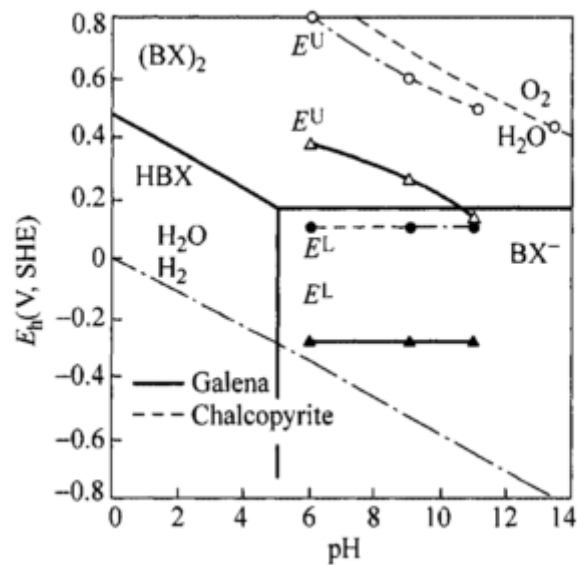

Figure 2-6: Eh-pH diagram for the butyl xanthate/oxygen system and the observed lower (E^L) and upper (E^U) limiting flotation potential of galena and chalcopyrite at which flotation recovery is greater than 50% ($\text{BX}^-: 2 \times 10^{-5}$ mol/L) (adapted from Hu *et al.*, 2009)

The Eh-pH diagrams indicate that the pulp potential decreases with an increase in pH during grinding and flotation. High dosages of pH modifiers can help maintain a stable pulp pH and potential which contribute to potential control in flotation (Hu *et al.*, 2009).

2.2.4 Dissolved oxygen (DO)

DO within the pulp is responsible for the oxidation of the mineral surface and strongly affects the rate of xanthate adsorption as oxygen is necessary for electrochemical reactions on the mineral surface (Corin *et al.*, 2013; Wills and Napier-Munn, 2006). Oxidation of the sulphide mineral surface can reduce mineral hydrophobicity and inhibit the separation of the mineral from gangue minerals in flotation (Shannon and Trahar, 1986; Guy and Trahar, 1985). DO and Eh can be used to control and monitor the flotation process and the manipulation of these factors can improve selectivity (Kuopanportti *et al.*, 1997). The standard concentration of dissolved oxygen at standard temperature and pressure (STP) is 8 mg O₂/L of water in contact with air and the dissolved oxygen concentration decreases with an increase in temperature (Lenntech Water Treatment Solutions, 2015).

The oxidation of sulphide minerals results in the production of oxygen-sulphur species which can exchange with the collector ion to form the metal collector salt. Depending on the mineral being floated and the collector used, the presence of oxygen may result in the formation of dixanthogen and other species essential for hydrophobicity. Eh, pH and time have significant effects on these oxidation products: the higher the Eh, the higher the oxidation rate of sulphide minerals. X-ray photoelectron spectroscopy (XPS) results have found the order of oxidation of certain sulphide minerals to be: pyrrhotite > pyrite > chalcopyrite > sphalerite > galena (Hu *et al.*, 2009).

DO can be controlled during the flotation process or during grinding which can affect selectivity when floating Cu-Ni sulphide ores. During flotation, oxygen is key to xanthate interactions with the sulphide mineral surface due to oxygen being the electron acceptor from the xanthate ion or from the sulphide (Corin *et al.*, 2013). Xanthates typically adsorb electrochemically on chalcopyrite and pyrite and for improved flotation of these minerals the pulp potential and DO concentration need to be manipulated. An increase in DO has been shown previously to result in an increase in adsorption of xanthates onto pyrite and chalcopyrite (Kuopanportti *et al.*, 1997).

Ross and van Deventer (1985) found that an increase in DO resulted in an increase in chalcopyrite and galena recoveries. They found that pre-aeration after milling in a steel mill resulted in an overall improvement in the chalcopyrite recovery. Copper-galena selectivity

was improved through increased DO. The chalcopyrite recovery increased with an increase in DO above a pH of 5.8. Below pH 5.8 the opposite trend was seen with sulphuric acid as a pH regulator. Sulphuric acid was seen to shift the maximum recovery of chalcopyrite to a higher pH value. There was, however, a decrease in the maximum galena recovery with an increase in DO (Ross and van Deventer, 1985). The amount of DO affects the effect of the pH and the modulators during flotation. A summary of some of the DO effects that were found by other authors is shown in

Table 2-3.

Table 2-3: Some observations of the effect of DO on the effects of pH in the flotation of chalcopyrite

| Mineral | pH | DO | Effect Observed | Reference |
|--|----------------|----------|--|--------------------------------|
| Chalcopyrite (collectorless flotation) | 5, 7.3 and 9.5 | | -Recovery decreases with increasing pH -Greater recovery in nitrogen (N ₂) than in oxygen (O ₂) -Rate constant more sensitive to pH. From pH 5 to 7.5 recovery reduced to half, from 5 to 9.5 recovery reduced to a third. | Fairthorne <i>et al</i> , 1997 |
| Chalcopyrite | 6 | Increase | Slight decrease in | Kuopanportti <i>et</i> |

| | | | | |
|------------------|-------|------------------|--|------------------|
| (with collector) | | from 8 to 37 ppm | xanthate adsorption rate and in Eh but fastest adsorption rate for all pH values tested. | <i>al</i> , 1997 |
| | *11.5 | 36 ppm | Fastest adsorption rate achieved | |
| | 11.5 | 0.005 ppm | No adsorption of xanthate | |

*Kuopanportti *et al.* (1997) also found that the adsorption of xanthates onto the minerals depends on the pH. This result is relative to other DO concentrations at this pH. It is, however, unknown how Kuopanportti *et al.* (1997) achieved a DO concentration of 36 ppm.

The effect of pH on DO can also be seen when pH modifiers are added to water in 2-phase. The modifiers affect the $[H^+]$ and $[OH^-]$ concentrations of the fluid and also the DO concentration. As seen in Equation 2-1 (Lenntech Water Treatment Solutions, 2015), an increase in $[OH^-]$ ions within the fluid can cause an equilibrium shift to the left of the reaction and result in an increase in the amount of dissolved oxygen in the system.

2.2.5 Ionic Strength (IS)

The presence of ions such as copper in plant water can result in collector sequestration as well as the unwanted activation of certain minerals. Other ions such as, Ca^{2+} , Mg^{2+} , Na^+ and Cl^- have been seen to reduce the surface tension which in turn improves froth stability. These ions have frothing properties when in a slurry, reducing the repulsive forces between the mineral particles and the air bubbles. An increase in IS has been found to reduce the bubble size in the pulp and therefore increase froth stability due to increased water content and smaller bubble size in the froth (Manono *et al.*, 2012), and subsequently increase the entrainment of gangue minerals.

2.2.5.1 IS Salts and their effect on froth stability

Certain salts and frothers share the ability to inhibit bubble coalescence. High salt content in plant water has been found to remove the need for the use of a frother in the flotation system and lower reagent consumption. However, frothers are still necessary as smaller quantities of frother are required to have the same effect that large concentrations of salt would have during flotation (Quinn *et al.*, 2007). Zieminski and Whitemore, 1971, found that the higher the valence of the ion the greater its effect in hindering bubble coalescence as compared to monovalent ions. Decades later Farrokhpay and Zanin, 2012, studied the effects of CaCl_2 , AlCl_3 and NaCl at different concentrations on froth stability. They concluded that the presence of multivalent metal ions increased froth stability due to the addition of AlCl_3 resulting in the highest increase in froth stability followed by CaCl_2 and NaCl (Farrokhpay and Zanin, 2012).

Craig (2011) investigated the effects of electrolytes on the drainage properties of the froth and found that electrolytes that consist of an α cation and an α anion ($\alpha\alpha$) or a β anion and a β cation ($\beta\beta$) are the electrolytes that inhibit bubble coalescence. Whereas the $\alpha\beta$ combination did not inhibit coalescence. These α and β assignments represent the positions of the ions in the air-water interface, where α ions are depleted at the interface and β ions are adsorbed or accumulate at the interface (Craig, 2011; Marcelja, 2006; Craig *et al.*, 1993 a; Craig *et al.*, 1993 b).

With respect to the salts used in the UCT laboratory plant water, the α and β ion combinations would, therefore, be as seen in Table 2-4 (adapted from Craig, 2011):

Table 2-4: α and β ion assignments of plant water salts

| Chemical Salt | Concentration (g/L) | Percentage of plant water (%) | α , β Assignment |
|--------------------|---------------------|-------------------------------|--|
| Magnesium Sulphate | 0.615 | 42,0 | $\alpha\alpha$ |
| Magnesium Nitrate | 0.107 | 7,31 | No $\alpha\alpha$ or $\beta\beta$ pair |
| Calcium Nitrate | 0.236 | 16,1 | $\alpha\alpha$ |
| Calcium Chloride | 0.147 | 10,0 | $\alpha\alpha$ |
| Sodium Chloride | 0.356 | 24,3 | $\alpha\alpha$ |
| Sodium Carbonate | 0.003 | 0,205 | No $\alpha\alpha$ or $\beta\beta$ pair |

Table 2-4 indicates that the majority of the plant water salts would inhibit bubble coalescence and result in a stable froth.

2.2.5.2 Ionic Strength and Depressant Effects

IS has been studied in relation to depressant dosage and has been found to affect the effectiveness of the gangue depressant used (Corin *et al.*, 2010). It has been found that a fixed IS coupled with an increasing depressant dosage results in reduced solids recovery to the concentrate which may be because of reduced NFG recovery. A fixed depressant dosage and increasing IS has been found to increase water recovery and froth stability (Corin *et al.*, 2010). For nickel recovery, higher IS (5 and 10 IS) was observed to allow for stronger guar depressant effects and the IS and depressant dosage of CMC has been found to affect the entrainment factor in that for each IS a higher entrainment factor was found for CMC than for guar depressant (Manono *et al.*, 2012).

2.3 The Froth Phase

The froth phase is where valuable minerals are collected into the concentrate launder. Froth stability occurs when the rate of smaller bubbles joining the froth from the pulp phase and the rate of bubbles bursting in the froth are equal. It also can be defined as the froth's ability to resist bubbles bursting and bubble coalescence (Farrokhpay, 2011). In essence, the smaller the bubbles the more stable the froth should be (Aldrich and Feng, 2000).

Froth layers are generally dynamic and spontaneously collapse. They are therefore classified into two extremes, namely, a metastable or persistent froth, which defines a more stable froth and an unstable or transient froth. The key difference between these classifications is in the drainage of the liquid between the bubbles. As the liquid drains in an unstable froth, the froth continuously collapses and the bubbles remain in a pseudo-spherical state until they coalesce. The drainage in a metastable froth, however, is such that the hydrophobic particles can remain in the froth long enough to reach the concentrate launder while the entrained particles are allowed to drain back into the pulp (Harris, 1982). Due to pressure differences, a slow diffusion from the small to large bubbles occurs in a metastable froth and the rate of diffusion eventually collapses the froth (Harris, 1982).

The stability of the froth greatly impacts the grade and recovery of valuable minerals in flotation. It is influenced by the presence of particles, particle size and hydrophobicity (Johansson and Pugh, 1992), reagents and operating factors such as the aeration rate, water quality and gas dispersion (Farrokhpay, 2011). Water recovery is a good indicator of froth stability as an increase in water recovery tends to correspond to a stable froth (Wiese and Harris, 2012).

2.3.1 Froth Stability Calculation

Barbian *et al.* (2003), modified the Bikerman test that was initially created for 2-phase foams (Bikerman, 1973), to be used for froth flotation systems. This modification gave rise to the stability column that can be used in industry as well as in the laboratory. The purpose of this column is to measure the dynamic froth stability factor of the flotation system. The dynamic stability factor is therefore linked to the equilibrium height of the froth in the column. This height is the maximum height at which the froth stabilises after rising (Barbian *et al.*, 2005).

The dynamic froth stability is generally calculated using Equation 2-3. The equation shows that the dynamic froth stability factor, Σ , is a function of the volume of the foam, V_f , and the gas volumetric flow rate, Q (Barbian *et al.*, 2003):

$$\Sigma = \frac{V_f}{Q} = \frac{H_{max} \times A}{Q} \quad \text{Equation 2-3}$$

Where:

Σ = the dynamic froth stability factor (s)

V_f = the volume of the foam (L)

Q = the gas volumetric flow rate (L/s)

H_{max} = the maximum equilibrium height achieved (m)

A = the cross-sectional area of the column (m²)

2.3.1.1 Bubble Elasticity and Surface Tension

Bubble elasticity refers to the ability of the bubbles within the pulp and froth to return to their initial state after deformations caused by forces within the cell. The elasticity is a

strong function of the resistance of the liquid film surrounding the bubble to deformation (Manev and Nguyen, 2005).

Gibbs determined the Gibbs elasticity based on the findings that increasing the liquid film area simultaneously increased the local surface tension and therefore increased the tendency of the film to contract. He, however, noted that elasticity was not enough to prevent film rupture and that other forces were at play (Gibbs, 1961).

The surface tension of the liquid affects the bubbles within the froth and subsequently the froth stability. It influences the size and stability of the bubbles in that the higher the surface tension, the larger and more unstable the bubbles are and the lower the interfacial area, leading to an unstable froth (Syeda *et al*, 2004).

2.3.2 Flotation of Fine Particles

The presence of solid particles in the froth can add to its stability by reducing drainage. Depending on the concentration, size and type of particles, different effects on the froth layer can be seen. Fine solid particles can significantly influence the rupturing of the thin films within the froth resulting in increased bubble coalescence, froth decay (Manev and Nguyen, 2005) and retardation of the flotation process. However, depending on the type of particle, froth stability can result, for example, fine quartz particles have been found to increase bubble resistance to coalescence which increases froth stability (Szatkowski and Freyburger, 1985). Particle size affects the overall flotation process by affecting the physical processes that make up the overall process. The most dominant of these processes are: impaction, adhesion and detachment between bubbles and particles in the flotation system (King, 1982).

Entrainment is the most obvious form of fine particles with sizes of about less than 38 μm of reporting to the froth (King, 1982). This affects both gangue and desired minerals.

2.3.3 Entrainment

Mechanical entrainment is the process in which mineral particles that are part of the slurry suspension in the flotation cell are transported to the froth layer and subsequently leave the cell via the concentrate with the mineral particles that were transported via true flotation. Entrainment is a physical, non-selective process as it results in the transport of hydrophobic

and hydrophilic mineral particles to the concentrate without the attachment of the particles to air bubbles. It may occur simultaneously with true flotation and whereas true flotation reaches a maximum at an intermediate size, entrainment increases with a decrease in particle size (Cilek, 2009).

Entrainment can generally be divided into two stages, with the first stage being the ascension of the mineral particles from below the pulp/froth interface to the froth, and the second stage being the transportation of these entrained particles with water to the concentrate launder. The division of these two stages allows for the contributing factors to be divided into those of the pulp and those of the froth. Entrainment largely affects ores with a significant amount of fine particles (particles < 50 μm in size) (Wang *et al.*, 2015). As a result of the recovery of undesired mineral particles, entrainment has a detrimental effect on the grade of the concentrates recovered. For this reason, it is important to understand how entrainment occurs, what the contributing factors of entrainment are as well as how it can be measured and reduced or controlled.

2.3.3.1 Mechanisms That Characterise Entrainment

Three theories combine to describe the basis of the process of entrainment. These are the Boundary Layer, Bubble Wake and Bubble Swarm Theory. Each theory describes the transport of mineral particles from the pulp to the froth. The Boundary Layer Theory explains how the mineral particles can be transported to the froth in the thin layer of water around a bubble called the bubble lamella without being directly attached to the bubble. The Bubble Wake Theory attributes some of the transport to the mineral particles being carried to the froth in the wake of a rising bubble. To complete the three theories, the Bubble Swarm Theory accounts for how the layers of the bubbles that swarm into the froth layer increase the entrained particles that can be retained in the froth (Wang *et al.*, 2015).

Once the mineral particles have been transported to the froth, drainage can occur through drainage channels such as the plateau borders in the froth. Plateau borders are formed when the bubble lamellae meet at 120° , contain the majority of the liquid found in the froth layer and allow for free movement and settling of both hydrophobic and hydrophilic particles within the froth (Wang *et al.*, 2015). Drainage will also occur if the froth collapses. For the purpose of this study, these mechanisms will not be explored in detail.

2.3.3.2 Factors Affecting Entrainment

Wang *et al.* (2015) stated that water recovery, the solids percentage in the pulp, particle size, impeller speed (turbulent flow), particle density, gas rate, froth height, froth retention time, rheology and froth structure are all factors that affect entrainment. Each factor influences entrainment to different degrees and overall these factors summarise the effect on entrainment in the pulp and froth phase.

Water recovery has generally and most commonly been associated with entrainment. From the theories for mineral particle transport in entrainment, water is the medium of transport used. Therefore, a direct correlation between water recovery and entrainment of fine particles to the concentrate is expected and is well observed (Vos *et al.*, 2014). An equation used for measuring entrainment as a function of water recovery is indicated in Equation 2-4 (Subrahmanyam and Forssberg, 1988).

$$R_{gangue} = \varepsilon R_{water} \quad \text{Equation 2-4}$$

Where:

R_{gangue} = the gangue recovered from the cell

R_{water} = the water recovered from the cell

ε = the probability of entrainment of gangue from the cell or the entrainment factor

This study will focus on water recovery as a means of monitoring entrainment.

2.4 The Bushveld Igneous Complex

The Bushveld Igneous Complex is the largest layered intrusion in the world. It contains large reserves of platinum group metals (PGMs), sulphides and chromite as well as other minerals. These three mineral reserves form part of the mafic parts of the layered complex. The complex has five main limbs, namely, the Eastern, Southeastern, Far Western, Western, and Northern Limbs, and is seven to nine kilometres thick (Schouwstra, 2000). Figure 2-7 shows a geological map of the Bushveld Complex. The layers are classified into the upper zone, the main zone, critical zone and the lower zone. The largest concentration of platinum group elements (PGEs) in the world is found in the upper Critical Zone. This zone contains the Upper Group Chromite No. 2 (UG2), the Merensky and the Platreef mineralisation of the

complex (Schouwstra, 2000). The largest percentage of platinum is found in the Merensky Reef, whereas the largest percentages of Palladium and other metals are found in the UG2 and Platreef, respectively (Dunne, 2011). Figure 2-8 shows the layers of the Bushveld Complex.

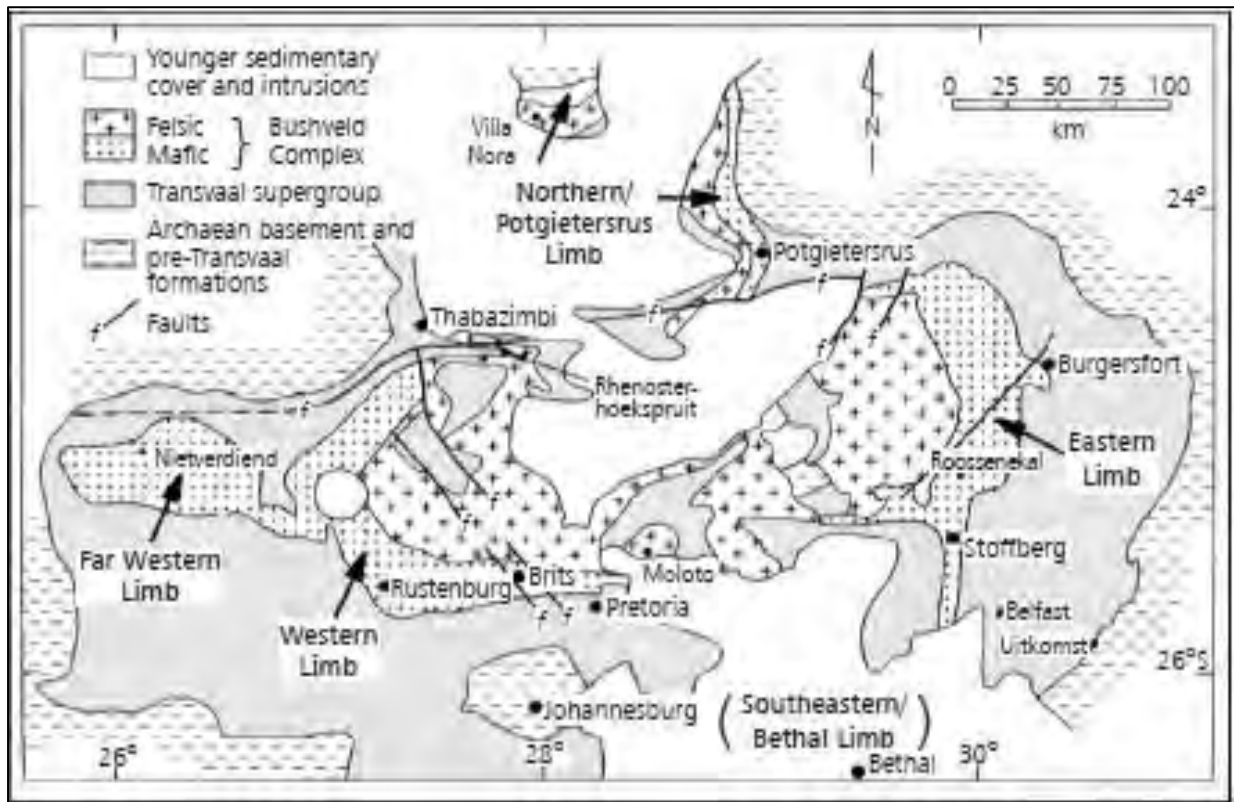

Figure 2-7: A Geological plan view map of the Bushveld Complex (O'Connor and Shackleton, 2013)

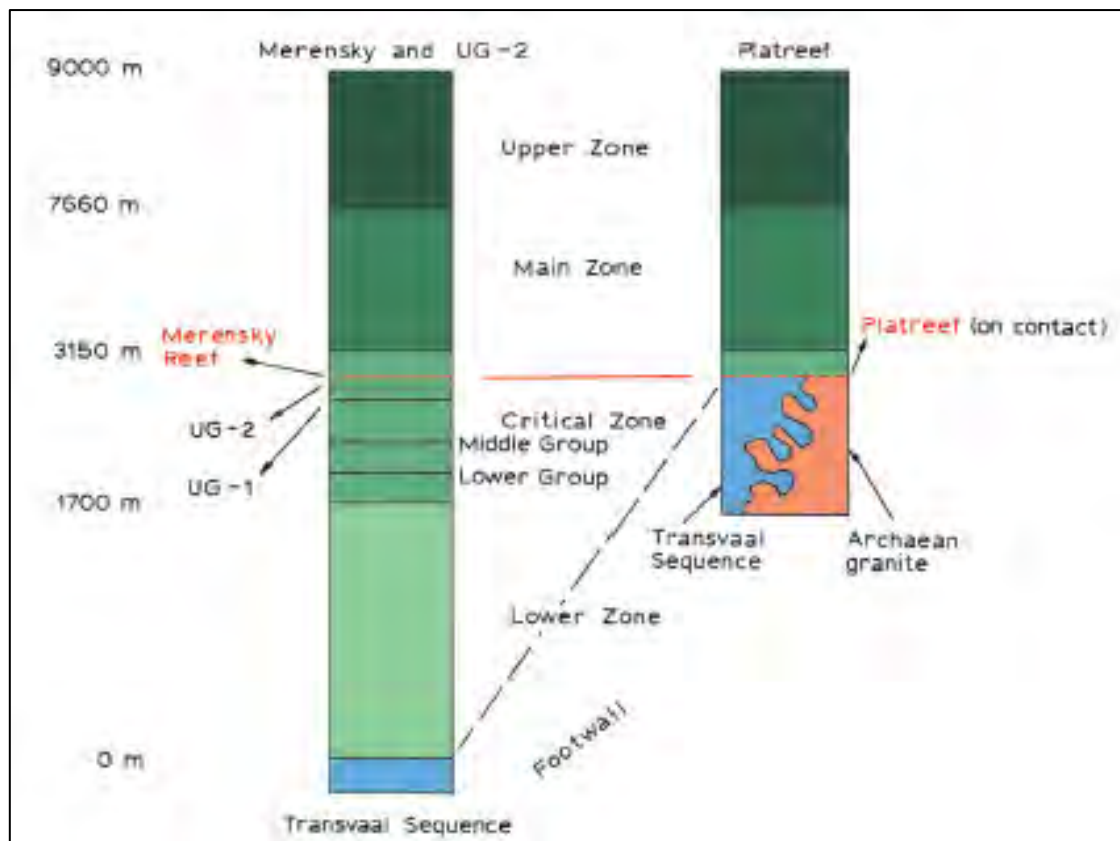

Figure 2-8: Stratigraphic column showing layers of the Bushveld Complex. UG-1=Upper Group Chromite No.1, UG-2=Upper Group Chromite No.2. (Schouwstra, 2000)

For the purposes of this study, the focus will be on the Platreef ore.

2.4.1 The Platreef

The Platreef is part of the Northern Limb of the Complex. The reef contains pyroxenites, serpentinites and calc-silicates. The PGE tellurides, arsenides and sulphides are the most mined part of the reef. The concentrations of these minerals vary throughout the reef with the platinum and palladium tellurides and arsenides making up about 50% of the PGMs in the ore (O'Connor and Shackleton, 2013). In certain areas of the Platreef, the mineralisation reaches a thickness of 40 m (Schouwstra, 2000).

Table 2-5 shows the percentages of platinum, palladium and other minerals found in the Merensky, UG2 and Platreef. Table 2-6 shows the bulk mineralogy and PGE distribution across the three Bushveld reefs.

Table 2-5: The percentage of the platinum, palladium and other elements in the Merensky, UG2 and Platreef (Dunne, 2011)

| % | MERENSKY | UG2 | PLATREEF |
|--------------|----------|-----|----------|
| Pt | 55 | 44 | 46 |
| Pd | 32 | 46 | 30 |
| Other | 13 | 10 | 24 |

Table 2-6: Bulk mineralogy and platinum distribution across the Platreef, Merensky and UG2 reef (Adapted from Shamaila and O'Connor, 2008)

| | Platreef | Merensky | UG-2 |
|-------------------------|---|--|---|
| Bulk mineralogy | Pyroxene Serpentine Calcium silicates Base metal sulphides | Pyroxene Feldspar Base metal sulphides | Chromite Pyroxene Feldspar Base metal sulphides |
| PGE distribution | Tellurides 30% Arsenides 21% Alloys 26% Sulphides 3% Rest 20% | Tellurides 30% Arsenides 7% Alloys 7% Sulphides 36% Rest 20% | Tellurides < 5% Arsenides < 5% Alloys 20% Sulphides 70% Rest < 5% |

3 Research Objectives

3.1 Objectives

The objective of this study is to understand the influence of various pulp chemical conditions during flotation on bubble size, froth stability and entrainment and the grades and recoveries of the valuable minerals.

3.2 Hypotheses

1. Improved flotation outcomes can be achieved with careful control of flotation pulp chemistry as this chemistry will determine both the stability of the froth phase as well as the ability of the valuable minerals to reach the froth phase.
2. Eh can be manipulated by careful control of pH during the flotation process as Eh is simply an indicator of other chemical factors within the system.
3. Increased ionic strength of process water lowers the likelihood of bubble coalescence, therefore smaller bubbles will be present in the froth phase and this will result in higher water recoveries and more entrained material entering the concentrate.

3.3 Key Questions

1. Can the careful control of the pulp chemistry improve froth stability?
2. Can the pulp chemistry factors be controlled such that flotation performance is improved in terms of grades and recoveries?
3. What conditions of IS, pH, DO and Eh will result in decreased entrainment?
4. What will be the effect of changing IS on bubble size in the froth phase?

4 Experimental Details

4.1 Ore Preparation

A sample of Platreef ore with a top size of -4 mm was used to conduct all testwork. A target grind of 60 % passing -75 μm was chosen for all the tests conducted. 1 kg aliquots of ore were milled in an Eriez stainless steel 1 kg rod mill and 2 kg aliquots of ore was milled in a SALA stainless steel 3 kg rod mill for batch flotation tests and stability column tests respectively. 500 ml of plant water per kg of ore was used in each mill resulting in a mill charge of 66 % solids in both mills. The 1 kg mill has an internal diameter of 195 mm and an internal length of 295 mm. The 1 kg mill contained a total of 20 stainless steel rods which had the following diameters; 6 x 25 mm, 6 x 20 mm, and 8 x 16 mm, and were all a length of 285 mm. The total weight of these rods was 13.40 kg. The 3 kg mill contained 22 stainless steel rods that were 25 mm in diameter and 285 mm in length. The internal diameter and length of the 3 kg mill were 300 mm.

In order to determine the milling curve needed to achieve the target grind, wet screening of 1 kg representative ore samples was done. The milling time was taken from the milling curve and found to be 11 minutes and 40 seconds for the 1 kg mill and 13 min and 19 seconds for the 3 kg mill (Figure 4-1).

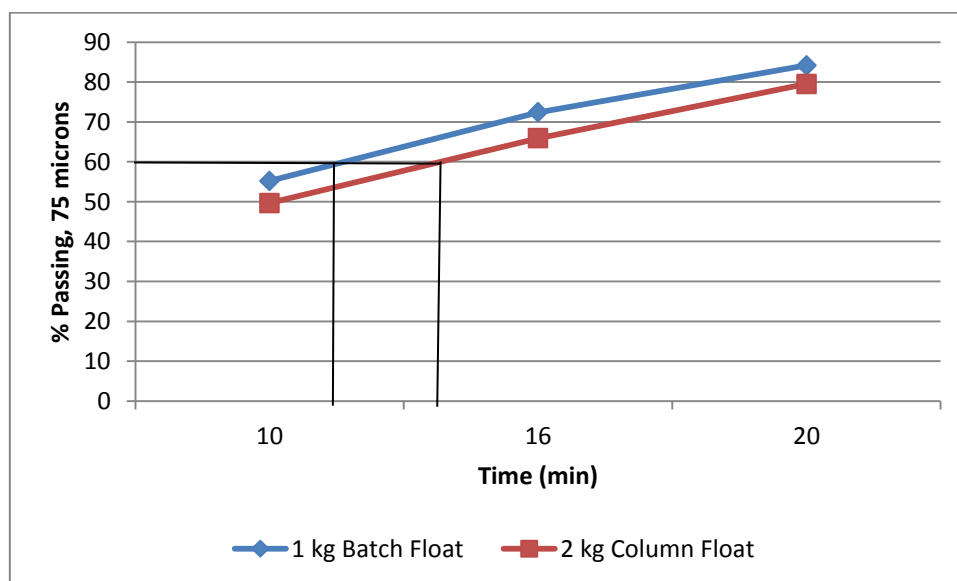

Figure 4-1: Milling curves for 1 kg batch float and 2 kg column float

4.2 Water

The IS is a blend of salts made to represent the type of water used in flotation in industry. Table 4-1 shows the salts and their dosages that are used to make up this water. The plant water salts were supplied by Merck in powder form and were blended in the concentrations as laid out in Table 4-1 to produce the plant water at 1 IS. The plant water at 5 IS was five times the concentration of each salt at 1 IS.

Table 4-1: Table of plant water salts in grams per litre

| Chemical Salt | Concentration (g/L) | Percentage (%) |
|--------------------|---------------------|----------------|
| Magnesium Sulphate | 0.615 | 42,0 |
| Magnesium Nitrate | 0.107 | 7,31 |
| Calcium Nitrate | 0.236 | 16,1 |
| Calcium Chloride | 0.147 | 10,0 |
| Sodium Chloride | 0.356 | 24,3 |
| Sodium Carbonate | 0.003 | 0,205 |

4.3 Reagents

A standard reagent suite was used for both the batch and column tests as listed in Table 4-2. 2 M Sodium hydroxide (NaOH) was used to adjust the pH and was supplied by Merck at an analytical grade. It was used as received. Sodium hypochlorite (NaClO), was used as an oxidising agent to adjust Eh and was supplied by Kimix as a stock solution of 12 % and was used as received. The collector, frother and depressant were supplied by Senmin. The collector was received in powder form and the frother in liquid form. The collector was mixed into a 1 % solution by mass and the frother was used as received. The depressant was received in powder form.

Table 4-2: Table of reagent suite

| Reagent | Reagent ID | Dosage (g/t) | Molecular Weight (g/mol) | Purity (%) |
|------------|--|--------------|--------------------------|---------------|
| Collector | SIBX | 150 | 172.2 | Close to 90 % |
| Frother | Senfroth 516 | 40 | 220 | |
| Depressant | Carboxymethyl cellulose (CMC) (Sendep 30D) | 500 | 160608 | 66.54 |

4.4 Stability Column Tests

The stability column was used to conduct 2-phase and 3-phase tests to see the effect of the pulp factor on froth stability as determined by the dynamic stability factor calculated using Equation 2-3 of Section 2.3.1. The column was made of Perspex and had a diameter of 10 cm and a height of 1 m. The air flow rate of the column was maintained at 7 L/min. A pore-2 frit was used to regulate the bubble size produced by the air flow rate. In total 12 column tests were performed. Duplicates for each test were performed.

Reagents were added to a feed bucket and allowed to condition for both the 3-phase slurry and 2-phase solution prior to running each column test. Once conditioning was complete, the slurry or solution was pumped into the column using a motor. The slurry was allowed to fill the column up till a height of 200 mm. The motor was then switched off and the valve to the column shut to prevent the fluid from leaking out. The agitator was switched on once the fluid reached the impeller and remained on until the end of the experiment. Air was sparged into the column and the rotameter was used to maintain the air flow rate. Each test was run until the equilibrium height (H_{\max}) was achieved. The time taken to reach the maximum height was recorded in 5 second intervals until 1 minute had passed and then in 30 second intervals until the H_{\max} was obtained. Each time interval was marked on the side of the column with a marker. Once the froth stopped rising the air was switched off and the slurry was drained from the column. The markings made on the side of the column were then measured with measuring tape and their heights from the base recorded. A figure of the stability column is shown in Figure 4-2.

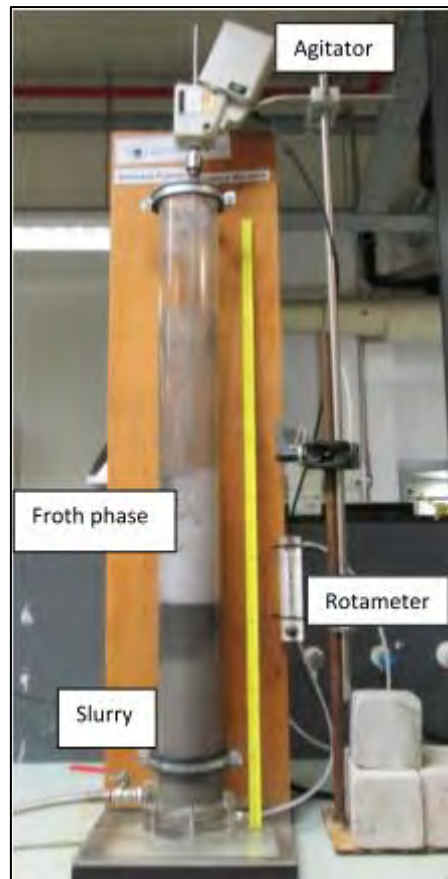

Figure 4-2: Stability column with agitator and rotameter, indicating slurry and froth phase.

Of the 12 column tests conducted 2 tests were 2-phase tests to see what effect changing the pulp conditions would have on froth stability in the absence of solids. The first test was Test 1 and the second was at the condition where all the pulp factors were changed to higher values except for the Eh because it was thought that Eh would only have an influence in 3-phase experiments.

10 tests were conducted in 3-phase in the stability column. These tests were performed after the batch flotation tests were conducted and the test conditions were selected from the batch tests that yielded the highest and lowest solids and water recoveries. The batch flotation procedure is discussed in Section 4.5.

4.5 Batch Flotation Tests

The experimental program for the batch flotation tests was based on a factorial design approach.

4.5.1 Factorial Design and Experimental Conditions Obtained

Factorial design is a method of analysis of data used when one needs to assess the effect that independent factors have on a system or on dependent factors. It helps to view every possible interaction the factors would have on the system, individually and collectively, as well as the interaction the factors would have with one another (Study.com, 2016). The design notation is based on the number of factors and levels tested for each factor. For example, a 2^3 factorial design has three factors and two levels for each factor being tested (PennState The Methodology Center, 2016). This results in eight experiments being conducted. For this reason, a factorial design was used in this thesis. The pulp factors made up the four factors to be assessed and each factor was varied across two levels, yielding a 2^4 factorial design and 16 experiments for the 3-phase tests. The 2-phase tests did not take into account Eh effects and therefore, the conditions in which only the Eh was changed were excluded from the 2-phase tests, resulting in 12 tests in 2-phase therefore these tests were not determined by factorial design. The two levels chosen for each factor are shown in Table 4-3.

Table 4-3: Table of pulp factor lower and higher levels

| Pulp Factor | Lower Level | Higher Level |
|-------------|-------------|--------------|
| IS | 1 IS | 5 IS |
| pH | 9 | 11 |
| DO | 0 ppm | 8 ppm |
| Eh | 200 mV | 700 mV |

However, it is important to note that these exact values were not always experimentally achieved for each factor.

The pH was only manipulated when it was increased to pH 11, therefore without any manipulation, the pH of the system was taken as the pH for that condition tested. Platinum bearing ores in South Africa are normally floated at pH 8.7 (Malysiak, 2003). Therefore, the natural pH varied between pH 8.5 to pH 9, was recorded as pH 9 for the results section (Chapter 5). pH 11 was also a rounded figure, ranging from pH 11 to pH 11.5.

The value of 8 ppm for DO is the DO level in a slurry at 25 °C, as DO is temperature dependent (Lenntech Water Treatment Solutions, 2015). The laboratory temperature varied depending on the season and the temperature of the slurry was not measured at any point in the experiments. The DO levels measured therefore varied between 7 and 9 ppm in a 3-phase slurry but could rise to 10 ppm in a 2-phase system. The presence of oxygen was therefore noted as 8 ppm and the lack thereof as 0 ppm.

Eh, varied the most as the redox potential of the system varies continually (Hu *et al.*, 2009). Therefore, the values written in the results section were rounded off figures for the highest or lowest value measured during the conditioning time of the float. It is also important to note that although the factorial design was initially set for 200 mV to 700 mV for Eh, the values experimentally obtained were from -120 mV to 730 mV. The lowest value of -120 mV obtained for Eh may be due to the properties of Platreef ore, because the ore has a natural Eh of approximately -200 mV.

The graphical keys for the 2-phase and 3-phase tests are shown in Table 4-4 and Table 4-5.

Table 4-4: 2-Phase Test Graphical Key





























| Symbol | Test | Condition |
|---|---------|-----------------------|
|  | Test 1 | 1 IS pH9 DO8 Eh(-50) |
|  | Test 2 | 1 IS pH11 DO8 Eh(-90) |
|  | Test 3 | 1 IS pH11 DO8 Eh430 |
|  | Test 4 | 5 IS pH9 DO8 Eh90 |
|  | Test 5 | 5 IS pH11 DO8 Eh(-90) |
|  | Test 6 | 5 IS pH11 DO8 Eh500 |
|  | Test 7 | 1 IS pH9 DO0 Eh40 |
|  | Test 8 | 1 IS pH11 DO0 Eh(-60) |
|  | Test 9 | 1 IS pH11 DO0 Eh370 |
|  | Test 10 | 5 IS pH9 DO0 Eh30 |
|  | Test 11 | 5 IS pH11 DO0 Eh(-70) |
|  | Test 12 | 5 IS pH11 DO0 Eh570 |

Table 4-5: 3-Phase Test Graphical Key

| Symbol | Test | Condition |
|---|---------|------------------------------|
|  | Test 13 | 1 IS, pH 9, DO 8, Eh (-70) |
|  | Test 14 | 1 IS, pH 11, DO 8, Eh (-100) |
|  | Test 15 | 1 IS, pH 9, DO 8, Eh 730 |
|  | Test 16 | 5 IS, pH 9, DO 8, Eh (-80) |
|  | Test 17 | 5 IS, pH 11, DO 8, Eh (-120) |
|  | Test 18 | 5 IS, pH 9, DO 8, Eh 730 |
|  | Test 19 | 5 IS, pH 11, DO 8, Eh 660 |
|  | Test 20 | 1 IS, pH 11, DO 8, Eh 500 |
|  | Test 21 | 1 IS, pH 9, DO 0, Eh 50 |
|  | Test 22 | 1 IS, pH 11, DO 0, Eh (-20) |
|  | Test 23 | 1 IS, pH 9, DO 0, Eh 700 |
|  | Test 24 | 1 IS, pH 11, DO 0, Eh 500 |
|  | Test 25 | 5 IS, pH 9, DO 0, Eh (-40) |
|  | Test 26 | 5 IS, pH 11, DO 0, Eh (-90) |
|  | Test 27 | 5 IS, pH 9, DO 0, Eh 720 |
|  | Test 28 | 5 IS, pH 11, DO 0, Eh 650 |

4.5.2 Batch Flotation Procedure

The standard UCT batch flotation procedure developed at the Centre for Minerals Research (CMR), University of Cape Town (UCT) was used to conduct all batch flotation tests. This procedure has proven to be an effective method for the investigation of the interactions that take place between minerals and reagents during the flotation process. The procedure allows for the separation of NFG from entrained gangue and accounts for changes in froth stability. The apparatus for the procedure includes a 3L UCT modified Leeds flotation cell with a top –driven impeller, and a Wilkerson ¼ inch 0-8 bar air regulator to control the air flow rate. An image of the batch flotation cell is shown in Figure 4-3.

The milled slurry was placed in the batch flotation cell and synthetic plant water (SPW) was added to the cell to bring the pulp density to 33 %. Reagents were then added to the cell and the impeller switched on, allowing the pulp to condition. Once the pulp was conditioned, the air was switched on and maintained at 7 L/min. Four concentrates were

collected at 2, 6, 12 and 20 minutes. The pulp chemistry was varied by changing the DO, pH, Eh and IS during the conditioning time, and solids and water recoveries were determined for all tests.



Figure 4-3: Picture of UCT Leeds 3 L laboratory batch flotation cell

The DO and pH of the system were measured using a TPS meter and the Eh using a HANNA meter as shown in Figure 4-4.

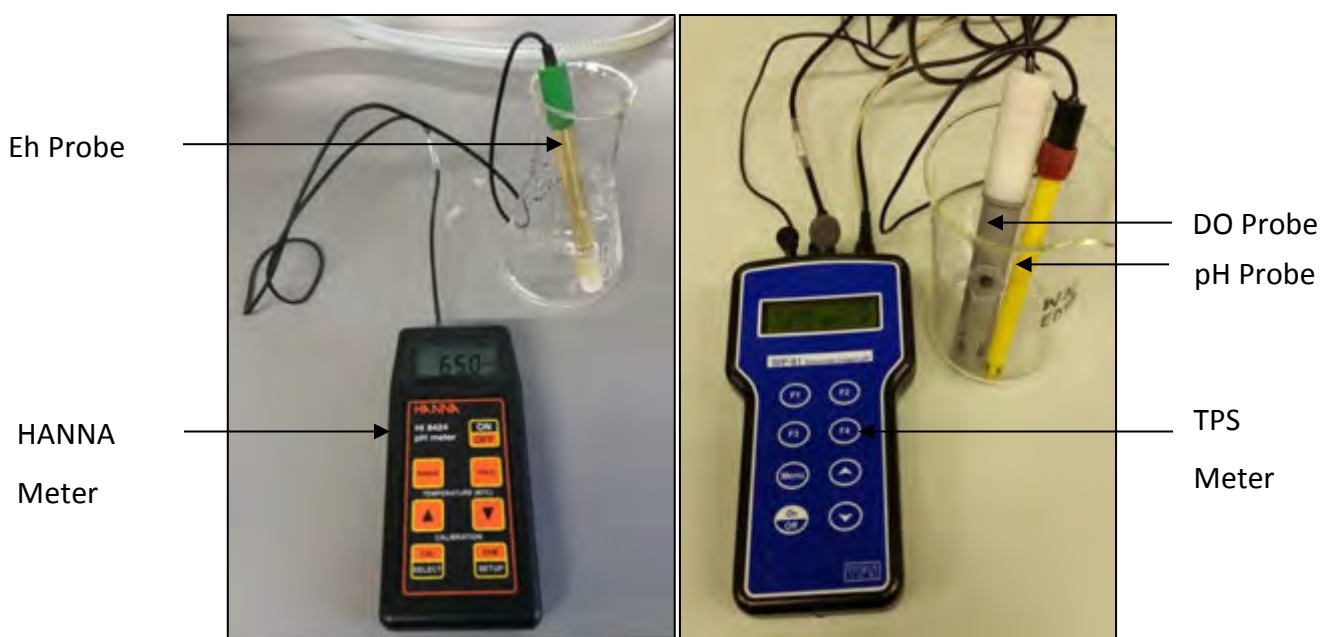

Figure 4-4: Pictures of HANNA meter and Eh probe, and TPS meter and DO and pH probes

The DO concentration was controlled by floating with nitrogen to reduce the oxygen concentration in the flotation cell to zero. The Eh was measured using a platinum electrode and expressed through the use of the standard hydrogen electrode (SHE) scale. The SHE scale is the scale that potentials recorded by Eh electrode are usually converted to. The reference electrode used is either the calomel ($\text{Hg}/\text{Hg}_2\text{Cl}_2$) or silver/silver chloride (Ag/AgCl). To convert the results obtained from these electrodes to a hydrogen scale, 0.2415 V or 0.2223 V are added to the results obtained on a hydrogen scale for the calomel and silver chloride electrode, respectively (Chander, 2003). The pH was adjusted using NaOH. IS was controlled using the SPW salts concentration. The Eh was manipulated using Sodium Hypochlorite (NaClO) as this altered the Eh without changing the pH (Chimonyo, 2016). The dosage of NaClO was 10 ml of a 12% laboratory solution for tests conducted at pH 9 and 100 ml of the same laboratory solution for tests conducted at pH 11.

4.6 Depressant Tests

High depressant tests were conducted on selected conditions from the batch flotation tests. The conditions selected were those that yielded the highest and lowest solids and water recoveries in the batch flotation tests. The depressant used was a CMC depressant (Sendep 30D) at a dosage 500 g/t. This dosage was chosen because studies have shown that at 500 g/t of depressant all the NFG can be assumed to be depressed and the gangue recovered is by entrainment (Wiese, 2009). These depressant tests were performed in both the stability column to assess froth stability and in the batch flotation cell to assess the grades and recoveries of valuable and gangue minerals. 1 % solution of depressant was freshly prepared each day by adding the depressant to de-ionised water and allowing the mixture to stir with a magnetic stirrer on a stirrer plate for 3 hours until completely dissolved as the depressant is 15 % insoluble material. Each batch flotation tests were performed in duplicates.

4.6.1 Gangue Recovery and Entrainment

The total gangue material was calculated by performing a sulphur balance on the solids recovered in the depressant tests using the method developed by Wiese (2009). The amount of sulphides were subtracted from the total solids recovered and the remaining material was considered gangue. The slope of the gangue recovery versus water recovery graph at high depressant dosage for each condition was determined and taken as the

entrainment factor. This factor was then multiplied by the cumulative water recovered to determine the amount of entrained gangue. The difference between the total gangue and the entrained gangue was taken as the naturally floating gangue (NFG).

4.7 Data Analysis

To better understand the interactions that were taking place within the pulp, a 3D surface plot was constructed. This plot brings further insight into the effects the pulp factors had on water and solids recoveries. This plot, and the grids that follow them, aided in understanding what effects, if any, the pulp factors had on one another. The grids generated showed the interaction of the pulp factors with one another on a colour scale. In the grid, the strong red colour indicated a strong positive reaction, the white a neutral interaction and the dark blue a strong negative interaction. Model equations were statistically determined using the Design Expert 9 software and written in coded form. Writing the equations in coded form allowed for the pulp factors: IS written as A, pH written as B, DO written as C, and Eh written as D, to be substituted with 1 or -1 in the equation depending on their positive or negative influence on the recovery. In certain cases, in order to find the equation of best fit for the statistical model, the recovery (water or solid) was written in its natural log or square root form.

4.8 Testing the Effect of pH on Eh

Further tests were conducted to assess the effect of pH on Eh and add to the importance of using NaClO to adjust the Eh. A 3-phase 33 % solids slurry was prepared and placed in the batch flotation cell. Reagents, collector and frother, were added to the slurry and allowed to condition. The pH meter and Eh meter were inserted into the slurry to measure the changes in pH and Eh. The pH was increased using NaOH and decreased using sulphuric acid (H_2SO_4) from pH 3 to pH 11. The changes in Eh were recorded.

4.9 Bubble Size Comparison

Still shots of the side view of the batch flotation cell were taken of each test at the same time (10 min) in the batch flotation process. These images were of the froth phase and the same 2 cm x 2 cm section was selected from each image. 2 cm was chosen as this is the froth depth in the batch cell. The purpose of these images was to compare the bubble sizes

when each pulp factor was changed to the bubble sizes at the condition of 1 IS, pH 9, DO 8 and an Eh of -70 mV.

4.10 Assays

On completion of the flotation tests, samples were assayed in order to determine the impact of pulp chemistry conditions on the grades and recoveries of the valuable minerals present in the ore. The assays performed were for copper and nickel, PGE (3E) and sulphur by Mintek. The methods used by Mintek were the ICP1 method to assay for copper, nickel and other elements, the 3E method to assay for platinum, palladium and gold, and the total sulphur (S) assay. In the ICP1 method, a minimum of 0.2g of the sample is fused with a strong alkali flux at LPG temperature followed by acidifying for conversion into a solution. The 3E method makes use of a fire assay Lead/Silver collection followed by the hotplate acid dissolution of the silver prill and ICP-OES or ICP-MS finish (depending on the concentration levels). The total S is a determination of S by combustion. In the total S method, samples are heated in the instrument furnace with an accelerator and sulphur is released and detected by IR.

5 Results

The objective of this study is to understand the influence of various pulp chemical conditions during flotation on bubble size, froth stability and entrainment and the grades and recoveries of the valuable minerals. This chapter shows the results obtained with the aim of achieving this objective. This chapter consists of six sections. Section 5.1 shows the 2-phase test results, and section 5.2 and 5.3 consist of the 3-phase test and depressant test results, respectively. Section 5.4 shows the effect of changing pH on Eh, and section 5.5 and 5.6 show the influence of changing conditions on bubble size and the key findings of this chapter, respectively. The Graphical Key attached may be used to understand the conditions outlined in this chapter by the tests labelled Test 1 to Test 12 for 2-phase and Test 13 to Test 28 for 3-phase.

5.1 2-Phase Tests

The objective of this work is to investigate and understand the effect of IS, pH, DO and Eh on froth stability and water recovery in a 2-phase system. 2-phase tests were conducted in order to decouple the effect of particles on froth stability. The stability column and batch flotation cell were used to conduct these tests and their experimental details are outlined in Chapter 4.

In comparing conditions tested, it is important to note that the reference case for flotation performance is referred to as the Test 1. Test 1 is the condition at 1 IS, pH 9, DO 8 and -50 mV. All other conditions are derived from Test 1 and are the result of changes in either IS, pH, DO or Eh, or due to changes in a combination of these factors.

5.1.1 2-Phase Stability Column Tests

The 2-phase stability column conditions are plotted against the dynamic froth stability factor as shown in Figure 5-1. The 1 IS condition yielded a slightly more stable froth. However, there was no change observed as indicated by the dynamic stability factor.

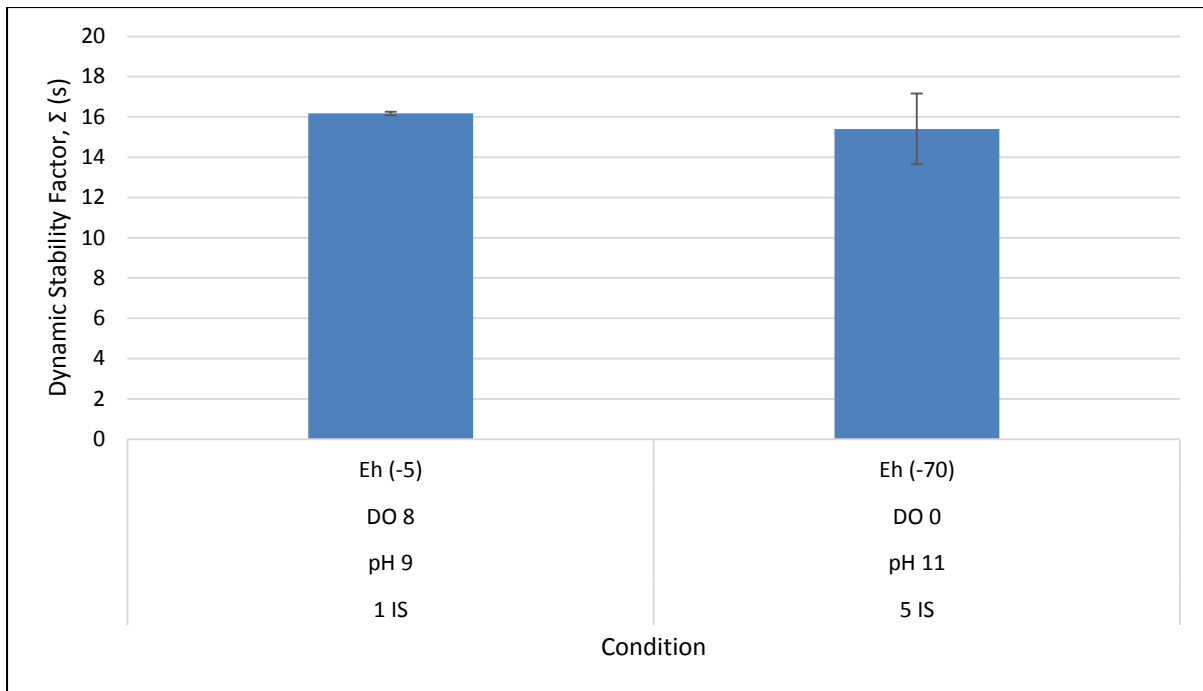

Figure 5-1: 2-Phase froth stability results for differing Eh, DO, pH and IS values. Error bars represent standard error.

5.1.2 2-Phase Batch Tests

The following sections present the results obtained from experiments conducted in a batch flotation cell.

5.1.2.1 Water Recovery As A Function Of Time

Water recovery as a function of time in a 2-phase system is shown in Figure 5-2. Figure 5-2 shows that the highest amount of water, 2600 g, was recovered at 5 IS, pH11, DO 0 and -70 mV (Test 11). The lowest recovery of 532 g was observed at the Test 1. Higher water recoveries were seen at DO 0 than at DO 8. Low Eh values gave higher water recoveries as compared to Test 1.

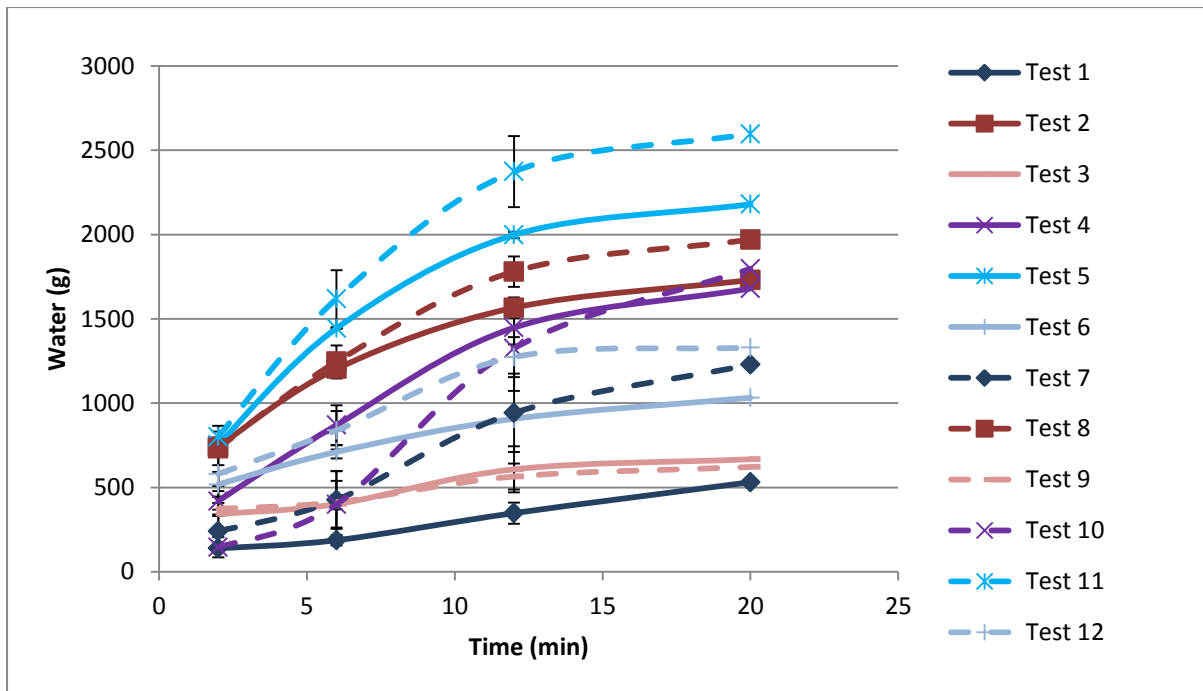

Figure 5-2: Cumulative water recovered as a function of time for 2-phase tests at all conditions. The dashed lines represent DO 0 and the solid lines DO 8 conditions. The Eh was increased by NaClO addition. Error bars represent standard error.

Figure 5-3 shows the total water recovered for every 2-phase condition tested. In this figure it can be clearly seen that the highest water recovery was achieved when floating with nitrogen at low Eh values. Upon closer inspection, the negative effect of the Eh on the water recovery at 5 IS seems more prevalent at DO 8 than at DO 0. This is evident when comparing the water recoveries at pH 11, DO 0 and 570 mV to those obtained at pH 11, DO 8 and 500 mV. At 1 IS the higher Eh at pH 11 and DO 8, resulted in similar water recoveries to that obtained at pH 11 and DO 0.

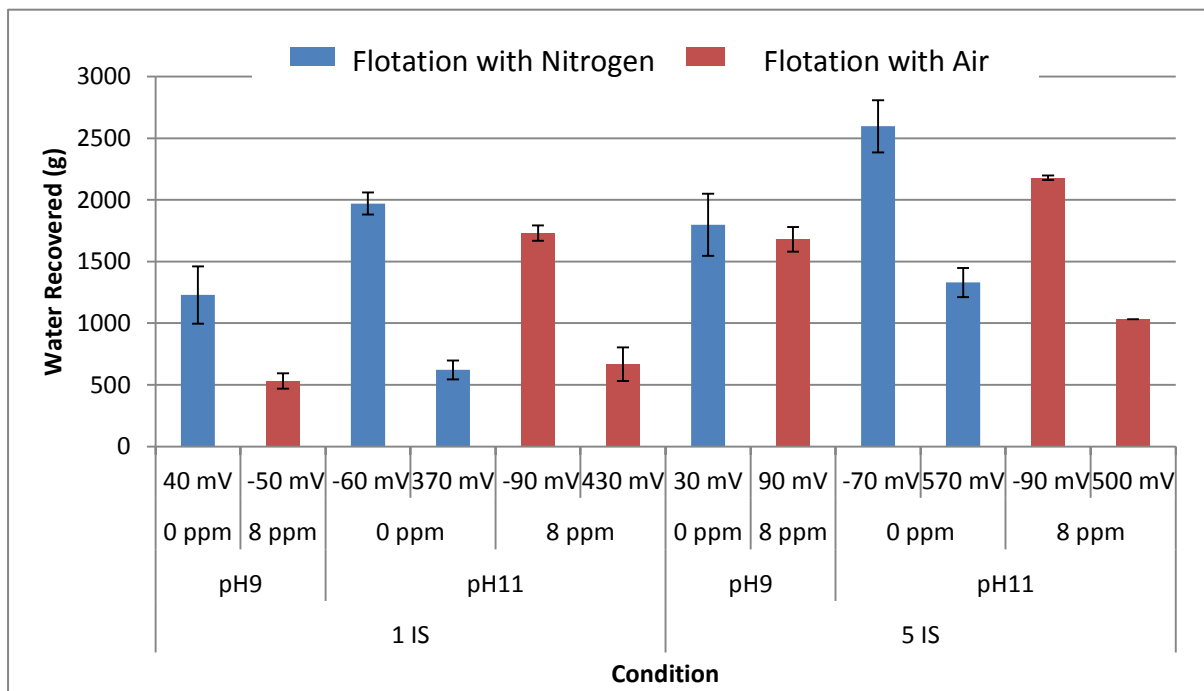

Figure 5-3: Final water recovery for batch flotation tests conducted at differing Eh, DO, pH and IS values in 2-phase. The Eh was increased by NaClO addition. Error bars represent standard error.

5.1.2.2 Water Recovery 3D Surface Plot

Figure 5-4 shows the 2-phase surface plot for the interaction observed between Eh and pH in relation to water recovery. It shows that Eh and pH have a significant influence on the water recovery with Eh showing the strongest influence. The more negative the Eh the more water was observed to be recovered. The highest amount of water recovered is at a large negative Eh and pH 9. Water recovery is also seen to increase with an increase in pH when Eh is low.

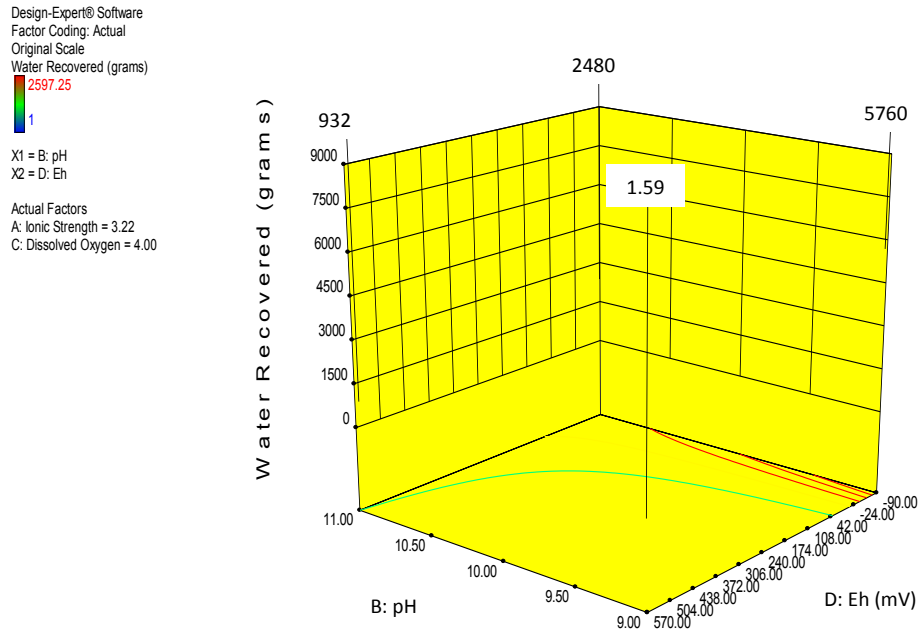

Figure 5-4: 3D surface plot of the interaction between pH and Eh in relation to water recovery in a 2-phase system

5.2 3-Phase Tests

In this section the effect of IS, pH, DO and Eh on water recovery and solids recovery in a 3-phase system using a batch flotation cell is considered. This section is subdivided into six sections. Section 5.2.1 describes the water and solids recovery, and sections 5.2.2 and 5.2.3 show the water and solids 3D surface plots, respectively. Section 5.2.4 shows the valuable mineral versus water recovery curves and section 5.2.5 shows the valuable mineral grade and recovery plots. Section 5.2.6 describes the copper and nickel recovery grid and model equations. For the 3-phase tests the reference condition is the condition at 1 IS, pH 9, DO 8 and -70 mV (Test 13).

5.2.1 Water and Solids Recovery

Figure 5-5, Figure 5-6 and Figure 5-7 show the water recovery as a function of time, the rate of solids recovery and the solids as a function of water recovery, respectively, for the 3 phase system.

Figure 5-5 shows the highest amounts of water, 3150 g, were recovered at 5 IS, pH 11, 650 mV and DO 0 (Test 28), as well as at 5 IS, pH 9, 720 mV and DO 0 (Test 27). The lowest water recovery, 1940 g, was obtained at Test 13 and an increase in IS at DO 8 did not show much of an increase in water recovery from Test 13.

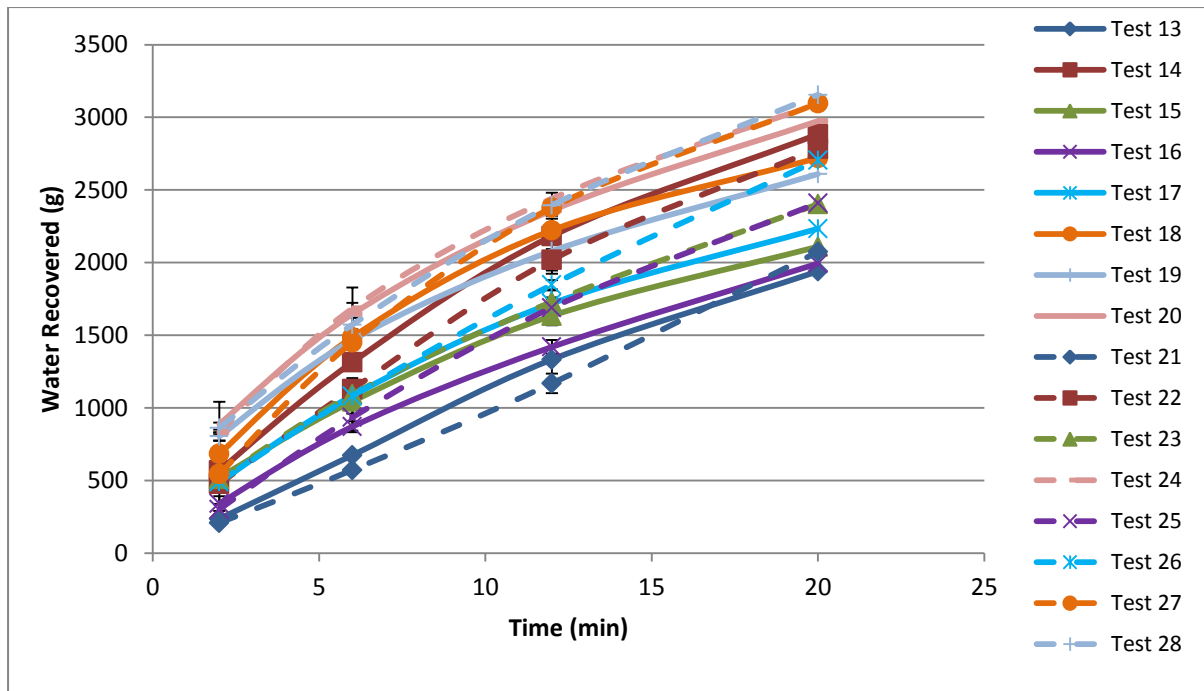

Figure 5-5: Water recovered as a function of time for 3-phase flotation tests. The Eh was increased by NaClO addition. Error bars represent standard error.

Figure 5-6 and Figure 5-7 show that the highest amount of solids was recovered at 5 IS, pH 9, DO 8 and 730 mV (Test 18). This was closely followed by 1 IS, pH 11, DO 8 and 500 mV (Test 20). The lowest solids recovery was obtained at 1 IS, pH 9, DO 0 and 50 mV (Test 21). Overall, high Eh conditions resulted in the highest amount of solids recovered. Removing oxygen from the system (DO 0) resulted in a general reduction in solids recovery. 5 IS and pH 11 did not result in a high solids recovery even though it had resulted in a high water recovery. Figure 5-8 and Figure 5-9 show the solids recovery versus water recovery at DO 8 and DO 0, respectively.

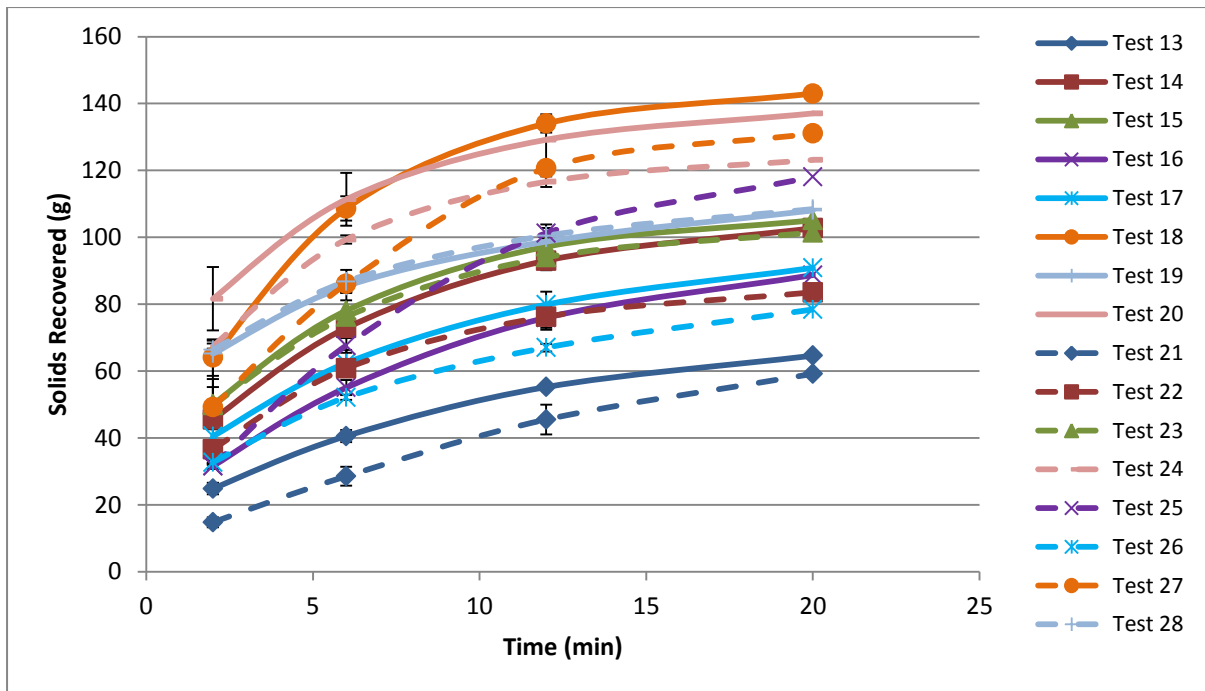

Figure 5-6: Solids recovered as a function of time for 3-phase flotation tests. The Eh was increased by NaClO addition. Error bars represent standard error.

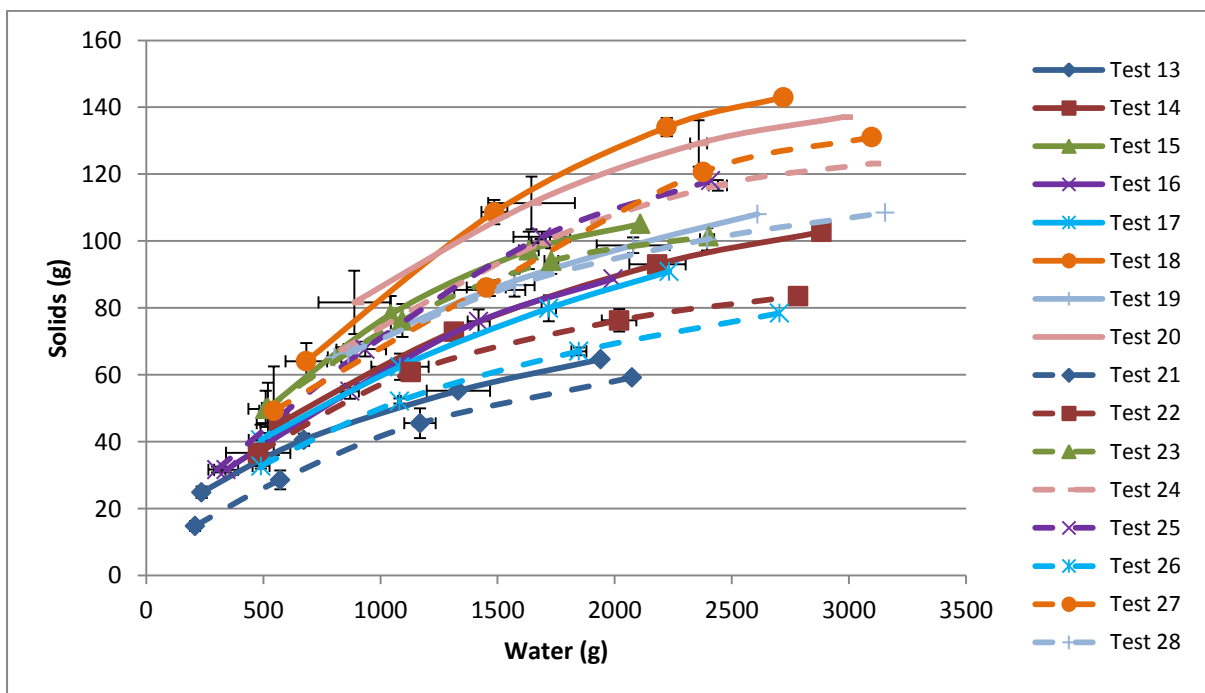

Figure 5-7: Solids recovered versus water recovered over time for 3-phase flotation tests. The Eh was increased by NaClO addition. Error bars represent standard error.

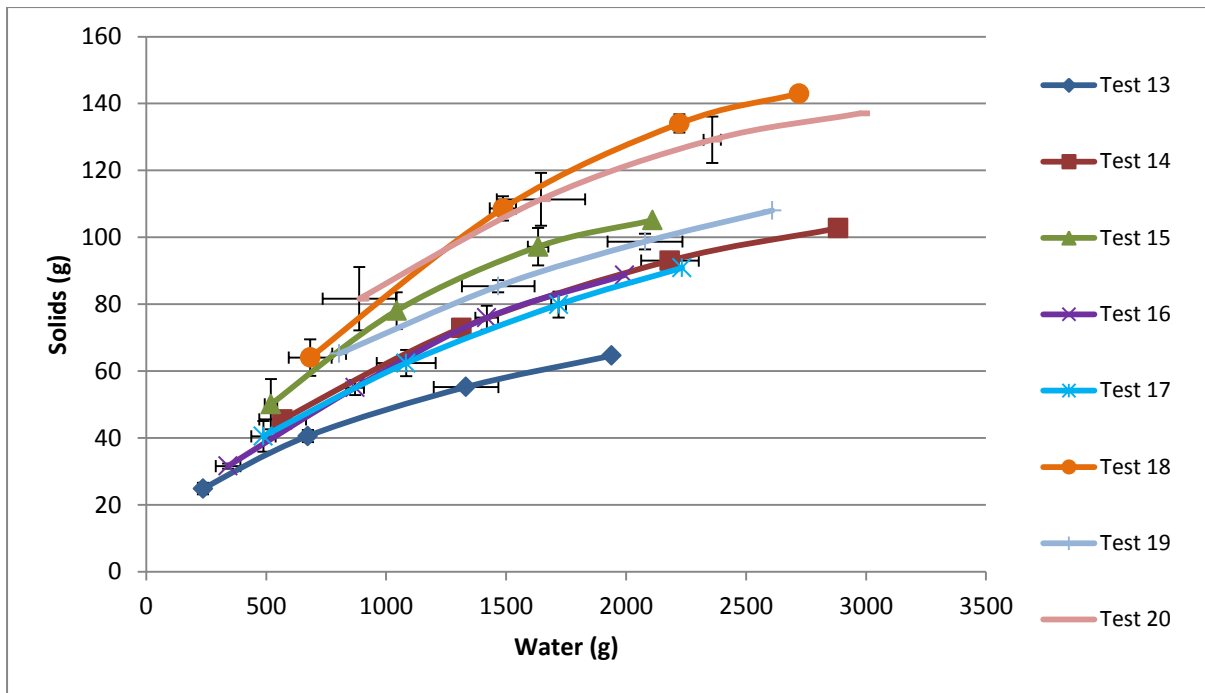

Figure 5-8: Solids recovered versus water recovered over time for 3-phase flotation tests at DO 8. The Eh was increased by NaClO addition. Error bars represent standard error.

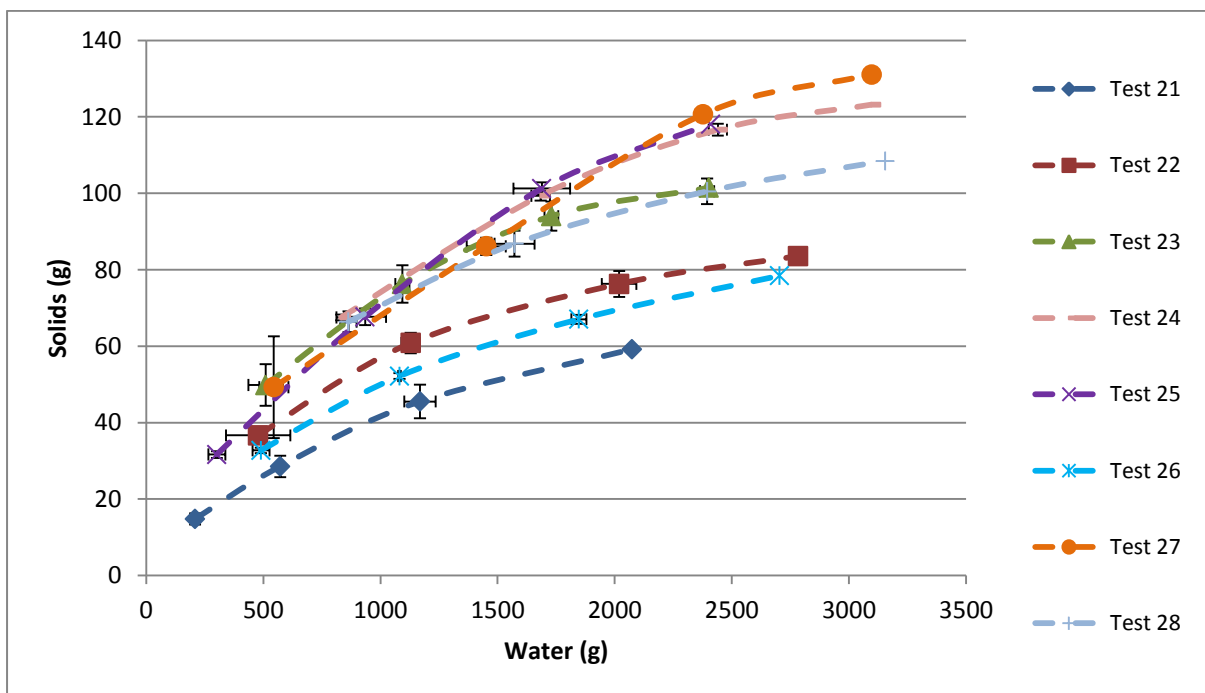

Figure 5-9: Solids recovered versus water recovered over time for 3-phase flotation tests at DO 0. The Eh was increased by NaClO addition. Error bars represent standard error.

The water and solids recoveries for all 3-phase batch flotation tests are shown in Figure 5-10 and Figure 5-11, respectively.

Figure 5-10 shows that the highest amount of water recovered, 3150 g, was from the test conducted at 5 IS, pH11, DO 0 and 650 mV (Test 28), closely followed by that conducted at 1 IS, pH11, DO 0 and 500 mV (Test 24). The lowest water recovery, 1940 g, was obtained at Test 13. Considering the IS and pH effect on water recovery, the distinction between 1 IS and 5 IS was not clearly seen but a test at 1 IS, pH11 resulted in higher water recoveries than at 1 IS and pH9. At 5 IS, the differences in water recoveries at higher pH were significantly smaller. This may indicate a dominating effect of pH at 1 IS and a dominating effect of IS at 5 IS.

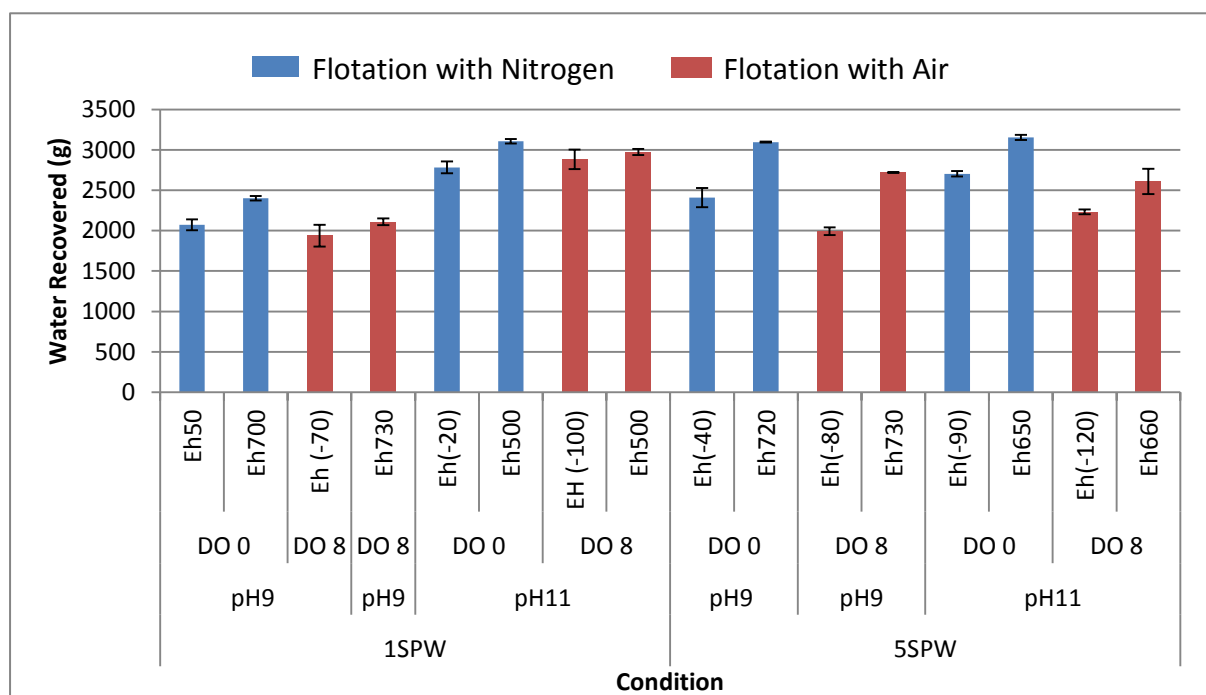

Figure 5-10: Final water recovery for batch flotation tests conducted at differing Eh, DO, pH and IS values in 3-phase. The Eh was increased by NaClO addition. Error bars represent standard error.

Figure 5-11 shows that air flotation (DO 8), high Eh and 5 IS yielded the highest solids recovery. This highest recovery of 143 g was obtained at 5 IS, pH 9, DO 8 and 730 mV (Test 18). In tests conducted at 1 IS, the amount of solids recovered increased with an increase in pH from 9 to 11. The opposite was seen at 5 IS, as there was a decrease in solids recovery with an increase in pH. The lowest solids recovery of 59.2 g was obtained at 1 IS, pH 9, DO 0 and Eh 50 (Test 21).

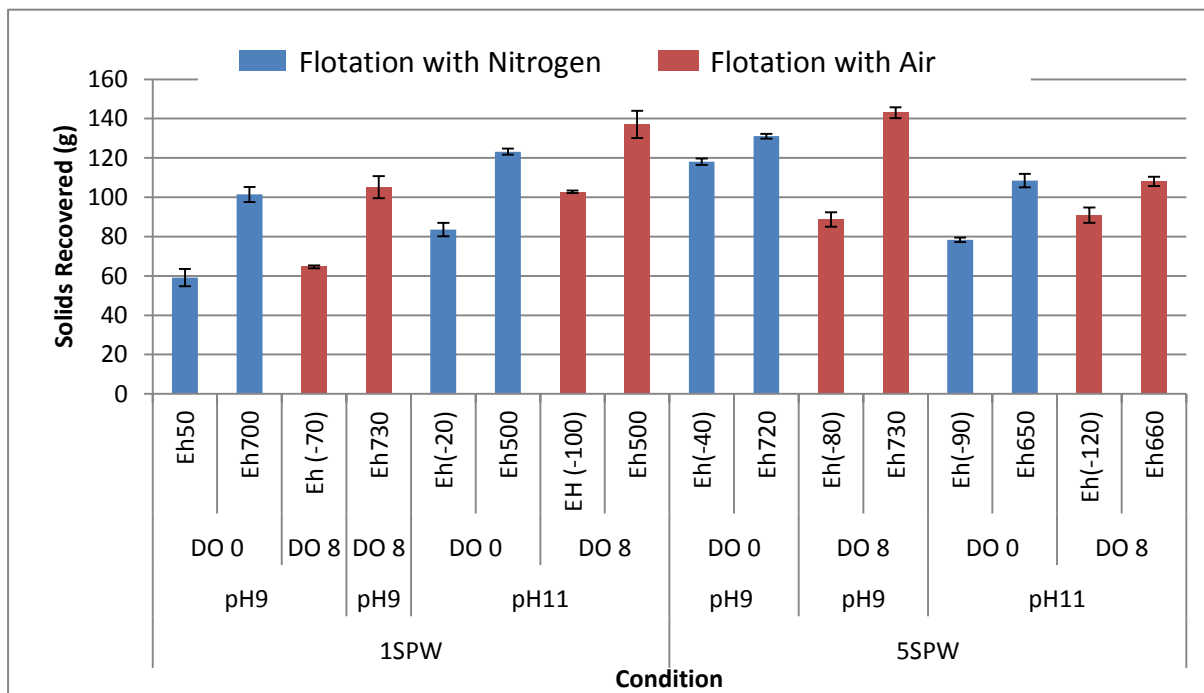

Figure 5-11: Final solids recovery for batch flotation tests conducted at differing Eh, DO, pH and IS values in 3-phase. The Eh was increased by NaClO addition. Error bars represent standard error.

5.2.2 Water Recovery 3D Surface Plots

To further understand the interactive effects of the pulp factors on one another with respect to the water and solids recovery, 3D surface plots were drawn. Figure 5-12 to Figure 5-17 show the surface plots for water recovery, and Figure 5-18 to Figure 5-21 show the plots for solids recovery.

In 3-phase, the water recovery was found to increase with an increase in pH more than it did with an increase in IS. At pH 11 higher water recoveries were obtained than at pH 9. The highest water recovery was obtained at pH 11 and 1 IS, followed by pH 11 and 5 IS as shown in Figure 5-12. The lowest water recovery was obtained at pH 9 and 1 IS. This figure shows the dominating effect of pH on water recovery at 1 IS as compared to that of IS on water recovery at 5 IS that was seen in Figure 5-10.

Design-Expert® Software
 Factor Coding: Actual
 Water Recovered (g)
 3154.84
 1939.73
 X1 = A: Ionic Strength
 X2 = D: pH
 Actual Factors
 B: Eh = 300.00
 C: Dissolved Oxygen = 4.00

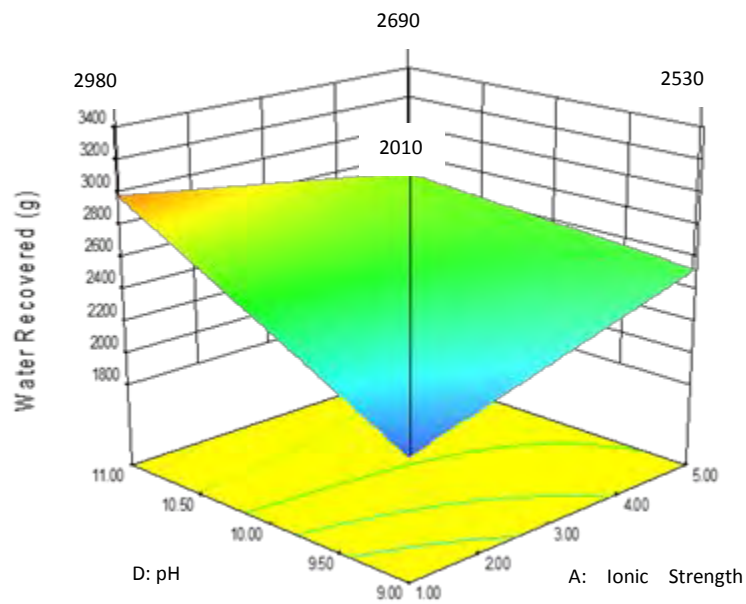

Figure 5-12: 3D surface plot of the interaction between pH and IS in relation to water recovery in a 3-phase system, where Eh and DO are kept constant at 300 mV and 4 ppm, respectively.

Figure 5-13 shows that the highest water recovery in 3-phase was obtained at high Eh and pH 11. The lowest water recovery was obtained at low Eh and pH 9.

Design-Expert® Software
 Factor Coding: Actual
 Water Recovered (g)
 3154.84
 1939.73
 X1 = B: Eh
 X2 = D: pH
 Actual Factors
 A: Ionic Strength = 3.00
 C: Dissolved Oxygen = 4.00

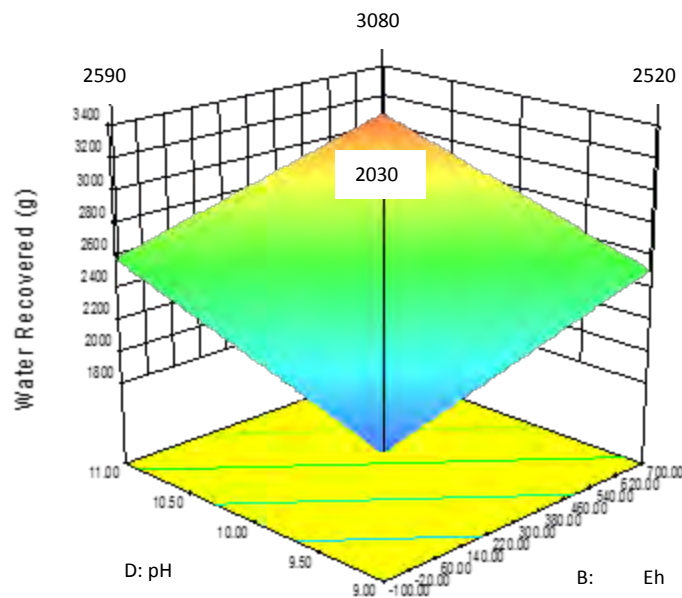

Figure 5-13: 3D surface plot of the interaction between pH and Eh in relation to water recovery in a 3-phase system, where IS and DO are kept constant at 3 IS and 4 ppm, respectively

Figure 5-14 shows that the highest water recovery was obtained at pH 11 and DO 0. DO showed an increase in water recovery with a decrease in DO. The pH was observed to have a greater influence on water recovery at DO 0 than at DO 8.

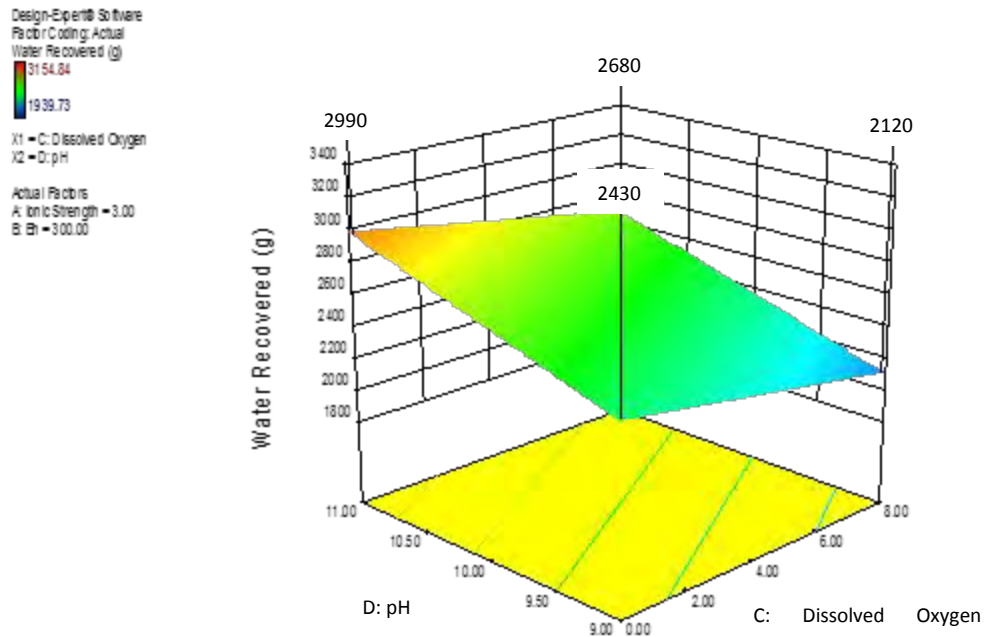

Figure 5-14: 3D surface plot of the interaction between pH and DO in relation to water recovery in a 3-phase system where IS and Eh are kept constant at 3 IS and 300 mV, respectively

In terms of IS and Eh with respect to water recovery, more water is recovered at higher Eh values irrespective of IS in 3-phase as shown in Figure 5-15.

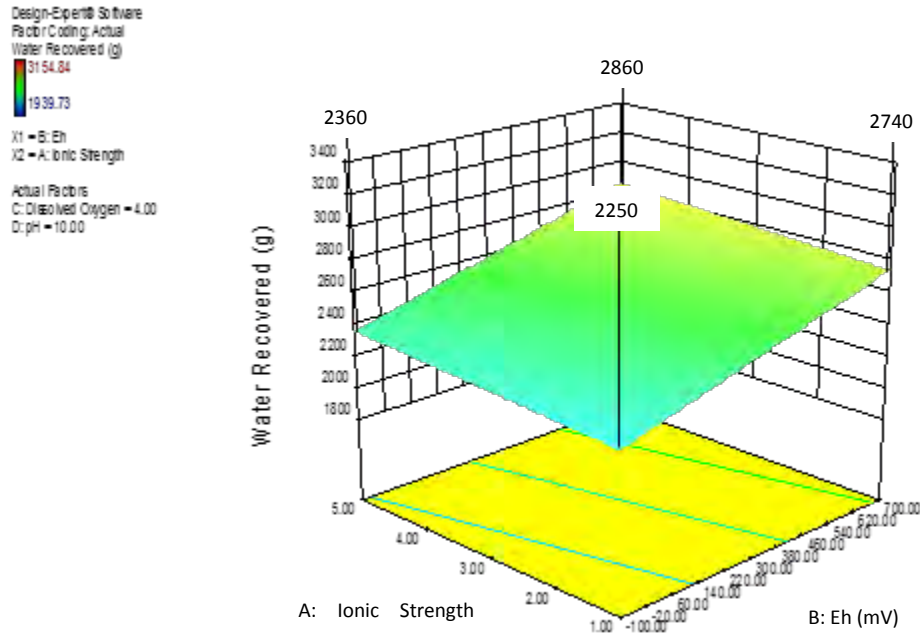

Figure 5-15: 3D surface plot of the interaction between IS and Eh in relation to water recovery in a 3-phase system where DO and pH are kept constant at 4 ppm and pH 10, respectively

Figure 5-16 shows that higher amounts of water was recovered at DO 0 irrespective of IS in 3-phase.

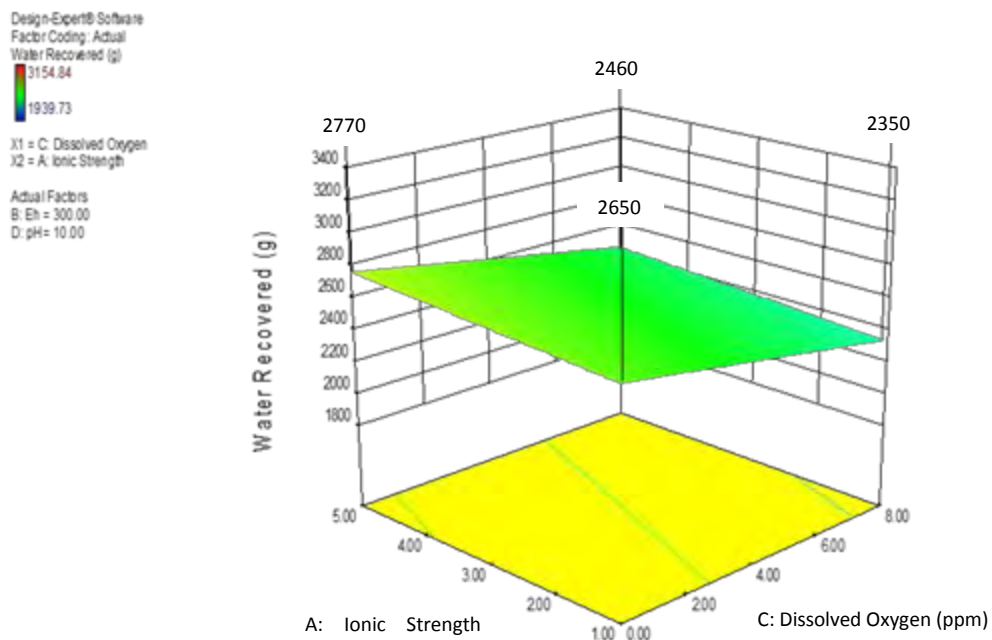

Figure 5-16: 3D surface plot of the interaction between IS and DO in relation to water recovery in a 3-phase system where Eh and pH are kept constant at 300 mV and pH 10, respectively

Figure 5-17 shows that as the Eh increased the water recovery increased and more water was recovered at DO 0 than at DO 8. There was a steeper increase in Eh at DO 0 than at DO 8, which mirrored what was seen in Figure 5-14. Eh and pH seemed to have the same interaction with DO with respect to water recovery.

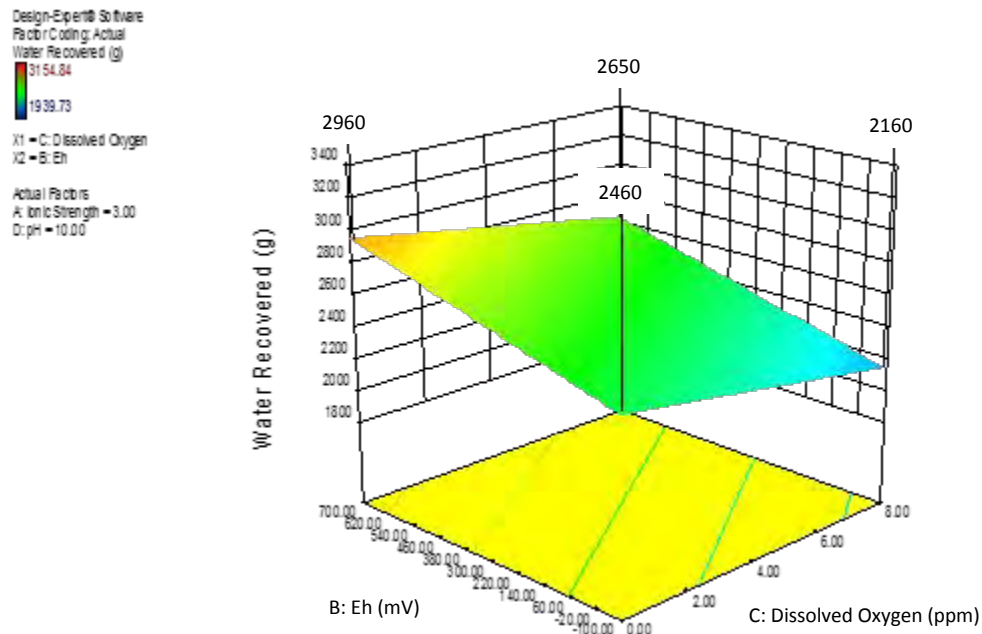

Figure 5-17: 3D surface plot of the interaction between Eh and DO in relation to water recovery in a 3-phase system where IS and pH are kept constant at 3 IS and pH 10, respectively

From Figure 5-12 to Figure 5-17 it can be seen that in 3-phase, the water recovery is strongly affected by Eh and pH. The more positive the Eh, the more water is recovered and the higher the pH the greater the water recovery.

5.2.3 Solids Recovery 3D Surface Plots

Concerning the solids recovery, Figure 5-18 shows that a high recovery can be achieved at 5 IS and pH 9 or 1 IS and pH11. This may mean that IS and pH are both dominating the solids recovery but together have a negative effect on the recovery.

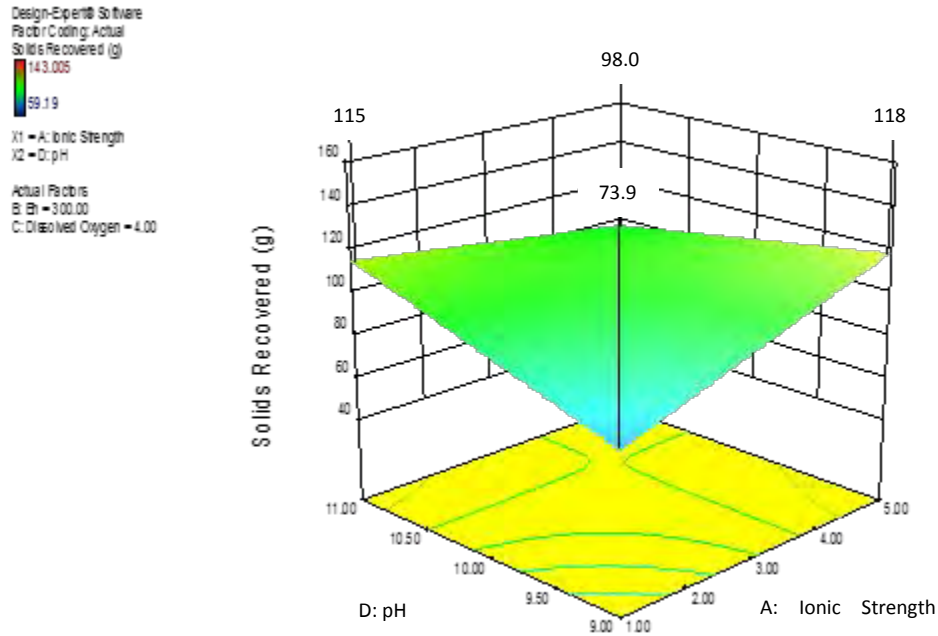

Figure 5-18: 3D surface plot of the interaction between pH and IS in relation to solids recovery in a 3-phase system where Eh and DO are kept constant at 300 mV and 4 ppm, respectively

Figure 5-19 shows that the solids recovery was higher at high Eh irrespective of pH and that pH did not show a significant effect on solids recovery in this range.

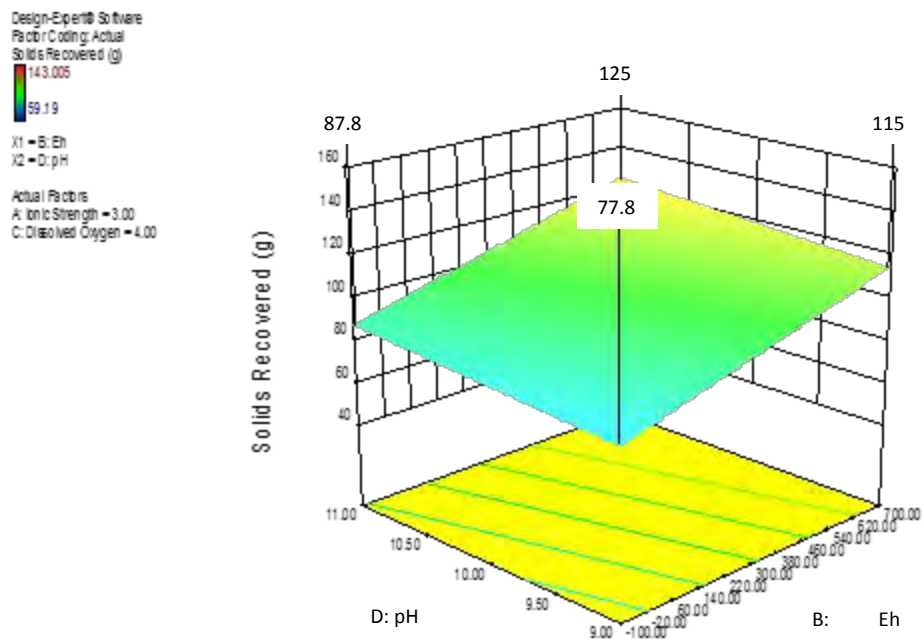

Figure 5-19: 3D surface plot of the interaction between pH and Eh in relation to solids recovery in a 3-phase system where IS and DO are kept constant at 3 IS and 4 ppm, respectively

Solids recovery was highest at high Eh irrespective of IS as shown in Figure 5-20. Figure 5-19 and Figure 5-20 show that Eh is the more dominant factor than pH or IS in terms of solids recovery.

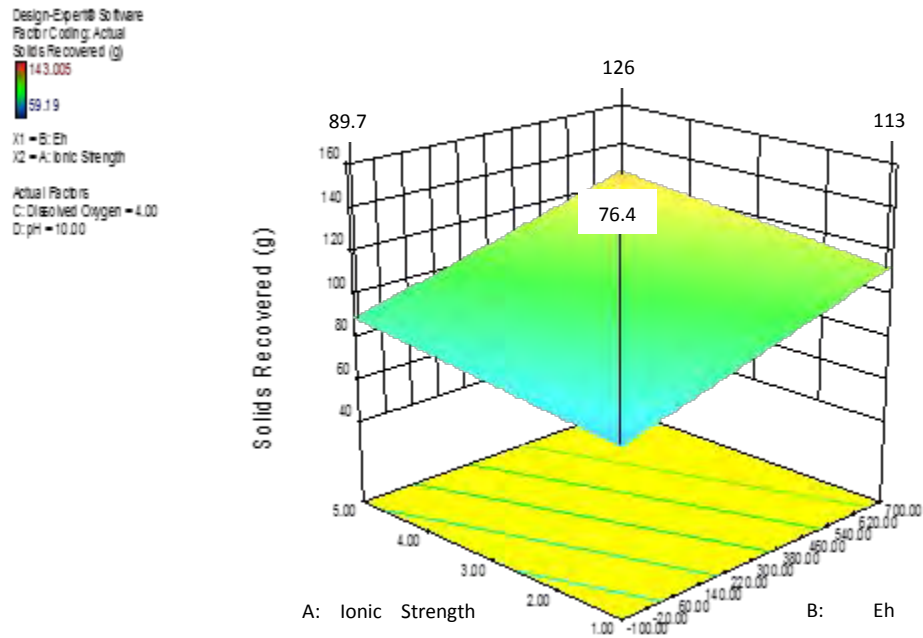

Figure 5-20: 3D surface plot of the interaction between IS and Eh in relation to solids recovery in a 3-phase system where DO and pH are kept constant at 4 ppm and pH 10, respectively

Figure 5-21 shows that the DO had no significant interaction with Eh in terms of solids recovery.

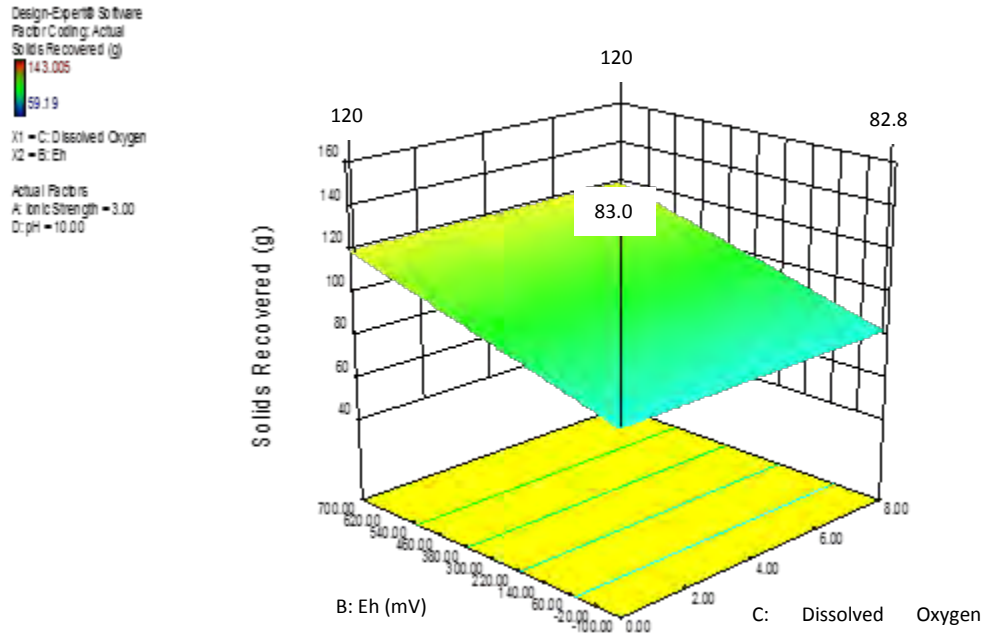

Figure 5-21: 3D surface plot of the interaction between Eh and DO in relation to solids recovery in a 3-phase system where IS and pH are kept constant at 3 IS and pH 10, respectively

A grid (Figure 5-22) was generated to show the interactive effects of the pulp chemistry factors on one another as well as on the water recovery in 2-phase and the water and solids recovery in 3-phase. From the grid, the strongest positive (marked deep red) and strongest negative (marked deep blue) contributors are highlighted. The neutral contributors are indicated using white squares. Equations were also generated to model the 2-phase and 3-phase systems. These are shown in Equation 5-1 to Equation 5-9 where A = IS, B = pH, C = DO, D = Eh and R^2 is a measure of the goodness of fit to the regression model. The coded values (A, B, C and D) can be replaced with -1, 0 or 1 in the equations to produce the model, where -1 is a strong negative effect and 1 is a strong positive effect.

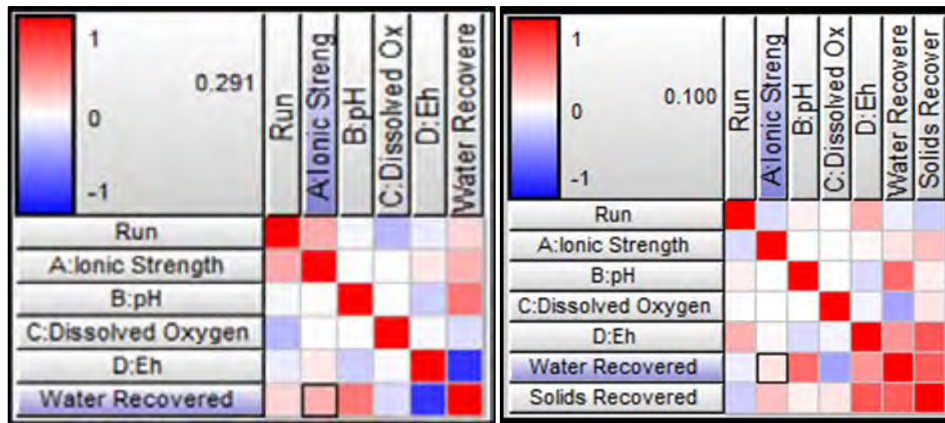

Figure 5-22: Summary grids of 2-phase and 3-phase effects of IS, pH, DO and Eh on water and, in 3-phase, solids recovery, as well as the factors' effects on one another. The dark red symbolises the strongest positive contributors and the dark blue the strong negative contributors. The white is a neutral interaction and no contribution.

Final Equation in Terms of Coded Factors:

2-phase:

$$\ln(\text{water recovered}) =$$

$$5.7142$$

$$+1.4302 B$$

$$-2.3243 D$$

$$+1.8614 (B)(D)$$

Equation 5-1

$$R^2 = 0.96419$$

Equation 5-2

3-Phase:

$$\text{Water Recovered} =$$

$$2577.6$$

$$+35.625 A$$

$$+258.23 B$$

$$-134.10 C$$

$$+224.29 D$$

$$-181.93(A)(B)$$

Equation 5-3

$$R^2 = 0.88714$$

Equation 5-4

Solids Recovered =

102.96

+5.2071 A

+3.5112 B

+18.474 D

−14.069(A)(B)

Equation 5-5

$R^2 = 0.85661$

Equation 5-6

Comparing the 2-phase and 3-phase grids, the effect of IS on water recovery decreases in 3-phase whereas the effect of pH slightly increases. DO has a slightly stronger negative effect on water recovery in 3-phase, and Eh goes from strongly negatively to strongly positively influencing water recovery from 2 to 3-phase. pH and IS show a neutral interaction with one another in both phases, but Eh and pH show a negative effect on each other which decreases from 2-phase to 3-phase.

From the model equations, in 2-phase pH is a more positive contributor to water recovery than Eh as an increase in pH would increase water recovery, however an increase in Eh would decrease water recovery. In 3-phase, pH has the strongest positive effect on water recovery followed by Eh and then IS indicating that an increase in these factors would increase water recovery. The combined effect of pH and IS strongly and negatively affects water recovery. An increase in DO would result in a decrease in water recovery in 3-phase.

Concerning solids recovery the model equations show that Eh is the strongest contributor to increased solids recovery followed by IS and then pH. DO shows no contribution to solids recovery and the combined effect of increasing pH and IS would result in a decrease in solids recovery.

Overall in 3-phase, the combination of IS and pH has a negative effect on both water and solids recovery.

5.2.4 Valuable Mineral Recovery-Water Recovery

Figure 5-23 to Figure 5-26 show the valuable mineral recovery as a function of water recovery obtained from all batch flotation tests conducted for copper, nickel, sulphur, platinum and palladium. All figures clearly show that the highest mineral recoveries were obtained from tests conducted at low Eh.

In all figures the recovery curves fall in 3 regions, low recovery, high recovery and intermediate recovery. The low and high recoveries correspond with the high Eh and low Eh values, respectively. The intermediate recoveries were generally obtained at low Eh values but high pH and DO 0, with the exception of copper. The copper recoveries showed that the intermediate recoveries were a combination of pH 11, 5 IS and Test 13.

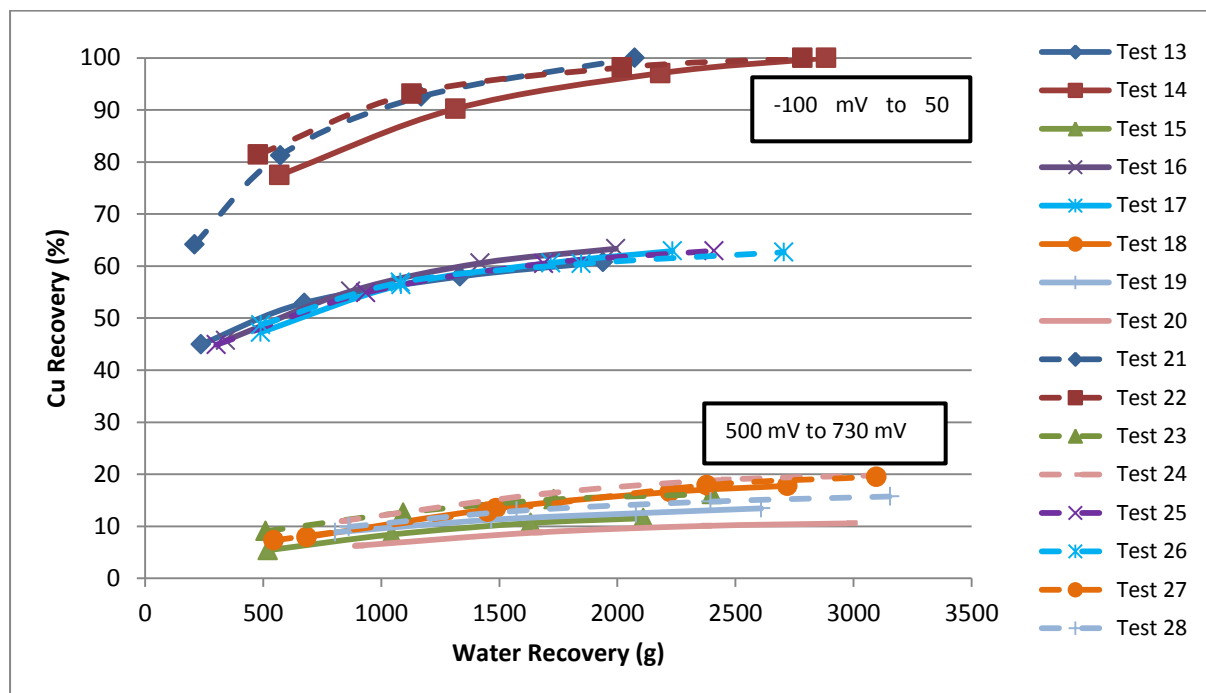

Figure 5-23: Copper recovery as a function of water recovery at different conditions. The Eh was increased by NaClO addition.

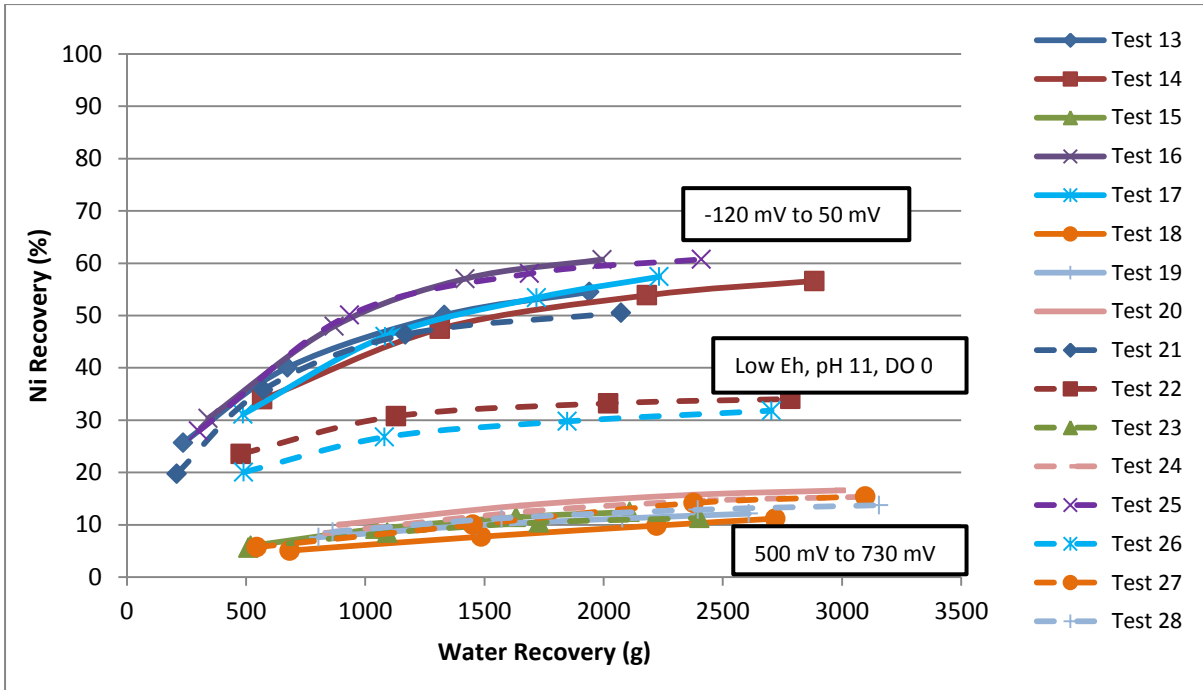

Figure 5-24: Nickel recovery as a function of water recovery at different conditions. The Eh was increased by NaClO addition.

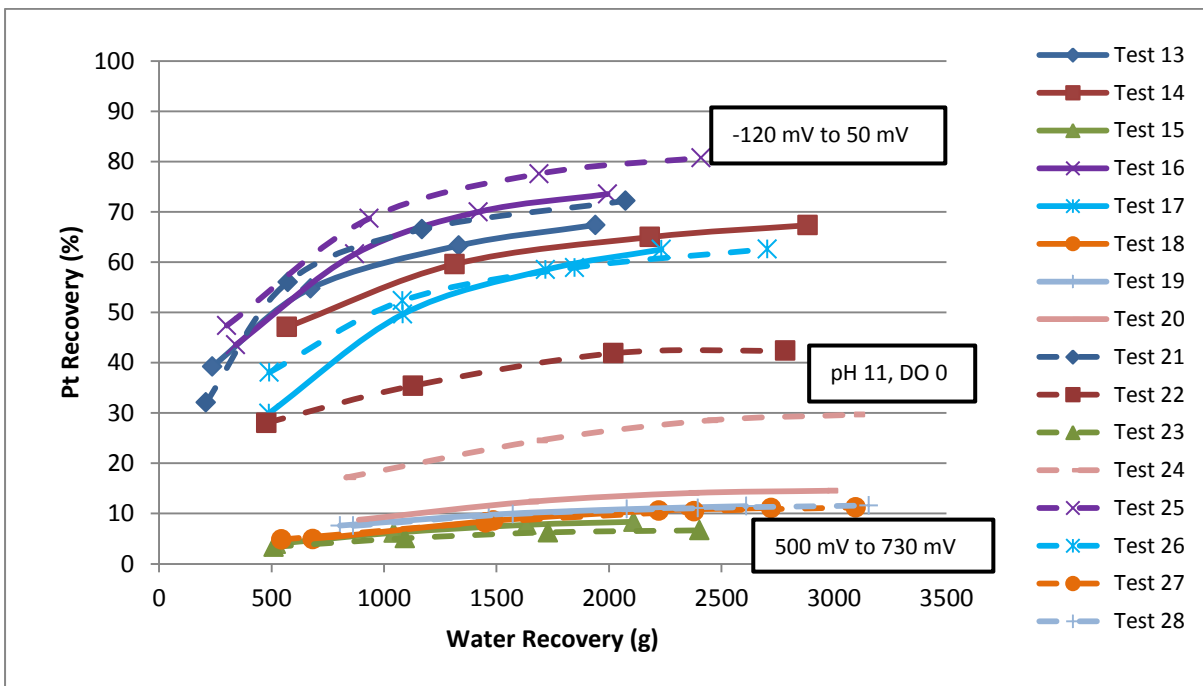

Figure 5-25: Platinum recovery as a function of water recovery at different conditions. The Eh was increased by NaClO addition.

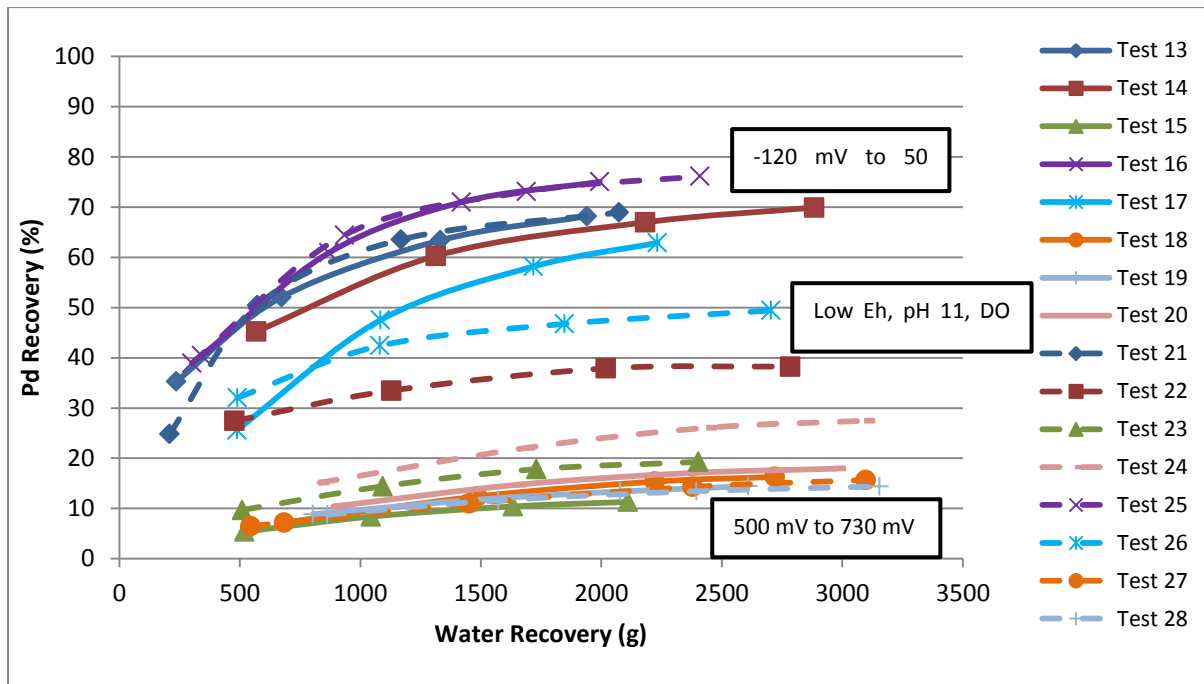

Figure 5-26: Palladium recovery as a function of water recovery at different conditions. The Eh was increased by NaClO addition.

5.2.5 Valuable Mineral Grade and Recovery Curves

Figure 5-27 to Figure 5-30 show the results obtained for the copper, nickel, sulphur, platinum and palladium for all tests conducted using batch flotation. The reference case for all the grade and recovery results is the condition of 1 IS, pH 9, DO 8 and -70 mV (Test 13).

Figure 5-27 shows that the highest grade for copper was achieved at DO 0 at Test 21, and the highest recovery at pH 11 (Test 14 and 22) and at DO 0 (Test 21).

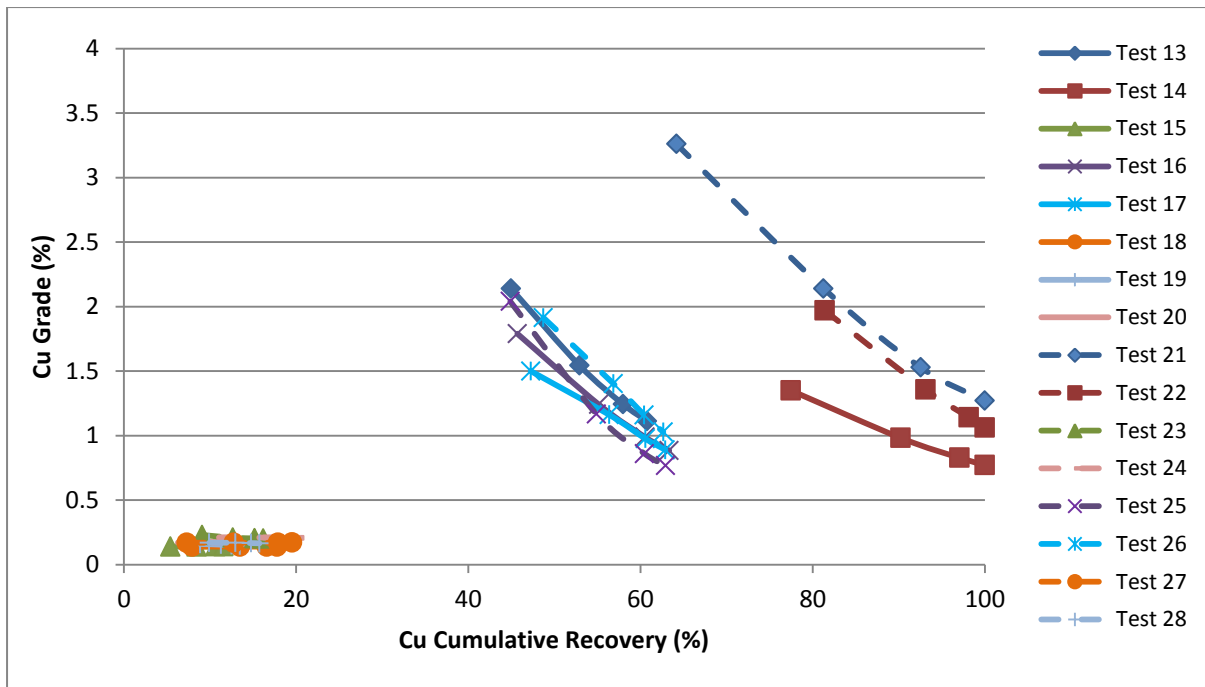

Figure 5-27: Copper grade as a function of copper recovery at different conditions. The Eh was increased by NaClO addition.

Figure 5-28 shows that the highest nickel grade was achieved at Test 21. The highest recovery was achieved from tests conducted at 5 IS, pH 9 and low Eh irrespective of the DO level (Test 16 and 25).

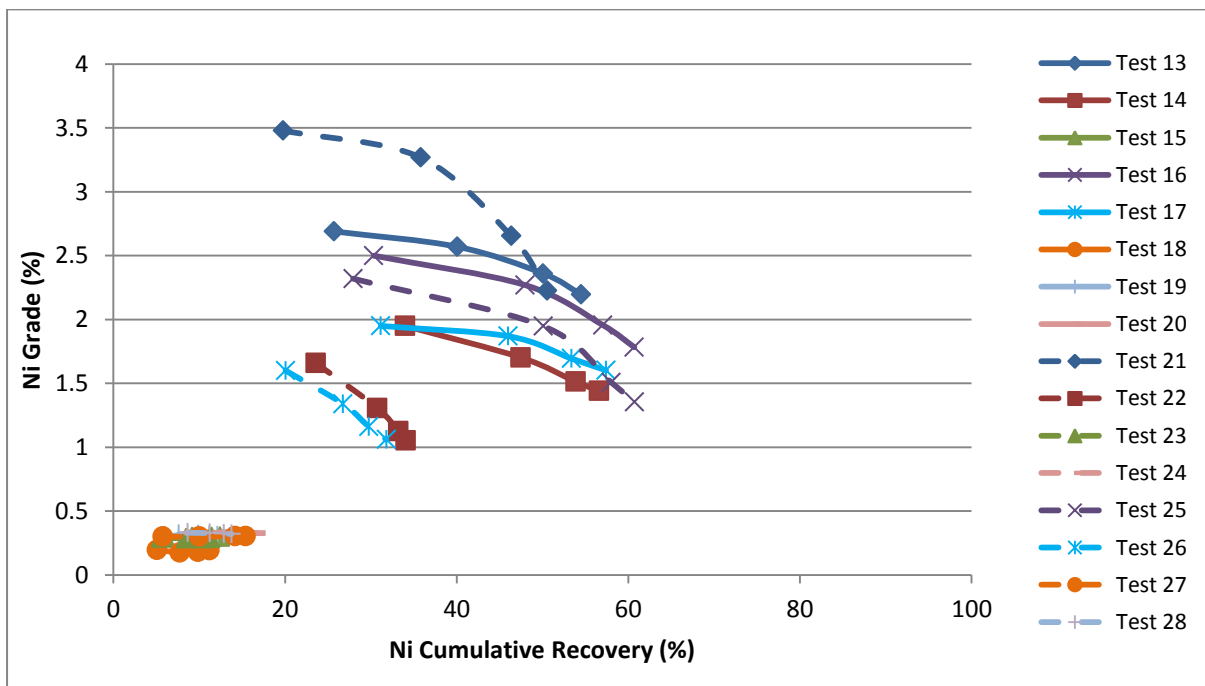

Figure 5-28: Nickel grade as a function of nickel recovery at different conditions. The Eh was increased by NaClO addition.

Figure 5-29 shows the platinum grade as a function of recovery curves obtained for all the tested conditions. The highest grade was obtained at Test 21. The highest recovery was obtained at 5 IS and DO 0 (Test 25).

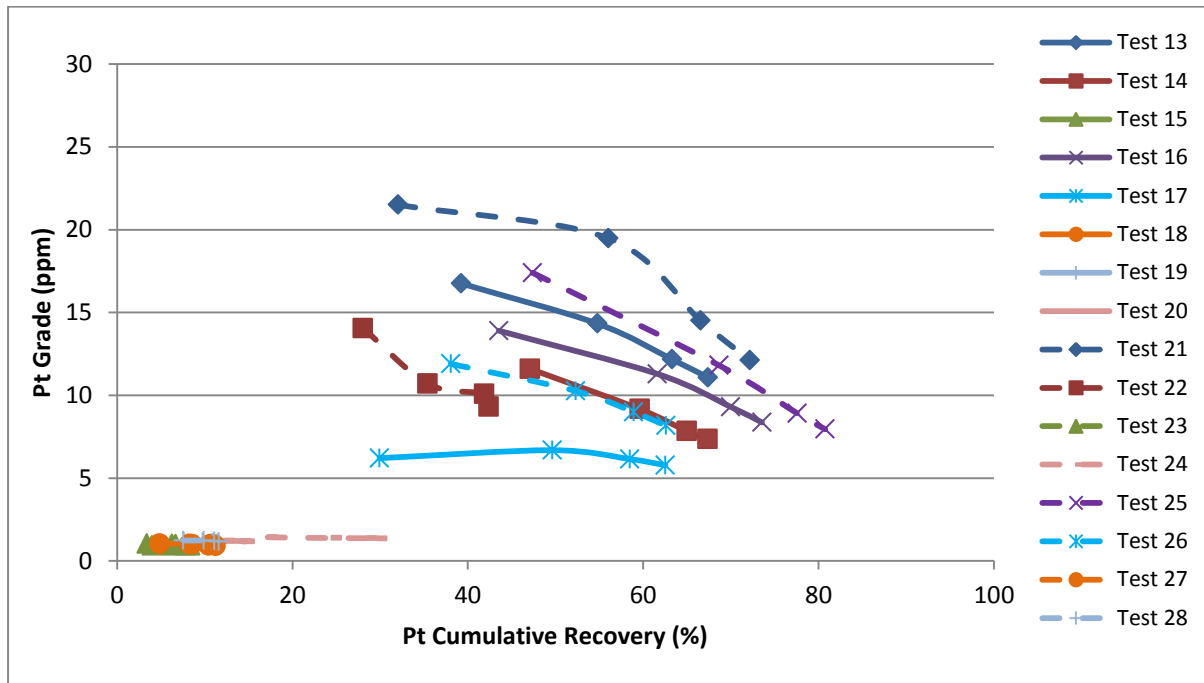

Figure 5-29: Platinum grade as a function of platinum recovery at different conditions. The Eh was increased by NaClO addition.

Figure 5-30 shows the grade and recovery curves for palladium for all tested conditions. The highest grade was obtained at Test 21. The largest recovery was obtained at 5 IS and DO 0 (Test 25).

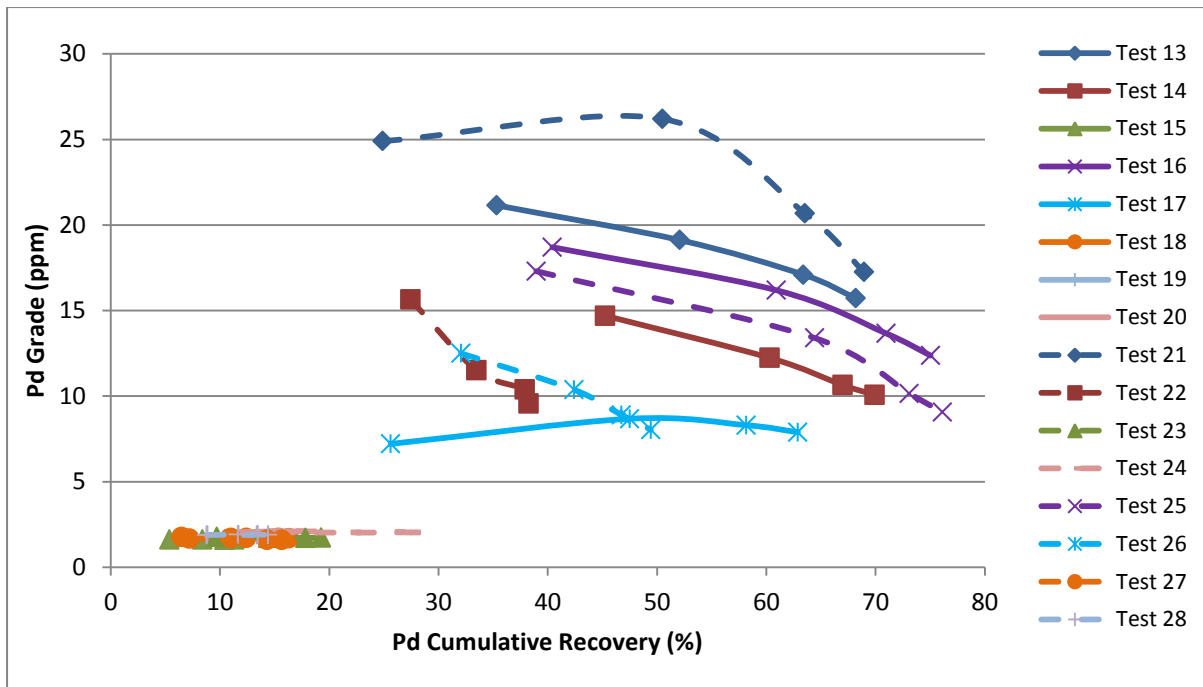

Figure 5-30: Palladium grade as a function of palladium recovery at different conditions. The Eh was increased by NaClO addition.

Overall, the highest grades for all minerals were achieved at Test 21 and the highest recoveries were achieved at 5 IS (Test 16 and 25) for every mineral except copper for which the highest recovery was obtained at pH 11 (Test 14 and 22).

5.2.6 Copper and Nickel Recovery Grid and Model Equations

The 3D surface plots for copper and nickel recovery may be viewed in Chapter 11 (Appendix B) Section 11.4.1.

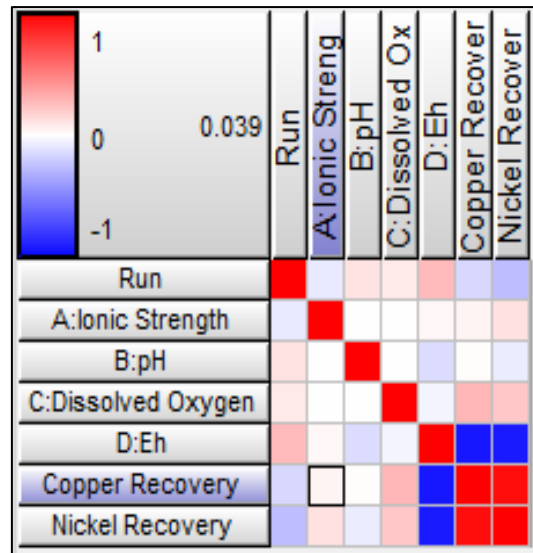

Figure 5-31: Summary grid of the effects of IS, pH, DO and Eh on copper and nickel recovery, as well as the factors' effects on one another. The dark red symbolises the strongest positive contributors and the dark blue the strong negative contributors. The white is a neutral interaction and no contribution.

Final Equation in Terms of Coded Factors:

Where A = IS, B = pH, C = DO, D = Eh and R^2 is a measure of the goodness of fit to the regression model.

$$\begin{aligned} \text{Copper Recovery} = \\ 47.140 + 7.0411 C \\ -29.938 D \end{aligned}$$

Equation 5-7

$$R^2 = 0.88420$$

Equation 5-8

$$\begin{aligned} \frac{1}{\sqrt{\text{Nickel Recovery}}} = \\ 0.19803 + 0.071293 D \end{aligned}$$

Equation 5-9

$$R^2 = 0.88745$$

Equation 5-10

From an examination of Figure 5-31 and the model equations (Equation 5-7 to Equation 5-10) it can be seen that Eh had a strong and negative effect on both copper and nickel recovery. DO had a positive effect on copper and nickel recovery but more so on copper than on nickel. Although seen in the grid and not in the model equations, IS has a slightly

positive effect on nickel recovery. Concerning the interactions of the pulp factors with one another, only the pH showed any interactions in that it showed a slightly negative effect on the Eh.

The positive effect of Eh on solids recovery may have been as a result of increased gangue recovery. This was therefore further investigated through high depressant tests to determine the entrainment factors.

5.3 Depressant Tests

The objective of this work is to investigate and understand the effect of IS, pH, DO and Eh on froth stability, water recovery and solids recovery in a 3-phase system when 500 g/t of a CMC depressant is added to the system. This section consists of three sections. Section 5.3.1 shows the stability column tests and section 5.3.2 shows the batch flotation cell tests. Section 5.3.3 shows the gangue recovery and entrainment. These conditions were selected for depressant tests as they all resulted in the highest and lowest solid and water recoveries in the batch flotation tests conducted in Section 5.2.

5.3.1 Stability Column Depressant Tests

5.3.1.1 Test Conditions

Stability column tests were conducted in 3-phase. Eh was directly manipulated by the addition of NaOCl. A CMC depressant at a dosage of 500 g/t was added to the system in an attempt to suppress all the naturally floating gangue (NFG) material present in the ore. From this data the effect of the pulp chemistry on froth stability was more clearly seen.

5.3.1.2 Results

Figure 5-32 provides a comparison of the froth stability obtained in the presence and absence of depressant. The highest dynamic stability factor of 29.3 s, indicative of the most stable froth, was obtained when no depressant was added at 5 IS, pH 9, DO 8 and 690 mV. When depressant was added to the system, the highest stability factor obtained was 17.6 s at 5 IS, pH 11, DO 8 and -30 mV. The least stable froth in the presence of depressant was 1.62 s at 1 IS, pH 9, DO 8 and 650 mV.

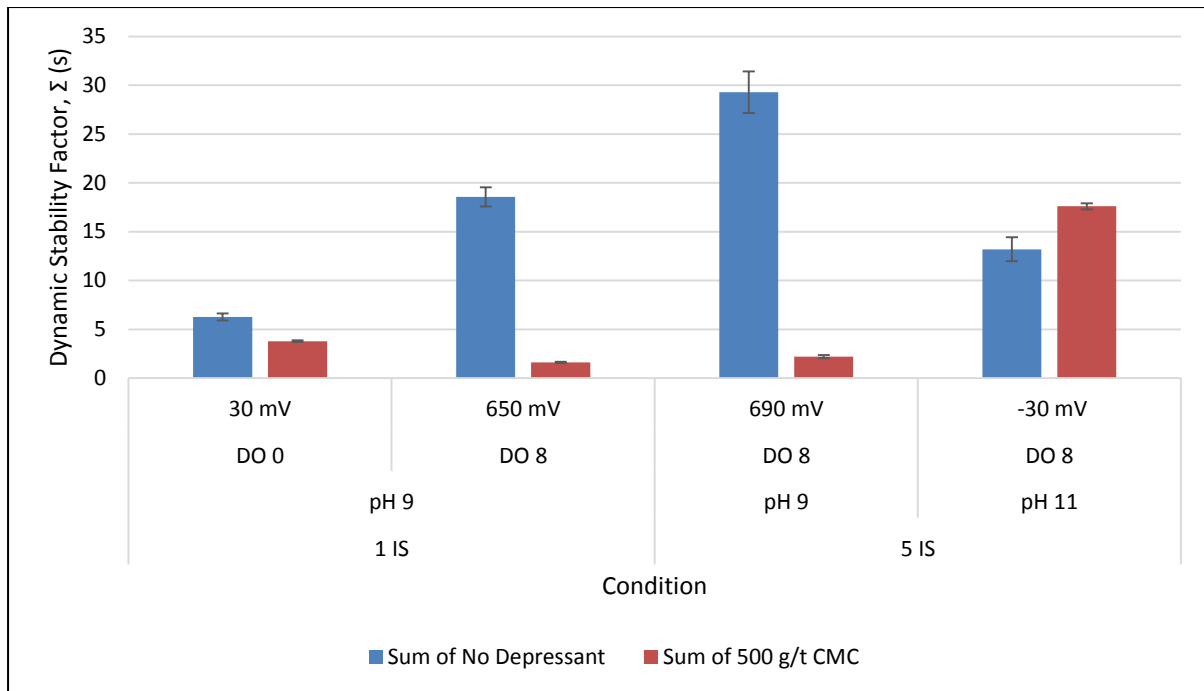

Figure 5-32: 3-Phase froth stability results for differing Eh, DO, pH and IS values with and without depressant. The Eh was increased by NaClO addition. Error bars represent standard error.

5.3.2 Batch Depressant Tests

Figure 5-33 to Figure 5-38 show the solids and water recovery results obtained from the selected batch flotation tests conducted in the presence and absence of a CMC depressant. A depressant dosage of 500 g/t was used.

Figure 5-33 shows that generally at 5 IS more water was recovered than at 1 IS. This was seen in both the absence and presence of depressant. The highest amount of water recovered in the presence of depressant, 2120 g, was obtained from tests conducted at -20 mV, DO 8, pH 11 and 5 IS. The lowest amount of water recovered in the presence of depressant, 1540 g, was at 40 mV, DO 0, pH 9 and 1 IS.

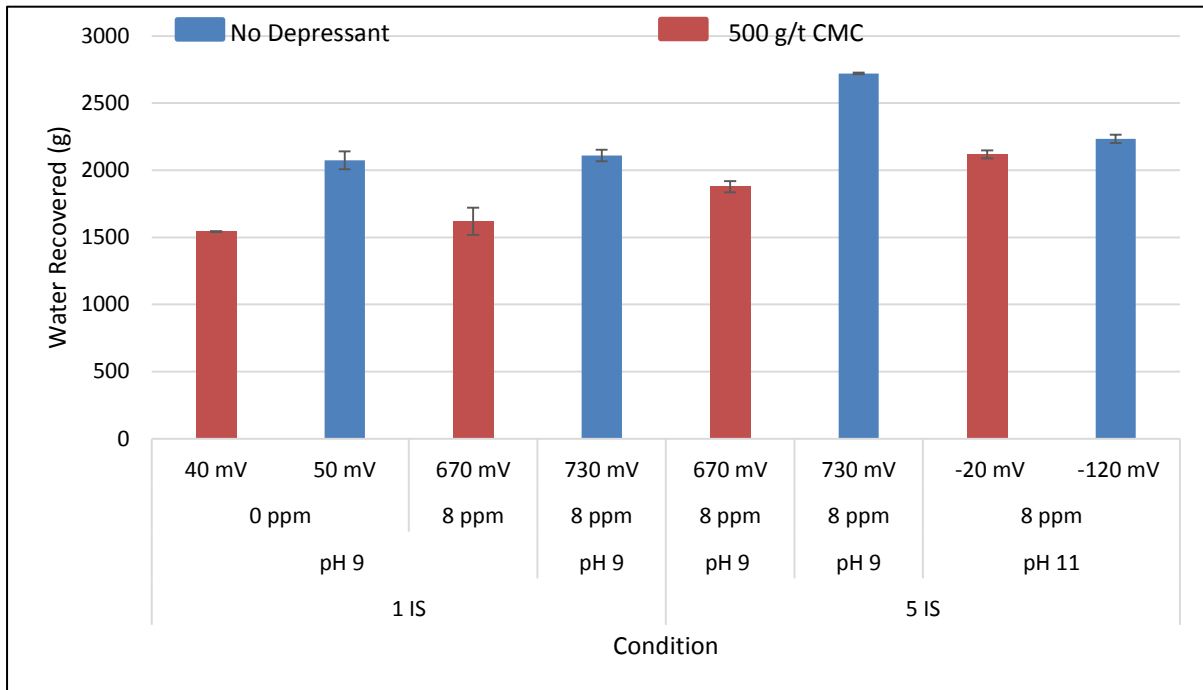

Figure 5-33: Final 3-phase water recovery for batch flotation tests conducted at differing Eh, DO, pH and IS values in the absence and presence of depressant. The Eh was increased by NaClO addition. Error bars represent standard error.

Figure 5-34 shows that the highest amount of solids recovered in the presence of depressant, 60.8 g, was recovered at 670 mV, DO 8, pH 9 and 5 IS. The lowest solids recovery in the presence of depressant, 45.3 g, was obtained at 40 mV, DO 0, pH 9 and 1 IS. The influence of higher IS and higher pH was observed for the solids but not as clearly as shown with the water recovery.

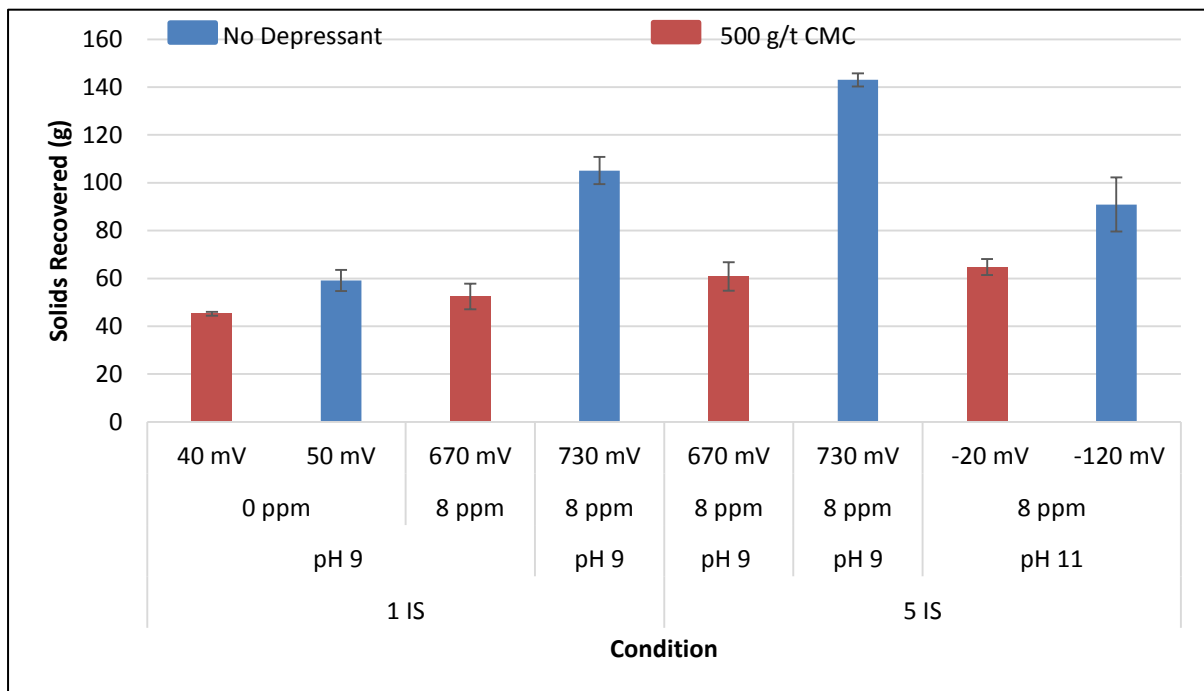

Figure 5-34: Final 3-phase solids recovery for batch flotation tests conducted at differing Eh, DO, pH and IS values in the absence and presence of depressant. The Eh was increased by NaClO addition. Error bars represent standard error.

5.3.2.1 Grade and Recovery Results

Figure 5-35 to Figure 5-38 show that in the presence of depressant, floating at 40 mV, DO 0, pH 9 and 1 IS resulted in the highest grade for copper and nickel, and the highest recovery for nickel. The highest recovery for copper was obtained at 5 IS, pH 11, DO 8 and -20 mV. The highest grades and recoveries for platinum and palladium were obtained at 5 IS, pH 11, DO 8 and -20 mV. High Eh values yielded the lowest grades and recoveries for all the elements determined.

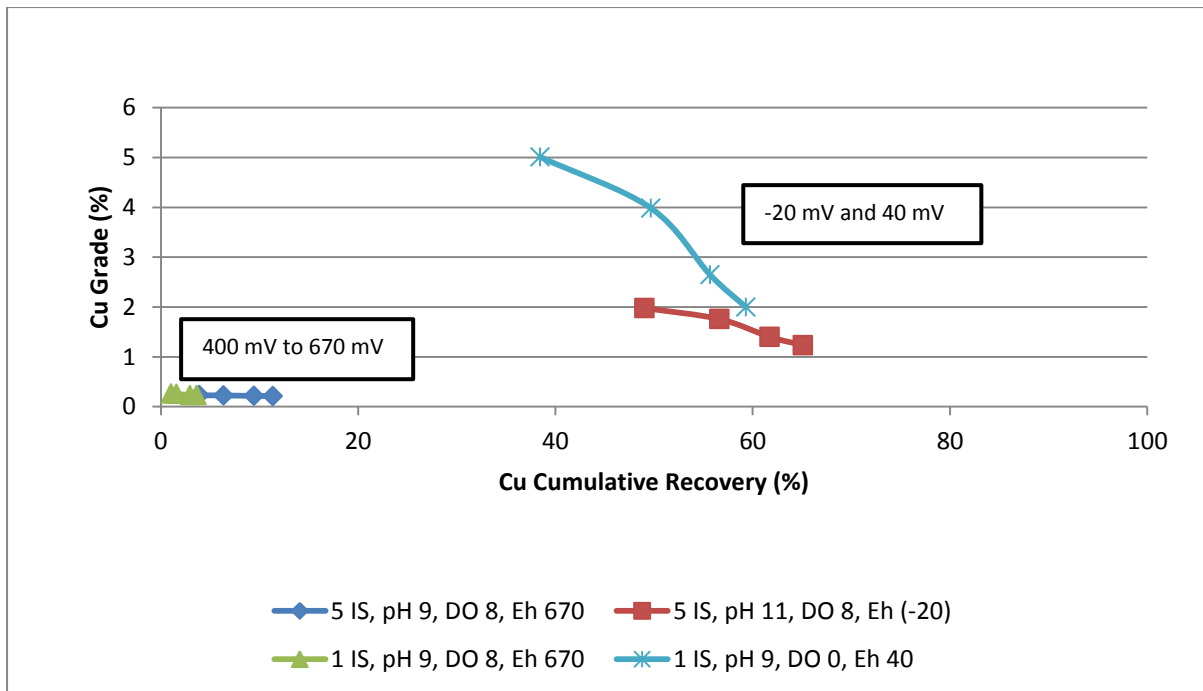

Figure 5-35: Copper grade as a function of copper recovery at different conditions in the presence of depressant. The Eh was increased by NaClO addition.

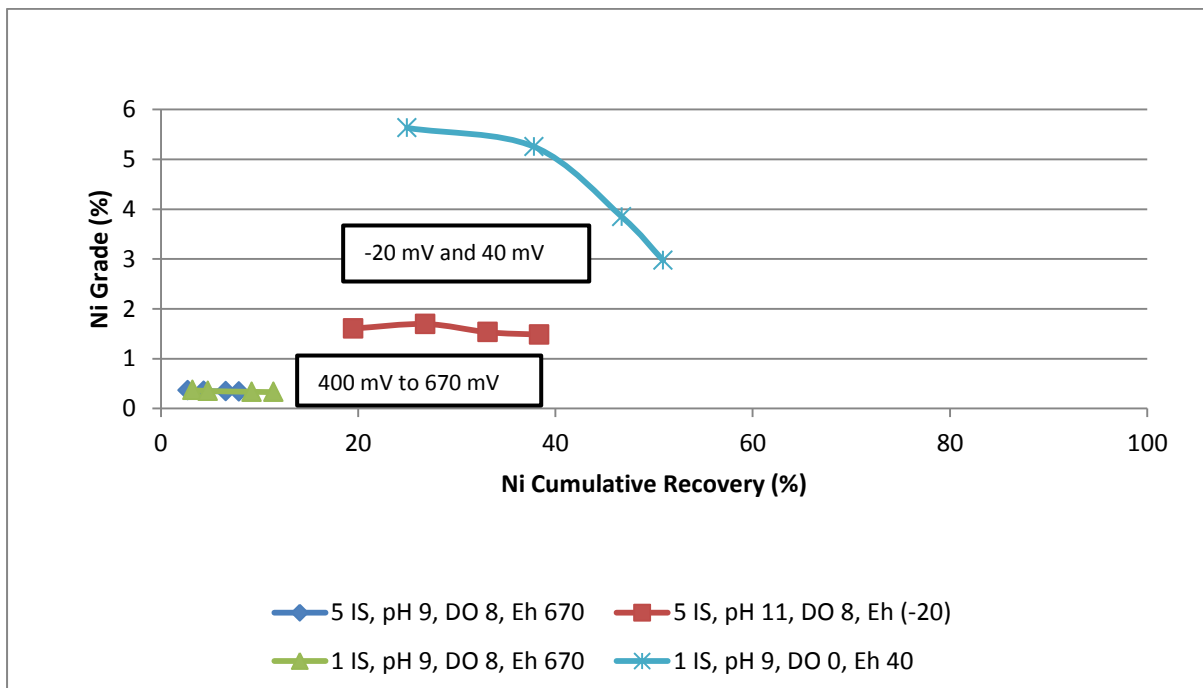

Figure 5-36: Nickel grade as a function of nickel recovery at different conditions in the presence of depressant. The Eh was increased by NaClO addition.

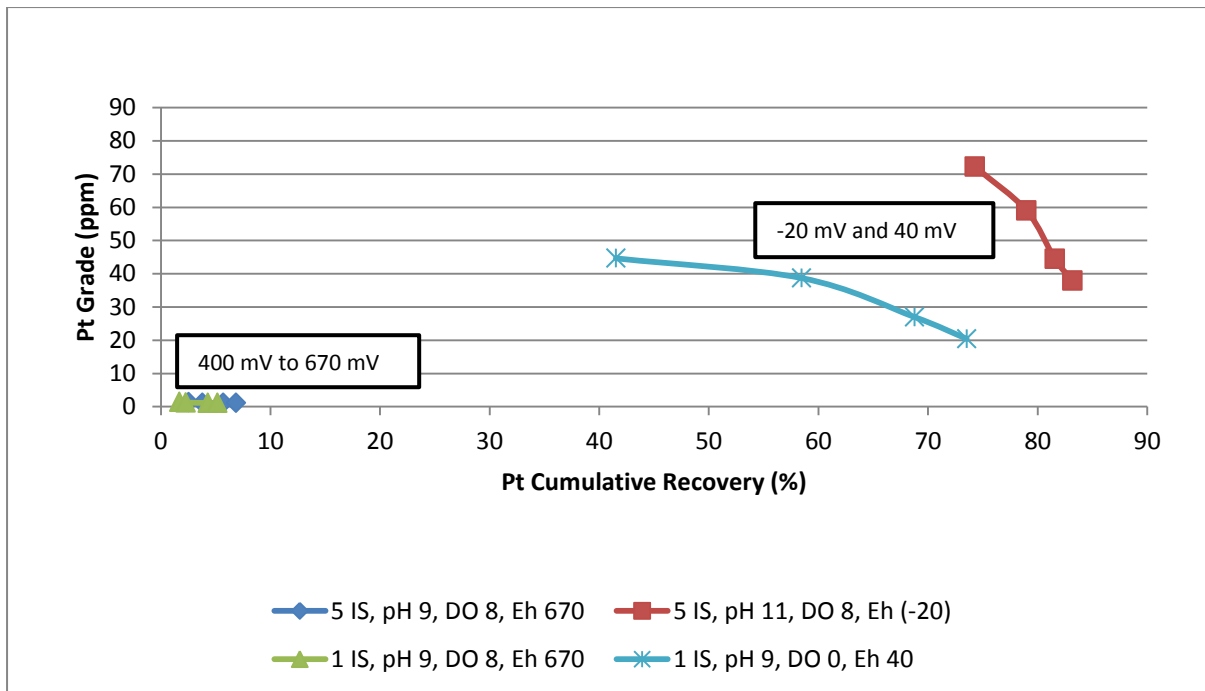

Figure 5-37: Platinum grade as a function of Platinum recovery at different conditions in the presence of depressant. The Eh was increased by NaClO addition.

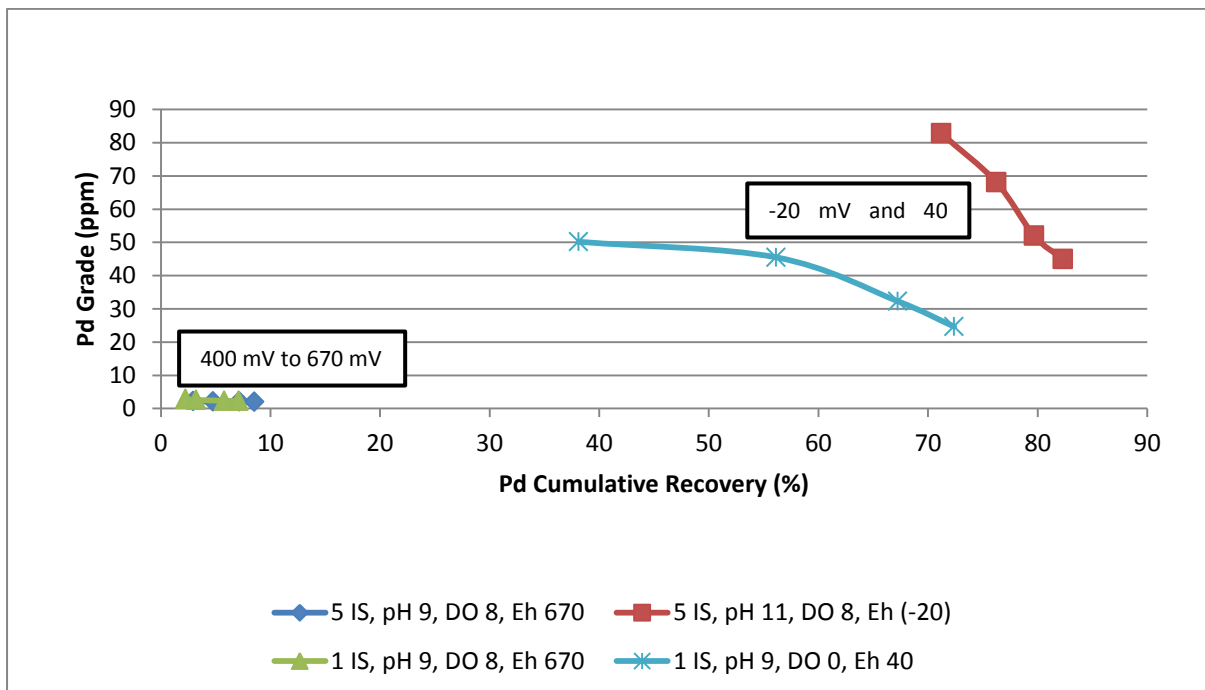

Figure 5-38: Palladium grade as a function of palladium recovery at different conditions in the presence of depressant. The Eh was increased by NaClO addition.

5.3.3 Gangue Recovery and Entrainment

5.3.3.1 Test Conditions

The depressant tests conducted in Section 5.3.2 were further assessed to determine the amount of entrained material obtained at different conditions.

5.3.3.2 Results

Figure 5-39 shows the total gangue as a function of water recovered in the presence of depressant. The highest amount of gangue recovered in the presence of depressant, 59.7 g, was at 5 IS, pH 9, DO 8 and 670 mV, and the least amount of gangue, 36.3 g, was recovered at the 1 IS, pH 9, DO 0 and 40 mV. At 500 g/t CMC it was assumed that all the NFG was depressed and therefore all the gangue recovered is entrained gangue. Therefore the increased IS and Eh are promoting froth stability and thereby increasing entrainment. The calculated entrainment factors are shown in the textboxes of Figure 5-39 and the highest and lowest entrainment factors correspond with the previously stated highest and lowest amount of entrained gangue recovered. The entrainment factors range from 0.0242 to 0.0351 showing a large difference in degree of entrainment over the conditions tested.

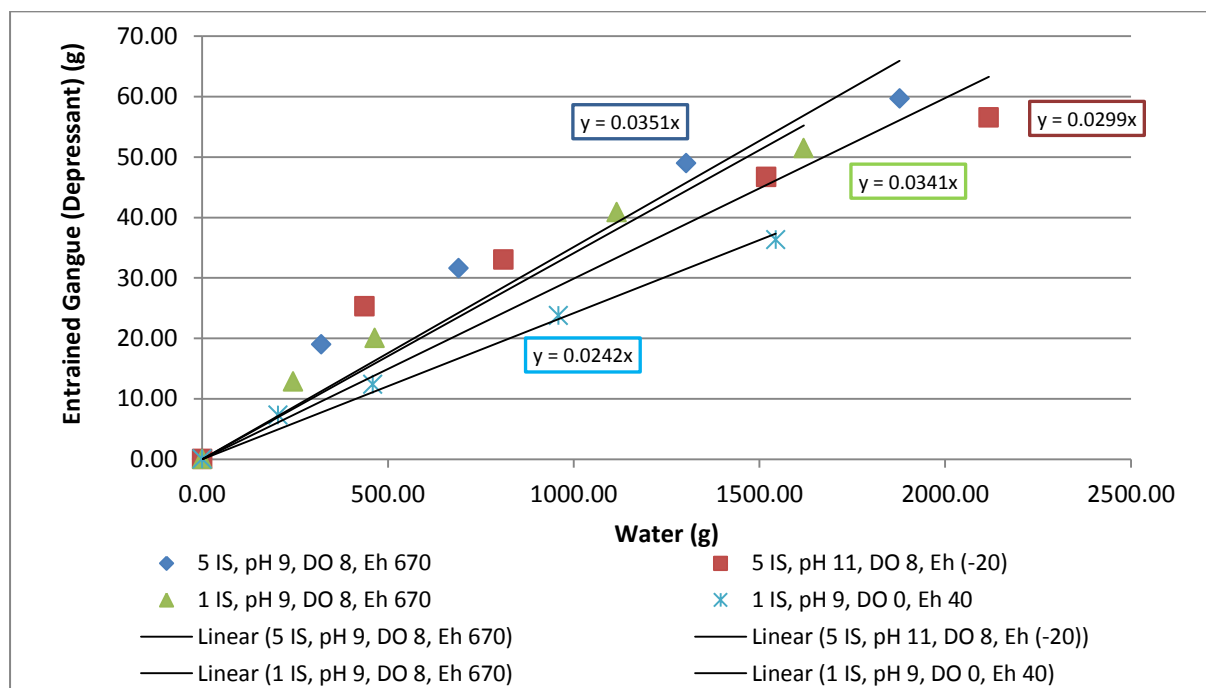

Figure 5-39: Total Entrained Gangue as a function of water recovery at different conditions at 500 g/t CMC. The Eh was increased by NaClO addition. The text boxes indicate the entrainment factor for each curve.

Figure 5-40 shows the NFG in the conditions tested in the absence of depressant and their corresponding test numbers from the batch flotation tests as written in Section 5.2. The trends in NFG recovered are the same as those seen for entrainment in the presence of depressant shown in Figure 5-39. The amount of NFG recovered in each condition seems to increase until it reaches a maximum between 1000 and 2000 g of water recovered and then decrease.

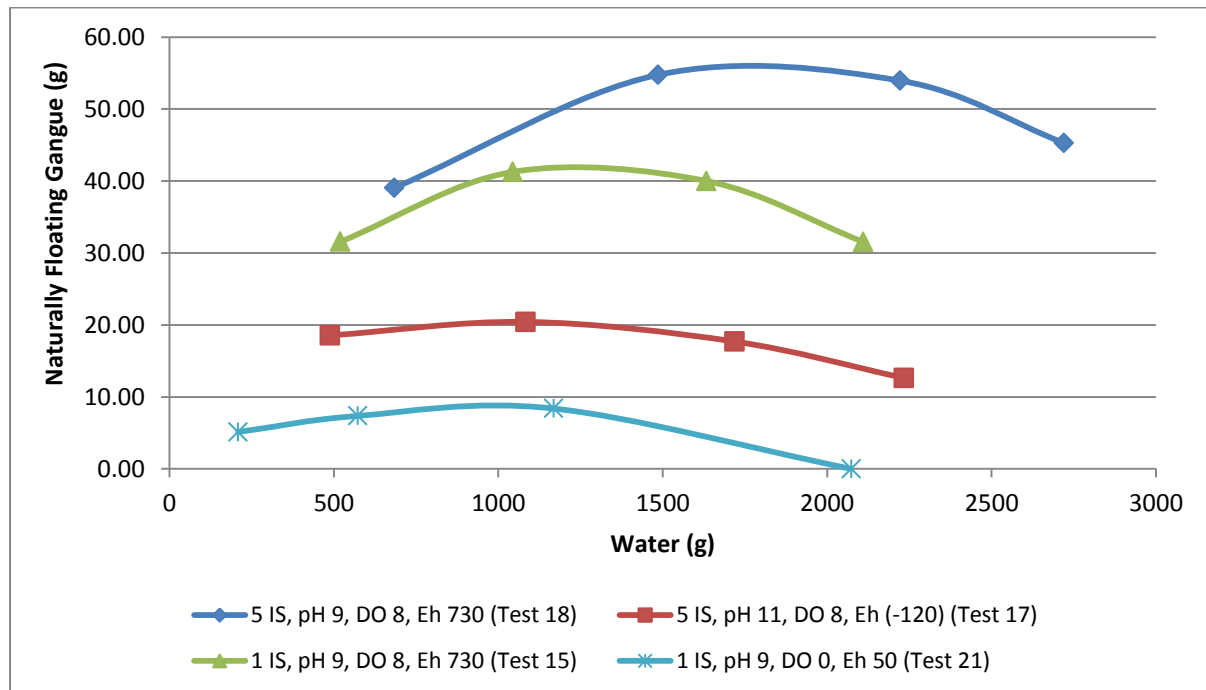

Figure 5-40: Naturally Floating Gangue (NFG) as a function of water recovery at different conditions in the absence of depressant. The Eh was increased by NaClO addition.

Figure 5-41 shows the entrained gangue in the conditions tested in the absence of depressant. The highest amount of entrained gangue in the absence of depressant was 95.5 g and was obtained at 5 IS, pH 9, DO 8 and 730 mV. The least amount of entrained gangue was 50.2 g and was obtained at 1 IS, pH 9, DO 0 and 50 mV. These trends were similar to those seen in Figure 5-39 in the presence of depressant.

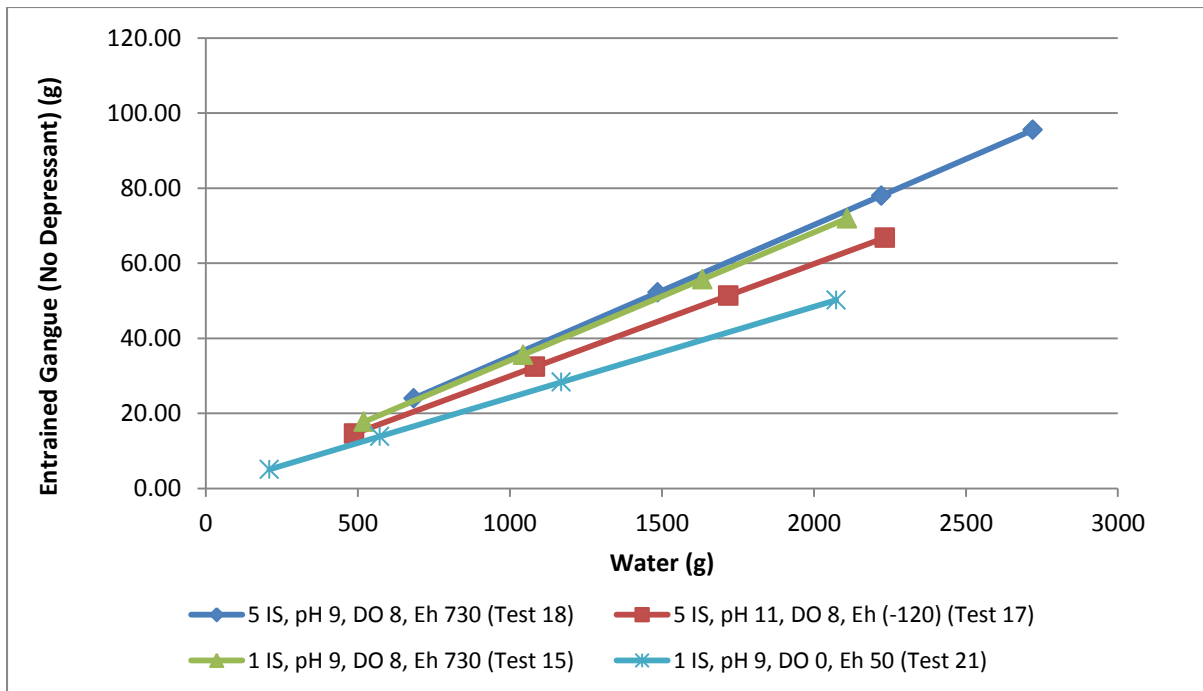

Figure 5-41: Entrained gangue recovered as a function of water recovery at different conditions in the absence of depressant. The Eh was increased by NaClO addition.

Figure 5-42 shows the total amount of solids and the total entrained material recovered for each test condition in the absence of depressant. The difference in solids mass is the NFG as well as the valuable minerals recovered. The difference between solids and entrained material for each condition increases as the overall mass increases.

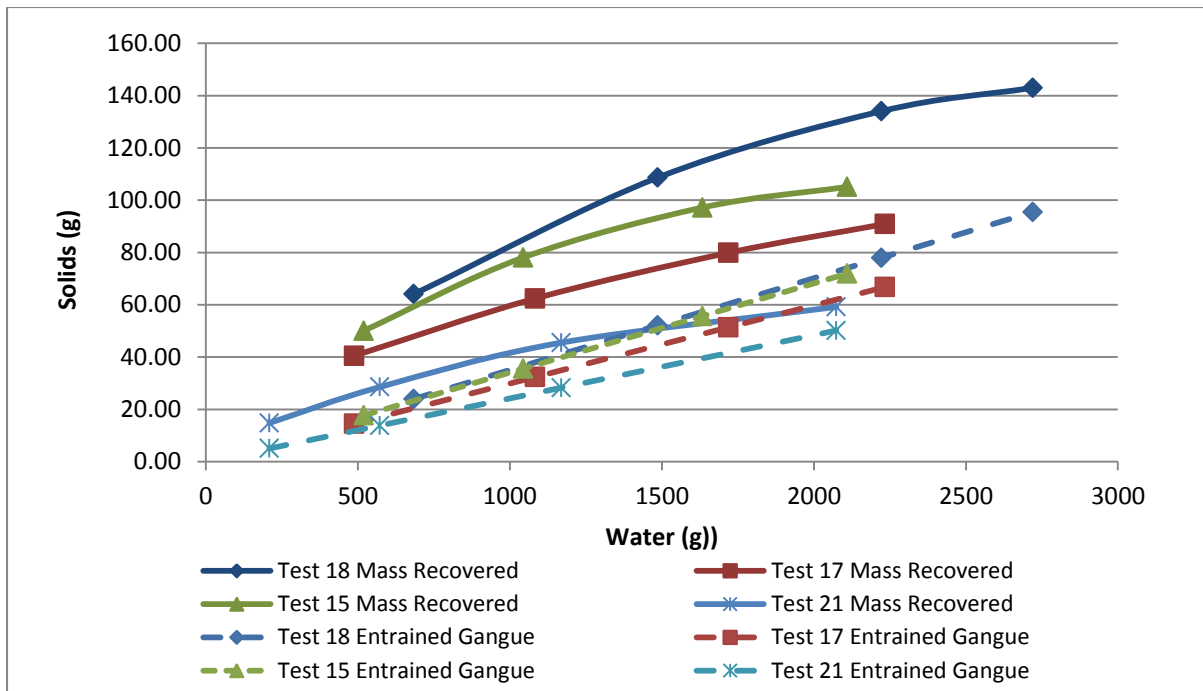

Figure 5-42: Total solids and entrained gangue recovered as a function of water recovery at different conditions in the absence of depressant for each. The Eh was increased by NaClO addition.

Table 5-1 summarises the dynamic stability factor obtained, the amount of water recovered, solids recovered, the amount of NFG and entrained gangue obtained at each condition. From Table 5-1 the highest percentage of entrained material of 84.8 % was found at Test 21, and the lowest percentage of 66.8 % was obtained at Test 18.

Table 5-1: Summary table of dynamic stability factor obtained, water recovered, solids recovered, NFG and entrained gangue obtained at each condition

| Condition | Dynamic Stability Factor (s) | Water Recovery (g) | Water Recovery in 500 g/t CMC (g) | Total Solids (g) | Maximum NFG (g) | Entrained Gangue (g) | Percentage Entrained Gangue (%) |
|-----------|------------------------------|--------------------|-----------------------------------|------------------|-----------------|----------------------|---------------------------------|
| Test 15 | 18.6 | 2110 | 1620 | 105 | 41.3 | 71.9 | 68.5 |
| Test 17 | 13.2 | 2230 | 2120 | 90.9 | 20.4 | 66.8 | 73.5 |
| Test 18 | 29.3 | 2720 | 1880 | 143 | 54.8 | 95.5 | 66.8 |
| Test 21 | 3.78 | 2070 | 1540 | 59.2 | 8.4 | 50.2 | 84.8 |

Table 5-2 shows the amount of NFG and entrained gangue that can be obtained when the froth stability is kept constant as indicated by a constant water recovery of 1500 g. The highest amount of entrained gangue obtained at constant froth stability, 52.0 g, was obtained at Test 18 which is at 5 IS and 730 mV. The lowest amount of entrained gangue obtained would be 38.0 g at Test 21 which is at DO 0.

Table 5-2: Amount of NFG and entrained gangue obtained at constant a water recovery of 1500 g at in the absence of depressant for each test condition

| Condition | NFG (g) | Entrained Gangue (g) |
|------------------|----------------|-----------------------------|
| Test 15 | 41.5 | 51.0 |
| Test 17 | 19.0 | 43.5 |
| Test 18 | 55.0 | 52.0 |
| Test 21 | 6.00 | 38.0 |

5.4 The Effect of Changing pH on Eh

5.4.1 Test Conditions

The following tests were conducted in a batch flotation cell to assess the changes in Eh as the pH was changed. The IS and DO conditions were kept constant at 1 IS and DO 8, respectively. The pH was decreased from 9 to 3 using H₂SO₄ and increased from 9 to 11 using NaOH, and the Eh was not controlled in any way.

5.4.2 Results

Figure 5-43 shows the changes in Eh observed as a function of pH. The trend seen was that as the pH increased from 3 to 11 there was a general decrease in Eh decreased from 409 mV to 27.2 mV.

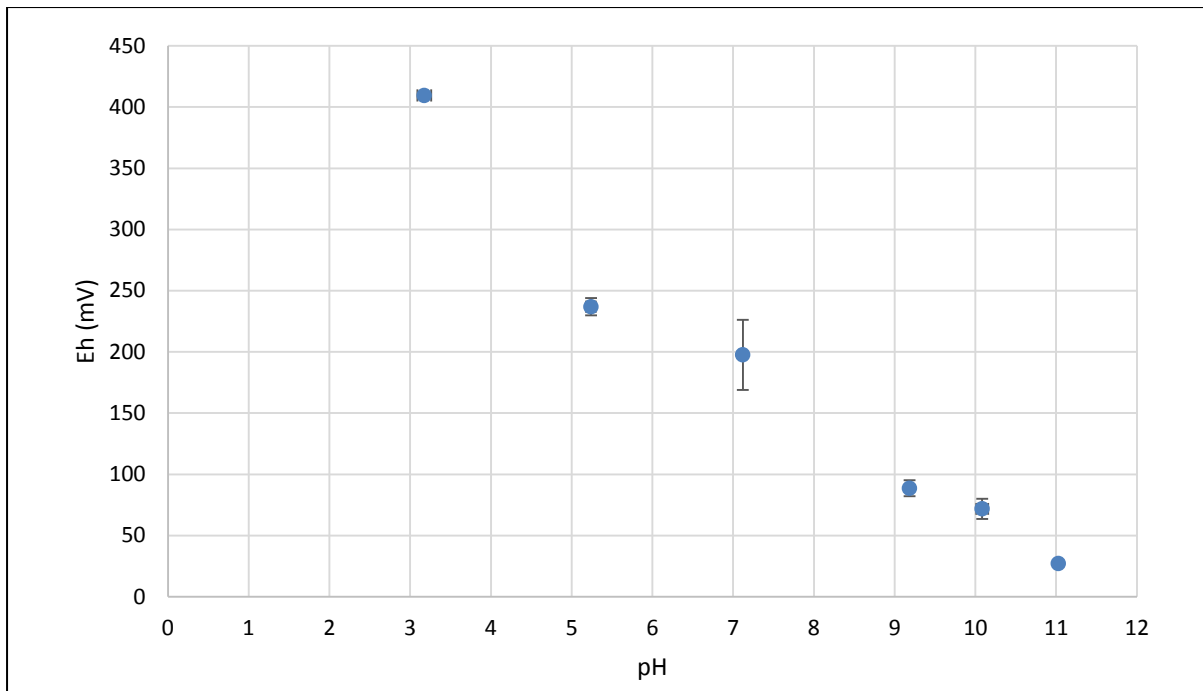

Figure 5-43: The response of changing pH on Eh in a 1 IS and DO 8 batch flotation system. Error bars represent standard error.

5.5 The Effect of Pulp Conditions on Bubble Size

5.5.1 Test Conditions

The following images are still shots that were taken during the 3-phase batch flotation tests of the side of the froth in the batch flotation cell. These images were taken of the same section, size and scale within the cell. Each image is 2 cm² in size and each pair of images compares the bubble sizes observed when one pulp factor was changed within the cell. The general difference in colour seen was not due to the froth content but was due to the lighting in the laboratory at the time of the test.

5.5.2 Results

Figure 5-44 to Figure 5-47 show the images taken of the bubbles in the froth section of the batch flotation cell. The image of bubbles in the froth in Test 13 are compared to bubbles in the froth when individual pulp factors were changed. Each image is divided into 3 sections for ease of comparison.

Figure 5-44 shows the difference in bubble size observed when IS was changed from 1 IS to 5 IS. In section (c) of Figure 5-44 a decrease in bubble size was seen from 1 IS to 5 IS. The general bubble size in section (c) of Test 13 was in the range of 0.25 mm to 0.75 mm on the

actual scale and these bubbles reduced to less than 0.25 mm in the 5 IS image. In section (b) the bubbles looked more stable at 5 IS than at 1 IS. The measurable bubble sizes in section (b) of Test 13 were in the range of 0.25 mm to 2.5 mm, whereas those at 5 IS were from 0.25 mm to 1.75 mm. This resulted in more bubbles present in section (a) at 5 IS than at 1 IS. This means that smaller bubbles were observed in the froth phase at 5 IS as compared to 1 IS.

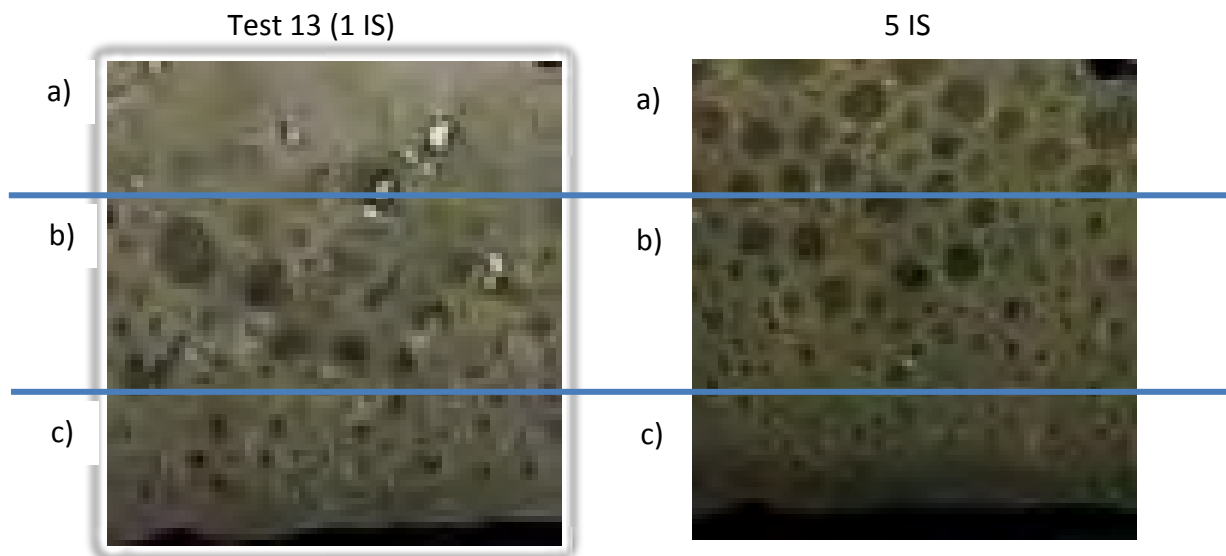

Figure 5-44: Comparison of bubble sizes observed at the Test 13 (1 IS) and 5 IS where pH, DO and Eh remained constant.

Figure 5-45 shows the difference in bubble size per unit area when the pH was changed from pH 9 to pH 11. In section (b) the bubble size decreased from a range of 0.25 mm to 0.75 mm at Test 13, to a range of 0.5 mm to 1 mm at pH 11. This meant that the bubbles were more stable at pH 11 than at pH 9. This resulted in more bubbles present in section (a) at pH 11 than at pH 9. Generally at pH 11, an increased amount of bubbles at smaller sizes were observed in the froth phase. This means that increasing the pH decreases the bubble size in the froth and thereby increases the water recovered to the concentrate.

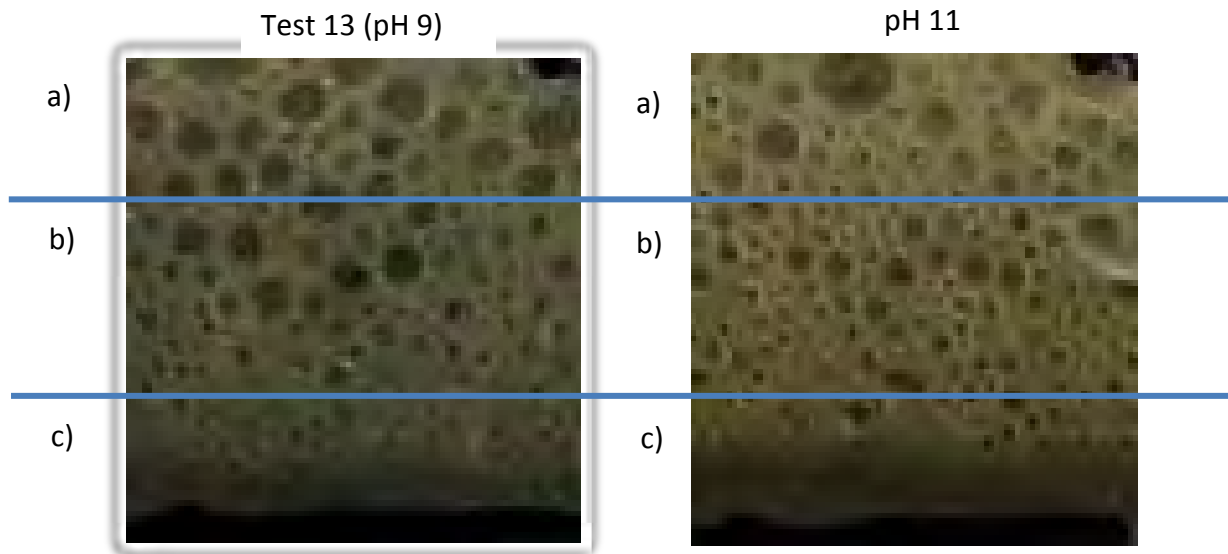

Figure 5-45: Comparison of bubble sizes observed at the Test 13 (pH 9) and pH 11 where IS, DO and Eh remained constant.

Figure 5-46 shows the bubble sizes observed at DO 8 and DO 0. There seems to be a slight increase in the number of bubbles observed at DO 0 as compared to DO 8. In section (c) larger bubbles were seen at DO 0 than at DO 8. The bubble size range increased from 0.25 mm to 0.75 mm at Test 13 to 0.25 mm to 1.25 mm at DO 0. In section (b), more stable bubbles were seen at DO 0 than at DO 8 as the largest bubble at pH 11 was 2 mm as compared to the largest bubble of 2.5 mm at Test 13. In section (a) the bubbles at DO 8 and at DO 0 both seemed unstable and ready to burst.

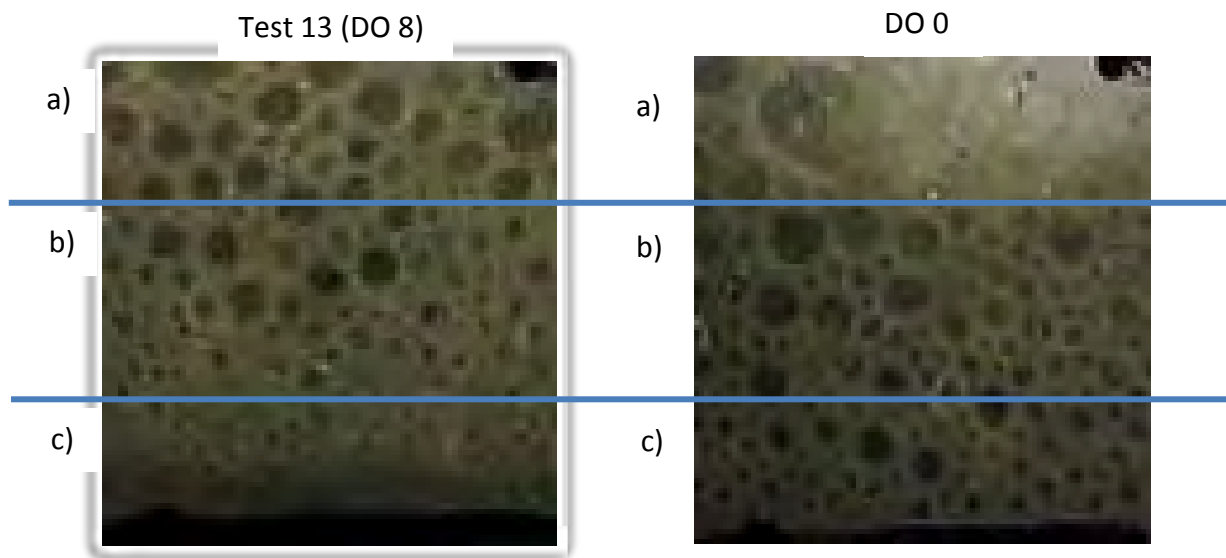

Figure 5-46: Comparison of bubble sizes observed at the Test 13 (DO 8) and DO 0 where IS, pH and Eh remained constant

Figure 5-47 shows the bubbles observed in the froth phase at low Eh and high Eh. In section (c) the bubbles are larger at high Eh than at low Eh, increasing from a range of 0.25 mm to 0.75 mm at Test 13, to a range of 0.25 mm to 1.5 mm at high Eh. In section (b) and in section (a) more stable bubbles are present at high Eh than at low Eh. The minimum measurable bubble size in section (b) at high Eh was 0.5 mm as compared to the minimum of 0.25 mm at Test 13. There seems to be an increase in bubble size at high Eh as compared to low Eh but the bubbles are more stable at high Eh than at low Eh. The lighter colour observed at high Eh may be due to an increase in gangue recovery.

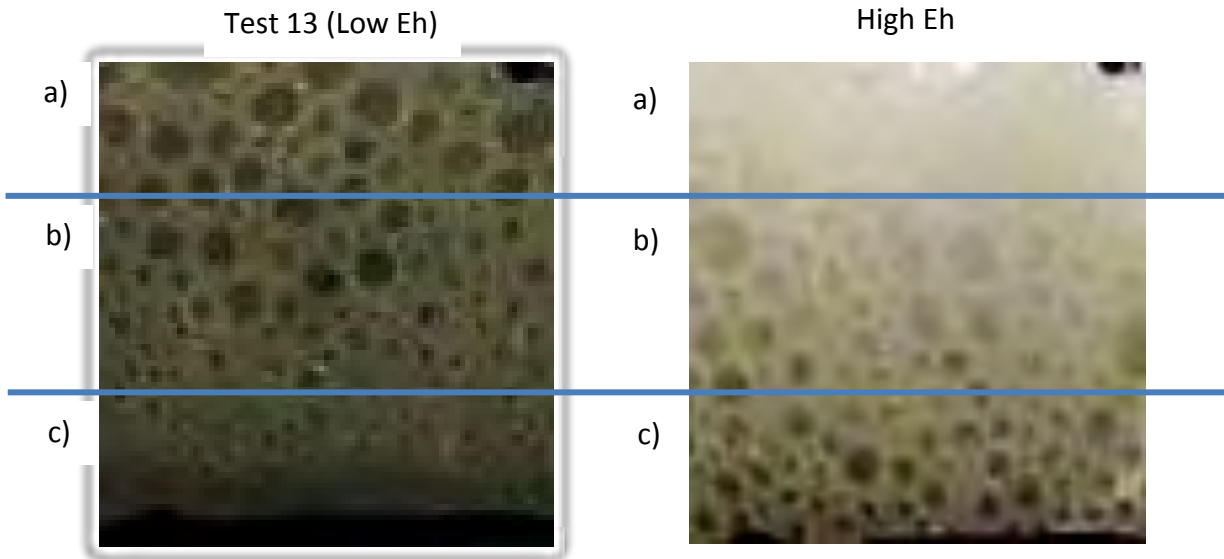

Figure 5-47: Comparison of bubble sizes observed at the Test 13 (Low Eh) and High Eh where IS, pH and DO remained constant. The Eh was increased by NaClO addition.

5.6 Key Findings

Table 5-3: Key findings of pulp factor effects on water and solids recovery, valuable mineral grade and recovery, froth stability and bubble size

| Pulp Factor Change | Effect of Pulp Factor Change | | | | | |
|--------------------|------------------------------|---------------------------|-----------------|-------------------------------------|-----------------|-------------|
| | Water Recovery in 2-Phase | Water Recovery in 3-Phase | Solids Recovery | Valuable Mineral Grade and Recovery | Froth Stability | Bubble Size |
| ↑ IS | ↑ | ↑ at pH 9 | ↑ at pH 9 | ↑ | ↑ | ↓ |
| | | ↓ at pH 11 | ↓ at pH 11 | | | |
| ↑ pH | ↑ | ↑ at 1 IS | ↑ at 1 IS | ↑ | ↑ | ↓ |
| | | | ↓ at 5 IS | | | |
| ↓ DO | ↑ | ↑ | ↓ at 1 IS | ↑ | ↑ | - |
| ↑ Eh | ↓ | ↑ | ↑ | ↓ | ↑ | ↑ |

6 Discussion

The objective of this study was to investigate the influence of various pulp chemical conditions during flotation on bubble size, froth stability, entrainment and the recovery and grade of the valuable minerals.

In order to achieve this objective different combinations of IS, pH, DO and Eh were evaluated as outlined in Chapter 4. The results obtained from these tests are discussed in this chapter in the form of answers to the key questions proposed in Chapter 3:

1. Can the careful control of the pulp chemistry improve froth stability?
2. Can the pulp chemistry factors be controlled such that flotation performance is improved in terms of grades and recoveries?
3. What conditions of IS, pH, DO and Eh will result in decreased entrainment?
4. What will be the effect of changing IS on bubble size in the froth phase?

A reference condition was chosen for both 2-phase and 3-phase tests. These reference conditions were 1 IS, pH 9, DO 8 and -50 mV for 2-phase (Test 1) and 1 IS, pH 9, DO 8 and -70 mV (Test 13) for 3-phase.

6.1 The Effect of Pulp Factors on Froth Stability

Froth stability has been defined as the froth's ability to resist bubble bursting and bubble coalescence (Farrokhpay, 2011), and is the condition existing when the rate of smaller bubbles joining the froth phase is equal to the rate of bubbles bursting at the top of the froth phase. The measure of froth stability used in this study was the dynamic stability factor as proposed by Barbian *et al.* (2003). In this study, water recovery was used as a proxy for froth stability (Wiese and Harris, 2012). Increased froth stability would, therefore, be linked to increases in the dynamic stability factor and water recovery. A summary of the effects of each pulp factor condition on water recovery from 2-phase and 3-phase tests is shown in Table 5-3. The same effects on water recovery were observed in 2-phase and 3-

phase with the exception of Eh where, in 3-phase, increased Eh resulted in increased water recovery.

The fact that the trends for water recovery were the same for 2 and 3-phase tests is indicative that these effects were as a result of chemical conditions in the pulp and not due to reagent addition or the presence of particles.

The effect of Eh on water recovery was different for 2-phase and 3-phase, indicating that the effect observed in 3-phase may be linked to increased froth stability. This may be as a result of the presence of more oxidised minerals at higher Eh values resulting in increased hydrophobicity and therefore greater froth stabilisation. The results obtained from 3-phase experiments also indicate that the increased solids recovery was due to an increase in entrained gangue minerals, as opposed to valuable minerals, which are known to stabilise the froth (Ata *et al.*, 2003). Figure 5-47 showed an increase in bubble size with an increase in Eh. This may be related to the increase in gangue and fine particle recovery at high Eh, as it has been found that fine particles can cause an increase in bubble coalescence by rupturing the thin films in the froth and causing froth decay (Manev and Nguyen, 2005). Therefore at high Eh values, this study has found an increase in gangue mineral recovery, an increase in entrainment and an increase in froth stability. This is in agreement with the findings of Ata *et al.*, (2003) who used a specialised flotation cell and studied the effect of particle hydrophobicity on froth stability. They found that it is possible for moderately to strongly hydrophobic minerals to stabilise the froth and that there exists an optimum particle hydrophobicity that promotes froth stability. They also noted that high flotation recoveries can still be achieved with high bubble coalescence rates. The increased Eh obtained in this study which led to increased froth stability is in agreement with the findings of Ata *et al.*, (2003), as the increased Eh may have promoted the presence of more moderately hydrophobic particles in the froth.

Increased pH and IS both resulted in an increase in froth stability. The high pH may be increasing water recovery due to an increase in OH^- ions in the system from the addition of NaOH which was used to increase the pH. The increased concentration of OH^- ions can inhibit the forward reaction in Equation 6-1 and Equation 6-2. The reduction of oxygen

(Equation 6-2) is the dominant reduction reaction that is coupled with collector oxidation (Rao and Leja, 2004).



An increase in OH^- ions also results in an increase in the amount of ions in the system and therefore an increase in IS. This increase may be small, as only a few millilitres of a 2 M NaOH solution were added to increase the pH from 9 to 11, but this may be the reason the combined increase in pH and IS resulted in an overall increase in water recovery in both 2-phase and 3-phase experiments. In the 2-phase system, at low Eh and pH 11 more water was recovered. As illustrated by Equation 6-3, this antagonistic relationship has been confirmed by Pourbaix (1966) and formed the basis of his Eh-pH diagrams.

$$\mathbf{E = E^0 - pH} \quad \text{Equation 6-3}$$

In 3-phase tests, an increase in pH resulted in a decrease in Eh when the pH was increased using NaOH (Figure 5-43) confirming that the 2-phase relationship of pH and Eh existed in 3-phase. However, the decrease in the Eh with an increase in pH was less than 100 mV. Therefore, it would be wrong to conclude that, as seen in 2-phase where low Eh and pH 11 resulted in increased water recoveries, the Eh and pH would have antagonistic effects on froth stability in 3-phase. The water recoveries obtained in 3-phase tests (Figure 5-5 and Figure 5-10) increased at pH 11 and high Eh. This indicates that the effect of increased Eh stabilising the froth overrides the antagonistic effect of pH and Eh on one another and allows for both increased Eh and increased pH to stabilise the froth. This is confirmed by the response shown in the 3D surface plot of Eh and pH (Figure 5-13). Thus for 3-phase tests, the increase in pH and the increase in Eh had an additive effect on increasing water recovery.

Increased IS has been shown to result in increased froth stability due to a decrease in bubble size in the pulp (Manono, 2010). In the present study, an increase in IS from 1 IS to 5 IS also resulted in a decrease in bubble size in the froth phase as shown in Figure 5-44. The strong contribution of increased IS to water recovery is in agreement with previous findings. Manono (2010) studied the effects of IS on a 2-phase system as well as on a 3-phase system using a platinum bearing ore from the Merensky Reef. He found that an increase in IS

increased the foam height, reduced the bubble size in the pulp and increased the water recovery in a 2-phase system. This effect may be explained by the presence of the salts used to make up the plant water. These salts have been found to inhibit bubble coalescence, reduce surface tension and exhibit frothing properties (Manono *et al.*, 2012; Quinn *et al.*, 2007). Craig's (2011) theory on the $\alpha\alpha$ or $\beta\beta$ pairing of electrolytes (as explained in Section 2.2.5.1) adds to the plant water salts' ability to inhibit bubble coalescence and indicates why increasing IS increases froth stability.

In terms of evaluating the effect of DO in the system, conducting flotation tests using nitrogen as the flotation gas (DO 0) resulted in higher amounts of water recovered overall than when conducting flotation tests using air (DO 8) in the 2-phase and 3-phase systems. The increase in water recovery in 2-phase due to changes in DO alone (an increase of 700 g) was more significant than that observed in 3-phase (an increase of 130 g). This indicates that in 3-phase the presence of particles reduced the effect of decreased DO levels on froth stability and that the overall increase in water recovery at DO 0 as compared to DO 8 may be due to the combined effect of DO and another pulp factor. Based on the model equation for water recovery in 3-phase (Equation 5-3), the strongest contributing factor to water recovery was pH followed by Eh with IS showing the weakest contribution. The pH and IS contribution to effects seen at different DO levels may be as a result of increased froth stability as was previously stated. The Eh contribution to the DO effect on water recovery may be due to an increase in Eh which resulted in an increase in the amount of oxidation reactions in the system and, at DO 8, the system may have been over-oxidised resulting in a reduction in the extent of bubble/particle attachment occurring in the cell (Hu *et al.*, 2009). This could result in a reduction in the amount of particles in the froth and in turn reduce froth stability as indicated by a reduction in water recovery. Therefore, an increase in Eh with a decrease in DO should result in increased water recovery.

The stability column tests performed in 3-phase at a CMC dosage of 500 g/t (Figure 5-32) showed that the highest dynamic stability factor was obtained at 5 IS, pH 11, DO 8 and -30 mV. Therefore, even in the presence of high depressant dosage which has been shown to reduce water recovery, IS and pH still demonstrated froth stabilising effects as evidenced by increased water recovery in the 3-phase batch flotation tests. The presence of oxygen in the system is necessary for the formation of dixanthogen (Wills and Napier-Munn, 2006) which

results in increased mineral hydrophobicity and likely resulted in the presence of more particles to stabilise the froth.

6.2 The Effect of Pulp Factors on Valuable Mineral Grade and Recoveries

Plots of mineral recovery as a function of water recovery are useful in determining the amount of solids recovered per gram of water recovered. The grade versus recovery curves for valuable minerals are important from an industrial perspective in that they aid the operators in determining what grades and recoveries could be achieved from their ores. It is, therefore, important to discuss the findings of this study in terms of these factors.

Improved valuable mineral grades achieved over and above those obtained from Test 13 were observed for Test 21 (1 IS, pH 9, DO 0 and 50 mV) for all valuable minerals determined with the difference between the two tests being the decrease in DO from 8 ppm to 0 ppm in Test 21. This may have been due to a lack of dixanthogen adsorption when little to no oxygen was present in the system (Usul and Tolun, 1974) and could mean that composite particles containing valuable and gangue minerals may have been lost to the tails. Flotation under nitrogen has been found to reduce the pulp potential to a less anodic potential, thereby requiring a higher pulp potential for xanthate interaction, and increasing the selectivity of certain minerals. For example, the selective flotation of pentlandite over that of pyrrhotite was increased when nitrogen was used instead of air as the flotation gas (Rao and Leja, 2004). However, low concentrations of oxygen would still be present in the flotation cell as it is not a closed unit. Tadie (2015) observed the presence of both metal xanthate and dixanthogen at pH 9.2 in an aerated cell with dixanthogen being the dominant species. The formation of metal xanthate is possible when floating under nitrogen if the mineral has been oxidised such that metal ions are present in solution with a strong enough driving force for the xanthate to react with the metal ions and form the metal xanthate. This indicates that the absence of oxygen and lowered amounts of oxidised species may have resulted in less gangue material reporting to the concentrate and therefore higher valuable mineral grades.

With the exception of copper, the highest valuable mineral recoveries were achieved at 5 IS, indicating that the froth stabilising effect of IS, discussed previously, was a strong contributor to increased recovery. Recoveries of copper at Test 14, 21 and 22 (tests at pH 11

and DO 0) were improved above those obtained from Test 13. The valuable mineral recovery results are in agreement with those of Manono (2010) for copper and nickel. He found that increasing IS did not affect the rate of copper recovery but did increase the final copper recovery. His study also showed that nickel recovery increased with an increase in IS but that the nickel grade remained fairly constant despite changes in IS (Manono, 2010). Results obtained from tests conducted at a CMC dosage of 500 g/t showed that the highest

valuable mineral grades and recoveries were obtained at either 5 IS, pH 11 or DO 0. Each of these factors, 5 IS, pH 11 and DO 0, resulted in increased water recovery and therefore increased froth stability, indicating that in the presence of depressant increased froth stability was necessary for improved grades and recoveries of the valuable minerals. The results for grade and recovery further showed that Eh had a strong effect on valuable mineral grade and recovery in that all conditions at high Eh values, in the range of 500 to

730 mV, resulted in the lowest grades and recoveries for all the valuable minerals tested. The low Eh conditions, in the range of -120 to 50 mV, yielded grades and recoveries that were significantly higher than those obtained at the high Eh conditions. In tests conducted at pH 11 and DO 0 significant improvements in froth stability were noted indicating that the intermediate recoveries may be due to froth stabilising effects. Improved grades and recoveries were, therefore, a result of improved froth stability due to increased IS and

reduced gangue recovery due to the low Eh. The decreased valuable mineral grade and recovery at high Eh values may be as a result of increased oxidation at high Eh values. The increase in oxidation in the system may result in a lack of selectivity due to an increase in dixanthogen formation in the system, as well as increase the formation of metal xanthate to such an extent that collector effectiveness is significantly reduced (Wills and Napier-Munn, 2006). Increased oxidation can hinder the adsorption of the surfactant or hinder the

adsorbed layer on the mineral surface from being hydrophobic (Rao and Leja, 2004). The high Eh range used in this study falls into the range of increased oxidation for the valuable

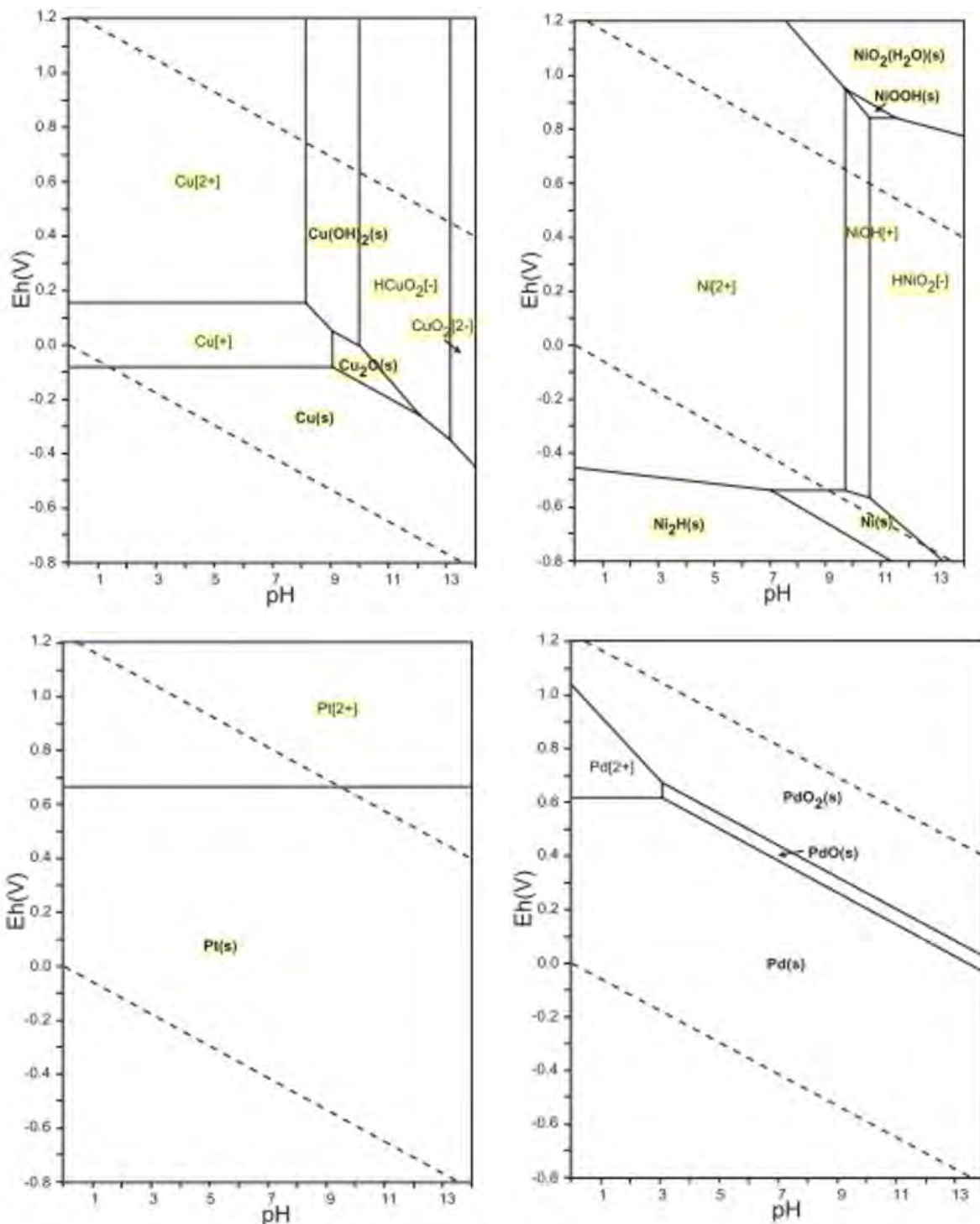

minerals tested within the pH 9 to pH 11 limits as seen in Figure 6-1.

Figure 6-1: Pourbaix diagrams of copper, nickel, platinum and palladium at STP (Takeno, 2005)

The figure illustrates that within an Eh range of 600 to 730 mV and between pH 9 and 11, the prevalent valuable mineral species present were the solid $\text{Cu}(\text{OH})_2$ for copper, Ni^{2+} and

NiOH^+ for nickel, Pt^{2+} for platinum, and solid PdO_2 for palladium. The ionic species, namely nickel and platinum, would remain in solution and the copper hydroxide and palladium oxide are hydrophilic (Woods, 1988). This would result in little to no recovery of the valuable minerals at high Eh values.

Upon analysis of the grid (Figure 5-31) and model equations for the copper and nickel recoveries, increasing the Eh was shown to have a strong negative effect on copper and nickel recovery. The previous observation of increased froth stability at high Eh, as measured by water recovery, in 3-phase tests may, therefore, be as a result of increased gangue recovery and not valuable mineral recovery. However, it is possible that within the range of Eh values tested there lies an optimum copper and/or nickel recovery which cannot be known without further test work.

6.3 The Effect of Pulp Factors on Entrainment

Entrainment is the recovery of material to the concentrate via means other than true flotation. An increase in the recovery of entrained gangue reduces the grade in the concentrate. Understanding which pulp factors affect and can reduce entrainment is key to improving the grades of valuable minerals and therefore improving flotation performance. In this study, the entrainment function was calculated by performing a sulphur balance as described in Chapter 4 on the amount of solids recovered from the tests conducted at high depressant dosage in Section 5.3.

At high Eh, 670 mV, entrainment factors greater than 0.034 were obtained and at low Eh values, -20 and 40 mV, entrainment factors marginally lower than 0.030 were obtained. This suggests that more entrained gangue per unit water was recovered at high Eh as compared to low Eh values. The difference in entrainment factors is however not very large indicating that despite the large difference in potential (630 mV), the Eh had no significant chemical influence on entrainment. This may be because entrainment is a mechanical process with no direct links to the mineral chemistry (Rao and Leja, 2004). The correlation between Eh and entrainment may therefore be due to the froth stabilising effect of Eh.

Previous authors (Wang *et al.*, 2015; Neethling and Cilliers, 2009; Zheng *et al.*, 2006; Szatkowski, 1987) have observed that there is a decrease in entrainment with an increase in froth depth. Zheng *et al.* (2006) and Szatkowski (1987) went on to state that this is due to an

increase in froth residence time and thus an increase in drainage. In a laboratory batch flotation cell, the froth depth is limited to 2 cm and a froth of a greater height would overflow into the concentrate. This indicates that the increase in water recovery resultant from an increase in Eh may be causing the entrained particles to proceed to the concentrate before they can drain back into the pulp.

The results of this study further show that reduced froth stability under the condition of 1 IS, pH9, DO 0 and low Eh yielded the lowest degree of entrainment. However, on an industrial scale, conducting flotation tests with little to no oxygen present and at low froth stability would hinder the recovery of valuable minerals and be uneconomical or even unfeasible. The valuable minerals showed better recoveries at 5 IS as discussed in Section 6.2 and therefore operating at low Eh alone may be a better option for reducing entrainment.

6.4 The Effect of Pulp Factors on Bubble Size in the Froth Phase

The sustained presence of small bubbles in the froth phase is an indication that bubble coalescence has been inhibited which is necessary for the maintenance of froth stability. A stable froth is key in improving flotation performance. Bubble size is largely a function of particle size, concentration and type (Manev and Nguyen, 2005), as well as liquid surface tension (Syeda *et al.*, 2004) and the electrolyte concentration (Rao and Leja, 2004).

The effect of increased IS and pH on bubble size indicates that the increase in electrolyte concentration reduced bubble coalescence, confirming their froth stabilising effects as well as the ionic contribution of increased pH to IS discussed in Section 6.1.

The effect of increased Eh on bubble size may be linked to the effect Eh has on the concentration of particles in the froth. An increase in Eh may cause increased bubble coalescence due to an increase in the amount of gangue material in the froth as suggested by the lighter colour of the froth in the image captured under these conditions (Figure 5-47). The increase in froth stabilising gangue material in the froth was supported by the observation of increased NFG with an increase in Eh (Figure 5-40). The increase in bubble size with an increase in Eh was also in agreement with Espinosa-Gomez *et al.* (1988) and Manev and Nguyen (2005) who observed that bubble coalescence was found to increase in

the presence of solids and that fine particles rupture the bubble films resulting in increased bubble coalescence.

The lack of any effect on bubble size when DO levels were changed may indicate that changes in DO affect species formation within the pulp rather than the bubble size in the froth and this effect is what causes an increase in froth stability in tests conducted at DO 0 as compared to DO 8.

6.5 The Effect of Eh Modifiers

There is a substantial literature (e.g., Corin *et al.*, 2013; Chander, 2003; Kuopanportti *et al.*, 1997) on the effect of DO and pH on Eh. In previous studies (Plackowski *et al.*, 2014; Khan and Kelebek, 2004) Eh control by DO and/or pH manipulation was performed on pure minerals systems. When nitrogen was used to decrease DO, Eh was reduced to between -95 mV and -5 mV (Khan and Kelebek, 2004). The effect of changes in pH on Eh was tested in a batch flotation cell. As the pH increased the Eh decreased. This is in agreement with the observations of Chimonyo (2016) who found that increasing the pH from 9 to 11 in a Merensky ore pulp decreased the Eh to between 0 mV and 100 mV. In this study, no significant effects of changes in DO on Eh were observed, however, as stated in Section 6.2 there may be a combined effect of DO and another pulp factor, namely, pH on Eh.

The influence of pH and/or DO on Eh may be due to the ability of a change in pH and/or DO to chemically alter the surface chemistry of the mineral. This change in surface chemistry can be seen by a change in zeta potential as observed by Farrokhpay and Zanin, 2012. The change in charge on the mineral surface would affect the type of redox reactions that can take place on the mineral including collector attachment and would subsequently affect mineral hydrophobicity (Kawatra and Eisele, 2001). Therefore as the pH increases, increasing the OH⁻ ions in the system, more reduction reactions are promoted and as the pH decreases, increasing the H⁺ ions, more oxidation reactions are promoted. Changes in pH have been found to change the upper and lower pulp potential limits of minerals (Hu *et al.*, 2009). Operating in the correct pH range will, therefore, determine the mineral product recovered.

Chemical oxidising agents, increase Eh, examples include NaClO and H₂O₂. Chimonyo (2016) observed that the addition of NaClO increased the pulp potential without changing the pH

and had no significant impact on the recovery and grades of valuable minerals. At the concentrations investigated in the study by Chimonyo (2016), the addition of H_2O_2 was observed to reduce the grades and recoveries as compared to NaClO. The mechanism by which NaClO affects pulp potential is not fully understood (Chanturiya and Vigdergauz, 2009), but Chimonyo (2016) proposed a mechanism whereby NaClO undergoes reduction (Equation 6-4) while the mineral surface, as well as the collector, undergo oxidation. This allows for the use of NaClO as an Eh modifier as it results in the formation of a preferred collector species in the form of dixanthogen.

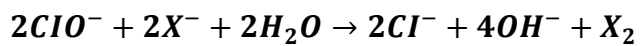

Equation 6-4

7 Conclusions

The objective of this study was to understand the influence of various pulp chemical conditions during flotation on froth stability and entrainment as well as the grades and recoveries of the valuable minerals. By addressing this objective this study would be adding to the body of knowledge of electrochemistry in flotation. This kind of knowledge contribution may be key in improving flotation performance and increasing the grades and recoveries of valuable minerals obtained in South Africa's PGM mining industry. Hypotheses were put forward and by way of conclusion to this thesis, answers to the hypotheses are proposed:

7.1 Improved flotation outcomes can be achieved with careful control of flotation pulp chemistry as this chemistry will determine both the stability of the froth phase as well as the ability of the valuable minerals to reach the froth phase.

This study has shown that careful manipulation of the pulp chemistry, namely, IS, pH, DO and Eh, resulted in improved froth stability. It was observed that any manipulation of the pulp factors in 3-phase resulted in improved water recoveries above those obtained in the reference case of 1 IS, pH 9, DO 8 and -70 mV. The highest amount of water was recovered in 3-phase at 5 IS, pH 11, DO 0 and 650 mV (Test 28) indicating that this was the most stable froth. However, the high Eh value resulted in the highest amount of gangue recovery and operating at DO 0 is not practical for dixanthogen formation as well as for industrial applications. Therefore, the optimal froth stability for the achievement of good grades and improved valuable mineral recovery was observed at 5 IS, pH 9, DO 8 and -80 mV (Test 16).

In tests conducted at a CMC dosage of 500 g/t, the most stable froth was obtained at 5 IS, pH 11, DO 8 and -120 mV (Test 17). In Test 17 an increased amount of water and solids were recovered with a minimal amount of entrained and naturally floating gangue material reporting to the concentrate. High grades and recoveries of platinum and palladium were obtained from Test 17. An analysis of the results obtained has shown that no individual factor can alone achieve significantly improved froth stability but rather optimal froth stability is achieved as a result of the combined effect of the pulp factors.

Overall, the 3-phase batch flotation tests and 500 g/t depressant tests showed that the common factor for improved flotation outcomes was increased IS. This resulted in both increased froth stability, good grades and improved recoveries. This suggests that the contribution to increased IS from the build-up of salts in recycled plant water may result in an improvement in flotation performance on an industrial plant.

7.2 Eh can be manipulated by careful control of pH during the flotation process as Eh is simply an indicator of other chemical factors within the system.

This study has shown that the Eh can successfully be increased by decreasing the pH using H_2SO_4 and can be decreased by increasing the pH using NaOH. This is due to the increase in hydrogen ions (H^+) resulting in increased oxidation potential in the system and the increase in the OH^- ions resulting in increased reduction potential in the system.

7.3 Increased ionic strength of process water lowers the likelihood of bubble coalescence, therefore, smaller bubbles will be present in the froth phase and this will result in higher water recoveries and more entrained material entering the concentrate.

This study has shown that increased water recoveries were observed at 5 IS as compared to 1 IS due to the froth stabilising nature of the pulp at 5 IS. The images of bubble sizes in the froth confirmed this as smaller bubbles were present at 5 IS compared to 1 IS. The increase in water recovery, therefore, led to an increase in entrainment at 5 IS due to entrainment being directly proportional to the amount of water recovered to the concentrate. However, the most entrained gangue was obtained under high Eh conditions indicating that although increasing IS increased the amount of material recovered by entrainment, operating at 5 IS and low Eh could reduce the amount of entrained gangue recovered in the system. It is important to note that the depth of froth, 2 cm, in the laboratory flotation cell is not sufficient to compare to large plant cells.

8 Recommendations

Based on the experimental findings and the conclusions drawn in this study, the following recommendations are made:

- ✓ The electrochemical factors tested in this study be tested in the highly instrumented Magotteaux mill, capable of monitoring and controlling in-situ grinding chemical parameters; Eh, pH, DO and temperature (Greet *et al.*, 2004)
- ✓ Broader ranges of IS, pH, Eh and DO should be experimentally tested to better understand their influence on the valuable minerals' recoveries.
- ✓ Potassium permanganate be used to manipulate the Eh as it is less reactive than sodium hypochlorite and may more clearly show the effect of changes in Eh on froth stability and valuable mineral grades and recoveries.
- ✓ Perform the 2-phase flotation tests in deionized water to observe the effect of changes in pH on the system without the dominating effect of IS.
- ✓ Optimisation testwork regarding metal grade and recovery should be performed.

9 References

- 911 Metallurgist. 2015. *The Froth Flotation Process Explained | Mining Examiner*. Available: <http://www.911metallurgist.com/blog/whats-a-froth-flotation-process> [2015, May 19].
- Aldrich, C., Feng, D. 2000. The effect of frothers on bubble size distributions in flotation pulp phases and surface froths. *Minerals Engineering*, 13(10-11) :1049-1057.
- Ata, S., Ahmed, N., Jameson, G.J. 2003. A study of bubble coalescence in flotation froths. *International Journal of Minerals Processing*, Volume 72:255-266.
- Barbian, N., Hadler, K., Ventura-Medina, E., Cilliers, J.J. 2005. The froth stability column: linking froth stability and flotation performance. *Minerals Engineering*, Volume 18:317-324.
- Barbian, N., Ventura-Medina, E., Cilliers, J.J. 2003. Dynamic froth stability in froth flotation. *Minerals Engineering*, Volume 16:1111-1116.
- Bikerman, J., 1973. *Foams*. Berlin: Springer-Verlag.
- Bloom, F., Heindel, T. J. 2003. Modelling flotation separation in a semi-batch process. *Chemical Engineering Science*, Volume 58:353-365.
- Castelyn, D. 2012. *The effect of mixing thiol collectors in the flotation of pure sulphide ores*, Cape Town: The Department of Chemical Engineering.
- Chander, S. 2003. A Brief Review of Pulp Potentials in Sulfide Flotation. *International Journal of Mineral Processing*, Issue 72:141-150.
- Chanturiia, V.A. and Vigdergauz, V.E., 2009. *Electrochemistry of Sulfides: Theory and Practice of Flotation*. Ore & Metals.
- Chaplin, M. 2015. *Water Structure and Science, Guar Gum*. Available: http://www1.lsbu.ac.uk/water/guar_gum.html [2016, March 10].
- Chimonyo, W. 2016. *An investigation into the relationship between electrochemical properties and flotation of sulphide minerals*, Cape Town: The Faculty of Engineering and the Built Environment.
- Cilek, E. C. 2009. The effect of hydrodynamic conditions on true flotation and entrainment in flotation of a complex sulphide ore. *International Journal of Mineral Processing*, Volume 90:35-44.

Corin, K. C., Mishra, J., O'Connor, C. T. 2013. Investigating the role of pulp chemistry on the floatability of a Cu-Ni sulfide ore. *International Journal of Mineral Processing*, Issue 120:8-14.

Corin, K. C., Reddy, A., Miyen, L., Wiese, J. G., Harris, P. J. 2010. The effect of ionic strength of plant water on valuable minerals and gangue recovery in a platinum bearing ore from the Merecsky reef. *Minerals Engineering*, Issue 24:131-137.

Craig, V.S.J., Ninham, B.W., Pashley, R.M. 1993a. Effect of electrolytes on bubble coalescence. *Nature*, Volume 364:317-319.

Craig, V.S.J., Ninham, B.W., Pashley, R.M. 1993b. The effect of electrolytes on bubble coalescence in water. *Journal of Physical Chemistry*, Volume 97:10192-10197.

Craig, V. S. J. 2011. Do hydration forces play a role in thin film drainage and rupture observed in electrolyte solutions?. *Current Opinion in Colloid & Interface Science*, Volume 16:597-600.

Dai, Z., Dukhin, S., Fornasiero, D., Ralston, J. 1998. The inertial hydrodynamic interaction of particles and rising bubbles with mobile surfaces. *Journal of Colloid and Interface Science*, Volume 197:275-292.

Drzymala, J. 2007. *Mineral Processing, Foundations of theory and practice of mineralogy*, s.l.: s.n.

Duan, J., Fornasiero, D., Ralston, J. 2003. Calculation of the flotation rate constant of chalcopyrite particles in an ore. *International Journal of Mineral Processing*, Volume 72:227-237.

Dunne, C. 2011. *UG2 The Ugly Duckling*. Johannesburg, South Africa, CJD Consulting:1-13.

Espinosa-Gomez, R., Finch, J.A., Yianatos, J.B., Dobby, G.S., 1988. Flotation column carrying capacity, particle size and density effects. *Mineral Engineering*, Volume 1:77-79.

Fairthorne, G., Fornasiero, D., Ralston, J. 1997. Effect of oxidation on the collectorless flotation of chalcopyrite. *International Journal of Mineral Processing*, Volume 49:31-48.

Farrokhpay, S., Zanin, M. 2012. An investigation into the effect of water quality on froth stability. *Advanced Powder Technology*, Volume 23:493-497.

Farrokhpay, S. 2011. The significance of froth stability in mineral flotation - A review. *Advances in Colloid and Interface Science*, Volume 166:1-7.

Gebhardt, J. E., Shedd, K. B. 1988. *Effect of solution composition on redox potentials of platinum and sulfide mineral electrodes..* Atlanta, GA, s.n., p. 17.

- Gibbs, J. W. 1961. *The Scientific Papers of J. Willard Gibbs*. Dover(New York) : s.n.
- Goktepe, F. 2002. Effect of pH on Pulp Potential and Sulphide Mineral Flotation. *Turkish Journal of Engineering and Environmental Science*, Volume 26:309-318.
- Greet, C.J., Small, G.L., Steinier, P., Grano, S.R., 2004. The Magotteaux Mill: investigating the effect of grinding media on pulp chemistry and flotation performance. *Minerals Engineering*, Volume 17:891-896.
- Guy, P. J., Trahar, W. J. 1985. *The effects of oxidation and mineral interaction on sulphide flotation*. New York, Elsevier:91-110.
- Harris, P. J. 1982. Frothing phenomena and frothers. In *Principles of Flotation*. R. P. King, ed. Johannesburg: South African Institute of Mining and Metallurgy:237-250.
- Hu, Y., Sun, W., Wang, D. 2009. *Electrochemistry of Flotation of Sulphide Minerals*. 1st ed. Beijing: Tsinghua University Press, Springer.
- Ingenito, E. S. A. T. L. 2013. *Polymer systems for lung volume reduction therapy*. United States, Patent No. US 8,361,484 B2.
- Johansson, G., Pugh, R. J. 1992. The influence of particle size and hydrophobicity on the stability of mineralized froths. *International Journal of Mineral Processing*, 34(1-2) :1-21.
- Kawatra, S. K., Eisele, T.C. 2001. *Froth Flotation - Fundamental Principles*. Available:
http://www.chem.mtu.edu/chem_eng/faculty/kawatra/Flotation_Fundamentals.pdf
 [2014, April 03].
- Khan, A., Kelebek, S., 2004. Electrochemical aspects of pyrrhotite and pentlandite in relation to their flotation with xanthate. Part-I: Cyclic voltammetry and rest potential measurements. *Journal of Applied Electrochemistry*:849-856.
- King, R. P. 1982. Flotation of fine particles. In *Principles of Flotation*. R. P. King, ed. 3rd ed. Johannesburg: South African Institute of Mining and Metallurgy:215-226.
- Kuopanportti, H., Suorsa, T., Pollanen, E. 1997. Effects of oxygen on kinetics of conditioning in sulphide ore flotation. *Minerals Engineering*, 10(11) :1193-1205.
- Kurniawan, A. U., Ozdemir, O., Nguyen, A. V., Ofori, P., Firth, B. 2011. Flotation of coal particles in MgCl₂, NaCl, and NaClO₃ solutions in the absence and presence of Dowfroth 250. *International Journal of Mineral Processing*, Volume 98:137-144.
- Labonte, G., Finch, J.A. 1989. *Behavior of redox electrodes during flotation and relationship to mineral floatabilities*. Las Vegas, s.n.

Laskowski, J. S. 2004. Testing flotation frothers. *Physicochemical Problems of Mineral Processing*, Volume 38:13-22.

Lenntech Water Treatment Solutions. 2015. *Oxygen (O) and water*. Available: <http://www.lenntech.com/periodic/water/oxygen/oxygen-and-water.htm> [2015, April 21].

Mailula, T. D. B. D. J. H. P. J. 2003. The effect of copper sulphate addition on the recovery of chromite in the flotation of UG2 ore. *The Journal of The South African Institute of Mining and Metallurgy*, 103(2) :143-146.

Malysiak, V. 2003. *Pentlandite-Pyroxene and Pentlandite-Feldspar Interactions and Their Effect on Separation by Flotation*, Cape Town: The Department of Chemical Engineering.

Manev, E. D., Nguyen, A. V. 2005. Effects of surfactant adsorption and surface forces on thinning and rupture of foam liquid films. *International Journal of Mineral Processing*, Volume 77:1-45.

Manono, M. S., Corin, K. C., Wiese, J. G. 2012. An investigation into the effect of various ions and their ionic strength on the flotation performance of a platinum bearing ore from the Merensky reef. *Minerals Engineering*, Issue 36-38:231-236.

Manono, M. 2010. *An investigation into the effect of ionic strength of plant water on valuable mineral and gangue recovery of a platinum bearing ore from the Merensky reef*, Cape Town: The Faculty of Engineering and the Built Environment .

Manyeruke, T. D. 2007. *Compositional and lithological variation of the Platreef on the farm Nonnenwerth, northern lobe of the Bushveld Complex: Implications for the origin of Platinum-group elements (PGE) mineralization*, Pretoria: The Geology Department of The Faculty of Natural & Agricultural Sciences.

Marcelja, S. 2006. Selective coalescence of bubbles in simple electrolytes. *Journal of Physical Chemistry*, Volume 110:13062-13067.

Miller, J. D., Li, J., Davidtz, J. C., Vos, F. 2005. A review of pyrrhotite flotation chemistry in the processing of PGM ores. *Minerals Engineering*, Issue 18:855-865.

Natarajan, K. A., Iwasaki, I. 1970. Behavior of platinum electrodes as redox potential indicators in some systems of metallurgical interest. *Trans. Soc. Minerals Engineering AIME*, Issue 247:317-324.

Natarajan, K. A., Iwasaki, I. 1972. Eh-pH response of noble metal and sulphide mineral electrodes. *Trans. AIME*, Issue 252:437-439.

Neethling, S.J., Cilliers, J., 2009. The entrainment factor in froth flotation: Model for particle size and other operating parameter effects. *International Journal of Mineral Processing*, 93(2):141-148.

O'Connor, C. T., Shackleton, N. J. 2013. Investigations into the recovery of platinum group minerals from the platreef ore of the Bushveld Complex of South Africa. *Platinum Metals Review*, 57(4) :302-309.

PennState The Methodology Center. 2016. *Introduction to Factorial Experimental Designs*. Available: <https://methodology.psu.edu/ra/most/factorial> [2016, February 18].

PERUMIN 32: Convencion Minera. 2015. *Effects of Organic Depressants on Talc Flotation*. Peru, Encuentro Tecnologia E Investigacion.

Plackowski, C., Bruckard, W.J., Nguyen, A.V., 2014. Surface characterisation, collector adsorption and flotation response of enargite in a redox potential controlled environment. *Minerals Engineering*, Volume 65:61–73.

Pourbaix, M. 1966. *Atlas of Electrochemical Equilibria in Aqueous Solutions*. London: Pergamon Press.

Quinn, J. J., Kracht, W., Gomez, C. O., Gagnon, C., Finch, J. A. 2007. Comparing the effect of salts and frother (MIBC) on gas dispersion and froth properties. *Minerals Engineering*, Volume 20:1296-1302.

Rand, D. A. J., Woods, R. 1984. Eh measurements in sulfide mineral slurries. *International Journal of Mineral Processing*, Issue 13:29-42.

Rao, S.R., Leja, J, 2004. *Surface Chemistry of Froth Flotation: Reagents and Mechanisms*. 2nd ed. New York: Plenum Publishers.

Ross, V. E., Van Deventer, J. S. J. 1988. *Column Flotation '88*. Littleton, s.n.:383-386.

Ross, V. E., Van Deventer, J. S. J. 1985. The interactive effects of the sulphite ion, pH, and dissolved oxygen on the flotation of chalcopyrite and galena from Black Mountain ore. *Journal of the South African Institute of Mining and Metallurgy*, 85(1) :13-21.

Schouwstra, R. P. K. E. D. 2000. A Short Geological Review of the Bushveld Complex. *Platinum Metals Review*, 44(1) :33-39.

Shackleton, N. J., Malysiak, V., O'Connor, C. T. 2007. Surface characteristics and flotation behaviour of platinum and palladium tellurides. *Minerals Engineering*, Volume 20:1232-1245.

Shannon, L. K., Trahar, W. J. 1986. *The role of collector in sulphide ore floatation*. Denver, CO, s.n.:408-426.

Sharman-Harris, E. R., Kinnaird, J. A., Harris, C., Horstmann, U. E. 2005. A new look at sulphide mineralisation of the northern limb, Bushveld Complex: a stable isotope study. *Applied Earth Science (Trans. Inst. Min. Metall. B)*, Volume 114:B252-B263.

Simulescu, V., Angarska, J., Manev, E. 2008. Drainage and critical thickness of foam films from aqueous solutions of mixed nonionic surfactants. *Colloids and Surfaces A: Physicochemical Engineering*, Volume 319:21-28.

Stat-Ease Inc. 2014. *Design-Expert (R) Software Version 9*. Minneapolis(Minnesota) : Stat-Ease.

Study.com. 2016. *What is Factorial Design? - Definition & Example*. Available: <http://study.com/academy/lesson/what-is-factorial-design-definition-example.html>
[2016, February 18].

Subrahmanyam, T.V., Forssberg, E. 1988. Froth Stability, Particle Entrainment and Drainage in Flotation - A Review. *International Journal of Mineral Processing*, 23(1/2) :33-53.

Sure Chemical. 1999. *SIBX*. Available: <http://www.surechemical.com/miningchemicals/images/SIBX.gif>
[2016, January 18].

Syeda, S. R., Afacan, A., Chuang, K. T. 2004. Effect of surface tension gradient on froth stabilization and tray efficiency. *Trans IChemE, Part A, Chemical Engineering Research and Design*, Volume 82:762-769.

Szatkowski, M., Freyburger, W. 1985. Kinetics of flotation with fine bubbles. *Transactions of the Institute of Mining and Metallurgy*, Volume 94:C61-C70.

Szatkowski, 1987. Factors influencing behaviour of flotation froth. *Transactions-Institution of Mining and Metallurgy (Section C. Mineral Processing and Extractive Metallurgy)*, Volume 96:115-122.

Szyszka, D. 2013. Critical coalescence concentration (CCC) as a parameter for evaluation of selected quaternary ammonium compounds. *Mining Science*, Volume 20:101-113.

Tadie, M., 2015. *An Electrochemical Investigation of Platinum Group Minerals*, Cape Town: The Faculty of Engineering and the Built Environment.

Takeno, N. 2005. *Atlas of EH-pH diagrams, Intercomparison of thermodynamic databases*, Ibaraki, Japan: National Institute of Advanced Industrial Science and Technology.

TechnoMine. 2016. *Flotation and Equipment Technology in Mining*. Available: <http://technology.infomine.com/reviews/Flotation/welcome.asp?view=full> [2016, March 10].

Tucker, J.P., Deglon, D.A., Franzidis, J-P, Harris, M.C., O'Connor, C.T. 1994. An evaluation of a direct method of bubble size distribution measurement in a laboratory batch flotation cell. *Minerals Engineering*, 7(5/6) :667-680.

U.S. Department of the Interior. 2015. *Minerals, USGS Science For A Changing World*. Available: <http://minerals.usgs.gov/minerals/pubs/mcs/2015/mcs2015.pdf> [2016, February 17].

Usul, A., Tolun, R., 1974. Electrochemical study of the pyrite-oxygen-xanthate system. *International Journal of Mineral Processing*, 1(2):135-140.

Van Tonder, E. D. D. A. N.-M. T. J. 2010. The effect of ore blends on the mineral processing of platinum ores. *Minerals Engineering*, Volume 23:621-626.

Vos, C. F., Stange, W., Bradshaw, D. J. 2014. A new small-scale test to determine flotation performance- Part 1: Overall performance. *Minerals Engineering*, Issue 66-68:62-67.

Wang, L., Peng, Y., Runge, K., Bradshaw, D. 2015. A review of entrainment: Mechanisms, contributing factors and modelling in flotation. *Minerals Engineering*, Volume 70:77-91.

WebElements. 2015. *Chemistry: Periodic Table: Platinum: Compound Data*. Available: <http://ipkc.whut.edu.cn/web18/main/wangluo/webelements/webelements/compounds/text/pt/pt1te2-12038298.html> [2015, May 18].

Wiese, J., Harris, P. 2012. The effect of frother type and dosage on flotation performance in the presence of high depressant concentrations. *Minerals Engineering*, Issue 36-38:204-210.

Wiese, J. G. 2009. *Investigating Depressant Behaviour in the Flotation of Selected Merensky Ores*, Cape Town: University of Cape Town.

Wills, B.A., Napier-Munn, T.J. , 2006. *Wills' Mineral Processing Technology: An introduction to the Practical Aspects of Ore Treatment and Mineral Recovery*. 7th ed. s.l.:Elsevier Science & Technology Books.

Woods, R., 1988. Flotation of Sulphide Minerals. In: P. M. B. Somasundaran, ed. *Reagents in Mineral Technology*. 1s ed. New York: Marcel Dekker: 69.

Yan, D. S., Hariyasa. 1997. Selective flotation of pyrite and gold tellurides. *Minerals Engineering*, 10(3) :327-337.

Zheng, X., Johnson, N.W., Franzidis, J-P, 2006. Modelling of entrainment in industrial flotation cells: Water recovery and degree of entrainment. *Minerals Engineering*, Volume 19:1191-1203.

Zieminski, S. A., Whittemore, R. C. 1971. Behavior of gas bubbles in aqueous electrolyte solutions. *Chemical Engineering Science*:509-520.

10 Appendix A

10.1 2-Phase Batch Flotation Data

| 1 IS DO 8 | | | | | | | |
|-----------|----|----------------------|----------------------------------|-----------------------|-----------------------------------|---------------------|---------------------------------|
| | | 1 IS pH9 DO8 Eh(-50) | 1 IS pH9 DO8 Eh(-50) (Duplicate) | 1 IS pH11 DO8 Eh(-90) | 1 IS pH11 DO8 Eh(-90) (Duplicate) | 1 IS pH11 DO8 Eh430 | 1 IS pH11 DO8 Eh430 (Duplicate) |
| Time | | Water | Water | Water | Water | Water | Water |
| 2 | C1 | 128.94 | 149.5 | 767.25 | 717.19 | 438.82 | 247.48 |
| 6 | C2 | 183.02 | 191.85 | 1257.81 | 1150.05 | 504.47 | 298.61 |
| 12 | C3 | 317.18 | 378.89 | 1623.71 | 1508.17 | 746.5 | 469.17 |
| 20 | C4 | 469.06 | 594.07 | 1791.88 | 1669.67 | 804.98 | 530.07 |
| 5 IS DO 8 | | | | | | | |
| | | 5 IS pH9 DO8 Eh90 | 5 IS pH9 DO8 Eh90 (Duplicate) | 5 IS pH11 DO8 Eh(-90) | 5 IS pH11 DO8 Eh(-90) (Duplicate) | 5 IS pH11 DO8 Eh500 | 5 IS pH11 DO8 Eh500 (Duplicate) |
| Time | | Water | Water | Water | Water | Water | Water |
| 2 | C1 | 358.57 | 480.7 | 808.54 | 699.31 | 577.47 | 458.43 |
| 6 | C2 | 781.1 | 959.42 | 1455.33 | 1432.61 | 785.56 | 636.5 |
| 12 | C3 | 1330.18 | 1564.82 | 2000.65 | 1994.91 | 945.55 | 868.71 |
| 20 | C4 | 1580.69 | 1778.91 | 2160.84 | 2199.35 | 1032.89 | 1032.04 |
| 1 IS DO 0 | | | | | | | |
| | | 1 IS pH9 DO0 Eh40 | 1 IS pH9 DO0 Eh40 (Duplicate) | 1 IS pH11 DO0 Eh(-60) | 1 IS pH11 DO0 Eh(-60) (Duplicate) | 1 IS pH11 DO0 Eh370 | 1 IS pH11 DO0 Eh370 (Duplicate) |
| Time | | Water | Water | Water | Water | Water | Water |
| 2 | C1 | 291.23 | 189.39 | 770.24 | 695.23 | 332.7 | 415.16 |
| 6 | C2 | 554.16 | 299.59 | 1345.92 | 1146.17 | 378.69 | 447.13 |
| 12 | C3 | 1114.31 | 770.37 | 1877.47 | 1683.39 | 607.08 | 522.57 |
| 20 | C4 | 1461.12 | 996.74 | 2060.32 | 1880.66 | 698.61 | 544.85 |
| 5 IS DO 0 | | | | | | | |
| | | 5 IS pH9 DO0 Eh30 | 5 IS pH9 DO0 Eh30 (Duplicate) | 5 IS pH11 DO0 Eh(-70) | 5 IS pH11 DO0 Eh(-70) (Duplicate) | 5 IS pH11 DO0 Eh570 | 5 IS pH11 DO0 Eh570 (Duplicate) |
| Time | | Water | Water | Water | Water | Water | Water |
| 2 | C1 | 132.82 | 157.16 | 814.48 | 787.98 | 657.53 | 502.6 |
| 6 | C2 | 340.82 | 459.52 | 1685.2 | 1553.92 | 940.1 | 737.91 |
| 12 | C3 | 1129.48 | 1520.3 | 2542.94 | 2204.39 | 1386.98 | 1159.78 |
| 20 | C4 | 1545.66 | 2049.24 | 2808.65 | 2385.85 | 1448.67 | 1211.27 |

10.2 3-Phase Batch Flotation Data

| 1 IS DO 8 | | | | | | | | | | | | | | | | | |
|-----------|----|----------------------|--------|----------------------------------|--------|--------------------|--------|--------------------------------|--------|------------------------|--------|------------------------------------|--------|---------------------|--------|---------------------------------|--------|
| | | 1 IS pH9 DO8 Eh(-70) | | 1 IS pH9 DO8 Eh(-70) (Duplicate) | | 1 IS pH9 DO8 Eh730 | | 1 IS pH9 DO8 Eh730 (Duplicate) | | 1 IS pH11 DO8 Eh(-100) | | 1 IS pH11 DO8 Eh(-100) (Duplicate) | | 1 IS pH11 DO8 Eh500 | | 1 IS pH11 DO8 Eh500 (Duplicate) | |
| Time | | Water | Solids | Water | Solids | Water | Solids | Water | Solids | Water | Solids | Water | Solids | Water | Solids | Water | Solids |
| 2 | C1 | 201.78 | 25.37 | 271.13 | 24.39 | 476.47 | 44.99 | 562.79 | 55.2 | 503.35 | 44.66 | 633.34 | 46.45 | 845.28 | 74.92 | 930.55 | 88.37 |
| 6 | C2 | 655.19 | 38.84 | 692.17 | 42.33 | 1017.96 | 70.59 | 1069.84 | 85.59 | 1216.37 | 71.63 | 1410.72 | 74.15 | 1491.82 | 101.88 | 1797.97 | 120.83 |
| 12 | C3 | 1343.92 | 53.42 | 1321.18 | 57.06 | 1629.87 | 91.69 | 1636.8 | 102.71 | 2219.03 | 93.23 | 2145.48 | 92.83 | 2173.91 | 121.27 | 2543.08 | 137.11 |
| 20 | C4 | 2074.5 | 63.85 | 1804.97 | 65.39 | 2067.37 | 99.48 | 2152.11 | 110.75 | 3003.68 | 103.38 | 2763.58 | 102.08 | 2938.07 | 130.16 | 3010.74 | 143.97 |
| 5 IS DO 8 | | | | | | | | | | | | | | | | | |
| | | 5 IS pH9 DO8 Eh(-80) | | 5 IS pH9 DO8 Eh(-80) (Duplicate) | | 5 IS pH9 DO8 Eh730 | | 5 IS pH9 DO8 Eh730 (Duplicate) | | 5 IS pH11 DO8 Eh(-120) | | 5 IS pH11 DO8 Eh(-120) (Duplicate) | | 5 IS pH11 DO8 Eh660 | | 5 IS pH11 DO8 Eh660 (Duplicate) | |
| Time | | Water | Solids | Water | Solids | Water | Solids | Water | Solids | Water | Solids | Water | Solids | Water | Solids | Water | Solids |
| 2 | C1 | 299.55 | 31.29 | 382.75 | 31.95 | 751 | 69.5 | 615.8 | 58.63 | 496.23 | 43.02 | 479.89 | 38.01 | 830.82 | 68.13 | 777.18 | 62.28 |
| 6 | C2 | 819.01 | 55.81 | 921.65 | 54.3 | 1575.46 | 114.09 | 1397.17 | 103.2 | 1032.19 | 66.98 | 1134.18 | 57.84 | 1495.08 | 85.42 | 1438.16 | 85.4 |
| 12 | C3 | 1456.41 | 78.22 | 1381.94 | 73.71 | 2277.13 | 137.66 | 2167.23 | 130.42 | 1596.29 | 83.82 | 1840.88 | 75.96 | 2230.5 | 96.93 | 1927.39 | 100.52 |
| 20 | C4 | 2040.66 | 92.34 | 1946.26 | 85.09 | 2714.72 | 145.72 | 2726.16 | 140.29 | 2202.16 | 94.74 | 2264.31 | 87.02 | 2765.36 | 105.7 | 2453.51 | 110.37 |
| 1 IS DO 0 | | | | | | | | | | | | | | | | | |
| | | 1 IS pH9 DO0 Eh50 | | 1 IS pH9 DO0 Eh50 (Duplicate) | | 1 IS pH9 DO0 Eh700 | | 1 IS pH9 DO0 Eh700 (Duplicate) | | 1 IS pH11 DO0 Eh(-20) | | 1 IS pH11 DO0 Eh(-20) (Duplicate) | | 1 IS pH11 DO0 Eh500 | | 1 IS pH11 DO0 Eh500 (Duplicate) | |
| Time | | Water | Solids | Water | Solids | Water | Solids | Water | Solids | Water | Solids | Water | Solids | Water | Solids | Water | Solids |
| 2 | C1 | 203.38 | 13.33 | 214.23 | 16.28 | 496.04 | 47.64 | 523.25 | 52.02 | 468.85 | 39.82 | 486.04 | 33.52 | 829.35 | 65.84 | 833.78 | 69.16 |
| 6 | C2 | 592.14 | 27.1 | 552.42 | 30.02 | 1019.2 | 70.81 | 1167.6 | 81.7 | 991.46 | 62.83 | 1266.53 | 58.81 | 1664.58 | 98.61 | 1702.53 | 100.11 |
| 12 | C3 | 1159.13 | 42.72 | 1178.16 | 48.33 | 1700.29 | 89.09 | 1759.41 | 98.95 | 1979.01 | 78.92 | 2059.29 | 73.62 | 2401.04 | 115.35 | 2479.85 | 117.91 |
| 20 | C4 | 2006.12 | 54.78 | 2141.09 | 63.6 | 2431.41 | 97.62 | 2372.62 | 105.27 | 2709.81 | 86.94 | 2857.75 | 80.2 | 3054.99 | 121.59 | 3133.8 | 124.75 |
| 5 IS DO 0 | | | | | | | | | | | | | | | | | |
| | | 5 IS pH9 DO0 Eh(-40) | | 5 IS pH9 DO0 Eh(-40) (Duplicate) | | 5 IS pH9 DO0 Eh720 | | 5 IS pH9 DO0 Eh720 (Duplicate) | | 5 IS pH11 DO0 Eh(-90) | | 5 IS pH11 DO0 Eh(-90) (Duplicate) | | 5 IS pH11 DO0 Eh650 | | 5 IS pH11 DO0 Eh650 (Duplicate) | |
| Time | | Water | Solids | Water | Solids | Water | Solids | Water | Solids | Water | Solids | Water | Solids | Water | Solids | Water | Solids |
| 2 | C1 | 309.33 | 32.03 | 293.05 | 31.3 | 499.19 | 45.84 | 590.26 | 52.69 | 464.22 | 31.17 | 514.95 | 34.3 | 874.21 | 67.68 | 852.3 | 65.1 |
| 6 | C2 | 970.5 | 68.54 | 898.03 | 66.78 | 1390.09 | 72.83 | 1513.19 | 99.41 | 1045.39 | 51.45 | 1117.43 | 52.89 | 1607.51 | 89.57 | 1537.4 | 84.06 |
| 12 | C3 | 1598.9 | 99.06 | 1778.97 | 103.42 | 2294.4 | 118.4 | 2461.76 | 122.93 | 1842.12 | 66.28 | 1852.29 | 67.79 | 2480.66 | 103.92 | 2309.03 | 97.09 |
| 20 | C4 | 2289.06 | 116.48 | 2530.28 | 119.7 | 3090.15 | 129.85 | 3104 | 132.3 | 2672.51 | 77.27 | 2736.75 | 79.58 | 3185.06 | 111.82 | 3124.63 | 105.1 |

10.3 Valuable Mineral Grade and Recovery Data

| Grade (%) | | | | | | | | | | | | | | | | | | | | | | | | | |
|-----------|-----------------------------|------|------|------|-----------|-------|----------|----------|----------|----------|----------|----------|----------|-------|----------|----------|----------|----------|----------|----------|----------|----------|----------|----------|----------|
| Run | | IS | pH | DO | Eh | Cu | | | | Ni | | | | S | | | | Pt (ppm) | | | | Pd (ppm) | | | |
| | | | | | | C1 | C2 | C3 | C4 | C1 | C2 | C3 | C4 | C1 | C2 | C3 | C4 | C1 | C2 | C3 | C4 | C1 | C2 | C3 | C4 |
| 1 | Test 13 | 1 IS | pH9 | DO 8 | Eh (-70) | 2.14 | 1.544073 | 1.243207 | 1.113552 | 2.69 | 2.570041 | 2.360445 | 2.196354 | 8.63 | 7.453624 | 6.624937 | 6.069723 | 16.75 | 14.33146 | 12.16891 | 11.07459 | 21.15 | 19.11843 | 17.09728 | 15.72015 |
| 2 | Test 14 | 1 IS | pH11 | DO 8 | Eh (-100) | 1.35 | 0.982483 | 0.828238 | 0.772695 | 1.95 | 1.702489 | 1.513604 | 1.440559 | 6.13 | 4.843691 | 4.180435 | 3.947171 | 11.6 | 9.173639 | 7.837112 | 7.354887 | 14.7 | 12.23989 | 10.65305 | 10.07112 |
| 3 | Test 15 | 1 IS | pH9 | DO 8 | Eh 730 | 0.14 | 0.14 | 0.141966 | 0.142571 | 0.3 | 0.296415 | 0.29712 | 0.29809 | 0.59 | 0.572075 | 0.565769 | 0.565335 | 0.925 | 0.923208 | 0.930441 | 0.926643 | 1.615 | 1.613208 | 1.608645 | 1.616277 |
| 4 | Test 16 | 5 IS | pH9 | DO 8 | Eh (-80) | 1.79 | 1.240892 | 0.987409 | 0.884304 | 2.5 | 2.270141 | 1.956308 | 1.782939 | 7.84 | 6.580031 | 5.456968 | 4.971635 | 13.9 | 11.29493 | 9.300702 | 8.367867 | 18.7 | 16.18858 | 13.66485 | 12.37212 |
| 5 | Test 17 | 5 IS | pH11 | DO 8 | Eh (-120) | 1.5 | 1.161454 | 0.975155 | 0.889881 | 1.95 | 1.86931 | 1.69442 | 1.60198 | 6.64 | 5.608574 | 4.930603 | 4.601604 | 6.21 | 6.687122 | 6.153878 | 5.783367 | 7.21 | 8.679958 | 8.303629 | 7.892033 |
| 6 | Test 18 | 5 IS | pH9 | DO 8 | Eh 730 | 0.14 | 0.14 | 0.14 | 0.140627 | 0.196045 | 0.176061 | 0.181827 | 0.193484 | 0.59 | 0.57769 | 0.570549 | 0.569261 | 0.98 | 1.008723 | 1.010859 | 0.992625 | 1.68 | 1.70462 | 1.711323 | 1.702463 |
| 7 | Test 19 | 5 IS | pH11 | DO 8 | Eh 660 | 0.16 | 0.155269 | 0.149163 | 0.14665 | 0.32 | 0.317634 | 0.31121 | 0.307659 | 0.59 | 0.578172 | 0.562234 | 0.547392 | 1.16 | 1.136344 | 1.095027 | 1.056677 | 1.885 | 1.898011 | 1.878049 | 1.851503 |
| 8 | Test 20 | 1 IS | pH11 | DO 8 | Eh 500 | 0.17 | 0.175336 | 0.173219 | 0.17131 | 0.33 | 0.33 | 0.327239 | 0.325099 | 0.62 | 0.62 | 0.613097 | 0.60545 | 1.18 | 1.220021 | 1.20069 | 1.169051 | 2.025 | 2.098371 | 2.097216 | 2.080139 |
| 9 | Test 21 | 1 IS | pH9 | DO 0 | Eh 50 | 3.26 | 2.140239 | 1.529 | 1.27066 | 3.48 | 3.268088 | 2.653924 | 2.225915 | 11.4 | 9.386838 | 7.096204 | 5.83424 | 21.5 | 19.47721 | 14.51079 | 12.10729 | 24.9 | 26.20037 | 20.68498 | 17.26238 |
| 10 | Test 22 | 1 IS | pH11 | DO 0 | Eh (-20) | 1.97 | 1.358507 | 1.14206 | 1.061953 | 1.66 | 1.306605 | 1.12498 | 1.052479 | 5.91 | 4.262146 | 3.591205 | 3.336906 | 14.05 | 10.6987 | 10.08518 | 9.318649 | 15.65 | 11.5125 | 10.3938 | 9.575859 |
| 11 | Test 23 | 1 IS | pH9 | DO 0 | Eh 700 | 0.23 | 0.209208 | 0.203689 | 0.201589 | 0.29 | 0.286535 | 0.287189 | 0.287395 | 0.6 | 0.579208 | 0.575579 | 0.573706 | 1.04 | 1.019208 | 1.019358 | 1.004766 | 1.765 | 1.714752 | 1.719523 | 1.722486 |
| 12 | Test 24 | 1 IS | pH11 | DO 0 | Eh 500 | 0.21 | 0.21 | 0.208519 | 0.206474 | 0.33 | 0.333207 | 0.331251 | 0.328795 | 0.64 | 0.636793 | 0.632826 | 0.628428 | 1.43 | 1.385109 | 1.373987 | 1.353067 | 2.045 | 2.024158 | 2.03983 | 2.03453 |
| 13 | Test 25 | 5 IS | pH9 | DO 0 | Eh(-40) | 2.04 | 1.167523 | 0.859876 | 0.767146 | 2.32 | 1.947601 | 1.507253 | 1.352829 | 7.2 | 4.901768 | 3.703791 | 3.307291 | 17.4 | 11.80338 | 8.909947 | 7.952519 | 17.3 | 13.39513 | 10.15285 | 9.066587 |
| 14 | Test 26 | 5 IS | pH11 | DO 0 | Eh(-90) | 1.915 | 1.402768 | 1.160447 | 1.028219 | 1.6 | 1.339228 | 1.159781 | 1.059602 | 6.45 | 4.818309 | 3.995992 | 3.556515 | 11.9 | 10.26458 | 8.995158 | 8.169478 | 12.5 | 10.37284 | 8.899793 | 8.04294 |
| 15 | Test 27 | 5 IS | pH9 | DO 0 | Eh 720 | 0.17 | 0.17 | 0.17 | 0.170794 | 0.3 | 0.3 | 0.302863 | 0.30343 | 0.6 | 0.591441 | 0.588166 | 0.588311 | 1.05 | 1.020044 | 0.922693 | 0.915331 | 1.765 | 1.715786 | 1.591025 | 1.604445 |
| 16 | Test 28 | 5 IS | pH11 | DO 0 | Eh 650 | 0.17 | 0.17 | 0.167276 | 0.165275 | 0.33 | 0.327647 | 0.323881 | 0.320663 | 0.605 | 0.594413 | 0.581553 | 0.572637 | 1.235 | 1.236176 | 1.195834 | 1.161667 | 1.885 | 1.912056 | 1.909052 | 1.893719 |
| 17 | 5 IS, pH 9, DO 8, Eh 670 | 5 IS | pH9 | DO 8 | Eh 670 | 0.23 | 0.226023 | 0.216814 | 0.213799 | 0.365 | 0.351081 | 0.343621 | 0.339385 | 0.81 | 0.758302 | 0.709357 | 0.68437 | 1.3 | 1.168767 | 1.130274 | 1.115881 | 2.19 | 2.126372 | 2.071032 | 2.022436 |
| 18 | 5 IS, pH 11, DO 8, Eh (-20) | 5 IS | pH11 | DO 8 | Eh (-20) | 1.98 | 1.757958 | 1.400067 | 1.235182 | 1.605 | 1.696361 | 1.531597 | 1.483996 | 6.15 | 6.022788 | 5.022176 | 4.620246 | 72.2 | 59.01623 | 44.51522 | 37.98634 | 82.8 | 68.13595 | 52.02877 | 44.97204 |
| 19 | 1 IS, pH 9, DO 8, Eh 670 | 1 IS | pH9 | DO 8 | Eh 670 | 0.26 | 0.256423 | 0.232852 | 0.228137 | 0.37 | 0.352113 | 0.335808 | 0.330483 | 0.84 | 0.789917 | 0.693487 | 0.670073 | 1.45 | 1.242513 | 1.159998 | 1.106357 | 2.85 | 2.621049 | 2.320945 | 2.26092 |
| 20 | 1 IS, pH 9, DO 0, Eh 40 | 1 IS | pH9 | DO 0 | Eh 40 | 5.01 | 3.983725 | 2.645968 | 1.997609 | 5.63 | 5.253315 | 3.846469 | 2.970772 | 13.8 | 12.76219 | 9.445145 | 7.206687 | 44.65 | 38.71144 | 26.9821 | 20.44537 | 50.2 | 45.51066 | 32.30688 | 24.64737 |

| Cumulative Recovery (%) | | | | | | | | | | | | | | | | | | | | | | | | | |
|-------------------------|-----------------------------|------|------|------|-----------|----------|----------|----------|----------|----------|----------|----------|----------|----------|----------|----------|----------|----------|----------|----------|----------|----------|----------|----------|----------|
| Run | | IS | pH | DO | Eh | Cu | | | | Ni | | | | S | | | | Pt | | | | Pd | | | |
| | | | | | | C1 | C2 | C3 | C4 | C1 | C2 | C3 | C4 | C1 | C2 | C3 | C4 | C1 | C2 | C3 | C4 | C1 | C2 | C3 | C4 |
| 1 | Test 13 | 1 IS | pH9 | DO 8 | Eh (-70) | 44.95502 | 52.91118 | 57.9844 | 60.75635 | 25.7013 | 40.05512 | 50.0726 | 54.50318 | 35.14438 | 49.51397 | 59.90045 | 64.19933 | 39.2428 | 54.77103 | 63.29946 | 67.38904 | 35.32246 | 52.08443 | 63.39733 | 68.1889 |
| 2 | Test 14 | 1 IS | pH11 | DO 8 | Eh (-100) | 77.47547 | 90.21681 | 97.06723 | 100 | 33.97845 | 47.46627 | 53.86024 | 56.60584 | 47.43091 | 59.96658 | 66.05556 | 68.87286 | 47.09395 | 59.591 | 64.97558 | 67.33555 | 45.25721 | 60.29478 | 66.97784 | 69.92127 |
| 3 | Test 15 | 1 IS | pH9 | DO 8 | Eh 730 | 5.407475 | 8.429378 | 10.63954 | 11.55495 | 5.965349 | 9.187891 | 11.46352 | 12.43747 | 5.33926 | 8.07018 | 9.934366 | 10.73507 | 3.977193 | 6.187786 | 7.762394 | 8.360219 | 5.385318 | 8.385521 | 10.40809 | 11.30902 |
| 4 | Test 16 | 5 IS | pH9 | DO 8 | Eh (-80) | 45.69636 | 55.15659 | 60.55879 | 63.33812 | 30.33761 | 47.9655 | 57.03351 | 60.70339 | 40.03982 | 58.51119 | 66.95441 | 71.2378 | 43.53945 | 61.60082 | 69.98992 | 73.53906 | 40.4262 | 60.93472 | 70.97049 | 75.04135 |
| 5 | Test 17 | 5 IS | pH11 | DO 8 | Eh (-120) | 47.26119 | 56.37073 | 60.58479 | 62.89238 | 31.15008 | 45.99856 | 53.37309 | 57.40294 | 43.65352 | 56.79917 | 63.91869 | 67.85986 | 29.92725 | 49.64241 | 58.4791 | 62.51849 | 25.61562 | 47.50349 | 58.17201 | 62.89425 |
| 6 | Test 18 | 5 IS | pH9 | DO 8 | Eh 730 | 7.930898 | 13.44966 | 16.59342 | 17.78251 | 5.075823 | 7.730399 | 9.849695 | 11.18214 | 6.813445 | 11.31354 | 13.78547 | 14.67428 | 4.909405 | 8.569661 | 10.59515 | 11.09989 | 7.201842 | 12.39226 | 15.34899 | 16.2908 |
| 7 | Test 19 | 5 IS | pH11 | DO 8 | Eh 660 | 8.860534 | 11.26294 | 12.50686 | 13.45569 | 7.612532 | 9.897704 | 11.20931 | 12.1264 | 6.877427 | 8.827926 | 9.922871 | 10.57196 | 7.607796 | 9.76199 | 10.87357 | 11.48224 | 8.869431 | 11.69798 | 13.37943 | 14.43419 |
| 8 | Test 20 | 1 IS | pH11 | DO 8 | Eh 500 | 6.245447 | 8.785491 | 10.06953 | 10.56562 | 10.007 | 13.64847 | 15.70197 | 16.55019 | 9.067258 | 12.36677 | 14.18773 | 14.86482 | 8.741079 | 12.32623 | 14.07386 | 14.53829 | 10.39826 | 14.69596 | 17.04033 | 17.93185 |
| 9 | Test 21 | 1 IS | pH9 | DO 0 | Eh 50 | 64.1724 | 81.27233 | 92.5507 | 100 | 19.76551 | 35.80736 | 46.35096 | 50.54488 | 29.32562 | 46.58129 | 56.13194 | 60.00212 | 32.05937 | 56.02644 | 66.53485 | 72.17774 | 24.87215 | 50.48602 | 63.53463 | 68.93735 |
| 10 | Test 22 | 1 IS | pH11 | DO 0 | Eh (-20) | 81.39946 | 93.10064 | 98.14924 | 100 | 23.55987 | 30.75704 | 33.20873 | 34.04222 | 38.29763 | 45.80873 | 48.40246 | 49.27967 | 28.04437 | 35.41897 | 41.86931 | 42.38985 | 27.43457 | 33.47255 | 37.89668 | 38.25612 |
| 11 | Test 23 | 1 IS | pH9 | DO 0 | Eh 700 | 9.075049 | 12.63213 | 15.16416 | 16.19304 | 5.590758 | 8.453319 | 10.44649 | 11.27955 | 5.503041 | 8.129492 | 9.960599 | 10.71226 | 3.385437 | 5.077169 | 6.260908 | 6.658649 | 9.698962 | 14.41981 | 17.82863 | 19.26974 |
| 12 | Test 24 | 1 IS | pH11 | DO 0 | Eh 500 | 11.02505 | 16.22888 | 18.91534 | 19.78007 | 8.438574 | 12.54228 | 14.63588 | 15.34199 | 7.977386 | 11.68388 | 13.62923 | 14.29346 | 17.1745 | 24.48724 | 28.51263 | 29.653 | 15.12899 | 22.0429 | 26.07456 | 27.46513 |
| 13 | Test 25 | 5 IS | pH9 | DO 0 | Eh(-40) | 44.87439 | 54.87649 | 60.47511 | 62.93325 | 27.92963 | 50.09909 | 58.01444 | 60.73705 | 40.5183 | 58.94188 | 66.64044 | 69.41045 | 47.38026 | 68.67633 | 77.57039 | 80.75819 | 38.95335 | 64.44633 | 73.0902 | 76.13356 |
| 14 | Test 26 | 5 IS | pH11 | DO 0 | Eh(-90) | 48.70367 | 56.85745 | 60.43765 | 62.64995 | 20.05581 | 26.75365 | 29.77047 | 31.82035 | 35.75562 | 42.56844 | 45.36266 | 47.23364 | 38.06012 | 52.32064 | 58.91437 | 62.59789 | 32.06281 | 42.40312 | 46.74775 | 49.42521 |
| 15 | Test 27 | 5 IS | pH9 | DO 0 | Eh 720 | 7.302754 | 12.76592 | 17.88667 | 19.52056 | 5.730095 | 10.01676 | 14.16868 | 15.41985 | 5.403972 | 9.311912 | 12.97491 | 14.09777 | 4.842948 | 8.224411 | 10.42367 | 11.2326 | 6.474352 | 11.00222 | 14.29458 | 15.65878 |
| 16 | Test 28 | 5 IS | pH11 | DO 0 | Eh 650 | 9.908029 | 12.95625 | 14.75898 | 15.73668 | 8.662078 | 11.24623 | 12.87002 | 13.75067 | 7.53149 | 9.676221 | 10.95972 | 11.64588 | 7.550965 | 9.883437 | 11.06856 | 11.60337 | 8.769692 | 11.6323 | 13.44546 | 14.39314 |
| 17 | 5 IS, pH 9, DO 8, Eh 670 | 5 IS | pH9 | DO 8 | Eh 670 | 3.901319 | 6.365104 | 9.450183 | 11.35467 | 2.720822 | 4.34494 | 6.58198 | 7.921107 | 2.86493 | 4.452871 | 6.447092 | 7.578889 | 2.548858 | 3.804513 | 5.694508 | 6.850238 | 2.948672 | 4.753247 | 7.16538 | 8.525945 |
| 18 | 5 IS, pH 11, DO 8, Eh (-20) | 5 IS | pH11 | DO 8 | Eh (-20) | 49.02682 | 56.62612 | 61.73616 | 65.09111 | 19.49304 | 26.80173 | 33.12617 | 38.35831 | 32.61569 | 41.55171 | 47.43136 | 52.14813 | 74.28108 | 78.9864 | 81.55896 | 83.17456 | 71.19815 | 76.21746 | 79.6717 | 82.3006 |
| 19 | 1 IS, pH 9, DO 8, Eh 670 | 1 IS | pH9 | DO 8 | Eh 670 | 1.041142 | 1.598744 | 2.949267 | 3.640664 | 3.2102 | 4.756624 | 9.215514 | 11.42689 | 1.997771 | 2 | | | | | | | | | | |

10.4 Depressant Batch Flotation Data

| 500 g/t CMC | | | | | | | | | |
|-------------|----|------------------------------|--------|--|--------|---------------------------|--------|---------------------------------------|--------|
| | | 5 SPW, pH 9, DO 8, Eh 670 | | 5 SPW, pH 9, DO 8, Eh 670 (duplicate) | | 1 SPW, pH 9, DO 8, Eh 670 | | 1 SPW, pH 9, DO 8, Eh 670 (duplicate) | |
| Time | | Water | Solids | Water | Solids | Water | Solids | Water | Solids |
| 2 | C1 | 247.11 | 14.39 | 394.08 | 24.46 | 269.54 | 16.03 | 220.86 | 10.29 |
| 6 | C2 | 543.08 | 23.25 | 838.07 | 41.25 | 546.15 | 25.33 | 382.76 | 15.65 |
| 12 | C3 | 1232.18 | 42.54 | 1373.16 | 57.29 | 1223.28 | 46.91 | 1008.18 | 36.34 |
| 20 | C4 | 1919.5 | 54.83 | 1835.72 | 66.81 | 1721.47 | 57.83 | 1517.43 | 47.06 |
| | | 5 SPW, pH 11, DO 8, Eh (-20) | | 5 SPW, pH 11, DO 8, Eh (-20) (duplicate) | | 1 SPW, pH 9, DO 0, Eh 40 | | 1 SPW, pH 9, DO 0, Eh 40 (duplicate) | |
| Time | | Water | Solids | Water | Solids | Water | Solids | Water | Solids |
| 2 | C1 | 428.95 | 32.78 | 444.98 | 28.04 | 185.55 | 11.71 | 223.98 | 11.69 |
| 6 | C2 | 793.03 | 45.19 | 829.49 | 33.93 | 339.87 | 17.92 | 578.15 | 20.09 |
| 12 | C3 | 1494.05 | 62 | 1542.4 | 46.31 | 890.26 | 32.79 | 1027.66 | 31.35 |
| 20 | C4 | 2085.83 | 76.03 | 2149 | 53.41 | 1543.24 | 46.02 | 1544.83 | 44.48 |

10.5 Stability Column Data

| 2-phase Tests | | | | | |
|------------------|-------|------|----------|----------|--|
| IS | pH | DO | Eh | Hmax | Dynamic Stability Factor, Σ (s) |
| 1 IS | pH 9 | DO 8 | Eh (-5) | 240.225 | 16.17190791 |
| 5 IS | pH 11 | DO 0 | Eh (-70) | 228.8191 | 15.40406717 |
| 3-phase Tests | | | | | |
| IS | pH | DO | Eh | Hmax | Dynamic Stability Factor, Σ (s) |
| 5 IS | pH 9 | DO 8 | Eh 690 | 435.0483 | 29.28738202 |
| 5 IS | pH 11 | DO 8 | Eh (-30) | 195.9852 | 13.19369126 |
| 1 IS | pH 9 | DO 8 | Eh 650 | 275.6828 | 18.55892572 |
| 5 IS | pH 11 | DO 0 | Eh 490 | 161.0722 | 10.84335762 |
| 1 IS | pH 9 | DO 0 | Eh 30 | 93.01283 | 6.261608913 |
| Depressant Tests | | | | | |
| IS | pH | DO | Eh | Hmax | Dynamic Stability Factor, Σ (s) |
| 5 IS | pH 9 | DO 8 | Eh 670 | 32.5 | 2.187894884 |
| 5 IS | pH 11 | DO 8 | Eh (-26) | 261.459 | 17.60138076 |
| 1 IS | pH 9 | DO 8 | Eh 660 | 24 | 1.615676222 |
| 1 IS | pH 9 | DO 0 | Eh (-10) | 56.19277 | 3.782888367 |

| Reagents | Sample | Time, min | Mass Pull, g | Water Rec, g | Cum Mass, g | Cum Water, g | Ave cum Mass, g | Ave cum w Rec, g | Copper % | Copper Mass | Cum Copper Mass | Copper Grade % | Copper Rec % | Ave Copper grade % | Ave Copper rec % | Nickel % | Nickel Mass | Cum Nickel Mass | Nickel Grade % | Nickel Rec % | Ave Nickel grade % | Ave Nickel rec % | Sulphur % | Sulphur Mass | Cum. Sulphur Mass | Sulphur Grade % | Sulphur Recovery % | Average S grade % | Average S recovery % | S mass chanco | S mass pent | S mass pyrhr | mass pyrhr, g | sulphide mass, g | entr (dep) mass, g | entrain (no depr) gang, g | Float gang (no depr),g | | |
|--|-------------------|-----------|--------------|--------------|-------------|--------------|-----------------|------------------|----------|-------------|-----------------|----------------|--------------|--------------------|------------------|----------|-------------|-----------------|----------------|--------------|--------------------|------------------|-----------|--------------|-------------------|-----------------|--------------------|-------------------|----------------------|---------------|-------------|--------------|---------------|------------------|--------------------|---------------------------|------------------------|--------|--|
| Test 3 1 IS, pH 9, DO 8, Eh 730 (Test 15) | | | | | | 0.00 | | | | | | | | | | | | | | | | | | | | | | | | | | | | | | | 0.0341 | | |
| | C1 | 2 | 50.095 | 519.63 | 50.10 | 519.63 | 50.10 | 519.63 | 0.14 | 7.01 | 7.01 | 0.14 | 5.25 | 0.14 | 5.25 | 0.30 | 15.03 | 15.03 | 0.30 | 5.79 | 0.30 | 5.79 | 0.59 | 29.56 | 29.56 | 0.59 | 5.18 | 0.59 | 5.18 | 7.07 | 16.34 | 6.15 | 0.16 | 0.81 | 49.28 | 17.72 | 31.56 | | |
| | C2 | 6 | 27.995 | 524.27 | 78.09 | 1043.9 | 78.09 | 1043.90 | 0.14 | 3.92 | 10.93 | 0.14 | 8.18 | 0.14 | 8.18 | 0.29 | 8.12 | 23.15 | 0.30 | 8.92 | 0.30 | 8.92 | 0.54 | 15.12 | 44.67 | 0.57 | 7.83 | 0.57 | 7.83 | 11.02 | 25.16 | 8.49 | 0.22 | 1.23 | 76.86 | 35.60 | 41.27 | | |
| | C3 | 12 | 19.11 | 589.44 | 97.20 | 1633.335 | 97.20 | 1633.34 | 0.15 | 2.87 | 13.80 | 0.14 | 10.32 | 0.14 | 10.32 | 0.30 | 5.73 | 28.88 | 0.30 | 11.12 | 0.30 | 11.12 | 0.54 | 10.32 | 54.99 | 0.57 | 9.64 | 0.57 | 9.64 | 13.91 | 31.39 | 9.69 | 0.25 | 1.51 | 95.69 | 55.70 | 39.99 | | |
| | C4 | 20 | 7.915 | 476.41 | 105.12 | 2109.74 | 105.12 | 2109.74 | 0.15 | 1.19 | 14.99 | 0.14 | 11.21 | 0.14 | 11.21 | 0.31 | 2.45 | 31.33 | 0.30 | 12.07 | 0.30 | 12.07 | 0.56 | 4.43 | 59.43 | 0.57 | 10.41 | 0.57 | 10.41 | 15.11 | 34.06 | 10.26 | 0.26 | 1.63 | 103.48 | 71.94 | 31.54 | | |
| | F | | 987.50 | | | | | | 0.12 | 118.50 | | | | | | 0.28 | 276.50 | | | | | | 0.59 | 582.63 | | | | | | | | | | | | | | | |
| | T | | 882.39 | | | | | | 0.13 | | | | | | | 0.25 | | | | | | | 0.56 | | | | | | | | | | | | | | | | |
| | T2 | | 15.47 | | | | | | 0.13 | 2.01 | | | | | | 0.25 | 3.87 | | | | | | 0.56 | 8.66 | | | | | | | | | | | | | | | |
| | T3 | | 15.2 | | | | | | 0.13 | 1.98 | | | | | | 0.25 | 3.80 | | | | | | 0.56 | 8.51 | | | | | | | | | | | | | | | |
| | Cc+Tt Mass Bal | | | | | | | | | 0.135 | 133.68 | | | | | | 0.263 | 259.60 | | | | | | 0.578 | 570.74 | | | | | | | | | | | | | | |
| DS3 1 IS, pH 9, DO 8, Eh 670 | | | | | | 0.00 | | | | | | | | | | | | | | | | | | | | | | | | | | | | | | | | 0.0341 | |
| | C1 | 2 | 13.16 | 245.20 | 13.16 | 245.20 | 13.16 | 245.20 | 0.26 | 3.42 | 3.42 | 0.26 | 1.00 | 0.26 | 1.00 | 0.37 | 4.87 | 4.87 | 0.37 | 3.10 | 0.37 | 3.10 | 0.84 | 11.05 | 11.05 | 0.84 | 1.92 | 0.84 | 1.92 | 3.45 | 5.29 | 2.31 | 0.06 | 0.30 | 12.86 | | | | |
| | C2 | 6 | 7.33 | 219.26 | 20.49 | 464.46 | 20.49 | 464.46 | 0.25 | 1.83 | 5.25 | 0.26 | 1.54 | 0.26 | 1.54 | 0.32 | 2.35 | 7.21 | 0.35 | 4.59 | 0.35 | 4.59 | 0.70 | 5.13 | 16.19 | 0.79 | 2.81 | 0.79 | 2.81 | 5.30 | 7.84 | 3.05 | 0.08 | 0.44 | 20.05 | | | | |
| | C3 | 12 | 21.14 | 651.28 | 41.63 | 1115.73 | 41.63 | 1115.73 | 0.21 | 4.44 | 9.69 | 0.23 | 2.84 | 0.23 | 2.84 | 0.32 | 6.76 | 13.98 | 0.34 | 8.89 | 0.34 | 8.89 | 0.60 | 12.68 | 28.87 | 0.69 | 5.02 | 0.69 | 5.02 | 9.77 | 15.19 | 3.90 | 0.10 | 0.79 | 40.83 | | | | |
| | C4 | 20 | 10.82 | 503.72 | 52.45 | 1619.45 | 52.45 | 1619.45 | 0.21 | 2.27 | 11.96 | 0.23 | 3.50 | 0.23 | 3.50 | 0.31 | 3.35 | 17.33 | 0.33 | 11.02 | 0.33 | 11.02 | 0.58 | 6.28 | 35.14 | 0.67 | 6.11 | 0.67 | 6.11 | 12.06 | 18.84 | 4.24 | 0.11 | 0.96 | 51.48 | | | | |
| | F | | 1012.07 | | | | | | 0.13 | 131.57 | | | | | | 0.26 | 263.14 | | | | | | 0.57 | 576.88 | | | | | | | | | | | | | | | |
| | T | | 959.62 | | | | | | 0.33 | | | | | | | 0.14 | | | | | | | 0.54 | | | | | | | | | | | | | | | | |
| | T2 | | 20.16 | | | | | | 0.33 | 6.65 | | | | | | 0.14 | 2.82 | | | | | | 0.54 | 10.89 | | | | | | | | | | | | | | | |
| | T3 | | 19.92 | | | | | | 0.33 | 6.57 | | | | | | 0.14 | 2.79 | | | | | | 0.54 | 10.75 | | | | | | | | | | | | | | | |
| | Cc+Tt Mass Bal | | | | | | | | | 0.338 | 341.86 | | | | | | 0.155 | 157.29 | | | | | | 0.568 | 574.98 | | | | | | | | | | | | | | |
| Test 9 1 IS, pH 9, DO 0, Eh 50 (Test 21) | | | | | | 0.00 | | | | | | | | | | | | | | | | | | | | | | | | | | | | | | | | 0.0242 | |
| | C1 | 2 | 14.805 | 208.81 | 14.81 | 208.805 | 14.81 | 208.81 | 3.26 | 48.26 | 48.26 | 3.26 | 64.17 | 3.26 | 64.17 | 3.48 | 51.52 | 51.52 | 3.48 | 19.42 | 3.48 | 19.42 | 11.40 | 168.78 | 168.78 | 11.40 | 28.91 | 11.40 | 28.91 | 48.65 | 56.00 | 64.12 | 1.63 | 4.63 | 10.17 | 5.05 | 5.12 | | |
| | C2 | 6 | 13.755 | 363.48 | 28.56 | 572.28 | 28.56 | 572.28 | 0.94 | 12.86 | 61.13 | 2.14 | 81.27 | 2.14 | 81.27 | 3.04 | 41.82 | 93.34 | 3.27 | 35.19 | 3.27 | 35.19 | 7.22 | 99.31 | 268.09 | 9.39 | 45.93 | 9.39 | 45.93 | 61.62 | 101.46 | 105.01 | 2.67 | 7.35 | 21.21 | 13.85 | 7.36 | | |
| | C3 | 12 | 16.965 | 596.37 | 45.53 | 1168.645 | 45.53 | 1168.65 | 0.50 | 8.48 | 69.61 | 1.53 | 92.55 | 1.53 | 92.55 | 1.62 | 27.48 | 120.82 | 2.65 | 45.55 | 2.65 | 45.55 | 3.24 | 54.97 | 323.05 | 7.10 | 55.34 | 7.10 | 55.34 | 70.17 | 131.33 | 121.55 | 3.09 | 8.86 | 36.66 | 28.28 | 8.38 | | |
| | C4 | 20 | 13.665 | 904.96 | 59.19 | 2073.605 | 59.19 | 2073.61 | 0.41 | 5.60 | 75.21 | 1.27 | 100.00 | 1.27 | 100.00 | 0.80 | 10.93 | 131.75 | 2.23 | 49.67 | 2.23 | 49.67 | 1.63 | 22.27 | 345.33 | 5.83 | 59.16 | 5.83 | 59.16 | 75.82 | 143.22 | 126.29 | 3.21 | 9.47 | 49.72 | 50.18 | 0.00 | | |
| | F | | 979.99 | | | | | | 0.11 | 107.80 | | | | | | 0.26 | 254.80 | | | | | | 0.52 | 509.59 | | | | | | | | | | | | | | | |
| | T | | 920.80 | | | | | | 0.00 | | | | | | | 0.14 | | | | | | | 0.25 | | | | | | | | | | | | | | | | |
| | T2 | | 15.69 | | | | | | 0.00 | 0.00 | | | | | | 0.14 | 2.20 | | | | | | 0.25 | 3.92 | | | | | | | | | | | | | | | |
| | T3 | | 17.205 | | | | | | 0.00 | 0.00 | | | | | | 0.14 | 2.41 | | | | | | 0.25 | 4.30 | | | | | | | | | | | | | | | |
| | Cc+Tt Mass Bal | | | | | | | | | 0.077 | 75.21 | | | | | | 0.271 | 265.27 | | | | | | 0.596 | 583.75 | | | | | | | | | | | | | | |
| DS5 1 IS, pH 9, DO 0, Eh 40 | | | | | | 0.00 | | | | | | | | | | | | | | | | | | | | | | | | | | | | | | | | 0.0242 | |
| | C1 | 2 | 11.70 | 204.77 | 11.70 | 204.77 | 11.70 | 204.77 | 5.01 | 58.62 | 58.62 | 5.01 | 37.81 | 5.01 | 37.81 | 5.63 | 65.87 | 65.87 | 5.63 | 24.44 | 5.63 | 24.44 | 13.80 | 161.46 | 161.46 | 13.80 | 29.46 | 13.80 | 29.46 | 59.09 | 71.60 | 30.77 | 0.78 | 4.43 | 7.27 | | | | |
| | C2 | 6 | 7.31 | 254.25 | 19.01 | 459.01 | 19.01 | 459.01 | 2.34 | 17.09 | 75.71 | 3.98 | 48.83 | 3.98 | 48.83 | 4.65 | 33.97 | 99.84 | 5.25 | 37.04 | 5.25 | 37.04 | 11.10 | 81.09 | 242.55 | 12.76 | 44.26 | 12.76 | 44.26 | 76.32 | 108.53 | 57.70 | 1.47 | 6.65 | 12.35 | | | | |
| | C3 | 12 | 13.07 | 499.95 | 32.07 | 958.96 | 32.07 | 958.96 | 0.70 | 9.15 | 84.86 | 2.65 | 54.73 | 2.65 | 54.73 | 1.80 | 23.52 | 123.36 | 3.85 | 45.77 | 3.85 | 45.77 | 4.62 | 60.36 | 302.91 | 9.45 | 55.27 | 9.45 | 55.27 | 85.54 | 134.09 | 83.27 | 2.12 | 8.31 | 23.76 | | | | |
| | C4 | 20 | 13.18 | 585.08 | 45.25 | 1544.04 | 45.25 | 1544.04 | 0.42 | 5.54 | 90.39 | 2.00 | 58.30 | 2.00 | 58.30 | 0.84 | 11.07 | 134.43 | 2.97 | 49.88 | 2.97 | 49.88 | 1.76 | 23.20 | 326.10 | 7.21 | 59.50 | 7.21 | 59.50 | 91.12 | 146.13 | 88.85 | 2.26 | 8.95 | 36.30 | | | | |
| | F | | 970.52 | | | | | | 0.13 | 126.17 | | | | | | 0.25 | 242.63 | | | | | | 0.57 | 553.20 | | | | | | | | | | | | | | | |
| | T | | 925.27 | | | | | | 0.07 | | | | | | | 0.14 | | | | | | | 0.23 | | | | | | | | | | | | | | | | |
| | T2 | | 19.45 | | | | | | 0.07 | 1.30 | | | | | | 0.14 | 2.72 | | | | | | 0.23 | 4.47 | | | | | | | | | | | | | | | |
| | T3 | | 20.24 | | | | | | 0.07 | 1.36 | | | | | | 0.14 | 2.83 | | | | | | 0.23 | 4.66 | | | | | | | | | | | | | | | |
| | Cc+Tt Mass Bal | | | | | | | | | 0.160 | 155.04 | | | | | | 0.278 | 269.52 | | | | | | | | | | | | | | | | | | | | | |

10.7 pH Eh Experimental Data

| pH (average) | Std Dev | Eh (average) | Std Dev | Conductivity (average) | Std Dev |
|--------------|----------|--------------|----------|------------------------|----------|
| 3.175 | 0.120208 | 409.5 | 2.687006 | 5.174807692 | 0.413875 |
| 5.24 | 0.084853 | 236.9 | 9.899495 | 3.6835 | 1.683621 |
| 7.12 | 0.056569 | 197.6 | 40.58793 | 5.164 | 0.802667 |
| 9.185 | 0.049497 | 88.55 | 9.263099 | 0.885 | 1.414214 |
| 10.085 | 0.106066 | 71.7 | 11.73797 | 3.772166667 | 0.102059 |
| 11.03 | 0.014142 | 27.15 | 0.494975 | 4.97 | 1.59099 |

10.8 Conductivity Experiments

| Condition | | | | | |
|-----------|-------|-------|--------|--------------|------|
| IS | pH | DO | Eh | Conductivity | Unit |
| 1 IS | pH 9 | 8 ppm | 40 mV | 1.777 | mS |
| 1 IS | pH 9 | 0 ppm | 40 mV | 0.02117 | mS |
| 1 IS | pH 9 | 8 ppm | 590 mV | 3.137 | mS |
| 1 IS | pH 9 | 0 ppm | 590 mV | 0.03583 | mS |
| 1 IS | pH 11 | 8 ppm | 50 mV | 4.64 | mS |
| 1 IS | pH 11 | 0 ppm | 50 mV | 4.014 | mS |
| 1 IS | pH 11 | 8 ppm | 450 mV | 6.538 | mS |
| 1 IS | pH 11 | 0 ppm | 460 mV | 14 | mS |
| 5 IS | pH 9 | 8 ppm | 30 mV | 128 | mS |
| 5 IS | pH 9 | 0 ppm | 30 mV | 0.03884 | mS |
| 5 IS | pH 9 | 8 ppm | 650 mV | 0.4059 | mS |
| 5 IS | pH 9 | 0 ppm | 680 mV | 0.9065 | mS |
| 5 IS | pH 11 | 8 ppm | 20 mV | 0.06961 | mS |
| 5 IS | pH 11 | 0 ppm | 20 mV | 6.2 | mS |
| 5 IS | pH 11 | 8 ppm | 520 mV | 19 | mS |
| 5 IS | pH 11 | 0 ppm | 520 mV | 20.3 | mS |

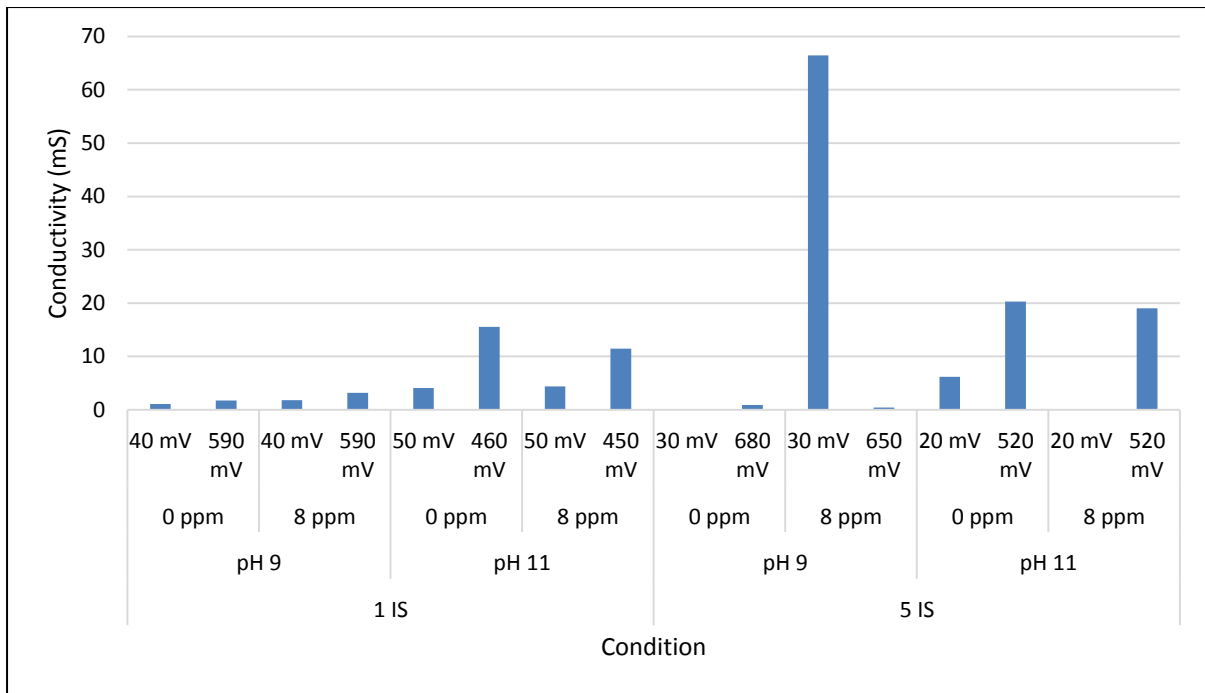

Figure 10-1: The effect of different conditions on conductivity.

| 3-Phase, 1 IS | | | |
|---------------|-------------------|--------|---------|
| DO (ppm) | Conductivity (mS) | pH | Eh (mV) |
| 0 | 0.8456 | 9.02 | -55.975 |
| 8 | 0.854180769 | 9.0025 | -23.75 |

| 3-Phase, 1 IS | | | |
|---------------|-------------------|--------|---------|
| NaClO (mL) | Conductivity (mS) | pH | Eh (mV) |
| 0 | 1.123557143 | 9.46 | 13.1 |
| 5 | 1.7305 | 9.585 | 560.3 |
| 10 | 2.145142857 | 9.66 | 606.45 |
| 20 | 3.2248 | 9.81 | 626.2 |
| 40 | 5.7630625 | 10.05 | 633.5 |
| 80 | 10.1881875 | 10.485 | 618.75 |
| 100 | 11.77705556 | 10.605 | 616.05 |

| pH | Conductivity (mS) | DO (ppm) | Eh (mV) |
|----|-------------------|----------|---------|
| 9 | 1.7935 | 8 | -38.6 |
| 11 | 4.38625 | 8 | -19.8 |

| 3-Phase, Distilled Water | | | |
|--------------------------|-------------------|------|---------|
| NaCl (mL) | Conductivity (mS) | pH | Eh (mV) |
| 0 | 124.2 | 9.16 | 54.5 |
| 10 | 0.09791 | 9.65 | 50.9 |
| 20 | 0.09791 | 9.54 | 49.6 |
| 40 | 0.09791 | 9.42 | 45.3 |
| 80 | 0.09791 | 9.25 | 41.4 |
| 100 | 0.09791 | 9.15 | 38.3 |

| NaCl (mL) | Conductivity (mS) | pH | Eh (mV) |
|-----------|-------------------|------|---------|
| 0 | 0.8128 | 6.34 | 253.7 |
| 10 | 0.864488889 | 6.59 | 267.3 |
| 20 | 0.907122222 | 6.68 | 268.9 |
| 40 | 0.997545455 | 6.74 | 269.5 |
| 80 | 1.198125 | 6.76 | 269.3 |
| 100 | 1.290571429 | 6.8 | 267.7 |

| 2-Phase | | | |
|-----------|-------------------|-------|---------|
| NaCl (mL) | Conductivity (mS) | pH | Eh (mV) |
| 0 | 0.2976 | 8.835 | -121.7 |
| 10 | 0.9786 | 8.865 | -124.55 |
| 20 | 1.637 | 8.95 | -123.55 |
| 40 | 2.76 | 8.84 | -122.05 |
| 80 | 4.6375 | 8.76 | -119.65 |
| 100 | 5.353 | 8.695 | -119.65 |

| 3-Phase, 1 IS | | | |
|---------------|-------------------|-------|---------|
| NaCl (mL) | Conductivity (mS) | pH | Eh (mV) |
| 0 | 0.3542 | 8.465 | -99.9 |
| 100 | 0.4411 | 8.415 | -90.8 |

| 3-Phase, 5 IS | | | |
|---------------|-------------------|-------|---------|
| NaCl (mL) | Conductivity (mS) | pH | Eh (mV) |
| 0 | 0.35065 | 8.87 | -117.85 |
| 100 | 1.161 | 8.765 | -109.5 |

11 Appendix B

11.1 2-Phase Water Recovery 3D Surface Plots

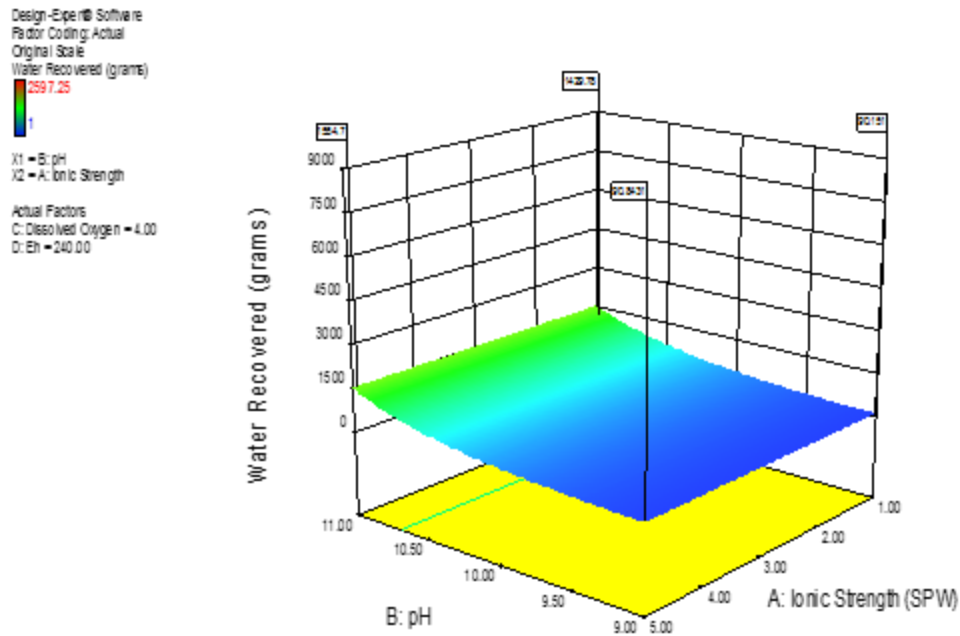

Figure 11-1: 3D surface plot of the interaction between pH and IS in relation to water recovery in a 2-phase system

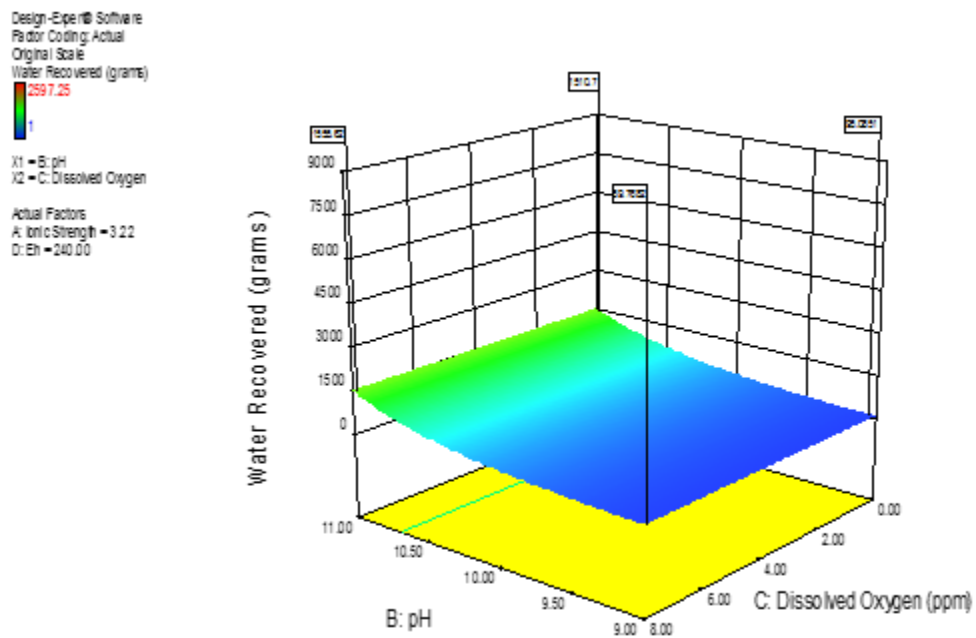

Figure 11-2: 3D surface plot of the interaction between pH and DO in relation to water recovery in a 2-phase system

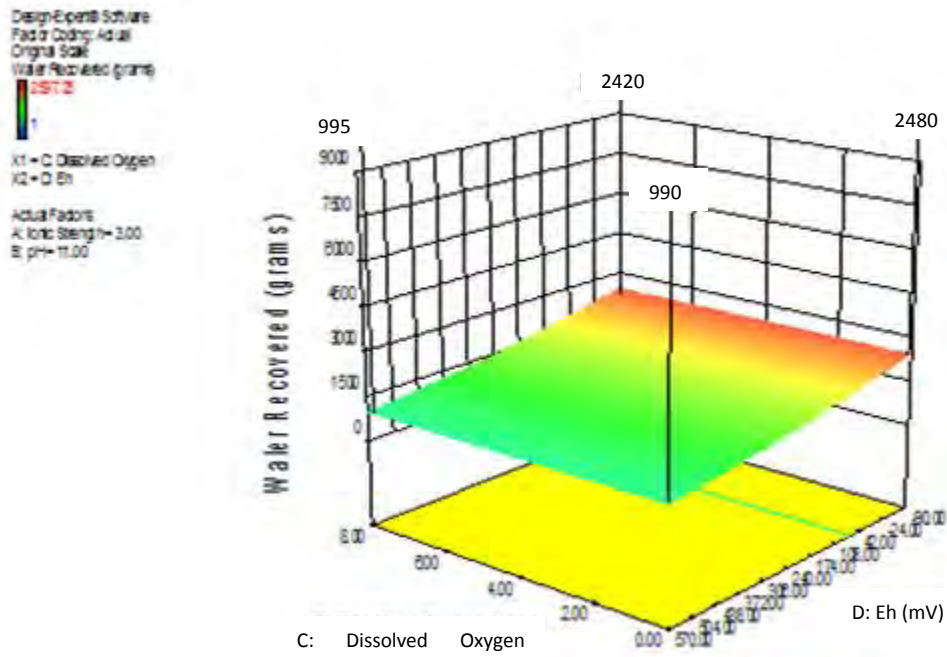

Figure 11-3: 3D surface plot of the interaction between DO and Eh in relation to water recovery in a 2-phase system

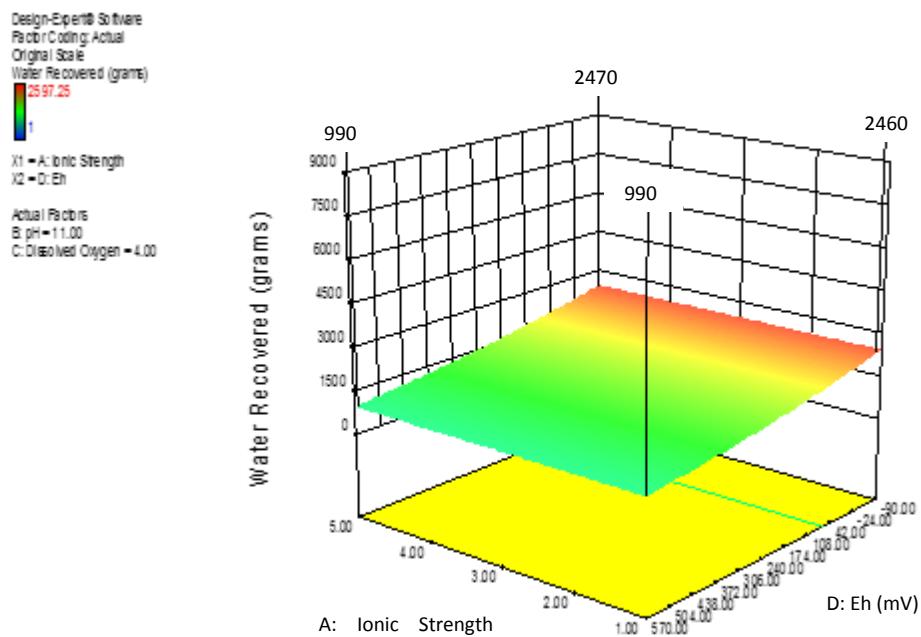

Figure 11-4: 3D surface plot of the interaction between IS and Eh in relation to water recovery in a 2-phase system

11.2 3-Phase Solids Recovery 3D Surface Plots

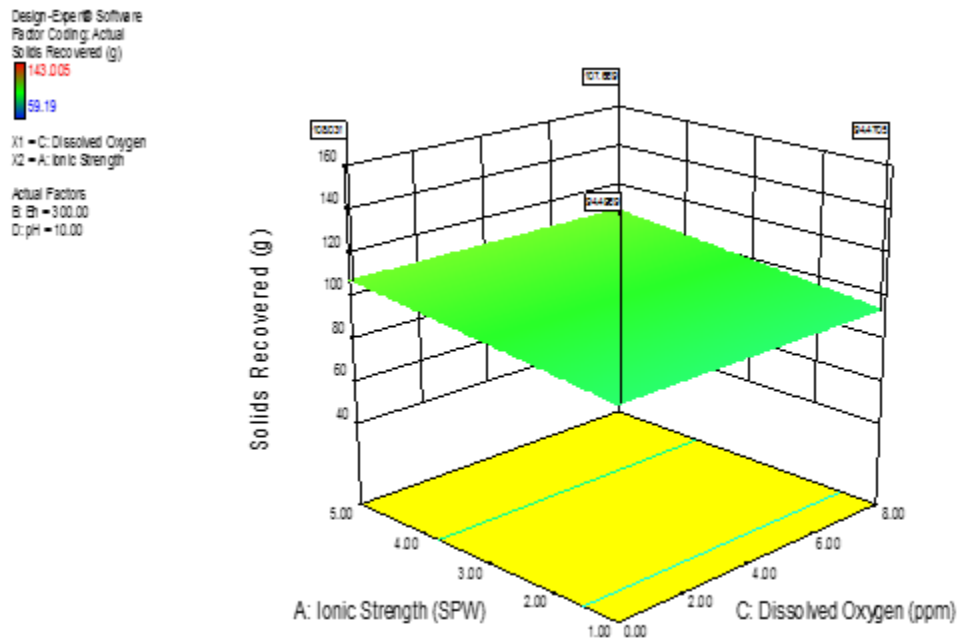

Figure 11-5: 3D surface plot of the interaction between IS and DO in relation to solids recovery in a 3-phase system

11.3 Grade and Recovery Curves

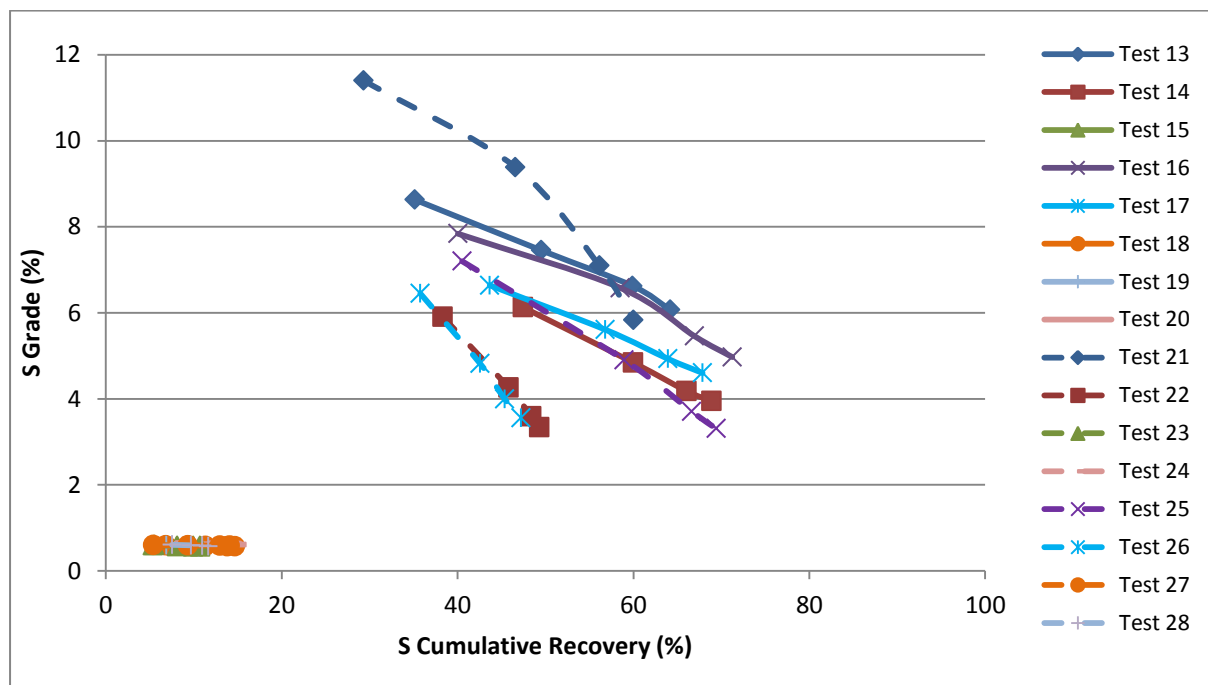

Figure 11-6: Grade-Recovery curves for sulfur at different conditions

11.4 Mineral Recovery-Water Recovery Results

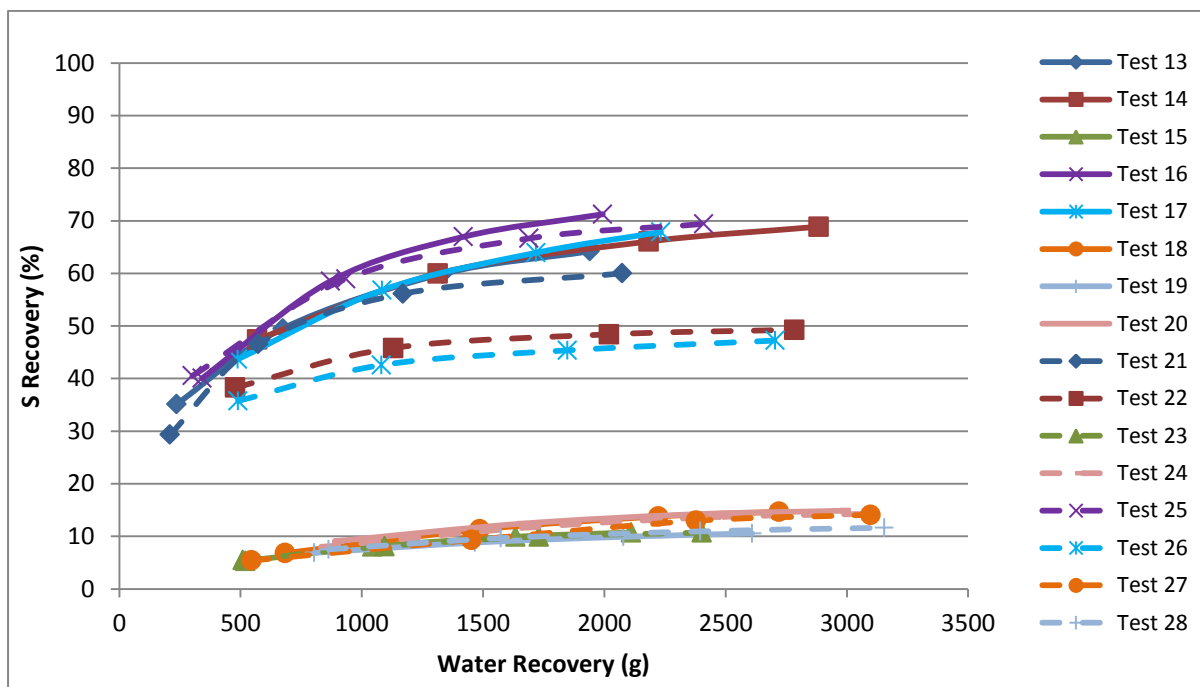

Figure 11-7: Recovery versus water curves for sulfur at different conditions

11.4.1 3-Phase Copper and Nickel Recovery 3D Surface Plots

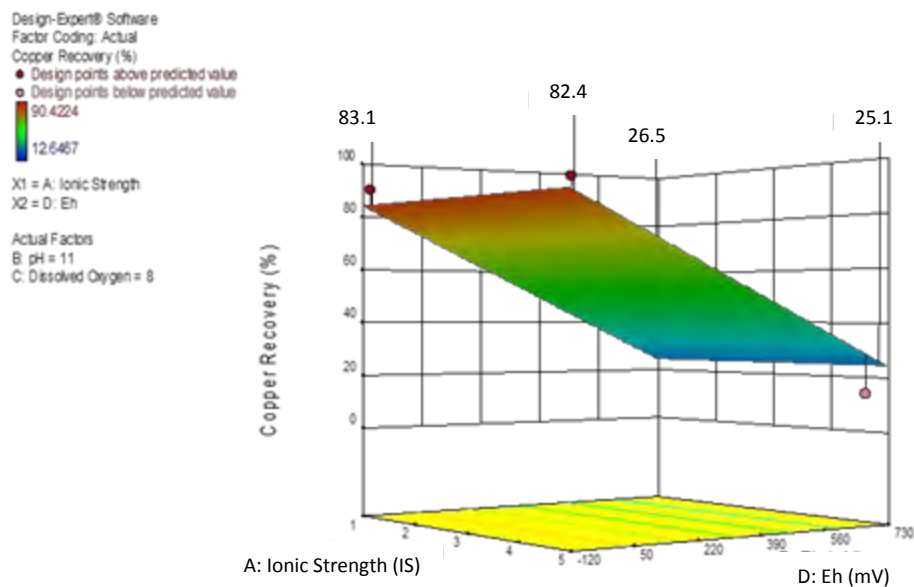

Figure 11-8: 3D surface plot of the interaction between IS and Eh in relation to copper recovery

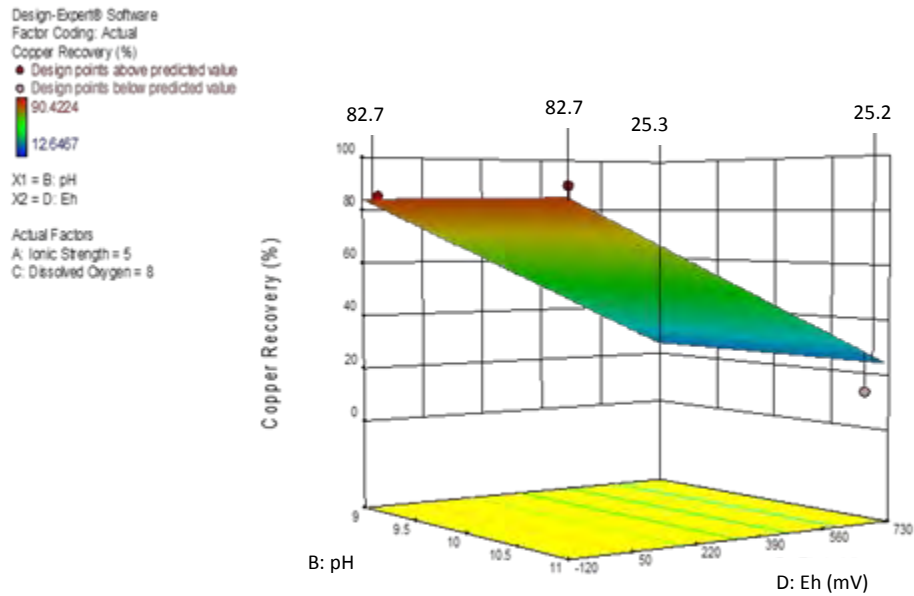

Figure 11-9: 3D surface plot of the interaction between pH and Eh in relation to copper recovery

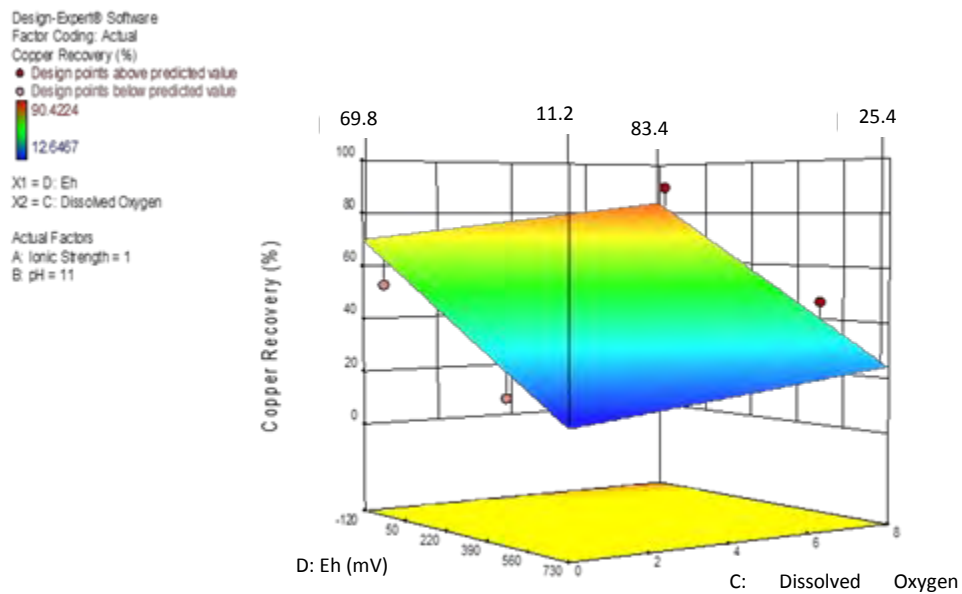

Figure 11-10: 3D surface plot of the interaction between Eh and DO in relation to copper recovery

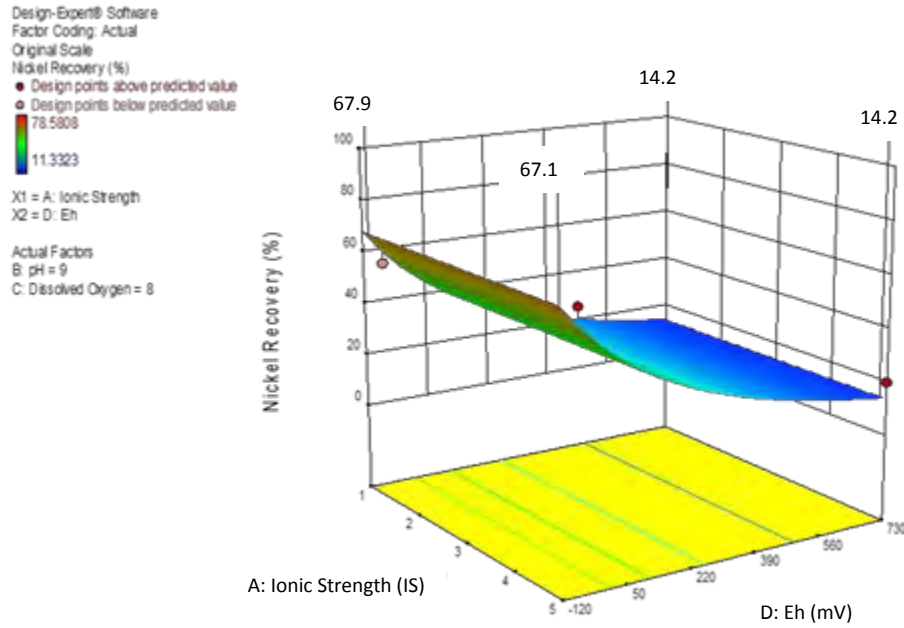

Figure 11-11: 3D surface plot of the interaction between IS and Eh in relation to nickel recovery

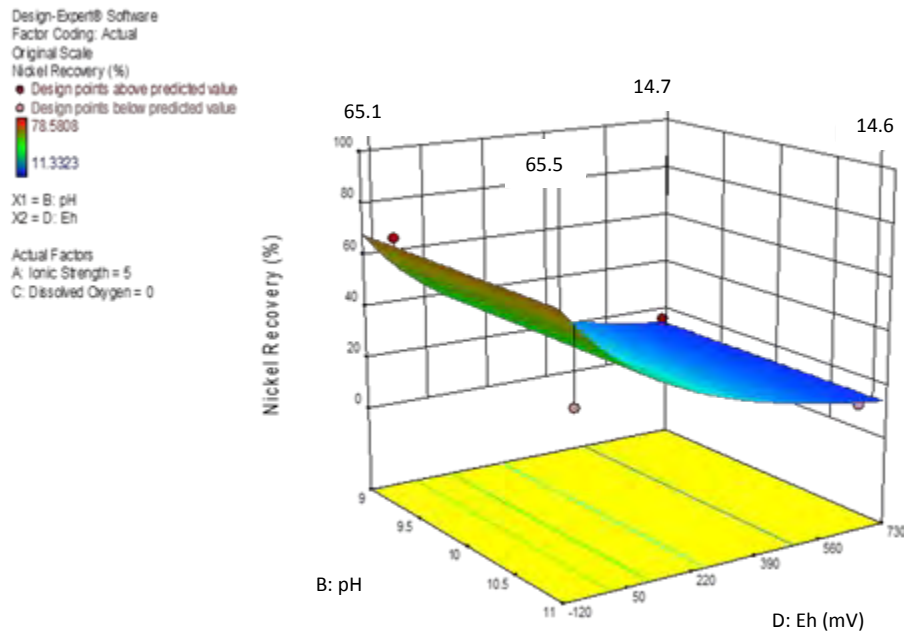

Figure 11-12: 3D surface plot of the interaction between pH and Eh in relation to nickel recovery

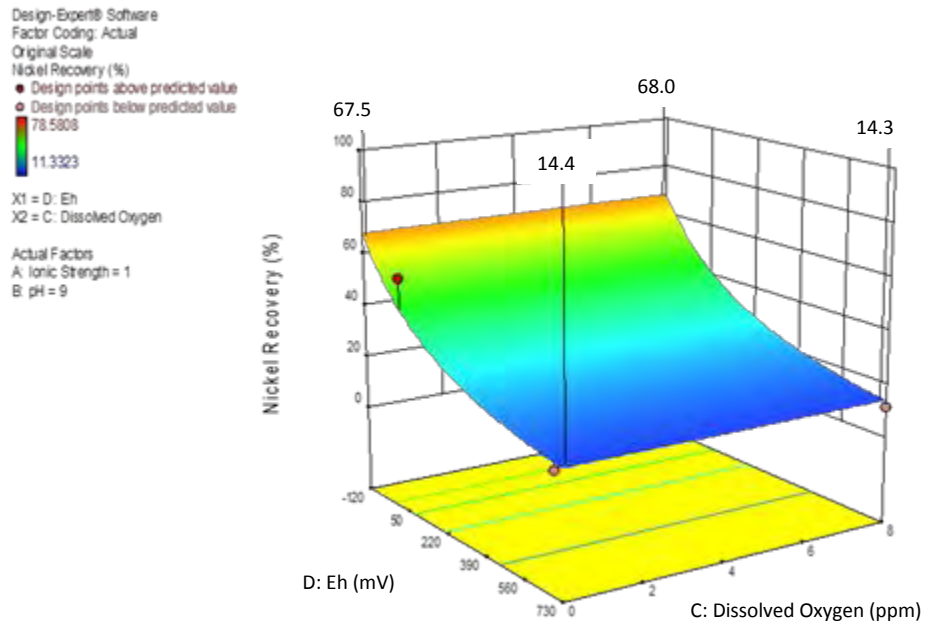

Figure 11-13: 3D surface plot of the interaction between Eh and DO in relation to nickel recovery

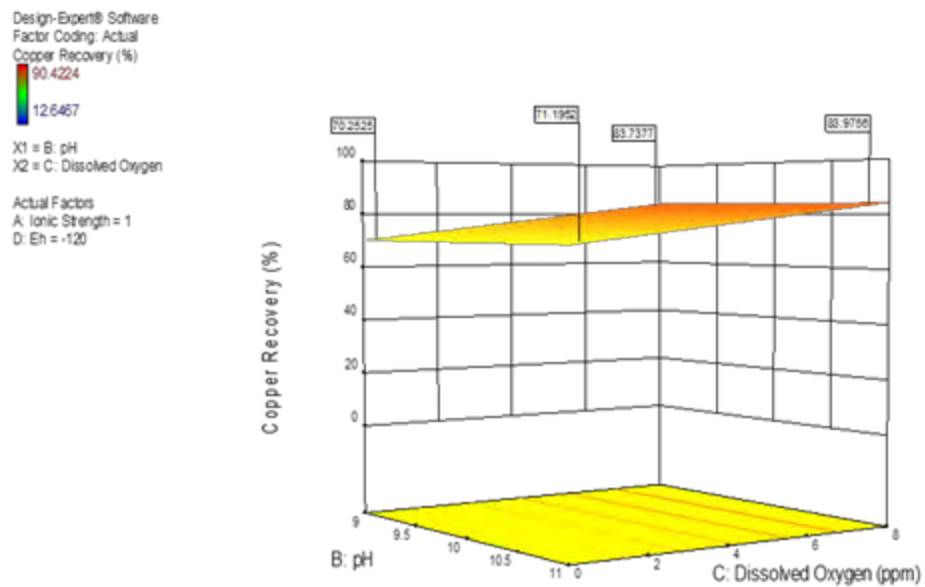

Figure 11-14: 3D surface plot of the interaction between pH and DO in relation to copper recovery

11.5 Depressant Results

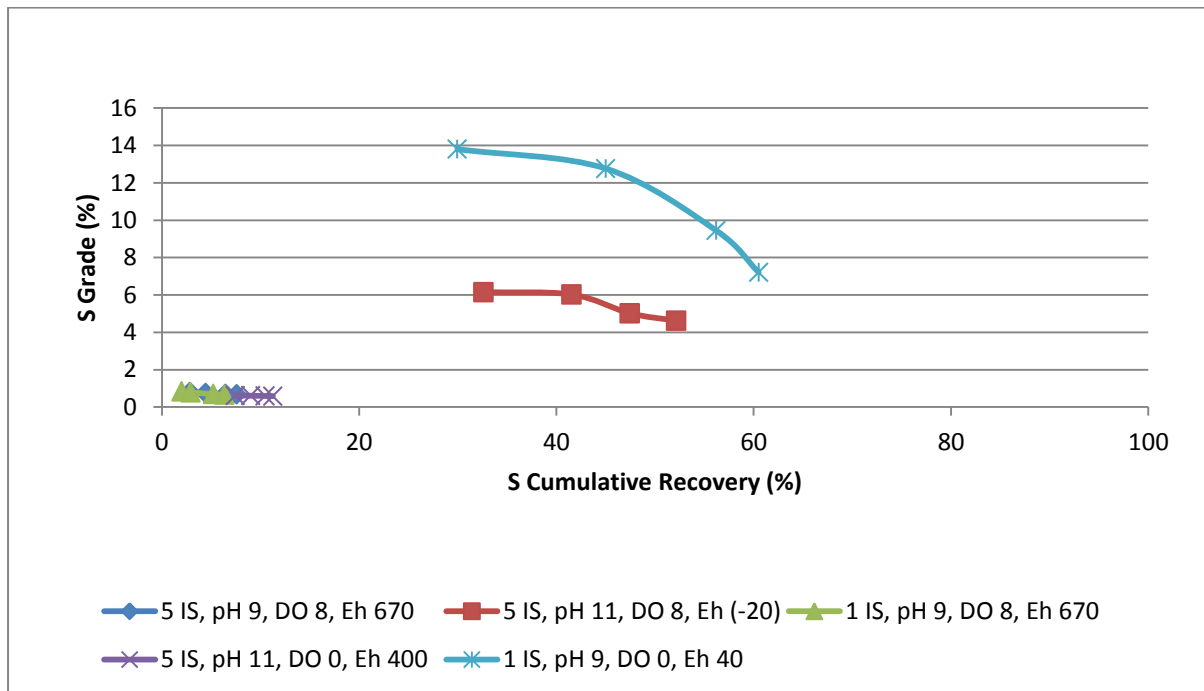

Figure 11-15: Grade-Recovery curves for sulfur at different conditions and a high depressant dosage

EBE Faculty: Assessment of Ethics in Research Projects

Any person planning to undertake research in the Faculty of Engineering and the Built Environment at the University of Cape Town is required to complete this form before collecting or analysing data. When completed it should be submitted to the supervisor (where applicable) and from there to the Head of Department. If any of the questions below have been answered YES, and the applicant is NOT a fourth year student, the Head should forward this form for approval by the Faculty EIR committee: submit to Ms Zulpha Geyer (Zulpha.Geyer@uct.ac.za, Chem Eng Building, Ph 021 650 4791). **NB: A copy of this signed form must be included with the thesis/dissertation/report when it is submitted for examination**

This form must only be completed once the most recent revision EBE EIR Handbook has been read.

Name of Principal Researcher/Student: NANZI SHENI Department CHEMICAL ENGINEERING

Preferred email address of the applicant: SHANNAN002@myuct.ac.za

If a Student: Degree: MSc Supervisor: DR KIRSTEN CORIN
MRS JEANNY WIESE

If a Research Contract indicate source of funding/sponsorship:

Research Project Title: Considering the effect of pulp chemistry during flotation on froth stability.

Overview of ethics issues in your research project:

| | | |
|--|-----|--|
| Question 1: Is there a possibility that your research could cause harm to a third party (i.e. a person not involved in your project)? | YES | <input checked="" type="checkbox"/> NO |
| Question 2: Is your research making use of human subjects as sources of data? If your answer is YES, please complete Addendum 2. | YES | <input checked="" type="checkbox"/> NO |
| Question 3: Does your research involve the participation of or provision of services to communities? If your answer is YES, please complete Addendum 3. | YES | <input checked="" type="checkbox"/> NO |
| Question 4: If your research is sponsored, is there any potential for conflicts of interest? If your answer is YES, please complete Addendum 4. | YES | <input checked="" type="checkbox"/> NO |

If you have answered YES to any of the above questions, please append a copy of your research proposal, as well as any interview schedules or questionnaires (Addendum 1) and please complete further addenda as appropriate. Ensure that you refer to the EIR Handbook to assist you in completing the documentation requirements for this form.

I hereby undertake to carry out my research in such a way that

- there is no apparent legal objection to the nature or the method of research; and
- the research will not compromise staff or students or the other responsibilities of the University;
- the stated objective will be achieved, and the findings will have a high degree of validity;
- limitations and alternative interpretations will be considered;
- the findings could be subject to peer review and publicly available; and
- I will comply with the conventions of copyright and avoid any practice that would constitute plagiarism.

Signed by:

| | Full name and signature | Date |
|-------------------------------|-------------------------|-------------------|
| Principal Researcher/Student: | <u>NANZI BETH SHENI</u> | <u>27/05/2016</u> |

This application is approved by:

| | | |
|--|----------------------------|-------------------|
| Supervisor (if applicable): | <u>KIRSTEN CLARE CORIN</u> | <u>27/05/2016</u> |
| HOD (or delegated nominee): <i>Final authority for all assessments with NO to all questions and for all undergraduate research.</i> | <u>ERIC VAN STEEN</u> | <u>31.5.16</u> |
| Chair: Faculty EIR Committee For applicants other than undergraduate students who have answered YES to any of the above questions. | | |

ADDENDUM 1:

Please append a copy of the research proposal here, as well as any interview schedules or questionnaires: