

Adoption of a Visual Model for Temporal Database Representation

By Tamindran Shunmugam

February 2016

Mini-Dissertation submitted in partial fulfilment for the degree of

Master of Science in Information Technology

Department of Computing Science

University of Cape Town

The copyright of this thesis vests in the author. No quotation from it or information derived from it is to be published without full acknowledgement of the source. The thesis is to be used for private study or non-commercial research purposes only.

Published by the University of Cape Town (UCT) in terms of the non-exclusive license granted to UCT by the author.

Abstract

Today, in the world of information technology, conceptual model representation of database schemas is challenging for users both in the Software Development Life Cycle (SDLC) and the Human-Computer Interaction (HCI) domain. The primary way to resolve this issue, in both domains, is to use a model that is concise, interpretable and clear to understand, yet encompasses all of the required information to be able to clearly define the database.

A temporal database is understood as a database capable of supporting reasoning of time-based data for e.g.: a temporal database can answer questions such as: - for what period was Mrs Jones single before she got married? On the other hand, an atemporal database stores data that is valid today and has no history.

In the thesis, I looked at different theoretical temporal visual conceptual models proposed by temporal researchers and aimed, by means of a user-survey consisting of business users, to ascertain towards which models users a preference has. I further asked the users for firstly; whether they prefer textual or graphical representations for the entities, attributes and constraints represented by the visual models, or secondly; whether there is a preference for a specific graphical icon for the temporal entities and lastly; to ascertain if the users show a preference towards a specific theoretical temporal conceptual model.

The methodology employed to reach my goal in this thesis, is one of experiments on business users with knowledge enhancements after each experiment. Users were to perform a task, and then based on analysis of the task results, they are taught additional temporal aspects so as improve their knowledge before the next experiment commences. The ultimate aim was to extract a visual conceptual model preference from business users with enhanced knowledge of temporal aspects. This is the first work done in this field and thus will aid researchers in future work, as they will have a temporal conceptual model that promotes effective communication, understandability and interpretability.

Contents

Abstract.....	2
Contents	3
Table of Figures	5
Tables List.....	7
1 Introduction.....	8
2 Motivations and Purpose of Study	10
3 Theoretical Principles and Related Works.....	12
3.1 Theoretical Principles.....	12
3.2 Systems for Temporal Data Visual Representations.....	13
3.3 Techniques for Temporal Data Visual Representations.....	20
4 Experimental Procedure.....	26
4.1 Experiment One.....	29
4.1.1 Experiment Intention and Technique.....	29
4.1.2 Results.....	29
4.1.3 Discussion.....	36
4.2 Experiment Two.....	37
4.2.1 Experiment Intention and Technique.....	37
4.2.2 Results.....	38
4.2.3 Discussion.....	41
4.3 Experiment Three.....	42
4.3.1 Experiment Intention and Technique.....	42
4.3.2 Results.....	43
4.3.3 Discussion.....	43
4.4 Experiment Four.....	44
4.4.1 Experiment Intention and Technique.....	44
4.4.2 Results.....	44
4.4.3 Discussion.....	48
4.5 Experiment Five.....	50
4.5.1 Experiment Intention and Technique.....	50
4.5.2 Results.....	56
4.5.3 Discussion.....	59
5 Overall Discussion and Findings	60
6 Conclusion	63
7 References.....	64
8 Appendix.....	66
8.1 Appendix 1 – Survey for Experiment One.....	66

8.1.1	Full Results Experiment One	75
8.2	Appendix 2 – Survey for Experiment Two	79
8.2.1	Full Results Experiment Two	85
8.3	Appendix 3 – Survey for Experiment Four	91
8.3.1	Full Results Experiment 4.....	96

Table of Figures

Figure 1 : A traditional approach of SDLC [Mujeeb 2014].....	13
Figure 2 : RAKE [Ferg 1985] Model.....	14
Figure 3 : TEER Model [Gregersen and Jensen 1999].....	14
Figure 4 : STEER Model [Gregersen and Jensen 1999].....	15
Figure 5 : ERT Model [Gregersen and Jensen 1999]	15
Figure 6 : LTRM Modelling : Employee Database [Mahmood et al. 2010]	16
Figure 7 : TER Model [Gregersen and Jensen 1999]	16
Figure 8 : ER _{VT} Model - [Artale et al. 2007]	17
Figure 9 : ER _{vt++} Model [Artale et al. 2007]	17
Figure 10 : MADS Schema Diagram [Parent et al. 1999]	18
Figure 11 : MOTAR model.....	18
Figure 12 : TEMPRT Model [Gregersen and Jensen 1999]	19
Figure 13 : The pointwise browser interface [Dumas et al. 2001].....	20
Figure 14 : Monthly Production using the Spiral Technique [Carlis and Konstan 1998]	21
Figure 15 : Monthly Production using Agenda [Daassi et al. 2000]	21
Figure 16 : Time Line Browser [Cousins and Kahn 1991].....	22
Figure 17 : Knave Interface (Shahar & Cheng 1998)	22
Figure 18 : AsbruView Plans Condition [Kosara et al. 2002]	23
Figure 19 : Graphical notation of three proposals [Chittaro and Combi 2001]	23
Figure 20 : Interval relations represented by three proposals (Chittaro & Combi 2001)	24
Figure 21 : Steinbring's model [Steinbring 1998].....	28
Figure 22 : Text or Pictures	29
Figure 23 : Academic and Business Users Text vs. Graphic	30
Figure 24 : Preference based on Database Experience	30
Figure 25 : Visual Icons	30
Figure 26 : Visual Preference for Class	31
Figure 27 : Visual Preference for Attributes.....	31
Figure 28 : Attributes and Classes should have the same Colour.....	31
Figure 29 : DEV Options (a) Text (ER _{VT++}), (b) Graphic (>>) (c) Graphic (LTRM Clock) ...	33
Figure 30 : DEV Preferences	33
Figure 31 : DEX Preferences Text (ER _{VT++}), (b) Graphic (>>) (c) Graphic (Time Icon).....	34
Figure 32 : DEX Preferences	34
Figure 33 : Temporal Conceptual Models	35
Figure 34 : Preference for Conceptual Designs – Open Survey	35
Figure 35 : Visual Interfaces for Temporal Intervals Representation.....	37
Figure 36 : Effectiveness	38
Figure 37 : Quality	38
Figure 38 : Layout.....	38
Figure 39 : Understandability of Diagram for Time Intervals	39
Figure 40 : Recommendations to friend or colleague.....	40
Figure 41 : Temporal Interval Preferences	40
Figure 42 : Image One	42
Figure 43 : Image Two.....	42
Figure 44 : Image Three.....	43
Figure 45 : Proficiency, Profession vs. Preference	44
Figure 46 : Temporal Graphic Preference Closed Group	44
Figure 47 : ER _{vt++} DEX Preferences	45
Figure 48 : ER _{vt++} DEV Preferences	45

Figure 49 : Closed Group Conceptual Model Choices	47
Figure 50 : Conceptual Model Preferences - Closed Group	48
Figure 51 : STEER Model	51
Figure 52 : TER Model	51
Figure 53 : ERvt Model	51
Figure 54 : MOTAR Model	51
Figure 55 : RAKE Model.....	51
Figure 56 : TEMPRT Model.....	51
Figure 57 : LTRM Model	51
Figure 58 : Modified MOTAR Model	52
Figure 59 : Modified ERvt Model	52
Figure 60 : LTRM Model	52
Figure 61 : Modified STEER Model	52
Figure 62 : Modified TER Model	52
Figure 63 : Modified RAKE Model.....	52
Figure 64 : Modified TEMPRT Model.....	52
Figure 65 : STEER with DEX	53
Figure 66 : ERvt with DEX	53
Figure 67 : TER with DEX	53
Figure 68 : LTRM with DEX	53
Figure 69 : MOTAR with DEX	53
Figure 70 : RAKE with DEX.....	53
Figure 71 : TEMPRT with DEX.....	54
Figure 72 : Modified LTRM with DEX.....	54
Figure 73 : Modified RAKE with DEX.....	54
Figure 74 : Modified STEER with DEX.....	54
Figure 75 : Modified MOTAR with DEX	54
Figure 76 : Modified TER with DEX	54
Figure 77 : Modified ERvt with DEX.....	54
Figure 78 : Modified TEMPRT with DEX.....	55
Figure 79 : Temporal Model Choices	56
Figure 80 : Temporal Model Preferences based - Clock Modification	56
Figure 81 : Temporal Model Preference with DEX.....	57
Figure 82 : Temporal Model Preference with Clock and DEX	57
Figure 83 : LTRM with DEX preference.....	61

Tables List

Table 1 : Summary of Temporal Conceptual Models.....	19
Table 2 : Summary of Temporal Data History Representations.....	25
Table 3 : Responses on difference between temporal and atemporal.....	32
Table 4 : Responses based on Years of Experience.....	32
Table 5 : Responses based on Conceptual Model Knowledge.....	33
Table 6 : After Training Responses to difference between temporal and atemporal.....	45
Table 7 : Responses to Question 5 Experiment 5.....	58

1 Introduction

Today, users with various profiles and tasks, find conceptual model representation of temporal databases [8] in both the Software Development Life Cycle (SDLC) and the Human-Computer Interaction (HCI) domains challenging due to the need to represent the time component effectively. The primary way to resolve this issue, in both domains, is to use a suitable model representation that is concise, yet easy to understand. The model must also encompass all entity and attributes relationships so that a user by looking at the model is able to clearly define the database structure. Furthermore, the conceptual representation should not be cumbersome or overly complex to extrapolate yet maximise the information shown in a readable format utilising a range of visually appealing representation techniques.

Suitable models based on Unified Modelling Language (UML) and Entity Relationship Diagram (ERD) models are well adopted and understood for atemporal databases. An atemporal database is understood as a database that stores data that is valid as it stands today e.g., Mrs Jones has a status of married. This type of data can be seen as a snapshot of the data in the history of the data, but does not keep track of past e.g. Mrs Jones was married three times already or the future e.g. Mrs Jones status will change to divorced two weeks from now, or Mrs Jones will be receiving a bonus from her workplace in three months' time. As stated by Dumas [11], future or past histories is useless to think of in this type of database.

On the other hand, a temporal database is understood as a database capable of supporting reasoning of time-based data e.g. a temporal database can answer questions such as: - for what period was Mrs Jones single before she got married? Moreover, what was her surname before she got married? Or how many times was Mrs Jones married before? Hence, the data stored in a temporal database always has a time history component attached to the data. This time history component indicates what time intervals the data is valid in the database. But why is this historic data important? Firstly; in the world today, medical, legal, atmospheric, and many other industries desire to utilise such important historical data due to the possible gains from answering time related queries e.g. a doctor wants to view patient history, or a lawyer wants to see who worked on case and for which time periods, and secondly; for application design needs [30]. This in turn means that a temporal conceptual model used to communicate the way temporal data is represented and stored will be of the utmost benefit going forward in the information systems industry.

To create an effective model that transfers any temporal reasoning system into real world application requires us to delve into the domain of HCI [20] and especially the realms of text and visual illustrations. There is also an old saying that "a picture is worth a thousand words" and this will be investigated further in this thesis. Modelling would indeed be difficult without colour, shapes, pictures, charts, drawings, and graphic symbols. In addition, for developing an effective model, it is very important to keep in mind the communication and understandability aspects of the model. This is where a pre-defined visual dictionary helps in understanding models and their meanings and thus preventing any ambiguous interpretations. Hence, there will also be a lesser possibility of errors [29] especially when getting specifications from an architect to a database administrator (DBA) along the SDLC.

Over the years, it has also been noticed that temporal conceptual models vary in size and complexity [10]. This could be due to different software manufacture interpretations, industry

needs, technology improvements, or even needs in different fields including biomedical, educational, and financial sectors.

The thesis will outline a first study in human dynamics with regard to temporal conceptual model adoption in a business context. I will highlight the need and purpose of this study, current theoretical research and techniques relating to the subject matter of temporal conceptual models; conduct research via a five experiments with teachings after each experiment relating to different temporal concepts and models, and eventually I will postulate a possible conceptual model that can be taken forward for further studies.

2 Motivations and Purpose of Study

To express anything we need some sort of communication mechanism. We communicate by both written and oral means. In this study, the focus will be on written communication. In order to communicate information effectively on a written medium using a conceptual model, we need an effective visual metaphor. To develop an effective metaphor, we need to incorporate different theoretical resources and references, learn from these and use them in a proper result-oriented evaluation to determine a temporal conceptual model that users prefer.

Preference is determined by many factors. Firstly, a graphical representation model requires human visual perception capabilities to extract valuable knowledge. In temporal models, perception is determined by analysing different models by factoring in understandability, interpretation, diagrammatic layout, effectiveness and acceptance of the time aspect. Secondly, the temporal object schema is usually different from other object schemas that users have come across before; its schema includes multiple temporal classes and temporal attributes. In temporal representations, time is an independent variable and it is orthogonal to other properties of an object. That is why it is vital for users to have sufficient knowledge of temporal objects and time-dependent navigational representations so as to enable them to choose a preferred model with confidence. Likewise, we need to keep in mind that a class is temporal if one of the properties is temporal, hence preference will need to be taken to a class as well as attribute level.

In this study of temporal conceptual models, our main focus will be on the communication and modelling phase of the Software Development Life Cycle (SDLC) (Figure 1) with the reasoning that this is where visual temporal conceptual models aid the most in terms of communication and any ambiguity during these phases are a recipe for disaster in the following phases such as implementation.

For example, in the communication phase, temporal conceptual models will allow users to discover the interactions of the temporal class and entity temporal relationships using known temporal conceptual models. However, the problem is which temporal conceptual model will be most clearly understood?

The problem presents itself in two scenarios: firstly when a database administrator needs to create the physical layout of the database from a conceptual model representation that is ineffective, and secondly users creating the supporting applications can interpret the objects of the database and their relationships differently from what the architect intended, thus creating a wrong implementation of the system requirements. This could prove to be a very costly and time consuming exercise. Therefore, it is of vital importance that an effective and concise understanding of the conceptual model is adopted so as enable flawless analysis going forward. So, which model will the users prefer?

Temporal models have been mainly theoretical and no temporal conceptual model has been investigated amongst the user community to test understandability or preference. For these reasons, adoption of a visual model for temporal modelling is an important research topic and will be discussed in this study. It is also very important and necessary to keep in mind that for any conceptual model to evolve, human feedback at every iteration step is essential and will also be implemented in this study.

This research intends to answer the following questions from a user perspective:

1. Will a graphical or textual representation be more understandable for a conceptual model?
2. How can a temporal entity be represented in the context of a conceptual data model?
3. Is it better to represent temporal entities and attributes using the same representation or different representations?

The study will take different temporal conceptual models and investigate readability, understandability, effectiveness, communication and model-ability in relation to human computer interaction metrics, constraints and physics of notation [24]. Additional visual representations including visual aids such as different colours, visual icons and line patterns, will also be used to ascertain preferences.

3 Theoretical Principles and Related Works

3.1 Theoretical Principles

The following theoretical principles will be adopted in the research and extrapolated into the experiment so as to get a better understanding of the preferred temporal conceptual model representation.

This first principle looked at is the principle of usability. This principle as per definition in **ISO 9241-11** standard is “the extent to which a product can be used by specified users to achieve specified goals with effectiveness, efficiency and satisfaction” [2] in a specified context of use. This principle will be experimented with in terms of the ability to use the proposed notation when communicating the conceptual model during the SDLC.

The second principle that will be analysed is the principle of notation, or “visual notation” as defined by Moody[24]. He further goes on to describe that the visual notation can also be represented as visual, graphical or diagramming notation consisting of a set of:

- Graphical symbols (visual vocabulary)
- Compositional rules (visual grammar)
- Definitions of the meaning of each symbol (visual semantics)

This research will highlight visual conceptual models and visual semantic components that are used to represent the temporal aspects of conceptual models and their perceived meanings they represent. Current composition rules relating to visual grammar will also be looked at such as the map representation. The map representation is taken from the traditional technique known as thematic cartography [9]. The line segment and colour hues of different intensities are the main part of the map representation; these are used for making routes stand out visually to identify different routes that the objects follow due to temporal history and evolutions.

The third principle is the principle of communication theory [27]. In this thesis, communication is a key concept for the interpretation of conceptual models to aid understandability. Most humans seemingly understand concepts better when they see how it works. This can be easily shown by the popularity of online training videos. The aim in this principle is to prove that preferred visual metaphors help:

- Communicate complex ideas effectively.
- Humans to retain information longer when they understand what they are looking at.
- Communicate to a wide range of people with different backgrounds.
- To condense information onto a limited canvas.
- Attract and hold the attention of observers as a learning tool.

Lastly, we introduce principles of the Software Development Lifecycle (SDLC) (Figure 1). This representation of the SDLC is chosen as it emphasises as to where the visual conceptual model plays the most important role viz. in the communication, planning and modelling phases.



Figure 1 : A traditional approach of SDLC [22]

3.2 Systems for Temporal Data Visual Representations

In previous research, as indicated below, many different models were introduced by various researchers for the visualisation of temporal conceptual layouts.

Since the Entity Relationship Diagrams (ERD) model is well researched and documented in many university studies and texts and used as the predominant model by practitioners [10], and is also well known in the business context, temporal conceptual models derived from this model will be investigated in this thesis. In this section, we will look at the temporal underpinnings of the TERM, RAKE, TEER, STEER, ERT, LTRM, TER, ER_{VT}, ER_{VT++}, MADS, MOTAR and TEMPRT models.

The TERM model [18] is based on the ER [5] model as stated by Gregersen [15] with the introduction of temporal constructs. These constructs provide the basis to capture the temporal aspects of entities and relationships concerning both validity and transactional times. Valid time is time for which a fact is true in the real world e.g., currently James is deceased. Transaction times are defined as the time period during which a fact stored in the database is considered to be true and normally has a start time and an end time [30].

This model as stated by Gregersen [15], “The temporal aspects of the modelling constructs are captured using either instants or temporal elements, and support for multiple granularities is included.” The database designer may, or may not, use the new temporal constructs, and the resulting model is upward compatible with respect to the EER model and the model is almost entirely text.

The Relationships, Attributes, Keys and Entities (RAKE) model [14] was introduced in 1985. It was part of the U.S. Federal Reserve Board project. The RAKE model is derived from the ER model with keys in the upper left corners of the entity rectangle to model the time varying aspect of type DATE. This is consistent with current DBMS systems relating to the TIMESTAMP/DATE property. In the RAKE model rectangles are used for entity types [15]. In addition, the primary key of an entity, be it a strong or weak entity, is placed in the upper left corner of a rectangle in a “keybox” (Figure 2).

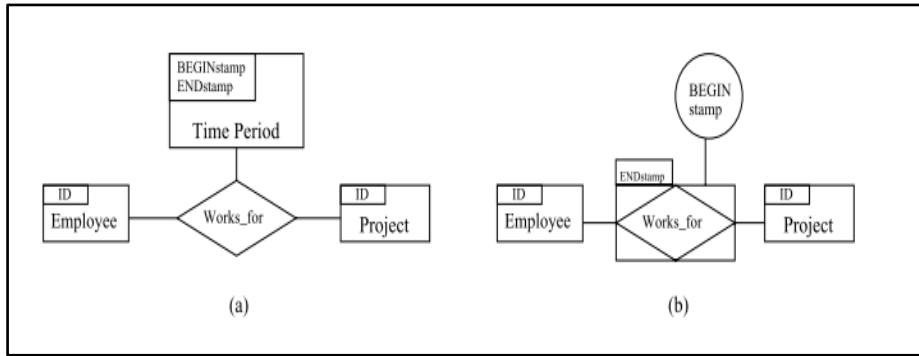

Figure 2 : RAKE [14] Model

The TEER and STEER models [13] graphical representations is similar to that of the atemporal EER model presented by Elmasri and Navathe [12]. From a temporal representation perspective, the TEER model is the same as the EER constructs except all constructs are temporal, i.e. all entities are given a lifespan even though this is hidden from the user (Figure 3).

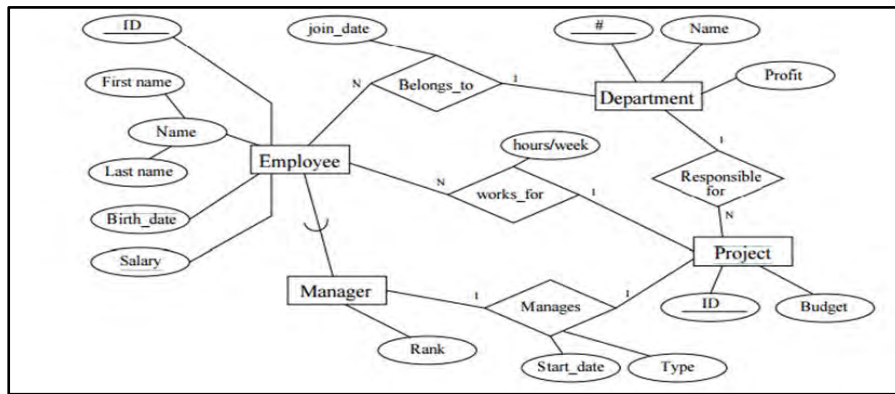

Figure 3 : TEER Model [15]

The STEER model introduces a concept called “entity roles” to denote temporal aspects of a standard entity. Entity role entities are denoted by shading (Figure 4). Atemporal attributes are circles and can only be associated with a conceptual entity e.g. ID of Project in Figure 4. Temporal attributes are represented by ellipses e.g., -Salary in W_Employee.

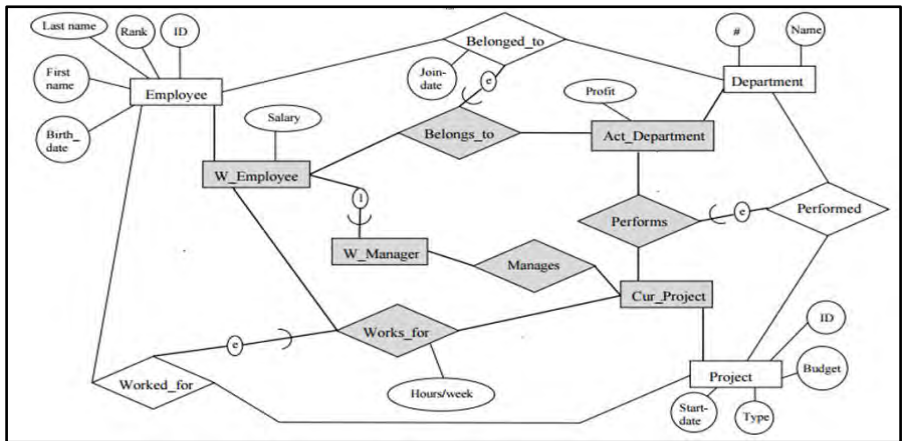

Figure 4 : STEER Model [15]

The ERT model [23] uses a very distinctive entity class notation called the time period class. A time period starts and ends in a tick (smallest unit of time permitted in ERT). The ERT shows various temporal and atemporal notations as follows:

- Simple entity class is shown as a rectangle and is regarded as atemporal; e.g. Department in Figure 5.
- Temporal entity class is denoted with the —T— extension e.g. Employee in Figure 5.
- Simple value class is shown as a rectangle with a black triangle in the right hand corner e.g. Name in Figure 5 and is atemporal.
- Relationship classes can also be denoted with —T— to show temporal aspects, e.g. Salary for Employee in figure 5.

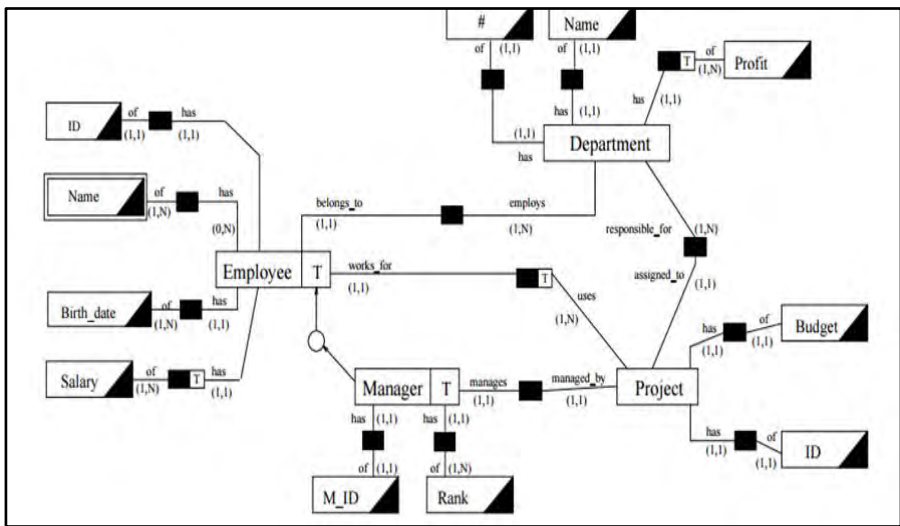

Figure 5 : ERT Model [15]

The Logical Temporal Data Model (LTRM), introduced in 2010, is a model based on mathematical expressions [21] where data is represented with past as well as present values (Figure 6). They have introduced a new concept called activation_start and activation_end on a temporal entity. Update time is also introduced and is used instead of transaction time. Temporal representation is denoted by the clock symbol (Figure 6).

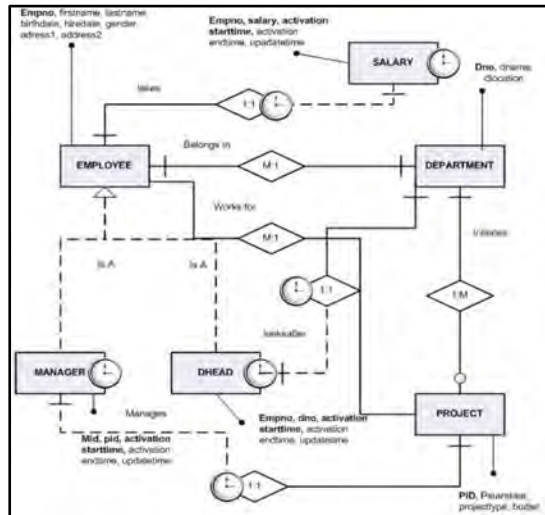

Figure 6 : LTRM Modelling : Employee Database [21]

The Temporal ER model (TER) [16], formed from the ER Model, differentiated by including lifetime and snapshot time varying cardinality constraints. The lifetime aspects are denoted by an L with minL and maxL and snapshot by S with minS and maxS and represented on the model using the following format as shown on Figure 7:

- L [minL,maxL]
- S [minS,maxS]

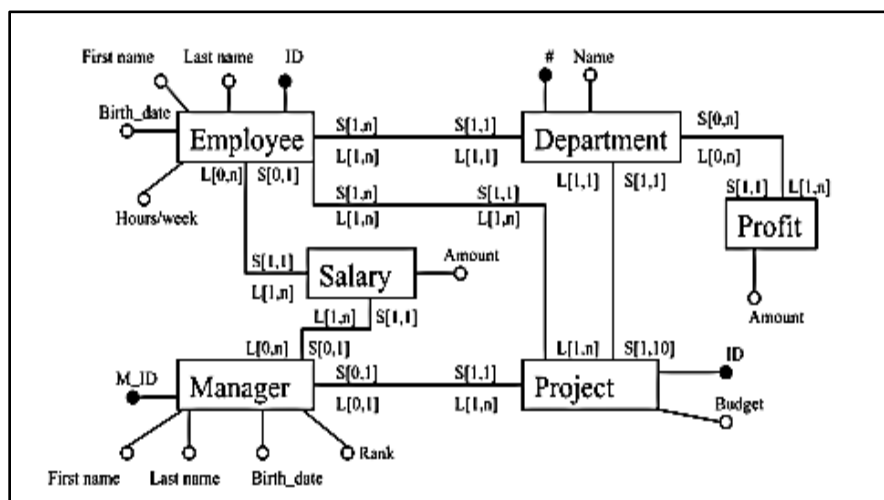

Figure 7 : TER Model [15]

The ER_{VT} model supports classes, relationships and attributes that can be time stamped or temporarily represented. Temporal representation is shown as text where classes can be

represented as snapshot (S in figure 8), M as mixed (an unmarked class in figure 8), or marked as temporal (T in figure 8) [1].

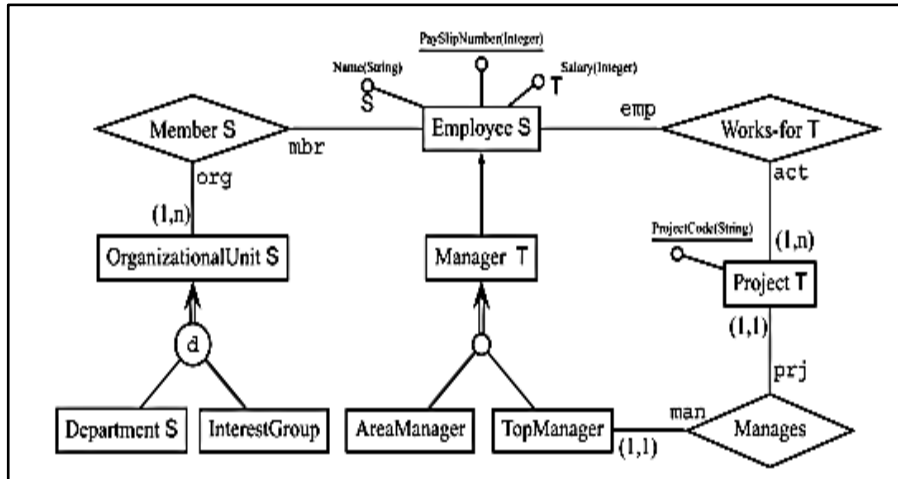

Figure 8 : ER_{VT} Model - [1]

An extension to the ER_{VT} model is the ER_{VT++} model with attribute class and relation migration. In figure 9, we see an ER_{VT++} diagram [1] as an extension to the EER diagram with class hierarchy of status classes represented by rectangles. Also shown is the class and attribute and relation migration (dash lines). This model introduced concepts such as dynamic extension (DEX) and dynamic evolution (DEV). Dynamic extension happens when an object exists in two classes, a typical example is when an employee becomes a middle manager i.e. the object will be a member of the employee and the middle manager class. Likewise, dynamic evolution is when the object moves from one class to another. Taking the above example, if the employee now becomes a top manager, the object will now move from the middle manager class to the top manager class.

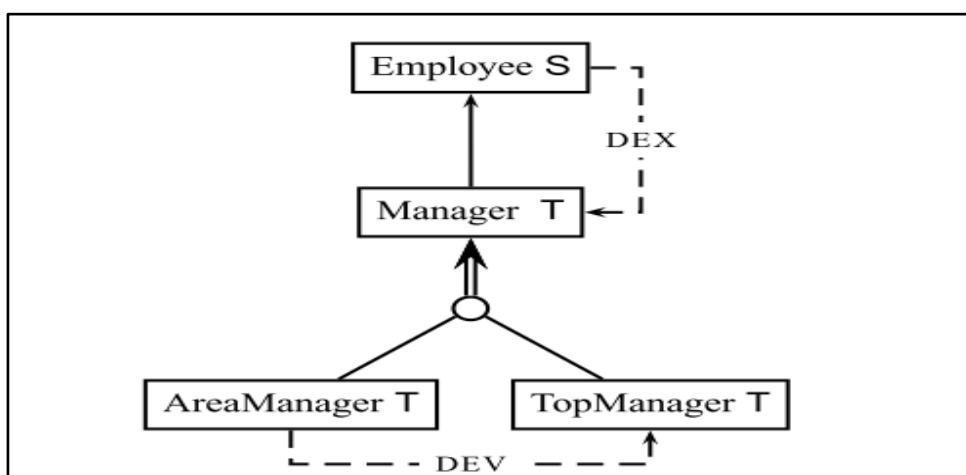

Figure 9 : ER_{vt++} Model [1]

The MADS (Modelling of Application Data with Spatial-Temporal features) [25] is based on ER diagrams but temporal icons (clock symbol in Figure 10) are included in the diagram to show that history for that particular object is kept.

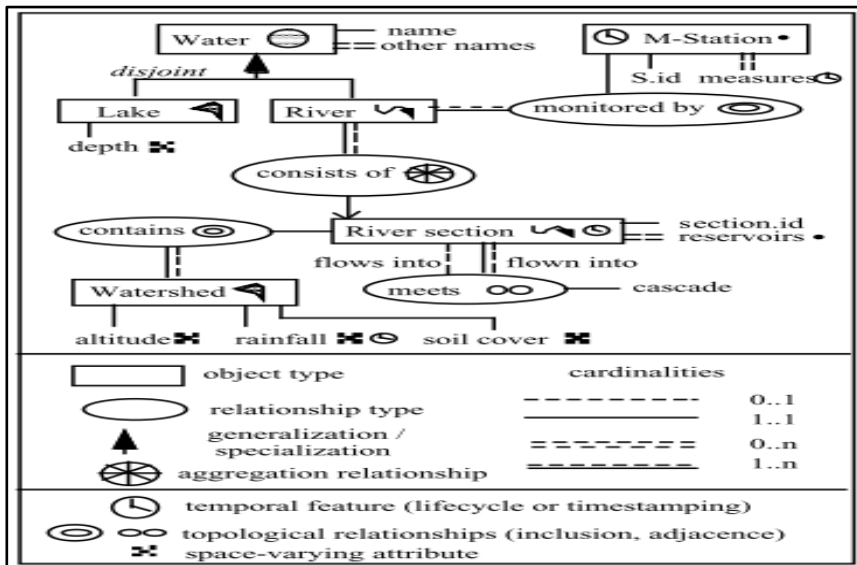

Figure 10 : MADS Schema Diagram [25]

The MOTAR (Model for Objects with Temporal Attributes and Relationships) model (Figure 11) is similar to the EER and TER models as there is no support for lifespans. The main temporal components from the diagram are the double diamonds representing temporal general relationships e.g. "Works for" in Figure 11, the double squares without lettering inside representing temporal attributes whose value changes over irregular intervals and double squares with lettering inside representing temporal attributes whose value changes over regular intervals e.g. Profits in Figure 11 which is viewed either monthly or annually for a specific department.

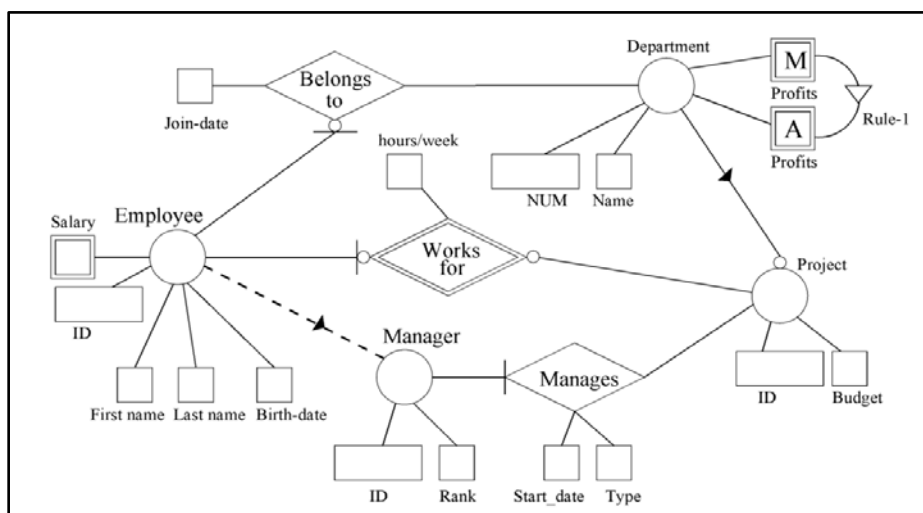

Figure 11 : MOTAR model

The TEMPRT binary ER model consists of only entity types (rectangles) and relationship types (rows with feet). Temporal constructs as shown using two parallel diagonal lines [15] e.g. Figure 12 shows that the relationship between Department and Profit is shown as temporal, as well as the Employee entity also being temporal in nature.

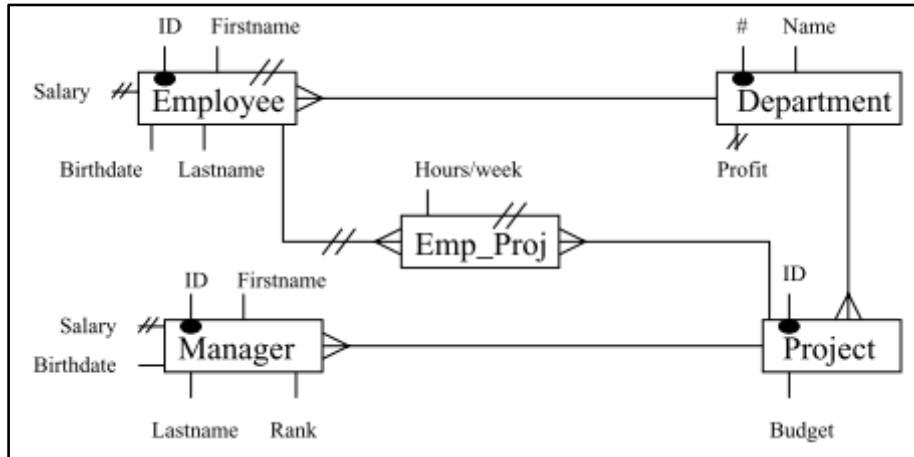

Figure 12 : TEMPRT Model [15]

Table 1 : Summary of Temporal Conceptual Models

Summary of Temporal Attributes for Conceptual Diagrams			
	<u>Temporal Constructs</u>	<u>Textual / Visual / Both</u>	<u>Has this model been tested on Users</u>
TERM Model	Almost entirely text based	Text	No
RAKE Model	Keys in the upper left corner of the entity rectangle	Visual	No
TEER / STEER Model	Differentiation using circles or ellipses and shading	Visual	No
ERT Model	T on the temporal class	Visual	No
LTRM Model	Clock on the temporal class	Visual	No
TER Model	Lifetime and Snapshot inclusions to ER Model	Visual	No
ER _{VT} Model	T for Temporal and constraint migrations	Visual	No
ER _{VT++}	Temporal Attribute Extension	Visual	No
MADS Model	Clock on the temporal feature	Visual	No
MOTAR	Double diamonds and double squares	Visual	No
TEMPRT	Diagonal lines	Visual	No

Delving deeper into Table 1, it is clearly shown that none of these theoretical models have been tested on users. It can also be noticed that every model differs in terms of the temporal constructs using components of HCI such as different shapes, shading and pictures. Only the TERM model is totally text based.

3.3 Techniques for Temporal Data Visual Representations

In the second part of this chapter, we will introduce other techniques of temporal data using graphical representations namely, Pointwise Object Browsing, Concentric Circles, Agenda, Time Line Browser, Lifelines, Knave and AsbruView.

The Pointwise Object Browsing representation [11] is used to display snapshots of a temporal data at a given instant. There are two ways for users to interact with the temporal data in this technique. The first way is by traversing through traditional object browsers or secondly by altering the reference instant (Figure 13). The feature of this technique is that it is not sequential, it supports value alteration and provides interaction devices for navigating to the previous, or next instant where a modification arises in a given conception track expression.

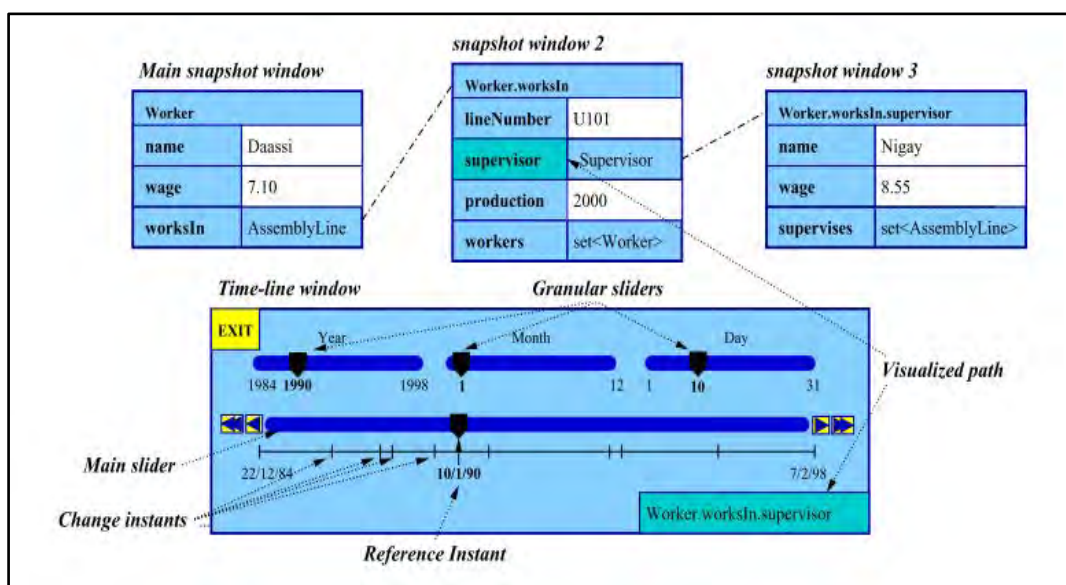

Figure 13 : The pointwise browser interface [11]

Concentric Circles [3][8] consisted of circles (Figure 14) with common midpoint and different radii. Each circle is important and represents one complete period of a given visualized history. Their size shows their values. The concentric circle's technique is very useful in terms of exhibiting periodic patterns and to retain associations between synchronous values of two quantifiable histories.

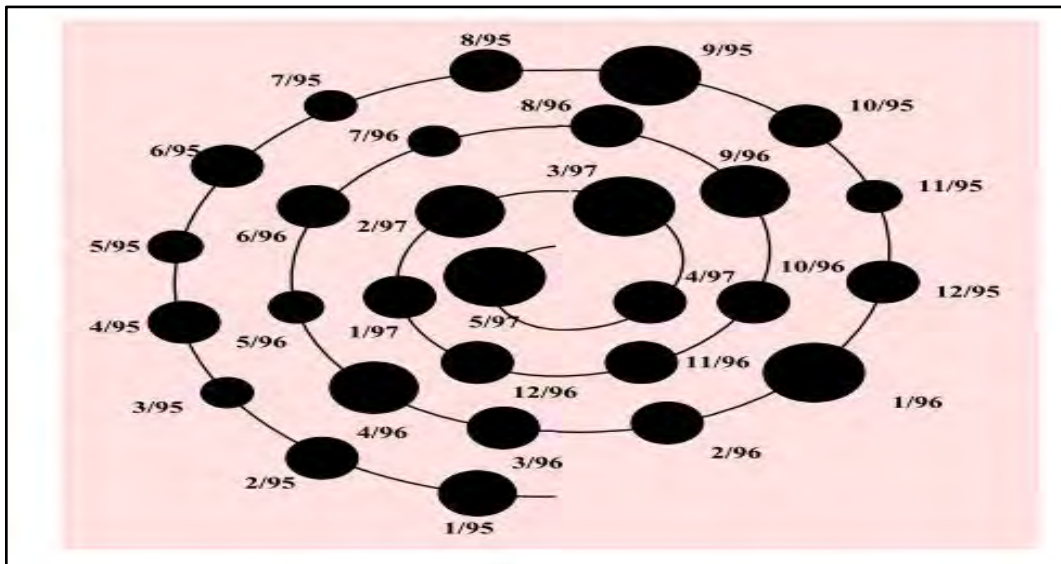

Figure 14 : Monthly Production using the Spiral Technique [4]

Agenda (Daassi et al. 2000) was a matrix in which the line is used to represent the evolution of a specific history over a specific time period (Figure 15). This technique mainly allows users to find out the periodic patterns by identifying hotspots and it may also be further used to find and view the layout of a particular history.

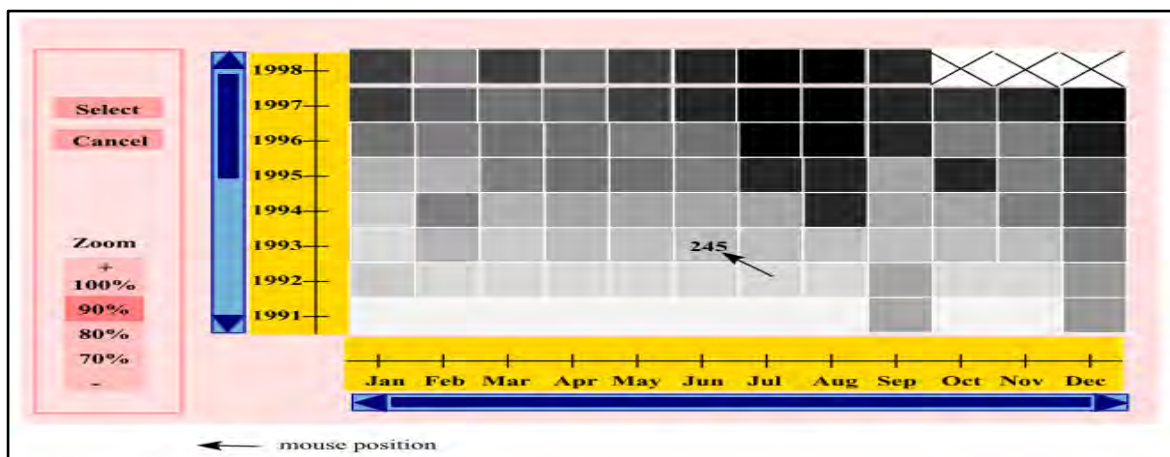

Figure 15 : Monthly Production using Agenda [8]

The user interface of Agenda [8] is very colourful consisting of a matrix of coloured cells. The colour of all the cells in an array is same but the higher the intensities reflected, the greater are the values. If a user wants to know the value of a cell, he has to place his mouse's cursor over a cell. The program is responsible for partitioning the cells and grouping them into rows for every visualized history.

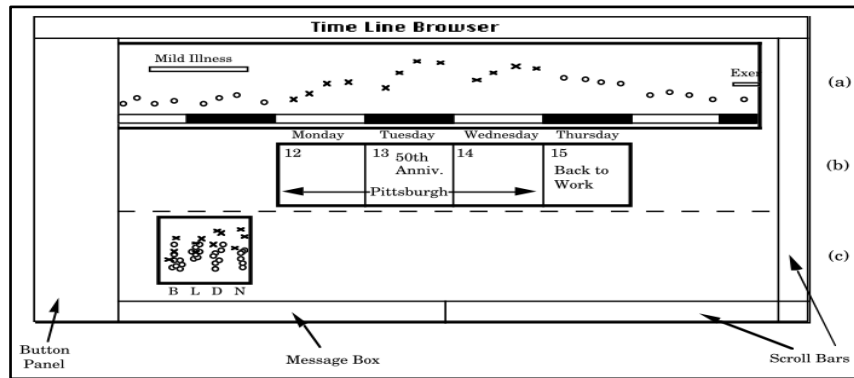

Figure 16 : Time Line Browser [7]

The Time Line Browser [7] was used to visualise events at different instants of time. This method controls the positions of different values of temporal histories with respect to time. It has main component known as the “time slider” [17], which helps the user to point out the current time at specific interval and also shows the specific value of a history in relation to other values in whole time span (Figure 16).

Additional research in the field of visualisation resulted in Lifelines [28], Knave [26] (Figure 17) and AsbruView [19] (Figure 18).

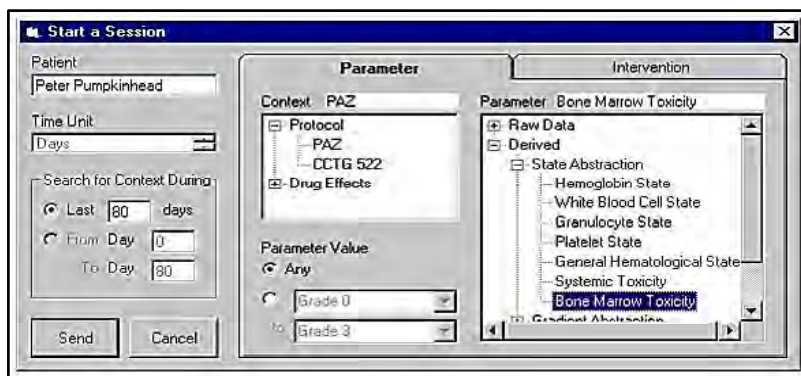

Figure 17 : Knave Interface (Shahar & Cheng 1998)

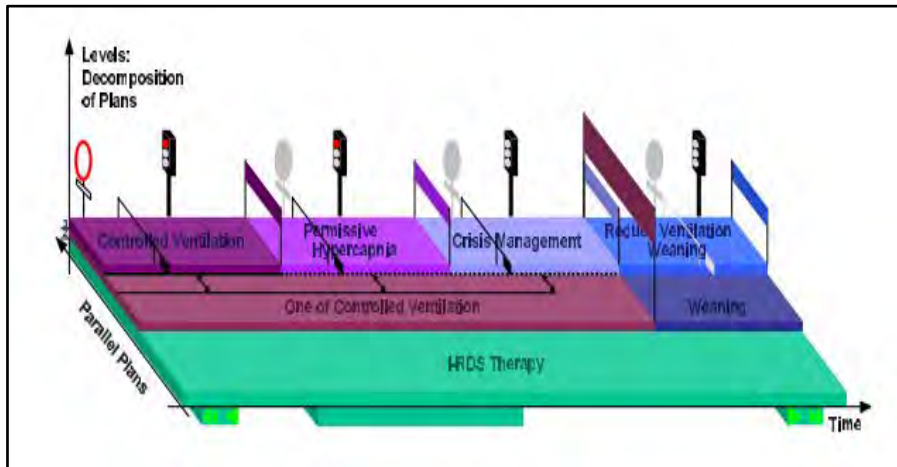

Figure 18 : AsbruView Plans Condition [19]

In order for one to grasp the more complex conceptual model representation of temporal data, one needs to understand the simplified time period visualisation of intervals introduced by Chittaro [6] during the user study for representation of time intervals for the building of a medical system. Consider the following case (Figure 19) suggests two intervals, “an interval A” and “an interval B”. In this case, “Interval A and Interval B both starts at the same time” but “Interval A could finish before Interval B”, or “Interval B could finish before Interval A” or both finish at the same time. Now, the question arises for visualisation of above three cases. These cases would be represented by the formula “(B starts A) OR ((A starts B) OR ((A equals B))” [6].

Certain methods used springs as their graphical element for visual representations [6] (Figure 19 and Figure 20).

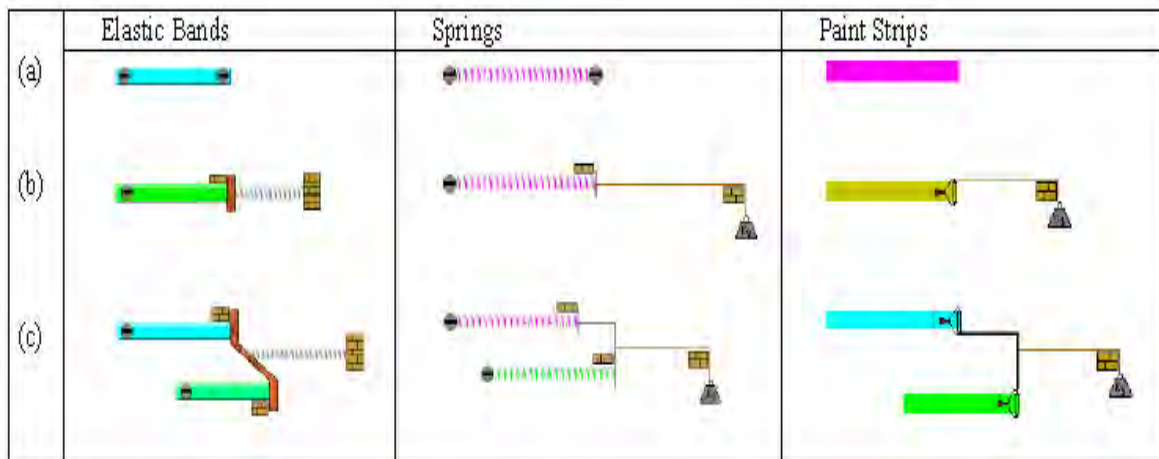

Figure 19 : Graphical notation of three proposals [6]

The spring can be connected with a screw or may be connected to a weight by means of a wire. It is also the possibility that weight is connected with multiple weights simultaneously. Other methods used elastic bands for the graphical representation of a temporal history. Intervals are represented by these bands; strip’s location on the time axis is defined in three diverse ways [6].

- The end of strips must be connected and fixed by screws. Interval ends in this case, have fixed and set positions in relation with other intervals. The reason mainly motivating for this choice is that “the fixed ends cannot move so the strip’s ends are fixed.”
- The inspiration for the second method is extracted from the common physics textbooks. The second way is to attach the end of the strip to a moving mass structure. This moving notation basically suggests that the ends of strips can acquire a different position on a given time-axis. It means the strip’s end can be stretched to the final destination.
- Lastly, more than one strip can be connected to a moving mass system simultaneously. It basically represents the end of interval, which is allowed to move in respect to its relative position.

There are also methods, in which the intervals are represented by paint strips [6]. The advantage of these paint strips is that they do not require any other system for attachment as they can work individually. However, in some cases, a paint roller is associated with one of the ends of a paint strip. Similarly, more than one paint roller can be connected to weight simultaneously.

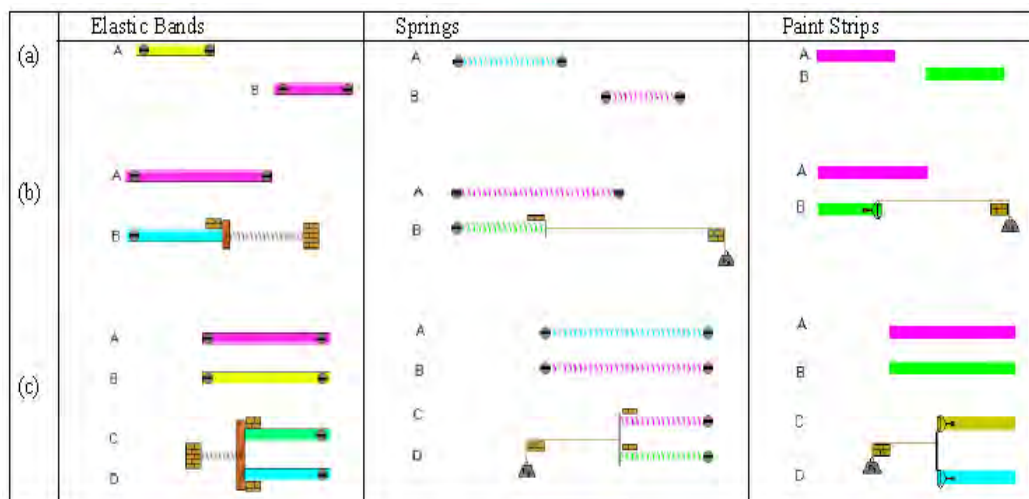

Figure 20 : Interval relations represented by three proposals (Chittaro & Combi 2001)

Table 2 : Summary of Temporal Data History Representations

<u>Summary of Temporal Data History Representations</u>		
	<u>Temporal Constructs</u>	<u>Textual / Visual / Both</u>
Pointwise Object Browsing Technique	Uses Linear visualisation to show events at different instants of time	Visual linear with value alteration
Concentric Circles	Circles with common midpoint and different radii	Visual indicator size shows values over time
Agenda	Matrix based with line shows evolution of history over time period	Visual via hotspots
Time Line Browser	Uses Linear visualisation to show events at different instants of time	Visual using snapshots
Lifelines	History based on different levels of granularity	Both text and visual indicators
AsbruView	Running track representation of history	Both text and visual indicators
Elastic Bands	Uses Linear visualisation to show events at different instants of time	Visual using bands to display events in Time
Springs	Uses Linear visualisation to show events at different instants of time	Visual using springs to display events in Time
Paint Strips	Uses Linear visualisation to show events at different instants of time	Visual using paint strips to display events in Time

Table 2 shows that the techniques for the representation of temporal data and history has been deeply delved into by many researchers. As we can see, some techniques are purely visual whilst others are a combination of text and visual indicators.

4 Experimental Procedure

All experiments performed used online surveys using the University of Cape Town Limesurvey System using open source software obtained from limesurvey.org. The only exception was experiment three that was done on paper in a classroom setting.

The methodology we followed in this study is known as “*reflective teachings*” [31] (Figure 21).

The aim with this methodology was for users to gain better knowledge of the subject matter being investigated. Essentially, “*reflective teachings*” is when a set of tasks is presented to a group of users and a set of results is obtained. These results are then critically analysed by the facilitator to ascertain the knowledge level of the population on the subject matter. If the group of users’ knowledge level is too low, the facilitator does a knowledge transfer to the group to increase their knowledge level. The knowledge transfer would be in any teaching form e.g. online training videos, personal discussions or classroom training. There could be many repeats of this cycle of task execution, results analysis and knowledge transfer as different facets of the subject matter are investigated. The main goals are to dispel all anxiety from the users in relation to the unknown and ensure that the population knowledge level is increased to an extent whereby a set of results can be obtained that can be used for effective analysis.

Firstly, an experiment was conducted whereby an online survey with tasks relating to the visual temporal conceptual modelling was sent to a wide group of students, academic faculty members and business users. These results were then received and analysed. Upon analysis, it was found that only a few subjects understood the subject matter and temporal aspects in general (See Experiment One discussion of results below).

It was then decided that in order to close this knowledge gap, a second exercise had to be initiated that presented a simpler view of temporal aspects and time principles. In order for us to gauge if the knowledge gap was indeed getting smaller, the wide audience had to be narrowed down to a smaller closed group. The closed group chosen consisted of twelve business users with varied knowledge levels of information technology and database concepts. This closed group was also a subset of the population of the respondents from the initial survey.

Secondly, in order to ascertain a baseline for the knowledge level of this group, a simple survey based on temporal interval representations was carried out. In this experiment, the group were asked to interpret three temporal interval representations namely; Paint Strips, Elastic Bands and Springs (Figure 19 and Figure 20), and answer some questions relating to their preferences around these three graphical notations (See Experiment two below). Before experiment two began, training was provided by using an online training video [32] with the aim to introduce temporal aspects to the participants for those who had not been exposed temporal knowledge previously. Once experiment two was completed, an analysis of the results was conducted and the results showed that the knowledge relating to temporal aspects had been increased due to some subjects stating that the temporal representations are effective, understandable and useful. On the other hand, some subjects thought that the representations were impractical and hard to read. This then prompted us to initiate a classroom discussion to firstly, clear any confusion that could have arisen during the experiment and secondly to evaluate if any additional training was still required. During these

discussions, it was found that there was still some consternation and confusion amongst the group about temporal data. To alleviate the confusion, temporal concepts were further explained to the group using the visual techniques of concentric circles (Figure 14), Agenda (Figure 15), time line browser (Figure 16) and AsbruView (Figure 18).

In this training, they learnt about temporal time intervals, transaction and valid time, history and why it is important, as well as the differences between atemporal and temporal databases. When questioned about the other obstacles relating to answer the questions posed to them in experiment one, I found that although now they understood the temporal concept, they still did not understand the proposed models and the meanings thereof. Hence, experiment three was setup to introduce modelling to the group.

In experiment three, I posed three tasks to the users to gauge their understanding of modelling and to set a baseline for the training (See experiment three below). Three images were set forward and each individual in the group had to state their understandings of the images. From the qualitative data received and analysed, it showed some members of the group understood concepts such as constraints, if-then loops, dependencies and flows whilst others did not grasp these concepts. The aim with this exercise was to show the group that without a visual language for understanding conceptual models, the interpretation of diagrams could be very diverse and ambiguous. Hence, the training revolved around the group understanding the visual language of modelling. Concepts such as classes, derivation of classes, superclass and subclass, entities, attributes, migrations, both evolution and extension, constraints, inheritance and relationships, were explained. Other concepts explained was that a symbol on a diagram has different meanings depending on the context it is used in, e.g.: a diamond on an ERD means a relationship, whilst a diamond on a flow chart means a branch happens in the data flow.

Once all the subjects were comfortable with their understanding of temporal data history and temporal conceptual modelling, I imitated experiment four. Experiment four was predominantly a repeat of experiment one but now carried out on “knowledgeable” subjects. This enabled data analysis of knowledgeable subjects understanding what tasks they were asked to perform. After analysis of data from experiment four, it was found that the preferred temporal conceptual model choice was still the RAKE model but after conducting interviews, it was ascertained that this was chosen because of the simplified view of the RAKE model. Also from the analysis, we noticed there were some inconsistencies. Firstly; there was a perceived preference for the pictorial representation over the textual representation, yet the conceptual model chosen was RAKE where the temporal indicators are text only and secondly; the preferred temporal representation based on pictures was the clock graphic, but the clock graphic was not chosen as the conceptual model of choice. In order to answer these questions, a discussion was initiated with the group. It was found that the preference for the group was the ERD diagram and hence the clock class layout was not chosen and the DEX / DEV textual representation was preferred by business users due to the need to draw on flipcharts and whiteboards and the graphical symbols were much more difficult to draw accurately and to interpret.

Hence, to get to the preferred model, experiment five had to be done. In this final experiment, the group of subjects were asked to rate their preferred temporal conceptual model on a linear scale from one to ten. Other self-created conceptual models were also added to the choice based on the discussions from experiment four, and a preferred temporal visual modelling could be envisaged for future research based on user study of business users.

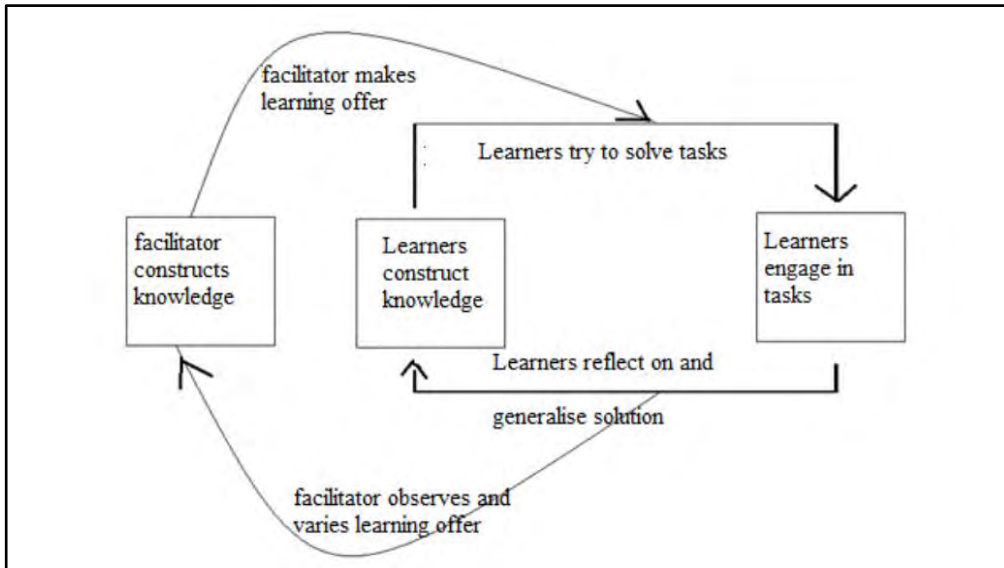

Figure 21 : Steinbring's model [31]

4.1 Experiment One

The first online survey was designed in a way to evaluate the effectiveness of text or visual representations, shape, colour and layout for temporal conceptual models.

4.1.1 Experiment Intention and Technique

A survey was created which consisted of seventeen exercises. The aim of the survey was to evaluate the temporal data, relations and their respective representations. The Uniform Resource Locator (URL) to the survey was sent to an open audience composed of computer science students, developers, database lecturers and business users. It was assumed before the experiment that the audience had some knowledge of databases and Entity Relationship Diagrams (ERD). The experiment also included sections in the survey where feedback and comments could be left by the survey respondent if there was any confusion with regard to the questions being asked. The models used in the survey has been taken from existing work mentioned previously and some models developed from visual metaphors in different temporal conceptual models and different colour schemes, different visual icons, text and graphics.

4.1.2 Results

Forty-two responses were received for the survey of which 15 were completed and 27 were incomplete. Firstly, in order to see if there was a preference between pictures or text for the temporal conceptual model representation, a single question was asked using figures whereby the respondent could choose as to which representation they preferred. (Figure 22)

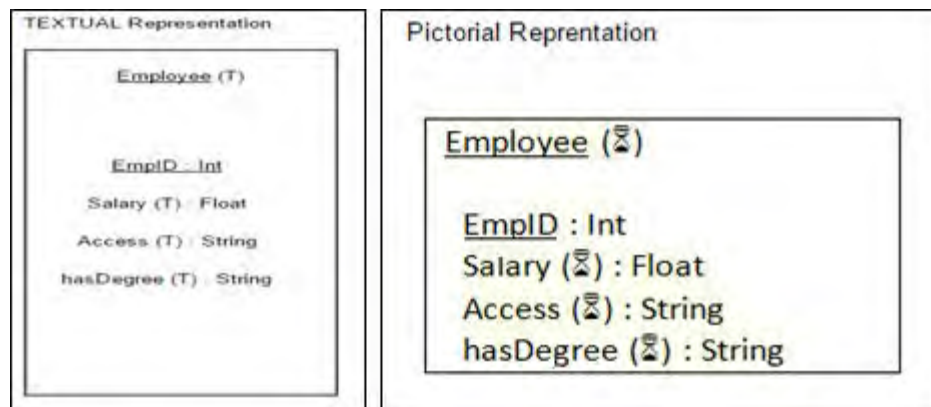

Figure 22 : Text or Pictures

Figure 23, shows the results of the text vs. graphics broken up by business and academic users and Figure 24 shows the same results based on years of database experience.

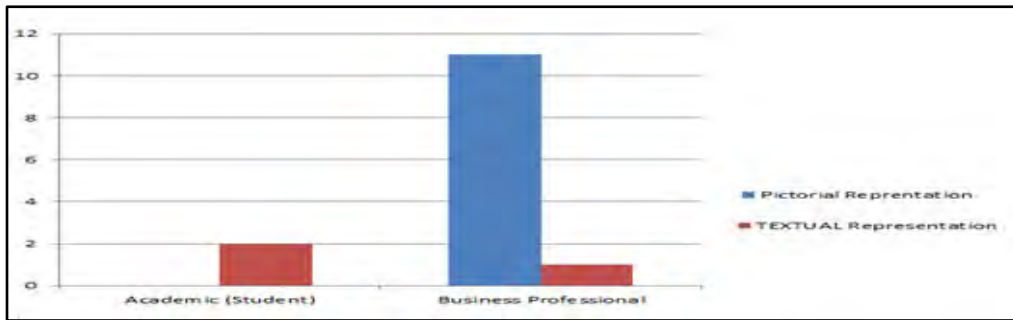

Figure 23 : Academic and Business Users Text vs. Graphic

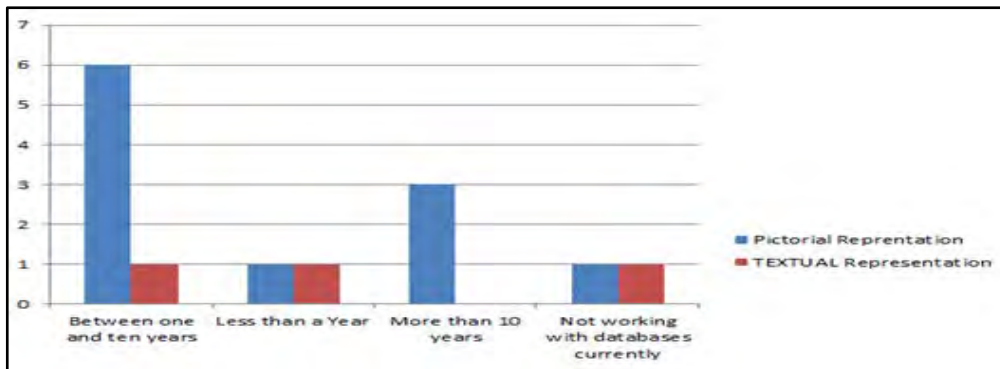

Figure 24 : Preference based on Database Experience

We also looked at a graphical icons preferred for both conceptual classes and attributes. The icons presented to them are as shown in Figure 25, these are the LTRM Clock graphic, derived from the LTRM model (Figure 6), a normal hourglass graphic, and lastly the Apple Macintosh Clock graphic.

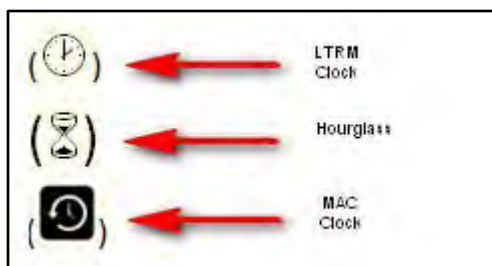

Figure 25 : Visual Icons

The results for the preferred icon for the pictorial class preference are shown in Figure 26. The results for the question for the pictorial attribute preference are shown in Figure 27.

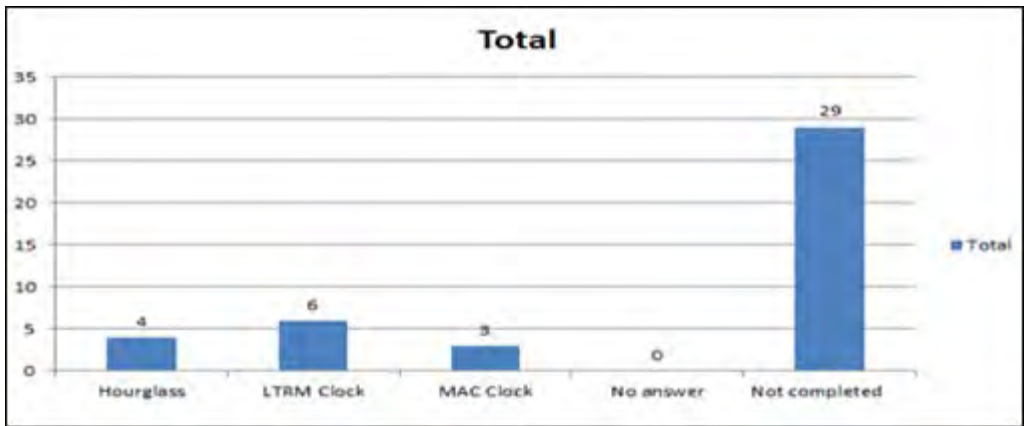

Figure 26 : Visual Preference for Class

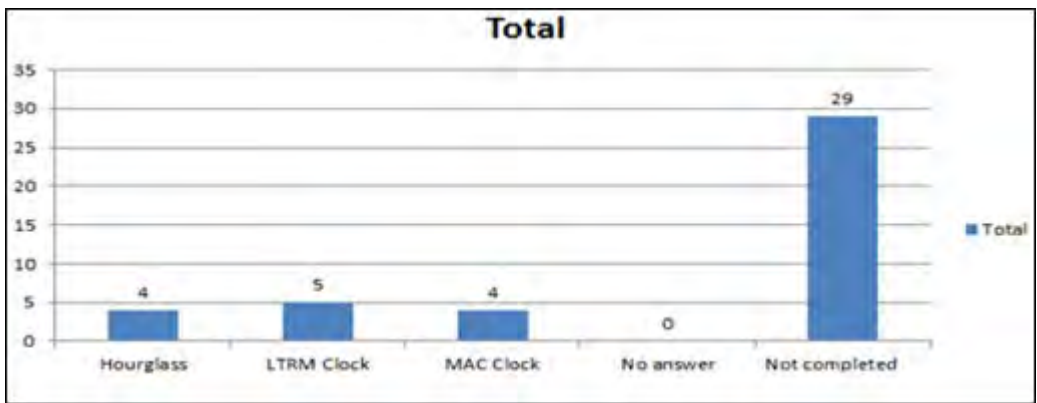

Figure 27 : Visual Preference for Attributes

The respondents were asked as to if they would prefer classes and attributes to have the same or different colours and the results are as shown in figure 28.

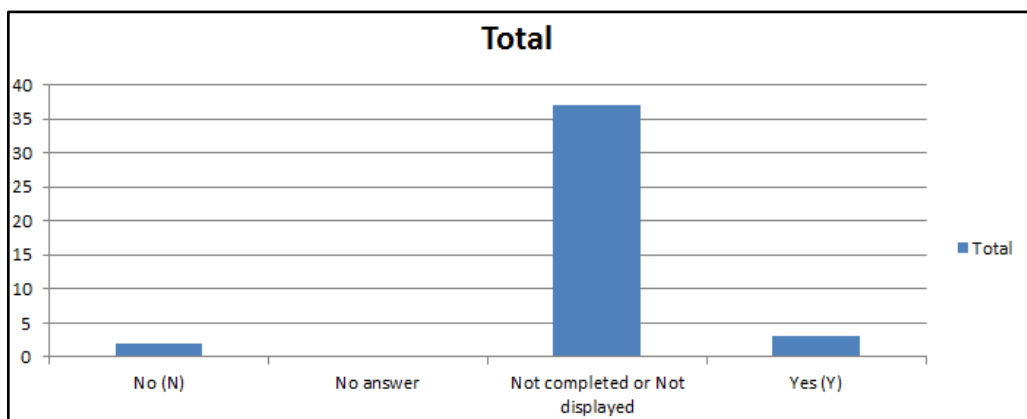

Figure 28 : Attributes and Classes should have the same Colour

I asked for the preferred colour of textual representation. The choices were red, black, blue and green and the results were that one respondent chose Red, none chose black or green and two chose blue.

Knowledge of temporal aspects was also tested in the survey where we were asked to describe the differences between temporal and atemporal databases. Their responses are tabulated in table 3.

Table 3 : Responses on difference between temporal and atemporal

leave blank
Temporal databases include and accommodate for the notion of time. This links to whether an entry is still considered valid or not. Atemporal does not include the notion of time.
Don't know
atemporal has no time intervals, Temporal is valid for certain times
database for events
No
No
history is in a temporal db

Note there were 34 respondents who left the answer blank as the question stated that if you did not know the answer, please leave the question blank. This means 34 out the 42 respondents did not know the difference between a temporal and an atemporal database.

I also wanted to correlate the answer to the difference between temporal and atemporal databases against the experience of the respondents. The results are shown in Table 4 for all completed responses. Blank responses state that the answer is not known.

Table 4 : Responses based on Years of Experience

Responses	Years of Experience
	Between one and ten years
leave blank	Not working with databases currently
Temporal databases include and accommodate for the notion of time. This links to whether an entry is still considered valid or not. Atemporal does not include the notion of time.	Not working with databases currently
Dont know	Not working with databases currently
atemporal has no time intervals, Temporal is valid for certain times	Between one and ten years
	Between one and ten years
database for events	Between one and ten years
	Less than a Year
No	Less than a Year
	More than 10 years
	Between one and ten years
	More than 10 years
	Between one and ten years
	Between one and ten years
No	More than 10 years
history is in a temporal db	Between one and ten years
	Not working with databases currently

Lastly, from a knowledge perspective, we wanted to correlate the knowledge of temporal aspects based on proficiency of conceptual models where proficiency could be denoted as, None, Moderate, Excellent and Guru. The results are in table 5.

Table 5 : Responses based on Conceptual Model Knowledge

leave blank	None
Temporal databases include and accommodate for the notion of time. This links to whether an entry is still considered valid or not. Atemporal does not include the notion of time.	Moderate
Dont know	None
atemporal has no time intervals, Temporal is valid for certain times	Moderate
database for events	Moderate
	None
No	Moderate
	Moderate
	Moderate
	Moderate
	Moderate
	Moderate
No	Moderate
history is in a temporal db	Moderate
	None

Other factors tested in the survey included the test for ER_{VT} migration constraints to see preference for text or graphic. The following diagram was presented to the respondent for DEV preferences (Figure 29) with option a being ER_{VT} representation, option b being "→>" and option c being the LTRM clock representation.

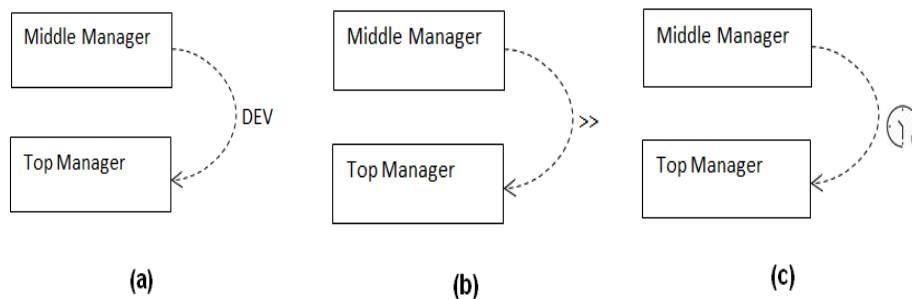

Figure 29 : DEV Options (a) Text (ER_{VT++}), (b) Graphic (>>) (c) Graphic (LTRM Clock)

The results with the DEV preferences are shown in Figure 30.

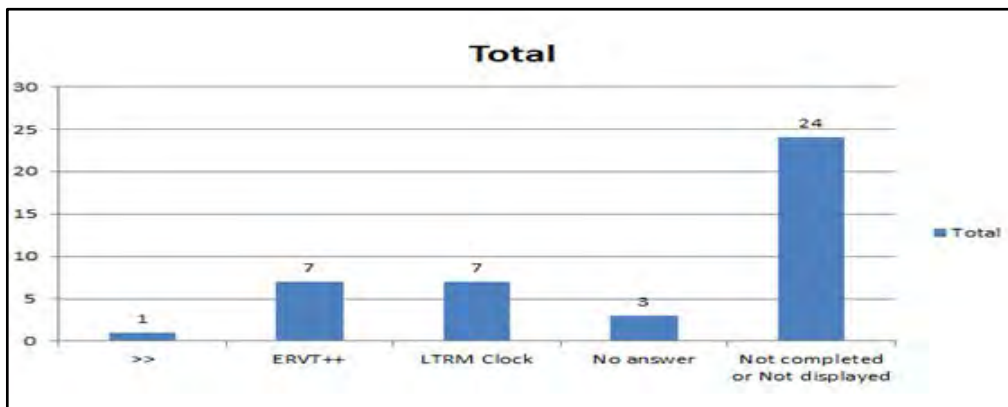

Figure 30 : DEV Preferences

In order to check if there is a difference for the DEX constraints, another question was asked with regards to DEX constraints as shown in with preferences (Figure 31) with option a being ER_{VT} representation, option b being "=>" and option c being the Time icon representation.

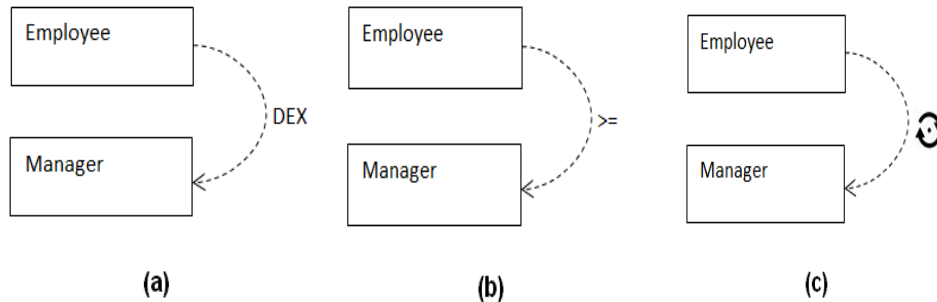

Figure 31 : DEX Preferences Text (ER_{VT++}), (b) Graphic (>=) (c) Graphic (Time Icon)

The results of the DEX preferences are shown in figure 32.

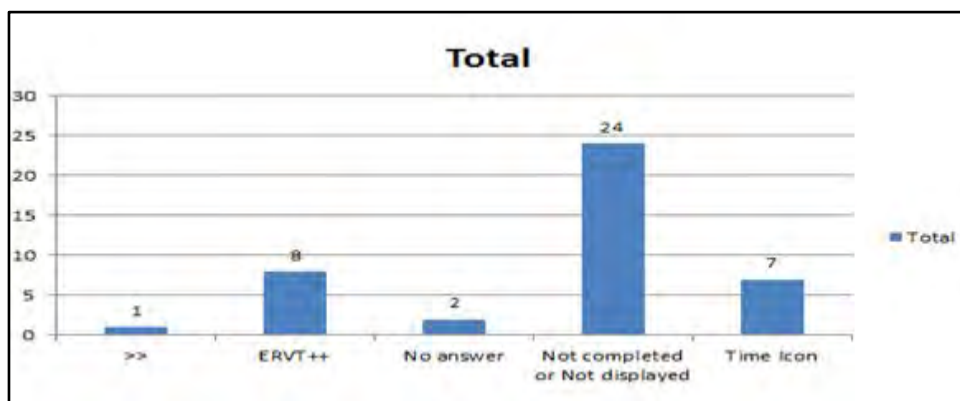

Figure 32 : DEX Preferences

Lastly, the final test was a preference rating for existing as well as self-drawn (Figure 33, Option d) temporal conceptual models. The respondents were given the following choices (figure 33) where option a is the RAKE model, option b being the STEER model, option c being TER model, option d being the LTRM clock synthesised model and option e being the TEMPRT model.

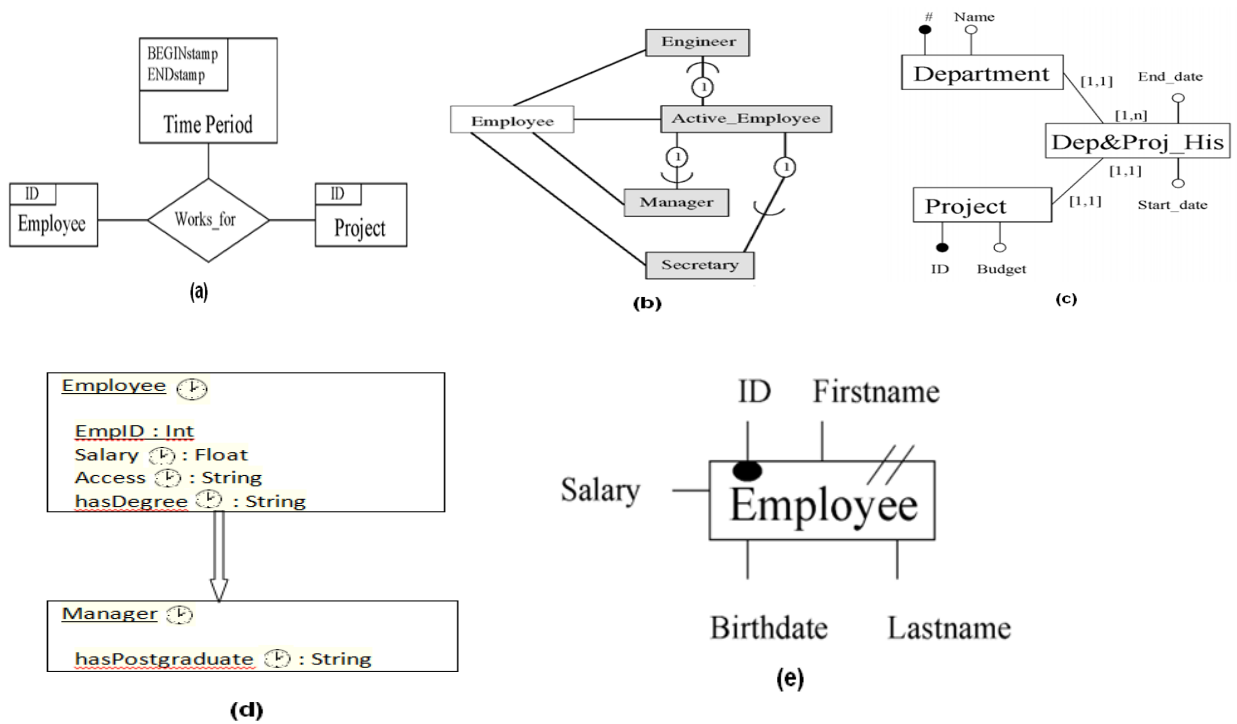

Figure 33 : Temporal Conceptual Models

The results are shown as figure 34.

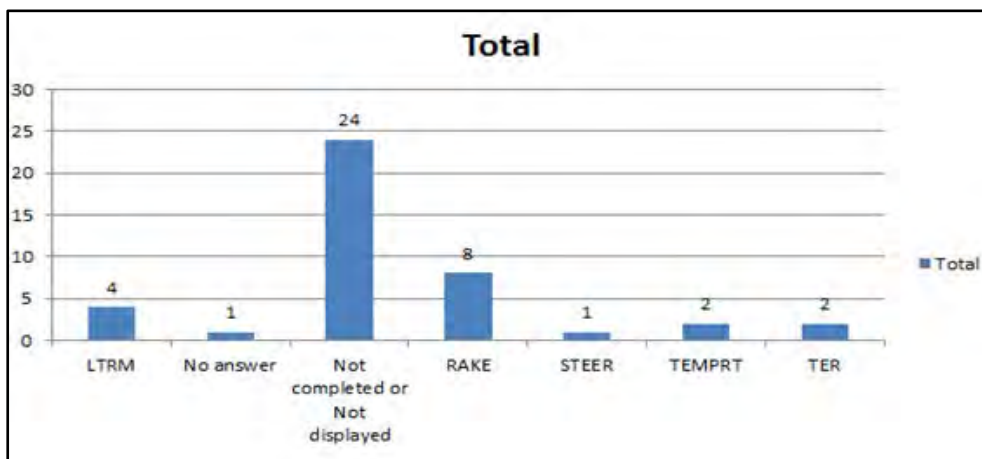

Figure 34 : Preference for Conceptual Designs – Open Survey

For a full list of results for Experiment 1, refer to Appendix 1.

4.1.3 Discussion

After examining the results from the survey, we can conclude the following:

1. Too few responses from the respondents to get conclusive results
2. The graphic versus the textual representation cannot conclusively say that academia prefer text representation over graphics but we can say business professionals (Figure 23) and users with more than one year of experience with databases prefer a graphical representation (Figure 24).
3. In order to answer the second research question, three temporal entities and finally, the overall model were looked at. From the few results, we see that there was no definitive difference in choice between the LTRM clock, the hourglass and the new graphic known as the MAC Clock (Figure 24). Secondly, from an attribute perspective, the results were along the same lines as there was no conclusive evidence to prove that either of the icons had a preference (Figure 26). Thirdly, the user choices for the DEV showed equal preference for both text and graphics notation (Figure 29).

In fact, what we did find out from the results received is most of the questions in the survey were left unanswered. Questions were asked as to the difference between temporal and atemporal databases, and four out of forty-four respondents answered partially correct (Table 3). Others participants even stated that they did not know even though they had worked with databases for over 10 years (Table 4). Some even stated that they had moderate knowledge of conceptual models but no knowledge of temporal aspects (Table 5). Hence, the data in this survey proved to be useless for analysis in terms of preferences for users for a visual temporal conceptual model representation but proved insightful in terms of understanding the level of knowledge of temporal concepts of the respondents who answered the survey. This knowledge levels was further proven to be low by qualitative data using ad-hoc interviews with some of the respondents that did the survey. Hence, it was decided to conduct another experiment that would aid in simplifying the temporal aspects and experiment two was initiated.

4.2 Experiment Two

The second experiment was designed using an online questionnaire (Appendix 2) for the evaluation of three temporal representation proposals i.e. Springs, Elastic Bands and Paint strips (Figure 34). The aim was to increase the subjects' knowledge and understanding of temporal databases and especially time intervals. The subjects chosen were all those interviewed in experiment one. The experiment consisted of a total of 12 exercises. A similar experiment was done before [6], but for a different purpose. In our experiment, the goal was to heighten the understanding of temporal elements.

4.2.1 Experiment Intention and Technique

The questionnaire was multiple choices and limited to a closed group of 12 business users as follows:

- There was one student who was studying IT.
- There were three IT database administrators, two of whom are industry database server certified and working in the business arena for over 15 years.
- There were four IT professionals, who were currently specializing in different sub-fields of IT such as automation and reporting.
- There were two subjects who were studying business analysis.
- There was one subject who was starting a general IT course.
- There was one subject who was a database developer.

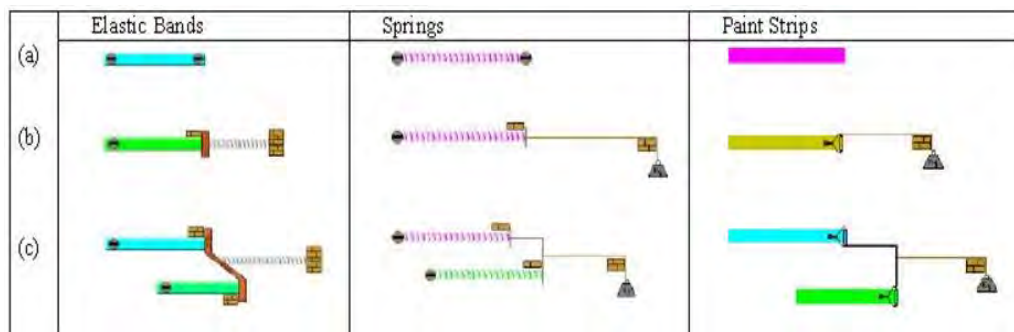

Figure 35 : Visual Interfaces for Temporal Intervals Representation

All subjects were required to fill the questionnaire using their own knowledge and understanding. Training provided before the experiment started was in the form of an online video explaining temporal aspects in Microsoft SQL Server 2016 [32]. This was the first step to raise the knowledge level of the candidates to understand temporal concepts.

The subjects were told not to ask questions or seek assistance from others. All the graphic elements (Figure 34) presented in the questionnaire had some meaning in relation to event correlation, but the subjects needed to understand these by themselves. There was also no time limit on the survey.

4.2.2 Results

To understand the overall effectiveness, quality and layout of the diagrams, the subjects could choose using a scale of 1 to 5 where 1 is low and 5 high. Results are shown in figure 36, 37 and 38.

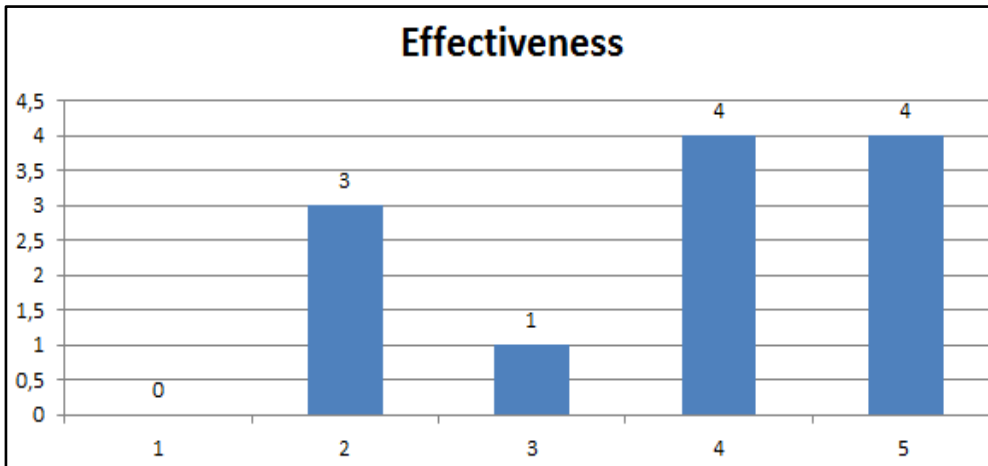

Figure 36 : Effectiveness

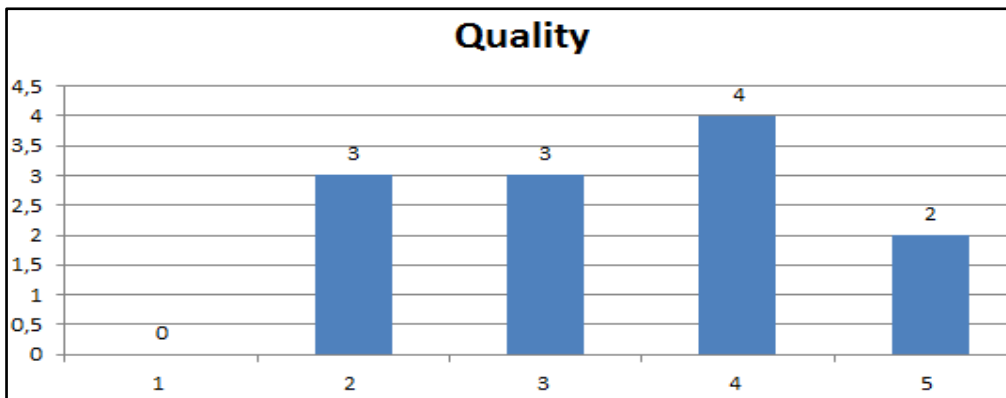

Figure 37 : Quality

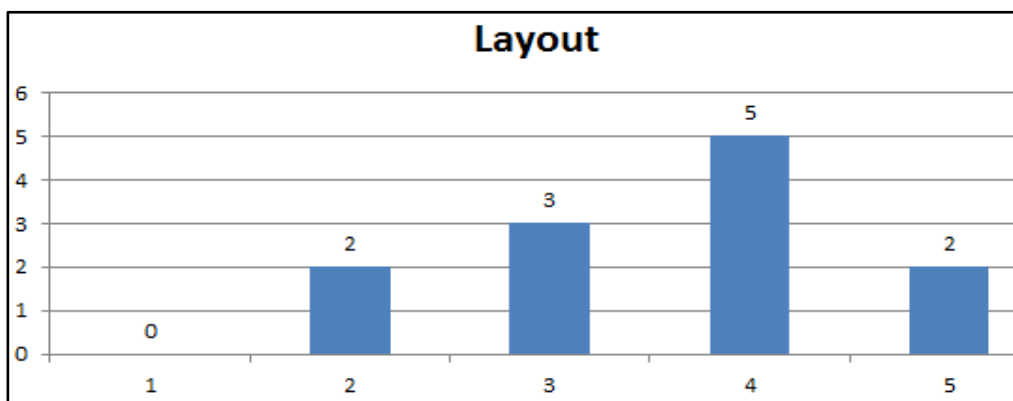

Figure 38 : Layout

In order to see if the subjects understood temporal intervals, a question was asked as to how they rate the ability to view the temporal interval in the representations given also using a scale of 1 to 5 where 1 is low and 5 high. Results are shown in figure 39.

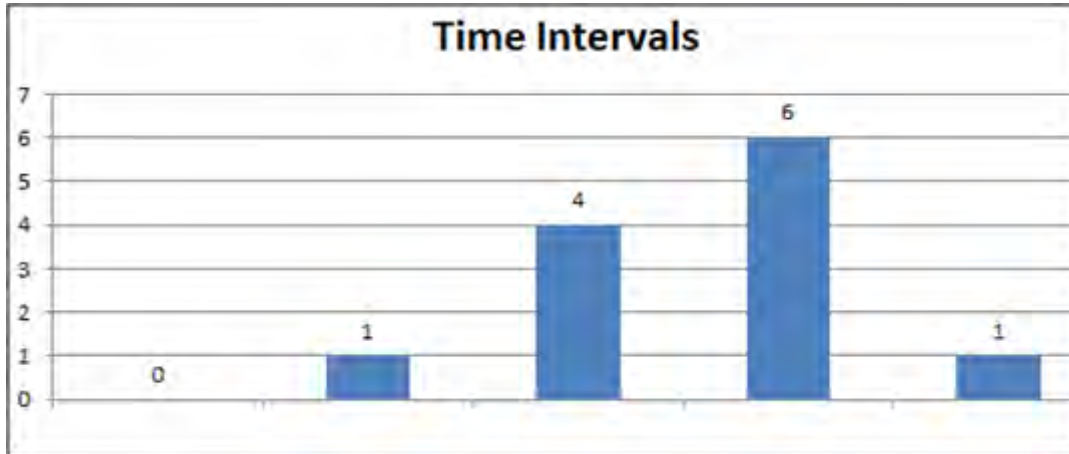

Figure 39 : Understandability of Diagram for Time Intervals

Furthermore, they were asked if they would recommend the proposals to a friend or colleague. Results are shown in figure 40 with 1 being less likely and 10 being most likely.

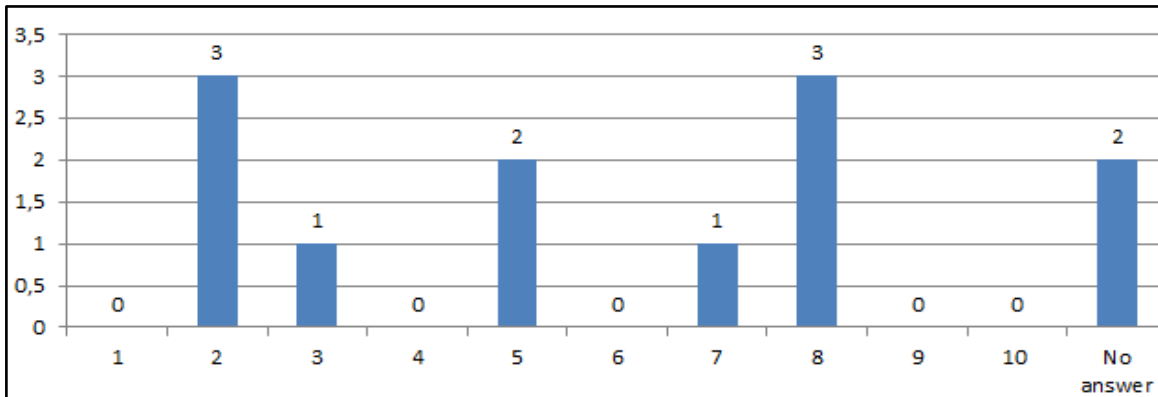

Figure 40 : Recommendations to friend or colleague

Lastly, the question was asked as to which model they would prefer and results are on figure 41.

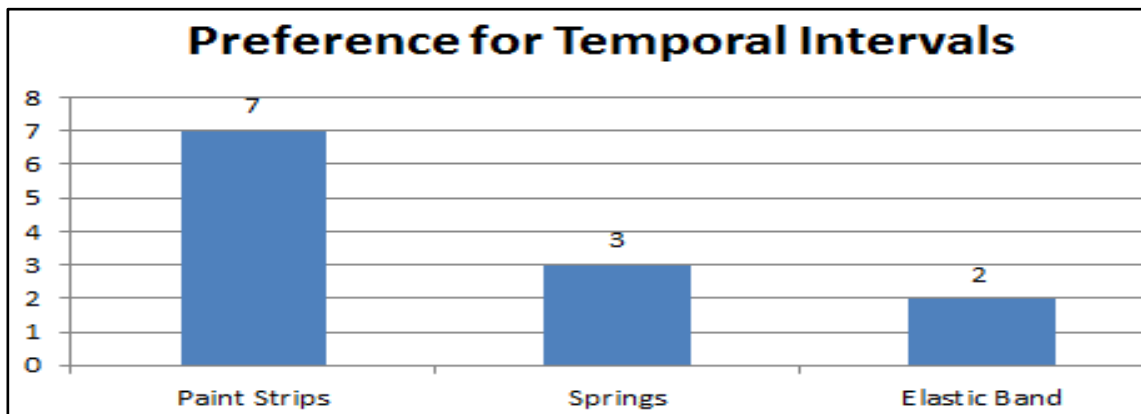

Figure 41 : Temporal Interval Preferences

4.2.3 Discussion

The results were analysed by looking at the understandability of temporal data aspects. The resultant values for three proposals are as follows:

1. The effectiveness, quality and layout of the diagrams were rated at an arithmetic mean of 3.75, 3.42 and 3.58 respectively. These values show that the subjects seem to grasp the concept of event modification in time intervals from these diagrams.
2. The data further supports the fact that the subjects are increasing their learning aspect of temporal data, Figure 37 which shows an arithmetic mean of 3.58, showing that the time interval of temporal data is now being better understood.
3. The data also shows the subject's preference was towards Paint Strips (Figure 41), even though this was not the reason for doing this exercise.
4. The most frequent comments given by subjects after the exercise and during the discussion were:
 - "I understand temporal data, but still some of the models are confusing—"
 - "How do I read a model —"
 - "I still cannot do experiment one as I do not know all the models meaning"
 - "I do not know what I am looking at"
 - Most subjects stated that paint strips provide a simple form of identification of an interval ends.
 - The mass used for elastic band proposal is common, but the presence of external force is not properly understood as the graphical element.

Hence, experiment three was initiated to work up the discussion on modelling and it was found that subjects had different levels of understanding of basic diagrams due to their different experience and knowledge levels. The teachings had to be re-tailored for basic diagram understandings so that the lessons could move from simple to the existing complexity required.

Lastly after reviewing the results of this experiment, it does in fact affirm findings done by previous experiments undertaken by Chittaro and Combi [6] relating to Figure 41 whereby Paint Strips is the user preference for temporal intervals.

4.3 Experiment Three

The third experiment was performed on the same subjects from experiment two. The aim of this experiment was to teach all the subjects how to understand diagram interpretation and how without a visual language, communication cannot be effective. The diagrams were self-generated so as to be ambiguous in their interpretations. This experiment consisted of interpretation exercises and the subjects were required to solve three exercises on paper by giving their own understandings on the given visual diagrams.

4.3.1 Experiment Intention and Technique

Each subject was asked to perform the experimental tasks. There was no constraint on the time taken for different parts of the experiment. Qualitative data was also recorded for each session and finally, the subjects were asked to describe their interpretations verbally.

The first image of the questionnaire is composed of two main graphical elements including squares and circles (Figure 42).

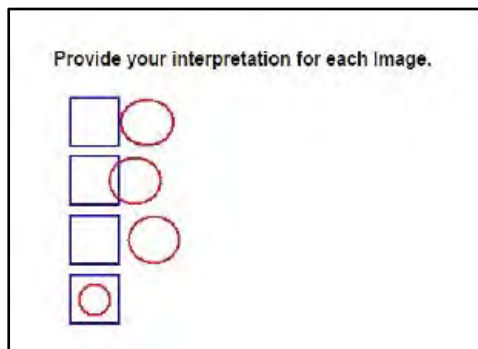

Figure 42 : Image One

The second image is as Figure 43. This image is composed of multiple elements, including rectangles, diamonds and arrows. In this image, the condition is expressed with the help of graphical notations. The image itself is divided into two sections. The first shows the diagram for sequence that if the user wants to perform second task then he has to first solve the first task. Moreover, the second section is conditional statement, where the diamond is representing the any condition given. If the condition is 'T' then it will proceed to 'Then part' otherwise to 'Else part'. In this way, whole cycle is completed in 'If-then-else' point.

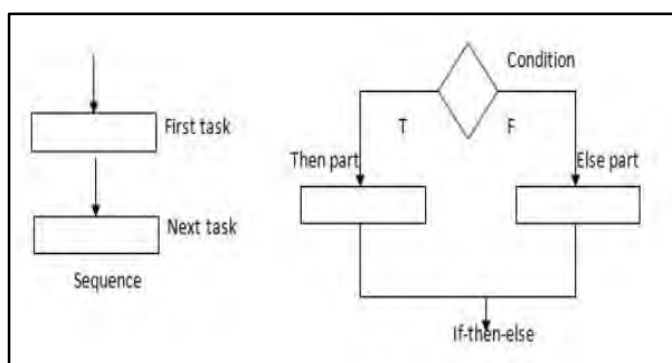

Figure 43 : Image Two

Lastly, image three was presented to the group (Figure 44). This image is basically focusing on the dependency factor of different temporal histories on each other. The black arrows are used to represent the flow of the diagram and grey arrows are used to represent the dependency factor. In this diagram, one temporal history is divided into two parts and three intervals. A and B are the two parts of the temporal data. A1 is the starting or the initial point and A2, B1 and B2 are the intervals. B1 and B2 are totally depending on A parts.

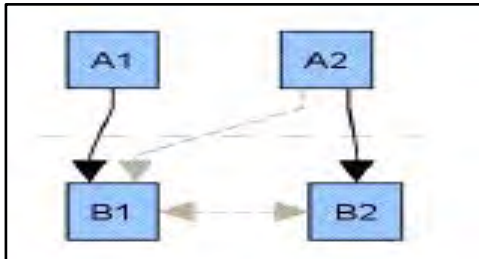

Figure 44 : Image Three

4.3.2 Results

For Image One (Figure 42), the responses given to this visual diagram were very diverse; where one subject said that the squares used in this image are symbolising possibly a specific project and the employees working will be represented by circles for a specific time period. Another subject said it means all the time allocated to a project in the organisation that it will be represented by a square and the total employee's time collectively spent on the project is the circles. Another response was that the size of the objects represented the project size in the organisation and whether the project has priority in the organisation. Another subject stated this representation in the snapshot of the project as it stands now in the organisation. The average time taken was 2 minutes. Image Two (Figure 43) was easy to understand for the developers / IT subjects but not for somebody starting off on an IT course. Answers received from IT subjects were unanimous in terms of "this is an if-then statement" but the subject starting the IT course still had not come across terms such as sequence and condition (Figure 43). The average time was 4 minutes and all subjects left with their knowledge being on the same level. The response for Image Three (Figure 44) was that the image was tricky to understand for all subjects. The average time was 15 minutes.

4.3.3 Discussion

As we can see, these interpretations are principally different and we can learn from this that there is an urgent need for a proper visual language if any conceptual model is to succeed. Hence, training was provided on conceptual modelling via a three-hour classroom session. The teachings were all relating to the conceptual diagrams and especially the temporal constructs outlined in Table one. Many respondents stated that their main concern was that the time aspects on Figure 44 are not displayed in the picture and the arrows representation with the different colour schemes is confusing. One of the comments from the subjects was that the picture was too complicated and not understandable at all. All the respondents agreed that the dashed representation stood out against the rest of the diagram.

4.4 Experiment Four

The fourth experiment was a repeat of experiment one with the same user group but now the user group had a more in-depth knowledge of temporal constructs and visual model representations. The addition to experiment four as opposed to experiment one is the ER_{VT} model, ER_{VT++} Constraints and the MADS Models due to the business preference for the ERD model.

4.4.1 Experiment Intention and Technique

Each subject was asked to perform an online survey consisting of ten questions (See Appendix 3). The intention in this experiment was to ascertain after training and coaching, which temporal visual representations the subjects would prefer.

4.4.2 Results

Concerning textual or pictorial preferences, the results with proficiency (Ratings being Guru, knows all aspects of temporal constructs, to none, knowing nothing about business constructs) and profession (all Business professionals in this case) are shown in Figure 45. The exact same procedure was followed as per experiment one whereby a single question was asked using figures in whereby the respondent could choose as to which representation they like better. (Figure 46)

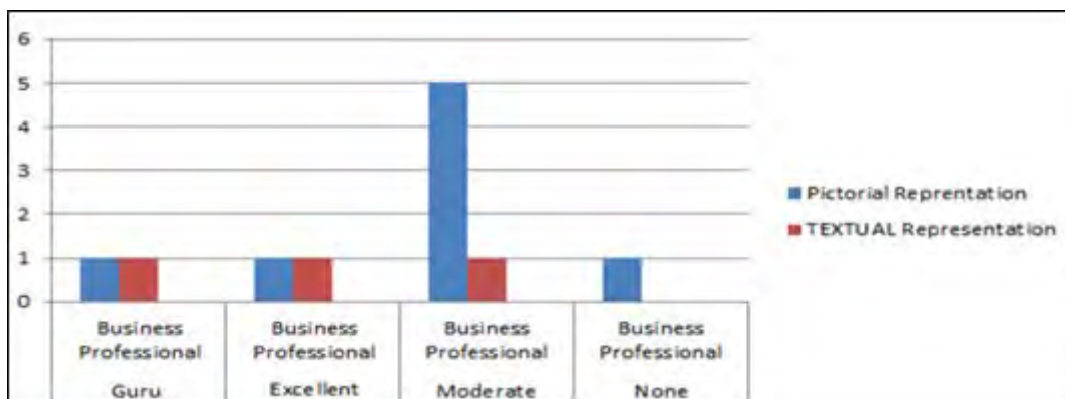

Figure 45 : Proficiency, Profession vs. Preference

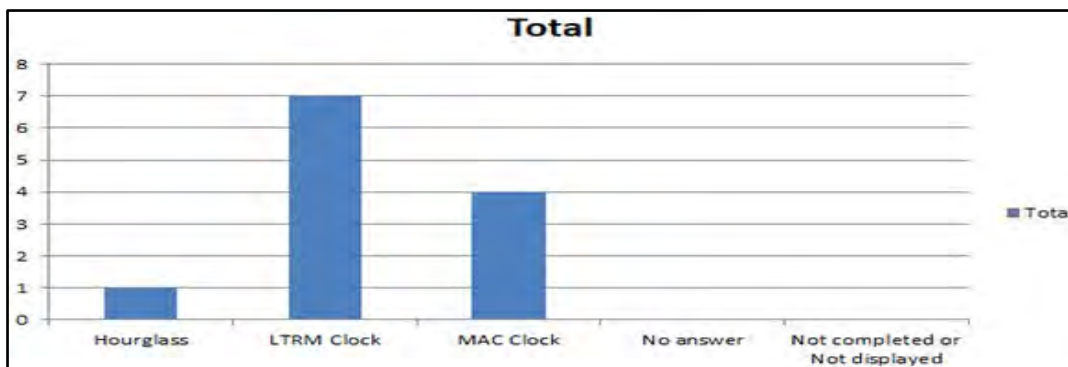

Figure 46 : Temporal Graphic Preference Closed Group

Concerning the question as to the difference between atemporal and temporal databases, the responses received are shown in Table 6.

Table 6 : After Training Responses to difference between temporal and atemporal

atemporal has no historic component
atemporal has data over a period of time
temporal is hard to visualise or even think how it is going to be implemented as history tables can become large
go back to certain date and see what has change I the data - temporal
the big thing in temporal is that I can view data at any time
I still do not completely understand the concept but it gives excellent time tracing
to create a time history in a database
atemporal is time travel database
atemporal shows moments in time
atemporal is complicated
atemporal is based on current db systems. Snapshot
databases with consolidated views over time are temporal

Other results also are the ER_{VT} DEX (Figure 47) and DEV (Figure 48).

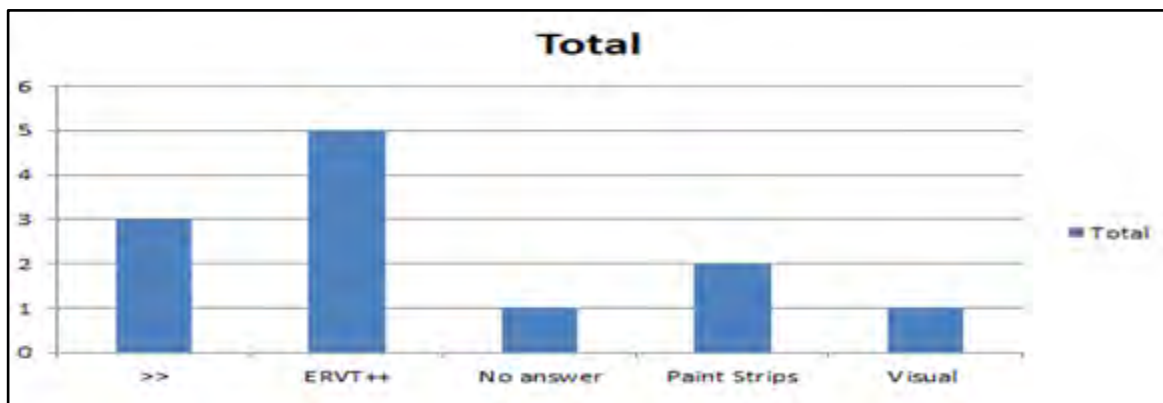

Figure 47 : ERvt++ DEX Preferences

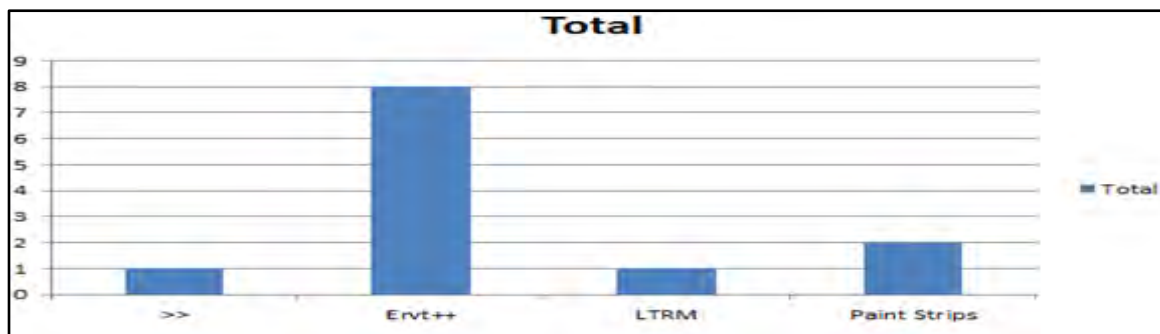

Figure 48 : ERvt++ DEV Preferences

Lastly, to gauge the preference for the conceptual model, with the addition of some of the newer models, the new question was to choose from the temporal diagrams (figure 49):

- a – RAKE Model
- b – STEER Model
- c – TER Model
- d – LTRM Model
- e – ER_{VT} Model
- f – ER_{VT++} Transition Constraints
- g – MADS Model
- h – TEMPRT Model

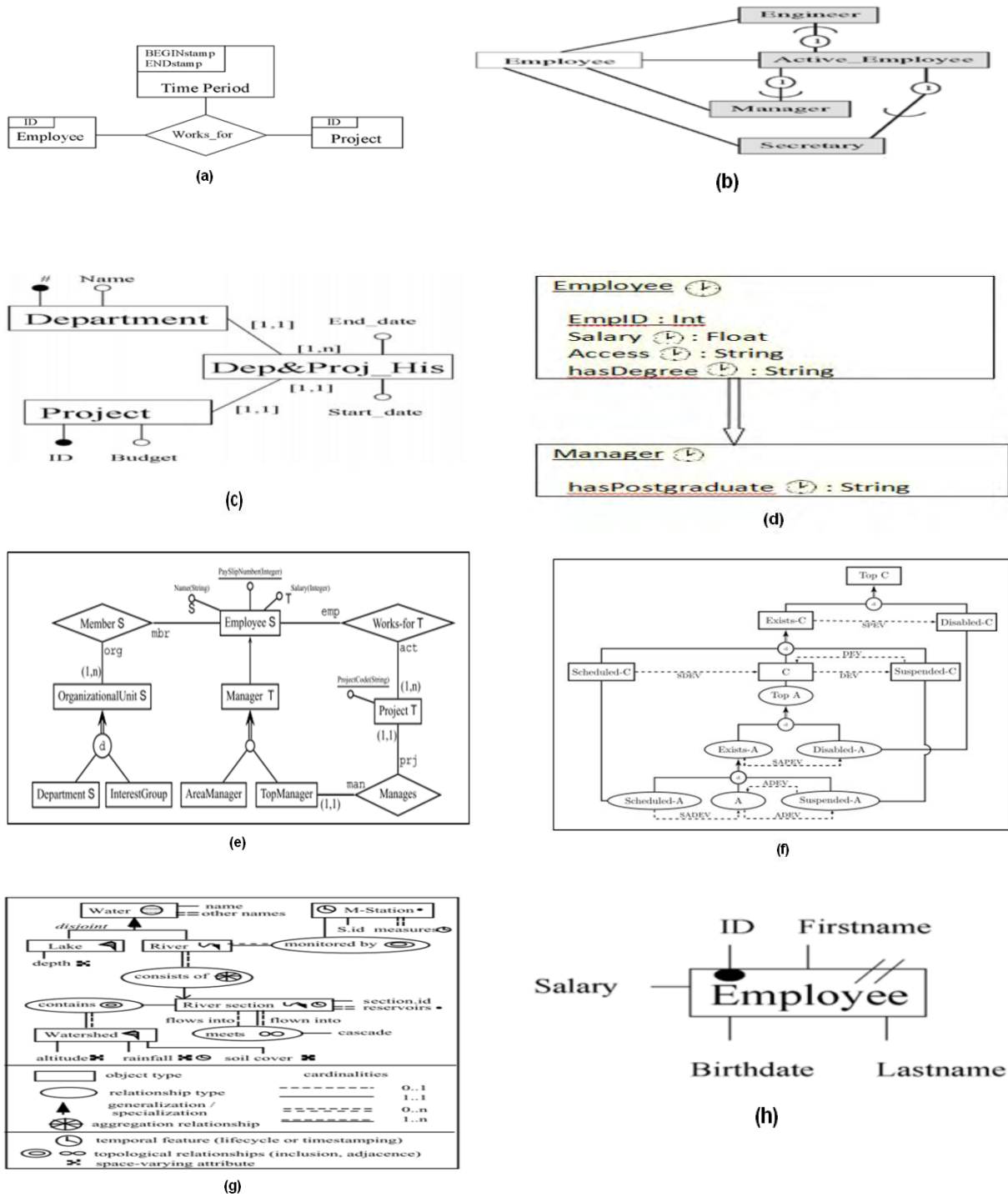

Figure 49 : Closed Group Conceptual Model Choices

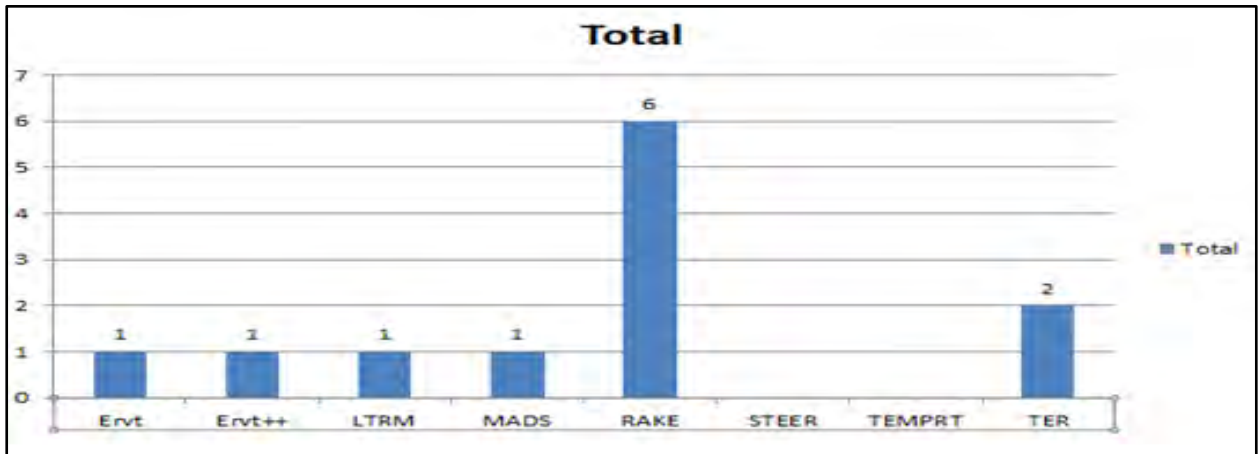

Figure 50 : Conceptual Model Preferences - Closed Group

The results show the users preferred the RAKE representation (Figure 50).

4.4.3 Discussion

Firstly, we can see that the knowledge levels of the respondents had increased by comparing result from experiment one (Table 3) to the results from experiment four (Table 6) for the question asked regarding the difference between temporal and atemporal databases. There were no participants that took part in this experiment that stated that they did not know the answer. Hence, the data in this survey comes from a knowledge level where the subject matter was better understood and analysis in terms of preferences would be much more insightful in terms of understanding user preferences.

Secondly, the data is not definitive to conclude that the graphical representation of the temporal aspect definitely has preference over the textual representation.

Thirdly, we looked at was the temporal class/entity. From the results, we see that there seems to be a preference for the clock icon represented in the LTRM clock (Figure 45). In addition, we relooked at transition constraints such as DEV and DEX. The data showed no preference for DEV and DEX for the text (ERVT model) rather than the graphics notation (Figure 47 and Figure 48) and will need to be further investigated in future research.

Lastly, we looked at the list of conceptual models and found out that the RAKE model was the preferred conceptual model, followed by the TER model. We also found this to be an anomaly as both RAKE and TER were not graphic representations for the temporal aspects but rather textual. In addition, the users preferred the LTRM clock but did not choose the LTRM clock synthesised model.

So in clarify these anomalies, interviews were carried out with the participants and to find out the reason for their choices and most of the answers were along the lines of:

1. "Text is easier to write on a whiteboard or planning session, rather than drawing icons which represent different transitions as not many business users are great artists" for DEX and DEV. This was probed a bit further in terms of asking if the dashed lines needed to be an arc or straight and the answer received was "It does not matter", as

the dashed line stood out more than shading as per Experiment 3, image 3 (figure 44) remarks.

2. –Clock was not chosen as it was not displayed as an ERD model and the ERD model is the preferred model we use in this department, so that is why we choose the models we did”
3. –Some of the other ERD diagrams were too complex. We like the choices due to the simplistic layout”

The answers lead to the creation of experiment five to get a conclusive choice by eliminating any models that were not based on the ERD model and also to reduce models with overcrowded complexity. This was achieved by creating equivalent information in all the models.

4.5 Experiment Five

Due to the users' responses that some of the models were too complex and their preference was the ERD model, and the preference for the textual representation of constraint migration, the fifth experiment was conducted where all models were drawn with equivalent entity representations.

4.5.1 Experiment Intention and Technique

Five questions were asked in this survey whereby the subjects could rate their model preference based on the same example represented using:

1. Each model derived from the ERD representation namely; STEER, TER, LTRM, MOTAR, RAKE, ER_{VT} and TEMPPR models, where the models were used unmodified.
2. Each model with modifications using the clock icon.
3. Modifications using with the textual representation for constraint migration of DEX.
4. Modifications using the clock icon and the textual representation for constraint migration of DEX.

Comments about the survey were also elicited.

The aim was to find the preferred model among existing models and enhancements to existing models based on user preferences from previous experiments.

The choices for Question 1 were:

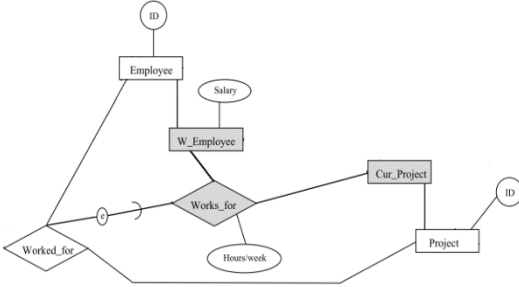
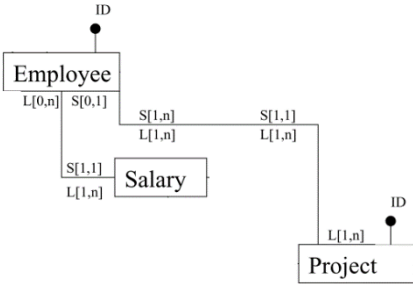
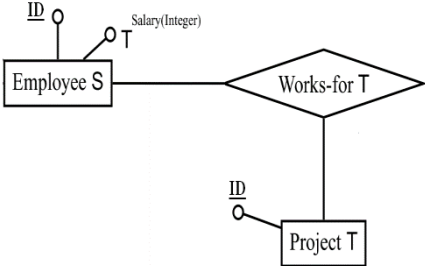
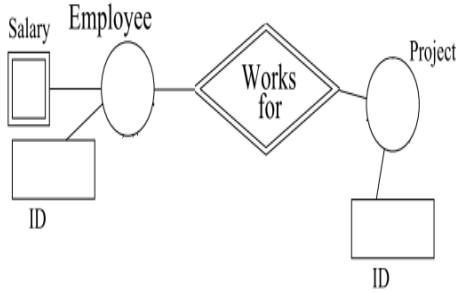
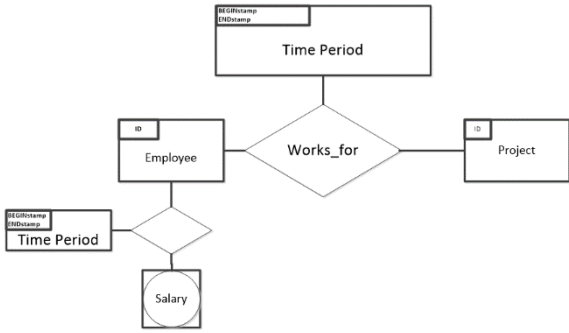
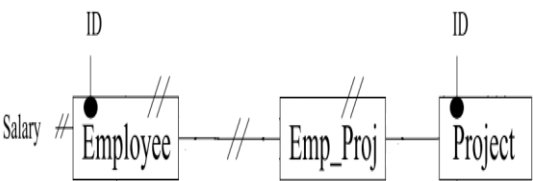
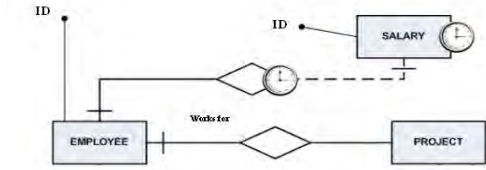
 <p>Figure 51 : STEER Model</p>	 <p>Figure 52 : TER Model</p>
 <p>Figure 53 : ERvt Model</p>	 <p>Figure 54 : MOTAR Model</p>
 <p>Figure 55 : RAKE Model</p>	 <p>Figure 56 : TEMPRT Model</p>
 <p>Figure 57 : LTRM Model</p>	

The choices for Question 2 were:

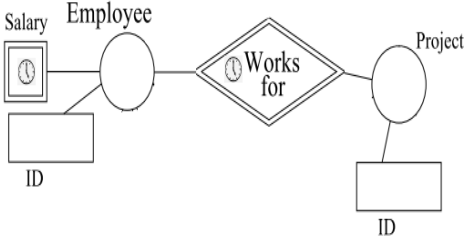
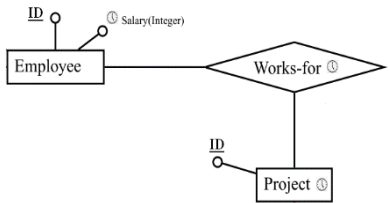
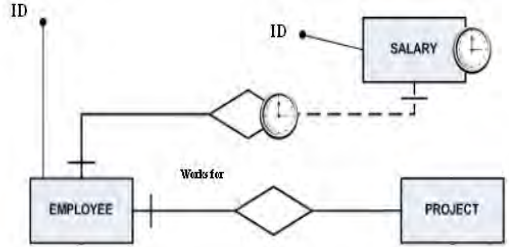
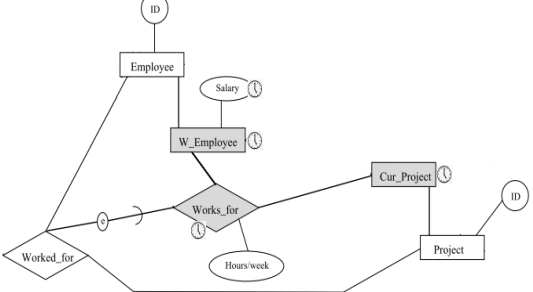
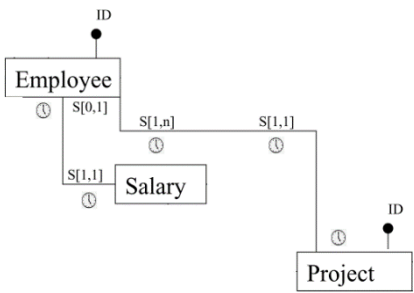
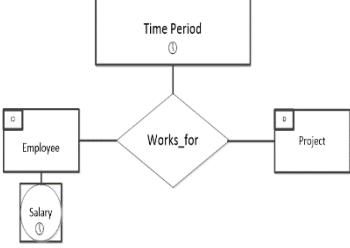
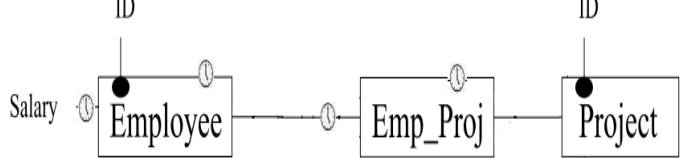
 <p>Figure 58 : Modified MOTAR Model</p>	 <p>Figure 59 : Modified ERvt Model</p>
 <p>Figure 60 : LTRM Model</p>	 <p>Figure 61 : Modified STEER Model</p>
 <p>Figure 62 : Modified TER Model</p>	 <p>Figure 63 : Modified RAKE Model</p>
 <p>Figure 64 : Modified TEMPRT Model</p>	

The choices for Question 3 were:

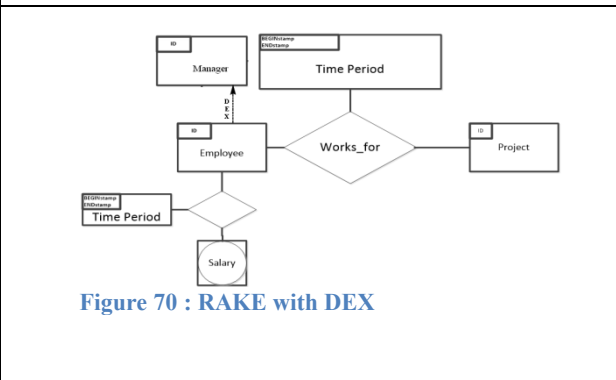
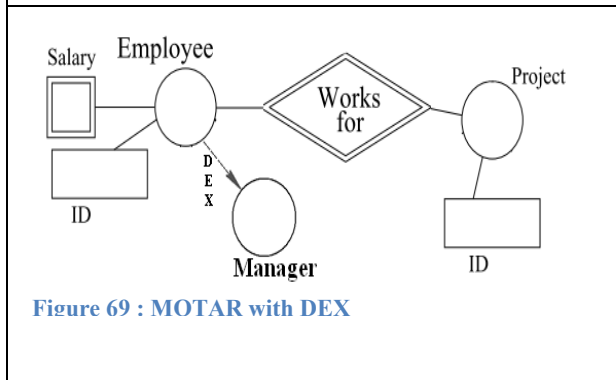
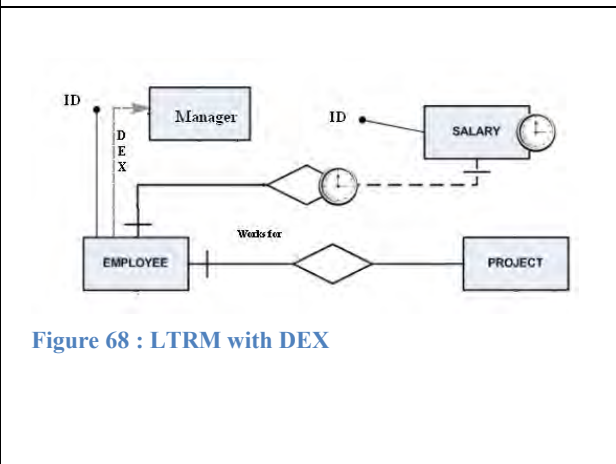
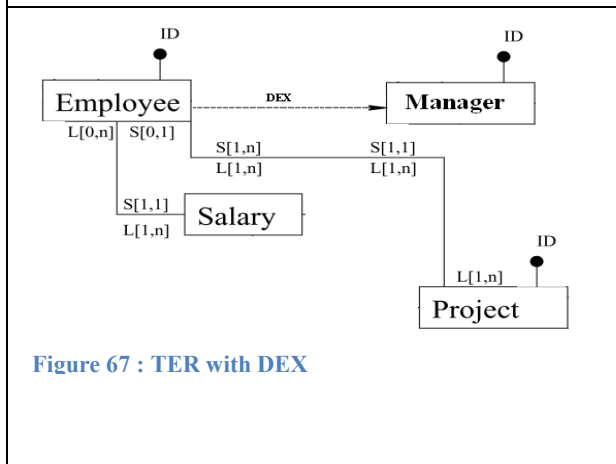
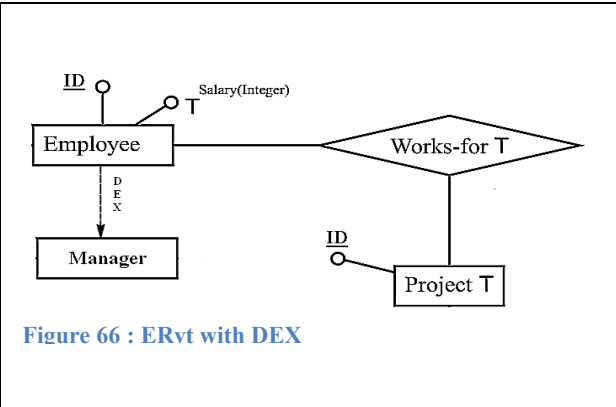
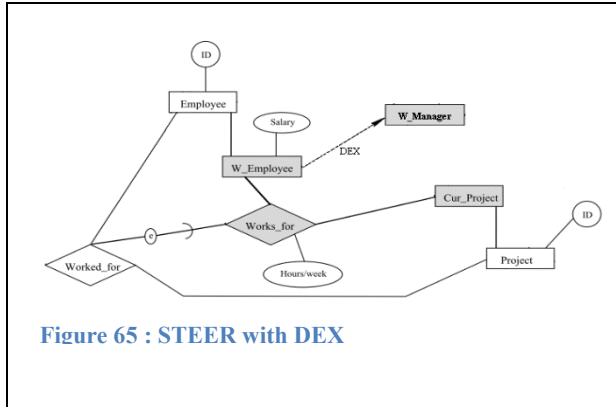

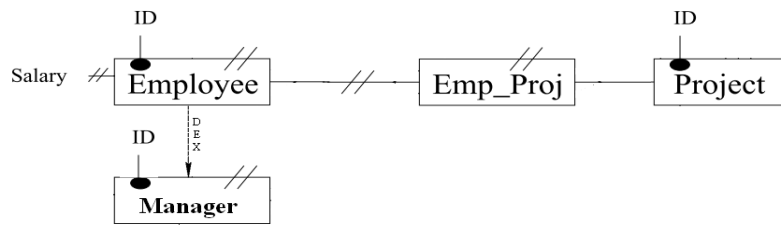

Figure 71 : TEMPRT with DEX

The choices for Question 4 were:

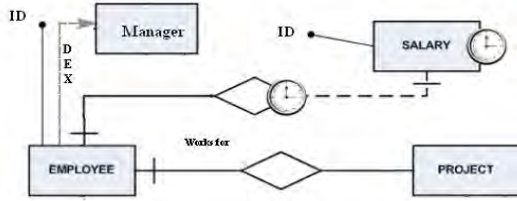

Figure 72 : Modified LTRM with DEX

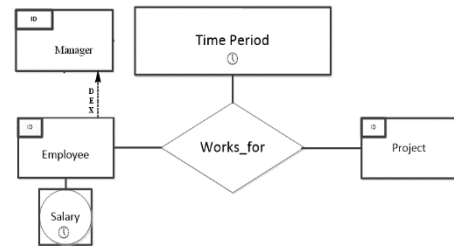

Figure 73 : Modified RAKE with DEX

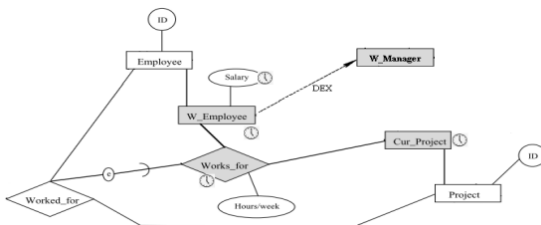

Figure 74 : Modified STEER with DEX

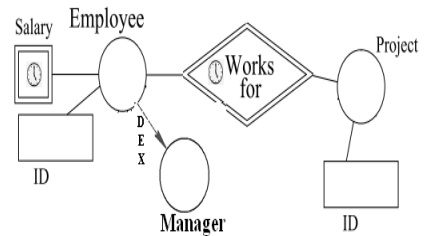

Figure 75 : Modified MOTAR with DEX

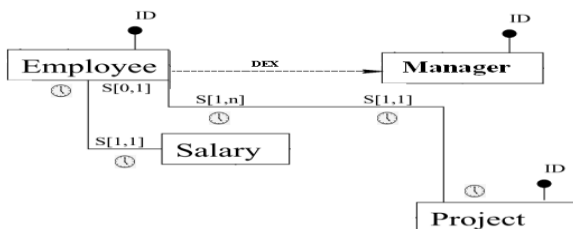

Figure 76 : Modified TER with DEX

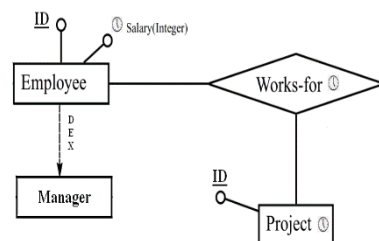

Figure 77 : Modified ERvt with DEX

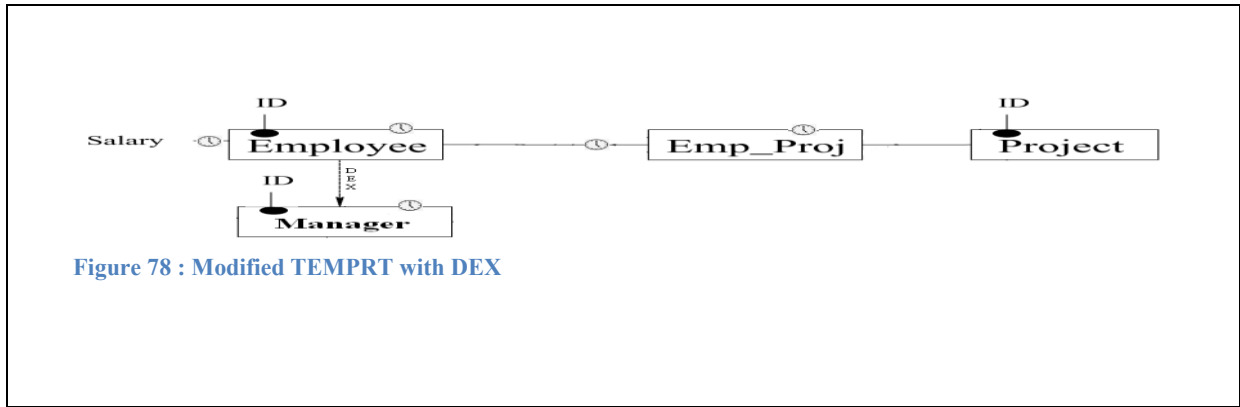

Figure 78 : Modified TEMPRT with DEX

Question five was: - Do you have any additional comments?

4.5.2 Results

Results for Question 1

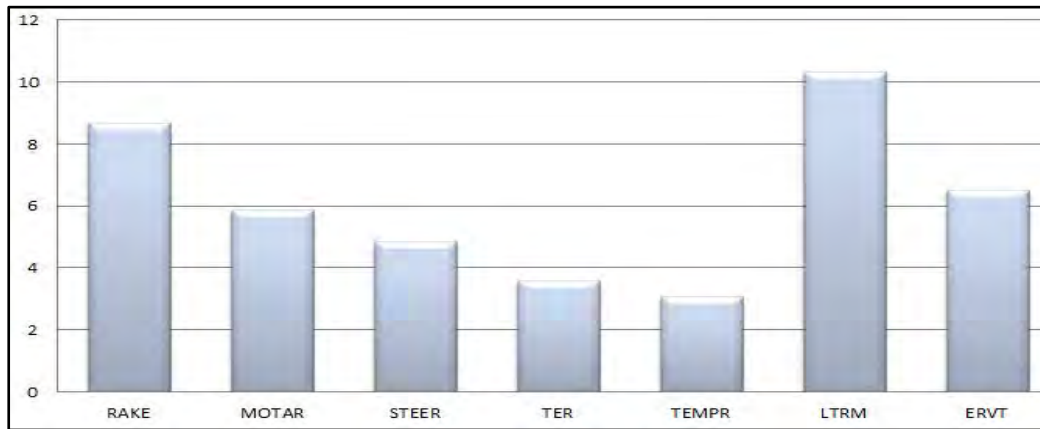

Figure 79 · Temporal Model Choices

Figure 79 shows results for preferences based on choices from question 1. The data shows that the LTRM model is most preferred, followed by the RAKE, ER_{VT}, MOTAR, STEER, TER and TEMPRT models respectively.

Results for Question 2



Figure 80 · Temporal Model Preferences based - Clock Modification

With all the temporal models given the clock modification for the temporal aspects the RAKE model was chosen as the preferred model, followed by the LTRM, STEER, ER_{VT}, MOTAR, TEMPRT and TER models respectively.

Results for Question 3

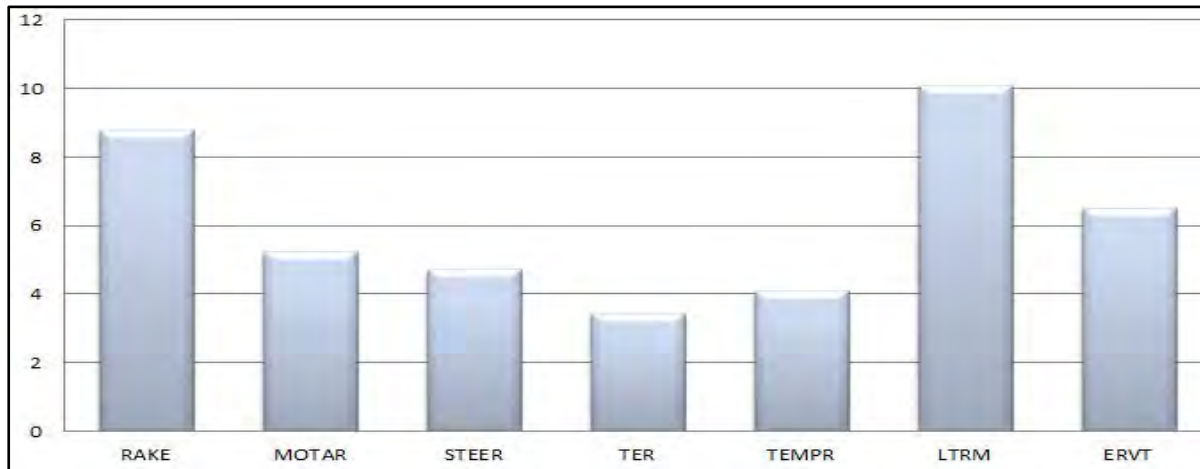

Figure 81 : Temporal Model Preference with DEX

The LTRM model is preferred with the DEX extension with a 75% preference.

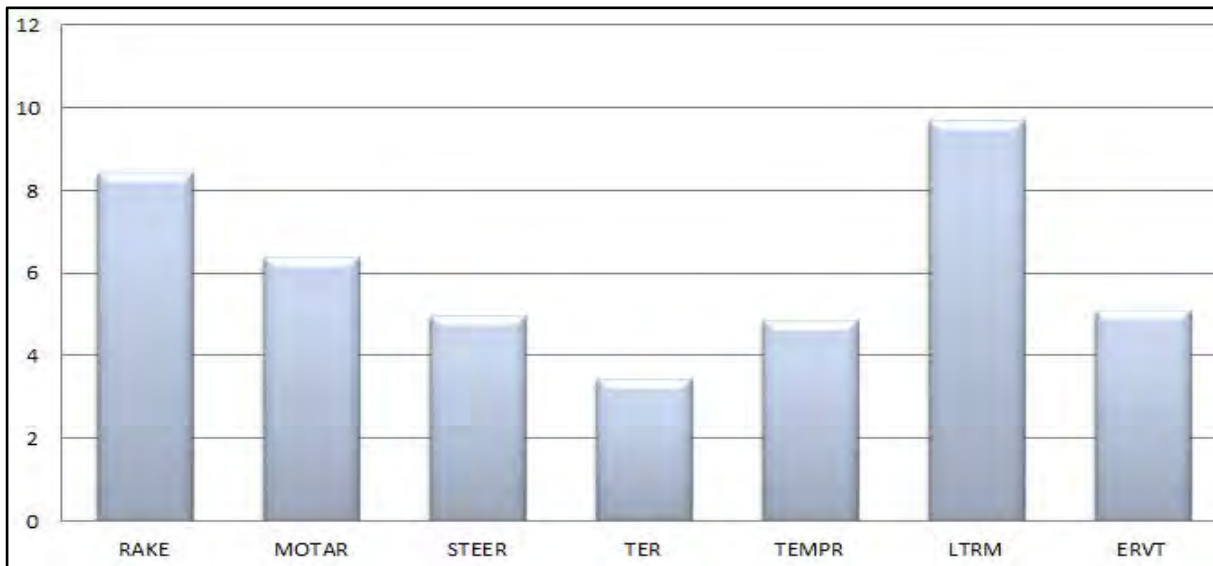

Figure 82 : Temporal Model Preference with Clock and DEX

Results for Question 4

With all the temporal models given the clock modification for the temporal aspects and the DEX extension, the LTRM model was chosen as the preferred model, followed by the RAKE, TEMPRT, STEER, ER_{VT}, TER and MOTAR models respectively.

Question 5 Results

Table 7 : Responses to Question 5 Experiment 5

Clock is a good icon for temporal
I like the DEX with the Clock
I find the diagrams with shading and double entity objects very distracting
L and S on the attributes seem to be cumbersome
S and L are not clear from the diagram
Diagrams with shading for temporal entities seem to take up lots of space and this is hard for explanation on a whiteboard
I do not like the //, I like the clock better
The double diamond and double square is not clear as these look like weak entities instead of temporal. Clock does add a bit to the clarity
None
Diagrams with a valid time period seem to display information clearly
None.
We never use circles for entities in our diagrams

4.5.3 Discussion

The experiment proves that, in an ERD model format, the clock icon is the users' preferred choice. This is definitive proof, that going forward in any study; the clock icon is best understandable in temporal diagrams.

In addition, from the results we can conclude the following:

1. Without any modifications on the existing theoretical model, the LTRM is preferred (75% of users chose this model) in a business context (Figure 78).
2. With the addition of the clock to the existing theoretical models, there is shift towards the RAKE model, (42% of users chose this model), but the LTRM model still shows a high preference (33% of users chose this model) (Figure 79).
3. With the modification of adding DEX (dashed line with text as preferred and validated from previous experiments), the LTRM model is still preferred with 75% of the subjects choosing this model (Figure 80).
4. Lastly, with the clock and the DEX extensions, LTRM and RAKE are the top two contenders of choice (Figure 81).
5. Shading is described as ~~–~~distracting” and needs to be considered carefully in future research. (Table 7)
6. Other aspects shown in table 7, that needs to be highlighted in future research is:
 - a. Some users do not relate to the use of circles as entity representations.
 - b. Lifespan and snapshots needs a more understandable representation.
 - c. Temporal representations should try not to use any ambiguous representation such as the double squares and double diamonds as one user remarked, ~~–~~these look like weak entities instead of temporal.”

The results indicate that in a business context, ERD and the LTRM model is the preferred model of choice. Hence, these results can confidently be used for final analysis as we have reached the goal of ~~–~~knowledgeable” subjects and user preferences for ERD representation.

5 Overall Discussion and Findings

From the results received from the general open audience survey to ascertain understandings of temporal conceptual models and preferences, it was found that temporal aspects were not very well understood within the user community. These results were discarded from this initial survey, as they were useless when it came to answer the questions asked in this study. Hence, a decision was taken to enhance the knowledge of a controlled business group in order to get usable results. Knowledge levels were enhanced using training by means of online videos, temporal concept simplification, classroom based lectures and question and answer sessions. The use of these techniques against knowledgeable users is extremely important because if the temporal conceptual model were not humanly interpretable then all the analysis would be of no importance. Certainly, it has also been noticed that the user should be involved in the early stages of a temporal conceptual model adoption as modelling and communications are essential in the SDLC to reduce ambiguity. Knowledge levels were then checked again based on tasks that were performed.

The tasks tested the user group understanding of:

- Time intervals and event correlation.
- The need for a proper visual dictionary.
- The modelling of time on conceptual models.
- The modelling of different associations through different visual metaphors.
- The modelling of interaction between objects in temporal conceptual models.

Another insight coming through clearly is the user preference towards the clock icon as the preferred graphic to show the temporal aspects on the models presented. Nevertheless, the question remains as to why the clock icon not selected in experiment four. From qualitative data received after experiment four, the ERD model is still the preferred communication mechanism in the user group tested, compared to other representations. Hence the shift from all other models to the ERD model and its derivatives in experiment five. In addition, from a business perspective, it was found that simplification for use on whiteboards and charts is essential for any model, and hence the intricate graphics for the DEX and DEV representations were ignored. Thus, we can conclude that the LTRM model with DEX/DEV migration constraints using the ER_{VT} notation (Figure 83) should be further looked at as models for future research for effective communication in the temporal conceptual model design.

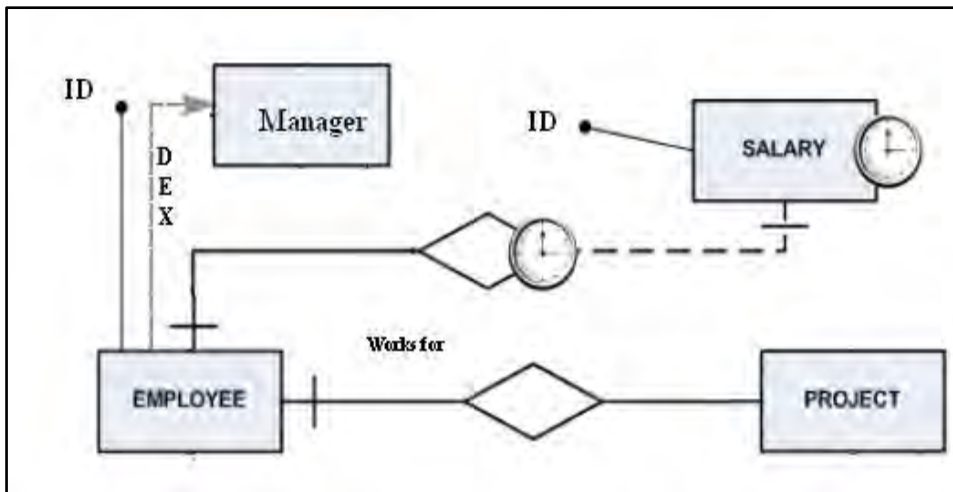

Figure 83 : LTRM with DEX preference

Note in figure 83, the DEX is not displayed as an arched line but rather a straight line;

Qualitative data from end of experiment four showed the preference for the temporal migration constraint was not the shape of the line but rather the fact that the line is “dashed”.

Also, this study cannot be compared against other theoretical works as this is the first time a user-study is done on temporal conceptual model representation.

Lastly, with regards to this research answering the following questions from a user perspective:

1. Will a graphical or textual representation be more understandable for a conceptual model?
 - Currently the data does not prove definitely that there is a preference for either the textual or graphical representation to be singularly but rather a combination of both these options. The choice is also situation dependent and should be reserved for further analyses and research.
2. How can a temporal entity be represented in the context of a conceptual data model?
 - Answered in this thesis from a user perspective
3. Is it better to represent temporal entities and attributes using the same representation or different representations?
 - Answered in this thesis from a user perspective

Furthermore, also other enhancements can also be included in future work. A main suggestion is that the research could be conducted using a larger target audience including more academia with not only the ERD model being the main focus but also incorporate the UML model in the preferred choices. Other improvements for future work should also look at the graphical and textual representations and look at improving them so that a more relevant result can be achieved.

In addition, I have touched briefly on the graphical representation of the DEX and DEV constraint migrations of the ER_{VT} model and further work can be useful in this field as these migration representations were of great interest in the business context. I would suggest looking at the textual descriptions and dashed lines shown Figure 29, 31 and 83.

Lastly, looking at the findings in perspective with the Physics of Notation, the data currently available not showing a definitive preference for a graphical or textual representation, the visual library and graphical symbols can only be reinforced based on cognitive profile for the preference of the visual clock to denote temporal constructs. These principles can be evaluated in future research once the data is more definitive.

6 Conclusion

Repeatable experimental results, based on the first user preference study of temporal models, have proved that the business users preferred temporal conceptual model representation is neither graphical nor purely text model but rather a combination dependent on the situation used as can be further investigated with a larger subject base. It has also been proven from both quantitative and qualitative data, in certain instances that a combination of graphics and text is preferred when it comes to explaining on a whiteboard since text is much simpler to scribe rather than drawing complex graphics. An example of this is the representation of temporal constraint migrations such as dynamic evolution and dynamic extension. In addition, it was found that the business user preference relating to conceptual models for the visual representation of temporal data is the clock icon from the LTRM model. The major benefit of these findings is that researchers can now start new research based on graphical attributes that can reduce the gap with regard to ambiguity and miscommunication in the SDLC. Another insight gained from this study is that classes and attributes do not need different visual representations and the clock icon is sufficient for temporal representation once the knowledge relating to temporal aspects is well understood.

As I have noted, the five experiments conducted and learnings has shown some trends towards a preferred conceptual model in the business user context. The model has been extrapolated as a modification to an existing model and will be useful and worth pursuing further.

7 References

- [1] Artale, A. et al. 2007. Evolving objects in temporal information systems. *Annals of Mathematics and Artificial Intelligence*. 50, 1-2 (Jul. 2007), 5–38.
- [2] Baxter, K. and Courage, C. 2005. Understanding Your Users: A Practical Guide to User Requirements Methods, Tools, and Techniques (Interactive Technologies). (Nov. 2005).
- [3] Carlis, J. V and Konstan, J. a 1998. Interactive visualization of serial periodic data. *Focus*. San Franci, (1998), 29–38.
- [4] Carlis, J. V. and Konstan, J.A. 1998. Interactive visualization of serial periodic data. *Proceedings of the 11th annual ACM symposium on User interface software and technology - UIST '98* (New York, New York, USA, Nov. 1998), 29–38.
- [5] Chen, P.P.-S. 1976. The entity-relationship model---toward a unified view of data. *ACM Transactions on Database Systems*.
- [6] Chittaro, L. and Combi, C. 2001. Representation of temporal intervals and relations: Information visualization aspects and their evaluation. *Proceedings of the International Workshop on Temporal Representation and Reasoning*. FEBRUARY 2001 (2001), 13–20.
- [7] Cousins, S.B. and Kahn, M.G. 1991. The visual display of temporal information. *Artificial Intelligence In Medicine*. 3, 6 (1991), 341–357.
- [8] Daassi, C. et al. 2000. Visual exploration of temporal object databases. *Proc. of BDA'00*. October 2000 (2000), 24–27.
- [9] Daniell, H. et al. 2002. Milestones in chloroplast genetic engineering: An environmentally friendly era in biotechnology. *Trends in Plant Science*. 7, 2 (2002), 84–91.
- [10] Davies, I. et al. 2006. How do practitioners use conceptual modeling in practice? *Data and Knowledge Engineering*. 58, 3 (Sep. 2006), 358–380.
- [11] Dumas, M. et al. 2001. Pointwise Temporal Object Database Browsing. *In Objects and Databases*. (2001), 170–184.
- [12] Elmasri, R. and Navathe, S.B. 2011. Chapter 8. *Fundamentals of Database Systems*. 1–35.
- [13] Elmasri, R. and Wu, G.T.J. 1990. A temporal model and query language for ER databases. *1990 Proceedings Sixth International Conference on Data Engineering* (Mar. 1990), 76–83.
- [14] Ferg, S. 1985. Modelling the Time Dimension in an Entity-Relationship Diagram. *4th International Conference on the Entity-Relationship Approach*. (Oct. 1985), 280–286.
- [15] Gregersen, H. and Jensen, C.S. 1999. Temporal entity-relationship models - a survey. *IEEE Transactions on Knowledge and Data Engineering*. 11, 3 (1999), 464–497.
- [16] Jensen, C.S. 2000. Introduction to temporal database research. *Temporal database management*. (2000), 1–27.
- [17] Kapler, T. and Wright, W. 2004. GeoTime information visualization. *Proceedings - IEEE Symposium on Information Visualization, INFO VIS*. 4, 2 (2004), 25–32.
- [18] Klopprogge, M.R. 1981. Term: An Approach to Include the Time Dimension in the Entity-Relationship Model. *Proceedings of International Conference on Entity-Relationship Approach, October 12-14, 1981, Washington, DC, USA*. (Oct. 1981), 477–508.

- [19] Kosara, R. et al. 2002. AsbruView: Capturing Complex, Time-Oriented Plans — Beyond Flow Charts. *Diagrammatic Representation and Reasoning*. (2002), 535–549.
- [20] Lieberman, M.D. et al. 2011. Visual exploration across biomedical databases. *IEEE/ACM Transactions on Computational Biology and Bioinformatics*. 8, 2 (2011), 536–550.
- [21] Mahmood, N. et al. 2010. A Logical Temporal Relational Data Model. *International Journal of Computer Science Issues*. 7, 1 (2010), 1–9.
- [22] Mapping Documentation Development Life Cycle (DDLDC) with SDLC - Ascezen Consulting: 2014. <http://www.ascezen.com/2013/11/mapping-documentation-development-life-cycle-ddlc-sdlc/>. Accessed: 2015-12-21.
- [23] McBrien, P. et al. 1992. An Entity--Relationship Model Extended to describe Historical Information. *Proceedings of the International Conference on Information Systems and Management of Data (CISMOD 92)*. (Jan. 1992), 244–260.
- [24] Moody, D. 2009. The physics of notations: Toward a scientific basis for constructing visual notations in software engineering. *IEEE Transactions on Software Engineering*. 35, 6 (Nov. 2009), 756–779.
- [25] Parent, C. et al. 1999. Spatio-temporal conceptual models. *Proceedings of the seventh ACM international symposium on Advances in geographic information systems - GIS '99*. (1999), 26–33.
- [26] Shahar, Y. and Cheng, C. 1998. Model-based visualization of temporal abstractions. *International Workshop on Temporal Representation and Reasoning (TIME)*. 16, 2 (1998), 11–20.
- [27] Shannon, C.E. and Weaver, W. 1963. A Mathematical Theory of Communication. (Oct. 1963).
- [28] Shneiderman, B. 1998. Visualizing Personal Histories. *ACM SIGCHI Bulletin*. 30, 1 (1998), 34–35.
- [29] Silva, S.F. and Catarci, T. 2015. Visualization of linear time-oriented data: a survey. *Proceedings of the First International Conference on Web Information Systems Engineering*. 1, FEBRUARY 2000 (2015), 310–319.
- [30] Snodgrass, R. and Ahn, I. 1986. Temporal Databases. *Computer*. 19, 9 (1986), 35–42.
- [31] Steinbring, H. 1998. Elements of epistemological knowledge for mathematics teachers. *Journal of Mathematics Teacher Education*. 1, 1 (1998), 157–189.
- [32] What's New in SQL Server 2016 - September Update: 2015. <https://msdn.microsoft.com/en-us/library/bb500435.aspx>. Accessed: 2016-04-28.

8 Appendix

8.1 Appendix 1 – Survey for Experiment One

Adoption rate of Visual Model for Temporal Database Representation

Mini-Dissertation submitted in partial fulfillment for the degree of
Master of Science in Information Technology Department of Computing Science University of Cape Town

Dear Students,

We invite all to participate in an online survey to help in the creation of a new visual representation for Temporal Database. Please note that your participation is **entirely voluntary** and you are free to decline to participate in this survey. There will be **no identifying information**. There is no financial remuneration for participating.

If you have any questions or concerns about this study, please feel free to contact Tamindran Shunmugam at shntam002@myuct.ac.za. I am UCT MSc student in the Department of Computer Science being supervised by Dr. Maria Keet. This study has been approved by the Faculty of Science Ethics Committee at The University of Cape Town (ref no: FSREC 081-2014).

There are 17 questions in this survey

Base Group of Questions

[] Please state your profession ? *

Please choose **only one** of the following:

- Academic (Student)
- Academic (Faculty)
- Business Professional

Other

What is your current job ?

[] In less than two lines, can you describe the difference between an atemporal database and a temporal database. (If you do not know, then write leave blank)

Please write your answer here:

[] How long have you been working with databases ?

Please choose **only one** of the following:

- Not working with databases currently
- Less than a Year
- Between one and ten years
- More than 10 years

[] Rate your knowledge of conceptual models for databases? *

Please choose **only one** of the following:

- None
- Moderate
- Excellent
- Guru

[] Which of the following conceptual model representation of a class appeal most to you ?

Please choose **only one** of the following:

TEXTUAL Representation

<p><u>Employee</u> (T)</p> <p><u>EmpID</u> : Int</p> <p>Salary (T) : Float</p> <p>Access (T) : String</p> <p>hasDegree (T) : String</p>
--

Pictorial Representation

<p><u>Employee</u> (T)</p> <p><u>EmpID</u> : Int</p> <p>Salary (T) : Float</p> <p>Access (T) : String</p> <p>hasDegree (T) : String</p>
--

[] Which of the following conceptual model representation of a class appeal most to you ? *

Only answer this question if the following conditions are met:

Answer was *

TEXTUAL Representation

<p><u>Employee</u> (T)</p> <p><u>EmpID</u> : Int</p> <p>Salary (T) : Float</p> <p>Access (T) : String</p> <p>hasDegree (T) : String</p>
--

* at question '5 [05]' (Which of the following conceptual model representation of a class appeal most to you ?)

Please choose **only one** of the following:

<p><u>Employee</u> (T)</p> <p><u>EmpID</u> : Int</p> <p>Salary (T) : Float</p> <p>Access (T) : String</p> <p>hasDegree (T) : String</p>
--

○

Employee (T)

EmpID : Int
Salary (T) : Float
Access (T) : String
hasDegree (T) : String

[] If colour, which colour ? *

Only answer this question if the following conditions are met:
Answer was :

TEXTUAL Representation

Employee (T)

EmpID : Int
Salary (T) : Float
Access (T) : String
hasDegree (T) : String

* at question '5 [Q5] (Which of the following conceptual model representation of a class appeal most to you ?)

Please choose all that apply:

- Red
- Black
- Blue
- Green
- Other:

[]

If colour, do you prefer classes and attributes to have the same or different colours ?

Employee (T)

EmpID : Int
Salary (T) : Float
Access (T) : String
hasDegree (T) : String

Manager (T)

hasPostgraduate (T) :
String

Only answer this question if the following conditions are met:
Answer was *

TEXTUAL Representation

Employee (T)

EmpID : Int

Salary (T) : Float

Access (T) : String

hasDegree (T) : String

* at question '5 [Q5]' (Which of the following conceptual model representation of a class appeal most to you ?)

Please choose only one of the following:

- Yes
 No

Q

Which of the following icons best represents of a temporal class in your opinion?

- a) Employee (🕒)
b) Employee (🕒)
c) Employee (🕒)

*

Only answer this question if the following conditions are met:
Answer was *

Pictorial Representation

Employee (🕒)

EmpID : Int

Salary (🕒) : Float

Access (🕒) : String

hasDegree (🕒) : String

* at question '5 [Q5]' (Which of the following conceptual model representation of a class appeal most to you ?)

Please choose only one of the following:

- option a
 option b
 option c

[]

Which of the following icons best represents of a temporal *attribute* your opinion?

- a) Employee (⌚)
- b) Employee (🕒)
- c) Employee (🕒)

*

Only answer this question if the following conditions are met:
Answer was:

Pictorial Representation

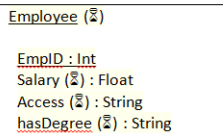

* at question '5 [Q5] (Which of the following conceptual model representation of a class appeal most to you ?)

Please choose **only one** of the following:

- option a
- option b
- option c

[]Based on questions answered thus far, represent the following using a diagram of font, colour and/or pictures.

- **A person takes a loan from a bank for a car but loan put on hold until previous loan is paid off**

Kindly attach the aforementioned documents along with the survey

[]

Based on questions answered thus far, in words, explain what the following diagram means

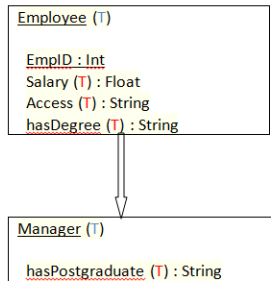

Only answer this question if the following conditions are met:
Answer was:

TEXTUAL Representation

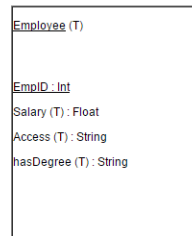

* at question 5 [Q5] (Which of the following conceptual model representation of a class appeal most to you ?)

Please write your answer here:

[]

A typical transition in temporal database management is known as dynamic evolution. In this case an object moves from one class to another, eg an middle manager moves to top manager.

Which of the following depictions best represents this transition graphically ? *

Please choose only one of the following:

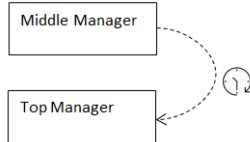
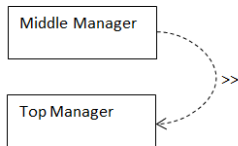
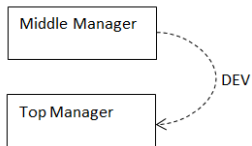

[]Another typical transition in temporal database management is known as dynamic extension. In this case an object exists in two classes , eg an employee becomes a manager. The object will be a member of the employee and the manager class.

Which of the following depictions best represents this transition graphically ?

Please choose only one of the following:

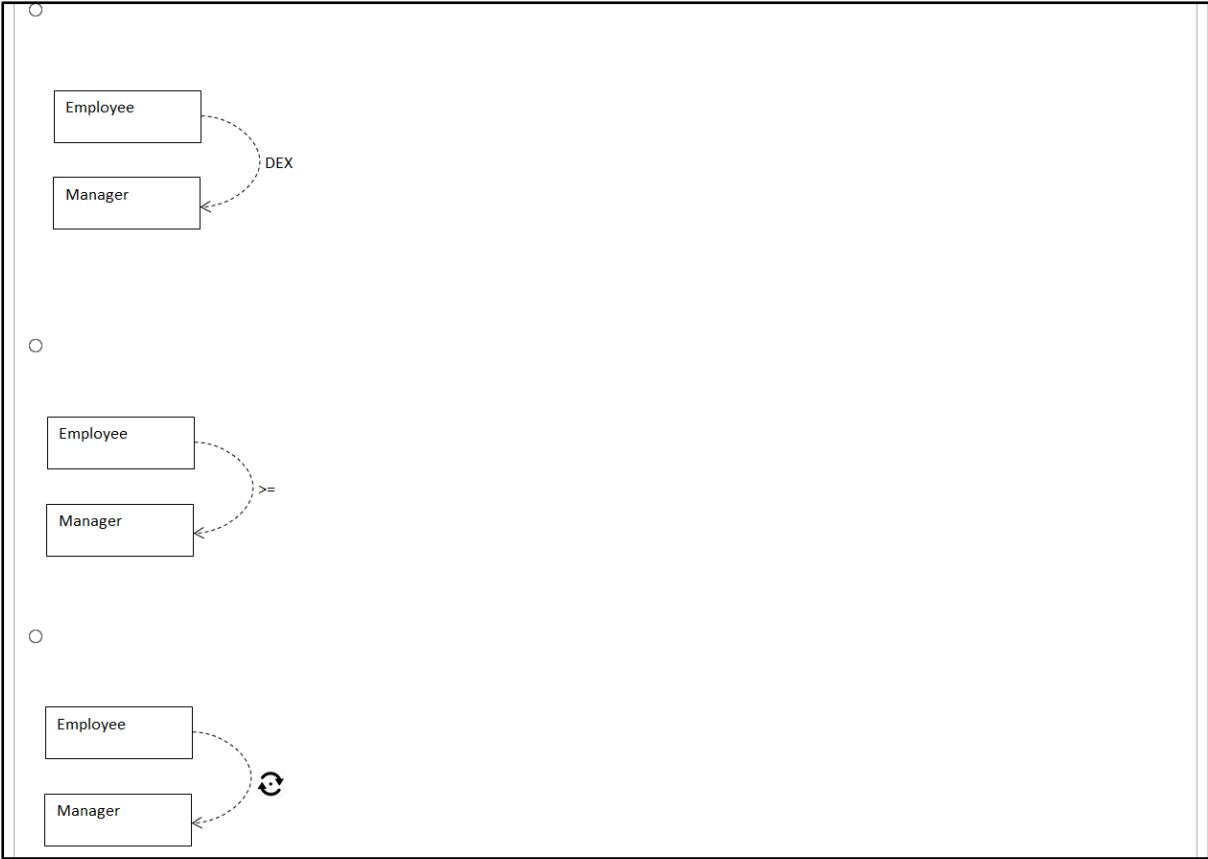

Based on questions answered thus far, in words, explain what the following diagram means

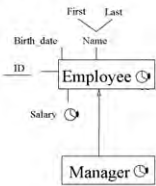

Only answer this question if the following conditions are met:
Answer was

Pictorial Representation

Employee (2)

EmpID : Int
 Salary (2) : Float
 Access (2) : String
 hasDegree (2) : String

*at question '5 [Q5] (Which of the following conceptual model representation of a class appeal most to you ?)

Please write your answer here:

[]
Which conceptual model do you prefer ?

a)

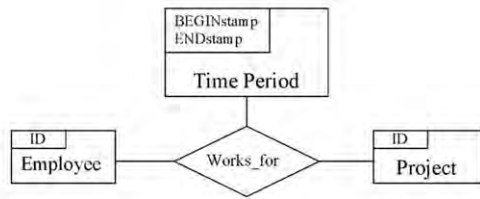

b)

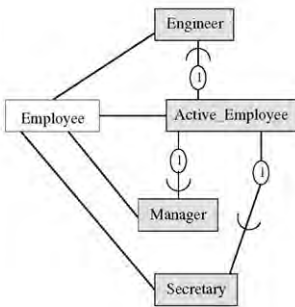

c)

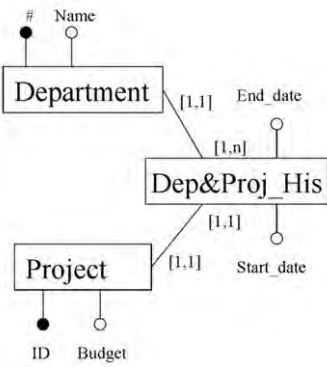

d)

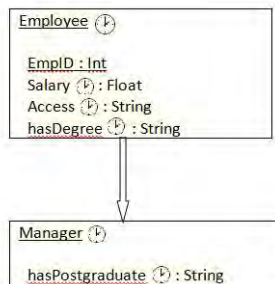

e)

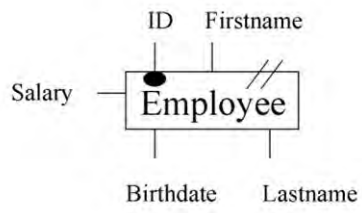

Please choose **only one** of the following:

- a
- b
- c
- d
- e

[]Upload your favourite representation

Kindly attach the aforementioned documents along with the survey

Thank you for your participation
22-12-2015 – 11:08

Submit your survey.
Thank you for completing this survey.

8.1.1 Full Results Experiment One

Relationship between Academic and Business Users Preferences of respondents who completed the Survey

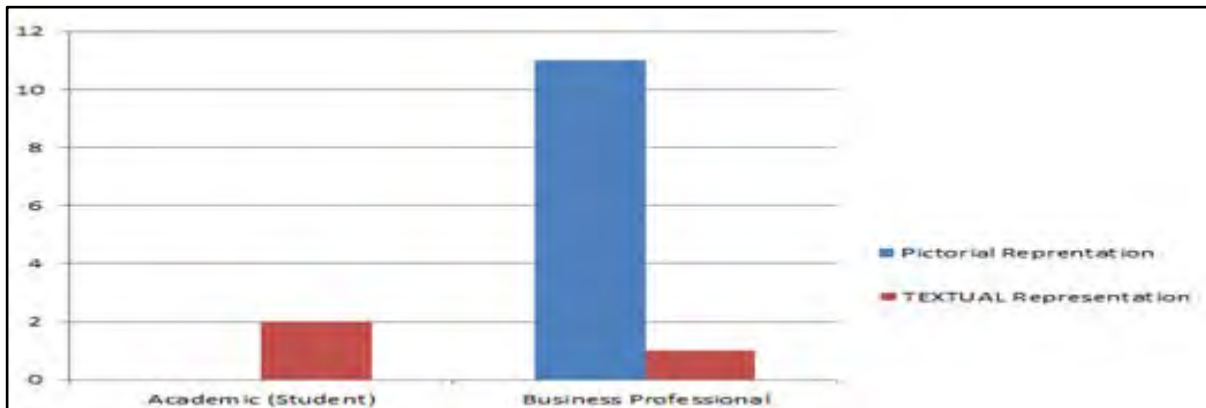

Relationship between Experience (Years of Work) and Preferences

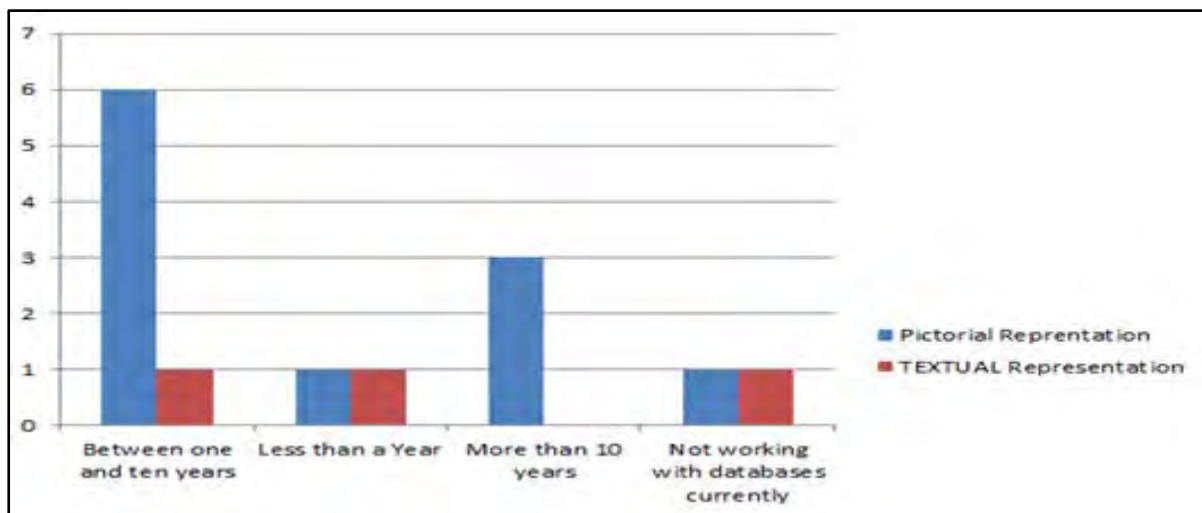

Responses to difference between atemporal and temporal – Open Survey

Relationship of Knowledge vs. Preferences

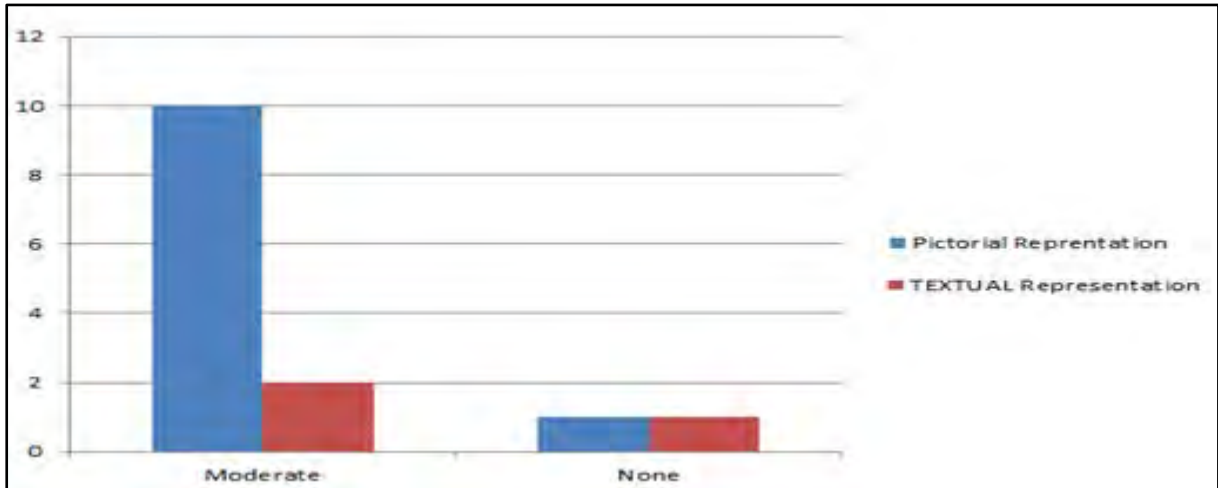

Preference for classes and attributes to have the same colour

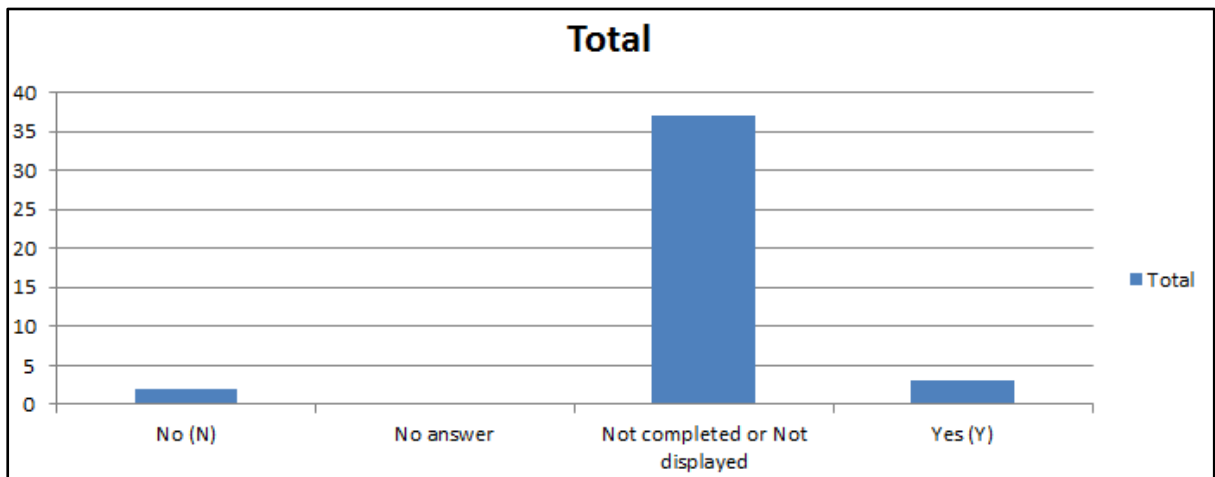

Question 15 with associated Responses

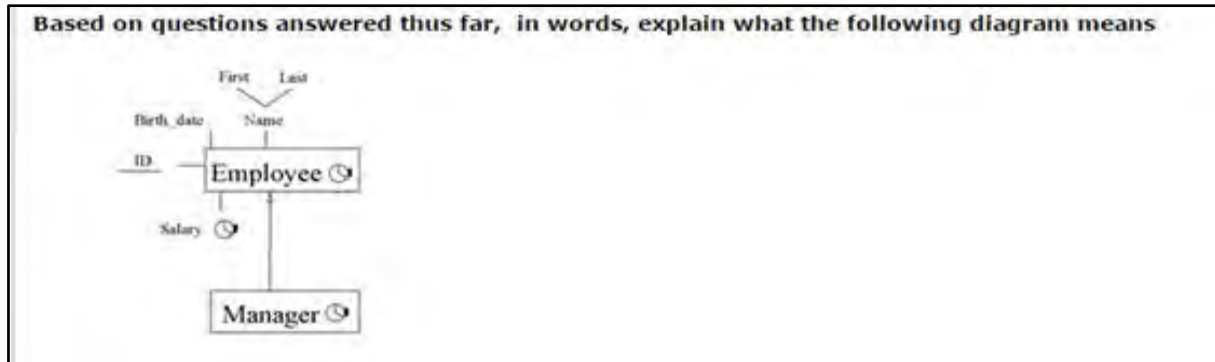

Response
This employee was promoted to a manager at some point and received a salary increase.
Employee and Manager has time events
the employee became a manager
The manager Table has a link to the Employee Table which contains columns with values of the employee information
Relationship diagram
Looks like a nosql db entry
Employee information who happens to be a manager
The relationship between Employee and Manager tables on a database
1 employee can only have 1 manager.
relationship entity
Dont know

Visual Preference for Class

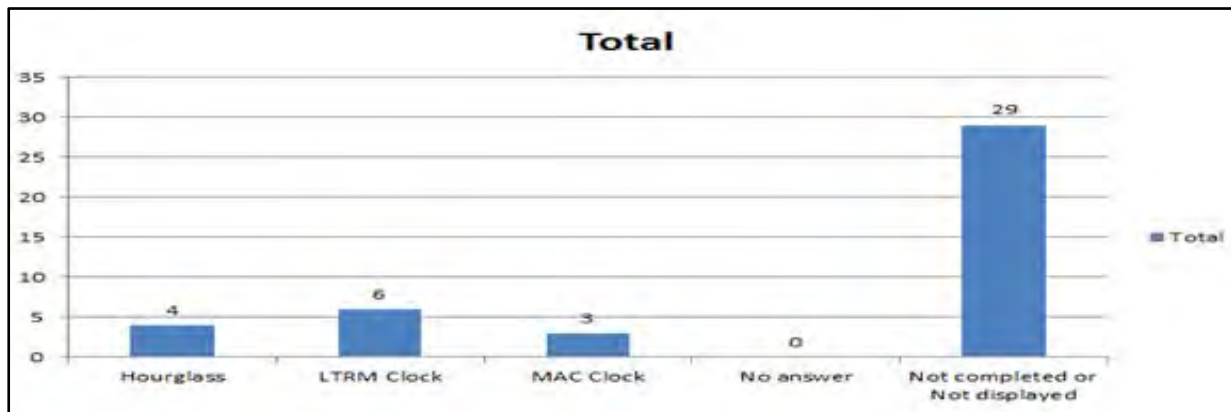

Visual Preference for Attribute

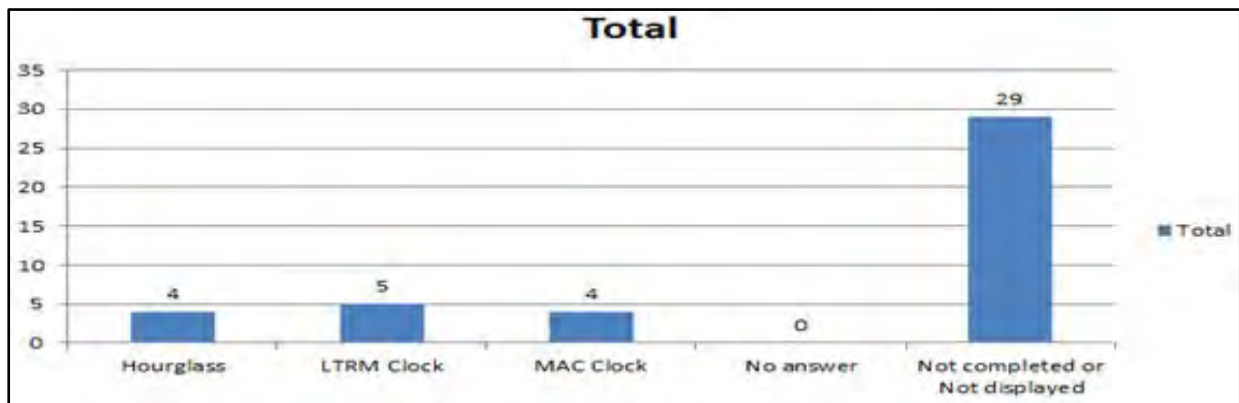

Preference for Conceptual Designs – Open Survey

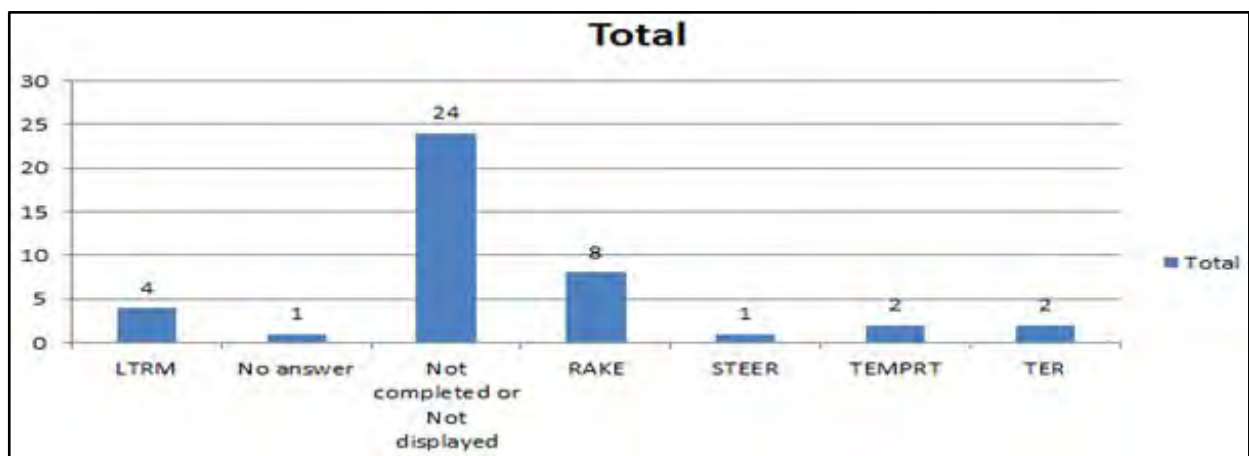

8.2 Appendix 2 – Survey for Experiment Two

Survey on Time Proposal for Information History

Mini-Dissertation submitted in partial fulfillment for the degree of
Master of Science in Information Technology Department of Computing Science University of Cape Town

Dear Students,

We invite all to participate in an online survey to help in the creation of a new visual representation for Temporal Database. Please note that your participation is **entirely voluntary** and you are free to decline to participate in this survey. There will be **no identifying information**. There is no financial remuneration for participating.

If you have any questions or concerns about this study, please feel free to contact Tamindran Shunmugam at shntam002@myuct.ac.za. I am UCT MSc student in the Department of Computer Science being supervised by Dr. Maria Keet. This study has been approved by the Faculty of Science Ethics Committee at The University of Cape Town (ref no: FSREC 081-2014).

There are 13 questions in this survey

Base Group of Questions

[]

Which proposal is justifying the best temporal relations ?

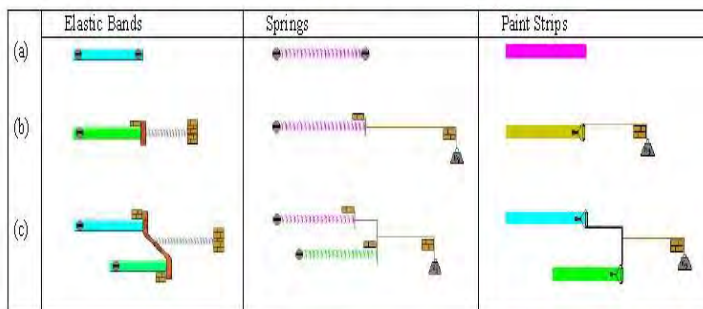







Please choose **only one** of the following:

- Springs
- Elastic Band
- Paint Strips

[]

Overall, how satisfied or dissatisfied are you with the layout ?

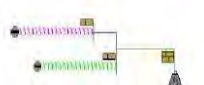
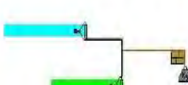
	Elastic Bands	Springs	Paint Strips
(a)			
(b)			
(c)			







Choose 1 as being very dissatisfied and 5 being most satisfied *

Please choose only one of the following:

- 1
- 2
- 3
- 4
- 5

[]

How would you rate the quality of the visualisation ?

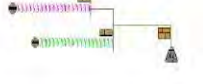
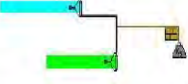
	Elastic Bands	Springs	Paint Strips
(a)			
(b)			
(c)			







Choose 1 as being very dissatisfied and 5 being most satisfied *

Please choose only one of the following:

- 1
- 2
- 3
- 4
- 5

[]

Overall, how would you rate the effectiveness of the visualisation ?

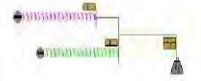
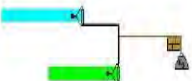
	Elastic Bands	Springs	Paint Strips
(a)			
(b)			
(c)			







Choose 1 as being very dissatisfied and 5 being most satisfied *

Please choose only one of the following:

- 1
- 2
- 3
- 4
- 5

[]

How happy are you with the size and colours in the visualisation ?

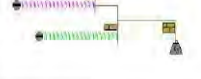
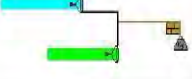
	Elastic Bands	Springs	Paint Strips
(a)			
(b)			
(c)			

Choose 1 as being very unhappy and 5 being very happy

*

Please choose only one of the following:

- 1
- 2
- 3
- 4
- 5

[]

Overall how satisfied or dissatisfied with the three proposals ?

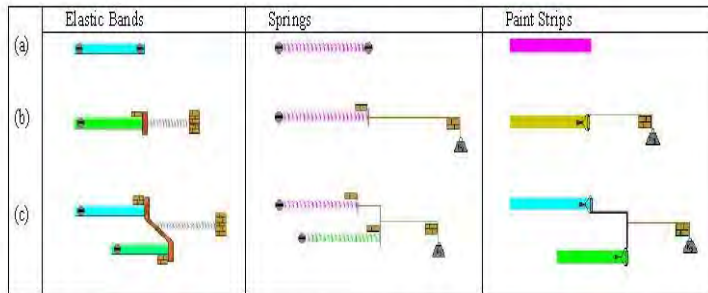

Choose one as being very dissatisfied and 5 being most satisfied *

Please choose only one of the following:

- 1
- 2
- 3
- 4
- 5

[] Which of the following terms would you use to describe the graphical elements ? *

Please choose all that apply:

- Reliable
- High Quality
- Useful
- Unique
- Good Interpretation
- Impracticable
- Hard to read
- Ineffective
- Poor Quality
- unreliable

[]

How would you rate the ability to view the temporal interval ?

	Elastic Bands	Springs	Paint Strips
(a)			
(b)			
(c)			

Choose 1 as being very dissatisfied and 5 being most satisfied *

Please choose only one of the following:

- 1
- 2
- 3
- 4
- 5

[]

Which proposal shows least clarity in terms of the changing period ?

	Elastic Bands	Springs	Paint Strips
(a)			
(b)			
(c)			

Please choose only one of the following:

- Springs
- Elastic Band
- Paint Strips

[]

How does each proposal handle the temporal interval representation ?

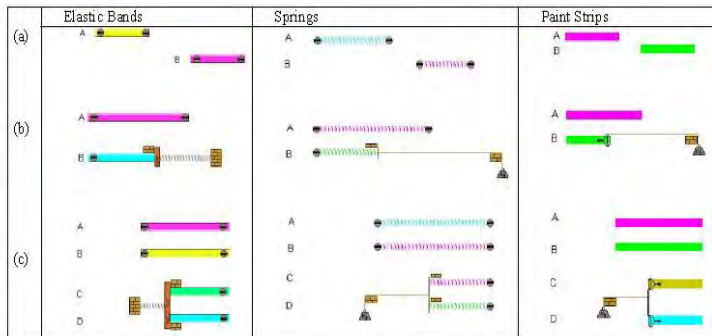

Please choose only one of the following:

- Springs was identifying better than the other two
- Elastic Bands was identifying better than the other two
- Paint strips was identifying better than the other two
- All three the same
- None of them

[]

How likely would you recommend the proposals to a friend or colleague ?

1 being less likely and 10 being most likely *

Please choose the appropriate response for each item:

- 1 2 3 4 5 6 7 8 9 10

8.2.1 Full Results Experiment Two

Q1: Which proposal is justifying the best temporal relations?

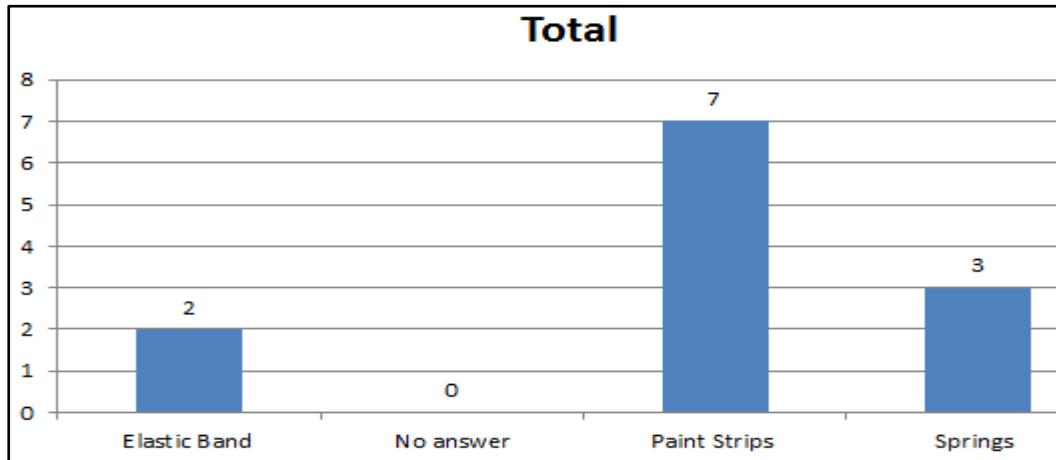

Q2: Overall, how satisfied or dissatisfied are you with the layout?
Choose 1 as being very dissatisfied and 5 being most satisfied

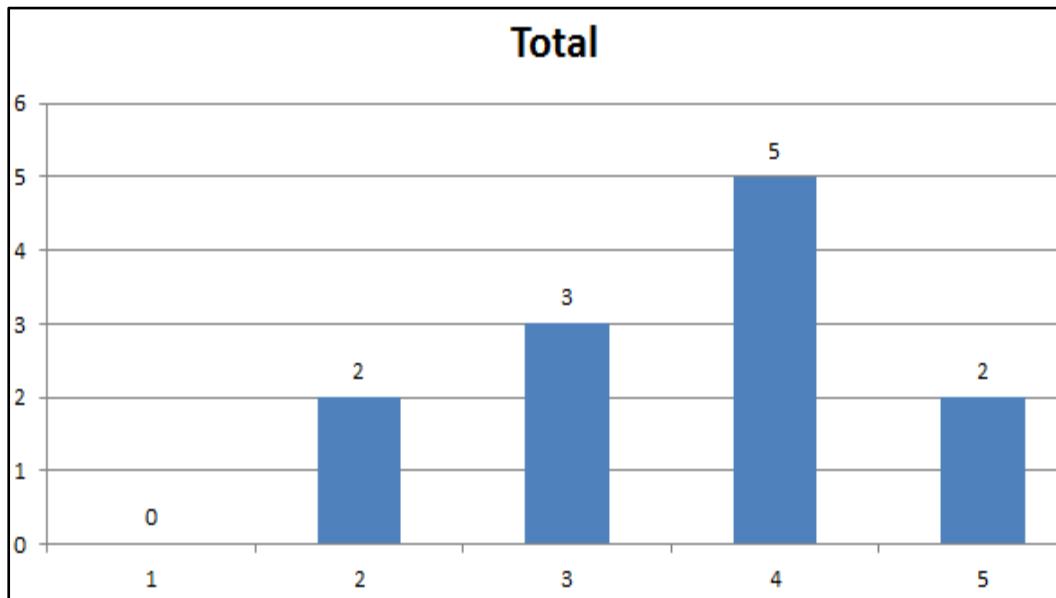

Q3: How would you rate the quality of the visualisation?
Choose 1 as being very dissatisfied and 5 being most satisfied

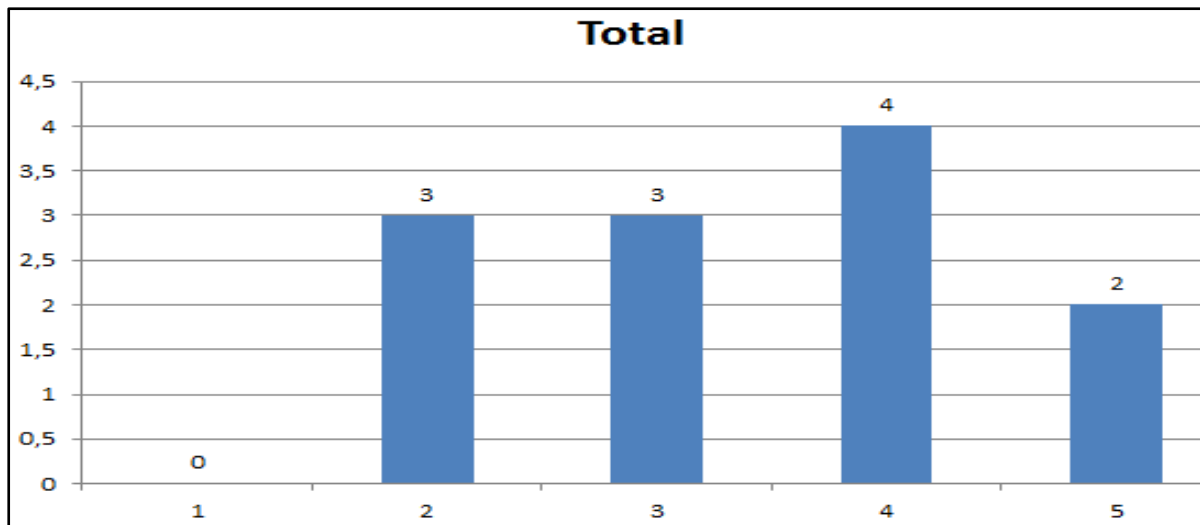

Q4: Overall, how would you rate the effectiveness of the visualisation?
Choose 1 as being very dissatisfied and 5 being most satisfied

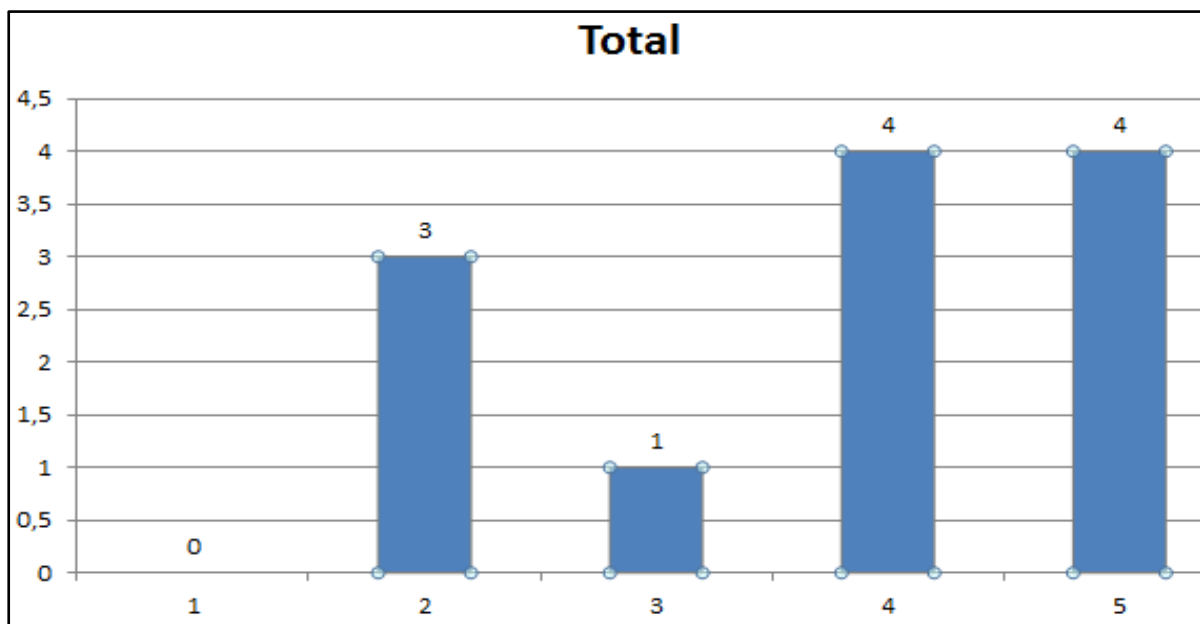

Q5: How happy are you with the size and colours in the visualisation?
Choose 1 as being very unhappy and 5 being very happy

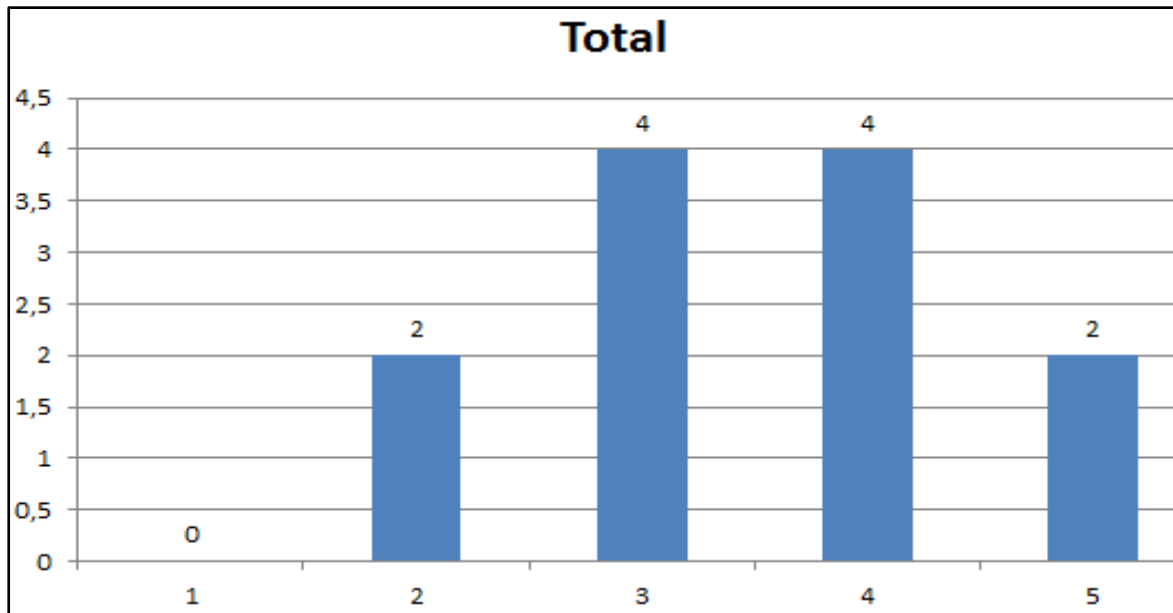

Q6: Overall how satisfied or dissatisfied with the three proposals?
Choose one as being very dissatisfied and 5 being most satisfied

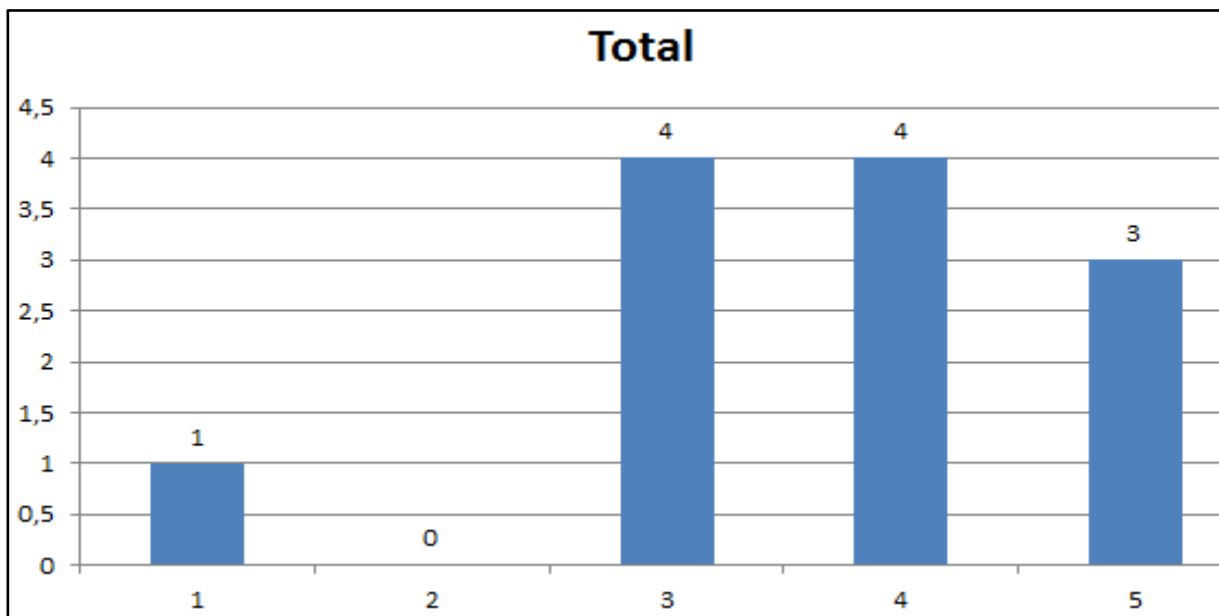

Q7: Which of the following terms would you use to describe the graphical elements?

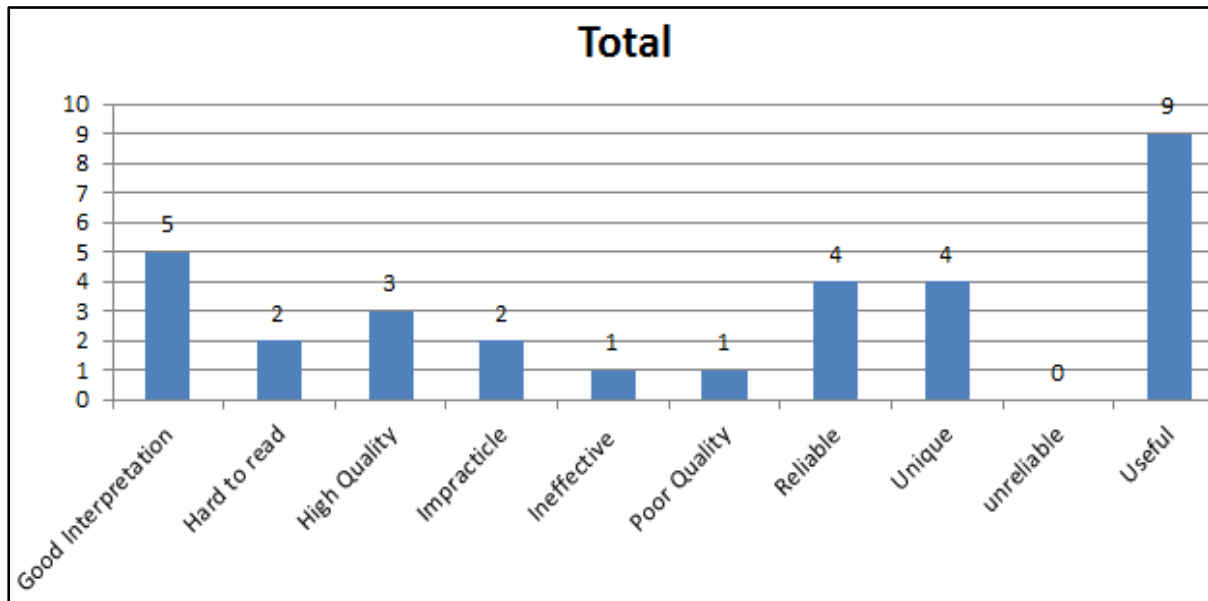

Q8: How would you rate the ability to view the temporal interval?
Choose 1 as being very dissatisfied and 5 being most satisfied

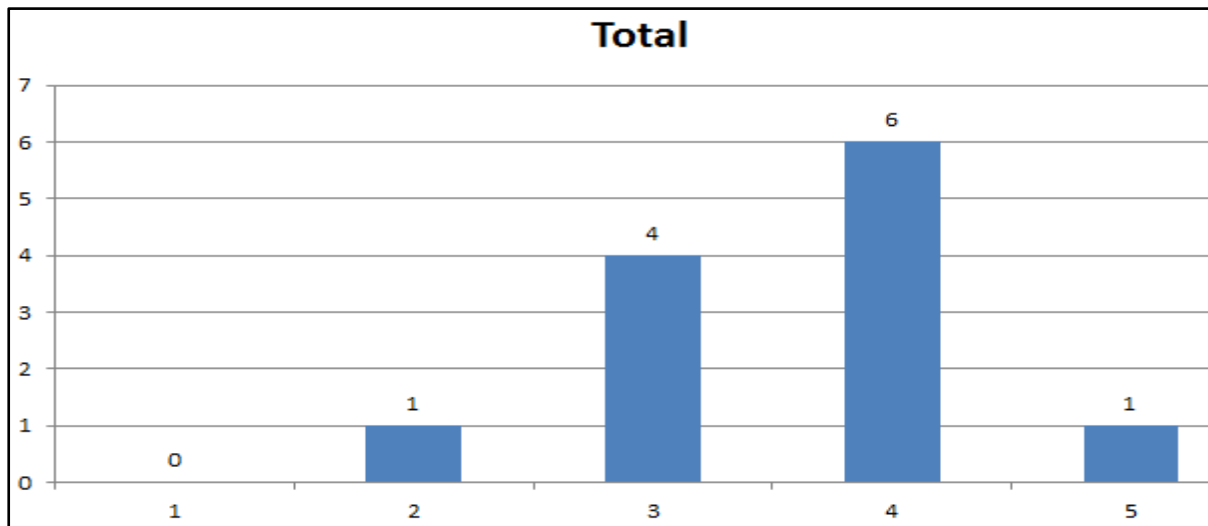

Q9: Which proposal shows least clarity in terms of the changing period?

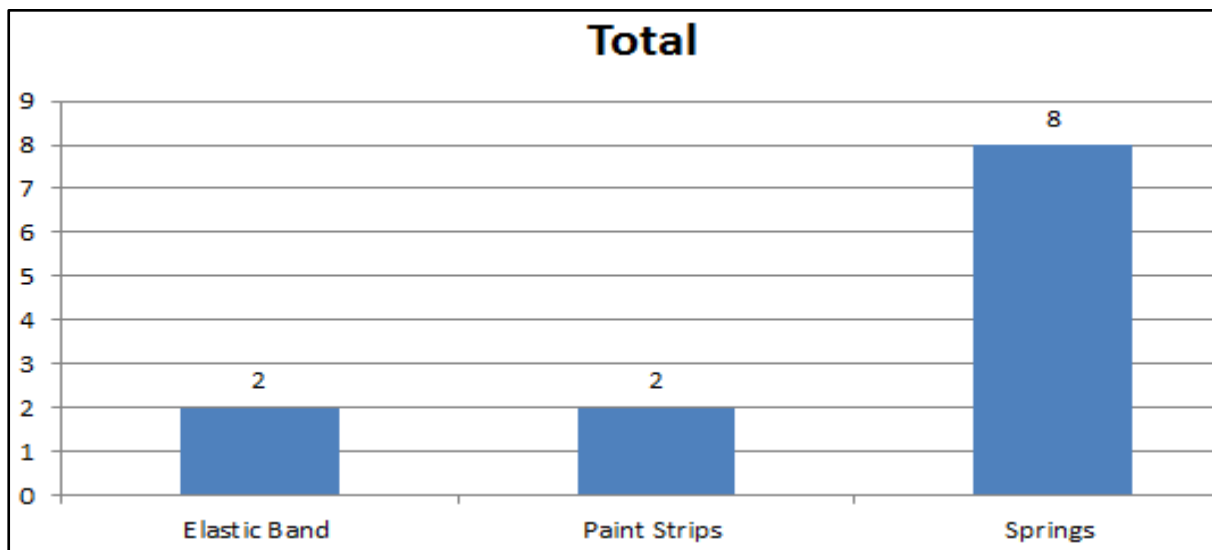

Q10: How does each proposal handle the temporal interval representation?

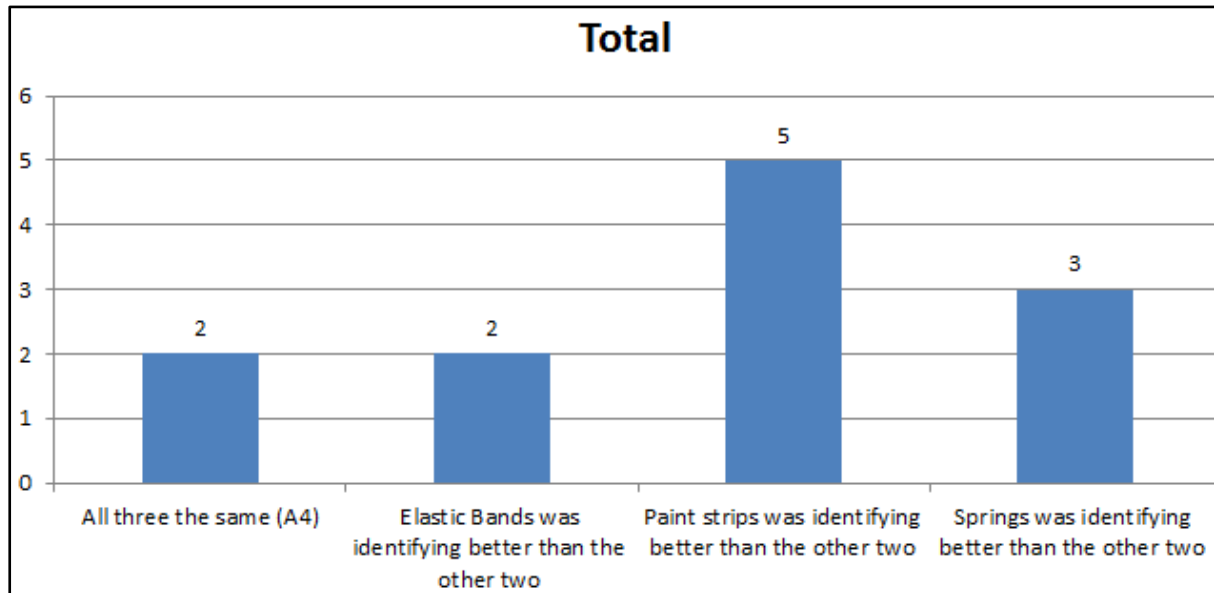

Q11: How likely would you recommend the proposals to a friend or colleague?
 1 being less likely and 10 being most likely

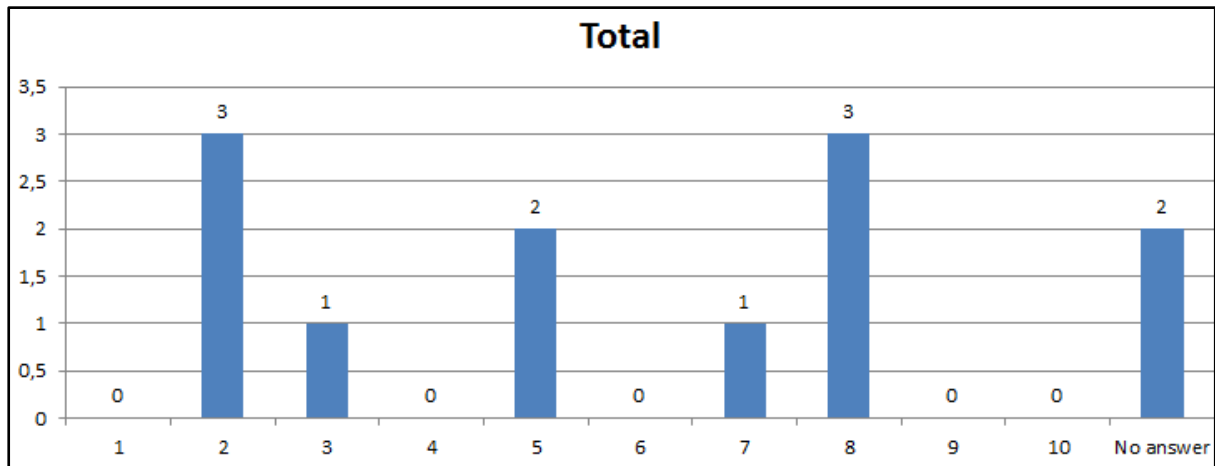

Q12: Please rank the three proposals in preference

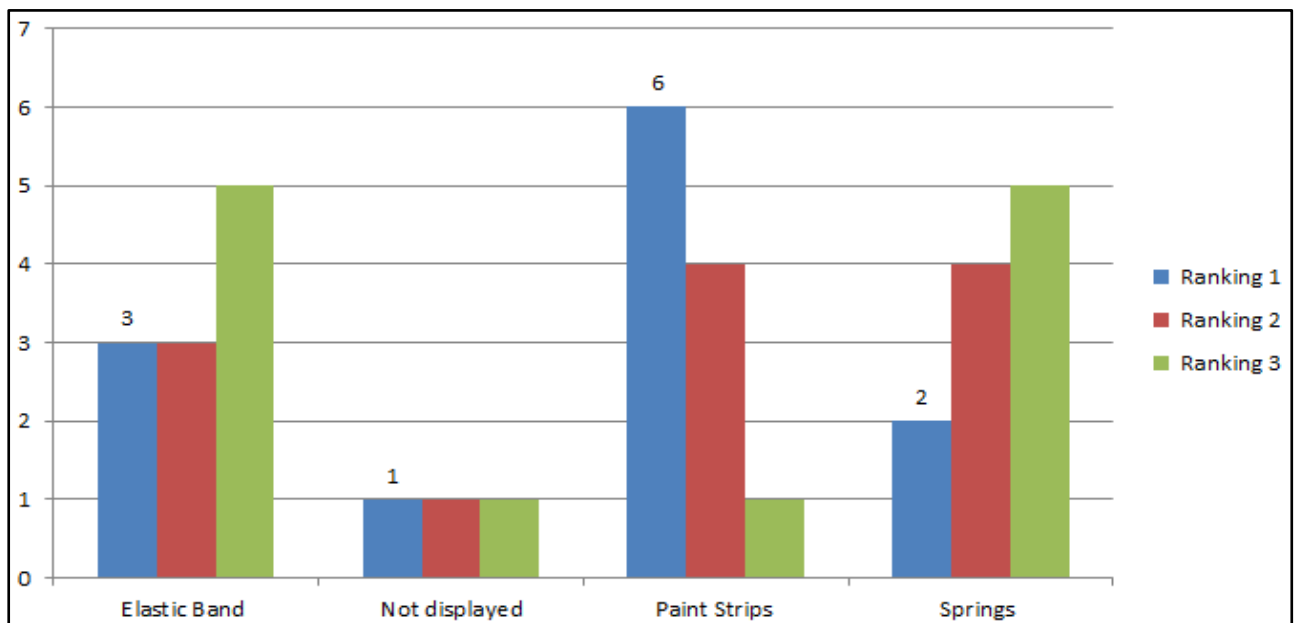

8.3 Appendix 3 – Survey for Experiment Four

Visual Model for changing Data

Mini-Dissertation submitted in partial fulfillment for the degree of
Master of Science in Information Technology Department of Computing Science University of Cape Town

Dear Participants,

We invite all to participate in an online survey to help in the creation of a new visual representation for Temporal Database. Please note that your participation is **entirely voluntary** and you are free to decline to participate in this survey. There will be **no identifying information**. There is no financial remuneration for participating.

If you have any questions or concerns about this study, please feel free to contact Tamindran Shunmugam at shntam002@myuct.ac.za. I am UCT MSc student in the Department of Computer Science being supervised by Dr. Maria Keet. This study has been approved by the Faculty of Science Ethics Committee at The University of Cape Town (ref no: FSREC 081-2014).

There are 10 questions in this survey

Base Group of Questions

[] Please state your profession ? *

Please choose **only one** of the following:

- Academic (Student)
- Academic (Faculty)
- Business Professional
- Other

[] In less than two lines, can you describe the difference between an atemporal database and a temporal database. (If you do not know, then write leave blank)

Please write your answer here:

[] Rate your knowledge of conceptual models for databases? *

Please choose **only one** of the following:

- None
- Moderate
- Excellent
- Guru

[]

Based on questions answered thus far, in words, explain what the following diagram means

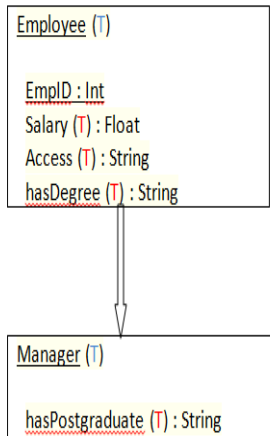

Please write your answer here:

[]

Which of the following icons best represents of a temporal class in your opinion?

- a) Employee (🕒)
- b) Employee (🕒)
- c) Employee (🕒)

*

Please choose only one of the following:

- option a
- option b
- option c

[]

A typical transition in temporal database management is known as dynamic evolution. In this case an object moves from one class to another, eg an middle manager moves to top manager.

Which of the following depictions best represents this transition graphically ? *

Please choose only one of the following:

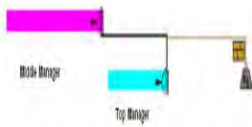
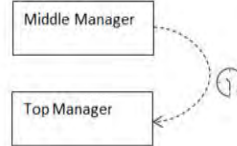
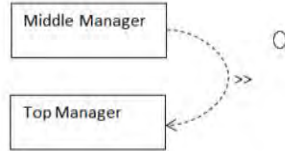
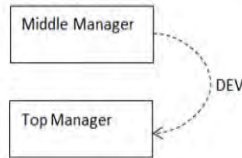

[] Another typical transition in temporal database management is known as dynamic extension. In this case an object exists in two classes , eg an employee becomes a manager. The object will be a member of the employee and the manager class.

Which of the following depictions best represents this transition graphically ?

Please choose only one of the following:

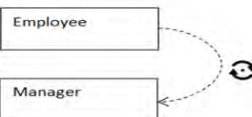
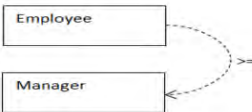
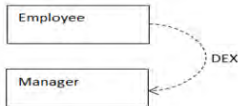



□

Based on questions answered thus far, in words, explain what the following diagram means

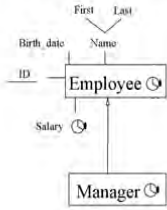



Please write your answer here:

□

Which conceptual model do you prefer ?

*

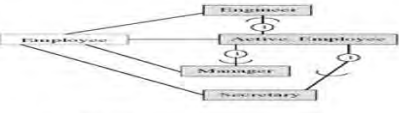
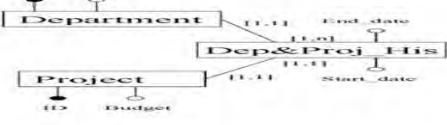
Please choose only one of the following:

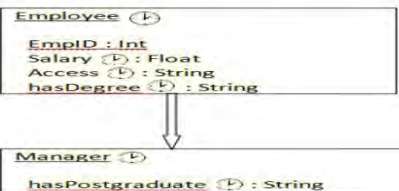
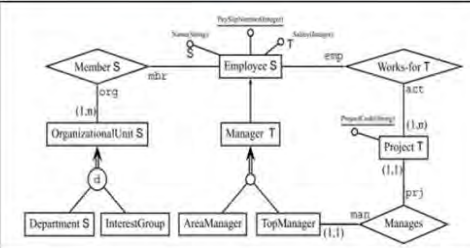
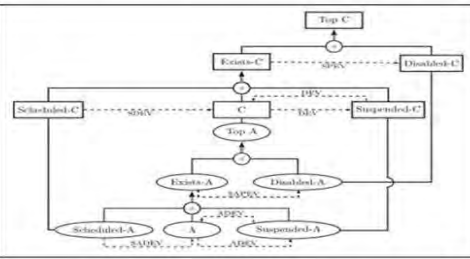
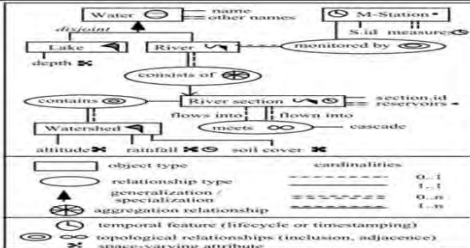
- 
- 
- 
- 
- 
- 
- 
- 

Thank you for your participation
22-12-2015 - 11:08

Submit your survey.
Thank you for completing this survey.

8.3.1 Full Results Experiment 4

Preference for Text or Graphics

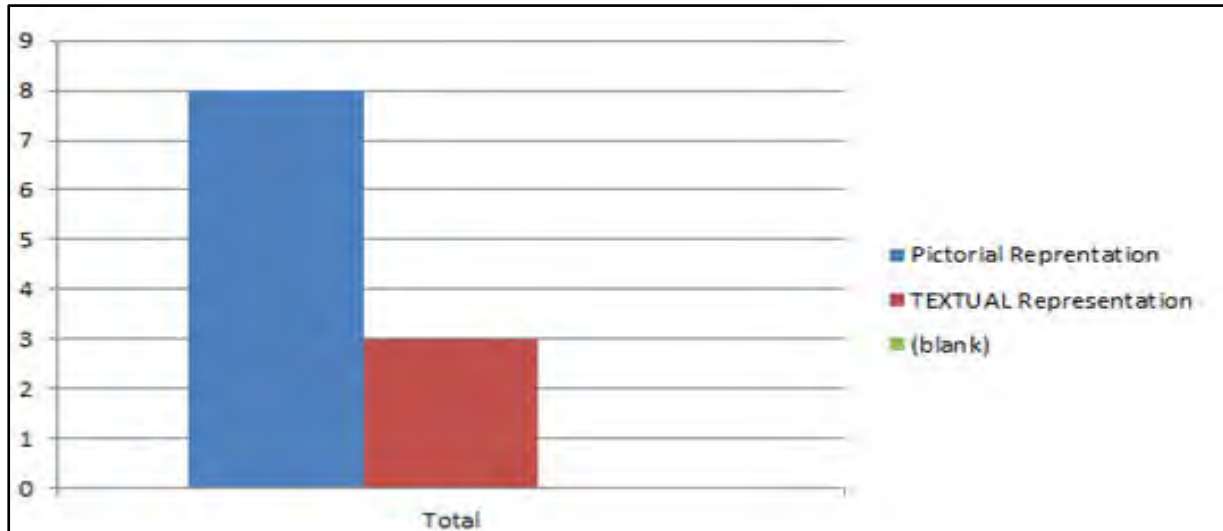

Responses between temporal and atemporal databases after training

<u>Responses relating to difference between atemporal and temporal Databases</u>
atemporal has no historic component
atemporal has data over a period of time
temporal is hard to visualise or even think how it is going to be implemented as history tables can become large
go back to certain date and see what has change I the data - temporal
the big thing in temporal is that I can view data at any time
I still do not completely understand the concept but it gives excellent time tracing
to create a time history in a database
atemporal is time travel database
atemporal shows moments in time
atemporal is complicated
atemporal is based on current db systems. Snapshot
databases with consolidated views over time are temporal

Preference for Text vs. Graphics based on Profession and Experience

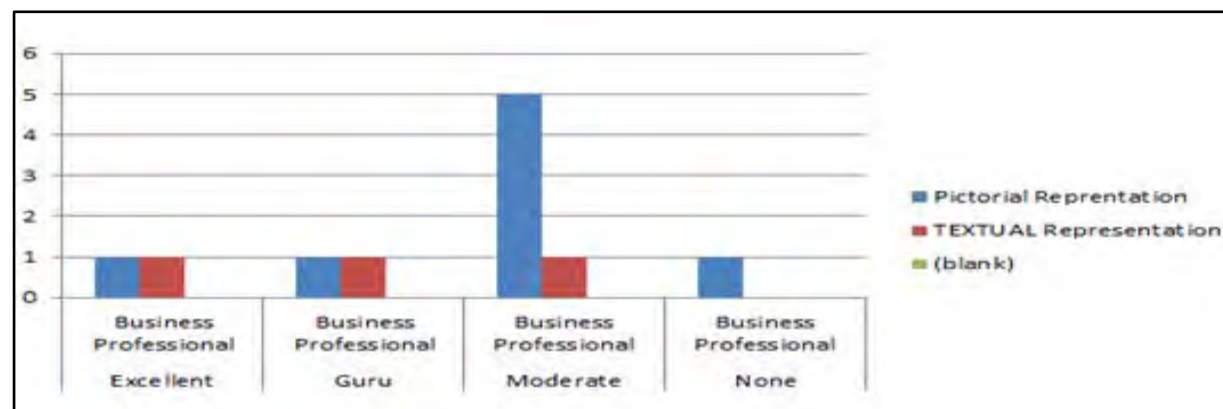

Preference for Conceptual Visual Temporal Class Preference

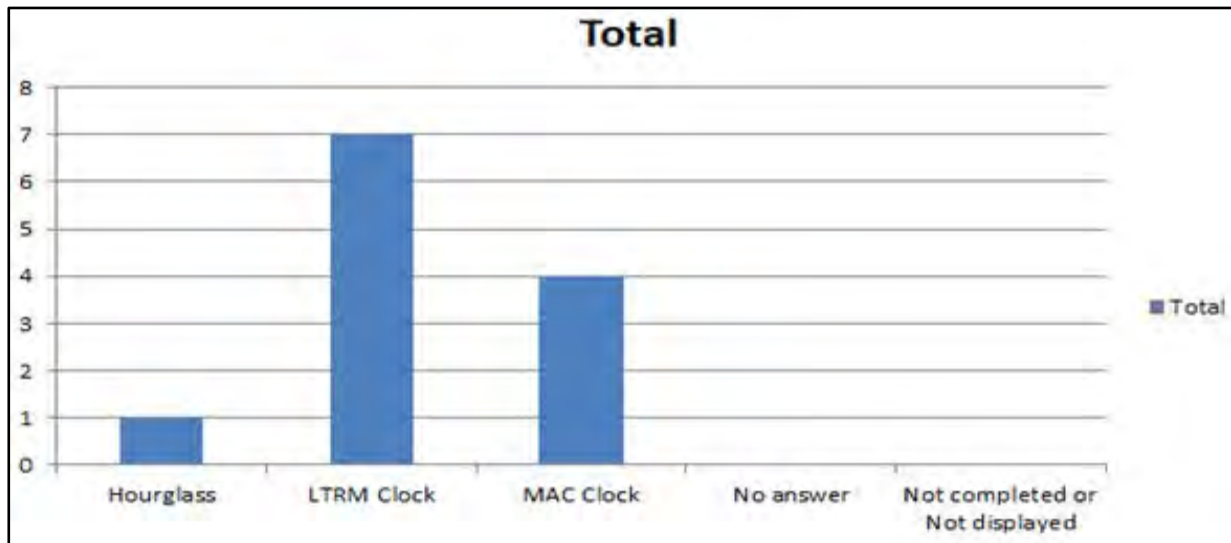
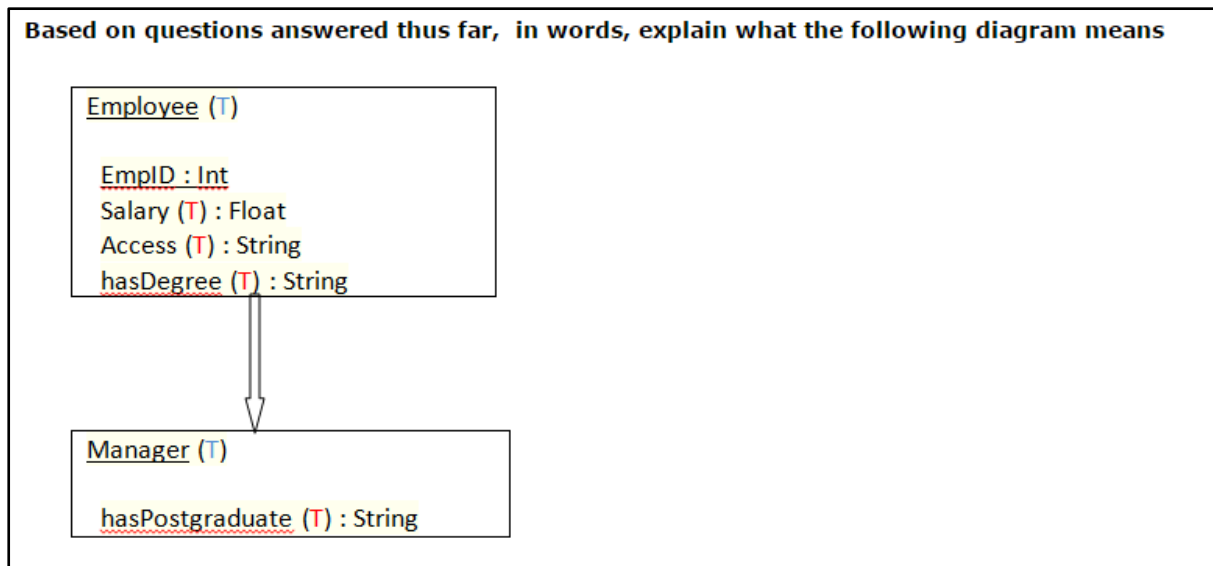
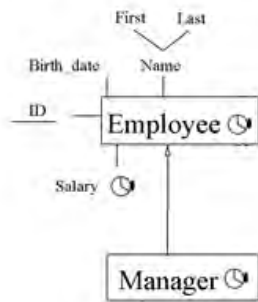

Diagram Responses



Response
T represents temporal aspect
One to many relationship between the tables
relationship diagram showing employees salary etc.
these relate to manager
Employees relate to manager and T is temporal
This is switch from a employee to a specialist employee called a manager
two tables are related over a period of time
employee becomes manager
employee table and Manager table related by emplid
T is temporal
A manager is derived from employee. Temporal classes, attributes represented by T.
View of a table interactions

Based on questions answered thus far, in words, explain what the following diagram means



Response

- employee and manager are temporal objects. Salary is temporal attribute
- Manager field has a relationship with the Employee Table.
- Diagram showing employee salary etc. and manager link if he/she is a manager
- the employee has a manager
- Employee and manager have history. Salary for employee also is time based
- Clock shows that some parts of the diagram need to have time components associated with them
- Manager is also an employee
- Manager is a subclass of employee
- Inheritance based on employee
- Clock is temporal aspects and shows changing over time
- employee is the main class.
- links on diagram with inheritance

Conceptual Model Preferences for closed Study

