

**Hierarchical Decision Making Patterns for the Placement of Physical Supply
Chain Entities**

Zal Navroze Phiroz

**A dissertation submitted to the University of Cape Town in fulfillment of the requirements
for the degree of Doctor of Philosophy in the Graduate School of Business.**

**Cape Town
2016**

Approved By:

Richard Chivaka

The copyright of this thesis vests in the author. No quotation from it or information derived from it is to be published without full acknowledgement of the source. The thesis is to be used for private study or non-commercial research purposes only.

Published by the University of Cape Town (UCT) in terms of the non-exclusive license granted to UCT by the author.

© 2016
Zal Navroze Piroz
ALL RIGHTS RESERVED

ABSTRACT

Zal Navroze Phiroz : Hierarchical Decision Making Patterns for the Placement of Physical Supply Chain Entities (Under the direction of Dr. Richard Chivaka)

One of the most important areas of development within the evolution of commerce, is the acknowledgement that businesses can no longer compete as individual entities, but rather must function as part of a supply chain. Within an ever-competitive business environment, the ultimate success of a business can often be tied directly to the overall functionality and efficiency of its supply chain.

Research within the area of supply chain management is vast, with prior contributions exploring the function of a supply chain from a plethora of social, economic, and commerce perspectives. Prior research has extended to evaluate multiple industries and geographies, over a number of economic and social issues (e.g. environmental sustainability through transport route modification, poverty reduction through global value chain refinement), along with core management and commerce areas (e.g. marketing initiatives through production cycle analysis, operations management through production capacity). Substantial contributions exist which focus on the role of supply chain management and the value of refining, optimizing and designing a chain to the requirements of an industry, economic environment, or business process. In addition to investigation on the definition, function, and applicability of the concept, prior contributions have effectively demonstrated the value of supply chain management in gaining competitive advantage, and improving the overall performance of a business. The notion that supply chain efficiency defines business advantage, has led to exploration of physical configurations and specifications of supply chains; with the primary undertone often centering around evaluating drivers of supply chain optimization, and therein organizational performance.

Within existing research, the process of physical site placement, and managerial decision makers within an organization are identified as being key factors in the optimization of a supply chain. As such, a number of prior studies have investigated the drivers which influence physical location decisions, with the majority of research focusing on the impact of geographical location factors. Other studies have centered on the impact of management structure as a catalyst in refining and optimizing a supply chain. While significant research has focused on both areas individually (Barney, 1991; Chopra & Meindl, 2002; Christopher, 1998), relatively little attention has been placed on evaluating the correlation between these paradigms, and therein exploring the root drivers for management decisions. There appears to be substantial value in directly investigating this relationship, as the analysis of this interaction would provide a comprehensive interpretation of specific factors contributing to physical supply chain development decisions.

This research evaluated decision making drivers impacting the placement of physical supply chain entities using augmented qualitative and quantitative primary data. One of the main

objectives of this study was to define the accepted sequence of decision making priority with respect to land value determination, transportation and accessibility considerations, and tax incentive structures. Data for the study was collected through electronic surveys and interviews, from supply chain managers working at organizations with a minimum annual revenue of \$1,000,000 USD. The proposed relationships were evaluated using rigorous statistical analysis including factor analysis and structural equation modelling.

Results indicated the existence of a clear sequence in decision structure, with a measurable pattern of priority placed on specific decision criteria. Aspects of corporate culture within the scope of supply chain decision making were explored with insight into the foundation for physical site evaluation. Empirical data suggested the value of land as having the most substantial influence when making physical location decisions. A number of factors influence how managers determine land value, however the location of a site and its proximity to a firms affiliates (e.g. potential partners, strategic alliances) were identified as having the strongest impact. Other considerations including transportation structures, tax incentives, and the ability of a firm to attract highly productive labor also influenced location decisions, albeit to a lesser degree. While prior research suggests businesses often design supply chains with the intention of attracting inexpensive labor, the results of this study were contradictory. Specifically, this study identified a common hierarchical decision making structure, and finds businesses often place value on highly productive labor (not inexpensive labor) when making supply chain location decisions.

Fundamentally, the results presented in this study allows firms to gain insight on how decision makers process and interpret information. Establishing the pattern and sequence of decision making priority in the initial physical site placement stage is critical in ascertaining how supply chain networks develop and grow. From an economic standpoint, findings from this study could be applied to competitor assessment, growth planning, and managerial assessment. Based on the notion that competition takes place through supply chain performance, the practical applications of this study provide a meaningful foundation for optimization and therefore competitive advantage. On a larger scale, this contribution is substantial, as it holds value to both academic and business paradigms in further evaluating the definition and optimization potential of a supply chain, and in providing insight into additional areas of business competitiveness.

ACKNOWLEDGEMENTS

The completion of this dissertation would not have been possible without the encouragement, guidance and consistent support from my supervisor Dr. Richard Chivaka.

The gratitude I have to my family, friends and those along the way who have surrounded and supported me, is beyond what words can describe. A special thank you to my mother, and to my grandfather who throughout my upbringing would assert the following quote...

“Impossible is a word to be found only in the dictionary of fools” – Napoleon Bonaparte.

TABLE OF CONTENTS

LIST OF TABLES	v
LIST OF FIGURES	vii
LIST OF ABBREVIATIONS	x
1.0 INTRODUCTION	11
1.1 Introduction.....	11
1.2 Background.....	12
1.3 Problem Statement.....	16
1.4 Rationale of the Study.....	19
1.5 Research Objectives.....	19
1.5.1 General Objective	20
1.5.2 Specific Objectives	20
1.6 Research Questions.....	20
1.7 Hypotheses.....	21
1.8 Significance of the Study.....	22
1.9 Conclusions.....	23
2.0 LITERATURE REVIEW	25
2.1 Introduction.....	25
2.2 What is Supply Chain Management?.....	26
2.3 The Importance of Supply Chain Management.....	32
2.4 Objectives and Principles of Supply Chain Management	33
2.5 Role of Supply Chain Management.....	37

2.6 The Literature of Supply Chain Management	38
2.7 Theories Explaining Supply Chain Management Elements	43
2.7.1 The Relational Based View.....	43
2.7.2 The Innovation Based View.....	44
2.7.3 The Transaction Cost Economics Theory View	46
2.7.4 The Resource Based View	48
2.7.5 The Knowledge Based View	55
2.8 Comparison of Knowledge Based and Resource Based views.....	59
2.9 Selection of Theory.....	60
2.10 Conclusions.....	62
3.0 RESEARCH METHODOLOGY	64
3.1 Introduction.....	64
3.2 Research Philosophy.....	65
3.3 Research Approach.....	66
3.4 Research Ontology, Epistemology, Axiology	69
3.5 Research Strategy	70
3.5.1 Interview Approach	72
3.5.2 Survey Approach	74
3.6 Data Collection Approaches	76
3.6.1 Instrumentation of survey	77
3.7 Data Analysis.....	78
3.7.1 Unit of Analysis.....	79
3.7.2 Statistical Technique.....	80
3.7.3 Factor Analysis	81
3.7.4 Structural Equation Modelling.....	83
3.8 Research Validity and Reliability.....	85
3.9 Ethical Considerations	87
3.10 Conclusions.....	87

4.0 RESULTS	89
4.1 Introduction.....	89
4.2 Survey Respondent Demographics.....	90
4.3 Transportation Decisions, Tax Structures & Land Value Affecting Physical Location Decisions.....	97
4.4 Transportation Decisions and Tax Structures Affecting Land Value.....	108
4.5 Economic Impact of Transportation Decisions, Land Value and Tax Structures.....	117
4.6 Key Insights Identified From Survey Data.....	120
4.7 Interview Data Approach.....	123
4.8 Interview Respondent Demographics.....	124
4.9 Tangible vs. Intangible Resources for Physical Location Decisions.....	124
4.10 Impact of Transportation and Land Value on Physical Location Decisions	126
4.11 Impact of Transportation, Land Value & Tax Structure on Physical Location Decisions Considering Varying Interpretations of Value.....	128
4.12 RBV vs. KBV on Physical Location Decisions.....	129
4.13 Reasons for Physical Location Decisions Being Resource or Knowledge Based.....	130
4.14 RBV vs. KBV Based Policy Amendments in Making Physical Location Decisions.....	132
4.15 RBV vs. KBV in Isolation Supporting a Physical Location Decision.....	133
4.16 Resource Based Culture Shift in Management for Physical Location Decisions.....	134
4.17 Maintenance of Historical Records for Knowledge Sharing.....	136
4.18 Conclusions.....	138
5.0 DISCUSSION, FINDINGS AND IMPLICATIONS	142
5.1 Introduction.....	142
5.2 Exploratory Factor Analysis – Physical Location Decisions (PLD)	143
5.3 Exploratory Factor Analysis – Land Value Decisions (LVD).....	148
5.4 Exploratory Factor Analysis – Economic Impact (EI)	152
5.5 Confirmatory Factor Analysis	156
5.5.1 Measurement Model and Goodness of Fit (Physical Location Decisions).....	156
5.5.2 Convergent and Discriminant Validity (Physical Location Decisions).....	157
5.5.3 Measurement Model and Goodness of Fit (Land Value Decisions).....	158
5.5.4 Convergent and Discriminant Validity (Land Value Decisions).....	159
5.6 Structural Equation Modeling (SEM).....	160
5.7 Qualitative Data Analysis	164

5.8 Summary of Data Analysis	168
5.9 Discussion of Key Findings	169
5.9.1 Consistent Research Areas.....	170
5.9.2 Conflicting Research Areas	172
5.9.3 Directions for Future Research	175
5.9.4 Managerial Implications	177
5.10 Conclusions.....	179
6.0 CONCLUSIONS, KEY CONTRIBUTIONS AND FURTHER RESEARCH	183
6.1 Introduction.....	183
6.2 Confirmation of Hypotheses	184
6.2.1 Hypothesis 1 (H1).....	184
6.2.2 Hypothesis 2 (H2).....	184
6.2.3 Hypothesis 3 (H3).....	185
6.2.4 Hypothesis 4 (H4)	185
6.3 Conclusions and Key Contributions	185
6.3.1 Conclusions and Key Contributions From Quantitative Analysis.....	187
6.3.2 Conclusions and Key Contributions From Qualitative Analysis.....	191
6.4 Applicability of Findings	195
6.5 Limitations of The Study	198
6.6 Suggestions For Further Research	200
6.7 Conclusions.....	201
7.0 REFERENCES.....	203
8.0 APPENDIX.....	216
Appendix 1: Correlations.....	216
Appendix 2: Interview Questionnaire.....	217
Appendix 3: Survey Questionnaire.....	219

LIST OF TABLES

Table 1: Critical Factors in Location Decisions	15
Table 2: Interpretations of Supply Chain Management.....	28
Table 3: Areas of Supply Chain Management and Effect on Competitive Advantage	40
Table 4: What is your present title within your current company?.....	90
Table 5: Within your current role, what is your area of focus? (Other)	93
Table 6: Other than the factors mentioned above, list any transportation, land value or tax related factor which your company considers when making physical location decisions.....	107
Table 7: Other than the factors mentioned above, list any other transportation or tax related factors which your company considers when determining or evaluating land value for physical supply chain entities.....	116
Table 8: What is your role, responsibility title and focus within your company?	124
Table 9: In making physical location decisions, does the company put emphasis on comparing tangible and mobile resources as opposed to intangible and immobile resources, or vice versa? Identify the reasons.	124
Table 10: How do transportation factors and overall land value analysis influence physical location decisions, considering that these factors are often variable, regularly changing, and unsustainable?	126
Table 11: How do transportation, land value and tax structure influence physical location decisions assuming decision makers may have different opinions, interpretations and knowledge on resource tangibility and importance?	128
Table 12: Are physical location decisions more dependent on a knowledge based view (the belief that the knowledge held by decision makers is most important) or a resource based view (the belief that tangible or intangible resources at the firm's disposal are most important)?.....	129
Table 13: What are the reasons for why physical location decisions are based on a knowledge based view or resource based view?	130
Table 14: Over the course of your employment with the company, in terms of physical location decisions, have there been any amendments in policies to shift from the paradigm of resource based view decisions to knowledge based view decisions, or vice versa? If yes, what amendments do you see?	132
Table 15: Do you believe that a resource based paradigm or a knowledge based paradigm cannot support a physical location decision in isolation. Why?.....	133

Table 16: Aside from policy shifts, has the management culture of the company shifted to integrate the resource based paradigm of the physical location decision determinants/factors with a knowledge based paradigm? What shifts have you observed?	134
Table 17: Does the company plan location decisions on the basis of historical information of location determinants which might be available? If yes, how does the company maintain historical records for knowledge sharing among the decision making hierarchy?	136
Table 18: Communalities (Physical Location Decisions)	143
Table 19: Total Variance Explained (Physical Location Decisions)	144
Table 20: Pattern Matrix (Physical Location Decisions)	145
Table 21: Factor Correlation Matrix (Physical Location Decisions)	146
Table 22: Communalities (Land Value Decisions)	148
Table 23: Total Variance Explained (Land Value Decisions)	149
Table 24: Pattern Matrix (Land Value Decisions)	150
Table 25: Factor Correlation Matrix (Land Value Decisions)	151
Table 26: Communalities (Economic Impact)	152
Table 27: Total Variance Explained (Economic Impact)	153
Table 28: Factors and Included Variables with Mean and Standard Deviation	154
Table 29: Goodness of Fit (Physical Location Decisions)	157
Table 30: Convergent and discriminant validity (Physical Location Decisions)	158
Table 31: Goodness of fit (Land Value Decisions)	159
Table 32: Convergent and discriminant validity (Land Value Decisions)	160
Table 33: Goodness of Model Fit Indicators	162
Table 34: Standardized Regression Weights and Statistical Significance	162

LIST OF FIGURES

Figure 1: What was your company’s approximate revenue in 2014 (in US Dollars)?	91
Figure 2: What is the size of your company, in terms of employees?	92
Figure 3: Within your current role, what is your area of focus?	92
Figure 4: What is your present title within your current company?	93
Figure 5: ‘Other’ responses to ‘What is your present title within your current company?’	94
Figure 6: Within your current role, which geographic region/s do you focus on?	94
Figure 7: Within your current capacity, what level of contribution do you have toward physical resource decisions (i.e. placement of warehouses, manufacturing plants etc.)?.....	95
Figure 8: ‘Other’ responses to ‘Within your current capacity, what level of contribution do you have toward physical resource decisions (i.e. placement of warehouses, manufacturing plants etc.)?’	95
Figure 9: How long have you worked in your current role?.....	96
Figure 10: How long have you worked within your current company?	96
Figure 11: Part A: Land Location Related Decisions -Physical land maintenance cost.....	97
Figure 12: Part A: Land Location Related Decisions -Land rental/ownership cost	98
Figure 13: Part A: Land Location Related Decisions - Flexibility of land usage, and possibility of land usage change	98
Figure 14: Part A: Land Location Related Decisions - Size/area of land.....	99
Figure 15: Part A: Land Location Related Decisions - Layout/dimension of land site	99
Figure 16: Part A: Land Location Related Decisions - Social policy and/or political risk of the region	100
Figure 17: Part A: Land Location Related Decisions - Proximity to affiliates (e.g. potential partners, strategic alliances, competing businesses).....	100
Figure 18: Part B: Transportation and Accessibility Decisions -Proximity to strategic partners (e.g. suppliers).....	101
Figure 19: Part B: Transportation and Accessibility Decisions-Proximity to target markets.....	101
Figure 20: Part B: Transportation and Accessibility Decisions-Accessibility to customers	102
Figure 21: Part B: Transportation and Accessibility Decisions-Strategic visibility of location from roads and highways	102

Figure 22: Part B: Transportation and Accessibility Decisions-Availability of parking area for trucks etc.	103
Figure 23: Part B: Transportation and Accessibility Decisions-Approachability to roads and freeways	103
Figure 24: Part B: Transportation and Accessibility Decisions-Availability of favorable labor	104
Figure 25: Part B: Transportation and Accessibility Decisions-Access for Private Vehicles	104
Figure 26: Part B: Transportation and Accessibility Decisions-Potential for automated transportation	105
Figure 27: Part C: Tax and Incentive Structures-Government tax incentives	105
Figure 28: Part C: Tax and Incentive Structures-Overall tax cost of the site	106
Figure 29: Part C: Tax And Incentive Structures-Government sponsored economic incentives	106
Figure 30: Part A: Land Location and Transportation Decisions-Proximity to strategic partners (e.g. suppliers).....	108
Figure 31: Part A: Land Location and Transportation Decisions-Proximity to affiliates (e.g. potential partners, strategic alliances, competing businesses)	108
Figure 32: Part A: Land Location and Transportation Decisions-Availability of diversified transport facilities.....	109
Figure 33: Part A: Land Location and Transportation Decisions-Overall transportation cost ...	109
Figure 34: Part A: Land Location and Transportation Decisions-Strategic visibility of location from roads and highways	110
Figure 35: Part A: Land Location and Transportation Decisions-Availability of parking area for trucks etc.	110
Figure 36: Part A: Land Location and Transportation Decisions-Approachability to roads, freeways etc.	111
Figure 37: Part A: Land Location and Transportation Decisions-Availability of favorable labor	111
Figure 38: Part A: Land Location and Transportation Decisions-Access for private vehicles ..	112
Figure 39: Part A: Land Location and Transportation Decisions-Potential for integration of automated transportation.....	112
Figure 40: Part A: Land Location and Transportation Decisions-Architecture of loading/unloading spaces	113
Figure 41: Part A: Land Location and Transportation Decisions-Price per square meter in comparison to similar sites.....	113

Figure 42: Part A: Land Location and Transportation Decisions-Social policy and/or political risk of the region	114
Figure 43: Part B: Tax and Incentive Structures-Overall tax cost of the site	114
Figure 44: Part B: Tax and Incentive Structures-Potential for tax reduction	115
Figure 45: Part B: Tax and Incentive Structures-Government sponsored economic incentives	115
Figure 46: Land value of physical entities has significant economic impact on the company...	117
Figure 47: Land value of physical entities has significant economic impact on the efficiency of the supply chain.	117
Figure 48: Tax structures and government incentives have a significant economic impact to the operational functionality of the firm.	118
Figure 49: Tax structures and government incentives have a significant economic impact on the supply chain value of the firm.	118
Figure 50: It is important to consider land value factors, when determining new physical locations of supply chain entities.....	119
Figure 51: It is important to consider transportation and accessibility factors, when determining new physical locations of supply chain entities.....	119
Figure 52: Scree Plot (Physical Location Decisions)	145
Figure 53: Scree Plot (Land Value Decisions)	150
Figure 54: Scree Plot (Economic Impact).....	153
Figure 55: Measurement model (Physical Location Decisions).....	157
Figure 56: Measurement model (Land Value Decisions).....	159
Figure 57: Structural Model of Land Value Determination, Physical Location Decisions and Economic Impact on Overall Chain and Firm	161

LIST OF ABBREVIATIONS

AVE	Average Variance Extracted
ASV	Shared Average Variance
CFI	Comparative Fit Index
CR	Composite Reliability
EI	Economic Impact
FMCG	Fast Moving Consumer Goods
GFI	Goodness of Fit Index
KBV	Knowledge Based View
LL	Land Location
LV	Land Value
LVD	Land Value Determination
MSV	Maximum Shared Variance
NFI	Normed Fit Index
PLD	Physical Location Decisions
RMR	Root Mean Square Residual
RMSEA	Root Mean Square Error of Approximation
RBV	Resource Based View
TAD	Transportation and Accessibility Decisions
TR	Transportation Decisions
TS	Tax Structure
TLI	Tucker-Lewis Index

1.0 CHAPTER ONE : INTRODUCTION

1.1 Introduction

An efficient and effective supply chain plays a crucial role in the process of production and therein commerce. This role is clearly reflected through the attention afforded to the overall study of supply chain management.

Prior research has focused on a variety of perspectives within the area of supply chain management. Penrose (1959), Bartlett (1954), and Guttman (1954) provide insight into research prior to 1975 focusing on the assessment of individual corporations, whereas Kaiser (1974) and McFadden (1974) point to research taking place before 1995 focused more so on the overall supply chain function. In evaluating the functionality of a supply chain, physical facility placement emerges as a key source of competitive advantage, and as such, the decision process maintained in the placement of physical supply chain entities is core. Opportunity exists to further existing research in the area, and expand on opportunities for competitive advantages through supply chain refinement.

The purpose of this study was to explore the underlying decision making structures which drive the placement of physical supply chain entities. In forming a framework to extract value from this proposed area of research, the background of the concept of supply chain management were discussed. A further examination of the significance and rationale of the study, also presents the value proposed by undertaking this area of research.

1.2 Background

Through various studies and observation, it has been established that supply chain management constitutes a major component of competitive strategies which enhance organizational productivity and profitability (Gunasekaran, Patel & McGaughey, 2004) while today's business environment trends often focus on exerting pressure on organizations to improve areas in which value can be added to enable a sustainable competitive advantage in the industry. Critical areas within the study which can be identified include supply and demand planning, procurement of material, and production planning (Shahrzad et al., 2013). Other critical items include maintenance of products and services, wastage assessment, inventory control, distribution structure, delivery model and customer service. One consequential result of this assessment and the criteria in allowing supply chain management to become a competitive avenue, is identifying the need for adequate and efficient control and coordination of a supply chain in ensuring that diverse needs of an organizations stakeholders are met.

Changes in the business environment and corporate trends suggest that supply chain is a core pillar for the success of any business today, irrespective of industry or nature (Bourlakis & Weightman, 2008; Lu, 2011). Further, supply chain management is described as a critical pillar (Collier & Evans, 2011) due mainly to the premise that an effective supply chain directly contributes to the productivity and growth of an organization on a macro-level. It can therefore be suggested, that an efficient supply chain exhibits features such as corporate profitability, employment cost reduction, production cost reduction, job security and positive contribution to industrial growth (Wisner et al., 2008; Langley et al., 2008; Lee & Katzorke, 2010).

The functionality of a supply chain is heavily dependent on several key success factors including procurement strategy, effective and efficient control systems, and the development of personnel expertise. One of the main goals in the development of an effective supply chain management structure should be to respond adequately to multiple needs of end consumers and stakeholders. In an attempt to develop a coherent and functional supply chain strategy, a business must create a supply chain which is a reflection of a sophisticated mixture of various considerations specific to the industry, scenario, business stage and stakeholder interest of a business (Collier & Evans, 2011). According to Lu (2011), there are numerous factors that contribute to the efficiency of a supply chain management structure. One of the main factors, which is the core area of focus within this study, is the geographical location in which land is positioned, in relation to the overall supply chain strategy (Collier & Evans, 2011). Land position is a critical factor in supply chain management, and plays a crucial role in determining the ultimate level of success of a supply chain. The determination and ultimate choice of geographical locations for supply chain operations is an important decision area for supply chain design and planning (Current et al., 1997), and ultimately contributes to the overall success of the corporate strategy. Locations of elements within a supply chain influence many other factors of an organization which ultimately have an impact (direct and indirect) on a supply chain operation (Collier & Evans, 2011), and overall functionality and profitability of a business. Factors such as labor cost, environmental impact, community acceptance, company reputation, material cost, taxation, currency exposure, legal regulations, etc. directly affect the functionality and ultimate success of a business, and are collateral results of supply chain design.

In a determination of land position and flexibility, the impact of facility location within a supply chain is considered to be crucial and one of the most complex issues impacting overall efficiency (Erlebacher & Meller, 2000). Facility location decisions are heavily dependent on the industry, geographical position, and climate, and are regarded as fixed and difficult to modify (Daskin, Snyder & Berger, 2003). Inefficient locations for production, mixing, distribution, or storage result in excess costs being incurred throughout the lifetime of the facilities (and therefore the operation of the business), irrespective of the efficiencies that may be realized with regard to production plans, transportation options, inventory management, and information sharing decisions (Jornsten & Bjorndal, 1994). The variable of short-term fixed costs also must be evaluated. Decisions on production quantities, capacities and locations for example are relatively more flexible, but still carry costs associated with production, and may be fixed in the short-term (Geoffrion & Powers, 1980). Several factors may also depend on these decisions (e.g. labor costs).

Not all changes to a supply chain are fixed and inflexible. Areas such as transportation, inventory, and information systems can be easily influenced or manipulated. As a result, decisions on these areas and components may allow for a fast response to a supply chain change, and an optimization of an existing chain.

According to Lu (2011), the primary goal of supply chain is to provide customers with accurate and quick response to their orders at the lowest possible cost. In order to achieve this, it is necessary for a concert of facilities to be strategically connected within a supply chain, and evolving to meet the ever-changing needs of the market. For global supply chains, coordination

and customization is even more complex, and required the consideration of factors such as transport costs between all demand and supply points within the network, fixed operating costs of each distribution or retail facility, revenue generated per customer location, facility labor, operating costs, and construction costs (Daskin, Snyder & Berger, 2003). In many cases, this results in a decision to locate a facility in a new geographic region, not motivated by cost or service efficiencies, but as a way of creating cultural ties between the firm and the community (Collier & Evans, 2011). Table 1 assesses several critical factors which require consideration when making location decisions.

Table 1: Critical Factors in Location Decisions

Factors related to location	Factors related to transport	Factors related to utilities	Environmental and social factors	Political, legal, governance factors
Access by customers	Convenience achieved	Availability of fuels	Adequate housing and roads	Payroll taxes
Demand and markets	Closeness to key markets	Waste disposal	Education facilities	Local and state tax structure
Sourcing	Access to sources of suppliers	Adequate supply of water	Climate and living conditions	Taxation climate and policies
Ability to access and retain labor force	Availability of diverse transport modes	Adequate supply of power	Community attitudes	Opportunity for advertisement in strategic points
Labor rates	Cost of transportation	Local energy costs	Health care facilities	Zoning laws
Location of competitors	Strategic visibility of the facility from major roads	Communications capability	Property costs	Health and safety laws
Traffic congestion around the location	Availability of parking space	Price/cost	Cost of living	Regulation agencies and policies
Access to adequate labor skills	Inbound and outbound capabilities	Utility regulatory laws and practices		Taxation incentives and abatements

Source: Collier & Evans (2011)

As seen in Table 1, physical location decisions, both for small and large brick and mortar businesses within the main supply chain sectors (manufacturing, distribution, and retail) are

relatively complex, and often correlated. Factors such as transport cost, infrastructure, tax structure, etc. have a considerable impact on location decision. It is therefore necessary to consider how each element is affected as a result of a location decision, and therein how each decision impacts the overall supply chain. The physical location of key supply chain processes must enable and allow a business to process inventory, maintain on-time delivery, and maintain sustainability within the chain. As such, the objective of this study is to assess the economic impact and value proposition of geographical (both global and domestic) location factors for manufacturing assemblies, distribution centers, and inventory levels in the wider supply chain management. As a more specific objective, this study aimed to understand the perceived economic impact of location factors, and the resulting perceived impact on the value of land. A number of factors may be considered as potential impacts to location decisions (e.g. geographic risk, political risk, and economic risk). In order to define a specific framework, emphasis is placed on specific location factors: cost of land on which a facility is located, geometric factors of the land and surrounding geography, distance from the site to and from other various supporting facilities, cost of transportation, area demographics, and tax structure. These factors are assumed to have greatest impact on the value of land located in any given geographical location.

1.3 Problem Statement

Lu (2011) suggests that firms which are able to strategically locate their manufacturing assemblies, distribution centers, and inventory stores in strategic geographical locations, have a competitive advantage in the market. The concept of defining a strategic location, must be evaluated and understood, as the process largely depends on how well a firm can appropriately and economically put into consideration factors of economy, environment, social, and cultural.

Lu (2011) also expresses that the cost of land as a factor of production varies to a great extent, which makes it necessary for a firm to select sites which are affordable within the financial ability of the organization. Often, when a firm makes location decisions, costs considerations of the land in the location are largely influenced by considerations of how the firm will gain profitability and remain competitive with regard to pursuing of its objectives and goals.

Observation made by Bourlakis & Weightman (2008) suggest that when a firm makes a physical location decision for a manufacturing assembly, distribution center, or inventory store, it has to ensure that the location or land on which the facility has to be established should develop in line with overall developments in the geographical location. The core of the suggestion is that location should add a positive value to the growth of the firm as changes continue to take place.

The cost of land and the value of the location are not the only major factors which should be focused on. In choosing a physical location, a firm must establish a detailed analysis of several other factors which have an indirect economic impact on the firms operation. Indirect costs to development patterns on the land, utility of the land, surrounding development, elevation, climate, political activity, accessibility to transportation streams, green-space restriction etc. are critical aspects which a manufacturing firm, distribution center, or storage center must consider before making appropriate physical location decisions (Lu, 2011). Specific consideration must also be defined for various industries, and for firms handling products with special storage and/or transportation requirements (Bourlakis & Weightman, 2008). Another key consideration is the identification of environmental regulation and policies (including waste disposal and pollution management) which may have a longstanding impact on business operation and overall profitability (Becht, 1970). Economic feasibility studies must contain a variety of factors which

assess the overall value of particular locations, in concert with the long-term potential obstacles faced by a location decision.

It is easily noted from a review of related literature that many studies have investigated the factors which influence physical location decisions. Past studies often look at the geographical location factors and how they impact on supply chain (Collier & Evans, 2011). The main emphasis of the many studies is directed at assessing how specific factors influence a physical location decisions. Relatively limited analysis has focused on the evaluation of each location factor in physical location decisions, with respect to economic impact of the firm over the lifespan of a corporation. The few studies which have explored the economic impact of location factors have focused mainly on the overall aggregate economic impact, as opposed to economic impact of each unique factor (Lu, 2011). Within this gap in research, exists an opportunity to assess the economic impact and influence which each specific factor has on an overall supply chain, with regard to the physical location decisions made at a given firm.

Through this evaluation, it is possible to conclude costs associated with property and accessibility to infrastructure, differ greatly based on location decisions. The business viability of any physical supply chain location, depends largely on the proximity to surrounding infrastructure. Assessing the longevity of key infrastructure factors is crucial in the assessment of land location viability. Inevitably, the impact is also felt within a supply chain process when combined with an evaluation of regulatory laws, tax structures and other guidelines. In this vein, the economic impact of ‘friendly’ business regulations and tax regimes must also be considered, in understanding the impact on land value growth and long-standing effects on stakeholder

placement and facilities relocation. What is significant from prior research, thus far is that there is no framework that currently exists which can be used to evaluate and identify a common pattern of decision making for the placement of physical supply chain entities. This research was therefore motivated by the need to contribute to insights that can be used to create a framework which identified and evaluates a common pattern of decision making, for the placement of physical supply chain entities.

1.4 Rationale of the Study

In acknowledging that supply chain management is identified as a critical aspect which enables a firm's competitive advantage (Lee & Katzorke, 2010), opportunity to develop effective supply chains in order to optimize business operation is omnipotent. As organizations continually strive to create and maintain sustainable competitive advantages, the importance of consumer satisfaction is elevated to being a deciding factor in bottom line profit for organizations.

Creating an effective and sustainable supply chain is heavily dependent on identifying appropriate geographical locations in which manufacturing assemblies, distribution centers, and inventory storage facilities may be placed. The rationale of this study is premised on the objective of establishing the nature of costs (from an independent assessment) associated with each individual factor which influences physical location decisions. Exploring the far-reaching economic impact of each factor is vital in assessing location decisions, in an attempt to reduce cost and maximize bottom line company profit.

1.5 Research Objectives

The research objectives for this research are categorized into two areas as outlined below.

1.5.1 General Objective

The over-arching objective of this study is to explore the economic impact of geographical location factors in assessing how a company may reduce cost and maximize bottom line profit for manufacturing assemblies, distribution centers, and inventory storage plants over specific time periods. This research applied relevant models (such as Structural equation Modeling) to analyze and explore correlations, and other interactions between the factors as discussed to draw appropriate conclusions and managerial insights.

1.5.2 Specific Objectives

Specific research areas to be evaluated include:

- Analysis of the economic impact of a subset of location factors of land in the land purchasing process, sustainability maintenance and supply chain process.
- Analysis of the economic impact of specific location factors in the assessment of transportation to and from the supply chain facility.
- Exploration of the economic impact of tax and zoning structures in relation to location decision.

1.6 Research Questions

As transparency exists within product manufacturing sectors, the study is conducted exclusively within the Fast Moving Consumer Goods (FMCG). As this study is exploratory, it attempts to answer a number of open ended questions through investigation and research:

- What are the geographical location factors for manufacturing assemblies, distribution centers, and inventory storage facilities in assessing the economic impact within the wider supply chain management of a firm?
- What is the longstanding economic impact and land usage value, in decisions related to placement of a supply chain facility?
- What is the economic impact, with respect to probability of evolving risk of change, of transportation decisions on a supply chain facility?
- What is the economic impact, with respect to probability and risk of change, of tax structures on supply chain facilities?

1.7 Hypotheses

Some of the hypotheses to be investigated in the research study include:

- Factors which influence physical location decisions for supply chain facilities have differing economic impact on the overall chain and firm.
- As a factor of production, land has a different economic value in various geographical locations and markets, which heavily impact physical location decisions for supply chain facilities.
- Transportation systems, in terms of transport networks and modes (including traffic flow) has economic impact on accessibility of land in various locations, and therefore an impact on land value, ultimately influencing physical location decisions.
- Jurisdictions in various locations have different regulatory and tax structures which have varying levels of economic impact on land value, ultimately influencing physical location decisions for supply chain facilities.

1.8 Significance of the Study

From the studies of Collier & Evans (2011) and Lu (2011), geography as a physical location factor has a great impact on decisions related to facility location within a supply chain. From a holistic perspective, supply chain management must operate based on its core ideals of aiding a firm in maximizing profits, minimizing costs, and satisfying the needs of customers and end consumers. Business trends and environmental changes impact firms in a number of capacities, including supply chain management policy, efficiency and innovation (Gunasekaran, Patel & McGaughey, 2004). As a result, in an attempt to transform supply chain functionality into an acknowledged source of competitive advantage (irrespective of the size of the firm), organizations must strategically locate their supply chain facilities in accordance with effective coordination and collaboration between the firm, the suppliers, and the consumers (Shahzad et al., 2013). While this goal can be achieved by locating supply facilities in areas regarded to be strategic in terms of responding to the needs of consumers, geographical and physical locations of land differ in significant measure. Land position (within a number of spectrums) remained a critical factor of production, and can be a strategic option in the creation and sustainability of a competitive advantage in the business environment (Taylor, 1997).

As posed previously, the interdependency of various factors in establishing the viability of land as a factor of production (within various geographical locations) vary greatly. As such, this study investigated and explored the overall economic impact of which specific factors may have on the manner in which physical location decisions are made (assuming that different

geographical locations hold varying value attached to land as a primary factor of production).

The value and significance of this study, is reflected through a detailed analysis and assessment of specific factors impacting land value in connection with supply chain processes in terms of economic impact.

1.9 Conclusions

In addition to exploring the background of the concept of supply chain management, a framework for establishing research parameters is presented, which inherently leads to defined guidelines in the progression of the proposed research. Supply chain management as a concept is by nature, inherently difficult to define. As such, there is the need to carefully articulate the process and structure of research, with pre-defined objectives, questions and overall expectations, in determining the framework for this study.

A defined problem statement noted in section 1.3 presents insight into the current position of industry and concept, thereby leading to the establishment of a target of research. The rationale of the study in section 1.4 further expands on benefits derived from research within the area of supply chain management, and served to present justification of the chosen area of research.

Acknowledgement of perceived benefits from the study related to competitive advantage were noted, as is the potential economic impact by way of cost reduction.

In establishing research targets and goals for the overall study, research objectives are defined in section 1.5, and present a framework for the design of primary research retrieval, as well as a

benchmark for analysis of findings and over-arching goals of the study. Further guidelines for research are discussed in section 1.7, outlining a subset of hypotheses which require confirmation through the process of data analysis.

In forming the foundation and parameters for research, the acknowledgement that evaluating existing literature which discusses and analyzes the area of supply chain management, is necessary. By way of this analysis, a clear indication of exactly where opportunity exists to undertake the area of proposed research in creating new knowledge.

2.0 CHAPTER TWO : LITERATURE REVIEW

2.1 Introduction

In assessing the value of the proposed area of research and addressing the problem statement noted in section 1.3, an examination of core concept in the perspectives of previous research related to the functionality, role, and general objectives of a supply chain is necessary.

The foundation of this study centered on the progression of research conducted within the area of supply chain management. As such, the objective of this literature review was to identify existing research which identified the value, principles and objective of a functional supply chain. As the function of a supply chain is largely impacted and non-universal, specific literature which categorizes the various types of supply chains is introduced, as is discussion on research pertaining to general and specific variations of a supply chain.

In analyzing the existing literature aimed at evaluating the overall function of a supply chain, a further evaluation into the type of theoretical framework is possible, and would be important in identifying the structure best suited to presenting the findings of this study, and in answering the research questions noted in section 1.6. A comparison of theoretical framework structures is discussed within this literature review, along with a comparison table and justification for framework selection.

2.2 What is Supply Chain Management?

In a global marketplace, increasing competition is changing the way companies strategize to gain advantage over competitors. Innes and LaLonde (1994), note that competition in the global market is no longer between companies, but often among supply chains. This perspective is noteworthy, as it illustrates the evolution of supply chain research. Earlier research points to a focus on how supply chain efficiency may improve specific businesses, whereas later studies focus on the overall improvement of industry supply chains. In evaluating prior literature, it becomes important for companies to understand their competitors' logistical strategies in order to benchmark the best option to gain competitive advantage.

Supply Chain Management, as an umbrella term, has served to describe various stages of critical planning and execution stages which are crucial to the success of any company. The concept however, has shifted from being a generalization to being more specific, largely driven by the need to recognize the cause and source of competitive advantage. The identification of specific areas within supply chain management are often foundation points for areas of analysis and competitive advantage (e.g. inventory control, storage replenishment). Changing trends within commerce, including innovative process changing and consumer facing trends (e.g. driverless transportation, 3-D printing) all depend largely on a sustainable and well established supply chain in order to efficiently and cost-effectively bring products into the hands of customers.

Despite the value placed on the efficiency of a supply chain, there does not exist a defined, clear definition of the term. The term is not a clear science, and does not allow for a one-size-fits-all application. This is in spite of the fact that the practice of supply chain management and that the

board of knowledge within the area of supply chain management has always existed within the practice of commerce.

Innes and LaLonde (1994) describe the concept of Supply Chain Management as “The delivery of enhanced customer and economic value through synchronized management of the flow of physical goods and associated information from sourcing to consumption”. In this statement, Innes and Lalonde (1994) underline the fact that efficient supply chain management required collaboration of both the internal workings of a company as well as the external partners of an organization. These external partners are referred to as the extended supply chain (Morehouse and Bowersox, 1995). Innes and Lalonde (1994) continue by stating “the goal of extended enterprise is to do a better job of serving the ultimate consumer” and “better service will eventually lead to increased market share which will generate more revenue”.

Supply Chain Management as defined by Gunasekaran and Ngai (2005) is the streamlining of a business’ supply-side activities to maximize customer value and gain a competitive advantage in the marketplace. While the term Supply Chain Management may focus on a company’s strategic vision, the role of a supply chain differs greatly within each application in the global marketplace. As noted by Cox (2001), several references to Supply Chain Management have become mainstream, however there are very few bodies of literature that concentrate solely on the concept of Supply Chain Management. Rather, the role Supply Chain Management plays as a piece of a larger puzzle is greatly explored across the global marketplace. The development of the concept began along the lines of physical distribution and transport, and was as a result of several overlapping concepts.

To comprehend the scope of the term, the following table is given:

Table 2: Interpretations of Supply Chain Management

Researchers	Year	Definition
Chopra and Meindl	2007	“A supply chain consists of all stages involved, directly or indirectly, in fulfilling a customer request.”
Mentzer et al.	2001	“The systemic, strategic coordination of the traditional business functions and the tactics across these business functions within the supply chain, for the purposes of improving the long-term performance of the individual companies and the supply chain as a whole.”
Handfield and Nichols	1999	“A supply chain encompasses all the activities with the flow and transformation of goods from the raw stage, through to the end user, as well as the associated information flows.”
Christopher	1998	“The supply Chain is the network of organizations that are involved through upstream and downstream linkages, in the different processes and activities that produce value in the form of products and services in the hands of ultimate customer.”
Cox	1995	“A supply chain is a network of facilities and distribution options that performs the functions for procurement of materials, transformation of these materials intermediate and

		finished products, and the distribution of these finished products.”
Cavinato	1992	“The supply chain concept consists of actively managed channels of procurement and distribution. It is the group of firms that add value along product flow from the original raw materials and final customer.”
Cooper and Ellram	1993	“Supply Chain Management is an integrated philosophy to manage the total flow of distribution channel from the supplier to ultimate user.”
Gunasekaran and Ngai	2005	“Supply chain is used to refer to chain linking each element of process from raw materials through to the end customers.”
Towill, Naim and Wikner	1992	“The supply chains are a system, the constituent parts of which include material suppliers, production facilities, distributions services, customers linked together via the feed forward flow of materials and the feedback flow information.”
Lee	1996	“The integration activities taking place among a network of facilities that procure Raw materials, transform them into intermediate goods and then final products, and deliver products to customers through distribution system.”

Morehouse and Bowersox	1995	“An integrative approach to dealing with the planning and control of the materials flow from the suppliers to end-users.
Sako	1993	“The set of entities, including suppliers, logistics services provides, manufacturers, distributors and resellers, through which materials, product and information flow.”
Lee and Billington	1992	“Networks of manufacturing and distribution sites that procure Raw materials, transform them into intermediate and finished products, and distribute the finished products to customers.”
Berry et al.	1994	“Supply chain management aims at building trust, exchanging information on market needs, developing new products and reducing the supplier base to a particular OEM (Original Equipment Manufacturer) so as to release management resources for developing meaningful, long-term relationships.”

By evaluating the changes in the definition over time, there appears to be a trend toward integrating the term of ‘Supply Chain Management’ with overall corporate strategy. There does not appear to be a trend toward a more defined description, and while each definition provides an insightful aspect, the vast number of definitions inherently result in the meaning of the term being unclear.

In addition to the definition of the term, the understanding of Supply Chain Management is still evolving, and often seen by the multitude of definitions, as holding multidisciplinary origins, resulting in the lack of a clearly-defined conceptual framework. The term Supply Chain Management has not only been used to mean the integration of a company's internal and external logistics activities and the planning and controlling of materials from distributors to customers, but some authors have used Supply Chain Management to describe the strategic, inter-organization issues (Cox, 2001). Martin (2005) uses Supply Chain Management to discuss the alternative organization form to vertical integration, while others referred to Supply Chain Management simply as the relationship between the company and the suppliers (Sako, 1993; Simchi-Levi D., Kaminsky P. and Simchi-Levi E., 2003; Hines and Rich, 1997).

In summary, there appears to be value and meaning in the diversity of the definition of Supply Chain Management. A list of subject literature related to the concept of Supply Chain Management from different broad perspectives is shown below:

- Supply and Purchasing Literature
- Transportation and logistics Literature
- Marketing Literature
- Organizational Behaviors Literature
- Industrial organization literature
- Transaction Cost Economics Literature
- Contract View Literature
- Contingency Theory

- Institutional Sociology
- System Engineering Literature
- Network Literature
- Strategic Management and Economic development Literature.

The preceding list includes some of the main bodies of literature from which the foundation of the definition of Supply Chain Management was derived and based upon (Lee, 1996).

2.3 The Importance of Supply Chain Management

How does a company remain competitive in the global market? A typical approach within business' related study of Supply Chain Management is to find strategic ways to improve the speed and functionality of the supply chain. "There is a substantial profit advantage for the extra time that you are in the market and your competitor is not, if you can be there first you are likely to get more orders and more market share" Christopher (1998). Speed, innovation, consumer research, attention to social causes, and meeting product requirements are some of the other objectives for which supply chains have evolved to meet. In an ever-changing arena in which consumer markets are constantly evolving, the effectiveness and efficiency of a supply chain must consider a variety of success metrics.

Aspects of physical distribution and material management are core to the study of Supply Chain Management. Some of the traditional core areas may include:

- Warehousing

- Inbound transportation
- Inventory Management
- Materials Handling
- Transportation Operations

An efficient supply chain management process is expected to increase its range of responsibilities in the fulfillment Process. Some of these functions are:

- Monitoring customer service
- Processing and ordering in the customer service department
- Forecasting of the supply chain management budget

These areas of focus lead to an assessment of sub-core areas including Computing and IT System Processes, Simulation, Operational Improvements, Distribution Strategy among others under the umbrella of Supply Chain Management.

2.4 Objectives and Principles of Supply Chain Management

Per previous assentation, on the assumption that the basis of Supply Chain Management is to add value to an existing process, the overall goal is therefore to ensure customer fulfillment as an over-arching objective. According to Morehouse and Bowersox (1995), Supply Chain Management has become a fundamental strategy in allowing corporations to strategically succeed as oppose to being a core study area in itself. Anderson et al. (1997), noted seven

principles which when used consistently and comprehensively, result in competitive advantages to a company. The principles are as follows:

- **Segment Customer Based on Service Needs:** Traditionally, customer segmentation was by way of industry, product or the trade channel. Effectively optimizing a supply chain would entail grouping customers with distinct similarities and customizing demand through tailoring services for specific customer segments.
- **Customize the Supply Chain Management Network:** As noted previously, the design of a supply chain network is crucial in ensuring a chain operates efficiently. When designing a supply chain of management networks, the focus should be on service needs, profitability of the customer, and customization of the supply chain network accordingly. This specific principle ties all the remaining principles by outlining guidelines on placement of supply chain entities to facilitate supply chain management to be effective.
- **Observe Signals of Market Demand:** A potential corporate error is allowing fragmentation of decision-making control. Ensuring that a flat structure is utilized, and assuring a multitude of teams are involved in the operations and planning stages of the supply chain allows for the detection of changes and trends in customer needs. This demand intensive approach leads to more consistent forecasts and better resource allocation.
- **Differentiate Products Closer to the Customer:** Due to cost restrictions and fluctuations in demand, forecasting and inventory management is core to the efficient

flow of a supply chain. As a result, product differentiation and customization becomes a topic which can often lead to vulnerabilities in demand projection. In order to reduce this risk, differentiation of the product in the manufacturing process should be made as close to the end of the chain as possible, in order to understand demand and meet actual customer demand.

- **Strategically Manage the Source of Supply:** From an external perspective, the relationship between key players within a supply chain is key (i.e. suppliers, production sources, distributors, retailers etc.). Based on an understanding of supplier constraints, opportunities may exist to reduce the overall cost of purchasing materials. Decisions based on when to purchase required materials may also be impacted based on cost/supplier demand etc. Anderson et al. (1997) notes the value of collaboration between manufacturers and suppliers to ensure overall profitability as oppose to sourcing the most cost-effective supplier.
- **Develop a Supply Chain Wide Technology Strategy:** As covered previously, Information Technology acts in many ways, as the cornerstone of effective and efficient supply chain management, and often support multiple levels of decision-making. The practice of an optimized supply chain strategy, also gives a clear view of the flow of product to the market, as well as indication of the reliability of services and information.
- **Adopt Channel-Spanning Performance Measures:** Simply monitoring internal factors and functions of a supply chain is often ineffective in optimizing an entire supply chain.

Successful supply chain modification and optimization often lies in ensuring operations strategies are outlined and clearly defined within every link in the entire supply chain.

While these principles may sound simple on paper, the execution and implementation are challenging, especially within an ever-changing supply chain landscape. Anderson et al. (1997) notes that enhanced growth is often as a result of organizations accepting the need to change, as oppose to maintaining their current supply chain structure.

More recent literature suggests the literature of Supply Chain Management is still fragmented. Despite several studies that discuss issues regarding Supply Chain Management, most of the research that exists explains or discusses only one stage of the chain, specific to an area, industry or process (Guinipero et al., 2008). A number of variables, including geography, industry, application, business size and objective, must be considered when assessing a supply chain. Business culture, for example, may present a different method of measuring and/or attributing successful implementation of a supply chain. Pertinent issues such as resource heterogeneity at organizational level and the influence on supply chain automation must therefore be assessed. While there are multiple supply chain perspectives which form the blueprint for theoretical framework selection, the assessment of industry, size and corporate culture helped identify a suitable theoretical framework which is adopted for the study. The objective in selection is to choose a framework based on its relevance to supply chain management, and more importantly on the ability to steer the study towards the realization of set objectives.

2.5 Role of Supply Chain Management

Overall, the popularity and importance of study within the field of Supply Chain Management can be clearly seen. The concept of Supply Chain Management is often considered to be a vital part of any production process and is part of an increasing trend which has not yet reached its full growth potential. This review demonstrated some of the theories and hypotheses behind the concept of Supply Chain Managements, and explored how various aspects may come together to form a link, and ultimately produce a competitive advantage. The platform for this area of analysis are described through the assessment of theoretical frameworks, whereby theories related to the study problem were discussed. The analysis of theories made it possible to answer the research question as they give valuable insight and support in explaining the impact of automation in a supply chain leading to the evaluation of land development value.

This literature review observes a notable increase in interest within the area of Supply Chain Management, both in industrial as well as research sectors. Key gaps still exist in the overall study and analysis of the practice, as there are many areas which have not yet been explored, nor efficiently researched. Various controversies also play a role in the establishment of research niches in evaluating the overall principle of Supply Chain Management from various perspectives. As industry and society progress, emerging challenges may require a focus on specific areas (e.g. driver-less transportation, the impact of technology such as GPS in various phases of the supply chain). Various controversies and societal inadequacies may also present opportunity for specific risk assessment of supply chain research (e.g. ship transit piracy, Ebola breakouts). As society progresses, further research into specific areas of optimizing, analyzing and evaluating a supply chain presents itself as an important and necessary practice.

2.6 The Literature of Supply Chain Management

Irrespective of the vast number of articles written on the concept of Supply Chain Management, the idea and the theory of the concept is not unified. Sub-concepts are often introduced as areas which categorize supply chain behavior, and demonstrate necessary crossovers between supply chain management and other industrial and production areas (Balakrishnan J. and Cheng C. H., 2005). Literature suggests that within an industrial district, for which there is a specific production model, a complex supply chain can be clearly identified (Daya et al., 2008).

Although the term Supply Chain Management is perceived to be relatively new, the concept has arguably always impacted the flow of commerce. Salvetat & Géraudel (2012) argues that the success of corporates and organizations is greatly dependent on the interactions between flows of information, materials, manpower, and capital equipment. Within this perspective, the concept of information flow points toward the need for automation across a supply chain. Arlbjorn (2011) supported this observation, by noting that businesses no longer compete in isolation or independently, but as supply chains. In expanding on the perception of Supply Chain Management, it is important to note that the word ‘chain’ should not be misunderstood to refer to a chain of businesses with a one-to-one business relationship, but rather a network or web of multiple businesses relationships. As such, Supply Chain Management can be identified as a way of managing business relationships within a total commerce process.

Having defined supply chain management, it is important to identify the benefits it brings into a company’s operations, especially in enhancing realization of marketing objectives. Various theories have been posed to support a company’s streamlined structure, in an effort to extend

competitive advantage. Inter-organizational relationships form the foundation for automation, on the assumption that the flow of commerce mirrors a network as oppose to an isolated hub. The Resource Based View (RBV) and Knowledge Based View (KBV) are two examples of theoretical structures which can be used to explain various aspects of how corporate networks relate to automation. Both theories are well-known, and provide valuable insight into the research problem. Additionally, each framework can facilitate the development of a comprehensive research model as well as form a basis for further analysis.

Many authors have come to conclusions regarding the need for an inter-disciplinary approach, in which technical and relational aspects from the respective fields of the system dynamics are integrated, in order to deliver a more sustainable solution (Baumgartner and Pieter, 2003). Product and service quality combined have a relative effect on the behavior of customers and end users who act as repeat buyers (Gunasekaran and Ngai, 2005) and therefore a direct effect on the supply chain's overall performance.

Burgess et al. (2006) reviewed 100 randomly selected articles from a selection of 614 articles over 19 years. The research addressed a variety of areas and focused on the operation management approach to supply chain management as a blanket study across a variety of industries. The result suggested a diverse application of the practice, as opposed to a unified interpretation of the practice of Supply Chain Management.

Carter and Ellram (2003) suggested that more literature reviews were needed for the development of theoretical frameworks of Supply Chain Management. While it is acknowledged that more sophisticated research-modeling techniques should be used (i.e. Discriminant Analysis

and Inferential Statistical techniques), Carter and Ellram (2003) proposed that at least 32 different categories in the field of Supply Chain Management existed.

Bommer et al. (2001) observes that building and sustaining competitive advantage for a firm required a deeper understanding of resource utilization within a firm, which at the root can be explained as a function of supply chain automation within an organization. Thatte et al. (2013) identifies broad dimensions of supply chain management and the effect on competitive advantage.

Table 3: Areas of Supply Chain Management and Effect on Competitive Advantage

Categories of Supply Chain Practices	Categories and Areas of Competitive Advantage
Strategic Supplier Partnership	Price/Cost
Customer Relationship	Quality and Market Share
Information Sharing	Delivery Dependability
Supplier Network Responsiveness	Time to Market
Operations/ Logistics Responsiveness	Product Innovation

Within the scope of this study, a number of ancillary areas of research are presented in support of the value in assessing physical location placement. Schmenner, Huber, & Cook (1987) argue that geographically defined differences do not fully account for the differences in attractiveness of certain locations as manufacturing sites and that the plant location decision can be usefully approached as a staged process. In evaluating placement of physical entities, Sheu (2003) contends that the facility location of manufacturing centers and regional product distribution centers should maximize the potential rate of return on facility investment. Moran, Stahl &

Boyer (2008) argue that site selection is determined by individual plant requirements for headquarters, back offices, R&D, the type of manufacturing operations and the life stage of product/company. Within the scope of geographic placement, Schmenner, Huber, & Cook (1987) state that geographically defined differences do not fully account for the differences in attractiveness of certain locations as manufacturing sites and that the plant location decision can be usefully approached as a staged process.

From an over-arching competitive advantage standpoint, Salvetat & Géraudel (2012) states that the success of corporates and organizations is greatly dependent on the interactions between flows of information, materials, manpower, and capital equipment. Further, Holl (2004) contends that the establishment of a manufacturing start-ups is mostly driven by increases in local market size and labor force qualification, lower labor costs, and a more diversified economic environment. This appears to dovetail with Chang & Lin (2015) who state that most global manufacturing firms move their plant locations to certain areas to maximize on lower cost and tax.

A number of prior studies have investigated the impact of physical location decisions on the supply chain, with the majority of research focusing on various management, geographic, or environmental factors. While prior contributions including Doeringer, Evans-Klock, & Terkla (2005) have suggested that the function of management is core to the concept of supply chain management, relatively little attention has been placed on evaluating the correlation between location decisions and management decision drivers. The analysis of this interaction would provide a comprehensive interpretation of specific factors contributing to physical supply chain

development decisions.

On the previously substantiated assumption that supply chain management as a concept often forms the basis for competitive advantages between organizations, several theoretical frameworks exist in which elements of supply chain management may be discussed. Amongst the potential frameworks are the Relational Based View, Innovation Based View, Transactional Cost Economics Theory, Resource Based View (RBV), and Knowledge Based View (KBV).

2.7 Theories Explaining Supply Chain Management Elements

2.7.1 The Relational Based View

The Relational Based View supplements existing views, by focusing on the measurement of an individual firm's performance within a network (Dyer, 1996). The core of the theory suggests that an individual firm is often unable to compete with global competition using solely their own resources and capabilities. This is because a firm in isolation, which reflects the make situation, is not part of a network and is therefore not able to generate relational rents (Dyer and Singh, 1998). As such, with the exception of enhancing their own core competencies, enterprises must seek out cooperation with other firms to establish relational networks. The relational networks potentially provide a firm with access to resources, markets, information and technologies; with advantages from scale and scope economies; and allow firms to share risks and outsource value-chain stages (Gulati, Nohria & Zaheer, 2000). Jarillo (1988) notes, that overall, the strategic implications of relational networks for firms' internationalization allow firms to specialize in core businesses of the value chain, the division of labor, improves efficiency and provides scale and scope of economies. Jarillo (1988) further states that firms in the network enjoy the added flexibility of not having fixed commitments to activities which are not essential to them, the flexibility enables firms to act quicker than rivals, which allow firms to access key resources from its environment.

While there are notable strengths within the theory, the view may not be suitable for this area of study, as a number of vulnerabilities exist. Within the capacity of business optimization, investments in relationships modeling are potentially based on continuity rather than value

creation. Furthermore, business network decisions involve a reduction in the supply base and the focus on strategic suppliers on the long term. Finally, elements such as partnership loyalty, cooperation and trust are essential to the use of this view, and not heavily focused on within this study.

2.7.2 The Innovation Based View

As a model, the Innovation Based View typically evaluates independent consideration and together with Resource Based View and Knowledge Based View enables the development of multiple theories to address the complexities of business research. Heinrichs and Lim (2003) suggest a firm's knowledge contributes in creating competitive advantage which at some stage may create new knowledge to further the firm's performance by solving complex business problems, through integrating web-based data mining tools with business models for knowledge management. Leonard and Sensiper (1998) suggest that successful organizations build and manage knowledge effectively. Furthermore, Leonard and Sensiper (1998), note the dimensions of the core capabilities by that all organizations must innovate following a set of categories: physical systems, managerial systems, skills, and norms of behaviors. As a result, the argument claims innovation can be used as a competitive benchmark, while all members of a particular organization should be able to process and manipulate knowledge. The view focuses on the role of an organization to act as a site of learning and information transfer as opposed to only a physical site or financial entity.

Criticism of this view often follows an assessment of the value of innovation and the usefulness of innovation as a holistic solution. Katz (2004) suggests that developing innovative solutions is

not always related to technical bottlenecks, but often caused by complex interplay and motivation. Chesbrough (2003) argues that the centralized approach to research and development within many industries, which he terms closed innovation, has become obsolete. He further argues that the concept of innovation as a term must be revisited to focus on the embracing of external ideas and knowledge. The connection of internal innovation with external resources required a process of corporate development. The value of innovation also comes into question, with Vanhaverbeke and Cloudt (2006) suggesting that the pursuit of innovation often dilutes corporate value, and that innovation as a whole should be a process, not a target.

The value of this view is notable, however within the confines of this study, there were a number of areas of uncertainty which this view introduces. While the study of Supply Chain Management often revolves around the concept of innovation, focusing strictly on the concept of innovation may not be effective.

2.7.3 The Transaction Cost Economics Theory View

Transaction Cost Economics Theory (TCE) is thought to be most useful for integrating the economic implication of organizational behavior into a strategic analysis of the firm (Kogut, 1988). A number of proponents of this theory exist, including Pearce (1997) who states that TCE can effectively define the various organizational relationships, boundary structures and activities. Williamson (1975) further suggests that TCE analysis is oriented specifically towards the minimization of the costs of the transactions among various assets. From a transactional cost perspective, Kogut (1988) suggests that firms will engage in alliances only if inter-organizational knowledge transfers are more efficient than market means. The condition most likely to foster alliance learning behavior is the environmental uncertainties that would affect and monitor a firm's market activities.

A limitation of the view is that it makes assumptions about the nature of human beings and organizations that have been criticized as being restrictive and culturally bound (Alter & Hage, 1993). Transaction cost theory by nature, assumed that there is a tendency of distrust in society as a whole, and further assumed that the main goal is to maximize profits in all business activities. As a result, where there are small numbers of players and a dependency between them, there is opportunism. While this assumption is valid in analyzing specific types of organizational behavior, there is a notable vulnerability in assuming that societies in all parts of the world operate with the same mentality (Boisot, 1988). As this study aimed to hold a global perspective, evaluating the functionality and interactivity tendencies between human resources would not make this view ideal.

Comparatively, the Resource Based View and Knowledge Based View are two theoretical explanations which may be used to explore various methods of competitive advantage within the scope of Supply Chain Management. These theories are often considered to be grounded, well-known, and hold the ability to provide valuable insight into specific areas of research. Additionally, each theory facilitates the development of a comprehensive research model in forming the basis for analysis (Grant, 1996).

2.7.4 The Resource Based View

By definition, the Resource Based View as a basis for the competitive advantage of a firm, lies primarily in the application of a bundle of valuable tangible or intangible resources at the firm's disposal (Mwailu & Mercer, 1983, Wernerfelt, 1984, Rumelt, 1984, Penrose, 1959).

The principal development on the theory took place between the mid 1980's and mid 1990's, with the Resource Based View emerging as one of the most influential and cited theories in management analysis and theorizing (Barney, 2001). Contributions to the theory were made by many scholars, most notably Rumelt (1984), Barney & Hansen (1994), Conner (1991; Conner & Prahalad, 1996), Helfat (Castanias & Helfat, 1991; Helfat & Lieberman, 2002), Amit and Schoemaker (1993), and Teece et al. (1997), in explaining, expanding and defining a wide variety of relationships and practices within the scope of theory.

The fundamental goal of the theory is the pursuit of explaining and assessing the internal sources of a firm's sustained competitive advantage (SCA) – a central proposition, which suggests that if a firm is to achieve a state of SCA, it must acquire and control valuable, rare, non-substitutable resources and capabilities, while have surrounding elements in place to absorb and apply them (Barney, 1991, 2001). The proposition of competitive value through resource based theory, is widely accepted. Largely based on its simplistic nature and its immediate face validity, the RBV's core message is appealing, easily grasped, and easily taught (Grant, 1996).

The Resource Based View has been used in a number of capacities, predominantly for investigating market dynamics and competitive advantages of firms within various areas (Mwailu & Mercer, 1983). The theory has its roots in marketing and technology (Mesner-

Andolšek, 2014) and can be used to explore benefits of establishing strategic alliances among firms, with mutual benefits such as resource conservation and risk sharing. From a larger perspective, corporate alliances present organizations with an opportunity to explore new competencies, thereby enabling supply chain integration and possibly automation, ultimately leading to a potential competitive advantage.

Within this theory, supply chain advantages can be measured and compared in terms of value presented within the entire chain. In assessing the competitive value of automation, Knott (2009) argues that this theoretical approach revolves heavily on the measurement of transaction cost and Debela (2009) emphasizes that transaction cost efficiency is the motivating factor for the establishment of strategic alliances. In relation to the study of supply chain management specifically, the resource based theory emphasizes transaction cost efficiency as the motivating factor for strategic alliances among firms, and can therefore be used to demonstrate automation within Supply Chain Management.

Nelson and Winter (1982) state that routines are the main organizational constituent element, with routines playing the same role as genes in human organism. In considering supply chains as unit of analysis, supply chain processes are the same as routines according to Nelson and Winter (1982), in which these functions constitute the core purpose of supply chains. This approach considers the organization as a combination of strategy and structure and process- each responsible for internal aspects of organization. The main constituent of supply chain configuration are strategic goals, in the one hand, and coordination mechanisms of supply chain material and information flows in the other (Kotzab et al., 2011).

According to Handfield and Nichols (1999) as a dependent variable, the business process effectiveness could be an appropriate measure to test within the Resource Based View. Within this perspective, supply chain resources and capabilities must be present within supply chain business processes, if not forming the core of the process. Further expansion has defined a business process as a set of structured activities with specified goals oriented to serve customers (Davenport et al., 1998). One often accepted principle is that business processes are considered a method of integrating commerce functions. Lambert et al. (1998), furthered this assumption, by stating that business processes are used to organize the activities between supply chain members.

Within these perspectives, the notion of competitiveness aligning through supply chain management can be observed. As we have noted the value of supply chain as a competitive tool, the Resource Based View presents itself as a meaningful method of examination. Hammer (2001), noted that most successful firms are those which have new approaches for business and work closely with partners for design and management processes, which are beyond the traditional boundaries of the firm. This assumption leads to a theory of business strategic goals impacting the overall success levels of a firm. Handfield and Nichols (1999) define strategic supply chain management as strategic management, and supply chain's partnerships. To further this concept, Miles and Snow (1978) argue that in assessing the strategic goals of supply chains, a great emphasis on environmental factors and less attention have paid to unique characteristics of firms which are members of the chain and also the supply chains itself. The ability of the Resource Based View to account for environmental factors and competitive advantage is therefore founded.

By nature, the Resource Based View is designed to complement and assess the competitiveness of an organization, with a number of prominent proponents noting its value (Bain, 1968; Porter, 1985). The pattern of the RBV in function is often to explicitly examine internal sources of competitive advantage (Handfield and Nichols, 1999) and by design aimed to explain why firms in the same industry might differ in performance.

A few notable assumptions are made within the Resource Based View, notably the assumption that firms are profit-maximizing entities directed by managers operating in distinctive markets that are to a reasonable extent predictable and moving toward equilibrium (Bromiley & Papenhausen, 2003; Leiblein et al., 2003). Further, the essence of the theory accepts that information about the subsequent or impending value of a resource is of extreme value. In this vein, if a firm can project the future value of a resource better than their competitors, they hold a competitive advantage (Leiblein et al., 2003). The application to the study of supply chain management within this regard is notable. Given that the theory heavily focuses on the resource value as the firm's significant component, and perhaps as a straight forward evaluation of a bundle of resources, the view is simplistic in nature.

As noted, there may be a number of advantages and disadvantages within the examination of the concept of Supply Chain Management through the Resource Based View.

Critique 1: The Lacking of Managerial Implications

A primary disadvantage of the Resource Based View is that it lacks substantial managerial implications or “operational validity” (Priem, 2001). By nature, the theory is heavily focused toward the progression and measurement of VRIN (valuable, rare, inimitable, non-substitutable) resources which develop within an organization, but as noted by Connor (2002), there is little expansion on methods in which to achieve these objectives. A related critique of the Resource Based View, is that there is often an illusion of total control which results from analysis, in many cases trivializing property-rights issues and not accurately measuring the scope of control managers have over a firms resources or projected future value (McGuinness & Morgan, 2000). Within the scope of supply chain management, the analysis of specific drivers to achieve competitive value is important. The disadvantages of this critique are limited, as this study evaluated multiple factors as drivers, and not focus solely on managerial drivers.

Critique 2: The Potential for Infinite Optimization

A critique of the Resource Based View entails an infinite regress (Collis, 1994; Priem, 2001). This constraint is described as identifying the value of innovation taking place at latter stages of development. As an example, a firm that has the superior capability to develop structures that better innovate products will, in due course, surpass the firm that has the best product innovation capability today. Because of the assumption that developing structures that better innovate products will inevitably be more valuable than initial product innovation, the Resource Based View suggests firms should strive to obtain such second-order capability (Collis, 1994). With innovation often core to many perspectives on the study of supply chain management (Daya et

al., 2008), this disadvantage is not necessarily detrimental, but suggested that narrow evaluations throughout the structural development phase may be most beneficial.

Critique 3: Limited Applicability

Connor (2002) argues that the Resource Based View applies mainly to large firms with significant market power. The focus of his argument centers on the notion that smaller firms competitive advantage cannot be based on their static resources, and as such they do not benefit from a Resource Based View. While this perspective is meaningful, the argument fails to consider other types of resources. Examples could include smaller firms who have unique competitive advantage capabilities, and do not need to depend on size and market power alone.

A by-product of this argument, is the suggestion that Resource Based View applies only to firms striving to attain a competitive advantage. For firms satisfied with their competitive position, the RBV does not bring much insight (Collis, 1994). As the nature of supply chain management often combines larger and smaller firms- often ones with unique competitive advantages, this limitation is not substantial.

Critique 4: Driving Strategy

Fahy and Smithee (1999) note that Resource Based View starts with the assumption that the desired outcome of managerial effort within the firm is a sustainable competitive advantage. The notion is that achieving this competitive advantage will allow the firm to earn above average returns, and will place focus on how to attain and sustain advantages.

It can be assumed that a sustainable competitive advantage can be obtained if the firm effectively deploys available resources within its respective supply chain. On this assumption, the Resource Based View emphasizes strategic choice, charging the firm's management with the important tasks of identifying, developing and deploying key resources to maximize returns (Fahy and Smithee, 1999).

2.7.5 The Knowledge Based View

Although in many ways, the Resource Based View recognizes the important role of knowledge within a firm which achieves a competitive advantage, proponents of the Knowledge Based View argue that the resource based perspective does not go far enough (Grant, 1996).

Specifically, the resource based view assumes knowledge to be a general and generic resource, as opposed to holding intrinsic and specific values (Alavi and Leidner 2001), and as such there is no clear identification of value through knowledge characteristics. The fundamental platform of the resource based theory, is to assume knowledge is a generic resource and not to recognize special characteristics, or distinguish between different types of knowledge based capabilities (Foss, 1996).

In many ways, the Knowledge Based View is an extension of the Resource Based View as it considers organizations as heterogeneous entities loaded with knowledge (Hoskisson et al., 1999). In contrast to the Resource Based View, the knowledge based theory of the firm considers knowledge as the most strategically significant resource of a firm. More attention is dedicated to the identification of differences and characteristics which way exist within various types of knowledge (Grant, 1996). By design, the knowledge based theory of the firm acknowledges knowledge as being the most strategically significant resource of a firm (Conner, 1991). Other areas, including Information technologies may also play an important role in the knowledge based view of the firm in that information systems can be used to synthesize, enhance, and expedite large-scale intra and inter-firm knowledge management (Alavi and Leidner 2001). Within the realm of supply chain management, and the concept of automation, this characteristic is noteworthy.

As transparency levels of operational structures gain prominence, the Knowledge Based View has been widely used in discussing the process of knowledge sharing as a crucial component of organizational success (Grant, 1996). The theory as a fundamental process, assumes that an organization's success is based on its ability to share the inherent knowledge embodied in organizational routines, and transfer knowledge from one organizational unit to the other. This assumption is compounded by a growing pattern of supply chain organizations having the ability to share knowledge effectively from one unit to the other, with increased chances of survival as compared to organizations that are less adept at knowledge sharing (Spender, 1996). The basis of the theory is to categorize knowledge sharing in two spheres based on the tacit-explicit dichotomy: soft and hard mechanisms.

The soft mechanisms entails transfer of tacit knowledge through face-to-face interface. In this view, knowledge sharing is prioritized with Davenport and Prusak (1998) suggesting that "firms hire smart people and let them talk to one another and use water coolers, talk rooms, and picnics as examples of places where the transfer of tacit knowledge can take place." The exploration of this approach, suggested that various methods are suitable for the transfer of tacit knowledge. Examples of knowledge transfer may include apprenticeships, brainstorming camps, the use of metaphors and analogies, social networking, and learning by doing as viable ways of tacit knowledge transfer. Comparatively, it can also be argued that active direct communication between individuals acts as a means of sharing tacit knowledge. The core platform is to facilitate basic knowledge transfer through providing an environment for organizational members to communicate.

The hard mechanism represents the transfer of explicit knowledge using information and communication technology. Proponents of hard mechanisms argue that information and communication technology enables the transmission of explicit knowledge to flow more seamlessly, and allows for a vast array of knowledge transfer, thereby reducing time and space barriers (Nonaka and Takeuchi, 1995). Generally, there is need to tailor the type of knowledge being transferred so as to enhance efficiency and effectiveness across the transmission mechanism.

Salvetat & Géraudel (2012) argues that the success of corporates and organizations is greatly dependent on the interactions between flows of information, materials, manpower, and capital equipment. Within the arena of supply chain management, the pattern of knowledge sharing is important as competitive advantages are often gained through collaboration (Arlbjorn, 2011).

Critique 1: Assumption of knowledge accessibility

By design, the knowledge based view assumes that the resource base of an organization increasingly consists of knowledge based assets (Stewart, 1997; Sveiby, 2001; Marr, 2004). The theory rests largely on the assumption that knowledge resources are important to ensure that a firms competitive advantages are sustainable, as these resources are difficult to imitate they are the foundation for sustainable differentiation (Wiklund and Shepherd, 2003). This perspective assumes that all firms, regardless of their size and breadth hold varying and accessible amounts of knowledge. With application to supply chain management, although this assumption is relevant, the notion of soliciting and engaging knowledge may not be seamless (Blackhurst et al., 2005).

Critique 2: Application of knowledge

One of the main characteristics of the knowledge based view is to recognize the fundamental economic changes resulting from the availability of knowledge. Barney (1991) noted that there is a structural change in the productive paradigm. Fulk and DeSanctis (1995) observed the change from manufacture to services in the majority of developed economies is based on the manipulation of information and symbols and not on the use of physical products. This characteristic is important within the study of supply chain management, but assumed that the accessibility to knowledge exists, and is within reach (Demsetz, 1982).

Critique 3: Knowledge forming existence

Demsetz (1982) notes that using the knowledge based view of the firm, the firm can create productive arrangements, which the market by itself cannot produce. The ability of the knowledge based view to acknowledge resource allocation is noteworthy, as it gives way to the creation of economies of scale, decreasing (transaction) costs, generating and creating value (Helfat and Peteraf, 2003). The application of these benefits within management and supply chain circles is valuable as cost reduction and value creation is synonymous with competitive advantage (Bommer et al., 2001).

2.8 Comparison of Knowledge Based and Resource Based Views

The primary difference between the Resource Based View and the knowledge based view, is that the Resource Based View sees knowledge as a generic resource (Barney 1991). This can provide a competitive advantage if expressed in combination with other resources, and skills (Barney 1991; Penrose 1959; Grant 1991). Knowledge based theorists consider knowledge to be the most strategic resource of the firm. The argument for value within the knowledge based view, argues that knowledge based resources are difficult to imitate, socially complex, and heterogeneous; and therefore are major contributors of sustained competitive advantage.

Spender (1996); Hoops & Postrel (1999) argue that competitive advantages are seen as shared, or collective, and tacit knowledge, which account for the ambiguity of knowledge as a resource. Within this paradigm, resource based proponents and knowledge based proponents are aligned on these determinants for sustained competitive advantage, however resource based proponents note that resources also must be rare, valuable and non-substitutable (Barney, 1991).

One important difference between the Resource Based View and the knowledge based view is that the Resource Based View consists primarily of intangible and immobile resources. Spender (1996) argues that as a society the shift from manufacturing to services has been accomplished through the usage and integration of knowledge, more than through usage of physical resources like land and materials.

According to Helfat and Peteraf (2003), the Knowledge Based View of the firm is the natural evolution of the Resource Based View, because the resource with the most sustained competitive

advantage is the most valuable, inimitable and immobile of all which is considered to be knowledge. In contrast, Grant (1996) believes that the Knowledge Based View is an extension of the Resource Based View of the firm, and not a theory in itself. Another reason for the Knowledge Based View to be an extension of the Resource Based View is the perception of organizations to be heterogeneous entities containing knowledge (Hoskisson et al., 1999). Within the study of supply chain management, the understanding of knowledge as a resource creates the notional connection with the Resource Based View (Makadok, 2001).

2.9 Selection of Theory

Comparatively, both theories aim to establish the cause for competitive advantage. Each perspective offers a valuable method of analysis, however the Resource Based View analyzes and interpret internal resources of the organizations and emphasizes resources and capabilities in formulating strategy to achieve sustainable competitive advantages. Within the study of supply chain management, resources may be considered as inputs enabling firms to collaborate, integrate and carry out activities (Makadok, 2001). The notion of internal resources and capabilities determining strategic choices made by firms is noteworthy within the evaluation of an integrated concept such as supply chain management.

In as much as knowledge based theory supports the issue of knowledge sharing, which is a basic construct of efficient supply chain management, it does not explicitly account for the automation needs of external factors relating to resource usage and development. Debela (2009) emphasizes that transaction cost efficiency is the motivating factor for the establishment of strategic commerce alliances, and thereby supply chain analysis. Within this perspective, the ability of

the resource based theory to emphasize transaction cost efficiency as the motivating factor for strategic alliances in commerce is valuable, and can therefore be used to demonstrate the impact of a supply chain management on a number of management drivers.

By nature, the resource based view justifies the existence of differences in performance between organizations as a consequence of knowledge asymmetries (capabilities and competences) aiming to create, transfer and transform knowledge into competitive advantage (Thatte et al., 2013). This notion suggested that there is value in the Hoskisson et al. (1999) observation that organizations to be heterogeneous entities containing knowledge.

In assessing the research focus, the RBV direction often explores areas of commerce strategy, transactional cost, strategic alliance, resource conservation and risk sharing. Resource based theory is considered to be more relevant in answering the research problem owing to its ability to identify underlying resource needs which drive organizations into forming strategic alliances, and establishing competitive advantages (Lado, Boyd, Wright, and Kroll, 2006). Within the context of market efficiency and effectiveness, this perspective would be most aligned. As a result of the Resource Based View focusing largely on relationships which can be optimized, the relationship between various functions of supply chain management (including knowledge based resources) and competitive advantage can be examined.

The overall discussion and comparison of framework strengths benefit the current study, however a distinct focus must be incorporated into the entire review. As such, while the Knowledge Based View approach supports the issue of knowledge sharing which is a basic

construct of automation, it does not explicitly account for automation needs in relation to land development and value. Comparatively, the Resource Based View approach may be more relevant in answering the research problem owing to its ability to identify underlying resources which that drive organizations into forming strategic alliances and thereby affecting land development. In summary, Resource Based View is advantageous in exploring the culture of commerce interaction, and in analyzing the relationship between supply chain automation and land development.

2.10 Conclusions

In establishing the definition of a supply chain, the recognition of the nature and diversity of the functionality of the concept of supply chain management can be ascertained. The acknowledgement of there not existing a defined, clear definition of the term, leads to the assumption of the concept being multi-faceted and constantly evolving.

The further identification of the role and objectives of a supply chain within commerce, is fundamental in evaluating potential academic and industry value, in conducting research within the concept. While the nature of supply chain management can be seen to be in a constant state of change, the volatility, reliance and application of the concept across the majority of supply chain areas, demonstrates the potential areas for continued research and further examination. In evaluating existing research, opportunity appears to exist within the evaluation of supply chain entity decision making structures, which supports the rationale of the study, noted in section 1.4, and allows for a defined path in meeting research questions (outlined in section 1.6).

While existing definitions present an overview of pre-conceived terminology and categorization of the concept, it is important to also understand how prior research has developed on the subject, and how the topic of supply chain management has been presented. As the concept of supply chain management applies to various components of a business, and therefore is integrated into multiple areas of commerce, defining a particular theoretical framework may depend on a number of factors.

In supporting the value of the proposed research outlined in section 1.8, an examination of various theoretical framework allows for an understanding of how prior research has engaged the topic of supply chain management. While several framework options exist, an examination of the Knowledge Based View and Resource Based View emerged as the most relevant options in discussing and presenting research questions noted in Section 1.6. Upon further examination, while the Knowledge Based View theory is based upon the issue of knowledge sharing; thereby allowing for the evaluation of automation within a supply chain, it does not specifically evaluate resource value and automation needs in relation to land and resource development.

In comparison, the Resource Based View is chosen, as it allows for the identification of cause-based relationships which is crucial when evaluating strategic relationships and supply chain entity placement. With reference to the goals of the proposed research objectives (outlined in section 1.5), and the defined problem statement (outlined in section 1.3), the Resource Based View framework appears to be the best suited option.

3.0 CHAPTER THREE : RESEARCH METHODOLOGY

3.1 Introduction

This study required the investigation of existing literature to identify the physical location of supply chain entities and the economic impact on a firm's supply chain. At the root of the study, the intention remained to identify a specific framework of land value, transportation decisions and tax structures impacting the economic value of physical location decisions of a firm within the supply chain context.

The methodological approach and tools aimed at meeting the objectives stated in section 1.5 of the study is discussed in detail throughout the chapter. Within the research methodology, an examination of the philosophical position, research approach and strategy adopted along with the instruments chosen in collection of data is discussed. An illustration of the actual processes undertaken to collect data is also evaluated, as well as a description of the data analysis processes in relation to the research methods previously noted. This chapter also handled issues pertaining to research ethics, establishment of data validity and reliability of authentication within the study.

The research variables presented are in line with both the general and specific research objectives presented in section 1.5.1 and 1.5.2. Research variables are identified along with a general discussion of factors influencing physical location decisions as well as a description of physical location factors assessed. In attempting to answer the research questions defined in section 1.6, the latter portion of the chapter discusses the research approach and explains the statistical analysis technique applied to in evaluating critical factors towards physical location decisions

within the FMCG manufacturing sector. This evaluation allowed for an understanding of decision making processes within the FMCG sector, thereby supporting the rationale of the study noted in section 1.4 and addresses the research questions noted in section 1.5.

The use of more than one method of data collection is called triangulation and it is a good means of minimizing the disadvantages of the two methods and using them in a complimentary manner to generate more authentic and credible data Creswell (2007). Because of the exploratory nature of this research, qualitative and quantitative data collection methodologies are used to triangulate the data collection process and strengthen the validity of findings.

3.2 Research Philosophy

A number of philosophical approaches exist with the intention of defining a process in assessing assumptions, strategy and design adopted in the research study. Three pillars in particular which can be identified as being the most prevalent approaches, include positivism, interpretivist and realism (Bryman et al., 2011).

Bryman et al. (2011), suggest that positivists assert that reality is stable and can be observed and researched without necessarily interfering with issues under study. The root of this position assesses that the concept of relatively can be objectively classified, and explained through identifying relationships. The main focus of this approach is on facts and observations that can be measured empirically using quantitative methods.

Comparatively, an interpretivist perspective assumes that there are significant differences

between natural and social sciences, and that often the meaning of a given phenomenon is translated through the researchers own views and perspectives. This method of study is associated with qualitative methods and approaches to data gathering (Easterby-Smith, Thorpe and Jackson, 2008).

Realism asserts that while human consciousness may affect the interpretation of research, knowledge is essentially created independently. Because realism approaches research from multiple angles, it can be seen as theory building or inductive in nature (Easterby-Smith, Thorpe and Jackson, 2008).

This study followed a theory building approach and incorporates the realism approach, because a combination of qualitative and quantitative assessment is required in understanding, assessing and analyzing the nature of physical location decisions within the context of supply chain management.

3.3 Research Approach

Saunders, Thornhill and Lewis (2009) identify the inductive and deductive method as being the two main methods of approaching and collecting research. The choice between inductive and deductive approaches is largely dictated by the purposes and goals of the study, which may be descriptive, predictive, analytical or exploratory in nature.

The Inductive approach follows a bottom to top approach, in which the researcher uses particular instances to generalize and establish a theoretical framework (Saunders, Lewis and Thornhill, ,

2009). In contrast, the Deductive approach assumes a top-down approach, with the assumption of the researcher already holding a theory with the purpose of the study being to authenticate or prove the theory (Saunders, Lewis and Thornhill, 2009).

The research process used a deductive approach to answer the research questions and to overcome the gap in literature, as its purpose is to draw a relationship between variables which have a direct impact on a supply chain. The deductive approach also corresponds with the study's objectives in providing an analysis of the economic impact of land location factors, and evaluating the economic impact of specific location factors in the assessment of transportation to and from a supply chain facility. The research is descriptive and investigated the relationship among selected factors after identification of significance from survey responses. Land value, transportation decisions and tax structures are the factors related to physical location decisions. The proposed conceptual framework and subsequent research proposes an empirical investigation into a theoretical relational path extracted from existing literature, and required testing through hypothesis and deduction. The conceptual model seeks to quantify the data from survey responses in order to explain the observed relationship in a theory building method. This approach required quantitative research tools and techniques which uses a positive paradigm and quantitative analysis. This study undertook a deductive method and tests hypothesized relationship among numerous factors including land value, transportation decisions, and tax structures by running a statistical experiment.

For the purposes of this study, land cost, land rent, land resources, productivity of land, land usage flexibility, accessibility to target customers, proximity to markets, size /area of land, layout

of land location, and building costs are the factors which can be grouped as land value. Factors contributing to transportation decisions include proximity to markets, access to suppliers, availability of diversified transport facilities, strategic visibility of location from major transport routes, availability of parking, inbound and outbound logistics, utility costs, approachability to roads, electricity and communication, climate, proximity to markets, availability of suppliers of raw materials, industrial or commercial incentives, architecture of loading/ unloading spaces, goods circulation, and automated transportation. As this is an exploratory study, an inductive, theory building approach was taken for which formal hypotheses are not being tested.

The research is also descriptive in nature. A descriptive research approach ensures that the research is conducted with the aim of studying the existing conditions and it reports on 'what already exists' (Robinson, 2014). As the research is aimed at understanding the current status of the variables under study, it can be best described as a descriptive study. A descriptive study is also in contrast to an exploratory study that is undertaken with the objective of finding out new possibilities or newer variables that may play a role in a given situation (Robinson, 2014).

The research applies hypothesis- deduction method and follows the seven step research process, outlined by Seakaran (2006), Pathirage, Amaratunga & Haigh (2008):

- a) Observation, identification of broad area of research.
- b) Identification of problem from initial information gathering.
- c) Conceptual framework formation with clear identification and labelling of variables
- d) Hypothesis development, explanation to proposed research
- e) Data collection through primary and/or secondary sources

- f) Data analysis
- g) Deduction and conclusion on interpretation of data after analysis. This step answers research questions and validate hypotheses.

Creswell (2009) suggested that a quantitative methodology is suitable for identification of antecedents of an outcome and the factors influencing the outcomes. Quantitative methodology is also appropriate when limited quantitative data is sufficient to test predictive theoretical hypothesis (Johnson and Christensen 2003). A quantitative methodology fit best with a survey data collection tool, which is the most appropriate to identify the correlation (Handfield & MeInyk 1998; Creswell 2009). While the qualitative methodology is used to understand the overall dynamics of the decision making process and to identify the crucial factors that impact managerial decision, the quantitative methodology is intended to test the hypotheses generated from the qualitative phase of the study.

3.4 Research Ontology, Epistemology, Axiology

The research approach described, provides a framework for the overall research philosophy, including the research ontology, epistemology and axiology.

Ontology refers to the philosophy of what comprises the reality and dictates which areas are to be considered the context of the research and what limitations are to be accepted (Reyle and Saric, 2001). The ontology defines the portion of the overall data which is going to form the basis of research. In this research, it was presumed that the focus should be to narrow down the relationship between variables which can be identified and isolated within a study.

Epistemology includes the assumptions about how information and knowledge is obtained and what sources are to be considered authentic (Reyle and Saric, 2001). It was assumed that the employees of FMCG firms chosen were credible, able and willing to provide useful information for this study. It is also assumed that the respondents were able to provide honest and authentic responses to the questions posed.

3.5 Research Strategy

In order to achieve consistency between the main questions of research, research methodology and theoretical approaches, a meaningful research strategy must be adopted (Creswell, 2009). In many cases, the decision of which strategy to undertake enables the researcher to offer insights that other methods of research may not achieve (Bryman and Bell, 2011). Location decision studies usually focus on three basic types of analyses (Murray & Dowell, 1999):

- 1) Empirical Analysis through historical data of firm's location
- 2) Analysis of data through survey questionnaires from firm's staff
- 3) Analysis through case studies of specific firm's location decisions and policies

The current study focused on structured and semi-structured questionnaire survey which is conducted specifically on fast moving consumer goods companies at production plants, distribution inventory storage units and other associated supply chain stations, to carry out the comprehensive analysis of location decisions that can be considered viable by FMCG companies.

The research is undertaken using both secondary research and primary data collection methods

and uses a combination of interviews and survey questionnaires to analyze the correlation among the selected variables, and in line with the research objectives noted.

Secondary Research

Secondary research is conducted by researching existing data and literature on topics surrounding corporate objectives, land usage, distance priorities, importance of raw materials, company structure etc. In addition to this approach allowing for a critical evaluation it also provides the background for developing the questions used in the interview and the survey methods within the primary research approach.

Primary Research

Primary research for the purposes of this research employs both qualitative and quantitative data collection methods. Qualitative research methods are found useful when the data needs to be of high quality and in depth (Robinson, 2014). As the current research involved developing a deeper understanding of how multiple benchmarks, policies, physical variables and managerial decisions may be affecting corporate progression, there was a need to gauge information on the various complex variables and their interrelationships. For example, there was a need to understand corporate objectives and to develop insight as to whether corporate culture influences risk adversity toward supply chain decisions. This type of conclusion can only be achieved if detailed information is gathered from the respondents. As such, a qualitative interview method was selected as one method of data collection.

One key disadvantage of qualitative research, is that it can only be used with a limited number of respondents as the method involves large amount of investment in terms of time (Creswell, 2007). While qualitative data collection may lead to the generation of a lot of useful data from a

small number of respondents, the size of the sample is restrictive and may not be an accurate representation of the larger population. As such a quantitative method of a survey for the collection of further data from a larger number of respondents is used. While the quantitative method may not collect in depth and personalized data, it allows for the gathering of the opinion of a large number of respondents (Creswell, 2007).

3.5.1 Interview Approach

The interview approach allows for a data collection method in which respondents are asked questions verbally. This method allows for the understanding of respondents perceptions, opinions, situations and unbound feedback. A key advantage of interviewing respondents is to collect data which is unlikely to be accessible using techniques such as surveys or passive observation. Creswell (2007) notes that interviews are useful when in depth information is required. Within the context of this research, management decisions and opinions are potentially valuable, and as such this approach is suitable. There are three types of interview methodologies: structured, semi-structured and unstructured interviews.

Structured interviews allow the interviewer to ask each respondent the same questions in the same way. This approach is a tightly controlled structured schedule of questions, and the format is used very much like a questionnaire Creswell (2007). The phrasing of questions within a structured interview may limit the number of options for a response. The possible answers are defined in advance so that the respondent is limited to one of the pre-coded responses and thus data analysis becomes similar to evaluating a quantitative study.

In contrast, an unstructured interview is substantially more open ended, and based solely on the discretion and the skills of the researcher to ask individualized and custom questions. The main drawback is that the focus of the research may be lost and side issues and digressions may lead to loss of time Creswell (2007). Further, results may not be meaningful as each respondent may be asked different questions.

This study utilized a semi-structured method of interviewing respondents as this approach allows for informal conversation based on predetermined topics (Creswell, 2007). Within this structure, a sense of direction and focus can be established, while more information or specific follow-up is also possible.

Creswell (2007) defines bias within qualitative research as allowing a particular influence to have more importance than it should warrant. Patton (1990) continues to note that because the researcher is the instrument of both data collection and data interpretation, and because a qualitative strategy includes having personal contact with and getting close to the people and the situation under study, bias is inevitable. Within the qualitative component of this research, the objective is not to collect data, but rather to produce findings. As such, the challenge becomes making sense of data, identifying patterns, and constructing a framework based on qualitative responses. This approach may result in an interview approach which cannot be perfectly replicated for each respondent, and as such may introduce elements of moderator and interviewer bias.

Because qualitative inquiry depends, at every stage, on the skills training, insights, and capabilities of the researcher, qualitative analysis ultimately depends on the analytical intellect and style of the analyst (Patton, 1990). The questions for each respondent are planned in advance and while there is discretion surrounding how areas might be elaborated on and explained, the objective is to standardize data as much as possible, and to eliminate bias due to inconsistent and different wording sequences. To meet this objective, questions, sequences of questions, and follow-up questions are established in advance of each interview.

For the current research, interviews are conducted over telephone or in person at times convenient to respondents. Results of interviews are noted electronically throughout the interview. Bogdan & Biklen (1982) note that the goal of qualitative research is to objectively study the subjective states of their subjects. This leads to the possibility of interpretation bias based on pre-conceived impressions, misunderstandings or researcher knowledge when evaluating data.

3.5.2 Survey Approach

A survey of sample data of people/subjects within a predetermined population is often useful when evaluating a relationship between multiple variables (Kelley et al., 1993). The survey component of data collection makes use of a close ended questionnaire. This questionnaire contains multiple choice questions and attempt to restrict responses to the already established set of responses. A survey produces responses from people or subjects whereas the statistical analysis of the survey reveals an assessment and relationship of study variables. An industrial survey focuses on identifying the significance of factors to identify the most critical factors

(Murray & Dowell, 1999). For the purpose of this study, surveys were conducted by approaching policy and decision makers within the FMCG sector, including strategic managers, and other plant and operational staff in manufacturing assemblies, distribution and inventory storage locations.

A survey research design helps in testing a hypothesis for a correlation between dependent, independent and moderating variables (Kelley et al., 1993; Creswell, 2009). The study intended to test the relationship among factor variables whereas the survey questionnaire served as the method of data collection.

A survey approach is beneficial in the following ways:

- a) Data from the manufacturing, distribution and warehouse sites of a particular firm can be accessed.
- b) Information is gathered from decision makers and strategic staff members at the plant, distribution and warehouse locations as well as associated departments within the supply chain.
- c) Inter-relationships within a supply chain can be studied through survey questions or interviews.
- d) Weights and significance of variable factors can be evaluated through responses.
- e) Context and perspective of location decision can be identified through responses.
- f) Survey responses can be easily interpreted as compared to complex quantitative data.

In order to reduce the potential for disinterest or confusion, the following is considered in the development of the survey:

- a) The fewest possible number of questions is used.
- b) Questions are addressed in the most simple and straight forward method possible.
- c) Questions are structured in a logical sequence which are easy to comprehend.
- d) Respondents are given questions which are applicable to their area of occupation.

As suggested by Maxwell (1992), validity of quantitative research is not a property of particular approaches or methods or research. Rather, it is a property of accounts or inferences or interpretations of data created in the process of a specific inquiry conducted for particular purposes. The bias in survey responses can be minimized through a number of methods including reducing consistency motif threats, improving item scaling, protecting the anonymous status of respondents and monitoring priming effect (Podsakoff & Organ, 1986).

3.6 Data Collection Approaches

According to Robinson (2014), the data collection procedure involves three sets of decisions:

- 1) Targeting the survey respondents
- 2) Explaining the selection of data collection mediums
- 3) General instructions which conform to the survey design

The target participants in this survey are FMCG policy and decision makers, including managers, analysts, purchasing officers, and operational staff.

An online survey questionnaire is designed and tested for reliability and validity, as oppose to a mail survey which could have reliability and distribution capacity constraints (Griffis et al., 2003). The structure and content of the survey followed the objectives noted in section 1.5, and draws on the notion of posing non-complex complimentary and exploratory questions. Respondents are able to note areas which are unclear, and as such testing for validity and reliability is possible.

Follow-up procedures take place after collection of the first 150 responses, at which point an evaluation of response rates, and responses takes place.

3.6.1 Instrumentation of survey

Factors pertaining to this survey are measured through multiple item scales. The structured questionnaire carries questions with 5-point Likert scale and other with a rank correlation. As the Likert scale is a consistent measurement scale, it is preferable for survey questionnaires as it uses a common ordinal measurement scale to reduce response bias (Vagias 2006; Kline 2011; Hair et al., 2014).

Within the possible responses, a range from ‘Very Good’, ‘Good’, ‘Neutral’, ‘Bad’ and ‘Very Bad’ are posed. Some sections also ask ‘Yes’ or ‘No’ or ‘N/A’ questions. Responses for these questions are interpreted in terms of respondents and percentage response rate. For example, analysis on a Yes or No question, are presented as “an X number or percentage of employees at Y company stated Yes, while the remaining said No”.

Pilot testing of the survey before administration assists in addressing potential bias in survey questions. As such, questions can be modified if responses from pilot testing are not valid and/or reliable (Dillman et al., 2009). If a low response rate is noted within the first period of circulating the survey, or if respondent feedback offers suggestions on optimizing survey questions, modifications may take place.

3.7 Data Analysis

The interview sample is comprised of respondents individually selected, and analyzed in a reflective manner. This is possible as a large portion of the respondents who are interviewed have had a previous working relationship with the researcher.

The questionnaire for the email survey of the customers is comprised of 10-15 questions presented in a Likert style multiple-choice format. Respondents are selected based on role, hierarchy within a firm, and relationship to variables identified in the research.

The collected data is analyzed through the use of statistical software (SPSS and AMOS), in performing exploratory factor analysis, confirmatory factor analysis and path analysis by structural equation modeling.

A number of data tests are performed to assess the consistency, reliability and significance of the collected data. Prior to conducting Exploratory Factor Analysis, the value of the Kaiser-Meyer-Olkin Measure of Sampling Adequacy (KMO) is calculated, in order to assess the suitability of data for factor analysis. According to Kaiser (1974), the KMO value must exceed 0.6 in order to conclude that the data is suitable for factor analysis. As a second test, Bartlett's test of sphericity

is used to test the feasibility of the use of factor analysis on the data. According to Bartlett (1954), statistical significance is reached if value of this indicator is 0.05 or less. In order to test reliability of scales used, the Cronbach's alpha coefficient is calculated. According to Pallant (2007) and DeVellis (2003), this coefficient should be greater than 0.7, in order to conclude that the measurement scale is reliable.

A third test is the scree plot, which displays the eigenvalues associated with the factors versus the factor number. This plot allows the assessment of each component, and demonstrated the variability within the data.

Finally, a factor correlation matrix, and a pattern matrix are used to determine discriminant validity and the correlation between factors. An extremely high correlation among factors (exceeding 0.7) may suggest that the two factors could be combined into a single factor.

Comparatively, extremely low correlations among all factors could suggest that factors are not correlated.

3.7.1 Unit of Analysis

A unit of analysis may be an organization, an individual, a geographical entity, group or social interaction (Sekaran, 2003; Trochim & Donnelly, 2001). According to Sekaran (2003), research questions are usually linked to specific units of analysis, on the basis of which the study determines a sample size and conducts data collection. The units of analysis identified for this study were decision makers, strategic and operation managers, strategic and operational level staff at manufacturing assemblies, distribution and inventory storage locations and other associated departments.

3.7.2 Statistical Technique

The use of traditional qualitative and quantitative tools for industrial location decisions are checklists, multivariate statistical analysis and dimensional analysis evaluation technique. However, these approaches are not sufficient when evaluating complex and strategic decisions (Rainey & McNamara, 1999). Location factors are qualitative as well as quantitative, while analysis of data into one specific analytical language required the use of a fuzzy logic approach, incorporating all factors in strategic decision making (Rikalovic & Cosic, 2015). A conditional logit model is traditionally applied for analysis of location factors (McFadden, 1974; Alcácer & Chung, 2007), however this model assumed the relative probability of any two alternatives remained independent from the inclusion or removal of other alternatives. Further, the model assumed that there was no correlation between error terms across two alternatives.

Location decision analysis studies frequently violate the assumption of logit model (Belderbos & Somers, 2015). To combat these drawbacks, recent studies now focus on advanced form of logit model which is known as mixed logit model (Alcácer and Chung, 2007).

The study was comprised of a set of latent variables which comprise of one or more variables. The variables and associated relationships are evaluated through questionnaire responses for further analysis and deductions. Outlier factors are grouped into another variable which was not covered in any of the above mentioned statistical techniques, for which structural equation modelling was used for the purpose of analysis.

3.7.3 Factor Analysis

Factor analysis is a structure equation statistical modelling method which explains variability among observed (correlated variables) and unobserved variables, and is a commonly used method in evaluating the strength of the relationship of individual items. In using this method, linear combinations of unobserved variables, along with error terms are modelled for observed variables. Interdependencies among the observed variables can reduce the number of total variables in a dataset. As factor analysis is widely used in management and operations research, and is similar to principal component analysis (Bartholomew et al., 2008), it formed the basis for evaluating the strength of relationships in this study between variables relating to land location, transportation, and tax implications.

Within factor analysis, exploratory factor analysis (EFA) and confirmatory factor analysis (CFA) are two statistical approaches used to examine the internal reliability of a measure. Typically, exploratory factor analysis is used in studies which do not have a set hypotheses about the nature of the underlying factor structure of their measure (Pallant, 2007). As a function of exploratory factor analysis, an extraction procedure such as principal axis factoring, and maximum likelihood are used to estimate the regression coefficients between factors, and measure the influence of a common factor on a measured variable. The maximum likelihood method was used in this study, as it allows for the testing of statistical significance of factor loadings, calculations of correlations among factors and the computing of confidence intervals (Guttman, 1954). A rotation method was also necessary, in which loadings are rotated, for the purpose of maximizing high loadings and minimizing low loadings, so that the simplest possible structure is achieved. Of the two basic types of rotation (orthogonal and oblique), oblique rotation derives factor loadings based on an assumption that factors are correlated, which is typical for most measures (Guttman,

1954). As such, this study made use of a promax rotation, which is noted as being efficient at achieving simple oblique structures (Pallant, 2007), and was used to develop factor correlation and pattern matrices for physical location decisions and land value decisions.

In this study, confirmatory factor analysis was conducted in order to confirm the factor structure extracted in the exploratory factor analysis, and provided a fit of the hypothesized factor structure, when physical location decision variables, land value decision variables were observed. The fit of the model was estimated for the measurement model, and explains how well the proposed model addressed the correlation between variables in the dataset, and provided value in understanding where relationships existed among variables relating to land location, transportation, and tax implications. This achieved the objective of understanding management decision making patterns within the areas of land location and transportation considerations.

The application of the above techniques revealed that all dimensions of land value determination have a direct and positive impact on economic impact and on dimensions of physical location decisions, while physical location dimensions have a direct and positive impact on respondents assumption of economic impact. This could demonstrate a management decision matter.

If the proposed model showed poor model fit, the model may be improved by eliminating specific connections between the constructs in the path diagram, which have statistically insignificant and low regression weights, or by establishing covariance between individual error terms and establishing new empirical relationships between constructs.

3.7.4 Structural Equation Modelling

Structural equation modeling is a powerful multivariate statistical analysis technique, which is used to analyze structural relationships of variables. SEM is the combination of factor analysis and multiple regression analysis, and is used to analyze the relationship between measured and latent variables. This method allows for the measurement of multiple and interrelated dependence in a single analysis (Bartholomew et al., 2008). According to Guttman (1954), Wiggins, Steiger, & Gaelick (1981), SEM is applicable in the following forms:

- a) Causal modeling, or a path analysis, analyzes causal relationship of hypothesized variables. Causal modeling or path analysis is tested with linear equation system. Causal models may include latent variables, manifest variables or both.
- b) Confirmatory factor analysis is an extended form of factor analysis which tests specific hypothesis related to structure of factor loadings and inter-correlations.
- c) Second order factor analysis, is another variation of factor analysis technique which represents correlation matrix of factors as factor itself.
- d) Regression models are an extension of linear regression where regression weights are constrained equal to one another, or specific values are assigned to them.
- e) Covariance structural model hypothesizes the particular form of covariance matrix. For instance, testing hypothesis that the whole set of variables possess equal variance with covariance structural model.
- f) Correlation structural model hypothesizes particular form of correlation matrix.
- g) For instance, a classical example of structure of correlation matrix is circumflex.

SEM was applied to quantitative data received to understand how factors of land value determination, physical location decisions and economic impact impacted the overall supply

chain and firm, with results being analyzed for goodness of fit and statistical significance. This is integral in understanding the relationships between the dimensions of physical location decisions, land value determination and attitude of respondents related to economic impact on the overall supply chain and firm.

3.8 Research Validity and Reliability

The validity of research is an important measure, as it ensuring that research is geared towards collecting data that is needed for the answering of the research questions (Bell and Opie, 2002), while research reliability depends upon the research instrument's ability to capture same data repeatedly without error (Bell and Opie, 2002). The sample of surveyed respondents was random, and respondents have only one opportunity to respond; hence there should be a meaningful applicability of the research findings to the general population.

Several calculations are used to determine goodness of fit of the measurement model. The metrics used belong to a group of absolute (χ^2/df , RMR, GFI, RMSEA) and incremental fit (CFI, NFI, TLI) indices. The sample size should be above the chi-square value threshold of 200, which allows the standardized chi-square value (χ^2/df) to be calculated, and show the sensitivity to the overall sample size. According to Tabachnick & Fidell (2007), 2.0 is the upper acceptable limit of chi-square. The goodness of fit index (GFI) indicates how well the observed variance is explained by the model. According to Hoyle (2000) and Kline (2005), the value should be between 0.9 and 1.0 in order to achieve a good model fit.

Schutz (1998) and Kline (2005) note the value for Comparative Fit Index (CFI) should be above 0.9, and the Root Mean Square Residual (RMR) should be between 0.0 and 0.1 (with values below 0.006 being optimal) in order to demonstrate a strong model fit. Further, the Root-Mean-Square Error of Approximation (RMSEA) should be close to 0 in order to indicate a strong model fit with the data. According to Hu and Bentler (1999), values below 0.06 are a good indicator of model fit, while values between 0.06 and 0.08 are considered acceptable, and values

greater than 0.1 represent an indicator of poor fit. The recommended value for the Normed Fit Index (NFI) is between 0.95 and 1.0 (Thompson, 2005). Lastly, the Tucker-Lewis Index (TLI) (also called the Non-Normed Fit Index (NNFI)) is calculated. Since this index has not been regulated in the range of 0.0 to 1.0, the values of this indicator should be close to 1.0.

Interviewed respondents have connectivity to the researcher, and as such attention was placed to ensure interpretation of data does not allow bias to be introduced.

If the initial model showed poor model fit, the model can be improved by co-varying error terms, or by removing items which have a low factor weight within parent factors, or establishing a greater connection with the variables which belong to other dimensions. The decision on how to improve the original model was made on the basis of examination of the standardized residual covariance's and modification indices covariance's. After a reassessment of the overall suitability, the measurement model validity and reliability was estimated, based on an assessment of convergent and discriminant validity of the constructs.

Convergent validity of the constructs was estimated based on the value of the Composite Reliability (CR) and the Average Variance Extracted (AVE). According to Hair et al. (2010), the value of the CR should be between 0.7 and 1.0, while the AVE should be 0.5 at minimum. Further, the Composite Reliability value should not exceed the value of the Average Variance Extracted, which indicates a greater convergent validity of the measurement constructs.

The formula used to calculate Variance Extracted is shown below:

$$VE = \frac{\sum_{i=1}^n \lambda_i^2}{n}$$

λ =Standardized Factor Loading; n=number of items

The formula used to calculate Composite Reliability is shown below:

$$CR = \frac{(\sum_{i=1}^n \lambda_i)^2}{(\sum_{i=1}^n \lambda_i)^2 + (\sum_{i=1}^n \delta_i)}$$

λ =Standardized Factor Loading; n=number of items; δ = error variance

In order to assess the discriminant validity of constructs, it is necessary to compare the value of the Average Variance Extracted to the Maximum Shared Squared Variance (MSV), as well as the Average Squared Shared Variance (ASV), from the correlation matrix. According to Hair et al. (2010), ASV and MSV should be less than the value of AVE, while the square root of AVE should be greater than the value of the correlation between constructs.

3.9 Ethical Considerations

Research Ethics are important as they assist a researcher to coordinate his/her actions to protect the well-being and interests of research participants in any research undertaken. Consent and permission were received from all respondents. Personal data received was maintained in a safe and secure manner, and responses are not coerced or influenced.

3.10 Conclusions

In attempting to meet the objectives noted in section 1.5, the research methodology elaborates on the role of land value, transportation decisions and tax structures in physical location decisions within manufacturing assemblies, distribution locations and warehouses or other inventory

storage locations. This chapter undertakes a conceptual model based on external and internal factors which may contribute to physical location decisions. The problem statement discussed in section 1.3 suggested location factors as being a core element to a supply chain and assumed that decisions within this area should add a positive value to the growth of the firm.

As noted in section 1.3, the study was conducted primarily within the Fast Moving Consumer Goods (FMCG) sector. As such, the target respondents are decision making employees within the FMCG industry, including executives, managers, purchase officers, operational staff.

The methods of primary data gathering are through the analysis of survey and interview data. The survey was a semi structured and structured questionnaire which carries questions with 5-point Likert scale and other with a rank correlation. Multiple choice questions are used, with areas provided for respondents to expand on their responses. A semi-structured method of interviewing respondents was used, as this allows for a more informal process, as well as a follow-up on responses to understand deeper areas for decisions.

With the intention of meeting the research objectives noted in section 1.5 and the research questions noted in section 1.6, factor analysis and structural equation modelling was used on survey data, aiming to identify a model which considers variables and ascertains the hierarchy of the most critical factors for location decisions by FMCG companies. An evaluation of survey and interview data was used to confirm the hypotheses noted in section 1.7, with the survey and interview process taking place through an online structure.

4.0 CHAPTER FOUR : RESULTS

4.1 Introduction

As noted in section 3.5.2, a survey and an interview are designed to invite feedback from policy and decision makers within the FMCG sector, in an effort to assess the impact of the physical location of supply chain entities and the economic impact on a firms supply chain regarding physical location decisions. Interviews are conducted to drive deeper into findings from the survey, and should provide justification and further clarity into observed conclusions. This process aimed to answer research questions noted in section 1.6, and attempts to identify a specific framework of land value, transportation decisions and tax structures impacting the economic value of physical location decisions of FMCG firms.

The results from the survey and interview are presented in this chapter, within a summarized table and figure structure to demonstrate findings.

4.2 Survey Respondent Demographics

Table 4: What is your present title within your current company?

Eligible	Respondent Role	# of Surveys	% of Eligible/Ineligible	% of All Surveyed
Yes	Executive Decision Maker (C-suite, VP, Director etc.)	156	61%	20%
	Senior Manager	51	20%	7%
	Middle Manager	12	5%	2%
	Operational Staff	8	3%	1%
	Analyst / Junior Manager	2	1%	0%
	Other:	27	11%	4%
Yes Total		256	100%	33%
No	Executive Decision Maker (C-suite, VP, Director etc.)	320	63%	42%
	Senior Manager	63	12%	8%
	Middle Manager	25	5%	3%
	Operational Staff	5	1%	1%
	Analyst / Junior Manager	4	1%	1%
	Other:	93	18%	12%
No Total		510	100%	67%
Grand Total		766		100%

Of the 766 surveys attempted, 256 (33%) were deemed eligible to complete the survey.

Executive Decision Makers comprised 61% of the respondents, Senior Managers accounted for 20%, and Middle Managers made up 5% of the demographic. Operational Staff, Analyst/Junior Managers, and Other roles accounted for 3%, 1%, and 11% respectively. As a result, 86% of the respondents held management roles.

Figure 1: What was your company’s approximate revenue in 2014 (in US Dollars)?

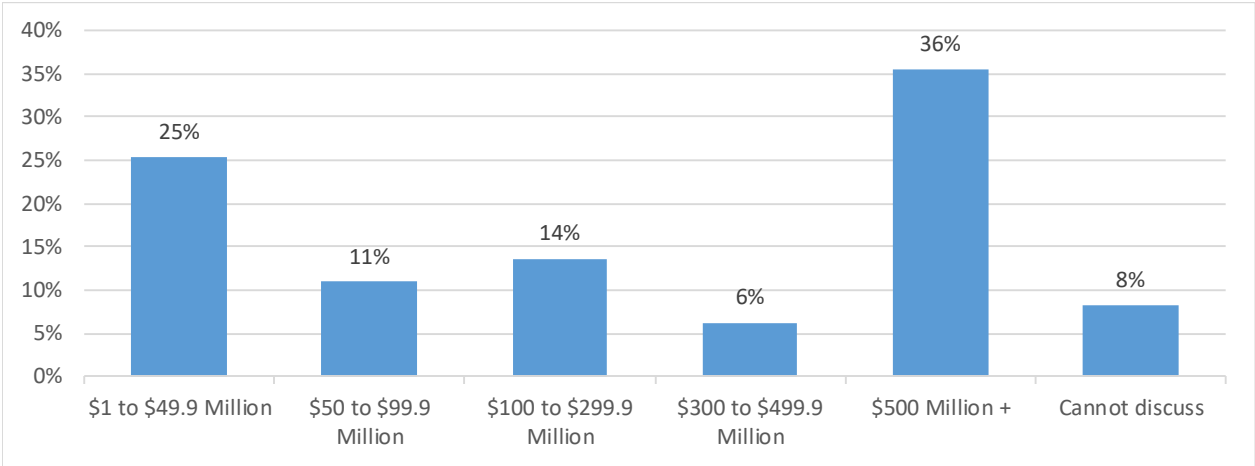

With exception of the 8% of respondents not able to disclose this information, all respondents have indicated that they work for companies with annual revenues between \$1 and \$500+ Million. The majority of respondents (61%) note that company revenues between \$1-\$49M (25%), and \$500M+ (36%), suggesting that the respondent pool was largely comprised of managers from large and medium firms.

Figure 2: What is the size of your company, in terms of employees?

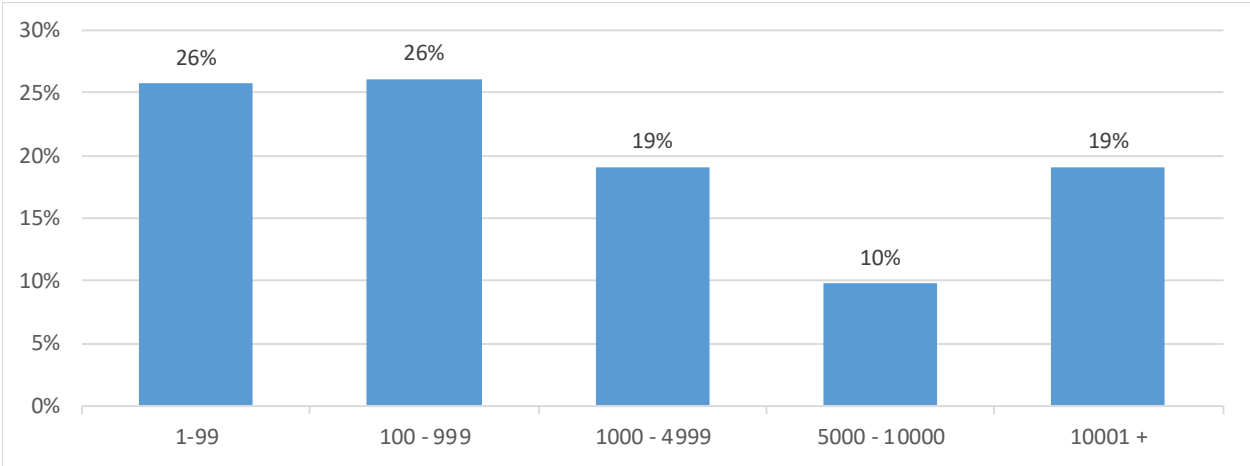

The majority of respondents (52%) indicated that their company employs 1-1000 employees. The remaining 48% of respondents indicated that their company employs 1000 – 10,000+ employees. These results appear to correlate to the data in figure 1, and further suggests that the respondent pool was largely comprised of managers from large and medium firms.

Figure 3: Within your current role, what is your area of focus?

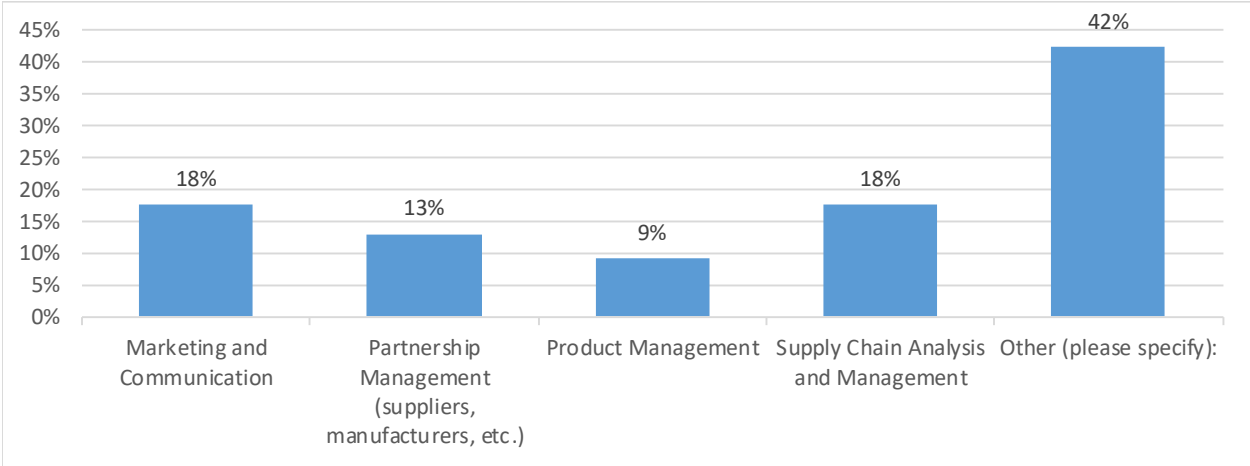

Of the respondents surveyed, 36% noted Marketing and Communication, and Supply Chain roles, suggesting that the respondent pool was largely comprised of managers able to view and influence the internal function of the supply chain. 42% selected ‘Other’, suggesting that approximately half roles of respondents are diverse and cannot easily be grouped into the four categories noted. Details on the specific responses are noted in table 2.

Table 5: Within your current role, what is your area of focus? (Other)

Area of Focus Specified	Count of Respondents	Percent of Respondents
Sales	22	25%
General Management	21	24%
Executive	15	17%
Consultant	7	8%
Finance	3	3%
All Roles	2	2%
Distribution	2	2%
IT	2	2%
Purchasing/Procurement	2	2%
Operations	2	2%
Business Development	2	2%
Manufacturing	2	2%
Product Design	2	2%
Marketing	2	2%
Quality Assurance	2	2%
Transportation	1	1%
Total	89	100%

The majority of respondents (49%) claim sales and general management was a core focus, suggesting that a large portion of respondents have direct interaction with the supply chain. A smaller pool of the respondents (17%) note that they are focused on executive areas, suggesting an overall management of the supply chain.

Figure 4: What is your present title within your current company?

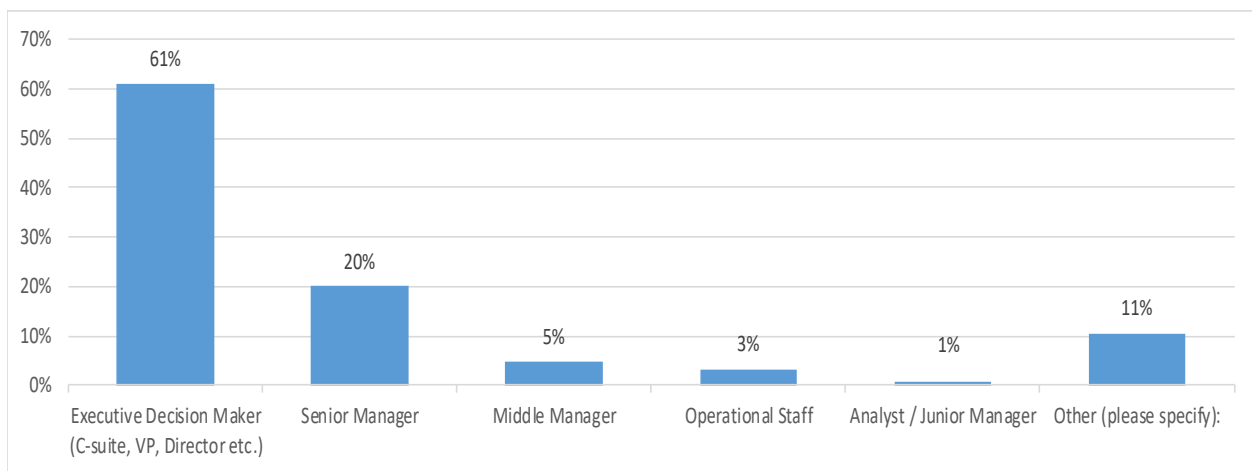

Of the respondents, 86% indicated they were at a manager level or higher, which meets the target respondent objective of the study, and suggests that the majority of respondents hold some level of decision making authority. 11% noted ‘Other’, which is expanded upon in Figure 5.

Figure 5: ‘Other’ responses to ‘What is your present title within your current company?’

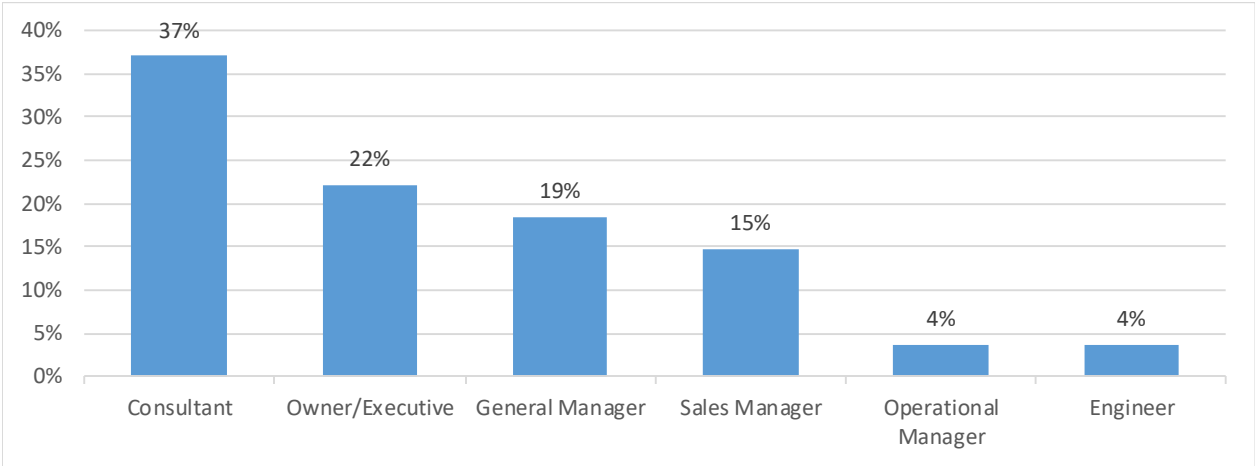

Of the 11% of respondents noting that they hold a separate title in Figure 4, the majority of respondents (60%) note that they hold senior managerial or ownership/executive role, further suggesting that the majority of respondents hold decision-making authority.

Figure 6: Within your current role, which geographic region/s do you focus on?

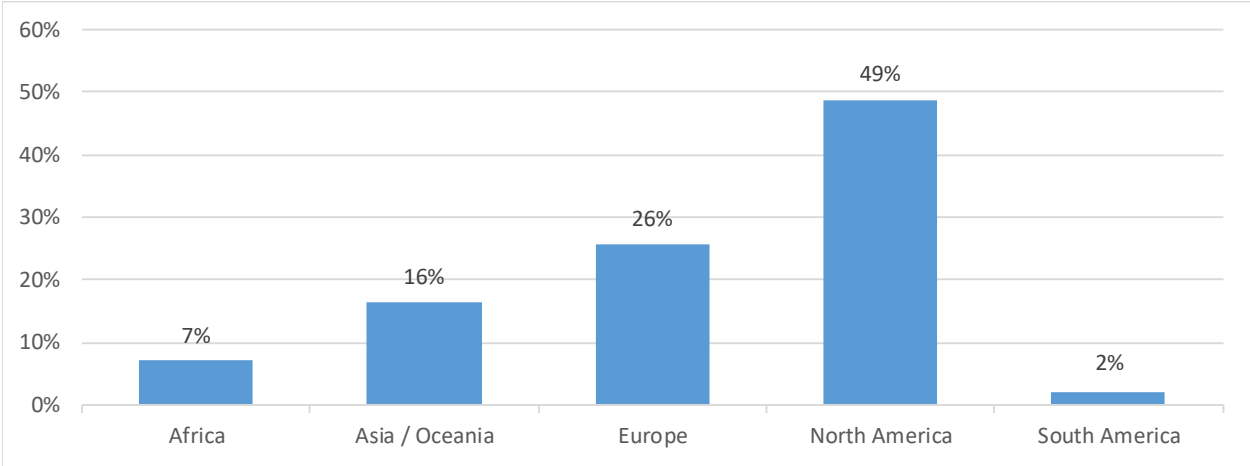

In their current role, 49% of those surveyed focus on North America, suggesting that the respondent pool was largely based in North America.

Figure 7: Within your current capacity, what level of contribution do you have toward physical resource decisions (i.e. placement of warehouses, manufacturing plants etc.)?

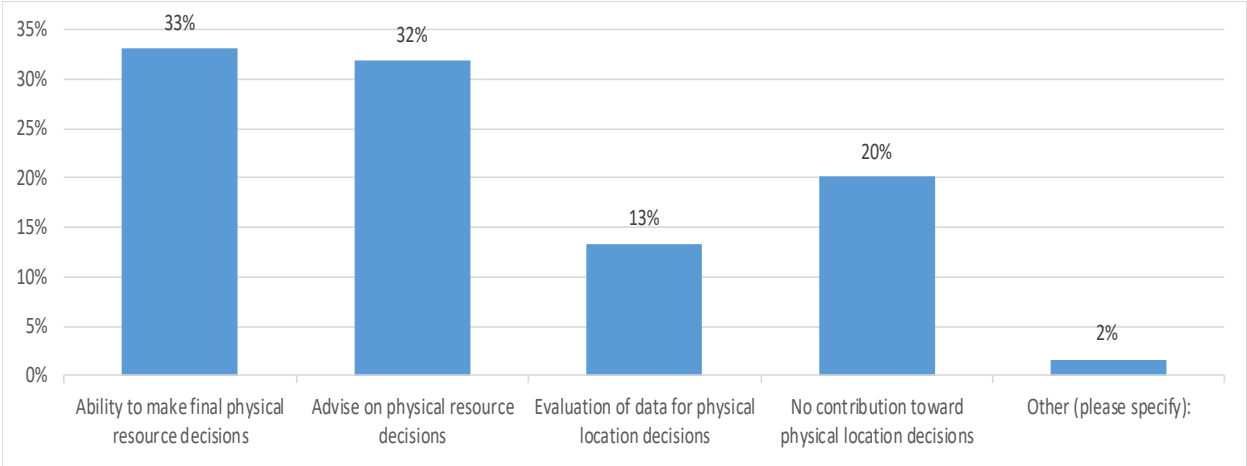

Of the respondents, 33% are able to make final decisions pertaining to physical resource placement, while 32% advise on the decisions, suggesting that the majority of respondents hold decision making or decision advising authority. A smaller percentage (13%) of respondents evaluate data for physical location decisions, which suggests that the majority (78%) of the respondent pool have some level of contribution to decisions pertaining to physical resource placement of supply chain entities, meeting the objective of the survey. 2% (3 respondents) selected “Other” levels of contribution, presented in Figure 8.

Figure 8: ‘Other’ responses to ‘Within your current capacity, what level of contribution do you have toward physical resource decisions (i.e. placement of warehouses, manufacturing plants etc.)?’

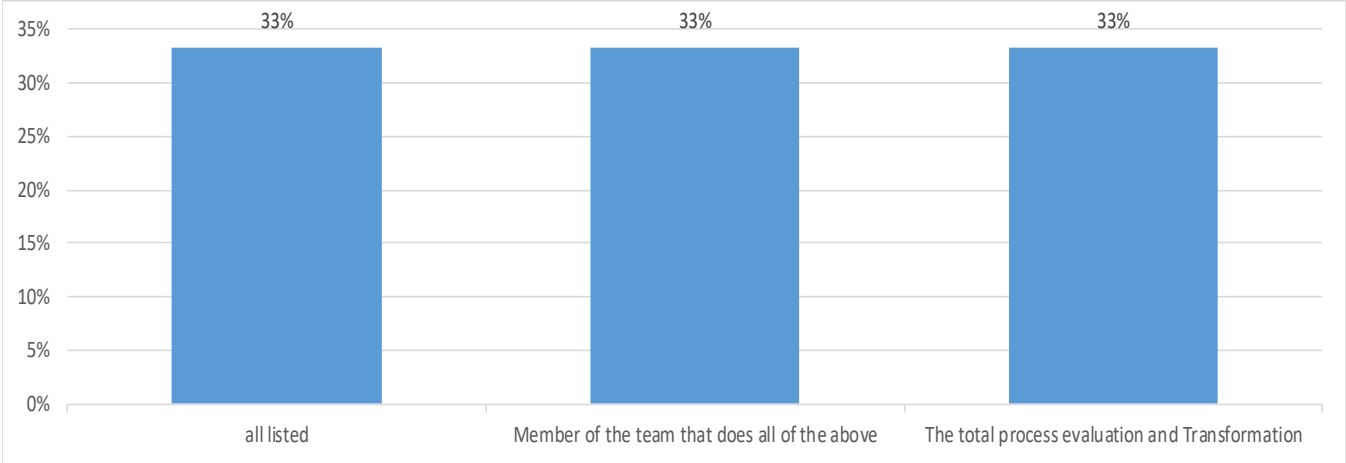

Of the 3 respondents who selected “Other” when questioned about their level of contribution toward decision making related to supply chain physical resource decisions, all respondents indicate that they contribute to final location decisions. This suggests that overall 80% of the respondent pool contributes to physical location resource decisions within the supply chain.

Figure 9: How long have you worked in your current role?

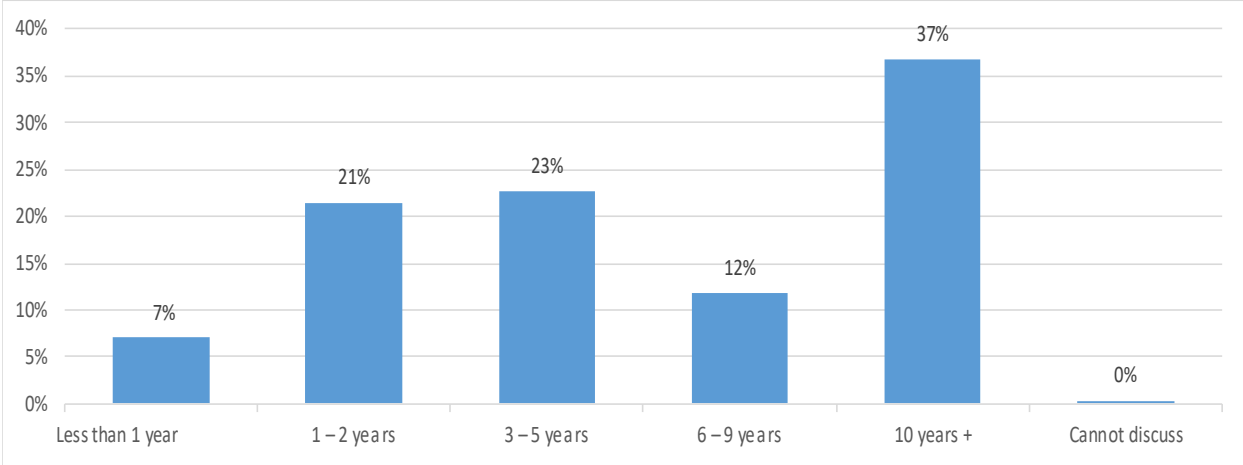

Overall, 72% of respondents hold over 3 years of experience within their current role. This may suggest that the majority of respondents are familiar with their role, and understand the supply chain physical resource decision making process.

Figure 10: How long have you worked within your current company?

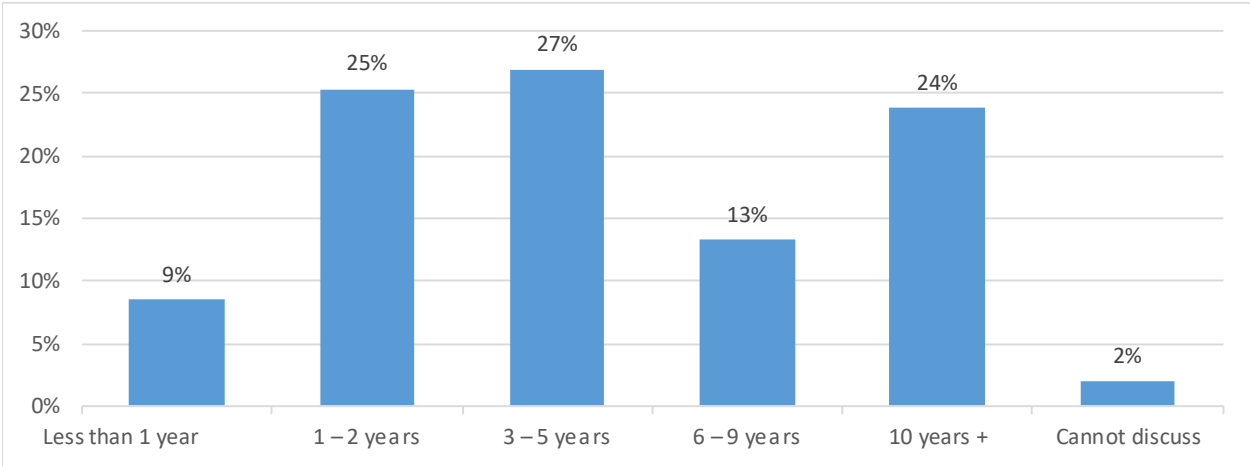

Of the respondents, 64% claim to have worked for their present company for over 3 years. This may suggest that the majority of respondents show familiarity with corporate policies and corporate culture within their company, in affecting supply chain physical resource decisions.

4.3 Transportation Decisions, Tax Structures & Land Value Affecting Physical Location Decisions

Please indicate to what extent you agree with the following factors, when reaching physical location placement decisions of various supply chain entities (specifically manufacturing plants, distribution centers, and storage facilities) within your organization.

Figure 11: Part A: Land Location Related Decisions -Physical land maintenance cost

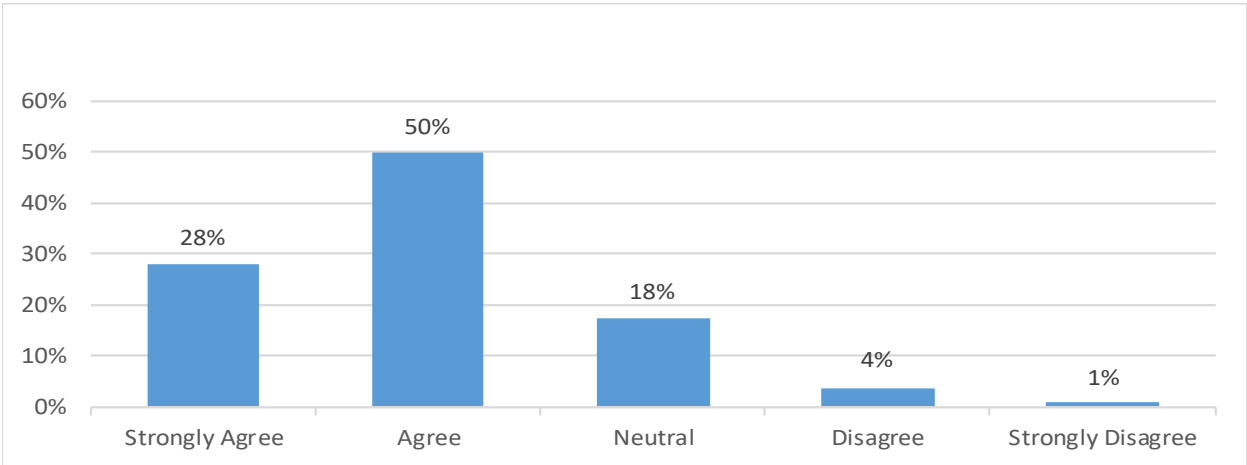

78% of respondents Strongly Agree or Agree that physical land maintenance cost is a key factor in physical location decision making, which could suggest that the overall cost to maintain the site may influence the timing of purchase, and size of land sought.

Figure 12: Part A: Land Location Related Decisions -Land rental/ownership cost

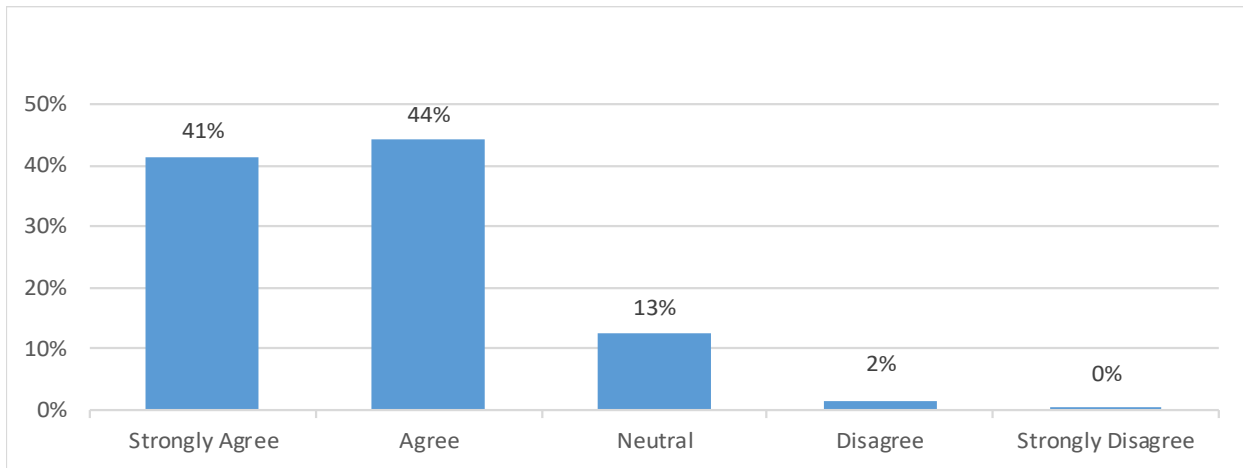

85% of respondents Strongly Agree or Agree that land rental/ownership cost is a key factor in physical location decision making, which may suggest that the cost of land rental/ownership may have an over-arching influence on overall land usage.

Figure 13: Part A: Land Location Related Decisions - Flexibility of land usage, and possibility of land usage change

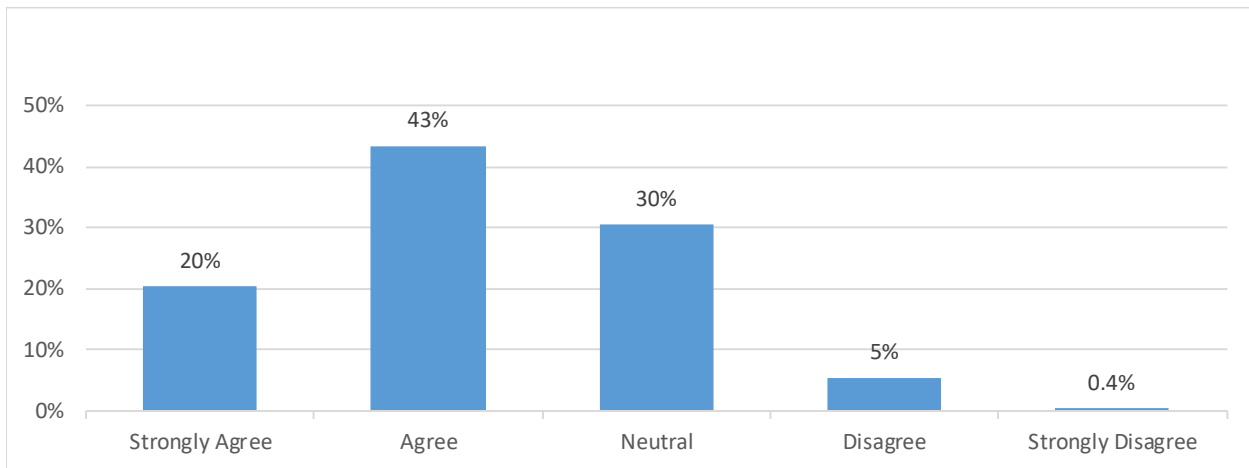

Of the respondents, 63% felt that the flexibility of land usage and the possibility of land usage change was an important consideration, while 30% were neutral, suggesting that the option to modify the intended use of the land site may be important.

Figure 14: Part A: Land Location Related Decisions - Size/area of land

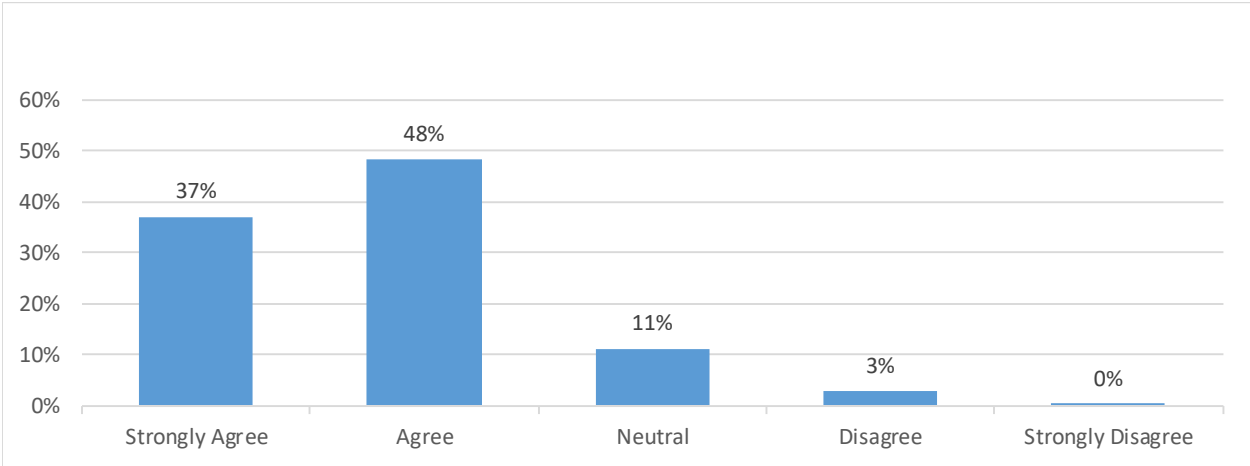

The size and area of the land was deemed important by 85% of respondents who strongly agreed or agreed. This result correlates to the data in Figure 12, and further suggests that cost and size of site are a related consideration for physical supply chain placement decisions.

Figure 15: Part A: Land Location Related Decisions - Layout/dimension of land site

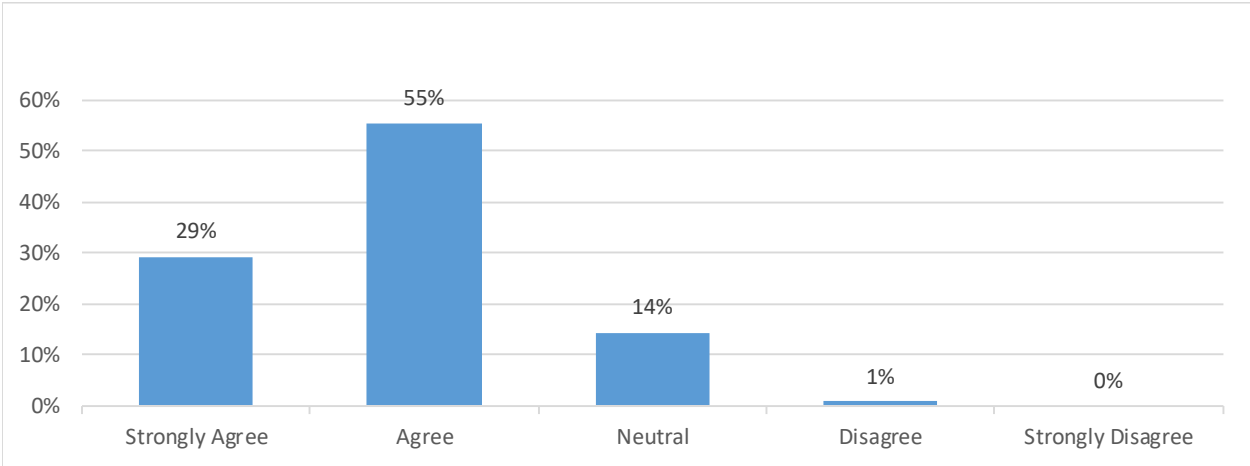

84% of respondents agreed or strongly agreed with land dimension and layout being a key factor, which correlates to the results shown in Figure 12 and 14, and may further suggest that land dimensions, size and cost are correlated in making physical supply chain placement decisions.

Figure 16: Part A: Land Location Related Decisions - Social policy and/or political risk of the region

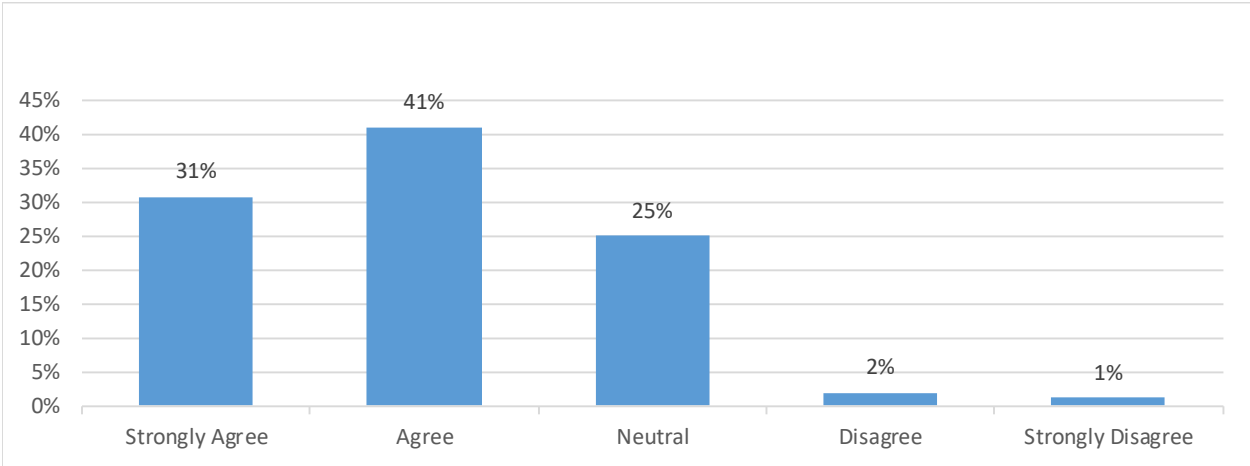

Of the respondents, 72% strongly agreed or agreed that social policy and/or political risk of the region were seen as important success factors. This data suggests that in addition to cost, political and social risk factors influence a physical supply chain resource decision.

Figure 17: Part A: Land Location Related Decisions - Proximity to affiliates (e.g. potential partners, strategic alliances, competing businesses)

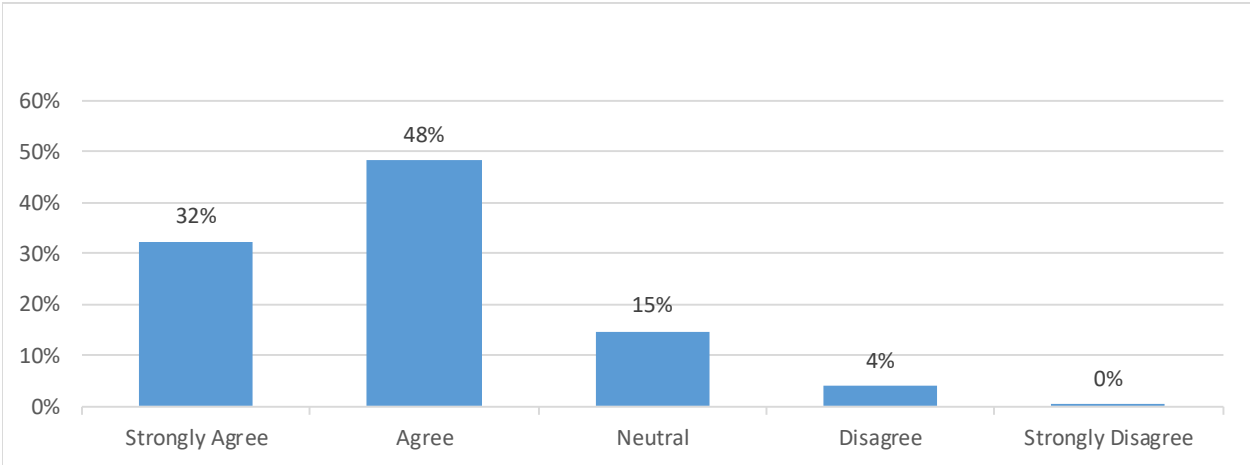

80% of the survey takers strongly agreed or agreed that the proximity to affiliates was central to the decision making process. This data suggests that in addition to size, cost and layout, the location of the site is a key factor for business operations, when making physical supply chain placement decisions.

Figure 18: Part B: Transportation and Accessibility Decisions -Proximity to strategic partners (e.g. suppliers)

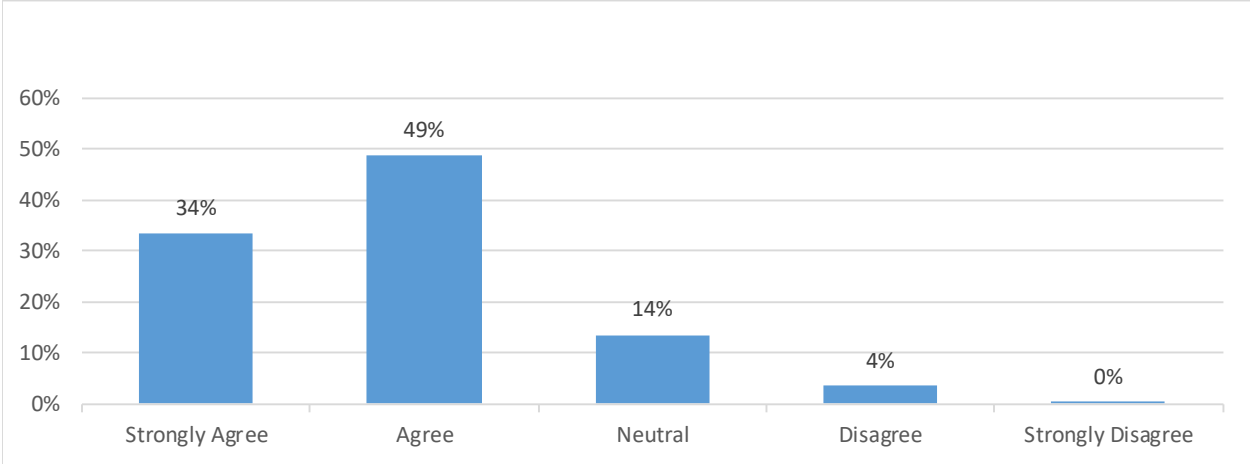

83% of those surveyed agreed or strongly agreed with proximity to strategic partners being a factor. This result correlates to Figure 17, and further suggests that the location of the site is a key factor for business operations, when making physical supply chain placement decisions.

Figure 19: Part B: Transportation and Accessibility Decisions-Proximity to target markets

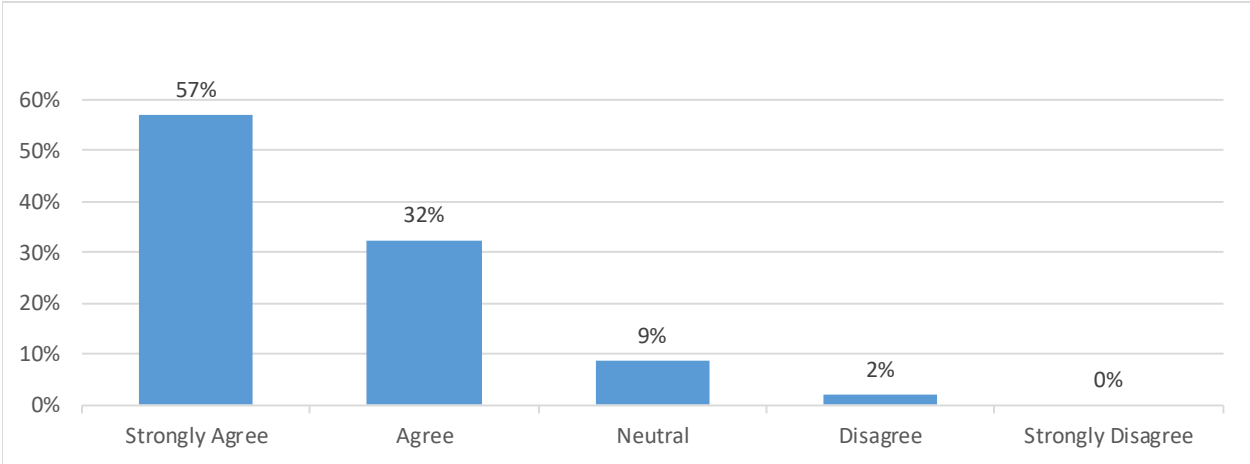

The proximity to target markets is viewed as a key factor by 89% (strongly agree, agree) while 11% were neutral or disagreed. The result further suggests a correlation between business operations and logistics, and physical supply chain site location decisions.

Figure 20: Part B: Transportation and Accessibility Decisions-Accessibility to customers

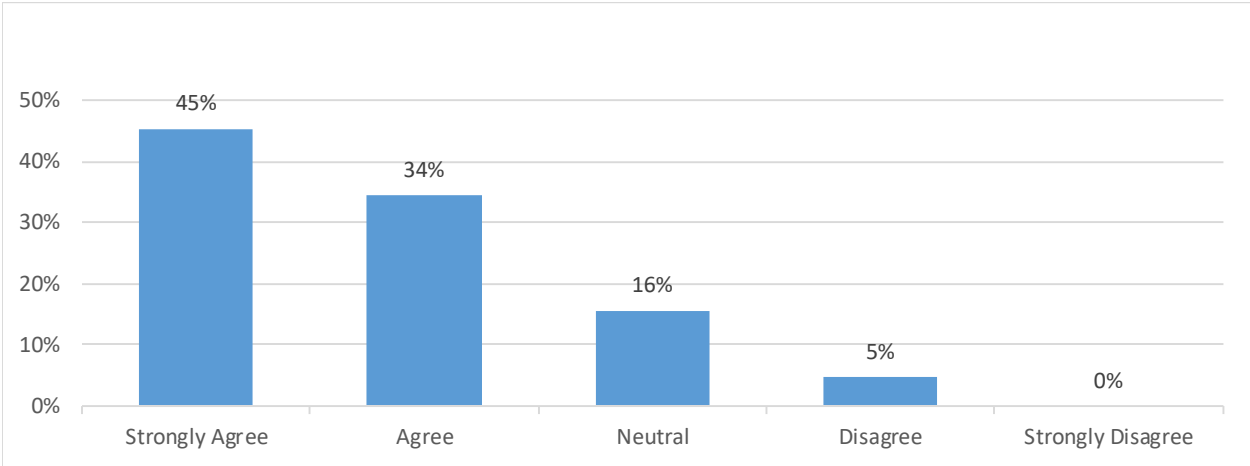

79% of respondents strongly agree or agree that accessibility to customers is a key factor in physical location decision making. This data suggests a correlation to Figure 19, and further suggests a relationship between business operations and logistics, and physical supply chain site location decisions.

Figure 21: Part B: Transportation and Accessibility Decisions-Strategic visibility of location from roads and highways

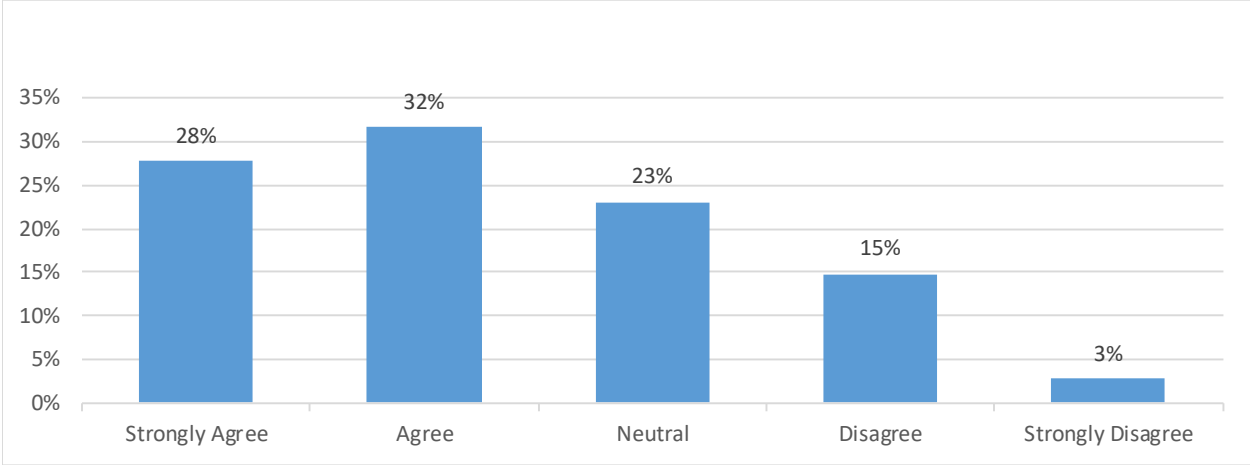

60% of those surveyed agreed or strongly agreed that strategic visibility of the location from roads and highways was important, possibly suggesting that many of the respondents considered the process of finding the site an important consideration.

Figure 22: Part B: Transportation and Accessibility Decisions-Availability of parking area for trucks etc.

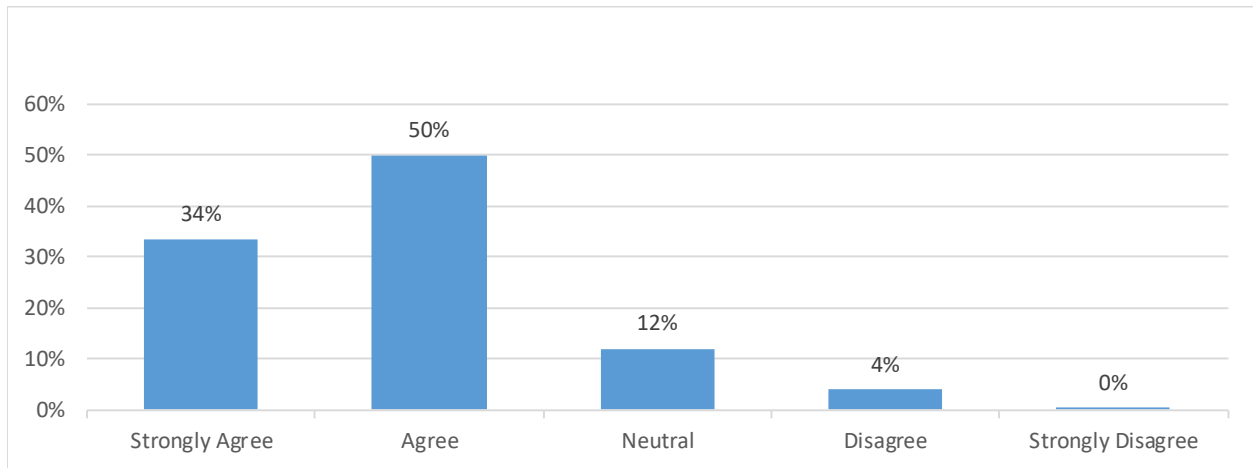

84% of the respondents strongly agreed that the availability of parking for trucks etc. was a key factor, further suggesting that the layout of the site (shown in Figure 15) is an important consideration.

Figure 23: Part B: Transportation and Accessibility Decisions-Approachability to roads and freeways

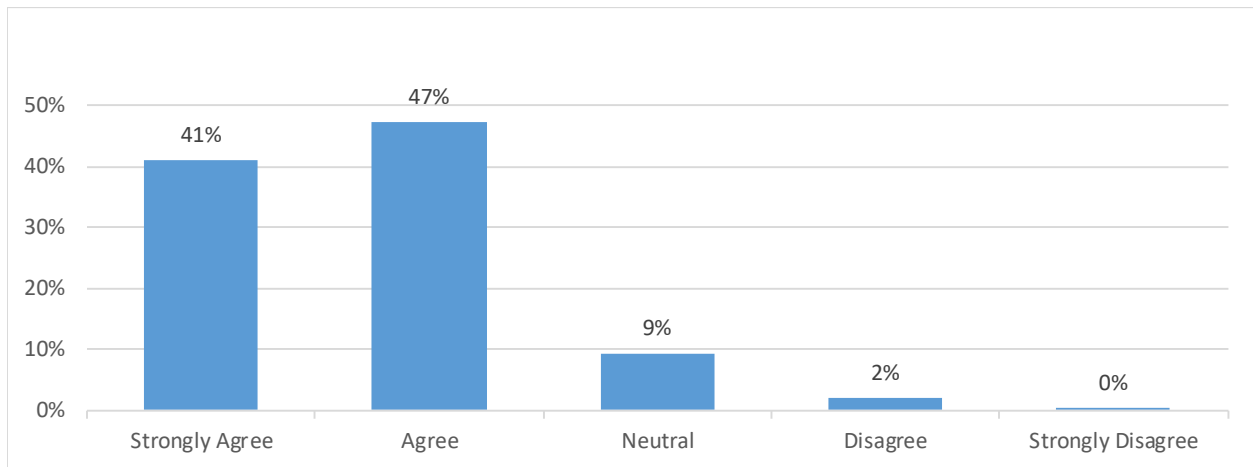

The approachability to roads and freeways was deemed important to 88% of those surveyed, suggesting that the ability for transporters to not only find the site (as suggested in Figure 21), but also enter the site easily from freeways and roads, is an important consideration.

Figure 24: Part B: Transportation and Accessibility Decisions-Availability of favorable labor

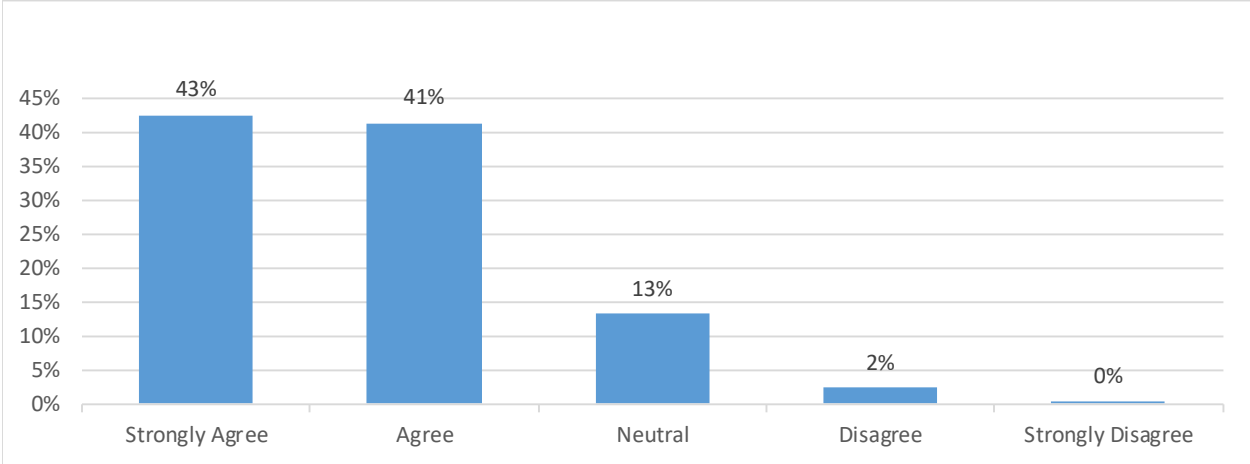

84% of respondents agree or strongly agree that the availability of favorable labor is key to physical location selection. This result may suggest that there would need to be consideration given to the location of the site, to ensure labor is available. This data could indicate the need for decision makers to consider labor availability in line with the effectiveness of the business operation.

Figure 25: Part B: Transportation and Accessibility Decisions-Access for Private Vehicles

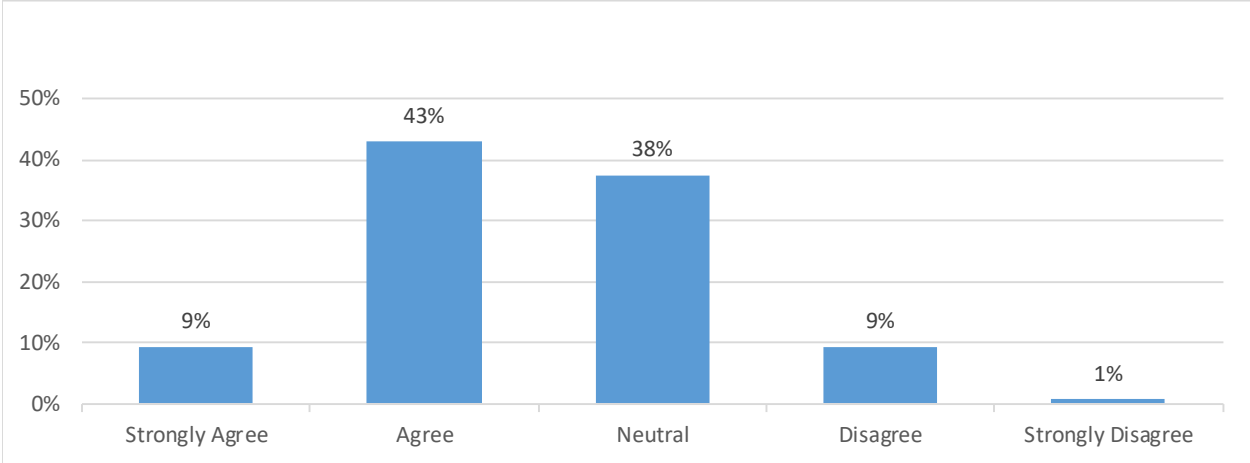

52% of the survey takers agree or strongly agree that access for private vehicles is considered important, while 38% are neutral. In consideration of the results shown in Figure 22 and 23, the responses could possibly suggest that respondents are more inclined to evaluate truck accessibility as opposed to private vehicle accessibility when making physical supply chain location decisions.

Figure 26: Part B: Transportation and Accessibility Decisions-Potential for automated transportation

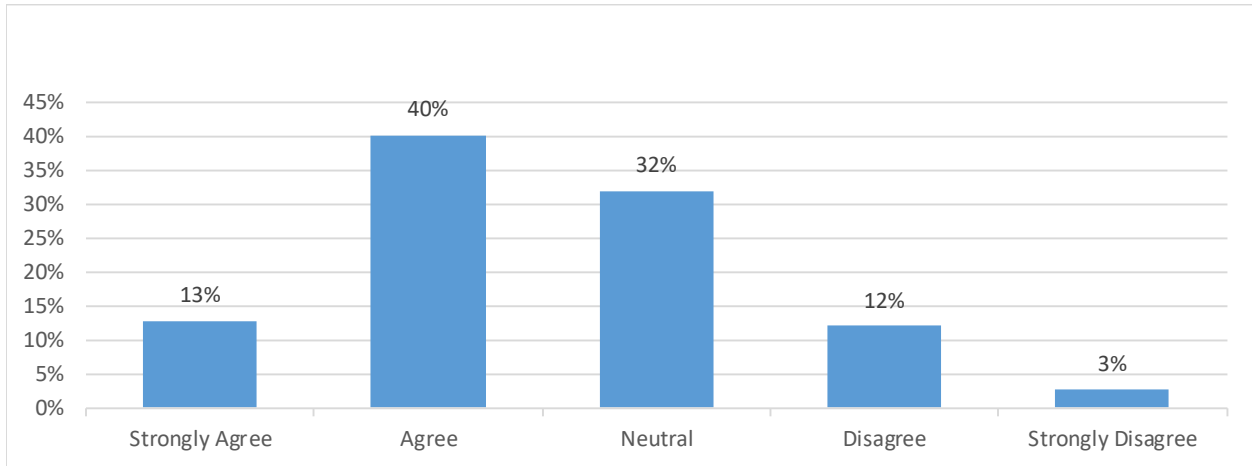

53% strongly agreed or agreed that potential for automated transportation is a key factor, while 32% were neutral and 15% strongly disagreed or disagreed. These results may correlate to data shown in Figure 13, and suggest that the majority of respondents foresee the potential of the land site to maintain some element of flexibility.

Figure 27: Part C: Tax and Incentive Structures-Government tax incentives

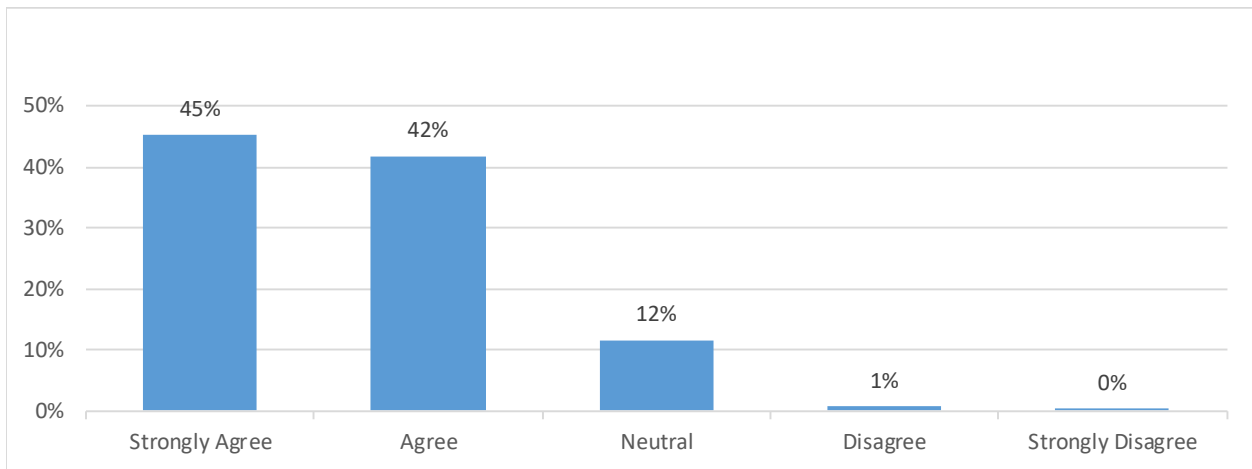

87% of the survey takers agreed or strongly agreed that tax and incentive structures were important in the decision making process. Considering the size of the businesses for which most respondents are working within (Figure 1), this may suggest that government tax incentives when evaluating a land site, are key to the business operation and overall strategy of the firm.

Figure 28: Part C: Tax and Incentive Structures-Overall tax cost of the site

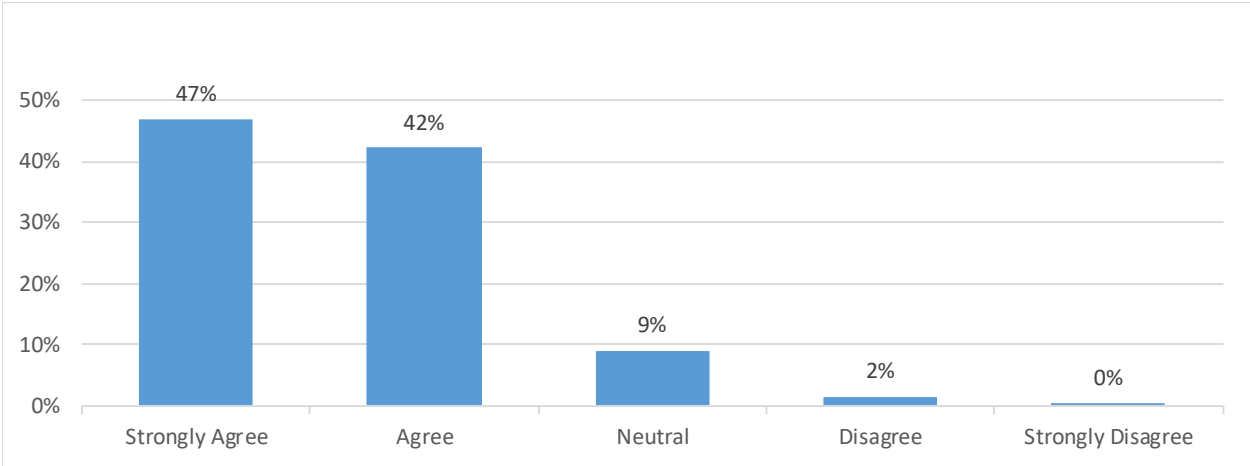

89% of the survey takers strongly agreed or agreed that the overall tax cost of the site was an important factor in the decision making process. This further correlates to data presented in Figure 27, and suggests tax costs of a land site may be an important consideration when evaluating the business operation and overall strategy of the firm.

Figure 29: Part C: Tax And Incentive Structures-Government sponsored economic incentives

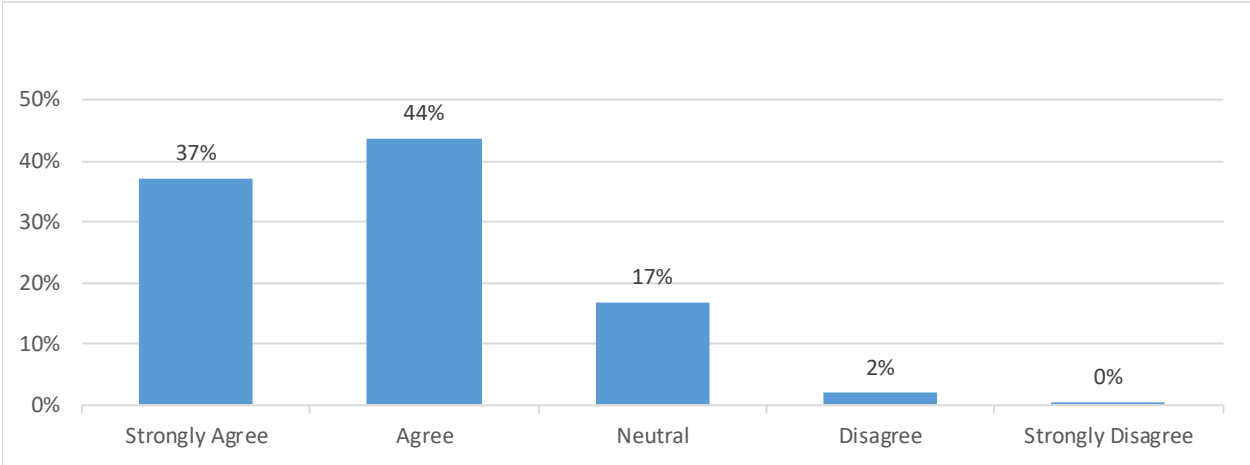

81% strongly agreed or agreed that government sponsored economic themes were valuable considerations in choosing a site. This further correlates to data presented in Figure 27 and Figure 11, and suggests that overall costs of a land site may be an important consideration when evaluating the business operation and overall strategy of the firm.

Table 6: Other than the factors mentioned above, list any transportation, land value or tax related factor which your company considers when making physical location decisions.

Other Factors for Consideration	Count of Respondents	Percent of Respondents
None at this time.	76	30%
Transportation Considerations	31	12%
Vendor/Client/Facilities Location	23	9%
Local Economy and Growth Opportunity	21	9%
Cost Considerations	21	8%
Labor Considerations	20	8%
Environmental Considerations and Weather	20	8%
Local Infrastructure	12	5%
Government Considerations and Incentives	10	4%
Security	5	2%
Resources	4	2%
Lease Agreement	3	1%
Utilities	3	1%
Total	249	100%

When asked for additional factors for consideration, the majority of respondents (30%) did not identify other factors. 12% of respondents indicated that transportation factors were important considerations, followed by Vendor/Client/Facilities locations and Local Economy (each at 9%). This data could suggest that the majority of areas of consideration were evaluated through the survey.

4.4 Transportation Decisions and Tax Structures Affecting Land Value

Please indicate to what extent you agree with the following factors when determining land value of physical supply chain entities (specifically manufacturing plants, distribution centers, and storage facilities) within your organization.

Figure 30: Part A: Land Location and Transportation Decisions-Proximity to strategic partners (e.g. suppliers)

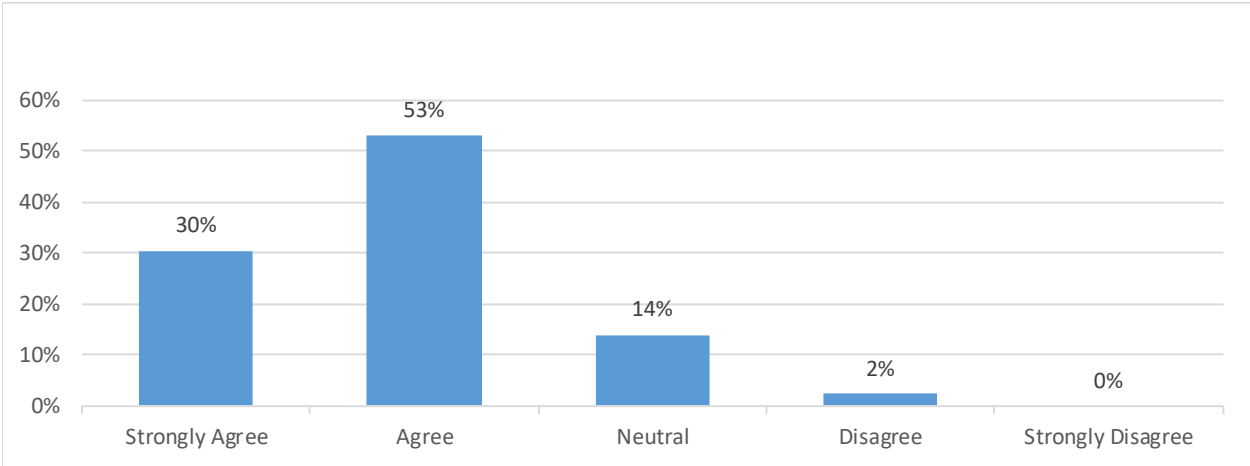

83% of the survey takers agreed or strongly agreed that proximity to strategic supplier partners was important. This data could suggest that the long-term value of the land site is an important consideration when evaluating the value of physical location sites for supply chain entities.

Figure 31: Part A: Land Location and Transportation Decisions-Proximity to affiliates (e.g. potential partners, strategic alliances, competing businesses)

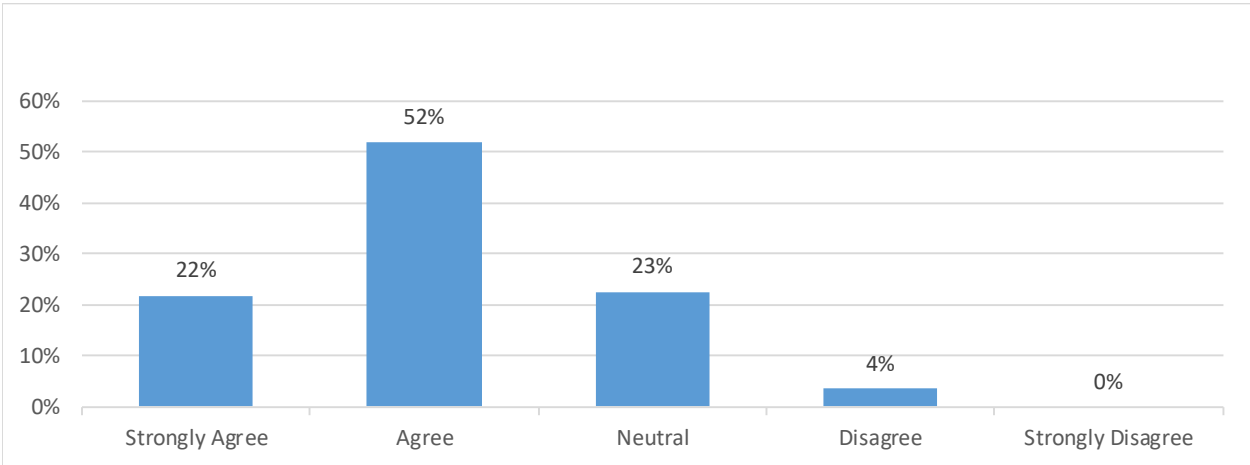

74% of respondents agreed that proximity to strategic partners (potential partners, strategic alliances, competing businesses) was important, which could suggest that the location of affiliates, and the potential for affiliates to remain within the same proximity, is important when evaluating the value of a land site.

Figure 32: Part A: Land Location and Transportation Decisions-Availability of diversified transport facilities

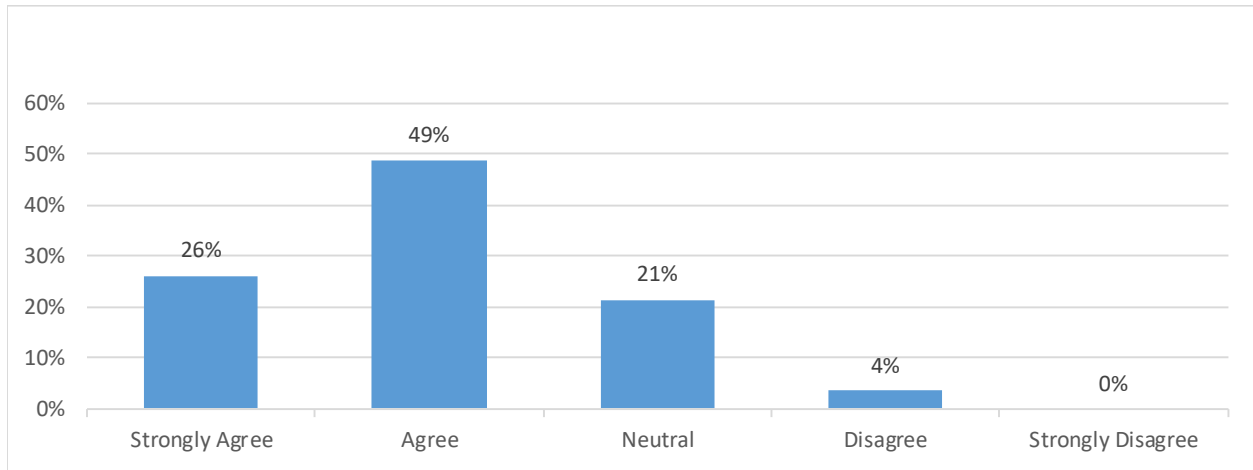

75% of respondents agreed or strongly agreed that the availability of diversified transport facilities was essential for site selection, further suggesting that approachability to roads and freeways (noted in Figure 23) is an important consideration when evaluating land value.

Figure 33: Part A: Land Location and Transportation Decisions-Overall transportation cost

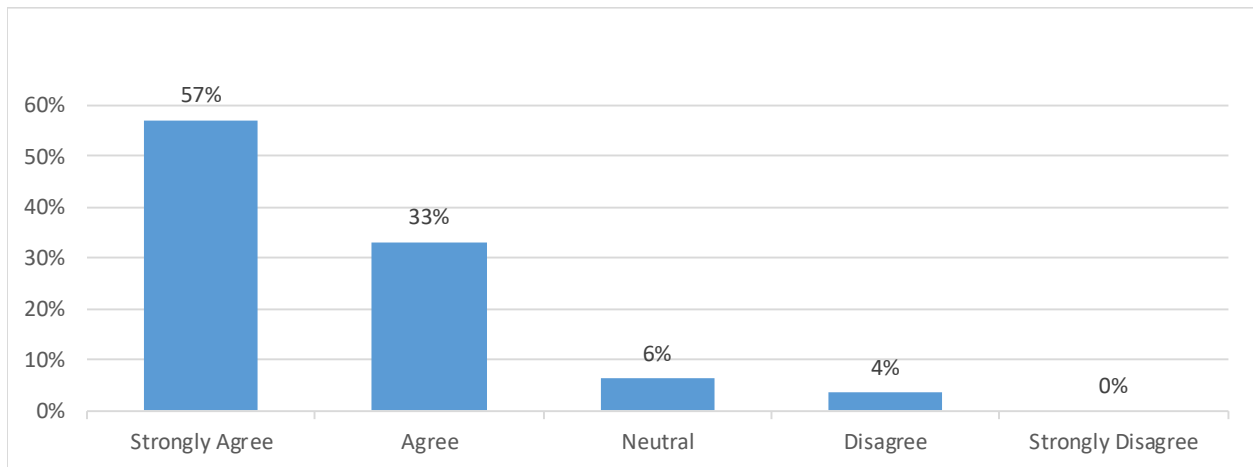

90% of the respondents agreed or strongly agreed that overall transportation cost considerations were considered to be essential to the physical location selection process. This data suggests that costs associated with transportation are present within a number of areas, and therefore a key land value indicator.

Figure 34: Part A: Land Location and Transportation Decisions-Strategic visibility of location from roads and highways

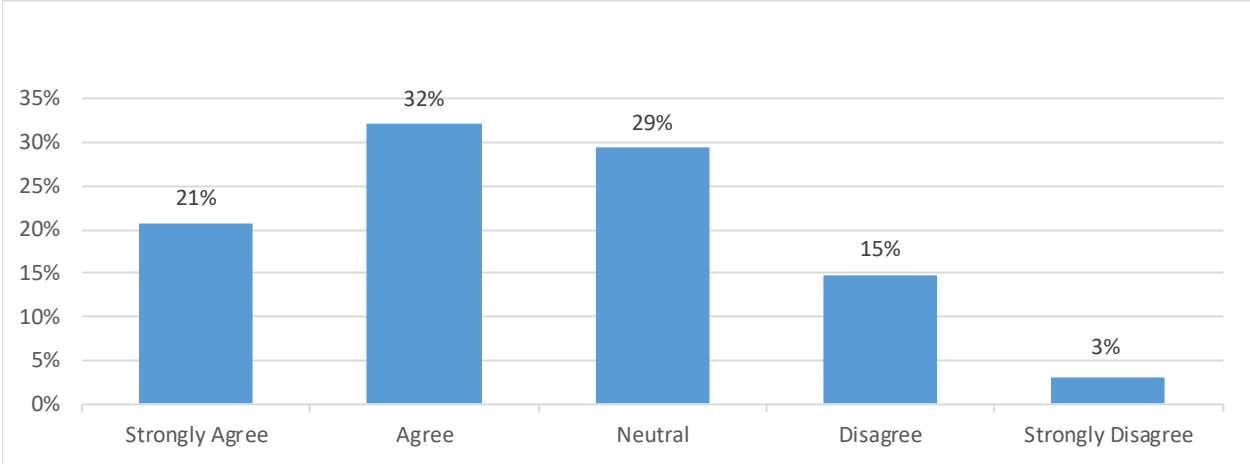

53% of the respondents agreed or strongly agreed that the strategic visibility of location from roads and highways was a key factor. This data may suggest that ease of transport access is a strong indicator of land value when considering supply chain entities.

Figure 35: Part A: Land Location and Transportation Decisions-Availability of parking area for trucks etc.

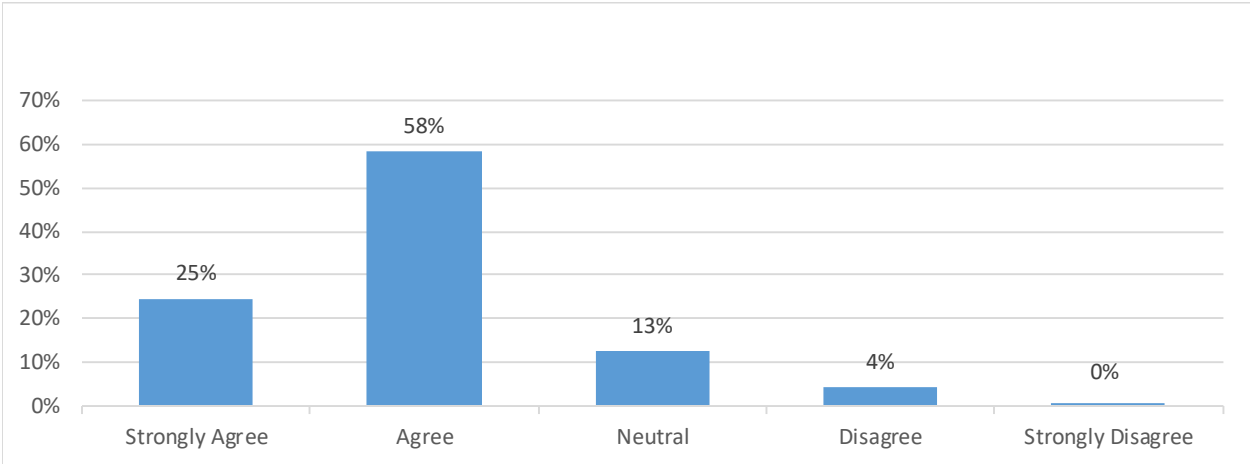

83% of respondents stated that availability of parking area for trucks etc. was important. These results may suggest that with the growth of the business and the potential for more parking, the layout of the site is an important land value consideration.

Figure 36: Part A: Land Location and Transportation Decisions-Approachability to roads, freeways etc.

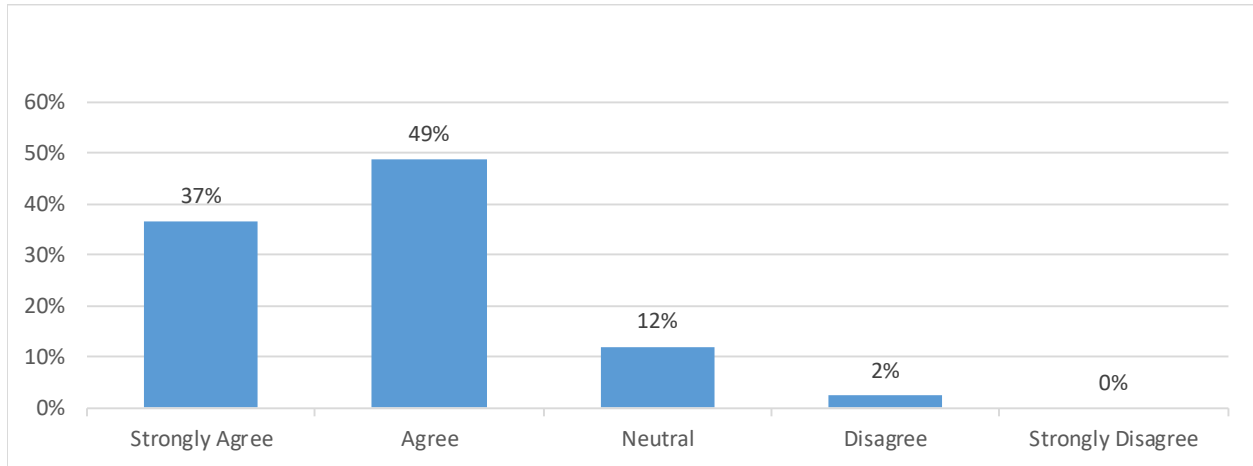

86% agreed or strongly agreed with approachability to roads, freeways etc. being important, which suggests that the ease of access to the land site for trucks and private vehicles is a key consideration when assessing land value. This could possibly indicate that respondents considered the potential growth of a business to be an important factor, when assessing land value.

Figure 37: Part A: Land Location and Transportation Decisions-Availability of favorable labor

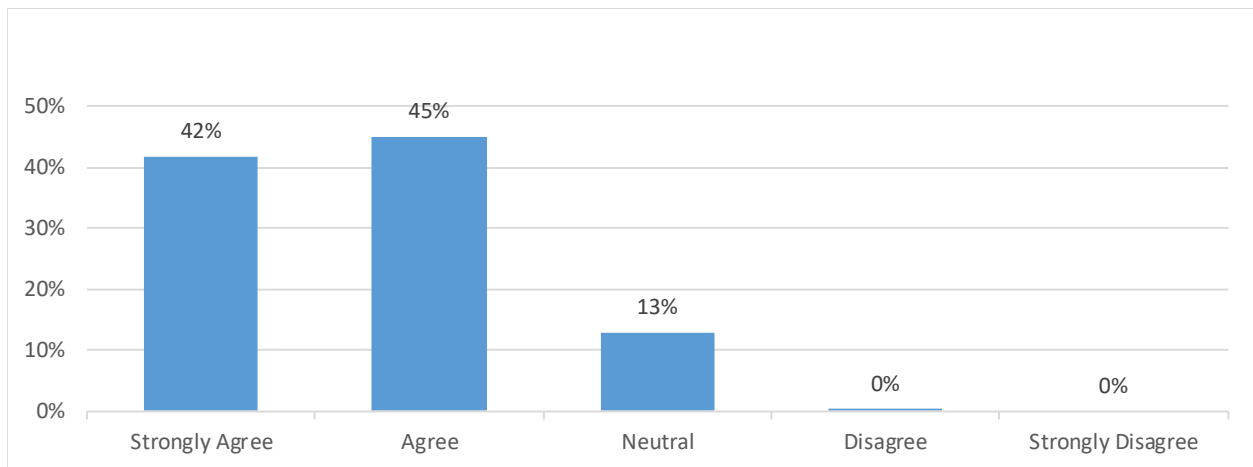

87% agreed or strongly agreed that the availability of favorable labor resources was considered important. These results further suggest that the proximity of the site to available labor is an important consideration when assessing value, and could indicate that the ease of access (Figure 35) is a land value consideration when assessing labor accessibility.

Figure 38: Part A: Land Location and Transportation Decisions-Access for private vehicles

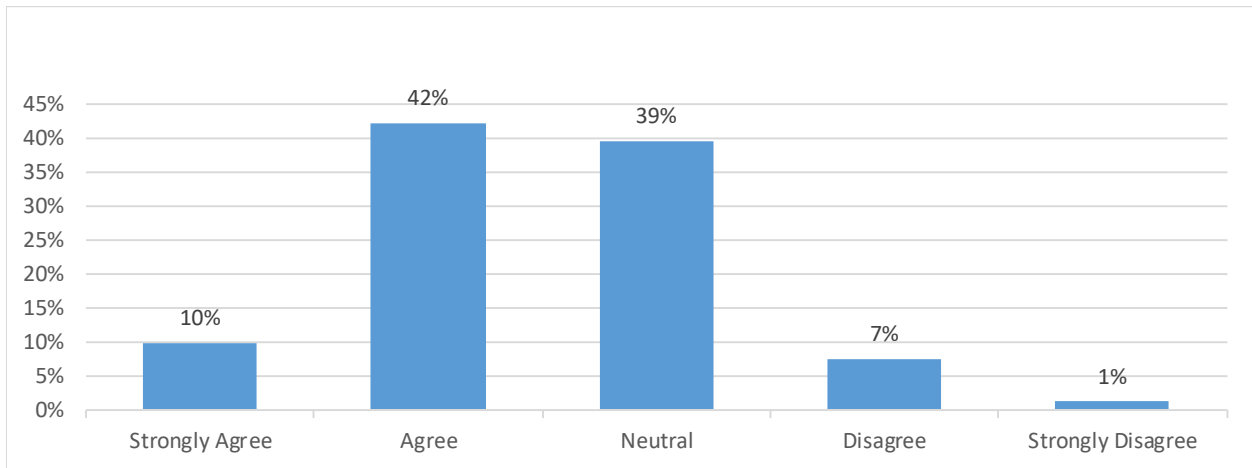

52% of respondents stated that access for private vehicles was a key factor in the decision process, while 39% were neutral. As the majority of respondents indicated that they Agree (and not Strongly Agree), this could suggest that land value is assessed more on truck accessibility as opposed to private vehicle accessibility.

Figure 39: Part A: Land Location and Transportation Decisions-Potential for integration of automated transportation

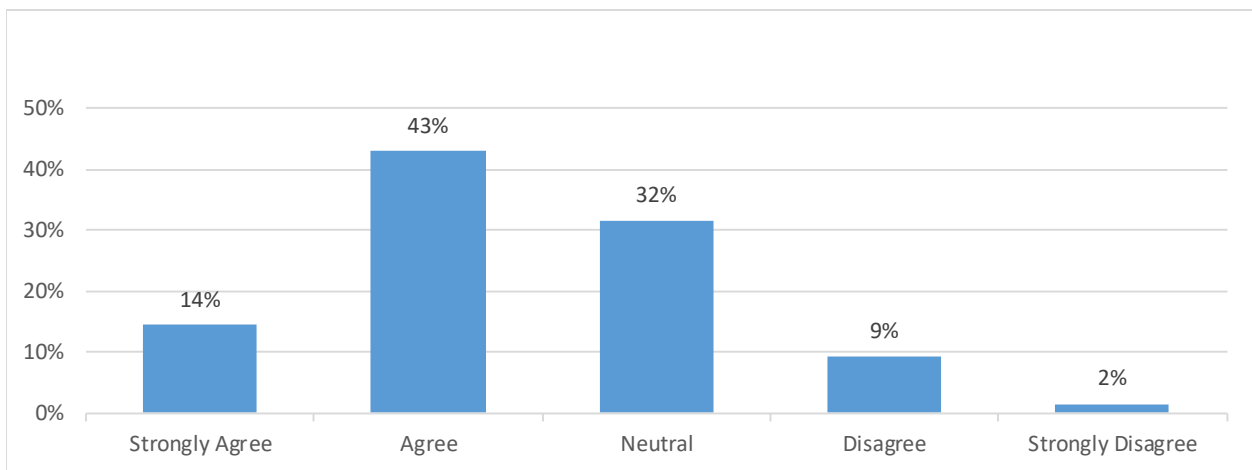

57% percent of respondents agreed or strongly agreed with the potential for integration of automated transportation being important to the decision making process, further suggesting that flexible land usage is a consideration when assessing land value.

Figure 40: Part A: Land Location and Transportation Decisions-Architecture of loading/unloading spaces

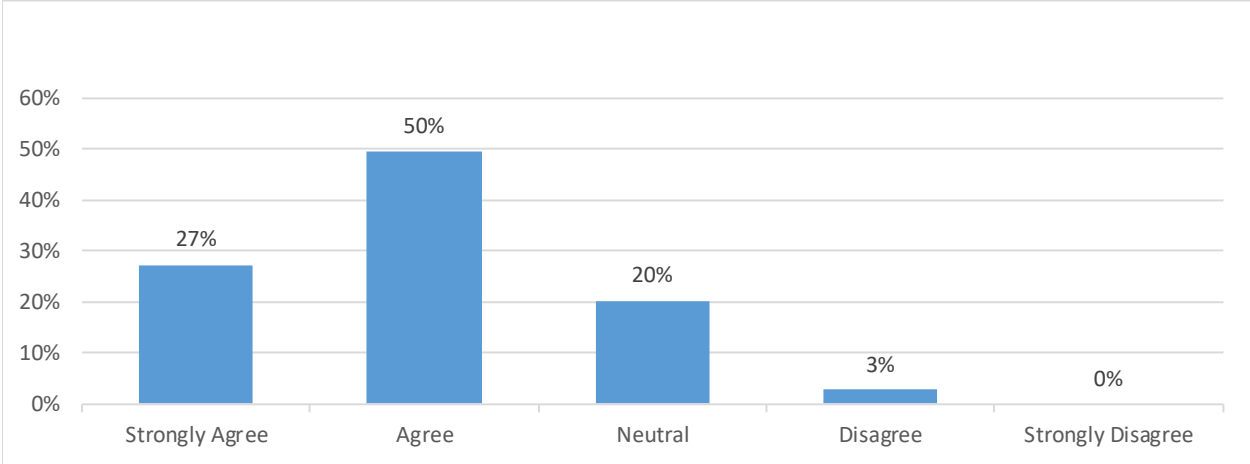

77% of respondents noted that the architecture of loading/unloading spaces was important. This may suggest a correlation to data presented in Figure 15, noting the value of the layout/dimensions of the land site.

Figure 41: Part A: Land Location and Transportation Decisions-Price per square meter in comparison to similar sites

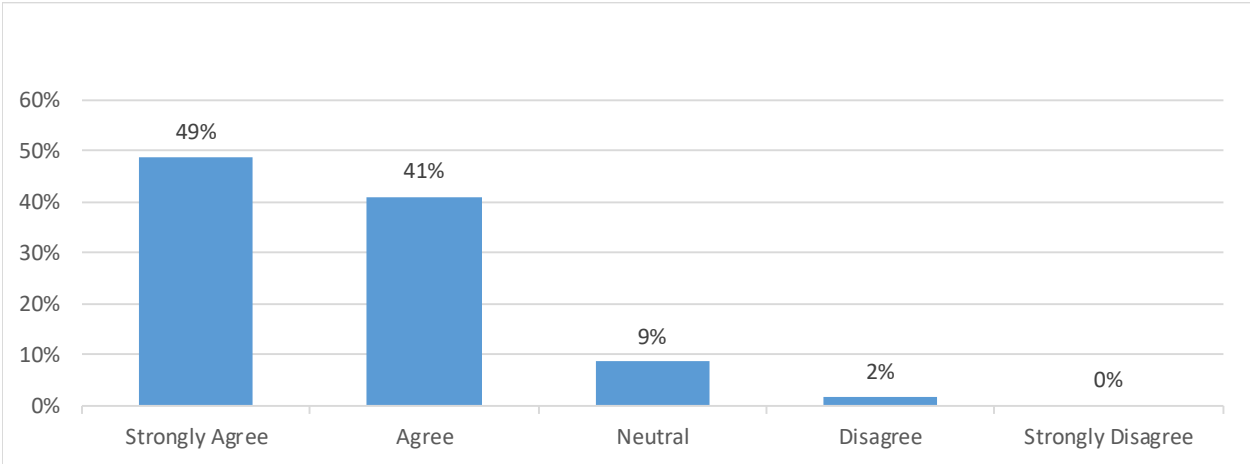

90% of respondents stated price per square meter in comparison to similar sites was a key determinant, suggesting that benchmarks are often used when assessing land value for physical supply chain sites.

Figure 42: Part A: Land Location and Transportation Decisions-Social policy and/or political risk of the region

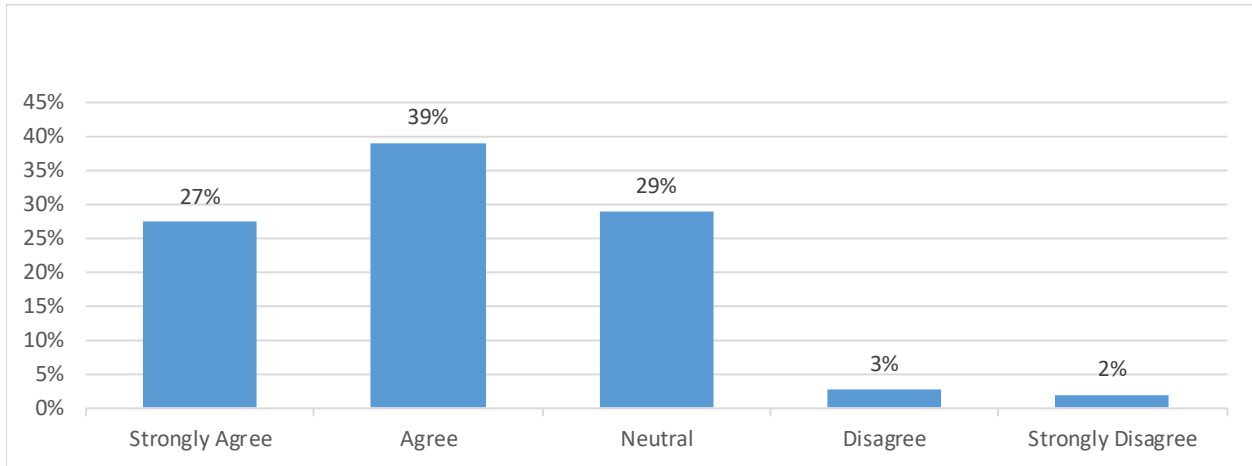

66% strongly agreed or agreed that social policy and/or political risk of the region was important. This could suggest that respondents are considering the long-term viability of the site in conjunction with political or social influence, when assessing land value.

Figure 43: Part B: Tax and Incentive Structures-Overall tax cost of the site

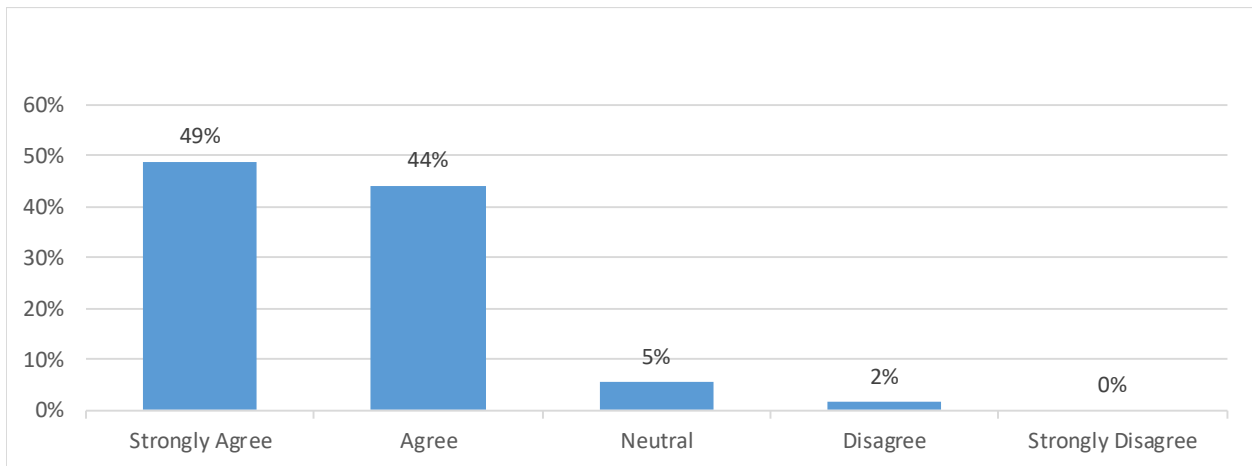

93% of respondents indicated that the overall tax cost of the site was a key factor, which suggests that the overall regular costs of the site is an important consideration of land value.

Figure 44: Part B: Tax and Incentive Structures-Potential for tax reduction

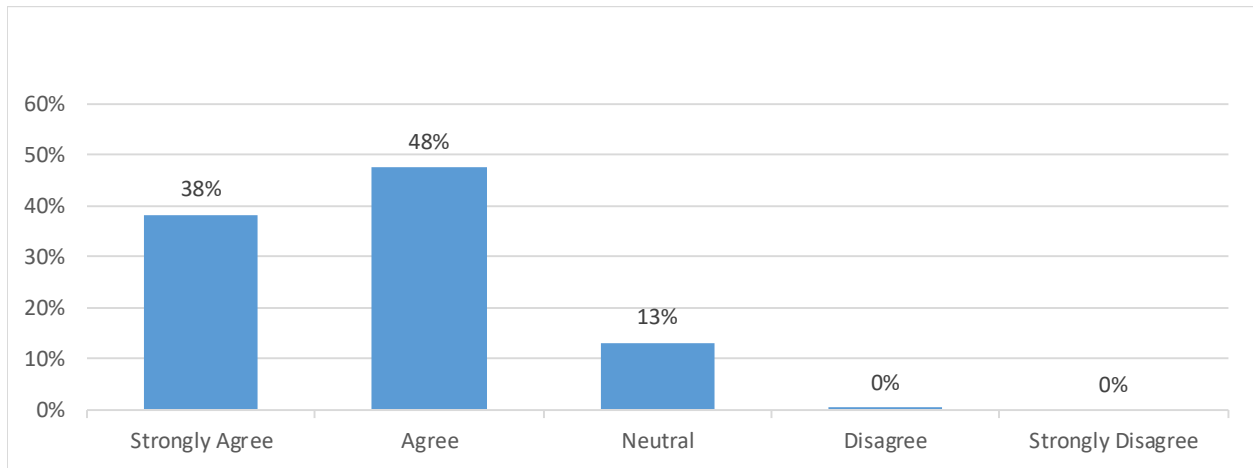

86% agreed or strongly agreed that the potential for tax reduction was a vital consideration in site selection, further suggesting that the overall regular costs of the site is an important consideration of land value.

Figure 45: Part B: Tax and Incentive Structures-Government sponsored economic incentives

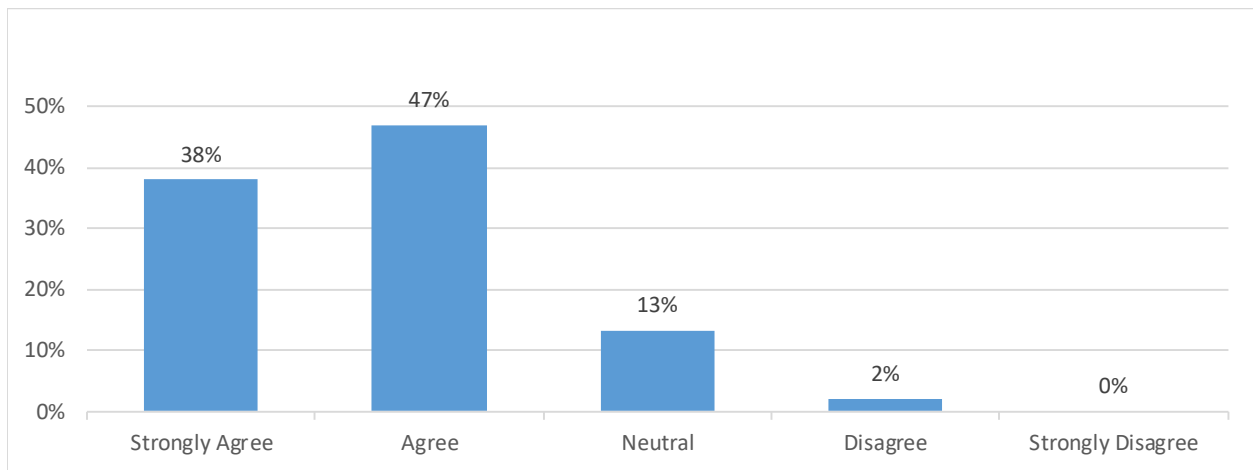

85% of respondents agreed or strongly agreed that government sponsored economic incentives were important. These results further indicate that the operational cost of the site, is an important consideration when assessing overall land value.

Table 7: Other than the factors mentioned above, list any other transportation or tax related factors which your company considers when determining or evaluating land value for physical supply chain entities.

Other Site Considerations	Count of Respondents	Percent of Respondents
None	119	52%
Transportation	12	5%
Labor Considerations	11	5%
Intermodal Access	10	4%
Taxes	8	4%
Site Costs	8	4%
Growth	6	3%
Safety/Security	6	3%
Supplier Considerations	6	3%
Regulatory Climate	5	2%
Business Climate	5	2%
Environmental	5	2%
Local Infrastructure	4	2%
Gov. Incentives	3	1%
Fuels Costs	3	1%
Airports	3	1%
Lease Terms	3	1%
Zoning	2	1%
Housing	2	1%
Other	6	3%
Total	227	100%

52% of those surveyed noted that there no other factors, which could suggest that the majority of consideration factors have been noted in the survey. Of the other 48%, Transportation (5%), Labor Considerations (5%), Intermodal Access (4%), Taxes (4%) and Site Costs (4%) were noted as the main consideration factors.

4.5 Economic Impact of Transportation Decisions, Land Value and Tax Structures

Please indicate to what extent you agree with the following statements impacting your organizational supply chain.

Figure 46: Land value of physical entities has significant economic impact on the company.

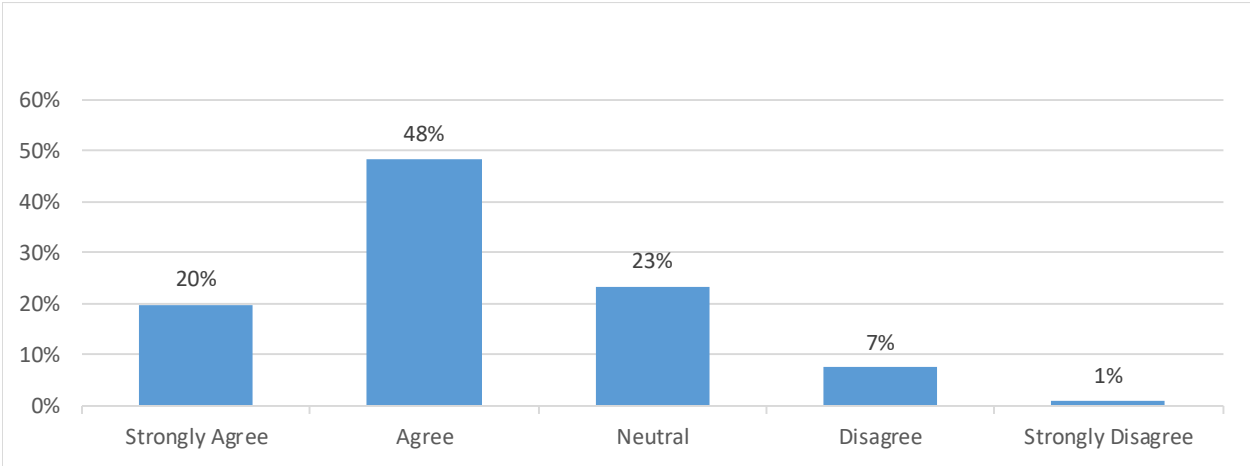

68% of the survey respondents agreed or strongly agreed with land value of physical entities having a significant economic impact on the company, which appears to correlate to earlier suggestions of respondents assuming long-term benefits (Figure 30 and 41) on the firms supply chain, when completing the survey.

Figure 47: Land value of physical entities has significant economic impact on the efficiency of the supply chain.

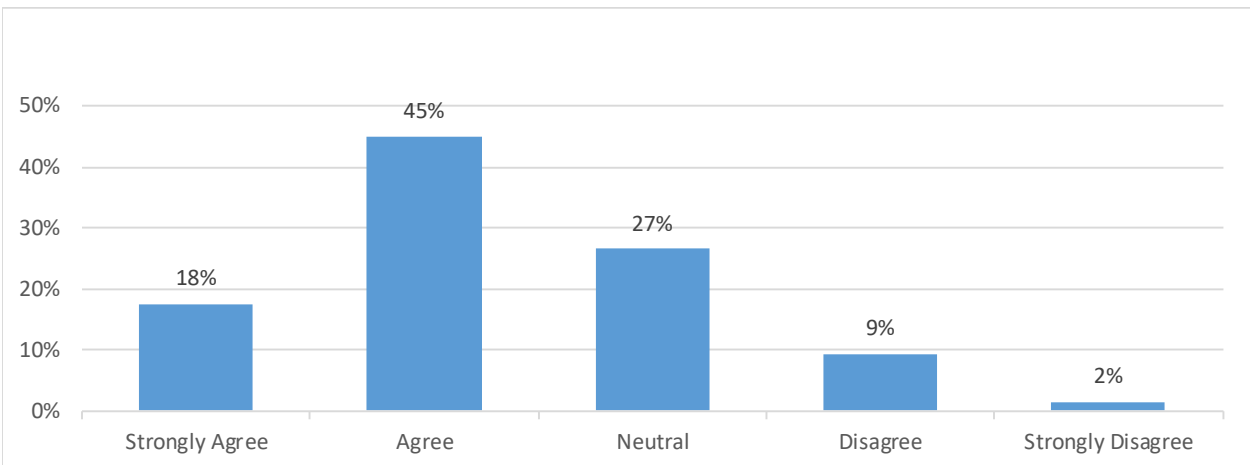

63% of those surveyed agreed or strongly agree with the land value of entities placed on the site, contributing to the overall economic impact of the supply chain. These responses could indicate that respondents are considering the potential investment in the entities placed on the land site, and therefore could further suggest that respondents are assuming a long-term assessment.

Figure 48: Tax structures and government incentives have a significant economic impact to the operational functionality of the firm.

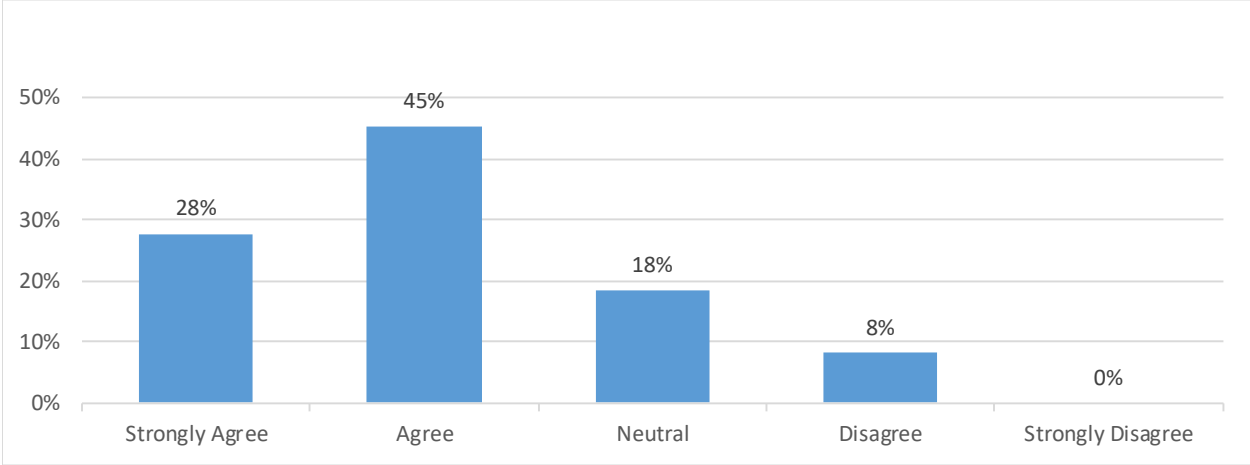

73% of those surveyed agreed or strongly agreed with tax structures and government incentives have a significant economic impact to the operational functionality of the firm. This may suggest that in addition to respondents noting an impact on land value, tax structures and government incentives indirectly influence the efficiency of the supply chain.

Figure 49: Tax structures and government incentives have a significant economic impact on the supply chain value of the firm.

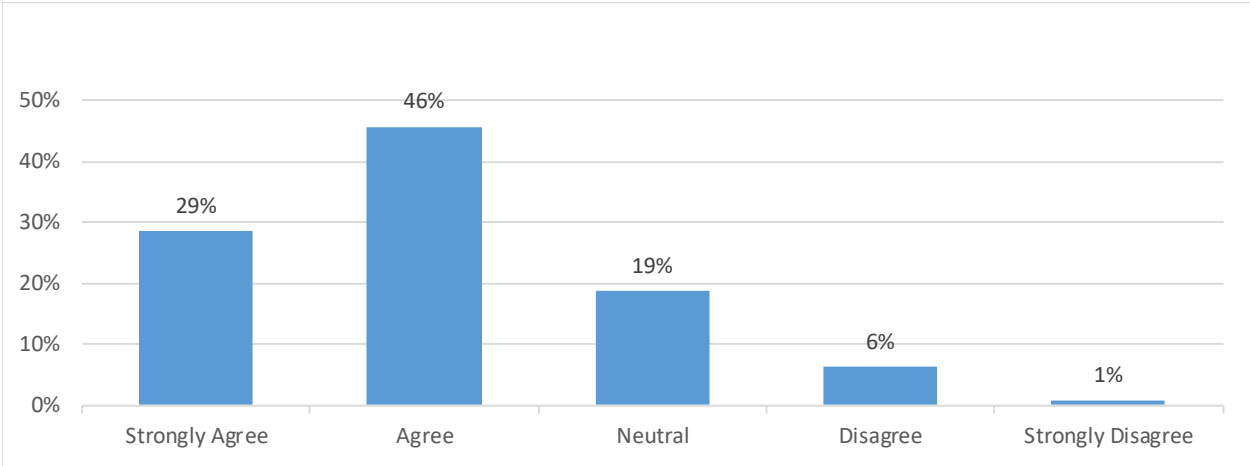

Of those surveyed, 75% agreed or strongly agreed that tax structures and government incentives have a significant economic impact on the supply chain value of the firm. This would appear to further suggest that tax structures and government incentives indirectly influence the efficiency and effectiveness of the supply chain.

Figure 50: It is important to consider land value factors, when determining new physical locations of supply chain entities.

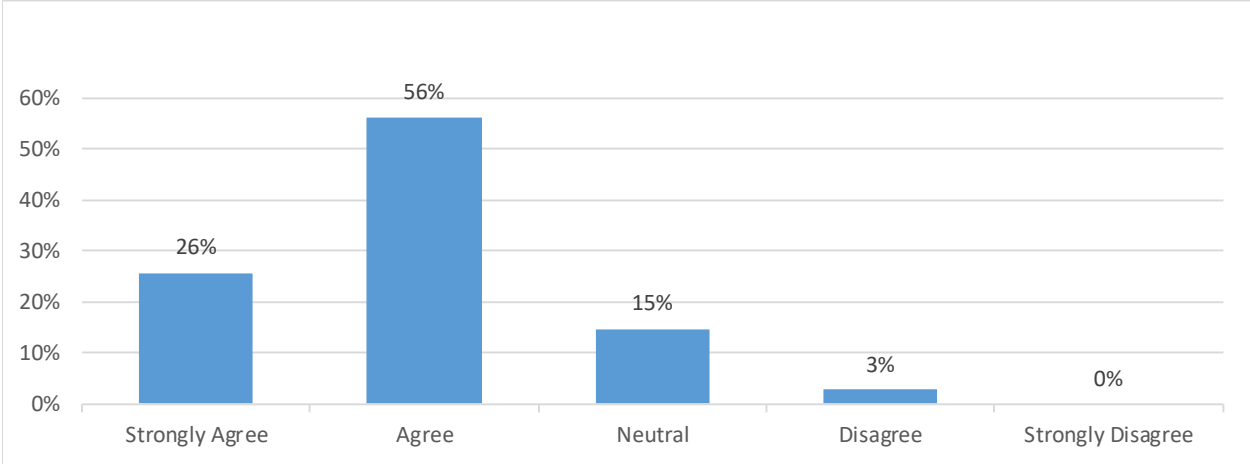

82% of those surveyed agreed or strongly agreed that it is important to consider land value factors, when determining new physical locations of supply chain entities. This may suggest that respondents also consider conventional land value indicators and valuations, in addition to assessing the land value from an individual business perspective.

Figure 51: It is important to consider transportation and accessibility factors, when determining new physical locations of supply chain entities.

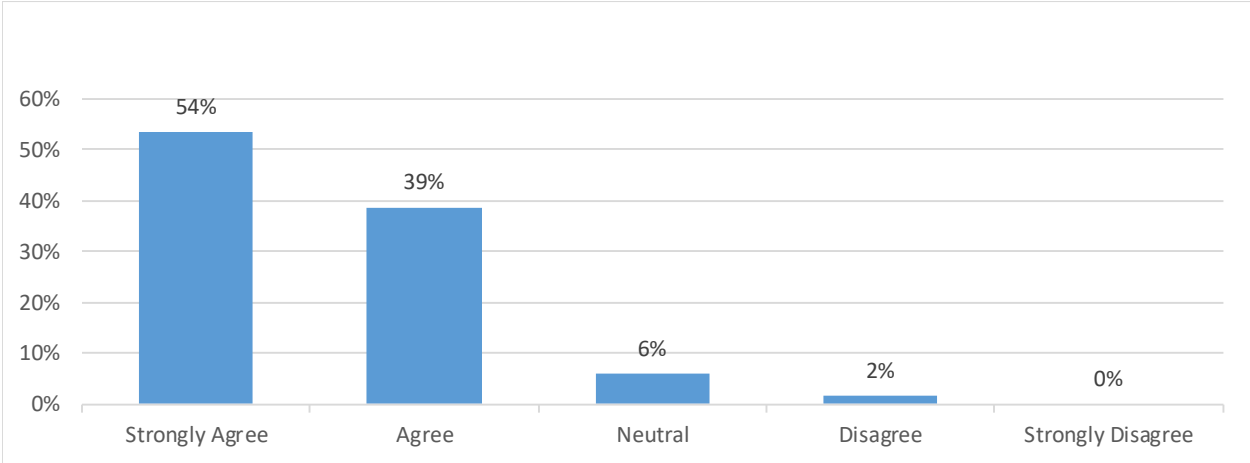

93% of those surveyed agreed or strongly agreed with it being important to consider transportation and accessibility factors, when determining new physical locations of supply chain entities, which could possibly suggest that accessibility indicators and transportation factors impact decisions on new (or additional) physical supply chain sites.

4.6 Key Insights Identified From Survey Data

Section 4.2 to 4.5 present the results drawn from survey responses, and summarize data within a percentage indication of responses. As such, the hierarchy of responses can be viewed at a glance in gaining an understanding of the opinions of respondents.

A number of key insights can be drawn from the survey data:

1. As shown in table 4, of the 766 total survey respondents, 256 (33%) were identified as meeting the target respondent specifications, as noted in section 3.5.2. The majority of eligible respondents held management roles (86%), while the 61% were comprised of executive decision makers. 40% of respondents noted their role as focusing on Partnership Management, Product Management, and Supply Chain Analysis, suggesting that the respondent pool was largely comprised of managers able to view and influence the internal function of the supply chain. The remaining 60% focused on Marketing, Sales and General Management suggesting a direct interaction with the supply chain.
2. The majority of respondents (52%) indicated that their company employs 1-1000 employees. Of the respondents, 61% noted that company revenues were between \$1-\$49M, and \$500M+, suggesting that the respondent pool was largely comprised of employees from large and medium firms.
3. Of the respondents, 33% are able to make final decisions pertaining to physical resource placement, while 32% advise on the decisions, suggesting that the majority of respondents hold decision making or decision advising authority. A smaller percentage (13%) of respondents evaluate data for physical location decisions, which suggests that

the majority (78%) of the respondent pool have some level of contribution to decisions pertaining to physical resource placement of supply chain entities, meeting the objective of the study.

4. With respect to the research questions identified in section 1.6, 85% of respondents believe that land rental/ownership cost was a key factor in physical location decision making, while 63% felt that the flexibility of land usage and the possibility of land usage change was an important consideration. Further, 84% of respondents believe that land dimension and layout was a key factor. This appears to suggest that the cost of land rental/ownership as well as flexibility may have an over-arching influence on overall land usage.
5. 80% of the survey takers believe that the proximity to affiliates was central to the decision making process. 90% of the respondents believe that overall transportation cost considerations were considered to be essential to the physical location selection process. This result suggests that in addition to size, cost and layout, the location of the site was a key factor for business operations, when making physical supply chain placement decisions.
6. The proximity to target markets was viewed as a key factor by 89%, with accessibility to customers noted as being a key factor in physical location decision making. The majority of respondents (84%) believe that the availability of parking for trucks etc. was a key factor, as was the approachability to roads and freeways (89%), and availability of favorable labor (84%). 83% of the respondents believe that proximity to strategic

supplier partners was important. This data could indicate the cost vs. benefit relationship affecting the effectiveness of the business operation.

7. In line with the hypothesis presented in section 1.7, 89% of respondents believe that the overall tax cost of the site was an important factor in the decision making process. To further substantiate the assumptions presented in point 5, the majority of respondents believe that government sponsored economic themes were valuable considerations in choosing a site.
8. 90% of respondents stated price per square meter in comparison to similar sites was a key determinant, suggesting that benchmarks are often used when assessing land value for physical supply chain sites.
9. 86% of respondents believe that the potential for tax reduction was a vital consideration in site selection with 93% indicating that the overall tax cost of the site was a key factor, further suggesting that the overall regular costs of the site was an important consideration of land value.
10. 93% of respondents believe it to be important to consider transportation and accessibility factors, when determining new physical locations of supply chain entities, with 82% believing that it was important to consider land value factors, when determining new physical locations of supply chain entities. This could suggest that respondents consider conventional land value indicators and valuations, in addition to assessing the land value from an individual business perspective.

4.7 Interview Data Approach

The second part of data retrieval focused on conducting live interviews with managers within the FMCG industry, in an effort to probe information and extract specific details on the impact of the physical location of supply chain entities and the economic impact on a firms supply chain regarding physical location decisions.

The objective in conducting live interviews was to understand reasons behind various decisions impacting the evaluation of physical supply chain land sites, and to identify a specific framework of land value, transportation decisions and tax structures impacting the economic value. The interview structure in comparison to the surveys, allowed for live follow-up questions and a two-way conversation.

Requests for interviews were sent to a several FMCG firms within North America, requesting voluntary meetings from managers with involvement within the supply chain management process. The goal of the interview was noted and respondents were told that the data they provide would be useful in conducting research. No time requirement was noted, nor was any compensation offered. Respondents were contacted by telephone, and interview questions were presented in an open-ended structure to allow respondents to freely dictate their responses without boundaries or guidelines. Using this approach was deemed valuable, as respondents were able to provide answers based on their individual experiences, their corporate culture, and their managerial approaches without influence or bias from guided response options.

The results from the interviews are presented below.

4.8 Interview Respondent Demographics

Table 8: What is your role, responsibility title and focus within your company?

Respondent No.	Number of Employees	Approximate Revenue	Title Within the Company	Geographical Regions Focused
1	1000-4999	\$50-\$100 Million	Supply Chain Manager	North America
2	1000-4999	\$50-\$100 Million	Supply Chain Manager	North America
3	5000-10000	\$300-\$499 Million	Group Director	North America
4	1000-4999	\$100-\$299 Million	Senior Manager	North America
5	100-999	\$100-\$299 Million	Supply Chain Manager	North America

Of the 14 interviews attempted, 5 (35%) respondents agreed to an interview. Supply Chain Managers comprised 60% of the respondent base, Senior Management accounted for 20%, and Group Director level roles accounted for 20%. As a result, all interview respondents held management roles which meets the objective of the interview selection criteria.

4.9 Tangible vs. intangible resources for physical location decisions

Table 9: In making physical location decisions, does the company put emphasis on comparing tangible and mobile resources as opposed to intangible and immobile resources, or vice versa? Identify the reasons.

Respondent No.	Response (Interviewer follow-up questions noted in italics)
1	<p>There is usually a combination of both.</p> <p><i>Can you expand on what you mean by a combination?</i></p> <p>Typically, both types of resources are considered.</p> <p><i>Is there a reason for this decision?</i></p>

	<p>Immobile resources are more important because often immobile resources cannot be effectively substituted.</p>
2	<p>Both types of resources are equally important. Each have different advantages.</p> <p><i>Can you expand on what you mean?</i></p> <p>Mobile resources can be versatile and applied differently. Immobile resources can be considered as part of the value of the site.</p> <p><i>Do you consider mobile resources to also be of value to the site?</i></p> <p>No, as these can be taken.</p>
3	<p>Immobile resources are perhaps more important as they add to the overall usage and function of the site.</p> <p><i>Are there instances in which mobile resources would also add value?</i></p> <p>Yes, however immobile resources would still be more important.</p>
4	<p>Resources which are mobile such as machinery etc. are typically resources which cost an additional fee. The benefit for immobile resources such as physical structure, is typically built into the cost. As such, both are equally valuable.</p> <p><i>Does this mean you would evaluate both in terms of the same value proposition?</i></p> <p>Yes.</p>
5	<p>Intangible resources, including placement of the site are much more important.</p> <p><i>Can you expand further here?</i></p> <p>The placement of a site is perhaps the most valuable component of any site, simply because of its value to the flow and function of business.</p>

Of the respondents, 3 (60%) stated that their company place equal emphasis on tangible and intangible resources. The remaining 2 (40%) stated that immobile resources are more important. The data suggests that respondents place a higher value on resources which are fixed, as oppose to resources which may be moveable to future land sites.

4.10 Impact of transportation and land value on physical location decisions

Table 10: How do transportation factors and overall land value analysis influence physical location decisions, considering that these factors are often variable, regularly changing, and unsustainable?

Respondent No.	Response
1	<p>Do you mean overall assessment of value for location decisions?</p> <p><i>Yes</i></p> <p>Transportation factors, and land placement typically contributes to the overall value of land.</p> <p><i>Are there any other areas of consideration?</i></p> <p>The budget restriction is key to this decision.</p>
2	<p>Transportation decisions are usually the most important here.</p> <p><i>Can you expand?</i></p> <p>Typically, transportation considerations dovetail with land value. Depending on the size of the operation and the stage of the business, these considerations are important.</p> <p><i>So there is a correlation between land value and transportation considerations?</i></p> <p>Yes.</p>
3	<p>Transportation factors are often most important due to the overall business model of an operation.</p> <p><i>Can you explain what you mean?</i></p> <p>These decisions are usually made based on the growth rate of a business.</p>
4	<p>Land value is an arbitrary measure, and often depends on the location and usage possibility.</p> <p><i>Do you mean that value is measured differently by different individuals?</i></p> <p>Yes.</p>

	<p><i>Can you expand on any other areas of consideration?</i></p> <p>Budget considerations are important here, as is an evaluation of the position a business needs to be in, and how flexible the firms operation is. The stage of growth a business is in will also impact this decision.</p>
5	<p>While land value as a whole may fluctuate, the function and usefulness of a site will also fluctuate. This must be considered.</p> <p><i>Do you mean that the usage of the land site may change?</i></p> <p>Yes, as well as the function and usefulness. The proximity of a site in comparison to other entities is important, as is budgetary considerations based on a firm's needs.</p>

Of the respondents, 3 (60%) stated that budgetary restrictions are most important. The stage and evolution of growth of the business were identified by 2 (40%) respondents. This may suggest that the size of the business may be important when evaluating various impacts (e.g. a smaller business may be more concerned with a budget as oppose to a larger business).

4.11 Impact of transportation, land value & tax structure on physical location decisions considering varying interpretations of value

Table 11: How do transportation, land value and tax structure influence physical location decisions assuming decision makers may have different opinions, interpretations and knowledge on resource tangibility and importance?

Respondent No.	Response
1	<p>This question is a difficult question to answer.</p> <p><i>Why?</i></p> <p>Typically, this is a committee or team approach, and is led by a management hierarchy.</p> <p><i>Do you mean that there is a group decision made?</i></p> <p>Yes.</p>
2	<p>Decisions such as these largely depend on the size of the business and which stage of development the firm is in.</p> <p><i>What do you mean? Can you expand?</i></p> <p>At early stages, an entrepreneur may decide. In established larger businesses, a group may decide.</p> <p><i>Have you any experience with either scenario? What happens if there is disagreement within the group?</i></p> <p>If decision makers have different opinions, typically, there are levels of considerations and shortlists of available sites.</p>
3	<p>Usually specific goals of a site are defined, and metrics are put in place for measuring the value based on agreed upon metrics.</p> <p><i>Who agrees upon the metrics?</i></p> <p>Depends on the business. Either the president of the company or a committee.</p>
4	<p>There is a defined statement of requirements which are agreed upon by all decision makers prior to evaluating sites.</p> <p><i>Are there often multiple decision makers?</i></p> <p>I have only seen situations with multiple decision makers.</p>

	<p><i>Do you have any exposure to small companies who may have one decision maker?</i></p> <p>No.</p>
5	<p>The basis for evaluating value/success is usually defined at the onset of the search. Once defined, various sites are evaluated, and a short list is developed and voted upon.</p> <p><i>Do you mean that this is a group decision?</i></p> <p>Yes.</p>

Of the respondents, 2 (40%) suggested that a corporate structure and culture influenced the progression of this decision. The remaining 3 (60%) of respondents suggested that a document which was agreed upon by a selection committee was formed to reduce conflict. This may suggest that each corporation is slightly different in terms of structure and process when making decisions on physical supply chain sites and land evaluation.

4.12 Knowledge vs. resource based view on physical location decisions

Table 12: Are physical location decisions more dependent on a knowledge based view (the belief that the knowledge held by decision makers is most important) or a resource based view (the belief that tangible or intangible resources at the firm's disposal are most important)?

Respondent No.	Response
1	<p>What do you mean?</p> <p><i>Do you believe that the knowledge of managers is most important, or a resource; either tangible or not, is most important?</i></p> <p>Could this resource be a consultant?</p> <p>Yes.</p> <p>A combination of both.</p>
2	<p>Both are required.</p> <p><i>Can you expand further?</i></p> <p>Decision makers must be knowledgeable to evaluate properly.</p>
3	<p>Do you mean a comparison between internal and external knowledge?</p>

	<p><i>Yes, but more specifically, do you believe that the knowledge of managers is most important, or a resource; either tangible or not, is most important?</i></p> <p>Both are equally important.</p>
4	<p>At any stage of a business, both would be equally important.</p> <p><i>Can you expand further?</i></p> <p>It is important for decision makers to know what they want, and also for the site to be useful and valuable for the process.</p> <p><i>Do both have to be present?</i></p> <p>Yes.</p>
5	<p>Both are important.</p> <p><i>Is this always the case?</i></p> <p>Yes.</p>

All 5 respondents (100%) stated that knowledge and resource based views are equally important in making a physical location decision. None of the respondents seemed to be particularly drawn to the notion of choosing one paradigm over the other. This may suggest that the respondents companies use a diverse decision methodology.

4.13 Reasons for physical location decisions being resource or knowledge based

Table 13: What are the reasons for why physical location decisions are based on a knowledge based view or resource based view?

Respondent No.	Response
1	<p>This relates to the last question?</p> <p>Yes.</p> <p>There must be a combination of both.</p>
2	Both are important.
3	Physical location decisions are based on both views.

4	<p>Depending on the stage, different approaches and views might be taken, however each view has specific values which are equally important.</p> <p><i>Can you expand further?</i></p> <p>As mentioned it is important for decision makers to know what they want, and also for the site to be useful and valuable for the process.</p>
5	Both are important.

All 5 respondents (100%) stated that knowledge and resource based views are equally important in making a physical location decision. This data may suggest that a company's management structure relies on all external and internal resources when forming a process or making a physical supply chain site decision. Once again, none of the respondents seemed to be particularly drawn to the notion of choosing one paradigm over the other.

4.14 Resource vs. knowledge based policy amendments in making physical location decisions

Table 14: Over the course of your employment with the company, in terms of physical location decisions, have there been any amendments in policies to shift from the paradigm of resource based view decisions to knowledge based view decisions, or vice versa? If yes, what amendments do you see?

Respondent No.	Response
1	No. <i>Can you expand further?</i> There have not been any switches.
2	All decisions are equal. <i>Can you expand?</i> There have not been any changes.
3	None.
4	As the company grows, there might be more knowledge which might impact decisions. Overall however a combination of both paradigms are required, and as such I don't believe there is a progression in this regard. <i>Can you expand?</i> There is no reason to believe that there needs to be, or that there will be a change here.
5	The decision structure has remained constant. <i>Do you believe that there will be a change in the future?</i> No.

All 5 the respondents (100%) noted that there have not been any policy shifts from RBV to KBV paradigms (or vice versa). This may suggest that the corporate culture within the respondents corporations is rigid.

4.15 Resource vs. knowledge based view in isolation supporting a physical location decision

Table 15: Do you believe that a resource based paradigm or a knowledge based paradigm cannot support a physical location decision in isolation. Why?

Respondent No.	Response
1	<p>No.</p> <p><i>Can you explain why? Is this always the case?</i></p> <p>It is important that both knowledge of where the business is moving, and an evaluation of the particular location is equally important.</p> <p><i>Is this always the case?</i></p> <p>Yes.</p>
2	<p>It is not possible to have either view operating in isolation.</p> <p><i>What do you mean? Why not?</i></p> <p>This would not make sense, as each compliments one another.</p>
3	<p>Any decision, including physical location decisions require managerial knowledge of the business, as well as an evaluation of the opportunity, in this case the location.</p> <p><i>Would this mean that one might lead the other?</i></p> <p>Both are equally important, and cannot be viewed in isolation.</p>
4	<p>An understanding of the ideal requirements for the business, as well as an evaluation of a land site is equally important. One cannot solely be used to make a physical location decision.</p> <p><i>Is there a scenario in which one paradigm may be used exclusively?</i></p> <p>No.</p>
5	<p>Both are equally important, and both methods of evaluation must work in unison.</p> <p><i>Can you expand further?</i></p> <p>Business cannot operate by isolating knowledge from opportunity.</p> <p><i>Is there a scenario in which one paradigm may be used exclusively?</i></p> <p>No.</p>

All 5 respondents (100%) did not believe that either a resource based or knowledge based paradigm in isolation could support a physical location decision. This data may further suggest that a company’s management structure relies on all external and internal resources when forming a process or making a physical supply chain site decision.

4.16 Resource based culture shift in management for physical location decisions

Table 16: Aside from policy shifts, has the management culture of the company shifted to integrate the resource based paradigm of the physical location decision determinants/factors with a knowledge based paradigm? What shifts have you observed?

Respondent No.	Response
1	<p>No observations of this type of change.</p> <p><i>Can you expand further?</i></p> <p>I have not seen any of these changes.</p>
2	<p>A change in culture has not been noticed.</p> <p><i>Can you expand further?</i></p> <p>Both areas are equally used.</p> <p><i>Do you foresee this changing?</i></p> <p>No.</p>
3	<p>None observed.</p> <p><i>Do you think that there will be any changes?</i></p> <p>No.</p>
4	<p>As the company has grown, there has been more emphasis on measuring and identifying the exact requirements of each physical site.</p> <p><i>Do you believe this is a pattern?</i></p> <p>I would argue that this is still a combination of both resource and knowledge, however this is a shift from earlier culture.</p> <p><i>Do you believe that there will be future changes?</i></p>

	No.
5	<p>The culture has remained the same.</p> <p><i>The culture has remained the same. Can you expand?</i></p> <p>Over time consultants and experts have been used, however every time both knowledge and resource is evaluated with equal importance.</p> <p><i>Do you have any reason to believe that there will be a change made in the future?</i></p> <p>No.</p>

All 5 respondents (100%) stated a belief that the management culture has not shifted to integrate a resource based paradigm. This may suggest that a company's corporate culture is not easily or quickly changed when considering physical location placement decisions.

4.17 Maintenance of historical records for knowledge sharing

Table 17: Does the company plan location decisions on the basis of historical information of location determinants which might be available? If yes, how does the company maintain historical records for knowledge sharing among the decision making hierarchy?

Respondent No.	Response
1	<p>The list of requirements for each site, as well as the evaluation criteria is maintained as a historical record of the transaction.</p> <p><i>Do you mean physical records are kept?</i></p> <p>Yes.</p>
2	<p>Records based on costs, budgets and shortlists are maintained.</p> <p><i>Can you expand on why all of this data is maintained?</i></p> <p>Through this data, an evaluation of steps taken to form physical location decisions can be found.</p> <p><i>Is there a specific set of guidelines used each time to evaluate the data?</i></p> <p>No.</p>
3	<p>Each physical location decision is usually somewhat different. Often, there is a model which is established, in which the goals of each site (for a specific purpose) must confirm to. However, these specifications regularly change, as the business grows.</p> <p><i>How do you ensure that different goals are evaluated each time?</i></p> <p>Usually, performance indicators of the business are used to evaluate success.</p> <p><i>How are these indicators used?</i></p> <p>These metrics can then be integrated to understand how well the location decision was.</p> <p><i>Do you mean you evaluate the overall decision by looking back at the success metrics?</i></p> <p>Yes.</p>
4	<p>Typically, the list of objectives for the site, as well as the budget are maintained.</p> <p><i>Is this all the information which is maintained?</i></p>

	Yes.
5	<p>Historical information is used, however the data is not maintained.</p> <p><i>Why are these records not maintained?</i></p> <p>Each decision is different, and while the process of deciding is maintained (the goals, the objectives etc.), each individual site meets a different purpose based on the stage of the business.</p> <p><i>Is there any value in maintaining the metrics or performance indicators for each decision?</i></p> <p>Possibly, however this is not done.</p>

Of the respondents, 40% stated that budget data is maintained, while 40% of respondents noted that the requirements of the site and scenario data are maintained, along with the goals and objectives of the site. This suggests that data is maintained in order to facilitate future decisions.

4.18 Conclusions

Of the 766 respondents surveys initiated, 256 were deemed eligible and completed the survey. The survey respondents were comprised of executive decision makers (61%), senior managers (20%), middle managers (5%), operational staff (3%), and analyst/junior managers (1%). 86% of those surveyed have decision making authority and some involvement in the strategic planning efforts of their respective companies. As such, the specific research objectives outlined in section 1.5.2 were met, as the data reflects the responses of the target demographic outlined in section 3.5.2.

For each survey question, more than 50% of the survey takers agreed or strongly agreed with the survey question posed. When those responding in agreement equaled or exceeded 80%, a number of key factors for decision making related to site location selection surfaced. These included considerations for the land itself, transportation factors, and tax structure, and is analyzed further in subsequent chapters.

From the survey data, factors influencing the land component of site selection include low maintenance cost of the property (85%), size and /or area of the plot (85%), as well as its layout (84%).

Proximity to other business entities was determined to be a vital consideration for the respondents. The site's location in relation to affiliates (80%), strategic partners (83%), and target markets (89%) influences transportation costs, production timelines, and speed to market.

Truck and transportation related matters are a notable consideration. Respondents acknowledge the facility must be able to provide parking (89%) for truck traffic to the site. Roads and freeways must be readily accessible (88%) to facilitate the movement and volume required, and there must be a labor force readily available to support the trucking need (84%). Tax structure (89%) and incentives (87%) along with other government sponsored subsidies (81%) were identified as key factors in site selection as well.

A second grouping of survey questions covered factors related to transportation decisions and tax structures. Responses to these questions resonate the same theme seen in earlier responses. Proximity to strategic partners (83%), overall transportation costs (90%), availability of parking (83%), accessibility of roads (86%), and favorability of labor (87%) were noted as responses and validated earlier findings. Overall tax costs (93%), potential for tax reduction (86%), and government sponsored tax incentives (88%) received respondent agreement as considerations central to the physical location decision making process.

82% of the respondents were in agreement with the statement “It is important to consider land value factors, when determining new physical locations of supply chain entities” and 93% agreed with “It is important to consider transportation and accessibility factors, when determining new physical locations of supply chain entities”.

The number of interviewees were relatively few in comparison to the survey respondents. Of the 14 interviews attempted, 5 (35%) respondents agreed to an interview. Supply Chain Managers comprised 60% of the respondent base, Senior Management accounted for 20%, and Group

Director level roles accounted for 20%. As a result, all interview respondents held management roles, thereby meeting objectives outlined in section 1.5.2.

Of the respondents, three (60%) stated that their company place equal emphasis on tangible and intangible resources. The remaining two (40%) stated that immobile resources are more important when making a physical location decision.

The second question aimed to understand the decision making process involved with a physical location decision. Two (40%) suggested that a corporate structure and culture influenced the progression of this decision. The remaining three (60%) of respondents suggested that a document which was agreed upon by a selection committee was formed to reduce potential conflict.

All five respondents stated that knowledge and resource based views are equally important in making a physical location decision, and noted that there have not been any policy shifts from RBV to KBV paradigms (or vice versa). Furthermore, all respondents did not believe that either paradigm in isolation could support a physical location decision, nor that there has been a management culture shift to incorporate a resource based view.

The question which divided most interviewees focused on historical data for knowledge sharing. Of the respondents, two stated that budget data is maintained. Two other respondents noted that the requirements of the site and scenario data are maintained, along with the goals and objectives of the site. One respondent noted that while historical information is used, data is not

maintained.

Results presented observe the methodology protocol outlined in Chapter 3, while meeting the research objectives noted in section 1.5. Overall collection methods met with ethical considerations outlined in section 3.9, and provided a table for analysis in answering research questions presented in section 1.6.

5.0 CHAPTER FIVE : DISCUSSION, FINDINGS AND IMPLICATIONS

5.1 Introduction

In order to analyze the data presented in section 4.2 to 4.16, several tools were used to generate useful insight for the purposes of answering the research questions noted in section 1.6 and to address the research objectives noted in section 1.5. This chapter focused on interpreting the data, by way of applying factor analysis and structural equation modelling discussed in section 3.7 and 3.8 to the results presented in chapter 4.

Due to the nature of the data collected and the research objectives pursued in this study, the initial step is to explore the factor structure of variables which were used. As noted in section 3.7.3, the research applied exploratory factor analysis (EFA), which transforms data into several factors and therefore simplifies further analysis. Within this step, the Kaiser-Meyer-Olkin Measure of Sampling Adequacy, the Bartlett Test, the Scree Plot test, the Pattern Matrix evaluation, and the Factor Correlation Matrix evaluation, was executed.

Once the EFA was generated, the following step is to apply Confirmatory Factor Analysis (CFA) which allows for the ability to confirm the factor structure extracted in the Exploratory Factor Analysis. The final step involves the application of Structural Equation Modelling, which generates insight on the interrelation between factors obtained in the CFA. This step essentially allows for the testing of the hypotheses presented in section 1.7 and the interpretation of research questions presented in section 1.6. The following sections detail the results of this approach.

5.2 Exploratory Factor Analysis - Physical Location Decisions (PLD)

The first factor analysis for Physical Location Decisions (PLD) was conducted over 19 variables (groups of variables: Q13, Q14, Q15). Prior to conducting the Exploratory Factor Analysis, the Kaiser-Meyer-Olkin Measure of Sampling Adequacy was calculated to be 0.733. Barlett's test of sphericity reached a statistical significance of 0.000. As noted in Chapter 3, this confirms the data is suitable for factor analysis and justifies the feasibility of factor analysis. In order to achieve discriminant and convergent validity (construct validity), variables with small factor weights (below 0.3) were excluded from further analysis, as were variables with cross-loading properties.

The Cronbach Alpha Coefficient for the physical location decision scale, is 0.764. This exceeds the recommended value of 0.70, and as such, it can be concluded that the measuring scale is reliable.

Table 18: Communalities (Physical Location Decisions)

	Initial	Extraction
Q134	0.383	0.624
Q135	0.339	0.527
Q142	0.319	0.331
Q143	0.261	0.999
Q151	0.597	0.739
Q152	0.528	0.607
Q153	0.628	0.759

On seven factors, the maximum likelihood method showed the presence of three factors with characteristic values above 1.0 (the Guttman-Kaiser criterion). These 3 factors show 65.48% of total variance explained.

Table 19: Total Variance Explained (Physical Location Decisions)

Factor	Initial Eigenvalues			Extraction Sums of Squared Loadings			Rotation Sums of Squared Loadings
	Total	% of Variance	Cumulative %	Total	% of Variance	Cumulative %	Total
1	3.013	43.040	43.040	1.334	19.061	19.061	2.438
2	1.284	18.338	61.378	2.409	34.413	53.474	1.437
3	1.200	17.145	78.523	.841	12.011	65.485	1.674
4	.477	6.807	85.330				
5	.424	6.062	91.392				
6	.353	5.044	96.436				
7	.249	3.564	100.000				

* Extraction Method: Maximum Likelihood.

As further confirmation, the Cattell scree test plots the components as the X axis and the corresponding eigenvalues as the Y-axis. By reviewing scree test below, all three factors were retained for further analysis.

Figure 52: Scree Plot (Physical Location Decisions)

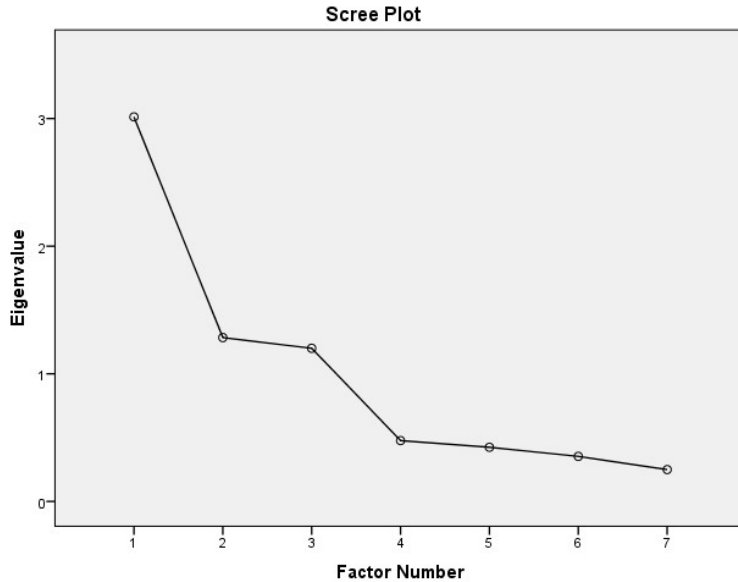

The Pattern Matrix (Table 20) and Factor Correlation Matrix (Table 21) illustrates a very clean factor structure in which convergent and discriminant validity are evident by the high loadings (coefficients) within factors, and no major cross-loadings between factors. As the correlations are beneath 0.7, there is no indication of a majority of shared variance.

Table 20: Pattern Matrix (Physical Location Decisions)

		Factor		
		1	2	3
Q151		0.902		
Q153		0.858		
Q152		0.733		
Q143			1.017	
Q142			0.472	
Q134				0.774
Q135				0.744

* Extraction Method: Maximum Likelihood.
 Rotation Method: Promax with Kaiser Normalization.
 * Rotation converged in 4 iterations.

Table 21: Factor Correlation Matrix (Physical Location Decisions)

Factor	1	2	3
1	1.000	0.247	0.451
2	0.247	1.000	0.163
3	0.451	0.163	1.000

* Extraction Method: Maximum Likelihood.
Rotation Method: Promax with Kaiser
Normalization.

The first factor within the Physical Location Decisions scale, included variables related to government tax incentives, government sponsored economic incentives and overall tax costs of the site. Three variables are included, and the Cronbach Alpha Coefficient is 0.869, which exceeds the threshold value of 0.70. As such, it can be concluded that the measuring scale is reliable. On account of the included variables, this factor can be nominated as "TAX STRUCTURE AFFECTING PHYSICAL LOCATION DECISIONS".

The second factor within the Physical Location Decisions scale, included variables related to proximity to target markets and accessibility to customers. Two variables are included, and the Cronbach Alpha Coefficient is 0.662, which is less than 0.70. According DeVellis (2003) taking into account the mean inter-item correlation with the optimal range of between 0.2 and 0.4 is recommended. The correlation value between the items within this factor is 0.286. As such, it can be concluded that the measuring scale is reliable. On account of the included variables, this factor can be nominated as "TRANSPORTATION AND ACCESSIBILITY DECISIONS AFFECTING PHYSICAL LOCATION DECISIONS".

The third factor within the Physical Location Decisions scale, included variables related to size/area of land and layout/dimension of the land site. Two variables are included, and the Cronbach Alpha Coefficient is 0.772 which exceeds the threshold value of 0.70. As such, it can be concluded that the measuring scale is reliable. On account of the included variables, this factor can be nominated as "LAND LOCATION RELATED DECISIONS AFFECTING PHYSICAL LOCATION DECISIONS".

5.3 Exploratory Factor Analysis – Land Value Decisions (LVD)

The second factor analysis for Land Value Decisions (LVD) was conducted over 16 variables (groups of variables: Q18, Q19). Prior to conducting the Exploratory Factor Analysis, the Kaiser-Meyer-Olkin Measure of Sampling Adequacy was calculated to be 0.681, indicating the data is suitable for factor analysis. Barlett's test of sphericity reached a statistical significance of 0.000, which justifies factor analysis. In order to achieve discriminant and convergent validity (construct validity), variables with small factor weights (below 0.3) were excluded from further analysis, as were variables with cross-loading properties.

The Cronbach Alpha Coefficient for the land value determination scale, is 0.717. As noted in Chapter 3, this exceeds the recommended value of 0.70, and as such, it can be concluded that the measuring scale is reliable.

Table 22: Communalities (Land Value Decisions)

	Initial	Extraction
Q181	0.324	0.329
Q182	0.323	0.999
Q186	0.292	0.794
Q187	0.289	0.353
Q191	0.361	0.430
Q192	0.506	0.773
Q193	0.431	0.531

* Extraction Method: Maximum Likelihood.

On seven factors, the maximum likelihood method showed the presence of three factors with characteristic values above 1.0 (the Guttman-Kaiser criterion). These 3 factors show 60.13% of total variance explained.

Table 23: Total Variance Explained (Land Value Decisions)

Factor	Initial Eigenvalues			Extraction Sums of Squared Loadings			Rotation Sums of Squared Loadings
	Total	% of Variance	Cumulative %	Total	% of Variance	Cumulative %	Total
1	2.622	37.455	37.455	1.467	20.956	20.956	1.907
2	1.462	20.887	58.342	1.800	25.712	46.668	1.528
3	1.116	15.947	74.289	0.943	13.466	60.134	1.400
4	0.537	7.674	81.962				
5	0.477	6.811	88.774				
6	0.451	6.441	95.215				
7	0.335	4.785	100.000				

* Extraction Method: Maximum Likelihood.

By reviewing the details of the scree plot in figure 52 and taking into account the Cattell (1966) criteria, all of three factors were retained for further research.

Figure 53: Scree Plot (Land Value Decisions)

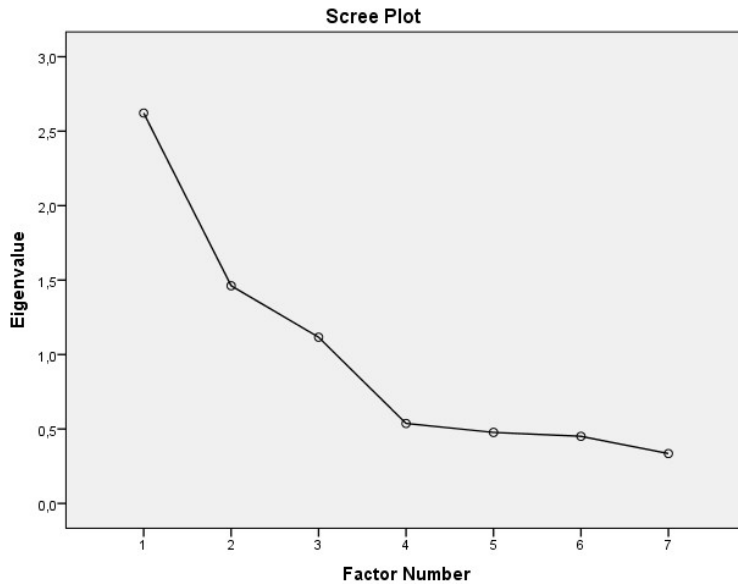

The Pattern Matrix (Table 24) illustrates a defined factor structure in which convergent and discriminant validity are evident by the high loadings (coefficients) within factors. No major cross-loadings are evident between factors.

Table 24: Pattern Matrix (Land Value Decisions)

	Factor		
	1	2	3
Q192	0.886		
Q193	0.728		
Q191	0.628		
Q182		1.018	
Q181		0.507	
Q186			0.900
Q187			0.549

* Extraction Method: Maximum Likelihood.
 Rotation Method: Promax with Kaiser
 Normalization.

* Rotation converged in 4 iterations.

The Factor Correlation Matrix (Table 25) is less than 0.7 indicating that shared variance does not occur within the factors.

Table 25: Factor Correlation Matrix (Land Value Decisions)

Factor	1	2	3
1	1.000	0.227	0.265
2	0.227	1.000	0.299
3	0.265	0.299	1.000

* Extraction Method: Maximum Likelihood.
 Rotation Method: Promax with Kaiser
 Normalization.

The first factor within the Land Value Determination scale, included variables related to potential tax reduction, government sponsored economic incentives and the overall tax cost of the site. Three variables are included, and the Cronbach Alpha Coefficient is 0.793, which exceeds the threshold value of 0.70. As such, it can be concluded that the measuring scale is reliable. On account of the included variables, this factor can be nominated as "TAX AND INCENTIVE STRUCTURES AFFECTING LAND VALUE DETERMINATION".

The second factor within the Land Value Determination scale, included variables related to proximity to affiliate and proximity to strategic partners. Two variables are included, and the Cronbach Alpha Coefficient is 0.707, which exceeds the threshold of 0.70. As such, it can be concluded that the measuring scale is reliable. On account of the included variables, this factor can be nominated as "LAND LOCATION DECISIONS AFFECTING LAND VALUE DETERMINATION".

The third factor within the Land Value Determination scale, included variables related to the availability of parking area for trucks and approachability to roads and freeways. Two variables are included, and the Cronbach Alpha Coefficient is 0.674, which is less than 0.70. DeVellis (2003) suggests taking into account the mean inter-item correlation with the optimal range of between 0.2 and 0.4. The correlation value between the items within this factor is 0.286. As such, it can be concluded that the measuring scale is reliable. On account of the included variables, this factor can be nominated as "TRANSPORTATION DECISIONS AFFECTING PHYSICAL LOCATION DECISIONS"

5.4 Exploratory Factor Analysis – Economic Impact (EI)

The third factor analysis for Economic Impact (EI) was conducted over 6 variables (groups of variables: Q21). Prior to conducting the Exploratory Factor Analysis, the Kaiser-Meyer-Olkin Measure of Sampling Adequacy was calculated to be 0.674, indicating the data is suitable for factor analysis. Barlett's test of sphericity reached a statistical significance of 0.000, which justifies factor analysis. In order to achieve discriminant and convergent validity (construct validity), variables with small factor weights (below 0.3) were excluded from further analysis, as were variables with cross-loading properties.

Table 26: Communalities (Economic Impact)

	Initial	Extraction
Q211	0.385	0.276
Q212	0.389	0.281
Q213	0.520	0.703
Q214	0.503	0.644

* Extraction Method: Maximum Likelihood.

On four factors, the maximum likelihood method showed the presence of one factor with a characteristic value above 1.0 (the Guttman-Kaiser criterion). This factor showed 47.6% of total variance explained.

Table 27: Total Variance Explained (Economic Impact)

Factor	Initial Eigenvalues			Extraction Sums of Squared Loadings		
	Total	% of Variance	Cumulative %	Total	% of Variance	Cumulative %
1	2.422	60.556	60.556	1.904	47.603	47.603
2	.870	21.760	82.316			
3	.409	10.213	92.529			
4	.299	7.471	100.000			

* Extraction Method: Maximum Likelihood.

By reviewing scree test in figure 53, the presence of one factor is confirmed.

Figure 54: Scree Plot (Economic Impact)

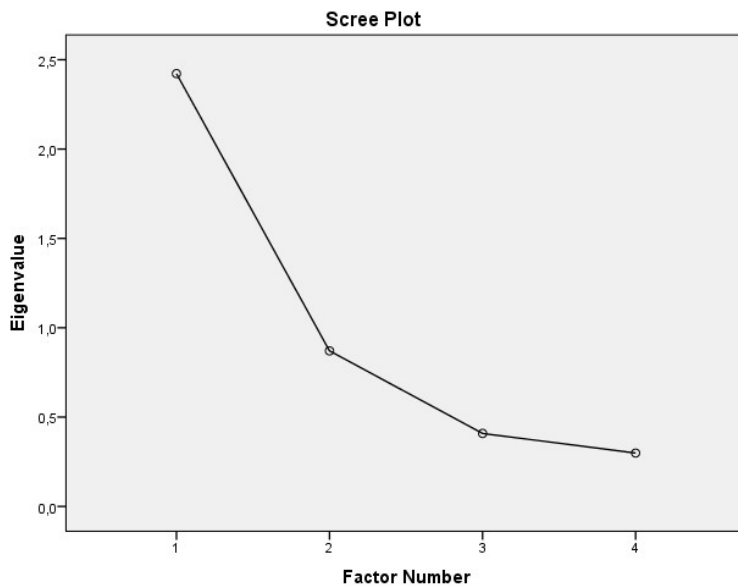

The only factor within the Economic Impact on the Overall Chain and Firm scale, included variables related to impressions of respondents on whether land value and tax structure have an economic impact on the firm and overall supply chain.

Four variables are included, and the Cronbach Alpha Coefficient is 0.782, which exceeds the threshold value of 0.70. As such, it can be concluded that the measuring scale is reliable. On account of the included variables, this factor can be nominated as "ECONOMIC IMPACT TO FIRM AND OVERALL SUPPLY CHAIN".

Table 28 demonstrates each of the included variables, along with the standard deviation and mean. The code of each question is also shown.

Table 28: Factors and Included Variables with Mean and Standard Deviation

NAME OF SECTION IN THE QUESTIONNAIRE	FACTORS	CODE OF QUESTIONS INCLUDED	MEAN	SD	QUESTIONS INCLUDED IN FACTORS
PHYSICAL LOCATION DECISIONS (PLD)	TS.PLD (Tax structure affecting PLD)	Q151	1.69	0.737	Government tax incentives
		Q153	1.66	0.739	Government sponsored economic incentives
		Q152	1.85	0.795	Overall tax cost of the site
	TAD.PLD Transportation and Accessibility Decision affecting PLD)	Q142	1.55	0.734	Proximity to target markets
		Q143	1.80	0.871	Accessibility to customers
	LL.PLD (Land Location Related Decisions affecting PLD)	Q134	1.81	0.771	Size/area of land
		Q135	1.87	0.673	Layout/dimension of land site
	TS.LVD (Tax and Incentive	Q192	1.60	0.667	Potential for tax reduction
		Q193	1.77	0.718	Government sponsored economic incentives

LAND VALUE DETERMINATION (LVD)	Structures affecting LVD)	Q191	1.79	0.741	Overall tax cost of the site
	LL.LVD (Land Location Decisions affecting LVD)	Q182	2.08	0.763	Proximity to affiliate
		Q181	1.88	0.726	Proximity to strategic partners
	TR.LVD (Transportation Decisions affecting LVD)	Q186	1.98	0.761	Availability of parking area for trucks
		Q187	1.80	0.738	Approachability to roads, freeways
ECONOMIC IMPACT TO FIRM AND OVERALL SUPPLY CHAIN (EI)	Land value has economic impact)	Q211	2.21	0.872	Land value of physical entities has significant economic impact on the company.
		Q212	2.32	0.925	Land value of physical entities has significant economic impact on the efficiency of the supply chain.
		Q213	2.08	0.906	Tax structures and government incentives have a significant economic impact to the operational functionality of the firm.
	Tax structure has economic impact)	Q214	2.05	0.891	Tax structures and government incentives have a significant economic impact on the supply chain value of the firm.

5.5 Confirmatory Factor Analysis

As noted in section 3.7.3, Confirmatory Factor Analysis is conducted in order to confirm the factor structure extracted in the Exploratory Factor Analysis. In order to justify the results from the Exploratory Factor Analysis, a Measurement Model, Goodness of Fit Calculation, and Convergent and Discriminant Validity calculation are conducted.

As the sample size is 256 and above the chi-square value threshold of 200, the standardized chi-square value (χ^2/df) is calculated, as this measurement showed sensitivity to the overall sample size. According to Tabachnick & Fidell (2007), 2.0 is the upper acceptable limit of chi-square. The Goodness of fit index (GFI) indicates how well the observed variance is explained by the model. According to Hoyle (2000) and Kline (2005), the value should be between 0.9 and 1.0 in order to achieve a good model fit.

The objective within this section is to assess the discriminant validity and verify the factor structure of the included variables. Through this analysis, the hypothesis that a relationship between included variables and underlying latent constructs exists, is confirmed.

5.5.1 Measurement Model and Goodness of Fit (Physical Location Decisions)

The Measurement Model for Physical Location Decisions (PLD) specifies that every observed variable measure only one dimension which have error terms not correlating with each other, nor with the latent variables.

Figure 55: Measurement model (Physical Location Decisions)

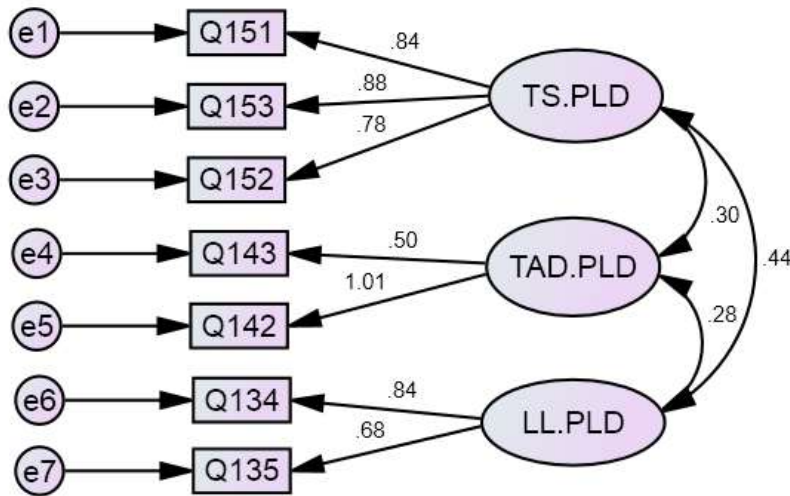

Indicators of fit as demonstrated in Table 29, suggest that the model achieves a good model fit.

Table 29: Goodness of Fit (Physical Location Decisions)

	χ^2/df	GFI	RMR	RMSEA	NFI	TLI	CFI
Measurement model PLD	1.141	0.986	0.016	0.024	0.980	0.995	0.997
Thresholds*	< 3	>0.90/95	<0.06/10	<0.08	>0.90/95	>0.90/95	>0.90/95

* χ^2/df = normed chi-square statistic; GFI = Goodness-of-Fit Index; RMR= Root-Mean-Square Residual; RMSEA = Root Mean Square Error of Approximation; NFI = Normed Fit Index; TLI= Tucker-Lewis Index; CFI = Comparative Fit Index.

5.5.2 Convergent and Discriminant Validity (Physical Location Decisions)

As noted in Chapter 3, convergent validity of the construct was evaluated on the basis of the Composite Reliability (CR) and Average Variance Extracted (AVE) test. As all three conditions are met (CR > 0.7 ; AVE > 0.5; CR > AVE), it can be assumed that there was a convergent validity of the measurement model.

In order to assess the discriminant validity of the constructs, values of Average Variance Extracted (AVE), Maximum Shared Variance (MSV), and Shared Average Variance (ASV)

must be compared. The correlation matrix with the square root of AVE is shown in Table 25, while the Convergent and Discriminant Validity is shown in Table 30. Both the necessary conditions are met ($MSV < AVE$; $ASV < AVE$), and the square root of the AVE value is greater than the value of the correlation between constructs. As such, it can be concluded that there is discriminant validity of the constructs.

Table 30: Convergent and discriminant validity (Physical Location Decisions)

	CR	AVE	MSV	ASV	TAD.PLD	TS.PLD	LL.PLD
TAD.PLD	0.803	0.633	0.092	0.086	0.796		
TS.PLD	0.923	0.692	0.195	0.144	0.303	0.832	
LL.PLD	0.848	0.585	0.195	0.138	0.284	0.442	0.765

5.5.3 Measurement Model and Goodness of Fit (Land Value Decisions)

The Measurement Model for Land Value Decisions (LVD) again required that every observed variable measure only one dimension which have error terms not correlating with each other, nor with the latent variables. Seven coded questions are used within the analysis.

Figure 56: Measurement model (Land Value Decisions)

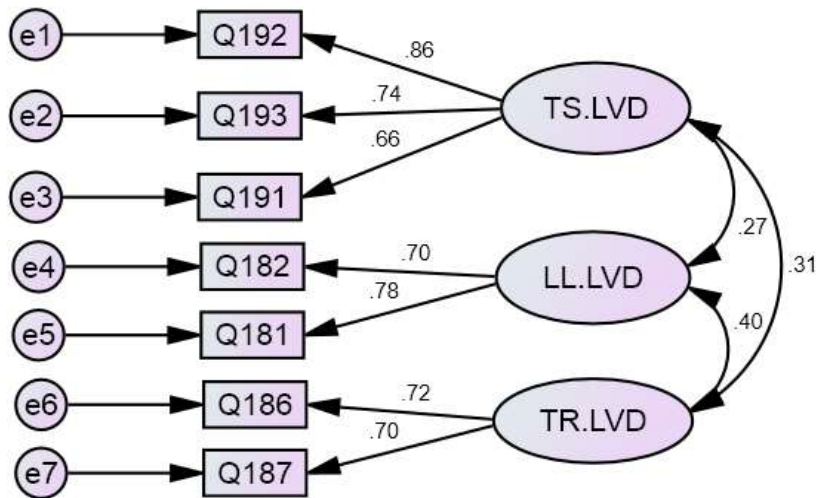

Based on these results, Table 31 showed that the indicators of fit suggest that the model achieves a good model fit.

Table 31: Goodness of fit (Land Value Decisions)

	χ^2/df	GFI	RMR	RMSEA	NFI	TLI	CFI
Measurement model LVD	0.956	0.988	0.016	0.000	0.977	1.000	1.000
Thresholds*	< 3	>0.90/95	<0.06/10	<0.08	>0.90/95	>0.90/95	>0.90/95

* χ^2/df = normed chi-square statistic; GFI = Goodness-of-Fit Index; RMR = Root-Mean-Square Residual; RMSEA = Root Mean Square Error of Approximation; NFI = Normed Fit Index; TLI = Tucker-Lewis Index; CFI = Comparative Fit Index.

5.5.4 Convergent and Discriminant Validity (Land Value Decisions)

As all three conditions of Composite Reliability, and Average Variance Extracted are met ($CR > 0.7$; $AVE > 0.5$; $CR > AVE$), it can be assumed that there is a convergent validity of the measurement model.

In assessing the discriminant validity of the constructs, both the necessary conditions are met ($MSV < AVE$; $ASV < AVE$), and the square root of the AVE value is greater than the value of

the correlation between constructs. As such, it can be concluded that there is discriminant validity of the constructs. Table 32 showed the values from each Convergent and discriminant validity calculation.

Table 32: Convergent and discriminant validity (Land Value Decisions)

	CR	AVE	MSV	ASV	LL.LVD	TS.LVD	TR.LVD
LL.LVD	0.814	0.550	0.158	0.115	0.741		
TS.LVD	0.889	0.573	0.095	0.084	0.268	0.757	
TR.LVD	0.787	0.508	0.158	0.127	0.398	0.309	0.713

5.6 Structural Equation Modeling (SEM)

While Exploratory and Confirmatory Factor Analysis have demonstrated the measurement perspective and have outlined relationships between variables, the use of Structural Equation Modeling outlines the structural element, and allow insight on variable dependencies. Within this section, the evaluation of fit, as well as impact was focused on.

Causal relationships between the dimensions of physical location decisions and land value determination, as well as the impact on respondents related to the economic impact on the overall supply chain and firm, have been tested by structural equation modeling. When modeling the relationship between those constructs, the value of the final factors in the path analysis were made by regression imputation. Preliminary analysis showed that the assumptions of normality, linearity and multicollinearity were not disturbed.

The model was designed to ensure all dimensions of land value determination have a direct and

positive effect on economic impact and physical location decisions, while physical location dimensions have a direct and positive impact on economic impact. The model does not include a correlation between measurement error.

The proposed model showed a poor model fit, and as such improvement of the model was attempted by eliminating certain connections between the constructs in the path diagram, which have statistically insignificant low regression weights, and by establishing covariance between individual measurement errors, and establishing new empirical relationships between constructs. These changes led to a significant improvement in the model fit.

Figure 57: Structural Model of Land Value Determination, Physical Location Decisions and Economic Impact on Overall Chain and Firm

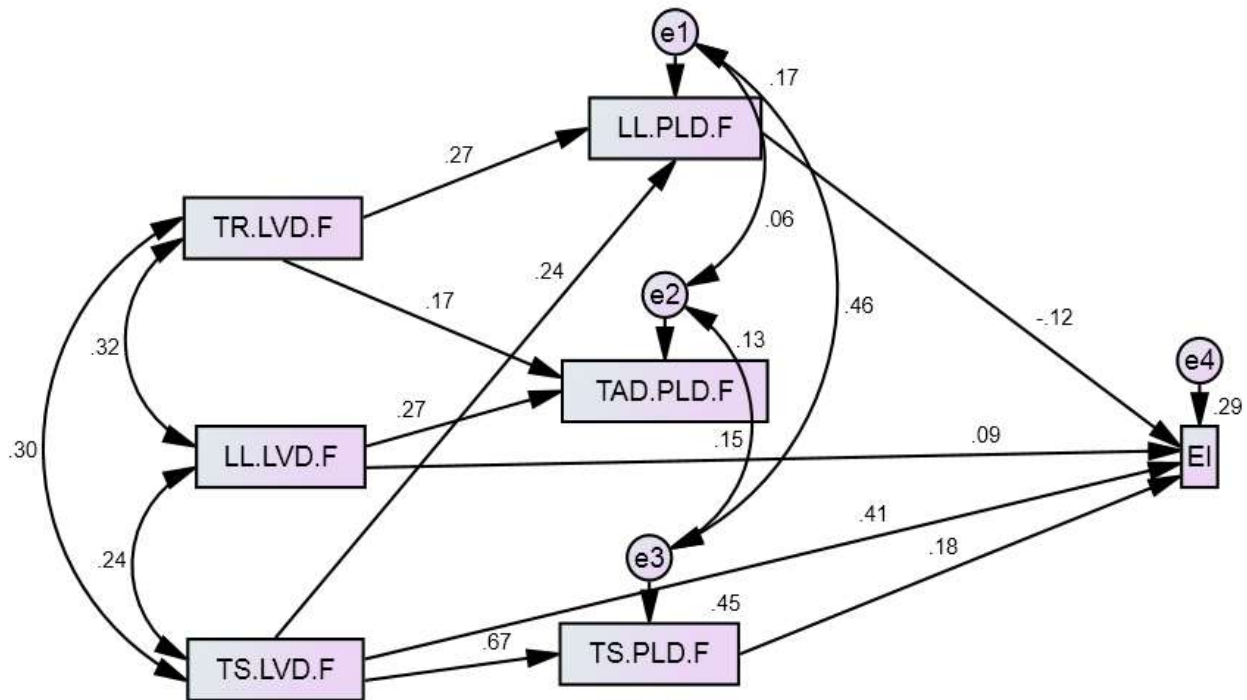

As shown in Table 33, calculating the model fit after retesting, suggested the model fits the data and achieves a good fit ($\chi^2 / df = 1.629$; RMR = 0.036; GFI = 0.989; NFI = 0.979; TLI = 0.970, CFI = 0.991, RMSEA = 0.050; P CLOSE = 0.438).

Table 33: Goodness of Model Fit Indicators

	χ^2/df	GFI	RMR	RMSEA	NFI	TLI	CFI
Indicator of fit*	1.629	0.989	0.036	0.050	0.979	0.970	0.991
Reference value**	< 3	>0.90/95	<0.06	<0.08	>0.90/95	>0.90/95	>0.90/95

* χ^2/df = normed chi-square statistic; GFI = Goodness-of-Fit Index; RMR= Root-Mean-Square Residual; RMSEA = Root Mean Square Error of Approximation; NFI = Normed Fit Index; TLI= Tucker-Lewis Index; CFI = Comparative Fit Index.

Table 34: Standardized Regression Weights (Path Coefficients) and Statistical Significance

		Estimate	S.E.	C.R.	P
H4:	LL.PLD.F <--- TR.LVD.F	0.267	0.051	5.009	***
	LL.PLD.F <--- TS.LVD.F	0.236	0.056	3.983	***
H4:	TS.PLD.F <--- TS.LVD.F	0.669	0.047	14.524	***
	TAD.PLD.F <--- LL.LVD.F	0.269	0.061	4.419	***
H1:	EI <--- LL.LVD.F	0.091	0.050	1.672	0.094
	EI <--- TS.LVD.F	0.413	0.072	5.707	***
	EI <--- TS.PLD.F	0.176	0.077	2.223	0.026
H3:	TAD.PLD.F <--- TR.LVD.F	0.174	0.067	2.865	0.004
	EI <--- LL.PLD.F	-0.116	0.065	-1.871	0.061

From the results shown in Table 34, it can be concluded that all factors of land value determination have a statistically significant positive impact on factors of physical location decisions. One factor of land value determination has a statistically significant positive impact on the interpretation of economic impact on the overall chain and firm, and was related to tax and incentive structures.

Conclusively, it can be assumed that tax and incentive structures affecting land value determination have a direct positive and strong impact on respondents in relation to the interpretation and attitude toward economic impact on the overall chain and firm.

The tax structure affecting the physical location decisions has a strong direct positive impact on respondents in relation to economic impact on the overall supply chain and firm.

5.7 Qualitative Data Analysis

In addition to quantitative data collected through surveys, qualitative data was collected from respondents, on factors affecting physical location decisions.

Of the 14 interviews attempted, 5 (35%) respondents agreed to an interview. Supply Chain Managers comprised 60% of the respondent base, Senior Management accounted for 20%, and Group Director level roles accounted for 20%. As a result, all interview respondents held management roles which meets the objective of the interview selection criteria.

When asked to identify the reasons why does the company put emphasis on comparing tangible and mobile resources as opposed to intangible and immobile resources, or vice versa, when making physical location decisions, 3 (60%) stated that their company place equal emphasis on tangible and intangible resources. The remaining 2 (40%) stated that immobile resources are more important. The data suggests that respondents place a higher value on resources which are fixed, as oppose to resources which may be moveable to future land sites.

When asked to indicate how transportation factors and overall land value analysis influence physical location decisions, considering that these factors are often variable and constantly changing, 3 (60%) stated that budgetary restrictions are most important. The stage and evolution of growth of the business were identified by 2 (40%) respondents. This may suggest that the size of the business may be important when evaluating various impacts (e.g. a smaller business may be more concerned with a budget as oppose to a larger business).

When asked to indicate how transportation, land value and tax structure influence physical location decisions, assuming decision makers may have different opinions, interpretations and knowledge on resource tangibility and importance, 2 (40%) suggested that a corporate structure and culture influenced the progression of this decision. The remaining 3 (60%) of respondents suggested that a document which was agreed upon by a selection committee was formed to reduce conflict. This may suggest that each corporation was slightly different in terms of structure and process when making decisions on physical supply chain sites and land evaluation.

When asked if physical location decisions were more dependent on a knowledge based view (the belief that the knowledge held by decision makers was most important) or a resource based view (the belief that tangible or intangible resources at the firm's disposal are most important), all 5 respondents (100%) stated that knowledge and resource based views are equally important in making a physical location decision. None of the respondents seemed to be particularly drawn to the notion of choosing one paradigm over the other. This may suggest that the respondents companies use a diverse decision methodology.

When asked to indicate the reasons for why physical location decisions are based on a knowledge based view or resource based view, all 5 respondents (100%) stated that knowledge and resource based views are equally important in making a physical location decision. This data may suggest that a company's management structure relies on all external and internal resources when forming a process or making a physical supply chain site decision. Once again, none of the respondents seemed to be particularly drawn to the notion of choosing one paradigm over the other.

When asked about any amendments in policies which shift the paradigm of resource based view decisions to knowledge based view decisions, or vice versa, in terms of physical location decisions, all 5 the respondents (100%) noted that there have not been any policy shifts from RBV to KBV paradigms (or vice versa). This may suggest that the corporate culture within the respondents corporations was rigid.

When asked if a resource based paradigm or a knowledge based paradigm could support a physical location decision in isolation, all 5 respondents (100%) did not believe that either a resource based or knowledge based paradigm in isolation could support a physical location decision. This result may further suggest that a company's management structure relies on all external and internal resources when forming a process or making a physical supply chain site decision.

When asked if the management culture of the company shifted to integrate the resource based paradigm of the physical location decision determinants/factors with a knowledge based paradigm, All 5 respondents (100%) stated a belief that the management culture has not shifted to integrate a resource based paradigm. This may suggest that a company's corporate culture is not easily or quickly changed when considering physical location placement decisions.

When asked if the company plans location decisions on the basis of historical information of location determinants which might be available, 40% stated that budget data is maintained, while 40% of respondents noted that the requirements of the site and scenario data are maintained, along with the goals and objectives of the site. This could suggest that data is maintained in

order to facilitate future decisions.

5.8 Summary of Data Analysis

The analysis of results presented a number of key findings. Interpretation of both qualitative and quantitative data allowed for a robust understanding of respondents perspectives, which in turn enabled the evaluation of relationships between various research drivers.

The majority of respondents believe intangible and immobile resources are more important than mobile resources when making physical location decisions. Further, respondents indicated along with budget constraints, and business growth, transportation factors and overall land value analysis influence physical location decisions.

Assuming decision makers may have different opinions, interpretations and knowledge on resource tangibility and importance, respondents noted equal importance toward KBV and RBV views, and voiced similar patterns of defining goals, metrics and requirements, in forming physical site location decisions for supply chain entities. Most companies keep some record of requirements, budgets, lists of objectives and goals as historical archives on previous supply chain entity placement decision, however there was recognition of the fact that each supply chain location decision is different, based on circumstance and business growth.

From the quantitative research, tax and incentive structures affecting land value determination have a positive and strong impact in relation to the interpretation and attitude toward economic impact on the overall chain and firm. Comparatively, the tax structure affecting the physical location decisions also has a strong direct positive impact in relation to economic impact on the overall supply chain and firm.

Analysis of the data implies factors which influence physical location decisions for supply chain facilities have a differing economic impact on the overall chain and firm, while land value determination factors have a statistically significant and positive impact on physical location decisions. Transportation decisions also have a positive impact on transportation and accessibility decisions which affect physical location decisions. As such it can be concluded that land value analysis has a substantial impact on physical location decisions for physical supply chain facilities.

The final area of analysis included the evaluation of tax and incentive structures. The data suggested tax and incentive structures which affect land value determination, have a direct positive impact on physical location decisions. As such, it can be concluded that (in concert with previous analysis) jurisdictions which have favorable tax and incentive structures are attractive when making physical location decisions for supply chain facilities.

5.9 Discussion of Key Findings

A number of insights and assumptions can be drawn from the data, and serve to aide in the progression of existing knowledge presented in section 2.1 to 2.9. In order to ascertain the value of the data presented, analysis into how the findings represent new knowledge must be undertaken in line with research objectives discussed in section 1.5, and research questions discussed in section 1.6.

5.9.1 Consistent Research Areas

In evaluating the data presented within section 4.2 to 4.17, a number of conclusions drawn from similar research sources may be substantiated and confirmed. Moran, Stahl & Boyer (2008) and Bhatnagar & Sohal (2005) both aim to evaluate supply chain location decision making, with Bhatnagar & Sohal (2005) asserting that decisions of a specific location for a manufacturing plant is influenced qualitative factors including proximity to markets, proximity to suppliers, key competitors' location, supply chain uncertainty and broad manufacturing practices. They further state that these factors are closely linked to the operational competitiveness of supply chains. These findings appear to be substantiated in figure 16, where 72% of respondents agreed that social policy and/or political risk of the region were seen as important success factor, suggesting that in addition to cost, political and social risk factors influence a physical supply chain resource decision.

In evaluation of location decisions, Hamedani, Jabalameli, & Bozorgi-Amiri, A. (2013) propose a robust optimization model for locating distribution centers, which specifies locations of distribution centers to be opened, inventory control parameters, and allocation of supply chain components, concurrently. Further, Holl (2004) states that establishment of a manufacturing start-ups is mostly driven by increases in local market size and labor force qualification, lower labor costs, and a more diversified economic environment. He continues to note that manufacturing plant relocations are motivated by better national market accessibility, availability of producer services, a larger industrial basis and the provision of inter-regional motorways. These notions are furthered by data presented in figure 21, showing 60% of respondents agreeing that strategic visibility of the location from roads and highways was important as a transportation and accessibility decision. Figure 34 further substantiates this data, by showing that 53% of the

respondents agreed that the strategic visibility of location from roads and highways was a key factor when making a land location decision.

Moran, Stahl & Boyer (2008) state that site selection is determined by individual plant requirements for headquarters, back offices, R&D, the type of manufacturing operations and the life stage of product/company. In line with decisions regarding geographical placement of supply chain entities presented in chapter 4, Schmenner, Huber, & Cook (1987) argue that geographically defined differences do not fully account for the differences in attractiveness of certain locations as manufacturing sites and that the plant location decision can be usefully approached as a staged process. Similarly, Alañón-Pardo & Arauzo-Carod (2013) note that agglomeration economies and accessibility are important in industrial location decision-making. This literature appears in line with findings presented in figure 12 and 14, where 85% of respondents agree that land rental/ownership cost is a key factor in physical location decision making. Further research from Sheu (2003) argues that the facility location of manufacturing centers and regional product distribution centers should maximize the potential rate of return on facility investment. Section 4.3, 4.4 and 4.5 aim to evaluate land valuation, which served to substantiate the notion that physical facility investment is core to a supply chain. Additional testament to this assumption, can be established from Coughlin & Segev (2000) who argue that the choice of manufacturing site for foreign owned plants is determined by factors such as the economic size of the location, educational attainment, the existing manufacturing base, transportation infrastructure, levels of taxes and labor-intensiveness

Finally, in evaluating tax implications, the data seems to confirm several existing areas of

literature, including Chang & Lin (2015) who state that most global manufacturing firms move their plant locations to certain areas to maximize on lower cost and tax. This appears in line with data presented in figure 27, showing 87% of the respondents agreed that tax and incentive structures were important in the supply chain physical entity decision making process.

Several notations presented in section 2.6 may also be substantiated, including Salvetat & Géraudel (2012) who argues that the success of corporates and organizations is greatly dependent on the interactions between flows of information, materials, manpower, and capital equipment. Also presented in section 2.6 and in line with the results of the data, Anderson et al. (1997) suggested that enhanced growth is often as a result of organizations accepting the need to change, as oppose to maintaining their current supply chain structure. This appears to be in line with findings presented in table 10, where respondents noted the growth stage of a business as being important.

5.9.2 Conflicting Research Areas

While there are a number of overlapping research areas, a number of existing literature appears to indirectly contradict data presented in chapter 4.

Crabbé & De Bruyne (2013) analysis of the effect of tax rates and agglomeration rents on manufacturing location decisions in Belgium, finds that location-specific supply-side agglomeration rents attract new firms and their impact appears to be stronger for more spatially concentrated sectors. The study found that a higher effective tax rate in a district does not

necessarily deter new firms in more agglomerated districts, as evidenced by the existence of taxable location-specific agglomeration rents. This data appears in contradiction of results presented in section 27 and 28, where 87% of respondents agreed that tax and incentive structures were important, and 89% agreed that the overall tax cost of the site was important, in the decision making process.

With perspective to labor and skill requirements, Malos (2009) argues that offshore manufacturing locations are picked due to the cheap labor, quality and available worker skills and the administrative and regulatory contexts of labor markets. Findings presented in figure 37 appear to contradict this data, as 87% of respondents noted that the availability of favorable labor resources was considered important (not cheap labor). Further substantiation of this data can be seen in figure 24, where 84% of respondents agree that the availability of favorable labor is key to physical location selection. This result may suggest that suitable (not cheap) labor is important in making land location supply chain decisions.

As presented in section 2.7.2, Chesbrough (2003) argues that the centralized approach to research and development within many industries, which he terms closed innovation, has become obsolete. He further argues that the concept of innovation as a term must be revisited to focus on the embracing of external ideas and knowledge. While this data appears to be in line with the flow of commerce, it was in contradiction to interview data presented in section 4.16, where few of the respondents noted the need to change decision making protocol, possibly suggesting that a company's corporate culture is not easily or quickly changed when considering physical location placement decisions.

A number of other areas of research exist, which while not contradictory in nature, aim to meet similar but different objectives. Chesire & Sheppard (1995) state that land rents can be estimated from structural characteristics of the neighborhood and a set of location specific characteristics which are then capitalized into land prices, possibly aligning with results presented in figure 12, showing 85% of respondents agree that land rental/ownership cost is a key factor in physical location decision making. Huchzermeier (1991) explores the dynamic programming formulation for the valuation of global supply chain networks under exchange rate uncertainty, while Chesire & Sheppard (1995) argue that a contingent valuation method for land sites is a useful alternative for analyzing the multiple dimensions of a public policy, both which speak to the overall value of physical land entity valuation.

5.9.3 Directions for Future Research

In evaluating existing literature, a number of new areas of knowledge are presented within this study, which may result in new knowledge within the area of supply chain management.

As noted in section 2.6, Arlbjorn (2011) states that businesses no longer compete in isolation or independently, but as supply chains. The findings of this study presented in chapter 4 appear to further this notion, by evaluating specific areas within the valuation of components of a supply chain, which may lead to competitive advantages. Within this vein, two broad areas of new knowledge are presented:

1. Data presented in section 4.3 to 4.5, quantitatively evaluated the decision making approach and cost/benefit analysis from FMCG decision makers when making physical supply chain location decisions including land valuation, transportation considerations, and tax considerations; as well identification of FMCG theoretical framework preferences, and possible corporate culture drivers.

The structure of the survey given to respondents allows for insight into land and facility valuation from a number of perspectives. As presented in section 5.6 a structure can be concluded, mapping the hierarchy and relationships between the dimensions of land location decisions, physical location decisions, transportation and accessibility decisions, economic impact and tax structure, on the overall supply chain. A statistical hierarchical evaluation of these variables when making physical supply chain location decisions was presented. This data provides insight into the perceptions held by practicing decision makers undertaking the task of implementing supply chain facilities, and therefore allows

for an understanding of the innate sequence of supply chain facility growth. The overall vision of decision makers which was presented through this data, allows for insight into the establishment of sustainable competitive advantage through supply chain planning.

While existing research exists in which evaluate supply chain competitiveness through location analysis (Bhatnagar & Sohal (2005)), there was currently no literature which supports the perspective of land location, transportation & accessibility and tax & incentive comparisons, when developing a valuation structure.

2. Data presented in section 4.9 to 4.17 discuss the results from interviews and explores assumptions drawn from responses. In evaluating the theoretical framework which exists in industry, as opposed to academia, respondents unanimously noted that knowledge and resource based views are equally important in making a physical supply chain location decision. Further, respondents unanimously claimed that there have not been any policy shifts from RBV to KBV paradigms (or vice versa), and that they did not believe that either a resource based or knowledge based paradigm in isolation could support a physical location decision. In evaluating corporate culture shifts, the respondent pool was again unanimous in stating a belief that the management culture has not shifted to integrate a resource based paradigm.

Doeringer, Evans-Klock & Terkla (2005) links a firms criteria for making location decisions to the performance management practices and cultures of the firms, and suggested plants that adopt high performance management practices and cultures rely on

different criteria from plants that are managed in more traditional ways. The data extracted from this research supports this theory, and presents new knowledge in describing perceptions of decision makers when making supply chain location decisions, with relation to theoretical framework.

5.9.4 Managerial Implications

As noted in section 2.6, Bommer et al. (2001) observes that building and sustaining competitive advantage for a firm required a deeper understanding of resource utilization within a firm, which at the root can be explained as a function of supply chain automation within an organization. The data presented within this study addresses this objective, and presents a platform for understanding the nature of supply chain competitiveness, from the perspective of decision making hierarchy.

As a result of this study, firms may establish a competitive advantage by evaluating the innate process of supply chain location decisions within industry, and adjusting larger corporate strategy to align with supply chain objectives (e.g. ensuring resources are aimed at establishing entities within low tax areas). Further, the results of this study provide a platform which allows firms to identify decision making drivers used for supply chain placement decisions. As such, firms may gain a competitive advantage by establishing a rigid and defined decision making process to ensure alignment across all decision makers. This structure would also be beneficial as a training protocol for new decision makers.

From a higher perspective, an understanding of decision making procedure within the area of

supply chain management facility decisions for large to medium businesses, may have a cascading effect in influencing location decisions of smaller stakeholders. Entities which aim to support a supply chain (e.g. third party storage facilities, third party transportation companies, logistics firms), may be able to gain competitive advantage by aligning placement decisions, and corporate strategy.

Other stakeholders unrelated to supply chain performance (e.g. land owners) may also benefit from this data, as it allows for potential forecasting of demand for supply chain entities.

Understanding the nature of a supply chain placement decision, could allow for the establishment of a price point for particular land locations. Pricing decisions could rely on variables noted within this study (e.g. accessibility to roads, parking allowance etc.), and could result in a defined structure at which land owners value their site, in line with projected demand.

From the internal perspective of a firm, the data presented within this study allows for insight into the corporate culture which exists when evaluating physical supply chain placement decisions. As noted in section 2.6, Carter and Ellram (2003) suggested that more literature reviews were needed for the development of theoretical frameworks of Supply Chain Management. Further, Carter and Ellram (2003) proposed that at least 32 different categories in the field of Supply Chain Management existed. The recognition of the decision making process, and the views decision makers hold on making changes was beneficial in understanding the theoretical framework which may exist in industry when addressing and defining the subject of supply chain management.

5.10 Conclusions

In observing the research objectives outlined in section 1.5, and in addressing the research questions noted in section 1.6, a number of key findings are presented which aim to discuss the overall value offered within this study.

In interpreting both qualitative and quantitative data, a number of new areas of knowledge are presented, which provide a platform for industry development, as well as allowing for a further refinement of academic and literary definitions of supply chain management.

As noted in section 1.8, Shahrzad et al. (2013), suggested that organizations must strategically locate their supply chain facilities in accordance with effective coordination and collaboration between the firm, the suppliers, and the consumers. Also noted in section 1.8, this study was significant in that it aimed to provide a detailed analysis and assessment of specific factors impacting land value in connection with supply chain processes in terms of economic impact. The analysis provided within this chapter aimed to meet this target, and establish a robust breakdown of data which served to provide applicable and useful information for industry and academic advancement.

In comparison to existing literature, the study focused directly on developing an understanding of the relationship between land value, transportation decisions, tax structures and location decisions, aiming to extract decision making tendencies in physical supply chain entity placement. By the nature of gathering data, the perceptions of decision makers are measured, as was the sequence of the decision making process when taking into account a number of

placement variables.

Existing research exists in areas which partially overlap the findings of this study, including evaluation of supply chain competitiveness through location analysis (Bhatnagar & Sohal (2005)), the decision making processes for specific supply chain entities under specific conditions (Alañón-Pardo, Á., & Arauzo-Carod, J. (2013)), geographic considerations in manufacturing facilities (Schmenner, R., Huber, J., & Cook, R. (1987)); however this study was unique and presents new knowledge in that it addresses both benefit and cost analysis in establishing a statistical hierarchy of relationships within the supply chain location decision making process.

As a result of quantitative analysis conducted in section 5.2 to 5.6, conclusions can be drawn with regards to relationships in the supply chain physical location, land valuation process and overall economic impact interpretation. Analysis of the data implies factors which influence physical location decisions have a differing economic impact on the overall chain and firm, and in performing statistical analysis as described in table 34, factors of land value determination are shown to have a statistically significant positive impact on factors of physical location decisions, with one factor of land value determination having a statistically significant positive impact on the interpretation of economic impact. Conclusively, it can be assumed that tax and incentive structures affecting land value determination have a direct positive and strong impact on economic impact.

Transportation decisions are shown have a positive impact on transportation and accessibility

decisions which affect physical location decisions. The data also suggested that tax and incentive structures which affect land value determination, have a direct positive impact on physical location decisions. Further, tax structures affecting physical location decisions have a strong direct positive impact in relation to economic impact on the overall supply chain and firm.

From a qualitative perspective, budget constraints, business growth, transportation factors and overall land value analysis influence physical location decisions. Decision makers also noted equal importance toward KBV and RBV views, and outlined similar structures of defining goals and objectives in forming physical site location decisions for supply chain entities. The acknowledgement of current perspectives and practices in industry, compliment quantitative data analysis, and lead to an evaluation of corporate culture and an understanding of drivers within the supply chain management decision process.

New areas of knowledge are discussed in section 5.9.3, and describe the two broad areas identified by this study, as being the statistical hierarchical analysis of decision making processes within supply chain management physical location placement, and the culture surrounding decision making which exists in industry. As such, section 5.9.4 notes several potential implications of the data, including the establishment of competitive advantage through internal decision protocol development, and alignment with overall firm strategy in defining a long term strategy. Further implications of results may impact external stakeholders (e.g. land owners, logistics companies, transportation companies), in expanding knowledge of decision making criteria for medium to large businesses with regards to supply chain facility placement.

As noted in section 1.2, Gunasekaran, Patel & McGaughey (2004) suggested that supply chain management constitutes a major component of competitive strategies which enhance organizational productivity and profitability. In meeting the research objectives outlined in section 1.5, the findings from this study demonstrate a platform for establishing competitive advantages in industry, while enabling the advancement of knowledge and research within the concept of supply chain management.

6.0 CHAPTER SIX : CONCLUSIONS, KEY CONTRIBUTIONS AND FURTHER RESEARCH

6.1 Introduction

As noted in section 1.5, the primary objective of this study was to evaluate the economic impact of geographical location factors for physical supply chain entities, in assessing decision making processes for how a company may reduce cost and maximize bottom line profit. In fulfilling this over-arching objective, a number of specific objectives were defined in section 1.5.2, which required analysis of economic impact through land purchasing processes, transportation considerations, and tax considerations. By way of defining the goals of the study, a subset of research questions were defined in section 1.6 which led to the outlining of a hypothesis to be investigated through the data within the study.

In evaluating the conclusions and benefits of the study, data presented in section 4.2 to 4.17, as well as analysis of findings presented in section 5.2 to 5.7 must be evaluated against the defined objectives noted in section 1.5, the research questions noted in section 1.6, and the hypothesis noted in section 1.7. The findings must also be defended from the perspective of significance, and must meet the value proposition noted in section 1.8, and must reflect an assessment of specific factors impacting land value in connection with supply chain processes in terms of economic impact.

Within this chapter, a review of the relationship between the results and pre-established hypothesis and problem definition was evaluated. Research contributions of this dissertation, and an overview of theoretical implications and limitations of the study was addressed, with a

focus on the impact to industry and academia. Based on derived conclusions, discussion on future potential research and discussions on complimentary areas of analysis are also presented.

6.2 Confirmation of Hypotheses

The following list demonstrates the main contributions of this study in line with the original hypothesis. In order to confirm the hypothesis, structural equation modeling was conducted, and obtained results indicate that all proposed hypothesis are confirmed.

6.2.1 Hypothesis 1 (H1): Factors which influence physical location decisions for supply chain facilities have differing economic impact on the overall chain and firm.

The analysis of data presented in section 5.5 and 5.6 implies that there was a statistically significant and positive relationship between the factors of physical location decisions, on the factor of economic impact. As other factors do not show a statistically significant impact, it can be concluded that factors which influence physical location decisions for supply chain facilities have a differing economic impact on the overall chain and firm. The first hypothesis can therefore be confirmed.

6.2.2 Hypothesis 2 (H2): As a factor of production, land has a different economic value in various geographical locations and markets, which heavily impact physical location decisions for supply chain facilities.

The analysis of data presented in section 5.5 and 5.6 implies that all factors of land value determination have a statistically significant and positive impact on factors of physical location decisions. As such, the second hypothesis is confirmed.

6.2.3 Hypothesis 3 (H3): Transportation systems, in terms of transport networks and modes (including traffic flow) has economic impact on accessibility of land in various locations, and therefore an impact on land value, ultimately influencing physical location decisions.

The analysis of the data shown in section 5.5 and 5.6 implies that transportation decisions which affect land value determination have a statistically significant and positive impact on transportation and accessibility decisions, affecting physical location decisions. As such, the third hypothesis is confirmed.

6.2.4 Hypothesis 4 (H4): Jurisdictions in various locations have different regulatory and tax structures which have varying levels of economic impact on land value, ultimately influencing physical location decisions for supply chain facilities.

The results of the analysis presented in section 5.6 indicate that tax and incentive structures which affect land value determination, have a direct positive impact on tax structure and land location related decisions affecting physical location decisions. As such, the fourth hypothesis is confirmed.

6.3 Conclusions and Key Contributions

Four research questions are identified in section 1.6, which build off the defined research objectives in section 1.5, and provide a framework for primary data retrieval design:

1. What are the geographical location factors for manufacturing assemblies, distribution centers, and inventory storage facilities in assessing the economic impact within the wider supply chain management of a firm?

2. What is the longstanding economic impact and land usage value, in decisions related to placement of a supply chain facility?
3. What is the economic impact, with respect to probability of evolving risk of change, of transportation decisions on a supply chain facility?
4. What is the economic impact, with respect to probability and risk of change, of tax structures on supply chain facilities?

In evaluating and assessing the data presented in section 4.2 to 4.17, with the intention of forming conclusions, the degree of correlation and strength of each factor in conjunction with the research questions presented in section 1.6 must be considered. Per the discussion of findings presented in section 5.9, and by way of both quantitative and qualitative analysis of retrieved data, conclusions can be drawn and analyzed.

6.3.1 Conclusions and Key Contributions From Quantitative Analysis

As proposed in section 5.9.3, new areas of knowledge are presented as a result of the establishment of a hierarchy between decision making processes, and therefore the understanding of relationships between variables.

Statistically, in an effort to understand which components have the strongest impact on respondents' perceptions, value determination, and location decision triggers for supply chain entities, the calculation of the mean of scores for every factor calculated can be evaluated. In doing so, the degree of impact for each variable can be measured, and the foundation for establishing a hierarchy can be set. By expanding on research areas which are new as presented in section 5.9.3, a number of assumptions, conclusions and new knowledge are drawn from this approach.

As presented in section 5.9.1, Chang & Lin (2015) state that most global manufacturing firms move their plant locations to certain areas to maximize on lower cost and tax, which appears to dovetail with the findings from the data. Within the over-arching scope of economic impact to the firm and overall supply chain, data presented in table 28 showed land value as having the most substantial impact to the company and efficiency of the supply chain, in comparison to tax structure. This conclusion, leads to the need to define how land value is determined, and how physical location decisions are made within a supply chain.

Within the context of land value determination, the most impactful variables appears to be within the area of land location decisions, followed by transportation decisions, and finally tax and

incentive structures. Further, within the context of physical location decisions, land location related decisions are also seen as being the most impactful consideration. A key implication of these findings, is the suggestion that proximity to affiliates within the context of land location has the highest mean value of all variables. Further to section 5.9.1, these results appear to confirm research by Bhatnagar & Sohal (2005) who note that decisions of a specific location for a manufacturing plant is influenced qualitative factors including proximity to markets, proximity to suppliers, key competitors' location, supply chain uncertainty and broad manufacturing practices. It can be therefore be concluded that the proximity of affiliates (e.g. potential partners, strategic alliances, competing businesses) to the physical placement of a supply chain entity has the strongest impact on the firms determination of land value.

According to table 28, within the perspective of land location related factors, the layout and dimension of the land site is the most important area of consideration, and has the strongest impact on physical location decisions for supply chain entities. As noted in section 5.9.1, this appears to confirm data presented by Coughlin & Segev (2000), who argue that the choice of manufacturing site for foreign owned plants is determined by factors such as the economic size of the location, educational attainment, the existing manufacturing base, transportation infrastructure, levels of taxes and labor-intensiveness. The second most impactful variable on physical location decisions falls within the category of tax structure, and is attributed to the overall tax cost of the site. This result further substantiates research proposed by Chang & Lin (2015), as outlined in section 5.9.1.

In addition to proximity to affiliates, the second most impactful variable when determining land

value, is the availability of parking areas for trucks and falls within the context of transportation decisions, followed by the potential for tax reduction. As availability to favorable labor is not noted as being one of the most impactful land location variables, and as presented in section 5.9.2, results further dispute previous research presented by Malos (2009), who argues that offshore manufacturing locations are picked due to the cheap labor, quality and available worker skills and the administrative and regulatory contexts of labor markets.

In evaluating the results from the quantitative data analysis, several observations can be made, and assumptions drawn. As all factors of land value determination have a statistically significant positive impact on factors of physical location decisions, there appears to be a correlation between processes. This relationship can be explained by assuming that a similar decision making process is conducted for both types of decisions. A possible further assumption might be that respondents believe land value and physical location decisions are inherently connected, and therefore both have similar evaluation requirements.

Tax and incentive structures within the perspective of land value determination and physical placement decisions, have a statistically significant positive impact on the interpretation of the economic impact on the supply chain and firm overall. As such, it can be assumed that the stronger the interpretation of the impact of tax structures in forming a decision, the stronger the opinion of the economic impact of a physical supply chain entity on the overall firm. Furthermore, it can be assumed that if a tax structure has strong impact on land value determination, it will have a strong impact on physical location decision as well, and therefore it can be concluded that jurisdictions which have attractive tax structures, ultimately influence

physical location decisions for supply chain facilities. As noted in section 5.9.1, these findings appear to support data presented by Coughlin & Segev (2000) and Chang & Lin (2015).

Further analysis in understanding the hierarchy of decision making, allows for an investigation into the relationships which exist between categories of variables. Data presented in table 34 showed implications of the data against pre-defined hypothesis discussed in section 1.7, and implies that as a result of establishing standardized regression weights under the context of structural equation modeling, relationships between categories can be investigated, thereby leading to an understanding of correlation between decision making processes.

Within this vein and as presented in table 34, the data suggested that there is no statistically significant relationship which exists in which economic impact to the firm and overall supply chain is affected by land location decisions affecting land value determination, nor land location related decisions affecting physical location decisions.

The strongest relationship exists between the perception of tax structure, with a positive correlation existing between tax structure affecting physical location decisions and tax structure affecting land value decisions. This result could be as a result of physical location decisions overlapping with land value decisions. Similarly, the weakest statistically significant relationship exists between transportation decisions which affect land value determination, and transportation and accessibility decisions which affect physical location decisions. This may be due to interpretation of transportation as a concept impacting two different but related decisions (land value and physical location).

Sequentially, economic impact and tax structure affecting land value determination hold a strong positive correlation, suggesting a relationship between valuation of land by way of taxation, and overall economic impact to the firm and supply chain. Remaining relationships are of relatively equal strength and show land value determination in terms of land location, tax structure and transportation decisions having a positive correlation with transportation and accessibility decisions affecting physical location decisions and overall land location.

6.3.2 Conclusions and Key Contributions From Qualitative Analysis

In addition to establishing a hierarchy of decision making processing, data is presented by way of developing insight into corporate culture. As noted in section 5.9.3, new knowledge is presented by providing perspective on decision making and information usage surrounding land value, as well as the underlying triggers in forming physical placement decisions of supply chain entities.

In comparison to the survey approach, the one on one interviews allowed for follow-up and probing questions within a two-way conversation. A full transcript of the dialogue within each interview is presented in section 4.8 to 4.17. In evaluating the qualitative data with the intention of drawing conclusions, similar results from the qualitative data must be calculated to form assumptions on respondents perspectives and intentions. The results can then be correlated to the quantitative data in establishing applicable contributions and forming useful conclusions.

A number of observations can be formed in evaluating the qualitative results. The majority of

responses received were complimentary, and overlapping in terms of perspective. Few questions received contradictory or unanimous responses. Since the respondents all held the rank of Supply Chain Manager or higher, and each worked within FMCG firms which had revenues of \$50MM or higher, it can be assumed that the majority of respondents largely follow a similar decision making approach, which may be influenced by individual factors (e.g. culture of the company, practices within the firm, individual tendencies, prior management experience).

In evaluating the data, the most unanimous decisions were surrounding knowledge and resource based views within firms. As noted by Lado, Boyd, Wright, and Kroll (2006), and as discussed in section 2.7.4, the selection of the RBV perspective presents explores areas of commerce strategy, transactional cost, strategic alliance, resource conservation and risk sharing, with the theory considered to be more relevant in answering the research problem owing to its ability to identify underlying resource needs which drive organizations into forming strategic alliances, and establishing competitive advantages. Within section 2.9 the literary approach taken within this study in addressing the research questions is presented, with the RBV perspective being noted as advantageous in exploring the culture of commerce interaction, and in analyzing the relationship between supply chain automation and land development.

In contrast, within the context of view selection respondents unanimously feel that there has never been a change in one view superseding the other, and that there will never be a reason for one view to be applied more than the other. Respondents noted that knowledge and resource based views are equally important in making a physical supply chain location decision.

Furthermore, all respondents strongly felt that in isolation a resource based view or a knowledge

based view would be insufficient in forming a physical supply chain location decision.

In evaluating the potential for culture changes (aside from policy changes), respondents unanimously noted that the corporate culture when evaluating physical location decisions has remained the same, during their tenure at the firm. None of the respondents observed any foreseen advantage in changing the proportion of the firms culture from RBV to KBV or vice versa, however one respondent did note a progression in corporate culture which maintained the same ratio. Within the perspective of corporate culture, respondents were divided when asked how transportation, land value and tax structure influence physical location decisions assuming decision makers may have different opinions, interpretations and knowledge on resource tangibility and importance. Approximately half the respondents suggested that a corporate structure and culture influenced the progression of this decision, while the other half noted that to reduce conflict, the use of a document, which is agreed upon by a selection committee was most beneficial.

The responses indicate that within industry, both the knowledge of decision makers and tangible or intangible resources at the firm are equally important. In probing further, respondents noted that it is important for decision makers to understand what the firm is looking for, while also being able to evaluate the overall value presented in making a decision. These opinions could suggest the preference of management structures to rely on all available resources (both resource and knowledge), in determining land value and making physical site decisions. Furthermore, this may suggest that within the parameters of the respondents demographics, the need to evaluate supply chain entities is from both a qualitative and quantitative perspective; with experience and

knowledge (as well as external measurement factors) each holding the same level of importance.

The remaining questions received responses which often overlapped one another. When asked about the process for making physical supply chain location decisions, most respondents noted that records of each transaction are maintained, however the types of data used in decision making processes varied. Approximately half the respondents noted that budget and financial data is maintained, while the other half of respondents noted that a combination of site and scenario data is maintained. As such it can be assumed that the knowledge gained from each transaction is acknowledged, and that records are often maintained in order to re-apply strategies, decision making processes, and prior learning.

In line with this area of questioning, respondents were divided when asked to indicate how transportation factors and overall land value analysis influence physical location decisions. Approximately half the respondents indicated that budget consideration is key in making these types of decisions, while the other half indicated that growth rate of the business will impact the decision.

As noted in section 5.9.3, analysis of qualitative data present new knowledge in describing perceptions of decision makers when making supply chain location decisions, with relation to theoretical framework.

6.4 Applicability of Findings

The nature of the data, suggested that there are similar patterns held with respect to decision making processes, and a hierarchy of values placed on specific areas, when evaluating the placement of physical supply chain entities. As such, contributions from both qualitative and quantitative areas may be applicable to firms within the FMCG space irrespective of size.

As noted in section 5.9.4, conclusions drawn from analysis of both quantitative and qualitative data may potentially be applied to both industry and concept progression. As noted in section 1.3, Lu (2011) suggested that firms which are able to strategically locate their manufacturing assemblies, distribution centers, and inventory stores in strategic geographical locations, have a competitive advantage in the market the market. In acknowledging the value of optimizing the supply chain, an over-arching understanding of supply chain decision making protocol yields a platform for competitive advantage and overall industry progression.

One of the more prominent conclusions drawn from both qualitative and quantitative analysis was the nature of decision making, and the importance placed on components of available information. This conclusion leads to the assumption of the findings of this study being applicable across a number of perspectives and commerce divisions.

As proposed in section 5.9.4, acknowledging the natural tendencies in decision making surrounding physical supply chain entities may allow firms to gain insight on how decision makers process and interpret information. Subsequent insight into the hierarchy of decision making processes, as well as relationships which may subconsciously exist, and could potentially

influence strategic planning by way of ensuring larger corporate goals align with supply chain placement planning. As such, potential unintended conflicts of interest arising from managers with supply chain decision experience, influencing areas of corporate growth could be identified. From a more granular perspective, human resource protocol may be influenced in terms of hiring processes, managerial training, team development etc.

Within the perspective of corporate growth, the results of this study provide a platform which would allow firms to identify supply chain placement decision making drivers. While this information is useful within internal settings, the understanding of over-arching decision making tendencies could allow firms to gauge and project competitor supply chain development, thus establishing a competitive advantage. On a larger scale, the acknowledgement of decision making criteria could allow for progression throughout the concept of supply chain management in industry. The establishment of physical entity 'rules' or 'guidelines' could enable transparency in terms of physical entity placement, and therefore present industry standards in terms of supply chain development and growth, thus leading to more granular areas of supply chain competition.

Stakeholders affiliated but not related to a firms supply chain may also benefit from the findings of this study, by being able to project future potential demand, thereby gaining a competitive advantage. Similarly, services supporting supply chain operations such as logistics companies, truck maintenance services, third party storage facilities, fuel stations etc. could potentially align growth strategies and benefit from a high level understanding of physical supply chain entity decisions by medium to large corporations.

Other stakeholders which may benefit from this study could include land owners and potential sellers or renters of land for supply chain entity placement. The understanding of variables which are important to FMCG decision makers when evaluating land sites is key for appropriate pricing decisions, and could lead to a more competitive marketplace based on a checklist of features and associated values, a site may have. This could in turn lead to neighboring land sites attracting investment from commercial entities which would be supportive of a supply chain entity.

Devereux and Griffith (1998) use evidence from a panel of US multinationals to underscore the importance of profit taxes and agglomeration effects to the location decisions by multinational companies. A further implication of this study, may be the establishment of municipality guidelines with regards to tax structures, and resource allocation. By way of understanding the needs of large to medium businesses with regards to land usage, initiatives regarding road creation, accessibility, zoning modification, tax structures and government incentives, may be a consideration for incentivizing physical placement decisions, and attracting investment from particular firms.

6.5 Limitations of The Study

While the study was largely successful in meeting research objectives, and addressing the problem statement identified in section 1.3, a number of research limitations were observed.

As the study used FMCG decision makers as a platform for primary research retrieval, conclusions drawn may only be applicable to industries deemed to fall under the category of fast moving consumer goods. While this approach allows for a more narrow focus, the study does not take into account the potential bias which may exist with respondents who hold experience in other industries in which decision making practices are different. Similarly, no consideration was given within the analysis of data in acknowledging how long employees have served in a decision making capacity.

Further limitations can be observed from the pool of respondents selected. Respondents were not targeted with respect to the size of company they worked for, nor a specific sub-category (e.g. pet-care, oral care etc.). Potential differences in decision making processes between sub-categories within the FMCG umbrella were not considered. Further, all of respondents are based in North America (Canada and US), which may result in potential conflict when applying results to geographic regions in which corporate culture may differ. Within the data collection, a number of respondents noted that committees were formed to evaluate physical placement decisions. The collection process did not specifically target committee members, nor did it probe as to whether respondents held experience in evaluating land value in other settings/ areas/ industries, and as such the potential for bias may exist. Further, respondents were asked to identify a specific subset of decision criteria, without considering the potential for external

influences including natural geographic risk (e.g. earthquakes, hurricanes etc.), political instability (e.g. political unrest etc.), economic risk (e.g. currency fluctuations, wage controls etc.).

Within the process of data collection, there is the possibility of a number of areas being vulnerable to misunderstanding. The study approaches data collection from an academic standpoint, and presents questions related to resource based views and knowledge based views. Respondents largely focused on industry practices may not be familiar with these views, nor have exposure to the definition of these areas, and therefore a potential for misunderstanding exists. Further, in an effort to draw unbiased data, respondents were asked questions from a data gathering perspective, which did not provide any direction or scope. Adding perspectives and asking questions focused on specific goals of a supply chain (e.g. agility and cost effectiveness) may have introduced different responses, albeit with perceived bias.

Fatigue of respondents in answering the quantitative survey, could have potentially resulted in a poorer quality of answers, which could subsequently result in inaccuracies with data analysis. A shorter and more poignant survey may have resulted in more meaningful responses.

Within the context of interview questions, the use of standardized questions, particularly for economic impact on firm, may have allowed for more reliability of data. From the perspective of data analysis, drawing relationship assumptions was difficult without the aid of a measurement table. This led to assumptions based on interpretation of answers, as opposed to numerical

standardized responses.

6.6 Suggestions For Further Research

Over the course of retrieving and analyzing data for this study, a number of other research areas emerged as potential opportunities for future investigation. Limitations noted in section 6.5 as well as observations made throughout the data retrieval process, have enabled the identification of further potential areas to create new knowledge.

As noted in section 6.5, in evaluating supply chain placement decision processes within this study, only FMCG decision makers were polled. Opportunity exists in evaluating the same research as this study proposes, and comparing results across multiple industries. Within this vein, the establishment of decision making approaches across multiple industries might be achievable, which would then lead to a comparison table of how each industry makes supply chain placement decisions. A further area of opportunity may exist in evaluating decision makers from different geographic regions, in confirming the findings of this study are globally applicable.

By design, this study focused on retrieving data from multiple respondents from multiple firms, within the fast moving consumer goods industry. Opportunity exists in focusing the research approach, and targeting specific entities to understand how the decision making process might differ (e.g. gaining insight on how the decision making process functions with decision makers of Manufacturers only). A focus on this area, would allow for the understanding of how decision

makers within each function of a supply chain operate and the differences which may exist in corporate culture.

6.7 Conclusions

A number of conclusions were proposed as a result of the analysis of data presented in section 5.2 to 5.7. In evaluating the overall value of the data and in measuring the relativity of conclusions to the original goals of the study, findings from the study were compared against predefined research objectives outlined in section 1.5. The hypothesis proposed in section 1.7 was evaluated against statistical conclusions drawn, while research questions noted in section 1.6 were satisfied through data analysis and expansion.

Based on the identification of new research areas as presented in section 5.9.3, the hierarchy of the decision making process when making supply chain facility decisions was discussed, as was an evaluation of the relationships which exist between various categories of variables. In describing existing relationships, conclusions are drawn with respect to how decision makers evaluate land value, tax structures, make physical location decisions and acknowledge overall economic impact.

Further to the acknowledgement of findings meeting the pre-defined study objectives, results were assessed from the perspective of applicability to industry. A number of applications were discussed, including the potential for firms to establish competitive advantage by ensuring larger corporate goals acknowledge supply chain location decisions. Within this vein, the definition of decision making processes within managerial training, recruitment, team development etc. was

identified as a method of managing and identifying corporate culture related to decision making.

In addition to applicability, limitations of the study were explored along with discussion on areas in which the study may present ambiguous results. Based on conclusions drawn and noted limitations, suggestions for further research expanded on potential areas which could compliment the findings of this study.

7.0 REFERENCES

- Alañón-Pardo, Á. & Arauzo-Carod, J. (2013). Agglomeration, Accessibility and Industrial Location: Evidence from Spain. *Entrepreneurship & Regional Development*. Volume 25, Issue 3-4, pp. 135-173.
- Alavi, M. & Leidner, D. E. (2001). Knowledge Management Systems: Emerging views and practices from the field. Conference Publication: 32nd Hawaii International Conference on System Sciences, Maui, HI, USA, 5-8 Jan. 1999, IEEE.
- Alcácer, J. & Chung, W. (2007). Location strategy and knowledge spillovers. *Management Science*. Volume 53, Issue 5, pp. 760-776.
- Alter, C. & Hage, J. (1993). *Organizations Working Together*. Newbury Park, CA: Sage Publishing.
- Amit, R. & Schoemaker P. (1993). Strategic assets and organizational rent. *Strategic Management Journal*, Vol. 14, Issue 1, pp. 33-46.
- Anderson, D. L., Britt, F.E. & Favre, D.J. (1997). The Seven Principles of Supply Chain Management. *Supply Chain Management*. *Supply Chain Management Review*. Summer, pp. 19-26.
- Arlbjorn, J. S. (2011). Logistics and Supply Chain Management in a Globalized Economy. *International Journal of Physical Distribution & Logistics Management*. Volume 41, Issue 4, pp. 340-342.
- Aronowitz, S. & Ausch, R. (2000). A Critique of Methodological Reason. *The Sociological Quarterly*. Volume 41, Issue 4, pp. 699-719.
- Bain, J. S. (1968). *Industrial Organization*. New York, NY: John Wiley Publishing.
- Balakrishnan, J. & Cheng, C. H. (2005). The Theory of Constraints and the Make or Buy Decision. *The Journal of Supply Chain Management*. Volume 41, Issue 1, pp. 40-47.
- Barney, J. (1991). Firm Resources and Sustained Competitive Advantages. *Journal of Management*. Vol 17, Issue 1, pp. 99-120.
- Barney, J. & Hansen, M. H. (1994). Trustworthiness as a Source of Competitive Advantage. *Strategic Management Journal*. Volume 15, pp. 175–190.
- Barney, J. (2001). Is the resource-based “view” a useful perspective for strategic management research? Yes. *Academy of Management Review*. Volume 26, Issue 1, pp. 41-56.

Bartholomew, D. J., Steele, F., Galbraith, J. & Moustaki, I. (2008). *Analysis of Multivariate Social Science Data*. Boca Raton, FL: CRC Press.

Bartlett, M. S. (1954). A note on multiplying factors for various chi-squared approximations. *Journal of the Royal Statistical Society*. Volume 16, Issue 2, pp. 296-298.

Baumgartner, H. & Pieter, R. (2003). The Structural Influence of Marketing Journals: A Citation Analysis of the Discipline and its Sub Areas Over Time. *Journal of Marketing*. Volume 67, Issue 2, pp. 123-139.

Becht, J. E. (1970). *A Geography of Transportation and Business Logistics*. Dubuque, IA: William C. Brown Co.

Belderbos, R. & Somers, D. (2015). Do technology leaders deter inward R&D investments? Evidence from regional R&D location decisions in Europe. *Regional Studies*. Volume 49, Issue 11, pp. 1805-1821.

Bell, J. & Opie, C. (2002). *Learning from Research: Getting More from Your Data*. Buckingham: Open University Press.

Berry, D., Towill, D. R. & Wadsley, N. (1994). Supply Chain Management in the Electronics Products Industry. *International Journal of Physical Distribution and Logistics Management*. Volume 24, Issue 10, pp. 20-32.

Bhatnagar, R. & Sohal, A. (2005). Supply Chain Competitiveness: Measuring the Impact of Location Factors, Uncertainty and Manufacturing Practices. *Technovation*. Volume 25, Issue 5, pp. 443-456.

Blackhurst J., Craighead, C. W., Elkins, D. & Handfield, R. B. (2005). An Empirical Derived Agenda of Critical Research Issues for Managing Supply Chain Disruptions. *International Journal of Production Research*. Volume 43, Issue 19, pp. 4067-4081.

Bogdan, R.C. & Biklen, S.K. (1982). *Qualitative Research for Education*. Allyn & Bacon, Boston: Allyn & Bacon Publishing.

Boisot, M. (1998). *Knowledge Assets: Securing Competitive Advantage in the Information Economy*. New York, NY: Oxford University Press.

Bommer, M., O'Neil, B. & Treat, S. (2001). Strategic Assessment of the Supply Chain Interface: A Beverage Industry Case Study. *International Journal of Physical Distribution and Logistics Management*. Volume 31, Issue 1, pp.11-25.

Bourlakis, M. A. & Weightman, P. W. (2008). *Food Supply Chain Management*. New York, NY: Blackwell Publishing.

- Bromiley, P. & Papenhausen, C. (2003). Assumptions of Rationality and Equilibrium in Strategy Research: The Limits of Traditional Economic Analysis. *Strategic Organization*. Volume 1, Issue 4, pp. 413-437.
- Bryman, B. & Bell, E. (2011). *Business Research Methods*. New York, NY: Oxford University Press.
- Burgess K., Singh, O. J. & Koroglu, R. (2006). Supply Chain Management: A Structured Literature Review and Implications for Future Research. *International Journal of Operations and Production Management*. Volume 26, Issue 7, pp. 703-729.
- Buss, T. F. (2001). The Effect of State Tax Incentives on Economic Growth and Firm Location Decisions: An Overview of the Literature. *Journal of Planning Literature*. Volume 15, Issue 1, pp. 90-105.
- Carter, C. R. & Ellram, L. M. (2003). Thirty-Five Years of The Journal of Supply Chain Management: Where Have We Been and Where Are We Going? *The Journal of Supply Chain Management*. Volume 39, Issue 2, pp. 27-40.
- Castanias, R. P. & Helfat, C. E. (1991). Managerial Resources and Rents. *Journal of Management*. Volume 17 Issue 1, pp. 155-171.
- Cattell, R. B. (1966). The scree test for the number of factors. *Multivariate Behavioral Research*. Volume 1, Issue 2, pp. 245-276.
- Cavinato, J. L. (1992). A Total Cost/Value Model for Supply Chain Competitiveness. *Journal of Business Logistics*. Volume 13, Issue 2, pp. 285-301.
- Chai, K.-H., Yap, C. M. & Pellerin, M. (2009). Manufacturing Capability Networks: A Case Study on Production Allocation Decision in the Pharmaceutical Industry. *Proceedings of the Institution of Mechanical Engineers. Part B: Journal of Engineering Manufacture*. Volume 223, Issue 7, pp. 885-903.
- Chang, P. & Lin, H. (2015). Manufacturing Plant Location Selection in Logistics Network Using Analytic Hierarchy Process. *Journal of Industrial Engineering and Management*. Volume 8, Issue 5, pp. 1547-1575.
- Chesbrough, H. (2003). *Open Innovation: The New Imperative For Creating And Profiting From Technology*. Cambridge, MA: Harvard Business School Press.
- Cheshire, P.C. & Sheppard, S. (1995). On the Price of Land and the Value of Amenities. *Economica*. Volume 62, Issue 246, pp. 247-267.
- Chopra, S. & Meindl, P. (2002). *Supply Chain Management: Strategy, Planning, and Operations*. Hoboken, NJ: Prentice Hall.

Christopher, M. (1998). *Logistics and Supply Chain Management: Strategies for Reducing Costs and Improving Services*. London: Pitman Publishing.

Collier, D. A. & Evans, J. R. (2011). *Operations Management*. Boston, MA: Cengage Learning.

Collis, D. (1994). How Valuable are Organisational Capabilities? *Strategic Management Journal*. Volume 15, Issue S1, pp. 143-152.

Conner, K. R. (1991). A Historical Comparison of Resource-Based Theory and Five Schools of Thought Within Industrial Organization Economics: Do We Have a New Theory of the Firm? *Journal of Management*. Volume 17, Issue 1, pp. 121-153.

Conner, K. R. & Prahalad, C. K. (1996). A resource-based theory of the firm: Knowledge versus opportunism. *Organization Science*. Volume 7, Issue 5, pp. 477-501.

Connor, T. (2002). The Resource-Based View of Strategy and Its Value to Practising Managers. *Strategic Change*. Volume 11, Issue 6, pp. 307-316.

Cooper M.C. & Ellram L.M. (1993). Characteristics of Supply Chain Management and the Implications for Purchasing and Logistics Strategy. *International Journal of Logistics Management*. Volume 4, Issue 2, pp. 13-24.

Coughlin, C. C. & Segev, E. (2000). Location Determinants of New Foreign-Owned Manufacturing Plants. *Journal of Regional Science*. Volume 40, Issue 2, pp. 323-351.

Cox, A. (2001). The Power Perspective in Procurement and Supply Chain Management. *Journal of Supply Chain Management*. Volume 37 Issue 1, pp. 4-7.

Crabbé, K. & De Bruyne, K. (2013). Taxes, Agglomeration Rents and Location Decisions of Firms. *De Economist*. Volume 161, Issue 4, pp. 421-446.

Creswell, J.W. (2007). *Qualitative inquiry and research design: Choosing among five approaches* (2nd ed.). Thousand Oaks, CA: Sage Publishing.

Creswell, J.W. (2009). *Research Design: Qualitative, Quantitative, and Mixed Methods Approaches*. Thousand Oaks, CA: Sage Publishing.

Current, J., Ratick, S. & ReVelle, C. (1998). Dynamic Facility Location When the Total Number of Facilities is Uncertain: A Decision Analysis Approach. *European Journal of Operational Research*. Volume 110, Issue 3, pp. 597-609.

Daskin, M.S., Snyder, L.V. & Berger, R.T. (2003). *Facility Location in Supply Chain Design*. Working Paper No. 03-010. Northwestern University, IL.

- Davenport, T. H. & Prusak, L. (1998). *Working Knowledge: How Organizations Manage What They Know*. Cambridge, MA: Harvard Business School Press.
- Daya, M., Hariga, M. & Khursheed, S.N. (2008). Economic Production Quantity Model with a Shifting Production Rate. *International Transactions in Operational Research*. Volume 15, Issue 1, pp. 87-101.
- Debela, T. (2009). Business Process Re-Engineering in Ethiopian Public Organizations: The Relationship Between Theory and Practice. *Journal of Business and Administrative Studies*. Volume 1, Issue 2, pp. 20-59.
- Demsetz, H. (1982). Barriers to Entry. *American Economic Review*. Volume 72, Issue 1, pp. 47-57.
- DeVellis, R. F. (2003). *Scale development: Theory and applications*, Second Edition. Thousand Oaks, CA: Sage.
- Devereux, M. & Griffith, R. (1998). Taxes and the Location of Production: Evidence From a Panel of US Multinationals. *Journal of Public Economics*. Volume 68, Issue 3, pp 335-367.
- Dillman, D. A., Smyth, J. D. & Christian, L. M. (2009). *Mail and Internet Surveys: The Tailored Design Method*, Third edition. New York, NY: John Wiley and Sons.
- Doeringer, P., Evans-Klock, C. & Terkla, D. (2005). Management Cultures and Regional Development: High Performance Management and the Location of New Manufacturing Plants. *European Planning Studies*. Volume 13, Issue 6, pp. 815-830.
- Dyer J. & Singh H. (1998). Cooperative Strategy and Sources of Interorganizational Competitive Advantage. *Academy of Management Review*. Volume 23, Issue 4, pp. 660-679.
- Dyer J. (1996). Specialized Supplier Networks as a Source of Competitive Advantage. *Strategic Management Journal*. Volume 17, Issue 4, pp. 271-291.
- Easterby-Smith, M., Thorpe, R. & Jackson, P. (2008). *Management Research*. Thousand Oaks, CA: Sage.
- Erlebacher, S.J. & Meller, R.D. (2000). The Interaction of Location and Inventory in Designing Distribution Systems. *IIE Transactions*. Volume 32, Issue 2, pp. 155-166.
- Fahy, J. & Smithee, A. (1999). Strategic Marketing and the Resource Based View of the Firm. *Academy of Marketing Science Review*. Volume 1999, Issue 10, pp. 1-21.
- Foss, N. (1996). More Critical Comments on Knowledge-Based Theories of the Firm. *Organization Science*. Volume 7, Issue 5, pp. 519-523.

- Fulk, J. & DeSanctis, G. (1995). Electronic Communication for Changing Organisational Forms. *Organization Science*. Volume 6, Issue 4, pp. 337-349.
- Geoffrion, A.M. & Powers, R.F. (1980). Facility Location Analysis is Just the Beginning (If you do it right). *Interfaces*. Volume 10, Issue 2, pp. 22-30.
- Grant, R. M. (1991). *Contemporary Strategy Analysis: Concepts. Techniques Applications*. Cambridge, MA. Basil Blackwell Publishing.
- Grant, R. M. (1996). Toward a Knowledge-Based Theory of the Firm. *Strategic Management Journal*. Volume 17, Issue SPEISS, pp. 109-122.
- Griffis, S. E., Goldsby, T. J. & Cooper, M. (2003). Web Based and Mail Servers: A Comparison of Response Data and Cost. *Journal of Business Logistics*. Volume 24, Issue 2, pp. 237-258.
- Guinipero, L., Hooker, R., Joseph-Matthews, S., Yoon, T. & Brudvig, S. (2008). A Decade of SCM Literature: Past, Present and Future Implications. *Journals of Supply Chain Management*. Volume 44, Issue 4, pp. 66-86.
- Gulati, R., Nohria, N. & Zaheer, A., (2000). Special Issue: Strategic Networks. *Strategic Management Journal*. Volume 21, Issue 3, pp. 191-201.
- Gunasekaran, A. & Ngai, E.W.T. (2005). Build-to-Order Supply Chain Management: Literature Review and Framework for Development. *Journal of Operations Management*. Volume 23, Issue 5, pp. 423-451.
- Gunasekaran, A., Patel, C. & McGaughey, R.E. (2004). A Framework for Supply Chain Performance Measurement. *International Journal of Production Economics*. Volume 87, Issue 3, pp. 333-347.
- Guttman, L.A. (1954). *A New Approach to Factor Analysis*. *Mathematical Thinking in Social Sciences*. New York, NY: Columbia University Press.
- Hair, J. F., Jr., Hult, G. T. M., Ringle, C. M., & Sarstedt, M. (2014). *A Primer on Partial Least Squares Structural Equation Modeling (PLS-SEM)*. Thousand Oaks, CA. Sage.
- Hair, J., Black, W., Babin, B. J. & Anderson, R. E. (2010). *Multivariate Data Analysis (7th ed.)*. Newark, NJ: Prentice Hall.
- Hamedani, S. G., Jabalameli, M. S. & Bozorgi-Amiri, A. (2013). A Multi-Objective Model for Locating Distribution Centers in a Supply Chain Network Considering Risk and Inventory Decisions. *Management Science Letters*. Volume 3, Issue 4, pp. 1077-1088.

- Hammer, M. (2001). *The Agenda: What Every Business Must Do to Dominate the Decade*. New York, NY: Three Rivers Press.
- Handfield, R. & Nichols, E. (1999). *Introduction to Supply Chain Management*. Newark, NJ: Prentice Hall.
- Handfield, R.B. & McInyk, S.A. (1998). The Scientific Theory-Building Process: A Primer Using the Case of TQM. *Journal of Operations Management*. Volume 16, Issue 4, pp. 321-339.
- He, C., Huang, Z. & Wang, W. (2012). *Land Use Changes and Economic Growth in China, Land Lines*, Lincoln Institute of Land Policy. Retrieved from <http://www.lincolninst.edu/publications/articles/land-use-changes-economic-growth-china?pubid=2147&URL=Land-Use-Changes-and-Economic-Growth-in-China&Page=5>.
- Heinrichs, J. H. & Lim, J. S. (2003). Integrating web-based data mining tools with business models for knowledge management. *Decision Support Systems*. Volume 35, Issue 1, pp. 103-112.
- Helfat, C. & Lieberman, M. (2002). The birth of capabilities: market entry and the importance of pre-history. *Oxford University Press*. Volume 11, Issue 4, pp. 725–760.
- Helfat, C. & Peteraf, M. (2003). *The dynamic resource-based view: capability lifecycles*. Hoboken, NJ: John Wiley & Sons.
- Hines, P. & Rich, N. (1997). The Seven Value Stream Mapping Tools. *International Journal of Operations and Production Management*. Volume 16, Issue 1-2, pp. 46-64.
- Holl, A. (2004). Start-Ups and Relocations: Manufacturing Plant Location in Portugal. *Regional Science Association International*. Volume 83, Issue 4, pp. 649-668.
- Hoops, D.G. & Postrel, S. (1999). Shared knowledge, “Glitches”, and Product Development Performance. *Strategic Management Journal*. Volume 20, Issue 9, pp. 837-865.
- Hoskisson, R.E., Hitt, M.A., Wan, W.P. & Yiu, D. (1999). Theory and research in strategic management: swings of a pendulum. *Journal of Management*. Volume 25, Issue 3, pp. 417-456.
- Hoyle, R.H. (2000). Confirmatory Factor Analysis. In H.E.A. Tinsley & S.D. Brown (Ed.), *Applied Multivariate Statistics and Mathematical Modeling*. San Diego, CA: Academic Press.
- Hu, L. & Bentler, P.M. (1999). Cutoff Criteria for Fit Indices in Covariance Structure Analysis: Conventional Criteria Versus New Alternatives. *Structural Equation Modelling*. Volume 6, Issue 1, pp. 1-55.

- Huchzermeier, A. H. (1991). *Global Manufacturing Strategy Planning Under Exchange Rate Uncertainty*. Philadelphia, PA: University of Pennsylvania.
- Innes, D. & LaLonde, B. (1994). Customer Service: The Key to Customer Satisfaction, Customer Loyalty and Market Share. *Journal of Business Logistics*. Volume 15, Issue 1, pp 1-28.
- Jarillo, J. C. (1988). On strategic networks. *Strategic Management Journal*. Volume 9, Issue 1, pp. 31-41
- Johnson, B. & Christensen, L. (2003). *Educational Research: Quantitative, Qualitative, and Mixed Approaches*. Thousand Oaks, CA: Sage Publishing.
- Jornsten, K. & Bjorndal, M. (1994). Dynamic Location Under Uncertainty. *Studies in Regional and Urban Planning*. Volume 1, Issue 3, pp. 163-184.
- Kaiser, H.F. (1974). An index of factorial simplicity. *Psychometrika*. Volume 39, Issue 1, pp. 31-36.
- Katz, C. (2004). *Growing up Global: Economic Restructuring and Children's Everyday Lives*. St. Paul, MN: University of Minnesota Press.
- Kelley, C. M. & Lindsay, D. S. (1993). Remembering mistaken for knowing: Ease of retrieval as a basis for confidence in answers to general knowledge questions. *Journal of Memory and Language*. Volume 32, Issue 1, pp. 1-24.
- Kline, R. B. (2011). *Convergence of structural equation modeling and multilevel modeling*. Thousand Oaks, CA: Sage Publishing.
- Kline, R.B. (2005). *Principles and Practice of Structural Equation Modeling*. New York, NY: The Guilford Press.
- Knott, P. (2009). Integrating Resource-Based Theory in a Practice-Relevant Form. *Journal of Strategy and Management*. Volume 2, Issue 2, pp. 163-174.
- Kogut, B. (1988). Joint ventures: Theoretical and empirical perspectives. *Strategic Management Journal*. Volume 9, Issue 4, pp. 319-332.
- Kotzab, H., Teller, C., Grant, D. & Sparks, L. (2011). Antecedents for the Adoption and Execution of Supply Chain Management. *Supply Chain Management an International Journal*. Volume 16, Issue 4, pp. 231-245.
- Lado, A., Boyd, N.G., Wright, P. & Kroll, M. (2006). Paradox and Theorizing Within the Resource Based View. *Academy of Management Review*. Volume 31, Issue 1, pp. 115-131.

- Lambert, D., Cooper, M. & Pagh, J. (1998). Supply Chain Management: Implementation Issues and Research Opportunities. *The International Journal of Logistics Management*. Volume 9, Issue 2, pp. 1-19.
- Langley, C. J., Gibson, B. J., Novack, R. A. & Bardi, E. J. (2008). *Supply Chain Management: A Logistics Perspective*. Boston, MA: Cengage Learning.
- Lee, H.L. (1996). Effective Inventory and Service Management Through Product and Process Redesign. *Operations Research*. Volume 44, Issue 1, pp. 151-159.
- Lee, H. & Billington, C. (1992). Supply Chain Management: Pitfalls and Opportunities. *Sloan Management Review*. Volume 33, Issue 3, pp. 65-71.
- Lee, W.B. & Katzorke, M. (2010). *Leading Effective Supply Chain Transformations: A Guide to Sustainable World-Class Capability and Results*. Temple, AZ: Newcastle: J. Ross Publishing.
- Leiblein, M. J., & Miller, D. J. (2003). An empirical examination of transaction- and firm-level influences on the vertical boundaries of the firm. *Strategic Management Journal*. Volume 24, Issue 9, pp. 839-859.
- Lin, G.C.S. (2007). Reproducing Spaces of Chinese Urbanisation: New City-Based and Land-Centred Urban Transformation. *Urban Studies*. Volume 44, Issue 9, pp. 1827-1855.
- Leonard, D., & Sensiper, S. (1998). The role of tacit knowledge in group innovation. *California Management Review*. Volume 40, Issue 3, pp. 112-132.
- Lu, D. (2011). *Fundamentals of Supply Chain Management*. Copenhagen: Ventus Publishing APS.
- Makadok, R. (2001). Toward a synthesis of the resource-based and dynamic-capability views of rent creation. *Strategic Management Journal*. Volume 22, Issue 5, pp. 387-401.
- Malos, S. (2010). Regulatory Effects and Strategic Global Staffing Profiles: Beyond Cost Concerns in Evaluating Offshore Location Attractiveness. *Employee Responsibility and Rights Journal*. Volume 22, Issue 2, pp. 113-131.
- Marr, B. (2004). Measuring and benchmarking intellectual capital. *Benchmarking: An International Journal*. Volume 11, Issue 6, pp. 559-570.
- Martin, C. (2005). *Logistics and Supply Chain Management: Strategies for Reducing Cost and Improving Service (Financial Times)*. Hoboken, NJ: FT Press.
- Maxwell, J. (1992). Understanding and Validity in Qualitative Research. *Harvard Educational Review*. Volume 62, Issue 3, pp. 279-301.

McFadden, D. (1974). Conditional logit analysis of qualitative choice behavior. In *Frontiers in Econometrics*. Zarembka, NY: Academic Press.

McGuinness, T. & Morgan, R. (2000). *Strategy, dynamic capabilities and complex science: management rhetoric vs. reality*. Hoboken, NJ: Wiley.

Mentzer, J., DeWitt, W., Keebler, J., Min, S., Nix, N., Smith, C. & Zacharia, Z. (2001). Defining Supply Chain Management. *Journal of Business Logistics*. Volume 22, Issue 2, pp. 1-25.

Mesner-Andolšek, D. (2014). Knowledge Management and Human Resource Management: A Strategic Perspective. *Journal of Process Management*. Volume 2, Issue 4, pp. 93-101.

Miles, R. & Snow, C. (1978). *Organizational Strategy, Structure, and Process*. New York, NY: McGraw-Hill Publishing.

Moran, L., Stahl, E.R. & Boyer, T. (2008). *Commonwealth of Massachusetts Site Evaluation Guide*. Retrieved from <http://www.mass.gov/hed/docs/permitting/chapter43d/msb-siteevaluationguide-october2008.pdf>

Morehouse, J. & Bowersox, D. (1995). *Supply Chain Management: Logistics for the Future*. US Food Marketing Institute.

Murray, M.N. & Dowell, P. (1999). *The Location Decision of Automotive Suppliers in Tennessee and the Southeast*. Department of Economic and Community Development, State of Tennessee.

Mwailu, M.I. & Mercer, K.. (1983). Human Resource Scorecard: A Road Map to Balanced Scorecard. *World Journal of Social Sciences*. Volume 4, Issue 1, pp. 70-79.

Nelson, R. & Winter, S. (1982). *An evolutionary theory of economic change*. Cambridge, MA: Harvard University Press.

Nonaka, I. & Takeuchi, H. (1995). *The knowledge creating company: how Japanese companies create the dynamics of innovation*. Oxford: Oxford University Press.

Pallant, J. (2007). *SPSS Survival Manual: A Step by Step Guide to Data Analysis Using SPSS for Windows (Version 15)*. Retrieved from http://www.academia.dk/BiologiskAntropologi/Epidemiologi/PDF/SPSS_Survival_Manual_Ver12.pdf

Pathirage, C.P., Amaratunga, R.D.G. & Haigh, R.P. (2008). The Role of Philosophical Context in the Development of Research Methodology and Theory. *The Built and Human Environment Review*. Volume 1, Issue 1, pp. 1-11.

- Patton, M. (1990). *Qualitative evaluation and research methods*. Thousand Oaks, CA: Sage Publishing.
- Pearce, D. (1997). *The Political Economy of the Global Environment*. *Scottish Journal of Political Economy*. Volume 44, Issue 4, pp. 462-483.
- Penrose, E. T. (1959). *The theory of the growth of the firm*. Hoboken, NJ: Wiley Publishing.
- Ping, Y.C. (2011). Explaining Land Use Change in a Guangdong County: The Supply Side of the Story. *The China Quarterly* 207. Volume 2011, Issue 3, pp. 626-648.
- Podsakoff, P. M. & Organ, D.W. (1986). Self-reports in organizational research: Problems and prospects. *Journal of Management*. Volume 12, Issue 4, pp. 531-539.
- Porter, M. (1985). *Competitive Advantage*. New York, NY: The Free Press.
- Priem, R. L. & Butler, J. E (2001). Is the Resource-Based 'View' a Useful Perspective for Strategic Management Research? *Academy of Management Review*. Volume 26, Issue 1, pp. 22-40.
- Rainey, D.V. & McNamara, K.T. (1999). Taxes and Location Decision of Manufacturing Establishments. *Review of Agricultural Economics*. Volume 21, Issue 1, pp. 86-98.
- Reyle, J. & Saric, J. (2001). *Ontology Driven Information Extraction*. Enschede, Netherlands. Workshop on Language Technology. Retrieved from <http://citeseerx.ist.psu.edu/viewdoc/download?doi=10.1.1.440.6687&rep=rep1&type=pdf>.
- Rikalovic, A. & Cosic, I. (2015). A Fuzzy Expert System for Industrial Location Factor Analysis. *Acta Polytechnica Hungarica*. Volume 12, Issue 2, pp. 33-49.
- Robinson, J.L. (2014). *Organizational Identification and Supply Chain Orientation: Examining a Supply Chain Integration Paradox*. Atlanta, GA: Georgia Southern University Publishing.
- Rumelt, R. (1984). *Towards a strategic theory of the firm*. *Competitive Strategic Management*. Hoboken, NJ: Prentice-Hall.
- Sako, M. (1993). *Prices, Quality and Trust: Inter Firm Relations in Britain and Japan*. Cambridge: Cambridge University Press.
- Salvetat, D. & Géraudel, M. (2012). The Tertius Roles in a Coopetitive Context: The Case of the European Aeronautical and Aerospace Engineering Sector. *European Management Journal*. Volume 30, Issue 6, pp. 603-614.

Saunders, M., Thornhill, A. & Lewis, P. (2009). *Research Methods for Business Students*. Hoboken, NJ: Prentice-Hall.

Schmenner, R., Huber, J. & Cook, R. (1987). Geographic Differences and the Location of New Manufacturing Facilities. *Journal of Urban Studies*. Volume 21, Issue 1, pp. 83-104.

Schutz, R.W. (1998). Assessing the Stability of Psychological Traits and Measures. *Advances in Sport and Exercise Psychology Measurement*. Virginia: West Virginia University Publishing. Volume 21, Issue 1, pp. 83-104.

Sekaran, U. (2006). *Research Methods for Business: A Skill Building Approach*. Hoboken, NJ: John Wiley & Sons.

Shahrzad, E., Ebrahim, S., Fomani, E. S., Sasan, E., Morteza, P. A., Maysam, R., Norezi, J. & Gasemi, M. (2013). Investigating the Role of Supply Chain Management in Electronic Commerce. *Interdisciplinary Journal of Contemporary Research in Business*. Volume 4, Issue 11, pp. 706-711.

Sheu, J. (2003). Locating Manufacturing and Distribution Centers: An Integrated Supply Chain-Based Spatial Interaction Approach. *Transportation Research Part E: Logistics and Transportation Review*. Volume 39, Issue 5, pp. 381-397

Simchi-Levi, D., Kaminsky, P. & Simchi-Levi, E. (2003). *Designing and Managing the Supply Chain: Concepts, Strategies and Case Studies*. Pittsburg, PA: McGraw Hill Professional.

Spender, J. C. (1996). Making Knowledge the Basis of a Dynamic Theory of the Firm. *Strategic Management Journal*. Volume 17, Issue SPEISS, pp. 45-62.

Stewart, T. (1997). *Intellectual Capital: The New Wealth Of Organizations*. Boston, MA: Nicholas Brealey Publishing.

Sveiby, K-E. (2001). Intellectual capital and knowledge management. Retrieved from <http://www.sveiby.com/articles/IntellectualCapital.html>.

Tabachnick, B.G. & Fidell, L.S. (2007). *Using Multivariate Statistics*. Boston, MA: Pearson/Allyn & Bacon.

Taylor, D.H. (1997). *Global Cases in Logistics and Supply Chain Management*. Boston, MA: Cengage Learning.

Teece, D. J., Pisano, G., & Shuen, A. (1997). Dynamic Capabilities and Strategic Management. *Strategic Management Journal*. Volume 18, Issue 7, pp. 509-533.

Thatte, A.A., Rao, S. & Ragu-Nathan T. S. (2013). Impact Of SCM Practices Of A Firm On Supply Chain Responsiveness And Competitive Advantage Of A Firm. *The Journal of Applied Business Research*. Volume 29, Issue 2, pp. 499-530.

Thompson, B. (2005). *Exploratory and Confirmatory Factor Analysis – Understanding Concepts and Applications*. Washington, DC: American Psychological Association.

Towill, D.R., Naim, M.M. & Wikner, J. (1992). Industrial Dynamics Simulation Models in the Design of Supply Chains. *International Journal of Physical Distribution & Logistics Management*. Volume 22, Issue 5, pp. 3-13.

Trochim, W. M. & Donnelly, J. P. (2001). *Research Methods Knowledge Base*. Mason, OH: Thomson Custom Publishing.

Vagias, W. M. (2006). *Likert-type scale response anchors*. Clemson, SC: Clemson University.

Vanhaverbeke, W. & Cloudt, M. (2006). *Open innovation in value networks. Researching a new paradigm*. Oxford: Oxford University Press.

Wernerfelt, B. (1984). A Resource-based view of the firm. *Strategic Management Journal*. Volume 5, Issue 2, pp. 171-180.

Wiggins, J.S., Steiger, J.H. & Gaelick, L. (1981). Evaluating circumplexity in models of personality. *Multivariate Behavioral Research*. Volume 16, Issue 3, pp. 263-289.

Wiklund, J. & Shepherd, D. (2003). Knowledge-based resources, entrepreneurial orientation, and the performance of small and medium sized businesses. *Strategic Management Journal*. Volume 24, Issue 13, pp. 1307-1314.

Williamson, O. E. (1975). *Markets and Hierarchies: Analysis and Anti-trust Implications: A Study in the Economics of Internal Organization*. New York, NY: Free Press.

Wisner, J.D., Tan, K. & Leong, G. K. (2008). *Principles of Supply Chain Management with Infotrac: A Balanced Approach*. Boston, MA: Cengage Learning.

8.0 APPENDIX

Appendix 1: Correlations

	EI	TS.PLD.F	TAD.PLD.F	LL.PLD.F	TS.LVD.F	LL.LVD.F	TR.LVD.F	
Pearson Correlation	EI	1.000	.413	.237	.123	.517	.212	.229
	TS.PLD.F	.413	1.000	.256	.528	.675	.214	.220
	TAD.PLD.F	.237	.256	1.000	.169	.201	.334	.263
	LL.PLD.F	.123	.528	.169	1.000	.321	.152	.348
	TS.LVD.F	.517	.675	.201	.321	1.000	.243	.303
	LL.LVD.F	.212	.214	.334	.152	.243	1.000	.320
	TR.LVD.F	.229	.220	.263	.348	.303	.320	1.000
Sig. (1-tailed)	EI	.000	.000	.025	.000	.000	.000	.000
	TS.PLD.F	.000	.	.000	.000	.000	.000	.000
	TAD.PLD.F	.000	.000	.	.003	.001	.000	.000
	LL.PLD.F	.025	.000	.003	.	.000	.008	.000
	TS.LVD.F	.000	.000	.001	.000	.	.000	.000
	LL.LVD.F	.000	.000	.000	.008	.000	.	.000
N	TR.LVD.F	.000	.000	.000	.000	.000	.000	.
	EI	256	256	256	256	256	256	256
	TS.PLD.F	256	256	256	256	256	256	256
	TAD.PLD.F	256	256	256	256	256	256	256
	LL.PLD.F	256	256	256	256	256	256	256
	TS.LVD.F	256	256	256	256	256	256	256
	LL.LVD.F	256	256	256	256	256	256	256
TR.LVD.F	256	256	256	256	256	256	256	

Appendix 2: Interview Questionnaire



Interview Questionnaire

Analysis of Physical Location Decisions Within FMCG Firms

1. In making physical location decisions, does the company put emphasis on comparing tangible and mobile resources as opposed to intangible and immobile resources, or vice versa? Identify the reasons.

2. How do transportation factors and overall land value analysis influence physical location decisions, considering that these factors are often variable, regularly changing, and unsustainable?

3. How do transportation, land value and tax structure influence physical location decisions assuming decision makers may have different opinions, interpretations and knowledge on resource tangibility and importance?

4.
 - a. Are physical location decisions more dependent on a knowledge based view (the belief that the knowledge held by decision makers is most important) or a resource based view (the belief that tangible or intangible resources at the firm's disposal are most important)?

 - b. What are the reasons of why physical location decisions are based on a knowledge based view or resource based view?

5. Over the course of your employment with the company, in terms of physical location decisions, have there been any amendments in policies to shift from the paradigm of resource based view decisions to knowledge based view decisions, or vice versa? If yes, what amendments do you see?

6. Do you believe that a resource based paradigm or a knowledge based paradigm cannot support a physical location decision in isolation. Why?

7. Aside from policy shifts, has the management culture of the company shifted to integrate the resource based paradigm of the physical location decision determinants/factors with a knowledge based paradigm? What shifts have you observed?

8. Does the company plan location decisions on the basis of historical information of location determinants which might be available? If yes, how does the company maintain historical records for knowledge sharing among the decision making hierarchy?

Appendix 3: Survey Questionnaire



Survey Questionnaire

Analysis of Physical Location Decisions Within FMCG Firms

Dear Participant-

I am a graduate student at the Graduate School of Business, University of Cape Town. As part of my PhD thesis, I am conducting a survey in an effort to **identify the relationship between land value and physical supply chain entity location decisions (specifically manufacturing plants, distribution centers, and storage facilities) within Fast Moving Consumer Goods companies.**

The following survey will take approximately 10-15 minutes to complete, and responses will be kept confidential. The statistical data collected from your responses (as well as others) will be documented in my final thesis.

Should you have any questions about this research protocol, please contact me directly at phrzal001@gsb.uct.ac.za. You may also contact my research supervisor, Dr. Richard Chivaka, at richard.chivaka@gsb.uct.ac.za.

By filling out the provided survey, you give me the permission to report your responses anonymously in the final manuscript to be submitted to my faculty supervisor as part of my course work.

Thank you for your participation and contribution.

Sincerely,

Signed by candidate

signature removed

Zal Phiroz
PhD Candidate, University of Cape Town (2016)

I have read the procedure described above. I voluntarily agree to participate in this research study.

SECTION A:

DEMOGRAPHIC INFORMATION

1. Are you currently employed within the Fast Moving Consumer Goods Industry? (Select one)
 Yes No

2. What was your company's approximate revenue in 2014 (in US Dollars)? (Select one)
 \$1 to \$49.9 Million
 \$50 to \$99.9 Million
 \$100 to \$299.9 Million
 \$300 to \$499.9 Million
 \$500 Million +

3. What is the size of your company, in terms of employees? (Select one)
 1 - 99
 100 - 999
 1000 - 4999
 5000 - 10000
 10001 +

4. What is your present area of focus within the company? (Select all which apply)
 Supply Chain Analysis and Management
 Marketing and Communication
 Partnership Management (suppliers, manufacturers, etc.)
 Product Management
 Other _____

5. What is your present title within the company? (Select one)
- Analyst/ Junior Manager
 - Middle Manager
 - Senior Manager
 - Operational Staff
 - Executive Decision Maker (VP, Director etc.)
 - Other _____
6. Within your current capacity, what level of contribution do you have toward physical resource decisions (i.e. placement of warehouses, manufacturing plants etc.)? (Select all which apply)
- Advise on physical resource decisions
 - Ability to make final physical resource decisions
 - Evaluation of data for physical location decisions
 - No contribution toward physical location decisions.
 - Other _____
7. How long have you worked in your current role? (Select one)
- Less than 1 year
 - 1 – 2 years
 - 3 – 5 years
 - 6 – 9 years
 - 10 years +
8. How long have you worked within your current company? (Select one)
- Less than 1 year
 - 1 – 2 years
 - 3 – 5 years
 - 6 – 9 years
 - 10 years +

SECTION B:

TRANSPORTATION DECISIONS, TAX STRUCTURES & LAND VALUE AFFECTING PHYSICAL LOCATION DECISIONS

Please indicate to what extent you agree with the following factors, when reaching physical location placement decisions of various supply chain entities (specifically manufacturing plants, distribution centres, and storage facilities) within your organization.

Statement	Strongly Agree	Agree	Neutral	Disagree	Strongly Disagree	N/A
Part A: Land Location Related Decisions						
1. Physical land maintenance cost						
2. Land rental/ownership cost						
3. Flexibility of land usage, and possibility of land usage change						
4. Size/area of land						
5. Layout/dimension of land site						
6. Social policy and/or political risk of the region						
7. Proximity to affiliates (e.g. potential partners, strategic alliances, competing businesses)						
Part B: Transportation and Accessibility Decisions						
8. Proximity to strategic partners (e.g. suppliers)						
9. Proximity to target markets						
10. Accessibility to customers						
11. Strategic visibility of location from roads and highways						
12. Availability of parking area for trucks etc.						
13. Approachability to roads and freeways						
14. Availability of favorable labor						
15. Access for private vehicles						
16. Potential for automated transportation						
Part C: Tax and Incentive Structures						
17. Government tax incentives						
18. Overall tax cost of the site						
19. Government sponsored economic incentives						

20. Other than the factors mentioned above, list any other transportation, land value or tax related factor which your company considers in making physical location decisions.

.....

SECTION C:

TRANSPORTATION DECISIONS AND TAX STRUCTURES AFFECTING LAND VALUE

Please indicate to what extent you agree with the following factors when determining land value of physical supply chain entities (specifically manufacturing plants, distribution centres, and storage facilities) within your organization.

Statement	Strongly Agree	Agree	Neutral	Disagree	Strongly Disagree	N/A
Part A: Land Location and Transportation Decisions						
21. Proximity to strategic partners (e.g. suppliers)						
22. Proximity to affiliates (e.g. potential partners, strategic alliances, competing businesses)						
23. Availability of diversified transport facilities						
24. Overall transportation cost						
25. Strategic visibility of location from roads and highways						
26. Availability of parking area for trucks etc.						
27. Approachability to roads, freeways etc.						
28. Availability of favorable labor						
29. Access for private vehicles						
30. Potential for integration of automated transportation						
31. Architecture of loading/ unloading spaces						
32. Price per square meter in comparison to similar sites						
33. Social policy and/or political risk of the region						
Part B: Tax and Incentive Structures						
34. Overall tax cost of the site						
35. Potential for tax reduction						
36. Government sponsored economic incentives						

37. Other than the factors mentioned above, list any other transportation or tax related factors that your company considers when determining or evaluating land value for physical supply chain entities.

.....

**SECTION D:
ECONOMIC IMPACT OF TRANSPORTATION DECISIONS, LAND VALUE AND TAX
STRUCTURES**

Please indicate to what extent you agree with the following statements impacting your organizational supply chain.

Statement	Strongly Agree	Agree	Neutral	Disagree	Strongly Disagree	N/A
38. Land value of physical entities has significant economic impact on the company.						
39. Land value of physical entities has significant economic impact on the efficiency of the supply chain.						
40. Tax structures and government incentives have a significant economic impact to the operational functionality of the firm.						
41. Tax structures and government incentives have a significant economic impact on the supply chain value of the firm.						
42. It is important to consider land value factors, when determining new physical locations of supply chain entities.						
43. It is important to consider transportation and accessibility factors, when determining new physical locations of supply chain entities.						