

Direct Shear and Direct Simple Shear Tests: A Comparative Study of the Strength Parameters and their Dependence on Moisture and Fines Contents



By:

Zainab Babalola

A thesis submitted to the University of Cape Town in partial fulfilment of the requirement for the degree of Master of Science in Engineering

Faculty of Engineering and Built Environment

Department of Civil Engineering

January 2016

Supervisor: Dr Denis Kalumba

Co Supervisor: Faridah Chebet

The copyright of this thesis vests in the author. No quotation from it or information derived from it is to be published without full acknowledgement of the source. The thesis is to be used for private study or non-commercial research purposes only.

Published by the University of Cape Town (UCT) in terms of the non-exclusive license granted to UCT by the author.

DECLARATION

1. I know that plagiarism is wrong. Plagiarism is to use another's work and pretend that it is one's own.
2. I have used the Harvard convention for citation and referencing. Each significant contribution to and quotation in this thesis from the work or works of other people has been attributed and has been cited and referenced.
3. This thesis is my own work.
4. I have not allowed and will not allow anyone to copy my work with the intention of passing it as his or her own.

Zainab Babalola

Signed by candidate

Signature Removed

BBLZAI001

Date: 29/01/2016

Dedicated to:

Saheed Babalola

For his endless love and support.

Acknowledgement

I would like to express my profound gratitude to God the Almighty, for the blessings and protection. The opportunity to study for this master's degree as given by Dr Denis Kalumba who willingly agreed to supervise me. Words are not enough to describe my appreciation for him. Sincere gratitude goes to him for the guidance, commitment, willingness to help on even the most minor issues and constructive criticism during the execution of this work. Thank you Denis for motivating me and guiding me all the way through. I am also grateful for the excellent contribution from my co-supervisor, Ms Faridah Chebet.

I acknowledge the assistance received from University of Cape Town Civil Engineering staff, particularly the Geotechnical laboratory manager, Mr Noor Hassen. Special thanks also goes to laboratory assistants, Elvino Witbooi, Hector Zwelixelile Mafungwa and Charles May, for their support at all times. I would also like to make a special mention of Charles Nicholas, the Principal Technical officer, who manufactured the hand compactor used in the study and who was always ready to help me in difficult times during my experiments.

I am grateful to Franki Africa for providing me access to their office. I am particularly thankful to Dr Nicol Chang for his support while executing my pile design.

A big thank you to my geotechnical research group colleagues: Joan Ongondia, Vincent Oderah, Dennis Kiptoo, Johnny Oriokot, Byron Mawer, Samuel Jjukko, Angela Lekea, Sam Wagener, Dercio Chim Jin, Lita Noluthshungu, Paul Wanyama, Sanelisiwe Buthelezi, Vuyiseka Mapangwana, and Laxmee Sobhee for their friendship, moral support and constructive discussion.

I would like to express my heartfelt gratitude to my husband, Saheed Babalola, for his financial and moral support. There are no words to describe my love for you, thank you sweetheart for always being there for me. Special words of utmost recognition are towards my sons, brothers, sisters and other family members for their love, patience, moral support and prayers. Thank you everyone and God bless you all.

Zainab Babalola

BBLZAI001

Abstract

Shear strength of soil is characterized by cohesion, angle of internal friction and dilatation. The first two parameters mentioned primarily define the soil's ability to resist shear stress under specified load. These parameters can be determined by tests conducted either in the laboratory or the field for use in design of geotechnical structures. Some of the tests in the laboratory to determine the shear strength of soil, include triaxial, ring shear, torsional shear, direct shear and direct simple shear.

Direct shear test is the most widely used geotechnical shear device due to its simplicity, however, the test suffers from stress inhomogeneity. Direct simple shear apparatus was developed because of the shortcomings in the direct shear test. In these two tests, different shearing conditions are applied to soil samples. For the direct shear test, shearing occurs at a predetermined center of the specimen which may not be the weakest plane of the soil while in direct simple shear, the entire specimen distorts without the formation of single shearing surface. The mode of shearing established in the direct simple shear device is similar to that which occurs around the shaft of a pile. In contrast to the extensive geotechnical application of direct shear test, limited information exists on direct simple shear test. This thesis endeavours to establish the relationship between the two tests by undertaking extensive testing to obtain a better understanding of direct simple shear test as used for testing local soils and to determine a correlation with the results from direct shear tests.

A series of shear tests were undertaken on Klipheuwel sand, Kaolin clay and composite of the sand and clay using universal shear device. The soils were mixed with water in percentages of 5, 10, 15, 20 and 25%, and the composite with clay percentages of 10, 25, 50 and 75%, to investigate the impact of water and clay on the shear parameters determined from the two tests.

The results showed that direct shear test gives higher shear strength when compared to direct simple shear test under the same soil condition. The addition of water, and clay, generally reduced the internal friction angle of sand for both tests. Furthermore, increase in cohesion was observed with the addition of water to Kaolin clay for the direct simple shear test and the reverse was true in the direct shear test. The correlation factors developed in this study for the direct simple shear test could be used to refine the results from the direct shear test.

Table of Content

Declaration	ii
Acknowledgement.....	iv
Abstract.....	v
Table of Content.....	vi
List of Figures.....	x
List of Tables.....	xiv
Acronyms and Annotations	xvi
1.0 Introduction.....	1
1.1 Background to the study.....	1
1.2 Relevance of the Study.....	2
1.3 Research objectives.....	3
1.4 Scope and limitation.....	3
1.5 Thesis overview.....	3
2.0 Literature Review.....	4
2.1 Introduction.....	4
2.2 Shear strength of soils.....	4
2.2.1 Mohr-Coulomb theory	5
2.2.2 Mohr-Coulomb failure criterion.....	6
2.3 Measurement of shear strength.....	9
2.3.1 Torsional shear test	9
2.3.2 Triaxial test.....	10
2.3.3 Ring shear test	14
2.3.4 Direct shear	16
2.3.5 Direct simple shear test.....	19
2.4 Summary of shearing methods.....	23
2.5 Previous studies	24
2.5.1 A study on the effects of relative density on friction angle using the direct shear test	24

2.5.2	A study of the effects of particle size on friction angle using the direct shear test.....	27
2.5.3	The study of the effects of relative density on shear strength parameters using the direct simple shear test.....	30
2.5.4	A study of the effects of clay and moisture content for clay-sand mixtures using direct shear test.....	37
2.5.5	A study of the effect of test quantity on shear strength parameters using direct simple shear test.....	39
2.5.6	Comparing results between direct shear test and direct simple shear Test.....	43
2.6	Conclusion.....	47
3.0	Research Materials and Methodology.....	48
3.1	Introduction.....	48
3.2	Research materials.....	48
3.2.1	Klipheuwel Sand.....	48
3.2.2	Kaolin.....	48
3.3	Soil classification tests.....	49
3.4	Test equipment.....	52
3.5	Sample preparation for direct shear test and direct simple shear test.....	54
3.5.1	Sample Preparation for direct shear test.....	55
3.5.1.1	Pure soil (Klipheuwel sand and Kaoiln clay).....	55
3.5.1.2	Sand-clay composite.....	56
3.5.1.3	Pure soil with varying moisture content	57
3.5.2	Sample preparation for direct simple shear test.....	58
3.5.2.1	Pure soil (Klipheuwel sand and Kaoiln clay).....	58
3.5.2.2	Sand-clay composite.....	59
3.5.2.3	Pure soil with varying moisture content	60
3.5.3	Direct shear device setup.....	61
3.5.4	Direct simple shear device setup.....	62
3.6	Test procedure.....	62
3.6.1	Procedure for direct shear test.....	62

3.6.2	Procedure for direct simple shear test.....	64
3.7	Testing schedule.....	66
3.8	Repeatability of the data.....	72
3.9	Bulk / dry density	74
3.10	Quality Control	75
3.11	Data processing.....	75
4.0	Results, Analysis and Discussion.....	77
4.1	Introduction.....	77
4.2	Shear stress - horizontal displacement relationship.....	77
4.2.1	Sand only.....	77
4.2.2	Sand at varying moisture content.....	78
4.2.3	Sand and clay	81
4.2.4	Kaolin clay	83
4.2.5	Kaolin clay at varying moisture content	83
4.3	Shear stress - normal stress relationship	86
4.3.1	Sand only	87
4.3.2	Sand at varying moisture content.....	88
4.3.3	Sand and clay	90
4.3.4	Kaolin clay.....	92
4.3.5	Kaolin clay at varying moisture content	93
4.4	Correlation factor.....	95
5.0	Practical Applications.....	100
5.1	Introduction.....	100
5.2	The proposed design	100
5.3	Design Example.....	100
5.3.1	Soil parameters	102
5.3.2	Design analysis using angle of internal friction from direct shear test...104	
5.3.3	Design analysis using angle of internal friction from direct simple shear test.....	105
6.0	Conclusions and Recommendation.....	107
6.1	Introduction.....	107

6.2	Summary of the findings.....	107
6.3	Recommendations.....	108

7.0 References

8.0 Appendices

List of Figures

Figure 1.1	Example of shear failure in soils.....	1
Figure 2.1	Failure surface and shear resistance.....	5
Figure 2.2	Mohr-Coulomb failure criterion and failure envelope	7
Figure 2.3	Mohr circles of different soil elements	7
Figure 2.4	Mohr circles for different stress condition.....	8
Figure 2.5	Mohr circles for total stress and effective stress condition.....	8
Figure 2.6	Schematic diagram of the torsional shear testing system.....	10
Figure 2.7	Triaxial Cell with Associated Hydraulic Loading System.....	11
Figure 2.8	Fully Automated Triaxial Load Frame	11
Figure 2.9	Generalised specimen response during shear for a normally-consolidated clay...13	
Figure 2.10	Cohesive specimen post-shear showing failure plane.....	13
Figure 2.11	Schematic of ring shear test shearing mechanism.....	14
Figure 2.12	Typical graphs from ring shear test	15
Figure 2.13	Shear box apparatus	16
Figure 2.14	Direct shear apparatus (manual).....	17
Figure 2.15	Shear box test	17
Figure 2.16	Typical deformation results from a direct shear test on loose and dense cohesionless soil specimen.....	18
Figure 2.17	Cambridge direct simple shear testing cubical sample.....	19
Figure 2.18	Principle of the direct simple shear test	20
Figure 2.19	Stability of slope	21
Figure 2.20	Cyclic loading of gravity base structure.....	21
Figure 2.21	NGI pile design method, static and cyclic testing of remoulded and undisturbed soil.....	22
Figure 2.22	Typical graphs on direct simple shear test.....	22
Figure 2.23	Relationship between shear box scale effect and footing scale effect.....	26
Figure 2.24	Results of direct shear test on Tergha sand.....	39
Figure 2.25	Shear Stress and Volumetric Strain Variations at Different Normal Stresses.....	31
Figure 2.26	Mohr-Culomb failure criteria (Effect of Normal Stress).....	32

Figure 2.27	Influence of normal stress on shear stiffness	32
Figure 2.28	Shear stress and volumetric strain variations (50kPa).....	33
Figure 2.29	Shear stress and volumetric strain variations (200kPa).....	34
Figure 2.30	Shear stress and volumetric strain variations (300kPa).....	34
Figure 2.31	Mohr-Coulomb Failure Criteria (Effect of Relative Density)	35
Figure 2.32	Influence of moisture content on angle of internal friction and cohesion	38
Figure 2.33	Influence of clay content on cohesion and internal angle of friction	39
Figure 2.34	Peak values of loose sand shear strength parameters.....	40
Figure 2.35	Peak shearing stress versus horizontal displacement.....	41
Figure 2.36	Characteristic angle of internal friction versus test quantity.....	41
Figure 2.37	Characteristic cohesion versus test quantity	42
Figure 2.38	Shear strength and stiffness data for direct simple shear test and direct shear test in Ariake clay.....	45
Figure 2.39	Shear strength and stiffness data for direct simple shear test and direct shear test in Drammen clay.....	46
Figure 3.1	Klipheuwel sand and Kaolin.....	49
Figure 3.2	Particle grading curve for Klipheuwel sand.	50
Figure 3.3	Standard proctor curves for Klipheuwel sand	51
Figure 3.4	Standard proctor curves for kaolin clay	51
Figure 3.5	Conversion of ShearTrac-II (DS) for direct shear to ShearTrac-II-DSS for direct simple shear (Geocomp, 2015).....	53
Figure 3.6	Simple shear arms	54
Figure 3.7	Hand compactor	55
Figure 3.8	Moist sample preparation Klipheuwel and Kaolin.....	58
Figure 3.9	Sample ready for testing.....	59
Figure 3.10	Direct shear test setup	61
Figure 3.11	Shear control window	63
Figure 3.12	Samples of direct shear test specimen after	64
Figure 3.13	Direct simple shear software window with different setting tabs	64
Figure 3.14	Sample of direct simple shear test specimen after test	65
Figure 3.15	Repeatable results for three samples tested at 50kPa dst.....	73

Figure 3.16	Repeatable results for three samples tested at 50kPa dsst.....	73
Figure 3.17	Summary of research methodology.....	76
Figure 4.1	Direct shear and direct simple shear test results for Klipheuwel sand only.....	78
Figure 4.2	Shear stress versus horizontal displacement for Klipheuwel sand with different Percentages of moisture content for direct shear and direct simple shear tests.....	79
Figure 4.3	Shear stress versus horizontal displacement for Klipheuwel sand and Kaolin clay at different a concentrations of Kaolin clay for direct shear and direct simple shear tests.....	81
Figure 4.4	Shear stress versus horizontal displacement for Kaolin clay.....	83
Figure 4.5	Shear stress versus horizontal displacement for Kaolin clay with different percentage of moisture content for direct and simple shear tests.....	84
Figure 4.6	Relationship between the maximum shear stress and normal applied pressure for Klipheuwel sand (direct shear test and direct simple shear test).....	88
Figure 4.7	Relationship between the maximum shear stress and normal applied pressure for Klipheuwel sand with varying moisture content (direct shear test and direct simple shear test).....	89
Figure 4.8	Relationship between the maximum shear stress and normal applied pressure for Klipheuwel sand and kaolin (direct shear test and direct simple shear test).....	91
Figure 4.9	Relationship between the maximum shear stress and normal applied pressure for kaolin clay (direct shear test and direct simple shear test).....	92
Figure 4.10	Relationship between the maximum shear stress and normal applied pressure f.or kaolin clay at varying moisture content (direct shear test and direct simple shear test).....	93
Figure 4.11	Relationship of angle of internal friction between direct shear test result and direct simple shear test result.....	96
Figure 5.1	The old and the proposed new bridge side by side.....	101
Figure 5.2	Pile capacity.....	102
Figure 5.3	Pile parameters (direct shear test).....	104

Figure 5.4	Pile parameters (direct simple shear test).....	105
------------	---	-----

List of Tables

Table 2.1	Summary of sample preparation techniques in the direct shear box testing program.....	25
Table 2.2	Direct shear box testing results using the constant volume shear strength.....	27
Table 2.3	Granular properties of sample	28
Table 2.4	Shear Strength Parameters (Effect of Relative Density).....	35
Table 3.1	Experiment Conducted for Soil Classification.....	49
Table 3.2	Summary of the results obtained from the classification tests for Kaolin And Klipheuwel sand.....	52
Table 3.3	Code terminology	66
Table 3.4	Direct shear test on Klipheuwel sand and clay.....	67
Table 3.5	Direct simple shear test on Klipheuwel sand and clay.....	70
Table 3.6	Repeatability results.....	73
Table 3.7	The densities achieved during the preparation of test specimens.....	74
Table 4.1	Peak shear stress for Klipheuwel sand with different percentage of moisture content.....	80
Table 4.2	Peak shear stress for Klipheuwel sand with different concentration of Kaolin clay.....	82
Table 4.3	Peak shear stress for Kaolin clay with different percentage of moisture content..	86
Table 4.4	Shear strength parameters (friction angle and cohesion) obtained from direct shear test and direct simple shear from Klipheuwel sand with varying moisture content	90
Table 4.5	Shear strength parameters (friction angle and cohesion) obtained from direct shear test and direct simple shear from Klipheuwel sand and Kaolin clay with different clay concentration.....	92
Table 4.6	Shear strength parameters (friction angle and cohesion) obtained from direct shear test and direct simple shear from Kaolin clay with varying moisture content.....	95
Table 4.7	Percentage difference of angle of internal friction for all the soil samples.....	98

Table 5.1	Parameters for design of pile in cohesionless soils	103
Table 5.2	Design calculations results.....	106

Acronyms and Annotations

ASCE	American Society of Civil Engineers
ASTM	American Society for Testing and Materials
BS	British standards
Cc	Coefficient of curvature
Cu	Coefficient of uniformity
DS	Direct shear
DSS	Direct simple shear
FOS	Factor of safety
OMC	Optimum Moisture Content
NGI	Norwegian geotechnical institute
UCT	University of Cape Town
USCS	Unified Soil Classification System
c	Cohesion of soil (kPa)
D50	Mean grain size
N	Normal applied load (kN)
ϕ	Angle of internal friction
ρ	Density

1.0 INTRODUCTION

1.1 Background to the study

Failure of soil may cause collapse of structures resulting in loss of lives as well as economic and financial damages. Soil failure and the associated problems are generally termed geotechnical stability problems. Most geotechnical instability problems are associated with shear failure. Shear strength is therefore one of the most important properties for design of engineering structures and also one of the most difficult to evaluate (Nagendra et al., 2013). The shear strength of soils is a necessary aspect in many foundation problems such as the bearing capacity of shallow foundations and piles, stability of the slopes of dams and embankments, and lateral earth pressure on retaining walls (Das, 1983). The safety of geotechnical structures depends on the strength properties of soil and therefore a proper understanding of soil strength parameters is essential in ensuring safe designs. Soil is strong in compression but weak in shear and tension, thus the strength of any soil under compression load is defined by its resistance to shearing forces. The limited ability of soil to resist shear can lead to structural failure when shear stresses exceed the shear resistance mobilized by the soil as shown in Figure 1.1.

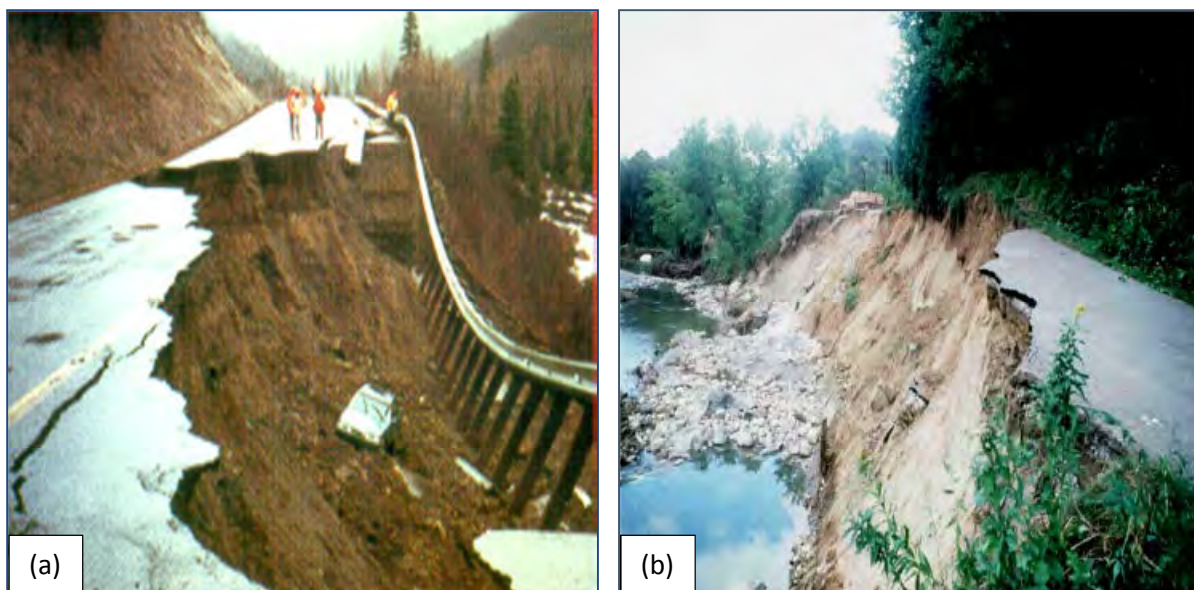

Figure 1.1 Example of shear failure in soils

Source: Noor et al. (2013)

In order to determine the parameters that govern shear strength, namely angle of internal friction and cohesion, laboratory tests or field tests are conducted. Laboratory shear testing has become an integral part of many soil investigations as a way to determine the shear strength parameters of a soil (Hanzawa et al., 2007). Many types and variations of laboratory shear tests have been developed and in most of these tests the rates of deformation are controlled and the resulting loads are measured. Field tests such as cone penetration test and vane shear test are very common in engineering projects. But, stress-strain relationships can not be measured directly. Laboratory tests are mostly of academic interest and the accuracy of this test is sufficient for practical purposes. The tests employed in the laboratory include ring shear, torsional shear, triaxial, direct shear and simple shear. Shear parameters derived from either field or laboratory test are used for design purposes. Direct shear test is a simple and relatively cheap method for determining the soil shear strength parameters. The apparatus is easy to use, the test is fast to perform, and the output data can be relatively easily processed to obtain the necessary parameters. Therefore the direct shear apparatuses are widely applied in engineering practice and for research purposes (Amsiejus et al., 2013). However, direct simple shear test is a relatively new improvement of direct shear test (Siti et al., 2015). Both devices apply shear directly to the soil specimen. This study investigated the relationship between the results generated from direct shear and direct simple shear test using South Africa soils.

1.2 Relevance of study

Direct simple shear test is not popular in practise (Dinesh, 2010). Information concerning direct simple shear test as compared to direct shear test is necessary to enhance its adaptability for shear testing of soils. Kjellman (1951) reported that the direct simple shear testing gave results that were closer to those deduced from back analysis of some field failures than the results of other shear test. Direct simple shear was found to have better results, when compared to other shear tests. It was anticipated therefore that a better understanding of measurement of shear strength parameters would be realized, when the results generated from direct shear test is compared to direct simple shear test.

1.3 Research objectives

The main objective of this study was to compare soil strength parameters determined using direct shear and direct simple shear test apparatuses. The specific objectives were;

- (1) To evaluate the effect of moisture content on shear strength parameters of sand and clay.
- (2) To determine the effect of fine content on shear strength parameters of sand in both the direct shear test and the simple shear test.
- (3) To compare the overall shear test results obtained from direct shear test and direct simple shear test.

1.4 Scope and limitations

The research conducted herein involved the investigation of shear strength parameters of soil as obtained using both direct shear and direct simple shear device, and to determine the relationship between the results as well as the benefits of their inclusion in the design of structures. The shear tests conducted were limited to these two tests, and no other shear tests included in the research. The investigation only considered two soils, Klipheuvel sand and Kaolin clay sourced locally.

1.5 Thesis overview

This thesis initially provides an introductory overview which includes the background, relevance, justification and objectives of the study. In order to provide additional background on the concepts of shear strength in soils, chapter 2 explores the literature review of different apparatus used for measuring shear strength. This is followed by the previous studies on direct shear test and direct simple shear test. The mechanical properties of the test materials, sample preparation, equipment and the details of the experimental procedure for both direct shear test and direct simple shear test are given in Chapter 3. All the results, their analysis and discussion are presented in Chapter 4. Results using both the direct shear test and direct simple shear test were compared and correlation factors are detailed. Chapter 5 looks at an example of the engineering application of the results generated from this study. Finally, the conclusion and recommendations for application and further research are given in Chapter 6.

2.0 LITERATURE REVIEW

2.1 Introduction

The object of laboratory shear testing is to study the behaviour of a given soil under conditions similar to those encountered in the field and to establish those parameters that describe this behaviour in a set of constitutive equations. In a laboratory shear test, the specimen is intended and generally assumed to represent a single point in a soil medium. Separate measurements are often made for the soil phase, the water phase and, sometimes, the air phase of the specimen in order to relate its contribution to the strength of the mass. This chapter explores the history of different laboratory shear tests and reviews previous studies that are related to this study.

2.2 Shear strength of soil

In most of the problems in soils engineering, such as those concerning the foundations of structures, earthwork engineering, etc., the soil mass has to withstand shearing stresses. The shearing stresses tend to displace a part of soil relative to the rest of the soil mass. The capacity of the soil to resist shearing stresses is referred to as shear strength. It can be explained further as the maximum value of shear stress that can be mobilised within a soil mass. If this value is equalled by the shear stress on any plane or a surface, the failure will occur in the soil because of the movement of a portion of the soil mass along that particular plane or surface. In this instance the soil has failed in shear. At the failure surface, shear stress reaches the shear strength (τ) of the soil, and sliding between the particles takes place as illustrated in Figure 2.1. Slopes of all kinds, such as hills or mountains, banks of canals or rivers, man-made cuts and fills, etc., remain stable only if the shear strength of the material of which they are composed is adequate.

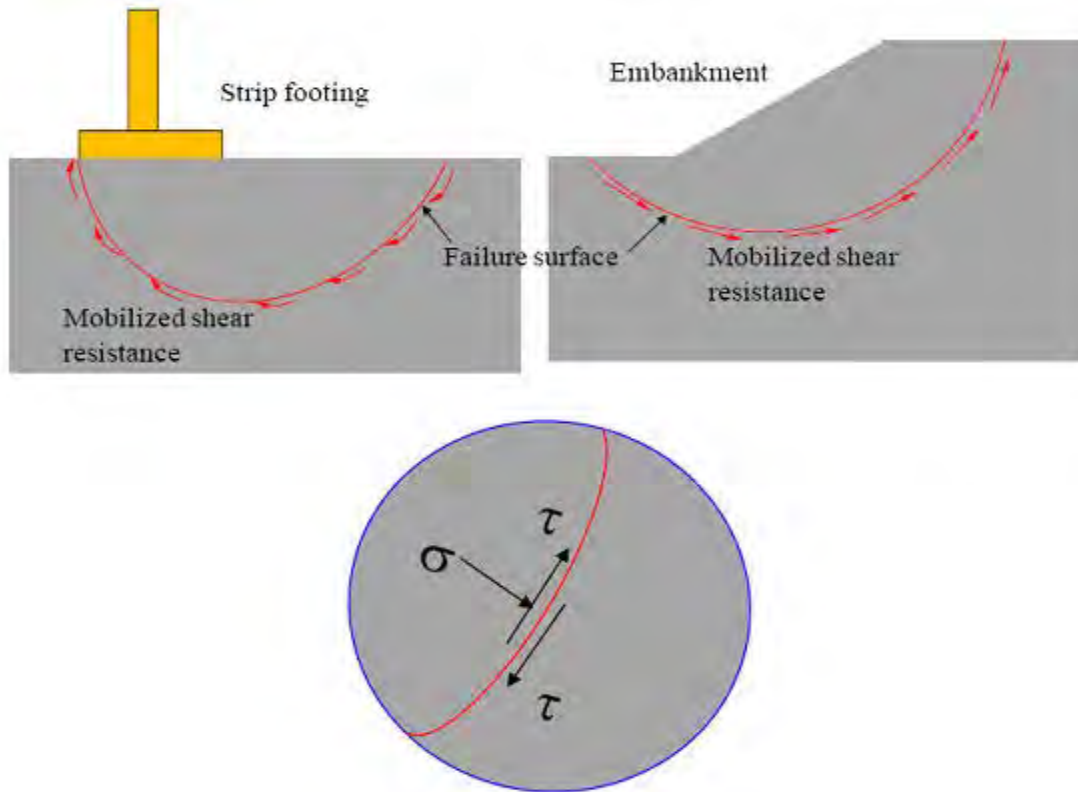

Figure 2.1. Failure surface and shear resistance

Source: Rajani et al. (2000)

2.2.1 Mohr-Coulomb theory

Mohr-Coulomb theory is a mathematical model describing the response of brittle materials, such as concrete, or rubble piles, to a combination of shear stress and normal stress. Most of the classical engineering materials somehow follow this rule in at least a portion of their shear failure envelope. Generally, the theory applies to materials for which the compressive strength far exceeds the tensile strength Juvinal et al., 1991. In geotechnical engineering, it is used to define shear strength of soils and rocks at different effective stresses. Mohr's circle is used to determine which principal stresses will produce this combination of shear and normal stresses, and the angle of the plane in which this will occur. According to the principle of normality, the stress introduced at failure will be perpendicular to the line describing the fracture condition.

2.2.2. Mohr-Coulomb Failure Criterion

Mohr (1900) presented a theory for rupture in materials that contended that a material fails because of a critical combination of normal stress and shearing stress, and not from either maximum normal or shear stress alone. Thus, the functional relationship between normal stress and shear stress on a failure plane can be expressed in the following form:

$$\tau = f(\sigma) \dots \dots \dots (2.1)$$

The failure envelope defined is generally a curved line. For most soil mechanics problems, it is sufficient to approximate the shear stress on the failure plane as a linear function of the normal stress (Coulomb, 1776). This linear function can be written as:

$$\tau = c + \sigma \tan \phi \dots \dots \dots (2.2)$$

- Where c: Cohesion
- ϕ : Angle of internal friction
- σ : Normal stress on the failure plane
- τ : Shear strength

The line satisfying the Equation (2.1) is called the Mohr-Coulomb failure envelope (as shown in Figure 2.2). It is shown that τ_f is the maximum stress soil can take without failure under an applied vertical stress σ . The Mohr circle of two identical soil elements, one at the failure surface (x) and one at any other location (y), is presented in Figure 2.3. The Mohr circle touches the failure envelope in case of a soil element taken from location of failure surface, whereas the Mohr circle of the soil element taken from other than the location of failure surface is situated below the failure envelope. Keeping σ_3 (minor principal stress) constant, if vertical stress (σ_1) increases, the Mohr Circle becomes larger and, finally, it will touch the failure envelope, and failure will take place (as shown in Figure 2.4). The Mohr circle for total stress and effective stress condition is presented in Figure 2.5. The Equation (2.1) represents the shear strength in terms of total stress (σ). In terms of effective stress ($\sigma' = \sigma - u$), Where u is called the pore water pressure. The shear strength of the soil can be expressed as:

$$\tau_f = c' + \sigma' \tan \phi' \dots \dots \dots (2.3)$$

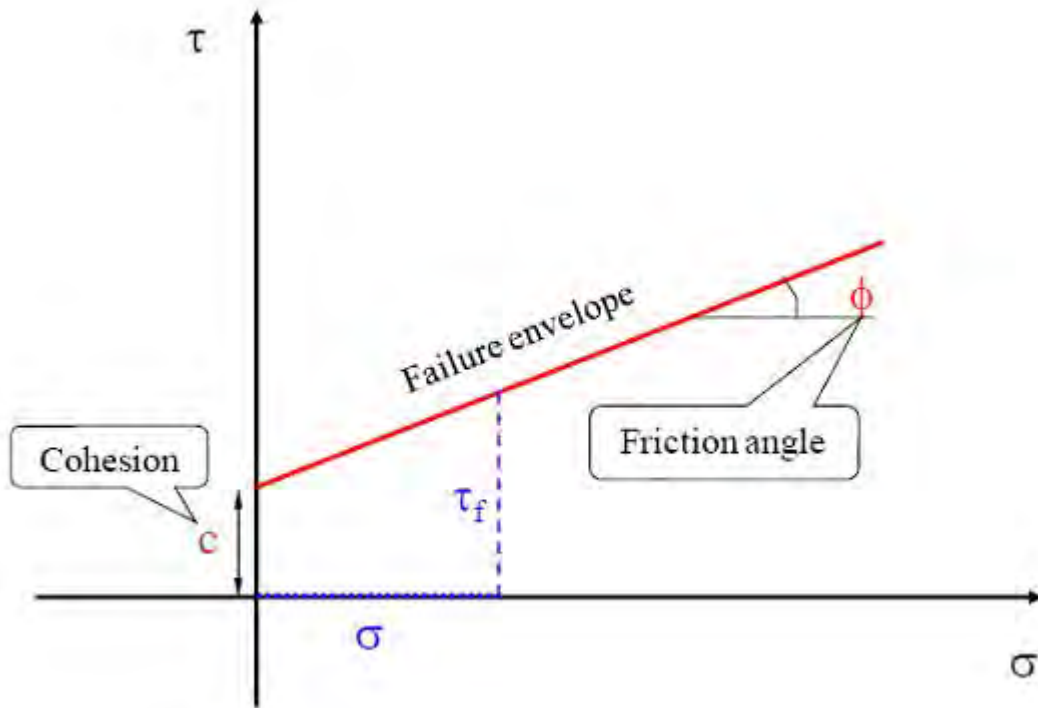

Figure 2.2. Mohr-Coulomb failure criterion and failure envelope

Source: Rajani et al. (2000)

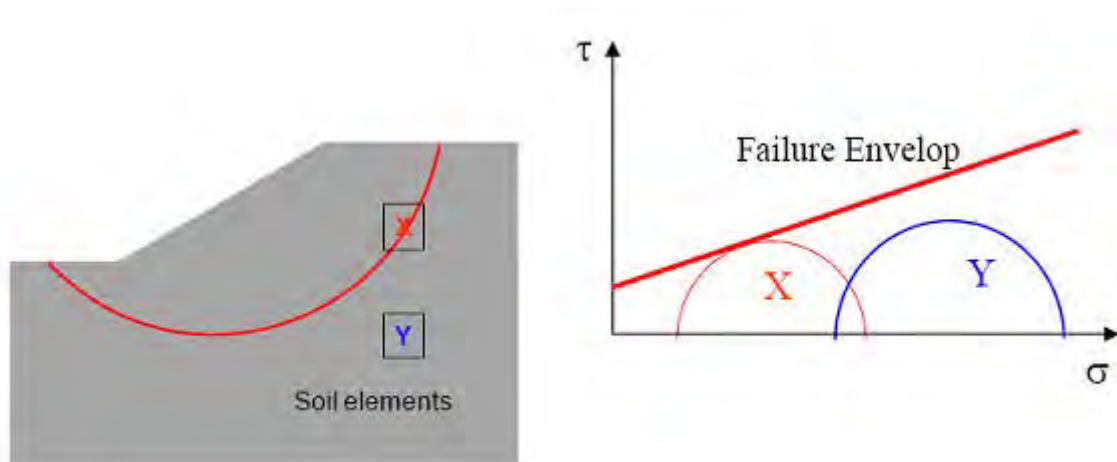

Figure 2.3. Mohr circles of different soil elements. Source: Rajani et al. (2000)

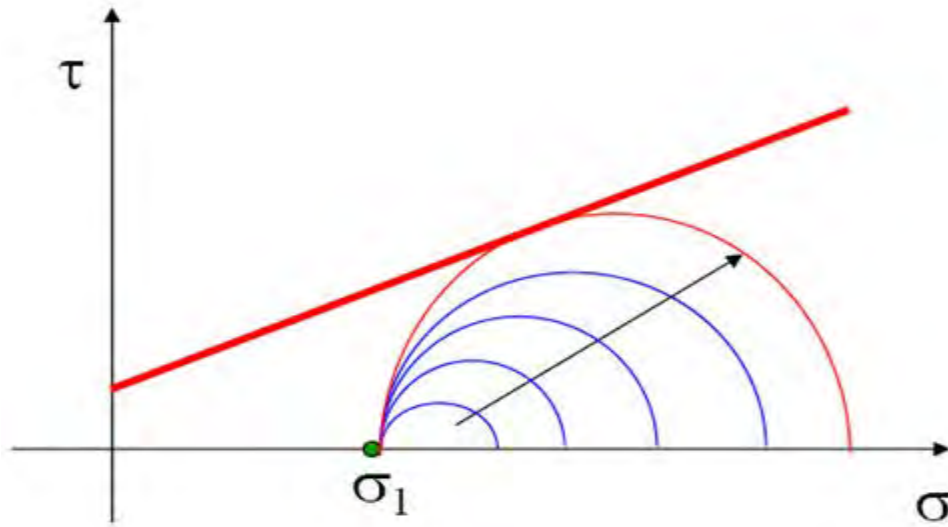

Figure 2.4. Mohr circles for different stress condition

Source: Rajani et al. (2000)

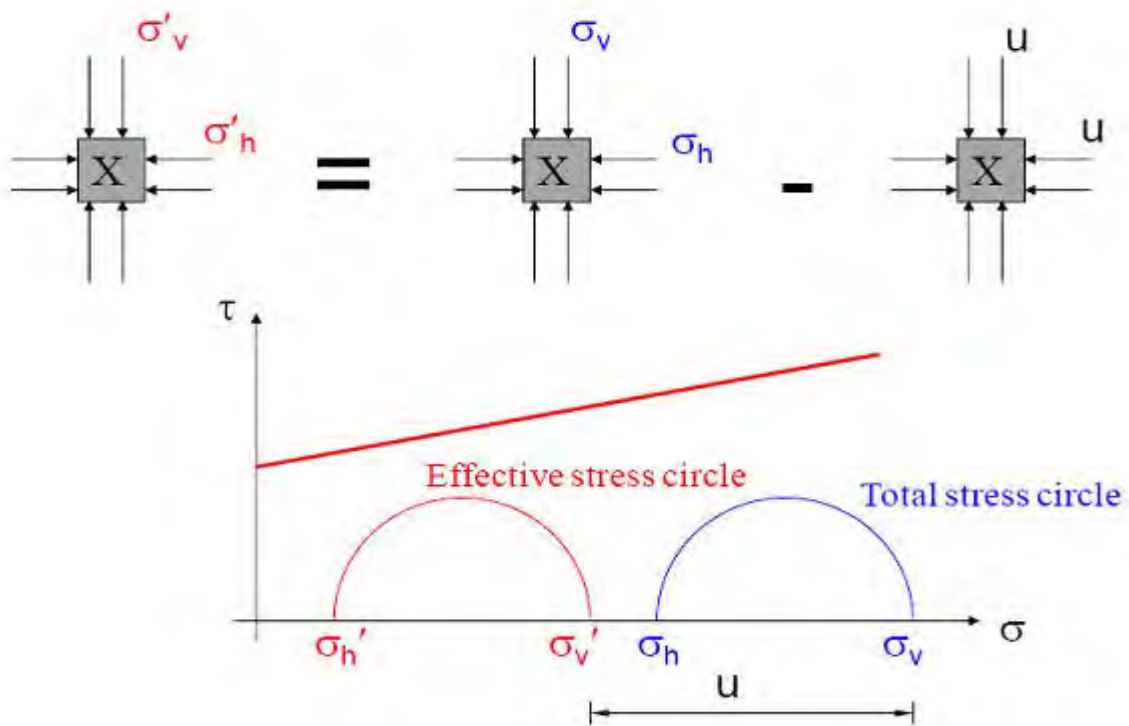

Figure 2.5. Mohr circles for total stress and effective stress condition

Source: Rajani et al. (2000)

2.3 Measurement of shear strength

Many types and variations of shear tests have been developed to measure shear strength of soils. In most of these tests the rate of deformation is controlled and the resulting loads are measured. In some tests, total stress parameters are determined while in others effective stress strength parameters are obtained.

2.3.1 Torsional shear test

Experience from past large-magnitude earthquakes (e.g., 1964 Great Alaskan, USA; 1964 Niigata, Japan; 1983 Nihonkai–Chubu, Japan; 1995 Hyogoken–Nambu or Kobe, Japan; etc.) indicates that extremely large horizontal ground deformation can occur in liquefied sandy deposits in coastal or river areas. When the lateral spreading of liquefied deposits takes place, the ground displacement may exceed several metres, even in very gentle slopes (e.g., Hamada et al., 1994) or in level ground behind retaining walls (e.g., Ishihara et al., 1996), resulting in severe damage to infrastructures and lifeline facilities. In order to thoroughly investigate the above liquefaction-induced large strain, Kiyota et al. (2008) modified a torsional shear apparatus for enlarging the range of torsional displacement, and performed a series of undrained cyclic torsional shear tests up to double amplitude shear strain (γ_{DA}) of about 100% on Toyoura sand specimens isotropically consolidated at different density states. The torsional shear device is designed to allow measurements at such large shearing strains. The soil is subjected to a normal stress, σ , and then the upper half of the box is subjected to a torque that causes the upper surface of the sample to rotate relative to the lower surface and thus a shearing stress is generated. A schematic diagram of the torsional shear device is shown in Fig.2.6.

This device has the advantage that theoretically unlimited shearing deformation can be applied without encountering any problems with area corrections, i.e., the area of the sample does not change as the soil shears. Strains in the sample vary linearly with radius so non uniform strains develop unless inner and outer radii are nearly the same, leading to an inconvenient sample shape. It has its application in earthquake geotechnical engineering.

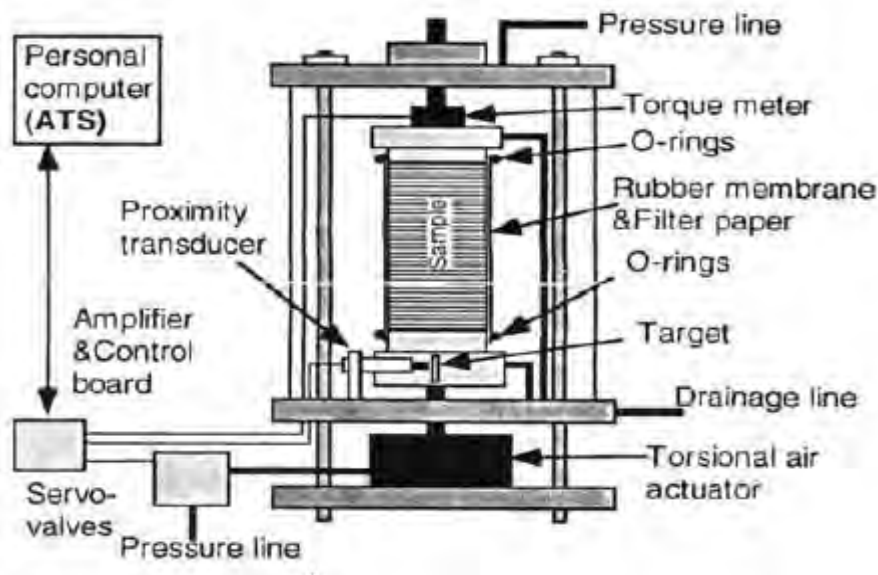

Fig. 2.6 Schematic diagram of the torsional shear testing system

Source: Nakagawa (1995)

2.3.2 Triaxial test

The triaxial test was developed by Casagrande in an attempt to overcome some of the serious disadvantages of direct shear test (Braja Das, 2012). These disadvantages include uncontrolled rotation of principal planes and stresses, the failure plane is forced to be horizontal and uncontrolled drainage. The triaxial shear device evolved over a period of years. Early devices with many of the characteristics of current triaxial devices were originated by Buisman (1924) and Hveem (1934) according to Endersby (1950), but the first device that resembled modern equipment was developed in the early 1930s by Casagrande at Harvard. A consensus developed during the late 1930s that the triaxial device was superior to the direct shear device and that view tends to persist today (Jiunnren Lai, 2004).

At Imperial College, London, Bishop and Henkel (1953) developed the so-called 'self-compensating mercury control apparatus' for applying cell pressure. Pressure comes from a column of mercury, and the unit weight of mercury is about 13.546 grams/ml at 20° Celsius. So the mercury pressure increases at a rate of about 5.87 psi per foot of elevation change. Mitchell (1981) developed a hydraulic system for testing rock or large diameter soil specimens (Janner Lai, 2004). The hydraulic system is ideal, because large loads can be generated with relatively

compact apparatus. The usual procedure is to use a single hydraulic cylinder, a high-pressure pump, and a set of metering valves. The valves can be computer-controlled so loads can be applied at any reasonable rate, and cyclic loadings are easily achieved. The hydraulic system is presented in Figure 2.7. In the 1990s, companies in the United States and the United Kingdom developed automated triaxial equipment as shown in Figure 2.8.

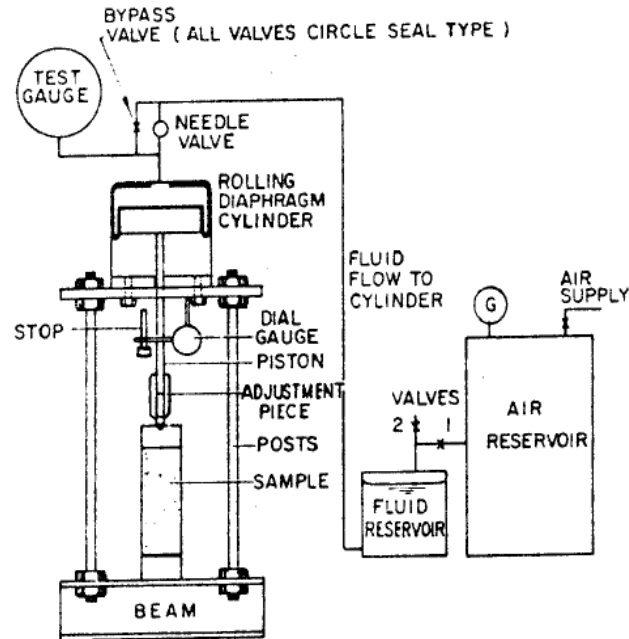

Figure 2.7 Triaxial Cell with Associated Hydraulic Loading System

Source: Mitchell (1981)



Figure 2.8 Fully Automated Triaxial Load Frame

Source: Geocomp

The fully automated shear apparatus programme the conduct of triaxial stress path tests on soils and soft rocks. This system operates by means of software, which automates all the stages involved in the test. This system also allows specifications of all steps required to perform a triaxial stress path test along any stress path test possible in a triaxial cell, including the ability to specify changes.

The test is called triaxial because the three principal stresses are assumed to be known and controlled. The three types of triaxial tests can be listed as follows: unconsolidated-undrained test (UU or Q) test; consolidated-undrained (CU or R) test and consolidated-drained (CD or S) test. The information, such as the shear strength parameters and the cohesion that is obtained from the triaxial test can be used to check the safety and predict the behaviours of long-term stability of slopes and earth fills and earth-retaining structures. The analysis carried out in terms of total stress obtained from an undrained test can be used to investigate the initial stability of the foundation of a structure or embankment on saturated clay. Alternatively, the analysis can also be used to determine the initial stability of an open cut or sheet piled excavation made in clay and the stability against the bottom heave of a deep excavation in clay. The triaxial test has the ability to control the drainage conditions so as to allow for different types of test (drained and undrained conditions) and measure pore pressure. Moreover, stability of relatively impervious rolled field can be investigated using the test Shawntiku, 2011. The shear strength parameters determined using triaxial test are more accurate than those obtained from shear box test because it allows soil to be sheared to failure along its natural weakest plane Shawntiku, 2011.

The triaxial test apparatus is elaborate, bulky and costly, the drained test takes place over a longer period in comparison with a direct shear test. A generalised response for normally consolidated clay is presented in Figure 2.9. This includes the excess pore pressure generated during a CU test, and an observed specimen volume change during a CD test. Figure 2.10 displays a cohesive specimen after completion of the shear stage, with the plane of failure highlighted (i.e. the plane in which the majority of shear strain occurs).

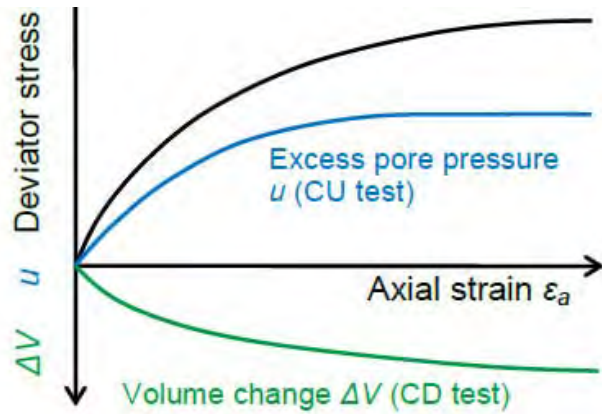

Figure 2.9 Generalised specimen response during shear for a normally-consolidated clay

Source: Ress (2012)



Figure 2.10 Cohesive specimen post-shear showing failure plane

Source: Ress (2012)

2.3.3 Ring shear test

A number of different forms of the ring shear apparatus have been developed, examples are: Hvorslev (1936 and 1939), La Gatta (1970), Bishop et al. (1971) and Bromhead (1979). However, the Bromhead (1979) ring shear apparatus is becoming more widely used because of cost and ease of operation. Bromhead and Curtis (1983) showed that this apparatus yields results that are in agreement with those obtained using the more sophisticated apparatus developed by the Norwegian Geotechnical Institute and Imperial College (Bishop et al., 1971).

In a ring shear test, an annular specimen is confined between the outer and inner rings and is sheared from its bottom or top, or mid-height surface, depending on the configuration and fixity of the rings, as illustrated in Figure 2.11. Both the split-ring and solid-ring devices are widely used especially in the United States, and both have advantages for specific types of testing. A fixed plate on the top surface helps in the measurement of the soil specimen's resistance to shearing.

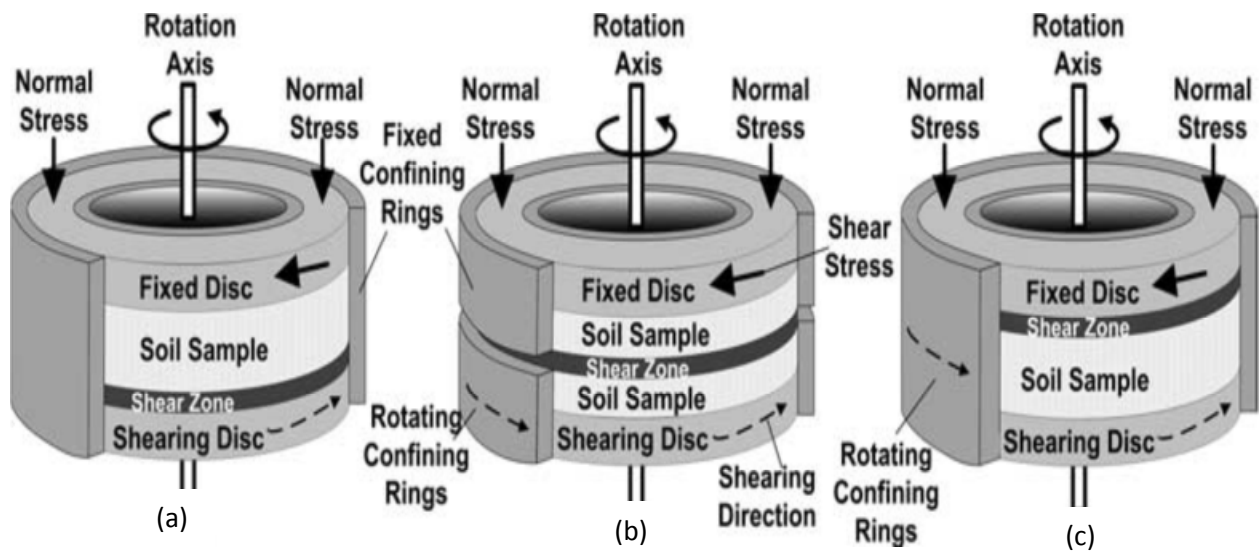

Figure 2.11 Schematic of ring shear test shearing mechanism in (a) solid-ring device with shear zone at the bottom of the specimen; (b) split-ring device with shear zone at mid height; (c) solid-ring device with shear zone at the top of the specimen. (Reproduced from Abouzan and Scott, 2009)

The ring shear test is designed in such a way that the total normal load and shear torque that is transferred through the soil across the plane of relative rotary motion is accurately known, thus, where appropriate, friction forces in the apparatus are demonstrably minimised or are

measured (Bishop et al., 1971). The ring shear test provides many advantages for measuring the large displacement shear resistance of sands. These include the ability to shear a sample uninterrupted to virtually unlimited displacement; ability to apply known shear stresses on a horizontal (depositional) shearing plane; the ability to continuously rotate (although uncontrolled) principal stress directions; the ability to consolidate a specimen prior to shear and the ability to accurately track volume changes because changes occur only in one dimension. The cross-sectional area of the shear plane remains unchanged during shearing and the geometry of the test specimen remains unchanged during shearing. In a ring shear test as opposed to the specimen in triaxial test where shape changes from rectangular to nearly an ovoid.

There are a number of limitations associated with this test, however including potentially non- uniform stress and strain distributions, potential soil extrusion, and wall friction (Abouzan & Scott, 2009). Figure 2.12 explains peak and residual shear strength parameters of ring shear test. If shearing is continued after the peak point to the maximum displacement of the apparatus, a curve of the type shown in Figure 2.12 for the brittle material is obtained (Manual of Soil Laboratory Testing, 1994). The shear strength at first reduces rapidly from the peak value, but eventually reaches a steady state (ultimate) value, which is maintained as the displacement increases.

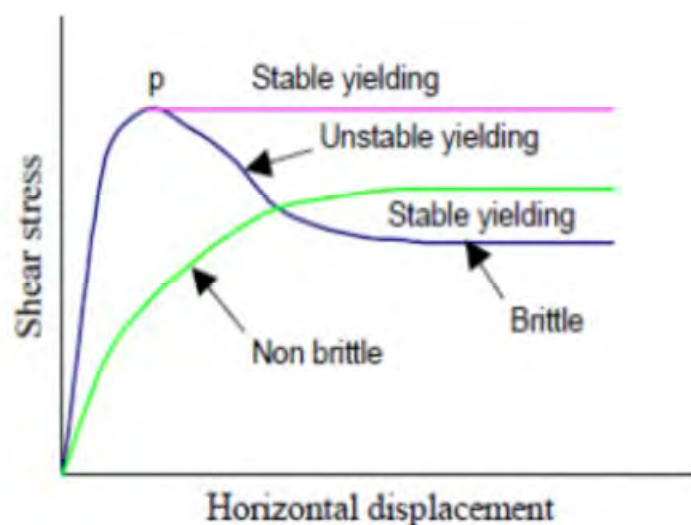

Figure 2.12 Typical graphs from ring shear test (reproduced from Osano, 2010).

2.3.4 Direct shear test

This is the oldest and simplest type of a laboratory shear test. The direct shear box test is a conceptually simple test that apparently was used for soil testing as early as 1776 by Coulomb (Lambe & Whitman, 1969) and was featured prominently by French engineer Alexandre Collin in 1846 (Skempton, 1984). In Britain, Bell (1915) made the earliest measurements and constructed a device which was to be the prototype for subsequent developments of the shear box. Bell was the first to carry out and publish practical results of shear tests on various types of soils (Skempton, 1958). A modern shear box was designed by Casagrande at Harvard (USA) in 1932. A constant rate of the displacement machine that applies the 'strain control' principle using a fixed speed motor, was developed in 1946 (Matthew, 2000). Bishop (1946) introduced the improvements of design using this principle in details. Vickers (1984) developed another shear box apparatus as shown in Figure 2.13. The shear box can perform both the drained and undrained test. The picture of a manual shear box apparatus is presented in Figure 2.14 and the fully automated shear box is presented in Chapter 3.

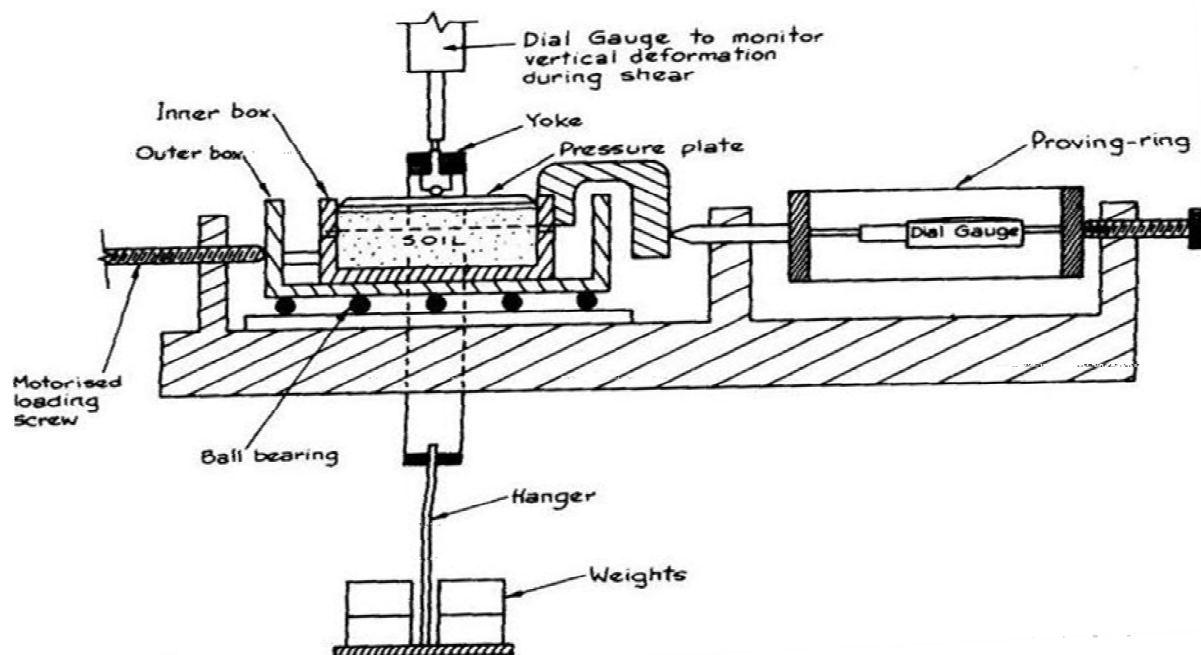

Figure 2.13 Shear box apparatus

Source: Vickers (1984)



Figure 2.14 Direct shear apparatus (manual)

Source: Das (2012)

There are many devices used to perform the direct shear test. In the direct shear test, a soil sample is placed in a shear box consisting of two parallel boxes. The lower box is fixed while the upper box is moved parallel to it in a horizontal direction. The soil fails by shearing along a plane assumed to be horizontal (Guyer, 2010). As shown in Figure 2.15, the displacement causes a reduction in the cross sectional area of the sample.

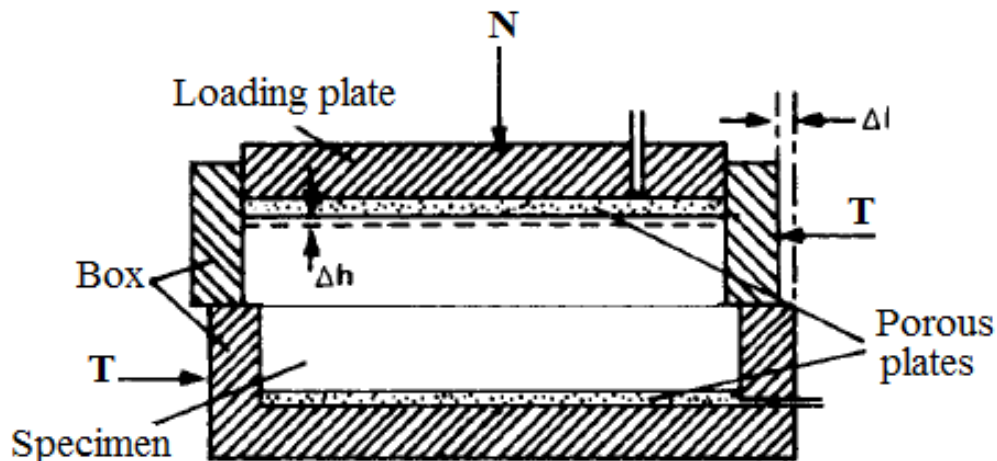

Figure 2.15 Shear box test

Source: Vickers (1984)

The purpose of the direct shear test is to establish the ultimate shear resistance, peak shear resistance, cohesion, angle of shearing resistance and stress-strain characteristics of the soils. Shear parameters are used in the design of civil engineering structures. These parameters, among others, are used to calculate the bearing capacity of soil-foundation systems, estimate the earth pressures behind the retaining walls and check the stability of natural slopes. The results for typical direct shear tests on dense and loose specimens of cohesionless soil are presented in Figure 2.16.

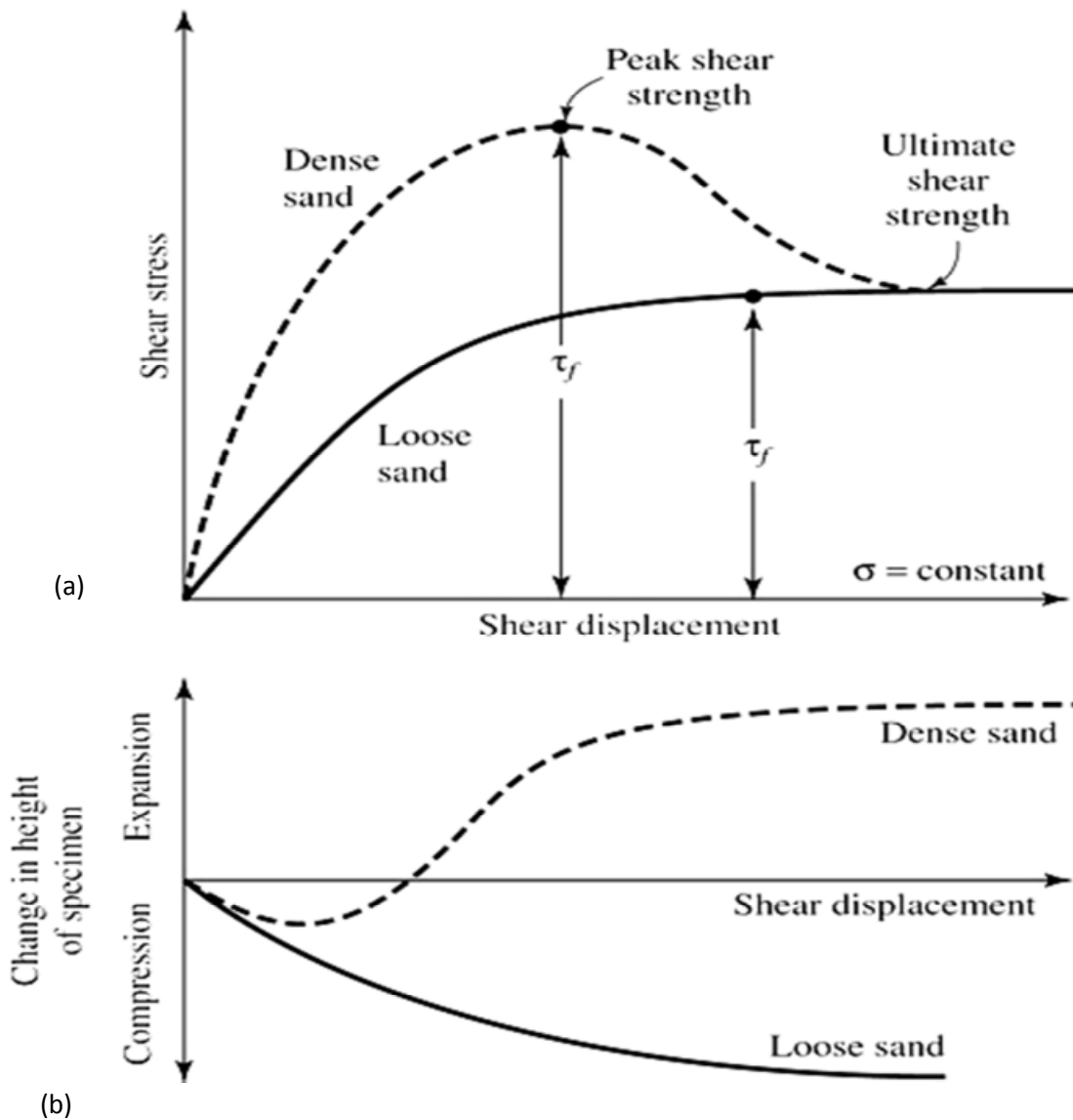

Figure 2.16 Typical deformation results from a direct shear test on loose and dense cohesionless soil specimen.

The peak shear strength and ultimate shear strength points are marked. Depending on the material density and normal stress level, the peak may be well defined or it may coincide with the residual condition. In all cases, the vertical displacement should be constant at the residual condition.

The advantage of the direct shear test over other shear tests is seen in the simplicity of the setup and the equipment used, and the ability to test under differing saturation, drainage, and consolidation conditions. There is a sample non-uniform stress and strain distribution. The vertical compressive load applied on the top is not completely transferred to the sample. The actual distribution of a normal load on a shear plane is unknown in the test and it cannot be performed under the constant volume condition (Amsiejus et al., 2013).

2.2.5 Direct simple shear test

In 1936, the Swedish Geotechnical Institute (SGI) built the first direct simple shear device that was able to uniformly deform a soil specimen in pure shear (Kjellam, 1951). This device confined specimens using a rubber membrane and aluminium rings. There have been many additional direct simple shear devices built since then.

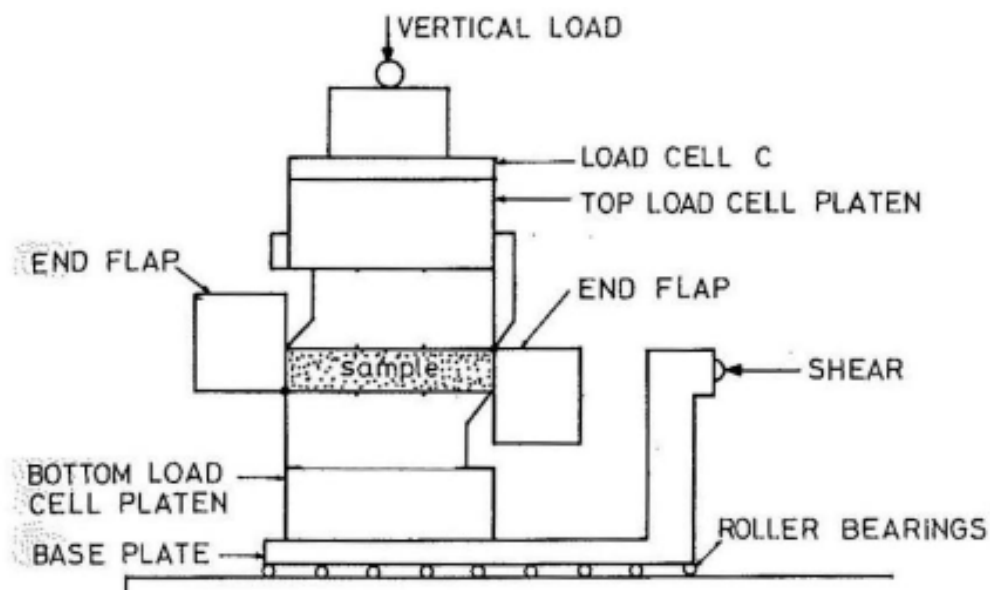

Figure 2.17 Cambridge direct simple shear testing cubical sample

Source: Roscoe (1953)

A device that used a square box for sand specimens, was designed at the University of Cambridge in 1953 (Figure 2.17). In the 1960s the Norwegian Geotechnical Institute (NGI) created a device that was able to strain in simple shear after vertical loading while using a rubber membrane reinforced with a wound wire encased by the rubber membrane (DeGroot et al, 1992).

Data acquisition and control systems became relatively inexpensive in the 1990s, and several companies in the U.S. and the United Kingdom developed automated triaxial, direct simple shear, consolidation, and cyclic equipment. These companies sell direct simple shear equipment exclusively with stacked rings to avoid the high costs of wire-reinforced membranes.

The principle of the test is inducing direct shear in a cylindrical soil sample which is confined by a flexible rubber membrane, usually inside metal rings. After the sample is placed between the base pedestal and the top cap, vertical stress is applied to the sample from the top cap. The sample is sheared by moving the rings from side to side. In the direct simple shear test, the cross-sectional area remains the same as shown in Figure 2.18.

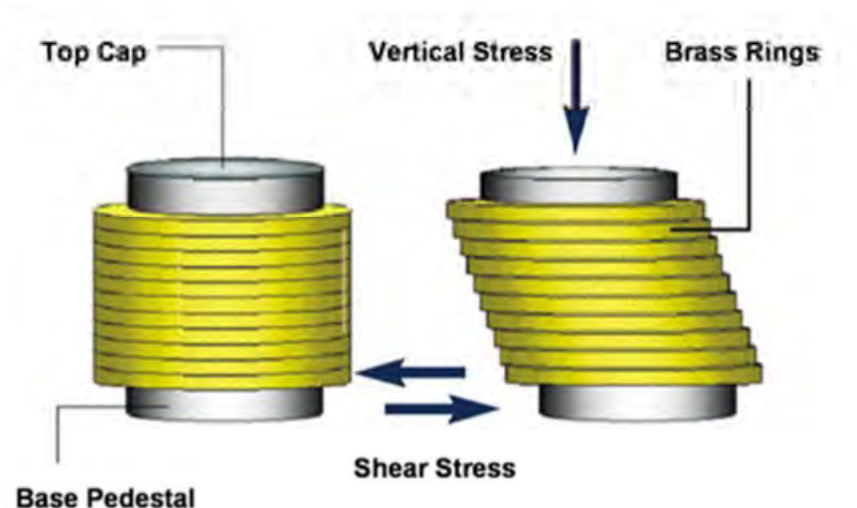

Figure 2.18 Principle of the direct simple shear test

Source: Imre (2001)

The direct simple shear test is especially important for the research of weak types of soil (clay and peat) in areas where the risk of shearing has to be determined. A direct simple shear test has the same initial stress state as a direct shear test, but avoids the stress concentration

occurrences seen with direct shear (ASTM, 2000). Examples of applications of a direct simple shear test and some typical graphs from the test results are presented in Figures 2.19 to 2.22.

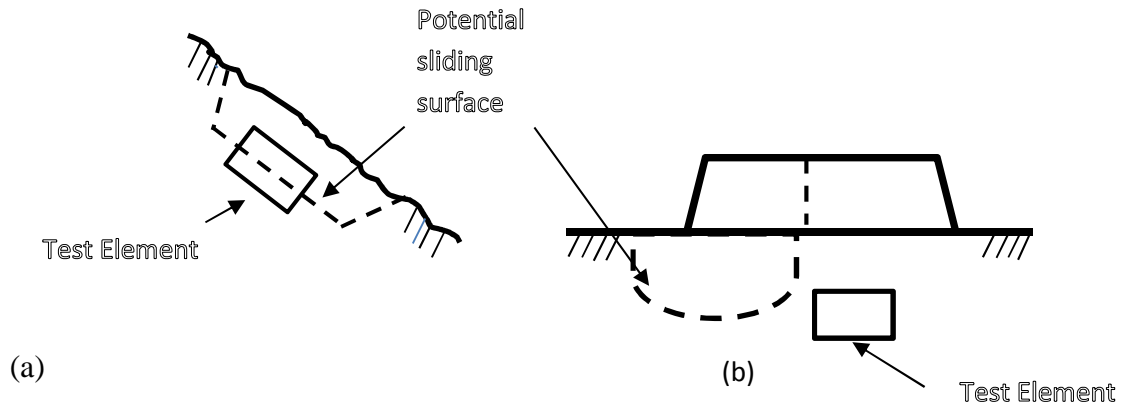

Figure 2.19 Stability of slope

Adapted from: Morten and Rune (2007)

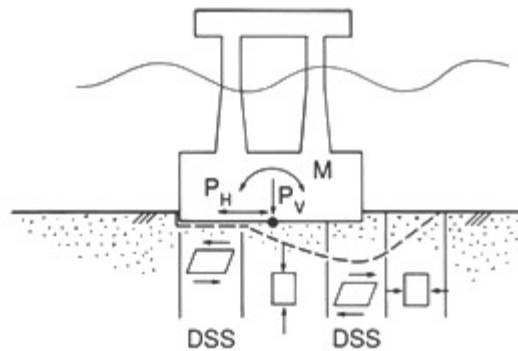

Figure 2.20 Cyclic loading of gravity base structure

Source: Morten and Rune (2007)

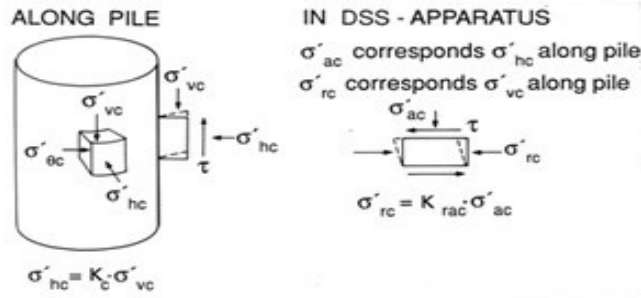

Figure 2.21 NGI pile design method, static and cyclic testing of remoulded and undisturbed soil

Source: Morten and Rune (2007)

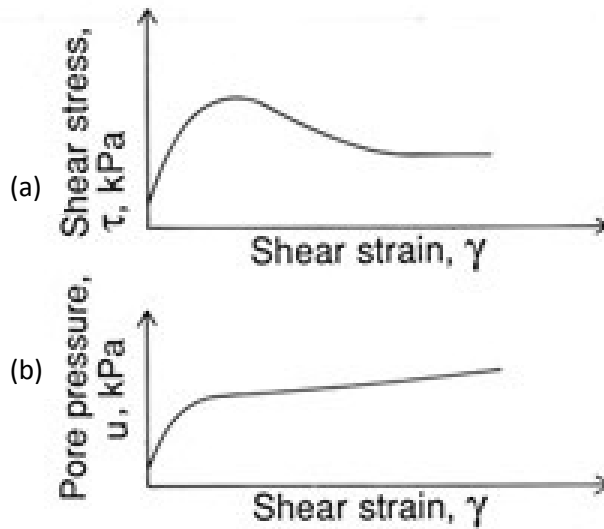

Figure 2.22 (a) and (b) Typical graphs on direct simple shear

Source : Morten and Rune (2007)

Direct simple shear has the ability to test either undisturbed or reconstituted specimens. The testing methods and sample preparations are well established. It has the capability to shear under stress or strain-controlled conditions and to rotate principal stress axes during shear. The area of shear remains constant, sidewall friction is also eliminated. The shear-induced lateral deformations are distributed fairly uniformly over the specimen height and cross section. However, the magnitude of shear displacement that can be imposed on a specimen is limited by the device itself, and limited further due to the possibility of ‘pinching’ at the specimen corners

where acute angles form (Kramer et al., 2002). Furthermore, the lack of complementary shear stresses on the sides of the specimen requires that the moment produced by the horizontal shear stresses are balanced by non-uniformly distributed normal and shear stresses. As shearing progresses, the non-uniformities of normal and shear stress distributions increase. Hence, the post-peak shear resistance is reliable only to a limited displacement (Saada & Townsend, 1981).

2.4 Overview of shearing methods.

Shear strength is an inherent property of soil mass. Various engineering approaches are available for shear strength testing of soil. Some of the laboratory shearing methods involved in shear strength testing of soils such as triaxial shear, torsional shear, direct shear, simple shear and ring shear have been presented.

Shear tests have been developed in order to investigate the failure of soil, which occurs by sliding along a surface when a critical value of shear stress is reached. The direct simple shear device was developed as an improvement to the direct shear box. In both devices, shear is applied directly to a soil sample, unlike the triaxial device in which shear develops from a difference of applied principal stresses (Matthieu Grognet, 2011). Although the direct application of shear stress closely mimics many modes of shear, the direct shear device in particular suffers from inhomogeneity of the applied stresses and resultant strains. In the direct simple shear device, these are alleviated, but not completely removed.

There has been an increasing interest worldwide in direct shear test and direct simple shear test, due to the relatively simpler testing procedure and partly also to observations made in the stability test (Airy et al., 1985; Franke et al., 1976) as well as to the requirement of determining shear strength parameters (Imre Szabo, 1994). It is by no chance that in 1987, *Geotechnique*, a leading review of soil mechanics, devoted a special volume to engineering applications of direct shear test and direct simple shear tests (Imre Szabo, 1994). The evaluation suggests that direct shear and simple shear devices are best utilized by engineers who have gained experience applying the results from such tests to structures that have behaved satisfactorily (Saada et al., 1981). Based on this and that the two tests closely mimic many modes of shear, only direct shear and direct simple shear test were considered for this research.

2.5 Previous studies on direct shear test and direct simple shear test

2.5.1 Effects of relative density on friction angle using the direct shear test

Amy and Alan (2006) performed a study on specimen size and scale effects on direct shear box tests of sands. Five sands with different properties were tested in three square shear boxes of varying sizes (60 mm, 101.6 mm, and 304.8mm), each at three relative densities dense, medium, and loose. Three of the sands were clean sands with significantly different values of D_{50} . The other two sands were natural sands found in the Connecticut Valley and McLean, Virginia.

The sands used in this investigation were characterised using specific gravity, maximum and minimum density, grain-size, and two dimensional (2D) image analysis tests. Direct shear box tests were performed on each soil in general accordance with ASTM D 3080-90. According to ASTM D 3080-90, the direct shear box test has several particle-sizes to box-size requirements when preparing specimens for testing.

Three different size shear boxes were used, the first square shear box had a width of 60 mm and a depth of 26.4 mm (aspect ratio, $H/L=0.44$). The samples were sheared at a constant rate of 0.25 mm/min, which is consistent with the standard rate for drained tests on sands. Tests were conducted in a water bath with the sample completely submerged to ensure that the samples had no cohesion. This was identical to the testing protocol of the surface footing tests. The thickness of the 60 mm shear box did not meet the ASTM minimum criteria of six times the maximum particle diameter, or 30 mm (maximum particle size was 5 mm), for the Winter Sand or Gravel Pack #3. The second square shear box had a width of 101.6 mm and a total depth of 40.64 mm ($H/L=0.40$). In the two smaller boxes, five tests were performed for each density with five increasing normal stresses (38, 68, 95, 122, and 150 kPa), using a dead-weight system. The third square shear box had a width of 304.8 mm and a depth of 177.8 mm ($H/L=0.58$). Five shear tests were performed for each density at five varying normal stresses (69, 103, 138, 172, and 207 kPa) for each relative density. These normal stresses in the larger box are slightly different from the normal stresses used in the two smaller boxes because the hydraulic arm of the 304.8 mm shear box could not apply a normal stress less than 69 kPa.

Two sands were prepared by moist compaction, two sands were prepared by dry pluviation and the Gravel Pack was prepared by dry compaction. The Summary of sample preparation techniques is presented in Table 2.1. The specimens in the two small shear boxes

were pluviated using a stationary pluviator with a constant fall height of 36.8 cm. This height was chosen because a large range of relative densities could be achieved with this fall height (25 to 100 %), constant relative densities were achieved at one particular angle and mesh setting, and the relative density was consistent throughout the thickness of the sample specimen. This fall height was 14 and 9 times greater than the shear box thickness respectively.

Table 2.1 Summary of sample preparation techniques in the direct shear box testing programme.

Box Size (mm)			
Sand Type	60	101.6	304.8
Brown Mortar	Moist Compaction	Moist Compaction	Moist Compaction
Winter	Moist Compaction	Moist Compaction	Moist Compaction
Ottawa	Stationary Pluviator	Stationary Pluviator	Traveling Pluviator
Morie	Stationary Pluviator	Stationary Pluviator	Traveling Pluviator
Gp#3	Dry Compaction	Dry Compaction	Dry Compaction

In most tests, the failure envelope went through zero because the tests were run under saturated conditions. However, in some of the dense well-graded specimens, the failure envelope showed some amount of cohesion ($c=1.5$ to 20 KPa). The friction angles were calculated accordingly. It is recognised that a failure envelope may show curvature, depending on relative density over a large range of normal stresses.

However, within the stress range used in these tests, the Mohr-Coulomb (M-C) failure envelope was reasonably linear. The friction angle was obtained by linear regression. Friction angles were obtained as a function of the shear stresses at the end of each test. The vertical displacement results were checked to make sure a constant volume state (no additional vertical displacement) had been reached, and at this point of no volume change the friction angles were obtained.

Five sands with different properties were tested in three square shear boxes of varying sizes, each at three densities: 1.96, 1.65, and 1.41 Mg/m³. The friction angle was seen to increase

with increasing relative density in each of the three boxes. The constant volume (residual) friction angle decreased or remained constant, with increasing box size dependent on the type of sand and the relative density. The results show that loose specimens (1.41Mg/m^3), as well as dense specimens (1.96 Mg/m^3) were affected by box size. The friction angles of the well-graded angular natural sands and the angular poorly graded manufactured gravel pack, GP#3, were most affected by specimen size. The constant volume friction angle of the Ottawa Sand, which was the most rounded and uniform sand, was only slightly affected by specimen size.

Results of the direct shear tests show that the friction angle can be dependent on specimen size and that the influence of specimen size is also a function of sand type and relative density. The tests indicated that for well-graded, angular sands, friction angle decreases as box size increases and that the influence of box size is dependent on relative density. The constant volume friction angle for each sand at each density in all three boxes are presented in Table 2.2

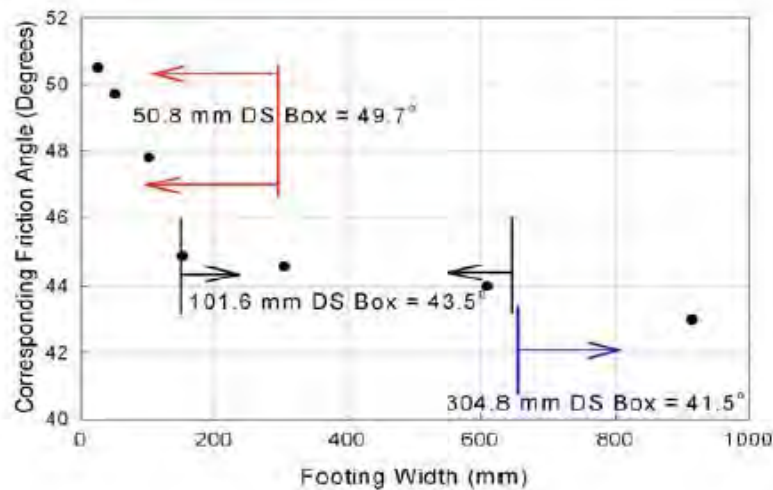

Figure 2.23 shows the relationship between shear box scale effect and footing scale effect

Source: Amy and Alan (2006)

Table 2.2 Direct shear box testing results using the constant volume shear strength

Source: Amy and Alan (2006)

Box Size (mm)					
Sand Type	d(Mg/m ³)	Df (%)	59.9 (deg)	101.6 (deg)	304.8 (deg)
Brown Mortar	1.44	13	36.5	28.5	26.1
	1.52	43	37.3	36.5	34.0
	1.62	75	39.7	38.4	38.0
Winter	1.71	34	47.4	42.0	40.2
	1.83	66	49.7	43.5	41.5
	1.92	91	51.6	45.0	46.0
Ottawa	1.6	23	30.7	30.05	30.3
	1.68	56	35.0	35.0	35.0
	1.76	86	36.0	36.0	36.3
Morie	1.51	25	38.01	37.0	36.0
	1.56	55	38.5	38.5	37.0
	1.61	65	40.5	39.2	37.5
Gp#3	1.46	25	42.0	36.5	34.0
	1.50	55	44.5	42.0	40.2
	1.54	85	45.5	43.0	42.0

2.5.2 Effects of particle size on friction angle using the direct shear test

Esma et al (2013) performed a study on the contribution of particle size to sand friction angle. The studies involved the correlation between certain physical properties of granular material such as the friction angle and the grain size distribution. Direct shear tests were performed on actual marine sand of Tergha (Algeria) and on seventeen different samples obtained from the same sand with various particle size ranges.

The study followed three stages which included separation of the various particle size ranges constituting the tested sand; the reconstitution of ten samples with different percentages from the seven particle size ranges; the realisation of direct shear tests on Tergha and seventeen

other samples derived from it. Table 2.3 presents the various grain size properties of the various reconstituted samples.

Table 2.3 Granular properties of test samples

Sample 1	d_{10} mm	d_{30} mm	d_{60} mm	UC	CC	e_{max}	e_{min}
Sample 1	0.16	0.22	0.41	2.50	0.75	0.709	0.45
Sample 2	0.21	0.24	0.30	1.42	0.93	0.811	0.535
Sample 3	0.18	0.28	0.38	2.13	1.16	0.737	0.474
Sample 4	0.15	0.34	0.54	3.66	1.43	0.64	0.393
Sample 5	0.16	0.23	0.60	3.64	0.53	0.641	0.394
Sample 6	0.14	0.17	0.31	2.28	0.63	0.725	0.464
Sample 7	0.31	0.63	0.86	2.74	1.46	0.693	0.437
Sample 8	0.17	0.2	0.31	1.88	0.76	0.76	0.493
Sample 9	0.16	0.23	0.54	3.37	0.63	0.655	0.405
Sample 10	-	-	-	-	-	-	-
Uniformity Coefficient = UC							
Coefficient of Curvature = CC							
Maximum Void Ratio = e_{max}							
Minimum Void Ratio = e_{min}							

Direct shear tests were applied to the eighteen samples referred to above (one of actual Tergha sand, seven samples with different particle size ranges and ten reconstituted samples with random percentages of particle size ranges). The tests were carried out on sand in a dry and dense state. The line of rupture was determined following the application of five normal stresses (100, 200, 300, 400 and 600 kPa) to obtain more precision for the statistical study. The result shows a direct relation between particle size and peak friction angle. It is noted that there is an increase in peak friction angle with the increase of particle size. The size of particles of marine sand can directly deduce the value of the peak friction angle. Results showed that the friction angle of sand is a result of the contribution of various constituent granular classes. The result of direct shear test on Tergha Sand is presented in Figure 2.24.

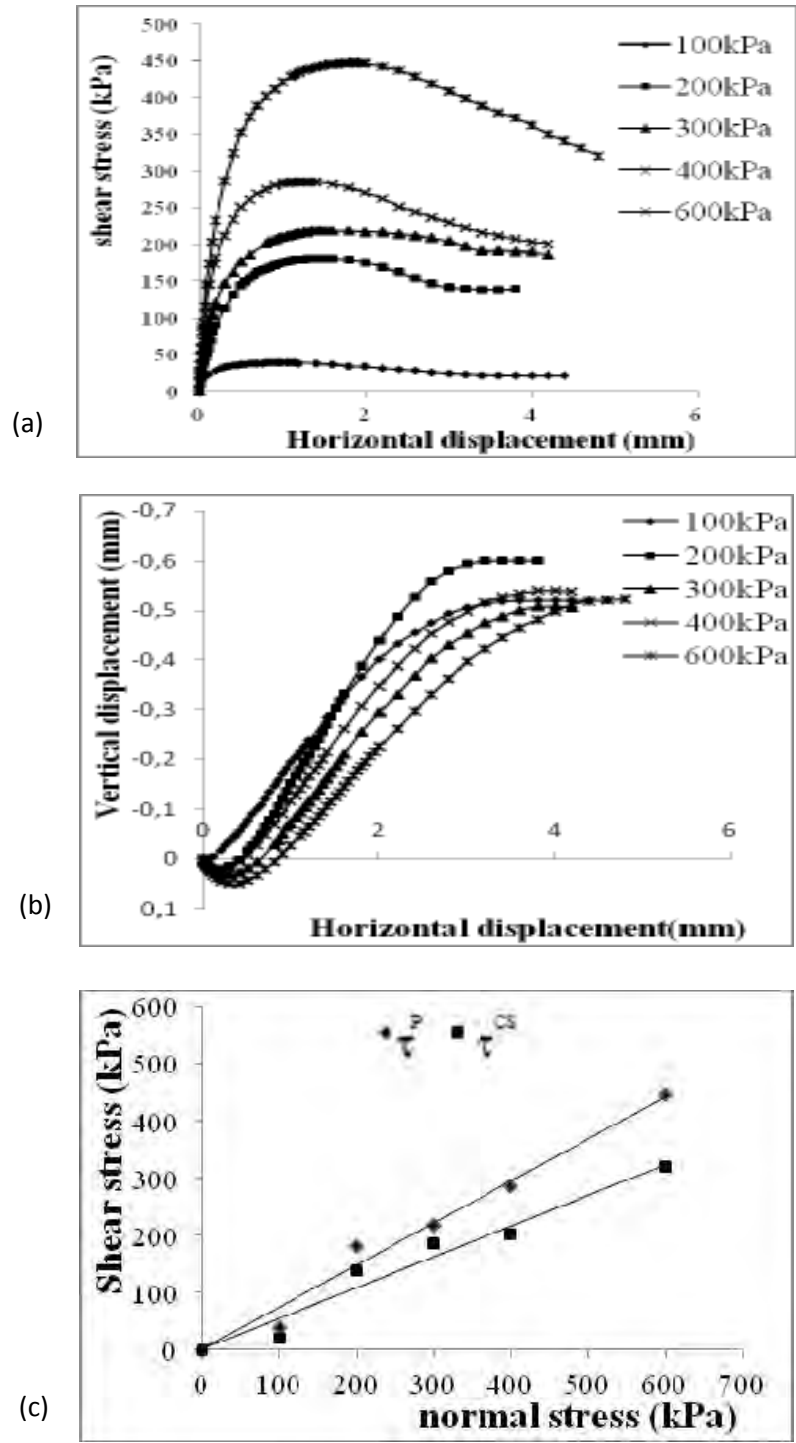

Figure 2.24 (a), (b) and (c) Results of direct shear test on Tergha sand.

Source: Esma et al (2013)

2.5.3 Effects of relative density on shear strength parameters using direct simple shear test

Sivadass and Lee (2008) performed a direct simple shear testing on residual soils with high silt content. These residual soils are the products of the insitu weathering of rocks due to the warm and wet climate of Malaysia. Malaysia's residual soils are composite soils of sand, silt and clay in varying proportions that depend on the geological setting of the soil. Because a general soil element in the ground can may experience varying directions and magnitudes of principal stresses, it becomes important to study the behaviour of soil samples in the laboratory under stress conditions in which a rotation of the principal axis can occur. Direct simple shear apparatus enables soil specimens to be tested in conditions in which the major principal stress axis rotates during shear while the specimen is kept under a condition of plane strain.

The soil used in the study was obtained from a construction site at the Universiti Tenaga Nasional (UNITEN) campus that is close to Putrajaya, the new government administrative centre of Malaysia. It consists of about 74% silt, 17% clay, 9% sand and no gravels. The specific gravity was 2.66. The maximum dry density obtained was 1.72 Mg/m^3 at optimum moisture content of 17.6%. The minimum dry density obtained was 0.93 Mg/m^3 . A conventional direct simple shear apparatus has been modified to be a computer-controlled testing system. This simple shear apparatus has three major components, namely, sample assembly, vertical loading system and horizontal loading system.

The soil samples used in the experiments were oven-dried and sieved to remove any particles larger than 2 mm. The reconstituted soil specimens were prepared by pouring a predetermined quantity of dried residual soils into the rubber membrane which was encased in a stack of metal washers at a constant height in order to achieve uniform density in each sample. A circular platen with a dimension of 70 mm was used in this study. The standard dry density used in the tests was about $1.05 \text{ Mg/m}^3 - 1.42 \text{ Mg/m}^3$. Gentle tappings were applied to the external body of the metal washers to minimise voids. Each soil sample was then saturated. A consolidation clamp had to be installed carefully, without causing disturbances to the sample prepared earlier. The applied normal stress in the tests varied from 50 kPa to 300 kPa. Upon completion of the primary consolidation, the sample was sheared at the rate of 0.24 mm/minute up to a maximum horizontal strain of 16%. The data acquisition and testing procedures were performed by using a computer software.

The results obtained for the respective circular soil samples (70 mm sample size) under different normal stresses were analysed to obtain the required shear strength parameters. It is observed that the shear stress increases as the normal stress increase as shown in figure 2.25. Shearing resistance in soils is the result of another across the contact area that increases as the normal force increases by Terzaghi and Peck (1967). The Hvorslev theory emphasised that an increase in effective stress will increase the particle-to-particle contact force, thus increasing the frictional resistance. During drained tests an increase in effective stress decreases the volume, thus increases the amount of interlocking. The volume change behaviour was always contractive to failure, even at higher normal stresses. The mechanism responsible for this volume change is the tendency of the soil particles to rearrange themselves during shear due to the expulsion of water. The amount of volume reduction was due to the compressibility of the loose silt.

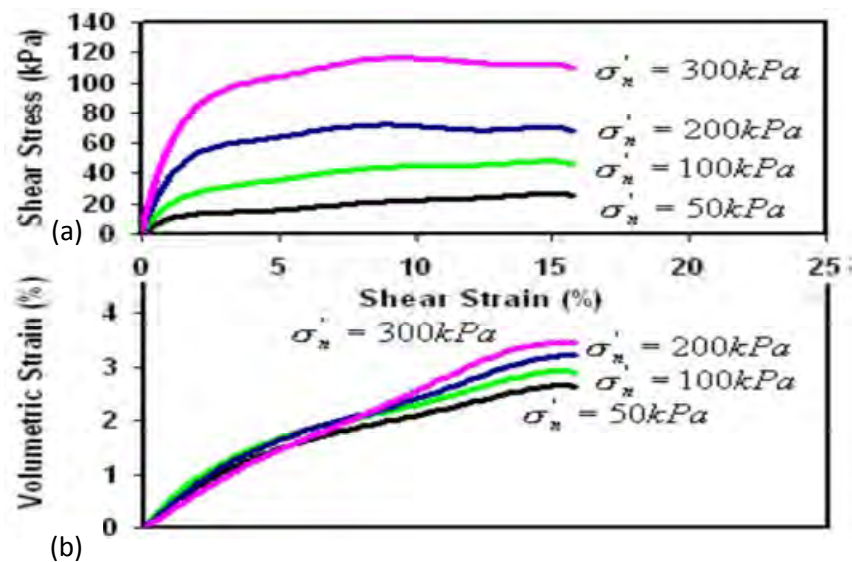

Figure 2.25 (a) and (b) Shear stress and volumetric strain variations at different normal stresses

Source: Sivadass and Lee (2008)

From Figure 2.26, by using Mohr-Coulomb failure criteria for tested silty soil, it was learnt that the cohesion c' is 9 kPa and angle of friction, σ , is 19° . From Figure 2.27 it was observed that the shear stiffness, G_{STIF} derived from stress-strain curve increases as the normal stress increases. The shear stiffness, G_{STIF} at a normal stress of 300 kPa, is about four times larger than that at normal stress of 50 kPa. Three different range of soil densities were tested: $D_r = 25\%$, $D_r = 50\%$ and $D_r = 75\%$. From Figures 2.28, 2.29 and 2.30, it was learnt that shearing

resistance increases as the relative density increases. For a given soil composition, increased density, as indicated by decreased void ratio, generally implies an increase in interparticle contact areas and, thus, in shearing resistance. It was found that loose specimen exhibits higher volumetric contraction compared to the medium and dense specimens. This behaviour is attributed to the higher degree of interlocking in the medium and dense specimens.

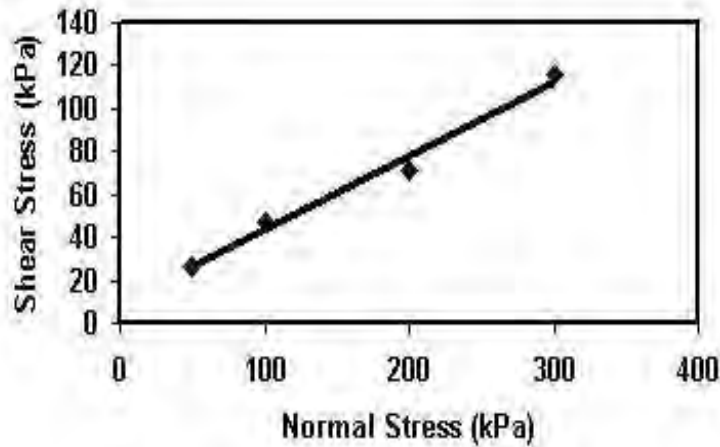

Figure 2.26 Mohr-Coulomb failure criteria (effect of normal stress)

Source: Sivadass and Lee (2008)

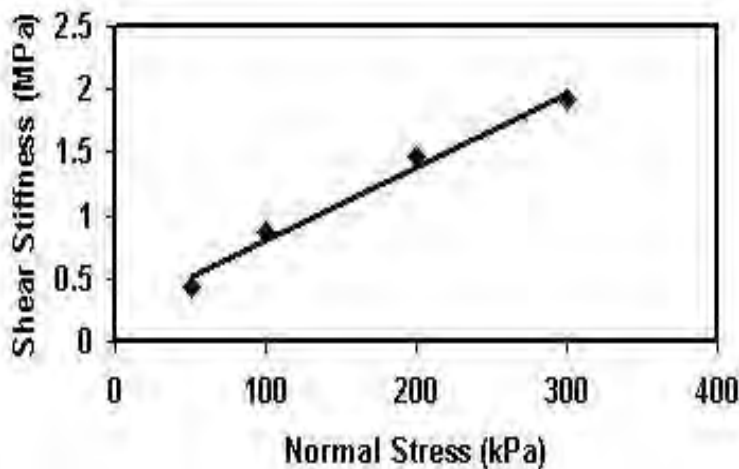

Figure 2.27 Influence of normal stress on shear stiffness

Source: Sivadass and Lee (2008)

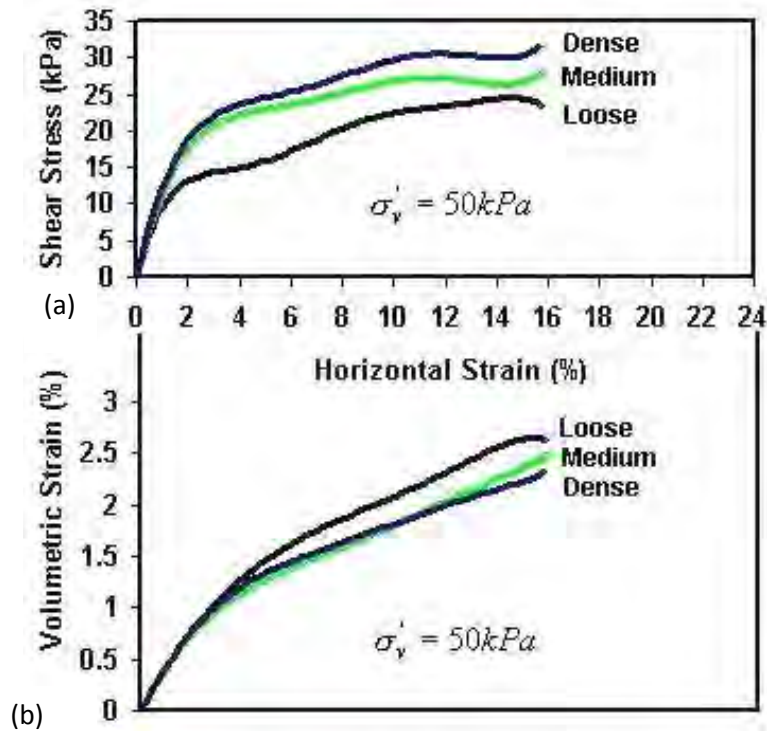

Figure 2.28 (a) and (b) Shear stress and volumetric strain variations (50KPa)

Source: Sivadass and Lee (2008)

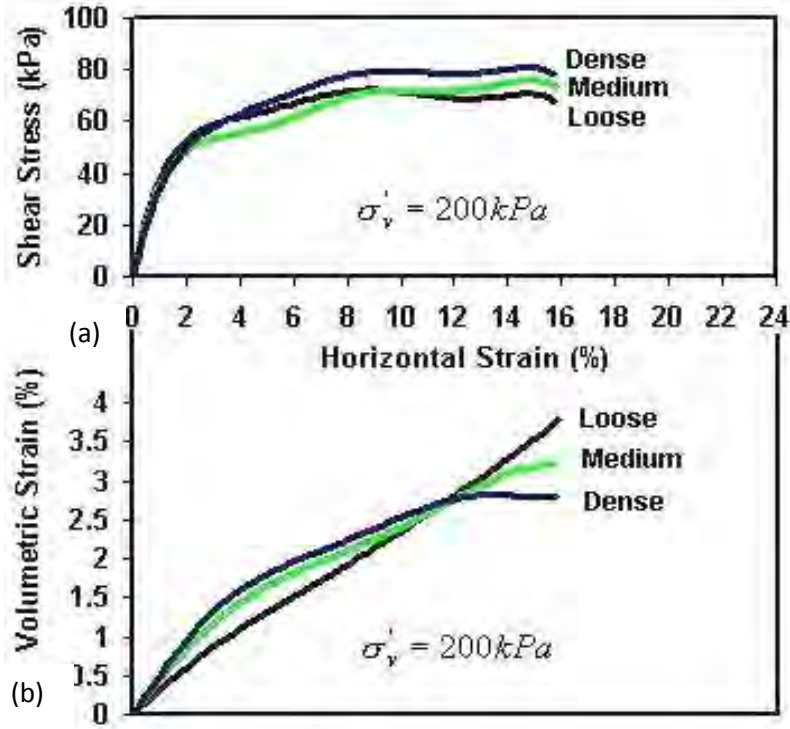

Figure 2.29 (a) and (b) Shear stress and volumetric strain variations (200kPa)

Source: Sivadass and Lee (2008)

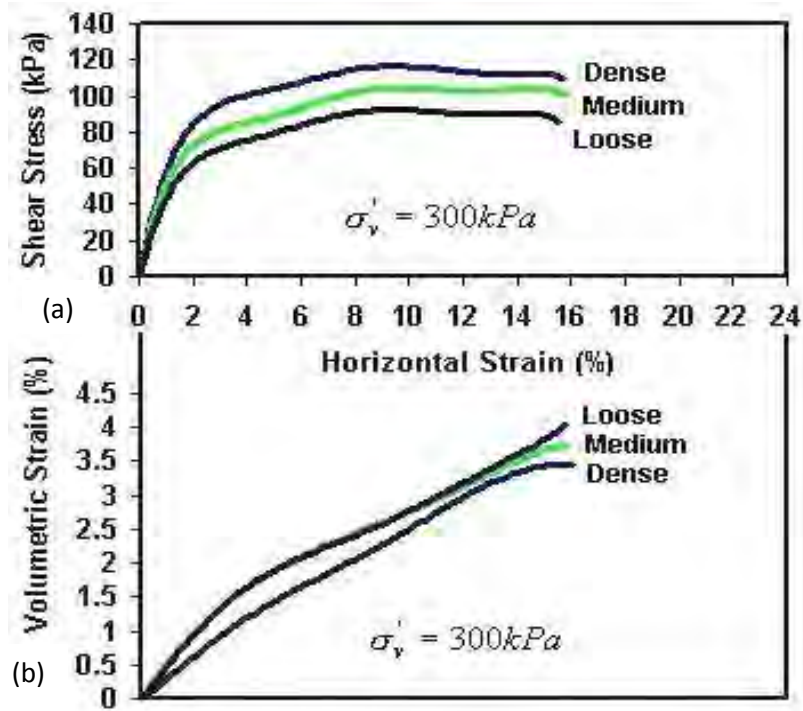

Figure 2.30 Shear stress and volumetric strain variations (300kPa)

Source: Sivadass and Lee (2008)

Figure 2.31 and those following it illustrate that as relative density increases, the shear strength parameters for silty soil increases. The obtained shear strength parameters are summarised in Table 2.4

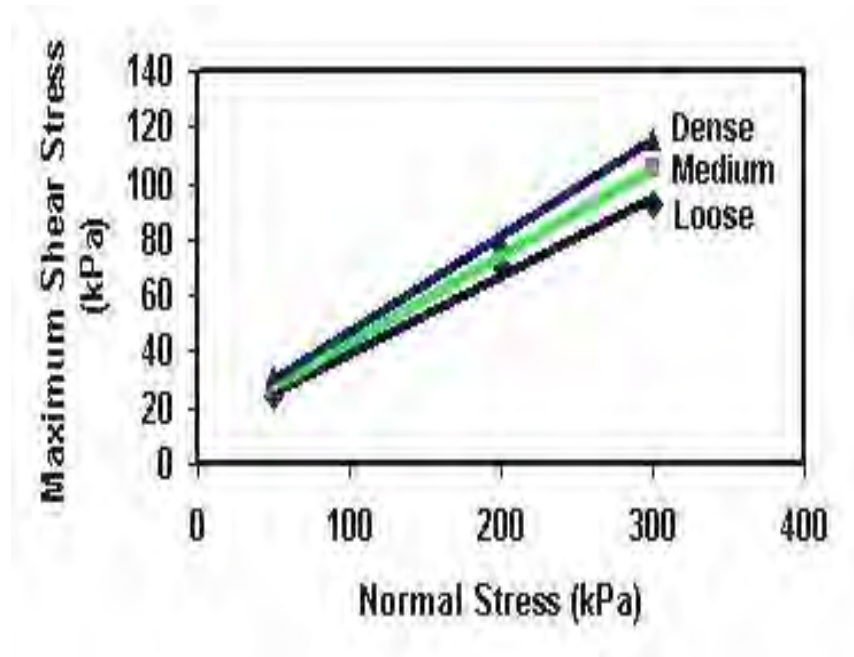

Figure 2.31 Mohr-Coulomb failure criteria (effect of relative density)

Source: Sivadass and Lee (2008)

Table 2.4 Shear Strength Parameters (Effect of Relative Density).

	Cohesion, c' (kPa)	Angle of friction, σ' ($^{\circ}$)
Loose ($D_r = 25\%$) 10 15	10	15
Medium ($D_r = 50\%$) 12 17	12	17
Dense ($D_r = 75\%$)	13	19

The study of shearing rate was conducted at a constant normal stress of 200 kPa at different shearing rates: 0.024 mm/minute, 0.08 mm/minute, 0.24 mm/minute and 1.2 mm/minute. Shear stress and volumetric strain increase as the shearing rate decreases. The test using a shearing rate of 0.024 mm/minute yields 15% more shear stress than the test using a shearing rate of 1.2 mm/minute. The mechanism that governs strain rate effects in soils relates to particle crushing, rearranging and consequent volume change tendencies. Higher strain rates do not allow as much time for particle crushing and rearranging, which makes the silty soil appear

less compressive. A shearing rate of 1.2 mm/minute used in the test yields the highest shear stiffness among the applied shearing rates.

It can be observed that the shear stress decreases as the over-consolidation ratio increases. For all soil samples, the residual shear strength was attained after large displacements. However, for soil sample with over-consolidation greater than 3, the tendency for the soil to exhibit dilating behaviour increases with increasing over-consolidation. This behaviour arises because soil particles must take up a suitable arrangement of packing corresponding to critical void ratio before continued shearing can take place. As the particles are initially more densely packed than the critical void ratio, some loosening will have to occur before steady shear can take place. A loosening of the packing requires an increase in void ratio and this corresponds to an increase in the overall volume (dilation).

The effect of an over-consolidation ratio was more significant on soil samples, which were initially consolidated at vertical stress, 100kPa. As long as the isotropic stress remains below the pre-consolidation pressure, when the stress state on a soil was increased, the deformation should be much less than if the soil were normally consolidated. A highly over-consolidated soil, therefore, should experience less strain than a normally consolidated soil under similar loading conditions. The amount of elastic strain under a given shear increment is controlled by the shear stiffness. As soils that are lightly over-consolidated to normally over-consolidate rarely experience purely elastic deformation, the effect of shear stiffness is much more noticeable in the highly over-consolidated soils.

It is found that for the Malaysian residual soil with high silt content, the shear stiffness derived from stress-strain curve increases as the normal stress increases. Loose specimen exhibits higher volumetric contraction compared to the medium and dense specimens. This behaviour is attributed to the higher degree of interlocking in the medium and dense specimens. As relative density increases, the shear strength parameter for silty soil increases. Shear stress and volumetric strain increase as the shearing rate decreases. Shear stress decreases as the over-consolidation ratio increases and, for all soil samples, the residual shear strength was attained after large displacements.

2.5.4 Effects of clay and moisture content for clay-sand mixtures using direct shear test

Muawia Dafalla (2013) investigated the effects of clay and moisture content on direct shear tests for clay-sand mixtures. The clay soil was brought from Al-Qatif town in the Eastern Province of Saudi Arabia. The sand material used is typical fine-grained sand used in construction in the country. Characterisation tests were carried out for Al-Qatif clay and the sand material. Classification tests included gradation, liquid limit, and plastic limit tests. The clay material was found to have a high liquid limit and plastic limit and classified within a CH group in accordance with the Unified Soil Classification System. The fine-grained sand and several sand clay mixtures were investigated for compaction properties. Standard compaction tests were carried out in accordance with ASTM D 698 to establish the compaction characteristics of sand-clay mixtures. The bentonite and the sand was obtained from Riyadh city.

The direct shear test was performed in accordance with ASTM standard D 3080 for 15 clay-sand mixture samples grouped in sets of three so as to allow for variations in moisture content and clay content. The shearing rate is between 1.2 to 1.3mm/min. All samples were prepared at the maximum dry density as obtained in a standard compaction tests. The moisture range considered for the clay sand mixtures is 15%, 17.5%, and 20% whereas for the sand alone 7%, 10%, and 13% were selected. The pure Al-Qatif clay was tested for three moisture contents, namely, 30%, 35%, and 40%, at a dry density of 1.2 Mg/m^3 . The moisture content values were all related to the initial state of the sample, as the drained test does not allow measurements of moisture during testing. It was observed that adding clay contributes to increase in the dry density of the mixture and an increase in optimum moisture content. The sand used is a poorly graded type, which contains more voids than well-graded type material. Adding small amounts of clay may therefore not be sufficient to fill up all the voids. The more clay added contributed to a higher unit weight. A decrease in shear strength as a result of increasing the moisture content for all normal stresses was observed. The general trends for varying clay content were found to be typical for all proportions except for the magnitude of change. For the two extreme clay contents tested, 5% and 15% clay sand mixtures, an increase in shear stress was observed. The presence of clay within the mix had a serious impact on the cohesion and the angle of internal friction. For moisture content slightly above the optimum, the clay addition improved the cohesion of the mix. This improvement may not be achieved if the moisture is far above the optimum moisture content. Figure 2.32 presents the influence of moisture content on friction angle and cohesion.

As shown in Figure 2.32, the 15% clay-sand mixture showed steep drop (6%) compared to 5% and 10% clay-sand mixtures where the drop was in the order of 2 to 3%. Figure 2.33 presents the influence of clay content on friction angle and cohesion. As shown in Figure 2.33, the 20% moist clay sand mixture is showing steep drop in both cohesion and angle of internal friction when the clay content is high. Testing clay sand mixture for as little as three different moisture contents and different clay contents can give a guide as to the strength properties of other mixes with variable moisture and clay contents. This approach can help in choosing the appropriate mix or applying corrections to the right quantity of clay to be added to achieve a certain shear strength. A very moist clay-sand mixture showed a steep drop in both the cohesion and the angle of internal friction when the clay content was high. An increase in the moisture content of Al-Qatif clay caused the cohesion to drop for 5% and 10% of the Al-Qatif clay-sand mixtures at a nearly similar rate, but the 20% clay mixture showed a very steep drop. Similarly, the angle of internal friction rate of drop increased for the 20% moisture content. An increase in clay can help increase the cohesion for 5% and 10% of Al Qatif clay. There will be limit for clay content beyond which the cohesion can drop due to high water content.

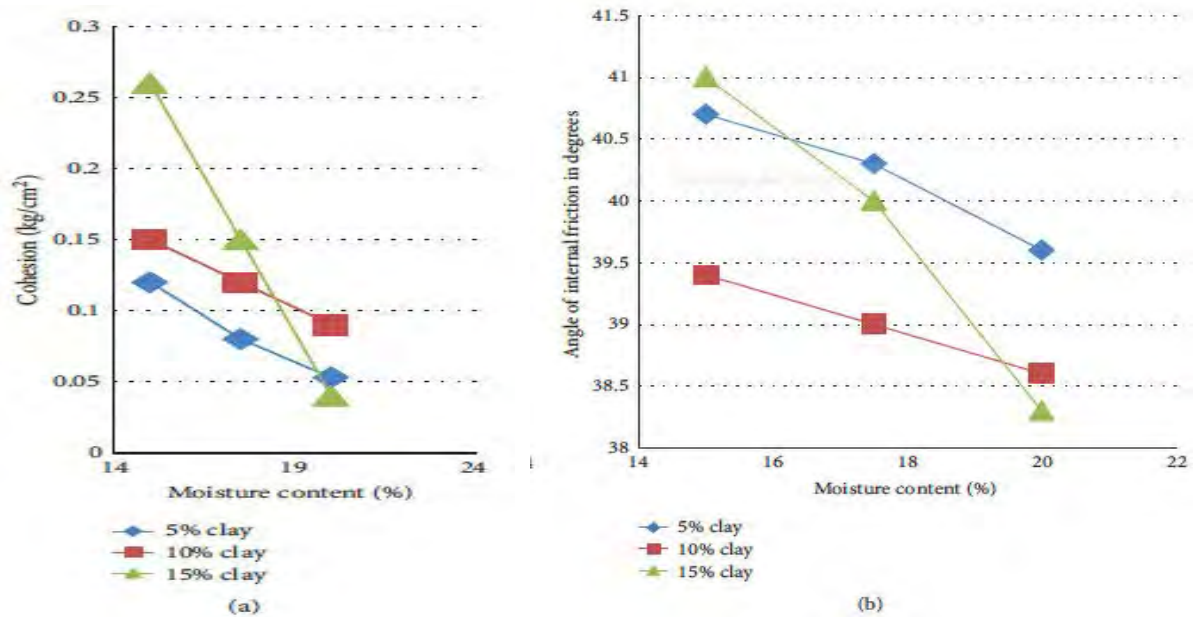

Figure 2.32 (a) and (b) Influence of moisture content on the angle of internal friction and cohesion Source: Muawia (2013)

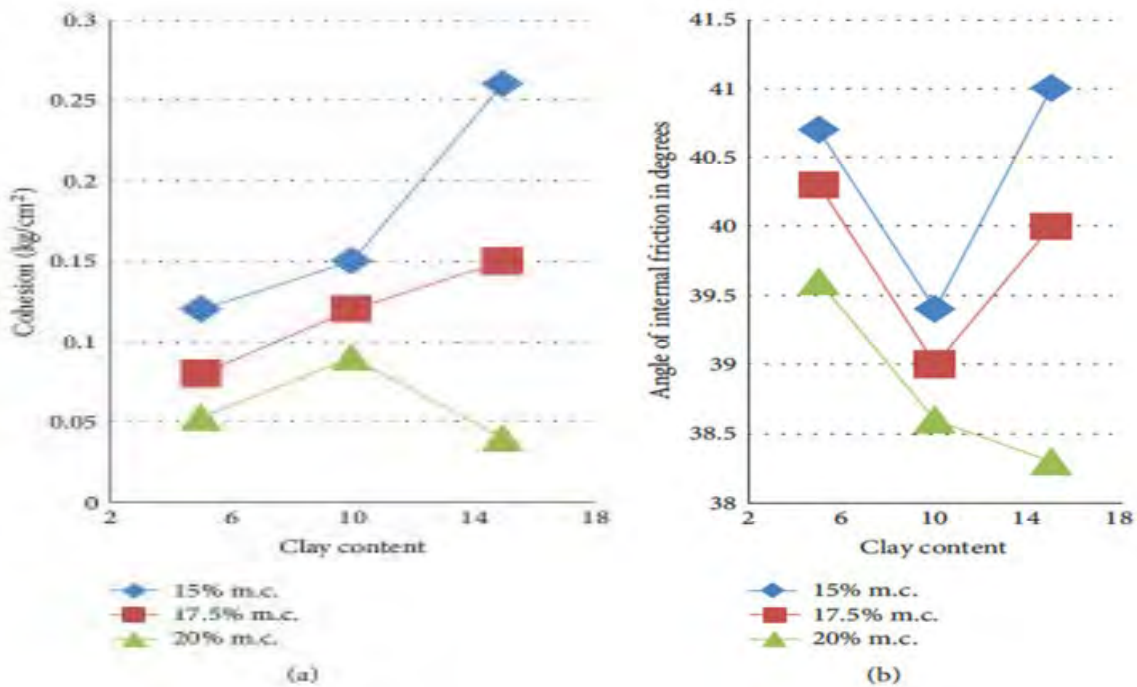

Figure 2.33 Influence of clay content on cohesion and the internal angle of friction

Source: Muawia (2013)

2.5.5 Effect of test quantity on shear strength parameters using direct simple shear test.

Sarunas and Arnoldas (2014) performed a direct simple shear testing on loose sand specimen (Klaipėda sand). The mineralogical composition of the sand was described basically by dominating ingredients, namely: 85% silica and 6% sunstone with remaining contribution of carbonate, mica and some other minerals (Amšiejus et al. 2010). This type of sand was selected due to the naturally higher smoothness and roundness of the sand grains (Dundulis, Gadeikis 2006; Medzvieckas et al. 2008). The air-dry Klaipėda sand sample was prepared from disrupted soil structure conforming an initial soil void ratio $e_0 = 0.784$. Determined solid density of sand sample was $\rho_s = 2.650 \text{ Mg/m}^3$. The test equipment used was the universal shear device ADS 1/3 (Wille Geotec Group 2010). Before shearing the soil sample was compressed (preloaded) by a constant vertical stress ramp of 50 kPa/min until the predetermined target vertical load levels (100; 200; 300 kPa) were reached. 36 tests were done in total, sheared equally among the 3 different above-mentioned vertical load magnitudes. The soil was sheared under the constant

horizontal displacement rate of 0.5 mm/min until the horizontal displacement at shear plane reached the limit of 9 mm (usually employed for safety of equipment) under constant vertical loading magnitudes of 100, 200 and 300 kPa, respectively. The tests were performed when the initial height of the gap between the upper and the lower shearing rings was 1mm. The determined soil peak shear stress values for 36 tests are given in Figure 2.34. The peak shearing stress values have been obtained for maximum ratio of shear and normal stresses. The coefficient of determination is $R^2 = 0.9448$ for the processed tests. It was more than 0.8, meaning high matching the linear relationship between the normal and shear values at shear plane of cut specimens (Rukšėnaitė 2011; Rice 2010). The angle of the internal friction ϕ and the cohesion c are calculated applying the least squares method technique. Based on Figure 2.34, the calculated characteristic angle of the internal friction is equal to $\phi = 27.02^\circ$, 0 and the cohesion $c = 1.12$ kPa.

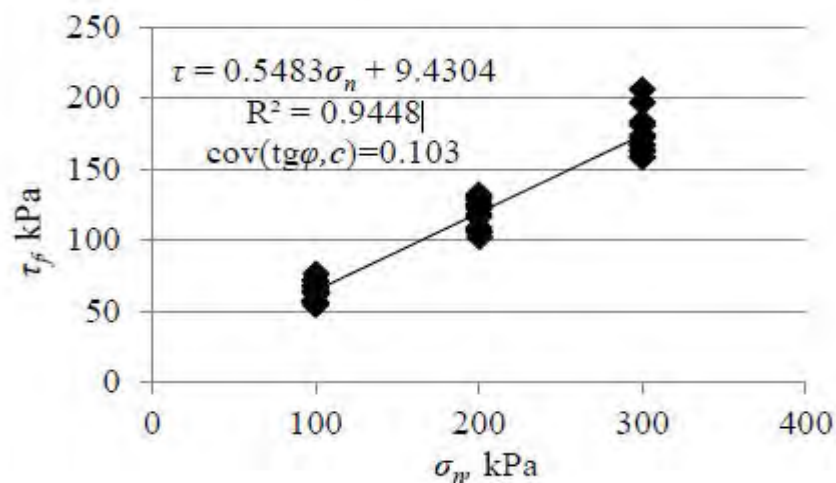

Figure 2.34 Peak values of loose sand shear strength parameters.

Source: Sarunas and Arnoldas (2014)

Figure 2.35 illustrates the relation of shearing stress peak values versus the horizontal displacement. An analysis of Figure 2.35 obviously shows that the maximum shear stress is reached when horizontal displacement is equal to $u = 5$ mm for loose sand under investigation.

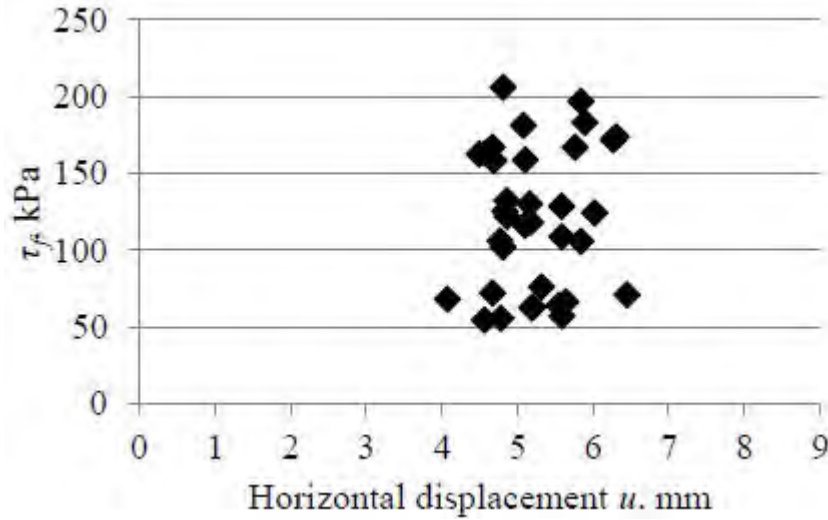

Figure 2.35 Peak shearing stress versus horizontal displacement

Source: Sarunas and Arnoldas (2014)

In order to reveal the influence of the test quantity on the characteristic shear strength parameters, the relationships between test quantity and the angle of internal friction ϕ (Figure 2.36) and that of cohesion, c (Figure 2.37) were developed.

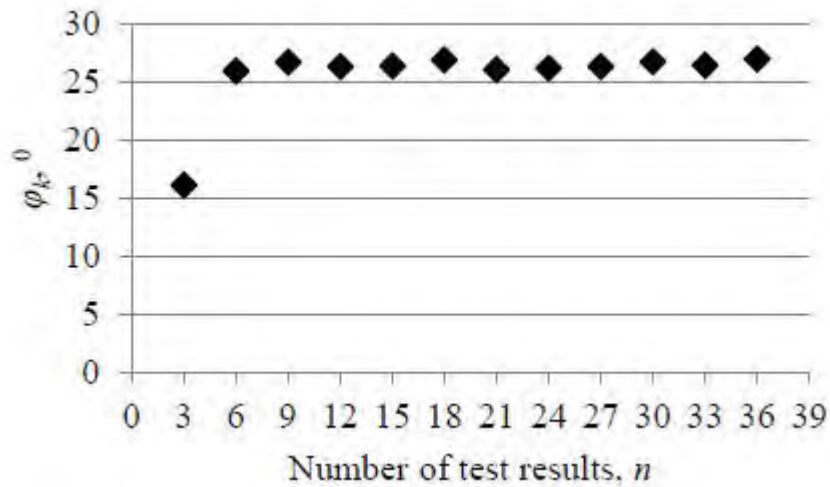

Figure 2.36 Characteristic angle of internal friction versus test quantity.

Source: Sarunas and Arnoldas (2014)

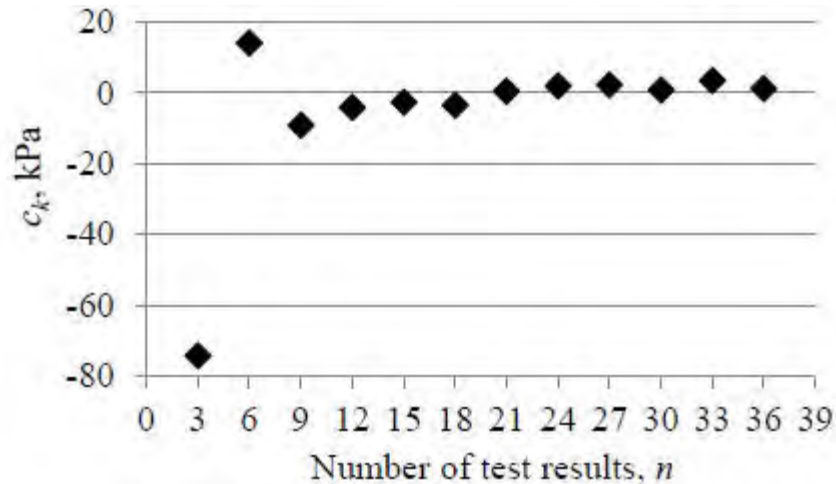

Figure 2.37 Characteristic cohesion versus test quantity

Source: Sarunas and Arnoldas (2014)

The analysis of results presented in Figure 2.36 - 2.37 clearly shows that the number of 3 shear tests is actually insufficient to conform to the least squares method calculation requirements, i.e. statistical analysis requirements in a proper way. For 3 tests the statistical coefficient depending on the confidence level and the number of degree of freedom is equal to $t\alpha = 6.3$; that of for 36 tests $t\alpha = 1.69$. Due to this reason the characteristic angle of internal friction is equal to $\phi = 16.14^\circ$, 0 and cohesion is equal to $c = -74.18$, kPa. Sandy soil or sand cohesion is approximately equal to zero (Amšiejus *et al.* 2006). Coefficient $t\alpha$ actually has no influence on the soil shear strength parameters, when the quantity of tests reaches the number of 18. The test quantity for loose sand has a significant influence on the characteristic shear strength parameters. The calculated characteristic magnitude for the angle of internal friction varies within the bounds of 16.140° (3 tests) and 27.020° (36 tests), for the cohesion within the bounds of -74.18 kPa (3 tests) and 1.12 kPa (36 tests), respectively. The analysis of test quantity influence on characteristic soil shear strength parameters demonstrated the necessity to perform more than 3 tests. It was recommend to perform at least 18 tests in order to avoid high influence of coefficient of confidence level $t\alpha$ ($\alpha = 0.95$) in concert with the degree of freedom $k = n-2$ (n is quantity of shear tests).

2.5.6 A comparison of the results between direct shear test and direct simple shear test

Hanzawa et al. (2007) performed a comparative study between the NGI direct simple shear apparatus and Mikasa direct shear Apparatus. The Mikasa direct shear apparatus was developed in 1960 to conduct constant volume shear tests, which correspond to undrained shear tests for saturated soils. The Mikasa direct shear apparatus overcomes several defects of the traditional apparatus. The apparatus was designed in such a way that friction between the upper and lower shear boxes, between the inside of the shear box and the loading plate and tilting of the loading plate could be minimised. Samples from Norwegian Drammen clay and Japanese Ariake clay were subjected to both types of test. Tsuji et al. (1998) have previously reported on tests carried out in Japan on both clays. This previous work was extended through a series of comparative tests in both apparatuses for the two clays, with work carried out both in Norway and in Japan. Samples involved consolidated clay (undisturbed and remoulded specimens). The study aimed at identifying any differences in the measured test results and determining the causes for the differences.

Undisturbed sampling of Ariake clay was performed to a depth of 15m using a stationary piston sampler, Drammen clay was also sampled using a piston sampler. Tests were performed with both the direct simple shear apparatus and the direct shear apparatus on specimens of upper and lower Ariake clay, and plastic and lean Drammen clay. For the Ariake clay, NGI carried out seven direct simple shear tests and TOA carried out fourteen direct shear tests. The division between upper and lower clay occurs at 12.1 m. This value was estimated based on the values of soil unit weight measured for each test. Consolidation of the NGI specimens was carried out with 4 load steps; each load step being applied for a minimum of 30 minutes. The fully loaded specimen was then left overnight before shearing. A rate of shear of about 0.1% shear strain per minute was applied to the specimens. In comparison, consolidation of the TOA specimens was carried out with one load step for 10 minutes. Shearing was then immediately performed at a rate of 0.25mm/minute (corresponding to about 1.25% shear strain per minute). The Drammen plastic and lean clays were separated by a thin layer of sand/gravel at a depth of about 10 to 11m. TOA carried out three series of direct shear tests on this clay. In the first series, a consolidation procedure was used that was the same as that used for the tests on Ariake clay, i.e. undisturbed specimens were reconsolidated to their estimated in situ overburden stress, in one load step, for 10 minutes immediately followed by a shearing load. The rate of shear under constant volume

conditions was 0.25mm/minute. Fifteen tests were carried out in this way on samples from depths ranging from 6m to 19m. In the second series of TOA tests, the trimmings from the samples taken from depths from 6m to 9m (i.e. plastic Drammen clay) were remoulded and then consolidated to a vertical effective stress of 392 kPa for one day, using the NGI procedure. On the following day the specimens were unloaded corresponding to a predetermined OCR. The rate of shearing under constant volume conditions of 0.1mm/minute (about 0.5% shear strain per minute) was used. Seven tests were carried out in this way, at laboratory OCR values between 1 and 40. In the third TOA series of DST tests, undisturbed samples of plastic Drammen clay were used, from depths of 6 m, 7 m and 8 m at OCR values of 1, 3 and 10 respectively. The consolidation procedure and the rate of shearing were the same as those described for the second TOA series of tests. No additional direct simple shear tests were performed by NGI on Drammen clay for this programme. Rather, use was made of previous tests performed on Drammen clay for a number of research projects. A selection of twelve tests was gathered from these projects, corresponding to the tests performed by TOA. In six of these tests (on both plastic and lean Drammen clay) the specimens were consolidated to in situ stresses using 4 load steps, over one day, with shear testing performed on the following day. Procedures of sample extrusion and preparation were similar. Average strain rate varied between 0.004 and 0.08 % per minute. In a further six tests specimens of plastic Drammen clay were first consolidated up to a maximum stress of 400kPa for one day, followed by unloading on the second day to a vertical stress corresponding to a predetermined OCR, with shear testing on the third day at a standard strain rate of about 0.08% per minute. Test results from the direct simple shear test and direct shear test on Ariake clay are shown in Figure 2.38. It is clear that the peak failure strengths from a direct simple shear test were significantly lower than for the direct shear test. The contribution of several factors to the observed differences in strength included: sample disturbance, different consolidation time (less significant), and rate of testing and shearing mechanism.

Many techniques are available for the assessment of sample quality. A disturbance index was used to evaluate sample disturbance. It was observed, that the differences in the disturbance index between the direct simple shear test and the direct shear test do not clearly echo the differences in shear strength exhibited in the soil samples. However, variations in the testing procedures will mask the effect of disturbance.

The effect of consolidation time was studied by Berre (1985), who showed from constant volume direct simple shear tests on Drammen clay that a consolidation time of 40 minutes resulted in a shear strength that was only 1.5% lower than a similar test performed with a consolidation time of 18 hours. However, the direct shear tests with the shorter consolidation times are exhibiting higher strengths than the direct simple shear test. Hence, the effect of different consolidation times may be considered less significant than other factors in assessing differences between a direct simple shear test and a direct shear test.

The strain rate for the direct shear test (1.25%/min) was approximately one order of magnitude higher than the direct simple shear test (0.1%/min). Thus the shear strengths for a direct shear test should be factored by about 0.88 in the upper clay and 0.86 in the lower clay to compare with the direct simple shear test results. It should be noted that these correction factors are being applied in the absence of more appropriate shear test data.

Combining the effects of strain rate and the shearing mechanism, the direct shear test strengths have been multiplied by a factor of 0.81 in the upper clay and 0.77 in the lower clay and compared to the direct simple shear strength. The agreement is greatly improved. However, even the modified direct shear test strengths are larger than the direct simple shear test strengths. It is concluded that the remaining discrepancy is most likely due to differences in the quality of the soil samples, although it is also possible that the rate effects were larger than estimated.

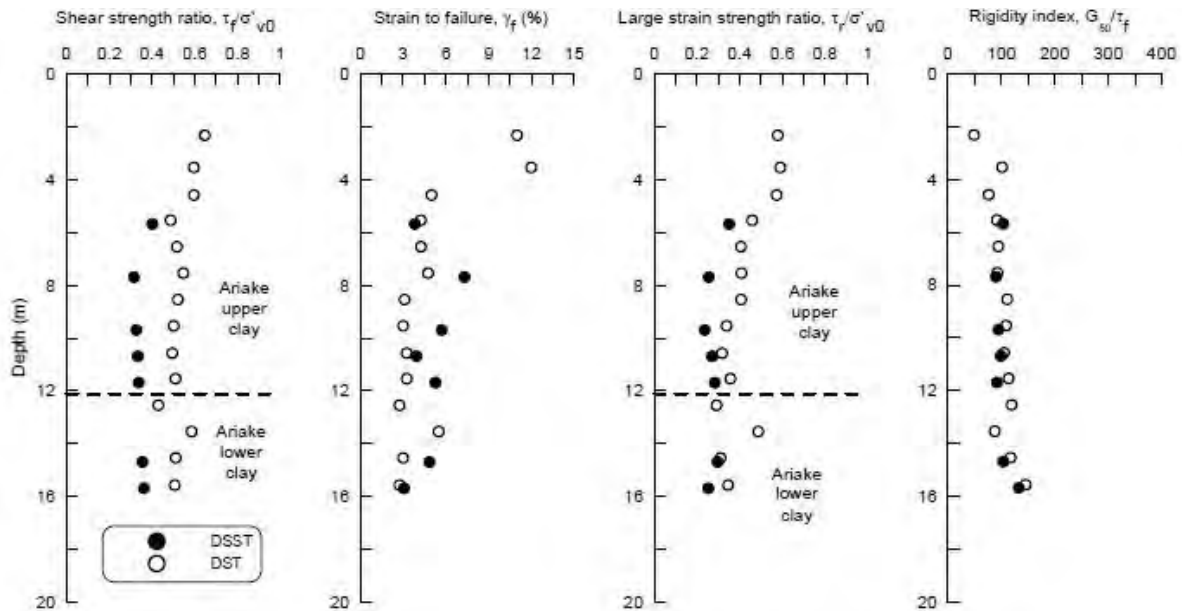

Figure 2.38 Shear strength and stiffness data for DST and DSST in Ariake clay
Source: Hanzawa et al. (2007)

A summary of test results from the direct simple shear test and direct shear test on specimens of Drammen clay is presented in Figure 2.39 from which it is clear that unmodified direct shear test strengths are higher.

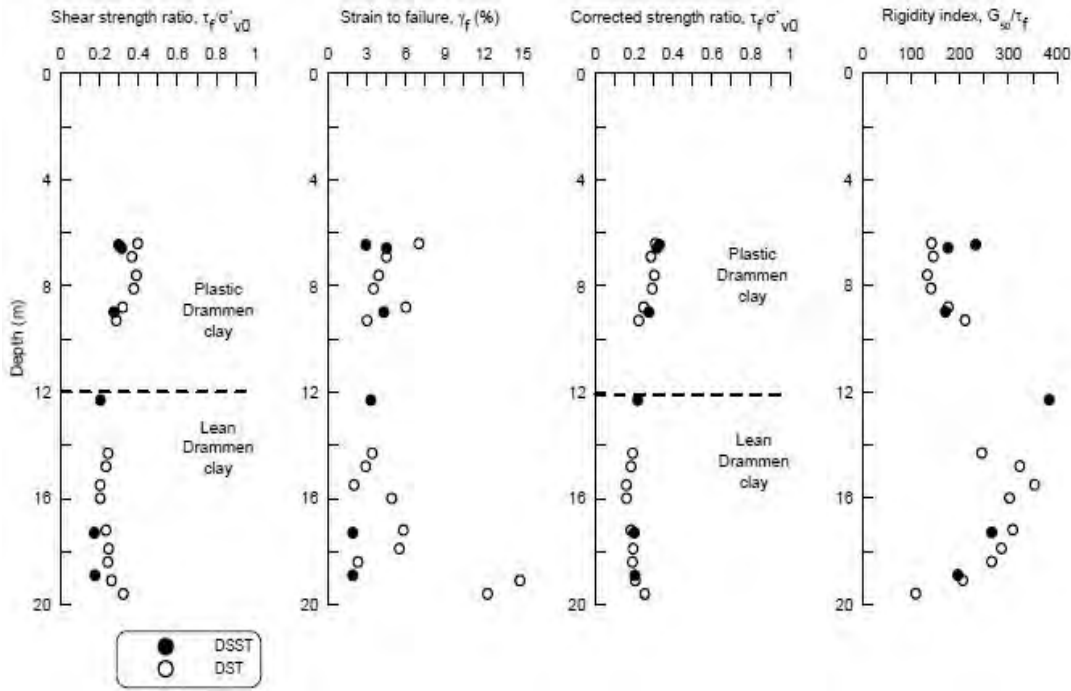

Figure 2.39 shear strength and stiffness data for direct simple shear test and direct shear test in Drammen clay.

Source: Hanzawa et al. (2007)

An evaluation of these test results and a theoretical consideration of the different shearing mechanisms have shown that, although the direct shear test gives generally higher stiffness and strength than the direct simple shear test, these differences can be accounted for mainly by the different shearing mechanisms and shearing rates. Sample disturbance due to transportation and handling may also be the reason for some of the difference.

George et al. (1993) performed a numerical analysis on drained direct shear and direct simple shear test. Drained direct and simple shear tests were analysed, assuming an isotropic elastoplastic constitutive law and plane strain conditions. The stress and strain distributions within the sample are examined. The computed stresses and displacements on the top boundary of the sample are used to interpret the numerical analyses as if they were actual tests. Stiffness and strength results for the direct shear are then compared with direct simple shear results based on computations over the whole top boundary (average) and over the middle third (core). With

the ideal simple shear as a reference state, direct simple shear results based on average measurements underestimate initial stiffness and peak strength by as much as 20%, while core measurements give a better but not perfect agreement. Direct shear tests overestimated the initial stiffness and, in most cases, the peak strength by as much as 7.5%. Stress and strain distribution in the direct simple shear test becomes highly non-uniform as peak conditions are approached.

2.6 Conclusion

It is clear that specimen size and particle size influence friction angle of sand. From previous studies, the shear strength parameters increase as the relative density increases for silty soil. The amount of moisture content and clay content influence the angle of internal friction and cohesion for clay-sand mixture. The test quantity for loose sand has influence on the shear strength parameters. A direct shear test gives higher strength and stiffness than does the direct simple shear test by Hanzawa et al (2007). Direct shear tests overestimated the initial stiffness and, in most cases, the peak strength by as much as 7.5% by George et al (1993), when compared with the direct simple shear test.

Studies conducted in the past have given limited attention to direct simple shear tests as the majority conducted have employed direct shear tests which are favoured by many geotechnical engineers because of their simplicity. In some cases, direct shear test may be the only feasible type of shear test available. The question arises as to how direct shear test data can be related to the results obtained from direct simple shear tests. This is of interest because the design procedures for many problems are based on direct shear tests, but soil response often bears more resemblance to direct simple shear. More knowledge is required to establish the relationship between the results generated from a direct shear test and a direct simple shear test, in order to also develop a correlation factor between the results from the two tests.

3.0 RESEARCH MATERIALS AND METHODOLOGY

3.1 Introduction

This chapter details the methodology followed to achieve the specific objectives of the study. The test materials, the soil classification tests method, the testing schedule and experimental procedures are discussed. To maintain consistency direct shear and direct simple shear tests were carried out on identical soil specimens with the same normal loads.

3.2 Test materials and equipment

The soil samples procured for the tests were Kliphuewel sand and Kaolin. The equipment employed for the direct shear and direct simple shear laboratory tests was the ShearTrac-II supplied by the Geocomp cooperation.

3.2.1 Klipheuwel sand

Klipheuwel sand is reddish-brown in colour with a natural moisture content of 2.63%. It was sourced from Cape Town, South Africa and classified by Kalumba (1998) according to the Unified Soil Classification System as a well-graded sand with little fines and particles that are angular in shape. This sand was selected due to local availability and its significant presence in Cape Town. It was clean and easy to work with, thus making it possible for the results to be repeatable.

3.2.2 Kaolin

Kaolin is an example of a typical soft soils. On this basis, it was selected for this research in order to compare the results obtained under similar conditions with Klipheuwel sand. In addition, it was consistent and easily controllable, which enabled repeatability of results. The kaolin clay material used in this research is extracted and supplied locally in Cape Town.

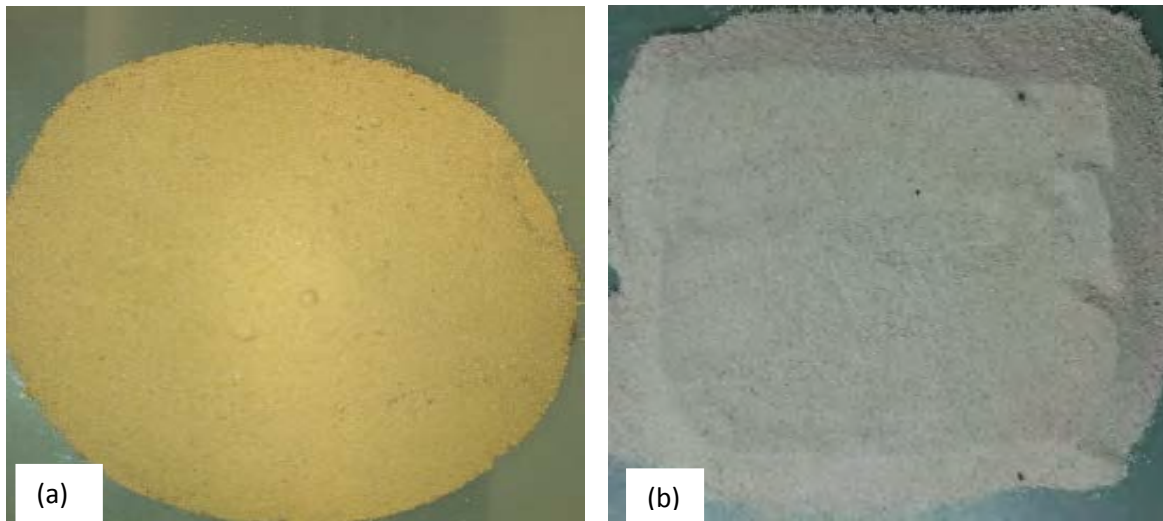

Figure 3.1 (a) Klipheuwel sand and (b) Kaolin clay

3.3 Soil classification tests

The characterization tests conducted were in accordance with the British Standard (BS) and the soils classified using the Unified Soil Classification System (USCS). The characterization of the soil materials was performed to assess their mechanical and physical properties. Some of them were considered significant in the preparation of soil samples while others were useful in the interpretation of the results. The different tests conducted on both Klipheuwel sand and kaolin clay are presented in Table 3.1, and the summary of the results obtained from the classification test are presented in Table 3.2.

Table 3.1 Experiment Conducted for Soil Classification

Soil Properties	Test Method	British Standard Code
Specific Gravity	Small Pycnometer method	BS 1377: Part 2: 1990
Natural Moisture Content	Oven Drying method	BS 1377: Part 2: 1990
Optimum Moisture Content	Standard Proctor Test	BS 1377: Part 4: 1990
Maximum Dry Density	Standard Proctor Test	BS 1377: Part 4: 1990
Particle Grading of Sands	Dry Sieve Analysis	BS 1377: Part 2: 1990
Shear Strength	Direct Shear & Direct Simple Shear Method	BS 1377: Part 7: 1990
Liquid and Plastic Limits	Atterberg Limits	BS 1377: Part 2: 1990

Sieve analysis results for Klipheuwel sand are presented in Figure 3.2. From the curve, Klipheuwel sand comprised 99.08 % sand and 0.92 % fines (passing the 0.063mm sieve). Its coefficient of uniformity was 1.75 and the coefficient of curvature was 0.89. It was classified as a uniformly graded sand with soil particles ranging from 3.350mm to 0.063 mm. Kaolin had a liquid limit of 36%, a plastic limit of 21.4% and a plasticity index of 14.6%. From Mitchell and Soga (2005) chart, soils with a liquid limit between 30% - 40%, a plastic limit between 20 - 25% and a plasticity index between 10 -15% are classified as low plasticity soil. Figures 3.3 and 3.4 show the Proctor curves obtained in the laboratory, where the maximum dry density and optimum moisture content for each of the soils was determined.

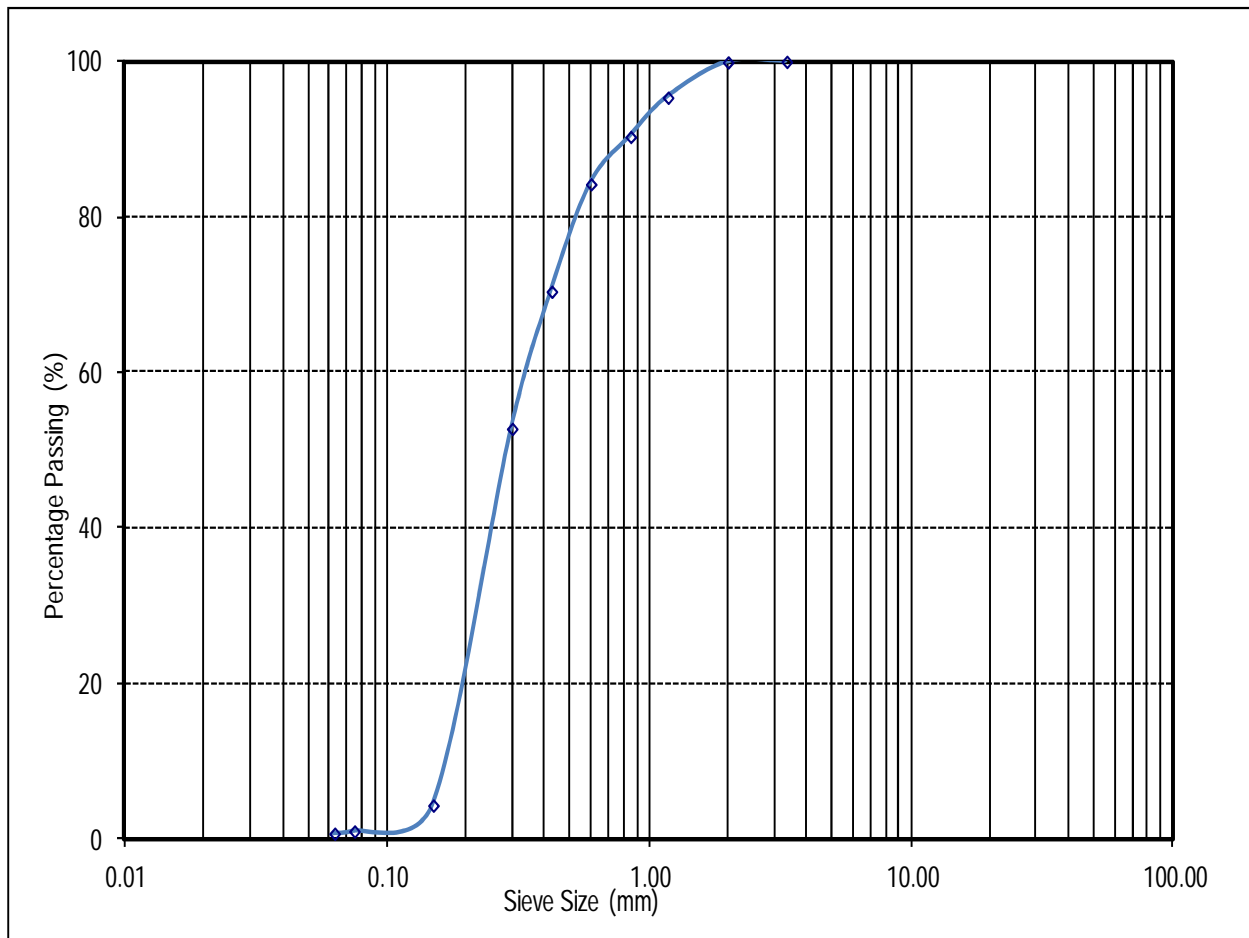

Figure 3.2 Particle grading curve for Klipheuwel sand

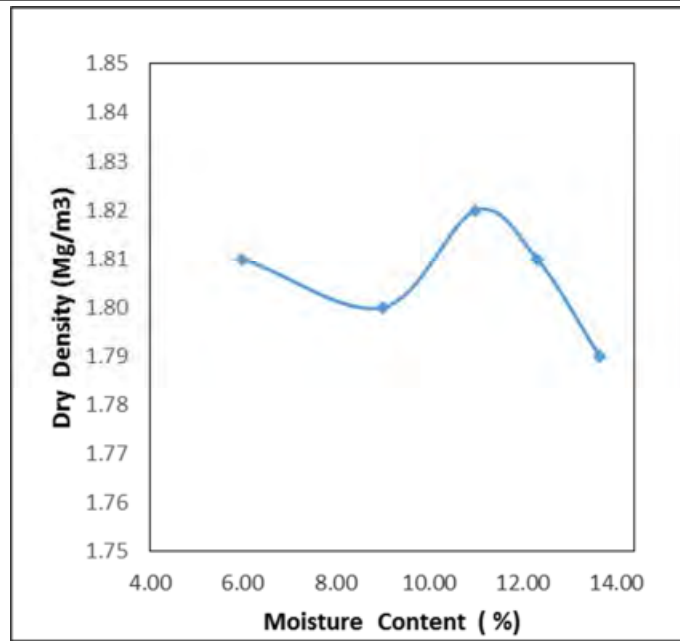

Figure 3.3 Standard proctor curves for Klipheuwel sand

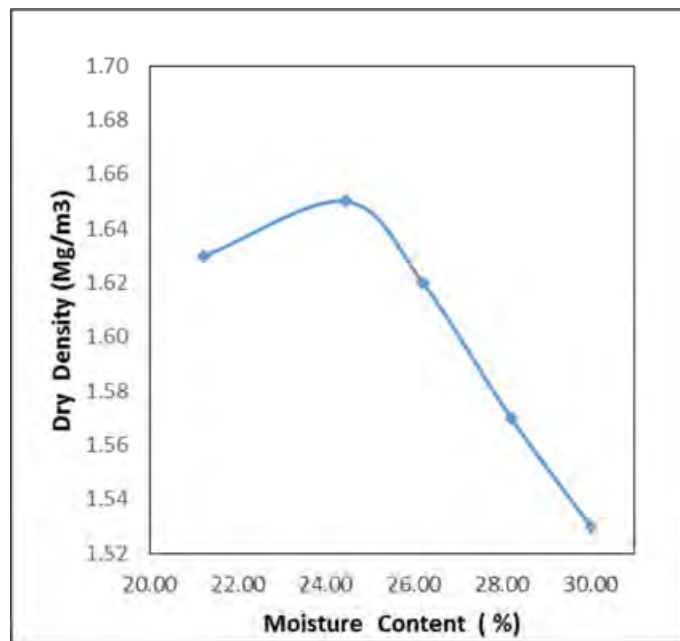

Figure 3.4 Standard proctor curves for kaolin clay

The summary of the results obtained from the classification test are presented in table 3.2. The detailed data are presented in Appendix A1 to A3 for Klipheuwel sand and Kaolin clay.

Table 3.2 Summary of the results obtained from the classification tests for Kaolin and Klipheuwel sand

Properties	Units	Kaolin Clay	Klipheuwel Sand
Specific Gravity, Gs	-	2.6	2.65
Natural Moisture Content	%	1.7	2.63
Optimum Moisture Content	%	23	10.7
Maximum Dry Density	Mg/m ³	1.65	1.82
Particle Range	mm	-	0.045-3.35
Coefficient of Uniformity,Cu	-	-	1.75
Coefficient of Curvature,Cc	-	-	0.89
Liquid Limit	%	36	-
Plastic Limit	%	21.4	-
Plastic Index	-	14.6	-
Angle of Friction (Peak) DST	Degrees	25.81	44.20
Cohesion (Peak) DST	kN/m ²	15.15	0
Angle of Friction (Peak)DSST	Degrees	16.54	27.02
Cohesion (Peak)DSST	kN/m ²	8.34	17.64

3.4 Test equipment

The Universal Shear Device manufactured by Geocomp Corporation used in this research have the capability of running fully automated consolidated and shear phases of direct simple shear and direct shear tests. The consensus from the researchers is that it dramatically reduces the labour involved in testing as the consolidation steps and shearing phases are pre-set before the test commences.

The system consists of a computer-controlled unit that uses micro-stepper motors to apply vertical and horizontal loads to the soil specimen. It allows the user to modify test parameters at any point during the test, and automatically saves and records data through the use

of Geocomp's software (Geocomp, Inc). Once a sample was in place and the test conditions selected, the system ran the test from start to finish with only minor adjustments between the consolidation phase and the shear phase. Test data were stored in a file for subsequent analysis and were also plotted by the report features in the software. It has the capacity to run a consolidation phase for up to 32 increments automatically. Horizontal shearing can be applied at a specified rate of deformation or at a specified rate of horizontal force change. The system displayed the current status of the test and graphically displayed its progress in real time. It also has the capability to alter the test process and conditions at any stage of the test. It was used as ShearTrac-II for a direct shear test and ShearTrac-II-DSS for a direct simple shear test, with the simple shear arm mounted on it. The shear devices are shown in Figure 3.5 and the simple shear arm is presented in Figure 3.6.

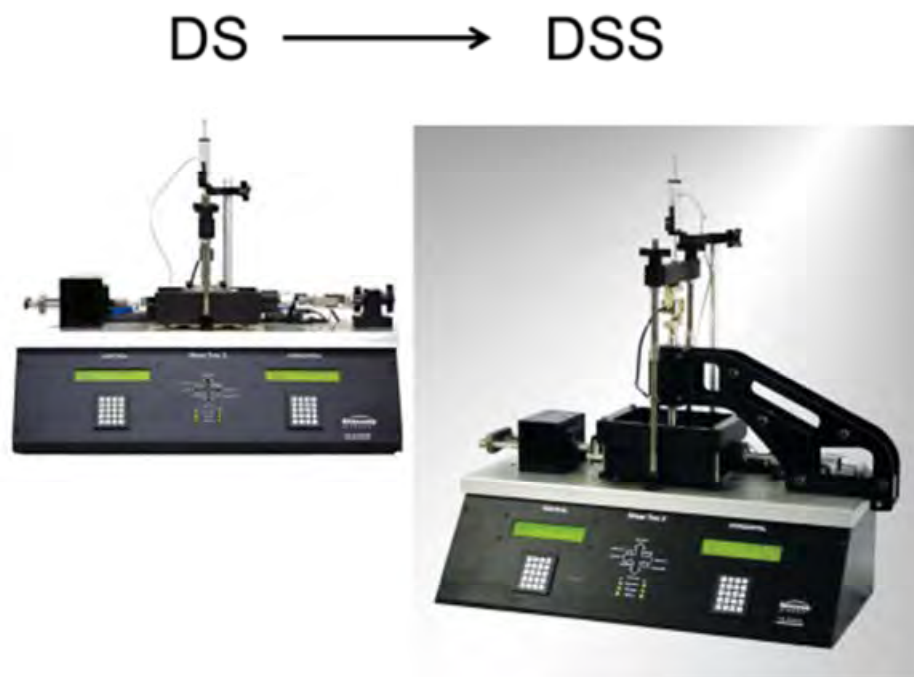

Figure 3.5 Conversion of ShearTrac-II (DS) for direct shear to ShearTrac-II-DSS for direct simple shear (Geocomp, 2015)



Figure 3.6 Simple shear arms

The ShearTrac-II direct shear has a maximum load capacity of 8.9 kN (2,000lbs), capable of applying a maximum normal pressure of up to 450 kPa. It also has the capacity of applying a constant strain rate or stress rate of up to 15 mm/minute. The ShearTrac-II-DSS system generated a fairly homogeneous state of shear stress throughout the specimen, which provides initial stress condition, stress path, and deformation configuration that models numerous field-loading conditions more closely than any other test (Geocomp). It has a maximum load capacity of 4.4 kN (1,000lbs), capable of applying a maximum normal pressure of up to 450 kPa. The machine was capable of applying a constant strain rate or stress rate of up to 15 mm/minute. The constant volume condition during the shear was achieved through a closed loop computer control with the vertical displacement sensor as the feedback.

3.5 Sample preparation for direct shear test and direct simple shear test

The preparation of all test samples was completed in accordance with the method outlined by Ladd (1978) and by Geocomp in the Shear Software User's Manual. The samples were obtained from storage at the University of Cape Town's Civil Engineering Laboratory. Klipheuwel sand was placed in an oven at 105°C for 24 hours and allowed to cool before it was stored in sealed containers to minimize any moisture absorption thereafter. In order to determine the natural moisture content of the Klipheuwel sand selected, samples were taken for the moisture content test from the trays before placing them in an oven for drying. Kaolin was not subjected to the drying process since its natural moisture content was minimal (1.7). Thus, its moisture content was checked only prior to mixing.

3.5.1 Sample preparation for direct shear test

3.5.1.1 Pure soil (Klipheuwel sand and Kaolin clay)

The test specimen was first prepared on Klipheuwel sand (dry condition). Based on its specific gravity and the volume of the shear box, a pre-estimated quantity of clean sand of about 400g was taken from the container and placed in a mixing bowl using a scoop. The two halves of a circular shear box with a diameter of 64mm and a height of 31mm, were assembled using the two alignment screws, and the weighed sand was poured in the assembled box. The sand was compacted in three different layers using a hand compactor with a standard weight of 476g, as shown in Figure 3.7. The compacting energy was applied to the soil in order to densify it with each subjected to 25 blows and the number of blows were selected based on the standard proctor test procedures outlined in the ASTM D698-12. That is, three layers of compaction and 25 blows per layer. The sand material remaining after the test specimen preparation was weighed and subtracted from the total to get the compacted material in the shear box to determine the density achieved. The loading plate was placed on top of the well-levelled sand surface for the purpose of spreading the applied normal pressure on the sample during the shear test. A sample was also prepared for clean Kaolin clay. The quantity of clay material was estimated and the procedure for sample preparation as for Klipheuwel sand was adopted. For each type of soil, three similar samples were prepared and tested at three different normal applied pressures of 50, 100 and 200 kPa in order to plot the Mohr-Coulomb failure envelope line.



Figure 3.7 Hand compactor

3.5.1.2 Sand-clay composite

Samples were also prepared at composite conditions corresponding to optimum moisture content for both Klipheuwel sand and Kaolin clay. The amount of water added was determined by the individual standard Proctor tests, carried out as per the clay concentration. It was crucial to compute the quantities required for the mixing before the sample of any mixture was prepared. Equation (3.1), below, was thus adopted during the preparation of the mixture;

$$W_c = \chi \cdot W_{csc} \dots\dots\dots (3.1)$$

Where

W_c : the weight of clay; χ : the concentration of clay in the mixture
 W_{csc} : the weight of clay sand composite

The concentrations of clay considered in this study were 10, 25, 50 and 75 % by dry weight. Each percentage of clay content was considered independently during sample preparation. The quantity of clay to be combined with sand was predetermined before mixing. Therefore, the concentration of 10% clay by dry mass was first considered with the Klipheuwel sand. The total quantity of sand to fill the shear box was estimated following the similar procedure used in pure soil calculations and 10% clay by dry mass of that sand was computed using equation (3.1). The weight of sand equivalent to clay was replaced by the weight of clay. After all the calculations were completed, the quantity of sand, clay and water to be used was taken and weighed using an electronic scale, after which they were thoroughly mixed in a mixing bowl using a scoop to obtain a well-mixed sample. Mixing was done for a predetermined period of five minutes, after which the material was placed in the shear box.

The two halves of a circular shear box were assembled on a table using the alignment screws and the clay sand composite was carefully transferred into the box in layers. The clay-sand composite was compacted in three layers to ensure that all the material in shear box received the same energy. Each layer was compacted using the similar equipment used in the preparation of the pure soil sample and received the same number of blows equal to 25. The volume of the specimen in the shear box was determined and consequently its mass and then the density achieved was calculated. Calculations based on 10% clay content were repeated for 25, 50 and

75% clay content. The sample was prepared for each mixing ratio following the procedure adopted in the preparation of the test specimen for the concentration of 10% clay in the mixture.

3.5.1.3 Pure soil with varying moisture content (Klipheuwel and Kaolin)

The test specimen was prepared on Klipheuwel sand at varying moisture content. The equation (3.2) below was thus adopted during the preparation of the mixture.

$$W_w = \chi \cdot W_{sw} \dots \dots \dots (3.2)$$

Where

W_w : the weight of water; χ : water content in the mixture

W_{sw} : the total weight of soil and water mixture

The concentrations of water considered in this study were 5, 10, 15, 20 and 25 %. Before mixing, the quantity of water to be combined with sand was predetermined. Therefore, the moisture content of 5% was first considered with Klipheuwel sand. The total quantity of sand to fill the circular shear box was estimated according to the similar procedure used in pure soil calculations and 5% water of that sand was computed using equation (3.2). The weight of sand equivalent to water was replaced by the water. After all the calculations, the quantity of each sand and water component to be used were taken and weighed using an electronic scale, after which they were thoroughly mixed in a mixing bowl using a scoop to obtain a well-mixed sample. The samples were placed in the shear box immediately after mixing to prevent the absorption of moisture content.

The shear boxes were assembled on a table using the alignment screws and the sand mixed with water was carefully transferred into the box in layers. The sand mixed with water was compacted in three layers to ensure all the material in the shear box received the same energy. Each layer was compacted using the similar equipment used in the preparation of the pure soil sample and received the same number of blows equal to 25. The volume of the specimen in the shear box was determined and consequently its mass and then the density achieved were calculated. Calculations based on a 5% moisture content were repeated for a moisture content of 10, 15%, 20% and 25%. For each mixing ratio, the sample was prepared following the procedure adopted in the preparation of the test specimen for the concentration of 5% moisture content in the mixture.

Tests specimens were also prepared on Kaolin clay at a varying moisture content. The estimates for the quantities to be mixed were done based on equation (3.2). The same concentrations of water used in the preparation of Klipheuwel sand were also used in the preparation of Kaolin clay. Test specimens were then prepared for 5, 10, 15, 20, and 25% moisture content using the same equipment and following the procedures used to prepare Klipheuwel sand at varying moisture content. Figures 3.8(a) and (b) show a typical appearance of the samples in moist conditions.

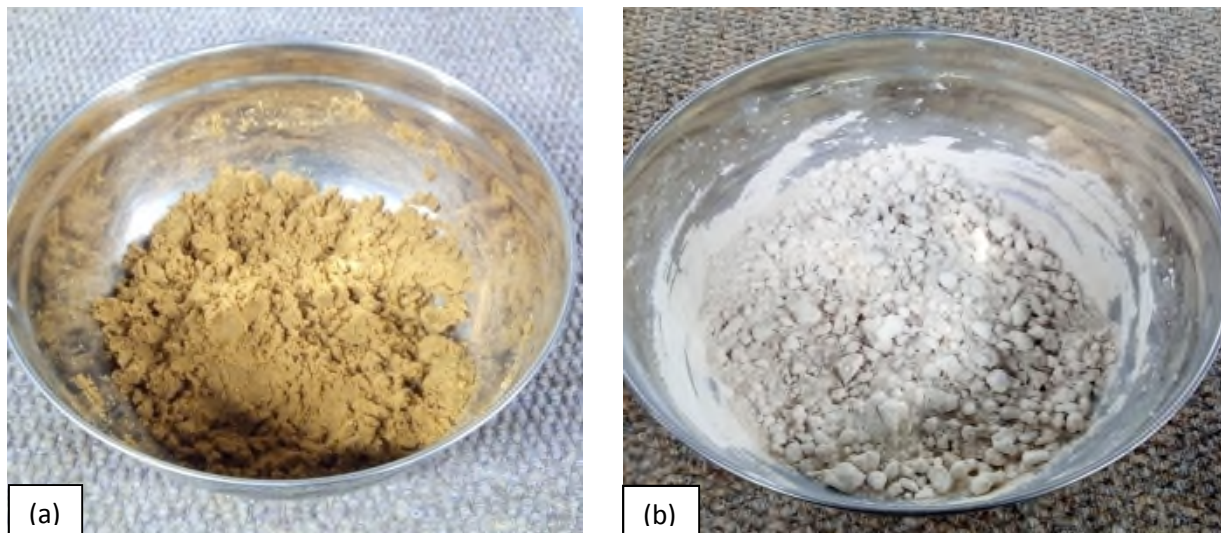

Figure 3.8 Moist sample preparation (a) Klipheuwel and (b) kaolin

3.5.2 Specimen preparation for direct simple shear test

3.5.2.1 Pure soil (Klipheuwel sand and Kaolin clay)

Klipheuwel sand was prepared with a pre-estimated quantity of clean sand of about 400g that was taken from the container. The shear base plate was mounted on the bottom porous plate and latex membrane, and secured with a rubber O-ring. Thirty stacked rings were aligned using the pins and were then placed over the rubber membrane. The diameter and height of the stacked rings were measured using electronic Vernier calipers. The diameter was found to be 64mm and the height was found to be 31mm. The sand was then funneled into the membrane and compacted in three layers with a hand tamper having a standard weight hammer of 476g, and each layer was subjected to 25 tamping blows. The rubber membrane was used to hold the sample within the stacked rings. Once the sample was compacted, the porous plate was gently placed on sand to

avoid any disturbance to the soil. The top cap was placed over the porous plate and finally an O-ring was placed over the membrane and into the groove on the top cap. After successfully completing all the above steps, the specimen was then ready for direct simple shear testing (Figure 3.9). The sand material remaining after the test specimen preparation was weighed and subtracted from the total to get the compacted material in the ring in order to determine the density achieved. A sample was also prepared for Kaolin clay, the amount of clay material was estimated and the procedure for Klipheuwel sand adopted. Three similar samples were prepared for each normal load and tested at three different normal applied pressures of 50, 100 and 200 kPa.

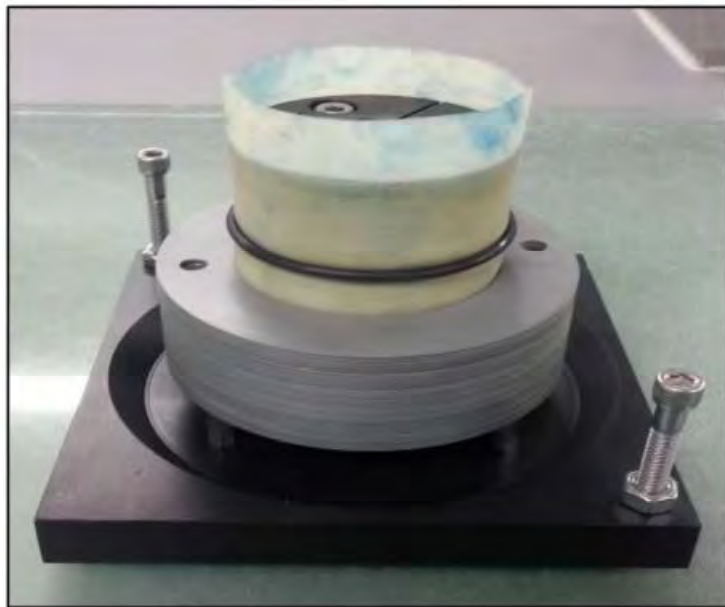

Figure 3.9 Sample ready for testing

3.5.2.2 Sand-clay composite

The amount of water needed for each sand-clay composite was calculated in a way similar to that for section 3.5.1.2. The concentrations of clay considered in this study were 10, 25, 50 and 75 % by dry weight. Each percentage of clay content was considered independently during sample preparation. The quantity of clay to be combined with sand was predetermined before mixing. The concentration of 10% clay by dry mass was first considered with Klipheuwel sand and total quantity of sand to fill the rings was estimated, following the similar procedure used in pure soil

calculations. The 10% clay by dry mass of sand was computed using equation (3.1) and the weight of sand equivalent to clay was replaced by the weight of clay. After all the calculation, the quantity of each sand, clay and water to be used were taken. They were then thoroughly mixed in a mixing bowl using a scoop to obtain a well-mixed sample. The sample was mounted and set up with the same procedure similar to 3.5.2.1.

The volume of the specimen was determined, as was its mass. Thereafter, the density achieved was calculated. The same calculation used for a 10% clay content was repeated for 25, 50 and 75% clay content. The sample was prepared for each mixing ratio following the procedure adopted in the preparation of the 10% clay concentration sample.

3.5.2.3 Pure soil with varying moisture content (Klipheuwel and Kaolin)

Klipheuwel sand was prepared at a varying moisture content. The equation (3.2) was adopted during the preparation of the mixture an approach similar to that seen in section 3.5.1.3. The concentrations of water considered in this study were 5, 10, 15, 20 and 25 %. The quantity of water to be combined with sand was predetermined before mixing occurred. The moisture content of 5% was first considered in respect of Klipheuwel sand. The total quantity of sand to fill the circular ring was estimated, following a similar procedure used in pure soil calculations and 5% water of that sand was computed using Equation 3.2. The weight of sand equivalent to water was replaced by the water. After all the calculations, the quantity of each sand and water to be used was taken and weighed, after which they were thoroughly mixed in a mixing bowl using a scoop to obtain a well-mixed sample. The sample was mounted and set up with the same procedure similar to 3.5.2.1. The volume of the specimen, and consequently its mass, was determined. Thereafter, the density achieved was calculated. Calculations based on a 5% moisture content were repeated for a 10, 15%, 20% and 25% moisture content. The sample was prepared for each mixing ratio following the procedure adopted in the preparation of the test specimen for the concentration of 5% moisture content in the mixture. Tests specimens were also prepared on kaolin clay at a varying moisture content. The estimates for the quantities to be mixed were done based on equation (3.2). The same concentration of water used in the preparation of Klipheuwel sand was also used in preparation of Kaolin clay. Test specimens were then prepared for a 5, 10, 15, 20, and 25% moisture content using the same equipment and following the procedures used to prepare Klipheuwel sand at varying moisture content.

3.5.3 Automated direct shear device setup

The ShearTrac-II system consists of a load frame, a computer with a network card for test control and data acquisition and Microsoft Windows application software, referred to as SHEAR. The software was used for controlling the test and creating a report of the results. The ShearTrac-II system comes as a complete, self-contained unit with all of the equipment required to perform fully automated direct shear tests. The ShearTrac-II load frame includes a water bath box (for immersing the sample in water if required by the test), a shear box (positioned in the water bath box) for retaining the sample, two high-speed precision micro-stepper motors that control the loading mechanisms for horizontal and vertical load, sensors for measuring load and displacement and two embedded controllers for test control and data acquisition (one each for vertical and horizontal motions). The test setup is shown in Figure 3.10. Specific information for the sample was entered for inclusion on the tabulated and graphed results.

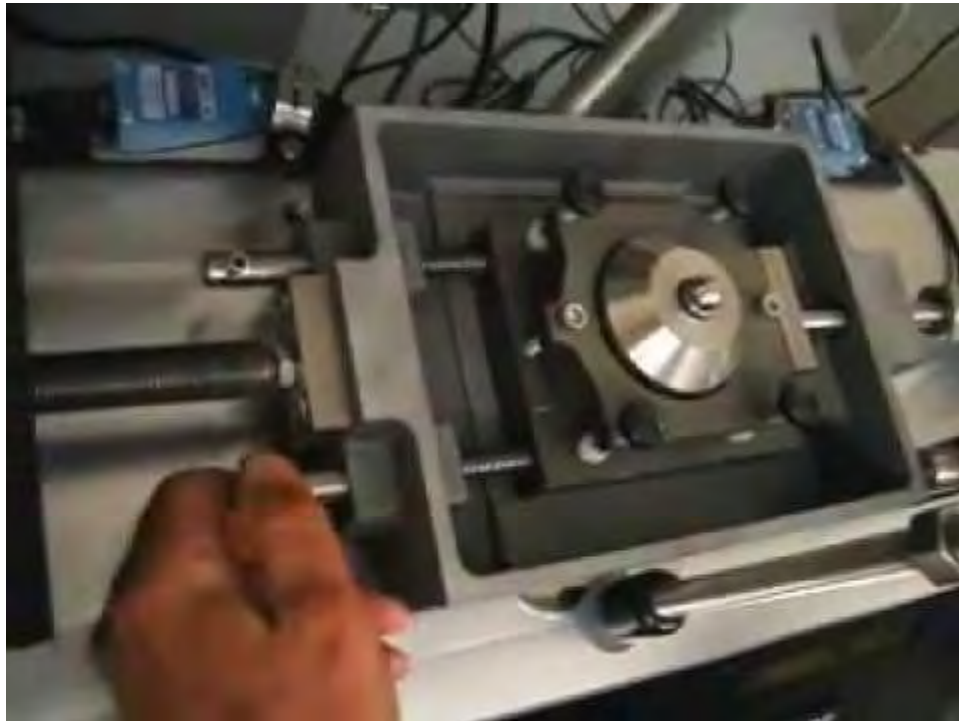

Figure 3.10 Direct shear test setup

3.5.4 Direct simple shear device setup

The ShearTrac-II-DSS system consists of a load frame, a computer with a network card for test control and data acquisition and Microsoft Windows application software, called SHEAR: DSS, for controlling the test and creating a report of the results. The ShearTrac-II DSS system comes as a complete, self-contained unit with all of the equipment required to perform fully automated direct simple shear tests. The ShearTrac-II-DSS load frame includes a water bath box (for immersing the sample in water if required by the test), a shear box (positioned in the water bath box) for retaining the sample, two high-speed precision micro-stepper motors that control the loading mechanisms for horizontal and vertical load, sensors for measuring load and displacement and two embedded controllers for test control and data acquisition (one each for vertical and horizontal motions).

3.6 Test procedure

Regarding the selection of the size of the box for a particular test, BS 1377-7:1990 and ASTM D3080-2003 recommend that the maximum size of sample particles must not exceed one-tenth of the height of the sample. Since the major aim of this research was to compare the two tests, a circular shear box was selected for a direct shear test, and a circular ring was selected for a direct simple shear test. The circular shear box and the circular ring share a diameter of 64mm, the same height of 31mm, while the same pre-estimated mass (400g) of the sample was used for both the direct shear test and direct simple shear test. The soil samples for both direct shear test and direct simple shear test were sheared at the same displacement rate of 1mm/min. This was chosen to enable the test to be completed within 15 to 20 minutes. There was no offset time input for the T100 parameter at the consolidation stage for both tests, because all soil samples were required to be fully consolidated before shear testing. Under the shear table, there was no delay time input for a change between the shear and consolidation phase for the test. This ensured that a test continued to the shearing phase without a lag, directly after the consolidation phase.

3.6.1 Procedure for direct shear test

All the required information for the test, such as normal applied pressure, shear displacement rate, maximum displacement for the test, displacement interval, minimum time for consolidation were input into the shear program (software). Shear stress was applied by maintaining a constant

displacement rate of 1 mm/min. After setting the test conditions, a template file was created before running the test to store the generated data. An example of the data input page from the software is shown in Figure 3.11.

The screenshot shows a software window titled 'SHEAR' with a menu bar (File, View, Run, Calibrate, Control, Report, Options, Help) and a tabbed interface. The 'Test Parameters' tab is active, showing input fields for Project, Specimen, Water Content, and Shear Table. The 'Project' section includes Project Number, Project Name, Location, Date of Test, Tester, and Checker. The 'Specimen' section includes Boiling Number, Test Number, Sample Number, Depth, Elevation, and Sample Type. There are also fields for Description and Remarks.

Figure 3.11 Shear control window

The direct shear testing was undertaken in accordance with ASTM D3080-2003. Therefore, according to the ShearTrac-II machine supplier based on the standard, the first phase of direct shear test was the consolidation by applying normal confining pressure on the sample using the vertical loading system via a vertical load cell. It was followed by the shearing phase by which a controlled constant rate of displacement to move the bottom half of the shear box relative to the fixed top box was applied. Before the shear phase was commenced, the alignment screws were removed and a suitable gap ensured. This gap was controlled by the gap screws. After the shearing had been completed, the horizontal and vertical loads were zeroed. The removal of the horizontal (shear) load from the sample was assisted by the horizontal loading system, whereas vertical loading was removed with the help of vertical loading system. The vertical load cell and crossbar were raised to facilitate the removal of the shear box from the water bath. The screws were loosened and removed, and the shear box was extracted from the ShearTrac-II machine and the sample was removed from the box after which the box was cleaned and dried prior to the preparation of the next test specimen. All steps were repeated for 72 tests performed on direct

shear test in this study. The samples of direct shear test specimen after test is presented in Figure 3.12.

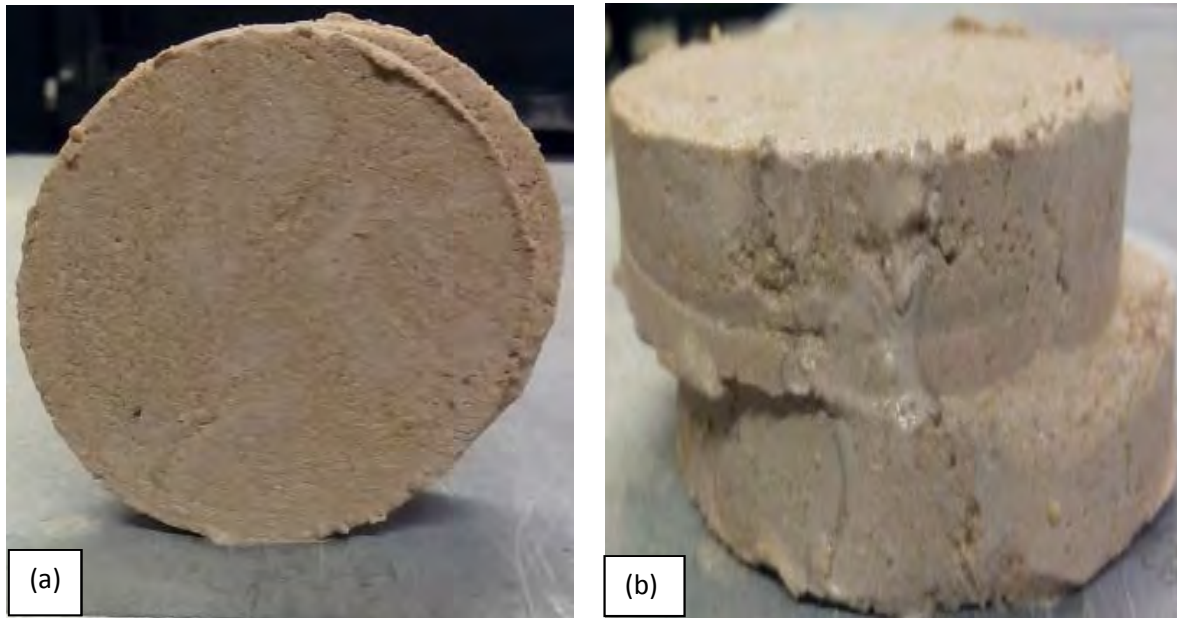

Figure 3.12 (a) and (b) Samples of direct shear test specimen after test (sand-clay composite)

3.6.2 Procedure for direct simple shear test

The direct simple shear software was configured, and the necessary settings were input into the different tabs displayed on the software window as shown in Figure 3.13. Shear stress was applied by maintaining a constant displacement rate of 1 mm/min.

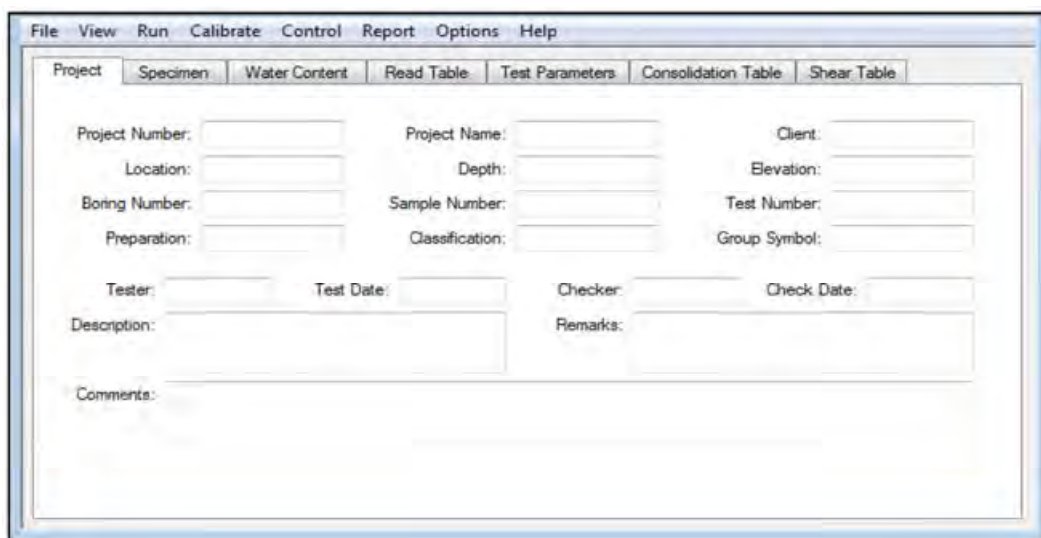

Figure 3.13 Direct simple shear software window with different setting tabs

Once the software was configured and the test sample prepared, testing began on the direct simple shear machine. The first stage of the test was the consolidation stage followed by the shearing stage. The shear base plate containing the prepared test sample, as shown in Figure 3.9, was first placed into the water bath and secured into the place using the two chamber knobs. Next, the shear arm was lowered into place and locked using the securing pins. Afterwards, the piston was inserted into the shear arm with the ball point facing up. The piston was aligned with the top cap of the prepared sample using the automatic control on the direct simple shear apparatus. Once aligned, the piston was lowered into the groove on the top cap. The crossbar containing the vertical load sensor was swung into place such that the load cell was directly above the piston. The crossbar was secured using the two four-pronged knobs on the top of the bar. Lastly, the LVDT was then positioned on top of the crossbar and secured with a knob on the mount.

Once the above steps were completed, the soil sample was set for testing. The lights on the display board of the direct simple shear test apparatus were checked to make sure they were all green before testing. A red light indicated that the maximum horizontal displacement or vertical displacement had been reached. It was also checked to ensure the pins on the stacked rings were removed, since they could damage the apparatus if left during the shearing phase. Before the test was run, the machine was calibrated using the direct simple shear computer software, after which a test was run. All steps were repeated for 72 tests performed on direct simple shear test in this research, and the sample of direct simple shear test specimen after test is shown in Figure 3.14.



Figure 3.14 Sample of direct simple shear test specimen after test (sand-clay composite)

3.7 Testing schedule

Direct shear tests and direct simple shear tests were conducted for Klipheuwel and kaolin soil specimens. 36 tests were run with Klipheuwel sands, six being on Klipheuwel sand only, 36 tests were run with kaolin clay, six being on kaolin only and 70 were run with a mixture of Kaolin and Klipheuwel sand. A total of 142 tests were carried out, 71 tests were run on direct shear device while the other 71 tests were run on a direct simple shear device. The dosages of the clay concentration were 10, 25, 50 and 75%. In addition, for moisture content slightly above the optimum moisture content, the clay addition improves the cohesion of the mixture (Muawi Dafalla, 2013). Numerous tests were repeated, as were the repeatability tests, which are not included in the test schedule. The experiments were run at normal pressures of 50kPa, 100kPa and 200kPa. The symbols and testing schedule was as follows:

Testing schedule: 142 tests

Table 3.3: Code terminology

Code	Description
SS	Sample Sand
SSC	Sample sand-Clay
SC	Sample Clay
K	Klipheuwel Sand
X	Clay Concentration X1=10%, X2=25%, X3=50%, X4=75%.
L	Load L1=50, L2=100, L3=200
MC	Moisture Content MC1=5%, MC2=10%, MC3=15%, MC4=20%, MC5=25%
OMC	Optimum moisture content

Table 3.4: Direct shear test on Klipheuwel sand and clay.

Sample	Materials	Parameters	Test numbers
SAND	KLIPHEUWEL	LOAD	SS/K/L1
			SS/K/L2
			SS/K/L3
		MOISTURE CONTENT	SS/K/L1/M1
			SS/K/L1/M2
			SS/K/L1/M3
			SS/K/L1/M4
			SS/K/L1/M5
			SS/K/L2/M1
			SS/K/L2/M2
			SS/K/L2/M3
			SS/K/L2/M4
			SS/K/L2/M5
			SS/K/L3/M1
			SS/K/L3/M2
SS/K/L3/M3			
SS/K/L3/M4			
SS/K/L3/M5			
		LOAD	SSC/K/L1/X3/OMC
			SSC/K/L2/X3/OMC
			SSC/K/L3/X3/OMC
		CONCENTRATION	SSC/K/L1/X1/OMC
			SSC/K/L1/X2/OMC
			SSC/K/L1/X3/OMC

Continuation of table 3.4

SAND + CLAY	KLIPHEUWEL AND CLAY	CONCENTRATION	SSC/K/L1/X4/OMC
			SSC/K/L2/X1/OMC
			SSC/K/L2/X2/OMC
			SSC/K/L2/X3/OMC
			SSC/K/L2/X4/OMC
			SSC/K/L3/X1/OMC
			SSC/K/L3/X2/OMC
			SSC/K/L3/X3/OMC
			SSC/K/L3/X4/OMC
			MOISTURE CONTENT
		SSC/K/L2/X1/M2	
		SSC/K/L2/X1/M3	
		SSC/K/L2/X1/M4	
		SSC/K/L2/X1/M5	
		SSC/K/L2/X2/M1	
		SSC/K/L2/X2/M2	
		SSC/K/L2/X2/M3	
		SSC/K/L2/X2/M4	
		SSC/K/L2/X2/M5	
		SSC/K/L2/X3/M1	
SSC/K/L2/X3/M2			
SSC/K/L2/X3/M3			
SSC/K/L2/X3/M4			
SSC/K/L2/X3/M5			
SSC/K/L2/X4/M1			

Continuation of table 3.4

CLAY	CLAY		SSC/K/L2/X4/M2 SSC/K/L2/X4/M3 SSC/K/L2/X4/M4 SSC/K/L2/X4/M5
		LOAD	SC/L1 SC/L2 SC/L3
		MOISTURE CONTENT	SC/L1/M1 SC/L1/M2 SC/L1/M3 SC/L1/M4 SC/L1/M5
			SC/L2/M1 SC/L2/M2 SC/L2/M3 SC/L2/M4 SC/L2/M5
			SC/L3/M1 SC/L3/M2 SC/L3/M3 SC/L3/M4 SC/L3/M5

Table 3.5: Direct simple shear test on Klipheuwel sand and clay.

Sample	Materials	Parameters	Test numbers
SAND	KLIPHEUWEL	LOAD	SS/K/L1
			SS/K/L2
			SS/K/L3
		MOISTURE CONTENT	SS/K/L1/M1
			SS/K/L1/M2
			SS/K/L1/M3
			SS/K/L1/M4
			SS/K/L1/M5
			SS/K/L2/M1
			SS/K/L2/M2
SS/K/L2/M3			
SS/K/L2/M4			
SS/K/L2/M5			
SS/K/L3/M1			
SS/K/L3/M2			
SS/K/L3/M3			
SS/K/L3/M4			
SS/K/L3/M5			
SAND + CLAY	KLIPHEUWEL AND CLAY	LOAD	SSC/K/L1/X3/OMC
			SSC/K/L2/X3/OMC
			SSC/K/L3/X3/OMC
		CONCENTRATION	SSC/K/L1/X1/OMC
			SSC/K/L1/X2/OMC
			SSC/K/L1/X3/OMC
SSC/K/L1/X4/OMC			
SSC/K/L2/X1/OMC			
SSC/K/L2/X2/OMC			

Continuation of table 3.5

		CONCENTRATION	SSC/K/L2/X3/OMC SSC/K/L2/X4/OMC
			SSC/K/L3/X1/OMC SSC/K/L3/X2/OMC SSC/K/L3/X3/OMC SSC/K/L3/X4/OMC
		MOISTURE CONTENT	SSC/K/L2/X1/M1 SSC/K/L2/X1/M2 SSC/K/L2/X1/M3 SSC/K/L2/X1/M3 SSC/K/L2/X1/M5
			SSC/K/L2/X2/M1 SSC/K/L2/X2/M2 SSC/K/L2/X2/M3 SSC/K/L2/X2/M4 SSC/K/L2/X2/M5
			SSC/K/L2/X3/M1 SSC/K/L2/X3/M2 SSC/K/L2/X3/M3 SSC/K/L2/X3/M4 SSC/K/L2/X3/M5
			SSC/K/L2/X4/M1 SSC/K/L2/X4/M2 SSC/K/L2/X4/M3 SSC/K/L2/X4/M4 SSC/K/L2/X4/M5
CLAY	CLAY	LOAD	SC/L1 SC/L2 SC/L3

Continuation of table 3.5

CLAY	CLAY	MOISTURE CONTENT	SC/L1/M1
			SC/L1/M2
			SC/L1/M3
			SC/L1/M4
			SC/L1/M5
			SC/L2/M1
			SC/L2/M2
			SC/L2/M3
			SC/L2/M4
			SC/L2/M5
			SC/L3/M1
			SC/L3/M2
			SC/L3/M3
			SC/L3/M4
			SC/L3/M5

3.8 Repeatability of test results

To verify the repeatability of results from the experimental procedure, tests done on Klipheuwel sand only were repeated three times for direct shear test and three times for direct simple shear test. These tests were conducted on Klipheuwel sand at 50 kPa normal load following the same procedure as described in section 3.5.1.1 and 3.5.2.1 respectively. Figure 3.15, 3.16 and Table 3.6 summarizes the results of these tests.

In analysing the repeatability results for this thesis, an error of less than 5% was considered within the acceptable limit. From the analysis of the results it was found that the maximum error was 1.69% and 1.19% for the peak shear stress and residual stress (direct shear test). For the direct simple shear test, the maximum error was 1.66% and 2.33% for the peak shear stress and the residual stress. The repeatability tests verified that the procedures adopted in running the tests and samples preparations were consistent, since the percentage error in peak shear stress and residual shear stress were below the acceptable error of 5%.

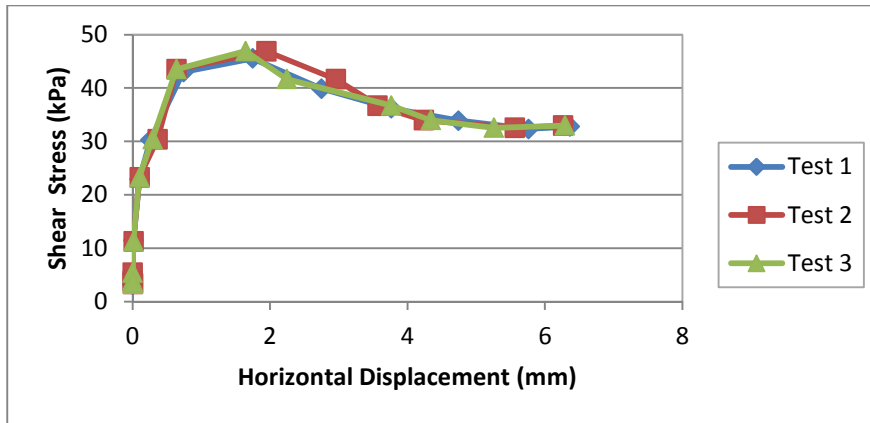

Figure 3.15 Repeatable results for three samples tested at 50kPa (direct shear test)

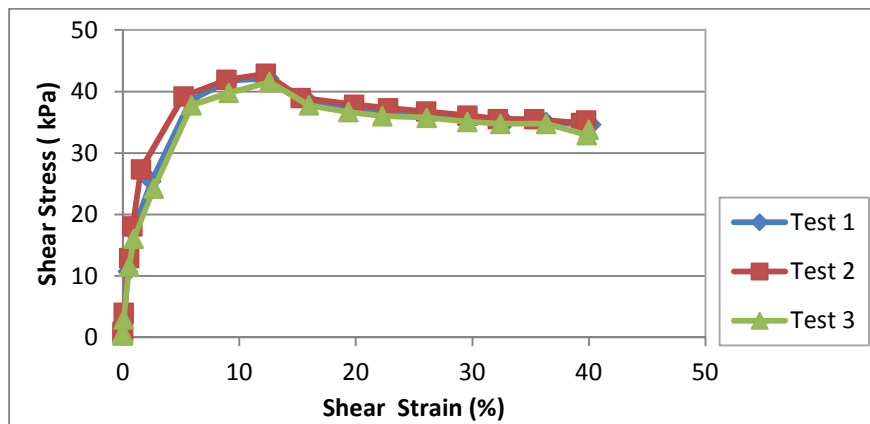

Figure 3.16 Repeatable results for three samples tested at 50kPa (direct simple shear test)

Table 3.6 Repeatability results

Direct Shear Test						
Test	Peak Strength (kPa)	Average	Error	Residual Strength (kPa)	Average	Error
1	45.55	46.32	-1.69%	32.78	33.08	-0.92%
2	46.89		1.22%	32.98		-0.303%
3	46.52		0.43%	33.48		1.19%
Direct Simple Shear Test						
Test	Peak Strength (kPa)	Error	Deviation	Residual Strength (kPa)	Average	Error
1	42.11	42.18	-0.16%	34.68	34.61	0.20%
2	42.89		1.66%	35.33		2.04%
3	41.55		-1.51%	33.82		-2.33%

3.9 Bulk / dry density

The density achieved during the preparation of test specimen is presented in Table 3.7

Table 3.7. The densities achieved during the preparation of test specimens

% Water	Dry density (Mg/m ³)											
	Klipheuwel Sand (50-200KPa)				Kaolin Clay (50-200KPa)				Klipheuwel-Kaolin Composite (50-200KPa)			
	DST		DSST		DST		DSST		DST		DSST	
	Load	Avg	Load	Avg	Load	Avg	Load	Avg	Load	Avg	Load	Avg
0%	1.70		1.63		1.64		1.63		1.69		1.68	
	1.66	1.66	1.66	1.64	1.61	1.62	1.65	1.64	1.65	1.67	1.67	1.68
	1.63		1.64		1.62		1.63		1.67		1.68	
5%	1.66		1.65		1.64		1.65		1.63		1.65	
	1.65	1.65	1.64	1.65	1.62	1.64	1.64	1.65	1.65	1.63	1.61	1.63
	1.65		1.65		1.65		1.65		1.62		1.64	
10%	1.65		1.65		1.66		1.64		1.58		1.62	
	1.70	1.67	1.65	1.65	1.64	1.64	1.63	1.63	1.55	1.56	1.61	1.61
	1.66		1.66		1.62		1.63		1.65		1.61	
15%	1.61		1.60		1.63		1.62		1.52		1.59	
	1.67	1.66	1.61	1.61	1.63	1.62	1.57	1.60	1.48	1.52	1.60	1.59
	1.70		1.61		1.59		1.62		1.56		1.58	
20%	1.58		1.55		1.44		1.52		1.44		1.55	
	1.52	1.52	1.60	1.59	1.33	1.39	1.48	1.48	1.39	1.40	1.51	1.51
	1.47		1.61		1.41		1.43		1.36		1.46	
25%	1.42		1.53		1.31		1.39		1.32		1.41	
	1.45	1.47	1.55	1.53	1.40	1.36	1.42	1.39	1.28	1.27	1.36	1.35
	1.53		1.50		1.38		1.35		1.22		1.28	

3.10 Quality control

To ensure that all tests were performed up to standard, several factors were taken into consideration as detailed below:

1. No soil sample or composite was reused once tested.
2. All equipment was cleaned and checked for any defects when soil samples were tested.
3. All samples were properly weighed using calibrated weighing scales and prepared prior to testing.
4. Mixing clay with sand was properly done with a scoop to ensure a homogenous random mixing. Water was added in small amounts to ensure balanced water absorption between clay and sand
5. The number of drops needed to compress the soil was kept unchanged for every sample and the height from which the hand compactor was dropped to compress the soil was maintained constant.

3.11 Data processing

All data were processed by ShearTrac-II universal shear device software. After the completion of the test, the data from the created template file in the form of tables and figures were downloaded and the results from tables such as shear stresses, vertical and horizontal displacements were transferred into excel sheets and the new graphs of shear stress versus horizontal displacement were plotted. In order to determine the internal friction angle and cohesion from the raw data, first the peak shear stress for each test run was recorded. A straight-line graph of peak shear stress versus the corresponding normal pressure used for that particular test was then drawn for normal pressures of 50kPa, 100kPa and 200kPa. A line of best fit was generated and the gradient and Y-intercept values were determined from the equation. The arctangent of the gradient value was then calculated to obtain the internal friction angle. The Y-intercept of the equation of the line of best fit corresponded to the apparent cohesion value.

Figure 3.17 Summary of the research methodology

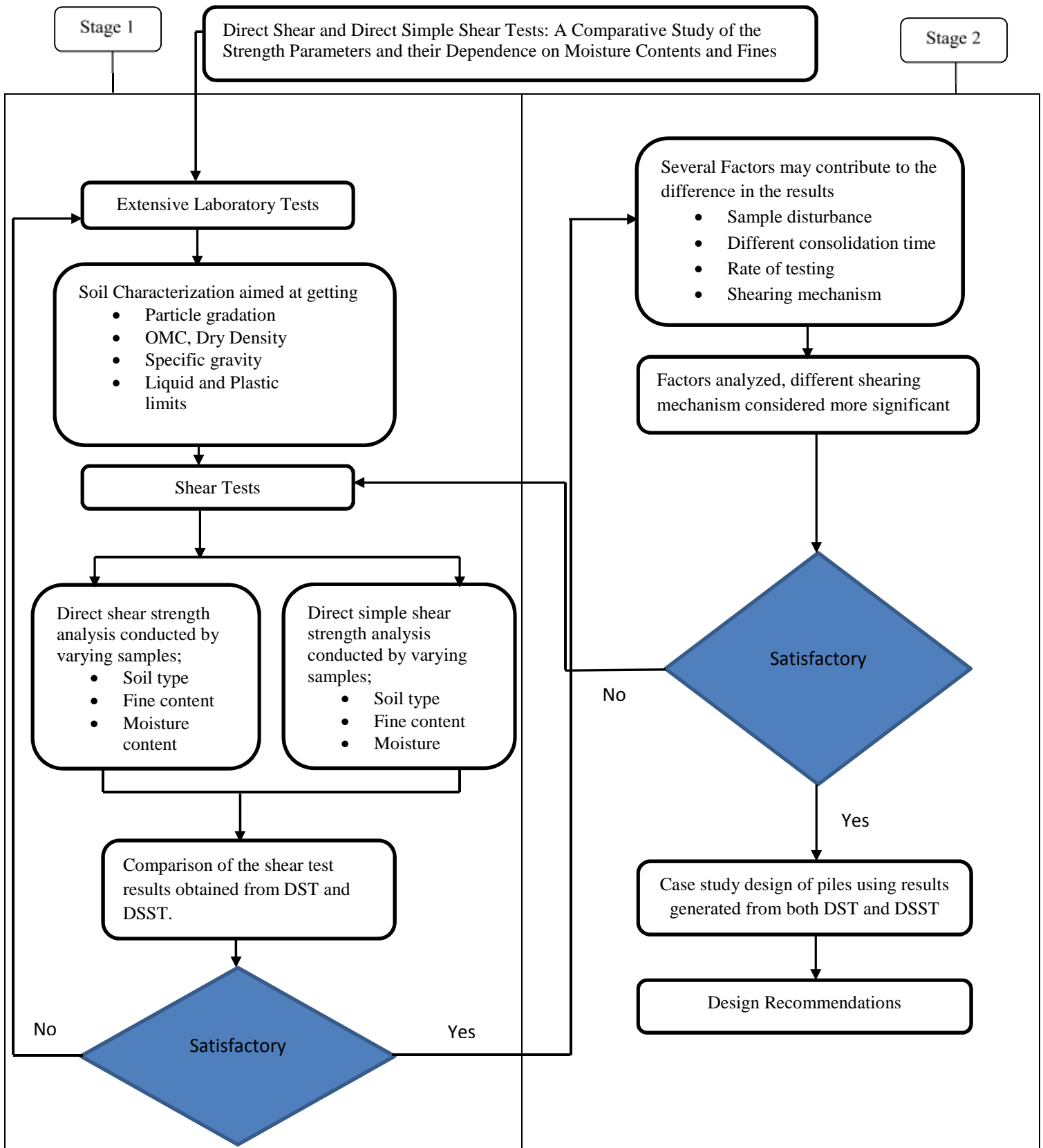

4.1 Introduction

This chapter presents the results generated from direct shear and direct simple shear tests conducted on Klipheuwel sand, Kaolin clay and sand-clay composites. The chapter is divided into four main sections. The first section details the evidence of repeatability. The shear deformation relationship results and discussion for both tests are covered in the second section while the shear stress - normal stress relationship is given in the section three. Lastly, the correlation factor based on the experimental outcomes are presented.

4.2 Shear stress - horizontal displacement relationship

The relationship between the shear stress and shear strain obtained from direct simple shear and direct shear tests are shown in Figures 4.1 - 4.5. Various graphs were plotted from the data obtained from the tested Klipheuwel sands and kaolin clay. The moisture content values are 5, 10, 15, 20 and 25%, and the clay content for the composite are 10, 25, 50 and 75% were considered. All the samples were tested at three different normal pressures of 50kPa, 100 kPa and 200 kPa, the different curves are based on these applied normal pressure. The shear stress increases with shearing shear strain initially until reaching a peak, after which shear failure occurs, which is signified by a plateau in the stress-strain response. In direct shear tests, the shear stress is increasing continuously based on the increment of the normal stresses. But, there are small differences of strains from each stress because the failure plane of the direct shear box is at horizontal plane and at the center of the specimen, and may not be the weakest plane. The middle of the specimen will be affected more than the other area of the specimen. This is because of the relative displacement of the two halves of the box. In direct simple shear test, the stresses within the sample are likely to be fairly uniform and give more realistic values. The graph of the direct shear test is increasing continuously because of the shearing process that only acting horizontally at the center of the specimen. A direct simple shear graph shows the peak stress of the specimen and finally decreasing because simple shear sheared around the entire specimen. The peak shear stresses generated for all the soil samples tested from direct shear is higher than direct simple shear test.

4.2.1 Sand only

The peak shear strengths from the tests run at normal pressures of 50,100 and 200kPa were found to be 46.70kPa, 97.50kPa and 193kPa for direct shear respectively. In a direct simple shear test, it was found to be 42.11kPa, 70.15kPa and 119.1kPa.

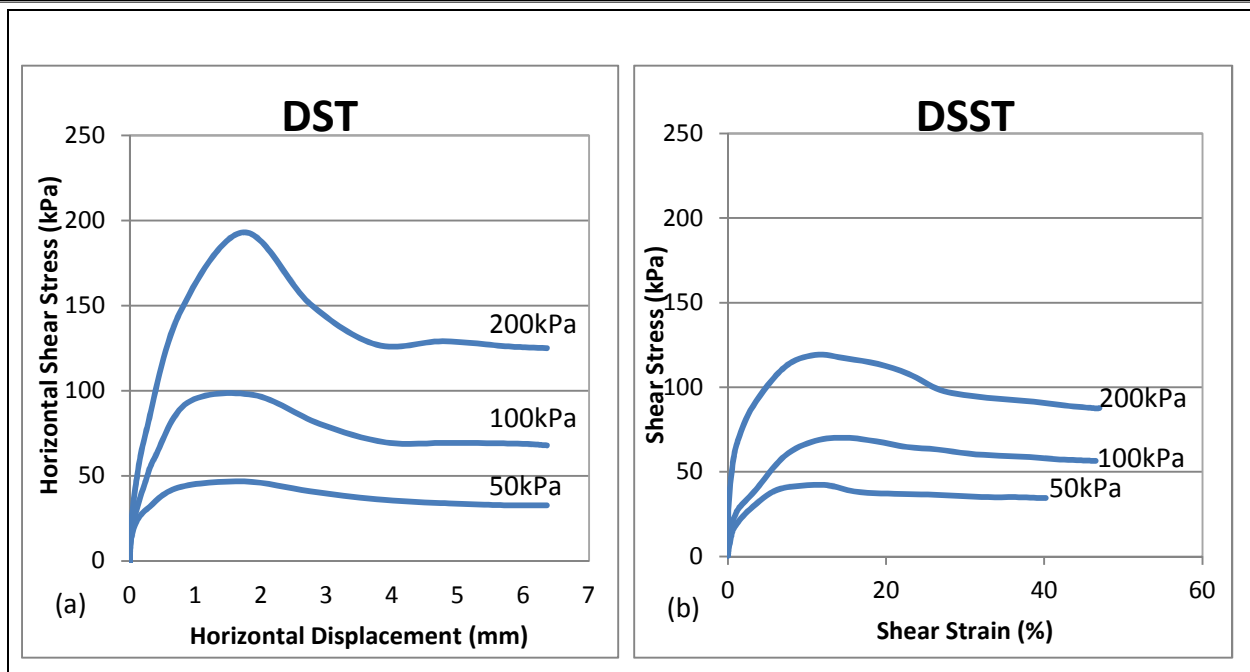

Figure 4.1 (a) and (b) Direct shear and direct simple shear test results for Klipheuwel sand only

4.2.2 Sand at varying moisture content

The results of the tests performed on Klipheuwel sand at varying moisture content from both tests are presented in Figure 4.2 (a to j). All the maximum values of shear stresses from all the different percentages of moisture content added to Klipheuwel sand are given in Table 4.1. The addition of water to the soil reduces the maximum shear stress when compared to the dry sample, but there is no direct correlation between increasing moisture content (MC) and maximum shear stress i.e. the maximum shear stress does not steadily decrease as the MC increases. Increasing water content of sand was found to cause drop in maximum shear stress (Muawia, 2013). This may be attributed to the effect of water that lubricated the particles, reducing the inter-particle friction and their resistance to shear. In direct simple shear tests (Figure 4.2 (b), (d), (f), (h) and (j)), addition of water to the soil samples reduces their maximum shear stress when compared to the dry sample (sand only) with the least having a maximum shear stress of 70.40kPa. However, for sample with 25% moisture content in direct shear, increase in shear stress was observed for normal pressure of 100kPa.

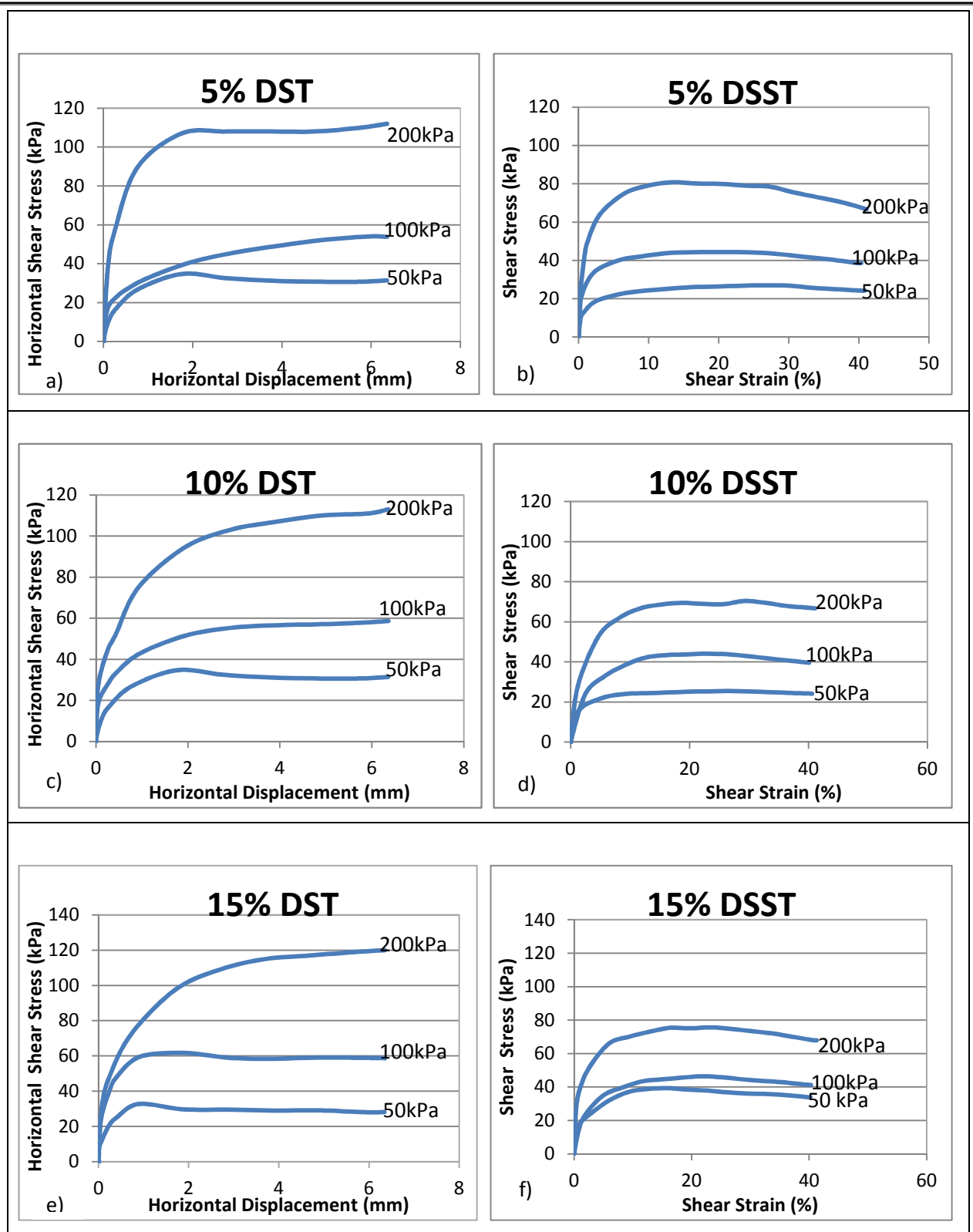

Figure 4.2 (a) to (j) Shear stress versus horizontal displacement for Klipheuwel sand with different percentages of moisture content for DST and DSST.

Continuation of Figure 4.2

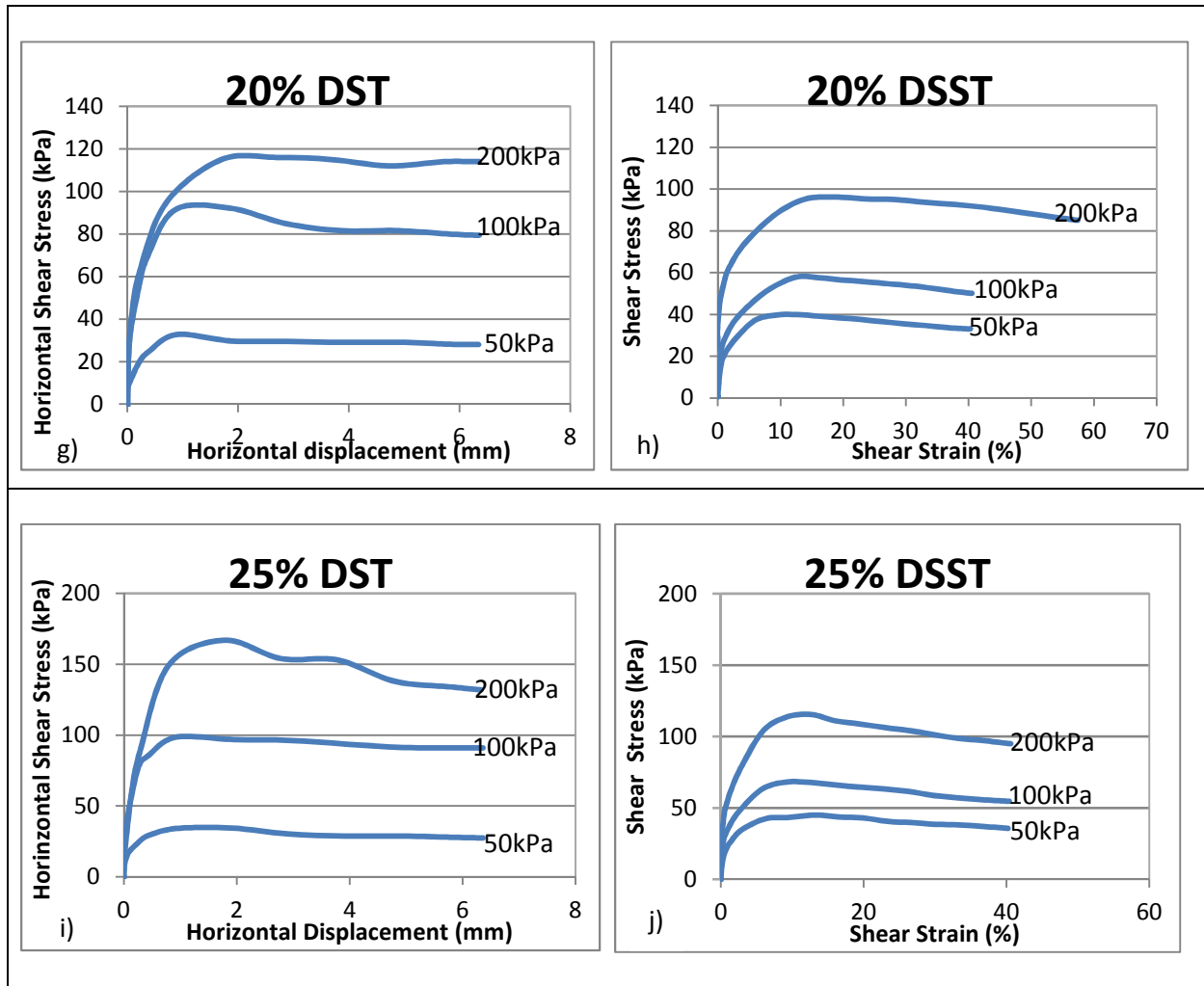

Table 4.1 Peak shear stress for Klipheuwel sand with different percentages of moisture content

% Water	Peak Shear Stress kPa (Klipheuwel sand and water)					
	50kPa		100kPa		200kPa	
	DST	DSST	DST	DSST	DST	DSST
5%	34.7	27.02	54.0	44.37	112	80.76
10%	34.7	25.46	58.7	44.06	113	70.40
15%	32.7	39.26	61.7	46.43	120	75.64
20%	32.7	39.94	92.2	58.04	116	96.18
25%	34.4	45.06	98.5	68.15	167	115.4

4.2.3 Sand and clay.

Maximum shear stresses showed a tendency to decrease as the clay content increased (Novais & Ferreira, 1971). It was observed from this trend that an increase in the amount of Kaolin clay added to Klipheuwel sand reduces its peak shear strength for both tests. The continuous increase in the amount of Kaolin clay added to Klipheuwel sand resulted in a reduction in maximum shear stress as well as the degree of strengthening. For a higher clay concentration of 75% for both tests, least maximum shear stress was observed for both tests as presented in Figure 4.3(a) to (h). All the maximum values of shear stresses from all the different Kaolin clay concentration added to Klipheuwel sand are given in Table 4.2.

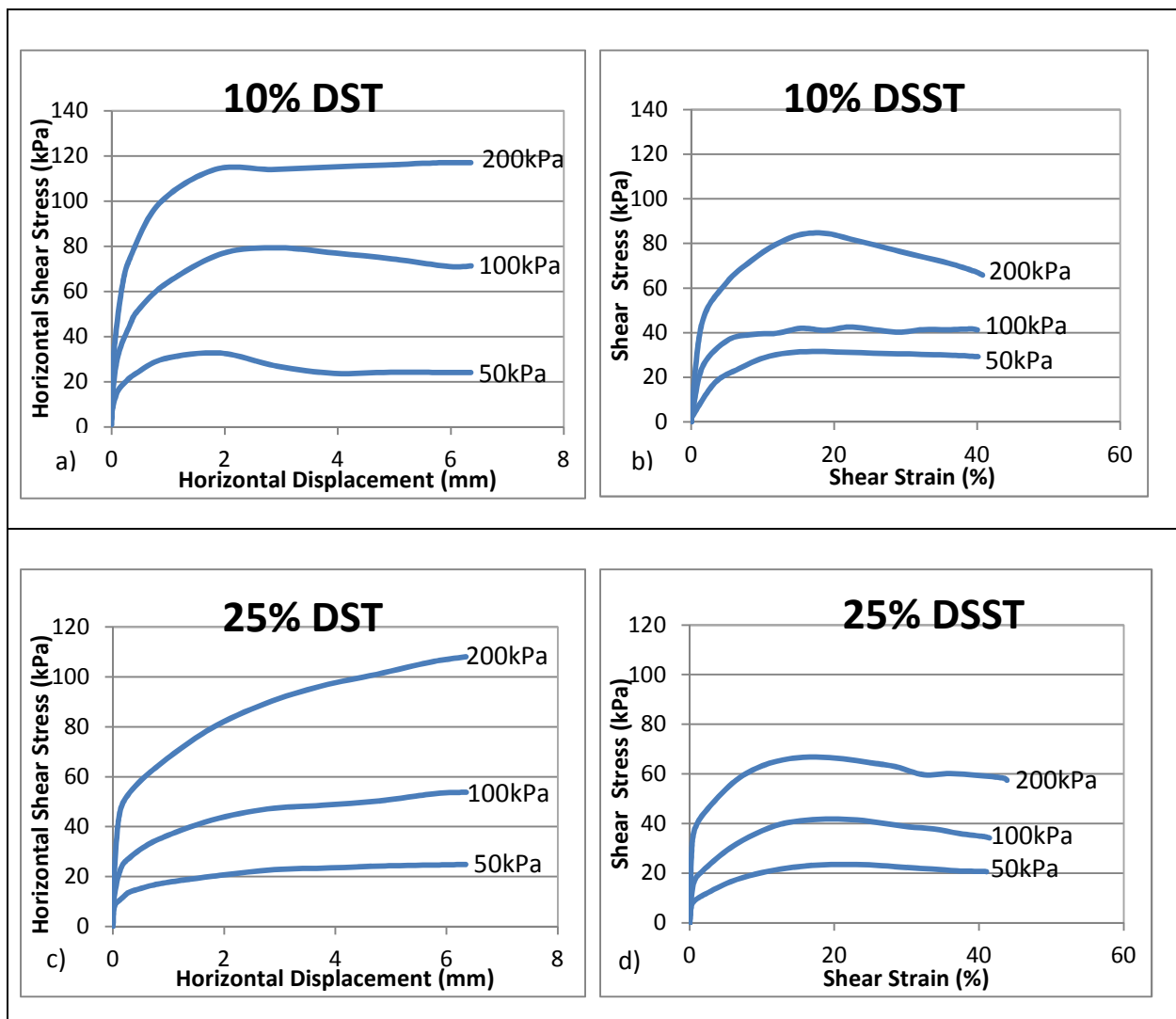

Figure 4.3 (a) to (h) Shear stress versus horizontal displacement for Klipheuwel and Kaolin clay at different concentrations of Kaolin clay for DST and DSST.

Continuation of Figure 4.3

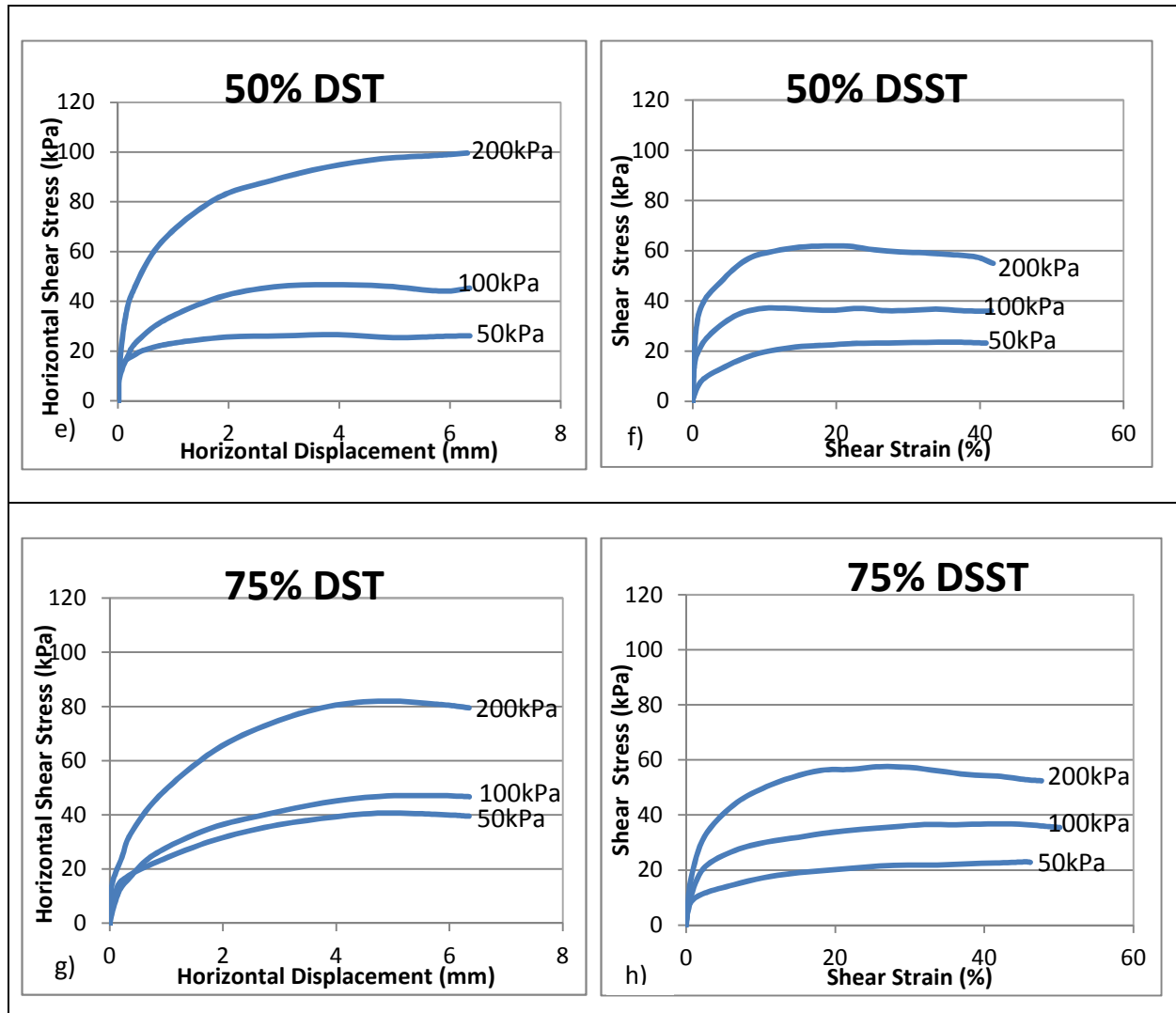

Table 4.2 Peak shear stress for Klipheuwel sand with a different concentration of Kaolin clay

% Clay concentration	Peak shear stress kPa (Klipheuwel sand and Kaolin clay)					
	50kPa		100kPa		200kPa	
	DST	DSST	DST	DSST	DST	DSST
10%	32.7	31.58	79.3	42.56	117	84.57
25%	24.9	23.53	53.8	41.82	108	66.78
50%	26.1	23.65	46.7	37.13	99.6	61.91
75%	40.6	22.97	47.1	36.76	82	57.54

4.2.4 Kaolin clay.

Figure 4.4 (a) and (b) shows the results obtained from direct shear and direct simple shear tests of Kaolin. The shear stress tends to be lower for clay compared to sand. The peak shear stress from the direct shear test were found to be 35.6kPa, 69.1kPa and 110kPa .The peak shear strengths from the direct simple shear tests were found to be 26.65kPa, 32.83kPa and 69.46kPa respectively, which is low compared to the peak shear strength results from Klipheuwel sand only.

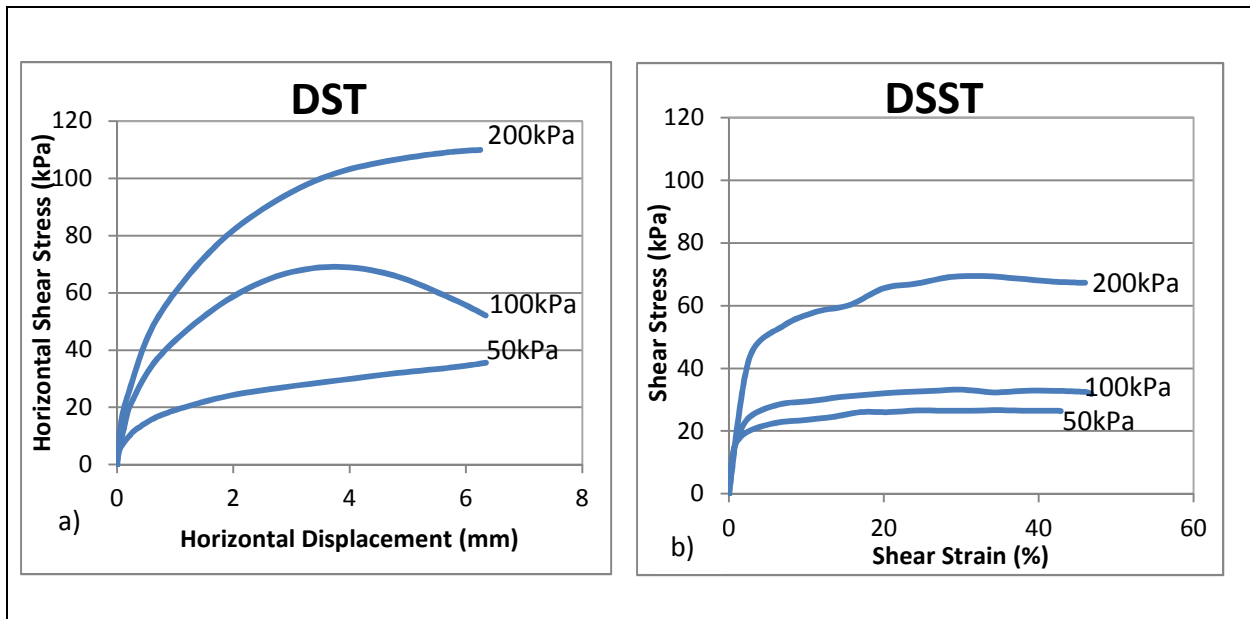

Figure 4.4 Shear stress versus horizontal displacement for Kaolin clay.

4.2.5 Kaolin clay at varying moisture content.

Water in soil acts both as a lubricant and as a binding agent among the soil particulate materials, thereby influencing the strength of soil (Ferre et al., 2002).The addition of water to Kaolin increases its maximum shear stress for DST. However, decrease in maximum shear stress was observed for DSST as compared to dry Kaolin. A decrease in the maximum shear stress compared to dry Kaolin in DSST not achieved throughout. There is variation in the result, at lower moisture contents true but maximum shear stress increases above dry value at higher moisture contents. In DST, values of maximum shear stress at 20 % water content were slightly higher than those at 15%, but notably lower than those at 25% water content. The results are presented in Figure 4.5. All the trend lines show similar increase of values of maximum shear stress. The peak shear stresses from all the different percentages of moisture content added to Kaolin clay are given in Table 4.3.

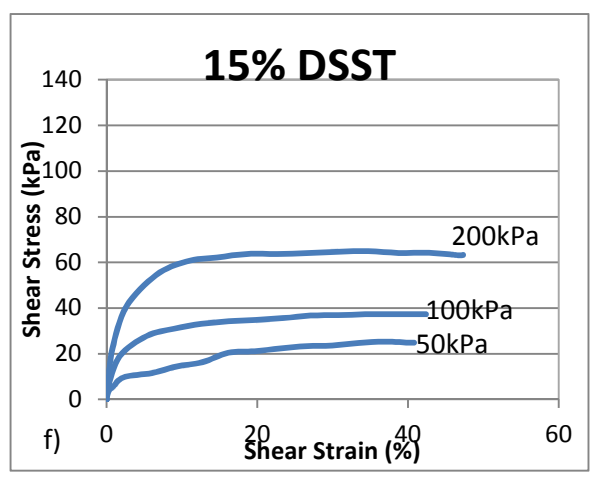
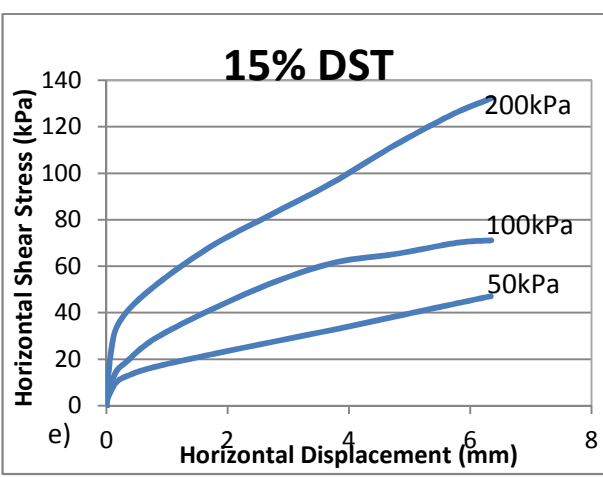
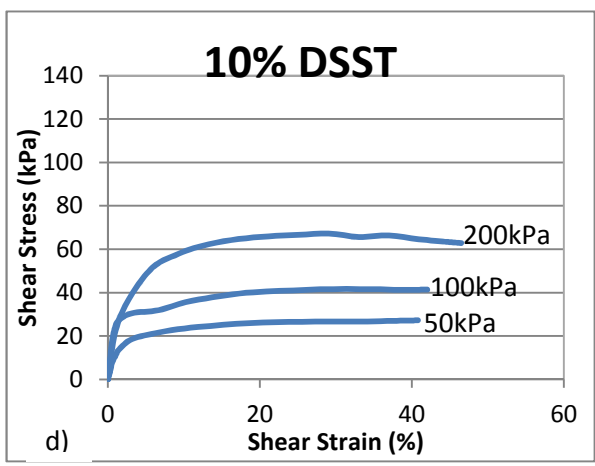
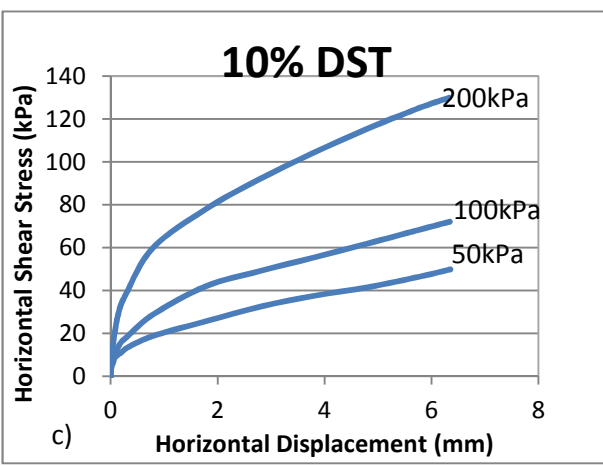
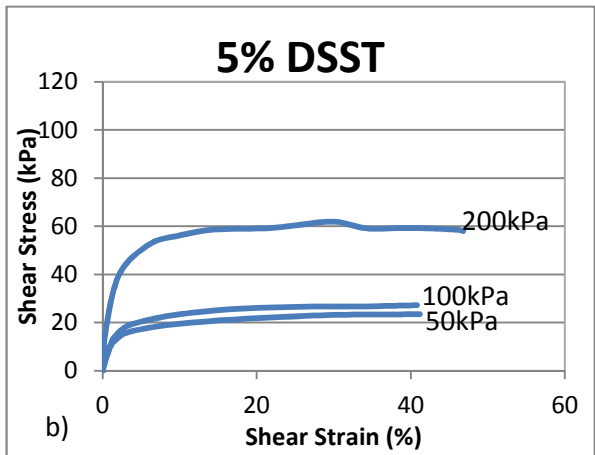
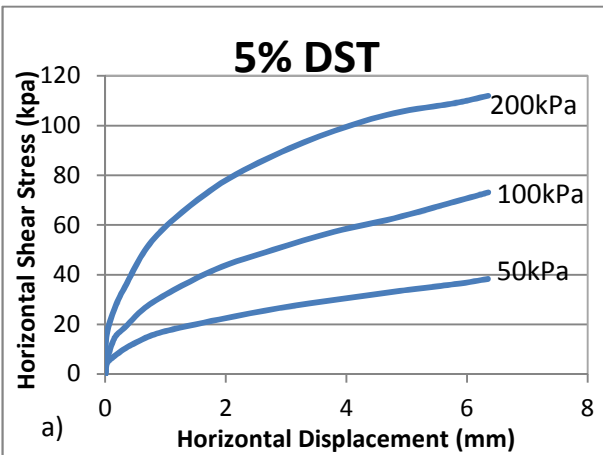

Figure 4.5 (a) to (j) Shear stress versus horizontal displacement for Kaolin clay with different percentage of moisture content for direct and simple shear tests.

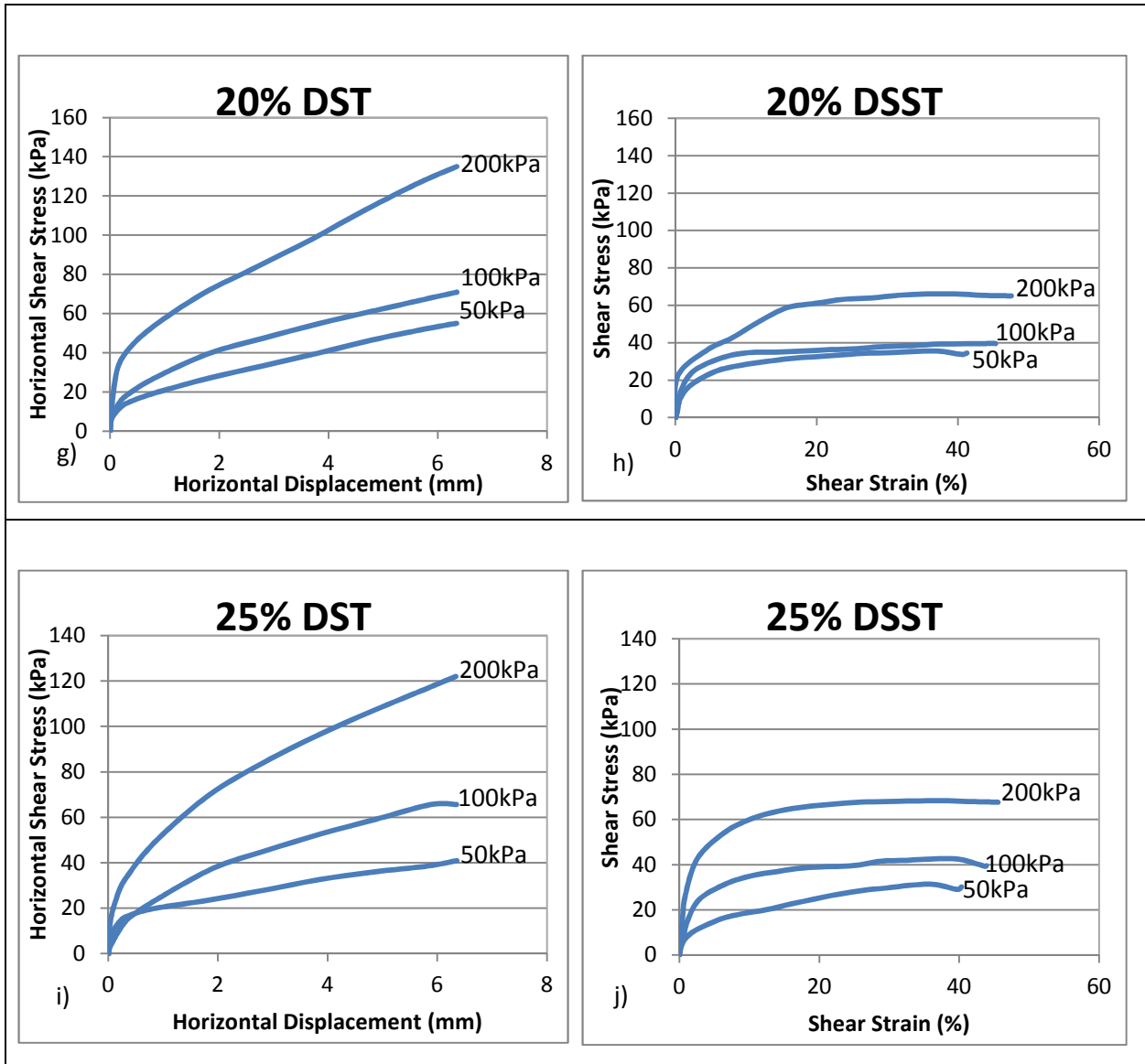

Table 4.3 Peak shear stress for Kaolin clay with different percentage of moisture content

% Water	Peak shear stress kPa (Kaolin clay and water)					
	50kPa		100kPa		200kPa	
	DST	DSST	DST	DSST	DST	DSST
5%	38.3	23.47	73.09	27.21	112	58.04
10%	49.8	27.21	72.1	41.63	130	67.22
15%	47.1	25.28	71.1	37.32	132.28	64.91
20%	55	35.57	70.09	39.63	135	66.09
25%	40.9	31.33	65.6	45.56	122	68.34

4.3 Shear stress - normal stress relationship

The relationship between maximum shear stress and applied normal pressure was analyzed which is the Coulomb failure envelope that was plotted using the data obtained for all tested samples. The maximum shear stress obtained for each test were plotted against applied normal pressures of 50kPa, 100kPa and 200kPa for all the soil samples, a line of best fit was added to the graph. The equation of this line was analyzed to determine the internal friction angle and apparent cohesion values. The arctangent value of the gradient of the line of best fit yielded the internal friction angle whereas the Y-intercept yielded the apparent cohesion, which were used to plot Coulomb failure envelope line.

For all the soil samples tested, with all the samples tested at almost the same density as presented in Table 3.6, the results show that direct shear test has a higher internal angle of friction than direct simple shear test. Several factors may contribute to the observed differences in strength, which may include; sample disturbance, different consolidation time (less significant), and rate of testing and shearing mechanism (Hanzawa et al., 2007). The effect of sample disturbance was evaluated by Hanzawa et al. (2007) and Lunne et al. (1997), it was observed, that the differences in the disturbance index between the direct simple shear test and the direct shear test do not clearly echo the differences in shear strength exhibited in the soil samples. However, variations in the testing procedures will mask the effect of disturbance. Similar testing procedures were observed for both tests, with all the soil samples tested under same condition. There was no

offset time input for the T100 parameter at the consolidation stage for both tests, because all soil samples were required to be fully consolidated before shear testing. The effect of consolidation time was studied by Berre (1985), who concluded that consolidation time is less significant in assessing differences between direct shear and direct simple shear tests. The soil samples for both direct shear test and direct simple shear test were sheared at the same displacement rate of 1mm/min. Similar results were obtained by Hanzawa et al. (2007) and Ohta et al. (1985), it was concluded that the differences between direct simple shear and direct shear tests can be attributed to different shearing mechanisms. In a direct shear test, the circular box is split horizontally into halves. Normal force on the specimen is applied from the top of the shear box. Shear force is applied by moving one half of the box relative to the other to cause failure in the soil specimen. The shear force is applied in equal increments until the specimen fails. The failure occurs along the plane of split of the shear box. The change in the height of the specimen (and thus the volume change of the specimen) was observed after the test. In a direct simple shear test, during the shearing phase of the test, the circular rings surrounding the test sample are forced to slide apart, thereby subjecting the soil sample to a shearing force. After a soil sample was tested, it was observed that the rings undergo maximum displacement at the bottom of the stack of rings, and that this deformation was reduced towards the top of the stack. This is a result of the shearing mechanism of the direct simple shear test machine and also the specimen height remains the same after the test. A soil sample is constrained against any vertical movement by a force that is transmitted through a piston which presses against the top of the soil sample. In a direct shear, the distribution of normal and shearing stresses during the test are not uniform. Failure of the soil occurs progressively from the edges towards the center of the sample.

4.3.1 Sand only.

The internal friction angle obtained from a direct shear test is 44.20° and cohesion is zero, while the internal friction angle obtained from a direct simple shear test is 27.02° with an apparent cohesion of 17.64. The density of sample tested for a direct shear test is 1.66 Mg/m³ while the density of samples tested for a direct simple shear test is 1.64 Mg/m³. Figure 4.6 represent the Coulomb failure envelopes for Klipheuwel sand for both a direct shear test and a direct simple shear test.

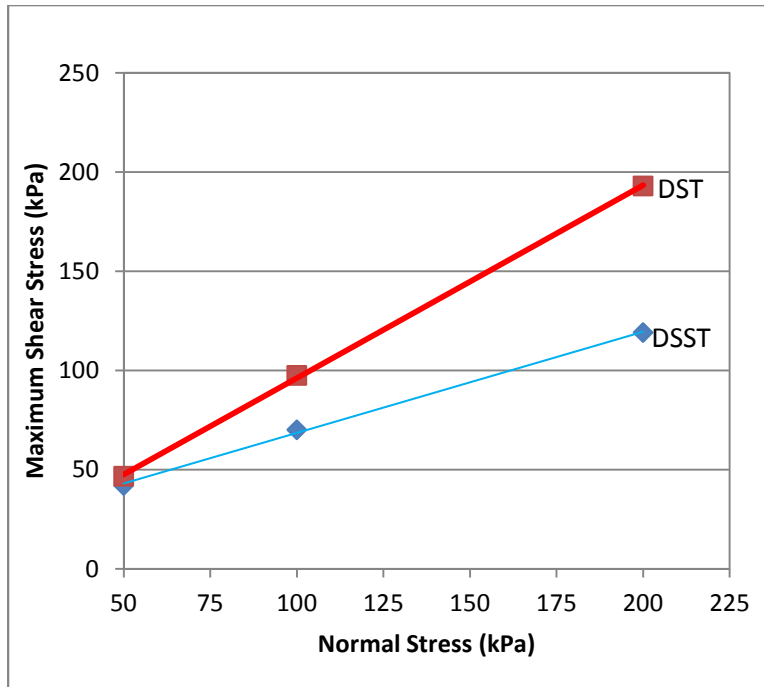

Figure 4.6 Relationship between the maximum shear stress and normal applied pressure for Klipheuwel sand (direct shear test and direct simple shear test)

4.3.2 Sand with varying moisture content

The addition of water to Klipheuwel sand increased its cohesion and reduced its angle of internal friction for both tests, when compared to the results from dry sand. This reduction may be due to a layer of hydration membrane enhancing lubricity on the surface of sand particles, thereby reducing the friction between the particles in the shearing process and decreasing the angle of internal friction of the samples. In both the DST and DSST the friction values are lower than when compared to dry sand, but there is no direct correlation between increasing MC% and decreasing friction angle i.e. the friction angle does not decrease as the water content increases. Figure 4.7 presents the Coulomb failure envelopes for Klipheuwel sand at varying moisture contents for both tests. Both cohesions and friction angles from the two tests with their percentage differences in angle of internal friction are presented in Table 4.4.

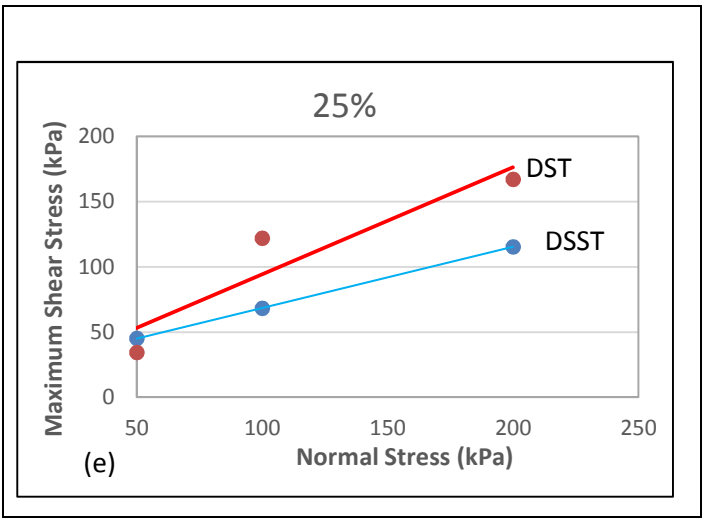
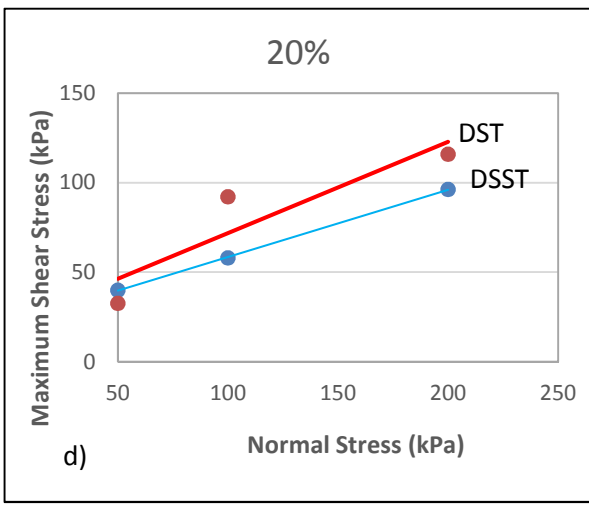
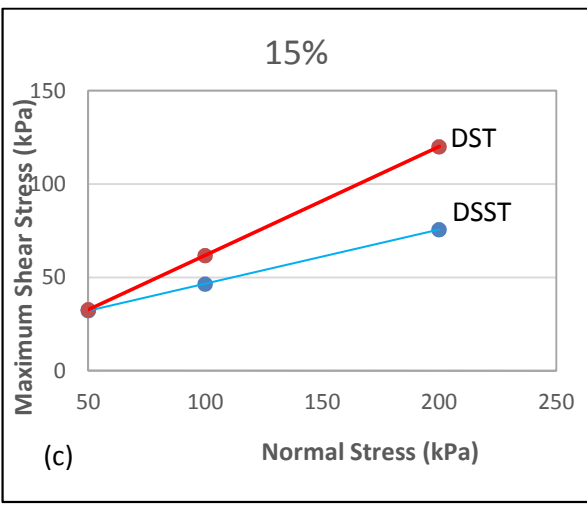
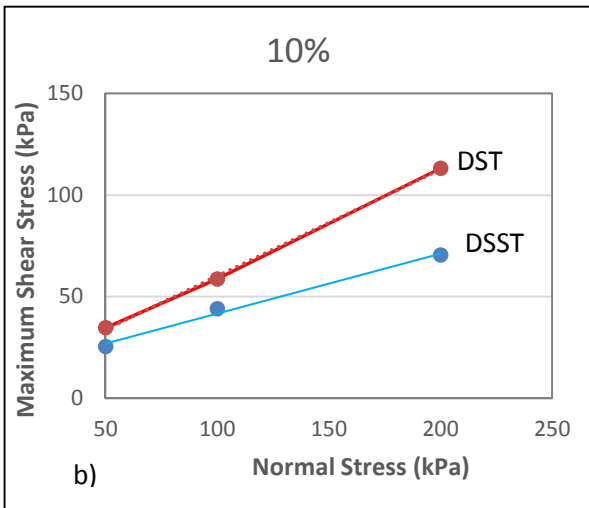
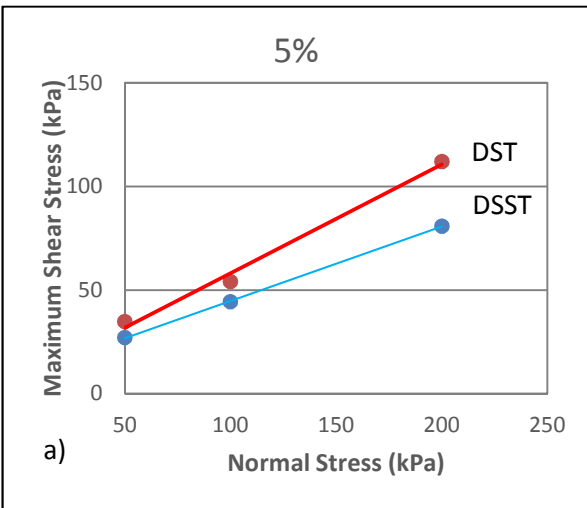

Figure 4.7 (a) – (e)

Figure 4.7 (a) to (e) Relationship between the maximum shear stress and normal applied pressure for Klipheuwel sand with varying moisture content (direct shear test and direct simple shear test)

Table 4.4 Shear strength parameters (internal friction angle and cohesion) obtained from direct shear test and direct simple shear from Klipheuwel sand with varying moisture content.

Klipheuwel sand with water	Direct Shear Test		Direct Simple Shear Test		% Difference	% Average
	c (kPa)	ϕ (°)	c (kPa)	ϕ (°)	ϕ	ϕ
5	5.7	27.68	8.83	19.75	28.65	36.69
10	7.55	27.70	12.29	16.40	40.79	
15	3.55	30.20	24.66	14.01	53.61	
20	20.8	27.20	20.87	20.60	24.27	
25	11.9	39.40	21.44	25.15	36.17	

4.3.3 Sand and clay at different clay concentrations

The presence of clay in a mixture has a significant impact on shear strength parameters (Muawia, 2013). Because of their high specific surface and electronegativity, physiochemical effects govern the behaviour of clay minerals. Increasing the quantity of clay in soil will, in general, cause an increase in plasticity, swell and shrinkage, compressibility and cohesiveness. At the same time the internal friction angle usually decreases. Al (1997), Naser (2001), Shanyoung et al. (2009), Mohammad et al. (2011), Yongshan and James (2002), Lius and Roger (2000) concluded that for a clay and sand mixture, the cohesion increases with increasing clay content while the internal friction angle decreases with increasing clay content. Figure 4.8 (a) to (d) presents the failure envelopes for sand-clay composites for both the direct shear test and the direct simple shear test. The continuous addition of clay to Klipheuwel sand improved cohesion and reduced angle of internal friction for both tests, when compared to the results from Klipheuwel sand only.

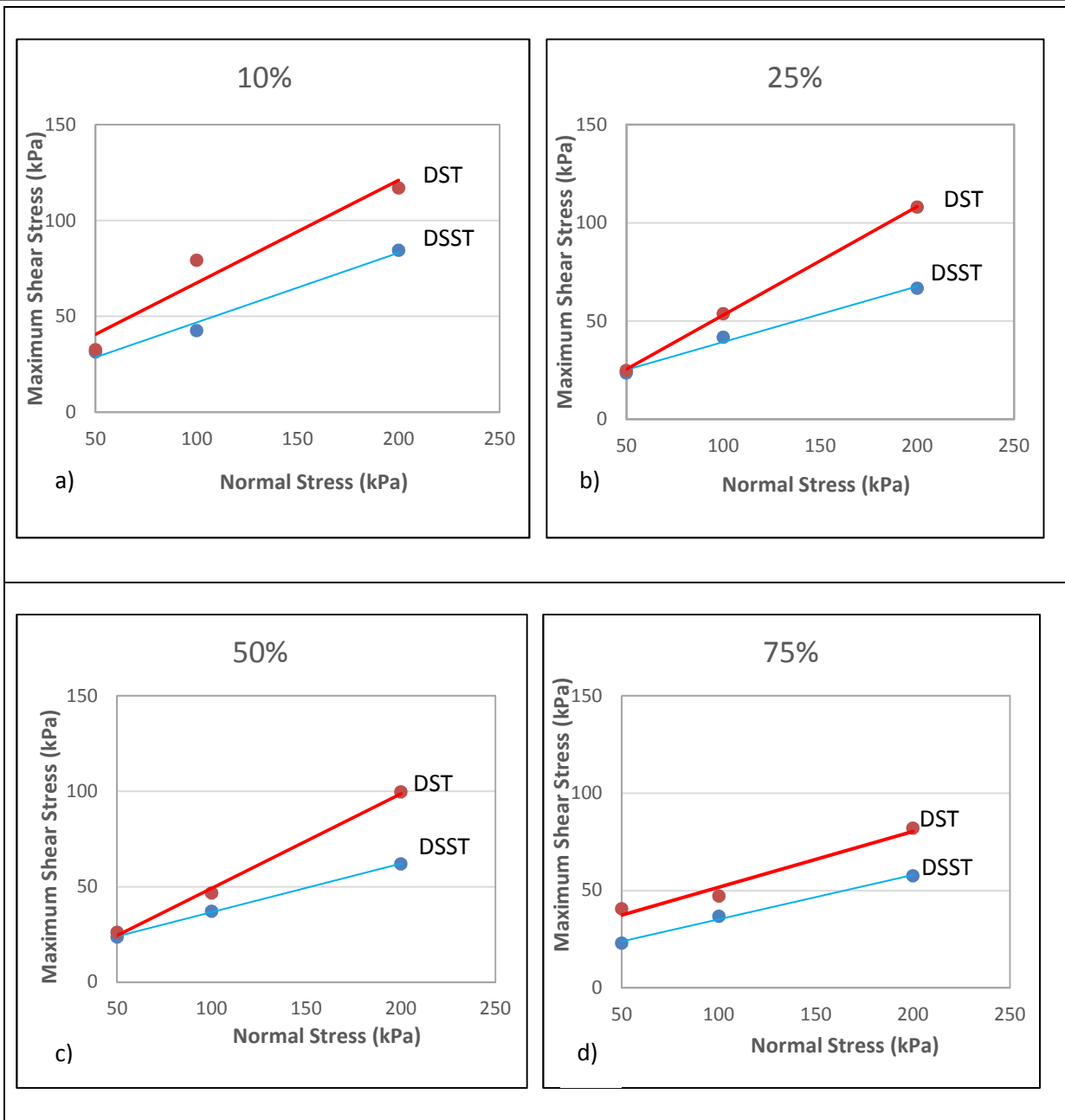

Figure 4.8(a) to (d) Klipheuwel sand and Kaolin (direct shear test and direct simple shear test)

The internal friction angle reduced from 44.20° to 15.80° (75% clay concentration) for the direct shear test, while for the direct simple shear test the internal friction angle was reduced from 27.02° to 12.80° (75% clay concentration). Both cohesions and internal friction angles from both tests with the percentage difference in internal angle of friction are presented in Table 4.5.

Table 4.5: Shear strength parameters (internal friction angle and cohesion) obtained from both tests on Klipheuwel sand and kaolin clay with a different clay concentration.

Klipheuwel sand with Kaolin clay	Direct Shear Test		Direct Simple Shear Test		% Difference	% Average
	c (kPa)	ϕ (°)	c (kPa)	ϕ (°)	ϕ	ϕ
10	13.85	28.17	10.75	19.94	29.2	34.05
25	16.22	28.01	11.05	15.79	45.38	
50	18.44	26.36	11.33	14.25	45.94	
75	23.15	15.18	12.58	12.80	15.68	

4.3.4 Kaolin clay.

The internal friction angle obtained from the direct shear test is 25.81° and cohesion is 15.15, while the internal friction angle obtained from the direct simple shear test is 16.5 ° and an apparent cohesion of 8.34. The density of the sample tested for the direct shear test is 1.62 Mg/m³, while the density of samples tested for the direct simple shear test is 1.64 Mg/m³. Figure 4.9 represents the failure envelopes for Kaolin clay for both the direct shear test and the direct simple shear test.

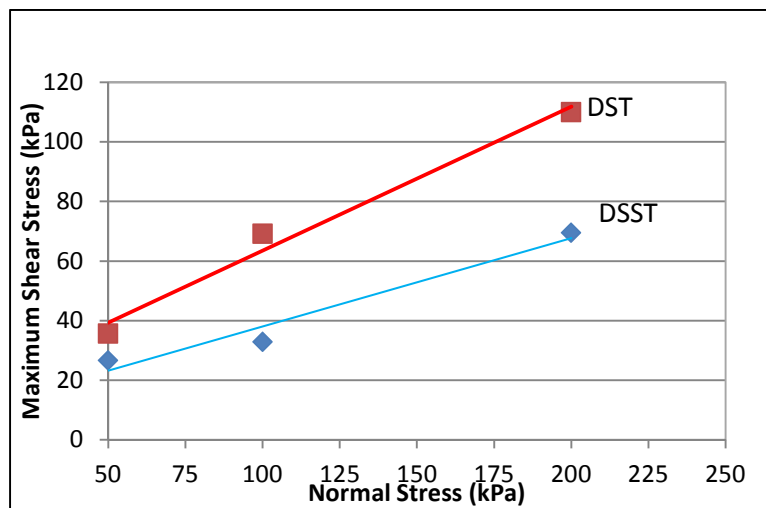

Figure 4.9 Relationship between the maximum shear stress and normal applied pressure for Kaolin clay (direct shear test and direct simple shear test)

4.3.5 Kaolin clay with varying moisture content.

The addition of water to Kaolin clay improve its cohesion for both tests, Figure 4.10 (a) to (e) present the results for Kaolin clay at varying moisture content. The increase in cohesion in clay soil can be attributed to the clay fabrics, which become deflocculated with the introduction of water, thereby increasing their cohesive force present. In direct simple shear tests, the angle of internal friction decrease with increasing moisture content. Increase in moisture content thickens the hydration membrane on the surface of the clay particles and separates the clay from each other, thus enhances lubricity between clay particles and results in a decrease in the angle of internal friction. The internal friction angle increased from 25.80° to 29.86° for the direct shear tests, with 15% moisture content having the highest internal friction angle. Both cohesions and internal friction angles from the both tests, with the percentage difference in internal friction angles, are presented in Table 4.6.

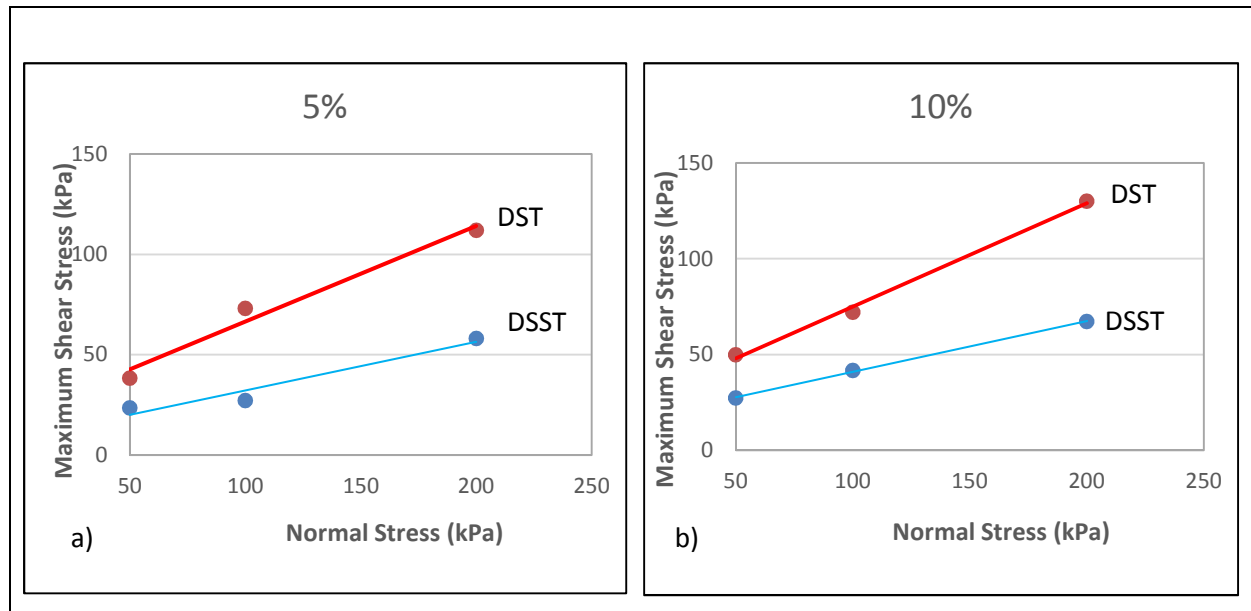

Figure 4.10 (a) to (e) Relationship between the maximum shear stress and normal applied pressure for Kaolin clay at varying moisture content (direct shear test and direct simple shear test)

Continuation of Figure 4.10

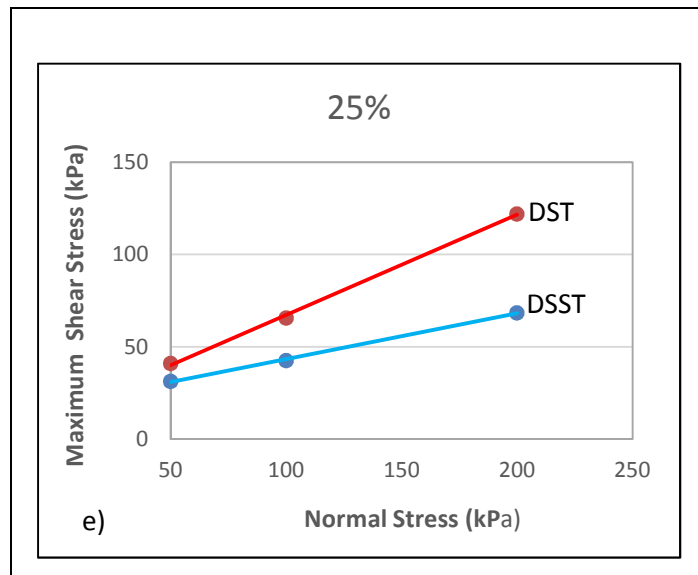
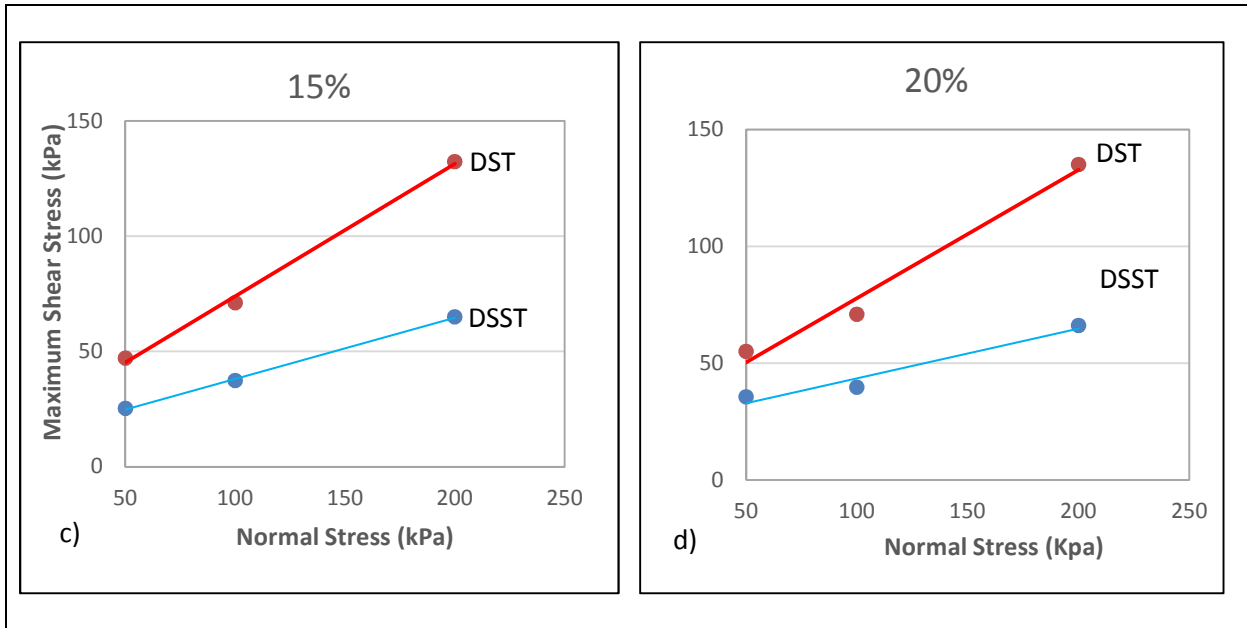

Table 4.6 Shear strength parameters (internal friction angle and cohesion) obtained from direct shear test and direct simple shear from Kaolin clay with varying moisture content.

Kaolin clay with water	Direct shear test		Direct simple shear test		% Difference	% Average
	c (kPa)	ϕ (°)	c (kPa)	ϕ (°)	ϕ	ϕ
5	18.85	25.45	8.06	15.80	37.90	49.04
10	20.85	28.40	14.42	14.85	47.71	
15	16.51	29.86	11.49	14.89	50.13	
20	22.95	28.75	22.34	11.98	58.33	
25	12.70	28.55	18.44	13.95	51.14	

4.4 Correlation factor

Figures 4.11 (a) to (e) compare the angle of internal friction results obtained from each soil sample (Klipheuwel, kaolin, and Klipheuwel-kaolin) mixed at different percentage of moisture content. It is evident that direct shear test has higher internal friction angle as compared to direct simple shear test. The difference was observed to be almost identical for all the soil samples tested showing consistency in dry samples, but a slight deviation was observed in moist samples. This deviation is higher in Kaolin compared to Klipheuwel sand, with Kaolin having average percentage difference of 49.04% from the internal friction angle generated from both tests (Table 4.6).

The effect of moisture content on the angle of internal friction increased with continuous addition of moisture up to a maximum moisture content of 25 % for both Klipheuwel sand and Kaolin. The results obtained from the composite (Klipheuwel-Kaolin) are significant, and it can be concluded that adding a small amount of clay may not be sufficient to influence the angle of internal friction, for the angle of internal friction rate of drop increased only for the 75% clay concentration. A clay-sand mixture shows a steep drop in the angle of internal friction when the clay content is high (Muawia, 2013).

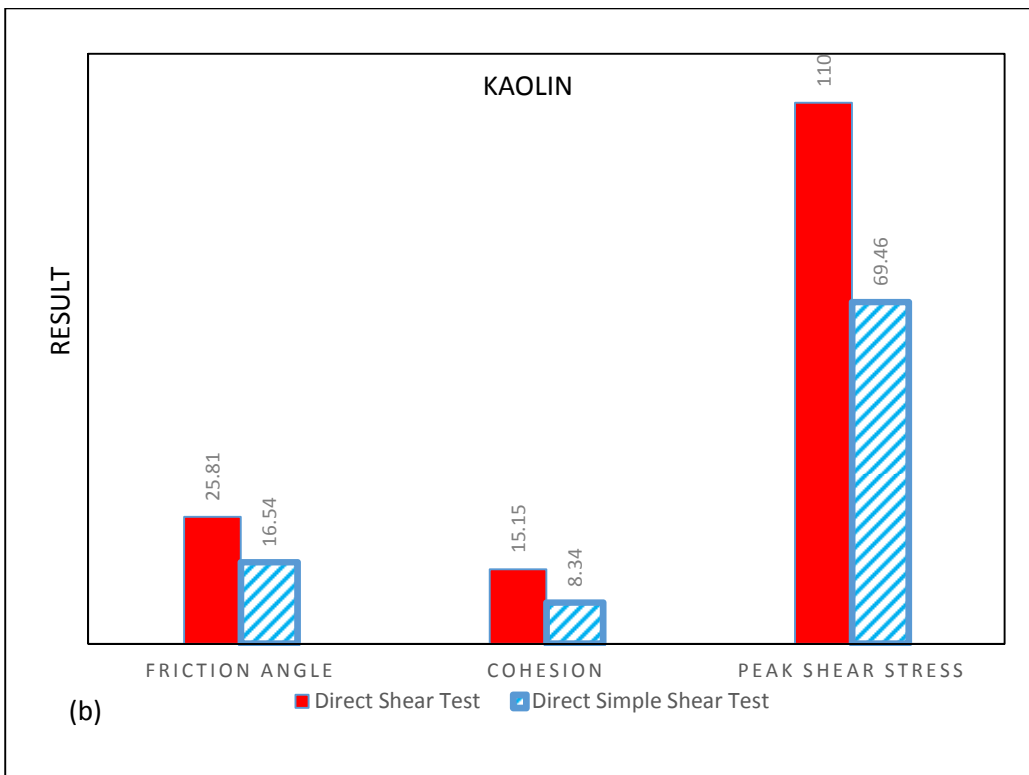
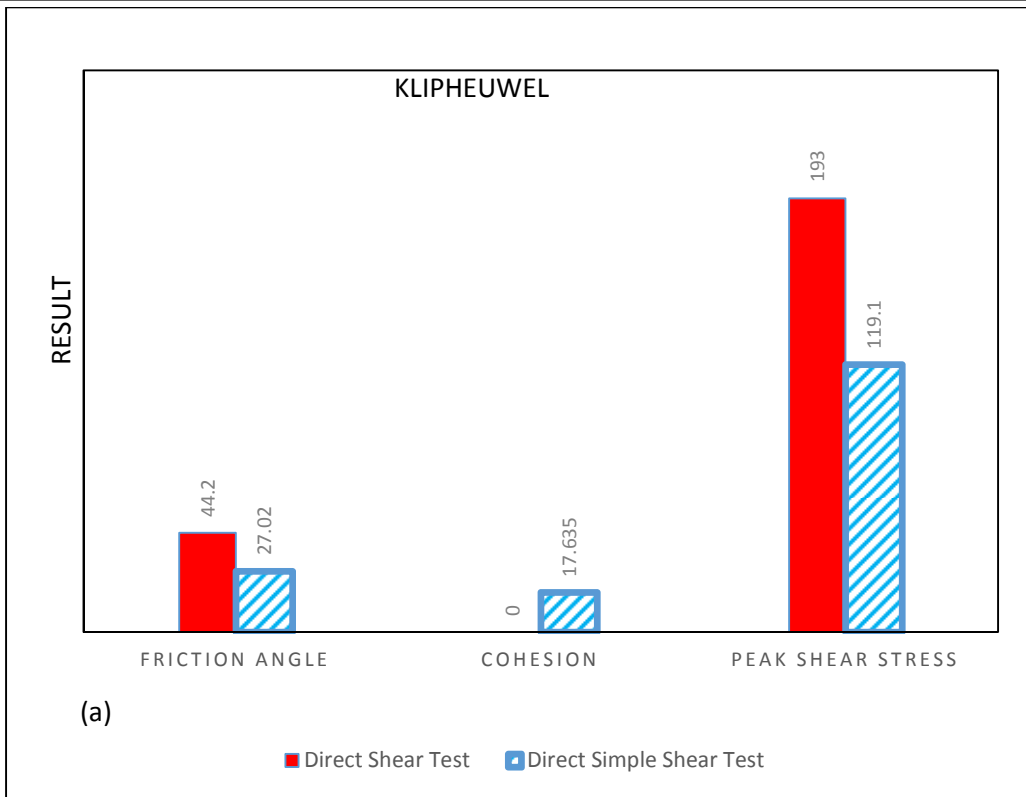
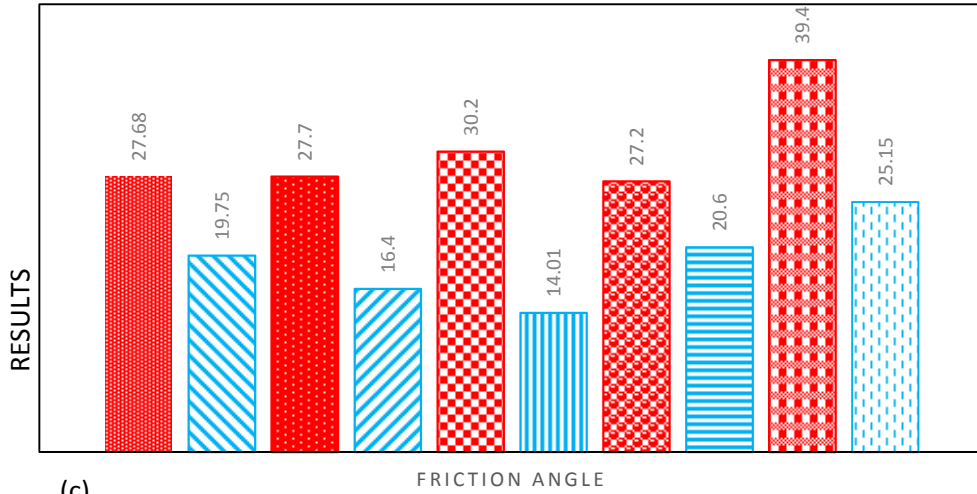

Figure 4.11 (a) to (e) Relationship of angle of internal friction between DST and DSST

KLIPHEUWEL AT VARYING MOISTURE

■ DST 5% ■ DSST 5% ■ DST 10% ■ DSST 10% ■ DST 15%
■ DSST 15% ■ DST 20% ■ DSST 20% ■ DST 25% ■ DSST 25%



(c)

KAOLIN AT VARYING MOISTURE

■ DST 5% ■ DSST 5% ■ DST 10% ■ DSST 10% ■ DST 15%
■ DSST 15% ■ DST 20% ■ DSST 20% ■ DST 25% ■ DSST 25%

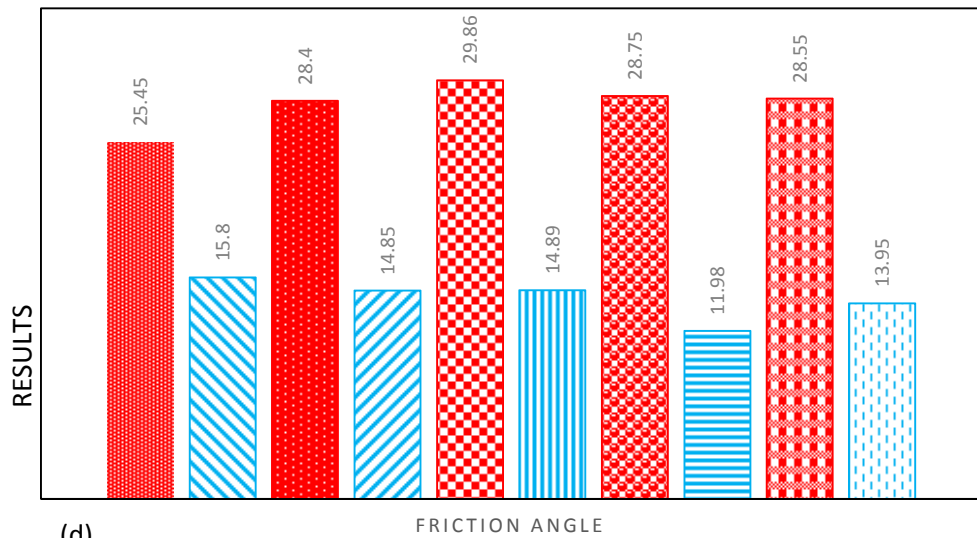

(d)

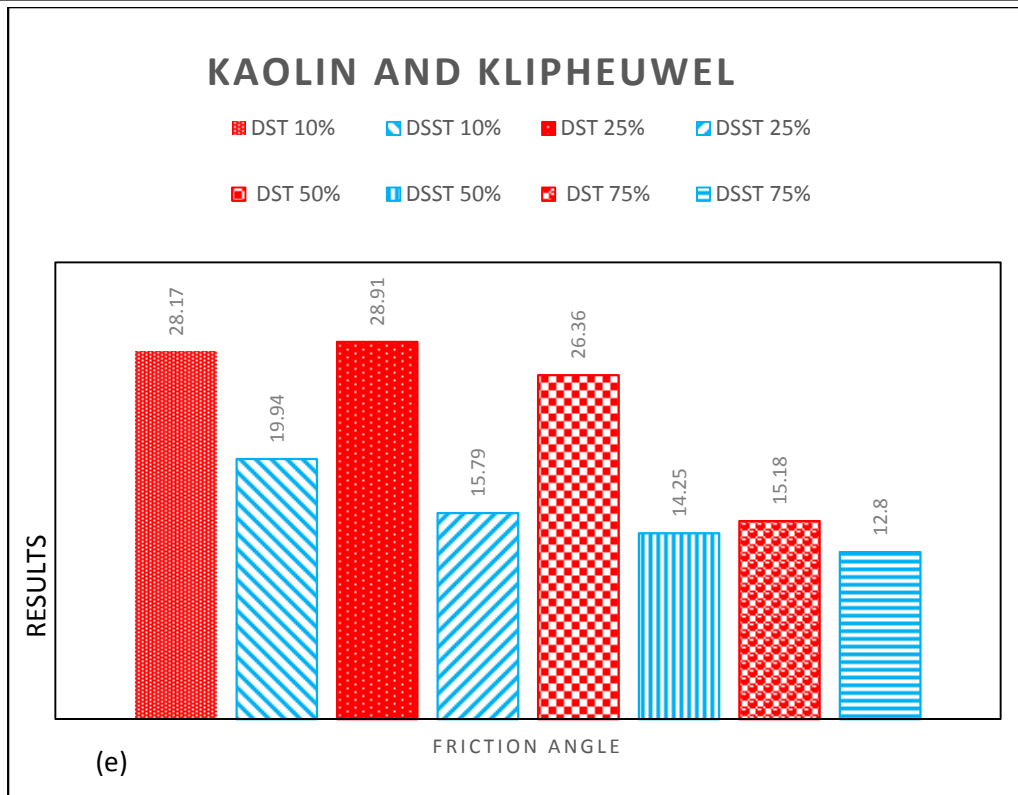

From the research it was found that there is a significant difference between the result of the angle of internal friction generated from direct shear and direct simple shear tests. From this research a correlation factor was generated between the direct simple shear and the direct shear tests conducted. The correlation was developed as follows:

- (1) The sum of all the percentage differences for all the soil samples tested for this research (Tables 4.4 to 4.6) gives an average, illustrated in Table 4.7. This average equals 0.389.

Table 4.7 Percentage difference of angle of internal friction for all the soil samples.

Soil sample	Direct shear	Direct simple shear	% Difference	% Average
Klipheuwel	44.20	27.02	38.87	38.91
Kaolin	25.81	16.54	35.91	
Klipheuwel at varying moisture content (MC)	30.44	19.18	36.69	
Klipheuwel-Kaolin	24.66	12.56	34.05	
Kaolin at varying MC	28.20	14.29	49.04	

(2) To derive the angle of internal friction for direct simple shear test (DSST) for any of the soil sample, the constant (0.389) is multiplied by its angle of internal friction for direct shear test (DST).

(3) The result derived above is then subtracted from the angle of internal friction from the same direct shear test.

The relationship can be estimated as follows:

$$\text{Dst } \phi - 0.389\text{Dst } \phi = \text{Dsst } \phi$$

Where Dst = direct shear test

Dsst= direct simple shear test.

ϕ =Angle of internal friction

5.0 PRACTICAL APPLICATIONS

5.1 Introduction.

The angle of internal friction and cohesion are among the important parameters contributing to the shear strength in a soil, and are used in design of structures. To limit deformations within tolerable limits, a suitable factor of safety is generally applied to soil structures so that the shear stress in the soil does not exceed a certain proportion of its maximum shear strength. This chapter discusses the application of the results generated from this study and presents a basic design example.

5.2 The proposed design

The extensive application of both shear tests depends on the mode of shear of the soil underlying proposed site. The behavior of soils adjacent to a pile can be closely reproduced by direct simple shear, since it allows for the rotation of principal stresses. The mode of shearing established in the simple shear device is similar to that which occurs around the shaft of a pile (Jose Fernando et al., 2002). It is on this basis that a pile design was chosen to explain the relevance of this study. The angle of internal friction from direct shear and direct simple shear for Klipheuwel sand was used to design a pile and the results were analyzed.

Piles are structural members that transmit the super structure loads to deep soil layers. They are preferred to be used as a foundation type when shallow foundations are not practical option for the purposes of safety and reliability of a project. Piles and pile foundations have been in use since prehistoric times (Shamsher, 1990).The Roman wooden piles are classic example for this. Today piles can be made of wood, concrete or steel. Piles are classified according to three different ways, namely nature of load support, construction method and material composition. If the piles do not reach a hard stratum, their load carrying capacity is derived partly from end bearing and partly from the skin friction; these piles are called friction piles. Piles that derive most of their load from placement hard rock or very dense sand or gravelly material are referred to as end bearing piles. Displacement piles are those piles, which displace the soil radially and vertically during driving. Timber and concrete piles are classified base on their material composition.

5.3 Design example

An existing box girder bridge comprises of a 2 lane road. The length of the existing bridge was 1892m and consists of 41 spans ranging from 37-60m. During the construction time, concrete

piles or a combination of concrete/timber piles were used. The soil varies from sand to glacial deposits. The traffic congestion over the existing 2 lane bridge connecting to the surrounding areas led the roads administration to come up with a solution to increase the lane from 2 to 4. During the pre- study to expand the existing bridge from 2 to 4 lanes; four solutions were proposed. The solutions were; building a twin bridge, a new bridge outside of the city, an immersed tunnel and a rock tunnel. Finally, based on the cost assessment, the last three options were rejected and the twin bridge cost as half as the other options proposed. The new bridge will consist of a total of 41 foundations of piles of which 11 of them located under water while the rest 30 located on land. The new bridge will have 42 spans varying from 20m to 60m and a clearance of 0.5m from the existing bridge. Figure 5.1 presents the proposed bridge and the old bridge side by side. For the study, design of one of the piles located on sand was calculated, using angle of internal friction for Klipheuwel sand from both direct shear and direct simple shear test.



Figure 5.1 The old and the proposed new bridge side by side

5.3.1 Soil parameters

The soil is sandy to an approximate depth of 30m. The bed rock start depth was not located from the geotechnical report, but it was assumed as deep, therefore the friction pile was the economical alternative. The groundwater water was observed at the depth of 1.5m below the surface (unit weight of water is 9.81N/m^3). The unit weight of sand was taken as 18kN/m^3 and saturated unit weight as 19.2kN/m^3 , based on sand specification. These embedded depth was chosen as 15m based on the soil condition. The pile is circular, the diameter was taken as 600mm with regards to the depth. The pile length was estimated as 20m with regard to the proposed design load. The allowable bearing capacity was estimated, using an angle of internal friction (ϕ) as:

- (a) 44.20° and 30.20° (dry and saturated direct shear test).
- (b) 27.02° and 14.01° (dry and saturated direct simple shear test).

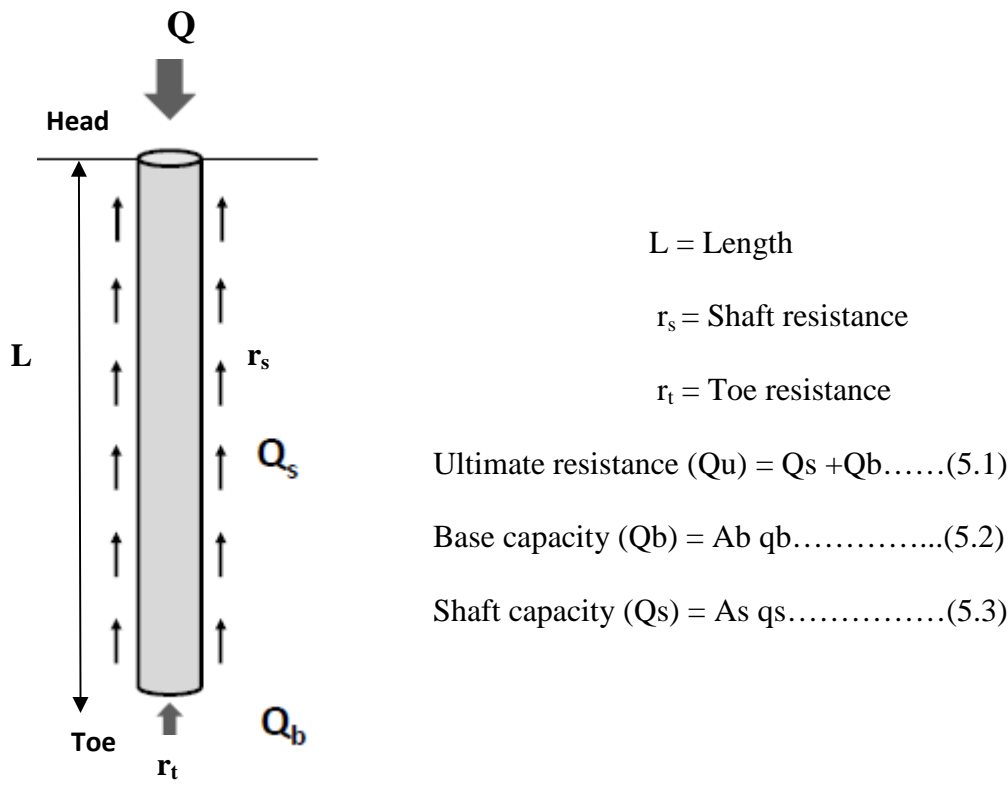

Figure 5.2 Pile capacity

Table 5.1 Parameters for design of pile in cohesionless soils (Meyerhof Formular)

$Q_b = N_q P'_o A_b$	$Q_s = 0.5 K_s P'_d \tan \delta A_s$	$Q_{all} = Q_u / FS$
A_b is the area the base	A_s is the area of the shaft	Q_{all} is the Allowable load
P'_o is the vertical effective stress in soil at pile-toe level	P'_d is the vertical effective stress at pile-toe level	Q_u is the Ultimate load
N_q is the bearing capacity factor	K_s is the coefficient of earth pressure	FS is the factor of safety
	δ is the angle of internal friction between pile and soil	

The calculation of piles in cohesionless soils is generally governed by the internal angle of friction and type of pile. The bearing capacity factor (N_q) which depends on ϕ has been empirically derived; therefore, the values given by Berezantsev et al. (1961) were used. K_s and δ are highly empirical formulas and depend on the nature of the soil. The allowable load (Q_{all}) is to consider this load as a proportion of the ultimate load capacity of the pile. The ratio is defined as a factor of safety and was assumed to be 2.5. The results of the design are summarized in Table 5.2 and the charts for design are presented in the Appendix.

5.3.2 Design analysis using angle of internal friction from direct shear test

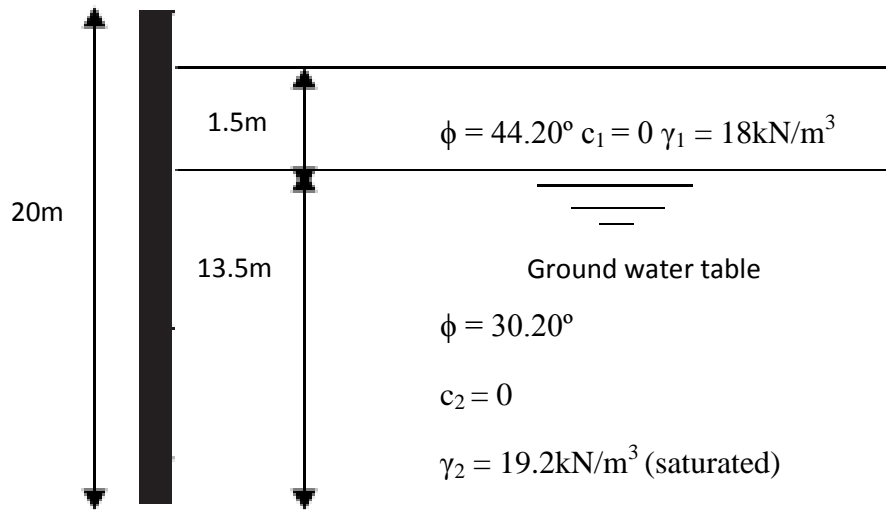

Figure 5.3 Pile parameters (direct shear test)

$$\text{At } z = 0 \quad \sigma'_o = 0$$

$$\text{At } z = 1.5\text{m} \quad \sigma'_o = 1.5 \times 18 = 27 \text{ kN/m}^2$$

$$\text{At } z = 15\text{m} \quad \sigma'_o = (1.5 \times 18) + (13.5)(19.2 - 9.81) = 153.77 \text{ kN/m}^2$$

$$P'd = \left(\frac{0 \text{ kPa} + 27 \text{ kPa} \times 1.5\text{m}}{2} + \frac{27 \text{ kPa} + 153.77 \text{ kPa} \times 13.5\text{m}}{2} \right)$$

$$= 20.25 + 1220.16 = 1240.41 \text{ kPa}$$

$$A_b = \Pi r^2 = 3.142 \times 0.3 \times 0.3 = 0.28 \text{ m}^2$$

$$A_s = \Pi dl = 3.142 \times 0.6 \times 20 = 37.70 \text{ m}^2$$

$$Q_s = 0.5 K_s \tan \delta P'd A_s = 0.5 \times 1.08 \times 1240.41 \times 37.70 = 25252.27 \text{ kN}$$

$$Q_b = N_q P'_o A_b = 56 \times 153.77 \times 0.28 = 2411.11 \text{ kN}$$

$$Q_u = Q_s + Q_b = 25252.27 + 2411.11 = 27663.38 \text{ kN}$$

$$Q_{all} = \frac{Q_u}{FS} = \frac{27663.38 \text{ kN}}{2.5} = 11065.35 \text{ kN}$$

5.3.3 Design analysis using angle of internal friction from direct simple shear test

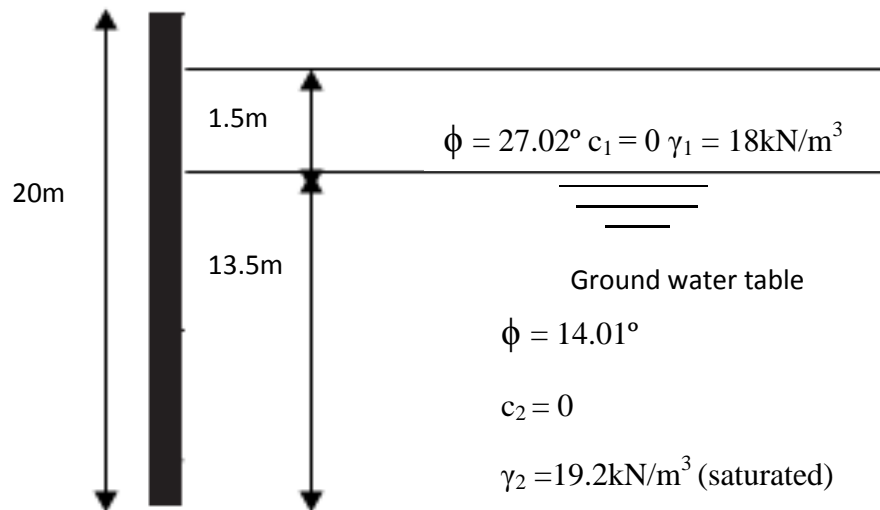

Figure 5.4 Pile parameters (direct simple shear test)

$$\text{At } z = 0 \quad \sigma'_o = 0$$

$$\text{At } z = 1.5\text{m} \quad \sigma'_o = 1.5 \times 18 = 27 \text{ kN/m}^2$$

$$\text{At } z = 15\text{m} \quad \sigma'_o = (1.5 \times 18) + (13.5)(19.2 - 9.81) = 153.77 \text{ kN/m}^2$$

$$P'd = \left(\frac{0 \text{ kPa} + 27 \text{ kPa} \times 1.5\text{m}}{2} + \frac{27 \text{ kPa} + 153.77 \text{ kPa} \times 13.5\text{m}}{2} \right)$$

$$= 20.25 + 1220.16 = 1240.41 \text{ kPa.}$$

$$A_b = \Pi r^2 = 3.142 \times 0.3 \times 0.3 = 0.28 \text{ m}^2$$

$$A_s = \Pi dl = 3.142 \times 0.6 \times 20 = 37.70 \text{ m}^2$$

$$Q_s = 0.5 K_s \tan \delta P'd A_s = 0.5 \times 0.5 \times 1240.41 \times 37.70 = 11690.86 \text{ kN}$$

$$Q_b = N_q P'_o A_b = 5 \times 153.77 \times 0.28 = 215.28 \text{ kN}$$

$$Q_u = Q_s + Q_b = 11690.86 + 215.28 = 11906.14 \text{ kN}$$

$$Q_{all} = \frac{Q_u}{FS} = \frac{11906.14 \text{ kN}}{2.5} = 4762.46 \text{ kN}$$

Table 5.2 Design calculations results

Parameter (name)	Direct shear test	Direct simple shear test
Qb (base capacity)	2411.11kN	215.28kN
Qs (shaft capacity)	25252.27kN	11690.86kN
Qu (ultimate load)	27663.38kN	11906.14kN
Qall (allowable load)	11065.35kN	4762.46kN

The result reveals that the ultimate and allowable load for a direct shear test is higher than that obtained from a direct simple shear test. In a direct shear test, half of the soil specimen is sheared and high strength is obtained. However, in a direct simple shear test, the whole of the soil sample is sheared and low strength is achieved. The use of higher shear strength to design when the actual shear strength of soil is low, could lead to settlement, minor cracking of finishes and structural failure overtime. Clearly, of all the parameters that affect Qu (ultimate load) and Qall (allowable load), the angle of internal friction of soil (ϕ), has its greatest influences. As ϕ increases, the bearing capacity also increases. The geotechnical engineer has a responsibility to design an economic foundation, which will ensure that the supported structure fulfils its function (Honjo et al., 2002). The use of higher strength than necessary can also cause unnecessary increase in life cycle costs.

6.0 CONCLUSIONS AND RECOMMENDATIONS.

6.1 Introduction

This study investigated the difference in the test results between direct shear test and direct simple shear test using Klipheuwel sand, Kaolin clay and some composites of Klipheuwel sand with Kaolin clay at varying moisture contents. Klipheuwel sand is a common source of fill material used in the construction of road embankments. The study was conducted to establish a relationship between the results. Klipheuwel sand and Kaolin clay were mixed with water in various percentages of 5, 10, 15, 20 and 25%, and composites of the sand and clay were tested using Universal Shear Trac-II. The summary of the findings as well as recommendations are given in the following sections.

6.2 Summary of the findings

Based on the findings of this study the following can be concluded.

- The addition of water to Klipheuwel sand reduced the internal friction angle for both direct shear and direct simple shear tests.
- The addition of water to Kaolin clay improved the internal friction angle for direct shear test and reduced the internal friction angle for direct simple shear test.
- An increase in water content by 20% for Klipheuwel sand resulted in a 39% reduction in shear strength for direct shear test and a 25% reduction in shear strength for the direct simple shear test.
- An increase in water content by 15% for Kaolin resulted in a 16% increase in shear strength for the direct shear test and a 10% reduction in shear strength for the direct simple shear test.
- An increase in cohesion was observed with the addition of water to Kaolin clay for the direct simple shear test.
- The addition of Kaolin clay to Klipheuwel sand reduced the internal friction angle in both the direct shear and the direct simple shear tests.
- An increase in clay content by 50% for Klipheuwel sand resulted in a 40% reduction in shear strength for the direct shear test and a 48% reduction in shear strength for the direct simple shear test.

-
- The direct shear test gives higher shear strength values compared to the direct simple shear test for the tests conducted in this study.

6.3 Recommendations.

- Research has shown the difference in results between direct shear and direct simple shear can be attributed to their different mode of shear. Further investigations into their shearing mechanism are required to further refine the correlation generated between the results from the two tests.
- The tamping blows could not be kept near constant with every sample since they were done manually. For consistency, it is recommended that a specially designed drop weight that is able to fall from a constant height, be used to compress test samples.
- Investigations using a wider variety of soils to develop a correlation factor for a broader range of soils on which the direct shear and direct simple shear tests is undertaken in geotechnical engineering.

7.0 REFERENCES

- Airey, D.W. and Wood, D., 1984. Discussion on: Specimen Size Effect in Simple Shear Test. *Journal of Geotechnical Engineering Division, ASCE* Vol. 110, No.3, pp 439-442.
- Airey, D. W. and Wood, D.M., 1987. An Evaluation of Direct Simple Shear Tests on Clay, *Geotechnique*, Vol. 37, No.1, pp 25-35.
- Amsiejus, J., Dirgeliene, N., Norkus, A. and Skuodis, S., 2013. Comparison of Sandy Soil Shear Strength Parameters obtained by various Construction Direct Shear Apparatuses. *Archives of Civil and Mechanical Engineering*, Vol. 14, pp 327-334.
- Amy, B. C. and Alan, J. L., 2006. Specimen Size and Scale Effects of Direct Shear Box Tests of Sands. *Geotechnical Testing Journal*, Vol. 29, No. 6, pp 1-10.
- Arthur, J. R. and Dunstan, T., 1988. The Engineering Application of Direct and Simple Shear Testing. *Sixth Geotechnique Symposium, Geotechnique* 38, No. 1, pp 139-154.
- ASTM D422. 2007. Standard Test method for Particle Size Analysis of Soils. ASTM International, West Conshohocken, PA, USA.
- ASTM D3080. 2011. Standard Test Method for Direct Shear Test of Soils under Consolidated Drained Conditions. ASTM International, West Conshohocken, PA, USA.
- ASTM D854. 2010. Standard Test Methods for Specific Gravity of Soil Solids by Water Pycnometer. ASTM International, West Conshohocken, PA, USA.
- ASTM D2216. 2010. Standard Test Methods for Laboratory Determination of Moisture Content of Soil and Rock by Mass. ASTM International, West Conshohocken, PA, USA.
- ASTM D1557-12. 2012. Standard Test Methods for Laboratory Compaction Characteristics of Soil using Modified Effort. ASTM International, West Conshohocken, PA, USA.
- ASTM, 2003. Standard Test Methods for Liquid Limit, Plastic Limit, and Plasticity Index of Soils. *Annual Book of ASTM Standards*, Vol. 04.08, pp. 582–595. American Society for Testing and Materials, West Conshohocken, PA, USA.
- Bareither, C. A., Benson, C.H. and Edil, T.B., 2008. Comparison of Shear Strength of Sand Backfills measured in Small-Scale and Large- Scale Direct Shear Tests. *Canadian Geotechnical Journal*, Vol. 45, pp 1224–1236.
- Bardet, J. P., 1997. *Experimental Soil Mechanics*, Prentice-Hall, Inc, United States.
- Bayoglu, E., 1995. Shear Strength and Compressibility Behavior of Sand-Clay Mixtures, M.S. Thesis, Middle East Technical University, Turkey

-
- Baxter, C., Bradshaw, A., Ochoa, L. and Hankou, R., 2010. Direct simple shear Test Results Using Wire-Reinforced Membrane and Stacked Rings. *ASCE Journals*, pp 600-614.
- Berre, T. and Bjerrum, L., 1973. Shear Strength of Normally Consolidated Clays. *Geotechnical Testing Journal*, Vol.14, pp 327-334.
- Borin, D.L., 1973. The Behaviour of Saturated Kaolin in the Simple Shear Apparatus. PhD thesis, University of Cambridge.
- Bishop, A. W., 1971. The Influence of Progressive Failure on the Method of Stability Analysis; *Géotechnique*; Vol. 21, No. 2, pp 47-59.
- Bishop, A. W., Green, G. E., Garga, V. K., Anderson, A., Brown, J. D., 1971. New Rings Shear Apparatus and its Application to the Measurement of Residual Strength. *Géotechnique*; Vol. 21, No. 4, pp 310-318.
- Braja, M.D., 2007. *Foundamentals of Geotechnical Engineering*. Third Edition.
- Braja, M.D., 2007. *Principles of Foundation Engineering*. Seventh Edition.
- Bromhead, E. N. *The stability of slopes*. Blackie Academic & Professional, Glasgow, UK, 1992.
- Bromhead, E. N., Dixon, N., 1986. The field Residual Strength of London Clay and its Correlation with Laboratory Measurements, especially Ring Shear Tests. *Géotechnique*; Vol. 36, No. 3, pp 1- 14.
- Budhu, M., 1984. Nonuniformities Imposed by Simple Shear Apparatus. *Canadian Geotechnical Journal*, Vol.21 No.1, pp 125-137.
- Castellanos, B.A. and Brandon, T.L, 2013. A Comparison between the Shear Strength Measured with Direct Shear and Triaxial Devices on Undisturbed and Remolded Soils. *Proceedings of the 18th International Conference on Soil Mechanics and Geotechnical Engineering*, Paris.
- Cerato, B.A. and Lutenegeger, A.J., 2006. Specimen Size and Scale Effects of Direct Shear Box Tests of Sands. *Geotechnical Testing Journal*, Vol. 29, No 6, pp 507–516
- Cernica, J. N., 1995. *Geotechnical Engineering: Soil Mechanics*, John Wiley & Sons, Inc, United States.
- Craig, R. F., 1997. *Soil Mechanics*, Sixth Edition, Spon Press, London.
- Craig, R.F., 2004. *Soil Mechanics*. Seventh Edition.
- Das, M. B., 1983. *Advanced Soil Mechanics*, Hemisphere Publishing Corp., McGraw Hill, London.
-

-
- Degroot, D.J. and John, T.G., 1996. Undrained Multidirectional Direct Simple Shear Behaviour of Cohesive Soils. *Journal of Geotechnical Engineering*, Vol.122, No 2.
- Dyvik, R., Berre, T., Lacasse, S. and Raadim, B. 1987. Comparison of Truly Undrained and Constant Volume Direct Simple Shear Tests. *Geotechnique*, Vol. 37, pp 3-10.
- Esma, M. k, Mourad, M., and Nabil, A., 2011. Contribution of Particles Size Ranges to Sand Friction. *Engineering, Technology & Applied Science Research* Vol. 3, No. 4, pp 497-50.
- George, T.D. and David, M.P., 1993. Numerical Analysis of Drained Direct Shear and Direct Simple Shear Test. *Journal of Geotechnical Engineering*, Vol. 119, No. 12, pp 1870-1892
- Guyer, J.P., 2010. Introduction to Laboratory Testing of Soils. Lecture notes.
- Hanzawa, H., Fukaya, T. and Suzuki, K., 1990. Evaluation of Engineering Properties for an Ariake Clay. *Soils and Foundations*, Vol. 30, No 4, pp 11-24.
- Hanzawa, H., Nutt, N., Lunne, T., Tang, Y. and Long, M., 2007. A Comparative Study between the NGI Direct Simple Shear Apparatus and the Mikasa Direct Shear Apparatus. *Japanese Geotechnical Society, Soils and Foundations*, Vol. 47, No 1, pp 47-58.
- Imre, S., 1994. Up-To-Date Means of Shear Strength Tests Comparison between Simple and Direct Shear. *Periodica Politechnical SER. Civil ENG.* Vol. 38, No. 1, pp. 109-126.
- Jewell, R.A., 1988. Direct Shear Test on Sand. A Soil Mechanics Report.
- Jiunnren, L. and Roy, E. O., 2004. Types of Laboratory Apparatus for Shear Testing of Soils. A summary report.
- John, T.G. and Amy V. G., 2009. *Geotechnical Laboratory Measurements for Engineers*.
- John, T.G., 2011. Characterization of Reconsistuted Low Plasticity Silt. Master thesis submitted to the Massachusetts Institute of Technology.
- Karsten, T., Christian, G. and Joachim T., 2006. Shear Strength Parameters from Direct Shear Tests – Influencing Factors and their Significance. *The Geological Society of London*, Vol. 10, pp. 484-496.
- Lambe, T.W., 1951. *Soil Testing for Engineers*, John Wiley, New York.
- Landva, A., 1966. Direct Simple Shear Tests on a Norwegian Quick Clay, *Geotechnique*, Vol.16 No.1, pp 1-20.
- Li-chang, W., Wei, L. and Shi-juan, G., 2014. Effect of Moisture Content, Void Ration and Compacted Sand Content on Remoulded Clay. *Chinese Journal of Geotechnical Engineering*, Vol.2, pp 3314 -3327.
-

-
- Lin, C.P., 2012. Shear Strength of Soils. Lecture notes at National Chiao Tung University.
- Kjellman, W., 1951. Testing the Shear Strength of Clay in Sweden. *Geotechnique*, Vol.2, No. 3, pp 225-235.
- Matthieu, G., 2011. The Boundary Conditions in Direct Simple Shear Tests, Development for Peat Testing at Low Vertical Stress. Master thesis submitted to Delft University of Technology.
- Mehmet, S.O., 2008. Shear Strength Behavior of Sand- Clay Mixtures. A thesis submitted to the graduate school of natural and applied sciences of Middle East technical university.
- Muawia, A. D., 2012. Effects of Clay and Moisture Content on Direct Shear Tests for Clay-Sand Mixtures. *Advances in Materials Science and Engineering*.
- Osano, S.N., 2012. Direct Shear Box and Ring Shear Test Comparison: Why does Internal Angle of Friction vary? *Journal of Engineering Indian Centre for Advanced Scientific and Technological Research (Icastor)*, Vol. 5, No. 2, 77 – 93.
- Paul, W.M., 1985. A Review of Undrained Shear Strength in Direct Simple Shear Test. *Journal of Japanese Geotechnical Society*, Vol. 25, No. 3, pp 64-72.
- Primesh, J., 2014. Direct Simple Shear Tests on Soil-Plastic (Polythene) Waste Composites. Undergraduate thesis submitted to the University of Cape Town.
- Rahnenma, A., Habibagahi, G. and Ghahramani, A., 2003. A New Simple Shear Apparatus for Testing Unsaturated Soil. *Iranian Journal of Science and Technology*, Vol. 27, No 1, pp 73 – 80.
- Saada, A.S. and Townsend, F.C, 1981. State of the Art: Laboratory Strength Testing of Soils. *ASTM Spec. Tech. Publ.*, No. 740, pp 7-77.
- Sarunus, S. and Arnoldas, N., 2014. Influence of Test Quantity on Loose Sand Shearing Strength Parameters. *Proceedings of the International Conference on Innovative Materials, Structures and Technologies*, pp 10-28.
- Sean, R., 2012. Introduction to Triaxial Testing. Lecture Note.
- Seth, M., 2011. Comparison of Direct Simple Shear Confinement Methods on Clay and Silt Specimens. Master thesis submitted to the University of Rhode Island.
- Sivadass, T. and Lee, C., 2008. Simple Shear Testing of Residual Soils with High Silt Content. *International Conference on Construction and Building Technology*, Vol. 38, pp 469-484.
-

-
- Sofian, M. A., 2004. Direct Shear Testing. Doctoral thesis submitted to University of Sumatera Utara.
- Takada, N., 1993. Mikasa's Direct Shear Apparatus, Test Procedures and Results. *Geotechnical Testing Journal*, Vol. 16, No 3, pp 314-322.
- Tanaka, H., Sharma, P., Tsuchida, T. and Tanaka, M., 1996. Comparative Study on Sample Quality Using Several Different Types of Samplers. *Soils and Foundations*, Vol.36, No 2, pp 67 -68.
- Terzaghi, K. and Peck, R.B., 1967. *Soil Mechanics in Engineering Practice*. Second Edition.
- Tsuji, K., Tang, Y.X. and Lunne, T., 1998. A comparative Study on Shear Strength of Marine Clays by Direct Shear and Direct Simple shear test. *Journal of Geotechnical Engineering, JSCE*, pp 275 – 285.
- Tomoyo, N. and Stephen, F., 2008. Direct Shear Testing of a Marginal Material Using a Large Shear Box. *Geotechnical Testing Journal*, Vol. 31, No. 5, pp 1-11.
- Touahmia, M., 2014. *Shear Strength of Soils*. Lecture Note.
- Vucetic, M. and Lacasse, S., 1982. Specimen Size Effect in Simple Shear Test. *Journal of Geotechnical Engineering*, pp 1567-1585.
- Wright, D.K., Gilbert, P.A. and Saada, A.S., 1978. Shear Devices for Determining Dynamic Soil Properties. *Proc. Spec. Conf. Earthquake Engineering and Soil Dynamics*, ASCE, Pasadena, 2, pp 1056-1075.
- Wroth, C.P., 1984. The Interpretation of In situ Soil Tests. 24th Rankine Lecture. *Geotechnique*, Vol. 34, No. 4, pp 449-489.
- Wroth, C.P., 1987. The Behaviour of Normally Consolidated Clay as Observed in Undrained Direct Shear Tests. *Geotechnique* 37, No.1, pp 37-43.

8.0 APPENDIX

Direct Shear and Direct Simple Shear Tests: A Comparative Study of the Strength Parameters and their Dependence on Moisture and Fines Contents

By:

ZAINAB BABALOLA

**SUPERVISED BY DR DENIS KALUMBA
CO-SUPERVISED BY FARIDAH CHEBET**



REPORT OF REVISIONS

**University of Cape Town
Department of Civil Engineering
April 2016**

TABLE OF CONTENTS

1. General.....	2
1.1 Minor Typographical Errors and Minor Changes	2
1.2 Review of Specific Chapters/Sections.....	5
1.2.1 Title of the study.....	5
1.2.2 Chapter 1.....	5
1.2.3 Chapter 2.....	6
1.2.4 Chapter 3.....	7
1.2.5 Chapter 4.....	9
1.3 References	9
2. Final Comments.....	14

1. General

1.1 Minor Typographical Errors and Minor Changes

Section/ Chapter	Page	Paragraph	Line/ Eqn	Corrected to.....
Whole document				'kaolin' was changed to 'Kaolin'
Abstract	v	3	1	...composites <u>of the sand and clay</u> using...
Chapter 1	1	1	2	" <u>Soil failure and the associated problems are generally termed geotechnical stability problems</u> " added.
			3	"including failure of soil" deleted.
			4	Shear strength is <u>therefore</u> one of the.....
			8	...structures depends on the..
			10	...is essential <u>in ensuring safe designs.</u>
	2	1	1strength, <u>namely</u> angle of internal...
			2	...laboratory tests <u>or</u> field tests are...
	3	1	9	...look at <u>an example of the engineering</u> ...
	3	1	last ...recommendations for <u>an example of further</u>	
Chapter 2	4	1	7	...studies <u>that are related to this study.</u>
			9	...as <u>illustrated</u> in.....
			11	... remain <u>stable</u> only if.....

Section/ Chapter	Page	Paragraph	Line/ Eqn	Corrected to.....	
Chapter 2	5	1	2	...or a <u>combination</u> of rubble pile...	
			2stress <u>and</u> normal stress...	
			5	Changed to 'Juvinal et al., 1991'	
			7normal stresses, and....	
	6	2	1	..defined is <u>generally</u> a curved..	
			3	Revised to (Coulomb, 1776)	
		3	...Mohr circle of two <u>identical</u> soil...		
	12	2	4	...cohesion that <u>is</u> obtained...	
			10	Moreover, stability of <u>relatively</u>	
			11	... <u>using</u> the test.....	
	14	2	4	<u>Especially</u> the split-ring.....	
			last	... <u>measurement</u> of the soil ...	
	15	2	1	...test, <u>however</u> including potentially....	
	Page 24 to Page 39				The third word of all the subsection headings changed to 'of '
	26	2	last	...friction <u>angle</u> for.....	
	27	Table 2.2			first column heading: <u>Sand Type</u> .
		2	2	2	...the <u>tested</u> sand; the....
	30	1	5	5	...ground <u>may</u> experience....
		2	1	1used in <u>the</u> study....
		3	1	1	...used <u>in the experiments</u>
31	2	2	2	...angle of friction, <u>σ</u> ', is...	
37	2		11	...which <u>contains</u> more voids..	
				...clay may <u>therefore</u> not be....	

Section/ Chapter	Page	Paragraph	Line/ Eqn	Corrected to.....
Chapter 2	39	1	1	...on loose <u>sand</u> specimen.....
			10	...the <u>predetermined target</u> vertical...
			11	... <u>shared equally among the 3..</u>
	41	1	1	<u>In order to reveal</u> the.....
	43	2	2	Tests were <u>sampled</u> with...
			11	...load step <u>for</u> 10 minutes....
	45	1	2	...shear tests <u>on</u> Drammen....
			6	...times <u>may be</u> considered...
46	1	2	...2.39 <u>from which</u> it is clear...	
Chapter 3	48	3	6	...results to be <u>repeatable</u>
	49	Table 3.1		BS 1377: Part 2: 1990
	52	2	2	...the <u>user</u> to modify.....
	53	1	4	...for subsequent <u>analysis</u> and
			8	...and graphically <u>displayed</u> ...
	54	1	9	...was <u>achieved</u> through.....
	55	1	17	...sand was <u>adopted</u> .
	56	1	3	'proctor' was changed to 'Proctor'
	58	1	6	...typical <u>appearance of the</u> ...
	58	2	9	...the top <u>cap</u> was gently.....
	62	2	3	...of the <u>height</u> of the sample.
64	2	1	...and <u>the necessary</u> settings..	
Chapter 4	77	2	2	... for direct shear <u>respectively</u> .
	78	1	10	... <u>increase</u> in shear stress....
	83	2	4	However, <u>decrease</u> in.....
	86	1	2	... <u>plotted using the data</u>
				...data obtained <u>for</u> all.....
	87	1	3	... <u>who</u> concluded that.....
88	1	5	... <u>thereby</u> reducing the....	

Section/ Chapter	Page	Paragraph	Line/ Eqn	Corrected to.....
Chapter 4	88	1	6	Figure 4.9 <u>presents</u> the.....
	95	1	3	...angle as <u>compared</u> to.....
			4	<u>This</u> difference was.....
			5	...slight <u>inconsistence</u> was...
Chapter 5	100	2	1	... <u>soil underlying</u> proposed...
		3	6	... <u>construction method</u> and....

1.2 Review of Specific Chapters/Sections

1.2.1 Title of the Study

The comment on the title of the study was noted and the title have been amended to read as;

Direct Shear and Direct Simple Shear Tests: A Comparative Study of the Strength Parameters and their Dependence on moisture and Fines Contents

1.2.2 Chapter 1

The sentence in line 6 p. 2 leading up to Laboratory test has been rephrased to provide information about field test and why the test were not pursued further. The sentence now reads as;

Field tests such as cone penetration test and vane shear test are very common in engineering projects. But, stress-strain relationships can not be measured directly. Laboratory tests are mostly of academic interest and the accuracy of this test is sufficient for practical purposes

The research objectives has been reviewed to read as below.

The main objective of this study was to compare soil strength parameters determined using direct shear and direct simple shear test apparatuses, and their dependence on moisture and fines content. The specific objectives were; to evaluate the effect of varying moisture content on shear strength parameters of sand and clay, to determine the effect of varying concentration of fine content on shear strength parameters of sand in both the

direct shear test and the simple shear test, and to compare the overall shear test results obtained from direct shear test and direct simple shear.

Section 1.4 has been added to discuss the scope and limitations of the study. It reads as;

The research conducted herein involved the investigation of shear strength parameters of soil as obtained using both direct shear and direct simple shear device, and to determine the relationship between the results as well as the benefits of their inclusion in the design of structures. The shear tests conducted were limited to these two tests, and no other shear tests included in the research. The investigation only considered two soils, Klipheuwel sand and Kaolin clay sourced locally.

1.2.3 Chapter 2

The last sentence of section 2.3.1 has been rephrased to read as;

It has its application in earthquake geotechnical engineering

The sentence in line 11 p. 12 has been deleted so that the paragraph read as;

The triaxial test has the ability to control the drainage conditions so as to allow for different types of test (drained and undrained conditions) and measure pore pressure. Moreover, stability of relatively impervious rolled field can be investigated using the test Shawntiku, 2011. The shear strength parameters determined using triaxial test are more accurate than those obtained from shear box test because it allows soil to be sheared to failure along its natural weakest plane Shawntiku, 2011.

The last sentence of section 2.3.3 has been modified to read as:

The cross-sectional area of the shear plane remains unchanged during shearing and the geometry of the test specimen remains unchanged during shearing. In a ring shear test as opposed to the specimen in triaxial test where shape changes from rectangular to nearly an ovoid.

The Table 2.3 has been reproduced for better appearance and readability as shown below.

Sample 1	d_{10} mm	d_{30} mm	d_{60} mm	UC	CC	e_{max}	e_{min}
Sample 1	0.16	0.22	0.41	2.50	0.75	0.709	0.45
Sample 2	0.21	0.24	0.30	1.42	0.93	0.811	0.535
Sample 3	0.18	0.28	0.38	2.13	1.16	0.737	0.474
Sample 4	0.15	0.34	0.54	3.66	1.43	0.64	0.393
Sample 5	0.16	0.23	0.60	3.64	0.53	0.641	0.394
Sample 6	0.14	0.17	0.31	2.28	0.63	0.725	0.464
Sample 7	0.31	0.63	0.86	2.74	1.46	0.693	0.437
Sample 8	0.17	0.2	0.31	1.88	0.76	0.76	0.493
Sample 9	0.16	0.23	0.54	3.37	0.63	0.655	0.405
Sample 10	-	-	-	-	-	-	-
Uniformity Coefficient = UC							
Coefficient of Curvature = CC							
Maximum Void Ratio = e_{max}							
Minimum Void Ratio = e_{min}							

1.2.4 Chapter 3

The statement about Kaolin clay material, also known as China clay is extracted and supplied locally in Cape Town in paragraph 4 (last paragraph, p.48) has been revised. The paragraph has been amended as:

Kaolin is a soft soils that pose problems on construction sites. On this basis, it was selected for this research in order to compare the results obtained under similar conditions with Klipheuwel sand. In addition, it was consistent and easily controllable, which enabled repeatability of results. The Kaolin clay material used in this research is extracted and supplied locally in Cape Town.

The explanation to the variables in equation 3.2 has been redefined as follows to provide clarity.

$$W_w = \chi \cdot W_{sw}$$

W_w : the weight of water; χ : water content in the mixture

W_{sw} : the total weight of soil and water mixture

A flow diagram has been added at the end of chapter 3 to summarise the methodology as shown below.

Direct Shear and Direct Simple Shear Tests: A Comparative Study of the Strength Parameters and their Dependence on Moisture Contents and Fines

Stage 1

Stage 2

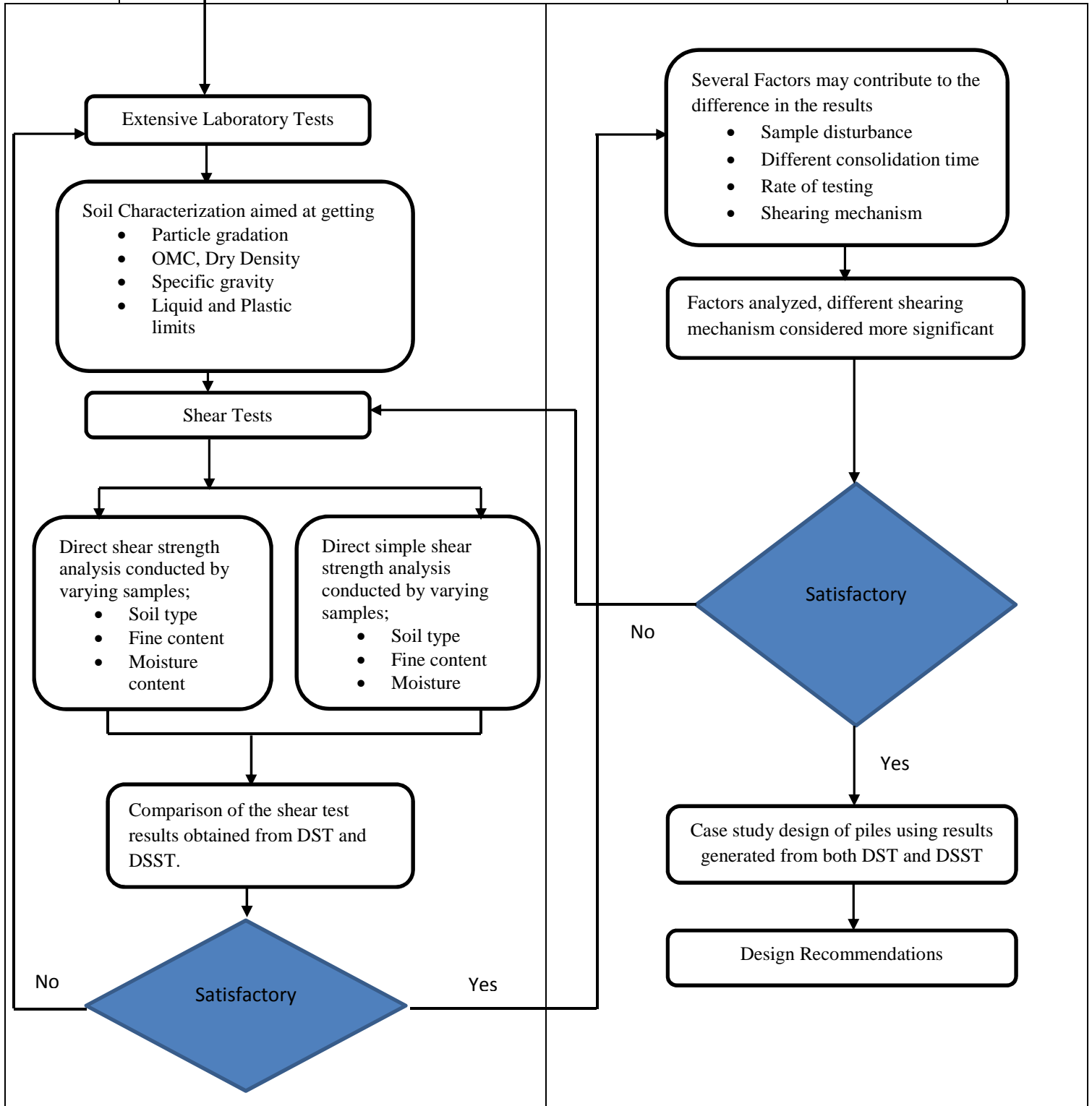

1.2.5 Chapter 4

The explanation for the reduction in maximum shear stress with increased moisture content has been amended, such that it reads:

The addition of water to the soil reduces the maximum shear stress when compared to the dry sample, but there is no direct correlation between increasing moisture content (MC) and maximum shear stress i.e. the maximum shear stress does not steadily decrease as the MC increases.

The statement about the decrease in maximum shear stress for DSST has compared to dry Kaolin in paragraph 2 (page 84) has been revised. It reads as;

The addition of water to Kaolin increases its maximum shear stress for DST. However, decrease in maximum shear stress was observed for DSST as compared to dry Kaolin. A decrease in the maximum shear stress compared to dry Kaolin in DSST not achieved throughout. There is variation in the result, at lower moisture contents true but maximum shear stress increases above dry value at higher moisture contents.

Regarding the effect of water content on strength parameter of sand in paragraph 1 (page 89) has been reviewed to read as below.

In both the DST and DSST the friction values are lower than when compared to dry sand, but there is no direct correlation between increasing MC% and decreasing friction angle i.e. the friction angle does not decrease as the water content increases.

1.3 References

All references were updated as follows:

Airey, D.W. and Wood, D., 1984. Discussion on: Specimen Size Effect in Simple Shear Test.

Journal of Geotechnical Engineering Division, ASCE Vol. 110, No.3, pp 439-442.

Airey, D. W. and Wood, D.M., 1987. An Evaluation of Direct Simple Shear Tests on Clay, Geotechnique, Vol. 37, No.1, pp 25-35.

Amsiejus, J., Dirgeliene, N., Norkus, A. and Skuodis, S., 2013. Comparison of Sandy Soil Shear Strength Parameters obtained by various Construction Direct Shear Apparatuses.

Archives of Civil and Mechanical Engineering, Vol. 14, pp 327-334.

Amy, B. C. and Alan, J. L., 2006. Specimen Size and Scale Effects of Direct Shear Box Tests of

-
- Sands. *Geotechnical Testing Journal*, Vol. 29, No. 6, pp 1-10.
- Arthur, J. R. and Dunstan, T., 1988. The Engineering Application of Direct and Simple Shear Testing. *Sixth Geotechnique Symposium*, *Geotechnique* 38, No. 1, pp 139-154.
- ASTM D422. 2007. Standard Test method for Particle Size Analysis of Soils. ASTM International, West Conshohocken, PA, USA.
- ASTM D3080. 2011. Standard Test Method for Direct Shear Test of Soils under Consolidated Drained Conditions. ASTM International, West Conshohocken, PA, USA.
- ASTM D854. 2010. Standard Test Methods for Specific Gravity of Soil Solids by Water Pycnometer. ASTM International, West Conshohocken, PA, USA.
- ASTM D2216. 2010. Standard Test Methods for Laboratory Determination of Moisture Content of Soil and Rock by Mass. ASTM International, West Conshohocken, PA, USA.
- ASTM D1557-12. 2012. Standard Test Methods for Laboratory Compaction Characteristics of Soil using Modified Effort. ASTM International, West Conshohocken, PA, USA.
- ASTM, 2003. Standard Test Methods for Liquid Limit, Plastic Limit, and Plasticity Index of Soils. *Annual Book of ASTM Standards*, Vol. 04.08, pp. 582–595. American Society for Testing and Materials, West Conshohocken, PA, USA.
- Bareither, C. A., Benson, C.H. and Edil, T.B., 2008. Comparison of Shear Strength of Sand Backfills measured in Small-Scale and Large- Scale Direct Shear Tests. *Canadian Geotechnical Journal*, Vol. 45, pp 1224–1236.
- Bardet, J. P., 1997. *Experimental Soil Mechanics*, Prentice-Hall, Inc, United States.
- Bayoglu, E., 1995. Shear Strength and Compressibility Behavior of Sand-Clay Mixtures, M.S. Thesis, Middle East Technical University, Turkey
- Baxter, C., Bradshaw, A., Ochoa, L. and Hankou, R., 2010. Direct simple shear Test Results Using Wire-Reinforced Membrane and Stacked Rings. *ASCE Journals*, pp 600-614.
- Berre, T. and Bjerrum, L., 1973. Shear Strength of Normally Consolidated Clays. *Geotechnical Testing Journal*, Vol.14, pp 327-334.
- Borin, D.L., 1973. The Behaviour of Saturated Kaolin in the Simple Shear Apparatus. PhD thesis, University of Cambridge.
- Bishop, A. W., 1971. The Influence of Progressive Failure on the Method of Stability Analysis; *Géotechnique*; Vol. 21, No. 2, pp 47-59.
- Bishop, A. W., Green, G. E., Garga, V. K., Anderson, A., Brown, J. D., 1971. New Rings Shear
-

-
- Apparatus and its Application to the Measurement of Residual Strength. *Géotechnique*; Vol. 21, No. 4, pp 310-318.
- Braja, M.D., 2007. *Foundamentals of Geotechnical Engineering*. Third Edition.
- Braja, M.D., 2007. *Principles of Foundation Engineering*. Seventh Edition.
- Bromhead, E. N. *The stability of slopes*. Blackie Academic & Professional, Glasgow, UK, 1992.
- Bromhead, E. N., Dixon, N., 1986. The field Residual Strength of London Clay and its Correlation with Laboratory Measurements, especially Ring Shear Tests. *Géotechnique*; Vol. 36, No. 3, pp 1- 14.
- Budhu, M., 1984. Nonuniformities Imposed by Simple Shear Apparatus. *Canadian Geotechnical Journal*, Vol.21 No.1, pp 125-137.
- Castellanos, B.A. and Brandon, T.L., 2013. A Comparison between the Shear Strength Measured with Direct Shear and Triaxial Devices on Undisturbed and Remolded Soils. *Proceedings of the 18th International Conference on Soil Mechanics and Geotechnical Engineering*, Paris.
- Cerato, B.A. and Lutenecker, A.J., 2006. Specimen Size and Scale Effects of Direct Shear Box Tests of Sands. *Geotechnical Testing Journal*, Vol. 29, No 6, pp 507–516
- Cernica, J. N., 1995. *Geotechnical Engineering: Soil Mechanics*, John Wiley & Sons, Inc, United States.
- Craig, R. F., 1997. *Soil Mechanics*, Sixth Edition, Spon Press, London.
- Craig, R.F., 2004. *Soil Mechanics*. Seventh Edition.
- Das, M. B., 1983. *Advanced Soil Mechanics*, Hemisphere Publishing Corp., McGraw Hill, London.
- Degroot, D.J. and John, T.G., 1996. Undrained Multidirectional Direct Simple Shear Behaviour of Cohesive Soils. *Journal of Geotechnical Engineering*, Vol.122, No 2.
- Dyvik, R., Berre, T., Lacasse, S. and Raadim, B. 1987. Comparison of Truly Undrained and Constant Volume Direct Simple Shear Tests. *Geotechnique*, Vol. 37, pp 3-10.
- Esma, M. k, Mourad, M., and Nabil, A., 2011. Contribution of Particles Size Ranges to Sand Friction. *Engineering, Technology & Applied Science Research* Vol. 3, No. 4, pp 497-50.
- George, T.D. and David, M.P., 1993. Numerical Analysis of Drained Direct Shear and Direct Simple Shear Test. *Journal of Geotechnical Engineering*, Vol. 119, No. 12, pp 1870-1892
- Guyer, J.P., 2010. *Introduction to Laboratory Testing of Soils*. Lecture notes.
- Hanzawa, H., Fukaya, T. and Suzuki, K., 1990. Evaluation of Engineering Properties for an
-

-
- Ariake Clay. *Soils and Foundations*, Vol. 30, No 4, pp 11-24.
- Hanzawa, H., Nutt, N., Lunne, T., Tang, Y. and Long, M., 2007. A Comparative Study between the NGI Direct Simple Shear Apparatus and the Mikasa Direct Shear Apparatus. *Japanese Geotechnical Society, Soils and Foundations*, Vol. 47, No 1, pp 47-58.
- Imre, S., 1994. Up-To-Date Means of Shear Strength Tests Comparison between Simple and Direct Shear. *Periodica Politechnical SER. Civil ENG.* Vol. 38, No. 1, pp. 109-126.
- Jewell, R.A., 1988. Direct Shear Test on Sand. A Soil Mechanics Report.
- Jiunnren, L. and Roy, E. O., 2004. Types of Laboratory Apparatus for Shear Testing of Soils. A summary report.
- John, T.G. and Amy V. G., 2009. *Geotechnical Laboratory Measurements for Engineers*.
- John, T.G., 2011. Characterization of Reconsistuted Low Plasticity Silt. Master thesis submitted to the Massachusetts Institute of Technology.
- Karsten, T., Christian, G. and Joachim T., 2006. Shear Strength Parameters from Direct Shear Tests – Influencing Factors and their Significance. *The Geological Society of London*, Vol. 10, pp. 484-496.
- Lambe, T.W., 1951. *Soil Testing for Engineers*, John Wiley, New York.
- Landva, A., 1966. Direct Simple Shear Tests on a Norwegian Quick Clay, *Geotechnique*, Vol.16 No.1, pp 1-20.
- Li-chang, W., Wei, L. and Shi-juan, G., 2014. Effect of Moisture Content, Void Ration and Compacted Sand Content on Remoulded Clay. *Chinese Journal of Geotechnical Engineering*, Vol.2, pp 3314 -3327.
- Lin, C.P., 2012. Shear Strength of Soils. Lecture notes at National Chiao Tung University.
- Kjellman, W., 1951. Testing the Shear Strength of Clay in Sweden. *Geotechnique*, Vol.2, No. 3, pp 225-235.
- Matthieu, G., 2011. The Boundary Conditions in Direct Simple Shear Tests, Development for Peat Testing at Low Vertical Stress. Master thesis submitted to Delft University of Technology.
- Mehmet, S.O., 2008. Shear Strength Behavior of Sand- Clay Mixtures. A thesis submitted to the graduate school of natural and applied sciences of Middle East technical university.
- Muawia, A. D., 2012. Effects of Clay and Moisture Content on Direct Shear Tests for Clay-Sand Mixtures. *Advances in Materials Science and Engineering*.
-

-
- Osano, S.N., 2012. Direct Shear Box and Ring Shear Test Comparison: Why does Internal Angle of Friction vary? *Journal of Engineering Indian Centre for Advanced Scientific and Technological Research (Icastor)*, Vol. 5, No. 2, 77 – 93.
- Paul, W.M., 1985. A Review of Undrained Shear Strength in Direct Simple Shear Test. *Journal of Japanese Geotechnical Society*, Vol. 25, No. 3, pp 64-72.
- Primesh, J., 2014. Direct Simple Shear Tests on Soil-Plastic (Polythene) Waste Composites. Undergraduate thesis submitted to the University of Cape Town.
- Rahnenma, A., Habibagahi, G. and Ghahramani, A., 2003. A New Simple Shear Apparatus for Testing Unsaturated Soil. *Iranian Journal of Science and Technology*, Vol. 27, No 1, pp 73 – 80.
- Saada, A.S. and Townsend, F.C, 1981. State of the Art: Laboratory Strength Testing of Soils. *ASTM Spec. Tech. Publ.*, No. 740, pp 7-77.
- Sarunus, S. and Arnoldas, N., 2014. Influence of Test Quantity on Loose Sand Shearing Strength Parameters. *Proceedings of the International Conference on Innovative Materials, Structures and Technologies*, pp 10-28.
- Sean, R., 2012. Introduction to Triaxial Testing. Lecture Note.
- Seth, M., 2011. Comparison of Direct Simple Shear Confinement Methods on Clay and Silt Specimens. Master thesis submitted to the University of Rhode Island.
- Sivadass, T. and Lee, C., 2008. Simple Shear Testing of Residual Soils with High Silt Content. *International Conference on Construction and Building Technology*, Vol. 38, pp 469-484.
- Sofian, M. A., 2004. Direct Shear Testing. Doctoral thesis submitted to University of Sumatera Utara.
- Takada, N., 1993. Mikasa's Direct Shear Apparatus, Test Procedures and Results. *Geotechnical Testing Journal*, Vol. 16, No 3, pp 314-322.
- Tanaka, H., Sharma, P., Tsuchida, T. and Tanaka, M., 1996. Comparative Study on Sample Quality Using Several Different Types of Samplers. *Soils and Foundations*, Vol.36, No 2, pp 67 -68.
- Terzaghi, K. and Peck, R.B., 1967. *Soil Mechanics in Engineering Practice*. Second Edition.
- Tsuji, K., Tang, Y.X. and Lunne, T., 1998. A comparative Study on Shear Strength of Marine Clays by Direct Shear and Direct Simple shear test. *Journal of Geotechnical Engineering, JSCE*, pp 275 – 285.
-

-
- Tomoyo, N. and Stephen, F., 2008. Direct Shear Testing of a Marginal Material Using a Large Shear Box. *Geotechnical Testing Journal*, Vol. 31, No. 5, pp 1-11.
- Touahmia, M., 2014. *Shear Strength of Soils. Lecture Note.*
- Vucetic, M. and Lacasse, S., 1982. Specimen Size Effect in Simple Shear Test. *Journal of Geotechnical Engineering*, pp 1567-1585.
- Wright, D.K., Gilbert, P.A. and Saada, A.S., 1978. Shear Devices for Determining Dynamic Soil Properties. *Proc. Spec. Conf. Earthquake Engineering and Soil Dynamics, ASCE, Pasadena, 2*, pp 1056-1075.
- Wroth, C.P., 1984. The Interpretation of In situ Soil Tests. 24th Rankine Lecture. *Geotechnique*, Vol. 34, No. 4, pp 449-489.
- Wroth, C.P., 1987. The Behaviour of Normally Consolidated Clay as Observed in Undrained Direct Shear Tests. *Geotechnique* 37, No.1, pp 37-43.

2. Final Comments

I am grateful for the insightful comments made by the external examiners. The shear strength of soil is important for design of engineering structures. Therefore, accurate and reliable tests are required to determine the strength parameters. The comparison between direct shear and direct simple shear tests is a good topic that needs further dedicated studies. Nevertheless, I hope that the information availed herein will be of help to researchers and any practicing engineer.

Signed: 

Date: April 2016

APPENDIX A. Characterization tests results

A.1 Natural water content

A.2 Determination of particle size distribution

A.3 Determination of the specific gravity

APPENDIX B. Shear Test Results

B.1 Klipheuwel sand and Kaolin at varying moisture content.

APPENDIX C. Design Charts

A.1 Natural water content

A.1.1 Natural water content-Klipheuwel sand

Can No	1	2	3
Mass of can (g)	9.7	9.7	9.7
Mass of wet soil + can (g)	31.70	33.00	34.90
Mass of dry soil + can (g)	31.00	32.40	34.40
Mass of dry soil (g)	21.30	22.70	24.70
Mass of water (g)	0.70	0.60	0.50
Water content (%)	3.3	2.6	2.0
Average water content (%)	2.63		

A.1.2 Natural water content-Kaolin Clay

Can No	1	2	3
Mass of can (g)	9.7	9.7	9.5
Mass of wet soil + can (g)	15.70	14.40	14.55
Mass of dry soil + can (g)	15.40	14.20	14.30
Mass of dry soil (g)	15.10	14.0	14.05
Mass of water (g)	0.30	0.20	0.25
Water content (%)	1.93	1.43	1.78
Average water content (%)	1.7		

A.2 Determination of particle size distribution

A.2.1 Sieve analysis – Klipheuwel Sand

Klipheuwel sand

Sieve Size (mm)	Mass of Container (g)	Mass of Sieve + Sand (g)	% Retained	Cumulative % Passing
Initial Dry Mass 1000g				
3.350	599.8	599.8	0	100
2.000	568.5	569.3	0.08	99.92
1.180	543.6	589.0	4.54	95.38
0.850	521.1	571.6	5.05	90.33
0.600	514.4	575.4	6.10	84.23
0.425	501.1	639.4	13.83	70.40
0.300	478.7	655.3	17.66	52.74
0.150	467.2	952.2	48.50	4.24
0.075	434.0	467.2	3.32	0.92
0.630	463.4	466.4	0.30	0.62
0.450	430.4	436.1	0.06	0.05
Base plate mass	457.0	457.29	0.03	0.02

$$Cu = \frac{D_{60}}{D_{10}} \quad Cc = \frac{(D_{30})^2}{D_{60} \times D_{10}}$$

$$Cu = \frac{0.35}{0.2} = 1.75$$

$$Cc = \frac{(0.25)^2}{0.35 \times 0.2} = 0.89$$

A.3 Determination of the specific gravity

A.3.1 Specific gravity-Klipheuwel sand

Test No	1	2	3
mass of bottle + soil + water m ₃ (g)	93.657	89.452	92.227
mass of bottle + soil m ₂ (g)	45.654	43.750	46.780
mass of bottle full of water m ₄ (g)	87.102	83.245	84.574
mass of bottle m ₁ (g)	35.164	33.750	34.518
mass of soil m ₂ - m ₁ (g)	10.490	10.000	12.262
mass of water in full bottle m ₄ - m ₁ (g)	51.938	49.495	50.056
mass of water used m ₃ - m ₂ (g)	48.003	45.702	45.447
volume of soil particles (m ₄ - m ₁) - (m ₃ - m ₂) ml	3.957	3.793	4.609
particle density $\rho_s = \rho_L(m_2 - m_1)/((m_4 - m_1) - (m_3 - m_2))$ (Mg/m ³)	2.655	2.640	2.66
Average value of particle density, ρ_s (Mg/m ³)	2.65		

A.3.2 Specific gravity-Kaolin clay

Test No	1	2	3
mass of bottle + soil + water m ₃ (g)	92.105	88.898	92.104
mass of bottle + soil m ₂ (g)	41.984	40.723	41.994
mass of bottle full of water m ₄ (g)	88.506	85.776	88.305
mass of bottle m ₁ (g)	36.094	35.617	35.893
mass of soil m ₂ - m ₁ (g)	5.890	5.106	6.101
mass of water in full bottle m ₄ - m ₁ (g)	52.410	50.159	52.412
mass of water used m ₃ - m ₂ (g)	50.121	48.128	50.110
volume of soil particles (m ₄ - m ₁) - (m ₃ - m ₂) ml	2.289	1.984	2.306
particle density $\rho_s = \rho_L(m_2 - m_1)/((m_4 - m_1) - (m_3 - m_2))$ (Mg/m ³)	2.600	2.57	2.64
Average value of particle density, ρ_s (Mg/m ³)	2.65		

APPENDIX B. Shear Test Results

B.1 Klipheuwel sand and Kaolin at varying moisture content (5%, 10%, 15%, 20%, and 25%).

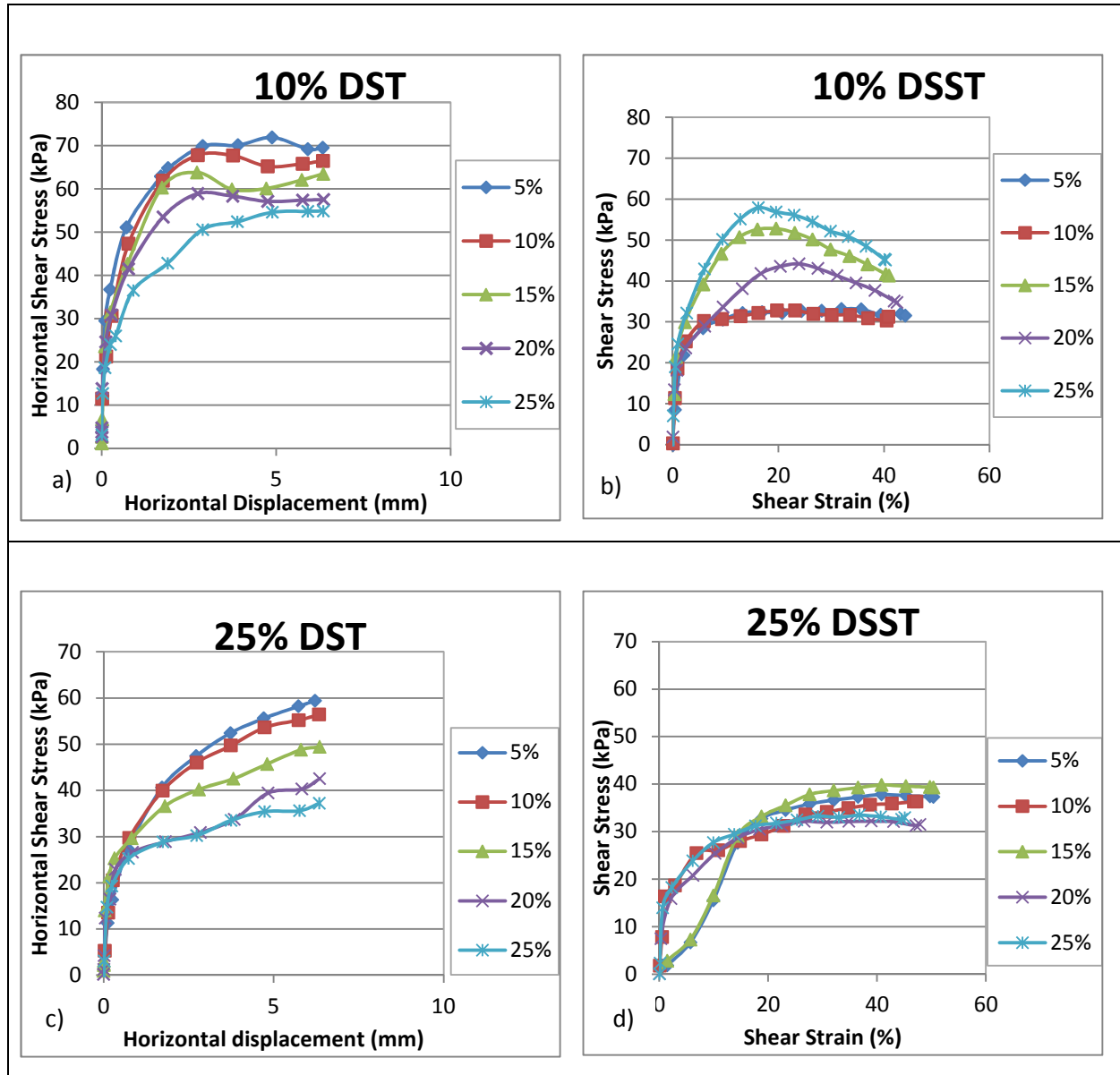

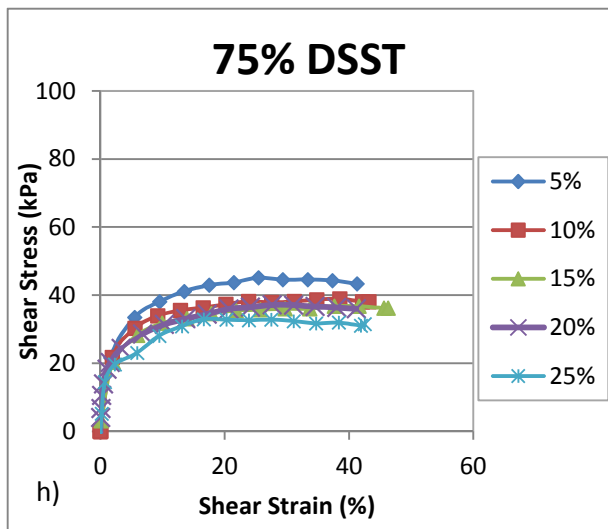
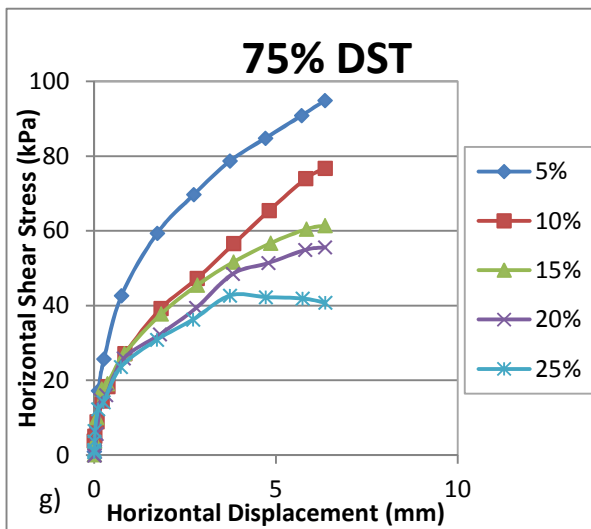
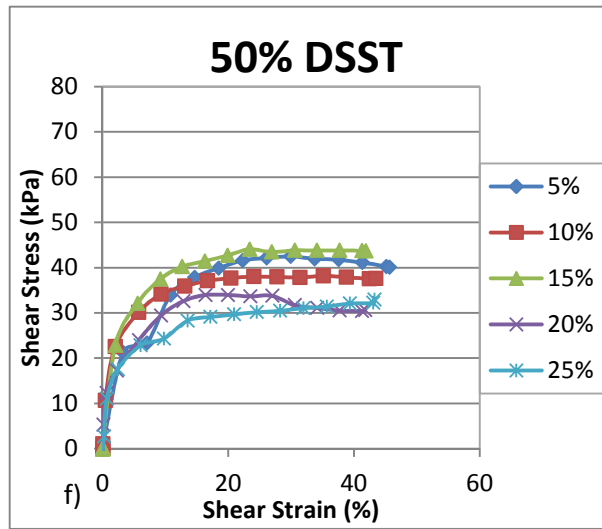
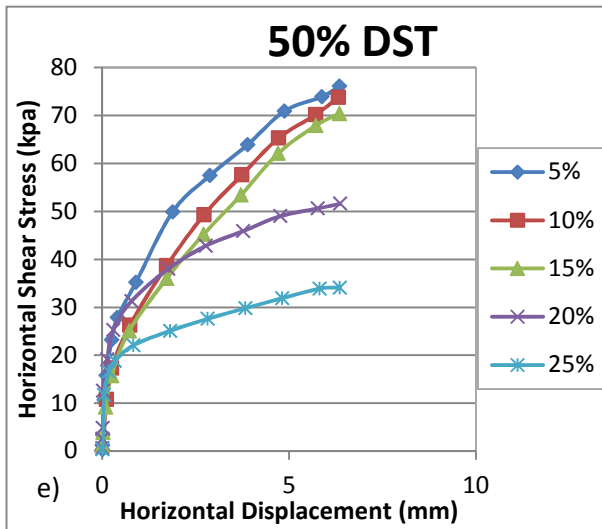

APPENDIX C. Design Charts.

C.1 Berenzentsev & Brinch Hansen

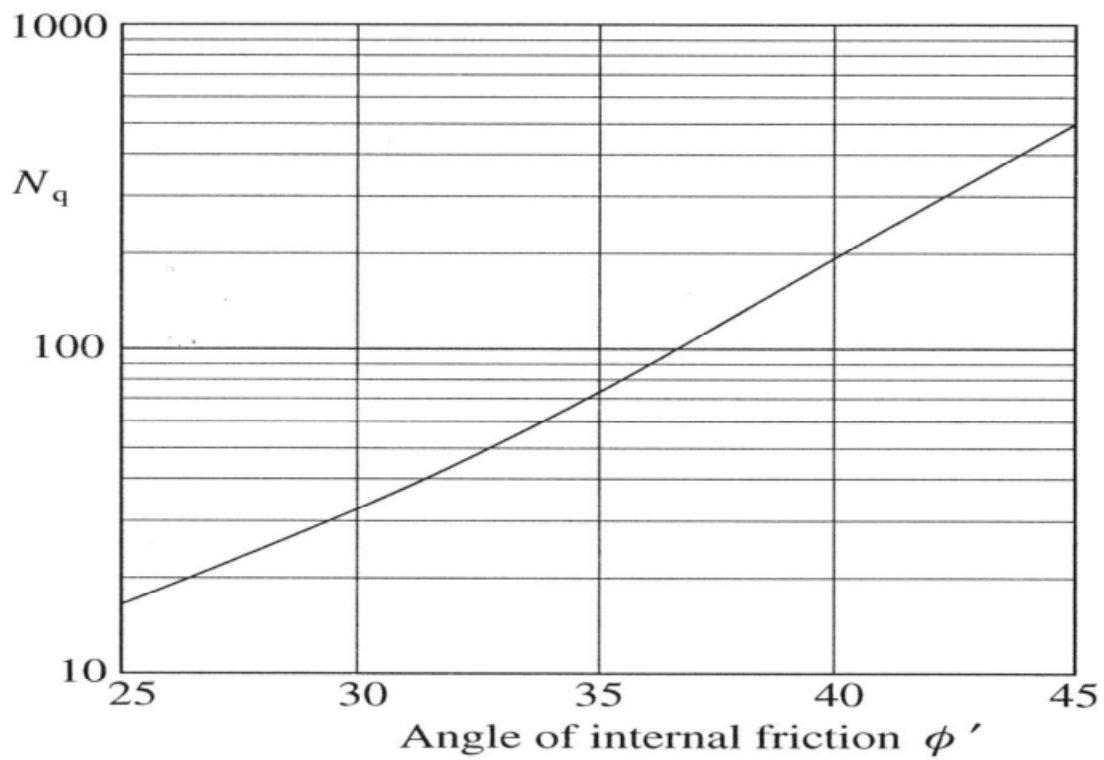

C.2 Tomlinson 1977

Pile Type	δ	Ks	
		Low Relative Density	High Relative density
Steel	20°	0.5	1.0
Concrete	0.75ϕ	1.0	2.0
Wood	0.67ϕ	1.5	4.0

C.3 Poulos 1980

