

The copyright of this thesis vests in the author. No quotation from it or information derived from it is to be published without full acknowledgement of the source. The thesis is to be used for private study or non-commercial research purposes only.

Published by the University of Cape Town (UCT) in terms of the non-exclusive license granted to UCT by the author.

**IMPROVED TRANSIENT EARTH FAULT
CLEARING ON SOLID AND RESISTANCE
EARTHED MV NETWORKS**

JP SCHOLTZ

DEPARTMENT OF ELECTRICAL ENGINEERING

UNIVERSITY OF CAPE TOWN

March 2011

**IMPROVED TRANSIENT EARTH FAULT CLEARING ON
SOLID AND RESISTANCE EARTHED MV NETWORKS**

JP Scholtz

Thesis Presented for a Masters Degree in Electrical Engineering

Supervisor: Professor CT Gaunt

University of Cape Town

March 2011

Contents

Abstract	2
Acknowledgements	3
1. Introduction	4
2. An Overview of Different MV Network Earthing Methods.....	6
2.1. Unearthed MV Networks	6
2.2. Solidly (or Effectively) Earthed MV Networks	16
2.3. Resistance Earthed MV Networks	18
2.4. Impedance Earthed MV Networks	24
2.5. Discussion of issues influenced by different network earthing methods.....	31
3. Proposed Transient Earth Fault Clearing Method.....	48
3.1. Temporarily Disconnecting the Neutral Earth Connection of a Solid or Low Resistance Earthed Network	52
4. Transient Earth Fault Clearing Scheme.....	56
4.1. A Typical Transient Earth Fault Clearing Scheme	56
4.2. Operation of the Transient Earth Fault Clearing Scheme	57
4.3. Safety of the Transient Earth Fault Clearing Scheme.....	60
5. Trial Site Proposal.....	63
5.1. Trial Site Selection	63
5.2. Trial Site Preparation.....	68
6. Test Protocol.....	70
6.1. Tests to be Conducted	70
6.2. Test Instruments Required	79
7. Risks	80
8. Trial Site Commissioning Test Results	81
8.1. Test 1	85
8.2. Test 2.....	86
8.3. Test 3.....	90
8.4. Test 4.....	94
8.5. Test 5.....	96
8.6. Test 6.....	98
9. Discussion of Trial Site Commissioning Test Results	99
9.1. Test specific discussions.....	99
9.2. General observations made during commissioning	101
10. TEFCS trial site operating history	105
11. Conclusion	116
References	119
Annex A	122

Abstract

It is known that not all earth faults on power system networks are permanent faults, but yet the standard approach is to momentarily open either a single-phase circuit breaker (HV systems) or a three-phase circuit breaker (HV and MV systems) to clear the fault. The obvious consequence of this is a loss of power to the load being fed.

The aim of this thesis is to endeavour to develop, through a literature study, a method or methods whereby **transient** earth faults on neutral earthed MV networks may be cleared without customer supply interruptions, without compromising public safety and without compromising network integrity. In order to propose such a method, or methods, it is important to understand the various earthing practices employed in MV networks in terms of network behaviour under earth fault conditions, as this may influence network component insulation rating requirements, as well as the way in which such a system may function.

Following the literature study the thesis aims to propose, design, build, test and implement a transient earth fault clearing scheme on an actual MV network, and to report on the operating experience of the implemented scheme.

University of Cape Town

Acknowledgements

I would hereby like to thank the South African power utility, Eskom Distribution Western Region, for affording me the opportunity to compile this thesis by providing me with a bursary and the resources to physically implement the transient earth fault clearing idea on an Eskom medium voltage network, Professor Trevor Gaunt for his valuable feedback sessions, my father who taught me to believe in myself and to never give up on an idea that you think might work, and lastly but not least, my dear wife Jackie for enduring the countless hours I've spent researching and writing this thesis, instead of spending the time with her.

University of Cape Town

1. Introduction

It is known that not all earth faults on power system networks are permanent faults, but yet the standard approach is to momentarily open either a single-phase circuit breaker (HV systems) or a three-phase circuit breaker (HV and MV systems) to clear the fault. The obvious consequence of this is a loss of power to the load being fed, with all the consequential problems to the customer when losing power to a production line for instance.

The aim of this thesis is to endeavour to develop, through a literary study, a method, or methods whereby **transient** earth faults on solidly earthed or resistance earthed radial overhead medium voltage (MV) networks may be cleared without customer supply interruptions, and without compromising public safety and network integrity.

In the search of a transient earth fault clearing method fulfilling the above requirements, a literature study has been done of the unearthed (isolated), solidly earthed, resistance earthed and impedance earthed (Petersen coil) neutral earthing practices in order to determine their advantages and disadvantages. Each of these earthing methods will be discussed in Chapter 2. Special attention has been devoted to the unearthed network practice as the proposed transient earth fault clearing method will, for a short duration, change the solidly earthed or resistance earthed network into an unearthed network.

The effects of an earth fault on a system will differ depending on the type of earthing method employed on a network. Different countries adopted different MV network earthing practices and may change from one method to another as the network composition changes over time. The type of earthing method applied to a network may be influenced by safety aspects, supply security requirements, maximum tolerable overvoltages on the healthy phases during an earth fault and maximum tolerable earth fault current.

A novel transient earth fault clearing method for solid and resistance earthed networks, fulfilling the above requirements, and operating on the principle of limiting the earth fault current to a very low level has been proposed. By limiting the earth fault current to a very low level a transient earth fault is prevented from developing into a permanent earth fault or a more severe phase-to-phase fault by limiting arcing at the fault point.

The literature studied did not reveal any reference or attempt to specifically clear transient earth faults, as opposed to clearing of permanent earth faults. All faults are dealt with in the same manner, i.e. open a circuit breaker in order to disconnect power, temporarily or permanent, to the fault. This identifies an apparently untested approach to dealing with transient earth faults specifically. An attempt was made to find a non-interruptive method of transient earth fault clearing for solidly and resistance earthed MV networks.

A transient earth fault is defined as a fault which is temporary in nature, such as faults caused by lightning, switching transients, conductor clashing, a tree branch momentarily touching a conductor during strong winds, or an animal that momentarily causes a short circuit between a live conductor or apparatus to earth, and then falls away, thus clearing the fault. In order to prevent such a fault from developing into a permanent fault, the fault arc is to be extinguished by reducing the fault current flow to zero or to a very low level. This is normally achieved by interrupting one or all of the phase currents by operating the upstream

circuit breaker on a solid or resistance earthed network. This action obviously results in total supply loss downstream of the tripped circuit breaker.

Transient earth faults are generally self-clearing on unearthed (isolated) and resonantly earthed networks due to the very low fault currents, that is, without protection intervention to auto reclose the feeder circuit breaker or auto recloser. Low earth fault currents aid self-extinguishing of arcing earth faults.

Strong focus will be placed on clearing of transient earth faults in existing solid and resistance earthed networks by temporary conversion to an unearthed network. Conversion to a resonant earthed network is deemed more expensive than temporary conversion to an unearthed network.

It has been documented that approximately 50% to 80% of all faults on medium voltage (MV) networks are earth faults, i.e. involving only one phase and earth [Dán et al, 2003 or later, 1; Erroa et al, 2006, 3; Hänninen, 2001, 13; Heine et al, 2004, 100; Nelson, 2002, 1, and Smeets & Knol, 2009, 3]. These faults include both transient and permanent earth faults. Of these earth faults 70% to 80% are transient in nature [Coopers, 1990, 7; Smeets & Knol, 2009, 3], and may be extinguished by interrupting the fault current flow for a short period (dead time), say 10 seconds, allowing the object causing the fault (conductor clashing, animal, tree branch blown into the line, etc.) to fall or move away, and ionised air to clear from the fault path.

Permanent earth faults are those faults that will not be cleared by temporarily preventing fault current from flowing. It has been documented by Coopers [1990, 7] that 30% of all permanent faults start off as transient faults.

Assuming then (very conservatively) that 50% of all network faults are earth faults, that 70% of these are transient in nature (thus 30% are deemed to be permanent earth faults), and that 30% of the "deemed to be" permanent earth faults may be cleared by interrupting the fault current very quickly, before it is given a chance to develop into a permanent fault, then about 40 faults out of a 100 network faults may be cleared. This constitutes successful clearing of 80% $[(40/(0.5 \times 100)) \times 100\%]$ of all earth faults.

This then implies that if a method can be found whereby transient earth faults can be cleared safely without customer supply interruptions, about 40 out of every 100 network faults, or put differently, about 80% of all earth faults may be cleared without affecting power supply to customers, and this represents a significant improvement in the quality of supply, and revenue saving.

2. An Overview of Different MV Network Earthing Methods

In order to better understand network earthing methods, and in particular unearthed networks, as the thesis is mainly concerned with temporary conversion of a solid or resistance earthed network into an unearthed network, all common earthing methods will be studied, but the bulk of attention will be devoted to unearthed networks.

A comparison is provided in Table 1, at the end of this chapter, of a number of selected characteristics of the different earthing methods to be discussed in this chapter

2.1. Unearthed MV Networks

In an unearthed network the system neutral is isolated from earth. The advantage of such a system is that for an earth fault there is no resulting fault current, except for a small capacitive current due to an imbalance in line capacitance to earth, caused by the earth fault short circuiting the faulted phase-to-earth capacitance. The whole system, therefore, remains operational until a second earth fault occurs on another phase, resulting in a phase-to-phase fault and significant fault current [Alstom, 2002, 139; Erroa et al, 2006, 1; Lehtonen & Hakola, 1996, 15].

In an unearthed network the source (substation) neutral-to-earth needs to be fully insulated to withstand full normal phase-to-phase voltage to earth. This is due to the neutral-to-earth voltage rising to full normal phase-to-neutral voltage during an earth fault condition on one phase.

Unearthed networks are popular in the Nordic countries, but are not very common in other countries due to alleged high, destructive transient overvoltages that may pose a hazard to network equipment [Hänninen, 2001, 13].

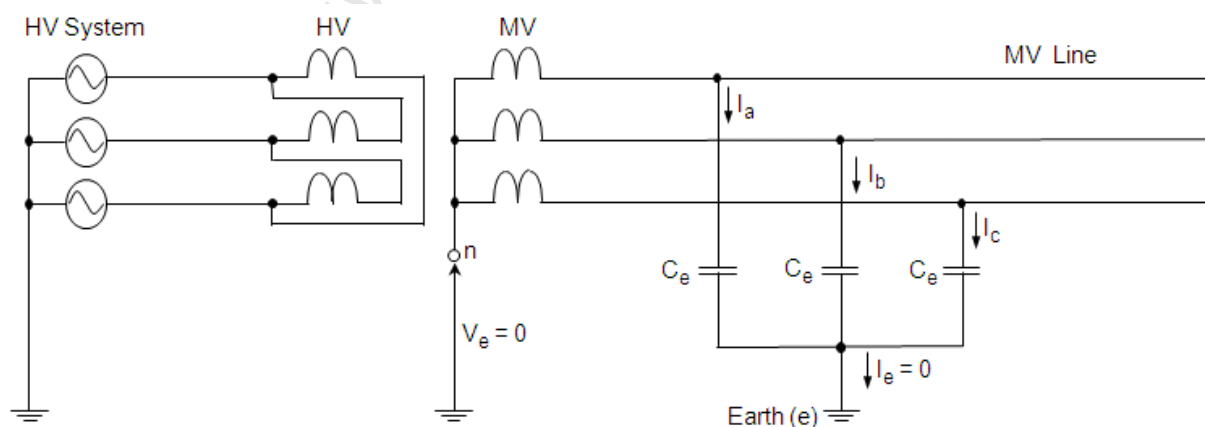

Figure 1: Capacitive currents in an unearthed MV network.

Under normal network conditions the three phase-to-earth capacitive currents of the three phase conductors are equal and the current vectors are spaced 120° apart. The summated

capacitive current flow to earth is therefore zero, as shown in Figure 1. The voltage and capacitive current vector diagram is depicted in Figure 2. The neutral-to-earth voltage will be zero if it is assumed that the network loading is balanced and that the phase-to-earth capacitances of all three phases are equal [Uppal, 1984, 909]. Since the neutral of the phase-to-earth capacitances is at earth potential, the supply transformer's neutral is also at earth potential as the balanced phase-to-earth capacitances are keeping it there. In either a 3-wire or 4-wire unearthed network the network loading will only affect the neutral voltage-to-earth magnitude if the loading on two phases is such that it actually pulls down these two phase voltages. The three conductor voltages to earth are now of different magnitudes, which will cause a shift in the network's neutral point voltage (and the transformer neutral voltage-to-earth) with respect to earth potential.

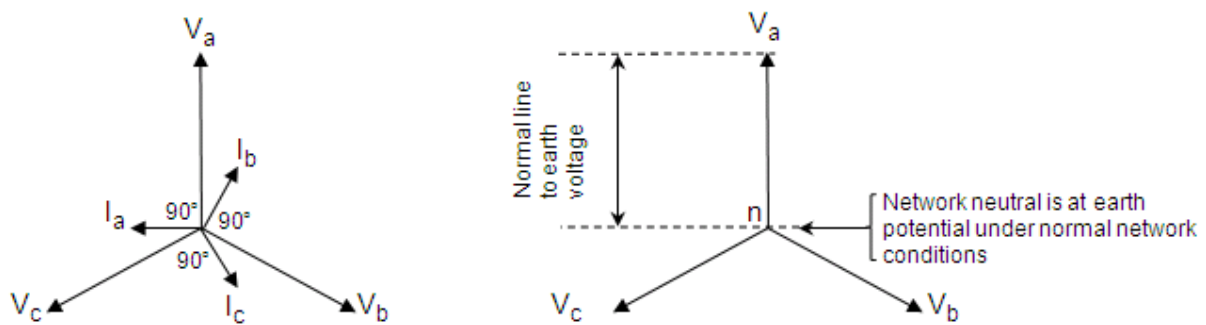

Figure 2: Vector diagram of system voltages and capacitive currents in an unearthed (isolated neutral) network under normal network conditions.

The only currents flowing as a result of an earth fault are the two capacitive currents, of the phase-to-earth capacitances, of the two healthy phases (ignoring load current). In Figure 3 it is indicated that the phase-to-earth capacitance of the faulted phase is being short circuited by the earth fault and will therefore produce no capacitive current. This is an approximation as phase-to-earth capacitances are actually distributed along the whole length of the line, but is represented for convenience as lumped quantities [ABB, 1994, 93; Allen & Waldorf, 1945, 299; Alstom, 2002, 140; Eaton Power, 2009, 2; Glover, 1978 or later, D-2; Uppal, 1984, 908; Westinghouse, 1944, 458]. The residual current measured at the substation on the faulted feeder will only include the capacitive currents from the two healthy phases on the other two feeders, as depicted in Figure 5, which represents an unearthed MV network with three feeders.

In practice, for an earth fault just outside the substation the capacitive fault current contribution from the faulted phase will be zero, as the driving voltage across the line capacitance-to-earth is zero. For an earth fault at the end of a long line, however, there will be a capacitive current contribution from the faulted feeder as the phase-to-earth voltage (driving voltage) is not zero as from the substation up to the fault, but will diminish approximately linearly from a maximum at the MV busbar to zero at the fault point. The magnitude of faulted phase capacitive current will, however, always be smaller than that of the two healthy phases, thus providing enough residual fault current for protective purposes.

The two capacitive current magnitudes (I_{be} and I_{ce}) during an earth fault will be $\sqrt{3}$ times the capacitive current per phase (I_a , I_b & I_c) flowing to earth under normal conditions. This is due to the healthy phases' normal phase-to-earth voltages rising to full phase-to-phase voltage across these healthy phases' phase-to-earth capacitances, if the fault point resistance is assumed as being zero, as vectorially shown in Figure 4.

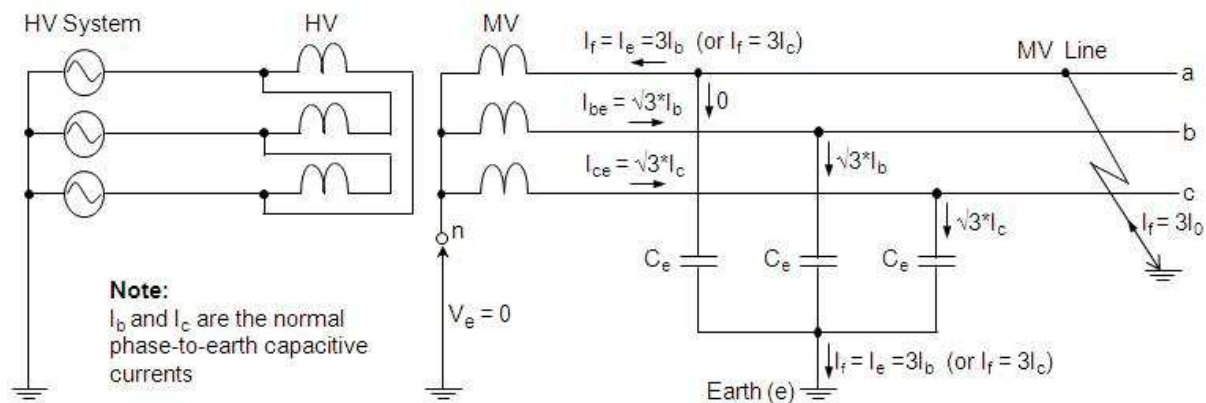

Figure 3: Capacitive currents in an unearthed MV network during an earth fault.

Based on the forgoing paragraph, for an a-phase earth fault, the phase-to-earth capacitive currents flowing from earth into the b- and c-phases are obtained by:

Current through the b phase-to-earth line capacitance, $I_{be} = \sqrt{3}I_b$

Current through the c phase-to-earth line capacitance, $I_{ce} = \sqrt{3}I_c$

where I_b and I_c are the b-phase and c-phase capacitive currents to earth, respectively, under normal network conditions.

The fault current magnitude, I_f , is given by the vector sum of I_{be} and I_{ce} , shown vectorially in Figure 4:

$$I_f = I_{\text{Capacitive total}} = I_{be} + I_{ce}$$

$$I_f = \sqrt{3}I_b \cos 30^\circ + \sqrt{3}I_c \cos 30^\circ$$

Let $I_{xc} = I_{be} = I_{ce}$, thus

$$I_f = I_{xc} \cos 30^\circ + I_{xc} \cos 30^\circ$$

$$I_f = 2I_{xc} \cos 30^\circ$$

$$I_f = 2I_{xc} \left(\frac{\sqrt{3}}{2}\right)$$

$$I_f = \sqrt{3}I_{xc}, \text{ or} \quad (1)$$

$$I_f = 3I_b, \text{ or} \quad [I_{xc} = I_{be} = \sqrt{3}I_b] \quad (2)$$

$$I_f = 3I_c \quad [I_{xc} = I_{ce} = \sqrt{3}I_c]$$

$$I_{\text{Residual}} = 3I_0 = I_f$$

From the above derivation it may be seen that the fault current is equal to 3 times the phase-to-earth capacitive current under normal system conditions.

During an earth fault the network neutral voltage will increase from zero to normal phase-to-earth voltage as the faulted phase is directly connected to earth.

According to Uppal [1984, 911] it has been determined that an earth fault current in excess of about 5 A is sufficient to maintain an arc in the ionized path of the fault (No mention has been made of the spark gap size.) This phenomenon is also known as *arcing ground*. This statement by Uppal [1984, 911] is not substantiated by laboratory or network tests, and therefore it seems to be a general statement. Based on the results of studies conducted on unearthed 20kV networks in Finland, Hänninen [2001, 28] found 35 A to be the maximum capacitive fault current that will allow arc extinction at the fault point.

It was also found that if arcing takes place across an arcing horn on a 20 kV unearthed network, the maximum capacitive fault current that will allow arc extinction is reduced to 5 A (No mention has been made of the spark gap size.). The reduced current level allowing for arc self-extinction is ascribed to the fact that the arc is not free to move across the arcing horn as in the case of an insulator flashover [Hänninen, 2001, 28].

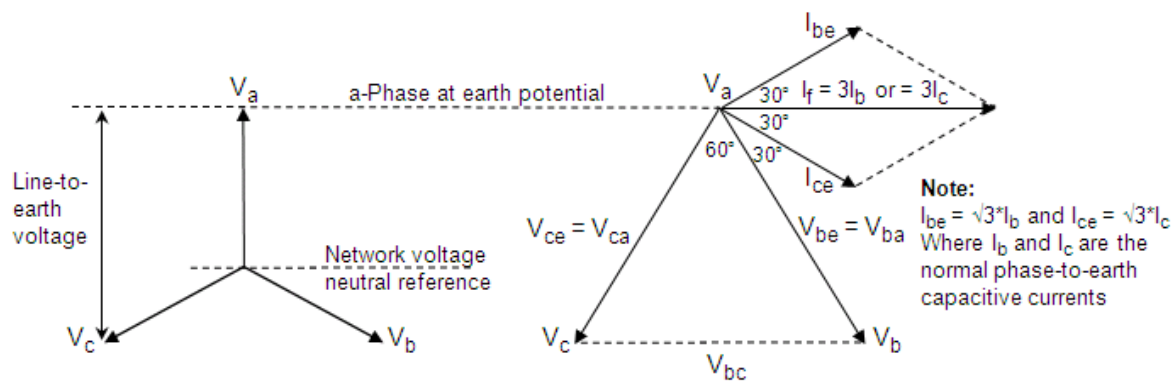

Figure 4: Capacitive current and system voltage vectors of an unearthed MV network during an earth fault condition.

Hänninen [2001, 28] did not offer an explanation as to why a free moving arc is more likely to self-extinguish as compared to an arcing horn arc. This effect is most likely as a result of the ionized air generated by the arc between the horns of an arcing horn, which provides a low resistance path to the arc and tends to prevent it from extinguishing. If the fault arc is able to move around, the ionized air will be spread over a wider area resulting in a higher resistance path to the arc, making it more likely to self-extinguish.

Under these arcing conditions the phase-to-earth capacitances of the two healthy phases are charged and discharged, resulting in (claimed) overvoltages.

From the literature study it seems as if there is no consensus on the actual magnitude of overvoltages attainable in unearthed networks. Phase-to-earth overvoltage magnitudes of 5 to 6 times the normal peak system phase-to-neutral voltage are claimed by some [Evans et al, 1939, 392; Glover, 1978 or later, D-2, & Uppal, 1984, 911]. On the other hand

Westinghouse [1944, 457] states that overvoltages, caused by faults and switching operations, are higher on unearthened networks than on earthed systems, but not to the magnitudes formerly suspected. No further explanation of this statement has been given. Furthermore Westinghouse [1944, 457] states that the operating records of unearthened networks do not show pronouncedly greater equipment failure rates than on earthed systems. This then may imply that (claimed) overvoltages generated by arcing earth faults are either not present, or are not high enough to cause equipment failure.

Allen & Waldorf [1946, 303] found, through arcing earth fault investigations on a 13 kV power station busbar with all connected equipment, that the highest overvoltages attained were not more than 2,8 times normal phase-to-neutral voltage. It was commented by Allen & Waldorf [1946, 301] that the voltages produced by arcing across the spark gap were not nearly as high as published theory indicates. Allen & Waldorf [1946, 302] stated that the total phase-to-earth capacitance of the power station busbar was 2,6 μF and that the spark gap size was set to 15 mm. The phase-to-earth capacitance of 2,6 μF would have resulted in a 6 A capacitive current per phase under normal network conditions, and by using equation 2 the capacitive earth fault current is calculated to be 18 A.

Overvoltages are reduced by circuit resistance, which will introduce damping of the transients, but the transients can be very high and represent the major disadvantage of an unearthened network [ABB, 1994, 94].

The above discussion assumed that the phase-to-earth capacitances of the three phases of the network are equal. This may not be true for untransposed lines on vertical or flat conductor configurations [Westinghouse, 1944, 459]. In practice MV lines (unearthed or otherwise) are seldom intentionally transposed. In extreme cases the imbalance with either flat or horizontal configuration may give as much as 5% zero-sequence voltage Westinghouse [1944, 459] (neutral-to-earth voltage displacement). For these line configurations then, in practice, the system neutral voltage on an unearthened network may be displaced from earth by as much as 6% of the normal line-to-neutral voltage under unfaulted conditions [Westinghouse, 1944, 459].

It should then be safe to deduce, from the above statement, that system neutral voltage shift will not be a problem with delta configured line constructions as vertical and flat conductor configurations have been singled out as to cause system neutral voltage shifts (zero-sequence voltage). It should also be noted that Westinghouse [1944, 459] was the only literature source encountered that mentioned the effect of untransposed lines, but it was not explicitly stated that the effect applies equally to MV and HV lines.

Neutral voltage shift (zero-sequence voltage) may become a quality of supply problem in 4-wire networks, but is irrelevant in 3-wire networks as the shift in neutral voltage will not be transferred to the customer supply through the MV/LV step-down distribution transformers.

During the early 1900s protection of unearthened networks was more difficult than for networks where the system neutrals were connected directly to earth, or via a resistance or impedance to earth, as the very low levels of fault currents during earth faults require good protection sensitivity and discrimination capability. With modern numeric protection this is no longer a concern.

In order to detect the presence of an earth fault, the offset of the transformer neutral from earth potential may be measured. Such a zero sequence overvoltage, however, only alarms the fact that an earth fault exists on the MV network, and do not identify the faulted feeder or the faulted phase. Other means of identifying earth faults therefore need to be employed.

A varmetric relay may be used per feeder for detecting earth faults on unearthed networks. The varmetric relay responds to the quadrature (imaginary) component of the zero sequence current, compared to the neutral displacement voltage (zero sequence voltage, $3V_0$). See Figure 6 and section 2.5.3. The zero sequence current has a high capacitive content and may be used to determine the fault direction [IEEE, 2006, 82]. The neutral displacement voltage measurement requires the use of three single phase VTs or a 5-limb VT in order to provide a low reluctance path to the residual magnetic flux in the VT [Alstom, 2002, 139].

Another method of identifying the faulted feeder amongst other feeders feeding from the same busbar employs a directional earth fault relay per feeder as the residual currents of the healthy and faulted feeders are in anti-phase [Alstom, 2002, 140]. This is illustrated in Figure 5 where I_1 and I_2 (residual currents) are flowing from the source to earth through the healthy feeders' b- and c-phases, and towards the source through the faulted a-phase conductor.

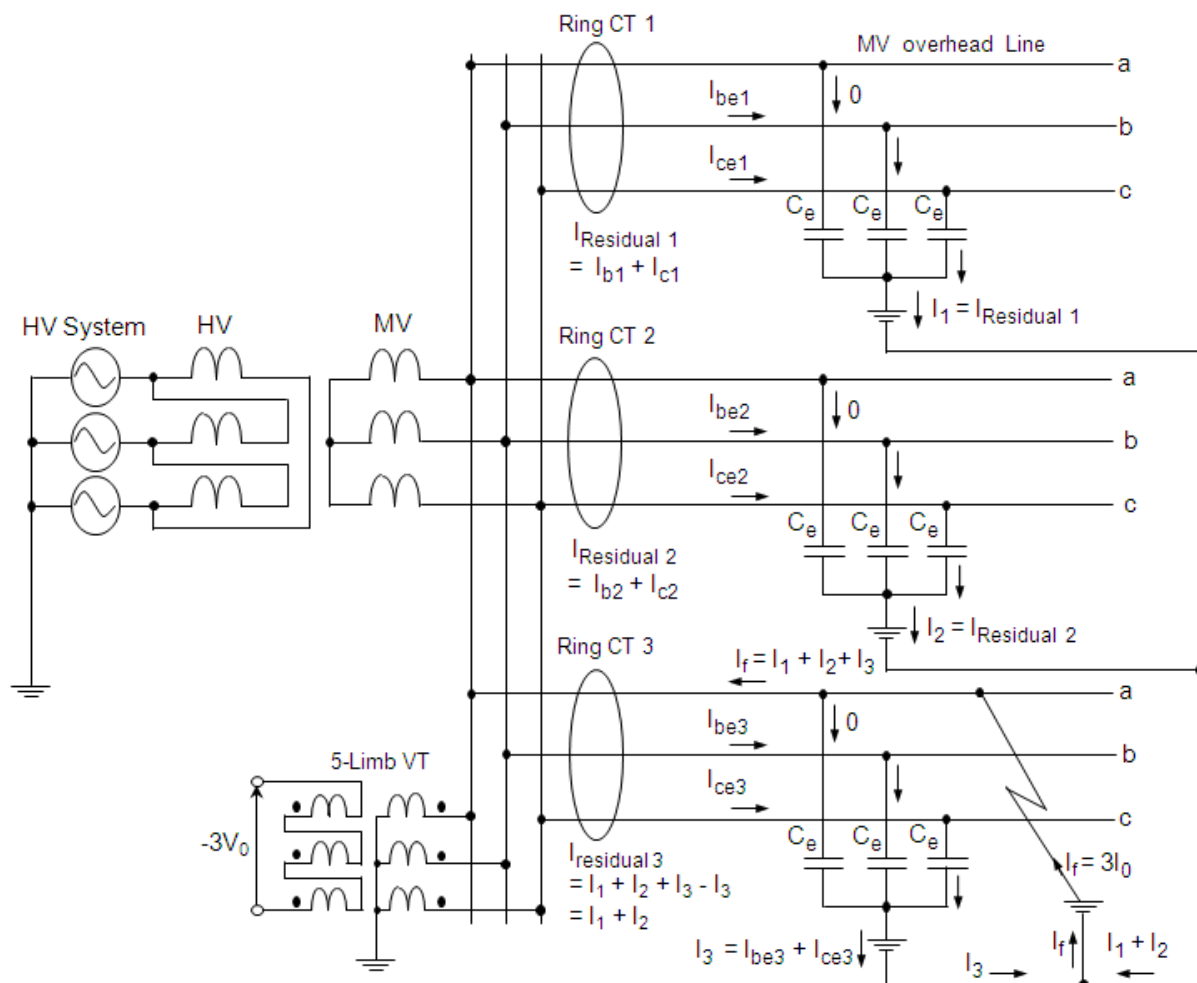

Figure 5: Current distribution in an unearthed network with an a-phase-to-earth fault.

The directional earth fault protection method makes use of the residual current obtained from a core balanced CT ($I_{\text{Residual } 3}$ in Figure 5) and the neutral displacement voltage ($-3V_0$) from a 5-limb VT or three single phase VTs with the secondary windings connected in open delta. The residual voltage is used as the polarising quantity in the directional protection relay.

As previously shown by the fault current derivation, the residual current of the faulted feeder is three times the normal steady state capacitive charging current per phase (equation 2) for the complete network as indicated in Figure 4 for a single feeder scenario.

Figure 6 vectorially depicts the a-phase fault scenario for the three feeders in an unearthed network depicted in Figure 5. The vector sums of the healthy feeders' capacitive currents, I_1 and I_2 , residual voltage, $-3V_0$, and residual current, $I_{\text{Residual } 3}$, of the faulted feeder with an a-phase-to-earth fault. For illustrative purposes it is simplistically assumed that the three feeders illustrated in Figure 5 have exactly the same phase-to-earth capacitances, and therefore the capacitive current vectors (I_1 , I_2 and I_3) will be exactly the same.

From Figure 5 it may be seen that the vector sum, I_3 , of the faulted feeder's two healthy phases' capacitive currents to earth will be vectorially subtracted from the capacitive fault current, I_f , by the ring type CT, and provide the resultant, $I_{\text{Residual } 3}$, to the protection relay.

Also from Figure 5 it may be seen that the residual current (vector) presented to the protection relay is given by,

$$\begin{aligned} I_{\text{Residual } 3} &= (I_{be1} + I_{ce1}) + (I_{be2} + I_{ce2}) \\ &= I_1 + I_2 \end{aligned}$$

The current vectors I_{be} and I_{ce} in Figure 6 represent the capacitive current vectors under an earth fault condition (I_{be1} , I_{ce1} , I_{be2} , I_{ce2} , I_{be3} and I_{ce3}) for each of the three feeders individually.

As an earth fault on an unearthed network does not affect the quality of supply or endanger the network itself (assuming that the network insulation co-ordination was properly done), some utilities have their own rules governing continued operation of such networks under a permanent earth fault condition until such time as the fault may be located and repaired. Network operating regulations in Croatia, for instance, dictate that an unearthed network may continue operating with a permanent earth fault if the capacitive earth fault current does not exceed 10 A for a 35 kV network, and 15 A for a 20 kV network. The German regulation, VDE 0228 (1987), on the other hand prescribes a maximum capacitive earth fault current of 35 A for a 20 kV network [Cucic et al, 2008, 82].

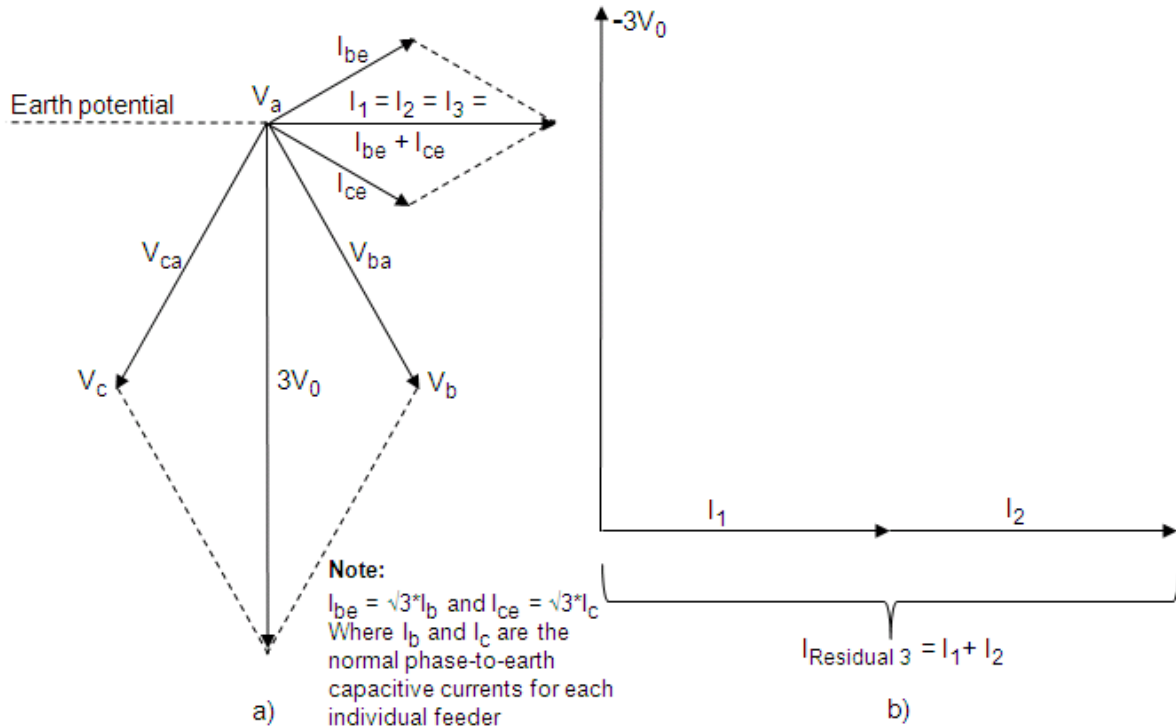

Figure 6: a) The vector summation of the capacitive currents I_{be} and I_{ce} of each of the three feeders which are simplistically assumed to have exactly the same phase-to-earth capacitive fault currents per phase, and b) the residual voltage ($-3V_0$), and residual current ($I_{Residual\ 3}$) of the faulted feeder in an unearthed network during an a-phase-to-earth fault.

2.1.1. Sub-harmonic Oscillation of the Neutral Voltage

When a transient (temporary) earth fault occurs, the charge stored in the earth capacitance of the faulted phase is removed [Lehtonen et al, 2001, 1183] as it is short circuited by the cause of the fault. Due to the faulted phase being connected to earth, the voltages on the two healthy phases rise to full phase-to-phase voltage with respect to earth. The phase-to-earth capacitances of the two healthy phases are now charged by these higher voltages. When the temporary connection to earth is broken again, the charges on the two healthy phase capacitances dies away slowly, causing sub-harmonic oscillation of the neutral voltage to earth. This sub-harmonic oscillation of the neutral voltage is generated by a circuit formed by the earth capacitances and voltage transformer inductance [Lehtonen et al, 2001, 1183].

2.1.2. Measurement of the Capacitive Reactance of an Unearthed Network

The capacitive reactance of an unearthed network may be measured by solidly earthing one phase of the network to earth through an ammeter, i.e. effectively putting an earth fault on the phase, say, the a-phase. When this is being done the a-phase capacitance-to-earth will be short circuited by the ammeter and the two healthy phases will pass their capacitive currents through the ammeter [Allen and Waldorf, 1946, 305]. See Figure 7.

For the network depicted in Figure 5 the fault current that will be measured by the ammeter will be:

$$\begin{aligned}
 I_f &= I_{\text{Capacitive total}} = 3I_0 = I_1 + I_2 + I_3 \\
 &= (I_{b1} + I_{b2} + I_{b3}) \cdot \cos 30^\circ + (I_{c1} + I_{c2} + I_{c3}) \cdot \cos 30^\circ \\
 &= I_{be} \cdot \cos 30^\circ + I_{ce} \cdot \cos 30^\circ \\
 &= (I_{be} + I_{ce}) \cdot \cos 30^\circ \quad [A]
 \end{aligned}$$

The vector sum of the capacitive currents I_{be} and I_{ce} , are the b- and c-phases' capacitive currents flowing to earth and passing through the a-phase (faulted phase), back to the source, for the total network, and are for practical purposes numerically equal. This is pictorially presented in Figure 7.

Let $I_{xc} = I_{be} = I_{ce}$

Thus, $I_f = 2 \cdot I_{xc} \cdot \cos 30^\circ$

Then from (1) $I_f = I_{\text{Capacitive total}} = \sqrt{3} \cdot I_{xc} \quad [2 \cdot \cos 30^\circ = \sqrt{3}]$

Thus, $I_{xc} = I_{\text{Capacitive total}} / \sqrt{3} \quad [A]$

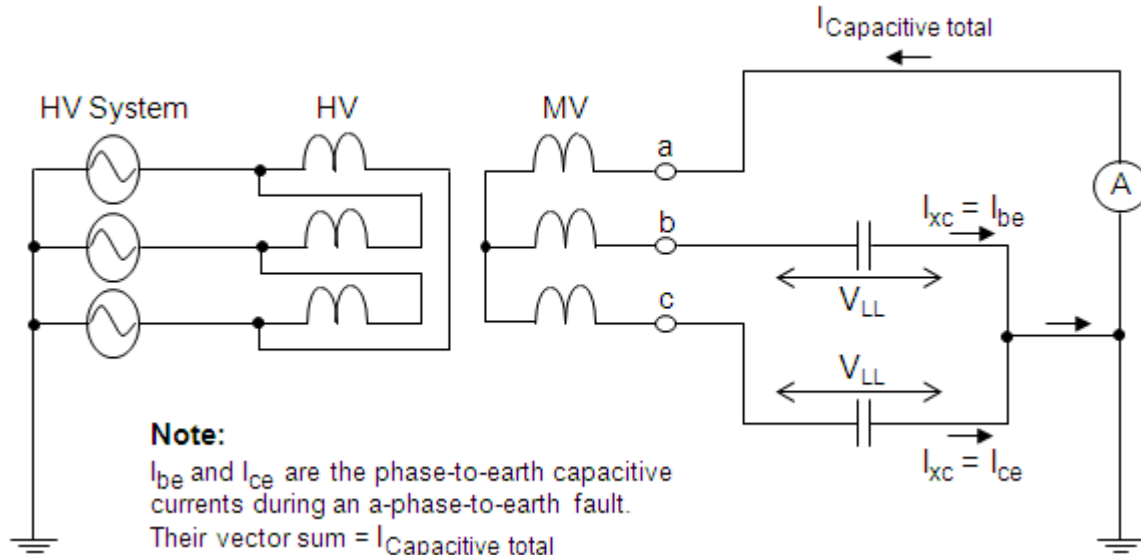

Figure 7: Simplified system diagram for an earth fault as depicted in Figure 5.

The capacitive reactance, X_C , between one phase and earth for the whole network is determined from the phase-to-phase voltage, V_{LL} , and $I_{\text{Capacitive total}}$ measured by the ammeter:

$$\begin{aligned} X_C &= V_{LL} / I_{x_c} & (3) \\ &= V_{LL} / (I_{\text{Capacitive total}} / \sqrt{3}) \\ &= \sqrt{3} \cdot V_{LL} / I_{\text{Capacitive total}} & [\Omega] \end{aligned}$$

The capacitance, C , of one phase of the total network may then be found from:

$$\begin{aligned} C &= 1 / (2 \cdot \pi \cdot f \cdot X_C) \\ &= I_{\text{Capacitive total}} / (2 \cdot \sqrt{3} \cdot \pi \cdot f \cdot V_{LL}) & [F] & (4) \end{aligned}$$

Where f is the power system frequency in hertz, and V_{LL} is the rated phase-to-phase system voltage in volt.

2.1.3. Advantages and Disadvantages of Unearthed Networks

Advantages

- The main advantages of an unearthed network are that it allows transient earth faults to self-extinguish and also allows the existence of an earth fault on one phase without the need to disconnect the affected phase from the source, until such time that someone may attend to the fault. For the duration of an earth fault no customer's electrical supply will be affected. The benefit of unearthed networks is to provide a better security of supply as compared to an earthed network.
- The earth fault current is of a capacitive nature and is very low, typically less than 20A in a 13.8kV network [Bridger, 1983, 16]. This results in minimal fault point and equipment damage during a fault, and requires a less extensive substation earth mat, as there are no high earth fault currents to be catered for.
- From a cost point of view the unearthed network may be cheaper to construct as no earthing devices (earth electrodes, solid earth connections and earthing resistors or earthing transformers on transformer star connected secondary winding neutrals, or neutral earth compensators on transformer delta connected windings) are required. Maintenance on these devices is therefore also not required.

Disadvantages

- Earth faults on unearthed networks tend to give rise to so called *arcing faults*, which may lead to substantial overvoltages on the affected network. According to Glover [1978 or later, D-2] overvoltages of up to six times normal phase-to-neutral voltage have been produced in laboratory tests. Field experience, however, indicates that a maximum of 3 times the normal phase-to-earth voltage may be a more realistic value [Allen & Waldorf, 1946, 305; Eaton et al, 1931, 1469]. On a 140 kV unearthed network

North and Eaton [1933, 70] measured overvoltages of up to 3.5 times normal phase-to-neutral voltage with respect to earth during earth faults.

- Although arcing faults occur in all network types they are particularly dominant in unearthed networks where arcing faults made up at least half of all the disturbances during an investigation by Lehtonen et al [2001, 1181]. The reason as to why arcing earth faults are more common in unearthed networks may lay in the fact that the earth fault current is capacitive in nature. The fault current, therefore, leads the voltage by 90° and as an arc will tend to self-extinguish at current zero, this will happen when the voltage is at its peak, and this may lead to re-striking.
- Traditionally earth fault detection was more difficult than in earthed networks, but easily achieved by modern numeric protection relays.
- If an unearthed network's capacitive current is too high transient faults may not self-extinguish.

2.2. Solidly (or Effectively) Earthed MV Networks

In a solidly earthed network the transformer neutrals are directly connected to earth without any intentional resistance in series between transformer neutrals and the earth electrodes. Even though a network may be solidly earthed, the actual earth fault current magnitude will depend on the positive, negative, and zero sequence impedance values of the specific network, as well as the fault point resistance to earth magnitude.

In solidly earthed networks the earth fault currents vary largely depending on the fault location and on fault resistance [Lehtonen & Hakola, 1996, 22].

According to Westinghouse [1944, 460] the earth fault current in a solidly earthed network may range from 0 to 2 times the three phase short circuit current in a given network.

A solidly earthed network is generally defined as a network where $X_0/X_1 \leq 3$, where X_0 represents the zero sequence network impedance and X_1 represents the positive sequence network impedance [Westinghouse, 1944, 460].

In addition to the Westinghouse requirement, Lehtonen & Hakola [1996, 22] states that for a network to be classified as solidly earthed it also has to conform to $R_0/X_1 \leq 1$, where X_1 represents the positive sequence network impedance, and R_0 the zero sequence resistance.

The advantage of a solidly earthed network is that the earth fault currents will generally have a high magnitude and will therefore ensure detection by simple protection equipment. A major disadvantage of such a network is the possibility of very high earth fault currents which may result in major equipment and fault point damage. For this reason the use of solidly earthing philosophy is generally not implemented on MV networks.

In a solidly earthed network the general practice is to disconnect all three phases (unlike in unearthed and Petersen coil earthed networks where an earth fault may be tolerated for some time until the fault may be located to effect repairs) up-stream of an earth fault in an attempt to clear a transient earth fault and to prevent it from developing into a phase-to-

phase fault. Some networks, mainly HV networks, may employ single phase auto reclosing for transient earth fault clearing. After the circuit breaker has tripped it will stay open for a short duration (dead time) after which the circuit breaker is closed and the protection resets after a set delay if no fault current is detected. If fault current is still present after the auto-reclose, the breaker will go through a set number of auto-reclose attempts before staying open (locking out).

Network capacitive currents will have no effect on a network clearing faults by means of a 3-phase circuit breaker as the complete network is isolated from the source. If, however, a single phase circuit breaker is used to clear an earth fault, capacitive currents from the two healthy phases will flow up the transformer neutral connection from earth. This current (vector sum of the two capacitive currents) will be much less than the earth fault current pick-up protection setting and will pose no risk in terms of tripping the other two phases as well.

When single-pole reclosing is employed, the user should be aware that the resultant capacitive current magnitude on extensive networks may approach that of the sensitive earth fault protection setting.

On a solidly earthed network it is therefore not possible to clear network faults without customer supply interruptions.

2.2.1. Advantages and Disadvantages of Solidly Earthed Networks

Advantages

- Solid earthing is the least expensive method of network earthing, apart from applying no network earthing.
- The fact that the system neutral is solidly earthed (grounded) inhibits the generation of extreme overvoltages as a result of arcing (re-striking) earth faults and power frequency overvoltages due to network switching operations. The potential rise of the sound phases will depend on the fault current magnitude, which is dependent on network impedance, the earth electrode resistance and fault point resistance.
- As a result of the lower overvoltages lower insulation levels may be used, which translates into lower network establishment cost.

Disadvantages

- Solid earthing of networks results in very high earth fault currents, and may even be higher than phase-to-phase fault currents due to the low resistance earth path as compared with the resistance of a phase conductor. These high earth fault currents may lead to severe fault point and equipment damage, such as conductors burning off due to hot connections and conductor or insulator damage due to arc damage at the fault point.
- The fault current energy is proportional to I_f^2t , where I_f is the fault current and t is the duration for which the fault current is flowing. A high I_f^2t will reduce circuit breaker contact life.

- Due to the high earth fault current, fast acting protection would be required.
- Every earth fault, transient or bolted, will result in disconnection of the affected feeder from the source.
- The larger fault currents may lead to high step and touch potentials within the substation during earth fault conditions, and therefore special care needs to be taken when designing earth electrodes/earth mats in areas of high soil resistivity.

2.3. Resistance Earthed MV Networks

In such a system the neutral is connected to earth through a resistance. The higher this resistance the closer the voltage and current characteristics will become to that of an unearthed network.

This earthing method may be employed on the MV neutral of a step-down transformer (say, 66kV to 11kV) with a star connected MV winding as shown in Figure 8. Alternatively the method may also be applied by installing a neutral earth compensator with a neutral resistor (NECR) on a step-down transformer with a delta connected MV winding as shown in Figure 9. In both cases the resistances are inserted in the neutral connections to earth in order to limit earth fault currents to acceptable levels, thereby limiting equipment damage in the fault current path and voltage dips on healthy adjacent networks feeding from the same busbar.

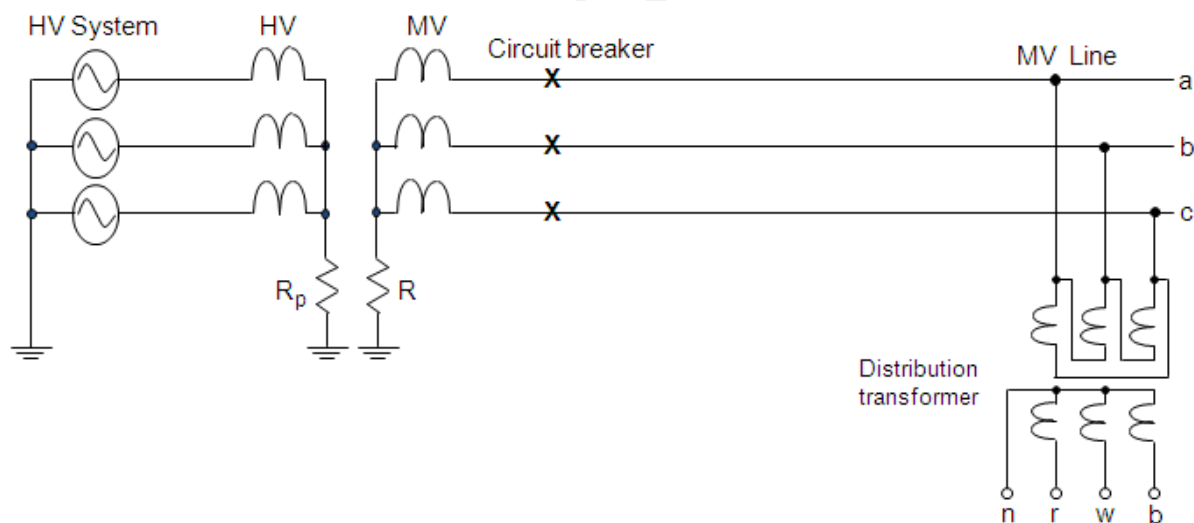

Figure 8: A typical resistance earthed star connected MV network employing a neutral resistor (R).

The earth fault current is primarily limited by the neutral resistor as its ohmic value is normally considerably more than the network reactance at the resistor location. Other than in exceptional cases, such as long lines at high voltages, or extensive cable networks, the capacitive current is small compared to the resistive current, and can be neglected [Westinghouse, 1944, 459].

The voltage and load current vectors for a resistively earthed network with a lagging power factor load under normal conditions are shown in Figure 10 a), and the vectors in Figure 10 b) are representative of a typical a-phase earth fault condition with the load currents ignored.

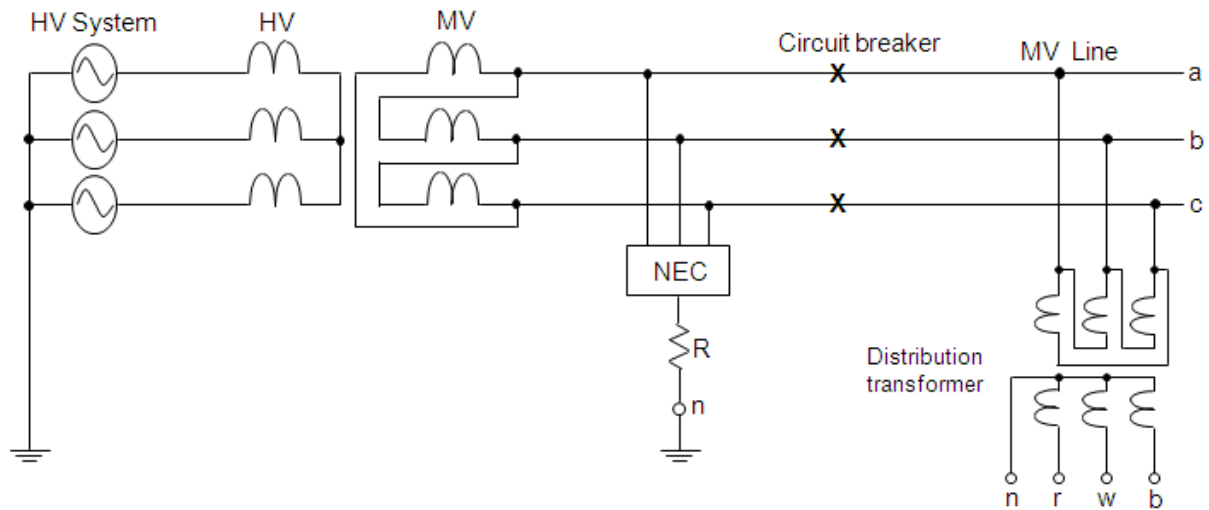

Figure 9: A typical resistance earthed delta connected MV network employing a neutral earth compensator (NEC) with a neutral resistor (R).

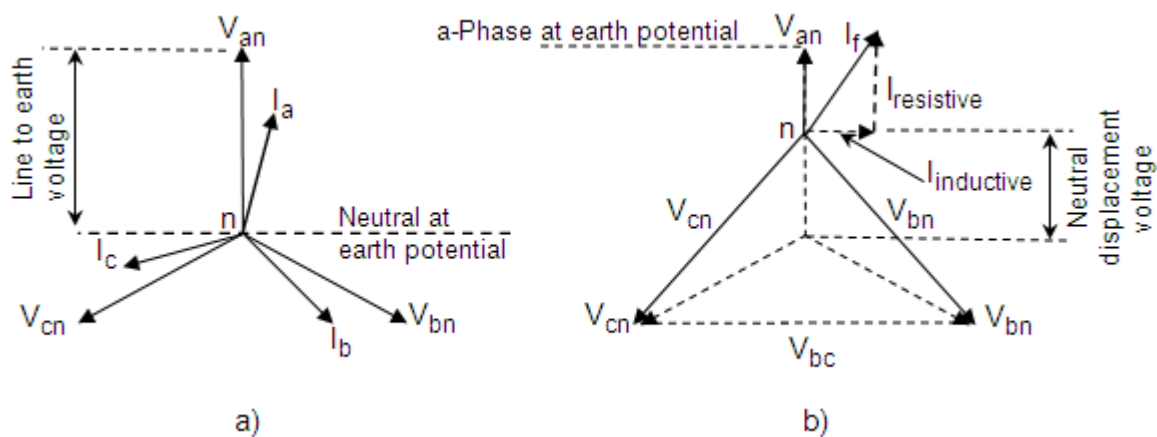

Figure 10: Voltage and load current vectors for a resistively earthed network a) under normal network conditions and b) with an earth fault on a-phase.

It will be noted that the neutral point shifted from the normal, and this offset is known as the neutral displacement voltage, residual voltage or $3V_0$. The fault current, I_f , may be broken down into two components, an inductive component lagging the a-phase voltage by 90° and a resistive component in phase with the a-phase voltage. The fault current magnitude is determined mainly by the neutral resistance value, but is also dependent on the zero sequence source impedance, line impedance and the fault point resistance.

The neutral resistor value is normally chosen to allow an earth fault current equal to the full load current of the largest transformer feeding onto the busbar to flow through the neutral

connection [Uppal, 1984, 914]. Choosing a neutral resistor value in this way will ensure that overvoltages are limited to values safe enough to be handled by all equipment and switchgear on the network.

When the neutral resistor value is increased to such an extent that the lagging current component, $I_{\text{inductive}}$, becomes less than the resultant capacitive line charging currents of the two healthy phases, the network will behave similar to an unearthed network.

With the resistance earthed neutral network the phase-to-earth voltages of the healthy phases will be slightly more than the phase-to-earth voltages, during an earth fault, for a similar fault condition on a solidly earthed network [Uppal, 1984, 914].

2.3.1. Low Resistance Earthing

Low resistance earthing of a system results in earth fault currents in a typical range of 25 to 2000 A, or higher [Glover, 1978 or later, D4]. A typical earthing resistor current limiting range of 50 to 800 A is specified by Lehtonen & Hakola [1996, 22].

In order for the resistor to provide adequate limitation of transient overvoltages, the magnitude of the earth fault current must be at least equal to the capacitive reactive current of one phase conductor to earth [Glover, 1978 or later, D4]. Any earth fault current higher than the capacitive reactive current will limit overvoltages satisfactorily.

The protection scheme is optimized by selecting a fault current low enough to minimize fault damage, but still allow earth fault protection to operate fast [Glover, 1978 or later, D4]. Fast clearance of faults limit fault damage, provide improved safety to personnel, prevent earth faults from developing into phase-to-phase faults and it limits overheating and mechanical stress, associated with high fault currents [Glover, 1978 or later, D4].

2.3.1.1. Direct Connection to Neutral

The standard connection for low resistance earthing is by direct connection of a transformer neutral through a resistor to earth. The network's neutral point will be displaced by the magnitude of the voltage drop across the neutral resistor during earth fault conditions, but maximum displacement will be by the full normal phase-to-neutral voltage.

2.3.1.2. Earthing Transformers and Resistors

In a delta connected system an artificial neutral point will have to be created by means of an earthing transformer. The earthing transformer is also known as a neutral earth compensator (NEC) and when a resistor is added between the NEC's neutral connection and earth it is called an NECR. An NECR typically limits the earth fault current to within the range of 25 to 400 A [Glover, 1978 or later, D4].

2.3.2. High Resistance Earthing

High resistance earthing may be used as an alternative to unearthed networks due to the earthing resistor limiting the potential transient overvoltages during arcing earth faults.

High resistance earthing is typically used in MV and LV industrial networks where continuity of supply is important [Lehtonen & Hakola, 1996, 21].

High resistance earthing is defined as the insertion of nearly the highest permissible resistance into an earth connection such that $R_0 \leq X_{c0}/3$, where R_0 is the zero sequence resistance ($R_0 = 3 \times \text{neutral resistance, } R$), and X_{c0} is the capacitive reactance between a phase and earth [Glover, 1978 or later, D4].

For high resistance earthing the neutral resistor is selected such that the fault current is limited to slightly more than the phase-to-earth capacitance current, and typically not more than 10 A [Glover, 1978 or later, D4].

The fault current in a high resistance earthed network is typically low enough to permit continued operation while the fault is being located and a shutdown scheduled to effect repairs [Glover, 1978 or later, D4]. The application of high resistance earthing to an ungrounded system will greatly enhance the network operation [Glover, 1978 or later, D4].

2.3.2.1. Direct Connection to Neutral

When a system neutral is available the resistor is connected as explained in 2.3.1.1 above.

2.3.2.2. Single Phase Transformers and Loading Resistor

With this earthing option the primary winding of a single phase distribution transformer is connected in series between the system neutral and earth. The secondary winding of the transformer is loaded with a resistor, which is sized to typically permit an earth fault current of between 2 and 10 A to flow in the primary winding [Glover, 1978 or later, D5].

2.3.2.3. Zig-Zag Earthing Transformer and Resistor

In South Africa the zig-zag transformer with internal current limiting resistor is commonly known as a neutral earth compensator (NECR). These transformers are used on the delta connected medium voltage (secondary) windings of power transformers to provide an artificial neutral point for earth fault detection purposes.

The NECs usually have a short time rating of about 10 s to 1 minute for which it can carry rated earth fault current [Glover, 1978 or later, D5]. The earth fault current limiting resistor is connected between the NEC neutral and earth, and the resistor is sized to permit low fault currents of typically 5 A in the USA [Glover, 1978 or later, D5].

The South African utility, Eskom, currently employ the practice of resistance earthing all MV networks. The MV networks are mainly rated at 11 kV and 22 kV. As a norm the MV overhead networks are 3-wire delta with NECRs providing the MV neutrals and limiting the earth fault currents to 350 A per NECR for overhead lines, and 960 A for MV cable networks.

These NECRs are equipped with two protection current transformers (CTs), one for power transformer MV restricted earth fault protection and one for the transformer MV earth fault protection, which is coordinated with the MV feeder earth fault protection.

The advantage of a NECR, apart from providing a physical neutral point to be earthed, is that it limits the earth fault current to an acceptably low level, thus preventing fault point and power network equipment damage during an earth fault. Without the neutral resistor, earth

fault currents may reach higher magnitudes than the 3-phase fault level due to the low resistance earth return path of the fault current.

2.3.2.4. Star-Earthed-Open Delta Transformer and Resistor

A transformer with a star connected primary and an open delta secondary winding loaded with a resistor may be used to provide an artificial neutral to an unearthed network. See Figure 11. Under normal conditions the star/delta transformer presents a high impedance to the three phase system, and consequently draws very little magnetizing current [Glover, 1978 or later, D6]. Under an earth fault condition the loading resistor limits the current in the delta secondary, which then in turn limits the primary earth fault current. Low fault currents are attained by appropriately sizing the loading resistor [Glover, 1978 or later, D6].

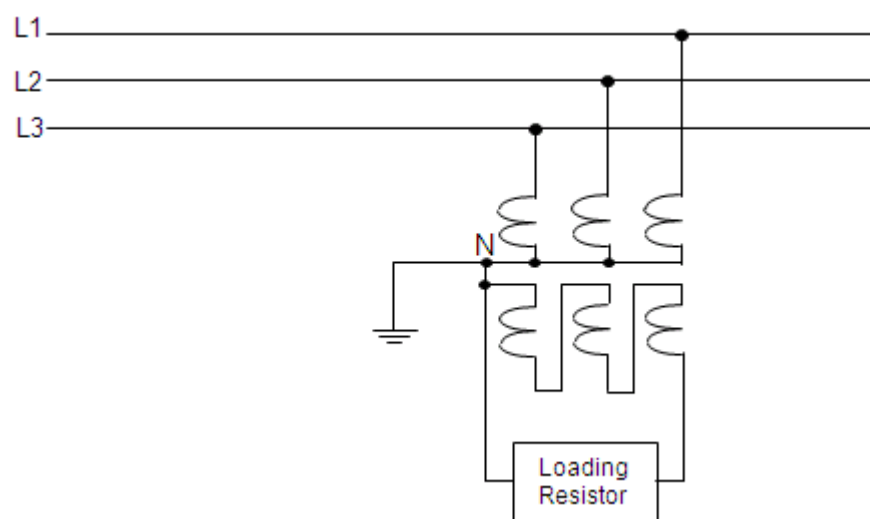

Figure 11: Star-Earthed-Open Delta Transformer and Resistor.

2.3.3. Advantages and Disadvantages of Resistance Earthed Networks

Advantages

- The main benefit of high resistance earthing is that an earth fault does not cause a system outage if the earthing resistor is chosen such as to allow the flow of only a small earth fault current. If the earthing resistor is chosen such that its current is higher than the system capacitive earth fault current, potential transient overvoltages are limited to 2.5 times the normal peak phase-to-earth voltage. [Lethonen & Hakola, 1996, 21].
- Low resistance earthing is typically used in large MV networks where the capacitive earth fault current is too high to only alarm an earth fault condition [Lethonen & Hakola, 1996, 21]. In such systems immediate tripping is required in order to prevent arcing faults.
- Resistance earthing reduces potential overvoltages on the system neutral and the two healthy phases, which are prevalent in unearthed networks, by limiting the fault current

magnitude to a value in the order of normal load current, or less. As a result of the low earth fault current, equipment damage and fault point damage is kept to a minimum.

- The highest neutral overvoltage in high resistance earthed networks is equal to the normal phase-to-earth voltage, and is attained when the fault resistance is zero [Lethonen & Hakola, 1996, 21].
- Power frequency overvoltages are usually smaller for low resistance earthed than for high resistance earthed networks [Lethonen & Hakola, 1996, 22].
- Simple protection, in comparison to unearthed neutral networks, may be used in low and high resistance earthed networks.
- Intermittent overvoltages cannot occur on a low resistance earthed network, thus reducing the chances of double phase-to-earth faults [Cucic, 2008 ,84].
- Overvoltages on a low resistance earthed network is lower than on an unearthed network [Cucic, 2008 ,84].

Disadvantages

- Resistance earthing is more expensive than both unearthed and solidly earthing methods due to the additional cost of the neutral resistor for a star connected network, or a neutral earth compensator with neutral resistor (NECR) in the case of delta network configuration, additional substation space occupied by the resistor or NECR, commissioning expenses and maintenance expenses.
- Additionally, a resistance earthed network needs to be fully insulated for phase-to-phase voltage-to-earth as the neutral may rise to rated phase-to-neutral voltage during an earth fault. For this reason only fully insulated power transformers may be employed on resistance earthed transformers. Fully insulated transformers are more expensive than graded insulation transformers. At this point it should be noted that graded insulation is normally only used on HV or higher voltage levels as this is where significant cost savings may be had as a result of using graded insulation.
- Every earth fault, transient or bolted, on a low resistance earthed network will result in disconnection of the affected feeder from the source [Cucic, 2008 ,84].
- The larger fault currents on a low resistance earthed networks may lead to high step and touch potentials within the substation during earth fault conditions, and therefore special care needs to be taken when designing earth electrodes/earth mats in areas of high soil resistivity. Lower earth mat resistance also comes at additional expense due to the requirement for a larger copper earth mat.

2.4. Impedance Earthed MV Networks

Impedance earthed (or resonant grounded as known in the USA) networks are normally employed where it is desirable to limit the earth fault current to a very low level in order to continue operating the network with an earth fault present on the network, without affecting customer supply. In such a system the capacitive current is tuned or neutralized by a neutral reactor, known as a Petersen coil.

The efficacy of the Petersen coil is theoretically independent of voltage, but in practice it is most effective and useful on relatively low voltage lines, say below 33 kV. For voltages of the order of 132 kV and above there is a good economic case for direct neutral earthing. Very high voltage lines are almost immune from faults, even without Petersen coils, and it seems rather difficult to justify their adoption in such cases [Marshall, 1930, 399].

The current rating of a Petersen coil is determined by the network charging current due to phase-to-earth capacitance. The coil is designed to pass an inductive reactive current which is equal in magnitude to the network charging current in the two healthy phase conductors when the third phase conductor is earthed and the system neutral is raised to normal phase-to-neutral voltage above earth potential [Hunter, 1937, 13].

Almost 90% of German MV networks are resonant earthed and Austria, Switzerland, Scandinavia and Eastern European countries have a long history with positive experiences of resonant earthing. France and Italy also changed their neutral earthing philosophy to that of resonant earthing to improve power system quality [Pühringer, 2003, 1].

The Petersen coil was first proposed by Professor W. Petersen of Germany during 1917 (German patent number 304 823) [Hunter, 1938, 12].

The exact location of a Petersen coil on a network is immaterial from a proper functioning of the coil point of view. It is however desirable, from an operating point of view, to have it in a centrally located position so that network switching operations will not separate the coil from the rest of the network.

According to Hunter [1938, 14] it is usually uneconomical to apply Petersen coil earthing to lines having less than 5 A charging currents.

The Petersen coil is simply a tapped reactor installed between a transformer neutral and earth. When one of the network phases is earthed, a lagging reactive current flows from earth, through the reactor, via the transformer to the fault and then to earth. At the same time a leading current flows from the phase-to-earth via the phase-to-earth capacitances. The actual current flowing at the fault point is very small as the leading capacitive current from the phase-to-earth capacitances, and the lagging reactive current from the reactor are practically 180° out of phase and therefore subtract from each other. See Figure 12. The two currents can be made almost exactly equal by tuning the reactor by selecting the correct tap.

Tuning of a Petersen coil is not critical. On medium voltage networks different network sections may be switched out up about 25 to 30% of the total network length, and still obtain successful arc extinction without retuning for the new network conditions Hunter [1938, 14].

Tuning of a Petersen coil is either achieved through manual off-load tap adjustment on the coil to change the inductance thereof, or automatically by on-load adjustment of the Petersen coil's magnetic circuit's reluctance in order to cancel out the network capacitive current component flowing to earth during an earth fault as closely as practically possible.

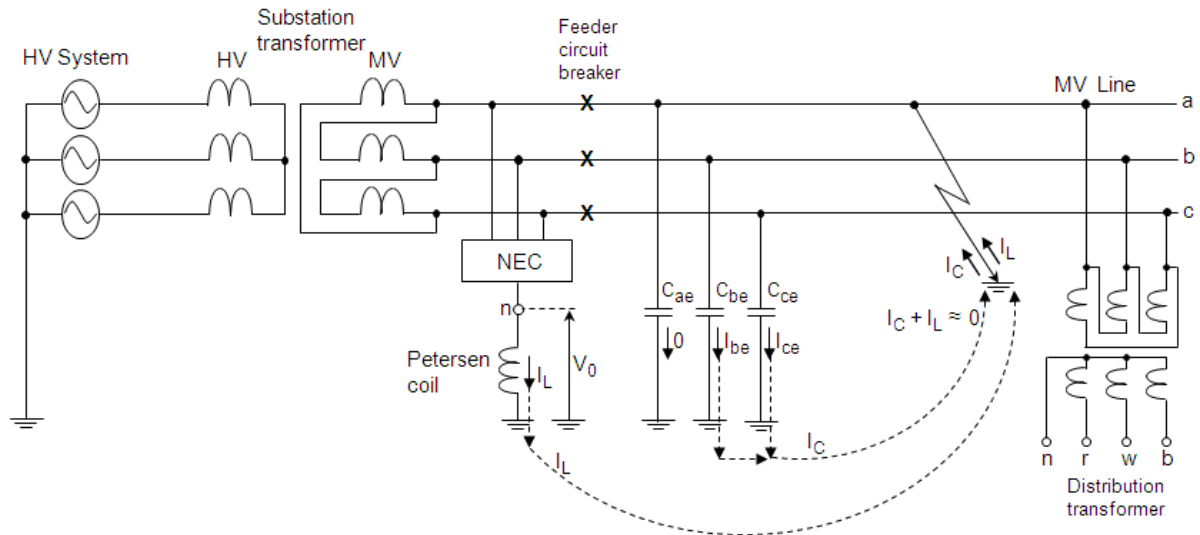

Figure 12: The Operating Principle of a Petersen Coil Earthed Network.

In the case of automatic Petersen coil adjustment the magnetic circuit reluctance is changed by altering the position of a plunger core inside the coil winding. The plunger core basically consist of two halves which are moved further apart or closer together, thereby altering the size of the air gap between them. The larger the air gap the larger the magnetic circuit's reluctance [Papp, 1992, 3]. This increase in reluctance is due to air having a larger relative permeability than a magnetic material. A larger permeability increases the Petersen coil inductance, resulting in a lower inductive coil current for a given driving voltage.

$$\text{Inductance, } L = \mu_r \mu_0 N^2 (A/l) \quad [\text{H}]$$

μ_r is the relative permeability of the magnetic circuit, $\mu_r = 1$ for air.

μ_0 is the permeability of free space and is equal to $4\pi \times 10^{-7}$.

N is the number of coil windings.

A is the magnetic circuit's cross-sectional area in m^2 .

l is the length of the magnetic circuit in ampere in metre.

As may be seen from the equations above and below, an increase in μ_r will result in a larger coil inductance, which in turn produces a larger inductive reactance, and therefore reduces the inductive current for a given voltage.

$$\text{Inductive reactance, } X_L = 2 \pi f L$$

$$\text{Inductive reactive current, } I_L = V / X_L$$

L is the coil inductance in henry.

V is the applied voltage across the coil in volt.

f is the power system frequency hertz.

When the reactor is correctly tuned the fault current is so small that the arc at the fault point cannot be maintained so that the arc is extinguished. A typical impedance earthed star connected MV network is shown in Figure 13.

For a permanent earth fault the network may be operated as per normal without opening the faulted feeder's circuit breaker. This allows field personnel to locate the fault and rectify the problem with the minimum supply outage time to the customers.

According to Pühringer [2003, 4] utilities in Germany and Austria are allowed to continue network operation under a permanent earth fault condition for as long as necessary in order to do fault location and effect repairs.

Application of Petersen coils in networks with more than 1.5% zero sequence voltage may result in a neutral voltage of 10 to 15 times the original zero sequence voltage [Westinghouse, 1944, 462]. This is due to a series resonant zero sequence circuit being formed by the reactance of the Petersen coil, the capacitive reactance of the line and the zero sequence voltage (network's neutral displacement voltage). In order to reduce the neutral-to-earth voltage under normal operating conditions it is necessary to transpose the phase conductors of the lines. This has a significant effect on the phase-to-earth capacitance imbalance on HV and higher voltage lines, but to a much lesser extent on MV lines due to their smaller line constructions, and usually much shorter lengths.

As with the unearthed network the phase-to-earth voltages of the healthy phases during an earth fault will increase by a factor of $\sqrt{3}$ times the normal phase-to-neutral voltage, and the magnitude of the resultant capacitive current will be three times the normal line charging current of one phase (i.e. the capacitive current to earth due to the phase-to-earth capacitance of one phase) [Uppal, 1984, 915]. This is illustrated in Figure 14 a). The residual capacitive current and reactor current, I_{Reactor} , will respectively lead and lag the faulty phase-to-neutral voltage by nearly 90° (circuit resistance and inductance will cause the angle to be slightly less than 90°).

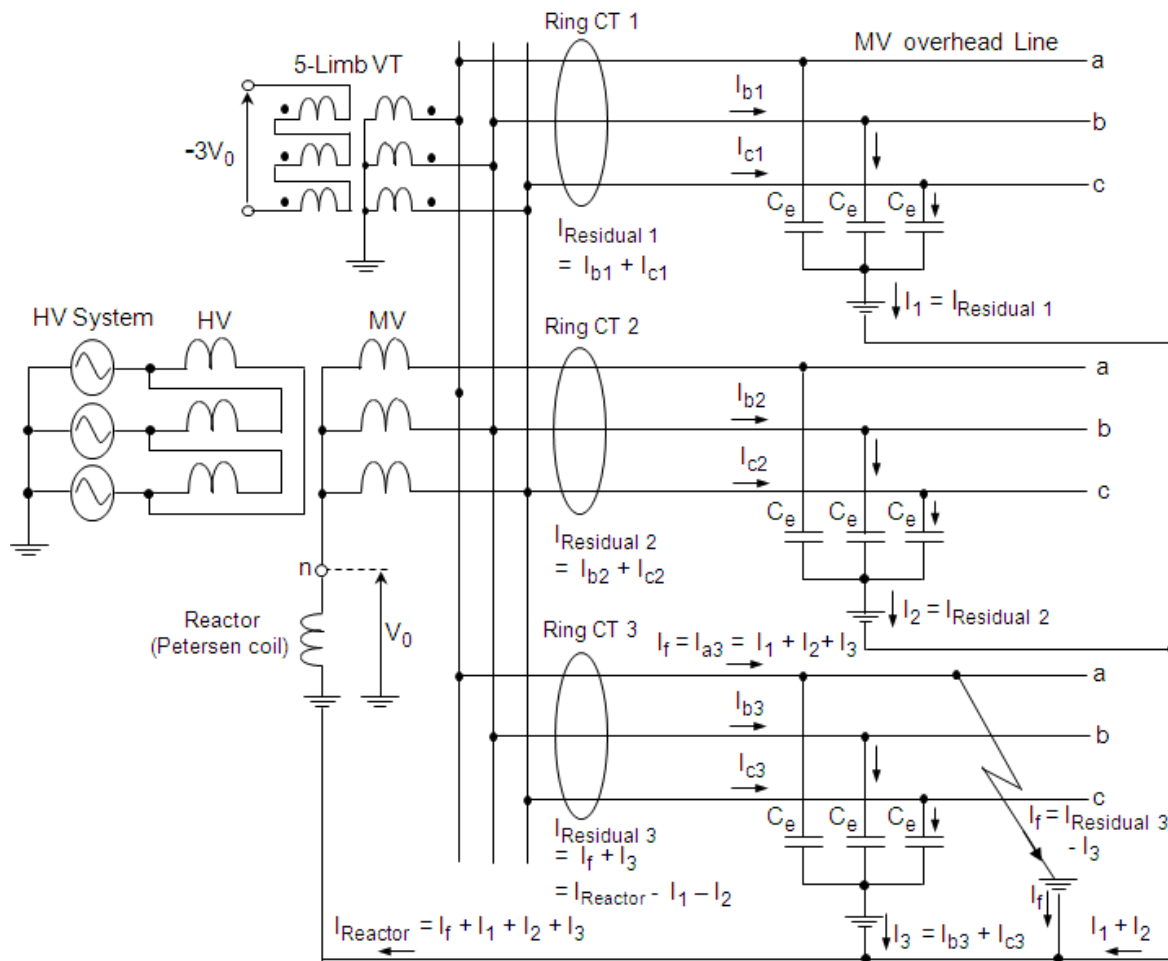

Figure 13: A typical Petersen coil (impedance earthed) star connected MV network.

On each of the two healthy feeders the vector sum (resultant) of the imbalanced line currents is provided by a core balanced CT (ring type CT). The resultant currents of the three feeders lag the residual voltage ($-3V_0$) vector by 90° as depicted in Figure 14 a) and b).

With reference to Figure 13 the residual current in the faulted feeder is:

$$I_{\text{Residual 3}} = I_f + I_3$$

$$I_f = I_{\text{Residual 3}} - I_3$$

$$I_{\text{Reactor}} = I_f + I_3 + I_1 + I_2$$

Substitute for I_f , thus

$$I_{\text{Reactor}} = (I_{\text{Residual 3}} - I_3) + I_3 + I_1 + I_2$$

$$I_{\text{Reactor}} = I_{\text{Residual 3}} + I_1 + I_2$$

$$I_{\text{Residual 3}} = I_{\text{Reactor}} - I_1 - I_2$$

From the above derivation it may be seen that the fault current, I_f , is equal to zero when the vector sum of the capacitive-to-earth currents ($I_1 + I_2 + I_3$) is equal to the reactor current,

I_{Reactor} . This then shows that by adjusting the Petersen coil through changing of taps (manually or automatically), the earth fault current may be made very small.

The voltage and b- and c-phase, phase-to-earth capacitive current vectors (I_{be} and I_{ce}) of the two healthy feeders depicted in Figure 13 is shown in Figure 14 a), and the faulty feeder's residual current, $I_{\text{Residual } 3}$, zero sequence voltage, $3V_0$, and reactor current, I_{Reactor} , vectors for an a-phase earth fault are indicated in Figure 14 b).

Currents I_{be} and I_{ce} represent the b-phase and c-phase capacitive currents to earth, respectively, for each of feeders 1, 2 and 3 **during an a-phase earth fault**.

The fault currents, I_{be} and I_{ce} , are respectively equal to $\sqrt{3} \cdot I_b$ and $\sqrt{3} \cdot I_c$ due to the healthy phases' voltage rising by a factor of $\sqrt{3}$, i.e. to full phase-to-phase voltage.

Currents I_b and I_c represent the **normal** b-phase and c-phase capacitive currents to earth, respectively, for each of feeders 1, 2 and 3.

Currents I_1 , I_2 and I_3 represent the vector sums of capacitive currents I_{be} and I_{ce} , respectively, for each of feeders 1, 2 and 3 **during an a-phase earth fault**.

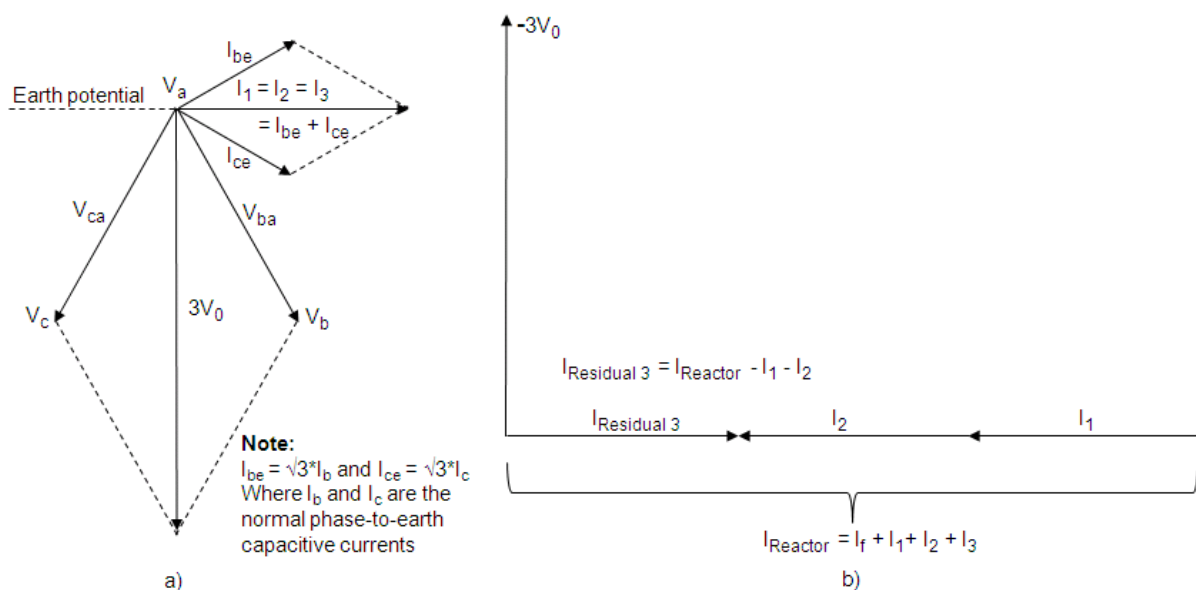

Figure 14: Voltage and current vector diagrams for an a-phase-to-earth fault, a) residual voltage and current vectors of the healthy feeders feeding from the same busbar as the faulty feeder, and b) the reactor current, I_{Reactor} , the resultant capacitive current vectors of the two healthy feeders, and the faulty feeder residual current, $I_{\text{Residual } 3}$.

Where Petersen coils rated for continuous operation during earth fault conditions are employed, cognisance should be taken of standards governing the maximum allowable step and touch potentials, as represented in Figure 15, to which such a network has to conform to [Fickert, 2009, 1].

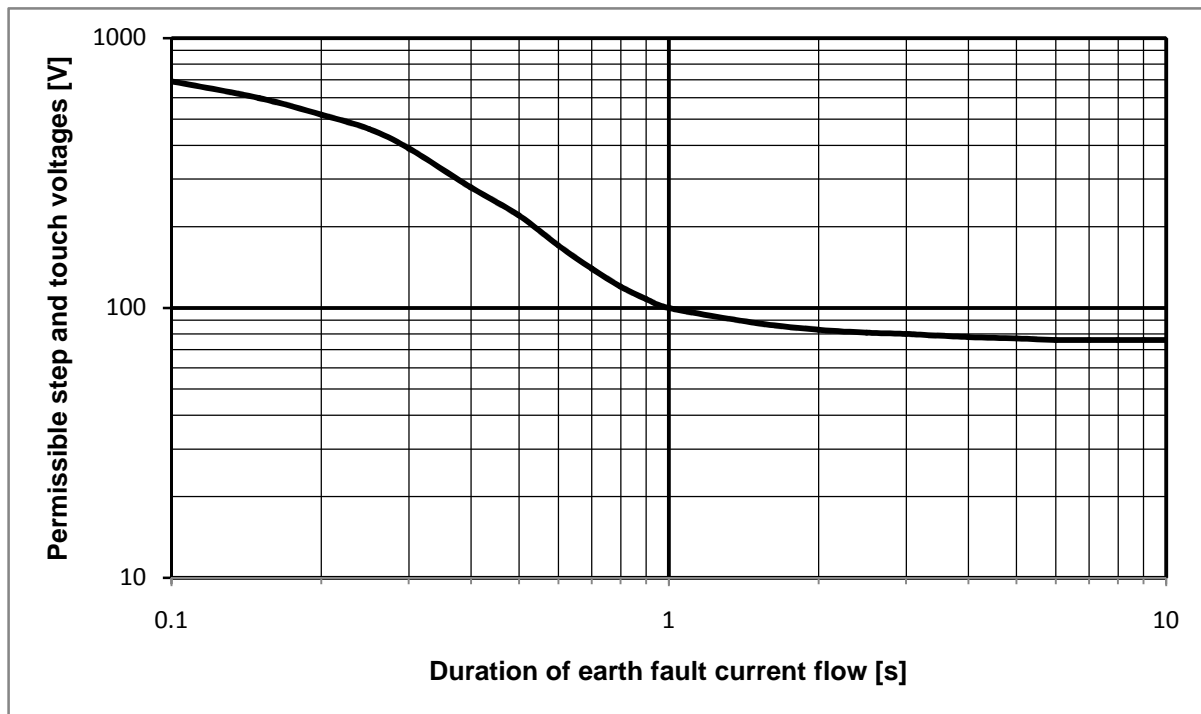

Figure 15: Permissible step and touch voltages [Fickert et al, 2009, 1].

2.4.1. Advantages and Disadvantages of an Impedance Earthed Network

Advantages

- A major advantage of an impedance earthed network is that an adequately rated Petersen coil is able to continuously carry fault current during an earth fault condition. The network may then continue operating normally with one earth fault (one phase earthed), until such time as the fault may be repaired, just as in the case of the unearthed network. This ensures high power supply quality as earth faults constitute 50% to 80% of all MV network faults [Dán et al, 2003 or later, 1; Erroa et al, 2006, 3; Hänninen, 2001, 13; Heine et al, 2004, 100; Nelson, 2002, 1, and Smeets & Knol, 2009, 3].
- A Petersen coil installation will prevent most arcing earth faults according to a study done by Lehtonen et al [2001, 1185], due to the very low capacitive fault current as a result of the reactive coil current mostly cancelling the capacitive fault current, and thereby reducing the number of overvoltage incidents caused by arcing earth faults, as experienced on some unearthed networks.
- Due to the low earth fault current present (mostly resistive) in a Petersen coil earthed system self extinguishing of transient earth faults may be achieved, thus preventing line disconnections in such instances.
- The rate of rise of the recovery voltage across the spark gap is slower after an arc has self-extinguished, than in an unearthed network. This is due to the Petersen coil delaying the return of full voltage across the arc path (recovery voltage) after the first extinction of the arc, and this gives the spark gap time to become de-ionized and

prevents re-striking [Sumner, 1946, 285]. This has the advantage that arc self-extinguishing can take place at higher earth fault current levels, as compared with an unearthed network. The chances are therefore small that an earth fault may develop into a phase-to-phase fault.

- Optimally tuned Petersen coils will result in low earth fault currents, which reduces the risk of high step and touch potentials in substations.
- Petersen coils are successfully applied to both MV and HV power systems. In Germany the highest voltage level compensated network is running at 220 kV [Lehtonen & Hakola, 1996, 19].

Disadvantages

- When Petersen coils are applied to MV or HV networks it is required that the entire network be fully insulated to withstand full phase-to-phase voltage-to-earth [ABB, 1994, 97], as the transformers' neutral voltages may rise to full normal phase-to-neutral voltage-to-earth, and the healthy phases may rise to full normal phase-to-phase voltage-to-earth during an earth fault.
- Petersen coil earthing is not suitable for application to systems with auto-transformers or where graded insulation is used on transformers, as graded insulation requires that transformer neutrals be solidly earthed. This implies that all star (wye) connected transformers on a compensated network be fully insulated for full phase-to-phase voltage [ABB, 1994, 97].
- Operation of compensated networks is more onerous as the Petersen coil requires re-tuning every time significant changes are made to a network [ABB, 1994, 97 & Lehtonen & Hakola, 1996, 19]. This problem may be overcome by implementing automated coil tuning [Lehtonen & Hakola, 1996, 19], alas at added cost.
- With Petersen coil earthed systems a high incidence of faults will occur essentially simultaneously in different parts of the network [ABB, 1994, 97]. This has not been substantiated in the reference literature.
- If a substantial number of lines are of wood pole construction the effectiveness of the Petersen coil earthed network may be reduced considerably. This is due to the high insulation to earth that will force a larger number of potential earth faults to develop into phase-to-phase faults [ABB, 1994, 97]. As Eskom's MV lines are mostly of wood pole construction, the previous statement implies that converting the current resistive earthed networks into compensated networks may pose the risk of increased phase-to-phase faults on such networks.
- Petersen coil earthing may prove more expensive than unearthed, solidly earthed and resistance earthing.
- Petersen coil earthed systems have a poor sensitivity to high resistance earth faults and may therefore require more sophisticated protection [Cucic, 2008, 87].

2.5. Discussion of issues influenced by different network earthing methods

This section discusses three issues, namely the effect of arcing earth faults, application of surge arresters and protection, which are common to all network types, irrespective of the earthing method.

2.5.1. Arcing Earth faults

Unearthed Networks

According to literature [ABB, 1994, 96; Allen & Waldorf, 1945, 304; Bridger, 1983, 15; Eaton et al, 1931, 1476; Eaton Power, 2009, 6; Glover, 1978 or later, D-1; Hänninen, 2001, 13; Nelson, 2002, 1638; Uppal, 1984, 910] arcing earth faults, or otherwise known as arcing grounds, may result in fast developing very high phase-to-earth voltages. Overvoltages of six times the normal phase-to-neutral voltage are theoretically attainable within 1.5 cycles of the fundamental frequency.

Eaton et al [1931, 1478] found the maximum overvoltages due to arcing earth faults on a 75 kV unearthed network to be not more than 3 times the normal phase-to-earth system voltage.

From earth fault statistics of a 20 kV unearthed network Lehtonen et al [2001, 1186] determined that the maximum overvoltages due to arcing earth faults to be about 2 times the normal phase-to-earth system voltage.

Through test conducted on a 140 kV unearthed network, North & Eaton [1933, 70] determined the maximum overvoltage due to arcing earth faults to be 3.5 times the normal phase-to-earth system voltage. It was further also found that the maximum overvoltage due to solid earth faults was 3.2 times the normal phase-to-earth system voltage.

In order to explain the rapid development of overvoltages due to an arcing earth fault, an explanation by Eaton Power [2009, 6], using a phasor diagram, is depicted in Figure 16.

Point 1 in Figure 16 represents a normal balanced phasor diagram without an earth fault. The phase rotation is anti-clockwise and the system frequency is 50 Hz (or 60 Hz in some countries).

If the a-phase is now earthed the phasor diagram will appear as at point 2. Earthing the a-phase causes the neutral point, n, to rise to the normal phase-to-neutral voltage, V_{l-n} , with respect to earth. If we assume now that the applied earth fault is not solid, but intermittent, it will result in arcing taking place at the fault point. Arcing is as a result of the line charging current (or that of the whole system if there is more than one line) of the a-phase previously flowing through the earth connection, but now discharging through an air gap of the intermittent earth fault. By definition the arc must extinguish at the next current zero, since there will be zero current flowing at that point.

As the fault current is capacitive it leads the voltage by 90°, and therefore the voltage across the phase-to-earth capacitance of the a-phase will be at a maximum when the arc extinguishes at the current zero crossing. The literature has it that as a result of the

extinguished arc there will be no current flowing to charge or discharge the phase-to-earth capacitor and as a result the voltage across the phase-to-earth capacitor remains at whatever value it has been charged to prior to the arc being extinguished [Eaton Power, 2009, 5], (This is assumed to be an assumption as a practical circuit is more complex and will always have stray capacitive coupling with the live conductors that will charge or discharge the phase-to-earth capacitance). This then establishes a new, higher, neutral-to-earth voltage reference point in the phasor diagram.

As the phasors continue to rotate in an anti-clockwise direction the a-phase phasor would have spun 180° in one half cycle. At this point the a-phase-to-earth potential is double the normal phase-to-earth potential as indicated at point 3.

If the voltage across the a-phase capacitance to earth is high enough to cause a restrike of the fault, the line capacitance is rapidly discharged through the arc to earth. Due to the capacitive discharge taking place through the phase inductance being in the opposite direction to the normal capacitive charging current, the voltage across the inductance will be inverted. This then has the effect that the voltage phasors will drop to a value equal to the negative of the previous value. See phasor diagram at point 4.

From the phasor diagram at point 4 it may be seen that, although the a-phase voltage simply changes from a positive to a negative value, the neutral-to-earth voltage actually increases from 1 to 3 times the normal phase-to-neutral voltage.

From point 4 to point 5 the phasors rotate by 180° , resulting in the a-phase-to-earth voltage to now being 4 times the normal phase-to-neutral voltage.

This higher voltage may again lead to a restrike with the process repeating itself, moving the neutral-to-earth voltage yet higher again. Theoretically this process of increased voltage-to-earth after every restrike may carry on indefinitely, but in practice some insulation will eventually break down to cause a permanent earth fault resulting in the overvoltages being ceased.

During 1998 and 1999 Lehtonen et al [2001, 1185] conducted a study on 20 kV unearthed overhead networks in Finland, and through analysis of 316 earth fault events, found that 67 % of all disturbances on the unearthed networks were arcing faults and the average duration of arcing current was approximately 60 ms, as compared to 28 % of all disturbances on, and arcing duration of 30 ms for a compensated network (Petersen coil).

During the same study the maximum measured residual current at which auto extinction of an earth fault took place was 9.5 A, compared to 23.8 A in the impedance earthed (Petersen coil) network. Lehtonen et al [2001, 1185] furthermore found that half the disturbances on the unearthed network were arcing faults, which could lead to overvoltages higher than double the normal phase-to-earth voltage.

According to Pühringer [2003, 2] German standards, dictating the operating of unearthed networks, prescribes a maximum phase-to-earth current of 35 A for system voltages below 20 kV in order to allow for reliable self-extinction of arcing earth faults.

As a result of an increase in phase-to-earth capacitance with increase in line length, and consequential increase in capacitive earth fault current, the lower the chances of self-extinction of arcing earth faults.

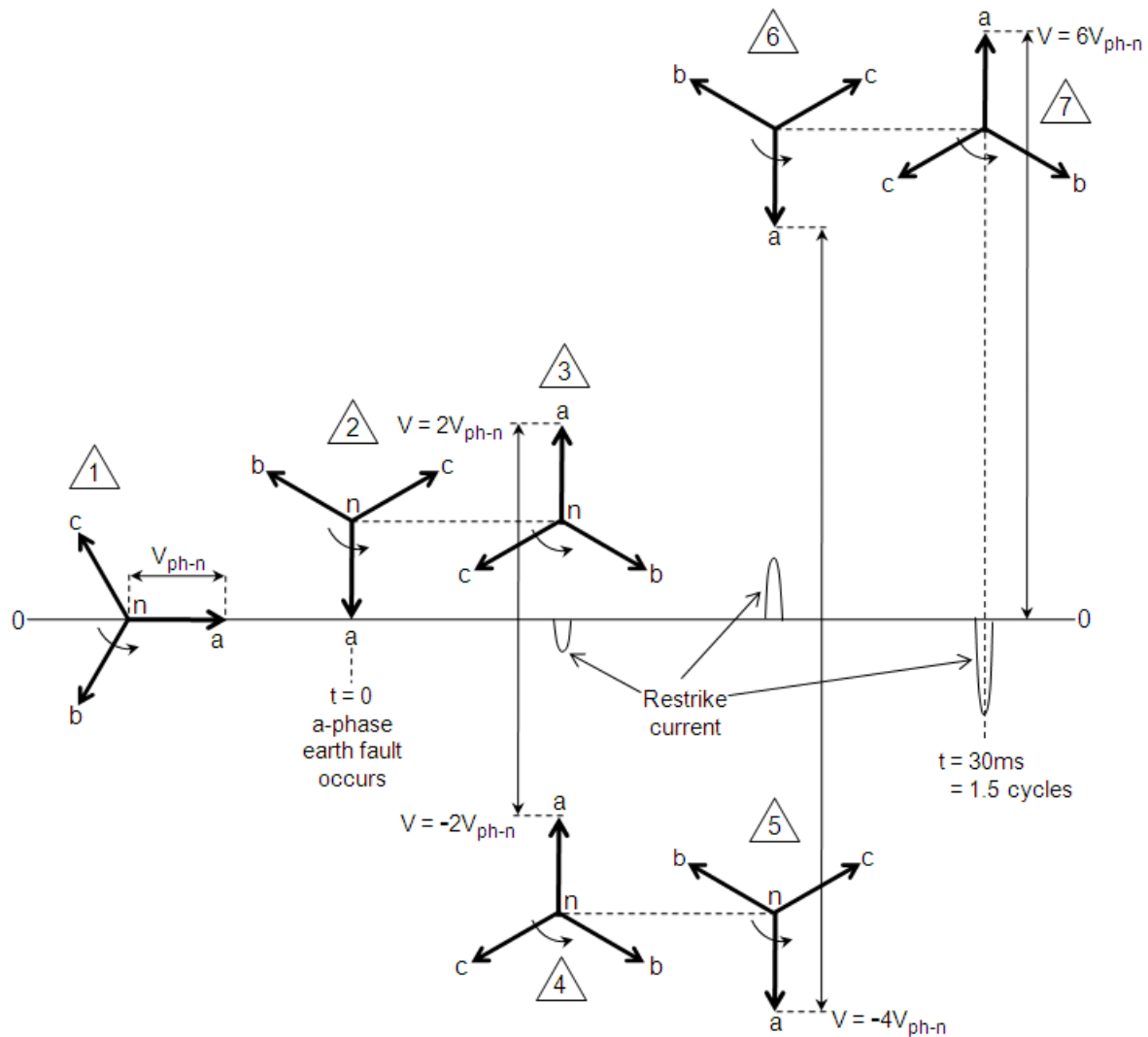

Figure 16: Pictorial representation of the development of overvoltages between the phases and earth due to arcing earth faults in unearthened networks.

An *arcing ground* study, conducted by Allen and Waldorf [1946, 305] on an unearthened 13 kV power station busbar, revealed the following information, some of which may be considered when designing the proposed transient earth fault clearing method:

1. Arcing grounds on the tested station bus did not produce voltages to earth exceeding three times the normal crest phase-to-neutral voltage. Higher overvoltages did not materialize even though conditions in some of the tests were probably as severe as any likely to occur under operating conditions. The highest overvoltages occurred during tests conducted with self-lengthening spark gaps, as compared with fixed length spark gaps.

2. The highest overvoltage measured on the two healthy phases was 3 times the peak phase-to-earth voltage.
3. The maximum voltages to earth on the unfaulted phases are not equal under most arcing ground conditions.
4. *Arcing grounds* occur sometimes on only one polarity of voltage.
5. The tests revealed arcing transients which raise the phase-to-phase voltages as high as 1,73 times normal. The frequency of these transients was found to be as high as 6780 Hz. Transients of this character may cause abnormal voltage stresses on the turn insulation of machines. In the author's opinion this statement applies equally well to transformer winding insulation.
6. Insulation on unearthed networks should be able to withstand phase-to-earth voltages in excess of three times the normal phase-to-neutral voltage.

Experimental studies of *arcing ground* faults on a 214 km unearthed 75 kV line, conducted by Eaton et al [1931, 1475 - 1478], revealed the following information:

1. The maximum overvoltage is approximately 3 times the normal peak phase-to-neutral voltage, and occurs most frequently during the first cycle of the fault.
2. From fault inception the healthy phase voltages change from normal phase-to-earth, to phase-to-phase voltage with respect to earth without going through an oscillation of appreciable amplitude. A DC transient is present for several cycles and shifts the zero of the normal frequency wave, and in some cases a third harmonic was present on the overvoltage waveform.
3. As the length of the isolated system was increased, there was a gradual increase in the overvoltages magnitudes on the sound phases attained during *arcing ground* faults.
4. The fault location on the line (middle or end of line) did not affect the attained overvoltages magnitudes on the sound phases.
5. The type of transformer connections (star or delta) had no effect on attained overvoltages magnitudes on the sound phases.
6. The method of initiating an arc (fuse, swinging wire, etc) had no effect on the attained overvoltages magnitudes on the sound phases.
7. An arc to a high resistance earth (e.g. a brushing tree branch) limits the shift of the system neutral and hence tends to reduce the magnitude of overvoltages produced.
8. It was concluded from the tests that an arc to a low resistance earth, which allows maximum fault current to flow when the arc resistance is low, is more conducive to overvoltages on the sound phases than one to a high resistance earth.
9. Tests carried out with the system neutral solidly earthed resulted in overvoltages on the sound phases of between 1.6 and 2.2 times the normal phase-to-neutral voltages. These are somewhat less than the maximum values attained with the system neutral unearthed.

Subsequent to the tests performed by Eaton et al [1931, 1478] on an unearthed 75 kV line, recorders on a 1072 km unearthed 140 kV line captured oscillographs of 18 earth faults and the highest overvoltages recorded during these faults varied between 1.2 and 2.6 times the normal peak phase-to-neutral voltage. The duration of the faults varied from 4 to 112 cycles. In most of these oscillograms evidence of arcing were observed in several cycles just prior to clearance of the fault, but in no case did cumulative oscillations appear in the voltage during the fault [Eaton et al 1931, 1478].

The above overvoltage test results from the 13 kV power station busbar tests, 214 km 75 kV line tests and the 1072 km 140 kV line test, all of them unearthed systems, show very similar maximum overvoltage magnitudes. The first two networks delivered maximum overvoltages of 3 times normal peak phase-to-neutral voltage and the 140 kV unearthed network delivered a maximum overvoltage of 2.6 times normal peak phase-to-neutral voltage. Although no reference has been made in the literature [Eaton et al 1931, 1469 - 1478] to the discrepancy between the 3 times and 2.6 times overvoltages, it may be partially attributed to the difference in network structures in terms of the conductor configuration and the conductor height above ground level, and also the lengths of the different lines. These factors all play a role in the capacitance-to-earth and therefore will determine the magnitude of capacitive earth fault current in the event of an earth fault. An increase in the conductor height above ground level will decrease the capacitance-to-earth, and an increase in line length will increase the capacitance-to-earth.

It was found by Eaton et al [1931, 1474] that arcs formed in capacitive circuits are less likely to self-extinguish than those in inductive and resistive circuits. Eaton et al [1931, 1477] also found that there is a gradual increase in overvoltages due to arcing earth faults as the unearthed system length is increased (increase in phase-to-earth capacitance).

Furthermore Eaton et al [1931, 1473] established that after an earth fault arc is extinguished the voltage across the fault point rises to normal phase-to-neutral voltage in resistance and inductive circuits, but rises to approximately twice normal phase-to-neutral in a capacitive circuit. Eaton et al [1931, 1473] contributes the greater persistence of arcing earth faults in capacitive systems to not only the rate of change of the recovery voltage, but also to the maximum value to which the recovery voltage rises. If the recovery voltage increases at a faster rate than what the arcing medium can recover at, the arc will be persistent. The recovery voltage is defined as the voltage developing across the arc gap immediately after arc extinction. During the test conducted by Eaton et al [1931, 1473] arc restriking was observed only in the capacitive circuit.

Allen & Waldorf [1946, 303] conducted an experiment with a self-lengthening spark gap. This is of particular interest as this would closely resemble a transient earth fault where a tree branch, for instance, makes contact with a live conductor and then moves away from it again, drawing an arc as it moves away, until the gap becomes too large for the arc to be sustained. Through the experiment it was established that overvoltages stabilized at 2.8 times normal phase-to-neutral voltage, even with an extended arcing period of 2.25 seconds before the arc self-extinguished.

From the above it therefore seems most likely that each transient earth fault will result in arcing as a fault will be caused by an earthed object getting into contact with live apparatus, which then subsequently moves away again from the live apparatus. In the process of

moving away from the live apparatus an arc will be drawn, which will generate overvoltages, but that these overvoltages will be limited to under 3 times normal peak phase-to-neutral voltage by system losses [Eaton et al, 1931, 1478]. These overvoltages were reached within 3 to 4 power frequency cycles after fault inception. This then implies that even if instantaneous tripping of the faulted feeder's circuit breaker upon fault detection in an unearthed network was implemented, the tripping action (about 60 ms) will most probably not be fast enough to prevent overvoltages on the network in any event.

During the conducted literature study no literature or reference documentation has been encountered relating to deliberate action being taken by protection devices to clear transient earth faults specifically. All earth fault clearing methods thus far encountered either,

- 1) interrupt customer supply by means of single- or three-pole tripping of the affected feeder,
- 2) reduce the fault current to virtually zero by means of a Petersen coil system, or
- 3) only allow the relatively small line charging (capacitive) current to flow due to the system neutral being isolated from earth on a permanent basis.

Solidly Earthed Networks

Arcing earth faults do occur on solidly earthed networks, but do not generate any significant overvoltages as the source transformer's MV neutral is solidly earthed.

Resistance Earthed Networks

Arcing earth faults do occur on both low and high resistance earthed networks, but do not generate any significant overvoltages on low resistance earthed networks due to the low earthing resistance. The lower the resistance the closer the earthing resembles that of a solidly earthed network.

On high resistance earthed networks overvoltages due to arcing earth faults may become more significant as the earthing resistance is increased and the closer it gets to resemble an unearthed network.

Petersen Coil Earthed (Compensated) Networks

In a real network study Lehtonen et al [2001, 1185] found that 28% of all disturbances on a Petersen coil earthed (compensated) network were arcing faults and the average duration of arcing was approximately 30 ms, as compared to 67% of all disturbances on, and arcing duration of 60ms for an unearthed network.

During the same study the maximum measured residual current at which auto extinction of an earth fault on the compensated network took place was 23.8 A, compared to 9.5 A in the unearthed network.

According to Fickert et al [2009, 3] utilities are motivated to keep on operating their resonant earthed networks due to the good quality of supply as a result of the inherent capability of such networks to self-extinguish arcing earth faults, especially on long overhead lines as a result of the large conductor phase-to-earth capacitances.

As a result of resistance losses in the coil, transformers and lines, corona losses and insulator leakage resistance, neither the Petersen coil current nor the capacitive conductor to earth current is exactly 90° out of phase with the faulty phase voltage. This will result in a small residual fault current. A system with low losses will have a small residual fault current. [Sumner, 1946, 284].

The small residual current (assuming a well tuned Petersen coil) in the fault, during an earth fault, is practically in phase with the faulty phase voltage (resistive current), and therefore it will pass through zero at the same instant as the voltage. The arc will therefore be less likely to re-strike than with a capacitive current as in an unearthed system [Sumner, 1946, 284].

From earth fault statistics of a 20 kV Petersen coil earthed network Lehtonen et al [2001, 1186] determined that the maximum overvoltages, due to arcing earth faults, to be about 1.7 times the normal phase-to-neutral system voltage.

Through tests conducted on a 140 kV unearthed network converted to a Petersen coil earthed network, North & Eaton [1933, 70] determined the maximum overvoltage due to arcing earth faults to be 2.2 times the normal phase-to-neutral system voltage, with the Petersen coil installed. It was further also found that the maximum overvoltage due to solid earth faults was 2.7 times the normal phase-to-neutral system voltage. The fact that the maximum overvoltage measured was actually higher for a solid earth fault than for an arcing earth fault is quite surprising, as all the studied literature ascribed high overvoltages to arcing earth faults. No other studied material made mention of this phenomenon.

Lehtonen and Hakola [1996, 64] mentions that it has been estimated that since the introduction of Petersen coils into traditional unearthed Finnish overhead networks, the number of line outages decreased by 70 to 90%.

The above findings suggest then that compensated earthing may be more successfully applied to longer lines (more capacitance = higher capacitive fault current) as auto extinction of arcing earth faults will take place at higher fault current levels in compensated networks, as compared to unearthed networks.

2.5.2. Application of Surge Arresters

General

Distribution transformers in MV networks are typically being protected from overvoltages, due to switching operations, or lightning by either surge arrestors or spark gaps (arcing horns). These devices remove overvoltages quickly and safely, thereby protecting human life and equipment.

MV distribution networks are typically operated radially, with one feeder supplying many distribution transformers, and therefore many customers. It is therefore important not to unnecessarily interrupt the feeder supply.

Although cheap compared to surge arresters, arcing horns have a major drawback in that once a power frequency arc has been established across an arcing horn air gap, it will most

probably not self-extinguish, and will have to be cleared by opening the upstream circuit breaker.

Interruption and re-establishing of supply to a feeder by auto-reclosing the feeder breaker, due to spark gap operations, will not only cause a short duration supply interruption to the customers on the affected line, but may also lead to voltage dips on the adjacent lines due to transformer inrush currents, especially on weak networks (high source/network impedance) and solidly earthed networks (high earth fault currents).

Unearthed Networks

According to Heine et al [2004, 100] the standard practice in Finland is to equip the large transformers with surge arresters and the smaller ones (200 kVA and below) with spark gaps. ESB Networks Ltd in Ireland, for example, applies 12 kV MCOV (maximum continuous overvoltage) surge arresters on their 10 kV unearthed overhead networks.

In the study conducted by Heine et al [2004, 105] on a 20kV unearthed network it was found that if arcing in a spark gap was sustained for longer than 10 cycles, the earth fault will most likely change to a phase-to-phase-to-earth fault. This is inherently a much more severe fault, which may lead to equipment and conductor damage.

Due to its own operation a spark gap may initiate re-striking of arcs across the spark gap as a result of high transient recovery voltages established upon sudden extinguishing of an arc across a spark gap. Heine et al [2004, 105] found that unearthed feeders equipped with spark gaps have 6 times more earth faults than feeders equipped with surge arresters. The same study revealed that feeders equipped with spark gaps have the tendency to develop a high number of phase-to-phase faults, presumably due to high recovery voltages. The modern gapless surge arresters may tend to smoothly conduct high transient voltage spike energy to earth, thereby reducing high recovery voltages to acceptable levels, with a consequential reduction in the possibility of an arc restriking.

With a spark gap equipped network the protection would most probably have to trip the feeder breaker upon detection of an earth fault in order to prevent a phase-to-phase fault as system frequency capacitive current may follow through after the initial flashover, and may not self-extinguish due to the ionized air in the arc path creating a conductive path to earth [Uppal, 1984, 1183; Heine et al, 2004, 100; Freeman, 1969, 253]. This obviously defeats the inherent benefit of an unearthed network, which is to leave the network operating with a permanent earth fault on one phase until such time as the fault may be located and repaired [Alstom, 2002, 140; Westinghouse, 1944, 457; Erroa, 2006,1].

According to Cotton & Barber [1970, 440] operation of a spark gap in an unearthed network may lead to an arcing fault.

Heine et al [2004, 100] states that when a spark gap flashes over, particularly in an unearthed MV network the faulted feeder's circuit breaker needs to be opened in order to clear the fault, as opposed to a network equipped with surge arresters where no opening of a circuit breaker is required..

In order to limit the number of short interruptions in an unearthed network Heine et al [2004, 105] recommends that all transformers be fitted with surge arresters instead of spark gaps

as surge arrester operation is smooth and without any arcing, and therefore do not require feeder breaker operation.

Correctly rated surge arresters are effective in providing protection against overvoltages due to lightning, switching operations, earth faults, and direct and indirect lightning strokes.

Solidly Earthed Networks

Surge arresters applied to solidly earthed networks should have a rating of 80% of rated phase-to-phase voltage [Coopers, 1990, 217], due to the fact that the neutral voltage will never be raised above normal phase-to-neutral voltage during an earth fault.

Resistance Earthed Networks

As the phase-to-earth voltages of the two healthy phase conductors in both low and high resistance earthed networks, during an earth fault, may rise to rated phase-to-phase voltage, due to the neutral being raised to rated phase-to-neutral voltage, surge arresters applied on the network should all be rated for continuous operation at rated phase-to-phase.

As a result of this potential maximum voltage rise during an earth fault, the power transformer neutrals should be insulated to withstand rated phase-to-neutral voltage.

The South Africa utility, Eskom, applies 12 kV MCOV and 24 kV MCOV surge arresters respectively to their low resistance earthed 11 kV and 22 kV networks as standard practice.

Petersen Coil Earthed (Compensated) Networks

As the phase-to-earth voltages of the healthy phases, in a compensated network, may rise to rated phase-to-phase voltage, surge arresters applied on the network should all be rated for continuous operation at rated phase-to-phase voltage.

2.5.3. Protection Issues

Unearthed Networks

Protection of unearthed MV networks against earth faults is easily achieved with directional protection relays. This directional protection will positively identify the faulty phase and feeder, and isolate it if required. The characteristic of a numeric directional earth fault protection relay is shown in Figure 17.

Normal load current is either resistive or inductive, or a combination of the two, but never capacitive. Directional protection may therefore be used on unearthed lines to identify the faulted feeder as such protection utilizes the zero sequence voltage, V_0 , (neutral to earth voltage) as a reference quantity and the zero sequence current, I_0 (residual), of the feeder as an operating quantity if I_0 is above a pre-set threshold level and leading V_0 by a certain minimum angle. The load current therefore does not affect the protection sensitivity, as long as it is not capacitive.

Tripping is initiated when both V_0 and $I_0 \sin \phi$ exceed their respective threshold settings.

The threshold setting for V_0 is determined by the highest expected earth fault resistance, which will result in the lowest V_0 due to the voltage drop across the earth fault resistance.

The threshold setting for $I_0 \sin \phi$ is determined by the smallest possible network to be in operation together with the feeder to be protected (connected to the same busbar). The smaller the total network (smallest capacitance), the smaller the capacitive current to be measured by the relay during an earth fault on the protected feeder and the lower the threshold current setting needs to be [Lehtonen & Hakola, 1996, 87]. The I_0 threshold should therefore be set according to the smallest expected network (smallest capacitance) being connected to the same busbar.

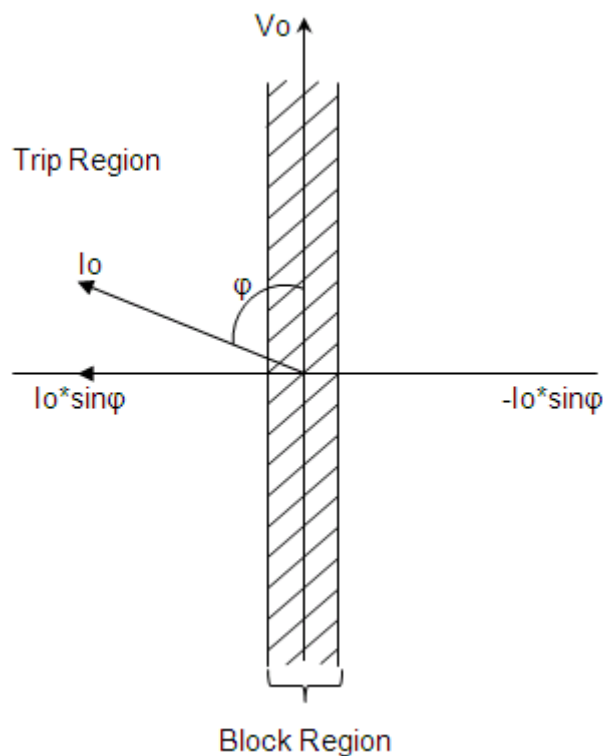

Figure 17: Directional earth fault relay characteristic for an unearthed network [Lehtonen & Hakola, 1996, 87].

In a study conducted by Lehtonen et al [2001, 1182] it was found that the majority of earth faults on an unearthed network disappeared (self-clearing) without any protection intervention. It was also found that one third of the self-clearing earth faults were caused by the operation of disconnectors on the network. Lehtonen et al [2001, 1182] did not provide any explanation as to why operation of the disconnectors caused earth faults. It is, however, plausible that arcing, as a result of breaking of load current when opening a disconnector, may result in an earth fault especially in windy conditions where the arc is blown out to one side towards earthed metal parts of the disconnector.

In the same study by Lehtonen et al [2001, 1182] it was found that high speed auto reclosing with an operating delay of 0.5 s was mostly successful in unearthed networks, but it was also found that the majority of earth faults disappeared without circuit breaker action.

Erroa et al [2006, 16] found that the application of numeric protection to unearthed 46 kV overhead distribution networks made a dramatic improvement in the performance of the networks. This is due to modern numeric protection employed on unearthed networks being able to identify the faulted feeder as well as the faulted phase, a function which older simple protection could not perform. This allows for selective tripping of the faulted feeder without first manually or automatically tripping a number of feeders in order to identify the faulted feeder, as is the (unacceptable) case with older protection. The modern protection therefore has a large positive impact on customer supply quality and also reduces revenue losses [Erroa et al, 2006, 3].

Solidly Earthed Networks

Due to high earth fault currents present in a solidly earthed network during an earth fault, simple overcurrent and directional earth fault protection may be applied.

In solidly earthed networks earth fault currents vary largely depending on the fault location and on fault resistance [Lehtonen & Hakola, 1996, 23].

The maximum earth fault current may in some cases be higher than the 3-phase short circuit current, and therefore require immediate fault clearing.

Resistance Earthed Networks

Protection of a high resistance earthed MV network against earth faults is achieved with a directional protection relay measuring the active component of the zero sequence current flowing in the line conductors by means of residually connected current transformers, and using the zero sequence voltage measured on the transformer neutral as the polarizing quantity. Alternatively the zero sequence current flowing through the neutral resistor may be used as the polarizing quantity [Lehtonen & Hakola, 1996, 96].

The earth fault currents in high resistance earthed networks are usually very small, dictating low earth fault protection settings. High resistance earthed network earth fault protection relays are typically set to pick-up at a primary current of 1 A or below [Lehtonen & Hakola, 1996, 96]. As a result of this, false relay operation may take place due to current transformer errors, load current imbalance or an open circuit phase conductor if residually connected current transformers are used instead of a core balance current transformer to measure the zero sequence current flowing in the feeder's conductors. Also, cold load pick-up, transformer inrush and short circuits may lead to false tripping of a feeder breaker due to imbalance in the phase currents [Lehtonen & Hakola, 1996, 96].

Standard inverse definite minimum time lag (IDMTL) overcurrent relays may be used in low resistance earthed networks as the fault currents are considerably larger than in high resistance earthed networks [Lehtonen & Hakola, 1996, 97].

Typical earth fault pick-up settings for an MV feeder would be in the range of 40 to 120A.

Sensitive earth fault protection is also used in low resistance earthed networks for the detection high impedance earth faults, typically a broken conductor on the ground. Typical setting ranges would be 3 to 20 A pick-up current and 5 to 15 seconds operating time.

Auto reclosing is normally not done with sensitive earth fault protection as its operation may indicate a potentially dangerous situation, e.g. a conductor on the ground.

The zero sequence impedance of distribution networks are relatively high, which leads to lower fault currents the further a fault is away from the substation. This enables easier coordination of protection relays [Lehtonen & Hakola, 1996, 97].

Petersen Coil Earthed (Compensated) Networks

Petersen coil earthed network protection cannot be based on the reactive current component of the earth fault current, since the inductive current of the Petersen coil will interfere with the protection relay operation [Lehtonen and Hakola, 1996, 88]. For this reason then the active (resistive) component ($I_0 \cos \phi$) of the earth fault current is used for selective tripping of circuit breakers.

The magnitude of the earth fault current's active component is usually small and may be increased by connecting a resistor in parallel with the Petersen coil.

The protection relay operating characteristic for a Petersen coil earthed network is similar to that of an unearthed network, but the characteristic is shifted by -90° [Lehtonen & Hakola, 1996, 88]. The characteristic of a numeric earth fault protection relay is shown in Figure 18:

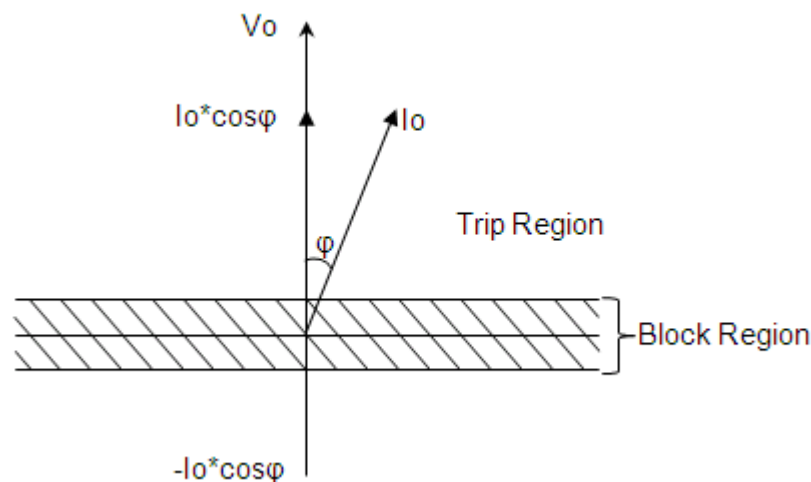

Figure 18: Numeric earth fault protection relay characteristic using the active component, $I_0 \cos \phi$, of the feeder's residual current for selectivity.

In a Petersen coil earthed network the protection must also be able to operate selectively in the event that the Petersen coil is temporarily out of order. In such an event auxiliary contacts from the Petersen coil's circuit breaker will automatically change the relay operating characteristic from an $I_0 \cos \phi$ to an $I_0 \sin \phi$ via a binary input on the numeric protection relay, where I_0 is the residual current of a specific feeder. At this stage now the network is being operated as an unearthed network [Lehtonen & Hakola, 1996, 89].

In the event of an earth fault with the Petersen coil in service, an overvoltage protection relay, measuring the neutral-to-earth voltage, will automatically switch a resistor into the circuit in parallel with the Petersen coil in order to increase the active component of the fault

current and reduce the neutral-to-earth voltage [Lehtonen and Hakola, 1996, 66]. The resistor stays connected in parallel until the earth fault has cleared.

2.5.4. Safety

The safest situation from a human or animal contact incident perspective will be where the one phase conductor has a solid earth fault. In this case there may be a minimal touch potential to earth at the fault point, but there is no guarantee of this.

Currently there is no protection sensitive, selective and/or reliable enough to detect a human or animal contact incident and operate fast enough to prevent serious injury or death.

Cases do exist where people or animals did survive electrical contact incidents on MV networks, but they were just fortunate and their survival cannot be ascribed to protection operations.

Unearthed Networks

With the aid of modern numeric protection it is possible to reliably detect earth faults on an unearthed network, but the risk of electrocution on such a network is just as high as in any other earthed type network.

Solidly, Resistance and Petersen Coil Earthed Networks

Base on the effects of electrical shock on the human body [IEC 60479-1: 2005], the chances of survival of a person involved in a contact incident resulting in a low level earth fault, are extremely slim on solid or resistance earthed networks due to the long fault clearing duration (5 to 15 s typically).

A Petersen coil earthed system's claim to fame is the fact that it may be operated for prolonged periods with an earth fault present on one phase. The Petersen coil will most probably not have its inductive current level adjusted in such a way as to completely cancel out the network's capacitive fault current during an EF, and therefore some current will still pass through the body of a person or animal during a contact incident. The chance of survival of such a contact victim may be better than that of a solid or resistance earthed network due to the low fault current during an earth fault condition, if the Petersen coil is optimally tuned.

IEC 60479-1: 2005 states that about 105 mA for 1000 ms through a human body from hand to foot is enough to be lethal to a 50% population sample.

Table 1: Comparison of the characteristics of different network earthing methods

		Unearthed	Solidly Earthed	Resistance Earthed	Resonant Earthed (Petersen Coil)
1	Network insulation (all lines and primary plant equipment)	Fully insulated [Westinghouse, 1944, 462]	Unfaulted phase voltages may be raised to 1.8 x normal phase-to-neutral voltage, therefore phase-to-phase voltage insulation is required. [Westinghouse, 1944, 460] The phase-to-earth voltage of the unfaulted phases may considerably exceed the normal phase-to-neutral voltage [Willheim et al, 1956, 72], therefore phase-to-phase voltage insulation is required.	The higher the neutral resistance the higher the neutral voltage to earth during an earth fault and will almost invariably be fully displaced to normal phase-to-neutral voltage and will require full phase-to-phase voltage insulation. [Westinghouse, 1944, 463]	The neutral will be fully displaced to normal phase-to-neutral voltage during an earth fault and will require full phase-to-phase voltage insulation. [Westinghouse, 1944, 464]
2	Earth fault current	Usually low [Westinghouse, 1944, 467]	Maximum value rarely higher than three-phase short circuit current [Westinghouse, 1944, 467]	Low [Westinghouse, 1944, 467]	Negligible except when the Petersen coil is short circuited for relay purposes when it may compare with solidly earthed systems [Westinghouse, 1944, 467]
3	Protection relaying	Difficult [Westinghouse, 1944, 467], but easily achieved with modern numeric protection.	Satisfactory [Westinghouse, 1944, 467]. Easily achieved with modern numeric protection.	Satisfactory [Westinghouse, 1944, 467]. Easily achieved with modern numeric protection.	Requires special provisions but can be made satisfactory [Westinghouse, 1944, 467]. Easily achieved with modern numeric protection.
4	Arcing grounds	Likely [Westinghouse, 1944, 467] 67% of all network faults [Lehtonen et al, 2001, 1185]	Unlikely [Westinghouse, 1944, 467] <u>Comment:</u> Arcing faults will take place on networks of any earthing type. Perhaps Westinghouse meant to say that overvoltages due to arcing earth faults are unlikely to happen in solidly earthed networks.	Unlikely [Westinghouse, 1944, 467] <u>Comment:</u> Arcing faults will take place on networks of any earthing type. Perhaps Westinghouse meant to say that overvoltages due to arcing earth faults are unlikely to happen in resistance earthed networks.	Unlikely [Westinghouse, 1944, 467] <u>Comment:</u> Arcing faults will take place on networks of any earthing type. Perhaps Westinghouse meant to say that overvoltages due to arcing earth faults are unlikely to happen in resonant earthed networks. 28% of all resonant earthed network faults are arcing faults [Lehtonen et al, 2001, 1185]).

		Unearthed	Solidly Earthed	Resistance Earthed	Resonant Earthed (Petersen Coil)
5	Lightning protection	Lightning arresters must be applied on the basis of full phase-to-phase voltage, which increases the cost of protection [Westinghouse, 1944, 467]	Lightning arresters rated for “solidly earthed neutral service” may be applied as the maximum neutral displacement will not be much higher than the normal phase-to-neutral voltage if the earth electrode resistance to earth is low [Westinghouse, 1944, 467].	Lightning arresters must be applied on the basis of full phase-to-phase voltage, which increases the cost of protection [Westinghouse, 1944, 467]	Lightning arresters must be applied on the basis of full phase-to-phase voltage, which increases the cost of protection [Westinghouse, 1944, 467]
6	Line availability	The line will inherently clear itself (self-extinguishing arcing earth faults) if total length of interconnected line is low and requires isolation from system in increasing percentages as length becomes greater [Westinghouse, 1944, 467]. The network may be operated for prolonged periods with a single permanent earth fault [Fickert et al 2009, 3].	The line must be isolated from the source for each fault [Westinghouse, 1944, 467].	Line must be isolated from the source for each fault [Westinghouse, 1944, 467].	Line need not be isolated from the source during a permanent earth fault [Westinghouse, 1944, 467]. Transient earth faults will inherently clear itself in about 60% to 80% of faults [Westinghouse, 1944, 467] (<u>Comment</u> : Clarification of what causes the range was not provided in the reference). Hunter [1937, 16] found that on a Petersen coil equipped 440 km long 140 kV network, 70% of all network earth faults were cleared without circuit breaker operation. ABB [1994, 97] states that about 75% of earth faults are self-extinguishing. A network may be operated with an earth fault until such time as repair can be effected [Marshall, 1937,402].
7	Circuit breakers	Interrupting capacity is determined by the three-phase fault conditions [Westinghouse, 1944, 467].	Interrupting capacity is determined by the three-phase fault conditions and in some cases even higher ratings are required for earth faults close to the neutral earth connections [Westinghouse, 1944, 467].	Interrupting capacity is determined by the three-phase fault conditions [Westinghouse, 1944, 467].	Interrupting capacity is determined by the three-phase fault conditions [Westinghouse, 1944, 467].

		Unearthed	Solidly Earthed	Resistance Earthed	Resonant Earthed (Petersen Coil)
8	Operating procedure	Ordinarily simple but double faults introduce complication [Westinghouse, 1944, 467]. Modern protection methods exist whereby the faulted feeder, faulted phase, and the fault location may be identified [Erroa et al, 2006,3]	Simple [Westinghouse, 1944, 467]. Distance to fault locating equipment is available, working on the travelling wave principle.	Simple [Westinghouse, 1944, 467]. Distance to fault locating equipment is available, working on the travelling wave principle.	Taps on Petersen coils have to be changed when major system switching is performed (<u>Comment</u> : Sections of a network connected or disconnected). Difficult to tell where faults are located [Westinghouse, 1944, 467] with electromechanical protection relays. Modern protection methods exist whereby the faulted feeder, faulted phase, and the fault location may be identified [Hänninen, 2001, 42]
9	Transient overvoltages	Up to 6 times normal peak phase-to-neutral voltage [Glover, 1978 or later, D-7]. A real life study by Allen and Waldorf [1946, 303 & 305] on a 13 kV busbar at a power station revealed maximum overvoltages of 3 times the normal peak phase-to-neutral voltage. A 140 kV network study by North & Eaton [1933, 70] revealed overvoltages of 3.5 times the normal peak phase-to-neutral voltage.	Up to 2.5 times normal peak phase-to-neutral voltage [Glover, 1978 or later, D-7] Up to 2.73 times normal phase-to-neutral voltage [Clark et al, 1938, 377].	Up to 2.5 times normal peak phase-to-neutral voltage for both high and low resistance earthing [Glover, 1978 or later, D-7 & North & Eaton 1933, 70].	Laboratory experiments conducted by Conwell & Evans [1922, 79] delivered overvoltages of 2.5 times the normal peak phase-to-neutral voltage during earth faults. A 140 kV network study by North & Eaton [1933, 70] revealed overvoltages of 2.7 times the normal peak phase-to-neutral voltage. <u>Comment</u> : This maximum overvoltage is not much lower than the 3 times normal peak phase-to-neutral voltage for an unearthed network, as found by Allen and Waldorf [1946, 303 & 305]..
10	Positive fault location	No [Glover, 1978 or later, D-7] Modern protection methods exist whereby the faulted feeder, faulted phase, and the fault location may be identified [Hänninen, 2001, 42]	Yes [Glover, 1978 or later, D-7] Methods to detect the earth fault location on radial networks include, travelling wave technique, earth fault initial charge transients can be utilised and Fourier transform methods [Hänninen, 2001, 55]	Yes [Glover, 1978 or later, D-7] Methods to detect the earth fault location on radial networks include, travelling wave technique, earth fault initial charge transients can be utilised and Fourier transform methods [Hänninen, 2001, 55]	Modern protection methods exist whereby the faulted feeder may be identified, as well as the fault location [Hänninen, 2001, 42]

		Unearthed	Solidly Earthed	Resistance Earthed	Resonant Earthed (Petersen Coil)
11	System interrupt upon 1st fault	Sometimes [Glover, 1978 or later, D-7]	Yes [Glover, 1978 or later, D-7]	Optional for high resistance and Yes for low resistance earthing [Glover, 1978 or later, D-7]	Sometimes
12	Safety to personnel	Poor [Glover, 1978 or later, D-7]	Fair [Glover, 1978 or later, D-7]	Best for high resistance and good for low resistance earthing [Glover, 1978 or later, D-7]	Fair, as most of the voltage drop during an earth fault will be across the Petersen coil, resulting in a low touch potential at the fault point. This, in theory makes it safer than the other earthing methods, but human or animal contact with a phase conductor will most probably be lethal.
13	I ₂ t damage	Low [Glover, 1978 or later, D-7]	High [Glover, 1978 or later, D-7]	Low to Medium [Glover, 1978 or later, D-7] <u>Comment:</u> Damage depends on the level of resistance earthing, e.g. low resistance, high damage.	Low
14	Coordination of protective devices	Impossible [Glover, 1978 or later, D-7] <u>Comment:</u> Protection co-ordination with downstream protection devices is surely possible by means of time grading at least.	Best [Glover, 1978 or later, 1978 or later, D-7]	Good [Glover, 1978 or later, D-7]	Good

3. Proposed Transient Earth Fault Clearing Method

Based on the knowledge gained from the aforementioned text in this thesis, it is now possible to suggest a number of methods likely to assist clearing of transient earth faults.

Four of the discussed earthing schemes are, to some extent, inherently capable of transient earth fault clearing without customer supply interruption. These are the Petersen coil system due to the fact that it reduces the fault current to a very small value (mostly resistive current component) when tuned correctly, a solidly earthed network if the fault current can be interrupted “instantaneously”, a resistance earthed network due to its fault current limiting effect, and an unearthed network if the capacitive current is not too high (<9.5 A according to Lehtonen et al, [2001, 1185], or <35 A in the case of the German standard VDE 0228 (1987) [Hänninen, 2001, 16 and Cucic et al, 2008, 82]), which is dictated by the type and size of line construction, and the total length of lines connected to the same busbar. The upper limit on capacitive fault current is imposed to still allow for reliable self-extinguishing of arcing earth faults in unearthed networks.

The high resistance and Petersen coil network earthing types are both theoretically suitable for temporary conversion to unearthed networks, but as mentioned elsewhere, the Petersen coil earthed network is in general a better performing network than an unearthed network in terms of (claimed) overvoltages, due to arcing earth faults, and the maximum capacitive earth fault current that may be tolerated in such a network in order to allow reliable self-extinguishing of arcing earth faults. Consequently there is no value in temporary conversion of a Petersen coil earthed network to an unearthed network. Basically the same argument applies to a high resistance earthed network as extreme overvoltages will not be generated due to arcing earth faults and arc self-extinguishing may be easily attained due to the small resistive earth fault current.

Another factor that may render permanent conversion of a solid or resistance earthed network into a Petersen coil earthed network less effective, is a wood pole line construction. A wood pole line construction may force a large number of potential earth faults to develop into phase-to-phase faults [ABB, 1994, 97]. Most of Eskom’s MV lines consist of wood pole constructions.

Low resistance earthed networks may contain transformers with graded insulation on the neutrals (HV networks), which render them unsuitable for unearthed network operation where the neutrals will be elevated to full normal phase-to-neutral voltage during an earth fault. As a norm graded insulation only becomes economically viable on HV equipment, and MV equipment is normally fully insulated to withstand full phase-to-phase voltage to earth.

None of the four network earthing philosophies specifically cater for transient earth fault clearing, but they are inherently able to clear transient earth faults without customer supply interruption if the cause of the fault, such as a tree branch momentarily touching a line conductor, moves away from the conductor before the protection operates to open the feeder circuit breaker or auto recloser.

The proposed method of transient earth fault clearing on solid or resistance earthed networks is to, as fast as practically possible, temporarily disconnect the source transformer’s MV neutral connection to earth. An alternative to the proposed method may

be to temporarily insert a high resistance (in the kilo-ohm range) in series between the transformer neutral and earth in order to limit the earth fault current to below, say, 1 A.

The pre-requisite for this to be done upon detection of an earth fault is that the network insulation be rated to withstand full phase-to-phase voltage to earth. Based on this insulation requirement, an existing solidly earthed network may not be suitable for temporary conversion to either a high resistance earthed or an unearthed network.

In general MV networks and associated equipment such as transformers do not make use of graded insulation as the cost benefit is very marginal compared to being fully insulated for full phase-to-phase voltage to earth. Surge arresters implemented on existing solidly earthed networks may have lower overvoltage ratings than those implemented on resistance earthed networks, and may require replacement.

For convenience Table 2 provides a few network parameters needing special attention when an existing solid or low resistance earthed network is to be temporarily converted into an unearthed network.

University of Cape Town

Table 2: Network parameters needing special attention when a solid or low resistance earthed MV network is to be temporarily converted into an unearthed network.

		Unearthed Network Requirements/characteristics	Systems that are normally Solidly Earthed	Systems that are normally low Resistance Earthed
1	Network insulation (all lines and primary plant equipment)	All network equipment to be fully insulated, i.e. it must be able to withstand full phase-to-phase voltage between any live part and earth	In general MV equipment insulation will be rated to withstand full phase-to-phase voltage between any live part and earth, but this needs to be verified for the given network. Graded transformer insulation is generally only adopted on HV networks.	In general MV equipment insulation will be rated to withstand full phase-to-phase voltage between any live part and earth, but this needs to be verified for the given network. Graded transformer insulation is generally only adopted on HV networks.
2	Arcing grounds	The occurrence of arcing earth faults are very likely due to the capacitive fault current, and requires full phase-to-phase voltage network insulation.	When operated as an unearthed network the occurrence of arcing earth faults are (apparently) very likely due to the capacitive fault current, and requires full phase-to-phase voltage network insulation. This type of network will most probably not require upgrading of the network's insulation level, as solidly earthed MV networks are generally fully insulated to withstand full phase-to-phase voltage between any live part and earth. Solidly earthed HV systems will most likely employ graded insulation.	When operated as an unearthed network the occurrence of arcing earth faults are very likely due to the capacitive fault current, and requires full phase-to-phase voltage network insulation. This type of network will most probably not require upgrading of the network's insulation level, as resistance earthed MV networks are generally fully insulated to withstand full phase-to-phase voltage between any live part and earth. This makes temporary conversion to an unearthed network possible without insulation modification.

Table 2: Continued

		Unearthed Network Requirements/characteristics	Systems that are normally Solidly Earthed	Systems that are normally low Resistance Earthed
3	Lightning protection (surge arresters)	Surge arresters must be rated for full phase-to-phase voltage. The MCOV voltage rating commonly used is 1.83 times normal phase-to-neutral voltage [Clarke et al, 1939, 383].	Surge arresters applied to a solidly earthed network may not be suitable for application on a solidly earthed network which is to be temporarily converted to an unearthed network. These surge arresters are to be replaced with arresters having a MCOV rating equal to about full phase-to-phase voltage, which will have a cost implication.	Surge arresters applied to resistance earthed networks are generally rated for full phase-to-phase voltage, and may therefore not have a cost implication when required to temporarily operate the resistance earthed network as an unearthed network. Eskom employs a 1.9 times normal phase-to-neutral voltage rating factor to determine the surge arrester's MCOV rating.
4	Safety to personnel/public	The inherent benefit of an unearthed network is the fact that it may be operated for extended periods with one permanent earth fault on the network. This poses a risk to personnel and the public alike as a live conductor may be lying on the ground. This very same condition may, however, be experienced with solid, resistance and impedance earthed networks during high impedance earth fault conditions. This therefore does not render the unearthed network more dangerous than other networks, especially not in the case of a network momentarily converted into an unearthed network as the unearthed state will only be maintained for tens of seconds as opposed to a permanently unearthed network or a permanent high impedance earth fault.	Same as for unearthed network.	Same as for unearthed network.
5	Multiple faults	Emanating from the literature study, arcing earth faults on unearthed networks may lead to insulation failures on the two healthy phases or equipment during an earth fault, which will result in more than one network fault, most likely a phase-to-phase fault.	Same as for unearthed network.	Same as for unearthed network.

3.1. Temporarily Disconnecting the Neutral Earth Connection of a Solid or Low Resistance Earthed Network

In a solid or low resistance earthed network the feeder breaker will most probably be opened for the majority of transient earth faults as arcing may not self-extinguish due to high earth fault currents.

It is envisaged that significant benefit may be derived from combining some of the advantages of both solid and low resistance earthed networks with the advantages of an unearthed network by temporarily converting such existing networks into unearthed networks upon detection of an earth fault.

It may be argued that by temporarily disconnecting the source transformer's MV neutral connection to earth, and effectively temporarily converting a network from solid or low resistance earthed to unearthed, that the action may allow transient earth faults to be cleared without the need to trip the feeder breaker, or any recloser upstream from the fault.

If the source transformer's neutral is disconnected during an earth fault on a solid or low resistance earthed network, the fault current magnitude will be reduced dramatically at the instant of opening of the circuit breaker, and the fault current will then only consist of the vector sum of the phase-to-earth capacitive currents of the two healthy phases. It is envisaged that the dramatic reduction in fault current will reduce the likelihood and severity of arcing significantly, and that the arcing will quench quicker, as the object causing the fault moves/drops away from the live conductor or apparatus. This implies that the disconnected neutral connection to earth should remain disconnected for long enough to allow the object to drop clear, which could take a number of seconds, say between 5s and 10s. This will then be the minimum dead time settings of the neutral circuit breaker.

The optimal duration of the neutral circuit breaker dead time for a practical application of such a protection scheme will have to be determined through experience gained over some period of operating such a network. The length of the dead time will not have an impact on overvoltages due to arcing earth faults as the maximum overvoltages are being generated, according to the studied literature, within the first power frequency cycles after an arcing fault inception on an unearthed network Eaton et al [1931, 1476]. In this case then, as soon as the neutral circuit breaker starts to open to create a temporary unearthed network, with an arcing earth fault still present, overvoltages are expected to be generated by the arcing, as predicted by the studied literature.

The intention is to interrupt the normal earth fault current as quickly as possible (without any intentional time delay) in order to prevent excessive air ionization from taking place, and also to prevent the normal protection from tripping the feeder breaker, or downstream auto-recloser, depending on the earth fault location. If ionized air is present at the fault point the chances of continued arcing after the neutral circuit breaker has opened is increased. Also if an arcing fault has cleared after opening of the neutral circuit breaker and the dead time is too short (1 or 2 seconds for instance), ionized air may cause the fault to re-establish itself after the neutral breaker has closed. In this regard the weather may play a role, for example, wind will quickly blow away ionized air making it more difficult for an arc to sustain itself.

In unearthed systems the network insulation level needs to be rated for at least full phase-to-phase voltage as the transformer neutral voltage may rise to normal phase-to-neutral voltage

and the two healthy phase voltages may rise to normal phase-to-phase voltage during an earth fault on one phase.

An arcing earth fault may theoretically result in overvoltages of up to 6 times normal phase-to-neutral voltage [Evans et al, 1939, 392; Glovers 1978 or later, D-2 and Uppal, 1984, 911], and the system insulation needs to be able to withstand these overvoltages. Physical measurements on unearthed networks did not substantiate this claim as the maximum overvoltages measures were not more than 3 times normal phase-to-neutral voltage, which occurred most frequently during the first cycle of the fault [Eaton et al, 1931, 1475 – 1478].

The neutrals of substation transformers therefore need to be fully insulated and not partially graded, but this should not be a problem on MV networks as insulation grading is normally applied to high voltage transformers only, and not on MV transformers. In the case of MV delta windings where neutral earth compensators with a neutral resistor (NECR) are utilized, the NECR neutral has to be fully insulated.

Apart from being able to withstand the expected earth fault current the neutral circuit breaker also needs to withstand normal phase-to-phase voltage, plus a safety margin, across its open contacts.

For a utility currently employing either solid or low resistance earthed MV networks it may not be feasible to convert these networks to Petersen coil earthed networks or even build all new networks based on Petersen coil earthing as this will require a change in protection equipment, protection philosophy, training of protection personnel in the new protection philosophy, training the network operating personnel in the working of the Petersen coils and adapting new network fault locating methods, and the Petersen coil itself may prove much more expensive than the neutral circuit breaker (including associated protection).

Changing a solid or low resistance earthed method to one where the neutral is temporarily (a few seconds) disconnected from earth, will not require any feeder fault locating method change (as the change in network earthing is only being done temporarily), but do require a slight earth fault protection philosophy change. Most modern numeric protection relays will be able to cater for such a protection philosophy change, therefore not requiring any protection refurbishment where these relays are employed.

Based on the findings of Allen & Waldorf [1946, 303], it seems most probable that even a network temporarily converted from solid or low resistance earthed into an unearthed network, will have to be able to withstand the inevitable overvoltages of up to 3 times normal phase-to-neutral voltage on the healthy phases for the duration of the dead time of the neutral circuit breaker.

As overvoltages may pose a problem when arcing earth faults occur during the time when the neutral is disconnected from earth, it is suggested that surge arresters rated for at least full phase-to-phase voltage be employed throughout the MV network. Gapless metal oxide surge arresters should be used as they control overvoltages in a smooth fashion, as opposed to gapped arresters which has a tendency to abruptly conduct or quench current flow. The abrupt termination of current flow may trigger re-striking of the fault due to high recovery voltages. On the other hand, spark gaps, once flashed over, keep on conducting 50 Hz current to earth until the current through it is interrupted. Operation of a spark gap will invariably result in opening of the upstream circuit breaker, thus defeating the object of transient earth fault clearing.

Permanently converting a solid or low resistance earthed network to an unearthed neutral network is not considered an option due mainly to the problem of (claimed) overvoltages caused by arcing earth faults, and the requirement for special protection to identify a specific feeder and phase with a permanent fault. This will also constitute a whole protection and feeder fault locating philosophy change within a utility not currently operating unearthed networks.

3.1.1. Enhancement of the Proposed Transient Earth Fault Clearing Method

As evident from the literature study arcing earth faults and their associated overvoltages may be problematic on unearthed overhead lines, especially long lines where the phase-to-earth capacitance is large, resulting in high capacitive earth fault currents.

The main foreseen problem with the proposed transient earth fault clearing method is that arcing earth faults are relied upon to self-extinguish, but an enhancement to the scheme will actively extinguish an arcing earth fault.

A method to quench arcing earth faults in unearthed networks shortly after inception has been proposed by Dutoit et al [2005, 1], Dutoit & Gonzalez [2009, 1] and Koepl et al [2005, 1], and works on the principle of short circuiting the faulted phase to earth. Burkholder & Marvin [1911, 327] suggested a similar method, called an “insulator protector”, in order to prevent arc damage to glass insulators during insulator flashovers, as a result of lightning.

This arc quenching method requires, apart from the proposed neutral circuit breaker of the transient earth fault clearing scheme, an additional three single phase circuit breakers to be installed, one on each phase, between each phase and earth. See Figure 19. They are normally in the open position. The most logical location for installation of such single phase earthing breakers would be within the source substation on the MV busbar.

As for the proposed transient earth fault clearings scheme, this arc quenching method operates for the whole network connected to the same busbar as the single phase earthing breakers/switches.

When employing the method suggested by Dutoit and Gonzalez [2009, 1], Koepl et al [2005, 1], and Burkholder and Marvin [1911, 327], in conjunction with the suggested transient earth fault clearing protection scheme, the method of operation would be as follows. These single phase switches or circuit breakers will operate in conjunction with the neutral circuit breaker, or breakers. When an earth fault occurs on, say, the b-phase, the neutral breaker/s will open instantaneously upon fault detection, the b-phase switch/breaker will close shortly afterwards to short circuit the fault and solidly earth the b-phase, thus preventing arcing at the fault point. After a set time the b-phase earthing switch/breaker will open, and the neutral circuit breaker/s will close shortly afterwards restoring the network to its normal state.

A transient fault would have been cleared by this action, and the network would not have been subjected to any supply interruption or overvoltage transients.

As mentioned earlier in this thesis, overvoltages due to arcing earth faults, are being generated in an unearthed network within the first power frequency cycles after the inception

of an earth fault Eaton et al [1931, 1475 - 1478]. The same will therefore happen at the instant that a solid or low resistance earthed network is being converted to a temporary unearthed network during an earth fault condition. If then the researched literature is correct, such a temporary unearthed network will most probably experience transient overvoltages on the network while there is an arcing earth fault on the line.

Permanent earth faults will require further action by the normal protection after closure of the neutral circuit breaker, and will disconnect the faulted feeder after going through the standard ARC sequence.

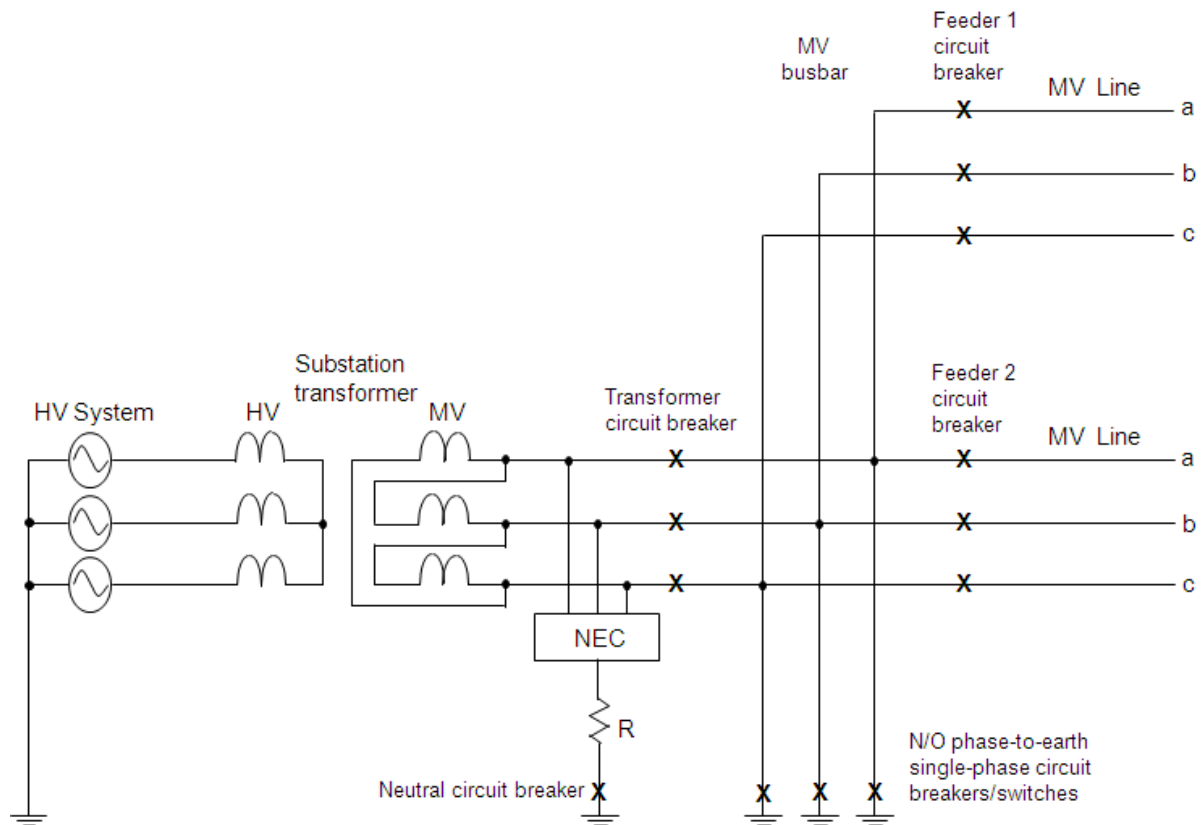

Figure 19: A variation on the proposed neutral earth switching, whereby three normally open single phase circuit breakers are installed between each phase and earth, in addition to the neutral circuit breaker.

The concept of earthing the faulty phase of an unearthed network was not pursued as it would have been more costly, more difficult to implement as a trial site, and more time consuming. This method may well be more applicable to larger networks (larger conductor capacitance-to-earth) where large capacitive currents may prevent reliable fault arc extinction when temporarily converting a resistance earthed network to an unearthed network by disconnecting the transformer neutral connection to earth.

4. Transient Earth Fault Clearing Scheme

4.1. A Typical Transient Earth Fault Clearing Scheme

Assume a typical step down substation from 66kV to 11kV with two 10MVA star/delta transformers, a NECR on the MV side of each transformer, a MV bus section circuit breaker and one MV line feeding from each of the two bus sections.

The neutral-to-earth connections of the two NECRs will have to be disconnected from the substation earth mat. Next the two NECR neutrals are connected together on one side of a single phase circuit breaker, and the other side of the circuit breaker is bonded to the substation earth mat. It goes without saying that the single pole circuit breaker needs to be adequately rated to carry the combined maximum earth fault current of the two NECRs and have an appropriate voltage rating of normal phase-to-neutral voltage plus some safety margin. See Figure 20 which depicts a substation station electrical diagram indicating the application of a neutral circuit breaker. As the HV protection has no bearing on this discussion, only the MV protection has been indicated.

If so desired, two single pole circuit breakers may be used, for switching each of the NECR neutrals individually during conditions when the bus section circuit breaker is open.

An instantaneous (no intentional time delay) earth fault protection element is to be used to control the neutral circuit breaker.

It is intended that the transient earth fault clearing protection scheme be set to detect any earth fault from well below sensitive earth fault (SEF) level upward, and trip the neutral circuit breaker without any intentional time delay. For the purpose of this document a SEF is defined as a high resistance earth fault resulting in a fault current in the range of about 3 A up to the earth fault protection pick-up setting.

The SEF protection pick-up setting may typically be set within a range of 3 A to 15 A with a definite trip time of 5 to 15 seconds, depending on protection grading requirements. Practical experience gained from protection operations on Eskom overhead MV networks indicates that current pick-up settings below 3 A may give rise to nuisance tripping due to normal network imbalances as a result of load imbalances and single phase fuse operations.

A normal earth fault protection pick-up setting for the Eskom MV networks would typically be in the range of 40 A to 80 A with a normal inverse definite minimum time lag (IDMTL) characteristic for a resistance earthed network.

As the neutral circuit breaker protection scheme will be measuring the actual earth fault current only, flowing through the NECR neutrals, its earth fault pick-up may be set lower than that of the SEF trip settings employed in the standard MV feeder protection schemes, which derives the earth fault current from the summation of the three phase current transformers (larger measurement error). For this reason the neutral circuit breaker trip pick-up setting may be set very low, say to 1 A, as there should only be a current in the NECR neutrals during an earth fault.

The neutral circuit breaker protection is therefore required to cover a settings range from below the lowest normal SEF setting up to, say, a maximum of 10 A as one will always want

to set the pick-up as low as possible in order to detect all earth faults, does not matter how small as all have the potential of developing into permanent faults.

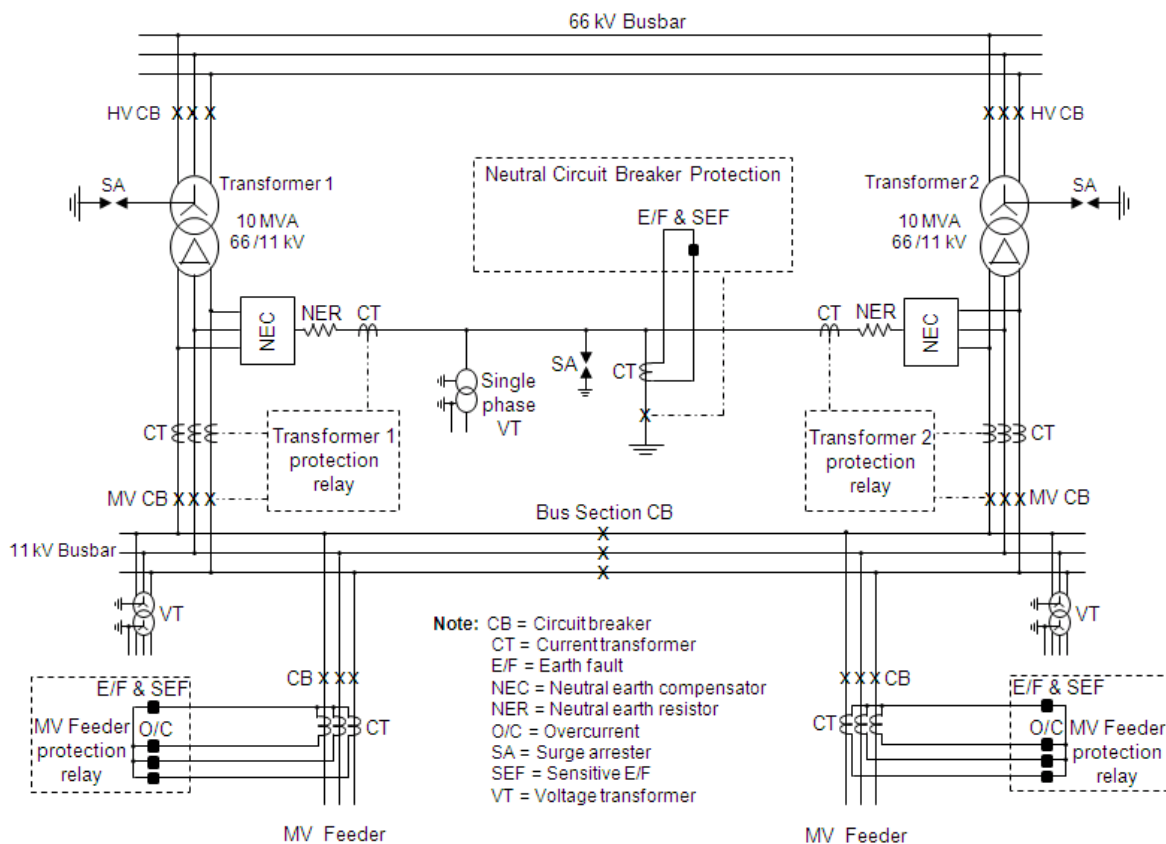

Figure 20: AC key diagram (only MV protection indicated) of a typical 66 kV/11 kV step down substation showing the implementation of a neutral circuit breaker.

4.2. Operation of the Transient Earth Fault Clearing Scheme

4.2.1. Transient Earth Fault Clearing

The transient earth fault clearing protection scheme (TEFCS), as proposed in Figure 20, will sense the presence of an earth fault condition and instead of opening the faulted feeder's 3-phase circuit breaker, the neutral circuit breaker will be opened instantaneously (about 60 ms for protection and circuit breaker operation) upon detection of an earth fault. The neutral circuit breaker will be opened for a predetermined time (dead time) after which it will be closed again. This neutral breaker auto-reclose (ARC) action will only happen once for any given earth fault. Thereafter the normal feeder protection will operate as required for permanent earth faults.

For a substation with more than one NECR, each on its own bus section, the NECR neutrals may be connected together and connected to earth via one adequately rated normally closed neutral circuit breaker. This saves the cost of an additional neutral circuit breaker and its associated protection. The connection of all NECR neutrals to earth through a single circuit

breaker is acceptable, even though the MV busbar may be separated into two sections by the bus section circuit breaker.

It is deemed acceptable to disconnect both NECR neutrals simultaneously from earth even though only one NECR will pass fault current through its neutral. The reason for this is that the neutral circuit breaker will never be in the open state for longer than a few tens of seconds, which is the dead time of the neutral circuit breaker (proposal is 10 to 20 s), and it is not required for passing load current. The protection should be set such that the neutral circuit breaker cannot be locked out in the open position due to a protection operation. Through this action no risk is being posed to the unfaulted 3-wire network and no disturbance will be experienced by the customers on such a network as they are being supplied through delta/star distribution transformers.

At the instant of fault inception on a solid or low resistance earthed network, the phase-to-earth voltages of the two healthy phases of the whole network will rise to some value between the normal phase-to-neutral voltage and full normal phase-to-phase voltage due to the fault current flowing through the NECR resistor. The voltage rise magnitude is determined by the NECR resistor value, the fault current magnitude (assuming a good substation earth mat), and the fault point resistance. The higher the current and the neutral resistor value, the higher the neutral voltage rise with respect to earth. The higher the fault point resistance, the lower the neutral voltage rise with respect to earth.

Upon opening the neutral circuit breaker the network is temporarily converted into an unearthed network. The only current flowing back to the source would be the vector sum of the phase-to-earth capacitive currents of the two healthy phases of all the feeders feeding from the same busbar as the faulted feeder, similar to those currents indicated in Figure 5.

For calculation purposes the capacitances of all the feeders connected to the same busbar as the faulted feeder may be lumped together. As only transient earth faults are of interest the magnitude of the total phase-to-earth capacitive current is of little concern as it is assumed that the object causing the earth fault will “disappear” by itself and the fault will be cleared. It would be safe to assume that all transient earth faults will lead to arcing as an arc will be drawn during the fault clearing process while the object responsible for the fault is in the process of moving away from the live conductor.

In this regard Lehtonen et al [2001, 1185] found during an unearthed 20 kV network study that 67% of earth faults were arcing faults and that the average duration of arcing was 60 ms. The study does not make mention of what the cause of these arcing earth faults were, but it is very unlikely that they were caused by, for example tree branches or animals that made contact with a live conductor, as it would take much longer than 60 ms for them to move away far enough from the conductor to a point where arcing would stop.

In the event of a transient earth fault due to an animal or tree branch briefly touching a live conductor of an overhead line, the fault will be successfully cleared if the animal or branch is to fall/move away far enough from the conductor during the dead time of the neutral breaker for the capacitive current arc to be extinguished.

Before the inception of an earth fault the phase-to-earth capacitive currents of the three phases will be balanced for all practical purposes. Phase-to-earth capacitance values for a

standard 3-wire Eskom 11 kV delta configured untransposed overhead line structure are listed in Table 4, and it shows that the imbalance is in the order of 2.5%.

While the earth fault is in progress the capacitive currents-to-earth of the three phases will become imbalanced as the capacitance of the faulted phase is being short circuited by whatever is causing the earth fault.

At the instant that the cause of a transient earth fault is being removed from the conductor (i.e. the faulted phase's phase-to-earth capacitance is no longer shorted out), during the dead time of the neutral circuit breaker, the capacitive currents-to-earth of the three phases will return to the balanced state, the phase-to-earth voltage of all three phases will return to normal, and no capacitive current will flow to earth.

The neutral-to-earth voltage (zero sequence voltage) is an indication of the phase-to-earth voltage imbalance on a network, and is a convenient quantity to measure as the reduction in zero sequence voltage may be used to close the neutral circuit breaker as soon as the transient fault cleared, instead of waiting for the dead time to expire.

Small phase-to-earth capacitance imbalances will exist on all overhead lines where line structures, unsymmetrical with respect to earth (e.g. flat, delta or staggered vertical arrangements), are being used, which will result in a zero sequence voltage on the NECR neutral. This zero sequence voltage is much smaller than what would be experienced during an earth fault and will therefore not impact on the decision of whether an earth fault is still present, or not.

4.2.2. Permanent Earth Fault Clearing by Three Pole Tripping

In the event of a permanent earth fault the neutral circuit breaker will auto reclose (ARC) once, as for a transient earth fault, as no distinction can be made between a transient and permanent fault at inception of the fault. After the neutral circuit breaker has closed the 3-phase feeder circuit breaker will be tripped after some set time delay, and will go through the normal ARC sequence as per the utility's ARC philosophy. It is not foreseen that any protection settings of the existing standard Eskom protection scheme will need to be changed in order to implement the TEFCS, but this is subject to change on findings during the commissioning tests and trial site operating performance data. The TEFCS may be viewed as an additional earth fault "protection layer" installed below the existing protection in order to filter out the transient earth faults.

Just before inception of a permanent earth fault the three phase-to-earth capacitive currents are equal in magnitude, bar the imbalance caused by unsymmetrical line structures. Upon inception of the earth fault, as with the transient fault, the phase-to-earth capacitive currents become imbalanced due to the capacitance-to-earth of the faulted phase being short circuited by the fault.

During an earth fault the earthing resistance (NECR) causes a rise in the phase-to-earth voltage on the two healthy phases, up to the normal phase-to-earth voltage, which is determined by the fault current magnitude, the NECR resistor value and the fault point resistance. The higher the NECR resistor value or fault current, the higher the voltage rises on the healthy phases due to the NECR neutral being elevated to some voltage above earth

potential. The higher the fault point resistance the lower the neutral voltage rise with respect to earth. This situation is valid for as long as the NECR neutral is connected to earth via the neutral circuit breaker.

Upon opening of the neutral circuit breaker the NECR neutral-to-earth voltage will be raised to the normal line-to-neutral voltage as the faulted phase is tied to earth by the low resistance fault. As a result of this the two healthy phases will now experience full phase-to-phase voltage to earth as indicated in Figure 4.

As per Table 1, rising of the healthy phases' voltages, with respect to earth, to full phase-to-phase voltage during an earth fault (assuming zero fault impedance) is not unique to unearthed neutral networks as solid, resistance and impedance earthed networks all suffer from the same problem. It is therefore a requirement that all these networks be insulated from earth to withstand full phase-to-phase voltage to earth, plus a safety margin for extra security. Temporarily converting an existing low resistance earthed network to an unearthed neutral network should therefore not present a problem in terms of insulation as all equipment associated with the network, such as transformers, insulators and surge arresters, have to be insulated for full phase-to-phase voltage to earth anyhow. The degree of insulation should, however, be verified for each network before applying a TEFCS.

The full phase-to-phase voltage to earth will be impressed upon the two healthy phases when zero fault resistance is present, i.e. the worst situation for a network with an unearthed neutral. Any fault resistance will have the effect of decreasing the neutral-to-earth voltage, and simultaneously also decreasing the two healthy phases' phase-to-earth voltages.

While the neutral circuit breaker is open, and the faulted phase is connected to earth, the earth fault current (residual current) measured by the feeder protection at the source substation is the vector sum of the capacitive currents of the phase-to-earth capacitances of the two healthy phases as indicated in Figure 4.

Due to the low resistance earth fault (permanent fault) there is no possibility of restoring the feeder to normal. The neutral circuit breaker will close after the dead time and the 3-phase feeder breaker or downstream auto-recloser, depending on the fault location, will go through the set ARC cycle and lock out, i.e. disconnecting the feeder from the busbar at the source substation, or the network downstream of the auto-recloser, as dictated by the fault location.

4.3. Safety of the Transient Earth Fault Clearing Scheme

The international standard on "Effects of current on human beings and livestock", IEC 60479-1: 2005 states, amongst others, the following:

1. For voltages $\geq 1000\text{V}$ the internal human body resistance of 50% of the population is about $775\ \Omega$.
2. The let go threshold for an adult male is 10 mA.
3. Ventricular fibrillation may occur for current magnitudes above 500 mA for shock durations below 100 ms.
4. Currents $>500\ \text{mA}$ through the human body from hand to feet for longer than 500 ms will most probably be fatal due to ventricular fibrillation.

5. With currents of several amperes lasting more than seconds, deep-seated burns and other internal injuries may occur. Surface burns may also be seen.
6. An average human body may endure
 - about 1250 mA for 10ms
 - about 900 mA for 100 ms
 - about 105 mA for 1000 ms
 - about 65 mA for 10 s, for a 50% probability for onset of ventricular fibrillation.

The Eskom Distribution standard on the application of sensitive earth fault protection provides the following SEF setting ranges:

$$\text{Current: } 3 \text{ A} \leq I_{\text{pick-up}} \leq 6 \text{ A}$$

$$\text{Trip time: } 5 \text{ s} \leq T_{\text{trip}} \leq 15 \text{ s}$$

In the case of a solid or resistance earthed network any EF above the SEF pick-up and below the EF pick-up will cause the circuit breaker (CB) to be tripped in the SEF definite trip time. In light of the IEC standard extracts above, the long SEF trip times will probably be lethal for human and animal alike in most accidental type contact incidents. EF protection from a survival point of view will not be any better as the IDMTL trip time may also be in the range of seconds, depending on the fault current magnitude.

In the event of an earth fault on a solid or resistance earthed network, employing a TEFCS, the resistive earth fault current will be interrupted within about 90 ms (neutral circuit breaker plus protection operating time) by the neutral circuit breaker, leaving only the lower capacitive current (sum of the phase-to-earth capacitive currents of the two healthy phases) to flow.

This lower fault current may allow quicker fault clearing (due to less arcing and less ionized air) and less burn damage inside and on the skin of a human or animal body in the event of a contact incident, than in the case where SEF protection is called upon to clear a similar fault.

It should be borne in mind that no existing protection technique will save a human or animal life in the event of good electrical contact with a live conductor.

Table 3 provides a short comparison of the effectiveness of transient earth fault clearing on a solid or low resistance earthed network with and without transient earth fault clearing capability for different earth fault types, compared to the capability of a normal earth fault clearing protection scheme employed on similar networks

Table 3: Effectiveness of transient earth fault clearing on a solid or low resistance earthed network with and without transient earth fault clearing capability for different earth fault types.

	Earth Fault Type	Solid or low resistance earthed network	Solid or low resistance earthed network fitted with transient earth fault clearing capability
1	MV earth fault (Transient or permanent)	<p>All three phases will be tripped, resulting in total supply loss to customers.</p> <p>(If single phase tripping functionality is employed a three-phase customers would have one healthy LV supply voltage and two phases at half normal voltage due to delta/star MV/LV distribution transformers, and two healthy phases in the case of star/star MV/LV distribution transformers, for the duration of the dead time of the single pole feeder circuit breaker.)</p>	<p>Initially only the neutral circuit breaker will be opened (if the fault current magnitude is above its pick-up setting) for a short duration (10 to 20 s), allowing the object causing the fault to fall clear of the line/equipment. The neutral circuit breaker will close and a reset time of 30 s is started. If successful (transient earth fault) it would have prevented a customer supply interruption.</p> <p>In the event of a permanent fault the normal feeder protection should clear the permanent fault, if the fault current is above the feeder's SEF or EF protection pick-up settings, within the 30 s reset time of the neutral circuit breaker by tripping all three phases (feeder breaker or an auto-recloser upstream of the fault).</p>
2	MV Sensitive earth fault (SEF)	As for MV earth fault above.	As for MV earth faults above.
3	MV Conductor on the ground on the source side of the fault	<p>This is a permanent fault, which may or may not fall into the sensitive earth fault category.</p> <p>The three phases will be disconnected by the feeder breaker or auto-recloser upstream of the fault, if the fault current is above the feeder's SEF or EF protection pick-up settings.</p>	<p>This is a permanent fault, which may or may not fall into the sensitive earth fault category.</p> <p>Initially only the neutral circuit breaker will be opened for a short duration (10 to 20 s), if the fault current magnitude is above its pick-up setting. The neutral circuit breaker will close and a reset time of 30 s is started during which the normal protection should clear the fault.</p> <p>The three phases will be disconnected by the feeder breaker or auto-recloser upstream of the fault, if the fault current is above the feeder's SEF or EF protection pick-up settings.</p>
4	MV Conductor on the ground on the load side of the fault	As above for the MV Conductor on the ground on the source side of the fault, if the fault is detected by both the neutral circuit breaker protection and normal feeder protection.	<p>As above for the MV Conductor on the ground on the source side of the fault, if the fault is detected by both the neutral circuit breaker protection and normal feeder protection.</p> <p>If the fault is only being detected by the neutral circuit breaker protection it will open and close again after the dead time. It will then stay closed for 30 s, the reset time, during which the normal protection should have operated. After expiry of the reset time the neutral circuit breaker will open again.</p>

5. Trial Site Proposal

5.1. Trial Site Selection

From the onset of this thesis the aim was to, through a literature study, determine the feasibility of a protection scheme specifically aimed at clearing of transient earth faults on an existing solid or resistance earthed MV network without customer supply interruptions. The low resistance earthed MV network is of special interest as it is widely applied within Eskom.

In Eskom, as it should be in all electricity supply utilities, there is an active drive to reduce the number of supply interruptions by, for example, performing required maintenance on time, replace obsolete equipment before failure rates escalate too much and to do effective vegetation management in substations and in line servitudes. Apart from these normal activities continuous improvement is sought through innovative thinking.

One initiative that came about is the proposal to establish a transient earth fault clearing (TEFCS) trial site to investigate a non supply disruptive method of earth fault clearing. The decision to establish a TEFCS trial site was based on guidance by findings during the literature study, taking into account the suitability of the existing MV networks to accommodate such a proposed method, the time frame within which a trial site may be established, consequential training of operators and network control centre personnel, and the actual trial site cost.

The literature study revealed advantages and disadvantages of different earthing methods, and although the Petersen coil earthed network seems to be favoured by many authors, it was decided to establish a TEFCS trial site based on the unearthed neutral network principle. This decision was mainly based on its simplicity of implementation and operation, the easy availability of the necessary equipment, relative inexpensiveness to implement, and the familiarity of staff with the equipment being used.

This trial site will be established on a typical Eskom rural overhead 3-wire delta configured 11 kV low resistance earthed network. The Eskom 11kV and 22kV overhead networks are being fed by star/delta substation power transformers and the customers are being supplied by pole-mounted delta/star distribution transformers. Any neutral voltage shift on the MV network would therefore not affect the customer's LV voltage levels. All star/delta substation power transformers have neutral earth compensators with neutral resistors (NECRs) on the delta side. The neutral resistor limits the earth fault current to 360 A per substation transformer.

The selected trial site is a 66/11 kV step-down substation comprising two 66/11 kV 10 MVA star/delta transformers with an NECR each, and four MV feeders out of the substation with a total combined length of 217 km overhead lines, including a small cable section on one of the feeders.

At this point it may be noted that the trial site is located in a high soil resistivity area comprising river sand and lots of boulders, where sensitive earth faults sometimes goes undetected by the conventional protection.

As part of the planned trial site a protection scheme specific to the TEFCS will have to be installed in the substation for controlling of the neutral circuit breaker. This protection scheme will physically function in isolation to the existing MV overhead feeder protection

schemes, and it will operate much faster than the conventional protection. Therefore there is no need for protection coordination between the TEFCS protection and the conventional protection of the MV feeders.

Due to the unavailability of an appropriately rated single phase circuit breaker a standard stock 3-phase pole-mounted auto recloser will fulfil this function. The recloser circuit breaker and control box will be mounted on an existing substation structure between the two NECRs. Two of the three recloser main contacts will be used to connect the two NECR neutrals to earth.

The station electrical diagram of the substation, identified for the proposed TEFCS trial site, amended to incorporate the neutral circuit breaker (auto-recloser) and its associated protection, is depicted in Figure 21.

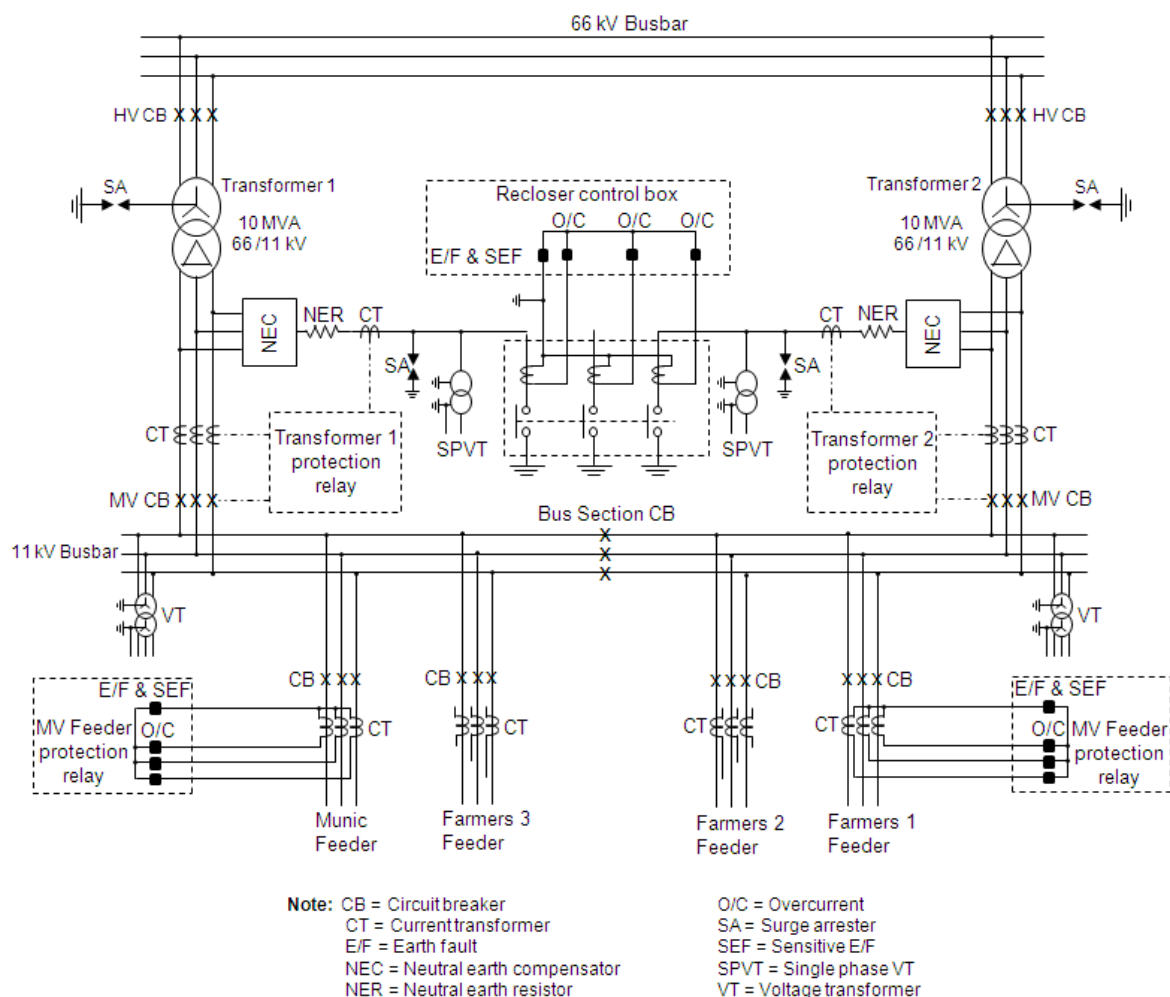

Figure 21: Station electrical diagram / AC key diagram of the proposed transient earth fault clearing scheme trial site substation.

For drawing clarity purposes only protection for two of the four MV feeders has been indicated on the station electrical diagram / AC key diagram of the trial site substation. Three of the MV feeders (Farmers 1, 2 & 3) are overhead and one is partly overhead and partly cable (Munic Feeder). The bus section circuit breaker is normally in the closed position and is normally only used during maintenance and substation fault situations. In the selected substation, as indicated in Figure 21, there are two MV feeders per bus section.

Interlinking points between the different MV feeders is not indicated on the diagram (see Figure 25). During commissioning testing of the trial site these interlinking points will be utilized to arrange the feeders from one feeder (fault throw feeder), two feeders, three feeders, or all four feeders on one busbar (bus section circuit breaker closed).

One major benefit of the Eskom MV overhead networks, with respect to implementation of the trial site, is that they are all fully insulated for phase-to-phase voltage to earth. This implies that all line insulators, surge arresters, all equipment connected to the lines and all substation equipment are fully insulated for normal phase-to-phase voltage to earth. All 3-wire MV networks utilize NECRs, of which the neutrals are fully insulated for normal phase-to-neutral voltage.

All pole-mounted line equipment is supposed to be fitted with gapless metal-oxide surge arresters (MOVs) with the following rating: 12 kV maximum continuous overvoltage (MCOV) and 10 kA peak value lightning current impulse (In). It is foreseen that these surge arresters will all contribute to quench any prospective overvoltages generated by arcing earth faults.

Even though the NECR neutrals are fully insulated for normal phase-to-neutral voltage, the neutrals will be further protected by equipping them with gapless metal-oxide surge arresters (MOVs) with the following rating: 8 kV maximum continuous overvoltage (MCOV) and 10 kA peak value lightning current impulse (In).

As all studied literature indicated that phase-to-earth capacitance (capacitive fault current) is the single most important factor limiting the implementation of an unearthed network earthing philosophy, it seems fitting to perform calculations to determine the line capacitance and line charging currents of the Eskom 3-wire delta configured 11 kV lines to be used for the trial site. The calculation results are deemed important due to the fact that Lehtonen et al, [2001, 1185] found 9.5 A and the German standard, VDE 0228 (1987) [Hänninen, 2001, 16 and Cucic et al, 2008, 82], specify 35 A to be the upper limit of capacitive fault current to still allow for reliable self-extinguishing of arcing earth faults.

Calculation of these phase-to-earth capacitance values and the prospective capacitive current magnitudes during earth fault conditions will provide some pre-commissioning knowledge about the fault currents to be expected during commissioning of the TEFCS.

The results of a few calculations are tabulated in Table 4. These calculations have been performed by means of MathCad and one set of calculations for the abovementioned MV line is attached in Annex A.

Table 4 should be read in conjunction with Figure 22 which indicates the capacitive current flow during an earth fault.

As one would expect, it may be seen from Table 4 that there is a linear increase in phase-to-earth capacitance and in capacitive charging current as the line length is increased. No provision has been made in the calculation for the effect of buildings or trees in close proximity to the lines, vegetation such as bushes and vineyards under the lines, variations in conductor height above ground level, and the proximity of other power lines. These factors may all have an influence on the phase-to-earth capacitance and may therefore influence the capacitive earth fault current magnitude, which may again have an effect on the success of arc quenching during an arcing earth fault.

Based on the literature study the abovementioned factors seem to be having a minor influence on the phase-to-earth capacitance as mention thereof was totally lacking from all the studied literature.

When comparing the calculated capacitive earth fault currents listed in Table 4 with the maximum current limits to ensure self-extinguishing of arcing earth faults, as proposed by Lehtonen et al [2001, 1185], 9.5 A, and by the German standard, VDE 0228 (1987) [Hänninen, 2001, 16 and Cucic et al, 2008, 82], 35 A, it effectively implies that the maximum total connected Eskom 11 kV feeder length connected to the same busbar should not exceed 39.4 km in the case of Lehtonen and 145.2 km in the case of the German standard.

This wide variation in allowable maximum capacitive earth fault current will have to be verified with the TEFCS trial site, if the network's capacitive current is large enough, as there are obviously environmental factors or line design/construction factors dictating the maximum allowable feeder length, which have not been addressed by the studied literature. The maximum allowable feeder length to ensure self-extinguishing of arcing earth faults will definitely determine the economic viability, or not, of the proposed transient earth fault clearing principle.

As may be seen from Table 4, the phase-to-phase capacitance values are about half the size of the phase-to-earth capacitance values, and this fact is also reflected in the total capacitive current flowing back to the source in the faulted phase. This will obviously not influence the self-extinguishing ability of arcing earth faults, as this additional capacitive current is not passing through the fault point, but may need to be taken into account when determining an appropriate protection setting for a feeder when operating as an unearthed network.

The phase-to-phase capacitive current magnitudes are determined by the physical conductor spacing and line length.

Physical selection of the transient earth fault clearing protection scheme trial site was based on the following criteria:

- Stakeholders of this specific Eskom substation and 11kV network are supportive of the idea to try a method specifically aimed at earth fault clearing that may be able to reduce the number of permanent faults and consequential network outages, in order to improve CAIDI and CAIFI performance figures.
- It is a rural network within reasonable distance from the main Eskom Distribution technical centre, thus making it easy to attend to unforeseen problems and enable regular site visits during the trial period.
- The selected network is a good representation of the average Eskom MV network and will not receive any special attention before or after installation of the trial site.
- All pole-mounted line equipment is equipped with gapless metal-oxide surge arresters (MOVs) with the following rating: 12 kV maximum continuous overvoltage (MCOV) and 10 kA peak value of a lightning current impulse (In). It is anticipated that the surge arresters will effectively clamp all large prospective overvoltage spikes, due to arcing earth faults, to an acceptable level during the time that the neutral circuit breaker is open, i.e. the unearthed network state.

Table 4: Capacitance values for a typical Eskom 3-wire delta configured overhead 11kV line with Hare conductor. The resulting capacitive currents during an a-phase earth fault are indicated for when the network is being operated as an unearthed network.

km	Phase-to-Phase Capacitance [μF]			Phase-to-Earth Capacitance [μF]			Normal Phase-to-Earth Capacitive charging Current [A]			Phase-to-Phase Capacitive Charging Current under Normal and Earth Fault conditions [A]			Phase-to-Earth Capacitive Charging Current during an Earth Fault [A]		Capacitive Fault Current Returning to the Source via the a-phase [A]	Total Capacitive Current Returning to the Source via the a-phase [A]
	C _{ab}	C _{bc}	C _{ca}	C _{ae}	C _{be}	C _{ce}	I _{ae}	I _{be}	I _{ce}	I _{ab}	I _{bc}	I _{ca}	I _{be}	I _{ce}	I _f	I _{Capacitive total}
1	0.0198	0.0191	0.0198	0.039	0.040	0.040	0.077	0.080	0.080	0.068	0.066	0.068	0.139	0.139	0.241	0.359
10	0.198	0.191	0.198	0.39	0.40	0.40	0.77	0.80	0.80	0.68	0.66	0.68	1.39	1.39	2.41	3.59
100	1.98	1.91	1.98	3.9	4.0	4.0	7.7	8.0	8.0	6.8	6.6	6.8	13.9	13.9	24.1	35.9

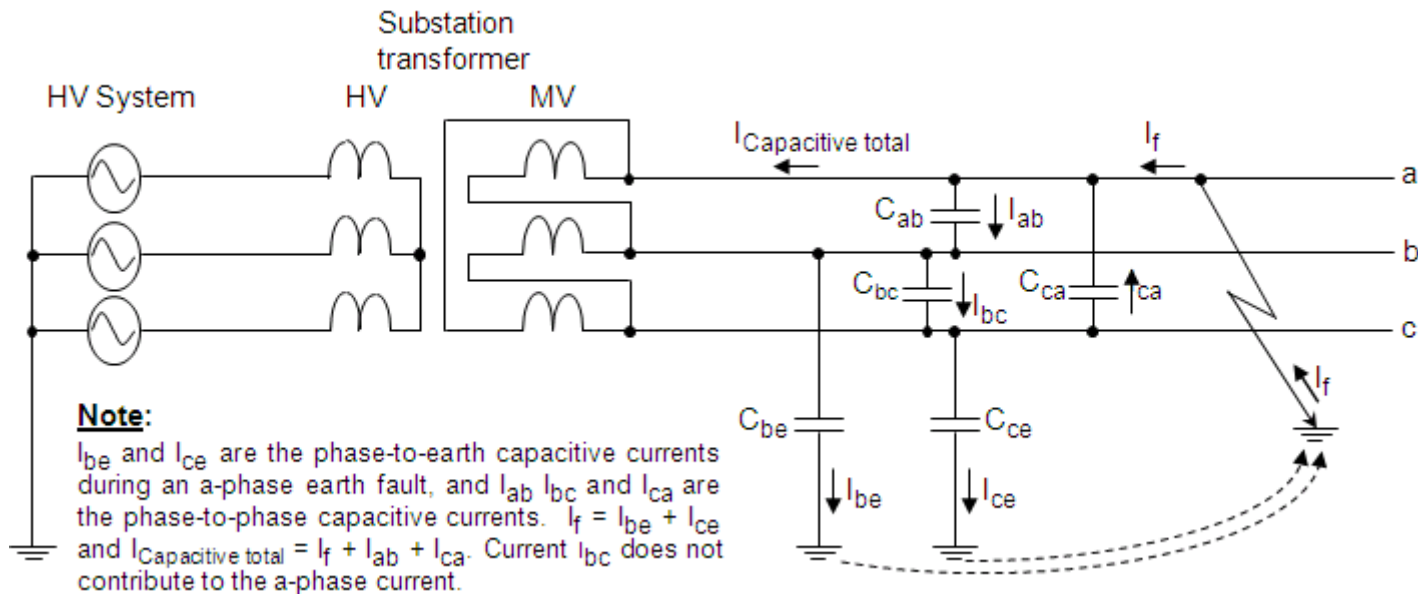

Figure 22: Overhead line capacitances and capacitive currents flowing during an a-phase earth fault. C_{ae} is not shown as it is effectively short circuited by the a-phase earth fault.

5.2. Trial Site Preparation

Briefly the following should be done to prepare the trial site for testing:

- All stakeholders, including the controllers at the Regional Network Control Centre, will be properly briefed about the trial site and its intended operation methodology before commissioning and testing of the protection scheme.
- All relevant official Eskom plant drawings will be updated to reflect the new equipment and cabling to be installed at the identified substation as the Regional Network Control Centre needs to be aware of all switchable equipment on all networks under its control.
- It needs to be ensured that all modifications are being done in a safe manner and that all conform to Eskom's electrical and safety standards.
- As indicated in section 5, a standard 3-phase pole-mounted auto recloser will be employed as the neutral circuit breaker due to the unavailability of a suitably rated single phase circuit breaker. The neutrals of the two NECRs will be connected to earth via two of the three recloser circuit breaker poles.
- The neutral circuit breaker, a single 3-phase pole-mounted recloser in this case, will be indicated on the single line system diagram at the Regional Network Control Centre, as if for a permanent installation.
- Two single phase VTs will be installed to monitor the neutral-to-earth voltage on each of the two NECR neutrals.
- The existing 11 kV 3-phase busbar VT on the bus section, onto which the fault throw feeder terminates, will be used by disturbance recorders in the relay room during the commissioning tests, as well as for monitoring the TEFCS's performance for some time after putting the trial site into service.
- Although it is a standard Eskom MV overhead network protection philosophy to have surge arresters installed at vulnerable primary plant equipment such as pole-mounted distribution transformers, pole-mounted reclosers, pole-mounted sectionalizers, pole-mounted capacitor banks, and pole-mounted voltage regulators, the actual installation thereof needs to be verified and defects corrected if encountered. This exercise is required in order to protect the network against the claimed prospective overvoltages as a result of arcing earth faults. These surge arresters are rated for 12 kV maximum continuous overvoltage (MCOV).
- A surge arrester of lower rating than the phase-to-phase voltage rated surge arresters will be installed on each of the two NECR neutrals in order to clamp any overvoltage spikes to a value close to, but greater than the normal phase-to-neutral voltage. A suitable surge arrester rating for this duty would be a standard Eskom 6.6 kV surge arrester rated at 8 kV maximum continuous overvoltage (MCOV).

- Disturbance recorders will be set up to record the following:
 - 11 kV busbar voltage via 3-phase busbar VT on the fault throw feeder's bus section.
 - Fault throw feeder's 3-phase currents.
 - Neutral voltages of the two NECRs.
 - NECR neutral currents.
 - Status of the neutral circuit breaker's main contact.
- Three customer installations have to be identified where quality of supply loggers are to be installed for the duration of the fault throws.
 - One close to the fault throw position.
 - The second near the end of the fault throw line.
 - The third one is to be installed at a customer supply point on one of the adjacent feeders.
- The controller of the pole-mounted auto-recloser to be used as neutral circuit breaker is able to provide all the required protection/control functionality and no special modifications are required.
- A special input/output electronic module needs to be added to the standard recloser in order to obtain external open and close indications to trigger the disturbance recorders.
- A suitable position has to be identified on one of the four available MV feeders at which fault throws may be done safely.
- Barricade netting, fire extinguishers and spades have to be arranged for the selected fault throw site on the day of the fault throws.
- All stakeholders are to be briefed on the operation of the TEFCS and what tests are to be conducted during the two commissioning days set aside for this exercise.
- It is to be arranged that a "local control" be established on the fault throw days in order to allow the operator on site to perform switching on the network without first reporting to the Regional Control Centre. This entails that the network be handed out to the operator on site. He then controls all switching operations from the fault throw location itself, and once all testing have been finished successfully, and the TEFCS is functioning as designed, the network is returned to its normal state, inclusive of the TEFCS, and handed back to the Regional Control Centre.

6. Test Protocol

General

Before any tests are to be conducted a risk assessment has to be performed and all persons present are to be made aware of the identified dangers, and all present are to sign the risk assessment as proof that they have been informed of the identified risks.

The actual trial site network (fault throw network) is exactly the same as that depicted in Figure 21. The 11 kV network is so designed that the feeders may be interlinked by means of strategically placed normally open points. See Figure 25. This feature is a requirement to determine the effect different line lengths (change in phase-to-earth capacitance) may have on the ability of an arc to self-extinguish.

6.1. Tests to be Conducted

It is envisaged that a number of earth fault throws be conducted on the TEFCS trial site, with the aid of the test arrangement shown in Figure 23, in order to verify correct operation during transient and bolted earth fault conditions.

The purpose of the fault throws is primarily to:

- Measure the capacitive fault current during a bolted earth fault when the neutral circuit breaker is open (unearthed network).
- Established if arcing earth faults do produce the harmful overvoltages as claimed by many literature sources.
- Establish to what extent the network's surge arresters are able to clamp overvoltages, if they are being generated during arcing earth faults.
- For a given spark gap size, determined up to what capacitive fault current level (network size) consistent self-extinguishing of arcing earth faults is still possible for the given 11 kV trial site network.
- Determined the minimum spark gap size that will allow consistent self-extinguishing of arcing earth faults for the maximum available 11 kV trial site network size (maximum capacitive earth fault current).
- Prove that the TEFCS can function as an integral part of the 11 kV network protection, without negatively interfering with the existing MV feeder or transformer protections.

For the overvoltage tests it is envisaged that a number of arcing earth faults will be initiated on the largest network configuration possible in order to obtain the largest possible capacitive fault current from the given network, which represents the worst case insofar arcing earth faults are concerned.

The tests to determine the maximum capacitive fault current level which still allows reliable arc extinction across a given spark gap will have to be conducted with some network sections disconnected from the same busbar as to which the “faulted feeder” is connected to in order to establish a trend.

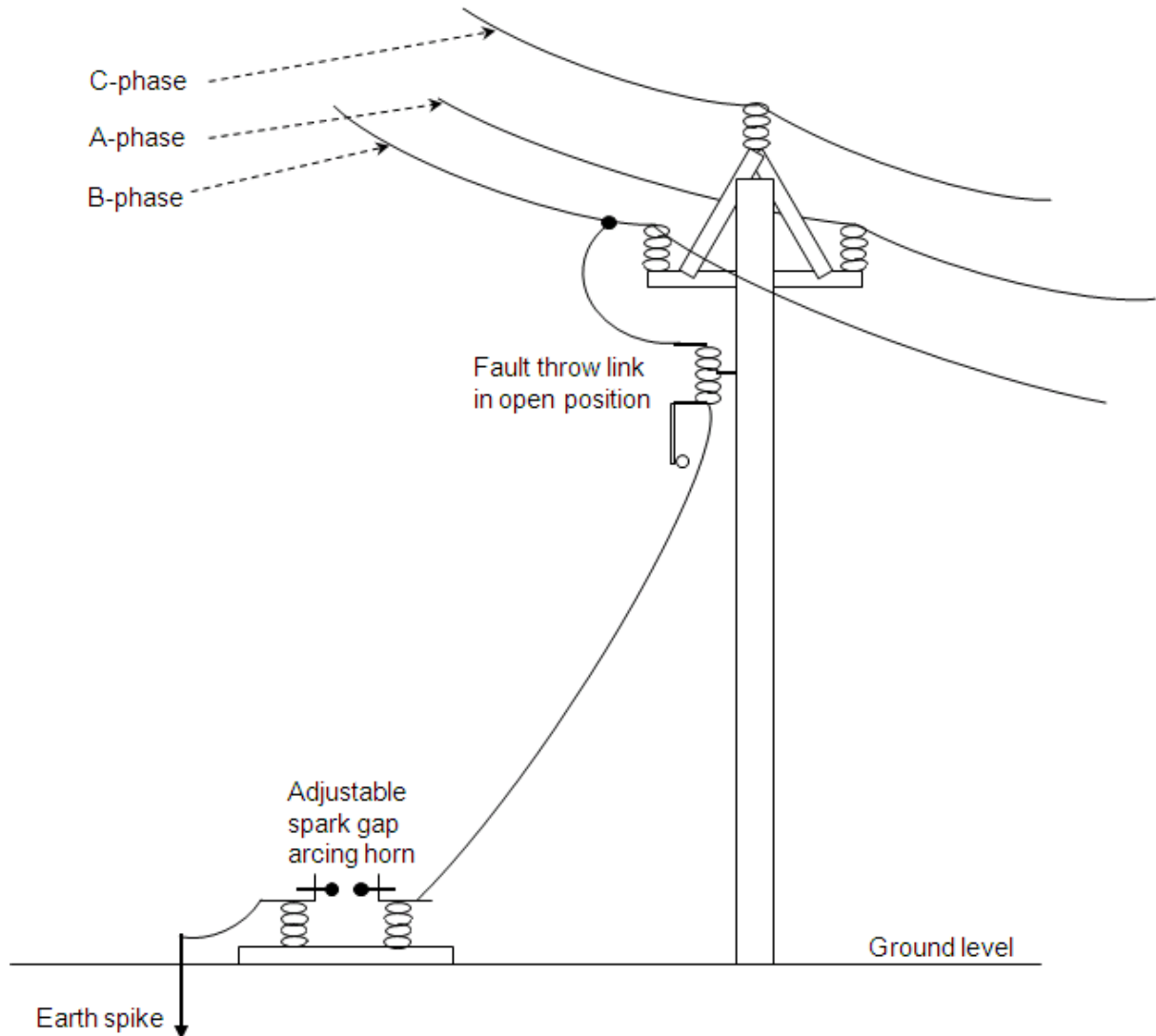

Figure 23: Fault throw arrangement showing fused link, arcing horn and earth spike.

A specially constructed adjustable arcing horn (Figure 24) will be employed to simulate arcing earth faults with.



Figure 24: Arcing horn for establishing arcing and transient earth faults with.

In an attempt to obtain the required information as listed above, the following six tests will be conducted:

Test 1:

Purpose: To measure the three MV phase voltages to earth on the network under test with one phase solidly earthed (arcing horn bypassed), and the neutral circuit breaker in the open position (unearthed network).

Pre-test network state: The complete network is connected to the same 11 kV busbar, the neutral circuit breaker is in the closed state and the fault throw link is open. The neutral circuit breaker protection is disabled.

Step 1: Deactivate the sensitive earth fault (SEF) protection on all four MV feeder protection devices within the substation, and on the recloser upstream (REC2516) of the fault throw point.

Step 2: Open the neutral circuit breaker.

Step 3: Apply a bolted earth fault to one of the overhead feeder conductors at the test position by means of the fault throw link, as indicated in Figure 23.

Step 4: With a MV voltmeter manually measure and record the voltages to earth of all three phases at the fault point, at a point about half way between the fault throw point and the end of the feeder, and at a point close to the end of the overhead feeder.

Step 5: Measure and record the capacitive fault current at the fault point.

Step 6: Remove the earth fault, by opening the fault throw link.

Step 7: Close the neutral circuit breaker.

Test 2:

Purpose: To establish the extent of overvoltages produced by arcing earth faults on an unearthed network. For this sustained arcing will be initiated between the arcing horns of the arcing horn test rig indicated in Figure 23.

Pre-test network state: The complete network is connected to the same 11 kV busbar, the neutral circuit breaker is in the closed state and the fault throw link is open. The neutral circuit breaker protection is disabled.

Step 1: Deactivate the SEF protection on all four MV feeder protection devices within the substation, and on the recloser upstream of the fault throw point.

Step 2: Ensure that the whole network is connected to the same 11 kV busbar.

Step 3: Adjust the arcing horn's spark gap to 10 mm

Step 4: Bridge the gap with thin (0.2 mm diameter) wire strand. (The capacitive fault current needs to burn off the binding wire.)

Step 5: Open the neutral circuit breaker.

Step 6: Close the fault throw link to initiate an earth fault via the arcing horn's spark gap.

Step 7: Measure and record the capacitive fault current at the fault point while the arc is maintained.

Step 8: If the thin wire strand does not burn off, open the fused link, close the neutral circuit breaker, substitute the binding wire with a thinner binding wire and repeat from Step 5.

Step 9: If arcing across the spark gap does not clear within about 15 s open the fused link.

Step 10: If the arcing quenched by itself, open the fused link.

Step 11: Close the neutral circuit breaker.

Step 12: In the case of sustained arcing record the spark gap length and repeat the test once more from Step 4 (to establish if the attained overvoltages are of similar magnitude for every fault).

Step 13: If the fault cleared by itself open the fault throw link.

Step 14: Close the neutral circuit breaker.

Step 15: Decrease the spark gap by 2 mm and repeated the test from Step 4.

Step 16: Record the arcing horn gap size which does not allow self-extinguishing of arcing earth faults.

Test 3:

Purpose: To established the effect of feeder length (influence of line conductor capacitance-to-earth size) on the self-extinction ability of an arc across an air gap.

Pre-test network state: The complete network is connected to the same 11 kV busbar, the neutral circuit breaker is in the closed state and the fault throw link is open. The neutral circuit breaker protection is disabled.

Step 1: Deactivate the SEF protection on all four MV feeder protection devices within the substation, and on the recloser upstream of the fault throw point.

Step 2: Link all feeders to the same 11 kV bus section.

Step 3: Use the recorded spark gap length at which sustained arcing was established, as measured in Step 14 of Test 2.

Step 4: Increase the arcing horn's spark gap by 2 mm from that in Test 2.

Step 5: Bridge the gap with thin (0.2 mm diameter) wire strand.

Step 6: Open the neutral circuit breaker.

Step 7: Close the fault throw link to initiate an earth fault via the arcing horn's spark gap.

Step 8: Measure and record the capacitive fault current at the fault point.

Step 9: If arcing across the spark gap does not clear within about 15 s open the fault throw link:

- Close the neutral circuit breaker.
- Repeat test from Step 4.

Step 10: If the fault cleared by itself open the fault throw link.

Step 11: Close the neutral circuit breaker.

Step 12: Repeat the test a few times from Step 5 in order to establish consistent arc clearance.

Step 13: Record the smallest arcing horn gap size which does allow repeated self-extinguishing of arcing earth faults.

Step 14: Ensure that the 11 kV bus section circuit breaker is closed.

- Step 15:** Move an 11 kV feeder (not the fault throw feeder) to the other 11 kV bus section, away from the test feeder's bus section.
- Step 16:** Open the bus section circuit breaker (Ensure that transformer overloading will not be a problem).
- Step 17:** Decrease the arcing horn spark gap by 2 mm and record the gap length.
- Step 18:** Repeat test from Step 5, but where a repeat is required of Step 4, decrease the spark gap instead of increasing it as requested, until the fault throw feeder alone is on one 11 kV bus section.

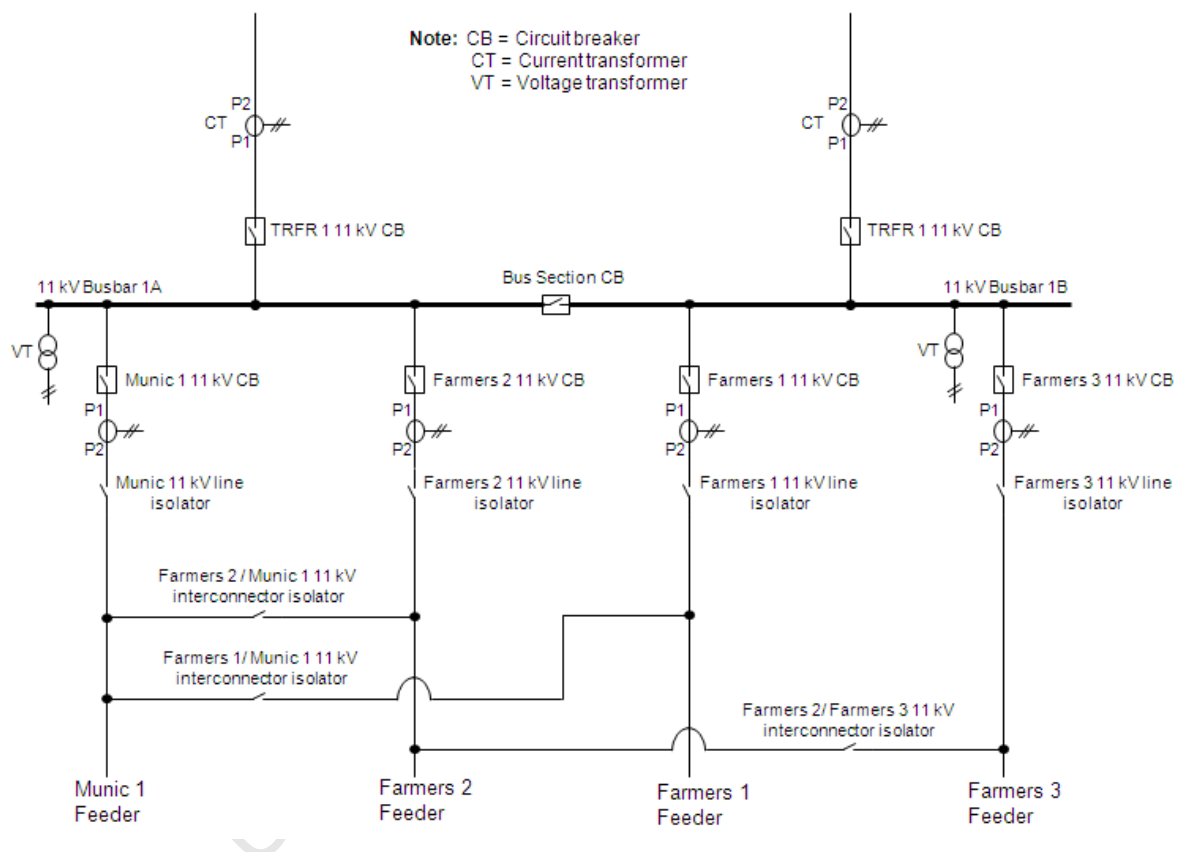

Figure 25: TEFCS trial site substation's 11 kV station electrical diagram.

Switching sequence during Test 3, as per Figure 25 ("F" designates a Farmers feeder):

- Test 3 a):**
- CBs closed – F1; F2; F3 ; Munic 1 & 11kV bus section
 - CBs open - None
 - Isolators closed – F1 line; F2 line; F3 line; Munic 1 line
 - Isolators open - F1/Munic 1; F2/Munic 1; F2/F3

Test 3 b): CBs closed – F1; F2; F3 (Fault throw feeder (F1), Munic 1 and F3 on the same busbar)

CBs open - Munic 1 & 11kV bus section

Isolators closed – F1 line; F2 line; F3 line, Munic 1 line; F1/Munic 1

Isolators open -; F2/Munic 1; F2/F3

Test 3 c): CBs closed – F1; F2; F3 & Munic 1 (Fault throw feeder (F1), and F3 on the same busbar)

CBs open - 11kV bus section

Isolators closed – F1 line; F2 line; F3 line; Munic 1 line

Isolators open - F1/Munic 1; F2/Munic 1; F2/F3

Test 3 d): CBs closed – F1; F2 & Munic 1 (Fault throw feeder (F1) alone on a busbar)

CBs open - 11kV bus section & F3

Isolators closed – F1 line; F2 line; Munic 1 line; F2/F3

Isolators open - F1/Munic 1; F2/Munic 1; F3 line

Test 4:

Purpose: To verify correct automatic operation of the TEFCS, due to a tree branch causing an arcing earth fault by wiping/sweeping across the gap between a live conductor and earth.

Pre-test network state: The complete network is connected to the same 11 kV busbar, the neutral circuit breaker is in the closed state and the fault throw link is open. The neutral circuit breaker protection is enabled.

Step 1: Activate all SEF protection that has previously been disabled on the 11 kV network.

Step 2: Adjust the arcing horn gap to the largest air gap size used in Test 3 (no bridging wire).

Step 3: Attach a small green (blue gum/pine) tree branch to the end of an operating stick.

Step 4: Close the single phase fault throw link to liven up the one side of the arcing horn.

Step 5: Slowly pass the branch over the arcing horn gap, in a direction from the live conductor towards the earthed end of the arcing horn in order to simulate a tree branch making contact with a live conductor and slowly moving away again.

- Step 6:** Measure and record the fault current at the fault point.
- Step 7:** Observe and record whether the neutral circuit breaker opened.
- Step 8:** As soon as the arc is cleared, due to the neutral circuit breaker opening, remove the tree branch.
- Step 9:** Observe that the neutral circuit breaker close again after the 10 s dead time.
- Step 10:** Repeat the test a number of times from Step 4, but wait for the neutral circuit breaker reset time of 30 s (the normal protection should operate for a fault within this time) to expire before applying the next fault. Note that from the second fault onward a reset time will have to be allowed for as the neutral circuit breaker will only perform one ARC operation and then stay closed for this reset time, during which the normal protection is supposed to clear a permanent fault.
- Step 11:** Immediately after the neutral circuit breaker has closed, after the last tree branch fault was applied, apply a tree branch fault again for about 2 seconds and observe (and record) that the neutral circuit breaker does not open. (It is assumed that the fault current will be above the SEF pickup, and by removing the fault after about 2 seconds, SEF operation and consequential feeder breaker operation will be prevented.)

Test 5:

Purpose: To verify correct operation for a **transient** earth fault by the TEFCS in co-operation with the standard 11 kV feeder protection schemes when an arc is establishing across the arcing horn air gap by means of a thin wire strand strung between the poles of the arcing horn test rig.

Pre-test network state: The complete network is connected to the same 11 kV busbar, the neutral circuit breaker is in the closed state and the fault throw link is open. The neutral circuit breaker protection is enabled. All 11kV feeder protection is in the normal state.

- Step 1:** Activate all SEF protection that has previously been disabled on the 11 kV network.
- Step 2:** Link all feeders to the same 11 kV bus.
- Step 3:** Adjust the arcing horn gap to the size that would allow reliable self-extinguishing of an arcing earth fault, as found in Test 3 for the complete network.
- Step 4:** Bridge the gap with a thin (0.2 mm diameter) wire strand.
- Step 5:** Close the fault throw link to initiate an earth fault across the arcing horn.
- Step 6:** The neutral circuit breaker should open immediately and stay open for a 10 s dead time.
- Step 7:** Arcing should stop during the neutral circuit breaker's dead time.

Step 8: The neutral circuit breaker should close after expiry of the dead time and no further action should take place.

Step 9: Repeat the test a number of times from Step 4.

Test 6:

Purpose: To verify correct operation of the TEFCS operation in conjunction with the standard 11 kV feeder protection schemes when a **permanent** earth fault is applied. This action should cause the upstream recloser (REC2516), to trip, go through its auto-reclose cycle, and lock out.

Pre-test network state: The complete network is connected to the same 11 kV busbar, the neutral circuit breaker is in the closed state and the fault throw link is open. The neutral circuit breaker protection is enabled. All 11kV feeder protection is in the normal state.

Step 1: Activate the SEF protection on all the protection devices on the test feeder.

Step 2: Ensure that all feeders are linked to the same 11 kV bus.

Step 3: Bridge the arcing horn gap with an adequately rated conductor able to handle the maximum expected earth fault current.

Step 4: Close the fault throw link to initiate a solid earth fault.

Step 5: The neutral circuit breaker should open immediately and stay open for the set 10 s dead time.

Step 6: Measure the capacitive earth fault current at the fault point during the neutral circuit breaker's dead time.

Step 7: The neutral circuit breaker should close after expiry of the dead time and a reset timer (30 s) should start automatically, effectively disabling the neutral circuit breaker protection for 30 s (longer than the longest expected fault clearing duration, which should effectively be longer than the sensitive earth fault timer setting and the ARC cycle of the feeder breaker protection).

Step 8: The recloser upstream from the fault point (REC2516) should detect the earth fault current and go through its set auto-reclose cycle and lock out in the open position.

Step 9: The neutral circuit breaker protection reset timer should time out after the set 30 s, and reset the protection to its normal state, ready for the next earth fault.

6.2. Test Instruments Required

- Three QOS loggers: Two QOS loggers to log the 400 V supply voltages at two customer installations on the faulted feeder (Farmers 1), one about half way between the substation and the fault throw point, and one about half way between the fault throw position and the end of the feeder. A third QOS logger will be installed on one of the other feeders (Farmers 2) to monitor an additional customer 400 V supply point. The three QOS loggers will be set to continuously monitor the three customer supply point voltages for the duration of the commissioning tests.
- Two disturbance recorders for recording the 11kV busbar voltage, the phase currents of the faulted feeder, the two NECR neutral voltages to earth, the NECR neutral currents, and the neutral circuit breaker main contact status. The one recorder is essentially a back-up for the first. Disturbance recorders within the substation is to be triggered upon every neutral circuit breaker trip and close operation, on an 11 kV busbar overvoltage condition with respect to earth of more than 15% of the nominal phase-to-neutral voltage, and on a NECR neutral overvoltage with respect to earth of more than 2 % the nominal phase-to-neutral voltage. The recorder's sampling rate will be set to 2.5 kHz, 500 ms pre-trigger recording duration and total recording duration of 2 s.
- Two medium voltage (40 kV) voltmeter, operating stick mountable, for measuring the three phase voltages to earth during a bolted earth fault on the third phase at the fault point, at a point half way between the fault throw point and the end of the faulted feeder, and at the end of the faulted feeder.
- A medium voltage (40 kV / 0 to 2000 A rms), ammeter, operating stick mountable, for measuring the capacitive earth fault current at the fault throw point during the different tests.
- A specially constructed arcing horn test rig with adjustable spark gap.
- Tape measure for adjusting the arcing horn's spark gap length.
- A cut-out base with solid link for initiating all the test faults.
- Two way radios for communication between all measurement points.
- Earth resistance tester for measuring the earth electrode's resistance to earth at the fault throw point.

7. Risks

A fault throw inherently has an element of risk as a network fault is deliberately initiated, but if conducted in a well planned and orderly fashion it could be conducted without any risk to personnel, as has been done on previous occasions on the same network. As far as network equipment is concerned there is always a risk that equipment may fail during a fault situation, but in this respect a fault throw fault is no different from a “normal” network fault.

The following risks applicable to the commissioning phase of the trial site, have been identified

- All stakeholders should be well informed of what the tests entail and what the responsibility of each person would be.
- At the fault throw site one person should be in charge of the operation.
- All personnel on site at the fault throw are to keep well clear of the applied fault and surrounding area in order to minimize the risk of step potentials and accidental contact with live parts. The fault throw area will be barricaded to prevent accidental entry.
- If public safety becomes a concern during the fault throw, a person is to be assigned the duty to keep them at a safe distance from the fault throw site.
- Spades should be kept at hand on the fault throw site as fault point arcing may cause a veld (bush) fire.
- An operator should be located at the substation in order to ensure that the neutral breaker does not inadvertently lock out in the open position and leave the MV network in an unearthed state for an extended period.
- An operator should be located at the fault throw site in order to close and open the single phase fault throw link which will be used to initiate the single phase faults, and to ensure that everyone on site adheres to the required HV Regulations.
- Good communication between all stakeholders is of extreme importance during the fault throws as all actions are to be clearly communicated to all involved in order to take the correct action when required.
- Depending on the magnitude of the literature-claimed overvoltages expected to be experienced during the fault throws, there may be some flashovers or surge arrester failures on the network. This should be expected as the insulation of some devices on the network may have degraded over time and an imminent failure may have been due anyway. Such failed equipment should be replaced, as soon as its failure has become known, before continuing with further fault throws. Some of these failures may not result in permanent faults and may therefore not be detected during the testing phase, but it may only be discovered during regular scheduled line patrols.

8. Trial Site Commissioning Test Results

General

Two sets of two days, a week apart, were set aside for conducting commissioning tests of the TEFCS. The second set of two days was reserved for backup test day in the event that something unforeseen should happen, such as bad weather, or emergency fault repairs, preventing the tests from taking place during the first set of two days.

While conducting the first test (Test 1 of section 6.1) on the very first day of commissioning testing, a combined current and voltage transformer (CT/VT metering unit), used at a 1 MVA metering point, failed catastrophically due to an internal insulation failure. From disturbance recordings captured during the test it was possible, afterwards, to see the insulation failure development over time. Initially, while the neutral circuit breaker was open, an earth fault developed, which then developed into a 3-phase fault upon which the unit failed. This incident happened about a kilometre from the substation during application of the solid earth fault on the B-phase of the 11 kV network. Fault currents recorded by the affected feeder's protection relay were about 5500 A per phase. Figure 26 depicts the failed CT/VT metering unit.



Figure 26: Failed CT/VT metering unit.

Due to this incident testing had to be stopped and all attention was shifted to getting supply restored to the affected customers.

This then lead to testing being postponed to the following week.

On the first test day the second week, everything went according to plan and it was managed to complete all required testing more or less as planned within one day.

The 11 kV test site has four 11kV feeders (delta configuration as depicted in Figure 27) feeding from a single busbar equipped with a bus section circuit breaker. The bus section circuit breaker, together with feeder interlinking points as depicted in Figure 25, allowed for different network configurations in order to attempt to simulate different feeder lengths connected to the faulted feeder bus section.

The total combined trial site MV feeder length, including all spurs, is 217 km.

A small section (4.443km) of the total Eskom trial site network consists of cable instead of overhead conductors. One of the Eskom overhead MV feeders (Munic feeder), however, supplies a small town of electricity, and the town obviously has its own underground cable reticulation network of a few kilometres.

Use was made, during the fault throw tests, of a pole-mounted recloser's earth electrode conveniently located at the fault throw site.

The resistance-to-earth of this earth electrode was measured to be 90 ohm.

Depicted in Figure 28 is the purposely built arcing horn used to facilitate the fault throws in order to verify operation of the TEFCS. On the right hand side of the arcing horn is the conductor leading to the fault throw link connected to the B-phase of the 11 kV line. On the left hand side is the conductor leading to the earth electrode. The bare earthing conductor was elevated from ground level by putting it on insulators in order to prevent veld fires due to arcing between the earthing conductor and earth, as was experienced during Test 1 when the CT/VT metering unit failed. Also shown on the left, hanging from the earth conductor, is a MV rated ammeter for measuring the earth fault current.

The fault throw link between the arcing horn and the B-phase of the 11 kV line was manually operated with a link stick, also visible in the picture.

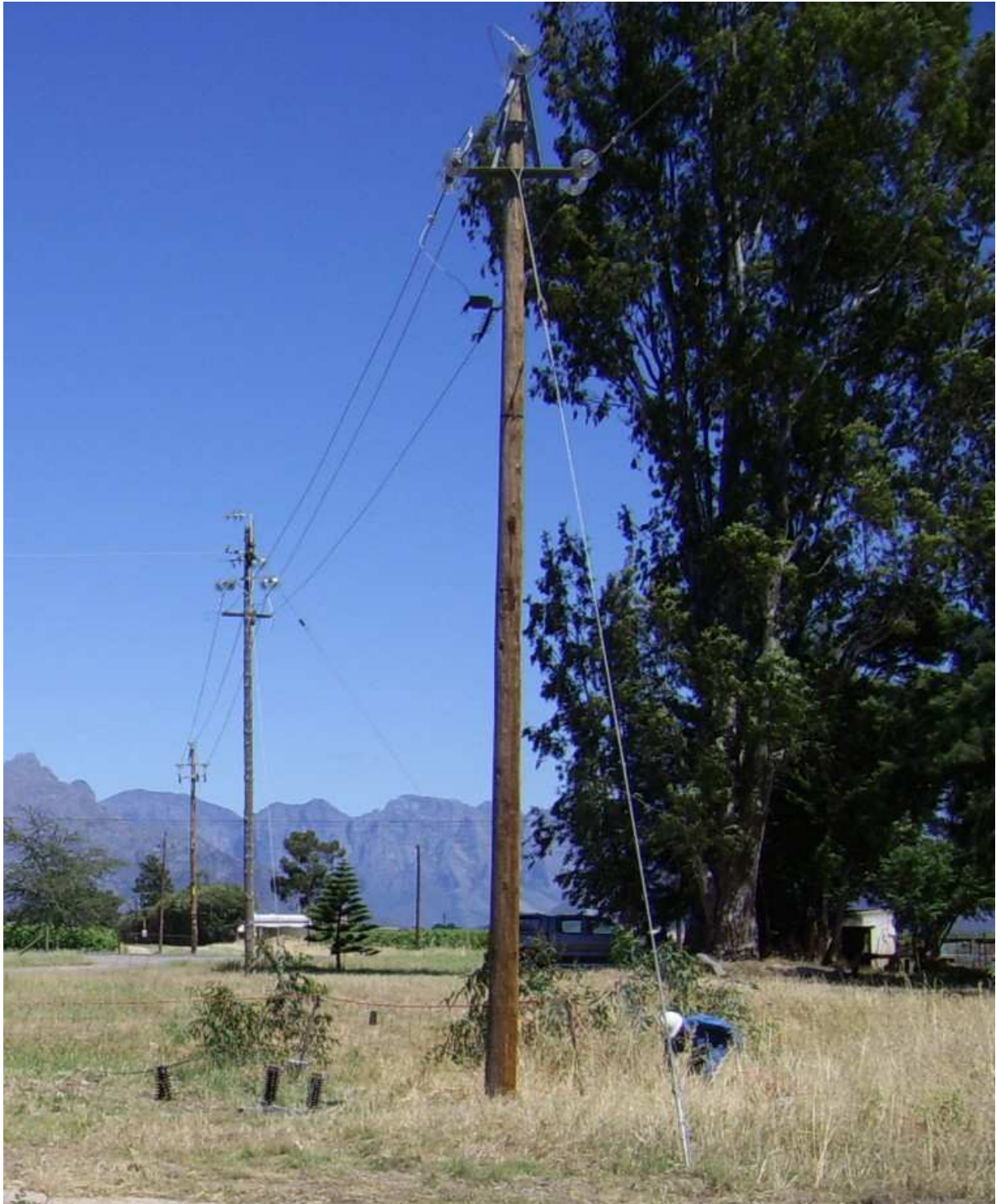

Figure 27: The actual fault throw point. Note the delta configuration line construction and the single phase cut-out base mounted on the closest pole, just below the phase conductors. A solid link was inserted into the cut-out base for initiating all the fault throws. The arcing horn is located on the ground to the left of the first pole.



Figure 28: The actual arcing horn purposely built to facilitate the fault throws in order to verify operation of the TEFCS.

It is important to note the following issues regarding the test phase disturbance recordings dated 17 and 24 November 2010:

- Voltages are displayed as primary values.
- Currents are displayed as primary values.
- Unfortunately the neutral CB open and close indications were accidentally not wired to disturbance recorder 2 during the commissioning tests, and therefore they are not being displayed by recordings from this device. This omission has been corrected subsequent to the commissioning test phase.
- There is a time lag of between 40 ms and 100 ms from the time that the neutral circuit breaker's main contacts open (or close) until the circuit breaker's auxiliary contacts are actually reflecting the main contact status. This delay will be noticed on all recordings from recorder 1. This is an inherent non-deterministic delay within the recloser as processor power is prioritised and the most important functions are serviced first.
- The main recorder, recorder 1, which recorded all three phase voltages and currents of the fault throw feeder, NECR 1 neutral voltage and current, as well as the neutral circuit breaker status, failed early during Test 2 on the second test day (24 November

2010). Fortunately recorder 2 recorded without a problem and provided some good recordings, but due to the limitation of the number of physical analogue inputs the B-phase voltage and current of the fault throw feeder could not be recorded. At the time of programming recorder 2 it was not known which phase was the actual fault throw phase. This only became known during the first fault throw, unfortunately too late for reprogramming of the recorder.

- All earth faults were applied to the B-phase of the test network by manually closing the fault throw link by means of a link stick.
- Note that the measurements listed on the right hand side of the disturbance recordings are those during the fault condition.

8.1. Test 1

Network status upon fault application: All four MV feeders were connected to the same busbar, and the neutral circuit breaker was open.

Protection status upon fault application: The neutral circuit breaker protection disabled. SEF switched off on all four MV feeders and on the recloser upstream of the fault throw point.

Spark gap: Was bridged out with a portable earth conductor in order to establish a solid earth fault upon closing the fault throw link.

Actions: The solid earth fault was sustained for 8 minutes and 20 seconds, after which the CT/VT metering unit failed catastrophically, and the feeder circuit breaker tripped. At this point the fault throw link was opened. The long fault application duration was not intentional, but it was due to time delays in getting the voltage measurements executed at the fault throw point, a point half way between the fault throw point and the feeder end, and at the end of the feeder.

Measurements: Figure 29 is relevant.

The Capacitive earth fault current measured at the fault point was about 16 A.

The NECR neutral voltage increased from zero to 6.3 kV with respect to earth at the instant of fault application.

The two healthy phase voltages rose from the normal phase-to-neutral voltage of 6.35 kV to 10.5 kV and 11.8 kV respectively, with respect to earth.

The faulted phase's phase-to-earth voltage measured at the substation was 1.35 kV, 0.1 kV at the fault throw point and 0.62 kV at the end of the faulted feeder.

Observations: This test proved that, when applying a solid single phase earth fault to an unearthed network, the two healthy phases rise to about full normal phase-to-phase voltage with respect to earth, and that the NECR neutrals will rise to about normal phase-to-earth voltage with respect to earth. The neutral voltage rise will depend on the voltage drop magnitude across the fault point, in this case the earth electrode employed at the fault throw

point. The higher the voltage drop across the earth electrode, the lower the NECR neutral voltage rise above earth potential will be.

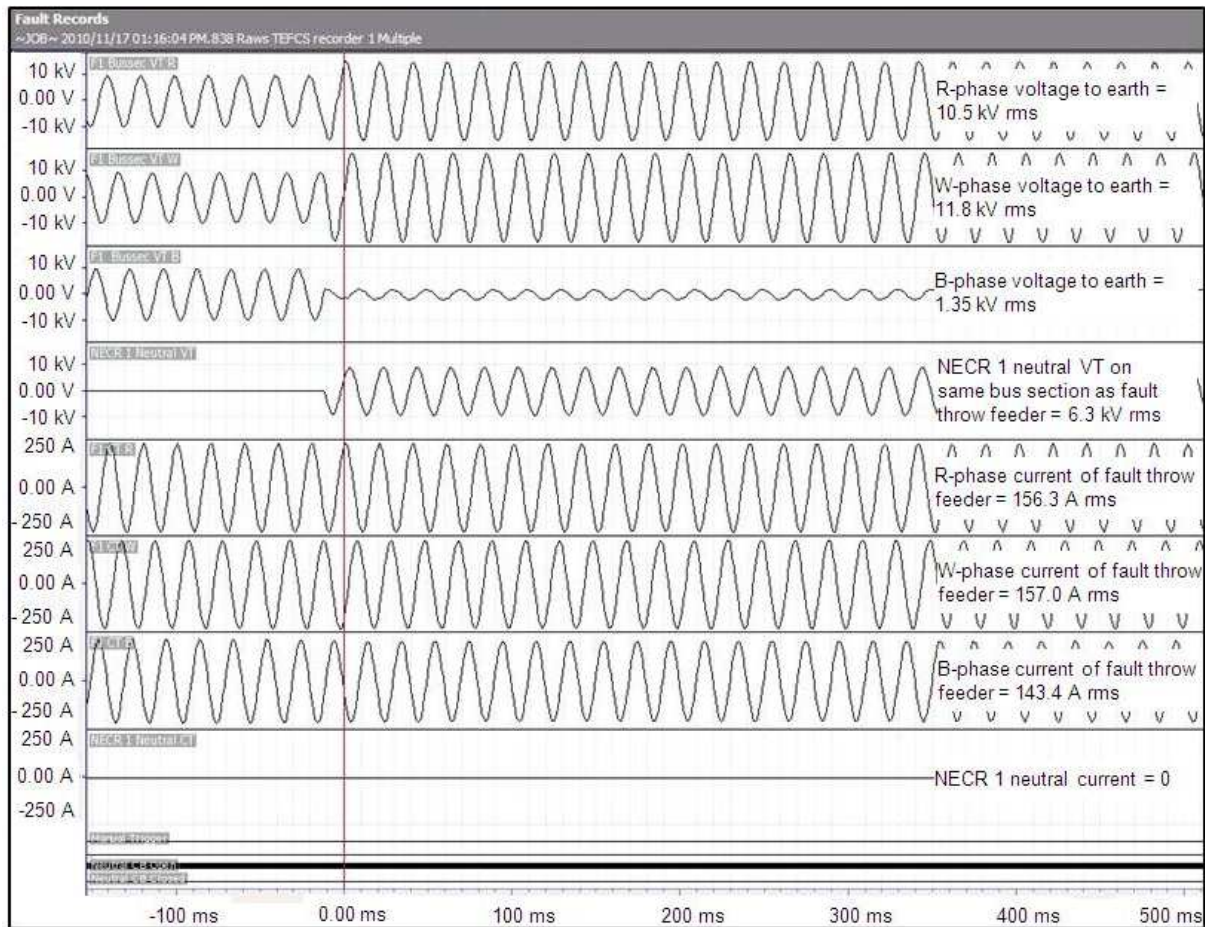

Figure 29: With neutral circuit breaker open a solid B-phase earth fault is applied to the B-phase. Note drop in B-phase voltage and rise in NECR neutral voltage and R- & W-phase voltages.

8.2. Test 2

Network status upon fault application: All four MV feeders were connected to the same busbar, and the neutral circuit breaker was open.

Spark gap: Was set to 10 mm, 7 mm and 4 mm alternatively, and bridged with a thin wire strand on each occasion before closing of the fault throw link.

Actions: It was attempted to generate sustained arcing across the spark gaps. Sustained arcing across the spark gap was allowed to carry on for about 25 seconds, after which the fault throw link was opened to clear the fault.

Measurements: Figure 30, Figure 31 and Figure 32 are relevant.

The Capacitive earth fault current measured at the fault point during sustained arcing across the 4 mm spark gap was about 18.5 A (neutral circuit breaker open).

Note that the NECR 2 neutral current is clipped in the disturbance recordings due to a recorder scaling error. The current of NECR 1 is correct and should be multiplied by 2 to obtain the total transformer neutral current.

The faulted phase-to-earth voltage measured at the fault throw point varied between 1.9 and 5.4 kV during the sustained arcing.

Observations: Due to a misunderstanding between the control officer and me, the first two tests (10 mm and 7 mm spark gaps) were conducted with the neutral circuit breaker closed. That is why there are neutral currents present in Figure 30 and Figure 31. The total earth fault current was about 88 A during these two tests.

With 10 mm and 7 mm spark gaps, arcing across the gap was initiated, but arcing was only sustained for about 50 ms with the 10 mm spark gap and 210 ms with the 7 mm spark gap. With the 4 mm spark gap (Figure 32) sustained arcing was established across the spark gap, which was cleared by opening of the fault throw link after about 25 s.

None of the disturbance recordings gathered during this test exhibited any trace of extreme overvoltages, except for the expected increase in healthy phase-to-earth voltage to normal phase-to-phase voltage and the increase of NECR neutral voltages to normal phase-to-neutral voltage, during repeated sustained arcing earth faults.

During the applied earth faults the healthy phase voltages with respect to earth were measured to be:

- 6.8 kV & 6.4 kV during the 10 mm spark gap test (neutral circuit breaker closed)
- 6.7 kV & 6.4 kV during the 7 mm spark gap test (neutral circuit breaker closed)
- 10.7 kV & 12.7 kV during the 4 mm spark gap test (neutral circuit breaker open)

During the applied earth faults the neutral voltage with respect to earth was measured to be:

- 745 V during the 10 mm spark gap test (neutral circuit breaker closed)
- 753 V during the 7 mm spark gap test (neutral circuit breaker closed)
- 7.1 kV during the 4 mm spark gap test (neutral circuit breaker open)

The highest peak overvoltages recorded on the healthy phases were:

- 10.5 kV during the 10 mm spark gap test (neutral circuit breaker closed)
- 10.7 kV during the 7 mm spark gap test (neutral circuit breaker closed)
- 18.1 kV during the 4 mm spark gap test (neutral circuit breaker open)

During both the solidly earthed neutral (10 mm and 7 mm spark gaps) and unearthed neutral (4 mm spark gap) tests the healthy phase voltages exhibited some distortion during fault inception.

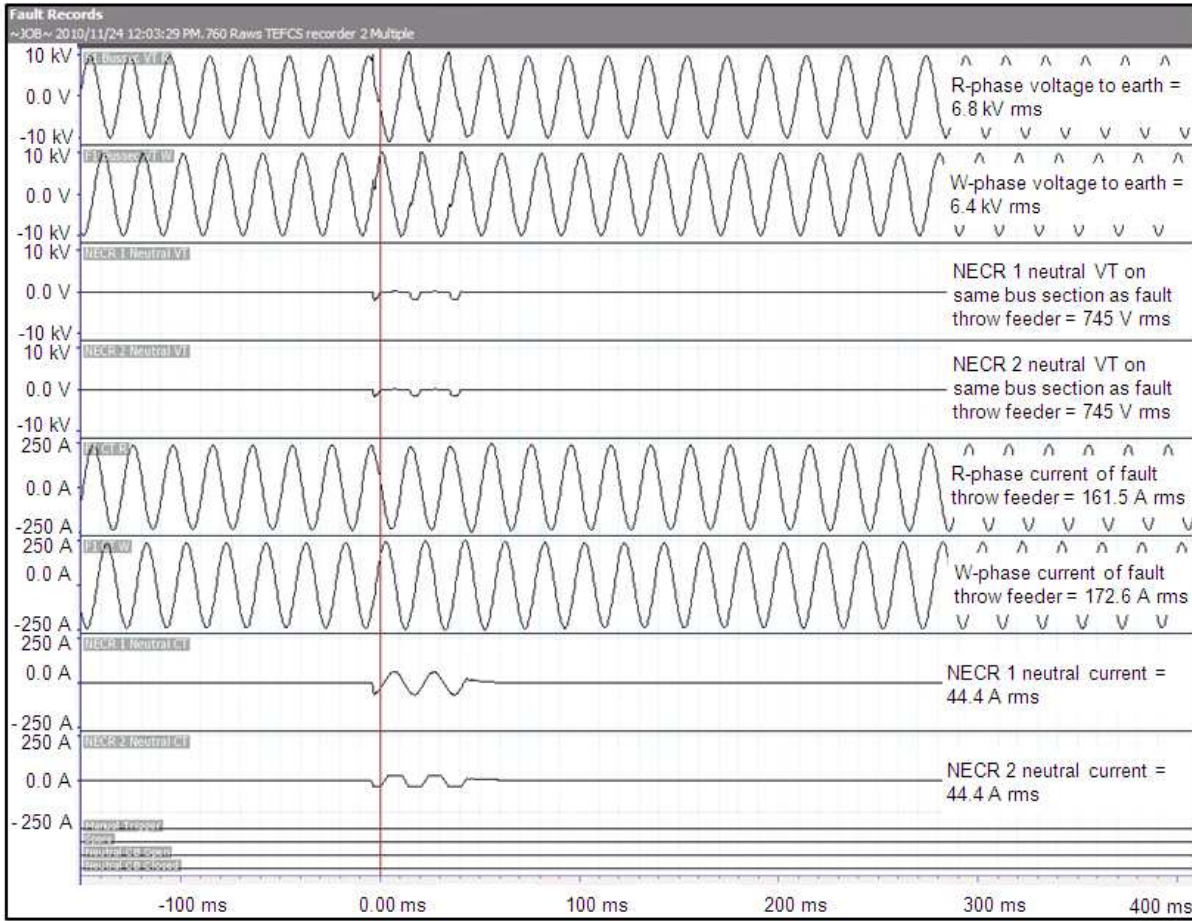

Figure 30: With the neutral circuit breaker closed, an arcing earth fault was initiated on the B-phase, across a 10 mm spark gap, but the arc self-extinguished within 48 ms.

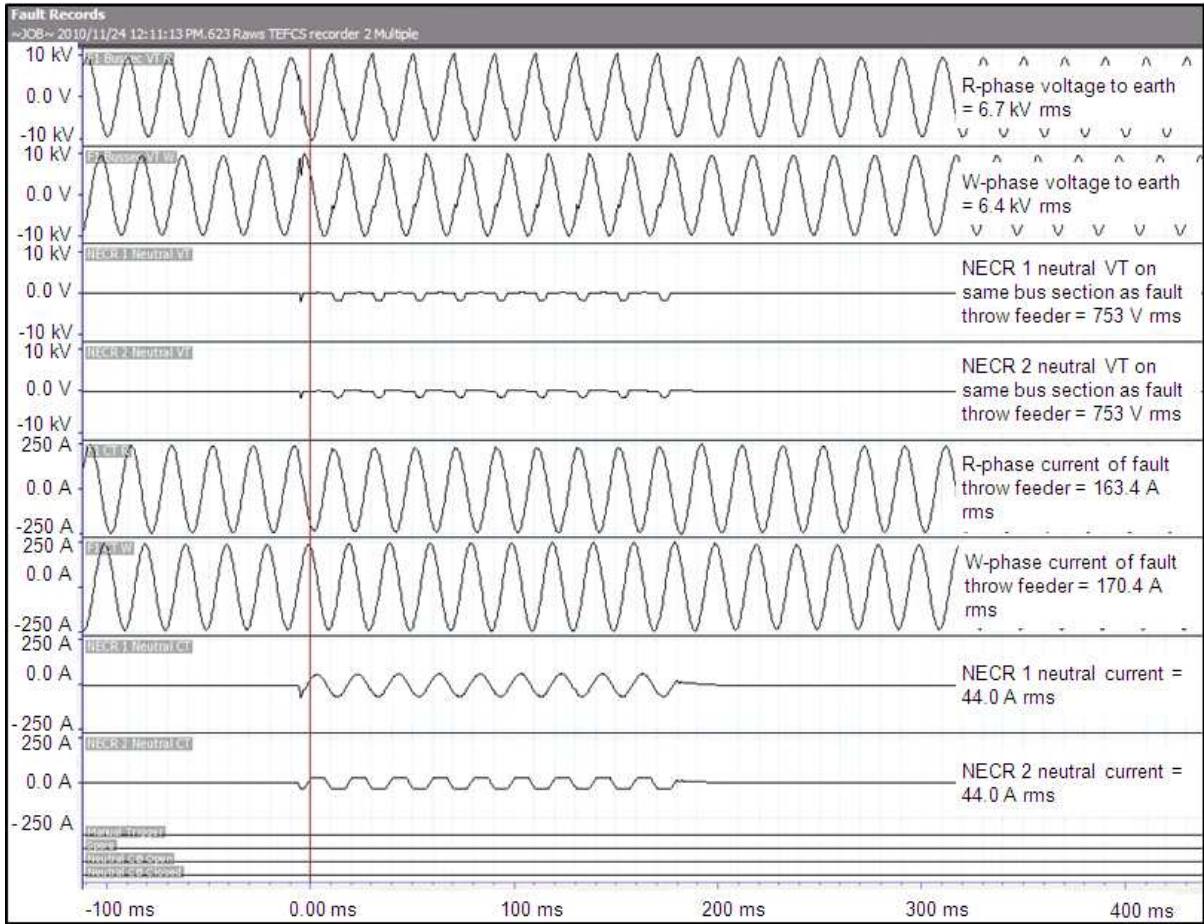

Figure 31: With the neutral circuit breaker closed, an arcing earth fault was initiated on the B-phase, across a 7 mm spark gap, but the arc self-extinguished within 186 ms.

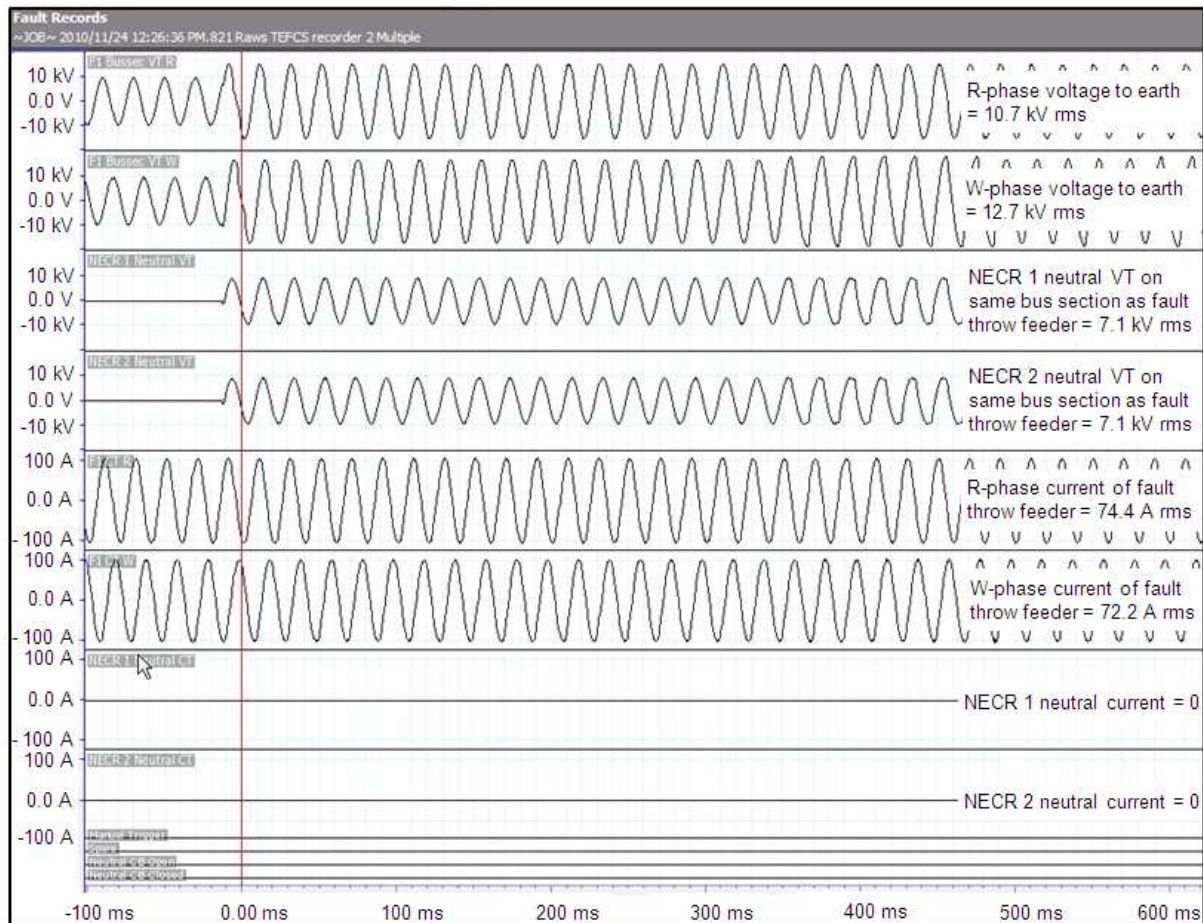

Figure 32: With the neutral circuit breaker open, an arcing earth fault was initiated on the B-phase, across a 4 mm spark gap, which resulted in sustained arcing across the spark gap. Note the rise in NECR neutral and R- & W-phase voltages and the absence of dangerously high overvoltages.

8.3. Test 3

Network status upon fault application: The test was started off with all four lines connected to the same busbar. The lines will then be moved over, one-by-one, to a bus section separate from that to which the fault throw line is connected. After removal of each line, the test will be repeated. Both the MV bus section and neutral circuit breakers were open.

Spark gap: Was set to 4 mm, and bridged with a thin wire strand (0.2 mm diameter).

Actions: Open the neutral circuit breaker, and then close the fault throw link onto the bridged 4 mm spark gap.

Measurements: Figure 33 through Figure 36 are relevant.

The Capacitive earth fault current measured at the fault point during an applied earth fault with the neutral circuit breaker open and with:

- All four MV feeders connected to the same busbar was about 18 A (wire strand burnt off and sustained arcing took place).
- Three MV feeders connected to the same busbar was about 15 A (wire strand burnt off and sustained arcing took place).
- Two MV feeders connected to the same busbar was about 5 A (wire strand did not burn off and sustained arcing could not be initiated).
- One MV feeder, the fault throw feeder, connected to the busbar was about 3 A (wire strand did not burn off and sustained arcing could not be initiated).

Observations:

As an unplanned experiment the fault throw link was closed onto an unbridged 4 mm spark gap, which flashed over spontaneously and developed sustained arcing across it. The spark gap was then increased to 5 mm and spontaneous arcing across the spark gap could not be established again by closing the fault throw link onto the unbridged spark gap.

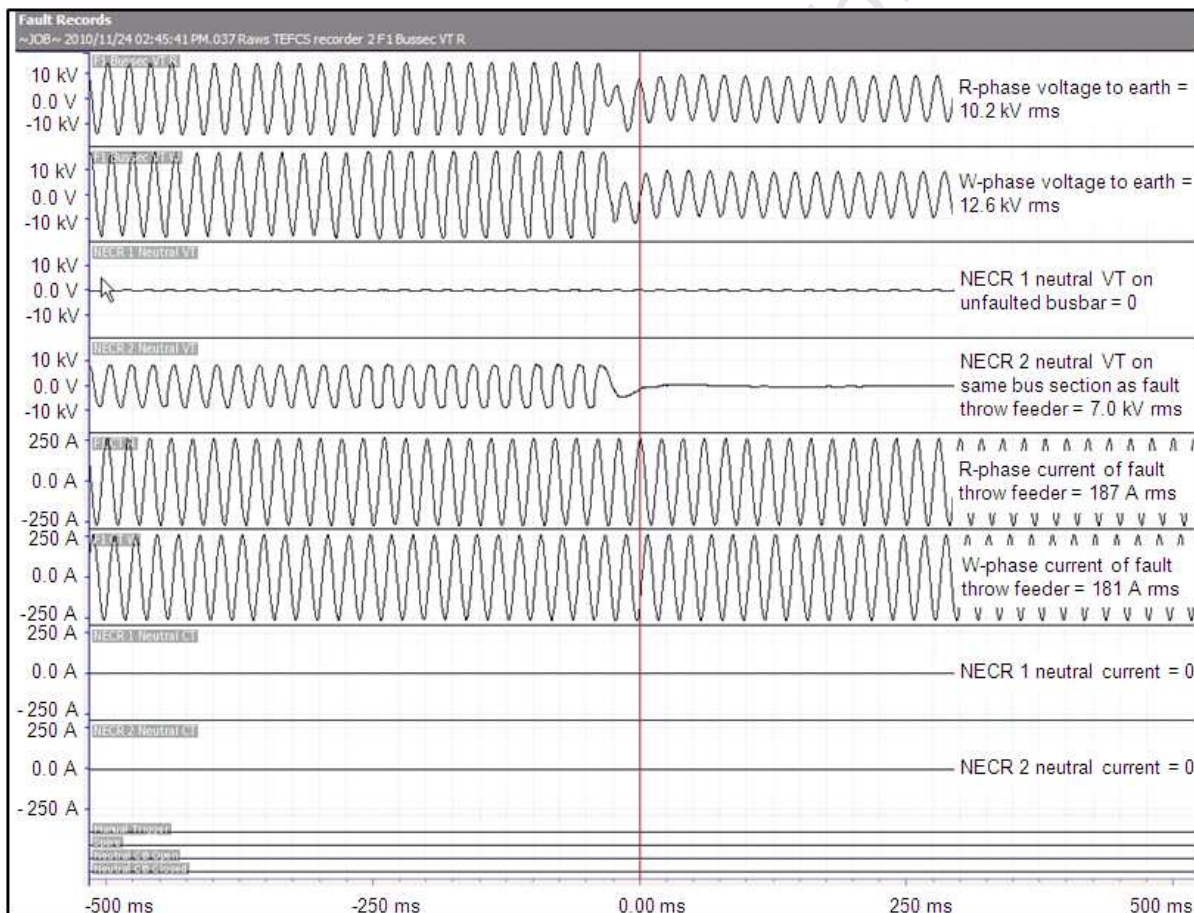

Figure 33: With three of the four feeders connected to the same busbar and the neutral circuit breaker open, an arcing earth fault was initiated on the B-phase across a 5 mm spark gap. Self-extinguishing of the arc did not take place and the fault throw link was opened (depicted here) after about 30 s to clear the fault.

With four or three feeders connected to the same busbar the thin wire strand across the 5 mm spark gap burnt off upon closing of the fault throw link, and sustained arcing across the spark gap had to be cleared by opening of the fault throw link.

The highest peak overvoltage, with respect to earth, attained during this test was 17.3 kV on the W-phase.

With one or two feeders connected to the same busbar the fault current was too low to burn off the thin wire strand and arcing could not be established.

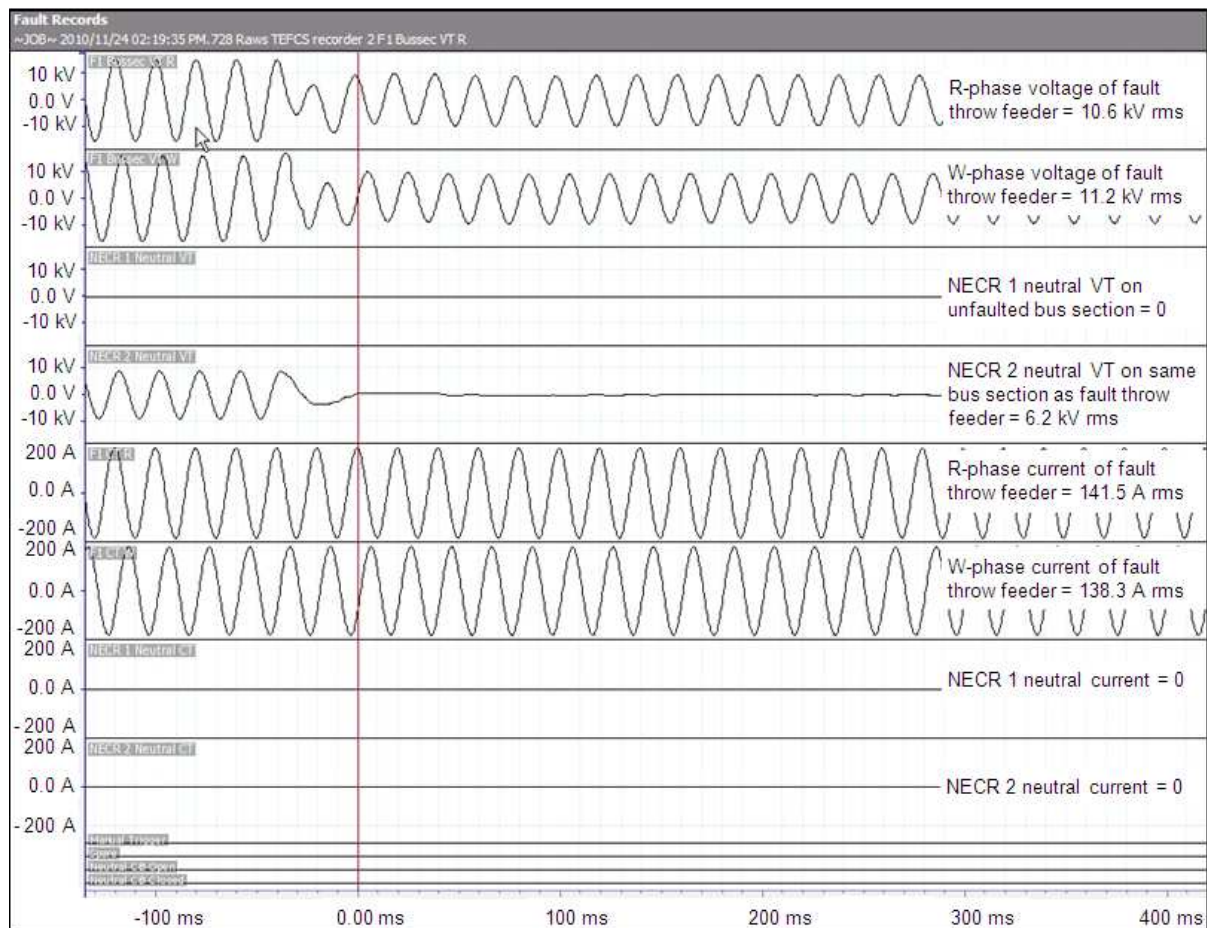

Figure 34: With two of the four feeders connected to the same busbar and the neutral circuit breaker open, an arcing earth fault could not be initiated on the B-phase across a 5 mm spark gap as the fault current was too low to burn off the thin bridging wire strand. The fault throw link was opened (depicted here) to clear the fault.

The highest peak overvoltage, with respect to earth, attained during this test was 15.6 kV on the W-phase.

NECR 1's neutral VT voltage is zero during the applied fault as the bus section circuit breaker was open during the fault in order to only have two of the four feeders on one bus section (fault throw feeder plus another).

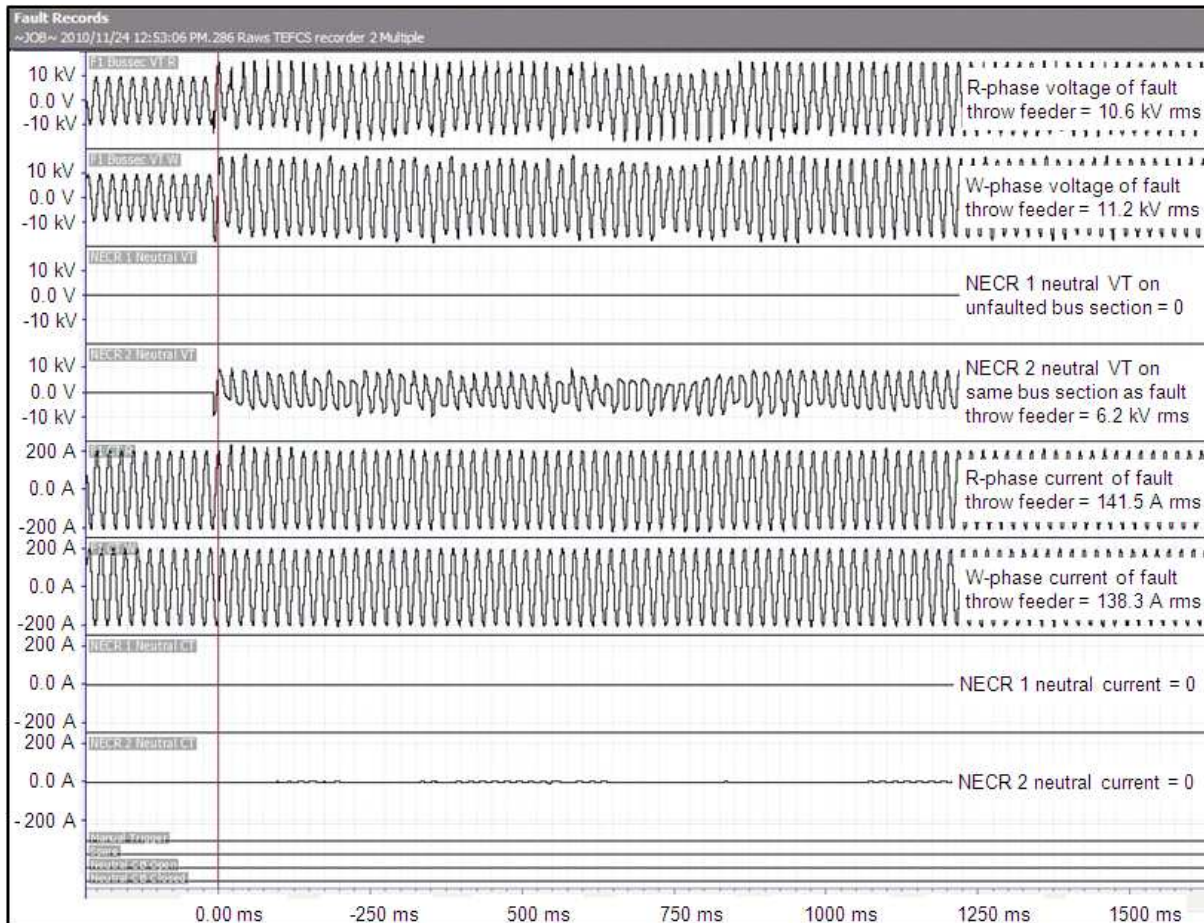

Figure 35: With the fault throw feeder connected to its own busbar and the neutral circuit breaker open, an arcing earth fault was spontaneously initiated on the B-phase across an unbridged 4 mm spark gap upon closing the fault throw link. Self-extinguishing of the arc did not take place and the fault throw link was opened after about 8 s to clear the fault.

The highest peak voltage on the two healthy phases, of 17.7 kV, was measured on the W-phase during the sustained arcing depicted in Figure 35.

The highest peak voltage on the NECR neutral during the same period was 9.6 kV.

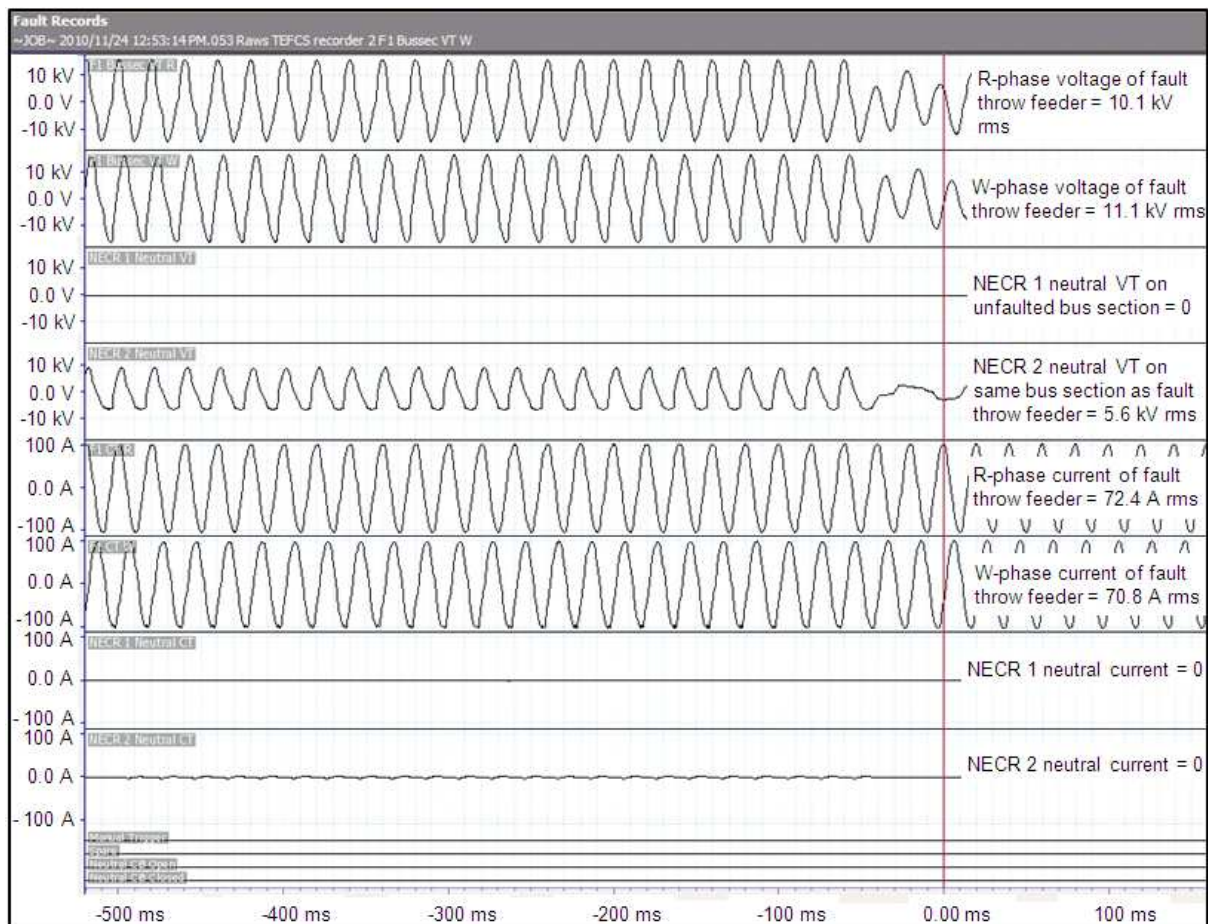

Figure 36: With the fault throw feeder connected to its own busbar and the neutral circuit breaker open, an arcing earth fault could not be initiated on the B-phase across a 5 mm spark gap as the fault current was too low to burn off the thin bridging wire strand. The fault throw link was opened (depicted here) to clear the fault.

8.4. Test 4

Network status upon fault application: The complete network (all four MV feeders) is connected to the same 11 kV busbar, the neutral circuit breaker is in the closed state and the fault throw link is open. All MV network protection, including the neutral circuit breaker protection, is switched on. Upstream SEF protection is switched off.

Spark gap: Was set to 5 mm.

Actions: Closed the fault throw link onto an unbridged 5 mm spark gap. Arcing across the air gap was initiated by sweeping a small green tree branch across the spark gap to simulate a tree branch sweeping across a live conductor/equipment.

Measurements: Figure 37 and Figure 38 are relevant.

Observations: A green tree branch being swept across the unbridged 5 mm spark gap initiated arcing across the air gap. Arcing was sustained for 4 seconds after tripping of the neutral circuit breaker and removal of the tree branch. Arcing therefore self-extinguished

before the neutral circuit breaker closed again after its 10 s dead time. A capacitive earth fault current of about 17 A was measured during arcing, which is well above the upstream SEF pick-up settings. As is evident from the disturbance recording of Figure 37, some earth faults are bound to clear very fast. This fault self-cleared within 37 ms, even before the neutral circuit breaker had a chance to physically open. The neutral circuit breaker did open after the fault self-cleared. While the neutral circuit breaker was open the tree branch was again swiped across the spark gap and arcing was re-established about 63 ms after the fault self-cleared. This time there was no NECR neutral current as the neutral circuit breaker was already open.

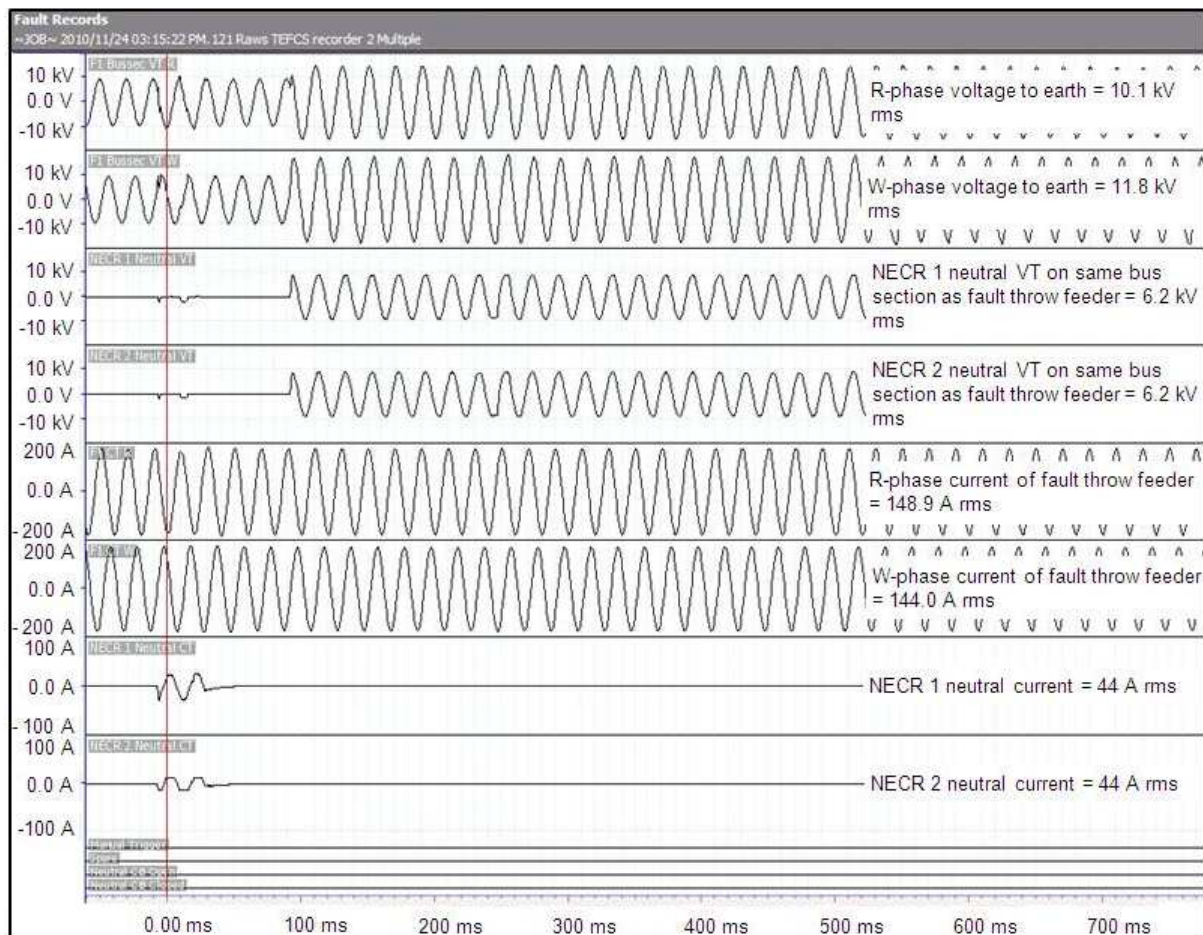

Figure 37: With neutral circuit breaker closed arcing was initiated with a green tree branch swept across a 5 mm spark gap and removed again quickly after arc initiation during the dead time (10 s) of the neutral circuit breaker.

About 4 s after the initial fault, arcing across the spark gap quenched and the neutral circuit breaker closed after expiry of the 10 s dead time.

It is interesting to note that during the arcing earth fault, while the neutral circuit breaker is open, that the R-phase peak voltage to earth (14 kV peak) is about 3 kV lower than that of the W-phase (17 kV peak). Perhaps this has some connection with the physical conductor position on the delta line structures. The W-phase is located at the middle on top of the structure. After the fault cleared in about 4 s the R- and W-phase voltage peaks were virtually the same at about 9 kV peak. See Figure 38.

The R-phase current on the fault throw feeder stayed constant during and after the fault at about 147 A. The W-phase current changed from about 143 A during the fault, to about 142 A after the fault.

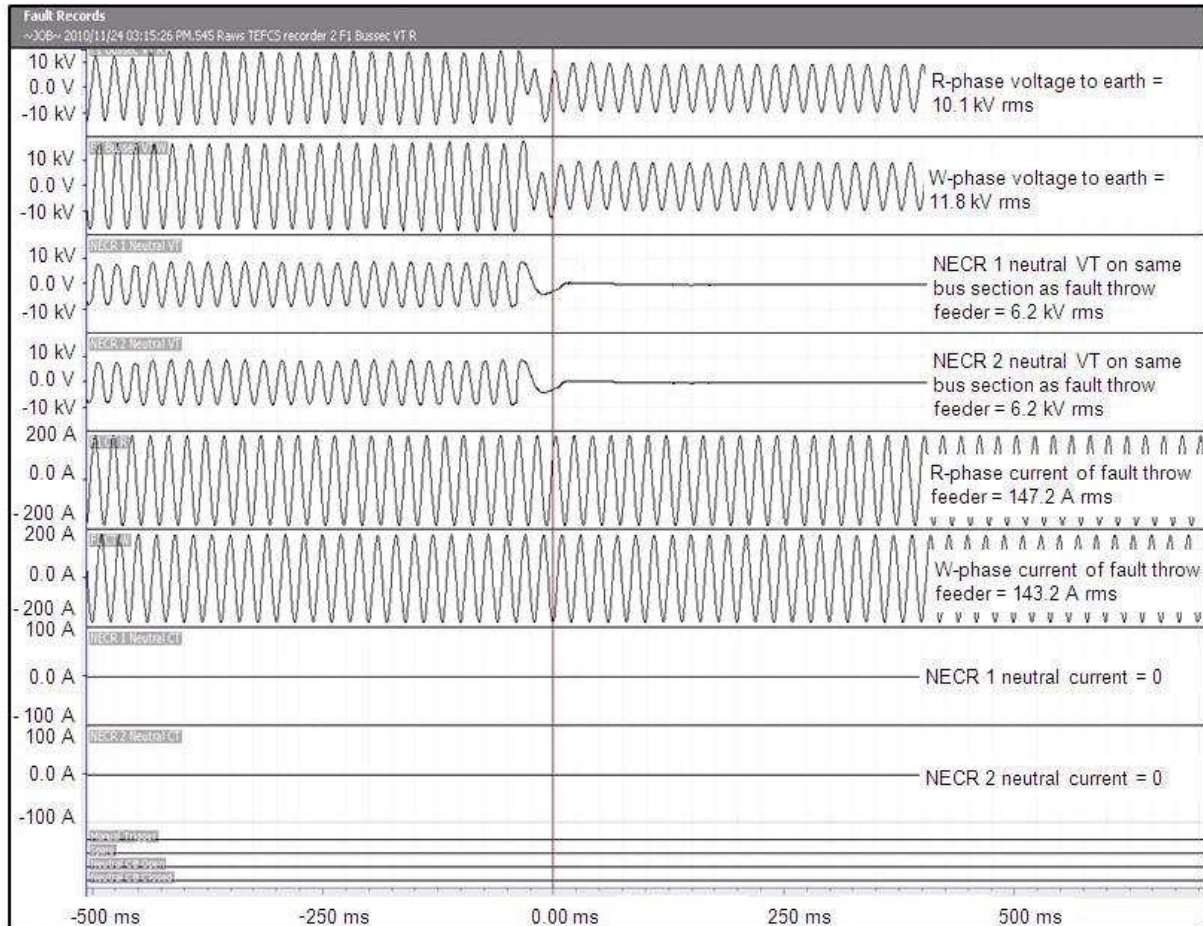

Figure 38: The arcing earth fault self-extinguished 4 s after initiation by means of a green branch tree branch swept across a 5 mm spark gap.

8.5. Test 5

Network status upon fault application: The complete network (all four MV feeders) is connected to the same 11 kV busbar, the neutral circuit breaker is in the closed state and the fault throw link is open. All MV network protection, including the neutral circuit breaker protection, is switched on.

Spark gap: Was set to 5 mm and bridged with a thin wire strand (0.2 mm diameter).

Actions: Closed the fault throw link onto a bridged 5 mm spark gap to establish an arcing earth fault across the spark gap.

Observations: Upon applying the fault with the neutral circuit breaker closed, the neutral circuit breaker opened, but sustained arcing took place even after opening of the neutral breaker by its protection. See Figure 39. This resulted in the recloser upstream of the fault

throw point tripping on SEF after 6 s. See Figure 40. The neutral circuit breaker closed after 10 s (dead time).

Next the spark gap was set to 6 mm and the test repeated a few times. Sometimes arcing stopped immediately upon neutral circuit breaker opening, and sometimes arcing was sustained for a few seconds, but during testing arcing was not sustained for longer than 6 s. All neutral circuit breaker clearing attempts were successful, i.e. cleared within the 10 s dead time of the neutral circuit breaker.

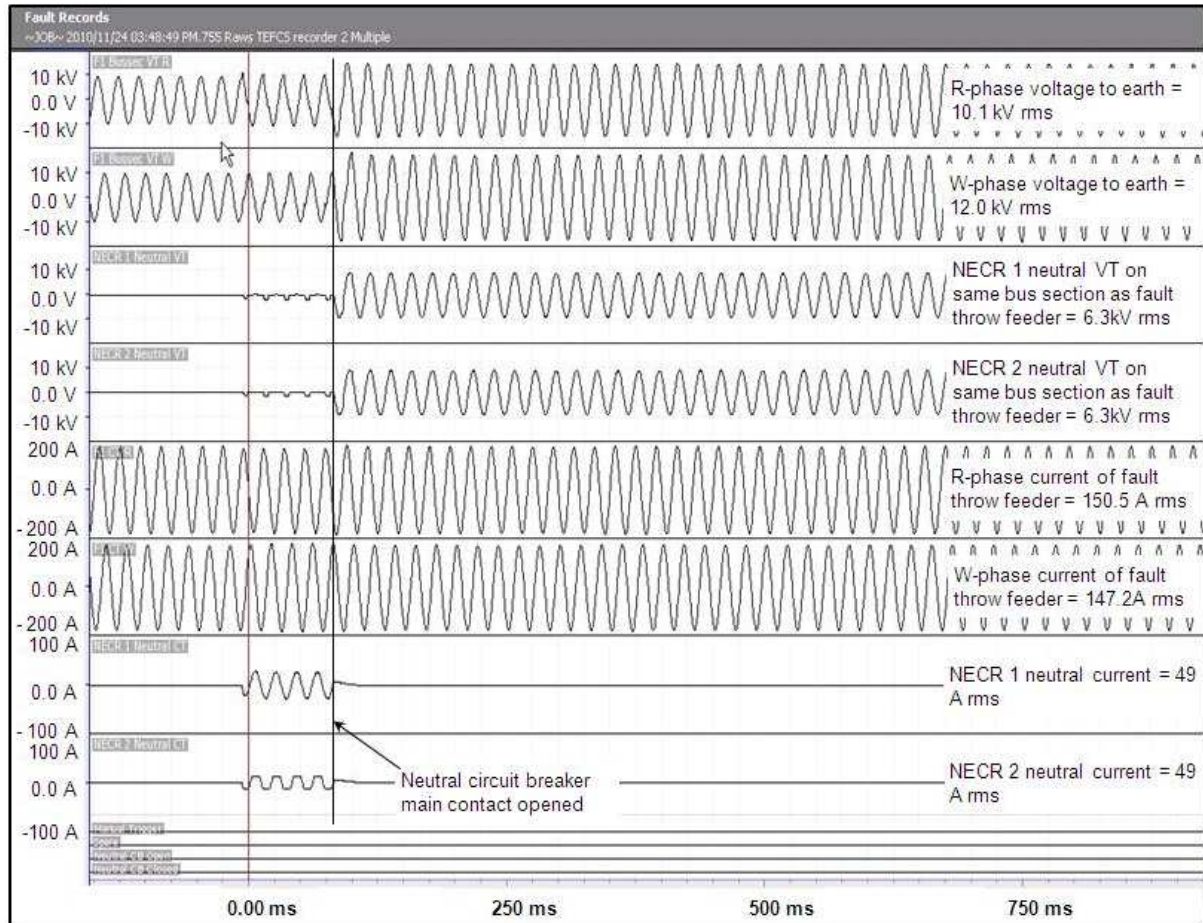

Figure 39: With neutral circuit breaker closed, the fault throw link was closed onto the 5 mm spark gap bridged with a thin wire strand. The wire strand burnt off and sustained arcing took place even after the neutral circuit breaker opened. Note that the disturbance recorder scaling of NECR 2's neutral current was incorrect.

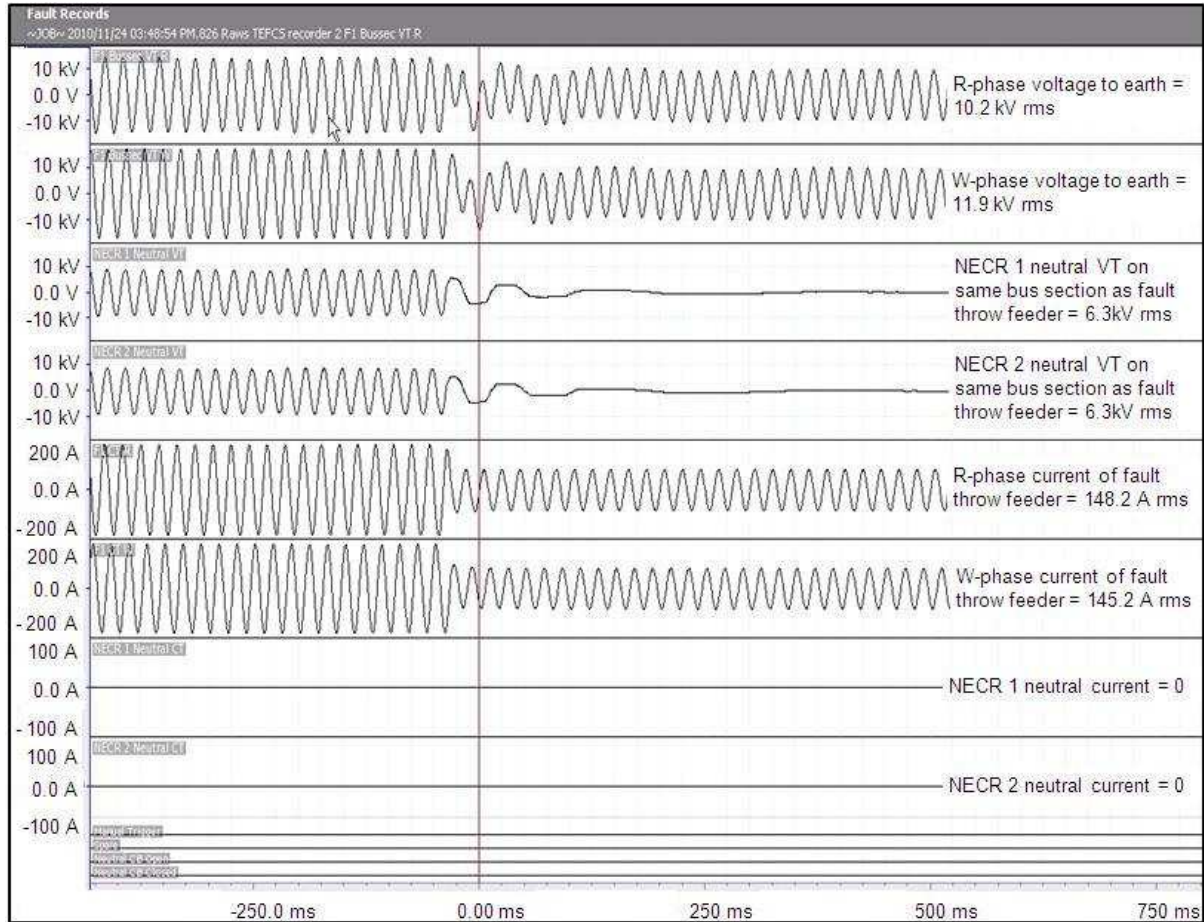

Figure 40: The recloser upstream of the fault throw point tripped on SEF within about 6 s after initiation of the arcing earth fault in Figure 39.

8.6. Test 6

Network status upon fault application: The complete network is connected to the same 11 kV busbar, the neutral circuit breaker is in the closed state and the fault throw link is open. All network protection, including SEF is enabled. The neutral circuit breaker protection is enabled.

Spark gap: The 6 mm spark gap was bridged with a standard portable earthing cable used by an operator for temporarily earthing line conductors, or other electrical apparatus to be worked on.

Actions: Closed the fault throw onto the solid earth fault.

Observations: Upon applying the solid earth fault with the neutral circuit breaker closed, the neutral circuit breaker was tripped immediately by its protection. After the 10 s dead time the neutral circuit breaker closed again, and after about 6 s the auto recloser immediately upstream of the fault throw point tripped on SEF. All these protection operations were executed as designed, and therefore successful. Waveforms obtained during this test were virtually identical to that depicted in Figure 39.

9. Discussion of Trial Site Commissioning Test Results

9.1. Test specific discussions

Test 1 confirmed that the healthy phase voltages with respect to earth of an unearthed network increase to full phase-to-phase voltage, and that the NECR neutral voltage increases to about normal phase-to-neutral voltage during an earth fault. This was as expected from the theory of unearthed networks.

The faulted phase-to-earth voltage measurements at the substation (1.35 kV), fault throw point (0.1 kV) and at the end of the feeder (0.62 kV) indicate that the faulted phase voltage rises in both directions as one moves further away from the fault point.

Test 2: With all four MV feeders connected to the same busbar, sustained arcing across the spark gap could not be established with the 10 mm or 7 mm spark gaps. Sustained arcing earth faults were, however, generated across a 4 mm spark gap.

This test proved without any doubt, that for the given network, no overvoltages of the order of 3 to 6 times normal peak phase-to-earth voltage are being generated during arcing earth faults, as predicted by a number of sources [ABB, 1994, 94, Evans et al, 1939, 392; Glover, 1978 or later, D-2; Hänninen, 2001, 13, Uppal, 1984, 911].

It may be possible to attribute the absence of any damaging overvoltages during the physical fault throws to the relatively low capacitive earth fault current of 16 to 18 A, and damping within the network that prevent generation of high voltages. Due to this uncertainty as to the lack of overvoltage generation during arcing earth faults, it is recommended that similar fault throw tests be performed on larger networks where such transient earth fault clearing schemes are to be implemented in order to determine generation of damaging overvoltages, or not.

At this point it should also be mentioned that Allen & Waldorf [1946, 301] commented that the voltages produced by arcing across a spark gap during their tests were not nearly as high as published theory indicates.

Allen & Waldorf [1946, 302] stated that the total phase-to-earth capacitance of one phase of their test network was about 2.6 μF . By using equation (3) in section 2.1.2, the total capacitive earth fault current for the complete TEFCS test network may be found.

$$C = I_{\text{Capacitive total}} / (2 \cdot \sqrt{3} \cdot \pi \cdot f \cdot V_{\text{LL}}) \quad [\mu\text{F}]$$

$$\begin{aligned} I_{\text{Capacitive total}} &= 2 \cdot \sqrt{3} \cdot \pi \cdot f \cdot V_{\text{LL}} \cdot C \\ &= 2 \cdot \sqrt{3} \cdot \pi \cdot 60 \text{ Hz} \cdot 13 \text{ kV} \cdot 2.6 \mu\text{F} \\ &= 22 \text{ A} \end{aligned}$$

This value is very close to the 16 A measured during Test 2. Similarly to the above, the total phase-to-earth capacitance for the TEFCS may be calculated as follow:

$$\begin{aligned} C &= I_{\text{Capacitive total}} / (2 \cdot \sqrt{3} \cdot \pi \cdot f \cdot V_{\text{LL}}) \\ &= 16 \text{ A} / (2 \cdot \sqrt{3} \cdot \pi \cdot 50 \text{ Hz} \cdot 11 \text{ kV}) \\ &= 2.67 \mu\text{F} \end{aligned}$$

This phase-to-earth capacitance of 2.67 μF calculated from the actual capacitive earth fault current measured during the fault throw is much lower than the calculated values depicted in Table 4. From Table 4 the phase-to-earth capacitance of the 217 km test network should have been about 8.5 μF .

This is quite a large discrepancy of about 3 times the actual phase-to-earth capacitance, for which there is no definite answer at this stage. A possible cause for the discrepancy could perhaps be due to the influence of trees and buildings close to the lines, as well as vineyards and bushes below the lines. These factors will tend to increase the total phase-to-earth capacitance of a line, but the error factor may be too large to be ascribed to these factors alone. A further influencing factor may be transposition of the lines. Transposition is not intentionally performed on the MV networks, but it may happen inadvertently at T-offs from the main line, as was the case at a T-off close to the fault throw point. There may therefore be other such unintentional transposition points on the test network, which will all contribute to lowering of the overall phase-to-earth capacitance of the total network.

The fact that neither the Allen & Waldorf, [1946, 304] and the TEFCS exhibited any overvoltages higher than normal phase-to-phase voltage between each of the healthy phases and earth during arcing earth fault conditions may be ascribed to the similarity of the two phase-to-earth capacitance values of the Allen & Waldorf [1946, 302] and that of the TEFCS network. It is possible that the phase-to-earth capacitances of the test networks were just too low to generate the overvoltages as claimed by literature.

Test 3. With both four and three lines connected to the same busbar, a 5 mm air gap was bridged by sustained arcing upon closing of the fault throw link and burning off of the thin bridging wire strand. Sustained arcing had to be cleared manually by opening of the fault throw link. No overvoltages were recorded during the sustained arcing earth faults.

With just the fault throw line, or one additional line connected to the same busbar as the fault throw line the capacitive currents were too low to burn off the thin wire strand across the spark gap to initiate an arcing fault. Fault current with two lines connected was 5.2 A and with just the fault throw line the capacitive fault current was 3.3 A.

Test 3, therefore, was not successful as it could not be established what the effect of line length (capacitive current magnitude) is on the self-extinction ability of an earth fault on an unearthed network. The reason for this may be attributed to the low capacitive fault currents with one or two lines comprising the fault throw network (3.3 A and 5.2 A respectively), which could not burn off the spark gap bridging wire strand (0.2 mm diameter) in order to establish arcing, across the air gap. Unfortunately there were no thinner wire strands available on site during the tests.

It is doubtful, even if a thinner wire strand was available and it did burn off, whether a conclusive test result would have been obtained with such a small spark gap (5 mm), and the given low capacitive earth fault current range.

As may be seen from Test 4 below, earth faults initiated across a 6 mm spark gap, with all four MV feeders connected to the same busbar, resulted in arcing which cleared by itself during the dead time of the neutral circuit breaker. Test 2 on the other hand established that a 4 mm unbridged spark gap flashed over spontaneously upon closing of the fault throw link, which is not impacted by the number of MV feeders connected to the same busbar, but rather dictated by the voltage level being applied across the air gap. This then leaves 2 mm within which to try and find the effect of different feeder lengths on the self-extinguishing ability of an arcing earth fault for this given test network. Based on the test results obtained

during all the conducted tests it does not seem easily attainable to achieve the desired test objective for this given test network.

A much larger capacitive earth fault current may probably lead to a conclusive test result, as logic dictates that the larger the capacitive fault current the larger the spark gap needs to be for successful arc quenching, up to some limit of cause.

If Test 3 is to be repeated in future, the following may be taken into account: Finer adjustment capability of the spark gap will allow much better control over the spark gap length. It may also be easier to perform the test if the range of capacitive earth fault currents is much larger (larger network) as any effect a change in network length may have on the self-clearing of earth faults for a given spark gap length, will be amplified and should make the effects more easily noticeable.

Test 4 successfully demonstrated that a transient earth fault may be cleared by “instantaneously” interrupting the earth fault current by temporarily (10 s) disconnecting the NECR neutral from earth, thereby temporarily converting the low resistance earthed network into an unearthed network.

Test 5 successfully demonstrated correct operation of the TEFCS for applied **transient** earth faults, in conjunction with all the normal substation and line protection. A 6 mm spark gap repeatedly ensured successful arc quenching in less than the SEF operating time of 6 s of the upstream auto recloser.

Test 6 successfully demonstrated correct operation of the TEFCS for an applied **permanent** earth fault, in conjunction with all the normal substation and line protection. The TEFCS operated correctly, and the auto recloser upstream of the fault throw point correctly tripped on SEF.

9.2. General observations made during commissioning

The most significant observation from sustained arcing EF tests is that no potentially harmful overvoltages were experienced on the 11 kV network as 17.7 kV was the highest peak voltage encountered. As a comparison it may be noted that an 11k V circuit breaker may be pressure tested at 24 kV (33.9 kV peak) for 5 minutes.

It is claimed that an arcing earth fault on an unearthed network may theoretically result in overvoltages of up to 6 times normal phase-to-neutral voltage on the two healthy phases [Evans et al, 1939, 392; Glovers 1978 or later, D-2 and Uppal, 1984, 911]. During sustained arcing earth fault tests on the fault throw network the highest recorded peak phase-to-earth voltage of the two healthy phases was about 17.4 kV peak. This was measured during sustained arcing across a 4 mm spark gap while performing the test when the fault throw feeder was connected on its own to a busbar. See Figure 35.

This 17.4 kV peak overvoltage is about twice the normal 11 kV peak phase-to-neutral voltage. It may therefore be possible for higher overvoltages to be attained for networks with higher network capacitance to earth than the trial site network.

From the commissioning tests it was found that SEF tripping of feeder CBs and auto-reclosers upstream of an EF may be a real possibility during sustained arcing EFs while the neutral CB open (dead time) as these protections operate on the residual current of the line. The capacitive fault currents returning to the source through the two healthy phases will cause a residual current in all feeders connected to the same busbar.

During testing there were two incidents where upstream SEF protection operated within the dead time of the neutral CB during sustained arcing periods. One SEF trip incident was on

the fault throw feeder and in the other incident the Farmers 2 feeder SEF protection tripped the feeder CB. SEF trip time settings were set at between 5 and 10 s. After these incidents all SEF protection upstream of the fault throw point, including the four feeder CB protections in the substation, were switched off in order to resume testing.

Seeing that it was found possible for feeder protection devices to operate on SEF during sustained arcing periods, with the neutral CB open, it may be concluded that there is not much sense in setting the neutral CB dead time much longer than the longest SEF operating time on the given network. This may be to the detriment of clearing EFs below SEF pick-up, but then again these low current EFs may self extinguish very quickly anyway.

With a 5 mm spark gap it was possible to initiate sustained arcing EFs by bridging the spark gap with a thin wire strand before closing the fault throw link.

With the neutral circuit breaker open and no earth fault applied to the network, no neutral-to-earth voltage was measured on the two NECR neutrals. This indicates that the delta configured line construction does not lead to significant zero sequence voltage during normal operation. Inadvertent transposition at T-off points from the backbone feeder may have contributed to the absence of zero sequence voltage on the NECR neutrals while the neutral circuit breaker is open (unearthed network).

It was determined that with the neutral circuit breaker closed, that a 4 mm arcing horn air gap flashed over spontaneously upon closing the fault throw link to energize the one side of the arcing horn, and that consequential arcing does not self-extinguish.

With a 5 mm arcing horn air gap it was possible to initiate sustained arcing earth faults by bridging the arcing horn gap with a thin wire strand and closing the fault throw link. Closing the fault throw link onto the 5 mm spark gap did not result in flashovers of the air gap, but arcing, once initiated by bridging the spark gap with a thin wire strand, did not self-extinguish in one EF instance and had to be manually cleared by opening of the fault throw link after about 38 s. Other arcing EFs across the 5 mm spark gap were successfully cleared by automatic opening of the neutral CB upon fault inception and closing after a 10 s dead time. From this then it may be deduced that a 5 mm gap is about the minimum size that might allow the TEFCS to clear a transient EF.

Adjustment of the spark gap to 6 mm allowed arcing to consistently self-extinguish without opening of the neutral CB, once initiated by a thin wire strand bridging the spark gap. During Test 2 it was found that sustained arcing was not possible with spark gap sizes of 7 mm and 10 mm.

From this then it may be deduced that a 6 mm spark gap is about the minimum size that will allow consistent clearing of a transient earth fault by the TEFCS, for the given 11 kV trial site network with a maximum capacitive fault current of about 16 A. Larger networks may require a larger minimum spark gap, and higher system voltages will most certainly dictate larger minimum spark gaps.

Transient earth faults downstream of fuses may not be cleared by the TEFCS as fuse operation may be too fast for the neutral circuit breaker. This will, however, depend largely upon the fuse rating and on the fault current magnitude. Earth faults in the SEF range will most like be cleared by the TEFCS. Similarly, for these low current SEF faults the TEFCS may succeed in saving fuses from operating due to its quick operation, irrespective of the fault current level (153 ms for <10 A and 86 ms for >10 A as determined by the auto-recloser's protection and cannot be changed).

Lethonen et al [2001, 1183] encountered sub-harmonic oscillation of the neutral voltage when the flow of earth fault current in an unearthed network was broken, i.e. upon clearing of a transient fault, during the time that the two healthy phase voltages return to normal phase-to-neutral voltage with respect to earth. This was verified by most of the commissioning test disturbance recordings. See Figure 41.

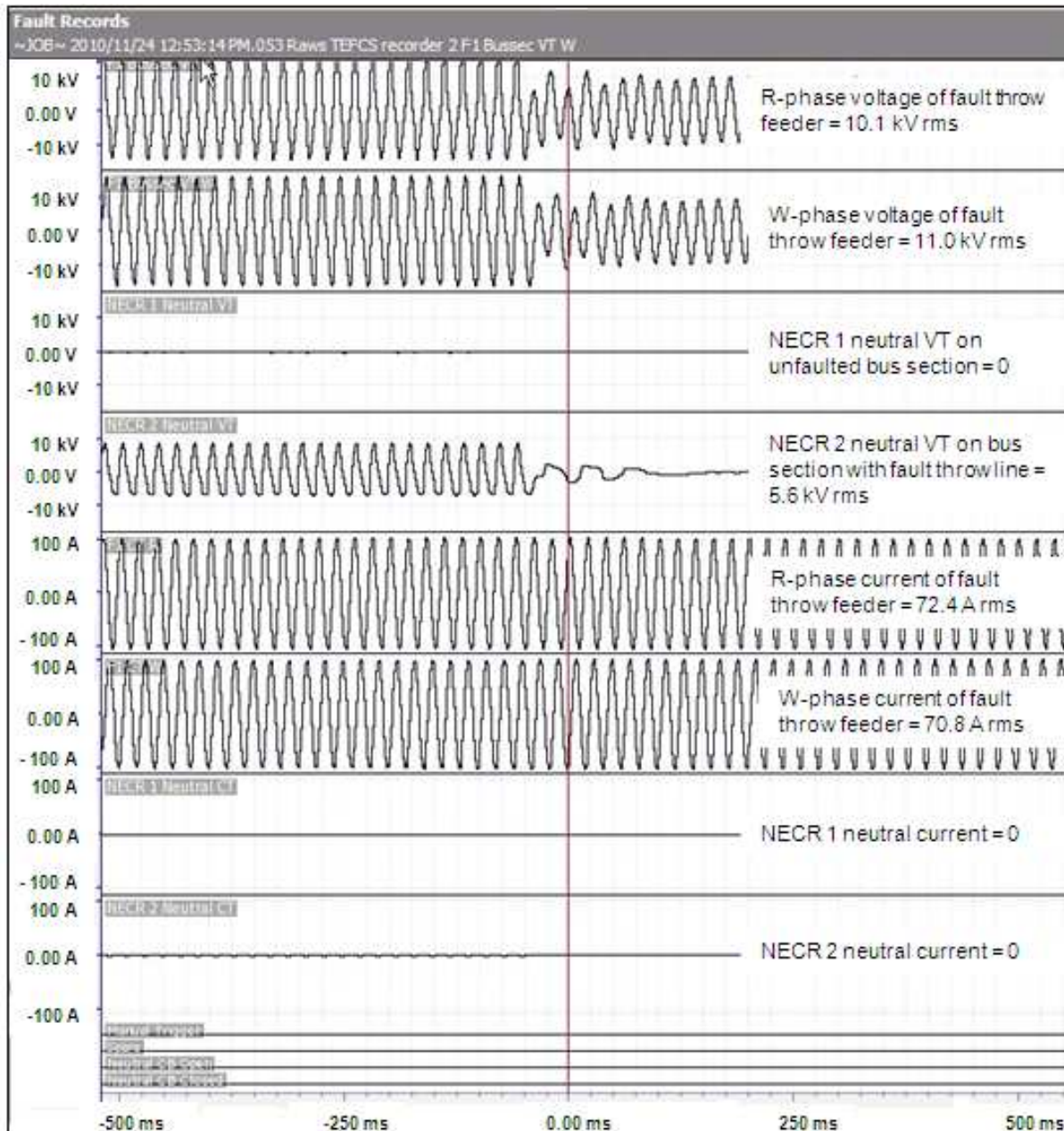

Figure 41: Disturbance recording indicating sub-harmonic oscillation of the NECR 2 neutral voltage when the flow of earth fault current of the unearthed trial site network is interrupted.

Heine et al [2004, 105] conducted a study on a 20 kV unearthed network and found that if arcing in a spark gap was sustained for longer than 10 cycles (200 ms for 50 Hz), the earth fault will most likely change to a phase-to-phase-to-earth fault. During commissioning of the TEFCS many arcing earth faults were sustained across a 4 mm spark gap for more than 30 s before manual opening of the fault throw link, without any one of them developing into a phase-to-phase fault.

For an earth fault to develop into a phase-to-phase fault mainly three factors will play a role in determining whether this will take place or not:

- Conductor spacing: The site has conductor spacings of 1.15 m in a triangular format (delta line configuration).

- Voltage difference between the phase conductors: Normally at 11 kV, but voltages up to about 20 kV has been measured.
- Quality of insulation on the network: Most, but not all insulators on the 11 kV trial site network are of heavy pollution rating with creepage lengths of 31 mm per kV. Some equipment, such as voltage regulators have 25 mm per kV creepage bushings, and other equipments, such as some of the auto-reclosers have 22 kV bushings with creepage lengths of 31 mm per kV. The latter is due to Eskom specifying all new 11 kV equipment with 22 kV insulation ratings at minimal additional cost, but with an immense reduction in stockholding and better equipment performance from an insulation point of view.

It is interesting to note that during all the arcing earth faults, while the neutral circuit breaker was open, that the W-phase peak voltage to earth was always higher by about 3 kV than the peak R-phase voltage. Perhaps this has some connection with the physical conductor position on the delta line structures, and that the R- and B-phases have been inadvertently transposed at least once in the trial site network. The W-phase is located at the middle on top of the structure.

Application of the pole-mounted auto-recloser as a neutral CB was found to be a very neat, effective and easily implementable solution as it is fully self-contained with its integrated protection and integrated remote terminal unit (RTU) for SCADA communication. From a cost, commissioning and maintenance point of view it is a much better solution than a conventional circuit breaker and its associated protection that needs to be located in a relay house, requiring lots of commissioning labour, cabling and space.

University of Cape Town

10. TEFCS trial site operating history

After completion of the TEFCS commissioning tests on 24 November 2010, the TEFCS officially became part of the protection for the complete 11 kV network it is installed on.

Since then, up to 16 March 2011, there have been a total of 24 earth faults on the 217 km 11 kV trial site network. Table 5 provides a list of all TEFCS operations during this period.

Three of the 24 faults were permanent faults for which downstream auto-reclosers locked out to clear two of the three faults, and the third fault was cleared by a fuse operation, after the neutral circuit breaker auto-reclosed. The remaining 21 EFs were transient in nature. Four of these self-cleared after the neutral CB protection issued a trip signal, but before the neutral CB could physically open. Two of these faults re-striking after the neutral CB opened, but manage to clear during the 10 s dead time of the neutral CB. These two EFs are therefore also deemed to have been cleared by the TEFCS. The other two transient EFs would not have caused protection operation without the TEFCS either, thus should not be counted as part of a TEFCS efficiency calculation.

This then shows that 19 of the 22 EFs were successfully cleared by the TEFCS during the 10 s dead time of the neutral circuit breaker, representing a 86% success rate $[(22-3)*100/22]$.

In total then, customers suffered supply interruptions during only 3 of the 22 fault incidents as a result of the three permanent faults.

The disturbance recorders also captured a few events due to the presence of NECR neutral currents. These events did not result in neutral CB operation as the current magnitudes were either below the protection pick-up of 4 A (lowest setting available), or did not last long enough for the protection to issue a neutral CB trip signal.

From the onset of the TEFCS idea the intention was to set the EF pick-up very low, say at about 1 A primary current, in order to attempt extinguishing faults before they manage to escalate into high fault current faults, which are more difficult to clear successfully. In this regard there is a short coming with the TEFCS in that the lowest attainable protection setting is 4 A for SEF and 10 for an EF. Application of the auto-recloser in this particular manner amplifies the problem because the EF current will split more or less equally between the two NECRs with the effect that the recloser protection will only start to pick up for a total EF current of 8 A (4 A per recloser phase). If this minimum pick-up setting could be lowered it may enable the TEFCS to clear EF even quicker than it does currently.

Disturbance recordings of the two earth faults, which cleared before the neutral circuit breaker's main contacts physically opened, and did not re-strike again, are presented in Figure 42 and Figure 43.

The highest peak overvoltage recorded by a disturbance recorder within the substation during one of the arcing EFs was 20.4 kV peak to earth, or 2.3 times the normal peak phase-to-neutral voltage. This is significantly lower than the overvoltages of the order of 3 to 6 times normal peak phase-to-neutral voltage predicted by others [Allen & Waldorf, 1946, 305; Evans et al, 1939, 392; Glover, 1978 or later, D-2, & Uppal, 1984, 911].

From the operational disturbance recordings it is not evident that surge arrester conduction took place due to overvoltages as no clipping of the voltage waveforms are visible. It is assumed that the surge arresters did conduct, but that the currents were of very low magnitudes. No surge arrester failures on the TEFCS trial site were reported thus far.

Overheating of the surge arresters is very unlikely as peak overvoltages were mostly of the order of 16 kV to 17 kV peak, under which conditions the surge arresters may operate indefinitely according to the network's surge arrester's data sheet. Also according to the data sheet for a surge arrester at an ambient temperature of 45 °C, a 20.4 kV peak

overvoltage condition may be tolerated for 900 s. This is an extreme condition and unlikely to occur on the TEFCS trial site network, as exposure to the overvoltages will only take place during the 10 s dead time of the neutral circuit breaker. Also, after each neutral circuit breaker operation the surge arresters will have 30 s (time for which the neutral circuit breaker protection is disabled after each operation) during which to cool down before it will be allowed to trip for another EF. This in itself is unlikely to occur as the normal protection would have removed a permanent fault from the network during the 30 s dead time.

It should be mentioned that the neutral circuit breaker's auxiliary contact operating time, indicated at the bottom of some of the disturbance recordings, is not mechanically linked to the main contact operation. According to the circuit breaker manufacturer, the auxiliary contact operating time is in-determined and may vary between 40 ms to 140 ms. This is due to its operation time being dependent on available processor power at any given time, due to being assigned a low priority.

Speed timing tests of the neutral circuit breaker's main contacts revealed that it operates in about 153 ms for an earth fault current below 4 A and in about 86 ms for an earth fault current above 10 A.

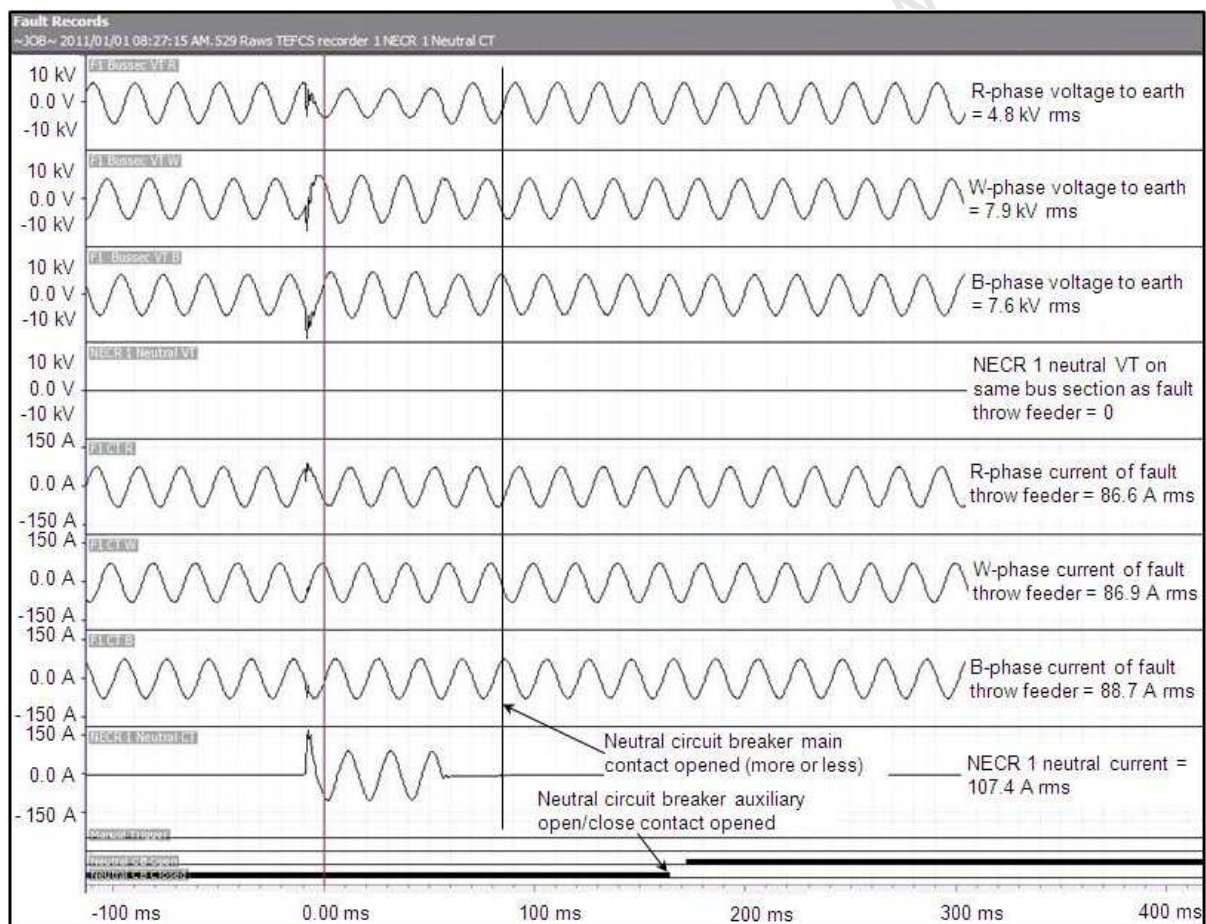

Figure 42: A transient earth fault disturbance recording, indicating that the fault cleared before the neutral circuit breaker could physically open. This recording is of a R-phase earth fault. Note that the actual earth fault current is about 214.8 A ($2 * 107.4$ A) as there are two NECRs in the substation sharing the earth fault current equally.

In order to obtain a much more deterministic auxiliary contact operating time in relation to the neutral circuit breaker's main contact, an auxiliary switch, operated by the mechanical open/close status indicator, was designed, fabricated, tested and successfully put into service. Operating time of the auxiliary switch is 169 ms for an earth fault current below 4 A and about 100 ms for an earth fault current above 10 A. The time lag between main contact and auxiliary contact operation is consistent at about 16 ms. This will be used in future to determine at what point in a disturbance recording the main circuit breaker contact actually opened in cases where earth faults self-clear before the CB's main contact physically manages to open after receiving a protection trip signal. All recordings in this thesis are from the period before implementation of the new auxiliary contact for open/close indications for the disturbance recorders.

The disturbance recording of Figure 42 indicates that the transient earth fault self-cleared in about 71 ms. Without knowing what the fault current magnitude was for a specific fault it is not possible to determine at what point on the disturbance recordings of Figure 42 and Figure 43 the neutral circuit breaker actually opened as there is no rise in the NECR 1 voltage trace. A sudden rise in neutral voltage is a definite indication that the neutral circuit breaker opened at that specific point in time, but for this to take place an EF should be present.

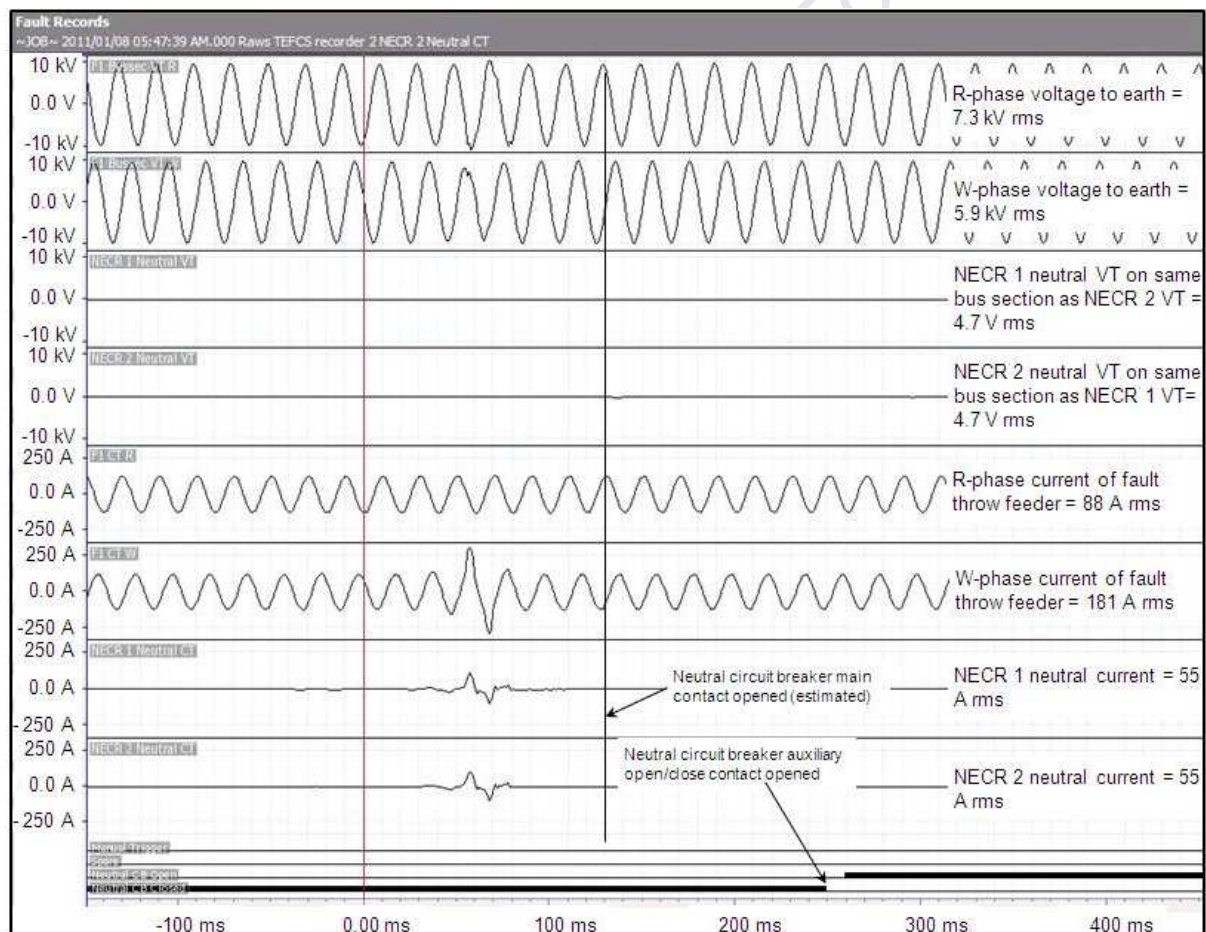

Figure 43: A transient earth fault disturbance recording, indicating that the fault cleared about 49 ms before the neutral circuit breaker could physically open. This recording is of a W-phase earth fault. Note that the actual earth fault current is about 110 A ($2 * 55$ A) as there are two NECRs in the substation sharing the earth fault current equally.

As explained above the neutral circuit breaker's in-built auxiliary contact operation is only indicative of the fact that the neutral circuit breaker did open, but operation time thereof is too inconsistent to determine the circuit breaker's main contact operating time by. If the earth fault current magnitude is sufficiently high and continuous in nature the main contact operating times, as verified through testing, and provided above, may be used to determine the point of main contact separation.

The disturbance recording of Figure 43 indicates that the transient earth fault self-cleared in about 37 ms, which is about 49 ms before the neutral CBs main contacts opened for the EF (assuming an 86 ms total CB operating time for an EF >10 A, as tested).

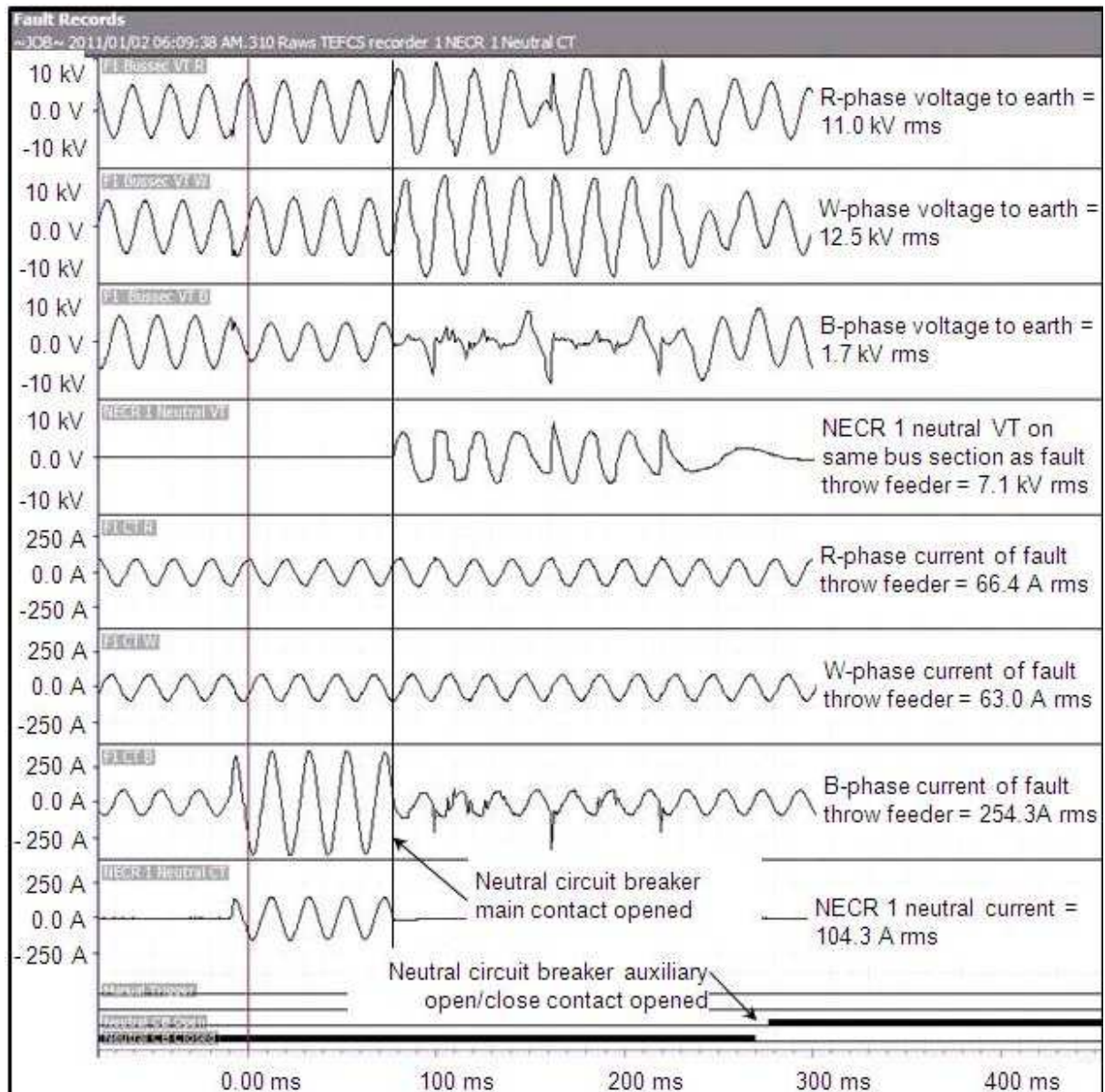

Figure 44: Typical earth fault clearing by the TEFCS. The neutral CB tripped in 98 ms and total fault clearing was achieved within 242 ms. This recording is of a B-phase earth fault. Note that the actual earth fault current is about 208.6 A ($2 * 104.3$ A) as there are two NECRs in the substation sharing the earth fault current equally.

In the case of the EF disturbance recording displayed in Figure 44, for instance, the Farmers 1 earth fault protection would only have tripped the feeder circuit breaker in 1.5 s, which is six times slower than the time taken by the TEFCS to clear the fault.

Had this EF been due to a human contact incident the chances of survival, may have been much better with the TEFCS than with the standard protection on its own as the fault current was reduced from 208 A to about 18 A within 98 ms by opening of the neutral CB. (Where 18 A is the capacitive EF current as was measured for the trial site network during the commissioning tests.)

Many factors influence the amount of current actually passing through the human/animal body during a contact incident making it very difficult, if not impossible, to state that one particular method of earth fault clearing is better than another. Each contact incident will have different factors influencing the severity of injuries sustained, but it is felt that if the prospective fault current may be reduced to as low a level as possible within as short a time as possible, the survival rate of accidental electrical contact victims may be increased substantially. This may be viewed in light of the fact that there are currently, with the existing conventional protection, electrical contact incident survivors. The victims may have suffered burns, but they survived.

In section 4.3 the assumption was made that a lower fault current may enable quicker fault clearing. This assumption has been verified by TEFCS operations, and may be explained as follows:

Of the 21 transient EFs experienced by the TEFCS trial site network thus far only one EF took longer than 2 s (but <10 s) to clear, as mentioned earlier in this section. SEFs constituted 9 of the 19 transient EFs cleared by the TEFCS. All 9 SEF operations would have taken at least 5 s to clear with the conventional protection, compared to the TEFCS's average fault clearing time of 499 ms for all 19 transient EFs. Also about 50% of the transient EFs were cleared in less than 200 ms.

This then is a clear indication that by lowering the earth fault current it is indeed possible to dramatically decrease EF clearing times.

It is very interesting to note that not in all instances did the fault current decrease upon opening of the neutral circuit breaker. During commissioning testing the measured capacitive earth fault current for the complete network was about 18 A. Performance history disturbance recordings show that there were four SEF instances with fault currents between 4 and 6 A before the neutral CB opened. In these cases the actual fault currents would have increased to about 18 A (capacitive) upon opening of the neutral CB, but the faults still cleared successfully. Two of the four faults took between 1 and 2 s to clear and re-striking a number of times before finally clearing.

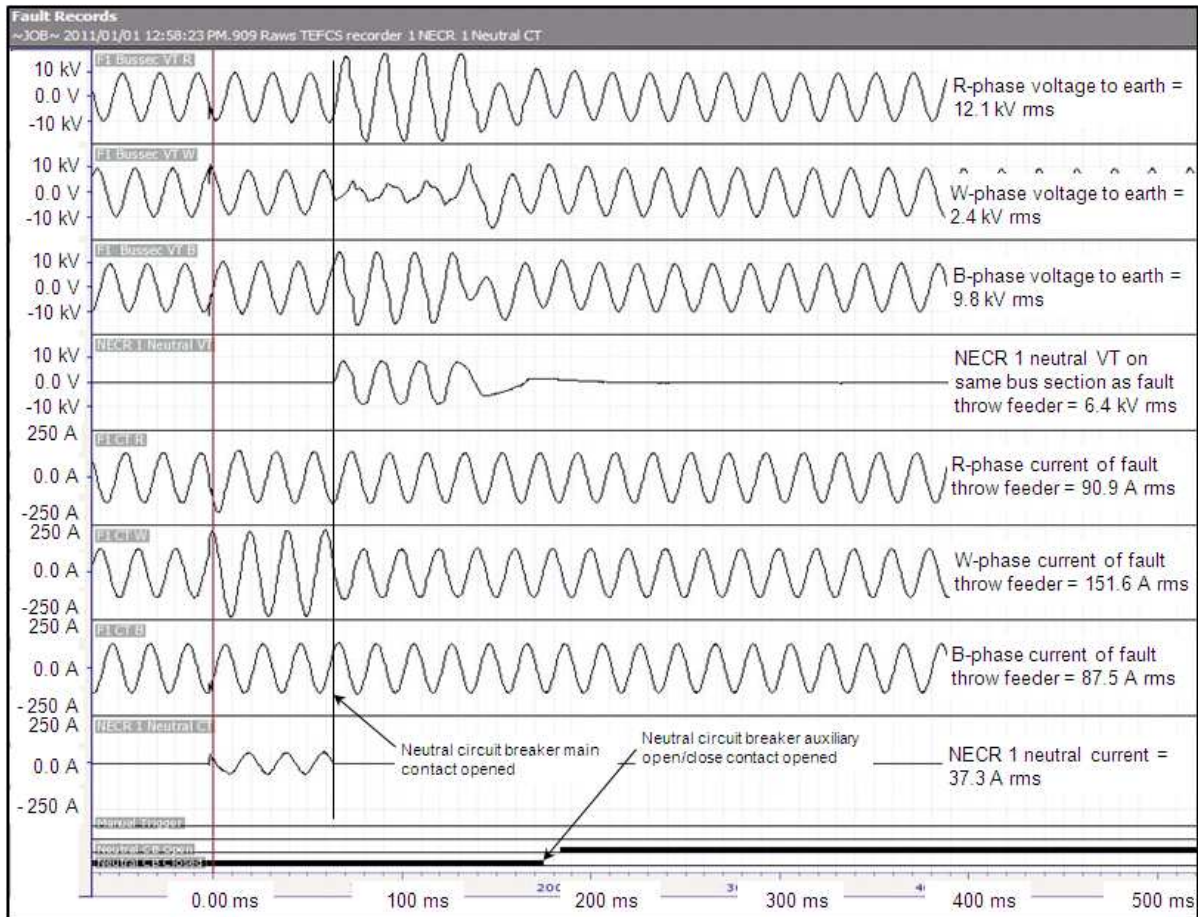

Figure 45: This W-phase EF from the TEFCS trial site cleared within 220 ms, and the neutral CB opened within 75 ms. Note that the actual earth fault current is 74.6 A as the neutral currents of the two NECRs in the substation needs to be summed to obtain the total earth fault current.

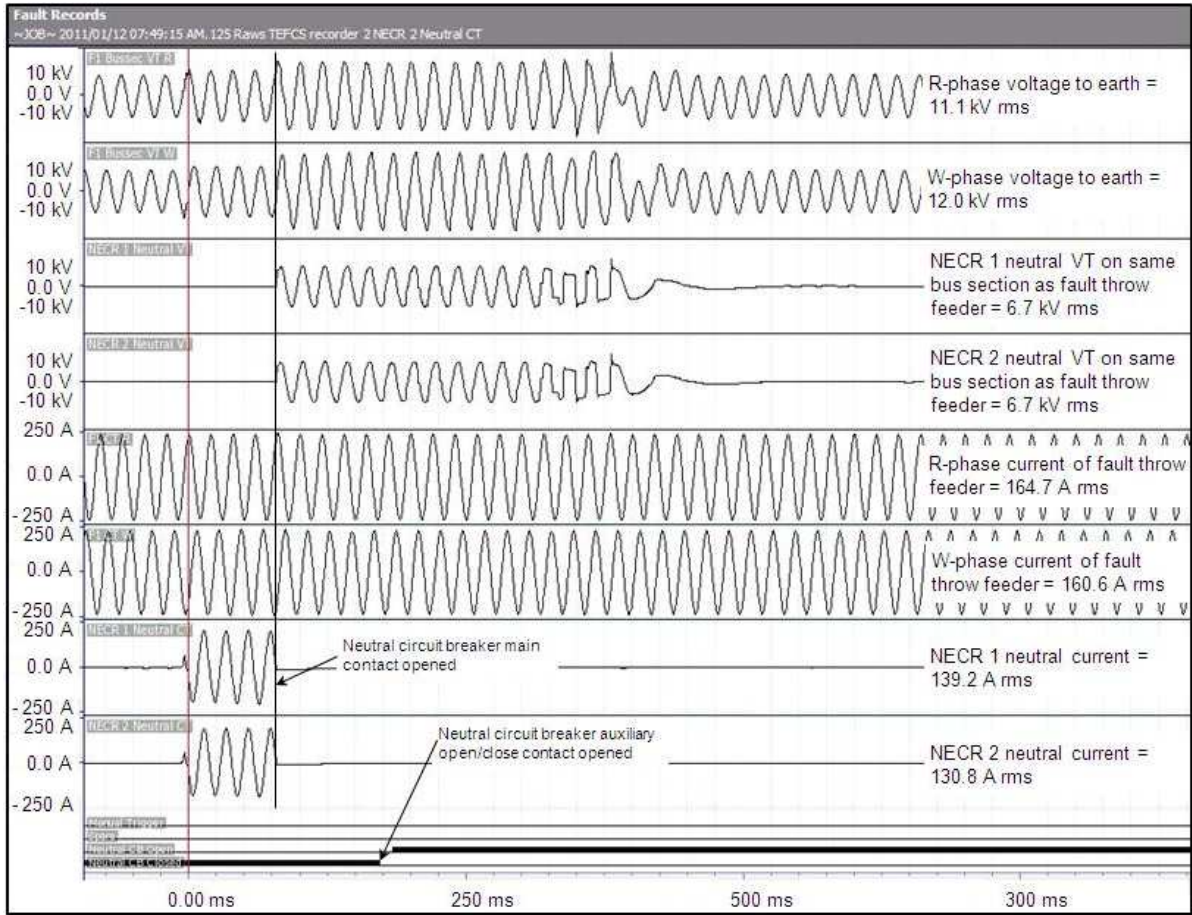

Figure 46: This B-phase EF (unfortunately not displayed in this recording) from the TEFCS trial site cleared within 392 ms, and the neutral CB opened within 89 ms. Note that the actual earth fault current is 270.0 A as the neutral currents of the two NECRs in the substation needs to be summed to obtain the total earth fault current.

The disturbance in Figure 46 is the only TEFCS trial site recording exhibiting the strange neutral voltage waveform during the last 4 cycles just before the arc extinguished. No explanation can be offered for this strange waveform other than that the fault point arc became very unstable just before it extinguished.

Disturbance recordings from the TEFCS trial site, listed in Table 5, indicate that:

- 12 of the 19 EFs cleared by the TEFCS cleared within 400 ms after the neutral CB opened.
- 8 of the 19 EFs cleared by the TEFCS cleared within 200 ms after the neutral CB opened.
- 2 of the 19 EFs cleared by the TEFCS cleared within 50 ms after the neutral CB opened.
- The average trip time of the neutral CB for the 24 faults was 110 ms.
- The shortest EF clearing time after the neutral CB opened was 40 ms.
- The longest an EF fault took to clear was >2000 ms, but < 10 000 ms. (The disturbance recorder records for 2000 ms after the trigger point, and the neutral CB dead time was set to 10 000 ms.)
- The average total fault duration time for the 19 EFs cleared by the TEFCS, but excluding the one fault that cleared between 2000 and 10 000 ms, was 499 ms. This is probably much faster in most cases than what the conventional protection will manage to clear the same fault. Compare this to SEF protection which is normally set to trip between 4 to 15 s.
- The longest physically recorded EF clearing time for the 19 EFs successfully cleared by the TEFCS was 1984 ms. Only one of the EFs cleared by the TEFCS took longer than this to clear.
- The maximum EF current recorded during the 24 EFs was 294 A.
- The TEFCS cleared transient EFs much faster (499 ms on average) than conventional SEF or EF protection.
- High magnitude EFs on average cleared faster than low magnitude EFs after neutral circuit breaker operation.
- There is no need, thus far, to alter MV feeder SEF settings as all transient EFs encountered on the TEFCS trial site network cleared before any feeder protection operated. From commissioning test results it was deduced that SEF settings may have to be made longer in order to allow more EFs to be cleared successfully. Fortunately the performance history suggests otherwise.
- It should be noted that successful clearance of transient EFs downstream of fuses will depend on the fuse size and fault current magnitude. Fuse saving may take place for low magnitude EFs.
- Five transient EFs took between 1.1 and 2 s to clear successfully. This finding may indicate a wrong assumption by Erroa [2006, 6] whereby he assumed that any earth fault lasting longer than 1 s is a permanent fault.

The disturbance recording of Figure 47 indicates one instance where the EF was cleared very quickly. Depending how one interprets the fault clearing, it may either have cleared within 44 ms after the neutral CB opened, or within 130 ms if one assumes that the fault only cleared when the neutral voltage transient died away.

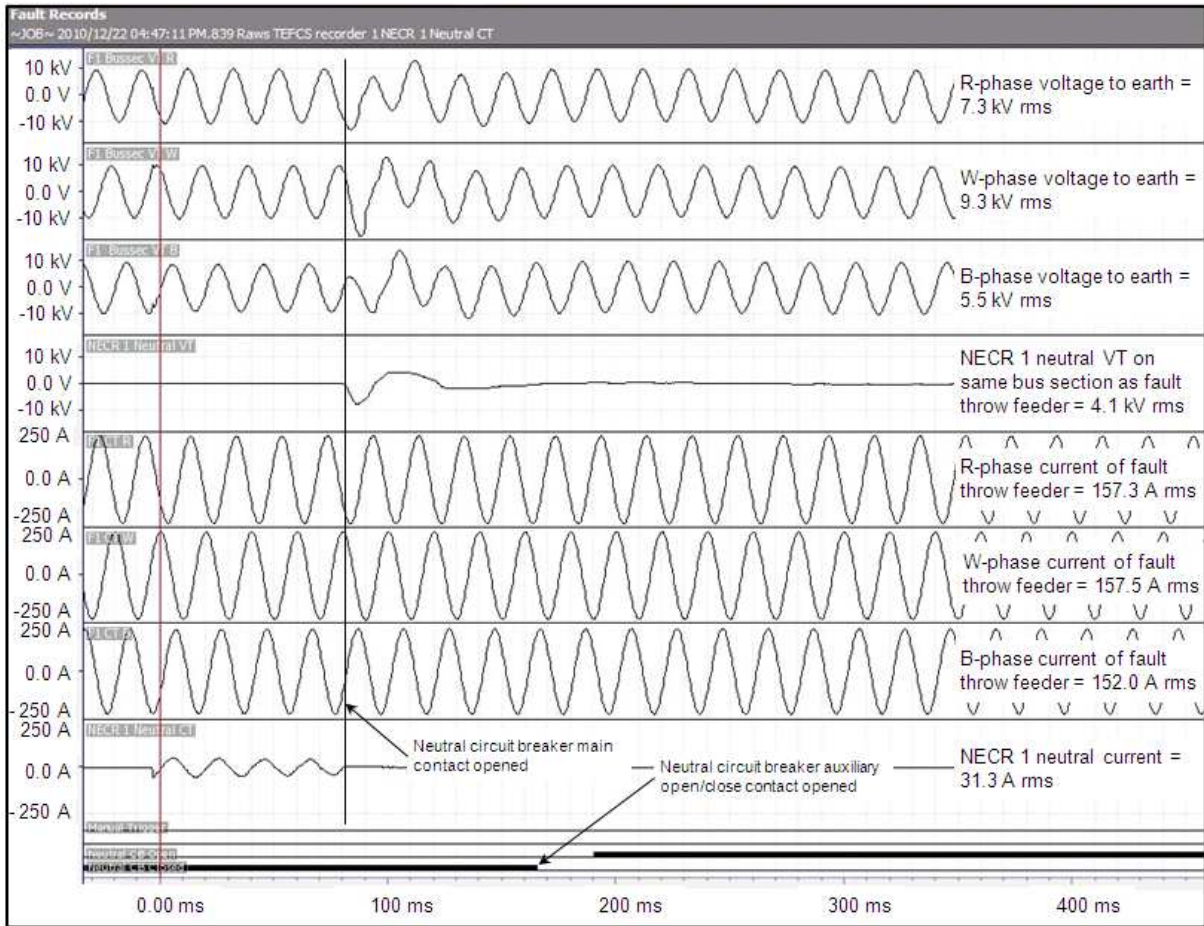

Figure 47: This B-phase EF from the TEFCS trial site cleared within 215 ms, and the neutral CB opened within 85 ms. Note that the actual earth fault current is about 62.6 A as the neutral currents of the two NECRs in the substation needs to be summed to obtain the total earth fault current.

Table 5: Summary of the TEFCS trial site’s fault statistics. Note that EF clearing times have been taken up to the point where the neutral voltage transient died away. The tabled “Fault clearing time after circuit breaker opened” and “Total fault duration” are therefore very conservative times.

Fault #	Date	Time	Circuit breaker operating time (including protection operation time) [ms]	Fault clearing time after circuit breaker opened [ms]	Total fault duration [ms]	Earth fault current before neutral CB opened [A]	Comments
1	03/12/2010	02h07:01	88	47	135	125	EF
2	14/12/2010	11h49:52	87	<5 s	±5s	152	EF: The fault cleared in just under 5 s within the neutral CB’s dead time of 10 s, but it seem that the fault re-established during the 30 s protection block time of the neutral CB as a downstream auto-recloser tripped and locked out. This EF fault was caused by a jumper that pulled out of a clamp.
3	22/12/2010	16h47:11	85	130	215	67	EF
4	01/01/2011	08h27:15	86 (estimated)	0	71	214	EF: <i>Fault cleared about 10 ms before the neutral CB physically opened and did not re-strike, according to the disturbance recording.</i>
5	01/01/2011	12h58:23	75	145	220	74	EF
6	02/01/2011	06h09:38	98	144	242	210	EF
7	04/01/2011	15h29:10	88	173	261	294	EF
8	05/01/2011	11h36:48	137	1141	1278	4.2	SEF
9	06/01/2011	15h24:12	158	44	202	60	SEF to EF: Fault started off as a SEF but escalated to an EF
10	06/01/2011	17h01:06	124	202	326	52	SEF to EF: Fault started off as a SEF but developed into an EF, which was cleared in 124 ms by the neutral CB. The fault re-struck a few times and died down after 202 ms.
11	08/01/2011	05h47:39	86 (estimated)	0	55	111	EF: <i>Fault cleared 49 ms before the neutral CB physically opened and did not re-strike, according to the disturbance recording.</i>
12	12/01/2011	07h49:15	89	303	392	270	EF
13	18/01/2011	05h31:25	104	2 s < t < 10 s	>10 s	23	EF: The fault cleared within the neutral CB’s dead time of 10 s, but it seem that the fault re-established during the 30 s protection block time of the neutral CB as a downstream auto-recloser tripped and locked out.
14	19/01/2011	04h39:22	144	1840	1984	4	SEF: Fault re-struck many times before finally clearing.
15	19/01/2011	04h40:52	153 (estimated)	601	754	7 to 10	SEF to EF: <i>Fault cleared about 40 ms before the neutral CB physically opened, but re-struck again after 740 ms, and extinguished finally after</i>

							<i>another 1486 ms, according to the disturbance recording..</i>
16	19/01/2011	04h41:37	153	1808	1961	8.4	<i>SEF: Fault cleared about 43 ms before the neutral CB physically opened, but re-struck again after 470 ms, extinguished and re-struck again, and extinguished finally after another 398 ms, according to the disturbance recording..</i>
17	27/01/2011	20h44:42	153	40	193	5.8	SEF
18	03/02/2011	14h40:21	99	182	281	45.3	EF
19	03/02/2011	15h00:15	86	307	393	60	EF
20	19/02/2011	16h08:19	143	235	378	5.4	SEF
21	05/03/2011	21h49:12	104	1422	1526	23.8	SEF to EF: Fault started off as a SEF but escalated to an EF
22	06/03/2011	10h19:22	95	>2000	<10 000	161.3	EF
23	07/03/2011	12h18:11	113	729	842	12.6	SEF to EF: Fault started off as a SEF but escalated to an EF
24	07/03/2011	17h18:29	92	1019	1111	265	EF: The neutral CB ARCD three times before a downstream fuse operated on Farmers 2.

11. Conclusion

The thesis proposed a unique transient earth fault clearing system (TEFCS) whereby transient earth faults on solid or low resistance earthed MV (or HV) networks may be cleared without customer supply interruptions, without compromising public safety and without compromising network integrity, if such networks conform, mainly, to the insulation requirements of such a TEFCS.

No prior attempts to selectively clear transient earth faults on MV or HV networks have been revealed by the conducted literature study.

Based on internationally verified MV network fault statistics, as stated in chapter 1, it is conservatively estimated that 80 out of every 100 earth faults are transient in nature and may therefore most likely be cleared by the TEFCS, without interrupting supply to customers. If such a high transient earth fault clearing success rate is attainable in practice it will realize a significant improvement in network performance, quality of supply, customer satisfaction and perhaps also a reduction in lost revenue. Performance of the TEFCS thus far attained a 79% success rate for all network earth faults, inclusive of permanent earth faults.

Mainly three earthing methods inherently allow transient earth fault clearing. These are the unearthed (or isolated neutral), high resistance earthed and resonant earthed (Petersen coil) methods.

Capacitive earth fault current magnitude during the neutral circuit breaker's dead time is dependent on the type of line construction (transposed or not), the combined length of lines connected to the same busbar, and whether underground cables or capacitor banks are part of the network or not. Through the commissioning tests it was verified that longer lines do have higher capacitive fault currents, but it could not be verified that the chance of arcing at the fault point is increased with increase in line length, which is suspected what will happen.

Interruption of capacitive current is more likely to cause arc re-striking due to current interruption (at zero crossing) taking place at a voltage maximum. Arcing earth faults are therefore less likely to self-extinguish. Success of the TEFCS may therefore be heavily dependent on the magnitude of the capacitive EF current in a given network, if one assumes that the spark gap to earth at the fault point is, and stays, relatively small (say 5 to 10 mm for an 11 kV network) for the duration of the earth fault.

The proposed concept of transient earth fault clearing is based on the premise that during the dead time of the neutral CB the cause of the transient earth fault is allowed to drop free of the live overhead conductor or equipment, i.e. the fault point spark gap to earth is assumed to increase. It is further assumed that arcing will quench faster due to the lower fault current during this period.

When implementing the TEFCS on a low resistance earthed network, such as the Eskom MV distribution network where the earth fault current is limited to a maximum of 360 A per NECR, the customers will most likely not be aware of a problem on the network due to the low EF current. This is especially true if the neutral current is interrupted without any intentional time delay upon EF detection, say within 120 ms. Quality of supply loggers installed on the TEFCS trial site network during the commissioning tests did not reveal any quality of supply problems.

In a solidly earthed network the earth fault currents will most probably be in the order of thousands of ampere, depending mainly on the fault's distance from the source transformer, as opposed to hundreds of ampere in a low resistance earthed network, with the result that the customers will most likely notice a dip in voltage with every earth fault, even if the neutral current is interrupted within about 120 ms. This situation may in most cases be more acceptable to the customer than a complete loss of supply by auto-reclosing or tripping of a feeder circuit breaker or auto-recloser.

This envisaged improvement in quality of supply and customer satisfaction comes mainly at the expense of installing a circuit breaker together with its associated protection in series with the substation transformer's neutral connection to earth.

The highest peak phase-to-earth overvoltage recorded during the TEFCS commissioning tests was 17.7 kV and during subsequent operations of the 11 kV TEFCS trial site a peak phase-to-earth overvoltage of 20.4 kV was recorded on the two healthy phases. This translates into an overvoltage of about 2.3 times the normal 11 kV peak phase-to-neutral voltage, which confirms some of the claims made by a number of papers obtained during the literature study. Total absence of very high overvoltages in the order of 3 to 6 times normal phase-to-neutral, as predicted by a number of literature sources [Allen & Waldorf, 1946, 305; Evans et al, 1939, 392; Glover, 1978 or later, D-2, & Uppal, 1984, 911], may possibly be attributed to the relatively low capacitive EF current of the trial site network. It therefore seems quite plausible for higher peak overvoltages to manifest itself on networks with higher network phase-to-earth capacitance than the trial site network. Peak phase-to-earth overvoltages of the order of 2.3 are not problematic for the trial site network as insulation levels of the Eskom distribution networks are sufficient to successfully withstand such temporary overvoltages.

Due to the uncertainty regarding the extent of overvoltages attainable during arcing earth faults during the unearthed network period of the TEFCS, it is suggested that fault throw tests be conducted on each network before implementation of a TEFCS on said network. This should be done until such time as enough experience has been gained regarding the implementation of a TEFCS on the Eskom MV distribution networks.

A TEFCS will improve customer supply quality and reduce customer losses by preventing nuisance supply interruptions. Implementation of a TEFCS may lead to better SAIDI and SAIFI figures as some potential EFs may be prevented from escalating from transient to permanent EFs by fast operation of the neutral CB. By the same token the electricity supply utility may experience a reduction in lost revenue and less equipment damage by high fault currents as a result of fast neutral CB operation.

The TEFCS may also enhance the safety/survival rate of humans and animals during accidental contact incidents through fast reduction of the fault current, and possibly faster fault clearance than possible with conventional protection. Many factors influence the amount of current actually passing through the human/animal body during a contact incident making it very difficult, if not impossible, to state that one particular method of earth fault clearing is better than another. Each contact incident will have different factors influencing the severity of injuries sustained, but it is felt that if the prospective fault current may be reduced to as low a level as possible within as short a time as possible, the survival rate of accidental electrical contact victims may be increased substantially. This may be viewed in light of the fact that there are currently, with the existing conventional protection (long operating times), electrical contact incident survivors. The victims may have suffered burns,

but they survived the ordeals. The fact that the TEFCS protection does not have to be coordinated with any other protection on the given network presents an immense advantage over the conventional protection employed on all the Eskom MV networks. It may therefore be set to operate for very low currents and in very short times as operation thereof does not result in any supply interruptions.

Through studying the TEFCS's operating history it was established (chapter 10) that by substantial lowering of EF currents it is indeed possible to dramatically decrease EF clearing times.

Performance history of the low resistance earthed MV TEFCS trial site network of 217 km (including all spurs) over the period 24 November 2010 up to 16 March 2011 is very encouraging with a 79% successful earth fault clearance rate of all earth faults (19 out of 24). Feedback from the operator responsible for the trial site network is that there has been a noticeable reduction in call-outs due to network problems since implementation of the TEFCS.

Successful operating history of the TEFCS should be viewed in contrast to a solid or low resistance earthed network without a TEFCS where customer supply would have been interrupted for almost 100% of the earth faults that occurred on the TEFCS trial site. (Almost 100% as it appears trial site operating history that two earth faults have cleared before the neutral circuit breaker physically opened.)

Based on the commissioning test results and the TEFCS trial site performance history, it may be concluded that it is indeed possible to successfully implement the proposed TEFCS on (some) solid and low resistance earthed networks.

The TEFCS trial site performance will be closely monitored over the next year, and if found satisfactory, it is foreseen that TEFCSs may be implemented on a large scale on Eskom's MV networks.

References

- ABB, 1994, "Protective Relaying Theory and Applications", first edition, ISBN: 0-8247-9152-5.
- Allen, J.E., and Waldorf, S.K., 1946 "Arcing Ground Tests on a Normally Ungrounded 13kV 3-Phase Bus, IEEE Transactions Volume 65, May.
- Alstom, 2002, "Network Protection and Application Guide", first edition, ISBN: 2-9518589-0-6.
- Bridger, Baldwin, J.R., 1983, IEEE Transactions, Vol. IA-19, No. 1, January/February.
- Burkholder, C.I. and Marvin, R.H, 1911, "Tests of Arcing Ground Suppressor on the 40 000 Volt System of the Southern Power Company", AIEE, 15 February, pp 327-335.
- Clarke, E., Crary, S.B. and Peterson, H.A., 1939, "Overvoltages During Power System Faults", AIEE Transactions, Vol. 58, August.
- Cornwell, R.N, and Evans, R.D., 1922 "The Petersen Coil", 10th Midwinter Convention of the AIEE, New York, N.Y., 15 – 17 February.
- Cotton, H., and Barber, H., 1970 "The Transmission and Distribution of Electrical Energy", The English Universities Press LTD., London, EC4.
- Coopers, 1990, "Electrical Distribution System Protection", Coopers Power Systems, third edition.
- Cucic, R., Komen, V., and Zivic Durovic, M., 2008, "Neutral Point Concept in Distribution Networks", Eng. Rev. 28-2, pp77-89.
- Dán, A.M., Czira, Z.S., and Raisz, D., 2003 or later, "Comparison of Different Methods to Decrease the Harmonic Content of the Fault Current during Single-Phase to Ground Faults in Compensated Networks.
- Dutoit, J.; Gonzalez M., 2009, "Shunt Circuit Breaker in Ungrounded Medium Voltage Systems", Paper 0875, CIRED's 20th International Conference on Electricity Distribution, Prague, 8-11 June.
- Dutoit, J.; Vonlanthen, X., Chamorel, P. A. And Richard, M, 2005 "Shunt Circuit Breaker Installed in Ungrounded Medium Voltage Systems", CIRED's 18th International Conference on Electricity Distribution, Turin, 6-9 June.
- Eaton, J.R., Peck, J.K. and Dunham, J.M., 1931, "Experimental Studies of Arcing Faults on a 75kV Transmission System", AIEE Transactions, December.
- Eaton Power Business Worldwide, 2009, "Transient Overvoltages on Ungrounded System from Intermittent Ground Faults", 11 May (www.eaton.com).
- Erroa, C.; Cruz, M. and Calero, F., 2006, "Experience, Improvements in Operation, Limitations, and Successes of ungrounded Distribution Network Protection Scheme", 22 August.

- Evans, R.D., Monteith, A.C. and Witzke, R.L., 1939, "Power System Transients Caused by Switching and Faults", AIEE Transactions, 23 – 27 January.
- Fickert, L., Achleitner, G., Schmutzger, E., Obkircher, C. and Raunig, C., 2009, "Resonant Grounding Grids – Quo Vadis!?", Paper 0307, CIRED's 20th International Conference on Electricity Distribution, Prague, 8-11 June.
- Freeman, P.J., 1968 "Electric Power Transmission & Distribution", George G. Harrap & CO. LTD, London.
- Glover, Martin, 1978 or later, "Resistive Grounding Techniques", Post Glover Resistors, Incorporated, Erlanger, Kentucky, USA.
- Hänninen, Seppo, 2001, "Single phase earth faults in high impedance grounded networks", VTT Publications 453.
- Heine, P., Lehtonen, M., and Oikarinen, A., 2004, "Overvoltage Protection, Faults and Sags", 11th International Conference on Harmonics and Quality of Power.
- Hutter, S., 2009, "Earthing System Evaluation and Influence on Protection Performance in Resonantly Earthed MV Networks", Paper 0620, CIRED's 20th International Conference on Electricity Distribution, Prague, 8-11 June.
- Hunter, E.M., 1938, "Some Engineering Features of Petersen Coils and their Application", AIEE, Vol. 57, January, pp 12-18.
- IEC 60479-1, 2005, "Effects of Current on Human Beings and Livestock".
- IEEE PC37.230/D4.0, 2006, "Draft guide for protective relay applications to distribution lines", Institute of Electrical and Electronic Engineers, New York, 18 February.
- Koepl, G., Abaecherli, P., Schmid, A. and Voss, G., 2005, "Concept and Practical Testing of Single Pole Operated Earthing Breakers in an Urban MV Cable Network", CIRED's 18th International Conference on Electricity Distribution, Turin, 6-9 June.
- Lehtonen, M., and Hakola, T., 1996, "Neutral Earthing and Power System Protection", ISBN 952-90-7913-3, ABB Transmit Oy.
- Lehtonen, M., Hänninen, S., and Hakola, T., 2001, "Earth Faults and Related Disturbances in Distribution Networks", 0-7803-7173-9/01, IEEE, pp 1181-1186.
- Marshall, C.W., 1930, "Discussion Before the Transmission Section", A.I.E.E., 15 December, pp 399–409.
- Nelson, John P., 2002, "System Grounding and Ground-Fault Protection in the Petrochemical Industry: A Need for a Better Understanding", IEE Transactions on Industry Applications, Vol. 38, No. 6, November/December, pp 1633-1640.
- North, J.R. and Eaton, J.R., 1933, "Petersen Coil Tests on 140 kV System", A.I.E.E., 13 November, pp 63–74.
- Papp, K., 1992 "Arc Suppression Coils for Neutral Grounding of Distribution Systems", Trench Electric Austria.
- Pühringer M, 2003 "Improving Power Quality by Resonant Earthing", Trench Electric Austria.

- Smeets, R.P.P., and Knol, P., 2009, "Verification of Lifetime Arcing Stress Withstand of Circuit Breakers Through Testing", Cigré 6th Southern Africa Regional Conference, 17 - 18 August, Somerset West, Paper no. P402.
- Sumner, J.H., 1946, "The Theory and Operation of Petersen Coils", AIEE, Vol. 94, Part 2, 17 August, pp 283-297.
- Uppal, Dr. S.L., 1984, "Electrical Power", tenth edition, Khanna Publishers.
- Westinghouse Electric & Manufacturing Company, 1944, "Electrical Transmission and Distribution Reference Book", third edition, ABB.
- Willheim, R., Waters, M., Rüdberg, R., 1956, "Neutral Grounding in High Voltage Transmission", Cleaver-Hume Press Ltd, London.

University of Cape Town

Annex A

CAPACITANCE CALCULATIONS FOR A 3-PHASE OVERHEAD DELTA LINE CONFIGURATION WITH SYMMETRICAL OR UNSYMMETRICAL SPACING

The following calculations of line capacitance-to-earth and between phases, are based on equations from the "Electrical Transmission and Distribution Reference Book", third edition, 1944, Westinghouse Electric, p509.

Input Data Required:

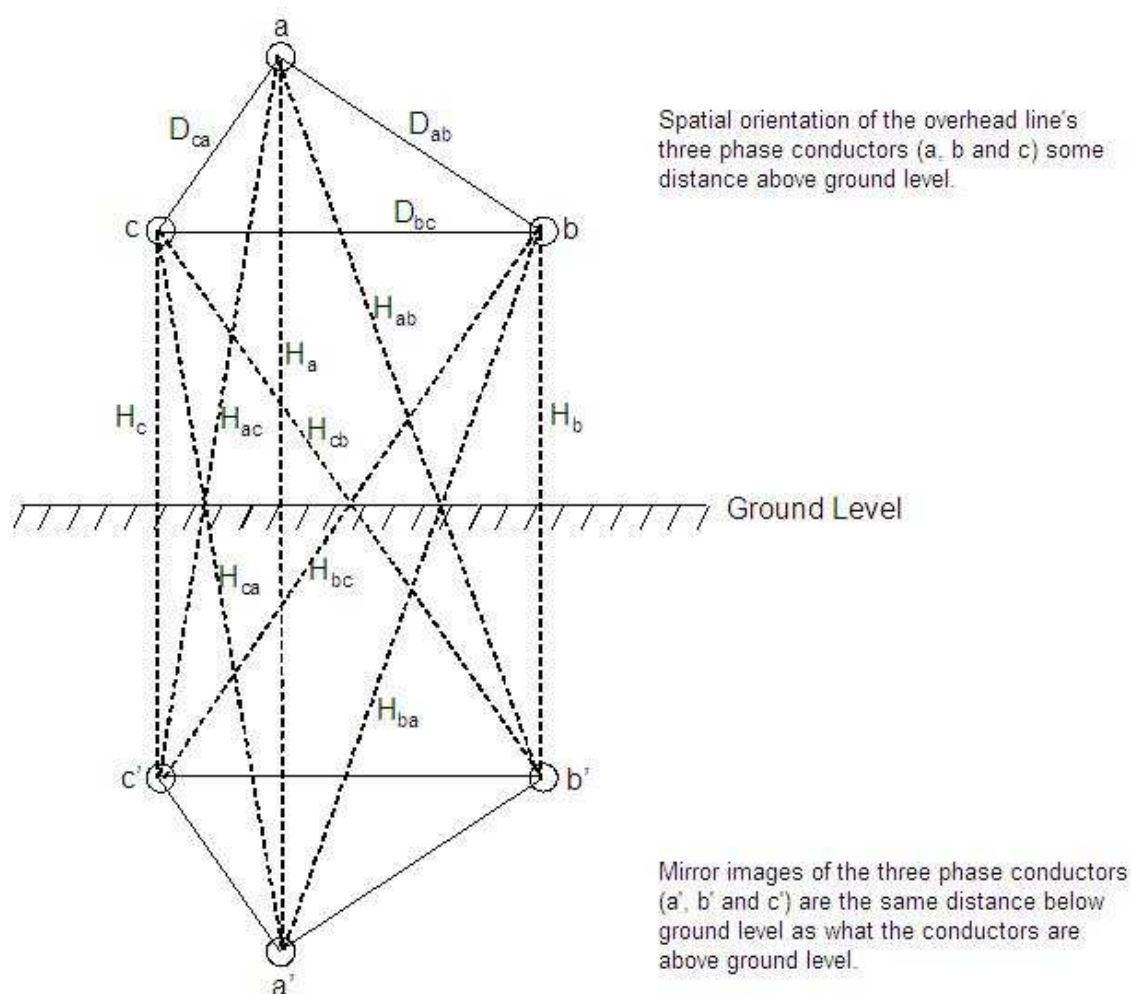

The above diagram depicts the spatial orientation of an overhead line's three phase conductors (a, b and c) some distance above ground level, and the mirror images of the three phase conductors (a', b' and c') at the same distance below ground level as what the physical conductors are above ground level.

System voltage: $V_{\text{line_line}} := 11 \cdot 10^3 + 0j$ V

System frequency: $f := 50$ Hz

Conductor radius: $r := 0.0071$ m [Hare conductor radius = 7.1mm]

$r_a := r$

$r_b := r$

$r_c := r$

Line length: $\text{Line_length} := 100$ km

$D_{ab} := 1.151$ m

$D_{bc} := 1.140$ m

$D_{ca} := 1.151$ m

Height of b and c phases above ground level: $H_{bg} := 6.800$ m

Calculations:

Phase-to-Neutral Voltages:

$$V_{an} := \frac{V_{\text{line_line}}}{\sqrt{3}} \text{ V}$$

$$V_{an_angle} := \text{angle}(\text{Re}(V_{an}), \text{Im}(V_{an})) \cdot \left(\frac{180}{\pi}\right)$$

$$V_{bn} := \frac{V_{\text{line_line}} \cdot (-0.5 + -0.866j)}{\sqrt{3}} \quad V_{bn} = -3.175 \times 10^3 - 5.5i \times 10^3$$

$$V_{bn_angle} := \text{angle}(\text{Re}(V_{bn}), \text{Im}(V_{bn})) \cdot \left(\frac{180}{\pi}\right)$$

$$V_{cn} := \frac{V_{\text{line_line}} \cdot (-0.5 + 0.866j)}{\sqrt{3}} \quad V_{cn} = -3.175 \times 10^3 + 5.5i \times 10^3$$

$$V_{cn_angle} := \text{angle}(\text{Re}(V_{cn}), \text{Im}(V_{cn})) \cdot \left(\frac{180}{\pi}\right)$$

$$V_{an} = 6.351 \times 10^3 \text{ V} \quad V_{an_angle} = 0 \text{ degrees}$$

$$|V_{bn}| = 6.351 \times 10^3 \text{ V} \quad V_{bn_angle} = 240 \text{ degrees}$$

$$|V_{cn}| = 6.351 \times 10^3 \text{ V} \quad V_{cn_angle} = 120 \text{ degrees}$$

Phase-to-Phase Voltages:

$$V_{ab} := \sqrt{3} \cdot |V_{an}|$$

[Subtract 150 degrees (2.618 radians) from V_{an} phase angle in order to get the correct phase angle (-150 degrees) for V_{ab}]

$$V_{ab_angle_adjust} := \text{angle}(\text{Re}(V_{an}), \text{Im}(V_{an})) - 2.618$$

$$V_{ab} := V_{ab} \cdot (\cos(V_{ab_angle_adjust}) + i \sin(V_{ab_angle_adjust}))$$

[Write V_{ab} in complex form again]

$$V_{bc} := \sqrt{3} \cdot |V_{bn}|$$

[Subtract 150 degrees (2.618 radians) from V_{bn} phase angle in order to get the correct phase angle (+90 degrees) for V_{bc}]

$$V_{bc_angle_adjust} := \text{angle}(\text{Re}(V_{bn}), \text{Im}(V_{bn})) - 2.618$$

$$V_{bc} := V_{bc} \cdot (\cos(V_{bc_angle_adjust}) + i \sin(V_{bc_angle_adjust}))$$

[Write V_{bc} in complex form again]

$$V_{ca} := \sqrt{3} \cdot |V_{cn}|$$

[Subtract 30 degrees (0.5236 radians) from V_{cn} phase angle in order to get the correct phase angle (+150 degrees) for V_{bc}]

$$V_{ca_angle_adjust} := \text{angle}(\text{Re}(V_{cn}), \text{Im}(V_{cn})) + 0.5236$$

$$V_{ca} := V_{ca} \cdot (\cos(V_{ca_angle_adjust}) + i \sin(V_{ca_angle_adjust}))$$

[Write V_{ca} in complex form again]

$$V_{ab} = -9.526 \times 10^3 - 5.5i \times 10^3 \quad \text{V}$$

$$V_{ab_angle_adjust} = -150 \text{ deg}$$

$$V_{bc} = 0.207 + 1.1i \times 10^4 \quad \text{V}$$

$$V_{bc_angle_adjust} = 89.999 \text{ deg}$$

$$V_{ca} = -9.526 \times 10^3 + 5.5i \times 10^3 \quad \text{V}$$

$$V_{ca_angle_adjust} = 150.001 \text{ deg}$$

Determining the different distances between the three line conductors and their mirror images beneath ground level as indicated in the figure above:

$$H_{cg} := H_{bg} \quad H_{cg} = 6.8 \quad \text{m}$$

$$H_b := 2 \cdot H_{cg} \quad H_b = 13.6 \quad \text{m}$$

$$H_c := H_b \quad H_c = 13.6 \quad \text{m}$$

$$\text{Angle}_B := \text{acos} \left[\left[\frac{(D_{ab}^2 + D_{bc}^2 - D_{ca}^2)}{2 \cdot D_{ab} \cdot D_{bc}} \right] \right]$$

[Trigonometry theorem used:
 $c^2 = a^2 + b^2 - 2ab \cdot \cos C$]

$$\text{Angle}_B = 60.32 \text{ deg}$$

$$H_a := H_b + 2 \cdot D_{ab} \cdot \sin(\text{Angle}_B)$$

$$H_{bc} := \sqrt{(D_{bc}^2 + H_b^2)}$$

$$H_{cb} := H_{bc}$$

$$H_{ba} := \sqrt{[(H_a - D_{ab} \cdot \sin(\text{Angle}_B))^2 + (D_{ab} \cdot \cos(\text{Angle}_B))^2]} \quad H_{ab} := H_{ba}$$

$$H_{ac} := \sqrt{[(H_a - D_{ab} \cdot \sin(\text{Angle}_B))^2 + (D_{bc} - D_{ab} \cdot \cos(\text{Angle}_B))^2]} \quad H_{ca} := H_{ac}$$

$$H_a = 15.6 \quad \text{m}$$

$$H_{bc} = 13.648 \quad \text{m}$$

$$H_{cb} = 13.648 \quad \text{m}$$

$$H_{ac} = 14.611 \quad \text{m}$$

$$H_{ba} = 14.611 \quad \text{m}$$

$$H_{ab} = 14.611 \quad \text{m}$$

$$H_{ca} = 14.611 \quad \text{m}$$

Equivalent distance between the three phase conductors:

$$D_{eq} := (D_{ab} \cdot D_{bc} \cdot D_{ca})^{0.333} \quad D_{eq} = 1.147 \quad \text{m}$$

Determining line capacitance to earth, and between phases, by using equations from "Electrical Transmission and Distribution Reference Book", third edition, 1944, Westinghouse Electric, p509.

$$D1 := \left(\frac{0.1786}{1.6} \right) \cdot \left[2 \cdot \ln \left(\frac{H_a}{r_a} \right) \cdot \left(2 \cdot \ln \left(\frac{H_b}{r_b} \right) \right) \cdot \left(2 \cdot \ln \left(\frac{H_c}{r_c} \right) \right) + 2 \cdot \left(2 \cdot \ln \left(\frac{H_{ab}}{D_{ab}} \right) \right) \cdot \left(2 \cdot \ln \left(\frac{H_{ac}}{D_{ca}} \right) \right) \cdot \left(2 \cdot \ln \left(\frac{H_{bc}}{D_{bc}} \right) \right) \right]$$

$$D2 := \left(\frac{0.1786}{1.6} \right) \cdot \left[- \left(2 \cdot \ln \left(\frac{H_{ab}}{D_{ab}} \right) \right)^2 \cdot \left(2 \cdot \ln \left(\frac{H_c}{r_c} \right) \right) - \left(2 \cdot \ln \left(\frac{H_{ac}}{D_{ca}} \right) \right)^2 \cdot \left(2 \cdot \ln \left(\frac{H_b}{r_b} \right) \right) - \left(2 \cdot \ln \left(\frac{H_{bc}}{D_{bc}} \right) \right)^2 \cdot \left(2 \cdot \ln \left(\frac{H_a}{r_a} \right) \right) \right]$$

$$D := D1 + D2 \quad D = 291.617$$

$$K_a := \frac{\left(\frac{0.1786}{1.6} \right) \cdot \left[\left(2 \cdot \ln \left(\frac{H_b}{r_b} \right) \right) \cdot \left(2 \cdot \ln \left(\frac{H_c}{r_c} \right) \right) - \left(2 \cdot \ln \left(\frac{H_{bc}}{D_{bc}} \right) \right)^2 \right]}{D} \quad K_a = 0.078 \quad \mu\text{F}/\text{km}$$

$$K_b := \frac{\left(\frac{0.1786}{1.6} \right) \cdot \left[\left(2 \cdot \ln \left(\frac{H_a}{r_a} \right) \right) \cdot \left(2 \cdot \ln \left(\frac{H_c}{r_c} \right) \right) - \left(2 \cdot \ln \left(\frac{H_{ac}}{D_{ca}} \right) \right)^2 \right]}{D} \quad K_b = 0.079 \quad \mu\text{F}/\text{km}$$

$$K_c := \frac{\left(\frac{0.1786}{1.6}\right) \left[\left(2 \cdot \ln\left(\frac{H_a}{r_a}\right)\right) \cdot \left(2 \cdot \ln\left(\frac{H_b}{r_b}\right)\right) - \left(2 \cdot \ln\left(\frac{H_{ab}}{D_{ab}}\right)\right)^2 \right]}{D}$$

$$K_c = 0.079 \quad \mu\text{F}/\text{km}$$

$$K_{ab} := \frac{\left(\frac{0.1786}{1.6}\right) \left[\left(2 \cdot \ln\left(\frac{H_{ab}}{D_{ab}}\right)\right) \cdot \left(2 \cdot \ln\left(\frac{H_c}{r_c}\right)\right) - \left(2 \cdot \ln\left(\frac{H_{ac}}{D_{ca}}\right)\right) \cdot \left(2 \cdot \ln\left(\frac{H_{bc}}{D_{bc}}\right)\right) \right]}{D}$$

$$C_{ab} := K_{ab} \quad C_{ab} = 0.01975 \quad \mu\text{F}/\text{km} \text{ between a and c phases}$$

$$K_{bc} := \frac{\left(\frac{0.1786}{1.6}\right) \left[\left(2 \cdot \ln\left(\frac{H_{bc}}{D_{bc}}\right)\right) \cdot \left(2 \cdot \ln\left(\frac{H_{ac}}{r_a}\right)\right) - \left(2 \cdot \ln\left(\frac{H_{ab}}{D_{ab}}\right)\right) \cdot \left(2 \cdot \ln\left(\frac{H_{ac}}{D_{ca}}\right)\right) \right]}{D}$$

$$C_{bc} := K_{bc} \quad C_{bc} = 0.01911 \quad \mu\text{F}/\text{km} \text{ between b and c phases}$$

$$K_{ca} := \frac{\left(\frac{0.1786}{1.6}\right) \left[\left(2 \cdot \ln\left(\frac{H_{ac}}{D_{ca}}\right)\right) \cdot \left(2 \cdot \ln\left(\frac{H_b}{r_b}\right)\right) - \left(2 \cdot \ln\left(\frac{H_{ab}}{D_{ab}}\right)\right) \cdot \left(2 \cdot \ln\left(\frac{H_{bc}}{D_{bc}}\right)\right) \right]}{D}$$

$$C_{ca} := K_{ca} \quad C_{ca} = 0.01975 \quad \mu\text{F}/\text{km} \text{ between a and c phases}$$

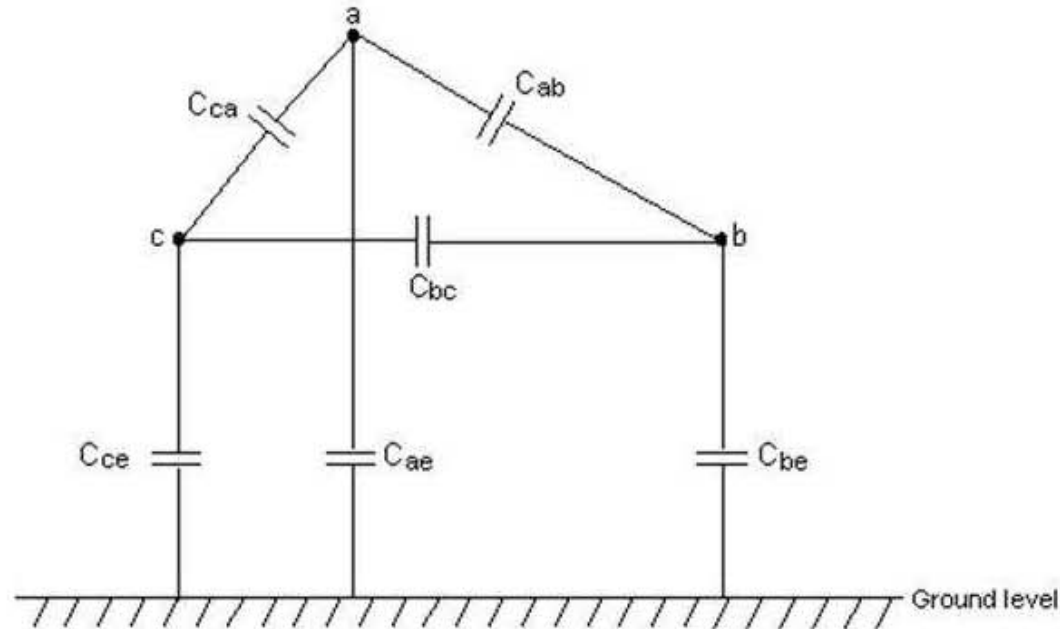

Phase-to-Earth Capacitances:

$$C_{ae} := K_a - K_{ab} - K_{ca} \quad C_{ae} = 0.039 \quad \mu\text{F}/\text{km} \text{ to earth}$$

$$C_{be} := K_b - K_{ab} - K_{bc} \quad C_{be} = 0.04 \quad \mu\text{F}/\text{km} \text{ to earth}$$

$$C_{ce} := K_c - K_{ca} - K_{bc} \quad C_{ce} = 0.04 \quad \mu\text{F}/\text{km} \text{ to earth}$$

Phase-to-Earth Capacitances of the total line length:

Conductor a to earth:	$Total_C_{ae} := Line_length \cdot C_{ae}$	$Total_C_{ae} = 3.853$	μF
Conductor b to earth:	$Total_C_{be} := Line_length \cdot C_{be}$	$Total_C_{be} = 4.03$	μF
Conductor c to earth:	$Total_C_{ce} := Line_length \cdot C_{ce}$	$Total_C_{ce} = 4.03$	μF

Phase-to-Phase Capacitances of the total line length:

Conductor a to b:	$Total_C_{ab} := Line_length \cdot C_{ab}$	$Total_C_{ab} = 1.975$	μF
Conductor b to c:	$Total_C_{bc} := Line_length \cdot C_{bc}$	$Total_C_{bc} = 1.911$	μF
Conductor c to a:	$Total_C_{ca} := Line_length \cdot C_{ca}$	$Total_C_{ca} = 1.975$	μF

Determining charging currents due to line capacitance to earth, and between phases.

Line Charging Current flowing to earth for the a-, b- and c-phases under normal conditions due to line capacitance between each phase and earth, for the total line length:

$$I_{charge_line_Cae_normal} := \left[j Total_C_{ae} \cdot (2 \cdot \pi \cdot f) \cdot \frac{V_{an}}{10^6} \right] \quad I_{charge_line_Cae_normal} = 7.687i \quad A$$

$$I_{charge_line_Cae_normal_angle} := angle(Re(I_{charge_line_Cae_normal}), Im(I_{charge_line_Cae_normal})) \quad \text{radians}$$

$$I_{charge_line_Cbe_normal} := \left[j Total_C_{be} \cdot (2 \cdot \pi \cdot f) \cdot \frac{V_{bn}}{10^6} \right] \quad I_{charge_line_Cbe_normal} = 6.963 - 4.02i \quad A$$

$$I_{charge_line_Cbe_normal_angle} := angle(Re(I_{charge_line_Cbe_normal}), Im(I_{charge_line_Cbe_normal})) \quad \text{radians}$$

$$I_{charge_line_Cce_normal} := \left[j Total_C_{ce} \cdot (2 \cdot \pi \cdot f) \cdot \frac{V_{cn}}{10^6} \right] \quad I_{charge_line_Cce_normal} = -6.963 - 4.02i \quad A$$

$$I_{charge_line_Cce_normal_angle} := angle(Re(I_{charge_line_Cce_normal}), Im(I_{charge_line_Cce_normal})) \quad \text{radians}$$

$$|I_{charge_line_Cae_normal}| = 7.687 \quad A \quad I_{charge_line_Cae_normal_angle} = 90 \text{ deg}$$

$$|I_{charge_line_Cbe_normal}| = 8.04 \quad A \quad I_{charge_line_Cbe_normal_angle} = 330 \text{ deg}$$

$$|I_{charge_line_Cce_normal}| = 8.04 \quad A \quad I_{charge_line_Cce_normal_angle} = 210 \text{ deg}$$

In an Unearthed Network: Line Charging Current flowing to earth for the b- and c-phase, when there is an earth fault on the a-phase, due to line capacitance between the b- and c-phases and earth, for the total line length. Under this condition there will be full phase-to-phase voltage between the b-phase and earth, and the c-phase and earth.

$$I_{\text{charge_line_Cbe_a_to_e}} := \left[j \text{Total_Cbe} \cdot (2 \cdot \pi \cdot f) \cdot \frac{V_{ab}}{10^6} \right] \quad I_{\text{charge_line_Cbe_a_to_e}} = 6.963 - 12.06i \quad \text{A}$$

$$I_{\text{charge_line_Cbe_a_to_e_angle}} := \text{angle}(\text{Re}(I_{\text{charge_line_Cbe_a_to_e}}), \text{Im}(I_{\text{charge_line_Cbe_a_to_e}})) \quad \text{radians}$$

$$I_{\text{charge_line_Cce_a_to_e}} := \left[j \text{Total_Cce} \cdot (2 \cdot \pi \cdot f) \cdot \frac{V_{ca}}{10^6} \right] \quad I_{\text{charge_line_Cce_a_to_e}} = -6.963 - 12.06i \quad \text{A}$$

$$I_{\text{charge_line_Cce_a_to_e_angle}} := \text{angle}(\text{Re}(I_{\text{charge_line_Cce_a_to_e}}), \text{Im}(I_{\text{charge_line_Cce_a_to_e}})) \quad \text{radians}$$

$$|I_{\text{charge_line_Cbe_a_to_e}}| = 13.926 \quad \text{A} \quad I_{\text{charge_line_Cbe_a_to_e_angle}} = 300 \text{ deg}$$

$$|I_{\text{charge_line_Cce_a_to_e}}| = 13.925 \quad \text{A} \quad I_{\text{charge_line_Cce_a_to_e_angle}} = 240 \text{ deg}$$

For a vector representation refer to the figure below (Figure 4 of the thesis)

$$\text{Charge_current_ratio} := \frac{I_{\text{charge_line_Cbe_normal}}}{I_{\text{charge_line_Cbe_a_to_e}}} \quad \text{Charge_current_ratio} = 0.5 + 0.289i$$

$$|\text{Charge_current_ratio}| = 0.577$$

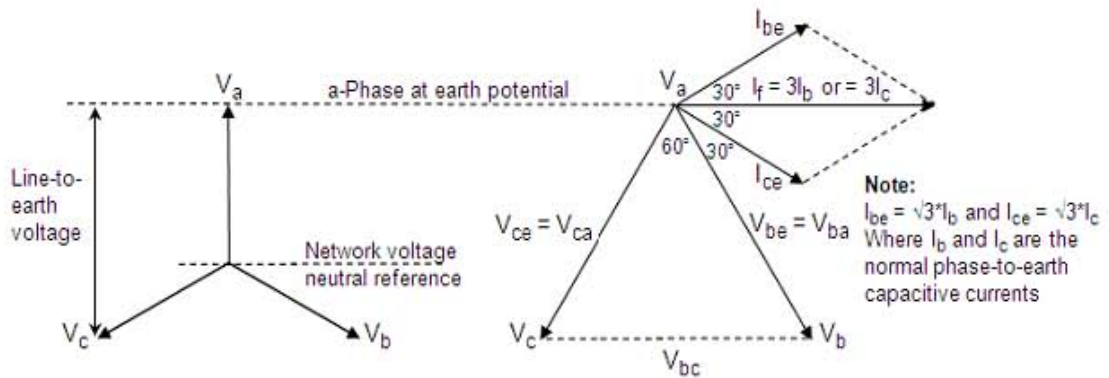

Voltage and capacitive current vectors for an unearthed network under an a-phase-to-earth fault condition

Line Charging Current, when there is an earth fault on the a-phase, for the b- and c-phase due to line capacitance between the a-phase and the b-phase, and between the a-phase and the c-phase, for the total line length:

$$I_{\text{charge_line_Cab}} := \left[j \cdot \text{Total_Cab} \cdot (2 \cdot \pi \cdot f) \cdot \frac{V_{ab}}{10^6} \right]$$

$$I_{\text{charge_line_Cab_angle}} := \text{angle}(\text{Re}(I_{\text{charge_line_Cab}}), \text{Im}(I_{\text{charge_line_Cab}})) \quad \text{radians}$$

$$I_{\text{charge_line_Cbc}} := \left[j \cdot \text{Total_Cbc} \cdot (2 \cdot \pi \cdot f) \cdot \frac{V_{bc}}{10^6} \right]$$

$$I_{\text{charge_line_Cbc_angle}} := \text{angle}(\text{Re}(I_{\text{charge_line_Cbc}}), \text{Im}(I_{\text{charge_line_Cbc}})) \quad \text{radians}$$

$$I_{\text{charge_line_Cca}} := \left[j \cdot \text{Total_Cca} \cdot (2 \cdot \pi \cdot f) \cdot \frac{V_{ca}}{10^6} \right]$$

$$I_{\text{charge_line_Cca_angle}} := \text{angle}(\text{Re}(I_{\text{charge_line_Cca}}), \text{Im}(I_{\text{charge_line_Cca}})) \quad \text{radians}$$

$$|I_{\text{charge_line_Cab}}| = 6.824 \quad \text{A} \quad I_{\text{charge_line_Cab_angle}} = 300 \text{ deg}$$

$$|I_{\text{charge_line_Cbc}}| = 6.605 \quad \text{A} \quad I_{\text{charge_line_Cbc_angle}} = 180 \text{ deg}$$

$$|I_{\text{charge_line_Cca}}| = 6.824 \quad \text{A} \quad I_{\text{charge_line_Cca_angle}} = 240 \text{ deg}$$

Summary of phase-to-earth and phase-to-phase line charging currents for an earth fault on the a-phase for the total line length

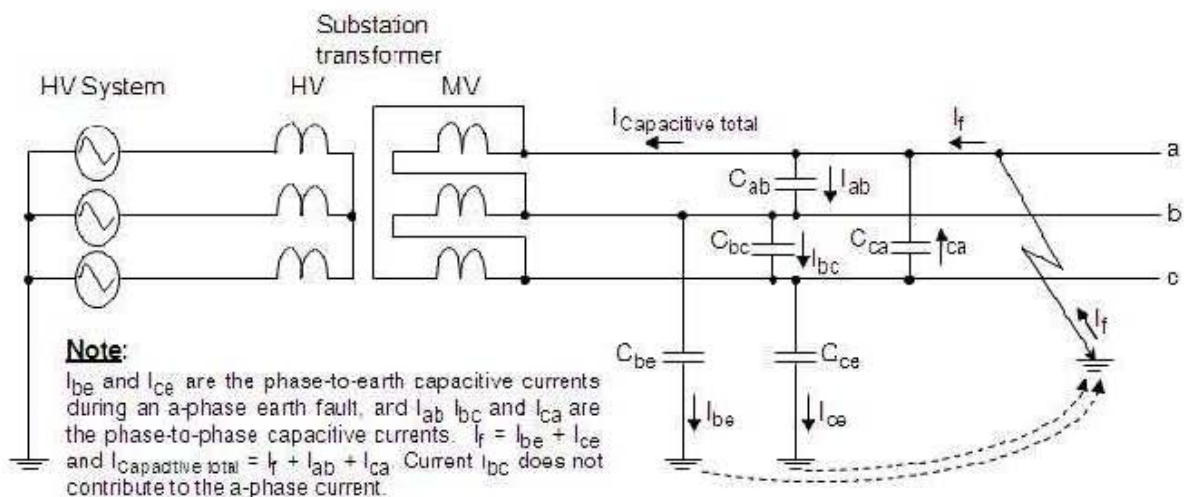

Total line b-phase to earth capacitance:	$C_{be} := \text{Total_Cbe}$	$C_{be} = 4.03$	μF
Total line c-phase to earth capacitance:	$C_{ce} := \text{Total_Cce}$	$C_{ce} = 4.03$	μF
Total line a- to b-phase capacitance:	$C_{ba} := \text{Total_Cab}$	$C_{ba} = 1.975$	μF
Total line b- to c-phase capacitance:	$C_{bc} := \text{Total_Cbc}$	$C_{bc} = 1.911$	μF
Total line c- to a-phase capacitance:	$C_{ca} := \text{Total_Cca}$	$C_{ca} = 1.975$	μF
Total line b-phase to earth charging current due to phase-to-earth capacitance:	$I_{be} := \text{Icharge_line_Cbe_a_to_e}$		$ I_{be} = 13.926$ A
	$I_{be_angle} := \text{Icharge_line_Cbe_a_to_e_angle}$		$I_{be_angle} = 300$ deg
Total line c-phase to earth charging current due to phase-to-earth capacitance:	$I_{ce} := \text{Icharge_line_Cce_a_to_e}$		$ I_{ce} = 13.925$ A
	$I_{ce_angle} := \text{Icharge_line_Cce_a_to_e_angle}$		$I_{ce_angle} = 240$ deg
Total line b- to a-phase charging current due to phase-to-phase capacitance:	$I_{ba} := \text{Icharge_line_Cab}$		$ I_{ba} = 6.824$ A
	$I_{ba_angle} := \text{Icharge_line_Cab_angle}$		$I_{ba_angle} = 300$ deg
Total line c- to a-phase charging current due to phase-to-phase capacitance:	$I_{ca} := \text{Icharge_line_Cca}$		$ I_{ca} = 6.824$ A
	$I_{ca_angle} := \text{Icharge_line_Cca_angle}$		$I_{ca_angle} = 240$ deg
Total capacitive fault current:	$I_f := I_{be} + I_{ce}$		$ I_f = 24.12$ A
	$I_{f_angle} := \text{angle}(\text{Re}(I_f), \text{Im}(I_f))$		$I_{f_angle} = 270$ deg

Total capacitive current flowing back to the source via the a-phase during an a-phase earth fault:

It may be seen from the diagram above that C_{be} and C_{cb} are effectively in parallel during an a-phase-to-earth fault. The same applies to C_{ce} and C_{ca} . The total line charging current during an a-phase-to-earth fault will therefore be the vector sum of all four charging currents.

	$I_{\text{Capacitive_total}} := I_{be} + I_{ce} + I_{ba} + I_{ca}$	$ I_{\text{Capacitive_total}} = 35.939$	A
	$I_{\text{Capacitive_total_angle}} := \text{angle}(\text{Re}(I_{\text{Capacitive_total}}), \text{Im}(I_{\text{Capacitive_total}}))$		$I_{\text{Capacitive_total_angle}} = 270$ deg