

**Analysis of ceramic assemblages from four Cape
historical sites dating from the late seventeenth
century to the mid-nineteenth century**

Jane Klose



**Submitted to the Faculty of Arts, University of Cape Town,
in fulfilment of the requirements for the degree of
Masters of Arts in Archaeology.**

1997

PART ONE OF TWO

The financial assistance of the Centre for Science Development (HSRC, South Africa) towards this research is hereby acknowledged. Opinions expressed and conclusions arrived at, are those of the author and are not necessarily to be attributed to the Centre for Science Development.

The copyright of this thesis vests in the author. No quotation from it or information derived from it is to be published without full acknowledgement of the source. The thesis is to be used for private study or non-commercial research purposes only.

Published by the University of Cape Town (UCT) in terms of the non-exclusive license granted to UCT by the author.

**ANALYSIS OF CERAMIC ASSEMBLAGES
FROM FOUR CAPE HISTORICAL SITES DATING FROM THE LATE
SEVENTEENTH CENTURY TO THE MID-NINETEENTH CENTURY**

Jane Klose

Department of Archaeology

University of Cape Town

7700 Rondebosch

ABSTRACT

This dissertation sets up a standardised system for analysing mid-seventeenth to mid-nineteenth century Cape colonial ceramic assemblages and then applies it to a number of Dutch and British historical sites in the south-western Cape region of South Africa in order to trace patterns of change in the availability and use of domestic ceramics in the colony. The system accommodates the wide range of African, Asian and European ceramics used during the period of Dutch East India rule from 1652 to 1795, the following Transitional years when the Cape was governed for short periods by both the British and Dutch governments and the period from 1815 onwards when the Cape became a British Crown Colony. A systematic ceramic classificatory system was required to form a framework for the first stage of a proposed study of the role of Asian porcelain in the Cape during the 17th and 18th centuries.

The resulting Cape Classificatory System has five sections. (i) Ware Table, a ware based classification, records ceramics by sherd count and minimum number of vessels, and acts as a check list for Cape colonial sites. (ii) Date Table provides the accepted dates of production and references for all ceramics excavated in the Cape. (iii) Form & Function Table lists excavated ceramics by vessel form within functional categories. (iv) The Site Catalogue accessions and references (where possible) all the ceramics in an assemblage. (v) A catalogue of previously unreferenced Asian market ware (coarse porcelain) excavated from 17th to 19th century colonial sites in the south-western Cape.

Thirty ceramic assemblages from Cape colonial sites and four assemblages from shipwrecks in Cape waters were analysed or examined. The Cape Classificatory System was applied in full to the ceramics from four sites: the Granary, a late seventeenth century Dutch East India site; Elsenburg, an elite mid-eighteenth century farmstead; Sea Street, Cape Town, a town midden in use from the last quarter of the eighteenth century to ca.1830; and a well in Barrack Street, Cape Town, that was open from ca.1775 till the late nineteenth century.

The results clearly demonstrated changes in ceramic availability, usage and discard in the Cape over a two hundred year period, differences in refuse disposal practices and the dependence of the colony on Asian porcelain, including Asian market coarse porcelain, during the late seventeenth century and eighteenth century.

ACKNOWLEDGEMENTS

I thank Professor Carmel Schrire for introducing me to historical archaeology and for her guiding hand both before and during this project.

I thank my supervisor Professor Martin Hall for his advice and interest in my work and Dr Antonia Malan for teaching me historical archaeology and for her unfailing kindness and encouragement.

The invaluable help and assistance from everyone in the Department of Archaeology is gratefully acknowledged. In particular, I thank Tim Hart and Dave Halkett, who excavated the sites, for helping with the interpretation of the artefacts; John Lanham for sorting out my computer problems; and Karim Sadr for drawing profiles of the Chinese porcelain and various maps. I am indebted to Dennis Neville who skilfully turned my manuscript into a presentable dissertation.

Many people outside the University were involved in my work. Dr Christiaan Jörg of the Groninger Museum regularly helped me with identifying the porcelains and I also thank him for his ongoing interest in my research. Jean Martin of the Oriental Ceramic Society in London kindly introduced me to many experts in the field of Chinese, Japanese and Persian ceramics. I thank Hennie Vos for the time we spent discussing Cape ceramic assemblages and for allowing me access to the archaeological collections at the Stellenbosch Museum.

Finally, I thank my family for their patience and support over the past four years.

TABLE OF CONTENTS

FIGURES & TABLES

APPENDICES A -L (please note: these are contained in a separate volume)

	page
1. INTRODUCTION	1
Outline of dissertation	2
The Cape of Good Hope	3
Historical archaeology in the Cape	7
Overview of ceramics used by colonists at the Cape	9
The seventeenth century	10
The eighteenth century	12
The nineteenth century	14
2. AN OVERVIEW OF DUTCH PERIOD CERAMIC STUDIES WITH RESPECT TO THE CAPE OF GOOD HOPE	 15
3. METHODOLOGY	27
Sites used in the project	28
Assessment of existing ceramic classifications	29
Ware Table	35
The use of ceramics in dating assemblages	38
Date Table	41
Further development of Ware Table	41
Porcelain	44
Stoneware	48
Coarse earthenware	51
Tin-glazed wares (Engobes)	52
Refined wares	53
Minimum vessel analysis	61
Classification by form and function	63
Identification of vessel forms excavated from Cape sites	64
1. Cooking and food preparation	66
2. Food and drink storage	68

	3. Food distribution and consumption	69
	4. Drinking	72
	5. Health & Hygiene	73
	6. Utilitarian	75
	7. Ornamental	75
	8. Unidentified	76
	Application of the CCS	76
4.	ASIAN MARKET WARE: 17TH - 19TH CENTURY COARSE PORCELAIN AND 19TH CENTURY REFINED WARES	81
	Outline	82
	Terminology	84
	Seventeenth to nineteenth century coarse porcelain	86
	The Inter-Asiatic trade	88
	Description of Asian market coarse porcelains and later refined wares with reference to excavated Cape assemblages	95
	Marks	97
	Attribution	97
	Nineteenth century Asian market ware - later refined wares	99
	Methodology	100
	Catalogue	101
	Presence on Cape sites	102
	Importance of Cape sites in international research	106
5.	THE GRANARY, THE CASTLE OF GOOD HOPE, CAPE TOWN	107
	History	107
	Archaeological investigations	110
	Summary of ceramic analysis	113
	Commentary	118
6.	ELSENBURG - THE KITCHEN MIDDEN	123
	History	123
	Archaeological investigations	123
	Summary of ceramic analysis	126
	Commentary	131

7.	JAMES' HOUSE, SEA STREET, CAPE TOWN	136
	History	136
	Archaeological investigations	136
	Summary of ceramic analysis	141
	Commentary	148
8.	THE BARRACK STREET WELL	151
	History	151
	Archaeological investigations	152
	Summary of ceramic analysis	154
	Commentary	162
9.	SUMMARY AND CONCLUSIONS	166
	REFERENCES	184
	Personal communications	184
	Shipwrecks	185
	General references	186

FIGURES AND TABLES

FIGURES

	page
Figure 1-1: Map of the south-western and southern Cape regions of South Africa. Inset shows central position of the Cape on the 16th to 18th century trade routes linking Europe to the East.	4
Figure 1-2: The Cape colony, 1705 (Bredekamp & van den Berg 1986).	6
Figure 3-1: Comparison of sherd counts and MNVs from two Cape colonial sites (Elsenburg and Sea Street)	40
Figure 3-2: European-style coarse earthenware cooking pots (Abrahams 1994)	66
Figure 3-3: Khoi pottery from the south western Cape (Rudner 1968)	66
Figure 3-4: Coarse earthenware dishes & bowls (Abrahams 1994)	67
Figure 3-5: Coarse earthenware colander & lids	67
Figure 3-6: Japanese stoneware <i>donabe</i> (Japanese Archaeological Reports 1989; 1990)	67
Figure 3-7: European stoneware jars (Thijssen 1991)	68
Figure 3-8: Chinese stoneware jar & martevans	68
Figure 3-9: European stoneware jugs	68
Figure 3-10: 'Ginger' jars	68
Figure 3-11: European stoneware mineral water or 'gin' bottles	68
Figure 3-12: Table / dinner plate	69
Figure 3-13: Deep / soup plate	69
Figure 3-14: Flared rim plate	69
Figure 3-15: Straight-sided bowl	70
Figure 3-16: S-shaped bowl	70
Figure 3-17: <i>Klapmuts</i>	70
Figure 3-18: Saucer-dish	70
Figure 3-19: Flared-rim dish	70
Figure 3-20: Flat-rimmed dish	70
Figure 3-21: Narrow rimmed deep dish	71
Figure 3-22: Covered bowl / tureen	71
Figure 3-23: Lidded jar	71

Figure 3-24: Hot water plate / dish	71
Figure 3-25: (a) Salts (b) Mustard pot (c) Condiment bottle	71
Figure 3-26: Porcelain cutlery handles	71
Figure 3-27: Chinese export porcelain cups & saucers	72
Figure 3-28: Chinese porcelain & Yixing stoneware teapots	72
Figure 3-29: Tea cannister	73
Figure 3-30: <i>Pattipan</i>	73
Figure 3-31: Punch bowl	73
Figure 3-32: Earthenware flasks - probably S.E. Asian	73
Figure 3-33: Chamber pots: (a) cream coloured (b) Chinese Imari (c) Japanese porcelain	73
Figure 3-34: Basin & goglet	74
Figure 3-35: Shaving dish	74
Figure 3-36: Spittoon	74
Figure 3-37: Japanese porcelain flask & bottle	74
Figure 3-38: Tin-glazed & porcelain apothecaries' ware	74
Figure 3-39: Coarse earthenware brazier / <i>Vuurtestje</i> (de Kleyn 1986)	75
Figure 3-40: Coarse earthenware chafing dish (de Kleyn 1986)	75
Figure 3-41: European stoneware ink & polish bottles	75
Figure 3-42: Dehua figurine with whistle	75
Figure 3-43: Dehua Buddhist lion	75
Figure 4-1: Asian market ware from eighteenth century Cape colonial sites	81
Figure 4-2: Map of Southeast Asia and China (after Rinaldi 1989:17)	83
Figure 4-3: Map illustrating the sphere of activity of the VOC in the 17th and 18th centuries (Bredekamp & van den Berg 1986)	89
Figure 4-4: Map of China showing Jingdezhen and the southern provinces as well as the approximate location of Annam and Tonkin (now Northern Vietnam) (after Kerr 1986:13)	98
Figure 5-1: Location of historical sites in the south-western Cape region	108
Figure 5-2: Plan of Cape Town showing the Castle of Good Hope, ca.1705 (Bredekamp & van den Berg 1986)	109
Figure 5-3: Position of the Granary within the Castle	109
Figure 5-4: Stratigraphy of the Granary site (adapted from drawing by Dave Halkett)	112

Figure 5-5: Ceramic profiles of Phases 1, 3-5 & 7, the Granary (ca.1685 - ca.1700)	121
Figure 5-6: Form and function of the ceramics from Phases 1, 3-5 & 7, the Granary, Castle of Good Hope (ca.1685 - ca.1700)	122
Figure 6.1: Location of the kitchen midden within the existing structure of Elsenburg Manor House (1761) (ACO 1993)	124
Figure 6.2: Stratigraphy of the Elsenburg kitchen midden (from ACO 1993)	125
Figure 6.3: Ceramic profiles of Layers dbyc, cf & sd, Elsenburg kitchen midden (ca.1730 - 1760)	134
Figure 6.4: Form & function of vessels in Layer dbyc. Elsenburg kitchen midden (ca.1730 - 1760)	135
Figure 7-1: Plan of Cape Town (ca.1845) showing location of Sea Street and Barrack Street (from Picard 1968:158)	137
Figure 7-2: Plan showing the four yards chosen for excavation in Sea Street and the position of the section used to illustrate the stratigraphy of James' Houyse (Figure 7.3) (Hall 1991a)	138
Figure 7-3: Stratigraphy of James' House, Sea Street (Hall 1991a)	140
Figure 7-4: Ceramic profiles of Phases 2-4, James' House, Sea Street (ca. 1770 - ca. 1830)	149
Figure 7-5: Form and function of vessels in Phases 2 & 3, James' House Sea Street	150
Figure 8-1: Stratigraphy of the Barrack Street well (Hall <i>et al.</i> 1990a)	153
Figure 8-2: Ceramic profiles of Levels 1-4, the Barrack Street well, Cape Town (ca.1775 - late 19th c.)	164
Figure 8-3: Form and function of the vessels in Levels 4,3,& 2, the Barrack Street well, Cape Town (ca.1775 - late 19th c.)	165
Figure 9-1: Ceramic profiles of the Granary (combined phases), Elsenburg, James' House, Sea Street, and the Barrack Street well	181
Figure 9-2: Ceramic profiles of the Grand Parade, Paradise, Bree Street, Verlorenvlei and Harrington Street	182
Figure 9-3: Comparison of the form and function of vessels from the Granary, Elsenburg, James' House, Sea Street and the Barrack Street well	183

TABLES

	page
Table 1-1: VOC official shipments of Asian ceramics to the Cape in the seventeenth century (adapted from Volker 1954)	11
Table 3-1: Comparison of ceramic classification systems	30
Table 3-2: Eighteenth century Chinese export porcelain from three archaeological sites in London expressed as MNVs (Barry 1993)	37
Table 3-3: Levels of analysis provided by the Cape Classificatory System	79
Table 4-1: Asian market ware on Cape colonial sites ca. 1690-1860 expressed as a percentage of the total ceramic MNV	103
Table 5-1: Ceramics from the Granary (combined phases) expressed as approximate MNVs and percentage MNVs.	113
Table 5-2: Ceramics from Phases 1-5 & 7, the Granary (ca.1685 - ca.1700) expressed as MNVs and percentage MNVs.	114
Table 5-3: Porcelain from <i>Dorothy</i> sold in London in 1696 by the East-India Company.	119
Table 6-1: Ceramics from Layers dbyc, cf & sd, Eisenburg kitchen midden (ca.1730 - ca.1760) expressed as MNVs and percentage MNVs	127
Table 7-1: Ceramics analyzed by layer from James' House, Sea Street, expressed as MNVs and percentage MNVs	142
Table 7-2: Ceramics analyzed by phase from James' House, Sea Street, expressed as MNVs and percentage MNVs	142
Table 7-3: Decorative categories of Asian teawares in Phase 2, James' House, Sea Street, expressed as percentage MNVs	144
Table 8-1: Ceramics analyzed by Phase from Levels 1-4, the Barrack Street well, Cape Town, expressed as MNVs and percentage MNVs	154
Table 8-2: White-bodied wares expressed as MNVs from Level 3, Barrack Street well, Cape Town	158
Table 8-3: White-bodied wares expressed as MNVs from Level 2, Barrack Street well, Cape Town	160
Table 8-4: White-bodied wares expressed as MNVs from Level 1. Barrack Street well, Cape Town	162

APPENDICES A - L

- APPENDIX A – Glossary of geographic terms
- APPENDIX B – Abbreviations
- APPENDIX C – Vessel form nomenclature
- APPENDIX D – Glossary of ceramic terms
- APPENDIX E – Ware Table
- APPENDIX F – Date Table
- APPENDIX G – Form & Function Table
- APPENDIX H – Minimum Vessel Analysis
- APPENDIX I.1 – Test Group: Ceramic assemblages studied in this project
- APPENDIX I.2 – Transcript of inventory of the deceased estate of Jan Gibelaar
- APPENDIX J – Asian market ware: Coarse porcelain & 19th century refined wares
- APPENDIX K – Photographs of ceramic assemblages
- APPENDIX L – Tables & Catalogues (Ware Table, Form / Function Table & Site Catalogue)

Chapter One

Introduction

The purpose of this study is to develop a method of systematically analysing and recording ceramic assemblages excavated from seventeenth, eighteenth and early nineteenth century colonial sites in the south-western Cape region of South Africa. It will use an internationally understood terminology and be compatible with systems used by historical archaeologists in North America and elsewhere. Although this study is concerned with the full range of ceramics used by the colonists, particular emphasis will be placed on the identification and classification of Asian porcelains.

When the Department of Archaeology and the Archaeology Contracts Office (ACO) at the University of Cape Town (UCT) began a new series of excavations of historical sites in 1988, it became imperative to standardise the methods used to record and analyse the artefactual material. The study of ceramic classifications was initially prompted by two particular problems that had appeared during the Archaeology Department's long term research into the material culture of eighteenth century Cape Town. The first was the difficulty in comparing ceramic assemblages from different Cape sites and the second problem was linking excavated ceramics to those recorded in probate inventories.

The main thrust of this study, however, has been to develop a framework for the first stage of a proposed study of the role of Asian porcelain in the Cape during the seventeenth and eighteenth centuries. Individual types of ceramic ware cannot be studied in isolation but must be evaluated as components of a complete ceramic assemblage whose composition, in turn, will be affected by the use of similar vessel forms in other materials.

A brief overall examination of the excavated assemblages made it apparent that the analysis of Cape colonial sites would need a broad based system to incorporate and adequately analyse the wide variety of ceramics from Asia, Africa and Europe imported into southern Africa from the mid-seventeenth century onwards. It was not possible to use existing ceramic classifications or vessel typologies in analysing such ceramic assemblages.

During the last twenty five years, historical archaeologists working in the south-western Cape have excavated sufficient sites for meaningful and comprehensive research projects to be undertaken into colonial lifestyles over a two hundred and fifty year period beginning in the mid- seventeenth century and extending into the early twentieth century. Such projects require standardised methods of artefact analysis and the proposed system of ceramic analysis is a contribution towards this end.

Outline of the dissertation

This chapter provides the background to the dissertation. It begins with a short history of the Cape settlement from its founding by the Dutch East India Company (VOC) in 1652 to the establishment of the region as a full British Crown Colony in 1815. This is followed by an account of the development and practice of historical archaeology in South Africa and ends with an overview of the ceramics used at the Cape from ca. 1652 to ca.1850. A glossary of ceramic terms pertaining to Cape assemblages is provided (see Appendix D).

Chapter Two is a review of the literature pertaining to the identification and interpretation of ceramics found in assemblages excavated from Cape colonial sites which form the foundation for the study of ceramics used during the colonial period.

Chapter Three reviews and discusses existing methods of ceramic analysis before explaining the methodology employed in the development and setting up of a system named the Cape Classificatory System (CCS), to classify, quantify and describe ceramic assemblages excavated from Cape colonial sites.

Chapter Four brings together all the available information on the so-called Asian coarse porcelains or provincial wares which appear in considerable quantities on mid-seventeenth to early nineteenth century Cape sites. These wares have been renamed Asian market wares to set them apart from the Chinese and Japanese fine export ware porcelains made at the same time for the European and North American markets. This chapter is accompanied by an appendix which catalogues all the Asian market ware excavated to date in South Africa (Appendix J).

Chapters Five to Eight describe the full application of the CCS to four ceramic assemblages from colonial sites in the south-western Cape. The first assemblage is from the Granary (Chapter 5), a late seventeenth site within the Castle of Good Hope, and the

second is from Elsenburg (Chapter 6), a mid-eighteenth century elite farmstead situated about fifty kilometres from Cape Town. The other assemblages were excavated in central Cape Town: James' House in Sea Street (Chapter 7), the site of an early nineteenth century house built over a town dump, and a household well in Barrack Street (Chapter 8) built ca.1775 which was open until the end of the nineteenth century. Each individual analysis is preceded by a short history of the site and a brief explanation of the excavation and stratigraphy and closes with a summary of the analysis and a short commentary on the ceramic assemblage.

Chapter Nine, the final chapter, gives an overview of the application of the CCS to Cape colonial assemblages, evaluates its strengths and weaknesses, and ends with a discussion of its proposed use in the study of Asian porcelain in the Cape in the seventeenth and eighteenth centuries.

The Cape of Good Hope

The Cape of Good Hope is situated on the southern tip of Africa (Figure 1-1) and has a Mediterranean-type climate. It includes large areas of grazing and arable land crossed by high mountain ranges. Before the founding of a permanent Dutch settlement in the mid-seventeenth century, the Cape was inhabited by two groups of related indigenous people; San (Bushmen) hunter-gatherers and Khoi (Hottentot) pastoralists or herders. Ships *en route* between Europe and the Indies regularly anchored in Table Bay from the 1590s onwards to take on water, to recuperate from the long voyage and, often, to bargain with the Khoi for fresh meat.

In 1652, the VOC decided to station a small garrison on the shores of Table Bay to assist the Company's outward and homeward bound ships that called at the Cape on the four to six month sea passage between the Netherlands and the Far East. The duties of the garrison included re-provisioning, attending to the welfare of the officers and crews, and facilitating the repairs and maintenance of the ships (Ross 1989:243). The first commander of the Cape, Jan van Riebeeck, was given orders to build a fort, cultivate vegetables and grain, and not to enslave or conquer the indigenous population but to remain on friendly terms with them to ensure a constant supply of cattle to the Company (Boucher 1986). Shortage of labour made it impossible for van Riebeeck to carry out this work. In 1657, a number of Company employees were released from their contracts to set up farms on condition they sold their grain and cattle to the VOC at a fixed price.

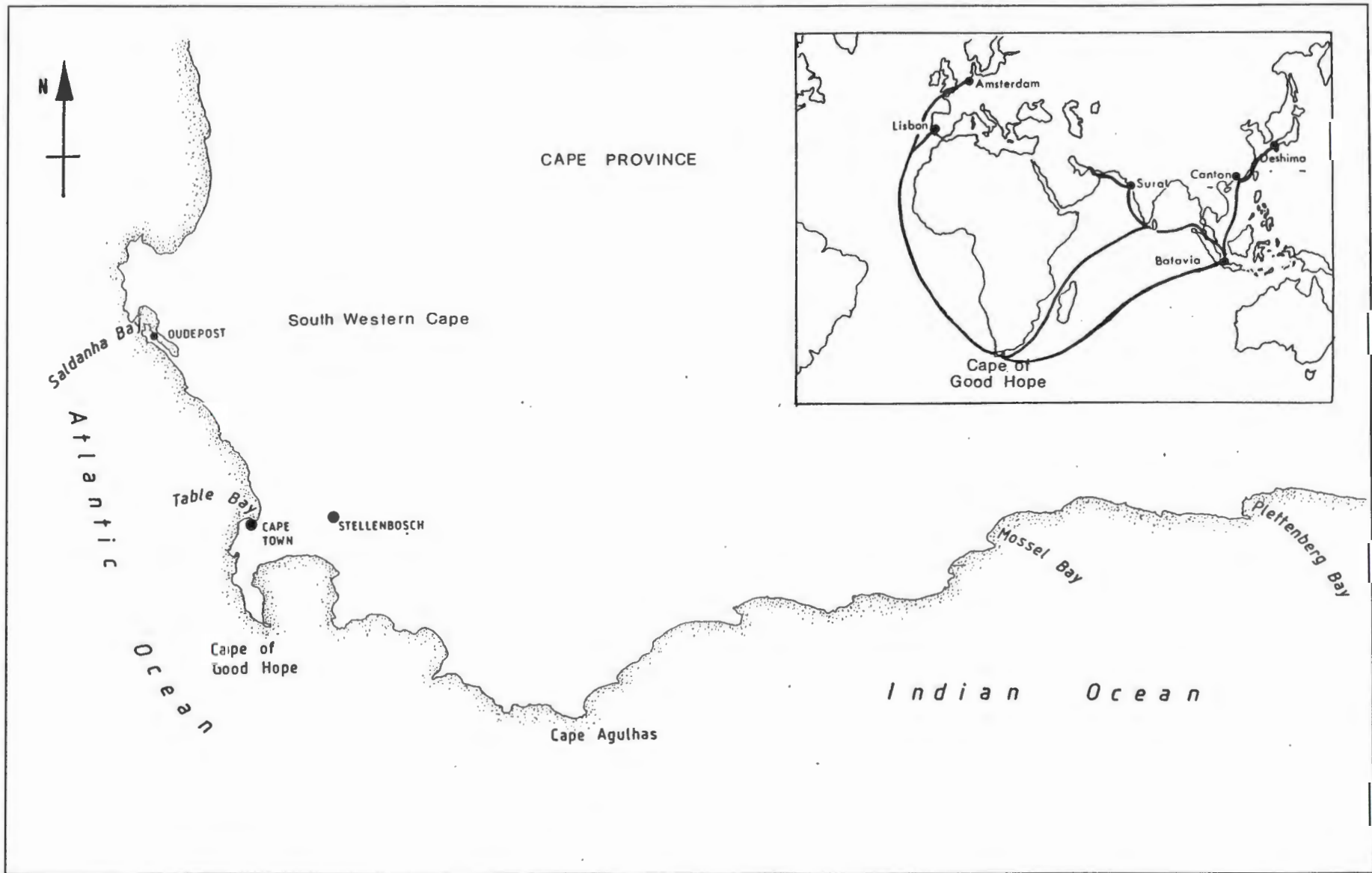

Figure 1-1: Map of the southern and southwestern Cape regions of South Africa. Inset shows central position of the Cape on the 16th to 18th century trade routes linking Europe to the East (drawing by Karim Sadr).

In 1658, slaves were imported as general labourers and to help build the Fort. The use of slave labour was common practice throughout the VOC holdings in the East and was to continue at the Cape after the demise of the Company in 1795 until 1838, when legal slavery was effectively abolished in the Cape Colony (Shell 1994:403).

The early Cape settlement was poor and under-populated. It was never the intention of the VOC to colonise the Cape, although this did happen in the following years. An increasing number of Company employees were released to farm the lands to the north and east of the Cape. They were joined by settlers from northern Europe, including a large group of Huguenot families in 1686, and people from passing ships. The Company governed the whole settlement and all the inhabitants of the Cape were subject to its laws. The colonial population, which excluded VOC employees, remained small and only numbered about 1,200 in 1690, out of which 788 were European free burghers, 381 were slaves and 48 were 'free blacks' (manumitted slaves or convicts) (Elphick & Giliomee 1989:524).

The Cape was a polyethnic society from its founding, with a population drawn from the East and Europe. The VOC employees and free burghers were not exclusively Dutch in origin but included Germans, French, Scandinavians, Swiss and Flemings (Boucher 1986). The majority of the slaves came from Madagascar, India and Indonesia with smaller numbers from elsewhere. Another minority group of people included Indonesian political exiles and Chinese convicts who had been sent to the Cape by the VOC in Batavia (Shell 1994). Colonial southern Africa was a slave-owning society but there was integration between the various groups from the beginning. By the middle of the eighteenth century, "[i]mmigration, interaction and creolization - both chosen and coerced - lead to the colony becoming recognisably 'Cape' to outsiders and to the colonists themselves" (Malan 1995).

The boundaries of the colony expanded throughout the eighteenth century and, apart from the extensive maritime activities in Cape Town, remained a rural society (Figure 1-2). The colonial population remained low and in 1750 it stood at about 10,000 of whom over half were slaves (Elphick & Giliomee 1989). Throughout VOC rule, the Cape was part of the Dutch world-wide mercantile system but it did not have a major export to support its economy. A small amount of grain was exported to VOC trading stations in the East (Ross 1994:20). It was a seaward looking community and relied on agricultural products to sustain both the business provided by passing ships and the internal markets.

The free burghers had very little say in the running of the country and were constantly complaining about the VOC's monopolistic hold on the economy.

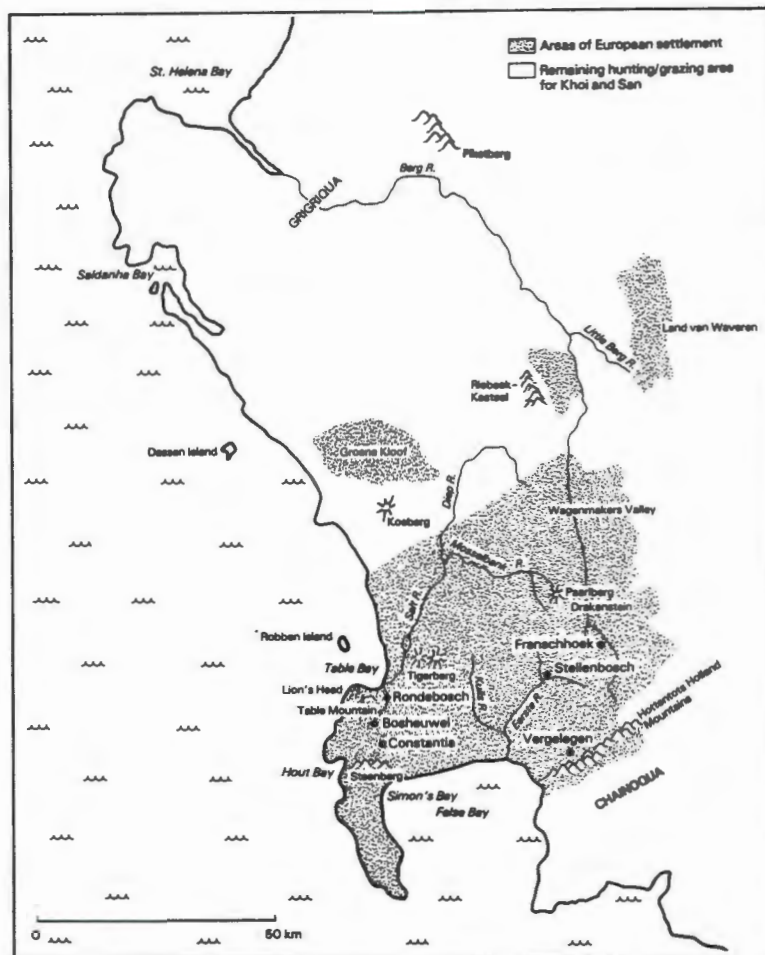

Figure 1-2: The Cape colony, ca.1705 (Bredekamp & van den Berg 1986).

Small towns sprang up inland but Cape Town remained the centre of trade and business throughout the seventeenth and eighteenth centuries. The colony imported textiles and consumer goods from the East and until the beginning of the nineteenth century (1807) "the most important imports of the Cape Colony were slaves, without whom the economy could not have functioned" (Ross 1994:22). The VOC and the town's population, including free burghers, slaves, and 'free blacks', were involved in supplying the needs of the visiting ships (Ross 1989). The town was full of warehouses and small retail outlets as well as chop houses, taverns and boarding houses which were frequented by the crew and passengers from ships that called at the Cape (Boucher 1986).

Dutch maritime power started to wane in the second half of the eighteenth century but the Cape remained an important port of call for world shipping. In 1795, the VOC was taken over by the newly established Batavian Republic in the Netherlands and in the same year

the British captured and occupied the Cape to prevent it falling into the hands of the French. At this stage "the largest sector of the colonial population was the slaves, of whom there were some 25,000. Next in number came the 20,000 white colonists, followed by 15,000 Khoikhoi and some 1,000 free blacks" (le Cordeur 1986:75). British military control lasted until 1803 when the Cape was handed over to the Batavian government in terms of the Treaty of Amiens. The war between Britain and France resumed. The British then recognised the strategic importance of the Cape and returned to recapture it from the Dutch in 1806. The second occupation lasted until the Cape was ceded to the British Government in 1814 (le Cordeur 1986).

The Cape became a Crown Colony within the British empire from 1815. Slavery was abandoned in favour of free labour and VOC mercantilism was replaced by capitalism and free trade. Land reform encouraged ownership of farms, and commercialised agriculture began. There was a great increase in shipping calling at the Cape, the import and export markets expanded and merchants came out from Britain to set up businesses (le Cordeur 1986). The Cape Colony remained under British jurisdiction until it became part of the Dominion of South Africa in 1910.

The original purpose of the VOC's Cape settlement had been to provision and attend to the needs of the Company's ships. The inhabitants of the Cape thus had access to most of the products of the East which were regularly shipped to Europe. One of these commodities was Asian porcelain. Cape probate inventories show that Chinese and Japanese ceramics were owned by a wide cross section of the community (Woodward 1974, 1982; Malan 1993). This is confirmed by the archaeological record where Asian porcelain and stoneware are the dominant ceramic types on eighteenth century Cape sites. The remaining ceramics consist of varying amounts of European stoneware, faience and earthenware, locally manufactured European-style coarse earthenware and small amounts of African / Asian indigenous pottery. Such ceramic assemblages are the subject of this dissertation.

Historical Archaeology in the Cape

This is a brief outline of the development of historical archaeology in South Africa, but focuses on research and field work carried out in the Cape region during the last twenty years. A wider picture is provided by Martin Hall in his review of the archaeology of European colonial expansion into Southern Africa, and "the archaeology of the impact of this expansion on the communities long-established there" (Hall 1993).

The rapid development of Cape Town during the 1970s and 1980s resulted in the exposure of early Cape colonial buildings during demolition activities (Abrahams 1984). It became apparent that valuable historical sites were being destroyed. Museums appointed historical archaeologists to their staff and became involved in monitoring and recording sites both in Cape Town and Stellenbosch (see the map in Figure 1-1).

In 1976, Hendrik Vos of the Stellenbosch Museum began a long term historical and archaeological study of the colonial settlement of Stellenbosch, founded 1679 (Vos 1993). He has excavated over twenty six sites in the course of his research which will provide information for a regional study and for comparison with other areas in the Cape. Gabeba Abrahams, the historical archaeologist at the South African Cultural History Museum, has concentrated on rescue archaeology in central Cape Town since 1981 and has undertaken excavations of the Fort and the Castle of Good Hope (Abrahams 1993). She has used the excavated artefacts from the Fort to produce specialised studies of seventeenth and eighteenth century glass bottles and locally produced coarse earthenwares, and to investigate the foodways of the Cape colonists in the mid-eighteenth century (Abrahams 1987, 1994, 1996).

The Department of Archaeology at the University of Cape Town (UCT) became involved in the excavation of outposts, industrial sites and fortifications in the 1980s (Saitowitz 1982; Heckroodt & Saitowitz 1985; Seemann 1989, 1992). The Historical Archaeology Research Group (HARG) was established at UCT in 1985 and concentrated on the archaeology and material culture of eighteenth century Cape Town and the hinterland. HARG has also investigated probate records and vernacular architecture (Hall *et al.* 1988, 1990a, 1990b, 1993a; Gribble 1990; Hall 1991b; Brink 1992; Malan 1993). A maritime archaeologist has been working out of the department since 1989 and a major project which is currently being undertaken is the excavation of the VOC ship *Oosterland* which sank in Table Bay in 1697 (Werz 1993a).

From the late 1980s onwards, South African archaeologists began working in Cultural Resource Management. The Archaeology Contracts Office started operating from UCT in 1988 and has excavated numerous historical sites in Cape Town and the surrounding areas including large scale excavations at the Castle of Good Hope (Archaeology Contracts Office (ACO) 1991a, 1991b, 1992, 1993, 1995). Archaeologists at Stellenbosch University have focused on rural sites in the south-western Cape.

Other major archaeological projects associated with the Department of Archaeology (UCT) were the excavation of a seventeenth century VOC outpost at Oudepost on the Cape west coast by Carmel Schrire of Rutgers University and a series of excavations directed by Anne Markell in 1991 at Vergelegen, an early eighteenth century estate owned by a Governor of the Cape (Schrire 1988; Schrire *et al.* 1990, 1993; Markell 1993).

Similar historical archaeological work has been carried out at other centres in South Africa, including the Albany Museum, Grahamstown (Webley 1993), National Cultural History Museum, Pretoria (van Schalkwyk *et al.* 1995) and the South African Museum, Cape Town (Sampson *et al.* 1994; Neville *et al.* 1994). The University of the Witwatersrand is involved with late nineteenth to twentieth century sites and industrial archaeology. A group of archaeologists from the United States has focused on the architecture and material culture of nineteenth century British settlers in the eastern Cape (Jeppson 1991; Winer & Deetz 1992; Winer 1994).

Overview of ceramics used by colonists at the Cape ca. 1652 to ca.1850

An accurate overview of the ceramics used by the colonists at the Cape requires both documentary and archaeological evidence as neither is a complete record on its own and each compliments the other. The main documentary evidence for ceramic usage is provided by contemporary probate inventories of deceased estates and auction lists. Woodward (1974, 1982) and Malan (1993) have studied probate inventories and have produced extensive information about the types and quantities of ceramics used in Cape households from the late 1680s to the mid-nineteenth century. The archaeological record is being built up by analysing and recording ceramic assemblages from colonial sites excavated by South African universities and resource management businesses.

The Cape, and the whole of southern Africa, did not have a refined ceramic ware industry until the mid-twentieth century and was totally reliant on imported wares (except for coarse earthenwares) throughout the period under discussion (Nilant 1963:40). During the time of Company rule (1652-1795) the Cape was provisioned from either Europe or the VOC Headquarters in Batavia and when it became a Crown Colony in 1815 its ceramics were imported from Britain. In addition to these major imports, small amounts of European and Asian ceramics continued to reach the Cape as private possessions of Company officials and immigrants. Little research has been undertaken into the official importation of ceramics into the Cape. Volker (1954, 1959) records the VOC shipments

of Asian porcelains to the Cape in the seventeenth century and Hardwick has done some preliminary work on the importation of British wares in the nineteenth century (Hardwick 1989).

The studies of Woodward (1974, 1982) and Malan (1993) have shown that vast amounts of Chinese and Japanese porcelains were in use in the Cape during the period of Company rule. The Cape had strong cultural as well as administrative and business links with the East and during the period of Dutch rule the Cape can be seen as part of Asia rather than being an integral part of the African continent. Many of the Company's employees stationed at the Cape had previously worked or spent their whole lives in Asia (a number of them had Asian mothers or wives) and had become accustomed to the *Indische* culture of the VOC stations. The widespread use of export porcelain and Asian market coarse wares by the inhabitants of the Cape was perhaps an aspect of this culture. The VOC was administered by merchants and the landed cost of the required commodities and provisions for the Cape station was of paramount concern to them. It was probably cheaper and more profitable for them to supply the Cape with oriental porcelains and stonewares rather than European ceramics.

The *Indische* culture¹ manifested itself in the language, architecture, furniture and cuisine of the Cape and is still evident today. Artisans responsible for skilled work were often slaves and free blacks from India and Indonesia whose own culture thus influenced the colony. Cape slave women lived within the houses of their owners and also helped to create a creole culture, cuisine and language (kitchen Dutch - Afrikaans) (Shell 1994:261). Antonia Malan's analysis of household material culture of colonial households between 1750 and 1850 "has revealed that the Cape colonists had built up their own identity within the Dutch East India Company dominions by the mid- eighteenth century" (Malan 1993:174).

The seventeenth century

The ceramics used during the early years at the Cape reflect the vast trading areas of the VOC with ceramics from China, Japan, Persia, India, Africa and Europe, but European manufactured wares appear to be in the majority. Many inhabitants still had strong ties with Holland: probate inventories of the 1670s show houses were furnished in Dutch style with woollen hangings and contained Delft and pewter tablewares (Woodward 1982; Klose & Malan 1993:34). Ceramics excavated from a seventeenth century site at the

¹ As described by Taylor, J.G. 1983. *The Social World of Batavia: European & Eurasian in Dutch Asia*. Wisconsin: University of Wisconsin Press. p.78

Castle of Good Hope also show a high percentage of European manufactured wares (Chapter 5).

This assemblage includes Dutch and German coarse earthenwares, Delft tin-glazed tablewares and Rhenish bellarmine stoneware jugs. The remaining wares are blue-and-white Chinese and Japanese export porcelains, very small quantities of blue-and-white Persian stone-paste and various African and Asian coarse earthenwares including indigenous Khoi pottery pots. European-style coarse earthenware had been locally manufactured from 1665, but it appears that good quality coarse wares were still imported and used at the Castle until the end of the seventeenth century.

The Company's warehouses in Batavia regularly provided porcelain for its outer offices including Japanese tablewares with the VOC monogram (Woodward 1974). The excavation of a well within the Castle's kitchens revealed a quantity of monogrammed plates (Hendrik Vos pers. comm.). Probate inventories of free burghers from later in the seventeenth century record their possession of increasing quantities of Asian porcelain alongside pewter dishes and plates (Malan 1993). The first Company consignments of Persian, Japanese and Chinese porcelain arrived in the Cape in the second half of the seventeenth century (Table 1-1). Early official shipments only contained useful wares and this pattern formed the basis of VOC shipments of porcelain to Europe in the eighteenth century (Jörg 1982:225-306).

Table 1-1: VOC official shipments of Asian ceramics to the Cape in the seventeenth century (adapted from Volker 1954).

Date & <i>name of ship</i>	Ceramic shipment
1666 <i>Westwoudt</i>	- Persian x 185 pieces
1675 <i>Swaardfisch</i>	- Japanese x 210
1676 <i>Cabeljauw</i>	- Japanese x 258
1678 <i>Bode</i>	- Chinese x unknown amount
1681 <i>Hollandse Tuyn</i>	- Chinese x 135
1682 <i>Vrijheyd</i>	- Persian x 140
1685	- Japanese x 220
Post 1685	- small official shipments of Chinese

Colonists obtained extra porcelain, including more expensive and elaborate wares, through private trading (Chapter 6). The VOC had tried to keep the porcelain trade in its own hands and constantly changed the rules with regard to illegal and 'permitted' trade during the seventeenth and eighteenth centuries. The Company did not enforce a monopoly over all the imports into the Cape and private business dealings were an important part of the local economy (Ross 1994:22). Colonists could place private orders for porcelain with individuals in the Netherlands and the East or buy it illegally from the passengers and crew of ships *en route* to Europe. This trade went unrecorded but the evidence is found in the large porcelain assemblages excavated in the Cape (Christiaan Jörg pers. comm.).

The eighteenth century

During the eighteenth century, the Cape colonists turned to the East for their supplies of table and teawares. The amount of Asian wares used in the Cape continued to increase and they can be seen as part of the signature of the Cape's cultural identity. Persian stone-paste 'porcelain' had disappeared completely by the early eighteenth century, as had most imported European coarse earthenwares. Chinese and Japanese export ware porcelain and Asian market coarse porcelains made up between 50% to 80% of the estimated minimum number of ceramic vessels (MNV) of a mid-eighteenth century Cape assemblage (Chapter 6). These high vessel counts far exceed the proportions of Asian ceramics found on contemporary domestic sites in the Netherlands, North America and England (Deetz 1973:21; Baart *et al.* 1986:94; Barker & Barker 1984). The colonists' use of significant quantities of coarse porcelain bowls and dishes is of particular interest. These ceramics were in everyday use in households throughout Southeast Asia (Rooney 1987) but were never officially shipped to Europe (Christiaan Jörg pers. comm.).

Most of the excavated porcelain is blue-and-white with only small amounts of Chinese Imari and the later enamelled wares that were popular in the West from about 1730 onwards (Sea Street Chapter 7 & Bree Street Appendix I.1). This information is virtually absent in inventories where only minimal descriptions are given. Perhaps the lower cost and the durability of underglaze-blue compared to overglaze enamelled decoration on porcelain made it the colonists' first choice but it is also possible that, in the eighteenth century, the company supplied the Cape with porcelain that was no longer saleable or profitable in Europe. It is not uncommon to find poorly fired and warped vessels amongst the excavated porcelains (Chapter 6).

Probate inventories show that use of porcelain *per se* in the Cape is not necessarily an indication of high status (Malan 1993). Asian porcelain was owned by a wide cross section of the community. The 1712 inventory of Abraham de Vijf, a free Chinese, lists eleven *porcelein leeuwtes* (presumably *blanc de Chine* Buddhist lions) and three red teapots amongst his porcelain. Maria Sultania, the daughter of an Indonesian political exile married to an illiterate Company Quartermaster, owned at her death in 1741 forty six porcelain plates and ten dishes. The sale in 1781 of goods belonging to free black Jephta van de Caab, included porcelain plates, dishes, a teapot and four *grove borden*, but Tobias Ronnenkamp, an attorney who died in 1793, owned about 1300 items of Chinese and Japanese porcelain including twenty tea sets all with different designs (Cape Archives: MOOC8/2.66, MOOC8/6.50, MOOC10/13.29, & MOOC8/46.28).

Tin-glazed wares were still used in the eighteenth Cape but occur in decreasing numbers and vessel forms in excavated assemblages (Chapter 6). The availability in the Cape of relatively cheap porcelain from the Far East from the late seventeenth century onwards had a great influence on the composition of colonial ceramic assemblages. In Cape households, weak, easily chipped tin-glazed earthenwares appear to have been displaced by stronger ceramics, in this case by porcelain, long before the replacement of faience by Staffordshire white salt-glaze or creamware took place in Europe and North America. The fragility of tin-glazed wares might not have been the only reason for its paucity on Cape sites. Perhaps some of the colonists did not order the Delft (Dutch tin-glazed ware) which mimicked the forms and designs of Asian porcelain, because they had direct access to the sturdier porcelain 'original' from China or Japan. In addition, it was far quicker for the VOC in Batavia to execute a request for locally available Asian porcelain than to supply Delft which had to be ordered from the Netherlands.

The use of Asian stoneware *martevans* by the colonists continued in the eighteenth century but there were changes in other ceramic categories: bellarmine jugs decreased in numbers but German salt-glazed stoneware mineral water ('gin') bottles start to appear in increasing numbers from the second half of the century onwards (Chapter 8). Khoi pottery and other African / Asian earthenwares were no longer found and the European-style coarse earthenwares were all locally manufactured (Abrahams 1994). A further difference between eighteenth century Cape assemblages and those from Europe and other European colonies is the almost complete absence of British refined earthenwares. They were mentioned in the inventories in the 1790s and only began to appear on sites in the last years of the century.

Asian porcelain also influenced the usage of other European ceramics apart from tin-glazed wares in the Cape colony. The wide-spread use of porcelain by all sectors of Cape society, coupled with the VOC monopoly of Cape trade and its anti-British stance, could have affected the acquisition or desire for British refined earthenwares during the second half of the eighteenth century. English fine red earthenwares and Staffordshire white salt-glazed ceramics were available in Amsterdam from ca.1740 and creamwares from ca.1760 onwards (Baart *et al.* 1986:98). Yet white salt-glazed plates only turn up in small numbers on late nineteenth century sites and cream coloured wares, blue and polychrome painted pearlwares and blue printed wares only occur in any quantity on Cape sites during the first decade of the nineteenth century (Chapter 7).

The nineteenth century

The nineteenth century saw a change to British manufactured wares in Cape colonial assemblages: undecorated cream coloured wares, blue and colour printed table and teawares, annular wares, shell edged plates and a variety of sponge decorated wares. The amount of porcelain present in excavated assemblages drops to a very low percentage: it is mainly European and is represented by minimally decorated bone china teawares. Asian ceramics, especially blue-and-white porcelains, never disappear completely but occur in small amounts on most nineteenth century sites, such as Harrington Street, Cape Town and Verlorenvlei (ACO 1991a; Taylor 1991) (Appendix I.1).

The foregoing brief overview of the ceramics available during colonial rule gives an indication of the range and quantities of wares that will be analysed and discussed in this dissertation.

Chapter Two

An overview of Dutch Period ceramic studies with respect to the Cape of Good Hope

The identification and interpretation of the ceramic assemblages analysed in this dissertation rely on a small corpus of specialist works. Few publications on European and Asian ceramics have the relevant information required for the identification and study of the commonplace European, Asian and African ceramics found in Cape colonial sites. Volker's and Jörg's surveys of the VOC trade in Asian ceramics during the seventeenth and eighteenth centuries are vital to the understanding of Chinese and Japanese export porcelain and Asian market ware. These wares dominate Cape assemblages for over a hundred years from late in the seventeenth century to the end of the eighteenth century (Volker 1954, 1959; Jörg 1982). Woodward's account of Oriental export wares at the Cape, and her later work on the interior of early Cape houses, were the first studies to list the types of Asian and European manufactured ceramics used during the first 150 years of colonial settlement at the Cape (Woodward 1974; 1982). The work of Volker, Jörg and Woodward provides a foundation for archaeological ceramic studies in the Cape.

The advent of historical archaeology in South Africa in the late 1970s increased the literature pertaining to the ceramics bought, used and discarded by Cape households. Archaeological site reports became available, followed by the publication of a small number of specialist works on the excavated porcelain and pottery (Vos 1985; Hall *et al.* 1990a & b, 1993a & b; Schrire *et al.* 1993; Klose 1993; Abrahams 1994, 1996).

Familiarity with Asian wares, especially Chinese export porcelain for the European and American markets, is necessary for the analysis of the four Cape sites under discussion. In the West, porcelains were, and many still are, studied as works of art in their own right with scant reference to their social and economic role. The dating and provenance of ceramics relied on technological attributes and stylistic changes in form and decoration over time. Volker's work revolutionised this art historical approach by demonstrating that European source material, especially the meticulous and extensive records of the VOC, could be used to study and date seventeenth century Chinese porcelains. Volker was one of a line of Dutch scholars who studied export porcelain as merchandise and

demonstrated its role as a small but indispensable commodity in the VOC trade with the East in the seventeenth and eighteenth century. Volker used the Dagb Registers, letter-books, bills of lading and invoices of the VOC and other relevant contemporary documents available to him in the 1950s, to compile yearly surveys of the Company's part in the Chinese, Japanese, Tonkinese and Persian ceramic trade in the Far and Middle East during the seventeenth century (Volker 1954; 1959).

Volker's first survey covered and recorded the important era of change in Chinese porcelains that took place in the years following the overthrow of the Ming dynasty by the Manchu in 1644 (Volker 1954). The ensuing civil war in southern China lasted until the firm establishment of the Qing dynasty in 1682 and caused radical shifts and changes in the ceramic industries and markets throughout the East. In China, the fighting caused a serious disruption in the production, ordering and export of the late Ming export wares (*kraak* porcelain) which were the mainstay of the Company's fine ceramic exports to Holland and Asia during the first half of the seventeenth century. Volker presumed that no Ming style porcelain was sold to the Dutch after 1657, forcing the VOC to turn to Japan and to a lesser extent to Tonking and Persia to make good and supplement the large yearly requirements of trade ceramics. This state of affairs continued till the re-organisation of the government and export kilns at Jingdezhen in the early 1680s, after which China again supplied the bulk of the porcelain exported by the VOC. This period covered the early years of the Cape settlement.

Volker divided his studies into several surveys "to separate the different markets where, and the periods during which, the activities of the Company took place" (Volker 1954). He identified three main markets to which the Company shipped porcelain; the Netherlands, which only accepted fine wares; the inter-insular market in the Malay Archipelago where coarse porcelain wares were dominant; and the Asian market, which comprised India, Persia, Arabia, Japan and Further India, which required almost equal amounts of both fine and coarse porcelains. The outer offices of the Company, including the Cape, were part of the Asian market. Volker's study also discussed the VOC ceramic transactions with Persia and Japan during the seventeenth century. Wares from these two countries are found on late seventeenth century Cape colonial sites.

Volker (1954) used contemporary data to list the types, forms and often the cost of most of the ceramics ordered and distributed by the Company from the beginning of their trade in the early seventeenth century through to 1682. The Company's business transactions were conducted and recorded in the Dutch merchants' shorthand of the day, making it difficult to recognise all of these vessels or the quantities involved when reading the documents. Despite this, Volker was able to identify all the new vessels and tabulate them in chronological order as they appeared in the orders. The orders show the important division of the porcelains into fine and coarse grades, although these terms are often ambiguous.

Volker's systematic research revealed that the records of the VOC could be used to give a more exact attribution and dating to the Chinese export porcelain of the seventeenth century and of the Japanese porcelains officially shipped by the VOC from the 1650s to the 1730s. The information was of immense importance to the general study of Asian export porcelains and especially to archaeologists working on sixteenth to eighteenth century European colonial sites in Asia, Africa and the Americas. Volker lists the names of ships, together with their itemised cargoes, ports of departure and destination. This revealed the dates and contents of early official consignments of Asian ceramics for the Cape station: Persian faience was shipped to the Cape in 1666 and 1682, Japanese porcelain in 1675 and 1676, and unspecified shipments of Chinese porcelain in 1678 and 1681 (Volker 1954:115,188-191).

Volker's survey of the VOC trade in Japanese wares was extended by the publication of a second volume devoted to the Japanese market after 1683 (Volker 1959). The survey showed that after 1683 the official VOC market for Japanese wares was limited to the Asian markets but that the VOC continued to buy Japanese porcelain for its outer offices (which included the Cape), for ships and for the surgeons, despite the fact that it was expensive and difficult to obtain. Volker suggested that the quality of Japanese blue-and-white useful porcelain was not equal to the Chinese wares and that the cost price of the official shipments of these wares to Holland were too high to guarantee a good profit for the Company.

The VOC records also revealed the importance of Tonkinese ceramics during the Chinese porcelain shortage (late 1650s to ca.1682) and again at the end of the seventeenth century when they were in direct competition with Japanese and Chinese

wares. Volker's research also revealed the market for Delft and Rhenish stoneware in Japan during the same century (Volker 1954:224).

Volker acknowledged that there were gaps in the VOC records that he was using and that most of his data was not suitable for statistical analysis. But he still felt that there was enough information to plot the growth and main changes in the official Dutch porcelain trade during the first 80 years of the seventeenth century. He was also aware that the private trade, including smuggling, was an unknown factor and could change much of the information he had tabled, especially the accounts of the Japanese export trade to Europe (Volker 1954). Volker's surveys of the official ceramic trade of the VOC (1602-1683) and the Japanese trade in the eighteenth century, form the basis of the analysis of seventeenth century Asian porcelains excavated in the Cape and give an insight into the Company's supply of ceramics to its outer stations.

Woodward's pioneering studies on ceramics used at the Cape between 1652 and 1795 showed, like Volker, that contemporary documentary sources could be used in the identification and study of ceramics (Woodward 1974). She realised that further investigations into the official importation of porcelain at the Cape would not measurably increase knowledge of locally used oriental wares, and she concentrated most of her research on the itemised household inventories of deceased estates recorded by the Orphan Chamber in the seventeenth and eighteenth centuries. Although these documents are not representative of all the existing households at the time, Woodward was able to list most of the ceramics used in the first 150 years of the colony during the period of VOC rule. Lack of detail in the inventories made it difficult for her to identify or quantify all the recorded vessels. Her work, however, presaged the later studies of excavated assemblages by showing that the position of the ceramics in the house recorded in the inventories could indicate their usage. To this information, Woodward added the comments and observations of visitors and travellers to the Cape (Woodward 1974).

It is important to understand that Woodward's studies of Chinese and Japanese porcelain relied to a great extent on Volker's, then unchallenged, work, and predated the advent of historical archaeology in South Africa. Throughout her overview of the VOC's extensive porcelain trade in the East she was aware that her information on the seventeenth century, especially about the private trade, was probably far from complete. The

dependence on Volker's studies led her to draw a few incorrect conclusions about the Japanese trade and the type of porcelains available during the years 1653-1757.

Nevertheless, her work is of special importance in archaeological research, as she linked the recorded ceramics to the people who used them. She did not study ceramics in isolation by simply cataloguing them as artefacts or works of art, but placed them in their historical and social context. Woodward used her wide knowledge of contemporary fashions, manners and social history, to provide possible contexts and usage for these ceramics in Cape households, demonstrating that they could be read as important and valuable social documents. This approach to ceramics is one of the strengths of her work.

Woodward's detailed descriptions of specific types of Asian porcelains, accompanied by comments on the execution of the decoration, have proved to be of inestimable importance for identification and analysis of excavated wares especially where reference collections are not readily available. Her art-historical knowledge is evident in her aesthetic assessment of the ceramics, yet she does not allow this method of evaluation to overshadow the fact that most of these items are classified as useful wares and were manufactured to function as basic utensils of everyday life. The book was written with South African collectors in mind and the majority of the photographs are of ceramics in local collections, of which over half are on view in public museums.

Woodward's interpretation of the ceramics used in early Cape colonial households did not tally with the small amounts of Delft and polychrome porcelains recorded in the early inventories. This led her to believe that these ceramics had been incorrectly itemised or insufficiently described. Recent archaeological excavations in Cape Town and the surrounding areas, however, have revealed a low incidence of these wares. While accepting Woodward's views on the shortcomings of documentary evidence, the analysis has shown that the inventories are more accurate than was expected. In later work (1982, 1983), Woodward retracts her comments on the paucity of Delft vessels and acknowledges the accuracy of the inventories.

Woodward's study of porcelain predated the start of historical archaeology at the Cape. She commented that archaeology is "the surest guide to the ceramics in use at a given time and place" (Woodward 1974). Woodward used a number of minimally provenanced collections of sherds from building sites in central Cape Town to show that *kraak* porcelain and Japanese porcelain plates with the VOC monogram were in use in the early

years of the settlement and that a variety of coarse porcelains were imported into the Cape (Woodward 1974:Appendix 1).

Woodward paid special attention to two types of ceramics that are linked to the presence of the VOC at the Cape; martevans and porcelain painted with the Company monogram (Woodward 1974). She records and discusses most of the known references to martevans and provides photographs and information on the martevans in South African collections. She suggests that many of these unprovenanced, unobtrusive jars could have been used in the Cape during the eighteenth century and subsequent excavations have proved her to be correct. Her survey and descriptions of the Japanese porcelain with the VOC monogram has helped in the identification and interpretation of blue-and-white Japanese wares from VOC and colonial sites in the Cape.

Woodward's studies of armorial services made for people who had lived or had spent part of their life in the Cape, remains the only detailed account of this ware. Although to date none has been excavated, this information alerts archaeologists to the possibility of finding such specially decorated porcelain on Cape colonial sites

Woodward's work stands as one of the major contributions to the study of Asian wares used in the Cape during the seventeenth and eighteenth centuries. Later research has led archaeologists to question some of her assumptions yet her work remains unquestionably a most important reference book for the analysis of ceramics acquired, used and discarded in Cape during Company rule. Woodward did not treat ceramics as an independent category but described them in terms of their varying contexts within different houses. She discussed their role in cooking, eating and drinking and their relationship to the metal, wood and glass vessels and other artefacts used in these household activities.

Woodward's later dissertation on the interior of the Cape house between 1670 and 1714 used the same type of source materials utilised in her earlier publication, but drew on a wider and more comprehensive range of inventories and auction lists (Woodward 1982:x-xiii; 8-9). In addition, she was able to benefit from the results of the first few years of historical archaeology in the Cape and to expand and amend her earlier studies (Woodward 1982). She made particular use of the wealth of information recorded in the probate inventories that were recorded room by room. Such documents made it possible

for her to recreate the interior and the position and possible use of ceramics in these houses.

Her published research was slanted towards the elite households of the Cape which has limited its use in archaeological studies. The value of this work (Woodward 1982) lies more in showing the context and usage of ceramics during the early years of the Cape rather than a means of identifying particular individual vessels used at the time. The line drawings accompanying the text show the probable type of vessel mentioned in the inventories and she comments that seventeenth and eighteenth century ceramics from local collections need to be properly researched before they can be used as examples of ceramics used in the Cape. By comparing the local inventories with similar contemporary documentation in the Hague and New York, she was able to reveal the distinct character of excavated Cape ceramic assemblages (Woodward 1982:6). This has been confirmed by the analysis of numerous eighteenth century sites in the western Cape region and by comparison with contemporary sites in Europe and north America (Appendix I.1, Hawke-Smith & Barker 1984, Baart *et al.* 1986, London sites (Jacqueline Pearce pers. comm.), Deetz 1973).

Christiaan Jörg followed in Volker's footsteps by extending the survey of the porcelain trade of the VOC into the eighteenth century (Jörg 1982). He used a similar research design to Volker to give an account of the Company's direct trade with Canton from 1729-94 and to list the types and decoration of the porcelain carried in the official VOC shipments to the Netherlands during that time (Jörg 1982). Before describing the porcelain trade in detail, he outlined the history of the whole China trade and gave a description of life and trade in Canton. This emphasised his point that porcelain has to be studied in its economic and historical context as merchandise in the VOC trade in order to fully understand the constantly changing markets of this commodity. Porcelain was carried by the VOC as genuine merchandise and "not regarded merely as ballast" (Jörg 1982:193). It only constituted, on average, 5% of the total profits that the Company made on the cargoes of the ships returning to the Netherlands, yet it appeared to remain one of the most important commodities imported into Europe (Jörg 1982:193).

Jörg showed that the Company's purchases for Europe concentrated on basic everyday household utensils (useful ware), a category of porcelain that could be bought at a reasonable price in Canton, packed and shipped economically, and sold in quantity at a

profit in the Netherlands. The majority of the Chinese export porcelain excavated from eighteenth century Cape colonial sites appear to belong to this category of porcelain.

Jörg's study included the descriptions and drawings which accompanied the lists (Requirements for the Return Shipments) of porcelain to be bought by the supercargoes for the Dutch market during 1729-95, as well as the year by year specifications of the types and decorations of the porcelains actually shipped to the Netherlands during this period (Jörg 1982:94-192; 225-306). The descriptions were taken from the Company's business transactions and are often difficult to match with extant porcelains, but Jörg showed that they can be linked to accurately dated shipwreck material to give a clearer picture of the ceramics in question. He used the Chinese porcelain salvaged from the VOC ship *Middelburg* (1781) as an example, to which can now be added the porcelain from the *Geldermalsen* (1752) (Jörg 1982:152; Jörg 1986).

Jörg's survey included an account of Chinese and Japanese porcelain, freighted to Europe by the VOC for private traders during the eighteenth century. It includes descriptions of elaborate and exclusive porcelains that formed part of these consignments and gives some indication of the type and class of porcelain carried by the vast undocumented private trade (Jörg 1982:140). This information allows a possible division to be made between official and private trade porcelains in Cape assemblages. Jörg also records shipments of Japanese porcelain in 1765 and 1766, showing that it was still possible to buy Japanese export wares for the European market after the VOC had ceased official dealings in porcelain with Japan in 1657, mainly because its price was too high (Jörg 1982:142).

Jörg's study concentrated on the Dutch market and only mentioned the Cape briefly, in connection with the official VOC shipments of porcelain from Batavia, but it is invaluable for comparative studies and the identification of eighteenth century Chinese export porcelain found on Cape archaeological sites.

The firm establishment of historical archaeology in Cape Town led to the production of specialist studies on the excavated ceramics. The earliest of these was an article by Hendrik Vos (1985) describing the 'coarse provincial wares' excavated from colonial sites in Stellenbosch. To date, this is the only published, illustrated reference for Asian market coarse porcelains excavated in South Africa and remains one of the few papers to study and evaluate these ceramics as a group.

Vos began by raising the unsolved problem of how the Dutch used the term 'coarse porcelain' in their business transactions in the East (Volker 1954 & 1959). While it is accepted that 'coarse porcelain' (Asian market coarse porcelain) denoted the thickly potted porcelaneous and stoneware bowls and dishes attributed to the kilns in the southern provinces, it appears that it could also have been used to describe certain blue-and-white export porcelain from the kilns in Jingdezhen which manufactured the bulk of the fine porcelain for the European export market (Jörg 1982:124).

Vos suggested that much of the ordinary fine blue-and-white Chinese porcelain from Cape excavations could have been classed as 'coarse porcelain' by the Dutch merchants. He described this category as having a "fine white body, but with less sophisticated decoration than the fine wares from the same area" (Jingdezhen) but added that these 'northern' wares could have a coarse body similar to many wares from the southern kilns. Jingdezhen Asian market coarse porcelain has yet to be positively identified and excavations of kiln sites and clay sourcing will be required to prove or disprove this theory (Ho Chuimei pers. comm.). Vos, along with all researchers in South Africa, commented that the term *grove* or *grof* in the Cape inventories indicates Asian Market coarse porcelain (provincial ware).

Vos gave an excellent description of the Asian market coarse porcelain category, using extant pieces. The article was well illustrated with photographs of eleven different coarse porcelain bowls and dishes excavated from eighteenth century colonial sites in Stellenbosch. He provided a good background history of the trade in these wares in the East although the later references to the Dutch trade have to be re-evaluated in terms of new documentary evidence (Jörg 1992). Using archival and archaeological evidence, Vos suggested that these vessels were probably used in the preparation and consumption of food even though the inventories record them in rooms other than the kitchen. His conclusion that coarse porcelains had little aesthetic appeal during the eighteenth century is questionable as many of them were either elegantly painted in underglaze-blue or decorated with overglaze red and green enamels and would no doubt have been pleasing to many sectors of Cape society.

Vos demonstrated the importance of archaeologically excavated Asian market coarse porcelains from the Cape in the study and dating of these poorly, and often incorrectly, attributed wares. He made the important point that the Cape assemblages could be representative of the coarse porcelains carried by the Dutch in the inter-Asiatic trade.

The next major work involving excavated ceramics was Antonia Malan's study of Cape households during the period 1750 to 1850 (Malan 1993). She used the layout and contents of urban and rural households to trace the changes in material culture that occurred in the colony during the transition from eighteenth century VOC control to full British colonial rule after 1815. Malan continued, and built on, Woodward's earlier studies of the interior of Cape houses (Woodward 1974, 1982) and based much of her research on the same contemporary documentary sources, namely probate inventories and auction lists, but with the addition of archaeological information from recently excavated Cape sites (Appendix I.1).

Malan covered the 100 year period from the mid-eighteenth to mid-nineteenth centuries in four phases and was able to show the changing context and usage of ceramics in different classes of households within specified time periods. She aided ceramic studies by compiling complete lists of the types and forms of ceramics recorded in individual inventories (Malan 1993:156, 160, 169-170). Malan showed that if documentary evidence is compiled in a form that allows direct comparison with lists of excavated material, it will provide "enhanced material cultural detail" (Malan 1993). She demonstrated that ceramics, particularly tablewares, are especially suited to this type of analysis and gave examples of how individual items from provenanced ceramic assemblages excavated in Cape Town have helped to identify and describe vessel types recorded in probate records (Malan 1993:164, 165).

Malan's work clearly demonstrated the importance of documents, especially probate inventories of deceased estates, in the analysis of excavated ceramics assemblages. Her method of presenting information in tabulated form makes the results more accessible and useful than Woodward's narrative approach.

Gabeba Abrahams extended the study of locally excavated ceramics by surveying the provenance, manufacture and availability of coarse earthenwares used in the Cape during the seventeenth and eighteenth centuries (Abrahams 1994). Coarse earthenwares from Cape sites incorporate two conceptually different types of pottery: unglazed pots made and used by the indigenous Khoi and the European-style coarse earthenware made

locally or imported from Europe for use by the VOC and in colonial households. Abrahams described and discussed the latter category under the heading 'VOC-period pottery'.

Abrahams based her survey on an assemblage of locally produced European-style earthenwares excavated from a section of the Grand Parade in central Cape Town. The site included a section of the moat that had surrounded the Fort de Goede Hoop (1652) "in which a large deposit of remains was preserved throughout the centuries" (Abrahams 1994:2). The earthenwares were attributed to the mid-eighteenth century on the basis of their association with artefacts dated to 1740-1760.

Khoi pottery has been adequately described by other researchers but Abrahams was the first person to compare locally produced European-style earthenwares with similarly styled pottery from other sources. She classified the European-style coarse earthenwares according to their vessel form and the results were tabulated with a full description of each vessel and its possible function. Fragmentation hindered the precise identification of many of the vessels especially the smaller thin-walled 'pots' and the large bowls/dishes. Despite this problem, Abrahams listed twelve basic groups of vessel forms and provided photographs, drawings and profiles of over twenty coarse earthenware items. Amongst these wares, Abrahams identified a small group of vessels whose vessel style and macroscopic appearance of the body and glaze suggested they were of European origin.

This assemblage of earthenwares from the Grand Parade site cannot be linked to any particular household as the moat was probably used as a dumping ground for any number of the surrounding houses. It does, however, give an indication of the range of coarse earthenwares available to the inhabitants of the Cape in the eighteenth century and forms the basis of a vessel typology for European-style coarse earthenwares found in the Cape.

Very little provenanced European-style coarse earthenware pottery had been preserved in local museums and until the publication of this survey, archaeologists working on excavated Cape assemblages were forced to rely on collections of European manufactured wares for referencing the excavated coarse earthenwares.

In a later study Abrahams (1996) used the Grand Parade ceramic assemblage and its associated faunal remains to investigate the foodways of the Cape colonists during the mid-eighteenth century. She used a social history paradigm to discover the cultural and social meanings of the excavated ceramics within the context of the eighteenth century Cape and aimed at explaining, rather than just describing, the ceramics. Her project was also aimed at setting up a method of systematically recording ceramic assemblages to facilitate the interpretation of ceramics and to permit accurate comparative analysis.

The ceramic assemblage from the Grand Parade was made up of the common ceramics of everyday life (Abrahams 1996:20). It had accumulated over a 150 year period: a few ceramics could be related to the occupation of the Fort (1652 - ca.1673), and the remainder could have been discarded by households from all over Cape Town (Abrahams 1996:245). They are considered to be representative of the range of ceramics used in the Cape during the eighteenth century.

Before describing the excavated ceramics, Abrahams provides a brief account of the acquisition and usage of ceramics at the Cape from before the settlement of the Cape by Europeans 1652 to the end of the nineteenth century. She sets up a typological classification based on the work by Mary Beaudry to catalogue and fully describe the excavated ceramics, before interpreting them by integrating the results with the faunal analysis and various documentary sources. Abrahams uses probate inventories, eighteenth century travellers' accounts of life at the Cape, old recipe books and the excavated ceramics together to recreate the preparation and consumption of food and drink in the eighteenth century and to identify vernacular trends in the foodways of the colonial inhabitants of the Cape.

Throughout her project, Abrahams is aware that her conclusions were constrained by the lack of suitable comparative material available to her at the time. Despite this, she has produced the first major study of ceramic usage in the Cape during the eighteenth century.

Together, the studies of Volker (1954, 1959), Woodward (1974, 1982), Jörg (1982), Vos (1985), Abrahams (1994, 1996) and Malan (1993) provide a firm foundation for the future archaeological analysis of ceramic assemblages from colonial sites in Cape Town and form the basis of the CCS which will be discussed in detail in the following chapter.

Chapter Three

Methodology

This chapter develops a method for describing, classifying and quantifying ceramics excavated from seventeenth, eighteenth and early nineteenth century colonial sites in the south-western Cape; a method that will be referred to as the Cape Colonial System (CCS). The classifications and systems of quantification are based on well established and accepted methods used in archaeological research. The compilation of the results of the analysis are presented in a form that is comparable with similar research from elsewhere and, wherever possible, compatible with descriptions in contemporary documents. Yentsch (1990:30-31) has commented that definitive comparative studies based on published works are not possible due to non-standardised reporting procedures. With this in mind, the core structure of the CCS is an adaptation and extension of the Potomac System, and the work of Beaudry and her associates (1983) and Yentsch (1990, 1991a) were the inspiration behind the system.

A primary objective in setting up the CCS was to establish a check list of ceramics found on Cape sites and to use it to create a system that could categorise and give equal recognition to all the ceramics found in colonial assemblages. Information would be presented in a form that would permit the easy construction of typologies as required. A second objective was to create a system that could produce accurate information at an early stage for relative dating within a site and for intra- and inter-site comparisons. This information could be of special importance to archaeologists working in Cultural Resource Management, where early assessments of ceramics and dating estimates are essential. Furthermore, the intention was to produce information that had 'analytical utility' in order that ceramic analysis could be used for more than just dating a site (Beaudry *et al.* 1983:19) This led to emphasis being placed on the identification of the form and possible function of every excavated vessel and sherd in an assemblage. The CCS should be seen as a stage in the development of a classification for Cape Colonial sites that will be modified and changed by further research and by its application to newly excavated sites, especially those dating to the nineteenth century.

The CCS is based on four overlapping areas of research. The first, and most important, research was the analysis and assessment of ceramic assemblages from urban and rural colonial sites in the south-western Cape, and from shipwrecks in Cape coastal waters (Appendix I.1). The second and third areas of study were the examination and evaluation of existing classifications: ceramic categorisations based on technological and decorative attributes used by archaeologists and non-archaeologists, and methods of classifying vessel form and function. Lastly, a survey was conducted of ceramic studies and research projects by historical archaeologists working in North America.

Sites used in the project

The colonial sites used in the research for this project are probably representative of most levels of Cape society during the first two hundred and fifty years of settlement, and the assemblages include examples of ceramic types and forms made locally or brought into the Cape from 1652 to the early nineteenth century. They will be referred to as the Test Group (Appendix I.1). The earliest ceramic assemblage in this group is from Oudepost 1, a VOC outpost approximately 120 km north of Cape Town, occupied from 1669 to 1732, and the latest comes from Harrington Street in Cape Town, an urban site dating from the early second half of the nineteenth century. The level of ceramic analysis carried out on the assemblages varied from a brief preliminary examination and sorting of the sherds, to a partial or complete application of the CCS.

Analysed ceramic assemblages from Cape museums, the Stellenbosch Museum and the South African Cultural History Museum, were studied to gain additional information about the Asian porcelains available during the colonial period. Also examined were the ceramics from three VOC ships which sank off the South African coast during the seventeenth and eighteenth centuries, the *Oosterland* (1697), the *Middelburg* (1781) and an early eighteenth century vessel, thought to be the *Bennebroek* (1713). The Asian porcelain cargoes on board these vessels were *en route* to the Netherlands for the European market and had not been ordered for the Cape, therefore vessel forms or decorative styles found only in these assemblages were not included in the listing of vessel forms for the analysis of Cape colonial sites. Complete and fragmented vessels from the shipwreck assemblages, however, have helped in the identification of porcelain from colonial sites, and provided valuable comparative information.

An overall assessment of the ceramic assemblages from the Test Group (Appendix I.1) of Cape historical sites indicated that the ceramic ware classifications and typologies used by archaeologists working in Europe and North America would be of limited use in a South African context. These classifications focus in detail on ceramics of European manufacture, especially British ceramics, but do not make the same fine analytical distinctions for Asian porcelains or for certain less commonly occurring European ceramics (South 1971; Worthy 1982; Barker & Barker 1984; Baart *et al.* 1986; Walthall 1991). Cape colonial sites require a broader based system to incorporate and adequately analyse the wide variety of ceramics from Asia, Africa and Europe that were imported into Southern Africa from the mid-seventeenth century onwards.

Assessment of existing ceramic classifications

In order to assess the strengths and weaknesses of different ceramic classifications it was convenient to begin with the simple and accurate method used by western potters, and subsequently by archaeologists, that divides ceramics into earthenware, stoneware and porcelain. This basic system will be referred to as the potters' classification (Table 3-1, Classification A). Its three primary wares are identified by easily recognised technical attributes, namely, the colour, texture, porosity and translucency of the body. They can also be defined by the materials and firing temperature used in their manufacture (Klose & Malan 1993), but variations in the firing temperature, either intentional or through faulty firing, can alter the physical properties of fired clay and lead to incorrect classification of sherds. For example, poorly fired stoneware can exhibit a high porosity and be mistakenly classified as an earthenware.

Many people, apart from archaeologists and potters, make clear distinctions between different kinds of ceramics. For this reason, a study was made of ceramic typologies and nomenclature used by lay persons, collectors and dealers, manufacturers, merchants and materials scientists, to investigate the possibility of incorporating them into an archaeological system of classification. The results of the study show that lay persons use decorative, functional and aesthetic attributes as well as generic and trade names to classify ceramics, for example, china, pottery (for a wide range of different types of wares), delft, cologne ware, tigerware, bone china, Nankin and 'ovenware'. Such terms give an indication of how people perceived the ceramics they bought and used.

CLASSIFICATION A	CLASSIFICATION B	CLASSIFICATION C	CLASSIFICATION D
POTTERS' CLASSIFICATION	MATERIALS SCIENCE	CCS - FIRST VERSION	CCS - FINAL VERSION
ware based appearance, texture materials & firing	materials & microstructure (after Kingery & Vandiver 1986)	ware based & partly chronological	ware based & partly chronological
PORCELAIN	PORCELAIN & WHITEWARES	PORCELAIN	PORCELAIN
Chinese export ware European porcelain Persian stone-paste	Chinese export ware European porcelain White-bodied semi-vitreous wares Feldspathic stoneware Asian market coarse porcelain	Chinese export ware European porcelain Persian stone-paste Asian market coarse porcelain	Chinese export ware European porcelain Persian stone-paste Asian market coarse porcelain
	WHITE QUARTZ PASTE		
	Persian stone-paste		
STONEWARE	STONEWARE	STONEWARE	STONEWARE
Yixing Rhenish salt-glazed British 'commercial' Staff. white salt-glazed Basalt Feldspathic stoneware Asian market coarse porcelain	Chinese blue & white Yixing Rhenish salt-glazed British 'commercial' Staff. white salt-glazed Basalt	Yixing Rhenish salt-glazed British 'commercial' Staff. white salt-glazed Basalt Feldspathic stoneware	Yixing Rhenish salt-glazed British 'commercial' Staff. white salt-glazed (utilitarian)
EARTHENWARE	EARTHENWARE	EARTHENWARE	COARSE EARTHENWARE
European-style coarse earthenware Khoi pottery Tin-glazed earthenware Cream coloured ware White-bodied semi-vitreous wares	European-style coarse earthenware Khoi pottery Cream coloured ware	European-style coarse earthenware Khoi pottery Tin-glazed earthenware	European-style coarse earthenware Khoi pottery
	ENGOBES & U/GLAZE COATINGS		TIN-GLAZED E/W (ENGOBES)
	Tin-glazed earthenware		Tin-glazed earthenware
		REFINED EARTHENWARE	REFINED WARES
		Cream coloured ware White-bodied semi-vitreous wares	Cream coloured ware White-bodied semi-vitreous wares Staff. white s-g (tea/tableware) Basalt Feldspathic stoneware

Table 3-1: Comparison of ceramic classifications using selected sub-categories from the CCS

Manufacturers and merchants used similar terminologies, but the categories employed by them usually reflect the basic decorative type or generic term for the ceramics, such as printed, edged, painted and c.c. (plain cream coloured ware). The potters made little reference to body composition and firing temperature which might be expected from ceramic ware producers. Museum curators, specialist collectors and dealers tend to describe ceramics using the potters' classification, which they often qualify with well known generic terms and trade names, but this method is being replaced by the use of a more precise archaeological-style terminology.

The most accurate and consistent approach to the identification and classification of ceramic bodies is based on materials science studies. An example of this method, proposed by David Kingery and Pamela Vandiver (1986), used specific technological concepts and divided the ceramics into generic families derived from the materials used and the microstructure of the fired body (Table 3-1, Classification B). This classification re-defined and re-grouped the basic body types of earthenware, stoneware and porcelain into five categories, four of which are based on the composition of the body and a fifth, conceptually different, category based on engobes - clay slips and underglaze coatings which are employed to cover and alter the appearance of the outer surface of a ceramic.

Kingery and Vandiver's classification produces two particularly interesting categories of ceramics for archaeological analysis and interpretation. It groups semi-vitreous whitewares with porcelain showing that the eighteenth century Staffordshire potters' quest to manufacture a hard, white porcelain-like body was eventually realised. Secondly, its engobe category brings together the various methods used to produce pure 'white' vessels in ceramic traditions that lacked the necessary materials and technology needed to produce white-bodied stoneware and porcelains. Tin-glazed earthenware, the generic term for faience, Delft and majolica, is an example of an engobe.

Although the materials science method of categorising ceramic bodies is extremely accurate, it is difficult to use as a primary archaeological classification. Some of the ceramics within its categories cannot be identified by easily observable features and it uses a modern terminology that cannot be directly related to that used by the manufacturers or purchasers of pottery and porcelain. The materials science approach, however, is invaluable for the accurate classification of nineteenth and twentieth century vitreous and semi-vitreous whitewares, but these wares fall outside the scope of this dissertation.

Ceramic classifications used by archaeologists world-wide are usually derived from the potter's classification and have three broad based primary ware categories: earthenware, stoneware and porcelain (Table 3-1, Classification A). This basic tripartite classification can be used where fine categorisation is not required for the interpretation of a site (Baart *et al.* 1986), or for describing damaged or unrecognisable sherds that cannot be fully identified. More precise classifications require subdivision of the primary wares into 'ware-types' based on variations of body, glaze and decoration, which are further divided into 'ware sub-types'.

Ware-based classifications, using categories that can be easily distinguished by noticeable differences in the body of the vessel or sherd, can be used effectively on archaeological sites pre-dating ca.1800 as well as on later excavations where the range of ceramics is limited and easily identified. Classification by observable ware type is a particularly useful method in archaeology as, in most cases, it employs a terminology used by the people who made, sold or bought these ceramics (Miller 1980).

Ceramic classification used by historical archaeologists in the United States "has developed through a synthesis of ceramic history and knowledge of common ceramic types recovered from excavations" (Miller 1980:1). It is heavily biased towards British manufactured earthenwares and stonewares, as they dominated the American ceramic market until the late 1800s (Majewski & O'Brien 1987:98).

The first historical archaeological excavations undertaken in North America and South Africa were on sites predating the nineteenth century and the ceramic assemblages could be adequately analysed using ware-based categories. The range of English refined white earthenwares manufactured in the eighteenth century was restricted to early cream coloured wares and pearlwares, both of which are easily identifiable. The classification of post-1800 manufactured English refined white earthenwares and white-bodied wares by ware type, however, becomes increasingly difficult from the early nineteenth century onwards. The minor differences between these wares are "the result of an evolution of one ware out of another" (Miller 1980:2). Technological developments that led to the whitening of the cream coloured and pearlware bodies and the parallel development of stone china and other refined whitewares produced a range of white-bodied ceramics with very similar body colours, textures and vitrification. These on-going developments meant that nineteenth century white-bodied wares were never static in composition or appearance.

George Miller showed that it was extremely difficult to identify and group nineteenth century British ceramics using a ware based classification. Analyses using this method were inconsistent and subjective and generated little interpretative information apart from producing a vague chronology for an excavation. In addition, this method of classifying ceramics could not be integrated with historical documents and provided no information about the social status of the ceramics (Miller 1980:3).

Miller studied the order books and invoices of the Staffordshire potters from a sixty year period spanning the late eighteenth and first half of the nineteenth centuries. His research revealed that the potters classified and priced most of their ceramics according to their decorative attributes alone, and that price fixing lists rarely referred to the body of the vessels. This information suggested that refined white earthenwares from the late eighteenth century to the third quarter of the nineteenth century could be classified by the decorative categories used by the potters. Not only was this a simple, non-subjective method of sorting the majority of mass-produced British china made between ca.1787 and ca.1880, but it also produced results that could be directly linked with the potters', merchants' and wholesalers' business documents. His research also showed that plain, undecorated cream coloured wares were always the cheapest ceramic available, and that their price did not fluctuate during the late eighteenth and early nineteenth centuries. More important was his discovery that the cost prices of decorated Staffordshire wares kept the same relationship to each other and to cream coloured ware during this same time period. His study of the Staffordshire potters' price fixing lists had revealed "that decoration was the variable that moved most consistently with ceramic cost, with undecorated pieces at the bottom of the scale and transfer-printed pieces at the top" (Potter 1992:14). Miller used this information to develop an economic scaling technique to assess and compare the relative cost and status of ceramic assemblages (Miller 1980;1991). This technique was an important break-through in ceramic analysis, as it demonstrated that it was possible to develop classifications that had 'meaning' and could be used directly for the interpretation of the assemblage and site. But it has to be remembered that Miller's classification does not utilise vessel form or function.

Miller's research simplified the classification of British refined white wares manufactured in the late eighteenth and first half of the nineteenth century. But later studies by Worthy (1982) and Majewski & O'Brien (1987) indicated that classification for nineteenth century white wares needs to incorporate both decoration and ware in order to have a wider analytical use.

In addition to the problems encountered with refined white earthenwares, many researchers in North America have expressed dissatisfaction with typologies used to classify other groups of ceramic wares from American colonial sites. These have included Chinese export porcelain, French faience and coarse earthenwares (Curtis 1988a, 1988b; Walthall 1991; Turnbaugh 1983). Vague and imprecise typologies for these wares have resulted in the loss of valuable analytical information and hindered the setting up of adequate typologies. Problems were caused by archaeologists either not making effective use of available sources of information, including the excavated material itself, or by lack of sufficient relevant historical documentation.

Seventeenth and eighteenth century Chinese export porcelain sherds formed a major part of the ceramic assemblages from the James River Basin in South-eastern Virginia, yet few attempts were made to classify and date them (Curtis 1988a:20). Curtis commented that this was partly due to the fact that, prior to late 1970s, there was very little suitable literature available for the identification of ordinary Chinese export porcelain. She suggested that the analysis of this type of porcelain could be aided by setting up chronological surveys of excavated porcelain and comparing them with existing historic collections and shipwreck material (Curtis 1988b:47). This method is being used to analyse porcelain on Cape sites (Klose 1993:73).

Lack of published references for other ceramic wares forced historical archaeologists to use information gained from their own analysis of sherds of eighteenth century French faience from fifteen North American sites to organise a system of analysis on observed stylistic and functional attributes. Previous typologies had been too simplistic and this had hidden important differences when sites were described and compared (Walthall 1991). Sarah Turnbaugh (1983) also used information from excavated assemblages to establish a method of analysing the types, styles, form and function of the large quantities of undecorated plain red earthenwares found on early seventeenth and eighteenth century sites in North America. Only a small percentage of these wares could be precisely identified by using documentary sources or the conventional analytical methods used in historical archaeology. Turnbaugh demonstrated that it was possible to describe and quantify whole assemblages of previously unidentified coarse earthenwares by using a typological classificatory system based on the technical attributes of the sherds, followed by conventional formal and functional analysis (Turnbaugh 1983).

Another method used in recording and classifying ceramic assemblages is the routine use of vessel profiles. Archaeologists working in Staffordshire in England have produced detailed site reports of eighteenth and nineteenth century refuse pits in which the ceramics are classified according to ware type and accompanied by full descriptions, drawings and profiles of individual vessels (Hawke-Smith & Barker 1984). Their use of profiles in cataloguing eighteenth and early nineteenth British refined wares was a continuation of a method used to record the ceramics from Roman and Medieval excavations. Such a procedure would be time consuming and unnecessary for documenting the majority of ceramics on Cape sites but would be important for recording items not referenced or unidentified forms. The English site reports using profiles are of great value for the identification of British white earthenware forms excavated in Southern Africa.

Ware Table

At the beginning of this project, the primary analysis of Cape ceramic assemblages was carried out using a classification similar to those employed by north American historical archaeologists. This was a ware-based classification using four primary categories; Porcelain, Stoneware, Earthenware and Refined Earthenware, which were subdivided according to area of manufacture. Porcelains and stonewares were divided into Asian (Chinese & Japanese) and European sub-categories. Earthenwares were split into European-style and indigenous Khoi pottery. All the refined earthenwares were classified as European and subdivided into Cream coloured ware, Pearlware, Whiteware, and Other Wares (Table 3-1, Classification C).

This classification became the first version of a section of the CCS and was named Ware Table. Initially it appeared to be satisfactory for recording all seventeenth to late eighteenth century sites, but the later re-working of these assemblages revealed the presence of Persian ceramics and Japanese stoneware, as well as Asian and African coarse earthenwares which had not been recognised during the initial analysis. Further problems were encountered when the classificatory system was applied to late eighteenth and early nineteenth century sites, as it resulted in large, cumbersome categories containing conceptually different vessels with widely differing periods of manufacture.

The most satisfactory categorisation of ceramics from Cape sites was eventually achieved by combining elements from the materials science, north American historical archaeologists' and Miller's classifications, in conjunction with the chronology of ware types as they occurred on Cape colonial sites (Table 3-1, Classification D). From this could be plotted the strong fluctuating influences of both Asia and Europe on the Cape settlement from its beginnings in 1652 to the end of the nineteenth century.

An additional objective was to investigate the possibility of utilising the composition of ceramic categories for estimating the occupation period of a site and as a relative dating tool for site interpretation. The aim was to identify ceramic wares and forms that could be used as 'chronological markers' for dating Cape collections and to construct typologies which would highlight their presence in an assemblage at an early stage in the analysis.

An overall view of the assemblages categorised in Ware Table revealed clear-cut patterning in ceramic wares, forms and decoration. In general, seventeenth century sites show almost equal amounts of imported European and Asian wares (the Granary - Chapter 5, Table 5-1), eighteenth century assemblages are dominated by Asian porcelains and locally produced European-style coarse earthenwares with isolated fragments of English refined earthenwares (Elsenburg - Chapter 6, Table 6-1). The early nineteenth century sites exhibit the gradual, but not total, replacement of Asian wares by mass produced European refined wares and porcelains (Sea Street - Chapter 7, Table 7-1). Further analysis revealed that Chinese export wares dominated the porcelains found on seventeenth and eighteenth century sites, Japanese export porcelains were most numerous during the late seventeenth and first half of the eighteenth century, Persian 'porcelain' only occurred on late seventeenth century sites, and European porcelain rarely appeared in any quantity until the first quarter of the nineteenth century.

The overview also revealed that the dominant decorative category of all Asian porcelains found on seventeenth to early nineteenth century Cape colonial sites was blue-and-white. Underlying this overall trend, the Chinese porcelains exhibited a marked increase in the number of enamelled wares at the end of the eighteenth century, while the Japanese porcelains showed an increase in enamelled wares in the first half of the eighteenth century. These enamelled wares, with a few exceptions, were tea or ornamental wares.

Due to the lack of suitable literature, comparative work with ceramic assemblages from other countries is difficult at present. Assemblages of excavated eighteenth century Asian porcelain from sites in London show a higher figure for enamelled wares than Cape sites (Table 3-2). The study of porcelain at the Cape is at an early stage. For this reason it is difficult to say whether the apparently low percentage of Chinese enamelled wares in Cape porcelain assemblages dated to the mid-eighteenth century is indicative of local availability, personal choice, or the status of the excavated sites. The high figure for blue-and-white wares in the Cape is probably due to the fact that Asian porcelain was the general household tableware of the colony and as in Europe, underglaze-blue was the standard decorative category for Chinese table ware throughout the eighteenth century in the Cape (Howard & Ayers 1978:63). Christiaan Jörg's figures for VOC shipments of porcelain during the period 1730 - 1795 are also dominated by blue-and-whitewares (Jörg 1982).

Table 3-2: Eighteenth century Chinese export porcelain from three archaeological sites in London expressed as MNVs (after Barry 1993)

Decoration	Sites					Total
	PEP 89	JON 89	LLK 26	LLK12	LLK 18	
Underglaze blue	1	42	35	46	13	137
Enamelled	5	5	10	30	8	58
Chinese Imari	-	2	3	15	1	21
Brown glaze	1	1	-	2	2	6
'soft' paste	-	-	2	-	-	2
Total MNV	7	50	50	93	24	224

The nineteenth century ceramic assemblages sites in the Test Group (Appendix I.1) show a sudden and almost total switch to mass produced British ceramics. British wares began to oust and replace the Asian ceramics from the late eighteenth century onwards and by the second quarter of the nineteenth century, Cape ceramic assemblages start to

resemble those in North America where the majority of table, tea and toilet wares were made from English refined earthenwares (Miller *et al.* 1989:3).

In addition to this information, analysis of the Test Group assemblages indicated that the date ranges for the occurrence of tin-glazed wares and refined earthenwares on Cape sites did not always coincide with those of the colonies in north America. Probate inventories and excavated ceramic assemblages show that tin-glazed wares were never as numerous at the Cape as they were in Europe or north America during the seventeenth century and eighteenth century (Deetz 1973; Baart *et al.* 1986; Yentsch 1991a; Janowitz 1993) and that British refined wares only begin to be recorded in small numbers in the 1790s (Antonia Malan pers. comm.).

The use of ceramics in dating assemblages

Ceramics have been used for both the relative and the absolute dating of archaeological sites. Any dating technique using ceramics relies on four factors: accurate identification of wares; knowledge of the dates of production; distribution of each specific ware; and an awareness of the time lag before deposition in the ground. The date of manufacture of any ceramic is not the same as the date of deposition in the ground. There is great variability in time lag for different ceramics (Adams & Gaw 1977, Riorden 1985), and valuable vessels can be curated for decades. Site dates derived from ceramic analysis must be used with caution and preferably used in conjunction with documentary sources and other evidence such as clay tobacco pipe analysis (Schrire *et al.* 1990; Yates *et al.* n.d.).

A simple technique to estimate the date of archaeological contexts is a presence/absence analysis but, used on its own, without any quantification of the ceramics, this can do little more than give a possible *terminus post quem* for an assemblage. However, if it is used in conjunction with a frequency distribution analysis of the ceramics (see below), it should be possible to estimate the occupation period of the site.

As one of the objectives of the project was to find ways of producing quick, accurate assessments of assemblages, it was decided to re-evaluate the use of sherd counts in

ceramic analysis. Comparison of analyses from the four sites used in this dissertation showed there was no constant relationship between vessel numbers (MNV) and sherd counts. There appeared to be a closer relationship between percentage MNVs and percentage sherd counts but, although the two sets of figures would occasionally coincide, the information was too variable to be considered a reliable indicator of the ceramic profile of a site. Sherd counts have minimal analytical value as they are affected by fragmentation and are not necessarily good indicators of vessel numbers. The CCS has restricted the use of sherd counts to presence/absence analysis and for the estimation of sherd fragmentation, but the judicious use of percentage sherd counts can give a reasonably accurate picture of the relative composition of a ceramic assemblage (see Figure 3-1).

In the early 1960s, Stanley South used frequency analysis of sherds to demonstrate, "that the use of this method to quantify European ceramics from eighteenth century British American sites would allow the archaeologist to date the occupation period of a ruin" (South 1962). Frequency distribution analysis quantifies ceramics by recording the percentages of ceramic types within an assemblage using sherd counts or, preferably, the estimated minimum number of vessels in each category. It allows comparison of ceramic categories within, or between, sites (Chapter 9, Figure 9-1) but can mask increases in numbers of items in an assemblage (Yentsch 1990:38). South's "Mean Ceramic Date Formula" for dating historical sites is a refinement of this technique, but was not utilised in the analysis on Cape colonial sites (South 1971).

Preliminary analysis of the excavated assemblages from different areas within the Castle of Good Hope (Appendix I.1) revealed patterning in the quantities and types of excavated ceramics which could be related to the date of the site. Percentage frequency distribution has therefore been included in the CCS and the results are being used to construct a series of 'ceramic profiles' for Cape colonial sites from the seventeenth to nineteenth centuries. These will be used for intersite comparisons and for constructing a chronology of Cape sites which could be used for estimating possible date ranges for newly excavated sites (Chapter 9, Figures 9-1 & 9-2).

Eisenburg - the kitchen midden (Layer dbyc)
Comparison of No. of fragments (3444) and MNV (313)

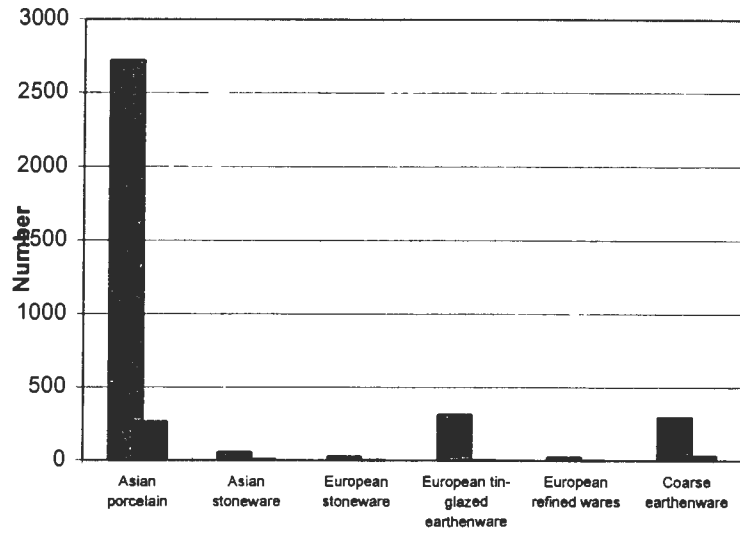

James' House 6, Sea Street (Phase 2)
Comparison of No. of fragments (2758) & MNV (852)

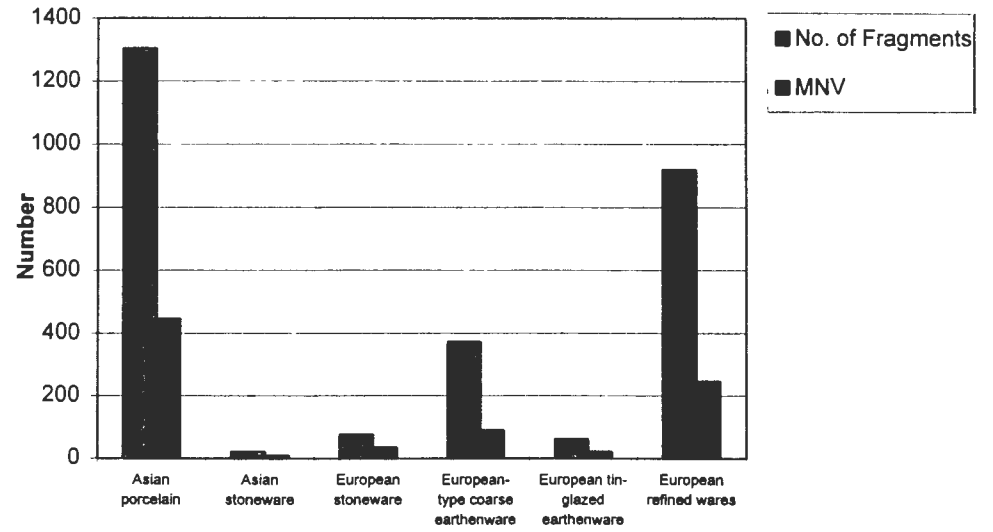

Eisenburg - the kitchen midden (Layer dbyc)
Comparison of %Fragments & %MNV

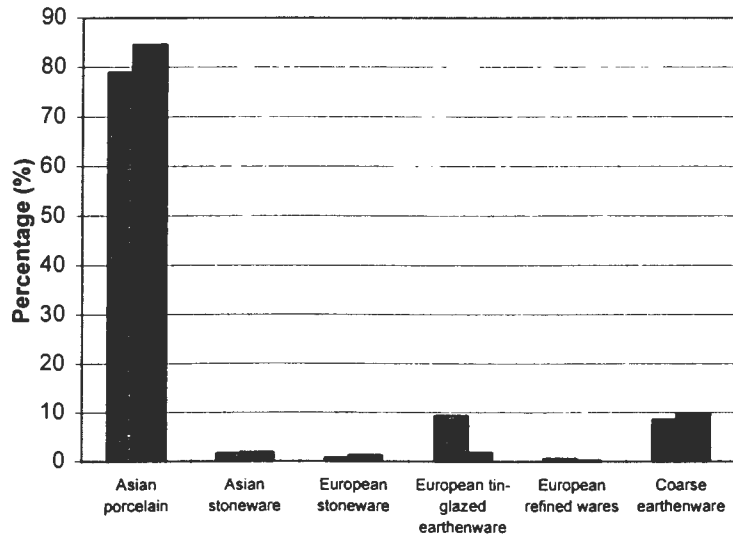

James' House 6, Sea Street (Phase 2)
Comparison of %Fragments & %MNV

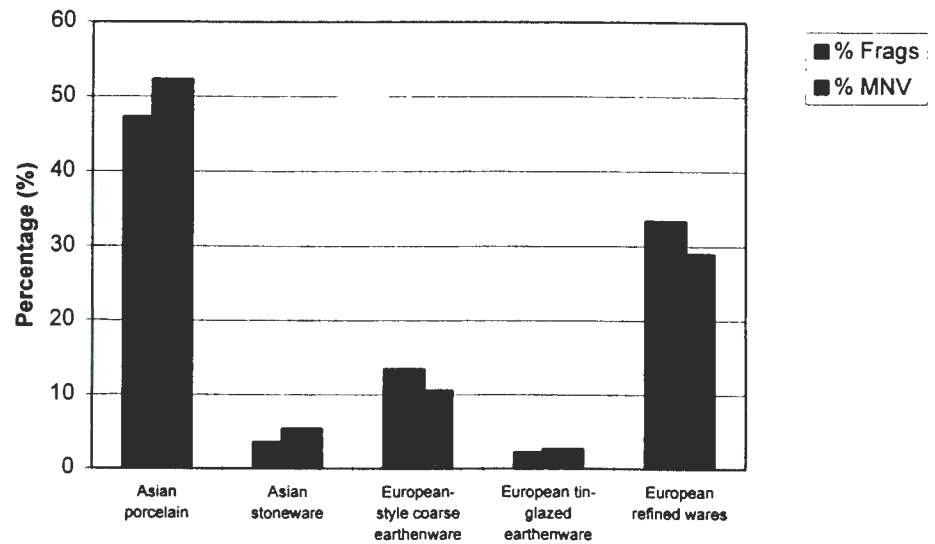

Figure 3-1: Comparison of sherd counts and MNVs from Eisenburg and Sea Street.

Date Table (Appendix F)

In order to standardise the results of ceramic analysis using the CCS, the accepted known dates of manufacture of all the wares listed in Ware Table, as well as their date of occurrence on Cape sites, have been recorded, referenced and tabulated as Date Table (Appendix F). It is incomplete in its present form and future research is planned to enlarge all the sections by including additional wares with datable decorative styles. Particular attention will be paid to Asian porcelains where changing border patterns are an indicator of date (Howard & Ayers 1978: 63).

Date Table (Appendix F) demonstrates the difficulties involved in dating ceramics from seventeenth to eighteenth century Cape assemblages. For example, sites are dominated by mass produced and commonplace Chinese and Japanese export porcelains. While these wares do have a chronology, Asian porcelain analysis still remains partly subjective and the resultant dating can often be vague and unreliable. Other frequently occurring seventeenth and eighteenth century wares, including European-type coarse earthenwares, Khoi pottery, Asian and European stonewares and Asian market coarse porcelains, show minimal change in form or decoration during their long periods of production, thus making them difficult, if not impossible, to date precisely.

Further development of Ware Table

The list of ceramics included in the CCS was derived from the repeated application of Ware Table to as many sites as possible. The Ware Table now records the full range of ceramics, excavated to date, from Cape colonial sites.

Following this thorough testing, it was decided to elaborate the structure of Ware Table further, to enhance its use as a dating tool. Tin-glazed earthenware was removed from the Earthenware group to form a separate category. This reorganisation highlighted tin-glazed wares as a chronological marker on Cape sites by emphasising the presence (and quantity), or absence of these wares in relation to the other categories in ceramic distribution analysis. In addition, this decision to classify tin-glazed earthenwares separately follows the materials science ceramic classification which would place them in the 'engobe' category (Table 3-1, Classification D). This modification of Ware Table

increased the basic ceramic ware categories of the CCS to five: Porcelains, Stonewares, Coarse Earthenwares, Tin-glazed Earthenwares (Engobes), and Refined Earthenwares.

Analysis of the Test Group of Cape sites (Appendix I.1) had shown the rarity of eighteenth century British refined earthenwares and refined stonewares on pre-1800 colonial sites. Further reorganisation of ware categories based on this information could make Ware Table even more effective as a dating and interpretative tool for Cape sites. Fine Staffordshire white-salt glazed wares and the other eighteenth and nineteenth century Staffordshire refined stonewares (redware, basalt, cane, Jasper) were removed from the European stoneware category, renamed British Refined Stonewares, and grouped with the Refined Earthenwares. Subsequently, the latter category was renamed Refined Wares and now incorporates all the ceramics, except bone china, that were developed and produced in Staffordshire from 1730-40 onwards. The European Stoneware category contains the thick, often coarse, hollow wares such as jugs, storage jars, bottles and chamber pots, while the Refined Stonewares category is used for fine stoneware tea and tableware, and ornamental items (Ware Table, Appendix E).

This suggested reorganisation of the stoneware classification is problematical on two counts. Firstly, it is dangerous to date the occurrence or absence of certain eighteenth century European ceramic types on the basis of their archaeological contexts, and secondly, it introduces vessel form into a ware based classification. Therefore, it was decided to provide alternative classifications for Refined Stonewares by listing them twice in Ware Table: first under European Stonewares and again in the Refined Wares category. This allows classification either by ware alone, or by ware-type and form, depending on how the classification is to be used in the interpretation of the site.

Problems encountered with analysing refined white earthenwares by ware led to a further reorganisation of the Refined Wares category. The final categories are Cream coloured ware, Pearlware, White-bodied wares (clear glazed), Other Refined Earthenwares and Refined Stonewares.

Ware Table in its final form (Appendix E) uses five basic ceramic categories: Porcelain [1.], Stoneware [2.], Coarse Earthenware [3.], Tin-glazed Earthenware (Engobes) [4.] and Refined Wares [5.]. Within each of these categories, the wares are divided first according to their area of manufacture (Asia, Africa, Europe) and then, where possible, by country of origin (Japan, Britain, Germany). For example, a sherd could be classified as Porcelain / Asian / Far Eastern: Chinese export porcelain [1.1.1], or Tin-glazed Earthenware /

European / Unprovenanced [4.1.1]. Area designated wares, known as 'ware-types', are split into 'ware sub-types' based on decoration alone or, occasionally, on minor differences in the composition of the body. Thus, blue-and-white is a ware sub-type of Chinese export porcelain (1.1.1.1), and 'scratch blue' a ware sub-type of British stoneware (2.2.2.2). The present format of Ware Table does not make allowance for non-British refined wares. Ware Table was constructed specifically for mid-seventeenth to mid-nineteenth century Cape Colonial assemblages and it has been assumed that only British refined wares were imported into the Cape during this period.

Ware Table incorporates all the ware-types and ware sub-types that have been found in the Test Group (Appendix I.1). Other types may have been used by the colonists but they have not yet been excavated. Ware Table makes allowance for unidentified ceramics within each ware and ware-type category. In its present tabulated form it can record additional ware sub-types only, but the computer spread sheet for Ware Table can be expanded to accommodate extra ware types. Ware Table records wares by sherd count, minimum vessel count (MNV) and percentage vessel count.

In the following sections, the individual wares, ware-types and ware sub-types will be defined and described in the same order they are listed in Ware Table and Date Table (Appendices E & F). In addition, examples of the most common forms of each ceramic type found on Cape colonial sites will be given, most of which will be referenced or site referenced using the four sites analysed in Chapters 5 to 8. The documented references refer to the type of ware but not necessarily the exact vessel form of the excavated ceramic. The term 'painted' is used to denote hand painted decoration under the glaze and 'enamelled' for on- or over-glaze hand painted ware. It must be emphasised that the ceramics itemised in Ware and Date Tables are not comprehensive lists of all the wares used in the Cape since 1652.

In order to avoid classifying too many highly fragmented sherds as unprovenanced or of uncertain form, assumptions were made about the probable country of origin and the form of several ware types, particularly stoneware and coarse earthenware sherds. These conjectures were based on information gained from the examination of a wide range of Cape colonial assemblages and documents, and from the general background history of the Cape, and will be individually discussed within the relevant categories.

1. PORCELAIN

ASIAN PORCELAIN [1.1]

Far Eastern: Chinese export porcelain [1.1.1] - CPO

The majority of the excavated Chinese fine porcelains are medium to good quality export wares specially ordered for the European market and manufactured in Jingdezhen (maps in Figures 4-2 & 4-4). The exceptions include large dishes originally made for the Near Eastern markets, some with Islamic style decoration, which were bought by European merchants and which eventually became part of their regular purchase orders (Krahl *et al.* 1986:1024, no. 2207; 1026, no. 2213). Another exception is a small dish, found in the Castle Moat, which has been identified as Qing domestic Transitional ware, produced for use within China in the second half of the seventeenth century (Kilburn 1981:151, no 103). John Ayers, however, has stated that it can be difficult to distinguish early fine export ware from wares for the Chinese domestic market (Howard & Ayers 1978:62).

Chinese export porcelain ware-type categories are based on decorative styles described and named by Western scholars and collectors. The porcelain ware-types in Ware table are listed using a modification and extension of Jörg's classification of the porcelains officially exported to the Netherlands during the period 1729-1795 (Jörg 1982:226). This has proved to be a satisfactory method of recording the changes in decoration of the excavated Chinese export porcelains that took place during the period under discussion. It will also allow direct comparison of Chinese porcelain assemblages from Cape sites with the porcelain ordered by the VOC for Europe.

The vessel forms of the excavated Chinese export porcelains include table plates and serving dishes, a wide range of different sized bowls and dishes, teawares and very small quantities of ornamental items and specialised tablewares.

Underglaze blue [1.1.1.1] is by far the most common decorative type for Chinese porcelain throughout the whole time period under discussion, and forms the largest ceramic category in eighteenth century assemblages. Ware Table makes no allowance for recording differences in the composition of the body. All Chinese porcelain is assumed to be 'hard' paste but when 'soft' paste bodies are identified, this important information is recorded in the Site Catalogue. Date Table provides a limited chronology

for rim border patterns on blue-and-white Chinese porcelain plates which helps to categorise this large decorative category into smaller meaningful groups (Appendix F).

Underglaze blue and enamels [1.1.1.4-5], also known as Chinese Imari, is classified separately from the other enamelled wares, following Jörg's classification. The most common vessel forms in this category are cups, saucers, and occasional table plates (ELS-dbyc/CPO.110-119).

Brown-glazed ware [1.1.6-13] items are initially recorded together regardless of their secondary decorative attributes, but Ware Table makes allowance for subdivision into decorative categories including decoration in panels (Batavian ware) when this is required. Vessel forms include cups, saucers, medium-sized bowls and lidded pots and jars (ELS-dbyc/CPO.125-146).

All varieties of **Enamel only** [1.1.1.14-26] wares are classified together for the purpose of overall ware-type frequency analysis, but provision is made for most individual wares to be assigned to a number of specifically dated groups: **famille verte** (the Granary F2-7/CPO.6); **red / red & gilt / red, gilt & black** (Bree St - not illustrated); **famille rose** (Elsenburg ELS dbyc/CPO.154-194), **encre de Chine** (Sea St JAM6-2/CPO.64); **simple borders, bands & lines** (Sea St, JAM6-2/CPO.60-63), and **Other**. These groupings are based on classifications used by Regina Krahl (Krahl *et al.* 1986) for the Topkapi Saray collection, and adaptations of the decorative categories used by David Howard (Howard 1974) for the classification of British armorial porcelain. If enamelled porcelains are correctly identified, many of these categories can provide reliable *termini post quem* for archaeological assemblages. The most common enamelled vessel forms in the Cape are teawares, especially those manufactured in the late eighteenth century (Sea St, JAM6-2/CPO.60-63).

Three different categories have been provided for undecorated fine Chinese porcelain. **White undecorated** [1.1.1.27] refers to white completely undecorated items, usually finely potted small bowls and saucers (Elsenburg ELS-dbyc/CPO.198-200). Care must be taken with this category, as sherds from minimally decorated enamelled items can be mistaken for undecorated wares. **Dehua** (*blanc de Chine*) [1.1.1.28] covers the small figurines (some incorporating whistles) made for the Dutch market as well as Buddhist lions and figures of Guanyin (Castle, F1; Howard & Ayers 1978:90-101). **Undecorated / Undiagnostic** [1.1.1.29] includes two varieties of undecorated porcelain sherds; those

with a bluish caste to the glaze from vessels that were completely or partially decorated in underglaze blue, and pure white sherds from undecorated vessels or vessels decorated with overglaze enamels only.

Allowance is made for less commonly occurring types of Chinese porcelain. **Monochrome** [1.1.1.30] includes all the overall ground glaze colours except brown - for example, blue, yellow and celadon green. Blue monochrome sherds are often decorated with gilt (Bree St Phase 1, Appendix I.1).

Far Eastern: Asian market ware - coarse porcelain & later refined wares [1.1.2] - CPW

This category incorporates all the coarse and less refined porcelain and porcelaneous bowls and dishes made for the Asian market (especially Southeast Asia - see map in Figure 4-2), that are found on Cape colonial sites (see Appendix L & Appendix J). The term 'coarse porcelain' is used in contemporary VOC documents and Cape probate records. Poor quality or second grade Chinese export porcelain is not included in this category and are classified with the good quality export porcelains.

It has been possible to identify a number of coarse porcelains exported from specific kiln areas in the southern provinces of China (especially Fujian), Vietnam and Japan (Ho Chuimei pers. comm.) (see map in Figure 4-4). All the coarse porcelains are recorded in Ware and Form/Function Tables according to their decorative and formal attributes only, and not by area of production or body type. The majority of them are blue-and-white bowls and dishes, **Underglaze blue** [1.1.2.1], (Sea St JAM6-2/CPW.1-30), and the remainder are **Enamelled** [1.1.2.2], usually enamelled in green and red alone (Sea St JAM6-3/CPW.15). To date, only two items of **Monochrome / incised** [1.1.2.3] have been found (Oudepost 1, Appendix I.1). The remaining Asian market ware categories are **Undiagnostic / undecorated** [1.1.2.4] and **Other** [1.1.2.5].

Outside Asia, large quantities of Asian coarse porcelain are most commonly found where ethnic Chinese communities were established. For example, nineteenth century Chinese American sites on the east coast of the United States (Garaventa & Pastron 1983). However, this type of ceramic constitutes a major component of European colonial sites at the Cape of Good Hope during the VOC period (1652-1795) and will be discussed at length in Chapter 4.

Far Eastern: Japanese export porcelain [1.1.3] - JPO

Ware Table lists five ware-types in this category: **Underglaze blue** [1.1.3.1], **Underglaze blue & enamels** [1.1.3.2] (Eisenburg ELS-dbyc/JPO.14-21), **Enamels only** [1.1.3.3] (Eisenburg ELS-dbyc/JPO.22-27), **White** [1.1.3.4] (Eisenburg ELS-dbyc/JPO.28), and **Undecorated / undiagnostic** [1.1.3.5]. The final category is **Other** [1.1.3.6]. No attempt has been made to use well known classifications such as Arita, Imari and Kakiemon. These terms are only used and recorded in the site catalogues when individual items have been positively identified as such by recognised experts.

The majority of the Japanese export porcelain vessel forms identified so far are blue-and-white plates, dishes and chamber pots, and enamelled cups and saucers.

It was possible to make an accurate distinction between Chinese and Japanese porcelains in most cases, but it is conceivable that some sherds have been incorrectly classified. Experience and further research will help to rectify this problem, but the number of vessels involved is minimal and any re-identifications will not affect the overall characteristics of a ceramic assemblage.

Near East: Persian stone-paste 'porcelain' [1.1.4] - PPO

Persian stone paste is not a true porcelain and is categorised in the materials science classification as a white quartz paste (Table 3-1, Classification B). The seventeenth century stone-paste bowls and dishes found on Cape sites have been identified as Kirman-type and classified as Islamic wares (Lane 1957:68; Yolande Crowe pers. comm.). These vessels are examples of Persia's attempts to imitate Chinese 'hard' paste porcelain and the CCS classes them as such to facilitate research using contemporary VOC documents. The VOC bought several consignments of Persian 'porcelain' (stone-paste) between 1652 and 1682, when Chinese export porcelain for the European market was in short supply. Persian stone-paste formed the first official VOC consignment of ceramics to the Cape in 1666 followed by a further shipment in 1682 (Volker 1954:115; Chapter 1, Table 1-1).

Two sub-categories are used for Persian stone-paste: **Underglaze blue** [1.1.4.1] which often has the blue outlined in black; and **Underglaze polychrome** [1.1.4.2] for blue-and-white wares decorated with underglaze coloured slips, usually red and green. Blue-and-white stone-paste bowls and dishes have been excavated from the Granary (F2-2/PPO.1 & 2), the Moat of the Castle of Good Hope and at Oudepost 1 (Appendix I.1).

Polychrome bowls and dishes were found on the VOC ship *Oosterland* (1697) (Werz & Klose 1994).

EUROPEAN PORCELAIN [1.2]

Rare occurrence and high fragmentation have hindered a more accurate identification of the country of origin for most of the European porcelain sherds found on Cape sites, with the exception of English bone china. Ware Table provided the following classifications: **Continental European porcelain** [1.2.1], **British porcelain & bone China** [1.2.2] and **Unprovenanced European porcelain** [1.2.3]. Within these categories, the porcelains are further subdivided into five ware sub-types based on their prime decorative attributes: **Blue-and-white** [-.1] which would include painted and printed wares (Sea St, Manon's House, Appendix I.1); **Enamelled** [-.2] (the Granary, F2-7/EPO.2); **White & gold** [-.3] (Barrack St, BAS-2/EPO.1); and **Undecorated** [-.4] and **Other** [-.5 & -.6]. Other-lilac sprig is in the bone china category only (Barrack St, BAS-2/EPO.2 & 3).

The identification of European porcelains is a very specialised field and no attempt has been made to classify them as either 'hard' or 'soft' paste varieties, but where the body can be positively identified it is recorded in the Site Catalogue. For the sites under discussion, it has been assumed that all the 'hard' paste porcelain sherds are of continental European manufacture. Excavated nineteenth century bone china is often crazed and yellowish in appearance and can be confused with other types of ceramics.

The European porcelains found in the Test Group of Cape colonial sites are predominantly teawares and medium sized dishes.

2. STONEWARE

ASIAN STONEWARE [2.1]

Far Eastern stoneware: Chinese / Japanese / Other countries - OST

The excavated Far Eastern stoneware is assumed to be of Chinese origin unless proved otherwise. The categories are: **Glazed / partially glazed** [2.1.1.1], usually martevans and jars (Sea St, JAM6-2/OST.1); **Yixing** [2.1.1.2], fine unglazed red stoneware, mostly teapots (Eisenburg, ELS-dbyc/OST.4-6); and **Japanese** [2.1.1.3], where only *donabe*

(brown-glazed footed cooking pots) have been identified so far (Elsenburg, ELS-dbyc/OST.7).

While it is possible that some unglazed red-bodied stoneware sherds recovered from pre-1800 Cape sites are European, all the sherds which have to date been positively identified are of Chinese origin. The first European imitations of Yixing were made at Delft, ca.1680 (Lo 1986:250), but the easy availability of Far Eastern ceramics in the Cape during the seventeenth and eighteenth centuries made it unlikely that colonists would have imported the more expensive European copies of Yixing tea pots (Christiaan Jörg pers. comm.). It is possible to distinguish between sherds of Chinese and European manufactured vessels but the process requires sophisticated analytical methods (Anders *et al.* 1992).

EUROPEAN STONEWARE [2.2]

The analysis of European stoneware in the CCS is based on the following assumptions: the fragments of mottled brown, or grey and blue salt-glazed wares on seventeenth and eighteenth sites are from northern Europe, while white salt-glazed and all commercial stonewares in late eighteenth and nineteenth century assemblages are probably British. Liquid-glazed stonewares from nineteenth century sites are also British (Robin Hildyard pers. comm.).

German / Rhenish salt-glazed stonewares [2.2.1] - EST

The Rhenish stoneware sub-categories chosen from the analysis of Cape ceramic assemblages are as follows: **Brown salt-glazed Frechen-type** [2.2.1.1] such as bellarmine jugs or similarly shaped vessels (the Granary, F2-1/EST.1); **Grey salt-glazed Westerwald-type** [2.2.1.2] for grey stonewares often with incised, stamped, sprigged or cobalt (sometimes manganese) painted decoration (Sea St, JAM6-2/EST.7 & 8); and **Other salt-glazed** [2.2.1.3], to accommodate large brown salt-glazed storage jars with horizontal handles and eighteenth and nineteenth century mineral water ('gin') bottles (Sea St, JAM6-3/EST.1 & 2). Seventeenth to nineteenth century continental European stonewares, with the exception of some late nineteenth century French wares, are always salt-glazed (Robin Hildyard pers. comm.).

British stoneware [2.2.2] - EST

Excavated British stoneware is divided into the following sub-categories: **Staffordshire white salt-glazed** [2.2.2.1], small bowls and press-moulded plates (Sea St, JAM6-

2/EST.6); **Staffordshire white salt-glazed - 'scratch blue'** [2.2.2.2], small bowls and thickly potted chamber pots (Sea St, JAM6-2/EST.7); and **Brown salt-glazed** [2.2.2.3], storage jars and bottles but excluding **Commercial / industrial** [2.2.2.4], pots, jars, shop pots and bottles made specially for commercially produced food and drink, and non-food products such as ink and polish. Commercial stonewares often have the name of the manufacturer impressed on the outside of the container (Barrack St, BAS-3/EST.1-4).

The remaining British stonewares include **Basalt & Cane** [2.2.2.5], teapots and milk jugs (Sea St), **Redware** [2.2.2.6], **Jasper / jasper-type** [2.2.2.7] and **Feldspathic & 19th century stonewares** [2.2.2.8]. These are all refined products and were mainly used for teapots, sugar pots and milk jugs, except for the '19th century stonewares' which were manufactured in many colours and often used for moulded jugs (Rumsey 1987). British stonewares can be salt-glazed, liquid-glazed, unglazed or a combination of these glazing techniques.

Staffordshire white salt-glazed wares (2.2.2.1 & 2) and the other refined stonewares (2.2.2.6-9) are given an alternate classification under Refined Wares (5.1) for the following reasons. White salt-glazed stoneware was developed and produced in Staffordshire during the first quarter of the eighteenth century as a result of the potters' experimentation with various ingredients to find a white-firing ceramic that could emulate the characteristics of porcelain. Its use included the manufacture of elegant moulded tablewares and teawares, thus designating it as a refined ware in the CCS classification. White salt-glazed stoneware was also used for the production of thick utilitarian hollow ware vessels, such as chamber pots, which equates it with similarly shaped brown salt-glazed wares in the European stoneware category. The other refined stonewares, basalt, cane and Jasper (2.2.2.5 & .7), were developed alongside refined white earthenwares in the second half of the eighteenth century and can thus be classified as British refined wares (5.1). Although redware (2.2.2.6) was first produced in England in the late seventeenth century, its manufacture was revived and improved in the eighteenth century and thus can be grouped with the other eighteenth century British refined stonewares.

European stoneware - unprovenanced [2.3] - EST

This category is used for unprovenanced salt-glazed vessels.

3. COARSE EARTHENWARES

Most of the coarse earthenwares from Cape colonial sites are **European-style coarse earthenware** [3.1] with smaller amounts of **African & Asian earthenwares** [3.2] and **Unprovenanced earthenware** [3.3].

The European-style coarse earthenware found on colonial sites has two possible areas of manufacture, Europe and the Cape, and is classified accordingly: **European manufactured coarse earthenware** [3.1.1] and **Cape (colonial) manufactured coarse earthenware** [3.1.2]. A third category, **European & Cape manufactured (European-style) coarse earthenware** [3.1.3], is required because of the present difficulty in positively distinguishing between the sherds of some of the European and colonial produced wares. Preliminary results of recent research by Stacey Jordan on coarse earthenwares from the Castle Moat, a pre-1750 Cape assemblage, indicate that Cape manufactured wares were all manufactured from irregular particled red-firing clays with large visible inclusions whereas European manufactured wares were made from much finer red or white burning clays (Stacey Jordan pers. comm.). In addition, Cape wares are mostly plain or minimally decorated with incising, in contrast to European wares which are often enhanced with coloured glazes, slip decoration, scraffito, rouletting and incising (Abrahams 1994).

European manufactured coarse earthenware [3.1.1] is recorded using the following sub-categories: **red body** [3.1.1.1], (the Granary, F2-1/CEW.4); **'white' body** [3.1.1.3], (the Granary, F2-1/CEW.6 & 7) and **glazed hard red body** [3.1.1.5], which falls midway between coarse and fine earthenware and may eventually be re-categorised within the Refined Ware category. Excavated examples are black-glazed bowls and jars (Barrack St, BAS-2/CEW.1). The remaining categories for European manufactured coarse earthenwares are **Terra-cotta** [3.1.1.6], unglazed wares, and **Other** [3.1.1.7], for unclassified wares. If any of these wares are decorated, it is recorded and described in the site catalogue.

At present, Ware Table uses only two categories for **Cape manufactured (European-style) coarse earthenware** [3.1.2], namely, **Red body** [3.1.2.1] and **Other** [3.1.2.2]. European & Cape manufactured coarse earthenwares [3.1.3] use the same sub-categories as European manufactured wares [3.1.3].

The majority of coarse earthenware forms found on Cape sites are undecorated kitchen utensils such as footed cooking pots and pans, basins, and colanders, as well as chafing dishes and *vuurtestjes*. Late seventeenth and early eighteenth century sites have Niederrheinische plates and dishes decorated with incising, rouletting and coloured slips (the Granary, F2-7/CEW.16-18).

The **African / Asian coarse earthenware** category [3.2] includes **Khoi pottery** [3.2.1.1], a sub-category of **African earthenware** [3.2.1]. It is a low-fired ware, made by the indigenous people of the southern Cape region in the form of cooking pots and jars with rounded or tapered bottoms. Widespread production of this ceramic only lasted in the Cape region until ca.1713 but it was possibly made in remote areas until the late eighteenth century (Andrew Smith pers. comm.). It has been found in the lower layers of seventeenth century colonial sites (the Granary, F2-1).

The **Asian earthenware** [3.2.2] category accommodates vessels that have been tentatively identified as Indian by researchers who have found these earthen wares on seventeenth century wrecks of European ships that called at Goa in the seventeenth century (Sassoon 1982; Werz & Klose 1994). Amy de la Torre identified somewhat similar vessels from the *San Diego* (1600) as Calatagan pottery from the Philippines (de la Torre 1994:252-55). Micaceous and slipped earthenware sherds found at the Granary are similar to those found on the wreck of the *Oosterland* (1697) (Werz & Klose 1994) and the *São Gonçalo* (1630). They all match the description of Calatagan pottery from archaeological sites in the Philippines given by Mijares and Jagoon (1996:45).

Unrecognised earthenwares awaiting identification are recorded as **Unprovenanced African / Asian earthenwares** [3.3] with subdivisions into **Coarse body** [3.3.1.1] and **Fine body** [3.3.1.2]. The examples found so far are all hollow wares.

4. TIN-GLAZED WARES (ENGOBES)

EUROPEAN TIN-GLAZED EARTHENWARES [4.1] - TEW

It has been assumed that the tin-glazed earthenwares are European manufactured and the majority are probably Dutch. The small size and poor condition of the sherds have made it difficult or impossible to provenance most of the excavated vessels. Tin-glazed vessels are classified under the heading **Provenanced & unprovenanced European tin-**

glazed ware [4.1.1], with the following sub-categories: **White undecorated** [4.1.1.1], lobed dishes, flat-rimmed plates and dishes, and apothecary's ware (the Granary, F2-7/TEW.1-2); **Blue & white** [4.1.1.2], plates, teawares and apothecary's ware (the Granary, F2-7/TEW.3, F2-1/TEW.3, Elsenburg, ELS-dbyc/TEW.6-10); **Other colours / polychrome** [4.1.1.3], teaware (the Castle Moat, Appendix I.1); **Brown glazed (Rouen)** [4.1.1.4], thickly potted dishes (Barrack St, BAS-4/TEW.3); and **Undecorated / undiagnostic** [4.1.1.5].

The majority of the identified forms from seventeenth and eighteenth century sites, which include white scalloped dishes (Baart *et al.* 1990/92) and blue-and-white teawares and plates, are almost certainly Dutch faience (Korf 1981). Two different types of decorated wares are found on sites dating to the second half of the eighteenth century: large, shallow brown-backed dishes decorated in blue and black made in Rouen (Noël Hume 1970:141), and plates and dishes with a broad blue band painted around the rim (Noël Hume 1970:142). Other forms include white undecorated plates, chamber pots, and apothecary's jars and pots.

5. REFINED WARES

EUROPEAN REFINED WARES [5.1] - REW

Ware Table classifies all the Refined Wares as British, although English-style refined white earthenwares were being produced in small quantities in many European countries, including the Netherlands, by the end of the eighteenth century (Towner 1957:59; Kybalova 1989:107). British refined earthenwares dominated the world export trade in household ceramics from the second half of the eighteenth century to the end of the nineteenth century. Britain was the main source of supply of ceramics to the Cape after 1815 once it became a Crown Colony.

British refined earthenwares, also known as Staffordshire wares, rarely occur on mid to late eighteenth century Cape sites and are only recorded in probate inventories at the end of the eighteenth century (Antonia Malan pers. comm.). During the first decades of the nineteenth century they oust Chinese porcelain as the dominant ceramic type in excavated Cape assemblages. Isolated single vessels have been found on earlier sites, such as a fine red earthenware bowl at Elsenburg Manor House (ca.1740-60) and a blackware bowl at Oudepost 1 (Appendix I.1). The change in ceramic wares on colonial

sites occurs during the move from VOC rule to full British control of the Cape. In order to distinguish the changes in material culture that took place during this transition, particular attention has been given to the identification of ware type, decoration and vessel form of all the ceramics discarded during this thirty year span.

Ware Table classifies late eighteenth and early nineteenth century British refined ceramics by ware: Cream coloured ware, Pearlware, White-bodied wares with a clear glaze, Other refined wares and Refined stonewares. This emphasises the chronology of refined white earthenwares and white-bodied wares, but divorces them from how they were retailed, used and perceived by retailers and purchasers. To partially overcome this problem, Ware Table takes cognisance of the system advocated by Miller and subdivides the three 'white' refined ware categories (Cream coloured ware, Pearlware and White-bodied wares) into identical decorative categories and incorporates, where possible, the potters' and merchants' terminology for these ceramics (Miller 1991 & 1993). This simplifies the combination of 'white' refined ware categories by decoration when required for specialised analysis. For example, to compare excavated assemblages with contemporary potters' and merchants' lists, or for socio-economic scaling techniques.

The identification and classification of British refined white earthenwares has always been controversial. Therefore, the development of cream coloured wares, pearlware and white-bodied wares and their relationship to other ceramics manufactured at the same time will be discussed in some detail before describing the individual ware sub-types within each of these categories.

There was a great demand for white wares in England at the start of the eighteenth century but the English potters were unable to make any light coloured fine table or teawares that could compete with Chinese porcelain (Halfpenny 1986:14). The North Staffordshire potters began experimenting with different clays and techniques to find an acceptable white-bodied pottery, and between 1725 and 1730 they began manufacturing a completely solid-white stoneware. This new ceramic, which required only one firing, became known as Staffordshire salt-glazed stoneware or English white salt-glazed stoneware.

From the end of the 1730s to the mid-1740s, the potters were able to take advantage of two new techniques, mould making and slip casting, to produce extremely finely potted, lightweight and elegant white salt-glazed wares which eventually became "the typical

English tableware of the mid-eighteenth century" (Noël Hume 1970:115). It was manufactured until the end of the eighteenth century and the initial popularity of this new ware caused a marked decline in the production of tin-glazed wares.

In the late 1740s to 1750s, the Staffordshire potters developed a completely new type of 'white' pottery known as creamware. It was a remarkable ceramic which not only superseded both white salt-glazed and tin-glazed wares but could "compete with porcelain in status" (Miller 1993:4). This new product had a refined white earthenware body covered with a pale yellow transparent lead glaze. The constituents of early creamware, white pipe clay and ground flint, were similar to those used for white salt-glazed stonewares, but it was fired at a much lower temperature, dipped in glaze and fired again. In the eighteenth century, its colour varied from deep creamy yellow to much lighter tones as "[i]ron impurities in the body varied with the quality of the ingredients, their preparation and the exact formula used" (Halfpenny 1986:14). The potters and merchants referred to the ware as 'cream coloured ware' and this term is used in the CCS. Using colour to assess the date of manufacture of cream coloured wares produced in the eighteenth and early nineteenth century is unreliable. Its colour fluctuated between cream and almost white from ca.1760 to ca.1820 and after this date it gradually became indistinguishable from many other white-bodied wares developed and produced during the nineteenth century (David Barker pers. comm.).

During the 1760s, the Staffordshire potters started manufacturing great quantities of cream coloured wares including beautifully enamelled tea and tablewares. English 'soft' paste porcelain was being produced at the same time but it was very expensive and was only used in wealthy English households. Cream coloured ware was vigorously and cleverly marketed by Wedgwood and, by presenting or selling it to royalty, he made it a fashionable ceramic in its own right which could vie with, and outshine, porcelain. He subsequently named it 'Queen's Ware' (Noël Hume 1970:124). Cream coloured ware's period of manufacture coincided with the age of Neo-classicism and it was an ideal medium to express this new style that was sweeping Europe in the second half of the eighteenth century. Initially, it was used on the tables of both the rich and the middle classes and was exported world-wide, especially throughout Europe and North America.

Cream coloured ware has been manufactured continuously in different versions of body paste and glaze from ca.1760 to the present day (David Barker pers. comm.). The novelty of this ware began to fade in the 1770s and the Staffordshire potters began to

search for a replacement. Two new ceramic wares evolved, both utilising refined white earthenware and a blue tinted glaze. The first to appear was 'China Glaze' in ca.1775, which made use of a blue tinted glaze over blue-and-white decoration on Chinese style vessels, to make a pottery that looked like Chinese porcelain. The second ware was Wedgwood's 'Pearl White' (ca.1779), again a refined white earthenware but using the pale blue tinted glaze with the intention of making the vessels white in appearance. Archaeologists and ceramic historians have since named these two conceptually different ceramic wares 'pearlware' (Miller 1993).

Miller, in his review of the classification of white earthenwares, links the introduction of pearlwares ('China Glaze' and 'Pearl White') to parallel new developments in the English porcelain industry (Miller 1993). The granting of sole patent rights to manufacture 'hard paste' porcelain from Cornish china clay (kaolin) and china stone to William Cookworthy in 1768, and later to Richard Champion (1774), prevented the use of these important raw materials by any other potter in Great Britain. The production of pearlwares only occurred after Wedgwood's successful petition to the British parliament in 1775 to permit the Staffordshire potters to use the same raw materials. The condition was that they did not utilise them to manufacture 'hard paste' porcelain and thus infringe Richard Champion's patent rights. Miller suggests that the 1775 ruling prompted several Staffordshire potters to use the Cornish china clay and china stone to manufacture pottery that *looked* like Chinese porcelain, namely 'China Glaze'. This ware "is the origin of pearlware" (Miller 1993:4). Wedgwood's 'Pearl White', which appeared about five years later (ca.1779), was made at the request of his business partner to develop a new product analogous to 'China Glaze'. However, Wedgwood described his new ware as a whiteware and something completely new, not an imitation of Chinese porcelain. It was basically a "creamware body, though modified by the inclusion of china clay, and which was covered with a glaze containing some china stone, but most importantly a small quantity of cobalt which gave a bluish caste to the glaze" (Lockett 1996:4). The names 'China Glaze' and 'Pearl White' did not catch on, and later scholars used the generic term pearlware to describe both these products (Miller 1993:5).

The appearance and composition of pearlwares were never static. The amount of cobalt in the glaze was gradually decreased during the first half of the nineteenth century, making pearlware indistinguishable in appearance from other nineteenth century whitewares (Miller 1980:16). Production of 'white' pearlwares continued into the twentieth century (Miller 1993:5).

Another type of whiteware manufactured by Wedgwood in the first decade of the nineteenth century had a clear glaze and is known as Whiteware. It is thought to have been developed to compete with English bone china which had become very popular at

the beginning of the nineteenth century (Miller 1980:17). English bone china was developed in Staffordshire at the end of the eighteenth century. When new, it is very white in appearance and does not have the bluish caste of most Chinese porcelain, although many Chinese enamelled wares have a pure white body and glaze. In the ground, early bone china becomes crazed and yellowish in appearance.

Refined white earthenware technology continued to advance. From the second decade of the nineteenth century onwards, pearlware and cream coloured ware appear to merge together and become indistinguishable in appearance from the new clear glazed white earthenware (Miller 1993:5). Numerous other white-bodied wares with varying degrees of vitrification were developed and produced throughout the nineteenth century, including stone china, first patented ca.1800 (Godden 1990:172); Mason's ironstone, manufactured from ca.1813 (Godden 1992:136); and white granite ware produced ca.1840 (Miller 1993:6). These wares will be the subject of future research and will not be discussed in detail in this dissertation.

Cream coloured ware [5.1.1] - REW

Only vessels identifiable by a definite cream colour, or which contrast with pearlware or whitewares, are recorded in the CCS as cream coloured ware. Very little decorated cream coloured ware has been excavated in the Cape and most of the identified items are undecorated plates, dishes, bowls and chamber pots.

The cream coloured categories are as follows: **Undecorated, plain rimmed** [5.1.1.1], undecorated wares such as bowls, chamber pots, and plates and dishes with flat or slightly concave rims (Sea St JAM6-3/REW.1-16, JAM6.4/REW.1 & 2; Noël Hume 1970: 116, Figure 35, nos. 4 & 5); **Undecorated, Queen / Royal rim** [5.1.1.2], undecorated plates and dishes with raised moulded rims (Sea St, JAM6-4/REW.3), **Undecorated, modified edge** [5.1.1.3], plates with feather, spearhead or shell edged (rare) rims (Noël Hume 1970:116 Figure 35, nos. 6, , & 8); **Painted or enamelled** [5.1.1.4], teacups decorated with simple designs in black or red (Sea St, JAM6-2/REW.24 & 25); **Printed overglaze black / red** [5.1.1.5], plate with central printed design (Sea St, JAM6-3/REW.19); **Printed underglaze** [5.1.1.6], none found; **Annular / dipped** [5.1.1.7], medium sized bowls (Sea St, JAM6-3/REW.21); **Lined - painted or enamelled** [5.1.1.8], plates with brown or olive green lines at the rim (Sea ST JAM6-3/REW.23); and two general categories, **Undiagnostic** [5.1.1.9] and **Other** [5.1.1.10].

Pearlware [5.1.2] - REW

This category includes two separate types of pearlware: 'China glaze' ware, manufactured between ca.1775 and ca.1812, identified by its Chinese style vessel forms and blue-and-white *Chinoiserie* decoration under a blue tinted glaze; and pearlwares (including Wedgwood's Pearl White) that was produced between ca.1780 and ca.1830, identifiable by the blue tint of its glaze only (Seidel 1990; Miller 1993:4-6). The identification of pearlware, excluding China Glaze, by its glaze alone can be misleading and highly subjective, but early pearlwares are associated with specific decorative styles and enamel colours. These include blue painted and printed *chinoiseries* and floral designs neatly painted in 'soft' early colours, namely, underglaze yellow, olive green, brown and blue (Lockett 1986 & 1996). Other decorative categories, such as shell edged and annular wares, appeared in creamware and whitewares and it is often extremely difficult to distinguish between them even when the sherd includes a footring showing the presence of a blue tinted glaze. Where doubt exists in the identification of pearlware, the sherds or vessels are classified as Whitewares.

The Pearlware categories are as follows: **Painted blue** [5.1.2.1], blue-and-white cups, saucers, bowls, saucer dishes and plates painted in *Chinoiserie* style (Sea St, JAM-6/REW.28-35; Roussel 1982; Lockett 1986 & 1996); **Painted other** [5.1.2.2], underglaze designs painted in colours other than blue alone (Sea St, JAM6-2/REW.37); **Enamelled** [5.1.2.3], cups, bowls, teapots painted in 'soft' early colours; **printed underglaze blue - Willow pattern** [5.1.2.4], tablewares; **Printed underglaze blue** [5.1.2.5] table and teawares, toilet wares (wash basins, ewers etc.) (Coysh & Henrywood 1982, 1989; Copeland 1990); **Printed underglaze colour** [5.1.2.6], tablewares; **Modified edge** [5.1.2.7], blue and green shell edged plates and dishes, tureen (Sea St, JAM6-3/REW.60; Sussman 1977; Miller 1990); **Annular / Dipped** [5.1.2.8], medium sized bowls; **Spatter** [5.1.2.9], bowls (Majewski & O'Brien 1987:161)). The final categories are for **Undecorated** [5.1.2.10], **Undiagnostic** [5.1.2.11], and **Other** [5.1.2.12] is for identified wares that have not been individually listed.

Excavated, recognisable pearlware forms are dominated by bowls and teawares, mainly blue-and-white hand painted and printed wares, and a small number of painted and enamelled teawares.

White-bodied Wares - clear glaze [5.1.3] - REW

Ware Table in its present form records the ceramics from the seventeenth to early nineteenth centuries with a high degree of precision but cannot do the same for all British white-bodied wares developed and manufactured during the nineteenth century from ca.1805 onwards. There is considerable debate about the archaeological definition of a whiteware (Miller 1993) and the term 'white-bodied ware' will be used. Nineteenth century British white-bodied wares include: clear glazed white refined earthenwares made from 1805 onwards (des Fontaines 1990:4); stone china, first patented ca.1800 (Godden 1991:116); ironstone, manufactured from 1813 (Godden 1992:136), white-bodied creamware and pearlware with a clear glaze that were manufactured after ca.1820-30, and white granite ware, produced ca.1840 (Miller 1993:6). Ware Table can be used in the primary analysis of nineteenth century sites. It records clear-glazed non-vitreous, semi-vitreous and vitrified white-bodied wares by decoration only, but if a specific ware is identified it is recorded in the site catalogue. An earlier version of Ware Table combined pearlwares and white-bodied wares in one category but this was rejected as it could disguise valuable chronological information provided by China Glaze and positively identifiable pearlwares. The CCS method of categorising refined white earthenwares and other white-bodied wares together, however, leads to an under-representation of pearlwares.

White-bodied ware categories include: **Painted blue** [5.1.3.1]; **Painted other** [5.1.3.2] for polychrome decoration or designs painted in a single colour other than blue; **Enamelled** [5.1.3.3], bowls with 'harsh' colours sometimes known as 'peasant ware'(Barrack St Well, BAS-1/REW.1)); **Printed overglaze** [5.1.3.4]; **Printed willow pattern** [5.1.3.5], tablewares and a few teawares; **Printed blue** [5.1.3.6], tea and tablewares; toilet wares (JAM6-3/REW.41-47); **Printed underglaze colour** [5.1.3.7], tea and tablewares (Barrack St, BAS-1/REW.11-27); **Printed & enamelled** [5.1.3.8], jugs (Sea St, JAM6-3/REW.52); **Printed flow** [5.1.3.9], table plates (Barrack St, BAS -1/REW.21); **Printed multi-coloured** [5.1.3.10], pot lids; **Modified edge (shell)** [5.1.3.11], plates and dishes (Barrack St, BAS-3/REW.55); **Annular / Dipped** [5.1.3.12], bowls (Barrack St, BAS-3/REW.31-34); **Spatter / Sponge** [5.1.3.13], plates, bowls, cups, saucers (Barrack St, BAS-3/REW.50-54); **Lined / Band & line** [5.1.3.14] plates, saucers (Barrack St, BAS-3/REW.56; Miller 1991: 12-15)); **Gold only** [5.1.3.15], lined or banded white teawares; **Relief decoration only** [5.1.3.16], plates. The remaining categories, **Other** [5.1.3.17], **Undecorated** [5.1.3.18] and **Undiagnostic** [5.1.3.19] cater for any remaining unclassified white-bodied wares.

Other Refined Earthenwares [5.1.4] - REW

This category of refined earthenwares made in Britain in the eighteenth and nineteenth centuries contains two separate groups of wares: refined earthenwares with coloured bodies (blackware, yellow ware) and modified white-bodied wares. The latter include wares with overall glazing, either in a single colour (monochromes) or multi-coloured (majolica-type), or wares with a tinted whiteware body covered by a clear glaze (tinted).

White-bodied wares with a white body completely disguised with a coloured glaze, and tinted refined earthenware bodies with a clear glaze, have moved away from the early influence of Chinese export porcelain and become a different type of ware altogether, and are therefore included with vessels made from naturally coloured refined earthenwares.

Other Refined Earthenware categories are as follows: **Early fine red earthenware** [5.1.4.1], bowls (Elsenburg ELS-dbyc/REW.1; Barker & Halfpenny 1990:23-30)); **Blackware / Jackfield** [5.1.4.2], teapots and matching jugs (Sea St, JAM6-3/REW.50; Noël Hume 1969:124-5)); **Lustre** [5.1.4.3], this category is for wares where the lustre is the primary form of decoration and not a secondary embellishment such a rim or special details picked out in lustre (Godden 1974: 214-221); **Yellow ware (including annular wares)** [5.1.4.4] yellow to putty coloured body with a clear glaze, kitchen wares decorated with annular rings (Barrack St, BAS-3/REW.35); **Teapot ware** [5.1.4.5] a brown to red earthenware body covered in a brown or clear glaze, teapots (Barrack St, BAS-3/REW.57); **Tinted body** [5.1.4.6] tea and tablewares with body tinted pale blue, green, orange, pink and covered with a clear glaze (Sea St, JAM6-4/REW.37; City Art Gallery, Stoke-on-Trent, ca. 1820s-30s onwards)); **Monochromes** [5.1.4.7], green glazed moulded plates, (Barrack St, BAS-1/REW.39); **Majolica-type** [5.1.4.8], figurines; **Undiagnostic** [5.1.4.9] and **Other** [5.1.4.10].

Refined stonewares [5.1.6] - REW

This category includes the refined stonewares developed in Britain (Staffordshire) after ca.1760 as well as the earlier redware and Staffordshire white salt-glazed stoneware used for table and tea wares.

The categories include: **Staffordshire white salt-glaze** [5.1.6.1], moulded rimmed plates (Sea St, JAM6-2 REW / EST.6; Mountford 1971; Noël Hume 1970:114-117 Figure 35, nos. 1-3) and its derivative '**Scratch blue**'- **fine** [5.1.5.2] small bowls (Noël Hume 1970: 117); **Basalt / Cane** [5.1.6.3], tea pots and sugar bowl (JAM6-3/REW.65; Godden 1974

(1990):164-5); **Fine redware** [5.1.6.4] (none identified); **Jasper / Jasper-type** [5.1.6.5] (none found); **Feldspathic stoneware & 19th C. stonewares** [5.1.6.6] moulded Castleford teapots and white or coloured moulded jugs; **Other** [5.1.6.7].

Miscellaneous [6.0]

The final category in the CCS contains miscellaneous ceramic items. These include dolls, dolls' tea sets and toys such as whistles, as well as decorative wall tiles. The MNVs are not calculated for this category and are not included with the other categories in comparative analysis tables.

Minimum vessel analysis

The CCS uses minimum vessel analysis for quantifying the number of vessels (MNV) in an assemblage. It is based on the concept behind a method used to quantify taxonomic abundance in faunal analysis (Klein & Cruz-Urbe 1984). It shares many of the same problems associated with this technique, namely, its accuracy is affected by the size and quality of the sample and it is a subjective and time consuming procedure. An MNV estimate can be defined as the minimum number of vessels necessary to account for all the sherds in an assemblage (after Klein & Cruz-Urbe 1984:26). It is estimated by using a modification of a technique described by Noël Hume for sorting and assigning sherds to individual vessels in order to locate cross-mends within a ceramic assemblage (Noël Hume 1969b:267)

Identification of vessel form and calculation of MNVs are carried out separately for each ware sub-type category. The two procedures can be carried out simultaneously as both use information from rim, footring and body fragments. Small to medium sized assemblages are analysed using Noël Hume's (1969b:267) technique of sorting sherds: first by tonal variation and then by form (identification of vessel form). Following this, each formal group is divided into rims, bases, handles and body fragments which are sorted and assigned to individual vessels (MNV). A slightly different technique is required for estimating the MNVs of very large assemblages. It is easier to start by using the rims and footrings alone, before looking at the other fragments using Noël Humes' sorting technique to find sherds of vessels that are not represented in an assemblage by the rims or footrings. Such sherds are named 'fragment types' (Noël Hume 1969b:267).

The MNV of a ceramic assemblage can therefore be described as the sum of either the rims or footrings from individual vessels, whichever is the greater, to which is added the sum of the fragment types.

During the analysis of the Cape sites, it became obvious that the size of an assemblage and the degree of fragmentation of the sherds could adversely affect the estimation of the MNVs. With high fragmentation, the ratio of the MNV to the sherd count tended to be inversely proportional to the size of the assemblage; the smaller the number of sherds, the greater the identification of individual vessels. This created problems with the analysis of very large groups of fragments, especially those comprising identical or minimally decorated vessels. This was overcome by calculating the MNVs from a randomly selected percentage of the rims (or footrings) and fragment types. The percentage chosen for this calculation was selected to give the largest possible sample that could be analysed satisfactorily.

Minimum vessel analysis is subjective. Arbitrary decisions have to be taken throughout the procedure which suggests that work done by different analysts would differ and not be comparable. Undecorated fragments were among the most difficult wares to analyse with any degree of confidence. In order to assess the accuracy of the MNVs calculated for this type of category, an assemblage of undecorated creamware was analysed independently by three analysts with varying degrees of expertise. The results showed that the total MNV remained reasonably constant but the identifications of the vessel shapes differed with each individual. This suggests that, apart from the obvious advantages of using experienced analysts, the accuracy of vessel identification is ultimately dependant on experience and the systematic use of an appropriate and accurately described vessel typology.

Careful examination of complete vessels, coupled with observations recorded during the analysis of the Test Group (Appendix I.1), have produced methods that can facilitate the identification of individual vessels. These are summarised in Appendix H.

Minimum vessel analysis is the cornerstone of ceramic analysis. Yentsch (1991a) used minimum vessel counts from sixteen north American sites and a modified version of Potomac Typological System (POTS), a system dependant on MNVs and described in the following section), to demonstrate that ceramic and faunal analysis can "yield information about incremental changes in everyday life and about its social dimensions and cultural

context" (1991a:52). Janowitz (1993) studied seventeenth century foodways in New Amsterdam/New York by using POTS with the addition of a number of Dutch vessel forms, such as *grapen*, skillets and colanders, to the vessel typology. Adams & Boling (1989) used MNVs, vessel form and Miller's ceramic scaling technique to investigate the relationship between ceramics and status by studying the ceramic assemblages of slaves and planters from three South Georgia plantations. Klein (1991) used the same type of information and techniques in her study of the differing social and economic contexts in which ceramics were manufactured, used and discarded in nineteenth century north America.

Classification by form and function

The next objective in the project was to classify the vessel shapes found on Cape colonial sites. The results are summarised in the Form / Function Table (Appendix G) and described in the text. The construction of the functional typologies was guided by Beaudry's (1983) account of the development of a vessel typology for seventeenth century north American colonial sites (the Potomac Typological System) as well as the later modifications to this system proposed by Yentsch (1990; 1991a).

The Potomac Typological System (POTS) was a milestone in the use and advancement of ceramic analysis in historical archaeology (Beaudry *et al.* 1983). It is a method of classifying vessel shapes based on the functional use of ceramics in foodways. The authors advocated the use of contemporary documents both to discover the names and functions of excavated vessels and to aid the interpretation of ceramic assemblages. They stated that the interpretation of ceramics needs "a scheme which will allow the systematic description and comparison of assemblages which, by attending to function in even a crude way, will allow a preliminary appreciation of just what sort of variation exists between assemblages in time and space" (Beaudry *et al.* 1983:19).

Beaudry and her co-authors advocated the use of standardised vessel nomenclature in ceramic analysis. Not only would this avoid having to describe or illustrate all the vessels in an assemblage but would facilitate functional interpretation of the ceramics. They began by studying the descriptions of named vessels mentioned in contemporary probate inventories and other historical documents. This information was used to reconstruct and record the size, shape, ware type and usage of the documented vessels. Following this, the vessels described in the documents were matched with the excavated vessels. Thus

they were able to construct a vessel typology and functional categories for the ceramics from a specific place and time period, namely, the ceramics from seventeenth century sites in the Chesapeake region in north America (Beaudry *et al.* 1983:29). This was a reversal of the archaeological practice of naming excavated vessels by their shape and giving them present day or antiquarian names, a method that has led to incorrect usage being attached to many excavated vessels.

POTS included drawings of these vessels and definitions of their usual function. Most of the names mentioned in the probate inventories were unambiguous but a number needed discussion, including the dish and basin categories (Beaudry *et al.* 1983:26-28). The descriptions of the categories used in the POTS typology provided a glossary of terms found in the probate records which enabled accurate comparisons to be made between the excavated and inventoried assemblages (1983:21).

POTS assigned the named vessels to six functional categories, primarily on the basis of their shape, and secondarily on function (Beaudry *et al.* 1983:29). Classification of the ceramics associated with food made a distinction between drinks and meals: the beverages category distinguished between vessels for individual use or for communal consumption and serving, while the ceramics used for food consumption were subdivided into vessels for individual consumption of either stews or solid food, or for serving. The authors were aware that some of the categories were too general to make observations about more specific vessel usage (Beaudry *et al.* 1983:28).

Anne Yentsch suggested modifications to POTS, dividing the food related activities into further categories which could be associated with particular social areas and groups of people. She also made additional divisions between food and drinks, including the separation of traditional drinks from the new beverages of tea, coffee and chocolate. She noted that this division provided a starting point for the ethnographic analysis of ceramic assemblages (Yentsch 1991a:63).

Identification of vessel forms excavated from Cape sites

Familiarity with examples of complete vessels, or access to suitable reference collections, is an advantage in formal analysis but high fragmentation can make it impossible to recognise vessel form, or only permit minimal identification as either hollow or flat ware. The present lack of a complete Cape vessel typology has hindered the formal analysis of

excavated vessels. Gabeba Abrahams has meticulously recorded and catalogued an eighteenth century assemblage of coarse earthenwares (Abrahams 1994). Stacey Jordon, currently completing her Ph.D. thesis on Cape coarse earthenwares, has extended this work to include European and locally produced coarse wares from seventeenth and early to mid-eighteenth century sites, the Granary and the Castle Moat (Stacey Jordon pers. comm.) Gabeba Abrahams has begun work on a vessel typology for mid-eighteenth century Cape colonial ceramic assemblages based on POTS (Abrahams 1996:193). A detailed and complete vessel typology for seventeenth and eighteenth century Cape sites will require extensive research into probate records and contemporary documents in the Cape, the Netherlands and the VOC stations in the Far East.

A combined English and Dutch terminology has been used for the naming of many of the items included in the CCS. Dutch terms, taken from seventeenth and eighteenth century Cape probate records, are used where there is no ambiguity in applying the term to an excavated item.

The functional categories used in the CCS follow POTS and Yentsch's (1991a:64-5) modifications of this system with the addition of two extra categories, Ornamental and Unidentified. These were used by Worthy (1982:339-340) in her construction of form and function categories for late nineteenth and early twentieth century ceramic assemblages from north American sites. The CCS categories are: **Cooking & food preparation**, **Food & drink storage**; **Food distribution & consumption**; **Drinking**: subdivided into **New beverages** and **Other beverages**; **Health & Hygiene**; **Utilitarian**; **Ornamental**; and **Unidentified**.

The CCS categories are listed with their associated vessels in the Form / Function Table (Appendix G). The vessels are recorded as MNVs of their ware type within a functional category. It is planned to extend Form Table, as indicated, to include vessels made in other materials, such as metal and glass, in order to aid the interpretation of the site.

The functional categories and related vessels are briefly described and explained in the following paragraphs using the categories used in Form / Function Table. The table can categorise all the excavated forms, even though it does not include all the named vessel forms used in the site catalogues, by utilising the 'Other' section within each functional category. The bar scale under the drawings is equal to 50mm. Dutch names for vessels are written in italics.

- The following illustrated vessels are Asian porcelain unless otherwise indicated.

1. Cooking and food preparation

The majority of the vessels in this category are undecorated coarse earthenwares. All sizes and types of flat-based and legged cooking pots have been grouped together under the heading **Cooking pot /pipkin/ skillet**. Fragmentation and the inconsistency of body and glaze colour for a single vessel have hindered the recognition of vessel shapes and the estimation of MNVs.

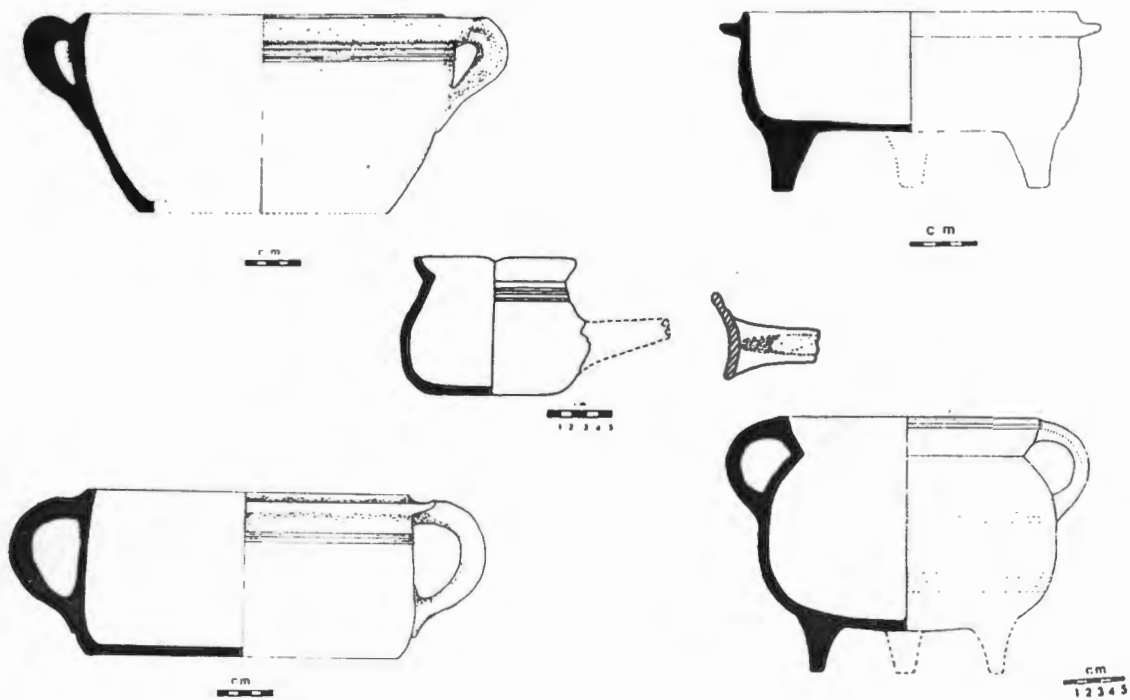

Figure 3-2: European-style coarse earthenware cooking pots (Abrahams 1994).

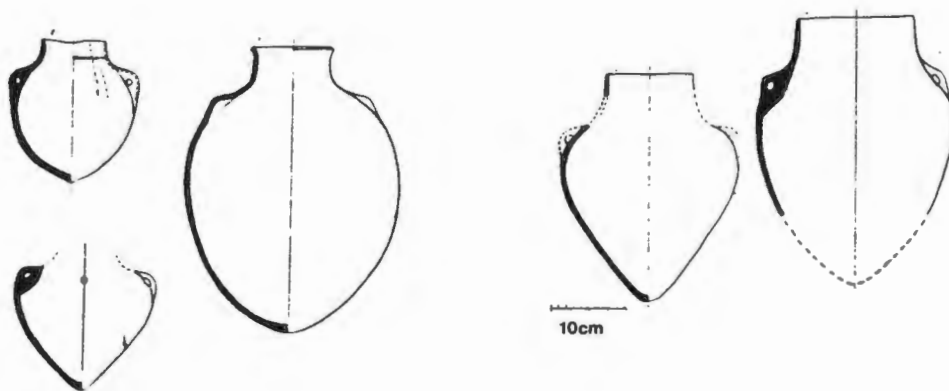

Figure 3-3: Khoi pottery from the south western Cape (Rudner 1968).

No attempt has been made to separate the items within the **Basin/bowl/dish** category. Many of the bowls could have been used for communal eating which was common amongst soldiers and sailors on board ships in the seventeenth and eighteenth centuries (Bruno Werz pers.. comm.). **Colanders** and most **Lids** can be easily identified.

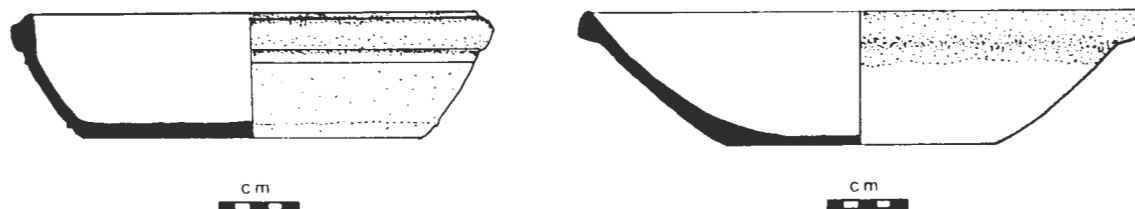

Figure 3-4: Coarse earthenware dishes & bowls (Abrahams 1994).

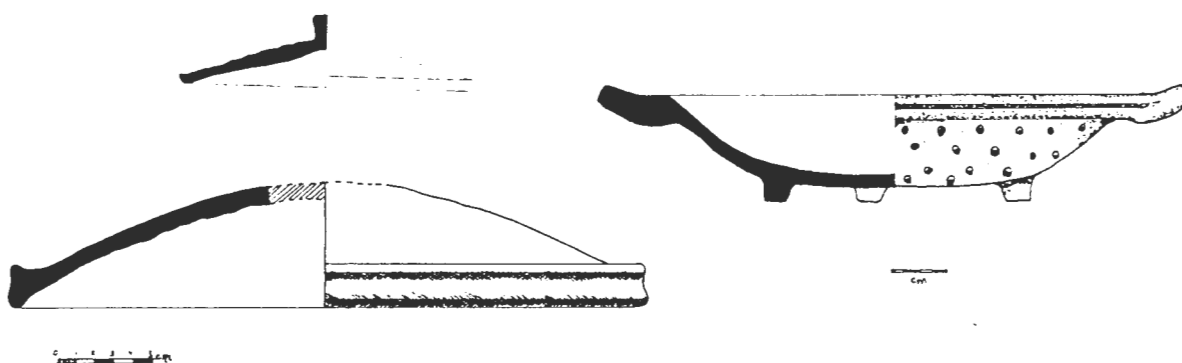

Figure 3-5: Coarse earthenware colander & lids (Abrahams 1994).

Japanese glazed stoneware footed cooking pots are tentatively included in this category. Excavated examples do not show any evidence of having been used on a fire so they possibly had another use in the Cape (Eisenburg ELS-dbyc/OST.7).

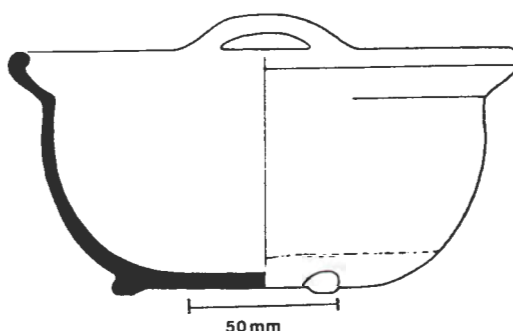

Figure 3-6: Japanese stoneware *donabe* (Japanese Archaeological Reports 1989; 1990)

2. Food and drink storage

The majority of these vessels on Cape sites are made from stoneware. **Jar/Martevan/Crock** category includes various sized Asian martevans (Appendix D), wide-mouthed European salt-glazed stoneware jars and the less numerous jars and pots made from coarse earthenware.

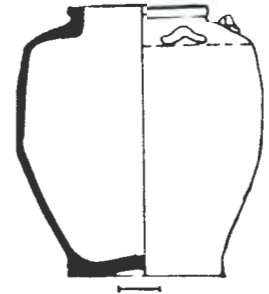
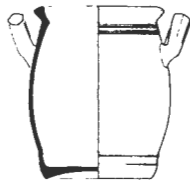
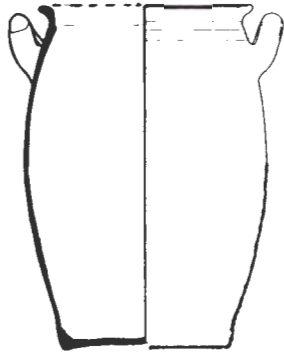

Figure 3-7: European stoneware jars (Thijssen 1991).

Figure 3-8: Chinese stoneware jar & martevan

The **Bottle / Jug / Bellarmine / flask** category usually includes German salt-glazed wares. They could be used for either storage of wine and spirits or other liquids, or purely for drinking. For this reason, they are given an alternative classification in the Drinking category. **Commercial / Shop pots** includes stoneware German mineral water bottles ('gin' bottles) and British nineteenth century stoneware beer and ginger beer bottles, as well as Shop pots, jars and pots which contained commercially produced food products. Nineteenth century Chinese porcelain 'ginger' jars are tentatively classified as storage vessels but many are attractively decorated and could have had an ornamental role in Cape households.



(Bellarmine)

Fig.3-9: European stoneware jugs.

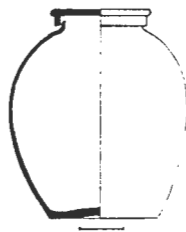

Fig.3-10: 'Ginger' jar



Fig.3-11: European stoneware mineral water or 'gin' bottles.

3. Food distribution / consumption

This is a combined functional category. It makes no division between **bowls, dishes and plates** used for individual consumption or food distribution, or between vessels for stews or solid food. This cannot be attempted until the diet of the seventeenth and eighteenth century colonists and slaves has been fully investigated. It is probably safe to assume that plates were for individual eating but small to medium porcelain bowls from earlier assemblages could have been for individual use or for the serving of pickles and relishes. Chinese porcelain bowls were sold as 'nests' (sets of graduated sized bowls) which could have been used for almost any purpose.

Plates and Deep plates (*vlakke, tafel* and *diep borden*) are rimmed and have diameters ranging from 220-260mm and can be round or angled. **Small plates** are less than 190mm in diameter. Although the small Chinese porcelain plates are probably under-dishes (*onder-schotels*) for bowls or tureens (Christiaan Jörg pers. comm.), no sub-classifications, into tea or desert types, are given for small plates made in other wares.

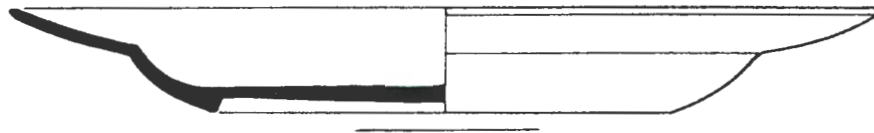

Figure 3-12: Table / dinner plate.

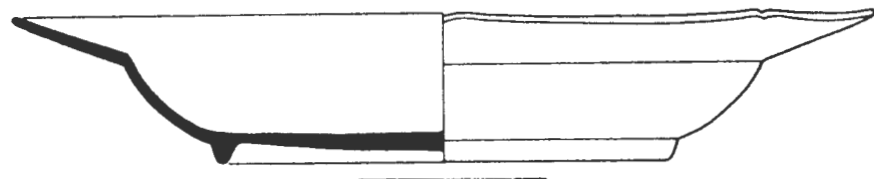

Figure 3-13: Deep / soup plate.

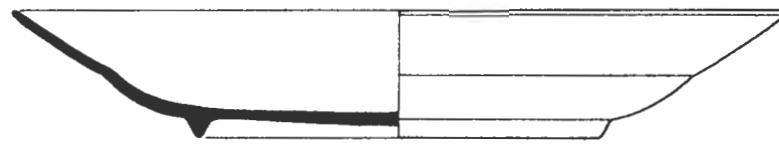

Figure 3-14: Flared rim plate.

Form / Function Table records bowls by size only. **Bowls** are classified according to their approximate rim diameter: **small** - less than 100mm; **medium** - approximately 150mm; **large** - greater than 200mm. The depth of the bowl is not taken into consideration. Unusual or specialised shapes are described in the catalogue.

These include: rimmed bowls (*klapmuts*) which are a sixteenth to seventeenth century Chinese porcelain form favoured by the Dutch (Rinaldi 1989:118), and square salad bowls with indented corners.

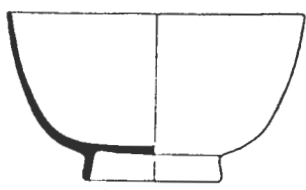

Fig. 3-15: Straight sided bowl.

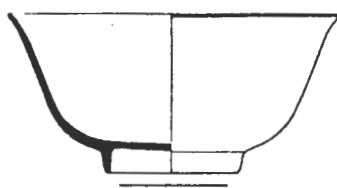

Fig. 3-16: S-shaped bowl.

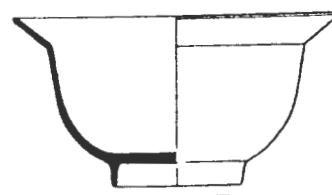

Fig. 3-17: *Klapmuts*.

Dishes are also classified by approximate rim diameter only: **small** - 150mm or less, **medium** - +/- 200-250mm and **large** - 300mm and larger. When specific shapes and forms are recognised, they are recorded in the catalogue. The following shapes of dishes occur on Cape sites: flat-rimmed dishes (*schotels*) are usually round but can be oval or angled, flared-rim dishes, saucer-dishes with a curved or s-shaped profile, and deep dishes usually oval or oblong with a narrow flat rim and approximately 70-100mm deep. Saucer-dishes (*pijnings*) are an eastern form and manufactured in both Chinese and Japanese fine and Asian market coarse porcelain. They occur frequently on Cape sites and could be related to the cuisine but considerable quantities of fine porcelain saucer-dishes were shipped to Europe in the mid- eighteenth and also formed part of dinner services shipped on the *Geldermalsen* (1752).

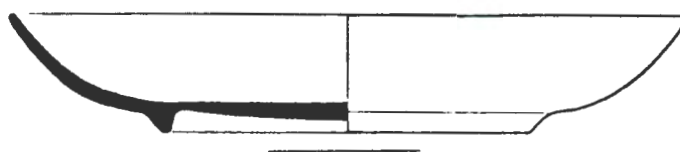

Figure 3-18: Saucer-dish.

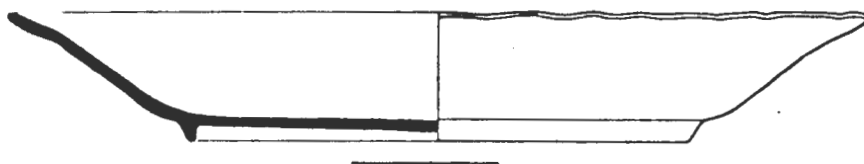

Figure 3-19: Flared-rim dish.



Figure 3-20: Flat-rimmed dish.

Dish/Bowl and **Dish/Plate** categories are for rim fragments where a positive division cannot be made between the two forms. **Hot water plates/dishes** are recorded separately. **Covered bowls/tureens/dishes** can be any shape or size and are often identified from the handles alone.



Fig. 3-21: Narrow rimmed deep dish

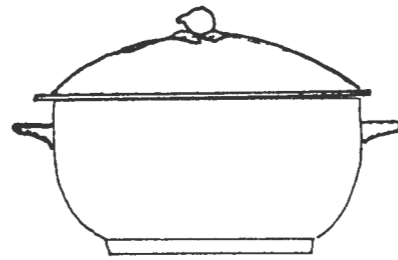

Fig. 3-22: Covered bowl / tureen

Various sized **Lidded pots / jars (potjies)** are common Far Eastern forms and could have had diverse uses in food distribution. **Hot water plate / dish** is a specialised shape.

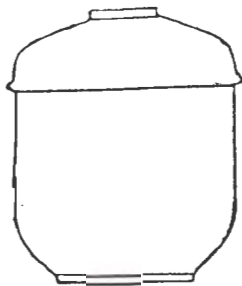

Fig. 3-23: Lidded jar.

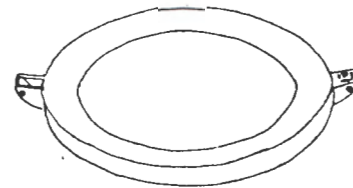

Fig. 3-24: Hot water plate/ dish.

Another group of excavated table wares include salts, lidded mustard pots, pepper pots and Japanese porcelain vinegar bottles, possibly for soy or vinegar. These are classified together as **Condiments**.

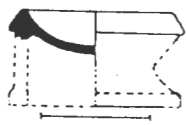
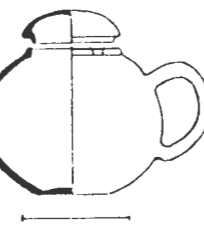

Figure 3-25: Salts



Mustard pot



Condiment bottle

Other includes: cutlery handles.

Figure 3-26: Porcelain cutlery handles

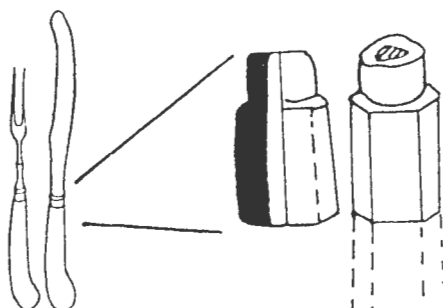

➔ Profile of excavated fragment of a Chinese porcelain cutlery handle (Elsenburg, Ch.6).

4. Drinking

The category is sub-divided into **New beverages** for tea, coffee, chocolate and punch, and **Other beverages** for other varieties of drinks.

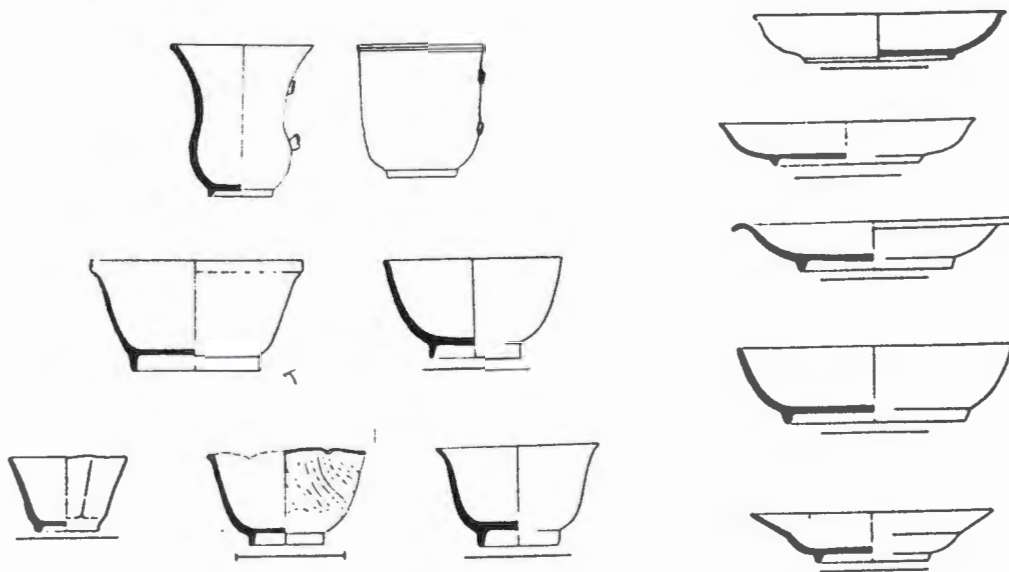

Figure 3-27: Chinese export porcelain cups and saucers.

The term **cup** is used for many shapes, sizes and types and no distinction is made between tea bowls and handled cups or between coffee, chocolate and breakfast cups. When this information is available it is recorded in the catalogue. A **saucer** without a central depression for the cup has to be distinguished from small dishes. When there is high fragmentation, cups and saucers are combined to give one figure.

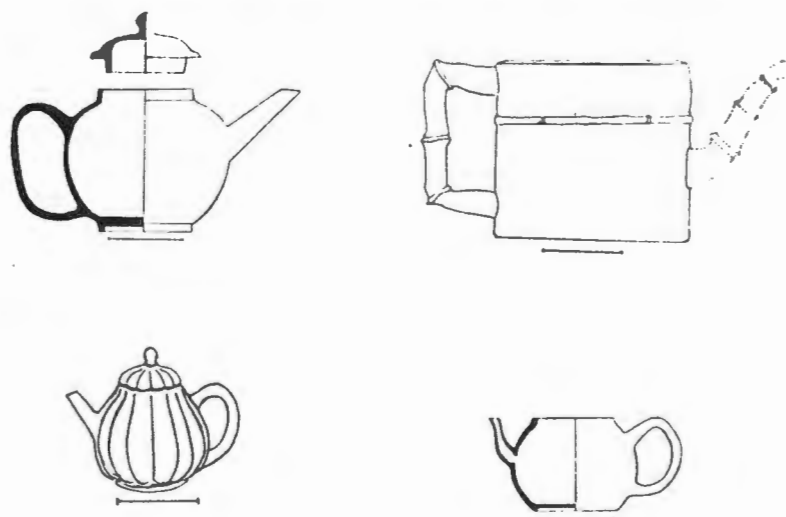

Figure 3-28: Chinese porcelain & Yixing stoneware teapots.

Tea/coffee pot is a combined category and **Additional teaware** is for milk jugs (lidded and without lids), sugar pots, slop basins, tea cannisters, teapot stands and spoon trays (*pattipans*) and trays. A **Punch bowl** is defined as a large bowl with slightly flared sides but no S-curve (Jörg 1982:181).



Fig. 3-29: Tea cannister.



Fig. 3-30: *Pattipan*.

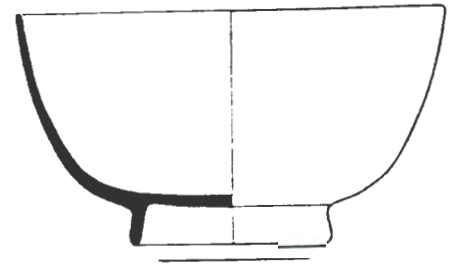

Fig. 3-31: Punch bowl.

Other beverages includes **Bottle / bellarmine / flask** for narrow necked and handled stoneware vessels (also listed in the Food and Drink category), **Beakers/Mugs**, and medium to large stoneware or refined ware jugs are classified under one heading, **Jugs**.

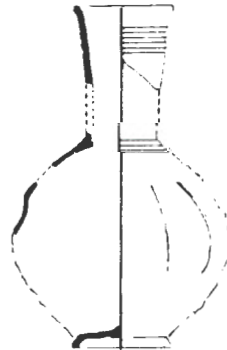
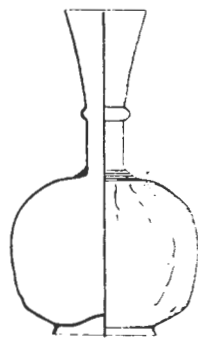

Figure 3-32: Earthenware flasks - probably S.E. Asian (Sassoon 1982, *São Gonçalo* (1630) & *Oosterland* (1697)).

5. Health & Hygiene

Chamber pots include the usual handled forms of this vessel in Chinese porcelain, coarse earthenware, stoneware and refined white earthenwares as well as a certain type of lidded Japanese porcelain bowl which is believed to have been used as chamber pots by the Dutch (Ohashi 1990:142).

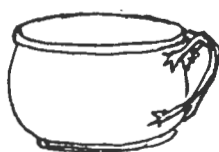

Fig. 3-33: Chamber pots: (a) cream coloured ware (b) Chinese Imari (c) Japanese porcelain

Flared mouthed **Spittoons** (*quispidoor*) were usually made in metal but examples made in porcelain have been excavated in the Cape.

Excavated items related to washing and shaving include matching large porcelain basins and goglets, and matching refined earthenware bowls, ewers and soap dishes. Japanese porcelain shaving dishes have also been found. All these items are classified under **Basin/ewer/shaving/soap dish**.

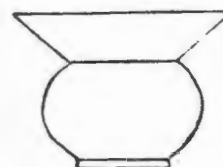
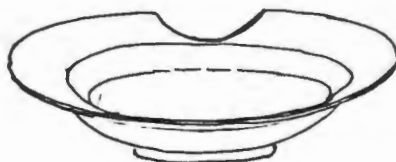
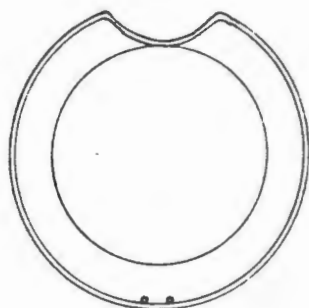

Fig. 3-34: Basin & goglet

Fig. 3-35: Shaving dish

Fig. 3-36: Spittoon

The **pharmaceutical** category includes Japanese porcelain bottles, square flasks, jars and pots, tin-glazed jars and ointment pots, and nineteenth century refined ware lidded pots, which often contained tooth powder.

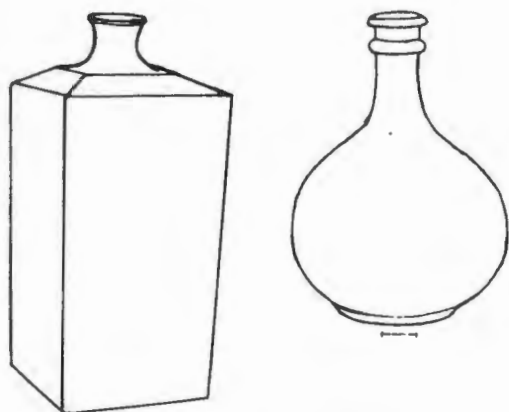

Fig. 3-37: Japanese flasks & bottles



Fig. 3-38: Tin-glazed and porcelain apothecaries' ware

6. Utilitarian

This is a small category containing the following: **Brazier** (*vuurtestje*) was a small handled and footed pot made in coarse earthenware, **Chafing dish** (*komfoor*) has only been identified in one form. **Candle sticks/Lamps**; and **Non-food containers** which includes bottles for ink and stove blacking.



Fig.3-39: Coarse earthenware
brazier / *Vuurtestje*
(de Kleyn 1986).

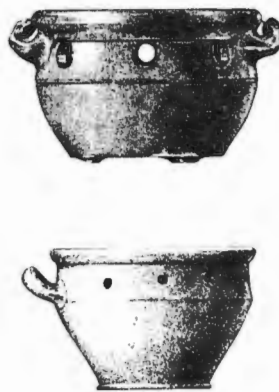

Fig.3-40: Coarse earthenware
Chafing dish

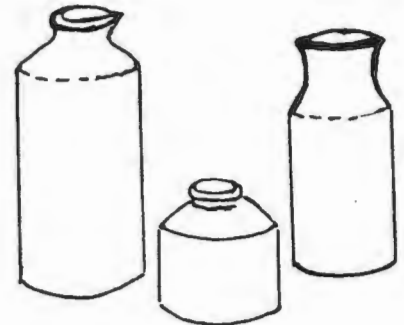

Fig.3-41: Ink & polish bottles
(Noël Hume 1970).

7. Ornamental

The ornamental ware categories are **Vase, jar, garniture, & flower pot** (not terra-cotta variety). These items were obviously well curated, and rarely occurred in the test group of Cape assemblages. Many of the decorated plates and dishes could have been used for display. A blue-and-white tin-glazed plate with holes drilled through the rim to affix it to the wall was excavated in the Castle (Buren Bastion, Appendix I.1). Excavated examples of the **Figure / figurine** category include small Dehua porcelain figurines some of which incorporate a whistle (the Castle F2, Appendix I.1) and a large polychrome figure of a woman (?) (Eisenburg, ELS-dbyc/CPO.194). **Toys, dolls & dolls' tea sets** are often found but they are not included in overall percentage analysis.



Fig. 3-42: Dehua figurine with whistle.



Fig. 3-43: Dehua Buddhist lion.

8. Unidentified

Form Table classifies the unidentified sherds and vessel forms using **Flatware** and **Hollow ware** categories. This was originally the Staffordshire potters' method of distinguishing press moulded items, such as plates and dishes, from wheel thrown vessels. But archaeologists now use this classification to investigate diet: hollow wares are associated with stews, and flat wares with solid food such as roasted meats. The CCS uses these categories to avoid lumping all the unidentified sherds together in one category - **Undiagnostic**. Handles, lids, and finials from unidentified vessels are placed in the hollow ware category. The Undiagnostic category is for sherds where there is absolutely no indication as to their vessel form or function.

Form / Function Table records individual functional categories as percentages of the whole assemblage which can be used for comparative work (see Chapter 9, Figure 9-3).

Application of the CCS

The application of the Cape Colonial System to an assemblage is carried out in four stages. Prior to this, the sherds are cleaned and marked, taking care not to damage glazes and overglaze decoration, or to remove food residues or other accretions which could help in the interpretation of the ceramic assemblage.

Stage 1

The first stage is the identification and quantification of the sherds. The sherds are first sorted into wares, then into ware types and ware sub-types. All the sub categories are quantified by sherd counts but certain minimally differentiated varieties, such as Khoi pottery, can be further quantified by weight. The information is entered on Ware Table.

If an estimation of the degree of fragmentation is required, the whole category under investigation is weighed before subdivision into ware sub-types and the result related to the total sherd count of the category. The identification and recording of cross-mends begins at this stage of the analysis.

Stage 1 level of analysis has limited use in the interpretation of the ceramics and can only present a general impression of an assemblage. Sherd counts have minimal analytical

value as they are affected by fragmentation and are not necessarily good indicators of vessel numbers. The presence and proportion of different ware sub-types can indicate the approximate occupation period of the site. Identified ware types can be used for presence/absence analysis to provide a *terminus post quem* for the assemblage. The cross-mends help in the interpretation of stratigraphic correlations while the relative sizes of the sherds can indicate, in some circumstances, whether the assemblage is primary or secondary refuse (Yentsch 1991a:32). However, the size of the sherd can also be the result of post depositional activity and can be misleading.

Stage 2

The second stage of analysis is the identification and quantification of vessel forms within each ware or ware sub-type category. Where possible, the vessels are identified and named using the Cape Vessel Typology (Form / Function Table Appendix G). Minimum vessel analysis is used for the quantification of the different vessel forms and the combined MNVs for each ware sub-type are recorded on Ware Table.

This level of analysis produces an accurate qualitative and quantitative description of the types of vessels present in the ceramic assemblage. The vessels have been named and an estimate made of their minimum numbers. The ceramics now have analytical utility: accurate comparisons can be made between sites, vessels can be linked to contemporary documents, especially probate records, and a start can be made in assessing their function within the assemblage.

Stage 3

The third stage is the assignment of function to the excavated vessels. The vessels are allocated to functional categories according to their shape or their function if this is known from other sources. This information is recorded on Form / Function Table (Appendix G).

At this level of analysis, the ceramic vessels can be integrated with artefacts with similar functions in other materials and with other artefacts. It is now possible to study what kinds of functional variability exists within and between assemblages.

Stage 4

The final stage in the application of the CCS is the compilation of a site catalogue of all the ceramics in the assemblage (Appendix L).

The ceramics are accessioned and catalogued following the order of the classificatory system used in Ware Table (Appendix E). Within each ware sub-type category, vessels are recorded by: site accession number; form; size (height and width of rim and footring expressed in millimetres). An estimation of a vessel's completeness is recorded as a percentage of the whole vessel, and the degree of fragmentation of the sherds is noted when it is significantly high or low.

The decoration is described but this only needs to be done briefly if photographs or drawings are to be made of the sherd or vessel (for the purpose of this dissertation, photographs have been taken of examples of all the vessels from the four sites)(Appendix K). Vessel profiles are not routinely made but are used when photographs are unable to record important information about vessel form, especially unusual or unidentified items. Any peculiarities of the glaze and body are noted, as well as evidence of wear (use marks), re-utilisation and repair.

Marks and manufacturers' trade marks are recorded and, where possible, references are provided for the identification and dating of the vessel. Asian market ware is identified and referenced using Appendix J. Cross-mends are recorded as well as references to similar vessels or decorative motifs found within the site or on other Cape sites.

The Cape Classification System records a ceramic assemblage using two tables, Ware Table and Form/Function Table, and a Site Catalogue. The vessels or sherds are recorded comprehensively in a form that permits the construction of suitable typologies for analysing the ceramic assemblage, accurate comparison with other sites and the integration of the information into other research strategies. It is organised as an hierarchical system and can be accessed and studied at different depths or levels of analysis. For example, Ware Table is programmed to produce frequency distribution tables (ceramic profiles) based on minimum vessel counts at different levels of identification of the ceramics. Ceramic profiles provide an overall view of the composition of each analytical unit at different depths of analysis within the assemblage or analytical unit at four levels of analysis (Table 3-3).

Table 3-3: Levels of analysis provided by the Cape Classificatory System.

Level 1

Porcelain
Stoneware
Coarse earthenware
Tin-glazed earthenware
Refined ware

Level 2

Porcelain	<i>Asian</i> <i>European</i>
Stoneware	<i>Asian</i> <i>European</i>
Coarse Earthenware	<i>European-style</i> <i>African/Asian</i>
Tin-glazed Earthenware	<i>European</i>
Refined Wares	<i>European</i>

Level 3

Porcelain	<i>Chinese</i> <i>Asian market ware</i> <i>Japanese</i> <i>Near Eastern</i> <i>European</i>
Stoneware	<i>Chinese /Japanese / Other</i> <i>German</i> <i>British</i>
Coarse Earthenware	<i>European manufactured</i> <i>Cape colonial manufactured</i> <i>Cape colonial & European manufactured</i> <i>Khoi</i> <i>Indian</i>
Tin-glazed Earthenware	<i>Dutch / French / British</i>
Refined wares	<i>Creamware</i> <i>Pearlware</i> <i>White-bodied wares</i> <i>Other Refined Wares</i> <i>Refined Stonewares</i>

Level 4 - Using Japanese export porcelain as an example

Japanese porcelain	<i>Blue-and-white</i> <i>Blue-and-white & enamels</i> <i>Enamels only</i> <i>White undecorated</i> <i>Undiagnostic</i>
---------------------------	--

It is accepted that a full systematic application of the CCS to an assemblage is a long process and requires an extensive knowledge of ceramics. Majewski & O'Brien comment in their study of the analysis of nineteenth century ceramics " the more involved a system becomes, the less other researchers will be inclined to use it" (Majewski & O'Brien 1987), but there are no short cuts in ceramic analysis. Future research questions may not require the detailed results provided by this proposed method but the four sites analysed for this project and the possible application of the CCS to further sites will provide a reliable 'reference collection' of Cape colonial assemblages for ceramic analysts.

The CCS has evolved through trial and error by application to as many sites as possible. It can now deal with the full range of ceramics found on Cape Colonial sites dating from the mid- seventeenth century to the early to mid- nineteenth century.

Chapter Four

Asian market ware: 17th - 19th century coarse porcelain and 19th century refined wares

Introduction

This chapter concentrates on a particular Asian porcelain category within the CCS, namely, 1.1.2. Far East: Asian market ware (see Appendix E). Cape assemblages are one of the most comprehensive known sources of archaeological information for Far Eastern coarse porcelain (Figure 4-1). Very little literature is available on this type of ceramic, especially with regard to its provenance and dating. With this in mind, it was decided to compile a catalogue of all the coarse porcelains found on Cape colonial sites and incorporate it within the CCS (Appendix J).



Figure 4-1: Asian market ware from 18th century Cape colonial sites.

Historical archaeologists working on seventeenth to early nineteenth century colonial sites in the south-western Cape, have reported the presence of considerable quantities of Far Eastern 'coarse porcelains' and 'provincial wares' (Vos 1985; Hall *et al.* 1990a, 1993a & b; Schrire *et al.* 1993; Markell 1993; Abrahams 1996). These are examples of the ordinary

everyday household ceramics that have been used throughout Southeast Asia for centuries (Figure 4-2)(Volker 1954; Rooney 1987). These wares will be referred to as 'Asian market ware', subdivided into seventeenth to nineteenth century coarse porcelains and more refined wares dating to the nineteenth century and later.

The majority of Asian market ware from Cape colonial sites are blue-and-white Chinese vessels and manufactured in coarse porcelain - less refined or poor quality porcelain and porcelaneous stoneware. The remainder include a very small number of possibly Vietnamese items and one vessel tentatively identified as Japanese. Most of them are, without doubt, examples of the coarse porcelain carried and bartered by the VOC in the inter-Asiatic trade, especially in Southeast Asia, throughout the seventeenth and eighteenth centuries (Volker 1954). Analysis has indicated that they comprise between 8% and 20% of the minimum number of vessels excavated from eighteenth century Cape sites (Table 4-1, Chapters 5-8). Late eighteenth to nineteenth century Cape sites yield examples of the second type of Asian market ware; sturdy blue-and-white saucer-dishes and bowls which are more carefully glazed and neatly potted than the coarse porcelain, and manufactured in white to off-white slightly granular porcelain.

Outline

This chapter will begin by evaluating the nomenclature used in western studies and descriptions of seventeenth to early twentieth century Asian domestic ceramics before proposing a terminology applicable to similar wares excavated in the Cape. The importance of the 'coarse porcelain' traded by the VOC in the inter-Asiatic trade in the seventeenth and eighteenth century will be discussed, and documentary sources and excavated material will be used to determine the probable variety and style of this particular group of ceramics. Later references to coarse porcelains in Western writings will be introduced as well as more recent studies and research projects based on finds from shipwrecks and archaeological excavations. Following this, coarse porcelain will be described in detail as well as its manufacture and attribution, with reference to the wares excavated in the Cape. The methodology used to identify and classify them in the CCS will be demonstrated and the catalogue of vessels recovered from both land and sea sites in southern Africa will be presented and explained (Appendix J). Finally, the presence and possible usage of coarse porcelain vessels in colonial households will be discussed before assessing the importance of archaeologically excavated Cape assemblages in international ceramic research.

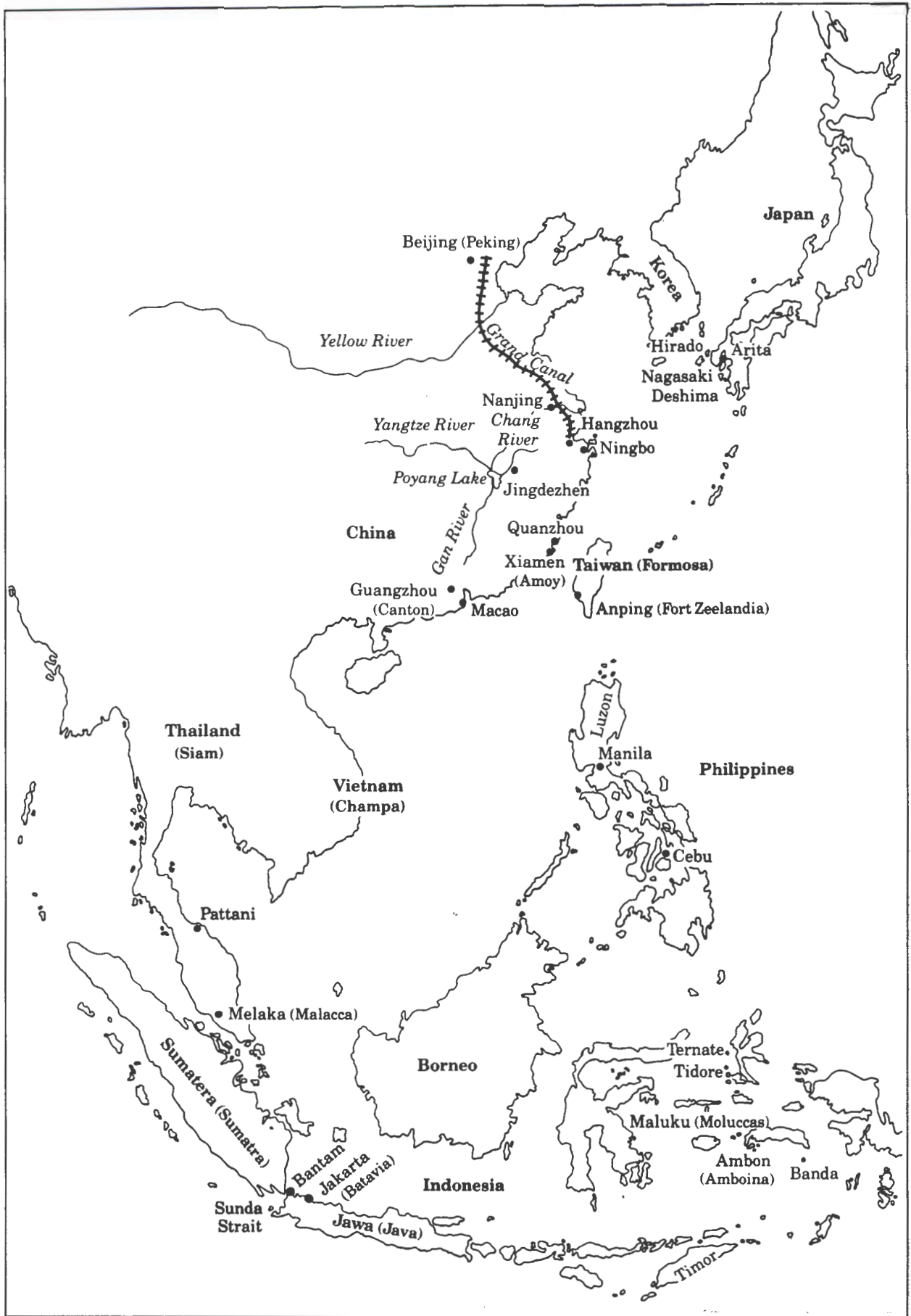

Figure 4-2: Map of Southeast Asia and China (Rinaldi 1989:17).

Terminology

Many terms have been used in the literature to describe coarse or less refined Asian porcelains excavated from Cape sites, but in recent years, 'provincial ware' has become an internationally accepted term for these wares. Earlier this century, the name 'provincial ware' was adopted by western ceramic scholars to describe porcelains produced at private commercial kilns throughout China from the Ming dynasty onwards, in order to distinguish them from the extra fine quality porcelains made in government and certain private kilns in Jingdezhen (Figure 4-2)(Hobson 1937:115-19; Jenyns 1988:203-227). This first definition of provincial ware covered a wide range of ceramics: blue-and-white wares, celadon, fine white wares produced at Dehua (*blanc de Chine*), Swatow¹, and Yixing stonewares. In the fifteenth and sixteenth century, provincial (private commercial) kilns produced the bulk of the wares for the export market in forms that were initially all similar in shape and design to the ceramics made for domestic use in China (Jenyns 1988:203)

Sir Harry Garner continued this method of classifying Chinese wares but used the term 'provincial blue-and-white' to describe a selected group of less refined and less carefully decorated porcelains (Garner 1970:54-57). These included underglaze blue wares from Annam (Vietnam), Fujian, (including Swatow), a more refined blue-and-white porcelain (possibly from Dehua), and lastly, a group of completely different blue-and-white wares, some of which he thought came from kilns in southern China and others which might have been made in the neighbourhood of Jingdezhen (Garner 1970:54-57). This classification was a new concept as Western ceramic scholars had previously thought that all blue-and-white wares originated in Jingdezhen.

There was no archaeological evidence available at the time to support Garner's view and, consequently, it was impossible to provenience or date 'provincial blue-and-white' with any degree of confidence. This gap in Western ceramic knowledge resulted, and often still results, in many late seventeenth and eighteenth century coarse porcelains being incorrectly dated as either late Ming dynasty (1342-1644) or nineteenth century (Jenyns 1951:80; Volker 1954:220; Willetts 1971:22 & 194; Willetts & Lim 1981:67 no. 43). Today, the term provincial ware appears to have taken on a more restricted meaning and has become an internationally understood name for thickly potted, coarse Far Eastern

¹ Swatow. Coarsely made large dishes and jars with dirty footings, manufactured in Fukien Province, southern China. Exported to Japan, Southeast Asia and India during the 16th and 17th centuries (Harrison 1974).

domestic wares and, in particular, for seventeenth to nineteenth century coarse blue-and-white bowls and dishes.

Other more recent studies published during the last twenty five years have described Far Eastern domestic wares, similar to those found on Cape sites, as 'Hong Kong', 'Singapore' and 'Okinawa' ware (Chan Gunn 1971), 'Kitchen Ch'ing' (Willetts & Lim 1981), 'coarse provincial ware' (Vos 1985), 'coarse porcelain' (Jörg 1986), *minyao* or 'people's ware' (Willetts & Lim 1981:2; Kerr 1986:15), 'folk pottery' and 'blue-and-white tableware' (Rooney 1987), 'Minnan blue-and-white' (Ho 1987; 1988), 'coarse blue-and-white ware' (Lam 1987), 'folk painted' private kiln porcelain (Keguan 1991) and 'Nineteenth Century Domestic Market Blue-and- White Porcelain' (Allen 1996:65). Other ceramic studies have included them in a class identified as 'trade ceramics' (Harrisson 1979; Guy 1990) or 'Chinese export ware' (Hagen Jones 1992).

The term 'Swatow' or 'Swatow-type' has also been used to describe certain coarse blue-and-white wares (Ho 1988:3). Swatow is a distinctive, yet poorly defined, group of sixteenth and seventeenth century Chinese coarse porcelains made in Fujian province (Hobson 1976; Volker 1954; Harrisson 1979). It is always included in general accounts and outlines of Far Eastern porcelains published in the west. The main reference for this ware is Harrisson's study of the Swatow dishes and plates housed in the Princessehof Museum, in the Netherlands (Harrisson 1979). The concept of Swatow as a ware will always remain, and be used and understood by everyone interested in Asian ceramics. Harrisson described it as "a class known through traders and collectors who marketed it outside China" (Harrisson 1979:9).

Not one of these collective terms for coarse porcelains, except for Minnan blue-and-white, has been precisely defined. Ho Chuimei correctly stated that "the concept of these wares in western writings was (and often still is), geographically, chronologically and typologically unclear" (Ho 1988:3). It is difficult to incorporate them as categories in the CCS Ware Table as they cannot be identified as exclusive ware-types.

A descriptive, generic term was needed in ceramic analysis to describe Far Eastern utilitarian domestic ceramics unaltered by European demands and to clearly set them apart from the fine Chinese and Japanese export porcelains made at the same time for the European market. Consideration was given to all the names used in the literature as it was important to try and avoid adding more names to this list. 'Provincial ware' was an appropriate term if it could be defined to include the more refined nineteenth century

domestic wares or 'folk pottery' (Appendix J: pp 52-53, 69-70). 'Coarse porcelain' was ideal for the roughly made wares which dominate the assemblages: it was a qualitative term, did not imply specific areas of manufacture, usage or ownership, and was used in seventeenth and eighteenth century VOC documents relating to the porcelain trade as well as in contemporary Cape probate records (Volker 1954). The Chinese term *Minyao* ('people's ware'), which could perhaps be loosely interpreted as 'Asian market domestic ware', appeared to be the most suitable term. It could be applied to all the types found on Cape colonial sites including the more refined nineteenth century wares.

For the purpose of this dissertation, however, the term 'Asian market domestic ware' was shortened to Asian market ware. These wares are sub-divided into 'coarse porcelain', from the seventeenth to nineteenth centuries, and 'later refined wares' manufactured from the end of the eighteenth and nineteenth centuries. Asian market ware is primarily a functional category and its two sub-categories can accommodate and classify all the porcelain, porcelaneous ware and stoneware Asian household utensils found in excavated Cape assemblages, and be used for direct comparison with historical documents. Most of the contemporary sources used in this dissertation concerning the VOC and the trade in coarse porcelain are taken from Volker (1954) and therefore are limited to activities that took place during the years 1602-82.

Seventeenth to nineteenth century coarse porcelain

From the start of direct trading between Europe and the Far East, beginning with the Portuguese in the sixteenth century, merchants graded porcelain as either fine or coarse quality in their business transactions with the Chinese (Volker 1954; Garner 1970:56). The two terms appear to be self explanatory but a further study of the VOC records suggests that the term 'coarse' was applied to two completely different classes of porcelain (Volker 1954:193; Jörg 1982:91-92, 139-40). Thus it is difficult to give a precise definition of seventeenth and eighteenth century coarse porcelain using contemporary documentary sources alone. Orders and bills of lading for Chinese ceramics were written by and for merchants, using abbreviated terms for size, ware type, decoration (when considered necessary) and quantity, that were fully understood by the traders and markets of the time. Today, we have no means of finding out exactly what such terms denoted other than comparing ceramics from controlled excavations with contemporary historical documents.

The VOC use of the term 'coarse porcelain' for cheap utilitarian Far Eastern glazed wares copied the Chinese practice of making no distinction between porcelains and stonewares as would have been the case in Europe. Porcelains and stonewares are both highly vitrified ceramics and, unlike earthenware, are covered with a high-fired feldspathic glaze. The Chinese name both these wares *Tz'u*, which is usually translated in the West as 'porcelain' (Medley 1977:58).

Seventeenth century records of the VOC's porcelain trade indicate that 'coarse porcelains' purchased by the Company were ordinary Far Eastern utilitarian shapes - mainly open forms, including dishes, bowls and cups (Volker 1954). This description fits the thickly potted blue-and-white bowls and dishes that have been unearthed both throughout the East, and on seventeenth and eighteenth century colonial sites in the Cape. Company records show that the coarse porcelain purchased by the VOC was considerably cheaper than fine porcelain. Volker's surveys show that coarse porcelains were at least a third of the price of fine porcelains mentioned in the same order (Volker 1954:46,96,194,). Great quantities were shipped by the Company and other traders, alongside fine porcelains, to the islands of Southeast Asia and in smaller amounts to India, Persia and Japan (Volker 1954:224). It was probably all blue-and-white, the cheapest type of decorated porcelain, with very small quantities of enamelled wares (Volker 1954:84). Swatow is known to have been made in, and exported from, China during the first half of the seventeenth century and it is thought that this type of coarse porcelain could have been shipped by the VOC although the Company records do not mention this ceramic ware by name (Volker 1954:194 quoting De Flines 1949). Swatow has been found in association with Chinese export porcelain, similar to that traded by the Dutch, on wrecks of seventeenth century Portuguese ships (Storror 1988:figures 22 & 31; Desroches 1994:354-59).

Certain other entries in the VOC records appear to use the term 'coarse' to describe thick, and probably 'second grade', fine porcelain (Jörg 1982:124). This variety of porcelain is difficult to identify positively, either in extant collections or in the archaeological record, and will be discussed later in the methodology section of this chapter. Some early Japanese porcelains, apart from the utilitarian bowls and dishes ordered by the VOC for the Asiatic market, were also described as 'coarse' in the records but this could also indicate the thickness and overall appearance of the ware more than the quality of the potting and body (Volker 1954:138, 155, 173). Much seventeenth century blue-and-white Arita porcelain, ordered for use by Company officials, including porcelain with the VOC

monogram, is thickly potted in a slightly granular looking off-white clay and boldly painted in dark blue-violet coloured cobalt (Woodward 1974:59-60). It would certainly have appeared coarse in Dutch merchants' eyes when compared with the more finely painted and very thin Chinese *kraak* porcelain which it temporarily replaced in the late 1650s to early 1680s.

The inter-Asiatic trade

An extensive inter-Asiatic maritime trade network, carrying spices, precious metals, silks, ceramics and other valuable eastern commodities, had been in existence long before the arrival of the Europeans in the late fifteenth century. In the seventeenth and eighteenth century the trading area extended from Japan to the east coast of Africa and included Arabia, Persia, India, China and the whole of present day Southeast Asia. There is archaeological evidence to show that glazed Chinese ceramics (stonewares and porcelains) were an important item in this market by the ninth century and were exported from the southern provinces from the ninth and tenth centuries onwards (Guy 1990:9-21). Porcelain, both fine and coarse varieties, remained an important commodity for all traders in Southeast Asia until the nineteenth century.

Before the arrival of the Europeans, the inter-Asiatic trade was in the hands of Muslim merchants, especially Arabs and Persians, followed in later years by Indians and Southeast Asians. From the end of the 14th century, a small number of Chinese merchants organised their own export arrangements and settled in the trading ports of Indonesia and Malaysia, especially in Malacca and Batavia (Medley 1980:216). In the sixteenth century, the Portuguese and Spanish forced their way into the trading area until they in turn were ousted by the Dutch and the English. The Dutch, through the VOC, eventually became the most powerful single nation operating in the inter-Asiatic network in the seventeenth and eighteenth century, and set up trading stations throughout Asia (see Figure 4-3).

Chinese coarse porcelain was a consistently important commodity in the inter-Asiatic network and was carried by all the traders, especially the VOC. It was always obtainable, even during the years ca.1657-80 when Chinese export porcelain was in very short supply, although in much smaller quantities (Volker 1954; Kilburn 1981:15). During the Chinese porcelain shortage, the Company bought large quantities of coarse wares from Tonking and lesser amounts from Japan, to enable it to continue its normal trading in the

Eastern markets (Volker 1954). Jörg showed that porcelain was taxed by weight by the Chinese (Jörg 1982:113) but the tax formed a very small percentage of the wholesale cost of ceramics and did not make the heavy Asian market wares more expensive than the finely potted export porcelain produced for the European market (Christiaan Jörg pers. comm.).

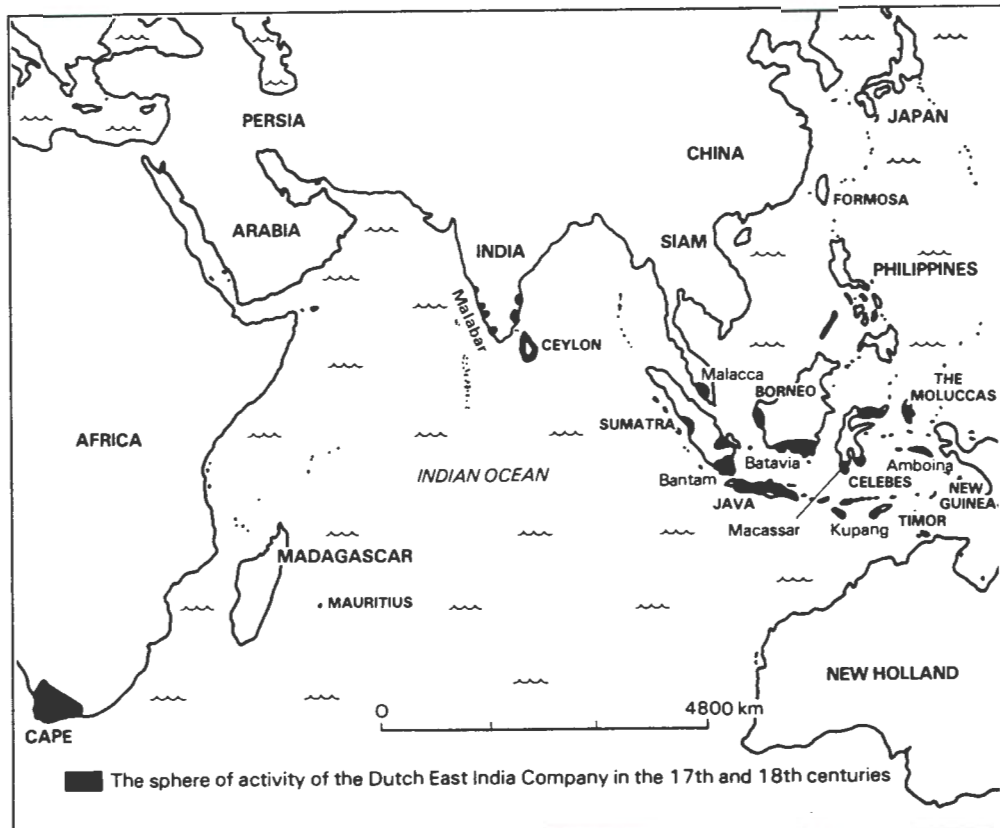

Figure 4-3: Map illustrating the sphere of activity of the VOC in the 17th and 18th centuries (from Bredekamp & van den Berg 1986)..

Coarse porcelains were not saleable in the Netherlands and were never officially shipped there by the VOC. Although coarse wares were cheap in the East, they were probably too bulky to ship economically to Europe and still make a reasonable profit for the Company. Their coarse manufacture would perhaps also not conform to European conceptions of exotic oriental porcelain and many of them were very similar in colour, thickness and texture to contemporary Rhenish stonewares.

Until the 1970s, little or no attention was paid to late sixteenth to nineteenth century coarse porcelain apart from the so-called Swatow wares. (Garner 1970:54-57). Early Chinese and the later European studies of Oriental ceramics were written by and for

connoisseurs and collectors (Hobson 1976:xv-xxvi). In China, scholars had concentrated on describing high quality porcelains made in Jingdezhen, especially "the official wares made under Imperial supervision for the Palace and the Court" (Jenyns 1988:203). European collectors and art historians, beginning in the mid- nineteenth century, tended to focus on Chinese and Japanese porcelains made for the European export market (Jörg 1982:11). Mary Tregear has commented that European taste in oriental art, which included porcelains, was formed on the trade goods sent to Europe from the East (Tregear 1994:7). The coarse porcelains manufactured in the last 300 years, routinely used as everyday domestic utensils in the east and similar to those found on Cape sites, would either not have been noticed by the Chinese and Western connoisseurs and collectors, or be considered too commonplace to be worthy of study.

The catalogue of the exhibition of 'ceremonial and common domestic pottery of the nineteenth and twentieth centuries commonly found in Malaysia' held in Hong Kong in 1981, was possibly the first publication to describe Chinese coarse porcelains in detail. The exhibits included examples of coarse Chinese blue-and-white porcelain bowls and dishes that were identical to those excavated on Cape colonial sites, in association with eighteenth century Chinese export porcelains (Willits & Lim 1981). William Willetts, who documented the exhibition, rejected the terms 'trade ware' and *minyao* (peoples ware) which had previously been used. He proposed the name '*Kitchen Ch'ing*', indicating their function in nineteenth century Chinese homes as well as their provenance (Ch'ing (Qing) dynasty 1644-1911).

Willetts discussed the different methods and styles of decoration (including the iconography) of '*Kitchen Ch'ing*' from an art historian's point of view, studying in particular the stylisation or devolution of motifs over time. He mentioned the usage of these wares in Malaysia, and by migrant Chinese world-wide, and provided archaeological, kiln and museum references for most of the vessels. Ceramics excavated from the site of an English East India Company factory, built on Balambangan Island and occupied between 1770 and 1805, were used to date many of the pieces in the exhibition (Willetts & Lim 1981).

Hendrik Vos described a collection of Asian market coarse porcelains excavated from colonial sites in Stellenbosch, a town founded in 1679 and lying about forty kilometres north east of Cape Town (Vos 1985). This study was discussed in Chapter 3.

Dawn Rooney included Chinese and Japanese coarse porcelain in her study of 'folk pottery', the term she used to describe everyday domestic utensils used in the past in Southeast Asia (Rooney 1987:33-48). She discussed the importance of Chinese ceramics in the inter-Asiatic trade, and how Southeast Asia became a primary market for these wares from the 10th century onwards, especially for blue-and-white wares during the fifteenth to seventeenth century and again from the late eighteenth to early twentieth centuries. Rooney divided Chinese coarse porcelains into three groups: fifteenth to seventeenth century coarsely potted 'hole-bottom saucers'; 'blue-and-white tableware' (coarse porcelain); and 'folk pottery' (nineteenth century refined ware).

Rooney describes folk pottery as a relatively cheap late eighteenth to early twentieth century Chinese blue-and-white porcelain produced for the local market and Southeast Asia. It was thickly potted in Asian domestic forms, of variable quality and decorated in certain characteristic patterns. No date range is given for 'blue-and-white tableware' other than the possibility that it could pre-date the Qing dynasty (1644-1912).

Rooney's separation of Far Eastern domestic ceramic utensils into three categories makes a useful typological distinction between these wares, but her suggested terminology is not suitable for vessels excavated from Cape sites. Throughout her study, she shows that all these wares, used in daily life by the people of Southeast Asia, were 'closely bound to the culture, the religion and the domestic needs of the inhabitants of the region' (Rooney 1987:69). The book has a short bibliography but, unfortunately, her statements and views are not backed by specific references or archaeological reports.

Ho Chuimei (1987 & 1988) analysed the results of archaeological surveys of sixteenth to nineteenth century kiln sites in southern Fujian Province in China. Her report identified kiln areas within a defined region (Dehua, Yongchun and Anxi) and described in detail the type and range of coarse porcelains produced at each site. Ho coined the term 'Minnan blue and white' for the wares from this region. Her research was based on surface collections from identified kiln sites and not from controlled archaeological excavations. Despite this, enough evidence was collected to record in detail the quality, form and decoration of the ceramics manufactured at each group of kilns (Ho 1988:141-233; Appendix J:viii). Chinese scholars have been unable to give dates to individual Minnan blue and white vessels other than to state that the manufacture of this ware did not begin until the mid-sixteenth century, was at its greatest production during the seventeenth and early eighteenth century, and lasted until the end of the nineteenth century. More precise

investigations into the dating of these wares are at an early stage and have tended to be based on stylistic and typological evidence alone. Ho is of the opinion that a detailed chronology of Minnan blue-and-white could possibly begin by using evidence from archaeological sites outside China (Ho 1988:6).

Lam (1987) studied the surface collections of ceramics that had been collected on different occasions from two areas of kiln sites in Dapu Wanyao, Hong Kong (previously part of Guangdong province in China). He was able to identify the range of vessels produced there and build vessel typologies for cups, bowls and dishes (Appendix J:viii). Lam also recorded the decorative patterns, both painted and block printed, and listed the blue-and-white marks used by the potters. He commented that one of the many kilns at Dapu Wanyao had a capacity of between six to seven thousand bowls per firing, indicating the mass production of coarse porcelains in the southern provinces in the nineteenth century (Lam 1987:139).

The works of Ho and Lam were amongst the first published reports available in English that linked certain blue-and-white coarse porcelains to identified areas of manufacture. It had long been assumed that most coarse wares, exported via the inter-Asiatic trade and found on overseas archaeological sites, originated in the southern provinces of China (Guangdong, Hunan and Fujian) and private kilns in Jingdezhen (Volker 1954:193), but there was no published archaeological evidence until the late 1980s to support this view.

A number of other publications on Far Eastern ceramics have mentioned Chinese blue-and-white coarse porcelains similar to those found on Cape colonial sites. The catalogue of an exhibition of eleventh to nineteenth century Trade Ceramics' found on Tioman Island, Malaysia, showed three examples, but the accompanying documentation added no new information to what is already known about coarse porcelain (Kwan & Martin 1985:69-137). Bi Keguan, a Chinese art historian, published a well illustrated study of the development of what he called 'folk painting', on porcelain manufactured for the local domestic market at private kilns throughout China (Keguan 1991). None of the illustrated vessels are assigned to kilns in the southern provinces but a number of bowls appear to be identical to Asian market coarse porcelains found on kiln sites in Fujian and on Cape excavations (Keguan 1991:134, 178, 180, & 182). These examples are attributed to Jingdezhen kilns and dated to the late Ming or early Qing dynasties (ca.1600-1700) but no precise archaeological references are given. This work is an art historical approach to Chinese domestic porcelain and is not concerned with the ownership or use of ceramics.

Keguan's research is based on material excavated by the Jingdezhen Museum and unprovenanced sherds and vessels from his own collection, many of them picked up on building sites in Beijing, which diminishes the value of his study as a reference work for archaeological finds.

Over the last twenty years, Asian market coarse porcelains have been archaeologically excavated from land sites and shipwrecks world-wide: a Portuguese ship wreck (ca.1680) in Mombassa (Sassoon 1982:103, figure 4); the VOC ship *Oosterland* (1697) in Table Bay, Cape Town (Werz & Klose 1994); Balambangan, Malaysia (Willetts & Lim 1981:1); Maldiv Islands (Carswell 1976:178 pl.64); St Helena harbour (van der Pijl-Ketel 1982:212-214); an eighteenth century site in New York City (Howard 1984:65); an eighteenth century house in Oostenburgermiddenstraat, Amsterdam (Baart *et al.* 1986:95, figure 9); eighteenth to nineteenth century archaeological sites in London (examination of ceramic assemblages by author in 1995); the *Frolic* (1854) off the coast of California (Hagan Jones 1992); a late nineteenth century dump site associated with the Chinese community in San Francisco (Garaventa & Pastron 1983:300-301) and the Cape colonial sites already mentioned. Hagan Jones has listed sites in Australia, Malaya, Southeast Asia and the west coast of the United States where Asian market ware has been excavated or found (Hagan Jones 1992:157-160). Paul Huey (1995) discussed the presence of a particular Asian market ware bowl decorated with dots and circles (Appendix J:SB-2) on North American sites. He used its world-wide archaeological distribution as evidence of eighteenth century marketing and trade patterns linking North America to the Indian Ocean and the Far East.

Today, there is widespread interest in coarse porcelain amongst collectors and dealers, awakened both by the exhibition of Kitchen Ch'ing in Hong Kong in 1981 (Willetts & Lim 1981), and by its presence in recent auction sales of ceramics from salvaged shipwrecks (Christies Amsterdam 1986, 1992, 1995). The small range of coarse porcelains retrieved from dated wrecks is enabling archaeologists to begin building a relative chronology of these wares which until now have not been dated. In addition, both the *Geldermalsen* (1752) and the *Diana* (1817) yielded identically decorated blue-and-white bowls, indicating the length of time certain patterns remained in production (Appendix J: 43, LB-4).

The *Vung Tau*, a junk which sank off Vietnam ca.1690, was probably *en route* to Batavia as it carried a cargo of coarse and fine porcelains suitable for both the Dutch European and Asian trade and other markets (Jörg 1992:198). The coarse wares included several thousand blue-and-white and undecorated bowls, saucer-dishes, saucers and jars (Christie's Amsterdam 1992:118-129). Coarse porcelain dishes and jars similar to those salvaged from the *Vang Tau* have been excavated in the Cape at Oudepost 1 (ca.1669-c.1732) and from the Castle Moat (pre ca.1750) (Christie's Amsterdam 1992: 121, figure 883).

The *Geldermalsen*, a ship belonging to the VOC, sank in the South China Sea in 1752 on her return voyage to Europe from Canton via the Cape (Jörg 1986; Sheaf & Kilburn 1986). Amongst the porcelains removed from the wreck were at least 2500 coarse porcelain bowls and dishes. VOC documents show that the *Geldermalsen* was carrying a consignment of ceramics for the Cape, and as there was no market for coarse wares in Europe it is reasonable to assume the coarse porcelain on board was destined for the Cape market (Jörg 1986:95). Examples of these wares have been found on numerous eighteenth century Cape sites, for example, Elsenburg, James' House, Sea Street, Barrack Street Well (Chapters 6-8) and Bree Street (Hall *et al.* 1993a).

The *Diana* sank off the coast of Malaysia in 1817. It was a privately owned 'country' ship licensed to trade between India, then controlled by the English East India Company, and Canton. It was carrying a mixed cargo of oriental goods including a large quantity of blue-and-white porcelain for the European and Indian communities in Madras (Ball 1995). The porcelain comprised fine export porcelain and a large quantity of blue-and-white Asian market wares which included both coarse porcelain and later refined ware bowls and dishes (Ball 1995:144-45; Christie's Amsterdam 1995)

The *Frolic*, an American owned ship carrying a cargo of Chinese trade goods from Canton to San Francisco, sank off the coast of California in 1850. The cargo included a consignment of 'Chinese export porcelain' which was intended for Chinese immigrant workers in the western United States. These wares would be classed as 'Asian market ware - coarse porcelain' in the CCS. Hagan-Jones developed a typology for this particular group of dishes and bowls based on five major decorative styles. She identified sites around the Pacific rim where they had been found and used this information to establish a relative chronology for them (Hagan Jones 1992).

Description of Asian market coarse porcelains and later refined wares with reference to excavated Cape assemblages

The Asian market coarse porcelains from seventeenth to early nineteenth century Cape sites, in contrast to the fine export porcelain for the European market, are all eastern forms in a limited range of shapes and sizes. The majority are medium and medium to large sized bowls, saucer-dishes and shallow flared-rimmed dishes. In addition, two cups, as well as a small number of rimmed bowls and plate-like dishes have been included in this category in the CCS (Appendix J:i-iii). The body varies between off-white reasonable quality porcelain, refined to coarse grey porcelaneous stoneware or granular, possibly low-fired, cream to buff stoneware. The body often contains impurities and blow holes.

The overall quality of the Asian market wares range from neat, well potted and glazed wares to thick, crudely finished vessels. The finer quality coarse porcelains could be a later development of the kilns, as they appear in increasing numbers on Cape sites dating to the second half eighteenth century and into the nineteenth century.

A large group of bowls and dishes has sturdy thick footrings which are either completely unglazed or partially or completely glazed. The footring can have kiln sand adhering to it which is characteristic of coarse porcelain. Many thickly potted wares have the glaze trimmed away in a ring around the inside centre of the vessel. This is called a biscuit ring and is always slightly larger than the diameter of the vessel's foot ring. Another group of wares has shallow, slightly concave and partially glazed bases with low, rounded and completely glazed footrings, often covered with fine kiln sand (Appendix J:iv, Type A1). Vessels with this kind of foot ring usually exhibit unglazed rims (Appendix J:1-3, 49, 55-59). Biscuit rings and unglazed rims allow for economical loading of the kilns and are characteristic features of mass produced cheap ceramics. Bowls and dishes with biscuit rings were stacked nesting within each other while vessels with unglazed rims were fired rim to rim.

Most coarse porcelains found in the Cape are decorated in underglaze blue under a clear to blue-grey glaze. The cobalt blue ranges from pale greeny-grey to dark inky blue, and is often reminiscent of that found on seventeenth to early eighteenth century Japanese porcelains. As with fine porcelain, the colour of the painting is dependant both on the purity of the cobalt and the quality and colour of the clay body and glaze. The firing technique can also affect the colour, and if the kiln and its contents are not allowed to cool

completely before being opened, the cobalt can re-oxidise to a darker colour. This is likely to occur when firing low quality wares where a fast turnover is possibly more important than quality. The less frequently occurring polychrome coarse porcelains are decorated with overglaze iron red and apple green enamels, occasionally with the addition of black enamel. Only one vessel decorated in underglaze blue and enamels (red and green) has been unearthed to date (Hall *et al.* 1993a).

The decoration of Asian market coarse porcelains differs from fine Chinese export porcelains both in execution and style. The majority are painted in a casual, stylised folk-style tradition and the designs, unlike those on contemporary export porcelains, do not appear to have been influenced by European taste even though the VOC ordered and traded them for nearly 200 years. Coarse porcelain vessels are vigorously and boldly painted, some minimally and others with more detailed work. The designs are often abstract or stylised, and are painted with a flowing fast hand or are block-printed (stencilled). Block printing is frequently used as it is a fast economical method of decorating mass produced wares (Appendix J: MB-22a to 22k). This technique is not used on fine porcelains.

Most coarse porcelains are painted with local traditional designs using quickly executed scrolls, flowers, leaves, fish or Chinese good luck symbols. A few designs are similar to those found on fine porcelains manufactured in Jingdezhen but are less carefully decorated (Appendix J: MB-1a, MB-17, SB-2). This might have been an attempt by the provincial kilns to capture part of the Jingdezhen export market. It has been suggested that Minnan kilns started to challenge the supremacy of Jingdezhen blue-and-white export porcelains in the late seventeenth century and although their products were less refined, they were cheaper and thus saleable outside China (Ho 1995:1). Yet in the case of the 'Sanskrit' pattern, which is extremely common amongst the coarse porcelains on Cape sites, the Jingdezhen potters could have been following provincial potters (Compare MB-14 in Appendix J with the fine porcelain version catalogued as JAM6-2/CPW.11 in Appendix K).

The late seventeenth and early eighteenth century Cape assemblages show a limited repertoire of designs. This could be the result of the relatively small amounts imported into the colony or because coarse porcelains were painted with 'folk' designs that were not subject to the rapid fashion-dictated changes that affected eighteenth century fine export porcelain for Europe. Later sites dating from the mid-eighteenth century yield a

much wider range of forms and designs which include enamelled wares (Bree Street Appendix I.1).

Marks

A small percentage of all the Asian market ware are marked, usually on the base. The marks include double rings with and without a central seal mark (Appendix J: MB-1b, MD-6), single or multiple Chinese characters (Appendix J:SB-1), or a single character in the centre of the bowl or dish (Appendix J: LD-3, LD-5). Unfamiliarity with Chinese script has made identification of marks, especially those painted on the upper surface of vessels, difficult or impossible for Western scholars. Correctly identified marks will eventually help to attribute vessels to particular areas and individual potters (Ho 1988). One bowl has a central impressed design which could either be a mark or simply be decorative (Appendix J: LB.3).

Attribution

The majority of the Asian market coarse porcelains excavated in the Cape, including the type known as 'Swatow', was manufactured in the southern seaboard provinces of China, especially Fujian province (Ho Chuimei 1995: pers. comm.; Lam 1987). Other vessels may have been produced at private kilns in Jingdezhen but it is not possible to identify them from references presently available in the West.

A small number of vessels could have been manufactured in Vietnam (Appendix J: LD.ena-1, LD.ena-2). The identifications are based on direct comparison with the largely unprovenanced collection of coarse porcelains in the Princessehof Museum in the Netherlands (Harrisson 1979). It is known that the VOC obtained coarse ware from Vietnam in the second half of the seventeenth century (Volker 1954:226). The identified, excavated vessels include dishes with narrow 'hooked' rims, a grey or creamy body, often decorated with red and green enamels, and appear to be lighter in weight than similar Chinese dishes. In 1985, South African researchers investigated the elemental composition of the body and glaze of different Asian and European ceramics and used correspondence analysis to analyse the results (Gihwala *et al.* 1985). The results of the analysis placed a 'Vietnamese' dish, similar to those found at Sea Street and Bree Street in Cape Town, apart from the Chinese porcelains known to have been manufactured in Jingdezhen or the southern provinces, thus suggesting a completely different kiln site for this ware (Figure 4-4).

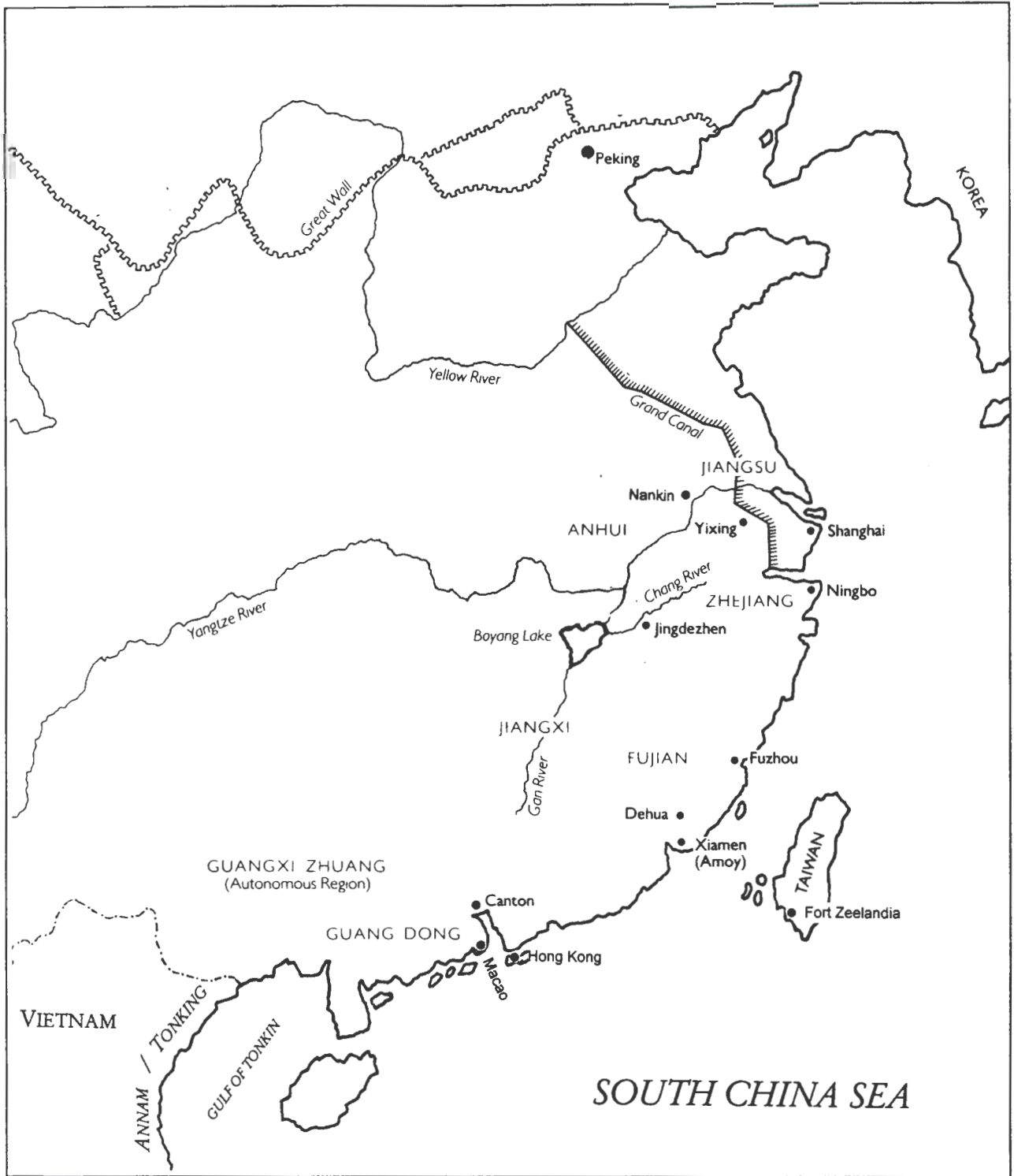

Figure 4-4: Map of China showing Jingdezhen and the southern provinces as well as the approximate location of Annam and Tonking (now Northern Vietnam)(after Kerr 1986:13).

One coarse porcelain bowl from an eighteenth century Cape site has been tentatively identified as Japanese by Dr Impey of the Ashmolean Museum and Ohashi Koji of the Kyushu Ceramic Museum, but there are no publications available to reference this attribution (Appendix K:40, James' House Sea St JAM6-2/JPO.9). Its style is quite different from all the other wares and it is known that the VOC purchased coarse porcelains from Japan for their Asian trade in the seventeenth century (Volker 1954:128). Gabeba Abraham's excavation in central Cape Town has yielded an enamelled dish with a biscuit ring which has been identified as Japanese coarse porcelain (Abrahams 1996:117, figure 25).

Nineteenth century Asian market ware - later refined wares

During the nineteenth century, but possibly in the late eighteenth century, Chinese potters started to produce a different type of blue-and-white ware for daily use in China and Southeast Asia. It is thickly potted and the quality varies from poorly finished wares to fine, well decorated pieces. Rooney calls this ware 'folk pottery' and suggests that the manufacture of these wares was a response by the Chinese potters to the loss of the European export market from the late eighteenth century onwards. This forced them to expand their Southeast Asian trade and to produce a new style ware specially for this market. It was popular because it was "attractive, colourful, less expensive than other ceramics, and durable as it was thickly potted" (Rooney 1987:39-40). The CCS classifies this class of porcelain as Asian market ware / later refined wares (Ware Table Appendix E).

Asian market later refined wares are found on Cape sites and include large thickly potted saucer-dishes decorated in underglaze blue with dragons or Sanskrit characters (Appendix J:LD-10 to 13) and a range of jars and lidded pots decorated with a sweet pea blossom and scroll design (Appendix J: SP-1). Many of these wares are still made and sold today.

Similar thickly potted porcelain with the 'sweet pea' type pattern was used to make toilet sets (wash basins, water bottles, soap dishes and chamber pots) for the western export market in America in the late nineteenth century (Terrey & Pastron 1990:77-78). The quality of these particular wares is similar to the Asian market refined wares or so-called 'folk pottery', but they are classified with the Chinese export porcelain in the CCS because they are European vessel forms.

Methodology

Assemblages of excavated seventeenth and eighteenth century Far Eastern porcelain sherds from Cape sites can be easily sorted into European export porcelain and Asian market coarse wares using present day conceptions of quality and by observing their general appearance and style of decoration. In contrast to the coarse wares, fine export porcelains are manufactured from high quality smooth white porcelain, are neatly potted and carefully decorated in a wide range of designs using clear bright colours under, or over, a clear, blemish-free glaze.

Inevitably, there are sherds that do not fall neatly into either the fine or coarse categories. For example, tea and table wares made for the European market are often thickly potted, carelessly painted and glazed, yet are manufactured from good quality porcelain. It is possible that this is 'second grade' export porcelain for the European market made at private kilns in Jingdezhen, which may have been classed either as coarse porcelain, stoneware or semi-porcelain by the VOC merchants (Volker 1954; Jörg 1982:124,139-40). This class of porcelain is categorised together with the fine quality porcelains as 'Chinese export porcelain' in the CCS.

Further analysis of the excavated Asian market ware sherds revealed that they are manufactured in a limited range of shapes and sizes, predominantly deep, medium sized bowls and shallow dishes. They are all functional eastern forms related to basic everyday Asian cuisine and show no modification in shape or decoration to make them more attractive and suitable for western markets.

The wide range of body-pastes found in assemblages of seventeenth to nineteenth century excavated Asian market ware initially led to a decision to consider basing the identification and categorisation of these wares primarily on form and decoration, and secondly, by reference to the quality of the body. This created a combined functional and decorative category and avoided further unnecessary subdivision by variations in body type and quality. Further analysis and cataloguing of Asian market ware questioned the inclusion of good quality nineteenth century wares ('later refined wares') in the same category as the coarse porcelains. But as the later refined wares are simply a more recent version of the coarse porcelain vessels, it was decided record them together in one category in the CCS Ware Table, but to distinguish between the two qualities in the catalogue and in any specialised analysis.

In the CCS Ware Table, all Asian market wares are categorised by decoration only, using the following categories: Underglaze blue, Enamelled, Monochrome/Incised, Undecorated / undiagnostic and Other. The area of origin, if it is thought to be other than Chinese, is recorded in the catalogue. Any sherds identified as Swatow ware are categorised as coarse porcelain but described as 'Swatow-type' coarse porcelain in the Catalogue and the interpretation of the site.

Catalogue

A catalogue has been compiled of most of the Asian market ware unearthed in the south-western Cape since the early 1980s and forms part of the CCS (Appendix J). The majority these vessels has been professionally excavated and the remainder are from either surface collections or are random unprovenanced finds. The catalogue also provides vessel and footring typologies derived from these wares. Vessel typologies of Minnan blue-and-white, and wares excavated from Dapu Wanyao, are also included for comparative purposes (Appendix J:viii).

In the Catalogue, all vessels are initially categorised according to their basic decorative category as either underglaze blue, enamelled or monochrome before being further subdivided by vessel form and size. Only three basic shapes are described: bowl, dish, and jar. The size of a vessel is judged to be either small, medium or large.

A satisfactory cataloguing system has been built on this elementary information which is encoded in the vessels' reference number. These numbers are prefaced by UCT (University of Cape Town) followed by letters S, M or L denoting size (small, medium, large) and B, RB, D, RD or J denoting vessel shape (bowl, rimmed bowl, dish, rimmed dish, jar). All vessels are assumed to be decorated in underglaze blue (ubw) unless recorded as enamelled (ena) or monochrome (mono). The final digit(s) of the reference number indicates the vessel's catalogue number within its vessel shape category. Any variations in the basic shape, such as ogee-shaped bowls or saucer-dishes, or decorative technique (stamped or incised decoration) are recorded in the description only and are not, as yet, used to form sub-divisions within the cataloguing system (Appendix J).

Certain vessels or groups of vessels can be identified by their footrings alone which provides an additional method of cataloguing and classifying Asian market ware. It enables vessels to be linked to specific kiln sites or perhaps provide a technological

chronology for these wares. Consideration was also given to grouping wares by decorative motives, for example by Sanskrit characters (Appendix J: MB-14, MD-6, LD-10), dragons (Appendix J: MB-19a -19g, LD-9, LD-11, LD-12) or fish (Appendix J: SD-1, MD-1, LD-1) but only a small percentage of the vessels could be categorised in this manner, and it was rejected.

After recording a vessel's basic description, the type, colour and texture of the body paste is noted as well as the footring type (Appendix J: iv-vii). The vessel's dimensions are recorded or estimated where only sherds are present. Colour photographs of the excavated vessels or sherds are provided as well as vessel profiles where it is considered to be important. A short written description is provided for each item to compliment the photograph and is not intended to be complete in itself. Where vessels are represented by sherds only, an attempt has been made to photograph them alongside complete examples from museums and private collections.

Two types of references are given for each vessel: firstly, published references or personal communications relating to unpublished information, and secondly, Cape archaeological site references.

Presence on Cape sites

Coarse porcelain is a consistent component of all the ceramic assemblages excavated so far from seventeenth to early nineteenth century Cape colonial sites. The number of ceramic reports suitable for comparative analysis is still very small and mainly confined to eighteenth and nineteenth century sites, so it is not possible to make anything other than suggestions about the availability and amount of coarse porcelain used in the Cape, especially during the seventeenth century.

Information from available ceramic reports shows variability in the amount of Asian market ware on Cape colonial sites (Table 4-1). The Granary, dating to the late seventeenth century, yielded the least amount of coarse porcelain, which made up 1.4% of the total MNV. This percentage rose to 10% for mid- eighteenth century sites and up to 18% to 23% for late eighteenth century assemblages. Asian market ware is still present on nineteenth century sites but in very small quantities (ACO 1991a).

Table 4-1: Asian market ware on Cape colonial sites ca.1690-1860 expressed as a percentage of the total ceramic MNV.

Site	Date	Total MNV of layer	% MNV Asian market
Granary Phase 7	c.1680-1700.	66	1.4%
Elsenburg Layer dbyc	c.1730-60)	313	10%
Paradise Outbuilding Phase.A	1735-50	164	9.7%
The Grand Parade	17th-18th c.	1135	10.8%
Paradise Main house Phase 4	1770-95	174	9.7%
Bree Street Phase 1	mid-late 18th c.	2761	18.6%
Barrack St Well Level 4	c.1770-90	51	23%
Sea St James' House Phase 2	late 18th-early 19thc.	853	11.7%
Sea St James' House Phase 3	early 19th c.	397	4.3%
Harrington St	2nd half 19th c.	3090	0.1%

Cape probate inventories include references to 'coarse' porcelain, but it is not always clear whether this means Asian market ware or second grade fine porcelain. Documentary and archaeological evidence makes it clear that coarse wares were used in all households and were not indicative of status. It is possible that, like coarse kitchen earthenwares, they were too commonplace to be 'seen' and thought worthy of recording in detail in household inventories. This is possible as the large quantities of excavated wares is out of proportion to small amounts mentioned in the inventories (Antonia Malan pers. comm.; Vos 1985).

Excavations undertaken in the Cape show that there appears to be a dramatic increase in the range of coarse wares available from the mid-eighteenth century onwards. This could be the result of increased exports to the Cape by the VOC as much as a wider selection of designs and forms produced in the East. Vos made a brief survey of eighteenth century inventories and noted a "significant increase of *grove porcelijn* approximately during the third quarter of the eighteenth century" (Vos 1985:17).

It is now possible to start building a chronology of Asian market wares based on the information from excavated Cape colonial sites and dated shipwrecks. For example, certain bowls (Appendix J: MD-3, 4 & 5) only occur on late seventeenth to early eighteenth century sites and have been retrieved from the wreck of the VOC ship *Oosterland* (1697) (Werz 1993b). Bowls decorated with roundels can be linked to the first half of the eighteenth century (Appendix J: MB-15a & 15b) while polychrome dishes and bowls are more common in the second half of the century (Appendix J: LD.ena.1; MB.ena.1 & .2). Large saucer dishes (Appendix J: LD.10 to .13) are associated with the early nineteenth century, and later medium bowls decorated with a floral scrolls occur throughout the eighteenth century (Appendix J: MB.1 to .3).

A number of theories have been put forward to explain the presence of large quantities of Asian market coarse porcelain on Cape sites, and many factors have to be considered when discussing their popularity in seventeenth and eighteenth century Cape colonial households. Asian market ware varies in quality, and even though they are coarse by today's standards, their appearance, glazing and strength were superior to most European manufactured ceramics of the time. To recap, they are all Asian open forms: deep bowls, and shallow dishes (mainly saucer-shaped) and are completely glazed inside and out, except for a number of vessels with biscuit rings or partially glazed bases. The nearest equivalent forms in European or locally manufactured wares are made in coarse earthenware. Asian market ware is always decorated, which sets it apart from most coarse earthenware vessels, especially those used for food preparation. Excavations show that Cape households used a range of coarse earthenwares and stonewares similar to that used in Europe, so it is unlikely that Asian market coarse porcelains displaced European ceramics but rather that they enlarged the range of cooking utensils.

Woodward suggested that the Cape was in not in a position to be selective about the type of porcelain it received from the VOC headquarters in Batavia during the Chinese porcelain shortage (ca.1657-81) and, consequently, was supplied with 'coarse porcelain'. During this period "it [the Cape] seems to have been supplied with not only Swatow but with lesser known provincial porcelain" (Woodward 1974:15). This could well be true, but the Cape continued to receive coarse porcelain alongside fine wares until the end of VOC rule in 1795 and possibly into the nineteenth century. The consignment of coarse wares on the *Geldermalsen* (1752) is evidence that the Cape specially requested this ware (Jörg 1986).

Slaves in the Cape, many of whom were from the Far East, lived within the houses of their owners and worked in the kitchens (Shell 1994:261). Much of the cuisine of the Cape was based on eastern-style dishes, rice and relishes (Abrahams 1996:229), and it is possible that Asian domestic utensils (coarse porcelains) were preferred by the Asian born householders and slaves for the preparation and serving of this food even though available European forms would have been adequate for the task.

This last theory assumes that coarse porcelains were used solely in the kitchen but there is little evidence to support this view. Vos (1985) has found archaeological evidence that a number of larger vessels were used over fires but careful analysis of other assemblages has showed no signs of such usage. Room by room probate inventories of the seventeenth and eighteenth centuries, which specifically mention *grove* (coarse) wares, record them throughout a house; in the kitchens, displayed on porcelain racks in living rooms and in storerooms of private houses from where they retailed to the public (Antonia Malan pers. comm.). Coarse porcelain dishes and bowls are, in contrast to coarse earthenwares, all decorated and many are on a par in appearance with Far Eastern export porcelain and European manufactured blue-and-white tin-glazed plates and dishes. Therefore, they could have also been used as tableware or ornamental ware (Woodward 1974:212). It is also possible that finely decorated, good quality coarse porcelains could have been listed as 'porcelain' in inventories.

Coarse porcelains were mentioned by Zacharias Wagenaer, the VOC Commander at the Cape from 1662-66, in a request he sent to Batavia in 1663. He noted that soldiers and sailors at the Castle were not issued with bowls or trenchers and would eat directly from the large metal or earthenware cooking pots, using spoons, shells, or even their hands. Wagenaer requested Batavia to send potters to the Cape, or he would have to ask for a consignment of coarse porcelain (Volker 1954:127). This indicates that he was aware of the form and usage of coarse porcelain in the East and that he possibly equated it with European coarse earthenware vessels. It is not clear whether the Cape required serving dishes or individual eating vessels. The crews of VOC ships ate in groups from large communal vessels (Bruno Werz pers. comm.) and it is possible that this practice was also used in the soldiers' messes at the Castle of Good Hope.

Importance of Cape sites in international research

The Cape assemblages of coarse porcelains can be directly linked to the activities of the VOC. They provide examples of the coarse bowls and dishes traded by the Company in the inter-Asiatic network during the second half of the seventeenth century and the whole of the eighteenth century. The presence of these wares on Cape sites in context with datable material such as clay pipes and fine porcelains, will allow archaeologists and art historians to link them to kiln sites in the Far East, especially China, and thus to date and provenance them accurately (Ho Chuimei 1995 pers. comm.).

Asian market ware has been excavated from nineteenth and twentieth century immigrant Chinese settlements in the United States. For example, a number of coarse porcelain dishes and bowls used by the newly arrived Chinese community in San Francisco in the late nineteenth century were excavated from a dump in association with European-style ceramics dating to ca.1880-1900 (Garaventa & Pastron 1983:figures 6,7,8 & 15). It is also possible that the small Chinese communities in South Africa used Asian market domestic wares after arriving in Africa, but this remains to be investigated.

Having reviewed in detail the production of Asian market ware and its occurrence at the Cape of Good Hope, the analyses of the full ceramic assemblages from four archaeological sites in Cape Town will now be presented, thus placing Asian market ware in its full context.

Chapter Five

The following four chapters present the results of the analysis, using the CCS, of the ceramics from four Cape colonial sites (Figure 5-1). The assemblages are described in chronological order beginning with the Granary, Castle of Good Hope, Cape Town (ca.1685 to ca.1700), followed by Elsenburg, Stellenbosch District (ca.1730 to 1760), and finally two Cape Town sites: James' House, Sea Street (ca.1770s to ca.1830s), and a well in Barrack Street (ca.1775 to the late nineteenth century).

Each chapter contains a brief history of the site and its former occupants, a description of the stratigraphy, a summary of the ceramic analysis and a commentary on the significance of the excavated ceramics. Photographs of each assemblage and the unabridged results of the ceramic analysis (Ware Table, Form / Function Table and Site Catalogue) for all the sites are presented separately in Appendices K and L.

The Granary (F2), The Castle of Good Hope, Cape Town

The earliest dated ceramic assemblage analysed using the CCS was excavated from the Granary, built after 1685 but before 1691, in the inner courtyard of the Castle (Figures 5-2 & 5-3).

History

The stone walled pentagonal Castle of Good Hope, which still stands today, replaced the inadequate earthen Fort built in 1652 by Jan van Riebeeck, the first Commander of the Cape. The foundation stones of the Castle were laid in 1666 and the five bastions, curtain walls and permanent gateway were completed by 1678 (Fitchett 1996). Occupation of the Castle began from 1674 onwards, beginning with the Garrison and followed at a later date (1680) by the new Commander, Simon van der Stel. In 1685, orders were given to build an additional defensive wall (the *Kat* wall) within the Castle which would divide the central open area into two separate courtyards. The *Kat* wall was completed before 1691, and a long, arched grain store (the Granary) was built against it on the inner courtyard side (Figure 5-3).

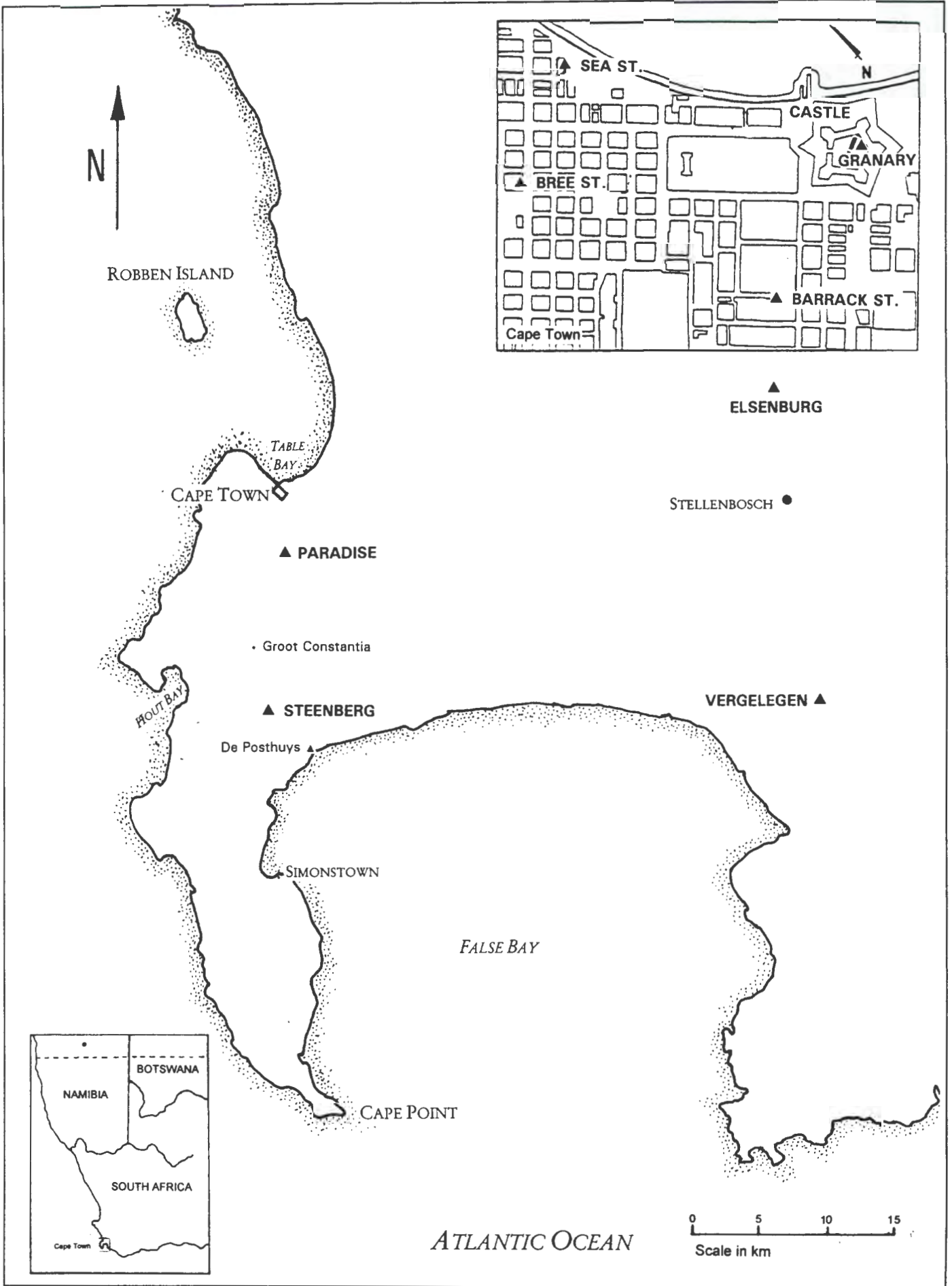

Figure 5-1: Location of historical sites in the south-western Cape region.

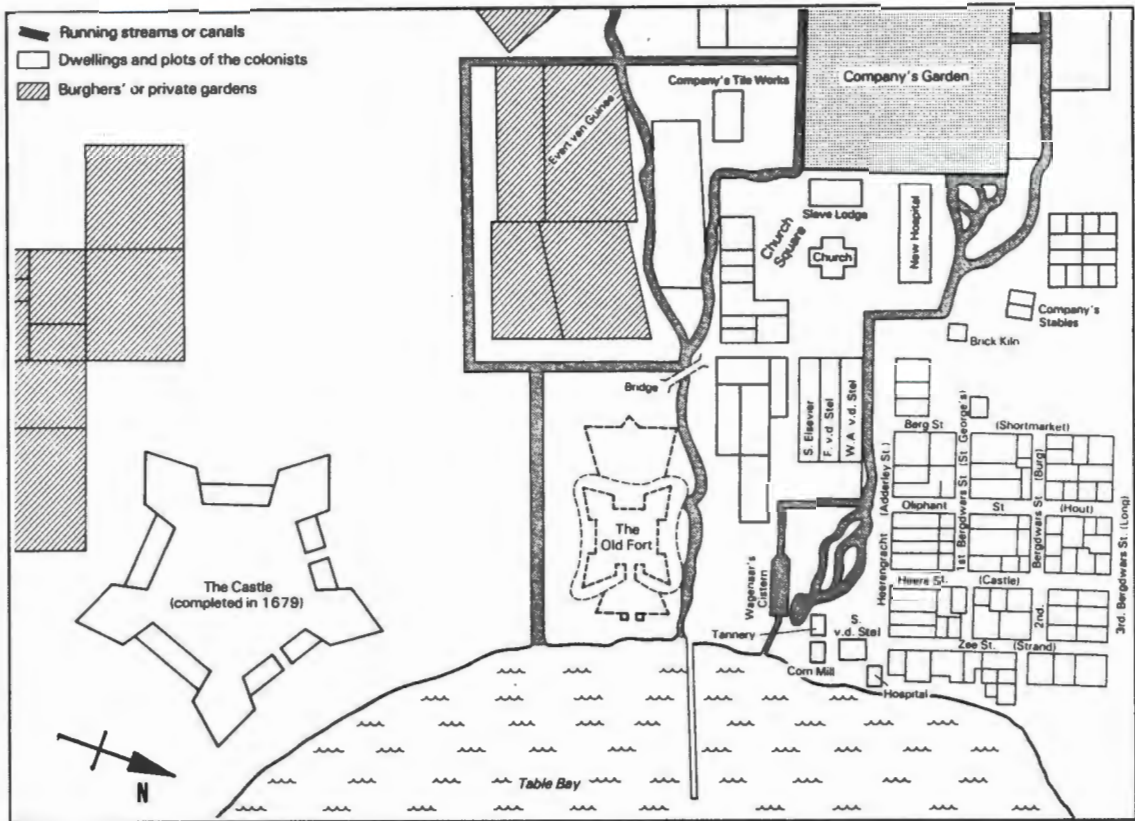

Figure 5-2: Plan of Cape Town showing the Castle of Good Hope, ca. 1705
 (from Bredekamp & van den Berg 1986).

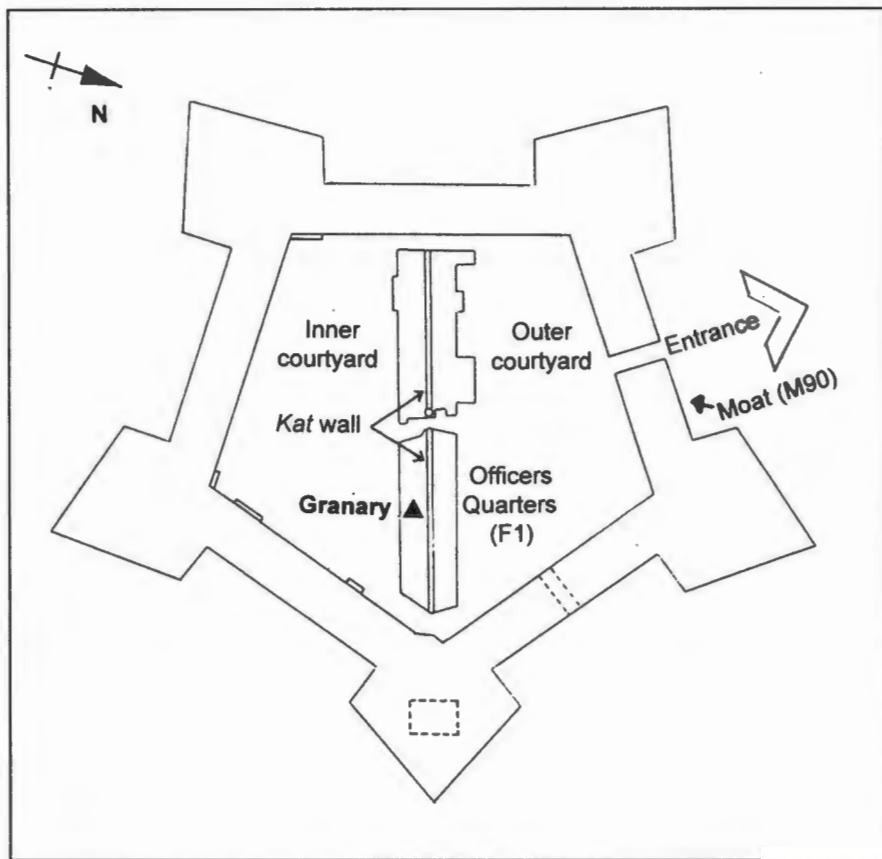

Figure 5-3: Position of the Granary within the Castle.

The Granary stored the grain from the Company's own fields and the free burgers' farms. It has been suggested that it was occasionally occupied by members of the under class, both slaves and low-ranking Company soldiers, during the early years of the Castle (Martin Hall pers. comm.)(Hall 1992a, 1992b, 1993). The inner structure and usage of the Granary changed over the years; at one stage it is known to have been an armoury and today it houses one of the Castle's museums.

Archaeological investigations

During extensive renovations to the Castle in the late 1980s, a chance arose to excavate beneath the original floor area of the Granary. A sequence of layers which related to pre-colonial times and the construction of the Castle from 1665 onwards were revealed. This time period included the erection of the *Kat* wall, the subsequent building of the Granary and ended with the usage and occupation of the Granary from the 1690s to the early eighteenth century.

Stratigraphy (Figure 5-4)

The stratigraphy of the site is shown in Figure 5-4. The excavated layers can be divided into pre-colonial and colonial deposits. It is a valuable archaeological excavation as very few Cape buildings of this age are standing today in which undisturbed deposits can be linked to a definite time period, in this case, the building of the *Kat* wall between 1685 and 1690.

Phase 1

Pre-colonial and colonial deposits that predate the building of the *Kat* wall ca.1690. This phase includes the clearing of the ground in 1665 prior to the building of the Castle in the follow year.

Phase 2

Fill from the first trench dug for the foundations of the *Kat* wall. This event took place between 1685 and ca.1690.

Phase 3

Post ca.1690 deposits that accumulated against the *Kat* wall after the first trench had been filled in and the ground levelled.

Phase 4

Trench fill from a partial re-excavation of the original fill around foundations of *Kat* wall.

Phase 5

Deposits from floor of the Granary after the second trench had been filled in and levelled. These layers contained remnants of hearths dug into a hard brown surface.

Phase 6

Walls with shallow foundations dug into Phase 5, built to form structures, possibly grain storage bins. This phase consists of architectural features only.

Phase 7

Deposits from the floor of the grain bins following re-occupation of the Granary.

These archaeological events ended with the building of a wooden floor resting on raised piers.

Cross-mends join Phases 1, 3 & 4 and Phases 5 & 7 both contain fragments from two identical vessels.

Martin Hall (1991c, 1992b) has shown that there is archaeological evidence to indicate that the Granary was occupied periodically and that certain artefacts were deposited *in situ* and are not evidence of secondary deposits brought from elsewhere in the Castle. Hall used this information, comparing it with reports of a North American slave site, to suggest that this part of the Castle was used intermittently as a living area by Company slaves before accommodation was provided for them elsewhere.

The full results of the ceramic analysis of the Granary assemblages are presented in Appendix L.

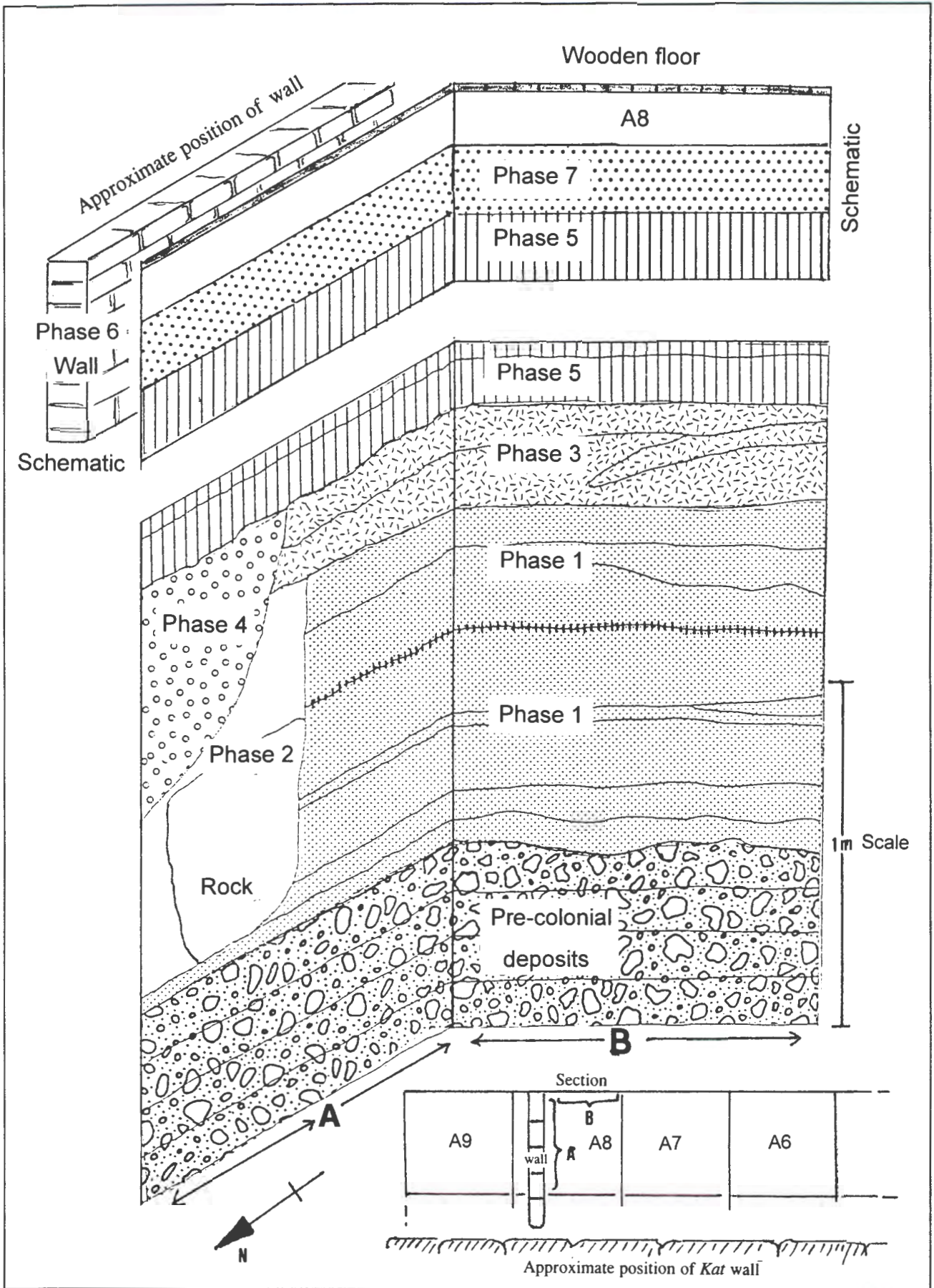

Figure 5-4: The stratigraphy of the Granary site (adapted from a drawing by Dave Halkett).

Summary of the ceramic analysis

The seven individual ceramic assemblages excavated from the Granary were small and highly fragmented; few complete or partially complete vessels were found. The problems commonly associated with high fragmentation, including the difficulty in estimating the number of vessels, were off-set by the small number of sherds in each ware sub-category, which made it possible to assess each sherd individually and in relation to the whole group.

The ceramics from the Granary will be described and discussed as one unit as there is little variation in the ware type, decoration, form and manufacturing dates of the vessels present in the whole assemblage. This method, however, can not reveal any small incremental changes in ceramic acquisition or usage that might have taken place between successive phases. The ceramics from the individual phases (Table 5-2) were re-analysed as one unit at a superficial level to estimate an approximate MNV for each category for the whole site (Table 5-1). The results are open to correction and this will be taken into consideration when discussing each individual ware type.

Table 5-1: Ceramics from the Granary (combined phases) expressed as approximate MNVs and percentage MNVs. Nineteenth century European wares shown in brackets.

		Approx. MNV	% MNV
Porcelain	1.1.1 Chinese export porcelain	40	23
	1.1.2 Asian market coarse ware	3	2
	1,1,3 Japanese export porcelain	12	7
	1.1.4 Persian 'stone-paste'	2	1
	1.2.2 British	[1]	-
	1.2.3 Unprovenanced European	[1]	-
	Stoneware	2.1.1 Chinese	8
2.2.1 German/Rhenish		25	14
Coarse earthenware	3.1.1 European	39	23
	3.1.3 European & Cape	9	5
	3.2.3 African/Asian	10	6
	3.2.3.1 Khoi	2	1
	3.3.1 Unprovenanced e/w	3	2
Tin-glazed earthenware	4.1.1 European	19	11
Refined earthenware	5.1.3 White bodied wares	[2]	-
Total approximate MNV excluding 19th c. wares		172	100%

Table 5-2:. Ceramics from Phases 1-5 & 7, the Granary (ca.1685 to ca.1700) expressed as MNVs and percentage MNVs.

The Granary Castle of Good Hope ca. 1685 - ca. 1700	Phase 1		Phase 2		Phase 3		Phase 4		Phase 5		Phase 7	
	MNV	%	MNV	%	MNV	%	MNV	%	MNV	%	MNV	%
		MNV		MNV		MNV		MNV		MNV		MNV
1.1.1 Chinese export porcelain	7	25	-	-	8	21.1	4	16	5	20.8	17	24.3
1.1.2 Asian market ware	-	-	-	-	1	2.6	1	4	-	-	1	1.4
1.1.3 Japanese export porcelain	1	3.6	-	-	3	7.9	-	-	2	8.3	6	8.6
1.1.4 Persian stone-paste	-	-	-	-	-	-	-	-	1	4.2	1	1.4
1.2.2 British porcelain	-	-	-	-	-	-	-	-	-	-	{1}	{1.4}
1.2.3 Unprov. European porcelain	-	-	-	-	-	-	-	-	-	-	{1}	{1.4}
2.1.1 Chinese/Japan./Other stoneware	1	3.6	-	-	2	5.3	1	4	1	4.2	5	7.1
2.2.1 German/Rhenish stoneware	4	14.3	1	50	10	26.3	5	20	4	16.7	5	7.1
2.2.3 Unprov. European stoneware	-	-	-	-	-	-	-	-	-	-	1	1.4
3.1.1 Euro. manufactured coarse e/w.	8	28.6	-	-	6	15.8	3	12	5	20.8	19	27.1
3.1.3 Euro./Cape manu. coarse e/w.	1	3.6	-	-	-	-	3	12	4	16.7	2	2.9
3.2.1 African coarse e/w. (Khoi)	2	7.2	1	50	1	2.6	1	4	-	-	-	-
3.2.3 Unprov. African/Asian coarse e/w.	-	-	-	-	1	2.6	2	8	-	-	3	4.3
3.3.1 Unprovenanced e/w.	-	-	-	-	-	-	-	-	1	4.2	2	2.9
4.1.1 European tin-glazed earthenware	4	14.3	-	-	6	15.8	5	20	1	4.2	4	5.7
5.1.3 Refined wares: White-bodied	-	-	-	-	-	-	-	-	-	-	{2}	{2.9}
TOTAL	28	100	2	100	38	100	25	100	24	100	66	100
											{4}	

{ } = intrusive 19th c. wares

On average, less than 10% of the ceramics in the whole assemblage were produced by the colonists. The majority were imported from northern Europe (Holland, the Rhinelands, England), the Near and Far East (China, Japan and Persia) and possibly from India and other parts of Africa. All the wares, with the exception of four nineteenth century British items, were in production during the last two decades of the seventeenth century. The Japanese porcelain and Persian 'stone-paste' porcelains could have been made in the 1670s or earlier while the white Delftware, Rhenish stoneware and Neiderrheinisches earthenware items were still being manufactured in the first decades of the eighteenth century. It is the Chinese porcelain tea and table wares present in all the

phases that confers a ca.1683 *terminus post quem* for the Granary assemblage. In addition, evidence from the analysis of the clay pipe stems found alongside the ceramics suggests that the deposition of all the layers in the Granary predate the lowest levels of the Castle Moat (post 1703) (Yates *et al.* n.d.).

The nineteenth century British sherds were all present in the uppermost layer (Phase 7). They will not be included in the analysis as their periods of production post-date the rest of the assemblage by at least 100-120 years which suggests that they are intrusive.

The ceramics from the Granary will now be described by ware category using the approximate MNV and percentage MNV as shown in Table 5-1. The porcelain is of Asian manufacture. It is all blue-and-white except for three vessels: two Chinese items, a *famille verte* tea bowl (F2-1/CPO.6) and an undecorated saucer (F2-1/CPO.7), and one undecorated Japanese bottle (F2-5/JPO.2).

1. PORCELAIN

1.1.1 Chinese export porcelain

MNV=40 (23.0%)

The Chinese porcelain is high quality export ware made for the European market in the late seventeenth century. It has a pure white body carefully decorated with sapphire blue cobalt under a clear glaze which is characteristic of the late Kangxi period (ca.1683 to 1720). Five items are marked with double rings including one exhibiting a central *lingzhi* (F2-3/CPO.7) and another with an unidentified mark (F2-7/CPO.16). Most of the identified items are teawares or small-sized dishes. There is one possible vase (F2-7/CPO.4). A small bowl, made from poorer quality porcelain, in Phase 3 might have been manufactured for the Asian market or be older than the other porcelains (F2-3/CPO.1).

1.1.2 Asian market ware - coarse porcelain

MNV=3 (2.0%)

The whole assemblage yielded three blue-and-white Asian market coarse porcelain vessels, two dishes and a bowl. High fragmentation hindered the precise identification or description of these wares.

1.1.3 Japanese export porcelain

MNV=12 (7.0%)

Japanese porcelains excavated in the Granary constitute about 7% of the total assemblage but almost a fifth of the porcelain category. They are all table wares: nine medium quality blue-and-white plates and flat-rimmed dishes, two blue-and-white bowls

(one lidded) (F2-1/JPO.1, F2-7/JPO.5) and a small undecorated white bottle, possibly a sauce bottle (F2-5/JPO.2). At least six of the plates and dishes have a panelled 'kraak porcelain' border. The large dishes in Phases 1 and 7 have alternate panels of peony and bamboo around the rim similar to that found on plates with the VOC monogram. (F2-3/JPO.1 & F2-7/JPO.1). A lidded bowl (F2-1/JPO.1) has only been tentatively classified as Japanese. The identification was based on the colour and texture of the body as well as the design which is reminiscent of seventeenth century Japanese coarse porcelain bowls (Ohashi 1990:157-163).

1.1.1 Persian stone-paste 'porcelain'

MNV=2 (1.0%)

A rim and two fragments of blue-and-white Persian stone-paste 'porcelain' were found in the upper layers of the Granary excavation and represent two vessels (F2-5/PPO.1 & F2-7/PPO.1). The body is friable with a granular texture and the glaze has become yellow and cracked.

2. STONEWARE

2.1.1 Chinese stoneware

MNV=8 (5.0%)

The whole assemblage contains sherds from six martevans (storage jars) and two Yixing vessels which are assumed to be tea pots.

2.2.1 German / Rhenish stoneware

MNV=25 (14.0%)

This category contains sherds from at least twenty bellarmine and bellarmine-style Rhenish stoneware bottles of various sizes, including one with a mask (F2-1/EST.1). The remaining stoneware vessels were jars, one with a wide flat rim which could possibly be a chamber pot (F2-5/EST.1).

3. COARSE EARTHENWARE

Coarse earthenware is the largest category of ceramics in the whole assemblage (37%) with the widest distribution of manufacturing countries. It is difficult to identify their precise area of manufacture and several sherds remain unprovenanced. The majority of the vessels are associated with cooking and food preparation.

3.1.1 European manufactured coarse earthenware

MNV=39 (23.0%)

This is the largest group within the coarse earthenware category. It includes cooking pots, skillets and lids, a colander (F2-7/CEW.13), plates/saucer-dishes, and a possible beaker

or mug (F2-1/CEW.8). Amongst the more unusual forms are Neiderrheinisches dishes, two decorated in green and brown with rouletting or scraffito (F2-7/CEW.16 & 17), and two others decorated on the upper surface, under a clear yellowish glaze, in green and brown over a white slipped body (F2-5/CEW.7; F2-7/CEW.18). This category also includes a red-bodied bottle or *kannetjie* with slip-trailed decoration (F2-1/CEW.4), two slipped and green glazed pipkins (F2-1/CEW.9 & .10), and a vessel tentatively identified as a crucible (F2-1/CEW.3) (Stacey Jordon pers. comm.).

3.1.3 European and Cape (European-style) manufactured coarse earthenware

MNV=9 (5.0%)

This category contains red-bodied cooking utensils. It is possible that many of the unprovenanced vessels in this combined European and Cape manufactured category will eventually be classified as European manufactured wares (Stacey Jordon pers. comm.)

3.2.1 African earthenware - Khoi

MNV=2 (1.0%)

Sherds from at least two Khoi pots were present in Phases 1 to 4. Most of the sherds (172) were found in Phase 1 while Phases 2, 3 & 4 yielded only five fragments.

3.2.3 Unprovenanced African / Asian earthenware

MNV=10 (6.0%)

This combined category contained four types of unidentified unglazed earthenwares (F2-3/AEW.1, F2-4/AEW.1, F2-7/AEW.1-3). Long-necked vessels found in Phases 3 and 7 (F2-3/AEW.1 & F2-7/AEW.3) have been tentatively classified as of Southeast Asian origin, possibly from the Philippines (Chapter 3).

3.3.1 Unprovenanced earthenware

MNV=3 (2.0%)

Phases 5 & 7 yielded a number of extremely thin, grey-bodied earthenware sherds (F2.7/EW.1) which have remained totally unidentified. They have not been found on any other Cape sites.

4. TIN-GLAZED WARES (ENGOBES)

4.1.1 Provenanced & unprovenanced tin-glazed earthenware MNV=19 (11.0%)

Two sub-categories of tin-glazed wares, white undecorated and blue-and-white, are evenly distributed throughout all the phases. Fragmentation made it difficult to identify all the individual vessel forms but most of the items are flat table wares including two blue-and-white plates (or dishes) (F2-3/TEW.5 & F2-7/TEW.3), an undecorated white flat-rimmed plate (F2-1/TEW.1) and lobed dish (F2-7/TEW.1). The assemblage contains at least one blue-and-white apothecaries' flask (F2-1/TEW.3).

Nineteenth century wares:

The nineteenth century European manufactured ceramics sherds were very small and included a fragment of undecorated white bone china, a rim of a polychrome porcelain bowl and two fragments of British refined white-bodied ware.

Commentary

The date of deposition of the ceramics in the Granary can be related to the building of the *Kat* wall ca.1685-90. After considering the known dates of manufacture of the ceramics, it is possible that they could have been deposited during a very short time period, perhaps as little as 20 years. This is difficult to prove as the stonewares, coarse earthenwares, and undecorated tin-glazed wares present in the assemblage remained unchanged in body, decoration and form for much longer periods of time than the Chinese and Japanese porcelains. Because decorative motifs on Asian export porcelain were regularly changed to suit the European markets, it should become possible to give more precise production dates for most of the Chinese porcelains from the Granary.

The composition of the whole Granary assemblage shows a reliance on European manufactured ceramics: coarse earthenware, tin-glazed wares (probably all Delftware) and Rhenish stonewares (see Figure 5-5). The ratio of Asian manufactured wares to all other wares is approximately 2:3 which differs from the mid-eighteenth century ratio of 4:1 (Eisenburg, Chapter 6 below). The most numerous ceramics present in the Granary assemblage are, in ascending order of frequency, European and colonial manufactured coarse earthenware dishes and kitchen utensils, German stoneware bottles, fine quality blue-and-white Chinese tea wares, Japanese, Persian and Delft tablewares, and Chinese martevans. The majority of the table wares are blue-and-white Japanese porcelain and blue-and-white and white Delft dishes and table plates.

All the excavated porcelains - Chinese, Japanese and Persian - are well known seventeenth century export wares and were probably part of the official consignments of ceramics shipped from Batavia to the Cape station from 1666 onwards (Chapter 1, Table 1-1). The high percentage of blue-and-white porcelain in the Granary assemblage is similar to that found in seventeenth century collections of Asian porcelain in Europe. Although the Japanese porcelain excavated in the Granary was probably part of the early official shipments to the Cape in 1675, 1676, and 1685, none of the fragments exhibited the VOC monogram. It is not known, however, if every item of Japanese porcelain

ordered by the Company for use by the officers in their outlying stations was marked in this way. The *kraak*-type border of peonies and bamboo found on the large flat-rimmed dishes in Phases 3 and 7 was used on panelled plates with the VOC monogram, but it also appeared on plates with other central designs (Ohashi 1990: 55-58).

The superb quality of the Chinese porcelain from the Granary was probably the norm for tea and tableware made in the late seventeenth century for the European market and is not necessarily indicative of special orders for expensive items. The high percentage of teawares and low number of table plates in the Granary assemblage matches the evidence from late seventeenth to early eighteenth century inventories (Antonia Malan pers. comm.). The popularity of teawares in Europe at the end of the seventeenth century is reflected in the sale of Chinese porcelain from an English East India Company ship *Dorothy* in London in 1696 (Table 5-3). In this shipment, eighty one percent of the items were tea, coffee and chocolate wares and less than one percent were plates (Richard Kilburn pers. comm.).

Table 5-3: Porcelain from the *Dorothy* sold in London in 1696 by the East-India Company.

	Nos. of items
Tea, coffee & chocolate wares	103,621
Ornamental wares	11,495
Bottles, flasks, jars & pots	7,231
Plates, dishes & bowls	6,062

Persian stone-paste 'porcelain' is a rarity on Cape sites and only two small official consignments are known to have been shipped to the Cape (Volker 1954:115). Isolated sherds have also been found in the Castle Moat and at Oudepost 1 (Appendix I.1). The presence of this ware in the Granary is strong evidence for a seventeenth century VOC context for the assemblage.

The Granary has a lower proportion of Asian market coarse porcelain when compared with mid to late eighteenth century Cape sites such as Elsenburg and Phases 1 & 2 of Sea Street (Chapters 6 & 7). Preliminary analyses of the ceramics from the Castle Moat (ca.1705-1750) give a low figure for these wares but results from Oudepost 1 (1669-1732) show that more than a third of the porcelain consists of Asian market ware.

All the European stoneware is from the Rhinelands and the majority of the vessels are Frechen-type bellarmine jugs, making them the most commonly occurring single vessel shape in the whole Granary assemblage. The Asian stonewares consist of martevans and Yixing teapots, a pattern which continues into the eighteenth century. The provenanced tin-glazed wares are Delftware and it has been assumed that the remaining highly fragmented wares are also of Dutch manufacture. The European manufactured coarse earthenwares are of much finer quality than the locally made wares.

There is evidence that artefacts in the upper layers of the Granary were deposited *in situ*, but it could be argued that the general characteristics of the ceramics in each phase, especially in the lower levels (Phases 1-4), indicate that all the sherds are in secondary context deposits, namely, high fragmentation, high MNV in relation to sherd count, few cross-mends and a low reconstruction of broken vessels.

The assemblages from individual phases are too small to use alone for reliable statistical analysis (see Table 5-2). They have similar but not identical ceramic profiles (Figure 5-5). A combination of all the phases could show the availability and usage of ceramics at the Castle at the end of the late seventeenth century (Figure 9-1, column 1 below). In addition, the low MNVs coupled with the high percentage of unidentifiable vessel shapes, make the comparison of form and function within the site unsatisfactory, especially when using pie charts (Figure 5-6). It would be unwise, though, to draw firm conclusions from this single assemblage until it can be compared with other late seventeenth century Cape VOC sites.

The range of ceramics found in the Granary is indicative of the enormous trading area of the VOC in the East during the last quarter of the seventeenth century and the ceramic profiles of the assemblages could donate the signature of a VOC occupation at the Cape in the late seventeenth century.

The Granary - Castle of Good Hope c.1685 - c.1700

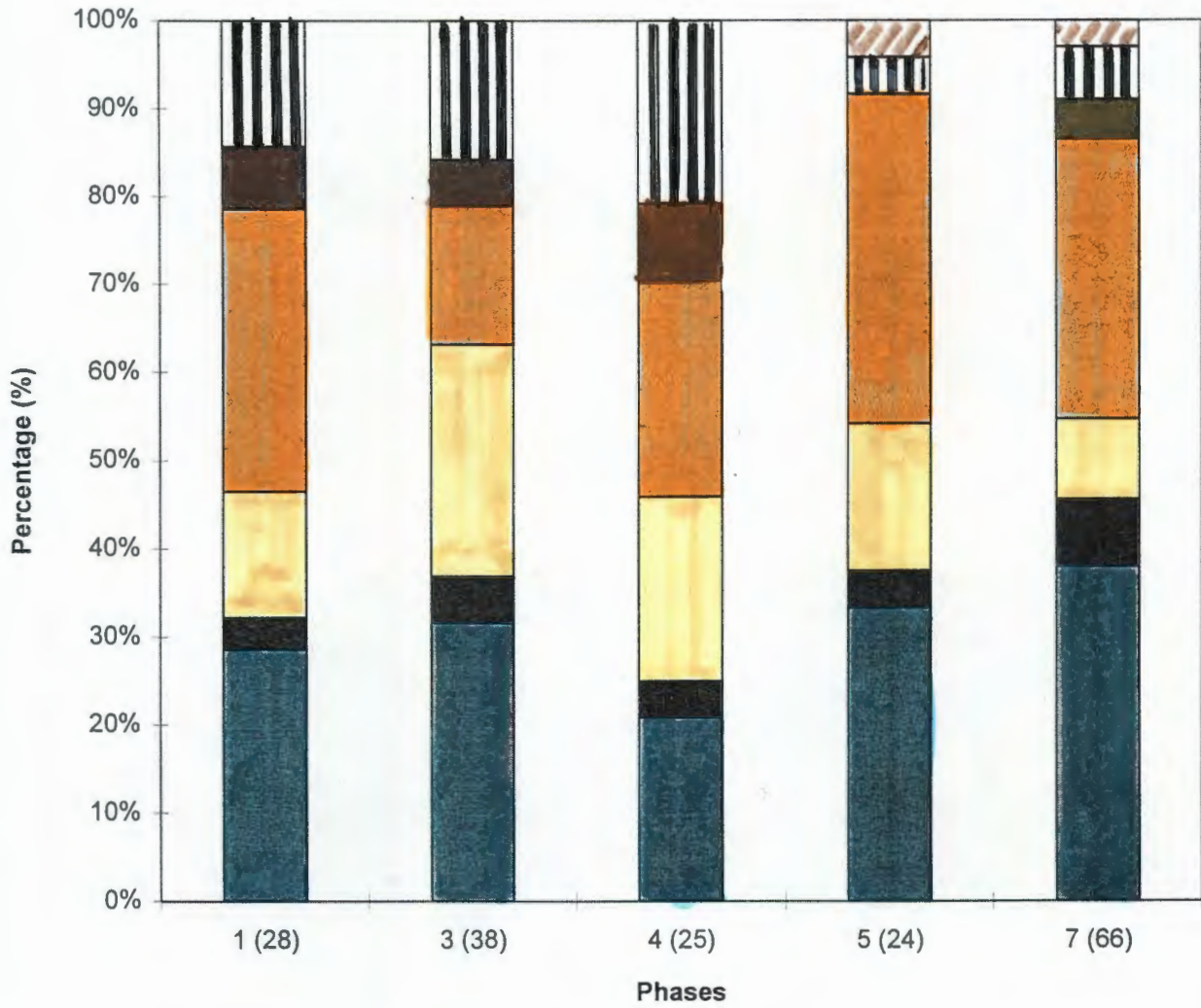

The Granary Castle of Good Hope		Phases (total MNV per phase)											
		1 (28)		2 (2)		3 (38)		4 (25)		5 (24)		7 (66)	
KEY	CERAMIC TYPES	MNV	% MNV	MNV	% MNV	MNV	% MNV	MNV	% MNV	MNV	% MNV	MNV	% MNV
	Unprovenanced earthenwares	-	-	-	-	-	-	-	-	1	4.2	2	3
	4.1 European tin-glazed earthenware	4	14.3	-	-	6	15.8	5	20	1	4.2	4	6
	3.2 African/Asian coarse earthenware	2	7.1	1	50	2	5.3	3	12	-	-	3	4.5
	3.1 European-style coarse earthenware	9	32.1	-	-	6	15.8	6	24	9	37.5	21	31.8
	2.2 European stoneware	4	14.3	1	50	10	26.3	5	20	4	16.7	6	9.1
	2.1 Asian stoneware	1	3.6	-	-	2	5.3	1	4	1	4.2	5	7.6
	1.1 Asian porcelain	8	28.6	-	-	12	31.6	5	20	8	33.3	25	37.9

Figure 5-5: Ceramic profiles of phases 1-5 & 7, the Granary (ca.1685 to ca.1700).

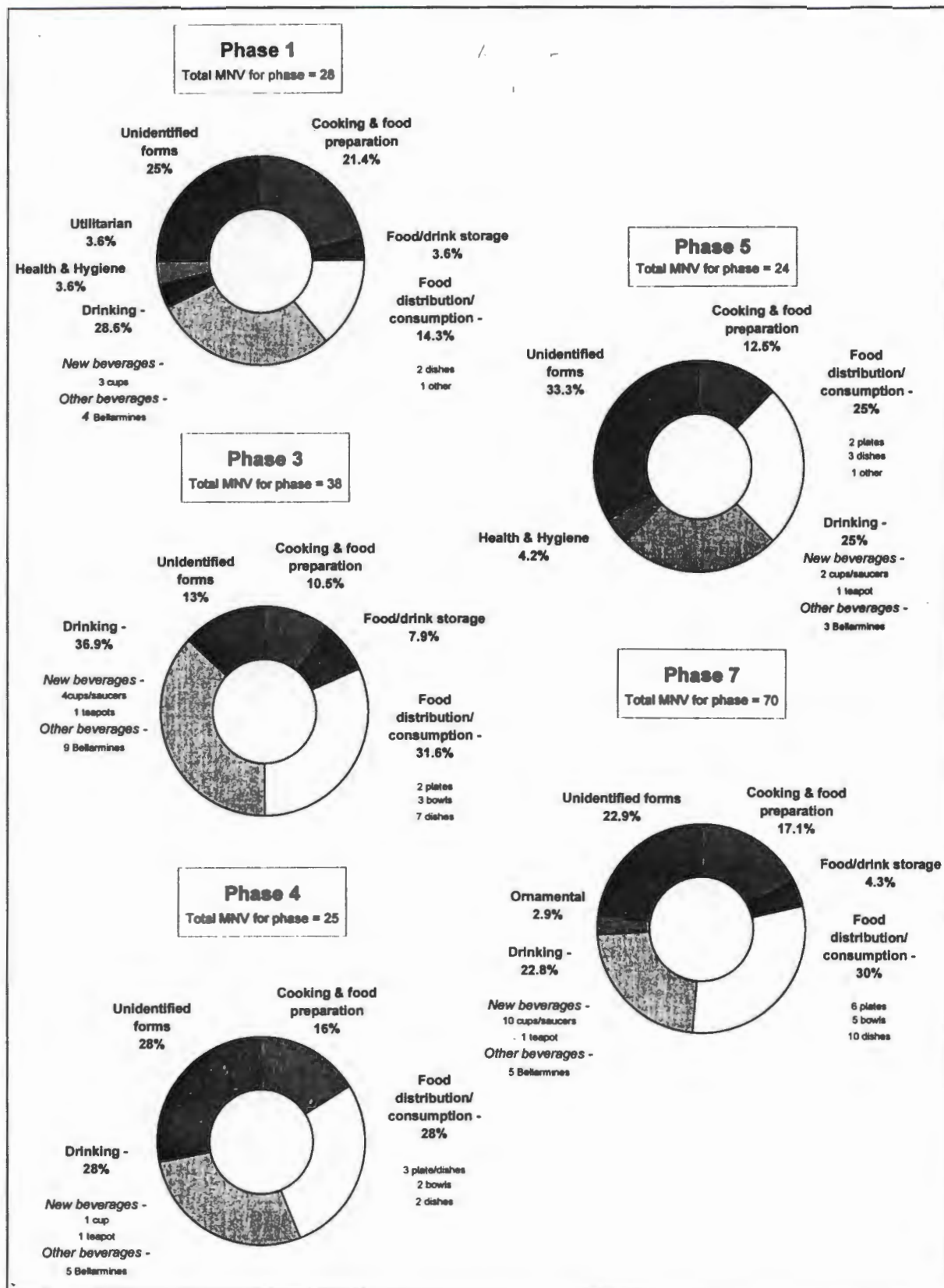

Figure 5-6: The form and function of the ceramics from Phases 1, 3-5 & 7, the Granary, Castle of Good Hope (ca.1685 to ca.1700).

Chapter Six

Eisenburg - the kitchen midden

History

Eisenburg is situated near Stellenbosch, a town founded in 1679 and lying inland and approximately 40 kilometres distant from Cape Town (see the map, Figure 5-1). In 1698, the farm was granted to Samuel Elsevier, the second in command of the VOC in the Cape, but it is not certain when the first house was built (Fransen & Cook 1980:166-167). Eisenburg became a prosperous and elite farmstead, with ownership of the property passing through several families before it was acquired by Martin Melk in 1752. His wife, Anna Hop, had inherited Eisenburg in 1747 from her first husband, Jan Gibelaar, who had owned the house from 1742 (ACO 1993). The Valck family had occupied Eisenburg from 1724-1741 but it is more likely that the contents of the excavated kitchen midden are linked to Anna Hop, first as wife and then widow of Jan Gibelaar and later when she was married to Martin Melk in 1752. The Melk family retained ownership of Eisenburg until it became Government property in the late nineteenth century and the land is now farmed by Stellenbosch University.

The present day Eisenburg was built by Martin Melk in 1761 but little of the original fabric of the building remains. The house was rebuilt following a fire in ca.1915 and has been altered and heavily restored on several occasions since then. The exact position of the previous house is not known.

Archaeological investigations

The latest renovations to Eisenburg took place in 1994 and were aimed at restoring the building to its original form (Figure 6-1). During these procedures, archaeologists were allowed to investigate a few of the remaining undisturbed deposits within, and adjacent to, the Manor House. The excavations resulted in the discovery of a large midden under the floor of the existing kitchen. Further excavation of adjacent areas revealed that the midden extended outside the house and that the foundations of the kitchen walls of the

present house and the *bakoond* (oven) cut through the midden, indicating that they post-dated the deposition of the ceramic bearing deposits (ACO 1993).

The analysed ceramics were all retrieved from midden material excavated from area D, situated within the foundation walls of the kitchen of the 1761 house (Figure 6-1). Sherds from the same midden, but situated outside the walls, were not included in the analysis. The thickest part of the midden lay in D1, D2, D5 & D6 and the deposit thinned out towards the front of the house. It is difficult to estimate what percentage of the midden has been excavated.

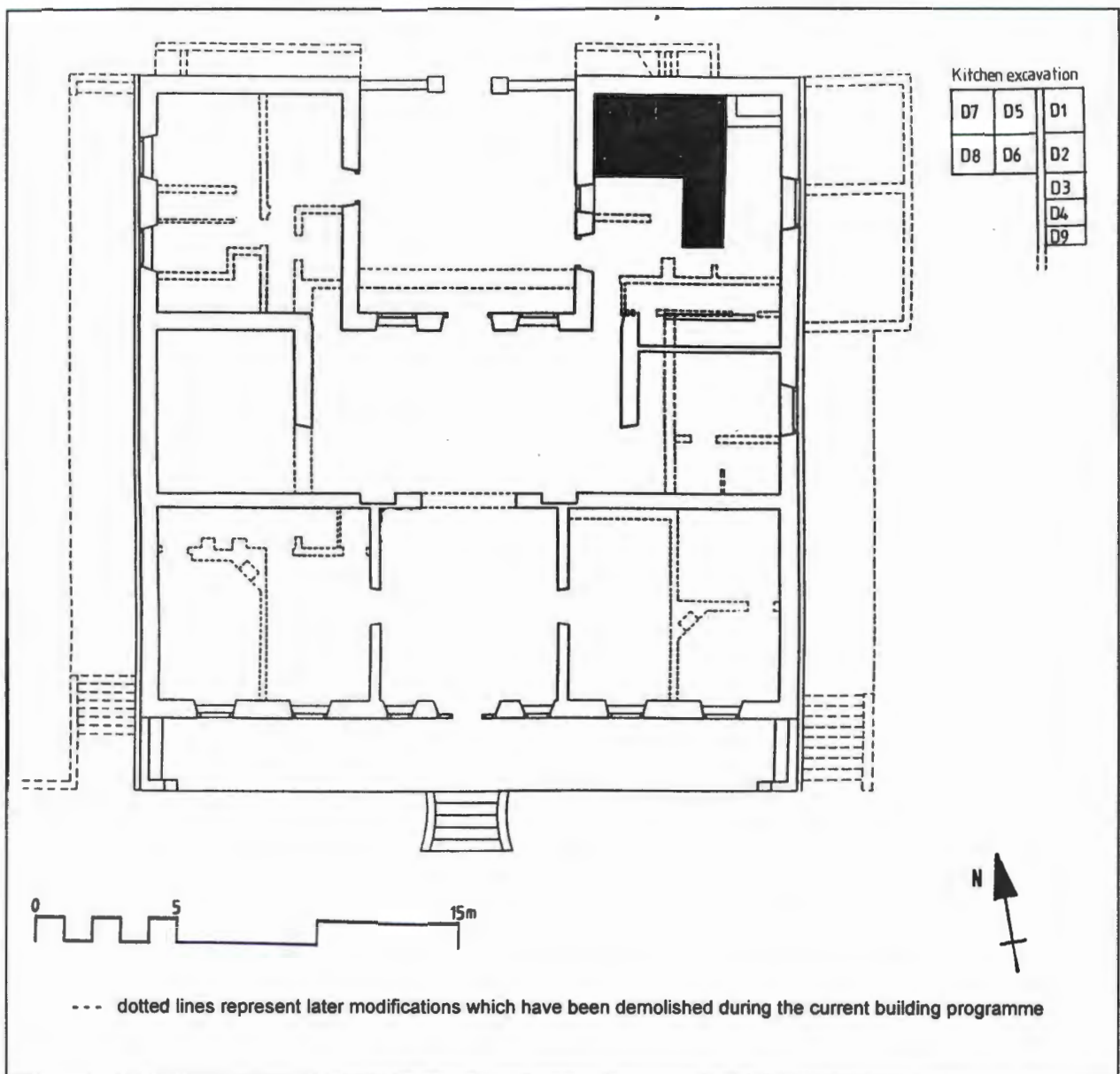

Figure 6-1: Location of the kitchen midden within the existing structure of Eisenburg Manor House (1761) (ACO 1993).

Stratigraphy (Figure 6-2)

The excavation in the kitchen area D had a clearly defined eight layer stratigraphy.

Layer 1 - Hard gritty clay. The original land surface.

Layer 2 - Dark brown deposit. (dbyc)

Layer 3 - Soil containing a charcoal fleck. (cf)

Layer 4 - Fill in wall trenches.

Layer 5 - Brick rubble layer.

Layer 6 - Loose brown gritty soil

Layer 7 - Charcoal and ash

Layer 8 - Loose brown soil

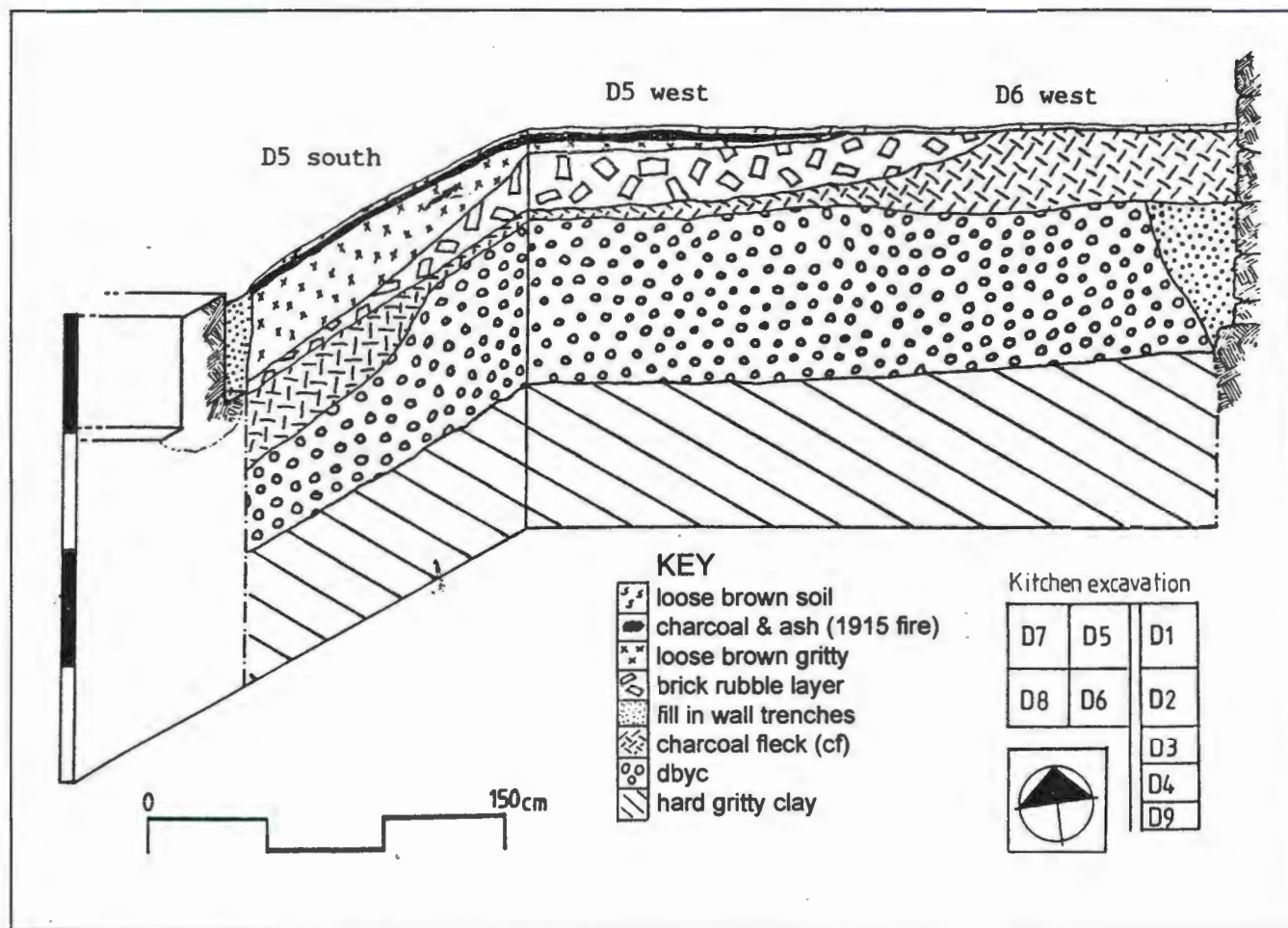

Figure 6-2: Stratigraphy of the Eisenburg kitchen midden (from ACO 1993).

The midden lay on the original land surface (Layer 1) and consisted of two layers: dbyc (Layer 2) which yielded the bulk of the artefactual material; and cf (Layer 3), derived from dbyc and other deposits. Layer 3 was spread over Layer 2 after the digging and filling-in of the foundation wall trenches. Following this event, Layers 2 and 3 were capped by a layer of broken and disintegrated bricks (Layer 5), which accumulated during the building of brick walls on top of the stone foundations of the 1761 house. The red-brick layer (Layer 5) was levelled off with soil (Layer 6) prior to the construction of the wooden floors in the original house. A thin layer of charcoal and ash (Layer 7) from the 1915 fire covered the whole area and was sealed by a layer of hard gritty clay (Layer 8) which lay directly under the rebuilt floor of the kitchen.

Ceramics were also recovered from Layer 4 (wall trench fill) and Layer sd (surface dump) present in areas D1, D2, D3, & D4/D9. Layer sd showed a reversed stratigraphy and came from a trench dug into the midden layers during the construction of the *bakoond* (oven) in the kitchen (not shown in Figure 6-1). Archaeological evidence indicates that the cf and sd deposits were partly derived from dbyc.

The complete results of the analysis of the ceramics from Elsenburg kitchen midden are presented in Appendix L.

Summary of ceramic analysis

An overall view of the assemblage shows that the ceramics from the midden were manufactured during the early to mid-eighteenth century. The majority, with the exception of the European-style coarse earthenwares, were probably imported into the Cape during the second quarter of the eighteenth century and deposited in the ground throughout the 1730s to 1750s. Evidence from the clay pipe analysis suggested a similar, but slightly wider, time span for usage of the midden (ACO 1993). The predominant ceramics are Chinese and Japanese export porcelains, some of which are of a very high quality. No indigenous pottery has been identified.

The largest assemblage came from Layer dbyc (MNV=313) with considerably lower vessel counts in Layer cf (MNV=83) and Layer sd (MNV=62) (Table 6-1). Many of the fragments are large and it has been possible to reconstruct a number of vessels. Over 40% of the vessels in Layers cf and sd cross-mend or match with Layer dbyc. All three layers, dbyc, cf and sd, have similar ceramic profiles (Table 6-1 & Figure 6-3) and almost identical dates of manufacture for their constituent vessels.

They will be discussed together but the quantities and percentages of ceramics mentioned in the summary of the ceramic analysis will refer to Layer dbyc only (Table 6-1). The form and function of the vessels in Layers cf and sd were almost identical to Layer dbyc (illustrated in Figure 6-4).

Table 6-1: Ceramics from layers dbyc, cf & sd, Elsenburg kitchen midden (ca.1730 - 1760) expressed as MNVs and percentage MNVs.

Elsenburg - the kitchen midden ca. 1730 - 1760	Layer dbyc		Layer cf		Layer sd	
	MNV	%	MNV	%	MNV	%
		MNV		MNV		MNV
1.1.1 Chinese export porcelain	204	65.1	59	71.1	42	67.7
1.1.2 Asian market ware	31	9.9	7	8.4	5	8.1
1.1.3 Japanese export porcelain	30	9.6	5	6	6	9.7
2.1.1 Chinese/Japan./Other stoneware	6	1.9	1	1.2	1	1.6
2.2.1 German/Rhenish stoneware	4	1.3	2	2.4	1	1.6
3.1.1 Euro. manufactured coarse e/w.	2	0.6	-	-	-	-
3.1.3 Euro./Cape manu. coarse e/w.	29	9.3	5	6	6	9.7
4.1.1 European tin-glazed earthenware	6	1.9	3	3.6	1	1.6
5.1.4 Other refined earthenwares	1	0.3	1	1.2	-	-
TOTAL	313	100	83	100	62	100

1. PORCELAIN

Porcelain is the largest ware category in all three assemblages: over three quarters is Chinese export porcelain for the European market and the remainder almost equally divided between Japanese export porcelain and Asian market coarse porcelain. No European porcelain was found. Blue-and-white porcelain wares outnumber the more expensive enamelled wares in the ratio of 3:1 in the whole assemblage, but Japanese porcelain alone shows a ratio of 1:1. The quality and variety of teawares surpasses that of the table wares. The porcelain assemblage also contains a small collection of

ornamental items: jars, garnitures and a figure. All the porcelains mentioned below are blue-and-white unless described otherwise.

1.1.1. Chinese export porcelain

MNV=204 (65.1%)

The quality and designs of the excavated Chinese blue-and-white porcelains are typical of eighteenth century export wares made for the European market. Overall, the wares show many similarities in form and decoration to the porcelains found on the wrecks of the *Goteborg* (1745) and the *Geldermalsen* (1752) (Jörg 1986, Sheaf & Kilburn 1986).

The table wares from Elsenburg include good quality blue-and-white matching table plates and serving dishes. The most frequently occurring rim designs are 'grape vine & bamboo' (ELS-dbyc/CPO.6-10, ca.1725-45), blossoms reserved in white on blue (ELS dbyc/CPO.3, found on eighteenth century Cape sites), floral sprays (ELS dbyc/CPO.12-20, 28-37), and overall incising below a narrow diaper border (ELS dbyc/CPO,22 & 38, ca.1720-40). Central designs include 'Hundred and One Antiquities' (ELS-dbyc/CPO.6-10), long handled baskets of flowers (ELS-dbyc/CPO.1), and groups of trees and flowering plants. Five matching dishes (ca.1720-40) with fluted sides and lobed edges, are painted with a panelled design (ELS-dbyc/CPO.43-47) and a graduated set of four flat-rimmed dishes have an overall incised design (ELS-dbyc/CPO.38-41 1720-40, 1720-40). Layer dbyc also contains three enamelled dinner plates decorated in red and gilt, one of which (ELS dbyc/CPO.165) is elaborately decorated and could have been manufactured in 1720 (Le Corbeiller 1974:43 figure 16).

Medium sized bowls form another large group of porcelain tablewares. They are painted with combinations of either flowers, rocks and trees, landscapes, or have incised designs. Less carefully executed designs include the 'aster' pattern (ELS-dbyc/CPO.59) and one with a wide honeycomb diaper at the outer rim which is frequently found on eighteenth century Cape sites (ELS-dbyc/CPO.52). Amongst the less commonly excavated porcelain tablewares are a salt (1/A13 dbyc, Appendix J:32), possible lids of mustard jars (ELS-dbyc/CPO.178) and two cutlery handles (ELS-dbyc/CPO.181).

The teawares include thirty six tea bowls (no handled cups were recovered) and fifty one saucers. They are decorated with at least twenty seven different patterns. Popular blue-and-white designs include river landscapes, rocks or fences with flowers and trees, and floral sprays. Amongst the enamelled teawares are examples of Chinese Imari and exceptionally fine quality *famille rose* wares, including two saucers enamelled with

cockerels (ELS-dbyc/CPO.150) and a matching set of moulded and incised cups and saucers decorated with peonies and insects (ELS-dbyc/CPO.157-163). Layer dbyc also yielded two identical blue-and-white globular teapots painted with chrysanthemums (ELS-dbyc/CPO.172).

Chinese porcelain ornamental wares comprise three blue-and-white jars (ELS-dbyc/CPO.183-5) and sherds from a large *famille rose* figurine, possibly of a woman (ELS-dbyc/CPO.194).

1.1.2 Asian market ware - coarse porcelain MNV=31 (9.9%)

Layer dbyc contains twenty seven blue-and-white Asian market coarse porcelain bowls and dishes. Two unprovenanced good quality porcelain bowls, enamelled in red and green (ELS-dbyc/CPW.39/40), have been included in this category as similar bowls, but with the addition of a biscuit ring, have been found on other mid-eighteenth century colonial assemblages (Bree Street & Mount Nelson sites, Cape Town, Appendix I.1). The blue-and-white coarse wares include two less commonly occurring forms; a large deep bowl painted with a landscape (ELS-dbyc/CPW.17) and a small bowl, possibly a tea bowl, decorated with fish and water weed (ELS-dbyc/CPW.22).

1.1.3 Japanese export porcelain MNV=30 (9.6%)

The Japanese porcelain category contains equal amounts of blue-and-white and enamelled wares. Table wares include blue-and-white plates with *kraak*-style panelled borders: two good quality ones with alternate peony and bamboo panels and ten painted in a paler cobalt blue, with peony and symbol panels surrounding a central design of fruit and leaves. One plate was poorly fired (ELS-dbyc/CPW.4). There are dishes painted in underglaze blue and enamelled with red and gilt (ELS-dbyc/CPW.14 & 15).

The assemblage includes four medium-sized underglaze blue and enamelled bowls with fluted sides and scalloped rims (ELS-dbyc/JPO.16-19). Three of them, possibly all four, are painted with flowers and running hares. There are also three identical small shallow dishes with fluted sides and scalloped rims, enamelled with a panelled design and flowers (ELS-dbyc/JPO.22-24).

Japanese teawares comprise two matching cups and saucers: one set decorated in Imari colours and the other with butterflies and millet in red enamel and gilt on very thin white porcelain.

Ornamental wares are represented by a set of four matching red and gilt vases and jars made in a greyish bodied porcelain (ELS-dbyc/CPO.186-9). The identification of these vessels as Japanese is tentative. The final item of Japanese porcelain is a neck of an apothecaries' flask, probably undecorated (ELS-dbyc/JPO.28).

2. STONEWARE

This is a small category, comprising just over 3% of the total MNV, with almost equal amounts of Asian and European wares.

2.1.1 Chinese & Japanese stoneware **MNV=6 (1.9%)**

The Chinese wares are two martevans, and two teapots and a lid (from an unidentified form) made from Yixing stoneware (ELS-dbyc/OST.5). Japanese stoneware is represented by a *donabe*, a brown-glazed footed cooking pot, made for the Japanese domestic market and rarely seen outside Japan (ELS-dbyc/OST.7) (Ohashi Koji pers. comm.).

3.1.1 German/Rhenish stoneware **MNV=4 (1.3%)**

Frechen-type brown salt-glazed wares include a possible Bellarmine-type jug (ELS-dbyc/EST.1) and the base of a small bottle or flask. Grey Westerwald-type salt-glazed items include a handled bottle splotted with cobalt blue (possibly part of a letter) (ELS-dbyc/EST.3), and an unidentified wide, flat rimmed vessel which could be a chamber pot (ELS-dbyc/EST.2).

3. COARSE EARTHENWARE

This category comprises 10% of the assemblage and is the second largest category in the Elsenburg midden. High fragmentation of the sherds made it difficult to identify specific forms and area of manufacture. All the vessel forms are European and most of them appear to have been made in the Cape. No indigenous pottery or other African or Asian wares were found.

3.1.1 European manufactured coarse earthenware **MNV=2 (0.6%)**

This category includes a lid and a finely potted buff-bodied jar with a yellow glaze (ELS-dbyc/CEW.5) which could possibly be of European manufacture (Stacey Jordon pers. comm.)

3.1.3 European & Cape manufactured coarse earthenware MNV=29 (9.3%)

The majority of the vessels were used for the preparation and cooking of food and included cooking pots, skillets and various sized lids.

3. TIN-GLAZED EARTHENWARE

4.1.1 European tin-glazed earthenwares MNV=6 (1.9%)

This was one of the smallest categories of ceramics. It contains at least three items of blue-and-white teaware decorated with flowers: a small bowl, and a tea bowl and matching saucer. The undecorated wares include one large and two small white chamber pots.

3. REFINED EARTHENWARE

5.1.4 Other refined earthenware MNV=1 (0.3%)

Only one item was recovered. It is an English fine red earthenware bowl with sprigged decoration under a shiny ginger glaze ca.1740-60 (ELS-dbyc/REW.1).

Commentary

Elsenburg kitchen midden is an important archaeological site for two reasons; it was sealed by the building of the extant Manor House in 1761 and its contents can be linked to individuals and their families who lived at Elsenburg during the first half of the eighteenth century. The results of the ceramic analysis suggest that the greater part of the kitchen midden accumulated throughout the 1740s-1750s, the period when Anna Hop was resident on the farm.

The large number of cross-mends between Layers dbyc, cf and sd suggest filtering of sherds down through the midden and deliberate post depositional movement of the discarded artefacts. Any possible differences in the date of deposition of the vessels in Layer dbyc and the overlying Layer cf are therefore difficult to detect using evidence from the ceramics alone.

The basic types and proportions of ceramic wares excavated at Elsenburg are similar to other eighteenth century Cape colonial assemblages (Bree Street, Appendix I.1 & Figure 6-1). The range and quality of the Elsenburg porcelains, however, are above the norm and indicate that the owners were prosperous and had access to expensive and fashionable porcelains. For example, the Japanese enamelled wares and the exquisite Chinese *famille rose* teawares were unlikely to have formed part of an official porcelain cargo and were probably specially ordered. Other less common porcelains, perhaps again indicating high status, are the ornamental wares: a four pieces of a Japanese red and gilt garniture, large blue-and-white Chinese jars and a *famille rose* figure of a woman. These items would have been well curated and it is unusual to find large quantities of them on Cape archaeological sites.

One out of every nine pieces of fine porcelain is Japanese export porcelain. This was an expensive commodity which always fetched a higher price in Europe than Chinese ware. The VOC had ceased its official trade with Japan in 1713 but Company representatives continued to trade in a private capacity until the second half of the eighteenth century (Nishida 1986:64). The Elsenburg porcelains are examples of this private trade, and illustrate the continuing popularity and availability of Japanese porcelain at the Cape, especially blue-and-white *kraak* style plates which had been produced since the 1670s.

The excavated Asian porcelains contain a wide range of tablewares, including sets of identical plates, dishes and bowls and more unusual items such as cutlery handles, lidded jars and a salt. Blue-and-white dinner services, containing a variety of matching plates, dishes, tureens, salts and sauce boats were ordered by the VOC for Europe from 1729 onwards but there is no evidence of such a service in the Elsenburg midden. This ties in with evidence from eighteenth century Cape probate inventories (Antonia Malan pers. comm.). There are at least twenty seven different decorative designs of teacups and saucers. Although this does not necessarily represent the number of tea-sets used at Elsenburg, there are enough matching items in blue-and-white, and enamelled wares to indicate the possession of an unusually large quantity of high status teawares.

All the coarse earthenware kitchen utensils, except for two items, appear to be locally made, showing that the Cape had become self sufficient and no longer needed to import coarse wares from Europe.

Elsenburg yielded an English fine red earthenware bowl manufactured between 1740-60, probably in the 1750s (David Barker pers. comm.) It is unusual to find early to mid- eighteenth century Staffordshire pottery on Cape colonial sites. Another unexpected result was finding blue-and-white Delft teaware amongst the numerous sets of delicate Chinese and Japanese cups and saucers.

The assemblage was examined alongside Gibelaar's 1747 inventory (Appendix I.2) a record of his possessions before they were inherited and used in the following years by Anna Hop. The written descriptions of ceramics are minimal and vague but they give an idea of the quantity and form of the porcelains at Elsenburg during the 1740s and 1750s. The inventory records that porcelain plates (77 items) and dishes (22 items) outnumber the pewter equivalents in the ratio of approximately 3:1 and 2:1 respectively. Other porcelain includes two garnitures, an unspecified amount of teaware and small bowls, and three jugs or tankards. The inventory also mentions a collection of unspecified coarse earthenwares.

The excavated assemblage of broken and discarded wares was compared with the inventory (Appendix I.2) and examined for possible matching or similar items. It contained a high percentage of plates, dishes and medium sized bowls, a wide variety of teawares, a garniture and two ornamental jars, and coarse earthenware kitchen utensils but no tankards or jugs. This demonstrates the difficulties encountered when comparing probate records with excavated material and shows that neither is a complete or accurate reflection on its own of the ceramics in use at Elsenburg in the early to mid eighteenth century.

Chart1

Elsenberg - the kitchen midden ca.1730 to 1760

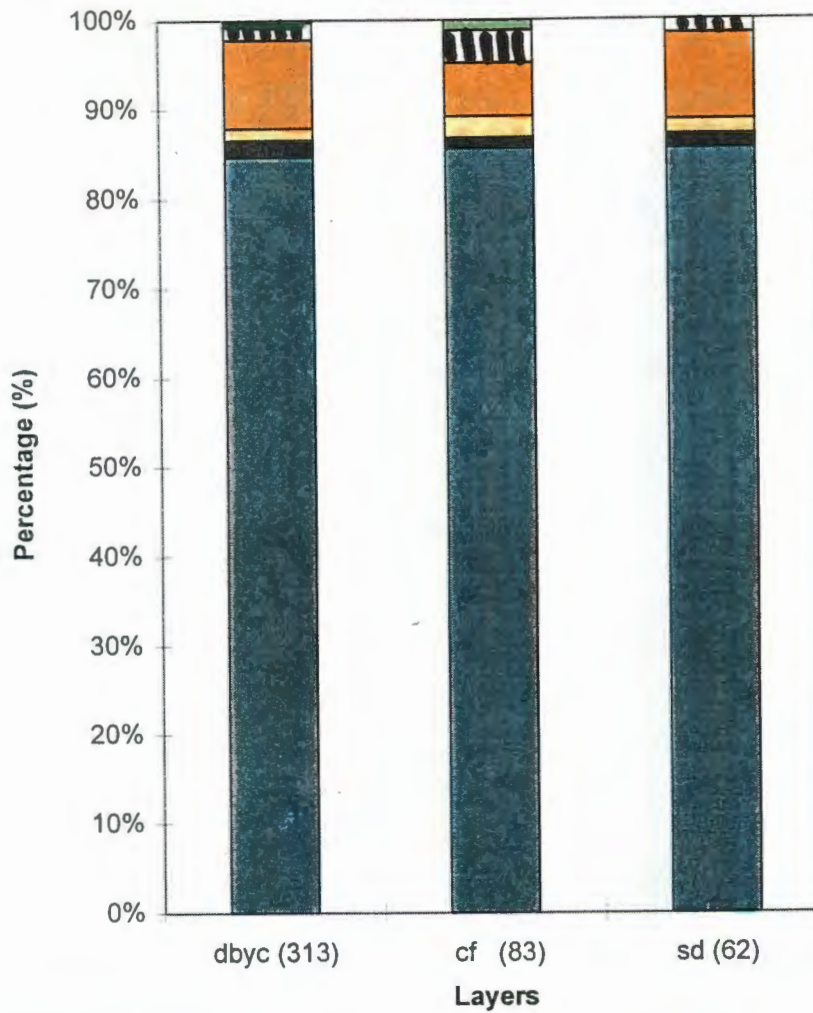

Elsenberg - the kitchen midden		Layers (total MNV per layer)					
		dbyc (313)		cf (83)		sd (62)	
KEY	CERAMIC TYPES	MNV	% MNV	MNV	% MNV	MNV	% MNV
	5.1 European refined wares	1	0.3	1	1.2	-	-
	4.1 European tin-glazed earthenware	6	1.9	3	3.6	1	1.6
	3.1 European-style coarse earthenware	31	9.9	5	6	6	9.7
	2.2 European stoneware	4	1.3	2	2.4	1	1.6
	2.1 Asian stoneware	6	1.9	1	1.2	1	1.6
	1.1 Asian porcelain	265	84.6	71	85.5	53	85.5

Figure 6-3: Ceramic profiles of Layers dbyc, cf & sd, Elsenburg kitchen midden (ca.1730 to 1760).

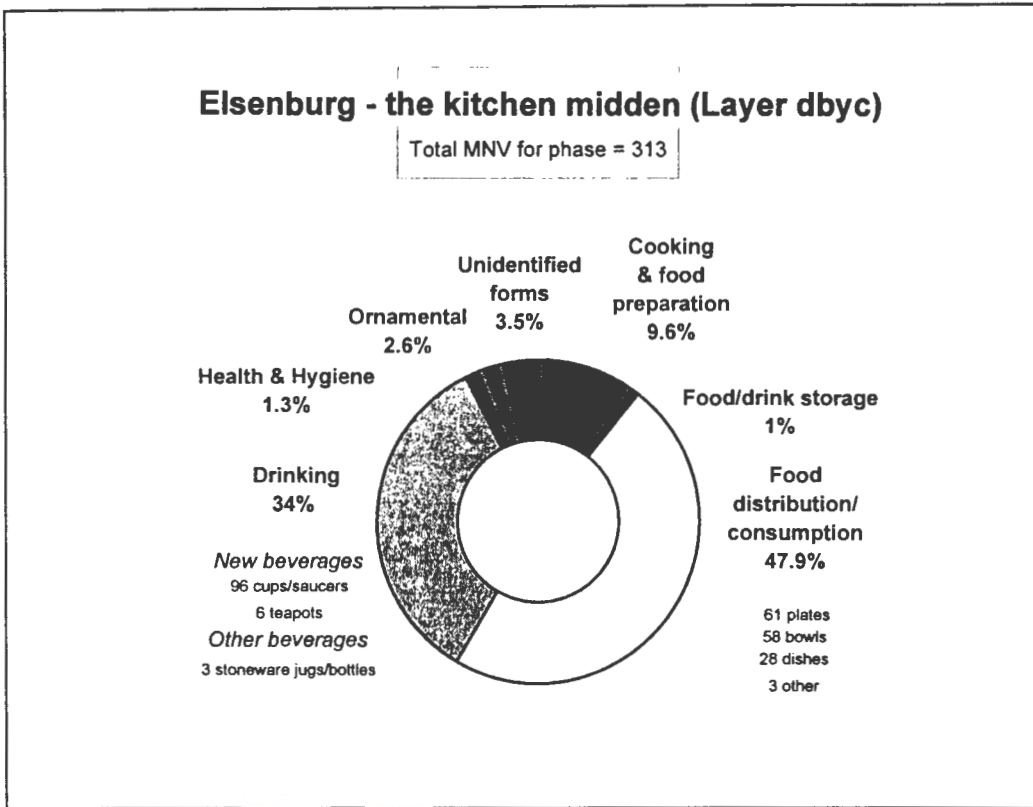

Figure 6-4: The form and function of vessels in Layer dbyc, Elsenburg kitchen midden (ca.1730 to 1760).

Chapter Seven

James' House (6), Sea Street, Cape Town

History

Sea Street is located in the central business area of Cape Town, adjacent to the harbour and waterfront (Figure 7-1). Early in the nineteenth century, this area was wasteland, lying directly above the original shoreline of Table Bay and below the grid of streets that formed Cape Town. Streets were laid out and the first houses built soon after land grants were awarded from 1814 onwards (Hall 1991a).

Houses were built in the late 1830s in response to the demand for low cost housing that followed the end of slavery in 1834. They were built for hire, not for occupation by the owners, and were let to tradesmen and members of the underclass: tailors, blacksmiths, coachmen and fishermen. The area soon became an overcrowded slum with poor roads and inadequate sanitation. Around the turn of the twentieth century, many of these houses were enlarged and converted into retail premises (Hall 1991a). This century saw the Sea Street area become more commercial in nature, with the buildings and houses still being bought and sold by property investors.

Archaeological investigation

Redevelopment of the Sea St area in 1990, provided an opportunity to excavate the sites of a number of the original hire houses. Although they had been rebuilt and continually renovated since the early 1900s, most of the original fabric of the houses still existed beneath the modern facades. A decision was taken to re-locate the original nineteenth century back yards as these were the most likely areas to reveal any remaining deposits accumulated during the early occupation of the houses (Hall 1991a).

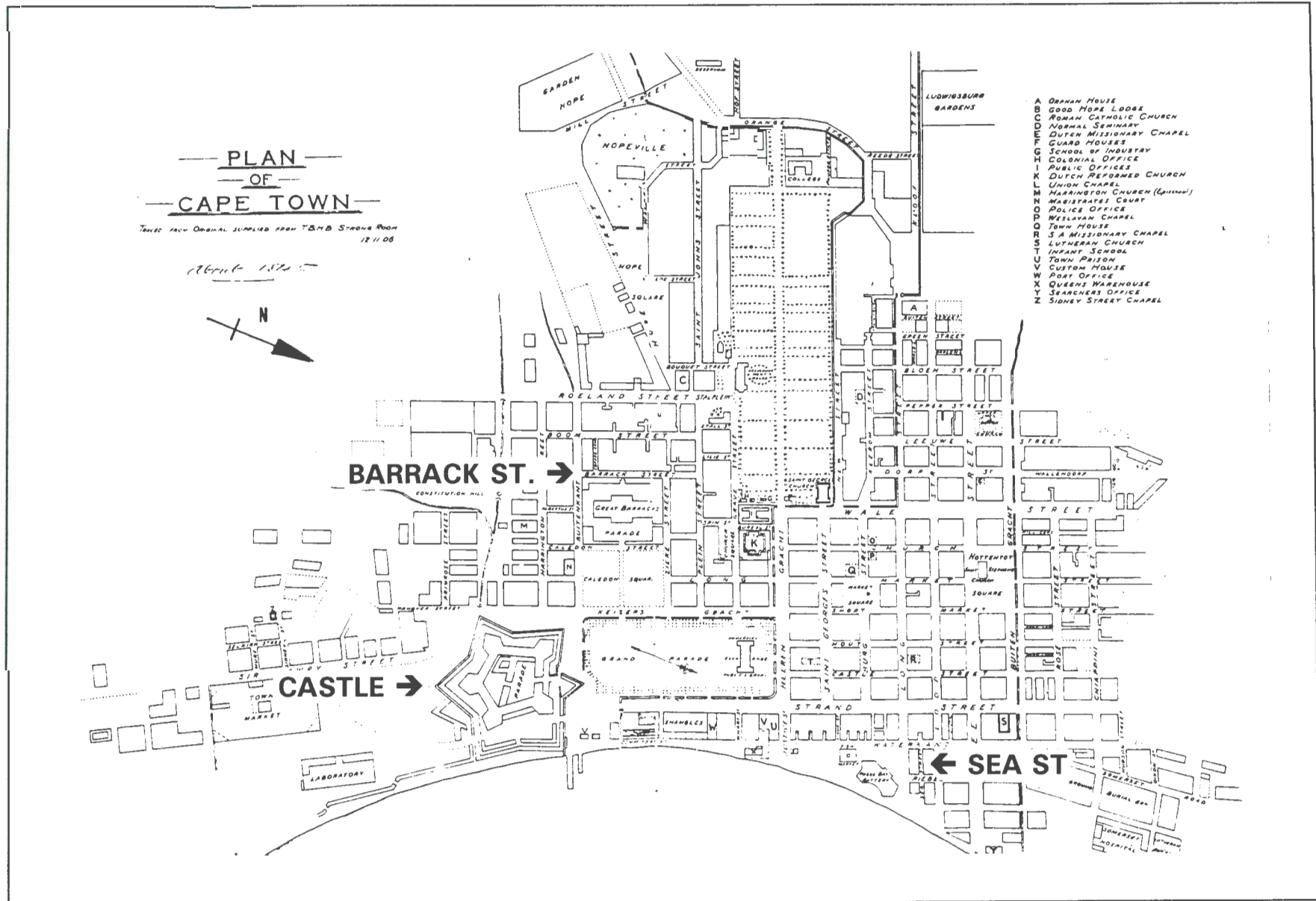

Figure 7-1: Plan of Cape Town (ca.1845) showing location of Sea Street and Barrack Street (from Picard 1968:158).

Four sites, houses 4, 5, 6 & 9 were excavated and named after early tenants of the houses (Figure 7-2). House 6, James' House (JAM-6), along with two neighbouring dwellings Houses 4 & 5, changed owners four times in the nineteenth century but remained a rented house. In 1899, the house was enlarged and altered by the building of a second floor to provide self contained living quarters, and changing the ground floor into a retail store and warehouse while retaining the backyard. The house underwent further building alterations and additions before it was demolished in 1990 (Hall 1991a).

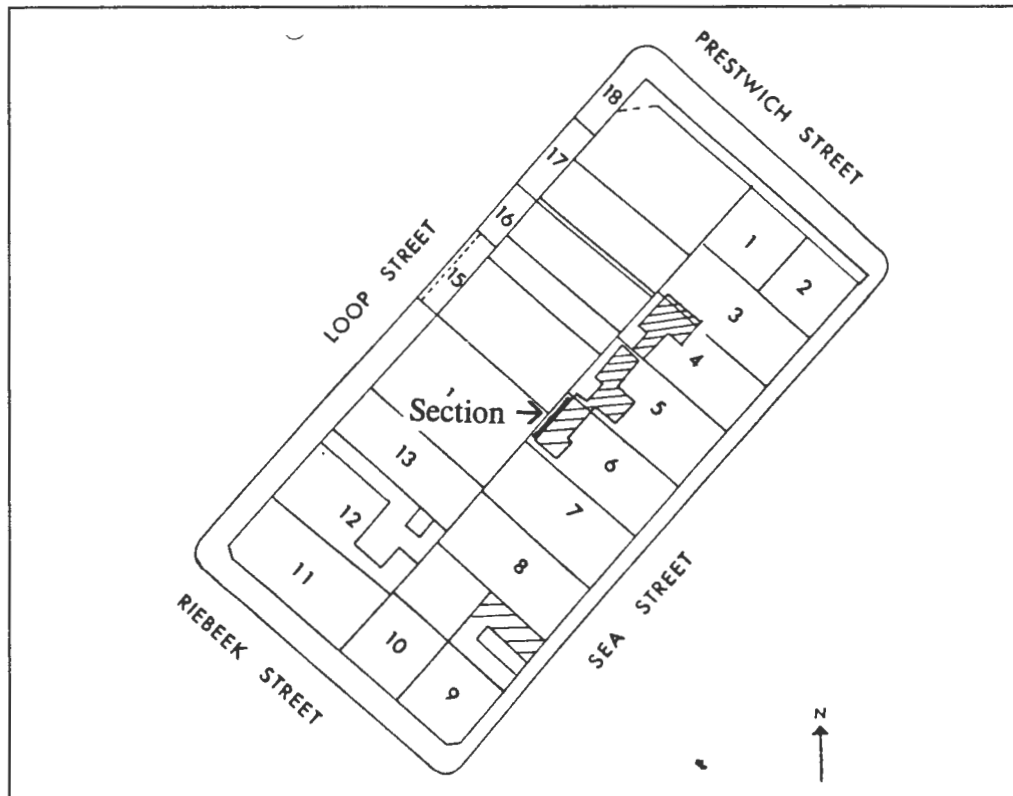

Figure 7-2: Plan showing the four yards chosen for excavation in Sea Street and the position of the section used to illustrate the stratigraphy of James' House (Figure 7-3)(Hall 1991a).

JAM-6 was excavated through the concrete floor of the extant building.

Stratigraphy (Figure 7-3)

Layer 1 (uppermost level of the excavation)

A rich brown deposit with rubble, stones, rocks and patches of clay, lying directly under a recently constructed concrete floor. It was heavily disturbed by building and trenching activities and was crossed by two sewage pipes.

Layer 2

A 5-8 cm layer of hard yellow clay. Part of the deposit had been disturbed by recent trenching.

Layer 3

A soft chocolate brown deposit with patches of stones and yellow clay. Part of the layer had been disturbed by the placing of a sewage pipe and a concrete wall footing.

Layer 3A

A dark deposit with charcoal and ash forming a thick lens with an irregular base.

Layer 4

A soft, homogeneous, grey-brown sandy layer. On the east side of the layer, the deposit changed to a gritty texture, red-brown in colour with charcoal inclusions. This layer did not contain any stones or rubble.

Layer 5

A soft, orange coloured, homogeneous deposit with a hearth in the eastern portion.

Layer 6

A light coloured deposit which became hard and gritty, and lighter in colour, towards the base of the layer.

Layer 7

A gritty grey-brown sandy deposit resembling beach sand. It contained a few bricks and shale slabs, and a high content of water-worn shells.

Layer 8

A coarse grey/brown sandy deposit alternating with clean white dune sand.

Layer 9

Predominantly beach sand with flecks of charcoal, a small hearth and some shale slab. This may have been an original beach surface.

Layer 10 (lowest level of the excavation)

Beach sand, water worn shells and shale. It was almost devoid of artefactual material.

Layers 6-10 all had a beach/dune sand matrix.

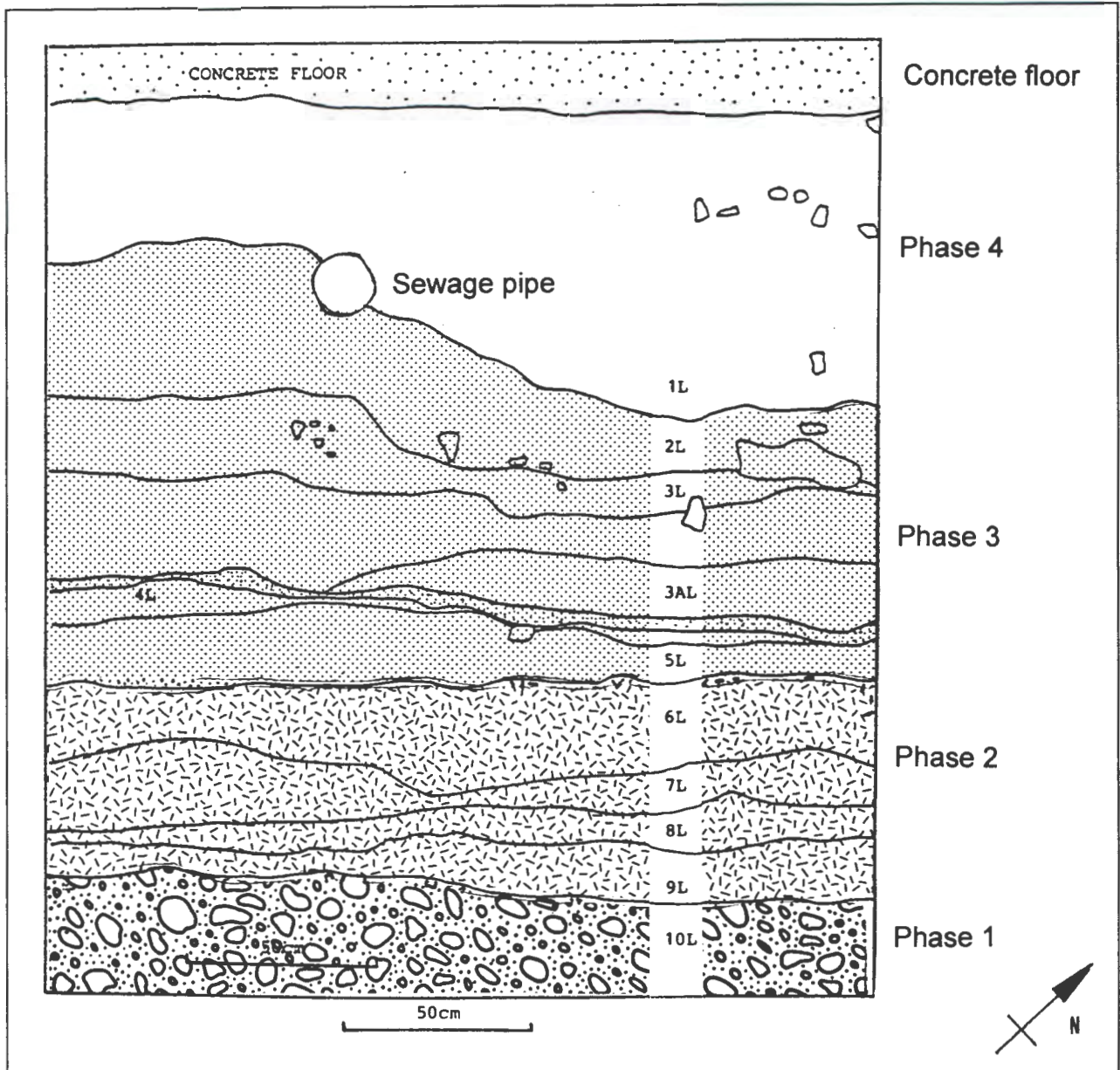

Figure 7-3: Stratigraphy of James' House, Sea Street (Hall 1991a)..

The complete analysis of the ceramic assemblage from James' house, Sea Street is presented in Appendix L.

The early interpretation of the site, based on documentary sources and the preliminary analysis of the artefactual material, divided the excavated material into three phases: Phase 1 (Layer 10) the natural substratum of beach/dune sand; Phase 2 (Layers 9-6), pre-1830s town dump accumulated before the erection of houses at Sea Street; and Phase 3 (Layers 2-5), back yard assemblages from 1830 to ca.1900. The uppermost layer (Layer 1) was discarded as it was badly disturbed. It was analysed separately as Phase 4 (Hall 1991a).

Further analysis of the site has led to a modification of the earlier interpretation. It is now thought that Layers 1-5 are also part of the pre-1830 town dump and that few, if any, of the excavated ceramics belonged to the occupants of James' House.

Summary of ceramic analysis

The ceramics were analysed twice; first by individual layer (Table 7-1) and secondly by phase (Table 7-2). It is a large assemblage of just over five thousand fragments with an estimated MNV of 1409. The degree of fragmentation is high and uniform throughout the assemblage. The reconstruction of vessels from sherds is very low and there are very few cross-mends between layers or phases.

The ceramic analysis will be summarised by phases but with references to individual layers when necessary.

1. PORCELAIN

PHASE 1 (JAM6-1, Layer 10 (see Table 7-1 & 7-2))

The small group of ceramics (23 fragments) in this layer were considered to have filtered down from the overlying layers. Although it was difficult to identify the form and decoration of many of the small sherds, its total composition appears to be similar to the lowest level of Phase 2 (Layer 9). It is a typical mid to late eighteenth century Cape ceramic assemblage: Chinese export porcelain, Asian market coarse porcelains and locally made coarse earthenware.

1.1.1 Chinese export porcelain

MNV=8 (61.5%)

This category contains small fragments of blue-and-white tablewares and blue-and-white and enamelled teawares dating from the mid-1740s to ca.1780.

1.1.2 Asian market ware - coarse porcelain

MNV=4 (30.8%)

This group has sherds from three coarse porcelain bowls and one dish, three of which had identifiable patterns.

3.1.3 European & colonial manufactured coarse earthenwares. MNV=1 (7.7%)

This consists of one glazed red-bodied sherd and was probably manufactured locally.

Table 7-1: Ceramics analysed by layer from James' House, Sea Street, expressed as MNVs and percentage MNVs.

James' House (6) Sea Street (Cape Town)	Youngest layer																		Oldest layer			
	MNV	% MNV	MNV	% MNV	MNV	% MNV	MNV	% MNV	MNV	% MNV	MNV	% MNV	MNV	% MNV	MNV	% MNV	MNV	% MNV	MNV	% MNV		
LAYER	1L		2L		3L		3aL		4L		5L		6L		7L		8L		9L		10L	
Porcelain oriental	28	20	9	18	14	18	0	0	44	23	33	33	179	36	92	54	147	53	20	83	10	81
Porcelain European	3	2	0	0	0	0	0	0	0	0	0	0	0	0	0	0	0	0	0	0	0	0
Stoneware oriental	0	0	0	0	0	0	0	0	1	0	1	1	3	0	2	1	5	2	0	0	0	0
Stoneware European	8	6	2	4	3	4	1	9	9	5	3	2	13	4	10	6	8	3	0	0	0	0
Coarse E/W Unprovenanced	6	4	3	6	7	9	1	9	11	6	14	14	25	8	15	9	36	13	4	17	1	9
Tin Glazed E/W European	1	0	0	0	1	1	1	9	3	2	2	2	14	5	5	3	8	3	0	0	0	0
Refined E/W Staffordshire type	91	66	35	71	52	68	8	73	124	65	47	47	76	25	48	27	76	27	0	0	0	0
TOTAL	137	100	49	100	77	100	11	100	192	100	100	100	310	100	170	100	280	100	24	100	11	100

Table 7-2: Ceramics analysed by Phase from James' House, Sea Street, expressed as MNVs and percentage MNVs.

James' House (6), Sea Street (Cape Town) ca.1770s - ca.1830	Phase 1		Phase 2		Phase 3		Phase 4	
	MNV	% MNV	MNV	% MNV	MNV	% MNV	MNV	% MNV
1.1.1 Chinese export porcelain	8	61.5	333	39	72	18	29	20
1.1.2 Asian market ware	4	30.8	100	11.7	17	4.3	5	3.4
1.1.3 Japanese export porcelain	-	-	13	1.5	4	1	1	0.7
1.2.2 British porcelain	-	-	-	-	-	-	1	0.7
1.2.3 Unprov. European porcelain	-	-	-	-	-	-	1	0.7
2.1.1 Chinese/Japan./Other stoneware	-	-	10	1.2	3	0.8	-	-
2.2.1 German/Rhenish stoneware	-	-	25	2.9	8	2	1	0.7
2.2.2. British stoneware	-	-	1	0.1	-	-	1	0.7
2.2.3 Unprov. European stoneware	-	-	10	1.2	8	2	3	2.1
3.1.3 Euro./Cape manu. coarse e/w.	1	7.7	90	10.6	29	7.3	5	3.4
3.2.3 Unprov. African/Asian coarse e/w.	-	-	1	0.1	-	-	-	-
4.1.1 European tin-glazed earthenware	-	-	23	2.7	3	0.8	-	-
5.1.1 Refined wares: Cream coloured	-	-	163	19.1	139	35	50	34.5
5.1.2. Refined wares: Pearlware	-	-	45	5.3	46	11.6	16	11
5.1.3 Refined wares: White-bodied	-	-	30	3.5	66	16.6	28	19.3
5.1.4 Other refined earthenwares	-	-	6	0.7	1	0.3	4	2.8
5.1.6 Refined stonewares	-	-	3	0.4	1	0.3	-	-
TOTAL	13	100	853	100	397	100	145	100

PHASE 2 (JAM6-2 Layers 6-9 (Tables 7-1 & 7-2))

The two largest components of Phase 2 are Asian porcelain and British refined wares. British wares were absent from the lowest layer. The majority of the Asian porcelain can be dated to the second half of the eighteenth century and all of the British wares could have been manufactured during the first decades of the nineteenth century, probably before the mid 1820s.

1.1 Asian Porcelain

All the porcelain apart from two items (a finely painted blue-and-white dish (JAM6-2/CPO.12a) and an *encre de Chine* tea bowl (JAM6-2/CPO.64), is average quality and is typical of the mass produced wares made for the western markets during the second half of the eighteenth century. Nearly three quarters of the porcelain is blue-and-white and the remainder is enamelled. About half of the porcelain assemblage is blue-and-white tableware and the rest is teaware (Table 7-3).

1.1.1. Chinese export porcelain

MNV=333 (39.0%)

1.1.3 Japanese export porcelain

MNV=13 (1.5%)

Chinese tablewares include ninety one blue-and-white plates and nine flat-rimmed dishes. The rim designs include flower sprays with or without simple diaper borders (JAM6-2/CPO.1 & 3), composite/ornate designs (JAM6-2/CPO.4), simple chains and scrolls (JAM6-2/CPO.6) and blue wash with blossoms reserved in white. These were all common designs in the second half of the eighteenth century. There are only six enamelled plates, one Chinese Imari (JAM6-2/CPO.42) and five painted with overglaze enamels (JAM6-2/CPO.70). The other identified Chinese tablewares included saucer-dishes (JAM6-2/CPO.16), under-dishes for bowls (JAM6-2/CPO.2), a deep serving dish (JAM6-2/CPO.15), and two tureens, a round one in blue-and-white (JAM6-2/CPO.17) and an enamelled one with hares-head handles (JAM6-2/CPO.69).

Japanese tablewares include two blue-and-white items: a 'kraak' style blue-and-white plate (JAM6-2/JPO.3) and a large dish. Both pieces are older than the Chinese porcelains and date to the first half of the eighteenth century.

Table 7-3: Decorative categories of Asian teawares in phase 2, James' House, Sea Street, expressed as percentage MNVs.

Chinese teaware decoration	(MNV=160)
Blue-and-white	37%
Blue-and-white + enamels	3%
Brown glazed	17%
Enamels only	37%
Other	6%
Japanese teaware decoration	(MNV=6)
Blue-and-white	17%
Blue-and-white + enamels	66%
Enamels only	17%

Other items of Chinese teaware include two enamelled *pattipans* (JAM6-2/CPO.67), a possible sugar pot (JAM6-2/CPO.66), and an intertwined strap handled vessel which could be part of a post 1780s tea or coffee pot (JAM6-2/CPO.37). There is also an Yixing stoneware teapot (JAM6-2/OST.3).

The Phase 2 assemblage includes medium and small porcelain bowls which could be associated with either dining or drinking. Vessels not related food or drink included three 'bowls' with thick rounded rims which could part of wash basins (JAM6-2/CPO.19), a blue-and-white lidded Japanese chamberpot (JAM6-2/JPO.1) and two ornamental items: a fragment of a blue-and-white Chinese vase or jar, possibly made in the early part of the eighteenth century (JAM6-2/CPO.20), and a Japanese flared rim vase in Imari colours (JAM6-2/JPO.6).

1.1.2 Asian market ware - coarse porcelain MNV=100 (11.7%)

Asian market coarse porcelains comprise over 11% of the total ceramics in Phase 2. They are medium to large blue-and-white bowls and dishes except for two dishes with red enamelled decoration. They could all have been produced during the second half of the eighteenth century but at least three of the designs have been found to be associated with the late eighteenth to early nineteenth century (JAM6-2/CPW.2, 3, 7 & 9).

2.2.1 Asian stoneware

MNV=10 (1.2%)

Asian stoneware items include six Chinese martevans (JAM6-2/OST.1) and three Japanese stoneware *donabe* (similar to cooking pots) (JAM6-2/OST.2).

2.2.2 German / Rhenish stoneware

MNV=25 (2.9%)

This category contains a large salt-glazed storage jar with horizontal handles (JAM6-2/EST.4) and at least twenty four mineral water bottles, twenty two brown-glazed 'gin bottles', and two grey-glazed ones with incised cobalt blue decoration.

2.2.3 British stoneware

MNV=1 (0.1%)

Only one item was found: a 'scratch blue' chamberpot (JAM6-2/EST.7).

The European stoneware category also contained fragments from at least ten unidentified bottles and jars.

3.1.3 European & Cape manufactured European-style coarse earthenware

MNV=90 (10.6%)

This is the third largest ware category in Phase 2 and is probably all locally manufactured ware. It comprises common coarse earthenware ware forms: cooking pots, lids, chafing dishes and braziers as well as five well glazed more refined bodied plates (JAM6-2/CEW.9).

3.2.3 Unprovenanced African/Asian earthenwares

MNV=1 (0.1%)

This is a single unglazed fragment with mica inclusions.

4.1.1 Unprovenanced European tin-glazed earthenwares

MNV=23 (2.7%)

Tin-glazed wares form the smallest group of vessels (MNV=23). Identified items include undecorated plates, dishes, apothecaries' jars and a chamber pot, and two blue-and-white plates or dishes.(JAM6-2/TEW.1-10).

5.1 European Refined Wares

British refined earthenwares and stonewares form 29% of the vessels in Phase 2. All of them could have been manufactured during the first decades of the nineteenth century and probably before the mid 1820s.

5.1.1 Cream coloured wares

MNV=163 (19.1%)

Cream coloured wares form the largest refined ware category of which the majority are undecorated pale cream coloured plates and tablewares with a much smaller amount of teawares. The decorated ware consists of two enamelled tea cups and seven lined plates.

5.1.2 Pearlware

MNV=45 (5.3%)

Identified pearlwares include hand-painted blue-and-white *chinoiserie* saucers and bowls, a smaller number of polychrome wares painted in soft 'early' colours, and smudgy dark blue transfer printed plates and teawares with *chinoiserie* designs.

5.1.1 White-bodied ware

MNV=30 (3.5%)

The moulded and scalloped shell edged plates (JAM6-2/REW.51-53) could possibly be pearlwares but have been classified as whitewares along with a small quantity of annular wares. The printed wares are all blue except for one coloured over-glaze brown printed saucer with over-glaze enamels.

The remaining ceramics include a blackware (Jackfield-type) jug and small bowl or cup (JAM6-2/REW.50), a basalt teapot and small vessel (JAM6-2/REW.49), and one or two moulded Staffordshire white salt-glazed plates (JAM6-2/EST.6).

PHASE 3 (JAM6-3 Layers 2-5 (Tables 7-1 & 7-2))

This phase contains a similar range of wares and decorative categories to Phase 2 but in different proportions; the refined British earthenwares and stonewares (63.5%) now outnumber the Asian porcelains (23.4%). The date range of the site may extend slightly further into the nineteenth century.

1.1.1 Chinese export porcelain

MNV=72 (18.0%)

The table wares are blue-and-white. The teawares are enamelled except for a few blue-and-white cups and saucers (two of which are brown glazed). Other enamelled wares include small plates and medium bowls.

1.1.2 Asian market ware - coarse porcelain

MNV=17 (4.3%)

This group of vessels includes a blue-and-white bowls and large dishes and one small cup, and a red and green enamelled dish (JAM6-3/CPW.15).

1.1.3 Japanese export porcelain

MNV=4 (1.0%)

This small category contains a small fragment of a fluted enamelled bowl, two saucers in under-glaze blue and enamels, and a blue-and-white lidded chamberpot.

2.1.1 Asian stoneware

MNV=3 (0.8%)

This category includes two Chinese martevans and one Japanese *donabe* (cooking pot) (JAM6-3/OST.1-3).

2.2 European stoneware

MNV=16 (4.0%)

These are all brown salt-glazed bottles and jars of which at least eight are handled German mineral water ('gin') bottles.

3.1.1 European & Cape manufactured coarse earthenwares MNV=29 (7.3%)

All the vessels are red-bodied except for one pale-bodied dish or plate with indistinct yellow, brown and green colouring. The assemblage contained two *vuurtesjes* and one *komfoor* and a plate with a shiny clear glaze. The other vessels are commonplace cooking pots and lids.

4.1 Tin-glazed earthenware

MNV=3 (0.8%)

Only three white undecorated items were found: an apothecaries' jar and the rims of two plates or dishes.

5.1 British refined wares

MNV=253 (63.7%)

The greatest changes from Phase Two are shown in the refined earthenware category. Cream coloured wares remain dominant and keep the same range of decoration and form but pearlwares and whitewares have increased. New sub-categories include willow pattern (MNV=1. JAM6-2/REW.45), brown and black printed wares (MNV=5. JAM6-2/REW.50, 51, 53-55) and printed and enamelled printed wares (MNV=2. JAM6-2/REW.52 & 56). The majority of the blue printed wares remain *chinoiserie*, though the range of prints has expanded to include later designs: Eastern and European scenes and geometric borders. The refined stoneware category is restricted to a single engine-turned slip moulded teapot (JAM6-2/REW.65).

PHASE 4 (JAM6-4 Layer 1 (Tables 7-1 & 7-2))

This phase is severely disturbed but follows the same pattern as Phase 3 except that it lacks tin-glazed wares and shows the addition of European porcelain (JAM6-2/EPO.1 & 2), British 'commercial' stoneware (JAM6-2/EST.3) and tinted bodied wares (JAM6-2/REW.37). This phase also shows an increase in annular wares.

Commentary

Excavation of the Sea Street site did not yield artefacts that could be definitely associated with the house built in the 1830s or with any particular house nearby. This was not unexpected. A recent reappraisal of excavations carried out in Cape Town shows that in the eighteenth and early nineteenth century, household rubbish was taken away from houses and dumped in nearby canals, natural depressions and watercourses and not deposited in backyards (Timothy Hart pers. comm.). The analysis of the ceramic assemblage from the midden on the site of James' House and the adjoining houses in Sea Street, however, demonstrates the value of excavating communal town dumps. The excavation has produced large samples of ceramics which reflect the range and quantities of ceramics that were available in the Cape in the closing years of the eighteenth century and the first decades of the nineteenth century. Analysis of the form and function of the vessels in the assemblage shows a similarity between Phases 2 and 3 (Figure 7-5).

The manufacturing dates of the ceramics suggests the majority of the Sea Street ceramics were discarded during the last quarter of the eighteenth century and the early years of the nineteenth century. The assemblage contains a high percentage of fine quality ceramics, both Chinese and Japanese porcelains and British refined wares. They probably came from the nearby houses in Strand, Loop, Waterkant and Bree streets and the small lanes that led off these thoroughfares, which are known to have been inhabited by a cross-section of the Cape community.

The manufacturing dates have been positioned in the second half of the eighteenth century for the Asian porcelains, and in the early nineteenth century for the British wares. The dates of deposition in the ground for these wares are more difficult to establish. The results of the layer by layer analysis (Table 7-1) neatly demonstrates the gradual and steady replacement of Asian porcelain in the Cape by British refined earthenwares during the first decades of the nineteenth century.

James' House (6), Sea Street (Cape Town) c.1770's - c.1830

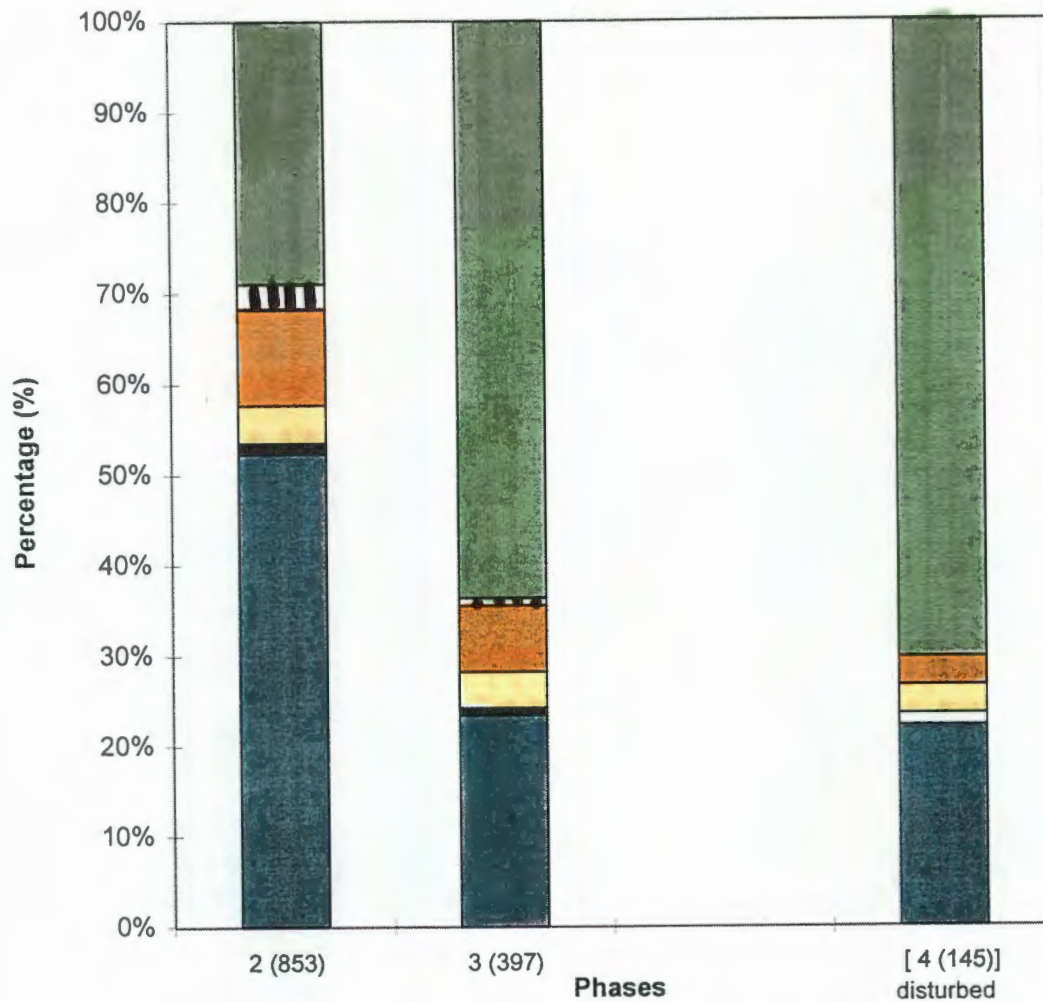

James' House (6) Sea Street (Cape Town)		Phases (total MNV per phase)							
		1 (13)		2 (853)		3 (397)		4 (145)	
KEY	CERAMIC TYPES	MNV	% MNV	MNV	% MNV	MNV	% MNV	MNV	% MNV
	5.1 European refined wares	-	-	247	29	253	63.7	98	76.6
	4.1 European tin-glazed earthenware	-	-	23	2.7	3	0.8	-	-
	3.2 African/Asian coarse earthenware	-	-	1	0.1	-	-	-	-
	3.1 European-style coarse earthenware	1	7.7	90	10.6	29	7.3	5	3.4
	2.2 European stoneware	-	-	36	4.2	16	4	5	3.4
	2.1 Asian stoneware	-	-	10	1.2	3	0.8	-	-
	1.2 European porcelain	-	-	-	-	-	-	2	1.4
	1.1 Asian porcelain	12	92.3	446	52.3	93	23.4	35	24.1

Figure 7-4: Ceramic profiles of phases 2 & 3, James' House, Sea Street.

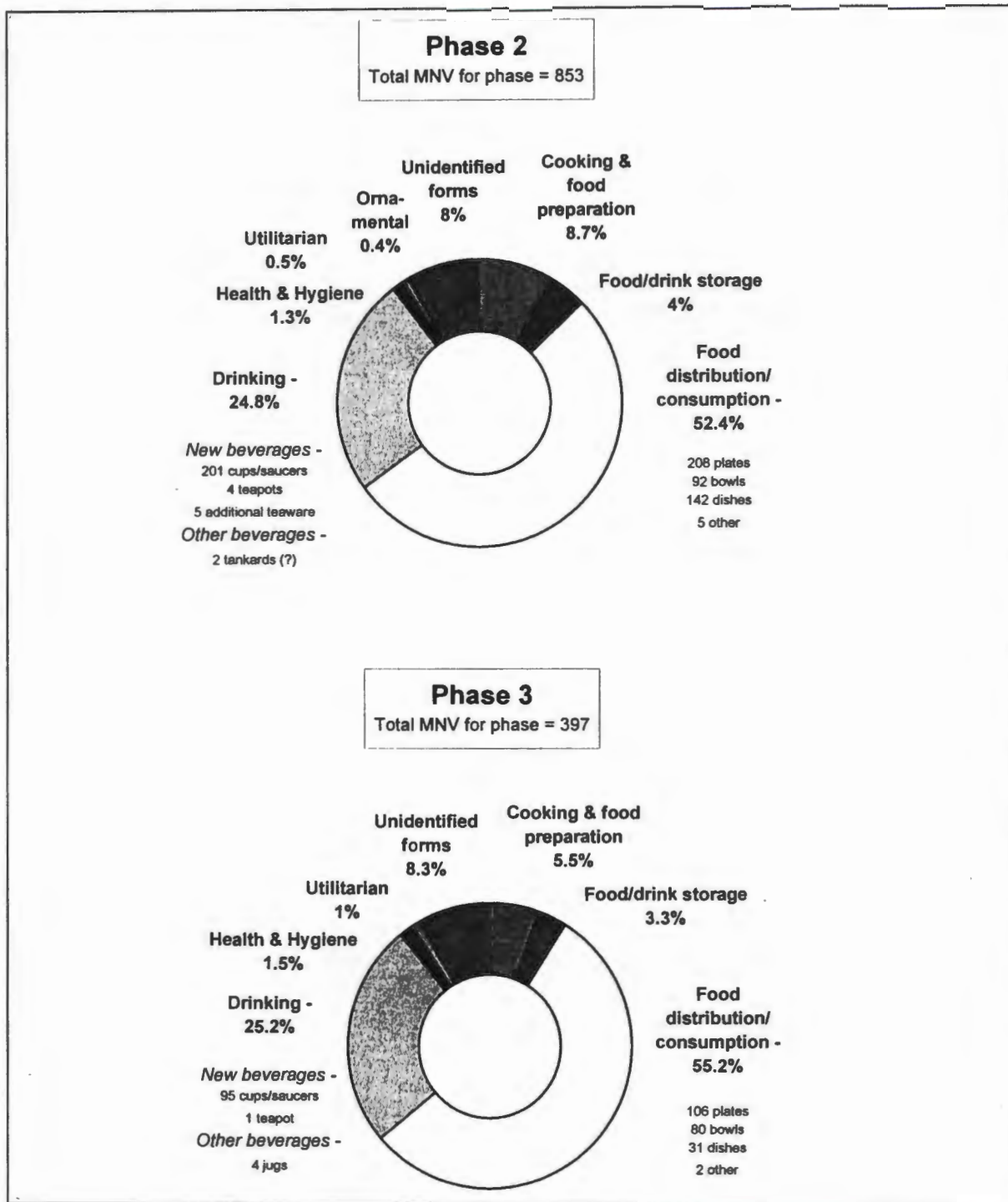

Figure 7-5: The form and function of vessels in Phases 2 & 3, James' House, Sea Street.

Chapter Eight

The Barrack Street well

In 1989, a disused well was discovered during the renovation of an existing modern commercial building in Barrack Street, Cape Town (see Figure 5-1 & Figure 7-1). The upper part of the well was damaged and the deposits down to the water level had been removed by the contractors prior to the commencement of a full archaeological excavation.

History

Archival research contained in the site report (Hall *et al.* 1990a) reveals that the well was associated with a house built in the last quarter of the eighteenth century on undeveloped ground on the outskirts of Cape Town. The well remained in use until the late nineteenth century when it was abandoned and deliberately filled in. A deed of transfer, dated 1791, records a house, store and garden in Ziekedwars Street (the original name for Barrack Street) and showed that the value of the property had increased almost fifty fold since 1770. This information almost certainly indicates that the first house on this ground (Erf 5178) was built during the period 1770-1791 (Hall 1990a:73).

During the following forty six years the house changed owners six times and the relevant deeds of transfer for these sales give the same description of the buildings recorded in the 1791 document. Hall suggests that during this time period the identity of the property changed from a typical eighteenth century Cape town house, incorporating a store, to a more commercial type of premises, a fore-runner of the business houses that would characterise the whole of Barrack Street in the nineteenth century (Hall 1990a).

It is not known whether the well was situated within or outside the building as no standing architecture of the original house remains and no records or descriptions of the house exist. The Cape Archives have a photograph, taken in the late nineteenth century, of a town house with an attached store standing on the adjacent property. Hall uses information from the Deeds Office and street directories to suggest that this house could indicate the type of house that was built on Erf 5178. The photograph shows a double storied, flat roofed building with a symmetrical facade, topped by a wide cornice and a pediment displaying a swan in bas relief (Hall 1990a:74).

The house standing on Erf 5178 in Barrack Street went through several phases of different usage. It began as an example of an eighteenth century Cape town house with a retail store attached. In the early nineteenth century, the house remained residential but became more commercial, first housing a bakery, then a retail store and later a soap and candle factory. During this time, some owners took in lodgers. In the second half of the nineteenth century, owners started to live away from their businesses and by the end of the century, Erf 5178 and its buildings formed part of a large furniture factory (Hall 1990a).

Use of the well began during the end years of VOC rule in the eighteenth century, continued through the transition to full British colonial occupation of the Cape in 1815, and ended when it was deliberately filled in during the last years of the nineteenth century.

Archaeological investigations

The walls and base of the well were built with dressed stone. The original depth was estimated to be approximately 5.8 metres measured from the base to the upper lip.

Stratigraphy (Figure 8-1)

There was a straightforward stratigraphy which divided the excavation of the well deposits into four clear-cut levels. The disturbed uppermost deposits of the well (Level One) had been kept on the site and archaeologists were able to wet sieve and process them. The remainder of the deposits in the well were *in situ*.

Layer One

This was reconstructed from a large sample of the deposits removed from within the well by the building contractors prior to the commencement of the excavation. It was a reddish brown sandy matrix that had filled the well above the water level to a depth of about 3.5 metres. Layer One was the result of a deliberate filling in of the well after it was no longer in use.

Layer Two

This layer lay below the water table and had a depth of 0.75 metres. It had a matrix of wood-shavings, off-cuts and sawdust, and ended on a layer of purposely placed stones and bricks. This re-furbished well would have had a water depth of approximately 1 metre or less.

Layer Three

The third layer was 0.6 metres thick and showed a change in matrix to a sandy fill containing stones and broken bricks. It lay above a hard surface constructed from carefully laid large rocks. The well would have had a water depth of 1.5 metres.

Layer Four

The fourth layer was the lowest level and consisted of a sandy matrix, 0.95 metres thick, lying on the original stone base of the well. The depth of water would have been approximately 2.5 metres.

The stratigraphy shows that the well was refurbished twice to improve the quality of the water, followed by a deliberate and complete filling in of the structure.

The complete analysis of the ceramic assemblages from the Well is presented in Appendix L.

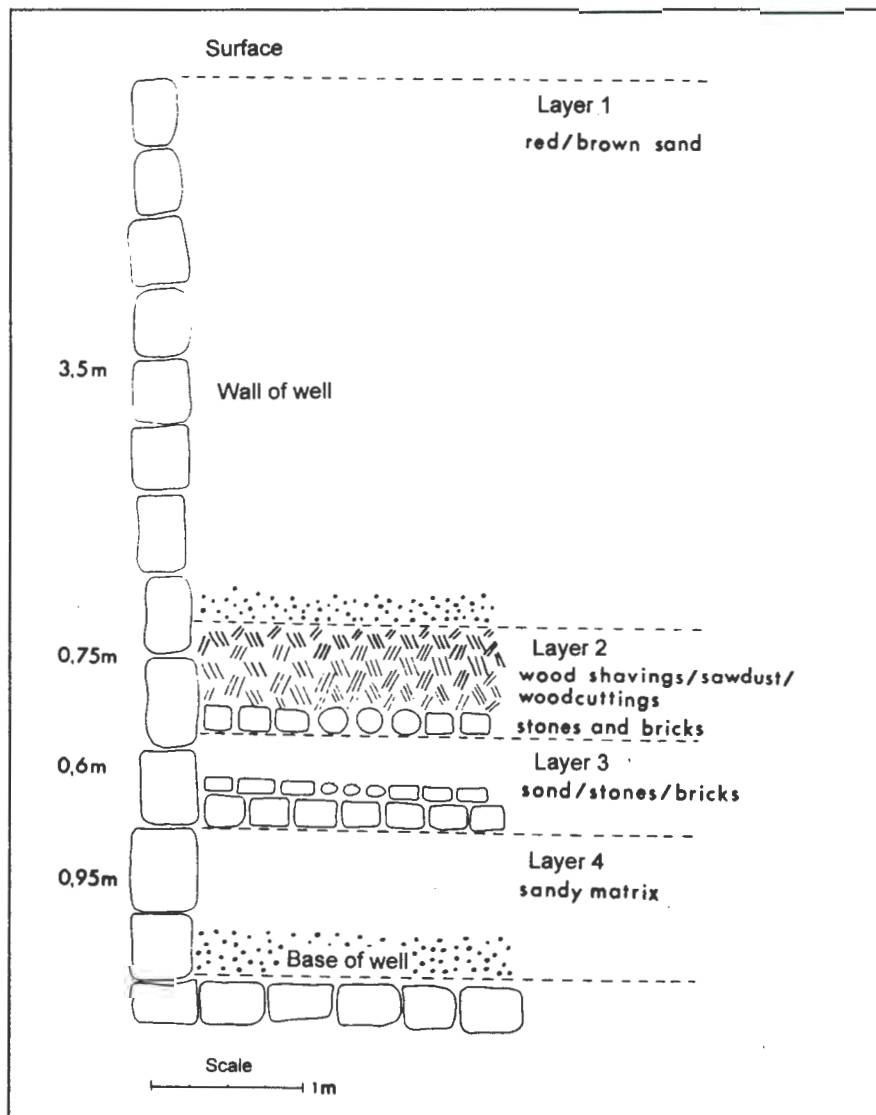

Figure 8-1: Stratigraphy of the Barrack Street well (Hall et al. 1990a).

Summary of the ceramic analysis

Level Four (lowest level)

The deposit was nearly a metre deep and yielded large fragments which allowed the reconstruction of eleven almost complete vessels. The Level Four assemblage can be split into two completely different groups of wares: a typical second half eighteenth century Cape assemblage of Chinese porcelain, German stoneware, European tin-glazed wares and locally produced coarse earthenware; and a smaller highly fragmented group of British refined wares dating to the first decades of the nineteenth century.

Table 8-1: Ceramics analysed by Phase from Levels 1-4, the Barrack Street well, Cape Town, expressed as MNVs and percentage MNVs.

Barrack Street well (Cape Town) ca.1775 - late 19th c.	Level 4		Level 3		Level 2		Level 1	
	MNV	%	MNV	%	MNV	%	MNV	%
		MNV		MNV		MNV		MNV
1.1.1 Chinese export porcelain	15	29.4	8	5.3	-	-	5	6.3
1.1.2 Asian market ware	12	23.5	6	3.9	-	-	2	2.5
1.2.2 British porcelain	-	-	2	1.3	5	11.4	3	3.8
1.2.3 Unprov. European porcelain	-	-	2	1.3	1	2.3	1	1.3
2.1.1 Chinese/Japan./Other stoneware	-	-	1	0.7	-	-	-	-
2.2.1 German/Rhenish stoneware	3	5.9	7	4.6	-	-	-	-
2.2.2. British stoneware	-	-	8	5.3	2	4.5	13	16.5
2.2.3 Unprov. European stoneware	2	3.9	-	-	2	4.5	-	-
3.1.1 Euro. manufactured coarse e/w.	-	-	2	1.3	1	2.3	-	-
3.1.3 Euro./Cape manu. coarse e/w.	4	7.8	1	0.7	-	-	2	2.5
4.1.1 European tin-glazed earthenware	3	5.9	2	1.3	-	-	-	-
5.1.1 Refined wares: Cream coloured	4	7.8	22	14.5	5	11.4	-	-
5.1.2. Refined wares: Pearlware	2	3.9	3	2	-	-	-	-
5.1.3 Refined wares: White-bodied	5	9.8	78	51.3	28	63.6	49	62
5.1.4 Other refined earthenwares	1	2	10	6.6	-	-	4	5.1
TOTAL	51	100	152	100	44	100	79	100

1.1.1. Chinese export porcelain . MNV=15 (29.4%)

The Chinese export porcelain consists of complete vessels or large fragments of good quality tea and tablewares dating to ca.1760-80. The tablewares (BAS-4/CPO.1-7) and half the teawares (BAS-4/CPO.8-12) are blue-and-white, painted with floral sprays or plants and rocks, and the remaining teawares are enamelled and include two saucers painted with a bamboo design popular ca.1770-75 (Howard 1974:136). A small enamelled domed cover could be from a lidded milk jug or ornamental jar.

1.1.2 Asian market ware - coarse porcelain. MNV=12 (23.5%)

The Asian market ware consists of semi-complete or large fragments of medium and large bowls, and saucer dishes. A large bowl painted with a dragon (BAS-4/CPW.1) has been tentatively classified as Asian market ware but should probably be classified as second grade export porcelain. The coarse porcelains could have been manufactured between ca.1750 and the early years of the nineteenth century

2.2.1/3 Rhenish & Unprovenanced European salt-glazed stoneware MNV=5 (9.8%)

The vessels in this category are all bottles and include three brown salt-glazed mineral water or 'gin' bottles, one of which cross-mends with Level 3. These sturdy handled bottles are commonly found on Cape sites dating from the second half of the eighteenth century to the first half of the nineteenth century.

3.1.3 European & Cape manufactured coarse earthenware. MNV=4 (7.8%)

There are four coarse earthenware vessels including a locally produced red-bodied cooking pot and skillet, and a large thickly potted 'white' bodied spouted 'kettle' with an overhead handle, possibly manufactured in Europe (BAS-4/CEW.1).

4.1.1 European tin-glazed earthenwares. MNV=3 (5.9%)

The tin-glazed wares comprise two white undecorated chamber pots (BAS-4/TEW.1-2) and an eighteenth century French Rouen ware dish, tin-glazed on the upper surface only and decorated at the rim in blue and black (BAS-4/TEW.3).

5.1 British Refined wares

The remaining ceramics are highly fragmented, British manufactured wares and fall into a slightly later date range of ca.1810-1820s. Five fragments cross-mend with, or match, vessels in Level 3 which suggests that all the British refined wares in Level 4 could have

filtered down from the upper levels and were not deposited in the well at the same time as the Asian porcelains and European tin-glazed wares.

5.1.1 Cream coloured wares

MNV=4 (7.8%)

The cream coloured ware is undecorated, very pale in colour, and comprises four plain rimmed unmarked plates (BAS-4/REW.1-1a & 1b),

5.1.2 Pearlware

MNV=2 (3.9%)

There are two painted pearlware vessels: a small bowl or cup decorated with a band of flowers in blue, green, yellow and brown, and a fragment of a vessel painted in blue and green. Both are examples of the so-called early 'soft' colours common in the early nineteenth century (BAS-4/REW.7a-7b).

5.1.3 White-bodied wares

MNV=5 (9.8%)

Five blue-printed sherds represent at least three items: one plate, one saucer and an unidentified vessel (BAS-4/REW.3,4,6). The designs of the five blue-and-white printed sherds, which include a possible chinoiserie-style decorated vessel and four items with flowers and European scenes, coupled with the absence of coloured transfer printing, suggests a ca.1820 date for these wares (Coysh & Henrywood 1982:10). The remaining white-bodied wares were undiagnostic.

5.14 Other refined earthenwares

MNV=1 (2.0%)

Only one item was excavated, a small figurine that appears to have been made from plaster of Paris (BAS-4/REW.10).

All ceramics described so far, except for the British refined earthenwares, are consistent with an initial occupation date for the house of ca.1770 -1790. The remaining vessels can be dated to the early nineteenth century.

Level Three

This level shows a considerable drop in Asian manufactured wares and a dramatic increase in European wares especially British refined earthenwares. The depth of the matrix was approximately 0.3m and, in contrast to Level Four, the majority of the sherds were highly fragmented except for a coarse porcelain bowl and some European stoneware bottles.

1.1.1 Chinese export porcelain MNV=8 (5.3%)

This category contains small fragments from blue-and-white plates and a bowl, and enamelled teawares. Their decorative styles and manufacturing dates are similar to those in Level Four.

1.1.3 Asian market ware - coarse porcelain MNV=6 (3.9%)

There are fragments from four blue-and-white bowls and dishes and two enamelled bowls, including an almost complete bowl decorated in black, red and green in an uncommon design (BAS-3/CPW.4).

1.2 European porcelain MNV=4 (2.6%)

This category includes two British bone china tea cups, one white and gold and one with sprigged decoration, and two sherds of unidentified and unprovenanced porcelain.

2.1.1 Asian Stoneware MNV=1 (0.7%)

This consists of one fragment of a Chinese martevan partially covered with a brown glaze (BAS-3/OST.1).

2.2.1 German Stoneware MNV=7 (4.6%)

Six brown salt-glazed mineral water ('gin') bottles and one large bottle or jug have been identified.

2.2.2 British Stoneware MNV=8 (5.3%)

These are all commercial containers including brown salt-glazed ink and blacking bottles and a clear glazed 'shop pot' which contained salt and is impressed with the manufacturer's name *D. Bumstead & Co, London* (BAS-3/EST.4)

3.1 European-type coarse earthenware MNV=3 (2.0%)

The three vessels, two dishes (one slip-decorated) and a bowl, have a thick, hard, refined red body and could all have been manufactured in Britain. They have been classified as 'coarse' on the basis of their form, thickness and decoration.

4.1.1. Unprovenanced tin-glazed earthenware MNV=2 (1.3%)

This category contains two undecorated white tin-glazed ointment jars which could be from the Netherlands.

5.1 British Refined Wares

The remaining 74% of the ceramics are all British refined earthenwares manufactured in the nineteenth century with production dates ranging from the 1820s onwards. The sherds are small and no vessels could be reconstructed.

5.1.1 Cream coloured ware

MNV=22 (14.5%)

The cream coloured wares are all undecorated pale coloured plates, dishes and bowls. One hollow ware item could be a tankard (BAS-3/REW.31).

5.1.2 Pearlware

MNV=3 (2.0%)

Three items were classified as pearlware: a chamberpot with a blue floral and leaf meander around the outside (BAS-3/REW.50) and two saucers with floral designs painted in early 'soft' colours (BAS-3/REW.41 & 60).

5.1.3 White-bodied wares (Table 8-2)

MNV=78 (51.3%)

The white-bodied wares comprise the following and are expressed as MNVs.

Table 8-2: White-bodied wares expressed as MNVs from Level 3, Barrack Street well, Cape Town.

5.1.3.2 painted other	5
5.1.3.5 printed blue (Willow)	9
5.1.3.6 printed blue	31
5.1.3.7 printed colour	7
5.1.3.11 shell edged	4
5.1.3.12 annular	11
5.1.3.13 spatter & sponge	5
5.1.3.14 band & line	1
5.1.3.18 undecorated / undiagnostic	2
5.1.3.19 undiagnostic	3

The painted wares are all medium-sized bowls painted in the later 'harsh' colours. Transfer-printing is the most common type of decoration for the tea and tablewares. The majority of the blue printed wares have a strong blue colour and, apart from nine willow

pattern plates and one possible Eastern scene, are mainly decorated with European scenes. The remaining printed wares are coloured in shades of green or lilac. This information indicates a post eighteenth century date for most of these wares. The annular and shell edged wares comprise early and late nineteenth century varieties while the sponge wares with simple stamped designs could have been made at any time from the mid- eighteenth century to the early twentieth century.

5.1.4 Other refined wares

MNV=10 (6.6%)

The other refined wares include a fragment of red-bodied copper lustre ware, a moulded green-glazed plate and four items of yellow bodied kitchen wares decorated with blue, brown and white rings,

An overall assessment of the ceramics in Layer Three suggest they were deposited in the second to third quarters of the nineteenth century. The majority are medium to low quality mass-produced British wares.

Level Two

No Asian ceramics were found in this layer. All the wares, with the possible exception of a stoneware bottle, are of British manufacture dating to the early mid-nineteenth century to very early twentieth century. Tin-glazed wares and early pearlwares are no longer present. There are eleven complete or nearly complete vessels out of a total MNV of 44.

1.2 European Porcelain

MNV=6 (13.7%)

Five of the vessels are British bone china and include a white cup and saucer with gilding, and a saucer and dish decorated with lilac sprigging. The white undecorated egg cup remains unprovenanced.

2.2 European Stoneware

MNV=4 (9.0%)

The stoneware is probably all of British manufacture. Identified items include a blacking bottle, a large brown salt-glazed handled bottle, and flat topped bottle stopper impressed with the manufacturer's name *David Storer, Glasgow* (BAS-2/EST.2),

3.1.1 European manufactured coarse earthenware

MNV=1 (2.3%)

This is a flat-rimmed bowl or basin made in hard red earthenware with a black glaze on the inside and is of British manufacture. It matches the fragments of the bowl in Level 3 (BAS-2/CEW.1).

British refined wares make up the remaining 75% of the MNV and comprise pale cream coloured wares and white-bodied wares only.

5.1.1 Cream coloured ware

MNV=5 (11.4%)

These vessels are all undecorated pale-coloured plates, dishes and bowls, and one possible tankard.

5.1.3 White-bodied Ware (Table 8-3)

MNV=28 (63.6%)

This category includes the following decorative categories expressed as vessel numbers:

Table 8-3: White-bodied wares expressed as MNVs from Level 2, Barrack Street well, Cape Town.

5.1.3.2 painted other	4
5.1.3.5 printed willow	2
5.1.3.6 printed blue	8
5.1.3.7 printed colour	3
5.1.3.11 shell edged	1
5.1.3.12 annular	1
5.1.3.13 spatter/sponge	7
5.1.3.22 undiagnostic	3

The hand painted white-bodied ware bowl and cups have the harsh colours used after the 1830s. The majority of the printed wares are pale blue except for the willow pattern tableware which is dark blue and the coloured printed patterns are green. The printed wares comprise table and toilet wares including a small plate marked *Asiatic Pheasants*, and a lidded soap dish and a large ewer marked G & S. The single piece of shell edged ware is unmoulded with a painted edge. Sixteen percent of the white-bodied vessels are poor quality, sponge decorated bowls and plates and one large, almost complete chamber pot.

Although the date ranges of the ceramics in this level overlap with the layer below, the vessels dated by manufacturers marks were produced in the later part of the nineteenth century. The date of deposition for Level Two could be from the mid-nineteenth to very early in the twentieth century.

Level One

Many of the artefacts from this layer were not *in situ* but retrieved from material removed from the well by the contractors before the commencement of the excavation. It was impossible to separate the ceramics that were deposited in the well when it was still open, from those that were part of the material used for the final filling in of the well.

The ceramics from Level One include many examples of ware types found in the underlying three layers. It is possible that the Asian porcelains, three pieces of which are badly worn, were originally in the final fill material which could have come from Erf 5178 or even else where.

Level One has five cross mends with Level Three and one linking it to Layer Two. It is difficult to identify and date the Layer One ceramics that were deposited when the well was still open.

1.1.1 Chinese export porcelain **MNV=5 (6.3%)**

This category contains fragments of blue-and-white tablewares and enamelled teawares dating to the late eighteenth century.

1.1.2 Asian market ware - coarse porcelain **MNV=2 (2.5%)**

Two forms have been identified, a medium-sized bowl and a possible jar.

1.2 European Porcelain **MNV=4 (5.1%)**

This category includes an almost complete white and gilt British bone china jug and unprovenanced undecorated white fragments.

2.2.2 British Stoneware **MNV=13 (16.5%)**

All the stoneware is commercial stoneware including ink and blacking bottles and seven identical lids from large stoneware bottles or flagons.

3.1 Coarse Earthenware **MNV=2 (2.5%)**

This category includes two unidentified items: a large thick glazed fragment and a small unglazed 'terra-cotta' sherd. Both could be building materials.

5.1 British Refined Wares

No creamwares or pearlwares were found in this level of the well.

5.1.3 White-bodied wares (Table 8-4)

MNV=49 (62.0%)

This category contains the following decorative sub-categories expressed as vessel counts:

Table 8-4: White-bodied wares expressed as MNVs from Level 1, Barrack Street well, Cape Town.

5.1.3.2 painted other	3
5.1.3.4 printed willow	2
5.1.3.5 printed blue	9
5.1.3.6 printed colour	14
5.1.3.8 printed flow	2
5.1.3.11 annular	3
5.1.3.12 spatter/sponge	11
5.1.3.15 band & line	3
5.1.3.17 undecorated	2

The vessel form and decoration of all these wares is identical to Level Three but shows a relative increase in coloured printed wares.

5.1.4 Other refined earthenwares

MNV=4 (5.1%)

The wares were similar to those in Level Three: yellow-bodied kitchenwares, a green-glazed moulded plate and a brown-glazed handled vessel.

Commentary on the ceramic assemblages

The assemblages from the Barrack Street well show the change in availability and usage of ceramics in the Cape over a hundred year period. This begins in the last quarter of the eighteenth century when the Cape was still governed by the VOC, followed by the twenty year transition to full British rule in 1814 and ends when Cape Town became completely integrated within the British Empire. The whole assemblage illustrates the change in ceramic imports from Batavia, the Chinese mainland and the Netherlands to a total British monopoly of the Cape ceramic trade in the nineteenth century.

The first refurbishment of the Barrack Street well cuts off the eighteenth century artefacts from the nineteenth century deposits in the three upper levels. The dates of manufacture for the Chinese porcelains in Level 4 could be confined to a ca.1760 - ca.1780, thus predating the nineteenth century British wares in the same level by at least twenty years. This suggests that the small sherds of British wares filtered down from the upper levels and were not deposited at the same time as the associated eighteenth century ceramics. It is difficult to be so specific when discussing the ceramics from the upper levels. Production dates for wares in Level Three fall within the period ca.1770 to the second half of the nineteenth century, and in Level Two from post 1830s to sometime in the last quarter of the nineteenth century. Level Four is disturbed and has wares dating from the second half of the eighteenth century to the late nineteenth and possibly the twentieth century.

At first sight, it appears that the ceramics from the four levels follow a continuum from the last quarter of the eighteenth century to last quarter of the nineteenth century. However, closer examination of the assemblages revealed the absence of certain Chinese porcelains and British refined earthenwares that are usually found on early nineteenth century (pre 1820) Cape colonial sites (Sea Street & Appendix I.1). Other sites that span the turn of the century yield a combination of cream coloured wares, pearlware with blue painted or printed *Chinoiserie* designs as well as Chinese export porcelain with Nankin or Canton borders. This observation could be interpreted in several ways. It might indicate that the early households using the Barrack Street well had continued to use Cape VOC-style ceramic assemblages¹ into the nineteenth century or that the well was not used for a period of time.

Although three of the four assemblages from the well are too small for reliable statistical analysis, ware types expressed as percentages can be used for comparison with other Cape sites (Figure 8-2 & Figure 9-1). The assemblages reveal a decline in production and use of coarse earthenwares and tin-glazed wares from the late eighteenth century onwards. The well ceramics show a decrease in the use of porcelain for table wares, and its replacement by mass-produced British refined wares, including cream coloured wares which were used in the Cape until the mid-nineteenth century and possibly later. The ceramic assemblages from the Barrack Street well clearly indicate many of the changes that took place in ceramic availability and choice in the Cape during the late eighteenth and nineteenth centuries.

¹. An assemblage dominated by Asian wares (fine and coarse porcelain and stonewares) with smaller amounts of coarse earthenware, European tin-glazed ware, and German stoneware.

Barrack Street Well (Cape Town) c.1775 - late 19th c.

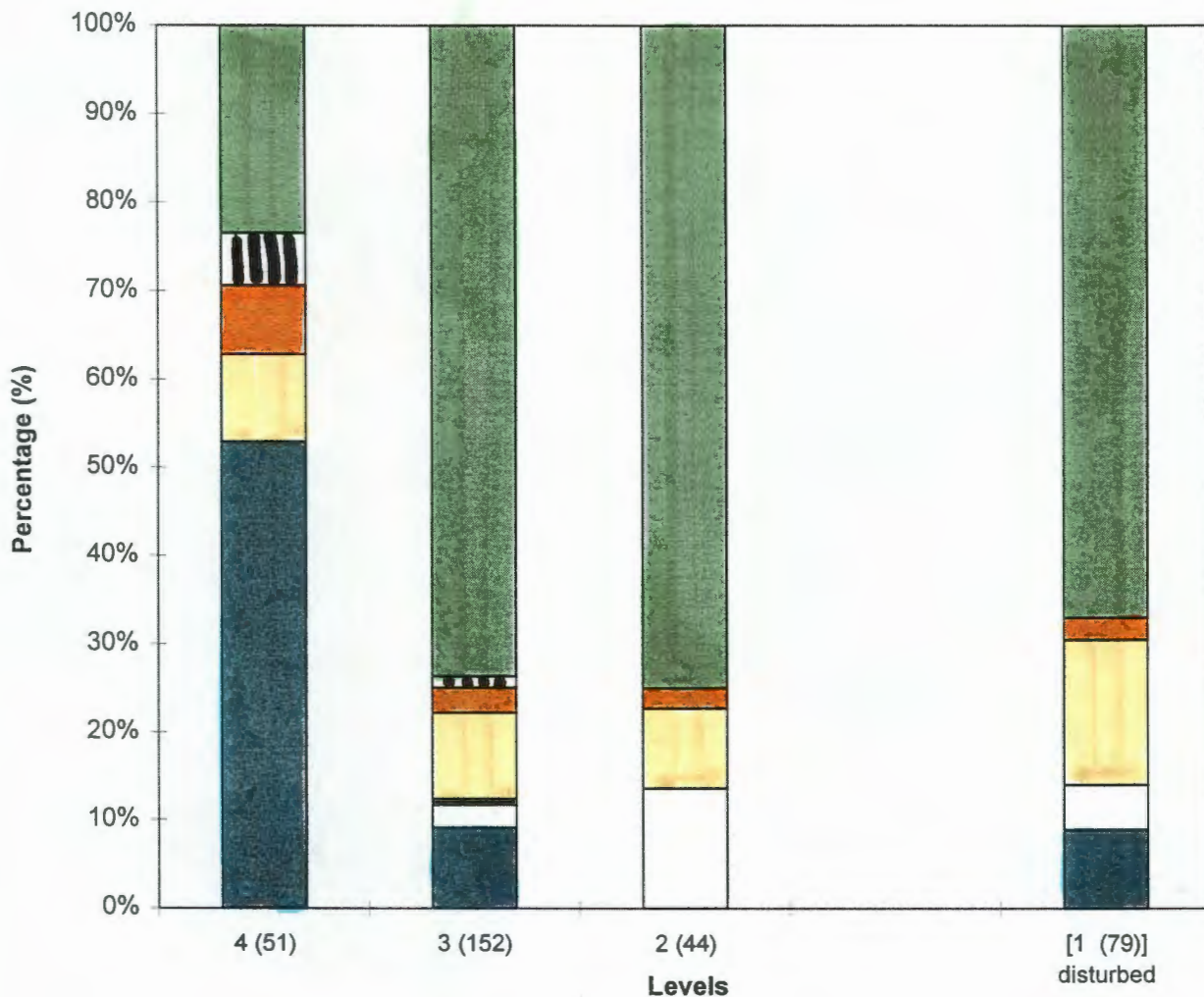

Barrack Street Well Cape Town		Levels (total MNV per level)							
		4 (51)		3 (152)		2 (44)		1 (79)	
KEY	CERAMIC TYPES	MNV	%	MNV	%	MNV	%	MNV	%
		MNV	MNV	MNV	MNV	MNV	MNV	MNV	MNV
	5.1 European refined wares	12	23.5	113	74.3	33	75	53	67.1
	4.1 European tin-glazed earthenware	3	5.9	2	1.3	-	-	-	-
	3.1 European-style coarse earthenware	4	7.8	3	2.9	1	2.3	2	2.5
	2.2 European stoneware	5	9.9	15	9.9	4	9.1	13	16.5
	2.1 Asian stoneware	-	-	1	0.7	-	-	-	-
	1.2 European porcelain	-	-	4	2.6	6	13.6	4	5.1
	1.1 Asian porcelain	27	52.9	14	9.2	-	-	7	8.9

Figure 8-2: Ceramic profiles of Levels 1-4, the Barrack Street well, Cape Town (ca.1775 - late 19th c.).

Level 4
Total MNV for phase = 51

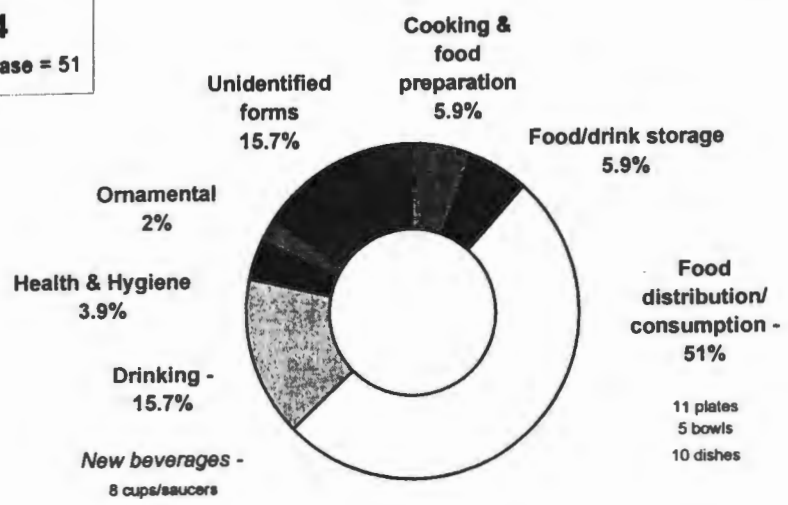

Level 3
Total MNV of phase = 152

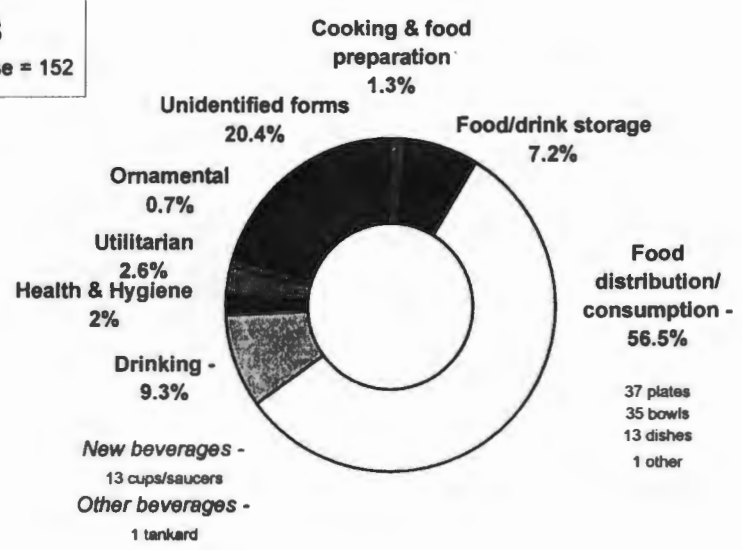

Level 2
Total MNV for phase = 44

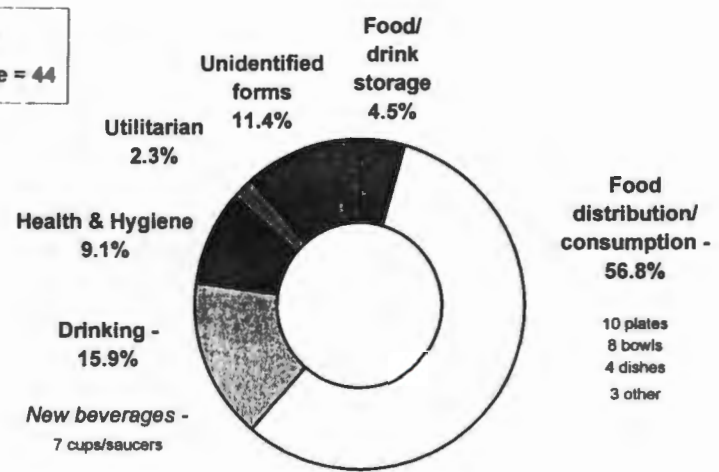

Figure 8-3: The form and function of the vessels in Levels 4, 3, & 2, the Barrack Street well, Cape Town (ca.1775 - late 19th c.).

Chapter Nine

Summary and Conclusions

This final Chapter gives an overall assessment of the Cape Classificatory System (CCS) as tested on a group of thirty ceramic assemblages from colonial sites at the Cape of Good Hope. A brief description of its development is followed by an overview of its application in full to the ceramic assemblages from four differently dated sites (Chapters 5 to 8). This is followed by an evaluation of its strengths and weaknesses as a classificatory system and the chapter ends by discussing the use of the CCS in developing a profile of the role of Asian porcelain in the Cape in the seventeenth and eighteenth centuries.

The CCS is a method of systematically recording ceramics excavated from colonial sites in the south-western Cape. It produces sets of information containing consistent and detailed observations of ware type, decoration, and vessel form and quantity of all the items in a ceramic assemblage. The CCS is a descriptive method of analysis constructed on a ware based classification and the information it produces has substantial analytical utility (Chapter 3). The results of an analysis using this system can be easily adapted or adjusted to form classifications based entirely on decoration, particular vessel forms, function, area of manufacture or combinations of these attributes. The CCS can discern and record gross as well as small incremental changes in ceramic assemblages which allows accurate inter-site comparisons to be carried out. It uses an internationally understood terminology and care was taken to avoid the coining of unnecessary new terms (Chapter 3). The classifications are compatible with those used by archaeologists working in other areas such as North America and Australia.

A completed ceramic analysis using the CCS consists of three inter-linked sections: Ware Table, Form & Function Table, and a Site Catalogue. Ware Table is a ware-based classification which categorises ceramics by ware, area of manufacture and decoration. It records each individual ceramic type by sherd count, MNV and percentage MNV (Appendix E). Form / Function Table records the form and probable function of the identified vessels by MNV and ware type (Appendix G). The Site Catalogue is an inventory of the whole assemblage and contains a written description, photograph and,

where possible, references for each individual type and form of ceramic present (Chapter 5-8 and Appendix K). CCS ceramic analysis is further standardised by the use of Date Table which records the dates of production and references for all the ceramics found on Cape colonial sites (Appendix F) and a catalogue of Asian market ware that is present in the Cape but which has no published references (Appendix J).

Prior to the use of the CCS, the analysis of Cape ceramic assemblages had been carried out with a ware-based classification used by historical archaeologists in North America. This method uses four categories: porcelain, stoneware, earthenware and refined earthenware. It is an extension of the western potters division of ceramic bodies into earthenware, stoneware and porcelain, "each category being distinguished by the fact that it is fired at a temperature higher than the preceding one" (Savage & Newman 1985:68). A cursory examination of several Cape colonial sites indicated that the existing classifications were incapable of dealing equitably with the wide range of Asian, African and European ceramics found on Cape Colonial sites. It was obvious that the existing categories and sub-categories used to classify ceramics had to be re-assessed and adapted to a Cape context.

Initial work on the CCS concentrated on compiling a checklist of ceramics found on colonial sites, and evaluating different methods of recording and classifying sherds based on technical and decorative attributes. This was followed by identification of vessel form, construction of a suitable vessel typology for Cape ceramics, and investigation of methods of quantifying specific ware categories (Chapter 3). Throughout the whole project, the developing methodology and its results were continuously compared with published ceramic studies in order to ensure that the CCS would be a fully comprehensive system of ceramic analysis.

The project began by describing and recording every type of ceramic ware excavated from eight sites within the Castle of Good Hope and examining other assemblages and collections from the Cape area (Appendix I.1). This work focused on meticulous examination of the excavated ceramics to observe ware type and decoration of each sherd in order to determine its exact area of origin and period of manufacture. Initially, many wares were not recognised as belonging to mutually exclusive categories and were incorrectly classified.

The majority of the ceramics from the Castle excavations were examples of pottery provided by the VOC for its employees at an isolated outpost on the tip of Africa (Chapter 5). Most of these wares could be identified and referenced but there was a small number of unfamiliar ceramics. These could only be described and temporally referenced by citing their presence in other Cape ceramic assemblages prior to being identified by experts or from reliable published references. The CCS has made adequate provision for unprovenanced ceramics in all the basic ware categories to allow for this problem.

The completed preliminary check-list for excavated seventeenth to early nineteenth century ceramics from the Castle provided the data base for setting up the categories in a ware-based classification. The first step was to create a categorical distinction between European, Asian and Cape indigenous wares at the start of the analysis. Later reworking of assemblages produced more accurate identifications of specific wares: Persian stone-paste 'porcelain' and Indian earthenware were recognised, which led to alterations and additions within the area-designated categories (Appendix E).

One of the secondary objectives of the project was to investigate the possibility of using ceramics as a dating tool. Ware categories were adjusted to allow the frequency distribution of ceramic types to signify the period of deposition of an assemblage more distinctively. Tin-glazed wares, which are indicative of seventeenth and early eighteenth century Cape assemblages, were placed in a separate category. British refined stonewares, used for tea and table wares, were removed from the European stoneware category and grouped separately but with the British refined earthenwares (Chapter 3, Table 3-1).

An adequate ware-based classification was now in place which could record all the ceramics from the Castle excavations (Ware Table, Appendix E). At this stage of the project, it was decided to study ceramic classifications used by non-archaeologists to see if they could offer alternative methods of analysing archaeological assemblages (Chapter 3). These included classifications utilised by pottery manufacturers, art historians, material scientists, collectors and dealers. They revealed the variety of names for ceramics used by the people who made, bought and used them. This suggested that many of these names could be used alongside the technical ware-based nomenclature to aid the interpretation of assemblages. Miller had advocated this technique for the analysis of nineteenth century refined white earthenwares (Miller 1981) and it was

decided to use his classification for the cream coloured, pearlware and white-bodied ware categories in the CCS (Chapter 3).

The materials science categorisation of ceramics proved to be the most accurate method of organising a ware-based classification but its terminology was too far removed from the usage of ceramics in everyday life (Chapter 3, Table 3-1). The classification placed tin-glazed wares in a category named 'engobes & clay slips'. These are ceramics with dark or impure bodies where the outer surface of the vessel is disguised with a coating of another material prior to decoration and glazing. The engobes category was integrated into the CCS as it contributed an interesting category for the interpretation of ceramic assemblages and provided a technical justification, as opposed to a chronological reason, for separating tin-glazed earthenwares from the other earthenware categories.

Another objective of the project was to find ways of facilitating the comparison of excavated ceramics with descriptions in contemporary documents. Because many vessels listed by the appraisers have yet to be found or identified in the archaeological record, a list is being compiled of all the vessel forms recorded in the documents. This will provide an important reference list for vessel form analysis. Re-analysed ceramic assemblages rarely show a change in the MNV but always show an increase in the identification of vessel forms. Woodward (1974, 1982) and Malan (1993) have commented on the minimal descriptions used to record ceramics in Cape probate inventories and auction lists. These written descriptions of decorated vessels are too vague to be included in Ware Table but the use of photography to record excavated ceramics will partially overcome this drawback.

Ware Table continued to evolve through trial and error. It now utilised the following categories and subcategories for each ware: area and country of manufacture, ware type and decorative type. The sherds in each category and their sub-categories were recorded by sherd count and MNV. The classification was applied to as many assemblages as possible. These included professionally excavated urban and rural colonial sites, small collections retrieved from building sites, previously analysed assemblages; and ceramics from shipwrecks in Cape waters (Appendix I.1). This operation also revealed additional ceramic sub-categories which were added to Ware Table.

The next stage of the project had to set up a method of recording the form, function and quantities of identified vessels in an assemblage. This section of the CCS is known as Form/Function Table (Appendix G) and is used in conjunction with the Site Catalogue. It is an adaptation and modification of the Potomac Typological System (POTS) which was based on the vessels found on seventeenth century British colonial sites on the east coast of north America (Beaudry *et al.* 1983). Form/Function Table was primarily constructed for the interpretation of seventeenth to early nineteenth century Cape colonial assemblages but, with modifications, it can be used for analysing later nineteenth and twentieth century ceramics. Seven functional categories are used: food preparation, food and drink storage, food distribution and consumption, drinking (subdivided into 'new beverages' and 'other beverages'), health and hygiene, utilitarian, and ornamental. A further category is provided for unidentified sherds with subdivisions into hollow, flat and undiagnostic wares (Appendix G). All seven categories are further subdivided by ware type to make the results of the analysis more accessible. Only excavated vessel forms have been included in Form/Function Table at present.

The assignment of function to many vessels from Cape colonial sites is at a preliminary stage (Abrahams 1996). At present, not enough is known about the foodways of the multi-ethnic population of the Cape to allocate all the excavated vessel forms to the correct functional categories. Form/Function Table has tried to overcome part of this problem by temporarily combining the food distribution and food consumption categories and providing alternate listings for some vessels. Vessels assigned to functional categories on the basis of shape alone may be re-classified when the contemporary documentary evidence is studied in depth. This will apply in particular to the large number of medium-sized bowls which could have been used for drinking, individual food consumption or food distribution.

The Site catalogue is the accession register of all the sherds in an assemblage (Appendix L). It uses Ware Table as its framework and describes each vessel form using the information from Ware and Form/Function Tables with the addition of published references, site references and photographs. An example of each type of ceramic ware is photographed. This avoids using vague and meaningless written descriptions for ceramics and is particularly useful for comparing vessels with written descriptions in probate inventories, and for recording wares which have not been referenced (Appendix K).

Ceramic assemblages from four dated sites have been fully analysed using the CCS (see the map in Figure 5-1): The Granary in the Castle of Good Hope, ca.1685 - ca.1700 (Chapter 5); Elsenburg midden, ca.1730-1761 (Chapter 6); James' House, Sea Street, Cape Town, ca.1870 - ca.1830 (Chapter 7); and the Barrack Street Well, Cape Town, ca.1775s - ca.1890s (Chapter 8). The sites were independently dated using information from clay smoking pipes found in association with the ceramics (Yates *et al.* unpublished manuscript). The following overview of the application of the CCS to these sites also takes cognisance of twenty six other ceramic assemblages which were either partially analysed during the project using selected components of the CCS, or had been fully analysed and recorded using earlier versions of the CCS (Appendix I.1).

The Granary (ca.1685 - ca.1700) excavation was the oldest site to be analysed (Chapter 5, Figure 5-2 & 5-3). The ceramic assemblage could be linked to the building of the *Kat* wall ca.1685 making it one of the earliest *in situ* collections excavated in Cape Town. Archaeological evidence suggests that it was intermittently occupied by slaves (Hall 1992b) during the last two decades of the seventeenth century and that all the ceramics were deposited within a fifteen to twenty year period (Chapter 5).

The Granary assemblage was small and fragmented with a total MNV of 173 which allowed every sherd to be examined in great detail. The Castle was the warehouse of the VOC and the Granary ceramics include examples of all the types known to have been shipped by the Company to the Cape from their headquarters in Batavia or directly from Europe. There are examples of wares from China, Japan, Persia, Africa, Germany, Holland, Britain and possibly India, making it the most widely sourced group of ceramics analysed in this project. The unidentified coarse earthenwares present in the Granary could have been obtained at ports of call throughout the East.

Frequency distribution analysis was carried out for all the phases in the Granary despite the fact that the individual MNVs were probably too small for reliable statistical analysis (Chapter 5, Table 5-2, Figure 5-5). The archaeological evidence indicated that the deposits were laid down in a short period of time and it was decided to combine the phases in one group and use it to discuss and evaluate all the ceramics from the Granary (Table 5-1). European manufactured wares dominate the assemblage. The estimated combined MNV for the whole assemblage shows that nearly half the vessels (48%) were imported from Europe, most of the remaining ceramics were from Asia (38%), with a

much smaller amount of unprovenanced African/Asian wares (8%) and the least amount from local sources (6%) (Chapter 5, Table 5-1).

The characteristics of the sherds in the lowest four levels differ from the two upper levels. The fragments are small and produce a high MNV coupled with a low vessel reconstruction rate and are similar to those found in large communally used dumps (Sea Street, Chapter 7). This suggested that the sherds in the lower layers were not in primary context and are examples of tertiary disposal (South 1977:296-299). Some of the sherds in the uppermost level (Phase 7) could be primary refuse discarded at its place of use as they included four vessels that can be partially reconstructed. The vessels could possibly be cast-offs or purloined goods used by slaves during their occupation of the Granary (Hall 1991c).

The vessel forms in the Granary assemblage showed that the tablewares were predominantly plates and dishes of Japanese porcelain, Delft and Niederrheinische earthenware, the drinking vessels were Rhenish stoneware jugs and Chinese tea cups, and a high proportion of the coarse earthenware cooking utensils was imported from Europe. It was impossible to identify the exact form of over 20% of the vessels due to high fragmentation of the sherds. Indigenous pottery found in the lowest levels may indicate the presence of Khoi at the Castle in the late seventeenth century.

The high quality of the blue-and-white Chinese teawares throughout the excavation was typical of late seventeenth century export porcelain for the European market. They are made from exceptionally fine, white porcelain and are carefully painted in bright sapphire blue with figures, flowers and symbols.

The ceramic profile of the Granary assemblage was constructed by taking an average of all six ceramic bearing Phases (Figure 9-1). This could be the signature of a VOC occupation at the Cape at the end of the seventeenth century but the analysis will have to be compared with figures from other similar sites before this can be verified.

The second assemblage to be analysed using the CCS was from Elsenburg (Chapter 6), a large prosperous farmstead owned by free burgers, situated about fifty kilometres from Cape Town (Chapter 5, Figure 5-1). The ceramics were excavated from a midden and had been discarded by a single household during the middle years of the eighteenth century. The midden was capped in 1761 and this information meant the ceramics could

be linked to individual families and their probate inventories, thus allowing the comparison of excavated material with documented descriptions.

The average sherd size was large and the vessel reconstruction rate was high, and could be the signature of immediate refuse disposal from a single household. The majority of the Eisenburg ceramics were produced between the 1730 and 1750s. The assemblage is dominated by Asian wares: 84.5% porcelain and 2% stoneware, followed by 10% locally manufactured European-style earthenwares and approximately 4% European produced stoneware, tin-glazed earthenware and one item of Staffordshire fine red earthenware (Chapter 6, Table 6-1). These figures differ from the composition of the earlier Granary ceramics and could indicate the mid-eighteenth century Cape's dependence on, or preference for, Asian porcelain and that European wares were no longer obtainable or requested in the colony.

The quality and range of the Asian porcelains from Eisenburg, which include matching blue-and-white tablewares and exquisitely enamelled *famille rose* teawares, have not been found on other sites analysed in this project. The high percentage of enamelled wares fits in with the popularity of enamelled wares in mid- eighteenth century Europe (Jörg 1982:157). The porcelain assemblage also included specialised tablewares (salts, mustard pots and cutlery handles) and a collection of blue-and-white and enamelled ornamental wares. The Eisenburg ceramic assemblage could be characteristic of elite Cape colonial households in the mid-eighteenth century.

The third ceramic assemblage to be analysed using the CCS was from James' House, one of the four excavations carried out on a site situated just above the shoreline in Sea Street, Cape Town (Chapter 7). The site covered a large town dump that was in use from the end of the eighteenth century to ca.1830 when low cost houses were built over it. The ceramics show the characteristics of a large communal midden, namely high fragmentation, high MNV, very few cross-mends and a negligible reconstruction of vessels.

The majority of ceramics consist of Asian porcelains from the second half of the eighteenth century and British refined earthenwares dating to the last years of the eighteenth century and the first decades of the nineteenth century. The Asian wares comprise good quality Chinese export porcelain tablewares and teawares, Asian market coarse porcelain bowls and dishes, and smaller amounts of Chinese martevans and

Japanese export porcelain. The European manufactured wares included stoneware mineral water bottles, and white undecorated tin-glazed wares. The only locally produced wares were European-style coarse earthenware cooking utensils, dishes and plates. British refined earthenwares had equal amounts of table and teawares: undecorated cream coloured ware, painted polychrome and blue-and-white wares, blue printed wares and isolated examples of colour printed wares.

It is not possible to link the contents of the midden to any specific households but Margaret Cairns has shown that the nearby houses ranged from overcrowded small houses inhabited by artisans, washerwomen and fishermen, to houses inhabited by business men, merchants and doctors (Cairns 1981:37-49). This might account for the wide range of types and quality of excavated ceramics but probate inventories show that the lower classes living in the Cape during the eighteenth century also possessed a wide selection of Asian porcelains (Malan 1993).

The results of the analysis demonstrate the gradual replacement of Asian porcelain in the Cape by Staffordshire refined earthenwares. The assemblage from James' House (Chapter 7, Table 7-1) shows the value of excavating town dumps. It contains examples of the ceramic wares and vessel forms that were available in the Cape in the second half of the eighteenth century and early nineteenth century and illustrates which ceramic wares were used concurrently during that time.

The last ceramic assemblage to be analysed was excavated from a household well in Barrack Street, Cape Town (see map in Chapter 5, Figure 5-1). The well was originally built to serve a late eighteenth century town house with a store attached. It remained open, but not necessarily for supplying water, throughout most of the nineteenth century. During this time period, the character and use of the property gradually changed and it eventually became incorporated within a factory (Chapter 8).

The well had a clear four part stratigraphy which could be linked to different occupants of the house and the changing usage of the property. Level Four, the lowest level, contained a typical eighteenth century Cape assemblage of Chinese export porcelain, tin-glazed wares and locally produced coarse earthenwares, mixed with small sherds of nineteenth century British refined earthenwares. Level Three was dominated by British manufactured wares with only small fragments of Asian wares similar to those found in the level below, and Level Two is totally British in content. The uppermost level consisted

of the fill used to seal off the well at the end of the nineteenth century. It was a heavily disturbed layer and contained examples of all the ceramics found in the underlying levels. It was fully analysed and recorded but not used for comparative analysis.

The Chinese porcelains and locally produced coarse earthenwares in the lowest level are consistent with a ca.1775-90 occupation and could be associated with early individual households. The majority of the ceramics from the other layers are nineteenth century British refined earthenwares. The early wares are of good quality but the later ceramics appear to be lower grade ceramics which could relate to the status of the users of the well. No fine quality European porcelains were excavated.

The four levels of the well demonstrate the change in availability of ceramics in the Cape over a hundred year period during which the Cape changed from monopolistic VOC rule to being administered as a colony within the British Empire (Chapter 8, Table 8-1 & Figure 8-2). However, there appears to be a break in this continuum when Level Two is compared with roughly contemporary assemblages from Phases Two and Three at Sea Street. The "missing" wares consist of a combination of cream coloured ware, hand-painted blue painted pearlwares, painted polychrome wares in soft colours and early nineteenth century Chinese porcelains that have been found in early nineteenth century Cape assemblages. This poses questions about an apparent hiatus in deposition as the Barrack Street site was occupied continuously from ca.1775 to the late nineteenth century.

Application of the CCS to a wide range of Cape sites highlighted the weaknesses and strengths of the system. The weaknesses are similar to those encountered with any method of ceramic analysis and include the problems associated with dealing with large assemblages, high fragmentation, and minimally decorated or undifferentiated sherds.

The main disadvantage of the CCS is that it is time consuming and requires a high level of expertise to carry out in full. The results showed the importance of examining every fragment no matter how small. The compilation of site catalogues takes a considerable amount of time but it is proving to be an important and useful component of the CCS. The need for fully illustrated catalogues may fall away when adequate published references for Cape ceramics become available. The analysis also showed that a fully comprehensive, illustrated vessel typology must be set up for seventeenth and eighteenth century Cape sites to ensure that assemblages are systematically recorded.

The analysis of the four sites demonstrated that the quality and reliability of any ceramic analysis is always affected by the size of the assemblage and the fragmentation of the sherds. Taphonomic factors were rarely a problem although low-fired ceramics such as tin-glazed wares and coarse earthenwares lost their glaze and certain overglaze decorations had been destroyed or degraded. The degree of fragmentation within a whole site yielded information about the disposal of ceramics: high fragmentation, usually linked to a high MNV, was more common in large communal dumps (Sea Street) or where refuse had been relocated (the lower levels of the Granary), while assemblages with low fragmentation and low MNVs tended to be associated with single households (Eisenburg kitchen midden; Barrack Street well, Level 4).

High fragmentation did not hinder the identification of ware categories but it did affect identification of vessel form and quantification. Familiarity with vessel forms found on Cape sites enabled many small undiagnostic sherds to be provisionally provenanced or assigned to vessel form categories. For example, fragments of unglazed red stoneware were classified as Yixing teapots and very thinly potted Asian porcelain sherds were assigned to the tea/coffee ware category.

Estimation of the MNV was not only influenced by fragmentation but also by the number of sherds and the type and decoration of the ceramic being analysed. Comparison of the analysis of the four sites showed that, in general, the lower the sherd count for individual wares categories, the higher the MNV and this result was independent of the degree of fragmentation. The Japanese porcelain category was always small but repeatedly yielded a high MNV, whereas coarse earthenwares and undecorated cream coloured wares had low MNVs when compared with their sherd counts. These results suggest that there can be considerable imbalance in the estimation of the MNVs within an assemblage and that this must be taken into consideration when using the results of analysis.

The use of percentage distribution of ceramic wares for relative dating within an assemblage, inter-site comparison, and for estimating the occupation date of a site proved to be worthwhile. This type of analysis provides a ceramic profile of a site, or phases within an excavation, which can be expressed numerically or graphically (Figures 9-1 & 9-2). Ceramic profiles are read in conjunction with Date Table (Appendix F). Date Table is not complete and is the first stage of a project to assign dates of manufacture and dates of occurrence on Cape sites to all the ceramics found in excavated Cape assemblages sites in order to help standardise the analysis of colonial sites. Pre-

nineteenth century colonial Cape ceramic assemblages are primarily dated by the Asian porcelains and make use of the chronology of plate rim designs that have been found on dated Cape sites (Klose 1993).

Ceramic profiles were calculated for five additional sites with known dates of use or occupation (Figure 9-2) and compared with those from the four fully analysed assemblages from the Granary, Elsenburg, Sea Street and Barrack Street (Figures 9-1). Comparison of the two sets of profiles suggested that a mid- eighteenth century Cape colonial household would show at least 60% to 70% Asian porcelain, lesser amounts of coarse earthenware and European stoneware, much smaller amounts of Asian stoneware and tin-glazed wares and isolated pieces of British refined earthenware. The one seventeenth century site shows a completely different profile with a much lower percentage of Asian porcelain but considerably higher percentages of tin-glazed wares and European stonewares and the presence of African/Asian coarse earthenwares. Other observations suggest that Khoi pottery is indicative of a seventeenth century occupation and European porcelain points to the nineteenth century. More precise differences between assemblages can be shown by using further subdivisions of the ware categories.

Comparison and dating of sites using percentage distribution analysis can only be adequately evaluated when more assemblages are analysed in this way. At this stage, it can give a general picture of a site and emphasise any anomalies within an assemblage. The results also question the value of statistical analysis carried out on small assemblages and whether they can be compared with results from much larger groups. Further research might well indicate that there is a minimum MNV count for making use of comparative percentages.

Ware Table was proved suitable for recording all the excavated wares types as it made provision for unprovenanced wares in all the major categories. Ware Table acts as a check-list and alerts analysts to the wide range of ceramic types found on Cape sites. The CCS is an hierarchical system which allows ceramics to be recorded at four different levels of analysis, from basic ware type to precisely identified ware sub-type (Chapter 3, Table 3-3). For example, a blue-and-white Chinese porcelain sherd can be recorded as follows: porcelain; porcelain - Asian; porcelain - Asian - Far Eastern, Chinese; porcelain - Asian - Far Eastern, Chinese - underglaze blue.

Ware Table can be used on its own for presence/absence analysis and also to obtain a quick overview of a ceramic assemblage. Another advantage of Ware Table is that it permits the instant integration of additional identified excavated ceramics in their correct category. It also provides alternative classifications for certain wares. Basalt, Cane and Jasper can be categorised as stoneware or alongside white earthenwares as an eighteenth to nineteenth century British refined ware. Late eighteenth to nineteenth century refined white earthenwares can be categorised by ware or by decoration alone.

The use of Form / Function Table highlighted the difficulties associated with recognition of vessel form from sherds and the association of form with function. It showed that coarse earthenwares, tin-glazed wares and refined white earthenwares have the highest number of unidentified vessel forms. The results of the functional analysis were expressed as percentages of the assemblage but this proved to be misleading when comparing different sized assemblages and disguised real increases in vessel forms (Figure 9-3).

Analysis of vessel form revealed the large quantities of medium and large bowls and the prevalence of saucer-dishes in Cape ceramic assemblages. These were the predominant forms in the Asian market ware category and can possibly be linked to the rice and relish Eastern-style cuisine of the Cape. But the number of export porcelain saucer-dishes must be compared with European assemblages before they can be interpreted as being characteristic of the Cape alone.

The four sites (Chapters 5 to 8) were from different time periods and it was difficult to make direct comparisons between them. The Granary assemblage showed the types of ceramics in use by Company officials, soldiers and slaves at the Castle in the seventeenth century, the Elsenburg ceramics had been discarded by an elite early mid-eighteenth century rural household, Sea Street was a town dump used by an unknown number of different status households in Cape Town at the end of the eighteenth century and early nineteenth century, and the Barrack Street well contained ceramics from a series of different status occupations over a hundred year period beginning in the last quarter of the eighteenth century.

The Cape did not have a refined ceramic industry of its own until the twentieth century. The four assemblages showed the change in availability, acquisition and usage of ceramics at the Cape over a two hundred year period. Although not enough sites have been analysed and published to say anything definitive about ceramic usage in the Cape,

it is possible to make the following generalisation. It appears that the colonists in the Cape region did not make use of indigenous Khoi pottery, which has only been found in the lowest levels of early colonial sites. Eighteenth century ceramic assemblages excavated from Cape colonial sites have a unique signature: they are dominated by Asian export porcelains which include considerable quantities of Asian market coarse porcelains. The same Chinese and, to a lesser extent, Japanese export porcelains are found in households throughout Europe and on colonial sites in North America. It is the coarse porcelain bowls and dishes that indicates the particular character of Cape ceramic assemblages. They indicate the creole nature of Cape society and its connections with the East, and signify the influence of Indonesian culture brought to the Cape by slaves and to a lesser extent by VOC officials and their families who had lived, and often been born, in the East.

The widespread use of porcelain by all sectors of the colonial community appears to have diminished the market for European tin-glazed tablewares and teawares in the Cape early in the eighteenth century. This sets the Cape apart from other eighteenth century European colonies, where widespread usage of these wares continued throughout most of the eighteenth centuries. Ownership of porcelain *per se* was not necessarily an indication of high status in the Cape colony. It was owned and used by people from all levels of society, from manumitted slaves to Company officials, and was acquired at Company and private auctions, and through legal and illegal private trading (Malan 1993). Status was indicated by the quantity, quality and decoration of the porcelain owned by individual families as demonstrated by the ceramic assemblages from Elsenburg and the lowest level of the Barrack Street well (Chapters 6 & 8). Fine enamelled porcelain was present in the Sea Street assemblage but it could not be associated with a particular household.

VOC control of the Cape markets delayed the introduction of fashionable British refined earthenwares, and Chinese porcelain remained the dominant table and teaware until the early nineteenth century. Other Asian wares such as coarse porcelain bowls and dishes, stoneware jars and pots were used throughout the seventeenth and eighteenth centuries alongside Rhenish salt-glazed bottles and jugs and small amounts of tin-glazed ware.

The presence of the British in the late eighteenth century and again in the early nineteenth, century changed the ceramic market significantly but auction lists show that the colonists still continued to buy Chinese porcelain in the early nineteenth century

(Malan 1993). Porcelain could be bought from passing ships that called at the Cape and through direct trade with the East. The interest in Asian merchandise was noticed by Lord Macartney, the Governor of the Cape. In 1798, he submitted a list to the British Government of the Asian commodities requested annually by the Burgher Senate for the inhabitants of the Cape. The list included teas, spices, materials and over 40,000 pieces of 'China ware'. This order prompted Macartney to comment that if Cape of Good Hope is ceded to the East India Company "it would prove to them an acquisition of prodigious importance" (Theal 1898:266).

In future work, the CCS will be used to develop a profile of the role of Asian porcelain in the Cape in the seventeenth and eighteenth centuries. No ceramic ware can be studied in isolation but must be seen in context with the other ceramic wares and similar vessels made in other materials. The CCS will provide a foundation for addressing questions of how Asian porcelains fitted into the economic and social fabric of the Cape. The Asian market wares are of particular interest because these thickly potted and coarse bodied bowls and dishes were never officially exported to Europe but they make up between 8% and 20% of the total vessel count on most eighteenth century Cape sites and appear in increasing numbers throughout the century. A vessel typology has been constructed for Asian market coarse porcelains as part of the Asian porcelain project. This information is included in a catalogue of coarse porcelains excavated from sites throughout the Cape (Appendix J). The catalogue is a record of the type of coarse wares shipped by the VOC throughout Southeast Asia in the seventeenth and eighteenth centuries.

It is difficult to draw definite conclusions about ceramic usage in the Cape based on the results of this project alone. The results of the study showed the importance of single household assemblages that can be linked to documentary evidence, but also the value of excavating large communal town middens. Ceramic analysis of colonial sites is at an early stage in South Africa but it is possible to discern changing overall trends and patterns for Cape colonial sites during a two hundred year period from the late seventeenth to the second half of the nineteenth century. Future research will be able to build further on this foundation of understanding.

Comparison of Ceramic profiles (sites considered in this dissertation)

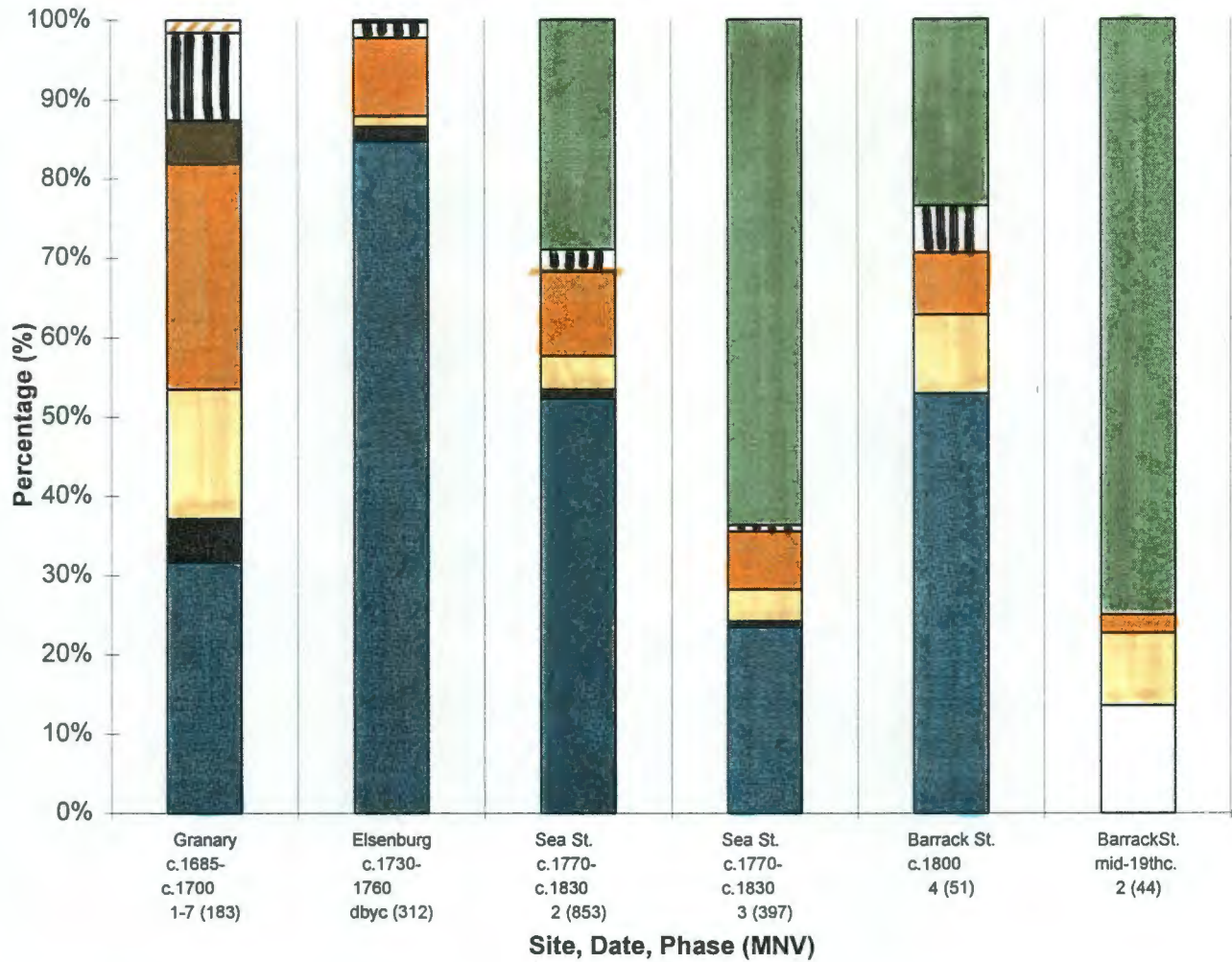

COMPARISON OF CERAMIC PROFILES		<i>Phases/levels (total MNV per phase/level)</i>													
		The Granary, Castle of Good Hope c.1685 - c.1700			Eisenburg Manor House c. 1730 - 1760			James' House (6) Sea Street Cape Town c. 1770's - c. 1830			Barrack Street Well Cape Town c. 1775 - late 19thc.				
		1 - 7 averaged (183)			dbyc (312)			2 (853)		3 (397)		4 (51)		2 (44)	
		KEY	CERAMIC TYPES	MNV	%	MNV	%	MNV	%	MNV	%	MNV	%	MNV	%
		MNV	MNV	MNV	MNV	MNV	MNV	MNV	MNV	MNV	MNV	MNV	MNV		
	Unprovenanced earthenwares	3	1.6	-	-	-	-	-	-	-	-	-	-		
	5.1 European refined wares	-	-	1	0.3	247	29	253	63.7	12	23.5	33	75		
	4.1 European tin-glazed earthenware	20	11	6	1.9	23	2.7	3	0.8	3	5.9	-	-		
	3.2 African/Asian coarse earthenware	10	5.5	-	-	1	0.1	-	-	-	-	-	-		
	3.1 European-style coarse earthenware	52	28.4	31	9.9	90	10.6	29	7.3	4	7.8	1	2.3		
	2.2 European stoneware	30	16.4	4	1.3	36	4.2	16	4	5	9.9	4	9.1		
	2.1 Asian stoneware	10	5.5	6	1.9	10	1.2	3	0.8	-	-	-	-		
	1.2 European porcelain	-	-	-	-	-	-	-	-	-	-	6	13.6		
	1.1 Asian porcelain	58	31.6	264	84.6	446	52.3	93	23.4	27	52.9	-	-		

Figure 9-1: Ceramic profiles of the Granary (combined phases), Eisenburg; Sea St; and the Barrack St well.

Figure 9-2: Selected ceramic profiles of the Grand Parade, Paradise, Bree St, Verlorenvlei & Harrington St..

Comparison of Ceramic profiles
(other Cape sites)

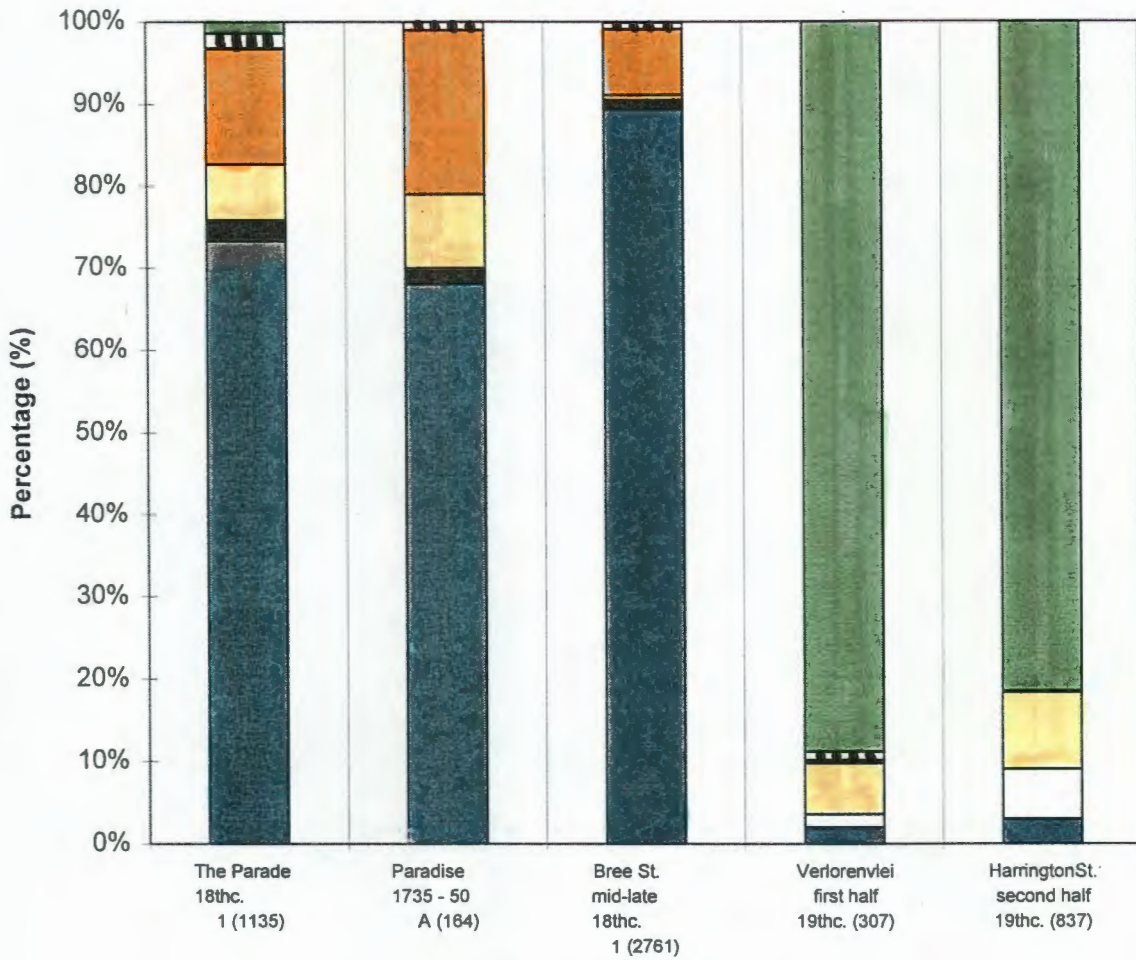

Site, Date, Phase (MNV)

COMPARISON OF CERAMIC PROFILES		Phases/levels (total MNV per phase/level)									
		The Parade (dump) mid. 18thc.		Paradise (outbuilding 1) c. 1735 - 50		Bree Street Cape Town mid-late 18thc		Verlorenvlei midden 1st half 19thc.		Harrington St. Cape Town 2nd half 19thc.	
		1 (1135)		A (164)		1 (2761)		midden (307)		site (837)	
KEY	CERAMIC TYPES	MNV	% MNV	MNV	% MNV	MNV	% MNV	MNV	% MNV	MNV	% MNV
	5.1 European refined wares	16	1.4	-	-	4	0.1	273	89	680	81.2
	4.1 European tin-glazed earthenware	20	1.8	2	1.0	20	0.8	3	1	-	-
	3.2 African/Asian coarse earthenware	-	-	-	-	-	-	1	0.4	-	-
	3.1 European-type coarse earthenware	160	14	32	20	225	8	-	-	2	0.2
	2.2 European stoneware	78	6.8	14	9	16	0.6	19	6.2	78	9.3
	2.1 Asian stoneware	25	2.2	4	2	24	1	-	-	-	-
	1.2 European porcelain	5	0.4	-	-	6	0.2	5	1.6	50	6
	1.1 Asian porcelain	831	73.2	112	68	2466	89.3	6	2	24	3

The Granary

(Phase 7 - Total MNV for phase = 70)

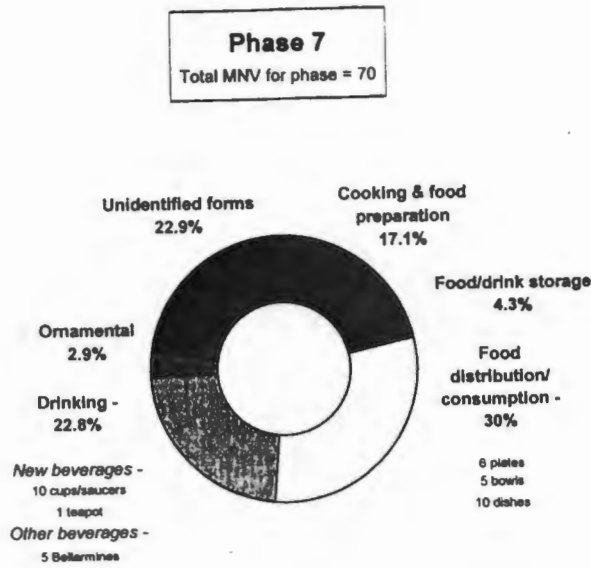

Elsenburg

(Layer dbyc - Total MNV for layer = 313)

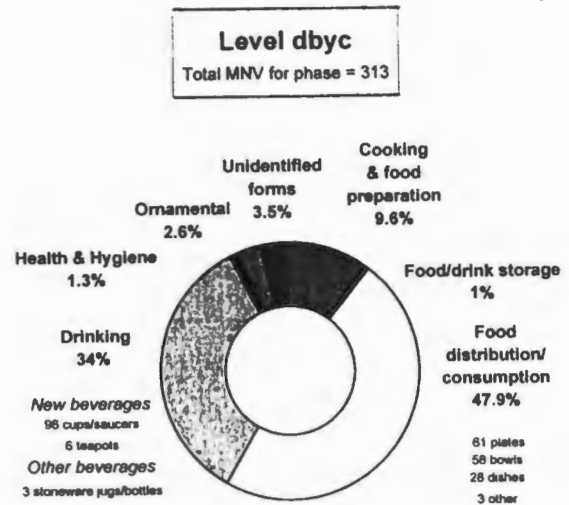

James' House Sea Street

(Phase 2 - Total MNV for phase = 853)

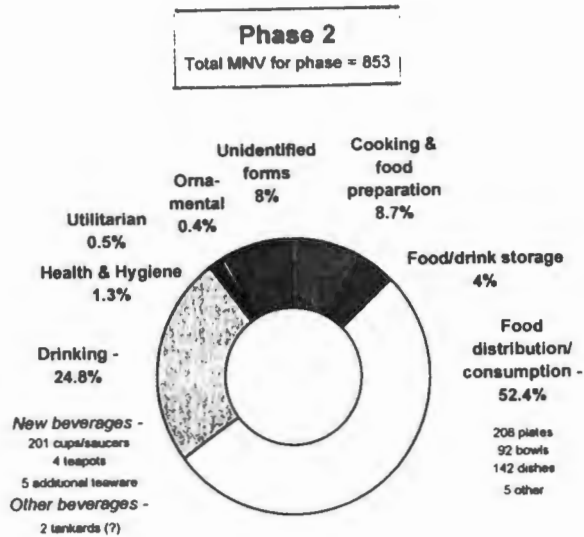

Barrack Street well

(Level 2 - Total MNV for level = 44)

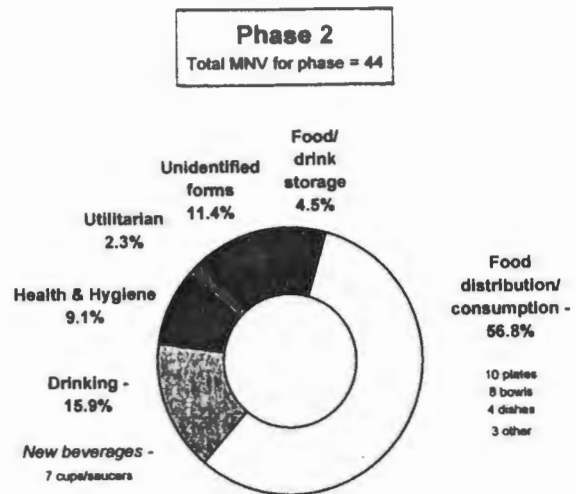

Figure 9-3: Comparison of the form and function of vessels from the Granary, Elsenburg, James' House, Sea Street and the Barrack Street well.

References

Personal communications

David Barker, City Museum & Art Gallery, Stoke-on-Trent.

Yolande Crowe, The Oriental Ceramic Society, London

James Deetz, University of Virginia

Helen Espir, The Oriental Ceramic Society, London

Robin Hildyard, Victoria & Albert Museum, London

Timothy Hart, ACO, University of Cape Town

Ho Chuimei, c/o Field Museum of Natural History, Chicago

John Hurst, Stamford, U.K.

Oliver Impey, Ashmolean Museum, Oxford

Stacey Jordan, Rutgers University

Christiaan Jorg, Groninger Museum, The Netherlands

Richard Kilburn, The Oriental Ceramic Society, London

Antonia Malan, University of Cape Town

Ohashi Koji, The Kyushu Ceramic Museum, Arita, Japan

Jacqueline Pearce, Museum of London

Peter Sachs, Cape Town

Andrew Smith, University of Cape Town

Hendrik Vos, Stellenbosch Museum

Bruno Werz, University of Cape Town

Shipwrecks

18th c. wreck, Transkei, S.Africa (possibly <i>Bennebroek</i> (1713) VOC)	No references (Peter Sachs pers comm.)
<i>Diana</i> (1817) English (Calcutta) Malaysia	Ball 1995; Christie's Amsterdam 1995
<i>Frolic</i> (1850) American California	Hagen Jones 1992
<i>Geldermalsen</i> (1752) VOC South China Sea	Sheaf & Kilburn 1988 Christie's Amsterdam 1986
<i>Gotheborg</i> (1745) Swedish Rivo Fjord, Sweden	Wastfelt <i>et al.</i> 1990/1
<i>Griffin</i> (1761) English Southern Philippines	Goddio & Jay 1988
<i>Maori</i> (1909) British Cape Peninsula	Turner 1988
<i>Middelburg</i> (1781) VOC Saldanha Bay	Woodward 1974; Turner 1988
<i>Oosterland</i> (1697) VOC Table Bay, Cape Town	Werz 1993
<i>San Diego</i> (1600) Spanish Philippines	Carré <i>et al.</i> 1994
<i>São Gonçalo</i> (1630) Portuguese Plettenberg Bay, S.Africa	Smith 1986; Storrar 1988
<i>Vang Tau</i> (c.1690) Con Dau, Vietnam	Christie's Amsterdam 1992
<i>Witte Leeuw</i> (1623) VOC St Helena	van der Pijl-Ketel 1982

General references

- ABRAHAMS, G. 1984. The development of historical archaeology at the Cape, South Africa. *Bulletin of the South African Cultural History Museum*, 5:20-32
- ABRAHAMS, G. 1987. Seventeenth and eighteenth century glass bottles excavated from Fort de Goede Hoop, Cape Town. *Annals of the South African Cultural History Museum* 1:1-38
- ABRAHAMS, G. 1993. The Grand Parade, Cape Town: archaeological excavations of the seventeenth century Fort de Goede Hoop. *South African Archaeological Bulletin* 48:3-15
- ABRAHAMS, G. 1994. Coarse earthenwares of the VOC period: 18th century pottery excavated from the Grand Parade at the Cape. *Annals of the South African Cultural History Museum* 6(1)
- ABRAHAMS, G. 1996. Foodways of the mid-18th century Cape: archaeological ceramics from the Grand Parade in central Cape Town. Unpublished Ph.D. thesis. Department of Archaeology, University of Cape Town
- ADAMS, H.A. & BOLING, S.J. 1989. Status and ceramics from planters and slaves on three Georgia coastal plantations. *Historical Archaeology* 23(1):69-96
- ADAMS, W. H. & GAW, L. 1977. A model for determining time lag of ceramic artifacts. *Northwest Anthropological Research Notes* 2:218-31
- ALLEN, A.J. 1996. *Allen's Introduction to Later Chinese Porcelain*. Auckland: Allen's Enterprises
- ALLEN, J.W. 1991. *Islamic Ceramics*. Oxford: Ashmolean Museum
- ANDERS, G.P.A., JORG, C.J.A., STERN, W.B. & ANDERS-BUCHER, N. 1992. On some physical characteristics of Chinese and European red wares. *Archaeometry* 34(1):43-52
- ARCHAEOLOGY CONTRACTS OFFICE. 1991a. Archaeological excavations at 109 Harrington Street, The Granite Lodge. Department of Archaeology, University of Cape Town
- ARCHAEOLOGY CONTRACTS OFFICE. 1991b. Preliminary archaeological investigation of Riebeeck Square, Cape Town. Report for the City Planners Department, Cape Town City Council. Department of Archaeology, University of Cape Town
- ARCHAEOLOGY CONTRACTS OFFICE. 1992. Archaeological survey: Steenberg Farm. Report for Johannesburg Consolidated Investments. Department of Archaeology, University of Cape Town
- ARCHAEOLOGY CONTRACTS OFFICE. 1993. Archaeological investigation of the Eisenburg *Herehuis*. Report for Dept of Local Government, Housing and Works. Department of Archaeology, University of Cape Town
- ARCHAEOLOGY CONTRACTS OFFICE. 1995. An archaeological investigation of the Cafe Royal Building, Church St, Cape Town. Report for Syfrets Ltd. Department of Archaeology, University of Cape Town
- ARTS, P.L.W. 1983. *Japanese Porcelain: A collector's guide to general aspects and decorative motifs*. Lochem: De Tijdstroom
- ATTERBURY, P. (ed.) 1982. *The History of Porcelain*. London: Orbis
- AYERS, J. 1986. *Famille rose* and the later enamelled wares. In: Krahl, R., Erbahar, N. & Ayers, J. (ed.) *Chinese ceramics in the Topkapi Saray Museum* III:1299-1301. London: Sotheby's Publications
- AYERS, J., IMPEY, O. & MALLET, J.V.G. 1990. *Porcelain for Palaces: the Fashion for Japan in Europe 1650-1750*. London: The Oriental Ceramic Society

- AZIZI, S., DALLAL, D., GORDON, M., JANOWITZ, M., MACZAF, N. & PIPES, M-L. 1993. Integrated approaches to artifact analysis. Papers read at the CNEHA Meetings, Plymouth, New Hampshire, October 1993
- BAART, J.M., KROOK, A.A. & LAGERWEIJ, A.C. 1986. Opgravingen aan de Oostenburgermiddenstraat. In: *Van VOC tot werkspoor: het Amsterdamse industrieterrein Oostenburg*:83-147. Matrijs: Utrecht
- BAART, J.M., KROOK, W. & LAGERWEIJ, A.C. 1990/2. Italiaanse en nederlandse witte faience 1600-1700. *Mededelingenblad Nederlandse Vereniging van Vrienden van de Ceramiek* 138
- BALL, D. 1995. *The Diana adventure*. Groningen: Kemper
- BARBER, E.A. 1967. *The Ceramic Collectors' Glossary*. New York: Da Capo Press
- BARKER, D. 1991. *William Greatbatch: a Staffordshire Potter*. London: Jonathan Horne
- BARKER, D. & BARKER, B. 1984. A late 18th century pit group from Haregate Hall, Leek, Staffordshire. In: *Staffordshire Archaeological Studies* 1:87-136. City Museum & Art Gallery, Stoke-on-Trent
- BARKER, D. & HALFPENNY, P. 1990. *Unearthing Staffordshire*. Exhibition catalogue. Christie's, London
- BARRY, J. 1993. Eighteenth century Chinese export porcelain from three London sites. Unpublished M.A. dissertation, Institute of Archaeology, University College, London
- BEAUDRY, M.C., LONG, J., MILLER, H., NEIMAN, F. & WHEELER STONE, G. 1983. A vessel typology for early Chesapeake ceramics: the Potomac typological system. *Historical Archaeology* 17(1):18-39
- BLAKEY, C. & BLAKEY, H. 1993. *St Anthony's Pottery, Newcastle upon Tyne: Joseph Sewell's book of designs*. Tyne & Wear Museums. England
- BOESEKEN, A.J. (ed.). 1948. *Geskiedenis-atlas vir Suid-Africa*. Cape Town: Nationale Pers
- BOUCHER, M. 1986. The age of exploration. In: Cameron, T., Spies, S.B. (eds) *An Illustrated History of South Africa*:55-74. Johannesburg: Jonathan Ball
- BREDEKAMP, H.C. & van den BERG, O. 1986. *A New History Atlas for South Africa*. Cape Town: Arnold
- BRINK, L.Y. 1990. The voorhuis as a central element in early Cape houses. *Social Dynamics* 16(1):38-54
- BRINK, L.Y. 1992. Places of discourse and dialogue: a study in the material culture of the Cape during the rule of the Dutch East India Company, 1652-1795. Unpublished Ph.D. thesis, Department of Archaeology, University of Cape Town
- BURLEY, D.V. 1989. Function meaning and context: ambiguities in ceramic use by the *Hivernant* Metis of the Northwestern Plains. *Historical Archaeology* 23(1):97-105
- CAIRNS, M. 1981. Genealogical kaleidoscope. *Familia XVIII* 2:37-49.
- CAMERON, T. (ed.) 1986. *An Illustrated History of South Africa*. Johannesburg: Jonathan Ball
- CARRÉ, D., DESROCHES, J-P. & GODDIO, F. 1994. *Le San Diego: un trésor sous la mer*. Paris: Réunion des musées nationaux.
- CARSWELL, J. 1976. China and Islam in the Maldive Islands. *Transactions of the Oriental Society* 41:121-198
- CARSWELL, J. 1985. *Blue and white: Chinese porcelain and its impact on the Western world*. Exhibition catalogue, The David and Alfred Smart Gallery, The University of Chicago

- CHAN GUNN, C. 1971. *The Talking Jars*. Exhibition catalogue of the Vancouver Society for Asian Art. Centennial Museum, Vancouver, Canada
- CHARLESTON, R.J. 1968. *World Ceramics*. London: Hamlyn
- CHINESE PORCELAIN COMPANY. 1988. *Kangxi Blue and White*. Exhibition and sale catalogue. New York
- CHRISTIE'S AMSTERDAM, 1986. *The Nanking Cargo*. Sale catalogue, April-May 1986
- CHRISTIE'S AMSTERDAM, 1992. *The Vang Tau Cargo*. Sale catalogue, April 1992
- CHRISTIE'S AMSTERDAM, 1995. *The Diana Cargo*. Sale catalogue, March 1995
- COPELAND, R. 1972. *A short history of pottery raw materials and the Cheddleton Mill*. Cheddleton Flint Mill Industrial Heritage Trust: Staffordshire, England
- COPELAND, R. 1982. *Blue and White Transfer-printed Pottery*. Aylesbury: Shire Publications
- COPELAND, R. 1990. *Spode's Willow Pattern*. London: Studio Vista
- COPELAND, R. 1995. *Wedgwood Ware*. Shire Album 321. Princes Risborough: Shire Publications
- COYSH, A.W. & HENRYWOOD, R.K. 1982. *The Dictionary of Blue and White Printed Pottery 1780-1880*. Woodbridge: The Antique Collectors' Club
- COYSH, A.W. & HENRYWOOD, R.K. 1989. *The Dictionary of Blue and White Printed Pottery. 1780-1880. Vol.II*. Woodbridge: The Antique Collectors' Club
- CROSSMAN, C.L. 1976. *A Design Catalogue of Chinese Export Porcelain for the American Market*. Peabody Museum, Salem, Mass.
- CROWE, Y. 1978. A preliminary enquiry into underglaze decoration of Savavid wares. In: Medley, M. (ed.) *Decorative Technique and Styles in Asian Ceramics. Colloquies on Art and Archaeology in Asia No.8:104-125*. Percival David Foundation of Chinese Art, London University
- CROWE, Y. 1995. *Once upon a time: the story of blue and white as seen from Persia*. Paper read at the International Ceramics Fair and Seminar, June 1995, London
- CURTIS, J.B. 1988a. Perceptions of an artifact: Chinese porcelain in colonial Tidewater Virginia. In: Beaudry, M. C. (ed.) *Documentary Archaeology in the New World*. Cambridge: Cambridge University Press
- CURTIS, J.B. 1988b. 17th & 18th century Chinese Exportware in Southeastern Virginia. *Transactions of the Oriental Ceramic Society (1988-89)* 53:47-64. London
- DAENDELS, H.A. 1981. Catalogus tentoonstelling Japans blauw en wit porcelein op Hollandse bestelling en in de Japanse smaak. *Mededelingenblad Nederlandse Vereniging van Vrienden van de Ceramiek*. 101/102
- DE LA TORRE, A. 1994. Les terres cuites. In: Carré, D., Desroches, J-P., Goddio, F. (eds), *Le San Diego: un trésor sous la mer*. 252-55. Paris: Réunion des musées nationaux
- DEETZ, J. 1967. *Invitation to archaeology*. New York: American Museum of Natural History
- DEETZ, J. 1973. Ceramics from Plymouth, 1620-1835: the archaeological evidence. In: Quimby, I. (ed.), *Ceramics in America*. Winterthur Conference Report 1972, University of Virginia Press
- DEETZ, J. 1977. *In Small Things Forgotten*. New York: Anchor Press
- DE KLEYN, J. 1986 edition. *Volkvaardewerk in Nederland sedert de Late Middeleeuwen*. Lochem: De Tijdstroom.
- DES FONTAINES, U. 1990. Wedgwood whiteware. *Proceedings of the Wedgwood Society* 13:1-8

- DESROCHES, J-P. 1994. La Chine à table. In: Carré, D., Desroches, J-P. & Goddio, F. (eds) *Le San Diego: un trésor sous la mer*. Paris: Réunion des musées nationaux.
- DIANA (1817) See CHRISTIE'S AMSTERDAM 1994
- DONCASTER LIBRARY SERVICE. 1983. *Don Pottery Pattern Book, 1807*. Doncaster Metropolitan Borough Council, England
- DOOLING, W. 1994. The Castle: its place in history of Cape Town in the VOC period. In: van Heiningen, E. (ed.) *Studies in the History of Cape Town* 7:9-31. Cape Town: U.C.T. Press
- ELLIOT, G. 1986. The technical characteristics of creamware and pearl-glazed earthenware. In: Lockett, T. & Halfpenny, P. (eds) *Creamware & Pearlware*. Exhibition catalogue of Northern Ceramic Society with City Museum & Art Gallery, Stoke-on-Trent
- ELPHICK, R. & GILIOMEE, H. 1989. *The Shaping of South African Society*. Cape Town: Maskew Miller
- EMMERSON, R. 1992. *British Teapots and Tea Drinking*. London: HMSO
- FEILD, R. 1987. *MacDonald Guide to Buying Antique Pottery and Porcelain*. London: MacDonald
- FISHER, C.L. 1987. The ceramics collection from the Continental Army cantonment at New Windsor, New York. *Historical Archaeology* 21(1):48-57
- FITCHETT, R.H. 1996. The Table Bay defences, Cape of Good Hope: 1652 - 1710. Unpublished paper read at the International Conference on Coastal Fortifications: history, restoration and utilisation, 18-21 June 1996, Mauritius
- FRANSEN, H. & COOK, M.A. 1980. *The Old Buildings of the Cape*. Cape Town: Balkema
- GABBERT, G. 1977. *Chinesisches Porzellan*. Museum für Kunsthandwerk, Frankfurt am Main
- GARAVENTA, D. & PASTRON, A. 1983. Chinese ceramics from a San Francisco dump site. In: Ward, A. (ed.) *Forgotten places and things: archaeological perspectives on American history*: 295-320. Center for Anthropological Studies, Albuquerque, New Mexico
- GARNER, H. 1970 edition. *Oriental Blue and White*. London: Faber & Faber
- GIHWALA, D., JACOBSON, L., PEISACH, M., PINADA, C.A., & VOS, H.N. 1985. Analysis of Chinese porcelains and ceramics. *South African Archaeological Bulletin* 142:96-105
- GODDEN, G.A. 1963. *British Pottery and Porcelain 1780-1850*. London: Barker
- GODDEN, G.A. 1974a. *British Pottery*. London: Barrie & Jenkins
- GODDEN, G.A. 1974b. *British Porcelain*. London: Barrie & Jenkins
- GODDEN, G.A. 1979. *Oriental Export Market Porcelain and its Influence on European Wares*. London: Granada
- GODDEN, G.A. 1985. *English China*. London: Barrie & Jenkins
- GODDEN, G.A. 1990. *The Concise Guide to British Pottery and Porcelain*. London: Barrie & Jenkins
- GODDEN, G.A. 1991 *The Encyclopaedia of British Pottery and Porcelain Marks*. London: Barrie & Jenkins
- GODDEN, G.A. 1992. *Godden's Guide to English Porcelain*. Radnor, Penn.: Wallace-Homestead Book Company
- GODDIO, F., JAY, E. 1988. *18th Century Relics of the Griffin Shipwreck*. Exhibition catalogue, National Museum, Manila, Philippines

- GRAF, O.H.T. 1996. Zooarchaeological analysis of an urban refuse dump on Cape Town's waterside at the turn of the 19th century. Unpublished M.A. dissertation, Department of Archaeology, University of Cape Town
- GRIBBLE, J. 1990. Verlorenvlei vernacular: a structuralist analysis of Sandveld folk architecture. Unpublished M.A. dissertation, Department of Archaeology, University of Cape Town
- GUY, J.S. 1990 edition. *Oriental Trade Ceramics in South-East Asia: Ninth to Sixteenth Centuries*. Singapore: Oxford University Press
- HAGEN-JONES, P. 1992. *A comparative study of mid-19th century Chinese blue and white export ceramics from the Frolic shipwreck, Mendocino County, California*. University of Idaho, USA
- HALFPENNY, P. 1986. Early creamware to 1770. In: Lockett, T. & Halfpenny, P. (eds) *Creamware and Pearlware:14-19*. Northern Ceramic Society
- HALFPENNY, P.(ed.) 1994. *Penny Plain, Twopence Coloured: Transfer Printing on English Ceramics 1750-1850*. Exhibition catalogue, City Museum & Art Gallery, Stoke-on-Trent
- HALL J.H. 1991. Faience in French colonial Illinois. *Historical Archaeology* 25(1):80-105
- HALL, M. 1989. Block 11 Cape Town - an archaeological assessment. Unpublished report, Archaeology Contracts Office, University of Cape Town
- HALL, M. 1991a. Archaeological work at Sea Street, Cape Town. Unpublished report, Archaeology Contracts Office, University of Cape Town
- HALL, M. 1991b. A study in the archaeology of early colonial settlement: Cape Town in the seventeenth, eighteenth and early nineteenth centuries. Final report to the Human Sciences Research Council
- HALL, M. 1991c. Material culture as text: a way of comparing things. Paper presented at the Conference of Historical and Underwater Archaeology, Richmond (Virginia)
- HALL, M. 1991d. Archaeological excavations at 109 Harrington Street 'The Granite Lodge'. Archaeology Contracts Office, University of Cape Town
- HALL, M. 1992a. People in a a changing urban landscape: excavating Cape Town: 1-27. Inaugural Lecture (New Series No.169), University of Cape Town
- HALL, M. 1992b. "Small things" and the "mobile, conflictual fusion of power, fear and desire". In: Yentsch, A. & Beaudry, M. (eds) *The Art and Mystery of Historical Archaeology. Essays in honor of James Deetz*. Boca Raton, Florida: CRC Press
- HALL, M. 1993. The archaeology of colonial settlement in southern Africa. *Annual Review of Anthropology* 22
- HALL, M., BRINK, Y. & MALAN, A. 1988. Onrust 87/1: an early colonial farm complex in the western Cape. *South African Archaeological Bulletin* 43:91-99
- HALL, M., HALKETT, D., KLOSE, J. & RITCHIE, G. 1990a. The Barrack Street Well: images of a Cape Town household in the 19th century. *South African Archaeological Bulletin* 45:73-92
- HALL, M., HALKETT, D., HUIGEN VAN BEEK, P., KLOSE, J. 1990b. 'A stone wall out of the earth that thundering cannon cannot destroy?' Bastion and Moat at the Castle. *Social Dynamics* 16(1):22-37.
- HALL, M., AMMAN, S., HALKETT, D., HART, T., KLOSE, J., MALAN, A., POGGENPOEL, C. & PORTUESI, J. 1993a. Haupt's Yard: a late 18th century site in Cape Town. Unpublished report, Department of Archaeology, University of Cape Town
- HALL, M., MALAN, A., AMMAN, S., HONEYMAN, L., KISER, T., RITCHIE, G. 1993b. The archaeology of Paradise. *South African Archaeological Society Goodwin Series* 7:40-55

- HARDWICK, M.J. 1989. A comparative study of Staffordshire ceramics of the 19th century in America and South Africa. Unpublished Honours dissertation, Department of Anthropology, University of California, Berkeley
- HARRISSON, B. 1979. *Swatow in het Princessehof*. Princessehof Museum, Leeuwarden
- HAWKE-SMITH, C. & BARKER, D. (eds). 1984. *Staffordshire Archaeological Studies*, No.1. City Museum & Art Gallery, Stoke-on-Trent
- HECKROODT, R., SAITOWITZ, S. 1985. Characterization of bottles manufactured at the Cape Glass Company, Glen Cairn, circa 1904. *South African Archaeological Bulletin* 142:94-95
- HENRYWOOD, R.K. 1992. *Jugs*. Shire Publications no.287. Princes Risborough. England
- HILDYARD, R. 1985. *Browne Mugs*. London: Victoria & Albert Museum
- HO, C. 1987. Minnan blue and white wares. In: Scott, R. & Hutt, G. (eds) *Style in the East Asian Tradition. Colloquies on Art & Archaeology in Asia* 14:120-135. School of Oriental Studies, London University
- HO, C. 1988. Minnan blue and white wares: an archaeological survey of kiln sites of the 16th-19th centuries in southern Fujian, China. *BAR International Series* 428. Oxford
- HO, C. 1995. Minnan wares in Africa and the New World. Ho, C. (ed.) *ACRO Update* 1995(3):1-2
- HOBSON, R.L. 1976. *Chinese Pottery and Porcelain*. reprint of 1915 edition. New York: Dover Press
- HOBSON, R.L. 1937. *Handbook of the Pottery and Porcelain of the Far East in the Department of Oriental Antiquities and of Ethnography*. London: British Museum
- HOWARD, D.S. 1974. *Chinese Armorial Porcelain*. London: Faber
- HOWARD, D.S. 1984. *New York and the China Trade*. New York. The New-York Historical Society
- HOWARD, D.S. & AYERS, J. 1978. *China for the West*.(2 vols) London: Sotheby Parke Bernet
- HUEY, P. 1995. "Dot & Circle" underglaze blue decorated porcelain bowls from China: their archaeological distribution as evidence of a marketing and trade pattern. Unpublished paper read at SHA Conference, Washington, January 1995
- HURST, J.G., NEAL, D.S. & VAN BEUNINGEN, H.J.E. 1986. *Pottery produced and traded in north-west Europe 1350-1650*. Rotterdam Papers VI. Rotterdam: Museum Boymans-van Beuningen
- IMPEY, O. 1989. The beginnings of the export trade in Japanese porcelain. *Hyakunenan Journal of Porcelain Study* 3. Arita
- IMPEY, O. 1990a. The trade in Japanese porcelain. In: Ayers, J., Impey, O. & Mallet, J.V.G. *Porcelain for Palaces, the fashion for Japan in Europe 1650-1750*: 15-25. London: Oriental Ceramic Society
- IMPEY, O. 1990b. Early enamelled ware. In: Ayers, J., Impey, O. & Mallet, J.V.G. *Porcelain for Palaces, The fashion for Japan in Europe 1650-1750*:117-134. London: The Oriental Ceramic Society
- IMPEY, O. 1990c. Imari. In: Ayers, J., Impey, O. & Mallet, J.V.G. *Porcelain for Palaces, The fashion for Japan in Europe 1650-1750*:204-232. London: The Oriental Ceramic Society
- IMPEY, O. 1994. Japanese porcelain before the time of the export trade. Summary of lecture, *Transactions of the Oriental Society* (1994-5) 59:81-82
- JANOWITZ, M.F. 1993. Indian corn and Dutch pots: seventeenth-century foodways in New Amsterdam, New York. *Historical Archaeology* 27(2):6-24
- JAPANESE ARCHAEOLOGICAL PAPERS. 1989, 1993. Tokyo University site, Hongo Campus Iseki; Saki Kango Iseki & Shimojuka Uchiyama Iseki.

- JEPPSON, P.L. 1991. Colonial systems and indigenous responses: black material expressions at a British Mission in South Africa. Paper presented at the SHA Conference for Historical and Underwater Archaeology, Richmond, Virginia
- JENYNS, S. 1951. *Later Chinese Porcelain*. London: Faber & Faber
- JENYNS, S. 1988 edition. *Ming Pottery and Porcelain*. London: Faber & Faber
- JORG, C.J.A. 1982. *Porcelain and the Dutch China Trade*. The Hague: Martinus Nijhoff
- JORG, C.J.A. 1986. *The Geldermalsen: History and Porcelain*. Groningen: Kemper
- JORG, C.J.A. 1992. Porcelain for the Dutch in the seventeenth century: Trading networks and private enterprise. In: Scott, R. (ed.) *The Porcelains of Jingdezhen. Colloquies on Art & Archaeology in Asia* 16:183-205. London: London University, Percival David Foundation of Chinese Art
- JORG, C.J.A. 1995. *Oosters Porcelein*. Rotterdam: Museum Boymans-van Beuningen
- KAUFMANN, G. 1979. *North German Folk pottery of the 17th-20th Centuries*. Richmond, International Exhibitions Foundation, Virginia
- KERR, R. 1986. *Chinese Ceramics: Porcelain of the Qing Dynasty 1644-1911*. London: Victoria and Albert Museum
- KEGUAN, B. 1991. *Chinese Folk Painting on Porcelain*. Beijing: Foreign Languages Press
- KILBURN, R.S. 1981. *Transitional Wares and their Forerunners*. Exhibition catalogue, Hong Kong Museum of Art
- KINGERY, W.D. & VANDIVER, P.B. 1986. *Ceramic Masterpieces: Art, Structure and Technology*. New York: The Free Press
- KLEIN, R. & CRUZ-URIBE, K. 1984. *The Analysis of Animal Bones from Archaeological sites*. Chicago: University of Chicago Press
- KLEIN, T.H. 1991. Nineteenth-century ceramics and models of consumer behaviour. *Historical Archaeology* 25(2):77-91
- KLOSE, J.E. 1993. Excavated Oriental ceramics from the Cape of Good Hope:1630-1830. *Transactions of the Oriental Ceramic Society* 1992-1993 57:69-81
- KLOSE, J.E. & MALAN, A. 1993. *Ceramics of the Southwestern Cape: 1650-1850*. Historical Archaeology Research Group, Handbook No.1. Students Handbook, Department of Archaeology, University of Cape Town
- KORF, D. 1981. *Nederlandse Majolica*. Harlem: De Haan
- KRAHL, R., ERBAHAR, N. & AYERS, J (ed.). 1986. *Chinese Ceramics in the Topkapi Saray Museum, Vols.I-III*. London: Sotheby's
- KWAN, K.K. & MARTIN, J. 1985. Introduction to the finds from Pulau Tioman. *A Ceramic Legacy of Asia's Maritime Trade*:69-82. Exhibition catalogue. South-east Asian Ceramic Society, West Malaysia Chapter
- KYBALOVA, J. 1989. *European Creamware*. London: Hamlyn
- LAM, P. 1987. Dapu Wanyao: a 19th-20th century kiln site in Hong Kong. In: Scott, R. & Hutt, G. (eds). *Style and the East African Tradition. Colloquies on Art & Archaeology* 14:136-147. School of Oriental and African Studies, University of London
- LANE, A. 1957. *Later Islamic Pottery: Persia, Syria, Egypt, Turkey*. London: Faber & Faber
- LANG, G. 1991. *Miller's Antiques Checklist: Porcelain*. London: Mitchell Beazley
- LASTOVICA, A. & LASTOVICA, E. 1982. *Bottles and Bygones*. Cape Town: Don Nelson

- LE CORBEILLER, C. 1974. *China Trade Porcelain: Patterns of Exchange*. New York: Metropolitan Museum of Art
- LE CORDEUR, B.A. 1986. The occupations of the Cape. In: Cameron, T. & Spies, s. (eds) *An Illustrated History of South Africa:75-93*. Johannesburg: Jonathan Ball
- LITTLE, W.L. 1969. *Staffordshire Blue*. London: Batsford
- LO, K.S. 1984. K.S. Lo Collection in the Flagstaff House Museum of Tea Ware. Part 2. Hong Kong Museum of Art
- LO, K.S. 1986. *The Stonewares of Yixing*. Hong Kong: Sotheby's Publications & Hong Kong University Press
- LOCKETT, T.A. 1996. Pearlware: origins and types. Parts 1 & 2. In: *Antique Collecting* 30 (10):4-7 & 31 (2):18-22
- LOCKETT, T.A. & HALFPENNY, P.A. (eds). 1986. *Creamware and Pearlware*. Exhibition catalogue: Northern Ceramic Society and City Museum & Art Gallery, Stoke-on-Trent
- LUNSINGH-SCHEURLEER, D.F. 1971. Japane porselein met blauwe decoraties uit de tweede helft van de zeventiende en de eerste helft van de achttiende eeuw. *Mededelingenblad van de Vereniging van Vrienden van de Nederlandse Ceramiek* 64/65, 1971/2-3
- LUNSINGH-SCHEURLEER, D.F. 1989 edition. *Chine de Commande*. Lochem: De Tijdstroom
- MAJEWSKI, T. & O'BRIEN, M. 1987. The use and misuse of nineteenth century English and American ceramics in archaeological analysis. In: Schiffer, M. (ed.) *Advances in Archaeological Method and Theory*. 98-210. New York: Academic Press
- MALAN, A. 1993. Households of the Cape, 1750 - 1850: Inventories and the archaeological record. Unpublished Ph.D. thesis, Department of Archaeology, University of Cape Town
- MALAN, A. 1995. Beneath the surface - behind the doors: the historical archaeology of households in mid-eighteenth century Cape Town. Unpublished paper presented at a seminar, Centre for African Studies, September 1995. University of Cape Town
- MARKELL, A. 1993. Building on the past: the architecture and archaeology of Vergelegen. *South African Archaeological Society Goodwin Series* 7:71-84
- MARTIN, J. 1993. *Colonel William Thomlinson's Collection of Chinese 18th Century Export Porcelain: 'Batavian' Style and Other Brown Glazed Wares*. Catalogue. Hartlepool Museum Services: Hartlepool. England
- MEDLEY, M. 1977 edition. *A Handbook of Chinese Art*. London: Bell & Hyman
- MEDLEY, M. 1980 edition. *The Chinese Potter*. Oxford: Phaidon Press
- MIJARES, A.S.B. & JAGOON, S.C. 1996. Finds and analysis of five archaeological pottery sites in the Philippines. *SPAFSA Journal* 6(1):44-46
- MILLER, G.L. 1980. Classification and economic scaling of 19th century ceramics. *Historical Archaeology* 14:1-40
- MILLER, G.L. 1983. Ceramic supply in an economically isolated frontier community: Portage County of the Ohio Western Reserve, 1800-1823. *Historical Archaeology* 17(2):80-91
- MILLER, G.L. 1991. A revised set of CC Index values for English ceramics. In: *Historical Archaeology* 25(1):1-25
- MILLER, G.L. 1993. Some thoughts on classification of white earthenwares. *Council for Northeast Historical Archaeology News Letter* No.26.
- MILLER, G.L., MARTIN, A.S. & DICKINSON, N.S. 1989. Changing consumption patterns, English ceramics and the American market from 1770-1840. *Proceedings of the 29th Winterthur Conference*. Henry Francis duPont Winterthur Museum, Winterthur, Delaware

- MILLER, G.L. & HUNTER, R. 1990. English shell edged earthenware: alias Leeds ware, alias feather edge. *35th Annual Wedgwood International Seminar*:107-136
- MORLEY-FLETCHER, H., McILROY, R. 1984. *Christie's Pictorial History of European Pottery*. Oxford: Phaidon Christie's
- MOUNTFORD, A. 1971. *Staffordshire Salt-Glazed Stoneware*. London: Barrie & Jenkins
- MUDGE, J.M. 1986. *Chinese Export Porcelain in North America*. New York: Clarkson N.Potter
- NEVILLE, D., SAMPSON, B.E. & SAMPSON, C.G. 1994. The frontier wagon track system in the Seacow River valley, North-Eastern Cape. *South African Archaeological Bulletin* 49:65-72
- NIENHAUS, H. 1980. Mineraalwaterkruiken van gres met zout glazuur en de daarop voorkomende bronmerken. *Antiek* 14 (9):567-583
- NIENHAUS, H. 1980. Mineralwaterkruiken met zout-glazuur, bron- en fabrikantenmerken, *Antiek* 15(9): 489-508
- NIENHAUS, H. 1985. Mineraalwaterkruiken en hun bronmerken. *Antiek* 19(7): 357-369
- NILANT, F.G.E. 1963. *Contemporary Pottery in South Africa*. Cape Town: Balkema
- NISHIDA, A. 1986. A history of Japanese porcelain and the export trade. In: *The Burghley Porcelains: An exhibition the Burghley House Collection, based on the 1688 Inventory and 1690 Devonshire Schedule*. Exhibition catalogue, Japan House Gallery, New York, 1986
- NOËL HUME, I. 1969a. *Pottery and Porcelain in Colonial Williamsburg's Archaeological Collections*. Colonial Williamsburg Archaeological Series no.2
- NOËL HUME, I. 1969b. *Historical Archaeology*. New York: Knopf
- NOËL HUME, I. 1970. *A Guide to Artifacts of Colonial America*. New York: Alfred Knopf
- OHASHI, K. 1987. Hizen porcelain in the second half of the 17th century. *The Dutch East India Company in the 17th century: life and work of Zacharias Wagenaar*:50-52. Exhibition catalogue, Holland Village Museum, Japan
- OHASHI, K. 1989. A recent study on Hizen trade ceramics from kiln sites. *Idemitsu Museum of Arts Bulletin* 64:7-42
- OHASHI, K. 1990. The Hizan ware exported toward Southeast Asia. In: *Hizan Wares Abroad*:88-176. Exhibition catalogue, Kyushu Ceramic Museum, Arita
- OSWALD, A., HILDYARD, R.J.C. & HUGHES, R.G. 1982. *English Brown Stoneware 1670-1900*. London: Faber & Faber
- PEARCE, J.E. 1981. Chinese porcelain. *LAMAS Transactions* 32. Museum of London
- PIERSON S. 1996. *Earth, Fire and Water: Chinese Ceramic Technology. A Handbook for Non-specialists*. Percival David Foundation of Chinese Art, University of London
- PIRAZZOLI-t'SERSTEVENS, M. 1985. Chinese ceramics in Bahrain and Oman. In: *Essays in honour of Prof. Dr. Tsvjio Mikami on his 77th birthday*, Tokyo: Heibenisha
- POTTER, P.B. 1992. Middle range theory, ceramics and capitalism in 19th century Rockbridge County, Virginia. In: Little, B.J. (ed.), *Text-aided Archaeology*, pp.9-23. CRC Press: Boca Raton, Florida
- RAWSON, J. 1992. *The British Museum Book of Chinese Art*. London: British Museum Press
- REILLY, R. & SAVAGE, G. 1980. *The Dictionary of Wedgwood*. Woodbridge: Antique Collectors' Club
- RINALDI, M. 1989. *Kraak Porcelain: a Moment in the History of Trade*. London: Bamboo

- RIORDEN, T.B. 1985. The relative economic status of black and white regiments in the pre-World War 1 Army: an example from Fort Walla Walla, Washington. Unpublished Ph.D. dissertation, Department of Anthropology, Washington State University, Pullman
- ROONEY, D. 1987. *Folk Pottery in South-East Asia*. Singapore: Oxford University Press
- ROSS, R. 1989. The Cape of Good Hope and the world economy, 1652-1835. In: Elphick, R. & Giliomee, H. (eds), *The Shaping of South African Society, 1652-1840*. Cape Town: Maskew Miller Longman
- ROSS, R. 1994. *Beyond the Pale: Essays on the History of Colonial South Africa*. Johannesburg: Witwatersrand University Press
- ROUSSEL, D.E. 1982. *The Castleford Pottery 1790-1821*. Wakefield Historical Publications
- ROYLE, E. 1984. Warming Castle, Poole Dole, Stoke-on-Trent. *Staffordshire Archaeological Studies No.1*. City Museum & Art Gallery, Stoke-on-Trent
- RUDNER, J. 1968. Strandloper pottery from south and southwest Africa. *Annals of the South African Museum* 49(2):634-639
- RUEMPOL, A.P.E. & van DONGEN, A.G.A. 1991. *Pre-industrial Utensils, 1150-1800*. Rotterdam: Museum Boymans-van Beuningen
- RUMSEY, J. 1987. *Victorian Relief-moulded Jugs*. Exhibition catalogue, Richard Dennis, London
- SAMPSON, C.G., SAMPSON, B.E. & NEVILLE, D. 1994. An early Dutch settlement pattern on the north east frontier of the Cape Colony. *Southern African Field Archaeology* 3:74-81
- SAVAGE, G. & NEWMAN, H. 1985 edition. *An Illustrated Dictionary of Ceramics*. London: Thames & Hudson
- SASSOON, H. 1982. Ceramics from the wreck of a Portuguese Ship at Mombasa. In: Chittick, N. (ed.) *Azania: The Journal of the British Institute of Eastern Africa* XVI:97-120
- SAITOWITZ, S. 1982. De Posthuys. Report for Anglo-American Corporation, Department of Archaeology, University of Cape Town
- SCHIFFER, H. & P. & N. 1975. *Chinese Export Porcelain: standard patterns and forms, 1780-1880*. Schiffer Publications: Exton, Penn.
- SCHLEGER, M. 1982. Eighteenth-century English porcelain. In: Atterbury, P. (ed.) *The History of Porcelain*. London: Orbis
- SCHRIRE, C. 1988. The historical archaeology of the impact of colonialism in 17th century South Africa. *Antiquity* 62:214-35
- SCHRIRE, C., DEETZ, J., LUBINSKY, D. & POGGENPOEL, C. 1990. The chronology of Oudepost 1, Cape, as inferred from an analysis of clay pipes. *Journal of Archaeological Science* 17:269-300
- SCHRIRE, C., CRUZ-URIBE, K. & KLOSE, J. 1993. The site history of the historical site at Oudepost 1, Cape. *South African Archaeological Society Goodwin Series* 7:21-33
- SEEMANN, U. 1989. The Amsterdam Battery. A short history of the Amsterdam Battery during the Dutch and English periods and an account of its excavation. B.Sc. (Honours) thesis, University of Cape Town
- SEEMANN, U. 1992. The Amsterdam Battery: a late 18th century Dutch military installation in Table Bay. *South African Field Archaeology* 1(2):72-79
- SEIDEL, J.L. 1990. "China glaze" wares on sites from the American Revolution: Pearlware before Wedgwood? *Historical Archaeology* 24(1):82-95
- SHEAF, C. & KILBURN, R. 1988. *The Hatcher Porcelain Cargoes*. London: Sotheby's

- SHELL, R.C-H. 1994. *Children of Bondage: a social history of the slave society at the Cape of Good Hope, 1652 - 1838*. Johannesburg: Witwatersrand University Press
- SMITH, A.B. 1986. Excavations at Plettenberg Bay, South Africa, of the camp site of the survivors of the wreck of the *Sao Goncalo*, 1630. *International Journal of Nautical Archaeology and Underwater Exploration* 15:53-63
- SNYDER, J. B. 1992. *Flow Blue; a Collector's Guide to Pattern, History, and Value*. West Chester, Penn.: Schiffer Publishing
- SOUTH, S. 1962. The ceramic types at Brunswick Town. *Southeastern Archaeological Conference Newsletter* 9(1)
- SOUTH, S. 1971. Evolution and horizons revealed in ceramic analysis in historical archaeology. *The Conference on Historical Sites Archaeology Papers* 1971, 6 (2): 71-116
- SOUTH, S. 1977. *Method and Theory in Historical Archaeology*. New York: Academic Press
- STORRAR, P. 1988. *Drama at Ponte Delgada*. Cape Town: Lowry Publishers
- SUSSMAN, L. 1977. Changes in pearlware dinner-ware, 1780-1830. *Historical Archaeology* 11:105-111
- TAYLOR, J.G. 1983. *The Social World of Batavia: European and Eurasian in Dutch Asia*. Wisconsin: University of Wisconsin.
- TAYLOR, M. 1991. The historical archaeology of the Verlorenvlei: The site of Verlorenvlei midden. Unpublished B.A. (Honours) dissertation, Department of Archaeology, University of Cape Town
- TERREY, P., PASTRON, A. 1990. Chinese export porcelain in gold rush San Francisco. In: Pastron, A. & Hattori, E. (eds), *The Hoff Store and Gold Rush Merchandise from San Francisco, California. Special Publications Series, No 7, Society for Historical Archaeology, California, Pennsylvania*
- THEAL, G.M. 1898. *Records of the Cape Colony: from December 1796 to December 1799. Vol.2*. Printed for the Government of the Cape Colony
- THIJSSSEN, J. (ed.). 1991. *Tot de bodem uitgezocht: glas en cermiek uit een beerput van de 'Hof van Batenburg' te Nijmegen*. Nijmegen: Stichting Stadsarchaeologie
- TOWNER, D. 1957. *English Cream Coloured Earthenware*. London: Faber
- TREGGAR, M. 1994. A Memoir. Speech given at the seventh Hills gold medal award. *Transactions of the Oriental Ceramic Society* (1994-5) 59:1-10
- TURNBAUGH, S.P. 1983. 17th and 18th century lead-glazed redwares in the Massachusetts Bay Colony. *Historical Archaeology* 17 (1):3-17
- TURNER, M. 1988. *Shipwrecks & Salvage in South Africa: 1505 to the present*. Cape Town: Struik
- VAINKER, S.J. 1991. *Chinese Pottery and Porcelain: From Prehistory to the Present*. London: British Museum
- VALENTYN, F. 1971. *Description of the Cape of Good Hope with matters concerning it. (1726)*. In: Serton, P., Raven-Hart, R. & de Kock, W.J.(eds) with final ed. E.h.Raidt, trans. R. Raven-Hart. Van Riebeeck Society II, 2. Cape Town.
- VALENTYN, F. 1973. *Description of the Cape of Good Hope with matters concerning it. (1726)*. In: Raidt, E.H. (ed.), trans. R.Raven (ed.), trans. R. Raven-Hart. Van Riebeeck Society II, 4. Cape Town
- VALENSTEIN, S.G. 1989. *A Handbook of Chinese Ceramics*. London: Weidenfeld & Nicolson
- VAN DER PIJL- KETEL, C.L. 1982. *The Ceramic Load of the Witte Leeuw*. Rijksmuseum, Amsterdam
- VAN SCHALKWYK, J.A., NAUDE, M. & VAN VOLLENHOVEN, A.C. 1995. Archaeological investigation of a nineteenth century water furrow in Church Street, central Pretoria. *South African Field Archaeology* 4:78-83

- VANG TAU (c.1690). See CHRISTIE'S AMSTERDAM 1994
- VOLKER, T. 1954. *Porcelain and the Dutch East India Company*. Leiden: Brill
- VOLKER, T. 1959. *The Japanese Porcelain Trade of the Dutch East India Company after 1683*. Leiden: Brill
- VON BOCK, G.R. 1986. *Steinzeug*. Kunstgewerbemuseum, Cologne
- VOS, H. 1985. Coarse provincial ware at the Cape. *Antiques in South Africa* 16:15-18
- VOS, H. 1993. An historical and archaeological perspective of colonial Stellenbosch 1680-1860. Unpublished M.A. dissertation, University of Stellenbosch, South Africa
- VOS, H., PEISACH, M. & PINNEDA, C. 1986. China to the Cape. *Nuclear Active* 35:2-6
- WALTHALL, J.A. 1991. Faience in French colonial Illinois. *Historical Archaeology* 25(1):80-105
- WASTFELT, B. GYLLENSVARD, B. & WEIBULL, J. 1990/91. *Porcelain from the East Indiaman Gotheborg*. Sweden: Wiken
- WEBLEY, L. 1993. Archaeological investigations at the battlefield of Rorke's Drift, Northern Natal. *South African Field Archaeology* 2:24-34
- WEDGWOOD EXHIBITION 1995. Exhibition leaflet. Victoria & Alfred Museum, London
- WERZ, B.E.J.S. 1993a. Maritime archaeological project Table Bay: aspects of the first field season. *South African Archaeological Society Goodwin Series* 7:33-39
- WERZ, B.E.J.S. 1993b. Ceramics from the VOC-Ship 'Oosterland'(1697). Report for the Institute for Research Development
- WERZ, B.E.J.S., KLOSE, J. 1994. Ceramic analysis from the VOC ship *Oosterland* (1697). *South African Journal of Science* 90:522-526
- WILCOXEN, C. 1987. *Dutch Trade and Ceramics in America in the Seventeenth Century*. Albany Institute of History and Art: Albany, N.Y.
- WILLETTS, W. 1971. *Ceramic Art of Southeast Asia*. Singapore: Southeast Asian Ceramic Society
- WILLETTS W. & LIM, S. 1981. *Nonyaware and Kitchen Ch'ing*. Exhibition catalogue, Southeast Asian Ceramic Society, West Malaysia Chapter, Kuala Lumpur: Oxford University Press
- WINER, M. 1994. Landscapes of Power: The Material Culture of the Eastern Cape Frontier, South Africa 1820-1860. Unpublished Ph.D. thesis, University of California, Berkeley
- WINER, M., DEETZ, J. 1992. The transformation of British culture in the Eastern Cape, South Africa, 1820-1860. *Social Dynamics* 16(1):55-75
- WITTOP KONING, D.A. 1976. Minerale waterkruiken. *Antiek*, vol.10, no.9, 851-862
- WOODWARD, C.S. 1974. *Oriental Ceramics at the Cape of Good Hope, 1652-1793*. Cape Town: Balkema
- WOODWARD, C.S. 1982. The interior of the Cape House 1670-1714. Unpublished M.A. dissertation, Department of Fine Arts, University of Pretoria
- WOODWARD, C.S. 1983. Ceramics in the Cape Dutch house 1652-1820. *The Boschendal Ceramic Collection*. Catalogue, Boschendal Manor House, Cape
- WORTHY, L.H. 1982. Classification and interpretation of late-nineteenth and early-twentieth-century ceramics. *Archaeology of Urban America* 329-358. New York: Academic Press
- YATES, R., WOODBOURNE, S. & HALL, M. n.d. The chronology of colonial settlement at the Cape of Good Hope: clay tobacco pipes. Unpublished manuscript, Department of Archaeology, University of Cape Town

YENTSCH, A. 1990. Minimum vessel counts as evidence of change in folk and courtly traditions of food use. *Historical Archaeology* 24(3):24-53

YENTSCH, A. 1991a. Chesapeake artifacts and their cultural context: pottery and the food domain. *Post-Medieval Archaeology* 25:25-72

YENTSCH, A. 1991b. Engendering visible and invisible ceramic artifacts. *Historical Archaeology* 25(4):132-155