

Towards a new South African geodetic datum.

Newling, M..

**Submitted to the University of Cape Town in fulfillment
of the requirements for the
degree of Master of Science in Engineering.**

CAPE TOWN

NOVEMBER 1989

LINEAR LIBRARY
C01 0068 2324



TOWARDS A NEW SOUTH AFRICAN GEODETIC DATUM

M. NEWLING

Submitted to the University of Cape Town in fulfillment of the requirements for the
degree of Master of Science in Engineering.

CAPE TOWN
NOVEMBER 1989

The University of Cape Town has been given
the right to reproduce this thesis in whole
or in part. Copyright is held by the author.

The copyright of this thesis vests in the author. No quotation from it or information derived from it is to be published without full acknowledgement of the source. The thesis is to be used for private study or non-commercial research purposes only.

Published by the University of Cape Town (UCT) in terms of the non-exclusive license granted to UCT by the author.

ACKNOWLEDGMENTS

I am grateful to the following people and organisations for enabling me to complete this piece of work:

Professor H.S. Williams who, despite initial cautions, proved to be a source of both friendship and encouragement.

Professor C.L. Merry for his helpful criticism and useful notes concerning Doppler positioning.

Mr D.P.M. Rousseau, director of control surveys, for allowing me the time and computer facilities to complete this work.

The Institute of Land Surveyors of the Western Cape for the post-graduate bursary that they kindly granted me.

Mendel Karpul and his 'GhostWriter' team for the laser printing and assistance in producing the final format.

My wife, Susan, for much of the typing and for suffering long evenings in front of the computer.

SYNOPSIS

The overall scale and orientation of the South African trigonometrical readjustment will depend both on the traditional distances and azimuths and on TRANSIT Doppler observations. The traditional observations are used to compute the relative positions of points within the control network. TRANSIT Doppler observations, as well as giving relative positions, can be used to determine absolute co-ordinates (in a global reference system) with an accuracy of about one metre. One purpose of the present study is to present a way of combining the the various Doppler observations to the TRANSIT satellites and to derive a single set of geocentric co-ordinates for the stations at which Doppler observations were recorded. Little work has been published concerning the combination of such Doppler observations.

Having arrived at a set of geocentric co-ordinates, in order to use them in the horizontal adjustment, they must be transformed to latitude, longitude and height with respect to a defined ellipsoid. The second purpose of the present study is to examine various criteria for choosing such a datum and thereby make a suitable datum selection.

There are various ways of processing observations to the TRANSIT satellites; these techniques along with the rest of the Doppler system are described in chapter 3. Chapter 4, which contains the bulk of the work in the present study, addresses the problem of the unification of Doppler subnets into a single geocentric network. Chapter 1 contains an introduction and gives a brief overview of the various reference systems used in Geodesy while Chapter 2, which is largely historical, describes the existing geodetic network in South Africa, particularly the Cape Datum on which this network is computed.

In chapter 5, using the co-ordinates for the Doppler stations derived in chapter 4, various criteria are considered for the selection of a datum on which to carry out the readjustment and recommendations are made for a replacement South African geodetic datum.

TABLE OF CONTENTS

	pg
ACKNOWLEDGMENTS	3
SYNOPSIS	4
CONTENTS	5
INDEX TO FIGURES	10
INDEX TO TABLES	11
SUMMARY OF NOTATIONS	14
CHAPTER 1: GEODETIC REFERENCE SYSTEMS	
1.0 Introduction	16
1.1 The Conventional Terrestrial System	16
1.1.1 The Instantaneous Terrestrial System	17
1.1.2 The Geodetic Reference Ellipsoid	17
1.1.3 The Horizontal Geodetic Datum	20
1.2 The Conventional Inertial System	20
1.3 The Orbital Co-ordinate system	21
1.4 Tranformations between 3-D co-ordinate systems	23
1.4.1 The Bursa-Wolf model	24
1.4.2 The Molodensky-Badekas model	24
1.4.3 A mathematical description of the two models	25
CHAPTER 2: A HISTORY OF THE GEODETIC SURVEY OF SOUTH AFRICA	
2.1 Abbe de la Caille	29
2.2 Maclear	29
2.3 Other Early networks in South Africa	30
2.4 Reasons for the Geodetic Survey of South Africa	30

		pg
2.5	The Thirtieth Arc of Meridian	31
2.6	The Datum for the Geodetic Survey of South Africa	32
2.7	Network Orientation - Laplace Stations	35
2.8	Baseline Measurement	35
2.9	Computation of the SA Geodetic Network	37
2.10	Monumentation of the Triangulated Points	39
2.11	Co-ordinate systems used in the SA network	39
2.12	Trilateration	40
2.13	Geodetic Traversing	40
2.14	Re-adjustment of the South African Control Network	41

CHAPTER 3: DOPPLER SATELLITE POSITIONING

3.0	The TRANSIT System	45
3.1	Satellite Doppler Measurements	46
3.2	Refraction in Satellite Doppler Measurements	49
3.2.1	Tropospheric Refraction	49
3.2.2	Ionospheric Refraction	51
3.3	Ephemerides	53
3.3.1	The Broadcast Ephemeris (B.E.)	53
3.3.2	The Precise Ephemeris (P.E.)	55
3.3.3	Comparison of the two Ephemerides	56
3.4	The Transit Satellites	56
3.5	The Doppler Satellite Receiver	57
3.6	Computation of the Satellite's Co-ordinates	57
3.7	Positioning	58
3.7.1	Point Positioning	58
3.7.2	Translocation	59
3.7.3	Multistation Positioning	60
3.8	Linearisation of the Doppler Equation	60
3.9	The Least Squares adjustment	61
3.9.1	The Sequential adjustment	64

		pg
3.9.2	Phase Adjustment	65
3.9.3	The LS solution of the Doppler Equation	67
3.10	Doppler Processing Software	68
3.10.1	GEODOP	69
3.11	The South African Doppler Survey	71
3.11.1	Network Design	71
3.11.2	Doppler Observing Procedure	71
3.11.3	GEODOP Options used in the SA Doppler Survey	72
3.12	The African Doppler Survey (ADOS)	72
3.13	Existing National Doppler Networks	73

CHAPTER 4: DEVELOPMENT OF A UNIFIED DOPPLER NETWORK

4.1	The Rigorous Approach	76
4.2.1	Some Statistical Considerations	78
4.2.2	Hypothesis Testing	79
4.2.3	The χ^2 test	79
4.3	Results of the Rigorous Approach	81
4.4	Further Evaluation of the GEODOP co-variance Matrix	81
4.4.1	Direct Comparison of B.E. Co-ordinates	82
4.5	Subnet Unification using a Similarity Transformation	84
4.5.1	Adjustment of the 7-parameter Network	87
4.5.2	Weighting	87
4.5.3	Formation of the Design Matrix	88
4.5.4	Results of the 7-parameter Adjustment	89
4.6	Network allowing Shifts and a single Rotation	90
4.7	Shifts and Scale Network	93
4.7.1	Results of the Shifts and Scale Network	94
4.8	Subnet unification using Shifts only	94
4.8.1	Design Matrix Formation (Shifts only)	94
4.9	Free network using shifts only	96
4.9.1	Addition of Pseudo Observations	97

	pg	
4.10	Transformation between B.E. and P.E. systems	98
4.10.1	Data Criteria for Transforming from B.E. to P.E.	99
4.10.2	Weighting of P.E. and B.E. co-ordinates	100
4.10.3	Design Matrix formation	101
4.10.4	Results of the P.E./B.E. transformation	102
4.10.5	Comparison with equivalent results obtained elsewhere	104
4.11	Incorporation of P.E. and B.E. in the same adjustment	107
4.11.1	Weighting of the P.E. and B.E. co-ordinates	107
4.12	Summary of the Doppler unification Procedure	108
4.13	Augmentation of the Co-variance matrix	108
4.14	Transformation of Doppler to BIH/CIO Orientation	110
4.15	The Purpose of this Doppler Network	111
4.16	Transformation between Cape Datum and CTS	111

**CHAPTER 5: SELECTION OF A DATUM FOR THE SOUTH AFRICAN
 TRIGONOMETRICAL READJUSTMENT**

5.1	The datum for the S.A.horizontal readjustment	114
5.1.2	N.A.D. '83	115
5.2	Minimising Geoid/Ellipsoid separation	116
5.2.2	Design matrix formation	117
5.2.3	The free terms	118
5.3	Ellipsoid determined from Astronomical Observations	119
5.3.1	Design matrix formation	121
5.4	Minimising horizontal co-ordinate changes	121
5.5.1	Minimising of 3-D co-ordinate changes	124
5.5.2	Minimising Co-ordinate changes by 'Mini-Max'	125
5.6	The definition of the new South African horizontal Geodetic Datum	126

CONCLUSION	pg
	132
REFERENCES	134
APPENDICES:	141
A Computer Results	
B Computer Programs	
C GEODOP Input Data	

INDEX TO FIGURES

	pg
1.1 Conventional and Instantaneous Terrestrial systems.	19
1.2 The Orientation of the Orbital Ellipse.	22
1.3 One quarter of a satellite Orbital Ellipse.	22
1.4 Relationship between geodetic datums.	27
1.5 Keplerian Orbital Elements	28
2.1 The state of the Geodetic Triangulation of South Africa in 1950.	36
2.2 E.D.M. traverse and Doppler networks in South Africa.	44
3.1 Illustration of the observed quantity in Doppler Positioning.	47
3.2 Distribution of non-zero terms in the Doppler equation design matrix.	68
3.3 The Doppler Survey of southern Africa.	75
4.1 The distribution of non-zero terms in the accumulated weight matrix.	78
4.2 An extract of some chord distances and their MSE's computed from GEODOP.	83
4.3 Illustration of the effect of actual and ephemeris orbits not being parallel.	85
5.1a Ellipsoid calculated so as to minimise geoidal separation.	120
5.1b Ellipsoid calculated so as to minimise plumbline deflections.	120

INDEX TO TABLES

	pg
1 Parameters defining the Clarke 1880 Ellipsoid.	33
2 Parameters defining the modified Clarke 1880 Ellipsoid.	34
3 A summary of the instruments and their accuracies used in the triangulation of South Africa until 1950.	38
4 A summary of Transit Doppler observations made in South and South West Africa.	42
5 Existing geodetic co-ordinates of Doppler stations in South and South West Africa.	43
6 Geographical co-ordinates and error ellipsoids computed from the 7-parameter adjustment.	91
7 Subnet transformation parameters (Shifts and one rotation).	92
8 Subnet transformation parameters (Shifts and Scale).	95
9a Molodensky-Badekas transformation parameters between B.E. and P.E. co-ordinates in Southern Africa.	102
9b M-B transformation parameters between B.E. and P.E. co-ordinates in Southern Africa. (X & Y rotations and Scale constrained to zero)	102
10a Bursa-Wolf transformation parameters between B.E. and P.E. co-ordinates in Southern Africa.	103
10b B-W transformation parameters between B.E. and P.E. co-ordinates in Southern Africa. (X & Y rotations and Scale constrained to zero).	104

		p9
11a	B-W transformation parameters for transforming from B.E. to P.E. according to [Kumar M. 1982].	104
11b	B-W transformation parameters for transforming from B.E. to P.E. according to [Boucher C. 1979].	105
11c	B-W transformation parameters for transforming from B.E. to P.E. according to [Jenkins and Leroy C.1982].	105
11d	A summary of transformations from B.E. to P.E. reference frames.	106
12a	Molodensky-Badekas Transformation Parameters between Cape Datum and WGS'84	112
12b	M-B Transformation Parameters between Cape Datum and WGS'84 (Rotations constrained to zero)	112
12c	M-B Transformation Parameters between Cape Datum and WGS'84 (Rotations and Scale constrained to zero)	113
13a	Shifts required between WGS'84 centre and new centre in order to minimise (by least squares) 3-dimensional co-ordinate changes of 23 Doppler points. (Modified Clarke 1880 ellipsoid).	124
13b	Shifts required between WGS'84 centre and new centre in order to minimise (by least squares) 3-dimensional co-ordinate changes of 20 Doppler points. (Modified Clarke 1880 ellipsoid).	125
14	Shifts required between WGS'84 centre and new centre in order to minimise (by mini-max) 3-dimensional co-ordinate changes of 20 Doppler points. (Modified Clarke 1880 ellipsoid).	125

	pg
15 Shifts required between WGS'84 centre and new centre in order to minimise (by mini-max) 3-dimensional co-ordinate changes of 20 Doppler points. (WGS'84 ellipsoid).	126
16a Defining parameters of the proposed South African Geodetic Datum	127
16b Horizontal co-ordinate changes around the main centres of development if the ellipsoid and shifts in Table 16a are adopted	127
17 Geocentric co-ordinates of 35 Doppler points transformed to WGS 84 centre and CTS orientation.	129
18 Geographical and plane (Lo) co-ordinates of the 35 Doppler points using the datum defined in Table 16a.	130
19 Geographical and Plane (Lo) co-ordinates of 23 Doppler points in the WGS 84 reference system	131

SUMMARY OF NOTATIONS USED

a	ellipse semi-major axis.
A	Astronomical azimuth.
A	Design matrix.
b	ellipse semi-minor axis.
c	speed of light in vacuo.
E	eccentric anomaly.
e	ellipse's first eccentricity.
é	ellipse's second eccentricity.
f	ellipse flattening.
f	frequency.
g	acceleration due to gravity.
h	ellipsoidal height.
H	orthometric height.
I	unit matrix.
i	inclination of orbital ellipse to equator.
L	vector of free terms.
n	number of observations.
N	geoidal separation.
N	doppler count.
P	weight matrix.
Q	covariance matrix.
r	range.
R	rotation.
s	scale.
t	time.
T	translation.
T	period.
u	number of unknowns.
v	vector of residuals.
v	true anomaly.

x	vector of unknowns.
X	} cartesian co-ordinates
Y	
Z	
α	geodetic azimuth.
η	plumbline deflection in the prime vertical.
Λ	astronomical longitude.
λ	geodetic longitude.
ν	ellipsoidal radius of curvature in prime vertical.
ξ	plumbline deflection in the meridian.
ρ	ellipsoidal radius of curvature in the meridian.
Σ_{xx}	covariance matrix of unknowns.
σ_o^2	a priori variance factor.
$\hat{\sigma}_o^2$	a posteriori variance factor.
σ	standard deviation.
ϕ	geodetic latitude.
Φ	Astronomical latitude.
Φ	function to be minimised (by least squares).
ω	argument of perigee.
Ω	right ascension of ascending node.

GEODETIC REFERENCE SYSTEMS

1.0 INTRODUCTION

The South African geodetic control network is shortly to undergo a complete re-adjustment. Together with all of the traditional triangulation and distance measurements, the new adjustment will include Doppler satellite observations taken at several of the geodetic stations. Most of the work in the present study is concerned with the various satellite Doppler observations and deriving from them a single set of co-ordinates (in the same geocentric reference frame) for each of the geodetic stations at which Doppler readings were recorded. The original adjustment, which has been carried out in stages over the last hundred years, is on the Cape Datum. This Datum is defined by the Modified Clarke 1880 ellipsoid implicitly positioned at the Buffelsfontein origin. (The definition of the Cape Datum is described more fully in chapter 2.) The principal purpose of the present study is to examine the aptness of this datum for this proposed re-adjustment and, using the Doppler observations, to compute a suitable replacement.

In order to understand the significance of geodetic observations to TRANSIT satellites one must first appreciate the reference system in which these observations are made.

1.1 THE CONVENTIONAL TERRESTRIAL SYSTEM

A co-ordinate system in space has six degrees of freedom, that is, six constants are required to define the position and orientation of that system [Veis G. 1981]. The object of a geodetic survey is to co-ordinate the stations of that survey in the conventional terrestrial system (CTS). This system, which has evolved over the past 3 to 4 centuries, is defined by its origin which is at the centre of mass of the earth, (or some approximation thereof) and the directions of two of its axes. The first axis (Z) is defined to be coincident with or parallel to, the earth's mean axis of rotation during the period 1900 to 1905 (CIO) and the second axis (X) so that the X-Z plane is parallel to

the Mean Greenwich Astronomical Meridian (MGAM). This meridian is very close to that containing the centre of the Greenwich Observatory or BIH (*Bureau internationale de l'heure.*) The third axis (Y) is defined so as to make an orthogonal right-handed system. Unfortunately the position and direction of the earth's axis of rotation are not constant either with respect to the stars or with respect to the solid mass of the earth itself. The North Pole moves approximately in a circle of radius 10 m. with a period of 430 days [Krakiwsky & Wells 1971] and furthermore the rate of rotation of the earth is not quite constant.

1.1.1 THE INSTANTANEOUS TERRESTRIAL SYSTEM

For the above reasons another co-ordinate system is introduced, namely the instantaneous terrestrial system (ITS) which is defined as above with the actual North Pole replacing the mean North Pole. The relationship between the CTS and the ITS is illustrated in figure 1.1 (on page 19). The orientation given by an astronomical azimuth (described in section 2.7) is in the ITS. The co-ordinates of a point in the CTS may be expressed directly in the system, that is, in Cartesian geocentric co-ordinates or, as is more usual, in ellipsoidal co-ordinates.

1.1.2 THE GEODETIC REFERENCE ELLIPSOID

In 1738 Clairaut showed the earth to be oblate by comparing the acceleration due to gravity at different latitudes. This was confirmed geometrically by the results of the Peru and Lapland arc measuring expeditions (the latter of which Clairaut was a member). Since this time the mathematical figure of the Earth used by geodesists has almost invariably been the oblate bi-axial ellipsoid whose equation takes the following form:

$$\frac{X^2}{a^2} + \frac{Y^2}{a^2} + \frac{Z^2}{b^2} = 1$$

..... 1.1

A bi-axial ellipsoid in space has seven degrees of freedom:

- The ellipsoid's semi-major and minor axes (2 constants)
- The position of its centre (3 constants)
- The direction of the minor axis (2 constants)

In order to express co-ordinates on the ellipsoid surface the position of zero longitude also needs specifying.

In the classical geodetic survey the ellipsoid was positioned by defining the latitude, longitude and ellipsoidal height of a single point, namely the Initial Point or Origin. In practice these were normally the astronomical co-ordinates and orthometric height of this point. Nowadays, using dynamic satellite positioning, the ellipsoid is given the same centre as the satellite co-ordinate system which is very close to the earth's centre of mass. The direction of the minor axis is defined as the Conventional International Origin (CIO) which is the mean direction of the earth's axis of spin during the period 1900-1905.

Much attention (e.g. [Harvey 1986], [Krakiwsky & Wells 1971(1)]) has been given to the conversion between ellipsoidal and geocentric Cartesian co-ordinates.

Exact formulae for transforming ellipsoidal to Cartesian co-ordinates are :

$$\begin{aligned} \nu &= a/\sqrt{1 - e^2 \sin^2 \phi} \\ X &= (\nu + h) \cos\phi \cos\lambda \\ Y &= (\nu + h) \cos\phi \sin\lambda \\ Z &= ((1 - e^2)\nu + h) \sin\phi \end{aligned}$$

..... 1.2

where ϕ and λ are geodetic latitude and longitude

a is the ellipsoid's semi-major axis

b is the ellipsoid's semi-minor axis

e is the ellipsoid's first eccentricity

e' is the ellipsoid's second eccentricity

h is the height above the ellipsoid

ν is the radius of curvature of the ellipsoid in the direction of the Prime Vertical.

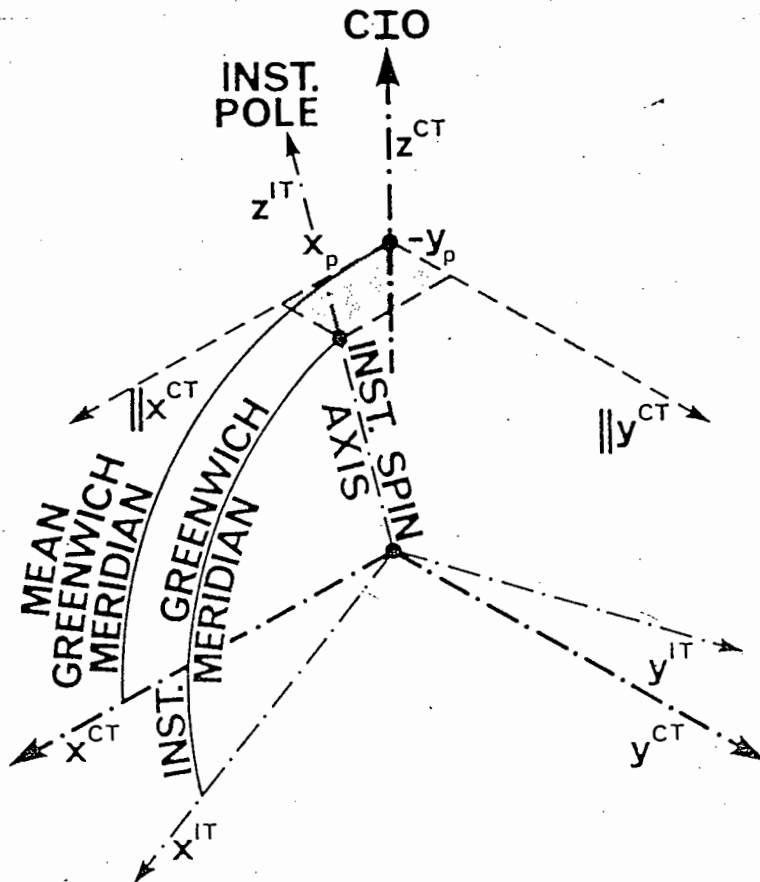

The relationship between Conventional and Instantaneous Terrestrial systems.
[Vanicek and Krakiwsky 1982]

fig 1.1

The reverse transformation involves solving a quartic equation in latitude. This can be done explicitly using the method given by [cf. Ozone M.I., 1985] or by iteration. The following formulae given by [Bowring 1976] are accurate to a thousandth of a millimetre without further iteration. These formulae will be used in further computations.

$$\lambda = \arctan(Y/X)$$

$$\rho = \sqrt{X^2 + Y^2}$$

$$\Theta = \arctan\{Za/(\rho b)\}$$

$$\phi = \arctan\{[Z + e^2 b \sin^3 \Theta]/[p - e^2 a(\cos^3 \Theta)]\}$$

$$\nu = a / (1 - e^2 \sin^2 \phi)$$

$$h = \rho / \cos \phi - \nu$$

..... 1.3

1.1.3 THE HORIZONTAL GEODETIC DATUM

A Horizontal Geodetic Datum comprises a reference ellipsoid, on which horizontal co-ordinates may be given, together with sufficient parameters to define the position and orientation of that ellipsoid.

In the classical datum these parameters comprised the geodetic co-ordinates of the origin station (ϕ_o, λ_o, h_o) , the components of the deflection of the vertical at this station (ξ_o, η_o) and a geodetic azimuth from this point (α_o) [Vanicek & Krakiwsky, 1980].

In the modern datum the parameters defining the ellipsoid position and orientation are $\Delta X, \Delta Y, \Delta Z, R_x, R_y, R_z$, these being the offset and rotation angles between the datum centre and axes and those of the CTS.

1.2 THE CONVENTIONAL INERTIAL SYSTEM

Because the earth is oblate, the asymmetrical attractions of the Sun and Moon upon it cause its axis of rotation to precess. The amplitude of this precession is equal to the obliquity of the ecliptic, that is some $23\frac{1}{2}$ degrees and its period about 26 000 years. The regression of the Lunar nodes adds a further irregularity to the earth's motion; this is known as nutation and has an amplitude of 18.4 arcseconds and a period of 18.6 years. A satellite orbiting a spherical earth is unaffected by the earth's spin and wobble

beneath it hence a common reference system is needed to which the motions of both the earth and the satellite may be referred. Such a reference frame is the Conventional Inertial System (CIS). The CIS, the most fundamental of all reference systems is 'in some prescribed way' attached to extra-galactic radio sources [Mueller I.I. 1980]. These very distant, and hence apparently stationary objects serve as beacons on which to orient the CIS. The relationship between the CIS and the CTS is monitored through a number of radio observatories on the earth. These observatories move with the earth with respect to the CIS.

1.3 THE ORBITAL CO-ORDINATE SYSTEM

The orbital system is used to co-ordinate a satellite orbiting the earth. The satellite is assumed to move in a Keplerian orbit, that is, an ellipse with the earth's centre of mass at one focus, any departures from this assumption are small and will be dealt with later. The orbital ellipse has five degrees of freedom [Krakiwsky & Wells 1971(2)], these being the two axes of the ellipse and three parameters needed to orient this ellipse. A sixth parameter is required to give the position of the satellite at a particular time.

An alternative interpretation of the six degrees of freedom would be to specify the satellite's position (3 parameters) and velocity (3 parameters) at a particular time.

The orientation of the orbital ellipse is defined by the three angles ω , Ω and i in fig 1.2. The orbital co-ordinate system is two-dimensional - it gives the X and Y co-ordinates of the satellite in the orbital plane (fig 1.3). The X axis is defined to contain the line of apsides (major axis) of the orbital ellipse and the Y axis is perpendicular to this, both axes passing through the earth's centre of mass.

The satellite's X,Y co-ordinates in the orbital plane are then given by:

$$\begin{bmatrix} X \\ Y \\ Z \end{bmatrix} = r \begin{bmatrix} \cos v \\ \sin v \\ 0 \end{bmatrix} = \begin{bmatrix} a(\cos E - e) \\ a\sqrt{1-e^2} \sin E \\ 0 \end{bmatrix}$$

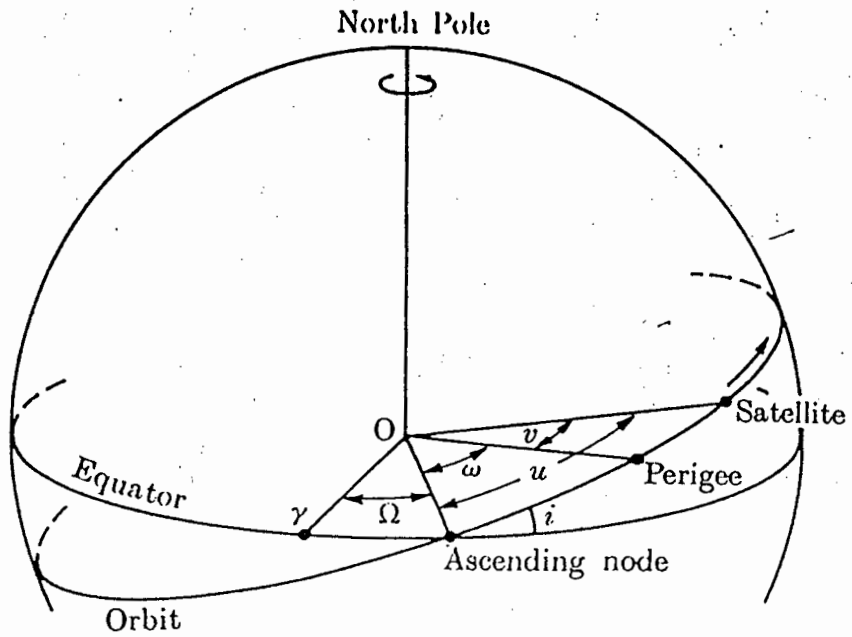

fig 1.2 The celestial sphere. Ω is measured in the plane of the equator, and ω and u in the plane of the orbit. γ is the equinox. [Bomford 1980]

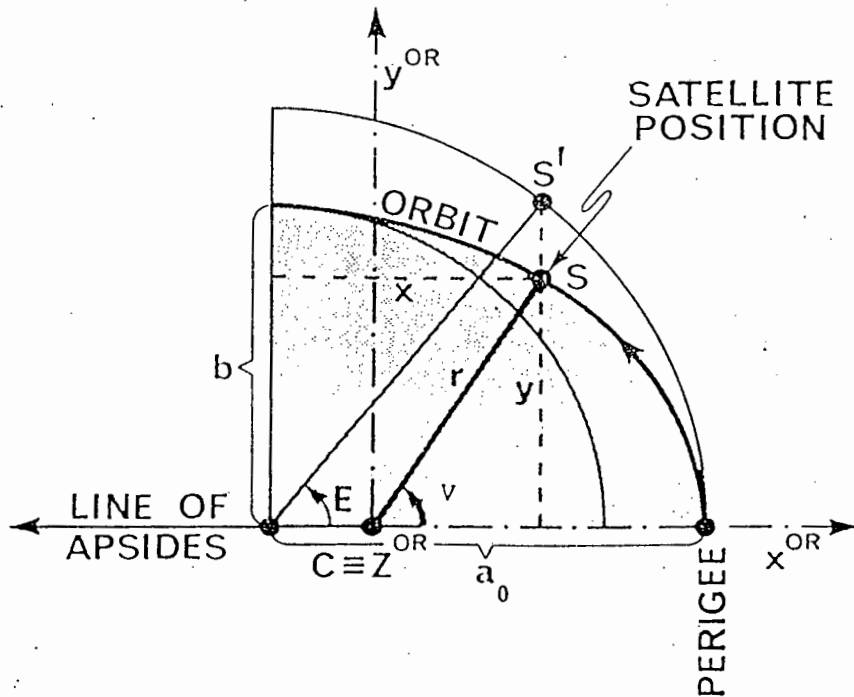

fig 1.3 One-quarter of a satellite orbital ellipse. [Vanicek and Krakiwsky 1982]

where v and E (the true and eccentric anomalies) are related by:

$$\tan v = \sqrt{1-e^2} \sin E / (\cos E - e)$$

..... 1.5

The zero Z co-ordinate has been added as the next step is to transform the orbital co-ordinates into the CTS.

The CTS and the orbital system have the same centre (the Geocentre) however there are six rotations required in order to transform orbital co-ordinates into the CTS. The rotation angles are as follows:

$\left. \begin{array}{l} \omega \\ \Omega \\ i \end{array} \right\}$	The angles defining the orbital plane
--	---------------------------------------

x_p	The direction of the instantaneous pole
y_p	with respect to CIO.

GAST - The Orbital system bears the same relationship to the CIS whereas the CTS rotates with the earth.
 The Greenwich Apparent Sidereal Time is the angle between the two.

The relationship between the Orbital system and the CTS is illustrated in fig 1.5 (on page 27).

1.4 TRANSFORMATIONS BETWEEN 3-D CO-ORDINATE SYSTEMS

In order to define a new datum it will be necessary to give the co-ordinates of some points in both the old and the new reference systems, we therefore need to consider the transformation models from one 3-D orthogonal system to another.

There are several mathematical models for transforming between three dimensional

co-ordinate systems. An affine transformation may be used, this takes the form:

$$x = AX + T$$

..... 1.6

in which **A** is the general 3*3 matrix, **T** is a 3-vector and **X** is being transformed onto **x**. This transformation involves 12 constants thus at least four common points are required in order to determine these constants. The affine transformation transforms straight lines into straight lines, parallel lines remain parallel but shape is not retained. In practice, for geodetic purposes **A** is orthogonal, shape is retained and the transformation comprises only seven parameters [Harvey 1986]. The seven parameters are three shifts, three rotations and a scale factor.

1.4.1 THE BURSA-WOLF MODEL (B-W MODEL)

If the rotations are applied about the origin of one co-ordinate system (in our case the geocentre) we have the Bursa-Wolf model [Harvey 1986]. Unless the data encompasses a sizeable proportion of the Globe then this model leads to a high correlation between parameters. In a small area for example the effects of a Z-rotation can be simulated by a combination of X and Y shifts.

1.4.2 THE MOLODENSKY-BADEKAS MODEL (M-B MODEL)

Alternatively the rotations may be applied about a point nearer the region of interest such as one of the common points. If the mean of all the common points (the centroid or Barycentre) is chosen as the rotation origin then we have the Molodensky-Badekas Model [Badekas J. 1969]. Using this model reduces the correlation between parameters.

The two transformation models lead to the same rotations, the same scale factor and give the same residuals - only the shifts are different. This is necessary so as to offset the effects of the same magnitude rotations about different centres. In the case of southern Africa the centre of the Bursa-Wolf model - the geocentre is some 6300 km away whereas the centre of the Molodensky-Badekas model is on average only 1500 km away.

When stating the parameters of the M-B transformation model it is essential to also give the co-ordinates of the rotation centre [Harvey 1986].

1.4.3 A MATHEMATICAL DESCRIPTION OF THE TWO MODELS

The rotation matrices about the X, Y and Z axes are:

$$R_x(w) = \begin{bmatrix} 1 & 0 & 0 \\ 0 & \cos w & \sin w \\ 0 & -\sin w & \cos w \end{bmatrix}$$

$$R_y(\theta) = \begin{bmatrix} \cos \theta & 0 & -\sin \theta \\ 0 & 1 & 0 \\ \sin \theta & 0 & \cos \theta \end{bmatrix}$$

$$R_z(k) = \begin{bmatrix} \cos k & \sin k & 0 \\ -\sin k & \cos k & 0 \\ 0 & 0 & 1 \end{bmatrix}$$

..... 1.7
These rotations are not generally commutative but provided the rotation angles are small (in fact they will seldom exceed 10° which easily satisfies this requirement) the product of the above rotations is given by:

$$R = \begin{bmatrix} 1 & k & -\theta \\ -k & 1 & w \\ \theta & -w & 1 \end{bmatrix}$$

..... 1.7b

The senses in which these rotations are applied are illustrated in figure 1.4 (on page 27).

The model for the B-W transformation from system b to a is:

$$\begin{bmatrix} X \\ Y \\ Z \end{bmatrix}_a = s R \begin{bmatrix} X \\ Y \\ Z \end{bmatrix}_b + \begin{bmatrix} T_x \\ T_y \\ T_z \end{bmatrix} \dots\dots\dots 1.8$$

while that for the M-B model is

$$\begin{bmatrix} X \\ Y \\ Z \end{bmatrix}_a = \begin{bmatrix} X_m \\ Y_m \\ Z_m \end{bmatrix} + s R \begin{bmatrix} X_b - X_m \\ Y_b - X_m \\ Z_b - X_m \end{bmatrix} + \begin{bmatrix} T'_x \\ T'_y \\ T'_z \end{bmatrix} \dots\dots\dots 1.9$$

where m denotes the centroid in system b. The translations T and T' will not in general be the same.

The applications of either of these transformations to a set of co-ordinates in system 'a' will not generally give the corresponding co-ordinates in system 'b' due to the presence of errors in either or both of the two co-ordinate sets.

In order to determine the most likely values of the shifts, rotations and scale a least squares solution is required. This will be dealt with in chapter 4 where the above transformations are applied.

In the present study transformations between three dimensional co-ordinate systems are required in order to convert between new and old South African geodetic co-ordinates. The following chapter describes the system in which these co-ordinates are given at present, in particular the reference ellipsoid to which the the horizontal co-ordinates refer.

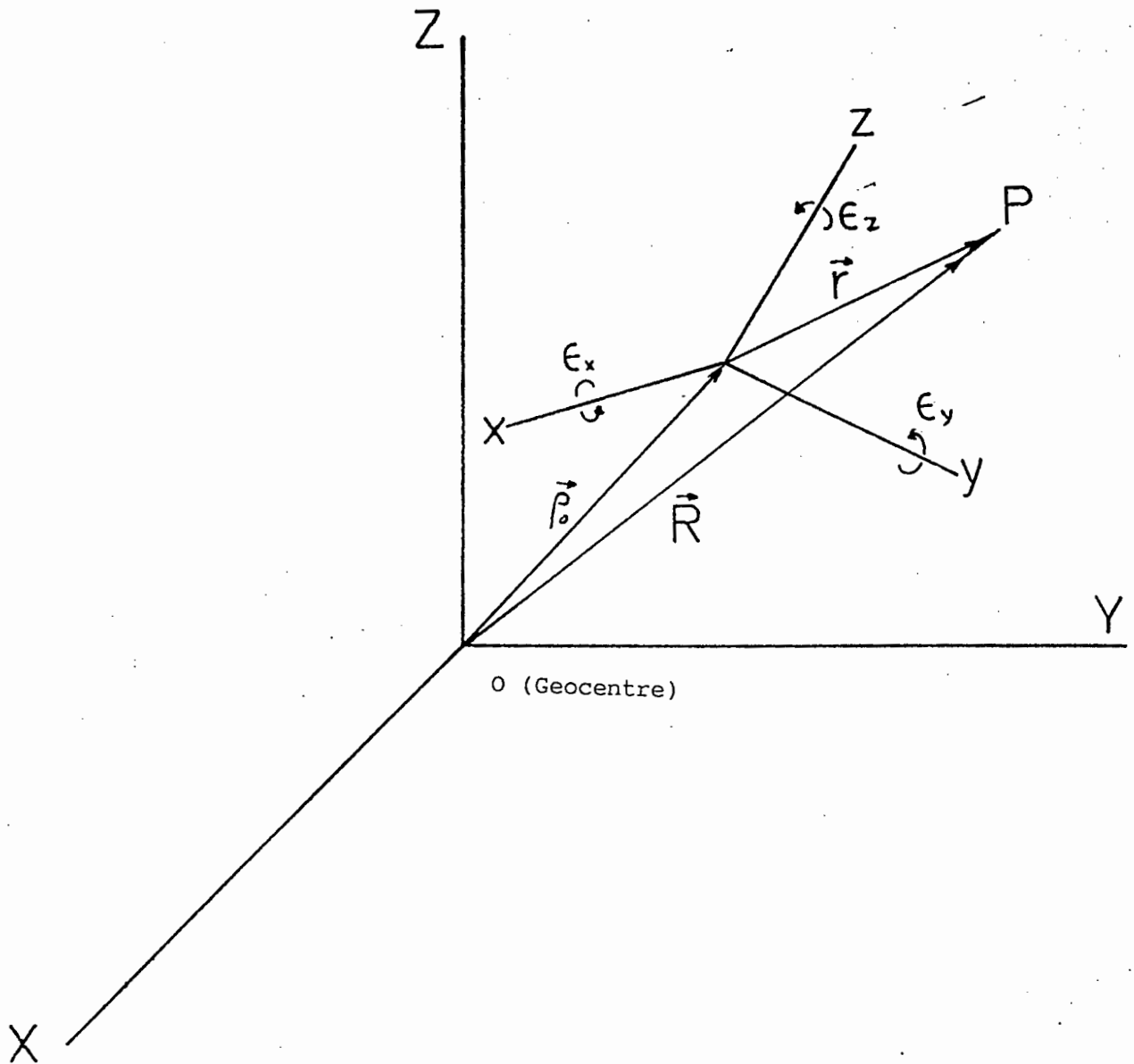

$$\vec{\rho}_0 = \begin{bmatrix} X_0 \\ Y_0 \\ Z_0 \end{bmatrix} ; \vec{R} = \begin{bmatrix} X \\ Y \\ Z \end{bmatrix} ; \vec{r} = \begin{bmatrix} x \\ y \\ z \end{bmatrix}$$

figure 1.4

Relationship between geodetic datums

A BRIEF HISTORY OF THE GEODETIC SURVEY OF SOUTH AFRICA

2.1 ABBE DE LA CAILLE

The first geodetic observations in South Africa, in fact the first in the southern hemisphere, were made by Abbe Nicolas de la Caille, a French astronomer sent to the Cape of Good Hope by the French Academy of Sciences in the middle of the eighteenth century. La Caille observed a triangulation network from Cape Town in the south to a point near the present day Piketberg in the north. He also observed the astronomical latitudes of these points and was thereby able to determine the meridional radius of curvature of the earth at the latitude of Cape Town. This work was done in order to substantiate the oblateness of the earth presumed from the Peru and Lapland expeditions sent out some fifteen years earlier by the same Academy [McIntyre 1951].

La Caille observed his triangulation with a quadrant three feet in radius, a baseline close to the present Swartland base being measured with wooden rods.

2.2 MACLEAR

The outcome of la Caille's survey was that the computed meridional radius was greater than expected; the earth appeared to be prolate in the southern hemisphere. This was not in agreement with Newton's theory and was the cause of a great deal of controversy and debate among prominent scientists of the day. La Caille himself was held in high regard - the soundness of his observations was not disputed and the matter was only settled when Colonel (later Sir George) Everest visited the Cape in 1821. After inspecting the site of la Caille's arc, Everest (whose measurement of the meridional arc in India is accounted unrivalled in geodesy [McIntyre D. 1951]) suggested that la Caille's arc be extended beyond Klipfonteyn in the north into Namaqualand. This was done by Thomas Maclear, the field work beginning in 1838 and being completed in 1847.

Maclear reobserved la Caille's network, although he could not find the original baseline, and extended it both southward and northward, the resulting arc being $4\frac{1}{2}$ degrees in length [Gill D. 1905]. The conclusions of Maclear's survey were that no fault could be found with la Caille's work but that a local plumbline deviation of 8 arcseconds, caused mainly by a large mountain at his northern terminal, had caused the anomaly. In retrospect, it was an oversight on the part of la Caille as Bouguer had already published work on the vertical deflection (and the consequential irregularity in the shape of the geoid) due to the presence of nearby mountain masses. The conclusion drawn from Maclear's arc was that there was no significant irregularity in the ellipsoidal shape of the earth.

2.3 OTHER EARLY NETWORKS IN SOUTH AFRICA

No further geodetic work was done in South Africa until 1859 when Captain Bailey of the Royal Engineers began the observation of the geodetic chain stretching along the southern Cape coast to Algoa Bay [Gill D. 1905]. The purpose of this chain was to provide a framework of control points for the registration of farms in the Cape Colony and what was then British Kaffraria and to improve the nautical charts of the southern Cape coast. Some triangulation was also observed in the northern part of the Cape of Good Hope bordering on German South West Africa by a Surveyor Bosman in 1890 [Gill 1905]. A dense network of triangulation was completed in 1892 in the Witwatersrand area for control of the gold mining leases and the associated development in Johannesburg. This network became known as the Goldfields System.

The idea of a geodetic survey of the whole of South Africa (in 1905 four separate states) was first put forward by David (later Sir David) Gill, H. M. Astronomer at the Cape from 1879 to 1907 [Gill D. 1905].

2.4 REASONS FOR THE GEODETIC SURVEY OF SOUTH AFRICA

The advantages of a geodetic network covering the whole country and computed on one datum were summarised by Sir Sidney Burrard [McCaw G.T. 1931] as follows :

"The first great practical use of geodetic triangulation is to prevent embarrassing accumulation of errors, no less in the country itself than at the frontiers thereof.

The second use is to unify and co-ordinate all the disparate surveys, of whatever kind, in the various regions of the country; to give them one origin; to combine them into one harmonious whole; to get rid of gaps and overlaps from internal mapping; to free the country from boundary disputes both internal and external. The third use is to facilitate and cheapen topographical, cadastral, boundary, engineering, mining and geological surveys and to control their accuracy.

The fourth use is to establish a feeling of public confidence in the security of land tenure by insuring that a public pronouncement on the precision of plans deposited for registration may be rendered possible.

The fifth use is to furnish perpetual points for the use of posterity, without which revision of maps would be impossible and future development grievously expensive."

2.5 THE 30TH ARC OF MERIDIAN

A further reason for establishing a geodetic network, one of a more scientific nature was envisaged by Gill. This was that the geodetic survey of South Africa could form the southern end of the longest meridional arc in the world. If this network were continued up the African continent, approximately following the 30th meridian, the resulting arc would have an amplitude of 65 degrees. "This would be a gain to geodesy so vastly important as alone to justify its inception" [Gill 1905]. Furthermore, this arc could be continued from Egypt through the Levant to link up to the Rumanian and Russian arcs, the total extent being from Cape Agulhas to the north Cape - some 105 degrees in all [McCaw G.T. 1931].

Under Gill's overall guidance and with Colonel Morris as superintendent of Surveys, the geodetic survey of South Africa progressed rapidly. When Gill left the Cape in 1907 chains of geodetic triangulation had been observed and computed from Cape Town to

the Limpopo and from Durban to South West Africa. Furthermore, through Gill's capturing the imagination of Cecil John Rhodes, Rhodes had sponsored the continuation of the chain further north and there was by this time a continuous chain of geodetic triangulation from Cape Town to Lake Tanganyika [McCaw 1931]. Gill's dream of a meridional arc from the Cape to Cairo was more than half realized [Whittingdale 1943].

2.6 THE DATUM FOR THE GEODETIC SURVEY OF SOUTH AFRICA

Colonel Morris chose Buffelsfontein, a geodetic point near to Port Elizabeth as the station of origin. Buffelsfontein was close to the coast thus its height above mean sea level was easily ascertained and it was also close to the central longitude of the country (the Cape Colony). Because there may have been a marked deflection of the vertical at Buffelsfontein, the geodetic latitude of this point was derived by computing the mean astronomical latitude from several nearby surrounding geodetic stations. This mean value then gave the geodetic latitude of Buffelsfontein. The geodetic longitude, on the other hand, was transferred from the Royal Observatory in Cape Town. In 1880, using the recently invented telegraph, a signal was sent from Greenwich to Cape Town via Berlin, Malta, Suez, Aden and Durban. This time signal facilitated the determination of the astronomical longitude of the observatory in Cape Town. Using the figure of the earth computed in 1880 by the English geodesist R.A. Clarke; the longitude difference between the Royal Observatory and Buffelsfontein was computed from the triangulation chains which had then been observed [Gill 1905].

In section 1.1 it was stated that a reference system in space has six degrees of freedom. By implication six quantities (in addition to the ellipsoid parameters) are needed in order to define a datum. In the case of the Cape Datum these six quantities were as follows:

- ϕ_0 the geodetic latitude of Buffelsfontein
- λ_0 the geodetic longitude of Buffelsfontein
- h_0 the ellipsoidal height of Buffelsfontein (the geoid height, N assumed zero)
- ξ_0 } the components of the vertical
- η_0 } deflection at Buffelsfontein.
- α_0 the geodetic azimuth from Buffelsfontein to Zuurberg, a nearby station.

The components of the deflection of the vertical at Buffelsfontein were not explicitly defined. Gill assumed these quantities to be zero but was aware of the possible shortcomings both of this assumption and of the parameters of the Clarke 1880 ellipsoid.

In addition to the ellipsoid parameters the defining parameters of the Cape Datum were:

ϕ_0 33° 59' 32.000"S
 λ_0 25° 30' 44.622"E
 h_0 918.9ft.
 α_0 183° 58' 15.000"

[Gill 1896]

Subsequent astronomical observations at Buffelsfontein in 1953 as part of the 30th arc of meridian showed its astronomical co-ordinates to be:

Φ 33° 59' 28.54"
 Λ 25° 30' 43.56"

[Union of South Africa Trig. Survey 1954]

The Clarke 1880 spheroid was defined according to the following table:

semi-major axis = 20926202 English feet (exact)
semi-minor axis = 20854895 English feet (exact)

Table 1.

The parameters defining the Clarke 1880 Ellipsoid [Clarke 1880].

Clarke also determined the relationship between the English foot and the metre as:

1 metre = 39.370432 inches [Clarke]

this is equivalent to

1 foot = 0,304797265 metres [Hendrikz D.R. 1943]

This factor was used by Morris in defining the South African geodetic datum. However, in 1896 Benoit and Chaney redefined the ratio of the foot to the metre as :

$$1 \text{ foot} = 0.304799735 \text{ metres [Hendrikz D.R. 1943]}$$

By the time this news reached South Africa most of the geodetic triangulation had already been computed. Instead of recomputing the entire network in English feet, a new unit of measure was defined, namely the South African geodetic foot.

$$1 \text{ S.A.G. foot} = 0,3047972654 \text{ international metres}$$

Furthermore, computations had not been done on the Clarke 1880 spheroid but on a new spheroid of dimensions:

$$\text{semi-major axis} = 20926202 \text{ S.A.G. feet}$$

$$\text{semi-minor axis} = 20854895 \text{ S.A.G. feet (exact).}$$

These values are equivalent to :

$\begin{aligned} \text{semi-major axis} &= 6378249.145326 \text{ international metres} \\ \text{semi-minor axis} &= 6356514.966721 \text{ international metres} \end{aligned}$
--

Table 2.
Parameters defining the modified Clarke 1880 Ellipsoid.

The new spheroid was renamed the Modified Clarke 1880 Spheroid.

The datum for the Trigonometrical Survey of South Africa was thus the Modified Clarke 1880 Spheroid implicitly positioned to be in contact with the geoid at Buffelsfontein. The latitude and longitude of Buffelsfontein were somewhat arbitrarily defined as above [Gill 1905].

One purpose of the present study is to re-evaluate the suitability of this datum and to suggest a possible replacement.

2.7 NETWORK ORIENTATION - LAPLACE STATIONS

The astronomical azimuth observed at Buffelsfontein was the horizontal angle between the celestial pole and the other ground station (in this case Zuurberg). The celestial pole is defined by the direction of the axis of rotation of the earth, however, this direction is not constant (Euler predicted the motion of the Pole in 1765 [Ashkenazi 1986]) and so geodetic networks are orientated with respect to the mean direction of the earth's axis of rotation (in fact this direction was defined as the mean during the period 1900 - 1905).

In most conventional geodetic networks this orientation is maintained through the observation of several astronomical azimuths regularly spaced throughout the network.

The astronomical azimuth (referring to the axis of rotation of the earth and the local vertical) and the geodetic azimuth (which is referred to the minor axis of the ellipsoid and the ellipsoidal normal) are not in general quite the same but are related by Laplace's Equation :

$$A = \alpha + (\Lambda - \lambda) \sin \phi$$

..... 2.1

- where α = the Geodetic (required) azimuth.
 A = the astronomical (observed) azimuth.
 λ = the Geodetic (computed) longitude.
 Λ = the astronomical (observed) longitude.
 ϕ = the latitude of the station.

For this reason the station at which these astronomical azimuths and longitudes are observed are known as Laplace Stations. There were no Laplace stations in Gill and Morris' Triangulation of South Africa.

2.8 BASELINE MEASUREMENT

Nine original baselines were measured in the Geodetic Survey of South Africa, these were measured with steel bars and had a length of 1-2 km. The accuracy of these lines (determined from the consistency of several measurements) was one part in 4 million [Gill 1896]. Gill estimated that systematic errors may have reduced this accuracy to 1/700 000. Later baselines were measured with Jaderin steel wires and had an average length of 20 km.

STATE OF GEODETIC TRIANGULATION
1950

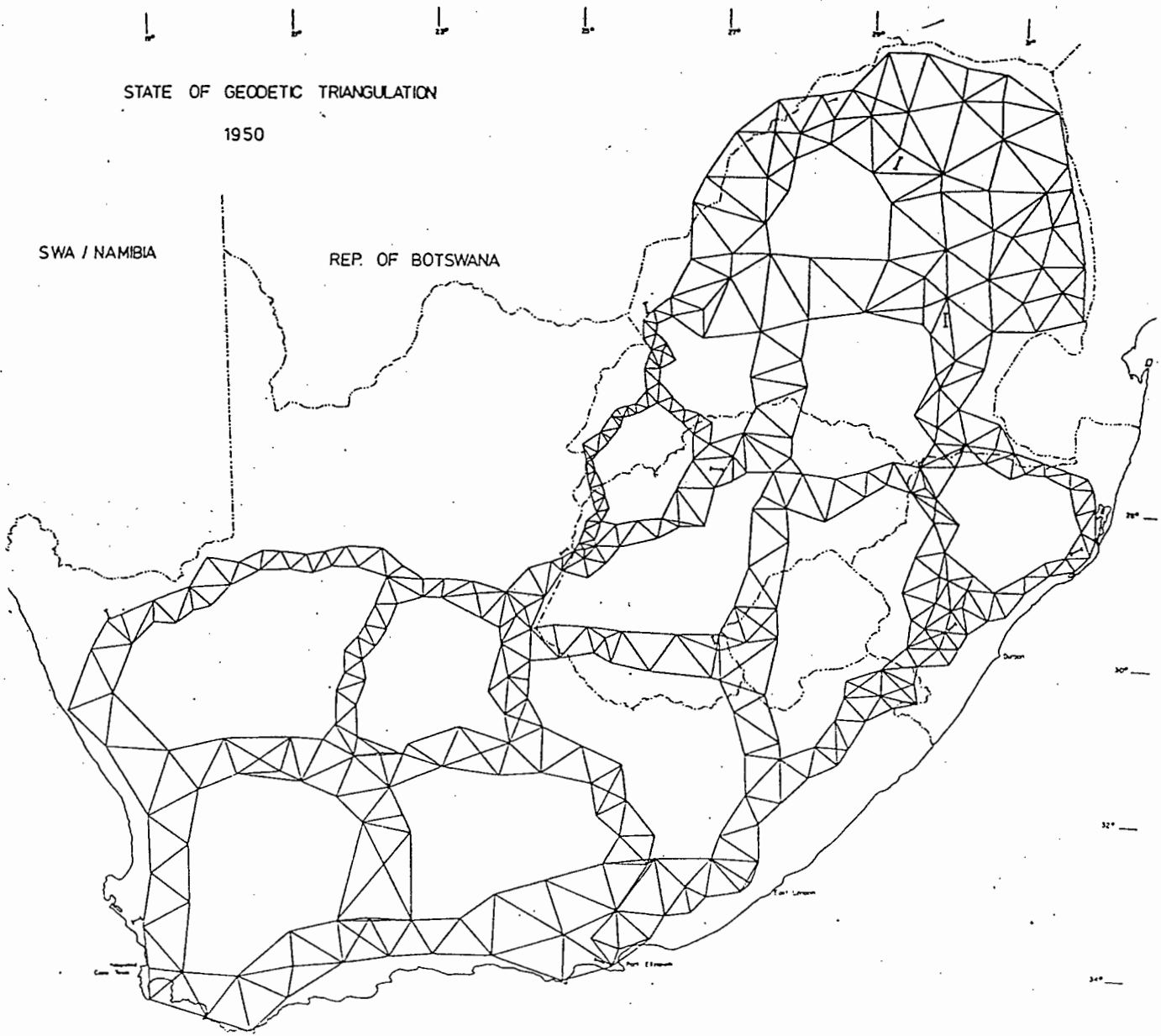

fig 2.1

2.9 COMPUTATION OF THE SOUTH AFRICAN GEODETIC NETWORK

Computation was done in geographical co-ordinates (latitude and longitude) on the ellipsoid. Modern geodetic networks are adjusted by the method of least squares first mentioned by Legendre and later developed by Gauss in the 1820's. The geodetic network of South Africa was not computed in one simultaneous adjustment - such a task would have been impossible before the invention of the electronic computer - however, individual circuits were adjusted by rigorous least squares using the method of condition equations. The mean misclosure of the loops of geodetic triangulation was one part in 242000 [v.d. Sterr 1927-30].

With the framework of geodetic chains completed, the task of filling in the intervening areas with subsidiary triangulation began. This primary triangulation network comprised triangles with an average side of approximately 42 km. The primary triangulation networks were adjusted freely (without the constraints of the surrounding geodetic chains) by the method of least squares. This free net was then fitted into the surrounding geodetic chain (the fixed points) by applying weights to the primary points inversely proportional to the distance to all of the fixed points [van der Sterr]. The mean error of an observed direction in the free network was 0"48. By forcing this network into the surrounding chain, this figure was increased to 0"64. Had the geodetic and primary triangulation been adjusted simultaneously, it is likely that this figure could have been reduced. However, a problem associated with all early triangulation networks was the limit in the number of points that could be included in the same adjustment. Provided that a least squares procedure was followed, it was practically impossible to solve for more than 100 unknowns [Bomford G. 1980] - this corresponded to a network of 50 points, or slightly more, depending on the procedure used. With this limit in mind, it was desirable for the geodetic stations to be widely spread in order for the geodetic chains to cover as large an area as possible.

Once the geodetic loops had been filled in with primary triangulation, the entire country (with the exception of part of the north western Cape) was covered with a network of first order triangulation. The average distance separating the triangulation points was about 50 kms but varied depending on the nature of the country - this distance was greater in mountainous country than in the flat areas of the Transvaal. In order to make this network more useful for mapping control and as a basis for other surveys, the

average station separation had to be reduced considerably. This was implemented by the introduction of secondary triangulation - a network of triangulation of average side about 13 km. Some secondary triangulation was observed by Bosman in the period 1904 - 1918 but the bulk of it was observed under the direction of Dr. W.C. van der Sterr in the period 1919 - 1933 [W. Whittingdale I.U.G.G. Report 1933].

Type	Date	Average Side (km)	M.S.E of Direction	Main Inst Type	Reference
Maclears	1840-1847	75	0.6arcsec	18"Fuller	Smuts1926
Geodetic	1883-1907	60	0.3	12"Repsold	Gill 1905
30th Arc Meridian	1895-1908	45	0.3	10"Repsold Grt Indian	Gill 1905
Primary	1900-1950	42	0.35	8"Repsold	vdS 1927
Secondary	1918-1933	13	0.6	8"Repsold	vdS 1933
Tertiary	1930-1950	5	1.5	Wild T2	Rousseau Personal comm

Table 3

A summary of the instruments and their accuracies used in the triangulation of S.A. up to 1950.

The secondary network was adjusted into the primary by the Schol's method - in this method the secondary triangulation was fitted to the primary, one primary triangle at a time. The result was that the secondary stations at the edges of the primary triangle were often in poor agreement with the adjacent secondary stations in the adjacent primary triangle [Whittingdale W. 1934]. Such stations were known as seamline points and were frequently the cause of poor triangulation fixes in these seamline areas. This was another example of the poor adjustment techniques used before electronic computers

2.10 MONUMENTATION OF THE TRIANGULATED POINTS

All triangulation stations were permanently marked with a white cylindrical concrete pillar 4 ft. (1.2 metres) high with diameter varying from 0.2 to 0.5 metres. This pillar was surmounted by a black square metal signal enabling the beacon to be observed from distances of 30 km or more. In case the beacon should be destroyed or disturbed in any way, witness marks were placed a few metres from the beacon. These marks consisted of either iron pegs or distinct holes or crosses in the surrounding rocks, the distances and directions to these marks from the beacon being recorded. Initially three witness marks were placed at each beacon but more recently four has become normal. The basic form of the trigonometrical beacon has not changed during this century.

2.11 THE CO-ORDINATE SYSTEMS FOR THE SOUTH AFRICAN NETWORK

In spite of the work of Gill and Morris in the development of the national triangulation network; several towns had their own networks computed in the Cassini-Soldner co-ordinate system.

In 1919 Dr van der Sterr introduced a series of conformal systems centred on all the odd meridians of longitude (17,19,21...31°E). The projection used was the transverse Mercator (or Gauss conformal) and the co-ordinates of all beacons were expressed in one of these systems.

By the middle of this century, the state of the geodetic survey of South Africa was comparable to that of most developed countries and better than many. That is, there was nearly complete coverage in primary and secondary triangulation and the more developed areas had additional denser control networks of tertiary triangulation and tape traversing through some of the larger towns. The surveying methods used in this network were essentially the same as those used by La Caille two centuries earlier. Angle and baseline measuring equipment had become more accurate but the same quantities, namely distances and angles, were measured and observed and the principles of triangulation remained.

2.12 TRILATERATION

The first commercially available electronic distance measuring equipment was the Tellurometer developed in South Africa in the early 1950's by Dr T.L.Wadley [Wadley 1957]. This instrument revolutionised geodetic surveying; previously scale had been maintained through the meticulous measurement of baselines with low expansion steel wires and tapes. Such baselines were expensive and time consuming to measure, e.d.m. obviated these baselines as the distance between almost any two intervisible points could now be measured directly. The South African Trigonometrical Survey Dept. attempted to go one step further than this and eliminate the use of angles altogether. By 1950 the only part of South Africa not covered by primary triangulation was a section of the northern Cape bordering on Bechuanaland. In 1962 a trilateration network (i.e. one consisting only of measured distances) was proposed in order to complete the country's first order geodetic control [Rousseau -personal communication]. This proved to be a mistake as a pure trilateration network has far fewer redundancies than the equivalent triangulation network - there is no check comparable to the 180 degree triangle closure. For this reason large errors in a trilateration network are comparatively difficult to isolate and may easily pass unnoticed.

2.13 GEODETIC TRAVERSING

A further form of geodetic control using the classical methods of distance and angle measurement is the traverse. Traversing has been used to provide geodetic control over very large areas in a comparatively short time. Distances are measured either by microwave or by electro-optical means as with the Geodimeter used in the geodetic traversing of north America [Meade 1968]. The early 1960's also saw the start of a geodetic traversing scheme in South Africa. The sides of this network have been measured exclusively with Tellurometer microwave instruments and traverse angles with the Wild T3 geodetic theodolite. The orientation of the network is controlled by a Laplace azimuth pair at every third traverse leg. Estimated accuracies of the various observations in this network are as follows:

Traverse angles	0"3
Distances	3 ppm
Azimuths	0"8

In the light of recent Doppler satellite control the necessity for the Laplace azimuths is questioned.

The overall length of this Traverse network was some 15000 km.

This traversing has revealed errors in some earlier geodetic control. The difference between measured distances and the same distances computed from Gill and Morris' triangulation is in some cases as much as 50 ppm; these errors are particularly apparent in the western part of South Africa [Wonnacott 1986]. These errors can be partly ascribed to poor triangulation but insufficient baselines and inferior adjustment techniques are more to blame.

2.14 THE READJUSTMENT OF THE SOUTH AFRICAN CONTROL NETWORK

Attempts have been made at readjusting some of the poorer areas of the South African control network. Invariably this causes a redistribution of the errors - normally to the margins of the new adjustment. It has been apparent for many years that the only real solution would be a complete readjustment of the entire horizontal control network. This adjustment would include all valid observations made since those of Gill and Morris together with the geodetic traversing mentioned in the previous section. The overall position and orientation of the network would be determined by the satellite Doppler control described in the next chapter. In all some thirty thousand points and several hundred thousands of observations would be involved in the readjustment.

Name of Subnet *1	P.E.or B.E.	No.of Stns	Station Numbers *2	date Year day	No.Acc Passes
185/1	B.E.	3	17 25 36	1980 236	53
185/3	B.E.	3	8 17 36	1985 245	71
185/4	B.E.	3	17 24 25	1981 80	60
185/5	B.E.	3	16 24 25	1981 86	52
185/6	B.E.	3	16 24 33	1981 94	54
185/7	B.E.	3	8 30 36	1980 323	62
185/8&19	B.E.	5	3 12 15 19 30	1985 165	105
185/9	B.E.	3	10 19 30	1982 193	51
185/10	B.E.	3	10 19 35	1985 245	57
185/11	B.E.	3	10 30 36	1982 205	59
185/12	B.E.	3	10 11 36	1982 212	118
185/13	B.E.	3	11 25 36	1982 211	56
185/14	B.E.	3	10 14 35	1982 270	62
185/15	B.E.	3	4 14 35	1982 274	51
185/16-18	B.E.	3	4 14 20 32 34	1984 235	85
185/20	B.E.	3	3 8 30	1984 128	66
185/21	B.E.	3	3 5 8	1984 140	55
185/22-23	B.E.	4	5 8 17 21	1984 321	80
185/24	B.E.	5	2 11 16 23 25	1985 238	74
185/25	B.E.	5	10 11 14 23 34	1984 225	78
185/26	B.E.	3	1 7 32	1984 267	73
185/27	B.E.	4	1 23 32 34	1984 285	68
185/28	B.E.	5	4 7 18 20 32	1984 294	69
185/29	B.E.	4	13 17 21 24	1984 330	71
185/30	B.E.	5	13 22 24 26 33	1985 222	68
185/31	B.E.	4	16 26 29 33	1985 229	62
185/32	B.E.	5	1 7 9 27 31	1985 312	77
185/33	B.E.	5	6 7 18 27 28	1985 319	97
196/1	P.E.	1	35	1983 234	102
196/2	P.E.	1	22	1983 311	102
196/3	P.E.	1	12	1983 27	133
196/4	P.E.	1	5	1983 27	94
196/5	P.E.	1	32	1983 233	86
185/6	P.E.	1	29	1982 312	65
185/7	P.E.	1	25	1982 309	80

Table 4

A summary of Transit Doppler Observations made in South Africa and South West Africa.

*1 see figure 3.3 on page 75

*2 for the names corresponding to these numbers see table 5 (page 43)

Station	Comp No.	Deg Sq.	No.	Published Geodetic Co-ordinates		
				Latitude (S)	Longitude (E)	Datum
Acorn (Apprx)	1	2120		22 00 00.000	21 00 00.000	SWA
Brit 44	2	2527	292	25 53 00.640	27 40 28.413	Cape
Blydeberg	3	3323	7	33 06 01.523	23 11 26.594	Cape
Burenkamp	4	2615	2	26 39 04.440	15 09 57.626	SWA
Coegakop	5	3325	133	33 46 08.177	25 37 18.180	Cape
Druse	6	2013	7	20 14 26.386	13 30 24.570	SWA
Esere	7	2017	26	20 01 06.0	17 34 18.2	SWA
Fransmanskop	8	3024	26	30 53 47.215	24 26 42.789	Cape
Geelhout	9	1920	9	19 35 46.953	20 41 50.651	SWA
Graskop	10	2919	10	29 03 02.118	19 56 52.901	Cape
Hadida	11	2621	3	26 56 34.118	21 30 05.619	Cape
Hexriver	12	3319	29	33 22 53.983	19 40 09.627	Cape
Inkominkulu	13	2930	51	29 46 43.365	30 27 41.448	Cape
Karasberg	14	2618	79	26 56 30.904	18 49 58.782	SWA
Karsrivier	15	3420	22	34 26 54.411	20 07 02.714	Cape
Kranzberg	16	2427	25	24 28 12.746	27 35 21.811	Cape
Leeukop (RSA)	17	2926	22	29 18 38.888	26 24 10.418	Cape
Leeukop (SWA)	18	2315	79	23 00 41.200	15 03 27.245	SWA
Louisfontein	19	3117	5	31 01 37.712	17 59 42.597	Cape
Lourkuppe	20	2416	68	24 54 27.164	16 42 07.557	SWA
Lubisi	21	3127	40	31 46 30.747	27 29 38.497	Cape
Magwaza	22	2732	4	27 41 41.073	32 08 07.211	Cape
Mannerheim	23	2523	4	25 36 50.937	23 10 24.354	Cape
Moodam	24	2728	50	27 05 29.417	28 44 11.594	Cape
Morgenzon	25	2725	79	27 07 25.909	25 15 27.191	Cape
M'Pumbe New	26	2431	66	24 10 46.968	31 53 47.098	Cape
Okotomare	27	1815	101	18 40 14.198	15 57 37.424	SWA
Ondondvengo	28	1712	4	17 53 49.398	12 15 43.537	SWA
Pont	29	2229	23	22 15 13.497	29 09 47.232	Cape
Potloer	30	3121	53	31 02 13.854	21 11 22.690	Cape
Rundu (Bcn B)	31	Cadastral		Beacon: local co-ordinates		SWA
Schwarzeck	32	2218	179	22 45 35.820	18 40 34.548	SWA
Thamakoosh	33	2430	62	24 43 28.163	30 02 57.387	Cape
Union's End	34	2419	318	24 50 18.279	19 58 44.944	SWA
Witbank New	35	2816	36	28 45 27.138	16 40 05.618	Cape
Witwater	36	2923	53	29 02 20.512	23 01 17.502	Cape

Table 5
Existing geodetic co-ordinates of Doppler Stations in South and South West Africa.

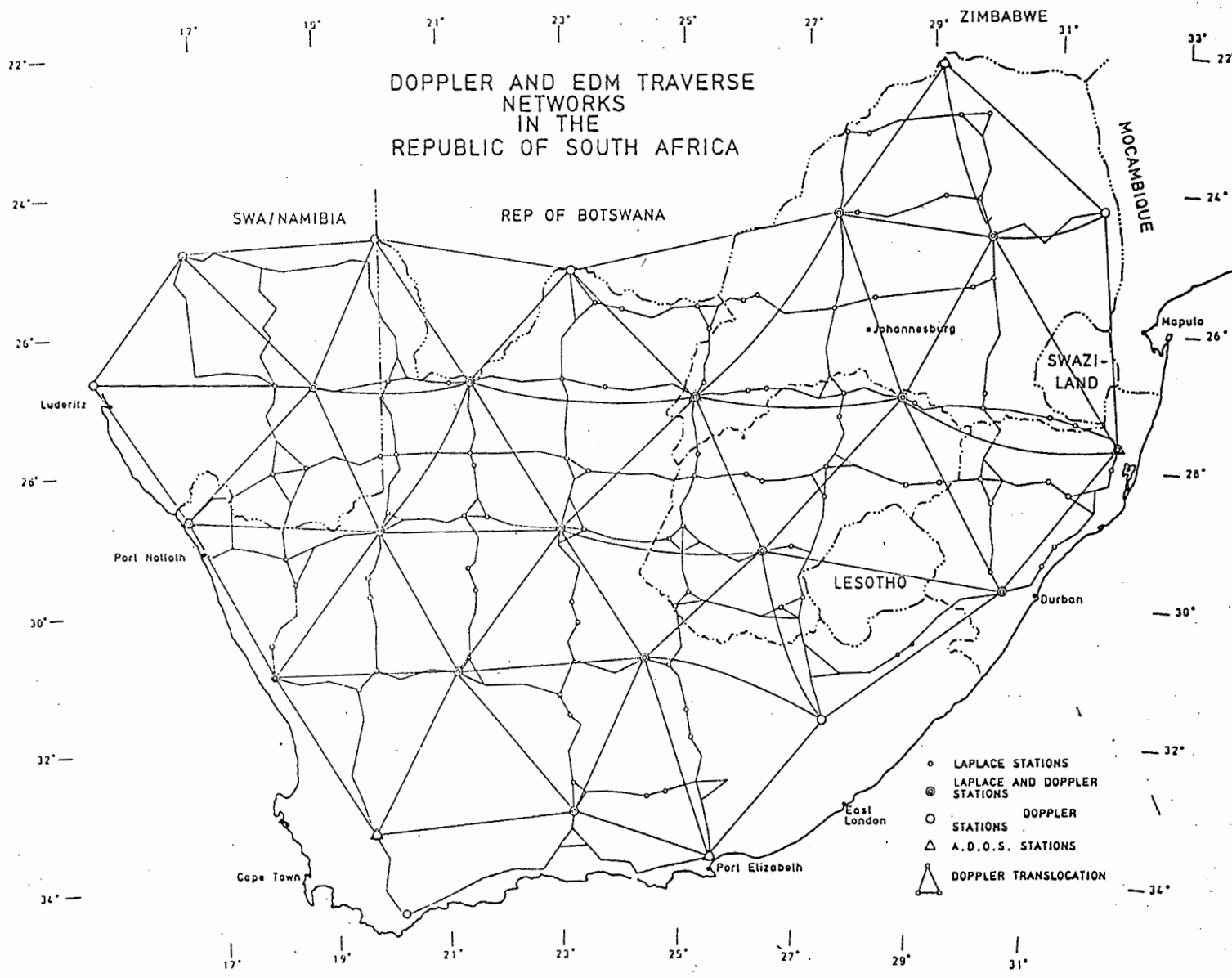

fig 2.2

DOPPLER SATELLITE POSITIONING

3.0 THE TRANSIT SYSTEM

Although not the first artificial earth satellites to be used for geodetic positioning, the US navy's NNSS (Navy Navigation Satellite System) or TRANSIT have affected geodesy in ways which will probably only be superseded by the Global Positioning System (GPS). The initial purpose of TRANSIT was the positioning of ships at sea to an accuracy of 100-200 metres. It subsequently transpired that, under certain conditions, the system was able to provide an accuracy of at least two orders better than this. The idea of using the Doppler effect for navigation was first proposed by Frank T. McClure whose idea was a development of studies done by two American physicists (George Weiffenbach and William Guier) who were studying the orbit of the first man made satellite - the Russian Sputnik 1. They showed that by measuring the satellite's Doppler shift (of what was presumably an unknown frequency) they could compute a fairly accurate orbit for the satellite. McClure's idea was to use this principle in reverse - by measuring the Doppler shift of a satellite emitting a known frequency in a known orbit; one could compute the position of the observer.

The TRANSIT system comprises some six satellites in polar orbits at altitudes of about 1100 km. The satellite's orbits are more or less evenly spaced around the equator; at latitude 45 degrees these satellites provide one usable pass every hour, this figure being two hours at the equator and 25 minutes above latitude 70 degrees. [Wells D.E. 1971] One purpose of the present study is concerned with the geodetic application of these satellites and the transformation of co-ordinates derived from them to the conventional terrestrial system.

3.1 SATELLITE DOPPLER MEASUREMENTS

There are three frequencies involved in satellite Doppler measurements :

1. the satellite emits a constant frequency f_s .
2. this signal, when detected by a receiver on the ground, has a frequency f_r , the difference being due to the Doppler effect.
3. the received signal is compared to a constant reference frequency f_o generated by the receiver.

[Krakiwsky and Wells. 1971(1)]

The emitted and received frequencies are related by the Doppler shift formula:

$$f_r = f_s (1 - r / c)$$

..... 3.1

where r is the rate of change of distance separating satellite and receiver and c is the velocity of light in vacuo.

When f_r is superimposed on the generated frequency f_o the result is a frequency of $(f_r - f_o)$.

Doppler measurements entail the counting of the beats of this frequency $(f_r - f_o)$ over a specified time interval.

$$N = \int_{t_1}^{t_2} (f_o - f_r) dt$$

..... 3.2

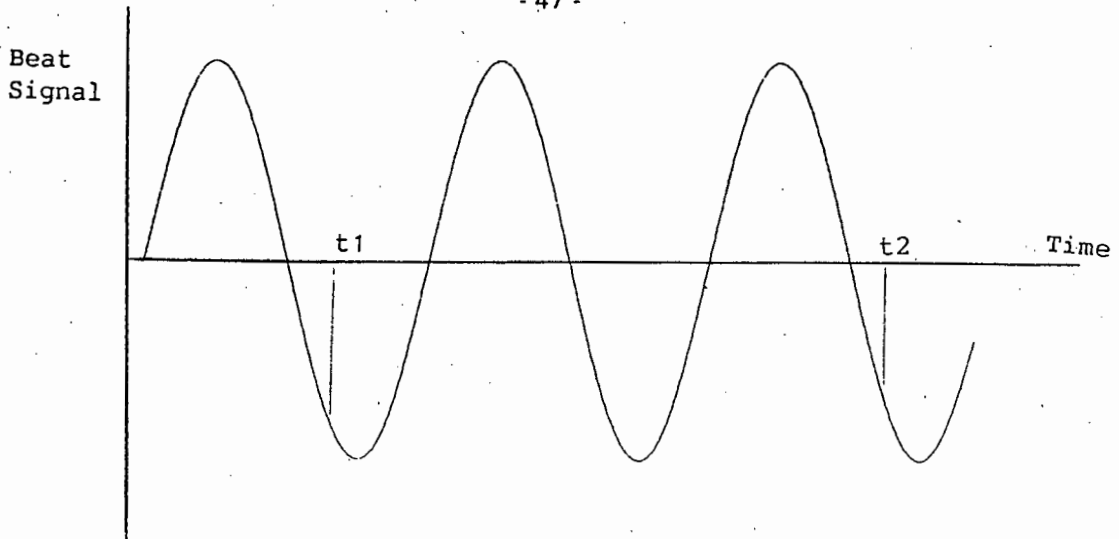

An illustration of the observed quantity in Doppler Positioning.
 fig 3.1

Doppler count (N) = No. of positive crossings of the zero axis between t1 and t2. (In this case 2.)

In the case of the NNSS, time marks are emitted by the satellite every two minutes. These marks (corresponding to t1 and t2 in equation 3.2) are used for navigation but geodetic receivers have an 'on board' clock which generates the receiver's own time marks. The receiver clock must be synchronised with the satellite clock at the beginning of the satellite pass. This synchronisation is not generally perfect but has an error which remains constant or varies linearly so long as the receiver remains switched on. The Transit satellites emit a principal frequency (fs) of just under 400 MHz, the satellites travel at approximately 7km/sec which means that the received frequency fr may be anywhere between 400 + δf and 400 - δf where

$$\begin{aligned} \delta f &= 400 \times 7 \times 10^3 / 3 \times 10^8 \text{ MHz} \\ &\approx 9.3 \text{ kHz} \end{aligned}$$

In practice fo is 400 Mhz and fs is 32 kHz less than the receiver generated frequency, that is 399.968 MHz. This 32 kHz offset ensures that the fo is always greater than fr and there is no possibility of a sign confusion when integrating (fo - fr).

A signal which left the satellite at time t1 arrives at the receiver a short time δt later (δt is the propagation time).

$$\delta t = r/c \dots\dots\dots 3.3$$

$$\text{and } \tau = t + \delta t \dots\dots\dots 3.4$$

Thus at the receiver equation 3.2 becomes :

$$N_{12} = \int_{\tau_2}^{\tau_1} (f_o - f_r) d\tau \dots\dots\dots 3.5$$

or in the more general case between time marks j and k :

$$N_{jk} = \int_{\tau_j}^{\tau_k} (f_o - f_r) d\tau$$

$$= \int_{\tau_j}^{\tau_k} f_o d\tau - \int_{\tau_j}^{\tau_k} f_r d\tau \dots\dots\dots 3.6$$

$$\#1 = f_o (\tau_k - \tau_j)$$

$$= f_o (t_k - t_j) - f_o/c \times (r_k - r_j) \dots\dots\dots 3.7$$

$$\#2 = \int_{\tau_j}^{\tau_k} f_r d\tau$$

$$= \int_{t_j}^{t_k} f_s dt$$

because there are as many cycles between t_j and t_k as between τ_j and τ_k although the time interval is different.

$$= f_s (t_k - t_j) \dots\dots\dots 3.8$$

$$\begin{aligned}
 \text{hence } N_{jk} &= (f_o - f_s) (t_k - t_j) + f_o/c \times (r_k - r_j) \\
 &= \delta f \cdot \delta t_{jk} + f_o/c \cdot \delta r_{jk}
 \end{aligned}
 \tag{3.9}$$

$$\text{where } r_k = \sqrt{[(X_k - X_p)^2 + (Y_k - Y_p)^2 + (Z_k - Z_p)^2]}$$

$$\text{and } r_j = \sqrt{[(X_j - X_p)^2 + (Y_j - Y_p)^2 + (Z_j - Z_p)^2]}$$

[Krakiwsky and Wells. 1971(1)]

In equation 3.9 N_{jk} is measured and, assuming that the satellite's position at times j and k are known; the only unknowns are the co-ordinates of the receiver X_p, Y_p, Z_p and the frequency offset δf .

This is the fundamental equation on which all positioning by Doppler Satellite measurements is based.

3.2 REFRACTION IN SATELLITE DOPPLER MEASUREMENTS

Equation 3.9 assumes the receiver and the signal travelling from the satellite to the receiver to be in vacuum. Clearly this is not so and conventionally the refraction correction is made directly to the Doppler count N itself. That is, N is corrected to what it would have been had the atmosphere been absent. The two components of the refraction correction are treated separately :

3.2.1 THE TROPOSPHERIC CORRECTION

The Doppler count, N is given by:

$$N = f_o/c \times (r_k - r_j) \tag{3.11}$$

differentiating:

$$\delta N = f_0/c \times (\delta r_k - \delta r_j)$$

.....3.12

Where δr_k the range correction at k is broken down further into the components due to :

- i. dry air
- ii. water vapour

$$\delta r_k = k_d \sin^2(E^2 + 6.26) + k_w \sin^2(E^2 + 2.25)$$

.....3.13

where E is the elevation angle in degrees and k_d and k_w are functions of the pressure and dry and wet bulb temperatures respectively :

$$k_d = 155.2 \times 10^{-7} \times P/T \times H_d$$

where $H_d = 40136 + 148.72 (T - 273.16)$

.....3.14

and $k_w = 155.2 \times 10^{-7} \times 4810 e/T^2 \times H_w$

where $H_w = 11000$

.....3.15

T = Absolute temperature in degrees Kelvin.

and P = Atmospheric pressure in millibars.

This is a simple model for tropospheric refraction derived empirically by [Hopfield 1969] and is more than accurate enough for navigational purposes but for Geodetic positioning a more refined model is required. [Black 1978] derived the following tropospheric refraction approximation:

$$\delta r = k_d I(E, H_d, l_c) - b(E) + k_w I(E, H_w, l_c) - b(E)$$

.....3.16

where the function I is defined:

$$I(E,H,L) = \{1 - [\cos(E)/(1 + (1 - L).H/R)]^2\}^{-\frac{1}{2}}$$

.....3.17

where the wet and dry constants k are defined as in 3.14 - 3.15 and :

$$L_c = 0.833 [(0.076 + 0.00015(T - 273))] \cdot \exp(-0.3E) \quad 2.20$$

and the 'bending function' b is defined :

$$b(E) = 1.92/(E^2 + 0.6)$$

.....3.18

The Doppler count N must be corrected by an amount

$$\delta N_{trop} = fo/c \times (\delta r_{ik} - \delta r_{ij})$$

.....3.19

where j and k refer to the times (and corresponding elevation angles at the start and end of the Doppler count).

The optical distance R_{ij} is greater than the geometrical distance r_{ij} , the difference being greatest at low elevation angles where the ray is passing through more atmosphere. Thus the correction δN is positive as the satellite approaches the receiver, zero at the point of closest approach and negative as the satellite recedes [Krakiwsky E.J. & Wells D.E. 1971(1)].

3.2.2 IONOSPHERIC REFRACTION

[Martin 1980] gives the delay of a microwave signal passing through the ionosphere as :

$$\delta L = -b \text{ lv } \sqrt{(\text{Cosec}(E^2 + 20.3^2))/(4 \pi^2 f^2)}$$

.....3.20

- where δL = delay in metres due to ionosphere
- b = constant
- f = frequency of signal (Hz)
- lv = vertical free electron density (electrons/m²)
- E = elevation angle in degrees

The factor lv can reach a maximum of 10^{18} electrons/m². In the case of the NNSS there are two frequencies emitted by the satellites; a principal frequency of 400 MHz and a secondary frequency of 150 MHz. Assuming a maximum value of lv , the effect of ignoring ionospheric refraction would be a zenith range error of 285 and 2028 metres for the 400 and 150 MHz signals respectively [Guier and Weiffenbach 1960] showed that the relationship between the observed and vacuum Doppler counts is of the form:

$$N_{vac} = N_{obs} + a_1/f + a_2/f^2 + \dots \dots \dots 3.21$$

The term in f being small and that in f^2 insignificantly small. The terms a_1, a_2 are constant for a particular time and place. Ignoring terms in f^2 and higher gives

$$\delta N = a_1/f \dots \dots \dots 3.22$$

Ignoring these high order terms causes small but systematic errors in height which are worst at times of high sunspot activity.

$$\begin{aligned} \delta N_1 &= -a_1/f_1 \\ &= N_0 - N_1 && (N_0 \text{ is what the Doppler count of } f_1 \text{ would have} \\ &&& \text{been without the ionosphere)} \\ N_0 &= N_1 - a_1/f_1 \\ &&& (\text{the vacuum count of } f_2 \text{ would be } N_0 \cdot f_2/f_1) \\ N_0 &= N_2 \cdot f_2/f_1 - a_1/f_2 \end{aligned}$$

from which

$$\delta N (=N_0-N_1) = [N_2 - (f_2/f_1)N_1] f_1 f_2 / (f_2^2 - f_1^2) \dots\dots\dots 3.23$$

Thus if the Doppler counts N_1 and N_2 are measured and the original frequencies of these two signals (f_1 and f_2) are known then the correction to N_1 to what it would have been without the ionosphere is found using equation 3.23. In the case of the NNSS.

$$N_{400} = -24/55 . [N_{150} - 3/8 . N_{400}] \dots\dots\dots 3.24$$

3.3 EPHEMERIDES

In order to use the basic Doppler equation 3.9 the co-ordinates of the satellite X_j, Y_j, Z_j at time t_j need to be known. These co-ordinates may be provided directly in Cartesian geocentric form or else in the orbital system, that is as parameters defining the orbital ellipse at time t_j . In the case of the NNSS we are concerned with two ephemerides:

- (i) the broadcast ephemeris which, as its name suggests, is a predicted ephemeris transmitted by the satellite.
- (ii) the precise ephemeris which is more accurate and is computed some time afterwards.

3.3.1 THE BROADCAST EPHEMERIS (B.E.)

The predicted ephemeris is based on data recorded at four tracking stations in the US (known as OPNET). From these four stations (Maine, Minnesota, California and Hawaii) a new orbit is determined every 12 hours based on data recorded over the previous 24 hours. After a 6 hour processing period, the new predicted orbit is injected into the satellite from one of the above four tracking stations. The B.E. is included in a message

superimposed on the satellite's carrier frequency. This message, which is repeated every two minutes, comprises 6103 binary digits organised into 156 words of 39 bits each and a final word of 19 bits [Wells, D.E. 1971].

The first three words contain timing information and 25 out of the remaining (154) words, orbital information, the other 129 words being irrelevant for navigation and geodetic purposes [Wells D.E. 1971]. Of the 25 orbital words, the first eight vary each time the message is broadcast and the final 17 remain the same for the 12 hours between satellite injections. These 17 words contain 11 parameters defining the mean orbital ellipse for that period, the 11 parameters being:

a	the ellipse's semi major axis	metres.
e	the ellipse's eccentricity	
tp	the time of perigee	Seconds U.T.
n	the mean motion of the satellite	Radians/minute.
ω	argument of perigee at tp	Radians.
$\dot{\omega}$	rate of change of ω	Radians/minute.
Ω	Right Ascension of ascending node	Radians.
$\dot{\Omega}$	precession rate of ascending node	Radians/minute.
sin(i)	i = inclination of ellipse to equator	
cos(i)		
GAST	Greenwich apparent sidereal time at tp	

The remaining eight words include:

T	Universal Time.	Minutes.
δE	eccentricity anomaly at T.	
δa	correction to a at T.	Metres.
n	out of plane component at T.	Metres.

The last three parameters describing the deviation in the satellite's position at time T from that described in the mean orbital ellipse. From the above information it is relatively simple to co-ordinate the satellite in the Orbital system at a particular time using equation 1.4. Other useful information included in the broadcast message is the amount by which the satellite's oscillator frequency differs from 400 MHz (in parts in 10^9) and the time since the last satellite injection.

The reference system in which the B.E. is given has been changed from time to time. Both this reference system and the gravity field from which the B.E. orbit is computed were changed five times between the start of TRANSIT and 1979 [Kumar 1982]. The most recent change was in January 1989 when the B.E. was given in the WGS 84 reference system. This system did not change during the period of the Doppler survey of Southern Africa (1980 - 1985). The accuracy of the B.E. varies depending on the time lapsed since the last update and on the part of the World over which the satellite is passing (the Earth's gravity field being known to a better degree in some areas than others) however, this accuracy is typically:

Along track	≈ 26 metres	
Across track	≈ 10 metres	
Radially	≈ 5 metres	[Kouba & Wells 1976]

3.3.2 THE PRECISE EPHEMERIS (P.E.)

The P.E. is computed by the US Defense Mapping Agency (DMA) and is based on data received from 18 stations around the World known collectively as TRANET. Because the P.E. orbit is computed 'after the event' errors are not extrapolated and the results are a much more accurate orbit. [Kouba J. and Wells D.E. 1976] gives the accuracy of a P.E. orbit as :

Along track	≈ 1.5 metres
Across track	≈ 1.5 metres
Radially	≈ 0.6 metres

The P.E. is only computed by special request to the DMA and then only for certain satellites. The form of the P.E. is not the orbital parameters of the satellite but instead the geocentric Cartesian co-ordinates of the satellite in the NSW-922 system are given at 1 minute intervals [Kouba and Wells 1976]. This reference system (which is an abbreviation for the Naval Surface Weapons Centre) is controlled by DMAHTC (Defense Mapping Agency/Hydrographic Topographic Command).

3.3.3 COMPARISON OF THE TWO EPHEMERIDES

The two ephemerides use different coefficients to model the Earth's gravity field and slightly different values for GM (G being the universal constant of gravitation and M the mass of the Earth). The former difference causes systematic local variations in co-ordinates derived from the two ephemerides and the latter an overall scale between the two.

During the period of interest of the present study (1980-1985) the B.E. used the WGS 72 gravity field and NWL-10D station co-ordinates; this is the NWL-10D reference system. The P.E. uses the NSWC-10E1 gravity field and NSWC-9Z2 station co-ordinates; this is the NSWC-9Z2 reference system or satellite datum [King R.W., Masters E.G. et al. 1985].

Furthermore the two ephemerides are based on different time standards; the P.E. using UT1 (UT minus polar motion) and the B.E. using UTC which depends on an atomic frequency and is independent of the Earth's rotation. The difference between the two times may be as much as 0.9 sec [Bomford G. 1980]. However this will be taken care of in the subsequent processing, more important is the change in this time difference which may be as much as 0.005 seconds per day and cause systematic longitude differences of up to 3 metres at the equator [Leroy and Jenkins 1979]. The relationship between the reference systems of the two ephemerides is thus complex and [Kumar 1982] suggests that this relationship be established independently for each project. The obvious advantage of the P.E. is its inherent accuracy, however, this advantage is often compensated by the difficulty in its acquisition and the additional time needed to record sufficient passes because the P.E. is only available for certain satellites [Bomford 1980]. Furthermore, in relative positioning modes, the additional ephemeris accuracy adds very little to the accuracy of the computed terrestrial co-ordinates [Brown D.C. 1976 (1)].

3.4 THE TRANSIT SATELLITES

There are 5 to 6 of these satellites in near circular polar orbit at an altitude of 1100 km. At this altitude they have a period of 106 minutes which means that a receiver on the Equator will have an average of one usable pass every two hours, at latitude 45° once every hour and above 70° once every 25 minutes [Wells D.E. et al. 1976]. The

satellites have a mass of 60 kg and a cross-sectional area of 0.98 m² [Henriksen S.W.1977]. The earliest satellites were termed TRANSIT (launched between 1960 and 1961), followed by OSCAR and more recently the NOVA satellites. The NOVA's are equipped with a stabiliser boom which ensures that the satellite maintains its orientation with respect to the Earth. These satellites are equipped with a drag compensating device known as DISCOS. This comprises a small mass floating inside an evacuated chamber inside the satellite, the mass has sensors on it and small rockets on the outside of the satellite ensure that the mass retains its position in free fall inside the chamber. This effectively counteracts the effect of non-gravitational external forces namely atmospheric drag and solar radiation pressure.

3.5 THE DOPPLER SATELLITE RECEIVER

In order to record the necessary data to compute its position, a Doppler satellite receiver comprises the following parts:

1. Antenna
2. Preamplifier
3. Oscillator
4. Data storage system
5. Power supply

Geodetic receivers, not relying on the satellite's signal for the measurement of time differences, also have a built in clock. An additional feature common to all but the most primitive receivers is a microprocessor enabling the predicted times of each satellite pass to be stored. This computer is also capable of doing some processing of the recorded Doppler counts. A Geodetic receiver incorporating all of the above components and one relevant to the present study is the JMR-1A manufactured by JMR Instruments Inc. of Chatsworth California.

3.6 COMPUTATION OF THE SATELLITE'S CO-ORDINATES

When the broadcast ephemeris is used the first step is the Majority Vote or data

cleaning. Inevitably, some bits of information are altered or lost while being transmitted from the satellite to the receiver. As this information is repeated every two minutes, the value which is recorded most often is assumed to be correct.

At this stage the refraction corrections (equations 3.16 & 3.23) are applied to the observed Doppler count. Orbital parameters are corrected to the relevant time instant using their first derivatives.

e.g.
$$a = a_0 + \dot{a} (t - t_0)$$
..... 3.28

Where, in this case, \dot{a} is the rate of change of the orbital semi-major axis and $t - t_0$ the time lapsed since the last ephemeris injection. a_0 is the semi-major axis at the time of that injection (t_0). The orbital co-ordinates at particular time instants are at this stage converted to geocentric cartesian co-ordinates. If the Precise Ephemeris is being used then this is in the form of the satellite's cartesian co-ordinates and their first derivatives at 60 second intervals. In order to compute the satellite's co-ordinates at instants between these specified times; a Chebychev polynomial is fitted to the computed positions. Once the satellite's co-ordinates have been determined there are three different ways of processing the observed Doppler counts.

3.7 POSITIONING

3.7.1 POINT POSITIONING

The simplest Doppler positioning model is that given by equation 3.9 where the satellite's co-ordinates are assumed to be error-free. In practice this is not the case and for geodetic purposes orbital biases are introduced. The effect of biasing the orbital parameters is to treat these parameters as unknown and to use the ephemeris as observations (with assumed standard deviations) of these unknowns. The computed orbit is thus constrained to lie within a certain tolerance of the ephemeris orbit.

In practice single point positioning only gives geodetic accuracy when used in conjunction with the P.E. in which the accepted biases are 2, 1 and 1 metres in the along track, radial and cross track directions respectively [Wells D.E. et al, 1976].

Using point positioning and knowing the satellite's ephemeris it is possible to co-ordinate the receiver from a single satellite pass, however the resulting fix would be very weak particularly in a direction perpendicular to the plane of the satellite's orbit. This plane is known as the Guier plane defined as containing the receiver and the velocity vector of the satellite at its point of closest approach to the receiver - William Guier being one of the original physicists responsible for the whole Doppler satellite concept.

In practice, to obtain a fix of useful geodetic accuracy by this method, at least 30 or so passes should be observed. These passes should be well balanced, the number of north travelling satellites being approximately the same as those travelling south, this reduces the effect of systematic along-track error manifested as latitude error in the receiver co-ordinates. Similarly, the numbers of satellites passing east and west of the receiver should be about equal - this reduces cross-track or longitude errors.

3.7.2 TRANSLOCATION

If two receivers are measuring the Doppler count of the same satellite at the same time then, depending on their separation, the errors in the satellite's position will have similar effects on the computed co-ordinates of both receivers.

Translocation is a method of relative positioning which uses this principle; in a strict translocation, Doppler counts recorded at only one receiver are discarded.

In figure 4.3 (on page 85), using strict translocation only the Doppler counts recorded between t_{n1} and t_{s2} are used

$$N_{1jk} = (t_k - t_j) \delta f_1 - f_o/c(r_{1k} - r_{2j}) \dots\dots\dots 3.25$$

$$N_{2jk} = (t_k - t_j) \delta f_2 - f_o/c(r_{2k} - r_{2j}) \dots\dots\dots 3.26$$

This system of equations is solved for X1, Y1, Z1, X2, Y2, Z2. Naturally, if points 1

and 2 are close together then X1, X2, etc will be strongly correlated, that is errors in the satellite's position will cause the same errors in both receiver positions. Alternatively, one receiver position may be treated as known and the other as unknown. Like ephemeris errors, ionospheric refraction errors will have similar effects on both receivers. The tropospheric correction, which depends on the local weather at each receiver, may be quite different at either end of a 300 km line. Translocation is strictly a relative positioning technique.

3.7.3 MULTI-STATION POSITIONING

The third positioning technique is a combination of the first two. In multi-station (or short-arc) positioning, all recorded Doppler counts may be used for the absolute positioning of the network while those Doppler counts recorded simultaneously from the same satellites at different receivers may be used for the relative positioning of points within the network. In principle any number of points may be incorporated in such a net but in practice this is limited by computer storage and the number of available receivers.

In multi-station positioning, as in single point positioning, the ephemeris orbit is biased and the six orbital parameters are solved for together with the co-ordinates of the ground stations. In semi short-arc positioning the orbit is only given three biases, the shape of the ephemeris orbit is maintained but it is allowed to shift in space [Brown D.C. 1976(1)].

In figure 4.3 (page 85) all Doppler counts recorded between t_{s1} and t_{n2} would be used in the multi-station mode, that is rigorous simultaneity of observations is not essential.

3.8 LINEARISATION OF THE DOPPLER EQUATION

Equation 3.9 is a relationship between the required cartesian co-ordinates of the receiver (X, Y & Z) and the observed Doppler count N. If there were no redundant observations in this system of equations, that is, if there were as many Doppler counts as unknowns then, the equation would have a unique solution and be trivial to solve. In practice there

are many more Doppler counts than unknowns and a least squares solution is indicated. In order to apply the theory of least squares, equation 3.9 must first be linearised.

$$N_{jk} = \delta f \cdot \delta t_{jk} + \frac{f_0}{c} \cdot \delta r_{jk} \dots\dots\dots 3.9$$

rearranging :

$$\delta r_{jk} = \frac{c}{f_0} \cdot [N_{jk} - (f_0 - f_s)(t_k - t_j)] \dots\dots\dots 3.29$$

where the observed integrated Doppler count N has been corrected for tropospheric and ionospheric refraction according to equations 3.16 and 3.23. The subscripts j and k represent successive satellite positions; using subscript i to denote the receiver position then

$$r_{ik} = \sqrt{[(X_k - X_i)^2 + (Y_k - Y_i)^2 + (Z_k - Z_i)^2]}$$

$$r_{ij} = \sqrt{[(X_j - X_i)^2 + (Y_j - Y_i)^2 + (Z_j - Z_i)^2]} \dots\dots\dots 3.30$$

Equation 3.30 is linearised by differentiating:

$$dr = \frac{X_k - X}{r_k} dX + \frac{Y_k - Y}{r_k} dY + \frac{Z_k - Z}{r_k} dZ$$

After substituting approximate values (X₀) for the unknown co-ordinates (X,Y,Z) and frequency offset (f₀), equations 3.29 are solved for X_i, Y_i, Z_i and f₀ by least squares.

3.9 THE LEAST SQUARES ADJUSTMENT

Before adjusting an over-observed set of equations there must be a known mathematical relationship between the parameters x and the observations l. For example:

$$f(x, l) = 0$$

in order to use the Least Squares Theory these equations must be linearised. This is done by

selecting approximate values of x :

$$x = x_0 + \Delta x$$

and then using a Taylor series expression to the first derivatives [Cross P.A. 1983].

$$\begin{aligned}
F(x, l) &= 0 \\
F(x_0 + \Delta x, l + \Delta l) &= 0 \\
F(x, l) &= F(x_0, l_0) + \frac{\delta F}{\delta x} \Delta x + \frac{\delta F}{\delta l} \Delta l = 0
\end{aligned}$$

the above equation holds for each observation.

The general linearised observation equation may then be written in the matrix form:

$$Ax + Bv + L = 0 \quad (n \geq m) \quad \dots\dots\dots 3.31$$

where x is an m -ordered vector comprising the corrections to the approximate values of the m unknowns to give their most probable values using the least squares criterion.

A is the design matrix of order m by n comprising the partial derivatives of the observed quantities with respect to the unknowns.

$$A = \frac{\delta F}{\delta x} \quad , \text{ evaluated at } x_0 \quad \dots\dots\dots 3.32$$

v is the n -ordered residual vector and L the n -ordered misclosure vector computed from the provisional values of the unknowns.

B is an n by n matrix comprising the partial derivatives of the observed quantities with respect to the misclosures (known as the design matrix of conditions). In the case of equation 2.28 this is simply a constant c/f_0 .

$$B = I$$

If no conditions are applicable we are dealing with the parametric adjustment represented by:

$$Ax + L + v = 0 \dots\dots\dots 3.33$$

The quantity to be minimised (by the least squares criterion) is

$$\Phi = \sum_{i=1}^n p_i v_i^2 (= v^t P v)$$

where p_i denotes a weight assigned to observation i whose residual is v_i .

For uncorrelated observations the weight matrix P is an n by n diagonal matrix, each diagonal term corresponding to the weight of that observation.

$$\begin{aligned} v &= Ax - L \\ \Phi &= (Ax - L)^t P (Ax - L) \dots\dots\dots 3.34 \\ &= (x^t A^t - L^t) P (Ax - L) \\ &= x^t A^t P Ax - L^t P Ax - x^t A^t P L + L^t P L \end{aligned}$$

These are all scalar quantities and are thus unaffected by transposition.

$$d\Phi = dx^t A^t P Ax + dx^t (A^t P A)^t - dx^t A^t P^t L - dx^t A^t P^t L$$

P is symmetrical thus $P = P^t$

$$\text{thus } d\Phi = 2dx^t (A^t P Ax - A^t P L) \dots\dots\dots 3.35$$

for this to be zero

$$A^T P A x = A^T P L \quad \dots\dots\dots 3.36$$

or $x = (A^T P A)^{-1} A^T P L \quad \dots\dots\dots 3.37$

This is the well known fundamental equation of the least squares parametric adjustment, eg [Wells D.E. & Krakiwsky E.J. 1971].

3.9.1 THE SEQUENTIAL ADJUSTMENT

For some applications it is useful to be able to determine the solution vector x as in equation 3.37 and then to re-evaluate x after adding one further observation. In this way the solution vector is continually updated as observations are added. This type of processing is particularly useful in real-time applications.

The derivation of this adjustment is as follows:

$$v = Ax - L \text{ with weight matrix } P \quad \dots\dots\dots 3.33$$

to which is added a further set of observations giving a new solution vector x_2 . x_1 and x_2 have the same dimensions as x .

$$\begin{bmatrix} v_1 \\ v_2 \end{bmatrix} = \begin{bmatrix} A_1 \\ A_2 \end{bmatrix} x_2 - \begin{bmatrix} L_1 \\ L_2 \end{bmatrix} \text{ with weight } \begin{bmatrix} P_1 & O \\ O & P_2 \end{bmatrix}$$

$\dots\dots\dots 3.38$

using the abbreviations $N = (A^T P A)$

and $U = A^T P L \quad \dots\dots\dots 3.39$

3.38 is expanded and making the substitution $x_1 = N_1^{-1}U_1$ leads to the result:

$$x_2 = x_1 - N_1^{-1}A_2^t(P_2^{-1} + A_2 N_1^{-1}A_2^t)^{-1}(A_2x_1 - L_2) \dots\dots\dots 3.40$$

The full derivation is given in [Cross P.A.1983 pp 109-114]. This result is the parametric form of the sequential least squares adjustment.

In 3.40, we already have N_1^{-1} from the previous cycle thus the only inversion needed is that of a matrix of dimension equal to the number of new observations. If this number is small compared to the total number of parameters (unknowns) then there will generally be a considerable saving in processing time [Cross P.A. 1983]. The above form assumes that the new observations do not contain any new parameters. In the case of the Doppler equation this is not the case as each new pass introduces new orbital, refraction and frequency unknowns, thus another form of least squares processing is required.

3.9.2 PHASE ADJUSTMENT

The phase adjustment is a means of separating the unknowns of a combined adjustment into two groups and then solving for the unknowns in only one of those groups. Remarkably, this technique was developed by Helmert in 1880, long before the invention of the electronic computer. The purpose of the Phase Adjustment, an example of which is Helmert Blocking, is to break down a large unmanageable system of equations into several smaller systems with the obvious proviso that the solution be the same as that given by a single simultaneous solution. Helmert proposed this method for the least squares adjustment of large horizontal networks. The geodetic network was divided into blocks, the unknowns in each block being local (connected only to points in that block) or global (connected to points in adjoining blocks) [Cross, P.A., 1983].

Denoting the global variables by y and the local variables in block i by x_i , the linearised observation equations are:

$$A_i x_i + B_i y = L_i + v_i \quad \dots\dots\dots 3.41$$

the least squares requirement is that:

$v^t P v$ - is a minimum

i.e. minimise

$$\sum_{i=1}^n v_i^t P_i v_i$$

$$\sum_{i=1}^n (A_i x_i + B_i y - L_i)^t P_i (A_i x_i + B_i y - L_i) \quad \text{to be a minimum}$$

expanding the above and equating the derivatives with respect to x and y to zero leads to the result:

$$(\sum N) y = \sum d \quad \dots\dots\dots 3.42$$

where

$$N_i = [B^t P B - B^t P A (A^t P A)^{-1} A^t P B]_i \quad \dots\dots\dots 3.43$$

and

$$d_i = [B^t P L - B^t P A (A^t P A)^{-1} A^t P L]_i \quad \dots\dots\dots 3.44$$

[Cross, P.A., 1983].

While this phased, or blocking procedure was originally designed for the solution of large classical geodetic networks (the North American readjustment NAD-83 involved 5 levels of Helmert blocking), in principle, this procedure may be used for any least squares adjustment which could in theory be carried out as a single parametric adjustment. It is

particularly suitable for Doppler processing where the required co-ordinate unknowns are treated as global parameters and the orbital and refraction unknowns, which vary from pass to pass are treated as local parameters [Cross, P.A., 1983].

3.9.3 THE LEAST SQUARES SOLUTION OF THE DOPPLER EQUATION

In the simplest case of point positioning with known satellite co-ordinates, the unknowns are the 3 co-ordinates of the receiver and a frequency offset for each pass observed [Krakiwsky and Wells 1971].

$$\begin{aligned} \text{No. of unknowns} &= 3 + \text{No. of Passes} && \text{(NU)} \\ \text{No. observations} &= \text{No. of Doppler measurements} && \text{(ND)} \end{aligned}$$

Thus in this case the matrices in equation 3.31 have the following dimensions:

$$\begin{aligned} \mathbf{A} &= \text{ND} * \text{NU} \\ \mathbf{x} &= \text{NU} * 1 \\ \mathbf{B} &= 1 * 1 \text{ (scalar)} \\ \mathbf{v} &= \text{ND} * 1 \\ \mathbf{L} &= \text{ND} * 1 \end{aligned}$$

And the matrix equation to be solved by least squares is:

$$\mathbf{A} \mathbf{x} - \frac{c}{f_0} \mathbf{v} + \mathbf{L} = \mathbf{0}$$

The j^{th} row of \mathbf{A} will then be of the form:

$$\frac{X_j - X_k}{r_j} - \frac{X_k - X_k}{r_k}, \frac{Y_j - Y_k}{r_j} - \frac{Y_k - Y_k}{r_k}, \frac{Z_j - Z_k}{r_j} - \frac{Z_k - Z_k}{r_k}, \frac{c \Delta t}{f_0}$$

The \mathbf{A} (design) matrix will then have the following form:

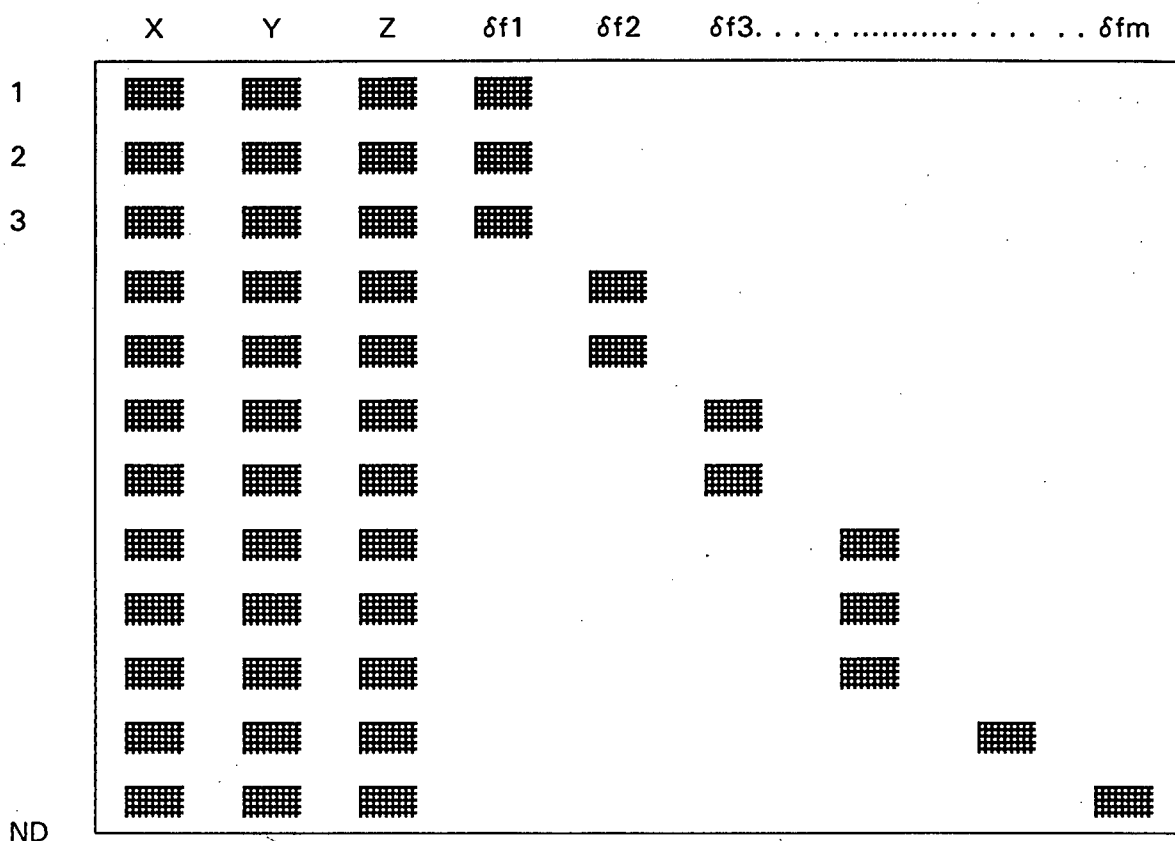

fig 3.2

Distribution of non-zero terms in the Doppler equation design matrix where the symbol denotes a non-zero term of the matrix (In the above example the passes have differing numbers of observed Doppler counts, the last two having only one each). In practice the number of recorded Doppler counts per pass is approximately 10 - 100.

The L terms (as in equation 3.37) are given by the difference between the recorded Doppler counts (corrected for refraction) and what the Doppler count should be using the ephemeris orbit and provisional ground co-ordinates.

3.10 DOPPLER PROCESSING SOFTWARE

There are several commercially available Doppler processing packages the best known of which are MAGNET (from the Magnavox Corporation) and GEODOP. In this study we are concerned with the latter.

3.10.1 GEODOP

GEODOP is a Doppler processing program suite developed by the Canadian Department of Energy and Mines under the leadership of Jan Kouba. This program is freely available to users worldwide and has been used for the processing of all Doppler data recorded in the Geodetic Survey of South Africa. [Kouba J. 1983].

Some features of GEODOP V (the most recent version) are:

- * It can be used in the three different positioning modes.
- * The program works in conjunction with either the recorded broadcast ephemeris or an externally provided (ie Precise) ephemeris.
- * The program offers a choice of tropospheric refraction models together with high order ionospheric corrections.
- * Up to six Keplerian orbital biases are catered for together with four station biases (frequency offset, frequency drift, time correction and tropospheric refraction correction).
- * The input data may include an estimated *a priori* co-variance matrix for all the unknown co-ordinates. If nothing is known beforehand about the co-ordinates of the unknown points then this matrix will comprise large diagonal terms (corresponding to the variances of the unknown co-ordinates) and zero off-diagonal terms.

The linearised observation equations for solving the doppler equation take the following form :

$$A_i x_i + B_i y = L_i + v_i \quad \dots\dots\dots 3.41$$

where the unknowns have been divided into two vectors, the x vector comprising the co-ordinate unknowns and the y vector the orbital and receiver unknowns [Husti G.J. 1985].

$$\mathbf{x}^t = (X, Y, Z)$$

$$\mathbf{y}^t = (da, adM, adi, ad\Omega, ade, ad\omega, df, dt, dk, \dot{df})$$

The orbital unknowns M , Ω , ω , e and i are all multiplied by a to give all the unknowns the same order of magnitude - this retains numerical stability and improves the accuracy of the solution. The receiver unknowns are:

df = frequency offset

\dot{df} = frequency drift

dt = time correction

dk = tropospheric correction

The only complete unknown in the \mathbf{y} vector is the frequency offset, the remaining parameters being biased [Kouba J. 1983].

GEODOP uses a rigorous phased adjustment technique as described in section 3.9.2 to sequentially process Doppler data pass by pass [Adams et al 1982]. The output of GEODOP comprises the geocentric cartesian co-ordinates (in the CTS) of the receiver antennae together with their variance/co-variance matrix. This covariance matrix, however, is misleading. From this matrix can be deduced the standard deviations of the receiver co-ordinates in the CTS and, in the case of multi-station positioning, the standard deviations of the relative positions of points in the multi-station network. Using GEODOP, the diagonal terms of this co-variance matrix are optimistically small (giving a false accuracy of the point co-ordinates). The reasons for this incorrect matrix are not clear. However, Jan Kouba himself (the principal author of GEODOP) suggests augmenting the covariance matrix by the addition of a constant to all diagonal terms when using the broadcast ephemeris [Kouba J. 1978] (see sections 4.1 to 4.4).

The output of GEODOP has been used in the present study.

3.11 THE SOUTH AFRICAN DOPPLER SURVEY

In 1979 the South African Trigonometrical Survey Office acquired three JMR-1A Doppler satellite receivers. These were to be used to establish a grid of 'zero-order' control points into which lower order existing geodetic observations, namely angles, distances and azimuths, would be incorporated.

3.11.1 NETWORK DESIGN

A network comprising approximately equilateral triangles of 300 km sides was chosen to form the basic control figure; thirty four points being required to cover the whole of South and South West Africa. There was initially some discussion about the optimum spacing of the Doppler control points; the expected accuracy of the conventional geodetic survey which the Doppler method was to control was estimated to be some 3 ppm or approximately one part in 300 000. By making the Doppler points too close to one another the conventional survey could actually be distorted; the accuracy of Doppler translocation was assumed to be of the order of 50-70 cm - [Brown D.C. 1976(2)]. The figure of 300 km was chosen so that the Doppler survey would control the scale and orientation of the network but at the same time distortion put into the net by the Doppler survey would be less than the internal accuracy of the conventional network itself. In retrospect, by appropriate weighting of the Doppler control (rather than holding all Doppler points fixed in the horizontal network adjustment) a closer spacing would not have distorted the net and the benefits would probably have outweighed the extra field work required.

3.11.2 DOPPLER OBSERVING PROCEDURE

Initially the observing procedure was to record some fifty satellite passes using the broadcast ephemeris with a receiver at each vertex of one triangle - this taking about four days. One receiver was then moved so that another triangle could be observed. This procedure was modified when a further two receivers were acquired. The recorded data was processed using GEODOP in the multi-station mode.

3.11.3 GEODOP OPTIONS USED

The GEODOP options and constraints used in the Doppler survey of South Africa are as follows:

- * Black's tropospheric refraction model with bending.
- * All 6 orbital constraints given a bias of 10 metres. This is not strictly correct as the along track component of the B.E. is considerably more accurate than the radial component.(Section 3.3.1).
- * Minimum satellite elevation = 7.5 degrees. If maximum elevation < 10 degrees then entire pass rejected.
- * Number of biases per station = 4.
- * Maximum Doppler count periods/pass = 32.
- * Maximum Doppler count periods from all satellites = 50.
- * Number of active stations recording a particular Doppler count at least 3.

The result was a series of 3-station networks with the 9 cartesian co-ordinates and corresponding (9 by 9) co-variance matrix for each net. In 1982 a further two JMR receivers were acquired which enabled five points to be occupied simultaneously. This reduced the total observing time and meant there could be more overlap between individual nets. Two further points were also added to the network, the first near to Hartebeeshoek (the South African VLBI station) in order that at a later stage the whole network could be positioned more accurately in relation to the centre of the earth and the second near to Cape Town was used for receiver testing. Thus giving a total of thirty six Doppler stations in all.

3.12 THE AFRICAN DOPPLER SURVEY (ADOS)

The idea of a Doppler survey spanning the African continent was first proposed at the International Association of Geodesy (IAG) meeting in 1981. The objects of ADOS were [Mueller I.I. 1982]:

- "1 to provide 'zero-order' control for future African geodetic networks which could support mapping.
- 2 to provide control for African datum unification and strengthening.

- 3 to provide an improved geoid for Africa.
- 4 to provide coastal calibration points for GEOS C altimetry."

Altogether the ADOS project comprised some 300 Doppler control points throughout Africa, many of which coincide with conventional triangulation stations of previous geodetic surveys. Six of these points are in South Africa and one in South West Africa/Namibia. All recorded data has been processed using single point positioning in conjunction with the precise ephemeris. Co-ordinates of the South African ADOS points have been computed both by the DMA in Washington DC using DOPL 79 software and locally using GEODOP V. The two sets of results differ, the mean difference in position being about 1 metre. The reasons for the different co-ordinates derived from the different Doppler processing programs are not clear but are probably due to the satellite's orbit being fixed by DOPL 79 and being relaxed (biased) by GEODOP V [Knopp T. 1987]. The differences between the two sets of co-ordinates do not appear to be systematic and cannot easily be modeled. The DOPL 79 co-ordinates will not be considered further. The state of the South African Doppler survey is thus 36 points more or less evenly distributed over the sub-continent - seven of these points being co-ordinated by point positioning using the P.E. and the remainder connected to one another and the seven P.E. points through three to five point multistation (short arc) nets using the B.E. The South African Doppler network is illustrated in figure 3.3.

3.13 EXISTING NATIONAL DOPPLER NETWORKS

Most national horizontal network readjustments elsewhere which have incorporated Doppler have relied on single point positioning using the P.E. One such readjustment is NAD'83 (North American Datum 1983) - the biggest ever single control network adjusted as one. NAD'83 covers the whole of North America and many surrounding islands including Hawaii [Kaula W.M. 1986]. Altogether the adjustment includes 267000 points, 1250 of which are 'Doppler points'. The Doppler observations were not processed simultaneously with the conventional observations but were first co-ordinated (using point positioning) and then in the subsequent adjustment these points were constrained according to their variances (in latitude and longitude) determined from the Doppler processing. A similar approach has been taken by

[Henry W.M. & Walker J.W. 1974] and [McClelland C.D. 1974] where all Doppler positioning has been by single point methods in conjunction with the P.E. For relative positioning (short arc and translocation methods) the P.E. has no advantage over the B.E. - even for distances as great as 2000km [Kouba J. and Wells D.E. 1976] [Brown D.C. 1976(1)] has shown relative positioning using the B.E. to be superior in accuracy to absolute point positioning at distances in excess of 300 km. That is, short arc methods using the B.E. are able to give the co-ordinates of a point relative to another point 300 km away more accurately than point positioning using the P.E. can co-ordinate that point relative to the centre of the earth.

In the light of this last point it is surprising that relative positioning short arc methods have not been used more in national Doppler nets. An exception is the Doppler survey of Indonesia described by [Adams J.R. et al 1982]. The Indonesian Doppler network was adjusted first using GEODOP and then using condition equations to combine the GEODOP subnets. Altogether this network comprises 238 stations and 90 constraints.

The first objective of the present study is to unify the observations from the South African Doppler survey into a single network and thence to derive, as accurately as possible, a set of co-ordinates for all 36 points expressed in the same Geocentric reference frame.

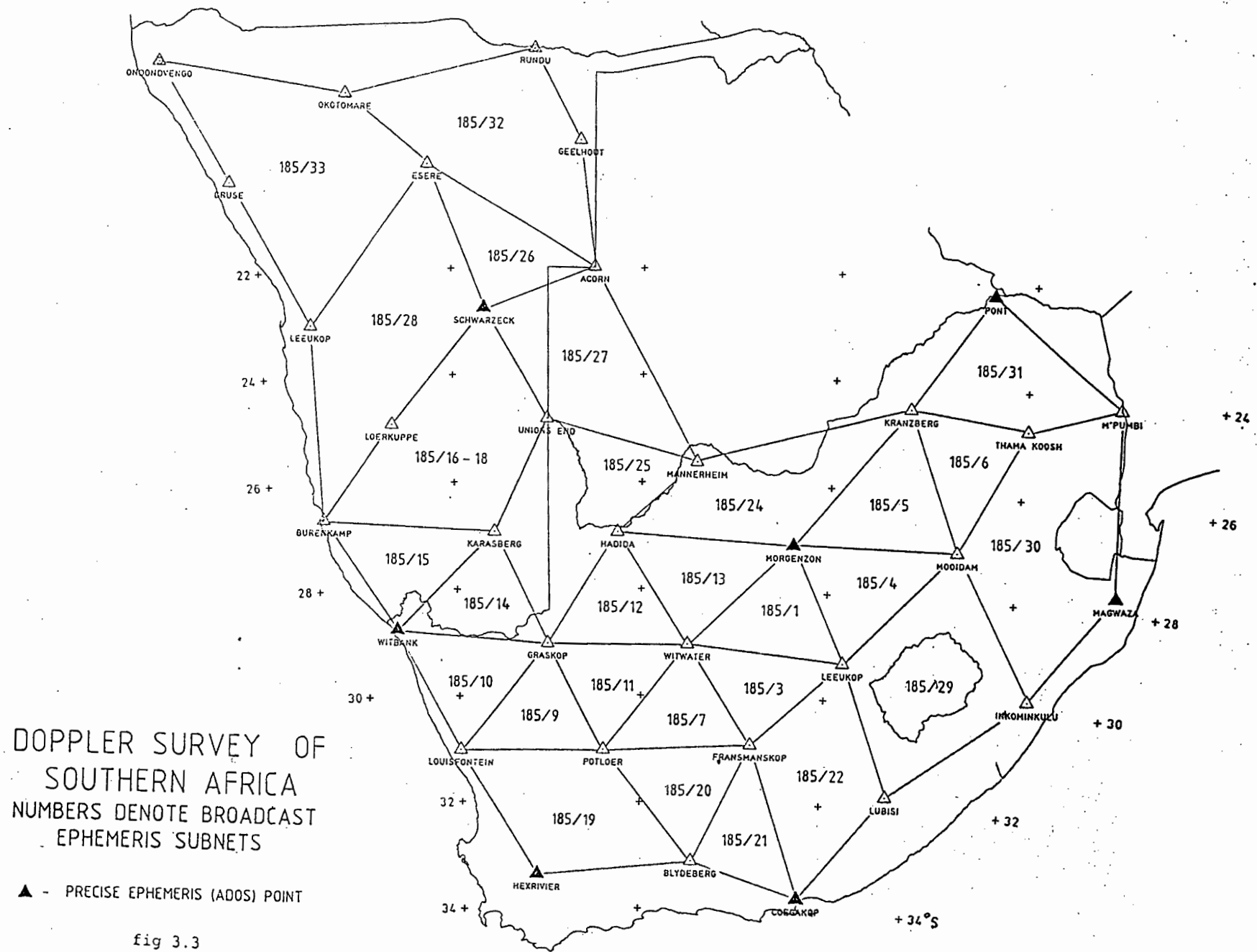

DOPPLER SURVEY OF
SOUTHERN AFRICA
NUMBERS DENOTE BROADCAST
EPHEMERIS SUBNETS

▲ - PRECISE EPHEMERIS (ADOS) POINT

fig 3.3

THE DEVELOPMENT OF A UNIFIED DOPPLER NETWORK

4.1 THE RIGOROUS APPROACH

The co-ordinates derived by combining the various B.E. subnets should, according to the least squares axiom, be the same as would have been derived by processing all the Doppler data in one simultaneous least squares adjustment. Unfortunately, computer memory limitations prevent such an adjustment - GEODOP allows a maximum of 15 points to be processed simultaneously. Furthermore, GEODOP assumes that each point is occupied by the same receiver (with the same frequency offset) for the whole period.

The unknowns in a given short arc subnet are the cartesian co-ordinates of the ground stations, the frequency offsets of the receivers and the parameters describing each satellite orbit. The only unknowns common to different subnets are the ground station co-ordinates. Given the values of these co-ordinates together with their co-variances it is thus possible to combine these subnets using a sequential blocking procedure.

In this procedure the output of the first adjustment (in this case GEODOP) is treated as the 'observations' for the following adjustment. Because these quantities - the geocentric co-ordinates of the unknown stations - are correlated through the previous adjustment, the quantity to be minimised is:

$$\Phi = v^T P v \quad \dots\dots\dots 4.1$$

where the weight matrix P is the inverse of the covariance matrix Q

$$P = Q^{-1} \quad \dots\dots\dots 4.2$$

In this case the vector v comprises the difference between the 'observed' GEODOP

co-ordinates (**L**) and the final co- ordinates (**x**).

$$\mathbf{v} = \mathbf{x} - \mathbf{L} \dots\dots\dots 4.3$$

$$\Phi = \Sigma (\mathbf{L} - \mathbf{x})^t \mathbf{P} (\mathbf{L} - \mathbf{x}) \text{ to be minimised} \dots\dots\dots 4.4$$

$$\begin{aligned} &= \mathbf{x}^t \mathbf{P}_1 \mathbf{x} - \mathbf{x}^t \mathbf{P}_1 \mathbf{L}_1 - \mathbf{L}_1^t \mathbf{P}_1 \mathbf{x} + \mathbf{L}_1^t \mathbf{P}_1 \mathbf{L}_1 \\ &+ \mathbf{x}^t \mathbf{P}_2 \mathbf{x} - \mathbf{x}^t \mathbf{P}_2 \mathbf{L}_2 - \mathbf{L}_2^t \mathbf{P}_2 \mathbf{x} + \mathbf{L}_2^t \mathbf{P}_2 \mathbf{L}_2 \\ &\dots\dots\dots \\ &+ \mathbf{x}^t \mathbf{P}_n \mathbf{x} - \mathbf{x}^t \mathbf{P}_n \mathbf{L}_n - \mathbf{L}_n^t \mathbf{P}_n \mathbf{x} + \mathbf{L}_n^t \mathbf{P}_n \mathbf{L}_n \\ &= \mathbf{x}^t \Sigma \mathbf{P} \mathbf{x} - \mathbf{x}^t \Sigma (\mathbf{P} \mathbf{L}) - \Sigma (\mathbf{L}^t \mathbf{P}) \mathbf{x} + \Sigma (\mathbf{L}^t \mathbf{P} \mathbf{L}) \dots\dots\dots 4.5 \end{aligned}$$

$$\frac{\delta \Phi}{\delta \mathbf{x}} = 2 \Sigma \mathbf{P} \mathbf{x} - 2 \Sigma (\mathbf{P} \mathbf{L}) \dots\dots\dots 4.6$$

thus to minimise Φ , $\Sigma \mathbf{P} \mathbf{x} - \Sigma (\mathbf{P} \mathbf{L}) = 0$

$$\mathbf{x} = (\Sigma \mathbf{P})^{-1} \Sigma (\mathbf{P} \mathbf{L}) \dots\dots\dots 4.7$$

The same result (equation 4.7) is obtained from the phase adjustment (equation 3.42 in section 3.9.2) by ignoring the local variables **x**. All the terms in equations 3.43 and 3.44 containing **A** vanish and the result is the same as 4.7. The weight matrix (**P**) thus constructed will be formed by a series of overlapping squares of non-zero terms symmetrical about the principal diagonal.

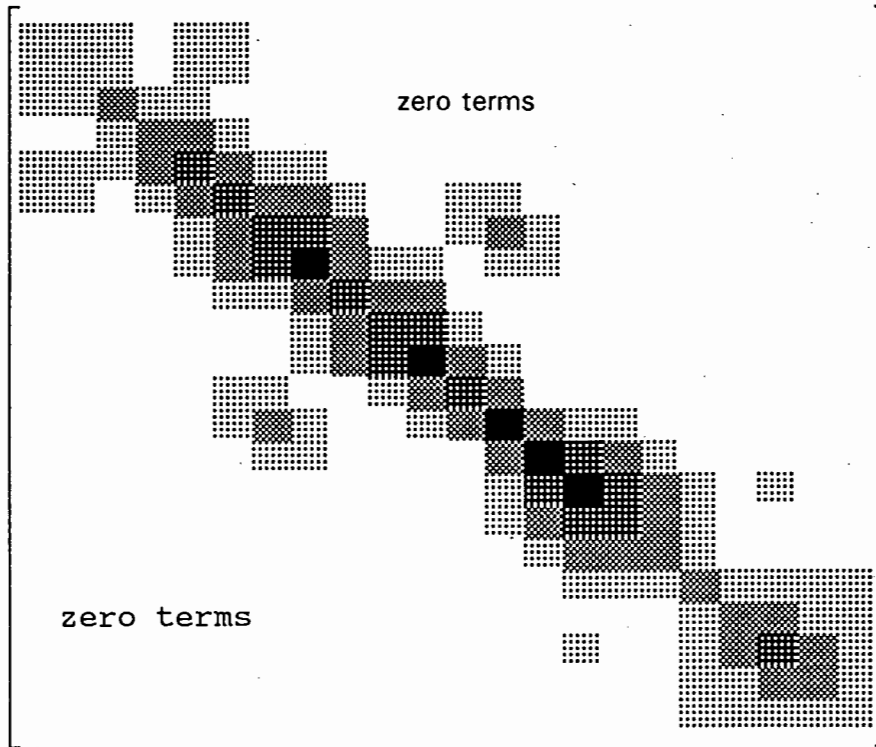

fig 4.1

The distribution of non-zero terms in the accumulated weight matrix.

The distribution of these terms is illustrated in figure 4.1.

4.2.1 SOME STATISTICAL CONSIDERATIONS

The Σ_{xx} matrix output by GEODOP is a measure of the accuracies (and relative accuracies) of the geocentric co-ordinates of the Doppler receivers. The elements of this matrix have the dimensions of metres².

When inverted Σ_{xx} becomes the weight matrix **P** for that particular subnet. The elements of **P** have dimensions metres⁻².

After the adjustment we can compute the accuracies of the subnets from their residuals in the overall network. By comparing the *a priori* weight matrix with its post adjustment counterpart we can determine whether the initial weighting was in fact valid. The first

step in this test is to compute the sum of the weighted squares of the residuals [pvv] or in the case where observations are correlated $v^t P v$. The variance factor is then computed:

$$\hat{\sigma}_0^2 = \frac{v^t P v}{n-u}$$

.....4.8
[Wells & Krakiwsky 1971]

where n = total number of observations
u = total number of unknowns
and n-u = the number of degrees of freedom.

$\hat{\sigma}_0^2$ is the *a posteriori* variance of an observation with a priori unit weight. If the weighting function is correct then σ_0^2 should be 1. Any significant departure from unity indicates an incorrect a priori weighting. Clearly an objective way of defining 'significant' is required.

4.2.2 HYPOTHESIS TESTING

In order to compare results from different adjustments some objective comparison test is required. We begin by making an assumption (the Null Hypothesis) concerning the distribution of the unknown parameters, and then determine whether in fact this assumption was valid. In applying such tests we cannot be certain that we have arrived at the correct outcome, we can merely state the probability that it is correct, thus the significance level (α) of the test needs to be given. In the case of the Doppler network using the output of GEODOP the null hypothesis will be that the errors in the given co-ordinates are normally distributed according to the accompanying co-variance matrix. In order to substantiate the validity of this hypothesis we use the Chi-squared test.

4.2.3 THE CHI-SQUARED DISTRIBUTION TEST

The Chi squared test may be used to give the allowable departure from unity of the

variance factor σ_0^2 . This quantity is a function of the confidence level and the number of degrees of freedom. When applying the chi-squared test it is usual to consult tables giving appropriate chi-squared values for varying confidence levels and degrees of freedom. The chi-squared and normal distributions have convenient numerical approximations. [Johnson N.I. and Kotz S. 1970] gives the following as an approximation to the normal distribution curve:

$$U_\alpha = t - (C_0 + C_1t + C_2t^2) / (1 + D_1t + D_2t^2 + D_3t^3) \dots\dots\dots 3.9$$

where for 95 % confidence $t = \text{Ln} (1/(0.025))$

and

$C_0 = 2.515517$	$D_1 = 1.432788$
$C_1 = 0.802853$	$D_2 = 0.189269$
$C_3 = 0.010328$	$D_3 = 0.001308$

[Milford K.S. 1983] approximates the χ^2 distribution as follows:

$$\chi^2_{C_{df}} = df[1 - (2/9df) \pm U_\alpha (1 / \{9df\})]^3 \dots\dots\dots 4.10$$

This function has been programmed (see appendix B pg 64)

The \pm give the upper and lower χ^2 values. This formula is correct to within 2% for all reasonable confidence limits provided the number of degrees of freedom (df) is greater than 7 [Milford K.S.1983]. In this study we shall confine ourselves to the 95 % confidence limit.

For the distribution to be appropriate for the given sample its variance factor should satisfy the following inequality:

$s_0^2 df < \sigma_0^2$	$< s_0^2 dt$
$\chi^2 \text{ upp}$	$\chi^2 \text{ lower}$

\dots\dots\dots 4.11

eg. [Rüther H 1981]

4.3 RESULTS OF THE RIGOROUS APPROACH

Combining the Doppler subnets as outlined in 4.1 gives the results as shown in appendix A (pages A8 - A12). The variance factor of this adjustment is 4.05 which is clearly very high. In this case there are 204 degrees of freedom and at the 95% confidence level the a posteriori variance factor should satisfy the inequality:

$$0.83 < \sigma_0 < 1.23$$

The adjustment fails the chi-squared test; the co-variance matrices of GEODOP show the subnets to be optimistically accurate.

It should be pointed out at this stage that combining the Doppler subnets (computed using the B.E.) with the ADOS points (computed from the P.E.) directly is not correct as the two ephemerides are based on different reference systems. That is, in the absence of any observational errors, the two sets of data would not quite 'fit together'. However, combining the subnets alone (only B.E.) in this manner still gives a variance factor of 3.95 Appendix A (pages A13-A16). The programs listing for the subnet combination using the entire covariance matrix for each subnet is listed in appendix B (pages B3 - B7). An alternative evaluation of the GEODOP covariance matrix follows in the next section.

4.4 FURTHER EVALUATION OF THE GEODOP CO-VARIANCE MATRIX

The chord distance between two receivers i and j is given by:

$$S = \sqrt{\{(X_i - X_j)^2 + (Y_i - Y_j)^2 + (Z_i - Z_j)^2\}} \dots\dots\dots 4.12$$

Given the co-variance matrix of (X Y Z)_i and (X Y Z)_j we require the variance of S. This is computed from the Co-variance Law eg. [Wells D.E. and Krakiwsky J. 1971].

$$\Sigma_{yy} = C \Sigma_{xx} C^t \dots\dots\dots 4.13$$

where y is a function (F) of x and the matrix C is formed by the partial derivatives:

$$C = \frac{\delta F}{\delta x} \text{ evaluated at } x_0$$

or in our case $\sigma_{ss} = A^t Q_{xyz} A$,

..... 4.14

where Q_{xyz} is the co-variance matrix of the six co-ordinates and A^t is the 6 by 1 vector:

$$A^t = \left[\delta S / \delta X_i, \delta S / \delta X_j, \delta S / \delta Y_i, \delta S / \delta Y_j, \delta S / \delta Z_i, \delta S / \delta Z_j \right]$$

and $\delta S / \delta X_i = (X_i - X_j) / S$

$\delta S / \delta X_j = -(X_i - X_j) / S$ etc.

..... 4.15

This function has been programmed - see appendix B (pages B 61 - B 62) and the results in appendix A (pages A 8 - A 12). The following sketch (fig. 4.2) is an extract of these results:

4.4.1 DIRECT COMPARISON OF B.E. CO-ORDINATES

An alternative way of estimating the accuracy of the B.E. co-ordinates (but not their relative accuracy) is simply to compare them for the same points derived in the different subnets. This has been done in the program AVERAGE - program listing in appendix B (pages B 1-2) and results in appendix A (pages A 1-2). This program also gives the mean (weighted according to number of passes) co-ordinates for each point. As can be seen, the B.E. co-ordinates vary by as much as 16 metres - this is not intended as a viable solution to the network unification problem - however, these mean B.E. co-ordinates will be used subsequently in the free network adjustment (see section 4.9).

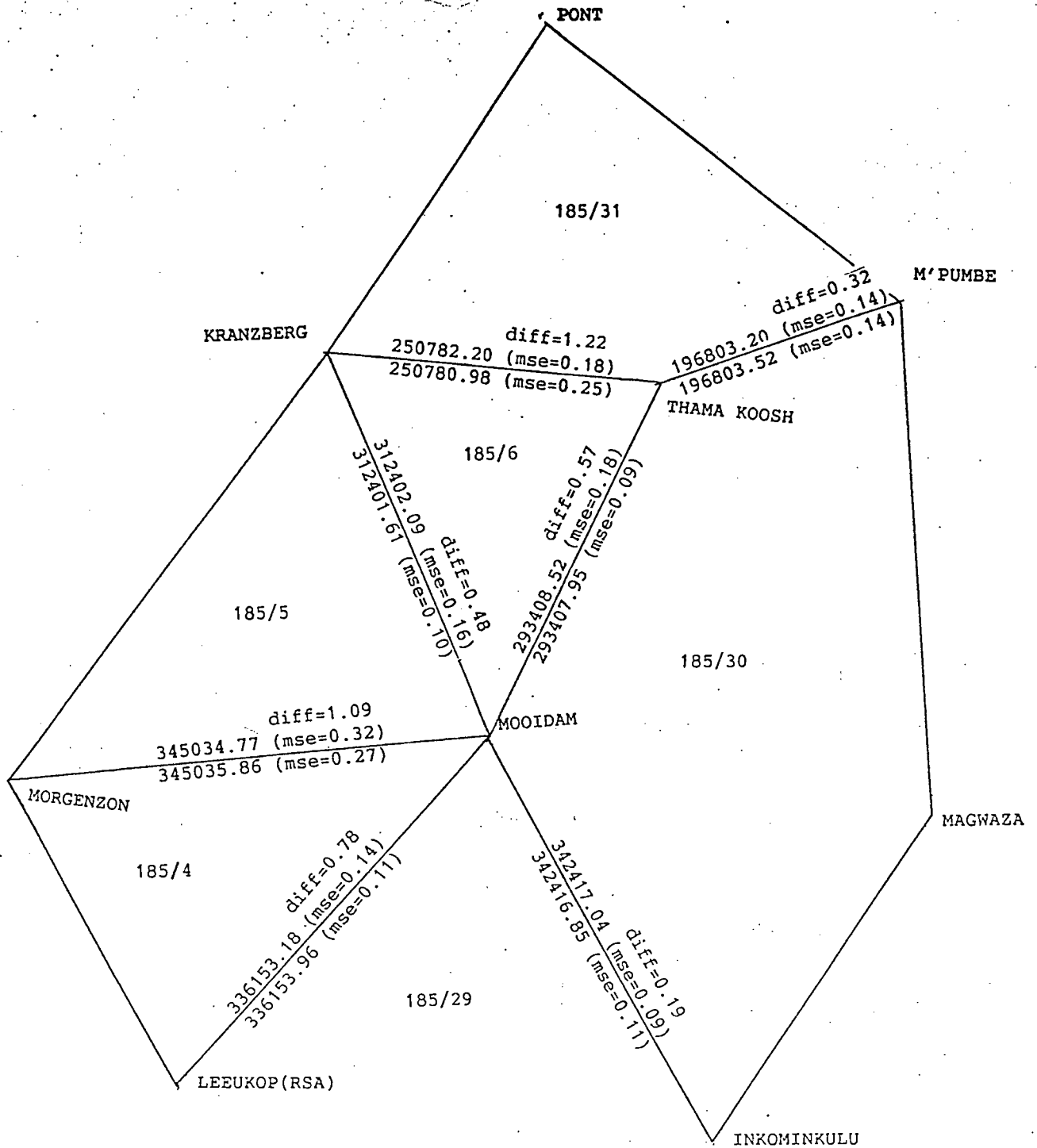

fig 4.2

An extract of some chord distances and their mean square errors computed from the GEODOP co-variance matrix

In most cases the difference between corresponding chord distances is 3 to 5 times more than either of the deduced mse's.

Having determined that the co-variance matrix output by GEODOP is incorrect, we are faced with two options, namely:

1. to modify or augment this matrix as recommended by [Kouba J. 1978] and to combine the Doppler subnets as above, that is 'sequential blocking'.
2. to reject this matrix in its entirety and to find an alternative function for combining the subnets. *The latter alternative has been explored in the following sections.*

4.5 SUBNET COMBINATION USING A SIMILARITY TRANSFORMATION

In this approach each short-arc subnet is allowed seven degrees of freedom - three shifts, three rotations and a scale factor.

In order to retain geometrical stability (prevent a rank defect) of the entire network, at least seven co-ordinates must be constrained in this approach. In fact the seven ADOS (P.E.) points have all been regarded as fixed (altogether 21 co-ordinates) and the subnets 'fitted onto' these points.

The theoretical justification for the seven degrees of freedom is dubious, however the following argument may dispel some doubt.

Consider a Doppler satellite passing over a Short-arc Subnet from south to north (see figure 4.3 on page 85).

The satellite first locks onto the southernmost groundpoint at time t_{s1} and loses contact with the northernmost point at time t_{n2} . t_s and t_n are the midpoints of the arcs recorded by P_s and P_n , these will correspond closely to the satellite's point of closest approach to these receivers. The distance travelled by the satellite between times t_s and t_n is S .

The actual satellite orbit differs from the broadcast orbit - assume that the displacement between actual and predicted positions at times t_s and t_n are δX_s and δX_n where:

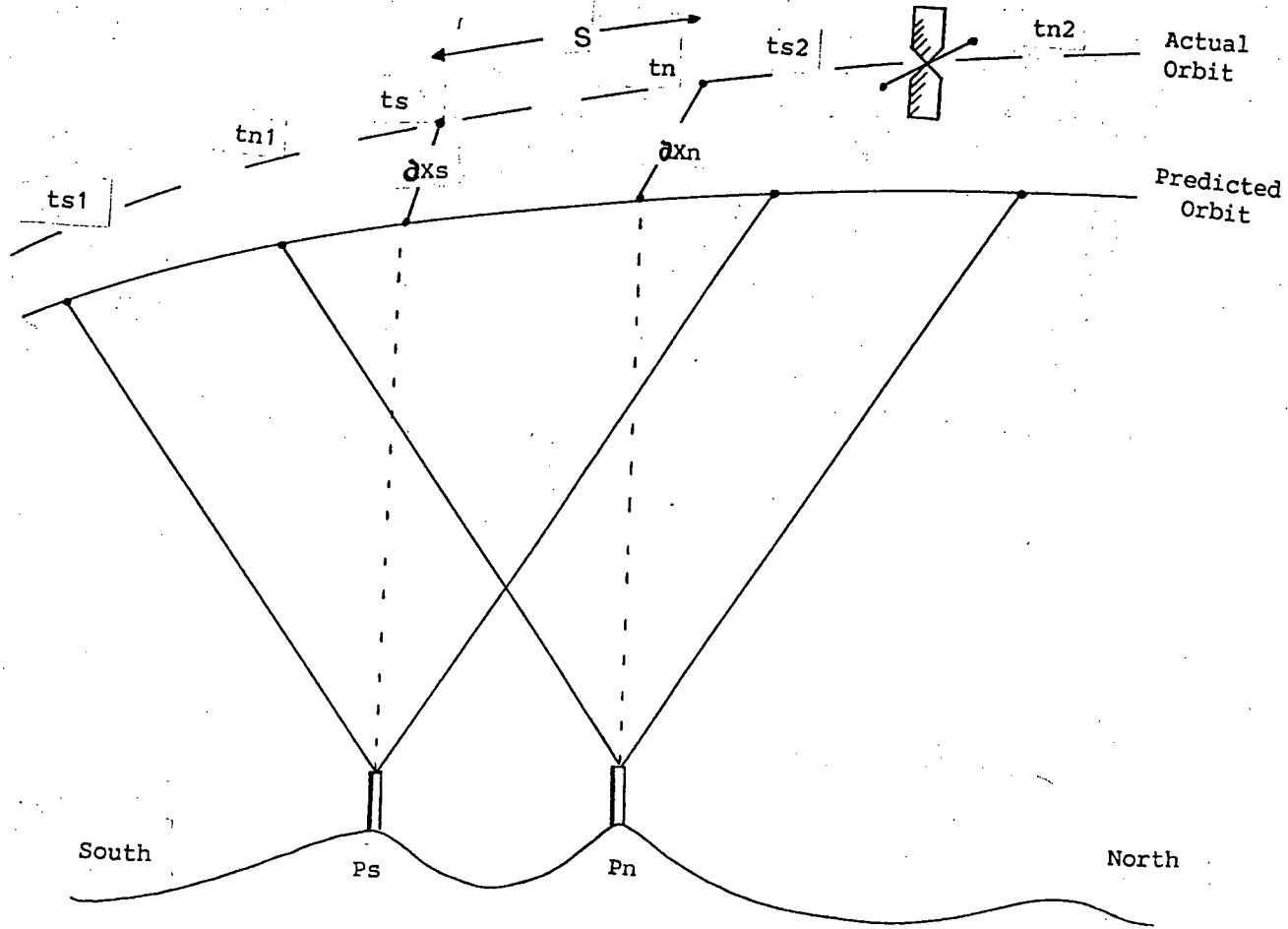

fig 4.3

An illustration of the effect of predicted and actual orbits not being parallel.

$$\delta X_s = \begin{bmatrix} X_p - X_a \\ Y_p - Y_a \\ Z_p - Z_a \end{bmatrix}_{t_s} \quad \text{and} \quad \delta X_n = \begin{bmatrix} X_p - X_a \\ Y_p - Y_a \\ Z_p - Z_a \end{bmatrix}_{t_n} \dots\dots\dots 4.16$$

And the difference between these two errors is given by:

$$\delta X_d = \delta X_s - \delta X_n \dots\dots\dots 4.17$$

As long as strict translocation techniques are used ephemeris errors will not affect the computed relative position of two ground stations. However using the short arc method, receiver A uses the Doppler counts from the frequency emitted between t_{s1} and t_{s2} while receiver B uses the frequency emitted between t_{n1} and t_{n2} . The result is a difference in positioning errors X_d for the two receivers. The errors in the satellite's orbit have been translated into errors in the relative ground co-ordinates. Errors in the satellite's direction and speed will be manifested as errors in orientation and scale.

The differential error δX_d can be expressed as components parallel and perpendicular to the satellite's orbit. Because the NN satellites are in circumpolar low eccentricity orbits; along-track, cross-track and radial errors correspond closely with errors in latitude, longitude and height.

If this type of ephemeris error does in fact exist, its effect on the difference of two ground co-ordinates will be much reduced by recording several passes. However the error will not be random as many Doppler passes are recorded from the same satellite between the same ephemeris updates, there being only 5 or 6 operational NN satellites and some 60 passes being recorded for each subnet. Furthermore errors caused by an incorrect gravity model for the earth will cause systematic orbital errors of a type similar to those indicated in fig 4.3.

In this and the following sections attempts will be made to combine the Doppler short-arc subnets using various combinations of the above geometrical transformations.

4.5.1 ADJUSTMENT OF THE 7 PARAMETER NETWORK

The unknowns in this adjustment are the Cartesian co-ordinates of the unknown points and the 7 transformation parameters of each subnet. These unknowns are arranged in each row of the design matrix as follows:

				1 . . .	No. subnets
1	2		Np	shift	rot scl
X Y Z	X Y Z . . .	X Y Z	X Y Z X Y Z S	X Y Z X Y Z S	X Y Z X Y Z S

The first group of terms correspond to the co-ordinates of the Np points and the second to the seven transformation parameters for each subnet. The coefficients in this matrix $\delta R_x / \delta X$ etc have been determined by numerical differentiation. A rotation of 10^{-6} radians is applied about an axis parallel to each of the principal axes and passing through the centre of gravity of the subnet.

$$R_x = \begin{bmatrix} 1 & 0 & 0 \\ 0 & 1 & -1E-6 \\ 0 & 1E-6 & 1 \end{bmatrix}$$

The effect that this rotation has on each of the required co-ordinates becomes that respective coefficient in the design matrix.

The effect of a scale factor on each subnet is dealt with similarly - the centre of gravity of the subnet is computed and treated as a temporary origin - the distances of all points in the subnet are then increased by 1 ppm from this temporary origin. This is effectively the same as increasing all co-ordinates in this temporary system by 1 ppm. The scale coefficients in the design matrix are the amounts (in metres) by which this 1ppm scale changes the respective co-ordinate values. The shift parameter coefficients are all -1 or 0 while the corresponding co-ordinate coefficients are +1 or 0.

4.5.2 WEIGHTING

Having rejected the GEODOP co-variance matrix, weighting is according to the number

of accepted passes in each subnet. Each subnet involves at least 50 balanced (E-W and N-S) passes - if any remaining errors are of a random nature then the positional accuracy of a point in the subnet will be of the form:

$$\sigma_r = k/\sqrt{n} \quad (n = \text{No. passes}) \quad \dots\dots\dots 4.17$$

weighting is according to $1/\sigma^2$.

thus

$$\text{weight} = n/k^2$$

i.e. subnet weight is proportional to number of passes.

\dots\dots\dots 4.18

The constant k is arbitrary thus the subnets do not have an a priori mse - weighting is only relative - in this case it is meaningless to carry out a χ^2 test on the results.

4.5.3 FORMATION OF DESIGN MATRIX

In the SA Doppler network there are 36 points, 7 of which have been held fixed for the purpose of this adjustment. There are 28 subnets thus the total number of unknowns in the adjustment is

$$\text{No. variables} = 3 * 29 + 7 * 28 = 283$$

The results of this adjustment are listed in appendix A (pages A21 - A25) and the Fortran program in appendix B (pages B8 -B12).

The application of rotations and scale in this adjustment affect X,Y and Z co-ordinates simultaneously thus in the final analysis these co-ordinates are all correlated.

σ_o^2 is computed by forming the weighted sum of the residuals as in equation 4.8 - in this case the weight matrix is a diagonal matrix.

$\hat{\sigma}_0^2 (\mathbf{A}^t \mathbf{P} \mathbf{A})^{-1}$ is then the covariance matrix of all the unknowns - the principal diagonal of this matrix being the variances of these unknowns. See appendix A (pgs A22 & A24).

From this co-variance matrix has been extracted the co-variance terms (a symmetrical 3*3 matrix) for each point. This matrix (\mathbf{Q}) has been used to compute error ellipsoids for each point - according to the method given by [Henriksen I. 1977]. The semi-axes of these ellipsoids are equal to the eigen-values of \mathbf{Q} (Subroutine EIGEN3, appendix B page B48).

Using the co-variance theorem, the co-variances of the Cartesian co-ordinates X,Y,Z have been transformed into geographical co-ordinates latitude(ϕ), longitude(λ) and height(h).

$$\mathbf{Q}_{\phi\lambda h} = \mathbf{R}^t \mathbf{Q}_{xyz} \mathbf{R} \dots\dots\dots 4.19$$

where the 3*3 matrix \mathbf{R} is formed by the partial derivatives:

$$\mathbf{R} = \begin{bmatrix} \frac{\delta\phi}{\delta X} & \frac{\delta\phi}{\delta Y} & \frac{\delta\phi}{\delta Z} \\ \frac{\delta\lambda}{\delta X} & \frac{\delta\lambda}{\delta Y} & \frac{\delta\lambda}{\delta Z} \\ \frac{\delta h}{\delta X} & \frac{\delta h}{\delta Y} & \frac{\delta h}{\delta Z} \end{bmatrix}$$

where X,Y,Z are related to ϕ,λ,h through equations 1.2. The partial derivatives have been found using numerical rather than the more cumbersome analytical differentiation. Fortran subroutine COVAR (in appendix B page B49) calls subroutine GEOGRAPH (page B51).

4.5.4 RESULTS OF THE SEVEN PARAMETER ADJUSTMENT.

The rotations and scale factors are mostly less than their MSE's (1σ) thus implying

that these transformations are not significant and that allowing each subnet 7 degrees of freedom is not a valid solution to the Doppler net unification problem. These results are listed on in appendix A on pages A21 -A25.

It is interesting to note, looking at the longest axes of the error ellipsoids that these are all very nearly the same as the MSE's of height. That is, the error ellipsoids are all positioned with their longest axis in an up-down orientation. This is what one would intuitively expect as there is very little constraint on a subnet rotation about an axis parallel to the subnet plane - because all subnets lie more or less in the same plane; points may move with comparative freedom perpendicular to this plane.

This effect is illustrated by table 6 (on page 91) which is an extract of the geographical co-ordinates computed using this seven parameter approach.

4.6 NETWORK ALLOWING SHIFTS AND A SINGLE ROTATION

Returning to the possible justification for allowing each subnet 7 degrees of freedom, the NN satellite's orbit is nearly circular, that is the satellite travels at approximately constant altitude for the period of the pass. It is with this in mind that each subnet is constrained to a single rotation about an axis perpendicular to the plane of that subnet. The necessity of such a rotation would be caused by the satellite's travelling in a different azimuth to that given in its ephemeris - this would prevent the inherent vertical weakness described above. The shifts in the previous adjustment will be retained as they are significant.

The adjustment procedure is similar to the 7 parameter approach. The rotation axis is found by finding the latitude and longitude of the centre of the subnet and then defining the rotation axis to be normal to the ellipsoid at this point. The effects of a small rotation on X, Y and Z then becomes those respective design matrix coefficients. Holding no points fixed the network would have a rank defect of four, two ADOS points being held fixed in this adjustment. The results are listed in appendix A on pages A26 - A30 and the program (SHIFTR) in appendix B on pages B13 - B17. The geometry of this network is stronger than in the 7 parameter

Point	Approximate Latitude σ (m)			Approximate Longitude σ (m)			Ht	σ (m)	Error Ellipsoid semi-axes (m)				
Acorn	21	59	04	1.02	20	59	34	0.85	1267	14.61	0.93	14.62	0.84
Brit 44	25	52	52	0.99	27	40	29	1.00	1636	7.16	7.16	1.02	0.97
Blydebg	33	05	51	0.86	23	11	27	0.70	1175	24.29	0.70	24.30	0.68
Burnkmp	26	38	54	0.92	15	09	58	1.01	106	19.69	0.91	19.70	0.86
Coegakp	33	45	58	0.00	25	37	18	0.00	143	0.00	Fixed by ADOS		
Druse	20	14	18	2.64	13	20	25	2.43	778	42.64	2.21	42.70	1.75
Esere	20	00	58	1.46	17	34	17	1.32	1667	23.47	1.42	23.49	1.09
Fransmk	30	53	37	0.63	24	26	43	0.61	1496	10.32	10.32	0.63	0.60
Geelht	19	35	39	1.69	20	41	48	2.29	1268	29.61	2.10	29.64	1.39
Graskop	29	02	53	0.59	19	56	52	0.61	1039	19.34	0.60	19.34	0.59
Hadida	26	56	25	0.64	21	30	05	0.64	976	13.84	13.84	0.64	0.63
Hexrivr	33	22	44	0.00	19	40	10	0.00	2254	0.00	Fixed by ADOS		
Inkomkl	29	46	33	0.96	30	27	42	0.87	1023	16.62	0.87	16.63	0.81
Karasbg	26	56	22	0.58	18	49	58	0.58	1610	12.54	0.57	0.57	0.57
Karsriv	34	26	44	0.82	20	07	03	1.10	214	10.40	10.41	0.98	0.80
Kransbg	24	28	04	0.75	27	35	22	0.73	2142	10.51	10.51	0.75	0.73
LkopRSA	29	18	29	0.62	26	24	11	0.62	1686	19.14	19.14	0.62	0.61
LkopSWA	23	00	32	1.17	15	03	27	1.24	687	21.51	21.52	1.10	1.03
Louisfn	31	01	28	0.79	17	59	42	0.94	548	25.88	25.89	0.75	0.71
Lourkp	24	54	17	0.70	16	42	07	0.74	1467	11.04	11.04	0.71	0.69
Lubisi	31	46	21	0.80	27	29	39	0.90	1806	18.17	18.17	0.77	0.76
Magwaza	27	41	32	0.00	32	08	07	0.00	598	0.00	Fixed by ADOS		
Mannehm	25	36	42	0.75	23	10	24	0.72	1074	13.33	13.33	0.73	0.71
Mooிடam	27	05	20	0.63	28	44	12	0.63	1645	11.10	11.10	0.63	0.62
Morgezn	27	07	17	0.00	25	15	27	0.00	1461	0.00	Fixed by ADOS		
M'pumbe	24	10	39	0.99	31	33	48	1.02	441	19.68	0.92	19.69	0.91
Okotomr	18	40	06	2.82	15	57	37	2.06	1172	39.92	2.09	39.99	1.66
Ondnvnq	17	53	42	4.83	12	15	45	4.09	966	64.12	3.59	64.28	2.51
Pont	22	15	06	0.00	29	09	48	0.00	698	0.00	Fixed by ADOS		
Potloer	31	02	04	0.59	21	11	23	0.59	1482	20.18	20.18	0.59	0.58
Rundu	17	53	21	2.65	19	46	24	3.26	1148	2.92	2.92	46.86	1.75
Schwzck	22	45	26	0.00	18	40	33	0.00	1523	0.00	Fixed by ADOS		
Thamksh	24	43	20	0.76	30	02	58	0.76	1985	13.53	13.53	0.74	0.74
UnionsE	24	50	08	0.56	19	58	43	0.56	1125	9.18	9.18	0.56	0.56
WitbnkN	28	45	18	0.00	16	40	05	0.00	340	0.00	Fixed by ADOS		
Witwatr	29	02	11	0.60	23	01	17	0.60	1534	19.20	19.20	0.60	0.59

Table 6
 Geographical co-ordinates and error Ellipsoids computed from the 7-parameter adjustment. Latitudes and Longitudes have been rounded off to the nearest second.

The table illustrates the weakness of the height determination in this adjustment and the consequent vertical orientation of the longest axis of the error ellipsoids.

Subnet Name	Shift values (metres)						Rotation		Date	
	X	σ	Y	σ	Z	σ	(")	σ	Year	Day
185/1	1.98	0.33	-0.59	0.32	-0.85	0.34	-0.03	0.21	1980	236
185/7	-1.09	0.52	0.96	0.45	-1.26	0.59	0.02	0.26	1980	323
185/4	1.84	0.32	1.53	0.30	-1.36	0.33	-0.05	0.19	1981	80
185/5	1.69	0.43	1.26	0.40	0.96	0.44	-0.13	0.21	1981	86
185/6	1.07	0.60	1.58	0.53	-2.54	0.62	0.31	0.23	1981	94
185/9	-3.56	0.72	3.40	0.51	0.58	0.94	-0.35	0.28	1982	193
/11	0.16	0.57	0.64	0.43	-0.97	0.73	0.53	0.26	1982	205
/13	3.16	0.38	-2.48	0.35	-4.28	0.48	0.16	0.22	1982	211
/12	-2.03	0.47	2.87	0.36	-0.01	0.69	0.07	0.22	1982	212
/14	-1.71	0.69	2.20	0.52	0.81	1.10	-0.06	0.26	1982	270
/15	2.99	0.76	0.06	0.63	-6.54	1.35	-0.12	0.26	1982	274
/20	-1.83	0.60	1.62	0.61	0.92	0.62	0.03	0.27	1984	128
/21	1.44	0.60	-2.07	0.76	-0.15	0.52	0.45	0.31	1984	140
/25	-7.89	0.47	-1.87	0.52	3.20	0.79	-0.06	0.19	1984	225
/16	-7.00	0.59	-4.94	0.86	-0.72	1.21	0.01	0.20	1984	235
/26	-4.28	0.61	2.26	1.56	1.40	1.08	-0.16	0.21	1984	267
/27	-13.56	0.52	0.55	1.03	2.98	0.84	-0.32	0.20	1984	285
/28	-12.57	0.63	0.25	1.23	4.02	1.44	-0.09	0.19	1984	294
/22	-0.39	0.38	-0.54	0.53	-0.94	0.32	0.34	0.25	1984	321
/29	-1.90	0.33	-1.17	0.38	1.63	0.44	0.33	0.20	1984	330
/8	-2.21	0.78	-1.82	0.70	2.62	0.85	-0.15	0.24	1985	165
/30	-4.58	0.59	-2.82	0.42	5.95	0.80	0.16	0.19	1985	222
/31	-0.55	0.76	-1.70	0.71	1.66	0.73	0.09	0.22	1985	229
/10	-2.79	0.77	0.11	0.49	1.80	1.12	-0.27	0.27	1985	245
/3	-2.89	0.36	-0.59	0.34	3.19	0.39	0.16	0.24	1985	245
/24	-6.56	0.32	-0.02	0.41	3.96	0.33	0.12	0.18	1985	238
/32	-3.55	0.68	2.36	1.99	0.31	1.11	-0.04	0.18	1985	312
/33	-4.46	0.66	-0.13	2.02	1.53	1.83	-0.11	0.19	1985	319

Table 7 .
Subnet Transformation Parameters: Shifts and one rotation.
(listed in Chronological order).

approach - the error ellipsoids are more nearly spherical - but the rotations are still smaller than their MSE's (1σ) and thus probably insignificant.

4.7 SHIFTS AND SCALE NETWORK

Consider a NN satellite passing overhead - its acceleration is governed by the gravitational attraction of the Earth. If its orbit is circular then the period of this orbit (T) is given by:

$$T = 2\pi\sqrt{R/g} \dots\dots\dots 4.20$$

where R is the orbital radius and
g the gravitational acceleration at that altitude.

For the NN satellites $R = 6370 + 1100$
 ≈ 7500 km

at this altitude the acceleration due to gravity is

$$g = 9.8 \times 6370^2 / 7500^2$$
$$\approx 7 \text{ m/sec}^2$$

$$T = 2\pi\sqrt{(7500000/7)}$$
$$= 6503.715 \text{ seconds}$$

and vel = 7245.688 m/sec

assume the satellite to be 15 metres lower than predicted (the Broadcast orbit is often 30 metres in error)

then $g = 7 (7500000^2 / 7499985)^2$
 $= 7.000028 \text{ m/s}^2$

$$T = 6503.695 \text{ sec}$$

and vel = 7245.696 m/sec

i.e. by travelling 15 metres lower the satellite is travelling 0.008 m/sec (1 ppm) faster than the predicted orbit. This would cause a scale of 1ppm in any relative co-ordinates

computed from Doppler measurements to a satellite in this orbit. With this principle in mind each subnet has been allowed its own scale factor along with three shifts. The programming details are very similar to the previous (single rotation) approach (Section 4.6).

4.7.1 RESULTS OF THE SHIFTS AND SCALE NETWORK

Once again the computed scales are not statistically significant, furthermore, any systematic orbital tilts or scale in one subnet are likely to be much the same in the next subnet. Examination of the results of adjustments 3.3 and 3.4 in appendix A (on pages A31 - A33 & A40 - A41) does not indicate either a position dependent or time dependent trend for these orbital errors. These results are summarised in tables 7 and 8 (on pages 92 and 95). The program listings for the shifts and scale network are given in appendix B (on pages B18 - B22).

4.8 SUBNET UNIFICATION USING SHIFTS ONLY

Having determined that all rotations and scale between the subnets are insignificant there remains the possibility of combining the subnets using only shifts.

The subnets have been combined with one another using shifts only in the program SHIFT3, appendix B (pages B23 - B27). Shifts are applied in the directions of the co-ordinate axes and as there are no covariance terms connecting X,Y and Z; the three adjustments (X, Y & Z) are effectively independent of one another. Initially the adjustment has been performed holding all the P.E. points fixed - this condition will be relaxed later.

4.8.1 DESIGN MATRIX AND FREE TERM FORMATION (Shifts only)

The unknowns are the Cartesian co-ordinates of all the floating points and the three shift values for each subnet. Consider the X co-ordinate of point no. l_p in subnet no. J_s . Suppose the GEODOP X co-ordinate for l_p in J_s is X_{obs} and the final co-ordinate of l_p (to be determined) is X_f then the observation equation is:

Subnet Name	Shift values (metres)						Scale fact (ppm)		Date	
	X	σ	Y	σ	Z	σ		σ	Year	Day
185/1	1.99	0.33	-0.52	0.37	-0.79	0.33	-0.66	2.21	1980	236
185/7	-0.81	0.42	1.04	0.69	-0.79	0.52	-0.61	2.61	1980	323
185/4	1.79	0.32	1.52	0.35	-1.44	0.32	0.80	2.08	1981	80
185/5	1.59	0.38	1.36	0.50	0.88	0.46	-1.58	2.41	1981	86
185/6	0.82	0.45	1.77	0.73	-2.75	0.64	-0.37	2.76	1981	94
185/9	-3.46	0.53	3.85	1.13	1.01	0.61	1.21	2.86	1982	193
/11	0.35	0.46	0.85	0.86	-0.53	0.50	3.20	2.73	1982	205
/13	3.22	0.39	-2.27	0.52	-4.01	0.36	0.59	2.49	1982	211
/12	-1.92	0.45	3.18	0.77	0.40	0.37	-1.87	2.36	1982	212
/14	-1.62	0.66	2.39	1.26	1.10	0.51	-2.24	2.86	1982	270
/15	3.09	0.80	0.22	1.52	-6.26	0.56	-2.64	2.90	1982	274
/20	-1.22	0.46	1.58	0.76	1.82	0.69	3.33	2.65	1984	128
/21	2.31	0.52	-2.52	0.65	0.82	0.82	2.25	3.00	1984	140
/25	-7.72	0.59	-1.60	0.86	3.71	0.47	-0.52	2.22	1984	225
/16	-6.86	0.89	-4.97	1.30	-0.51	0.74	1.54	2.46	1984	235
/26	-4.09	1.15	1.41	1.07	1.12	1.49	1.35	3.01	1984	267
/27	-13.35	0.84	0.26	0.85	3.19	0.97	0.07	2.60	1984	285
/28	-12.53	1.13	0.01	1.51	3.86	1.09	2.20	2.51	1984	294
/22	-0.14	0.39	-1.09	0.36	-0.55	0.55	2.11	2.52	1984	321
/29	-1.81	0.40	-1.62	0.44	1.41	0.36	0.76	2.12	1984	330
/8	-1.74	0.45	-1.22	1.10	3.67	0.84	3.83	2.30	1985	165
/30	-4.89	0.51	-2.91	0.89	5.38	0.50	-0.57	2.16	1985	222
/31	-0.96	0.48	-1.34	0.91	1.31	0.87	0.56	2.83	1985	229
/10	-2.85	0.60	0.54	1.33	1.98	0.56	0.34	2.85	1985	245
/3	-2.74	0.33	-0.55	0.44	3.44	0.37	1.35	2.44	1985	245
/24	-6.53	0.35	0.22	0.35	4.22	0.42	0.67	2.19	1985	238
/32	-3.39	1.31	1.26	1.07	-0.23	1.96	1.19	2.88	1985	312
/33	-4.67	1.55	-0.64	1.85	0.51	1.89	1.73	2.91	1985	319

Table 8
Subnet Transformation Parameters: Shifts and scale.
(listed in Chronological order)

$$X_{obs_{Js,lp}} - X_{s_{Js}} - X_{f_{lp}} + v_{Js,lp} = 0 \quad \dots\dots\dots 4.20$$

X_s being the X shift to be applied to subnet J_s - this has a provisional value of 0 thus the free terms are simply the differences between the 'observed' GEODOP co-ordinates and the provisional co-ordinates of each point.

$$L_{Js,lp} = X_{obs_{Js,lp}} - X_{prov_{lp}} \quad \dots\dots\dots 4.21$$

The adjustment is linear thus the provisional co-ordinates do not need to be even approximately correct.

The design matrix has dimensions:

- No of rows $\quad\quad\quad = 3 \times$ No of observations
- No of Columns $\quad\quad\quad = 3 \times$ (No Floating points + No of subnets)

This is wasteful in terms of Computer memory as X,Y and Z, which are independent of one another, are being adjusted simultaneously. In previous adjustments involving shifts and rotations X, Y and Z were correlated thus a single design matrix was required. The same form of matrix has been used here although three smaller matrices (with consequent much smaller inversion time) would have done the job.

The results of this adjustment are in appendix A(pages A42 - A46) and the Fortran program listing in appendix B(pages B23 - B27).

4.9 FREE NETWORK USING SHIFTS ONLY

The above adjustment (section 4.5) neglects the fact that the fixed points are expressed in the P.E. reference frame while the Doppler subnets are in the B.E. reference frame. In order to establish the local relationship between the two systems the subnets have been adjusted independently of the P.E. This can be done either by using the above (section 4.5) adjustment with only one point fixed or else by using a free net procedure in which

no points are fixed. The principle behind the free-net is that the overall network should have the same shape as the minimum constraint net (in the case of the 3-shift network this is one fixed point). In order to constrain the network in space a condition is imposed which gives the centre of the final network the same centroid as that of the provisional co-ordinates (these are the B.E. co-ordinates derived in section 4.4.1).

This can be achieved by following the method of Mittermayer [Mittermayer E. 1972] - this method was found to be demanding on computer space- or else by the addition of sufficient pseudo observations to constrain the network in space without distorting it at all. The pseudo observations should not favour any one point more than any other.

4.9.1 ADDITION OF PSEUDO-OBSERVATIONS

The Doppler shift network has a rank defect of 3 - that is 3 co-ordinates need to be held to constrain the network in space - thus 3 pseudo observations are required. Such pseudo-observations are formed by any three eigenvectors of A^tPA . These three vectors are included in a matrix G , GG^t being added to A^tPA to prevent the rank defect. The physical interpretation of the addition of GG^t is that the centroid of the network is held in space giving the final solution the same centre of gravity as the provisional co-ordinates. In other words the sum of the unknown corrections is zero, i.e.

$$[x] = 0$$

or $x^t x = \text{minimum}$

..... 4.22

While the final co-ordinates in the minimum constraint adjustment depend on which points are regarded as 'fixed'; the relative accuracies of these points are the same in any minimum constraint or free adjustment. This is borne out by the chord distances and their mse's which are identical in the two cases. These are listed in appendix A (on pages A51 & A56). The addition of any three independent eigenvectors will give the correct solution set but in order that Q_{xx} - the final co-variance matrix - is correct the eigenvectors should be normalised. The form of G is thus:

$$\begin{bmatrix} 1/\sqrt{n} & 0 & 0 & 1/\sqrt{n} & 0 & 0 & 1/\sqrt{n} & \dots \\ 0 & 1/\sqrt{n} & 0 & 0 & 1/\sqrt{n} & 0 & 0 & \dots \\ 0 & 0 & 1/\sqrt{n} & 0 & 0 & 1/\sqrt{n} & 0 & \dots \end{bmatrix},$$

where n is the number of points in the network. The above matrix **G** is removed after inversion.

The Free-network program is listed in appendix B (on pages B28 - B33 and the results in appendix A (on pages A52 - A56).

4.10 TRANSFORMATION BETWEEN THE B.E. AND P.E. SYSTEMS.

Having adjusted the subnets according to section 4.6 we have two sets of Cartesian co-ordinates for the 7 ADOS points - the first set derived directly from GEODOP using the P.E. and the second from the subnet unification using the B.E. *Each of these sets of co-ordinates will be inherently dependent on the reference system used to define its satellite ephemeris.* The relationship between the two systems has been determined in a global sense by [Leroy & Jenkins 1979], [Boucher C. et al 1979], [Meade B.K.1982] and [Hothem et al 1982] but may vary locally [Kumar M. 1982]. [Meade B.K. 1982] lists the differences between P.E. and B.E. derived co-ordinates together with their standard deviations for a number of stations in six different countries. They vary considerably, for example Canada shows a longitude difference (= Z rotation) between the two ephemerides of $+0.098 \pm 0.015$ arcsec while the equivalent figures in Oman are -0.054 ± 0.026 arcsec. There is no simple transformation between the two ephemerides that can be applied worldwide.

4.10.1 DATA CRITERIA FOR TRANSFORMING FROM P.E. TO B.E.

In determining B.E./P.E. transformation parameters, the data from which the P.E. and B.E. co-ordinates were computed should meet certain requirements. These standards will depend on the purpose for which the transformation is required; for example, in order to determine global transformation parameters, the data should be geographically as well distributed as possible [Leroy C. and Jenkins R.E. 1979]. give the following criteria for acceptance of data for this transformation:

- "(1) The broadcast positions had to be based on data from at least four different satellites to insure we were not being unduly biased by correlated ephemeris prediction errors.
- (2) Both positions had to be based on the same data span (although the NSWC-9Z2, or NWL 9D prior to June 1977, positions were based on only two of the satellites).
- (3) The same software program had to be used for both positions.
- (4) The correct value for earth rotation had to be used with the broadcast ephemeris.
- (5) The data had to be taken after November 1975, since this was the time that last major changes were introduced in both NAG and DMAHTC software.
- (6) The number of passes on which the broadcast positions were based had to be known, at least approximately. This was so that data could be properly weighted because the random error in point positioning is a strong function of the number of passes with the broadcast ephemeris.
- (7) The position differences had to be based on simple geocentric Cartesian positions with no geodetic transformations applied.

The criteria we were trying to meet with the complete data set were as follows:

- (1) The distribution of locations had to be as globally uniform as possible to avoid any conditioning and aliasing problems in fitting a 7-parameter transformation.
- (2) The time of the overall set had to cover more than one year, as uniformly distributed in time as possible, this was to help average out polar motion effects."

The data set being used in the present study comes nowhere near satisfying these last two criteria but as we are not attempting to determine global parameters this is of no consequence. Regarding the first seven conditions, 1, 3, 4, 6, and 7 are satisfied by the present data (the two ephemerides have used the same value for earth rotation since 1979 [Leroy C. and Jenkins R.E. 1979]), the fifth condition is irrelevant but the second condition is not fulfilled. The broadcast ephemeris data in the present study cover a period from 1980 to 1985, most of the subnets being recorded between 1982 and 1985, whereas the precise ephemeris data was all recorded between November 1982 and November 1983. In conclusion any P.E./B.E. parameters being deduced from this data are valid in the context of this study but should not be used for data recorded outside of these periods. Chronological details of the different subnets are given in table 4 in chapter 3.

4.10.2 WEIGHTING OF THE P.E. AND B.E. CO-ORDINATES.

In the case of the transformation from the B.E. to the P.E. system; the internal accuracy of the former is given by the co-variance matrix in the adjustment of section 4.6 while the accuracy of the P.E. co-ordinates remains uncertain - the P.E. co-ordinates are thus considered to be error free and the parameters are found which transform B.E. to P.E. so as to minimise $v^t P v$ in the broadcast system. The weight matrix P is extracted from the $(\Sigma_{xx})^{-1}$ in the free adjustment. The Bursa-Wolf (B-W) transformation has been computed using both this weight matrix and a unit weight matrix. The results are listed in appendix A on pages A37 - A39 and A34 - A36 respectively.

In the final analysis the P.E. points will not be considered as error free but will also be relaxed - see section 4.8. Using the Bursa-Wolf model:

$$\begin{bmatrix} V_x \\ V_y \\ V_z \end{bmatrix} = \begin{bmatrix} X \\ Y \\ Z \end{bmatrix} -sR \begin{bmatrix} X \\ Y \\ Z \end{bmatrix} + \begin{bmatrix} T_x \\ T_y \\ T_z \end{bmatrix}$$

..... 4.26

With 7 common points the residual vector v will have a dimension of 21 and the weight matrix P will have dimensions 21x21. The values of the 7 parameters which minimise $v^t P v$ are found as before using the least squares principle. The provisional value of the scale factor is taken as unity while those of the other parameters are all zero.

4.10.3 DESIGN MATRIX FORMATION

The design matrix coefficients $\delta F / \delta X$ can be found analytically by differentiating equation 4.26 with respect to each of the unknown parameters. However, this differentiation is achieved more easily numerically (without fear of a sign error). Unlike adjustment PARA-7 (section 4.2) which involved some 300 unknowns and in which $A^t P A$ was updated for each observation; in the Bursa-Wolf and Molodensky-Badekas models we are dealing with only 7 unknown parameters and the entire design matrix A is retained in computer memory. This also simplifies programming as in this case P is a full matrix and not simply a diagonal matrix. The program to determine transformation parameters between the two ephemeris systems is listed in appendix B (on pages B37 - B41) and the results (parameters, sigmas and residuals) in appendix A (on pages A66 - A68).

The Molodensky-Badekas transformation parameters and their mse's are as follows:

4.10.4 RESULTS OF THE B.E./P.E. TRANSFORMATION

Tx	= - 3.29	σ =	0.16 metres
Ty	= - 1.72		0.21
Tz	= - 0.68		0.18
Rx	= - 0.14	σ =	0.10 arcseconds
Ry	= - 0.12		0.09
Rz	= - 0.36		0.10
Scale	= + 0.16	σ =	0.41 ppm
co-ordinates of rotation centre :		X =	5118311.14
		Y =	2269947.71
		Z =	2965162.01

Table 9a.

Molodensky-Badekas Transformation Parameters between B.E. and P.E. co-ordinates in Southern Africa.

The only parameters that are apparently significant are the three shifts and the Z-rotation.

Constraining the X and Y rotations to zero and the scale factor to unity and then solving for the remaining 4 parameters gives:

Tx	= - 3.36	σ =	0.15 metres
Ty	= - 1.71		0.20
Tz	= - 0.51		0.16
Rz	= - 0.31		0.10 arcseconds
With centre of rotation as above.			

Table 9b.

Molodensky-Badekas Transformation Parameters between B.E. and P.E. co-ordinates in Southern Africa (constraining X & Y rotations and scale).

The full results are given in appendix A (on pages A57 - A59). This procedure (constraining the insignificant transformation parameters) is recommended by [Harvey 1985]. These will be assumed to be the appropriate transformation parameters for transforming B.E. to P.E. Doppler co-ordinates in the region of southern Africa.

Using the Bursa-Wolf model (that is applying the rotations about the Geocentre gives) the following:

Tx	=	- 9.84	σ	=	3.06 metres
Ty	=	+ 8.97			3.12
Tz	=	- 1.60			2.91
Rx	=	- 0.14	σ	=	0.10 arcseconds
Ry	=	- 0.12			0.09
Rz	=	- 0.36			0.10
Scale	=	+ 0.16	σ	=	0.41 ppm
co-ordinates of rotation centre :				X	= 0.00
				Y	= 0.00
				Z	= 0.00

Table 10a.
Bursa-Wolf Transformation Parameters between B.E. and P.E. co-ordinates in southern Africa.

Once again constraining Rx, Ry and the Scale:

Tx	= - 6.74	σ = 1.15 metres
Ty	= + 5.92	σ = 2.78
Tz	= - 0.51	σ = 0.18
Rz	= - 0.31	σ = 0.10 arcseconds
With centre of rotation at the origin.		

Table 10b.
Bursa-Wolf Transformation Parameters between B.E. and P.E. co-ordinates in Southern Africa
(constraining X & Y rotations and scale).

4.10.5 COMPARISON WITH EQUIVALENT RESULTS OBTAINED ELSEWHERE

Compare these parameters with those determined globally by [Kumar M. 1982] from 14 TRANET stations around the world:

Tx	= + 0.5	σ = 0.4 metres
Ty	= - 0.5	σ = 0.4
Tz	= - 0.9	σ = 0.4
Rx	= - 0.01	σ = 0.01 arcsec
Ry	= - 0.01	σ = 0.01
Rz	= - 0.03	σ = 0.01
Scale	= + 0.2	σ = 0.1ppm
with centre of rotation		0.00
		0.00
		0.00

Table 11 a.
Bursa-Wolf parameters for transforming from B.E. to P.E. according to
[Kumar M. 1982].

[Boucher C. et al-1979] gives the equivalent figures derived from 29 Doppler stations in Europe as:

Tx	= - 0.5	σ = 0.9 metres
Ty	= - 0.6	σ = 1.3
Tz	= - 8.8	σ = 0.9
Rx	= + 0.04	σ = 0.04 arcsec
Ry	= - 0.04	σ = 0.03
Rz	= - 0.08	σ = 0.03
Scale	= + 0.85	σ = 0.12 ppm

Table 11 b. B-W parameters for transforming from B.E. to P.E. according to [Boucher C et al 1979].

While [Jenkins and Leroy 1979], using 56 stations around the world, give

Tx	= - 0.8	σ = 0.5 metres
Ty	= + 0.2	σ = 0.5
Tz	= - 2.6	σ = 0.5
Rx	= + 0.05	σ = 0.02 arcsec
Ry	= - 0.02	σ = 0.02
Rz	= - 0.01	σ = 0.07
Scale	= + 0.22	σ = 0.07 ppm

Table 11 c. B-W parameters for transforming from B.E. to P.E. according to [Jenkins and Leroy 1979].

The comparisons of the transformations listed in tables 9a-11c are simplified by considering their effect on a particular point. The point chosen to demonstrate this

effect is Morgenzon, the ADOS point closest to the centre of South Africa. The approximate Cartesian geocentric co-ordinates of Morgenzon are:

Morgenzon: X = 5138732
Y = 2424368
Z = -2981143

TABLE	Trnsfmtn	para mtrs	Reference	Effect on Morgenzon		
				X	Y	Z
9a	M-B	7	Present Study	-3.06	-1.68	-0.76
9b	M-B	4	" "	-3.13	-1.74	-0.51
10a	B-W	7	" "	-3.10	-1.57	-0.72
10b	B-W	4	" "	-3.10	-1.80	-0.51
11a	B-W	7	Kumar M. 1982	+2.02	-0.90	+0.45
11b	B-W	7	Boucher C. 1979	+3.89	+4.01	-9.79
11c	B-W	7	Jenkins & Leroy 1979	+0.17	+1.19	-3.15

Table 11 d.
A summary of transformations from B.E. to P.E. Reference frames.

The small differences between the effects of 9a and 10a and between 9b and 10b are due to the rounding off of the rotation angles which have only been given to the nearest 0."01. *The effects of the Bursa-Wolf and Molodensky-Badekas transformations computed from the same data are identical.*

4.11 INCORPORATION OF P.E. AND B.E. IN THE SAME ADJUSTMENT

Having determined the scale and rotation between the P.E. and B.E. reference systems we are now able to combine the two co-ordinate sets in one adjustment following the procedure of section 4.9.

4.11.1 WEIGHTING OF THE B.E. AND P.E. CO-ORDINATES

In the free adjustment of section 4.9 weighting of the B.E. subnets was according to k times no. of accepted passes. It is possible to choose a value of k so that the variance factor of this adjustment is 1. If this is the case then

$$wt = k \times n \quad \dots\dots\dots 4.27$$

and $\sigma_i = 1/\sqrt{k \times n} \quad \dots\dots\dots 4.28$

Thus given the number of accepted passes in a given subnet it is possible to compute the relative accuracies of points within the subnet. The required value of k (to give a unit *a posteriori* variance factor) is 0.02.

The value of k chosen will not affect the σ 's of the resulting co-ordinates as the same constant is used for all subnets and weighting is only relative. Weighting of the P.E. is not as simple. The B.E. subnets are compared with one another in order to determine their accuracy but there is no such possible comparison in the case of the P.E. In order to estimate the accuracy of the P.E. Doppler fixes we have to appeal to other sources.

[Anderle R.J. 1976(3)] quotes the accuracy of P.E. derived positions as 0.7 - 0.9 metres (0.4 - 0.5 metres in each co-ordinate). The P.E. co-ordinates are thus given a weight of $1/0.4^2$.

4.12 SUMMARY OF THE DOPPLER UNIFICATION PROCEDURE

In summary, the unified Doppler net has been achieved as follows:

1. The B.E. subnets are combined as a free net by applying 3 orthogonal shifts to each subnet (section 4.6).
2. The relative scale and orientation between the B.E. and P.E. reference systems are found by transforming the co-ordinates from (1) onto the P.E. co-ords. Only the Z-rotation and shifts were found to be significant (section 4.10)
3. All B.E. co-ordinates are transformed into the P.E. reference system using the above parameters.
4. Using appropriate weights (section 4.11.1) the P.E. points are constrained by their variances while the B.E. subnets are shifted so as to 'fit' onto one another and onto the P.E. points.

An alternative interpretation of this procedure is that the P.E. co-ordinates are treated as direct observations of the unknowns while the B.E. subnets are treated as co-ordinate differences. After transforming the B.E. subnets into the P.E. reference system, and assigning appropriate variances, all of these Doppler results are combined in a single least squares adjustment.

The full results of this procedure are given in appendix A (on pages A60 - A65).

4.13 AUGMENTATION OF THE CO-VARIANCE MATRIX

Returning to sections 4.1 - 4.4 where the GEODOP co-variance matrix was rejected, there remained two options, namely to combine the subnets using geometrical transformations as outlined in sections 4.5 - 4.9 or alternatively to augment the covariance matrix and proceed along the 'rigorous' lines of section 4.1.

Accepting the validity of the addition of an arbitrary constant to the diagonal terms of the co-variance matrix, the logical constant to add is one which will give the adjustment a unit variance factor. The augmented co-variance matrix (Σ) will then be given by:

$$\Sigma = \Sigma_g + \begin{bmatrix} \Sigma b & \Sigma b & \dots & \Sigma b \\ \Sigma b & \Sigma b & \dots & \Sigma b \\ \cdot & \cdot & \cdot & \\ \cdot & \cdot & \cdot & \\ \cdot & \cdot & \cdot & \\ \Sigma b & \Sigma b & \dots & \Sigma b \end{bmatrix}$$

where Σ_g is the co-variance matrix estimated in GEODOP and

$$\Sigma b = \begin{bmatrix} b & 0 & 0 \\ 0 & b & 0 \\ 0 & 0 & b \end{bmatrix}$$

(this is the notation used by [Kouba J. and Wells D. 1976])

In adjustment SHIFZ (Appendix B pages B3 -B7) all the subnets have been transformed into the P.E. framework by applying the scale, rotations and shifts determined in section 4.10. The appropriate constant (b above) to be added to give unit variance factor was found to be 3.0m². [Adams 1982] recommends the addition of 4 m² to all diagonal terms and [Kouba J.and Wells D.E. 1976] suggest the addition of 1 m² when the P.E. is used and 4 m² with the B.E.

The results of this adjustment are in appendix A (on pages A17 - A20).

The question now is whether to accept these co-ordinates (appendix A page A19) or those from the adjustment outlined in section 4.12 (page A74).

The two sets of co-ordinates (sections 4.12 and this section) are listed in appendix A (pages A57 - A62). This page also shows the co-ordinate differences (the 'L' terms). The Molodensky-Badekas transformation on the following page indicates that there is no systematic scale or rotation between the co-ordinates derived from the so-called rigorous method and those derived from the method outlined in section 4.12. The two co-ordinate sets are incompatible; by accepting one set and the accompanying method we are necessarily rejecting the other method.

In view of the assessment of the GEODOP co-variance matrix in section 4.1 it is preferable to reject this matrix in its entirety rather than use the modification in this section for which there is no apparent justification. The Doppler co-ordinates found using the method outlined in section 4.12 will be used in further analyses.

4.14 TRANSFORMATION OF DOPPLER TO BIH/CIO ORIENTATION

Before using these Doppler co-ordinates as a 'zero-order' network to control the South African readjustment and as a basis for the establishment of a geocentric South African datum they should first be transformed from the Precise Ephemeris reference system (NSWC-9Z2) to the Conventional Terrestrial System. That is, to a geocentric reference system which is aligned with BIH and CIO and with centre at the earth's centre of mass. In order to achieve this all Z co-ordinates should be increased by 4 metres (the origin of the P.E. system is 4 metres 'above' the earth's centre of mass), a rotation of -0.8 arcsec should be applied about the Z axis and all co-ordinates should be scaled by -0.5ppm. The reason for the scale difference is not clear but it is apparent from comparing Doppler with the more precise VLBI and SLR positioning techniques [Lachapelle G. and Kouba J. 1980]. These transformations are summarised below:

$$\begin{aligned}T_z &= + 4.0 \text{ metres} \\R_z &= - 0.8 \text{ arcseconds} \\s &= - 0.5 \text{ ppm}\end{aligned}$$

The effect of these minor modifications will be to bring the co-ordinates into the more modern 'World Geodetic System 1984' reference frame (WGS 84) [Decker B.L. 1986]. More recently the above transformations have been redetermined by the DMA [Defense

Mapping Agency 1987] as follows:

Tz	= + 4.5	σ = 0.5 metres
Rz	= - 0.814	σ = 0.2 arcseconds
s	= - 0.6	σ = 0.1 ppm

Calculations using the former (Lachapelle and Kouba) parameters have already reached an advanced stage and as these all lie within 1 sigma of the latter (DMA) parameters there is little reason to recompute. The former set of parameters has been used for transforming from NSWC-9Z2 to CTS in this study.

4.15 THE PURPOSE OF THIS DOPPLER NETWORK

Returning to section 2.2.4, the purpose of this Doppler network is the overall control and strengthening of the conventional horizontal geodetic network. In order to accomplish this the Cartesian geocentric co-ordinates of these Doppler points must be expressed as latitudes and longitudes on a suitable datum surface. The purpose of the following chapter will be the determination of the most suitable datum onto which to transform these Cartesian co-ordinates.

4.16 TRANSFORMATION BETWEEN THE CAPE DATUM AND THE CTS

It is not intended that the present study should give a detailed analysis of transformations between the existing Cape Datum co-ordinates and the CTS. This transformation has been considered by [Merry C.L. & Rens J., 1989] using the CTS co-ordinates listed in table 19 (page 129) of the present study. A brief analysis of the relationship between these two co-ordinate systems is given here.

In order to determine transformation parameters between the two systems (the Cape Datum and CTS), the Cape Datum co-ordinates (table 5 on page 43) have been expressed in their geocentric form using the modified Clarke 1880 ellipsoid parameters, the published geographical co-ordinates and the ellipsoidal heights. The two sets of geocentric co-ordinates are summarised on page in appendix A (on page A99)

A Molodensky-Badekas transformation has been computed between the two systems using the 23 common points. Initially seven parameters (three shifts, three rotations and a scale factor) were allowed to vary. These parameters are given in table 12a.

Tx	= -133.95	σ =	0.86 metres
Ty	= -112.14		0.86
Tz	= -291.67		0.86
Rx	= - 0.349	σ =	0.335 arcseconds
Ry	= - 0.585		0.585
Rz	= - 0.672		0.451
Scale	= + 11.086	σ =	1.528 ppm
co-ordinates of rotation centre			:
			X = 5049401.74
			Y = 2354626.88
			Z = -3045716.49

Table 12a.

Molodensky-Badekas Transformation Parameters between Cape Datum and WGS 84.

These results are given more fully in appendix A (pages A100 - A103). Constraining the three rotations (which appear insignificant) gives the remaining four parameters listed in table 12b.

Tx =	-133.95	σ =	0.86 metres
Ty =	-112.14		0.86
Tz =	-291.67		0.86
Sc =	+ 11.086		1.535 ppm
With centre of rotation as above.			

Table 12b

Molodensky-Badekas Transformation Parameters between Cape Datum & WGS 84
(Rotations constrained to zero).

If the scale is also constrained then the three shifts are given in table 12c.

Tx =	-133.95	σ =	1.15 metres
Ty =	-112.14		1.15
Tz =	-291.67		1.15
With centre of rotation as in 12a			

Table 12c

M-B Transformation Parameters between Cape Datum & WGS 84 (Rotations and scale constrained to zero).

These results (tables 12a,b,c) are the same as those given by [Merry C.L. & Rens J., 1989] except that they have used the Bursa-Wolf model hence the rotations are about the Geocentre; this changes the shift values where shifts and rotations are solved for simultaneously.

THE DATUM FOR THE SA HORIZONTAL READJUSTMENT

Since the days of Cassini and Gauss, the mathematical - figure of the earth used for the expression of geodetic co-ordinates has been the oblate bi-axial ellipsoid. In today's world of computers and real-time satellite positioning co-ordinates may be given in space in the Conventional Terrestrial System without reference to an arbitrary datum surface. However, for many purposes this would be inconvenient and surveyors will probably be working on the oblate ellipsoid for some time hence.

From the scientific point of view the most suitable datum to use would be one based on the most modern reference system. At present this is the World Geodetic System 1984 (WGS 84) [Defense Mapping Agency, 1987]. Using the WGS 84 ellipsoid in its geocentric position gives the co-ordinates listed in table 19 for the 23 Doppler points in South Africa.

An adjustment of this nature affects a wider community of users than only scientists thus in selecting an ellipsoid on which to carry out the South African trigonometrical readjustment the following questions should be borne in mind:

1. *Should the ellipsoid be geocentric?* A geocentric ellipsoid has the advantage that satellite derived co-ordinates may be converted directly to latitude, longitude and height without first being shifted. Furthermore, provided there is no rotation of the axes, the co-ordinates of ground points would be in the same international reference frame as the satellites from whose reference system they are derived.
2. *How closely should the ellipsoid approximate the local geoid?* A geoid/ellipsoid separation of 6 metres has the effect of a scale factor of 1 ppm in the reduction of observed distances to the ellipsoid. With present technology this is for most purposes negligible; it would thus be convenient if this separation could be constrained to within a certain tolerance within the area of the present adjustment.
3. *Following a national geodetic re-adjustment, the co-ordinates of all control points will change.* This will have a disruptive effect on any large scale mapping. Short of

recompiling all maps, plans and orthophotos of scale 1/50000 or greater - a prohibitively expensive task - there are two possible courses:

- (i) as is being done in the US following the NAD 83 re-adjustment, the physical area on the ground covered by each 1/25000 map is the same as before the re-adjustment. However, the latitudes and longitudes of the map corners have changed - these are no longer whole numbers of degrees and minutes [Vincenty T. 1979].
- (ii) The choice of datum will have a marked effect on the magnitude of this co-ordinate change. If it were possible to select a datum that constrained co-ordinate changes to less than, say, 10 metres (1 mm at 1/10000) then this would save the mapping industry a great deal of trouble and expense.

If there were no historical influences, the obvious choice for the datum of the South African re-adjustment would be a modern geocentric ellipsoid such as GRS 80 as was used for for the North American re-adjustment NAD 83.

5.1.2 NAD 83

Before computing or selecting a Datum for the South African re-adjustment it is helpful to examine the American experience. 1985 saw the completion of the re-adjustment of the horizontal control network of North America (NAD 83). This adjustment superseded the previous American adjustment completed in 1927 [Kaula W.M. 1986]. In all NAD 83 included some 270 000 points and several million observations. Covering such a large area (approximately 5000 by 6000 km) there was no question of selecting an ellipsoid to fit the local shape of the earth as the geoid ellipsoid separation (with respect to GRS 80) varies from -20 to +30 metres within the area of NAD 83. Furthermore, the overall 'width' of North America increased by some 250 metres through NAD 83 - even by retaining the Clarke 1866 ellipsoid this figure would have been over 150 metres thus there was no advantage to be gained by retaining the old datum.

South Africa, being much smaller, may be able to fulfill both of the above criteria (the minimising of geoidal height and co-ordinate shifts) to a greater degree than North

America.

5.2 MINIMISING GEOID/ELLIPSOID SEPARATION

Orthometric heights have been computed for most of the Doppler points co-ordinated using the procedure outlined in section 4.12. The idea in this approach is to compute an ellipsoid which will make these orthometric heights as close as possible to their ellipsoidal counterparts.

In general a bi-axial ellipsoid in space has seven degrees of freedom:

The ellipsoid axes a and b (or a and the flattening f). That is two parameters define the shape of the ellipsoid itself.

Three parameters (X, Y and Z) are required to define the position of the centre.

The direction of the minor axis (two parameters). This is conventionally taken to be the same as the mean direction of the Earth's axis of rotation defined by the CIO.

In order to use this surface to co-ordinate points in latitude and longitude a further constant, the position of the zero meridian must also be defined.

Using the Cartesian co-ordinates of the 36 Doppler points derived in section 4.12 an ellipsoid has been computed so as to make the ellipsoidal heights of these points 'as close as possible' to their orthometric heights. Orthometric heights have been determined for all of these points using a combination of spirit and trigonometrical leveling. The expression 'as close as possible' is not well defined - once again the least squares procedure using the parametric method has been used. The quantity to be minimised is the sum of the squares of the differences between orthometric and ellipsoidal heights. One would intuitively expect a poor ellipsoid determination using data from only a small part of the Earth's surface. This calculation was performed more out of interest than as a serious attempt at arriving at a new datum.

It should be mentioned at this stage that the height system used in South Africa is not

strictly orthometric - heights do not refer to the geoid but to a nearby non-equipotential surface or quasi-geoid. The difference between these two surfaces is likely to be small and considerably less than the expected error in either the orthometric heights or the Doppler derived heights [Merry 1977].

5.2.2 DESIGN MATRIX FORMATION

The ellipsoidal height (h) of a point (X,Y,Z) is given by equation 1.3. In the program ELLIPSOID (Appendix B pages B52 - B56) this height has been numerically differentiated with respect to:

- a the semi-major axis of the ellipsoid.
- b the semi-minor axis of the ellipsoid.
- X }
Y } the position of the centre.
Z }
- X-rot }
Y-rot } the direction of the minor (=Z) axis.

The linear quantities (axes and shifts) are each in turn changed by one metre. The effect that this has on the ellipsoidal height is the partial derivative of that respective quantity. The rotational partial derivatives are similarly computed; in this case the rotations are changed by 10^{-6} radians. The effect of this small rotation is of a similar magnitude to that of a 1 metre shift - this ensures that the unknowns are of the same magnitude thus retaining numerical stability of the matrix inversion.

The direction of the minor axis should be the same as CIO (= the Z axis in the CTS or WGS 84 reference system); the last two variables have only been added for the sake of completeness. Each row of the design matrix (**A**) comprises the seven partial derivatives above computed at a particular point. The partial derivatives are formed by differentiating ellipsoidal height in equation 1.3 with respect to each of the seven variables listed above. The program allows for any of these seven variables to be constrained to their provisional values. The dimension of **A** is :

No. of points(36) by No. of variables (7)

5.2.3 THE FREE TERMS

The free terms (l) are given by the differences between the orthometric heights and the ellipsoidal heights computed from the provisional ellipsoid. This is a vector of dimension 36.

The system of equations is set up and solved in the usual parametric manner, the solution vector x containing the corrections to the provisional quantities. As a check the final values are used as provisionals and the process iterated.

The resulting ellipsoid (appendix A pages A78 - A79) is that which best fits the geoid in the southern region of Africa. These results include the correlation matrix between the unknown quantities; the high correlation (99 %) between the semi-major axis and the X shift is a numerical expression of what one would intuitively expect, *namely that we are dealing with too small an area of the Globe to meaningfully determine ellipsoidal parameters.*

The program ELLIPSOID allows for any of the variable quantities to be held fixed. This can be done either by eliminating that particular unknown from the design matrix or more easily by adding a sufficiently large term into the appropriate position on the diagonal of the $A^T P A$ matrix. In this program the former method has been used.

Constraining the centre and orientation of the ellipsoid to be the same as that of the WGS 84 system gives:

$$\begin{aligned} \text{semi-major axis (a)} &= 6378155.73 \quad \sigma = 2.60 \\ \text{semi-minor axis (b)} &= 6356826.80 \quad \sigma = 9.47 \end{aligned}$$

The ellipsoid flattening is given by:

$$f = (a - b) / a$$

.....5.1

In order to find the mse of $1/f$ from this adjustment the co-variance law is used.

$$\begin{aligned}
 \text{let } r &= 1/f \\
 \text{i.e. } r &= a / (a - b) \\
 dr/da &= (2a - b) / (a - b)^2 \\
 dr/db &= a / (a - b)^2 \\
 d &= (dr/da, dr/db) \\
 \text{Then } \sigma^2_r &= d Q_{ab} d^t
 \end{aligned}$$

.....5.2

This has been programmed into ELLIPSOID giving a reciprocal of the flattening :

$$1/f = 299.04 \quad \sigma = 0.17$$

Full results are given in appendix A (pages A80 - A81).

5.3 ELLIPSOID DETERMINED FROM ASTRONOMICAL OBSERVATIONS

An alternative way of determining the 'best-fitting' ellipsoid for a particular region is to minimise the differences between astronomical and geodetic co-ordinates. This is a similar computation to that which Bessel must have carried out in 1841 in computing the ellipsoid that bears his name.

As part of the geodetic traversing scheme described in section 2.13 first order astronomical latitudes and longitudes have been observed at some 120 Laplace stations. These points have not all been co-ordinated by Doppler in the P.E. reference system however they all have geodetic co-ordinates in the Cape Datum. These Cape Datum (Modified Clarke 1880) co-ordinates have all been transformed to WGS 84 using a similarity transformation based on local common points. The error incurred by the transformation is unlikely to exceed 1-2 metres whereas the observational accuracy of the astronomical co-ordinates is at best 0.5 arcseconds (15 metres).

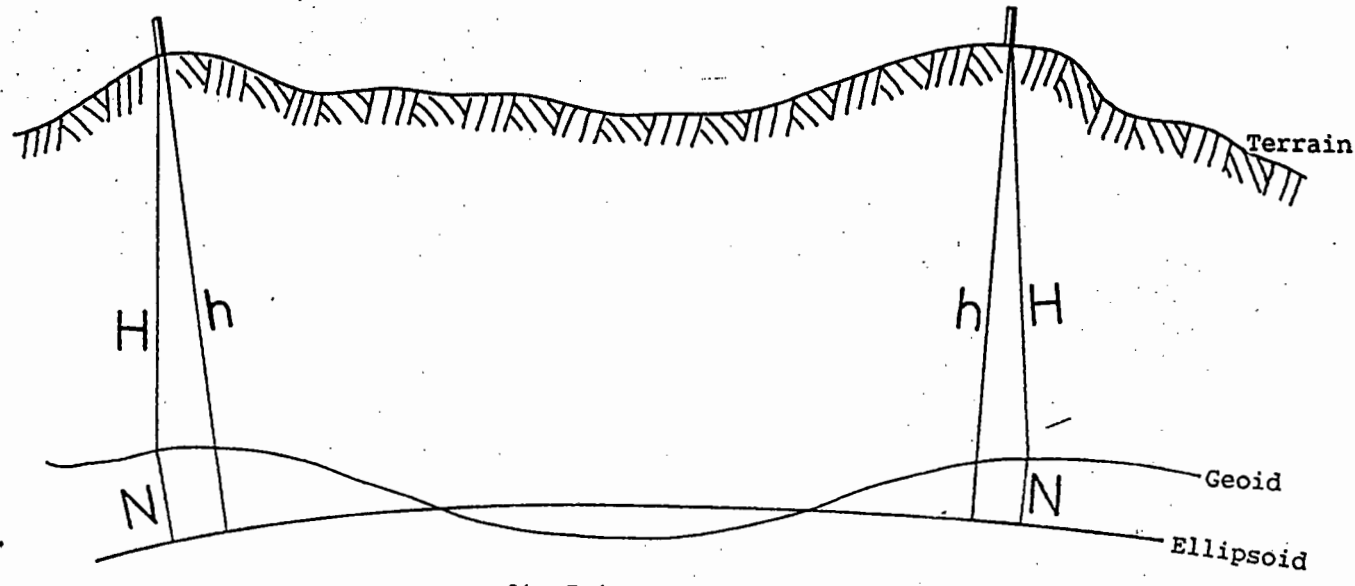

fig 5.1 a

Ellipsoid calculated so as to minimise geoidal separation.

$[N^2] = \text{minimum}$

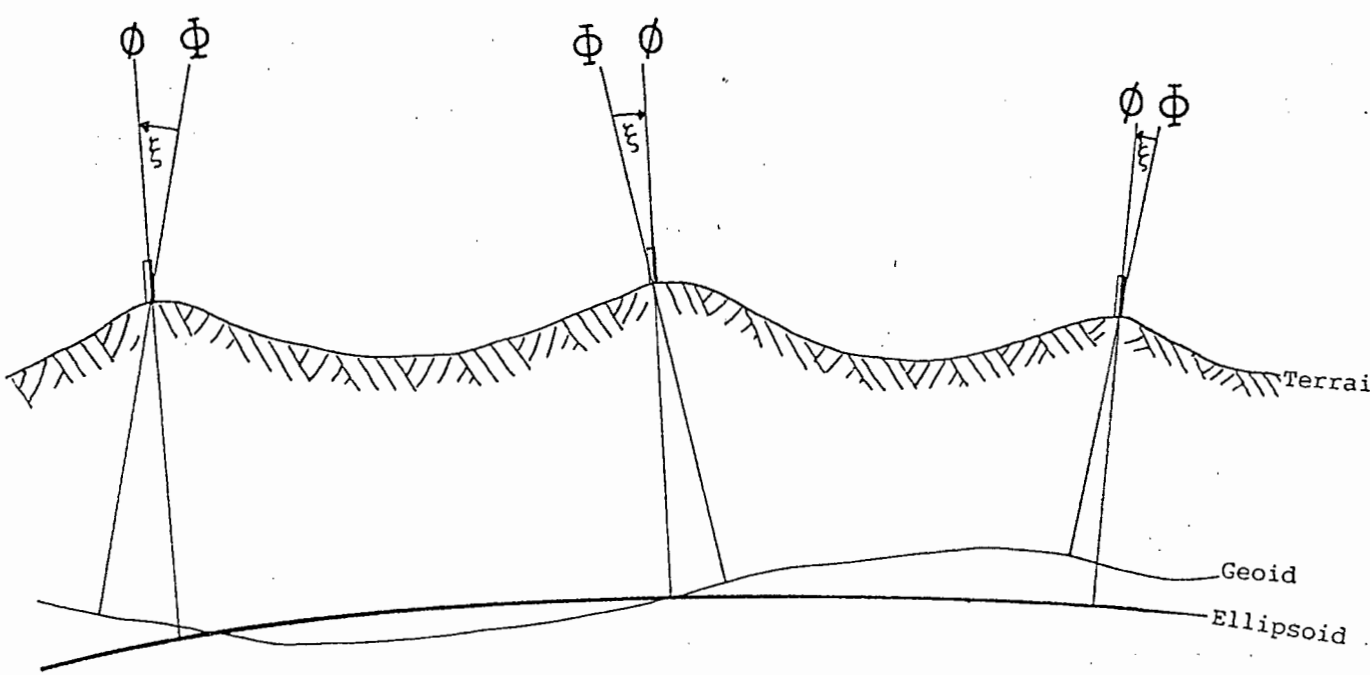

fig 5.1 b

Ellipsoid chosen so as to minimise plumb-line deflections.
(north-south section)

$[\xi^2 + \eta^2] = \text{minimum}$

5.3.1 DESIGN MATRIX FORMATION

The quantity to be minimised is the sum of the squares of the vertical deflections (differences between astronomical and geodetic co-ordinates).

The north-south deflection is given by

$$\xi = \Phi - \phi$$

and the east-west deflection by

$$\eta = (\Lambda - \lambda) \cos\phi$$

Thus $[\eta^2 + \xi^2]$ is to be minimised.

Retaining the WGS 84 centre and orientation axes a and b were found in order to minimise the above quantity. Using only astronomical observations a and b cannot both be solved for (this is analogous to solving a single triangle using only angles) - the system has no scale. Constraining the height of one point gave a reciprocal flattening:

$$1/f = 299.33 \quad \sigma = 0.16$$

which is in good agreement with the value arrived at by minimising geoid/ellipsoid separation. This is probably a realistic approximation for the shape of the African geoid between 18° and 34° S. The advantages of using an ellipsoid which fits the local figure of the Earth are slight; the geoid/ellipsoid separation will still exceed 10 metres in some places. The determination of ellipsoidal parameters to fit the local gravity field is not advocated as a means of defining the new South African geodetic Datum.

5.4 MINIMISING HORIZONTAL CO-ORDINATE CHANGES

The effect that a trigonometrical re-adjustment will have on the South African

surveyor is more serious than that on his American counterpart due to the nature of land registration in this country. South Africa is fortunate in having a numerical cadastre; all parcels of land are defined by their sides and angles. Since Dr van der Sterr's secondary triangulation programme the Surveyors General have strongly encouraged the connection of all cadastral surveys to the national network. In consequence today nearly all cadastres are co-ordinated in one or other of the conformal projection panels (or Lo's) advocated by Dr van der Sterr in 1919.

This data is also recorded pictorially in the form of noting sheets - a series of plans of various scales - depicting the extent of all land parcels in the country. A large co-ordinate shift would mean the redraughting of many of these plans, particularly those of larger scales in the main centres of development, namely the PWV complex, Eastern and Western Cape and Durban.

With this point in mind the advantage of a datum which would minimise these co-ordinate shifts is apparent. It is pertinent at this stage to mention that for some purposes, the larger the co-ordinate change through readjustment, the better. Two co-ordinates referring to the same point which differ by a few decimetres are more likely to cause confusion than two co-ordinates differing by a hundred metres.

The mathematical approach is the same as that for determining ellipsoid parameters from astronomical observations (section 5.3), observed astronomical latitudes and longitudes being replaced by existing published co-ordinates. In this case we are only concerned with the 23 Doppler points in South Africa as South West Africa has its own geodetic network computed on the Bessel spheroid.

The function to be minimised is the sum of the squares of the differences between existing and Doppler co-ordinates.

$$\Phi = \sum [(\Delta\phi)^2 + (\Delta\lambda\cos\phi)^2] \dots\dots\dots 5.4$$

Allowing both the ellipsoid centre to move and the axes to vary gives the results in appendix A (pages A89 - A90). If the trigonometrical readjustment is computed on this ellipsoid then the shift between old and new geodetic co-ordinates will be minimised. The axes of this ellipsoid (6378268 and 6356515) are not significantly

different from those of the Modified Clarke 1880 ellipsoid (this is hardly surprising as the existing co-ordinates are given on this ellipsoid). Constraining the ellipsoid axes to be the same as those of Modified Clarke 1880 ellipsoid and allowing the centre to move gives the results in appendix A (pages A91 & A92). The shifts which minimise the change of existing co-ordinates are:

$$X \text{ shift} = - 176.79 \quad \sigma = 8.9 \text{ metres}$$

$$Y \text{ shift} = - 156.03 \quad \sigma = 4.2 \text{ metres}$$

$$Z \text{ shift} = - 265.04 \quad \sigma = 5.5 \text{ metres}$$

In this solution all Doppler points have been given equal weight. The residual shift is greatest at Witbank New (15 metres). This point is situated in the remote N.W. Cape near to the mouth of the Orange River and is thus of little consequence when considering the effect of its new co-ordinates on large scale noting sheets and maps. Omitting Witbank New, Hadida and Mannerheim (all points in this remote part of the country) and solving for the shifts which will minimise the horizontal co-ordinate changes at the remaining 20 points gives the results in appendix A (pages A93 - A94).

$$X \text{ shift} = - 164.59 \quad \sigma = 7.3 \text{ metres}$$

$$Y \text{ shift} = - 149.14 \quad \sigma = 3.6 \text{ metres}$$

$$Z \text{ shift} = - 272.72 \quad \sigma = 4.6 \text{ metres}$$

This solution gives a strong correlation between the shifts (98% between the X and Z). The co-ordinate changes near to the main centres of development using the above shifts are as follows:

3.3 metres at Brit 44 (West of Pretoria)

0.3 metres at Moodam (S.E. of the Witwatersrand)

5.2 metres at Inkominkulu (near Pietermaritzburg)

6.5 metres at Coegakop (north of Port Elizabeth)

6.0 metres at Hexrivier (the two Doppler points

and 7.4 metres at Karsrivier (closest to Cape Town)

5.5 MINIMISING OF 3-D CO-ORDINATE CHANGES

In the above (section 5.4) computation no cogniscance has been taken of the heights of the Doppler stations either above sea level or any arbitrary ellipsoid. Having decided which points to include and which to reject the three shifts were computed so as to minimise:

$$[(\Delta\phi)^2 + (\Delta\lambda\cos\phi)^2] \dots\dots\dots 5.4$$

Alternatively the shifts may be computed so as to minimise:

$$(\Delta\phi^2 + \Delta\lambda^2 + \Delta h^2) \dots\dots\dots 5.5$$

where $\Delta\phi$ and $\Delta\lambda$ are expressed in metres. In this case the existing ellipsoidal height (h) is given by the sum of the orthometric height (H) and geoid/ellipsoid separation (N).

$$h = H + N \dots\dots\dots 5.6$$

N, the separation with respect to the Modified Clarke 1880 ellipsoid (Cape Datum), has been computed by [Merry C.L.,van Gysen H. 1987] using gravimetric data independently of the present Doppler survey.

Minimising the three dimensional co-ordinate shifts using equation 5.5 gives the displacement of the centre of the new datum from the WGS 84 centre to be:

$\Delta X = - 133.70$	$\sigma = 0.78$
$\Delta Y = - 112.06$	$\sigma = 1.52$
$\Delta Z = - 291.79$	$\sigma = 1.03$

Table 13 a
..... 5.7

Shifts required between WGS 84 centre and new centre in order to minimise (by least squares) 3-D co-ordinate changes at all 23 Doppler points. (Mod. Clarke 1880 ellipsoid)

Excluding the points in the N.W. Cape gives the following shifts:

$\Delta X = - 134.73 \quad \sigma = 0.51$
$\Delta Y = - 110.92 \quad \sigma = 1.27$
$\Delta Z = - 292.66 \quad \sigma = 0.77$

Table 13 b

Shifts required between WGS 84 centre and new centre in order to minimise (by least squares) 3-D co-ordinate changes at 20 Doppler points. (Mod. Clarke 1880 ellipsoid)5.8

These results, while significantly different from those in section 5.4 show the same mean square change in horizontal co-ordinates, furthermore this solution is more robust as there is no correlation between the shifts. Results are in appendix A (pages A77 - A78).

5.5.2 MINIMISING CO-ORDINATE CHANGES BY 'MINI-MAX'

By computing the mean shift of several points we are effectively applying the principle of least squares. Alternatively we may use the 'Mini-Max' principle in which the absolute value of the largest 'error' is kept as small as possible. In the present case we are dealing with co-ordinate changes and not errors but the principle remains the same.

Retaining the Modified Clarke 1880 ellipsoid and applying the Mini- Max principle to the 20 Doppler points excluding those in the NW Cape gives the following shifts:

$\Delta X = - 130.68$
$\Delta Y = - 112.42$
$\Delta Z = - 295.74$

Table 14

Shifts between WGS 84 centre and new centre in order to minimise (by Mini-Max) 3-D co-ordinate changes at 20 Doppler points. (Modified Clarke 1880 ellipsoid)5.9

Using the shifts listed in Table 14 the maximum horizontal co-ordinate change of any of the 20 Doppler points is 12.5 metres.

If the GRS 80 ellipsoid is used instead of the Modified Clarke 1880 then the largest co-ordinate change is far greater. In this case the required shifts are:

$\Delta X = + 23.13$
$\Delta Y = - 49.32$
$\Delta Z = - 58.56$

Table 15

Shifts required between WGS 84 centre and new centre in order to minimise (by Mini-Max) 3-D co-ordinate changes at 20 Doppler points (WGS 84 ellipsoid). 5.10

Using the shifts listed in Table 15 together with the WGS 84 ellipsoid parameters would cause a maximum horizontal co-ordinate change of 46.1 metres.

The full results of Tables 14 and 15 are given in appendix A (pages A97 - A98).

5.6 THE DEFINITION OF THE NEW SA HORIZONTAL DATUM

There is little to choose between the shifts in tables 13 b and 14 but the co-ordinate changes around the main development centres (particularly the PWV area) are less in table 13b (5.92 m as opposed to 9.44 metres). It is thus proposed that the shifts computed by least squares given in table 13b together with the existing Modified Clarke 1880 ellipsoid parameters define the new South African horizontal Geodetic Datum.

In summary the proposed new datum will be defined by its ellipsoid axes and offset of the centre from the WGS 84 Centre. There will be no rotations between the proposed datum and WGS 84, that is, the new datum will be parallel to the CTS.

a	=	6378249.145 m
b	=	6356514.967 m
ΔX	=	- 134.73 m
ΔY	=	- 110.92 m
ΔZ	=	- 292.66 m

Table 16a
Defining parameters of the proposed
S.A. Geodetic Datum.

.....5.10

If this proposal is accepted then the horizontal co-ordinate changes near to the the main centres of development will be as follows:

5.92 metres at Brit 44 (West of Pretoria)
2.99 metres at Moodam (S.E. of the Witwatersrand)
1.37 metres at Inkominkulu (near Pietermaritzburg)
1.15 metres at Coegakop (north of Port Elizabeth)
8.29 metres at Hexrivier (the two Doppler points)
7.94 metres at Karsrivier (closest to Cape Town)

Table 16b
Horizontal co-ordinate changes around the main centres of development if the ellipsoid and shifts in Table 16a are adopted.

The new co-ordinates resulting from the adoption of this new datum are listed in table 17. The Cartesian co-ordinates from which the latitudes and longitudes in table 18 were computed are those from section 4.12 transformed to the CTS according to section 4.14. The output of the program FNSLN, outlined in section 4.12, are the geocentric co-ordinates of the 36 Doppler points and their accompanying covariance matrix. This covariance matrix (in X,Y,Z) has been transformed into ϕ, λ, ht using the covariance law. From this 108 square matrix the latitude/longitude terms have been extracted (a 72 square matrix). These two processes are

carried out in program QFINAL listed in appendix B (page B66). The resulting covariance matrix, together with the co-ordinates listed in table 18, will be used in the subsequent horizontal trigonometrical readjustment.

The adoption of this new datum (defined in table 16a) will cause surveyors the inconvenience of having to apply shifts to satellite derived co-ordinates in order to convert them to S.A. geodetic co-ordinates. This inconvenience will be more than offset by the economic gains of not having to recompile a large number of cadastral and topographic plans. Furthermore the adoption of this new datum and the rigorous adjustment of the horizontal control network upon it will ensure that the shifts which need to be applied to satellite derived co-ordinates to give local geodetic co-ordinates will be the same country-wide. Retaining the Modified Clarke 1880 ellipsoid will mean that geodetic calculations such as transformation between plane and geographical co-ordinates will be unaffected.

Station	Geocentric (FINS LN) co-ordinates transformed to WGS'84 centre and CIO/BIH orientation					
	X	σ	Y	σ	Z	σ
Acorn	5525344.55	0.34	2120127.11	0.47	-2373568.43	0.42
Brit 44	5086360.38	0.45	2667484.06	0.61	-2768214.69	0.55
Blydeberg	4917162.90	0.30	2106502.72	0.41	-3463953.56	0.37
Burenkamp	5505758.94	0.31	1492319.27	0.42	-2843788.48	0.38
Coegakop	4785788.81	0.18	2295151.49	0.25	-3525278.06	0.23
Druse	5821776.27	0.50	1398368.29	0.68	-2193040.57	0.62
Esere	5716867.54	0.34	1810293.28	0.46	-2170231.96	0.42
Fransmanskop	4988029.47	0.27	2267368.02	0.37	-3256847.81	0.33
Geelhout	5624101.46	0.52	2124746.37	0.71	-2126138.76	0.64
Graskop	5246210.54	0.24	1904000.25	0.33	-3079356.77	0.30
Hadida	5294618.60	0.26	2085701.67	0.36	-2873050.37	0.32
Hexriver	5022031.28	0.16	1795050.02	0.22	-3490656.90	0.20
Inkominkulu	4776484.34	0.36	2809212.05	0.49	-3149643.05	0.44
Karasberg	5386567.84	0.27	1837105.67	0.37	-2873255.84	0.33
Karsrivier	4944244.90	0.39	1810979.09	0.54	-3587729.71	0.48
Kranzberg	5149761.51	0.29	2690982.25	0.40	-2626713.64	0.36
Leeukop (RSA)	4986765.22	0.26	2475721.88	0.36	-3104837.61	0.33
Leeukop (SWA)	5672545.54	0.40	1525997.46	0.54	-2478190.99	0.49
Louisfontein	5203320.12	0.30	1690097.08	0.42	-3268801.69	0.37
Lourkuppe	5545409.01	0.35	1663846.12	0.48	-2670424.47	0.43
Lubisi	4815636.21	0.35	2506182.66	0.48	-3340238.67	0.43
Magwaza	4786098.20	0.19	3006405.31	0.25	-2946912.44	0.23
Mannerheim	5291495.88	0.29	2264981.24	0.40	-2741082.60	0.36
Moodiam	4983705.32	0.28	2732598.93	0.38	-2888034.05	0.34
Morgenzon	5138732.45	0.18	2424367.64	0.25	-2891142.55	0.22
M'Pumbe New	4943053.11	0.37	3076329.11	0.50	-2596691.59	0.45
Okotomare	5812579.61	0.42	1662305.59	0.58	-2029284.74	0.52
Ondondvengo	5933769.42	0.50	1289619.67	0.68	-1947917.44	0.62
Pont	5157756.90	0.23	2878190.79	0.31	-2400772.91	0.28
Potloer	5101244.33	0.27	1977515.43	0.37	-3270220.74	0.33
Schwarzeck	5575903.84	0.19	1884656.49	0.26	-2452840.06	0.23
Thamakoosh	5019241.63	0.33	2903592.48	0.45	-2652266.05	0.41
Union's End	5443979.25	0.29	1979090.62	0.40	-2663329.43	0.36
Witbank New	5360989.00	0.18	1605040.21	0.24	-3050578.69	0.21
Witwater	5137508.95	0.25	2182963.19	0.34	-3078455.04	0.31

Table 17

Final geocentric co-ordinates of 35 Doppler points transformed to WGS'84 centre and CTS orientation.

σ 's are from adjustment FNSLN (Appendix A pages A72 - A77).

Station	Final Geographical and plane Co-ordinates of 35 Doppler points								
	Latitude(S)			Longitude(E)			Lo	Y	X
Acorn	21	59	11.4438	20	59	34.1414	21	741.82	2432101.58
Brit 44	25	53	00.5424	27	40	28.5958	27	-67609.76	2863866.30
Blydeberg	33	06	01.5727	23	11	26.5871	23	-17803.66	3663627.72
Burenkamp	26	39	03.0187	15	09	58.2934	15	-16546.55	2948715.01
Coegakop	33	46	08.1679	25	37	18.2235	25	-57595.75	3737926.76
Druse	20	14	25.2498	13	30	25.5263	13	-52986.36	2238863.52
Esere	20	10	05.0204	17	34	17.1923	17	-59795.15	2214277.90
Fransmanskop	30	53	47.1420	24	26	42.7463	25	53044.34	3419359.15
Geelhout	19	35	46.0730	20	41	48.3032	21	31815.16	2167499.06
Graskop	29	03	02.0751	19	56	52.3857	19	-92320.93	3214992.17
Hadida	26	56	33.6904	21	30	05.1862	21	-49797.45	2981138.52
Hexriver	33	22	54.2293	19	40	09.4994	19	-62280.69	3695008.26
Inkominkulu	29	46	43.3234	30	27	41.4297	31	52073.97	3295445.85
Karasberg	26	56	30.7149	18	49	57.7951	19	16612.30	2980959.19
Karsrivier	34	26	54.6666	20	07	02.6838	21	81110.66	3813485.69
Kranzberg	24	28	12.6857	27	35	22.0134	27	-59759.78	2707271.29
Leeukop (RSA)	29	18	38.7816	26	24	10.4251	27	58008.62	3243607.59
Leeukop (SWA)	23	00	40.0188	15	03	27.5809	15	-5909.21	2545556.66
Louisfontein	31	01	37.9902	17	59	42.1808	17	-95009.84	3434152.51
Lourkuppe	24	54	25.8403	16	42	07.3086	17	30103.55	2755578.18
Lubisi	31	46	30.6841	27	29	38.4957	27	-46797.46	3516761.79
Magwaza	27	41	41.1324	32	08	07.3029	33	85290.22	3064669.57
Mannerheim	25	36	50.3899	23	10	24.3643	23	-17420.72	2833850.90
Moodiam	27	05	29.3706	28	44	11.6896	29	26125.30	2997553.78
Morgenzon	27	07	25.7064	25	15	27.2987	25	-25539.10	3001133.12
M'Pumbe New	24	10	46.9562	31	53	47.2654	31	-91094.47	2675263.48
Okotomare	18	40	13.1450	15	57	37.2570	15	-101320.71	2065268.63
Ondondvengo	17	53	48.2192	12	15	44.9348	13	78155.72	1979534.06
Pont	22	15	13.4431	29	09	47.5054	29	-16822.27	2461698.60
Potloer	31	02	13.9062	21	11	22.4554	21	-18098.40	3434848.73
Schwarzeck	22	45	34.4129	18	40	33.1152	19	33290.66	2517735.76
Thamakoosh	24	43	28.1163	30	02	57.5939	31	96188.46	2735642.45
Union's End	24	50	16.7781	19	58	43.2457	19	-98932.75	2748237.07
Witbank New	28	45	27.3302	16	40	04.8037	17	32425.88	3182195.55
Witwater	29	02	20.3488	23	01	17.3370	23	-2092.51	3213336.92

Table 18
Geographical and Plane (Lo) co-ordinates of 35 Doppler points on the datum defined in Table 16a.

Station	Final Geographical and plane Co-ordinates of 23 Doppler points								
	Latitude(S)		Longitude(E)		Lo	Y	X		
Brit 44	25	53	02.6195	27	40	27.3153	27	-67571.89	2864163.59
Blydeberg	33	06	02.1350	23	11	24.7015	23	-17754.14	3663920.44
Coegakop	33	46	08.6523	25	37	16.6010	25	-57551.93	3738220.06
Fransmanskop	30	53	48.1223	24	26	41.0439	25	53087.70	3419653.76
Graskop	29	03	03.3592	19	56	50.2310	19	-92259.50	3215284.92
Hadida	26	56	35.4561	21	30	03.2355	21	-49741.99	2981433.23
Hexriver	33	22	54.6843	19	40	07.2137	19	-62219.40	3695298.73
Inkominkulu	29	46	44.5845	30	27	40.4133	31	52099.47	3295742.76
Karsrivier	34	26	54.9533	20	07	00.4191	21	81165.55	3813776.73
Kranzberg	24	28	15.0959	27	35	20.7387	27	-59721.95	2707569.05
Leeukop(RSA)	29	18	40.0991	26	24	08.9640	27	58046.06	3243903.58
Louisfontein	31	01	38.8428	17	59	39.7727	17	-94942.68	3434443.09
Lubisi	31	46	31.5368	27	29	37.1205	27	-46759.62	3517056.75
Magwaza	27	41	42.8377	32	08	06.4906	33	85309.60	3064967.61
Mannerheim	25	36	52.4830	23	10	22.6101	23	-17371.21	2834146.98
Mooïdam	27	05	31.1833	28	44	10.5108	29	26156.90	2997851.19
Morgenzon	27	07	27.4782	25	15	25.7439	25	-25495.43	3001429.32
M'Pumbe New	24	10	49.4670	31	53	46.4512	31	-91068.55	2675562.26
Pont	22	15	16.4172	29	09	46.4157	29	-16790.54	2461997.49
Potloer	31	02	14.8121	21	11	20.3923	21	-18043.06	3435141.49
Thamakoosh	24	43	30.4842	30	02	56.5784	31	96213.89	2735941.06
Witbank New	28	45	28.6198	16	40	02.3115	17	32492.40	3182487.38
Witwater	29	02	21.6808	23	01	15.5118	23	-2043.05	3213631.54

Table 19

Geographical and Plane (Lo) co-ordinates of 23 Doppler points in the WGS'84 Reference System.

CONCLUSION

This study is concerned largely with the Doppler processing program GEODOP. It has been shown (section 4.1) that the GEODOP covariance matrix is over optimistically accurate.

Ignoring this covariance matrix, the GEODOP broadcast ephemeris subnets have been successfully combined by applying three orthogonal shifts to each subnet.

It has also been shown (in section 4.10) that, in the region of southern Africa and during the period 1982 - 1985, the relationship between the broadcast and precise ephemerides may be adequately modelled using three shifts and a single (Z) rotation.

The readjustment using the co-ordinates of the Doppler points from chapter 4 could be computed in WGS 84 but for certain administrative reasons this would be impractical.

Southern Africa is too small a region to determine meaningful ellipsoid parameters from physical observations. Instead the criterion of minimising of co-ordinate changes has been used for the determination of a new ellipsoid. The ellipsoid thus determined has axes close in size to those of the extant Modified Clarke 1880 ellipsoid.

The new proposed datum is the Modified Clarke 1880 ellipsoid positioned so as to minimise co-ordinate changes. This may appear to be simply a rehashing of the existing Cape datum but the important difference is in its definition. The position of the Cape datum is defined by the adopted latitude, longitude and height of its initial point, Buffelsfontein, whereas that of the new datum is defined by its offset from centre of the WGS 84 co-ordinate system. The two datums are very close to one another and for many purposes (specifically mapping) will be indistinguishable.

Shifts will still have to be applied to satellite derived co-ordinates to give SA geodetic co-ordinates but, following readjustment, one set of shifts will be applicable country-wide.

It is felt that by adopting this new datum the wide community of users of geodetic co-ordinates will benefit from having a sounder network and at the same time be

inconvenienced as little as possible.

The Cartesian co-ordinates of the 36 Doppler points computed in section 4.12 and transformed to WGS 84 in section 4.14 have been converted to latitude and longitude on the new South African Datum given in section 5.6. These co-ordinates are listed in table 18. The covariance matrix associated with these co-ordinates will be used to constrain them in the forthcoming national trigonometrical readjustment.

The South African trigonometrical readjustment is not yet complete. It is likely that before sufficient observations are in computer readable form for this adjustment to be worthwhile, many trigonometrical stations will have been connected using the Global Positioning system (GPS). This will not affect the argument in chapter 5 (although some of the values might change slightly). Furthermore, in order to get the most benefit from GPS, a network will need to be built up similar to the existing Doppler network. The station separation in this GPS network will probably be a good deal less than the 300 km in the present Doppler network. The principles used in chapter 4 are not specifically 'Doppler related' - they could be applied to any three dimensional net - and may well prove useful in developing a GPS network.

REFERENCES

- Adams, J.R., et al., (1982). Consolidation of Doppler Satellite subnets (GEOSEW). *Proc. of 3rd symposium on Doppler satellite positioning*. New Mexico, vol 1: 429-446.
- Allman, J.S., & Veenstra C., (1984). *Geodetic Model of Australia*. Australian Dept. of Energy and Mines.
- Anderle, R.J., (1976)(1). Error models for geodetic positions derived from Doppler satellite observations. *Bulletin Geodesique*, 50(1): 43-77.
- Anderle, R.J., (1976)(2). Polar motion from Doppler satellite observations. *Bulletin Geodesique*, 50(4): 377-390.
- Anderle, R.J., (1976)(3). Point Positioning concept using the Precise Ephemeris. *Proc of 1st Doppler Symposium*, New Mexico, vol 1: 47-76.
- Ashkenazi, V., (1986). How to get your position very precise and completely wrong. *Journal of Navigation*. 39(2): 269-278.
- Ashkenazi, V., Crane B.A., et al., (1979). Terrestrial Doppler Adjustment and analysis of the primary triangulation of Great Britain. *Phil. Trans. of the Royal Society*.
- Badekas, (1969) Investigations related to the establishment of a World geodetic system. *Report No. 124 Dept of Geodetic Science, Ohio State University*.
- Black, H.D., et al., (1975). The Transit system. *Proc. of A.G.U. meeting Washington DC*.
- Black, H.D., (1978). An easily implemented algorithm for the tropospheric range correction. *J of Geophysical Research*, 83: 1925.

- Boal, J.D., and Morris R.J., (1982). Evaluation of transit data using a refined version of the program GEODOP. *Proc. of 3rd international symposium on Doppler satellite positioning*. Las Cruces, vol 1: 353-361.
- Bomford, G., (1980). *Geodesy* (4th Edition) - Oxford University Press
- Boucher, C., et al, (1979). The second European Doppler Observation Campaign (EDOC). *Proc. of 2nd International Doppler Conference*. Austin Texas, vol 2: 819-850.
- Bowring, B.R., (1976). Transformation from Spatial to Geographical Co-ordinates. *Survey Review*, XXIII (181):323-327.
- Brown, D.C., (1976)(1). Doppler positioning by the short arc method. *Proc. of 1st Symposium on Doppler Satellite Positioning*. New Mexico, vol 1: 97-140.
- Brown, D.C., (1976)(2). Doppler Surveying with the JMR Receiver. *Bulletin Geodesique*, 50(1): 9-26.
- Clarke, A.R., (1880). *Geodesy*. Oxford University Press.
- Cross, P., (1983). Advanced Least Squares Applied to Position Fixing. *North East London Polytechnic Working Paper no. 6*.
- Cross, P., (1986). Prospects for Satellite and Inertial Positioning. *Land and Minerals Surveying*, 4(4): 196-204.
- Decker, B.L., (1986). The World Geodetic System 1984. *Proc. of fourth Symposium on Satellite Positioning* Austin, Texas, vol 2: 69-92.
- Defense Mapping Agency,(1987). Department of defense World Geodetic System 1984. DMA technical Report TR 8350.2
- Gill, David, (1896). First Report on Geodetic Survey of South Africa
- Gill, David, (1905). The Origin and Progress of the Geodetic Survey of South Africa. British Association for the Advancement of Science.

- Guier, W.H., and Weiffenbach, G.C., (1960). A Satellite Doppler Navigation system.
Proc. IRE 48: 507-516
- Harvey, B.R., (1986). Transformation of 3-D Co-ordinates. *Australian Surveyor*, 33(2):
105-125.
- Hendrikz, D.R., (1943). Trigonometrical Survey Office Special Publications Nos.
1 and 2. Government Printer, Pretoria.
- Henriksen, I., (editor) (1977). National Geodetic Satellite Program. NASA-SP 365.
- Henry, W.M., and Walker, J.W., (1974). Doppler Geodetic Point Positioning in
Kenya using artificial Earth Satellites. *African Geodetic Journal* (2): 72-102.
- Hoar, G.J., (1982). *Satellite Surveying*. Magnavox corporation, Torrance California.
- Hopfield, H.S., (1969). Two Quartic Tropospheric Refraction Profiles for
Correcting Satellite Data. *Journal of Geophysical Res.* 74 : 4487.
- Hothem L.D., Vincenty, T., et al., (1982). Relationship Between Doppler and
other advanced Geodetic System Measurements based on Global Data.
Proc. of Third Symposium on Doppler Satellite Positioning. Las Cruces, New
Mexico, vol 1: 109-128.
- Husti G.J. (1985). Over de Absolute en Relatieve nauwkeurigheid van Doppler Satelliet
Waarnemingen. *Geodesia* . March 1985: 98-101
- Johnson, N.I., and Kotz, S., (1970). *Distributions in Statistics - Continuqus and Univariate
distributions*. Houghton Mifflin Co.
- Kaula, W.M., (1986). North American Datum of 1983. (NAD-83) *Symposium on Geodetic
positioning* held at the University of Cape Town.
- Kershner, R.B., (1976). The Doppler Concept and the Operational Navy
Navigation System. *Proc. of First Symposium on Doppler Satellite Positioning*.
New Mexico, vol 1: 5-24.

- King, R.W., Masters E.G. et al (1985). Surveying with GPS.
University of New South Wales, Kensington NSW.
- Knopp, T., (1987). A Comparison of ADOS Point Positioning Results 1987 using various softwares. Ohio State University.
- Kouba, J., and Wells, D.E., (1976). Semi-Dynamical Doppler Satellite Positioning. *Bulletin Geodesique*, 119: 27-42.
- Kouba, J., (1978). Geodetic Satellite Doppler Positioning and applications to Canadian test adjustments. *Proc of Royal Society discussion meeting on Satellite Doppler tracking*. October 1978, London.
- Kouba, J., (1983). Geodop V (Program Manual). Canadian dept. of Energy and Mines, Ottawa.
- Krakiwsky, E.J., and Wells, D.E., (1971)(1). Mathematical Models for Positioning by Satellite. University of New Brunswick.
- Krakiwsky, E.J., and Wells, D.E., (1971)(2). Co-ordinate systems used in Geodesy. University of New Brunswick.
- Krakiwsky, E.J., Wells, D.E., and Kirkham, P., (1972). Geodetic Control from Doppler Satellites Observations. *Canadian Surveyor*, 26(2): 146-162.
- Krakiwsky, E.J., Wells, D.E., et al., (1973). Geodetic control from Doppler Satellite Observations for lines under 200 km. *Canadian Surveyor*, 27(2): 141-148.
- Kumar, M., (1982). An unbiased Analysis of Doppler Co-ordinate Systems. *Proc. of 3rd Doppler Satellite Symposium*. New Mexico, vol 1: 169 - 182.
- Lachapelle, G., and Kouba, J., (1980). Relationship between terrestrial and Satellite Doppler systems. Reference Co-ordinate systems for earth dynamics: 195-203, D. Reidal, Dordrecht.

- Leroy, C., and Jenkins, R.E., (1979). Broadcast versus Precise Ephemeris. *Proc. of 2nd Doppler Symposium, Austin, Texas, vol 2: 39-62.*
- Martin, E.H., (1980). G.P.S. User equipment error models. *Institute of Navigation Special Publication (1980).*
- McCaw, G.T., (1931). The African Arc of Meridian. *South African Survey Journal vol IV (1931 - 1934).*
- McIntyre, D., (1951). Abbe de Lacaille's visit to the Cape 1751-1753. *Astronomical Society of South Africa.*
- McClelland, C.D., (1974). Geodetic Networks in Canada. *Canadian Surveyor, 28(5): 457-461*
- Meade, B.K., (1968) High Precision Geodimeter Traverse Survey in the United States *Bulletin Geodesique, 90: 371-385.*
- Meade, B.K., (1982). NWL-10F versus WGS'72. *Proc of 3rd Doppler Symposium. New Mexico, vol 1: 151-168.*
- Merry, C.L., (1977). Gravity and the South African Height system. *South African Survey Journal, 16(1): 44-53.*
- Merry, C.L., Rens J.(1989). Transformation Parameters for the Cape Datum. *SAJ of S&M, 20(3):95-102.*
- Merry, C.L., van Gysen, H., (1987). A Regional Geoid for Southern Africa presented at 19th General Assembly of the IUGG, Vancouver.
- Milford, K.S., (1983). A note on the calculation of the Chi-squared and F statistics. *Survey Review 27(210): 179-187.*

- Mittermayer, E., (1972). A Generalisation of the least square method for the adjustment of free networks. *Bulletin Geodesique*, 104: 139-157.
- Mueller, I.I., (1980).(Ed) Reference co-ordinate systems for Earth Dynamics .
Warsaw.
- Mueller, I.I., (1982). ADOS. *Proc. of 3rd Symposium on Doppler Satellite Positioning*. New Mexico, vol 1: 151-168.
- Ozone, M.I., (1985). Non-iterative solution of the ϕ equation. *ACM Surveying and Mapping*. 45(2) : 169-171.
- Rüther, H., (1981). Survey Network Adjustment. Parts 1 & 2 *South African Survey Journal*. Sept - Dec 1981.
- Saastemoinen, J., (1973). Contributions to the theory of atmospheric refraction. *Bulletin Geodesique* no. 107.
- Union of South Africa (1954). Trigonometrical Survey. Observation of the S.A. section of the arc of 30th Meridian. Mowbray, C.P.
- van der Sterr, W.C., (1920-44). South African Reports to the IUGG.
- Vanicek, P., and Krakiwsky, E.J., (1982) *Geodesy : The Concepts*. North Holland Publishing company, Amsterdam.
- Veis, G., (1981). Ideal Reference Frames, Concepts and Interrelationships. Reference Co-ordinate systems for earth dynamics. D. Reidel, Dordrecht.
- Vincenty, T., (1979). Determination of North American Datum 1983 Co-ordinates of Map Corners. (Second prediction) National Geodetic Survey, Rockland Md.
- Vincenty, T., (1985). On the Meaning of Geodetic Orientation. *Bulletin Geodesique*, 59: 189 - 199.

- Wadley, T.W., (1957). The Tellurometer System of Measurement. *Empire Survey Review* nos 105 & 106
- Wells, D.E., (1971). Orbital Information for US Navy Navigation Satellite System. Dept of Surveying Engineering University of New Brunswick.
- Wells, D.E., et al., (1976). Review of Doppler Satellite Positioning in Canada. *Bulletin Geodesique*, 50(4): 307-319
- Wells, D.E., and Krakiwsky, E.J., (1971). The Method of Least Squares. University of New Brunswick Dept of Surveying Engineering. (lecture notes)
- Whittingdale, W., (1934). Willem Cornelis van der Sterr, *South African Survey Journal*, 4(7): 272-277
- Whittingdale, W., (1943). Address on the centenary of Sir David Gill.
- Wonnacott, R.T., (1985). Modern Geodetic Surveying and distortions in the national network. *Proc. of 8th Conference of South African Surveyors*. Durban.
- Ziegler, R.E., (1979). Ephemeris Comparisons. *Proc. of 2nd Symposium on Doppler Satellite Positioning*. Austin, vol 1: 135-156.

APPENDIX A: COMPUTER RESULTS

INDEX TO COMPUTER RESULTS (Appendix A)

Program		Pg
AVERAGE	Only Broadcast Ephemeris used	A 1
AVERAGE	Broadcast and Precise ephemerides used	2
SHIFTZ	B.E. and P.E. Augmentation constant=0	3- 7
VARDIS	Computed for all B.E. subnets (10 pages in all)	8-12
SHIFTZ	B.E. only. Augmentation constant = 0	13-16
SHIFTZ	B.E. only. Augmentation constant = 3.0	17-20a
PARA7		23-25
SHIFT_R		26-30
SHIFT_S		31-33 & 40-41
BURSA	B.E. to P.E. 4 parameters (3 shifts & Z-rotation)	34-36
BURSA	7 parameters, Full weight matrix	37-39
SHIFT3	All P.E. points held fixed	42-46
SHIFT3	Only 1 point (Morgenzon) held fixed	47-51
SHIFT_F		52-56
MOLBAD	Summary of co-ordinates derived from SHIFTZ and FINSLN, 7 parameters allowed to vary in transforming between them.	57-62
BURSA	B.E. to P.E. 7 parameters	63-65
MOLBAD	B.E. to P.E. 7 parameters	66-68
MOLBAD	B.E. to P.E. 4 parameters (3 shifts & Z rotation)	66-68
FINSLN		72-77
ELLIPSOID	Ellipsoid axes and 3 shifts allowed to vary	78-79
ELLIPSOID	2 axes allowed to vary	80-81
ELLIPSOID	3 shifts allowed to vary, GRS'80 ellipsoid axes	82-83

Index to computer Results (cont.)

		pg
ASTROSP	Observed Astronomical Co-ordinates; one axis and three shifts allowed to vary.	84-88
ASTROSP	23 published trig. co-ordinates; one axis and shifts allowed to vary.	89-90
ASTROSP	23 trig. co-ordinates. 3 shifts vary; Mod Clarke 1880 parameters retained.	91-92
ASTROSP	20 trig. co-ordinates. 3 shifts vary; Mod Clarke 1880 parameters retained.	93-94
MIN 3-D SHIFTS	23 points; Clarke 1880 parameters retained	95
MIN 3-D SHIFTS	20 points; Clarke 1880 parameters retained	96
MINIMAX	Shifts computed from 20 points (excl NW Cape) results given for all 23 points in RSA. Mod Clarke 1880 parameters retained.	97
MINIMAX	As above but GRS'80 ellipsoid parameters used	98

POINT	N/SBNETS	X	SPREAD	Y	SPREAD	Z	SPREAD	AVERAGE
ACORN	3	5525476.61	10.54	2120236.53	.98	-2373275.48	2.96	
BRIT 44	1	5086492.99	.00	2667595.37	.00	-2767923.91	.00	
BLYDEBERG	3	4917288.01	3.57	2106615.29	3.61	-3463660.97	2.79	
BURENKAMP	3	5505888.41	16.52	1492431.95	4.03	-2843493.62	10.36	
COEGAKOP	2	4785913.16	2.03	2295265.11	1.44	-3524983.04	1.19	
DRUSE	1	5821904.69	.00	1398479.01	.00	-2192747.47	.00	
ESERE	4	5716998.25	8.67	1810402.99	2.76	-2169939.08	2.84	
FRANSMANSKOP	5	4988155.09	5.04	2267479.92	4.23	-3256553.91	4.50	
GEELOHOUT	1	5624230.27	.00	2124855.29	.00	-2125844.46	.00	
GRASKOP	6	5246337.65	7.88	1904110.12	6.08	-3079063.82	4.04	
HADIDA	4	5294746.89	10.99	2085812.37	5.70	-2872757.23	8.62	
HEXRIVIER	1	5022156.49	.00	1795163.19	.00	-3490365.54	.00	
INKOMINKULU	2	4776613.95	3.22	2809326.41	1.43	-3149351.41	3.76	
KARASBERG	4	5386696.09	9.78	1837218.04	7.40	-2872961.37	10.10	
KARSRIEVER	1	4944370.27	.00	1811092.31	.00	-3587438.45	.00	
KRANZBERG	4	5149889.47	7.85	2691093.00	2.83	-2626419.87	7.45	
LEEUKOP (RSA)	5	4986891.11	4.37	2475834.00	2.41	-3104543.30	4.48	
LEEUKOP (SWA)	2	5672677.30	8.11	1526108.31	.90	-2477898.98	2.58	
LOUISFNTN	3	5203446.13	1.21	1690208.01	4.32	-3268509.87	2.30	
LOURKOP	2	5545542.57	5.56	1663959.23	5.67	-2670132.07	7.01	
LUBISI	2	4815762.56	2.41	2506295.95	.39	-3339944.11	1.88	
MAGWAZA	1	4786229.78	.00	3006520.51	.00	-2946622.93	.00	
MANNERHEIM	3	5291630.29	6.76	2265092.73	1.54	-2740791.71	1.75	
MOOIDAM	5	4983832.46	6.41	2732710.57	4.99	-2887740.02	7.69	
MORGENZON	5	5138858.00	9.79	2424478.71	4.24	-2890847.72	8.06	
M' PUMBE NEW	2	4943182.06	3.57	3076443.65	1.43	-2596399.80	4.22	
OKOTOMARE	2	5812708.22	1.12	1662415.26	2.41	-2028991.12	.98	
ONDONDVENGO	1	5933897.86	.00	1289729.99	.00	-1947624.35	.00	
PONT	1	5157884.43	.00	2878303.57	.00	-2400479.13	.00	
POTLOER	5	5101369.94	3.74	1977625.59	4.87	-3269927.49	3.71	
RUNDU (BCN B)	1	5714711.93	.00	2054402.84	.00	-1947079.33	.00	
SCHWARZECK	4	5576037.78	10.04	1884767.78	7.18	-2452547.56	3.86	
THAMAKOOSH	3	5019370.25	5.76	2903705.00	4.86	-2651972.59	8.36	
UNIONS END	3	5444113.17	6.10	1979203.65	5.41	-2663037.03	3.86	
WITBANK NEW	3	5361113.01	5.70	1605150.54	1.95	-3050283.90	8.08	
WITWATER	6	5137634.17	6.27	2183074.06	5.65	-3078160.45	6.65	

POINT	N/SBNETS	X	SPREAD	Y	SPREAD	Z	SPREAD	AVERAGE (Incl P.E. Points)
ACORN	3	5525476.61	10.54	2120236.53	.98	-2373275.48	2.96	
BRIT 44	1	5086492.99	.00	2667595.37	.00	-2767923.91	.00	
BLYDEBERG	3	4917288.01	3.57	2106615.29	3.61	-3463660.97	2.79	
BURENKAMP	3	5505888.41	16.52	1492431.95	4.03	-2843493.62	10.36	
COEGAKOP	3	4785913.40	2.03	2295264.32	2.76	-3524984.19	3.27	
DRUSE	1	5821904.69	.00	1398479.01	.00	-2192747.47	.00	
ESERE	4	5716998.25	8.67	1810402.99	2.76	-2169939.08	2.84	
FRANSMANSKOP	5	4988155.09	5.04	2267479.92	4.23	-3256553.91	4.50	
GELHOUT	1	5624230.27	.00	2124855.29	.00	-2125844.46	.00	
GRASKOP	6	5246337.65	7.88	1904110.12	6.08	-3079063.82	4.04	
HADIDA	4	5294746.89	10.99	2085812.37	5.70	-2872757.23	8.62	
HEXRIVIER	2	5022155.66	1.48	1795161.56	2.92	-3490365.13	.73	
INKOMINKULU	2	4776613.95	3.22	2809326.41	1.43	-3149351.41	3.76	
KARASBERG	4	5386696.09	9.78	1837218.04	7.40	-2872961.37	10.10	
KARSRIVIER	1	4944370.27	.00	1811092.31	.00	-3587438.45	.00	
KRANZBERG	4	5149889.47	7.85	2691093.00	2.83	-2626419.87	7.45	
LEEUKOP (RSA)	5	4986891.11	4.37	2475834.00	2.41	-3104543.30	4.48	
LEEUKOP (SWA)	2	5672677.30	8.11	1526108.31	.90	-2477898.98	2.58	
LOUISFNTN	3	5203446.13	1.21	1690208.01	4.32	-3268509.87	2.30	
LOURKOP	2	5545542.57	5.56	1663959.23	5.67	-2670132.07	7.01	
LUBISI	2	4815762.56	2.41	2506295.95	.39	-3339944.11	1.88	
MAGWAZA	2	4786227.70	3.46	3006518.51	3.33	-2946621.06	3.12	
MANNERHEIM	3	5291630.29	6.76	2265092.73	1.54	-2740791.71	1.75	
MOOIDAM	5	4983832.46	6.41	2732710.57	4.99	-2887740.02	7.69	
MORGENZON	6	5138858.10	9.79	2424478.63	4.24	-2890848.28	8.06	
M' PUMBE NEW	2	4943182.06	3.57	3076443.65	1.43	-2596399.80	4.22	
OKOTOMARE	2	5812708.22	1.12	1662415.26	2.41	-2028991.12	.98	
ONDONDVENGO	1	5933897.86	.00	1289729.99	.00	-1947624.35	.00	
PONT	2	5157884.53	.20	2878302.31	2.47	-2400479.62	.95	
POTLOER	5	5101369.94	3.74	1977625.59	4.87	-3269927.49	3.71	
RUNDU (BCN B)	1	5714711.93	.00	2054402.84	.00	-1947079.33	.00	
SCHWARZECK	5	5576035.54	14.65	1884767.12	7.18	-2452547.52	3.86	
THAMAKOOSH	3	5019370.25	5.76	2903705.00	4.86	-2651972.59	8.36	
UNIONS END	3	5444113.17	6.10	1979203.65	5.41	-2663037.03	3.86	
WITBANK NEW	4	5361112.62	5.70	1605149.98	2.40	-3050284.58	8.08	
WITWATER	6	5137634.17	6.27	2183074.06	5.65	-3078160.45	6.65	

AUGM CONSTANT= .000

RESIDUALS

SHIFTZ

	PT	X	Y	Z	PT	X	Y	Z	PT	X	Y	Z	PT	X	Y	Z				
1851	17	1.98	-1.32	-2.96	25	1.98	-.95	-2.58	36	2.50	-1.37	-2.82								
18510	10	-3.10	-1.02	.52	19	-2.35	-1.83	.23	35	-2.74	-1.48	.53								
18511	10	.43	-1.20	-2.44	30	.68	1.21	-2.37	36	.30	-1.21	-2.28								
18512	10	-1.71	1.36	-1.36	11	-1.80	2.03	-1.56	36	-1.77	2.53	-1.59								
18513	11	3.37	-3.67	-6.72	25	3.26	-2.65	-6.29	36	3.55	-3.12	-5.25								
18514	10	-1.43	1.23	-.75	14	-1.70	.64	-.43	35	-1.86	-.14	-.30								
18515	4	3.75	-2.50	-8.56	14	2.19	-1.06	-8.14	35	2.96	-2.09	-7.55								
1851618	20	-6.92	-7.01	-3.10	4	-6.97	-6.52	-2.15	32	-6.87	-6.87	-2.10	34	-6.88	-6.70	-2.15	14	-6.93	-6.76	-2.32
18520	8	-.80	.68	-.90	30	-1.99	.65	-.19	3	-1.41	.47	-.55								
18521	8	2.21	-3.55	-1.89	3	1.73	-3.14	-1.83	5	1.78	-3.06	-1.81								
1852223	17	.19	-1.80	-2.97	8	-.45	-1.64	-2.97	21	.19	-1.59	-2.62	5	-.25	-1.62	-3.00				
18524	25	-6.53	-.80	1.77	11	-6.46	-.19	1.90	23	-6.38	-.78	2.08	16	-6.25	-.52	2.09	2	-6.49	-.58	1.88
18525	10	-7.45	-2.98	1.60	11	-7.62	-3.08	1.86	14	-7.59	-3.56	1.96	23	-8.04	-2.30	1.69	34	-7.85	-3.02	1.49
18526	7	-3.92	.00	-.24	1	-3.94	-.19	-.57	32	-3.65	.31	-.85								
18527	1*****	-.58	1.35		32*****	-1.29	1.76		34*****	-1.29	1.71		23*****	-.76	.33					
18528	7*****	-1.56	1.22		18*****	-2.25	1.70		32*****	-2.26	1.53		20*****	-1.34	3.91		4*****	-2.49	1.80	
18529	24	-1.02	-2.49	-.69	13	-1.32	-1.92	-.53	17	-2.30	-1.83	-.49	21	-2.22	-1.98	-.74				
1853	36	-2.72	-1.42	1.40	17	-2.39	-1.25	1.31	8	-2.83	-1.25	1.53								
18530	22	-4.19	-3.28	3.24	13	-4.54	-3.35	3.23	24	-4.70	-3.37	3.35	33	-4.56	-3.50	3.33	26	-4.19	-3.39	3.27
18531	29	-.38	-1.99	-.96	16	-.76	-1.79	-.87	33	-.30	-2.09	-.99	26	-.62	-1.96	-.95				
18532	31	-2.80	-.13	-1.74	27	-2.92	-.43	-1.98	9	-2.80	.07	-1.68	7	-3.14	-.42	-1.62	1	-2.78	.40	-1.61
18533	28	-4.01	-3.03	-.91	27	-4.04	-2.84	-1.00	6	-4.06	-3.06	-.91	7	-3.98	-2.76	-1.25	18	-4.14	-3.15	-.88
1854	17	1.98	.58	-3.17	24	1.38	.77	-3.20	25	2.46	1.59	-4.02								
1855	16	1.60	1.04	-1.33	24	1.71	1.08	-1.57	25	2.08	.30	-.83								
1856	16	1.41	.58	-5.36	24	.69	1.62	-4.34	33	1.20	1.36	-5.03								
1857	8	-.63	.44	-2.92	30	-.93	-.83	-2.66	36	-.68	.53	-2.87								
185819	19	-2.19	-2.73	1.40	30	-1.91	-3.17	1.05	12	-1.89	-2.97	1.08	3	-1.84	-2.87	.96	15	-1.95	-3.01	1.13
1859	10	-3.53	3.10	-.48	19	-3.40	1.59	-.90	30	-3.06	1.70	-1.06								

- A 3 -

'AUGMENTATION CONSTANT' = 0.00

	Pt	Residuals			
		X	Y	Z	
1961	35	.57	.31	-.59	(Precise Ephemeris - ADOS)
1962	22	-.73	.05	.12	
1963	12	-.41	-.05	.35	
1964	5	.00	-.30	.27	
1965	32	.96	.18	-.22	
1966	29	-.58	.48	-.01	
1967	25	-.27	-.14	.42	

- A 4 -

VtPV = 3690.13
Global Test 95% Confidence

sigma0 a priori = 1.00 sigma0 a posteriori = 4.05 Degrees of Freedom = 225 TEST FAILED sig0 (apriori) too low

			FINAL CO-ORDINATES						SHIFTZ
			X	MSEX	Y	MSEY	Z	MSEZ	
1	0	ACORN	5525470.146	.431	2120236.433	.494	-2373275.823	.297	
2	0	BRIT 44	5086486.500	.540	2667594.789	.543	-2767922.035	.370	
3	0	BLYDEBERG	4917287.161	.333	2106613.334	.372	-3463661.131	.247	
4	0	BURENKAMP	5505882.622	.434	1492427.864	.491	-2843496.323	.308	
5	0	COEGAKOP	4785913.743	.321	2295262.899	.364	-3524985.562	.230	
6	0	DRUSE	5821900.626	.652	1398475.951	.726	-2192748.382	.452	
7	0	ESERE	5716992.780	.423	1810401.700	.507	-2169939.649	.296	
8	0	FRANSMANSKOP	4988154.466	.319	2267478.886	.355	-3256555.329	.229	
9	0	GEELHOUT	5624227.475	.606	2124855.357	.680	-2125846.144	.409	
10	0	GRASKOP	5246334.818	.322	1904110.200	.370	-3079064.335	.228	
11	0	HADIDA	5294743.529	.337	2085811.692	.384	-2872758.067	.241	
12	0	HEXRIVIER	5022154.596	.303	1795160.225	.345	-3490364.465	.220	
13	0	INKOMINKULU	4776611.045	.482	2809323.791	.487	-3149350.103	.317	
14	0	KARASBERG	5386692.060	.341	1837214.966	.392	-2872963.346	.241	
15	0	KARSRIVIER	4944368.320	.356	1811089.296	.420	-3587437.319	.260	
16	0	KRANZBERG	5149888.020	.456	2691092.745	.467	-2626420.940	.306	
17	0	LEEUKOP (RSA)	4986890.828	.350	2475832.813	.369	-3104544.866	.243	
18	0	LEEUKOP (SWA)	5672669.790	.472	1526105.526	.567	-2477898.786	.343	
19	0	LOUISFNTN	5203443.614	.324	1690206.558	.378	-3268509.327	.246	
20	0	LOURKOP	5545533.157	.477	1663954.758	.546	-2670132.033	.335	
21	0	LUBISI	4815761.623	.425	2506294.179	.476	-3339945.853	.305	
22	0	MAGWAZA	4786225.593	.448	3006517.232	.449	-2946619.690	.289	
23	0	MANNERHEIM	5291621.226	.381	2265091.416	.426	-2740790.315	.271	
24	0	MOOIDAM	4983831.860	.414	2732709.865	.419	-2887741.102	.276	
25	0	MORGENZON	5138858.202	.347	2424478.213	.381	-2890849.896	.231	
26	0	M' PUMBE NEW	4943179.574	.539	3076440.938	.527	-2596398.538	.347	
27	0	OKOTOMARE	5812704.684	.510	1662413.490	.610	-2028992.549	.359	
28	0	ONDONDVENGO	5933893.854	.742	1289726.956	.833	-1947625.265	.515	
29	0	PONT	5157884.045	.506	2878301.575	.575	-2400480.094	.331	
30	0	POTLOER	5101368.475	.307	1977625.064	.357	-3269928.246	.224	
31	0	RUNDU (BCN B)	5714709.127	.608	2054402.705	.671	-1947081.072	.401	
32	0	SCHWARZECK	5576028.833	.329	1884765.054	.383	-2452547.606	.222	
33	0	THAMAKOOSH	5019368.819	.443	2903703.403	.483	-2651973.170	.297	
34	0	UNIONS END	5444104.175	.347	1979199.788	.401	-2663036.805	.243	
35	0	WITBANK NEW	5361112.496	.310	1605149.311	.348	-3050286.395	.224	
36	0	WITWATER	5137633.938	.325	2183073.849	.363	-3078162.460	.231	

		GEOGRAPHICAL CO-ORDINATES (GRS 80)							SHIFTZ	
		LATITUDE			LONGITUDE			HEIGHT		
		mse(M)			mse(M)			mse		
1	0	ACORN	21 59	3.6879	.26	20 59	34.2034	.49	1252.73	.45
2	0	BRIT 44	25 52	51.7524	.32	27 40	28.7334	.57	1629.45	.54
3	0	BLYDEBERG	33 05	51.3882	.21	23 11	26.7352	.37	1151.35	.36
4	0	BURENKAMP	26 38	54.1116	.27	15 09	58.3167	.49	110.94	.46
5	0	COEGAKOP	33 45	57.8593	.18	25 37	18.4053	.37	143.74	.35
6	0	DRUSE	20 14	18.0284	.41	13 30	25.5006	.72	797.69	.69
7	0	ESERE	20 00	57.8503	.26	17 34	17.2088	.50	1668.98	.45
8	0	FRANSMANSKOP	30 53	37.3130	.19	24 26	42.8961	.36	1498.93	.34
9	0	GEELHOUT	19 35	39.0089	.37	20 41	48.3468	.70	1253.10	.60
10	0	GRASKOP	29 02	52.6234	.19	19 56	52.4838	.37	1062.47	.34
11	0	HADIDA	26 56	24.6867	.20	21 30	5.2862	.38	990.60	.36
12	0	HEXRIVIER	33 22	44.0257	.18	19 40	9.6219	.35	2251.46	.32
13	0	INKOMINKULU	29 46	33.6531	.26	30 27	41.6075	.51	1012.92	.48
14	0	KARASBERG	26 56	21.7217	.21	18 49	57.8623	.39	1623.31	.36
15	0	KARSRIVIER	34 26	44.3054	.23	20 07	2.8099	.43	206.17	.37
16	0	KRANZBERG	24 28	4.2424	.26	27 35	22.1352	.49	2136.32	.46
17	0	LEEUKOP (RSA)	29 18	29.2379	.20	26 24	10.5758	.38	1672.29	.36
18	0	LEEUKOP (SWA)	23 00	32.0152	.30	15 03	27.5077	.56	698.23	.51
19	0	LOUISFNTN	31 01	28.1769	.21	17 59	42.2600	.38	559.54	.35
20	0	LOURKOP	24 54	17.3385	.30	16 42	7.3391	.55	1465.44	.50
21	0	LUBISI	31 46	20.6756	.26	27 29	38.6793	.48	1789.98	.45
22	0	MAGWAZA	27 41	31.8901	.23	32 08	7.4763	.47	591.68	.46
23	0	MANNERHEIM	25 36	41.6921	.23	23 10	24.4721	.43	1082.69	.41
24	0	MOOIDAM	27 05	20.2817	.23	28 44	11.8330	.44	1637.16	.42
25	0	MORGENZON	27 07	16.6346	.19	25 15	27.4264	.39	1461.77	.36
26	0	M'PUMBE NEW	24 10	38.5623	.30	31 53	47.4474	.56	438.72	.53
27	0	OKOTOMARE	18 40	6.3901	.32	15 57	37.2485	.60	1181.55	.54
28	0	ONDONDVENGO	17 53	41.7133	.46	12 15	44.8884	.82	992.77	.79
29	0	PONT	22 15	5.5761	.29	29 09	47.6304	.58	697.00	.53
30	0	POTLOER	31 02	4.0755	.19	21 11	22.5544	.36	1474.02	.33
31	0	RUNDU (BCN B)	17 53	21.5982	.37	19 46	23.5145	.70	1137.35	.60
32	0	SCHWARZECK	22 45	26.4597	.19	18 40	33.1463	.38	1514.63	.35
33	0	THAMAKOOSH	24 43	19.5898	.25	30 02	57.7283	.50	1980.73	.46
34	0	UNIONS END	24 50	8.2742	.21	19 58	43.3063	.40	1130.47	.37
35	0	WITBANK NEW	28 45	17.9592	.19	16 40	4.8583	.35	340.97	.33
36	0	WITWATER	29 02	10.8789	.19	23 01	17.4689	.37	1519.73	.35

CHORD DISTANCES AND THEIR MSE'S

SHIFTZ

				DISTANCE	MSE	PPM
MORGENZON	2725.00079	WITWATER	2923.00053	305554.516	.295	.96
LEEUKOP (RSA)	2926.00022	FRANSMANSKOP	3024.00026	257914.979	.237	.92
GRASKOP	2919.00010	POTLOER	3121.00053	250696.446	.237	.95
INKOMINKULU	2930.00051	WITWATER	2923.00053	726356.799	.531	.73
LEEUKOP (SWA)	2315.00079	UNIONS END	2419.00318	540196.943	.486	.90
DRUSE	2013.00007	GEELHOUT	1920.00009	755762.942	.776	1.03
ONDONDVENGO	1712.00004	ESERE	2017.00026	606277.123	.601	.99
BLYDEBERG	3323.00007	LUBISI	3127.00040	430531.861	.483	1.12
GRASKOP	2919.00010	INKOMINKULU	2930.00051	1022248.578	.562	.55
LOUISFNTN	3117.00005	UNIONS END	2419.00318	712763.332	.275	.39
M' PUMBE NEW	2431.00066	INKOMINKULU	2930.00051	636279.873	.299	.47
PONT	2229.00023	HEXRIVIER	3319.00029	1542551.655	.458	.30
SCHWARZECK	2218.00179	COEGAKOP	3325.00133	1393884.323	.309	.22
LOUISFNTN	3117.00005	INKOMINKULU	2930.00051	1203664.547	.572	.48
HEXRIVIER	3319.00029	COEGAKOP	3325.00133	554176.006	.435	.79
HEXRIVIER	3319.00029	KARSRIVIER	3420.00022	125409.645	.221	1.76
COEGAKOP	3325.00133	ONDONDVENGO	1712.00004	2194772.511	.564	.26
KRANZBERG	2427.00025	BRIT 44	2527.00292	156826.230	.309	1.97

- A 7 -

CHORD DISTANCE MSE COMPUTED RIGOROUSLY FROM CO-VARIANCE MATRIX OUTPUT BY GEODOP(V)

 INPUT FILE= GDOP.1851

FROM	TO	DIST	MSE(1 SIG)	PPM
LEEUKOP	MORGENZON	267201.782	.104	.39
LEEUKOP	WITWATER	330343.960	.266	.81
MORGENZON	WITWATER	305554.034	.153	.50

INPUT FILE= GDOP.1853

FROM	TO	DIST	MSE(1 SIG)	PPM
WITWATER	LEEUKOP	330344.246	.143	.43
WITWATER	FRANSMANS	247572.865	.076	.31
LEEUKOP	FRANSMANS	257915.104	.085	.33

INPUT FILE= GDOP.1854

FROM	TO	DIST	MSE(1 SIG)	PPM
LEEUKOP	MOOIDAM	336153.183	.140	.42
LEEUKOP	MORGENZON	267202.616	.133	.50
MOOIDAM	MORGENZON	345035.862	.269	.78

INPUT FILE= GDOP.1855

FROM	TO	DIST	MSE(1 SIG)	PPM
KRANS	MOOIDAM	312401.611	.101	.32
KRANS	MORGENZON	375669.429	.203	.54
MOOIDAM	MORGENZON	345034.766	.317	.92

CHORD DISTANCE MSE COMPUTED RIGOROUSLY FROM CO-VARIANCE MATRIX OUTPUT BY GEODOP(V)

INPUT FILE= GDOP.1856

FROM	TO	DIST	MSE(1 SIG)	PPM
KRANZBERG	MOOIDAM	312402.091	.162	.52
KRANZBERG	THAMAKOOSH	250780.982	.252	1.01
MOOIDAM	THAMAKOOSH	293408.523	.179	.61

INPUT FILE= GDOP.1857

FROM	TO	DIST	MSE(1 SIG)	PPM
FRANSMANS	POTLOER	311465.610	.199	.64
FRANSMANS	WITWATER	247572.921	.114	.46
POTLOER	WITWATER	283369.038	.116	.41

INPUT FILE= GDOP.1859

FROM	TO	DIST	MSE(1 SIG)	PPM
GRASKOP	LOUISFONTEIN	288934.306	.169	.59
GRASKOP	POTLOER	250696.689	.141	.56
LOUISFONTEIN	POTLOER	305009.422	.245	.80

INPUT FILE= GDOP.18510

FROM	TO	DIST	MSE(1 SIG)	PPM
GRASKOP	LOUISFONTEIN	288935.002	.129	.45
GRASKOP	WITBANK NEW	321526.580	.219	.68
LOUISFONTEIN	WITBANK NEW	282339.366	.085	.30

CHORD DISTANCE MSE COMPUTED RIGOROUSLY FROM CO-VARIANCE MATRIX, OUTPUT BY GEODOP(V)

INPUT FILE= GDOP.18511

FROM	TO	DIST	MSE(1 SIG)	PPM
GRASKOP	POTLOER	250695.940	.119	.48
GRASKOP	WITWATER	299395.040	.237	.79
POTLOER	WITWATER	283371.656	.119	.42

INPUT FILE= GDOP.18512

FROM	TO	DIST	MSE(1 SIG)	PPM
GRASKOP	HADIDA	279143.260	.088	.31
GRASKOP	WITWATER	299393.967	.155	.52
HADIDA	WITWATER	276286.471	.081	.29

INPUT FILE= GDOP.18513

FROM	TO	DIST	MSE(1 SIG)	PPM
HADIDA	MORGENZON	373258.426	.326	.87
HADIDA	WITWATER	276287.654	.183	.66
MORGENZON	WITWATER	305554.778	.226	.74

INPUT FILE= GDOP.18514

FROM	TO	DIST	MSE(1 SIG)	PPM
GRASKOP	KARASBERG	258171.667	.096	.37
GRASKOP	WITBANK	321525.977	.228	.71
KARASBERG	WITBANK	293175.580	.137	.47

CHORD DISTANCE MSE COMPUTED RIGOROUSLY FROM CO-VARIANCE MATRIX OUTPUT BY GEODOP(V)

INPUT FILE= GDOP.18515

FROM	TO	DIST	MSE(1 SIG)	PPM
BURENKAMP	KARASBERG	365993.861	.258	.70
BURENKAMP	WITBANK NEW	276453.871	.146	.53
KARASBERG	WITBANK NEW	293175.742	.184	.63

INPUT FILE= GDOP.1851618

FROM	TO	DIST	MSE(1 SIG)	PPM
LOURKUPPE	BURENKAMP	247081.592	.111	.45
LOURKUPPE	SCHWARZECK	311495.826	.111	.36
LOURKUPPE	UNIONS END	331236.185	.164	.49
LOURKUPPE	KARASBERG	310467.980	.115	.37
BURENKAMP	SCHWARZECK	558292.107	.109	.19
BURENKAMP	UNIONS END	522809.057	.161	.31
BURENKAMP	KARASBERG	365995.918	.155	.42
SCHWARZECK	UNIONS END	265758.694	.074	.28
SCHWARZECK	KARASBERG	463528.445	.065	.14
UNIONS END	KARASBERG	259855.532	.068	.26

- A 11 -

CHORD DISTANCE MSE COMPUTED RIGOROUSLY FROM CO-VARIANCE MATRIX OUTPUT BY GEODOP(V)

INPUT FILE= GDOP.185819

FROM	TO	DIST	MSE(1 SIG)	PPM
LOUISFNTN	POTLOER	305009.919	.105	.35
LOUISFNTN	HEXRIVIER	305124.060	.064	.21
LOUISFNTN	BLYDEBERG	541631.316	.106	.20
LOUISFNTN	KARSRIVIER	428307.980	.062	.14
POTLOER	HEXRIVIER	296918.284	.063	.21
POTLOER	BLYDEBERG	296742.725	.063	.21
POTLOER	KARSRIVIER	391401.721	.054	.14
HEXRIVIER	BLYDEBERG	329716.912	.104	.32
HEXRIVIER	KARSRIVIER	125409.660	.057	.45
BLYDEBERG	KARSRIVIER	321540.592	.087	.27

INPUT FILE= GDOP.18520

FROM	TO	DIST	MSE(1 SIG)	PPM
FRANSMANS	POTLOER	311467.107	.191	.61
FRANSMANS	BLYDEBERG	271648.132	.086	.32
POTLOER	BLYDEBERG	296743.074	.108	.36

INPUT FILE= GDOP.18521

FROM	TO	DIST	MSE(1 SIG)	PPM
FRANSMANS	BLYDEBERG	271648.312	.088	.32
FRANSMANS	COEGAKOP	337235.666	.080	.24
BLYDEBERG	COEGAKOP	237925.003	.168	.70

CHORD DISTANCE MSE COMPUTED RIGOROUSLY FROM CO-VARIANCE MATRIX, OUTPUT BY GEODOP(V)

INPUT FILE= GDOP.1852223

FROM	TO	DIST	MSE(1 SIG)	PPM
LEEUKOP	FRANSMANS	257915.104	.119	.46
LEEUKOP	LUBISI	292620.702	.094	.32
LEEUKOP	COEGAKOP	499767.466	.083	.17
FRANSMANS	LUBISI	306114.801	.173	.57
FRANSMANS	COEGAKOP	337235.995	.083	.25
LUBISI	COEGAKOP	282249.202	.120	.43

INPUT FILE= GDOP.18524

FROM	TO	DIST	MSE(1 SIG)	PPM
MORGENZON	HADIDA	373259.894	.160	.43
MORGENZON	MANNERHEIM	266942.766	.106	.40
MORGENZON	KRANZBERG	375669.156	.120	.32
MORGENZON	BRIT 44	277415.929	.114	.41
HADIDA	MANNERHEIM	222635.632	.109	.49
HADIDA	KRANZBERG	669350.892	.203	.30
HADIDA	BRIT 44	626764.395	.201	.32
MANNERHEIM	KRANZBERG	463298.601	.184	.40
MANNERHEIM	BRIT 44	452576.108	.163	.36
KRANZBERG	BRIT 44	156825.930	.094	.60

- A 12.1 -

CHORD DISTANCE MSE COMPUTED RIGOROUSLY FROM CO-VARIANCE MATRIX OUTPUT BY GEODOP(V)

INPUT FILE= GDOP.18525

FROM	TO	DIST	MSE(1 SIG)	PPM
GRASKOP	HADIDA	279143.435	.091	.33
GRASKOP	KARASBERG	258171.567	.094	.37
GRASKOP	MANNERHEIM	496776.732	.115	.23
GRASKOP	UNIONS END	466722.963	.072	.15
HADIDA	KARASBERG	265055.955	.154	.58
HADIDA	MANNERHEIM	222634.729	.106	.47
HADIDA	UNIONS END	278671.745	.082	.30
KARASBERG	MANNERHEIM	457804.914	.181	.40
KARASBERG	UNIONS END	259855.855	.089	.34
MANNERHEIM	UNIONS END	333212.004	.154	.46

INPUT FILE= GDOP.18526

FROM	TO	DIST	MSE(1 SIG)	PPM
ESERE	ACORN	417161.901	.136	.33
ESERE	SCHWARZECK	324449.822	.082	.25
ACORN	SCHWARZECK	253549.067	.144	.57

INPUT FILE= GDOP.18527

FROM	TO	DIST	MSE(1 SIG)	PPM
ACORN	SCHWARZECK	253548.291	.162	.64
ACORN	UNIONS END	332375.167	.097	.29
ACORN	MANNERHEIM	459058.354	.154	.34
SCHWARZECK	UNIONS END	265759.112	.117	.44
SCHWARZECK	MANNERHEIM	555534.670	.241	.43
UNIONS END	MANNERHEIM	333211.812	.263	.79

CHORD DISTANCE MSE COMPUTED RIGOROUSLY FROM CO-VARIANCE MATRIX OUTPUT BY GEODOP(V)

INPUT FILE= GDOP.18528

FROM	TO	DIST	MSE(1 SIG)	PPM
ESERE	LEEUKOP	421458.819	.108	.26
ESERE	SCHWARZECK	324450.460	.098	.30
ESERE	LOURKUPPE	548671.168	.125	.23
ESERE	BURENKAMP	774179.072	.094	.12
LEEUKOP	SCHWARZECK	372315.439	.189	.51
LEEUKOP	LOURKUPPE	268552.214	.144	.54
LEEUKOP	BURENKAMP	403253.745	.075	.19
SCHWARZECK	LOURKUPPE	311498.941	.163	.52
SCHWARZECK	BURENKAMP	558291.896	.135	.24
LOURKUPPE	BURENKAMP	247078.268	.157	.64

INPUT FILE= GDOP.18529

FROM	TO	DIST	MSE(1 SIG)	PPM
MOOIDAM	INKOMINKULU	342416.850	.105	.31
MOOIDAM	LEEUKOP	336153.959	.113	.34
MOOIDAM	LUBISI	532917.052	.084	.16
INKOMINKULU	LEEUKOP	396789.361	.198	.50
INKOMINKULU	LUBISI	360119.988	.151	.42
LEEUKOP	LUBISI	292620.303	.078	.27

CHORD DISTANCE MSE COMPUTED RIGOROUSLY FROM CO-VARIANCE MATRIX OUTPUT BY GEODOP(V)

INPUT FILE= GDOP.18530

FROM	TO	DIST	MSE(1 SIG)	PPM
MAGWAZA	INKOMINKULU	282979.280	.091	.32
MAGWAZA	MOOIDAM	342761.639	.160	.47
MAGWAZA	THAMAKOOSH	389542.161	.089	.23
MAGWAZA	MPUMBE NEW	390100.917	.087	.22
INKOMINKULU	MOOIDAM	342417.038	.092	.27
INKOMINKULU	THAMAKOOSH	561446.876	.074	.13
INKOMINKULU	MPUMBE NEW	636279.759	.090	.14
MOOIDAM	THAMAKOOSH	293407.953	.085	.29
MOOIDAM	MPUMBE NEW	452420.438	.128	.28
THAMAKOOSH	MPUMBE NEW	196803.516	.141	.72

INPUT FILE= GDOP.18531

FROM	TO	DIST	MSE(1 SIG)	PPM
PONT	KRANS	293531.026	.119	.41
PONT	THAMA	288236.887	.078	.27
PONT	MPUMBE	351768.600	.125	.35
KRANS	THAMA	250782.201	.183	.73
KRANS	MPUMBE	438318.556	.218	.50
THAMA	MPUMBE	196803.204	.140	.71

CHORD DISTANCE MSE COMPUTED RIGOROUSLY FROM CO-VARIANCE MATRIX OUTPUT BY GEODOP(V)

INPUT FILE= GDOP.18532

FROM	TO	DIST	MSE(1 SIG)	PPM
RUNDU	OKOTOMARE	412271.653	.179	.44
RUNDU	GEELHOUT	212385.146	.090	.42
RUNDU	ESERE	330465.684	.111	.34
RUNDU	ACORN	470943.185	.090	.19
OKOTOMARE	GEELHOUT	508681.040	.204	.40
OKOTOMARE	ESERE	225671.043	.117	.52
OKOTOMARE	ACORN	640808.914	.183	.29
GEELHOUT	ESERE	330802.819	.167	.50
GEELHOUT	ACORN	266450.429	.082	.31
ESERE	ACORN	417161.491	.156	.37

INPUT FILE= GDOP.18533

FROM	TO	DIST	MSE(1 SIG)	PPM
ONDONDVENGO	OKOTOMARE	400253.091	.165	.41
ONDONDVENGO	DRUSE	290609.985	.086	.30
ONDONDVENGO	ESERE	606276.775	.183	.30
ONDONDVENGO	LEEUKOP	636634.020	.098	.15
OKOTOMARE	DRUSE	310746.643	.125	.40
OKOTOMARE	ESERE	225670.735	.102	.45
OKOTOMARE	LEEUKOP	489598.241	.077	.16
DRUSE	ESERE	425685.922	.174	.41
DRUSE	LEEUKOP	346222.365	.092	.27
ESERE	LEEUKOP	421458.970	.107	.25

- A 12.5 -

AUGM CONSTANT= .000

RESIDUALS				RESIDUALS				RESIDUALS				RESIDUALS				SHIFTZ					
PT	X	Y	Z	PT	X	Y	Z	PT	X	Y	Z	PT	X	Y	Z	PT	X	Y	Z		
1851	17	4.12	-.47	-1.72	25	4.12	-.05	-1.31	36	4.82	-.41	-1.69									
18510	10	-.59	.14	1.48	19	.17	-.59	1.14	35	.11	.02	1.09									
18511	10	2.94	-.04	-1.48	30	3.07	2.29	-1.30	36	2.62	-.25	-1.15									
18512	10	.80	2.52	-.40	11	.60	3.08	-.49	36	.55	3.49	-.46									
18513	11	5.77	-2.62	-5.65	25	5.40	-1.75	-5.02	36	5.87	-2.16	-4.12									
18514	10	1.08	2.39	.21	14	1.01	1.89	.43	35	.99	1.36	.26									
18515	4	6.52	-1.03	-7.76	14	4.90	.19	-7.28	35	5.81	-.59	-6.99									
1851618	20	-4.15	-5.64	-2.25	4	-4.20	-5.05	-1.35	32	-4.02	-5.58	-1.19	34	-4.22	-5.52	-1.20	14	-4.22	-5.51	-1.46	
18520	8	1.51	1.57	.27	30	.40	1.73	.88	3	.98	1.49	.54									
18521	8	4.52	-2.66	-.72	3	4.12	-2.12	-.74	5	4.17	-2.29	-.57									
1852223	17	2.33	-.95	-1.73	8	1.86	-.75	-1.80	21	2.37	-.80	-1.42	5	2.14	-.85	-1.76					
18524	25	-4.39	.10	3.04	11	-4.06	.86	2.97	23	-4.06	.19	3.21	16	-4.50	.37	3.41	2	-4.47	.22	3.19	
18525	10	-4.94	-1.82	2.56	11	-5.22	-2.03	2.93	14	-4.88	-2.31	2.82	23	-5.72	-1.33	2.82	34	-5.19	-1.84	2.44	
18526	7	-1.23	1.26	.71	1	-1.25	.94	.39	32	-.80	1.60	.06									
18527	1	*****	.55	2.31	32	*****	.00	2.67	34	*****	-.11	2.66	23	*****	.21	1.46					
18528	7	-9.12	-.30	2.17	18	-9.55	-.86	2.59	32	-9.60	-.97	2.44	20	-9.71	.03	4.76	4	*****	-1.02	2.60	
18529	24	.82	-1.67	.59	13	.48	-1.15	.72	17	-.16	-.98	.75	21	-.04	-1.19	.46					
1853	36	-.40	-.46	2.53	17	-.25	-.40	2.55	8	-.52	-.36	2.70									
18530	22	-2.88	-2.47	4.54	13	-2.74	-2.58	4.48	24	-2.86	-2.55	4.63	33	-3.03	-2.66	4.65	26	-2.73	-2.59	4.60	
18531	29	1.00	-1.09	.38	16	.99	-.90	.45	33	1.23	-1.25	.33	26	.84	-1.16	.38					
18532	31	-.19	1.01	-.74	27	-.29	.87	-1.02	9	-.15	1.18	-.70	7	-.45	.84	-.67	1	-.09	1.53	-.65	
18533	28	-1.45	-1.63	.04	27	-1.41	-1.54	-.04	6	-1.44	-1.66	.02	7	-1.29	-1.50	-.30	18	-1.44	-1.76	.01	
1854	17	4.12	1.43	-1.93	24	3.22	1.59	-1.92	25	4.60	2.49	-2.75									
1855	16	3.35	1.93	-.01	24	3.55	1.90	-.29	25	4.22	1.20	.44									
1856	16	3.16	1.47	-4.04	24	2.53	2.44	-3.06	33	2.73	2.20	-3.71									
1857	8	1.68	1.33	-1.75	30	1.46	.25	-1.59	36	1.64	1.49	-1.74									
185819	19	.33	-1.49	2.31	30	.48	-2.09	2.12	12	.49	-1.82	2.14	3	.55	-1.85	2.05	15	.52	-1.86	2.11	
1859	10	-1.02	4.26	.48	19	-.88	2.83	.01	30	-.67	2.78	.01									

- A 13 -

VtPV = 3122.84
 SIGMA 0 = 3.913

Global Test 95% Confidence

 sigma0 a priori = 1.00 sigma0 a posteriori = 3.91 Degrees of Freedom = 204 TEST FAILED sig0 (apriori) too low

13

			FINAL CO-ORDINATES					
			X	MSEX	Y	MSEY	Z	MSEZ
1	0	ACORN	5525472.839	.999	2120237.563	1.030	-2373274.858	.865
2	0	BRIT 44	5086488.521	1.079	2667595.594	1.012	-2767920.724	.872
3	0	BLYDEBERG	4917289.549	.993	2106614.350	.982	-3463660.040	.796
4	0	BURENKAMP	5505885.393	.983	1492429.332	1.061	-2843495.519	.851
5	0	COEGAKOP	4785916.127	1.033	2295263.675	1.008	-3524984.320	.808
6	0	DRUSE	5821903.249	1.073	1398477.346	1.177	-2192747.455	.930
7	0	ESERE	5716995.469	.985	1810402.964	1.049	-2169938.702	.874
8	0	FRANSMANSKOP	4988156.776	.991	2267479.778	.958	-3256554.158	.802
9	0	GEELHOUT	5624230.120	1.075	2124856.474	1.121	-2125845.158	.914
10	0	GRASKOP	5246337.334	.961	1904111.359	.979	-3079063.379	.808
11	0	HADIDA	5294745.928	.965	2085812.744	.966	-2872756.996	.818
12	0	HEXRIVIER	5022156.979	.999	1795161.369	1.026	-3490363.399	.808
13	0	INKOMINKULU	4776612.846	1.105	2809324.557	1.004	-3149348.853	.853
14	0	KARASBERG	5386694.772	.965	1837216.219	.996	-2872962.489	.827
15	0	KARSRIVIER	4944370.787	1.004	1811090.451	1.025	-3587436.344	.799
16	0	KRANZBERG	5149889.770	1.054	2691093.630	.975	-2626419.621	.860
17	0	LEEUKOP (RSA)	4986892.974	1.004	2475833.655	.949	-3104543.633	.813
18	0	LEEUKOP (SWA)	5672672.490	.991	1526106.924	1.092	-2477897.895	.876
19	0	LOUISFNTN	5203446.133	.973	1690207.802	1.007	-3268508.417	.813
20	0	LOURKOP	5545535.929	1.009	1663956.132	1.079	-2670131.175	.869
21	0	LUBISI	4815763.803	1.045	2506294.975	1.001	-3339944.654	.823
22	0	MAGWAZA	4786226.902	1.175	3006518.039	1.027	-2946618.391	.897
23	0	MANNERHEIM	5291623.554	.988	2265092.387	.972	-2740789.182	.834
24	0	MOOIDAM	4983833.698	1.048	2732710.682	.961	-2887739.816	.840
25	0	MORGENZON	5138860.339	.999	2424479.106	.957	-2890848.625	.824
26	0	M'PUMBE NEW	4943181.025	1.155	3076441.744	1.008	-2596397.213	.898
27	0	OKOTOMARE	5812707.307	1.011	1662414.793	1.103	-2028991.588	.898
28	0	ONDONDVENGO	5933896.414	1.123	1289728.362	1.243	-1947624.314	.967
29	0	PONT	5157885.434	1.133	2878302.483	1.068	-2400478.747	.908
30	0	POTLOER	5101370.858	.969	1977626.138	.977	-3269927.184	.800
31	0	RUNDU (BCN B)	5714711.742	1.075	2054403.852	1.117	-1947080.072	.916
32	0	SCHWARZECK	5576031.681	.969	1884766.341	1.017	-2452546.705	.852
33	0	THAMAKOOSH	5019370.352	1.090	2903704.243	.992	-2651971.847	.870
34	0	UNIONS END	5444106.834	.966	1979200.969	.991	-2663035.865	.835
35	0	WITBANK NEW	5361115.354	.981	1605150.806	1.038	-3050285.828	.834
36	0	WITWATER	5137636.257	.975	2183074.814	.957	-3078161.328	.807

GEOGRAPHICAL CO-ORDINATES (GRS 80)

SHIFTZ

			LATITUDE		mse(M)	LONGITUDE		mse(M)	HEIGHT	mse		
1	0	ACORN	21	59	3.6233	.80	20	59	34.2066	1.02	1255.07	1.06
2	0	BRIT 44	25	52	51.6834	.82	27	40	28.7252	1.06	1630.82	1.08
3	0	BLYDEBERG	33	05	51.3125	.78	23	11	26.7349	.98	1152.93	1.00
4	0	BURENKAMP	26	38	54.0436	.80	15	09	58.3417	1.03	113.31	1.05
5	0	COEGAKOP	33	45	57.7809	.79	25	37	18.3924	1.03	145.12	1.02
6	0	DRUSE	20	14	17.9677	.86	13	30	25.5263	1.15	800.07	1.16
7	0	ESERE	20	00	57.7886	.81	17	34	17.2224	1.02	1671.42	1.06
8	0	FRANSMANSKOP	30	53	37.2391	.78	24	26	42.8907	.97	1500.45	1.00
9	0	GEELHOUT	19	35	38.9474	.85	20	41	48.3506	1.13	1255.47	1.12
10	0	GRASKOP	29	02	52.5528	.77	19	56	52.4923	.97	1064.42	1.00
11	0	HADIDA	26	56	24.6171	.77	21	30	5.2898	.96	992.45	1.01
12	0	HEXRIVIER	33	22	43.9499	.80	19	40	9.6325	1.01	2253.07	1.02
13	0	INKOMINKULU	29	46	33.5866	.81	30	27	41.5981	1.07	1013.98	1.08
14	0	KARASBERG	26	56	21.6532	.78	18	49	57.8736	.98	1625.57	1.02
15	0	KARSRIVIER	34	26	44.2295	.80	20	07	2.8192	1.02	207.85	1.01
16	0	KRANZBERG	24	28	4.1770	.80	27	35	22.1342	1.02	2137.56	1.06
17	0	LEEUKOP (RSA)	29	18	29.1665	.78	26	24	10.5684	.98	1673.69	1.01
18	0	LEEUKOP (SWA)	23	00	31.9508	.82	15	03	27.5305	1.06	700.61	1.08
19	0	LOUISFNTN	31	01	28.1050	.79	17	59	42.2752	.99	561.46	1.02
20	0	LOURKOP	24	54	17.2714	.81	16	42	7.3576	1.06	1467.85	1.08
21	0	LUBISI	31	46	20.6032	.79	27	29	38.6679	1.03	1791.31	1.04
22	0	MAGWAZA	27	41	31.8295	.83	32	08	7.4758	1.11	592.44	1.14
23	0	MANNERHEIM	25	36	41.6235	.78	23	10	24.4713	.98	1084.48	1.02
24	0	MOOIDAM	27	05	20.2148	.79	28	44	11.8269	1.01	1638.36	1.04
25	0	MORGENZON	27	07	16.5636	.78	25	15	27.4226	.98	1463.25	1.02
26	0	M'PUMBE NEW	24	10	38.5010	.83	31	53	47.4445	1.10	439.69	1.13
27	0	OKOTOMARE	18	40	6.3305	.83	15	57	37.2666	1.07	1183.97	1.10
28	0	ONDONDVENGO	17	53	41.6559	.89	12	15	44.9166	1.21	995.14	1.22
29	0	PONT	22	15	5.5152	.83	29	09	47.6344	1.11	698.02	1.15
30	0	POTLOER	31	02	4.0023	.78	21	11	22.5597	.97	1475.71	1.00
31	0	RUNDU (BCN B)	17	53	21.5388	.85	19	46	23.5211	1.12	1139.76	1.13
32	0	SCHWARZECK	22	45	26.3936	.79	18	40	33.1570	1.00	1517.15	1.04
33	0	THAMAKOOSH	24	43	19.5270	.81	30	02	57.7268	1.05	1981.77	1.08
34	0	UNIONS END	24	50	8.2069	.78	19	58	43.3135	.98	1132.71	1.02
35	0	WITBANK NEW	28	45	17.8936	.79	16	40	4.8808	1.01	343.47	1.04
36	0	WITWATER	29	02	10.8071	.77	23	01	17.4682	.96	1521.38	1.00

CHORD DISTANCES AND THEIR MSE'S

			DISTANCE	MSE	SHIFTZ PPM	
MORGENZON	2725.00079	WITWATER	2923.00053	305554.544	.299	.98
LEEUKOP (RSA)	2926.00022	FRANSMANSKOP	3024.00026	257914.976	.234	.91
GRASKOP	2919.00010	POTLOER	3121.00053	250696.417	.237	.94
INKOMINKULU	2930.00051	WITWATER	2923.00053	726356.874	.570	.78
LEEUKOP (SWA)	2315.00079	UNIONS END	2419.00318	540196.760	.477	.88
DRUSE	2013.00007	GEELOHOUT	1920.00009	755762.675	.756	1.00
ONDONDVENGO	1712.00004	ESERE	2017.00026	606276.957	.584	.96
BLYDEBERG	3323.00007	LUBISI	3127.00040	430531.736	.491	1.14
GRASKOP	2919.00010	INKOMINKULU	2930.00051	1022248.540	.624	.61
LOUISFNTN	3117.00005	UNIONS END	2419.00318	712763.379	.287	.40
M'PUMBE NEW	2431.00066	INKOMINKULU	2930.00051	636279.864	.292	.46
PONT	2229.00023	HEXRIVIER	3319.00029	1542551.601	.543	.35
SCHWARZECK	2218.00179	COEGAKOP	3325.00133	1393884.173	.398	.29
LOUISFNTN	3117.00005	INKOMINKULU	2930.00051	1203664.392	.650	.54
HEXRIVIER	3319.00029	COEGAKOP	3325.00133	554175.662	.540	.97
HEXRIVIER	3319.00029	KARSRIVIER	3420.00022	125409.664	.222	1.77
COEGAKOP	3325.00133	ONDONDVENGO	1712.00004	2194772.105	.612	.28
KRANZBERG	2427.00025	BRIT 44	2527.00292	156826.140	.304	1.94

AUGM CONSTANT= 3.000

RESIDUALS

SHIFTZ

	PT	X	Y	Z	PT	X	Y	Z	PT	X	Y	Z	PT	X	Y	Z		
1851	17	2.61	-.26	-1.59	25	2.63	-.40	-1.32	36	3.31	-.81	-1.24						
1857	8	-.02	1.36	-1.49	30	.51	-.23	-1.69	36	.13	1.09	-1.29						
1854	17	2.61	1.64	-1.80	24	2.42	1.56	-2.25	25	3.11	2.14	-2.76						
1855	16	2.99	1.79	-.26	24	2.75	1.87	-.62	25	2.73	.85	.43						
1856	16	2.80	1.33	-4.29	24	1.73	2.41	-3.39	33	2.41	2.48	-4.24						
1859	10	-1.01	3.54	.26	19	-1.30	2.80	-.71	30	-1.62	2.30	-.09						
18511	10	2.95	-.76	-1.70	30	2.12	1.81	-1.40	36	1.11	-.65	-.70						
18513	11	6.16	-2.80	-5.49	25	3.91	-2.10	-5.03	36	4.36	-2.56	-3.67						
18512	10	.81	1.80	-.62	11	.99	2.90	-.33	36	-.96	3.09	-.01						
18514	10	1.09	1.67	-.01	14	2.48	2.51	.88	35	.10	1.10	.68						
18515	4	8.86	.42	-6.84	14	6.37	.81	-6.83	35	4.92	-.85	-6.57						
18520	8	-.19	1.60	.53	30	-.55	1.25	.78	3	-.52	1.86	.07						
18521	8	2.82	-2.63	-.46	3	2.62	-1.75	-1.21	5	1.96	-2.16	-.78						
18525	10	-4.93	-2.54	2.34	11	-4.83	-2.21	3.09	14	-3.41	-1.69	3.27	23	-2.62	-1.20	2.04		
1851618	20	-.25	-4.37	-3.00	4	-1.86	-3.60	-.43	32	-1.78	-5.12	-1.68	34	-.79	-4.43	-1.77		
18526	7	1.26	1.48	.55	1	1.57	.53	-.04	32	1.44	2.06	-.43						
18527	1	-7.81	.14	1.88	32	-8.60	.46	2.18	34	-6.89	.98	2.09	23	-7.72	.34	.68		
18528	7	-6.63	-.08	2.01	18	-6.22	.15	2.22	32	-7.36	-.51	1.95	20	-5.81	1.30	4.01		
1852223	17	.82	-.74	-1.60	8	.16	-.72	-1.54	21	1.20	-.27	-1.26	5	-.07	-.72	-1.97		
18529	24	.02	-1.70	.26	13	.21	-.38	-.52	17	-1.67	-.77	.88	21	-1.21	-.66	.62		
185819	19	-.09	-1.52	1.59	30	-.47	-2.57	2.02	12	-.50	-2.07	.75	3	-.95	-1.48	1.58		
18530	22	-3.49	-2.71	2.80	13	-3.01	-1.81	3.24	24	-3.66	-2.58	4.30	33	-3.35	-2.38	4.12		
18531	29	-.15	-1.54	-.60	16	.63	-1.04	.20	33	.91	-.97	-.20	26	.74	-.46	-.99		
18510	10	-.58	-.58	1.26	19	-.25	-.62	.42	35	-.78	-.24	1.51						
1853	36	-1.91	-.86	2.98	17	-1.76	-.19	2.68	8	-2.22	-.33	2.96						
18524	25	-5.88	-.25	3.03	11	-3.67	.68	3.13	23	-.96	.32	2.43	16	-4.86	.23	3.16		
18532	31	1.37	.67	-.54	27	1.58	1.29	-.82	9	1.36	.65	-.54	7	2.04	1.06	-.83		
18533	28	.66	-.57	-.11	27	.46	-1.12	.16	6	.66	-.58	-.11	7	1.20	-1.28	-.46		
																18 1.89	-.75	-.36

- A 17 -

AUGM CONSTANT= 3.000

	RESIDUALS												SHIFTZ			
	PT	X	Y	Z	PT	X	Y	Z	PT	X	Y	Z	PT	X	Y	Z
1961	35	1.54	1.18	.39												
1962	22	1.06	1.12	-.32												
1963	12	.27	1.00	.02												
1964	5	.22	1.10	1.30												
1965	32	5.48	1.25	.20												
1966	29	.55	.87	.35												
1967	25	.61	.38	1.68												

VtPV = 224.30

Global Test 95% Confidence

.84 <1.00 <1.21

SIGma0 a priori = 1.00

SIGma0 a posteriori = 1.00

Degrees of Freedom = 225

TEST PASSED

FINAL CO-ORDINATES

SHIFTZ

			X	MSEX	Y	MSEY	Z	MSEZ
1	0	ACORN	5525475.439	1.182	2120236.540	1.168	-2373275.293	1.138
2	0	BRIT 44	5086490.873	1.916	2667595.683	1.902	-2767922.005	1.889
3	0	BLYDEBERG	4917287.803	1.152	2106615.024	1.151	-3463660.507	1.131
4	0	BURENKAMP	5505886.575	1.163	1492430.203	1.168	-2843494.603	1.134
5	0	COEGAKOP	4785913.960	1.094	2295264.300	1.091	-3524984.531	1.076
6	0	DRUSE	5821904.055	1.942	1398477.382	1.950	-2192747.584	1.907
7	0	ESERE	5716997.272	1.033	1810402.285	1.026	-2169938.864	.996
8	0	FRANSMANSKOP	4988155.081	.899	2267480.001	.893	-3256553.904	.876
9	0	GEELHOUT	5624231.415	1.980	2124855.182	1.964	-2125844.999	1.931
10	0	GRASKOP	5246336.795	.835	1904110.449	.829	-3079063.597	.803
11	0	HADIDA	5294746.044	.988	2085812.299	.989	-2872756.840	.964
12	0	HEXRIVIER	5022155.278	1.277	1795161.267	1.281	-3490364.792	1.272
13	0	INKOMINKULU	4776613.383	1.380	2809325.839	1.373	-3149350.089	1.349
14	0	KARASBERG	5386695.592	1.020	1837216.443	1.015	-2872962.043	.992
15	0	KARSRIVIER	4944369.357	1.877	1811091.504	1.885	-3587437.687	1.860
16	0	KRANZBERG	5149890.042	1.030	2691093.441	1.023	-2626419.869	.990
17	0	LEEUKOP (RSA)	4986891.766	.901	2475834.064	.896	-3104543.503	.872
18	0	LEEUKOP (SWA)	5672674.713	1.394	1526107.108	1.399	-2477898.273	1.363
19	0	LOUISFNTN	5203444.845	1.153	1690207.644	1.152	-3268509.140	1.124
20	0	LOURKOP	5545538.923	1.383	1663956.766	1.387	-2670131.930	1.361
21	0	LUBISI	4815762.984	1.370	2506295.955	1.368	-3339944.488	1.341
22	0	MAGWAZA	4786227.383	1.295	3006518.299	1.291	-2946620.128	1.283
23	0	MANNERHEIM	5291626.645	1.142	2265092.265	1.136	-2740789.960	1.117
24	0	MOOIDAM	4983833.587	.925	2732710.849	.919	-2887740.152	.886
25	0	MORGENZON	5138859.080	.815	2424478.725	.813	-2890848.639	.788
26	0	M' PUMBE NEW	4943182.136	1.410	3076442.700	1.392	-2596398.578	1.374
27	0	OKOTOMARE	5812708.270	1.418	1662414.175	1.420	-2028991.391	1.382
28	0	ONDONDVENGO	5933897.059	1.941	1289728.205	1.953	-1947624.461	1.911
29	0	PONT	5157885.184	1.314	2878301.967	1.315	-2400479.731	1.295
30	0	POTLOER	5101369.474	.897	1977625.681	.896	-3269927.283	.873
31	0	RUNDU (BCN B)	5714712.978	1.978	2054402.626	1.964	-1947079.869	1.934
32	0	SCHWARZECK	5576033.347	.883	1884766.117	.880	-2452547.189	.862
33	0	THAMAKOOSH	5019370.976	1.187	2903704.664	1.176	-2651972.383	1.144
34	0	UNIONS END	5444109.830	1.141	1979201.578	1.140	-2663036.426	1.120
35	0	WITBANK NEW	5361113.470	.986	1605150.184	.984	-3050285.408	.960
36	0	WITWATER	5137634.623	.818	2183074.380	.815	-3078160.877	.790

GEOGRAPHICAL CO-ORDINATES (GRS 80)

SHIFTZ

			LATITUDE		mse(M)	LONGITUDE		mse(M)	HEIGHT	mse		
1	0	ACORN	21	59	3.6113	1.13	20	59	34.1408	1.17	1257.15	1.18
2	0	BRIT 44	25	52	51.6907	1.88	27	40	28.6889	1.91	1633.29	1.91
3	0	BLYDEBERG	33	05	51.3490	1.12	23	11	26.7853	1.15	1152.07	1.16
4	0	BURENKAMP	26	38	53.9971	1.13	15	09	58.3609	1.17	114.12	1.17
5	0	COEGAKOP	33	45	57.8170	1.07	25	37	18.4507	1.09	143.83	1.10
6	0	DRUSE	20	14	17.9628	1.90	13	30	25.5210	1.95	800.85	1.95
7	0	ESERE	20	00	57.7767	.99	17	34	17.1814	1.03	1672.90	1.04
8	0	FRANSMANSKOP	30	53	37.2563	.87	24	26	42.9247	.89	1499.07	.91
9	0	GEELHOUT	19	35	38.9343	1.93	20	41	48.2934	1.98	1256.13	1.97
10	0	GRASKOP	29	02	52.5718	.79	19	56	52.4675	.83	1063.81	.84
11	0	HADIDA	26	56	24.6134	.96	21	30	5.2732	.99	992.33	1.00
12	0	HEXRIVIER	33	22	44.0169	1.27	19	40	9.6510	1.28	2252.47	1.28
13	0	INKOMINKULU	29	46	33.6035	1.34	30	27	41.6291	1.37	1015.56	1.39
14	0	KARASBERG	26	56	21.6278	.98	18	49	57.8717	1.02	1626.12	1.03
15	0	KARSRIVIER	34	26	44.2835	1.86	20	07	2.8771	1.89	207.81	1.87
16	0	KRANZBERG	24	28	4.1823	.98	27	35	22.1238	1.02	2137.81	1.04
17	0	LEEUKOP(RSA)	29	18	29.1771	.86	26	24	10.6019	.90	1672.84	.91
18	0	LEEUKOP(SWA)	23	00	31.9342	1.36	15	03	27.5164	1.40	702.78	1.40
19	0	LOUISFNTN	31	01	28.1464	1.12	17	59	42.2846	1.15	560.74	1.16
20	0	LOURKOP	24	54	17.2519	1.36	16	42	7.3486	1.39	1470.93	1.39
21	0	LUBISI	31	46	20.6033	1.33	27	29	38.7153	1.37	1790.99	1.39
22	0	MAGWAZA	27	41	31.8712	1.28	32	08	7.4745	1.29	593.73	1.30
23	0	MANNERHEIM	25	36	41.6071	1.11	23	10	24.4237	1.14	1087.33	1.14
24	0	MOOIDAM	27	05	20.2248	.87	28	44	11.8342	.92	1638.50	.94
25	0	MORGENZON	27	07	16.5833	.78	25	15	27.4296	.81	1462.10	.82
26	0	M'PUMBE NEW	24	10	38.5222	1.36	31	53	47.4525	1.40	441.57	1.41
27	0	OKOTOMARE	18	40	6.3166	1.38	15	57	37.2373	1.42	1184.63	1.42
28	0	ONDONDVENGO	17	53	41.6545	1.90	12	15	44.9068	1.95	995.76	1.95
29	0	PONT	22	15	5.5506	1.29	29	09	47.6229	1.31	697.96	1.32
30	0	POTLOER	31	02	4.0294	.87	21	11	22.5625	.90	1474.52	.90
31	0	RUNDU(BCN B)	17	53	21.5250	1.93	19	46	23.4677	1.97	1140.41	1.98
32	0	SCHWARZECK	22	45	26.3892	.86	18	40	33.1309	.88	1518.73	.89
33	0	THAMAKOOSH	24	43	19.5327	1.13	30	02	57.7287	1.18	1982.67	1.20
34	0	UNIONS END	24	50	8.1821	1.11	19	58	43.2974	1.14	1135.69	1.15
35	0	WITBANK NEW	28	45	17.9126	.95	16	40	4.8788	.98	341.53	1.00
36	0	WITWATER	29	02	10.8207	.78	23	01	17.4771	.82	1519.70	.83

CHORD DISTANCES AND THEIR MSE'S

				DISTANCE	MSE	SHIFTZ	PPM
MORGENZON	2725.00079	WITWATER	2923.00053	305554.302	1.065		3.49
LEEUKOP (RSA)	2926.00022	FRANSMANSKOP	3024.00026	257915.051	1.176		4.56
GRASKOP	2919.00010	POTLOER	3121.00053	250696.949	1.119		4.46
MOOIDAM	2728.00050	M'PUMBE NEW	2431.00066	452420.202	1.560		3.45
INKOMINKULU	2930.00051	WITWATER	2923.00053	726357.439	1.585		2.18
LEEUKOP (SWA)	2315.00079	UNIONS END	2419.00318	540196.853	1.764		3.27
DRUSE	2013.00007	GEELHOUT	1920.00009	755761.297	2.704		3.58
ONDONDVENGO	1712.00004	ESERE	2017.00026	606276.100	2.055		3.39
BLYDEBERG	3323.00007	LUBISI	3127.00040	430531.984	1.763		4.09
GRASKOP	2919.00010	INKOMINKULU	2930.00051	1022250.055	1.601		1.57
LOUISFNTN	3117.00005	UNIONS END	2419.00318	712765.275	1.573		2.21
M'PUMBE NEW	2431.00066	INKOMINKULU	2930.00051	636279.766	1.810		2.85
PONT	2229.00023	HEXRIVIER	3319.00029	1542551.726	1.820		1.18
SCHWARZECK	2218.00179	COEGAKOP	3325.00133	1393886.386	1.379		.99
WITBANK NEW	2816.00036	MAGWAZA	2732.00004	1518246.717	1.622		1.07
LOUISFNTN	3117.00005	INKOMINKULU	2930.00051	1203665.032	1.789		1.49
HEXRIVIER	3319.00029	COEGAKOP	3325.00133	554176.443	1.674		3.02
HEXRIVIER	3319.00029	KARSRIVIER	3420.00022	125409.605	2.148		17.13
COEGAKOP	3325.00133	ONDONDVENGO	1712.00004	2194773.980	2.201		1.00
KRANZBERG	2427.00025	BRIT 44	2527.00292	156826.189	2.038		13.00

- A 21 -

Residuals

PARA-7

	PT	X	Y	Z	PT	X	Y	Z	PT	X	Y	Z	PT	X	Y	Z				
1851	17	-.05	.01	-.08	25	.06	-.08	.04	36	-.01	.07	.04								
18510	10	.12	-.31	.04	19	-.21	.10	-.30	35	.09	.21	.26								
18511	10	.32	-.26	.36	30	-.21	.54	.01	36	-.12	-.29	-.38								
18512	10	.04	.03	.08	11	.01	-.09	-.04	36	-.05	.06	-.04								
18513	11	-.01	-.14	-.14	25	-.10	.13	-.08	36	.11	.02	.21								
18514	10	-.11	.01	-.19	14	.12	-.18	.10	35	-.01	.17	.09								
18515	4	.03	-.41	-.17	14	-.22	.19	-.30	35	.19	.22	.48								
1851618	20	-.08	-.55	-.73	4	.02	.61	.51	32	.21	.09	.66	34	-.10	-.02	-.28	14	-.06	-.14	-.17
18520	8	.12	-.29	.00	30	.08	.16	.22	3	-.20	.13	-.22								
18521	8	-.16	-.10	-.29	3	.31	-.26	.27	5	-.16	.36	.02								
1852223	17	.03	-.01	.09	8	-.07	.17	-.03	21	.11	-.11	.02	5	-.07	-.05	-.08				
18524	25	-.10	-.42	-.49	11	-.26	.55	-.12	23	.32	-.25	.47	16	.04	.12	.14	2	.00	.00	.00
18525	10	-.18	.17	-.20	11	.23	-.28	.26	14	.15	.14	.34	23	-.19	.24	-.20	34	-.01	-.28	-.20
18526	7	-.01	.10	.06	1	.07	-.06	.11	32	-.06	-.04	-.17								
18527	1	-.03	-.01	-.08	32	.02	-.32	-.22	34	.13	.33	.58	23	-.13	-.01	-.28				
18528	7	-.02	.03	-.04	18	-.01	-.06	-.07	32	-.01	-.26	-.32	20	.09	.68	.90	4	-.05	-.39	-.48
18529	24	.13	-.23	.07	13	-.11	-.06	-.28	17	.11	.16	.23	21	-.12	.13	-.02				
1853	36	.16	-.22	.10	17	-.09	-.12	-.24	8	-.07	.34	.13								
18530	22	-.16	-.08	-.37	13	.12	.07	.29	24	-.08	.00	-.19	33	.02	.05	.17	26	.11	-.04	.11
18531	29	.17	-.12	.19	16	-.19	.28	-.02	33	.13	-.20	-.04	26	-.12	.04	-.12				
18532	31	.00	.00	.00	27	-.07	.10	-.10	9	.00	.00	.00	7	.11	-.17	.14	1	-.04	.06	-.04
18533	28	.00	.00	.00	27	.05	-.08	.08	6	.00	.00	.00	7	-.06	.04	-.13	18	.01	.05	.05
1854	17	-.01	-.04	-.05	24	.03	-.02	.04	25	-.02	.06	.01								
1855	16	.05	-.24	-.13	24	-.17	.24	-.09	25	.12	.01	.22								
1856	16	.11	-.24	-.05	24	.07	.08	.21	33	-.18	.16	-.16								
1857	8	.18	-.22	.14	30	-.10	-.11	-.23	36	-.08	.33	.09								
185819	19	.12	.07	.24	30	.03	-.32	-.15	12	-.12	.20	-.09	3	-.04	.05	.00	15	.00	.00	.00
1859	10	-.18	.30	-.12	19	-.01	-.26	-.17	30	.20	-.04	.29								

VtPV 17.62 NO OF VARIABLES= 283 NO OF OBSERVTVNS= 312

21

FINAL CO-ORDINATES

			X	mseX	Y	mseY	Z	mseZ
1	0	ACORN	5525483.57	12.50	2120241.58	4.86	-2373277.69	5.94
2	0	BRIT 44	5086492.25	5.75	2667598.59	3.10	-2767923.50	3.25
3	0	BLYDEBERG	4917305.73	18.99	2106623.21	8.08	-3463672.47	12.86
4	0	BURENKAMP	5505879.65	16.91	1492427.91	5.20	-2843491.43	8.75
5	1	COEGAKOP	4785913.16	.00	2295265.11	.00	-3524983.04	.00
6	0	DRUSE	5821884.40	38.01	1398471.90	10.79	-2192737.56	16.43
7	0	ESERE	5716992.56	20.89	1810401.80	6.14	-2169935.48	8.98
8	0	FRANSMANSKOP	4988152.86	8.05	2267479.24	3.75	-3256552.53	5.32
9	0	GEELHOUT	5624241.33	26.33	2124860.67	8.88	-2125847.67	10.64
10	0	GRASKOP	5246316.19	15.90	1904104.31	5.88	-3079051.95	9.35
11	0	HADIDA	5294732.57	11.49	2085808.31	4.52	-2872749.15	6.32
12	1	HEXRIVIER	5022156.49	.00	1795163.19	.00	-3490365.54	.00
13	0	INKOMINKULU	4776619.00	12.78	2809328.27	7.19	-3149354.29	7.94
14	0	KARASBERG	5386681.70	10.58	1837212.37	3.65	-2872954.76	5.71
15	0	KARSRIVIER	4944373.76	7.94	1811094.14	3.58	-3587441.03	5.85
16	0	KRANZBERG	5149892.56	8.47	2691096.62	4.51	-2626422.14	4.41
17	0	LEEUKOP (RSA)	4986902.49	15.00	2475839.14	7.37	-3104550.53	9.38
18	0	LEEUKOP (SWA)	5672661.61	18.78	1526103.50	5.81	-2477891.19	8.89
19	0	LOUISFNTN	5203434.47	21.04	1690204.22	7.50	-3268502.51	13.14
20	0	LOURKOP	5545535.33	9.49	1663955.55	3.14	-2670130.02	4.78
21	0	LUBISI	4815774.83	14.04	2506301.63	6.80	-3339952.43	9.38
22	1	MAGWAZA	4786229.78	.00	3006520.51	.00	-2946622.93	.00
23	0	MANNERHEIM	5291614.61	11.01	2265089.62	4.67	-2740783.57	5.97
24	0	MOOIDAM	4983838.07	8.67	2732713.83	4.84	-2887744.10	5.05
25	1	MORGENZON	5138858.00	.00	2424478.71	.00	-2890847.72	.00
26	0	M' PUMBE NEW	4943180.50	15.36	3076443.21	9.07	-2596398.94	8.44
27	0	OKOTOMARE	5812697.32	35.76	1662411.76	10.16	-2028985.41	14.97
28	0	ONDONDVENGO	5933870.77	57.96	1289721.91	15.60	-1947611.83	23.42
29	1	PONT	5157884.43	.00	2878303.57	.00	-2400479.13	.00
30	0	POTLOER	5101375.02	16.12	1977629.02	6.35	-3269931.32	10.37
31	0	RUNDU (BCN B)	5714719.85	41.88	2054407.15	13.71	-1947081.04	16.31
32	1	SCHWARZECK	5576037.78	.00	1884767.78	.00	-2452547.56	.00
33	0	THAMAKOOSH	5019371.75	10.67	2903706.48	6.00	-2651974.05	5.86
34	0	UNIONS END	5444101.24	7.82	1979199.12	2.89	-2663031.81	3.92
35	1	WITBANK NEW	5361113.00	.00	1605150.53	.00	-3050283.90	.00
36	0	WITWATER	5137645.99	15.50	2183079.81	6.57	-3078167.72	9.29

GEOGRAPHICAL CO-ORDINATES (GRS 80)

PARA-7

			LATITUDE	mse(M)	LONGITUDE	mse(M)	HEIGHT	mse	Error Ellipsoid	Axes		
1	0	ACORN	21 59	3.5693	20 59	34.2034	.86	1266.76	14.61	14.62	.93	.84
2	0	BRIT 44	25 52	51.6980	27 40	28.7585	1.00	1636.26	7.16	7.16	1.02	.97
3	0	BLYDEBERG	33 05	51.3249	23 11	26.8032	.70	1175.10	24.29	24.30	.70	.68
4	0	BURENKAMP	26 38	54.0110	15 09	58.3465	1.02	106.19	19.69	19.70	.91	.86
5	1	COEGAKOP	33 45	57.7835	25 37	18.4924	.00	142.70	.00	.00	.00	.00
6	0	DRUSE	20 14	17.8863	13 30	25.4955	2.43	778.26	42.64	1.75	1.75	1.75
7	0	ESERE	20 00	57.7250	17 34	17.2143	1.32	1667.39	23.47	23.49	1.20	1.09
8	0	FRANSMANSKOP	30 53	37.2570	24 26	42.9331	.61	1496.36	10.32	10.32	.63	.60
9	0	GEELHOUT	19 35	38.8939	20 41	48.3492	2.29	1267.59	29.61	29.64	2.10	1.39
10	0	GRASKOP	29 02	52.5795	19 56	52.5139	.61	1039.39	19.34	19.34	.60	.59
11	0	HADIDA	26 56	24.5968	21 30	5.3177	.64	976.38	13.84	13.84	.64	.63
12	1	HEXRIVIER	33 22	44.0052	19 40	9.7052	.00	2254.37	.00	.00	.00	.00
13	0	INKOMINKULU	29 46	33.6238	30 27	41.6011	.87	1022.92	16.62	16.63	.87	.81
14	0	KARASBERG	26 56	21.6299	18 49	57.8947	.58	1609.93	12.54	12.54	.59	.57
15	0	KARSRIVIER	34 26	44.2805	20 07	2.9146	1.10	213.85	10.40	10.41	.98	.80
16	0	KRANZBERG	24 28	4.1995	27 35	22.1824	.73	2142.11	10.51	10.51	.75	.73
17	0	LEEUKOP (RSA)	29 18	29.1875	26 24	10.5937	.62	1686.62	19.14	19.14	.62	.61
18	0	LEEUKOP (SWA)	23 00	31.8951	15 03	27.5135	1.24	687.50	21.51	21.52	1.10	1.03
19	0	LOUISFN TN	31 01	28.1446	17 59	42.2826	.94	547.96	25.88	25.89	.75	.71
20	0	LOURKOP	24 54	17.2475	16 42	7.3438	.74	1466.69	11.04	11.04	.71	.69
21	0	LUBISI	31 46	20.5981	27 29	38.6989	.90	1806.33	18.17	18.17	.77	.76
22	1	MAGWAZA	27 41	31.9034	32 08	7.4963	.00	597.87	.00	.00	.00	.00
23	0	MANNERHEIM	25 36	41.5899	23 10	24.5064	.72	1073.65	13.33	13.33	.73	.71
24	0	MOOIDAM	27 05	20.2595	28 44	11.8507	.63	1645.07	11.10	11.10	.63	.62
25	1	MORGENZON	27 07	16.5714	25 15	27.4458	.00	1460.80	.00	.00	.00	.00
26	0	M' PUMBE NEW	24 10	38.5479	31 53	47.4983	1.02	440.70	19.68	19.69	.92	.91
27	0	OKOTOMARE	18 40	6.2487	15 57	37.2609	2.06	1172.11	39.92	1.66	1.66	1.66
28	0	ONDONDVENGO	17 53	41.5336	12 15	44.8875	4.09	966.16	64.12	3.59	64.28	2.51
29	1	PONT	22 15	5.5310	29 09	47.6847	.00	697.85	.00	.00	.00	.00
30	0	POTLOER	31 02	4.0348	21 11	22.6044	.59	1482.06	20.18	20.18	.59	.58
31	0	RUNDU (BCN B)	17 53	21.4814	19 46	23.5332	3.26	1148.38	46.80	2.92	46.86	1.75
32	1	SCHWARZECK	22 45	26.3407	18 40	33.1363	.00	1523.23	.00	.00	.00	.00
33	0	THAMAKOOSH	24 43	19.5604	30 02	57.7707	.76	1984.80	13.53	13.53	.74	.74
34	0	UNIONS END	24 50	8.1676	19 58	43.3196	.56	1125.66	9.18	9.18	.56	.56
35	1	WITBANK NEW	28 45	17.8750	16 40	4.8961	.00	340.50	.00	.00	.00	.00
36	0	WITWATER	29 02	10.8167	23 01	17.4974	.60	1534.02	19.20	19.20	.60	.59

SUBNET TRANSFORMATION PARAMETERS

PARA-7

	X-SH	sig	Y-SH	sig	Z-SH	sig	X"ROT	sig	Y"ROT	sig	Z"ROT	sig	PPM	sig
1851	9.99	7.67	3.05	3.52	-5.70	4.68	-143.04	184.22	288.82	307.10	-33.78	321.45	-2.61	3.32
18510	-11.82	10.17	-3.78	3.74	7.66	6.21	-135.46	221.22	-75.30	466.73	-307.47	257.65	-1.10	3.42
18511	.46	11.66	.94	4.65	-1.01	7.13	116.17	227.21	449.05	428.82	538.44	314.51	.80	3.74
18512	-7.61	11.81	.87	4.67	3.85	6.88	191.61	119.07	300.49	237.26	540.22	318.27	-3.00	3.25
18513	3.69	7.47	-2.12	3.12	-4.14	4.35	-131.62	175.52	483.89	359.57	127.84	159.68	-.07	2.94
18514	-11.16	8.58	-1.84	3.10	7.33	4.89	-126.74	127.32	-82.61	144.66	-290.38	255.31	-1.78	3.25
18515	-1.31	7.94	-2.32	2.59	-2.76	4.24	-108.12	99.65	137.61	327.36	-130.54	196.45	-2.15	2.95
1851618	-7.94	6.87	-6.71	2.27	1.74	3.63	20.25	99.69	-229.50	130.04	-82.57	208.86	-.04	1.89
18520	6.44	10.56	5.33	4.44	-4.41	6.91	-241.16	242.56	387.00	429.05	-100.28	286.17	.47	3.21
18521	7.37	7.37	.89	3.21	-3.85	4.93	-408.92	363.44	64.55	147.47	-497.82	488.74	-.59	3.38
1852223	5.59	7.65	2.42	3.68	-4.62	4.90	196.01	218.18	-13.86	129.61	311.27	326.82	1.06	2.29
18524	-7.92	4.88	.03	2.20	4.98	2.55	66.46	75.80	57.83	217.34	146.12	155.97	.64	2.30
18525	-17.61	10.17	-5.86	3.86	10.05	5.65	58.91	69.15	-175.22	175.00	-11.58	126.30	-1.35	2.41
18526	3.55	6.80	2.70	2.18	.23	2.85	13.89	121.35	132.31	314.07	129.72	294.52	-1.54	3.60
18527	-10.08	5.02	.37	2.10	3.77	2.62	111.99	168.08	-257.19	232.23	17.75	194.79	-3.43	2.30
18528	-12.40	8.85	-1.65	2.65	5.78	4.20	78.26	88.70	83.53	304.68	234.27	270.08	.37	2.24
18529	8.04	8.37	3.50	4.28	-5.47	5.36	-53.55	190.15	41.00	123.81	-44.55	317.36	.83	2.49
1853	4.72	8.97	2.91	4.10	-1.29	5.52	199.07	209.14	-382.65	362.43	40.18	317.47	-.97	3.45
18530	.01	3.88	.04	2.22	.94	2.16	-31.12	180.11	45.51	192.84	-30.65	167.31	-1.30	1.99
18531	1.68	6.95	.84	3.94	-1.32	3.81	-40.84	107.73	57.59	195.79	-37.86	235.47	-.83	2.77
18532	3.20	20.49	2.55	6.27	-.14	8.12	87.74	287.33	-.64	534.74	225.73	414.07	-1.32	3.58
18533	-15.06	33.22	-5.52	9.29	7.64	14.06	68.37	76.67	48.66	331.59	192.51	241.41	.19	3.43
1854	7.83	6.10	4.58	3.11	-5.62	3.76	-50.68	186.58	237.61	340.21	85.67	138.46	-.06	2.92
1855	5.31	5.61	3.59	3.08	-1.91	3.11	74.68	84.75	26.73	63.92	104.87	140.17	-2.01	2.89
1856	5.66	7.23	4.83	3.97	-6.60	3.97	-35.52	192.68	28.26	100.75	-34.08	259.38	-1.42	3.51
1857	4.92	9.24	3.47	3.88	-4.66	5.76	28.38	235.68	-294.70	403.60	-143.11	289.46	-3.53	3.50
185819	2.71	5.87	.91	2.47	-1.35	3.75	119.65	193.78	130.71	371.74	273.45	311.88	-1.86	2.43
1859	-10.40	13.83	.71	5.21	4.57	8.57	-16.76	241.74	546.13	445.07	267.52	315.24	-1.97	3.68

CHORD DISTANCES AND THEIR MSE'S

PARA-7

			DISTANCE	sig	PPM	
MORGENZON	2725.00079	WITWATER	2923.00053	305554.708	.747	2.44
LEEUKOP (RSA)	2926.00022	FRANSMANSKOP	3024.00026	257914.760	.783	3.03
GRASKOP	2919.00010	POTLOER	3121.00053	250696.550	.941	3.75
INKOMINKULU	2930.00051	WITWATER	2923.00053	726357.452	1.550	2.13
LEEUKOP (SWA)	2315.00079	UNIONS END	2419.00318	540196.752	1.271	2.35
DRUSE	2013.00007	GEELHOUT	1920.00009	755762.978	2.454	3.25
ONDONDVENGO	1712.00004	ESERE	2017.00026	606276.759	2.122	3.50
BLYDEBERG	3323.00007	LUBISI	3127.00040	430532.245	1.252	2.91
GRASKOP	2919.00010	INKOMINKULU	2930.00051	1022246.689	1.923	1.88
LOUISFNTN	3117.00005	UNIONS END	2419.00318	712764.554	1.471	2.06
M' PUMBE NEW	2431.00066	INKOMINKULU	2930.00051	636280.387	1.296	2.04
PONT	2229.00023	HEXRIVIER	3319.00029	1542552.282	.000	.00
SCHWARZECK	2218.00179	COEGAKOP	3325.00133	1393887.671	.000	.00
LOUISFNTN	3117.00005	INKOMINKULU	2930.00051	1203663.734	2.483	2.06
HEXRIVIER	3319.00029	COEGAKOP	3325.00133	554176.153	.000	.00
HEXRIVIER	3319.00029	KARSRIEVER	3420.00022	125409.725	.859	6.85
COEGAKOP	3325.00133	ONDONDVENGO	1712.00004	2194771.912	7.065	3.22
KRANZBERG	2427.00025	BRIT 44	2527.00292	156825.995	.880	5.61

- A 25 -

25

- A 26 -

Residuals

	PT	X	Y	Z	PT	X	Y	Z	PT	X	Y	Z	PT	X	Y	Z	SHIFT-R			
1851	17	-.07	-.06	-.08	25	-.18	.10	.46	36	.25	-.04	-.37								
1857	8	.04	.26	.02	30	-.20	-.58	-.05	36	.16	.33	.03								
1854	17	.02	-.23	.16	24	-.42	-.27	.39	25	.40	.50	-.56								
1855	16	-.02	-.09	.05	24	.02	.49	-.19	25	.01	-.39	.14								
1856	16	.24	-.22	-.15	24	-.08	-.01	.36	33	-.16	.23	-.21								
1859	10	-.07	.43	.23	19	-.19	-.26	-.32	30	.26	-.17	.08								
18511	10	.16	-.18	.39	30	.46	1.09	.00	36	-.62	-.91	-.39								
18513	11	.02	-.23	-.57	25	-.29	.36	-.13	36	.27	-.13	.70								
18512	10	.08	-.36	-.04	11	-.07	.03	.07	36	.00	.33	-.03								
18514	10	.00	.27	-.26	14	.09	-.02	.19	35	-.09	-.25	.08								
18515	4	.60	-.54	-.27	14	-.63	.46	.02	35	.03	.08	.25								
18520	8	.60	-.14	-.15	30	-.52	.27	.25	3	-.08	-.13	-.10								
18521	8	.04	-.01	-.04	3	.09	-.12	.08	5	-.13	.13	-.04								
18525	10	.06	.21	-.42	11	.02	-.41	.32	14	.29	-.08	.06	23	-.28	.05	.21	34	-.09	.24	-.17
1851618	20	.02	-.29	-1.02	4	-.05	.56	.54	32	-.04	.22	.56	34	-.05	-.25	.12	14	.12	-.24	-.21
18526	7	-.21	-.09	.30	1	-.14	-.32	.07	32	.35	.42	-.37								
18527	1	-.03	.14	.12	32	-.42	-.26	.00	34	.17	.04	.05	23	.29	.08	-.18				
18528	7	.36	.35	-.44	18	.05	-.05	-.06	32	.09	-.45	-.31	20	-.02	.36	1.25	4	-.47	-.21	-.43
1852223	17	.13	.02	-.15	8	-.33	-.04	.07	21	.11	.10	.04	5	.09	-.09	.03				
18529	24	.38	-.08	-.31	13	-.01	.02	-.03	17	-.24	.18	.39	21	-.13	-.11	-.05				
185819	19	-.06	.21	.15	30	.06	-.35	-.16	12	.00	.00	.00	3	.00	.15	.02	15	.00	.00	.00
18530	22	.00	.00	.00	13	.01	-.02	.03	24	.03	-.03	-.16	33	-.13	-.02	.16	26	.09	.07	-.03
18531	29	.00	.00	.00	16	-.18	.26	-.04	33	.28	-.18	.00	26	-.10	-.08	.03				
18510	10	-.35	-.04	.33	19	.28	-.15	.01	35	.06	.18	-.35								
1853	36	-.01	.06	.07	17	.27	-.01	-.13	8	-.26	-.05	.07								
18524	25	-.11	-.44	-.03	11	.09	.56	-.01	23	.03	-.13	-.06	16	-.01	.01	.11	2	.00	.00	.00
18532	31	.00	.00	.00	27	.03	.03	-.06	9	.00	.00	.00	7	-.19	-.21	.24	1	.16	.18	-.17
18533	28	.00	.00	.00	27	-.02	-.02	.05	6	.00	.00	.00	7	.06	-.01	-.10	18	-.03	.03	.05

VtPV

27.59

NO OF VARIABLES= 214

NO OF OBSERVATIONS= 312

26

FINAL CO-ORDINATES

SHIFT-R

			X	mseX	Y	mseY	Z	mseZ
1	0	ACORN	5525469.55	.63	2120238.42	1.44	-2373274.18	.89
2	0	BRIT 44	5086486.58	.62	2667595.40	.57	-2767919.63	.71
3	0	BLYDEBERG	4917286.64	.68	2106614.39	.83	-3463659.76	.64
4	0	BURENKAMP	5505882.52	.83	1492430.02	.75	-2843494.38	1.66
5	0	COEGAKOP	4785913.28	.65	2295264.60	1.02	-3524983.56	.48
6	0	DRUSE	5821900.32	.80	1398478.85	2.02	-2192745.73	2.16
7	0	ESERE	5716992.21	.62	1810404.26	1.94	-2169937.40	1.32
8	0	FRANSMANSKOP	4988154.06	.45	2267479.68	.46	-3256553.63	.45
9	0	GELHOUT	5624226.68	.86	2124857.64	2.01	-2125844.25	1.06
10	0	GRASKOP	5246334.52	.59	1904111.38	.39	-3079063.12	.88
11	0	HADIDA	5294743.26	.42	2085812.46	.44	-2872756.45	.70
12	0	HEXRIVIER	5022154.37	.95	1795161.28	.88	-3490362.84	1.00
13	0	INKOMINKULU	4776610.70	.50	2809324.81	.60	-3149347.37	.78
14	0	KARASBERG	5386692.11	.60	1837216.58	.60	-2872961.94	1.06
15	0	KARSRIVIER	4944368.18	.98	1811090.24	1.07	-3587435.80	.95
16	0	KRANZBERG	5149887.94	.56	2691093.11	.60	-2626418.65	.53
17	1	LEEUKOP (RSA)	4986890.76	.00	2475833.45	.00	-3104542.88	.00
18	0	LEEUKOP (SWA)	5672669.57	.74	1526108.05	1.41	-2477896.37	1.77
19	0	LOUISFNTN	5203443.61	.86	1690207.97	.55	-3268507.70	1.15
20	0	LOURKOP	5545533.09	.70	1663956.53	.99	-2670130.68	1.44
21	0	LUBISI	4815761.31	.42	2506295.54	.68	-3339943.74	.45
22	0	MAGWAZA	4786225.20	.75	3006517.91	.65	-2946616.75	1.10
23	0	MANNERHEIM	5291621.01	.44	2265091.95	.61	-2740788.72	.60
24	0	MOOIDAM	4983831.84	.44	2732710.36	.35	-2887738.96	.53
25	1	MORGENZON	5138858.00	.00	2424478.71	.00	-2890847.72	.00
26	0	M'PUMBE NEW	4943179.61	.90	3076441.20	.68	-2596395.69	1.05
27	0	OKOTOMARE	5812704.12	.68	1662416.39	2.31	-2028990.15	1.64
28	0	ONDONDVENGO	5933893.45	.78	1289730.25	2.60	-1947622.40	2.45
29	0	PONT	5157883.96	1.00	2878301.69	1.13	-2400477.53	.83
30	0	POTLOER	5101368.09	.64	1977626.27	.51	-3269926.93	.76
31	0	RUNDU (BCN B)	5714708.32	.90	2054405.30	2.42	-1947079.06	1.11
32	0	SCHWARZECK	5576028.68	.56	1884767.16	1.31	-2452545.65	1.12
33	0	THAMAKOOSH	5019368.82	.72	2903703.70	.62	-2651970.48	.76
34	0	UNIONS END	5444104.01	.53	1979201.30	.86	-2663035.23	.92
35	0	WITBANK NEW	5361112.62	.83	1605151.38	.56	-3050285.11	1.36
36	0	WITWATER	5137633.70	.40	2183074.58	.32	-3078160.82	.52

GEOGRAPHICAL CO-ORDINATES (GRS 80)

		GEOGRAPHICAL CO-ORDINATES (GRS 80)				SHIFT-R							
		LATITUDE		mse(M)	LONGITUDE		mse(M)	HEIGHT	mse	Error Ellipsoid Axes			
1	0	ACORN	21 59	3.6365	.98	20 59	34.2754	1.40	1252.26	.58	1.53	.78	.56
2	0	BRIT 44	25 52	51.6772	.75	27 40	28.7515	.62	1628.72	.53	.79	.56	.53
3	0	BLYDEBERG	33 05	51.3519	.69	23 11	26.7804	.94	1150.55	.44	1.03	.54	.44
4	0	BURENKAMP	26 38	54.0484	1.82	15 09	58.3928	.65	110.48	.52	1.84	.58	.52
5	0	COEGAKOP	33 45	57.7996	.49	25 37	18.4728	1.11	142.90	.44	1.12	.48	.44
6	0	DRUSE	20 14	17.9431	2.30	13 30	25.6003	1.91	797.12	.72	2.87	.81	.71
7	0	ESERE	20 00	57.7790	1.43	17 34	17.2988	1.87	1668.42	.58	2.24	.73	.57
8	0	FRANSMANSKOP	30 53	37.2662	.48	24 26	42.9296	.52	1498.02	.33	.60	.37	.33
9	0	GEELOUT	19 35	38.9500	1.14	20 41	48.4298	2.00	1252.53	.76	2.08	1.01	.73
10	0	GRASKOP	29 02	52.5869	.98	19 56	52.5285	.42	1061.98	.36	.99	.39	.36
11	0	HADIDA	26 56	24.6394	.77	21 30	5.3157	.40	989.90	.34	.78	.37	.34
12	0	HEXRIVIER	33 22	43.9792	1.12	19 40	9.6633	1.05	2250.68	.56	1.42	.59	.56
13	0	INKOMINKULU	29 46	33.5726	.85	30 27	41.6466	.55	1011.76	.44	.87	.51	.44
14	0	KARASBERG	26 56	21.6728	1.17	18 49	57.9173	.53	1623.18	.45	1.19	.49	.45
15	0	KARSRIVIER	34 26	44.2613	1.06	20 07	2.8464	1.25	205.47	.56	1.52	.62	.56
16	0	KRANZBERG	24 28	4.1735	.56	27 35	22.1479	.71	2135.46	.36	.80	.42	.36
17	1	LEEUKOP (RSA)	29 18	29.1781	.00	26 24	10.5981	.00	1671.51	.00	.00	.00	.00
18	0	LEEUKOP (SWA)	23 00	31.9372	1.90	15 03	27.5955	1.30	697.69	.62	2.18	.73	.62
19	0	LOUISFNTN	31 01	28.1243	1.31	17 59	42.3106	.67	559.07	.45	1.38	.51	.45
20	0	LOURKOP	24 54	17.2924	1.57	16 42	7.4003	.88	1465.28	.56	1.69	.60	.56
21	0	LUBISI	31 46	20.6114	.47	27 29	38.7307	.69	1789.17	.39	.72	.41	.39
22	0	MAGWAZA	27 41	31.8049	1.19	32 08	7.5050	.64	590.34	.61	1.18	.64	.61
23	0	MANNERHEIM	25 36	41.6453	.65	23 10	24.4927	.58	1082.01	.41	.71	.51	.41
24	0	MOOIDAM	27 05	20.2165	.57	28 44	11.8492	.41	1636.38	.32	.61	.34	.32
25	1	MORGENZON	27 07	16.5714	.00	25 15	27.4458	.00	1460.80	.00	.00	.00	.00
26	0	M'PUMBE NEW	24 10	38.4755	1.14	31 53	47.4547	.92	437.71	.51	1.35	.55	.51
27	0	OKOTOMARE	18 40	6.3135	1.76	15 57	37.3488	2.23	1181.02	.65	2.74	.77	.64
28	0	ONDONDVENGO	17 53	41.6217	2.59	12 15	45.0007	2.50	992.18	.72	3.50	.80	.71
29	0	PONT	22 15	5.4991	.87	29 09	47.6355	1.33	696.01	.66	1.41	.74	.66
30	0	POTLOER	31 02	4.0376	.85	21 11	22.6020	.61	1473.41	.39	.95	.42	.39
31	0	RUNDU (BCN B)	17 53	21.5348	1.20	19 46	23.6068	2.42	1136.85	.76	2.53	.99	.73
32	0	SCHWARZECK	22 45	26.3945	1.23	18 40	33.2180	1.23	1514.36	.51	1.63	.63	.51
33	0	THAMAKOOSH	24 43	19.5085	.82	30 02	57.7374	.78	1979.75	.45	1.02	.48	.45
34	0	UNIONS END	24 50	8.2228	1.02	19 58	43.3589	.79	1130.15	.47	1.17	.55	.47
35	0	WITBANK NEW	28 45	17.9116	1.52	16 40	4.9301	.55	340.98	.49	1.52	.55	.49
36	0	WITWATER	29 02	10.8312	.57	23 01	17.4972	.35	1519.00	.30	.58	.33	.30

SUBNET TRANSFORMATION PARAMETERS

SHIFT-R

	X-SH	sig	Y-SH	sig	Z-SH	sig	Rot	sig	Year	Day
1851	1.98	.33	-.59	.32	-.85	.34	-.03	.21	1980	236
1857	-1.09	.52	.96	.45	-1.26	.59	.02	.26	1980	323
1854	1.84	.32	1.53	.30	-1.36	.33	-.05	.19	1981	80
1855	1.69	.43	1.26	.40	.96	.44	-.13	.21	1981	86
1856	1.07	.60	1.58	.53	-2.54	.62	.31	.23	1981	94
1859	-3.56	.72	3.40	.51	.58	.94	-.35	.28	1982	193
18511	.16	.57	.64	.43	-.97	.73	.53	.26	1982	205
18513	3.16	.38	-2.48	.35	-4.28	.48	.16	.22	1982	211
18512	-2.03	.47	2.87	.36	-.01	.69	.07	.22	1982	212
18514	-1.71	.69	2.20	.52	.81	1.10	-.06	.26	1982	270
18515	2.99	.76	.06	.63	-6.54	1.35	-.12	.26	1982	274
18520	-1.83	.60	1.62	.61	.92	.62	.03	.27	1984	128
18521	1.44	.60	-2.07	.76	-.15	.52	.45	.31	1984	140
18525	-7.89	.47	-1.87	.52	3.20	.79	-.06	.19	1984	225
1851618	-7.00	.59	-4.94	.86	-.72	1.21	.01	.20	1984	235
18526	-4.28	.61	2.26	1.56	1.40	1.08	-.16	.21	1984	267
18527	-13.56	.52	.55	1.03	2.98	.84	-.32	.20	1984	285
18528	-12.57	.63	.25	1.23	4.02	1.44	-.09	.19	1984	294
1852223	-.39	.38	-.54	.53	-.94	.32	.34	.25	1984	321
18529	-1.90	.33	-1.17	.38	1.63	.44	.33	.20	1984	330
185819	-2.21	.78	-1.82	.70	2.62	.85	-.15	.24	1985	165
18530	-4.58	.59	-2.82	.42	5.95	.80	.16	.19	1985	222
18531	-.55	.76	-1.70	.71	1.66	.73	.09	.22	1985	229
18510	-2.79	.77	.11	.49	1.80	1.12	-.27	.27	1985	245
1853	-2.89	.36	-.59	.34	3.19	.39	.16	.24	1985	245
18524	-6.56	.32	-.02	.41	3.96	.33	.12	.18	1985	238
18532	-3.55	.68	2.36	1.99	.31	1.11	-.04	.18	1985	312
18533	-4.46	.66	-.13	2.02	1.53	1.83	-.11	.19	1985	319

CHORD DISTANCES AND THEIR MSE'S

SHIFT-R

			DISTANCE	sig	PPM	
MORGENZON	2725.00079	WITWATER	2923.00053	305554.656	.396	1.30
LEEUKOP (RSA)	2926.00022	FRANSMANSKOP	3024.00026	257915.018	.378	1.46
GRASKOP	2919.00010	POTLOER	3121.00053	250696.430	.412	1.64
INKOMINKULU	2930.00051	WITWATER	2923.00053	726356.992	.607	.84
LEEUKOP (SWA)	2315.00079	UNIONS END	2419.00318	540196.354	.606	1.12
DRUSE	2013.00007	GEELHOUT	1920.00009	755762.413	.681	.90
ONDONDVENGO	1712.00004	ESERE	2017.00026	606276.778	.498	.82
BLYDEBERG	3323.00007	LUBISI	3127.00040	430532.310	.670	1.56
GRASKOP	2919.00010	INKOMINKULU	2930.00051	1022248.352	.658	.64
LOUISFNTN	3117.00005	UNIONS END	2419.00318	712763.274	.619	.87
M' PUMBE NEW	2431.00066	INKOMINKULU	2930.00051	636279.762	.589	.93
PONT	2229.00023	HEXRIVIER	3319.00029	1542551.677	.961	.62
SCHWARZECK	2218.00179	COEGAKOP	3325.00133	1393884.347	.715	.51
LOUISFNTN	3117.00005	INKOMINKULU	2930.00051	1203664.413	.739	.61
HEXRIVIER	3319.00029	COEGAKOP	3325.00133	554176.667	.841	1.52
HEXRIVIER	3319.00029	KARSRIVIER	3420.00022	125409.660	.518	4.13
COEGAKOP	3325.00133	ONDONDVENGO	1712.00004	2194772.435	.940	.43
KRANZBERG	2427.00025	BRIT 44	2527.00292	156826.024	.588	3.75

- A 30 -

- A 31 -

	Residuals					Residuals					Residuals					Residuals				SHIFT-S	
	PT	X	Y	Z		PT	X	Y	Z		PT	X	Y	Z		PT	X	Y	Z	PT	X
1851	17	-.01	-.23	-.13	25	-.25	.03	.30	36	.26	.20	-.17									
1857	8	.23	.04	.16	30	-.11	-.44	.18	36	-.12	.40	-.34									
1854	17	.08	-.36	.15	24	-.63	-.12	.20	25	.55	.47	-.34									
1855	16	-.33	.23	-.18	24	.12	.02	-.43	25	.21	-.26	.60									
1856	16	.31	-.49	-.33	24	-.28	.35	.37	33	-.03	.14	-.04									
1859	10	-.17	.81	.32	19	-.15	-.13	-.19	30	.32	-.67	-.13									
18511	10	.18	-.93	-.05	30	.16	1.54	-.23	36	-.34	-.61	.28									
18513	11	.11	-.29	-.43	25	-.20	.23	-.07	36	.08	.05	.50									
18512	10	.00	-.04	.02	11	-.10	-.01	.02	36	.10	.04	-.04									
18514	10	.20	.07	-.02	14	.05	-.07	.10	35	-.25	.00	-.07									
18515	4	.49	.06	-.17	14	-.56	.01	-.10	35	.07	-.07	.27									
18520	8	.37	.31	-.22	30	-.42	-.07	.20	3	.06	-.24	.02									
18521	8	.10	-.22	-.10	3	.00	.02	.08	5	-.09	.20	.02									
18525	10	.14	.18	-.34	11	.03	-.31	.41	14	.36	-.07	.18	23	-.33	.15	.26	34	-.20	.05	-.51	
1851618	20	.05	-.37	-1.02	4	-.03	.39	.47	32	.06	-.16	.50	34	-.11	.04	.22	14	.03	.11	-.17	
18526	7	-.21	.01	.42	1	-.13	-.41	.00	32	.34	.39	-.42									
18527	1	-.14	.12	-.08	32	-.39	.01	.29	34	.36	-.10	.32	23	.17	-.03	-.53					
18528	7	.44	.33	-.30	18	.06	-.03	-.07	32	-.05	-.24	-.46	20	-.06	.46	1.26	4	-.40	-.53	-.43	
1852223	17	.17	.12	-.01	8	-.40	-.09	-.06	21	.17	.10	.08	5	.06	-.14	-.01					
18529	24	.69	-.31	-.03	13	-.01	.11	.01	17	-.49	.31	.11	21	-.19	-.11	-.09					
185819	19	-.06	.10	.09	30	.09	-.24	-.04	12	.00	.00	.00	3	-.03	.14	-.05	15	.00	.00	.00	
18530	22	.00	.00	.00	13	.01	-.11	-.01	24	-.03	.13	-.11	33	-.17	.01	.11	26	.19	-.03	.01	
18531	29	.00	.00	.00	16	.00	.11	.10	33	.21	-.14	-.08	26	-.21	.03	-.01					
18510	10	-.43	-.01	.21	19	.24	-.06	.00	35	.20	.07	-.21									
1853	36	-.05	-.11	-.13	17	.22	.16	-.08	8	-.16	-.05	.21									
18524	25	-.24	-.53	-.35	11	.05	.56	-.14	23	.19	-.14	.22	16	.01	.10	.28	2	.00	.00	.00	
18532	31	.00	.00	.00	27	-.02	-.03	-.20	9	.00	.00	.00	7	-.23	-.25	.13	1	.25	.28	.07	
18533	28	.00	.00	.00	27	.02	.02	.16	6	.00	.00	.00	7	.03	-.05	-.21	18	-.04	.02	.05	

VtPV 29.96 NO OF VARIABLES= 214 NO OF OBSERVTVNS= 312

			FINAL CO-ORDINATES					SHIFT-S
			X	mseX	Y	mseY	Z	mseZ
1	0	ACORN	5525469.97	1.01	2120237.38	.89	-2373274.08	1.40
2	0	BRIT 44	5086486.53	.57	2667595.43	.79	-2767919.69	.63
3	0	BLYDEBERG	4917287.69	.54	2106614.24	.81	-3463658.29	.91
4	0	BURENKAMP	5505882.68	.95	1492430.23	1.86	-2843493.99	.64
5	0	COEGAKOP	4785914.43	.68	2295263.48	.59	-3524982.66	1.06
6	0	DRUSE	5821899.97	1.67	1398478.61	2.22	-2192746.91	1.86
7	0	ESERE	5716992.25	1.38	1810403.30	1.28	-2169938.08	1.86
8	0	FRANSMANSKOP	4988154.46	.36	2267479.60	.53	-3256553.07	.52
9	0	GEELHOUT	5624226.94	1.29	2124856.35	1.06	-2125844.69	2.02
10	0	GRASKOP	5246334.64	.49	1904111.70	1.02	-3079062.69	.44
11	0	HADIDA	5294743.44	.51	2085812.89	.75	-2872755.83	.40
12	0	HEXRIVIER	5022154.81	.60	1795162.28	1.29	-3490361.59	1.04
13	0	INKOMINKULU	4776610.64	.66	2809324.06	.79	-3149348.13	.56
14	0	KARASBERG	5386692.32	.72	1837216.77	1.17	-2872961.44	.53
15	0	KARSRIVIER	4944368.89	.65	1811091.34	1.26	-3587434.13	1.21
16	0	KRANZBERG	5149887.77	.41	2691093.41	.64	-2626418.63	.71
17	1	LEEUKOP (RSA)	4986890.76	.00	2475833.45	.00	-3104542.88	.00
18	0	LEEUKOP (SWA)	5672669.42	1.31	1526108.08	1.86	-2477896.80	1.25
19	0	LOUISFNTN	5203443.37	.56	1690208.89	1.41	-3268507.54	.69
20	0	LOURKOP	5545533.18	1.04	1663956.59	1.54	-2670130.50	.85
21	0	LUBISI	4815761.90	.56	2506294.52	.43	-3339943.63	.67
22	0	MAGWAZA	4786224.83	.81	3006517.66	1.16	-2946617.61	.66
23	0	MANNERHEIM	5291621.20	.56	2265092.40	.62	-2740787.98	.59
24	0	MOOIDAM	4983831.69	.37	2732710.35	.61	-2887739.21	.41
25	1	MORGENZON	5138858.00	.00	2424478.71	.00	-2890847.72	.00
26	0	M' PUMBE NEW	4943179.09	.59	3076441.49	1.25	-2596396.28	.89
27	0	OKOTOMARE	5812704.03	1.62	1662415.50	1.61	-2028991.11	2.22
28	0	ONDONDVENGO	5933892.95	1.93	1289729.78	2.49	-1947624.21	2.45
29	0	PONT	5157883.42	.74	2878302.24	1.02	-2400477.91	1.32
30	0	POTLOER	5101368.49	.43	1977626.39	.93	-3269926.23	.62
31	0	RUNDU (BCN B)	5714708.50	1.46	2054403.98	1.08	-1947079.77	2.45
32	0	SCHWARZECK	5576028.77	1.07	1884766.62	1.13	-2452545.90	1.22
33	0	THAMAKOOSH	5019368.40	.49	2903704.00	.92	-2651970.90	.77
34	0	UNIONS END	5444104.16	.81	1979201.24	.96	-2663035.01	.78
35	0	WITBANK NEW	5361112.56	.73	1605151.45	1.58	-3050285.17	.57
36	0	WITWATER	5137633.73	.35	2183074.78	.59	-3078160.64	.36

GEOGRAPHICAL CO-ORDINATES (GRS 80)

			GEOGRAPHICAL CO-ORDINATES (GRS 80)				HEIGHT	mse	SHIFTS			
			LATITUDE	mse(M)	LONGITUDE	mse(M)			Error	Ellipsoid	Axes	
1	0	ACORN	21 59	3.6331	1.54	20 59 34.2364	1.05	1252.24	.59	1.67	.81	.58
2	0	BRIT 44	25 52	51.6793	.66	27 40 28.7533	.78	1628.72	.55	.84	.58	.55
3	0	BLYDEBERG	33 05	51.2961	1.02	23 11 26.7592	.73	1150.51	.46	1.12	.56	.45
4	0	BURENKAMP	26 38	54.0338	.69	15 09 58.3987	1.99	110.50	.56	2.02	.61	.54
5	0	COEGAKOP	33 45	57.7653	1.21	25 37 18.4142	.51	142.85	.46	1.21	.50	.46
6	0	DRUSE	20 14	17.9836	2.09	13 30 25.5950	2.49	797.16	.81	3.15	.85	.74
7	0	ESERE	20 00	57.8027	2.05	17 34 17.2668	1.56	1668.43	.63	2.46	.76	.59
8	0	FRANSMANSKOP	30 53	37.2452	.56	24 26 42.9207	.50	1498.02	.35	.65	.39	.35
9	0	GEELHOUT	19 35	38.9660	2.19	20 41 48.3852	1.22	1252.48	.78	2.27	1.06	.76
10	0	GRASKOP	29 02	52.5711	.45	19 56 52.5381	1.06	1061.97	.38	1.08	.41	.38
11	0	HADIDA	26 56	24.6166	.42	21 30 5.3278	.83	989.90	.35	.84	.39	.35
12	0	HEXRIVIER	33 22	43.9318	1.14	19 40 9.6941	1.21	2250.62	.59	1.55	.61	.58
13	0	INKOMINKULU	29 46	33.6010	.58	30 27 41.6238	.90	1011.76	.46	.93	.53	.46
14	0	KARASBERG	26 56	21.6543	.56	18 49 57.9211	1.27	1623.18	.47	1.30	.51	.46
15	0	KARSRIVIER	34 26	44.1972	1.36	20 07 2.8775	1.14	205.38	.59	1.65	.65	.58
16	0	KRANZBERG	24 28	4.1727	.77	27 35 22.1601	.59	2135.45	.38	.86	.44	.38
17	1	LEEUKOP(RSA)	29 18	29.1781	.00	26 24 10.5981	.00	1671.51	.00	.00	.00	.00
18	0	LEEUKOP(SWA)	23 00	31.9519	1.41	15 03 27.5977	2.08	697.74	.67	2.40	.76	.64
19	0	LOUISFNTN	31 01	28.1188	.71	17 59 42.3463	1.42	559.04	.48	1.50	.54	.47
20	0	LOURKOP	24 54	17.2858	.95	16 42 7.4014	1.71	1465.30	.59	1.86	.63	.58
21	0	LUBISI	31 46	20.6073	.74	27 29 38.6859	.49	1789.16	.41	.78	.43	.41
22	0	MAGWAZA	27 41	31.8366	.67	32 08 7.5043	1.26	590.34	.64	1.27	.66	.63
23	0	MANNERHEIM	25 36	41.6185	.63	23 10 24.5048	.68	1082.01	.42	.76	.54	.42
24	0	MOOIDAM	27 05	20.2257	.43	28 44 11.8513	.61	1636.37	.34	.65	.36	.34
25	1	MORGENZON	27 07	16.5714	.00	25 15 27.4458	.00	1460.80	.00	.00	.00	.00
26	0	M'PUMBE NEW	24 10	38.4968	.98	31 53 47.4730	1.21	437.69	.53	1.45	.57	.53
27	0	OKOTOMARE	18 40	6.3467	2.44	15 57 37.3205	1.92	1181.02	.73	3.00	.81	.66
28	0	ONDONDVENGO	17 53	41.6836	2.72	12 15 44.9887	2.80	992.17	.88	3.84	.83	.75
29	0	PONT	22 15	5.5132	1.43	29 09 47.6612	.91	695.97	.69	1.51	.77	.69
30	0	POTLOER	31 02	4.0114	.66	21 11 22.6008	.91	1473.41	.41	1.04	.44	.40
31	0	RUNDU(BCN B)	17 53	21.5597	2.65	19 46 23.5626	1.29	1136.80	.80	2.76	1.03	.76
32	0	SCHWARZECK	22 45	26.4030	1.35	18 40 33.1990	1.34	1514.38	.54	1.78	.66	.53
33	0	THAMAKOOSH	24 43	19.5239	.84	30 02 57.7543	.87	1979.73	.47	1.10	.50	.47
34	0	UNIONS END	24 50	8.2147	.86	19 58 43.3551	1.10	1130.16	.49	1.27	.57	.48
35	0	WITBANK NEW	28 45	17.9139	.58	16 40 4.9330	1.66	340.97	.52	1.67	.57	.51
36	0	WITWATER	29 02	10.8245	.37	23 01 17.5038	.60	1519.00	.31	.62	.34	.31

BURSA-WOLF TRANSFORMATION

POINT	WEIGHT	FREE-NET CO-ORDINATES (BROADCAST EPHEMERIS)			ADOS (PRECISE EPHEMERIS)		
		X	Y	Z	X	Y	Z
COEGAKOP	1.00	4785917.33	2295264.20	-3524984.89	4785913.74	2295263.20	-3524985.83
HEXRIVIER	1.00	5022158.01	1795162.07	-3490363.97	5022155.01	1795160.27	-3490364.81
MAGWAZA	1.00	4786228.24	3006518.50	-2946619.00	4786226.32	3006517.18	-2946619.81
MORGENZON	1.00	5138861.40	2424479.52	-2890849.15	5138858.47	2424478.35	-2890850.32
PONT	1.00	5157886.80	2878303.07	-2400479.33	5157884.63	2878301.10	-2400480.08
SCHWARZECK	1.00	5576032.36	1884767.21	-2452547.16	5576027.87	1884764.87	-2452547.39
WITBANK NEW	1.00	5361116.18	1605151.88	-3050286.53	5361111.93	1605149.00	-3050285.80

PRECISE CO-ORDINATES
TRANSFORMED BROADCAST CO-ORDINATES

				VX	VY	VZ	VLAT	VLON	VHGT	LX	LY	LZ
COEGAKOP	4785913.74	2295263.20	-3524985.83									
	4785914.01	2295262.99	-3524985.40	-.27	.21	-.43	-.44	.31	.11	-3.59	-1.00	-.94
HEXRIVIER	5022155.01	1795160.27	-3490364.81									
	5022153.95	1795160.51	-3490364.48	1.06	-.24	-.33	.23	-.58	.95	-3.00	-1.80	-.84
MAGWAZA	4786226.32	3006517.18	-2946619.81									
	4786225.98	3006517.29	-2946619.51	.34	-.11	-.30	-.16	-.27	.34	-1.92	-1.32	-.81
MORGENZON	5138858.47	2424478.35	-2890850.32									
	5138858.27	2424477.78	-2890849.66	.20	.57	-.66	-.40	.43	.67	-2.93	-1.17	-1.17
PONT	5157884.63	2878301.10	-2400480.08									
	5157884.35	2878301.31	-2400479.84	.28	-.21	-.24	-.17	-.32	.22	-2.17	-1.97	-.75
SCHWARZECK	5576027.87	1884764.87	-2452547.39									
	5576028.43	1884764.82	-2452547.67	-.56	.05	.28	.06	.22	-.58	-4.49	-2.34	-.23
WITBANK NEW	5361111.93	1605149.00	-3050285.80									
	5361111.83	1605149.81	-3050287.04	.10	-.81	1.24	1.03	-.81	-.72	-4.25	-2.88	.73

THE FOLLOWING PARAMETERS ARE FOR TRANSFORMING
FROM BROADCAST DATUM TO PRECISE DATUM

X-SHIFT=	-6.74	Y-SHIFT=	+5.92	Z-SHIFT=	-.51
	+/- 1.15		+/- 2.78		+/- .18
X-ROT(")=	+ .000	Y-ROT(")=	+ .000	Z-ROT(")=	-.307
	FIXED		FIXED		+/- .109
SCALE=	+.0000 PPM		FIXED		

TRANSFORMATION MATRIX (SCALE & ROTATIONS)
ABOUT CO-ORDINATE ORIGIN (GEOCENTRE)

1.00000000	.00000149	.00000000
-.00000149	1.00000000	.00000000
.00000000	.00000000	1.00000000

COVARIANCE-MATRIX

BURSA-WOLF (4 PARAMETERS)

	SCALE	X-ROT	Y-ROT	Z-ROT	X-SH	Y-SH	Z-SH
SCALE	.28E-30	-.18E-48	-.13E-48	-.36E-31	-.15E-23	-.41E-24	.81E-24
X-ROT	-.18E-48	.14E-29	-.55E-48	.27E-30	.57E-24	-.53E-23	-.29E-23
Y-ROT	-.13E-48	-.55E-48	.37E-30	.67E-31	.12E-23	-.35E-24	.19E-23
Z-ROT	-.36E-31	.27E-30	.67E-31	.12E-12	.27E-06	-.65E-06	-.33E-24
X-SH	-.15E-23	.57E-24	.12E-23	.27E-06	.58E+00	-.14E+01	.64E-18
Y-SH	-.41E-24	-.53E-23	-.35E-24	-.65E-06	-.14E+01	.34E+01	.84E-17
Z-SH	.81E-24	-.29E-23	.19E-23	-.33E-24	.64E-18	.84E-17	.15E-01

CORRELATION-MATRIX

	SCALE	X-ROT	Y-ROT	Z-ROT	X-SH	Y-SH	Z-SH
SCALE	1.00	.00	.00	.00	.00	.00	.00
X-ROT	.00	1.00	.00	.00	.00	.00	.00
Y-ROT	.00	.00	1.00	.00	.00	.00	.00
Z-ROT	.00	.00	.00	1.00	.99	-1.00	.00
X-SH	.00	.00	.00	.99	1.00	-.99	.00
Y-SH	.00	.00	.00	-1.00	-.99	1.00	.00
Z-SH	.00	.00	.00	.00	.00	.00	1.00

BURSA-WOLF TRANSFORMATION

Using full Weight Matrix for Free-Net Co-ords

POINT	WEIGHT	FREE-NET CO-ORDINATES (BROADCAST EPHEMERIS)			ADOS (PRECISE EPHEMERIS)		
		X	Y	Z	X	Y	Z
COEGAKOP	1.00	4785917.33	2295264.20	-3524984.89	4785913.74	2295263.20	-3524985.83
HEXRIVIER	1.00	5022158.01	1795162.07	-3490363.97	5022155.01	1795160.27	-3490364.81
MAGWAZA	1.00	4786228.24	3006518.50	-2946619.00	4786226.32	3006517.18	-2946619.81
MORGENZON	1.00	5138861.40	2424479.52	-2890849.15	5138858.47	2424478.35	-2890850.32
PONT	1.00	5157886.80	2878303.07	-2400479.33	5157884.63	2878301.10	-2400480.08
SCHWARZECK	1.00	5576032.36	1884767.21	-2452547.16	5576027.87	1884764.87	-2452547.39
WITBANK NEW	1.00	5361116.18	1605151.88	-3050286.53	5361111.93	1605149.00	-3050285.80

PRECISE CO-ORDINATES
TRANSFORMED BROADCAST CO-ORDINATES

				VX	VY	VZ	VLAT	VLON	VHGT	LX	LY	LZ
COEGAKOP	4785913.74	2295263.20	-3524985.83									
	4785914.36	2295262.67	-3524985.87	-.62	.53	.04	-.15	.74	-.30	-3.59	-1.00	-.94
HEXRIVIER	5022155.01	1795160.27	-3490364.81									
	5022154.18	1795160.07	-3490364.46	.83	.20	-.35	.17	-.09	.90	-3.00	-1.80	-.84
MAGWAZA	4786226.32	3006517.18	-2946619.81									
	4786226.18	3006517.50	-2946620.39	.14	-.32	.58	.49	-.34	-.31	-1.92	-1.32	-.81
MORGENZON	5138858.47	2424478.35	-2890850.32									
	5138858.34	2424477.84	-2890849.91	.13	.51	-.41	-.21	.41	.48	-2.93	-1.17	-1.17
PONT	5157884.63	2878301.10	-2400480.08									
	5157884.25	2878301.78	-2400480.32	.38	-.68	.24	.22	-.77	-.09	-2.17	-1.97	-.75
SCHWARZECK	5576027.87	1884764.87	-2452547.39									
	5576028.17	1884764.98	-2452547.22	-.30	-.11	-.17	-.28	-.01	-.23	-4.49	-2.34	-.23
WITBANK NEW	5361111.93	1605149.00	-3050285.80									
	5361111.81	1605149.57	-3050286.62	.12	-.57	.82	.69	-.58	-.44	-4.25	-2.88	.73

THE FOLLOWING PARAMETERS ARE FOR TRANSFORMING
FROM BROADCAST DATUM TO PRECISE DATUM

BURSA-WOLF

X-SHIFT= -9.84 Y-SHIFT= +8.97 Z-SHIFT= -1.60
 +/- 3.06 +/- 3.12 +/- 2.91

X-ROT(")= -.145 Y-ROT(")= -.121 Z-ROT(")= -.362
 +/- .101 +/- .096 +/- .100

SCALE= +.1625 PPM +/- .4127

TRANSFORMATION MATRIX (SCALE & ROTATIONS)
ABOUT CO-ORDINATE ORIGIN (GEOCENTRE)

1.00000016	.00000175	-.00000059
-.00000175	1.00000016	.00000070
.00000059	-.00000070	1.00000016

COVARIANCE-MATRIX

BURSA-WOLF

	SCALE	X-ROT	Y-ROT	Z-ROT	X-SH	Y-SH	Z-SH
SCALE	.98E-13	-.42E-14	-.14E-13	-.16E-13	-.59E-06	-.11E-06	.22E-06
X-ROT	-.42E-14	.14E-12	-.17E-13	.24E-13	.24E-07	-.51E-06	-.40E-06
Y-ROT	-.14E-13	-.17E-13	.13E-12	.21E-13	.48E-06	-.31E-07	.65E-06
Z-ROT	-.16E-13	.24E-13	.21E-13	.14E-12	.44E-06	-.74E-06	.13E-07
X-SH	-.59E-06	.24E-07	.48E-06	.44E-06	.54E+01	-.11E+01	.77E+00
Y-SH	-.11E-06	-.51E-06	-.31E-07	-.74E-06	-.11E+01	.56E+01	.61E+00
Z-SH	.22E-06	-.40E-06	.65E-06	.13E-07	.77E+00	.61E+00	.49E+01

CORRELATION-MATRIX

	SCALE	X-ROT	Y-ROT	Z-ROT	X-SH	Y-SH	Z-SH
SCALE	1.00	-.04	-.13	-.14	-.81	-.15	.31
X-ROT	-.04	1.00	-.13	.18	.03	-.58	-.48
Y-ROT	-.13	-.13	1.00	.16	.58	-.04	.83
Z-ROT	-.14	.18	.16	1.00	.51	-.85	.02
X-SH	-.81	.03	.58	.51	1.00	-.20	.15
Y-SH	-.15	-.58	-.04	-.85	-.20	1.00	.12
Z-SH	.31	-.48	.83	.02	.15	.12	1.00

SUBNET TRANSFORMATION PARAMETERS

SHIFT-S

	X-SH	sig	Y-SH	sig	Z-SH	sig	PPM	sig	Year	Day
1851	1.99	.33	-.52	.37	-.79	.33	-.66	2.21	1980	236
1857	-.81	.42	1.04	.69	-.79	.52	-.61	2.61	1980	323
1854	1.79	.32	1.52	.35	-1.44	.32	.80	2.08	1981	80
1855	1.59	.38	1.36	.50	.88	.46	-1.58	2.41	1981	86
1856	.82	.45	1.77	.73	-2.75	.64	-.37	2.76	1981	94
1859	-3.46	.53	3.85	1.13	1.01	.61	1.21	2.86	1982	193
18511	.35	.46	.85	.86	-.53	.50	3.20	2.73	1982	205
18513	3.22	.39	-2.27	.52	-4.01	.36	.59	2.49	1982	211
18512	-1.92	.45	3.18	.77	.40	.37	-1.87	2.36	1982	212
18514	-1.62	.66	2.39	1.26	1.10	.51	-2.24	2.86	1982	270
18515	3.09	.80	.22	1.52	-6.26	.56	-2.64	2.90	1982	274
18520	-1.22	.46	1.58	.76	1.82	.69	3.33	2.65	1984	128
18521	2.31	.52	-2.52	.65	.82	.82	2.25	3.00	1984	140
18525	-7.72	.59	-1.60	.86	3.71	.47	-.52	2.22	1984	225
1851618	-6.86	.89	-4.97	1.30	-.51	.74	1.54	2.46	1984	235
18526	-4.09	1.15	1.41	1.07	1.12	1.49	1.35	3.01	1984	267
18527	-13.35	.84	.26	.85	3.19	.97	.07	2.60	1984	285
18528	-12.53	1.13	.01	1.51	3.86	1.09	2.20	2.51	1984	294
1852223	.14	.39	-1.09	.36	-.55	.55	2.11	2.52	1984	321
18529	-1.81	.40	-1.62	.44	1.41	.36	.76	2.12	1984	330
185819	-1.74	.45	-1.22	1.10	3.67	.84	3.83	2.30	1985	165
18530	-4.89	.51	-2.91	.89	5.38	.50	-.57	2.16	1985	222
18531	-.96	.48	-1.34	.91	1.31	.87	.56	2.83	1985	229
18510	-2.85	.60	.54	1.33	1.98	.56	.34	2.85	1985	245
1853	-2.74	.33	-.55	.44	3.44	.37	1.35	2.44	1985	245
18524	-6.53	.35	.22	.35	4.22	.42	.67	2.19	1985	238
18532	-3.39	1.31	1.26	1.07	-.23	1.96	1.19	2.88	1985	312
18533	-4.67	1.55	-.64	1.85	.51	1.89	1.73	2.91	1985	319

CHORD DISTANCES AND THEIR MSE'S

SHIFT-S

				DISTANCE	sig	PPM
MORGENZON	2725.00079	WITWATER	2923.00053	305554.386	.573	1.88
LEEUKOP(RSA)	2926.00022	FRANSMANSKOP	3024.00026	257914.756	.642	2.49
GRASKOP	2919.00010	POTLOER	3121.00053	250696.011	.564	2.25
INKOMINKULU	2930.00051	WITWATER	2923.00053	726356.308	1.298	1.79
LEEUKOP(SWA)	2315.00079	UNIONS END	2419.00318	540195.931	1.393	2.58
DRUSE	2013.00007	GEELHOUT	1920.00009	755761.306	2.110	2.79
ONDONDVENGO	1712.00004	ESERE	2017.00026	606275.750	1.795	2.96
BLYDEBERG	3323.00007	LUBISI	3127.00040	430531.221	.989	2.30
GRASKOP	2919.00010	INKOMINKULU	2930.00051	1022247.574	1.729	1.69
LOUISFNTN	3117.00005	UNIONS END	2419.00318	712763.057	1.364	1.91
M'PUMBE NEW	2431.00066	INKOMINKULU	2930.00051	636280.225	1.295	2.04
PONT	2229.00023	HEXRIVIER	3319.00029	1542550.110	2.633	1.71
SCHWARZECK	2218.00179	COEGAKOP	3325.00133	1393882.690	2.471	1.77
LOUISFNTN	3117.00005	INKOMINKULU	2930.00051	1203662.710	2.061	1.71
HEXRIVIER	3319.00029	COEGAKOP	3325.00133	554174.471	1.151	2.08
HEXRIVIER	3319.00029	KARSRIVIER	3420.00022	125409.179	.612	4.88
COEGAKOP	3325.00133	ONDONDVENGO	1712.00004	2194769.322	4.328	1.97
KRANZBERG	2427.00025	BRIT 44	2527.00292	156826.097	.678	4.33

Residuals

SHIFT3

	PT	X	Y	Z	PT	X	Y	Z	PT	X	Y	Z	PT	X	Y	Z	PT	X	Y	Z
1851	17	-.02	.32	-.43	25	-.94	-.39	.76	36	.96	.07	-.33								
18510	10	.29	.38	-.12	19	.55	.11	-.95	35	-.84	-.49	1.07								
18511	10	.42	-.82	.07	30	.10	1.91	-.31	36	-.52	-1.09	.24								
18512	10	.32	-.44	.06	11	.24	-.02	.10	36	-.56	.46	-.16								
18513	11	.99	-.22	-.76	25	-1.33	-.09	.29	36	.34	.31	.47								
18514	10	.04	.73	-.58	14	1.84	.32	-.47	35	-1.88	-1.05	1.05								
18515	4	2.96	.01	-1.04	14	-.09	.81	-.47	35	-2.88	-.82	1.50								
1851618	20	.51	-.28	-1.20	4	-.56	.45	.58	32	2.93	.37	-.28	34	-.87	-.12	.33	14	-2.01	-.43	.56
18520	8	.23	-.12	.03	30	-.24	.08	.10	3	.01	.04	-.14								
18521	8	.60	-.58	-.21	3	.51	.20	-.67	5	-1.11	.38	.88								
1852223	17	.58	-.35	-.36	8	-.07	-.04	-.22	21	.65	-.06	-.18	5	-1.15	.45	.76				
18524	25	-2.03	-.93	.40	11	.24	.58	-.08	23	2.09	-.02	-.01	16	-.30	.37	-.31	2	.00	.00	.00
18525	10	-1.14	-.01	-.03	11	-1.30	-.36	.47	14	.79	-.41	.12	23	.04	.41	.19	34	1.62	.38	-.75
18526	7	-.63	-.03	.63	1	-.80	-.60	.09	32	1.43	.62	-.72								
18527	1	.75	.36	-.06	32	2.32	.37	-.17	34	-.76	-.29	.44	23	-2.31	-.45	-.20				
18528	7	.63	.29	-.56	18	.14	.01	-.14	32	1.78	-.07	-.98	20	-.62	.34	1.48	4	-1.93	-.57	.20
18529	24	.92	-.47	-.29	13	.69	.28	-.54	17	-.88	.13	.63	21	-.73	.06	.21				
1853	36	.24	-.30	-.09	17	.10	.08	-.14	8	-.35	.23	.22								
18530	22	2.52	1.23	-2.89	13	-.72	-.29	.57	24	-.95	-.50	1.10	33	-.63	-.30	.74	26	-.21	-.14	.48
18531	29	-.61	.08	.31	16	-.12	-.19	.59	33	.50	-.04	-.37	26	.23	.15	-.53				
18532	31	.00	.00	.00	27	.02	-.05	-.13	9	.00	.00	.00	7	-.12	-.19	.17	1	.09	.25	-.03
18533	28	.00	.00	.00	27	-.02	.04	.11	6	.00	.00	.00	7	.12	-.03	-.21	18	-.10	-.01	.10
1854	17	.17	-.06	.27	24	.09	.19	-.49	25	-.26	-.13	.22								
1855	16	.30	.53	-.26	24	.38	.70	-1.01	25	-.68	-1.23	1.27								
1856	16	.26	-.80	.00	24	-.48	.37	.51	33	.22	.43	-.51								
1857	8	-.28	.44	.17	30	.14	-.60	-.21	36	.15	.17	.04								
185819	19	-.20	.08	.66	30	-.01	-.58	.41	12	.48	.63	-1.51	3	-.27	-.13	.44	15	.00	.00	.00
1859	10	.15	.68	.67	19	-.20	-.29	-.30	30	.05	-.39	-.36								

VtPV = 222.59 NO OF VARIABLES= 171 NO OF OBSERVATIONS= 312

sigma-0 = 1.26 sigX = 1.72 sigY = .80 sigZ = 1.07

- A 42 -

w
h

			FINAL CO-ORDINATES						SHIFT3
			X	mseX	Y	mseY	Z	mseZ	
1	0	ACORN	5525477.16	1.17	2120238.44	.54	-2373275.24	.73	
2	0	BRIT 44	5086488.29	1.66	2667595.99	.77	-2767920.37	1.04	
3	0	BLYDEBERG	4917288.25	1.10	2106615.44	.51	-3463660.14	.69	
4	0	BURENKAMP	5505888.18	1.07	1492430.32	.50	-2843495.36	.66	
5	1	COEGAKOP	4785913.16	.00	2295265.11	.00	-3524983.05	.00	
6	0	DRUSE	5821907.75	1.82	1398478.67	.85	-2192747.73	1.13	
7	0	ESERE	5716999.94	1.15	1810404.09	.53	-2169938.87	.72	
8	0	FRANSMANSKOP	4988155.17	.96	2267480.62	.45	-3256553.82	.60	
9	0	GEELHOUT	5624234.41	1.91	2124857.45	.89	-2125845.46	1.19	
10	0	GRASKOP	5246336.81	.86	1904111.84	.40	-3079063.02	.54	
11	0	HADIDA	5294745.53	.93	2085813.08	.43	-2872756.51	.58	
12	1	HEXRIVIER	5022156.49	.00	1795163.19	.00	-3490365.54	.00	
13	0	INKOMINKULU	4776612.35	1.33	2809325.62	.62	-3149349.87	.83	
14	0	KARASBERG	5386696.13	.94	1837216.79	.44	-2872962.24	.59	
15	0	KARSRIVIER	4944369.79	1.46	1811091.68	.68	-3587436.94	.91	
16	0	KRANZBERG	5149889.27	1.04	2691094.25	.48	-2626419.79	.65	
17	0	LEEUKOP (RSA)	4986891.54	.93	2475834.39	.43	-3104543.50	.58	
18	0	LEEUKOP (SWA)	5672676.89	1.40	1526108.33	.65	-2477898.07	.87	
19	0	LOUISFNTN	5203445.12	1.11	1690208.74	.52	-3268508.56	.69	
20	0	LOURKOP	5545539.73	1.22	1663956.98	.56	-2670131.90	.76	
21	0	LUBISI	4815762.40	1.28	2506295.85	.59	-3339944.66	.80	
22	1	MAGWAZA	4786229.78	.00	3006520.51	.00	-2946622.93	.00	
23	0	MANNERHEIM	5291624.99	1.04	2265092.80	.48	-2740788.86	.65	
24	0	MOOIDAM	4983833.09	.98	2732711.50	.46	-2887740.46	.61	
25	1	MORGENZON	5138858.00	.00	2424478.71	.00	-2890847.72	.00	
26	0	M'PUMBE NEW	4943181.03	1.34	3076442.96	.62	-2596398.43	.84	
27	0	OKOTOMARE	5812711.76	1.51	1662416.03	.70	-2028991.70	.94	
28	0	ONDONDVENGO	5933900.92	1.82	1289729.65	.85	-1947624.61	1.13	
29	1	PONT	5157884.43	.00	2878303.57	.00	-2400479.13	.00	
30	0	POTLOER	5101369.89	.98	1977627.02	.45	-3269927.38	.61	
31	0	RUNDU (BCN B)	5714716.07	1.91	2054405.00	.89	-1947080.33	1.19	
32	1	SCHWARZECK	5576037.78	.00	1884767.78	.00	-2452547.56	.00	
33	0	THAMAKOOSH	5019370.23	1.21	2903705.36	.56	-2651972.86	.75	
34	0	UNIONS END	5444109.32	1.02	1979201.86	.47	-2663036.09	.63	
35	1	WITBANK NEW	5361113.01	.00	1605150.54	.00	-3050283.90	.00	
36	0	WITWATER	5137635.12	.89	2183075.22	.41	-3078161.13	.55	

		GEOGRAPHICAL CO-ORDINATES								SHIFT3	
		LATITUDE			mse(M)	LONGITUDE			mse(M)	HEIGHT	mse
1	0	ACORN	21 59	3.5820	.80	20 59	34.1812	.66	1259.25	1.07	
2	0	BRIT 44	25 52	51.6732	1.15	27 40	28.7419	1.03	1630.65	1.44	
3	0	BLYDEBERG	33 05	51.3289	.81	23 11	26.7932	.64	1152.34	.95	
4	0	BURENKAMP	26 38	53.9960	.76	15 09	58.3499	.55	115.87	.97	
5	1	COEGAKOP	33 45	57.7835	.00	25 37	18.4924	.00	142.70	.00	
6	0	DRUSE	20 14	17.9234	1.23	13 30	25.5345	.92	804.56	1.72	
7	0	ESERE	20 00	57.7424	.77	17 34	17.2129	.61	1675.80	1.07	
8	0	FRANSMANSKOP	30 53	37.2483	.69	24 26	42.9447	.57	1499.32	.83	
9	0	GEELHOUT	19 35	38.9092	1.28	20 41	48.3301	1.07	1259.68	1.76	
10	0	GRASKOP	29 02	52.5477	.62	19 56	52.5155	.48	1063.96	.76	
11	0	HADIDA	26 56	24.6066	.65	21 30	5.3064	.53	992.01	.83	
12	1	HEXRIVIER	33 22	44.0052	.00	19 40	9.7052	.00	2254.37	.00	
13	0	INKOMINKULU	29 46	33.6134	.93	30 27	41.6414	.86	1014.58	1.11	
14	0	KARASBERG	26 56	21.6243	.67	18 49	57.8772	.51	1626.76	.85	
15	0	KARSRIVIER	34 26	44.2549	1.09	20 07	2.8778	.81	207.77	1.26	
16	0	KRANZBERG	24 28	4.1841	.71	27 35	22.1621	.64	2137.50	.90	
17	0	LEEUKOP (RSA)	29 18	29.1779	.66	26 24	10.6165	.57	1672.79	.80	
18	0	LEEUKOP (SWA)	23 00	31.8973	.97	15 03	27.5381	.72	704.93	1.30	
19	0	LOUISFNTN	31 01	28.1202	.81	17 59	42.3207	.60	560.95	.98	
20	0	LOURKOP	24 54	17.2396	.85	16 42	7.3477	.64	1471.68	1.11	
21	0	LUBISI	31 46	20.6176	.92	27 29	38.7219	.79	1790.59	1.08	
22	1	MAGWAZA	27 41	31.9034	.00	32 08	7.4963	.00	597.87	.00	
23	0	MANNERHEIM	25 36	41.5931	.72	23 10	24.4646	.60	1085.68	.92	
24	0	MOOIDAM	27 05	20.2354	.68	28 44	11.8636	.62	1638.53	.84	
25	1	MORGENZON	27 07	16.5714	.00	25 15	27.4458	.00	1460.80	.00	
26	0	M'PUMBE NEW	24 10	38.5284	.91	31 53	47.4810	.89	440.79	1.14	
27	0	OKOTOMARE	18 40	6.2860	1.01	15 57	37.2655	.79	1188.39	1.42	
28	0	ONDONDVENGO	17 53	41.6183	1.22	12 15	44.9269	.91	999.69	1.74	
29	1	PONT	22 15	5.5310	.00	29 09	47.6847	.00	697.85	.00	
30	0	POTLOER	31 02	4.0175	.71	21 11	22.6040	.55	1475.31	.85	
31	0	RUNDU (BCN B)	17 53	21.5023	1.27	19 46	23.5082	1.05	1144.08	1.77	
32	1	SCHWARZECK	22 45	26.3407	.00	18 40	33.1363	.00	1523.23	.00	
33	0	THAMAKOOSH	24 43	19.5507	.82	30 02	57.7635	.77	1982.61	1.03	
34	0	UNIONS END	24 50	8.1776	.71	19 58	43.3130	.56	1135.21	.92	
35	1	WITBANK NEW	28 45	17.8750	.00	16 40	4.8961	.00	340.50	.00	
36	0	WITWATER	29 02	10.8156	.63	23 01	17.4987	.51	1520.51	.78	

SUBNET SHIFT VALUES

SHIFT3

	No Passes	X	mseX	Y	mseY	Z	mseZ
1851	53	2.71	1.08	-.06	.50	-1.16	.67
18510	57	-1.39	1.07	.24	.50	1.96	.67
18511	59	2.00	1.15	1.26	.53	-1.19	.71
18512	118	-.04	.94	3.44	.44	-.10	.59
18513	56	4.39	1.06	-2.06	.49	-4.40	.66
18514	62	.53	1.01	2.14	.47	1.15	.63
18515	61	6.34	1.05	-.05	.49	-6.56	.65
1851618	85	-.85	.82	-4.51	.38	-1.77	.51
18520	66	-.33	1.16	2.54	.54	.58	.72
18521	55	2.31	1.10	-1.23	.51	-.17	.69
1852223	80	.32	.90	.14	.42	-1.24	.56
18524	74	-4.70	.88	.62	.41	3.54	.55
18525	78	-4.31	.87	-1.33	.41	2.95	.54
18526	73	3.87	1.06	2.42	.49	-.08	.66
18527	68	-7.06	.93	1.07	.43	1.99	.58
18528	69	-5.28	.94	.54	.44	2.56	.59
18529	71	-.71	1.07	-.38	.50	.25	.67
1853	71	-1.78	1.08	.26	.50	2.82	.67
18530	68	-2.52	.95	-1.23	.44	2.89	.59
18531	62	.61	1.02	-.08	.47	-.31	.64
18532	77	4.14	1.32	2.16	.61	-1.00	.82
18533	97	3.06	1.34	-.34	.62	-.26	.83
1854	60	2.52	1.04	2.22	.48	-2.07	.65
1855	52	2.56	1.12	2.02	.52	.08	.70
1856	54	2.40	1.25	2.89	.58	-4.21	.78
1857	62	.35	1.14	1.74	.53	-1.58	.71
185819	105	-.48	.85	-.63	.39	1.51	.53
1859	51	-1.69	1.23	4.06	.57	.17	.77

CHORD DISTANCES AND THEIR MSE'S

SHIFT3

				DISTANCE	MSE	PPM
MORGENZON	2725.00079	WITWATER	2923.00053	305554.334	.471	1.54
LEEUKOP(RSA)	2926.00022	FRANSMANSKOP	3024.00026	257914.767	.569	2.21
GRASKOP	2919.00010	POTLOER	3121.00053	250697.219	.805	3.21
INKOMINKULU	2930.00051	WITWATER	2923.00053	726357.230	.978	1.35
LEEUKOP(SWA)	2315.00079	UNIONS END	2419.00318	540197.156	.992	1.84
DRUSE	2013.00007	GEELHOUT	1920.00009	755762.396	1.145	1.52
ONDONDVENGO	1712.00004	ESERE	2017.00026	606276.781	.917	1.51
BLYDEBERG	3323.00007	LUBISI	3127.00040	430531.590	.841	1.95
GRASKOP	2919.00010	INKOMINKULU	2930.00051	1022249.135	.955	.93
LOUISFNTN	3117.00005	UNIONS END	2419.00318	712764.468	.953	1.34
M'PUMBE NEW	2431.00066	INKOMINKULU	2930.00051	636279.885	1.026	1.61
PONT	2229.00023	HEXRIVIER	3319.00029	1542552.282	.000	.00
SCHWARZECK	2218.00179	COEGAKOP	3325.00133	1393887.671	.000	.00
LOUISFNTN	3117.00005	INKOMINKULU	2930.00051	1203664.233	.957	.80
HEXRIVIER	3319.00029	COEGAKOP	3325.00133	554176.153	.000	.00
HEXRIVIER	3319.00029	KARSRIVIER	3420.00022	125408.710	1.149	9.16
COEGAKOP	3325.00133	ONDONDVENGO	1712.00004	2194774.949	1.311	.60
KRANZBERG	2427.00025	BRIT 44	2527.00292	156825.588	1.231	7.85

Residuals

SHIFT3

	PT	X	Y	Z	PT	X	Y	Z	PT	X	Y	Z	PT	X	Y	Z	PT	X	Y	Z
1851	17	-.13	-.06	-.19	25	-.26	.16	.38	36	.39	-.10	-.19								
18510	10	-.46	.13	.27	19	.35	-.49	-.07	35	.10	.37	-.19								
18511	10	.00	-.62	-.14	30	.28	1.64	.02	36	-.28	-1.03	.12								
18512	10	.12	-.40	.00	11	-.05	.02	.14	36	-.08	.37	-.14								
18513	11	.06	-.37	-.58	25	-.24	.34	-.07	36	.18	.03	.65								
18514	10	.09	.35	-.05	14	.05	-.03	.12	35	-.14	-.32	-.07								
18515	4	.64	-.50	-.22	14	-.68	.52	-.03	35	.05	-.02	.25								
1851618	20	.01	-.35	-1.08	4	-.13	.58	.38	32	.03	-.10	.48	34	-.06	-.07	.25	14	.15	-.07	-.02
18520	8	.51	-.10	-.25	30	-.52	.18	.21	3	.01	-.08	.04								
18521	8	.19	-.34	-.03	3	-.19	.30	-.03	5	.00	.03	.06								
1852223	17	.18	-.05	-.11	8	-.45	.08	-.01	21	.27	-.01	.16	5	.00	-.02	-.04				
18524	25	-.22	-.38	-.21	11	.05	.54	-.15	23	.22	-.21	.21	16	-.04	.06	.15	2	.00	.00	.00
18525	10	.23	.07	-.25	11	-.02	-.28	.35	14	.33	-.30	-.05	23	-.35	.34	.36	34	-.19	.18	-.41
18526	7	-.19	.05	.50	1	-.12	-.51	-.05	32	.31	.45	-.45								
18527	1	-.11	.26	.09	32	-.34	.02	.39	34	.29	-.12	.16	23	.16	-.16	-.64				
18528	7	.39	.23	-.47	18	.04	-.01	-.10	32	-.02	-.38	-.49	20	-.02	.43	1.33	4	-.40	-.27	-.27
18529	24	.69	-.39	-.08	13	.08	.06	.12	17	-.47	.32	.15	21	-.30	.01	-.18				
1853	36	-.08	-.09	-.14	17	.25	.06	-.09	8	-.17	.03	.22								
18530	22	.00	.00	.00	13	-.09	-.06	-.12	24	.05	.05	-.04	33	-.13	-.03	.12	26	.17	.04	.04
18531	29	.00	.00	.00	16	-.03	.18	.11	33	.21	-.13	-.07	26	-.18	-.04	-.05				
18532	31	.00	.00	.00	27	.01	-.05	-.14	9	.00	.00	.00	7	-.23	-.20	.18	1	.22	.25	-.03
18533	28	.00	.00	.00	27	-.01	.04	.11	6	.00	.00	.00	7	.04	-.05	-.18	18	-.03	.01	.07
1854	17	.13	-.34	.24	24	-.60	-.19	.18	25	.47	.53	-.42								
1855	16	-.27	.31	.01	24	-.05	.28	-.48	25	.31	-.59	.47								
1856	16	.34	-.58	-.35	24	-.27	.39	.42	33	-.08	.19	-.08								
1857	8	.07	.27	.06	30	-.07	-.69	.07	36	.00	.42	-.13								
185819	19	-.17	.44	.11	30	.08	-.34	-.10	12	.00	.00	.00	3	.09	-.11	-.01	15	.00	.00	.00
1859	10	-.23	.96	.32	19	-.04	-.36	-.15	30	.27	-.59	-.17								

VtPV = 36.23 NO OF VARIABLES= 189 NO OF OBSERVATIONS= 312

sigma-0 = .54 sigX = .44 sigY = .63 sigZ = .54

- A 47 -

14

FINAL CO-ORDINATES

			X	mseX	Y	mseY	Z	mseZ
1	0	ACORN	5525470.14	.48	2120237.32	.68	-2373273.82	.58
2	0	BRIT 44	5086486.48	.45	2667595.45	.64	-2767919.76	.55
3	0	BLYDEBERG	4917287.21	.41	2106614.17	.58	-3463659.10	.50
4	0	BURENKAMP	5505882.69	.45	1492429.54	.64	-2843494.49	.54
5	0	COEGAKOP	4785913.93	.43	2295263.39	.62	-3524983.47	.53
6	0	DRUSE	5821900.58	.60	1398477.56	.86	-2192746.32	.74
7	0	ESERE	5716992.69	.48	1810402.96	.69	-2169937.43	.59
8	0	FRANSMANSKOP	4988154.42	.35	2267479.50	.50	-3256553.24	.42
9	0	GEELHOUT	5624227.26	.62	2124856.33	.89	-2125844.04	.76
10	0	GRASKOP	5246334.89	.33	1904111.26	.47	-3079062.58	.40
11	0	HADIDA	5294743.52	.30	2085812.50	.43	-2872755.97	.37
12	0	HEXRIVIER	5022154.61	.50	1795161.26	.71	-3490362.55	.61
13	0	INKOMINKULU	4776610.56	.41	2809324.26	.59	-3149348.10	.50
14	0	KARASBERG	5386692.37	.39	1837216.24	.56	-2872961.75	.48
15	0	KARSRIVIER	4944368.39	.50	1811090.38	.71	-3587435.46	.61
16	0	KRANZBERG	5149887.72	.32	2691093.40	.46	-2626418.73	.39
17	0	LEEUKOP (RSA)	4986890.76	.30	2475833.45	.43	-3104542.88	.36
18	0	LEEUKOP (SWA)	5672669.79	.52	1526107.24	.75	-2477896.69	.64
19	0	LOUISFNTN	5203443.75	.41	1690207.81	.59	-3268507.62	.50
20	0	LOURKOP	5545533.33	.48	1663956.00	.68	-2670130.71	.58
21	0	LUBISI	4815761.64	.40	2506294.66	.57	-3339943.94	.48
22	0	MAGWAZA	4786224.84	.53	3006517.69	.76	-2946617.57	.65
23	0	MANNERHEIM	5291621.32	.35	2265092.07	.51	-2740788.03	.43
24	0	MOOIDAM	4983831.67	.31	2732710.45	.44	-2887739.14	.38
25	1	MORGENZON	5138858.00	.00	2424478.71	.00	-2890847.72	.00
26	0	M'PUMBE NEW	4943178.98	.44	3076441.55	.64	-2596396.41	.54
27	0	OKOTOMARE	5812704.60	.54	1662414.91	.78	-2028990.29	.66
28	0	ONDONDVENGO	5933893.75	.60	1289728.54	.86	-1947623.20	.74
29	0	PONT	5157883.40	.56	2878302.26	.81	-2400477.90	.69
30	0	POTLOER	5101368.58	.36	1977625.97	.52	-3269926.41	.45
31	0	RUNDU (BCN B)	5714708.92	.62	2054403.88	.89	-1947078.91	.76
32	0	SCHWARZECK	5576028.96	.44	1884766.40	.62	-2452545.73	.53
33	0	THAMAKOOSH	5019368.31	.40	2903704.05	.58	-2651971.02	.49
34	0	UNIONS END	5444104.22	.40	1979201.00	.58	-2663035.11	.49
35	0	WITBANK NEW	5361112.77	.43	1605151.07	.62	-3050285.10	.53
36	0	WITWATER	5137633.87	.29	2183074.51	.42	-3078160.61	.36

		GEOGRAPHICAL CO-ORDINATES										
		LATITUDE			mse(M)	LONGITUDE			mse(M)	HEIGHT	mse	
1	0	ACORN	21	59	3.6238	.58	20	59	34.2324	.66	1252.27	.52
2	0	BRIT 44	25	52	51.6817	.54	27	40	28.7548	.60	1628.71	.51
3	0	BLYDEBERG	33	05	51.3264	.48	23	11	26.7639	.56	1150.56	.46
4	0	BURENKAMP	26	38	54.0509	.53	15	09	58.3746	.62	110.57	.48
5	0	COEGAKOP	33	45	57.7959	.51	25	37	18.4192	.59	142.90	.49
6	0	DRUSE	20	14	17.9618	.73	13	30	25.5548	.85	797.28	.64
7	0	ESERE	20	00	57.7794	.58	17	34	17.2512	.68	1668.49	.52
8	0	FRANSMANSKOP	30	53	37.2514	.41	24	26	42.9178	.47	1498.04	.39
9	0	GEELOUT	19	35	38.9428	.75	20	41	48.3807	.86	1252.53	.67
10	0	GRASKOP	29	02	52.5669	.39	19	56	52.5196	.46	1062.00	.36
11	0	HADIDA	26	56	24.6217	.36	21	30	5.3135	.41	989.91	.33
12	0	HEXRIVIER	33	22	43.9673	.58	19	40	9.6596	.69	2250.70	.55
13	0	INKOMINKULU	29	46	33.5996	.49	30	27	41.6316	.55	1011.76	.47
14	0	KARASBERG	26	56	21.6651	.47	18	49	57.9023	.54	1623.21	.43
15	0	KARSRIEVER	34	26	44.2475	.58	20	07	2.8490	.69	205.48	.55
16	0	KRANZBERG	24	28	4.1764	.39	27	35	22.1607	.43	2135.44	.36
17	0	LEEUKOP (RSA)	29	18	29.1780	.36	26	24	10.5981	.40	1671.51	.34
18	0	LEEUKOP (SWA)	23	00	31.9468	.63	15	03	27.5657	.74	697.81	.56
19	0	LOUISFNTN	31	01	28.1209	.48	17	59	42.3033	.57	559.10	.45
20	0	LOURKOP	24	54	17.2922	.57	16	42	7.3797	.67	1465.36	.52
21	0	LUBISI	31	46	20.6187	.47	27	29	38.6950	.54	1789.17	.45
22	0	MAGWAZA	27	41	31.8352	.64	32	08	7.5050	.70	590.34	.61
23	0	MANNERHEIM	25	36	41.6204	.42	23	10	24.4924	.48	1082.01	.39
24	0	MOOIDAM	27	05	20.2231	.37	28	44	11.8550	.42	1636.37	.35
25	1	MORGENZON	27	07	16.5714	.00	25	15	27.4458	.00	1460.80	.00
26	0	M'PUMBE NEW	24	10	38.5016	.54	31	53	47.4768	.59	437.69	.51
27	0	OKOTOMARE	18	40	6.3172	.66	15	57	37.2960	.76	1181.12	.57
28	0	ONDONDVENGO	17	53	41.6471	.73	12	15	44.9417	.85	992.36	.63
29	0	PONT	22	15	5.5130	.68	29	09	47.6622	.75	695.96	.64
30	0	POTLOER	31	02	4.0173	.43	21	11	22.5848	.50	1473.44	.40
31	0	RUNDU (BCN B)	17	53	21.5292	.75	19	46	23.5545	.86	1136.88	.67
32	0	SCHWARZECK	22	45	26.3965	.52	18	40	33.1896	.61	1514.41	.47
33	0	THAMAKOOSH	24	43	19.5280	.49	30	02	57.7573	.54	1979.72	.46
34	0	UNIONS END	24	50	8.2178	.48	19	58	43.3464	.56	1130.18	.44
35	0	WITBANK NEW	28	45	17.9103	.51	16	40	4.9174	.60	341.02	.47
36	0	WITWATER	29	02	10.8231	.35	23	01	17.4924	.40	1519.01	.33

SUBNET SHIFT VALUES

SHIFT3

	No Passes	X	mseX	Y	mseY	Z	mseZ
1851	53	2.04	.30	-.61	.43	-.78	.37
18510	57	-2.57	.41	-.09	.59	2.01	.50
18511	59	.51	.37	.48	.53	-.55	.45
18512	118	-1.76	.32	2.82	.45	.40	.38
18513	56	3.30	.30	-2.49	.43	-4.04	.36
18514	62	-1.44	.41	1.94	.59	1.06	.50
18515	61	3.19	.44	-.31	.63	-6.51	.53
1851618	85	-6.77	.41	-5.42	.58	-.70	.50
18520	66	-1.36	.40	1.38	.57	1.44	.49
18521	55	1.97	.42	-2.61	.60	.22	.51
1852223	80	-.06	.35	-1.11	.50	-.87	.43
18524	74	-6.51	.26	.08	.38	4.15	.32
18525	78	-7.61	.34	-1.99	.48	3.61	.41
18526	73	-3.83	.48	1.21	.69	1.48	.59
18527	68	-13.22	.41	.05	.59	3.25	.50
18528	69	-12.30	.45	-.53	.65	3.90	.55
18529	71	-1.90	.34	-1.51	.48	1.36	.41
1853	71	-2.71	.34	-.67	.49	3.39	.42
18530	68	-4.94	.37	-2.82	.53	5.36	.45
18531	62	-1.03	.40	-1.31	.57	1.23	.49
18532	77	-3.01	.51	1.04	.73	.42	.62
18533	97	-4.11	.51	-1.45	.74	1.15	.63
1854	60	1.79	.29	1.56	.42	-1.42	.36
1855	52	1.57	.31	1.39	.44	.87	.38
1856	54	.77	.38	1.82	.54	-2.80	.46
1857	62	-.75	.37	.77	.53	-.89	.45
185819	105	-1.88	.39	-1.93	.56	2.99	.48
1859	51	-3.22	.41	3.20	.59	.95	.50

CHORD DISTANCES AND THEIR MSE'S

SHIFT3

				DISTANCE	MSE	PPM
MORGENZON	2725.00079	WITWATER	2923.00053	305554.579	.397	1.30
LEEUKOP(RSA)	2926.00022	FRANSMANSKOP	3024.00026	257914.946	.395	1.53
GRASKOP	2919.00010	POTLOER	3121.00053	250696.319	.345	1.38
INKOMINKULU	2930.00051	WITWATER	2923.00053	726356.823	.572	.79
LEEUKOP(SWA)	2315.00079	UNIONS END	2419.00318	540196.641	.569	1.05
DRUSE	2013.00007	GEELHOUT	1920.00009	755762.383	.794	1.05
ONDONDVENGO	1712.00004	ESERE	2017.00026	606276.789	.548	.90
BLYDEBERG	3323.00007	LUBISI	3127.00040	430531.506	.617	1.43
GRASKOP	2919.00010	INKOMINKULU	2930.00051	1022248.293	.617	.60
LOUISFNTN	3117.00005	UNIONS END	2419.00318	712763.286	.539	.76
M'PUMBE NEW	2431.00066	INKOMINKULU	2930.00051	636280.012	.534	.84
PONT	2229.00023	HEXRIVIER	3319.00029	1542551.542	.935	.61
SCHWARZECK	2218.00179	COEGAKOP	3325.00133	1393883.867	.628	.45
LOUISFNTN	3117.00005	INKOMINKULU	2930.00051	1203664.066	.703	.58
HEXRIVIER	3319.00029	COEGAKOP	3325.00133	554175.422	.712	1.29
HEXRIVIER	3319.00029	KARSRIVIER	3420.00022	125409.660	.493	3.93
COEGAKOP	3325.00133	ONDONDVENGO	1712.00004	2194771.835	.822	.37
KRANZBERG	2427.00025	BRIT 44	2527.00292	156826.058	.555	3.54

- A 52 -

	RESIDUALS																SHIFTF				
	PT	X	Y	Z	PT	X	Y	Z	PT	X	Y	Z	PT	X	Y	Z		PT	X	Y	Z
1851	17	-.13	-.06	-.19	25	-.26	.16	.38	36	.39	-.10	-.19									
1857	8	.07	.27	.06	30	-.07	-.69	.07	36	.00	.42	-.13									
1854	17	.13	-.34	.24	24	-.60	-.19	.18	25	.47	.53	-.42									
1855	16	-.27	.31	.01	24	-.05	.28	-.48	25	.31	-.59	.47									
1856	16	.34	-.58	-.35	24	-.27	.39	.42	33	-.08	.19	-.08									
1859	10	-.23	.96	.32	19	-.04	-.36	-.15	30	.27	-.59	-.17									
18511	10	.00	-.62	-.14	30	.28	1.64	.02	36	-.28	-1.03	.12									
18513	11	.06	-.37	-.58	25	-.24	.34	-.07	36	.18	.03	.65									
18512	10	.12	-.40	.00	11	-.05	.02	.14	36	-.08	.37	-.14									
18514	10	.09	.35	-.05	14	.05	-.03	.12	35	-.14	-.32	-.07									
18515	4	.64	-.50	-.22	14	-.68	.52	-.03	35	.05	-.02	.25									
18520	8	.51	-.10	-.25	30	-.52	.18	.21	3	.01	-.08	.04									
18521	8	.19	-.34	-.03	3	-.19	.30	-.03	5	.00	.03	.06									
18525	10	.23	.07	-.25	11	-.02	-.28	.35	14	.33	-.30	-.05	23	-.35	.34	.36	34	-.19	.18	-.41	
1851618	20	.01	-.35	-1.08	4	-.13	.58	.38	32	.03	-.10	.48	34	-.06	-.07	.25	14	.15	-.07	-.02	
18526	7	-.19	.05	.50	1	-.12	-.51	-.05	32	.31	.45	-.45									
18527	1	-.11	.26	.09	32	-.34	.02	.39	34	.29	-.12	.16	23	.16	-.16	-.64					
18528	7	.39	.23	-.47	18	.04	-.01	-.10	32	-.02	-.38	-.49	20	-.02	.43	1.33	4	-.40	-.27	-.27	
1852223	17	.18	-.05	-.11	8	-.45	.08	-.01	21	.27	-.01	.16	5	.00	-.02	-.04					
18529	24	.69	-.39	-.08	13	.08	.06	.12	17	-.47	.32	.15	21	-.30	.01	-.18					
185819	19	-.17	.44	.11	30	.08	-.34	-.10	12	.00	.00	.00	3	.09	-.11	-.01	15	.00	.00	.00	
18530	22	.00	.00	.00	13	-.09	-.06	-.12	24	.05	.05	-.04	33	-.13	-.03	.12	26	.17	.04	.04	
18531	29	.00	.00	.00	16	-.03	.18	.11	33	.21	-.13	-.07	26	-.18	-.04	-.05					
18510	10	-.46	.13	.27	19	.35	-.49	-.07	35	.10	.37	-.19									
1853	36	-.08	-.09	-.14	17	.25	.06	-.09	8	-.17	.03	.22									
18524	25	-.22	-.38	-.21	11	.05	.54	-.15	23	.22	-.21	.21	16	-.04	.06	.15	2	.00	.00	.00	
18532	31	.00	.00	.00	27	.01	-.05	-.14	9	.00	.00	.00	7	-.23	-.20	.18	1	.22	.25	-.03	
18533	28	.00	.00	.00	27	-.01	.04	.11	6	.00	.00	.00	7	.04	-.05	-.18	18	-.03	.01	.07	

VtPV 120.75 NO OF VARIABLES= 189 NO OF OBSERVTS= 312

SIGMA 0 = .99 SIGX= .81 SIGY= 1.15 SIGZ= .98

FINAL CO-ORDINATES

			X	MSEX	Y	MSEY	Z	MSEZ	SHIFTF
1	0	ACORN	5525473.53	.33	2120238.11	.47	-2373275.24	.40	
2	0	BRIT 44	5086489.87	.43	2667596.25	.61	-2767921.17	.52	
3	0	BLYDEBERG	4917290.60	.33	2106614.96	.47	-3463660.52	.40	
4	0	BURENKAMP	5505886.08	.30	1492430.34	.43	-2843495.90	.37	
5	0	COEGAKOP	4785917.32	.38	2295264.18	.54	-3524984.88	.46	
6	0	DRUSE	5821903.97	.47	1398478.35	.67	-2192747.73	.57	
7	0	ESERE	5716996.08	.32	1810403.75	.46	-2169938.85	.39	
8	0	FRANSMANSKOP	4988157.81	.28	2267480.29	.40	-3256554.66	.34	
9	0	GEELHOUT	5624230.65	.49	2124857.13	.70	-2125845.45	.60	
10	0	GRASKOP	5246338.28	.22	1904112.05	.32	-3079064.00	.27	
11	0	HADIDA	5294746.91	.23	2085813.29	.34	-2872757.38	.29	
12	0	HEXRIVIER	5022158.00	.42	1795162.06	.60	-3490363.96	.51	
13	0	INKOMINKULU	4776613.95	.38	2809325.05	.54	-3149349.51	.46	
14	0	KARASBERG	5386695.76	.26	1837217.03	.37	-2872963.16	.31	
15	0	KARSRIVIER	4944371.78	.42	1811091.18	.60	-3587436.87	.51	
16	0	KRANZBERG	5149891.11	.30	2691094.19	.43	-2626420.14	.37	
17	0	LEEUKOP (RSA)	4986894.15	.27	2475834.25	.38	-3104544.29	.33	
18	0	LEEUKOP (SWA)	5672673.18	.38	1526108.03	.54	-2477898.10	.46	
19	0	LOUISFNTN	5203447.14	.32	1690208.60	.45	-3268509.04	.38	
20	0	LOURKOP	5545536.72	.34	1663956.79	.49	-2670132.12	.42	
21	0	LUBISI	4815765.03	.36	2506295.45	.51	-3339945.35	.43	
22	0	MAGWAZA	4786228.23	.50	3006518.48	.71	-2946618.99	.61	
23	0	MANNERHEIM	5291624.71	.26	2265092.86	.37	-2740789.44	.31	
24	0	MOOIDAM	4983835.06	.29	2732711.25	.42	-2887740.55	.36	
25	0	MORGENZON	5138861.39	.26	2424479.50	.37	-2890849.14	.32	
26	0	M'PUMBE NEW	4943182.37	.41	3076442.34	.59	-2596397.82	.50	
27	0	OKOTOMARE	5812707.99	.39	1662415.71	.56	-2028991.70	.48	
28	0	ONDONDVENGO	5933897.14	.47	1289729.33	.67	-1947624.61	.57	
29	0	PONT	5157886.79	.53	2878303.06	.76	-2400479.32	.65	
30	0	POTLOER	5101371.97	.27	1977626.76	.39	-3269927.82	.33	
31	0	RUNDU (BCN B)	5714712.31	.49	2054404.68	.70	-1947080.32	.60	
32	0	SCHWARZECK	5576032.35	.28	1884767.20	.40	-2452547.14	.34	
33	0	THAMAKOOSH	5019371.70	.37	2903704.84	.53	-2651972.43	.45	
34	0	UNIONS END	5444107.61	.27	1979201.80	.39	-2663036.52	.33	
35	0	WITBANK NEW	5361116.16	.32	1605151.86	.46	-3050286.52	.39	
36	0	WITWATER	5137637.26	.23	2183075.31	.34	-3078162.02	.29	

		GEOGRAPHICAL CO-ORDINATES (GRS 80 ELLIPSOID PARAMETERS)								SHIFT
		LATITUDE	MSE(M)	LONGITUDE		MSE(M)	HEIGHT	MSE		
1	0	ACORN	21 59 3.6245	.39	20 59 34.2159	.45	1255.99	.36		
2	0	BRIT 44	25 52 51.6752	.51	27 40 28.7235	.58	1632.36	.48		
3	0	BLYDEBERG	33 05 51.3041	.38	23 11 26.7405	.45	1154.21	.36		
4	0	BURENKAMP	26 38 54.0412	.36	15 09 58.3703	.43	114.31	.33		
5	0	COEGAKOP	33 45 57.7727	.45	25 37 18.3901	.52	146.51	.43		
6	0	DRUSE	20 14 17.9657	.56	13 30 25.5541	.66	801.04	.49		
7	0	ESERE	20 00 57.7839	.39	17 34 17.2420	.45	1672.24	.34		
8	0	FRANSMANSKOP	30 53 37.2339	.33	24 26 42.8922	.38	1501.69	.31		
9	0	GEELOUT	19 35 38.9485	.59	20 41 48.3651	.68	1256.26	.53		
10	0	GRASKOP	29 02 52.5525	.26	19 56 52.5045	.31	1065.71	.24		
11	0	HADIDA	26 56 24.6119	.28	21 30 5.2952	.32	993.63	.26		
12	0	HEXRIVIER	33 22 43.9438	.49	19 40 9.6444	.58	2254.37	.47		
13	0	INKOMINKULU	29 46 33.5858	.45	30 27 41.5931	.50	1015.35	.43		
14	0	KARASBERG	26 56 21.6550	.31	18 49 57.8898	.36	1626.94	.28		
15	0	KARSRIVIER	34 26 44.2219	.49	20 07 2.8325	.58	209.13	.47		
16	0	KRANZBERG	24 28 4.1729	.36	27 35 22.1299	.41	2139.10	.34		
17	0	LEEUKOP (RSA)	29 18 29.1641	.32	26 24 10.5685	.37	1675.16	.30		
18	0	LEEUKOP (SWA)	23 00 31.9449	.45	15 03 27.5617	.53	701.57	.40		
19	0	LOUISFNTN	31 01 28.1021	.37	17 59 42.2923	.44	562.81	.35		
20	0	LOURKOP	24 54 17.2864	.41	16 42 7.3721	.48	1469.10	.37		
21	0	LUBISI	31 46 20.6001	.42	27 29 38.6623	.48	1792.79	.40		
22	0	MAGWAZA	27 41 31.8262	.60	32 08 7.4637	.66	593.92	.58		
23	0	MANNERHEIM	25 36 41.6136	.31	23 10 24.4707	.35	1085.71	.28		
24	0	MOOIDAM	27 05 20.2144	.35	28 44 11.8211	.40	1640.00	.33		
25	0	MORGENZON	27 07 16.5619	.31	25 15 27.4193	.36	1464.47	.29		
26	0	M'PUMBE NEW	24 10 38.4996	.49	31 53 47.4372	.54	441.27	.47		
27	0	OKOTOMARE	18 40 6.3246	.47	15 57 37.2902	.55	1184.87	.42		
28	0	ONDONDVENGO	17 53 41.6560	.56	12 15 44.9436	.66	996.10	.49		
29	0	PONT	22 15 5.5143	.64	29 09 47.6287	.72	699.60	.60		
30	0	POTLOER	31 02 3.9989	.32	21 11 22.5665	.38	1477.12	.30		
31	0	RUNDU (BCN B)	17 53 21.5384	.59	19 46 23.5409	.68	1140.61	.53		
32	0	SCHWARZECK	22 45 26.3953	.34	18 40 33.1779	.39	1518.16	.30		
33	0	THAMAKOOSH	24 43 19.5245	.45	30 02 57.7213	.49	1983.34	.42		
34	0	UNIONS END	24 50 8.2123	.32	19 58 43.3317	.38	1133.91	.30		
35	0	WITBANK NEW	28 45 17.8963	.38	16 40 4.9096	.45	344.75	.35		
36	0	WITWATER	29 02 10.8091	.28	23 01 17.4704	.32	1522.69	.26		

TRNLCTN SHIFT VALUES

SHIFTF

	X	MSEX	Y	MSEY	Z	MSEZ
1851	5.431	.313	.181	.447	-2.192	.382
1857	2.639	.307	1.566	.438	-2.303	.374
1854	5.177	.314	2.351	.450	-2.833	.383
1855	4.956	.334	2.184	.478	-.539	.407
1856	4.156	.359	2.614	.513	-4.215	.437
1859	.166	.327	3.997	.468	-.459	.399
18511	3.898	.298	1.271	.426	-1.960	.363
18513	6.691	.300	-1.696	.429	-5.457	.366
18512	1.631	.240	3.611	.343	-1.014	.292
18514	1.947	.302	2.733	.432	-.358	.368
18515	6.576	.317	.480	.453	-7.923	.387
18520	2.026	.324	2.177	.464	.024	.395
18521	5.361	.353	-1.814	.505	-1.189	.431
18525	-4.216	.217	-1.194	.310	2.195	.264
1851618	-3.377	.255	-4.628	.365	-2.109	.311
18526	-.439	.332	2.001	.475	.065	.405
18527	-9.828	.271	.840	.388	1.840	.331
18528	-8.908	.292	.262	.417	2.490	.356
1852223	3.334	.297	-.316	.424	-2.283	.362
18529	1.494	.303	-.717	.434	-.058	.370
185819	1.509	.297	-1.132	.425	1.581	.362
18530	-1.553	.337	-2.030	.482	3.943	.411
18531	2.363	.369	-.515	.527	-.186	.450
18510	.822	.315	.707	.450	.597	.384
1853	.681	.294	.124	.421	1.977	.359
18524	-3.121	.240	.876	.344	2.739	.293
18532	.381	.350	1.835	.501	-.991	.427
18533	-.723	.354	-.659	.506	-.263	.432

CHORD DISTANCES AND THEIR MSE'S

SHIFTF

				DISTANCE	MSE	PPM
MORGENZON	2725.00079	WITWATER	2923.00053	305554.579	.397	1.30
LEEUKOP (RSA)	2926.00022	FRANSMANSKOP	3024.00026	257914.946	.395	1.53
GRASKOP	2919.00010	POTLOER	3121.00053	250696.319	.345	1.38
MOOIDAM	2728.00050	M' PUMBE NEW	2431.00066	452420.480	.518	1.14
INKOMINKULU	2930.00051	WITWATER	2923.00053	726356.823	.572	.79
LEEUKOP (SWA)	2315.00079	UNIONS END	2419.00318	540196.641	.569	1.05
DRUSE	2013.00007	GEELHOUT	1920.00009	755762.383	.794	1.05
ONDONDVENGO	1712.00004	ESERE	2017.00026	606276.789	.548	.90
BLYDEBERG	3323.00007	LUBISI	3127.00040	430531.506	.617	1.43
GRASKOP	2919.00010	INKOMINKULU	2930.00051	1022248.293	.617	.60
LOUISFNTN	3117.00005	UNIONS END	2419.00318	712763.286	.539	.76
M' PUMBE NEW	2431.00066	INKOMINKULU	2930.00051	636280.012	.534	.84
PONT	2229.00023	HEXRIVIER	3319.00029	1542551.542	.935	.61
SCHWARZECK	2218.00179	COEGAKOP	3325.00133	1393883.867	.628	.45
WITBANK NEW	2816.00036	MAGWAZA	2732.00004	1518246.190	.874	.58
LOUISFNTN	3117.00005	INKOMINKULU	2930.00051	1203664.066	.703	.58
HEXRIVIER	3319.00029	COEGAKOP	3325.00133	554175.422	.712	1.29
HEXRIVIER	3319.00029	KARSRIVIER	3420.00022	125409.660	.493	3.93
COEGAKOP	3325.00133	ONDONDVENGO	1712.00004	2194771.835	.822	.37
KRANZBERG	2427.00025	BRIT 44	2527.00292	156826.058	.555	3.54

- A 56 -

MOLODENSKY-BADEKAS TRANSFORMATION

MOLBAD.CORDATA

POINT	WEIGHT	SHIFT-Z (ENTIRE COVAR SOLN)			FINSLN (3 SHIFTS TO EACH SUBNET)		
		X	Y	Z	X	Y	Z
1 ACORN		5525475.439	2120236.540	-2373275.293	5525469.700	2120235.770	-2373275.510
2 BRIT 44		5086490.873	2667595.683	-2767922.005	5086487.210	2667594.700	-2767921.850
3 BLYDEBERG		4917287.803	2106615.024	-3463660.507	4917287.330	2106613.510	-3463661.200
4 BURENKAMP		5505886.575	1492430.203	-2843494.603	5505881.400	1492427.910	-2843496.050
5 COEGAKOP		4785913.960	2295264.300	-3524984.531	4785913.870	2295263.150	-3524985.770
6 DRUSE		5821904.055	1398477.382	-2192747.584	5821899.050	1398475.550	-2192747.970
7 ESERE		5716997.272	1810402.285	-2169938.864	5716991.770	1810401.110	-2169939.090
8 FRANSMANS		4988155.081	2267480.001	-3256553.904	4988154.600	2267478.830	-3256555.380
9 GEELHOUT		5624231.415	2124855.182	-2125844.999	5624226.820	2124854.630	-2125845.700
10 GRASKOP		5246336.795	1904110.449	-3079063.597	5246334.510	1904110.040	-3079064.370
11 HADIDA		5294746.044	2085812.299	-2872756.840	5294743.380	2085811.350	-2872757.940
12 HEXRIVIER		5022155.278	1795161.267	-3490364.792	5022154.870	1795160.300	-3490364.760
13 INKOMINKU		4776613.383	2809325.839	-3149350.089	4776611.580	2809323.930	-3149350.310
14 KARASBERG		5386695.592	1837216.443	-2872962.043	5386691.710	1837214.750	-2872963.330
15 KARSRIVIE		4944369.357	1811091.504	-3587437.687	4944368.220	1811089.610	-3587437.510
16 KRANZBERG		5149890.042	2691093.441	-2626419.869	5149888.550	2691092.530	-2626420.900
17 LEEUKOP (R		4986891.766	2475834.064	-3104543.503	4986891.240	2475832.860	-3104545.080
18 LEEUKOP (S		5672674.713	1526107.108	-2477898.273	5672668.460	1526105.440	-2477898.330
19 LOUISFNTN		5203444.845	1690207.644	-3268509.140	5203443.270	1690206.610	-3268509.510
20 LOURKOP		5545538.923	1663956.766	-2670131.930	5545532.240	1663954.370	-2670132.340
21 LUBISI		4815762.984	2506295.955	-3339944.488	4815762.130	2506294.310	-3339946.150
22 MAGWAZA		4786227.383	3006518.299	-2946620.128	4786226.290	3006517.210	-2946619.810
23 MANNERHEI		5291626.645	2265092.265	-2740789.960	5291621.320	2265090.910	-2740789.900
24 MOOIDAM		4983833.587	2732710.849	-2887740.152	4983832.570	2732709.860	-2887741.360
25 MORGENZON		5138859.080	2424478.725	-2890848.639	5138858.430	2424478.090	-2890850.070
26 M' PUMBE N		4943182.136	3076442.700	-2596398.578	4943180.440	3076440.920	-2596398.610
27 OKOTOMARE		5812708.270	1662414.175	-2028991.391	5812703.470	1662412.920	-2028991.950
28 ONDONDVEN		5933897.059	1289728.205	-1947624.461	5933892.060	1289726.360	-1947624.850
29 PONT		5157885.184	2878301.967	-2400479.731	5157884.610	2878301.150	-2400480.080
30 POTLOER		5101369.474	1977625.681	-3269927.283	5101368.490	1977625.020	-3269928.430
31 RUNDU (BCN		5714712.978	2054402.626	-1947079.869	5714708.380	2054402.040	-1947080.570
32 SCHWARZEC		5576033.347	1884766.117	-2452547.189	5576028.060	1884764.800	-2452547.390
33 THAMAKOOS		5019370.976	2903704.664	-2651972.383	5019369.490	2903703.320	-2651973.220
34 UNIONS EN		5444109.830	1979201.578	-2663036.426	5444103.710	1979199.540	-2663036.820
35 WITBANK N		5361113.470	1605150.184	-3050285.408	5361111.910	1605149.210	-3050286.120
36 WITWATER		5137634.623	2183074.380	-3078160.877	5137633.940	2183073.610	-3078162.650

FINSLN CO-ORDINATES
 TRANSFORMED SHIFTZ CO-ORDINATES

				VX	VY	VZ	VLAT	VLON	VHGT	LX	LY	LZ	
1	ACORN	5525469.700	2120235.770	-2373275.510									
		5525471.457	2120234.868	-2373275.742	-1.76	.90	.23	-.28	1.47	-1.31	-5.74	-.77	-.22
2	BRIT 44	5086487.210	2667594.700	-2767921.850									
		5086488.860	2667594.211	-2767922.999	-1.65	.49	1.15	.50	1.20	-1.61	-3.66	-.98	.15
3	BLYDEBERG	4917287.330	2106613.510	-3463661.200									
		4917286.675	2106614.351	-3463661.369	.66	-.84	.17	.29	-1.03	.14	-.47	-1.51	-.69
4	BURENKAMP	5505881.400	1492427.910	-2843496.050									
		5505882.773	1492429.149	-2843494.793	-1.37	-1.24	-1.26	-1.87	-.84	-.91	-5.18	-2.29	-1.45
5	COEGAKOP	4785913.870	2295263.150	-3524985.770									
		4785913.332	2295263.657	-3524985.599	.54	-.51	-.17	.01	-.69	.32	-.09	-1.15	-1.24
6	DRUSE	5821899.050	1398475.550	-2192747.970									
		5821898.450	1398475.881	-2192747.645	.60	-.33	-.33	-.13	-.46	.59	-5.00	-1.83	-.39
7	ESERE	5716991.770	1810401.110	-2169939.090									
		5716992.267	1810400.581	-2169939.112	-.50	.53	.02	-.09	.65	-.30	-5.50	-1.17	-.23
8	FRANSMANS	4988154.600	2267478.830	-3256555.380									
		4988153.664	2267479.067	-3256554.761	.94	-.24	-.62	-.14	-.60	.96	-.48	-1.17	-1.48
9	GEELHOUT	5624226.820	2124854.630	-2125845.700									
		5624226.821	2124853.336	-2125845.440	.00	1.29	-.26	-.09	1.21	.52	-4.59	-.55	-.70
10	GRASKOP	5246334.510	1904110.040	-3079064.370									
		5246334.282	1904109.440	-3079064.095	.23	.60	-.28	-.04	.49	.50	-2.28	-.41	-.77
11	HADIDA	5294743.380	2085811.350	-2872757.940									
		5294743.291	2085811.043	-2872757.378	.09	.31	-.56	-.41	.25	.43	-2.66	-.95	-1.10
12	HEXRIVIER	5022154.870	1795160.300	-3490364.760									
		5022153.695	1795160.714	-3490365.449	1.17	-.41	.69	1.11	-.78	.43	-.41	-.97	.03

FINSLN CO-ORDINATES
 TRANSFORMED SHIFTZ CO-ORDINATES

				VX	VY	VZ	VLAT	VLON	VHGT	LX	LY	LZ	
13	INKOMINKU	4776611.580	2809323.930	-3149350.310									
		4776612.649	2809324.727	-3149351.416	-1.07	-.80	1.11	.30	-.14	-1.70	-1.80	-1.91	-.22
14	KARASBERG	5386691.710	1837214.750	-2872963.330									
		5386692.424	1837215.268	-2872962.418	-.71	-.52	-.91	-1.20	-.26	-.34	-3.88	-1.69	-1.29
15	KARSRIVIE	4944368.220	1811089.610	-3587437.510									
		4944368.071	1811091.058	-3587438.429	.15	-1.45	.92	.56	-1.41	-.82	-1.14	-1.89	.18
16	KRANZBERG	5149888.550	2691092.530	-2626420.900									
		5149887.701	2691091.842	-2626420.840	.85	.69	-.06	.39	.22	1.00	-1.49	-.91	-1.03
17	LEEUKOP(R)	4986891.240	2475832.860	-3104545.080									
		4986890.305	2475832.936	-3104544.460	.94	-.08	-.62	-.15	-.48	1.00	-.53	-1.20	-1.58
18	LEEUKOP(S)	5672668.460	1526105.440	-2477898.330									
		5672670.025	1526105.746	-2477898.401	-1.57	-.31	.07	-.56	.11	-1.49	-6.25	-1.67	-.06
19	LOUISFNTN	5203443.270	1690206.610	-3268509.510									
		5203442.487	1690206.899	-3268509.604	.78	-.29	.09	.42	-.52	.51	-1.57	-1.03	-.37
20	LOURKOP	5545532.240	1663954.370	-2670132.340									
		5545534.946	1663955.490	-2670132.154	-2.71	-1.12	-.19	-1.40	-.29	-2.56	-6.68	-2.40	-.41
21	LUBISI	4815762.130	2506294.310	-3339946.150									
		4815762.217	2506295.069	-3339945.615	-.09	-.76	-.53	-.68	-.63	-.08	-.85	-1.65	-1.66
22	MAGWAZA	4786226.290	3006517.210	-2946619.810									
		4786226.470	3006516.980	-2946621.575	-.18	.23	1.77	1.56	.29	-.85	-1.09	-1.09	.32
23	MANNERHEI	5291621.320	2265090.910	-2740789.900									
		5291623.853	2265090.845	-2740790.589	-2.53	.07	.69	-.38	1.06	-2.37	-5.32	-1.35	.06
24	MOOIDAM	4983832.570	2732709.860	-2887741.360									
		4983832.008	2732709.480	-2887741.259	.56	.38	-.10	.22	.06	.65	-1.02	-.99	-1.21

FINSLN CO-ORDINATES
 TRANSFORMED SHIFTZ CO-ORDINATES

					VX	VY	VZ	VLAT	VLON	VHGT	LX	LY	LZ
25	MORGENZON	5138858.430	2424478.090	-2890850.070									
		5138856.958	2424477.402	-2890849.452	1.47	.69	-.62	.19	-.01	1.73	-.65	-.64	-1.43
26	M'PUMBE N	4943180.440	3076440.920	-2596398.610									
		4943180.428	3076441.058	-2596399.967	.01	-.14	1.36	1.22	-.12	-.61	-1.70	-1.78	-.03
27	OKOTOMARE	5812703.470	1662412.920	-2028991.950									
		5812702.678	1662412.443	-2028991.570	.79	.48	-.38	-.07	.24	.97	-4.80	-1.26	-.56
28	ONDONDVEN	5933892.060	1289726.360	-1947624.850									
		5933890.681	1289726.607	-1947624.499	1.38	-.25	-.35	.06	-.53	1.34	-5.00	-1.84	-.39
29	PONT	5157884.610	2878301.150	-2400480.080									
		5157882.602	2878300.169	-2400480.846	2.01	.98	.77	1.56	-.12	1.78	-.57	-.82	-.35
30	POTLOER	5101368.490	1977625.020	-3269928.430									
		5101367.596	1977624.836	-3269927.925	.89	.18	-.50	.03	-.15	1.03	-.98	-.66	-1.15
31	RUNDU (BCN	5714708.380	2054402.040	-1947080.570									
		5714707.825	2054400.689	-1947080.272	.56	1.35	-.30	.02	1.08	1.02	-4.60	-.59	-.70
32	SCHWARZEC	5576028.060	1884764.800	-2452547.390									
		5576029.174	1884764.584	-2452547.496	-1.11	.22	.11	-.28	.56	-.95	-5.29	-1.32	-.20
33	THAMAKOOS	5019369.490	2903703.320	-2651973.220									
		5019369.090	2903703.070	-2651973.585	.40	.25	.36	.53	.02	.28	-1.49	-1.34	-.84
34	UNIONS EN	5444103.710	1979199.540	-2663036.820									
		5444106.352	1979200.176	-2663036.831	-2.64	-.64	.01	-1.13	.30	-2.46	-6.12	-2.04	-.39
35	WITBANK N	5361111.910	1605149.210	-3050286.120									
		5361110.391	1605149.263	-3050285.724	1.52	-.05	-.40	.35	-.49	1.45	-1.56	-.97	-.71
36	WITWATER	5137633.940	2183073.610	-3078162.650									
		5137632.579	2183073.287	-3078161.571	1.36	.32	-1.08	-.28	-.23	1.73	-.68	-.77	-1.77

THE FOLLOWING PARAMETERS ARE FOR TRANSFORMING
 BETWEEN THE TWO SOLUTION SETS (FINSLN ⁷ SHIFT-Z)

X-SHIFT= -2.810 Y-SHIFT= -1.266 Z-SHIFT= -.663
 +/- .155 +/- .155 +/- .155

X-ROT(")= +.030 Y-ROT(")= -.447 Z-ROT(")= -.281
 +/- .055 +/- .061 +/- .060

SCALE= -.8333 PPM +/- .210

TRANSFORMATION MATRIX (SCALE & ROTATIONS)
 ABOUT CENTRE OF GRAVITY OF 36 POINTS

.99999916667	.00000136447	-.00000216899
-.00000136447	.99999916667	-.00000014408
.00000216899	.00000014408	.99999916667

CENTRE OF ROTATION

X: 5261664.586
 Y: 2138976.006
 Z: -2800286.969

COVARIANCE-MATRIX

MOLBAD.CORDATA

	SCALE	Z-ROT	Y-ROT	X-ROT	X-SH	Y-SH	Z-SH
SCALE	.44E-13	.79E-40	-.79E-40	.40E-40	-.12E-12	-.56E-13	-.29E-13
Z-ROT	.79E-40	.84E-13	-.20E-13	.28E-13	-.12E-12	.22E-12	.93E-13
Y-ROT	-.79E-40	-.20E-13	.89E-13	-.28E-13	.84E-13	-.38E-13	-.28E-12
X-ROT	.40E-40	.28E-13	-.28E-13	.70E-13	-.55E-13	.33E-13	.17E-12
X-SH	-.12E-12	-.12E-12	.84E-13	-.55E-13	.24E-01	-.14E-12	-.22E-12
Y-SH	-.56E-13	.22E-12	-.38E-13	.33E-13	-.14E-12	.24E-01	.19E-12
Z-SH	-.29E-13	.93E-13	-.28E-12	.17E-12	-.22E-12	.19E-12	.24E-01

CORRELATION MATRIX

	SCALE	Z-ROT	Y-ROT	X-ROT	X-SH	Y-SH	Z-SH
SCALE	1.00	.00	.00	.00	.00	.00	.00
Z-ROT	.00	1.00	-.23	.37	.00	.00	.00
Y-ROT	.00	-.23	1.00	-.36	.00	.00	.00
X-ROT	.00	.37	-.36	1.00	.00	.00	.00
X-SH	.00	.00	.00	.00	1.00	.00	.00
Y-SH	.00	.00	.00	.00	.00	1.00	.00
Z-SH	.00	.00	.00	.00	.00	.00	1.00

BURSA-WOLF TRANSFORMATION

POINT	WEIGHT	FREE-NET CO-ORDINATES (BROADCAST EPHEMERIS)			ADOS (PRECISE EPHEMERIS)		
		X	Y	Z	X	Y	Z
		COEGAKOP	1.00	4785917.33	2295264.20	-3524984.89	4785913.74
HEXRIVIER	1.00	5022158.01	1795162.07	-3490363.97	5022155.01	1795160.27	-3490364.81
MAGWAZA	1.00	4786228.24	3006518.50	-2946619.00	4786226.32	3006517.18	-2946619.81
MORGENZON	1.00	5138861.40	2424479.52	-2890849.15	5138858.47	2424478.35	-2890850.32
PONT	1.00	5157886.80	2878303.07	-2400479.33	5157884.63	2878301.10	-2400480.08
SCHWARZECK	1.00	5576032.36	1884767.21	-2452547.16	5576027.87	1884764.87	-2452547.39
WITBANK NEW	1.00	5361116.18	1605151.88	-3050286.53	5361111.93	1605149.00	-3050285.80

PRECISE CO-ORDINATES
TRANSFORMED BROADCAST CO-ORDINATES

				VX	VY	VZ	VLAT	VLON	VHGT	LX	LY	L
COEGAKOP	4785913.74	2295263.20	-3524985.83									
	4785914.36	2295262.67	-3524985.87	-.62	.53	.04	-.15	.74	-.30	-3.59	-1.00	-.9
HEXRIVIER	5022155.01	1795160.27	-3490364.81									
	5022154.18	1795160.07	-3490364.46	.83	.20	-.35	.17	-.09	.90	-3.00	-1.80	-.8
MAGWAZA	4786226.32	3006517.18	-2946619.81									
	4786226.18	3006517.50	-2946620.39	.14	-.32	.58	.49	-.34	-.31	-1.92	-1.32	-.8
MORGENZON	5138858.47	2424478.35	-2890850.32									
	5138858.34	2424477.84	-2890849.91	.13	.51	-.41	-.21	.41	.48	-2.93	-1.17	-1.1
PONT	5157884.63	2878301.10	-2400480.08									
	5157884.25	2878301.78	-2400480.32	.38	-.68	.24	.22	-.77	-.09	-2.17	-1.97	-.7
SCHWARZECK	5576027.87	1884764.87	-2452547.39									
	5576028.17	1884764.98	-2452547.22	-.30	-.11	-.17	-.28	-.01	-.23	-4.49	-2.34	-.2
WITBANK NEW	5361111.93	1605149.00	-3050285.80									
	5361111.81	1605149.57	-3050286.62	.12	-.57	.82	.69	-.58	-.44	-4.25	-2.88	.7

THE FOLLOWING PARAMETERS ARE FOR TRANSFORMING
FROM BROADCAST DATUM TO PRECISE DATUM

X-SHIFT= -9.84 Y-SHIFT= +8.97 Z-SHIFT= -1.60
+/- 3.06 +/- 3.12 +/- 2.91

X-ROT(")= -.145 Y-ROT(")= -.121 Z-ROT(")= -.362
+/- .101 +/- .096 +/- .100

SCALE= +.1625 PPM +/- .4127

TRANSFORMATION MATRIX (SCALE & ROTATIONS)
ABOUT CO-ORDINATE ORIGIN (GEOCENTRE)

1.00000016	.00000175	-.00000059
-.00000175	1.00000016	.00000070
.00000059	-.00000070	1.00000016

COVARIANCE-MATRIX

BURSA-WOLF MODEL

	SCALE	X-ROT	Y-ROT	Z-ROT	X-SH	Y-SH	Z-SH
SCALE	.98E-13	-.42E-14	-.14E-13	-.16E-13	-.59E-06	-.11E-06	.22E-06
X-ROT	-.42E-14	.14E-12	-.17E-13	.24E-13	.24E-07	-.51E-06	-.40E-06
Y-ROT	-.14E-13	-.17E-13	.13E-12	.21E-13	.48E-06	-.31E-07	.65E-06
Z-ROT	-.16E-13	.24E-13	.21E-13	.14E-12	.44E-06	-.74E-06	.13E-07
X-SH	-.59E-06	.24E-07	.48E-06	.44E-06	.54E+01	-.11E+01	.77E+00
Y-SH	-.11E-06	-.51E-06	-.31E-07	-.74E-06	-.11E+01	.56E+01	.61E+00
Z-SH	.22E-06	-.40E-06	.65E-06	.13E-07	.77E+00	.61E+00	.49E+01

CORRELATION-MATRIX

	SCALE	X-ROT	Y-ROT	Z-ROT	X-SH	Y-SH	Z-SH
SCALE	1.00	-.04	-.13	-.14	-.81	-.15	.31
X-ROT	-.04	1.00	-.13	.18	.03	-.58	-.48
Y-ROT	-.13	-.13	1.00	.16	.58	-.04	.83
Z-ROT	-.14	.18	.16	1.00	.51	-.85	.02
X-SH	-.81	.03	.58	.51	1.00	-.20	.15
Y-SH	-.15	-.58	-.04	-.85	-.20	1.00	.12
Z-SH	.31	-.48	.83	.02	.15	.12	1.00

MOLODENSKY-BADEKAS TRANSFORMATION

MOLBAD.DATA

POINT	WEIGHT	BROADCAST EPHEMERIS (FREE NET)			P.E.		
		X	Y	Z	X	Y	Z
* COEGAKOP	4785917.330	2295264.200	-3524984.890	4785913.740	2295263.200	-3524985.830	
* HEXRIVIER	5022158.010	1795162.070	-3490363.970	5022155.010	1795160.270	-3490364.810	
* MAGWAZA	4786228.240	3006518.500	-2946619.000	4786226.320	3006517.180	-2946619.810	
* MORGENZON	5138861.400	2424479.520	-2890849.150	5138858.470	2424478.350	-2890850.320	
* PONT	5157886.800	2878303.070	-2400479.330	5157884.630	2878301.100	-2400480.080	
* SCHWARZECK	5576032.360	1884767.210	-2452547.160	5576027.870	1884764.870	-2452547.390	
* WITBANK NEW	5361116.180	1605151.880	-3050286.530	5361111.930	1605149.000	-3050285.800	

P.E. CO-ORDINATES

TRANSFORMED B.E. CO-ORDINATES

POINT	WEIGHT	X	Y	Z	VX	VY	VZ	VLAT	VLON	VHGT	LX	LY	LZ
* COEGAKOP	4785913.740	2295263.200	-3524985.830										
	4785914.359	2295262.675	-3524985.874	-.62	.53	.04	-.15	.74	-.30	-3.59	-1.00	-.94	
* HEXRIVIER	5022155.010	1795160.270	-3490364.810										
	5022154.180	1795160.073	-3490364.459	.83	.20	-.35	.17	-.09	.90	-3.00	-1.80	-.84	
* MAGWAZA	4786226.320	3006517.180	-2946619.810										
	4786226.179	3006517.495	-2946620.389	.14	-.32	.58	.49	-.34	-.31	-1.92	-1.32	-.81	
* MORGENZON	5138858.470	2424478.350	-2890850.320										
	5138858.342	2424477.841	-2890849.915	.13	.51	-.41	-.21	.41	.48	-2.93	-1.17	-1.17	
* PONT	5157884.630	2878301.100	-2400480.080										
	5157884.254	2878301.776	-2400480.322	.38	-.68	.24	.22	-.77	-.09	-2.17	-1.97	-.75	
* SCHWARZECK	5576027.870	1884764.870	-2452547.390										
	5576028.170	1884764.984	-2452547.219	-.30	-.11	-.17	-.28	-.01	-.23	-4.49	-2.34	-.23	
* WITBANK NEW	5361111.930	1605149.000	-3050285.800										
	5361111.814	1605149.566	-3050286.616	.12	-.57	.82	.69	-.58	-.44	-4.25	-2.88	.73	

THE FOLLOWING PARAMETERS ARE FOR TRANSFORMING
FROM B.E. (FREE NET) TO P.E. (NWL 9D)

X-SHIFT= -3.289 Y-SHIFT= -1.720 Z-SHIFT= -.680
 +/- .156 +/- .206 +/- .182

X-ROT(")= -.145 Y-ROT(")= -.121 Z-ROT(")= -.362
 +/- .101 +/- .096 +/- .100

SCALE= +.1625 PPM +/- .413

TRANSFORMATION MATRIX (SCALE & ROTATIONS)
ABOUT CENTRE OF GRAVITY OF 7 POINTS

1.00000016252 .00000175439 -.00000058554
-.00000175439 1.00000016252 .00000070166
.00000058554 -.00000070166 1.00000016252

CENTRE OF ROTATION

X: 5118311.139
Y: 2269947.710
Z: -2965162.006

COVARIANCE-MATRIX

MOLBAD.DATA

	SCALE	Z-ROT	Y-ROT	X-ROT	X-SH	Y-SH	Z-SH
SCALE	.17E-12	.28E-13	.25E-13	.72E-14	-.13E-07	.24E-07	-.19E-07
Z-ROT	.28E-13	.23E-12	.37E-13	.42E-13	.30E-07	.26E-07	-.12E-07
Y-ROT	.25E-13	.37E-13	.22E-12	-.30E-13	.22E-07	.99E-08	-.23E-07
X-ROT	.72E-14	.42E-13	-.30E-13	.24E-12	.17E-08	-.16E-07	-.27E-07
X-SH	-.13E-07	.30E-07	.22E-07	.17E-08	.24E-01	.15E-02	-.14E-02
Y-SH	.24E-07	.26E-07	.99E-08	-.16E-07	.15E-02	.42E-01	-.13E-02
Z-SH	-.19E-07	-.12E-07	-.23E-07	-.27E-07	-.14E-02	-.13E-02	.33E-01

CORRELATION MATRIX

	SCALE	Z-ROT	Y-ROT	X-ROT	X-SH	Y-SH	Z-SH
SCALE	1.00	.14	.13	.04	-.21	.28	-.26
Z-ROT	.14	1.00	.16	.18	.39	.26	-.14
Y-ROT	.13	.16	1.00	-.13	.30	.10	-.27
X-ROT	.04	.18	-.13	1.00	.02	-.16	-.30
X-SH	-.21	.39	.30	.02	1.00	.05	-.05
Y-SH	.28	.26	.10	-.16	.05	1.00	-.03
Z-SH	-.26	-.14	-.27	-.30	-.05	-.03	1.00

MOLODENSKY-BADEKAS TRANSFORMATION

MOLBAD DATA

POINT	WEIGHT	BROADCAST EPHEMERIS (FREE NET)			P.E.		
		X	Y	Z	X	Y	Z
* COEGAKOP		4785917.330	2295264.200	-3524984.890	4785913.740	2295263.200	-3524985.830
* HEXRIVIER		5022158.010	1795162.070	-3490363.970	5022155.010	1795160.270	-3490364.810
* MAGWAZA		4786228.240	3006518.500	-2946619.000	4786226.320	3006517.180	-2946619.810
* MORGENZON		5138861.400	2424479.520	-2890849.150	5138858.470	2424478.350	-2890850.320
* PONT		5157886.800	2878303.070	-2400479.330	5157884.630	2878301.100	-2400480.080
* SCHWARZECK		5576032.360	1884767.210	-2452547.160	5576027.870	1884764.870	-2452547.390
* WITBANK NEW		5361116.180	1605151.880	-3050286.530	5361111.930	1605149.000	-3050285.800

P.E. CO-ORDINATES

TRANSFORMED B.E. CO-ORDINATES

POINT	WEIGHT	BROADCAST EPHEMERIS (FREE NET)			P.E. CO-ORDINATES			TRANSFORMED B.E. CO-ORDINATES					
		X	Y	Z	VX	VY	VZ	VLAT	VLON	VHGT	LX	LY	LZ
* COEGAKOP		4785913.740	2295263.200	-3524985.830									
		4785914.011	2295262.989	-3524985.402	-.27	.21	-.43	-.44	.31	.11	-3.59	-1.00	-.94
* HEXRIVIER		5022155.010	1795160.270	-3490364.810									
		5022153.946	1795160.507	-3490364.482	1.06	-.24	-.33	.23	-.58	.95	-3.00	-1.80	-.84
* MAGWAZA		4786226.320	3006517.180	-2946619.810									
		4786225.980	3006517.289	-2946619.512	.34	-.11	-.30	-.16	-.27	.34	-1.92	-1.32	-.81
* MORGENZON		5138858.470	2424478.350	-2890850.320									
		5138858.273	2424477.784	-2890849.662	.20	.57	-.66	-.40	.43	.67	-2.93	-1.17	-1.17
* PONT		5157884.630	2878301.100	-2400480.080									
		5157884.349	2878301.305	-2400479.842	.28	-.21	-.24	-.17	-.32	.22	-2.17	-1.97	-.75
* SCHWARZECK		5576027.870	1884764.870	-2452547.390									
		5576028.429	1884764.822	-2452547.672	-.56	.05	.28	.06	.22	-.58	-4.49	-2.34	-.23
* WITBANK NEW		5361111.930	1605149.000	-3050285.800									
		5361111.833	1605149.812	-3050287.042	.10	-.81	1.24	1.03	-.81	-.72	-4.25	-2.88	.73

THE FOLLOWING PARAMETERS ARE FOR TRANSFORMING
FROM B.E. (FREE NET) TO P.E. (NWL 9D)

X-SHIFT= -3.357 Y-SHIFT= -1.706 Z-SHIFT= -.512
 +/- .148 +/- .201 +/- .165

X-ROT(")= +.000 Y-ROT(")= +.000 Z-ROT(")= -.307
 FIXED FIXED +/- .099

SCALE= +.0000 PPM FIXED

TRANSFORMATION MATRIX (SCALE & ROTATIONS)
ABOUT CENTRE OF GRAVITY OF 7 POINTS

1.00000000000	.00000148961	.00000000000
-.00000148961	1.00000000000	.00000000000
.00000000000	.00000000000	1.00000000000

CENTRE OF ROTATION X: 5118311.139
 Y: 2269947.710
 Z: -2965162.006

COVARIANCE-MATRIX

MOLBAD . DATA

	SCALE	Z-ROT	Y-ROT	X-ROT	X-SH	Y-SH	Z-SH
SCALE	.14E-20	.18E-21	.17E-29	.72E-30	-.14E-15	.20E-15	-.13E-15
Z-ROT	.18E-21	.23E-12	.33E-21	.39E-21	.29E-07	.26E-07	-.10E-15
Y-ROT	.17E-29	.33E-21	.18E-20	-.21E-29	.21E-15	.37E-16	-.20E-15
X-ROT	.72E-30	.39E-21	-.21E-29	.20E-20	.49E-16	-.14E-15	-.25E-15
X-SH	-.14E-15	.29E-07	.21E-15	.49E-16	.22E-01	.32E-02	-.17E-10
Y-SH	.20E-15	.26E-07	.37E-16	-.14E-15	.32E-02	.40E-01	-.47E-11
Z-SH	-.13E-15	-.10E-15	-.20E-15	-.25E-15	-.17E-10	-.47E-11	.27E-01

CORRELATION MATRIX

	SCALE	Z-ROT	Y-ROT	X-ROT	X-SH	Y-SH	Z-SH
SCALE	1.00	.00	.00	.00	.00	.00	.00
Z-ROT	.00	1.00	.00	.00	.41	.27	.00
Y-ROT	.00	.00	1.00	.00	.00	.00	.00
X-ROT	.00	.00	.00	1.00	.00	.00	.00
X-SH	.00	.41	.00	.00	1.00	.11	.00
Y-SH	.00	.27	.00	.00	.11	1.00	.00
Z-SH	.00	.00	.00	.00	.00	.00	1.00

Residuals

FINSLN

	PT	X	Y	Z	PT	X	Y	Z	PT	X	Y	Z	PT	X	Y	Z	PT	X	Y	Z
1851	17	-.15	-.10	-.19	25	-.25	.32	.23	36	.40	-.22	-.04								
18510	10	-.52	.30	.04	19	.51	-.37	-.40	35	.00	.07	.35								
18511	10	-.07	-.69	.03	30	.39	1.63	-.05	36	-.32	-.94	.02								
18512	10	.13	-.50	.14	11	-.08	.07	.11	36	-.05	.43	-.25								
18513	11	.02	-.47	-.42	25	-.22	.53	-.30	36	.20	-.06	.72								
18514	10	.16	.53	-.37	14	-.05	.09	.00	35	-.11	-.62	.38								
18515	4	.51	-.35	-.39	14	-.69	.65	-.22	35	.18	-.30	.62								
1851618	20	-.02	-.34	-1.08	4	-.11	.53	.45	32	-.15	-.01	.44	34	.00	-.04	.17	14	.28	-.15	.02
18520	8	.40	-.03	-.31	30	-.47	.13	.28	3	.07	-.10	.03								
18521	8	.23	-.35	.01	3	.02	.19	.06	5	-.25	.15	-.07								
1852223	17	.25	-.04	-.10	8	-.35	.01	.06	21	.31	-.01	.16	5	-.20	.04	-.13				
18524	25	-.16	-.17	-.46	11	.04	.45	-.03	23	.09	-.32	.43	16	.02	.04	.06	2	.00	.00	.00
18525	10	.35	.01	-.25	11	.07	-.19	.17	14	.27	-.41	.15	23	-.38	.41	.27	34	-.32	.18	-.34
18526	7	-.16	.03	.51	1	-.08	-.51	-.07	32	.24	.48	-.44								
18527	1	-.17	.26	.14	32	-.52	.03	.46	34	.36	-.16	.18	23	.33	-.12	-.78				
18528	7	.38	.25	-.49	18	.04	.00	-.11	32	-.13	-.32	-.52	20	.02	.42	1.33	4	-.31	-.35	-.20
18529	24	.71	-.38	-.10	13	.12	.02	.12	17	-.49	.34	.16	21	-.35	.01	-.18				
1853	36	-.07	-.12	-.05	17	.24	.12	-.16	8	-.17	.01	.22								
18530	22	.10	-.10	-.02	13	-.13	-.02	-.12	24	.01	.13	-.05	33	-.15	-.03	.14	26	.16	.02	.06
18531	29	.05	-.14	.01	16	-.08	.27	.13	33	.21	-.10	-.08	26	-.18	-.03	-.06				
18532	31	.00	.00	.00	27	.01	-.05	-.13	9	.00	.00	.00	7	-.23	-.21	.19	1	.23	.26	-.06
18533	28	.00	.00	.00	27	-.01	.04	.10	6	.00	.00	.00	7	.03	-.04	-.19	18	-.03	.00	.08
1854	17	.10	-.40	.30	24	-.58	-.27	.21	25	.48	.67	-.51								
1855	16	-.27	.22	.08	24	-.04	.22	-.46	25	.31	-.44	.38								
1856	16	.33	-.57	-.32	24	-.27	.43	.40	33	-.05	.14	-.08								
1857	8	.02	.32	-.01	30	.03	-.77	.12	36	-.05	.45	-.11								
185819	19	-.30	.40	.28	30	-.09	-.28	-.07	12	.45	-.08	-.16	3	-.06	-.04	-.05	15	.00	.00	.00
1859	10	-.36	.95	.43	19	.05	-.41	-.14	30	.32	-.54	-.30								

Precise Ephemeris (ADOS points)

	Pt	Vx	Vy	Vz
1961	35	-.02	.21	-.32
1962	22	-.03	.03	.00
1963	12	-.14	.03	.05
1964	5	.13	-.05	.06
1965	32	.19	-.07	.00
1966	29	-.02	.05	.00
1967	25	-.04	-.26	.25

VtPV = 41.44 NO OF VARIABLES= 192 NO OF OBSERVATIONS= 333

sigma-0 = .54 sigX = .45 sigY = .61 sigZ = .55

FINAL CO-ORDINATES

FINSLN

			X	mseX	Y	mseY	Z	mseZ
1	0	ACORN	5525469.70	.34	2120235.77	.47	-2373275.51	.42
2	0	BRIT 44	5086487.21	.45	2667594.70	.61	-2767921.85	.55
3	0	BLYDEBERG	4917287.33	.30	2106613.51	.41	-3463661.20	.37
4	0	BURENKAMP	5505881.40	.31	1492427.91	.42	-2843496.05	.38
5	0	COEGAKOP	4785913.87	.18	2295263.15	.25	-3524985.77	.23
6	0	DRUSE	5821899.05	.50	1398475.55	.68	-2192747.97	.62
7	0	ESERE	5716991.77	.34	1810401.11	.46	-2169939.09	.42
8	0	FRANSMANSKOP	4988154.60	.27	2267478.83	.37	-3256555.38	.33
9	0	GELHOUT	5624226.82	.52	2124854.63	.71	-2125845.70	.64
10	0	GRASKOP	5246334.51	.24	1904110.04	.33	-3079064.37	.30
11	0	HADIDA	5294743.38	.26	2085811.35	.36	-2872757.94	.32
12	0	HEXRIVIER	5022154.87	.16	1795160.30	.22	-3490364.76	.20
13	0	INKOMINKULU	4776611.58	.36	2809323.93	.49	-3149350.31	.44
14	0	KARASBERG	5386691.71	.27	1837214.75	.37	-2872963.33	.33
15	0	KARSRIEVER	4944368.22	.39	1811089.61	.54	-3587437.51	.48
16	0	KRANZBERG	5149888.55	.29	2691092.53	.40	-2626420.90	.36
17	0	LEEUKOP (RSA)	4986891.24	.26	2475832.86	.36	-3104545.08	.33
18	0	LEEUKOP (SWA)	5672668.46	.40	1526105.44	.54	-2477898.33	.49
19	0	LOUISFNTN	5203443.27	.30	1690206.61	.42	-3268509.51	.37
20	0	LOURKOP	5545532.24	.35	1663954.37	.48	-2670132.34	.43
21	0	LUBISI	4815762.13	.35	2506294.31	.48	-3339946.15	.43
22	0	MAGWAZA	4786226.29	.19	3006517.21	.25	-2946619.81	.23
23	0	MANNERHEIM	5291621.32	.29	2265090.91	.40	-2740789.90	.36
24	0	MOOIDAM	4983832.57	.28	2732709.86	.38	-2887741.36	.34
25	0	MORGENZON	5138858.43	.18	2424478.09	.25	-2890850.07	.22
26	0	M'PUMBE NEW	4943180.44	.37	3076440.92	.50	-2596398.61	.45
27	0	OKOTOMARE	5812703.47	.42	1662412.92	.58	-2028991.95	.52
28	0	ONDONDVENGO	5933892.06	.50	1289726.36	.68	-1947624.85	.62
29	0	PONT	5157884.61	.23	2878301.15	.31	-2400480.08	.28
30	0	POTLOER	5101368.49	.27	1977625.02	.37	-3269928.43	.33
31	0	RUNDU (BCN B)	5714708.38	.52	2054402.04	.71	-1947080.57	.64
32	0	SCHWARZECK	5576028.06	.19	1884764.80	.26	-2452547.39	.23
33	0	THAMAKOOSH	5019369.49	.33	2903703.32	.45	-2651973.22	.41
34	0	UNIONS END	5444103.71	.29	1979199.54	.40	-2663036.82	.36
35	0	WITBANK NEW	5361111.91	.18	1605149.21	.24	-3050286.12	.21
36	0	WITWATER	5137633.94	.25	2183073.61	.34	-3078162.65	.31

GEOGRAPHICAL CO-ORDINATES

			LATITUDE		mse(M)	LONGITUDE		mse(M)	HEIGHT	mse		
1	0	ACORN	21	59	3.6864	.42	20	59	34.1875	.45	1252.01	.37
2	0	BRIT 44	25	52	51.7386	.54	27	40	28.7188	.58	1629.89	.50
3	0	BLYDEBERG	33	05	51.3859	.36	23	11	26.7388	.40	1151.58	.34
4	0	BURENKAMP	26	38	54.1206	.37	15	09	58.3299	.41	109.78	.33
5	0	COEGAKOP	33	45	57.8609	.22	25	37	18.4121	.24	144.04	.21
6	0	DRUSE	20	14	18.0341	.61	13	30	25.4998	.67	796.02	.53
7	0	ESERE	20	00	57.8458	.41	17	34	17.2000	.45	1667.72	.36
8	0	FRANSMANSKOP	30	53	37.3127	.32	24	26	42.8921	.35	1499.04	.30
9	0	GELHOUT	19	35	39.0049	.64	20	41	48.3313	.69	1252.14	.56
10	0	GRASKOP	29	02	52.6297	.29	19	56	52.4820	.32	1062.19	.27
11	0	HADIDA	26	56	24.6867	.32	21	30	5.2767	.35	990.31	.29
12	0	HEXRIVIER	33	22	44.0287	.19	19	40	9.6210	.22	2251.85	.18
13	0	INKOMINKULU	29	46	33.6505	.43	30	27	41.6018	.46	1013.48	.41
14	0	KARASBERG	26	56	21.7271	.32	18	49	57.8591	.36	1622.95	.29
15	0	KARSRIEVER	34	26	44.3102	.46	20	07	2.8230	.52	206.29	.44
16	0	KRANZBERG	24	28	4.2363	.35	27	35	22.1199	.38	2136.64	.33
17	0	LEEUKOP (RSA)	29	18	29.2377	.32	26	24	10.5707	.34	1672.73	.30
18	0	LEEUKOP (SWA)	23	00	32.0182	.48	15	03	27.5171	.53	696.84	.42
19	0	LOUISFNTN	31	01	28.1871	.36	17	59	42.2658	.41	559.37	.33
20	0	LOURKOP	24	54	17.3608	.42	16	42	7.3352	.47	1464.68	.37
21	0	LUBISI	31	46	20.6751	.42	27	29	38.6747	.45	1790.57	.39
22	0	MAGWAZA	27	41	31.8847	.22	32	08	7.4620	.24	592.25	.21
23	0	MANNERHEIM	25	36	41.6815	.35	23	10	24.4541	.38	1082.41	.32
24	0	MOOIDAM	27	05	20.2801	.33	28	44	11.8204	.36	1637.83	.31
25	0	MORGENZON	27	07	16.6373	.22	25	15	27.4189	.24	1461.98	.20
26	0	M'PUMBE NEW	24	10	38.5550	.45	31	53	47.4307	.47	439.41	.42
27	0	OKOTOMARE	18	40	6.3853	.52	15	57	37.2413	.57	1180.11	.45
28	0	ONDONDVENGO	17	53	41.7193	.61	12	15	44.8816	.67	990.86	.52
29	0	PONT	22	15	5.5723	.28	29	09	47.6079	.29	697.26	.25
30	0	POTLOER	31	02	4.0807	.32	21	11	22.5527	.36	1474.11	.30
31	0	RUNDU (BCN B)	17	53	21.5921	.64	19	46	23.5019	.69	1136.32	.56
32	0	SCHWARZECK	22	45	26.4635	.23	18	40	33.1467	.25	1513.80	.20
33	0	THAMAKOOSH	24	43	19.5840	.40	30	02	57.7139	.43	1981.25	.37
34	0	UNIONS END	24	50	8.2817	.35	19	58	43.3038	.39	1130.00	.32
35	0	WITBANK NEW	28	45	17.9606	.21	16	40	4.8608	.23	340.32	.19
36	0	WITWATER	29	02	10.8858	.30	23	01	17.4609	.33	1519.74	.28

SUBNET SHIFT VALUES

FINSLN

	No Passes	X	mseX	Y	mseY	Z	mseZ
1851	53	2.23	.31	-1.36	.42	-2.98	.38
18510	57	-2.34	.30	-1.29	.41	.45	.37
18511	59	.74	.31	-.48	.43	-2.50	.38
18512	118	-1.60	.26	1.89	.36	-1.53	.32
18513	56	3.48	.30	-3.27	.41	-6.16	.37
18514	62	-1.35	.29	.73	.39	-.41	.35
18515	61	3.18	.30	-1.53	.41	-7.90	.37
1851618	85	-6.91	.25	-6.43	.35	-2.32	.31
18520	66	-1.06	.32	.45	.43	-.64	.39
18521	55	2.12	.31	-3.46	.42	-1.95	.38
1852223	80	.04	.26	-1.90	.35	-3.08	.32
18524	74	-6.37	.26	-.72	.35	2.06	.31
18525	78	-7.56	.25	-2.96	.34	1.83	.31
18526	73	-4.09	.32	.27	.44	-.19	.40
18527	68	-13.37	.28	-.89	.38	1.52	.34
18528	69	-12.52	.29	-1.51	.40	2.27	.36
18529	71	-1.71	.30	-2.31	.40	-.86	.36
1853	71	-2.53	.30	-1.51	.41	1.26	.37
18530	68	-4.69	.27	-3.70	.37	3.14	.33
18531	62	-.78	.29	-2.22	.40	-.96	.36
18532	77	-3.23	.38	.09	.52	-1.24	.46
18533	97	-4.34	.38	-2.41	.52	-.50	.47
1854	60	1.98	.30	.84	.41	-3.68	.37
1855	52	1.77	.32	.66	.43	-1.38	.39
1856	54	.98	.34	.99	.47	-5.00	.42
1857	62	-.51	.31	-.13	.43	-2.96	.38
185819	105	-1.37	.24	-2.95	.33	.94	.30
1859	51	-2.93	.33	2.18	.45	-.94	.41

- A 76 -

CHORD DISTANCES AND THEIR MSE'S

FINSLN

				DISTANCE	MSE	PPM
MORGENZON	2725.00079	WITWATER	2923.00053	305554.620	.340	1.11
LEEUKOP (RSA)	2926.00022	FRANSMANSKOP	3024.00026	257914.968	.377	1.46
GRASKOP	2919.00010	POTLOER	3121.00053	250696.412	.329	1.31
INKOMINKULU	2930.00051	WITWATER	2923.00053	726356.854	.517	.71
LEEUKOP (SWA)	2315.00079	UNIONS END	2419.00318	540196.601	.549	1.02
DRUSE	2013.00007	GEELHOUT	1920.00009	755762.389	.771	1.02
ONDONDVENGO	1712.00004	ESERE	2017.00026	606276.794	.537	.89
BLYDEBERG	3323.00007	LUBISI	3127.00040	430531.670	.568	1.32
GRASKOP	2919.00010	INKOMINKULU	2930.00051	1022248.467	.534	.52
LOUISFNTN	3117.00005	UNIONS END	2419.00318	712763.314	.485	.68
M'PUMBE NEW	2431.00066	INKOMINKULU	2930.00051	636280.009	.529	.83
PONT	2229.00023	HEXRIVIER	3319.00029	1542551.551	.360	.23
SCHWARZECK	2218.00179	COEGAKOP	3325.00133	1393884.286	.306	.22
LOUISFNTN	3117.00005	INKOMINKULU	2930.00051	1203664.312	.602	.50
HEXRIVIER	3319.00029	COEGAKOP	3325.00133	554176.227	.313	.56
HEXRIVIER	3319.00029	KARSRIVIER	3420.00022	125409.825	.450	3.59
COEGAKOP	3325.00133	ONDONDVENGO	1712.00004	2194772.343	.638	.29
KRANZBERG	2427.00025	BRIT 44	2527.00292	156826.002	.556	3.55

- A 77 -

'BEST-FIT' SPHEROID PROV A0= 6378137.00 B0= 6356752.31 DATA FILE: ALL.DATA

DATE=1988 11 23

POINT	X	Y	Z	GEOIDAL HEIGHT	WT	L	V	PV
ACORN	5525355.54	2120106.74	-2373569.62	1201.00	.400	19.42	6.79	2.72
BLYDEBERG	4917173.53	2106484.70	-3463955.29	1150.20	.530	31.86	2.31	1.22
BRIT 44	5086373.27	2667465.67	-2768216.07	1585.40	1.000	28.23	-.44	-.44
BURENKAMP	5505767.48	1492298.66	-2843789.90	80.60	.800	32.48	2.87	2.30
COEGAKOP	4785800.10	2295134.08	-3525279.82	146.80	.900	29.01	3.83	3.45
DRUSE	5821784.60	1398346.41	-2193041.67	739.00	.610	25.91	.93	.57
ESERE	5716877.42	1810272.01	-2170233.05	1602.00	.750	27.29	-2.95	-2.21
FRANSMANSKOP	4988040.76	2267349.81	-3256849.44	1478.30	.670	36.99	-3.83	-2.56
GEELHOUT	5624112.51	2124725.62	-2126139.82	1186.00	.340	21.08	.67	.23
GRASKOP	5246220.55	1903980.85	-3079358.31	1038.70	.420	34.04	.71	.30
HADIDA	5294629.34	2085682.18	-2873051.81	956.40	.690	30.27	2.13	1.47
HEXRIVIER	5022040.75	1795031.44	-3490658.65	2251.70	.770	35.90	.04	.03
INKOMINKULU	4776497.62	2809194.93	-3149644.62	984.70	.780	32.93	-3.71	-2.89
KARASBERG	5386577.66	1837085.70	-2873257.28	1585.00	.700	37.76	-3.96	-2.77
KARSRIVIER	4944254.40	1810960.82	-3587731.50	213.70	.780	34.22	1.36	1.06
KRANZBERG	5149774.52	2690963.62	-2626714.95	2089.40	.470	22.72	3.41	1.60
LEEUKOP (RSA)	4986777.32	2475703.78	-3104839.16	1643.10	.720	34.57	-3.20	-2.30
LEEUKOP (SWA)	5672554.29	1525976.22	-2478192.23	647.00	.670	32.35	-1.38	-.92
LOUISFNTN	5203329.28	1690077.74	-3268803.32	549.50	.640	34.29	2.25	1.44
LOURKOP	5545418.24	1663825.44	-2670425.81	1421.00	.750	34.62	-1.87	-1.40
LUBISI	4815648.34	2506165.24	-3340240.34	1773.10	.530	35.92	-4.24	-2.25
MAGWAZA	4786112.25	3006388.25	-2946913.91	555.30	.900	27.39	-.61	-.55
MANNERHEIM	5291507.31	2264961.85	-2741083.97	1040.00	.530	29.23	.90	.48
MOOIDAM	4983718.41	2732580.97	-2888035.49	1594.00	.800	33.49	-5.13	-4.10
MORGENZON	5138744.42	2424348.92	-2891144.00	1423.50	.560	31.66	-1.21	-.68
M' PUMBE NEW	4943067.51	3076312.08	-2596692.89	392.70	.510	17.68	5.34	2.72
OKOTOMARE	5812588.96	1662283.88	-2029285.75	1110.40	.690	25.84	-3.60	-2.48
ONDONDVENGO	5933777.39	1289597.30	-1947918.41	924.60	.330	23.75	-1.51	-.50
PONT	5157770.64	2878172.22	-2400774.11	643.20	.470	15.15	6.62	3.11
POTLOER	5101254.55	1977496.63	-3270222.38	1458.30	1.000	36.58	-1.64	-1.64
SCHWARZECK	5575913.94	1884635.81	-2452841.29	1461.00	.660	28.71	.03	.02
THAMAKOOSH	5019255.40	2903574.46	-2652267.38	1933.70	.440	22.26	2.67	1.18
UNIONS END	5443989.65	1979070.49	-2663330.76	1090.00	.430	26.18	4.79	2.06
WITBANK NEW	5360997.91	1605020.22	-3050580.22	320.40	.750	33.23	2.99	2.24
WITWATER	5137519.99	2182944.36	-3078456.58	1492.40	.490	34.13	-1.02	-.50

- A 78 -

[PVV]= 204.65

SIGMA_0= 2.61

NEW SEMI-MAJOR AXIS=6378043.03 +/- 160.66

NEW SEMI-MINOR AXIS=6356371.86 +/- 144.60

1/FLATTENING= 294.310 +/- 2.363

X-SHIFT= -47.15 +/- 153.02

Y-SHIFT= 18.82 +/- 66.02

Z-SHIFT= 335.60 +/- 109.65

Q-MATRIX

A	B	XSH	YSH	ZSH	A	B	XSH	YSH	ZSH	
25810.11	8954.46	24344.77	10369.94	2462.34	A	1.000	.385	.990	.978	.140
8954.46	20910.06	5650.90	1993.91	-13603.50	B		1.000	.255	.209	-.858
24344.77	5650.90	23414.01	10026.26	4609.50	XSH			1.000	.993	.275
10369.94	1993.91	10026.26	4358.25	2314.37	YSH				1.000	.320
2462.34	-13603.50	4609.50	2314.37	12023.57	ZSH					1.000

'BEST-FIT' SPHEROID PROV A0= 6378137.00 B0= 6356752.31 DATA FILE: ALL.DATA

DATE=1988 11 23

POINT	X	Y	Z	GEOIDAL HEIGHT	WT	L	V	PV
ACORN	5525355.54	2120106.74	-2373569.62	1201.00	.400	19.42	7.11	2.84
BLYDEBERG	4917173.53	2106484.70	-3463955.29	1150.20	.530	31.86	3.47	1.84
BRIT 44	5086373.27	2667465.67	-2768216.07	1585.40	1.000	28.23	1.10	1.10
BURENKAMP	5505767.48	1492298.66	-2843789.90	80.60	.800	32.48	-2.56	-2.05
COEGAKOP	4785800.10	2295134.08	-3525279.82	146.80	.900	29.01	6.91	6.22
DRUSE	5821784.60	1398346.41	-2193041.67	739.00	.610	25.91	-.53	-.32
ESERE	5716877.42	1810272.01	-2170233.05	1602.00	.750	27.29	-2.05	-1.53
FRANSMANSKOP	4988040.76	2267349.81	-3256849.44	1478.30	.670	36.99	-3.59	-2.40
GEELHOUT	5624112.51	2124725.62	-2126139.82	1186.00	.340	21.08	3.90	1.33
GRASKOP	5246220.55	1903980.85	-3079358.31	1038.70	.420	34.04	-2.19	-.92
HADIDA	5294629.34	2085682.18	-2873051.81	956.40	.690	30.27	-.12	-.08
HEXRIVIER	5022040.75	1795031.44	-3490658.65	2251.70	.770	35.90	-.33	-.25
INKOMINKULU	4776497.62	2809194.93	-3149644.62	984.70	.780	32.93	-.47	-.37
KARASBERG	5386577.66	1837085.70	-2873257.28	1585.00	.700	37.76	-7.61	-5.33
KARSRIVIER	4944254.40	1810960.82	-3587731.50	213.70	.780	34.22	2.31	1.81
KRANZBERG	5149774.52	2690963.62	-2626714.95	2089.40	.470	22.72	5.56	2.61
LEEUKOP(RSA)	4986777.32	2475703.78	-3104839.16	1643.10	.720	34.57	-2.51	-1.80
LEEUKOP(SWA)	5672554.29	1525976.22	-2478192.23	647.00	.670	32.35	-5.13	-3.43
LOUISFNTN	5203329.28	1690077.74	-3268803.32	549.50	.640	34.29	-.78	-.50
LOURKOP	5545418.24	1663825.44	-2670425.81	1421.00	.750	34.62	-6.03	-4.52
LUBISI	4815648.34	2506165.24	-3340240.34	1773.10	.530	35.92	-1.76	-.93
MAGWAZA	4786112.25	3006388.25	-2946913.91	555.30	.900	27.39	3.36	3.02
MANNERHEIM	5291507.31	2264961.85	-2741083.97	1040.00	.530	29.23	-.10	-.05
MOOIDAM	4983718.41	2732580.97	-2888035.49	1594.00	.800	33.49	-3.22	-2.58
MORGENZON	5138744.42	2424348.92	-2891144.00	1423.50	.560	31.66	-1.37	-.77
M'PUMBE NEW	4943067.51	3076312.08	-2596692.89	392.70	.510	17.68	10.39	5.30
OKOTOMARE	5812588.96	1662283.88	-2029285.75	1110.40	.690	25.84	-1.41	-.97
ONDONDVENGO	5933777.39	1289597.30	-1947918.41	924.60	.330	23.75	.24	.08
PONT	5157770.64	2878172.22	-2400774.11	643.20	.470	15.15	11.55	5.43
POTLOER	5101254.55	1977496.63	-3270222.38	1458.30	1.000	36.58	-3.06	-3.06
SCHWARZECK	5575913.94	1884635.81	-2452841.29	1461.00	.660	28.71	-1.66	-1.09
THAMAKOOSH	5019255.40	2903574.46	-2652267.38	1933.70	.440	22.26	6.20	2.73
UNIONS END	5443989.65	1979070.49	-2663330.76	1090.00	.430	26.18	2.37	1.02
WITBANK NEW	5360997.91	1605020.22	-3050580.22	320.40	.750	33.23	-1.62	-1.22
WITWATER	5137519.99	2182944.36	-3078456.58	1492.40	.490	34.13	-2.29	-1.12

- A 80 -

[PVV]= 379.76

SIGMA_0= 3.39

NEW SEMI-MAJOR AXIS=6378155.73 +/- 2.60

NEW SEMI-MINOR AXIS=6356826.80 +/- 9.47

1/FLATTENING= 299.038 +/- .166

Q-MATRIX

A	B	A	B
6.78	-23.12	1.000	-.938
-23.12	89.69		1.000

'BEST-FIT' SPHEROID PROV A0= 6378137.00 B0= 6356752.31 DATA FILE: ALL.DATA DATE=1988 11 23

POINT	X	Y	Z	Orthometric GEODAL HEIGHT	WT	L	V	PV
ACORN	5525355.54	2120106.74	-2373569.62	1201.00	.400	19.42	6.81	2.72
BLYDEBERG	4917173.53	2106484.70	-3463955.29	1150.20	.530	31.86	3.83	2.03
BRIT 44	5086373.27	2667465.67	-2768216.07	1585.40	1.000	28.23	-1.21	-1.21
BURENKAMP	5505767.48	1492298.66	-2843789.90	80.60	.800	32.48	.79	.63
COEGAKOP	4785800.10	2295134.08	-3525279.82	146.80	.900	29.01	6.27	5.64
DRUSE	5821784.60	1398346.41	-2193041.67	739.00	.610	25.91	2.01	1.23
ESERE	5716877.42	1810272.01	-2170233.05	1602.00	.750	27.29	-1.44	-1.08
FRANSMANSKOP	4988040.76	2267349.81	-3256849.44	1478.30	.670	36.99	-3.81	-2.55
GEELHOUT	5624112.51	2124725.62	-2126139.82	1186.00	.340	21.08	2.91	.99
GRASKOP	5246220.55	1903980.85	-3079358.31	1038.70	.420	34.04	-.63	-.26
HADIDA	5294629.34	2085682.18	-2873051.81	956.40	.690	30.27	.51	.35
HEXRIVIER	5022040.75	1795031.44	-3490658.65	2251.70	.770	35.90	1.49	1.15
INKOMINKULU	4776497.62	2809194.93	-3149644.62	984.70	.780	32.93	-3.37	-2.63
KARASBERG	5386577.66	1837085.70	-2873257.28	1585.00	.700	37.76	-5.81	-4.07
KARSRIVIER	4944254.40	1810960.82	-3587731.50	213.70	.780	34.22	3.91	3.05
KRANZBERG	5149774.52	2690963.62	-2626714.95	2089.40	.470	22.72	2.95	1.39
LEEUKOP (RSA)	4986777.32	2475703.78	-3104839.16	1643.10	.720	34.57	-3.71	-2.67
LEEUKOP (SWA)	5672554.29	1525976.22	-2478192.23	647.00	.670	32.35	-2.45	-1.64
LOUISFNTN	5203329.28	1690077.74	-3268803.32	549.50	.640	34.29	1.73	1.11
LOURKOP	5545418.24	1663825.44	-2670425.81	1421.00	.750	34.62	-3.65	-2.74
LUBISI	4815648.34	2506165.24	-3340240.34	1773.10	.530	35.92	-3.23	-1.71
MAGWAZA	4786112.25	3006388.25	-2946913.91	555.30	.900	27.39	-.57	-.52
MANNERHEIM	5291507.31	2264961.85	-2741083.97	1040.00	.530	29.23	-.46	-.24
MOOIDAM	4983718.41	2732580.97	-2888035.49	1594.00	.800	33.49	-5.77	-4.62
MORGENZON	5138744.42	2424348.92	-2891144.00	1423.50	.560	31.66	-2.37	-1.33
M'PUMBE NEW	4943067.51	3076312.08	-2596692.89	392.70	.510	17.68	5.76	2.94
OKOTOMARE	5812588.96	1662283.88	-2029285.75	1110.40	.690	25.84	-.58	-.40
ONDONDVENGO	5933777.39	1289597.30	-1947918.41	924.60	.330	23.75	2.44	.81
PONT	5157770.64	2878172.22	-2400774.11	643.20	.470	15.15	7.59	3.57
POTLOER	5101254.55	1977496.63	-3270222.38	1458.30	1.000	36.58	-1.89	-1.89
SCHWARZECK	5575913.94	1884635.81	-2452841.29	1461.00	.660	28.71	-.67	-.45
THAMAKOOSH	5019255.40	2903574.46	-2652267.38	1933.70	.440	22.26	2.55	1.12
UNIONS END	5443989.65	1979070.49	-2663330.76	1090.00	.430	26.18	3.27	1.41
WITBANK NEW	5360997.91	1605020.22	-3050580.22	320.40	.750	33.23	1.32	.99
WITWATER	5137519.99	2182944.36	-3078456.58	1492.40	.490	34.13	-2.06	-1.01

[PVV]= 253.34

SIGMA_0= 2.81

X-SHIFT= -13.13 +/- 3.81

Y-SHIFT= 25.24 +/- 7.41

Z-SHIFT= 62.09 +/- 7.45

Q-MATRIX

XSH	YSH	ZSH	XSH	YSH	ZSH	
14.54	-7.83	19.78	XSH	1.000	-.277	.697
-7.83	54.96	26.29	YSH		1.000	.476
19.78	26.29	55.49	ZSH			1.000

- A 83 -

POINT	DOPPLER						ASTRO				'L'		'V' (")		'V' (M)			
	LAT			LON			LAT		LON	LAT	LON	LAT	LON	LAT	LON			
1 BLYDEBERG	33	6	2.24	23	11	23.90	33	6	4.91	23	11	29.85	2.67	5.95	4.944	4.377	152.88	113.39
2 FRANSMANSKOP	30	53	48.23	24	26	40.24	30	53	43.94	24	26	42.39	-4.29	2.15	-2.100	.575	-64.93	15.25
3 GRASKOP	29	3	3.47	19	56	49.43	29	3	.84	19	56	53.35	-2.63	3.92	-.519	2.348	-16.04	63.47
4 HADIDA	26	56	35.57	21	30	2.44	26	56	38.34	21	30	3.68	2.77	1.24	4.780	-.327	147.81	-9.01
5 KARASBERG	26	56	32.56	18	49	54.77	26	56	27.29	18	49	56.29	-5.27	1.52	-3.255	-.048	-100.66	-1.32
6 KARSRIVIER	34	26	55.06	20	6	59.62	34	26	58.18	20	7	1.06	3.12	1.44	5.443	-.130	168.30	-3.32
7 KRANZBERG	24	28	15.21	27	35	19.94	24	28	12.41	27	35	9.38	-2.80	-10.56	-.926	-12.130	-28.64	-341.39
8 LEEUKOP(RSA)	29	18	40.21	26	24	8.16	29	18	34.69	26	24	10.08	-5.52	1.92	-3.396	.345	-105.03	9.29
9 LOUISFNTN	31	1	38.95	17	59	38.97	31	1	40.18	17	59	42.35	1.23	3.38	3.426	1.806	105.93	47.86
10 MAGWAZA	27	41	42.95	32	8	5.69	27	41	41.82	32	8	9.89	-1.13	4.20	.917	2.628	28.36	71.96
11 MOOIDAM	27	5	31.30	28	44	9.71	27	5	26.61	28	44	8.74	-4.69	-.97	-2.670	-2.542	-82.55	-69.98
12 MORGENZON	27	7	27.59	25	15	24.94	27	7	27.11	25	15	26.00	-.48	1.06	1.537	-.515	47.53	-14.18
13 POTLOER	31	2	14.92	21	11	19.59	31	2	14.51	21	11	18.18	-.41	-1.41	1.786	-2.983	55.24	-79.05
14 WITWATER	29	2	21.79	23	1	14.71	29	2	23.81	23	1	21.00	2.02	6.29	4.129	4.717	127.68	127.52
15 SPRINGFNTN	29	3	43.80	23	26	14.35	29	3	46.10	23	26	20.44	2.30	6.09	4.420	4.515	136.66	122.04
16 SPITZKOP	25	51	4.14	23	33	24.21	25	51	4.55	23	33	27.45	.41	3.24	2.367	1.673	73.19	46.54
17 MORGENZON**	27	7	27.60	25	15	24.96	27	7	27.74	25	15	26.00	.14	1.04	2.160	-.529	66.79	-14.55
18 HOUTNEK	27	57	22.52	25	19	39.69	27	57	21.19	25	19	38.59	-1.33	-1.10	.728	-2.668	22.50	-72.88
19 UITKYK	28	15	25.03	25	15	24.78	28	15	23.65	25	15	22.98	-1.38	-1.80	.701	-3.368	21.68	-91.72
20 HUGO NEW	26	54	30.14	25	24	10.57	26	54	28.65	25	24	7.17	-1.49	-3.40	.523	-4.975	16.17	-137.18
21 GOSCHEN	26	6	15.52	25	25	29.49	26	6	12.87	25	25	25.72	-2.65	-3.77	-.682	-5.345	-21.10	-148.41
22 CROYDON	25	51	52.54	25	9	17.52	25	51	50.22	25	9	17.25	-2.32	-.27	-.362	-1.841	-11.19	-51.22
23 WITKOP I	25	45	15.48	26	2	4.29	25	45	8.45	26	2	6.49	-7.03	2.20	-5.084	.629	-157.20	17.52
24 ONVERWACHT	25	40	18.92	26	15	9.53	25	40	10.17	26	15	14.53	-8.75	5.00	-6.802	3.430	-210.32	95.59
25 WITWATER	29	2	21.79	23	1	14.72	29	2	23.84	23	1	23.81	2.05	9.09	4.162	7.521	128.68	203.33
26 THAKWANENG	28	2	55.06	23	7	10.57	28	2	51.05	23	7	9.79	-4.01	-.78	-1.945	-2.352	-60.13	-64.18
27 OUPLAAS	28	13	52.99	23	27	21.43	28	13	53.47	23	27	30.00	.48	8.57	2.558	6.996	79.09	190.61
28 BAKENSKOP	26	56	37.82	23	3	15.38	26	56	33.54	23	3	21.81	-4.28	6.43	-2.271	4.861	-70.23	133.99
29 KEANGKOP	27	1	1.13	23	43	46.29	27	0	49.68	23	43	47.10	-11.45	.81	-9.433	-.760	-291.69	-20.93
30 PADDAPAN	25	55	45.39	23	57	7.65	25	55	44.92	23	57	10.87	-.47	3.22	1.484	1.646	45.90	45.77
31 HARTEBEEESHK	25	52	57.99	27	42	22.25	25	52	49.03	27	42	27.67	-8.96	5.42	-7.001	3.848	-216.48	107.06
32 NOOITGDCT I	25	51	38.65	27	31	51.05	25	51	35.57	27	31	56.11	-3.08	5.06	-1.127	3.484	-34.85	96.95
33 KLIPKOPPIES	28	52	18.14	21	21	1.02	28	52	17.80	21	20	57.62	-.34	-3.40	1.763	-4.975	54.50	-134.71
34 KLEINBEGIN	28	53	5.32	21	44	29.37	28	53	3.20	21	44	33.13	-2.12	3.76	-.011	2.184	-.35	59.14
35 CERES	28	8	7.29	21	31	13.40	28	8	5.50	21	31	13.30	-1.79	-.10	.284	-1.667	8.79	-45.45

POINT	DOPPLER			ASTRO			'L'		'V' (")		'V' (M)	
	LAT		LON	LAT		LON	LAT	LON	LAT	LON	LAT	LON
36 ENKELDE KB	27 55	9.82	21 28 48.77	27 55	5.40	21 28 49.95	-4.42	1.18	-2.360	-.388	-72.96	-10.60
37 BALLATER	26 57	42.31	21 11 4.24	26 57	39.80	21 11 8.41	-2.51	4.17	-.501	2.600	-15.50	71.65
38 HADIDA	26 56	35.65	21 30 2.35	26 56	38.20	21 30 3.68	2.55	1.33	4.558	-.243	140.95	-6.71
39 BUYSKOP	26 55	.09	20 7 17.44	26 55	1.80	20 7 19.13	1.71	1.69	3.722	.118	115.10	3.26
40 NAROEGAS	27 11	1.60	20 4 23.81	27 11	5.00	20 4 19.57	3.40	-4.24	5.429	-5.811	167.88	-159.83
41 KALKVLEI N	27 54	51.42	20 16 12.92	27 54	48.50	20 16 14.58	-2.92	1.66	-.863	.085	-26.68	2.32
42 GAPUTZ	27 55	45.54	19 55 23.10	27 55	43.10	19 55 28.10	-2.44	5.00	-.384	3.427	-11.86	93.63
43 BYSTEEK	28 44	3.53	20 3 35.00	28 43	58.10	20 3 38.80	-5.43	3.80	-3.332	2.233	-103.02	60.55
44 GRASKOP	29 3	3.45	19 56 49.43	29 3	1.10	19 56 53.35	-2.35	3.92	-.239	2.346	-7.39	63.43
45 WEGDRAAI	29 10	17.29	24 51 .18	29 10	13.70	24 50 58.84	-3.59	-1.34	-1.474	-2.915	-45.58	-78.71
46 PAARDEBG	28 58	28.17	25 5 7.00	28 58	23.50	25 5 8.71	-4.67	1.71	-2.562	.143	-79.22	3.86
47 LUIPERDSR	29 55	50.34	25 11 24.72	29 55	47.60	25 11 18.97	-2.74	-5.75	-.586	-7.318	-18.13	-196.10
48 KNAPSAKBG	30 9	43.41	25 0 .26	30 9	43.40	24 59 59.40	-.01	-.86	2.156	-2.428	66.67	-64.91
49 BULHOEK	30 59	7.56	24 49 20.25	30 59	.47	24 49 20.94	-7.09	.69	-4.896	-.880	-151.38	-23.33
50 FRANSMANS	30 53	48.22	24 26 40.25	30 53	44.13	24 26 42.39	-4.09	2.14	-1.897	.571	-58.66	15.16
51 NAIB	29 20	55.29	18 18 59.85	29 20	49.00	18 19 2.55	-6.29	2.70	-4.158	1.126	-128.57	30.34
52 KOEBERG	29 43	56.75	18 28 54.20	29 43	54.50	18 28 53.03	-2.25	-1.17	-.106	-2.745	-3.28	-73.71
53 EISENBERG	28 6	51.40	18 7 46.34	28 6	53.40	18 7 41.42	2.00	-4.92	4.067	-6.488	125.77	-176.96
54 BULT	28 3	28.23	18 45 2.42	28 3	31.00	18 45 2.97	2.77	.55	4.837	-1.025	149.57	-27.98
55 KARASBERG	26 56	32.55	18 49 54.77	26 56	27.50	18 49 56.29	-5.05	1.52	-3.042	-.051	-94.08	-1.41
56 NORDECK	26 53	35.30	18 13 16.59	26 53	26.40	18 13 9.95	-8.90	-6.64	-6.886	-8.212	-212.93	-226.47
57 NOOITGDCT I	25 51	38.65	27 31 51.05	25 51	37.90	27 31 58.53	-.75	7.48	1.203	5.904	37.20	164.29
58 CABLE HILL	25 41	29.29	28 10 6.04	25 41	24.77	28 10 6.71	-4.52	.67	-2.571	-.898	-79.51	-25.03
59 BOSHOFSBG	24 51	13.68	27 38 6.49	24 51	12.37	27 38 4.27	-1.31	-2.22	.593	-3.795	18.33	-106.47
60 KRANZBERG	24 28	15.22	27 35 19.94	24 28	12.51	27 35 9.38	-2.71	-10.56	-.830	-12.133	-25.65	-341.49
61 ZOETENDAL	23 18	7.24	28 1 52.24	23 18	2.18	28 1 49.83	-5.06	-2.41	-3.251	-3.980	-100.51	-113.04
62 WITKOP I	23 18	1.73	27 40 21.88	23 18	.21	27 40 21.39	-1.52	-.49	.289	-2.063	8.94	-58.59
63 KUIP	30 4	7.38	23 10 30.88	30 4	5.36	23 10 35.46	-2.02	4.58	.135	3.010	4.19	80.56
64 TIERPOORT	30 25	32.12	23 15 20.03	30 25	24.63	23 15 24.87	-7.49	4.84	-5.318	3.273	-164.45	87.27
65 SPIOENKOP	31 25	10.92	22 56 35.19	31 25	4.90	22 56 35.50	-6.02	.31	-3.806	-1.263	-117.69	-33.34
66 BIESIESPRT	31 41	26.76	23 7 52.14	31 41	29.48	23 7 56.95	2.72	4.81	4.944	3.242	152.87	85.31
67 RHENOSTFNTN	24 26	59.80	27 52 24.54	24 26	55.55	27 52 24.60	-4.25	.06	-2.373	-1.507	-73.37	-42.41
68 HANGLIP	22 59	47.57	29 53 1.34	22 59	47.86	29 53 5.01	.29	3.67	2.084	2.098	64.46	59.73
69 PORTUGAL	24 10	21.26	29 14 36.84	24 10	22.51	29 14 50.79	1.25	13.95	3.113	12.375	96.25	349.12
70 RHEBOKKOP	24 7	20.50	29 51 11.99	24 7	27.50	29 51 25.63	7.00	13.64	8.863	12.068	274.06	340.59

POINT	DOPPLER		ASTRO		'L'		'V' (")		'V' (M)		
	LAT	LON	LAT	LON	LAT	LON	LAT	LON	LAT	LON	
72	GRT RTVLEI	25 28 16.54	29 44 57.46	25 28 1.48	29 44 49.38	-15.06	-8.08	-13.122	-9.649	-405.77	-269.35
73	TAFELBERG	31 38 45.51	25 9 53.04	31 38 43.10	25 9 56.48	-2.41	3.44	-.190	1.869	-5.87	49.19
74	KOUDEHEUVEL	32 1 34.46	25 14 18.09	32 1 33.88	25 14 22.40	-.58	4.31	1.659	2.737	51.31	71.75
75	BUFFELSHOEK	32 46 27.26	24 47 10.69	32 46 36.80	24 47 7.76	9.54	-2.93	11.809	-4.503	365.17	-117.07
76	GRASBERG	32 51 28.21	24 29 31.16	32 51 37.14	24 29 37.72	8.93	6.56	11.199	4.992	346.30	129.67
77	SCHILPADKOP	32 39 19.42	23 10 41.66	32 39 26.14	23 10 46.54	6.72	4.88	8.986	3.308	277.88	86.13
78	BLYDEBERG	33 6 2.24	23 11 23.90	33 6 4.91	23 11 29.85	2.67	5.95	4.944	4.380	152.88	113.45
79	LEJUMA	23 1 29.49	29 25 43.44	23 1 16.92	29 25 45.47	-12.57	2.03	-10.780	.454	-333.33	12.92
80	HANGLIP	22 59 47.57	29 53 1.34	22 59 41.83	29 53 7.70	-5.74	6.36	-3.946	4.788	-122.00	136.30
81	ADAMS PUT	27 2 47.38	26 7 46.89	27 2 47.79	26 7 51.85	.41	4.96	2.426	3.393	75.01	93.45
82	DOORNPLAATS	27 1 23.41	26 26 37.06	27 1 22.43	26 26 39.32	-.98	2.26	1.033	.686	31.93	18.89
83	LEEUKUIL	27 2 50.75	27 41 34.77	27 2 47.79	27 41 32.82	-2.96	-1.95	-.947	-3.521	-29.29	-96.97
84	HOUTKRANS	27 22 26.19	27 38 30.90	27 22 21.24	27 38 28.35	-4.95	-2.55	-2.919	-4.123	-90.27	-113.22
85	BIESIESPAN	28 13 1.24	26 7 34.88	28 12 55.79	26 7 38.33	-5.45	3.45	-3.371	1.883	-104.23	51.31
86	SCHOONGEZ	28 19 26.43	26 23 56.59	28 19 21.84	26 23 58.83	-4.59	2.24	-2.514	.671	-77.74	18.26
87	MYNHDTS RN	28 5 59.77	27 27 18.41	28 5 59.22	27 27 16.22	-.55	-2.19	1.520	-3.763	47.02	-102.64
88	SPITZKOP N	28 34 11.00	27 27 3.67	28 34 7.36	27 26 58.91	-3.64	-4.76	-1.553	-6.327	-48.01	-171.83
89	LEEUKOP	29 18 40.22	26 24 8.17	29 18 34.69	26 24 10.08	-5.53	1.91	-3.400	.339	-105.13	9.13
90	THABA NCHU	29 15 9.86	26 53 27.35	29 15 5.24	26 53 26.78	-4.62	-.57	-2.495	-2.137	-77.14	-57.66
91	GOBO GOBO	29 59 26.99	27 4 51.48	29 59 23.07	27 4 45.63	-3.92	-5.85	-1.765	-7.418	-54.58	-198.67
92	GREYSDAL	30 7 24.89	26 48 42.38	30 7 20.56	26 48 38.49	-4.33	-3.89	-2.172	-5.465	-67.18	-146.16
93	MOOIDAM	27 5 31.30	28 44 9.71	27 5 26.61	28 44 8.74	-4.69	-.97	-2.670	-2.546	-82.57	-70.09
94	SCHAAPBULT	27 9 48.80	28 55 32.55	27 9 42.54	28 55 31.74	-6.26	-.81	-4.234	-2.384	-130.92	-65.58
95	LANGBERG I	27 11 39.90	30 1 39.39	27 11 37.54	30 1 43.63	-2.36	4.24	-.331	2.670	-10.24	73.43
96	ELANDBG III	26 59 56.57	30 1 25.42	26 59 57.31	30 1 27.28	.74	1.86	2.755	.290	85.20	7.99
97	KORFSKOP	28 18 1.52	28 45 54.08	28 17 55.58	28 46 9.18	-5.94	15.10	-3.865	13.527	-119.53	368.28
98	NTABAZWE	28 16 8.65	29 12 49.26	28 16 9.22	29 13 3.91	.57	14.65	2.650	13.078	81.94	356.16
99	BIGGARSBG	28 12 46.50	30 1 21.37	28 12 56.84	30 1 29.20	10.34	7.83	12.420	6.259	384.04	170.55
100	JOBSKOP	28 34 45.95	30 12 41.16	28 34 47.20	30 12 43.44	1.25	2.28	3.342	.705	103.35	19.15
101	WITKOPPIES	29 37 22.50	21 25 43.90	29 37 19.44	21 25 42.42	-3.06	-1.48	-.921	-3.051	-28.49	-82.01
102	GRT STRNDBG	30 0 45.17	21 37 37.97	30 0 41.56	21 37 38.10	-3.61	.13	-1.455	-1.437	-45.00	-38.47
103	LEMIETKOP	30 53 17.67	21 30 10.66	30 53 11.77	21 30 5.89	-5.90	-4.77	-3.705	-6.338	-114.58	-168.19
104	POTLOER	31 2 14.92	21 11 19.59	31 2 13.31	21 11 18.18	-1.61	-1.41	.591	-2.984	18.26	-79.07
105	KARSRIVIER	34 26 55.44	20 6 59.43	34 26 58.18	20 7 1.06	2.74	1.63	5.067	.056	156.69	1.44
106	KORINGHOEK	30 35 6.83	17 55 47.87	30 35 10.76	17 55 43.26	3.93	-4.61	6.111	-6.185	188.98	-164.66

POINT	DOPPLER			ASTRO			'L'		'V' (")		'V' (M)	
	LAT		LON	LAT		LON	LAT	LON	LAT	LON	LAT	LON
108 SKANSKOP	30	1 48.15	19 47 8.24	30	1 45.03	19 47 9.53	-3.12	1.29	-.960	-.279	-29.67	-7.48
109 BOKSKOLK	29	48 16.08	19 46 53.87	29	48 12.48	19 46 57.81	-3.60	3.94	-1.448	2.365	-44.76	63.47
110 RYNEVELDKP	31	16 43.90	19 32 48.57	31	16 41.98	19 32 37.46	-1.92	-11.11	.290	-12.683	8.96	-335.19
111 SPIOENBG II	30	59 35.72	19 45 44.80	30	59 33.50	19 45 39.58	-2.22	-5.22	-.022	-6.788	-.68	-179.93
112 PYPKLIPBERG	27	16 38.87	31 7 13.48	27	16 34.71	31 7 18.34	-4.16	4.86	-2.133	3.293	-65.96	90.50
113 UMKWAKWENI	27	19 16.49	31 29 32.12	27	19 13.26	31 29 37.24	-3.23	5.12	-1.200	3.553	-37.11	97.61
114 MAGWAZA	27	41 42.95	32 8 5.69	27	41 41.82	32 8 9.89	-1.13	4.20	.917	2.630	28.36	71.99
115 MAKOWE	27	57 51.05	32 7 2.19	27	57 49.49	32 7 5.35	-1.56	3.16	.504	1.592	15.59	43.49

'BEST-FIT' ASTRO CO-ORD SPHEROID

PROV A0= 6378137.00 B0= 6356752.31

INPUT FILE= ALL.DATA

DATE= 1988 11 2

NEW SEMI-MAJOR AXIS=6378060.20 +/- 12.55

FLATTENING=1/299.3286 $\sigma = 0.176$

Z-ROT(")= -1.57 +/- .54

COVARIANCE-MATRIX

A	Z-R	A	Z-R
157.59	.00	A	1.000 .000
.00	.30	Z-R	1.000

NOMINAL WEIGHT: LAT= 2.0 LON= 1.0

'BEST-FIT' TRIG. CO-ORD SPHEROID

PROV A0= 6378249.14 B0= 6356514.97

INPUT FILE= ALL.TRIGFIN

DATE= 1989 02 14

NEW SEMI-MAJOR AXIS=6378268.10 +/- 15.21

FLATTENING=1/293.2115 +/- 0.204

X-SHIFT= -198.43 +/- 11.78

Y-SHIFT= -142.21 +/- 5.54

Z-SHIFT= -270.97 +/- 11.54

COVARIANCE-MATRIX

A	XSH	YSH	ZSH	A	XSH	YSH	ZSH	
231.29	114.23	52.72	153.18	A	1.000	.637	.626	.873
114.23	138.87	63.91	25.56	XSH		1.000	.980	.188
52.72	63.91	30.64	11.62	YSH			1.000	.182
153.18	25.56	11.62	133.26	ZSH				1.000

NOMINAL WEIGHT: LAT= 1.0 LON= 1.0

POINT	DOPPLER			TRIG.			'L'		'V' (")		'V' (M)							
	LAT		LON	LAT		LON	LAT	LON	LAT	LON	LAT	LON						
1 BLYDEBERG	33	6	12.50	23	11	24.70	33	6	1.52	23	11	26.59	-10.98	1.89	.052	-.139	1.59	-3.60
2 BRIT 44	25	53	11.52	27	40	27.32	25	53	.64	27	40	28.41	-10.88	1.09	-.013	-.119	-.40	-3.30
3 COEGAKOP	33	46	19.12	25	37	16.60	33	46	8.17	25	37	18.18	-10.95	1.58	.129	-.070	4.00	-1.79
4 FRANSMANSKOP	30	53	58.10	24	26	41.04	30	53	47.21	24	26	42.78	-10.89	1.74	.105	-.047	3.24	-1.23
5 GRASKOP	29	3	12.98	19	56	50.23	29	3	2.11	19	56	52.90	-10.87	2.67	.010	.230	.31	6.22
6 HEXRIVIER	33	23	5.09	19	40	7.21	33	22	53.98	19	40	9.62	-11.11	2.41	-.143	-.190	-4.41	-4.90
7 INKOMINKULU	29	46	54.35	30	27	40.41	29	46	43.36	30	27	41.44	-10.99	1.03	.037	.208	1.14	5.59
8 KARSRIVIER	34	27	5.52	20	7	.42	34	26	54.41	20	7	2.71	-11.11	2.29	-.115	-.267	-3.55	-6.80
9 KRANZBERG	24	28	23.64	27	35	20.74	24	28	12.74	27	35	21.81	-10.90	1.07	-.096	-.141	-2.96	-3.96
10 LEEUKOP (RSA)	29	18	49.77	26	24	8.96	29	18	38.88	26	24	10.41	-10.89	1.45	.088	-.004	2.71	-.11
11 LOUISFNTN	31	1	48.85	17	59	39.77	31	1	37.71	17	59	42.59	-11.14	2.82	-.251	.029	-7.76	.76
12 LUBISI	31	46	41.68	27	29	37.12	31	46	30.74	27	29	38.49	-10.94	1.37	.120	.057	3.71	1.49
13 MAGWAZA	27	41	52.16	32	8	6.49	27	41	41.07	32	8	7.21	-11.09	.72	-.127	.176	-3.91	4.83
14 MOOIDAM	27	5	40.37	28	44	10.51	27	5	29.41	28	44	11.59	-10.96	1.08	-.037	.016	-1.16	.44
15 MORGENZON	27	7	36.67	25	15	25.74	27	7	25.90	25	15	27.19	-10.77	1.45	.119	-.150	3.67	-4.12
16 M' PUMBE NEW	24	10	57.94	31	53	46.45	24	10	46.96	31	53	47.09	-10.98	.64	-.159	.076	-4.91	2.14
17 PONT	22	15	24.36	29	9	46.42	22	15	13.49	29	9	47.23	-10.87	.81	-.164	-.146	-5.07	-4.17
18 POTLOER	31	2	24.82	21	11	20.39	31	2	13.85	21	11	22.69	-10.97	2.30	-.019	.003	-.59	.07
19 THAMAKOOSH	24	43	39.09	30	2	56.58	24	43	28.16	30	2	57.38	-10.93	.80	-.101	-.043	-3.13	-1.20
20 WITWATER	29	2	31.30	23	1	15.51	29	2	20.51	23	1	17.50	-10.79	1.99	.141	.019	4.35	.52
21 HADIDA	26	56	44.61	21	30	3.24	26	56	34.11	21	30	5.61	-10.50	2.37	.336	.215	10.39	5.91
22 MANNERHEIM	25	37	1.32	23	10	22.61	25	36	50.93	23	10	24.35	-10.39	1.74	.421	-.147	13.01	-4.10
23 WITBANK NEW	28	45	38.18	16	40	2.31	28	45	27.13	16	40	5.61	-11.05	3.30	-.243	.375	-7.50	10.15

'BEST-FIT' TRIG. CO-ORD SPHEROID

PROV A0= 6378249.14 B0= 6356514.97

INPUT FILE= ALL.TRIG

DATE= 1988 12 0

X-SHIFT= -176.79 +/- 8.88

Y-SHIFT= -156.03 +/- 4.22

Z-SHIFT= -265.04 +/- 5.52

COVARIANCE-MATRIX

XSH	YSH	ZSH	XSH	YSH	ZSH	
78.91	36.25	-47.94	XSH	1.000	.966	-.978
36.25	17.83	-22.29	YSH		1.000	-.957
-47.94	-22.29	30.44	ZSH			1.000

POINT	DOPPLER		TRIG.		'L'		'V' (")		'V' (M)	
	LAT	LON	LAT	LON	LAT	LON	LAT	LON	LAT	LON
1 COEGAKOP	33 46 19.23	25 37 15.80	33 46 8.17	25 37 18.18	-11.06	2.38	.186	-.118	5.74	-3.02
2 FRANSMANSKOP	30 53 58.22	24 26 40.24	30 53 47.21	24 26 42.78	-11.01	2.54	.137	-.057	4.24	-1.51
3 INKOMINKULU	29 46 54.46	30 27 39.61	29 46 43.36	30 27 41.44	-11.10	1.83	.099	.157	3.08	4.20
4 KRANZBERG	24 28 23.76	27 35 19.94	24 28 12.74	27 35 21.81	-11.02	1.87	-.097	-.131	-3.01	-3.69
5 LEEUKOP (RSA)	29 18 49.88	26 24 8.16	29 18 38.88	26 24 10.41	-11.00	2.25	.121	-.019	3.75	-.51
6 LUBISI	31 46 41.79	27 29 36.32	31 46 30.74	27 29 38.49	-11.05	2.17	.178	.012	5.49	.31
7 MOOIDAM	27 5 40.49	28 44 9.71	27 5 29.41	28 44 11.59	-11.08	1.88	-.008	-.001	-.25	-.03
8 MORGENZON	27 7 36.79	25 15 24.94	27 7 25.90	25 15 27.19	-10.89	2.25	.128	-.138	3.96	-3.80
9 BLYDEBERG	33 6 12.61	23 11 23.90	33 6 1.52	23 11 26.59	-11.09	2.69	.088	-.157	2.73	-4.07
10 BRIT 44	25 53 11.64	27 40 26.52	25 53 .64	27 40 28.41	-11.00	1.89	-.001	-.119	-.02	-3.31
11 GRASKOP	29 3 13.09	19 56 49.43	29 3 2.11	19 56 52.90	-10.98	3.47	.004	.278	.12	7.51
12 HADIDA	26 56 44.73	21 30 2.44	26 56 34.11	21 30 5.61	-10.62	3.17	.324	.261	10.01	7.20
13 HEXRIVIER	33 23 5.20	19 40 6.41	33 22 53.98	19 40 9.62	-11.22	3.21	-.128	-.175	-3.95	-4.51
14 KARSRIVIER	34 27 5.63	20 6 59.62	34 26 54.41	20 7 2.71	-11.22	3.09	-.092	-.266	-2.86	-6.79
15 LOUISFNTN	31 1 48.96	17 59 38.97	31 1 37.71	17 59 42.59	-11.25	3.62	-.257	.082	-7.94	2.17
16 MAGWAZA	27 41 52.28	32 8 5.69	27 41 41.07	32 8 7.21	-11.21	1.52	-.071	.130	-2.21	3.55
17 MANNERHEIM	25 37 1.43	23 10 21.81	25 36 50.39	23 10 24.35	-11.04	2.54	-.133	-.107	-4.12	-2.99
18 M'PUMBE NEW	24 10 58.05	31 53 45.67	24 10 46.96	31 53 47.09	-11.09	1.42	-.136	.037	-4.22	1.05
19 PONT	22 15 24.48	29 9 45.62	22 15 13.49	29 9 47.23	-10.99	1.61	-.181	-.135	-5.60	-3.87
20 POTLOER	31 2 24.93	21 11 19.59	31 2 13.85	21 11 22.69	-11.08	3.10	-.006	.022	-.19	.59
21 THAMAKOOSH	24 43 39.21	30 2 55.78	24 43 28.16	30 2 57.38	-11.05	1.60	-.087	-.053	-2.70	-1.50
22 WITBANK NEW	28 45 38.29	16 40 1.51	28 45 27.13	16 40 5.61	-11.16	4.10	-.268	.458	-8.30	12.42
23 WITWATER	29 2 31.41	23 1 14.71	29 2 20.51	23 1 17.50	-10.90	2.79	.152	.037	4.71	.99

NOMINAL WEIGHT: LAT= 1.0 LON= 1.0

'BEST-FIT' TRIG. CO-ORD SPHEROID

PROV A0= 6378249.14 B0= 6356514.97

INPUT FILE= ALL.TRIG

DATE= 1988 12 0

X-SHIFT= -164.59 +/- 7.28

Y-SHIFT= -149.14 +/- 3.57

Z-SHIFT= -272.72 +/- 4.59

COVARIANCE-MATRIX

XSH	YSH	ZSH	XSH	YSH	ZSH	
52.99	25.16	-32.74	XSH	1.000	.969	-.979
25.16	12.72	-15.73	YSH		1.000	-.960
-32.74	-15.73	21.10	ZSH			1.000

NOMINAL WEIGHT: LAT= 1.0 LON= 1.0

Handwritten note: ... 10.5 M, ...

- A 93 -

POINT	DOPPLER		TRIG.		'L'		'V' (")		'V' (M)	
	LAT	LON	LAT	LON	LAT	LON	LAT	LON	LAT	LON
1 COEGAKOP	33 46 19.23	25 37 15.80	33 46 8.17	25 37 18.18	-11.06	2.38	.140	-.081	4.34	-2.09
2 FRANSMANSKOP	30 53 58.22	24 26 40.24	30 53 47.21	24 26 42.78	-11.01	2.54	.118	-.011	3.65	-.29
3 INKOMINKULU	29 46 54.46	30 27 39.61	29 46 43.36	30 27 41.44	-11.10	1.83	.090	.147	2.78	3.95
4 KRANZBERG	24 28 23.76	27 35 19.94	24 28 12.74	27 35 21.81	-11.02	1.87	-.059	-.115	-1.82	-3.23
5 LEEUKOP (RSA)	29 18 49.88	26 24 8.16	29 18 38.88	26 24 10.41	-11.00	2.25	.116	.009	3.60	.23
6 LUBISI	31 46 41.79	27 29 36.32	31 46 30.74	27 29 38.49	-11.05	2.17	.150	.030	4.64	.78
7 MOOIDAM	27 5 40.49	28 44 9.71	27 5 29.41	28 44 11.59	-11.08	1.88	.007	.005	.21	.14
8 MORGENZON	27 7 36.79	25 15 24.94	27 7 25.90	25 15 27.19	-10.89	2.25	.143	-.101	4.42	-2.78
9 BLYDEBERG	33 6 12.61	23 11 23.90	33 6 1.52	23 11 26.59	-11.09	2.69	.050	-.098	1.55	-2.54
10 BRIT 44	25 53 11.64	27 40 26.52	25 53 .64	27 40 28.41	-11.00	1.89	.025	-.103	.78	-2.88
11 GRASKOP	29 3 13.09	19 56 49.43	29 3 2.11	19 56 52.90	-10.98	3.47	.004	.363	.12	9.82
12 HEXRIVIER	33 23 5.20	19 40 6.41	33 22 53.98	19 40 9.62	-11.22	3.21	-.166	-.083	-5.14	-2.13
13 KARSRIVIER	34 27 5.63	20 6 59.62	34 26 54.41	20 7 2.71	-11.22	3.09	-.141	-.177	-4.35	-4.52
14 LOUISFNTN	31 1 48.96	17 59 38.97	31 1 37.71	17 59 42.59	-11.25	3.62	-.273	.187	-8.44	4.95
15 MAGWAZA	27 41 52.28	32 8 5.69	27 41 41.07	32 8 7.21	-11.21	1.52	-.062	.106	-1.92	2.89
16 M'PUMBE NEW	24 10 58.05	31 53 45.67	24 10 46.96	31 53 47.09	-11.09	1.42	-.095	.016	-2.94	.45
17 PONT	22 15 24.48	29 9 45.62	22 15 13.49	29 9 47.23	-10.99	1.61	-.123	-.133	-3.80	-3.80
18 POTLOER	31 2 24.93	21 11 19.59	31 2 13.85	21 11 22.69	-11.08	3.10	-.025	.098	-.77	2.60
19 THAMAKOOSH	24 43 39.21	30 2 55.78	24 43 28.16	30 2 57.38	-11.05	1.60	-.051	-.059	-1.59	-1.65
20 WITWATER	29 2 31.41	23 1 14.71	29 2 20.51	23 1 17.50	-10.90	2.79	.151	.095	4.66	2.56

POINT	<i>Exg. Trig</i>				<i>shifted Doppler</i>				VLAT(")	VLON(")	VHGT	VLAT(M)	VLON(M)				
	SHIFTED		DOPPLER		CLARKE 1880		TRIG										
1 BLYDEBERG	33	6	1.523	23	11	26.594	33	6	1.605	23	11	26.643	.082	.049	-2.36	2.54	1.27
2 BRIT 44	25	53	.640	27	40	28.413	25	53	.573	27	40	28.649	-.067	.236	.23	-2.06	6.56
3 COEGAKOP	33	46	8.177	25	37	18.180	33	46	8.199	25	37	18.281	.022	.101	.31	.69	2.59
4 FRANSMANSKOP	30	53	47.215	24	26	42.789	30	53	47.174	24	26	42.801	-.041	.012	.28	-1.27	.33
5 GRASKOP	29	3	2.118	19	56	52.901	29	3	2.109	19	56	52.438	-.009	-.463	-1.08	-.28	-12.50
6 HEXRIVIER	33	22	53.983	19	40	9.627	33	22	54.263	19	40	9.554	.280	-.073	-.42	8.66	-1.88
7 INKOMINKULU	29	46	43.365	30	27	41.448	29	46	43.353	30	27	41.486	-.012	.038	2.79	-.37	1.01
8 KARSRIVIER	34	26	54.411	20	7	2.714	34	26	54.700	20	7	2.739	.289	.025	-.30	8.94	.65
9 KRANZBERG	24	28	12.746	27	35	21.811	24	28	12.717	27	35	22.066	-.029	.255	-.56	-.91	7.17
10 LEEUKOP(RSA)	29	18	38.888	26	24	10.418	29	18	38.813	26	24	10.480	-.075	.062	.98	-2.32	1.66
11 LOUISFNTN	31	1	37.712	17	59	42.597	31	1	38.025	17	59	42.234	.313	-.363	.10	9.66	-9.62
12 LUBISI	31	46	30.747	27	29	38.497	31	46	30.715	27	29	38.552	-.032	.055	.86	-1.00	1.45
13 MAGWAZA	27	41	41.073	32	8	7.211	27	41	41.161	32	8	7.358	.088	.147	2.90	2.73	4.02
14 MOOIDAM	27	5	29.417	28	44	11.594	27	5	29.401	28	44	11.744	-.016	.150	2.12	-.49	4.12
15 MORGENZON	27	7	25.909	25	15	27.191	27	7	25.738	25	15	27.352	-.171	.161	-.13	-5.28	4.43
16 M'PUMBE NEW	24	10	46.968	31	53	47.098	24	10	46.986	31	53	47.319	.018	.221	3.06	.54	6.22
17 PONT	22	15	13.497	29	9	47.232	22	15	13.473	29	9	47.558	-.024	.326	1.09	-.73	9.31
18 POTLOER	31	2	13.854	21	11	22.690	31	2	13.940	21	11	22.509	.086	-.181	-.97	2.64	-4.78
19 THAMAKOOSH	24	43	28.163	30	2	57.387	24	43	28.146	30	2	57.647	-.017	.260	.90	-.52	7.30
20 WITWATER	29	2	20.512	23	1	17.502	29	2	20.381	23	1	17.391	-.131	-.111	-1.16	-4.04	-3.01
21 HADIDA	26	56	34.118	21	30	5.619	26	56	33.724	21	30	5.238	-.394	-.381	1.79	-12.18	-10.48
22 MANNERHEIM	25	36	50.937	23	10	24.354	25	36	50.422	23	10	24.416	-.515	.062	3.49	-15.89	1.74
23 WITBANK NEW	28	45	27.138	16	40	5.618	28	45	27.365	16	40	4.855	.227	-.763	-1.34	7.02	-20.67

X-SHIFT= 133.70

Y-SHIFT= 112.06

Z-SHIFT= 291.79

These shifts applied to geocentric co-ordinates will minimise the 3-D co-ordinate changes from existing published co-ordinates to Doppler co-ordinates.

Reg. Trig. *shifted Doppler*

POINT	SHIFTED-DOPPLER				CLARKE 1880	TRIG				VLAT(")	VLON(")	VHGT	VLAT(M)	VLON(M)				
1	BLYDEBERG	33	6	1.523	23	11	26.594	33	6	1.573	23	11	26.587	.050	-.007	-2.42	1.54	-.18
2	BRIT 44	25	53	.640	27	40	28.413	25	53	.543	27	40	28.596	-.097	.183	.20	-3.01	5.08
3	COEGAKOP	33	46	8.177	25	37	18.180	33	46	8.168	25	37	18.224	-.009	.044	.19	-.28	1.12
4	FRANSMANSKOP	30	53	47.215	24	26	42.789	30	53	47.142	24	26	42.746	-.073	-.043	.23	-2.25	-1.13
5	GRASKOP	29	3	2.118	19	56	52.901	29	3	2.075	19	56	52.386	-.043	-.515	-1.00	-1.32	-13.92
6	HEXRIVIER	33	22	53.983	19	40	9.627	33	22	54.230	19	40	9.499	.247	-.128	-.41	7.61	-3.29
7	INKOMINKULU	29	46	43.365	30	27	41.448	29	46	43.324	30	27	41.430	-.041	-.018	2.63	-1.28	-.49
8	KARSRIVIER	34	26	54.411	20	7	2.714	34	26	54.667	20	7	2.684	.256	-.030	-.31	7.90	-.77
9	KRANZBERG	24	28	12.746	27	35	21.811	24	28	12.686	27	35	22.013	-.060	.202	-.57	-1.86	5.69
10	LEEUKOP(RSA)	29	18	38.888	26	24	10.418	29	18	38.782	26	24	10.425	-.106	.007	.92	-3.28	.19
11	LOUISFNTN	31	1	37.712	17	59	42.597	31	1	37.990	17	59	42.181	.278	-.416	.19	8.60	-11.02
12	LUBISI	31	46	30.747	27	29	38.497	31	46	30.684	27	29	38.496	-.063	-.001	.73	-1.94	-.03
13	MAGWAZA	27	41	41.073	32	8	7.211	27	41	41.133	32	8	7.303	.060	.092	2.73	1.84	2.51
14	MOOIDAM	27	5	29.417	28	44	11.594	27	5	29.371	28	44	11.690	-.046	.096	2.04	-1.43	2.63
15	MORGENZON	27	7	25.909	25	15	27.191	27	7	25.707	25	15	27.299	-.202	.108	-.13	-6.25	2.96
16	M'PUMBE NEW	24	10	46.968	31	53	47.098	24	10	46.956	31	53	47.265	-.012	.167	2.95	-.36	4.72
17	PONT	22	15	13.497	29	9	47.232	22	15	13.443	29	9	47.505	-.054	.273	1.07	-1.66	7.82
18	POTLOER	31	2	13.854	21	11	22.690	31	2	13.906	21	11	22.455	.052	-.235	-.95	1.62	-6.21
19	THAMAKOOSH	24	43	28.163	30	2	57.387	24	43	28.116	30	2	57.594	-.047	.207	.82	-1.44	5.80
20	WITWATER	29	2	20.512	23	1	17.502	29	2	20.349	23	1	17.337	-.163	-.165	-1.14	-5.04	-4.46

X-SHIFT= 134.73

Y-SHIFT= 110.92

Z-SHIFT= 292.66

These shifts applied to geocentric co-ordinates will minimise the 3-D co-ordinate changes from existing published co-ordinates to Doppler co-ordinates.

Points in the N.W. Cape have been excluded from the above list.

FINAL DOPPLER CO-ORDINATES (Mini-Max Solution)
 ===== INCLUDES 0"8 Z-ROT, 4M Z-SHIFT, -.5PPM SCALE

1989 7 4

SEMI MAJOR=	6378249.14	SEMI-MINOR=	6356514.97	X-SHIFT=	+130.68	Y-SHIFT=	+112.42	Z-SHIFT=	+295.74	SHIFTS FROM PUBLISHED CO-ORDS				
	X	Y	Z	LAT	LON	LO	Y	X	Y	X	HT			
BLYDEBERG	4917162.90	2106502.72	-3463953.56	33 06	1.5444 23 11	26.7017	23	-17806.639	3663626.851	-2.79	.67	-3.28		
BRIT 44	5086360.38	2667484.06	-2768214.69	25 53	.4934 27 40	28.7111	27	-67612.977	2863864.805	-8.32	-4.47	1.31		
COEGAKOP	4785788.81	2295151.49	-3525278.06	33 46	8.1390 25 37	18.3442	25	-57598.863	3737925.887	-4.23	-1.15	-4.61		
FRANSMANSKOP	4988029.47	2267368.02	-3256847.81	30 53	47.1073 24 26	42.8608	25	53041.303	3419358.069	-1.89	-3.33	3.72		
GRASKOP	5246210.54	1904000.25	-3079356.77	29 03	2.0396 19 56	52.4888	19	-92323.729	3214991.097	11.13	-2.50	-1.79		
HEXRIVIER	5022031.28	1795050.02	-3490656.90	33 22	54.2050 19 40	9.6067	19	-62283.470	3695007.529	.57	6.84	-2.25		
INKOMINKULU	4776484.34	2809212.05	-3149643.05	29 46	43.2806 30 27	41.5543	31	52070.625	3295444.520	-2.84	-2.61	3.94		
KARSRIVIER	4944244.90	1810979.09	-3587729.71	34 26	54.6445 20 07	2.7935	21	81107.860	3813484.985	-2.09	7.18	-3.76		
KRANZBERG	5149761.51	2690982.25	-2626713.64	24 28	12.6335 27 35	22.1272	27	-59762.989	2707269.696	-8.92	-3.42	-2.51		
LEEUKOP (RSA)	4986765.22	2475721.88	-3104837.61	29 18	38.7415 26 24	10.5416	27	58005.485	3243606.340	-3.31	-4.53	3.65		
LOUISFNTN	5203320.12	1690097.08	-3268801.69	31 01	37.9612 17 59	42.2818	17	-95012.525	3434151.637	8.43	7.60	-4.59		
LUBISI	4815636.21	2506182.66	-3340238.67	31 46	30.6487 27 29	38.6173	27	-46800.663	3516760.713	-3.18	-3.01	4.19		
MAGWAZA	4786098.20	3006405.31	-2946912.44	27 41	41.0836 32 08	7.4279	33	85286.805	3064668.044	-5.95	.28	.83		
MOOIDAM	4983705.32	2732598.93	-2888034.05	27 05	29.3234 28 44	11.8080	29	26122.036	2997552.319	-5.89	-2.89	5.90		
MORGENZON	5138732.45	2424367.64	-2891142.55	27 07	25.6621 25 15	27.4107	25	-25542.188	3001131.763	-6.07	-7.59	1.83		
M' PUMBE NEW PONT	4943053.11	3076329.11	-2596691.59	24 10	46.9001 31 53	47.3863	31	-91097.892	2675261.773	-8.15	-2.04	-5.20		
	5157756.90	2878190.79	-2400772.91	22 15	13.3849 29 09	47.6201	29	-16825.550	2461696.813	-11.12	-3.43	-5.88		
POTLOER	5101244.33	1977515.43	-3270220.74	31 02	13.8746 21 11	22.5633	21	-18101.261	3434847.761	3.36	.63	.66		
THAMAKOOSH	5019241.63	2903592.48	-2652266.05	24 43	28.0628 30 02	57.7122	31	96185.151	2735640.781	-9.12	-3.15	-1.91		
WITWATER	5137508.95	2182963.19	-3078455.04	29 02	20.3108 23 01	17.4466	23	-2095.474	3213335.748	1.50	-6.19	.97		
HADIDA	5294618.60	2085701.67	-2873050.37	26 56	33.6486 21 30	5.2906	21	-49800.335	2981137.242	9.00	-14.48	-2.39		
MANNERHEIM	5291495.88	2264981.24	-2741082.60	25 36	50.3437 23 10	24.4708	23	-17423.696	2833849.480	-3.28	-18.25	-.60		
WITBANK NEW	5360989.00	1605040.21	-3050578.69	28 45	27.2964 16 40	4.8995	17	32423.287	3182194.507	19.48	4.93	-5.69		

- A 97 -

FINAL DOPPLER CO-ORDINATES (Mini-Max Solution)
 ===== INCLUDES 0"8 Z-ROT, 4M Z-SHIFT, -.5PPM SCALE

1989 7 4

SEMI MAJOR=	6378137.00	SEMI-MINOR=	6356752.31	X-SHIFT=	-23.13	Y-SHIFT=	+49.32	Z-SHIFT=	+58.56	SHIFTS FROM PUBLISHED CO-ORDS		
	X	Y	Z	LAT	LON	LO	Y	X	Y	X	HT	
BLYDEBERG	4917162.90	2106502.72	-3463953.56	33 06	.5755 23 11	26.8007	23	-17808.657	3663872.495	-5.41	-29.18	-4.85
BRIT 44	5086360.38	2667484.06	-2768214.69	25 53	.8735 27 40	29.2698	27	-67626.577	2864110.141	-23.81	7.31	1.66
COEGAKOP	4785788.81	2295151.49	-3525278.06	33 46	7.0638 25 37	18.7179	25	-57606.694	3738171.450	-14.05	-34.22	-6.33
FRANSMANSKOP	4988029.47	2267368.02	-3256847.81	30 53	46.5018 24 26	43.0945	25	53033.493	3419603.583	-8.00	-22.01	3.17
GRASKOP	5246210.54	1904000.25	-3079356.77	29 03	1.7743 19 56	52.2361	19	-92314.143	3215236.554	17.90	-10.73	-1.88
HEXRIVIER	5022031.28	1795050.02	-3490656.90	33 22	53.1902 19 40	9.3109	19	-62273.901	3695253.041	8.01	-24.48	-3.83
INKOMINKULU	4776484.34	2809212.05	-3149643.05	29 46	42.8523 30 27	42.4322	31	52045.488	3295689.168	-26.36	-15.91	5.06
KARSRIVIER	4944244.90	1810979.09	-3587729.71	34 26	53.4735 20 07	2.5449	21	81111.677	3813730.651	4.57	-28.85	-6.01
KRANZBERG	5149761.51	2690982.25	-2626713.64	24 28	13.3326 27 35	22.6707	27	-59776.592	2707515.028	-24.13	18.15	-2.59
LEEUKOP (RSA)	4986765.22	2475721.88	-3104837.61	29 18	38.4218 26 24	10.9817	27	57991.880	3243851.662	-15.14	-14.43	3.77
LOUISFNTN	5203320.12	1690097.08	-3268801.69	31 01	37.3267 17 59	41.8107	17	-94997.154	3434396.875	20.75	-12.05	-4.87
LUBISI	4815636.21	2506182.66	-3340238.67	31 46	29.8825 27 29	39.1885	27	-46814.268	3517006.042	-18.32	-26.55	3.80
MAGWAZA	4786098.20	3006405.31	-2946912.44	27 41	41.0531 32 08	8.4637	33	85255.924	3064912.289	-34.32	-.85	2.87
MOOIDAM	4983705.32	2732598.93	-2888034.05	27 05	29.4392 28 44	12.4838	29	26102.657	2997797.388	-24.51	.63	6.69
MORGENZON	5138732.45	2424367.64	-2891142.55	27 07	25.7834 25 15	27.7215	25	-25550.000	3001377.265	-14.62	-3.84	1.89
M'PUMBE NEW PONT	4943053.11	3076329.11	-2596691.59	24 10	47.6452 31 53	48.3676	31	-91123.009	2675506.557	-35.70	21.07	-3.93
	5157756.90	2878190.79	-2400772.91	22 15	14.6082 29 09	48.3133	29	-16844.931	2461941.901	-30.92	34.21	-6.66
POTLOER	5101244.33	1977515.43	-3270220.74	31 02	13.2458 21 11	22.4412	21	-18097.476	3435093.349	6.57	-18.74	-.01
THAMAKOOSH	5019241.63	2903592.48	-2652266.05	24 43	28.6924 30 02	58.5090	31	96160.010	2735885.551	-31.65	16.07	-1.17
WITWATER HADIDA	5137508.95	2182963.19	-3078455.04	29 02	20.0497 23 01	17.5233	23	-2097.488	3213581.335	-.58	-14.23	.76
	5294618.60	2085701.67	-2873050.37	26 56	33.8109 21 30	5.2060	21	-49796.548	2981382.808	11.35	-9.50	-2.53
MANNERHEIM	5291495.88	2264981.24	-2741082.60	25 36	50.7934 23 10	24.5611	23	-17425.711	2834095.053	-5.78	-4.41	-.95
WITBANK NEW	5360989.00	1605040.21	-3050578.69	28 45	27.0776 16 40	4.2975	17	32438.657	3182439.754	35.83	-1.76	-5.16

- A 98 -

MOLODENSKY-BADEKAS TRANSFORMATION

MOLBAD. TRIG

POINT	WEIGHT	PUBLISHED TRIG CO-ORDINATES (CAPE DATUM)			WGS'84 DOPPLER DERIVED CO-ORDINATES		
		X	Y	Z	X	Y	Z
BLYDEBERG		4917300.194	2106614.934	-3463660.933	4917162.901	2106502.718	-3463953.558
BRIT 44		5086496.161	2667589.782	-2767924.642	5086360.381	2667484.064	-2768214.686
COEGAKOP		4785923.750	2295261.268	-3524985.524	4785788.805	2295151.494	-3525278.057
FRANSMANSKOP		4988162.505	2267479.415	-3256556.956	4988029.472	2267368.022	-3256847.812
GRASKOP		5246340.776	1904124.373	-3079065.769	5246210.542	1904000.246	-3079356.770
HADIDA		5294745.605	2085822.380	-2872770.638	5294618.603	2085701.672	-2873050.373
HEXRIVIER		5022169.159	1795165.571	-3490358.120	5022031.277	1795050.020	-3490656.905
INKOMINKULU		4776616.308	2809321.915	-3149350.191	4776484.336	2809212.051	-3149643.045
KARSRIVIER		4944383.796	1811092.357	-3587430.728	4944244.904	1810979.091	-3587729.706
KRANZBERG		5149898.662	2691088.002	-2626422.901	5149761.508	2690982.248	-2626713.637
LEEUKOP (RSA)		4986897.884	2475831.561	-3104547.350	4986765.225	2475721.883	-3104837.608
LOUISFONTEIN		5203455.487	1690219.814	-3268501.584	5203320.123	1690097.076	-3268801.686
LUBISI		4815769.474	2506292.856	-3339947.267	4815636.212	2506182.664	-3340238.670
MAGWAZA		4786232.946	3006513.265	-2946616.885	4786098.167	3006405.330	-2946912.477
MANNERHEIM		5291623.406	2265088.764	-2740804.789	5291495.880	2264981.241	-2741082.599
MOOIDAM		4983839.156	2732706.355	-2887741.727	4983705.320	2732598.933	-2888034.046
MORGENZON		5138865.981	2424474.714	-2890855.493	5138732.448	2424367.638	-2891142.554
M'PUMBE NEW		4943187.938	3076434.526	-2596398.053	4943053.107	3076329.714	-2596691.592
PONT		5157894.033	2878294.085	-2400481.374	5157756.898	2878190.785	-2400772.910
POTLOER		5101378.348	1977632.749	-3269927.188	5101244.330	1977515.426	-3270220.745
THAMAKOOSH		5019378.108	2903697.692	-2651974.346	5019241.629	2903592.475	-2652266.054
WITBANK NEW		5361120.581	1605173.249	-3050281.099	5360989.004	1605040.210	-3050578.695
WITWATER		5137640.613	2183077.658	-3078167.325	5137508.955	2182963.194	-3078455.041

7 parameters.

DOPPLER DERIVED CO-ORDINATES
TRANSFORMED TRIG CO-ORDINATES

				VX	VY	VZ	VLAT	VLON	VHGT	LX	LY	LZ
BLYDEBERG	4917162.901	2106502.718	-3463953.558									
	4917165.156	2106499.773	-3463957.193	-2.26	2.95	3.63	2.56	3.59	-2.75	-137.29	-112.22	-292.63
BRIT 44	5086360.381	2667484.064	-2768214.686									
	5086362.853	2667481.465	-2768213.657	-2.47	2.60	-1.03	-1.36	3.45	-.43	-135.78	-105.72	-290.04
COEGAKOP	4785788.805	2295151.494	-3525278.057									
	4785788.044	2295148.523	-3525283.155	.76	2.97	5.10	5.35	2.35	-1.20	-134.95	-109.77	-292.53
FRANSMANSKOP	4988029.472	2267368.022	-3256847.812									
	4988028.189	2267366.156	-3256850.990	1.28	1.87	3.18	3.74	1.17	.03	-133.03	-111.39	-290.86
GRASKOP	5246210.542	1904000.246	-3079356.770									
	5246207.635	1904006.545	-3079356.489	2.91	-6.30	-.28	.04	-6.91	.65	-130.23	-124.13	-291.00
HADIDA	5294618.603	2085701.672	-2873050.373									
	5294613.008	2085706.757	-2873059.241	5.60	-5.09	8.87	9.46	-6.78	-1.04	-127.00	-120.71	-279.73
HEXRIVIER	5022031.277	1795050.020	-3490656.905									
	5022034.345	1795046.570	-3490653.852	-3.07	3.45	-3.05	-3.51	4.28	.24	-137.88	-115.55	-298.78
INKOMINKULU	4776484.336	2809212.051	-3149643.045									
	4776481.109	2809215.534	-3149644.553	3.23	-3.48	1.51	1.82	-4.63	.13	-131.97	-109.86	-292.85
KARSRIVIER	4944244.904	1810979.091	-3587729.706									
	4944248.446	1810973.622	-3587727.784	-3.54	5.47	-1.92	-2.41	6.35	-.10	-138.89	-113.27	-298.98
KRANZBERG	5149761.508	2690982.248	-2626713.637									
	5149765.732	2690979.978	-2626710.207	-4.22	2.27	-3.43	-4.26	3.96	-1.03	-137.15	-105.75	-290.74
LEEUKOP(RSA)	4986765.225	2475721.883	-3104837.608									
	4986763.802	2475720.873	-3104840.055	1.42	1.01	2.45	2.99	.27	.30	-132.66	-109.68	-290.26
LOUISFONTEIN	5203320.123	1690097.076	-3268801.686									
	5203321.711	1690099.434	-3268794.164	-1.59	-2.36	-7.52	-7.63	-1.75	1.96	-135.36	-122.74	-300.10

7 parameters.

DOPPLER DERIVED CO-ORDINATES
TRANSFORMED TRIG CO-ORDINATES

				VX	VY	VZ	VLAT	VLON	VHGT	LX	LY	LZ
LUBISI	4815636.212	2506182.664	-3340238.670									
	4815634.262	2506182.666	-3340243.119	1.95	.00	4.45	4.71	-.90	-.87	-133.26	-110.19	-291.40
MAGWAZA	4786098.167	3006405.330	-2946912.477									
	4786097.921	3006409.382	-2946909.305	.25	-4.05	-3.17	-3.73	-3.56	-.25	-134.78	-107.93	-295.59
MANNERHEIM	5291495.880	2264981.241	-2741082.599									
	5291490.984	2264975.362	-2741092.241	4.90	5.88	9.64	11.69	3.48	1.98	-127.53	-107.52	-277.81
MOOIDAM	4983705.320	2732598.933	-2888034.046									
	4983705.262	2732598.892	-2888032.471	.06	.04	-1.57	-1.38	.01	.78	-133.84	-107.42	-292.32
MORGENZON	5138732.448	2424367.638	-2891142.554									
	5138732.810	2424363.323	-2891145.311	-.36	4.32	2.76	3.16	4.05	.09	-133.53	-107.08	-287.06
M'PUMBE NEW	4943053.107	3076329.714	-2596691.592									
	4943053.887	3076331.498	-2596686.264	-.78	-1.78	-5.33	-5.55	-1.10	.72	-134.83	-104.81	-293.54
PONT	5157756.898	2878190.785	-2400772.910									
	5157761.161	2878188.492	-2400766.468	-4.26	2.29	-6.44	-6.98	4.08	.03	-137.14	-103.30	-291.54
POTLOER	5101244.330	1977515.426	-3270220.745									
	5101244.381	1977515.885	-3270220.560	-.05	-.46	-.19	-.27	-.41	-.09	-134.02	-117.32	-293.56
THAMAKOOSH	5019241.629	2903592.475	-2652266.054									
	5019244.497	2903592.407	-2652262.665	-2.87	.07	-3.39	-4.12	1.49	-.81	-136.48	-105.22	-291.71
WITBANK NEW	5360989.004	1605040.210	-3050578.695									
	5360987.657	1605051.781	-3050570.669	1.35	-11.57	-8.03	-8.05	-11.46	2.08	-131.58	-133.04	-297.60
WITWATER	5137508.955	2182963.194	-3078455.041									
	5137507.174	2182963.278	-3078458.815	1.78	-.08	3.77	4.10	-.77	-.43	-131.66	-114.46	-287.72

- A 101 -

7 parameters

COVARIANCE-MATRIX

MOLBAD.TRIG

	SCALE	Z-ROT	Y-ROT	X-ROT	X-SH	Y-SH	Z-SH
SCALE	.23E-11	-.76E-34	.00E+00	.64E-34	-.31E-09	-.26E-09	-.68E-09
Z-ROT	-.76E-34	.48E-11	.32E-11	-.41E-13	.41E-09	.65E-09	-.44E-09
Y-ROT	.00E+00	.32E-11	.80E-11	-.71E-12	.20E-08	.64E-09	-.12E-08
X-ROT	.64E-34	-.41E-13	-.71E-12	.26E-11	-.20E-09	-.78E-09	.39E-09
X-SH	-.31E-09	.41E-09	.20E-08	-.20E-09	.74E+00	.15E-06	-.20E-06
Y-SH	-.26E-09	.65E-09	.64E-09	-.78E-09	.15E-06	.74E+00	-.96E-07
Z-SH	-.68E-09	-.44E-09	-.12E-08	.39E-09	-.20E-06	-.96E-07	.74E+00

CORRELATION MATRIX

	SCALE	Z-ROT	Y-ROT	X-ROT	X-SH	Y-SH	Z-SH
SCALE	1.00	.00	.00	.00	.00	.00	.00
Z-ROT	.00	1.00	.52	-.01	.00	.00	.00
Y-ROT	.00	.52	1.00	-.15	.00	.00	.00
X-ROT	.00	-.01	-.15	1.00	.00	.00	.00
X-SH	.00	.00	.00	.00	1.00	.00	.00
Y-SH	.00	.00	.00	.00	.00	1.00	.00
Z-SH	.00	.00	.00	.00	.00	.00	1.00

DOPPLER DERIVED CO-ORDINATES
 TRANSFORMED TRIG CO-ORDINATES

*4 parameters
 (3 shifts + scale)*

				VX	VY	VZ	VLAT	VLON	VHGT	LX	LY	LZ
BLYDEBERG	4917162.901	2106502.718	-3463953.558									
	4917164.778	2106500.049	-3463957.237	-1.88	2.67	3.68	2.72	3.19	-2.57	-137.29	-112.22	-292.63
BRIT 44	5086360.381	2667484.064	-2768214.686									
	5086362.621	2667481.116	-2768213.233	-2.24	2.95	-1.45	-1.58	3.65	.08	-135.78	-105.72	-290.04
COEGAKOP	4785788.805	2295151.494	-3525278.057									
	4785786.878	2295148.474	-3525282.508	1.93	3.02	4.45	5.41	1.89	.06	-134.95	-109.77	-292.53
FRANSMANSKOP	4988029.472	2267368.022	-3256847.812									
	4988027.875	2267366.313	-3256850.964	1.60	1.71	3.15	3.83	.89	.24	-133.03	-111.39	-290.86
GRASKOP	5246210.542	1904000.246	-3079356.770									
	5246209.008	1904007.243	-3079357.809	1.53	-7.00	1.04	.45	-7.09	-1.33	-130.23	-124.13	-291.00
HADIDA	5294618.603	2085701.672	-2873050.373									
	5294614.374	2085707.264	-2873060.391	4.23	-5.59	10.02	9.83	-6.75	-2.86	-127.00	-120.71	-279.73
HEXRIVIER	5022031.277	1795050.020	-3490656.905									
	5022034.906	1795047.233	-3490654.720	-3.63	2.79	-2.19	-3.20	3.84	-.87	-137.88	-115.55	-298.78
INKOMINKULU	4776484.336	2809212.051	-3149643.045									
	4776479.333	2809214.820	-3149643.010	5.00	-2.77	-.03	1.42	-4.92	2.54	-131.97	-109.86	-292.85
KARSRIVIER	4944244.904	1810979.091	-3587729.706									
	4944248.680	1810974.196	-3587728.404	-3.78	4.90	-1.30	-2.13	5.89	-.80	-138.89	-113.27	-298.98
KRANZBERG	5149761.508	2690982.248	-2626713.637									
	5149765.825	2690979.597	-2626709.923	-4.32	2.65	-3.71	-4.48	4.35	-.83	-137.15	-105.75	-290.74
LEEUKOP (RSA)	4986765.225	2475721.883	-3104837.608									
	4986763.240	2475720.769	-3104839.673	1.99	1.11	2.06	2.93	.11	.97	-132.66	-109.68	-290.26

4 parameters

DOPPLER DERIVED CO-ORDINATES
TRANSFORMED TRIG CO-ORDINATES

				VX	VY	VZ	VLAT	VLON	VHGT	LX	LY	LZ
LOUISFONTEIN	5203320.123	1690097.076	-3268801.686									
	5203323.244	1690100.312	-3268795.724	-3.12	-3.24	-5.96	-7.18	-2.11	-.33	-135.36	-122.74	-300.10
LUBISI	4815636.212	2506182.664	-3340238.670									
	4815632.933	2506182.402	-3340242.199	3.28	.26	3.53	4.61	-1.28	.72	-133.26	-110.19	-291.40
MAGWAZA	4786098.167	3006405.330	-2946912.477									
	4786096.077	3006408.357	-2946907.457	2.09	-3.03	-5.02	-4.39	-3.67	2.47	-134.78	-107.93	-295.59
MANNERHEIM	5291495.880	2264981.241	-2741082.599									
	5291492.140	2264975.636	-2741093.079	3.74	5.61	10.48	11.95	3.68	.56	-127.53	-107.52	-277.81
MOOIDAM	4983705.320	2732598.933	-2888034.046									
	4983704.478	2732598.411	-2888031.646	.84	.52	-2.40	-1.69	.05	1.97	-133.84	-107.42	-292.32
MORGENZON	5138732.448	2424367.638	-2891142.554									
	5138733.022	2424363.353	-2891145.446	-.57	4.29	2.89	3.19	4.12	-.15	-133.53	-107.08	-287.06
M'PUMBE NEW	4943053.107	3076329.714	-2596691.592									
	4943052.809	3076330.393	-2596684.742	.30	-.68	-6.85	-6.32	-.73	2.71	-134.83	-104.81	-293.54
PONT	5157756.898	2878190.785	-2400772.910									
	5157761.285	2878187.755	-2400765.891	-4.39	3.03	-7.02	-7.43	4.78	.48	-137.14	-103.30	-291.54
POTLOER	5101244.330	1977515.426	-3270220.745									
	5101244.973	1977516.434	-3270221.344	-.64	-1.01	.60	.02	-.71	-1.13	-134.02	-117.32	-293.56
THAMAKOOSH	5019241.629	2903592.475	-2652266.054									
	5019243.824	2903591.644	-2652261.651	-2.19	.83	-4.40	-4.64	1.82	.49	-136.48	-105.22	-291.71
WITBANK NEW	5360989.004	1605040.210	-3050578.695									
	5360990.086	1605052.805	-3050572.820	-1.08	-12.59	-5.88	-7.42	-11.75	-1.25	-131.58	-133.04	-297.60
WITWATER	5137508.955	2182963.194	-3078455.041									
	5137507.640	2182963.621	-3078459.355	1.31	-.43	4.31	4.30	-.91	-1.18	-131.66	-114.46	-287.72

THE FOLLOWING PARAMETERS ARE FOR TRANSFORMING
FROM TRIG (CAPE DATUM) TO CTS (WGS'84)

X-SHIFT= -133.951 Y-SHIFT= -112.136 Z-SHIFT= -291.670
+/- .862 +/- .862 +/- .862

X-ROT(")= +.000 Y-ROT(")= +.000 Z-ROT(")= +.000
FIXED FIXED FIXED

SCALE= +11.0865 PPM +/- 1.535

TRANSFORMATION MATRIX (SCALE & ROTATIONS)
ABOUT CENTRE OF GRAVITY OF 23 POINTS

1.00001108650	.00000000000	.00000000000
.00000000000	1.00001108650	.00000000000
.00000000000	.00000000000	1.00001108650

CENTRE OF ROTATION X: 5049401.740
 Y: 2354626.878
 Z: -3045716.488

4 parameters.

COVARIANCE-MATRIX

MOLBAD. TRIG

	SCALE	Z-ROT	Y-ROT	X-ROT	X-SH	Y-SH	Z-SH
SCALE	.24E-11	.33E-51	.00E+00	.46E-49	-.32E-09	-.26E-09	-.69E-09
Z-ROT	.33E-51	.35E-26	.24E-41	.24E-42	-.39E-24	.47E-24	-.29E-39
Y-ROT	.00E+00	.24E-41	.57E-26	-.66E-42	.17E-23	.51E-39	-.76E-24
X-ROT	.46E-49	.24E-42	-.66E-42	.26E-26	-.22E-39	-.75E-24	.29E-24
X-SH	-.32E-09	-.39E-24	.17E-23	-.22E-39	.74E+00	.35E-07	.92E-07
Y-SH	-.26E-09	.47E-24	.51E-39	-.75E-24	.35E-07	.74E+00	.77E-07
Z-SH	-.69E-09	-.29E-39	-.76E-24	.29E-24	.92E-07	.77E-07	.74E+00

CORRELATION MATRIX

	SCALE	Z-ROT	Y-ROT	X-ROT	X-SH	Y-SH	Z-SH
SCALE	1.00	.00	.00	.00	.00	.00	.00
Z-ROT	.00	1.00	.00	.00	.00	.00	.00
Y-ROT	.00	.00	1.00	.00	.00	.00	.00
X-ROT	.00	.00	.00	1.00	.00	.00	.00
X-SH	.00	.00	.00	.00	1.00	.00	.00
Y-SH	.00	.00	.00	.00	.00	1.00	.00
Z-SH	.00	.00	.00	.00	.00	.00	1.00

3 parameters.
(X, Y, Z - shift.)

DOPPLER DERIVED CO-ORDINATES
TRANSFORMED TRIG CO-ORDINATES

				VX	VY	VZ	VLAT	VLON	VHGT	LX	LY	LZ
BLYDEBERG	4917162.901	2106502.718	-3463953.558									
	4917166.244	2106502.800	-3463952.600	-3.34	-.08	-.96	-2.51	1.24	-2.08	-137.29-112.22-292.63		
BRIT 44	5086360.381	2667484.064	-2768214.686									
	5086362.211	2667477.648	-2768216.309	-1.83	6.42	1.62	2.06	6.53	.51	-135.78-105.72-290.04		
COEGAKOP	4785788.805	2295151.494	-3525278.057									
	4785789.800	2295149.134	-3525277.191	-1.00	2.36	-.87	-.65	2.56	.58	-134.95-109.77-292.53		
FRANSMANSKOP	4988029.472	2267368.022	-3256847.812									
	4988028.555	2267367.281	-3256848.623	.92	.74	.81	1.29	.30	.56	-133.03-111.39-290.86		
GRASKOP	5246210.542	1904000.246	-3079356.770									
	5246206.826	1904012.239	-3079357.436	3.72	-11.99	.67	.29	-12.53	-.85	-130.23-124.13-291.00		
HADIDA	5294618.603	2085701.672	-2873050.373									
	5294611.655	2085710.246	-2873062.305	6.95	-8.57	11.93	12.20	-10.51	-2.45	-127.00-120.71-279.73		
HEXRIVIER	5022031.277	1795050.020	-3490656.905									
	5022035.209	1795053.437	-3490649.787	-3.93	-3.42	-7.12	-8.64	-1.89	-.14	-137.88-115.55-298.78		
INKOMINKULU	4776484.336	2809212.051	-3149643.045									
	4776482.358	2809209.781	-3149641.858	1.98	2.27	-1.19	.39	.95	3.07	-131.97-109.86-292.85		
KARSRIVIER	4944244.904	1810979.091	-3587729.706									
	4944249.846	1810980.223	-3587722.395	-4.94	-1.13	-7.31	-8.90	.64	-.01	-138.89-113.27-298.98		
KRANZBERG	5149761.508	2690982.248	-2626713.637									
	5149764.712	2690975.868	-2626714.568	-3.20	6.38	.93	.90	7.13	-.28	-137.15-105.75-290.74		
LEEUKOP (RSA)	4986765.225	2475721.883	-3104837.608									
	4986763.934	2475719.427	-3104839.017	1.29	2.46	1.41	2.34	1.62	1.27	-132.66-109.68-290.26		
LOUISFONTEIN	5203320.123	1690097.076	-3268801.686									
	5203321.537	1690107.680	-3268793.251	-1.41	-10.60	-8.43	-9.65	-9.64	.39	-135.36-122.74-300.10		

3 parameters.

DOPPLER DERIVED CO-ORDINATES
TRANSFORMED TRIG CO-ORDINATES

				VX	VY	VZ	VLAT	VLON	VHGT	LX	LY	LZ
LUBISI	4815636.212	2506182.664	-3340238.670									
	4815635.524	2506180.722	-3340238.934	.69	1.94	.26	1.02	1.40	1.14	-133.26	-110.19	-291.40
MAGWAZA	4786098.167	3006405.330	-2946912.477									
	4786098.996	3006401.131	-2946908.552	-.83	4.20	-3.92	-2.78	3.99	3.18	-134.78	-107.93	-295.59
MANNERHEIM	5291495.880	2264981.241	-2741082.599									
	5291489.456	2264976.630	-2741096.456	6.42	4.61	13.86	15.91	1.71	.97	-127.53	-107.52	-277.81
MOOIDAM	4983705.320	2732598.933	-2888034.046									
	4983705.206	2732594.221	-2888033.394	.11	4.71	-.65	.50	4.07	2.40	-133.84	-107.42	-292.32
MORGENZON	5138732.448	2424367.638	-2891142.554									
	5138732.031	2424362.580	-2891147.160	.42	5.06	4.61	5.28	4.39	.16	-133.53	-107.08	-287.06
M'PUMBE NEW	4943053.107	3076329.714	-2596691.592									
	4943053.988	3076322.392	-2596689.720	-.88	7.32	-1.87	-.43	6.68	3.61	-134.83	-104.81	-293.54
PONT	5157756.898	2878190.785	-2400772.910									
	5157760.083	2878181.951	-2400773.041	-3.19	8.83	.13	.70	9.26	1.36	-137.14	-103.30	-291.54
POTLOER	5101244.330	1977515.426	-3270220.745									
	5101244.398	1977520.615	-3270218.855	-.07	-5.19	-1.89	-2.63	-4.81	-.69	-134.02	-117.32	-293.56
THAMAKOOSH	5019241.629	2903592.475	-2652266.054									
	5019244.158	2903585.558	-2652266.013	-2.53	6.92	-.04	.50	7.25	1.17	-136.48	-105.22	-291.71
WITBANK NEW	5360989.004	1605040.210	-3050578.695									
	5360986.631	1605061.115	-3050572.766	2.37	-20.90	-5.93	-7.02	-20.69	-.41	-131.58	-133.04	-297.60
WITWATER	5137508.955	2182963.194	-3078455.041									
	5137506.663	2182965.524	-3078458.992	2.29	-2.33	3.95	4.05	-3.04	-.87	-131.66	-114.46	-287.72

THE FOLLOWING PARAMETERS ARE FOR TRANSFORMING
FROM TRIG (CAPE DATUM) TO CTS (WGS'84)

X-SHIFT= -133.950 Y-SHIFT= -112.134 Z-SHIFT= -291.667
+/- 1.149 +/- 1.149 +/- 1.149

X-ROT(")= +.000 Y-ROT(")= +.000 Z-ROT(")= +.000
FIXED FIXED FIXED

SCALE= +.0000 PPM FIXED

TRANSFORMATION MATRIX (SCALE & ROTATIONS)
ABOUT CENTRE OF GRAVITY OF 23 POINTS

1.0000000000	.0000000000	.0000000000
.0000000000	1.0000000000	.0000000000
.0000000000	.0000000000	1.0000000000

CENTRE OF ROTATION X: 5049401.740
 Y: 2354626.878
 Z: -3045716.488

3 parameters
(X, Y, Z shift)

COVARIANCE-MATRIX

MOLBAD.TRIG

	SCALE	Z-ROT	Y-ROT	X-ROT	X-SH	Y-SH	Z-SH
SCALE	.42E-26	-.68E-64	-.18E-64	.72E-64	-.56E-24	-.47E-24	-.12E-23
Z-ROT	-.68E-64	.62E-26	.42E-41	.43E-42	-.69E-24	.83E-24	-.51E-39
Y-ROT	-.18E-64	.42E-41	.10E-25	-.12E-41	.30E-23	.90E-39	-.14E-23
X-ROT	.72E-64	.43E-42	-.12E-41	.46E-26	-.39E-39	-.13E-23	.51E-24
X-SH	-.56E-24	-.69E-24	.30E-23	-.39E-39	.13E+01	-.30E-22	-.23E-21
Y-SH	-.47E-24	.83E-24	.90E-39	-.13E-23	-.30E-22	.13E+01	-.13E-22
Z-SH	-.12E-23	-.51E-39	-.14E-23	.51E-24	-.23E-21	-.13E-22	.13E+01

- A 111 -

CORRELATION MATRIX

	SCALE	Z-ROT	Y-ROT	X-ROT	X-SH	Y-SH	Z-SH
SCALE	1.00	.00	.00	.00	.00	.00	.00
Z-ROT	.00	1.00	.00	.00	.00	.00	.00
Y-ROT	.00	.00	1.00	.00	.00	.00	.00
X-ROT	.00	.00	.00	1.00	.00	.00	.00
X-SH	.00	.00	.00	.00	1.00	.00	.00
Y-SH	.00	.00	.00	.00	.00	1.00	.00

APPENDIX B: COMPUTER PROGRAMS

THE FOLLOWING PROGRAMS HAVE BEEN WRITTEN IN FORTRAN F77.

THEY HAVE ALL BEEN SUCCESSFULLY COMPILED AND RUN ON A
DATA GENERAL MV-4000 COMPUTER WITH 4 MEGABYTES OF RAM.

INDEX TO PROGRAMS

denotes subroutine

		Pg
AVERAGE	Weights Doppler nets according to number of passes and computes weighted mean of all B.E. co-ordinates and maximum variation (spread) of these co-ordinates	B 1
SHIFTZ	Combines Doppler subnets rigorously using GEODOP covariance matrix. Option of adding augmentation constant to diagonal terms.	3
PARA7	Combines Doppler subnets by allowing each subnet 7 degrees of freedom.	8
SHIFT_R	Combines Doppler subnets by allowing each subnet 3 shifts and a single rotation.	13
SHIFT_S	Combines Doppler subnets by allowing each subnet 3 shifts and a scale factor.	18
SHIFT3	Combines Doppler subnets by allowing each subnet 3 shifts.	23
SHIFT_F	Free net combination of subnets allowing each subnet 3 shifts.	28
BURSA	Bursa-Wolf model for transforming from one 3-D system to another.	34
MOLBAD	Molodensky-Badekas model. This program and Bursa have option to constrain any of the 7 parameters. Also has option of weight matrices.	37
FINAL	Doppler network unification using a combination of SHIFT_F and MOLBAD. (Summarised in 4.12)	42
#EIGEN3	Computes Eigen value of a 3*3 matrix.	48
#NEWTON	Iterative soln of cubic equation by Newton's method.	48
#COVAR	Transforms co-variance matrix in X,Y,Z into co-variances in Lat,Lon,Hgt	49
#JACOBIAN	Numerical differentiation of Lat,Lon,Height with respect to X,Y,Z to form Jacobian matrix.	49
#ROTV	Transforms errors in X,Y,Z to errors in Lat,Lon,Hgt	50
#GEOGRAPH	Transforms Geocentric Cartesian co-ordinates to Geographical co-ordinates and ellipsoidal height.	51
#GEOCEN	Reverse transformation of GEOGRAPH	51

ELLIPSOID	Computes ellipsoid so as to minimise geoidal separation (by least squares). Up to 7 parameters may be allowed to vary.	B 52
ASTROSP	Computes ellipsoid so as to minimise vertical deflections. Published geodetic co-ordinates have also been substituted for observed astro. co-ords.	57
#VARDIS	Computes mse of chord distances from GEODOP co-variance matrix.	61
#INVERSE	Choleski inverse of Positive Definite Symmetrical matrix	63
#MATMUL	Matrix multiplication.	63
#DMS	Converts radians to degrees, minutes, seconds.	64
#GLOBAL	Uses Chi-squared test on null hypothesis.	64
#BE_PE	Transforms co-ordinates in Broadcast Ephemeris system to precise ephemeris system using significant parameters determined by MOLBAD.	65
QFINAL	Reads X,Y,Z co-ordinates and accompanying 108*108 co-variance matrix and transforms to co-variance in Lat,Lon,Ht. Latitude and longitude co-variances are written to another file for further processing.	66
#RDDOP	Reads GEODOP co-ordinates and covariance matrices from appropriate files, adds 'augmentation constant' (if applicable) and inverts covariance matrix to give weight matrix.	67

DOPPLER:AVERAGE.F77

```

C   AVERAGE..COMBINES DOPPLER NETWORKS BY SIMPLY TAKING THE WEIGHTED
C   (ACCORDING TO NO OF PASSES) MEAN.
C   RESULTS WILL BE USED AS PROVISIONAL (B.E.) CO-ORDINATES
C   FOR FREE NETWORK ADJUSTMENT (SHIFTF)

      IMPLICIT REAL*8(A-H,O-Z)
      DIMENSION FCORD(40,3),PCORD(40,3),ATPL(240),SPREAD(40,3),
*     OCG(3), QMAT(15,15),JPASS(50,7),
*     OBCORD(5,3),NOBS(40),RCORD(40,3,7),ISTAT(40),ISTA(5)
      CHARACTER*12 NAME(40),RUNFILE,POINT,QFILE
      CHARACTER*8 TNAME(40)
      DO 2 I=1,40
      NOBS(I)=0
      DO 2 J=1,3
      DO 2 K=1,7
2     RCORD(I,J,K)=0.D0
      DATA GF,SMJ,SMN /1.D0,6378137.D0,6356752.314D0/
      PRINT*,' INPUT FILE= :DPG0:FIELD:DOPPLER:DOPRUN.'
      READ(5,'(A)') RUNFILE
      OPEN(14,FILE=' :DPG0:FIELD:DOPPLER:DOPRUN.55',FORM='FORMATTED')
      OPEN(15,FILE=' :DPG0:FIELD:DOPPLER:DOPRUN.'//RUNFILE,
*     FORM='FORMATTED',PAD='YES',RECFM='DS',BLANK='ZERO')
      CALL PRINTER
      WRITE(6,905)
905  FORMAT(' ',5X,'POINT',9X,'N/SBNETS',10X,'X   SPREAD',
*7X,'Y   SPREAD',7X,'Z   SPREAD',4X,'AVERAGE',/)
900  FORMAT(A12,3F12.3,I5,1X,I5,I2,I7)
      IP=0
100  READ(15,900) POINT,X,Y,Z,IDS,IBN,II
      IF(X.EQ.0.D0.AND.Y.EQ.0.D0.AND.Z.EQ.0.D0) GO TO 200
      IP=IP+1
      NAME(IP)=POINT
      PCORD(IP,1)=X
      PCORD(IP,2)=Y
      PCORD(IP,3)=Z
      ISTAT(IP)=IDS*100000+IBN
      GO TO 100
200  NP=IP
      ITRN=0
1000 READ(15,'(A12)',END=3000) QFILE
      IF(QFILE(1:6).EQ.' ') GO TO 3000
      ITRN=ITRN+1
      TNAME(ITRN)= QFILE(6:12)
      OPEN(20+ITRN,FILE=' :DPG0:FIELD:DOPPLER:'//QFILE,
*     FORM='FORMATTED',RECFM='DS',PAD='YES',BLANK='ZERO')
      CALL RDDOP(20+ITRN,NSTA,NPASS,QMAT,OBCORD,ISTA,OCG,GF)

C   DETERMINE COMPUTER NOS. FROM DEG SQ & BCN NOS.

      DO 1100 I=1,NSTA
      DO 1110 J=1,NP
      IF(ISTAT(J).EQ.ISTA(I)) THEN
      ISTAT(I)=J
      GO TO 1100
      END IF
1110  CONTINUE
      WRITE(10,*) '<BEL> NO PROVISION FOR ',ISTA(I)
1100  CONTINUE
      DO 1500 I=1,NSTA
      NOBS(ISTA(I))=NOBS(ISTA(I))+1
      JPASS(ISTA(I),NOBS(ISTA(I)))=NPASS

```

```

      DO 1500 J=1,3
1500   RCORD(ISTA(I),J,NOBS(ISTA(I)))=OBCORD(I,J)

      GO TO 1000
3000   CONTINUE

C     FIND 'SPREADS'

      DO 3010 I=1,NP
      DO 3010 J=1,3
          AMIN= 1.D8
          AMAX=-1.D8
          TOTPASS=0.D0
          SUM=0.D0
          DO 3030 K=1,7
              IF (RCORD(I,J,K).NE.0.D0) THEN
                  VQ=RCORD(I,J,K)
                  TOTPASS=TOTPASS+JPASS(I,K)
                  SUM=SUM+VQ*JPASS(I,K)
                  IF (VQ.GT.AMAX) AMAX=VQ
                  IF (VQ.LT.AMIN) AMIN=VQ
              END IF
          END IF
3030   CONTINUE
          SPREAD(I,J)=AMAX-AMIN
3010   FCORD(I,J)=SUM/TOTPASS
      DO 4000 I=1,NP
          IF((I/3)*3.EQ.I) WRITE(6,(' '))
          IDS=ISTAT(I)/100000
          IBN=ISTAT(I)-IDS*100000
          WRITE(14,915) NAME(I), (FCORD(I,J),J=1,3),IDS,IBN,0
4000   WRITE(6,910) NAME(I),NOBS(I),FCORD(I,1),SPREAD(I,1),
          *                                     FCORD(I,2),SPREAD(I,2),
          *                                     FCORD(I,3),SPREAD(I,3)
910   FORMAT(' ',5X,A12,2X,I4,7X,3(F13.2,F6.2))
          STOP
915   FORMAT(' ',A12,3F12.3,I5,'.',I5.5,I2,I7)
          END

```

^DOPPLER:SHIFTZ.F77

```
C   SHIFTZ...COMBINES DOPPLER NETWORKS USING ENTIRE VAR/COVAR MATRIX
C   OUTPUT FROM GEODOP.
C   SEQUENTIAL ADJUSTMENT (GEODOP IS THE FIRST 'PHASE')
C   PROVISIONAL DATA READ FROM DOPRUN.##
C   GEODOP DATA READ FROM GDOP.185####
```

```
      IMPLICIT REAL*8(A-H,O-Z)
      DIMENSION FCORD(40,3),PCORD(40,3),ATPL(310),ATPA(310,310),
*      QXYZ(3,3),QLLH(3,3),QMAT(15,15),                      XX(310),
*      OBCORD(5,3),TV(5,3),V(15),AL(15),ATQL(15),          SUM(3),
*      OCG(3),ISTAT(40),IPOS(15),IFIX(40),ISTA(5),ITIME(3),KVAR(40)
! PASS ATPA ACROSS (DO NOT KEEP IN COMMON)
      COMMON /DOPPL/NP,FCORD      ,IFIX      ,ATPA      ,NVNEW
      CHARACTER*12 NAME(40),RUNFILE,POINT,QFILE,CPASS*35
      CHARACTER*8 TNAME(40)
      DATA KVAR /40*0/
      DATA SMJ,SMN /6378137.000D0,6356752.314D0/      ! GRS'80
      PRINT*,' INPUT FILE= :DPG0:FIELD:DOPPLER:DOPRUN.'
      READ(5,'(A)') RUNFILE
      OPEN(15,FILE=':DPG0:FIELD:DOPPLER:DOPRUN.'//RUNFILE,
*      FORM='FORMATTED',PAD='YES',RECFM='DS',BLANK='ZERO')
      PRINT*,' INPUT GYPO CONSTANT FOR DIAG TERMS '
      READ *,GC
      CALL PRINTER
      WRITE(6,'(////" AUGM CONSTANT= ",F9.3)') GC
900  FORMAT(A12,3F12.3,I5,1X,I5,I2,I7)
      IP=0
100  READ(15,900) POINT,X,Y,Z,IDS,IBN,II
      IF(X.EQ.0.D0.AND.Y.EQ.0.D0.AND.Z.EQ.0.D0) GO TO 200
      IP=IP+1
      NAME(IP)=POINT
      PCORD(IP,1)=X
      PCORD(IP,2)=Y
      PCORD(IP,3)=Z
      ISTAT(IP)=IDS*100000+IBN
      IFIX(IP)=II
      GO TO 100
200  NP=IP
      ITRN=0
1000 READ(15,'(A12)',END=3000) QFILE
      IF(QFILE(1:6).EQ.'      ') GO TO 3000
      ITRN=ITRN+1
      TNAME(ITRN)= QFILE(6:12)
      OPEN(20+ITRN,FILE=':DPG0:FIELD:DOPPLER:'//QFILE,
*      FORM='FORMATTED',RECFM='DS',PAD='YES',BLANK='ZERO')
      CALL RDDOP(20+ITRN,NSTA,NPASS,QMAT,OBCORD,ISTA,OCG,GC)

C   DETERMINE COMPUTER NOS. FROM DEG SQ & BCN NOS.

      DO 1100 I=1,NSTA
        DO 1110 J=1,NP
          IF(ISTAT(J).EQ.ISTA(I)) THEN
                                ISTA(I)=J
                                GO TO 1100
          END IF
1110  CONTINUE
        WRITE(10,*) '<BEL> NO PROVISION FOR ',ISTA(I)
1100  CONTINUE

C   DETERMINE POSITIONS OF UNKNOWNNS IN MAIN ATPA
```

```

DO 1200 I=1,NSTA
DO 1200 J=-2,0,1
1200 IPOS(3*I+J)=3*ISTA(I)+J

C          SET AL (CONSTANT TERMS) TO ZERO
DO 1411 I=1,15
1411 AL(I)=0.D0

C          FORM ATQL

DO 1500 I=1,NSTA
DO 1500 J=1,3
TL= OBCORD(I,J) - PCORD(ISTA(I),J)
IF(DABS(TL).GT.1.D3) THEN
WRITE(10,*)' *** LARGE CONSTANT TERM *** (GT 1 km) ***'
WRITE(10,*)' ITRN= ',ITRN
WRITE(10,*)' QFILE= ',QFILE
WRITE(10,*)' STA No= ',I
WRITE(10,*)' CO-ORD No = ',J
END IF
1500 AL(3*(I-1)+J)=TL

CALL MATMUL(QMAT,AL,3*NSTA ,3*NSTA,1,ATQL,15,15,1)

C          ADD ATQA INTO ATPA
C          & ADD ATQL INTO ATPL IN APPROPRIATE POSITIONS

DO 2300 I=1,3*(NSTA )
ATPL(IPOS(I))=ATPL(IPOS(I))+ATQL(I)
DO 2300 J=1,3*(NSTA )
2300 ATPA(IPOS(I),IPOS(J))=ATPA(IPOS(I),IPOS(J))+QMAT(I,J)

GO TO 1000
3000 NTRN=ITRN
NVAR=3*NP
KFIX=0

DO 3100 I=1,NP
IF(IFIX(I).EQ.1) THEN
KFIX=KFIX+1
DO 3150 J=3*I-3*KFIX+1,NVAR ! ELIMINATE TERM
! IN L VECTOR
3150 ATPL(J)=ATPL(J+3)
DO 3200 J=1,NVAR ! 'ZEROISE' ROWS &
DO 3200 K=-2,0 ! COLUMNS IN ATPA
ATPA(3*I+K,J)=0.D0
3200 ATPA(J,3*I+K)=0.D0
END IF
3100 CONTINUE
CALL ELIM0RC(ATPA,XX,NVAR,NVAR,310,NVNEW)
WRITE(10,*)' AFTER ELIMINATION NO VARIABLES= ',NVNEW

CALL TIME(ITIME)
WRITE(10,*) 'START INVERSE @ ', (ITIME(J),J=1,3)
CALL INVERSE(ATPA,NVNEW,310)
CALL TIME(ITIME)
WRITE(10,*) ' END INVERSE @ ', (ITIME(J),J=1,3)

CALL MATMUL(ATPA,ATPL,NVNEW,NVNEW,1,XX,310,310,1)

IFLT=0
DO 3400 I=1,NP
IF (IFIX(I).EQ.1) THEN
DO 3405 J=1,3

```

```

3405          FCORD(I,J)=PCORD(I,J)
              GO TO 3400
              ELSE
                IFLT=IFLT+1
                KVAR(I)=IFLT
                DO 3410 J=1,3
3410          FCORD(I,J)=PCORD(I,J)+XX(3*IFLT-3+J)
              END IF
3400    CONTINUE
        NFLT=IFLT      !   NFLT = No of floating points

        NOBS=0
        VTPV=0.D0
        WRITE(6,925)
        DO 4000 ITRN=1,NTRN
          REWIND (20+ITRN)
          CALL RDDOP(20+ITRN,NSTA,NPASS,QMAT,OBCORD,ISTA,OCG,GC)

C      DETERMINE COMPUTER NOS. FROM DEG SQ & BCN NOS.

        DO 4050 I=1,NSTA
          DO 4060 J=1,NP
            IF(ISTAT(J).EQ.ISTA(I)) THEN
                                  ISTA(I)=J
                                  GO TO 4050
            END IF

4060    CONTINUE
4050    CONTINUE
        IOBS=0
        DO 4100 I=1,NSTA
          DO 4100 J=1,3
            IOBS=IOBS+1
            V(IOBS)=FCORD(ISTA(I),J)-OBCORD(I,J)
4100    TV(I,J)=V(IOBS)
        VTQV=0.D0
        DO 4200 I=1,IOBS
          DO 4200 J=1,IOBS
4200    VTQV=VTQV+V(I)*V(J)*QMAT(I,J)
        VTPV=VTPV+VTQV
        NOBS=NOBS+IOBS
        WRITE(6,(' ',A8)) TNAME(ITRN)
        DO 4000 I=1,NSTA
4000    WRITE(6,('1H#,4X,I3,3F5.2')) ISTA(I),(TV(I,J),J=1,3)
        WRITE(6,('//' VtPV =" ,F12.2')) VTPV
        SIG0=VTPV/(NOBS-NVNEW)
        CALL GLOBAL(1.D0,DSQRT(SIG0),NOBS-NVNEW,KPASS) ! ?? SQRT ??
934    FORMAT(' ',10X,'Global Test 95% Confidence',//,10X,27('-'))
        WRITE(6,934)
        IF (KPASS.EQ.0) CPASS='TEST PASSED'
        IF (KPASS.EQ.1) CPASS='TEST FAILED sig0 (apriori) too high'
        IF (KPASS.EQ.-1) CPASS='TEST FAILED sig0 (apriori) too low'
        WRITE(6,935) 1.D0,DSQRT(SIG0),NOBS-NVNEW,CPASS
935    FORMAT(' ',3X,'sigma0 a priori = ',F4.2,
*      ' sigma0 a posteriori = ',F5.2,4X,'Degrees of Freedom = ',I4
*      ',6X,A35)
        DO 4010 I=1,NVNEW
          DO 4010 J=1,NVNEW
4010    ATPA(I,J)=ATPA(I,J)*SIG0
        WRITE(6,923) ! PRINT FINAL CO-ORDINATES
        IFLT=0
927    FORMAT (" ",2I4,4X,A12,3(5X,F12.3,F8.3))
        DO 3500 I=1,NP
          IF(IFIX(I).EQ.1) GO TO 3510
          IFLT=IFLT+1

```

```

DO 4030 J=1,3
4030     SUM(J)=DSQRT(ATPA(3*IFLT-3+J,3*IFLT-3+J))
        GO TO 3520
3510     DO 4040 J=1,3
4040     SUM(J)=0.D0
3520     WRITE(6,927) I,IFIX(I),NAME(I),FCORD(I,1),SUM(1),
*       FCORD(I,2),SUM(2),FCORD(I,3),SUM(3)
3500     CONTINUE
936     FORMAT('1',////40X,'GEOGRAPHICAL CO-ORDINATES (GRS 80)',41X,
* 'SHIFTZ' /,31X,'LATITUDE  mse(M)',8x,'LONGITUDE mse(M)',
* 5X,'HEIGHT  mse'/)
        WRITE(6,936)
        IFL=0
        DO 3700 I=1,NP
        CALL GEOGRAPH(FCORD(I,1),FCORD(I,2),FCORD(I,3),SMJ,SMN,
*   ALAT,ALON,AHT)
        IF(IFIX(I).EQ.1) THEN
                                SLAT=0.D0
                                SLON=0.D0
                                SHT =0.D0
                                GO TO 3530
                                END IF

        IFL=IFL+1
        DO 3505 II=1,3
        DO 3505 JJ=1,3
3505     QXYZ(II,JJ)=ATPA(3*IFL-3+II,3*IFL-3+JJ)
        CALL COVAR(QXYZ,FCORD(I,1),FCORD(I,2),FCORD(I,3),SMJ,SMN,QLLH)
        SLAT=DSQRT(QLLH(1,1))
        SLON=DSQRT(QLLH(2,2))
        SHT =DSQRT(QLLH(3,3))
3530     CALL DMS(ALAT,I1,I2,SS)
        CALL DMS(ALON,J1,J2,TT)
3700     WRITE(6,937) I,IFIX(I),NAME(I),I1,I2,SS,SLAT,J1,J2,TT,
*       SLON,AHT,SHT
937     FORMAT(' ',2I4,4X,A12,2(3X,2I3.2,F8.4,F7.2),3X,F8.2,F6.2)

923     FORMAT('1',////54X,'FINAL CO-ORDINATES',51X,'SHIFTZ',
* /,35X,'X',10X,'MSEX',10X,'Y',10X,'MSEY',10X,'Z',10X,'MSEZ',/)
924     FORMAT('1',48X,'TRNLCTN SHIFT VALUES',57X,'SHIFTZ',
* /,27X,'X', 7X,'MSEX',13X,'Y', 7X,'MSEY',13X,'Z', 7X,'MSEZ')
925     FORMAT(1H0,18X,' RESIDUALS',94X,'SHIFTZ'//,14X,
*       5('PT  X   Y   Z',6X))
926     FORMAT (" ",A8,4X,3(5X,F12.3,F8.3))

        IPR=0
5000     READ(15, '(I4,1X,I5,1X,I4,1X,I5)',END=6000) IDS,IBN,JDS,JBN
        II=IDS*100000+IBN
        JJ=JDS*100000+JBN
        DO 5100 I=1,NP
        IF (ISTAT(I).EQ.II) THEN
                                JF=I
                                GO TO 5200
                                END IF

5100     CONTINUE
        WRITE(10,*) II , ' NOT SPECIFIED'
        GO TO 5000
5200     DO 5300 I=1,NP
        IF (ISTAT(I).EQ.JJ) THEN
                                JT=I
                                GO TO 5400
                                END IF

5300     CONTINUE
        WRITE(10,*) JJ , ' NOT SPECIFIED'
        GO TO 5000

```

```
5400 IPR=IPR+1
      IF(IPR.EQ.1) WRITE(6,929)
      IF(KVAR(JF).EQ.0.OR.KVAR(JT).EQ.0) GO TO 5000
      CALL SIGCRD(JF,JT,KVAR(JF),KVAR(JT),DIS,SDIS,AL,QMAT,IPOS)
      PPM=SDIS/DIS*1.D6
      WRITE(6,930) NAME(JF),IDS,IBN,NAME(JT),JDS,JBN,DIS,SDIS,PPM
      GO TO 5000
929  FORMAT(1H1,29X,"CHORD DISTANCES AND THEIR MSE'S",35X,'SHIFTZ',/
*    ,62X,'DISTANCE',5X,'MSE',9X,'PPM'/)
930  FORMAT(" ",2(A12,2X,I4,".",I5.5,5X),F12.3,F7.3,F12.2)
6000 STOP
      END
```

^DOPPLER:PARA7.F77

C PARA7 ...COMBINES DOPPLER NETWORKS USING 7 PARAMETER TRANSFORMATN
C ON EACH SUBNET OUTPUT FROM GEODOP.
C PROVISIONAL DATA READ FROM DOPRUN.##
C GEODOP DATA READ FROM GDOP.185####
C CONSTRAINED OR MINIMUM CONSTRAINT ADJUSTMENT.

```
      IMPLICIT REAL*8(A-H,O-Z)
      DIMENSION FCORD(40,3),PCORD(40,3),ATPL(310),ATPA(310,310),
*      QMAT(15,15),XX(310),OBCG(40,3),RLAT(3,3),RLON(3,3),
*      RX(3,3),RY(3,3),RZ(3,3),QXYZ(3,3),QLLH(3,3),
*      OBCORD(5,3),TV(5,3),V(15),IFIX(40),AL(15),
*      OCG(3),ISTAT(40),IPOS(18),ISTA(5),ITIME(3),CSH(3),
*      VV(3),SIG(3),VQ(3),VX(3),VY(3),VZ(3),AV(6),IVAR(6)
      CHARACTER*12 NAME(40),RUNFILE,POINT,QFILE
      CHARACTER*8 TNAME(40)
      COMMON /DOPPL/NP,FCORD ,IFIX ,ATPA ,NVAR
      PI=DATAN(1.D0)*4.D0
      RHO=180.D0*60.D0*60.D0/PI
      DATA SMJ,SMN /6378137.000D0,6356752.314D0/ ! GRS'80
C      SET ROTATION MATRICES
      NOBS=0
      DO 11 I=1,3
          RLAT(I,I)=1.0D0
          RLON(I,I)=1.0D0
          RX(I,I)=1.0D0
          RY(I,I)=1.0D0
          RZ(I,I)=1.0D0
          DO 11 J=1,3
              IF (I.NE.J) THEN
                  RLAT(I,J)=0.0D0
                  RLON(I,J)=0.0D0
                  RX(I,J)=0.0D0
                  RY(I,J)=0.0D0
                  RZ(I,J)=0.0D0
              END IF
          END DO
      END DO
11      CONTINUE
          RX(2,3)= -1.D-6
          RX(3,2)= 1.D-6
          RY(1,3)= 1.D-6
          RY(3,1)= -1.D-6
          RZ(1,2)= -1.D-6
          RZ(2,1)= 1.D-6
      DO 12 I=1,100
          ATPL(I)=0.D0
          DO 12 J=1,100
12              ATPA(I,J)=0.D0
          PRINT*,' INPUT FILE= :DPG0:FIELD:DOPPLER:DOPRUN.'
          READ(5,'(A)') RUNFILE
          OPEN(15,FILE=:DPG0:FIELD:DOPPLER:DOPRUN.'//RUNFILE,
*          FORM='FORMATTED',PAD='YES',RECFM='DS',BLANK='ZERO')
          GF=1.D0
          CALL PRINTER
900      FORMAT(A12,3F12.3,I5,1X,I5,I2,I7)
          NFIX=0
          IP=0
100     READ(15,900) POINT,X,Y,Z,IDS,IBN,II
          IF(X.EQ.0.D0.AND.Y.EQ.0.D0.AND.Z.EQ.0.D0) GO TO 200
          IP=IP+1
          NAME(IP)=POINT
          PCORD(IP,1)=X
          PCORD(IP,2)=Y
```

```

PCORD(IP,3)=Z
ISTAT(IP)=IDS*100000+IBN
NFIK=NFIK+II
IFIX(IP)=II
GO TO 100
200 NP=IP
ITRN=0
1000 READ(15,'(A12)',END=3000) QFILE
IF(QFILE(1:6).EQ.' ') GO TO 3000
ITRN=ITRN+1
TNAME(ITRN)= QFILE(6:12)
OPEN(20+ITRN,FILE=' :DPG0:FIELD:DOPPLER://QFILE,
* FORM='FORMATTED',RECFM='DS',PAD='YES',BLANK='ZERO')
CALL RDDOP(20+ITRN,NSTA,NPASS,QMAT,OBCORD,ISTA,OCG,GF)
NOBS=NOBS+NSTA*3
WT=2.D-2*NPASS
C DETERMINE COMPUTER NOS. FROM DEG SQ & BCN NOS.

DO 1100 I=1,NSTA
DO 1110 J=1,NP
IF(ISTAT(J).EQ.ISTA(I)) THEN
ISTA(I)=J
GO TO 1100
END IF
1110 CONTINUE
WRITE(10,*) '<BEL> NO PROVISION FOR ',ISTA(I)
1100 CONTINUE

C FIND CENTRE OF GRAVITY OF TRANSLCTN # ITRN

DO 1030 J=1,3
1030 OBCG(ITRN,J)=OCG(J) ! CENTRE OF GRAVITY FROM OBSERVED CO-ORDS

DO 1040 I=1,NSTA
DO 1050 J=1,3
1050 VQ(J)=OBCORD(I,J)-OCG(J) ! VQ CONTAINS CO-ORD W.R.T. C/G

CALL MATMUL (RX,VQ,3,3,1,VX,3,3,1)
CALL MATMUL (RY,VQ,3,3,1,VY,3,3,1)
CALL MATMUL (RZ,VQ,3,3,1,VZ,3,3,1)
DO 1200 J=1,3
AV(1)= 1.D0
AV(2)=-1.D0 ! SHIFT
AV(3)=VX(J)-VQ(J) ! X-ROT
AV(4)=VY(J)-VQ(J) ! Y-ROT
AV(5)=VZ(J)-VQ(J) ! Z-ROT
AV(6)=VQ(J)*1.D-6 ! SCALE

C DETERMINE POSITIONS OF UNKNOWNNS IN ATPA
IVAR(1)=3*(ISTA(I)-1)+J
IVAR(2)=3*NP+7*(ITRN-1)+J
IVAR(3)=3*NP+7*(ITRN-1)+4
IVAR(4)=3*NP+7*(ITRN-1)+5
IVAR(5)=3*NP+7*(ITRN-1)+6
IVAR(6)=3*NP+7*ITRN
C DETERMINE L (CONSTANT TERMS)
TL= OBCORD(I,J) - PCORD(ISTA(I),J)
DO 1200 II=1,6
ATPL(IVAR(II))=ATPL(IVAR(II))+TL*AV(II)*WT
DO 1210 JJ=1,6
ATPA(IVAR(II),IVAR(JJ))=ATPA(IVAR(II),IVAR(JJ))
* +AV(II)*AV(JJ)*WT
1210 CONTINUE
1200 CONTINUE

```

```

1040 CONTINUE
GO TO 1000

3000 DO 3090 I=1,NP
      IF (IFIX(I).EQ.1) THEN
                                DO 3092 K=1,3
                                KK=3*(I-1)+K
3092 ATPA(KK, KK)=ATPA(KK, KK)+1.D8
                                END IF
3090 CONTINUE
      NTRN=ITRN
      NVAR=3*NP+7*NTRN
      NDF = NOBS+3*NFIX-NVAR
      CALL TIME(ITIME)
      WRITE(10,*) 'START INVERSE @ ', (ITIME(J),J=1,3)
      CALL INVERSE(ATPA,NVAR,310)
      CALL TIME(ITIME)
      WRITE(10,*) ' END INVERSE @ ', (ITIME(J),J=1,3)
      WRITE(10,*) '      NVAR = ',NVAR
      WRITE(10,*) '      NDF = ',NDF

C   FIND UNKNOWNNS (XX)

      CALL MATMUL(ATPA,ATPL,NVAR,NVAR,1,XX,310,310,1)

      DO 3400 I=1,NP !   CALC FINAL CO-ORDS
        DO 3400 J=1,3
3400 FCORD(I,J)=PCORD(I,J)+XX(3*I-3+J) !   + OR - ???

      NOBS=0
      VV(1)=0.D0
      VV(2)=0.D0
      VV(3)=0.D0
      VTPV=0.D0
      WRITE(6,925)
      DO 4000 ITRN=1,NTRN
        REWIND (20+ITRN)
        CALL RDDOP(20+ITRN,NSTA,NPASS,QMAT,OBCORD,ISTA,OCG,GF)
        WT=2.D-2*NPASS
        CSH(1)=XX(3*NP+7*(ITRN-1)+1)
        CSH(2)=XX(3*NP+7*(ITRN-1)+2)
        CSH(3)=XX(3*NP+7*(ITRN-1)+3)
        ARX=-XX(3*NP+7*(ITRN-1)+4)
        ARY=-XX(3*NP+7*(ITRN-1)+5)
        ARZ=-XX(3*NP+7*(ITRN-1)+6)
        ASC=-XX(3*NP+7*ITRN)

C   DETERMINE COMPUTER NOS. FROM DEG SQ & BCN NOS.

      DO 4050 I=1,NSTA
        DO 4060 J=1,NP
          IF(ISTAT(J).EQ.ISTA(I)) THEN
                                ISTA(I)=J
                                GO TO 4050
                                END IF
4060 CONTINUE
4050 CONTINUE
      DO 4100 I=1,NSTA !   COMPUTE RESIDUALS FROM OBSERVED
        RX(2,3)=-ARX*1.D-6
        RX(3,2)= ARX*1.D-6
        RY(1,3)= ARY*1.D-6
        RY(3,1)=-ARY*1.D-6
        RZ(1,2)=-ARZ*1.D-6
        RZ(2,1)= ARZ*1.D-6

```

```

DO 4110 J=1,3          !   AND FINAL VALUES
4110   VQ(J)=OBCORD(I,J)-OCG(J)
      CALL MATMUL(RX,VQ,3,3,1,VX,3,3,1)
      CALL MATMUL(RY,VX,3,3,1,VY,3,3,1)
      CALL MATMUL(RZ,VY,3,3,1,VZ,3,3,1)
      DO 4100 J=1,3
        VQ(J)=VZ(J)*(1+ASC*1.D-6)
        VQ(J)=VQ(J)+OCG(J)+CSH(J) !   +XSH, YSH, ZSH   ????????
        VOBS_=FCORD(ISTA(I),J)-VQ(J)
        VV(J)=VV(J)+VOBS**2*WT
4100   TV(I,J)=VOBS
      NOBS=NOBS+3*NSTA
      WRITE(6,(' ',A8)) TNAME(ITRN)
      DO 4000 I=1,NSTA
4000   WRITE(6,('1H#,4X,I3,3F5.2')) ISTA(I),(TV(I,J),J=1,3)
      VTPV=VV(1)+VV(2)+VV(3)
      WRITE(6,('//' VtPV   ",F12.2)) VTPV
      WRITE(6,('#      NO OF VARIABLES= ",I4)) NVAR-3*NFIX
      WRITE(6,('#      NO OF OBSERVTVNS= ",I4)) NOBS
      SIG0= VTPV/(NDF)
      DO 4020 I=1,3
4020   SIG(I)=DSQRT(VV(I)/NDF*3.D0)

      DO 4010 I=1,NVAR
      DO 4010 J=1,NVAR
4010   ATPA(I,J)=ATPA(I,J)*SIG0

923   FORMAT('1',////54X,'FINAL CO-ORDINATES',48X,'PARA-7',
* /,35X,'X',10X,'mseX',10X,'Y',10X,'mseY',10X,'Z',10X,'mseZ',/)
924   FORMAT('1',////48X,'SUBNET TRANSFORMATION PARAMETERS ',40X,
* 'PARA-7',/
* /17X,'X-SH',4X,'sig', 5X,'Y-SH',4X,'sig',5X,'Z-SH',4X,'sig',
* 5X,'X"ROT',3X,'sig',5X,'Y"ROT',3X,'sig',5X,'Z"ROT',3X,'sig',
* 5X,'PPM',5X,'sig'/)
925   FORMAT(1H0,////18X,'Residuals',92X,'PARA-7',/14X,
* 5('PT X Y Z',6X))
      WRITE(6,923) ! PRINT FINAL CARTESIAN CO-ORDINATES
      DO 3500 I=1,NP
3500   WRITE(6,(' ',2I4,4X,A12,3(5X,F12.2,F8.2))) I,IFIX(I),NAME(I),
* (FCORD(I,J),DSQRT(ATPA(3*I-3+J,3*I-3+J)),J=1,3)

      WRITE(6,927) ! WRITE FINAL GEOGRAPHICAL CO-ORDS
927   FORMAT('1',////40X,'GEOGRAPHICAL CO-ORDINATES (GRS 80) ',41X,
* 'PARA-7'/
* 31X,'LATITUDE mse(M)',8X,'LONGITUDE mse(M)',5X,'HEIGHT mse',
* 10X,'Error Ellipsoid Axes'/)

      DO 3520 I=1,NP
      CALL GEOGRAPH(FCORD(I,1),FCORD(I,2),FCORD(I,3),SMJ,SMN,
* ALAT,ALON,AHT)
      DO 3525 II=1,3
      DO 3525 JJ=1,3
3525   QXYZ(II,JJ)=ATPA(3*I-3+II,3*I-3+JJ)
      CALL COVAR(QXYZ,FCORD(I,1),FCORD(I,2),FCORD(I,3),SMJ,SMN,QLLH)
      CALL DMS(ALAT,I1,I2,SS)
      CALL DMS(ALON,J1,J2,TT)
      SLAT=DSQRT(QLLH(1,1))
      SLON=DSQRT(QLLH(2,2))
      SHGT=DSQRT(QLLH(3,3))
      CALL EIGEN3(QXYZ,EV1,EV2,EV3) !FIND EIGEN VALUES OF CVRNC MTRX
3520   WRITE(6,928) I,IFIX(I),NAME(I),I1,I2,SS,SLAT,J1,J2,TT,SLON,
* AHT,SHGT,
* DSQRT(DABS(EV1)),DSQRT(DABS(EV2)),DSQRT(DABS(EV3))
928   FORMAT(' ',2I4,4X,A12,2(3X,2I3.2,F8.4,F7.2),3X,F8.2,F6.2,3X,3F9.2)

```

```

WRITE(6,924) ! PRINT FINAL SUBNET PARAMETER VALUES
DO 3550 I=1,NTRN
  IXSH= 3*NP+7*(I-1)+1 ! POSITION IN ATPA OF UNKNOWN PARAMETERS
  IYSH= 3*NP+7*(I-1)+2
  IZSH= 3*NP+7*(I-1)+3
  IXRT= 3*NP+7*(I-1)+4
  IYRT= 3*NP+7*(I-1)+5
  IZRT= 3*NP+7*(I-1)+6
  ISCL= 3*NP+7*I
  XSH =XX(IXSH) ! X SHIFT OF SUBNET # I
  SXSH =DSQRT(ATPA(IXSH,IXSH)) ! 1 SIGMA OF X-SHIFT
  YSH =XX(IYSH)
  SYSH =DSQRT(ATPA(IYSH,IYSH))
  ZSH =XX(IZSH)
  SZSH =DSQRT(ATPA(IZSH,IZSH))
  XRT = XX(IXRT)*1.D6/RHO
  SXRT= DSQRT(ATPA(IXRT,IXRT))*1.D6/RHO
  YRT = XX(IYRT)*1.D6/RHO
  SYRT= DSQRT(ATPA(IYRT,IYRT))*1.D6/RHO
  ZRT = XX(IZRT)*1.D6/RHO
  SZRT= DSQRT(ATPA(IZRT,IZRT))*1.D6/RHO
  SCL = XX(ISCL)
  SSCL=DSQRT(ATPA(ISCL,ISCL))
3550 WRITE(6,' (" ",A8,4X,7(F8.2,F8.2))' )TNAME(I),
* XSH,SXSH,YSH,SYSH,ZSH,SZSH,XRT,SXRT,YRT,SYRT,ZRT,SZRT,SCL,SSCL

  IPR=0
5000 READ(15,' (I4,1X,I5,1X,I4,1X,I5)',END=6000) IDS,IBN,JDS,JBN
  II=IDS*100000+IBN
  JJ=JDS*100000+JBN
  DO 5100 I=1,NP
    IF (ISTAT(I).EQ.II) THEN
      JF=I
      GO TO 5200
    END IF
5100 CONTINUE
  WRITE(10,*) II , ' NOT SPECIFIED'
  GO TO 5000
5200 DO 5300 I=1,NP
  IF (ISTAT(I).EQ.JJ) THEN
    JT=I
    GO TO 5400
  END IF
5300 CONTINUE
  WRITE(10,*) JJ , ' NOT SPECIFIED'
  GO TO 5000
5400 IPR=IPR+1
  IF(IPR.EQ.1) WRITE(6,929)
  CALL SIGCRD(JF,JT,JF,JT,DIS,SDIS,AL,QMAT,IPOS)
  PPM=SDIS/DIS*1.D6
  WRITE(6,930) NAME(JF),IDS,IBN,NAME(JT),JDS,JBN,DIS,SDIS,PPM
  GO TO 5000
929 FORMAT('1',////29X,"CHORD DISTANCES AND THEIR MSE'S",52X,'PARA-7'/
* ,62X,'DISTANCE',5X,'sig',9X,'PPM'/)
930 FORMAT(" ",2(A12,2X,I4," ",I5.5,5X),F12.3,F7.3,F12.2)
6000 STOP
END

```

^DOPPLER:SHIFT_R.F77

C SHIFT_R...COMBINES DOPPLER NETWORKS APPLYING 3 SHIFTS AND 1
C ROTATION TO EACH SUBNET OUTPUT FROM GEODOP.
C AXIS OF ROTATION IS PASSES THROUGH CENTRE OF SUBNET AND IS
C NORMAL TO THE ELLIPSOID AT THAT CENTRE.
C PROVISIONAL DATA READ FROM DOPRUN.##
C GEODOP DATA READ FROM GDOP.185####
C CONSTRAINED (AT LEAST 2 FIXED POINTS) ADJUSTMENT.

IMPLICIT REAL*8(A-H,O-Z)
DIMENSION FCORD(40,3),PCORD(40,3),ATPL(310),ATPA(310,310),
* QMAT(15,15),XX(310),OBCG(40,3),RLAT(3,3),RLON(3,3),
* CROSS(3),R(3,3), QXYZ(3,3),QLLH(3,3),
* OBCORD(5,3),TV(5,3),V(15),IFIX(40),AL(15),
* OCG(3),ISTAT(40),IPOS(18),ISTA(5),ITIME(3),CSH(3),
* VV(3),SIG(3),VQ(3),VX(3),VY(3),VZ(3),AV(3),IVAR(3)
CHARACTER*12 NAME(40),RUNFILE,POINT,QFILE
CHARACTER*8 TNAME(40)
COMMON /DOPPL/NP,FCORD ,IFIX ,ATPA ,NVAR
PI=DATAN(1.D0)*4.D0
RHO=180.D0*60.D0*60.D0/PI
DATA SMJ,SMN /6378137.000D0,6356752.314D0/ ! GRS'80
OPEN(1,STATUS='SCRATCH',MODE='BINARY',FORM='UNFORMATTED')

C SET ROTATION MATRICES

NOBS=0
DO 11 I=1,3
RLAT(I,I)=1.0D0
RLON(I,I)=1.0D0
DO 11 J=1,3
IF (I.NE.J) THEN
RLAT(I,J)=0.0D0
RLON(I,J)=0.0D0
END IF
11 CONTINUE
DO 12 I=1,100
ATPL(I)=0.D0
DO 12 J=1,100
12 ATPA(I,J)=0.D0
PRINT*,' INPUT FILE= :DPG0:FIELD:DOPPLER:DOPRUN.'
READ(5,'(A)') RUNFILE
OPEN(15,FILE=':DPG0:FIELD:DOPPLER:DOPRUN.'//RUNFILE,
* FORM='FORMATTED',PAD='YES',RECFM='DS',BLANK='ZERO')
GF=1.D0
CALL PRINTER
900 FORMAT(A12,3F12.3,I5,1X,I5,I2,I7)
NFIX=0
IP=0
100 READ(15,900) POINT,X,Y,Z,IDS,IBN,II
IF(X.EQ.0.D0.AND.Y.EQ.0.D0.AND.Z.EQ.0.D0) GO TO 200
IP=IP+1
NAME(IP)=POINT
PCORD(IP,1)=X
PCORD(IP,2)=Y
PCORD(IP,3)=Z
ISTAT(IP)=IDS*100000+IBN
NFIX=NFIX+II
IFIX(IP)=II
GO TO 100
200 NP=IP
ITRN=0
1000 READ(15,'(A12)',END=3000) QFILE

```

IF(QFILE(1:6).EQ.'      ') GO TO 3000
ITRN=ITRN+1
TNAME(ITRN)= QFILE(6:12)
OPEN(20+ITRN,FILE=' :DPG0:FIELD:DOPPLER:'//QFILE,
*   FORM='FORMATTED',RECFM='DS',PAD='YES',BLANK='ZERO')
CALL RDDOP(20+ITRN,NSTA,NPASS,QMAT,OBCORD,ISTA,OCG,GF)
NOBS=NOBS+NSTA*3
WT=2.D-2*NPASS
C.....
C  AXIS OF ROTATION (CROSS) IS NORMAL TO SPHEROID AT C OF G OF TRNSLCTN
CALL GEOGRAPH(OCG(1),OCG(2),OCG(3),SMJ,SMN,ALT,ALN,HGT)
CALL GEOCEN(ALT,ALN,HGT+1000.,SMJ,SMN,X,Y,Z)
CROSS(1)=OCG(1)-X
CROSS(2)=OCG(2)-Y
CROSS(3)=OCG(3)-Z
C  MATRIX R GIVES A ROTATION OF 1E-6 1 arc sec. RADIANS ABOUT CROSS VECTOR
R(1,1)= 1.0D0
R(2,2)= 1.0D0
R(3,3)= 1.0D0
R(1,2)=-1.0D0/RHO
R(2,1)= 1.0D0/RHO
R(1,3)= 1.0D0/RHO*CROSS(2)/CROSS(3)
R(3,1)=-R(1,3)
R(3,2)= 1.0D0/RHO*CROSS(1)/CROSS(3)
R(2,3)=-R(3,2)
WRITE(1) CROSS

C=====
C  DETERMINE COMPUTER NOS. FROM DEG SQ & BCN NOS.

DO 1100 I=1,NSTA
DO 1110 J=1,NP
IF(ISTAT(J).EQ.ISTA(I)) THEN
                                ISTA(I)=J
                                GO TO 1100
                                END IF
1110  CONTINUE
WRITE(10,*) '<BEL> NO PROVISION FOR ',ISTA(I)
1100  CONTINUE

C  FIND CENTRE OF GRAVITY OF TRANSLCTN # ITRN

DO 1030 J=1,3
1030  OBCG(ITRN,J)=OCG(J) ! CENTRE OF GRAVITY FROM OBSERVED CO-ORDS

DO 1040 I=1,NSTA
DO 1050 J=1,3
1050  VQ(J)=OBCORD(I,J)-OCG(J) ! VQ CONTAINS CO-ORD W.R.T. C/G

CALL MATMUL(R,VQ,3,3,1,VX,3,3,1)

DO 1200 J=1,3
AV(1)= 1.D0
AV(2)=-1.D0          ! SHIFT
AV(3)=VX(J)-VQ(J)   ! ROTATION

C  DETERMINE POSITIONS OF UNKNOWNNS IN ATPA
IVAR(1)=3*(ISTA(I)-1)+J
IVAR(2)=3*NP+4*(ITRN-1)+J
IVAR(3)=3*NP+4*ITRN
C  DETERMINE L (CONSTANT TERMS)
TL= OBCORD(I,J) - PCORD(ISTA(I),J)
DO 1200 II=1,3
ATPL(IVAR(II))=ATPL(IVAR(II))+TL*AV(II)*WT

```

```

DO 1210 JJ=1,3
      ATPA(IVAR(II),IVAR(JJ))=ATPA(IVAR(II),IVAR(JJ))
*
1210 CONTINUE
1200 CONTINUE
1040 CONTINUE
      GO TO 1000

3000 DO 3090 I=1,NP
      IF (IFIX(I).EQ.1) THEN
                                DO 3092 K=1,3
                                KK=3*(I-1)+K
3092 ATPA(KK, KK)=ATPA(KK, KK)+1.D8
                                END IF
3090 CONTINUE
      NTRN=ITRN
      NVAR=3*NP+4*NTRN
      NDF = NOBS+3*NFIX-NVAR
      CALL TIME(ITIME)
      WRITE(10,*) 'START INVERSE @ ', (ITIME(J),J=1,3)
      WRITE(10,*) '      NVAR = ',NVAR
      WRITE(10,*) '      NDF = ',NDF
      WRITE(10,*) '      NP  = ',NP
      WRITE(10,*) '      NTRN = ',NTRN
      REWIND(1)
      CALL INVERSE(ATPA,NVAR,310)
      CALL TIME(ITIME)
      WRITE(10,*) ' END INVERSE @ ', (ITIME(J),J=1,3)
      WRITE(10,*) '      NVAR = ',NVAR
      WRITE(10,*) '      NDF = ',NDF

C   FIND UNKNOWNNS (XX)

      CALL MATMUL(ATPA,ATPL,NVAR,NVAR,1,XX,310,310,1)

      DO 3400 I=1,NP !   CALC FINAL CO-ORDS
      DO 3400 J=1,3
3400 FCORD(I,J)=PCORD(I,J)+XX(3*I-3+J)

      NOBS=0
      VV(1)=0.D0
      VV(2)=0.D0
      VV(3)=0.D0
      VTPV=0.D0
      WRITE(6,925)
      DO 4000 ITRN=1,NTRN
      REWIND (20+ITRN)
      CALL RDDOP(20+ITRN,NSTA,NPASS,QMAT,OBCORD,ISTA,OCG,GF)
      WT=2.D-2*NPASS
      CSH(1)=XX(3*NP+4*(ITRN-1)+1)
      CSH(2)=XX(3*NP+4*(ITRN-1)+2)
      CSH(3)=XX(3*NP+4*(ITRN-1)+3)
      ROT=-XX(3*NP+4*ITRN)
      READ(1) CROSS

      R(1,1)= 1.0D0
      R(2,2)= 1.0D0
      R(3,3)= 1.0D0
      R(1,2)=-ROT/RHO
      R(2,1)= ROT/RHO
      R(1,3)= CROSS(2)/CROSS(3)*ROT/RHO
      R(3,1)=-R(1,3)
      R(3,2)= CROSS(1)/CROSS(3)*ROT/RHO
      R(2,3)=-R(3,2)

```

```

C      DETERMINE COMPUTER NOS. FROM DEG SQ & BCN NOS.

      DO 4050 I=1,NSTA
        DO 4060 J=1,NP
          IF(ISTAT(J).EQ.ISTA(I)) THEN
                                ISTA(I)=J
                                GO TO 4050
          END IF

4060      CONTINUE
4050      CONTINUE
      DO 4100 I=1,NSTA          ! COMPUTE RESIDUALS FROM OBSERVED
        DO 4110 J=1,3          ! AND FINAL VALUES
4110          VQ(J)=OBCORD(I,J)-OCG(J)
          CALL MATMUL(R,VQ,3,3,1,VX,3,3,1)
          DO 4100 J=1,3
            VQ(J)=VX(J)+OCG(J)+CSH(J)
            VOBS =FCORD(ISTA(I),J)-VQ(J)
            VV(J)=VV(J)+VOBS**2*WT
4100          TV(I,J)=VOBS
          NOBS=NOBS+3*NSTA
          WRITE(6,('( " ",A8)') TNAME(ITRN))
          DO 4000 I=1,NSTA
4000          WRITE(6,('(1H#,4X,I3,3F5.2)') ISTA(I),(TV(I,J),J=1,3)
          VTPV=VV(1)+VV(2)+VV(3)
          WRITE(6,('(/" VtPV " ,F12.2)') VTPV
          WRITE(6,('( "# NO OF VARIABLES=" ,I4)') NVAR-3*NFIX
          WRITE(6,('( "# NO OF OBSERVATIONS=" ,I4)') NOBS
          SIG0= VTPV/(NDF)
          DO 4020 I=1,3
4020          SIG(I)=DSQRT(VV(I)/NDF*3.D0)

          DO 4010 I=1,NVAR
          DO 4010 J=1,NVAR
4010          ATPA(I,J) =ATPA(I,J)*SIG0

923          FORMAT('1',///54X,'FINAL CO-ORDINATES',48X,'SHIFT-R',
          */35X,'X',10X,'mseX',10X,'Y',10X,'mseY',10X,'Z',10X,'mseZ',/)
924          FORMAT('1',///48X,'SUBNET TRANSFORMATION PARAMETERS ',40X,
          *'SHIFT-R',/
          */17X,'X-SH',4X,'sig', 5X,'Y-SH',4X,'sig',5X,'Z-SH',4X,'sig',
          * 5X,'Rot',5X,'sig',4X,'Year Day'/)
925          FORMAT(1H0,///18X,'Residuals',92X,'SHIFT-R',/14X,
          * 5('PT X Y Z',6X))
          WRITE(6,923) ! PRINT FINAL CARTESIAN CO-ORDINATES
          DO 3500 I=1,NP
3500          WRITE(6,('( " ",2I4,4X,A12,3(5X,F12.2,F8.2)') I,IFIX(I),NAME(I),
          * (FCORD(I,J),DSQRT(ATPA(3*I-3+J,3*I-3+J)),J=1,3)

          WRITE(6,927) ! WRITE FINAL GEOGRAPHICAL CO-ORDS
927          FORMAT('1',///40X,'GEOGRAPHICAL CO-ORDINATES (GRS 80) ',41X,
          *'SHIFT-R'/
          *31X,'LATITUDE mse(M)',8X,'LONGITUDE mse(M)',5X,'HEIGHT mse',
          *10X,'Error Ellipsoid Axes'/)

          DO 3520 I=1,NP
            CALL GEOGRAPH(FCORD(I,1),FCORD(I,2),FCORD(I,3),SMJ,SMN,
          * ALAT,ALON,AHT)
            DO 3525 II=1,3
            DO 3525 JJ=1,3
3525          QXYZ(II,JJ)=ATPA(3*I-3+II,3*I-3+JJ)
            CALL COVAR(QXYZ,FCORD(I,1),FCORD(I,2),FCORD(I,3),SMJ,SMN,QLLH)
            CALL DMS(ALAT,I1,I2,SS)
            CALL DMS(ALON,J1,J2,TT)

```

```

      SLAT=DSQRT(QLLH(1,1))
      SLON=DSQRT(QLLH(2,2))
      SHGT=DSQRT(QLLH(3,3))
      CALL EIGEN3(QXYZ, EV1, EV2, EV3) ! FIND EIGEN VALUES OF CVRNCE MTRX
3520  WRITE(6,928) I, IFIX(I), NAME(I), I1, I2, SS, SLAT, J1, J2, TT, SLON,
      *      AHT, SHGT,
      *      DSQRT(DABS(EV1)), DSQRT(DABS(EV2)), DSQRT(DABS(EV3))
928   FORMAT(' ', 2I4, 4X, A12, 2(3X, 2I3.2, F8.4, F7.2), 3X, F8.2, F6.2, 3X, 3F9.2)

      WRITE(6,924) ! PRINT FINAL SUBNET PARAMETER VALUES
      DO 3550 I=1, NTRN
          IXSH= 3*NP+4*(I-1)+1 ! POSITION IN ATPA OF UNKNOWN PARAMETERS
          IYSH= 3*NP+4*(I-1)+2
          IZSH= 3*NP+4*(I-1)+3
          IROT= 3*NP+4*I
          XSH =XX(IXSH)           ! X SHIFT OF SUBNET # I
          SXSH =DSQRT(ATPA(IXSH, IXSH)) ! 1 SIGMA OF X-SHIFT
          YSH =XX(IYSH)
          SYSH =DSQRT(ATPA(IYSH, IYSH))
          ZSH =XX(IZSH)
          SZSH =DSQRT(ATPA(IZSH, IZSH))
          ROT = XX(IROT)
          SROT=DSQRT(ATPA(IROT, IROT))
          REWIND (20+I)
          READ(20+I, '(5X, I5, I4)') IYEAR, IDAY
3550  WRITE(6, '( " ", A8, 4X, 4(F8.2, F8.2), I7, I6)') TNAME(I),
      *  XSH, SXSH, YSH, SYSH, ZSH, SZSH, ROT, SROT, IYEAR, IDAY

      IPR=0
5000  READ(15, '(I4, 1X, I5, 1X, I4, 1X, I5)', END=6000) IDS, IBN, JDS, JBN
      II=IDS*100000+IBN
      JJ=JDS*100000+JBN
      DO 5100 I=1, NP
          IF (ISTAT(I).EQ.II) THEN
                                  JF=I
                                  GO TO 5200
          END IF
5100  CONTINUE
      WRITE(10,*) II , ' NOT SPECIFIED'
      GO TO 5000
5200  DO 5300 I=1, NP
          IF (ISTAT(I).EQ.JJ) THEN
                                  JT=I
                                  GO TO 5400
          END IF
5300  CONTINUE
      WRITE(10,*) JJ , ' NOT SPECIFIED'
      GO TO 5000
5400  IPR=IPR+1
      IF(IPR.EQ.1) WRITE(6,929)
      CALL SIGCRD(JF, JT, JF, JT, DIS, SDIS, AL, QMAT, IPOS)
      PPM=SDIS/DIS*1.D6
      WRITE(6,930) NAME(JF), IDS, IBN, NAME(JT), JDS, JBN, DIS, SDIS, PPM
      GO TO 5000
929   FORMAT('1', ////29X, "CHORD DISTANCES AND THEIR MSE'S",
      * 52X, 'SHIFT-R'//, 62X, 'DISTANCE', 5X, 'sig', 9X, 'PPM' /)
930   FORMAT(" ", 2(A12, 2X, I4, ".", I5.5, 5X), F12.3, F7.3, F12.2)
6000  STOP
      END

```

^DOPPLER:SHIFT_S.F77

C SHIFTS...COMBINES DOPPLER NETWORKS APPLYING 3 SHIFTS AND 1 SCALE
C FACTOR TO EACH SUBNET OUTPUT FROM GEODOP.
C PROVISIONAL DATA READ FROM DOPRUN.##
C GEODOP DATA READ FROM GDOP.185####
C CONSTRAINED (AT LEAST 2 FIXED POINTS) ADJUSTMENT.

IMPLICIT REAL*8(A-H,O-Z)
DIMENSION FCORD(40,3),PCORD(40,3),ATPL(310),ATPA(310,310),
* QMAT(15,15),XX(310),OBCG(40,3),RLAT(3,3),RLON(3,3),
* QXYZ(3,3),QLLH(3,3),
* OBCORD(5,3),TV(5,3),V(15),IFIX(40),AL(15),
* OCG(3),ISTAT(40),IPOS(18),ISTA(5),ITIME(3),CSH(3),
* VV(3),SIG(3),VQ(3),VX(3),VY(3),VZ(3),AV(3),IVAR(3)
CHARACTER*12 NAME(40),RUNFILE,POINT,QFILE
CHARACTER*8 TNAME(40)
COMMON /DOPPL/NP,FCORD ,IFIX ,ATPA ,NVAR
PI=DATAN(1.D0)*4.D0
RHO=180.D0*60.D0*60.D0/PI
DATA SMJ,SMN /6378137.000D0,6356752.314D0/ ! GRS'80
C SET ROTATION MATRICES
NOBS=0
DO 11 I=1,3
RLAT(I,I)=1.0D0
RLON(I,I)=1.0D0
DO 11 J=1,3
IF (I.NE.J) THEN
RLAT(I,J)=0.0D0
RLON(I,J)=0.0D0
END IF
11 CONTINUE
DO 12 I=1,100
ATPL(I)=0.D0
DO 12 J=1,100
12 ATPA(I,J)=0.D0
PRINT*,' INPUT FILE= :DPG0:FIELD:DOPPLER:DOPRUN.'
READ(5,'(A)') RUNFILE
OPEN(15,FILE=' :DPG0:FIELD:DOPPLER:DOPRUN.'//RUNFILE,
* FORM='FORMATTED',PAD='YES',RECFM='DS',BLANK='ZERO')
GF=1.D0
CALL PRINTER
900 FORMAT(A12,3F12.3,I5,1X,I5,I2,I7)
NFIX=0
IP=0
100 READ(15,900) POINT,X,Y,Z,IDS,IBN,II
IF(X.EQ.0.D0.AND.Y.EQ.0.D0.AND.Z.EQ.0.D0) GO TO 200
IP=IP+1
NAME(IP)=POINT
PCORD(IP,1)=X
PCORD(IP,2)=Y
PCORD(IP,3)=Z
ISTAT(IP)=IDS*100000+IBN
NFIX=NFIX+II
IFIX(IP)=II
GO TO 100
200 NP=IP
ITRN=0
1000 READ(15,'(A12)',END=3000) QFILE
IF(QFILE(1:6).EQ.' ') GO TO 3000
ITRN=ITRN+1
TNAME(ITRN)= QFILE(6:12)
OPEN(20+ITRN,FILE=' :DPG0:FIELD:DOPPLER:'//QFILE,

```

*      FORM='FORMATTED',RECFM='DS',PAD='YES',BLANK='ZERO')
CALL RDDOP(20+ITRN,NSTA,NPASS,QMAT,OBCORD,ISTA,OCG,GF)
NOBS=NOBS+NSTA*3
WT=2.D-2*NPASS
C      DETERMINE COMPUTER NOS. FROM DEG SQ & BCN NOS.

DO 1100 I=1,NSTA
  DO 1110 J=1,NP
    IF(ISTAT(J).EQ.ISTA(I)) THEN
      ISTA(I)=J
      GO TO 1100
    END IF
1110   CONTINUE
      WRITE(10,*) '<BEL> NO PROVISION FOR ',ISTA(I)
1100   CONTINUE

C      FIND CENTRE OF GRAVITY OF TRANSLCTN # ITRN

DO 1030 J=1,3
1030   OBCG(ITRN,J)=OCG(J) ! CENTRE OF GRAVITY FROM OBSERVED CO-ORDS

      DO 1040 I=1,NSTA
        DO 1050 J=1,3
1050         VQ(J)=OBCORD(I,J)-OCG(J) ! VQ CONTAINS CO-ORD W.R.T. C/G

DO 1200 J=1,3
  AV(1)= 1.D0
  AV(2)=-1.D0           ! SHIFT
  AV(3)=VQ(J)*1.D-6    ! SCALE

C      DETERMINE POSITIONS OF UNKNOWNNS IN ATPA
      IVAR(1)=3*(ISTA(I)-1)+J
      IVAR(2)=3*NP+4*(ITRN-1)+J
      IVAR(3)=3*NP+4*ITRN
C      DETERMINE L (CONSTANT TERMS)
      TL= OBCORD(I,J) - PCORD(ISTA(I),J)
      DO 1200 II=1,3
        ATPL(IVAR(II))=ATPL(IVAR(II))+TL*AV(II)*WT
      DO 1210 JJ=1,3
        ATPA(IVAR(II),IVAR(JJ))=ATPA(IVAR(II),IVAR(JJ))
          +AV(II)*AV(JJ)*WT
*
1210   CONTINUE
1200   CONTINUE
1040   CONTINUE
      GO TO 1000

3000   DO 3090 I=1,NP
      IF (IFIX(I).EQ.1) THEN
        DO 3092 K=1,3
          KK=3*(I-1)+K
3092         ATPA(KK,KK)=ATPA(KK,KK)+1.D8
        END IF
3090   CONTINUE
      NTRN=ITRN
      NVAR=3*NP+4*NTRN
      NDF = NOBS+3*NFIX-NVAR
      CALL TIME(ITIME)
      WRITE(10,*) 'START INVERSE @ ', (ITIME(J),J=1,3)
      WRITE(10,*) '      NVAR = ',NVAR
      WRITE(10,*) '      NDF = ',NDF
      WRITE(10,*) '      NP  = ',NP
      WRITE(10,*) '      NTRN = ',NTRN
      CALL INVERSE(ATPA,NVAR,310)
      CALL TIME(ITIME)

```

```

WRITE(10,*) ' END INVERSE @ ',(ITIME(J),J=1,3)
WRITE(10,*) '      NVAR = ',NVAR
WRITE(10,*) '      NDF  = ',NDF

```

C FIND UNKNOWN(S) (XX)

```
CALL MATMUL(ATPA,ATPL,NVAR,NVAR,1,XX,310,310,1)
```

```
DO 3400 I=1,NP ! CALC FINAL CO-ORDS
DO 3400 J=1,3
```

```
3400 FCORD(I,J)=PCORD(I,J)+XX(3*I-3+J) ! + OR - ???
```

```
NOBS=0
```

```
VV(1)=0.D0
```

```
VV(2)=0.D0
```

```
VV(3)=0.D0
```

```
VTPV=0.D0
```

```
WRITE(6,925)
```

```
DO 4000 ITRN=1,NTRN
```

```
REWIND (20+ITRN)
```

```
CALL RDDOP(20+ITRN,NSTA,NPASS,QMAT,OBCORD,ISTA,OCG,GF)
```

```
WT=2.D-2*NPASS
```

```
CSH(1)=XX(3*NP+4*(ITRN-1)+1)
```

```
CSH(2)=XX(3*NP+4*(ITRN-1)+2)
```

```
CSH(3)=XX(3*NP+4*(ITRN-1)+3)
```

```
ASC=-XX(3*NP+4*ITRN)
```

C DETERMINE COMPUTER NOS. FROM DEG SQ & BCN NOS.

```
DO 4050 I=1,NSTA
```

```
DO 4060 J=1,NP
```

```
IF(ISTAT(J).EQ.ISTA(I)) THEN
```

```
ISTA(I)=J
```

```
GO TO 4050
```

```
END IF
```

```
4060 CONTINUE
```

```
4050 CONTINUE
```

```
DO 4100 I=1,NSTA ! COMPUTE RESIDUALS FROM OBSERVED
```

```
DO 4110 J=1,3 ! AND FINAL VALUES
```

```
4110 VQ(J)=OBCORD(I,J)-OCG(J)
```

```
DO 4100 J=1,3
```

```
VQ(J)=VQ(J)*(1+ASC*1.D-6)
```

```
VQ(J)=VQ(J)+OCG(J)+CSH(J) ! +XSH, YSH, ZSH ????????
```

```
VOBS =FCORD(ISTA(I),J)-VQ(J)
```

```
VV(J)=VV(J)+VOBS**2*WT
```

```
4100 TV(I,J)=VOBS
```

```
NOBS=NOBS+3*NSTA
```

```
WRITE(6,'(" ",A8)') TNAME(ITRN)
```

```
DO 4000 I=1,NSTA
```

```
4000 WRITE(6,'(1H#,4X,I3,3F5.2)') ISTA(I),(TV(I,J),J=1,3)
```

```
VTPV=VV(1)+VV(2)+VV(3)
```

```
WRITE(6,'(/" VtPV ",F12.2)') VTPV
```

```
WRITE(6,'("# NO OF VARIABLES= ",I4)') NVAR-3*NFIX
```

```
WRITE(6,'("# NO OF OBSERVATIONS= ",I4)') NOBS
```

```
SIG0= VTPV/(NDF)
```

```
DO 4020 I=1,3
```

```
4020 SIG(I)=DSQRT(VV(I)/NDF*3.D0)
```

```
DO 4010 I=1,NVAR
```

```
DO 4010 J=1,NVAR
```

```
4010 ATPA(I,J) =ATPA(I,J)*SIG0
```

```
923 FORMAT('1',///54X,'FINAL CO-ORDINATES',48X,'SHIFT-S',
*/,35X,'X',10X,'mseX',10X,'Y',10X,'mseY',10X,'Z',10X,'mseZ',/)
```

```

924  FORMAT('1',////48X,'SUBNET TRANSFORMATION PARAMETERS ',40X,
*'SHIFT-S',/
*/17X,'X-SH',4X,'sig', 5X,'Y-SH',4X,'sig',5X,'Z-SH',4X,'sig',
* 5X,'PPM',5X,'sig',4X,'Year Day'/)
925  FORMAT(1H0,////18X,' Residuals',92X,'SHIFT-S',/14X,
*      5('PT X Y Z',6X))
WRITE(6,923) ! PRINT FINAL CARTESIAN CO-ORDINATES
DO 3500 I=1,NP
3500  WRITE(6,(' ',2I4,4X,A12,3(5X,F12.2,F8.2))) I,IFIX(I),NAME(I),
* (FCORD(I,J),DSQRT(ATPA(3*I-3+J,3*I-3+J)),J=1,3)

WRITE(6,927) ! WRITE FINAL GEOGRAPHICAL CO-ORDS
927  FORMAT('1',////40X,'GEOGRAPHICAL CO-ORDINATES (GRS 80) ',41X,
*'SHIFTS'/
*31X,'LATITUDE mse(M)',8X,'LONGITUDE mse(M)',5X,'HEIGHT mse',
*10X,'Error Ellipsoid Axes'/)

DO 3520 I=1,NP
CALL GEOGRAPH(FCORD(I,1),FCORD(I,2),FCORD(I,3),SMJ,SMN,
* ALAT,ALON,AHT)
DO 3525 II=1,3
DO 3525 JJ=1,3
3525  QXYZ(II,JJ)=ATPA(3*I-3+II,3*I-3+JJ)
CALL COVAR(QXYZ,FCORD(I,1),FCORD(I,2),FCORD(I,3),SMJ,SMN,QLLH)
CALL DMS(ALAT,I1,I2,SS)
CALL DMS(ALON,J1,J2,TT)
SLAT=DSQRT(QLLH(1,1))
SLON=DSQRT(QLLH(2,2))
SHGT=DSQRT(QLLH(3,3))
CALL EIGEN3(QXYZ,EV1,EV2,EV3) !FIND EIGEN VALUES OF CVRNC MTRX
3520  WRITE(6,928) I,IFIX(I),NAME(I),I1,I2,SS,SLAT,J1,J2,TT,SLON,
*      AHT,SHGT,
*      DSQRT(DABS(EV1)),DSQRT(DABS(EV2)),DSQRT(DABS(EV3))
928  FORMAT(' ',2I4,4X,A12,2(3X,2I3.2,F8.4,F7.2),3X,F8.2,F6.2,3X,3F9.2)

WRITE(6,924) ! PRINT FINAL SUBNET PARAMETER VALUES
DO 3550 I=1,NTRN
IXSH= 3*NP+4*(I-1)+1 ! POSITION IN ATPA OF UNKNOWN PARAMETERS
IYSH= 3*NP+4*(I-1)+2
IZSH= 3*NP+4*(I-1)+3
ISCL= 3*NP+4*I
XSH =XX(IXSH) ! X SHIFT OF SUBNET # I
SXSH =DSQRT(ATPA(IXSH,IXSH)) ! 1 SIGMA OF X-SHIFT
YSH =XX(IYSH)
SYSH =DSQRT(ATPA(IYSH,IYSH))
ZSH =XX(IZSH)
SZSH =DSQRT(ATPA(IZSH,IZSH))
SCL = XX(ISCL)
SSCL=DSQRT(ATPA(ISCL,ISCL))
REWIND (20+I)
READ(20+I,(' ',5X,I5,I4)) IYEAR,IDAY
3550  WRITE(6,(' ',A8,4X,4(F8.2,F8.2),I7,I6))TNAME(I),
* XSH,SXSH,YSH,SYSH,ZSH,SZSH,SCL,SSCL,IYEAR,IDAY

IPR=0
5000  READ(15,(' ',I4,1X,I5,1X,I4,1X,I5)',END=6000) IDS,IBN,JDS,JBN
II=IDS*100000+IBN
JJ=JDS*100000+JBN
DO 5100 I=1,NP
IF (ISTAT(I).EQ.II) THEN
JF=I
GO TO 5200
END IF

5100  CONTINUE

```

```

WRITE(10,*) II , ' NOT SPECIFIED'
GO TO 5000
5200 DO 5300 I=1,NP
      IF (ISTAT(I).EQ.JJ) THEN
                                JT=I
                                GO TO 5400
                                END IF
5300 CONTINUE
WRITE(10,*) JJ , ' NOT SPECIFIED'
GO TO 5000
5400 IPR=IPR+1
      IF(IPR.EQ.1) WRITE(6,929)
      CALL SIGCRD(JF,JT,JF,JT,DIS,SDIS,AL,QMAT,IPOS)
      PPM=SDIS/DIS*1.D6
      WRITE(6,930) NAME(JF),IDS,IBN,NAME(JT),JDS,JBN,DIS,SDIS,PPM
      GO TO 5000
929  FORMAT('1',////29X,"CHORD DISTANCES AND THEIR MSE'S",52X,'SHIFT-S'
* ,62X,'DISTANCE',5X,'sig',9X,'PPM'/)
930  FORMAT(" ",2(A12,2X,I4,".",I5.5,5X),F12.3,F7.3,F12.2)
6000 STOP
      END

```

^DOPPLER:SHIFT3.F77

C SHIFT3...COMBINES DOPPLER SUBNETS BY APPLYING THREE ORTHOGONAL
C SHIFTS TO EACH SUBNET.
C WEIGHTING ACCORDING TO NO OF PASSES (WT= NPASS/50)
C PROVISIONAL DATA READ FROM DOPRUN.##
C GEODOP DATA READ FROM GDOP.185####
C CONSTRAINED OR MINIMUM CONSTRAINT ADJUSTMENT.

```
IMPLICIT REAL*8(A-H,O-Z)
DIMENSION FCORD(40,3),PCORD(40,3),ATPL(310),ATPA(310,310),
* A(15,18),AT(18,15),QMAT(15,15),ATQA(18,18),CG(40,3),XX(310),
* OBCORD(5,3),TV(5,3),V(15),AL(15),ATQL(18),ATQ(18,15),IFIX(40),
* OCG(3),ISTAT(40),IPOS(18),ISTA(5),ITIME(10),QXYZ(3,3),QLLH(3,3)
* ,VV(3),SIG(3),IPASS(40)
CHARACTER*12 NAME(40),RUNFILE,POINT,QFILE
CHARACTER*8 TNAME(40)
COMMON /DOPPL/NP,FCORD ,IFIX ,ATPA ,NVNEW
DATA SMJ,SMN /6378137.000D0,6356752.314D0/ ! GRS'80
PRINT*, ' INPUT FILE= :DPG0:FIELD:DOPPLER:DOPRUN.'
READ(5,'(A)') RUNFILE
OPEN(15,FILE=':DPG0:FIELD:DOPPLER:DOPRUN.'//RUNFILE,
* FORM='FORMATTED',PAD='YES',RECFM='DS',BLANK='ZERO')
CALL PRINTER
900 FORMAT(A12,3F12.3,I5,1X,I5,I2,I7)
NFIX=0
IP=0
100 READ(15,900) POINT,X,Y,Z,IDS,IBN,II
IF(X.EQ.0.D0.AND.Y.EQ.0.D0.AND.Z.EQ.0.D0) GO TO 200
IP=IP+1
NAME(IP)=POINT
PCORD(IP,1)=X
PCORD(IP,2)=Y
PCORD(IP,3)=Z
ISTAT(IP)=IDS*100000+IBN
NFIX=NFIX+II
IFIX(IP)=II
GO TO 100
200 NP=IP
ITRN=0
1000 READ(15,'(A12)',END=3000) QFILE
IF(QFILE(1:6).EQ.' ') GO TO 3000
ITRN=ITRN+1
TNAME(ITRN)= QFILE(6:12)
OPEN(20+ITRN,FILE=':DPG0:FIELD:DOPPLER:'//QFILE,
* FORM='FORMATTED',RECFM='DS',PAD='YES',BLANK='ZERO')
CALL RDDOP(20+ITRN,NSTA,NPASS,QMAT,OBCORD,ISTA,OCG,0.D0)
C DETERMINE COMPUTER NOS. FROM DEG SQ & BCN NOS.
DO 1100 I=1,NSTA
DO 1110 J=1,NP
IF(ISTAT(J).EQ.ISTA(I)) THEN
ISTA(I)=J
GO TO 1100
END IF
1110 CONTINUE
WRITE(10,*) '<BEL> NO PROVISION FOR ',ISTA(I)
1100 CONTINUE
C FIND CENTRE OF GRAVITY OF TRANSLCTN # ITRN
DO 1030 J=1,3
```

1030 CG(ITRN,J)=OCG(J) ! CENTRE OF GRAVITY FROM OBSERVED CO-ORDINATES

C DETERMINE POSITIONS OF UNKNOWNNS IN MAIN ATPA

```
DO 1200 I=1,NSTA
  IPOS(3*I-2)=3*ISTA(I)-2
  IPOS(3*I-1)=3*ISTA(I)-1
1200  IPOS(3*I )=3*ISTA(I)
  IPOS(3*NSTA+1)=3*NP+3*ITRN-2
  IPOS(3*NSTA+2)=3*NP+3*ITRN-1
  IPOS(3*NSTA+3)=3*NP+3*ITRN
```

C SET LOCAL DESIGN MATRICES TO ZERO

```
DO 1210 I=1,15
DO 1210 J=1,18
  A(I,J)=0.D0
1210  AT(J,I)=0.D0
```

C FORM ATQA

```
DO 1300 I=1,NSTA
  DO 1300 J=1,3
    A(3*I-3+J,3*I-3+J)=1.D0
1300  A(3*I-3+J,3*NSTA+J)=-1.D0
DO 1400 I=1,3*(NSTA+1)      ! THIS COULD BE MADE MORE
  DO 1400 J=1,3*NSTA        ! EFFICIENT BY DISPENSING WITH A & AT
1400  AT(I,J)=A(J,I)        ! ALTOGETHER (DEVELOP ATA DIRECTLY)
  IPASS(ITRN)=NPASS
DO 1410 I=1,3*NSTA      ! SET Q MATRIX TO DIAGONAL (NPASS/50)
  QMAT(I,I)=2.D-2*NPASS
  DO 1410 J=1,3*NSTA
1410  IF(I.NE.J) QMAT(I,J)=0.D0
```

```
CALL MATMUL(AT,QMAT,3*NSTA+3,3*NSTA,3*NSTA,ATQ,18,15,15)
CALL MATMUL(ATQ,A,3*NSTA+3,3*NSTA,3*NSTA+3,ATQA,18,15,18)
```

C SET AL (CONSTANT TERMS) TO ZERO

```
DO 1411 I=1,15
1411  AL(I)=0.D0
```

C FORM ATQL

```
DO 1500 I=1,NSTA
  DO 1500 J=1,3
  TL= OBCORD(I,J)          - PCORD(ISTA(I),J)
  IF(DABS(TL).GT.1.D3) THEN
    WRITE(10,*)' *** LARGE CONSTANT TERM *** (GT 1 km) ***'
    WRITE(10,*)' ITRN= ',ITRN
    WRITE(10,*)' QFILE= ',QFILE
    WRITE(10,*)' STA No= ',I
    WRITE(10,*)' CO-ORD No = ',J
    END IF
1500  AL(3*(I-1)+J)=TL
```

```
CALL MATMUL(ATQ,AL,3*NSTA+3,3*NSTA,1,ATQL,18,15,1)
```

C ADD ATQA INTO ATPA

C & ADD ATQL INTO ATPL IN APPROPRIATE POSITIONS

```
DO 2300 I=1,3*(NSTA+1)
  ATPL(IPOS(I))=ATPL(IPOS(I))+ATQL(I)
  DO 2300 J=1,3*(NSTA+1)
2300  ATPA(IPOS(I),IPOS(J))=ATPA(IPOS(I),IPOS(J))+ATQA(I,J)
```

```

GO TO 1000
3000 NTRN=ITRN
      NVAR=3*NP+3*NTRN

C   CONSTRAIN FIXED POINTS

      DO 3090 I=1, NP
          IF (IFIX(I).EQ.1) THEN
              DO 3092 K=1, 3
                  KK=3*I-3+K
3092             ATPA(KK, KK)=1.D8
                  END IF
3090     CONTINUE

      CALL TIME(ITIME)
      WRITE(10,*) 'START INVERSE @ ', (ITIME(J), J=1, 3)
      CALL INVERSE(ATPA, NVAR, 310)
      CALL TIME(ITIME)
      WRITE(10,*) ' END INVERSE @ ', (ITIME(J), J=1, 3)
      WRITE(10,*) '      NVAR = ', NVAR-3*NFIX

C   FIND UNKNOWNNS (XX)

      CALL MATMUL(ATPA, ATPL, NVAR, NVAR, 1, XX, 310, 310, 1)

      DO 3400 I=1, NP      !   CALC FINAL CO-ORDS
          DO 3400 J=1, 3
3400             FCORD(I, J)=PCORD(I, J)+XX(3*I-3+J)

      DO 3600 I=1, NTRN
          DO 3600 J =1, 3      !   COMPUTE POSNS OF CENTRES OF G OF SUBNETS
3600             CG(I, J)=CG(I, J)+XX(3*NP+3*(I-1)+J)

      NOBS=0
      VV(1)=0.D0
      VV(2)=0.D0
      VV(3)=0.D0
      VTPV=0.D0
      WRITE(6, 925)
      DO 4000 ITRN=1, NTRN
          REWIND (20+ITRN)
          CALL RDDOP(20+ITRN, NSTA, NPASS, QMAT, OBCORD, ISTA, OCG, 0.D0)

          DO 4001 I=1, 3*NSTA
              QMAT(I, I)=2.D-2*NPASS
              DO 4001 J=1, 3*NSTA
4001             IF(I.NE.J) QMAT(I, J)=0.D0

C   DETERMINE COMPUTER NOS. FROM DEG SQ & BCN NOS.

      DO 4050 I=1, NSTA
          DO 4060 J=1, NP
              IF(ISTAT(J).EQ.ISTA(I)) THEN
                  ISTA(I)=J
                  GO TO 4050
              END IF
4060     CONTINUE
4050     CONTINUE
      IOBS=0
      DO 4100 I=1, NSTA      !   COMPUTE RESIDUALS FROM OBSERVED
          DO 4100 J=1, 3      !   AND FINAL VALUES
              IOBS=IOBS+1

```

```

          V(IOBS)=FCORD(ISTA(I),J)-CG(ITRN,J)-OBCORD(I,J)+OCG(J)
          VV(J)=VV(J)+V(IOBS)**2*NPASS*2.D-2
4100      TV(I,J)=V(IOBS)
          VTQV=0.D0
          DO 4200 I=1,IOBS
            DO 4200 J=1,IOBS
4200      VTQV=VTQV+V(I)*V(J)*QMAT(I,J)
          VTPV=VTPV+VTQV
          NOBS=NOBS+IOBS
          WRITE(6,'(" ",A8)') TNAME(ITRN)
          DO 4000 I=1,NSTA
4000      WRITE(6,'(1H#,4X,I3,3F5.2)') ISTA(I),(TV(I,J),J=1,3)
          WRITE(6,'(// "      VtPV = ",F7.2)') VTPV
          WRITE(6,'("#      NO OF VARIABLES= ",I4)') NVAR-3*NFIX
          WRITE(6,'("#      NO OF OBSERVATIONS= ",I4)') NOBS
          IDF = NOBS-NVAR+3*NFIX           ! TOTAL DEGREES OF FREEDOM
          SIG0= VTPV/(IDF)
          DO 4020 I=1,3
4020      SIG(I)=DSQRT(VV(I)/IDF*3.D0)
          WRITE(6,915) DSQRT(SIG0),(SIG(K),K=1,3)

          DO 4010 I=1,NVAR/3
          DO 4010 IC=1,3           ! * ATPA BY APPROPRIATE VARIANCE FACTORS
            DO 4010 J=1,NVAR/3     ! (X,Y AND Z) BECAUSE THIS IS EFFECT-
            DO 4010 JC=1,3         ! IVELY 3 SEPARATE ADJUSTMENTS)
4010      ATPA(3*I-3+IC,3*J-3+JC)=ATPA(3*I-3+IC,3*J-3+JC)*SIG(IC)*SIG(JC)

915      FORMAT("      sigma-0 = ",F8.2,"      sigX = ",F8.2,
* "      sigY = ",F8.2,"      sigZ = ",F8.2)
923      FORMAT('1',////,54X,'FINAL CO-ORDINATES',48X,'SHIFT3',
*/,35X,'X',10X,'mseX',10X,'Y',10X,'mseY',10X,'Z',10X,'mseZ',/)
924      FORMAT('1',////,48X,'SUBNET SHIFT VALUES',52X,'SHIFT3',/
*/,9X,'No Passes',11X,'X',08X,'mseX',12X,'Y',08X,'mseY',12X,'Z',
* 08X,'mseZ'/)
925      FORMAT(1H0,////,18X,' Residuals',92X,'SHIFT3'//,14X,
*      5('PT X Y Z',6X)/)
          WRITE(6,923) ! PRINT FINAL CARTESIAN CO-ORDINATES
          DO 3500 I=1,NP
C          IF(2*(I/2).EQ.I) WRITE(6,'(1H )')
3500      WRITE(6,'(" ",2I4,4X,A12,3(5X,F12.2,F8.2)') I,IFIX(I),NAME(I),
* (FCORD(I,J),DSQRT(ATPA(3*I-3+J,3*I-3+J)),J=1,3)

          WRITE(6,927) ! WRITE FINAL GEOGRAPHICAL CO-ORDS
927      FORMAT('1',////,40X,'GEOGRAPHICAL CO-ORDINATES',47X,'SHIFT3'/
*31X,'LATITUDE mse(M)',7X,'LONGITUDE mse(M)',4X,
* 'HEIGHT mse'/)

          DO 3520 I=1,NP
C          IF(2*(I/2).EQ.I) WRITE(6,'(1H )')
          CALL GEOGRAPH(FCORD(I,1),FCORD(I,2),FCORD(I,3),SMJ,SMN,
* ALAT,ALON,AHT)
          DO 3525 II=1,3
          DO 3525 JJ=1,3
3525      QXYZ(II,JJ)=ATPA(3*I-3+II,3*I-3+JJ) !TRANSFORM COVRNCE MATRIX
C          INTO LAT LON HGT
          CALL COVAR(QXYZ,FCORD(I,1),FCORD(I,2),FCORD(I,3),SMJ,SMN,QLLH)
          CALL DMS(ALAT,I1,I2,SS)
          CALL DMS(ALON,J1,J2,TT)
          SLAT=DSQRT(QLLH(1,1))
          SLON=DSQRT(QLLH(2,2))
          SHGT=DSQRT(QLLH(3,3))
3520      WRITE(6,928) I,IFIX(I),NAME(I),I1,I2,SS,SLAT,J1,J2,TT,SLON,
* AHT,SHGT
928      FORMAT(' ',2I4,4X,A12,2(3X,2I3.2,F8.4,F7.2),3X,F8.2,F6.2)

```

```

WRITE(6,924) ! PRINT FINAL TRANSLOCATION SHIFT VALUES
DO 3550 I=1,NTRN
C   IF(3*(I/2).EQ.I) WRITE(6,'(1H)')
3550 WRITE(6,'(" ",A8,2X,I4,2X,3(5X,F12.2,F8.2))')TNAME(I),IPASS(I),
*   (XX(3*NP+3*(I-1)+J),DSQRT(ATPA(3*NP+3*(I-1)+J,
*   3*NP+3*(I-1)+J)),J=1,3)

IPR=0
5000 READ(15,'(I4,1X,I5,1X,I4,1X,I5)',END=6000) IDS,IBN,JDS,JBN
II=IDS*100000+IBN
JJ=JDS*100000+JBN
DO 5100 I=1,NP
  IF (ISTAT(I).EQ.II) THEN
    JF=I
    GO TO 5200
  END IF
5100 CONTINUE
WRITE(10,*) II , ' NOT SPECIFIED'
GO TO 5000
5200 DO 5300 I=1,NP
  IF (ISTAT(I).EQ.JJ) THEN
    JT=I
    GO TO 5400
  END IF
5300 CONTINUE
WRITE(10,*) JJ , ' NOT SPECIFIED'
GO TO 5000
5400 IPR=IPR+1
IF(IPR.EQ.1) WRITE(6,929)
IF((IPR/2)*2.EQ.IPR) WRITE(6,'(1H)')
CALL SIGCRD(JF,JT,JF,JT,DIS,SDIS,AL,QMAT,IPOS) ! COMPUTE CHORD
PPM=SDIS/DIS*1.D6 ! DISTANCES AND THEIR mseS
WRITE(6,930) NAME(JF),IDS,IBN,NAME(JT),JDS,JBN,DIS,SDIS,PPM
GO TO 5000
929  FORMAT(1H1,////29X,"CHORD DISTANCES AND THEIR MSE'S",42X,'SHIFT3'/
* ,62X,'DISTANCE',5X,'MSE',9X,'PPM'/)
930  FORMAT(" ",2(A12,2X,I4,".",I5.5,5X),F12.3,F7.3,F12.2)
6000 STOP
END

```

```

C   SHIFTF...COMBINES DOPPLER NETWORKS USING ENTIRE VAR/COVAR MATRIX
C   OUTPUT FROM GEODOP.
C   PROVISIONAL DATA READ FROM DOPRUN.##
C   GEODOP DATA READ FROM GDOP.185####
C   FREE-NET ADJUSTMENT

```

```

      IMPLICIT REAL*8(A-H,O-Z)
      DIMENSION FCORD(40,3),PCORD(40,3),ATPL(310),ATPA(310,310),
*   A(15,18),AT(18,15),QMAT(15,15),ATQA(18,18),CG(40,3),XX(310),
*   OBCORD(5,3),TV(5,3),V(15),AL(15),ATQL(18),ATQ(18,15),IFIX(40),
*   OCG(3),ISTAT(40),IPOS(18),ISTA(5),ITIME(10),QXYZ(3,3),QLLH(3,3)
*   ,VV(3),SIG(3),IPRE(21)
      CHARACTER*12 NAME(40),RUNFILE,POINT,QFILE
      CHARACTER*8 TNAME(40)
      COMMON /DOPPL/NP,FCORD      ,IFIX      ,ATPA      ,NVNEW
      DATA SMJ,SMN /6378137.000D0,6356752.314D0/ ! GRS'80
      PRINT*,' INPUT FILE= :DPG0:FIELD:DOPPLER:DOPRUN.'
      READ(5,'(A)') RUNFILE
      OPEN(15,FILE=':DPG0:FIELD:DOPPLER:DOPRUN.'//RUNFILE,
*   FORM='FORMATTED',PAD='YES',RECFM='DS',BLANK='ZERO')
      PRINT*,' INPUT AUGMENTATION CONSTANT FOR OFF/DIAG TERMS
      READ *,GF
      CALL PRINTER
900  FORMAT(A12,3F12.3,I5,1X,I5,I2,I7)
      IP=0
100  READ(15,900) POINT,X,Y,Z,IDS,IBN,II
      IF(X.EQ.0.D0.AND.Y.EQ.0.D0.AND.Z.EQ.0.D0) GO TO 200
      IP=IP+1
      IFIX(IP)=II      ! NO POINTS ARE 'FIXED' IN THIS ADJUSTMENT -
      NAME(IP)=POINT  ! IFIX IS TO TAG THE POINTS FOR WHICH THE
      PCORD(IP,1)=X   ! CO-VARIANCES MUST BE WRITTEN TO DISC - FOR
      PCORD(IP,2)=Y   ! A FULL MOLODENSKY/BADEKAS TRANSFMTN BETWEEN
      PCORD(IP,3)=Z   ! FREE-NET AND P.E.
      ISTAT(IP)=IDS*100000+IBN
      GO TO 100
200  NP=IP
      ITRN=0
1000 READ(15,'(A12)',END=3000) QFILE
      IF(QFILE(1:6).EQ.'      ') GO TO 3000
      ITRN=ITRN+1
      TNAME(ITRN)= QFILE(6:12)
      OPEN(20+ITRN,FILE=':DPG0:FIELD:DOPPLER:'//QFILE,
*   FORM='FORMATTED',RECFM='DS',PAD='YES',BLANK='ZERO')
      CALL RDDOP(20+ITRN,NSTA,NPASS,QMAT,OBCORD,ISTA,OCG,GF)

C   DETERMINE COMPUTER NOS. FROM DEG SQ & BCN NOS.

      DO 1100 I=1,NSTA
      DO 1110 J=1,NP
      IF(ISTAT(J).EQ.ISTA(I)) THEN
      ISTA(I)=J
      GO TO 1100
      END IF
1110  CONTINUE
      WRITE(10,*) '<BEL> NO PROVISION FOR ',ISTA(I)
1100  CONTINUE

C   FIND CENTRE OF GRAVITY OF TRANSLCTN # ITRN

      DO 1030 J=1,3
1030  CG(ITRN,J)=OCG(J) ! CENTRE OF GRAVITY FROM OBSERVED CO-ORDINATES

C   DETERMINE POSITIONS OF UNKNOWNNS IN MAIN ATPA

```

```

DO 1200 I=1,NSTA
  IPOS(3*I-2)=3*ISTA(I)-2
  IPOS(3*I-1)=3*ISTA(I)-1
1200  IPOS(3*I )=3*ISTA(I)
  IPOS(3*NSTA+1)=3*NP+3*ITRN-2
  IPOS(3*NSTA+2)=3*NP+3*ITRN-1
  IPOS(3*NSTA+3)=3*NP+3*ITRN

C          SET LOCAL DESIGN MATRICES TO ZERO

DO 1210 I=1,15
DO 1210 J=1,18
  A(I,J)=0.D0
1210  AT(J,I)=0.D0

C          FORM ATQA

DO 1300 I=1,NSTA
  DO 1300 J=1,3
    A(3*I-3+J,3*I-3+J)=1.D0
1300  A(3*I-3+J,3*NSTA+J)=-1.D0
DO 1400 I=1,3*(NSTA+1)      ! THIS COULD BE MADE MORE
DO 1400 J=1,3*NSTA        ! EFFICIENT BY DISPENSING WITH A & AT
1400  AT(I,J)=A(J,I)      ! ALTOGETHER (DEVELOP ATA DIRECTLY)

DO 1410 I=1,3*NSTA
  QMAT(I,I)= NPASS/15.D0
DO 1410 J=1,3*NSTA
1410  IF(I.NE.J) QMAT(I,J)=0.D0

CALL MATMUL(AT,QMAT,3*NSTA+3,3*NSTA,3*NSTA,ATQ,18,15,15)
CALL MATMUL(ATQ,A,3*NSTA+3,3*NSTA,3*NSTA+3,ATQA,18,15,18)

C          SET AL (CONSTANT TERMS) TO ZERO
DO 1411 I=1,15
1411  AL(I)=0.D0

C          FORM ATQL

DO 1500 I=1,NSTA
  DO 1500 J=1,3
    TL= OBCORD(I,J)          - PCORD(ISTA(I),J)
    IF(DABS(TL).GT.1.D3) THEN
      WRITE(10,*)' *** LARGE CONSTANT TERM *** (GT 1 km) ***'
      WRITE(10,*)' ITRN= ',ITRN
      WRITE(10,*)' QFILE= ',QFILE
      WRITE(10,*)' STA No=',I
      WRITE(10,*)' CO-ORD No =',J
    END IF
1500  AL(3*(I-1)+J)=TL

CALL MATMUL(ATQ,AL,3*NSTA+3,3*NSTA,1,ATQL,18,15,1)

C          ADD ATQA INTO ATPA
C          & ADD ATQL INTO ATPL IN APPROPRIATE POSITIONS

DO 2300 I=1,3*(NSTA+1)
  ATPL(IPOS(I))=ATPL(IPOS(I))+ATQL(I)
DO 2300 J=1,3*(NSTA+1)
2300  ATPA(IPOS(I),IPOS(J))=ATPA(IPOS(I),IPOS(J))+ATQA(I,J)

GO TO 1000
3000  NTRN=ITRN
      NVAR=3*NP+3*NTRN

```

```

C      DETERMINE TRACE OF ATPA
      TRM=0.D0
      DO 3050 I=1,NVAR
3050   TRM=TRM+ATPA(I,I)
      WRITE(10,*) 'TRM = ',TRM

C      DETERMINE TRACE OF GGT
      TRG= 3.D0 ! TESTING (TRG SHOULD BE 3)
      WRITE(10,*) 'TRG = ',TRG

C      SCALE ATPA IN CASE ATPA>>GTG (EIGEN VECTOR MATRIX)

      SF=      (TRG/TRM)
      DO 3090 I=1,NVAR
      DO 3090 J=1,NVAR
3090   ATPA(I,J)=ATPA(I,J)*SF**2

C      ADD PSEUDO OBSERVATION (= EIGEN VECTOR) INTO ATPA TO PREVENT
C      WHOLE NETWORK SHIFTING

      PSEUDO=1.D0/NP

      DO 3110 K=1,3
      DO 3110 I=1,NP
      DO 3110 J=1,NP
      II=3*(I-1)+K
      JJ=3*(J-1)+K
3110   ATPA(II,JJ)=ATPA(II,JJ)+PSEUDO

      CALL TIME(ITIME)
      WRITE(10,*) 'START INVERSE @ ', (ITIME(J),J=1,3)
      CALL INVERSE(ATPA,NVAR,310)
      CALL TIME(ITIME)
      WRITE(10,*) ' END INVERSE @ ', (ITIME(J),J=1,3)
      WRITE(10,*) '      NVAR = ',NVAR

C      REMOVE PSEUDO OBSERVATION FROM ATPA

      DO 3120 K=1,3
      DO 3120 I=1,NP
      DO 3120 J=1,NP
      II=3*(I-1)+K
      JJ=3*(J-1)+K
3120   ATPA(II,JJ)=ATPA(II,JJ) -PSEUDO

C      REMOVE SCALE FACTOR FROM ATPA

      DO 3300 I=1,NVAR
      DO 3300 J=1,NVAR
3300   ATPA(I,J)=ATPA(I,J)*SF**2

C      FIND UNKNOWNNS (XX)

      CALL MATMUL(ATPA,ATPL,NVAR,NVAR,1,XX,310,310,1)

      DO 3400 I=1,NP ! CALC FINAL CO-ORDS
      DO 3400 J=1,3
3400   FCORD(I,J)=PCORD(I,J)+XX(3*I-3+J)

      DO 3600 I=1,NTRN
      DO 3600 J =1,3 ! COMPUTE POSNS OF CENTRES OF G OF TRNLCTNS
3600   CG(I,J)=CG(I,J)+XX(3*NP+3*(I-1)+J)

```

```

NOBS=0
VV(1)=0.DO
VV(2)=0.DO
VV(3)=0.DO
VTPV=0.DO
WRITE(6,925)
DO 4000 ITRN=1,NTRN
  REWIND (20+ITRN)
  CALL RDDOP(20+ITRN,NSTA,NPASS,QMAT,OBCORD,ISTA,OCG,GF)

  DO 4001 I=1,3*NSTA
    QMAT(I,I)=NPASS/15.DO
    DO 4001 J=1,3*NSTA
4001    IF(I.NE.J) QMAT(I,J)=0.DO

C    DETERMINE COMPUTER NOS. FROM DEG SQ & BCN NOS.

  DO 4050 I=1,NSTA
    DO 4060 J=1,NP
      IF(ISTAT(J).EQ.ISTA(I)) THEN
                                ISTA(I)=J
                                GO TO 4050
      END IF

4060    CONTINUE
4050    CONTINUE
    IOBS=0
    DO 4100 I=1,NSTA          ! COMPUTE RESIDUALS FROM OBSERVED
      DO 4100 J=1,3          ! AND FINAL VALUES
        IOBS=IOBS+1
        V(IOBS)=FCORD(ISTA(I),J)-CG(ITRN,J)-OBCORD(I,J)+OCG(J)
        VV(J)=VV(J)+V(IOBS)**2*NPASS/15.DO
4100    TV(I,J)=V(IOBS)
        VTQV=0.DO
        DO 4200 I=1,IOBS
          DO 4200 J=1,IOBS
4200    VTQV=VTQV+V(I)*V(J)*QMAT(I,J)
        VTPV=VTPV+VTQV
        NOBS=NOBS+IOBS
        WRITE(6,('0",A8')) TNAME(ITRN)
        DO 4000 I=1,NSTA
4000    WRITE(6,('1H#,4X,I3,3F5.2')) ISTA(I),(TV(I,J),J=1,3)
        WRITE(6,('///" VtPV " ,F12.2')) VTPV
        WRITE(6,('"# NO OF VARIABLES= ",I4')) NVAR-3
        WRITE(6,('"# NO OF OBSERVTVNS= ",I4')) NOBS
        IDF = (NOBS-NVAR+3)          ! TOTAL DEGREES OF FREEDOM
        SIG0= VTPV/(IDF)
        DO 4020 I=1,3
4020    SIG(I)=DSQRT(VV(I)/IDF*3.DO)
        WRITE(6,915) DSQRT(SIG0),(SIG(K),K=1,3)
915    FORMAT(" SIGMA 0 = ",F7.2," SIGX= ",F7.2,
* " SIGY= ",F7.2," SIGZ= ",F7.2)

        DO 4010 I=1,NVAR/3
        DO 4010 IC=1,3          ! * ATPA APPROPRIATE VARIANCE FACTORS
          DO 4010 J=1,NVAR/3    ! (X,Y AND Z BECAUSE THIS IS EFFECT-
            DO 4010 JC=1,3      ! IVELY 3 SEPARATE ADJUSTMENTS)
4010    ATPA(3*I-3+IC,3*J-3+JC)=ATPA(3*I-3+IC,3*J-3+JC)*SIG(IC)*SIG(JC)

923    FORMAT('1',////,54X,'FINAL CO-ORDINATES',48X,'SHIFTF',
*/,35X,'X',10X,'MSEX',10X,'Y',10X,'MSEY',10X,'Z',10X,'MSEZ',/)
924    FORMAT('1',////,48X,'TRNLCTN SHIFT VALUES',52X,'SHIFTF',
*/,25X,'X',08X,'MSEX',12X,'Y',08X,'MSEY',12X,'Z',10X,'MSEZ')
925    FORMAT(1H0,////,18X,' RESIDUALS',92X,'SHIFTF',14X,
* 5('PT X Y Z',6X))

```

```

WRITE(6,923) ! PRINT FINAL CARTESIAN CO-ORDINATES
DO 3500 I=1,NP
3500 WRITE(6,(' ',2I4,4X,A12,3(5X,F12.2,F8.2))) I,0,NAME(I),
* (FCORD(I,J),DSQRT(ATPA(3*I-3+J,3*I-3+J)),J=1,3)

WRITE(6,927) ! WRITE FINAL GEOGRAPHICAL CO-ORDS
927 FORMAT(' ',////,40X,'GEOGRAPHICAL CO-ORDINATES (GRS 80)',47X,
* 'SHIFTF'/
*31X,'LATITUDE MSE(M)',8X,'LONGITUDE MSE(M)',5X,'HEIGHT MSE'/)

DO 3520 I=1,NP
CALL GEOGRAPH(FCORD(I,1),FCORD(I,2),FCORD(I,3),SMJ,SMN,
* ALAT,ALON,AHT)
DO 3525 II=1,3
DO 3525 JJ=1,3
3525 QXYZ(II,JJ)=ATPA(3*I-3+II,3*I-3+JJ)
CALL COVAR(QXYZ,FCORD(I,1),FCORD(I,2),FCORD(I,3),SMJ,SMN,QLLH)
CALL DMS(ALAT,I1,I2,SS)
CALL DMS(ALON,J1,J2,TT)
SLAT=DSQRT(QLLH(1,1))
SLON=DSQRT(QLLH(2,2))
SHGT=DSQRT(QLLH(3,3))
3520 WRITE(6,928) I,0,NAME(I),I1,I2,SS,SLAT,J1,J2,TT,SLON,AHT,SHGT
928 FORMAT(' ',2I4,4X,A12,2(3X,2I3.2,F8.4,F7.2),3X,F8.2,F6.2)

WRITE(6,924) ! PRINT FINAL TRANSLOCATION SHIFT VALUES
DO 3550 I=1,NTRN
3550 WRITE(6,(' ',A8,4X,3(5X,F12.3,F8.3))) TNAME(I),
* (XX(3*NP+3*(I-1)+J),DSQRT(ATPA(3*NP+3*(I-1)+J,
* 3*NP+3*(I-1)+J)),J=1,3)

IPR=0
5000 READ(15,('I4,1X,I5,1X,I4,1X,I5'),END=6000) IDS,IBN,JDS,JBN
II=IDS*100000+IBN
JJ=JDS*100000+JBN
DO 5100 I=1,NP
IF (ISTAT(I).EQ.II) THEN
JF=I
GO TO 5200
END IF
5100 CONTINUE
WRITE(10,*) II ,' NOT SPECIFIED'
GO TO 5000
5200 DO 5300 I=1,NP
IF (ISTAT(I).EQ.JJ) THEN
JT=I
GO TO 5400
END IF
5300 CONTINUE
WRITE(10,*) JJ ,' NOT SPECIFIED'
GO TO 5000
5400 IPR=IPR+1
IF(IPR.EQ.1) WRITE(6,929)
IF((IPR/2)*2.EQ.IPR) WRITE(6,('1H '))
CALL SIGCRD(JF,JT,JF,JT,DIS,SDIS,AL,QMAT,IPOS)
PPM=SDIS/DIS*1.D6
WRITE(6,930) NAME(JF),IDS,IBN,NAME(JT),JDS,JBN,DIS,SDIS,PPM
GO TO 5000
929 FORMAT(1H1,////,29X,"CHORD DISTANCES AND THEIR MSE'S",45X,
* 'SHIFTF'//,62X,'DISTANCE',5X,'MSE',9X,'PPM'/)
930 FORMAT(" ",2(A12,2X,I4,".",I5.5,5X),F12.3,F7.3,F12.2)

6000 J=0

```

```

OPEN(19,FILE='QPRE.01',FORM='FORMATTED',PAD='YES')
DO 6010 I=1,NP          ! WRITE CO-VARIANCES OF ALL P.E.
IF (IFIX(I).EQ.1) THEN ! POINTS TO FILE QPRE.01
      J=J+1
      ATP=ISTAT(I)
      WRITE(19,(' ',F10.5," ",A12)) ATP/1.D5,NAME(I)
      IPRE(3*J-2)=3*I-2
      IPRE(3*J-1)=3*I-1
      IPRE(3*J )=3*I
      END IF
6010 CONTINUE
      NFIX=J
      DO 6020 I=1,3*NFIX
      DO 6020 J=1,3*NFIX
6020   WRITE(19,(' ',E25.15)) ATPA(IPRE(I),IPRE(J))
      CLOSE(19)
      END

```

```

C   BURSA = BURSA-WOLF   TRANSFORMATION
C -----
C   THIS PROGRAM DETERMINES PARAMETERS TO TRANSFORM
C   GEOCENTRIC CO-ORDINATES IN THE BROADCAST EPHEMERIS SYSTEM (=1)
C   (TRANSLOCATION FREE-NET) INTO THE PRECISE EPHEMERIS SYSTEM(=2)
C   ROTATIONS ARE ABOUT THE CENTRE OF CO-ORDINATE SYSTEM (GEOCENTRE)

```

```

      IMPLICIT REAL*8(A-H,O-Z)
      CHARACTER*20 NAME(30)
      CHARACTER*20 FILENAME
      CHARACTER*7  VARNAME(7)
      DIMENSION R(3,3),X1(30),Y1(30),Z1(30),X2(30),Y2(30),Z2(30)
      DIMENSION A(90,7),P(90,90),WT(30),X(7),AT(7,90),ATP(7,90)
      DIMENSION ATPA(7,7),AN(7,90),DL(90),VQ(3),VR(3),V(90)
      DATA SMJ,SMN/6378249.14D+0,6356514.94D+0/
      DATA VARNAME/'SCALE','X-ROT','Y-ROT','Z-ROT','X-SH','Y-SH','Z-SH'/
      FILENAME(1:7)='MOLBAD.'
      PRINT*,'INPUT FILE=MOLBAD.'
      READ(5,'(A)')FILENAME(8:20)
      OPEN(8,FILE=FILENAME,FORM='FORMATTED',RECFM='DS',PAD='YES')
500  FORMAT(1H1,50X,25HBURSA-WOLF TRANSFORMATION/50X,27('-')/
      *5X,5HPOINT,13X,6HWHEIGHT,11X,21HFREE-NET CO-ORDINATES,47X,4HADOS/
      *40X,21H(BROADCAST EPHEMERIS),40X,19H(PRECISE EPHEMERIS)/
      *14X,2(24X,'X',14X,'Y',14X,'Z'))
      CALL PRINTER
      WRITE(6,500)
      I=1
100  READ(8,'(A20,3F15.2)')NAME(I),X2(I),Y2(I),Z2(I)
      IF (Y2(I).EQ.0.0D0.AND.X2(I).EQ.0.0D0) GO TO 110
      READ(8,'(F6.2,14X,3F15.2)')WT(I),X1(I),Y1(I),Z1(I)
      WRITE(6,'(A20,F7.2,3F15.2,10X,3F15.2)')NAME(I),WT(I)
      *,X1(I),Y1(I),Z1(I),X2(I),Y2(I),Z2(I)
      I=I+1
      GO TO 100
110  NP=I-1
      NOBS=3*NP

```

```

C   FORMATION OF 'A' & 'P' MATRICES & 'L' VECTOR

```

```

C           1.....2.....3.....4.....5.....6.....7
C   SCALE  Rx      Ry      Rz      X-S      Y-S      Z-S

```

```

DO 140 J=1,NP
  A(3*J-2,1)= X1(J)
  A(3*J-2,2)=0.0D+0
  A(3*J-2,3)= Z1(J)
  A(3*J-2,4)=-Y1(J)
  A(3*J-2,5)=1.0D+0
  A(3*J-2,6)=0.0D+0
  A(3*J-2,7)=0.0D+0
  A(3*J-1,1)= Y1(J)
  A(3*J-1,2)=-Z1(J)
  A(3*J-1,3)=0.0D0
  A(3*J-1,4)= X1(J)
  A(3*J-1,5)=0.0D0
  A(3*J-1,6)=1.0D0
  A(3*J-1,7)=0.0D0
  A(3*J ,1)= Z1(J)
  A(3*J ,2)= Y1(J)
  A(3*J ,3)=-X1(J)
  A(3*J ,4)= 0.0D+0

```

```

      A(3*J ,5)= 0.0D+0
      A(3*J ,6)= 0.0D+0
      A(3*J ,7)= 1.0D+0
      DL(3*J-2)=X2(J)-X1(J)
      DL(3*J-1)=Y2(J)-Y1(J)
      DL(3*J )=Z2(J)-Z1(J)
      P(3*J-2,3*J-2)=WT(J) ! THIS WEIGHT IS OVERWRITTEN BY INVERSE
      P(3*J-1,3*J-1)=WT(J) ! OF ENTIRE CO-VARIANCE MATRIX
140   P(3*J ,3*J )=WT(J)
      DO 150 I =1,NOBS
        DO 150 J=1,7
150     AT(J,I)=A(I,J)
          OPEN(20,FILE=' :DPG0:FIELD:DOPPLER:QPRE.'//FILENAME(8:20),
*           FORM='FORMATTED',RECFM='DS',PAD='YES')
            DO 155 I=1,NP
155             READ(20,'(A15)') DUMMY
              DO 158 I=1,NOBS
                DO 158 J=1,NOBS
158               READ(20,'(E26.15)') P(I,J)
                 WRITE(10,*) I,J,P(I,J)
                  CALL INVERSE(P,NOBS,90)
                CALL MATMUL(AT,P,7,NOBS,NOBS,ATP,7,90,90)
                CALL MATMUL(ATP,A,7,NOBS,7,ATPA,7,90,7)
                CALL INVERSE(ATPA,7,7,DET)
                CALL MATMUL(ATPA,ATP,7,7,NOBS,AN,7,7,90)
                CALL MATMUL(AN,DL,7,NOBS,1,X,7,90,1)
                CALL MATMUL(A,X,NOBS,7,1,V,90,7,1)
163       DO 163 IOP=1,NOBS
          V(IOP)=V(IOP)-DL(IOP)
          VTPV=0.D0
          DO 164 IOP=1,NOBS
            DO 164 JOP=1,NOBS
164       VTPV=VTPV+V(IOP)*V(JOP)*P(IOP,JOP)
          R(1,1)=1.+X(1) ! X(1) = SCALE
          R(1,2)=-X(4) ! X(2) = X-ROTATION
          R(1,3)= X(3) ! X(3) = Y-ROTATION
          R(2,1)= X(4) ! X(4) = Z-ROTATION
          R(2,2)=1.+X(1)
          R(2,3)=-X(2)
          R(3,1)=-X(3)
          R(3,2)= X(2)
          R(3,3)=1.+X(1)
          WRITE(6,580)
580   FORMAT(//,20X,' PRECISE CO-ORDINATES'/
*23X,'TRANSFORMED BROADCAST CO-ORDINATES',59X, /
*64X,'VX',5X,'VY',5X,'VZ',7X,'VLAT',3X,'VLON',3X,'VHGT',10X, /
*'LX',5X,'LY',5X,'LZ')
          XSH=X(5)
          YSH=X(6)
          ZSH=X(7)
          PVV=VTPV
          DO 190 I=1,NP
            VQ(1)=X1(I)+XSH
            VQ(2)=Y1(I)+YSH
            VQ(3)=Z1(I)+ZSH
            CALL MATMUL(R,VQ,3,3,1,VR,3,3,1)
            VX=X2(I)-(VR(1))
            VY=Y2(I)-(VR(2))
            VZ=Z2(I)-(VR(3))

```

CONVERSION OF ERRORS IN X,Y,Z TO CORRESPONDING ERRORS IN LAT, LONG, HGT

```

      CALL GEOGRAPH(X2(I),Y2(I),Z2(I),SMJ,SMN,ALAT,ALON,AHGT)
      CALL GEOGRAPH(X2(I)-VX,Y2(I)-VY,Z2(I)-VZ,SMJ,SMN,BLAT,BLON,BHGT)

```

```

      VLAT=-(ALAT-BLAT)*SMJ      !- BECAUSE LAT +VE S , Z +VE N
      VLON=(ALON-BLON)*SMJ*DCOS(ALAT)
      VHGT=AHGT-BHGT
190  WRITE(6,510)NAME(I),X2(I),Y2(I),Z2(I),VR(1),VR(2),VR(3)
      * ,VX,VY,VZ,VLAT,VLON,VHGT,DL(3*I-2),DL(3*I-1),DL(3*I)
510  FORMAT(A20,3F13.2,/,20X,3F13.2,3F7.2,4X,3F7.2,5X,3F7.2/)
      PPM = X(1)*1.0D+6
      XROT =X(2)*2.062648062D+5  !ROT ABOUT X-AXIS
      YROT =X(3)*2.062648062D+5  ! " " Y- "
      ZROT =X(4)*2.062648062D+5  ! " " Z- "
      SPPM =DSQRT(PVV*ATPA(1,1)/(NOBS-7))*1.D+6
      SXROT=DSQRT(PVV*ATPA(2,2)/(NOBS-7))*206265.D+0
      SYROT=DSQRT(PVV*ATPA(3,3)/(NOBS-7))*206265.D+0
      SZROT=DSQRT(PVV*ATPA(4,4)/(NOBS-7))*206265.D+0
      SXSH =DSQRT(PVV*ATPA(5,5)/(NOBS-7))
      SYSH =DSQRT(PVV*ATPA(6,6)/(NOBS-7))
      SZSH =DSQRT(PVV*ATPA(7,7)/(NOBS-7))
      IF(NP.GT.7)WRITE(6,'(1H1)')
      WRITE(6,590)
590  FORMAT(//30X,45HTHE FOLLOWING PARAMETERS ARE FOR TRANSFORMING
      * /34X,37HFROM BROADCAST DATUM TO PRECISE DATUM)
      WRITE(6,520)XSH,YSH,ZSH
520  FORMAT(//22X,'X-SHIFT=',SP,F7.2,8X,'Y-SHIFT=',F7.2,9X,'Z-SHIFT=',F
      WRITE(6,522) SXSH,SYSH,SZSH
522  FORMAT(29X,'+/- ',F4.2,15X,'+/- ',F4.2,16X,'+/- ',F4.2)
      WRITE(6,530) XROT,YROT,ZROT
530  FORMAT(//20X,' X-ROT(")=' ,SP,F8.3,' Y-ROT(")=' ,F8.3,' Z
      WRITE(6,545)SXROT,SYROT,SZROT
545  FORMAT(29X,'+/- ',F6.3,14X,'+/- ',F6.3,15X,'+/- ',F6.3)
      WRITE(6,535) PPM,SPPM
535  FORMAT(//20X,'SCALE= ',SP,F8.4,' PPM +/- ',S,F6.4)
      WRITE(6,540)
540  FORMAT(//,31X,41HTRANSFORMATION MATRIX (SCALE & ROTATIONS)/
      *31X,36HABOUT CO-ORDINATE ORIGIN (GEOCENTRE) )
      DO 200 I=1,3
200  WRITE(6,550)(R(I,J),J=1,3)
550  FORMAT(/,30X,3F13.8)
      WRITE(6,570) (VARNAME(K),K=1,7)
570  FORMAT(1H1,10X,17HCOVARIANCE-MATRIX /10X,5(2H--),//,13X,7A10)
      DO 224 I=1,7
      WRITE(6,'(1H0,A10)') VARNAME(I)
      DO 224 J=1,7
224  WRITE(6,556) ATPA(I,J)
556  FORMAT(1H#,E10.2)
      WRITE(6,560) (VARNAME(K),K=1,7)
560  FORMAT(///1H0,10X,18HCORRELATION-MATRIX /10X,9(2H--),//,11X,7A7)
      DO 222 I=1,7
      WRITE(6,'(1H0,A7)') VARNAME(I)
      DO 222 J=1,7
222  WRITE(6,555) ATPA(I,J)/DSQRT(ATPA(I,I)*ATPA(J,J))
555  FORMAT(1H#,F7.2)
      END

```

^MOLBAD.F77

```
C      MOLBAD = MOLODENSKY-BADEKAS TRANSFORMATION
C-----
C      THIS PROGRAM DETERMINES PARAMETERS TO TRANSFORM
C      GEOCENTRIC CO-ORDINATES IN THE BROADCAST EPHEMERIS SYSTEM (=1)
C      (TRANSLOCATION FREE-NET) INTO THE PRECISE EPHEMERIS SYSTEM(=2)
C      ANY OF THE 7 TRANSFORMATION PARAMETERS MAY BE HELD FIXED

      IMPLICIT REAL*8(A-H,O-Z)
      CHARACTER*15 NAME(30),FILENAME*20,DUMMY
      CHARACTER*10 SXSH,SYSH,SZSH,SPPM,SXROT,SYROT,SZROT
      CHARACTER*7  VARNAME(7)
      DIMENSION R(3,3),X1(30),Y1(30),Z1(30),X2(30),Y2(30),Z2(30),
*   A(90,7),P(90,90),XX(7),AT(7,90),ATP(7,90),
*   ATPA(7,7),AN(7,90),DL(90),VQ(3),VR(3),AV(90),IFIX(7),PV(90)
      LOGICAL QW
      DATA SMJ,SMN/6378137.00D+0,6356752.31D+0/ ! GRS'80
      DATA VARNAME/'SCALE','Z-ROT','Y-ROT','X-ROT','X-SH','Y-SH','Z-SH'/
      FILENAME(1:7)='MOLBAD.'
      PRINT*,'INPUT FILE=MOLBAD.'
      READ(5, '(A)')FILENAME(8:20)
      PI=4.D+0*DATAN(1.0D+0)
      RHO=180.D+0*60.D+0*60.D+0/PI
      NVAR=0
      PRINT*,' for each variable input  0 to float & 1 to hold'
      DO 50 I=1,7
        PRINT*,VARNAME(I), '      ?      = '
        READ*, IFIX(I)
        IF(IFIX(I).EQ.0) NVAR=NVAR+1
50      CONTINUE
      CALL PRINTER
      OPEN(8, FILE=FILENAME, FORM='FORMATTED', RECFM='DS', PAD='YES')
500     FORMAT(1H ,///50X,33HMOLODENSKY-BADEKAS TRANSFORMATION,25X,A20,
*   /,50X,35('-')/
*   5X,5HPOINT,13X,6HWEIGHT,11X,21H BROADCAST EPHEMERIS ,47X,6HP.E. /
*   40X,21H (FREE NET) ,40X,19H /
*   14X,2(24X,'X',14X,'Y',14X,'Z'))
      WRITE(6,500) FILENAME
      I=1
100     READ(8, '(A15,6X,3(3X,F12.3))', END=110)NAME(I),X2(I),Y2(I),Z2(I)
      IF (X1(I).EQ.0.0D0.AND.X2(I).EQ.0.0D0) GO TO 110
      READ(8, '(F6.2,15X,3(3X,F12.3))')WT,X1(I),Y1(I),Z1(I)
      WRITE(6, '( " ",A15,5X,A7 ,3F15.3,10X,3F15.3)')NAME(I), '
*   ,X1(I),Y1(I),Z1(I),X2(I),Y2(I),Z2(I)
      I=I+1
      GO TO 100
110     NP=I-1
      NOBS=3*NP
      INQUIRE(FILE=' :DPG0:FIELD:DOPPLER:QPRE.'//FILENAME(8:20), EXIST=QW)
      IF(QW) THEN
        OPEN(20, FILE=' :DPG0:FIELD:DOPPLER:QPRE.'//FILENAME(8:20),
*   FORM='FORMATTED', RECFM='DS', PAD='YES')
155         DO 155 I=1,NP
          READ(20, '(A15)') DUMMY
          DO 158 I=1,NOBS
            DO 158 J=1,NOBS
              READ(20, '(E26.15)') P(I,J)
158             WRITE(10,*) I,J,P(I,J)
              CALL INVERSE(P,NOBS,90)
        ELSE
          DO 170 I=1,NOBS
            DO 170 J=1,NOBS
```

```

                P(I,J)=0.D0
                IF (I.EQ.J) P(I,J)=1.D0
170             CONTINUE
                END IF
                WTSUM=0.0D0
                SUMX2=0.0D0
                SUMY2=0.0D0
                SUMZ2=0.0D0
                DO 120 I=1,NP
                    SUMX2=SUMX2+X2(I)
                    SUMY2=SUMY2+Y2(I)
                    SUMZ2=SUMZ2+Z2(I)
120             WTSUM=WTSUM+1.D0
                CGX=SUMX2/WTSUM
                CGY=SUMY2/WTSUM
                CGZ=SUMZ2/WTSUM
                DO 130 I=1,NP
                    X1(I)=X1(I)-CGX
                    Y1(I)=Y1(I)-CGY
                    Z1(I)=Z1(I)-CGZ
                    X2(I)=X2(I)-CGX
                    Y2(I)=Y2(I)-CGY
130             Z2(I)=Z2(I)-CGZ

C             FORMATION OF 'A' & 'P' MATRICES & 'L' VECTOR
                DO 140 J=1,NP
                    A(3*J-2,1)=X1(J)
                    A(3*J-2,2)=Y1(J)
                    A(3*J-2,3)=-Z1(J)
                    A(3*J-2,4)=0.0D0
                    A(3*J-2,5)=1.0D+0
                    A(3*J-2,6)=0.0D+0
                    A(3*J-2,7)=0.0D+0
                    A(3*J-1,1)=Y1(J)
                    A(3*J-1,2)=-X1(J)
                    A(3*J-1,3)=0.0D0
                    A(3*J-1,4)=Z1(J)
                    A(3*J-1,5)=0.0D+0
                    A(3*J-1,6)=1.0D+0
                    A(3*J-1,7)=0.0D+0
                    A(3*J ,1)=Z1(J)
                    A(3*J ,2)=0.0D0
                    A(3*J ,3)=X1(J)
                    A(3*J ,4)=-Y1(J)
                    A(3*J ,5)=0.0D+0
                    A(3*J ,6)=0.0D+0
                    A(3*J ,7)=1.0D+0
                    DL(3*J-2)=X2(J)-X1(J)
                    DL(3*J-1)=Y2(J)-Y1(J)
140             DL(3*J )=Z2(J)-Z1(J)
                DO 150 I =1,NOBS
                    DO 150 J=1,7
150             AT(J,I)=A(I,J)
                CALL MATMUL(AT,P,7,NOBS,NOBS,ATP,7,90,90)
                CALL MATMUL(ATP,A,7,NOBS,7,ATPA,7,90,7)
                DO 160 I=1,7
                    IF(IFIX(I).EQ.1) ATPA(I,I)=ATPA(I,I)*1.D8 ! ADD LARGE NUMBER TO
! DIAGONAL OF ATPA TO
! HOLD FIXED PARAMETERS
160             CONTINUE
                DO 151 I=1,7
151             WRITE(10,'(7E9.2)') (ATPA(I,J),J=1,7)
                CALL INVERSE(ATPA,7,7)
                CALL MATMUL(ATPA,ATP,7,7,NOBS,AN,7,7,90)
                CALL MATMUL(AN,DL,7,NOBS,1,XX,7,90,1)

```

```

CALL MATMUL(A,XX,NOBS,7,1,AV,90,7,1)
DO 330 I=1,NOBS
330   AV(I)=AV(I)-DL(I)
      R(1,1)=1.+XX(1)           ! XX(1) = SCALE
      R(1,2)=XX(2)             ! XX(2) = Z-ROTATION
      R(1,3)=-XX(3)            ! XX(3) = Y-ROTATION
      R(2,1)=-XX(2)            ! XX(4) = X-ROTATION
      R(2,2)=1.+XX(1)          ! XX(5) = X-SHIFT
      R(2,3)=XX(4)             ! XX(6) = Y-SHIFT
      R(3,1)=XX(3)             ! XX(7) = Z-SHIFT
      R(3,2)=-XX(4)
      R(3,3)=1.+XX(1)
      WRITE(6,580)
580   FORMAT(/,20X,' P.E. CO-ORDINATES '/
*23X,' TRANSFORMED B.E. CO-ORDINATES',58X,'
*64X,' VX',5X,' VY',5X,' VZ',7X,' VLAT',3X,' VLON',3X,' VHGT',9X,
*' LX',5X,' LY',5X,' LZ')
      XSH=XX(5)
      YSH=XX(6)
      ZSH=XX(7)
      VV=0.0D0
      DO 190 I=1,NP
        VQ(1)=X1(I)
        VQ(2)=Y1(I)
        VQ(3)=Z1(I)
        CALL MATMUL(R,VQ,3,3,1,VR,3,3,1)
        VX=X2(I)-VR(1)-XSH
        VY=Y2(I)-VR(2)-YSH
        VZ=Z2(I)-VR(3)-ZSH
        VV=VV+(VX*VX+VY*VY+VZ*VZ)

```

CONVERSION OF ERRORS IN X,Y,Z TO CORRESPONDING ERRORS IN LAT, LONG, HGT

```

      CALL GEOGRAPH(X2(I)+CGX,Y2(I)+CGY,Z2(I)+CGZ,SMJ,SMN,ALAT,ALON
*   ,AHGT)
      CALL GEOGRAPH(X2(I)+CGX-VX,Y2(I)+CGY-VY,Z2(I)+CGZ-VZ
*   ,SMJ,SMN,BLAT,BLON,BHGT)
      VLAT=-(ALAT-BLAT)*SMJ      !- BECAUSE LAT +VE S , Z +VE N
      VLON=(ALON-BLON)*SMJ*DCOS(ALAT)
      VHGT=AHGT-BHGT
190   WRITE(6,510)NAME(I),X2(I)+CGX,Y2(I)+CGY,Z2(I)+CGZ,
*   VR(1)+XSH+CGX,VR(2)+YSH+CGY,VR(3)+ZSH+CGZ,VX,VY,VZ
*   ,VLAT,VLON,VHGT,DL(3*I-2),DL(3*I-1),DL(3*I)
510   FORMAT(/,A20,3F13.3,/,20X,3F13.3,3F7.2,4X,3F7.2,4X,3F7.2)
511   FORMAT(/,A20,3F13.3,/,20X,3F13.3,10X,2(5X,2I3,F8.4))
      CALL MATMUL(P,AV,NOBS,NOBS,1,PV,90,90,1)
      CALL MATMUL(AV,PV,1,NOBS,1,VTPV,1,90,1)
      PRINT*,' VTPV= ',VTPV
      PRINT*,' VV= ',VV
      DO 210 I=1,7
        DO 210 J=1,7
210   ATPA(I,J)=ATPA(I,J)*VTPV/(NOBS-NVAR)
      PPM= XX(1)*1.0D+6
      ZROT=XX(2)*RHO             ! ROT ABOUT Z-AXIS
      YROT=XX(3)*RHO             ! " " Y- "
      XROT=XX(4)*RHO             ! " " X- "
      WRITE(SPPM,' (" +/-",F6.3)') DSQRT(ATPA(1,1))*1.D+6
      WRITE(SZROT,' (" +/-",F6.3)') DSQRT(ATPA(2,2))*RHO
      WRITE(SYROT,' (" +/-",F6.3)') DSQRT(ATPA(3,3))*RHO
      WRITE(SXROT,' (" +/-",F6.3)') DSQRT(ATPA(4,4))*RHO
      WRITE(SXSH,' (" +/-",F6.3)') DSQRT(ATPA(5,5))
      WRITE(SYSH,' (" +/-",F6.3)') DSQRT(ATPA(6,6))
      WRITE(SZSH,' (" +/-",F6.3)') DSQRT(ATPA(7,7))
      IF (IFIX(1).EQ.1) WRITE(SPPM,' (A10)') ' FIXED '

```

```

IF (IFIX(2).EQ.1) WRITE(SZROT,'(A10)') '    FIXED '
IF (IFIX(3).EQ.1) WRITE(SYROT,'(A10)') '    FIXED '
IF (IFIX(4).EQ.1) WRITE(SXROT,'(A10)') '    FIXED '
IF (IFIX(5).EQ.1) WRITE(SXSH,'(A10)') '    FIXED '
IF (IFIX(6).EQ.1) WRITE(SYSH,'(A10)') '    FIXED '
IF (IFIX(7).EQ.1) WRITE(SZSH,'(A10)') '    FIXED '
WRITE(6,505)
505  FORMAT(1H1,29X,11H NEW POINTS,/,30X,10(1H-),/,15X,
*    19H      B.E. CO-ORDS,/,15X,23HTRANSFORMED INTO P.E. )
400  READ(8, '(A15,6X,3(3X,F12.3))',END=420) NAME(1),VR(1),VR(2),VR(3)
VR(1)=VR(1)-CGX
VR(2)=VR(2)-CGY
VR(3)=VR(3)-CGZ
CALL MATMUL ( R,VR,3,3,1,VQ,3,3,1)
VQ(1)=VQ(1)+CGX+XSH
VQ(2)=VQ(2)+CGY+YSH
VQ(3)=VQ(3)+CGZ+ZSH
VR(1)=VR(1)+CGX
VR(2)=VR(2)+CGY
VR(3)=VR(3)+CGZ
CALL GEOGRAPH(VQ(1),VQ(2),VQ(3),SMJ,SMN,ALAT,ALON,AHGT)
CALL DMS(ALAT,ILAT1,ILAT2,SLAT)
CALL DMS(ALON,ILON1,ILON2,SLON)
WRITE (6,511) NAME(1),(VR(K),K=1,3),(VQ(K),K=1,3),
*  ILAT1,ILAT2,SLAT,ILON1,ILON2,SLON
GO TO 400
420  IF(NP.GT.7)WRITE(6,'(1H1,100X,A20)') FILENAME
WRITE(6,590)
590  FORMAT(1H ,30X,45HTHE FOLLOWING PARAMETERS ARE FOR TRANSFORMING
* /34X,39HFROM B.E. (FREE NET) TO P.E. (NWL 9D) )
WRITE(6,520)XSH ,YSH ,ZSH
WRITE(6,525)SXSH,SYSH,SZSH
520  FORMAT(//20X,' X-SHIFT=',SP,F10.3,' Y-SHIFT=',F10.3,
*' Z-SHIFT=',F10.3)
525  FORMAT(26X,4X,A10,13X,A10,14X,A10)
WRITE(6,530)-XROT,-YROT,-ZROT
530  FORMAT(//20X,' X-ROT(")=' ,SP,F8.3,' Y-ROT(")=' ,F8.3,' Z
WRITE(6,545)SXROT,SYROT,SZROT
545  FORMAT(28X,A10,13X,A10,14X,A10)
WRITE(6,535) PPM,SPPM
535  FORMAT(//20X,'SCALE= ',SP,F8.4,' PPM ',A10)
WRITE(6,540)NP
540  FORMAT(//,31X,41HTRANSFORMATION MATRIX (SCALE & ROTATIONS)/
*31X,27HABOUT CENTRE OF GRAVITY OF ,I5,7H POINTS)
DO 200 I=1,3
200  WRITE(6,550)(R(I,J),J=1,3)
WRITE(6,591)CGX,CGY,CGZ
591  FORMAT(//10X,31HCENTRE OF ROTATION X:,F14.3,
* /,39X,'Y:',F14.3, /
*39X,'Z:',F14.3 )
550  FORMAT(/,30X,3F15.11)
WRITE(6,570) FILENAME,(VARNAME(K),K=1,7)
570  FORMAT(1H1,////,10X,18HCOVARIANCE-MATRIX ,70X,A20,/10X,9(2H--),
* //,13X,7A10)
DO 224 I=1,7
WRITE(6,'(1H0,A10)') VARNAME(I)
DO 224 J=1,7
224  WRITE(6,556) ATPA(I,J)
556  FORMAT(1H#,E10.2)
WRITE(6,560) (VARNAME(K),K=1,7)
560  FORMAT(///1H0,10X,18HCORRELATION MATRIX /10X,10(2H--),//,11X,7A7)
DO 222 I=1,7
WRITE(6,'(1H0,A7)') VARNAME(I)
DO 222 J=1,7

```

```
222      WRITE(6,555) ATPA(I,J)/DSQRT(ATPA(I,I)*ATPA(J,J))
555      FORMAT(1H#,F7.2)
      END
```

^DOPPLER:FINAL.F77

```
C   FINAL ...COMBINES DOPPLER SUBNETS BY APPLYING THREE ORTHOGONAL
C   SHIFTS TO EACH SUBNET.
C   WEIGHTING ACCORDING TO NO OF PASSES (WT= NPASS/50)
C   PROVISIONAL DATA READ FROM DOPRUN.##
C   GEODOP DATA READ FROM GDOP.185#### (B.E. SUBNETS)
C   AND GDOP.196# (P.E. =ADOS)
C   P.E. ALSO WEIGHTED ACC TO NPASS/20 BUT THESE ARE NOT
C   ALLOWED TO SHIFT FREELY.
C   BEFORE COMBINING B.E. WITH P.E.; ALL B.E. SUBNETS UNDERGO
C   SMALL ROTATIONS AND SCALE TO BRING THEM INTO P.E. SYSTEM
```

```
IMPLICIT REAL*8(A-H,O-Z)
```

```
DIMENSION FCORD(40,3),PCORD(40,3),ATPL(310),ATPA(310,310),
```

```
* A(15,18),AT(18,15),QMAT(15,15),ATQA(18,18),CG(40,3),XX(310),
* OBCORD(5,3),TV(5,3),V(15),AL(15),ATQL(18),ATQ(18,15),IFIX(40),
* OCG(3),ISTAT(40),IPOS(18),ISTA(5),ITIME(10),QXYZ(3,3),QLLH(3,3)
* ,VV(3),SIG(3),IPASS(40),RBP(3,3),OACG(3),V1(3),V2(3)
```

```
CHARACTER*12 NAME(40),RUNFILE,POINT,QFILE
```

```
CHARACTER*8 TNAME(40)
```

```
COMMON /DOPPL/NP,FCORD ,IFIX ,ATPA ,NVNEW
```

```
DATA SMJ,SMN /6378137.000D0,6356752.314D0/ ! GRS'80
```

```
PRINT*, ' INPUT FILE= :DPG0:FIELD:DOPPLER:DOPRUN.'
```

```
READ(5, '(A)') RUNFILE
```

```
OPEN(15, FILE=' :DPG0:FIELD:DOPPLER:DOPRUN.'//RUNFILE,
```

```
* FORM='FORMATTED', PAD='YES', RECFM='DS', BLANK='ZERO')
```

```
CALL PRINTER
```

```
900 FORMAT(A12,3F12.3,I5,1X,I5,I2,I7)
```

```
IP=0
```

```
DO 50 I=1,3 ! DEFINE PARAMETERS FO TRANSFORMING FROM
```

```
DO 50 J=1,3 ! BROADCAST TO PRECISE REFERENCE FRAME
```

```
50 RBP(I,J)=0.D0
```

```
DO 60 I=1,3
```

```
60 RBP(I,I)=1.D0
```

```
RBP(1,2)= 0.00000148961D0
```

```
RBP(2,1)=-0.00000148961D0
```

```
OACG(1)=5118311.139D0
```

```
OACG(2)=2269947.710D0
```

```
OACG(3)=-2965162.006D0
```

```
100 READ(15,900) POINT,X,Y,Z,IDS,IBN,II
```

```
IF(X.EQ.0.D0.AND.Y.EQ.0.D0.AND.Z.EQ.0.D0) GO TO 200
```

```
IP=IP+1
```

```
NAME(IP)=POINT
```

```
PCORD(IP,1)=X
```

```
PCORD(IP,2)=Y
```

```
PCORD(IP,3)=Z
```

```
ISTAT(IP)=IDS*100000+IBN
```

```
GO TO 100
```

```
200 NP=IP
```

```
ITRN=0 ! ITRN= NO OF B.E.& P.E. SUBNETS
```

```
ISBN=0 ! ITRN= NO OF B.E. SUBNETS
```

```
1000 READ(15, '(A12)', END=3000) QFILE
```

```
IF(QFILE(1:6).EQ.' ') GO TO 3000
```

```
ITRN=ITRN+1
```

```
TNAME(ITRN)= QFILE(6:12)
```

```
OPEN(20+ITRN, FILE=' :DPG0:FIELD:DOPPLER:'//QFILE,
```

```
* FORM='FORMATTED', RECFM='DS', PAD='YES', BLANK='ZERO')
```

```
CALL RDDOP(20+ITRN,NSTA,NPASS,QMAT,OBCORD,ISTA,OCG,0.D0)
```

```
IF (NSTA.NE.1) CALL BE_PE(RBP,OBCORD,NSTA,OACG,OCG,V1)
```

```

C      DETERMINE COMPUTER NOS. FROM DEG SQ & BCN NOS.

DO 1100 I=1,NSTA
      DO 1110 J=1,NP
          IF(ISTAT(J).EQ.ISTA(I)) THEN
                                  ISTA(I)=J
                                  GO TO 1100
                                  END IF
1110      CONTINUE
          WRITE(10,*) '<BEL> NO PROVISION FOR ',ISTA(I)
1100      CONTINUE

      IF (NSTA.EQ.1) THEN ! IE PRECISE EPHEMERIS
          NOBS=NOBS+3
          WT=NPASS/20.D0
          IPASS(ITRN)=NPASS
          WRITE(10,*)J
          DO 1105 I=1,3
              CG(ITRN,I)=OCG(I)
              TL=OCG(I)-PCORD(J,I)
              WRITE(10,*) I,TL,WT
              KK= 3*(J-1)+I
              ATPL(KK)=ATPL(KK)+WT*TL
1105          ATPA(KK,KK)=ATPA(KK,KK)+WT
              GO TO 1000
              END IF

C      FIND CENTRE OF GRAVITY OF TRANSLCTN # ITRN

      ISBN=ISBN+1
      DO 1030 J=1,3
1030      CG(ISBN,J)=OCG(J) ! CENTRE OF GRAVITY FROM OBSERVED CO-ORDINATES

C      DETERMINE POSITIONS OF UNKNOWNNS IN MAIN ATPA

DO 1200 I=1,NSTA
      IPOS(3*I-2)=3*ISTA(I)-2
      IPOS(3*I-1)=3*ISTA(I)-1
1200      IPOS(3*I )=3*ISTA(I)
      IPOS(3*NSTA+1)=3*NP+3*ISBN-2
      IPOS(3*NSTA+2)=3*NP+3*ISBN-1
      IPOS(3*NSTA+3)=3*NP+3*ISBN

C      SET LOCAL DESIGN MATRICES TO ZERO

DO 1210 I=1,15
DO 1210 J=1,18
      A(I,J)=0.D0
1210      AT(J,I)=0.D0

C      FORM ATQA

DO 1300 I=1,NSTA
      DO 1300 J=1,3
          A(3*I-3+J,3*I-3+J)=1.D0
1300      A(3*I-3+J,3*NSTA+J)=-1.D0
      DO 1400 I=1,3*(NSTA+1) ! THIS COULD BE MADE MORE
          DO 1400 J=1,3*NSTA ! EFFICIENT BY DISPENSING WITH A & AT
1400          AT(I,J)=A(J,I) ! ALTOGETHER (DEVELOP ATA DIRECTLY)
      IPASS(ITRN)=NPASS
      DO 1410 I=1,3*NSTA ! SET Q MATRIX TO DIAGONAL (NPASS/50)
          QMAT(I,I)=2.D-2*NPASS
          DO 1410 J=1,3*NSTA
1410          IF(I.NE.J) QMAT(I,J)=0.D0

```

```
CALL MATMUL(AT,QMAT,3*NSTA+3,3*NSTA,3*NSTA,ATQ,18,15,15)
CALL MATMUL(ATQ,A,3*NSTA+3,3*NSTA,3*NSTA+3,ATQA,18,15,18)
```

```
C          SET AL (CONSTANT TERMS) TO ZERO
DO 1411 I=1,15
1411      AL(I)=0.DO
```

```
C          FORM ATQL
```

```
DO 1500 I=1,NSTA
DO 1500 J=1,3
TL= OBCORD(I,J)          - PCORD(ISTA(I),J)
IF(DABS(TL).GT.1.D3) THEN
    WRITE(10,*)' *** LARGE CONSTANT TERM *** (GT 1 km) ***'
    WRITE(10,*)' ITRN= ',ITRN
    WRITE(10,*)' QFILE= ',QFILE
    WRITE(10,*)' STA No= ',I
    WRITE(10,*)' CO-ORD No = ',J
    END IF
1500      AL(3*(I-1)+J)=TL
```

```
CALL MATMUL(ATQ,AL,3*NSTA+3,3*NSTA,1,ATQL,18,15,1)
```

```
C          ADD ATQA INTO ATPA
C          & ADD ATQL INTO ATPL IN APPROPRIATE POSITIONS
```

```
DO 2300 I=1,3*(NSTA+1)
    ATPL(IPOS(I))=ATPL(IPOS(I))+ATQL(I)
    DO 2300 J=1,3*(NSTA+1)
2300      ATPA(IPOS(I),IPOS(J))=ATPA(IPOS(I),IPOS(J))+ATQA(I,J)
```

```
GO TO 1000
3000      NTRN=ITRN      ! TOTAL NO OF P.E. & B.E. SUBNETS
        NSBN=ISBN      ! TOTAL NO OF B.E. SUBNETS
        NVAR=3*NP+3*NSBN
```

```
WRITE(10,*)'      NP = ',NP
WRITE(10,*)'      NTRN = ',NTRN
WRITE(10,*)'      NSBN = ',NSBN
WRITE(10,*)'      NVAR = ',NVAR
CALL TIME(ITIME)
WRITE(10,*)' START INVERSE @ ',(ITIME(J),J=1,3)
CALL INVERSE(ATPA,NVAR,310)
CALL TIME(ITIME)
WRITE(10,*)' END INVERSE @ ',(ITIME(J),J=1,3)
WRITE(10,*)'      NVAR = ',NVAR
```

```
C          FIND UNKNOWNNS (XX)
```

```
CALL MATMUL(ATPA,ATPL,NVAR,NVAR,1,XX,310,310,1)
```

```
DO 3400 I=1,NP      ! CALC FINAL CO-ORDS
DO 3400 J=1,3
3400      FCORD(I,J)=PCORD(I,J)+XX(3*I-3+J)
```

```
DO 3600 I=1,NSBN
DO 3600 J=1,3      ! COMPUTE POSNS OF CENTRES OF G OF SUBNETS
3600      CG(I,J)=CG(I,J)+XX(3*NP+3*(I-1)+J)
```

```
NOBS=0
VV(1)=0.DO
VV(2)=0.DO
```

```

VV(3)=0.D0
VTPV=0.D0
WRITE(6,925)
DO 4000 ITRN=1,NTRN
  REWIND (20+ITRN)
  CALL RDDOP(20+ITRN,NSTA,NPASS,QMAT,OBCORD,ISTA,OCG,0.D0)
  IF(NSTA.NE.1) CALL BE_PE(RBP,OBCORD,NSTA,OACG,OCG,V2)

  DO 4001 I=1,3*NSTA
  QMAT(I,I)=2.D-2*NPASS
  DO 4001 J=1,3*NSTA
4001   IF(I.NE.J) QMAT(I,J)=0.D0

C   DETERMINE COMPUTER NOS. FROM DEG SQ & BCN NOS.

DO 4050 I=1,NSTA
  DO 4060 J=1,NP
  IF(ISTAT(J).EQ.ISTA(I)) THEN
                                ISTA(I)=J
                                GO TO 4050
  END IF

4060   CONTINUE
4050   CONTINUE
  IOBS=0
  DO 4100 I=1,NSTA           ! COMPUTE RESIDUALS FROM OBSERVED
  DO 4100 J=1,3             ! AND FINAL VALUES
    IOBS=IOBS+1
    V(IOBS)=FCORD(ISTA(I),J)-CG(ITRN,J)-OBCORD(I,J)+OCG(J)
    VV(J)=VV(J)+V(IOBS)**2*NPASS*2.D-2
4100   TV(I,J)=V(IOBS)
  VTQV=0.D0
  DO 4200 I=1,IOBS
  DO 4200 J=1,IOBS
4200   VTQV=VTQV+V(I)*V(J)*QMAT(I,J)
  VTPV=VTPV+VTQV
  NOBS=NOBS+IOBS
  WRITE(6,(' ',A8)) TNAME(ITRN)
  DO 4000 I=1,NSTA
4000   WRITE(6,('1H#,4X,I3,3F5.2')) ISTA(I),(TV(I,J),J=1,3)
  WRITE(6,('//'      VtPV = ",F7.2)') VTPV
  WRITE(6,('"#      NO OF VARIABLES= ",I4)') NVAR
  WRITE(6,('"#      NO OF OBSERVATIONS= ",I4)') NOBS
  IDF = NOBS-NVAR           ! TOTAL DEGREES OF FREEDOM
  SIG0= VTPV/(IDF)
  DO 4020 I=1,3
4020   SIG(I)=DSQRT(VV(I)/IDF*3.D0)
  WRITE(6,915) DSQRT(SIG0),(SIG(K),K=1,3)

  DO 4010 I=1,NVAR/3
  DO 4010 IC=1,3           ! * ATPA BY APPROPRIATE VARIANCE FACTORS
  DO 4010 J=1,NVAR/3       ! (X,Y AND Z) BECAUSE THIS IS EFFECT-
  DO 4010 JC=1,3           ! IVELY 3 SEPARATE ADJUSTMENTS)
4010   ATPA(3*I-3+IC,3*J-3+JC)=ATPA(3*I-3+IC,3*J-3+JC)*SIG(IC)*SIG(JC)

915   FORMAT("      sigma-0 = ",F8.2,"      sigX = ",F8.2,
* "      sigY = ",F8.2,"      sigZ = ",F8.2)
923   FORMAT('1',////,54X,'FINAL CO-ORDINATES',48X,'FINSLN',
*/,35X,'X',10X,'mseX',10X,'Y',10X,'mseY',10X,'Z',10X,'mseZ',/)
924   FORMAT('1',////,48X,'SUBNET SHIFT VALUES',52X,'FINSLN',/
*/,9X,'No Passes',11X,'X',08X,'mseX',12X,'Y',08X,'mseY',12X,'Z',
* 08X,'mseZ'/)
925   FORMAT(1H0,////,18X,' Residuals',92X,'FINSLN'//,14X,
* 5('PT X Y Z',6X)/)
  WRITE(6,923) ! PRINT FINAL CARTESIAN CO-ORDINATES

```

```

DO 3500 I=1,NP
C   IF(2*(I/2).EQ.I) WRITE(6,'(1H)')
3500 WRITE(6,'(" ",2I4,4X,A12,3(5X,F12.2,F8.2))') I,IFIX(I),NAME(I),
* (FCORD(I,J),DSQRT(ATPA(3*I-3+J,3*I-3+J)),J=1,3)

WRITE(6,927) ! WRITE FINAL GEOGRAPHICAL CO-ORDS
927  FORMAT('1',////40X,'GEOGRAPHICAL CO-ORDINATES',47X,'FINSLN'/
*31X,'LATITUDE mse(M)',7X,'LONGITUDE mse(M)',4X,
* 'HEIGHT mse'/)

DO 3520 I=1,NP
C   IF(2*(I/2).EQ.I) WRITE(6,'(1H)')
CALL GEOGRAPH(FCORD(I,1),FCORD(I,2),FCORD(I,3),SMJ,SMN,
* ALAT,ALON,AHT)
DO 3525 II=1,3
DO 3525 JJ=1,3
3525 QXYZ(II,JJ)=ATPA(3*I-3+II,3*I-3+JJ) !TRANSFORM COVRNCE MATRIX
C INTO LAT LON HGT
CALL COVAR(QXYZ,FCORD(I,1),FCORD(I,2),FCORD(I,3),SMJ,SMN,QLLH)
CALL DMS(ALAT,I1,I2,SS)
CALL DMS(ALON,J1,J2,TT)
SLAT=DSQRT(QLLH(1,1))
SLON=DSQRT(QLLH(2,2))
SHGT=DSQRT(QLLH(3,3))
3520 WRITE(6,928) I,IFIX(I),NAME(I),I1,I2,SS,SLAT,J1,J2,TT,SLON,
* AHT,SHGT
928  FORMAT(' ',2I4,4X,A12,2(3X,2I3.2,F8.4,F7.2),3X,F8.2,F6.2)

WRITE(6,924) ! PRINT FINAL TRANSLOCATION SHIFT VALUES
DO 3550 I=1,NSBN
C   IF(3*(I/2).EQ.I) WRITE(6,'(1H)')
3550 WRITE(6,'(" ",A8,2X,I4,2X,3(5X,F12.2,F8.2))')TNAME(I),IPASS(I),
* (XX(3*NP+3*(I-1)+J),DSQRT(ATPA(3*NP+3*(I-1)+J,
* 3*NP+3*(I-1)+J)),J=1,3)

IPR=0
5000 READ(15,'(I4,1X,I5,1X,I4,1X,I5)',END=6000) IDS,IBN,JDS,JBN
II=IDS*100000+IBN
JJ=JDS*100000+JBN
DO 5100 I=1,NP
IF (ISTAT(I).EQ.II) THEN
JF=I
GO TO 5200
END IF
5100 CONTINUE
WRITE(10,*) II , ' NOT SPECIFIED'
GO TO 5000
5200 DO 5300 I=1,NP
IF (ISTAT(I).EQ.JJ) THEN
JT=I
GO TO 5400
END IF
5300 CONTINUE
WRITE(10,*) JJ , ' NOT SPECIFIED'
GO TO 5000
5400 IPR=IPR+1
IF(IPR.EQ.1) WRITE(6,929)
IF((IPR/2)*2.EQ.IPR) WRITE(6,'(1H)')
CALL SIGCRD(JF,JT,JF,JT,DIS,SDIS,AL,QMAT,IPOS) ! COMPUTE CHORD
PPM=SDIS/DIS*1.D6 ! DISTANCES AND THEIR mses
WRITE(6,930) NAME(JF),IDS,IBN,NAME(JT),JDS,JBN,DIS,SDIS,PPM
GO TO 5000
929  FORMAT(1H1,////29X,"CHORD DISTANCES AND THEIR MSE'S",42X,'FINSLN'/
* ,62X,'DISTANCE',5X,'MSE',9X,'PPM'/)

```

```
930  FORMAT(" ",2(A12,2X,I4,".",I5.5,5X),F12.3,F7.3,F12.2)  
6000 STOP  
      END
```

^EIGEN3.F77

C EIGEN3...FINDS EIGEN VALUES OF A SYMMETRICAL 3*3 MATRIX
C PROGRAM RE-WRITTEN 11/4/86 AFTER ACCIDENTAL ERASURE

```
SUBROUTINE EIGEN3(Q,EI1,EI2,EI3)
IMPLICIT REAL*8(A-H,O-Z)
DIMENSION Q(3,3)
A3=-1.D0
A2=Q(1,1)+Q(2,2)+Q(3,3)
A1=Q(1,2)**2+Q(1,3)**2+Q(2,3)**2
* -Q(1,1)*Q(2,2)-Q(1,1)*Q(3,3)-Q(2,2)*Q(3,3)
A0=-Q(1,1)*Q(2,3)**2-Q(2,2)*Q(1,3)**2-Q(3,3)*Q(1,2)**2
* +Q(1,1)*Q(2,2)*Q(3,3)+2.D0*Q(1,2)*Q(1,3)*Q(2,3)
CALL NEWTON(A3,A2,A1,A0, 1.D+2,EI1,1.D-5) ! LARGEST ROOT
CALL NEWTON(A3,A2,A1,A0,-1.D+2,EI3,1.D-5) ! SMALLEST ROOT
CALL NEWTON(A3,A2,A1,A0,(EI1+EI3)/2.D0,EI2,1.D-5) ! MIDDLE ROOT
RETURN
END
```

^NEWTON.F77

```
C NEWTON... FINDS ROOT(X1) OF CUBIC EQU'N APPROX ROOT APP
SUBROUTINE NEWTON(A,B,C,D,APP,X1,TOL)
IMPLICIT REAL*8(A-H,O-Z)
X=APP
N=1
10 N=N+1
IF(N.GT.50) THEN
WRITE (10,*) 'DIVERGENCE ;NO REAL ROOT @ ',X1
RETURN
END IF
X1=X-(A*X**3+B*X**2+C*X+D)/(3.D0*A*X**2+2.D0*B*X+C)
IF (DABS(X1-X).LT.TOL) RETURN
X=X1
GO TO 10
END
```

COVAR...TRANSFORMS CO-VARIANCE MATRIX IN X,Y,Z (QXYZ) INTO
C CO-VARIANCE MATRIX IN LAT,LON,HGT (QLLH)

C*****
C T *
C [QLLH]=[DERIV]*[QXYZ]*[DERIV] * DERIV=JACOBIAN MATRIX
C *
C*****

```

SUBROUTINE COVAR (QXYZ,X1,Y1,Z1,SMJ,SMN,QLLH)
IMPLICIT REAL*8 (A-H,O-Z)
DIMENSION QXYZ(3,3),QLLH(3,3),DER(3,3),DERT(3,3)
CALL JACOBIAN(X1,Y1,Z1,SMJ,SMN,DER)
CALL MATMUL(DER,QXYZ,3,3,3,QLLH,3,3,3)
DO 100 I=1,3
  DO 100 J=1,3
100   DERT(I,J)=DER(J,I)
CALL MATMUL(QLLH,DERT,3,3,3,DER,3,3,3)
DO 110 I=1,3
  DO 110 J=1,3
110   QLLH(I,J)=DER(I,J)
RETURN
END

```

C JACOBIAN... COMPUTES JACOBIAN MATRIX
C (PARTIAL DERIVATIVES OF XYZ WRT LAT LON HT)
C DLAT AND DLON IN UNITS OF METRES

```

SUBROUTINE JACOBIAN(X1,Y1,Z1,SMJ,SMN,DER)
IMPLICIT REAL*8(A-H,O-Z)
DIMENSION DER(3,3)
CALL GEOGRAPH(X1,Y1,Z1,SMJ,SMN,ALAT,ALON,AHGT)
CALL GEOGRAPH(X1+1.D0,Y1,Z1,SMJ,SMN,XLAT,XLON,XHGT)
CALL GEOGRAPH(X1,Y1+1.D0,Z1,SMJ,SMN,YLAT,YLON,YHGT)
CALL GEOGRAPH(X1,Y1,Z1+1.D0,SMJ,SMN,ZLAT,ZLON,ZHGT)
E2=(SMJ**2-SMN**2)/SMJ**2 ! RMD IS RADI
RMD=SMJ*(1.D0-E2)/(1.D0-E2*(DSIN(ALAT))**2)**1.5D0 ! IN MERIDIAN
RPV=SMJ/(1.D0-E2*(DSIN(ALAT))**2) ! RADIUS IN PRIME VERTIC
DER(1,1)=(XLAT-ALAT)*RMD ! DLAT/DX
DER(1,2)=(YLAT-ALAT)*RMD ! DLAT/DY
DER(1,3)=(ZLAT-ALAT)*RMD ! DLAT/DZ
DER(2,1)=(XLON-ALON)*RPV*DCOS(ALAT) ! DLON/DX
DER(2,2)=(YLON-ALON)*RPV*DCOS(ALAT) ! DLON/DY
DER(2,3)=(ZLON-ALON)*RPV*DCOS(ALAT) ! DLON/DZ
DER(3,1)=(XHGT-AHGT) ! DHGT/DX
DER(3,2)=(YHGT-AHGT) ! DHGT/DY
DER(3,3)=(ZHGT-AHGT) ! DHGT/DZ
RETURN
END

```

^ROTV.F77

C ROTV --- THIS SUBROUTINE ROTATES ERRORS IN XYZ (IN VECTOR VW)
C TO ERRORS IN LAT LONG HGT (IN VECTOR VT)

```

SUBROUTINE ROTV(X,Y,Z,SMJ,SMN,VW,VT)
IMPLICIT REAL*8(A-H,O-Z)
DIMENSION VW(3),VT(3),RLAT(3,3),RLON(3,3),RT(3,3)
DATA RLAT,RLON,RT/27*0.0D+0/
DO 10 I=1,3
    RLAT(I,I)=1.0D+0
    RLON(I,I)=1.0D+0
10    RT(I,I)=1.0D+0
CALL GEOGRAPH(X,Y,Z,SMJ,SMN,ALAT,ALON,HGT)
RLAT(1,1)= DCOS(ALAT)
RLAT(1,3)=-DSIN(ALAT)
RLAT(3,1)= DSIN(ALAT)
RLAT(3,3)= DCOS(ALAT)
RLON(1,1)= DCOS(ALON)
RLON(1,2)= DSIN(ALON)
RLON(2,1)=-DSIN(ALON)
RLON(2,2)= DCOS(ALON)
CALL MATMUL(RLAT,RLON,3,3,3,RT,3,3,3)
CALL MATMUL(RT,VW,3,3,1,VT,3,3,1)
RETURN
END
```

^GEOGRAPH.F77

```
SUBROUTINE GEOGRAPH(X, Y, Z, A, B, ALAT, ALONG, HGT)
  IMPLICIT REAL*8(A-H, O-Z)
  E2=(A*A-B*B)/(A*A)
  E=(A*A-B*B)/(B*B)
  ALONG=DATAN(Y/X)
  P=(X*X+Y*Y)**(0.5D+0)
  U=DATAN(Z*A/P/B)
  ALAT=-DATAN((Z+E*B*(DSIN(U))**3)/(P-E2*A*(DCOS(U))**3))
  V=A/DSQRT(1.0-E2*DSIN(ALAT)**2)
  HGT=-Z/DSIN(ALAT)-(1-E2)*V
  RETURN
  END
```

^GEOCEN.F77

```
CSUBROUTINE TO CONVERT GEOGRAPHICAL CO-ORDS TO GEOCEN (LAT +VE S)
SUBROUTINE GEOCEN(ALAT, ALON, HT, A, B, X, Y, Z)
  IMPLICIT REAL*8(A-H, O-Z)
  E2=(A*A-B*B)/(A*A)
  E=(A*A-B*B)/(B*B)
  V=A/DSQRT(1.0-E2*(DSIN(ALAT))**2)
  X=(V+HT)*DCOS(ALAT)*DCOS(ALON)
  Y=(V+HT)*DCOS(ALAT)*DSIN(ALON)
  Z=-((1.0-E2)*V+HT)*DSIN(ALAT)
  RETURN
  END
```

```

C              ELLIPSOID
C              =====
C              THIS PROGRAM FINDS THE SPHEROID WHICH BEST FITS A SET OF
C              POINTS GIVEN IN GEOCENTRIC CO-ORDINATES.THE INPUT FILE COMPRISES
C              POINT NAMES,WEIGHTS,CO-ORDS(XYZ) AND GEOIDAL HEIGHTS.THE GEOIDAL
C              HEIGHT IS SUBTRACTED IN A DIRN PERPENDICULAR TO THE SURFACE OF
C              THE SPHEROID.THE PROGRAM THEN COMPUTES PARAMETERS OF THE SPHEROID
C              WHICH BEST FITS THE RESULTING POINTS WHICH HAVE BEEN REDUCED TO
C              GEOID LEVEL.
C              THE PARAMETERS TO BE DETERMINED ARE:
C              1      SEMI-MAJOR AXIS      (A)
C              2      SEMI-MINOR AXIS     (B)
C              3      X-SHIFT
C              4      Y-SHIFT              ANY OF THESE VALUES
C              5      Z-SHIFT              } MAY BE HELD CONSTANT
C              6      X-ROT
C              7      Y-ROT
C              Z-ROT IS EQUIVALENT TO A CHANGE OF LONGITUDE ORIGIN
C              AND IS NOT CONSIDERED AS AN UNKNOWN

IMPLICIT REAL*8(A-H,O-Z)
CHARACTER*20 FINAME
CHARACTER*20 NAME(400)
CHARACTER*3 VARNAME(7)
DIMENSION A(400,7),ARED(7,7),ATPA(7,7),ATPL(7),ATPLT(7),AR(400,7),
* WT(400),XX(7),IQ(7),V(400),QRED(7,7),IDATE(3)
DIMENSION XT(400),YT(400),ZT(400),GHT(400),R(3,3),GV(3),RGV(3)
DIMENSION XG(400),YG(400),ZG(400),DL(400),RX(3,3),RY(3,3)
DATA SDA,SDB,SAB,XS,YS,ZS /6*0.D0/
DATA DSCL /1.0000000D+0/
CALL DATE(IDATE)
XR=0.0D0
YR=0.0D0
PI=4.*DATAN(1.0D+0)
RHO=648000.D0/PI
PRINT*,'          YES=1,NO=0'
PRINT*,'          -----'
PRINT*,'DO YOU WISH "A" TO BE A VARIABLE?      '
READ(5,'(I2)') IQ(1)
PRINT*,'DO YOU WISH "B" TO BE A VARIABLE?      '
READ(5,'(I2)') IQ(2)
PRINT*,'DO YOU WISH X-SHIFT TO BE A VARIABLE?  '
READ(5,'(I2)') IQ(3)
PRINT*,'DO YOU WISH Y-SHIFT TO BE A VARIABLE?  '
READ(5,'(I2)') IQ(4)
PRINT*,'DO YOU WISH Z-SHIFT TO BE A VARIABLE?  '
READ(5,'(I2)') IQ(5)
PRINT*,'DO YOU WISH X-ROTATION TO BE A VARIABLE? '
READ(5,'(I2)') IQ(6)
PRINT*,'DO YOU WISH Y-ROTATION TO BE A VARIABLE? '
READ(5,'(I2)') IQ(7)
FINAME(1:4)='ALL.'
PRINT*,'INPUT NAME OF DATA FILE  ALL.'
READ(5,'(A)')FINAME(5:20)
CALL PRINTER
OPEN(8,FILE=FINAME,RECFM='DS',FORM='FORMATTED',PAD='YES')
520  FORMAT(5F12.2)
READ(8,520)A0,B0,XS0,YS0,ZS0
ANEW=A0
BNEW=B0
DO 60 I=1,3                      !SET ROTATION MATRICES TO IDENTITY

```

```

R(I,I)=1.0D+0
RX(I,I)=1.0D0
RY(I,I)=1.0D0
DO 60 J=1,3
    IF(J.NE.I) THEN
        R(I,J)=0.0D+0
        RX(I,J)=0.0D+0
        RY(I,J)=0.0D+0
    END IF
60    CONTINUE
    WRITE(6,510) A0,B0,FINAME,(IDATE(KD),KD=1,3)
510   FORMAT(/,20X,19H'BEST-FIT' SPHEROID,4X,'PROV A0= ',F11.2,' B0= '
*,F11.2,' DATA FILE: ',A16,'DATE=',I4,2I3.2
*,/,28X,21('-'),/,5X,5HPOINT,20X
*,'X',13X,'Y',13X,'Z',11X,7HGEOIDAL,4X,'WT',7X,'L',7X,'V',7X,'PV',
*/,70X,6HHEIGHT,/)
    I=1
500   FORMAT(A12,3F11.2,F8.2,F6.2)
100   READ(8,500)NAME(I),XT(I),YT(I),ZT(I),GHT(I),WT(I)
    IF(GHT(I).EQ.-99.99D+0) GO TO 250
    XT(I)=XT(I)*DSCL+XS0      ! DSCL=SCALE BETWEEN DOPPLER & OTHER
    YT(I)=YT(I)*DSCL+YS0      ! METHODS(-.5PPM...HOTHEM(1982)
    ZT(I)=ZT(I)*DSCL+ZS0+4.D0!4m TO BRING TO GEOCENTRE LACHAPELLE &
                                !KOUBA...REFERENCE CO-ORD SYSTEMS 1980
C     THE 'L' TERMS ARE IN VECTOR DL
C     THESE TERMS ARE FORMED BY THE DIFFERENCE BETWEEN THE GEOIDAL HEIGHT
C     & THE SPHEROIDAL HEIGHT DERIVED FROM THE PROVISIONAL SPHEROID

    CALL GEOGRAPH(XT(I),YT(I),ZT(I),A0,B0,ALAT,ALON,SPHHT)
    DL(I)=SPHHT-GHT(I)
    CALL GEOCEN(ALAT,ALON,DL(I),A0,B0,XG(I),YG(I),ZG(I))

C     THE 1ST COLUMN OF 'A' MATRIX CORRESPONDS TO SEMI-MAJOR AXIS A
    CALL GEOGRAPH(XG(I),YG(I),ZG(I),A0+1.,B0,ALAT,ALON,DHT)
    A(I,1)=(DL(I)-DHT)*IQ(1)

C     THE 2ND COLUMN OF 'A' MATRIX CORRESPONDS TO SEMI-MINOR AXIS B
    CALL GEOGRAPH(XG(I),YG(I),ZG(I),A0,B0+1.,ALAT,ALON,DHT)
    A(I,2)=(DL(I)-DHT)*IQ(2)

C     THE 3RD COLUMN OF 'A' MATRIX CORRESPONDS TO X-SHIFT
    CALL GEOGRAPH(XG(I)+1.,YG(I),ZG(I),A0,B0,ALAT,ALON,DHT)
    A(I,3)=(DL(I)-DHT)*IQ(3)

C     THE 4TH COLUMN OF 'A' MATRIX CORRESPONDS TO Y-SHIFT
    CALL GEOGRAPH(XG(I),YG(I)+1.,ZG(I),A0,B0,ALAT,ALON,DHT)
    A(I,4)=(DL(I)-DHT)*IQ(4)

C     THE 5TH COLUMN OF 'A' MATRIX CORRESPONDS TO Z-SHIFT
    CALL GEOGRAPH(XG(I),YG(I),ZG(I)+1.,A0,B0,ALAT,ALON,DHT)
    A(I,5)=(DL(I)-DHT)*IQ(5)

C     THE 6TH COLUMN OF 'A' MATRIX CORRESPONDS TO X-ROTATION
    R(2,3)=-1.D+0/RHO
    R(3,2)= 1.D+0/RHO
    GV(1)=XG(I)
    GV(2)=YG(I)
    GV(3)=ZG(I)
    CALL MATMUL(R,GV,3,3,1,RGV,3,3,1)
    CALL GEOGRAPH(RGV(1),RGV(2),RGV(3),A0,B0,ALAT,ALON,DHT)
    A(I,6)=(DL(I)-DHT)*IQ(6)
    R(2,3)=0.0D0
    R(3,2)=0.0D0

```

```

C      THE 7TH COLUMN OF 'A' MATRIX CORRESPONDS TO Y-ROTATION
      R(1,3)= 1.D+0/RHO
      R(3,1)=-1.D+0/RHO
      GV(1)=XG(I)
      GV(2)=YG(I)
      GV(3)=ZG(I)
      CALL MATMUL(R,GV,3,3,1,RGV,3,3,1)
      CALL GEOGRAPH(RGV(1),RGV(2),RGV(3),A0,B0,ALAT,ALON,DHT)
      A(I,7)=(DL(I)-DHT)*IQ(7)
      R(1,3)=0.0D0
      R(3,1)=0.0D0
      DO 200 J=1,7
200     ATPLT(J)=ATPLT(J)+WT(I)*A(I,J)*DL(I)
      DO 210 J=1,7
        DO 210 K=1,7
210         ATPA(J,K)=ATPA(J,K)+A(I,J)*A(I,K)*WT(I)
      I=I+1
      GO TO 100
250     NP=I-1
      CALL REDUCE(A,NP,7,AR,NVAR,400,7)
      CALL REDUCE(ATPLT,1,7,ATPL,NVAR,1,7)
      CALL REDUCE(ATPA,7,7,ARED,NVAR,7,7)
      DO 230 I=1,7
        DO 230 J=1,7
230         ATPA(I,J)=ARED(J,I)
      CALL REDUCE(ATPA,7,7,ARED,NVAR,7,7)
      DO 260 I=1,7
        DO 260 J=1,7
260         ATPA(I,J)=ARED(I,J)
      CALL INVERSE(ATPA,NVAR,7)
      CALL MATMUL(ATPA,ATPL,NVAR,NVAR,1,XX,7,7,1)
      CALL MATMUL(AR,XX,NP,NVAR,1,V,400,7,1)
560     FORMAT(' ',A20,3F14.2,5X,F10.2,F8.3,3F8.2)
      PV=0.D0
      PVV=0.0D0
      DO 240 I=1,NP
        V(I)=V(I)-DL(I)
        PV=PV+WT(I)*V(I)
        PVV=PVV+WT(I)*V(I)*V(I)
240     WRITE(6,560)NAME(I),XT(I),YT(I),ZT(I),GHT(I),WT(I),DL(I),V(I)
*      ,WT(I)*V(I)
      WRITE(6,' (/81X,A20,F8.2)')'      [PVV]= ',PVV
      WRITE(10,' (81X,A20,F8.2)')'      [PV]= ',PV
      DO 245 I=1,7
        DO 245 J=1,7
245         ATPA(I,J)=ATPA(I,J)*PVV/(NP-NVAR) !ATPA IS CO-VARIANCE MATRIX
      SIGMA0=DSQRT(PVV/(NP-NVAR))
      WRITE(6,' (/81X,A20,F8.2)')'      SIGMA_0= ',SIGMA0
575     FORMAT(1H#,20X,'1/FLATTENING=',F8.3,' +/-',F8.3)
      IVAR=1
      DO 300 I=1,7
        IF(I.EQ.3.AND.(IQ(1).EQ.1.OR.IQ(2).EQ.1)) THEN
          IF(IQ(1).EQ.1.AND.IQ(2).EQ.1) THEN
            SAB=ATPA(1,2)
          ELSE
            SAB=0.0D0
          END IF
          SF=DSQRT((SDA**2*B0**2-2*A0*B0*SAB+SDB**2*A0**2)/(A0-B0)**4)
          WRITE(6,575) ANEW/(ANEW-BNEW),SF
        ENDIF
        IF(IQ(I).EQ.0) GO TO 300
        GO TO (310,320,330,340,350,360,370) I
310     SDA=DSQRT(ATPA(IVAR,IVAR))
      WRITE(6,550)' NEW SEMI-MAJOR AXIS=',A0+XX(IVAR),SDA

```

```

ANEW=A0+XX(IVAR)
VARNAME(IVAR)=' A '
GO TO 380
320 SDB=DSQRT(ATPA(IVAR,IVAR))
WRITE(6,550)' NEW SEMI-MINOR AXIS=',B0+XX(IVAR),SDB
BNEW=B0+XX(IVAR)
VARNAME(IVAR)=' B '
GO TO 380
330 SDXS=DSQRT(ATPA(IVAR,IVAR))
WRITE(6,550)' X-SHIFT=',XX(IVAR),SDXS
XS=XS0+XX(IVAR)
VARNAME(IVAR)='XSH'
GO TO 380
340 SDYS=DSQRT(ATPA(IVAR,IVAR))
WRITE(6,550)' Y-SHIFT=',XX(IVAR),SDYS
YS=YS0+XX(IVAR)
VARNAME(IVAR)='YSH'
GO TO 380
350 SDZS=DSQRT(ATPA(IVAR,IVAR))
WRITE(6,550)' Z-SHIFT=',XX(IVAR),SDZS
ZS=ZS0+XX(IVAR)
VARNAME(IVAR)='ZSH'
GO TO 380
360 SDXR=DSQRT(ATPA(IVAR,IVAR))
WRITE(6,550)' X-ROTATION(")=',XX(IVAR),SDXR
XR=XX(IVAR)/RHO
VARNAME(IVAR)='X-R'
GO TO 380
370 SDYR=DSQRT(ATPA(IVAR,IVAR))
WRITE(6,550)' Y-ROTATION(")=',XX(IVAR),SDYR
YR=XX(IVAR)/RHO
VARNAME(IVAR)='Y-R'
380 IVAR=IVAR+1
300 CONTINUE
550 FORMAT(/A22,F10.2,' +/- ',F8.2)
DO 440 I=1,NVAR
DO 440 J=1,NVAR
440 QRED(I,J)=ATPA(I,J)/DSQRT(ATPA(I,I)*ATPA(J,J))
IF((NP+2*NVAR).GT.39.AND.IPRINT.EQ.2) WRITE(6,'(1H1)')
WRITE(6,570)
570 FORMAT(/,10X,'Q-MATRIX',/,9X,11(1H-),/)
DO 470 I=1,NVAR
470 WRITE(6,'(1H#,A12)')VARNAME(I)
WRITE(6,'(1H#,A8)')'
DO 480 I=1,NVAR
480 WRITE(6,'(1H#,A7)')VARNAME(I)
DO 410 I=1,NVAR
WRITE(6,'(/)')
WRITE(6,'(1H#,F12.2)')(ATPA(I,J),J=1,NVAR)
WRITE(6,'(1H#,3A3)')',VARNAME(I),'
DO 460 K=1,I-1
460 WRITE(6,'(1H#,A)')'
410 WRITE(6,'(1H#,F7.3)')(QRED(I,J),J=I,NVAR)
IF(XR.EQ.0.0D0.AND.YR.EQ.0.0D0) STOP
WRITE(6,'(1H1)')
OPEN(19,FILE='ALL.TEMPDATA',RECFM='DS',FORM='FORMATTED',PAD='YES')
WRITE(19,520)ANEW,BNEW,XS,YS,ZS
DO 430 I=1,NP
GV(1)=XT(I)
GV(2)=YT(I)
GV(3)=ZT(I)
C RX=ROTATION MATRIX ABOUT X-AXIS
RX(2,2)= DCOS(XR)
RX(2,3)=-DSIN(XR)

```

```

RX(3,2)= DSIN(XR)
RX(3,3)= DCOS(XR)
C      RY=ROTATION MATRIX ABOUT Y-AXIS
RY(1,1)= DCOS(YR)
RY(1,3)= DSIN(YR)
RY(3,1)=-DSIN(YR)
RY(3,3)= DCOS(YR)
C      R =MATRIX OF COMBINED ROTATIONS
CALL MATMUL(RX,RY,3,3,3,R,3,3,3)
CALL MATMUL(R,GV,3,3,1,RGV,3,3,1)
WRITE(19,500)NAME(I),RGV(1)+XS-XS0,RGV(2)+YS-YS0,RGV(3)+ZS-ZS0
*      ,GHT(I),WT(I)
CALL GEOGRAPH(RGV(1)+XS-XS0,RGV(2)+YS-YS0,RGV(3)+ZS-ZS0,
*           ANEW,BNEW,ALAT,ALON,HGT)
430    WRITE(6,'(1H ,A20,F10.2)')NAME(I),GHT(I)-HGT
WRITE(19,500)'      ',0.0D0,0.0D0,0.0D0,0.0D0,0.0D0
END

```

```

C          ASTROSP = ASTRONOMICALLY DETERMINED SPHEROID
C          =====
C          THIS PROGRAM FINDS THE SPHEROID WHICH BEST FITS A SET OF
C          ASTRONOMICAL DATA (OBS LATITUDE & LONGITUDE) TOGETHER WITH THE
C          CORRESPONDING GEOCENTRIC CO-ORDS.
C          THE FREE TERMS ARE THE DIFFERENCES BETWEEN THE OBS LAT & LONG
C          AND THE LAT & LONG COMPUTED FROM THE GEOCENTRIC CO-ORDS USING THE
C          PROVISIONAL SPHEROID  L(LAT)=(A-G)lat
C                               L(LON)=(A-G)lon*cos(LAT)

C          THE PARAMETERS TO BE DETERMINED ARE:
C          1      SEMI-MAJOR AXIS   (A)
C          2      SEMI-MINOR AXIS  (B)
C          3      X-SHIFT
C          4      Y-SHIFT           } ANY OF THESE VALUES
C          5      Z-SHIFT           } MAY BE HELD CONSTANT
C          6      Z-ROT

IMPLICIT REAL*8(A-H,O-Z)
CHARACTER*20 FINAME,POINT
CHARACTER*20 NAME(150)
CHARACTER*3  VARNAME(5)
DIMENSION A(300,6),ARED(300,6),P(300,300),AT(6,300),ATP(6,300)
DIMENSION AN(6,300),ATPA(6,6),XX(6),IQ(6),V(300),QRED(6,6)
DIMENSION R(3,3),GV(3),RGV(3),ALAT(150),ALON(150),DLAT(150),
*DLON(150),XG(150),YG(150),ZG(150),DL(300),RX(3,3),RY(3,3),IDATE(3)
DATA PLAT,PLON /1.0D+0,1.0D+0/
PI=4.*DATAN(1.0D+0)
RHO=648000.D0/PI
PRINT*,'          YES=1,NO=0'
PRINT*,'          -----'
PRINT*,'DO YOU WISH "A" TO BE A VARIABLE?          '
READ(5,'(I2)') IQ(1)
PRINT*,'DO YOU WISH "B" TO BE A VARIABLE?          '
READ(5,'(I2)') IQ(2)
PRINT*,'DO YOU WISH X-SHIFT TO BE A VARIABLE?       '
READ(5,'(I2)') IQ(3)
PRINT*,'DO YOU WISH Y-SHIFT TO BE A VARIABLE?       '
READ(5,'(I2)') IQ(4)
PRINT*,'DO YOU WISH Z-SHIFT TO BE A VARIABLE?       '
READ(5,'(I2)') IQ(5)
PRINT*,'DO YOU WISH Z-ROTATION TO BE A VARIABLE?    '
READ(5,'(I2)') IQ(6)
FINAME(1:4)='ALL.'
PRINT*,'INPUT NAME OF DATA FILE ALL.'
READ(5,'(A)')FINAME(5:20)
CALL PRINTER
OPEN(8,FILE=FINAME,RECFM='DS',FORM='FORMATTED',PAD='YES',
*   BLANK='ZERO')
520  FORMAT(5F12.2)
READ(8,520)SMJ,SMN,XS0,YS0,ZS0
XS=XS0
YS=YS0
ZS=ZS0
ANEW=SMJ
BNEW=SMN
WRITE(6,510) SMJ,SMN
510  FORMAT(///// ,29X,33H'BEST-FIT' ASTRO CO-ORD SPHEROID,11X,
* 'PROV A0= ',F11.2,' B0= ',F11.2,/,25X,44(2H--),/)
CALL DATE(IDATE)
WRITE(6,530) FINAME ,(IDATE(K),K=1,3)

```

```

530  FORMAT(' ',80X,'INPUT FILE= ',A20,' DATE= ',I4,2I3.2)
      I=1
500  FORMAT(A12,3F11.2,F8.2,F6.2,2I2,F5.2,4X,2I2,F5.2)
100  READ(8,500,END=200) POINT,X,Y,Z,HGT,WT,IA1,IA2,A3,IB1,IB2,B3
      IF (IA1.EQ.0.AND.IB1.EQ.0) GO TO 100
      XG(I)=X
      YG(I)=Y
      ZG(I)=Z
      NAME(I)=POINT
      ALAT(I)=(IA1*3600.+IA2*60.+A3)/RHO
      ALON(I)=(IB1*3600.+IB2*60.+B3)/RHO
      CALL GEOGRAPH(X,Y,Z,SMJ,SMN,DLAT(I),DLON(I),HGT)
      CALL DMS (DLAT(I),ILAD,ILAM,SLAT)
      CALL DMS (DLON(I),ILOD,ILOM,SLON)
C    FORM 'L' TERMS (2*I-1)->LAT , (2*I)->LON
      DL(2*I-1)=(DLAT(I)-ALAT(I))*RHO
      DL(2*I)=(DLON(I)-ALON(I))*RHO*DCOS(DLAT(I))
C    FORM 'A' MATRIX
C    1ST COLUMN REPRESENTS SMJ
      CALL GEOGRAPH(X,Y,Z,SMJ+1.,SMN,QLAT,QLON,HGT)
      A(2*I-1,1)=(QLAT-DLAT(I))*IQ(1)*RHO
      A(2*I,1)=(QLON-DLON(I))*IQ(1)*RHO*DCOS(QLAT)
C    2ND COLUMN REPRESENTS SMN
      CALL GEOGRAPH(X,Y,Z,SMJ,SMN+1.,QLAT,QLON,HGT)
      A(2*I-1,2)=(QLAT-DLAT(I))*IQ(2)*RHO
      A(2*I,2)=(QLON-DLON(I))*IQ(2)*RHO*DCOS(QLAT)
C    3RD COLUMN REPRESENTS X-S
      CALL GEOGRAPH(X+1.,Y,Z,SMJ,SMN,QLAT,QLON,HGT)
      A(2*I-1,3)=(QLAT-DLAT(I))*IQ(3)*RHO
      A(2*I,3)=(QLON-DLON(I))*IQ(3)*RHO*DCOS(QLAT)
C    4TH COLUMN REPRESENTS Y-S
      CALL GEOGRAPH(X,Y+1.,Z,SMJ,SMN,QLAT,QLON,HGT)
      A(2*I-1,4)=(QLAT-DLAT(I))*IQ(4)*RHO
      A(2*I,4)=(QLON-DLON(I))*IQ(4)*RHO*DCOS(QLAT)
C    5TH COLUMN REPRESENTS Z-S
      CALL GEOGRAPH(X,Y,Z+1.,SMJ,SMN,QLAT,QLON,HGT)
      A(2*I-1,5)=(QLAT-DLAT(I))*IQ(5)*RHO
      A(2*I,5)=(QLON-DLON(I))*IQ(5)*RHO*DCOS(QLAT)
C    6TH COLUMN REPRESENTS Z-ROT
      A(2*I,6)=1.D0*IQ(6)*DCOS(QLAT)
C    FORM WEIGHT MATRIX (P)
      P(2*I-1,2*I-1)=WT*PLAT
      P(2*I,2*I)=WT*PLON
      I=I+1
      GO TO 100
200  NP=I-1
      NOBS=2*NP
      CALL REDUCE(A,NOBS,6,ARED,NVAR,300,6)
      DO 230 I=1,NOBS
        DO 230 J=1,NVAR
230   AT(J,I)=ARED(I,J)
      CALL MATMUL(AT,P,NVAR,NOBS,NOBS,ATP,6,300,300)
      CALL MATMUL(ATP,ARED,NVAR,NOBS,NVAR,ATPA,6,300,6)
      CALL INVERSE(ATPA,NVAR,6)
      CALL MATMUL(ATPA,ATP,NVAR,NVAR,NOBS,AN,6,6,300)
      CALL MATMUL(AN,DL,NVAR,NOBS,1,XX,6,300,1)
      CALL MATMUL(ARED,XX,NOBS,NVAR,1,V,300,6,1)
      PVV=0.0D0
      DO 240 I=1,NOBS
        V(I)=V(I)-DL(I)
240   PVV=PVV+P(I,I)*V(I)*V(I)
      DO 260 I=1,NVAR
        DO 260 J=1,NVAR
260   ATPA(I,J)=ATPA(I,J)*PVV/(NOBS-NVAR)

```

```

IVAR=1
575  FORMAT(' ',50X,'FLATTENING=1/',F8.4)
      DO 300 I=1,6
          IF(I.EQ.3.AND.(IQ(1).EQ.1.OR.IQ(2).EQ.1))
*           WRITE(6,575) ANEW/(ANEW-BNEW)
          IF(IQ(I).EQ.0) GO TO 300
          GO TO (310,320,330,340,350,360) I
310     SDA=DSQRT(ATPA(IVAR,IVAR))
          WRITE(6,550)' NEW SEMI-MAJOR AXIS=',SMJ+XX(IVAR),SDA
          ANEW=SMJ-XX(IVAR)
          VARNAME(IVAR)=' A '
          GO TO 380
320     SDB=DSQRT(ATPA(IVAR,IVAR))
          WRITE(6,550)' NEW SEMI-MINOR AXIS=',SMN+XX(IVAR),SDB
          BNEW=SMN+XX(IVAR)
          VARNAME(IVAR)=' B '
          GO TO 380
330     SDXS=DSQRT(ATPA(IVAR,IVAR))
          WRITE(6,550)' X-SHIFT=',XX(IVAR),SDXS
          XS=XS0-XX(IVAR)
          VARNAME(IVAR)=' XSH'
          GO TO 380
340     SDYS=DSQRT(ATPA(IVAR,IVAR))
          WRITE(6,550)' Y-SHIFT=',XX(IVAR),SDYS
          YS=YS0-XX(IVAR)
          VARNAME(IVAR)=' YSH'
          GO TO 380
350     SDZS=DSQRT(ATPA(IVAR,IVAR))
          WRITE(6,550)' Z-SHIFT=',XX(IVAR),SDZS
          ZS=ZS0-XX(IVAR)
          VARNAME(IVAR)=' ZSH'
          GO TO 380
360     SDZR=DSQRT(ATPA(IVAR,IVAR))
          WRITE(6,550)' Z-ROT(")=',XX(IVAR),SDZR
          ZR=XX(IVAR)
          VARNAME(IVAR)=' Z-R'
380     IVAR=IVAR+1
300  CONTINUE
550  FORMAT(/A22,F10.2,' +/- ',F8.2)
      DO 440 I=1,NVAR
          DO 440 J=1,NVAR
440     QRED(I,J)=ATPA(I,J)/DSQRT(ATPA(I,I)*ATPA(J,J))
          WRITE(6,570)
570  FORMAT(/,10X,'COVARIANCE-MATRIX',/,9X,20(1H-),/)
      DO 470 I=1,NVAR
470     WRITE(6,'(1H#,A12)')VARNAME(I)
          WRITE(6,'(1H#,A8)')'
          DO 480 I=1,NVAR
480     WRITE(6,'(1H#,A7)')VARNAME(I)
          DO 410 I=1,NVAR
          WRITE(6,'(/)')
          WRITE(6,'(1H#,F12.2)')(ATPA(I,J),J=1,NVAR)
          WRITE(6,'(1H#,3A3)')' ',VARNAME(I),' '
          DO 460 K=1,I-1
460     WRITE(6,'(1H#,A)')'
410     WRITE(6,'(1H#,F7.3)')(QRED(I,J),J=I,NVAR)
          WRITE(6,586) PLAT,PLON
586  FORMAT (' ',//,20X,'NOMINAL WEIGHT:   LAT=',F6.1,' LON='F6.1)
          IF(IPRINT.EQ.1) PAUSE
          WRITE(6,'(1H1)')
          WRITE (6,580)
580  FORMAT(1H ,////,5X,5HPOINT,20X,7HDOPPLER,26X,5HASTRO,20X,3H'L',9X
*  ,6H'V'("),10X,6H'V'(M),/25X,'LAT',12X,'LON',16X,'LAT',10X,'LON',
*  ,12X,'LAT',4X,'LON',4X,'LAT',4X,'LON',6X,'LAT',4X,'LON'/)

```

```

ILINE=0
DO 250 I=1,NP
  CALL GEOGRAPH(XG(I),YG(I),ZG(I),SMJ,SMN,GLAT,GLON,HGT)
  CALL DMS(GLAT,L1,M1,S1)
  CALL DMS(GLON,L2,M2,S2)
  CALL DMS(ALAT(I),L3,M3,S3)
  CALL DMS(ALON(I),L4,M4,S4)
  ILINE=ILINE+1
  IF (ILINE.EQ.36) THEN
    ILINE=0
    WRITE(6,"(1H1)")
    WRITE(6,580)
  END IF
250  WRITE(6,505)I,NAME(I),L1,M1,S1,L2,M2,S2,L3,M3,S3,L4,M4,S4,
* -DL(2*I-1),-DL(2*I)/DCOS(GLAT),V(2*I-1),V(2*I)/DCOS(GLAT),
* V(2*I-1)*SMJ/RHO,V(2*I)*SMJ/RHO
505  FORMAT(' ',I3,2X,A12,2(3X,2I3,F6.2),2X,2(3X,2I3,F6.2),3X,2F7.2
*,2F7.3,2X,2F7.2)
END

```

VARDIS...COMPUTES VARIANCE IN DISTANCES FROM VAR/COVAR MATRIX
 OUTPUT BY GEODOP PROGRAM

```

  IMPLICIT REAL*8(A-H,O-Z)
  DIMENSION GDOP(21,21),Q(6,6),R(1,6)
  CHARACTER*12 NAME(7),FINAME
  DIMENSION X(7),Y(7),Z(7),DER(1,6),DET(6,1)
  FINAME(1:5)='GDOP.'
  WRITE(10,*)'INPUT FILE=GDOP.'
  READ(11,'(A)') FINAME(6:12)
  OPEN(12,FILE=FINAME,FORM='FORMATTED',RECFM='DS',
* PAD='YES')
  READ(12,'(I2)') NP
  WRITE(10,*) 'NP= ',NP
  DO 100 I=1,NP
100  READ(12,'(A12,3F12.3)') NAME(I),X(I),Y(I),Z(I)
  DO 200 I=1,3*NP
200  READ(12,'(21F9.6)') (GDOP(I,J),J=I,3*NP)
  DO 300 I=2,3*NP
    DO 300 J=1,I-1
300  GDOP(I,J)=GDOP(J,I)
  CALL PRINTER
  WRITE(6,905) FINAME
905  FORMAT(' CHORD DISTANCE MSE COMPUTED RIGOROUSLY FROM CO-VARIANCE
* MATRIX OUTPUT BY GEODOP(V)'/ ' ',84('-'),/
* 65X,'INPUT FILE= ',A12//
* 4X,'FROM',7X,'TO',14X,'DIST',5X,'MSE(1 SIG)',3X,'PPM')
  DO 400 I=1,NP
  WRITE(6,*)
  DO 400 J=I+1,NP
    WRITE(10,*) 'NP= ',NP
    WRITE(10,*) ' I= ',I
    WRITE(10,*) ' J= ',J
    Q(1,1)=GDOP(3*I-2,3*I-2)
    Q(1,2)=GDOP(3*I-2,3*I-1)
    Q(1,3)=GDOP(3*I-2,3*I )
    Q(1,4)=GDOP(3*I-2,3*J-2)
    Q(1,5)=GDOP(3*I-2,3*J-1)
    Q(1,6)=GDOP(3*I-2,3*J )
    Q(2,2)=GDOP(3*I-1,3*I-1)
    Q(2,3)=GDOP(3*I-1,3*I )
    Q(2,4)=GDOP(3*I-1,3*J-2)
    Q(2,5)=GDOP(3*I-1,3*J-1)
    Q(2,6)=GDOP(3*I-1,3*J )
    Q(3,3)=GDOP(3*I ,3*I )
    Q(3,4)=GDOP(3*I ,3*J-2)
    Q(3,5)=GDOP(3*I ,3*J-1)
    Q(3,6)=GDOP(3*I ,3*J )
    Q(4,4)=GDOP(3*J-2,3*J-2)
    Q(4,5)=GDOP(3*J-2,3*J-1)
    Q(4,6)=GDOP(3*J-2,3*J )
    Q(5,5)=GDOP(3*J-1,3*J-1)
    Q(5,6)=GDOP(3*J-1,3*J )
    Q(6,6)=GDOP(3*J ,3*J )
    DO 405 K1=2,6
    DO 405 K2=1,K1-1
405  Q(K1,K2)=Q(K2,K1)
    S0=DSQRT((X(I)-X(J))**2+(Y(I)-Y(J))**2+(Z(I)-Z(J))**2)
    S1=DSQRT((X(I)+1.D0-X(J))**2+(Y(I)-Y(J))**2+(Z(I)-Z(J))**2)
    S2=DSQRT((X(I)-X(J))**2+(Y(I)+1.D0-Y(J))**2+(Z(I)-Z(J))**2)
    S3=DSQRT((X(I)-X(J))**2+(Y(I)-Y(J))**2+(Z(I)+1.D0-Z(J))**2)
    S4=DSQRT((X(I)-X(J)-1.D0)**2+(Y(I)-Y(J))**2+(Z(I)-Z(J))**2)
    S5=DSQRT((X(I)-X(J))**2+(Y(I)-Y(J)-1.D0)**2+(Z(I)-Z(J))**2)
    S6=DSQRT((X(I)-X(J))**2+(Y(I)-Y(J))**2+(Z(I)-Z(J)-1.D0)**2)

```

```

DER(1,1)=S1-S0
DER(1,2)=S2-S0
DER(1,3)=S3-S0
DER(1,4)=S4-S0
DER(1,5)=S5-S0
DER(1,6)=S6-S0
DO 404 II=1,6
404  WRITE(10,'(6F9.6)') (Q(II,JJ),JJ=1,6)
WRITE(10,'(6F6.2)')( DER(1,K8),K8=1,6)
DO 410 II=1,6
410  DET(II,1)=DER(1,II)
WRITE(10,'(6F6.2)')( DET(K8,1),K8=1,6)
CALL MATMUL(DER,Q,1,6,6,R,1,6,6)
CALL MATMUL(R,DET,1,6,1,QS,1,6,1)
WRITE(10,*) 'QS= ',QS
SIGS=DSQRT(QS)
WRITE(10,*) 'SIGS= ',SIGS
PPM=SIGS/S0*1.D6
400  WRITE( 6,901) NAME(I),NAME(J),S0,SIGS,PPM
901  FORMAT(' ',2A12,F10.3,F7.3,6X,F7.2)
STOP
END

```

SUBROUTINE MATMUL(A,B,J,K,L,E,MAXAR,MAXAC,MAXBC)
IMPLICIT REAL*8 (A-H,O-Z)

C MATMUL = MATRIX MULTIPLICATION
C A IS J * K
C B IS K * L
C MAT E=A*B (RETURNS E (J * L))

DIMENSION A(MAXAR,MAXAC)
DIMENSION B(MAXAC,MAXBC)
DIMENSION E(MAXAR,MAXBC)
DO 500 M=1,J
DO 500 N=1,L
500E(M,N)=0.0D0

DO 510 I=1,J
DO 510 M=1,K
DO 510 N=1,L
510E(I,N)=E(I,N)+A(I,M)*B(M,N)
RETURN
END

C THIS SUBROUTINE FORMS 'IN SITU' INVERSE OF A
C POSITIVE DEFINITE SYMMETRICAL MATRIX USING CHOLESKI ALGORITHM
C -----

SUBROUTINE INVERSE(A,N,MAXR)
IMPLICIT DOUBLE PRECISION (A-H,O-Z)
DIMENSION A(MAXR,MAXR)

A(1,1)=DSQRT(A(1,1))
DO 220 I=2,N
220 A(I,1)=A(I,1)/A(1,1)
DO 230 J=2,N
 Z=0.D0
 DO 240 K=1,J-1
240 Z=Z+A(J,K)*A(J,K)
 A(J,J)=DSQRT(A(J,J)-Z)
 IF (J.EQ.N) GO TO 230
 DO 250 I=J+1,N
 Z=0
 DO 260 K=1,J-1
260 Z=Z+A(I,K)*A(J,K)
250 A(I,J)=(A(I,J)-Z)/A(J,J)
230 CONTINUE

DO 270 I=1,N
270 A(I,I)=1.D0/A(I,I)
DO 280 J=1,N-1
 DO 280 I=J+1,N
 Z=0
 DO 300 K=J,I-1
300 Z=Z+A(I,K)*A(K,J)
280 A(I,J)=-A(I,I)*Z

DO 320 J=1,N
 DO 320 I=J,N
 P=0
 DO 330 K=I,N
330 P=P+A(K,I)*A(K,J)
 A(J,I)=P
320 A(I,J)=P
RETURN
END

```

SUBROUTINE DMS(RAD, IDEG, IMIN, SEC)
IMPLICIT REAL*8(A-H, O-Z)
PI=DATAN(1.0D0)*4.0D0
DEG=RAD*180.0D+0/PI
IDEG=DEG
AMIN=(DEG-IDEG)*60.0D+0
IMIN=AMIN
SEC=(AMIN-IMIN)*60.0D+0
RETURN
END

```

```

SUBROUTINE GLOBAL(APRIOR, APOST, NDF, IPASS, CHSQL, CHSQU)
IMPLICIT REAL*8(A-H, O-Z)
P=0.025D0      !   SET FOR 95% CONFIDENCE INTERVAL
C0=2.515517D0
C1=0.802853D0
C2=0.010328D0
D1=1.432788D0
D2=0.189269D0
D3=0.001308D0
T=DSQRT(DLOG(1.D0/P**2))
ANORM=DABS(T-(C0+C1*T+C2*T**2)/(1.D0+D1*T+D2*T**2+D3*T**3))
CHSQL=NDF*(1.D0-2.D0/(9.D0*NDF)+ANORM*DSQRT(2.D0/(9.D0*NDF)))**3
CHSQU=NDF*(1.D0-2.D0/(9.D0*NDF)-ANORM*DSQRT(2.D0/(9.D0*NDF)))**3
CHSQL=(APOST*NDF)/CHSQL
CHSQU=(APOST*NDF)/CHSQU
IF (APRIOR.LT.CHSQL) THEN
        IPASS=-1
        RETURN
        END IF
IF (APRIOR.GT.CHSQU) THEN
        IPASS=1
        RETURN
        END IF
IPASS=0
RETURN
END

```

C BE-PE TRANSFORMS BROADCAST EPHEMERIS CO-ORDINATES INTO
C PRECISE EPHEMERIS REFERENCE FRAME.

```
SUBROUTINE BE PE(ROT,OBCORD,NSTA,CG,OCG,V1)
IMPLICIT REAL*8(A-H,O-Z)
DIMENSION ROT(3,3),OBCORD(5,3),CG(3),V1(3),OCG(3)
DO 100 I=1,NSTA
  DO 200 J=1,3
200    V1(J)=OBCORD(I,J)-CG(J)
    CALL MATMUL(ROT,V1,3,3,1,OCG,3,3,1)
    DO 300 J=1,3
300      OBCORD(I,J)=OCG(J)+CG(J)
100    CONTINUE
  DO 400 I=1,3
400    OCG(I)=0.D0
  DO 500 I=1,NSTA
    DO 500 J=1,3
500      OCG(J)=OCG(J)+OBCORD(I,J)/NSTA
RETURN
END
```

```

C   QFINAL... READS XYZ COVARIANCE MATRIX OUTPUT BY FINAL
C   AND TRANSFORMS INTO LAT LON HGT COV MATRIX
C   AND THEN ENTIRE LAT/LON CO-VARIANCE MATRIX
C   INTO "FINSLN.QLL"

```

```

      IMPLICIT REAL*8(A-H,O-Z)
      DIMENSION QXYZ(120,120),R(120,120),RT(120,120),FCORD(40,3),
*         DER(3,3),QLLH(120,120),RTQ(120,120)
      CHARACTER*12 NAME(40)
      OPEN(23,FILE='FINSLN.COVAR',FORM='UNFORMATTED')
      DATA SMJ,SMN /6378137.000D0,6356752.314D0/
      READ (23) NP
      DO 10 I=1,NP
10    READ (23) NAME(I),(FCORD(I,J),J=1,3)
      DO 50 I=1,3*NP
50    READ (23) (QXYZ(I,J),J=1,3*NP)

      DO 100 I=1,3*NP
      DO 100 J=1,3*NP
100   RT(I,J)=0.D0
      R(I,J)=0.D0

      DO 200 I=1,NP
      PRINT*,NAME(I),FCORD(I,1),FCORD(I,2),FCORD(I,3)
      CALL JACOBIAN(FCORD(I,1),FCORD(I,2),FCORD(I,3),SMJ,SMN,DER)
      DO 200 J=1,3
          JPOS=3*(I-1)+J
          DO 200 K=1,3
              KPOS=3*(I-1)+K
              RT(JPOS,KPOS)=DER(J,K)
200   R(JPOS,KPOS)=DER(K,J)

      CALL MATMUL(RT,QXYZ,3*NP,3*NP,3*NP,RTQ,120,120,120)
      CALL MATMUL(RTQ,R,3*NP,3*NP,3*NP,QLLH,120,120,120)

      OPEN(24,FILE='FINSLN.QLL',FORM='UNFORMATTED')
      WRITE (24) NP
      DO 210 I=1,NP
210   WRITE (24) NAME(I),(FCORD(I,J),J=1,3)

C           EXTRACT LAT/LON TERMS FROM LAT/LON/HGT COVARIANCE MATRIX

      DO 220 I=1,NP
      DO 220 J=1,NP
          DO 220 II=1,2
          DO 220 JJ=1,2
220   R(2*I-2+II,2*J-2+JJ)=QLLH(3*I-3+II,3*J-3+JJ)

C           WRITE LAT/LON CO-VARIANCE MATRIX INTO FINSLN.QLL

      DO 250 I=1,2*NP
250   WRITE (24) (R(I,J),J=1,2*NP)

C           CHECK THAT DIAGONAL TERMS ARE LATITUDE & LONGITUDE VARIANCES

      DO 300 I=1,NP
          QLAT=DSQRT(R(2*I-1,2*I-1))
          QLON=DSQRT(R(2*I,2*I))
300   PRINT*,NAME(I),QLAT,QLON

      STOP
      END

```

```

C      RDDOP...READS GEODOP OUTPUT FROM GDOP QMAT FILES

SUBROUTINE RDDOP(IFILE,NSTA,NPASS,QMAT,OBSC,ISTA,SUM,GC)
IMPLICIT REAL*8(A-H,O-Z)
DIMENSION QMAT(15,15),OBSC(5,3),SUM(3),ISTA(5)
DO 50 I=1,15
DO 50 J=1,15
50    QMAT(I,J)=0.D0
READ (IFILE,'(I1,I4)') NSTA,NPASS
DO 100 I=1,NSTA
    READ(IFILE,'(12X,3F12.3,I5,1X,I5)') (OBSC(I,J),J=1,3),IDS,IBN
100    ISTA(I)=IDS*100000+IBN
DO 200 I=1,3*NSTA
200    READ(IFILE,'(15F9.6)') (QMAT(I,J),J=I,3*NSTA)
DO 210 I=2,3*NSTA
    DO 210 J=1,I
210    QMAT(I,J)=QMAT(J,I)
DO 220 I=1,NSTA      ! Add 'augmentation constant (GC) to diagonal
DO 220 J=1,NSTA      ! terms according to [Kouba J. 1978]
DO 220 K=1,3         !
220    QMAT(3*(I-1)+K,3*(J-1)+K)=QMAT(3*(I-1)+K,3*(J-1)+K)+GC

CALL INVERSE(QMAT,3*NSTA,15)!Changes co-variance matrix to Wt Mtrx

DO 500 I=1,3
500    SUM(I)=0.D0
DO 550 I=1,NSTA
    DO 550 J=1,3
550    SUM(J)=SUM(J)+OBSC(I,J)
DO 600 I=1,3
600    SUM(I)=SUM(I)/NSTA  !SUM CONTAINS C/GRAV OF SUBNET
RETURN
END

```

APPENDIX C: GEODOP INPUT

This appendix contains the co-ordinates and co-variance matrices produced by GEODOP.

There is one set of geocentric co-ordinates and one co-variance matrix corresponding to each subnet.

This data was used in the various 'unification procedures' described in chapter 4.

3 53 1980 236 185/1

LEEUKOP	4986888.85	2475834.13	-3104541.910	2926.00022				
MORGENZON	5138856.22	2424479.16	-2890847.320	2725.00079				
WITWATER	5137631.44	2183075.22	-3078159.640	2923.00053				
2.1443	-0.055168	-0.44349	2.1169	0.020613	-0.43866	2.0787	0.12249	-0.45506
1.8785	-0.13428	-0.06938	1.8549	-0.11985	-0.11245	1.8915	-0.10765	
1.3170	-0.46577	-0.17920	1.3298	-0.40996	-0.21447	1.3134		
2.1086	0.002189	-0.46599	2.0646	0.10739	-0.48275			
1.8643	-0.16664	-0.039347	1.8998	-0.15526				
1.3527	-0.41023	-0.20257	1.3342					
2.0544	0.053747	-0.43404						
1.9717	-0.19530							
1.3288								

No. of stations in subnet

No. of accepted passes

Year and Day No.

Name of Subnet

'Observed' Cartesian co-ordinates (X,Y,Z)

Degree Square and Point Number

3	57	1985	245	185/10				
GRASKOP	5246337.92	1904111.22	-3079064.860	2919.00010				
LOUISFONTEIN	5203445.96	1690208.39	-3268509.560	3117.00005				
WITBANK NEW	5361115.24	1605150.79	-3050286.920	2816.00036				
1.9641	-0.020833	-0.44820	1.9317	0.065712	-0.46464	1.9029	0.11609	-0.44469
1.6320	-0.10264	-0.037059	1.6305	-0.093346	-0.050542	1.6275	-0.084738	
1.1982	-0.40360	-0.13105	1.1797	-0.42236	-0.16540	1.1896		
1.9232	0.042956	-0.42584	1.8920	0.094587	-0.40601			
1.6602	-0.12531	0.029607	1.6540	-0.11566				
1.1729	-0.44456	-0.15989	1.1807					
1.8740	0.079955	-0.42912						
1.6688	-0.15004							
1.1962								

Co-ordinate co-variances

Diagonal terms are variances of co-ordinates

1 102 1983 234 196/1
WITBANK NEW 5361111.93 1605149.00 -3050285.80 2816.00036
0.011928-0.000249-0.003455
0.013874-0.001158
0.006112
1 102 1983 311 196/2
MAGWAZA 4786226.32 3006517.18 -2946619.81 2732.00004
0.022901-0.002165-0.006857
0.025844-0.004522
0.009218
1 133 1983 27 196/3
HEXRIVIER 5022155.01 1795160.27 -3490364.81 3319.00029
0.012041-0.001638-0.004217
0.014137-0.001088
0.006235
1 94 1983 27 196/4
COEGAKOP 4785913.74 2295263.20 -3524985.83 3325.00133
0.013124-0.001442-0.005082
0.016451-0.002660
0.006774
1 86 1983 233 196/5
SCHWARZECK 5576027.87 1884764.87 -2452547.39 2218.00179
0.014770-0.000694-0.003759
0.017995-0.001686
0.005496
1 65 1982 312 196/6
PONT 5157884.63 2878301.10 -2400480.08 2229.00023
0.054210-0.008716-0.011018
0.086203-0.009370
0.020538
1 80 1982 309 196/7
MORGENZON 5138858.47 2424478.35 -2890850.32 2725.00079
0.037200-0.006864-0.012243
0.046431-0.005931
0.012746

3 53 1980 236 185/1

LEEUKOP 4986888.85 2475834.13 -3104541.910 2926.00022
MORGENZON 5138856.22 2424479.16 -2890847.320 2725.00079
WITWATER 5137631.44 2183075.22 -3078159.640 2923.00053
2.1443 -0.055168-0.44349 2.1169 0.020613-0.43866 2.0787 0.12249 -0.45506
1.8785 -0.13428 -0.06938 1.8549 -0.11985 -0.11245 1.8915 -0.10765
1.3170 -0.46577 -0.17920 1.3298 -0.40996 -0.21447 1.3134
2.1086 0.002189-0.46599 2.0646 0.10739 -0.48275
1.8643 -0.16664 -0.039347 1.8998 -0.15526
1.3527 -0.41023 -0.20257 1.3342
2.0544 0.053747-0.43404
1.9717 -0.19530
1.3288

3 57 1985 245 185/10

GRASKOP 5246337.92 1904111.22 -3079064.860 2919.00010
LOUISFONTEIN 5203445.96 1690208.39 -3268509.560 3117.00005
WITBANK NEW 5361115.24 1605150.79 -3050286.920 2816.00036
1.9641 -0.020833-0.44820 1.9317 0.065712-0.46464 1.9029 0.11609 -0.44469
1.6320 -0.10264 -0.037059 1.6305 -0.093346-0.050542 1.6275 -0.084738
1.1982 -0.40360 -0.13105 1.1797 -0.42236 -0.16540 1.1896
1.9232 0.042956-0.42584 1.8920 0.094587-0.40601
1.6602 -0.12531 0.029607 1.6540 -0.11566
1.1729 -0.44456 -0.15989 1.1807
1.8740 0.079955-0.42912
1.6688 -0.15004
1.1962

3 59 1982 205 185/11

GRASKOP 5246334.39 1904111.40 -3079061.900 2919.00010
POTLOER 5101367.79 1977623.85 -3269925.880 3121.00053
WITWATER 5137633.64 2183075.06 -3078160.180 2923.00053
1.9475 0.14493 -0.47849 1.9575 0.093457-0.48685 1.9713 0.021933-0.46834
1.8660 -0.23444 0.16929 1.8259 -0.24916 0.19715 1.7886 -0.25129
1.2768 -0.45963 -0.19500 1.2577 -0.50205 -0.16688 1.2685
1.9884 0.11565 -0.47381 1.9991 0.043949-0.45524
1.8239 -0.21200 0.14449 1.7806 -0.21382
1.2512 -0.51685 -0.18277 1.2594
2.0318 0.068330-0.50321
1.7660 -0.18897
1.2780

3 118 1982 212 185/12

GRASKOP 5246336.53 1904108.84 -3079062.980 2919.00010
HADIDA 5294745.33 2085809.66 -2872756.510 2621.00003
WITWATER 5137635.71 2183071.32 -3078160.870 2923.00053
0.93314 -0.023078-0.17590 0.93178 -0.045227-0.16808 0.94260 -0.069816-0.17310
0.94903 -0.073552-0.015261 0.92566 -0.070963-0.013438 0.92398 -0.074233
0.58607 -0.19496 -0.065762 0.58826 -0.18339 -0.049099 0.58176
0.94486 -0.039044-0.19031 0.95285 -0.063458-0.19505
0.92010 -0.066085-0.036746 0.91292 -0.069234
0.59722 -0.17861 -0.048624 0.58925
0.97204 -0.060712-0.18692
0.92332 -0.052592
0.58772

3 56 1982 211 185/13

HADIDA 5294740.16 2085815.36 -2872751.350 2621.00003
MORGENZON 5138854.94 2424480.86 -2890843.610 2725.00079
WITWATER 5137630.39 2183076.97 -3078157.210 2923.00053
2.7722 0.095565-0.62339 2.7997 -0.13741 -0.59124 2.8026 0.000383-0.63072
2.6199 -0.27020 0.19340 2.5140 -0.30232 0.14297 2.5764 -0.29080
1.7063 -0.65103 -0.15721 1.6877 -0.60207 -0.20813 1.6804
2.8977 -0.053984-0.63968 2.8565 0.098370-0.66780
2.5087 -0.19848 -0.096278 2.5172 -0.17818
1.6993 -0.57850 -0.24343 1.6746
2.8743 0.037563-0.61794
2.6028 -0.23129
1.6788

3 62 1982 270 185/14

GRASKOP 5246336.25 1904108.97 -3079063.590 2919.00010

KARASBERG 5386693.76 1837214.33 -2872962.920 2618.00079

WITBANK 5361114.36 1605149.45 -3050286.090 2816.00036

2.5089 0.027858-0.53405 2.4808 0.093293-0.51928 2.4540 0.18777 -0.53519

2.2788 -0.14640 0.021598 2.2666 -0.13718 0.010359 2.2931 -0.13948

1.7260 -0.56964 -0.19385 1.7427 -0.51468 -0.22747 1.7235

2.4711 0.085930-0.56059 2.4388 0.18263 -0.57596

2.2840 -0.18541 0.075560 2.3062 -0.18659

1.7691 -0.50482 -0.21901 1.7475

2.4330 0.16916 -0.52652

2.3614 -0.22597

1.7386

3 61 1982 274 185/15

BURENKAMP 5505878.87 1492430.36 -2843487.76 2615.00002

KARASBERG 5386689.87 1837216.03 -2872955.21 2618.00079

WITBANK NEW 5361109.54 1605151.40 -3050278.84 2816.00036

3.0861 0.20635 -0.73258 3.1395 0.012122-0.73416 3.1162 0.12791 -0.76210

2.7760 -0.29182 0.25909 2.6842 -0.31603 0.21806 2.7434 -0.30842

1.9991 -0.76103 -0.19580 1.9925 -0.69721 -0.24129 1.9779

3.2460 0.057618-0.77917 3.1891 0.18487 -0.79835

2.6564 -0.22266 0.025150 2.6816 -0.21135

2.0112 -0.70588 -0.26592 1.9825

3.1791 0.14171 -0.73641

2.7596 -0.26023

1.9766

5 85 1984 235 185/16-18

LOURKUPPE 5545540.08 1663961.77 -2670128.930 2416.00068
BURENKAMP 5505889.59 1492434.38 -2843494.17 2615.00002
SCHWARZECK 5576035.70 1884771.92 -2452545.51 2218.00179
UNIONS END 5444111.05 1979206.49 -2663034.66 2419.00318
KARASBERG 5386698.99 1837221.73 -2872961.03 2618.00079

1.4032 -0.011852-0.11309 1.3880 0.009234-0.11552 1.3994 -0.042556-0.10723 1.4183 -0.062736-0.11656 1.4216 -0.045559-0.
1.5134 -0.049131 0.003711 1.5142 -0.056767-0.024793 1.4786 -0.038886-0.030806 1.4701 -0.038092-0.019687 1.4844 -0.046902
1.1994 -0.079218-0.048215 1.1806 -0.15142 -0.045089 1.2110 -0.12008 -0.024255 1.1947 -0.084065-0.021586 1.1802
1.3923 0.022911-0.085633 1.3887 -0.026765-0.074673 1.4084 -0.047315-0.084396 1.4144 -0.031024-0.094060
1.5392 -0.058915-0.004251 1.4889 -0.037163-0.010625 1.4808 -0.035718-0.000309 1.4975 -0.045920
1.1710 -0.15502 -0.052173 1.1949 -0.12383 -0.032076 1.1782 -0.088215-0.030764 1.1649
1.4147 -0.057709-0.14913 1.4305 -0.077817-0.15771 1.4289 -0.059199-0.16654
1.4681 -0.038214-0.063559 1.4529 -0.037327-0.051789 1.4642 -0.044549
1.2310 -0.11727 -0.015619 1.2134 -0.080454-0.011413 1.1975
1.4566 -0.083717-0.12893 1.4515 -0.064130-0.13708
1.4527 -0.014981-0.071408 1.4603 -0.022540
1.2010 -0.091707-0.010060 1.1832
1.4576 -0.053690-0.10216
1.4808 -0.019486
1.1703

3 66 1984 128 185/20

FRANSMANS 4988155.27 2267478.21 -3256554.430 3024.00026
POTLOER 5101370.46 1977624.41 -3269928.060 3121.00053
BLYDEBERG 4917288.57 2106612.86 -3463660.580 3323.00007

2.1515 -0.074241-0.36979 2.0902 0.024981-0.36769 2.1370 -0.034706-0.38654
2.0351 -0.14684 -0.079900 2.0545 -0.14204 -0.075536 2.0489 -0.15083
1.7143 -0.33456 -0.19748 1.7033 -0.31439 -0.14835 1.6857
2.0548 0.017756-0.34131 2.0895 -0.044070-0.35493
2.1110 -0.19867 0.021550 2.0828 -0.20508
1.7079 -0.31580 -0.14735 1.6817
2.1392 -0.039655-0.33548
2.0838 -0.15603
1.6657

3 55 1984 140 185/21

FRANSMANS 4988152.26 2267482.44 -3256553.440 3024.00026

BLYDEBERG 4917285.43 2106616.47 -3463659.300 3323.00007

COEGAKOP 4785911.96 2295265.96 -3524983.750 3325.00133

2.1441 0.065773-0.40936 2.1147 0.11616 -0.41922 2.1627 0.019877-0.42537

1.9495 -0.17997 0.057977 1.9669 -0.18179 0.073636 1.9333 -0.18615

1.7211 -0.34620 -0.18811 1.6888 -0.36001 -0.12701 1.6828

2.1035 0.10368 -0.36038 2.1412 0.010831-0.36459

2.0051 -0.19279 0.12178 1.9589 -0.19424

1.6650 -0.37123 -0.12994 1.6540

2.1982 0.025565-0.38202

1.9437 -0.13375

1.6533

4 80 1984 321 185/22-23

LEEUKOP 4986890.64 2475834.61 -3104541.90 2926.00022

FRANSMANS 4988154.92 2267480.53 -3256552.36 3024.00026

LUBISI 4815761.43 2506295.77 -3339943.23 3127.00040

COEGAKOP 4785913.99 2295264.52 -3524982.56 3325.00133

1.2719 0.046901-0.33760 1.2481 0.086146-0.34209 1.2749 0.022066-0.34170 1.2616 0.063265-0.35520

1.2164 -0.15658 0.037942 1.2245 -0.15452 0.054315 1.2063 -0.16224 0.042442 1.2262 -0.16428

0.99661 -0.30793 -0.17022 0.98276 -0.31478 -0.12873 0.97755 -0.28450 -0.14284 0.96824

1.2419 0.074557-0.31628 1.2561 0.011375-0.31235 1.2497 0.051195-0.32754

1.2537 -0.17129 0.091100 1.2201 -0.17593 0.078969 1.2452 -0.18029

0.97841 -0.31925 -0.12738 0.96625 -0.29095 -0.14330 0.95946

1.2939 0.026951-0.32281 1.2721 0.069634-0.33410

1.2214 -0.13590 0.016728 1.2274 -0.13728

0.96806 -0.29054 -0.14932 0.95316

1.2703 0.055727-0.30623

1.2589 -0.15443

0.94957

5 74 1985 238 185/24

MORGENZON 5138864.73 2424479.01 -2890851.670 2725.00079
 HADIDA 5294749.99 2085811.88 -2872759.97 2621.00003
 MANNERHEIM 5291627.61 2265092.20 -2740792.39 2523.00004
 KRANZBERG 5149894.27 2691093.26 -2626423.03 2427.00025
 BRIT 44 5086492.99 2667595.37 -2767923.91 2527.00292

1.5438 -0.042225-0.17676 1.4919 0.013505-0.16531 1.5112 -0.011516-0.16508 1.5418 -0.069044-0.15943 1.5481 -0.080914-0.
 1.4845 -0.056731-0.030705 1.5144 -0.066009-0.032895 1.4928 -0.059200-0.057679 1.4470 -0.042345-0.056585 1.4523 -0.043820
 1.1932 -0.16175 -0.087574 1.1874 -0.19158 -0.083661 1.2004 -0.21889 -0.060297 1.2066 -0.19720 -0.044766 1.1952
 1.4613 0.023918-0.15567 1.4699 -0.000756-0.15323 1.4882 -0.056373-0.14502 1.4949 -0.068962-0.14903
 1.5700 -0.098979 0.022543 1.5352 -0.090548-0.004749 1.4795 -0.071458-0.003885 1.4817 -0.073070
 1.1933 -0.18364 -0.092125 1.2008 -0.20825 -0.067544 1.2001 -0.18569 -0.053216 1.1882
 1.4915 -0.002733-0.18361 1.5127 -0.060207-0.17524 1.5184 -0.072645-0.17915
 1.5192 -0.086561-0.029632 1.4606 -0.069284-0.028745 1.4629 -0.070718
 1.2149 -0.20876 -0.061916 1.2149 -0.18619 -0.047013 1.2029
 1.5728 -0.092838-0.20677 1.5578 -0.097455-0.20814
 1.4341 -0.049803-0.085163 1.4233 -0.050191
 1.2332 -0.18238 -0.032874 1.2139
 1.5685 -0.097850-0.18761
 1.4350 -0.034294
 1.2047

5 78 1984 225 185/25

GRASKOP 5246342.27 1904113.18 -3079065.94 2919.00010
 HADIDA 5294751.15 2085814.77 -2872759.93 2621.00003
 KARASBERG 5386699.65 1837218.53 -2872965.31 2618.00079
 MANNERHEIM 5291629.27 2265093.72 -2740792.00 2523.00004
 UNIONS END 5444112.02 1979202.81 -2663038.30 2419.00318

1.7550 0.055676-0.19056 1.7550 0.020124-0.17961 1.7290 0.072885-0.17520 1.7601 -0.019989-0.16935 1.7295 0.052984-0.
 1.6890 -0.082485 0.047076 1.6534 -0.068973 0.062344 1.6809 -0.081799 0.034885 1.6286 -0.056537 0.053398 1.6632 -0.069207
 1.3478 -0.23223 -0.076767 1.3626 -0.22381 -0.10427 1.3629 -0.25957 -0.065084 1.3693 -0.26522 -0.10821 1.3793
 1.7698 0.009553-0.22450 1.7353 0.063273-0.21859 1.7752 -0.031443-0.21372 1.7396 0.042749-0.20860
 1.6370 -0.066297 0.026534 1.6554 -0.076962-0.002552 1.6094 -0.055419 0.016592 1.6402 -0.065718
 1.3845 -0.21433 -0.092731 1.3806 -0.25176 -0.055422 1.3907 -0.25633 -0.098127 1.3982
 1.7206 0.080375-0.21369 1.7409 -0.013943-0.20393 1.7127 0.059996-0.20083
 1.6981 -0.10556 0.049977 1.6301 -0.081020 0.070538 1.6699 -0.092284
 1.3874 -0.24619 -0.065259 1.3870 -0.25314 -0.10763 1.3988
 1.7949 -0.046316-0.24404 1.7485 0.029069-0.23608
 1.5982 -0.046625-0.024980 1.6169 -0.055071
 1.4037 -0.24614 -0.087972 1.4058
 1.7220 0.050237-0.24442
 1.6622 -0.097675
 1.4185

3 73 1984 267 185/26

ESERE 5716996.70 1810401.70 -2169939.41 2017.00026
ACORN 5525474.09 2120236.62 -2373275.25 2120.00001
SCHWARZECK 5576032.48 1884764.74 -2452546.76 2218.00179
2.0666 0.052916-0.30033 2.0890 -0.057519-0.30627 2.0807 0.020408-0.31688
1.7724 -0.094873 0.035074 1.7340 -0.092711 0.047245 1.7599 -0.097613
1.3389 -0.26893 -0.043833 1.3208 -0.25148 -0.066658 1.3196
2.1326 -0.070820-0.28105 2.1123 0.005690-0.28827
1.7275 -0.041587-0.061127 1.7361 -0.044910
1.3130 -0.26084 -0.062692 1.3058
2.1099 0.015097-0.27145
1.7685 -0.069359
1.3074

4 68 1984 285 185/27

ACORN 5525483.47 2120237.01 -2373277.17 2120.00001
SCHWARZECK 5576042.52 1884766.34 -2452549.37 2218.00179
UNIONS END 5444117.15 1979201.08 -2663038.52 2419.00318
MANNERHEIM 5291634.37 2265092.18 -2740790.64 2523.00004
2.2372 0.066351-0.30644 2.2011 0.14279 -0.30705 2.2190 0.10343 -0.31833 2.2769 0.001094-0.33028
2.1313 -0.12585 0.063215 2.1434 -0.12358 0.063403 2.1452 -0.13114 0.073193 2.1018 -0.13500
1.5261 -0.27723 -0.14723 1.5143 -0.23824 -0.11681 1.4982 -0.24452 -0.074951 1.4935
2.1882 0.14202 -0.28300 2.1945 0.098676-0.29084 2.2440 -0.004003-0.30054
2.1872 -0.15016 0.13903 2.1709 -0.15575 0.14617 2.1153 -0.15590
1.5138 -0.24038 -0.11854 1.4912 -0.24368 -0.074961 1.4822
2.2217 0.098315-0.25317 2.2657 -0.001540-0.26374
2.1912 -0.12679 0.10975 2.1282 -0.12530
1.4802 -0.25727 -0.081263 1.4683
2.3666 0.010282-0.28351
2.1421 -0.085880
1.4858

5 69 1984 294 185/28

ESERE 5717004.59 1810403.26 -2169940.87 2017.00026
LEEUKOP 5672682.04 1526107.78 -2477900.49 2315.00079
SCHWARZECK 5576041.28 1884767.31 -2452549.14 2218.00179
LOURKUPPE 5545545.64 1663956.10 -2670135.94 2416.00068
BURENKAMP 5505895.39 1492430.35 -2843498.12 2615.00002

1.7926 0.049702-0.17416 1.7558 0.11188 -0.18333 1.8000 0.023447-0.18425 1.7931 0.077646-0.19881 1.7739 0.11731 -0.
1.7485 -0.073379 0.067386 1.7702 -0.085094 0.043199 1.7292 -0.074848 0.062708 1.7580 -0.084693 0.071860 1.7721 -0.094828
1.4241 -0.10111 -0.075767 1.3960 -0.11720 -0.044046 1.3987 -0.072398-0.051036 1.3834 -0.031245-0.054161 1.3651
1.7457 0.12639 -0.11452 1.7726 0.041013-0.11275 1.7760 0.091902-0.12888 1.7653 0.13013 -0.13400
1.8195 -0.093300 0.10418 1.7615 -0.077850 0.12243 1.7984 -0.091592 0.13012 1.8186 -0.10397
1.3785 -0.12760 -0.058751 1.3738 -0.084204-0.068688 1.3619 -0.044302-0.074376 1.3458
1.8306 0.017284-0.13282 1.8149 0.072192-0.14506 1.7954 0.11123 -0.14866
1.7388 -0.045788 0.037189 1.7566 -0.056609 0.046431 1.7698 -0.068558
1.3837 -0.085931-0.052288 1.3632 -0.044380-0.055397 1.3439
1.8372 0.084360-0.10621 1.8028 0.12799 -0.10614
1.8165 -0.065108 0.096538 1.8095 -0.079731
1.3614 -0.061237-0.071853 1.3328
1.8002 0.13439 -0.067966
1.8433 -0.087569
1.3208

4 71 1984 330 185/29

MOOIDAM 4983832.88 2732712.35 -2887740.41 2728.00050
INKOMINKULU 4776612.37 2809325.71 -3149349.57 2930.00051
LEEUKOP 4986893.13 2475834.64 -3104544.38 2926.00022
LUBISI 4815763.84 2506296.16 -3339945.11 3127.00040

1.3839 0.12974 -0.34570 1.3938 0.096257-0.35153 1.3386 0.16867 -0.34866 1.3572 0.14920 -0.36308
1.29650 -0.20783 0.13217 1.2714 -0.21255 0.11091 1.3160 -0.20694 0.11477 1.3103 -0.21814
1.0475 -0.31998 -0.17127 1.0271 -0.29710 -0.21554 1.0282 -0.27798 -0.19057 1.0173
1.4242 0.097738-0.33218 1.3539 0.16984 -0.32300 1.3747 0.15156 -0.33915
1.2770 -0.17829 0.078121 1.2978 -0.17202 0.082314 1.2977 -0.18292
1.0183 -0.30347 -0.22060 1.0098 -0.28581 -0.19605 1.0005
1.3156 0.14663 -0.30462 1.3295 0.12729 -0.31723
1.3572 -0.21876 0.15075 1.3420 -0.22905
1.0186 -0.28386 -0.19308 1.0039
1.3549 0.13134 -0.30023
1.3484 -0.20575
0.99712

3 71 1985 245 185/3

WITWATER 5137636.66 2183075.27 -3078163.86 2923.00053
LEEUKOP 4986893.22 2475834.06 -3104546.18 2926.00022
FRANSMANS 4988157.30 2267480.14 -3256556.86 3024.00026
1.6743 0.087942-0.28779 1.7056 0.034291-0.29046 1.6964 0.063797-0.30346
1.6727 -0.17891 0.095929 1.6253 -0.17744 0.093470 1.6534 -0.18546
1.2754 -0.30172 -0.14458 1.2710 -0.26939 -0.15234 1.2619
1.7575 0.040882-0.31067 1.7360 0.072665-0.32075
1.5973 -0.14531 0.039857 1.6173 -0.15147
1.2766 -0.27538 -0.15102 1.2622
1.7287 0.069067-0.28863
1.6487 -0.15972
1.2540

5 68 1985 222 185/30

MAGWAZA 4786229.78 3006520.51 -2946622.93 2732.00004
INKOMINKULU 4776615.59 2809327.14 -3149353.33 2930.00051
MOOIDAM 4983836.56 2732713.23 -2887744.45 2728.00050
THAMAKOOSH 5019373.38 2903706.90 -2651976.50 2430.00062
MPUMBE NEW 4943183.76 3076444.33 -2596401.81 2431.00066
1.5148 0.009183-0.18015 1.4886 0.032504-0.18639 1.4462 0.046637-0.16294 1.4616 0.033208-0.15663 1.4863 0.012760-0.
1.4394 -0.072329 0.011380 1.4580 -0.081345 0.002096 1.4688 -0.077881 0.005939 1.4456 -0.068549 0.001306 1.4241 -0.060904
1.2207 -0.13863 -0.065901 1.2004 -0.16149 -0.10068 1.2164 -0.20667 -0.11399 1.2359 -0.22470 -0.10599 1.2412
1.4820 0.031045-0.14876 1.4337 0.047145-0.12388 1.4430 0.034182-0.11655 1.4642 0.013833-0.12003
1.4917 -0.077530 0.022620 1.4960 -0.073640 0.027493 1.4704 -0.063000 0.023378 1.4471 -0.054048
1.1878 -0.17057 -0.11118 1.2017 -0.21496 -0.12273 1.2195 -0.23244 -0.11368 1.2234
1.4048 0.036532-0.15162 1.4059 0.025022-0.14272 1.4259 0.004304-0.14483
1.5210 -0.10795 0.042581 1.4885 -0.09722 0.037209 1.4628 -0.088955
1.2243 -0.19476 -0.11833 1.2384 -0.21169 -0.10925 1.2409
1.4249 0.028565-0.18886 1.4443 0.007927-0.19019
1.4749 -0.11083 0.023154 1.4433 -0.10317
1.2596 -0.20541 -0.10168 1.2611
1.4834 0.000573-0.21011
1.4322 -0.097194
1.2716

4 62 1985 229 185/31

PONT 5157884.43 2878303.57 -2400479.13 2229.00023
KRANS 5149888.78 2691094.53 -2626420.07 2427.00025
THAMA 5019369.12 2903705.49 -2651972.18 2430.00062
MPUMBE 4943180.19 3076442.90 -2596397.59 2431.00066

2.1247 0.16406 -0.31862 2.09790 0.18748 -0.32519 2.1406 0.13729 -0.33550 2.1722 0.086612-0.33018
1.9046 -0.19218 0.15942 1.9194 -0.19994 0.16462 1.8854 -0.20011 0.17279 1.8485 -0.19463
1.4044 -0.26785 -0.17942 1.3839 -0.27916 -0.15531 1.3859 -0.30057 -0.13852 1.3873
2.1000 0.18331 -0.27846 2.1212 0.13214 -0.28612 2.1484 0.082821-0.28084
1.9688 -0.19518 0.18705 1.9088 -0.18790 0.19501 1.8696 -0.18037
1.3771 -0.28640 -0.16847 1.3678 -0.30739 -0.14676 1.3677
2.1722 0.13809 -0.30032 2.1963 0.087682-0.29404
1.8870 -0.16435 0.14639 1.8438 -0.15711
1.3749 -0.32069 -0.14598 1.3729
2.2394 0.094276-0.31839
1.8202 -0.14101
1.3796

5 77 1985 312 185/32

RUNDU 5714711.93 2054402.84 -1947079.33 1719.00000
OKOTOMARE 5812707.60 1662413.92 -2028990.57 1815.00101
GEELHOUT 5624230.27 2124855.29 -2125844.46 1920.00009
ESERE 5716995.92 1810402.12 -2169938.03 2017.00026
ACORN 5525472.93 2120236.03 -2373274.21 2120.00001

1.7512 -0.077413-0.16155 1.7094 0.008098-0.16544 1.7502 -0.10305 -0.16556 1.7347 -0.020882-0.17342 1.7608 -0.10664 -0.
1.6039 -0.028612-0.047586 1.6253 -0.035646-0.080740 1.5942 -0.027266-0.055985 1.6150 -0.035309-0.081302 1.5961 -0.028289
1.2499 -0.13955 -0.048484 1.2409 -0.12929 -0.009411 1.2364 -0.12016 -0.030926 1.2351 -0.087355 0.007268 1.2202
1.6997 0.036746-0.14925 1.7136 -0.076101-0.14412 1.7101 0.005938-0.15381 1.7258 -0.081803-0.15389
1.6798 -0.058686 0.000878 1.6192 -0.047071 0.027907 1.6525 -0.058056-0.000511 1.6202 -0.048903
1.2463 -0.13284 -0.018160 1.2287 -0.12624 -0.041796 1.2333 -0.090233-0.004028 1.2125
1.7660 -0.10999 -0.13629 1.7410 -0.027355-0.14147 1.7716 -0.11055 -0.14566
1.6044 -0.007375-0.084461 1.6117 -0.016684-0.10794 1.6003 -0.008269
1.2291 -0.12549 -0.029158 1.2237 -0.094080 0.009663 1.2107
1.7389 -0.001720-0.13523 1.7544 -0.089683-0.13585
1.6481 -0.041284-0.028735 1.6151 -0.030839
1.2290 -0.099438-0.001627 1.2080
1.7955 -0.11316 -0.10728
1.6216 0.009416
1.2003

5 97 1985 319 185/33

ONDONDVENGO 5933897.86 1289729.99 -1947624.35 1712.00004
OKOTOMARE 5812708.72 1662416.33 -2028991.55 1815.00101
DRUSE 5821904.69 1398479.01 -2192747.47 2013.00007
ESERE 5716996.76 1810404.46 -2169938.40 2017.00026
LEEUKOP 5672673.93 1526108.68 -2477897.91 2315.00079

1.2233 -0.002911-0.10610 1.2256 -0.053681-0.10388 1.2210 -0.019920-0.10921 1.2352 -0.079878-0.10714 1.2353 -0.038467-0.
1.2845 -0.035421-0.023253 1.2515 -0.030672-0.004667 1.2694 -0.036539-0.028465 1.2392 -0.029420-0.014633 1.2615 -0.034529
0.95553 -0.093691-0.016857 0.94483 -0.070247-0.022688 0.94043 -0.075748-0.004550 0.93643 -0.032454-0.008463 0.92397
1.2561 -0.076062-0.097348 1.2357 -0.040278-0.099574 1.2651 -0.10114 -0.10089 1.2562 -0.056621-0.10887
1.2462 -0.011006-0.056337 1.2505 -0.016426-0.079118 1.2327 -0.009472-0.064908 1.2489 -0.013420
0.94600 -0.071286-0.014995 0.93461 -0.079772 0.002797 0.93742 -0.035627 0.002163 0.92107
1.2368 -0.024567-0.077352 1.2471 -0.082249-0.075245 1.2479 -0.040487-0.084654
1.2750 -0.022218-0.044724 1.2409 -0.012999-0.031534 1.2638 -0.019399
0.93180 -0.082088-0.003455 0.92684 -0.039348-0.007205 0.91408
1.2881 -0.10615 -0.086612 1.2706 -0.059822-0.092501
1.2351 0.004937-0.090473 1.2431 0.000524
0.93448 -0.040804 0.005155 0.91448
1.2774 -0.050126-0.051067
1.2760 -0.002901
0.90385

3 60 1981 80 185/4

LEEUKOP 4986888.85 2475832.23 -3104541.70 2926.00022
MOOIDAM 4983830.48 2732709.09 -2887737.90 2728.00050
MORGENZON 5138855.74 2424476.62 -2890845.88 2725.00079

2.2132 0.15009 -0.58584 2.2330 0.065080-0.55983 2.1866 0.20527 -0.57296
2.0189 -0.32203 0.21438 1.9545 -0.33228 0.13393 2.0125 -0.30267
1.3570 -0.64425 -0.28769 1.3646 -0.60508 -0.36225 1.3639
2.2900 0.12142 -0.62725 2.2144 0.26699 -0.63168
1.9219 -0.30314 0.047686 1.9551 -0.27004
1.3868 -0.58067 -0.37290 1.3752
2.1934 0.18747 -0.60244
2.0596 -0.34743
1.3903

3 52 1981 86 185/5

KRANS	5149886.42	2691091.70	-2626419.61	2427.00025				
MOOIDAM	4983830.15	2732708.78	-2887739.53	2728.00050				
MORGENZON	5138856.12	2424477.91	-2890849.07	2725.00079				
2.5778	0.27004	-0.57250	2.5900	0.20727	-0.58248	2.5123	0.38921	-0.58067
2.3735	-0.3128	0.29140	2.3543	-0.32978	0.18473	2.4245	-0.29324	
1.5117	-0.53516	-0.26244	1.4879	-0.48825	-0.34242	1.4796		
2.6282	0.22597	-0.55275	2.5345	0.40614	-0.54401			
2.3715	-0.28136	0.12057	2.4130	-0.24450				
1.4758	-0.49867	-0.35974	1.4591					
2.5075	0.29464	-0.51074						
2.5573	-0.33397							
1.4715								

3 54 1981 94 185/6

KRANZBERG	5149886.61	2691092.16	-2626415.58	2427.00025				
MOOIDAM	4983831.17	2732708.24	-2887736.76	2728.00050				
THAMAKOOSH	5019367.62	2903702.04	-2651968.14	2430.00062				
2.8173	0.12788	-0.58883	2.8429	0.053072	-0.59887	2.8513	-0.016022	-0.57097
2.6196	-0.32830	0.14549	2.6122	-0.35027	0.21714	2.5467	-0.35600	
1.5833	-0.55288	-0.27750	1.5574	-0.61452	-0.26239	1.5730		
2.9179	0.060938	-0.57403	2.8961	0.000294	-0.54181			
2.6822	-0.30372	0.14402	2.5713	-0.30779				
1.5578	-0.63271	-0.28512	1.5577					
2.9361	0.065055	-0.61126						
2.5336	-0.29537							
1.5835								

- C 14 -

3 62 1980 323 185/7

FRANSMANS 4988155.10 2267478.45 -3256552.41 3024.00026
POTLOER 5101369.40 1977625.89 -3269925.59 3121.00053
WITWATER 5137634.62 2183073.32 -3078159.59 2923.00053
0.78178 -0.010593-0.043505 0.74844 0.032526-0.039724 0.76056 0.008011-0.035906
0.66153 -0.009943-0.016238 0.65342 -0.006803-0.012494 0.64610 -0.006085
0.51678 -0.029907-0.023958 0.50715 -0.049967-0.021566 0.51710
0.74514 0.024647-0.035068 0.74111 0.002022-0.026989
0.68505 -0.026279 0.030986 0.65954 -0.022168
0.51456 -0.051497-0.019151 0.51629
0.75789 0.004669-0.047457
0.66016 -0.019211
0.52872

5 105 1985 165 185/8&19

LOUISFNTN 5203445.80 1690209.29 -3268510.73 3117.00005
POTLOER 5101370.38 1977628.23 -3269929.30 3121.00053
HEXRIVIER 5022156.49 1795163.19 -3490365.54 3319.00029
BLYDEBERG 4917289.00 2106616.20 -3463662.09 3323.00007
KARSRIVIER 4944370.27 1811092.31 -3587438.45 3420.00022
0.84226 -0.036866-0.018051 0.85117 -0.059887-0.019656 0.85588 -0.046276-0.027543 0.86617 -0.072920-0.027283 0.86106 -0.049086-0.
0.98806 -0.026243-0.054047 0.96802 -0.016094-0.044209 0.97948 -0.024125-0.062105 0.96102 -0.012623-0.045417 0.97789 -0.024130
0.80912 -0.020397-0.011902 0.80585 0.004890-0.011497 0.79239 -0.001352 0.003416 0.79012 0.015122-0.005899 0.78487
0.86917 -0.076952-0.024454 0.86919 -0.062417-0.031413 0.88387 -0.088902-0.032378 0.87466 -0.064637-0.036250
0.95939 -0.002857-0.066859 0.96551 -0.009929-0.083916 0.95031 0.000443-0.067756 0.96489 -0.010006
0.80842 0.001508-0.000685 0.79223 -0.006008 0.013559 0.79294 0.011455 0.005249 0.78512
0.87666 -0.053403-0.007023 0.88573 -0.079333-0.007225 0.87995 -0.055726-0.011601
0.98164 -0.009587-0.069519 0.96051 0.002936-0.054133 0.97712 -0.009120
0.78021 -0.013325 0.005764 0.77767 0.003323-0.003384 0.77144
0.90421 -0.095465-0.015956 0.89183 -0.071261-0.018619
0.95066 0.016463-0.079958 0.96124 0.005724
0.78142 0.002279 0.008904 0.77104
0.88843 -0.056884-0.002456
0.98091 -0.003701
0.76606

3 51 1982 193 185/9

GRASKOP 5246338.35 1904107.10 -3079063.86 2919.00010

LOUISFONTEIN 5203447.01 1690204.97 -3268508.43 3117.00005

POTLOER 5101371.53 1977623.36 -3269927.19 3121.00053

3.2058 0.002782-0.70823 3.1486 0.10457 -0.72437 3.1945 -0.090670-0.70642

2.6410 -0.18069 -0.004200 2.6416 -0.17585 0.016391 2.6101 -0.18705

2.0339 -0.63354 -0.20989 1.9988 -0.65774 -0.11593 1.9944

3.1347 0.089658-0.65937 3.1554 -0.10098 -0.63509

2.6937 -0.21106 0.11221 2.6311 -0.21594

1.9846 -0.67610 -0.11246 1.9666

3.2159 -0.081802-0.66418

2.6285 -0.12415

1.9715

1ACORN	LAT	.19	-.01	.03	.00	.01	.00	.07	-.01	.01	.00	.12	-.01	.12	-.01	.02	.00	.15	-.01	.03	.00
1ACORN	LAT	.03	.00	.01	.00	.01	.00	.05	.00	.01	.00	.02	.00	.02	.00	.11	-.01	.02	.00	.08	-.01
1ACORN	LAT	.01	.00	.00	.00	.06	.00	.01	.00	.02	.00	.01	.00	.13	-.01	.12	-.01	.01	.00	.02	.00
1ACORN	LAT	.15	-.01	.07	-.01	.01	.00	.07	-.01	.02	.00	.02	.00								
1	LON	.23	.00	.04	.00	.02	.00	.08	.00	.01	.00	.15	-.01	.15	.00	.02	-.01	.18	.00	.04	.00
1	LON	.04	.00	.01	.00	.02	.00	.06	.00	.02	.00	.02	.00	.02	.00	.13	.00	.02	.00	.09	.00
1	LON	.02	.00	.00	-.01	.07	.00	.02	.00	.02	.00	.01	.00	.16	.00	.15	.00	.01	.00	.02	-.01
1	LON	.18	.00	.08	.00	.02	-.01	.08	.00	.03	.00	.03									

2BRIT 44	LAT	.30	-.03	.02	.00	.03	-.01	.01	.00	.03	-.01	.03	.00	.03	.00	.03	.00	.04	-.01	.06	-.01
2BRIT 44	LAT	.01	.00	.03	.00	.03	-.01	.02	.00	.06	-.01	.03	.00	.03	-.01	.02	.00	.03	-.01	.03	.00
2BRIT 44	LAT	.01	.00	.06	-.01	.04	.00	.04	-.01	.03	.00	.03	-.01	.03	-.01	.02	.00	.03	.00	.03	.00
2BRIT 44	LAT	.02	.00	.04	.00	.04	-.01	.02	.00	.04	-.01										
2	LON	.35	.00	.03	.00	.03	.00	.01	.00	.03	.00	.03	.00	.03	.00	.04	.00	.04	.00	.07	.00
2	LON	.01	.00	.04	.00	.04	.00	.02	-.01	.07	.00	.04	.00	.03	.00	.03	.00	.03	.00	.03	.00
2	LON	.01	.00	.08	.00	.04	.00	.05	.00	.04	.00	.03	.00	.03	.00	.02	.00	.03	.00	.04	.00
2	LON	.03	.00	.04	.00	.05	.00	.02	.00	.05											

3BLYDEBER	LAT	.14	-.02	.02	.00	.03	.00	.01	.00	.01	.00	.06	-.01	.01	.00	.03	-.01	.03	.00	.03	.00
3BLYDEBER	LAT	.02	.00	.02	.00	.07	-.01	.02	.00	.03	.00	.01	.00	.06	-.01	.01	.00	.03	.00	.01	.00
3BLYDEBER	LAT	.02	.00	.02	.00	.02	.00	.01	.00	.01	.00	.01	.00	.01	.00	.06	-.01	.01	.00	.01	.00
3BLYDEBER	LAT	.02	.00	.02	.00	.01	.00	.04	.00												
3	LON	.17	.00	.02	.00	.03	.00	.02	.00	.02	-.01	.07	.00	.02	.00	.04	.00	.03	.00	.03	.00
3	LON	.03	.00	.02	-.01	.09	.00	.02	.00	.04	.00	.02	.00	.07	.00	.02	-.01	.04	.00	.01	.00
3	LON	.03	.00	.03	.00	.02	.00	.02	.00	.02	.00	.02	.00	.01	-.01	.08	.00	.02	.00	.01	.00
3	LON	.02	.00	.02	.00	.02	.00	.05													

4BURENKAM	LAT	.15	-.01	.01	.00	.08	-.01	.08	.00	.02	.00	.07	.00	.03	.00	.03	.00	.01	.00	.01	.00
4BURENKAM	LAT	.07	.00	.02	.00	.02	.00	.02	.00	.09	-.01	.02	.00	.09	-.01	.01	.00	.00	.00	.04	.00
4BURENKAM	LAT	.01	.00	.02	.00	.01	.00	.08	-.01	.08	-.01	.00	.00	.02	.00	.07	.00	.06	.00	.01	.00
4BURENKAM	LAT	.06	.00	.03	.00	.02	.00														
4	LON	.19	.00	.01	.00	.10	-.01	.10	.00	.02	-.01	.09	.00	.04	.00	.04	.00	.01	.00	.01	-.01
4	LON	.08	.00	.02	.00	.02	.00	.02	-.01	.11	.00	.03	-.01	.11	.00	.02	.00	.00	-.01	.05	.00
4	LON	.02	.00	.02	.00	.01	.00	.10	.00	.10	.00	.01	.00	.02	-.01	.09	-.01	.07	.00	.01	-.01
4	LON	.08	.00	.04	.00	.03															

5COEGAKOP	LAT	.08	-.01	.01	.00	.01	.00	.03	.00	.01	.00	.01	.00	.01	.00	.01	.00	.02	.00	.01	.00
5COEGAKOP	LAT	.02	.00	.01	.00	.03	.00	.01	.00	.02	.00	.01	.00	.04	.00	.00	.00	.01	.00	.02	.00
5COEGAKOP	LAT	.01	.00	.01	.00	.01	.00	.01	.00	.00	.00	.02	.00	.01	.00	.00	.00	.01	.00	.01	.00
5COEGAKOP	LAT	.01	.00	.02	.00																
5	LON	.10	.00	.01	.00	.01	.00	.04	.00	.01	.00	.02	.00	.02	.00	.01	.00	.02	.00	.01	.00
5	LON	.02	.00	.02	.00	.03	.00	.01	.00	.02	.00	.01	-.01	.04	.00	.01	.00	.01	.00	.02	.00

11	LON	.13	.00	.01	-.01	.03	.00	.05	.00	.03	-.01	.05	-.01	.04	.00	.04	.00	.04	.00	.04	-.01
11	LON	.03	.00	.01	-.01	.07	.00	.04	.00	.04	.00	.03	.00	.04	.00	.04	.00	.01	.00	.04	.00
11	LON	.04	.00	.03	.00	.03	.00	.06	.00	.03	-.01	.07									
12	HEXRIVIE LAT	.06	-.01	.01	.00	.01	.00	.04	.00	.01	.00	.01	.00	.01	.00	.03	.00	.01	.00	.01	.00
12	HEXRIVIE LAT	.00	.00	.01	.00	.01	.00	.01	.00	.00	.00	.01	.00	.01	.00	.00	.00	.02	.00	.01	.00
12	HEXRIVIE LAT	.00	.00	.01	.00	.01	.00	.01	.00	.01	.00										
12	LON	.08	.00	.01	.00	.01	.00	.05	.00	.01	.00	.01	.00	.01	.00	.03	.00	.01	.00	.01	.00
12	LON	.00	.00	.01	.00	.01	.00	.01	.00	.01	.00	.01	.00	.01	.00	.00	.00	.03	.00	.01	.00
12	LON	.01	.00	.01	.00	.01	.00	.01	.00	.02											
13	INKOMINK LAT	.20	-.03	.01	.00	.02	.00	.05	-.01	.06	-.01	.01	.00	.02	.00	.01	.00	.07	-.01	.03	.00
13	INKOMINK LAT	.02	.00	.07	-.01	.03	-.01	.07	-.01	.01	.00	.01	.00	.02	.00	.02	.00	.01	.00	.01	.00
13	INKOMINK LAT	.07	-.01	.02	.00	.01	.00	.03	-.01												
13	LON	.22	.00	.02	.00	.02	.00	.06	-.01	.06	.00	.01	.00	.02	.00	.01	-.01	.08	.00	.03	.00
13	LON	.03	-.01	.08	.00	.03	-.01	.08	.00	.01	.00	.01	.00	.03	.00	.03	.00	.01	.00	.01	-.01
13	LON	.08	.00	.02	.00	.01	.00	.04													
14	KARASBER LAT	.12	-.01	.02	.00	.02	.00	.02	.00	.05	-.01	.03	.00	.06	-.01	.02	.00	.00	.00	.05	.00
14	KARASBER LAT	.02	.00	.02	.00	.01	.00	.05	-.01	.05	-.01	.01	.00	.03	.00	.05	.00	.04	.00	.01	.00
14	KARASBER LAT	.06	.00	.03	.00	.03	.00														
14	LON	.15	.00	.03	.00	.03	.00	.02	.00	.07	.00	.03	.00	.08	.00	.02	.00	.01	-.01	.06	.00
14	LON	.02	.00	.02	.00	.02	.00	.06	.00	.07	.00	.01	.00	.03	.00	.06	.00	.05	.00	.02	-.01
14	LON	.08	.00	.04	.00	.04															
15	KARSRIVI LAT	.22	-.03	.02	.00	.03	.00	.01	.00	.07	-.01	.01	.00	.02	.00	.00	.00	.02	.00	.02	.00
15	KARSRIVI LAT	.02	.00	.01	.00	.01	.00	.01	.00	.00	.00	.06	-.01	.01	.00	.01	.00	.01	.00	.02	.00
15	KARSRIVI LAT	.02	.00	.03	.00																
15	LON	.29	.00	.02	.00	.03	.00	.02	-.01	.09	.00	.02	.00	.03	.00	.01	.00	.02	.00	.02	.00
15	LON	.02	.00	.01	.00	.02	.00	.02	.00	.01	-.01	.08	.00	.02	.00	.01	.00	.02	.00	.02	.00
15	LON	.02	.00	.04																	
16	KRANZBER LAT	.13	-.01	.04	.00	.02	.00	.02	.00	.02	.00	.04	.00	.02	.00	.04	-.01	.06	-.01	.04	.00
16	KRANZBER LAT	.06	.00	.02	.00	.02	.00	.03	.00	.02	.00	.02	.00	.01	.00	.07	-.01	.02	.00	.01	.00
16	KRANZBER LAT	.03	.00																		
16	LON	.16	.00	.04	.00	.02	.00	.02	.00	.02	.00	.04	.00	.02	.00	.05	-.01	.07	.00	.05	-.01
16	LON	.07	.00	.02	.00	.02	.00	.04	.00	.03	.00	.02	.00	.02	-.01	.08	.00	.03	.00	.01	.00
16	LON	.04																			
17	LEEUKOP(LAT	.11	-.01	.01	.00	.03	.00	.02	.00	.07	-.01	.01	.00	.03	.00	.05	-.01	.04	.00	.03	.00
17	LEEUKOP(LAT	.01	.00	.01	.00	.01	.00	.03	-.01	.01	.00	.01	.00	.04	.00	.02	.00	.01	.00	.05	-.01
17	LON	.13	.00	.02	.00	.03	.00	.02	-.01	.08	.00	.02	.00	.03	-.01	.06	.00	.04	-.01	.04	.00
17	LON	.02	.00	.02	.00	.02	.00	.04	.00	.02	.00	.01	.00	.04	.00	.02	.00	.01	.00	.06	

