



Thinking Through Making

25

The Rural Building Workshop

Peter Alexander Neokorides | NKRPE001
October 2010 | M. Arch. Design Document

The copyright of this thesis vests in the author. No quotation from it or information derived from it is to be published without full acknowledgement of the source. The thesis is to be used for private study or non-commercial research purposes only.

Published by the University of Cape Town (UCT) in terms of the non-exclusive license granted to UCT by the author.

Table of Contents

Introduction	3	Part 4: The Rural Building Workshop	
Part 1: My Theory of Making	4	Programme	46
Part 2: Structure and Structural Concepts	11	The Site	48
Trussing and Triangulation	12	Materiality, Structure and Adaptability	51
Aircrafts and Hangars	14	Part 5: Design development according	55
Space Grid Structures	18	to siting and programme	
Structural Concepts	20	Conclusion	59
Part 3: The Concept of <i>Techné</i>		Table of Figures	61
Model 1	29	References	70
Model 2	31	Appendices	72
Model 3	34		
En-loge Exam	36		
Model 4	37		
Model 5	38		
Model 6	40		
Model 7	42		
Model 8	45		

Introduction

This thesis is about the link between thinking and making, and how designing and physically building or prototyping what is designed (or parts there of) aids in the generation of ideas, and has a potential for architectural education.

The ideas that have transpired through the course of the year from building models and doing research for my theory and technology papers has led me in the direction of developing components and techniques for construction made from easily sourced tools and materials - ones from local industry and the landscape - that give rise to a tectonic expression as well as allows for an adaptable type of architecture. The methodology informing the design has therefore developed from the bottom up through the use of these components, as well as from the top down by means of a structural concept.

The first part of the paper looks at the theory of making which deals with aspects of making in current society that I find relevant to this thesis.

Part two and three of this paper is comprised of reciprocal components. Part two deals with the theory of structure and how my findings have helped guide the process of making, and have led to an appropriate structural system for my concept of

a 'growing' or adaptable building. The third part of this paper describes the models I have built this year to illustrate the concept of 'techne', or the process of creation that is guided by the thing made, in order to demonstrate the qualities that materials possess, as well as how the act of making can be a design generator. It also describes how the initial stage of building models has led to the exploration of structural systems and components, and how models relating to the programme and site have been able to start informing the form of a building.

The fourth and final part of this paper looks at the programme, site, and materiality of the 'Rural Building Workshop'.

Part 1:

My Theory of Making

Although the majority of this document focuses the physical objects that have been made during the course of the year, it is necessary to explain the personal influences that have informed this process. The ideas put forward in this section originate from my attempt to embrace the world in which I find myself, but at the same time to try creatively resist it. This section therefore describes my point of view regarding the act of making, and in particular, how it relates to our industrialised and wasteful society, the role of the architect, and its implications for architectural education.

Industrialisation and the role of the Architect

In one sense industrialisation represents progress, growth and technology which have positive connotations to my perceptions of it; in another sense, industrialisation and capitalist culture has encouraged and advanced something that the sociologist and economist Thorstein Veblen has described as "conspicuous consumption" and "conspicuous waste".

In his paper *The Theory of the Leisure Class*, Veblen explains that in a society where there is an habitual comparison of persons with one another, visible success becomes an end sought for its own utility on the basis of esteem, and esteem is gained by making evident ones efficiency or superior "instinct of workmanship". Conveying this is ultimately achieved through "conspicuous leisure" and "conspicuous consumption" in which the element of waste, in time and effort or commodities respectively, is a means of demonstrating the possession of wealth.

Veblen also describes that through industrialisation, the coercive

use of man by man has become representative of this superior "instinct of workmanship" or prowess in which man is exploited by being employed or in personal service to another. This has resulted in manual labour acquiring "a character of irksomeness by virtue of the indignity imputed to it", and that "...the handling of the tools and implements of industry falls beneath the dignity of able-bodied men". (Veblen 1899) We see this in modern-day society where physical labour has connotations associated with lower classes, and I feel that this is partly the reason for it being absent from academic practices.

Veblen points out that a "...certain standard of wealth in the one case, and of prowess in the other, is a necessary condition of reputability, and anything in excess of this normal amount is meritorious." (Veblen 1899) From this it is evident that "conspicuous consumption" stands in opposition to sustainability because of its dependency on natural resources that ultimately have a negative environmental impact due to our wasteful society.

Besides the "indignity" associated with manual labour, this physical act has been further removed from society by what Knorad Wachsmann has described as a "...discrepancy between the performance of machines and mechanical tools and that of hand tools [which] creates a state of instability characterized by almost unnatural competition." (Wachsmann 1961: 49) In order for the industrial process to become economical, the machine has to produce a large number of identical objects since the machine, in relation to a single manufactured article, constitutes a completely irrational expenditure of capital and energy. (Wachsmann 1961: 49) I believe that this causes the disturbing perception that a product produced by industrial processes has less embodied value than a product made by hand. The linear method of consumption that we currently follow "...exists nowhere in nature, and, before the Industrial Revolution, was not found to any extent in human culture either. The desire for it may have been there,

but the sheer time and effort of the handmade gave pause for thought. It was much easier to re-use than to throw out and start again." (Hagan 2007: 250)

I attribute the link between the above two views of manual labour and material consumption and waste to have its origins in the act of making. I say this because I have a deep appreciation for the thinking that goes into technology that actually "makes stuff" because I am aware of the effort it takes to manipulate materials manually. However, for someone who is not inclined to do manual labour that lives in a society in which industrialisation has substituted human labour with mechanization for the means of production, the tangible value of material objects is removed to a point where an object only has value as long as it serves a purpose, and the materials it is made from only serves the form of the object, which can also be seen as a purpose in itself. It is from this I believe we have a society that consumes devalued material objects where "...market forces" tend to alienate the meaning of objects in order to ease their consumption" (Zambonini 1988: 621) and we therefore live in a world in which waste generation has no moral impact:

Today, so-called 'late capitalism' has reduced the Modernist project for ceaseless revolution to rampant consumerism: novel objects in novel forms in ever-increasing numbers, flowing from arrival into obsolescence with increasing speed, to promote increased consumption and profit. As the distance between sites of production and sites of consumption continues to increase, so too does the consumer's inability to see the human and environmental price of this production. (Hagan 2007: 253)

In today's society one of the biggest determining factors on the design and construction of structures is cost, and can be broken down in to the cost of labour and the cost of materials (Fig. 1.1). However, cost is a man-made yardstick which is influenced by

Comparison between material cost and labour cost

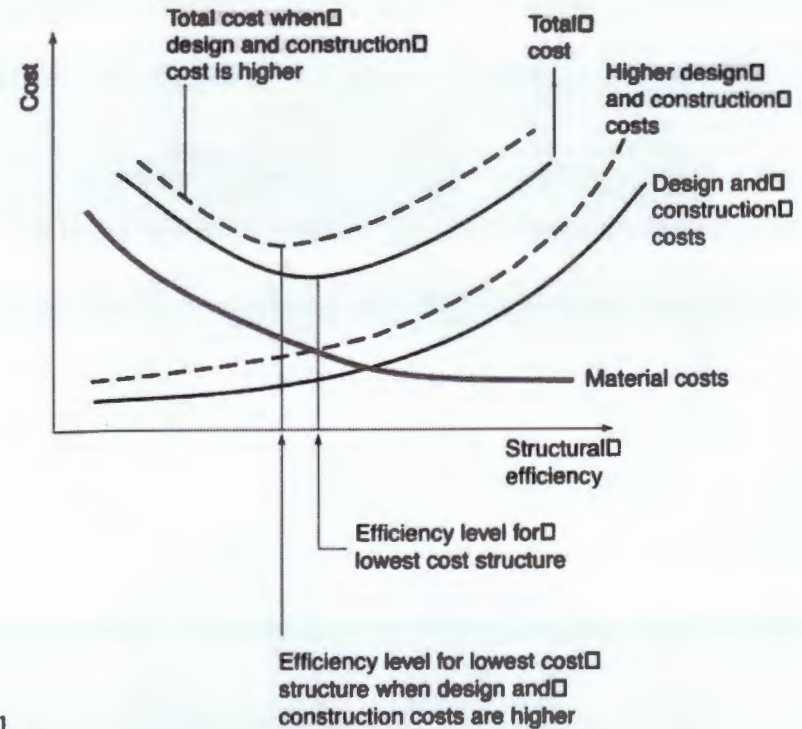

Fig. 1.1

The relationship between structural efficiency and structural costs for a structure with a particular span and load condition are shown here diagrammatically. The quantity and therefore cost of material decreases as more efficient types of structure are used. The latter have more complex forms, however, so the cost of construction and design increases with increased structural efficiency. The curve showing total cost has a minimum point which gives the level of efficiency which is most cost-effective for that particular structure. If labour costs increase in relation to material costs, the location of the minimum in the total cost curve is displaced to the left indicating that a structural form of lower efficiency will now be the most cost-effective. (Macdonald 2002: 65)

the ways in which a society chooses to order its priorities and is increasingly related to the realities of shortages of materials and energy, and to the need to reduce levels of industrial pollution. (Macdonald 2002: 64)

Because my thesis deals with the act of making, where labour and materials come together, the element of cost must be taken into account in the design process. It is interesting to look at the vernacular architecture of tribal societies, in which cost was not a factor, and where a range of very complex and efficient structural forms were generated, for example: the Bedouin tent, the igloo, the tepee, and the yurt. These structures were all the result of the availability of an abundant reserve of labour to build and maintain these structures and the fact that they are the most effective ways of using locally available materials. On this point Jean Prouve has stated: "All production relations being equal, some periods of the past offer us a far more highly industrialized architecture than our own, based on extremely sound and well-defined techniques." (Prouve 1971)

If we compare these skilfully made structures of the past to the structures we have in the industrialised societies where labour is generally expensive in relation to material, we find ourselves in a situation that favours the use of forms which are structurally inefficient but which are relatively straight forward to build. The majority of the structures found in the developed world are inefficient post-and beam types (Fig. 1.5), which is a good example of the wasteful use of material of our industrialised culture. (Macdonald 2002: 65)

Another component of building in our industrialised culture has to do with some viewing industrialized building systems as the panacea for the growing demand from an increasing population due to the advantage offered by the economies of scale in this type of construction. This can be seen in this excerpt by Konrad Wa-



Fig. 1.2

The igloo (Fig. 1.2) is a self-supporting compressive envelope forming a protective dome made from ice blocks where the structure and the space enclosing elements are one and the same thing. (Macdonald 2002: 1)



Fig. 1.3

The tepee (Fig 1.3) is an example where there is a total separation of the structure and the space enclosing elements in which the protecting envelope is a non-structural skin of fabric or hides which has insufficient rigidity to form an enclosure by itself and which is supported on a structural framework of timber poles. (Macdonald 2002: 1)

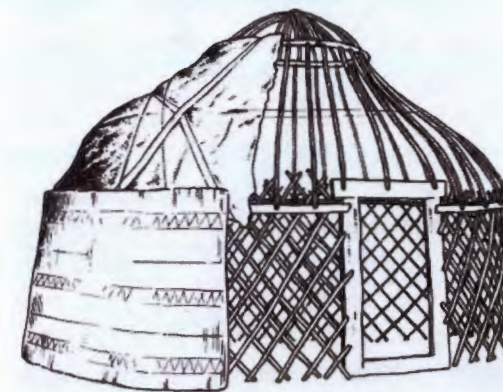

Fig. 1.4

The yurt (Fig 1.4) consists of a highly sophisticated arrangement of self-bracing semi-form-active timber structural elements which support a non-structural felt skin. It is light and its domed shape, which combines maximum internal volume with minimum surface area, is ideal for heat conservation and also minimises wind resistance. When judged by purely technical criteria this building-type will stand comparison with many of those produced by the so-called technological societies of the late twentieth century. (Macdonald 2002: 65)

chsmann:

...there are no skilled building tradesmen needed on the factory floor, since automatic fabrication takes care of everything, except perhaps the movement of materials from one place to another and supervision of the machines. On the job site a building of this kind would simply be put together by an erection crew, and it would make no difference to them whether the parts to be assembled were made of metal, concrete, wood, glass, plastic or anything else, provided they were in the form of finished products. Thus, we no longer need to have carpenters only qualified to put up wooden houses, steelworkers only good for structures built of steel, and concrete workers only trained to pour concrete; instead, like the universal toolmakers, who form our anonymous products, we shall have universal erectors to assemble them. (Wachsmann 1961: 52)

It is however interesting to note that the modern-day construction workers resistance to prefabricated buildings, such as Buckminster Fuller's Dymaxion Houses (Fig 1.6) (that were structurally efficient, and of similar design to benefit from the economies and precision of mass production) had to be overcome by an incentive to actually do the work – the incentive was an easily-stolen set of tools that came in the crate with each house, which would help cut the erection time due to unenthusiastic assemblers. (Baldwin 1996: 38) There is a popular misconception in the building industry, where people believe that in order to get high standards of construction and finishes, professional builders and contractor need to be used as the DIY approach might result in poor quality. However, myself and others engaged in these types of activities believe the opposite to be true where the highly motivated self-builder is prepared to spend time and effort to achieve results that are normally prohibitively expensive if obtained commercially. "The key factor is that the self-builder cares about the quality of the work rather than how quickly or profitably it can be carried

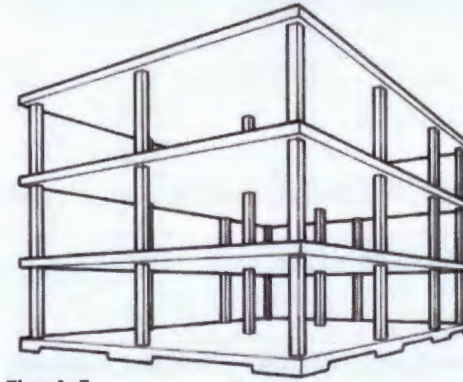

Fig. 1.5

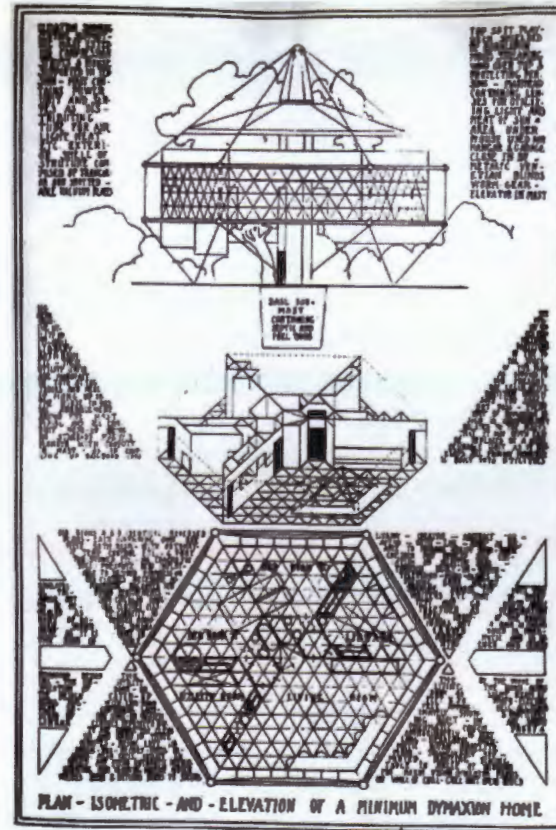

Fig. 1.6

Despite the mouldability of the material, reinforced concrete structures normally have a relatively simple form so as to economise on construction costs. A typical arrangement for a multi-storey framework is shown. (Macdonald 2002: 35)

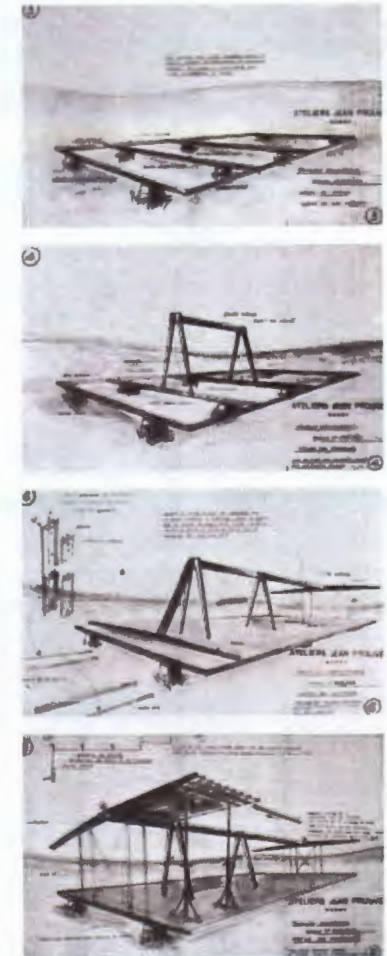

Fig. 1.7

out." (Broome, Richardson 1991:233, 234)

I believe there to be a positive offshoot that has been generated from industrialised processes, that is bringing a more craft based element back into manufacturing, namely the technological development of machinery that relates better to the scale of the individual again such as efficient hand operated power tools, 3-D printers, laser cutters and CNC routers which allow small scale manufacturing and prototyping of building components. This offers some hope to a building industry where the majority of traditional tried and tested craft practices have been dispensed of in favour of mechanisation, evident in the above mentioned issues of inefficient material use and the standardisation of building components resulting in the homogeneous built landscapes that are "...divorced from the contingencies of craft and culture." (LeCuyer 2001: 15). I will argue that this state of affairs is largely due to the maximisation of profits which ties into the theory of "conspicuous consumption", as well as the result of an altered and misguided role that the architect plays modern society.

The misunderstanding of the role of the architect today has been attributed to the writing of Leon Battista Alberti (1485) in his work *On the Art of Building in Ten Books*, where he portrays "...an innovative practice of architecture as an art but attempts to separate the architect from the constructor." (Carpenter 1997: 2) It is this role of the architect that I am challenging in order to emphasise the potential of construction and its conception by connecting the world of ideas to reality by manual labour through the act of making. This sentiment is also echoed in the words of one of the greatest exponents of industrialised thinking in architecture, Jean Prouve:

Men have always built in situ and let their work appear so that it might be judged. We owe the most monumental of our cathedrals and the glorious dwellings of the past to master carpenters

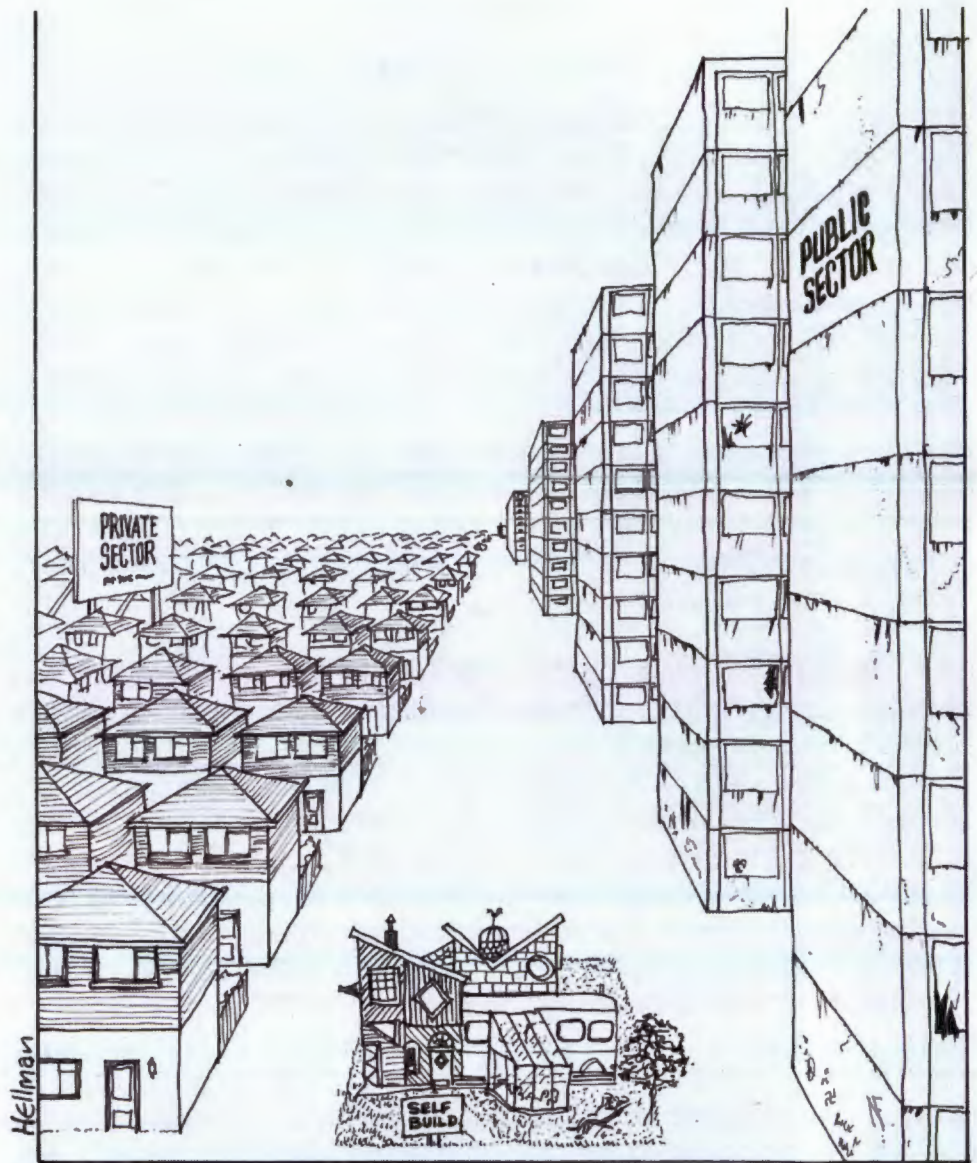

Fig. 1.8

Where once a street was the product of many minds, now a single mind works on a whole neighbourhood. Homes for a democratic society should arise from a complexity of design interests rather than be the result of submerging them into identical forms. (Broome, Richardson 1991: 223)

and stonemasons.

It may well be that the present formula, which consists of displaying a drawing and requesting a builder to follow it, is at the root of our present decay. Those who came before worked as responsible men. Today, they delegate. I believe that the present state of despondency among young architects is due to the latter formula.

An honest approach must lead to that osmosis of science, the mind and the hand which can be seen almost everywhere, except in the construction of mass housing. (Prouve 1971)

I have been looking at the work of architects, engineers and thinkers such as Joseph Paxton, Buckminster Fuller, Konrad Wachsmann, Jean Prouve, Frei Otto, Charles and Ray Eames, Carlo Scarpa, Renzo Piano and the work of the Rural Studio in which one can see the progressive and inspirational use of technologies and an understanding of contemporary materials and mass produced objects afforded by industrial processes. Although their personal theories differ as to what industrialisation and modern construction techniques offer to architecture, they have all embraced it in one way or another that serves to inspire and engage with the world in which we live. It is this visible, honest, workmanlike aspect of industrialisation and technology that I have chosen to focus on for this thesis, whilst at the same time being mindful of the destructive and wasteful potential that can be attributed to processes of industrialisation as a means to inform and guide my efforts. ←

The Cyclical Nature of Learning through Making

The part of the work which surprises me most invariably leads to new works - Richard Serra (Carpenter 1997: 20)

Whatever the standpoint is with regard to the means of production in architecture, there is no doubt that the act of making has another important role in architecture as well as for the individual architect, in that it is a valuable tool for the generation of ideas. This act can be of particular value to current practice and education where the making of prototypes and large scale models can be used to generate research and investigations into physically built forms as well as promote dexterity in decision making regarding construction techniques and their documentation in building specifications with which others labour. (Chandler 2007: 124) Renzo Piano best describes how this process of making is applicable to contemporary practice and academic education:

An architect must be a craftsman. Of course any tools will do. These days, the tools might include a computer, an experimental model, and mathematics. However, it is still craftsmanship - the work of someone who does not separate the work of the mind from the work of the hand. It involves a circular process that draws you from an idea to a drawing, from a drawing to an experiment, from an experiment to a construction, and from construction back to an idea again. - Renzo Piano (Frampton 2001: 383)

From working in this manner as well as having knowledge of the processes involved in industry and production, the value and potential in materials that lies beyond their aesthetics has been made apparent, where their working properties serve as grounds for inspiration and experimentation, and the thought processes concerning the relationship materials have to one another can be directed towards a more tectonically expressive end result. "The fascination of architecture is method and creation, not just

the final objects." (Cook 1967: 85) This act of making is made evident in the work of painters and sculptors who understand that the process of making is the generation of the work itself, and where the stimulation of ideas can come from different influences such as found objects or varying media, as well as the understanding of materials (Carpenter 1997: 19)

Professor Christopher Alexander has stated that "...current architectural theory is out of touch with human needs and that the current theory has no connection with the process of construction." (Carpenter 1997: 23) This issue has been further analysed by Lauri Koskela and Ruben Vrijhoef where they argue that construction innovation is significantly hindered by the prevalent theory of construction, which is implicit and deficient. (See Appendix 1)

My thesis is therefore a response to the above mentioned issues that I believe to be having an influence on our built environment and ultimately our natural environment, and which affects the quality of life experienced by all its inhabitants. There is no one solution to the concerns outlined above due to the vast interconnectedness of them all. The way in which I intend on tackling these issues is by creating an awareness of an approach to working and learning which engages with the physical and mental dimensions of our existence that counters the accepted academic processes in which the act of making is the predictable demonstration of previously defined outcomes. This approach is intended to inspire by making visible the possibilities of keeping an open mind to the building and "making" process.

Quite apart from my desire to work as a builder quite apart from my desire to see buildings with this quality built, and quite apart from my belief that architects should be builders, there is just the simple, plain, ordinary fact of the necessity for having first-hand acquaintance with building and making things. And it seems ridiculous to have to mention it except for the fact that most archi-

itects today do not understand this. In a woodworking shop, one of the distinctions between somebody who understands working with tools and somebody who does not is to realize that the process of sharpening or sweeping up are absolutely fundamental to the activity of making something. Most people who do not really understand tools properly, you realize that sharpening the tool is an integral part of its use. For example, I used to spend day after day, out on the site in Martinez, trying our gunnite experiments. It is the love of making, and the instinct for making, which has led me in the right direction. - Christopher Alexander (Carpenter 1997: 23)

A lot can be said and analysed regarding theories about the act of making. However, I feel that one will be missing the point if that's where it ends as the true value of these theories will only make sense once the physical act is embarked upon. "To build is everything or nothing is built." (Wachsmann 1975: 156)



Fig. 1.9

Part 2:

Structure and Structural Concepts

For my technology study I researched structures that related to my concerns about wasting time, effort and materials, and about spatial and structural adaptability. Ideas generated from looking at these structures became the focus of the models I was constructing. High-lighted in *Table 2.1* are the types of structures that I researched due to their characteristics of structural efficiency that results in an economic use of materials and ties in with the theme of my project.

Table 2.1

This system links the form, and therefore the appearance, of a structure with its technical performance and provides a basis for reading a building, or indeed any artefact, as a structural object... The system is based on the idea of efficiency: structural elements are classified according to the level of efficiency which they make possible in the resistance of load which is, of course, their principal function. The main objective of structural design, however, is the achievement of an appropriate level of efficiency rather than the maximum possible level of efficiency... An aspect of the relationship between structure and architecture... is the possibility that the features associated with structural efficiency can be used as the basis of a visual vocabulary which conveys architectural meaning...

(Macdonald 2002: 46)







STRUCTURAL EFFICIENCY	LOW	Simple	 <p>Timber joist Reinforced concrete slab</p>	
	Non-form-active	Improved	 <p>Steel I-beam Reinforced concrete trough waffle slab</p>	 <p>Steel castellated beam Steel timber or reinforced concrete folded plate</p>
			 <p>Steel & timber trusses Space frame</p>	
	Semi-form-active	Simple	 <p>Laminated timber portal frame</p>	
		Improved	 <p>Trussed portal</p>	Improved - semi - form - active, trussed portal frame
	HIGH	Form-active	 <p>Arch or shell</p>	
 <p>Tensile membrane or cable net</p>				

Table 2.1

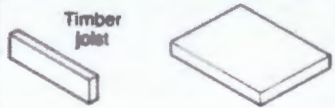
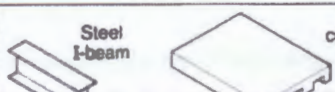
Trussing and Triangulation

Besides always having an interest in trusses, the decision to focus on trussing for this part of my paper was due to two things: my interest in Buckminster Fullers geodesic domes, and subsequently the diagram I came across whilst reading a book on him (Fig. 2.1); as well as my interest and hobby - working on and flying micro-lights, which are completely triangulated structures, and will be discussed in more detail in the next section.

A truss can be described as a longitudinal structure in which a superimposed load is carried to its supports, in the same way they would do in a beam, but because of its structural optimisation, a truss is lighter and more efficient than an equivalent beam carrying the same load over an equal span. The loads travel through the members of the truss, stressing them with axial forces only (tension or compression). All the members of a truss lie in one plane and are joined at their ends with other members forming a series of consecutive triangles. All the joints or points of connection in a truss are assumed to be frictionless hinges, even if this is not physically possible.

As mentioned above, a truss refers to a structure where all the components lie in the same plane, however, the terms "trussing systems" or "trussed structures" incorporates all structures consisting of pin-connected members where the parts are connected and arranged so that the inefficient stresses of bending, torsion, and shear are eliminated and are replaced with axially stressed members working only in tension or compression. These structures include three-dimensional trusses, space frames, framed or geodesic domes, and structures of any configuration which contain

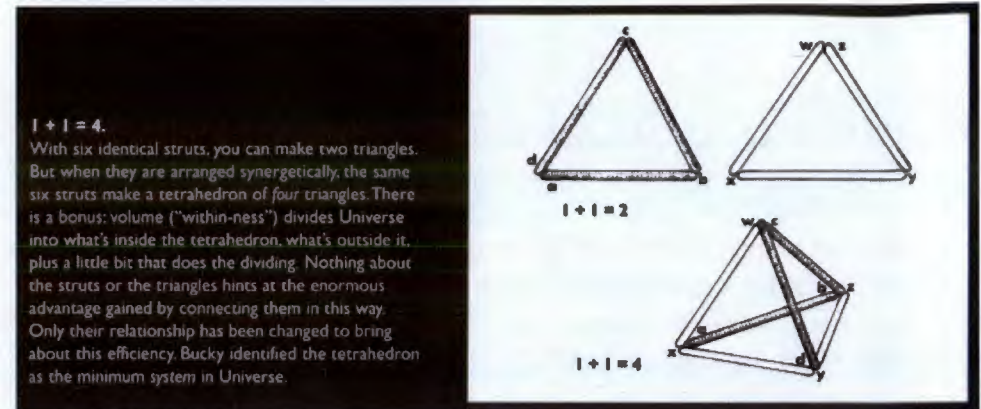
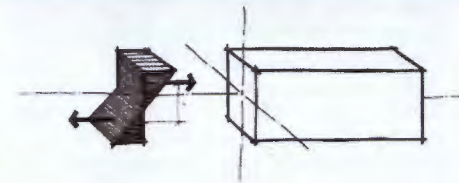
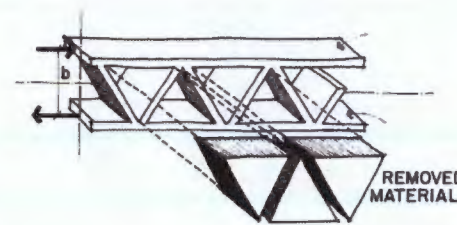

Fig. 2.1



A truss can be understood to be a modification of a beam so that its structural efficiency is improved; the diagram illustrates the forces of a beams action in bending.



The inefficient material along the neutral axis of the beam is removed where the stresses are small, and the material that is left functions to resist horizontal and vertical forces or shear.

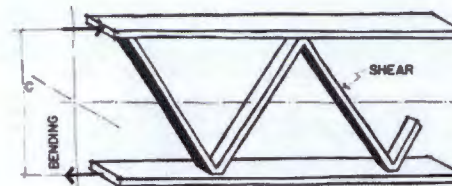

Fig. 2.2

The remaining material is then expanded away from the neutral axis to increase the resisting moment and a truss is produced.

a multitude of irregularly arranged struts and ties. "The resulting geometrical configuration of the whole embodies a process of optimization where mass is minimized by the rational use of form. Aesthetic values, as the product of rationality and creative design, are potentially associable to such forms." (Melaragno 1981: 86)

Structures of Expediency

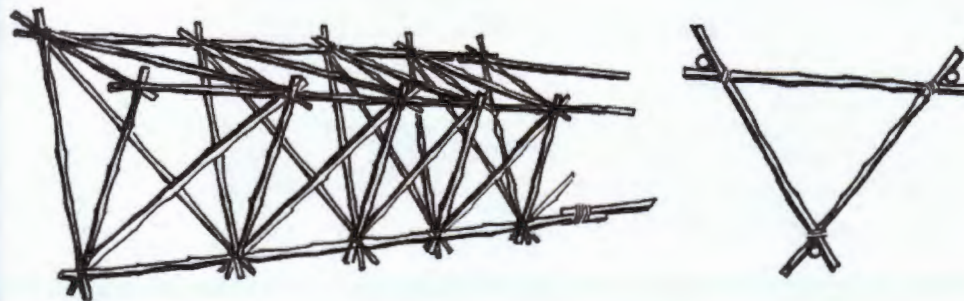
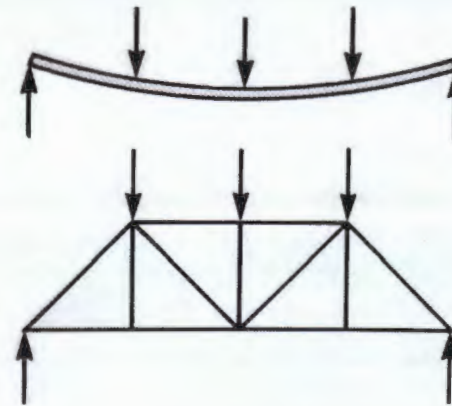
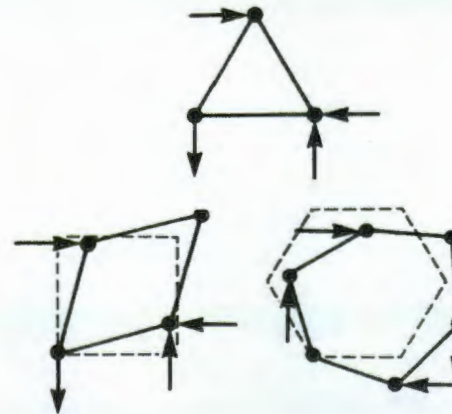

Fig. 2.3

No other structural system is as flexible as trussing for ease and rapidity of construction. Even in emergency situations, the system can be employed without special tools, equipment, and materials. Consider, for instance, that short tree branches or bamboos tied at the end with vines can be used to build trussed structures in a wilderness. Light, short members can form light components, which in turn can be joined to form the total structure, using only the muscles of man. Likewise, planar and space trusses, three-dimensional columns, trussed domes, space frames, etc., can all be constructed for emergency or temporary structures with such primitive materials and methods. Although this aspect may not have common daily applications in engineering or architectural practices and is usually overlooked in literature, it remains a significant characteristic. (Melaragno 1981: 136)



A solid beam is less strong and rigid than a triangulated structure of equivalent weight.



An alteration of the geometry of a triangle can only occur if the length of one of the sides changes. Application of load to a triangle, which tends to distort its geometry, is therefore resisted by axial internal forces in the elements.

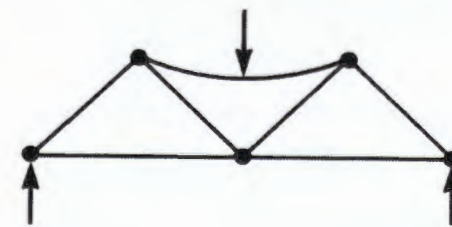

The axial - internal - force - only condition does not occur if load is applied to a triangulated structure other than at its joints.

Fig. 2.4

Aircrafts and Hangars

The overall form of an aircraft is determined mainly from non-structural considerations and is based primarily on aerodynamic performance requirements. The supporting structures are therefore non-form-active, but the importance of saving weight results in the adoption of configurations in which structural improvements are incorporated into their design. (Macdonald 2002: 43)

The microlight (Fig. 2.6) was developed in an attempt to re-invent the aeroplane through the use of composite materials and various types of control systems to create a cheaper way to experience flying. The early development of a type now known as 'weight-shift microlights' or 'trikes', where the undercarriage hangs from the wing and is controlled through shifting ones weight, was initially from the addition of an engine to a hang glider during the late 1970s to early 1980s. (Cosgrove 2007: 9) This type of microlight is a completely triangulated structural frame, similar to that of early 'stick and string' biplanes (Fig. 2.5), and are different from conventional all metal aircraft where the wings and fuselage are essentially hollow box-beams in which the skin plays a crucial structural role (Fig. 2.7). These improved types of aircraft structures are called semi-monocoque structures where the metal skin acting with the ribs and stringers form a composite structure called a 'stressed-skin semi-monocoque'.

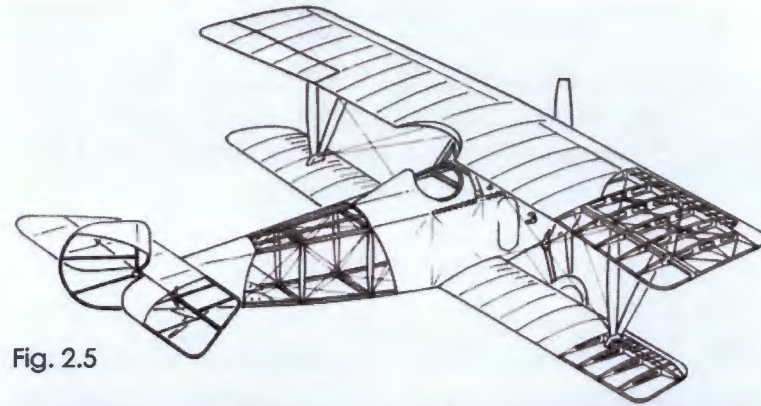

Fig. 2.5



Fig. 2.6

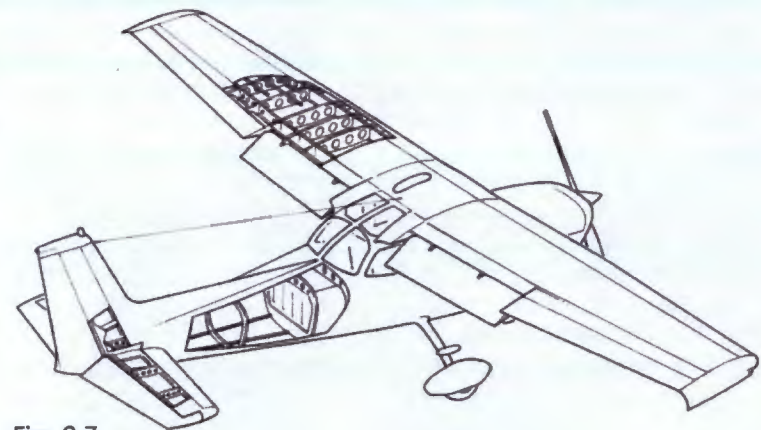

Fig. 2.7

My fascination with microlight aircraft and other 'experimental' type aircraft, as opposed to the more conventional types planes described above, has to do with the DIY factor involved in their construction and maintenance (Fig 2.8), their on going development to achieve lighter airframes and more efficient controls, and how the entire workings of the planes are exposed (see appendix 2). By not covering up the working parts of the plane, the components serve a dual purpose in that they have to be structural as well as aerodynamic, which then requires a specific type of jointing system to accommodate the irregular shapes of their components.

In analysing the structure of the particular microlight I fly, I came across the same tetrahedral shape I had found in the book on Buckminster fuller as indicated in *Figure 2.1*. This structurally stable form was used in the rear shock assembly of the plane, but what I found particularly interesting was the fact that one of the elements could change it's length (the shock) and the rest of the elements were hinged to accommodate this movement which created a structurally stable system where the form could change by changing only the length of one member (Fig. 2.10). This idea of spatial adaptability then led to the exploration of space grid structures, and how this idea could be implemented in their construction (see model 5 on page 38).



Fig. 2.8



Fig. 2.9

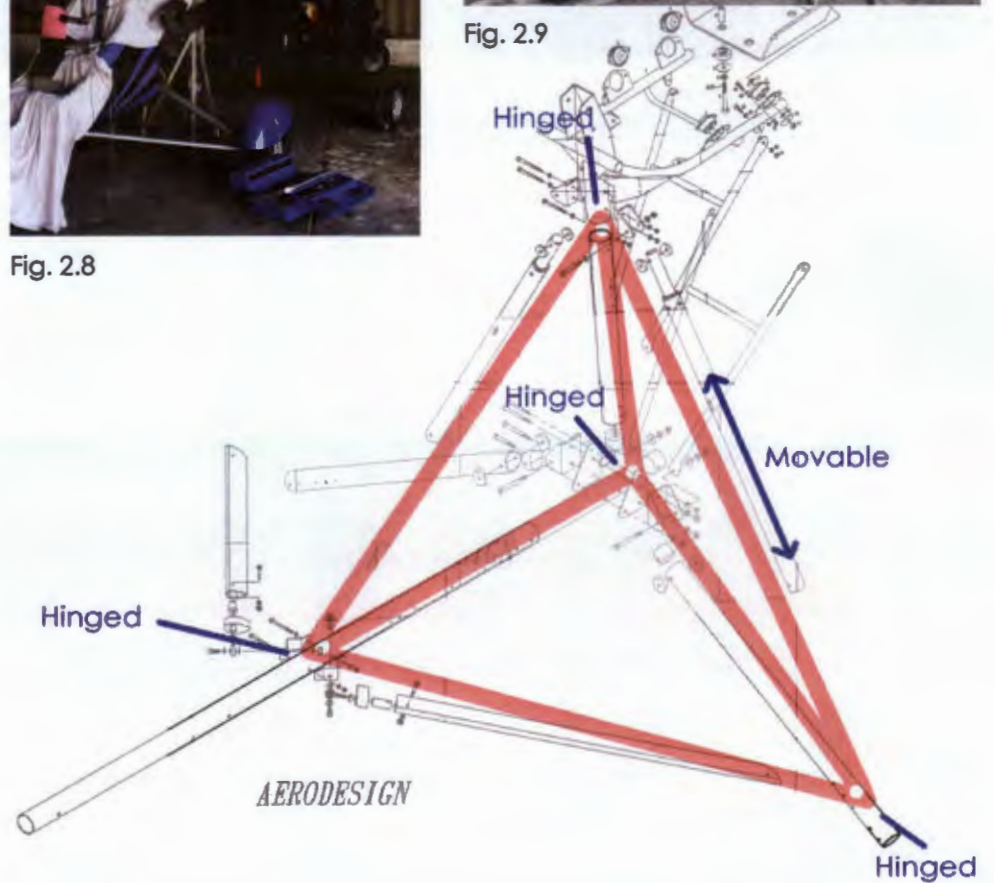

Fig. 2.10

It is also interesting to note that probably the earliest examples of what we now commonly call 'space frames' or more correctly 'space grids' (light, strong, three-dimensional, modular structures) were developed through experiments done on tetrahedral and octahedral forms (Fig. 2.11) during the first decade of the twentieth century by the inventor of the telephone, Alexander Graham Bell. (Chilton 2000: 1) He had worked on a long series of designs for box kites (Fig. 2.13) and developed a framework based on the tetrahedron. It was also the first direct transition from structures associated with flight to those required in building construction. (Kronenberg 1995: 33). The tetrahedron is the minimum stable, three-dimensional, pin-jointed bar and node structure, and has four joints or nodes connected by six bars or members.

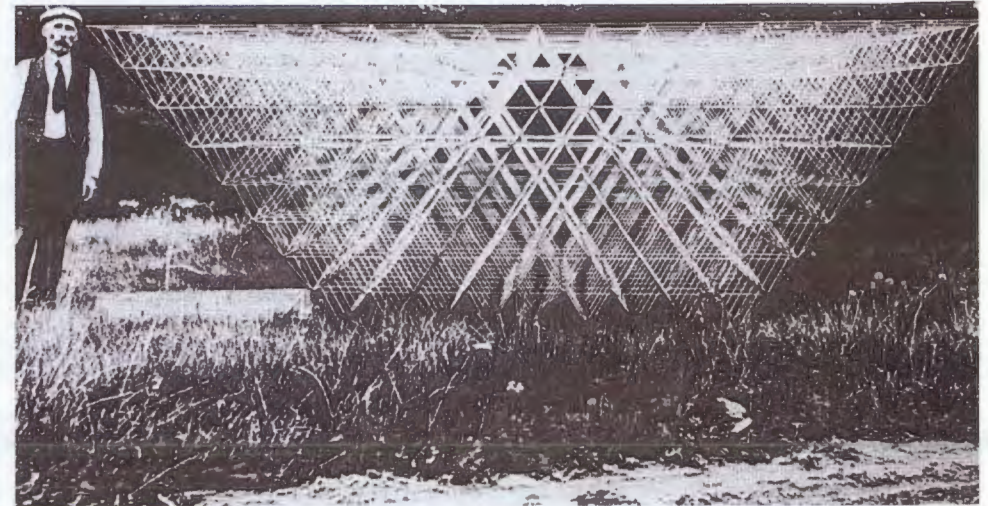

Fig. 2.11

Alexander Graham Bell wrote this about his discoveries in an article on kite construction in the National Geographic Magazine, in 1903:

Of course, the use of a tetrahedral cell is not limited to the construction of a framework for kites and flying-machines. It is applicable to any kind of structure whatever in which it is desirable to combine the qualities of strength and lightness. Just as we can build houses of all kinds out of bricks, so we can build structures of all sorts out of tetrahedral frames and the structures can be so formed as to possess the same qualities of strength and lightness which are characteristic of the individual cells.

(Chilton 2000: 1)

Along with aircraft go the structures that house them (Fig. 2.17). I find these massive and simple forms aesthetically compelling through the way in which they provide enclosure through structure, and how they portray a clear expression of purpose from the demands of function and economy, similar to that of the vernacular structures described at the beginning of this paper. I am also attracted to the 'Universal Space' they afford, and how they



Fig. 2.12

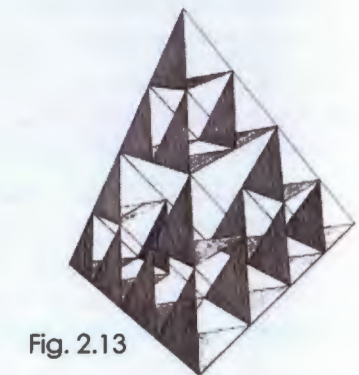

Fig. 2.13

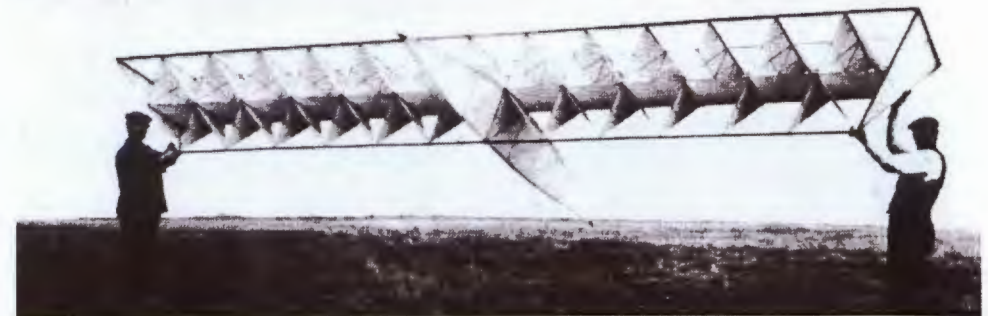

Fig. 2.14

are forever changing in their circulation routes due to the planes being parked in different positions and temporary work spaces being setup where they are required.

Besides the structural link between aircraft and architecture illustrated by Alexander Graham Bell, the advances in aeroplane technology has also played a role in the development of these long-span, large volume, 'shed' type structures, initially during wartime where there was a need for economical, quick to erect, low profile hangars, and more recently with the requirements to house the larger passenger planes, some with wingspans of up to 60m, in clear-span hangars. However, the potential for modern-day aircraft manufacturing technology of stressed-skin or mono-coque construction, described above, which has reached such a high level of refinement, is still to be realised in building construction. (Wilkinson 1998)

I have been particularly inspired by the work of Konrad Wachsmann and his efforts in developing a space grid system for large span aircraft hangars for the United States Air Force (Fig. 2.15). His brief required a system that was flexible in construction, geometry and building type, and at the same time ensured that the components would be demountable and reusable in the same or other configurations. The system he developed was an ingenious universal connector made from a kit of parts that was composed of four mass-produced, prefabricated die forged nickel steel elements that allowed up to twenty tubular members to be connected at each node (Fig. 2.18). The joints between the chords and diagonals were designed in such a way that only a hammer and unskilled labour were required to drive three soft steel wedges through notches to lock the connectors into position on the main chord members for its assembly on site. I would like to incorporate some of these principals to help guide my design process.

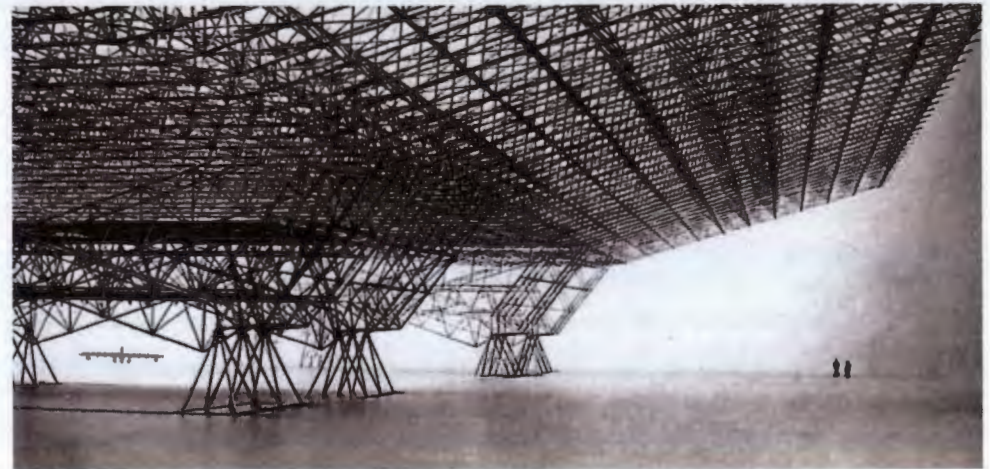

Fig. 2.15



Fig. 2.16



Fig. 2.17



Fig. 2.18

Space Grid Structures

This section explains what space structures are and why I have chosen to focus on them for my research.

The word 'space frame' that we commonly use to describe three-dimensional structures that are either portal frame or trussed structures are, in an engineering definition of terms, almost all 'space trusses' and have different structural actions to 'space frames'. The word 'space grid' is a better substitute to use when describing features that are common to both. (Chilton 2000: 1) Space grid structures are three-dimensional assemblies of linear members in which the interconnections are such that a load at any point is distributed in all directions throughout the assembly. (Wilkinson 1998: 99)

I have been focussing on space trusses composed of a pin-jointed bar and node type assembly that depend on their geometrical configuration to ensure stability as opposed to rigid jointed space frames that depend on the bending resistance of the joints for their structural integrity. The geometry of space truss structures is characterized by two features, namely: an assembly of two parallel plane grids, equal or not, connected by diagonal web members; and, an assembly of modular three-dimensional units formed by the edges of a tetrahedron, a square pyramid, or other polyhedral forms. (Melaragno 1981:132)

A necessary condition for stability in a three-dimensional pin-jointed space truss structures can be deduced from the equation known as Maxwell's Equation or Foppl's Principle in which:

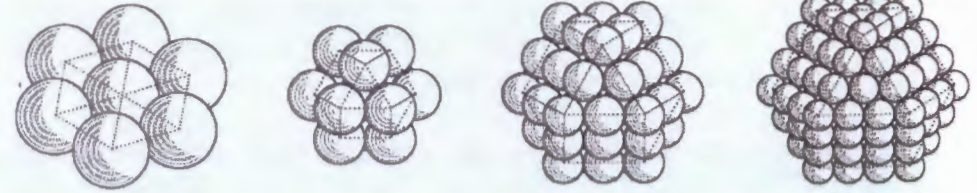

Fig. 2.19

$$n = 3j - 6,$$

where

n = number of bars in the structure

j = number of joints in the structure

6 is the minimum number of support reactions.

"From this equation... it follows that a structure that is not fully triangulated can be made stable if suitable and sufficient additional external supports are provided. Alternatively, the stability of common space grid geometries can be related to the stability of simple polyhedra" (Chilton 2000: 15; 16) (see Fig. 2.20)

Space truss structures generally achieve a span to depth ratio of between 1:20 and 1:40, but are influenced by the method of support, type of loading, and on the system being used. Higher ratio's can be achieved if all or most of the perimeter nodes are supported. However, the ratio should be reduced to about 1:15 to 1:20 when the grid is only supported at or near the corners. The two most important structural considerations that have to be taken into account when designing space truss elements are the buckling of compression chords and web bracing members, and the design of joints to effectively and efficiently transmit axial forces between the bars and nodes whilst minimizing secondary bending effects. (Chilton 2000: 52, 53)

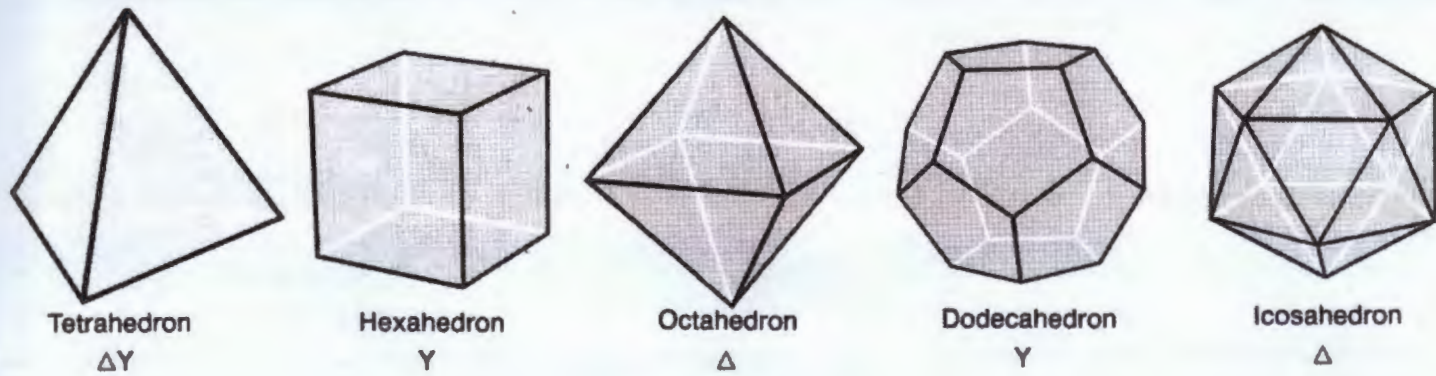

Lattice structures – stable: Δ movable: Y

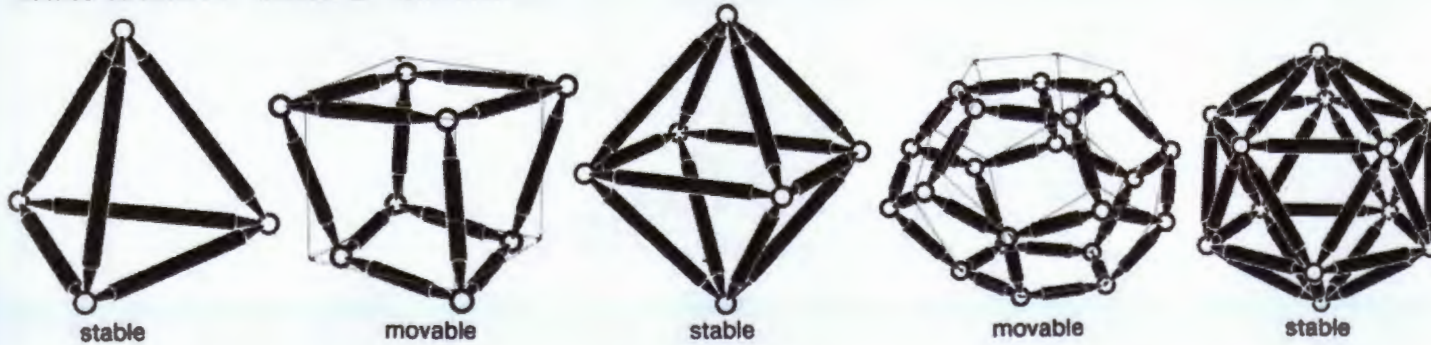

Plate structures – stable: Y movable: Δ



Fig. 2.20

Polyhedral forms are bodies in three-dimensional space... The most basic of these forms are termed the regular or Platonic polyhedra (Fig. 1.26) and consist of the tetrahedron, cube (or hexahedron), octahedron, dodecahedron and icosahedron. Each of these is composed of similar faces of regular polygons (i.e. the sides of each face are the same length and each polyhedron has faces of only one polygonal shape). In the study of space grids we are primarily concerned with bar and node structures. However, to understand the stability of three-dimensional structures in general, it is advantageous to study the behaviour of simple, regular, polyhedral shapes (composed as either bar and node or plate structures) when loads are applied to their vertices (or nodes).

(Chilton 2000: 16)

Structural Concepts

The following structural concepts were developed through thinking about how relatively big structures could be built manually and without the use of temporary scaffold and cranes that would have to be transported to site, assembled for use and then disassembled, as I feel that this is a waste of labour and energy, and discourages structural adaptability. Two ideas were thought of in which either the energy required to construct a building was all concentrated in a small area (Fig.2.23), or the scaffold required for construction was a functioning and integrated element of the building. (Fig 2.21 and 2.22) This approach would require a lot more thinking and planning in the initial stages of the design process, but would result in a saving of time, energy and materials during the life span of the building by allowing an effective means of dismantling and recycling of building components.

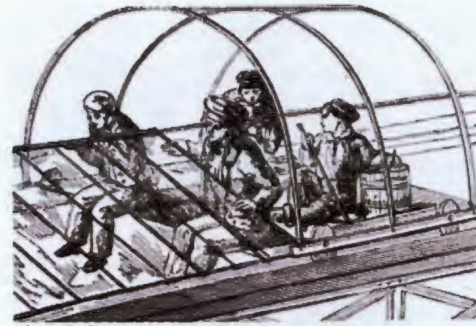

Fig. 2.21

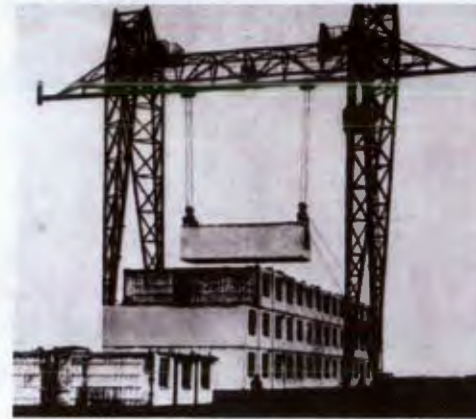

Fig. 2.22



Fig. 2.23



Fig. 2.24

Concept to raise a structure through forces generated in a concentrated area

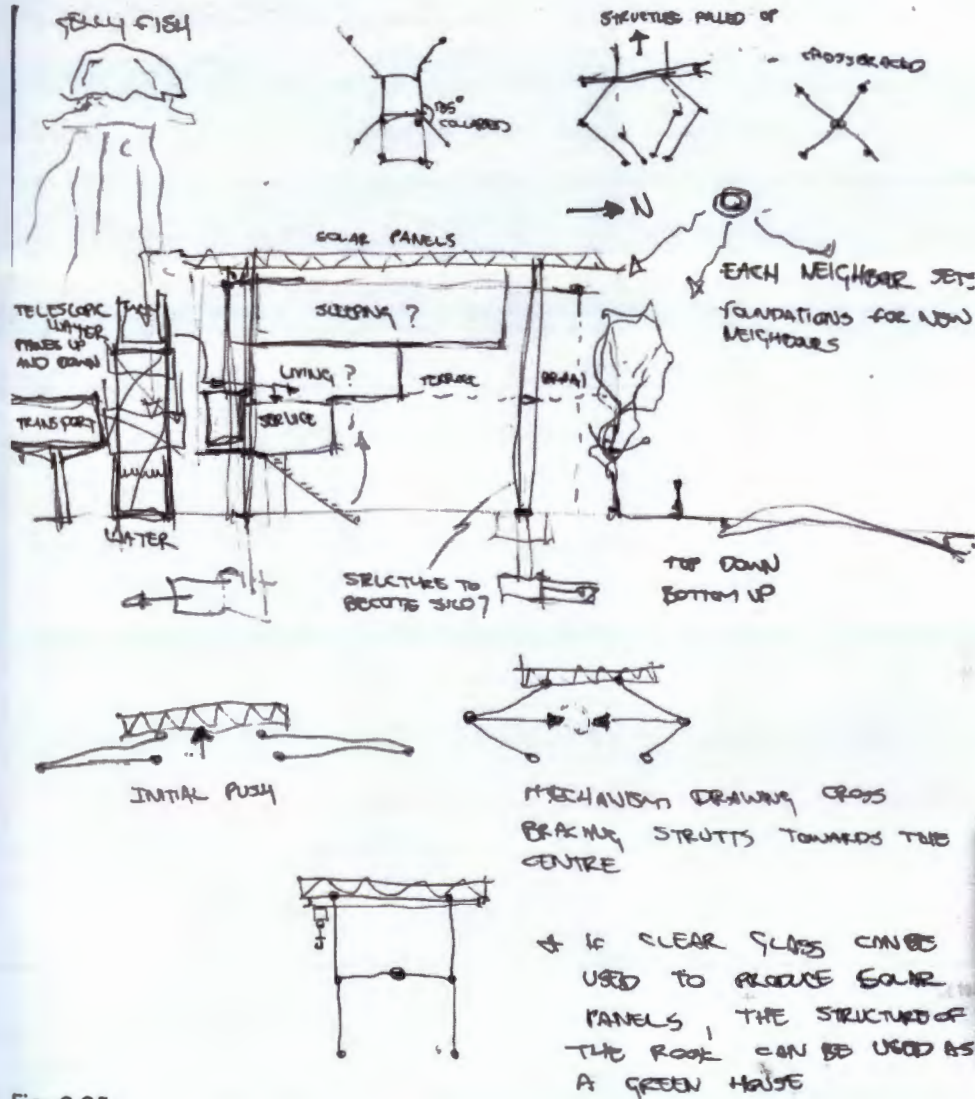

Fig. 2.25



Fig. 2.26

This idea developed as a result of the research being done on structures for this thesis and from daydreaming, which in our culture is not generally believed to have legitimate merit (Pollan 1997: 7). This idea for construction is similar to that of having jacks fixed directly to columns for raising floors (Fig. 2.23) where a relatively small and easily transportable piece of machinery is able to do the work that would normally be done by crane or scaffolding. In this idea the small machine would be a winch of sorts that would draw four steel cables together horizontally that are connected to a hinged portion of the columns, therefore raising the structure vertically (Fig. 2.26). Once the structure is in its final position the steel cables act as cross-bracing, and the whole building becomes a permanent scaffold to which other elements can be pulled up from and attached to. Due to the direction my thesis took regarding siting and programming this idea was shelved.

Concept for folding roof and integrated moving scaffold structure

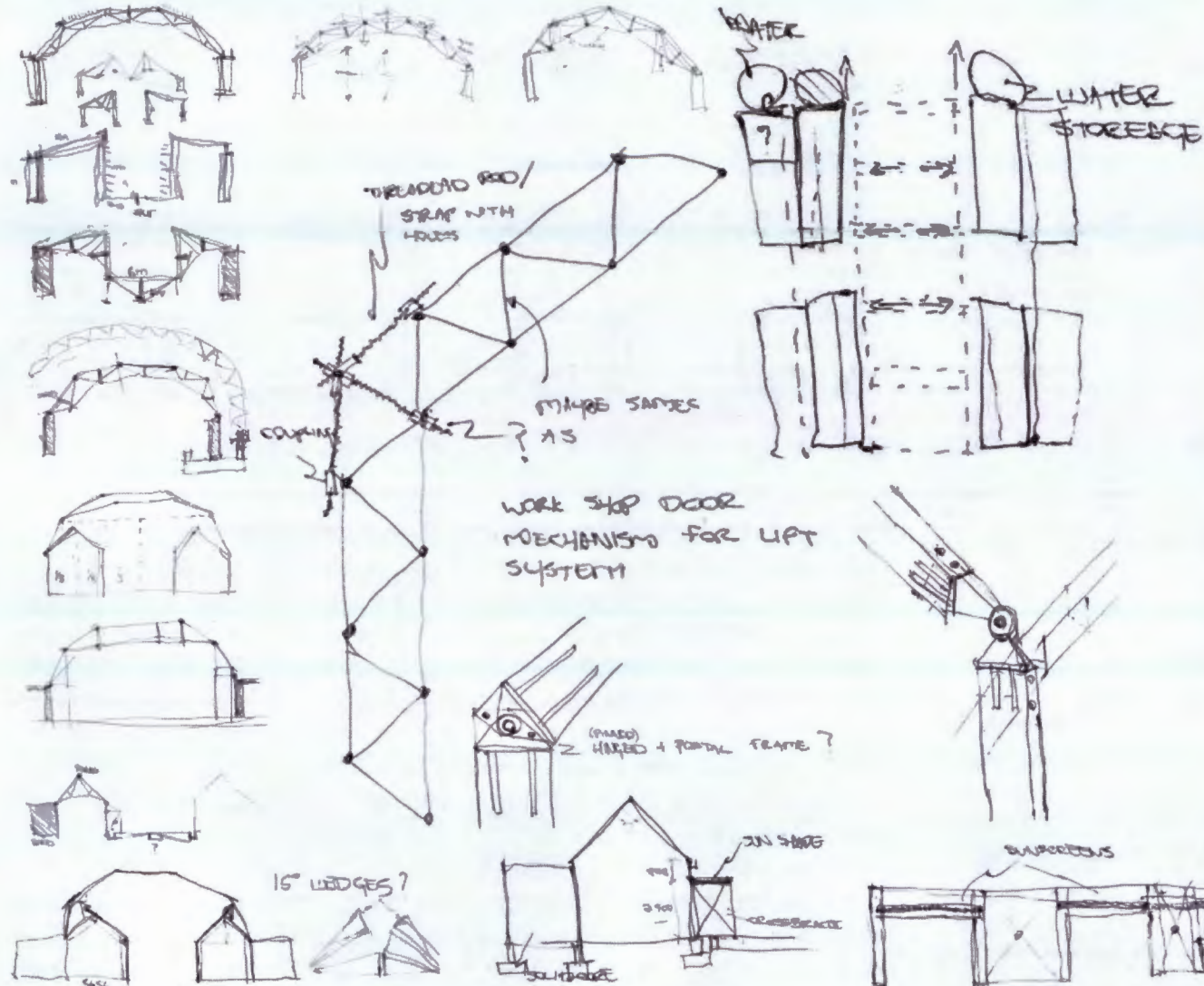

Fig. 2.27



Fig. 2.28



Fig. 2.29



Fig. 2.30

The other structural idea I had was partly due to the rejuvenation of the footbridges over the Eastern Boulevard and the road works of the new turnpike linking the N1 with the M5 where scaffolds on tracks were clipped to the sides of the bridges that allowed access to areas where work was being done, I related this to a possible building system where the moving scaffold and the stationary building could both be part of a single structure. The movable scaffold/crane element would be used for erection, maintenance, adaptation, and disassembly, and would be the first thing that arrives on site and the last thing that leaves the site, but in the time between it would form an integral functioning part of the building such as a sun screening device, large door, or circulation mechanism. This idea merged with the idea of a simple faceted dome structure with a folding roof that was initially indented to be raised into position by jacking up the central horizontal beam. (Fig. 2.32) This idea was settled upon due to the requirements of my programme and site.

Structure

From looking at the advantages of space grid structures it has become clear that it is the best structural solution for executing my proposed design of a 'growing building'. The practical significance of space trusses to my concept where walls eventually become roofs is mainly due to the fact that they have lateral stability and integrity, and are suitable for being used horizontally, as well as vertically. (Melaragno 1981: 131)

In conventional two-dimensional structures such as ordinary roof trusses or portal frames, all the elements lie in the same plane and can only resist loads in that plane (Fig. 2.33 a). However, in three-dimensional structures the loads are spread in all directions and the forces are balanced out, therefore their peak loads



Fig. 2.32

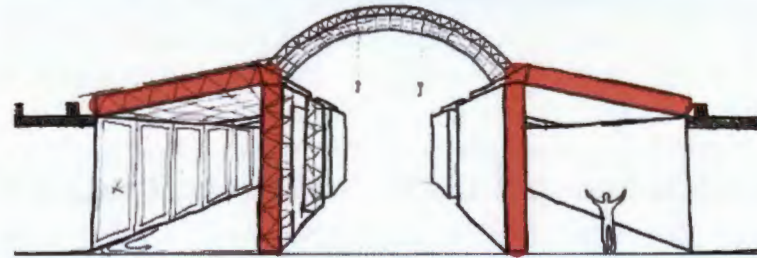

Fig. 2.31 a



Fig. 2.31 b

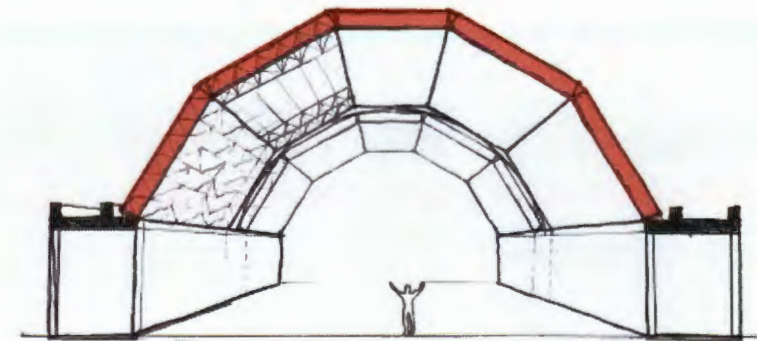

Fig. 2.31 c



are diminished and the inner stresses are reduced which results in a decrease in the cross sections of compression and tension members (Fig. 2.33 b). (Wilkinson 1998: 99) The relationship of efficiency between a series of simple parallel trusses and a space grid structure, under the same loading conditions, can be seen by the comparison of their span to depth ratios which are 1:10, and between 1:20 and 1:30 respectively. (Melaragno 1981: 132) This reduction in depth and in size of the cross section of members requires less material and therefore results in a lower weight. This is an ideal condition for the structure I'm investigating where the wall elements need to be as shallow and as strong as possible in order for them to initially conserve space, and then to be lifted to become roof elements. The reduced weight also makes it easier to hoist the wall and roof elements into their alternate configuration.

Space grids are not limited to planar surfaces (Fig. 2.34) and more complex geometries such as barrel vaults, domes, hyperbolic paraboloids or even free-form surfaces may be created through their ability to be pre-cambered (Fig. 2.35). Pre-cambering can be used in order to get a slope for water runoff or to counteract the predicted vertical deflection of the structure under imposed loading. It is possible to achieve any required camber by varying the chord lengths very slightly. (Chilton 2000: 55) The three forms that relate to the structure under investigation are a barrel vault, an angular ridge, and a stepped arch.

A barrel vault or arch of any required radius can be generated by lengthening the upper chord members in one direction of a grid pattern as depicted in *Figure 2.36 a*, an angular ridge can be formed by shortening, or totally eliminating, one of the lower chord members as depicted in *Figure 2.36 b*, and a stepped arch can be achieved by reducing the length of lower chords at regular intervals along a section of the grid as depicted in *Figure 2.36 c*

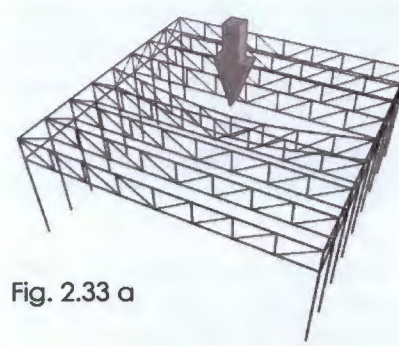

Fig. 2.33 a

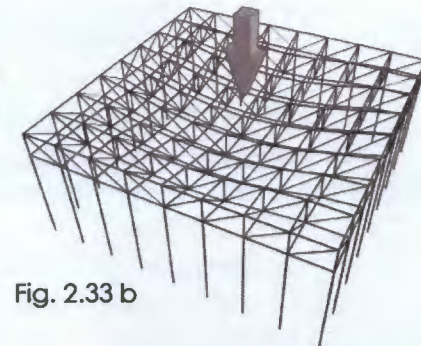

Fig. 2.33 b

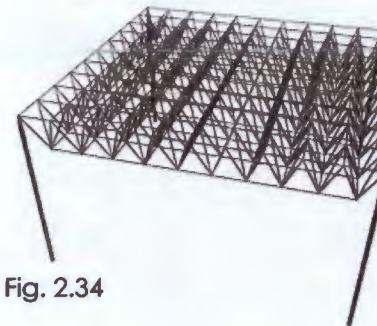

Fig. 2.34

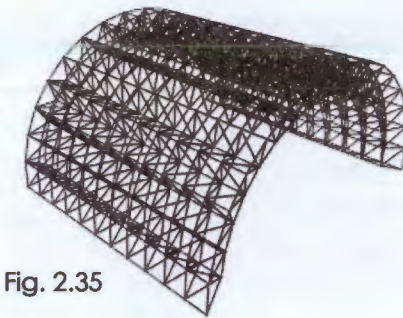

Fig. 2.35



Fig. 2.36 a

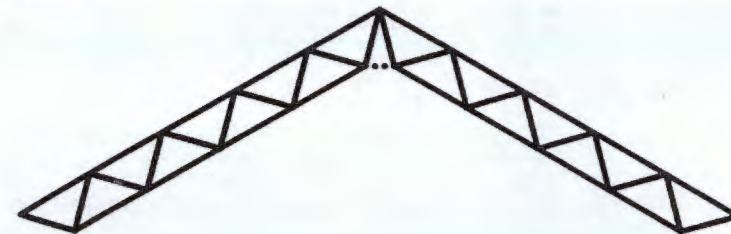

Fig. 2.36 b



Fig. 2.36 c

An informant as to how the space truss is positioned in the proposed structure has to do with the node supports and whether they are supported at the bottom or the top. The optimum configuration will be to have the nodes supported at the top so as to keep the most heavily loaded diagonals adjacent to the supports in tension. If the structure is supported at the lower nodes with the adjacent diagonal in compression, it may result that failure of one compression diagonal may cause a progressive collapse of the whole structure. (Chilton 2000: 26)

Because of the nature of the building, where the program consists of workshop type spaces that require mechanical, electrical services, air-handling ducts and sprinkler systems a space grid structure is ideal in that it can accommodate these services within its structural depth.

Materials

The site I have chosen has an abundance of natural and recyclable materials such as stone, sand, clay, various types of trees, as well as reusable building rubble and farming surplus. It is with these materials that I intend to construct most of my proposed building from.

The trees on the site are mainly a type of Saligna that have been planted close together which has encouraged them to grow fast and straight (Fig. 2.37). Other types of trees around the site that might be considered for this application include pine, poplars, black wattle, and bamboo.

Although steel is the most widely used material for the members of space grid structures in the form of circular tubes, timber has also been used quite successfully in the form of round wood poles, solid sawn timber and of glued laminated timber. Because of the mainly axial forces experienced in the members of space trusses,



Fig. 2.37



Fig. 2.38



Fig. 2.39



Fig. 2.40



Fig. 2.41

the solid circular cross-section of round wood poles is an ideal resolution for resisting these axial stresses. I have therefore started exploring the space truss technologies that will allow me to use the trees on the site for the roof structure and some of the wall elements. (see model 6 on page 40)

The fibres in a section of a tree trunk run approximately longitudinally, and when the cross-section is sawn into smaller rectangular sections the strength of the timber is reduced as some of the fibres cease to be continuous along the piece of wood, and much of the original cross-section is cut off and wasted as can be seen in Figure 2.42 (Chilton 2000: 114) By cutting the four sides of a circular trunk to form a square section the usable cross-sectional area is reduced by 36%; the elastic section modulus, that is directly related to the bending resistance of the beam, is reduced by 40%; and the second moment of area, which is related to buckling of struts under axial compression and deflection of beams, is reduced by 57%. (Chilton 2000: 114) The permissible stresses in bending, tension and compression of sawn structural timber is approximately one-third, one-quarter and two-thirds respectively of that found in round debarked timber. (Chilton 2000: 114) However, machine-rounded timber is only slightly weaker than debarked timber, and might be a better choice combining strength and aesthetic considerations for my project.

The main concern in the design of timber structures is the transfer of the mainly axial forces between members at the joints or nodes, and it is therefore necessary for metal components to be inserted at the ends of the individual members so that the forces can be transferred over a greater length. (Chilton 2000: 30) It would also make sense to develop a jointing system that is cheap and simple because of the low costs involved in sourcing the roundwood pole members that are in abundance on the chosen site.

From the analysis in Table 2.2, it is evident that the current state of



Fig. 2.42 The shaded area represents the discarded timber when cutting square sections from roundwood.

The trees were measured at a height of approximately 1.5m from the ground. The height of the trees on the site range from about 14m to 20m

Tree number	Patch A 10m x 10m Cultivated	Patch B 9m x 9m Haphazard
1	185	95
2	135	50
3	60	45
4	145	30
5	120	30
6	210	120
7	80	180
8	80	50
9	120	85
10	125	135
11	105	125
12	160	160
13	195	105
14	90	30
15	125	50
16	175	30
17	140	130
18	125	70
19	150	40
20	145	180
21	35	160
22	105	40
23	85	40
24	130	30
25	105	30
26	130	210
27	105	35
28	215	75
29	100	70
30	155	100
31	160	60
32		190
33		40
34		100
35		90
36		165
37		130
38		120
39		
40		
Average diameter of all trees	129	90
Amount of usable trees	30	23
Average diameter of useable trees > 60mm	132	124

Table 2.2

the trees found on the site are relatively small in cross section and would not be viable for machining into structural timber components, and would probably end up being reduced to wood chips or pulp. However, using this timber for a roundwood space truss assembly allows the timber to be cut into relatively short straight pieces that are easy to source and manage single handily, and if one is selective of the pieces being sourced it is possible to allow the trees to continue growing.

An example of where this timber technology has been used quite ingeniously is evident in the work of Pieter Hybers from the Technical University in Oelft, in the Netherlands, who has developed a simple wire lacing method by using a lacing tool (Fig. 2.43) for clamping galvanized steel connector plates in pre-slotted ends of roundwood poles (Fig. 2.44). He has also developed several different plate connectors some of which require a separate node and others that are nodeless constructions that can be connected together directly. (Chilton 2000: 117)

Figure 2.46 is of an equipment storage shed designed by Pieter Hybers, that is 16.2 m x 10.8 m, and has a space truss roof made from 100mm diameter larch poles, and is supported on eleven timber columns. The four by six bay square on square offset grid was built using 6 x 90 x 260mm galvanized steel connector plates inserted and fixed to the ends of the timber poles (Fig 2.45) that were then connected to a 6mm thick circular node. The timber was impregnated with CCA (copper cyanide arsenic) preservative for durability. (Chilton 2000: 117)

Safety

Space grids are highly redundant structures in which failure of one or a limited number of elements does not necessarily lead to an overall collapse of the structure. (Chilton 2000: 18) However, an important consideration in the use of timber as a material for the



Fig. 2.43

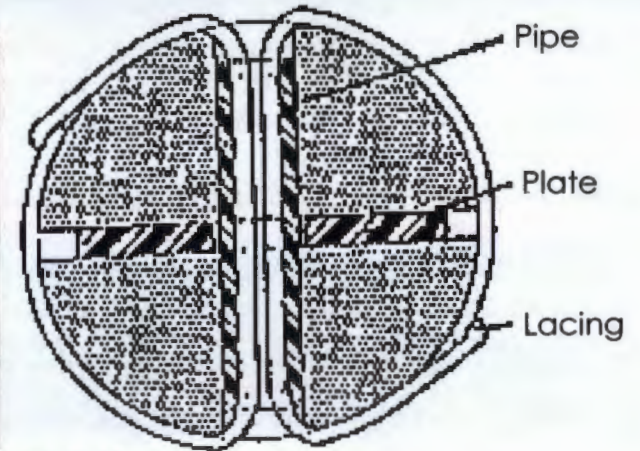

Fig. 2.44

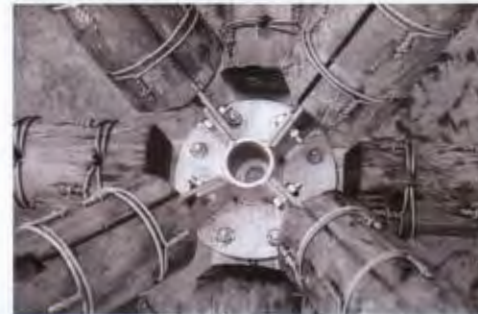

Fig. 2.45



Fig. 2.46



Fig. 2.47



Fig. 2.48

members of a space truss is its performance in the event of a fire. Timber burns or chars at a predictable rate and usually the members can be oversized so that structural integrity is maintained for a prescribed period of time. (Chilton 2000: 77)

Making and Cost

In the South African building industry, where labour is relatively cheap and materials are expensive, simple and efficient structures seem to be the most logical choice. Space truss structures are extremely efficient and can be built at almost any location using only manual labour and simple lightweight tools and materials. Because of the regular system of supports available in space structures, cladding and service fixings are also simplified due to a reduction or even elimination of a secondary structure, and therefore a decrease in labour costs.

There are several methods of erection for space grids and the most commonly used techniques have been outlined by John Chilton:

- 1. Assembly of all the individual space grid elements or modules on a temporary staging or scaffolding, in their permanent position.*
- 2. Assembly of space grid elements or modules in the air, by cantilevering from existing portions of the roof. Usually, individual or small subsets of members are lifted into position by crane.*
- 3. Assembly of space grid elements or modules into larger panels (usually on the ground or a floor slab) before lifting them by crane and connecting them in the air to areas of the grid that have already been installed.*
- 4. Assembly of the whole grid on the ground before lifting it on to*

the permanent supports by crane in one operation.

- 5. Assembly of a part or the whole space grid on the ground before jacking or winching it into its final position over temporary or permanent supports. (Chilton 2000: 57)*

It is important to select the most suitable method of erection because of the cost implications involved. Since the project I am working on is built in two stages, it is likely that method 1 will be used for the initial stage in the absence of the crane and then method 3 will be used once the overhead crane has been built. It is also important that the lifting points on the space grid are correctly selected so that individual members are not over-stressed and the structure is not permanently damaged during the lifting process.

Part 3: The Concept of *Techné*

Model 1

That which gives things their constancy and pith but is also at the same time the source of their particular mode of sensuous pressure - coloured, resonant, hard, massive - is the matter in things. In this analysis of the thing as matter; form is already co-positd. What is constant in a thing, its consistency, lies in the fact that matter stands together with a form. The thing is formed matter.

Heidegger – (Frampton 2001: 23)

The first model built was an abstract form that housed a graphic explanation, in the form of a collage, of ideas I had for my thesis project.

There was no design for the object. The form of the object could have taken any shape. The parameters were the objects available in the workshop at the time, the machinery (technology) that made putting these objects together possible, and my imagination. The objective was to have a display piece that was able to accommodate a collage.

The objects that were found could have been arranged to lean on each other, or they could have been glued and welded together. The reason for choosing not to fix them in this manner was so that a rigid intact model could be built that was not fixed in a permanent manner. It was therefore decided to mechanically

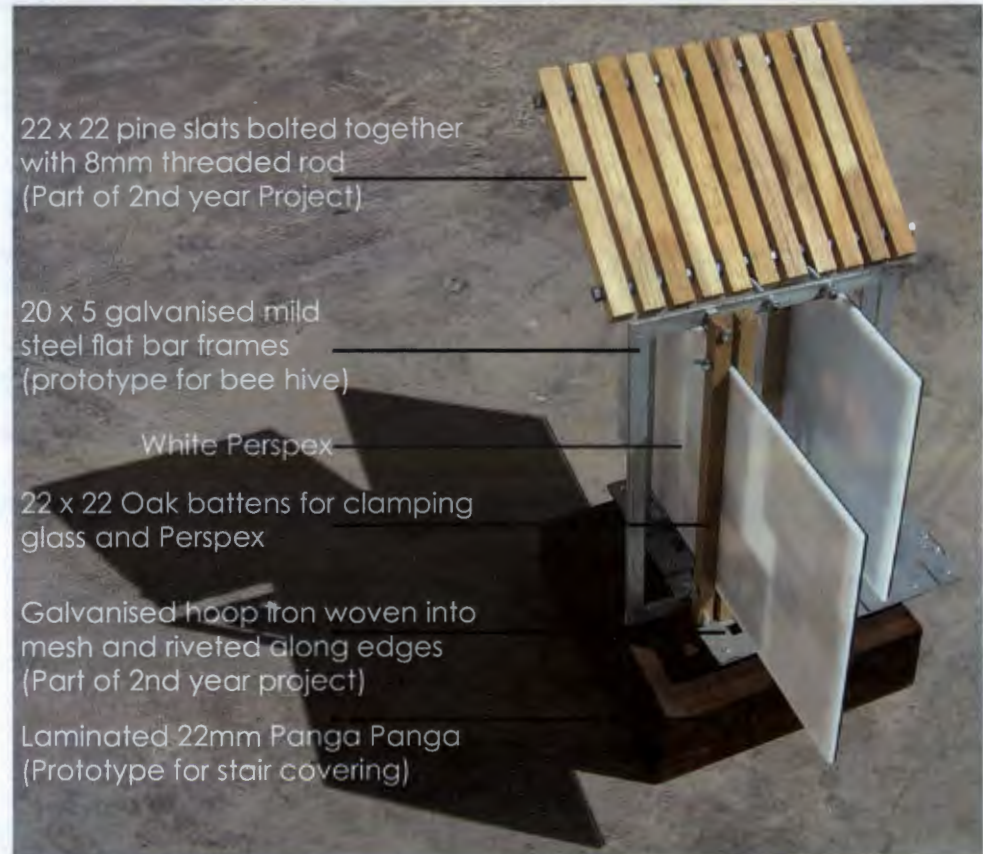

Fig. 3.1 a



Fig. 3.1 b

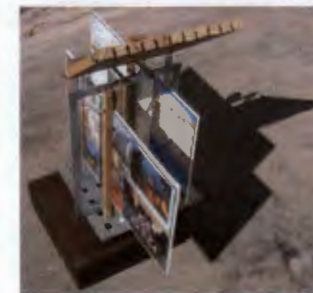

Fig. 3.1 c



Fig. 3.1 d

fix the separate components together. By mechanically fixing the objects together, with nuts and bolts, two things were accomplished: the model had the appearance of being in a final state of completion; and, it was also still possible to take the model apart into its individual components and re-configured, if so required, without diminishing its original structural properties.

The model could have also been made from the sheet material (melamine boards) lying around the workshop, however, if it had been created from this 'anonymous' material, its form would have had to have been inspired by something other than the material, it would need some kind of a concept. The elements selected for constructing this model, which were mainly left over products from other processes, had their own forms and were made from different, but easily obtainable materials from local industry. From the selection a kit of parts started to develop. As there was no manual for this kit, putting the parts together was informed by the shape of the parts, their structural properties, and gravity.

From this it followed that the big heavy piece of wood (left over from a stair covering sample) was used for the base, the thin woven hoop-iron mesh was used as a platform above the base, and was bolted in position with the use of large washers to spread the force over a greater surface area. The platform was able to support the steel frames (part of a bee hive) that looped around the glass and Perspex panes at 90°. Because there was no way of mechanically fixing the glass the idea that surfaced was to clamp it between two pieces of timber, and then fix the timber to the steel frames. The idea developed to put a second pane made from Perspex cut to the same size as the glass next to one another which gave rise to the opportunity to have the graphic sandwiched between the two. The steel frames were by chance bolted in a manner that corresponded to the grooves in the timber slats of the screen, and it was therefore able to be wedged into place. The screens position is not functional; it is where it is because it fits.

The materials had to come together in a way that supported the outcome of having a model that displayed a graphic. I was only a mediator in a process between the materials and objects I had and the intended outcome. The meeting point was the model.



Fig. 3.1 e



Fig. 3.1 f



Fig. 3.1 g

Model 2

On the one hand, historically, discourses and theories of architecture have tended to concern themselves with formal questions and to establish the architect as form giver. On the other, the very method we use to develop architectural proposals - orthographic drawing - describes only form, and relegates material to the empty spaces between the lines. The privileging of form is deeply embedded into our working practices, and material is rarely examined beyond its aesthetic or technological capacities to act as a servant to form. (Thomas 2007: 2)

The second model built came about as a top down approach, where a form was to be explored through making. In starting the research component for my thesis project, I took out a book on Buckminster Fuller, I have always been interested in geodesic domes and tensegrity structures, but have never understood the underlying principals of these forms, I learnt that $1 + 1 = 4$ (see diagram). From my philosophy of mechanically joining objects, I wanted to explore how mechanically joining would work in this type of complex structure. I chose an octahedron to explore due to time constraints relative to the complexity of the shape. The process began by me constructing the pure form of the object in 3D on my computer (Fig 2.3). The project was also governed to an extent by what I had available in my workshop and also what the surrounding industries had to offer. Once again this model could

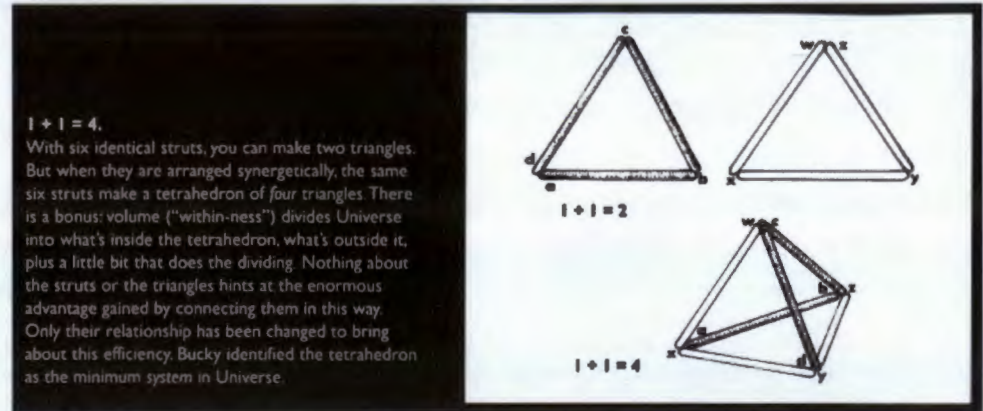

Fig. 3.2

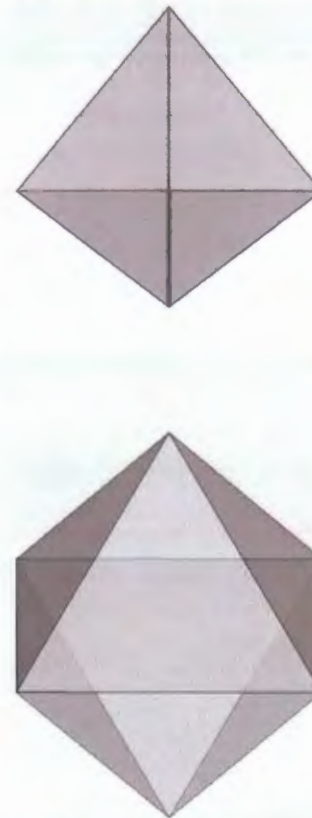

Fig. 3.3

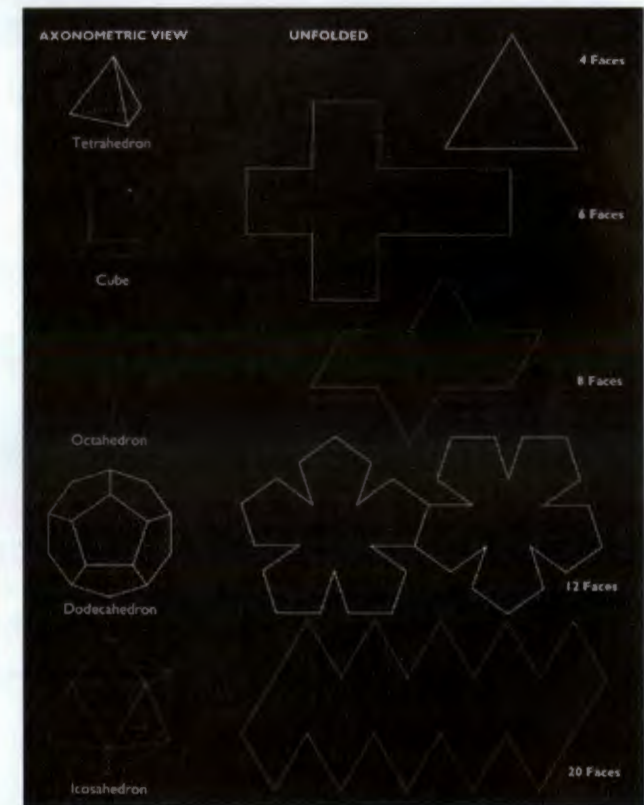

Fig. 3.4

have acquired its form by triangular shapes glued together at the seams or even mechanically fixed together at the seams with hinges; however I wished to explore the type of connection that would result from the joint that informed the geometry: how do 4 equilateral triangles diverge from one point? It started by making a jig, the jig being 4 equilateral triangles with a square base. These components were made from 2mm sheet metal and welded together to form a pyramid. From this I was able to make the corner components of the model. This comprised of four pieces of flat steel arranged in a pinwheel around the apex of the pyramid. A pinwheel seemed the most natural position that 4 rectangle pieces of steel could assume in this situation (Fig 2.5). What I ended up with was six pyramid shaped pinwheels that the form could now grow from. They were the generators of what was to come next.

The manner in which these pyramids were finished speaks of the way in which they were made. They were welded by hand to a point where they were structurally stable, and grinded clean to a point where they were deemed safe to touch. Anything more than that would have been a waste of time and a waste of material, anything less than that would have been dangerous and unstable. Because it was done by hand, the irregularities caused in the manufacturing process gave each piece its own uniqueness, left unfinished each piece will rust according to where and how the steel was left after the grinding process. I know that under the normal conditions that these pieces of steel will be exposed to, they will never rust in a way that their structural integrity will be compromised, so I am comfortable in taking the material to this point and then letting nature take over to create various patterns and colours which will never be repeated again in quite the same way. I only know this because I have worked with the material; I know its capabilities and its weaknesses, not only in a technical way, but also in an expressive way.

The reason for the size of the steel components is that it was not necessary to make them any bigger and not possible to make them any smaller – any bigger and weight becomes an issue, it is a material with a high embodied energy, and it is expensive; any smaller and it becomes difficult to work by hand. These are all very practical reasons for the steel being what it is.



Fig. 3.5

Connected at 90° on either side of each arm of the steel pinwheel are two pieces of square timber. They were sourced from off cuts in the workshop, and because of what was available, it ended up being of two different varieties, which I feel has enriched the model's expression. The two different colours and textures of timber, by contrast, indirectly say something about the process of the making of the model that would be missing or without meaning had they been purchased. Timber was used in this instance because of its material qualities, if finished properly it does not tend to scratch softer materials and it is also flexible to a certain degree. The fixing between the timber and the steel is achieved through one bolt, this was done because of the complex shape of the model, if the joint was rigid, there would be no play, and anything slightly out would have resulted in a failure to complete the structure.

Because of the material qualities of timber described above, it was used to clamp onto Perspex triangles that formed plate members between the nodes. Perspex was used for this plate element because I wanted a transparent medium so that the inner workings of the model could be expressed. The triangles were made up from two 3mm sheets of Perspex laid on top of one another so that text and images could also be inserted between the triangles as in the previous model. The material properties of Perspex are also more forgiving than glass in this instance because it allows for slight deformation when being clamped between the timber elements, and was able to be cut and drilled using a CNC router. *(The glass in the previous model has subsequently broken)*

The steel and timber elements are held together mechanically, but these combined elements are held together through friction by clamping onto the Perspex (Fig 2.6).

I am writing this in retrospect: the model was a failure in the structural method employed to create this form. Octahedrons are only stable if a bar and node structure is used in their construction, this model has been made from plates and is therefore not structurally rigid. (see Fig. 1.26 on page 14)



Fig. 3.6 a



Fig. 3.6 b



Fig. 3.6 c

Model 3

From building the previous two models, the idea of clamping elements together set in motion a new line of inquiry that related to structural elements in buildings, namely trusses. From having plenty of cut pieces of timber in the workshop, the idea that developed was a structural element that in one clamped various pieces of timber together and acted as a node where all the structural elements came together. This type of system would be made in a way that allows this particular node to be used and reused to create different structural possibilities by being able to change the structural depth of the truss. It is able to achieve this for two reasons, firstly the nodes can be moved to any position along the parallel members of the bunched timber, and secondly the bunched timber is not structurally damaged by fixing points as the nodes are only clamped to the material.

Due to timber being a material that is composed of long fibrous cells that are aligned parallel to the original tree trunk, its strength is approximately equal in tension and compression in the direction of the grain. However, if timber is stressed in compression or tension perpendicular to the grain the fibres are easily crushed or pulled apart and is therefore much weaker in this direction. Because of this, timber has low shear strength when subjected to bending-type loads which make it unable to resist the stress concentrations that occur around the area of mechanical fasteners such as



Fig. 3.7 a. Different lengths of timber bunched together and laid out parallel to each other.



Fig. 3.7 b. Outer halves of the clamping nodes bolted to each other through the purlin cleats.

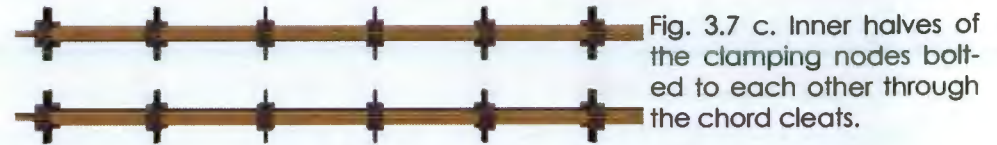

Fig. 3.7 c. Inner halves of the clamping nodes bolted to each other through the chord cleats.

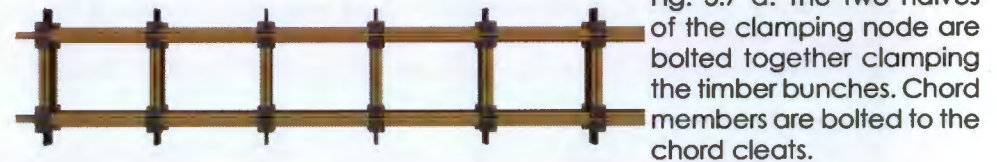

Fig. 3.7 d. The two halves of the clamping node are bolted together clamping the timber bunches. Chord members are bolted to the chord cleats.

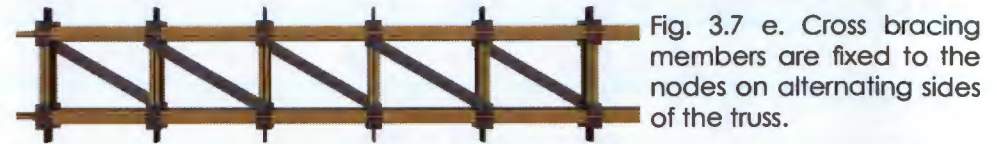

Fig. 3.7 e. Cross bracing members are fixed to the nodes on alternating sides of the truss.

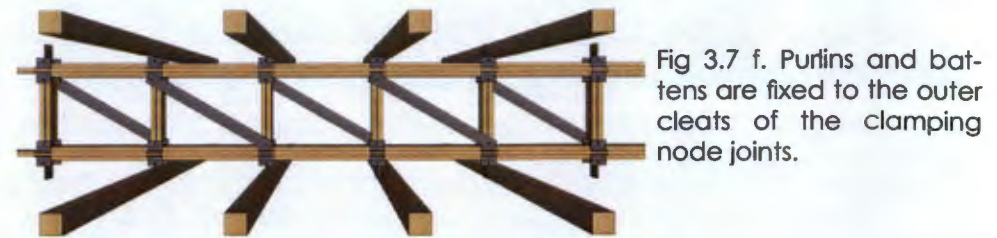

Fig. 3.7 f. Purlins and battens are fixed to the outer cleats of the clamping node joints.

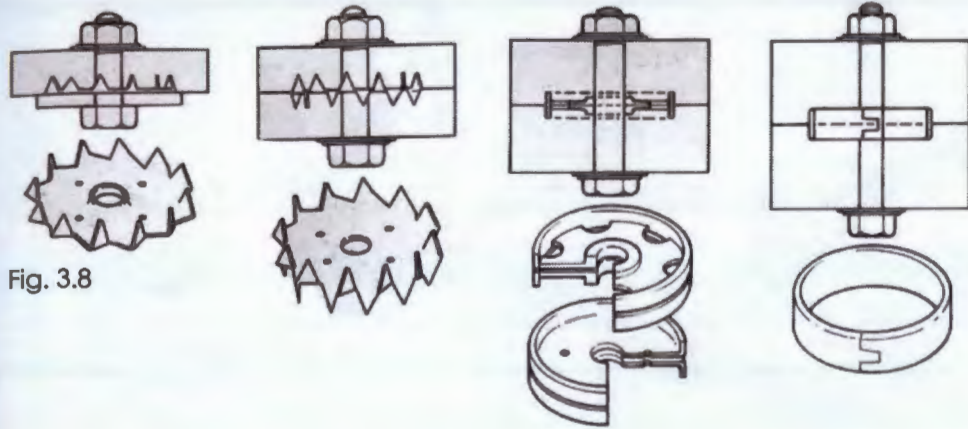

Fig. 3.8

bolts and screws. Timber connectors are therefore used in order to lessen the loads that are transmitted at a joint by increasing the contact area (Fig 2.8). (Macdonald 2002: 25) From this it can be deduced that the clamping node has a further advantage by distributing the forces experienced in the joints over an even larger area than is possible by conventional timber connectors as illustrated in Figure 2.12

This model ties together a number of feelings I have regarding flexibility and change, recycling, and drawing from the immediate environment to create an architectural language. However, it falls short of being a realistic solution to a timber joining method due to the complexity and time consuming nature of its construction.



Fig. 3.9



Fig. 3.10

The clamping nodes are made from 30 x 30 x 5mm mild steel angles that are cut in to 80mm lengths and are welded to a second steel angle as depicted above. The cleats are made from 60 x 6mm mild steel flat bar, and are cut in to 80mm lengths that are welded to a hollow pipe which hinges around the bolt that holds the steel angles to each other as depicted below.



Fig. 3.11



Fig. 3.12

En-loge Exam

It was during the en-loge exam that I first started experimenting with the design of a space truss structures. It began by using the clamping node of the previous model to connect three parallel pieces of timber with diagonal steel web members to form a single space truss (Fig. 2.13). I also looked at how the clamping node could be cut from a steel angle as efficiently as possible so that the off cuts from the parts that were mitred could be used as another functioning part of the node (Fig. 2.14).

Even though the manner in which the space trusses meet and join to form the trussed portal frame have been left unresolved (Fig. 2.15), the way in which the two sets of parallel members 'touch' each other in the diagram has lead me to think about what the implications could be on the form of the trussed portal frame if the parallel members were lengthened or shortened individually. There are no drawings to describe the exploration, but there is a model that was designed by Frei Otto (Fig. 2.17) that is based on a similar idea in which triangular shaped "vertebrae", are rigidly connected to a steel wire spring, and to controlling cables via nylon threads passing through holes formed in the ends of the "vertebrae". The thin elastic rod is braced in three planes by means of the nylon threads, and three dimensional movement of the column is effected by shortening or lengthening the groups of threads with the aid of the control cables (Fig. 2.16). (Roland 1970: 111)



Fig. 3.13

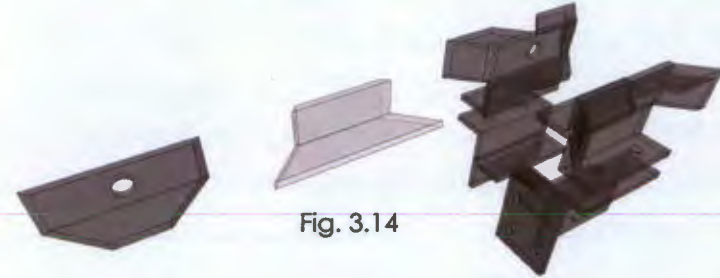

Fig. 3.14



Fig. 3.15



Fig. 3.16



Fig. 3.17

Model 4

This was a conceptual model of two tetrahedrons where the members creating the tetrahedral forms were made from space truss structures (Fig. 2.20 a). The exploration was primarily focused on how these forms worked spatially and how an enclosing skin could be created from connecting the nodes of the structures (Fig. 2.18 b). Because the form is stable as long as all three feet are secured, it is possible to fix the structure to any surface plane - vertically, horizontally and anything in between.



Fig. 3.18 a

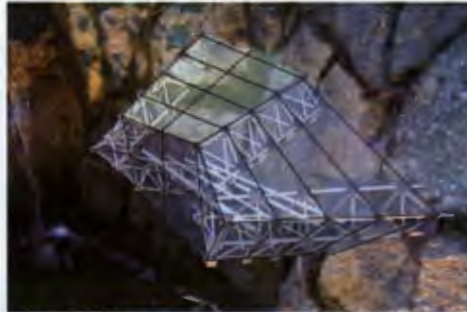

Fig. 3.18 b

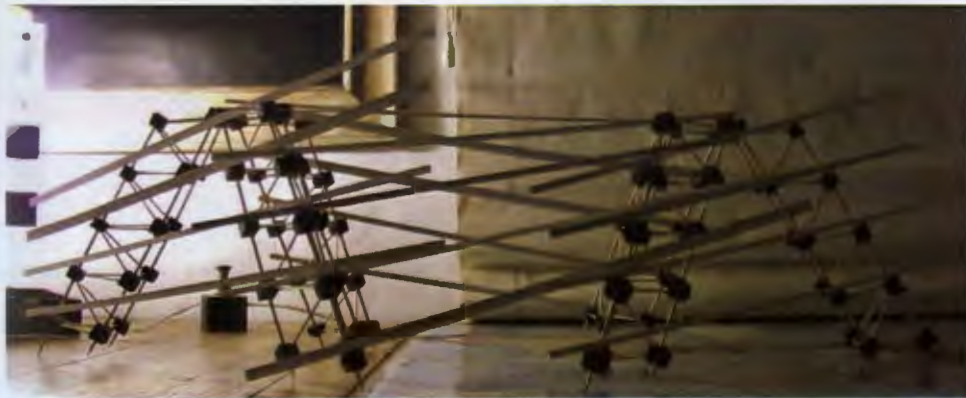

Fig. 3.19



Fig. 3.20 a



Fig. 3.20 b



Fig. 3.20 c



Fig. 3.20 d

Model 5

This model was a further investigation into the node construction in space frames that allowed for the structure to change form through the bottom nodes being hinged (Fig. 2.24) so that the top members could be lengthened or shortened which allowed the structure to camber.

The ideas that came through from previous explorations was to be as resourceful with materials as possible especially due to the large amounts of nodes required in a space grid structure. The nodes were therefore made from square boxings bolted to steel angles that were cut in a certain way (Fig. 2.23) that eliminates off-cuts, and the difficulty in generating a connection point that lies in a plane 45° horizontally and 45° vertically from the rest of the members in the structure. The nodes were made with hand tools and easily obtainable standard steel elements. (To view the tools and components for a DIY space frame see appendix 3).

The emphasis in this model was on the node connections rather than the type of members that were used to join them. These will be looked at in the next models.



Fig. 3.23



Fig. 3.24

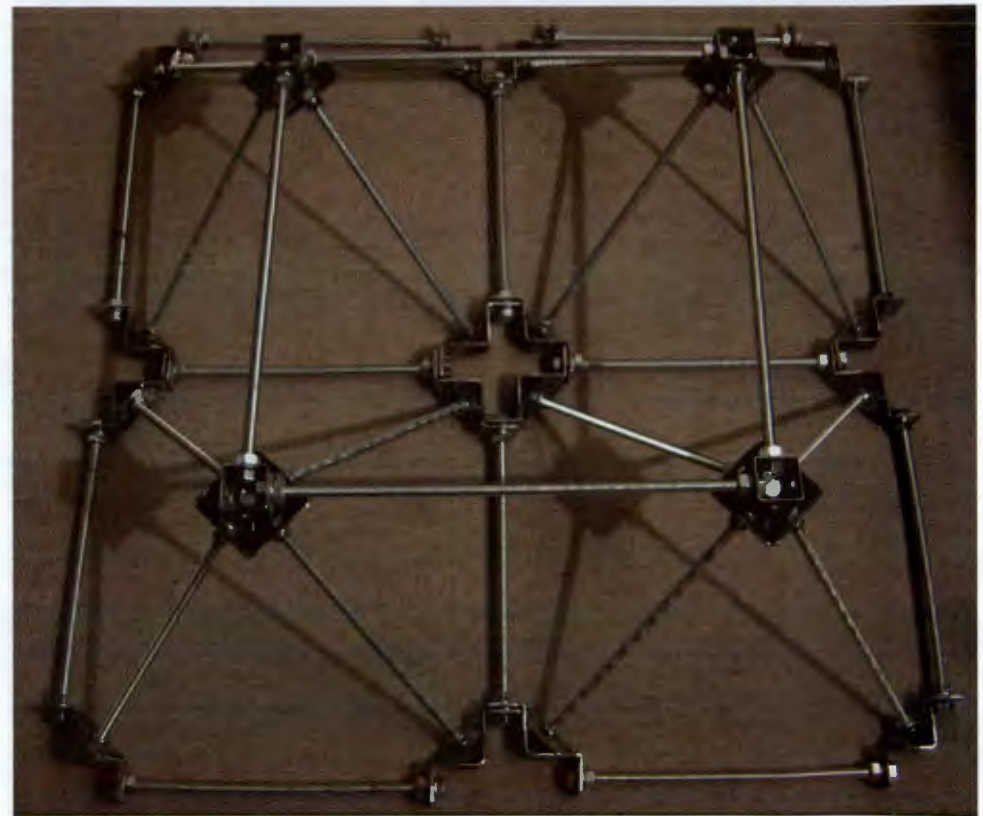

Fig. 3.25



Fig. 3.21



Fig. 3.22

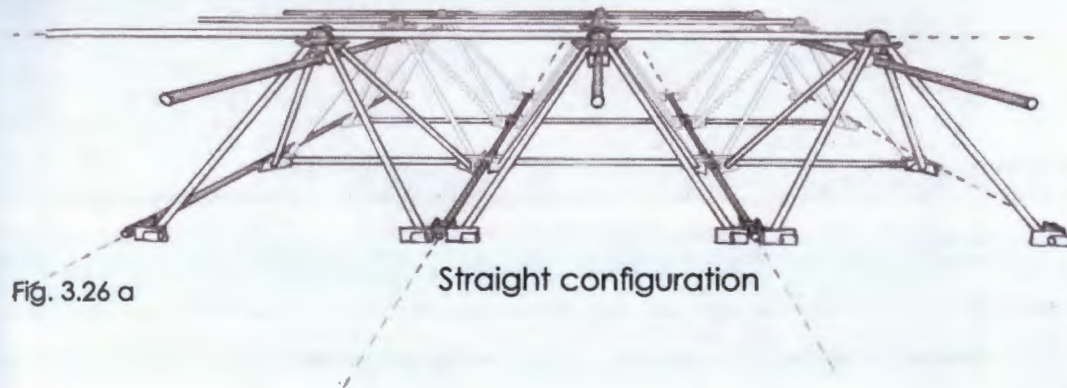

Fig. 3.26 a

Straight configuration

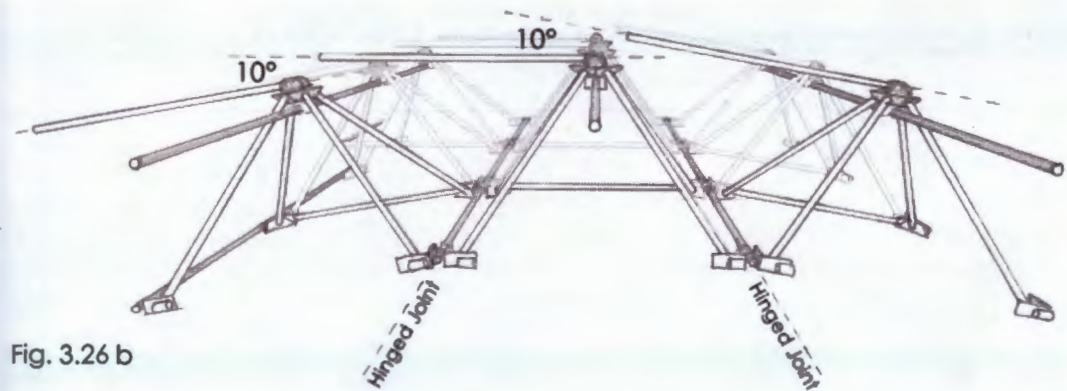

Fig. 3.26 b

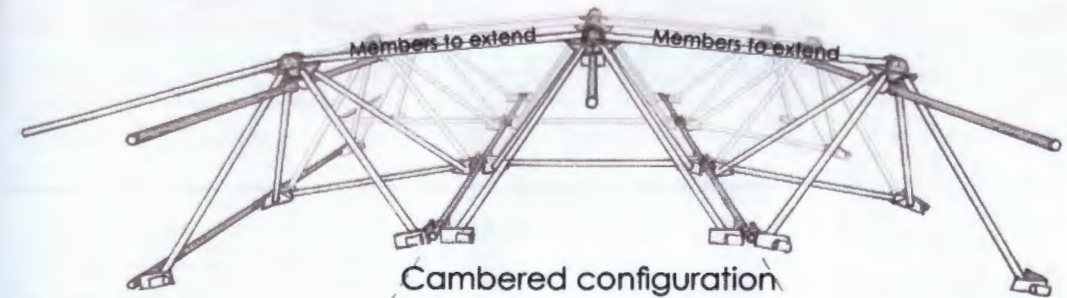

Fig. 3.26 c

Cambered configuration

Commercially made 'piece-small' systems

Standard Mero KK node with 18 threaded bearing holes and machined bearing surfaces at angles of 45°, 60° and 90° relative to each other... Mero standard member tapered cone sections welded to each end (complete with connection bolt and sleeve). (Chilton 2000: 33)



Fig. 3.27

The Nodus system... was developed during the late 1960s by the Tubes Division of the British Steel Corporation [and]... uses a relatively complex assembly of parts. Special cast steel end connectors are butt-welded to the chord and web bracing members in fabrication jigs, to ensure dimensional accuracy of the space truss components. The node itself is composed of two half-casings (one plain and one with lugs for attachment of the web bracing). (Chilton 2000: 37)

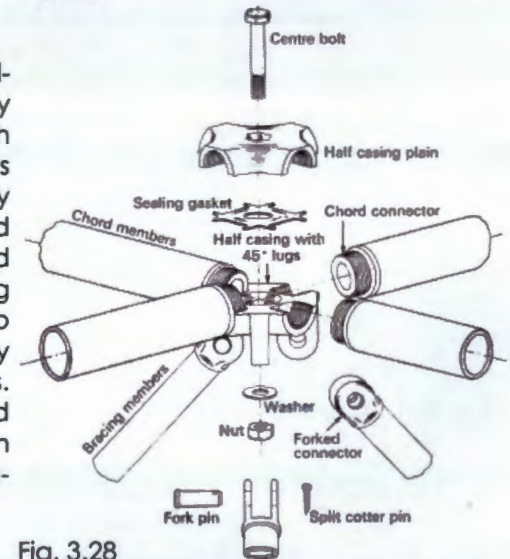

Fig. 3.28

Triodetic system introduced in 1960, by Fentiman Bros. of Ottawa, using aluminium for the bars and solid hub joints... Triodetic nodes (or hubs) are extruded in generally cylindrical sections with longitudinal profiled slots ready to receive the crimped ends of the members. (Chilton 2000: 5, 39)



Fig. 3.29

Model 6

These models are a continuation of the previous one, where the members connecting the nodes have been further developed and an alternate node design is being experimented with that is able to accommodate the new type of fixings in the members. The way this has developed was due to a site that has been found for my proposed building, and the materials found on the site that have been considered to be used as members of a space truss.

This model has incorporated ideas generated from previous models, such as: clamping, using materials from the direct surroundings, and my explorations of triangulation and space truss systems. It has also been inspired by the work of Pieter Hybers mentioned earlier in this paper, however, clamps and expansion bolts are used to fix the steel inserts as opposed to wire.

The first model (Fig. 2.30) was built using a piece of bamboo, but because bamboo is hollow, fixings become problematic. I therefore inserted an expansion bolt into the end of the bamboo which, when tightened, would expand against the inner wall of the bamboo. Over expansion would cause the bamboo to split, and a hose clamp was added to the outside to counter this. The bamboo is essentially clamped along its wall between two pieces of steel. This member, when used in a space truss, resists tension due to the expansion bolt expanding when pulled, and resists compression by the use of a washer that is larger than the cross-section of the bamboo and prevents the mechanism from sliding further into the opening.

The second model (Fig. 2.31) is quite a lot simpler than the first and is made from solid roundwood saligna poles cut from the for-



Fig. 3.30 a



Fig. 3.30 b



Fig. 3.31 a



Fig. 3.31 b



Fig. 3.32



Fig. 3.33

est adjacent to my site. This fixing method is comprised of a steel, wedge shaped, insert that is slotted into a corresponding cutout in the timber pole, and then clamped around a thinner part of the wedge. The member resists tension through the thicker part of the wedge trying to squeeze through the narrower section that is resisted by the clamp working in tension to compress the timber when pulled (Fig. 2.34 a). It resists compression through the thicker part of the steel wedge butting against the timber (Fig. 2.34 b). The clamp used in this model has quite an ingenious design and is used for heavy duty connections of irrigation pipes. (Fig. 2.33)

The advantage of these types of members and fixing methods is that all that is required on site for their harvesting and construction is a saw and spanner. However, my concern with these types of members is that there is a possibility of the clamps working themselves loose due to 'moisture movement' (the shrinking and swelling of timber due to relative humidity).

The greatest change to the moisture content of a specimen of timber occurs following the felling of a tree after which it undergoes a reduction from a value of around 150 per cent in the living tree to between 10 and 20 per cent, which is the normal range for moisture content of timber in a structure. This initial drying out causes a large amount of shrinkage and must be carried out in controlled conditions if damage to the timber is to be avoided. (Macdonald 2002: 26)

It can be noted that the design of the nodes in these models are generally quite basic and quite clumsy. This has to do with the machinery I have available to me, my skill level in metal work, and the materials I am able to find and afford. I do however intend on designing a node that is a lot more technical and efficient, and that is made from cast steel as opposed to being made up of industry standard steel sizes.

Component in tension

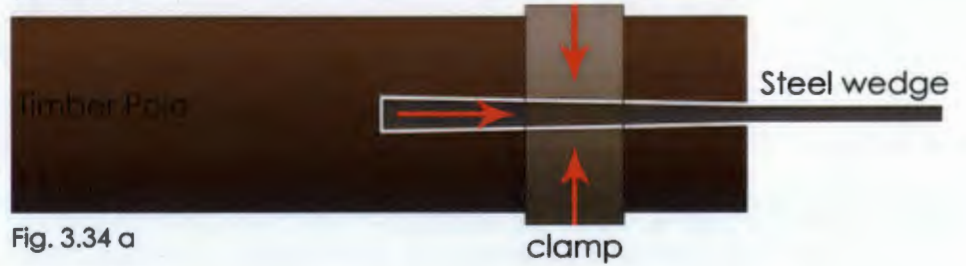

Fig. 3.34 a

Component in compression

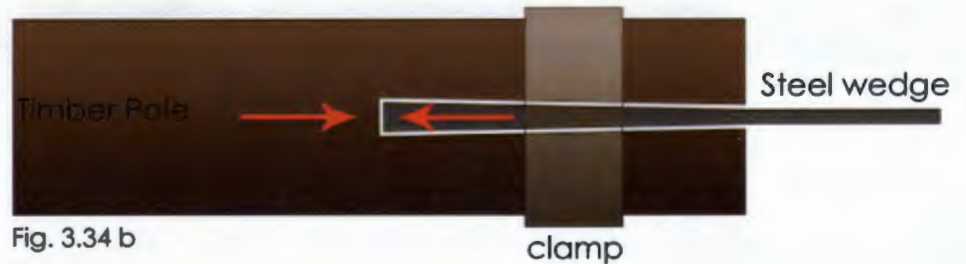

Fig. 3.34 b



Fig. 3.35

Model 7

At this stage of the project the focus had shifted from the resolution of the main folding roof and moving scaffold structures, and began to focus on the auxiliary buildings (Fig. 3.38) and the concrete service and circulation structure that linked the two (Fig. 3.37). It can be seen by these sketches (Fig. 3.36) that there was a vague notion of what I wanted to achieve with this element of the building, and it was quite crucial to the design due to this element being the mediator between public and private spaces, as well as between the large form of the main structure and the landscape.

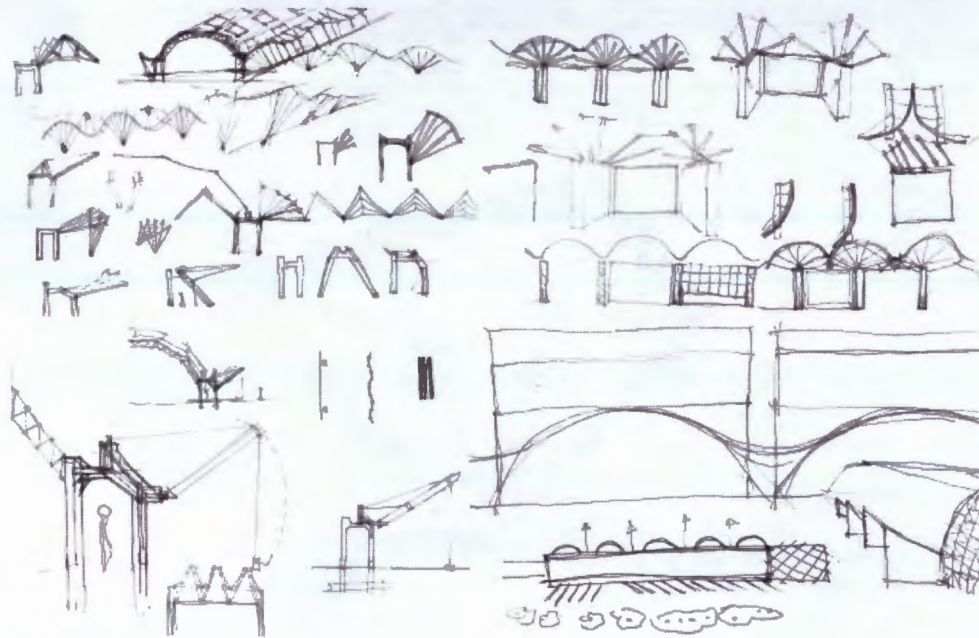

Fig. 3.36

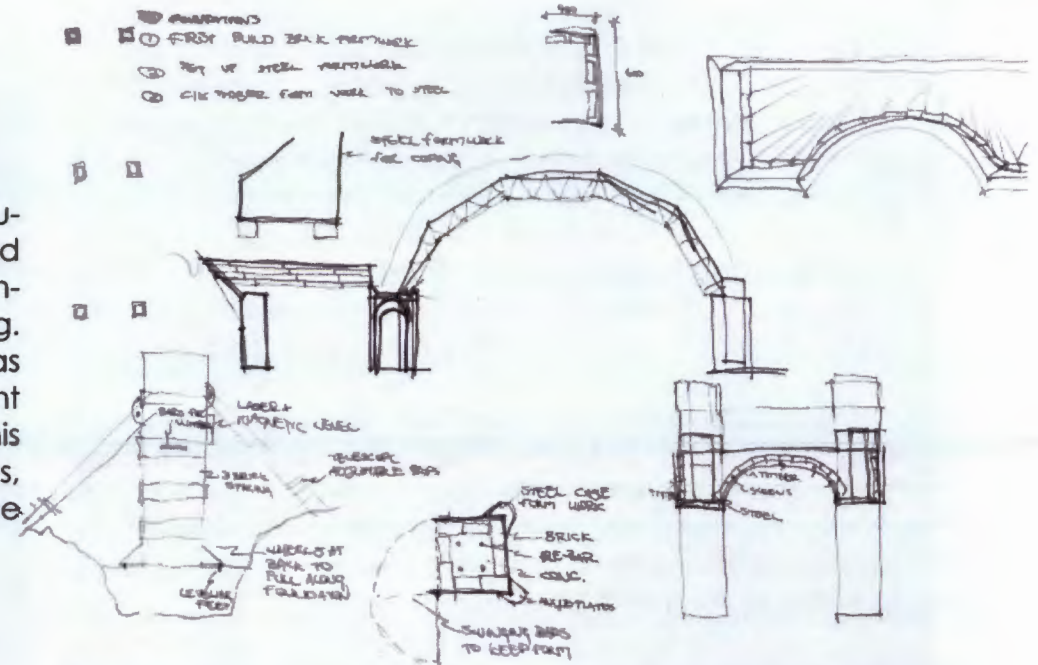

Fig. 3.37

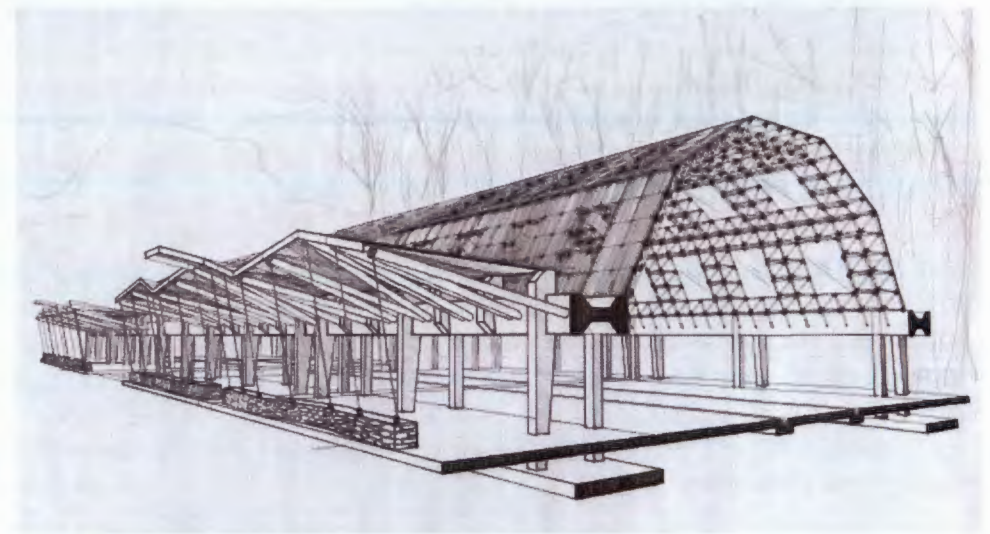

Fig. 3.38

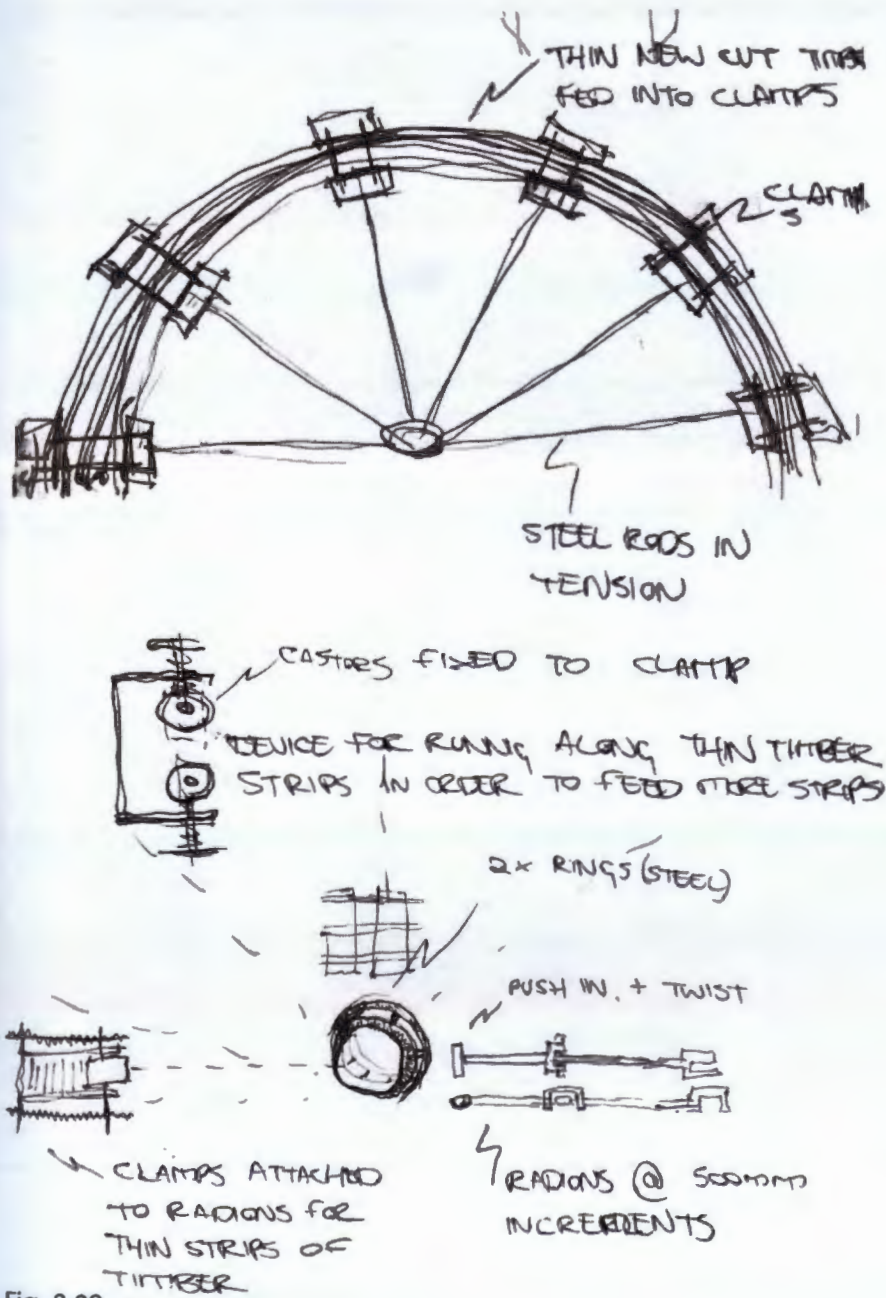

Fig. 3.39

Before the link had been made between the structural concept I had been exploring and the models I was building, an idea was considered that was inspired by the clamping node truss model, and which made use of the clamping node idea to create semi-circular arches by clamping thin strips of timber together by using equal lengths of steel cables radiating from a point that were connected to the clamping node (Fig. 3.42) At the time, this idea had no relevance to my project except for the fact that it was inspired by it.



Fig. 3.40



Fig. 3.41



Fig. 3.42

The main consideration for the auxiliary building was to find a form or a series of forms that complemented both the pitched roof and segmented arch roof configurations of the main structure. It was realised that if the semicircular arch was positioned at a 45° angle its side elevation would complement the 45° angle of the pitched roof of the main structure in the initial position (Fig. 3.43), and the front elevation of the arch, that became squatter in proportion due to the angle, would complement the faceted arch of the main structure in its raised position (Fig. 3.44). Having the arch lean over like this also provides the additional benefit of a sun shading device.

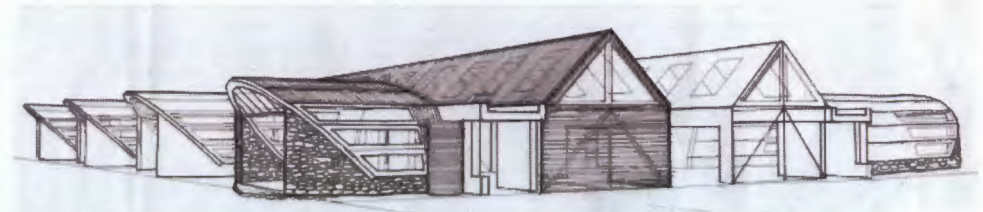

Fig. 3.43

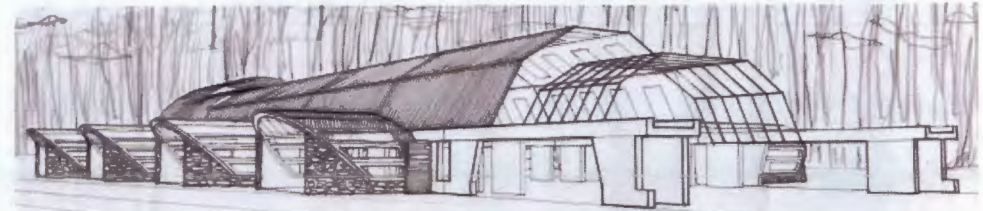

Fig. 3.44

The working concept of this model is based on the steel cables being held in tension due to the timber wanting to bend straight to resume its natural position. When constructed for use in the building, the cables would be required until the arch had been positioned and tied back to the foundations and main structure before they could be removed in order to maintain its shape. (see fig??) This idea is also an attempt to deal with waste material by making use of thin strips of off-cut timber that is generated when timber is squared up for construction purposes at saw mills.



Fig. 3.45

During the making process of this model that eventually required some sort of sub-structure to hold the model steady, an idea was formulated which made use of materials at my disposal in my workshop at the time, where a segmented arch was developed that would be used as an intermediate structural member for the extruded shape formed by the semi-circular arch at an angle. (Fig. 3.45) The method for constructing this irregular curve would also be used as a means for creating the floor line for the terrace where required.

Model 8

Once the primary structure of the above model had been resolved, it became necessary to consider the secondary structural element that would be required for its cladding. How to bring the clamping device used in road traffic signs into this project had been in the back of my mind for a while, and this type of round wood construction became an ideal situation to test this. I also discovered additional type of industrial clamping mechanism used on the steel I-beams of the electricity pylons that crossed my site, that work in a similar way to the timber ones, and which would have been a good substitute if the structure had been made from steel as opposed to timber (Fig. ??)



Fig. 3.46



Fig. 3.47



Fig. 3.48

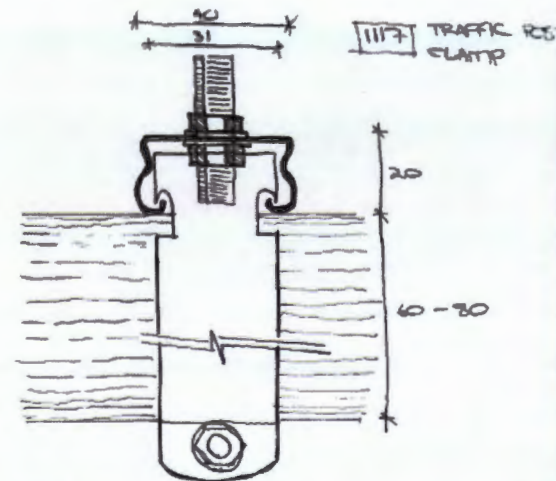

Fig. 3.49



Fig. 3.50

Part 4:

The Rural Building Workshop: Programme

The siting and programme for this project were intentionally not decided upon until quite late in the year in order for the act of making to remain the dominant focus of my efforts. Once I had reached the point where the models I was constructing and the structural concepts I was considering began to merge I decided to ground the project in order to give direction to a new wave of models and experiments relating to siting and programme, which can be seen in Model 6, 7 and 8 of the previous section.

Because of the nature of this thesis that has focused on the act of making being used as a valid tool for learning and instruction in an academic institute, it was decided to take a step back and to view my own situation as an example of this way of working. From doing this it was revealed through research that there is currently a real need for this type of learning through making within the architectural curriculum. Precedence for the type of requirements that this sort of programme called for came from ideas based on the Architectural Association's Hooke Park in Dorset, England (Fig. 4.1 - 4.3) and Ciudad Abierta (the Open City), or what has been described as "Valparaiso University's architectural playground" in Chile (Fig. 4.4 - 4.6).

Since the structural system I had begun to focus on was a large shed type building that grew incrementally, it lent itself to this type of programme in two respects: Firstly it would afford the students indented to use the building a workshop space to carry out their own building research and experiments; and secondly, because the building grew incrementally, it would be a didactic example of the art of construction, as the skill and energy of the students would be the resource used to build it. Once the building of the



Fig. 4.1



Fig. 4.2



Fig. 4.3

workshop gets completed the programme would require the surrounding area to become the "architectural playground" or area where students would be able to construct their designs and ideas which would then become their accommodation for the duration of their stay.

Never has there been a more opportune time to include construction studios in architectural education. With the recent focus on redesigning the way an architect learns, construction studios are an ideal vehicle to synthesize complex areas of knowledge. Technology can be linked with the design studio. One of the criticisms usually levelled against architecture schools is the students' inability to deal with pragmatic things. Construction studios offer a way to learn in a practical sense without sacrificing a high calibre of design. Another criticism often heard is that schools are too insular, sealed off from other departments on campus and from the surrounding communities. Construction studios can offer students the opportunity for cross-disciplinary approaches and projects that reach out to the community groups who are in need. Most of all, students learn the ability to communicate with team mates and actual clients. Students learn that architecture is a collaborative effort and not an exercise in isolation. (Carpenter 1997: x, xi)



Fig. 4.4



Fig. 4.5



Fig. 4.6

The Site

The site that was chosen is one that I am quite familiar with, and is located on a farm called La Folie just outside of Wellington in the Cape Wine lands (Fig. 4.8). This particular piece of the farm was chosen because it is separated from the rest of the farm by a road, and is surrounded by an abundance of natural resources that are intended to be used by students in order to experiment and build with (Fig. 4.7). Directly adjacent to the site along two edges there are blue gum timber plantations, and the road that separates the site from the rest of the farm leads directly to the pine forestry plantations on the mountain (Fig. 4.9).

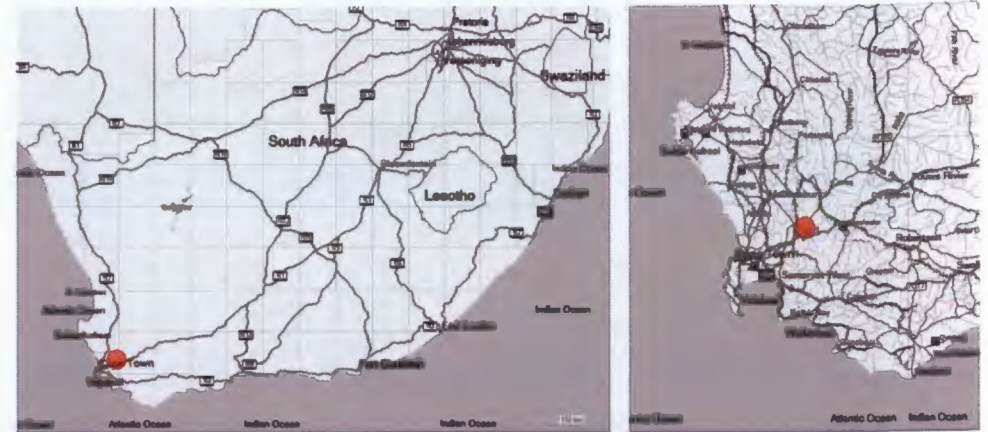

Fig. 4.8



Fig. 4.7



Fig. 4.9

There is also bamboo growing near the river that forms the boundary at the lower end of the farm, as well as Black Wattle, Poplars, Wild Olives and African Mahoganies dispersed throughout the rest of the farm.

Because of the abundance of timber in the area, the focus of the experimentation will be on sustainable timber technologies, which will also be the dominant structural



Fig. 4.10. View lookig South



Fig. 4.11. View looking East towards timber plantations



Fig. 4.12. View looking North

expression of the workshop building. Besides the timber in the area there are large quantities of natural rock, sandstone and granite, as well as big patches of clayey ground (Fig. 4.13). Many of the surrounding farms have unused or redundant materials such as corrugated roof sheeting, wire and wire mesh, gum poles, irrigation piping, plastic sheeting from green house construction, and other items used in farming and building operations (Fig. 4.14 - 4.15). There are also old farm buildings that have fallen into disrepair that can be recycled for building materials (Fig. 4.16). The idea is not just to take from the site, but also to give back to the area, and indigenous plants and trees will be cultivated on the site as part of the education that students will receive. The site lends itself to this kind of activity as it is on a north facing slope and receives a full day's sun.

The siting also allows the possibility of the programme of the Rural Building Workshop to extend into the sphere of doing building work for and with poorer communities, similar to that of the work of the Rural Studio, as it is located nearby the informal settlement of Mbekweni between Paarl and Wellington in which there is already precedent of this type of work as illustrated by the "Stone House" project. (Fig. 4.17)

Construction sites reveal the way a building is made. The life of a structure is marked when the materials are stacked, when some order is assembled amid the chaos of activity at a site. Building sites are intriguing because of their potential; the materials could become anything. When the dirt is churned, it is like the earth is giving birth to a building. This act of man is similar to that of many animals in that it simultaneously marks a place in time and an activity. So often, I have watched construction and appreciated the process of a building's birth even more than the final product. Raw materials such as exposed framing, ducts, sheathing all reveal the story of a building's existence. It is not until a building's death, as a ruin, that the building tells its story again. (Carpenter 1997: x)



Fig. 4.13



Fig. 4.14



Fig. 4.15



Fig. 4.16



Fig. 4.17

Materiality, Structure and Adaptability

This section deals with environmental issues regarding the approach of architecture where the proliferation of 'novel forms' being continually built and demolished in architecture is causing damage to the natural systems we rely on for our existence. It is from my ability and desire to build, as well as a concern for the environment that this approach to adaptability in architecture has developed. Adaptability in architecture can be a very broad subject, and I have approached it in a manner that begins to deal with waste in materials and labour. My approach has to do with the putting more initial energy into the construction of buildings so that all future adaptations require less energy and little or no waste. This idea has been explored in the development of a system of building where all parts of the building are accessible, and are put together in a manner that is easy to disassemble, but whilst assembled the building fulfils the role of being permanent, legitimate architecture, not a nomadic, temporary structure.

It should also be noted that the start of a project that is developed with adaptability in mind through the use of less permanent or perishable materials does not necessarily mean that a buildings lifetime is determined by such factors. Buildings that function well and that are generally liked, will always be reconstructed. Because their life-time depends mainly upon their technical and humane adaptability and not upon the materials from which they are made, they can gradually become more permanent. (Otto 1975: 167)

In order for buildings to become more adaptable and to extend their lifespan they need to become less functionally specialised regarding their material attributes. This can be achieved through different building technologies which allow an easy disassembly and recycling of building-materials and components. A consequence of this principle would also mean that the responsibility of the owner for the eventual pulling-down of the building would change their role from being a "passive" capitalist to an "active" environmentalist. (Sieverts 1975: 181) The Rural Building Workshop building is therefore not only didactic in its construction, but also in its structural concept of adaptability and in its function of promoting regeneration of depleted resources from integrating a green house for timber cultivation.

Industrialisation means ever more rigid technology and thus, ever less adaptivity and humanity... Adaptive building must, however, permit the user to react spontaneously. This calls for a flexible technology which gives the user more opportunity for self-realization and self-expression than the basic existential needs of people allow... With in a superimposed, durable, form-giving structural frame, the encouragement of "self-building"



Fig. 4.18

could lead to an enrichment of anonymous architecture and thus to a wealth of local form systems. (Wienands 1975: 197)

In the Rural Building Workshop, this was achieved by keeping adaptability in mind through understanding that the beginning and end of the buildings existence is as important as its life which directed the design of the structural concept from which the building took its form. A waste of building materials during the construction process represented a waste of energy and needed to be avoided. This resulted in the structural concept that reduced waste by designing for a selective dismantling in renovation, and for recycling of structural systems, components and materials (Fig. 4.20). The method of building is intended operate like an ecosystem in a waste not want not cyclical manner where the waste of a depleted process becomes the raw material of a new process, such as the idea behind moving scaffolds (Fig. 4.18).

The new aim of overcoming Modernism may contain within it a return to nature - but to the materially sophisticated workings of nature, not to a 'state of' nature. This return is only possible through new environmental sciences capable of understanding our dependence on ecosystems and measuring our damage of them; on new environmental technologies, like photovoltaics and wind power, which enable us to extract what we need from nature without destroying what we need; on new environmental methodologies that enable us to design buildings - new or renewed - whose materiality does less damage to the natural matter from which it springs, and yet isn't all wattle and daub. (Hagan 2007: 256)

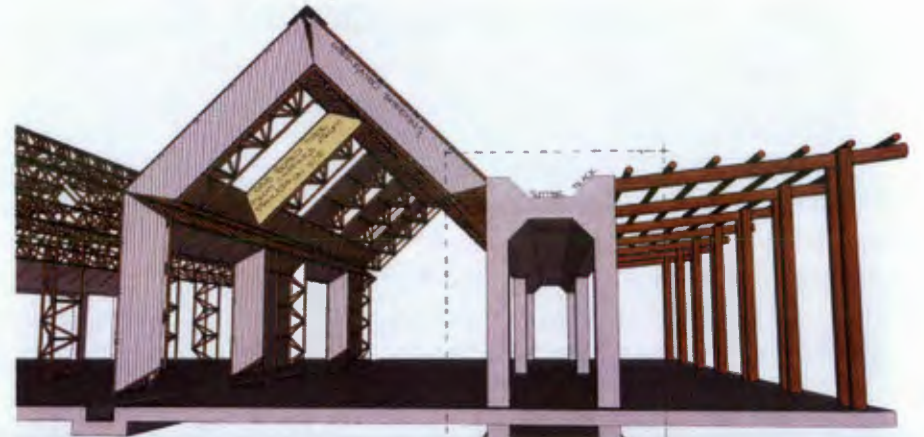

Fig. 4.19

- TRUSS 1
- SMALLER ROUND WOOD POLES
- 60CM-80CM ALTHOUGH PORTAL
- PLATE MADE FROM SPIKE TRUSSED
- TRUSS 2
- LARGER ROUND WOOD POLES
- 100-120CM ALTHOUGH STRUCTURE
- SEMI-TRUSSED ROOF TRUSS
- KICKOUT
- MEMBERS
- TRUSS FOR SCAFFOLD
- SHORT WATER DROFF

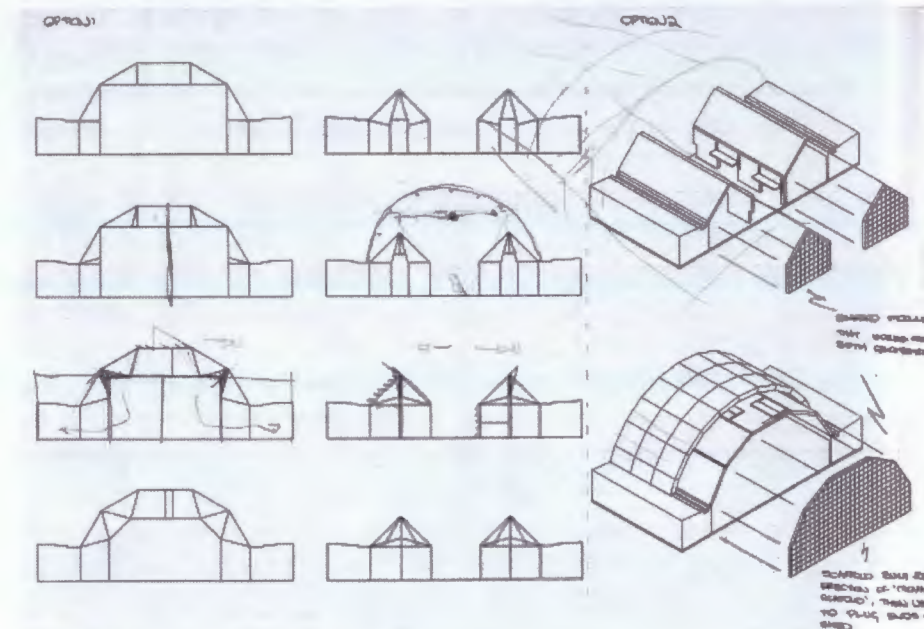

Fig. 4.20

Materials with low embodied energy considered for cladding and infill materials

Stone



Fig. 4.21

Timber



Fig. 4.22

Sheet Metal



Fig. 4.23

Cordwood and Cob

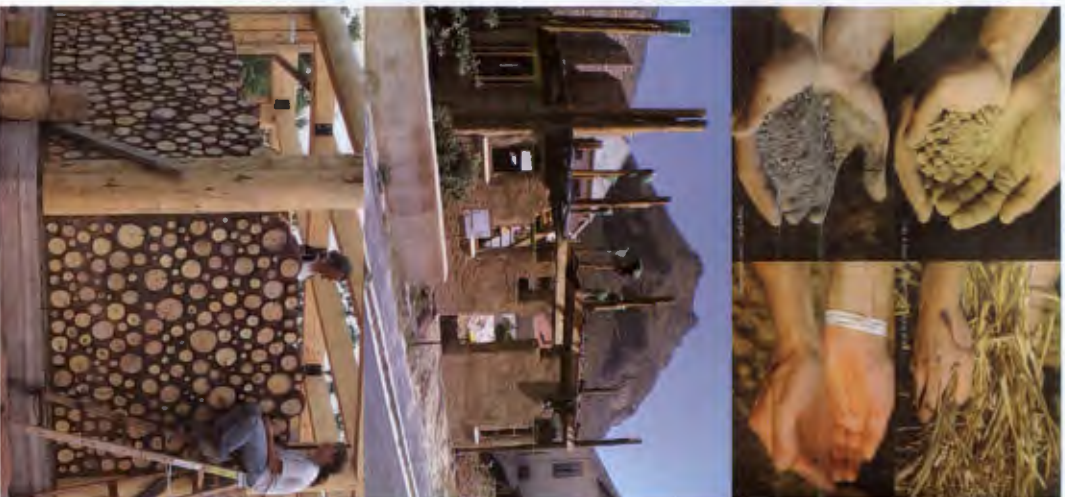

Fig. 4.24

Straw Bale and Cob



Fig. 4.25

Sand Bags and Cob

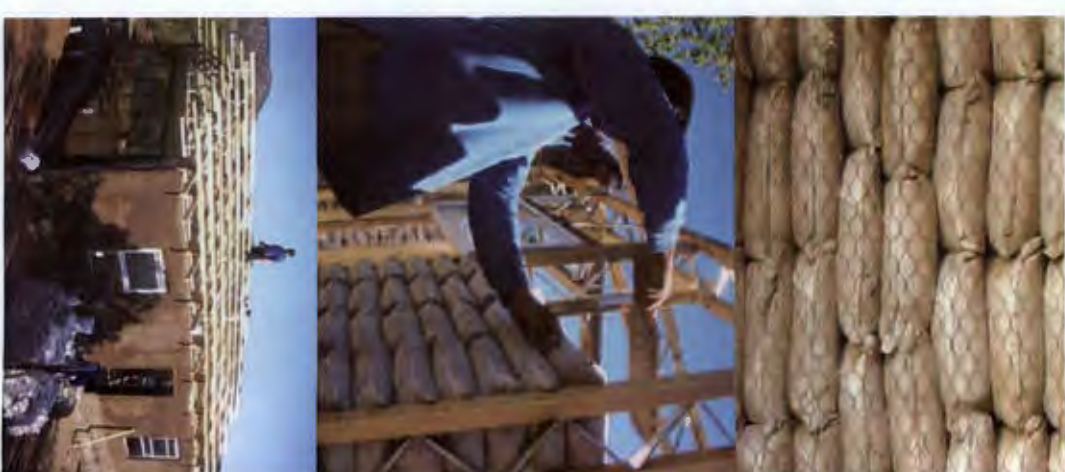
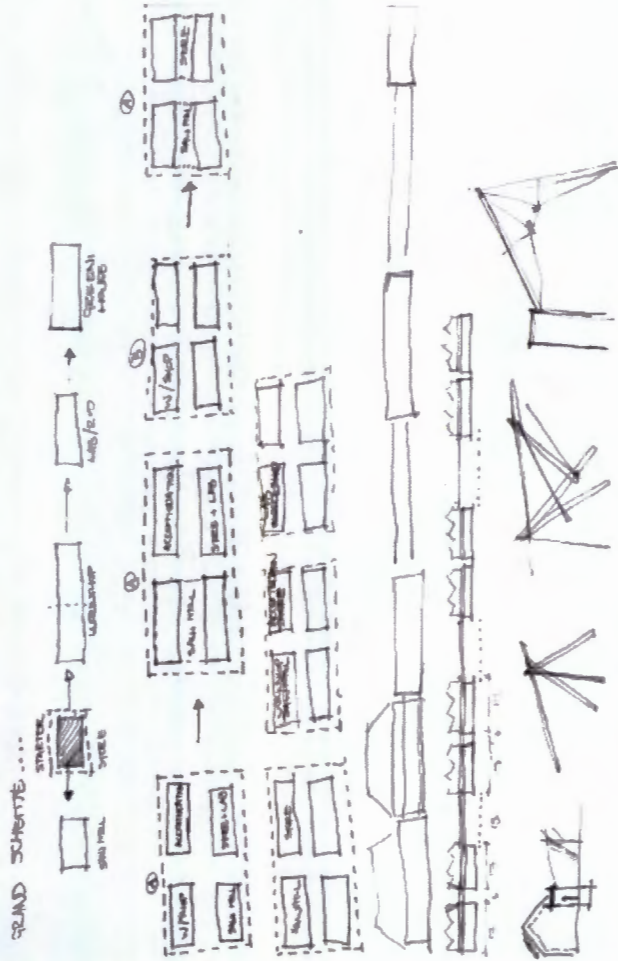

Fig. 4.26

Part 5:

Design development according to siting and programme



REQUIREMENTS:

- ↓ OUTSIDE AREA FOR CUTTING + CLEANING NEW CUT TREES
- ↓ SAW MILL FOR PROCESSING INTO ROUGH CUT STEES
- ↓ STORE AREA FOR MATERIALS
- ↓ WORK-SHOP
- ↓ STUDENT + STAFF ACCOMMODATION

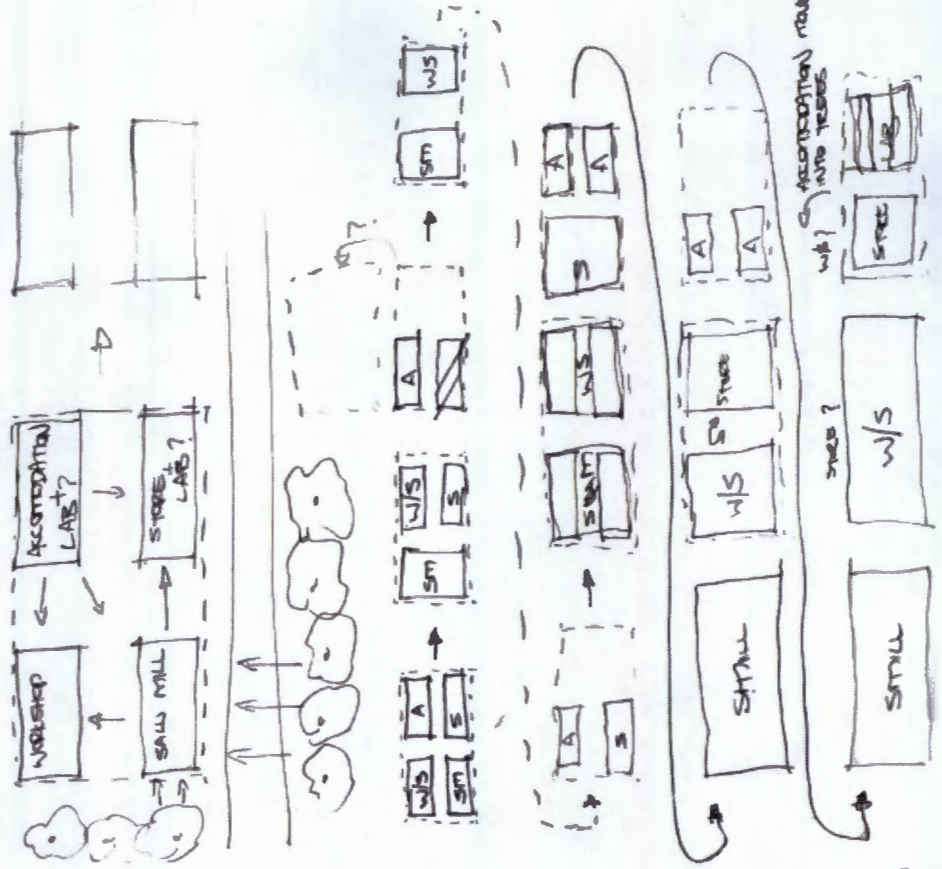

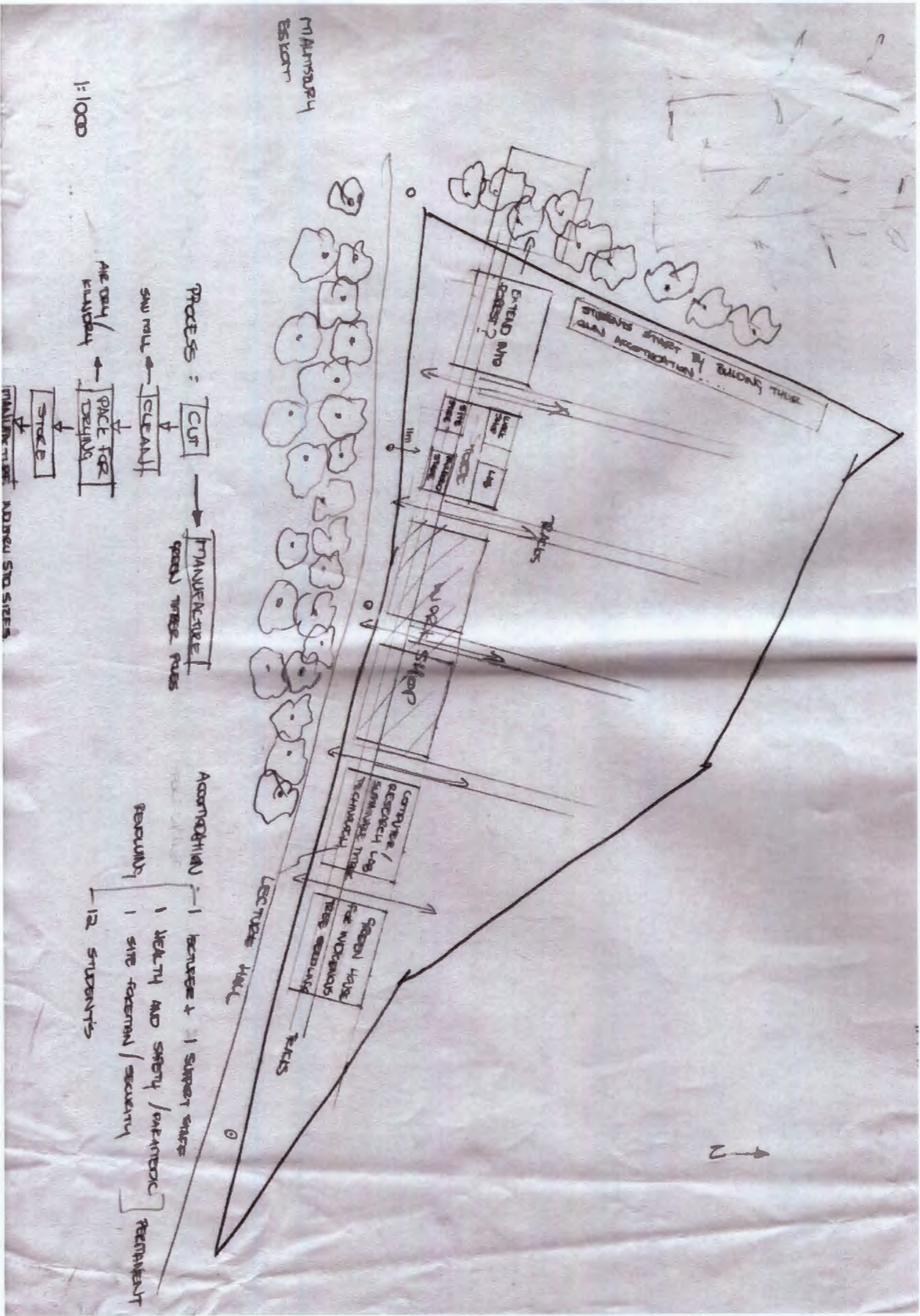

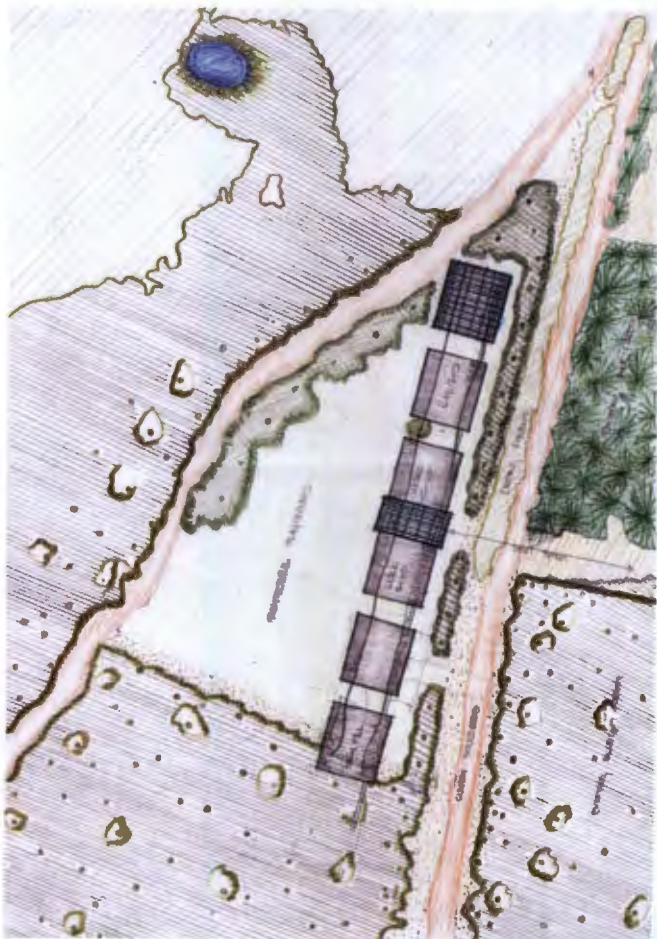
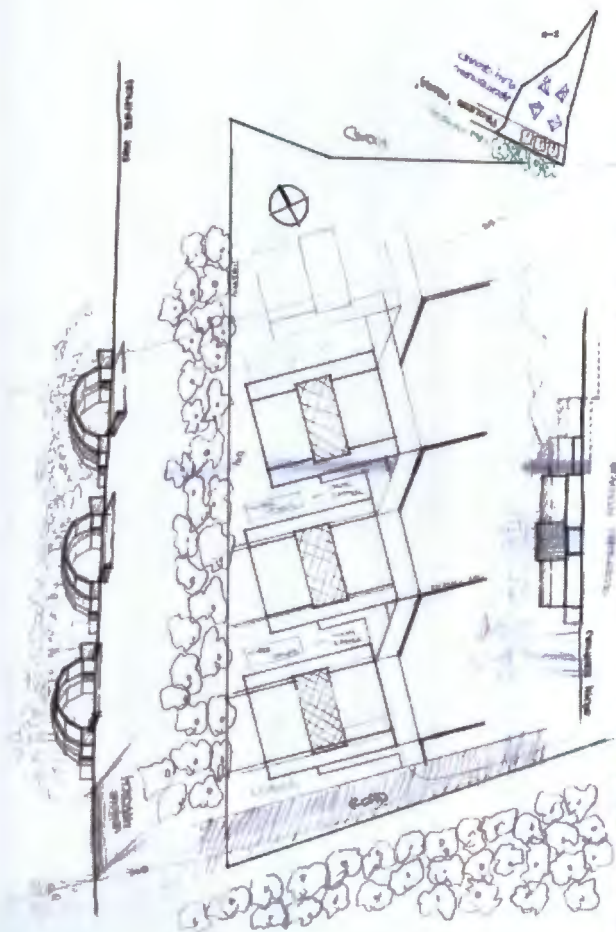
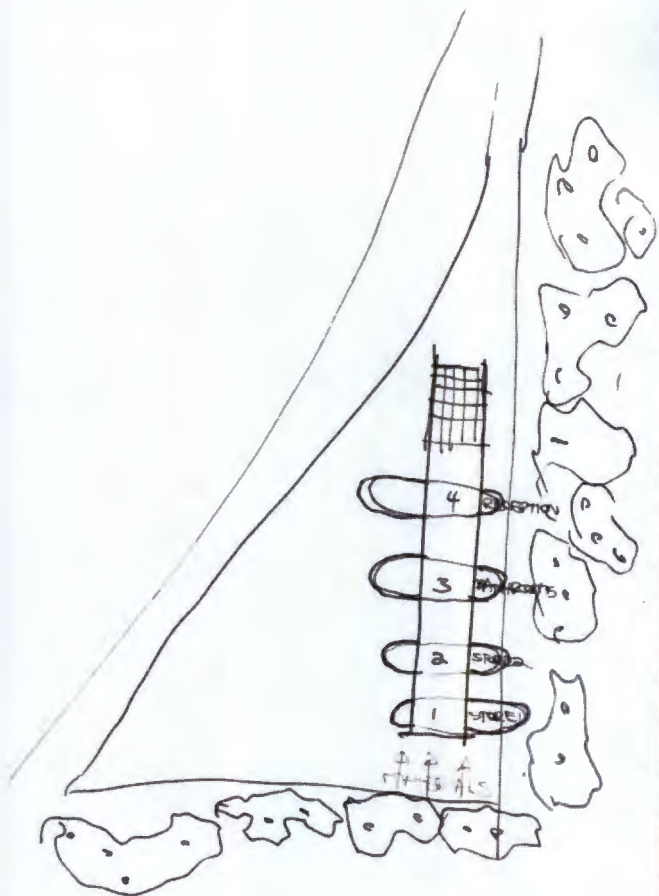

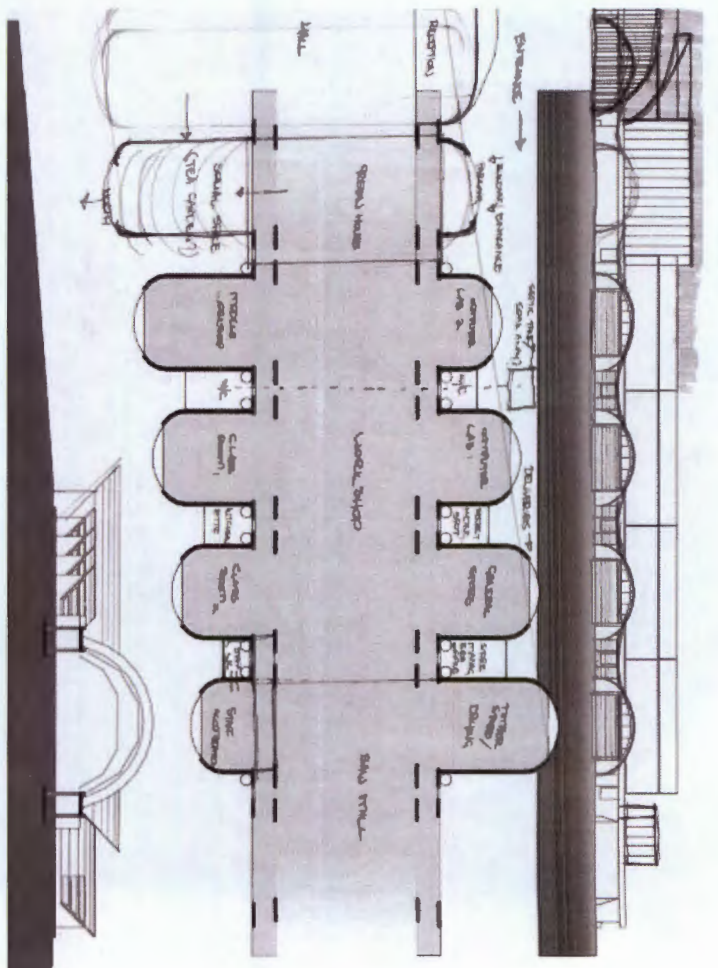
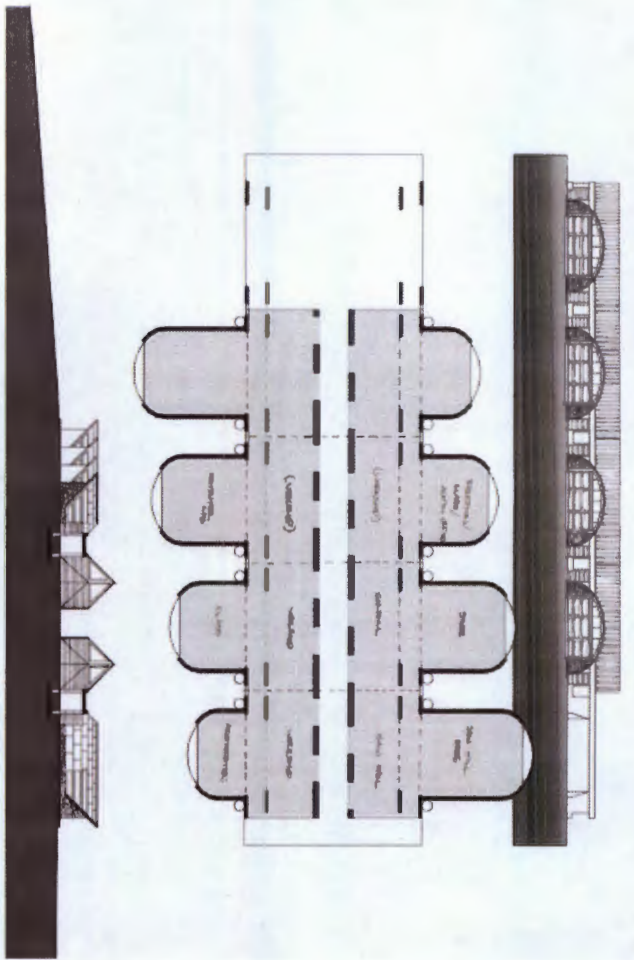

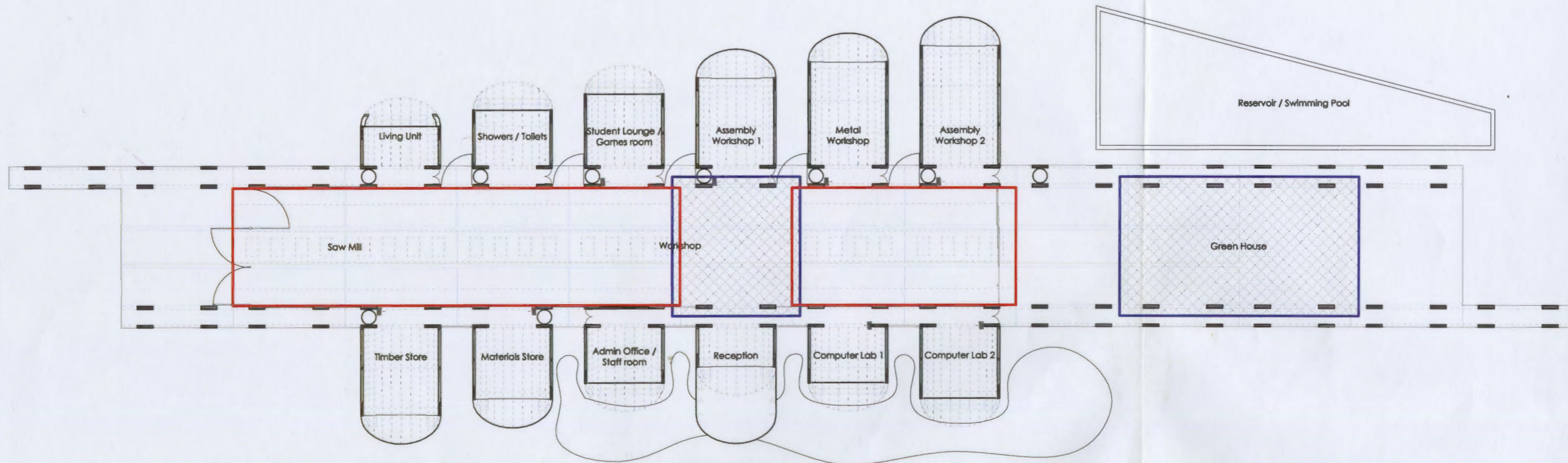

Rural Building Workshop
 Scale 1:500
 Peter Alexander Neokorides

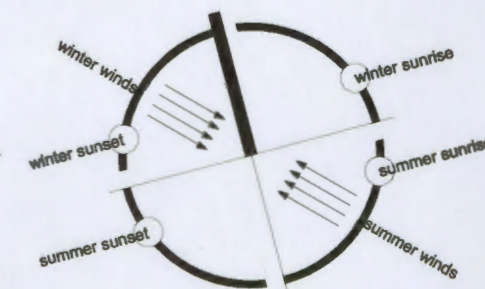

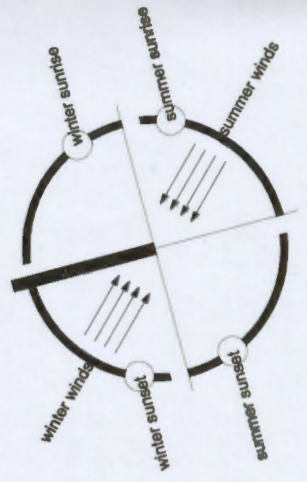
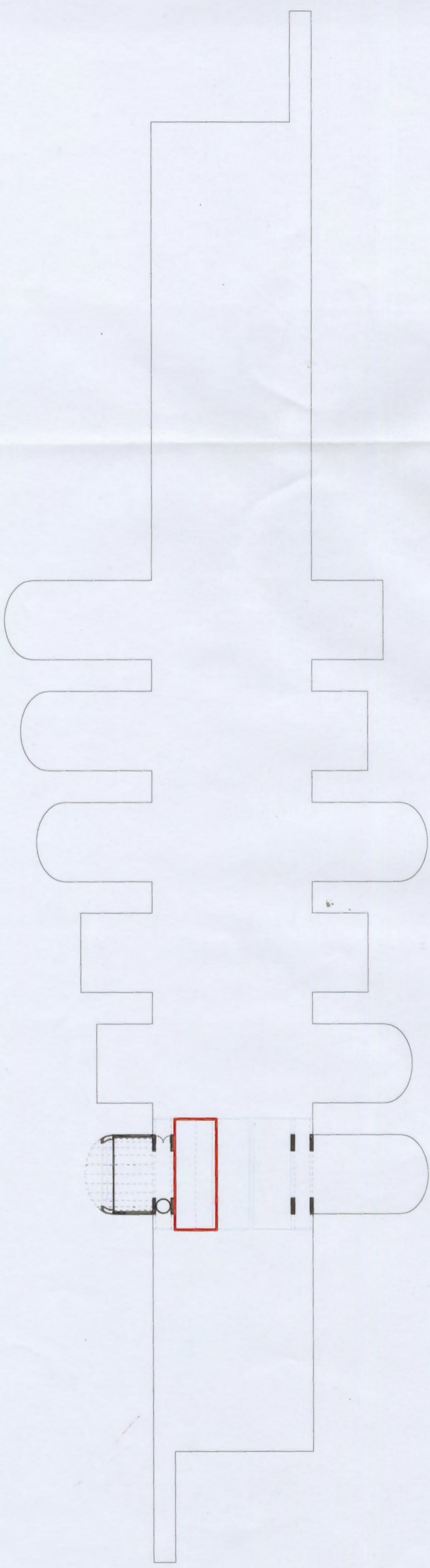

Rural Building Workshop
Scale 1:500
Peter Alexander Neokorides

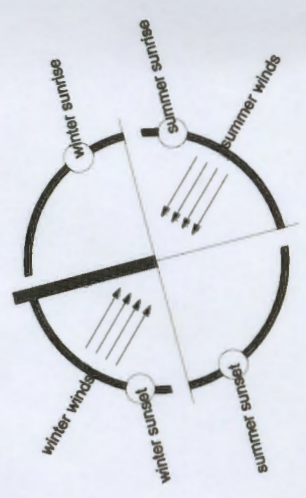
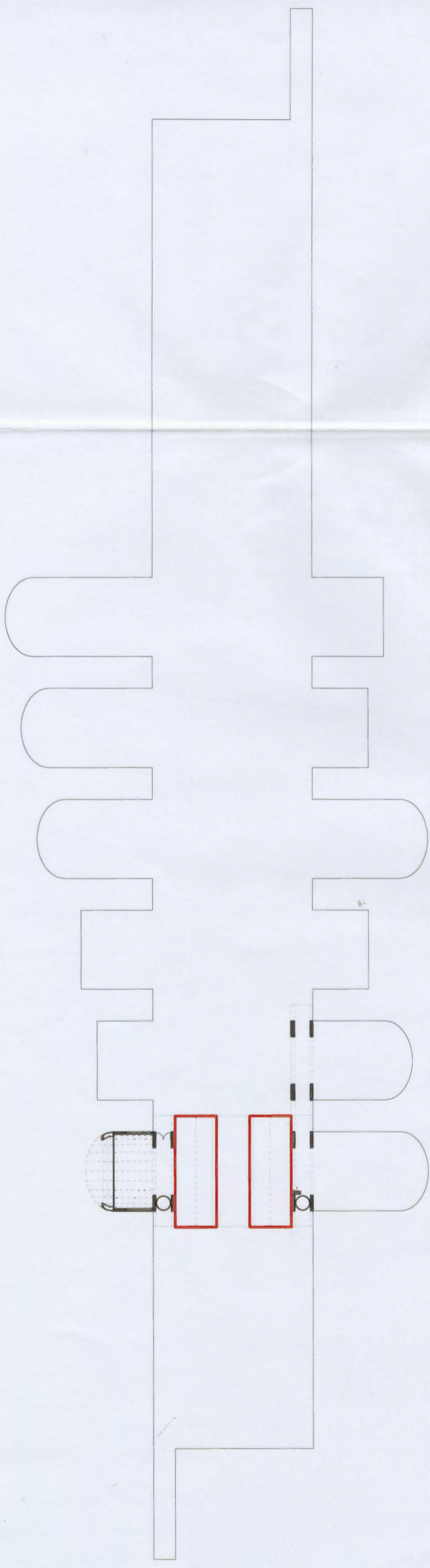

Rural Building Workshop
Scale 1:500
Peter Alexander Neokorides

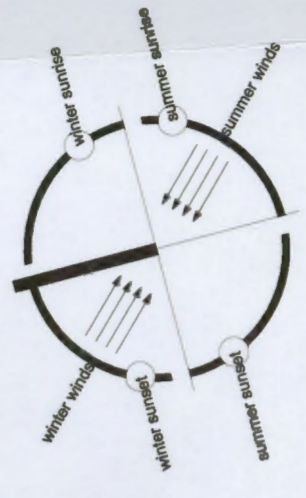
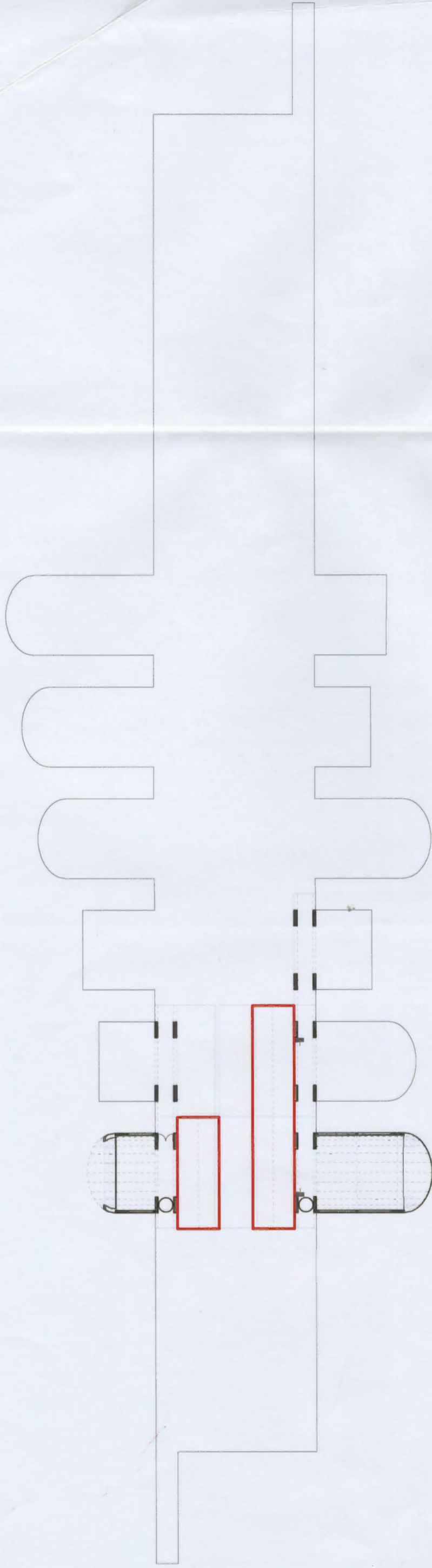

Rural Building Workshop
Scale 1:500
Peter Alexander Neokorides

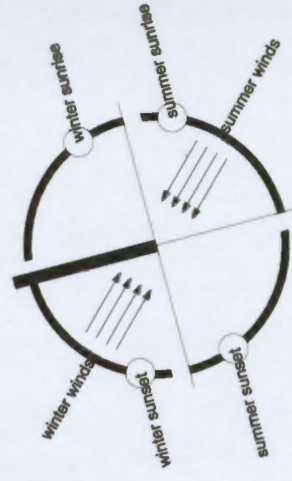
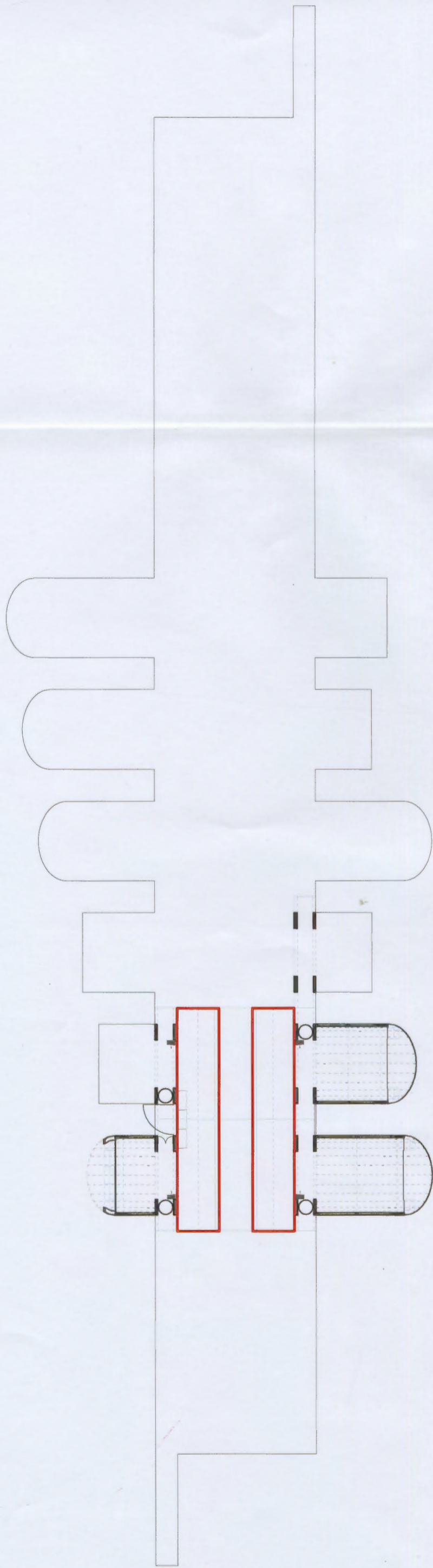

Rural Building Workshop
Scale 1:500
Peter Alexander Neokorides

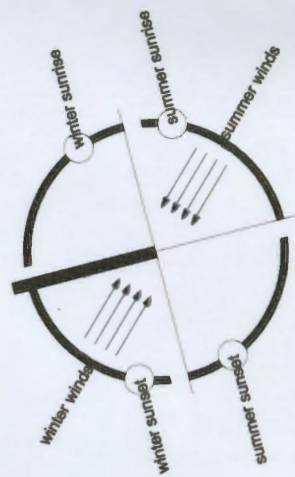
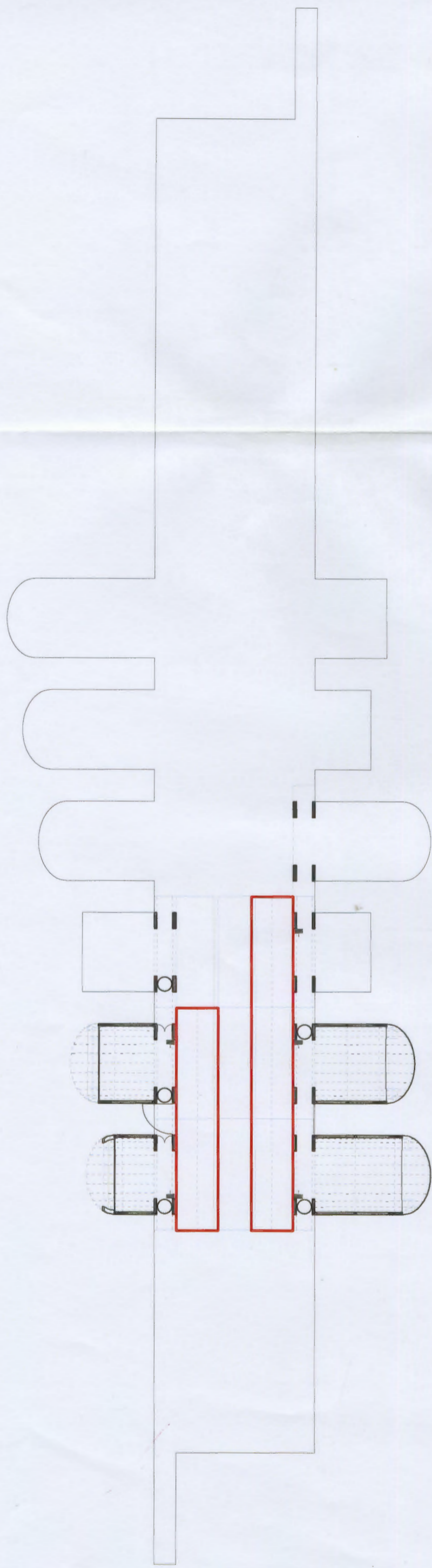

Rural Building Workshop
Scale 1:500
Peter Alexander Neokorides

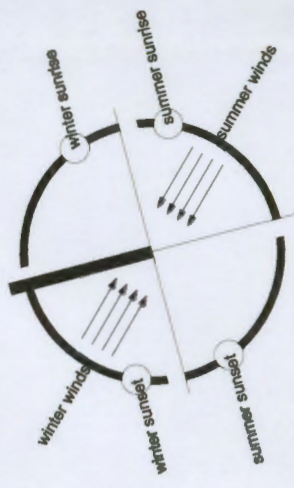
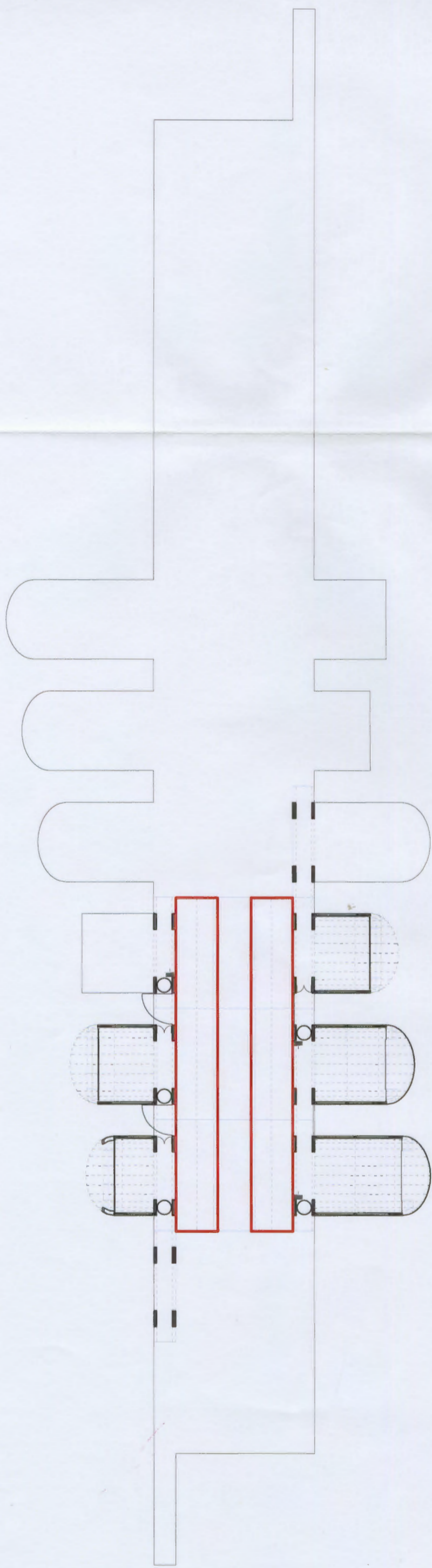

Rural Building Workshop
 Scale 1:500
 Peter Alexander Neokorides

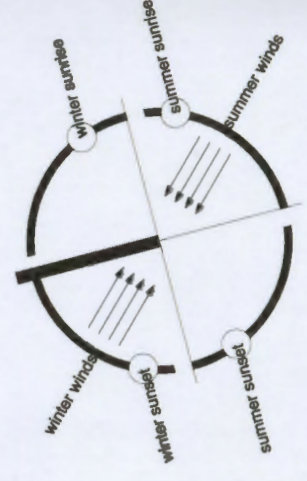
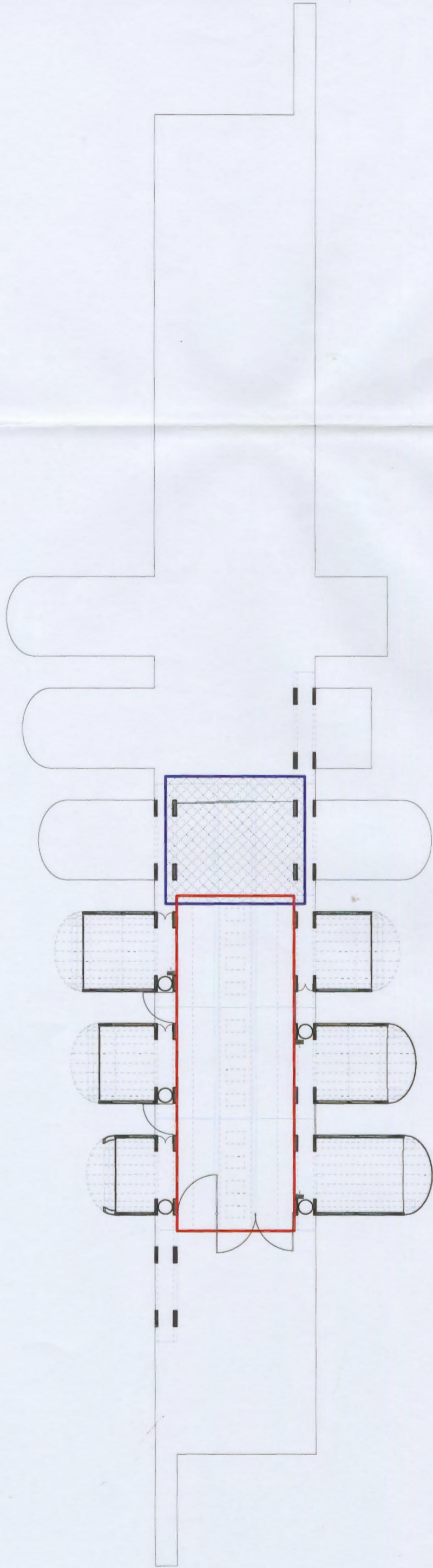

Rural Building Workshop
Scale 1:500
Peter Alexander Neokorides

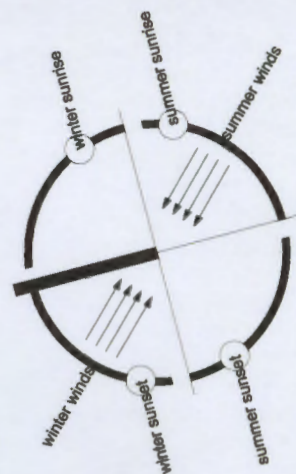
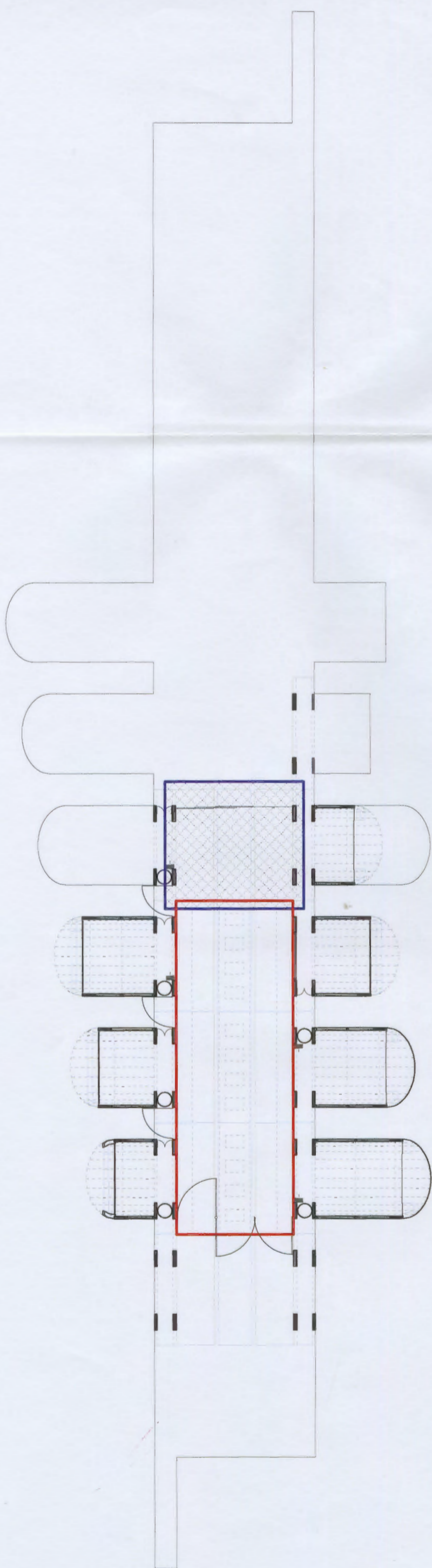

Rural Building Workshop
Scale 1:500
Peter Alexander Neokorides

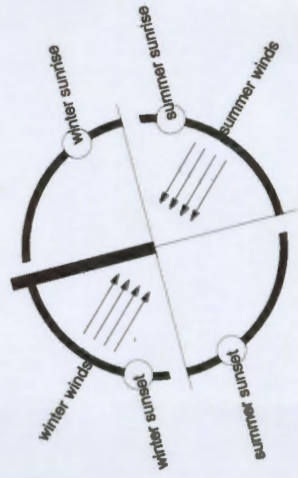
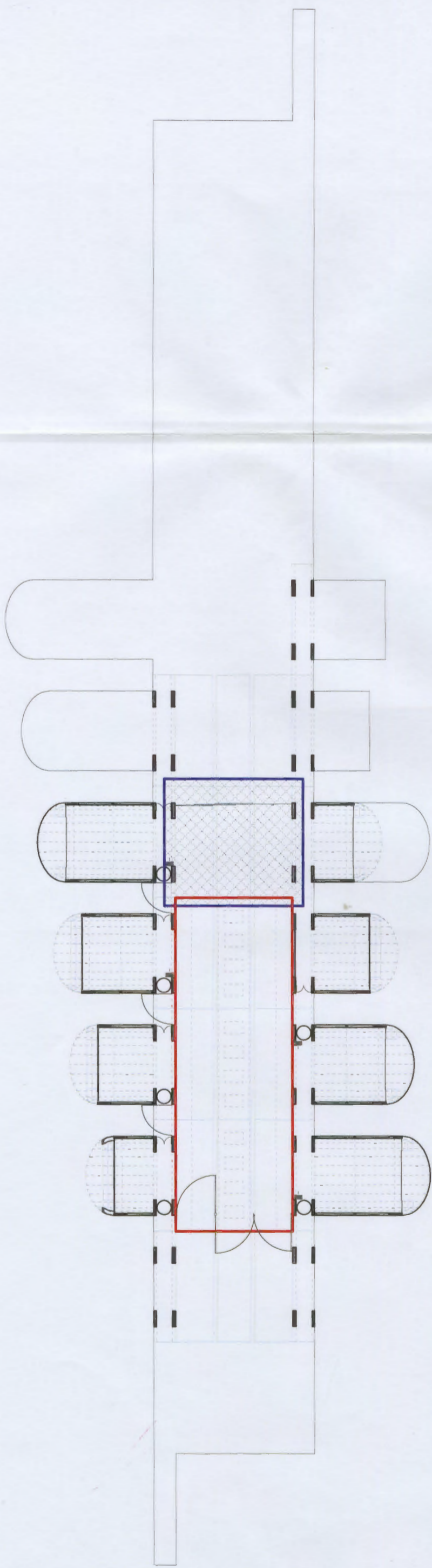

Rural Building Workshop
Scale 1:500
Peter Alexander Neokorides

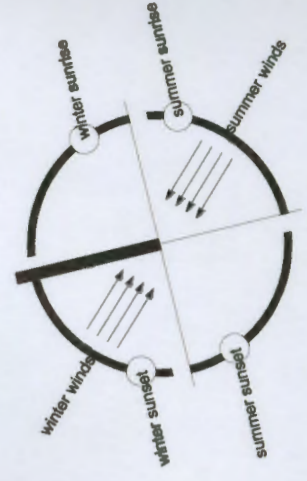
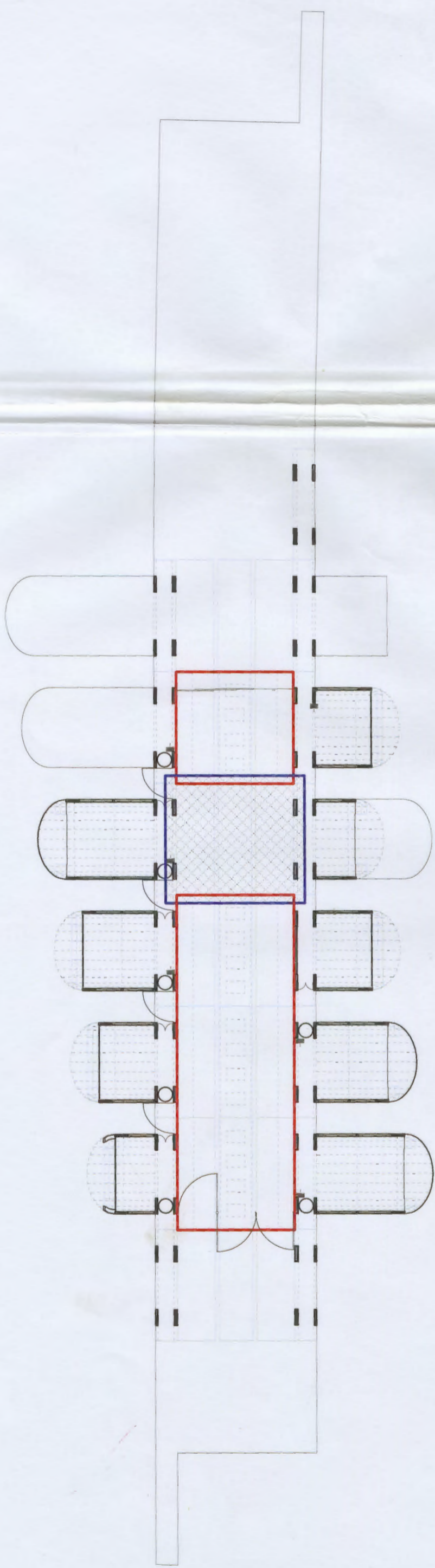

Rural Building Workshop
Scale 1:500
Peter Alexander Neokorides

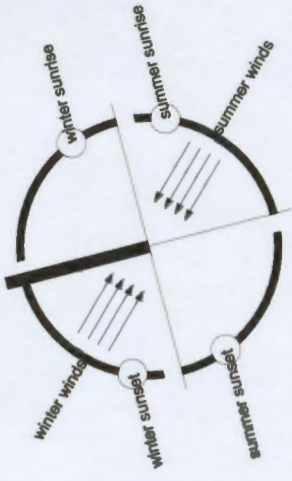
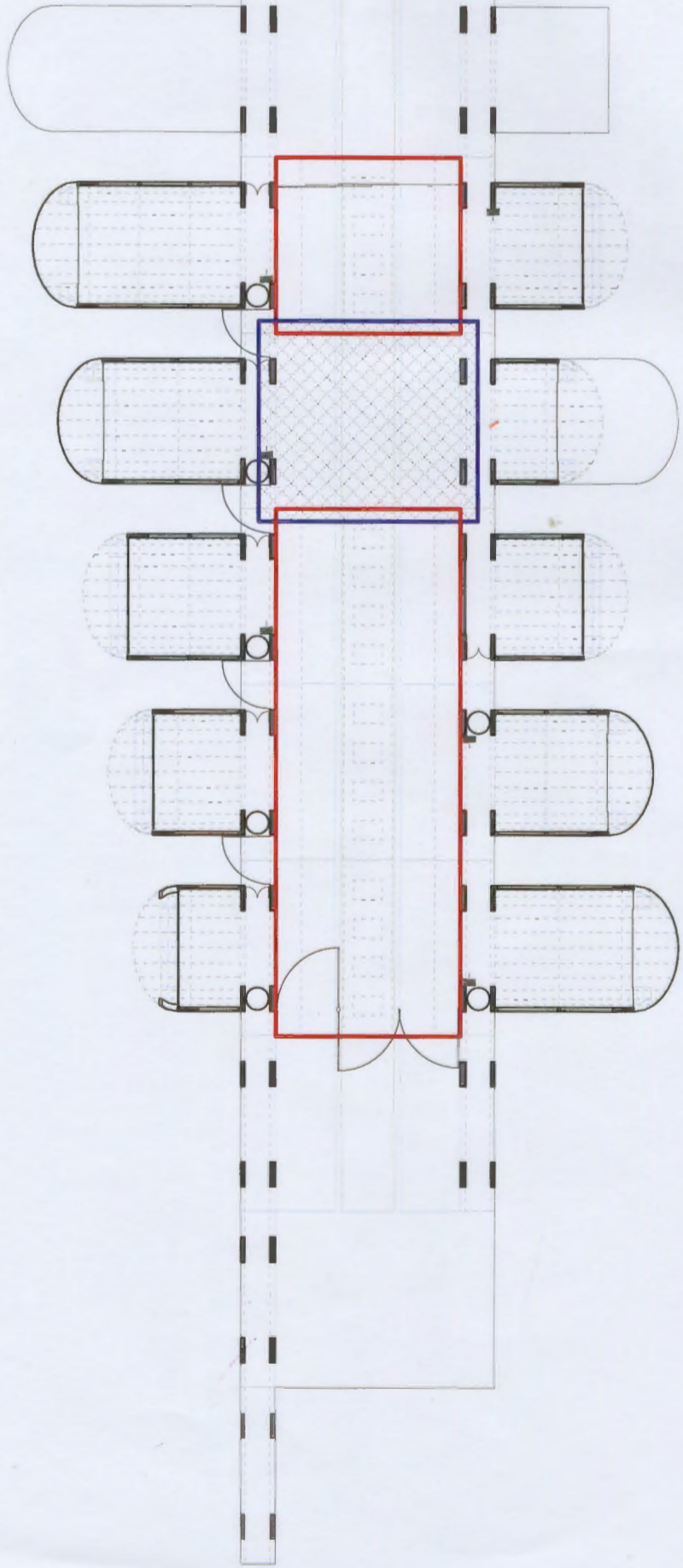

Rural Building Workshop
 Scale 1:500
 Peter Alexander Neokorides

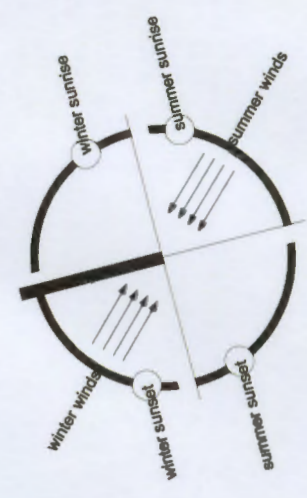
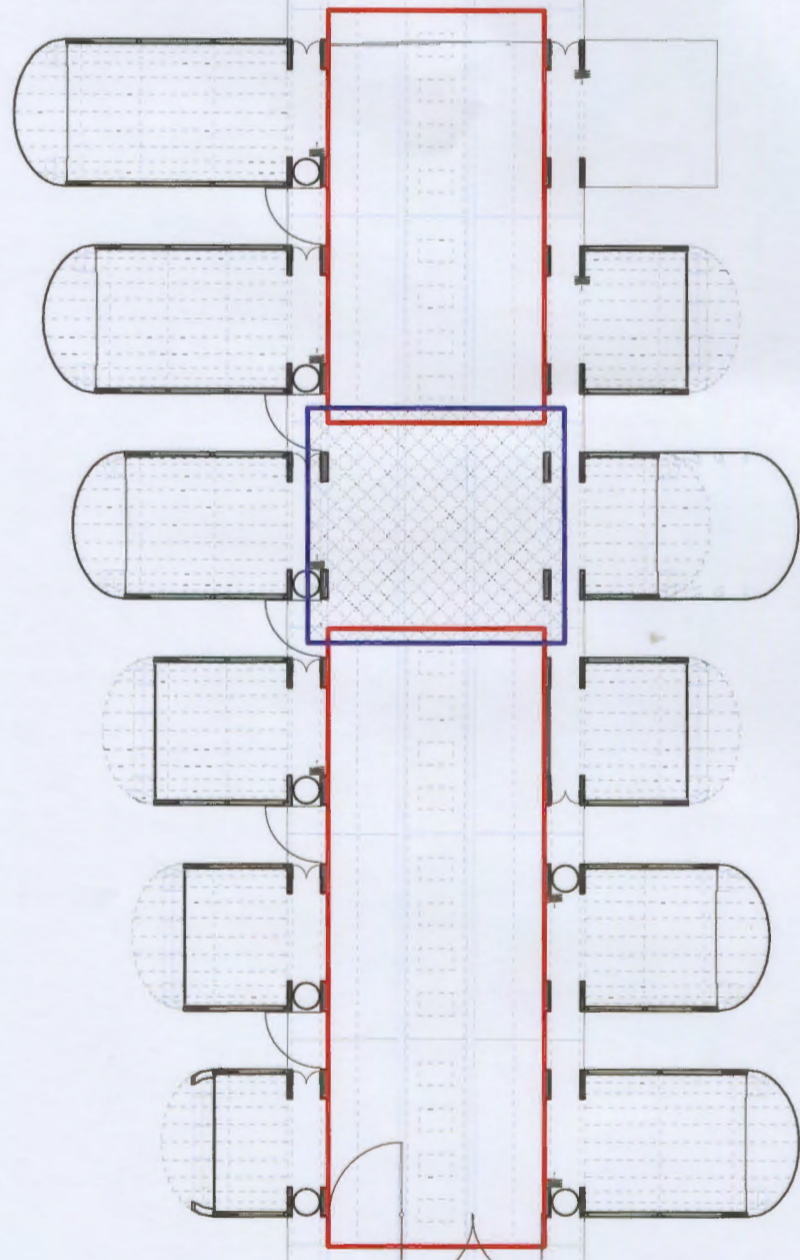

Rural Building Workshop
 Scale 1:500
 Peter Alexander Neokorides

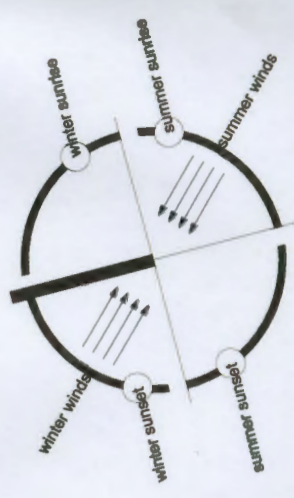
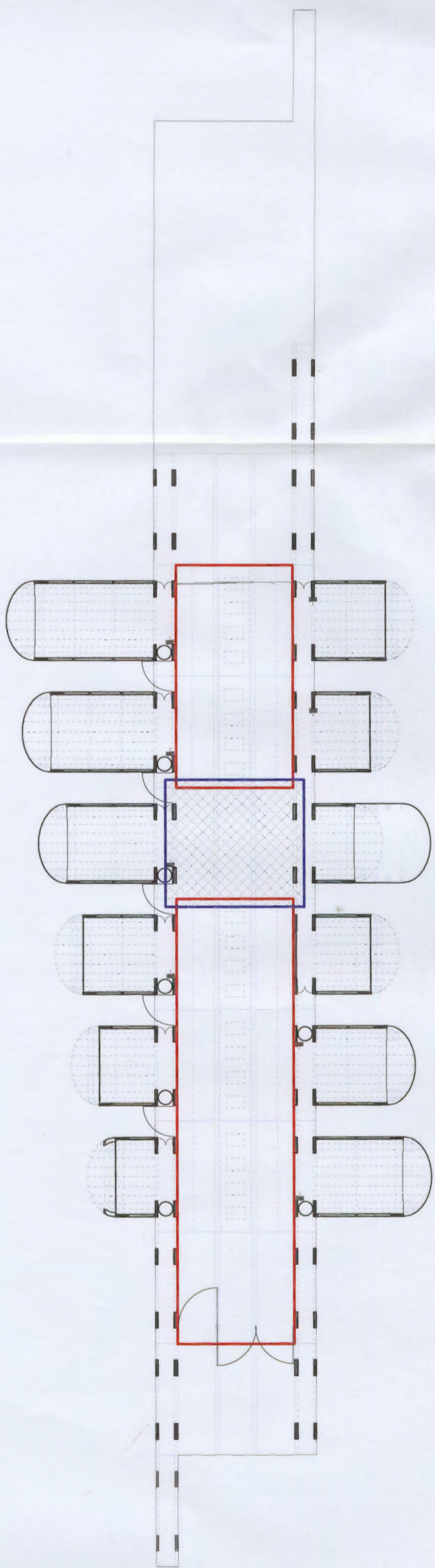

Rural Building Workshop
Scale 1:500
Peter Alexander Neokorides

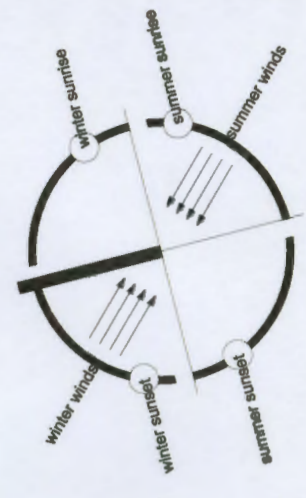
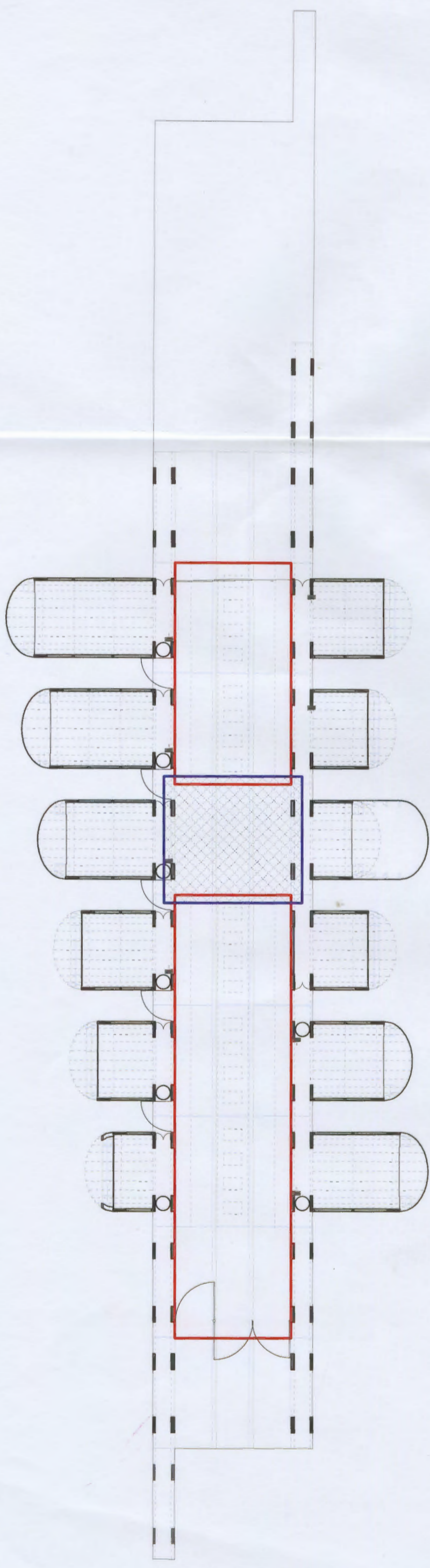

Rural Building Workshop
Scale 1:500
Peter Alexander Neokorides

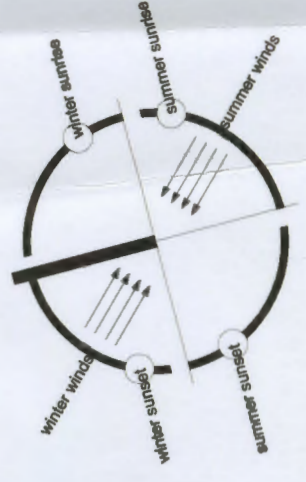
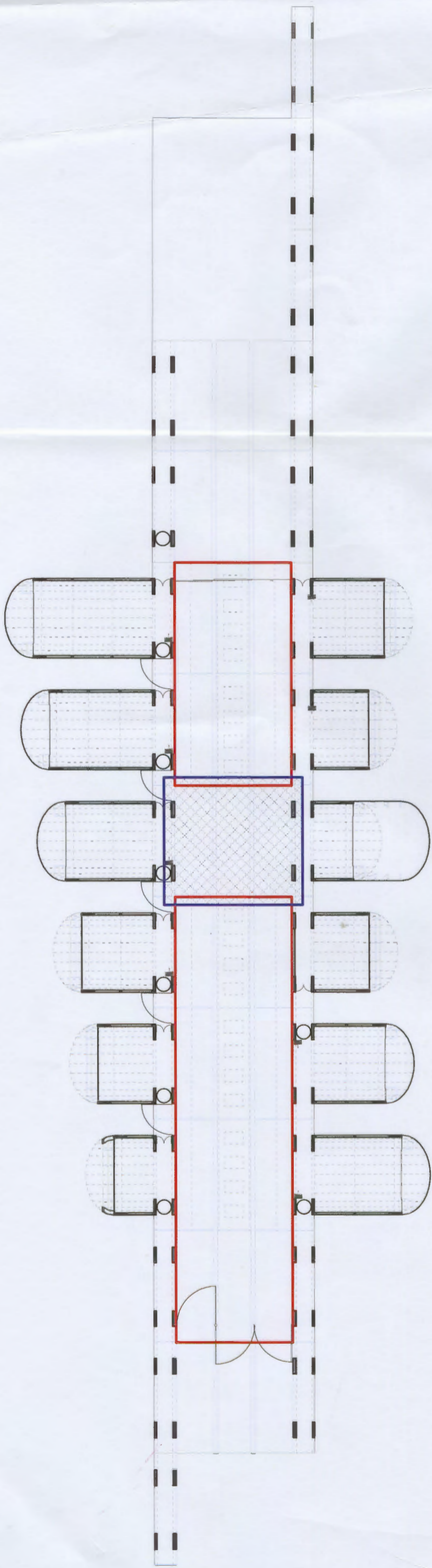

Rural Building Workshop
Scale 1:500
Peter Alexander Neokorides

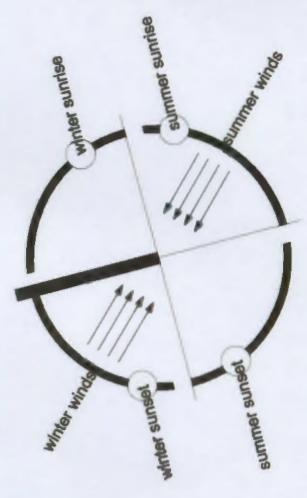
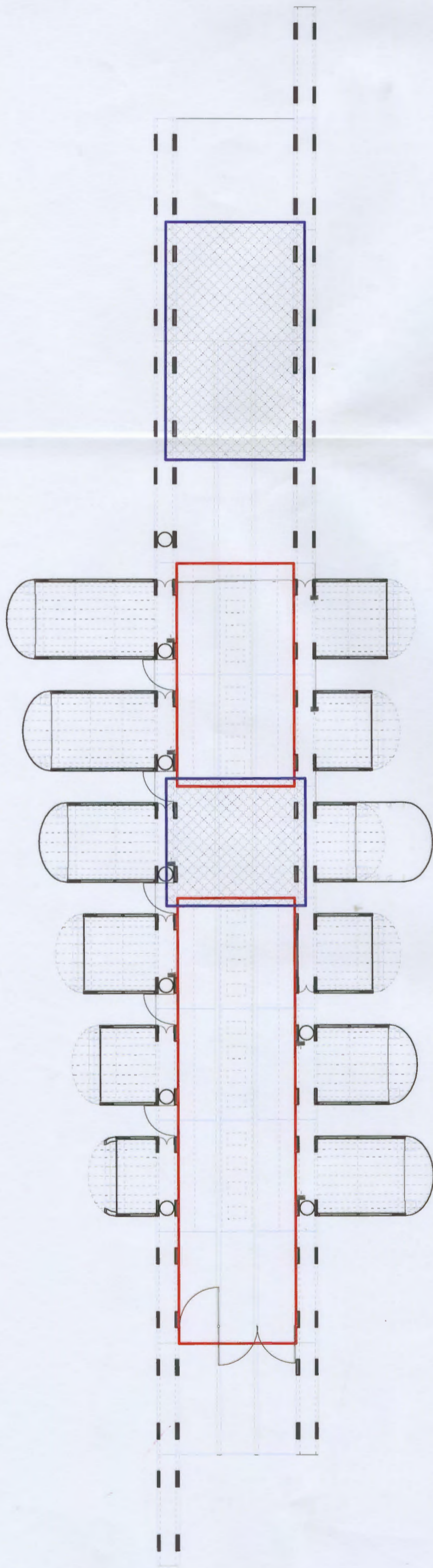

Rural Building Workshop
 Scale 1:500
 Peter Alexander Neokorides

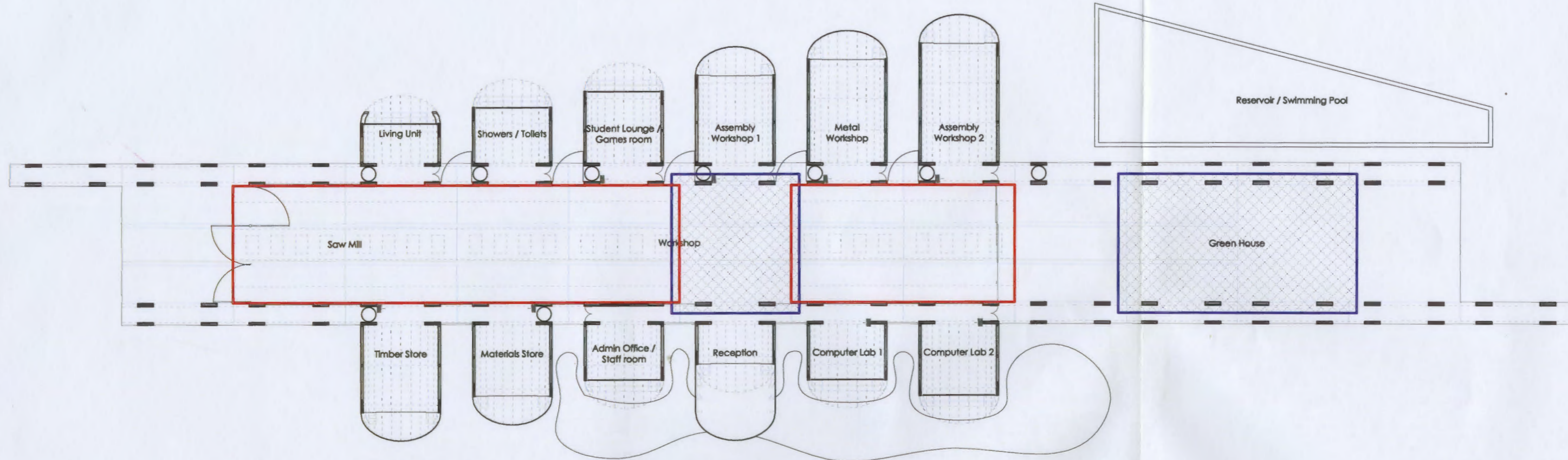

Rural Building Workshop
 Scale 1:500
 Peter Alexander Neokorides

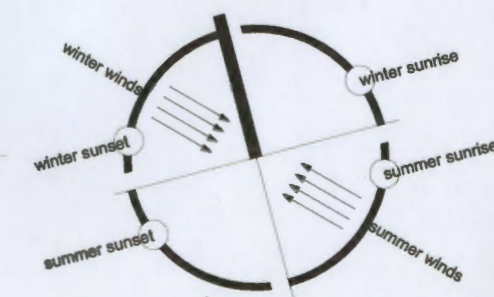

Conclusion

The architect's role in today's practice has eroded as other professions absorb parts of our once comprehensive profession. Interior designers overtake the building from within, engineers have begun to offer complete building design services, and builders now provide services as design/builders, allowing clients to have a project designed and constructed by the same entity. Architects should have a knowledge of building and the respect once given to them by clients and other professionals. (Carpenter 1997: x)

This approach of thinking through making has a practical significance to practicing architects. Besides being a student, I am involved with the design, manufacture and installation of interior furnishings for a range of building uses including private residences, offices, restaurants and retail outlets, and what is becoming more apparent is an inability of architects and designers to think practically and ergonomically about the detailing and finishing in interior spaces. The result of this division between architects, interior designers and manufactures is normally a waste of time and labour, and therefore money, due to poor spatial planning and a lack of insight as to how things work, which more often than not, requires electricity and water points to be chased up to be moved, walls having to be broken down or built, and on occasion windows having to be changed. There is also the issue of actually getting interior objects into buildings, which is sometimes impossible. It is all good and well for a building to be aesthetically pleasing externally, but when it becomes a compromise between its "looks" and how a building functions, then a question in my mind is raised regarding where society is placing its values, because it seems that so many buildings lean towards being pretentious

statements, where more attention is given to outward appearances as opposed to the actual inhabited spaces. I attribute a lot of this inefficiency to architects not being able to think through making and how things are put together, and therefore not making informed and holistic decisions regarding practicality and aesthetics. Space is not an abstract quality of buildings that is bound to lines and words on paper. When built, space has a physical dimension that is made from something, but the potential of that "something" is often neglected by architects.

...the material investment of the architectural image has been devalued for the sake of expediency and performance. This dislocation of material meaning is an understandable concomitant of a media society that accepts readily devalued imagery of all types. It is no longer necessary, for example, to rely on heavy stone construction to denote permanence. The formal allusion is adequate. Here, the metaphysical implications of material and detail investment are reduced to gestures which imply, but do not denote; they express ideas which represent architecture's customary functions-the registration of built form with its physical and cultural context-but they are phenomenally weak. This has further confused the role of figuration in architecture because it now has less to do with anchoring spatial experience through a fundamental response to material (Which must be grounded in the traditions of its manufacture, use and configuration) and more to do with the associative qualities of the shape selected. The envelope has ceased to be a reflection of cultural operations that include evidence of the production of material and the production of device. It has become instead a reflection of cultural fashion. (Frampton 2001: 382)

Personally the development of the idea is realised in the making process, rather than through a process of sketches. I find the physical act of making to be a form of instruction and inspiration in the way objects resist or allow you to work them. Exploring

my ideas this way has rendered detailed hand drawings obsolete because it is not feasible in the given time, and I am physically making the object as opposed to speculating over it. I therefore lose a part of the documenting process as the building develops, however each step of development goes from the overall form of the building right down to how the building will be detailed to create that form, even if it is just in my mind. I won't create forms that I can't personally build or at least direct anyone else to build. I think through making and the processes involved with building, and because of time constraints in previous years I have never been fully able to explain or explore this in terms of my studies, but rather in my life outside of my studies.

Because of the time we had for our thesis it was an opportunity for me to explore this line of enquiry that has been a synthesis of my private life, interests and hobbies with my studies which have resulted in a building. I feel that architecture is not a discipline that can stand in isolation to the lives of people who choose to pursue it as a career. For me it is as much a form of personal expression as it is about responsible decision making towards the built environment, and its expression and the manner in which it is realised, like art, has no fixed rules.

Through physically making the above modes, the ideas that are being generated most of the time generally relate to how the process can be simplified and perfected. I have also come to realise that although a lot is learned through the making process, it by itself is not enough to push the boundaries of new ideas. A critical analysis of all things related to the particular field of enquiry is therefore necessary to ensure that only ideas of quality surface, eliminating redundancy in the making process.

Table of figures

- Front Cover. Men at work - Schulitz, Helmut C.; Sobek, Werner; Habermann, Karl J. - *Steel Construction Manual*
- Fig. 1.1. Comparison between material cost and labour cost - Macdonald, Angus J. *Structure and Architecture*, p65
- Fig. 1.2. Igloo - Macdonald, Angus J. *Structure and Architecture*, p2
- Fig. 1.3. Tepee - Macdonald, Angus J. *Structure and Architecture*, p2
- Fig. 1.4. Yurt - Macdonald, Angus J. *Structure and Architecture*, p65
- Fig. 1.5. Concrete Frame - Macdonald, Angus J. *Structure and Architecture*, p35
- Fig. 1.6. Dymaxion House - Baldwin, J. *Bucky Works: Buckminster Fuller's Ideas for Today*, p25
- Fig. 1.7. Assembly of a house with jointed frames - Prouve, Jean, *Industrial Architecture*, p33
- Fig. 1.8. Homes for a democratic society - Broome, Jon and Richardson, Brian. *The Self-build Book*
- Fig. 1.9. Prototyping and team work - Buchanan, Peter - Renzo Piano Building Workshop: Complete Works Volume 1, p116
- Fig. 2.1.1. Tetrahedron - Baldwin, J. *Bucky Works: Buckminster Fuller's Ideas for Today*, p68
- Fig. 2.1.2. Explanation of truss design - Melaragno, Michele G. *Simplified Truss Design*, p87
- Fig. 2.1.3. Structures of expediency - Melaragno, Michele G. *Simplified Truss Design*, p137
- Fig. 2.1.4. Triangulation - Macdonald, Angus J. *Structure and Architecture*, p42
- Fig. 2.1.5. Stick and string biplane - Macdonald, Angus J. *Structure and Architecture*, p43

Fig. 2.1.6. Microlight trike - Neokorides, Peter A

Fig. 2.1.7. Stressed-skin semi-monocoque aircraft - Macdonald, Angus J. *Structure and Architecture*, p43

Fig. 2.8. Dad working on his microlight - Neokorides, Peter A

Fig. 2.9. Tetrahedral form found in microlight - Neokorides, Peter A

Fig. 2.10. Tetrahedral form from AEROTRIKE microlight manual - Neokorides, Peter A

Fig. 2.11. Alexander Graham Bell with tetrahedral structure - Chilton, John. *Space Grid Structures*, p2

Fig. 2.12. Futuristic tetrahedral pyramid - Chilton, John. *Space Grid Structures*, p161

Fig. 2.13. Tetrahedral kite design by Alexander Graham Bell - Kronenburg, Robert. *Houses in Motion*, p32

Fig. 2.14. Tetrahedral kite by Alexander Graham Bell - Wilkinson, Chris. *Supersheds*, p99

Fig. 2.15. Hangar Structure by Konrad Wachsmann - Schulitz, Sobek, Habermann. *Steel Construction Manual*, p72

Fig. 2.16. Airship hangar at Orly Airport in France by Eugene Freyssinet - Macdonald, Angus J. *Structure and Architecture*, p88

Fig. 2.17. Interior view of hangar structure - Neokorides, Peter A

Fig. 2.18. Space truss node by Konrad Wachsmann - Wachsmann, Konrad. *The Turning Point of Building: Structure and Design*, p160

Fig. 2.19. Study of the closest packing of spheres by Buckminster Fuller - Chilton, John. *Space Grid Structures*, p2

Fig. 2.20. Polyhedral forms - Chilton, John. *Space Grid Structures*, p16

Fig. 2.21. Rolling platform for installing roof glazing at the Crystal Palace - Wachsmann, Konrad. *The Turning Point of Building*, p19

Fig. 2.22. A heavy-weight Russian crane system erecting precast concrete units - Cook, Peter. *Architecture: Action and Plan*, p85

Fig. 2.23. Hoisting jack's mounted directly to columns - Wachsmann, Konrad. *The Turning Point of Building*, p121

Fig. 2.24. AU MAGAZINE

Fig. 2.25. Concept to raise a structure through forces generated in a concentrated area - Neokorides, Peter A

Fig. 2.26. Concept to raise a structure through forces generated in a concentrated area - Neokorides, Peter A

Fig. 2.27. Concept for folding roof and integrated moving scaffold structure - Neokorides, Peter A

Fig. 2.28. Bridge scaffold over Eastern Boulevard - Neokorides, Peter A

Fig. 2.29. Bridge scaffold on turnpike linking the N1 with the M5 - Neokorides, Peter A

Fig. 2.30. Bridge scaffold over Eastern Boulevard - Neokorides, Peter A

Fig. 2.31. Concept of structure being pulled up by overhead crane - Neokorides, Peter A

Fig. 2.32. Initial concept of growing structure - Neokorides, Peter A

Fig. 2.33. Two-dimensional trusses and a three-dimensional space grid structure - Chilton, John. *Space Grid Structures*, p13

Fig. 2.34. Straight and level space grid structure - Chilton, John. *Space Grid Structures*, p25

Fig. 2.35. Barrel vault space grid structure - Chilton, John. *Space Grid Structures*, p25

Fig. 2.36. Various cambers of space grid structures - Chilton, John. *Space Grid Structures*, p55

Fig. 2.37 - 2.41. Materials found on and around site - Neokorides, Peter A

Fig. 2.42. Area of discarded timber - Chilton, John. *Space Grid Structures*, p115

Fig. 2.43. Lacing tool for wire clamping - Chilton, John. *Space Grid Structures*, p115

Fig. 2.44. Section through node fixing element - Pieter Hybers, <http://www.pieterhuybers.nl/pagina712.html>

Fig. 2.45. Roundwood node fixing by Pieter Hybers - Chilton, John. *Space Grid Structures*, p116

Fig. 2.46. Roundwood agricultural building by Pieter Hybers - Chilton, John. *Space Grid Structures*, p116

Fig. 2.47. Roundwood agricultural building by Pieter Hybers - Pieter Hybers, <http://www.pieterhuybers.nl/pagina712.html>

Fig. 2.48. Roundwood node fixing by Pieter Hybers - Pieter Hybers, <http://www.pieterhuybers.nl/pagina712.html>

Table 2.1. Structural efficiency - Macdonald, Angus J. *Structure and Architecture*, p46

Table 2.2. Measurement of trees on selected sites - Neokorides, Peter A

Fig. 3.1. Model 1 - Neokorides, Peter A

Fig. 3.2. Tetrahedron - Baldwin, J. *Bucky Works: Buckminster Fuller's Ideas for Today*, p68

Fig. 3.3. 3D model of octahedron - Neokorides, Peter A

Fig. 3.4. Polyhedral forms folded flat - Baldwin, J. *Bucky Works: Buckminster Fuller's Ideas for Today*, p70

Fig. 3.5. 3D model of corner node for octahedral structure - Neokorides, Peter A

Fig. 3.6. Completed, habitable octahedron - Neokorides, Peter A

Fig. 3.7. 3D model showing the making of a roof truss - Neokorides, Peter A

Fig. 3.8. Timber connectors - Macdonald, Angus J. *Structure and Architecture*, p26

Fig. 3.9. Working drawing of clamping node - Neokorides, Peter A

Fig. 3.10. Completed clamping node - Neokorides, Peter A

Fig. 3.11. Completed truss model - Neokorides, Peter A

Fig. 3.12. Clamping node doing its thing - Neokorides, Peter A

Fig. 3.13. 3D space truss model - Neokorides, Peter A

Fig. 3.14. 3D model of space truss node based on clamping node - Neokorides, Peter A

Fig. 3.15. Conceptual 3D space truss portal frame - Neokorides, Peter A

Fig. 3.16. Moving tower - Roland, Conrad. *Frei Otto - Structures*, p111

Fig. 3.17. Triangle vertebrae of moving tower - Roland, Conrad. *Frei Otto - Structures*, p111

Fig. 3.18. Space truss model showing possible envelope - Neokorides, Peter A

Fig. 3.19. Space truss model on horizontal surface showing structure between nodes - Neokorides, Peter A

Fig. 3.20. Progress of space truss model on vertical surface showing structure between nodes - Neokorides, Peter A

Fig. 3.21. Before and after a 30x30x5mm steel angle has been cut to form components of a node - Neokorides, Peter A

Fig. 3.22. Positioning of node components before welding - Neokorides, Peter A

Fig. 3.23. Complete top node bolted to 38x38x2mm steel box section for receiving other grid members - Neokorides, Peter A

Fig. 3.24. Complete bottom node hinged in two directions around threaded rod grid members - Neokorides, Peter A

Fig. 3.25. The complete hinged space grid model - Neokorides, Peter A

Fig. 3.26. Diagram showing how the model could be pre-cambered - Neokorides, Peter A

Fig. 3.27. Mero KK system - Chilton, John. *Space Grid Structures*, p33

Fig. 3.28. Nodus system - Chilton, John. *Space Grid Structures*, p37

Fig. 3.29. Triodetic system - Chilton, John. *Space Grid Structures*, p5

Fig. 3.30. Bamboo and node connection - Neokorides, Peter A

Fig. 3.31. Blue Gum (Saligna) and node connection - Neokorides, Peter A

Fig. 3.32. Possible node joint for Blue Gum member connection - Neokorides, Peter A

Fig. 3.33. Heavy duty pipe clamp - Neokorides, Peter A

Fig. 3.34. Force diagrams of Blue Gum type node connection - Neokorides, Peter A

Fig. 3.35. Possible space grid module with Blue Gum type members and nodes - Neokorides, Peter A

Fig. 3.36. Sketches - Neokorides, Peter A

Fig. 3.37. Sketches - Neokorides, Peter A

Fig. 3.38. Sketches - Neokorides, Peter A

Fig. 3.39. Sketches - Neokorides, Peter A

Fig. 3.40. Clamping Node - Neokorides, Peter A

Fig. 3.41. Timber Strips - Neokorides, Peter A

Fig. 3.42. Processes - Neokorides, Peter A

Fig. 3.43. 3D Drawings - Neokorides, Peter A

Fig. 3.44. 3D Drawings - Neokorides, Peter A

Fig. 3.45. Completed Arch Model - Neokorides, Peter A

Fig. 3.46. Steel to timber Road Traffic sign clamp - Neokorides, Peter A

Fig. 3.47. Steel to timber Road Traffic sign clamp - Neokorides, Peter A

Fig. 3.48. Steel to steel I-beam Clamp - Neokorides, Peter A

Fig. 3.49. Sketches - Neokorides, Peter A

Fig. 3.50. Steel to timber Road Traffic sign clamp - Neokorides, Peter A

Fig. 4.1. Exterior of the AA's workshop in Hooke Park in Dorset, England - <http://www.aaschool.ac.uk/AALIFE/HOOKEPARK/hooke.php>

Fig. 4.2. Experiment in Hooke Park in Dorset, England - <http://www.aaschool.ac.uk/AALIFE/HOOKEPARK/hooke.php>

Fig. 4.3. Interior of the AA's workshop in Hooke Park in Dorset, England - <http://www.aaschool.ac.uk/AALIFE/HOOKEPARK/hooke.php>

Fig. 4.4. Structure at Valparaiso University's architectural playground -
http://movingcities.org/movingmemos/santiago-de-chile_lev-kerimol/

Fig. 4.5. Structure at Valparaiso University's architectural playground -
http://movingcities.org/movingmemos/santiago-de-chile_lev-kerimol/

Fig. 4.6. Structure at Valparaiso University's architectural playground -
http://movingcities.org/movingmemos/santiago-de-chile_lev-kerimol/

Fig. 4.7. Site with Drakenstein Municipality aerial image underlay - Neokorides, Peter A

Fig. 4.8. Site with Garmin map image underlay - Neokorides, Peter A

Fig. 4.9. Site with Google Earth image underlay - Neokorides, Peter A

Fig. 4.10. Site image - Neokorides, Peter A

Fig. 4.11. Site image - Neokorides, Peter A

Fig. 4.12. Site image - Neokorides, Peter A

Fig. 4.13. Site materials - Neokorides, Peter A

Fig. 4.14. Site materials - Neokorides, Peter A

Fig. 4.15. Site materials - Neokorides, Peter A

Fig. 4.16. Site materials - Neokorides, Peter A

Fig. 4.17. Stone House project between Paarl and Wellington in the Mbekweni township, South Africa - Neokorides, Peter A

Fig. 4.18. Adaptable structure concept model - Neokorides, Peter A

Fig. 4.19. 3D image of material ideas - Neokorides, Peter A

Fig. 4.20. Sketch looking at options for resolving openings - Neokorides, Peter A

Fig. 4.21.1. Stone House project between Paarl and Wellington in the Mbekweni township, South Africa - Neokorides, Peter A

Fig. 4.21.2. Desert rock filled gabions - http://www.gabions.net/flash/Taliesin_West.html

Fig. 4.21.3. Interesting little gabion building - http://www.treehugger.com/2008-02-08_094022-TreeHugger-gabion-night-shot.jpg

Fig. 4.22.1. Douglas Fir post and beam construction with OSB infill panels to be later plastered, Park City, Utah - Neokorides, Peter A

Fig. 4.22.2. Timber shingle cladding, Monterrey, California - Neokorides, Peter A

Fig. 4.22.3. Exposed timber shed like structure, Sundance, Utah - Neokorides, Peter A

Fig. 4.23.1. Corrugated sheeting used as ceiling panels, Park City, Utah - Neokorides, Peter A

Fig. 4.23.2. Corrugated sheet profiles - Schulitz, Sobek, Habermann. *Steel Construction Manual*, p66

Fig. 4.23.3. Corrugated texture found in Mbekweni informal settlement, South Africa - Neokorides, Peter A

Fig. 4.24.1. Ingredients for cob mixture - Weismann, Adam and Bryce Katy. *Building with Cob*, p52

Fig. 4.24.2. Muizenberg's first cob house - http://biophile.co.za/wp-content/uploads/2007/09/cobhouse_muizenberg2.jpg&imgrefurl

Fig. 4.24.3. A cordwood house being built - http://home-n-stead.com/about/blog_files/page1_blog_entry15_3.jpg

Fig. 4.25. A post & beam construction with strawbale infill and cob plaster - http://www.buildingwithbales.com/Straw_Bale_Walls.php

Fig. 4.26. Sandbags piled up to create walls and then plastered with cob - Kracht, Stefan. *The Sandbag House*,
<http://www.zoas.co.za/pdf/ecobag.pdf> - accessed on 23 may 2010

All drawings in section 5 by Peter Alexander Neokorides

References

Baldwin, J. 1996. *Bucky Works: Buckminster Fuller's Ideas for Today*, John Wiley & Sons, Inc., New York

Broome, Jon and Richardson, Brian. 1991. *The Self-build Book*, Green Books, Devon

Carpenter, William.J. 1997. *Learning by Building - Design and Construction in Architectural Education*, Van Nostrand Reinhold, New York

Chandler, Alan. 2007. A Philosophy of Engagement: Developing a Strategic Ability through Direct Engagement with Material, Process and Collective Action, pp 116 - 124. In *Material Matters – Architecture and Material Practice*, Edited by Katie Lloyd Thomas Routledge, Oxon

Chilton, John. 2000. *Space Grid Structures*, Architectural Press, Great Britain

Cook, Peter. 1967. *Architecture: Action and Plan*, Studio Vista Ltd, London

Cosgrove, Brian. 2007. *Microlight Pilots Handbook - 7th Edition*, Airlife, Hong Kong

Frampton, Kenneth. 2001. *Studies in Tectonic Culture: The Poetics of Construction in Nineteenth and Twentieth Century Architecture*, MIT Press, Cambridge

Hagan, Susannah. 2007. The New and the Renewed, pp 250 - 257. In *Material Matters – Architecture and Material Practice*, Edited by Katie Lloyd Thomas. Routledge, Oxon

Kronenburg, Robert. 1995. *Houses in Motion - The Genesis, History and Development of the Portable Building*, Academy Editions, Singapore

LeCuyer, Annette W. 2001. *Radical Tectonics*, Thames and Hudson, London

Macdonald, Angus J. 2002. *Structure and Architecture*, Architectural Press, Great Britain

- Melaragno, Michele G. 1981. *Simplified Truss Design*, Van Nostrand Reinhold Company, New York
- Otto, Frei. 1975. Adaptability, p 166 – 167, in *Adaptable Architecture: Volume 14 of Information of the Institute for Lightweight Structures Series*, Edited by Frei Otto and Berthold Burkhardt, George Wittenborn Incorporated, New York
- Pollan, Michael. 1997. *A Place of My Own – The Education of an Amateur Builder*, Bloomsbury Publishing, London
- Prouve, Jean. 1971. *Industrial Architecture*, Translated by Alexander Lieven, Architektur Artemis, Zurich ?
- Roland, Conrad. 1970. *Frei Otto - Structures*, Translated by C V Amerongen, Longman Group Limited, London
- Thomas, Katie Lloyd. 2007. *Material Matters – Architecture and Material Practice*, Routledge, Oxford
- Veblen, Thorstein. 1899. *The Theory of the Leisure Class*,
<http://socserv2.mcmaster.ca/~econ/ugcm/3ll3/veblen/leisure/index.html>, Accessed on Friday 17th September 2010 @ 13:40 pm
- Wachsmann, Konrad. 1961. *The Turning Point of Building: Structure and Design*, Translated by Thomas E. Burton, Reinhold Publishing Corporation, USA
- Wachsmann, Konrad. 1975. Building is Energy and Motion in Time and Space, pp 154 – 159, in *Adaptable Architecture: Volume 14 of Information of the Institute for Lightweight Structures Series*, Edited by Frei Otto and Berthold Burkhardt, George Wittenborn Incorporated, New
- Wienands, Rudolf. 1975. Dwelling: More "Individual Construction" in "System Construction", p 197, in *Adaptable Architecture: Volume 14 of Information of the Institute for Lightweight Structures Series*, Edited by Frei Otto and Berthold Burkhardt, George Wittenborn Incorporated, New York
- Wilkinson, Chris. 1998. *Supersheds - The Architecture of long-span, large-volume buildings*, Architectural Press, Great Britain
- Zambonini, Guiseppi. 1988. Notes on a Theory of Making in a Time of Necessity, pp 612 – 623, in *Perspecta No. 24, Yale Architectural Journal, Volume 24*, Edited by David Thompson , Peter MacKeith; Robert Bostwick, Rizzoli, New York

THE PREVALENT THEORY OF CONSTRUCTION IS A HINDRANCE FOR INNOVATION

Lauri Koskela¹ and Ruben Vrijhoef²

ABSTRACT

It is argued that construction innovation is significantly hindered by the prevalent theory of construction, which is implicit and deficient. There are three main mechanisms through which this hindrance is being caused.

Firstly, because production theories in general, as well as construction theories specifically, have been implicit, it has not been possible to transfer such radical managerial innovation as mass production or lean production from manufacturing to construction. Direct application of these production templates in construction has been limited due to different context in construction in correspondence to manufacturing. On the other hand, without explicit theories, it has not been possible to access core ideas of concepts and methods of these templates, and to recreate them in construction environment. In consequence, theory and practice of construction has not progressed as in manufacturing.

Secondly, it is argued that the underlying, even if implicit, theoretical model of construction is the transformation model of production. There are two first principles in the transformation model. First, the total transformation can be achieved only by realising all parts of it. Thus, we decompose the total transformation into parts, finally into tasks, ensure that all inputs are available and assign these tasks to operatives or workstations. Second, minimising the cost of each task, i.e. each decomposed transformation, minimises the cost of production. It is argued that these principles, in which uncertainty and time are abstracted away, are counterproductive, and lead to myopic control and inflated variability. Practical examples show that these deficiencies and related practical constraints hinder the top-down implementation of innovations.

Thirdly, empirical research shows that also bottom-up innovation - systematic learning and problem solving - is hindered by this deficient theory. Thus, the advancement of construction innovation requires that a new, explicit and valid theory of construction is created, and business models and control methods based on it are developed.

KEYWORDS

Production theory, innovation in construction, radical innovation, top-down innovation, bottom-up innovation, diffusion of manufacturing templates

¹ Senior Researcher, VTT Building Technology, Concurrent Engineering, P.O.Box 1801, FIN-02044 VTT, Finland, Phone +358 9 4564556, Fax +358 9 4566251, E-mail lauri.koskela@vtt.fi

² Research Scientist, TNO Building and Construction Research, Department of Strategic Studies, Quality Assurance and Building Regulations, P.O.Box 2600, NL-2600 AA Delft, The Netherlands, Phone +31 15 2695228, Fax +31 15 2695335, E-mail r.vrijhoef@bouw.tno.nl

INTRODUCTION

In the discussion on lean construction, it has been a leading argument that the prevalent theory of production (or specifically, theory of construction) is counterproductive, and leads to added costs and reduced overall performance through the deficient production control principles based on the theory (Koskela 1992, Ballard & Howell 1998, Santos 1999). In this paper, the angle of analysis is widened: the prevalent theory of construction production is analysed from the point of view of innovation. It is generally viewed that there is a need for more innovation in the construction industry (Slaughter 1998, Winch 1998). The causes for this low rate of innovation have been investigated, and among other issues, institutional factors or peculiarities of construction have been pointed out as reasons. This paper ends up with a new, emergent explanation that is complementary to the prior view on institutional factors as hindrance for innovation. The conclusion is that the prevalent theory of construction is deficient and implicit, and this is the major barrier for innovation in the construction industry.

MODELS OF INNOVATION IN CONSTRUCTION

Innovation has been defined as the actual use of a nontrivial change and improvement in a process, product or system that is novel to the institution developing the change (Freeman 1989). Innovation scholars have presented a variety of models of innovation in construction and related explanations for the lack of innovation. In the following, we review and evaluate three theoretical strands: innovation typology, institutional view, and firm view.

Slaughter (1998) presents a typology of innovations in construction. An *incremental* innovation is a small change with limited impacts on surrounding elements. A *modular* innovation is a more significant change in the basic concept, but also with limited impact on its surroundings. An *architectural* innovation may consist of a small change in the respective component, but with many and strong links to other surrounding components. In a *system* innovation, there are multiple, linked innovations. A *radical* innovation is based on a breakthrough in science or technology and changes the character of the industry itself. Slaughter rightly argues that the implementation of these different types of innovation requires different levels of management and supervision.

From the five types of innovation presented by Slaughter (1998), it can be argued that the incremental and modular innovations are the most frequent in construction. Most construction innovations originate from material and component producers (Pries 1995), and their diffusion is easier if no changes in surroundings are needed. However, the most powerful is radical innovation. Such an innovation may be related to new materials, but also to managerial and organisational methods (Slaughter (1998) presents the example of steel construction).

The institutional view focuses on the structural features of the construction industry from the point of view of innovation (Winch 1998). Based on analyses of other complex systems industries, it is possible to distinguish the *innovation superstructure*, consisting of clients, regulators and professional institutions, *system integrators*, consisting of principal designer and principal contractor, as well as the *innovation infrastructure*, consisting of trade contractors, specialist consultants and component suppliers. Winch (1998) recognises several problems in this system. Especially, the systems integrator role is shared between the principal architect and the principal contractor. Other research has stressed the weakness of the client behaviour (Pries 1995).

Another variant of the institutional view focuses on the peculiarities of construction. For example, Nam and Tatum (1988) argue that the characteristics of the constructed products result in limitations for construction technology. They describe five characteristics: immobility, complexity, durability, costliness, and a high degree of social responsibility.

Brouseau and Rallet (1995) argue that certain institutional characteristics and organisational principles of construction itself constrain innovations and restrict parties to apply innovations. Particularly, decentralised decision-making and informal co-ordination prevent all systematic optimisation and innovative evolution (Brouseau & Rallet 1995).

In the firm view, the focus is firstly on the *top-down* adoption and implementation of innovations emanating from an outside source, and secondly on the *bottom-up* problem-solving and learning in projects. Winch (1998) finds such barriers for top-down innovation as lack of incentives, split role of systems integrators and relative lack of demanding clients. Regarding bottom-up innovation, he sees it as a problem that downstream system integrators do no or little actual site work, so whatever problem-solving goes on remains outside the firm.

In this paper, a complementary explanation for the low innovation activity in construction is put forward. The central argument is that the deficient and implicit theory of construction, as presently in use, is one root cause for low innovation activity. Instead, an explicit and more powerful theory is needed for further innovation, which is 'to manage new ideas in good currency' (Van de Ven 1986).

From the innovation types as defined by Slaughter, theoretical problems related to construction affect those requiring system-wide changes, especially radical innovation. Thus, the following analysis is restricted to radical innovation regarding this typology. Both firm innovation types, top-down and bottom-up innovation can be argued to be affected by theoretical problems related to construction. Thus, the relations between theory and innovation as depicted in Figure 1 will be discussed in the following.

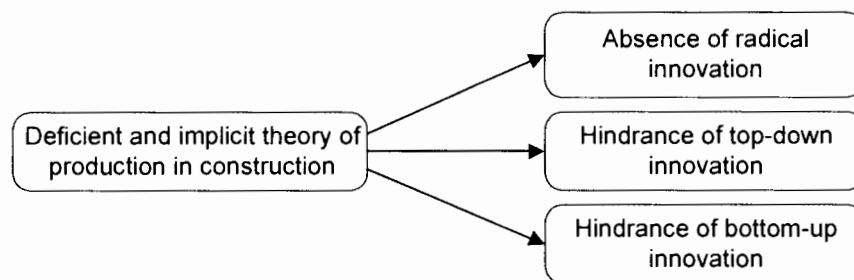

Figure 1 Relation between deficient and implicit theory, and hindered innovation

THEORY OF CONSTRUCTION

WHAT IS A THEORY OF CONSTRUCTION?

The theory of construction should answer to three fundamental, interrelated questions (Koskela 2000):

- What is production in general?
- Which principles should be used for achieving the goals set to production?
- Which methods and tools can be used for translating these principles into practice, taking the peculiar characteristics of construction into account?

The first two questions deal actually with the concepts and principles of production in general (i.e. theory of production), and the third with their application to construction.

THEORY OF PRODUCTION

Analysis of literature (e.g. Koskela 2000) shows that scientists have proposed three different theories of production. Production has been viewed as transformation, flow and value

generation. All these views have been practically applied, but the patterns of diffusion have been drastically different.

The view of production as a *transformation* was sharply defined by Walras (1952) at the end of the 19th century. In this view, production is conceptualised as a transformation of inputs to outputs. There are two first principles in the transformation model. Firstly, the total transformation can be achieved only by realising all parts of it. Thus, we decompose the total transformation into parts, finally into *tasks*, ensure that all inputs are available and assign these tasks to operatives or workstations. Secondly, minimising the cost of each task, i.e. each decomposed transformation, minimises the cost of production. In turn, for minimising the cost of each task, a number of ways are available: division of labour, economy of scale and technology. This has been the dominating concept in production and business management in the 20th century. An early proponent was Taylor (1913) who viewed that the task idea as the most prominent single element in scientific management. This view can also easily be recognised as the underlying theory of project management, for example.

Frank and Lillian Gilbreth (1922) suggested the view of production as a *flow*. The central idea was to introduce time as a resource of production. Two types of activities consume time when viewed from the point of view of the product: transformation activities and others, apparently non-transformation activities, categorised by the Gilbreths as transfer, delay and inspection activities. The first principle of this theory is to eliminate waste, i.e. non-transformation activities. The maybe most important insight related to the flow concept is that *time compression* leads to waste reduction. Another powerful principle states that *variability reduction* leads to waste reduction. This is the underlying concept of JIT, lean production and business process re-engineering.

The conceptualisation of production as *value generation* was proposed by Shewhart (1931) at the outset of the quality movement: "looked at broadly there are at a given time certain human wants to be fulfilled through the fabrication of raw materials into finished products of different kinds." The first principle in this view is to fulfil the requirements and wishes of the customer, i.e. generate value for him. This has been the founding concept of the quality movement, customer-oriented management and similar approaches.

The first two of these theories have been the root cause of two radical innovations in manufacturing in the 20th century, leading to new production templates. First, mass production and the associated "modern enterprise form" was primarily based on the transformation model, and secondly lean production, based on the flow model. At both instances, the productivity was significantly improved across manufacturing industries. Also in both cases the innovation diffused as a practical template, whereas the underlying theory tended to be neglected or forgotten.

THEORY OF CONSTRUCTION: APPLICATION OF THE THEORY OF PRODUCTION TO CONSTRUCTION

Regarding practical implementation, the generic theory of production has always to be applied to the specific situation in question. Thus, the theory of construction is an application of the generic theory of production to the characteristic context of construction: one-of-a-kind production, site production and temporary project organisation (for a more detailed discussion on the characteristics of construction, see Carassus 1998). These characteristics of construction are shared by many other industries, even if usually not in the same combination.

Thus, for example, mining and agriculture share site production. One-of-a-kind production is relatively common in manufacturing industries. Temporary project organisations are widely used in the film industry. Thus, construction faces similar problems regarding tailoring solutions to the characteristics of the situation as any other industry. However, the

characteristics of construction have theoretically not been understood well, as discussed below.

ABSENCE OF RADICAL MANAGERIAL INNOVATIONS IN CONSTRUCTION

As discussed above, two radical innovations of manufacturing, mass manufacturing and lean production have not replicated in construction. The template of mass manufacturing was based on the powerful principles of economy of scale, division of work, centralised control and mechanisation, but due to the peculiarities of the constructed product, they could - and can - be utilised only to a limited extent in construction. The bulkiness of buildings prevent economy of scale, work was already divided into trades in construction, centralised control does not match well with the uncertain site conditions and the need for mobility on site is a barrier for mechanisation. Nevertheless, mass production has fascinated construction professionals, and already in the 1930s, a house factory with a moving belt was organised in the United States. However, 'Fordized, mass-produced housing never caught on' (Hounshell 1984).

Like mass manufacturing, also lean production originated in the car industry. In contrast to mass production with focus on a highly visible moving belt and regimented work, lean production is based on rather subtle principles for production and material flow control, and it has required a long time to get a grasp on it from the production science community. The concepts and methods used to promote lean production, such as JIT, andon, one-piece-flow, etc., have been too far from the situation of construction to make direct diffusion possible.

Lillrank (1995), who argues that organisational innovations do not transfer well in their original setting over industrial borders gives a theoretical explanation for the absence of corresponding radical innovations in construction. The core idea or concept of organisational innovations must be abstracted and then recreated in an application that fits local conditions. Thus, an explicit theory is needed. In reality, there has not been an explicit theory of production; rather the new production templates have diffused on the level of methods and practices. In consequence, neither of the templates of manufacturing - mass production and lean production - has yet been successfully introduced into construction. The reason for this has essentially been the inability to abstract the theoretical core of these production templates and to apply it to the situation of construction (Figure 2).

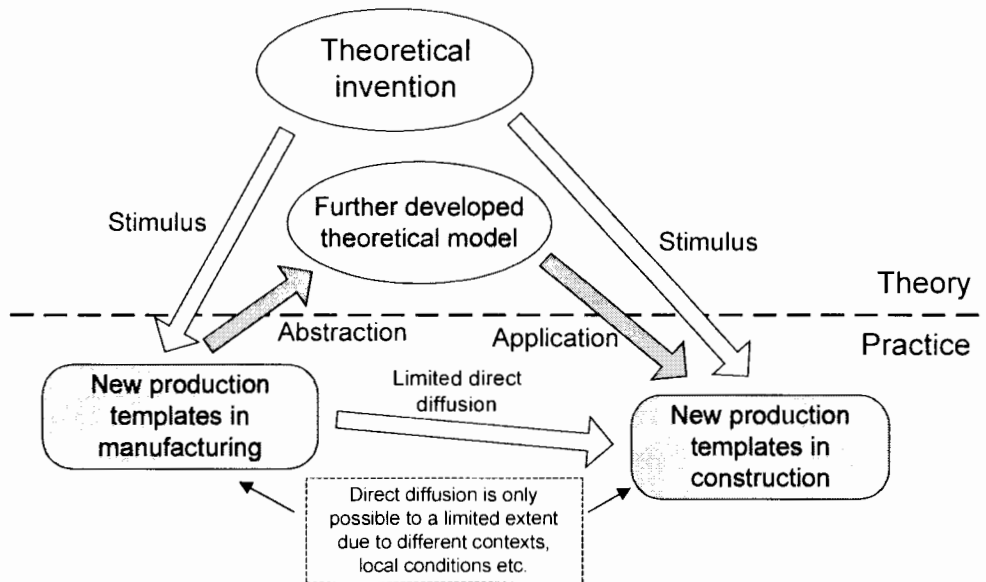

Figure 2 Different trajectories to diffuse production templates from manufacturing towards construction

PRESENT THEORY AND PRACTICE OF CONSTRUCTION

In consequence of the absence of radical managerial innovations, present practice of construction management is characterised partly by methods originating from the craft period, partly by leftovers from manufacturing, especially centralised control. According to recent empirical studies (Santos 1999, Koskela 2000), construction is predominantly managed according to the transformation concept. Management efforts are centred on task management and based on principles of the transformation concept. However, task management is not implemented systematically across all phases, resulting in added variability. Even where there is an intention to implement systematic task management, it corrupts, due to the high level of inherent variability, to unsystematic management, as already noted by Tavistock Institute (1966). Thus, *bad control* (i.e. deficient attention in control to the principles of production) across all phases results. The goal of not using resources unnecessarily is realised by minimising the costs of each task and each task input. Unfortunately, there are a variety of interactions between tasks that are assumed away. Thus, in practice, complexity and variability increase, leading to *unfavourable design* of the production system (i.e. production system design where the principles of production have been deficiently realised).

Thus, the present underlying theory behind construction management is simply counterproductive, and leads to a systematic creation of added costs and reduced functionality in construction. In fact, extensive evidence from different countries shows that managerial methods are neglecting or violating the principles related to the flow and value generation views (Koskela 2000, Santos 1999). One of the most evident consequences is the increase of variability in information and material flows, and the associated long cycle times needed for coping with this variability.

There is a second issue playing a role, namely *construction peculiarities* (one-of-a-kindness, site production, temporary production). Because of these, flows are more variable and complex than otherwise, and also value generation is hindered. However, to which extent they are root causes for waste and value loss is an open question: there are many practical examples where those peculiarities have been eliminated or mitigated.

TOP-DOWN INNOVATION IN CONSTRUCTION

The next argument is that the present managerial methods in construction significantly hamper top-down innovation, as defined above. In support of this hypothesis, two cases of top-down innovation are examined: industrialisation and information technology.

INDUSTRIALISATION

Since the Second World War, the idea of industrialisation has received much attention both in Europe, North America and elsewhere. However, in spite of a great number of attempts, there has been a relative lack of success of industrialised building methods (Warszawski 1990). The share of prefabricated components has gradually risen, but a breakthrough for industrialised construction has still not occurred. According to Warszawski (1990), the main problem of prefabrication of today is the lack of a system approach to its deployment on the part of the various parties involved. But there is another significant point: when analysed as flow processes, industrialised construction shows widely different characteristics in comparison to site construction. In industrialised construction the flow is longer due to multiple production locations, the amount of design required is larger, the error correction cycle is longer, and requirements for dimensional accuracy are higher than in site construction (Koskela 2000).

Thus, the total process of industrialised construction tends to become more complex and vulnerable in comparison to site construction. It seems plausible that in design, prefabrication, and site processes of industrialised construction that are managed in the myopic mode suggested by the transformation theory, the increase of costs due to increased waste has often consumed the theoretical benefits to be gained from industrialisation.

INFORMATION TECHNOLOGY

It is well known that information technology (IT) has been a dominating theme in the development of construction in the last decade. Nevertheless, the impact of IT has been disappointingly modest. Howard et al. (1998) found high levels of benefit from IT in design and administration in Scandinavia, while management applications have resulted in little change: '(...) contractors (...) reported little change in productivity resulting from materials or site management'. Similarly, in their study on construction IT in Finland, Enkovaara et al. (1998) found that for contractors, *IT had not produced any benefits*, whereas in subcontracting and client procurement activities, *IT benefits were negative*, i.e. the benefits accrued have not offset the costs. In many cases, the level of personnel competence or the degree of structured data have not corresponded to those required by an IT application.

We relate this situation with the chaotic nature of construction. Implementation of new technology is difficult when there are many intervening disturbances (e.g. Hayes et al. 1988, Chew et al. 1991). Beyond that, there is some evidence for the claim that computers have for their part increased the variability of flows in construction.

The explanation to the lack of success of industrialisation and information technology is basically the same: the inflated level of variability in flow processes, due to prevalent managerial methods based on the theory of production as transformation (Figure 3).

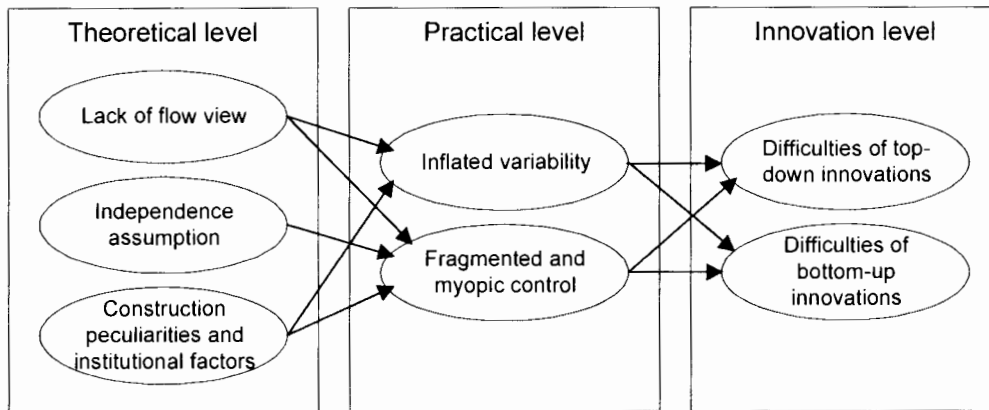

Figure 3 Theoretical and practical constraints of innovations in construction

BOTTOM-UP INNOVATION IN CONSTRUCTION

In addition to top-down innovations, bottom-up innovations have been constrained by the managerial methods, organisational deficiencies and institutional context currently present in construction. Basically, four mechanisms can be distinguished which lead to hindered bottom-up innovation:

1. *Many problems are not seen or ignored*, and are rated among the “normal features of the business” (Vrijhoef & Koskela 1999). Research shows that problems in construction are often of a basic kind and are deeply rooted in construction practice causing considerable waste and inconvenience (e.g. Vrijhoef 1998). However, many problems are often not classified as such. In this context, the transformation view of construction adds to the problem while neglecting the presence of waste, focussing only on value-adding parts of the construction process (Santos 1999), and therefore misunderstanding problems. The inability or reluctance to spot problems obviously hampers the urge to resolve them, and is thus hindering bottom-up innovation. It has been argued that within firms it is the management level that should create an atmosphere of awareness to spot and eliminate problems systematically involving the workforce, and by that supporting bottom-up innovation (Imai 1986).
2. *Many problems are caused in another stage of the construction process*, by another actor. Therefore, problems are often not accessible by the party that is encountering them, and not resolvable by that party alone neither (Vrijhoef & Koskela 1999). Research shows that there is often clear causality between problems within the supply chain (e.g. Vrijhoef 1998). The independence assumption that is included in the transformation view adds to the problems while overlooking causal relationships in the supply chain. Therefore, awareness of the interdependence is essential, including the intention to resolve the problems in a collaborative framework. This is rarely negotiated in construction projects, however, while the duration of co-operation within projects is relatively short, which prevents parties to invest resources and effort in the resolution of problems.
3. *Many problems are caused by myopic control* of the construction supply chain, while many actors in the supply chain seem unable or reluctant to recognise the impact of their behaviour on other stages and parties in the supply chain (Vrijhoef & Koskela 1999). An orderly approach to problem solving on construction sites suffers under “fire fighting” consuming managerial time (Oglesby et al. 1989), and thus frustrating systematic learning and problem solving.
4. *Diffusion of solutions is being complicated and hindered due to organisational and institutional problems*. In spite of all the difficulties discussed above, construction projects

involve considerable problem solving when accomplishing the building (Winch 1998). However, problem solving is only becoming innovation when the solutions found during the particular project are retained and reapplied to future projects systematically. As mentioned earlier, the problem here is that main contractors, i.e. downstream system integrators, often do no or little actual site work, so whatever problem solving goes on is not absorbed and retained by the firm. Instead, in most cases, the site work is subcontracted to various trade contractors on a competitive tendering basis. Therefore the trades have no incentive to share learning experiences for the sake of reapplying them on future projects of the main contractor. However, bottom-up innovation needs a clear definition of the institutional context and the innovation infrastructure involving all relevant actors into the innovation process (e.g. subcontractors and suppliers) (Winch 1998). In this context, it has been argued that the involvement of the supply base is important because most of the innovations in construction come from the supply base (Pries & Janszen 1995). Therefore, materials manufacturers play a key role in the diffusion of manufacturing technology and methods towards construction.

Thus, the basic issue is that managerial and organisational factors both on the theoretical level and on the practical level frustrate systematic learning and problem solving, and thus bottom-up innovation (Figure 3).

CONCLUSIONS

Analysis leads to three main results. *Firstly*, the present underlying theory behind construction management is counterproductive, and leads to a systematic creation of added costs and reduced functionality. A new production template for construction – implying radical innovation - is needed, based on a more appropriate, explicit theory of production and recognition of construction peculiarities.

Secondly, the generic problems of construction management, caused by deficient and implicit theory, are an obstacle for top down product and production process innovation in construction. The inflated level of variability in construction represents one form of this obstacle.

Thirdly, the underlying theory of construction is also an obstacle for bottom-up innovation. Especially, the myopic control and the fragmented, unstable organisation of supply chains frustrate problem solving and innovation between different actors and stages in the chain.

The issue is that construction cannot effectively innovate due to constraints caused by the intrinsic organisation of construction practice (peculiarities, institutional problems), and deficiencies in the present theory (theoretical deficiencies). On the other hand, the managerial mode and organisation of construction cannot be altered without radical innovation and adequate theory. Therefore, the way forward is to develop an adequate and explicit theory of production in construction that stimulates radical innovation, which in turn facilitates top-down and bottom-up innovation processes in firms.

These conclusions are based on initial evidence and illustrations. More research is necessary for charting all theory-related mechanisms hindering innovation and for confirming the empirical validity for the propositions presented. On the other hand, the impact of construction peculiarities, organisational characteristics and institutional factors on innovation should be clarified more thoroughly.

REFERENCES

Ballard, G. and Howell, G. (1998). "Shielding production: essential step in production control." *Journal of Construction Engineering and Management*. 124 (1) 11-17.

- Brouseau, E. and Rallet A. (1995). "Efficacité et inefficacité de l'organisation du bâtiment: une interprétation en termes de trajectoire organisationnelle." (In French: Efficiency and inefficiency of the organisation of building: an interpretation in terms of organisational trajectories) *Revue d'Economie Industrielle*. 74 (4) 9-30.
- Carassus, J. (1998). *Produire et gérer la construction: une approche économique* (In French: Producing and managing construction: an economic approach). Cahiers du CSTB, Livraison 395, Cahier 3085. CSTB, Paris. 12 p.
- Chew, B.W., Leonard-Barton, D. and Bohn, R.E. (1991). "Beating Murphy's Law." *Sloan Management Review*. Spring, pp. 5-16.
- Enkovaara, E., Heikkonen, A. and Taiponen, T. (1998). *Rakennusalan informaatioteknologian kypsyys- ja hyötytason mittaus* (In Finnish: Measurement of maturity and benefits of construction information technology). Mimeo. 7 p.
- Freeman, C. (1989). *The economics of industrial innovation*. MIT Press, Cambridge.
- Gilbreth, F.B. and Gilbreth, L.M. (1922). "Process charts and their place in management." *Mechanical Engineering*. January (70) 38-41.
- Hayes, R.H., Wheelwright, S.C. and Clark, K.B. (1988). *Dynamic manufacturing*. The Free Press, New York. 429 p.
- Howard, R., Kiviniemi, A. and Samuelson, O. (1998). "Surveys of IT in the construction industry and experience of the IT barometer in Scandinavia." *Icon*. Vol. 3, pp. 45-56.
- Hounshell, D.A. (1984). *From the American system to mass production 1800-1932: the development of manufacturing technology in the United States*. John Hopkins University Press, Baltimore. 411 p.
- Imai, M. (1986). *Kaizen: the key to Japan's competitive success*. McGraw-Hill, New York. 259 p.
- Koskela, L. (1992). *Application of the new production philosophy to construction*. Technical report 72. CIFE, Stanford University. 75 p.
- Koskela, L. (2000). *An exploration into a production theory and its application to construction*. VTT Publications 408. VTT, Espoo.
- Lillrank, P. (1995). "The transfer of management innovations from Japan." *Organization Studies*. 16 (6) 971-989.
- Nam, C.H. and Tatum, C.B. (1988). "Major characteristics of constructed products and resulting limitations of construction technology." *Construction Management and Economics*. 6, 133-148.
- Oglesby, C.H., Parker, H.W. and Howell, G.A. (1989). *Productivity improvement in construction*. McGraw-Hill, New York. 588 p.
- Pries, F. (1995). *Innovatie in de bouwnijverheid* (in Dutch: Innovation in the construction industry). Eburon, Delft. 222 p.
- Pries, F. & Janszen F. (1995). "Innovation in the construction industry; the dominant role of the environment." *Construction Management and Economics*. 13 (1) 43-51.
- Santos, A., dos (1999). *Application of flow principles in the production management of construction sites*. PhD Thesis. School of Construction and Property Management, University of Salford. 463 p. + app.
- Shewhart, W.A. (1931). *Economic control of quality of manufactured product*. Van Nostrand, New York. 501 p.
- Slaughter, E.S. (1998). "Models of construction innovation." *Journal of Construction Engineering and Management*, 124 (3) 226-231.
- Tavistock Institute (1966). *Interdependence and uncertainty*. Tavistock Publications, London. 83 p.
- Taylor, F.W. (1913). *The principles of scientific management*. Harpers & Brothers, New York. 144 p.

- Van de Ven, A.H. (1986). "Central problems in the management of innovation." *Management Science*. 32 (5) 570-607.
- Vrijhoef, R. (1998). *Co-makership in construction: towards construction supply chain management*. Delft University of Technology / VTT Building Technology, Espoo. 181 p.
- Vrijhoef, R. and Koskela, L. (1999). "Roles of supply chain management in construction." *Proc. 7th Annual Conf. of the Int. Group for Lean Constr.* Berkeley, 26-27 July 1999. Pp. 133-146.
- Walras, L. (1952). *Éléments d'économie politique pure ou théorie de la richesse sociale*. (ed.) Pichon R. and Durand-Auzias, R., Paris. 487 p.
- Warszawski, A. (1990). *Industrialization and robotics in building: a managerial approach*. Harper & Row, New York. 466 p.
- Winch, G. (1998). "Zephyrs of creative destruction: understanding the management of innovation in construction." *Building Research and Information*. 26 (4) 268-279.

This manual has been put together in as User Friendly manner as possible. Read the notes and study the drawings carefully. If you find any discrepancies or difficulties kindly notify your AEROTRIKE Sales Centre and the manual will be updated and a copy will be sent to you.

Do not deviate from the drawings and notes without prior approval from your AEROTRIKE Sales Centre.

ABOUT THE MATERIALS USED IN THE AEROTRIKE

Almost all of the materials used in the AEROTRIKE are specially manufactured or processed and it is vitally important that only genuine parts are used. Do not even consider using locally purchased or self-made components. Apart from the obvious danger of using inferior parts, the fitment of a non-genuine AEROTRIKE part will result in your Authority to Fly being cancelled. To obtain an Authority to Fly again, will probably mean having to fly under Proving Flight Authorisation and a full Flight Test.

SPACE NEEDED FOR ASSEMBLY

It is possible to assemble the undercarriage in a single car garage - however to assemble the wing a space the size of a 3 car garage or larger is required. It is possible to assemble the final stages of the wing outside on the lawn.

The workshop area must be clean, well lit and well ventilated.

Before starting to assemble the AEROTRIKE take some time to prepare the tools and working area. It is a good idea to work on a clean carpet where possible for the large components and a carpeted workbench for the smaller components.

TAKE YOUR TIME

The AEROTRIKE is a very precisely made and designed aircraft. Take your time with the assembly. Make 100 % certain that everything you do is correct. If you take the trouble to do a really good job - the AEROTRIKE will fly so much better.

Part of the enjoyment of having a microlight is being able to work on it yourself. Enjoy the assembly work.

NOTES

1. BOLTS

All bolts used in your AeroTrike should be installed with the thread facing downwards or backwards unless otherwise specified.

2. POP RIVETS

When pop rivets are called up for an assembly sequence they will be either aluminium or stainless steel. Make 100% certain the correct rivets are used.

3. PART NUMBERS

Part numbers shown in brackets mean that those parts have already been called up in a previous assembly sequence.

4. Some of the plastic plugs, guides, etc. will already be fitted into the aluminium tubes.

TOOLS AND ACCESSORIES NEEDED

The following tools and accessories are needed to assemble your AEROTRIKE:

HAND TOOLS

1. A metric ring / open spanner set 8mm to 19mm
2. A metric socket set
3. A metric Allen key set to 4mm to 10mm
4. A flat screwdriver set
5. A Philips screwdriver set
6. Waterpump pliers
7. Vise grips
8. Side cutters
9. Long nose pliers
10. Circlip pliers
11. Torque wrench
12. Rubber mallet
13. Ball pene hammer
14. Normal hammer
15. Centre punch
16. Hole deburring tool
17. Large square
18. Small square
19. Electrical crimping pliers
20. Small round file
21. Small flat file
22. Pop rivet gun
23. Marking scribe
24. Pencil
25. Knife
26. Metric tape measure
27. Torch or lead light
28. 1200 mm long adjustable carpenters clamp
29. Workbench with soft jaw vise
30. Electric Drill
31. Drill bits: 2.5mm, 3.2mm, 4mm, 4.8mm, 5mm, 5.5mm, 6mm, 6.35mm, 7mm, 8mm, 10mm, 12mm.
32. Pair of Scissors

POWER TOOLS

33. Electric soldering iron and solder
34. C D Player (Optional)
35. Bench Disc Grinder
36. Small Electrical Grinder

LUBRICANTS, GLUES & CONSUMABLES

- 37. Lithium based general purpose grease
- 38. Medium strength thread LOCTITE
- 39. Bostic clear glue
- 40. Contact Adhesive
- 41. Medium and fine sandpaper
- 42. Black insulation tape
- 43. Black high heat exhaust spray
- 44. Copperslip high heat lubricant

PARTS LIST BREAKDOWN

- A. Aluminium Tubes
- B. Aluminium machined parts and brackets
- C. Bolts, Caps, Screws and Studs
- D. Nuts
- E. Washers
- F. Pop Rivets
- G. Wood, Paper and Stickers
- H. Engines, Props and related items
- I. Steel Brackets
- J. Electrical components
- K. Cables, Rope, Tangs & Shackles
- L. Fuel-related items
- M. Spirex, heat-shrink and covering materials
- N. Seats, Belts, Webbing, Velcro and material
- O. Plastic-machined parts
- P. Saddles
- Q. Plastic caps and Nut caps
- R. Wheels and related items
- S. Steel sleeves, Bushes, Pins and machined-parts
- T. Tyres and Tubes
- U. Rubber mountings and Rubber Components
- V. Mudguards, Fairings and Instrument Pods
- W. Bearings of Rod Ends
- X. Safety rings, Clips, and Split Pins
- Y. ORings and Pulleys
- Z. Springs

BOLT AND NUT TORQUING SPECIFICATIONS

M6 Nuts and bolts on the ROTAX engine	8Nm
M6 Nuts on the AEROTRIKE frame where there is a plug sleeve	8Nm
M6 Nuts on any aluminium part where there is no plug or sleeve	6Nm
M8 Nuts and bolts on the Rotax engine	22Nm
M8 Nuts on the AEROTRIKE frame where there is a plug or a sleeve	20Nm
M8 Nut on any aluminium part where there is no plug or sleeve	8Nm

Above all, it is vitally important that no component, especially thin-walled aluminium tubes, get distorted or flattened. If the aluminium is starting to distort, slacken off the nut or bolt slightly.

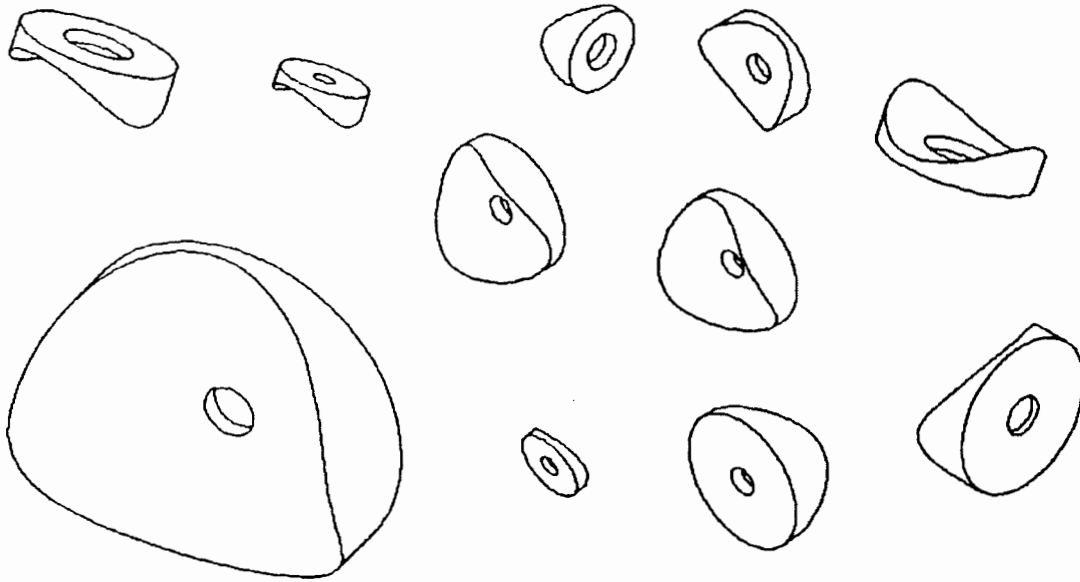

AERODESIGN SADDLES

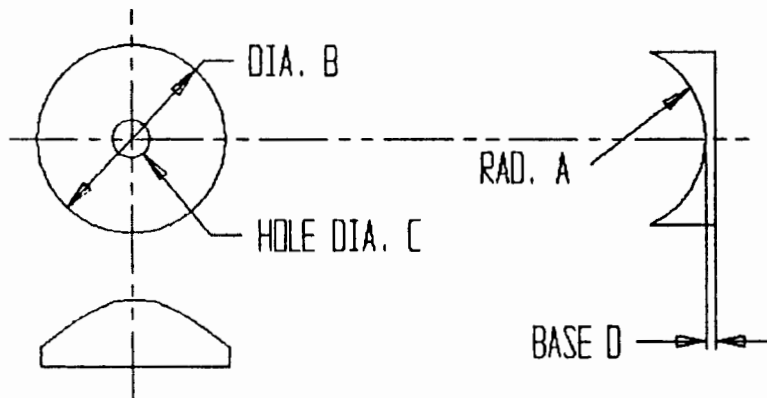

PART No.	RAD. A	DIA. B	DIA. C	BASE D	LOCATION	QTY
PSA 01	12,5	23	12	4	FRONT AXLE	2
PSA 02	13,8	28	8	3,5	UPPER RR SHOCK	4
PSA 03	20,5	40	8	4	LOWER RR SHOCK	4
PSA 04	25,5	25	6	4	FRT. AER. FUL TUBE BRKTS	6
PSA 05	25,5	45	8	4	UPPER RR AXLE	4
PSA 06	26,5	48	10	4	UPPER PYLON	6
PSA 07	27,5	50	25,5	4,2	GOOSENECK	2
PSA 08						
PSA 09						
PSA 10						

(+WING)

REAR AXLES / TENSION STRUT / REAR SHOCK JOINT

ITEM	DESCRIPTION	QUANTITY	PART NO.
1.	Rear Axle (Double Wall Tube)	2	AXL01
2.	Tension Strut (LH)	1	AFT02
	Tension Strut (RH)	1	AFT03
3.	Inner Alum Sleeve	2	AXL02
4.	Rear Shock	2	ASH01
5.	Axle Shock Alum Brkt RR LH	1	BAX03
	Axle Shock Alum Brkt RR RH	1	BAX05
6.	Axle Shock Alum Brkt FRT LH	1	BAX04
	Axle Shock Alum Brkt FRT RH	1	BAX06
7.	Rear Axle / Tension Strut Channel	2	BAX01
8.	Plug - Rear Chock Lower	2	OPL07
9.	Plug - Aerofoil Tube	2	OPL02
10.	Saddle 45 Dia x 8 I/D	4	PSA03
11.	M6 Nylon Washers	4	EO610
12.	M8 x 70 Cap Screw	2	CO812
13.	M6 x 75 Cap Screws	4	CO613
14.	M6 x 70 Cap Screws	2	CO612
15.	M6 x 40 Cap Screws	2	CO606
16.	M6 Flat Washers	8	EP602
17.	M8 Flat Washers	2	EO802
18.	M6 Nylok Nuts	8	DO601
19.	M8 Nylok Nut	2	DO801

- a) Assemble the levers as shown. Ensure the axle (item 1) has a double wall. (2 sleeves).
- b) Ensure the sleeve (item 3) is in place. (3rd sleeve)
- c) Do not overtighten the bolts going through the axle tube.
- d) Do not fit the rear chocks at this stage - wait until the engine mounting is fitted.

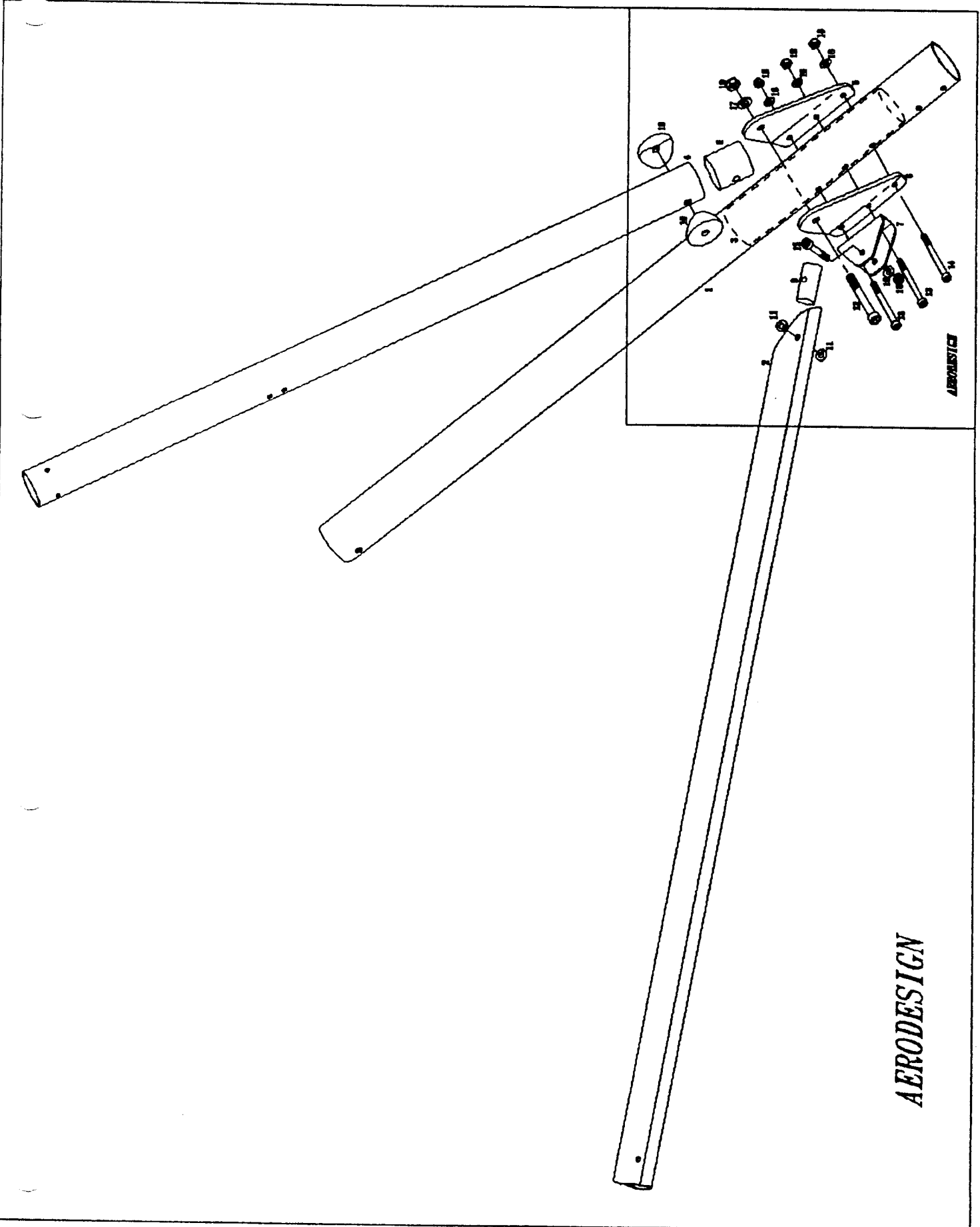

AERODESIGN

AERONAUTIC

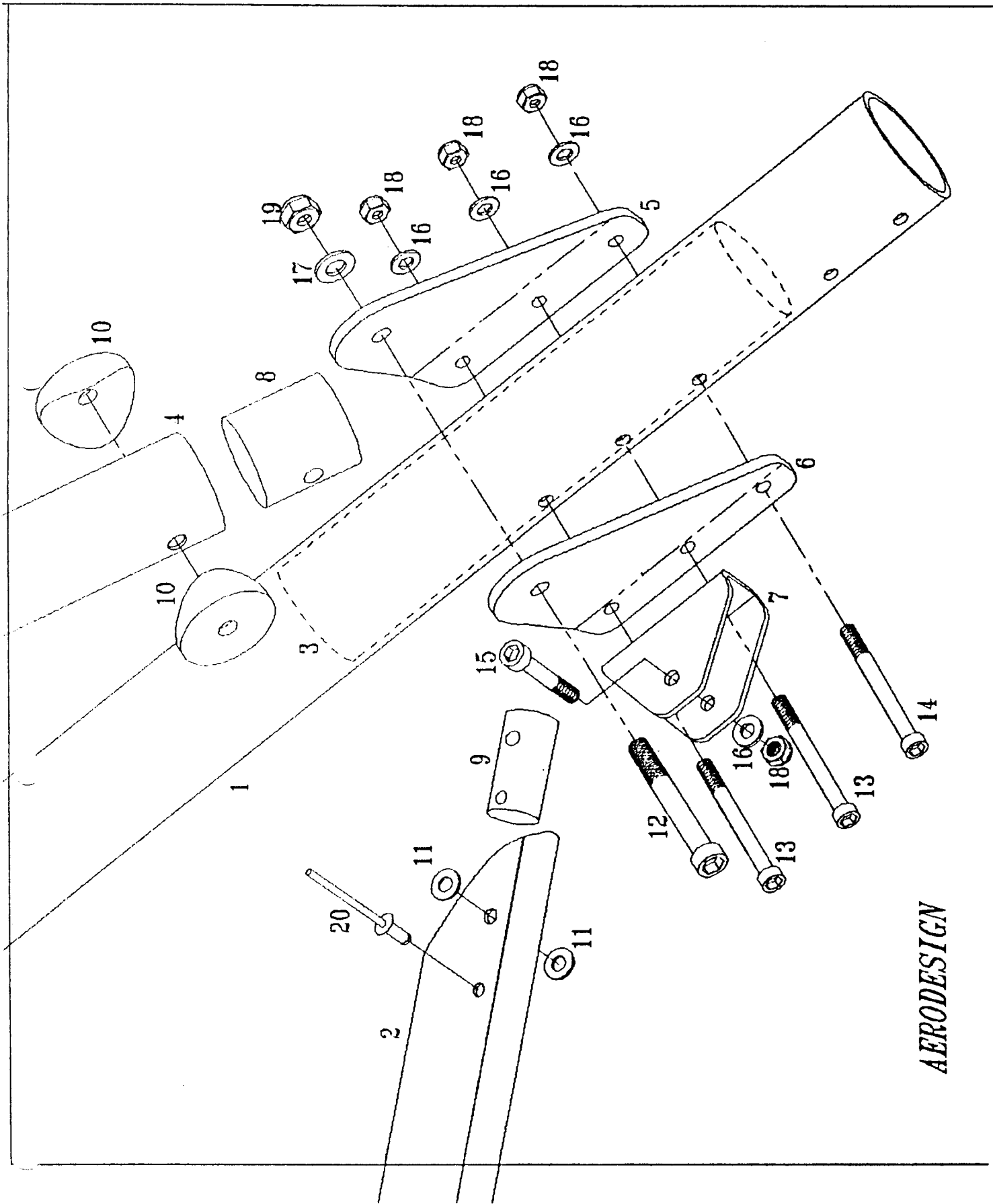

AERODESIGN

LOWER PYLON / LOWER KEEL JOINT

ITEM	DESCRIPTION	QUANTITY	PART NO
1.	Lower Keel	1	AKL01
2.	Axle Tubes	2	AXL01
3.	Lower Pylon	1	ALP01
4.	Engine Mounting Brace	1	IEB02
5.	Safety Cable	1	KSA01
6.	Axle Tube Channel Brackets	2	BAX01
7.	Flat Brackets - Lower Pylon	2	BLP01
8.	Plug - Axle Tube Top	2	OPL04
9.	Plug - Lower Keel Rear	1	OPL03
10.	Plug - Lower Pylon	1	OPL08
11.	Addle - 45 Tubex 8 I/D	4	PSA05
12.	M6 x 70 Cap Screw	1	CO812
13.	M8 x 80 Cap Screws	2	CO814
14.	M6 x 70 Cap Screw	1	co612
15.	M8 x 85 Cap Screws	2	CO815
16.	M8 Nylok Nuts	4	DO801
17.	M6 Nylok Nut	2	DO601
18.	M8 Flat Washers	4	EO802
19.	M6 Flat Washer	2	EO602
20.	M8 Medium Penny Washers	2	EO803

- a) Assemble as shown. Ensure the safety cable is attached to the otp M8 and M6 bolts (items 13 and 14).
- b) When fitting the lower pylon between the flat bracket (item 7), check that there is no contact with the lower keel. If necessary file the bottom forward edge of the lower pylon.

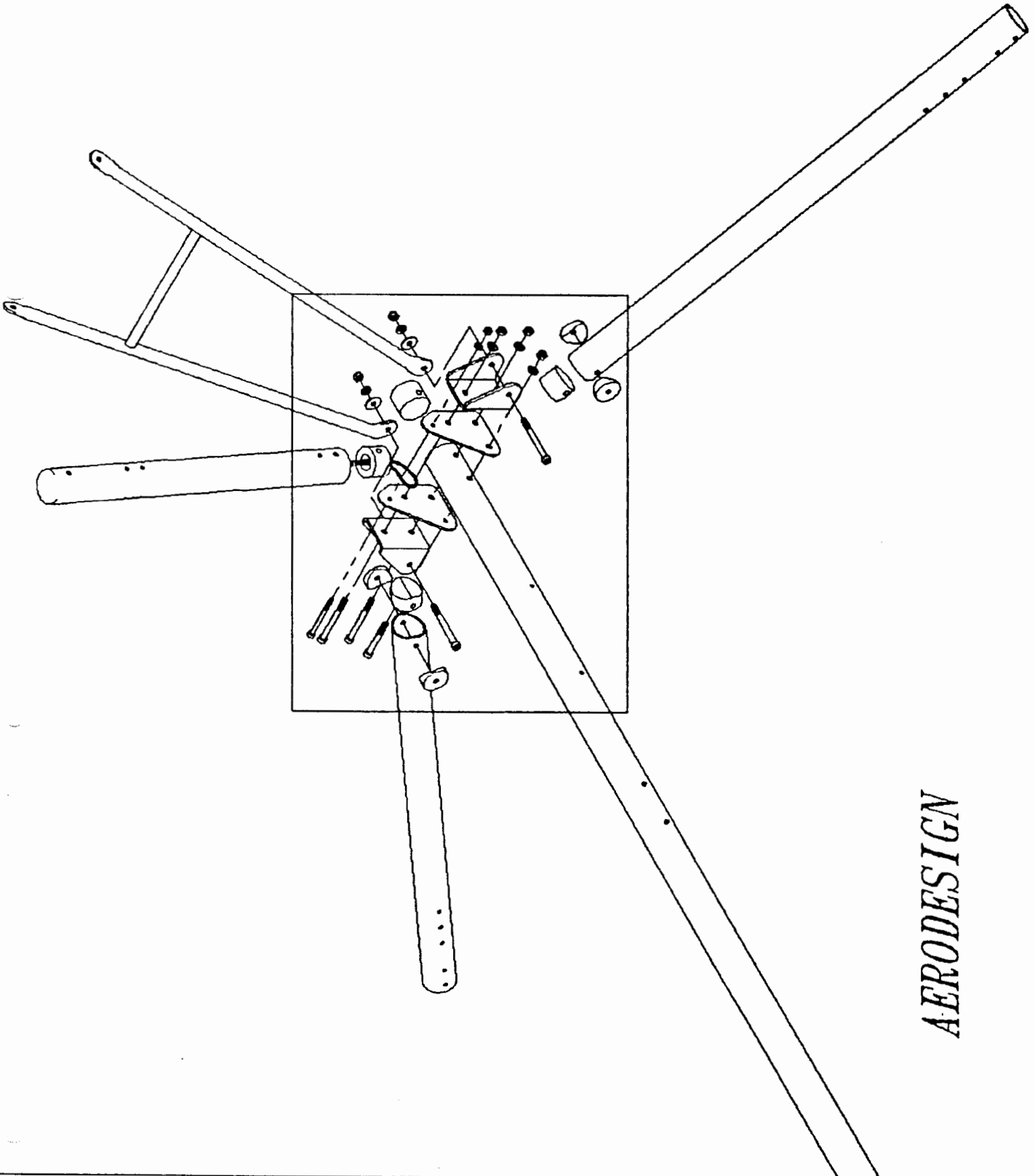

AERODESIGN

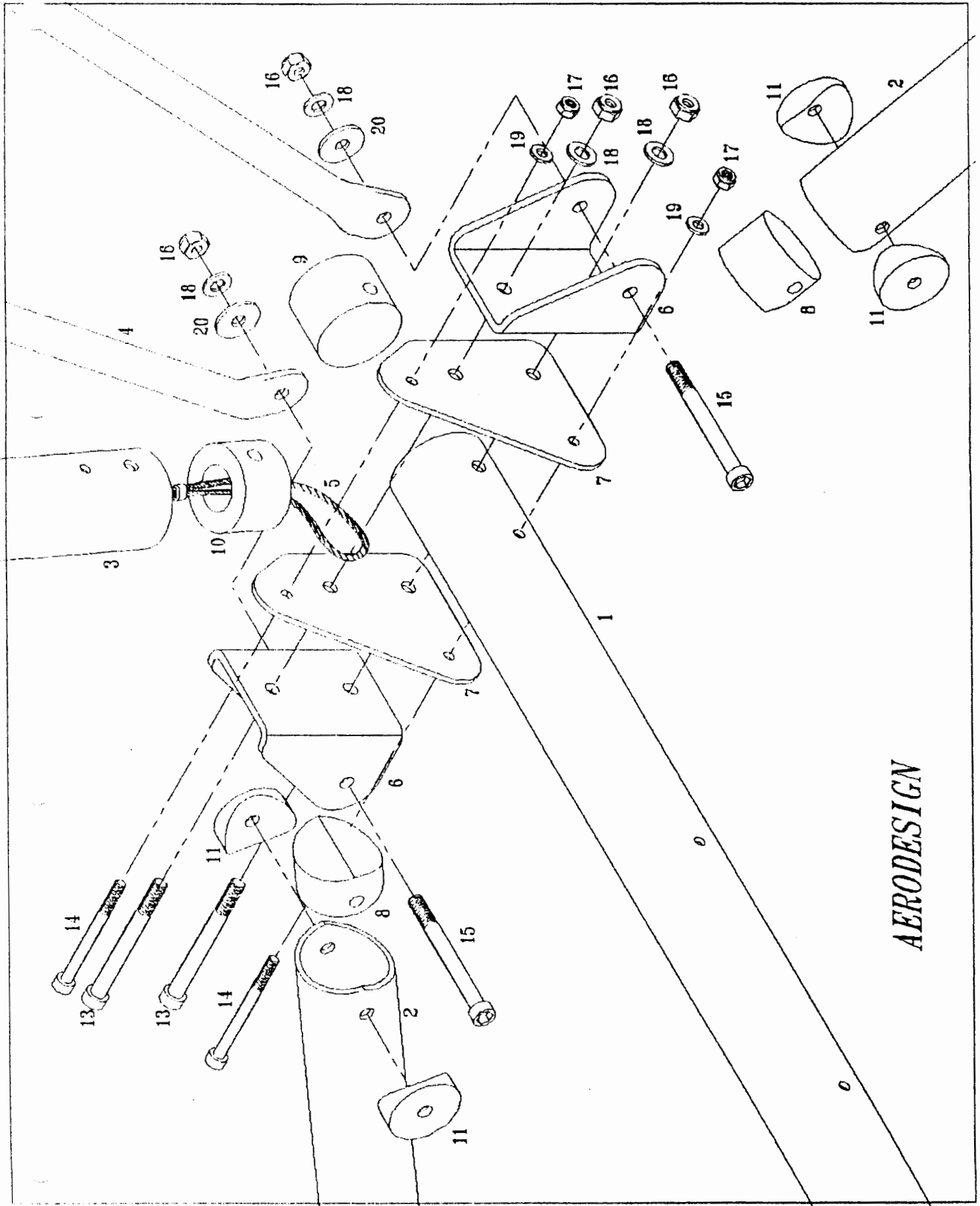

AERODESIGN

AXLE TENSION STRUTS - FRONT JOINT

ITEM	DESCRIPTION	QUANTITY	PART No.
1.	Lower Keel	1	AKL01
2.	Tension Strut - RH	1	AFT03
3.	Tension Strut - LH	1	AFT02
4.	Steel Bracket - RH	1	IFB02
5.	Steel Bracket - LH	1	IFB01
6.	Aluminium Threaded Plugs	2	SAL01
7.	Plastic Aerofoil Ends	2	QFE01
8.	M8 Eye Bolt Bearings	2	WEB01
9.	M8 x 30 Cap Screws	2	CO804
10.	M6 x 70 Cap Screws	2	CO612
11.	M6 x 35 Cap Screws	2	CO605
12.	M8 Flat Lock Nuts	2	DO802
13.	M8 Nylok Nuts	2	DO801
14.	M6 Nylok Nuts	4	DO601
15.	M8 Flat Washers	6	EO802
16.	M6 Flat Washers	6	EO601
17.	Loctite	as required	

- a) Assemble as shown. If the aluminium threaded plugs (item 6) do not fit snugly into the aerofoil tube then either wrap some insulation tape around them, or put some glue or onto them before fitting.
- b) The 8mm hole in the brackets (item 4 & 5) must face forwards and be BELOW the tube centre line.
- c) The eye bolt bearings can be adjusted by turning them in or out of the threaded bush. To determine the position of the eye bolt bearing, lie the whole frame flat on the floor. Now take a large square and check that the angle between the lower keel and the rear axles is EXACTLY 90° when they are flat on the floor. Make any adjustment to this angle by screwing the eye bolt bearing in or out as required.
- d) Lock the eye bolt bearing in place with the lock nut (item 12).
- e) Don't forget to put Loctite onto the threads of the eye bolt bearing.

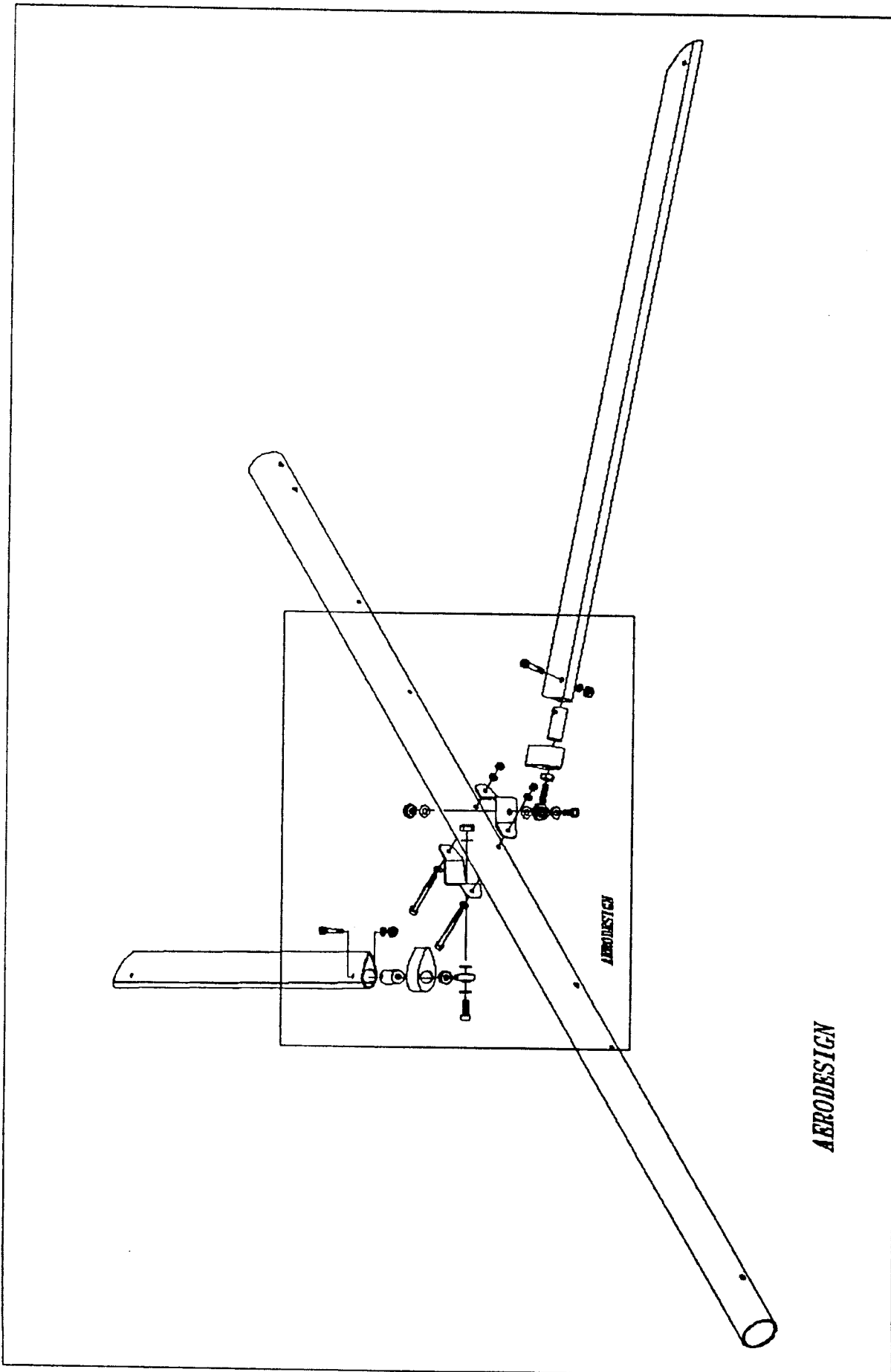

AERODESIGN

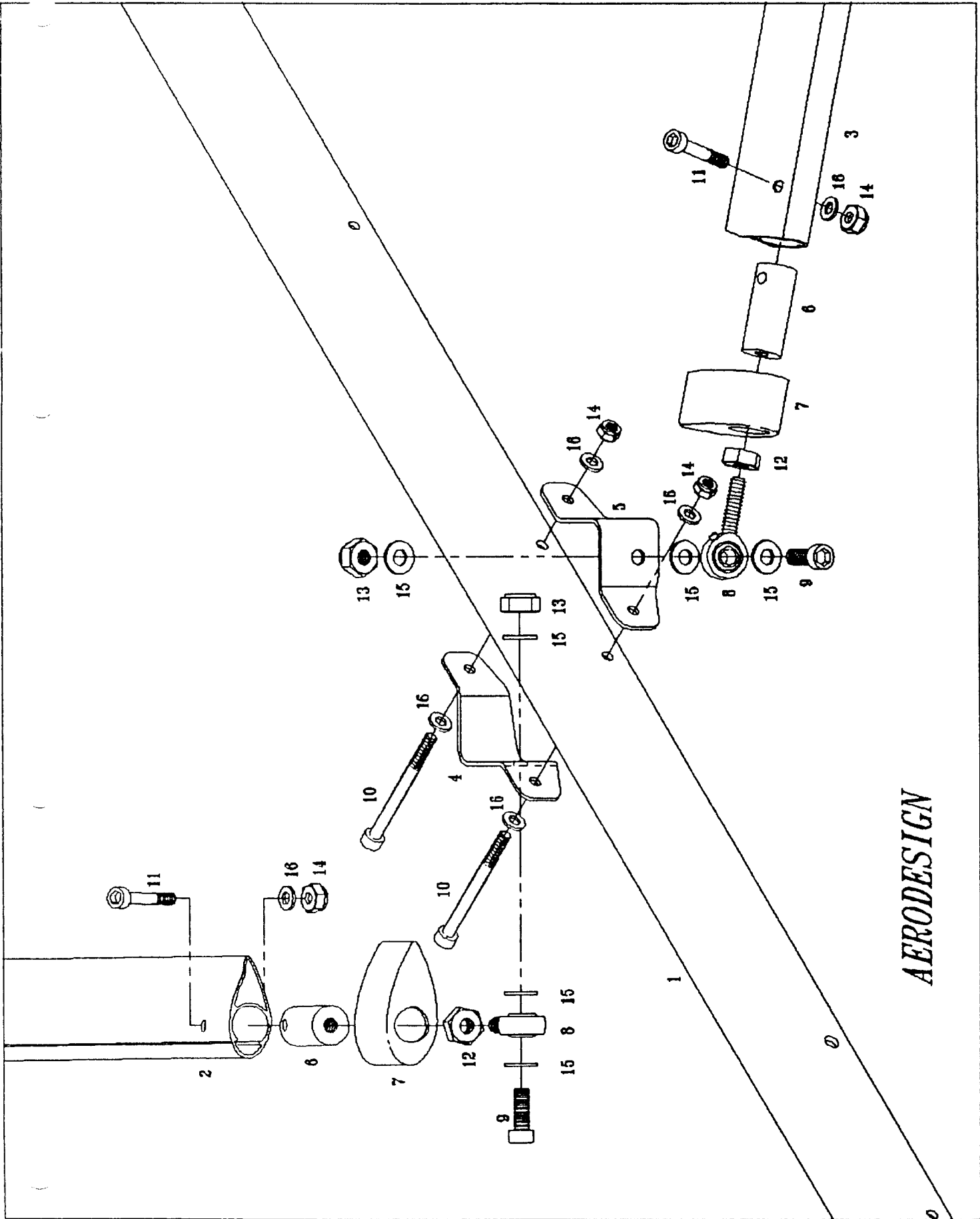

AERODESIGN

ENGINE BRACKET AND REAR SHOCK TOP MTG

ITEM	DESCRIPTION	QUANTITY	PART NO
1.	Engine Bracket	1	IEB01
2.	Lower Pylon	1	ALP01
3.	Rear Shocks	2	
4.	Channel Brackets - Shock Top	2	BSH01
5.	M6 x 80 Cap Screws	2	CO614
6.	M8 x 80 Cap Screw	1	CO814
7.	M8 x 60 Cap Screws	2	CO810
8.	M6 Flat Washers	4	EO602
9.	M6 Nylok Nuts	2	DO601
10.	M8 Flat Washers	6	EO802
11.	M8 Nylok Nuts	3	DO801
12.	Saddle - 28 Tube x 8 I/D	4	PSA02
13.	Safety Cable	1	KSA01

- a) Assemble as shown.
- b) Slide the engine mounting bracket (Item 1) onto the lower pylon. If the fit is a bit loose then wrap some insulation tape around the lower pylon first.
- c) The channel brackets (item 4) **MUST** be lined up correctly so that the rear shocks are not stressed. Mount the rear shocks at the bottom onto the axles. Now fit the top channel (item 4) onto the engine mounting. If the top of the shocks do not line up within 15mm of the top bracket, check to see where the problem is - do not force the shocks into position if they do not line up properly.

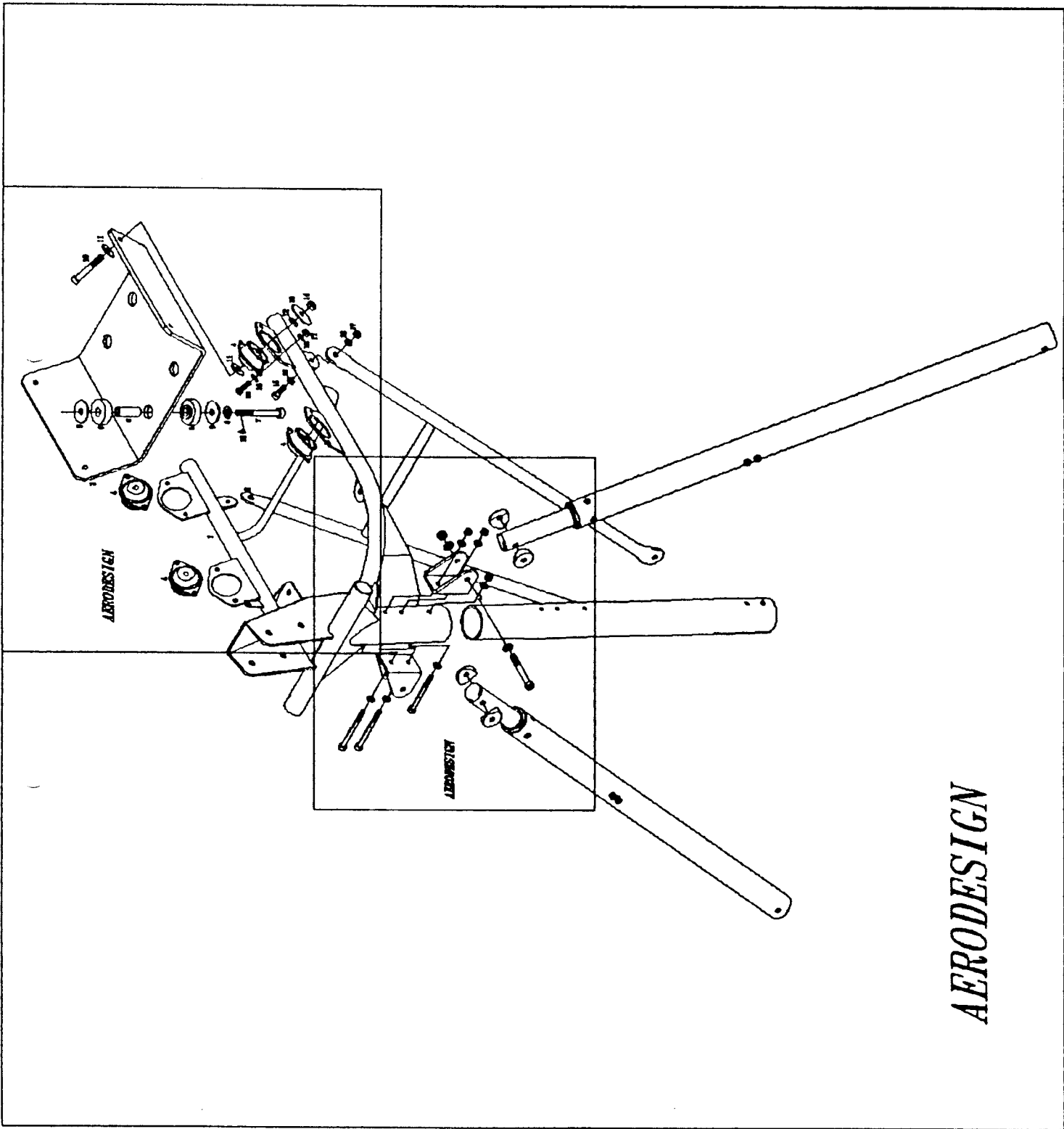

AERODESIGN

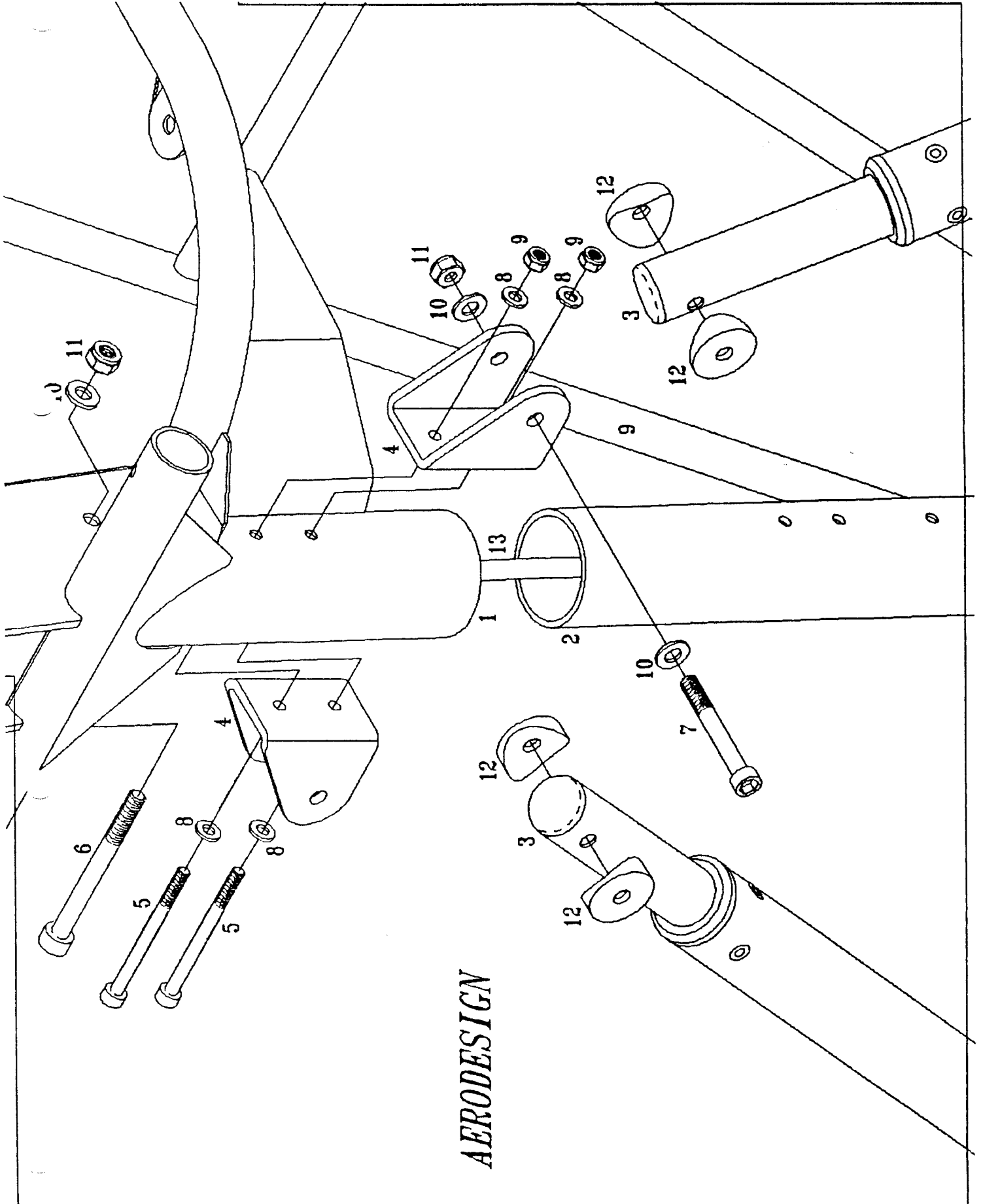

AERODESIGN



Fowkes Bros. (PTY) LTD.
 Co. Reg. No. 1946/024152/07 VAT Reg. No. 4420101034

HEAD OFFICE:

45 NEPTUNE ST.
 PAARDEN ELAND 7405
 ☒ 836 CAPE TOWN 8000
 ☎ +27 21 508 7500
 ☎ +27 21 508 4920



INVOICE D61233

ENGINEERING SUPPLIES
 CUTTING, TURNING, BORING TOOLS, HAND
 TOOLS, ADHESIVES, ABRASIVES, BOLTS,
 NUTS & FASTENERS & TOGGLE CLAMPS, ETC.
 SPECIALISING IN FIBREGLASS
 RESINS AND ALLIED MATERIALS
 e-mail: info@fowkes.co.za

BRANCHES

CNR. OSSIE URBAN RD &
 PW BOTHA BLVD, TAMSUI IND 6529
 ☒ 3569 GEORGE IND. 6536
 ☎ +27 44 805 5500
 ☎ +27 44 805 5502

NO 1 TRIANGLE ST.
 TRIANGLE PARK PAARL 7620
 ☒ 2557 PAARL 7620
 ☎ +27 21 862 6142
 ☎ +27 21 862 6404

NO 1/432 STRAUSS CRESCENT
 WADEVILLE EXTENSION 6 1428
 ☒ 14196 WADEVILLE 1422
 ☎ +27 11 865 0800
 ☎ +27 11 865 0802

Webpage: www.fowkes.co.za

TAX INVOICE

DOCUMENT	NUMBER	PAGE
1		
ACCOUNT NUMBER	BRANCH	DATE
CASHPA1	MB	07 Jun 2010
YOUR ORDER No.		
ZAS		
TERMS	TIME	OUR REF No.
CASH	16:58	D61233
SALES PERSON		REP
Nicolaas Jonck		39
DELIVERY METHOD		
TAKEN BY CUSTOMER		

SEND TO ADDRESS
 CASH PAARL 1

VAT NO: 22

DELIVERY ADDRESS
 CASH PAARL 1

STOCK CODE	DESCRIPTION	QTY	PL	CH	UNIT PRICE	UOM	DISC. %	TOTAL
FL203	FLAT BAR 20 X 3MM	2			15.27	M	35.00	19.85

PAID BY CASH

STEEL CHECKED
 FOWKES BROS. (PTY) LTD

Bank Details: Standard Bank Acc. No.: 070875758 Branch: 020909
 THANK YOU FOR YOUR SUPPORT : REF / TEL: Nicolaas Jonck

RECEIVED IN GOOD ORDER AND CONDITION

NAME (Please print) Signature Date

PULLED BY	CHECKED BY	DELIVERED BY	SALES TOTAL	19.85
			VAT % 14.00%	2.78
			TOTAL	22.63

TAX INVOICE

Doc:030439736

10/06/10 08:34 am

PAARL MICA HARDWARE

267 MAIN ROAD

PAARL

7646

VAT Registration: 4470174352

Description	Price	Qty	Net
HEX SET SCREW + NUT 12X50 Q8	35.50	1.00	35.50
SUBTOTAL:			35.50
TOTALS:	1.00		35.50
VAT INCLUDED:			4.36
AMOUNT TEND:			40.00
CHANGE:			4.50

Cash 40.00

Rep/Dep :NOAH
Operator:CHANDRE
Our Ref :
Your Ref:

TAX INVOICE

Doc:020227006

09/06/10 04:10 pm

PAARL MICA HARDWARE

267 MAIN ROAD

PAARL

7646

VAT Registration: 4470174352

Description	Code	Qty	Net
THREADED ROD 12MMX1M	4E70	3.00	75.00
THREADED ROD 10MMX1M	4D70	2.00	35.90
SPRING WASHER 12MM Q15	7AI70U	4.00	32.00
SPRING WASHER 10MM Q20	7AI60U	3.00	21.00
SUBTOTAL:			163.90
TOTALS:	12.00		163.90
VAT INCLUDED:			20.13
AMOUNT TEND:			163.90

Cash 163.90

Rep/Dep :NOAH
Operator:GRETCHEN
Our Ref :
Your Ref:

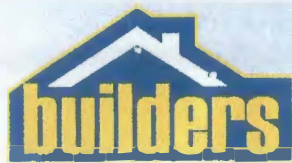

TRADE DEPOT

BUILDING MATERIAL SUPPLIES

BUILDERS TRADE DEPOT (PTY) LTD T/A
 BUILDERS TRADE DEPOT
 Reg. No. 2004/035206/07
 VAT Reg. No. 4720218876

DOCUMENT DISTRIBUTION:
 Original - Tax Invoice (Customer)
 Grey - Delivery Note (File Copy)
 Green - Delivery Note (Customer Copy)
 Yellow - Accounts Copy

BRANCH ADDRESS DETAILS:

Driebege Street
 Dal Josaphat
 7620

TEL 021 8683040
FAX 021 8682898

DELIVERY ADDRESS DETAILS:

GREEN WAY INTERIORS
 Cash Sales

Cash Sales - Paarl
 Cash Sales

Customer VAT Reg No:

TAX

Cash Invoice

CUSTOMER No.	INT. ORDER No.	CUSTOMER'S ORDER No.	DOCUMENT DATE	DOCUMENT No.	PAGE
9999810	617445	/	17:03 210mar 08/06/2010	3210 / 00346758	1

ITEM CODE AND DESCRIPTION	UNIT	V.A.T.	QUANTITY	Excl. UNIT PRICE	BARCODE	TOTAL AMOUNT
#32335 BP Nuts Galv M10 Q25 Q25 VP VPGN10	EA	S	3.00	17.06	6007411014460	51.18
#32337 BP Nuts Galv M12 Q25 Q25 VP VPGN12	EA	S	2.00	23.64	6007411014477	47.28
#45219 BP Washer Flat Galv 12mm Q25 VPFLW12	EA	S	2.00	9.17	6007411014439	18.34
T00562 Drill Bit Metal Indus 10.0mm RMGC31000	EA	S	1.00	39.08	6005721018925	39.08
#55932 Bracket M/Purpose Type C 50x50x20 EMPB-C	EA	S	4.00	3.93	6006473020112	15.72
#94240 Washer Sq 36x4mm EW36x13S8	EA	S	30.00	2.14	6006473030111	64.20
Sub-Total (excluding VAT)						235.80
VAT @ 14% (for VATABLE items)						33.02

BUILDERS TRADE DEPOT

08 JUN 2010
 CHECKED

COMMENTS:

Delivery: C Collections Margaret Rantsani
 Payment: NT
 When paying please state:

E. & O.E.
 RECEIVED IN GOOD ORDER & CONDITION:

PLEASE PRINT NAME

268.82

INVOICE TOTAL

Driver Sign

Checker Sign

SIGNATURE VEHICLE REG. NO.
 SEE REVERSE FOR CONDITIONS OF SALE



Fowkes Bros. (PTY) LTD.
 No. 1946/024152/07 VAT Reg. No. 4420101034

HEAD OFFICE:

45 NEPTUNE ST.
 PAARDEN ELAND 7405
 ☒ 636 CAPE TOWN 8000
 ☎ +27 21 508 7500
 FAX: +27 21 508 4920



INVOICE 061232

TAX INVOICE

DOCUMENT	NUMBER	PAGE
1		
ACCOUNT NUMBER	BRANCH	DATE
CASHPAI	MB	07 Jun 2010
YOUR ORDER No.		
ZAS		
TERMS	TIME	OUR REF No.
CASH	16:54	061232
SALES PERSON		REP
Nicolaas Jonck		39
DELIVERY METHOD		
TAKEN BY CUSTOMER		

ENGINEERING SUPPLIES
 CUTTING, TURNING, BORING TOOLS, HAND
 TOOLS, ADHESIVES, ABRASIVES, BOLTS,
 NUTS & FASTENERS & TOGGLE CLAMPS, ETC.
 SPECIALISING IN FIBREGLASS
 RESINS AND ALLIED MATERIALS
 e-mail: info@fowkes.co.za

BRANCHES

CNR. OSSIE URBAN RD &
 PW BOTHA BLVD. TAMSUI IND 0529
 ☒ 3569 GEORGE IND. 0536
 ☎ +27 44 805 5500
 FAX: +27 44 805 5502

NO 1 TRIANGLE ST.
 TRIANGLE PARK PAARL 7620
 ☒ 2557 PAARL 7620
 ☎ +27 21 862 6142
 FAX: +27 21 862 6404

NO 1/432 STRAUSS CRESCENT
 WADEVILLE EXTENSION 6 1428
 ☒ 14196 WADEVILLE 1422
 ☎ +27 11 885 0800
 FAX: +27 11 885 0802

Webpage: www.fowkes.co.za

SEND TO ADDRESS
 CASH PAARL 1

VAT NO: 22

DELIVERY ADDRESS
 CASH PAARL 1

STOCK CODE	DESCRIPTION	QTY	PL	CH	UNIT PRICE	UOM	DISC. %	TOTAL
AI253	ANGLE IRON 25 X 25 X 3MM	2.			17.00	M	35.00	22.10
FL253	FLAT BAR 25 X 3MM	1.			12.96	EA	35.00	8.42
RT16X1.6	ROUND TUBING 16 X 1.6	1.			15.00	M	35.00	9.75
TMSG10	(THREADED) ROD GALV 1 MTR L 10MM	4.			21.36	M	40.00	51.26
TMSG12	THREADED ROD GALV 1 MTR L 12MM	4.			29.06	M	40.00	69.74

FOWKES BROS (PTY) LTD
 L CHECKED

PAID BY
 CREDIT CARD

Bank Details: Standard Bank Acc. No.: 070875758 Branch: 020909
 THANK YOU FOR YOUR SUPPORT : REF / TEL: Nicolaas Jonck

RECEIVED IN GOOD ORDER AND CONDITION

NAME (Please print) Signature Date

PULLED BY	CHECKED BY	DELIVERED BY	SALES TOTAL	161.27
			VAT % 14.00	22.58
			TOTAL	183.85

Forms Made Independent (Africa) Tel: (021) 595-2423 Fw1863 Email: info@fowkes.co.za

QUOTATION

QUOTE NO: 040000898
 DATE: 01/05/10 Page: 1

From: PAARL MICA HARDWARE
 267 MAIN ROAD
 PAARL
 7646
 Vat Registration: 4470174352

Code	Description	Retail	Qty	Nett
P02063	MAKTEC CUT OFF SAW 355MM MT24	1999.00	1.00	1999.00
151005	DISC GRINDING ST 115X4.5MM	14.95	1.00	14.95
HA6566	DISC CUTTING ST 115X3X22.2	9.95	1.00	9.95
P02050	MAKITA DRILL HP2050	1299.00	1.00	1299.00
T00571	GLOVE WAN PIGSKIN CANDY STRIP	24.95	1.00	24.95
T03032	WELDING HELMET MTS FLIP FRONT	49.95	1.00	49.95
T04100	WELDER INVERTER 160AMP FRAGRA	1999.00	1.00	1999.00
HA1770	WELDING CLAMP MAGNET LD FRAGR	39.95	1.00	39.95
T00277	WELDING ROD 2.5MM PER KG	24.95	1.00	24.95
RAZ65096	RAZOR BENCH VISE 4INCH SWIVEL	329.95	1.00	329.95
600572101888	DRILL BIT METAL 8.0MM	34.95	1.00	34.95
RMGC30600	DRILL BIT METAL 6.0MM	21.95	1.00	21.95
P07335	FLAP DISC ALL £	29.95	1.00	29.95
P01016	RY DRILL PRESS DP-10	1345.00	1.00	1345.00
T01556	SQUARE OMNI TRY MITRE 200MM	34.95	1.00	34.95
RAZ65333	RAZOR BEVEL 250MM	24.95	1.00	24.95
T06011	TAPE STANLEY POWERLOCK 5X19MM	89.95	1.00	89.95
HA6338	CLAMP G 150MM RIBBED	149.95	1.00	149.95
GTR480-08	SWIVEL MITRE BOX GTR480-08	299.00	1.00	299.00
RAZ65146	RAZOR HAND SAW 610MM W/H	59.95	1.00	59.95
T08993	RULE STEEL 300MM	19.95	1.00	19.95
T01429	WELDING HAMMER CHIPPING	35.95	1.00	35.95
T04301	BRUSH WIRE F4301	27.95	1.00	27.95

TOTAL: 7966.10

VAT INCLUSIVE: 978.29

Rep/Dept:NOAH
 10:57 am

Operator name:GAWIE

Our Ref:
 Your Ref: