

The copyright of this thesis vests in the author. No quotation from it or information derived from it is to be published without full acknowledgement of the source. The thesis is to be used for private study or non-commercial research purposes only.

Published by the University of Cape Town (UCT) in terms of the non-exclusive license granted to UCT by the author.

Bounds on Basket Option Prices

N.C. de Swardt

Submitted to the faculty of Science UCT in partial fulfillment
of requirements for the degree of MSc Financial Mathematics
Supervised by Dr D. Polakow

July 11, 2005

University of Cape Town

Abstract

The celebrated Black-Scholes option pricing model is unable to produce closed-form solutions for arithmetic basket options. This problem stems from the lack of an analytical form for the distribution of a sum of lognormal random variables. Market participants commonly price basket options by assuming the basket follows lognormal dynamics, although it is known that this approximation performs poorly in some circumstances. The problem of finding an analytical approximation to the sum of lognormally distributed random variables has been widely studied. In this dissertation we seek to draw these studies together and apply them in an option pricing setting. We propose some new option pricing formulae based on these approximations. In order to examine the utility of these new formulae and compare them to commonly used market approximations we present rigorous analytical bounds for the price of arithmetic basket options using the theory of comonotonicity. In this we follow the ideas in Deelstra et al. [7]. Additionally we provide an interval of hedge parameters (the Greeks). We carry out a numerical sensitivity analysis and identify circumstances under which the market approximation misprices basket options.

Acknowledgements

I would like to thank Dr. Daniel Polakow for his time, effort and direction over the last year, Mark de Araujo for his time and helpful comments and Dr Sara Lowe for her patience, encouragement and support.

University of Cape Town

Contents

1	Introduction	5
1.1	Discussion	5
1.2	Literature Review	7
1.3	Objectives	8
1.4	Structure of the Dissertation	9
2	Pricing an Option in the Black-Scholes Framework	10
3	Basket Options	15
3.1	The problem	15
3.2	Implied volatility and market methods	16
3.3	A normal approximation	18
3.4	A first order approximation	21
3.5	Moment matching techniques	22
4	Bounds on the Option Price	27
4.1	Comonotonic bounds	27
4.1.1	Some Probability Theory	27

<i>CONTENTS</i>	3
4.1.2 Comonotonic random variables and Convex Order	28
4.1.3 Basket Options : Splitting the integral	37
4.1.4 The Greeks	43
5 Testing in the Black-Scholes World	48
5.1 Quantifying the Error	50
5.2 Dimensional Issues	51
5.3 Initial Discussion	61
5.4 Multivariate Statistical Analysis	61
5.5 Classification Trees	61
6 Conclusions	68
6.1 Further Research	68
A The Lognormal Distribution	72
A.1 Genesis	72
A.2 Characteristics of the lognormal distribution	73
A.3 Approximation of the lognormal distribution by the normal distribution	74
A.4 Reproductive Properties	75
A.4.1 A lognormal approximation for a sum of lognormal variables	75
A.4.2 A normal approximation for a sum of lognormal variables	76
B Correlation and Covariance	77
C Contour Plots	84

Notation

The following notational conventions will be used throughout this dissertation unless otherwise indicated.

- C_t is the time t price of a European call option
- K is the strike price
- r is the interest rate
- T is the options maturity date
- t is the time at which we are valuing the call option
- B_t is the price of the basket at time t
- S_t^i is the price of the i 'th asset in the basket at time t
- a_i is the predetermined and constant weight of the i 'th asset in the basket ¹
- $\Phi(x)$ is the cumulative distribution function of a standard normal variate
- $\bar{\Phi}(x) = 1 - \Phi(x)$
- $X \sim N(\mu, \sigma^2)$ indicates that X is normally distributed with mean μ and variance σ^2
- Z_t is a Brownian Motion under the real world measure \mathbb{P}
- W_t is a Brownian motion under the risk neutral measure \mathbb{Q}

¹These weights are determined by the proportions of the assets in the portfolio we are averaging. So, for example if we have a portfolio P with

$$P_0 = \sum_{i=1}^n q_i S_0^i$$

Where q_i is the quantity of S_i in the portfolio, then $a_i = \frac{q_i S_0^i}{P_0}$ so that a_i is the weight of S_0^i in P_0 not B_0 .

Chapter 1

Introduction

In this dissertation we examine the problems surrounding the pricing of European basket options. A basket option is an option on the weighted average of a portfolio of assets, with the typical European payoff structure.

$$C_t = e^{-r(T-t)} \mathbb{E}^{\mathbb{Q}}[(B_T - K)^+], \quad (1.1)$$

where

$$B_T = \sum_{i=1}^n a_i S_T^i.$$

1.1 Discussion

Basket options are widely traded in the marketplace. They enable portfolio managers to hedge portions of their portfolios without having to manage correlation risk, whilst banks, for whom managing correlation risk is commonplace, can charge a premium for doing so. Despite their prevalence in the marketplace, there is no closed-form solution to (1.1) under the usual assumptions about asset distribution.

As a starting point let us look at how these options might be priced in the market. In markets where there is no liquid market for options on all of the baskets components, a first approach is normally to construct an index from the basket elements and use the annualised standard deviation of the log index returns as the implied Black-Scholes volatility. This approach suffers from the assumption of a link between historic volatility and future volatility as well as the more serious flaw of assuming that index options may be priced using the Black-Scholes formula.

In more developed markets the implied volatilities of the underlyings are extracted from options

traded on the basket's components. These are then combined using a first order approximation to obtain an estimate of implied volatility of the basket.

$$\sigma_B^2 = \frac{W\Sigma W^T}{T}, \quad (1.2)$$

where Σ is the variance/covariance matrix of the log basket elements and W is the row vector of the weights of the elements in the basket.

Immediately we find ourselves faced with four problems of varying difficulty.

Firstly, in using the basket's implied volatility based on either the historic index volatility or the implied volatilities of the basket's components, we are implicitly assuming that the Black-Scholes formula is the correct vehicle for converting the basket's volatility to an option price. This is not the case.

Secondly, if the basket contains elements with unstable volatility structures¹ they will exhibit different implied volatilities for different strikes. Clearly the basket strike price can be made up of any number of combinations of prices of the basket's elements. Consequently we are faced with the difficult question: 'For each basket component, which implied volatility should we use as inputs to (1.2) ?'

Thirdly, we have the problem that correlations do not remain constant throughout the life of an option. Indeed, there is evidence to suggest that correlations are strongly dependent on market levels. Consequently the correlations we use to calculate Σ will be unstable and our hedge will become increasingly inaccurate through time.

Lastly, The fact that σ_B^2 relies on the weights of the assets in the basket ensures that it is not constant (as assumed in the Black-Scholes framework). This indicates that even assuming constant volatility for the underlying components would not allow us to make the same assumption for a basket of such assets.

This dissertation is restricted to the investigation of the first of these problems and consequently all discussion takes place within the Black-Scholes framework.

In the Black-Scholes framework it is assumed that volatilities, correlations and interest rates are constant (or at least deterministic). However, even under these restrictive assumptions, the model is unable to produce a closed-form solution to the basket option pricing problem. This difficulty stems solely from the lack of an analytical form for the distribution of a sum of lognormal random variables. This problem has been widely studied and occurs in many disciplines J. Aitchinson [15], ben Slimane [3]. Romeo et al. [22]. Below we present a review of the relevant literature.

¹In other words, if the volatilities are not deterministic

1.2 Literature Review

With the publication of the celebrated Black and Scholes paper [10], option pricing had its first major breakthrough. The remarkable idea behind this paper was that all risk in an option contract could be instantaneously hedged away using a replicating portfolio of the underlying assets. These ideas were later formalised in Merton [20] and Harrison and Pliska [12] among others and generalised in Jarrow and Rudd [17] to include arbitrary stochastic processes.

Despite its overwhelming success, the Black-Scholes model remained incapable of pricing more exotic options, and even simple European basket options had no closed-form pricing solution within the Black-Scholes framework. This is because of the lack of an analytical form for a sum of lognormally distributed random variables. This problem has been widely studied in many fields, and the literature is extensive.

A general study of the lognormal distribution is presented in J. Aitchinson [15], together with its applications in finance. Romeo et al. [22] examine broad distribution effects in sums of lognormal random variables and present some approximations. Order statistics are examined as possible bounds in ben Slimane [3]. Whilst these studies have ready applications in other fields, the results are not directly applicable to the option pricing problem, as they deal primarily with very narrow, or very broad lognormal distributions.

The problem of random variables whose marginal distributions are known, but whose joint distribution is not known or too cumbersome to work with, is one which occurs frequently in actuarial science. Dhaene et al. [8, 9] use the ideas of comonotonicity to bound sums of such variables, and to calculate their stop-loss premiums. Valdez and Dhaene [25] present the same theory applied to the more general family of log-elliptic random variables. Kaas et al. [18] give a simple geometric proof that comonotonic risks have the convex largest sum.

This theory finds a ready application in basket option pricing. Deelstra et al. [7] use conditioning to split the expectation integral, one part of which may be solved exactly, and the other part of which may be bounded using the comonotonic theory discussed in the papers above.

Others attempt to approximate the basket terminal distribution. Brigo et al. [5] present various moment matching techniques with good results. In order to match higher moments they resort to a mixture of lognormal densities. The calibration of such a mixture is discussed. Laplace transforms are examined in Sudler [24] with an application to Asian options which have in similar properties to basket options.

The failure of Black-Scholes to consistently price all quoted options in one market has directed some research towards non-parametric methods. These techniques seek to extract distributions from prices quoted in the market. The canonical valuation approach in Stutzer [23] uses the

distribution of historic returns as a statistical prior which is then ‘risk neutralised’. In other words, the distribution is transformed in such a way as to constrain it to match forward prices, and possibly certain option prices, with the minimum addition of information (as measured by the Kullback - Leibler distance). Zou and Derman [26] demonstrate a simple method of obtaining a such a Risk Neutralised Historic Distribution (RNHD) and briefly discuss its uses for pricing basket options. Jackwerth and Rubinstein [16] use a lognormal distribution as a prior and compare the merits of using different metrics to measure the closeness of the posterior distribution after the transformation. Ait-Sahalia and Lo [1] use a non-parametric kernel regression to extract risk neutral distributions from option prices. All these techniques have a ready application in basket option pricing, as all that is required are the prices of either the index or options on the index. No functional form is assumed about the distribution of the underlying assets so the problem of finding their joint distribution analytically is side-stepped. These methods suffer from being computationally expensive.

Lee et al. [19] use a Gram-Charlier expansion to find the basket price in terms of the skewness and kurtosis of its components. This enables us to include important information implicit in the volatility smiles of the basket components in the option price. They use a simple local volatility model to account for fluctuations in the correlations between the individual assets through time. The Gram-Charlier expansion, whilst allowing for a convenient interpretation as a normal distribution multiplied by a polynomial accounting for departure from normality in terms of skewness and kurtosis, is not a true distribution. This is because it is a truncated expansion, including only the first four terms of the series expansion in terms of the Hermite polynomials. Consequently, it can take on negative values, and can only be used for moderate departures from normality.

Allevaneda et al. [2] use the methods of steepest descent to find the basket volatility surface, and this method obtains similar results to those in Lee et al. [19].

1.3 Objectives

The central aim of this dissertation is to investigate circumstances under which the market approximations to the basket price break down. To the best of our knowledge such a study has not been carried out in previous research although there are several studies comparing various basket option price approximations to Monte-Carlo simulated prices.

The price of a European option depends only on the terminal distribution of the underlying. Consequently, if we can derive good approximations to the distribution of a sum of lognormal random variables we can derive good approximations to the option price. To this end the lognormal distribution is examined in detail in the appendix and several such approximations are proposed in Chapter 3, of which the normal approximation and the first order approximation are new. We also draw from the work of Brigo et al. [5] who match the first two moments of the baskets distribution

with an approximating lognormal distribution.

We compare these methods to the common market approximation of assuming that the basket follows a standard Geometric Brownian motion (GBM). In order to compare these approximations, tight analytical bounds on the option price are derived using the theory of comonotonicity and convex order. This theory has been discussed in Kaas et al. [18], Dhaene et al. [8, 9] and Valdez and Dhaene [25] amongst others. The theory outlined in those papers is applied to basket options in Deelstra et al. [7]. We have collected the ideas in these papers and laid out the results starting from first principles for completeness. In addition intervals of hedge parameters (the Greeks) are provided.

Using these bounds we proceed to identify characteristics of a basket that result in the basket option being mispriced by the market method.

1.4 Structure of the Dissertation

In the following chapter the theory behind the Black-Scholes model is examined. In the third chapter, basket options are discussed, and several pricing methods are presented. In the fourth chapter we present analytical bounds on the option price. In the fifth chapter we carry out a sensitivity analysis to isolate regions in the variable space where the market pricing techniques violate these bounds. In the sixth chapter we present our conclusions and discuss further areas of research. In the interests of brevity and readability an appendix is included in which much of the background mathematics can be found.

Chapter 2

Pricing an Option in the Black-Scholes Framework

The Black-Scholes model is unable to price basket options in closed-form. This is because a central assumption in the Black-Scholes framework is that the underlying assets are lognormally distributed and, clearly, the sum of such assets no longer shares this property. We could argue that the Black-Scholes model is just that: a model, and consequently we can ‘model’ the basket as being lognormal, and indeed this is a common approach to the problem. However, such an approach runs the risk of inconsistent pricing when either of the parties involved in a basket option trade are trading not only basket options but other options on individual components of the basket. We cannot assume that both single assets *and* baskets are lognormally distributed.

Before we proceed further, we will derive the Black-Scholes pricing formula to re-familiarise readers with the argument. The results presented below are well-known and are given for completeness. If the reader is familiar with the argument, nothing is lost by proceeding directly to the next chapter.

In this chapter we develop the theory required to price European call options on a single underlying asset (the price of the corresponding put is easily obtained through put-call parity). There are several approaches to the problem of pricing a call. Black and Scholes used a continuous hedging argument to arrive at a PDE which (under a change of variables) can be transformed into the heat transfer PDE. The solution to this PDE is well-known (Churchill [6]), and from the solution we obtain the option pricing formula. The same result is arrived at if we use martingale methods (the Feynman-Kac theorem provides a link between the PDE and stochastic approaches to option pricing).

We will provide two derivations of the price of a European call option starting from the statement

that:

$$C_0 = \mathbb{E}^{\mathbb{Q}}[e^{-\int_0^T r(t)dt}(S_T - K)^+].$$

This statement is not obvious in itself. The existence and uniqueness of the martingale measure \mathbb{Q} is obtained through the assertion that markets are complete and arbitrage free, which, in the Black-Scholes framework, can be shown to be true via the Martingale Representation Theorem and Girsanov's Theorem (if there are as many sources of noise as there are traded assets). The continuous hedging argument in the Black-Scholes paper ([10]) can be seen to produce this statement through the Feynman-Kac theorem.

We recall the following assumptions from the Black-Scholes paper:

1. Trading is continuous.
2. No transaction costs.
3. Markets are liquid for each security.
4. No charges for short sales.
5. Assets are perfectly divisible.

These assumptions simplify the continuous hedging argument that leads to the closed-form solution presented by Black and Scholes. However, the assumption that concerns us here is the one made about the stock price dynamics.

Assume that stock prices follow the standard Geometric Brownian motion (GBM) dynamics under the real world measure.

$$\frac{dS_t^i}{S_t^i} = \mu_i dt + \sigma_i dZ_t^i, \quad (2.1)$$

We can transform (2.1) using Girsanov's Theorem with kernel $\lambda = \frac{r-\mu}{\sigma}$ to move to the risk neutral measure \mathbb{Q} where (2.1) becomes:

$$\frac{dS_t^i}{S_t^i} = r dt + \sigma_i dW_t^i. \quad (2.2)$$

Solving equation (2.2) yields

$$S_t^i = S_0^i e^{(r - \frac{1}{2}\sigma_i^2)t + \sigma_i W_t^i}. \quad (2.3)$$

Consequently S_t^i is lognormally distributed under \mathbb{Q} with

$$\ln S_t^i \sim N(\ln S_0^i + (r - \frac{1}{2}\sigma_i^2)t, \sigma_i^2 t). \quad (2.4)$$

Now, when we assume that interest rates are deterministic we can write the value of a call option C_0 on one underlying at time T as:

$$C_0 = e^{-\int_0^T r(t)dt} \mathbb{E}^{\mathbb{Q}}[(S_T - K)^+]. \quad (2.5)$$

More generally this is not the case and we cannot bring the discount factor outside the expectation operator. However, the problem may be easily avoided by changing the numeraire to $p(t, T)$: the time t value of the discount bond maturing at T . This is equivalent to changing measure to the T-forward measure \mathbb{Q}^T (again, using a Girsanov transformation). After this change of measure we obtain:

$$\begin{aligned} C_0 &= p(0, T) \mathbb{E}^{\mathbb{Q}^T} [(S_T - K)^+], \\ &= p(0, T) \mathbb{E}^{\mathbb{Q}^T} [(S_T - K); S_T \geq K], \\ &= p(0, T) \left(\mathbb{E}^{\mathbb{Q}^T} [S_T; S_T \geq K] - \mathbb{E}^{\mathbb{Q}^T} [K; S_T \geq K] \right), \\ &= p(0, T) \left(\mathbb{E}^{\mathbb{Q}^T} [S_T; S_T \geq K] - K \mathbb{Q}^T [S_T \geq K] \right). \end{aligned} \quad (2.6)$$

Now recall the change of numeraire formula

$$A_1(0) \mathbb{E}^{\mathbb{Q}^1} \left[\frac{M(t)}{A_1(t)} \right] = A_2(0) \mathbb{E}^{\mathbb{Q}^2} \left[\frac{M(t)}{A_2(t)} \right], \quad (2.7)$$

where $A_1(t), A_2(t)$ are numeraires (traded assets with strictly positive price processes) and $\frac{M_t}{A_i(t)}$ is a \mathbb{Q}^i martingale for $i = 1, 2$. Setting $A_1(t) = S_t$, $A_2(t) = p(t, T)$ and $M(t) = S_t$ we obtain

$$S_0 \mathbb{E}_S \left[\frac{S_T}{S_T} \right] = p(0, T) \mathbb{E}^{\mathbb{Q}^T} \left[\frac{S_T}{P(T, T)} \right]. \quad (2.8)$$

So we can write (2.6) as

$$C_0 = S_0 \mathbb{Q}_S [S_T \geq K] - p(0, T) K \mathbb{Q}^T [S_T \geq K]. \quad (2.9)$$

Under \mathbb{Q}^T the dynamics of $S'_t = \frac{S_t}{p(t, T)}$ are:

$$\frac{dS'_t}{S'_t} = \sigma dW'_t. \quad (2.10)$$

Solving this equation gives us the distribution of S'_t under \mathbb{Q}^T as:

$$\ln S'_t \sim N(\ln S'_0 - \frac{1}{2} \sigma^2 t, \sigma^2 t). \quad (2.11)$$

Knowing the distribution of S'_t under \mathbb{Q}^T , the second term in (2.9) can be written as:

$$\begin{aligned} \mathbb{Q}^T \left(\frac{S_T}{p(T, T)} \geq K \right) &= \mathbb{Q}^T (S'_T \geq K), \\ &= \mathbb{Q}^T (\ln S'_T \geq \ln K), \\ &= \mathbb{Q}^T \left(\ln S'_T - \ln \frac{S_0}{p(0, T)} + \frac{1}{2} \sigma^2 T \geq \ln K - \ln \frac{S_0}{p(0, T)} + \frac{1}{2} \sigma^2 T \right), \\ &= \mathbb{Q}^T \left(\frac{\ln S_T - \ln \frac{S_0}{p(0, T)} + \frac{1}{2} \sigma^2 T}{\sigma \sqrt{T}} \geq \frac{\ln K - \ln \frac{S_0}{p(0, T)} + \frac{1}{2} \sigma^2 T}{\sigma \sqrt{T}} \right), \\ &= \Phi(d_2), \end{aligned}$$

where

$$d_2 = \frac{\ln \frac{S_0}{K p(0, T)} - \frac{1}{2} \sigma^2 T}{\sigma \sqrt{T}}.$$

Similarly, by considering $\check{p}(t, T) = \frac{p(t, T)}{S_t}$ and noting that $\check{p}(t, T)$ is a martingale under \mathbb{Q}_S we find that

$$\begin{aligned}\mathbb{Q}_S S[S_T \geq K] &= \mathbb{Q}_S \left[\frac{p(T, T)}{S_T} \leq \frac{1}{K} \right], \\ &= \mathbb{Q}_S \left[\check{p}(T, T) \leq \frac{1}{K} \right], \\ &= \Phi(d_1),\end{aligned}$$

where

$$d_1 = \frac{\ln \frac{S_0}{Kp(0, T)} + \frac{1}{2}\sigma^2 T}{\sigma\sqrt{T}}.$$

So, we can write the value of a European call on a single underlying as

$$\begin{aligned}C_0 &= p(0, T)\mathbb{E}^{\mathbb{Q}^T}[(S_T - K)^+], \\ &= S_0\Phi(d_1) - p(0, T)K\Phi(d_2),\end{aligned}$$

where

$$d_1 = \frac{\ln \frac{S_0}{Kp(0, T)} + \frac{1}{2}\sigma^2 T}{\sigma\sqrt{T}}, \quad (2.12)$$

$$(2.13)$$

and

$$d_2 = d_1 - \sigma\sqrt{T}. \quad (2.14)$$

Below we present an alternative derivation of the same result (see [14]). This derivation may be more approachable for those unfamiliar with Girsanov's theorem, and the change of numeraire process.

Theorem 2.1. *If V is lognormally distributed with $\ln(V) \sim N(m, s^2)$ then*

$$\mathbb{E}[(V - K)^+] = \mathbb{E}[V]\Phi(d_1) - K\Phi(d_2), \quad (2.15)$$

where

$$d_1 = \frac{\ln \left(\frac{\mathbb{E}[V]}{K} \right) + s^2/2}{s}, \quad (2.16)$$

and

$$d_2 = d_1 - s. \quad (2.17)$$

Proof. From the definition of the moment generating function of a normal random variable, we can write that

$$\mathbb{E}[V] = e^{m+1/2s^2}.$$

so

$$m = \ln(\mathbb{E}[V]) - 1/2s^2. \quad (2.18)$$

Define a new variable $Q = \frac{\ln(V)-m}{s}$ so $Q \sim N(0, 1)$ and denote the density function of Q as $h(Q)$.

We can now write

$$\begin{aligned} \mathbb{E}[(V - K)^+] &= \int_{\frac{\ln(K)-m}{s}}^{\infty} (e^{Qs+m} - K)h_Q(Q)dQ. \\ &= e^{m+s^2/2} \int_{\frac{\ln(K)-m}{s}}^{\infty} h_Q(Q - s)dQ - \int_{\frac{\ln(K)-m}{s}}^{\infty} Kh_Q(Q)dQ. \end{aligned}$$

The first integral can be written as

$$\begin{aligned} 1 - \Phi\left(\frac{\ln(K) - m}{s} - s\right) &= \Phi\left(\frac{-\ln(K) + m}{s} + s\right), \\ &= \Phi\left(\frac{-\ln(K) + \ln(\mathbb{E}[V]) - s^2/2}{s} + s\right), \\ &= \Phi\left(\frac{\ln\left(\frac{\mathbb{E}[V]}{K}\right) + s^2/2}{s}\right), \\ &= \Phi(d_1). \end{aligned}$$

The second integral can be written as

$$\begin{aligned} 1 - \Phi\left(\frac{\ln(K) - m}{s}\right) &= \Phi\left(\frac{-\ln(K) + m}{s}\right), \\ &= \Phi\left(\frac{-\ln(K) + \ln(\mathbb{E}[V]) - s^2/2}{s}\right), \\ &= \Phi\left(\frac{\ln\left(\frac{\mathbb{E}[V]}{K}\right) - s^2/2}{s}\right), \\ &= \Phi(d_2), \end{aligned}$$

□

Now, recall that in the Black-Scholes framework S'_T is lognormally distributed under \mathbb{Q}^T (see (2.11)) with:

$$\ln S'_T \sim N\left(\ln S'_0 - \frac{1}{2}\sigma^2 T, \sigma^2 T\right). \quad (2.19)$$

Applying the results from the theorem above, we immediately obtain

$$\begin{aligned} C_0 &= p(0, T)\mathbb{E}^{\mathbb{Q}^T}[(S'_T - K)^+], \\ &= S_0\Phi(d_1) - p(0, T)K\Phi(d_2), \end{aligned} \quad (2.20)$$

where d_1 and d_2 are defined as above.

Note: In the case where interest rates are constant we can use Theorem 1 to write

$$\begin{aligned} C_0 &= e^{-rT}\mathbb{E}^{\mathbb{Q}}[(S_T - K)^+], \\ &= S_0\Phi(d_1) - e^{-rT}K\Phi(d_2). \end{aligned} \quad (2.21)$$

Chapter 3

Basket Options

We now turn our attention to basket options. Pricing these options using the same techniques outlined previously does not produce a closed-form solution. Note that we are discussing this problem within the context of the Black-Scholes model. Consequently we assume that stock prices follow standard GBM dynamics and the volatility and correlations of assets are constant throughout the life of the option. Note that we do not consider the case of dividend paying assets. The central investigation of this dissertation is the subject of sums of lognormal random variables and the use of dividend yields complicates the mathematics and doesn't add significantly to the argument.

3.1 The problem

In the previous section we demonstrated that asset prices are lognormally distributed in the Black-Scholes framework. Recall that we solved the asset's risk neutral SDE to find that

$$S_t^i = S_0^i e^{(r - \frac{1}{2}\sigma_i^2)t + \sigma_i W_t^i},$$

which led us to the assets distribution as

$$\ln S_t^i \sim N(\ln S_0^i + (r - \frac{1}{2}\sigma_i^2)t, \sigma_i^2 t),$$

under the risk neutral measure \mathbb{Q} . Knowing the distribution of the underlying was crucial to evaluating (2.9).

Now let us define a basket of n stocks by

$$\begin{aligned} B_t &= \sum_{i=1}^n w_i S_t^i, \\ &= \sum_{i=1}^n \alpha_i e^{Y_i}, \end{aligned} \tag{3.1}$$

where

$$\alpha_i = w_i S_0^i e^{(r - \frac{1}{2}\sigma_i^2)t}, \quad (3.2)$$

and

$$Y_i = \sigma_i W_t^i.$$

So Y_i is normally distributed with $Y_i \sim N(0, \sigma_i^2 t)$.

Note that B_t is not lognormally distributed. There is no analytical expression for the distribution of B_t . Consequently, we are unable to follow the same steps that we did in (2.9), where we used our knowledge of the assets distribution to evaluate

$$C_0 = S_0 \mathbb{Q}_S[S_T \geq K] - p(0, T)K \mathbb{Q}^T[S_T \geq K].$$

Indeed, attempting to find a closed-form solution to $\mathbb{E}[(B_T - K)^+]$ without an analytical form for the distribution of B_T is bound to prove hopeless. However, there are several methods we may employ to obtain closed-form approximations for the distribution of the basket. Using these distributions allows us to write out analytical expressions for the approximate price of the basket option. In the next sections we will examine these approximations and compare them to market methods.

3.2 Implied volatility and market methods

If we write the value of the call as a function of the assets in the basket $C(t, B_t)$ and apply Ito's lemma we obtain the following:

$$dC = \frac{\partial C}{\partial t} + \frac{\partial C}{\partial B_t} dB_t^i + \frac{1}{2} \frac{\partial^2 C}{\partial B_t^2} dB_t^2. \quad (3.3)$$

If we expand dB_t^2 in terms of the underlying stocks we obtain:

$$dB_t^2 = \sum_{i=1}^n \sum_{j=i}^n (a_i r S_t^i dt + a_i \sigma_i S_t^i dW_t^i) (a_j r S_t^j dt + a_j \sigma_j S_t^j dW_t^j), \quad (3.4)$$

$$= \sum_{i=1}^n \sum_{j=i}^n a_i \sigma_i S_t^i dW_t^i a_j \sigma_j S_t^j dW_t^j, \quad (3.5)$$

$$= \sum_{i=1}^n \sum_{j=i}^n B_t^2 \frac{a_i S_t^i}{B_t} \frac{a_j S_t^j}{B_t} \Sigma_{ij}, \quad (3.6)$$

$$= B_t^2 W \Sigma W^T. \quad (3.7)$$

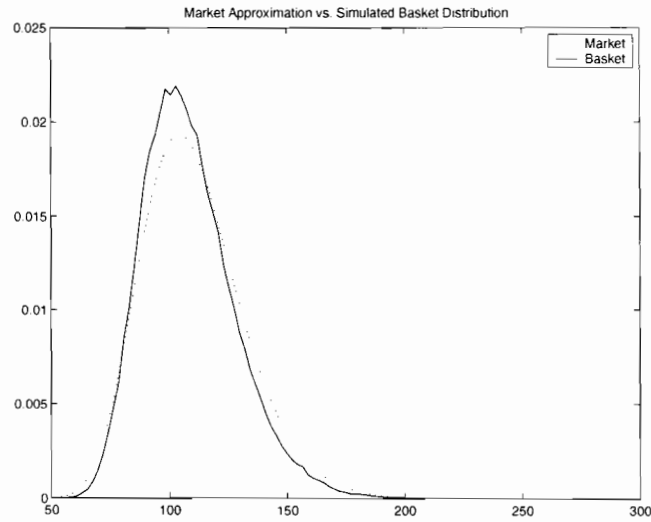

Figure 3.1: $a_1 = a_2 = 0.5\sigma_1 = \sigma_2 = 0.2$, $T = 1$, $r = 0.05$, $S_1 = S_2 = 100$

From this we easily obtain the general Black-Scholes PDE where the call has payoff function $\Phi(B_T)$.¹

$$\frac{\partial C}{\partial t} + \frac{\partial C}{\partial B_t} r B_t + \frac{1}{2} W \Sigma W^T B_t^2 \frac{\partial^2 C}{\partial B_t^2} - r C = 0. \quad (3.8)$$

(3.9)

where

$$C(T, B_T) = \Phi(B_T), \quad (3.10)$$

The Feynman-Kac Theorem allows us to write the solution to this PDE as discounted expected value of the payoff, where B_t has the following dynamics

$$dB_t = r B_t dt + \sqrt{W \Sigma W^T} B_t dW_t. \quad (3.11)$$

This looks similar to the dynamics of the single stock we examined in the previous section, however, in this case, the volatility is stochastic (since it depends on the weights of the stocks in the basket) and the basket is no longer lognormally distributed.

It is common practice to use the quantity $\sqrt{W \Sigma W^T}$ as the implied Black-Scholes volatility. The market assumption that this quantity is constant results in what is known as ‘tracking error’.

¹Note change of notation here.

3.3 A normal approximation

As a first naive approach we might approximate the lognormal distribution by a normal one. Then, noting that the sum of a set of normal random variables is still normal, we may proceed to price the option. The main problem with this is that the normal distribution is light-tailed, whereas assets typically exhibit heavy tailed distributions¹. Consequently this method is likely to underprice the option. Below we give an approximation noticing that that $\sigma_i^2 t$ is typically small for small t , allowing us to employ the approximation developed in Appendix A.16. This states that if X is lognormally distributed, with $\ln X \sim N(\mu, \sigma^2)$ and $\sigma \ll 1$ we may approximate X by a variable Y where $Y \sim N(e^\mu, (\sigma e^\mu)^2)$.² In the case of basket options, we may approximate a single stock's distribution by a normal distribution, and then note that the sum of normal random variables is still normally distributed. This gives us a closed-form approximation for the basket density.

Now, since $\ln S_t \sim N(\ln S_0 + (r - \frac{1}{2}\sigma^2)t, \sigma^2 t)$ we can use this method to write

$$S_t^i \sim N(S_0^i e^{(r - \frac{1}{2}\sigma_i^2)t}, (\sigma_i \sqrt{t} S_0^i e^{(r - \frac{1}{2}\sigma_i^2)t})^2),$$

where

$$\begin{aligned} \text{Cov}(S_t^i, S_t^j) &= \sigma_i \sqrt{t} S_0^i e^{(r - \frac{1}{2}\sigma_i^2)t} \rho_{ij}^S \sigma_j \sqrt{t} S_0^j e^{(r - \frac{1}{2}\sigma_j^2)t} \\ &= S_0^i S_0^j \sigma_i \sigma_j \rho_{ij}^S t e^{(2r - \frac{1}{2}(\sigma_i^2 + \sigma_j^2))t}. \end{aligned} \quad (3.12)$$

(Note that ρ^S in the above expression is the correlation between the stock prices and NOT the correlations between the driving Brownian motions. We assume that this correlation does not change as a result of the approximation. Appendix B.13 contains the derivation for this quantity.)

Now, we can write the approximate distribution of B_t as

$$B_t \sim N \left(\sum_{i=1}^n (a_i S_0^i e^{(r - \frac{1}{2}\sigma_i^2)t}), \sum_{i,j=1}^n (a_i a_j S_0^i S_0^j \sigma_i \sigma_j \rho_{ij}^S t e^{(2r - \frac{1}{2}(\sigma_i^2 + \sigma_j^2))t}) \right). \quad (3.13)$$

To simplify the notation, write this as

$$B_t \sim N(\mu_B, \sigma_B^2), \quad (3.14)$$

where

$$\mu_B = \sum_{i=1}^n (a_i S_0^i e^{(r - \frac{1}{2}\sigma_i^2)t}), \quad (3.15)$$

and

$$\sigma_B^2 = \sum_{i,j=1}^n (a_i a_j S_0^i S_0^j \sigma_i \sigma_j \rho_{ij}^S t e^{(2r - \frac{1}{2}(\sigma_i^2 + \sigma_j^2))t}). \quad (3.16)$$

$$= A \Sigma A^T, \quad (3.17)$$

¹This means that events further from the mean have higher probabilities

²This condition is less likely to be satisfied as T increases

where A is the row vector $A = (a_1, a_2, \dots, a_n)$ and Σ is the variance-covariance matrix of the S_t^i 's. Knowing the approximate distribution of B_t under \mathbb{Q} , we can proceed to evaluate a call price.

$$C_B(0) = e^{-rT} \mathbb{E}^{\mathbb{Q}}[(B_T - K)^+]. \quad (3.18)$$

To solve this consider, a normally distributed variable, $X \sim N(\mu, \sigma^2)$:

$$\mathbb{E}^{\mathbb{Q}}[(X - K)^+] = \int_{-\infty}^{\infty} (x - K)^+ f(x) dx, \quad (3.19)$$

$$= \int_{-\infty}^{\infty} \frac{(x - K)^+}{\sqrt{2\pi}\sigma} \exp\left(-\frac{(x - \mu)^2}{2\sigma^2}\right) dx. \quad (3.20)$$

Now, consider $Z = \frac{X - \mu}{\sigma}$ so we can write (3.20) as

$$\begin{aligned} \mathbb{E}^{\mathbb{Q}}[(X - K)^+] &= \int_{-\infty}^{\infty} \frac{(\sigma z + \mu - K)^+}{\sqrt{2\pi}} e^{-\frac{z^2}{2}} dz, \\ &= \int_{(K - \mu)/\sigma}^{\infty} \frac{\sigma z + \mu - K}{\sqrt{2\pi}} e^{-\frac{z^2}{2}} dz, \\ &= \frac{\sigma}{\sqrt{2\pi}} \int_{(K - \mu)/\sigma}^{\infty} z e^{-\frac{z^2}{2}} dz - (K - \mu) \int_{(K - \mu)/\sigma}^{\infty} \frac{1}{\sqrt{2\pi}} e^{-\frac{z^2}{2}} dz, \\ &= \frac{\sigma}{\sqrt{2\pi}} \int_{(K - \mu)/\sigma}^{\infty} z e^{-\frac{z^2}{2}} dz - (K - \mu)(1 - \Phi((K - \mu)/\sigma)). \end{aligned} \quad (3.21)$$

The first part of (3.21) may be evaluated as

$$\begin{aligned} \frac{\sigma}{\sqrt{2\pi}} \int_{(K - \mu)/\sigma}^{\infty} z e^{-\frac{z^2}{2}} dz &= \frac{\sigma}{\sqrt{2\pi}} \left[-e^{-\frac{z^2}{2}} \right]_{(K - \mu)/\sigma}^{\infty}, \\ &= \frac{\sigma}{\sqrt{2\pi}} \exp\left(-\frac{(K - \mu)^2}{2\sigma^2}\right). \end{aligned} \quad (3.22)$$

Using the fact that $B_T \sim N(\mu_B, \sigma_B^2)$, we may use the above to evaluate the call as

$$\begin{aligned} C_B(0) &= e^{-rT} \left[\frac{\sigma_B}{\sqrt{2\pi}} \exp\left(-\frac{(K - \mu_B)^2}{2\sigma_B^2}\right) - (K - \mu_B)(1 - \Phi((K - \mu_B)/\sigma_B)) \right], \\ &= e^{-rT} \left[\frac{\sigma_B}{\sqrt{2\pi}} \exp\left(-\frac{(K - \mu_B)^2}{2\sigma_B^2}\right) - (K - \mu_B)\Phi((\mu_B - K)/\sigma_B) \right]. \end{aligned} \quad (3.23)$$

See Fig. 3.2

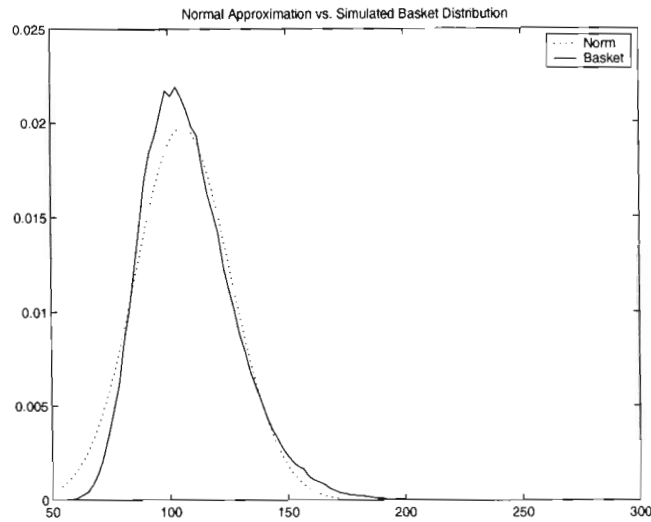

Figure 3.2: $a_1 = a_2 = 0.5$, $\sigma_1 = \sigma_2 = 0.2$, $T = 1$, $r = 0.05$, $S_1 = S_2 = 100$

3.4 A first order approximation

Noting the problem of light tails, we may instead approximate the basket's distribution as being lognormal which will have heavier tails than the approximating normal distribution. The markets estimation of the basket volatility comes from this approximation, however, in the market method, the mean is not appropriately adjusted. Below we give an option price based on this first order approximation.

We can employ the first order approximation to the exponential function to approximate a log-normal distribution. Recall that each $S_T^i = S_0^i \exp\left(\left(r - \frac{1}{2}\sigma_i^2\right)T + \sigma_i W_T^i\right)$. Let us assume that the basket is also distributed lognormally, so $B_T = B_0 e^Y$ where Y is normally distributed with $Y \sim N(\mu, \sigma^2)$. Writing the expression for B_T yields

$$\begin{aligned} B_T &= B_0 e^Y, \\ &= \sum_{i=1}^n a_i S_T^i, \\ &= \sum_{i=1}^n a_i S_0^i \exp\left(\left(r - \frac{1}{2}\sigma_i^2\right)T + \sigma_i W_T^i\right), \end{aligned}$$

where the a_i 's are the quantities of each element in the basket. So, we can write e^Y as a weighted sum:

$$e^Y = \sum_{i=1}^n \frac{a_i S_0^i}{B_0} \exp\left(\left(r - \frac{1}{2}\sigma_i^2\right)T + \sigma_i W_T^i\right).$$

Using the first order approximation developed in Appendix A.28 we can write

$$Y \sim N\left(\sum_{i=1}^n w_i \left(r - \frac{1}{2}\sigma_i^2\right)T, W \Sigma W^T\right),$$

where Σ is the covariance matrix, w_i is the weight of the i 'th asset in the basket and W is the row vector of the weights.

Consequently B_T is lognormally distributed with

$$\ln B_T \sim N \left(\ln B_0 + \left(r - \frac{1}{2} \sum_{i=1}^n w_i \sigma_i^2 \right) T, W \Sigma W^T \right). \quad (3.24)$$

To simplify notation let us write

$$\begin{aligned} \sigma_{av}^2 &= \sum_{i=1}^n w_i \sigma_i^2, \\ \sigma_B^2 &= \frac{W \Sigma W^T}{T}, \\ \text{so } \ln B_T &\sim N \left(\ln B_0 + \left(r - \frac{1}{2} \sigma_{av}^2 \right) T, \sigma_B^2 T \right). \end{aligned}$$

Using Theorem 1 we immediately obtain

$$\begin{aligned} C_B(0, T) &= e^{-rT} \mathbb{E}^\mathbb{Q}[(B_T - K)^+], \\ &= e^{-rT} (\mathbb{E}^\mathbb{Q}[B_T] \Phi(d_1) - K \Phi(d_2)), \\ &= e^{-rT} \left(B_0 e^{(r - \frac{1}{2} \sigma_{av}^2 + \frac{1}{2} \sigma_B^2) T} \Phi(d_1) - K \Phi(d_2) \right), \\ &= B_0 e^{\frac{1}{2} (\sigma_B^2 - \sigma_{av}^2) T} \Phi(d_1) - e^{-rT} K \Phi(d_2), \end{aligned} \quad (3.25)$$

where

$$d_1 = \frac{\ln \frac{B_0}{K} + (r - \frac{1}{2} \sigma_{av}^2 + \sigma_B^2) T}{\sigma_B \sqrt{T}},$$

and

$$d_2 = d_1 - \sigma_B \sqrt{T}.$$

This is very similar to the option pricing formula used in the market. The formula above differs from the market approximation because σ_{av} is not the same as σ_B as in the case of a single underlying asset so they don't cancel (as they did in the proof of Theorem 1). Note, the use of this approximation is only justified when $(r - \frac{1}{2} \sigma^2)t + \sigma W_t$ is small ($\ll 1$). Fig. 3.3 shows a first order approximate distribution against a simulated basket.

3.5 Moment matching techniques

We now see what happens if, instead of trying to approximate the distribution by ignoring higher order terms, we simply constrain it to match the first two moments of the theoretical distribution. So, for example, if we decide the final distribution is normal, we can generate a normal distribution with the same mean and variance as the 'true' distribution.

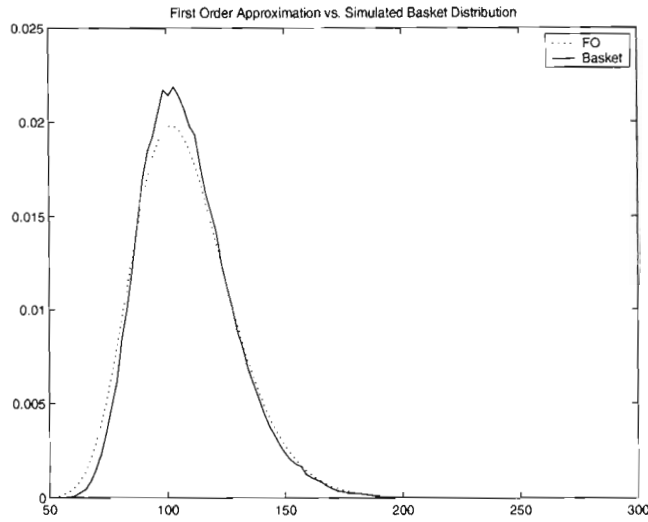

Figure 3.3: $a_1 = a_2 = 0.5\sigma_1 = \sigma_2 = 0.2, T = 1, r = 0.05, S_1 = S_2 = 100$

This approach has been used in several papers, but we shall follow Brigo et al. [5].

Since the market has settled on the lognormal distribution as a reasonable approximation, let us see what happens when we match the first two moments of a lognormal distribution.

Since we are still working in the Black-Scholes world, we assume that stock prices follow the standard dynamics

$$\frac{dS_t^i}{S_t^i} = rdt + \sigma_i dW_t^i,$$

and the Brownian motions driving these processes are correlated according to

$$dW_t^i dW_t^j = \rho_{ij} dt,$$

and the basket is, as usual, defined by

$$B_t = \sum_{i=1}^n a_i S_t^i.$$

The moments of the basket are straightforward to calculate.

$$\begin{aligned} \mathbb{E}^{\mathbb{Q}}[B_t] &= \mathbb{E}^{\mathbb{Q}}\left[\sum_{i=1}^n a_i S_t^i\right], \\ &= \sum_{i=1}^n a_i \mathbb{E}^{\mathbb{Q}}[S_t^i], \\ &= \sum_{i=1}^n a_i \mathbb{E}^{\mathbb{Q}}\left[S_0^i e^{(r-1/2\sigma_i^2)t + \sigma_i W_t^i}\right], \\ &= \sum_{i=1}^n a_i S_0^i e^{(r-1/2\sigma_i^2)t} \mathbb{E}^{\mathbb{Q}}\left[e^{\sigma_i W_t^i}\right]. \end{aligned} \tag{3.26}$$

Recall that $\sigma W_t \sim N(0, \sigma^2 t)$ so $E[e^{\sigma_i W_t^i}] = e^{\frac{1}{2}\sigma_i^2 t}$ (from the moment generating function of a normal random variable) therefore, we can write the expression in (3.26) as

$$\begin{aligned}\mathbb{E}^{\mathbb{Q}}[B_t] &= \sum_{i=1}^n a_i S_0^i e^{(r-1/2\sigma_i^2)t} e^{\frac{1}{2}\sigma_i^2 t}, \\ &= \sum_{i=1}^n a_i S_0^i e^{rt}.\end{aligned}\tag{3.27}$$

Similarly we may calculate the second moment of the distribution as

$$\begin{aligned}\mathbb{E}^{\mathbb{Q}}[B_t^2] &= \mathbb{E}^{\mathbb{Q}}\left[\left(\sum_{i=1}^n a_i S_t^i\right)^2\right], \\ &= \sum_{i,j=1}^n a_i a_j \mathbb{E}^{\mathbb{Q}}[S_t^i S_t^j], \\ &= \sum_{i,j=1}^n a_i a_j \mathbb{E}^{\mathbb{Q}}\left[S_0^i e^{(r-1/2\sigma_i^2)t + \sigma_i W_t^i} S_0^j e^{(r-1/2\sigma_j^2)t + \sigma_j W_t^j}\right], \\ &= \sum_{i,j=1}^n a_i a_j S_0^i S_0^j e^{(2r-1/2(\sigma_i^2 + \sigma_j^2))t} \mathbb{E}^{\mathbb{Q}}[e^{\sigma_i W_t^i + \sigma_j W_t^j}].\end{aligned}$$

Recall again that $\sigma_i W_t^i + \sigma_j W_t^j \sim N(0, (\sigma_i^2 + \sigma_j^2 + 2\rho_{ij}\sigma_i\sigma_j)t)$ consequently we may write the second moment as

$$\begin{aligned}\mathbb{E}^{\mathbb{Q}}[B_t^2] &= \sum_{i,j=1}^n a_i a_j S_0^i S_0^j e^{(2r-1/2(\sigma_i^2 + \sigma_j^2))t} e^{\frac{1}{2}(\sigma_i^2 + \sigma_j^2 + 2\rho_{ij}\sigma_i\sigma_j)t}, \\ &= \sum_{i,j=1}^n a_i a_j S_0^i S_0^j e^{(2r+\rho_{ij}\sigma_i\sigma_j)t}.\end{aligned}\tag{3.28}$$

Now, let us make the assumption that the approximate distribution is lognormal, so the approximate basket dynamics are

$$\frac{d\bar{B}_t}{\bar{B}_t} = rdt + \sigma_B dW_t.\tag{3.29}$$

The approximate moments are easily calculated as

$$\begin{aligned}\mathbb{E}^{\mathbb{Q}}[\bar{B}_t] &= \mathbb{E}^{\mathbb{Q}}[B_0 e^{(r-1/2\sigma_B^2)t + \sigma_B W_t}], \\ &= B_0 e^{rt}.\end{aligned}\tag{3.30}$$

and

$$\begin{aligned}\mathbb{E}^{\mathbb{Q}}[\bar{B}_t^2] &= \mathbb{E}^{\mathbb{Q}}[B_0^2 e^{(2r-\sigma_B^2)t + 2\sigma_B W_t}], \\ &= B_0^2 e^{(2r-\sigma_B^2)t} e^{2\sigma_B^2 t}, \\ &= B_0^2 e^{(2r+\sigma_B^2)t}.\end{aligned}\tag{3.31}$$

(since $2\sigma_B W_t \sim N(0, 4\sigma_B^2 t)$ and $E[e^{2\sigma_B W_t}] = e^{2\sigma_B^2 t}$).

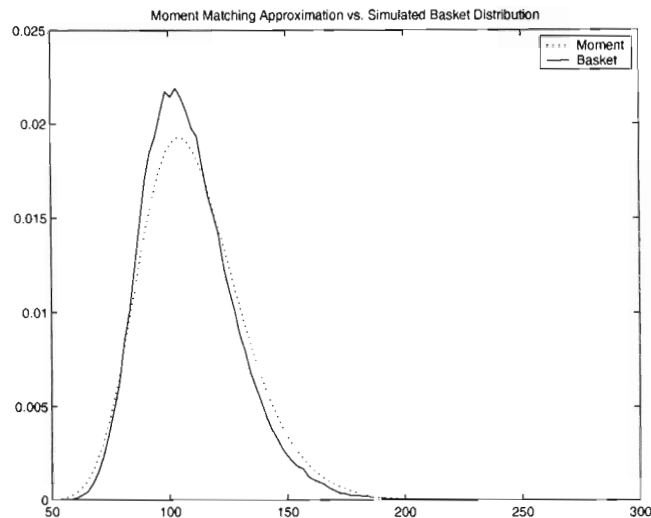

Figure 3.4: $a_1 = a_2 = 0.5$, $\sigma_1 = \sigma_2 = 0.2$, $T = 1$, $r = 0.05$, $S_1 = S_2 = 100$

The first moments are already equal. Equating the “true” and approximate second moments yields:

$$\sum_{i,j=1}^n a_i a_j S_0^i S_0^j e^{(2r + \rho_{ij} \sigma_i \sigma_j)t} = B_0^2 e^{(2r + \sigma_B^2)t}, \quad (3.32)$$

therefore

$$\frac{\sum_{i,j=1}^n a_i a_j S_0^i S_0^j e^{\rho_{ij} \sigma_i \sigma_j t}}{B_0^2} = e^{\sigma_B^2 t}. \quad (3.33)$$

Rearranging, we obtain

$$\sigma_B^2 = \frac{1}{t} \ln \left(\frac{\sum_{i,j=1}^n a_i a_j S_0^i S_0^j e^{\rho_{ij} \sigma_i \sigma_j t}}{(\sum_{i=1}^n a_i S_0^i)^2} \right). \quad (3.34)$$

See Fig. 3.4

Chapter 4

Bounds on the Option Price

4.1 Comonotonic bounds

These are the best and most analytically tractable bounds we have been able to find. The theory presented here has been developed in Kaas et al. [18], Dhaene et al. [8], Dhaene et al. [9] and Valdez and Dhaene [25]. The theory allows us to decompose the stop-loss premium on the basket as a sum of the stop-loss premiums on its components. These sums can be expressed as averages of Black-Scholes formulae which, in turn, allows us to easily calculate the Greeks for the bounds. Before we discuss the derivation of these bounds it is necessary to introduce some theory.

4.1.1 Some Probability Theory

In this section we state, without proof, some well-known results from probability theory.

Proposition 4.1. Jensen's inequality

For any convex function v The following inequality holds

$$v(\mathbb{E}[X|\Lambda]) \leq \mathbb{E}[v(X)|\Lambda], \quad (4.1)$$

provided $v(X)$ is integrable.

Proposition 4.2. The Tower Property

If Λ_1 and Λ_2 are random variables and $\sigma_{\Lambda_1} \subseteq \sigma_{\Lambda_2}$ where σ_{Λ_i} refers to the sigma algebra generated by Λ_i , $i = 1, 2$ then

$$\mathbb{E}[\mathbb{E}[X|\Lambda_1]|\Lambda_2] = \mathbb{E}[X|\Lambda_1].$$

Specifically, in the case where $\Lambda_1 = \{\phi, \Omega\}$

$$\begin{aligned}\mathbb{E}[\mathbb{E}[X|\Lambda_1]|\Lambda_2] &= \mathbb{E}[\mathbb{E}[X|\Lambda_1]], \\ &= \mathbb{E}[X].\end{aligned}\quad (4.2)$$

Proposition 4.3. *If g is left continuous and non-decreasing then*

$$F_{g(X)}^{-1} = g(F_X^{-1}), \quad (4.3)$$

where F_X^{-1} is defined as

$$F_X^{-1}(p) = \inf \{x | P(X \leq x) \leq p\}.$$

Theorem 4.1. The Quantile Transform Theorem

If U is a standard uniform random variable then

$$F_X^{-1}(U) \stackrel{d}{=} X. \quad (4.4)$$

Theorem 4.2. The Probability Integral Transform Theorem

$$F_X(X) \stackrel{d}{=} U(0, 1). \quad (4.5)$$

4.1.2 Comonotonic random variables and Convex Order

Definition 4.1. *A random variable X is said to precede another random variable Y in convex order, written as $X \prec_{cx} Y$ if for all convex functions v for which expectations exist*

$$\mathbb{E}[v(X)] \leq \mathbb{E}[v(Y)].$$

Alternatively, it can be shown ([8], [25]) that $X \prec_{cx} Y$ if and only if $\mathbb{E}[X] = \mathbb{E}[Y]$ and

$$\mathbb{E}[(X - K)^+] \leq \mathbb{E}[(Y - K)^+]. \quad (4.6)$$

Equation (4.6) is referred to as *stop-loss order* and is written \prec_{sl} . Since stop-loss premiums amount to measures for the upper tail of the distribution function, $X \prec_{cx} Y$ means that observing large outcomes for Y is more likely than for X .

Now, consider an n -dimensional random vector $X = (X_1, X_2, \dots, X_n)^T$ with multivariate distribution function given by $F_X(x) = \mathbb{P}(X_1 \leq x_1, X_2 \leq x_2, \dots, X_n \leq x_n)$ for any $x = (x_1, x_2, \dots, x_n)^T$. It is well-known that this distribution function satisfies the so-called Fréchet bounds (Fréchet [11], Hoeffding [13]):

$$\max \left(\sum_{k=1}^n F_{X_k}(x_k) - (n-1), 0 \right) \leq F_X(x) \leq \min(F_{X_1}(x_1), F_{X_2}(x_2), \dots, F_{X_n}(x_n)). \quad (4.7)$$

Definition 4.2. A Set S in \mathbb{R}^n is said to be comonotonic if, for all (x_1, x_2, \dots, x_n) and (y_1, y_2, \dots, y_n) in S , $x_i \leq y_i \Rightarrow x_j \leq y_j \forall j$.

Note that comonotonic sets are ‘thin’ sets. Since the top left and bottom right corner of any rectangle cannot both be contained in the set, the set must be a curve that is monotonically increasing in each component. It cannot have a subset of dimension larger than 1.

Proposition 4.4. The connected closure \bar{S} of a comonotonic set S is a continuous comonotonic curve.

Definition 4.3. The support of a random variable X is defined as the set A s.t $\mathbb{P}(X \in A) = 1$.

Proposition 4.5. If the support of a random vector (X_1, X_2, \dots, X_n) is contained within the connected closed curve \bar{S} then the joint cdf of (X_1, X_2, \dots, X_n) must have the following form:

$$F_X(x) = \min(F_{X_1}(x_1), F_{X_2}(x_2), \dots, F_{X_n}(x_n)). \quad (4.8)$$

Proof. We are looking at the total probability of the region $R = R_1 \cap R_2 \cap \dots \cap R_n$ where $R_j = \{t \in \mathbb{R}^n | t_j \leq x_j\}$. As the vector s traverses \bar{S} in the upward direction it must reach one of the boundary planes $\{t \in \mathbb{R}^n | t_j = x_j\}$ first. Let k be the index corresponding to this boundary plane. Then $\mathbb{P}[X_k \leq x_k] = \min_j \mathbb{P}[X_j \leq x_j]$ Hence the event, $X_1 \leq x_1, X_2 \leq x_2, \dots, X_n \leq x_n$ has the same probability as $X_k \leq x_k$. \square

Definition 4.4. A random vector X is said to be comonotonic if its joint distribution is given by the Frechet upper bound as in (4.7).

Proposition 4.6. The following vector has a comonotonic support, and moreover, it has the same marginal distributions as (X_1, X_2, \dots, X_n) :

$$(Y_1, Y_2, \dots, Y_n) = (F_{X_1}^{-1}(U), F_{X_2}^{-1}(U), \dots, F_{X_n}^{-1}(U)). \quad (4.9)$$

Where U is uniform $[0,1]$ random variable.

Proof. Clearly (Y_1, Y_2, \dots, Y_n) has the same marginals as (X_1, X_2, \dots, X_n) , since $F_{X_i}^{-1}(U)$ is distributed according to F_{X_i} . Now let (y_1, y_2, \dots, y_n) and (z_1, z_2, \dots, z_n) be two outcomes of (Y_1, Y_2, \dots, Y_n) . Therefore, if $F_{X_i}^{-1}(u) = z_i \leq y_i = F_{X_i}^{-1}(v)$ then $u \leq v$. Consequently, $\forall j, z_j = F_{X_j}^{-1}(u) \leq F_{X_j}^{-1}(v) = y_j$. \square

Proposition 4.7. The joint cdf of the comonotonic vector (Y_1, Y_2, \dots, Y_n) with the same marginals as (X_1, X_2, \dots, X_n) satisfies:

$$\mathbb{P}[Y_1 < y_1, Y_2 < y_2, \dots, Y_n < y_n] = \min_{j=1, \dots, n} \mathbb{P}[X_j < y_j]. \quad (4.10)$$

Proof. By definition, since (Y_1, Y_2, \dots, Y_n) is comonotonic it has the joint cdf

$$\mathbb{P}[Y_1 < y_1, Y_2 < y_2, \dots, Y_n < y_n] = \min_{j=1, \dots, n} \mathbb{P}[Y_j < y_j].$$

and, since (Y_1, Y_2, \dots, Y_n) has the same marginals as (X_1, X_2, \dots, X_n) ,

$$\min_{j=1, \dots, n} \mathbb{P}[Y_j < y_j] = \min_{j=1, \dots, n} \mathbb{P}[X_j < y_j].$$

□

Note that this implies that the cdf of (Y_1, Y_2, \dots, Y_n) is as large as it possibly can be whilst still having the required marginal distributions. (Recall that Y has the same distribution as the Fréchet upper bound for X , and the Fréchet upper bound is a bound on ALL random vectors with the same marginals.)

Proposition 4.8. *If the random vector (Y_1, Y_2, \dots, Y_n) is comonotonic and has the same marginals as (X_1, X_2, \dots, X_n) , then*

$$X_1 + X_2 + \dots + X_n \prec_{cx} Y_1 + Y_2 + \dots + Y_n. \quad (4.11)$$

Proof. It suffices to show that $X \prec_{sl} Y$ since it is obvious that these two sums have the same mean. The following holds for all (x_1, x_2, \dots, x_n) when $K_1 + K_2 + \dots + K_n = K$:

$$\begin{aligned} (x_1 + x_2 + \dots + x_n - K)^+ &= ((x_1 - K_1) + (x_2 - K_2) + \dots + (x_n - K_n))^+, \\ &\leq ((x_1 - K_1)^+ + (x_2 - K_2)^+ + \dots + (x_n - K_n)^+)^+, \\ &= (x_1 - K_1)^+ + (x_2 - K_2)^+ + \dots + (x_n - K_n)^+. \end{aligned}$$

Now, since Y is comonotonic, the support S of Y is upwards pointing in all components, consequently it only has one point of intersection with the hyperplane $(x_1 + x_2 + \dots + x_n = K)$. Without loss of generality we can assume (K_1, K_2, \dots, K_n) is this point (since we have made no specification about how K is decomposed). We may now write the following equality.

$$(y_1 + y_2 + \dots + y_n - K)^+ \equiv (y_1 - K_1)^+ + (y_2 - K_2)^+ + \dots + (y_n - K_n)^+.$$

This follows from the fact that whenever $y_i > K_i$ for some i then $y_j > K_j$ for all j by comonotonicity. Taking expectations and using the relationships above, we can write:

$$\begin{aligned} \mathbb{E}[(Y_1 + Y_2 + \dots + Y_n - K)^+] &= \mathbb{E}[(Y_1 - K_1)^+] + \mathbb{E}[(Y_2 - K_2)^+] + \dots + \mathbb{E}[(Y_n - K_n)^+], \\ &= \mathbb{E}[(X_1 - K_1)^+] + \mathbb{E}[(X_2 - K_2)^+] + \dots + \mathbb{E}[(X_n - K_n)^+] \quad (4.12) \\ &\geq \mathbb{E}[(X_1 + X_2 + \dots + X_n - K)^+]. \end{aligned}$$

□

In what follows S denotes the sum $\sum_{i=1}^n X_i$ and we shall use the superscript c to denote comonotonicity of a random vector. Hence the vector $X = (X_1^c, X_2^c, \dots, X_n^c)^T$ is the comonotonic random vector

with the same marginals as the vector $X = (X_1, X_2, \dots, X_n)^T$. It is called the comonotonic counterpart of X .

Consider the comonotonic sum $S^c = X_1^c + X_2^c + \dots + X_n^c$.

Proposition 4.9. *Each quantile of S^c is equal to the sum of the corresponding quantiles of the marginals :*

$$F_{S^c}^{-1}(q) = \sum_{i=1}^n F_{X_i^c}^{-1}(q). \quad (4.13)$$

Proof. This follows from (4.3). Let $g(X) = \sum_{i=1}^n X_i$ then

$$\begin{aligned} F_{S^c}^{-1}(q) &= F_{g(X^c)}^{-1}(q), \\ &= g(F_{X^c}^{-1}(q)), \\ &= \sum_{i=1}^n F_{X_i^c}^{-1}(q). \end{aligned}$$

□

In the case where all the marginal distributions F_{X_k} are strictly increasing, the stop-loss premiums of a comonotonic sum can easily be computed to be the sum of the stop-loss premiums of the marginals.

$$\mathbb{E}[(S^c - K)^+] = \sum_{i=1}^n \mathbb{E}[(X_i - K_i)^+], \quad (4.14)$$

where K_j is determined as

$$K_j = F_{X_j}^{-1} F_{S^c}(K).$$

To see that this is the correct definition of the K_j 's note that

$$\begin{aligned} K &= F_{S^c}^{-1} F_{S^c}(K), \\ &= \sum_{i=1}^n F_{X_i}^{-1} F_{S^c}(K). \end{aligned}$$

We have now shown that S^c is a convex order upper bound for S (see (4.11)) Indeed, since the cdf of the random vector (Y_1, Y_2, \dots, Y_n) is the largest it can possibly be (i.e. equal to the Fréchet upper bound of X), S^c is the least upper bound for S . Let us now suppose that we have more information about X in the sense that we have a random variable Λ^1 with a known distribution, and that we also know the conditional distributions of the random variables $X_k | \Lambda = \lambda$ for all outcomes λ of Λ and for all $k = 1, 2, \dots, n$. Moreover, let us assume that there exists a Λ such that $\mathbb{E}[X_i | \Lambda]$ is a continuous non-decreasing function of Λ and that the cdfs of $\mathbb{E}[X_i | \Lambda]$ are continuous

¹(4.68)

and non-decreasing. Let $F_{X_k|\Lambda}^{-1}(U)$ be notation for the random variable $f_k(U, \Lambda)$ where the function f_k is defined by $f_k(u, \lambda) = F_{X_k|\Lambda=\lambda}^{-1}(u)$. Now, consider a random vector $X^u = (X_1^u, X_2^u, \dots, X_n^u)^T$ where X_k^u is given by

$$X_k^u = F_{X_k|\Lambda}^{-1}(U).$$

So, X_k^u is distributed as $X_k|\Lambda$

Proposition 4.10. X_k^u has the same distribution as X_k .

Proof.

$$\begin{aligned} F_{X_k}(x) &= \mathbb{P}(X_k \leq x), \\ &= \int_{-\infty}^{\infty} \mathbb{P}(X_k \leq x | \Lambda = \lambda) dF_{\Lambda}(\lambda), \\ &= \int_{-\infty}^{\infty} \mathbb{P}(F_{X_k|\Lambda=\lambda}^{-1}(U) \leq x) dF_{\Lambda}(\lambda), \\ &= \int_{-\infty}^{\infty} \mathbb{P}(f_k(U, \Lambda) \leq x) dF_{\Lambda}(\lambda), \\ &= \mathbb{P}(f_k(U, \Lambda) \leq x). \end{aligned}$$

□

Proposition 4.11. S^u is an improved upper bound for S .

Proof. We have shown that X^u and X have the same marginals, the result follows from (4.11). □

Proposition 4.12. $S \prec_{cx} S^u$.

Proof. Recall the definition of convex order : $X \prec_{cx} Y \Leftrightarrow \mathbb{E}[v(X)] \leq \mathbb{E}[v(Y)]$ for all convex functions v . So

$$\begin{aligned} \mathbb{E}[v(S)] &= \mathbb{E}[v(X_1 + X_2 + \dots + X_n)], \\ &= \mathbb{E}[\mathbb{E}[v(X_1 + X_2 + \dots + X_n) | \Lambda]], \\ &= \int_{-\infty}^{\infty} \mathbb{E}[v(X_1 + X_2 + \dots + X_n) | \Lambda = \lambda] dF_{\Lambda}(\lambda), \\ &\leq \int_{-\infty}^{\infty} \mathbb{E}[v(f_1(U, \lambda) + f_2(U, \lambda) + \dots + v(f_n(U, \lambda)))] dF_{\Lambda}(\lambda), \\ &= \mathbb{E}[v(f_1(U, \lambda) + f_2(U, \lambda) + \dots + v(f_n(U, \lambda)))] \end{aligned}$$

These results show that S^u is indeed an improved upper bound for S so

$$S \prec_{cx} S^u \prec_{cx} S^c.$$

□

Finally, consider the random vector $X^l = (X_1^l, X_2^l, \dots, X_n^l)^T$, where X_k^l is given by

$$X_k^l = \mathbb{E}[X_k | \Lambda].$$

Proposition 4.13. $S^l = X_1^l + X_2^l + \dots + X_n^l$ is a convex order lower bound for S .

Proof. We are required to show that $\mathbb{E}[(S^l - K)^+] \leq \mathbb{E}[(S - K)^+]$ and that $\mathbb{E}[S^l] = \mathbb{E}[S]$. Clearly this latter is true, by the tower property of conditional expectation. As for the first condition, let us write

$$\begin{aligned} \mathbb{E}[(S^l - K)^+] &= \mathbb{E}\left[\left(\sum_{i=1}^n \mathbb{E}[X_i | \Lambda] - K\right)^+\right], \\ &= \mathbb{E}\left[\left(\mathbb{E}\left[\sum_{i=1}^n X_i | \Lambda\right] - K\right)^+\right], \\ &\leq \mathbb{E}\left[\mathbb{E}\left[\left(\sum_{i=1}^n X_i - K\right)^+ | \Lambda\right]\right], \\ &= \mathbb{E}\left[\left(\sum_{i=1}^n X_i - K\right)^+\right], \end{aligned}$$

So we have shown that

$$S^l \prec_{cx} S \prec_{cx} S^u \prec_{cx} S^c. \quad (4.15)$$

□

We now apply these bounds for the case where the X_i 's are lognormally distributed. The results we obtain here will be useful in the next section when we deal with basket options.

Example 4.1. A comonotonic bound for the stop-loss premiums of a sum of lognormal random variables.

Consider $X = (X_1, X_2, \dots, X_n)$, where X_i is lognormally distributed for each i with

$$\ln X_i \sim N(\mu_i, \sigma_i^2).$$

Now, from the moment generating function of a normal random variable we easily obtain

$$\mathbb{E}[X_i] = e^{\mu_i + 1/2\sigma_i^2},$$

and

$$\text{Var}[X_i] = e^{2\mu_i + \sigma_i^2} (e^{\sigma_i^2} - 1). \quad (4.16)$$

Note that

$$F_{X_i}^{-1}(p) = e^{\mu_i + \sigma_i \Phi^{-1}(p)}. \quad (4.17)$$

Theorem 1 allows us to write the stop-loss premium as

$$\mathbb{E}[(X_i - K_i)^+] = e^{\mu_i + 1/2\sigma_i^2} \Phi(d_{i,1}) - K_i \Phi(d_{i,2}),$$

where

$$d_{i,1} = \frac{\mu_i + \sigma_i^2 - \ln(K_i)}{\sigma_i}, \quad (4.18)$$

and

$$d_{i,2} = d_{i,1} - \sigma_i. \quad (4.19)$$

Let us now look at the stop-loss premium of the comonotonic sum S^c

$$\begin{aligned} \mathbb{E}[(S^c - K)^+] &= \sum_{i=1}^n \mathbb{E}[(X_i - K_i)^+], \\ &= \sum_{i=1}^n e^{\mu_i + 1/2\sigma_i^2} \Phi(d_{i,1}) - K_i \Phi(d_{i,2}). \end{aligned} \quad (4.20)$$

Now, $K_i = F_{X_i}^{-1}(F_{S^c}(K))$ which we know from (4.17) can be written as $e^{\mu_i + \sigma_i \Phi^{-1}(F_{S^c}(K))}$ so $d_{i,1} = \sigma_i - \Phi^{-1}(F_{S^c}(K))$ and $d_{i,2} = -\Phi^{-1}(F_{S^c}(K))$. So we can rewrite (4.20) as

$$\begin{aligned} \mathbb{E}[(S^c - K)^+] &= \sum_{i=1}^n e^{\mu_i + 1/2\sigma_i^2} \Phi(\sigma_i - \Phi^{-1}(F_{S^c}(K))) - e^{\mu_i + \sigma_i \Phi^{-1}(F_{S^c}(K))} \Phi(-\Phi^{-1}(F_{S^c}(K))), \\ &= \sum_{i=1}^n e^{\mu_i + 1/2\sigma_i^2} \Phi(\sigma_i - \Phi^{-1}(F_{S^c}(K))) - \sum_{i=1}^n F_{X_i}^{-1}(F_{S^c}(K)) (1 - \Phi(\Phi^{-1}(F_{S^c}(K))))), \\ &= \sum_{i=1}^n e^{\mu_i + 1/2\sigma_i^2} \Phi(\sigma_i - \Phi^{-1}(F_{S^c}(K))) - K(1 - F_{S^c}(K)). \end{aligned}$$

Example 4.2. A convex lower bound for the stop-loss premiums of a sum of lognormal random variables.

Let $X_k^l = \mathbb{E}[X_k | \Lambda]$. Now, let us assume that $g_i(\lambda) = \mathbb{E}[X_i | \Lambda = \lambda]$ are non-decreasing left continuous functions of λ , which makes S^l a sum of comonotonic random variables. So, using (4.3) we can write

$$\begin{aligned} F_{S^l}^{-1}(p) &= \sum_{i=1}^n F_{\mathbb{E}[X_i | \Lambda]}^{-1}(p), \\ &= \sum_{i=1}^n F_{g_i(\Lambda)}^{-1}(p), \\ &= \sum_{i=1}^n g_i(F_{\Lambda}^{-1}(p)), \\ &= \sum_{i=1}^n \mathbb{E}[X_i | \Lambda = F_{\Lambda}^{-1}(p)]. \end{aligned}$$

Now, since S^l is comonotonic we may write

$$\begin{aligned} K &= F_{S^l}^{-1}(F_{S^l}(K)), \\ &= \sum_{i=1}^n F_{\mathbb{E}[X_i | \Lambda]}^{-1}(F_{S^l}(K)), \\ &= \sum_{i=1}^n \mathbb{E}[X_i | \Lambda = F_{\Lambda}^{-1}(F_{S^l}(K))]. \end{aligned}$$

Let $K_i = F_{\mathbb{E}[X_i|\Lambda]}^{-1}(F_{S^t}(K))$. The stop-loss premiums can be written as

$$\begin{aligned}\mathbb{E}[(S^t - K)^+] &= \sum_{i=1}^n \mathbb{E}[(\mathbb{E}[X|\Lambda] - K_i)^+], \\ &= \sum_{i=1}^n \mathbb{E}[(\mathbb{E}[X|\Lambda] - \mathbb{E}[X_i|\Lambda = F_{\Lambda}^{-1}(F_{S^t}(K))])^+].\end{aligned}$$

Now, if X is lognormally distributed, we wish to find a Λ such that we know the conditional distributions of $\mathbb{E}[X_i|\Lambda]$ for all i . Since $X_i = e^{Y_i}$ where Y_i is normally distributed, let us assume we can find a Λ such that (Y_i, Λ) is bivariate normal for all i . So let us choose

$$\Lambda = \sum_{i=1}^n \beta_i Y_i.$$

We shall discuss choices for the β_i 's later. Now, from standard results on conditional probability we have that

$$(Y|\Lambda) \sim N(\mu, \sigma),$$

where

$$\mu = \mu_Y + r_i \frac{\sigma}{\sigma_{\Lambda}} (\lambda - E^Q[\Lambda]), \quad (4.21)$$

$$\sigma^2 = (1 - r_i^2) \sigma_Y^2, \quad (4.22)$$

and

$$r_i = \frac{\text{Cov}(Y_i, \Lambda)}{\sigma_Y \sigma_{\Lambda}}. \quad (4.23)$$

This implies that $\mathbb{E}[X_i|\Lambda]$ is lognormally distributed. To see this note that

$$\begin{aligned}\mathbb{E}[X_i|\Lambda] &= \mathbb{E}[e^{Y_i}|\Lambda], \\ &= \exp(\mu + 1/2\sigma^2), \\ &= \exp\left(\mu_Y + r_i \frac{\sigma_Y}{\sigma_{\Lambda}} (\lambda - \mathbb{E}[\Lambda]) + \frac{1}{2}(1 - r_i^2)\sigma_Y^2\right), \\ &= \exp\left(\mu_Y + r_i \sigma_Y \Phi^{-1}(U) + \frac{1}{2}(1 - r_i^2)\sigma_Y^2\right), \\ &= \alpha_i e^Z.\end{aligned}$$

where $\alpha_i = \exp(\mu_Y + \frac{1}{2}(1 - r_i^2)\sigma_Y^2)$ and $Z = r_i \sigma_Y \frac{(\lambda - \mathbb{E}[\Lambda])}{\sigma_{\Lambda}}$. Since $\mathbb{E}[X_i|\Lambda]$ is lognormally distributed, and S^t is a comonotonic sum we can use the result from the previous example to yield:

$$\begin{aligned}\mathbb{E}[(S^t - K)^+] &= \sum_{i=1}^n \mathbb{E}[(X_i^t - K_i)], \\ &= \sum_{i=1}^n e^{\mu_{Y_i} + \frac{1}{2}(1 - r_i^2)\sigma_{Y_i}^2 + \frac{1}{2}r_i^2\sigma_{Y_i}^2} \Phi(d_{i,1}) - K_i \Phi(d_{i,2}), \\ &= \sum_{i=1}^n e^{\mu_{Y_i} + \frac{1}{2}\sigma_{Y_i}^2} \Phi(d_{i,1}) - K_i \Phi(d_{i,2}), \\ &= \sum_{i=1}^n e^{\mu_{Y_i} + 1/2\sigma_{Y_i}^2} \Phi(\sigma_i r_i - \Phi^{-1}(F_{S^t}(K))) - K(1 - F_{S^t}(K)).\end{aligned} \quad (4.24)$$

Note that $F_{S^t}(K)$ can be determined by solving the nonlinear equation

$$\begin{aligned} K &= F_{S^t}^{-1}(F_{S^t}(K)), \\ &= \sum_{i=1}^n F_{\mathbb{E}[X_i|\Lambda]}^{-1}(F_{S^t}(K)), \\ &= \sum_{i=1}^n \exp\left(\mu_{Y_i} + r_i \sigma_{Y_i} \Phi^{-1}(F_{S^t}(K)) + \frac{1}{2}(1 - r_i^2) \sigma_{Y_i}^2\right). \end{aligned}$$

K_i is found from $K_i = F_{X_i}^{-1}(F_{S^t}(K))$, so

$$K_i = \exp\left(\mu_{Y_i} + r_i \sigma_{Y_i} \Phi^{-1}(F_{S^t}(K)) + \frac{1}{2}(1 - r_i^2) \sigma_{Y_i}^2\right). \quad (4.25)$$

Example 4.3. *An improved upper bound for the stop-loss premiums of a sum of lognormal random variables.*

Once again, let us assume that we have additional information in the form of a conditioning random variable Λ . Define $X_k^u = F_{X|\Lambda}^{-1}(U)$ as before so that we have that $(S|\Lambda = \lambda)^c$ is an improved upper bound. Now,

$$\begin{aligned} (S|\Lambda = \lambda)^c &= \sum_{i=1}^n (X_i|\Lambda = \lambda), \\ &= \sum_{i=1}^n (e^{Y_i}|\Lambda = \lambda), \\ &= \sum_{i=1}^n \exp\left(\mu_{Y_i} + r_i \frac{\sigma_{Y_i}}{\sigma_\Lambda} (\lambda - \mathbb{E}[\Lambda]) + \sqrt{1 - r_i^2} \sigma_{Y_i} \Phi^{-1}(U)\right), \\ &= \sum_{i=1}^n \exp\left(\mu_{Y_i} + r_i \sigma_{Y_i} \Phi^{-1}(v) + \sqrt{1 - r_i^2} \sigma_{Y_i} \Phi^{-1}(U)\right). \end{aligned}$$

Note, $v = \frac{(\lambda - \mathbb{E}[\Lambda])}{\sigma_\Lambda}$ is a specific realisation of $V = \frac{(\Lambda - \mathbb{E}[\Lambda])}{\sigma_\Lambda}$

Let us now consider the stop-loss premiums

$$\mathbb{E}[(S^u - K)^+] = \sum_{i=1}^n \mathbb{E}[(X_i^c|\Lambda = \lambda) - K_i]^+,$$

where

$$K_i = \exp\left(\mu_{Y_i} + r_i \sigma_{Y_i} \Phi^{-1}(v) + \sqrt{1 - r_i^2} \sigma_{Y_i} \Phi^{-1}(F_{S^c}(K))\right). \quad (4.26)$$

So we can rewrite the above as

$$\begin{aligned}
&= \sum_{i=1}^n e^{(\mu_{Y_i} + r_i \sigma_{Y_i} \Phi^{-1}(v) + 1/2(1-r_i^2)\sigma_{Y_i}^2)} \Phi \left(\frac{\mu_{Y_i} + r_i \sigma_{Y_i} \Phi^{-1}(v) + (1-r_i^2)\sigma_{Y_i}^2 - \ln(K_i)}{\sqrt{1-r_i^2}\sigma_{Y_i}} \right) \\
&+ K_i \Phi \left(\frac{\mu_{Y_i} + r_i \sigma_{Y_i} \Phi^{-1}(v) - \ln(K_i)}{\sqrt{1-r_i^2}\sigma_{Y_i}} \right), \tag{4.27} \\
&= \sum_{i=1}^n \exp(\mu_{Y_i} + r_i \sigma_{Y_i} \Phi^{-1}(v) + 1/2(1-r_i^2)\sigma_{Y_i}^2) \Phi \left(\sqrt{(1-r_i^2)}\sigma_{Y_i} - \Phi^{-1}(F_{S^c}(K)) \right) \\
&+ K_i(1 - F_{S^c}(K)), \\
&= \sum_{i=1}^n \left[\exp(\mu_{Y_i} + r_i \sigma_{Y_i} \Phi^{-1}(v) + 1/2(1-r_i^2)\sigma_{Y_i}^2) \Phi \left(\sqrt{(1-r_i^2)}\sigma_{Y_i} - \Phi^{-1}(F_{S^c}(K)) \right) \right] \\
&+ K(1 - F_{S^c}(K)).
\end{aligned}$$

In the Black-Scholes world stock prices are lognormally distributed, and we can use the results above to find bounds on the price of a basket option. However, by using an appropriate conditioning variable, we may split the expectation integral into two parts, one of which we can evaluate exactly, and the other can be bounded above and below using the results presented above.

4.1.3 Basket Options : Splitting the integral

Recall the framework set up in chapter 3, where we defined the following. Assume that stock prices follow the standard GBM dynamics:

$$\frac{dS_t^i}{S_t^i} = r dt + \sigma_i dW_t^i. \tag{4.28}$$

Furthermore, assume that the Brownian motions are correlated such that

$$dW_t^i dW_t^j = \rho_{ij} dt. \tag{4.29}$$

Solving equation (4.28) yields

$$S_t^i = S_0^i e^{(r - \frac{1}{2}\sigma_i^2)t + \sigma_i W_t^i}, \tag{4.30}$$

consequently S_t^i is lognormally distributed with

$$\ln S_t^i \sim N(\ln S_0^i + (r - \frac{1}{2}\sigma_i^2)t, \sigma_i^2 t), \tag{4.31}$$

and

$$\text{Cov}(\ln S_t^i, \ln S_t^j) = \rho_{ij} \sigma_i \sigma_j t. \tag{4.32}$$

Now define the basket as

$$\begin{aligned}
B_t &= \sum_{i=1}^n a_i S_t^i, \\
&= \sum_{i=1}^n \alpha_i e^{Y_i},
\end{aligned} \tag{4.33}$$

where

$$\alpha_i = a_i S_0^i e^{(r - \frac{1}{2}\sigma_i^2)t}, \quad (4.34)$$

and

$$Y_i = \sigma_i W_t^i.$$

Now, for any normally distributed random variable Λ with cdf F_Λ there exists a d_Λ , such that $\Lambda \geq d_\Lambda$ implies $B \geq K$. It follows that

$$\mathbb{E}^\mathbb{Q}[(B - K)^+ | \Lambda] = \mathbb{E}^\mathbb{Q}[B - K | \Lambda] \stackrel{d}{=} (B^l - K)^+, \quad (4.35)$$

where $B^l = \mathbb{E}^\mathbb{Q}[B | \Lambda]$ and dependence on T is suppressed in the notation for simplicity. Now, for such Λ , we can decompose the option price in the following way

$$\begin{aligned} e^{-rT} \mathbb{E}^\mathbb{Q}[(B - K)^+] &= e^{-rT} \mathbb{E}^\mathbb{Q}[\mathbb{E}^\mathbb{Q}[(B - K)^+ | \Lambda]], \\ &= e^{-rT} \left\{ \int_{-\infty}^{d_\Lambda} \mathbb{E}^\mathbb{Q}[(B - K)^+ | \Lambda = \lambda] dF_\Lambda(\lambda) + \int_{d_\Lambda}^{\infty} \mathbb{E}^\mathbb{Q}[B - K | \Lambda = \lambda] dF_\Lambda(\lambda) \right\}. \end{aligned} \quad (4.36)$$

The second integral in the above expression can be evaluated exactly. Noting that the integrand in the first integral is a stop-loss premium, we can bound it using the results in the previous section.

Note that we could have used these results (4.20, 4.24, 4.27) directly on $e^{-rT} \mathbb{E}^\mathbb{Q}[(B - K)^+]$ but a tighter bound is obtained by evaluating part of this exactly and employing bounds on the remaining part. Let us proceed to evaluate the exact part of (4.36) Using standard results on conditional distributions we know that if (Y_i, Λ) is bivariate normal, then $Y_i | \Lambda$ is normally distributed with parameters

$$\mu_i = r_i \frac{\sigma_i}{\sigma_\Lambda} (\lambda - E^\mathbb{Q}[\Lambda]), \quad (4.37)$$

and

$$\sigma_i^2 = (1 - r_i^2) \sigma_{Y_i}^2, \quad (4.38)$$

where

$$r_i = \frac{\text{Cov}(Y_i, \Lambda)}{\sigma_{Y_i} \sigma_\Lambda}. \quad (4.39)$$

Note that to ensure that $\mathbb{E}[Y_i | \Lambda]$ is continuous and increasing functions of Λ we must have that the r_i 's are all the same sign. This places certain constraints on the correlation regimes we can

examine when testing these bounds. So, we can write

$$\begin{aligned}
 B^l &= \mathbb{E}^{\mathbb{Q}}[B|\Lambda], \\
 &= \sum_{i=1}^n \mathbb{E}^{\mathbb{Q}}[a_i S_T^i | \Lambda], \\
 &= \sum_{i=1}^n a_i S_0^i e^{(r-1/2\sigma_i^2)t} \mathbb{E}^{\mathbb{Q}}[e^{\sigma_i W_t^i} | \Lambda], \\
 &= \sum_{i=1}^n a_i S_0^i \exp\left(\left(r - \frac{1}{2}\sigma_i^2 r_i^2\right)T + \sigma_i r_i \sqrt{T} \Phi^{-1}(V)\right),
 \end{aligned}$$

where

$$V = \Phi\left(\frac{\Lambda - \mathbb{E}^{\mathbb{Q}}[\Lambda]}{\sigma_\Lambda}\right). \quad (4.40)$$

Recall that

$$\int_{-\infty}^{d_\Lambda} e^{b\Phi^{-1}(v)} f_\Lambda(\lambda) d\lambda = e^{b^2/2} \Phi(d_\Lambda^* - b), \quad (4.41)$$

where

$$d_\Lambda^* = \frac{d_\Lambda - \mathbb{E}^{\mathbb{Q}}[\Lambda]}{\sigma_\Lambda}.$$

We can write the second term in (4.36) as

$$\begin{aligned}
 &e^{-rT} \int_{d_\Lambda}^{\infty} \mathbb{E}^{\mathbb{Q}}[B - K | \Lambda = \lambda] dF_\Lambda(\lambda), \\
 &= \int_{d_\Lambda}^{\infty} \mathbb{E}^{\mathbb{Q}}[B | \Lambda = \lambda] f_\Lambda(\lambda) d\lambda - e^{-rT} K (1 - F_\Lambda(d_\Lambda)), \\
 &= e^{-rT} \sum_{i=1}^n a_i S_0^i e^{(r-1/2\sigma_i^2 r_i^2)T} \int_{d_\Lambda}^{\infty} e^{r_i \sigma_i \sqrt{T} \Phi^{-1}(v)} f_\Lambda(\lambda) d\lambda - e^{-rT} K (1 - F_\Lambda(d_\Lambda)), \\
 &= \sum_{i=1}^n a_i S_i(0) \Phi\left[\sigma_i r_i \sqrt{T} - d_\Lambda^*\right] - e^{-rT} K (\Phi(-d_\Lambda^*)).
 \end{aligned}$$

So, the second term in (4.36) can be written out explicitly if, for all i , (Y_i, Λ) is bivariate normal. We shall discuss choices for Λ later. The first term in 4.36 is bounded below by

$$\int_{-\infty}^{d_\Lambda} \mathbb{E}^{\mathbb{Q}}[(B - K)^+ | \Lambda = \lambda] dF_\Lambda(\lambda) \geq \int_{-\infty}^{d_\Lambda} (\mathbb{E}^{\mathbb{Q}}[B | \Lambda = \lambda] - K)^+ dF_\Lambda(\lambda), \quad (4.42)$$

as can easily be seen using Jensen's inequality.

Adding the exact part and using (4.15) we find that

$$\mathbb{E}^{\mathbb{Q}}[(B - K)^+] \geq \mathbb{E}^{\mathbb{Q}}[(B^l - K)^+]. \quad (4.43)$$

Now, recall that B^l is a convex order lower bound for B and B^l is a sum of n comonotonic variables. So we can use results from this section to show that,

$$\mathbb{E}^{\mathbb{Q}}[(B^l - K)^+] = \sum_{i=1}^n \mathbb{E}^{\mathbb{Q}}[(B_i^l - K_i)^+], \quad (4.44)$$

$$= \sum_{i=1}^n \mathbb{E}^{\mathbb{Q}}[(B_i^l - F_{B_i^l}^{-1}(F_{B^l}(K)))^+], \quad (4.45)$$

$$= \sum_{i=1}^n \mathbb{E}^{\mathbb{Q}}[(\mathbb{E}^{\mathbb{Q}}[S_i|\Lambda] - \mathbb{E}^{\mathbb{Q}}[S_i|\Lambda = F_{\Lambda}^{-1}(F_{B^l}(K))])^+], \quad (4.46)$$

$$= \sum_{i=1}^n a_i S_0^i \Phi \left[\sigma_i \sqrt{T} r_i - \Phi^{-1}(F_{B^l}(K)) \right] - e^{-rT} K (1 - F_{B^l}(K)). \quad (4.47)$$

Note that $F_{B^l}(K)$ can be determined by solving the nonlinear equation,

$$K = F_{B^l}^{-1}(F_{B^l}(K)), \quad (4.48)$$

$$= \sum_{i=1}^n F_{E[S_i|\Lambda]}^{-1}(F_{B^l}(K)). \quad (4.49)$$

Let us now turn our attention to an upper bound for B . Firstly, the work we have already done on the comonotonic upper bound gave us the following result for the stop-loss premium of the sum.

$$\mathbb{E}^{\mathbb{Q}}[(B^c - K)^+] = \sum_{i=1}^n e^{\mu_i + 1/2\bar{\sigma}_i^2} \Phi(\bar{\sigma}_i - \Phi^{-1}(F_{B^c}(K))) - K(1 - F_{B^c}(K)),$$

where B^c is the comonotonic counterpart of B .

Noting that for stock prices $\mu_i = \ln S_0^i + (r - 1/2\sigma_i^2)t$ and $\bar{\sigma}_i = \sigma_i\sqrt{t}$ we immediately obtain the following upper bound,

$$\mathbb{E}^{\mathbb{Q}}[(B^c - K)^+] = \sum_{i=1}^n S_0^i e^{rt} \Phi(\sigma_i\sqrt{t} - \Phi^{-1}(F_{B^c}(K))) - K(1 - F_{B^c}(K)),$$

and we need now only calculate $F_{B^c}(K)$. This may be unambiguously determined from

$$K = F_{B^c}^{-1}(F_{B^c}(K)), \quad (4.50)$$

$$= \sum_{i=1}^n F_{S_i}^{-1}(F_{B^c}(K)). \quad (4.51)$$

We now move on the improved upper bound. Recall that we have already shown that the comonotonic sum is a convex upper bound for B and that $Y_i|\Lambda = \lambda$ is normally distributed for all i with parameters μ_i and σ_i^2 . Consequently we may bound the first term in (4.36) by replacing $B|\Lambda = \lambda$ with B_{Λ}^c where we define

$$B_{\Lambda}^c = (B|\Lambda = \lambda)^c, \quad (4.52)$$

$$= \sum_{i=1}^n \alpha_i \exp \left(r_i \sigma_{Y_i} \Phi^{-1}(v) + \sqrt{1 - r_i^2} \sigma_{Y_i} \Phi^{-1}(U) \right), \quad (4.53)$$

where U and $V = \Phi\left(\frac{\Lambda - \mathbb{E}^\mathbb{Q}[\Lambda]}{\sigma_\Lambda}\right)$ are independent random variables. We can now write the first term in (4.36) as

$$e^{-rT} \int_{-\infty}^{d_\Lambda} \mathbb{E}^\mathbb{Q}[(B - K)^+ | \Lambda = \lambda] f_\Lambda(\lambda), \quad (4.54)$$

$$\leq e^{-rT} \int_{-\infty}^{d_\Lambda} \mathbb{E}^\mathbb{Q}[(B_{\Lambda=\lambda}^c - K)^+] f_\Lambda(\lambda), \quad (4.55)$$

$$= e^{-rT} \int_{-\infty}^{\Phi(d_\Lambda^*)} \mathbb{E}^\mathbb{Q}[(B_{\Lambda=\lambda}^c - K)^+] dv, \quad (4.56)$$

$$= e^{-rT} \int_{-\infty}^{\Phi(d_\Lambda^*)} \underbrace{\mathbb{E}^\mathbb{Q}\left[\left(\sum_{i=1}^n \alpha_i \exp\left(r_i \sigma_{Y_i} \Phi^{-1}(v) + \sqrt{1 - r_i^2} \sigma_{Y_i} \Phi^{-1}(U)\right) - K\right)^+\right]}_{\text{stop loss premium}} dv. \quad (4.57)$$

Noting that $B_{\Lambda=\lambda}^c$ is a comonotonic bound allows us to use the results on stop-loss premiums (4.14). We can write out the bracketed expression above as

$$\mathbb{E}^\mathbb{Q} \left[\left(\sum_{i=1}^n \alpha_i \exp\left(r_i \sigma_{Y_i} \Phi^{-1}(v) + \sqrt{1 - r_i^2} \sigma_{Y_i} \Phi^{-1}(U)\right) - K \right)^+ \right] = \quad (4.58)$$

$$\sum_{i=1}^n \mathbb{E}^\mathbb{Q} \left[\left(\alpha_i \exp\left(r_i \sigma_{Y_i} \Phi^{-1}(v) + \sqrt{1 - r_i^2} \sigma_{Y_i} \Phi^{-1}(U)\right) - F_{S_i | \Lambda=\lambda}^{-1}(F_{B_\Lambda^c}(K)) \right)^+ \right]. \quad (4.59)$$

Now, using the standard results for stop-loss premiums, and letting $K_i = F_{S_i | \Lambda=\lambda}^{-1}(F_{B_\Lambda^c}(K))$ we can write this as:

$$\sum_{i=1}^n \mathbb{E}^\mathbb{Q} \left[\left(\alpha_i \exp\left(r_i \sigma_{Y_i} \Phi^{-1}(v) + \sqrt{1 - r_i^2} \sigma_{Y_i} \Phi^{-1}(U)\right) - K_i \right)^+ \right]. \quad (4.60)$$

Substituting for α_i and using the results on conditioning yields

$$\begin{aligned} & \sum_{i=1}^n a_i S_0 e^{-1/2\sigma_i^2 r_i^2 t} \int_{-\infty}^{\Phi(d_\Lambda^*)} e^{r_i \sigma_i \sqrt{T} \Phi^{-1}(v)} \Phi\left(\sqrt{1 - r_i^2} \sigma_i \sqrt{T} - \Phi^{-1}(F_{B_{\Lambda=\lambda}^c}(K))\right) dv \\ & - e^{-rT} K \left(\Phi(d_\Lambda^*) - \int_0^{\Phi(d_\Lambda^*)} F_{B_{\Lambda=\lambda}^c}(K) dv \right). \end{aligned} \quad (4.61)$$

Adding this to the exact part of (4.36) results in the improved upper bound. For specific realisations of v (or equivalently of Λ) we may write the bound on the first term in (4.36) as a sum of Black-Scholes prices on synthetic underlyings $\tilde{S}_{i,v}$ with volatilities given by $\tilde{\sigma}_{i,v} = \sigma_i \sqrt{1 - r_i^2}$ with new strikes $\tilde{K}_{i,v}$ where

$$\tilde{S}_{i,v}(0) = S_i(0) e^{-1/2\sigma_i^2 r_i^2 T + r_i \sigma_i \sqrt{T} \Phi^{-1}(v)}, \quad (4.62)$$

and

$$\tilde{K}_{i,v} = S_i(0) e^{(r - \sigma_i^2/2)T + r_i \sigma_i \sqrt{T} \Phi^{-1}(v) + \sqrt{1 - r_i^2} \sigma_i \sqrt{T} \Phi^{-1}(F_{B_{\Lambda=\lambda}^c}(K))}. \quad (4.63)$$

As before, $F_{B_{\Lambda}^c}(K)$ is given by solving the nonlinear equation

$$K = \sum_{i=1}^n a_i S_0^i \exp \left[(r - 1/2\sigma_i^2)T + r_i \sigma_i \sqrt{T} \Phi^{-1}(v) + \sqrt{1 - r_i^2} \sigma_i \sqrt{T} \Phi^{-1}(F_{B_{\Lambda}^c}(K)) \right]. \quad (4.64)$$

Now, in (4.61) we have an explicit dependence on the value of d_{Λ}^* and we must find it. Additionally we have a dependence on the r_i 's, the correlations between the Y_i 's and Λ . Recall we have defined Λ as

$$\Lambda = \sum_{i=1}^n \beta_i Y_i, \quad (4.65)$$

$$(4.66)$$

where

$$Y_i = \sigma_i W_T^i. \quad (4.67)$$

d_{Λ} is the specific realisation of Λ such that $\Lambda > d_{\Lambda} \rightarrow B_T > K$.

It makes sense for our conditioning variable to contain as much information about B_T as possible. To this end, define

$$\Lambda = \sum_{i=1}^n a_i S_0^i \sigma_i W_T^i. \quad (4.68)$$

So, σ_{Λ} , σ_{Y_i} and $\sigma_{\Lambda Y_i}$ are easy to work out, and this yields

$$r_i = \frac{\sigma_{\Lambda Y_i}}{\sigma_{\Lambda} \sigma_{Y_i}}, \quad (4.69)$$

$$= \frac{\sum_{j=1}^n a_j S_0^j \rho_{ij} \sigma_j \sigma_i \sqrt{T}}{\sigma_i \sqrt{T} \sqrt{\sum_{k=1}^n \sum_{j=1}^n a_k a_j S_0^k S_0^j \sigma_k \sigma_j \rho_{kj} T}}, \quad (4.70)$$

$$= \frac{\sum_{j=1}^n a_j S_0^j \rho_{ij} \sigma_j}{\sqrt{\sum_{k=1}^n \sum_{j=1}^n a_k a_j S_0^k S_0^j \sigma_k \sigma_j \rho_{kj} T}}. \quad (4.71)$$

Now we must find the corresponding value of d_{Λ} . Using a first order approximation of $e^{(r - \sigma^2/2)T + \sigma_i W_T^i}$ we may write

$$d_{\Lambda} = K - \sum_{i=1}^n a_i S_0^i (1 + (r - \sigma_i^2/2)T).$$

Now, since $\Lambda > d_{\Lambda}$

$$K < \sum_{i=1}^n a_i S_0^i \sigma_i W_T^i + \sum_{i=1}^n a_i S_0^i (1 + (r - \sigma_i^2/2)T),$$

$$K < \sum_{i=1}^n a_i S_0^i (1 + (r - \sigma_i^2/2)T + \sigma_i W_T^i).$$

$$B_T > K.$$

Since the first order approximation is a lower bound for B_T .

Recall that d_Λ^* is defined as $\frac{d_\Lambda - \mathbb{E}^\mathbb{Q}[\Lambda]}{\sigma_\Lambda}$. We have now calculated all the parameters we need to evaluate the bounds on the option price. Clearly there are other choices for Λ . However Deelstra et al. [7] it is found that this bound performs best under most circumstances. They provide an optimisation procedure to find the best choice for the β_i 's and this optimal choice is more computationally expensive and does not offer a significant improvement on the choice we have settled on.

4.1.4 The Greeks

We have noted that the lower bound can be written as sum of Black-Scholes formulae and this makes the Greeks especially easy to calculate.

Greeks for the Lower Bound

The Lower bound is given by

$$\mathbb{E}^\mathbb{Q}[(B^l - K)^+] = \sum_{i=1}^n \mathbb{E}^\mathbb{Q}[(S_i^l - K_i)]. \quad (4.72)$$

This immediately suggests that we can write the lower bound as a sum of Black-Scholes formulae from which the Greeks may be easily obtained by the linearity of the partial differentiation operator. Recall from (4.24) and (4.25) that

$$\mathbb{E}^\mathbb{Q}[(B^l - K)^+] = \sum_{i=1}^n e^{\mu_{Y_i} + \frac{1}{2}\sigma_{Y_i}^2} \Phi(d_{i,1}) - K_i \Phi(d_{i,2}), \quad (4.73)$$

$$(4.74)$$

and

$$K_i = \exp\left(\mu_{Y_i} + r_i \sigma_{Y_i} \Phi^{-1}(F_{S^l}(K)) + \frac{1}{2}(1 - r_i^2)\sigma_{Y_i}^2\right). \quad (4.75)$$

Now in the case of stocks $\mu_{Y_i} = \ln(a_i S_0^i) + (r - 1/2\sigma_i^2)T$ and $\sigma_{Y_i}^2 = \sigma^2 T$, so we may write the bound on the option price as

$$e^{-rT} \mathbb{E}^\mathbb{Q}[(B^l - K)^+] = \sum_{i=1}^n a_i S_i(0) \Phi(d_{i,1}) - e^{-rT} K_i \Phi(d_{i,2}), \quad (4.76)$$

where

$$K_i = a_i S_i(0) e^{(r - r_i \sigma_i^2/2)T + r_i \sigma_i \sqrt{T} \Phi^{-1}(F_{B^l}(K))}. \quad (4.77)$$

Now let $\tilde{\sigma}_i = \sigma_i r_i$ and $\tilde{S}_i(0) = a_i S_i(0)$ so

$$\tilde{K}_i = \tilde{S}_i(0) e^{(r - \tilde{\sigma}_i^2/2)T + \tilde{\sigma}_i \sqrt{T} \Phi^{-1}(F_{S^l}(K))}. \quad (4.78)$$

So we may write the lower bound as

$$LB = \sum_{i=1}^n \tilde{S}_i(0) \Phi(d_{i,1}) - e^{-rT} \tilde{K}_i \Phi(d_{i,2}). \quad (4.79)$$

where

$$d_{i,1} = \frac{\ln\left(\frac{\tilde{S}_i(0)}{\tilde{K}_i}\right) + (r + \tilde{\sigma}_i^2/2)T}{\tilde{\sigma}_i \sqrt{T}}, \quad (4.80)$$

and

$$d_{i,2} = d_{i,1} - \tilde{\sigma}_i \sqrt{T}. \quad (4.81)$$

The Greeks are given by the usual formulae,

$$\Delta_l = \sum_{i=1}^n \Phi(d_{i,1}), \quad (4.82)$$

$$\Gamma_l = \sum_{i=1}^n \frac{\phi(d_{i,1})}{\tilde{S}_{i,v}(0) \tilde{\sigma}_{i,v} \sqrt{T}}, \quad (4.83)$$

$$\Theta_l = \sum_{i=1}^n \left(-\frac{\phi(d_{i,1}) \tilde{S}_{i,v}(0) \tilde{\sigma}_{i,v}}{2\sqrt{T}} - r \tilde{K}_{i,v} e^{-rT} \Phi(d_{i,2}) \right), \quad (4.84)$$

$$\rho_l = \sum_{i=1}^n \tilde{K}_{i,v} T e^{-rT} \Phi(d_{i,2}), \quad (4.85)$$

$$v_l = \sum_{i=1}^n \tilde{S}_{i,v}(0) \sqrt{T} \phi(d_{i,1}). \quad (4.86)$$

Greeks for the Improved Upper Bound

For the improved upper bound we have to take a slightly different approach. From (4.27) we note that given a specific realisation of V (or equivalently Λ) we may write the improved upper bound as a sum of Black-Scholes formulae. (However, note that we are not considering the split integral approach used in the previous section but are applying the improved upper bound directly to the Basket as in Example 3)

Using (4.27) we can write $\mathbb{E}^{\mathbb{Q}}[(S^u - K)^+]$

$$\begin{aligned} &= \sum_{i=1}^n e^{(\mu_{Y_i} + r_i \sigma_{Y_i} \Phi^{-1}(v) + 1/2(1-r_i^2)\sigma_{Y_i}^2)} \Phi\left(\frac{\mu_{Y_i} + r_i \sigma_{Y_i} \Phi^{-1}(v) + (1-r_i^2)\sigma_{Y_i}^2 - \ln(K_i)}{\sqrt{1-r_i^2}\sigma_{Y_i}}\right) \\ &+ K_i \Phi\left(\frac{\mu_{Y_i} + r_i \sigma_{Y_i} \Phi^{-1}(v) - \ln(K_i)}{\sqrt{1-r_i^2}\sigma_{Y_i}}\right), \end{aligned} \quad (4.87)$$

where

$$K_i = \exp\left(\mu_{Y_i} + r_i \sigma_{Y_i} \Phi^{-1}(v) + \sqrt{1-r_i^2}\sigma_{Y_i} \Phi^{-1}(F_{S^c}(K))\right). \quad (4.88)$$

and, as with the lower bounds, noting that $\mu_{Y_i} = \ln(a_i S_0^i) + (r - 1/2\sigma_i^2)T$ and $\sigma_{Y_i}^2 = \sigma^2 T$ allows us to write:

$$e^{-rT} \mathbb{E}^{\mathbb{Q}}[(B^u - K)^+] = \sum_{i=1}^n a_i S_i(0) e^{(-\frac{1}{2}\sigma_i^2 r_i^2 T + r_i \sigma_i \sqrt{T} \Phi^{-1}(v))} \Phi(d_{i,1}) + e^{-rT} K_i \Phi(d_{i,2}),$$

where

$$K_i = S_i(0) \exp\left(\left(r - \frac{1}{2}\sigma_i^2\right)T + r_i \sigma_i \sqrt{T} \Phi^{-1}(v) + \sqrt{1 - r_i^2} \sigma_i \sqrt{T} \Phi^{-1}(F_{S_i}^c(K))\right)$$

So, we may write the improved upper bound as a sum of Black-Scholes prices on synthetic underlyings $\tilde{S}_{i,v}$ with volatilities given by $\tilde{\sigma}_{i,v} = \sigma_i \sqrt{1 - r_i^2}$ with new strikes $\tilde{K}_{i,v}$ where

$$\tilde{S}_{i,v}(0) = S_i(0) e^{-1/2\sigma_i^2 r_i^2 T + r_i \sigma_i \sqrt{T} \Phi^{-1}(v)} \quad (4.89)$$

$$\text{and } \tilde{K}_{i,v} = S_i(0) e^{(r - \sigma_i^2/2)T + r_i \sigma_i \sqrt{T} \Phi^{-1}(v) + \sqrt{1 - r_i^2} \sigma_i \sqrt{T} \Phi^{-1}(F_{S_i}^c(K))} \quad (4.90)$$

Consequently the Greeks for the improved upper bound are simple to calculate and can be given as follows for a call option:

$$\Delta_u = \sum_{i=1}^n \Phi(d_{1,i}), \quad (4.91)$$

$$\Gamma_u = \sum_{i=1}^n \frac{\phi(d_{1,i})}{\tilde{S}_{i,v}(0) \tilde{\sigma}_{i,v} \sqrt{T}}, \quad (4.92)$$

$$\Theta_u = \sum_{i=1}^n -\frac{\phi(d_{1,i}) \tilde{S}_{i,v}(0) \tilde{\sigma}_{i,v}}{2\sqrt{T}} - r \tilde{K}_{i,v} e^{-rT} N(d_{2,i}). \quad (4.93)$$

$$\rho_u = \sum_{i=1}^n \tilde{K}_{i,v} T e^{-rT} \Phi(d_{2,i}), \quad (4.94)$$

$$v_u = \sum_{i=1}^n \tilde{S}_{i,v}(0) \sqrt{T} \phi(d_{1,i}). \quad (4.95)$$

$$(4.96)$$

where $d_{1,i}$ and $d_{2,i}$ are given as usual by

$$d_{1,i} = \frac{\ln \frac{\tilde{S}_{i,v}(0)}{\tilde{K}_{i,v}} + (r + \frac{\tilde{\sigma}_{i,v}^2}{2})T}{\tilde{\sigma}_{i,v} \sqrt{T}}, \quad (4.97)$$

and

$$d_{2,i} = \frac{\ln \frac{\tilde{S}_{i,v}(0)}{\tilde{K}_{i,v}} + (r - \frac{\tilde{\sigma}_{i,v}^2}{2})T}{\tilde{\sigma}_{i,v} \sqrt{T}}. \quad (4.98)$$

It must be stressed that these are the Greeks derived from the improved upper bound applied directly to the basket option price (as in (4.27)) and not for the improved upper bound obtained by splitting the integral with a conditional variable (as in (4.36)).

An Upper Bound based on the Lower Bound

Here we present an upper bound based on the lower bound. This result is given in Rogers and Shi [21]. It is the result we use in the numerical testing in the next section as it is much faster to compute and in general a tighter bound than the improved upper bound given above.

Using Jensen's inequality we can find an error bound to the first term in (4.36):

$$0 \leq \mathbb{E}^{\mathbb{Q}} \left[\mathbb{E}^{\mathbb{Q}} [(B - K)^+ | \Lambda] - (B^l - K)^+ \right], \quad (4.99)$$

$$= \int_{-\infty}^{d_\Lambda} \left(\mathbb{E}^{\mathbb{Q}} [(B - K)^+ | \Lambda] - (\mathbb{E}^{\mathbb{Q}} [B | \Lambda = \lambda] - K)^+ \right) f_\Lambda(\lambda) d\lambda, \quad (4.100)$$

$$\leq \frac{1}{2} \int_{-\infty}^{d_\Lambda} (\text{Var}(B | \Lambda = \lambda))^{\frac{1}{2}} f_\Lambda(\lambda) d\lambda, \quad (4.101)$$

$$\leq \frac{1}{2} \left(\mathbb{E}^{\mathbb{Q}} [\text{Var}(B | \Lambda) 1_{[\Lambda < d_\Lambda]}] \right)^{\frac{1}{2}} \left(\mathbb{E}^{\mathbb{Q}} [1_{[\Lambda < d_\Lambda]}] \right)^{\frac{1}{2}}. \quad (4.102)$$

We can now derive an easily computable expression for (4.102). The second expectation factor in (4.102) is $\Phi(d_\Lambda^*)$. The first expectation factor in the product can be expressed as

$$\mathbb{E}^{\mathbb{Q}} [\text{Var}(B | \Lambda) 1_{[\Lambda < d_\Lambda]}] = \mathbb{E}^{\mathbb{Q}} [\mathbb{E}^{\mathbb{Q}} (B^2 | \Lambda) 1_{[\Lambda < d_\Lambda]}] - \mathbb{E}^{\mathbb{Q}} [\mathbb{E}^{\mathbb{Q}} (B | \Lambda)^2 1_{[\Lambda < d_\Lambda]}].$$

The second term in (4.103) can be rewritten as

$$\begin{aligned} & \mathbb{E}^{\mathbb{Q}} [\mathbb{E}^{\mathbb{Q}} (B | \Lambda)^2 1_{[\Lambda < d_\Lambda]}] = \int_{-\infty}^{d_\Lambda} (B | \Lambda = \lambda)^2 f_\Lambda(\lambda) d\lambda, \\ & = \sum_{i=1}^n \sum_{j=1}^n a_i a_j S_0^i S_0^j \exp \left(\left(2r - \frac{\sigma_i^2 r_i^2 + \sigma_j^2 r_j^2}{2} \right) T \right) \int_{-\infty}^{d_\Lambda} \exp \left[(\sigma_i r_i + \sigma_j r_j) \sqrt{T} \Phi^{-1}(v) \right] f_\Lambda(\lambda) d\lambda. \end{aligned}$$

Using the result from (4.41) we can express this as

$$\sum_{i=1}^n \sum_{j=1}^n a_i a_j S_0^i S_0^j \exp \left((2r + \sigma_i r_i + \sigma_j r_j) T \right) \Phi \left(d_\Lambda^* - (r_i \sigma_i + r_j \sigma_j) \sqrt{T} \right). \quad (4.103)$$

To transform the first term in (4.103) we use the fact that the product of two lognormal variables is again lognormal.

$$\begin{aligned} \mathbb{E}^{\mathbb{Q}} [B^2 | \Lambda] &= \sum_{i=1}^n \sum_{j=1}^n \mathbb{E}^{\mathbb{Q}} \left[a_i a_j S_T^i S_T^j | \Lambda \right], \\ &= \sum_{i=1}^n \sum_{j=1}^n a_i a_j S_0^i S_0^j \exp \left[\left(2r - \frac{\sigma_i^2 + \sigma_j^2}{2} \right) T + r_{ij} \sigma_{ij} \sqrt{T} \Phi^{-1}(V) + \frac{1}{2} (1 - r_{ij}^2) T \sigma_{ij}^2 \right]. \end{aligned}$$

apply (4.41) again to get that $\mathbb{E}^{\mathbb{Q}} [\mathbb{E}^{\mathbb{Q}} (B^2 | \Lambda) 1_{[\Lambda < d_\Lambda]}]$ can be written as:

$$\begin{aligned} &= \sum_{i=1}^n \sum_{j=1}^n a_i a_j S_0^i S_0^j e^{(2r - \frac{\sigma_i^2 + \sigma_j^2}{2})T + r_{ij} \sigma_{ij} \sqrt{T} \Phi^{-1}(V) + \frac{1}{2} (1 - r_{ij}^2) T \sigma_{ij}^2} \int_{-\infty}^{d_\Lambda} e^{r_{ij} \sigma_{ij} \sqrt{T} \Phi^{-1}(v)} f_\Lambda(\lambda) d\lambda, \\ &= \sum_{i=1}^n \sum_{j=1}^n a_i a_j S_0^i S_0^j \exp \left((2r + \sigma_i \sigma_j \rho_{ij}) T \right) \Phi \left(d_\Lambda^* - (r_i \sigma_i + r_j \sigma_j) \sqrt{T} \right). \end{aligned}$$

Combining these results we obtain the following expression for the error bound

$$\epsilon(d_\Lambda) = \frac{1}{2} (\Phi(d_\Lambda^*))^{\frac{1}{2}} \left[\sum_{i=1}^n \sum_{j=1}^n a_i a_j S_0^i S_0^j e^{(2r + \sigma_i \sigma_j r)T} \Phi \left(d_\Lambda^* - (r_i \sigma_i + r_j \sigma_j) \sqrt{T} \right) \left(e^{\sigma_i \sigma_j (\rho_{ij} - r)T} - 1 \right) \right]^{\frac{1}{2}}.$$

The upper bound is given by adding this error term to the lower bound.

University of Cape Town

Chapter 5

Testing in the Black-Scholes World

In this section we test our bounds in the Black-Scholes world. In this setting, interest rates, volatility and correlations are assumed to be constant and stock prices are assumed to be distributed lognormally at any time horizon T with the familiar distribution

$$\ln S_T^i \sim N \left(\ln S_0^i + \left(r - \frac{1}{2} \sigma_i^2 \right) T, \sigma_i^2 T \right). \quad (5.1)$$

The purpose of this test is to isolate regions in the variable space where our approximations violate the bounds we have developed. Recall that we have the following

The market approximation (M),

$$\ln B_T \sim N \left(\ln B_0 + \left(r - \frac{1}{2} \sigma_B^2 \right) T, \sigma_B^2 T \right),$$

where $\sigma_B^2 = \frac{w \Sigma w^T}{T}$ and w is the row vector of weights of each stock in the basket.

A first order approximation (F)

$$\ln B_T \sim N \left(\ln B_0 + \left(r - \frac{1}{2} \sigma_{av}^2 \right) T, \sigma_B^2 T \right),$$

where σ_B is as above and $\sigma_{av}^2 = \sum_{i=1}^n w_i \sigma_i^2$.

A normal approximation (N)

$$\begin{aligned} B_T &\sim N \left(\sum_{i=1}^n \left(S_0^i e^{(r - \frac{1}{2} \sigma_i^2) T} \right), \sum_{i,j=1}^n \left(S_0^i S_0^j \sigma_i \sigma_j \rho_{ij} T e^{(2r - \frac{1}{2} (\sigma_i^2 + \sigma_j^2)) T} \right) \right), \\ &= N(\mu_B, \sigma_B^2), \end{aligned}$$

where

$$\mu_B = \sum_{i=1}^n \left(S_0^i e^{(r - \frac{1}{2}\sigma_i^2)T} \right),$$

and

$$\sigma_B = \sum_{i,j=1}^n \left(S_0^i S_0^j \sigma_i \sigma_j \rho_{ij} T e^{(2r - \frac{1}{2}(\sigma_i^2 - \sigma_j^2))T} \right).$$

A moment matching approximation

$$\ln B_T \sim N \left(\ln B_0 + (r - \frac{1}{2}\sigma_B^2)T, \sigma_B^2 T \right),$$

where

$$\sigma_B^2 = -\frac{1}{t} \ln \left(\frac{\sum_{i,j=1}^n a_i a_j S_0^i S_0^j e^{(-q_i - q_j - \rho_{ij} \sigma_i \sigma_j)t}}{\sum_{i=1}^n a_i S_0^i e^{(-q_i)t}} \right).$$

A comonotonic upper bound (CB)

$$CB_T \sim \sum_{i=1}^n a_i S_0^i \exp \left((r - \frac{1}{2}\sigma_i^2)T + \sigma_i \Phi^{-1}(U) \right),$$

where

$$U \sim \text{Uniform}(0, 1).$$

An improved upper bound (UB)

$$UB_T(v) \sim \sum_{i=1}^n a_i S_0^i \exp \left(rT + r_i \sigma_i \sqrt{T} \Phi^{-1}(v) + \sqrt{(1 - r_i^2)T} \sigma_i \Phi^{-1}(U) \right). \quad (5.2)$$

A Comonotonic lower bound (LB)

$$LB_T \sim \sum_{i=1}^n a_i S_0^i \exp \left(rT + r_i \sigma_i \sqrt{T} \Phi^{-1}(U) - \frac{1}{2}(r_i^2) \sigma_i^2 T \right). \quad (5.3)$$

Whilst implementing the code to produce prices for each of these bounds / approximations is fairly straightforward, deciding on how to test them over a multi-dimensional variable space poses several problems. Since the main purpose of this dissertation is to identify regions in the variable space where the market approximation breaks down, we confine ourselves to dealing with that approximation here. Results for the other cases may be found in Appendix D.

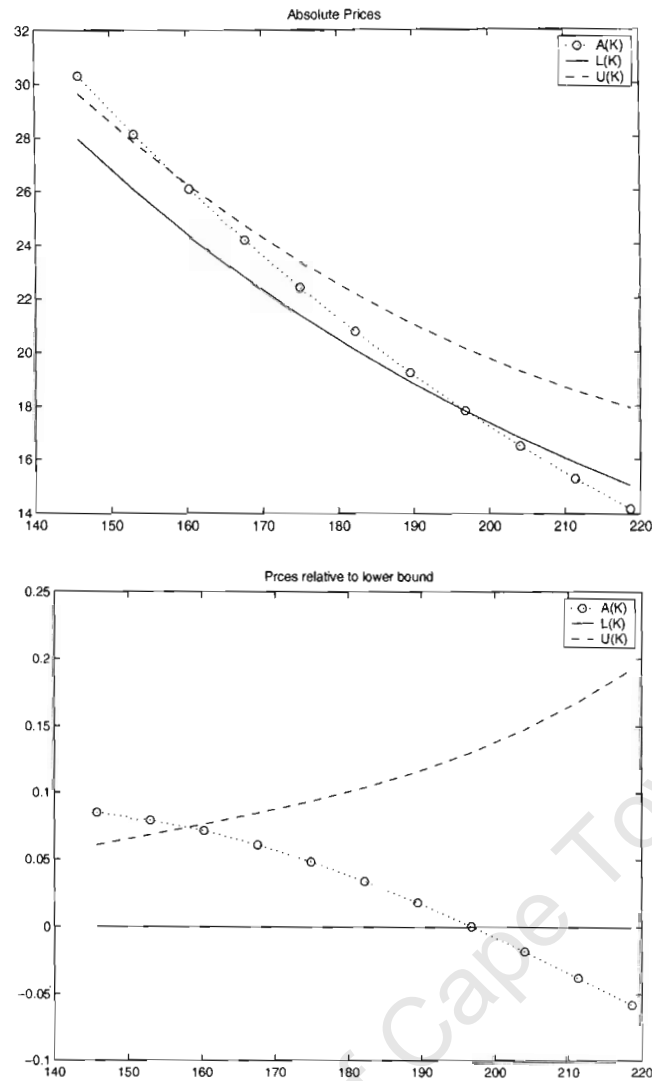

5.1 Quantifying the Error

First let us look at how to quantify the error. Fig. 5.1 shows a typical price graph for an approximation, we must decide how to rank the error terms at A, B and C .

Clearly the absolute error is not very informative and we must normalise this in some way. For example, an absolute error of R10 does not tell us very much. We need to know how tight the bounds are at that point, and what percentage error is compared to the bounds. Below, we give the same charts, normalised to the lower bound and upper bound (Figures 5.2 and 5.3).

Whilst this approach is informative, it contains information only in terms of violation of one

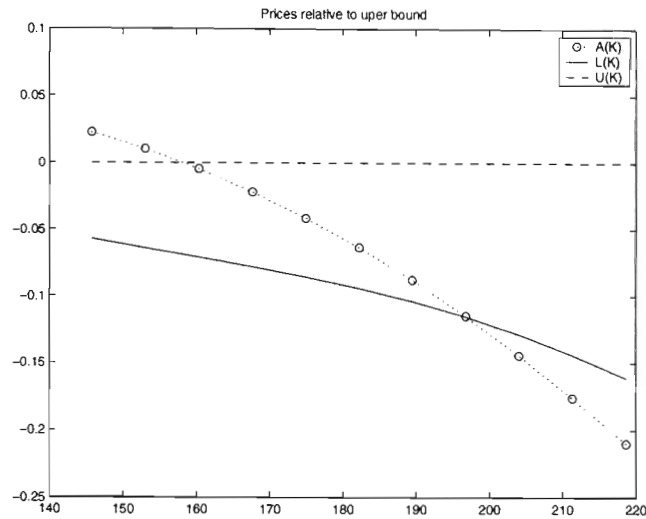

bound.

$$\epsilon_L = \frac{A(X) - L(X)}{L(X)}, \quad (5.4)$$

or

$$\epsilon_U = \frac{A(X) - U(X)}{U(X)}, \quad (5.5)$$

where $A(X)$ is the approximation value, $L(X)$ is the lower bound, $U(X)$ is the upper bound and X is a point in the variable space.

Lastly let us look at the error term normalised against the range of the bounds. This gives us information on violation of both upper and lower bounds, but no information on the relative severity of the violation (Fig. 5.4),

$$\epsilon = \frac{A(X) - L(X)}{U(X) - L(X)}. \quad (5.6)$$

Considering ϵ gives us information on violation of both upper and lower bounds. A value greater than 1 indicates violation of the upper bound and a value less than 0 indicates a violation of the lower bound.

5.2 Dimensional Issues

We are attempting to isolate regions of the variable space where we expect violations to occur. Consequently we must look at all points

$$X = (T, r, K, S_0^1, S_0^2, \dots, S_0^n, \sigma_1, \sigma_2, \dots, \sigma^n, a_1, a_2, \dots, a_n, \rho_{1,2}, \rho_{1,3}, \dots, \rho_{n-1,n}), \quad (5.7)$$

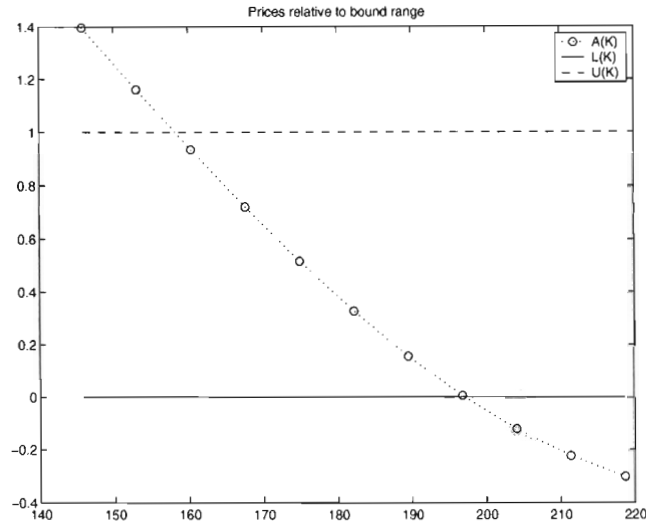

over the valid ranges of each variable. This multidimensional dependence is non-trivial and in order to gain intuition we have carried out a simple contour plot analysis of the error term for a two asset basket using the market approximation. For each Correlation/Maturity/Weight regime we consider the contour plot of the error term over a range of strikes. We consider the following correlation regimes: $\rho = 0, 0.3, 0.9$ ¹ over maturities $T = 0.3, 3, 5$ years

We examine two baskets, one with equal weights $a_1 = 0.5, a_2 = 0.5$ and one with skewed weights $a_1 = 0.3, a_2 = 0.7$. We give four enlarged contour plots as examples (Figures 5.5 to 5.8). A full catalogue of plots is included below.

¹We cannot consider negative correlations as we have to ensure the positiveness of the r_i 's in (4.39)

Equal Weights

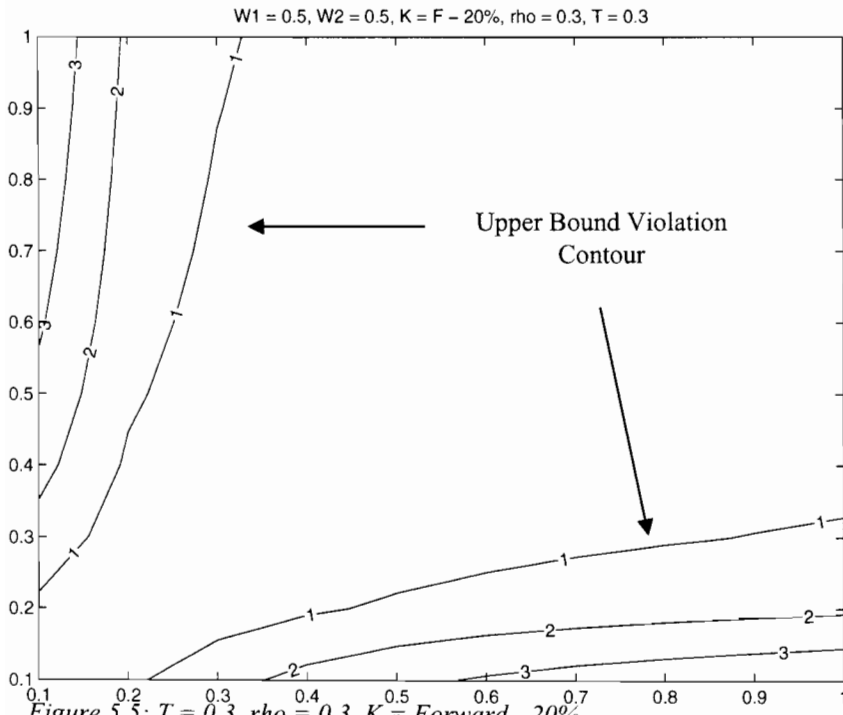

Figure 5.5: $T = 0.3, \rho = 0.3, K = \text{Forward} - 20\%$

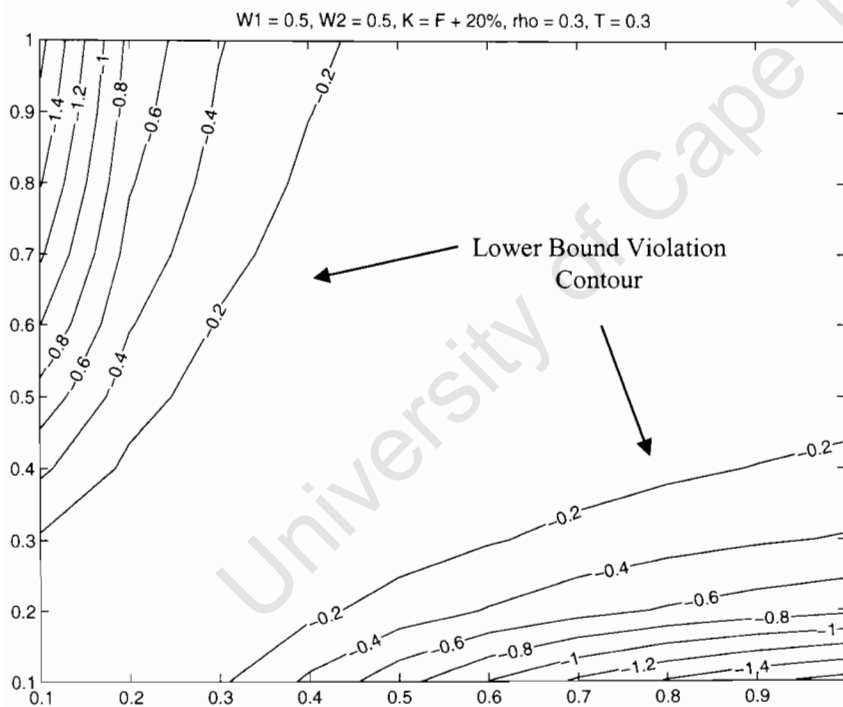

Figure 5.6: $T = 0.3, \rho = 0.3, K = \text{Forward} + 20\%$

Skewed Weights

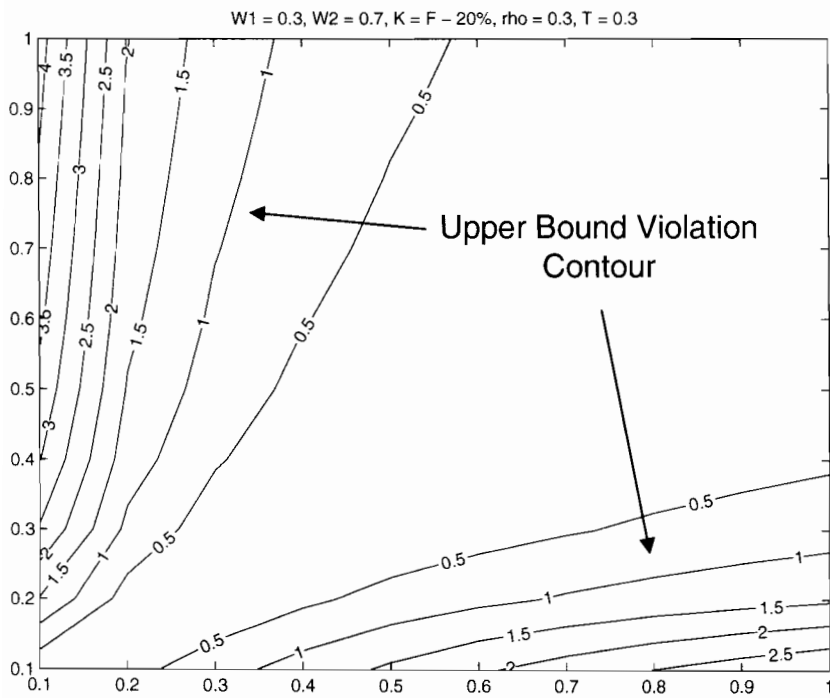

Figure 5.7: $T = 0.3, \rho = 0.3, K = \text{Forward} - 20\%$

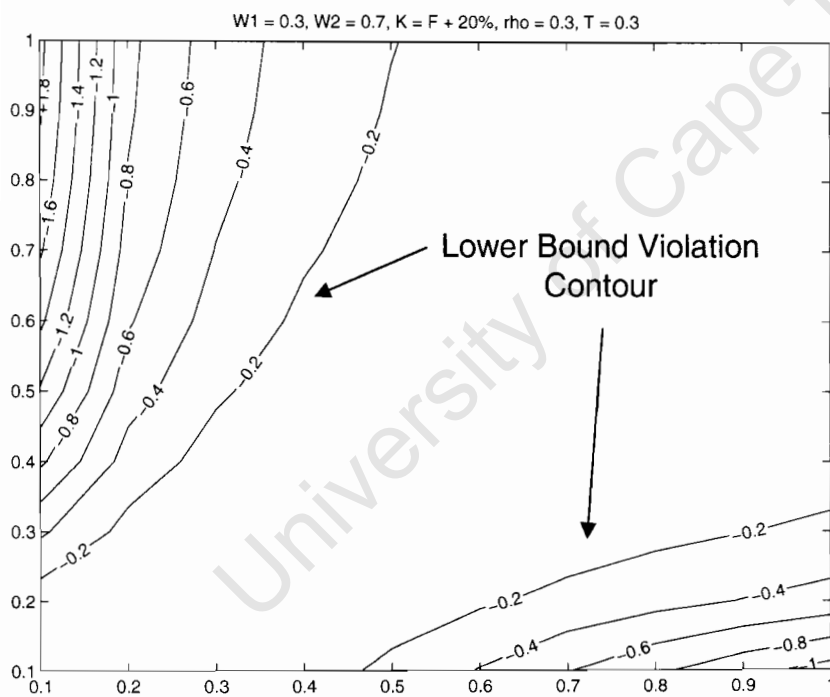

Figure 5.8: $T = .3, \rho = 0.3, K = \text{Forward} + 20\%$

Equal Weights, T = 0.3

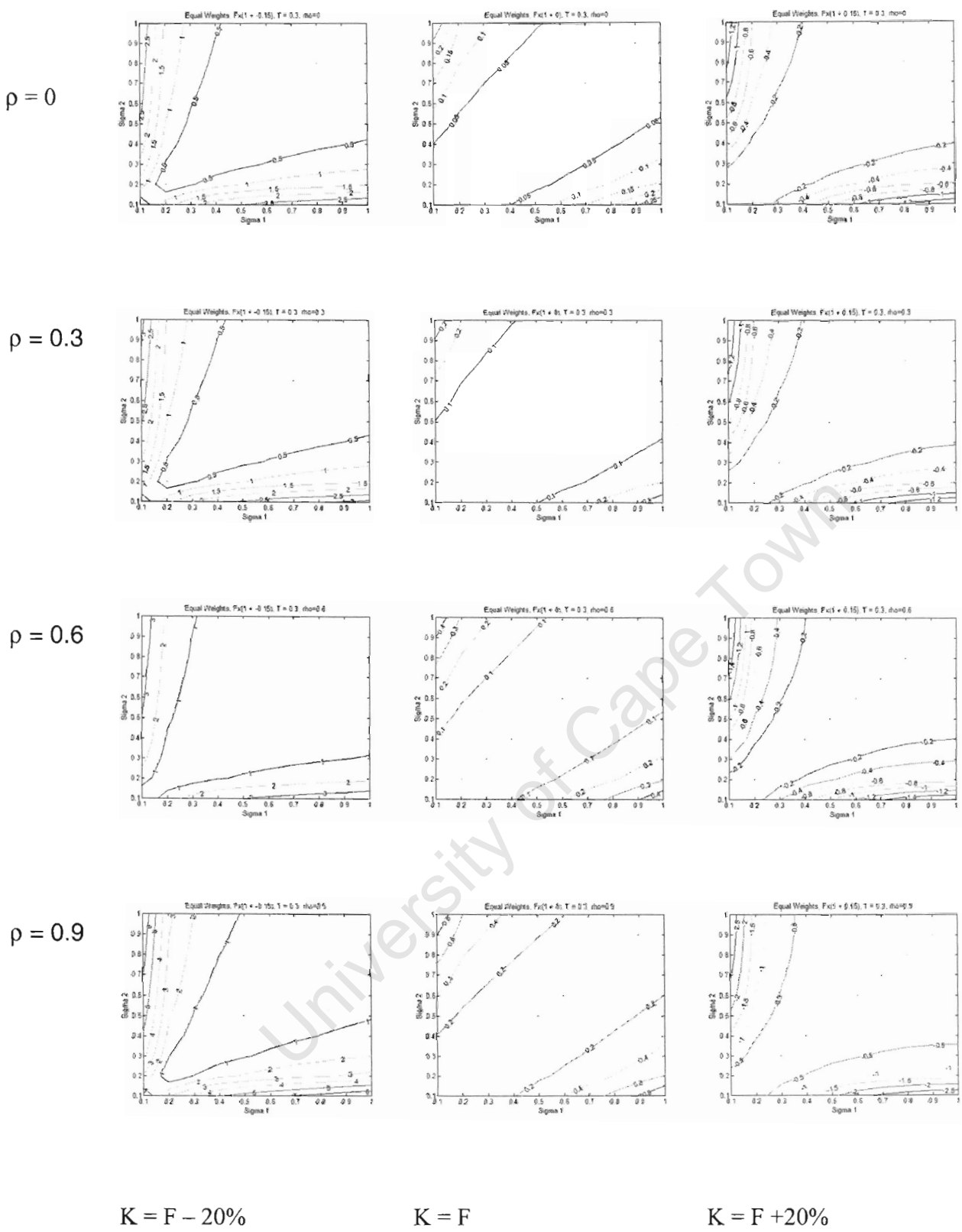

Figure 5.9: Contour Plots of Error term over the sigma plane. T = 0.3, Equal Weights

Equal Weights, $T = 3$

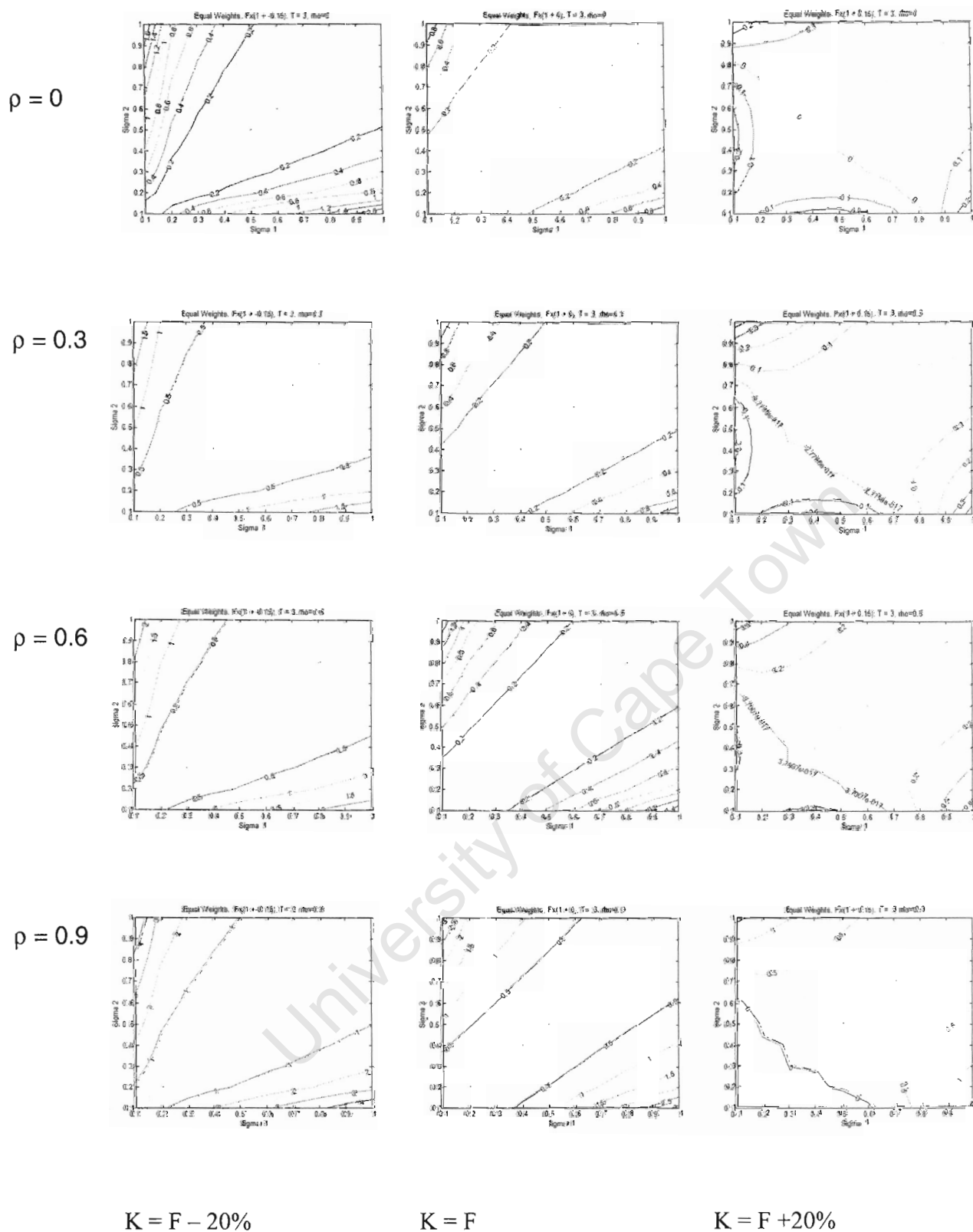

Figure 5.10: Contour Plots of Error term over the sigma plane. $T = 3$, Equal Weights

Equal Weights, T = 5

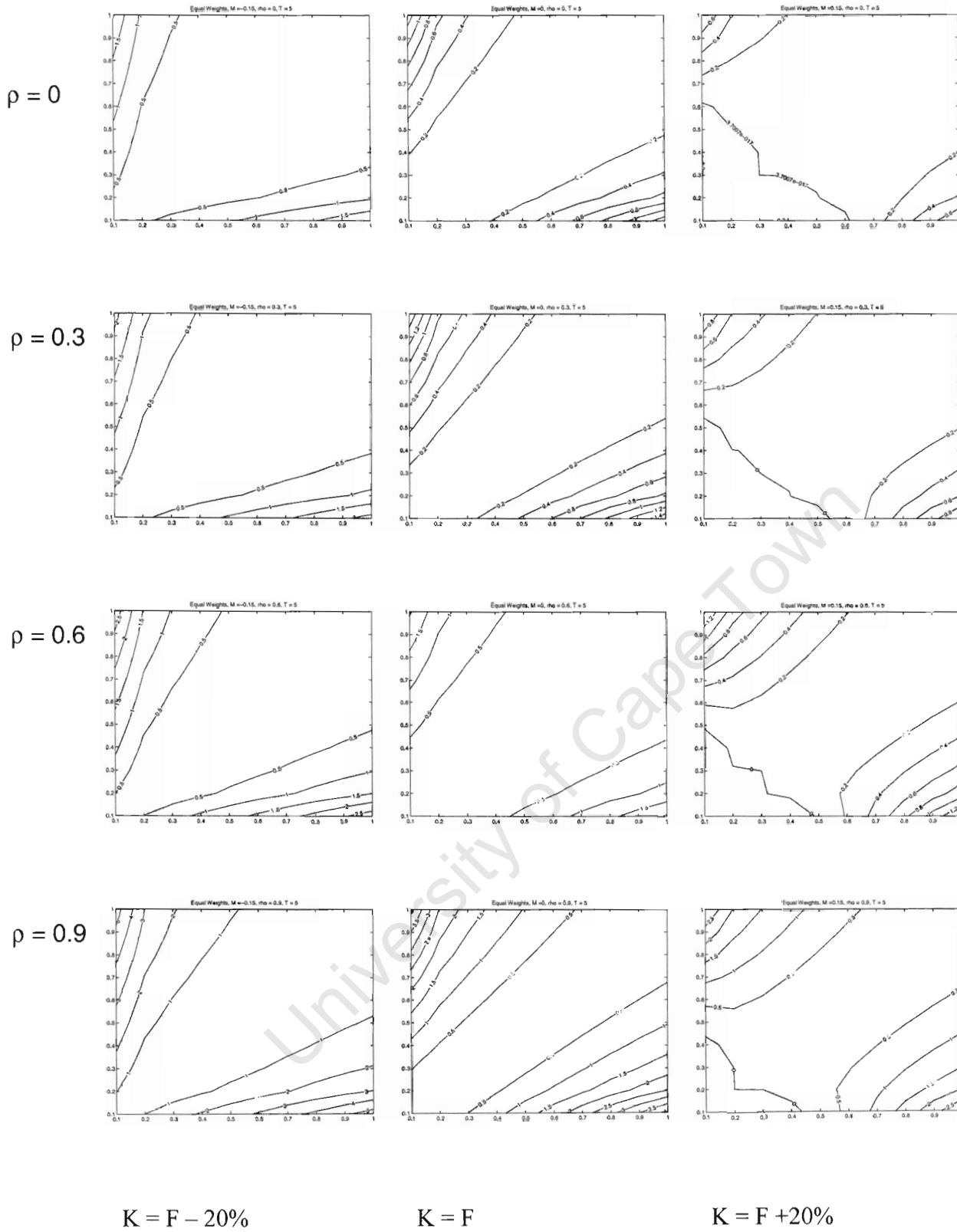
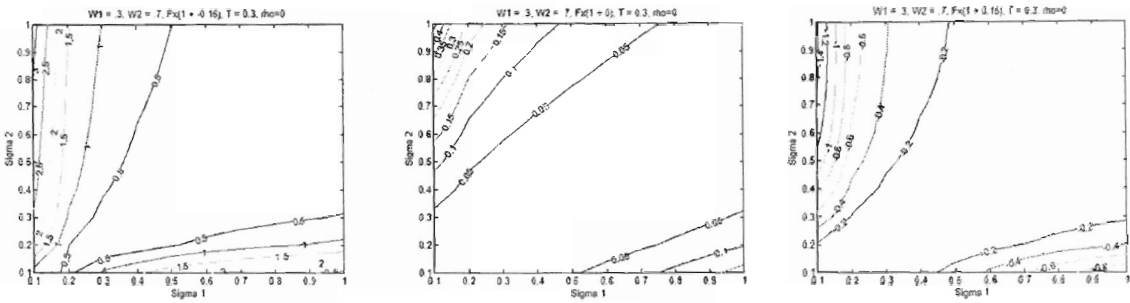

Figure 5.11: Contour Plots of Error term over the sigma plane. T = 5, Equal Weights

$W1 = 0.3, W2 = 0.7, T = 0.3$

$\rho = 0$



$\rho = 0.3$

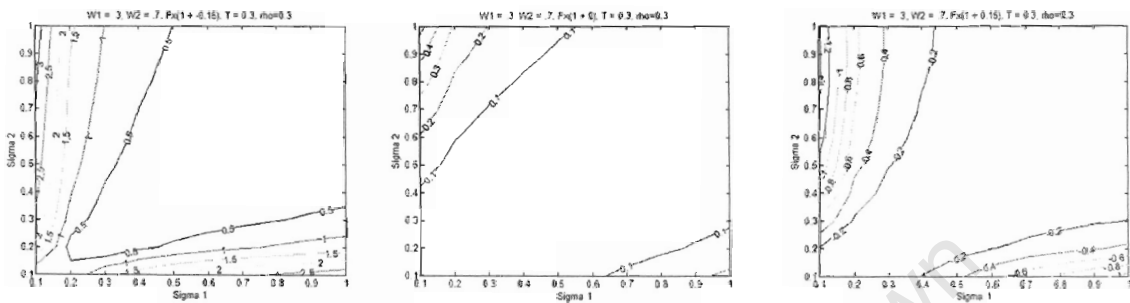

$\rho = 0.6$

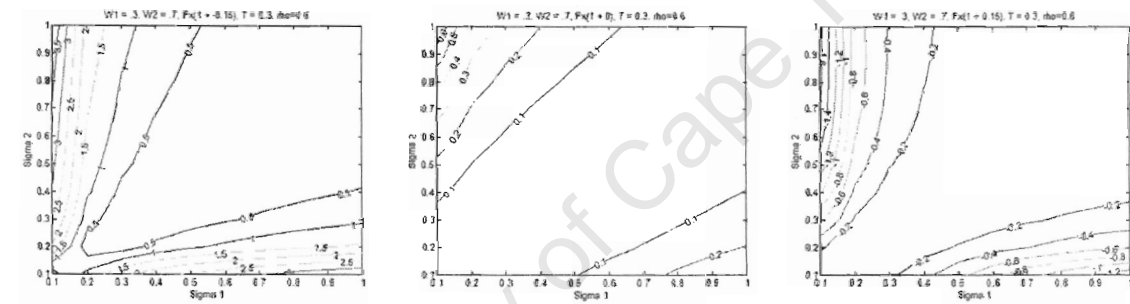

$\rho = 0.9$

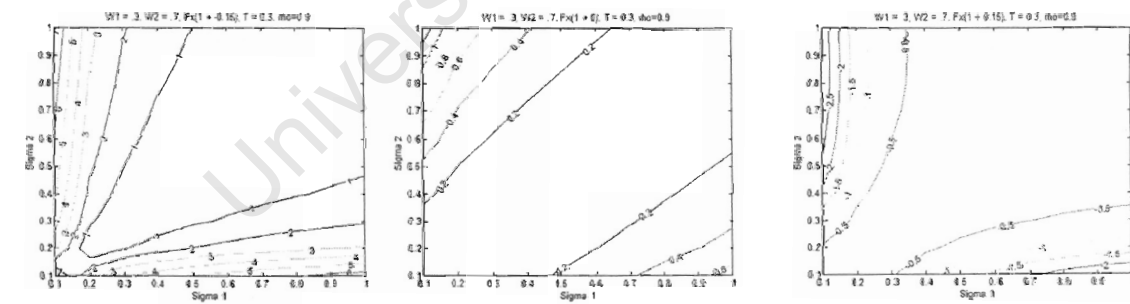

$K = F - 20\%$

$K = F$

$K = F + 20\%$

Figure 5.12: Contour Plots of Error term over the sigma plane. $T = 0.3$, Unequal Weights

$W1 = 0.3, W2 = 0.7, T = 3$

$\rho = 0$

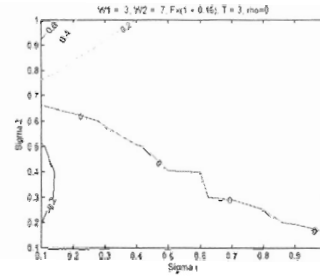
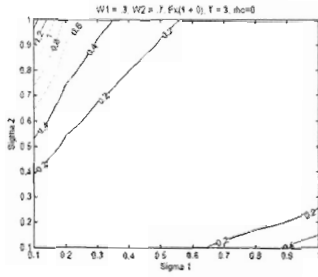
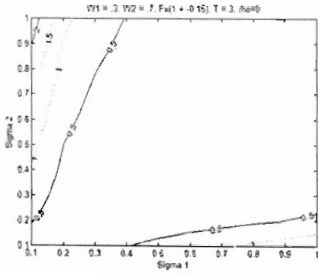

$\rho = 0.3$

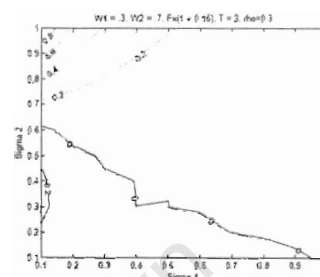
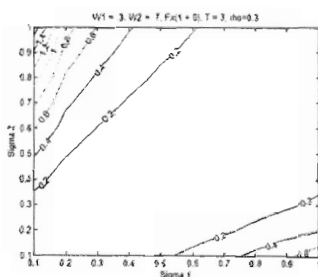
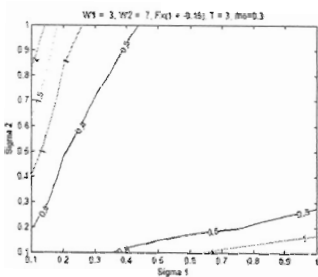

$\rho = 0.6$

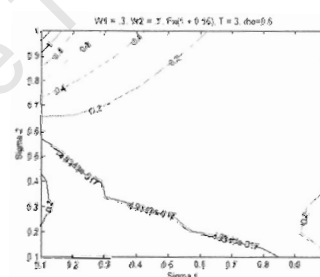
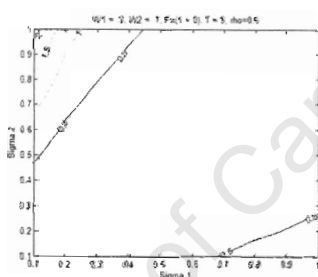
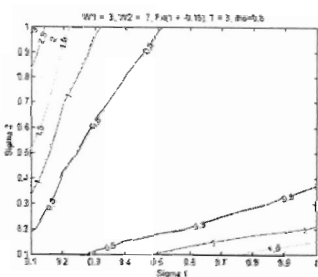

$\rho = 0.9$

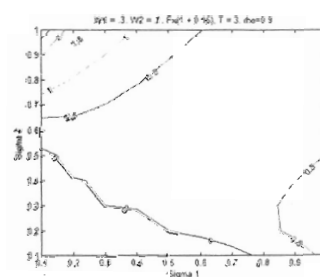
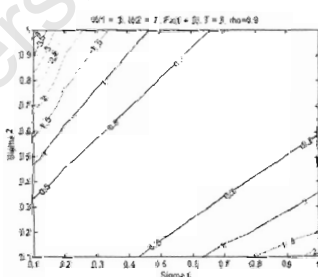
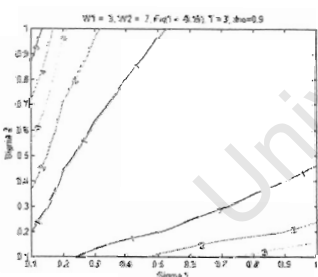

$K = F - 20\%$

$K = F$

$K = F + 20\%$

Figure 5.13: Contour Plots of Error term over the sigma plane. $T = 3$, Unequal Weights

$W1 = 0.3, W2 = 0.7, T = 10$

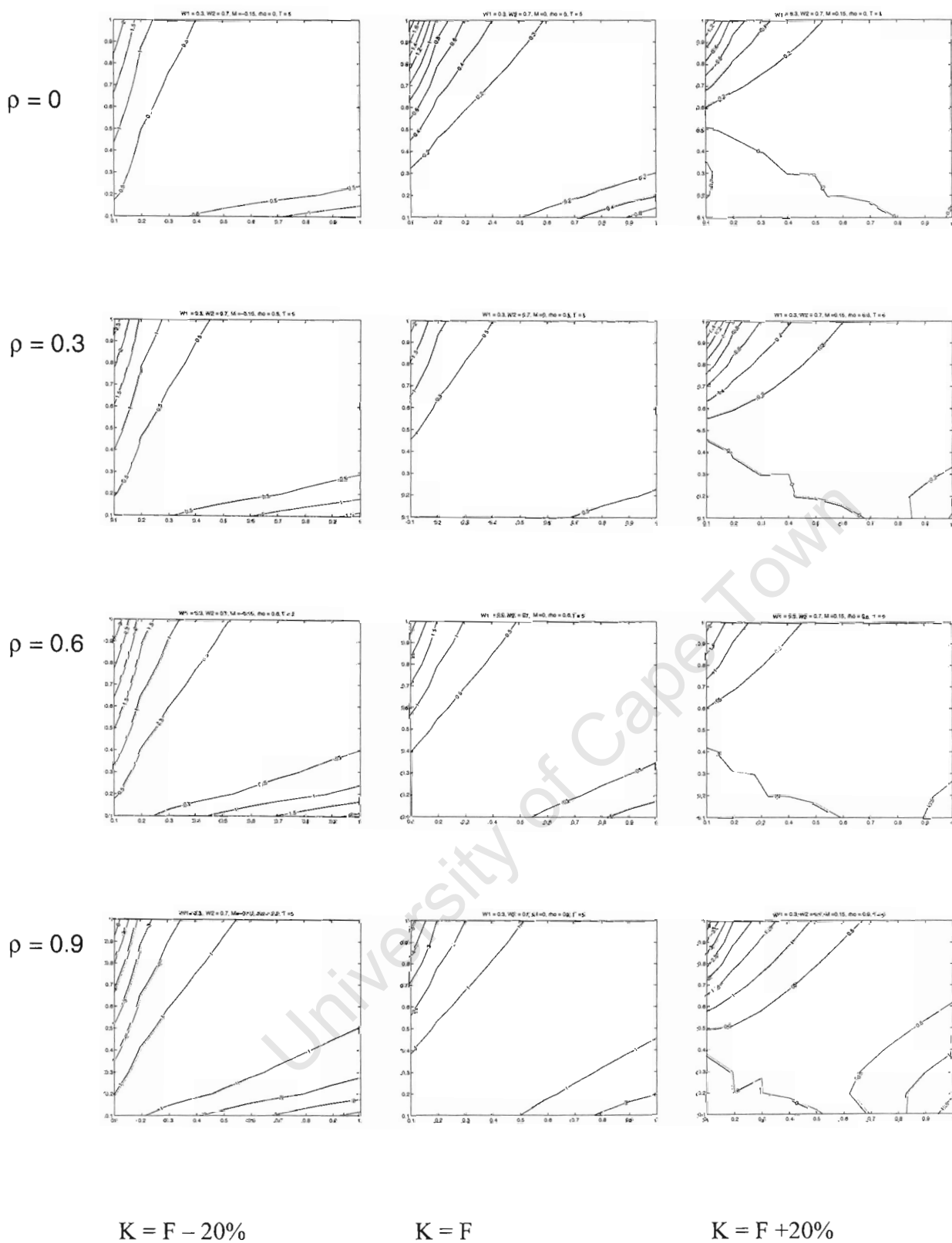

Figure 5.14: Contour Plots of Error term over the sigma plane. $T = 10$, Unequal Weights

5.3 Initial Discussion

From these charts we can immediately note the following.

1. Out-of-the money options violate the lower bound, whilst in-the-money options. violate the upper bound. Options struck at-the-money tend to be within the bounds.
2. As ρ increases the area of the violation region increases.
3. As T increases the area of the violation region decreases.
4. As the difference between σ_1 and σ_2 increases, violation is more frequent.
5. Making the weights unequal creates a larger region of violation on the side of the heavier asset (effectively skewing the contours away from the heavier asset).

Although this analysis is useful, it is not readily transferable to baskets comprising more than two assets. We turn to multivariate statistical techniques to identify sensitivities for larger baskets.

5.4 Multivariate Statistical Analysis

Although we have analytical forms for our bounds and approximations. they are too complicated to admit meaningful analysis. We are attempting to identify characteristics of a basket that will lead to market mispricing, and there are several multivariate statistical techniques that will give us a heuristic answer to this question. It is important to remember that for any given basket, our methods will quickly give us an answer as to whether the approximate price lies within the bounds. Therefore we are not trying to rigorously identify regions of violation in the variable space, but rather gain heuristic insight as to what factors most affect violation.

5.5 Classification Trees

Classification trees were introduced by Brieman et al. [4]) as a means for identifying important predictor variables in a data set. We have used the classification tree module in Statistica to identify the most important predictors in our variable space. Statistica describes classification trees saying:

“Classification trees are used to predict membership of classes in cases of a categorical dependent variable from their measurement on one or more predictor variables. The goal of classification trees

is to predict or explain responses on a categorical dependent variable, and as such, these techniques have much in common with the techniques used in the more traditional methods of Discriminant Analysis, Cluster Analysis, Nonparametric Statistics, and Nonlinear Estimation. The flexibility of classification trees make them a very attractive analysis option, but this is not to say that their use is recommended to the exclusion of more traditional methods. Indeed, when the typically stringent theoretical and distributional assumptions of traditional methods are met, the traditional methods may be preferable. But as an exploratory technique, or as a technique of last resort when traditional methods fail, classification trees are, in the opinion of many researchers, unsurpassed.

The study and use of classification trees are not widespread in the fields of probability and statistical pattern recognition (Ripley, 1996), but classification trees are widely used in applied fields as diverse as medicine (diagnosis), computer science (data structures), botany (classification), and psychology (decision theory). Classification trees readily lend themselves to being displayed graphically, helping to make them easier to interpret than they would be if only a strict numerical interpretation were possible.”

We have implemented them with some success enabling us to identify the variables that most heavily influence the categorisation of the error term in multiple asset basket options. We prepared a random sample of 3000 inputs for a 5 and 10 asset basket², and then calculated the option prices and bounds for a range of 5 strikes, ranging from 20 percent out-of-the-money to 20 percent in-the-money. This gave us a data set of 15,000 prices for each basket. This set was divided randomly into two equal groups. The first group was used as training data and the second group was used as test data.

The problem with using this method is that there is a clear non-linear dependence between the input variables and the price. Classification trees look for univariate splits to identify membership of classes in the categorical dependent variable, and as such, their ability to identify splits in variables whose dependence is non-linear is limited.

To assist the process, we introduce various non-linear combinations of the input variables which summarise important information about the basket. From our heuristic analysis of the 2 dimensional case we can see that the difference of the volatilities of the assets in the basket is a key indicator as to whether a bound will be violated or not. Additionally, the skewness in the weights is also an important predictor. To capture this information about higher dimensional baskets we have introduced the following variables:

1. The concentration of the basket: $Conc$
2. The market estimation of the basket variance: $Bvar$
3. The weighted sum of the variances of the basket elements: $Wvar$

²The random correlation matrices were adjusted using spectral decomposition to ensure their positive definiteness

Below we present a classification tree for a 5 and 10 asset basket where (1) indicates a violation of the lower bound, (2) indicates the approximation lies within the bounds and (3) indicates a violation of the upper bound.

We can see that the trees are able to distinguish between cases 2 and 1 easily (achieving 98% and 96% respectively on the test data for the 5 asset case and 97% and 96% for the 10 asset case), whereas the results for case 3 are disappointing (40%). This is possibly because the upper bound violations tend to be fewer and smaller.

Note, that K is once again the main variable that distinguishes between the 3 cases. This is what we would expect from our observations of the contour plots, where it was seen that out-of-the-money options violate the lower bound, whereas in-the-money options violate the upper bound.

After the strike, $Wvar$ and $Bvar$, are successfully used to separate the cases. These variables are indications of the basket's skewness and, again, this is what was expected from the results of the contour plots where it was shown that violation only occurs in skewed baskets.

University of Cape Town

Classification Tree for Category
 Number of splits = 11; Number of terminal nodes = 12

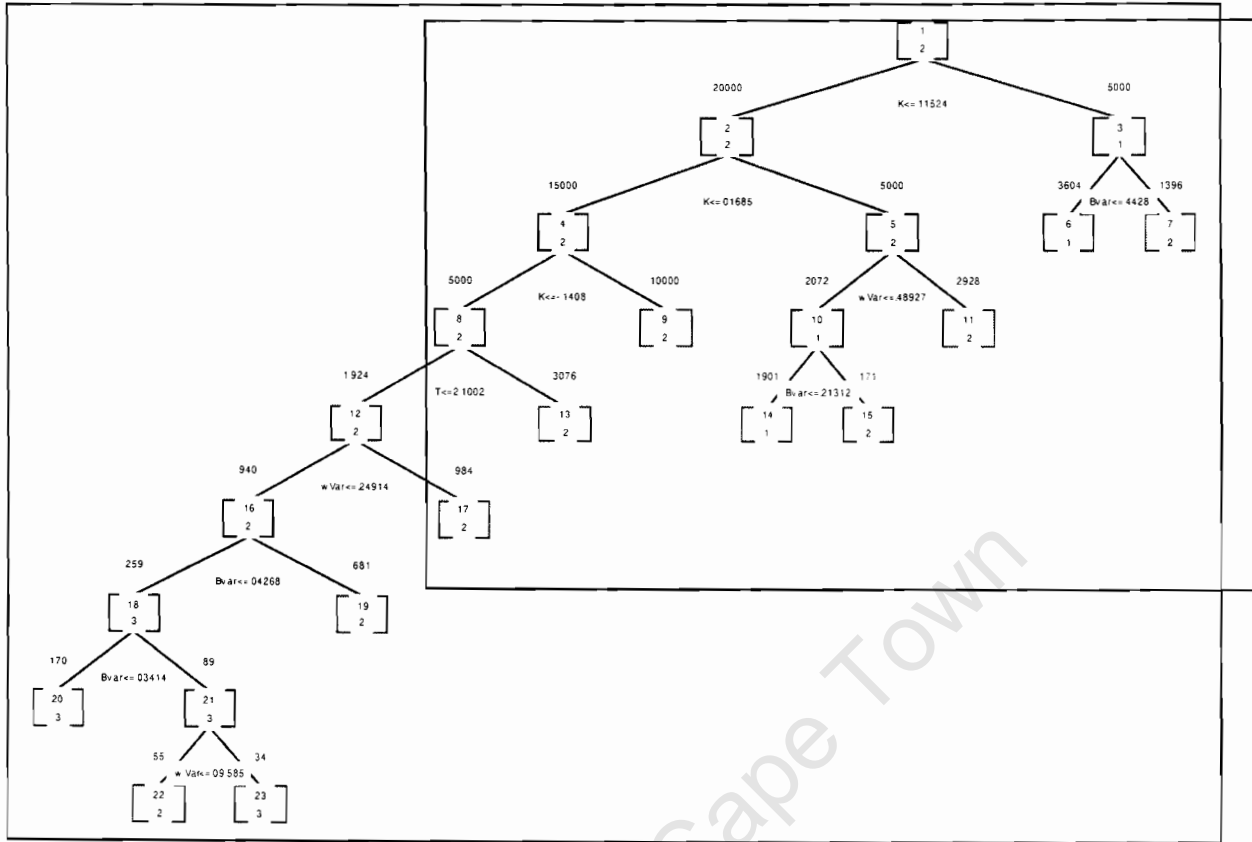

Figure 5.15: Classification Tree for 10 Asset Basket

University of Cape Town

Classification Tree for Category
 Number of splits = 11; Number of terminal nodes = 12

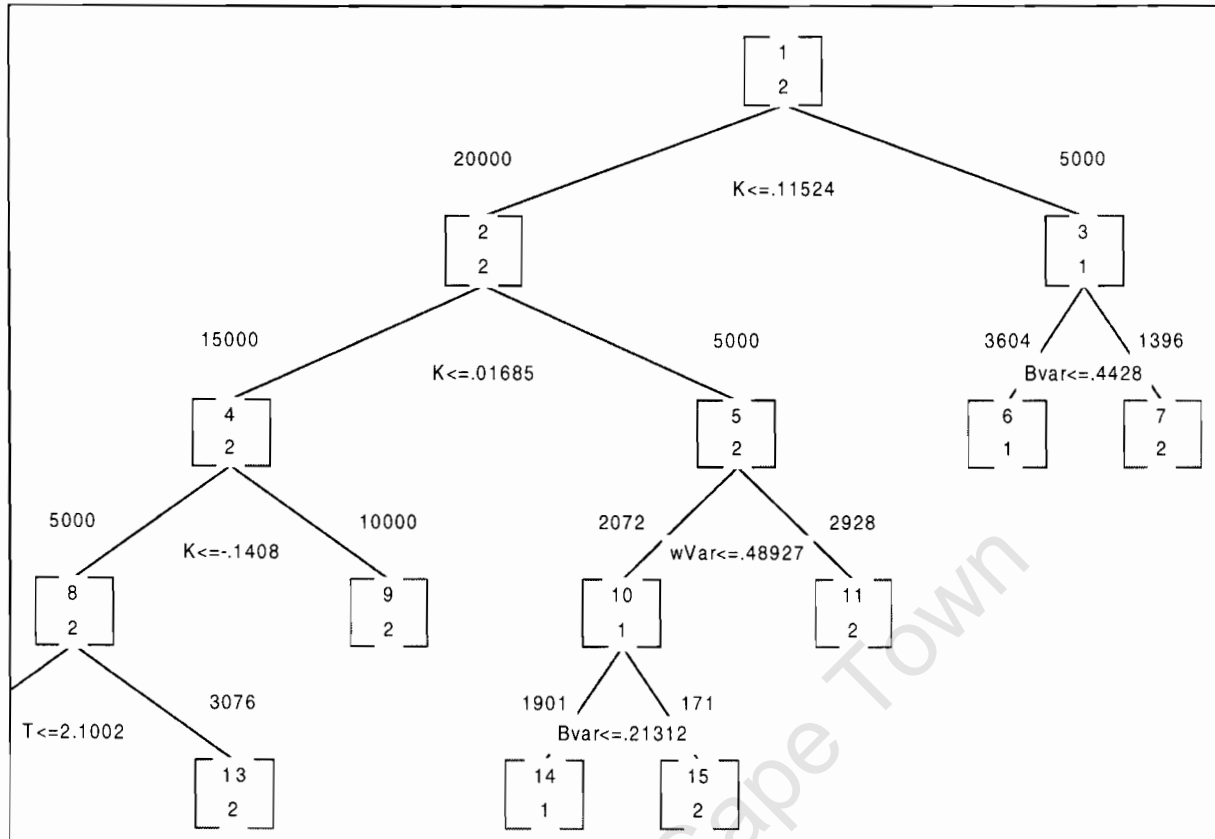

Figure 5.16: Enlarged region of Classification Tree (10 Asset Case)

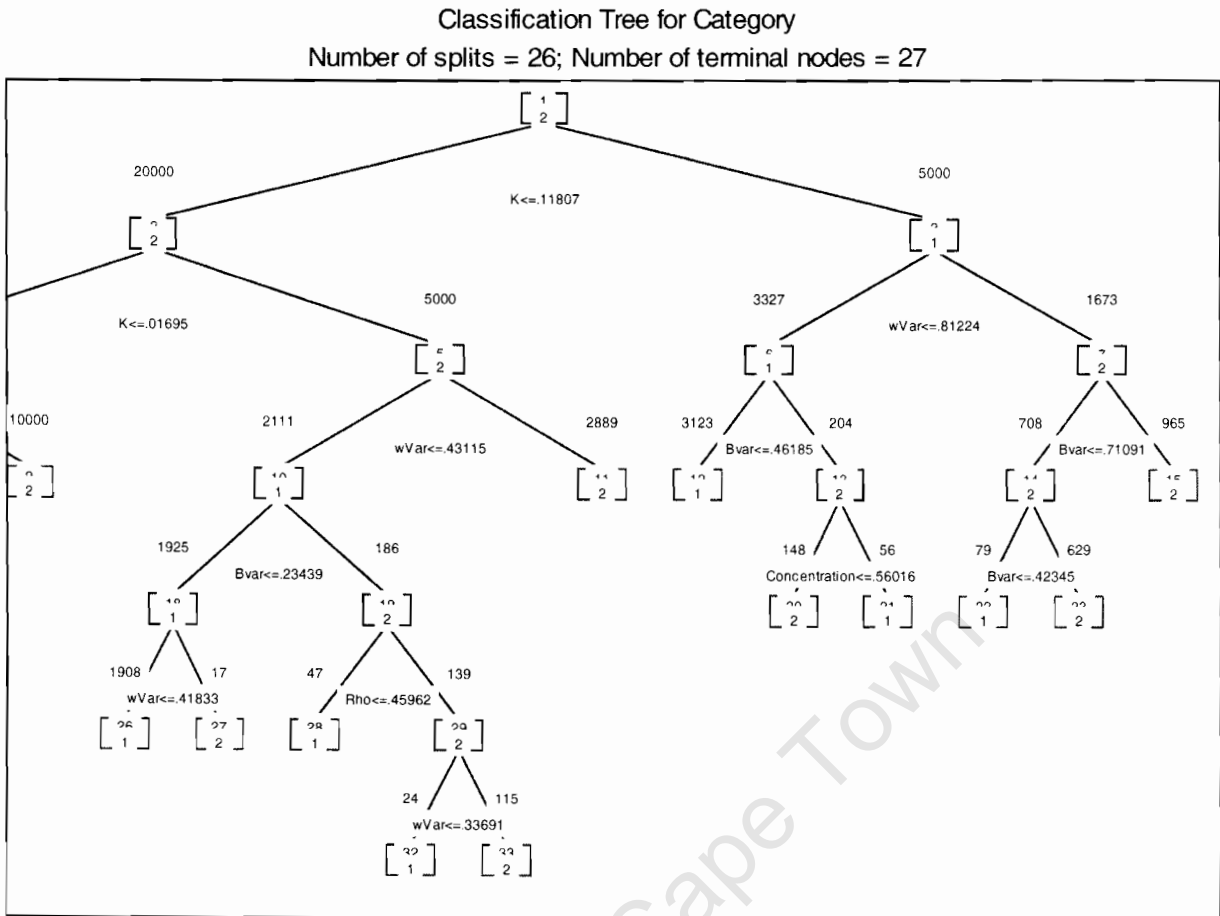

Figure 5.18: Enlarged region of Classification Tree (5 Asset Basket)

University of Cape Town

Chapter 6

Conclusions

We have examined several approximations to the price of a basket option where the individual elements are assumed to follow standard GBM dynamics. We have presented analytical bounds for these options and tested the market approximation against these bounds. From the graphical and statistical analysis we have carried out, we can draw the following conclusions.

1. Baskets that are strongly asymmetric are more likely to be mispriced by market techniques.
2. In-the-money options tend to be overpriced and out-of-the-money options tend to be underpriced.
3. Short maturity options are more likely to be mispriced whereas long dated options tend to lie within the bounds.

It is important to remember that the advantage of the bounds we have presented here is that they may be easily and quickly calculated. Therefore, for any given basket it is easy to check whether the price lies within the bounds or not.

6.1 Further Research

We end this dissertation with three ideas for further study.

The difficulty of approximating sums of lognormal variables is only one of the problems surrounding basket option pricing. The difficulties of unstable correlations and of volatility skews in the individual underlyings have not been addressed in this dissertation and are obvious areas for further study. Since the theory of comonotonic bounds presented in this dissertation allows us to

express the bounds as sums of Black-Scholes prices it would be interesting to see we could apply results from stochastic volatility models to our prices to explain the volatility surface of the basket. If our bound says that the option price is bounded by

$$C_0 \geq \sum_{i=1}^n BS_i(\tilde{S}_0^i, T, \tilde{K}, \tilde{\sigma}_i, r), \quad (6.1)$$

where BS_i is the Black-Scholes price for a call option on the synthetic underlying \tilde{S}_t^i with a strike \tilde{K} , can we adapt each BS_i in the usual way to include stochastic volatility and then recombine them in a sum that theoretically bounds the option price?

Secondly, it is necessary for any coherent basket option price to explain the unstable correlations between the assets in the baskets. Introducing such a model, perhaps linking correlations to the basket price, is an essential development of this theory.

Lastly, since the basic results do not rest on distributional assumptions, the theory can be extended to include baskets of assets in different classes. For example we may wish to trade a basket containing a commodity and a stock, for example gas and stock of a gas distribution company. Now the gas price does not follow a Geometric Brownian motion, but exhibits large spikes which may be modelled by a mixed jump diffusion process. Using the theory presented in this dissertation can we bound an option on this basket?

University of Cape Town

Bibliography

- [1] Y. Ait-Sahalia and A.W. Lo. Nonparametric estimation of state price densities implicit in financial asset prices. *Journal of finance*, 53 No. 2, 1998.
- [2] M. Allevaneda, D. Boyer-Olsen, J. Busca, and P. Fritz. Reconstructing volatility. *Risk*. October:87–91, 2002.
- [3] Slimane ben Slimane. Bounds on the distribution of a sum of independent lognormal random variables. *IEEE transactions on communication*, 49 No. 6, 2001.
- [4] L. Brieman, J. H. Friedman, R. A. Olshen, and C. J. Stone. *Classification and Regression Trees*. Wadsworth, 1984.
- [5] D. Brigo, F. Mercurio, F. Rapisarda, and R. Scotti. Approximated moment matching dynamics for basket simulation. 2002. Working Paper, Banco Milano.
- [6] R.V Churchill. *Fourier Series and Boundary Value Problems*. New York: McGraw-Hill. 1963. 2nd Edition.
- [7] G. Deelstra, J. Liinev, and M. Vanmaele. The pricing of arithmetic basket options and asian baskets by conditioning. 2003. Working Paper.
- [8] J. Dhaene, M. Denuit, M.J. Goovaerts, R. Kaas, and D. Vyncke. The concept of comonotonicity in actuarial science and finance : Theory. *Insurance : Mathematics and Economics*, 31: 3–33. 2002.
- [9] J. Dhaene, M. Denuit, M.J. Goovaerts, R. Kaas, and D. Vyncke. The concept of comonotonicity in actuarial science and finance : Applications. *Insurance : Mathematics and Economics*, 31:133–161, 2002.
- [10] M. Scholes F. Black. The pricing of options and corporate liabilities. *Journal of Political Economy*, 81:637–659, 1973.
- [11] M. Frechet. Sur les tableaux de corrlation dont les marges sont donnees et programmes lineaires. *Ann. Univ. Lyon*, pages 53–77, 1951.
- [12] J. Harrison and R. Pliska. Martingales and stochastic integrals in the theory of continuous trading. *Stochastic Processes and their applications*, 11:215–260, 1979.

- [13] W. Hoeffding. Masstabvariante korrelationstheorie. *Schriften Math. Inst. Univ. Berlin*, 5: 181–233, 1940.
- [14] J.C. Hull. *Options, Futures and other Derivatives*. Pearson Educational International, Prentice Hall, 2003. Fifth Edition.
- [15] J.A.C. Brown J. Aitchinson. *The lognormal distribution with special reference to its use in economics*. Cambridge Univeristy Press, 1957.
- [16] J.C. Jackwerth and M. Rubinstein. Recovering probability distributions from contemporary security prices. *Journal of Finance*, 51:1611–1631, 1996.
- [17] R. Jarrow and A. Rudd. Approximate option valuation for arbitrary stochastic processes. *Journal of Financial Economics*, 10:347–369, 1982.
- [18] R. Kaas, J. Dhaene, D. Vyncke, and M. Denuit M.J. Goovaerts and. A simple geometric proof that comonotonic risks have the convex largest sum. *ASTIN Bulletin*, 32:71–80, 2002.
- [19] P. Lee, L. Wang, and A. Karim. Index volatility surface via moment matching techniques. *Risk*, December:85–89, 2003.
- [20] R. Merton. Rational theory of option pricing. *Bell Journal of Economics and Manangement Science*, 4:141–183, 1973.
- [21] L.C.G. Rogers and Z. Shi. The value of an asian option. *Journal of applied probability*, 32: 1077–1088.
- [22] M. Romeo, V. Da Costa, and F. Bardou. Broad distribution effects in sums of lognormal random variables. *The European Physical Journal*, B 32:513–525, 2003.
- [23] M. Stutzer. A simple non-parametric approach to derivative security valuation. *Journal of Finance*, 51:1633–1652, 1996.
- [24] G.F. Sudler. Asian options : Inverse laplace transforms and martingale methods revisited. 1999. MSc Thesis.
- [25] E.A. Valdez and J. Dhaene. Bounds for sums of non-independent log-elliptical random variables. 2003.
- [26] J. Zou and E. Derman. Strike adjusted spread: a new metric for estimating the value of equity options. *Goldman Sachs : Quantitative Research Notes*, 1999.

Appendix A

The Lognormal Distribution

A.1 Genesis

The lognormal distribution is centrally important to the Black-Scholes model. It arises in many other disciplines but we shall focus on the mechanism that generates it in finance.

We consider x a random variable, exponentially dependent on a Gaussian¹ random variable y with mean μ_y and variance σ_y^2

$$x = x_0 e^{y/y_0}, \quad (\text{A.1})$$

where x_0 and y_0 are scale parameters for x and y respectively. The density function of y is given by

$$N(\mu_y, \sigma_y^2)(y) = \frac{1}{\sqrt{2\pi\sigma_y^2}} \exp\left(-\frac{(y - \mu_y)^2}{2\sigma_y^2}\right). \quad (\text{A.2})$$

¹Normally distributed

and the probability density function for x is given by

$$f(x) = \ln(\mu, \sigma^2), \quad (\text{A.3})$$

$$= N(\mu_y, \sigma_y^2)(y) \frac{dy}{dx}, \quad (\text{A.4})$$

$$= \frac{1}{\sqrt{2\pi\sigma^2 x}} \exp\left(\frac{-(\ln x - \mu)^2}{2\sigma^2}\right). \quad (\text{A.5})$$

$$\text{where} \quad (\text{A.6})$$

$$\mu = \frac{\mu_y}{y_0} + \ln x_0, \quad (\text{A.7})$$

$$\text{and} \quad (\text{A.8})$$

$$\sigma^2 = \left(\frac{\sigma_y}{y_0}\right)^2. \quad (\text{A.9})$$

A.2 Characteristics of the lognormal distribution

If we set the scale parameters $x_0 = y_0 = 1$ we see that the parameters μ and σ^2 are the mean and variance of the Gaussian random variable $\ln x$.

The parameter μ is a *scale* parameter as can be seen from the fact that if

$$x \sim \ln(\mu, \sigma^2),$$

then

$$\alpha x \sim \ln(\mu' = \mu + \ln \alpha, \sigma'^2 = \sigma^2).$$

So, we see that we can set $\mu = 0$ by using a suitable choice of units. On the other hand σ^2 is the *shape* parameter of the distribution.

Let x^t be the typical value, corresponding to the maximum of the distribution. x^m be the median value with $\int_{-\infty}^{x^m} f(x)dx = \int_{x^m}^{\infty} f(x)dx$ and $\langle x \rangle$ be the expected value. Where the variance, as usual, is given by $\text{Var}(x) = \langle x^2 \rangle - \langle x \rangle^2$. Then we have:

$$x^t = e^{\mu - \sigma^2},$$

$$x^m = e^{\mu},$$

$$\langle x \rangle = \mathbb{E}[e^y] = e^{\mu + \sigma^2/2},$$

and

$$\text{Var}(x) = e^{2\mu + \sigma^2} (e^{\sigma^2} - 1).$$

The dispersion of the distribution is characterized by the *coefficient of variation*

$$\begin{aligned} C &\equiv \sqrt{\text{Var}(x) / \langle x \rangle}, \\ &\equiv \sqrt{e^{\sigma^2} - 1}. \end{aligned}$$

A.3 Approximation of the lognormal distribution by the normal distribution

For the normal distribution, most of the distribution is contained within $[\mu - \sigma, \mu + \sigma]$. For the lognormal distribution the same probability is contained within $[e^\mu e^{-\sigma}, e^\mu e^\sigma]$. If σ is small ($\ll 1$) then we can approximate this interval by:

$$e^\mu(1 - \sigma) \leq x \leq e^\mu(1 + \sigma). \quad (\text{A.10})$$

We therefore expand $f(x)$ around its typical value e^μ by introducing a new random variable ϵ defined by:

$$x \equiv e^\mu(1 + \epsilon),$$

where ϵ is a random variable on the order of

$$-\sigma \leq \epsilon \leq \sigma.$$

Since $\sigma \ll 1$ $\epsilon \ll 1$. We can expand the lognormal distribution function $f(x)$ of (A.5) in powers of ϵ to obtain:

$$f(x) = \frac{1}{\sqrt{2\pi\sigma^2 x}} \exp\left(-\frac{(\ln x - \mu)^2}{2\sigma^2}\right), \quad (\text{A.11})$$

$$= \frac{1}{\sqrt{2\pi\sigma^2 e^\mu(1 + \epsilon)}} \exp\left(-\frac{(\ln(e^\mu(1 + \epsilon)) - \mu)^2}{2\sigma^2}\right), \quad (\text{A.12})$$

$$\approx \frac{1}{\sqrt{2\pi\sigma^2 e^\mu}} (1 - \epsilon + \epsilon^2 + \dots) \exp\left(-\frac{\epsilon^2}{2\sigma^2} + \frac{\epsilon^3}{2\sigma^2} + \dots\right), \quad (\text{A.13})$$

$$\approx \frac{1}{\sqrt{2\pi\sigma^2 e^\mu}} \exp\left(-\frac{\epsilon^2}{2\sigma^2}\right), \quad (\text{A.14})$$

$$\approx \frac{1}{\sqrt{2\pi\sigma^2 e^\mu}} \exp\left(-\frac{(x - e^\mu)^2}{2(\sigma e^\mu)^2}\right). \quad (\text{A.15})$$

In other words, a *narrow* lognormal distribution can be well approximated by a normal distribution with

$$\ln(\mu, \sigma^2) \approx N(e^\mu, (\sigma e^\mu)^2). \quad (\text{A.16})$$

In the case of stock prices σ is typically small so we can safely make the approximation.

Alternatively, any normal distribution may be approximated by a three parameter lognormal distribution with

$$N(\mu, \sigma^2) \sim \ln\left(\ln(\mu + A), \left(\frac{\sigma}{\mu + A}\right)^2, A\right) \quad (\text{A.17})$$

where the density function of the three parameter lognormal distribution is

$$\ln(\mu, \sigma^2, A) = \frac{1}{\sqrt{2\pi\sigma^2}(x-A)} \exp\left(\frac{-(\ln(x-A) - \mu)^2}{2\sigma^2}\right). \quad (\text{A.18})$$

When $\sigma \ll \mu$ we can use a two parameter lognormal distribution with

$$N(\mu, \sigma^2) \sim \ln\left(\ln(\mu), \left(\frac{\sigma}{\mu}\right)^2\right), \quad (\text{A.19})$$

where the density function of the two parameter lognormal distribution is given by (A.5).

A.4 Reproductive Properties

Finally, let us consider the reproductive properties of lognormal variable.

Let X_1, X_2, \dots, X_n be a set of lognormal variables with $X_i = e^{Y_i}$ for some Y_i where $Y_i \sim N(\mu_i, \sigma_i^2)$.

Now, consider the product $\prod_{i=1}^n X_i$

$$\begin{aligned} \prod_{i=1}^n X_i &= \prod_{i=1}^n e^{Y_i}, \\ &= e^{\sum_{i=1}^n Y_i}, \\ &= e^Z, \end{aligned}$$

where

$$Z \sim N\left(\sum_{i=1}^n \mu_i, \sum_{i,j=1}^n \sigma_i \sigma_j \rho_{ij}\right).$$

So the product is also lognormally distributed. However, the sum $\sum_{i=1}^n X_i = \sum_{i=1}^n e^{Y_i}$ is obviously *not* lognormally distributed. It can't be written as $\sum_{i=1}^n X_i = e^Z$ where Z is normally distributed. However, we may make some approximations.

A.4.1 A lognormal approximation for a sum of lognormal variables

Consider a set of variables X_i where $\ln X_i \sim N(\mu_i, \sigma_i^2)$. Now, since X is lognormally distributed, there must be a set of variables Y_i where $X_i = e^{Y_i}$ and $Y_i \sim N(\mu_i, \sigma_i^2)$. Let S be a weighted sum of these variables, so

$$S = \sum_{i=1}^N w_i X_i, \quad (\text{A.20})$$

where

$$w_i = \frac{a_i X_0}{\sum_{i=1}^N a_i X_0}. \quad (\text{A.21})$$

Note that $\sum_{i=1}^n w_i = 1$. By expanding the Taylor series for e^{Y_i} and dropping terms of more than first order, we obtain

$$S = \sum_{i=1}^N w_i X_i, \quad (\text{A.22})$$

$$= \sum_{i=1}^N w_i e^{Y_i}, \quad (\text{A.23})$$

$$\approx \sum_{i=1}^N w_i (1 + Y_i). \quad (\text{A.24})$$

Now, suppose that $S = e^Y$ which we may again approximate as $e^Y \approx (1 + Y)$: this yields

$$(1 + Y) \approx \sum_{i=1}^N w_i (1 + Y_i), \quad (\text{A.25})$$

and, since $\sum_{i=1}^n w_i = 1$ we can write

$$Y \approx \sum_{i=1}^n w_i Y_i. \quad (\text{A.26})$$

So we may find the distribution of Y since it is a weighted sum of normal variables. This distribution is

$$Y \sim N\left(\sum_{i=1}^n w_i \mu_i, \sum_{i=1}^n \sum_{j=1}^n w_i w_j \sigma_i \sigma_j \rho_{ij}\right), \quad (\text{A.27})$$

which can be written as

$$Y \sim N\left(\sum_{i=1}^n w_i \mu_i, W \Sigma W^T\right), \quad (\text{A.28})$$

where W is the row vector of weights and Σ is the variance-covariance matrix. So, $S = e^Y$ is lognormally distributed.

A.4.2 A normal approximation for a sum of lognormal variables

We have shown previously, that under certain conditions, we may approximate a lognormal distribution by a normal distribution. Specifically, if $\ln X \sim N(\mu, \sigma^2)$ and $\sigma \ll \mu$ then we may write $X \sim N(e^\mu, (\sigma e^\mu)^2)$

Now, if we have a set of such variables X_i with $\ln X_i \sim N(\mu_i, \sigma_i^2)$ and the conditions $\sigma_i \ll \mu_i \forall i$ then we may approximate $X_i \sim N(e^{\mu_i}, (\sigma_i e^{\mu_i})^2)$. Consequently, the weighted sum $S = \sum_{i=1}^n w_i X_i$ is approximately normal (being the sum of normal variables), and its distribution can be written as

$$S \sim N\left(\sum_{i=1}^n w_i e^{\mu_i}, \sum_{i=1}^n \sum_{j=1}^n w_i w_j (\sigma_i e^{\mu_i})^2 (\sigma_j e^{\mu_j})^2 \rho_{ij}\right). \quad (\text{A.29})$$

Appendix B

Correlation and Covariance

The purpose of this chapter is to discuss the effects of stock prices being generated by correlated Brownian motions and to derive expressions for variance, covariance and correlation between log-stock prices in the first case and the stock prices themselves in the second.

Consider two stocks S_t^1 and S_t^2 with risk-neutral dynamics

$$\frac{dS_t^i}{S_t^i} = rdt + \sigma_i dW_t^i. \quad (\text{B.1})$$

Furthermore, assume that the Brownian motions generating these price processes are correlated such that $\text{Corr}(W_t^i, W_t^j) = \rho_{i,j}$, or alternatively,

$$dW_t^i dW_t^j = \rho_{ij} dt. \quad (\text{B.2})$$

We will first consider log stock prices and then consider stock prices themselves. Solving the equation (B.1) yields

$$S_t^i = S_0^i e^{(r - \frac{1}{2}\sigma_i^2)t + \sigma_i W_t^i}, \quad (\text{B.3})$$

which implies that

$$\ln(S_t^i) \sim N\left(\ln(S_0^i) + (r - \frac{1}{2}\sigma_i^2)t, \sigma_i^2 t\right). \quad (\text{B.4})$$

Consider the log returns of S_t^i

$$\begin{aligned} LR_t^i &= \ln\left(\frac{S_{t+\Delta t}^i}{S_t^i}\right), \\ &= \ln\left(\frac{S_0^i e^{(r - \frac{1}{2}\sigma_i^2)t + \Delta t + \sigma_i W_{t+\Delta t}^i}}{S_0^i e^{(r - \frac{1}{2}\sigma_i^2)t + \sigma_i W_t^i}}\right), \\ &= \ln\left(e^{(r - \frac{1}{2}\sigma_i^2)\Delta t + \sigma_i W_{\Delta t}^i}\right). \end{aligned} \quad (\text{B.5})$$

This implies that the log returns are distributed as

$$\ln\left(\frac{S_{t+\Delta t}^i}{S_t^i}\right) \sim N\left(\left(r - \frac{1}{2}\sigma_i^2\right)\Delta t, \sigma_i^2\Delta t\right). \quad (\text{B.6})$$

(Whence we get the expression of volatility as the annualised standard deviation of log returns)

Now, let us consider the covariance between the log-returns.

$$\text{Cov}\left(LR_t^i, LR_t^j\right) = \mathbb{E}\left[\ln\left(\frac{S_{t+\Delta t}^i}{S_t^i}\right)\ln\left(\frac{S_{t+\Delta t}^j}{S_t^j}\right)\right] \quad (\text{B.7})$$

$$- \left(r - \frac{1}{2}\sigma_i^2\right)\Delta t\left(r - \frac{1}{2}\sigma_j^2\right)\Delta t,$$

$$= \mathbb{E}\left[\left(\left(r - \frac{1}{2}\sigma_i^2\right)\Delta t + \sigma_i W_{\Delta t}^i\right)\left(\left(r - \frac{1}{2}\sigma_j^2\right)\Delta t + \sigma_j W_{\Delta t}^j\right)\right] \quad (\text{B.8})$$

$$- \left(r - \frac{1}{2}\sigma_i^2\right)\Delta t\left(r - \frac{1}{2}\sigma_j^2\right)\Delta t.$$

$$= \mathbb{E}\left[\sigma_i\sigma_j W_t^i W_t^j\right]. \quad (\text{B.9})$$

$$= \sigma_i\sigma_j\rho_{i,j}\Delta t \quad (\text{B.10})$$

From the definition of the correlation coefficient ($\rho_{x,y} = \frac{\sigma_{x,y}}{\sigma_x\sigma_y}$) we easily find that the correlation between the log-returns is indeed ρ .

Consider now the log-prices. The distribution of these has already been given as (B.4) and from this, and the expression for the log stock price we can see that

$$\text{Cov}\left(\ln(S_t^i), \ln(S_t^j)\right) = \mathbb{E}\left[\ln(S_t^i)\ln(S_t^j)\right] \quad (\text{B.11})$$

$$- \left(\ln(S_0^i) + \left(r - \frac{1}{2}\sigma_i^2\right)t\right)\left(\ln(S_0^j) + \left(r - \frac{1}{2}\sigma_j^2\right)t\right).$$

$$= \mathbb{E}\left[\left(\ln(S_0^i) + \left(r - \frac{1}{2}\sigma_i^2\right)t + \sigma_i W_t^i\right)\left(\ln(S_0^j) + \left(r - \frac{1}{2}\sigma_j^2\right)t + \sigma_j W_t^j\right)\right]$$

$$- \left(\ln(S_0^i) + \left(r - \frac{1}{2}\sigma_i^2\right)t\right)\left(\ln(S_0^j) + \left(r - \frac{1}{2}\sigma_j^2\right)t\right),$$

$$= \mathbb{E}[\sigma_i W_t^i \sigma_j W_t^j],$$

$$= \sigma_i\sigma_j\rho_{i,j}t.$$

Which again implies that the correlation between the log-prices at any time horizon is ρ

We now move on to the stock prices themselves

The expectation can be easily calculated as

$$\mathbb{E}[S_t] = \mathbb{E}[S_0 e^{(r - \frac{1}{2}\sigma^2)t + \sigma W_t}],$$

$$= S_0 e^{(r - \frac{1}{2}\sigma^2)t} E[e^{\sigma W_t}],$$

$$= S_0 e^{(r - \frac{1}{2}\sigma^2)t} e^{\frac{1}{2}\sigma^2 t},$$

$$= S_0 e^{rt}.$$

The variance may be similarly calculated as

$$\begin{aligned}
 \text{Var}[S_t] &= \mathbb{E}[(S_t - S_0 e^{rt})^2], \\
 &= \mathbb{E}[(S_0 e^{(r-\frac{1}{2}\sigma^2)t + \sigma W_t})^2] - (S_0 e^{rt})^2, \\
 &= S_0 e^{(2r-\sigma^2)t} \mathbb{E}[e^{2\sigma W_t}] - (S_0 e^{rt})^2, \\
 &= S_0^2 e^{2rt} (e^{\sigma^2 t} - 1).
 \end{aligned}$$

The correlation coefficient is given as $\rho = \frac{\sigma_{x,y}}{\sigma_x \sigma_y}$ so it remains for us to calculate the covariance $\sigma_{x,y}$.

$$\begin{aligned}
 \text{Cov}(S_t^1, S_t^2) &= \mathbb{E}[(S_t^1 - S_0^1 e^{rt})(S_t^2 - S_0^2 e^{rt})], \\
 &= \mathbb{E}[S_t^1 S_t^2] - S_0^1 S_0^2 e^{2rt}, \\
 &= \mathbb{E}[S_0^1 e^{(r-\frac{1}{2}\sigma_1^2)t + \sigma_1 W_t} S_0^2 e^{(r-\frac{1}{2}\sigma_2^2)t + \sigma_2 W_t}] - S_0^1 S_0^2 e^{2rt}, \\
 &= S_0^1 S_0^2 e^{2rt} \left(e^{-\frac{1}{2}(\sigma_1^2 + \sigma_2^2)t} \mathbb{E}[e^{\sigma_1 W_t^1 + \sigma_2 W_t^2}] - 1 \right), \\
 &= S_0^1 S_0^2 e^{2rt} (e^{\rho \sigma_1 \sigma_2} - 1).
 \end{aligned}$$

So the correlation coefficient can be written as

$$\rho = \frac{S_0^1 S_0^2 e^{2rt} (e^{\rho \sigma_1 \sigma_2} - 1)}{\sqrt{(S_0^1)^2 e^{2rt} (e^{\sigma_1^2 t} - 1) (S_0^2)^2 e^{2rt} (e^{\sigma_2^2 t} - 1)}} \quad (\text{B.12})$$

$$= \frac{(e^{\rho \sigma_1 \sigma_2} - 1)}{\sqrt{(e^{\sigma_1^2 t} - 1)(e^{\sigma_2^2 t} - 1)}} \quad (\text{B.13})$$

Let us move on to calculating the volatility of a basket of stocks defined as $B_t = \sum_{i=1}^n q_i S_t^i$. First we consider the variance of the basket simple returns.

Let $R_t^i = \frac{S_t^i - S_0^i}{S_0^i}$ and $R_t^B = \frac{B_t - B_0}{B_0}$ so

$$R_B = \frac{B_t - B_0}{B_0}, \quad (\text{B.14})$$

$$= \frac{\sum_{i=1}^n q_i (S_t^i - S_0^i)}{B_0}, \quad (\text{B.15})$$

$$= \sum_{i=1}^n \frac{w_i (S_t^i - S_0^i)}{S_0^i}, \quad (\text{B.16})$$

$$= \sum_{i=1}^n w_i R_t^i. \quad (\text{B.17})$$

where $w_i = \frac{q_i S_0^i}{B_0}$. The mean of the returns may be written as

$$\mathbb{E}[R_B] = \mathbb{E}\left[\sum_{i=1}^n w_i R_t^i\right], \quad (\text{B.18})$$

$$= \sum_{i=1}^n w_i \mu^i. \quad (\text{B.19})$$

and the variance can be written as

$$\sigma(R)^2 = E[(R - \mu)^2], \quad (\text{B.20})$$

$$= E\left[\left(\sum_{i=1}^n w_i (R_i - \mu_i)\right)^2\right], \quad (\text{B.21})$$

$$= E\left[\sum_{i=1}^n \sum_{j=1}^n w_i w_j (R_i - \mu_i)(R_j - \mu_j)\right]. \quad (\text{B.22})$$

$$= \sum_{i=1}^n \sum_{j=1}^n w_i w_j \text{Cov}(R_i, R_j). \quad (\text{B.23})$$

$$= W^T \Sigma W. \quad (\text{B.24})$$

Where Σ is the covariance matrix of the simple returns.

Finally we turn to the log-returns of the basket.

Define $r_B = \ln\left(\frac{B_t}{B_0}\right)$ and $r_i = \ln\left(\frac{S_t^i}{S_0^i}\right)$. So we can write r_B as

$$r_B = \ln\left(\frac{B_t}{B_0}\right), \quad (\text{B.25})$$

$$= \ln\left(\frac{\sum_{i=1}^n q_i S_t^i}{B_0}\right), \quad (\text{B.26})$$

$$= \ln\left(\sum_{i=1}^n \frac{w_i S_t^i}{S_0^i}\right). \quad (\text{B.27})$$

Now, we can't bring the logarithm function inside the sum, so we can't simplify this expression as we did in the case of the basket's simple returns. Finding the expectation and variance of the log-returns in closed-form is not analytically possible. However, we may employ the first order approximation given in (A.28), to write the variance of the basket's log returns as $W^T \Sigma W$ where Σ in this case is the variance covariance matrix of the log returns of the underlying assets in the basket.

Appendix C

Contour Plots

University of Cape Town

Moment Matching Method Equal Weights, $T = 3$

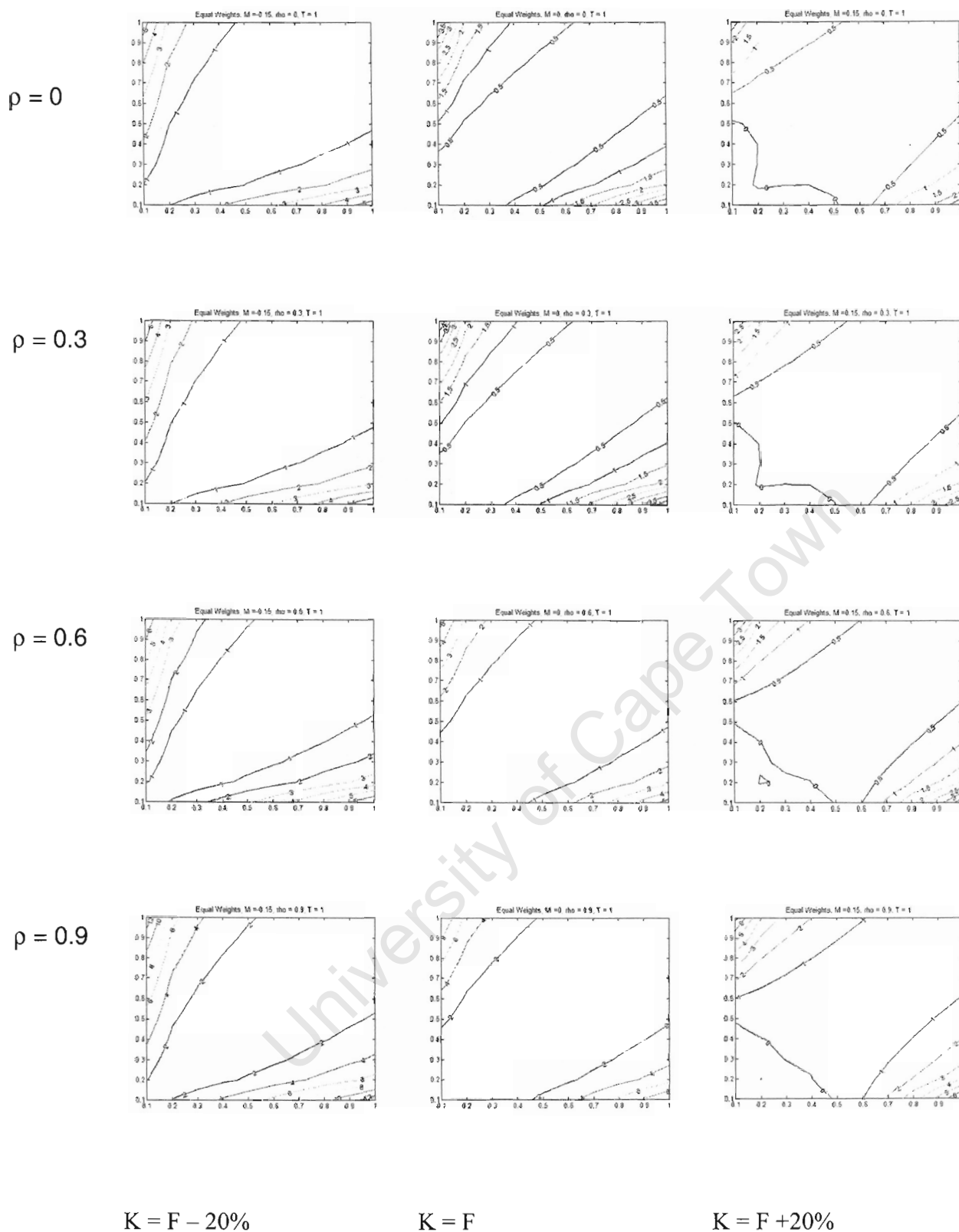

Figure C2: Contour Plots of Error term over the sigma plane. $T = 1$, Equal Weights

Moment Matching Method Equal Weights, $T = 5$

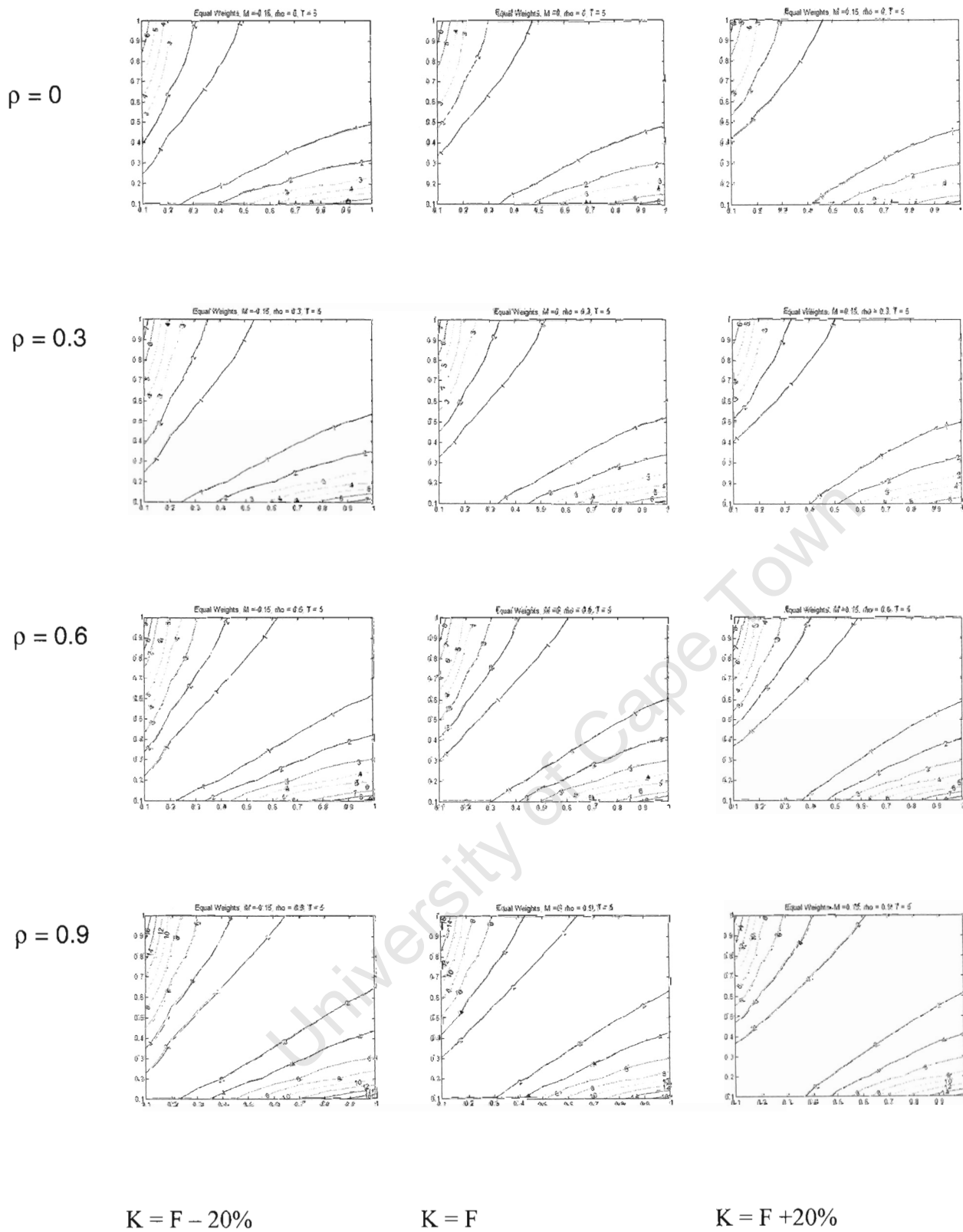

Figure C3: Contour Plots of Error term over the sigma plane. $T = 5$, Equal Weights

First Order pproximation
Equal Weights, $T = 1$

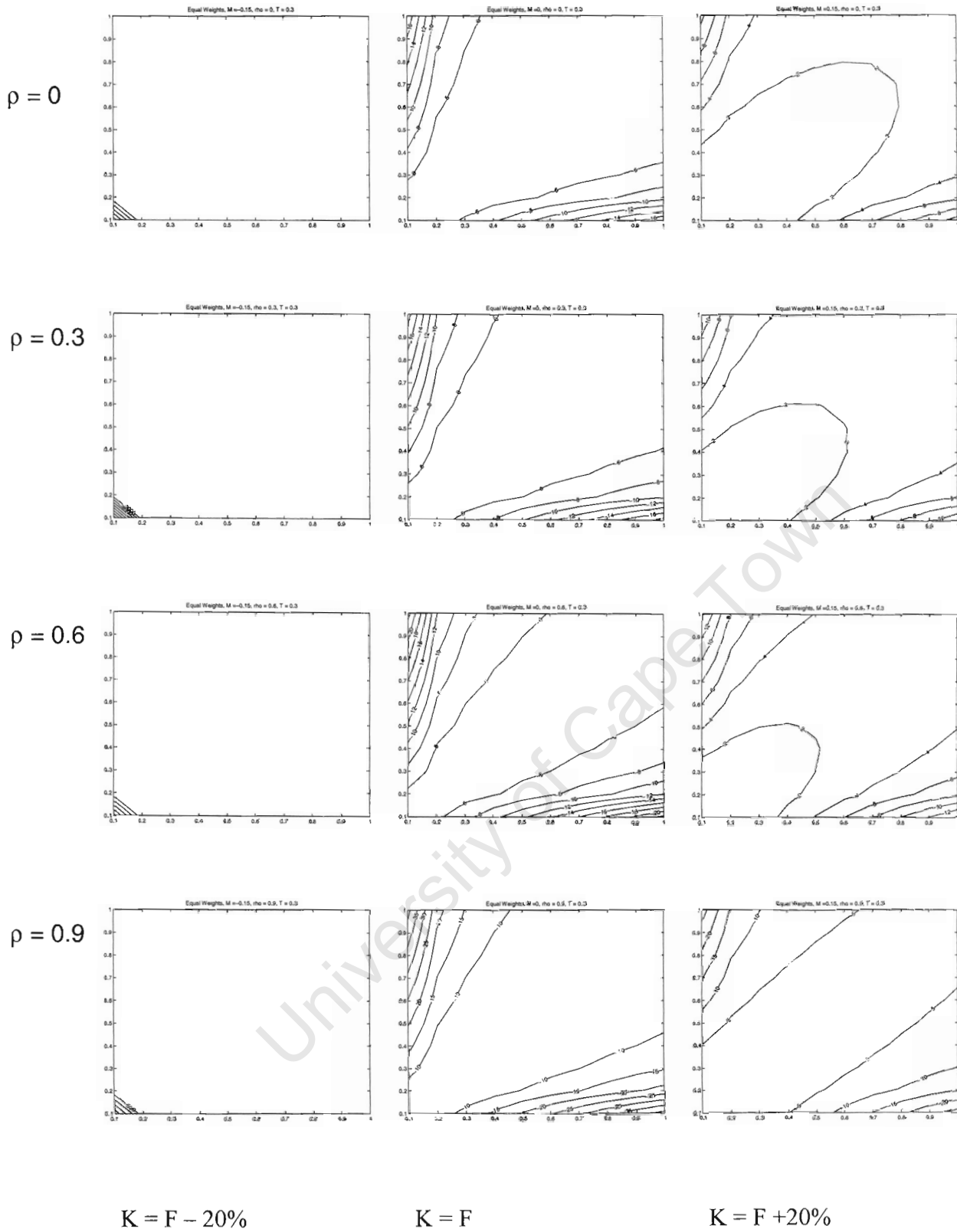

Figure C4: Contour Plots of Error term over the sigma plane. $T = 0.3$, Equal Weights

First Order Approximation
Equal Weights, T = 1

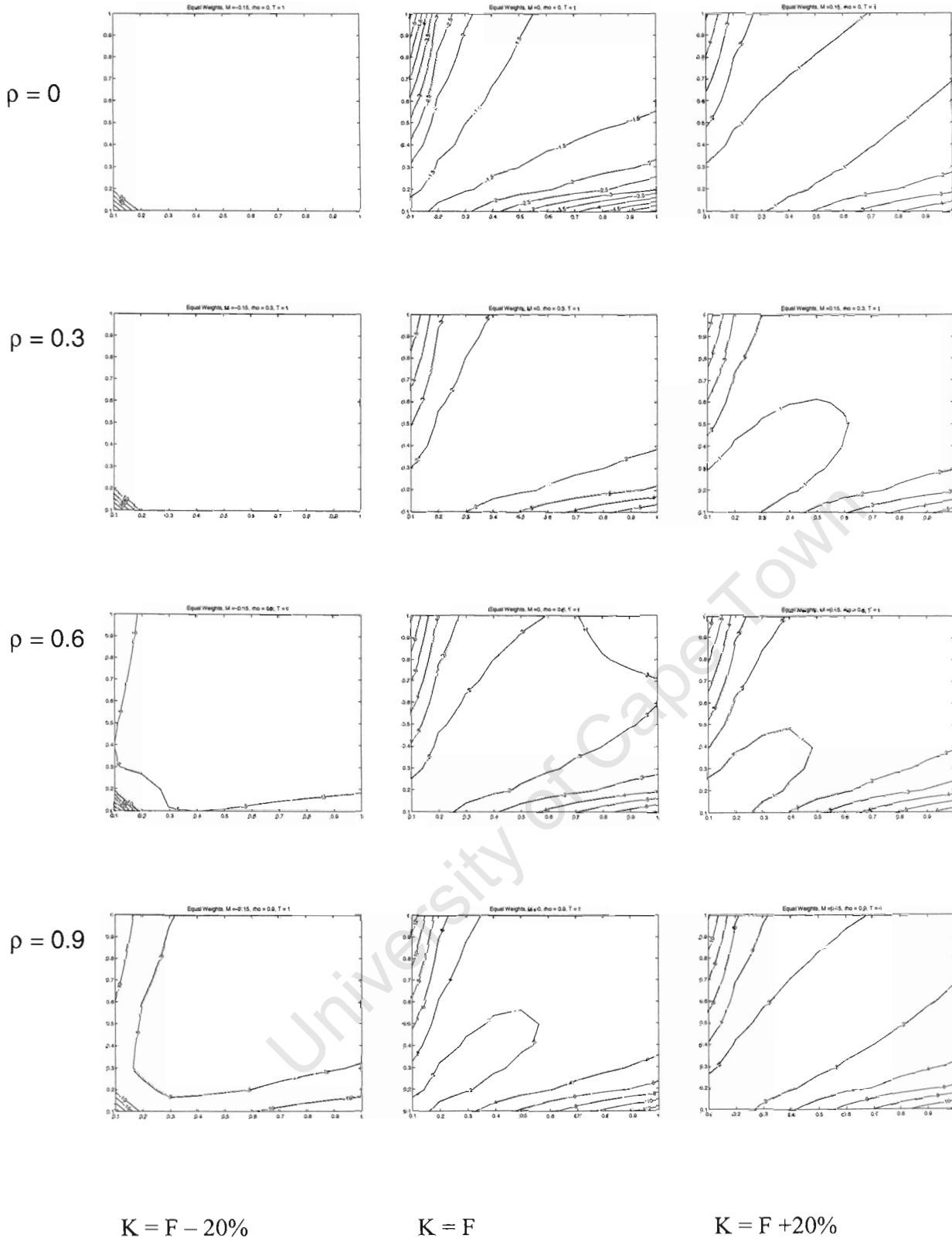

Figure C5: Contour Plots of Error term over the sigma plane. T = 1, Equal Weights

First Order Approximation
Equal Weights, $T = 5$

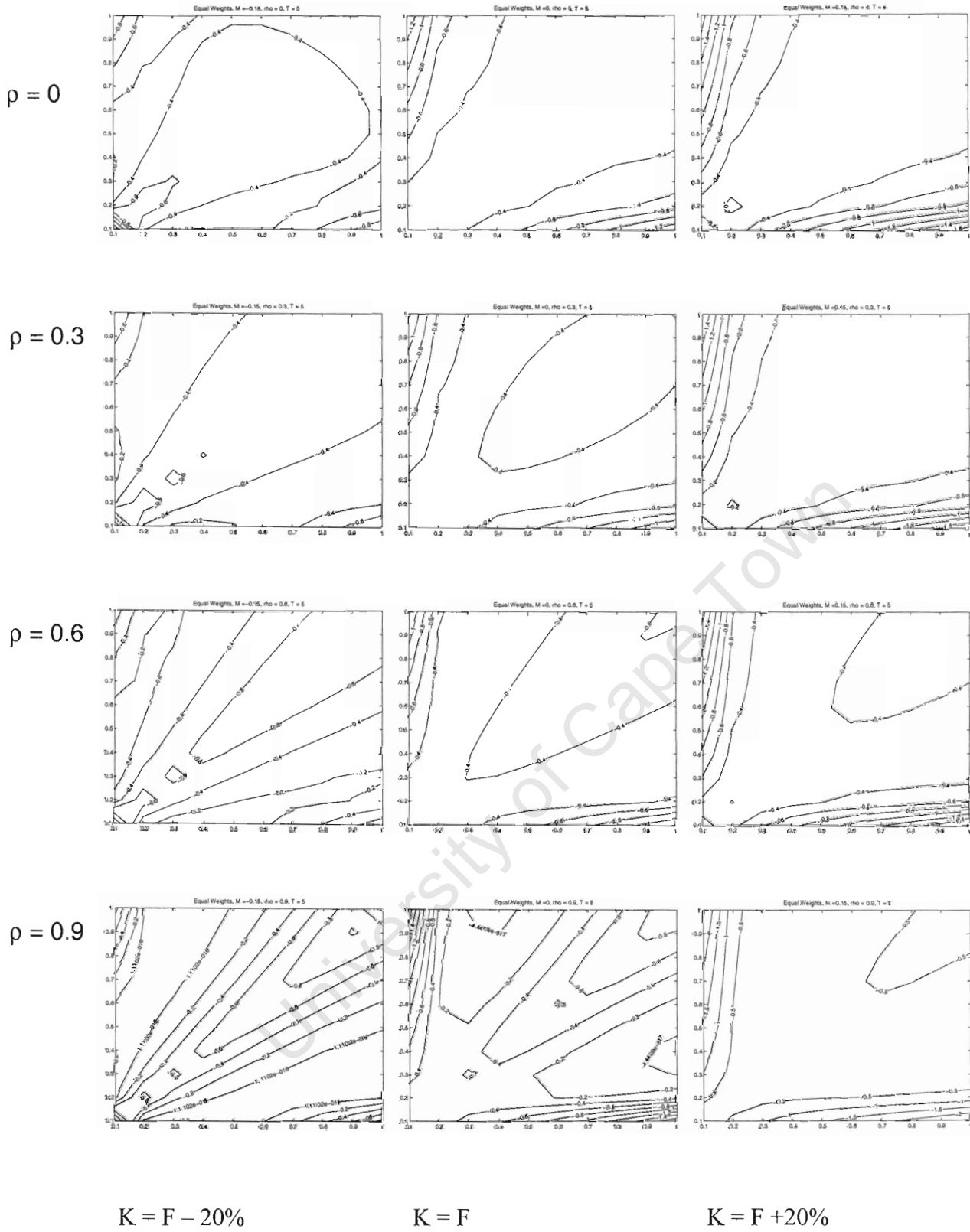

Figure C6: Contour Plots of Error term over the sigma plane. $T = 5$, Equal Weights

Matlab Code

Below is included the main subroutine for producing prices over a range of strikes for the various parameters. References to the relevant sections of the dissertation are provided.

Main Subroutine

```
close all
clear
flag=1;
sampsiz = 10000; %% Number of simulations for the Monte Carlo simulation
max = 3000;

%% SET UP RANDOM 2 ASSET BASKET

a = rand()
A1 = [a ;1- a] %% QUANTITIES OF THE ASSET IN THE BASKET
sig = [rand(); rand()] %%VOLATILITIES
c = rand() %%CORRELATION
Corr = [1 c ; c 1]
S0 = [100* rand() ;100*rand()] %% PRICES
T = 2 %% MATURITY
r = 0.05 %% RISK FREE RATE

B = sum(S0);
A = A1.*S0./B

B0 = sum(A.*S0);
W=A%.*S0./B0;

dt= T/sampsiz;

LnS0 = log(A.*S0);
LnS = log(S0)
Cov = sig*sig.*Corr;
C=exp(Cov.*T);
AS = A.*S0;
AvCor = avSum(Corr,sig,W,n);

%% Parameters for Market approximation
Bvol = sqrt(W.*Cov*W);
Bmean = log(B0)+(r-0.5*Bvol^2)*T;

%% Parameters for First Order Approximation
SW = S0.^W
BP = prod(SW)
AvvolF = sqrt(sum(W.*sig.^2));
FOmean = log(BP)+(r-0.5*AvvolF^2)*T;
FOVol = sqrt((W)*Cov*(W));

%%Parameters for Normal aproximation
Se= A.*S0.*exp((r-0.5*sig.^2)*T);
Nmean = sum(Se);
NVar = Se.*Cov.*Se.*T;

%% Parameters for Moment Matching
Movol=sqrt(log(W.*C*W)/T);
MoMean = log(B0)+(r-0.5*Movol.^2)*T;

lim=B0*exp(r*T)*0.2
step =lim / 5

K=28:5:58 %% SET UP RANGE OF STRIKES

MC = Monte(K',LnS,r,n,sig,T,A,S0,Corr); %% MONTE CARLO
Exact = OPEXact(K',LnS0,r,n,sig,T,A,S0,Corr); %% EXACT PART OF IMPROVED UPPER BOUND
Moment = OPMoment(K',Movol,B0,r,T); %% MOMENT MATCHING
Market = OPMarket(K',Bvol,B0,r,T); %%MARKET APPROXIMATION
```

```

Correct = OPFO(K',AvvolF,FOVol,BP,r,T); %%FIRST ORDER APPROXIMATION
Norm = OPNorm(K',Nmean,NVar,r,n,sig,T,A,S0,Corr); %% NORMAL APPROXIMATION
Cu = OPCub(K',LnS0,r,n,sig,T); %% COMMONOTONIC UPPER BOUND
Cl=OPClb(K',LnS0,r,n,sig,T,A,S0,Corr); %%COMMONOTONIC LOWER BOUND
I = OPIub(K',LnS0,r,n,sig,T,A,S0,Corr); %% IMPROVED UPPER BOUND
IU=Exact+I'

```

```
%% Plot approximations
```

```

plot(K,Market,'-or');
hold on
plot(K,Correct,'-sg');
plot(K,Norm,'--*b');
plot(K,Moment,':dy');
plot(K,Cl,'+c');
plot(K,IU,'-pm');
plot(K,MC,'-hk');
plot(K,Cu,'-xk');
hold off
legend('M','Cor','Norm','Mo','CL','IU','MC','Cu');
grid('on')

```

Approximations

Below we give the coding for the pricing formulae corresponding to the various Basket Option price approximations.

Market Approximation (See Section 3.1)

This function returns the Market approximation to the basket price

```

function Market=OPMarket(x,Bvol,B0,r,T)

d1=(log(B0)-log(x) +(r+0.5*Bvol.^2)*T)/(Bvol*sqrt(T));
d2 = d1-(Bvol*sqrt(T));
nd1 = normcdf(d1,0,1);
nd2 = normcdf(d2,0,1);

disc = exp(-r*T);

Market = B0.*nd1 -disc.*x.*nd2;

```

Normal Approximation (Section 3.2)

This function returns the Normal approximation to the basket price

```

function Price = OPNorm(K,Nmean,NVar,r,T)
sigB = sqrt(NVar);
temp = K-Nmean;
temp2 = temp/sigB;

nd1 = 1-normcdf(temp2,0,1);
Price = exp(-r*T)*((sigB/sqrt(2*pi))*exp(-0.5*temp2.^2) - temp.*nd1);

```

First order Approximation

OPFO returns the price of a basket option using the First Order approximation

```

function Price = OPFO(x,Avvol,Bvol,B0,r,T)
d1=(log(B0)-log(x) +(r-0.5*Avvol.^2+Bvol.^2)*T)/(Bvol*sqrt(T));

d2 = d1-(Bvol*sqrt(T));
nd1 = normcdf(d1,0,1);
nd2 = normcdf(d2,0,1);
Price = B0.*exp(0.5*(Bvol.^2-Avvol.^2)).*nd1 -exp(-r*T).*x.*nd2

```

Moment Matching Approximation

Moment returns the price of a basket option using the Moment Matching approximation

```
function Moment=OPMoment(x,vol,B0,r,T)
d1=(log(B0)-log(x) +(r+0.5*vol.^2)*T)/(vol*sqrt(T));
d2 = d1-(vol*sqrt(T));
nd1 = normcdf(d1,0,1);
nd2 = normcdf(d2,0,1);
disc = exp(-r*T);
Moment = B0.*nd1 -disc.*x.*nd2;
```

Bounds

Comonotonic Upper Bound (Section 4.1.3 (4.50))

```
function Cu = OPCub(K,S0,Q,r,n,sig,T)
LnS0 = log(Q.*S0);
%% Solve the non-linear equation (4.50) to find F_B(K) for each K
for i = 1:length(K)
    FK(i)=fzero(@CUif,.9,optimset('disp','off'),K(i),n,r,T,LnS0,sig);
end

for i=1:n
    MargOP(i,:) = exp(LnS0(i)).*normcdf((sig(i).*sqrt(T)-norminv(FK,0,1)),0,1);
end
Ca=sum(MargOP);
Cb=exp(-r*T).*K.*(1-FK);
Cu=Ca-Cb;
```

Comonotonic Lower Bound (Section 4.1.3 (4.47))

```
function [Cl,rho] = OPClb(K,W,r,n,sig,T,S0,Corr)
W1=W.*S0.*sig;
Den = sqrt(W1.*Corr*W1);
rho=(W1.*Corr)./Den;

LnS0 = log(W.*S0);

%% Solve the non-linear equation (4.49) to find F_B(K) for each K
for i=1:length(K)
    FK(i)=fzero(@CLif,.9,optimset('disp','off'),K(i),n,r,T,LnS0,sig,rho);
end

for i=1:n
    MargOP(i,:) = W(i).*S0(i).*normcdf((rho(i).*sig(i).*sqrt(T)-norminv(FK,0,1)),0,1);
end
Cl=sum(MargOP)-exp(-r*T).*K.*(1-FK);

%%%%%%%%%%%%%%%%%%%%%%%%%%%%%%%%%%%%%%%%%%%%%%%%%%%%%%%%%%%%%%%%%%%%%%%%
function F = CLif(FK,K,n,r,T,LnS0,sig,rho)
for j = 1:length(FK)
    if FK(j) >= 1
        F(j)= 10^10;
    elseif FK(j) <= 0
        F(j)=-10^10;
    else
        for i = 1:n
            M(i,:) = exp(LnS0(i)+(r-0.5*(rho(i).*sig(i)).^2)*T+rho(i).*sig(i).*sqrt(T).*norminv(FK(j)));
        end

        F(j)=sum(M)-K;
    end
end
```

Improved Upper Bound (Section 4.1.3 (4.62))

```

function IU = OPIub(K,W,S0,r,n,sig,T,Corr)

A1=W.*S0.*sig;
Den = sqrt(A1**Corr*A1);
rho=(A1**Corr)./Den;
LnS0 = log(W.*S0);

EL = 0;
sigL = Den*sqrt(T);

dL=K-W*(S0.*(1+(r-(sig.^2)/2)*T));
dstar=(dL-EL)./sigL;
lim = normcdf(dstar,0,1);
step = lim/20;

%% for each K integrate over v
for i=1:length(K)
    IU(i) = quad(@IUB,0.0000001,lim(i),[],[],K(i),n,r,T,LnS0,sig,rho);
End
%%%%%%%%%%%%%%%%%%%%%%%%%%%%%%%%%%%%%%%%%%%%%%%%%%%%%%%%%%%%%%%%%%%%%%%%55

function X=IUB(v,K,n,r,T,LnS0,sig,rho);
options = optimset('disp','off','TolFun',1e-8,'TolX',1e-6);
% x=0.000001:0.001:.999999;
guess=.9;

for i= 1:length(v)

%% At each v evaluate F(K) by solving the non-linear equation (4.64)

[FK(i),fv,exit] =fzero(@IUif,guess,options,K,n,r,T,LnS0,sig,rho,v(i));
while (exit < 0 ) & (guess >0)
    guess = guess - 0.1;
    [FK(i),fv,exit] =fzero(@IUif,guess,options,K,n,r,T,LnS0,sig,rho,v(i));
end

end
for i=1:n
    disc(i,:) = exp(rho(i).*sig(i).*sqrt(T)).*norminv(v)-0.5.*(sig(i).*rho(i)).^2.*T);
    M1= exp(LnS0(i)).*disc(i,:);
    D=(sqrt(1-rho(i).^2).*sig(i).*sqrt(T)-norminv(FK,0,1));
    MargOP(i,:) = M1.*normcdf(D,0,1);
end

Y=sum(MargOP);
X=Y-exp(-r*T).*K.*(1-FK);

%%%%%%%%%%%%%%%%%%%%%%%%%%%%%%%%%%%%%%%%%%%%%%%%%%%%%%%%%%%%%%%%%%%%%%%%
function V = IUif(FK,K,n,r,T,LnS0,sig,rho,v)
for j = 1:length(FK)

    if FK(j) >=1
        V(j)= 10^10;
    elseif FK(j) <= 0
        V(j)=- (10^10);
    else
        if v >=1
            v = 0.999999;
        end
        for i = 1:n
            M(i,:) = exp(LnS0(i)+(r-0.5.*sig(i).^2)*T+rho(i).*sig(i).*sqrt(T)).*norminv(v) + sqrt(1-
rho(i).^2).*sig(i).*sqrt(T).*norminv(FK(j)));
        end
        S=sum(M);
        F = S - K;
        V(j)=F;
    end
end
end

```

Improved Upper Bound based on Lower Bound (4.1.5)

```
function IU = OPIub2(K,A,S0,r,n,sig,T,Corr)

A1=A.*S0.*sig;
Den = sqrt(A1.*Corr*A1);
rho=(A1.*Corr)./Den;
LnS0 = log(A.*S0);

EL = 0;
sigL = Den*sqrt(T);

dL=K-A*(S0.*(1+(r-(sig.^2)/2)*T));
dstar=(dL-EL)./sigL;
lim = normcdf(dstar,0,1);
step = lim/20;
M=0
for i=1:n
    for j=1:n
        Temp = dstar-(rho(i)*sig(i)+rho(j)*sig(j))*sqrt(T);
        Temp2 = exp(sig(i)*sig(j)*(Corr(i,j)-rho(i)*rho(j))*T) - 1;
        M = M + A(i)*A(j)*S0(i)*S0(j)*exp((2*r+sig(i)*sig(j)*rho(i)*rho(j))*T)*normcdf(Temp)*Temp2;
    end
end

IU = exp(-r*T)*0.5*sqrt(normcdf(dstar)).*sqrt(M);
```

Monte Carlo Simulation

```
function [Price,SE] = MC(S0,W,r,sig,T,K,Corr,sampsize,n);
Sum2=0;
Sum=0;
C = chol(Corr);

sigT=sig.*sqrt(T);
nudt = (r-0.5*sig.^2).*T;
LnS = log(S0);
for j=1:sampsize
    LnSt=LnS;
    LnSt2=LnS;
    noise = normrnd(0,1,n,1);
    corrnnoise1 = noise.*C;
    corrnnoise2 = (-noise).*C;
    LnSt=LnSt + nudt + sigT.*corrnnoise1';
    LnSt2=LnSt2 + nudt + sigT.*corrnnoise2';
    ST1 = exp(LnSt);
    B = W.*ST1;
    OP1 = max(B-K,0);
    ST2 = exp(LnSt2);
    B2 = W.*ST2;
    OP2 = max(B2-K,0);
    OP = (OP1+OP2)/2;
    Sum=Sum+OP;
    Sum2 = Sum2 + OP.^2;
end
Price = exp(-r*T)*(Sum./(sampsize));
SD = sqrt((Sum2-(Sum.^2)/sampsize)*exp(-2*r*T)/(sampsize-1));
SE = SD/sqrt(sampsize);
```