

The copyright of this thesis vests in the author. No quotation from it or information derived from it is to be published without full acknowledgement of the source. The thesis is to be used for private study or non-commercial research purposes only.

Published by the University of Cape Town (UCT) in terms of the non-exclusive license granted to UCT by the author.

---

**NATURAL AND HUMAN INDUCED LATE QUATERNARY  
ENVIRONMENTAL CHANGE ON THE NOORDHOEK  
VALLEY, CAPE TOWN, SOUTH AFRICA**

---

**BY EU AKUNJI**

**Submitted in fulfilment of the requirements for the degree of  
MASTERS OF ARTS**

**Department of Environmental and Geographical Science**



**UNIVERSITY OF CAPE TOWN**

**Rondebosch 7701  
South Africa**

August 2004

## THE NOORDHOEK VALLEY



FRONTISPIECE: Lake Michelle and the twin Wildevleis in the background  
(Photo: E. Akunji, July 2004)

## ABSTRACT

This research project attempts to determine the relative influences of climate, sea level changes and human activities during the period of sediment accumulation in the Noordhoek basin in the southwestern Cape, South Africa. The research relies on lacustrine sedimentary deposits and their compositional changes as evidence of the dynamic depositional environments from which environmental conditions are inferred. Data on spatial changes on land surfaces have also been employed to complement the sedimentary chronology from catchments beyond historic records. Assessment of the extent of human influence on the Noordhoek basin has been achieved through comparison with the pristine conditions found on the Cape Nature Reserve.

Analysis of dated sediment cores from the Noordhoek valley and the Cape Peninsula Nature reserve has facilitated the reconstruction of major environmental changes for the late Pleistocene and Holocene periods. An extended record of environmental change from the longest core (LM-Core) has enabled environmental reconstruction and the determination of the relative influences of climate, sea level change and human activities on the local environment of the basin during the late Quaternary. Sedimentological evidence from the cores reveals the long-term evolution of the wetlands as being influenced by fluctuating sea levels and climate change until the mid Holocene. Short-term environmental processes during the late Holocene, resulting from direct anthropogenic activities such as irrational uses of the wetlands for agriculture and urbanisation are responsible for polluting and transforming the status of the wetlands.

Heavy metal concentrations in sediment cores from the two Noordhoek wetlands have allowed the elucidation of recent human impacts. The vertical distribution of these metals correlates with and complements the evidence of spatial changes in land use and land cover. Metal enrichment in the modern Noordhoek wetland sediments and increased organic matter content indicates increasing anthropogenic impacts on the valley as agriculture and urbanisation increased. In comparison, there is a much lower concentration of heavy metals at Groot Rondevlei, as its catchment has been less prone to severe local disturbance such as urban development and recent agricultural activities.

The absence of a tightly resolved chronology for these cores restricts the understanding of the commencement and duration of major environmental changes, which have been accounted for elsewhere in the region. This limits the opportunity for direct comparison between this and other known sites. However, the Noordhoek valley is a potential resource for longer-term Quaternary environmental study. The application of a multi-disciplinary approach and high-resolution dating are highly recommended for future research in this area.

**EU AKUNJI**  
**University of Cape Town**

## Acknowledgements

I sincerely wish to give thanks to all who assisted me throughout this project:

- ❖ Foremost I am deeply indebted to my supervisors. Firstly, I thank Professor Mike Meadows for his overwhelming patience, advice and enthusiasm for all aspects of this research. Special thanks to you Mike for financing the fieldworks, cartography and dating of the sediments. Secondly, I acknowledge Professor Peter J. Holmes for his advice and assistance, especially during the early stages of the research. I appreciate your time and effort in assisting me locate the study sites.
- ❖ Thanks are due to Dr. John Rogers, Assoc. Prof. John Compton, Dr. Roychoudhury, Andreas Späth and Ms. Meris Smith of the Department of Geological Sciences, Mrs Shirley Butcher, Brett Smith in Environmental and Geographical Science and Brian Chase of Sheffield University.
- ❖ I thank Michelle Walker of the South Peninsula Municipality and Glenn Ashton of Noordhoek Environmental Group for the supply of valuable information. And New Era Coaching Africa for printing of this thesis.
- ❖ Thanks to Sayed Hess, Mrs. Sharon Adams, Mrs. Mandy Innes and Mr Tony George (Departmental of Environmental and Geographical Science) for their willingness to assist with logistical aspects of the project.
- ❖ To the university of cape Town for granting me the INTER Schoraship.
- ❖ To Dr. Gideon Akunji and the family without whom I would never have had university education. I thank you for the financial and moral support. Your encouragement all along and most especially during the last quarter when I thought my social life was crumbling. You directed me toward God in whom I found everlasting security and protection. To Him be the glory.
- ❖ To the entire Akunji family resident in Cameroon thanks a lot for your love and encouragement. Your prayers helped me through. I love you all.
- ❖ To sister Mary for her support throughout my undergraduate years when a Master degree was a lifetime dream, but her encouragement made it a reality. Thanks sister for your endless hospitality and jokes. I miss you.
- ❖ Lastly, I thank my friends Vicky Stevens, Kennedy Efugenum, Emmanuel Mbakwa, Ayuk James, Itoe Maurice, Taku Philipian, Wan'Mbuta, and Thato Monste for their tireless support during the course of this research.
- ❖ Above all, I joyfully dedicate this thesis to **Jesus Christ** who has been a source of strength and inspiration to my family and I for all these years.

**EU Akunji**  
**University of Cape Town**

## CONTENTS

|   |            |
|---|------------|
| <b>ABSTRACT</b>   | <b>I</b>   |
| <b>ACKNOWLEDGEMENTS</b>   | <b>II</b>  |
| <b>CONTENTS</b>   | <b>III</b> |
| <b>LIST OF APPENDICES</b>   | <b>VII</b> |
| <b>LIST OF FIGURES</b>  | <b>IX</b>  |
| <b>LIST OF TABLES</b>   | <b>X</b>   |
| <b>LIST OF PLATES</b>   | <b>XI</b>  |
| <b>CHAPTER 1 INTRODUCTION</b>   |            |
| 1.1 INTRODUCTION  | 1          |
| 1.2 BACKGROUND TO STUDY AREA  | 3          |
| 1.3 SIGNIFICANCE OF NOORDHOEK WETLANDS AS STUDY SITES                           | 5          |
| 1.4 RATIONAL FOR STUDY  | 6          |
| 1.5 RESEARCH QUESTIONS  | 7          |
| 1.6 AIMS AND OBJECTIVES   | 8          |
| 1.7 THESIS OUTLINE  | 9          |
| <b>CHAPTER 2 NATURAL AND ANTHROPOGENIC LATE QUATERNARY ENVIRONMENTAL CHANGE</b> |            |
| 2.1 INTRODUCTION  | 10         |
| 2.2 RATIONALE FOR RECONSTRUCTING LATE QUATERNARY ENVIRONMENTS                   | 11         |
| 2.3 SEDIMENTS IN ENVIRONMENTAL RECONSTRUCTION                                   | 12         |
| 2.3.1 Applications and limitations in using sediments                           | 13         |
| 2.4 SOUTHERN AFRICA QUATERNARY ENVIRONMENTAL CHANGE                             | 15         |
| 2.5 LATE QUATERNARY ENVIRONMENTAL CHANGE IN THE SOUTHWESTERN CAPE               | 17         |
| 2.5.1 Spatial and temporal climatic chronology                                  | 18         |

|  |  |    |
|--|--|----|
| 2.6  | LAND USE AND LAND COVER CHANGES                                      | 22 |
|  | 2.6.1 Land use and land cover change in the southwestern Cape region | 23 |
| 2.6  | CURRENT AND POTENTIAL IMPACTS OF LAND USE CHANGE AND URBANISATION    | 24 |
|  | 2.7.1 Hydrology and Erosion  | 25 |
|  | 2.7.2 Pollution  | 26 |
|  | 2.7.3 Vegetation   | 27 |
| 2.7  | CONCLUSION   | 28 |
| <b>CHAPTER 3 CONTEMPORARY VLEI ENVIRONMENT OF THE NOORDHOEK VALLEY</b> |  |    |
| 3.1  | INTRODUCTION   | 29 |
| 3.2  | THE SOUTHERN CAPE PENINSULA REGION                                   | 29 |
| 3.3  | PHYSICAL CHARACTERISTICS OF THE STUDY REGION                         | 30 |
|  | 3.3.1 Geology, geomorphology and soils                               | 32 |
|  | 3.3.2 Contemporary climate   | 37 |
|  | 3.3.3 Hydrology  | 41 |
|  | 3.3.4 The wetlands   | 42 |
|  | 3.3.4 Vegetation   | 46 |
| 3.4  | CONCLUSION   | 51 |
| <b>CHAPTER 4 METHODOLOGY AND LABORATORY TECHNIQUES</b>                 |  |    |
| 4.1  | INTRODUCTION   | 53 |
| 4.2  | IDENTIFYING STUDY LOCALITIES   | 54 |
| 4.3  | CORING TECHNIQUES  | 55 |
|  | 4.3.1 Elevations   | 57 |
| 4.4  | LABORATORY ANALYSIS OF SEDIMENTS                                     | 58 |
|  | 4.4.1 Physical analysis  | 58 |
|  | 4.4.2 Mineralogy   | 59 |
|  | 4.4.3 Munsell notations  | 59 |
|  | 4.4.4 Dating   | 59 |

|   |  |    |
|---|--|----|
| 4.5   | CHEMICAL ANALYSIS                                | 60 |
| 4.5.1   | pH   | 60 |
| 4.5.2   | Conductivity                                     | 61 |
| 4.5.3   | Total organic fraction                           | 61 |
| 4.6   | GEOCHEMICAL ANALYSIS                             | 61 |
| 4.7   | SPATIAL LAND USE AND LAND COVER CHANGE           | 63 |
| 4.7.1   | Data acquisition                                 | 62 |
| 4.7.2   | Image processing                                 | 62 |
| 4.7.3   | Analysis   | 64 |
| 4.8   | STATISTICAL TECHNIQUES                           | 65 |
| 4.8.1   | Principal component analysis                     | 65 |
| 4.8.2   | Normalisation of geochemical data                | 66 |
| 4.9   | CONCLUSION                                       | 66 |
| <b>CHAPTER 5 SEDIMENTOLOGY, GEOCHEMISTRY AND SPATIAL LAND USE IN THE NOORDHOEK VALLEY</b> |  |    |
| 5.1   | INTRODUCTION                                     | 67 |
| 5.2   | SEDIMENTOLOGICAL AND GEOCHEMICAL EVIDENCE        | 67 |
| 5.2.1   | Lake Michelle Core (LM-Core)                     | 67 |
| 5.2.2   | Wildevolvllei Core (WV- Core)                    | 76 |
| 5.2.3   | Groot Rondevlei Core (GR-Core)                   | 84 |
| 5.3   | TIME SERIES SPATIAL LAND USE/COVER CHANGE        | 91 |
| 5.3.1   | Introduction                                     | 91 |
| 5.3.2   | Patterns in agricultural land use changes        | 91 |
| 5.3.3   | Patterns in urban land use changes               | 92 |
| 5.3.4   | Patterns in vegetation (alien dominated) change  | 93 |
| 5.3.5   | Patterns in vegetation (fynbos dominated) change | 93 |
| 5.3.6   | Beach and sand dunes                             | 94 |
| 5.3.7   | Waterbodies                                      | 94 |
| 5.4   | CONCLUSION                                       | 97 |

|   |   |     |
|---|---|-----|
| <b>CHAPTER 6 PALAEOENVIRONMENTAL RECONSTRUCTION</b>     |   |     |
| 6.1   | INTRODUCTION                                    | 98  |
|   | 6.1.1 Regional synthesis                        | 98  |
| 6.2   | STRATIGRAPHY AND CHRONOLOGY                     | 100 |
|   | 6.2.1 LM-Core                                   | 100 |
|   | 6.2.2 WV-Core                                   | 107 |
|   | 6.2.3 GR-Core                                   | 111 |
| 6.3   | GEOCHEMICAL IMPLICATIONS                        | 112 |
| 6.4   | DEVELOPMENT OF THE NOORDHOEK COASTAL LANDFORMS  | 113 |
|   | 6.4.1 Upper Pleistocene development             | 113 |
|   | 6.4.2 Holocene                                  | 114 |
|   | 6.4.3 Evolution of the Noordhoek wetlands       | 115 |
| 6.5   | ANTHROPOGENIC INFLUENCE ON THE NOORDHOEK VALLEY | 116 |
|   | 6.5.1 Surface pollution                         | 116 |
|   | 6.5.2 Land use and land cover change            | 118 |
| 6.6   | CONCLUSION                                      | 123 |
| <b>CHAPTER 7 CONCLUSIONS AND FUTURE RECOMMENDATIONS</b> |   |     |
| 7.1   | INTRODUCTION                                    | 124 |
| 7.2   | REVIEW OF AIMS AND OBJECTIVES                   | 124 |
| 7.3   | FUTURE RESEARCH DIRECTIONS                      | 128 |
| 7.4   | CONCLUSION                                      | 129 |
|   | <b>REFERENCES</b>                               | 130 |
|   | <b>APPENDICES</b>                               | 140 |

## LIST OF APPENDICES

| APPENDIX    |   | PAGE NUMBER |
|-------------|---|-------------|
| APPENDIX A: | Blueprint of a vibracorer   | 56          |
| APPENDIX B: | Particle Size determination   | 59          |
| APPENDIX C: | Determination of pH, electrical conductivity and total organic fraction | 61          |
| APPENDIX D: | LM-Core grain size raw data analysis                                    | 67          |
| APPENDIX E: | LM-Core heavy metal concentrations                                      | 72          |
| APPENDIX F: | WV-Core grain size raw data analysis                                    | 77          |
| APPENDIX G: | WV-Core heavy metal concentrations                                      | 81          |
| APPENDIX H: | GR-Core grain size raw data analysis                                    | 84          |
| APPENDIX I: | GR-Core heavy metal concentrations                                      | 88          |

## LIST OF FIGURES

|                     |   |    |
|---------------------|---|----|
| <b>Figure 1.1:</b>  | The southwestern Cape winter rainfall region  | 3  |
| <b>Figure 1.2:</b>  | Location of the study region with the study sites   | 4  |
| <b>Figure 2.1:</b>  | A revised sea level curve for the Verlorenvlei  | 20 |
| <b>Figure 2.3:</b>  | An increase in impervious surface coverage often decrease the amount of rainfall available for infiltration | 26 |
| <b>Figure 3.1:</b>  | Noordhoek valley showing the study sites  | 31 |
| <b>Figure 3.2:</b>  | Geological map of the southern Cape Peninsula   | 34 |
| <b>Figure 3.3:</b>  | Average monthly rainfall for Noordhoek  | 39 |
| <b>Figure 3.4:</b>  | Windrose for Cape Point   | 40 |
| <b>Figure 3.5:</b>  | Vegetation map for Southern Cape Peninsula  | 48 |
| <b>Figure 3.6:</b>  | Vegetation types of the Noordhoek valley  | 50 |
| <b>Figure 5.1:</b>  | LM-Core log and textural analysis   | 68 |
| <b>Figure 5.2:</b>  | Scatterplots of mean sand size, sorting and skewness  | 70 |
| <b>Figure 5.3:</b>  | Organic, pH and conductivity vertical distribution  | 72 |
| <b>Figure 5.4:</b>  | LM-Core: Trace elements concentration in parts per million  | 75 |
| <b>Figure 5.5:</b>  | LM-Core: Graphs depicting distribution of metals  | 76 |
| <b>Figure 5.6:</b>  | LM-Core: Normalised graphs depicting distribution of metals   | 76 |
| <b>Figure 5.7:</b>  | WV-Core log and textural analysis   | 78 |
| <b>Figure 5.8:</b>  | WV-Core: Scatterplots of mean sand size, sorting and skewness   | 79 |
| <b>Figure 5.9:</b>  | WV-Core: Organic, pH and conductivity vertical distribution   | 80 |
| <b>Figure 5.10:</b> | WV-Core: Trace elements concentration in parts per million  | 82 |
| <b>Figure 5.11:</b> | WV-Core: Graphs depicting distribution of metals  | 83 |
| <b>Figure 5.12:</b> | WV-Core: Normalised graphs depicting distribution of metals   | 83 |
| <b>Figure 5.13:</b> | GR-Core log and textural analysis   | 85 |
| <b>Figure 5.14:</b> | GR-Core: Scatterplots of mean sand size, sorting and skewness   | 87 |
| <b>Figure 5.15:</b> | GR-Core: Organic, pH and conductivity vertical distribution   | 88 |
| <b>Figure 5.16:</b> | GR-Core: Trace elements concentration in parts per million  | 89 |
| <b>Figure 5.17:</b> | GR-Core: Graphs depicting distribution of metals  | 90 |
| <b>Figure 5.18:</b> | GR-Core: Normalised graphs depicting distribution of metals   | 90 |
| <b>Figure 5.19:</b> | Land use changes in the Noordhoek basin (1944-2000)   | 94 |

|   |     |
|---|-----|
| <b>Figure 5.20:</b> Graphs of land use changes in the Noordhoek basin (1944-2000)   | 95  |
| <b>Figure 5.21:</b> Relative percentages of land use changes in the Noordhoek basin | 96  |
| <b>Figure 6.1:</b> Stratigraphy of the Noordhoek and Cape of Good Hope cores        | 101 |
| <b>Figure 6.2:</b> Marine and freshwater sponge spicules                            | 108 |
| <b>Figure 6.3:</b> Hypothesized development of the Noordhoek coastal landforms      | 115 |
| <b>Figure 6.4:</b> Metal concentrations in surface sediments at the three sites     | 117 |
| <b>Figure 6.5:</b> Townships in the Noordhoek valley and the environs               | 121 |

University of Cape Town

## LIST OF TABLES

|                    |  |     |
|--------------------|--|-----|
| <b>Table 2.1:</b>  | Summary of environmental change in the southwestern Cape                       | 19  |
| <b>Table 3.1:</b>  | Lithostratigraphy of the Cape Peninsula  | 33  |
| <b>Table 3.2:</b>  | Soils of the Noordhoek basin   | 36  |
| <b>Table 4.1:</b>  | Aerial photographs for Noordhoek basin 1944-2000                               | 64  |
| <b>Table 5.1:</b>  | Lake Michelle: General description of the stratigraphic units                  | 67  |
| <b>Table 5.2:</b>  | LM-Core: Textural analysis, values in percentage                               | 70  |
| <b>Table 5.3:</b>  | LM-Core: Textural description of sand  | 70  |
| <b>Table 5.4:</b>  | LM-Core: Graphical statistics of sand fraction                                 | 70  |
| <b>Table 5.5:</b>  | LM-Core: pH and conductivity (EC)  | 72  |
| <b>Table 5.6:</b>  | LM-Core: Relative percentages of each element into the units                   | 75  |
| <b>Table 5.7:</b>  | LM-Core: Correlation between heavy elements with silt/clay and organics        | 75  |
| <b>Table 5.8:</b>  | Wildevleivlei core general description   | 77  |
| <b>Table 5.9:</b>  | WV-Core: Textural analysis values in percentages                               | 79  |
| <b>Table 5.10:</b> | WV-Core: Textural description of sand  | 79  |
| <b>Table 5.11:</b> | WV-Core: Graphical statistics of sand grains                                   | 79  |
| <b>Table 5.12:</b> | WV-Core: Organics, p H and conductivity  | 80  |
| <b>Table 5.13:</b> | WV-Core: Zonal distribution of heavy metals                                    | 83  |
| <b>Table 5.14:</b> | WV-Core: Correlation coefficient between various metals sand, silt and organic | 84  |
| <b>Table 5.15:</b> | GR-Core: General description   | 84  |
| <b>Table 5.16:</b> | GR-Core: Textural analysis values in percentages                               | 86  |
| <b>Table 5.17:</b> | GR-Core: Textural description of sand  | 86  |
| <b>Table 5.18:</b> | GR-Core: Graphical statistics of sand grains                                   | 86  |
| <b>Table 5.19:</b> | GR-Core: Organics, p H and conductivity  | 88  |
| <b>Table 5.20:</b> | Correlation between various metals, sand, silt and organics                    | 91  |
| <b>Table 5.21:</b> | Relative percentages in land use and land cover over time                      | 92  |
| <b>Table 6.1:</b>  | Elevations, depths and geographic coordinates of core sites                    | 101 |

## LIST OF PLATES

|                   |   |    |
|-------------------|---|----|
| <b>Plate 3.1:</b> | Townships in the east of the Noordhoek valley | 31 |
| <b>Plate 3.2:</b> | Vegetation at Wildevoelwei                    | 44 |
| <b>Plate 3.3:</b> | Coastal fynbos at Groot Rondevlei             | 45 |
| <b>Plate 3.2:</b> | Vlei vegetation at Noordhoek                  | 47 |

University of Cape Town

---

# CHAPTER 1

---

## INTRODUCTION

---

### 1.1 INTRODUCTION

In recent years the number of palaeoenvironmental studies used in reconstructing environmental changes in southern Africa has increased markedly. Meadows *et al.* (1999) attributed the increase in interest in palaeoenvironmental studies in the region to the growing recognition that an understanding of past environmental changes is important in making more accurate predictions on the nature of future environments. The southern Africa region has provided a wide range of evidence that has been used in reconstructing its past environment. This evidence is present in different forms and is preserved in a variety of Quaternary archives.

A wetland is an example of a Quaternary archive that has spawned a great deal of interest in palynological, sedimentological and geomorphological research in southern Africa as in the rest of the world. Wetlands act as sediment sinks and store signals resulting from changes in other reservoirs such as the atmosphere, the hydrosphere and the lithosphere so building up a temporal record of change. Meadows (1988) noted that, because of their sensitivity in response to environmental change, wetlands in southern Africa may provide a wealth of information on climate change and human induced activities in the recent past.

Wetlands feature over a wide variety of sites, ranging from mountainous areas to coastal lowlands. In addition to this variation, different terms like fens, ponds, bog, swamps and marshlands have been used interchangeably when referring to wetlands. Due to the variation in wetland types, an all-inclusive definition of wetlands has been elusive. In southern Africa indigenous terms such as *vlei*, *mbuga* and *dambo* have been used to refer to wetlands (Dewey, 1988). Dewey (1988) noted that the term *vlei* has a less restrictive usage in South Africa and

applies to several geomorphological structures. She equated *vlei* to wetland described by Cowardin *et al.* (1976) as the interfaces between aquatic and terrestrial ecosystems whether permanently or temporarily inundated with fresh or salt water. In this research the term *vlei* will be used as an equivalent to or as a substitute for “palustrine wetland” used by Cowardin *et al.* (1979) to include all nontidal wetlands dominated by trees, shrubs, mosses or lichens, and all such wetlands that occur in tidal areas where salinity due to ocean-derived salts is below 0.5 ‰.

Unlike in parts of the tropics, where humid conditions have favoured the accumulation of organic sediments in wetlands, the predominantly xeric climates in southern Africa have restricted the accumulation of organic rich sediments (Meadows, 1988). This has limited the application of Quaternary sediments in environmental reconstruction. However, accumulation and preservation of organic bearing sediments in wetland environments studied more intensely in recent years is providing opportunities for Quaternary researchers in the region. For example, sedimentary deposits in the low-lying Noordhoek wetlands in the southern Cape Peninsula offer a rare opportunity for extensive Quaternary study in the winter rainfall region (Figure 1.1) where organic sediments are scarce (Meadows, 1988).

Coastal wetlands in the southern Cape Peninsula (Figure 1.2) formed during the worldwide late Quaternary marine transgression, which saw most coastal valleys drowned (Hart, 1994). Until the late Holocene, the supply of sediments to these wetlands was mainly from the inner shelf favoured by the fluctuating sea levels. Thereafter local constraints such as sediment availability from catchments and land management practices became the essential and dominant source of sediment to these wetlands.

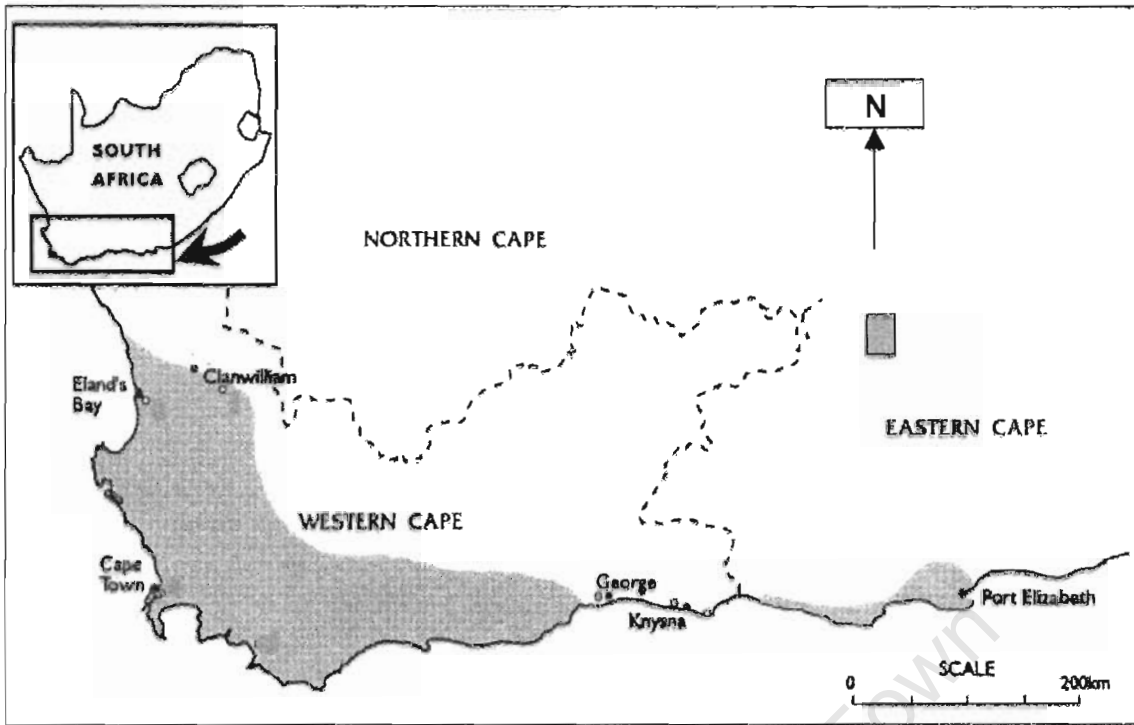

Figure 1.1 The southwestern Cape winter rainfall region (after Meadows, 1997)

## 1.2 BACKGROUND TO STUDY AREA

Coastal wetlands and their watersheds have been impacted by a variety of major environmental changes prior to the arrival of Europeans in the Cape, dating back to around the 18<sup>th</sup> century (Deacon, 1992). These impacts increased with the settlement of these colonists in the southwestern Cape and the rest of South Africa. Prior to colonial occupation, human communities had survived in the Cape Peninsula by hunting, fishing and collecting edible plants for many thousands of years. These communities are the ancestors of the Khoisan people of modern times - the Bushmen (San) and the Hottentot (Khoikhoi). Evidence of this early human occupation is reflected in archaeological records from Peers and Tunnel caves above the Noordhoek valley. There is, however, no clear evidence of a broader human impact or activity on the landscape prior to the arrival of colonial farmers in the region (Deacon, 1992).

Evidence of vegetation change and increased erosion and sedimentation present in wetlands within the southwestern Cape coincides with the arrival of colonial

farmers in the Cape from the seventeenth century onward (Meadows *et al.*, 1994). The transition from essentially pristine local environmental conditions dominated and influenced by natural processes, to conditions in which a succession of human activities dominated was probably a characteristic of much of the region. Accelerated erosion in the Swartland and Sandveld region also coincided with the arrival of European farmers and emanated from poor farming practices (Talbot, 1947, Morel, 1998, Meadows, 2003).

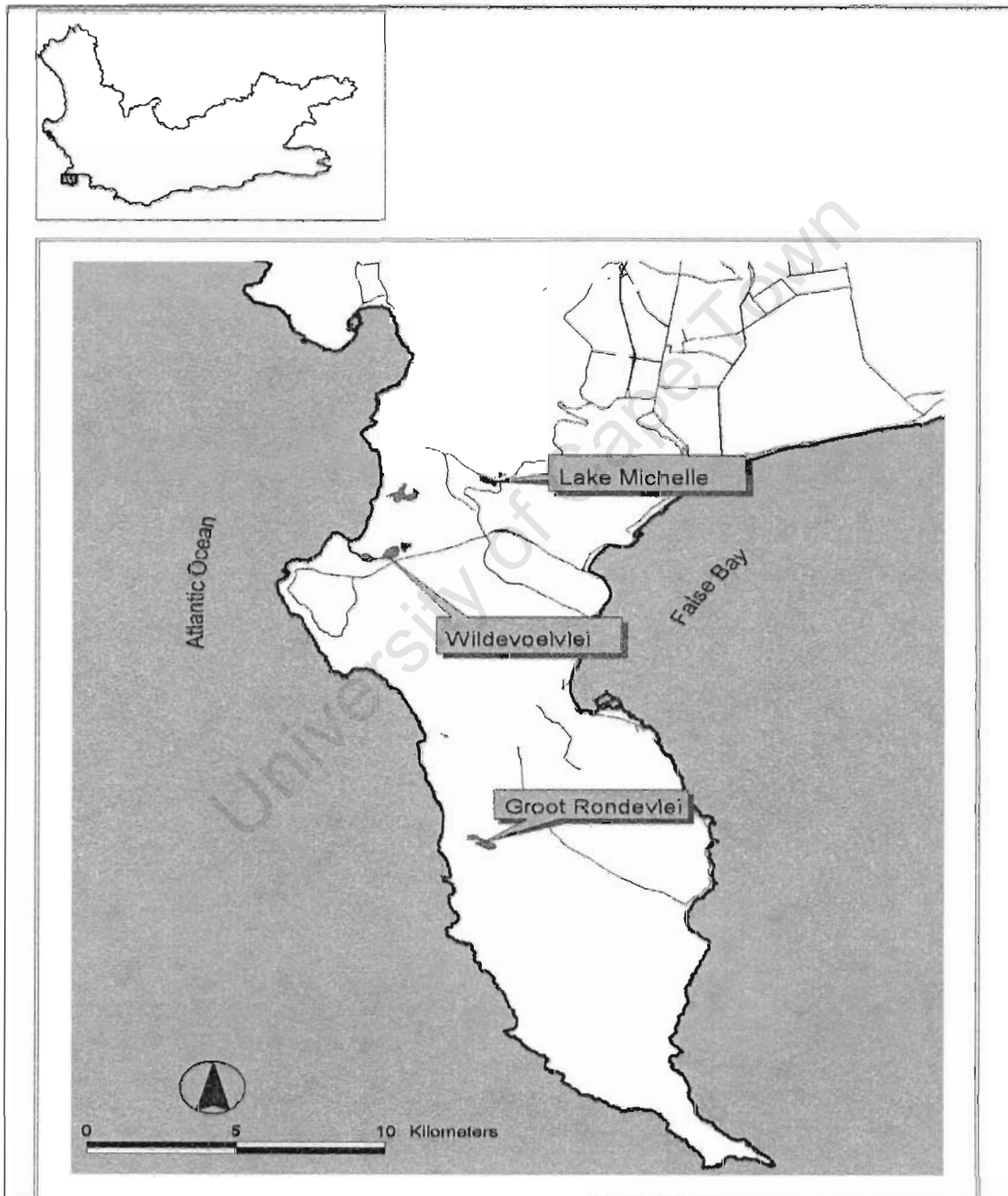

Figure 1.2 Location of the study region with the study sites

Until now, the southern Cape Peninsula has not been explored in terms of the human role played in the modification of its landscape, that may have enhanced erosion and sedimentation elsewhere. Human interference resulted in spatial modification of the landscape in the form of land cover and land use changes that modified the geochemical composition of sedimentary deposits in surrounding wetlands.

### **1.3 SIGNIFICANCE OF THE NOORDHOEK WETLANDS AS STUDY SITES**

The Noordhoek valley, measuring 31km<sup>2</sup> in area is situated on the Atlantic coast of the southern Cape Peninsula. Characteristically, this valley consists of three permanent wetlands namely the Salt Pan (now Lake Michelle), Papkuilsvlei and the Wildevoelvlies. Apart from the perennial Goede River which drains the Chapman's Peak range, the rest of the catchment is made up of ephemeral streams with no channel leading into any of the wetlands. The absence of defined links with these streams qualifies them as valley fill headwater wetlands (Brinson, 1993).

Preliminary investigations on sediments from Lake Michelle (Figure 1.2), one of Noordhoek valley's major wetlands suggested that it could provide scope for an extensive multi-disciplinary study of late Quaternary environmental fluctuations in the area. Coetzee (1978) assigned the peaty sand deposit on the Noordhoek basin to a member of the Pleistocene Springfontyn Formation (Gassner, 1999). In addition, an organic layer from Lake Michelle dating > 50 000BP is effectively infinite considering the methodological limitations of radiocarbon dating (Scott, *et al.*, 1997). This date is consistent with nominally infinite dates from organic deposits in vleis elsewhere in the region (Irving, 1998). In a temperate climatic region such as the southwestern Cape where long, continuous organic records of environmental fluctuation are scarce (Meadows, 1988), such deposits are of particular interest to Quaternary scientists in the region.

In addition to the potentially long Quaternary records that these wetlands have stored, undisturbed sediments from the surface should provide evidence for human induced environmental change during the recent past. Heinecken (1985) noted that increased human activities in the catchment (Heinecken, 1985) have turned the vleis from perennial into permanent wetlands. These wetlands have acted as centres for agricultural, urban and industrial concentration. Signals from these activities preserved in wetland deposits and undisturbed by post-depositional remobilisation may help determine the onset and the rate of human-induced changes in the catchment. Therefore, an understanding of wetland responses to past environmental change would be helpful in developing future management practices aimed at preserving these natural resources.

#### **1.4 RATIONALE FOR STUDY**

In spite of worldwide recognition of wetland environments as potentially valuable geomorphic archives, there has been limited research on the late Quaternary sediments that accumulated under these vleis in the southern Cape Peninsula. Shaw *et al.* (2001) reported a unique late Quaternary sedimentary sequence preserved within a steep-sided ravine between Cape Point and Cape Maclear at the southern tip of the Peninsula. Other related studies on the late Quaternary vegetation change in the region include Schalke (1973) on the Cape Flats, Coetzee (1978) in the Noordhoek basin, Agar (1988) and Marcus (1998) in the Fish Hoek valley.

By virtue of their location, urban wetlands within the Cape Peninsula have been particularly vulnerable to, and affected by, both localized activities, as well as larger scale catchment activities such as rapid urbanization and the demands for more land for housing, agriculture and recreational facilities. This trend has been going on for sometime, resulting in the conversion of "waste land" into arable land and housing environments. For example, the former Salt Pan on Noordhoek valley was developed into housing units at what is now known as the Lake

Michelle Estate. Major threats to these wetlands include eutrophication, marina developments and wetland infilling resulting from catchment erosion.

Knowledge of the exact rate of erosion and sedimentation in these wetlands is very limited in the study region. These uncertainties necessitate the need to look into the past records of sedimentation in order to put present and possible future changes in perspective. Thus the use of palaeoenvironmental data to determine past and future directions of change and at the same time distinguish natural from human-induced processes in the wetlands is the main focus of this study.

The waterlogged nature of these vleis, and their developing sedimentary sequences, may provide the opportunity to seek evidence for changing spatial and temporal distribution of processes such as erosion and deposition influenced by climate, sea level change as well as human activities.

There have been a number of investigations on the quality and status of wetlands within the basin by various authors (Ringdhal, 1995; Gassner, 1999) although none of this research recommended an assessment or quantification of sedimentation patterns in vleis over time. Assessing sediment input rates into wetlands and identifying the source of these sediment loads is a vital component for an effective management strategy. Insight into the long-term development of the wetlands (sedimentation processes) is highly relevant to the issue of the sustainable use of the Noordhoek wetlands.

## **1.5 RESEARCH QUESTIONS**

This research project addresses three basic questions;

- i) What is the spatial and temporal pattern of sedimentation and pollution in these wetlands?
- ii) What factors affect the spatial and temporal pattern of the wetlands and how have these developed over time?
- iii) How may the understanding of the above help our appreciation of macro-scale geomorphic processes influencing coastal wetlands in the region?

## 1.6 AIMS AND OBJECTIVES

The broad aim of this research is to determine the relative influences of climate, sea level changes and human activities during the period of sediment accumulation in the Noordhoek basin. This study will attempt to provide a description and chronology of sediments within the wetland areas from which inferences of past climatic and human impacts on the landscape in the Cape Peninsula can be made. Spatial data on land use and land change will complement the sedimentary records of human interference.

The following objectives have been designed to achieve these aims;

- To describe the wetlands in question and their sediment environments.
- To assess spatial and temporal changes in the Noordhoek basin and catchment during the recent past.
- To describe the physical, chemical and geochemical characteristics of the sediments found in these wetlands.
- To construct stratigraphic diagrams for all the core samples to facilitate comparison between and within sites.
- To determine the age of the deposits through radiocarbon dating of the organic samples thereby establishing sedimentary chronology for the deposits.
- To deduce from the stratigraphic units changing depositional environments and conditions and also to infer changing sedimentation rates.
- To determine if the late Quaternary environmental changes in the Noordhoek basin have been chronologically consistent with those of the rest of the winter rainfall region.
- To determine the significance of these findings in the context of predicted changes in local and global climates.

To achieve the aims and objectives of this research, a carefully thought out decision on the choice of the study sites was imperative. It was realised that in

order to assess the impacts of the manipulative human activities in the Noordhoek basin a “pristine” condition was needed as a reference point. The Groot Rondevlei wetland (Figure 1.2) located in the Cape of Good Hope Nature Reserve was ideally suited to provide the “pristine” conditions with which to compare and assess the extent of human disturbance on the Noordhoek basin.

## **1.7 THESIS OUTLINE**

In this chapter a brief introduction of the research and the significance of wetland sediments in environmental reconstruction followed by the aims of the study was presented. Chapter two places the research within a spatial and temporal context with previous related studies. Given that the interpretation of past environments is often constrained when using sediment analysis, it is important to understand past processes that helped shape the contemporary environment. Chapter three discusses issues relating to the contemporary Noordhoek environment. Chapter four specifically describes each of the methods used in deriving the detailed results presented in Chapter five. Chapter six and finally Chapter seven deal with discussion and conclusion of the findings of the research with some recommendations for future research.

---

## CHAPTER 2

### NATURAL AND ANTHROPOGENIC LATE QUATERNARY ENVIRONMENTAL CHANGE

---

*The history of mankind is a long and diverse series of steps by which he has achieved ecological dominance... largely he has prospered by disturbing the natural order.*

C. Sauer (1952)

#### 2.1 INTRODUCTION

Environmental change during the Quaternary (approximately the last two million years of earth's history) has attracted much attention from scientists in the recent past for the following reasons:

- Firstly, it is during this period that human interaction with natural agencies, the climate in particular, played an important role in determining the character of contemporary environments. This means that future environments will be determined by contemporary interactions between human impacts and other natural agencies. Therefore, a good understanding of the Quaternary will help predict future impacts.
- Secondly, the Quaternary has been a period of considerable environmental change oscillating from glacial to interglacial phases (Lowe and Walker, 1997).

This review chapter aims briefly to address some of the evidence for Quaternary environmental change in the southwestern Cape region of South Africa (Figure 1.1). This region receives much of its rainfall in the winter season and is known for its diverse fynbos plant community (see Cowling *et al.*, 1992).

The purpose of this chapter is threefold. Firstly, it intends to highlight the significance and limitations in using wetland sediments in environmental reconstruction; secondly, it presents an overview of environmental changes in the southwestern Cape using recent literature based on multi-proxy evidence;

thirdly, it summarises potential impacts of human interactions on the natural landscape. Therefore, it is imperative to summarise the principles and limitations of sedimentary evidence in environmental reconstruction.

## **2.2 RATIONALE FOR RECONSTRUCTING LATE QUATERNARY ENVIRONMENTS**

Meadows and Baxter (1999) stated that increased research into the Quaternary period within the southern African region is based on the principle that an understanding of the past is an important key to making more accurate predictions about the future environments.

The pace, magnitude and spatial reach of human alterations of the earth's surface have raised concerns over issues such as global warming and environmental degradation which are likely to change the intensity of local and regional climates for the southwestern Cape (Reason, 2002). Evidence of warmer temperatures with drier conditions over the late Quaternary in the winter-rainfall region in contrast to the rest of southern Africa (Partridge *et al.*, 1990) points to the need for more research of this type in the winter rainfall region. It is undisputable that future environments will change in response to changes in contemporary climates, but the pattern and intensity of change over the different regions of South Africa remains unknown. However, a lesson from the late Quaternary (Meadows and Baxter, 1999) may assist climate modellers to predict, with a higher degree of precision, the pattern and rate of future change in climate.

Multi-proxy evidence from biological, geomorphological, archaeological and sedimentological sources has been used to characterise late Quaternary environmental change in the southwestern Cape in the recent past. However, this research tends to rely on the physical and chemical characteristics of clastic and biogenic sediments as evidence of environmental change. Even though the study of sedimentary environments has a long history, the use of clastic and biogenic sediments on their own as a tool in reconstructing palaeoenvironments

in the region has not received adequate attention. Presented in the following section is an outline of the significance, and the limitations, of clastic and biogenic sediments in evaluating depositional environments.

### **2.3 SEDIMENTS IN ENVIRONMENTAL RECONSTRUCTION**

Bulk sediment trapped in wetlands or lake environments allows an inference to be made about environmental changes in the surrounding catchment. Preserved within these sediments is a continuous record of environmental change. Evidence includes that related to changes in vegetation cover and changes in the rate of geomorphological processes on the catchment (erosion and transportation) and within the wetland (sedimentation and accretion) (Lowe and Walker, 1997). This may be a reflection of natural (climate induced) or anthropogenically induced environmental change. Such preserved evidence used in environmental reconstruction comes in different forms. Firstly, biological evidence (e.g. pollen) has provided clues to regional ecological and climatic changes. Fossils in the form of, for example, diatoms as proxy for environmental change have received much attention (Lowe and Walker, 1997).

Secondly, the physical, chemical and biogenic characteristics of the sediments offer clues as to surrounding environmental change and changes in rates of geomorphological processes within the catchment. The physical characteristics include particulate material otherwise known as clastic sediments that accumulates over time to form a stratigraphic unit that can readily account for erosion and depositional mechanisms. While chemical characteristics result from chemical weathering of minerals in the deposits, organic sediments and peat accumulation, developed under waterlogged conditions in wetlands, also preserve potential information on past environmental conditions. Owing to the link between organic sediment accumulation and climate, it can be argued that changes in the pattern of organic sediments and sedimentation can be linked to changes in prevailing climates (Meadows, 1988). Barber (1981) linked the phasic acceleration of peat, a stratified organic deposit, in northwest Europe to climatic shifts in the region.

Thirdly, records of sea level fluctuations in response to regional and global climatic changes are preserved in sediments associated with shoreline features (Lowe and Walker, 1997) such as the sediments deposited in the Verlorenvlei located in the southwestern Cape Province of South Africa (Meadows and Baxter, 1999). The Verlorenvlei sediments have been used to reconstruct sea level changes for the region during the Holocene (Baxter and Meadows, 1999). Apart from reconstructing sea level changes, variation in composition and texture of vlei sediments can be used as proxies for palaeo-temperatures, as well as for changing depositional environments.

It is well established that environmental change impacts on natural landscapes are stored in sedimentary deposits. These sedimentary deposits are geomorphic archives that store evidence of the relationship between the causal mechanisms and the resulting changes in the landscape. In addition, these sedimentary deposits are in chronological order according to the law of superposition and can therefore be used directly as indicators of climate fluctuation and change (Thomas, 2004). However, there are some challenges in the application of sedimentary deposits in environmental reconstruction that arise from a number of assumptions (Thomas, 2004) made by sedimentologists.

### **2.3.1. Applications and limitations in using sediments**

Clastic sedimentation, a remarkable archive of environmental change, has provided the most comprehensive account of environmental change. However, some challenges posed by its application as a proxy for environmental change limit its use and it has thus not received much attention. These limitations stem from a number of assumptions usually made on studies of sedimentary cores and the conditions under which the sediments were deposited (Thomas, 2004).

- Firstly, the assumption that sedimentary records are complete and have no unconformities is likely to be invalid given that the sedimentation process may itself disturb the underlying deposits (Thomas, 2004).

- Secondly, the assumption that each depositional event accurately reflects the magnitude of a corresponding climatic/hydrologic event (intensity and duration) cannot be guaranteed. This is because pre-event catchment conditions, such as soil saturation and vegetation cover, can influence the flow magnitude at the depositional site and because different systems respond to similar processes differently through time.
- Thirdly, the assumption that sediments in the same layer of the core come from the same source is not likely to be true in all cases given that there exist many potential sources within a catchment that can contribute to sediment deposition.
- Fourthly, the assumption that sediment source areas show the same degree of sensitivity to erosion over time cannot be true, given that local factors like change in soil properties and vegetation cover might have occurred over time (Thomas, 2004).

Using sediments in environmental reconstruction relies heavily on radiometric dating techniques that are also based on many assumptions (see Lowe and Walker 1997). Theoretical issues arising from dating organic sediments using the radiocarbon dating method impede attempts to establish a reliable chronology of events from palaeosediments beyond the range of radiocarbon dating (Holmes, 1997).

Despite these problems, Meadows (1988) suggested that the physical and chemical analysis of sediments, coupled with radiocarbon dating, might prove a valuable additional tool in the reconstruction of Quaternary palaeoenvironments in southern Africa. Recognising the potential difficulties of the above listed problems, Quaternary scientists have made extensive use of organic and inorganic stratified deposits to reconstruct a sequential chronology of events in an effort to account for past environmental changes in the southwestern Cape. For example, textural and geochemical analyses of inorganic sediments, such as those from Verlorenvlei, have provided an insight into the nature of the complex interactions between late Holocene climate change, sea-level fluctuation,

vegetation change, vlei hydrology and human activity in the Western Cape coastal region (Meadows *et al.*, 1996).

Although the Quaternary period has attracted attention as stated earlier, the late Quaternary, that is the late Pleistocene and Holocene, has been especially well researched. This can be attributed to the availability of datable organic sediments that accumulated during the warm climatic phase that followed the Last Glacial Maximum (LGM), approximately 21 000 years ago. Limitations imposed by radiocarbon dating of organic sediments to around 40 000 years fall away for this period.

However important, research into late Quaternary environments in southern Africa has not received much attention compared to Europe, probably owing to insufficient funds and the scarcity of suitable sites that favour accumulation of organic sediments, especially in the winter rainfall region of South Africa. Meadows *et al.* (1999) noted that, despite the wide variety of palaeoenvironmental evidence which has accumulated from within the southern Africa region, a coherent pattern of environmental change and evolution has remained elusive. However, the southern Africa region has provided evidence and trends that suggest high magnitude environmental perturbations in the past. The following section is a summary of late Quaternary change in southern Africa based on multi-proxy sources of evidence from previous authors.

## **2.4 SOUTHERN AFRICA QUATERNARY ENVIRONMENTAL CHANGE**

Research on environmental change in southern Africa has attracted increasing interest in the recent past. In 1984, Deacon and Lancaster regretted that, despite much work on late Quaternary palaeoclimate, no reliable spatial reconstruction for the region could be given. Partridge (1993), Partridge *et al.* (1999) and Tyson *et al.* (2001) reviewed climatic change and variability in environmental conditions in southern Africa from the last glacial maximum through to the Holocene.

A brief summary of environmental change for the southern Africa region is presented below. The summary intends to span the timeframe appropriate to this research. Therefore, the late Pleistocene, LGM and the Holocene are the periods of interest. Unless otherwise stated the summary is based on a synthesis by Partridge *et al.* (1999).

1. Approximately 30 000 years ago the southern Africa climate was characterised by a cold, largely arid phase known as the Last Glacial Cold Stage that extended to approximately 21 000 years ago. The Last Glacial Maximum, with maximum increase in global ice, occurred between ~21 000 years - 18 000 years ago. Rainfall and temperatures during the LGM were generally lower than present over most of the subcontinent. Variations in rainfall levels over the subcontinent were more spatially disparate than temperatures.
2. A rapid warming phase took place in southern Africa from 16 000 years ago onwards (Tyson *et al.*, 2001). Partridge *et al.* (1997) suggested that there may have been a time lag prior to the onset of moister conditions that accompanied this warming period on the subcontinent.
3. The rapid warming phase that started approximately 16 000 years ago was, however, punctuated by the Younger Dryas cooling phase (11 000 BP) on most of the subcontinent except in the western region where the dry phase continued into the early Holocene (Partridge *et al.*, 1997).
4. The Holocene that commenced circa 10 000 years ago was marked by a return to warmer, moister conditions in southern Africa. Warmer conditions, both in the winter and summer rainfall regions, peaked at between 7 500 and 4 500 years ago during what became known as the Holocene altithermal. Although most of southern Africa appeared to have been characterised then by wetter conditions, discrepancies still existed in moisture patterns within the summer rainfall region.
5. The oxygen isotope record from Makapansgat cave shows that conditions in the southern Africa region were both warmer and drier during the Little

Ice Age (AD 1300 to 1800) (Tyson *et al.*, 2001). Tyson *et al.*, (2001) also noted that the last four millennia starting from the closing phase of the Holocene altithermal have been characterised by high variability on a decadal to centennial scales in climates over the southern African region.

Late Quaternary environments in southern Africa have been extremely variable and changes in climate within the region have been frequent, complex and varied. This complexity and uncertainty may be a result of the poor spatio-temporal resolution of the evidence used thus far. Partridge (1997) suggested that this may be due to real sub-regional differences. He noted that the southernmost tip of the sub-continent has not responded synchronously to global and regional changes, thereby reiterating the view that different regions within southern Africa have responded uniquely to global changes that have characterised the last 20 000 years of the earth's history.

Following the Partridge (1997) observation, and because this research falls within the southwestern Cape region of South Africa, it is imperative to review the history of environmental change in this particular region from accredited published works with several case studies used to support the evidence.

## **2.5 LATE QUATERNARY ENVIRONMENTAL CHANGE IN THE SOUTHWESTERN CAPE**

The unique contemporary environments of the southwestern Cape have prompted research into its Quaternary response to global changes and whether or not changes in this sub region have been spatially and chronologically synchronous with the rest of the southern Africa region (Meadows and Baxter, 1999). These questions formed the basis for Meadow's and Baxter's (1999) paper as a synthesis of the southwestern Cape region.

In the following review of late Quaternary change for the southwestern Cape, the Meadows and Baxter (1999) paper has been extensively used because it is the most comprehensive and most recent synthesis for the region. Other evidence

for the region has been reviewed by a number of other authors (Irving *et al.*, 1998; Vankervelsvlei), (Meadows *et al.*, 1994), Meadows *et al.*, 1996 Verlorenvlei), (Meadows and Sudgen, 1990, 1991; Cederberg), (Meadows, 1988; Driehoek.), (Dewey, 1988; Meadows *et al.*, 1987; Winterberg), (Schalke, 1973: Cape Flat), (Martin, 1963; Groenvlei).

## **2.5.1 Spatial and temporal climatic chronology**

### *2.5.1.1 Last glacial maximum 30 000 - 18 000 BP*

Meadows and Baxter (1999), in their most comprehensive account of the southwestern environments synthesised from previous and recent Quaternary evidence pointed out that the LGM climatic condition within the winter rainfall region was significantly cooler than today and was also wetter with greater moisture available (based on evidence from Eland's Bay cave and Cederberg). It is safe to conclude that the period spanning the LGM was colder than today (Table 2.1), although the moisture signal is less firmly resolved.

### *2.5.1.2 Late Pleistocene and 18 000BP - 5 000 BP (Early Holocene)*

This period has received little attention in the southwestern Cape region and was not mentioned in the Meadows and Baxter (1999) comprehensive report. This may be due to the fact that there is insufficient data and the proxy evidence is insufficient for the period thus far. Meadows (1988) commented that organic sediments younger than 15 000 BP from the winter rainfall region could be suggestive of moister conditions that prevailed during the late Pleistocene. Elsewhere in South Africa the generally wetter conditions established after 18 000 BP continued to prevail until the Holocene (Cockcroft *et al.*, 1987).

According to Deacon *et al.* (1983) the early Holocene in the southwestern Cape was warmer and drier than today, even though no absolute data for temperature and precipitation were provided (Table 2.1). To this early view, Deacon and Lancaster (1988) noted that the Holocene was generally a period of temperature amelioration, experiencing drier conditions in its early phase while the warmer

conditions prevailed during the mid-Holocene. Partridge (1990) remarked that, although moisture availability might have fluctuated during the Holocene, the early phase was drier and coincidental with a recorded warmest temperature (Meadows and Baxter, 1999). Like Deacon *et al.*, (1988), Meadows and Baxter (1999) agreed that the first half of the Holocene was warmer (altithermal) and drier (Table 2.1).

### 2.5.1.3 Late Holocene 5 000 – 0 BP

This period seems to have attracted much research understandably so given that during the later part of this period human played a major role in reshaping the natural environment at an unprecedented scale.

Table 2.1 Summary of environmental change in the southwestern Cape (after Meadows and Baxter 1999)

| TIME (YEARS BP)     | SOUTHWESTERN CAPE CLIMATIC CONDITIONS   |
|---------------------|---|
| 5000 - 0            | <ul style="list-style-type: none"> <li>• Late Holocene characterised by several fluctuations of small amplitude in temperature and precipitation (Partridge <i>et al.</i>, 1990);</li> <li>• Wetter than present (Partridge <i>et al.</i>, 1990)</li> <li>• Moister and warmer conditions than present (Partridge <i>et al.</i>, 1990)</li> </ul> |
| 10000 - 5000        | <ul style="list-style-type: none"> <li>• Warmer and drier than today (Meadows and Baxter, 1999)</li> </ul>  |
| LGM (30000 - 18000) | <ul style="list-style-type: none"> <li>• Colder and moister than today (Meadows and Baxter, 1999)</li> </ul>  |
| 40000 - 250000      | <ul style="list-style-type: none"> <li>• Lower temperatures but not as low as during the Last glacial maximum (Partridge, 1993)</li> </ul>  |

Organic sediment accumulation from the mid-Holocene from the Cederberg (Cornell, 2001), Winterberg Mountains (Meadows and Sudgen, 1990.), Verlorenvlei (Meadows, 1994; Baxter and Meadows, 1994; Baxter and Davies, 1994 and Meadows *et al.*, 1996) and Rietvlei (Schalke, 1973) are consistent with other evidence from the region. Evidence presented by these authors suggests conditions similar to present day conditions prevailed, although perhaps the climate was moister than today for at least some of the time. In summary, the winter rainfall region has been out of phase with the summer rainfall region from

the end of the late Pleistocene to the late Holocene, and was warmer and moister than the rest of South Africa.

Organic sediments accumulated in the Verlorenvlei, a coastal lake, apart from providing evidence for climate change, have also provided an up to date record of sea level changes for the region (Baxter and Meadows 1999) (Figure 2.1). Following the 3 - 4m drop in sea level that coincided with the deposition of sand dunes approximately 6 500 years ago at Verlorenvlei was a rapid rise in sea water to a record high of 4m at approximately 4 000 years ago (Figure 2.1). This mid-Holocene transgression was immediately followed by a drop in sea level below the present day level approximately 3 500 years ago. Fluctuations in sea levels evident in the Verlorenvlei cores indicate the rapidity with which sea level change can occur and invoke other forms of environmental response in coastal region such as the southwestern Cape (Baxter and Meadows 1999). This explains why the southwestern Cape has been extremely dynamic in response to changes in climate and sea levels.

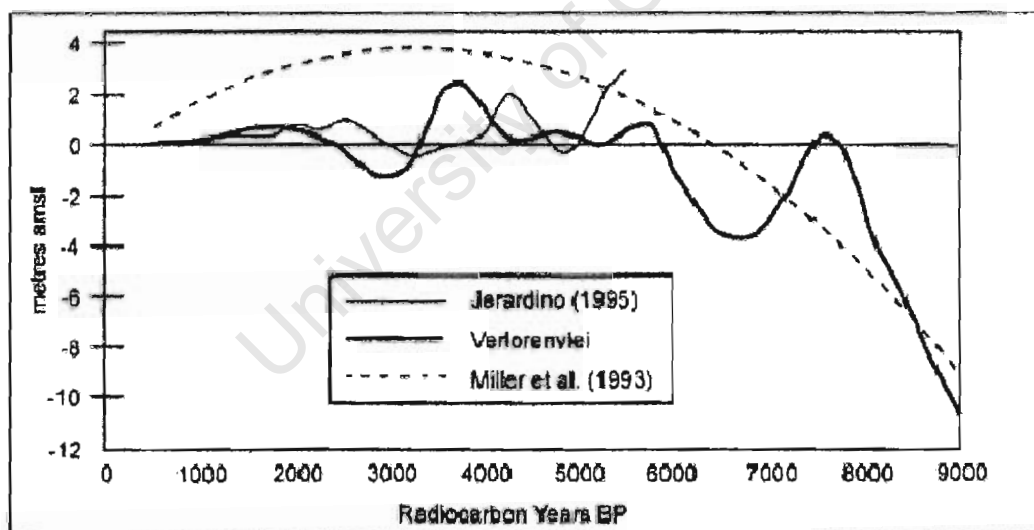

Figure 2.1: A revised sea level curve for the Verlorenvlei (after Baxter and Meadows 1999)

However dynamic, evidence suggests that the southwestern Cape region has not responded uniformly to the changes of the Late Quaternary (Meadows and Baxter 1999). They cited regional changes in climate between the winter and

summer rainfall regions during the late Quaternary as evidence. Indeed, current differences in seasonality and quantity of rainfall between the regions confirms this.

#### *2.5.1.4 The southwestern Cape during the last millennium*

It is believed that climate change has affected and influenced water resources, land use and life of the people of the southwestern Cape. Climate is, of course, inextricably linked to patterns of land cover and land use changes. Abrupt changes from one climatic regime to another have major implications for local and regional systems depending on the scale of change. It can be said with absolute certainty that humans, beside climate, have been altering the natural environment throughout the several million years they have inhabited the earth. However, human activities during the later part of the Holocene are known to have impacted on local and regional environments at an unprecedented rate and scale.

Multidisciplinary investigations (palynology, geomorphology and archaeology) at Verlorenvlei and Eland's Bay in the southwestern Cape have provided a high-resolution study on the environments of the southwestern Cape from the late Pleistocene up to the time of the arrival of people in the region. Up until the arrival of colonial settlers, the moister conditions of the later Holocene prevailed (evidence from Verlorenvlei). The arrival of colonial settlers 300 years ago (Baxter and Meadows, 1994) coincided with an increase in sedimentation and change in pollen composition, indicating the introduction of new species and new ploughing techniques in the region. Evidence of gully erosion in the Swartland (Talbot, 1947; Morel, 1999 and Meadows, 2003), and in the Noordhoek basin (Ringdahl, 1995), attributed to land use changes brought about by colonial farmers has also been documented. Prior to that, environmental variability was mainly a function of climate and sea level changes. However, today and in the recent past, humans have contributed significantly to changes in the natural environment.

Human induced environmental change has been in the form of land use and land cover changes. Land use and land cover changes are very important so that, when combined, can significantly affect key aspects of the earth system's functioning, resulting in local and regional climate change, as well as global climate warming, soil degradation and ecosystem services alterations (Tolba *et al.*, 1992 and Chase *et al.*, 1999, Houghton *et al.*, 1999 and).

## **2.6 LAND USE AND LAND COVER CHANGES**

Land use is the way people utilise the land resources, for example, agriculture, housing and recreation; land cover is a description of the current use of the land surface. Land use affects land cover and changes in land cover affect land use (Bottomley, 1998). Thus, the similarity between land use and land cover and how both change over time is significant to the study of global environmental change. This is because land cover change impacts on the global biogeochemical cycles, affecting the levels of greenhouse and other trace gases in the atmosphere. Changing land use impacts upon climate and hydrology, as well as natural habitat (Briggs *et al.*, 1998). It is because of this that global environmental change bodies such as the International Geosphere-Biosphere Programme (IGBP) and the International Human Dimensions Programme on Global Environmental Change (IHDP) have recognised the significance of land use and land cover change and the need for an interdisciplinary research approach to the issue. The land use and land cover change (LUCC) core project is one such programme designed to better understand the driving forces underlying global land use changes, as well as document temporal and spatial dynamics of changes (<http://www.geo.ucl.ac.be/LUCC/lucc.html>, LUCC website).

In South Africa, as in the rest of the world, land use/cover changes are often driven by human factors such as demographic changes (fertility, migration and mortality), as well as changes in climate and global biogeochemistry (Biggs *et al.*, 2002). In response to both domestic and global increases in population, food production in South Africa more than tripled during the twentieth century, while

the plantation area increased more than tenfold (Biggs *et al.*, 2002). Plantation and agriculture constitute 1.5% and 12% respectively of South Africa's land surface (Biggs *et al.*, 2002). Increased demand for food and fibre necessitates intensive and extensive use of agricultural land and, not infrequently, more widespread use of marginal lands such as wetlands. At the same time, more living space and more urban infrastructure are required. Conversion of sensitive areas such as wetlands into residential and agricultural areas has, in a way, reduced their potential in flood control and as habitat for wildlife; the wetlands of the Noordhoek basin provide a good case in point.

### **2.6.1 Land use and land cover changes in the southwestern Cape region**

For more than a million years of human occupation of the southwestern Cape, evident in the number of occupational sites and stone artefacts (Deacon, 1992), human impacts on the environment have been cumulative and are superimposed on the changes brought about by climate change and species evolution (Deacon, 1992). Today, no part of the region is pristine or "natural" and the artificial character of the region is evident in the presence of exotic species that have adapted themselves to living in an environment, which is itself an artefact of human evolution and change. Thus, the contemporary environment of the southwestern Cape as described by Deacon (1992, p.268) "is the result of the consequence of 1 000 000 years of fire-stick farming, 2 000 years of stock raising and 300 years of cultivation. Added to this is the disturbance caused by roads, dams and urban expansion".

Human impact on the environment of the southwestern Cape region will increase in proportion to population growth (immigration and fertility). With an urbanisation rate of 90% and an annual growth rate of 2.83% (Wesgro, cited in Morel, 1998), the population of the Western Cape Province and the peri-urban settlements alone, as predicted by Deacon (1992), has increased to more than three million. Over the last 300 years of human occupation of Cape Town, its population has risen from approximately 75 000 in 1805 (Christopher, cited in Deacon, 1992) to

approximately 600 000 in the 1970's and to approximately 3 000 000 by 1994 (Palmer Development Group, cited in Morel, 1998). In most cases, this explosion in urban population took place without planning and has changed and is changing natural resources dramatically. Degradation and conversion of natural land to agricultural and urbanised landscapes at a rate of one hectare per day reported in the 1970's, doubled in the 1980's (Gasson, cited by Meadows, 1999).

Conversion of natural land to agricultural landscape has led to severe forms of land degradation e.g. gullies left behind as a result of human induced erosion in the Swartland. Talbot in 1947 (reviewed by Morel, 1998) employed aerial photography surveys of the distribution of gullies and wind erosion in the Swartland and suggested that widespread degradation and erosion in the Swartland was a response to poor agricultural practices. Increased soil erosion in the region through impairment of the vegetation (mainly renosterveld and fynbos) cover is equated to significant anthropogenic impacts that have taken different forms in the region over the years. Deacon (1992, p. 268) remarked that "the demographic profile of the biome has changed and is changing dramatically" with urbanisation. Landscape alteration accelerated significantly with the arrival of European settlers in the western Cape from 1652 onward (Meadows and Baxter, 1999).

## **2.7 CURRENT AND POTENTIAL IMPACTS OF LAND USE CHANGE AND URBANISATION**

Explosive population growth, together with rapid urbanisation in many developing countries, including South Africa, has caused severe and, in some cases, irreversible changes on the natural landscape (Brink *et al.*, 1990). Urbanisation, defined as the process of altering land uses to create and further develop urban centres, is one of the major forces driving land use/land cover change in South Africa (Brink *et al.*, 1990). Land formerly used mainly for agriculture, forestry and open space has been extensively converted to urban uses. The most obvious effect of urbanisation results from changing land use pattern, often characterised by a shift from less intensive to more intensive uses of land resources. The rapid

rate of urbanisation like that experienced in most South African cities, including Cape Town, has resulted in significant impacts on natural vegetation, the hydrological cycle and the rate of erosion and sedimentation.

### **2.7.1 Hydrology and erosion**

In natural or rural catchments much of the rainfall absorbed into the porous soils (infiltration) is stored as groundwater, and later moves back to the river or streams through seeps and springs. Urbanisation alters the natural characteristics of a watershed by replacing much of the natural vegetation and topsoil with alien vegetation and impervious surfaces such as roads, roofs, parking lots and pavements. Because the natural landscape has been altered, rainwater that used to infiltrate into the ground must now be collected by storm water networks that send the running water into the local streams. Unfortunately, these receiving streams are not naturally designed to handle large amounts of runoff, and become flooded in the event of major rainfall.

Response to rainfall in catchments varies markedly between natural and urbanised environments. In a natural catchment, the time graph of runoff (or hydrograph) is flat and prolonged and the response primarily that of groundwater or interflow (Brink *et al.*, 1990). Urbanised catchments, on the other hand, because of their impervious surfaces, have a flood discharge hydrograph that is tall and sharp-peaked, representing mostly direct surface runoff (Brink *et al.*, 1990, Figure 2.2).

In addition to the increase in flood peaks and peak discharge, the frequency of bankfull flows also increases with increased urbanisation. Bankfull flows are simply runoff events that fill the normal channel of a stream to the top of the banks (Brink *et al.*, 1990). These flows become significant because they form channel flow conditions in a stream and are highly erosive, and damaging to the natural morphology of the stream. In an urban setting where bankfull is frequent, damage to stream morphology is unavoidable.

In natural catchments, the moisture status of the soil determines the volume of storm rainfall that becomes runoff. An already wet surface will turn all the rainfall into runoff whereas a dry, unsaturated surface will first absorb rainwater until it is saturated and the groundwater fully charged before runoff occurs. An increase in impervious surface in an urban watershed often decreases the amount of rainfall available for infiltration. Without infiltration, the groundwater recharge is effectively inhibited (Brink *et al.*, 1990) (Figure 2.2).

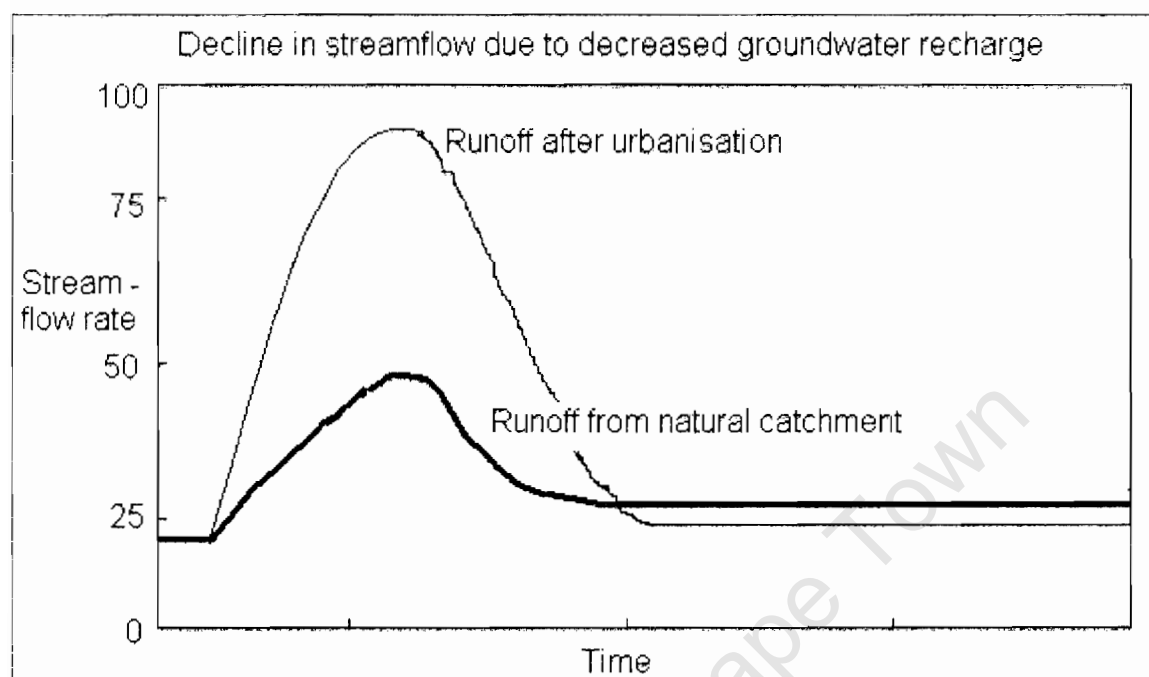

Figure 2.2 An increase in impervious surface coverage often decrease the amount of rainfall available for infiltration (after Brink *et al.*,1990).

### 2.7.2 Pollution

The high population density and industrial concentration in highly urbanised cities are responsible for the increased amount of waste, such as sediment, nutrients, organic matter, trace metals (copper, cadmium, lead), pesticides, herbicides and hydrocarbons, and others, entering water bodies (Ruiz, 2001). Pollutants in storm water are highly associated with impervious areas because these areas act as both collector and conveyor for pollutants that arrive via several pathways. For example, pollutants from automobiles such as wear of tyres (a known source of zinc), deteriorating brake pads, or simply leaks, drips and spills of oil and other

pollutants from the car accumulate on impervious surfaces are later washed off the surface into drainage networks and finally to receiving streams (Centre for Watershed Protection, undated). These pollutants, together with nutrients, can enhance the growth of algae downstream.

### **2.7.3 Vegetation**

The human population has increased significantly in the recent past, thereby placing more pressure on limited resources such as land. Many world cities have expanded and are still expanding, transforming expanses of indigenous vegetation through clearance into paved roads, suburbs and industrial parks (Cowling *et al.*, 1995). This has amounted to large-scale degradation of the natural environment. Fragmentation through selective landscape transformation for agricultural, industrial and housing purposes has negatively impacted on most natural vegetation in urban environments. Agriculture and urbanisation has transformed approximately 32% of the Cape Peninsula natural vegetation and of the remaining area, 10.7% is currently under dense stands of alien plants and another 32.9% is lightly invaded (Cowling *et al.*, 1997). Coastal renosterveld, among other lowland fynbos species largely confined to fine-grained soils areas rich in clays and silts, has been heavily impacted on because of the fertile soils and gentle slopes in most coastal lowlands that attract agricultural and industrial activities.

However, a more serious threat to natural vegetation in the southwestern Cape has come from alien plants, which infest large tracts of otherwise undisturbed mountains and flats. These alien species, introduced by European settlers from 1652 to replace indigenous species that had less direct commercial value, have become problematic to indigenous species and water supply (Cowling *et al.*, 1995). The effects of these invasive alien species are many and include the acceleration of erosion in river catchments, the alteration of coastal sediment movements, a reduction in stream flow as indicated earlier and changes in fire regimes (Cowling *et al.*, 1997).

Environmental change is a major problem at both local and global levels. Climatic perturbations have been solely responsible for major vegetation changes on earth prior to the arrival of people. The arrival of humans marked a distinct era in earth's history. Human alteration of the natural vegetation that began during the early part of the Holocene has continued at a rate and scale that has never before been witnessed in the 4.5 billion years of earth's history. Deacon (1992) and Meadows (1999) acknowledged that the human imprint upon the landscapes of the southwestern Cape has been cumulative and superimposed upon natural changes. These cumulative impacts, they said, are a consequence of the lengthy history of human occupation and are coupled with an increased resource utilisation in the twentieth century (Meadows, 1999).

## **2.8 CONCLUSIONS**

In the absence of historical records on environmental changes dating back to the early Holocene, Quaternary scientists and environmental managers have been compelled to rely on proxy data for environmental reconstruction as discussed above. The southwestern Cape was apparently out of phase with the rest of the region and that resulted in its contemporary uniqueness. Attributing its contemporary uniqueness to events of the recent past, it is important to review the contemporary environment in order to contextualise the research. In the following chapter a summary of the contemporary vlei environment of the Noordhoek basin and its surrounds will be presented to enable an assessment of the late Quaternary and recent changes.

---

## CHAPTER 3

# CONTEMPORARY VLEI ENVIRONMENTS OF THE NOORDHOEK VALLEY

---

### 3.1 INTRODUCTION

This chapter contextualises the research within its geographical location (georeference) and inform the reader of its contemporary physical environment, a product of past environmental change, which occurred throughout geological time scale. Physical and chemical alterations of the contemporary environment, accelerated by human actions, may affect the direction of future change. The nature and size of a wetland catchment can exert a major influence on the input and composition of its sediments. It is for these reasons that a detailed review of the contemporary environment around the study sites is provided in this chapter.

### 3.2 THE SOUTHERN CAPE PENINSULA REGION

The southern Cape Peninsula is located at the southwestern tip of Africa. The southern Cape Peninsula extends some 40km from the Constantiaberg Mountains around Oukaapseweg in the north to Cape Point in the south. The cold waters of the Atlantic Ocean in the west and the warmer waters of False Bay in the east surround it. The region has a number of interesting geomorphic landscapes that provide opportunities for palaeoenvironmental reconstruction, revealing evidence of fluctuating sea levels, climate and anthropogenically induced changes on the environment. As noted in Chapter 2, environmental reconstruction for the whole of southern Africa region has been hampered by factors such as a scarcity of suitable study sites as well as a lack of chronological analysis at available sites (Dewey, 1988). The southern Cape Peninsula as a whole has been under-researched with respect to its late Quaternary environmental reconstruction. However, organic sediments deposited in vleis within the region could provide a rare opportunity for long-term environmental

reconstruction beyond the Last Glacial Maximum. For example, organic sediments in vleis on the Noordhoek basin dating beyond the radiocarbon age limit are used in reconstructing its local environment.

### **3.3 PHYSICAL CHARACTERISTICS OF THE STUDY REGION**

The Noordhoek valley is situated on the Atlantic coast of the southern Cape Peninsula, about 25km from the Cape Town's Central Business District on grid reference 34° 07'S, 18° 22'E (Figure 3.1). It consists of an extensive low-lying flat basin flanked by mountains to the north and south, interrupted by a low sandy ridge in the east – the Fish Hoek Gap – and the Atlantic Ocean in the west. It is bounded in the north by Chapman's Peak, 590m, and Noordhoek Peak, 550m, above sea level; the Dassenberg (135m) and Spitskop (441m) mountains in the east. The southern boundary is formed by the Rooikrans Peak, 364m, and Brakkloof Ridge, 300m, southeast of the valley (Figure 3.1). The perimeter of the basin dips down into what is referred to as the Fish Hoek/ Noordhoek Gap at Sun Valley.

In recent years, residential development has altered the natural landscape east of the valley (Plate 3.1). The western part, however, remains almost pristine with an extensive marshland, bordered by a 5km long beach. Purseglove (1998, cited in Gassner, 1999), described this marshland portion of the valley as one of the most magnificent stretches of unspoiled landscapes on the Cape Peninsula.

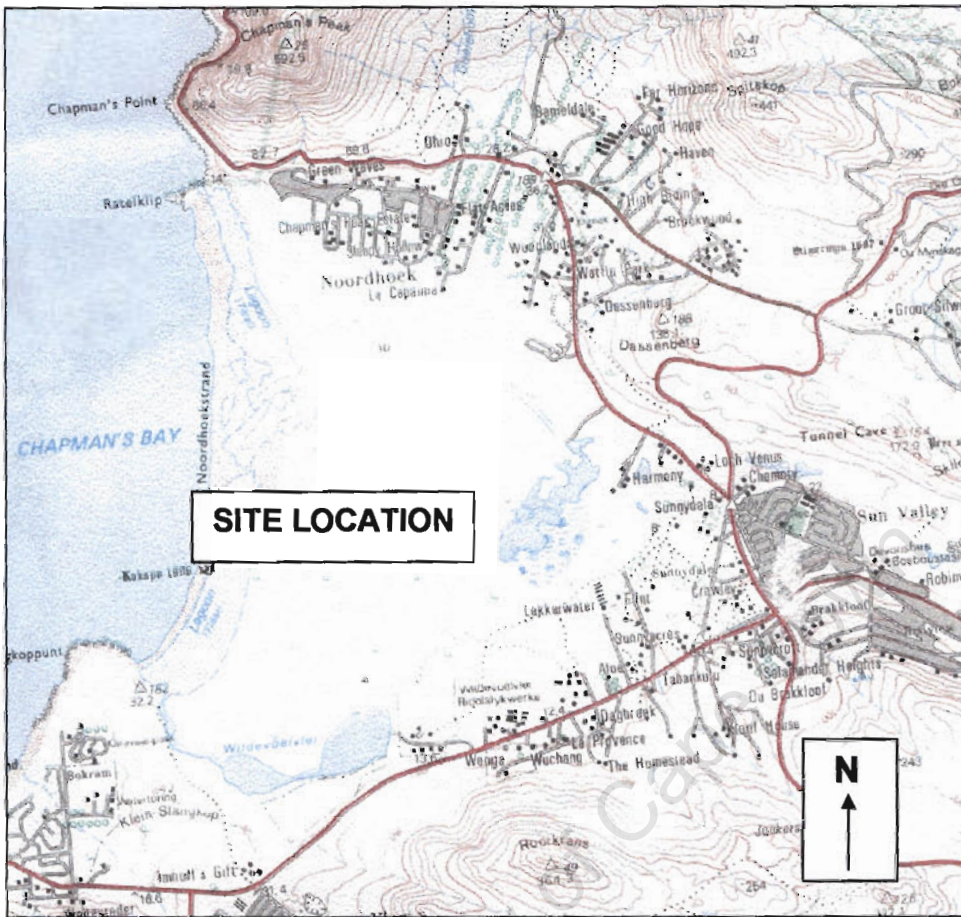

Figure 3.1 Noordhoek valley, showing the study site (from 1:50 000 Map)



Plate 3.1 Townships in the east of the Noordhoek valley (Photo: E. Akunji)

### 3.3.1 Geology, geomorphology and soils

#### 3.3.1.1 Geology

The geological history of the Cape Peninsula region spans a lengthy time sequence from the Precambrian (almost 1000 million years ago) to the Holocene (the last 10 000 years). Three major rock types dominate in this region - the Malmesbury Group shales, the Cape Granite and the Table Mountain Sandstone (TMS). The oldest rocks are the late Precambrian Malmesbury Group shales, which underlie the northeast portion of the Peninsula. These Malmesbury shales include metamorphosed sandstones (greywackes), which have been intruded into the southwestern Cape by numerous plutons of the Cape Granite Suite (Reid *et al*, 1999). The sandy and nutrient-poor soils in this region are derived from the erosion of these rocks.

The Noordhoek valley is surrounded by quartzitic sandstone of the TMS, which rests on a basement formed by the Cambrian Cape Granite (Figure 3.2). This TMS is comprised of two formations: the oldest sediments of the Graaftwater Formation and the somewhat younger Peninsula Formation. The pale brown Graaftwater Formation consists of laminated pink siltstone, characterized by thin, ferruginous fine-grained mudstone, while the horizontal quartz arenite sequences are typical of the Peninsula Formation (Theron, 1983). Chemical and mechanical weathering in the Tertiary period had little effect on the quartz-dominated sandstone of the TMS that today form the impressive sheer faces of the mountain chain.

Intense weathering has decomposed the underlying granite into feldspar, which has given rise to exploitable deposits of high quality kaolin. Reid *et al*. (1999) estimated the total quantity of kaolin underlying the northern flanks of the valley to be approximately 60 million tones.

Inland of the Noordhoek basin the area is dominated by coastal dunes, which are underlain by peaty silica sand forming the Noordhoek Member of the Pleistocene

Springfontyn Formation (Table 3.1 after Reid *et al.*, 1999). These peat deposits contain pollen typical of the contemporary fynbos vegetation and the abundance of *Asteraceae* (daisies) indicates a Quaternary age of less than 2 Ma, (Reid *et al.*, 1999). Below this formation, angular coarse sand of the Elandsfontyn Formation contain peat layers up to 10m thick, rich in tree pollen of *Podocarpus* (yellowwood), which suggests a sub-tropical climate in late Tertiary (Coetzee, 1978). This would explain how and when the granite was so deeply weathered, (Reid *et al.*, 1999).

Closer to the coast, white calcareous sand of the semi-consolidated, littoral late Pleistocene Velddrif Formation and the unconsolidated, aeolian Holocene Witzand Formation overlie the siliceous sands of the Springfontyn Formation (Reid *et al.*, 1999). Harmse *et al.* (1980, cited in Heineken, 1985) noted that the presence of this calcareous white sand on the Noordhoek coastline is indicative of a prograded coast.

Reid *et al.* (1999) supported the notion of a prograded coast on Noordhoek beach. They noted that during the Late Pleistocene, 125 000 years ago, sea level was more than 6m amsl enabling the sea, via an estuary, to link Wildevoelvi with the Salt Pan, where abundant marine shells were excavated. Then during the LGM, 20 000 years ago, sea level fell to -130m and later recovered to about +3m about 6 000 years ago during the Holocene climatic optimum. As sea level slowly dropped to its present position, the barrier dune complex and backshore lagoon of the Noordhoek basin prograded seaward. The wreck of the Kakapo ship that ran aground on the southern part of the Noordhoek beach in 1900 and is now exposed, is the most recent evidence of this progradation (Reid *et al.*, 1999).

Deposition and formation of the modern dunes located landward of the present shoreline took place during the Holocene transgression, when sea level was rising. This transgression was followed by a major regression when the coastal zone prograded seaward again leaving behind an extensive marshland (Rogers,

pers.com. cited in Davies and Gassner, 1999) which today is known as the Noordhoek basin. This interpretation is in line with mid Holocene regional fluctuations in sea level discussed in Chapter two.

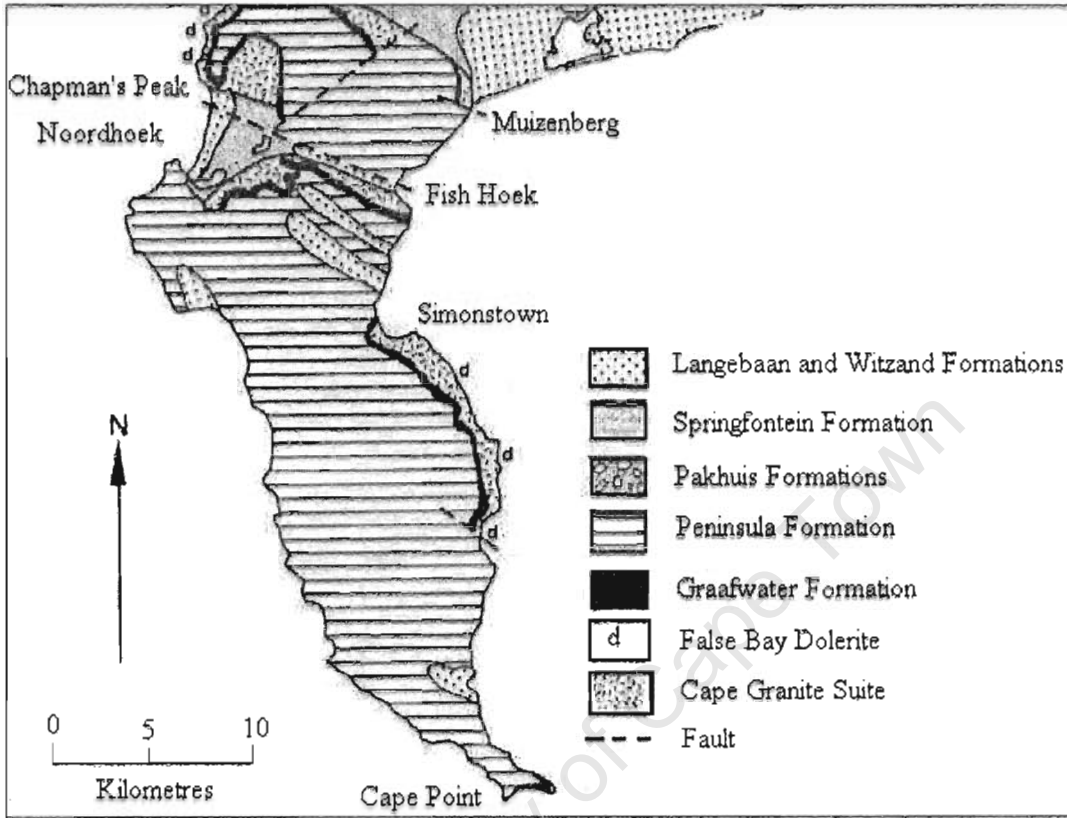

Figure 3.2. Geological map of the southern Cape Peninsula revised after Tankard and Hobday (1977), Dunlevey (1978) and Theron (1984)

Table 3.1 Lithostratigraphy of the Cape Peninsula (after Reid *et al.*, 1999)

|                               |                          |                   |
|-------------------------------|--------------------------|-------------------|
| Sandveld Group                | Witzand Formation        | Holocene          |
|                               | Langebaan Formation      | Pleistocene       |
|                               | Veldrif Formation        | Pleistocene       |
|                               | Springfontyn Formation   | Pleistocene       |
|                               | Varswater Formation      | Pliocene          |
| False Bay Dolerite Dyke Swarm | Elandsfontyn Formation   | Miocene           |
|                               |                          | Cretaceous        |
| Table Mountain Group          | Pakhuis Formation        | Upper Ordovician  |
|                               | Peninsula Formation      | Middle Ordovician |
|                               | Graafwater Formation     | Lower Ordovician  |
| Cape Point Intrusive Breccia  |                          |                   |
| Cape Granite Suite            | Cape Peninsula Pluton    | Cambrian          |
| Malmesbury Group              | Sea Point Formation      | Neoproterozoic    |
|                               | Bloubergstrand Formation | Neoproterozoic    |

### 3.3.1.2 Geomorphology

The relief map of the southern Cape Peninsula conveys the impression of an island plateau descending gradually from the north to the south, with an average width of 7km and a maximum width of 15km (Figure 3.2). More than half of its total area of about 315km<sup>2</sup> stands at a height in excess of 300m above sea level (King, 1983). A sea level rise of some 30 m would submerge the low lying areas and separate the region into two distinct islands of almost equal size along the Fish Hoek/ Noordhoek valley. Mabbutt (1952) remarked that its rugged scenery is largely the surface expression of the three types of rocks, altered by their contact with the atmosphere, and acted upon by erosion.

The extensive 2-5km wide Fish Hoek gap that divides the southern Cape Peninsula region into two equal halves is speculated to have formed along the east/west fault line in the geological past (Figure 3.2). This gap widens in the west into a low-lying expanse of recent sediments overlying weathered kaolinised granite, (Heinecken, 1985).

### 3.3.1.3 Soils

Soil, a term used in its broadest sense to include surface material, is the product of parent material (geological rock type), slope, and a variety of primarily climate-driven processes interacting over time. The composition of a soil is a reflection of its parent material as well as the resulting sediments eroded and deposited downstream. The composition of a particular soil depends on all of the above factors such that the vulnerability of a particular soil type to forces of erosion and transportation directly depends on the soil-forming factors. Sediments eroded and deposited in a wetland or vlei over time take with them various signatures of the surrounding environment and climate at the time of erosion and deposition. This information may be preserved in the sedimentary units in wetlands and can be very useful in reconstructing environmental changes of a particular region.

The soils of the surrounding mountain slope of the southern Cape Peninsula are largely derived from the Peninsula Formation sandstone. They are shallow, acidic, water repellent, and deficient in most important minerals and trace elements (Gasson, 1990). Weathered sandstone provides the acidic and low nutrient soil on which Mountain Fynbos and Sand Plain Fynbos thrive. The viticulture for which the Cape is well known is largely supported by the more nutrient rich granitic soils on the lower mountain slopes (Cowling, 1992).

Heineken (1985) attributed the poor drainage conditions of the extensive Noordhoek floodplain to its low slope gradients, numerous vleis, and the high water table due to its proximity to the sea.

The following is an account of the different soil types on the Noordhoek basin as presented by Chapman and Kreutzweiser in 1997 and reviewed by Gassner (1999). Soils within the basin are varied and can be grouped in eight categories: sandy soils typical of quartzitic mountain fold ranges are restricted to the drier south facing slopes of the Kommetjie side, while in the wetter north facing Noordhoek amphitheatre soils of the Lamotte and Fernwood forms (Macvicar *et al.*, 1977) are dominant. Escourt form soils (good for agriculture) overlay the kaolinite on the lower slopes. Coastal foreland soils have developed from dune sand or the more recent drift sands where wind is more dominant in sediment deposition. While the Lamotte and Fernwood soils in the valley are subjected to a degree of wetness, the unweathered quartzitic layers in the valley bottom give rise to a perched water table. Within the basin, soils types such as the Mispah, Darling and Longlands series (Table 3.2) are characterized by high interflow (potential for agriculture), while the rest of the soils in the catchment are considered to have low interflow potential.

Table 3.2 Soils of the Noordhoek basin (after Chapman and Kreutzweiser, 1997, in Gassner 1999)

| Terrain morphological units        | 1 <sup>o</sup> Soil Series | 2 <sup>o</sup> Soil Series | 3 <sup>o</sup> Soil Series | 4 <sup>o</sup> Soil Series |
|------------------------------------|----------------------------|----------------------------|----------------------------|----------------------------|
| <b>CRESTS</b>                      | Saldanha                   | Rock                       | Mispah                     |                            |
|                                    | Fw32 (90%)                 | 8%                         | Ms10 (2%)                  |                            |
| <b>Middle Slope (North facing)</b> | Saldanha                   | Mispah                     | Lamotte                    | Waterridge                 |
|                                    | Fw22 (60%)                 | Ms10 (15%)                 | Lt12 (15%)                 | cf20 (20%)                 |
| <b>Middle Slope (South facing)</b> | Darling                    | Sonneblom                  | Chester                    | Longlands                  |
|                                    | Es42 (55%)                 | (Cv21 30%)                 | Hu22 (10%)                 | Lo21 (5%)                  |
| <b>Valley Bottom</b>               | Saldanha                   | Lamotte                    | Longlands                  | Darling                    |
|                                    | Fw22 (40%)                 | Lt12 (30%)                 | lo21 (15%)                 | Es42 (15%)                 |
| <b>Depression</b>                  | Pan                        | Chester                    |                            |                            |
|                                    | -80%                       | Hu22 (30%)                 |                            |                            |

### 3.3.2 Contemporary climate

Climate is one of the main factors that controls facies change in a deposition sequence in addition to sea-level changes, erosion and sedimentation. It is considered an essential element in the development of a stratigraphic sequence because an abrupt change in climate affects the quantity and composition of sediments deposited in a vlei. Therefore, it is important to review contemporary climate patterns in the study area.

The study area lies within the temperate region of South Africa and has a Mediterranean type climate characterised by warm dry summers and cold wet winters. Frosts are light and snow rarely falls on Table Mountain. The marked difference between the hot summers and cold winters makes the area a good site for studying environmental change, in that, changes in the length and intensity of a season may be reflected in its sedimentary records. For example marked fluctuations in temperatures and rainfall will be reflected in significant changes in the rates of erosion and deposition of sediment downstream. Increased temperature and rainfall may ease weathering processes, erosion and deposition of sediments in the lowlands. Therefore past climatic conditions may be inferred from an undisturbed depositional sequence.

### 3.3.2.1 Rainfall and wind

The role of rainfall in sediment accumulation in non-point source wetlands (those with no major feeding streams) like those of the Noordhoek basin is crucial. Like wind, rainwater, through surface flow, is a significant transporting and depositional agent. Therefore, the duration and the intensity of the rainfall patterns, among other factors, will determine the amount of sediment inputs into a non-point source wetland system. Under normal circumstances, high intensity rainfall over a longer period of time will transport and deposit larger amount of sediments of varying composition into a wetland than a short duration, low intensity rainfall. Large storm water and flooding events may transport large quantities of sediments varying from clay/silt to coarse sand, while less storm water resulting in low energy flow may transport little material and mainly medium to fine silt. Vegetation and vegetation cover is also known to depend on the amount and availability of rainfall (Mitsch *et al.*, 2000).

Rainfall varies considerably in different parts of the study area. Rainfall over the Noordhoek basin as in the rest of the region is cyclonic and orographic with pronounced winter peaks (Figure 3.3). Mean annual rainfall in the Noordhoek basin varies depending upon proximity to surrounding highlands (Heinecken, 1985), for example;

- The high cool wet slopes (160m and above) of the Noordhoek amphitheatre experiences annual rainfall in the region of 1000-1200mm, much of which can be attributed to the orographic effect. In winter this area is dominated by strong northwesterly winds.
- The south facing bowl of the amphitheatre has a more temperate climate with an annual average rainfall of 850mm. This falls predominantly in winter and is also affected by the strong winter winds.
- The warmer eastern slopes located at an altitude of between 30 and 160m have annual rainfall records of between 700-800mm. The effects of the

northerlies and the southerlies dominate in the neck between Clovelly and Noordhoek valley.

- The North-facing, southern slopes on the Kommetjie side of the basin receive the highest sun and would be the hottest part of the valley were it not for the moderating effect of the altitude and the prevailing winds. Average annual rainfall in this region is 700mm.
- The low-lying central area, less than 20m amsl is the warmest and driest in the basin in terms of rainfall. The average annual rainfall is 600mm: orographic type rainfall accounts for less in this basin compared to areas close to the mountains.
- The coastal strip, a 1km belt adjacent to the Noordhoek beach has the lowest summer temperatures. The average annual rainfall is less than 600mm but sea fog is common in the area, mainly in autumn, (Heinecken 1985). The coastal strip is subjected to the full force of both summer and winter winds.

Overall the mean annual rainfall varies between 1200mm in the mountains and 600mm in the coastal wetland areas (Heinecken 1985).

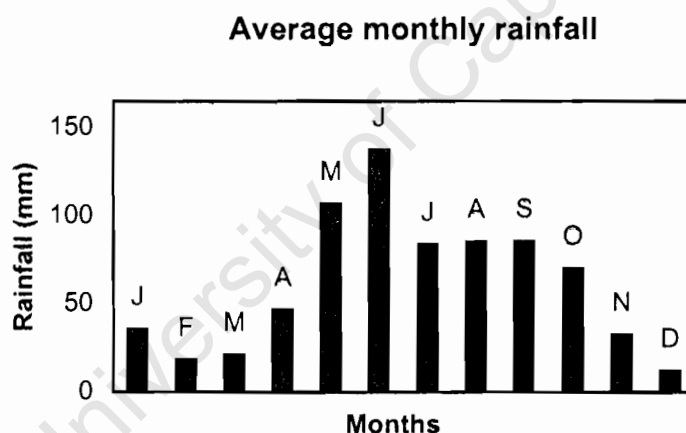

Figure 3.3 Average monthly rainfall for Noordhoek (Heinecken, 1985)

Within the study area, southeasterly winds dominate in summer while the northwesterly winds occur mainly in winter, as is the case in the Cape of Good Hope (Figure 3.4). Acceleration of the southerly winds through the Fish Hoek gap leading down into Noordhoek basin occurs particularly along the southern flanks of the basin. The strong northerly winds which blow in winter come straight of the sea or through the gap between Noordhoek and Chapman's Peak at high speed causing unpleasant vortex conditions within the basin (Heinecken, 1985). However, wind speeds are not as high in winter as in summer.

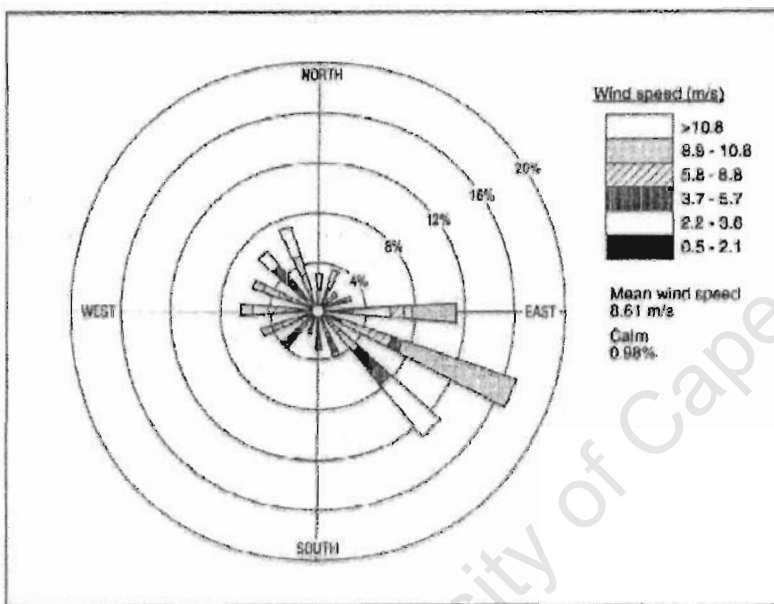

Figure 3.4 Windrose for Cape Point (after Shaw *et al.*, 2001)

### 3.3.2.2 Temperature

The southern Cape Peninsula experiences cool winter months with an average minimum temperature of 7°C. Cold fronts sweep across the Atlantic and together with the northwest gales that hit the Peninsula contribute to these low temperatures. On the contrary, the summer months are warm and dry, dominated by strong south-easterly winds locally referred to as the Cape Doctor because it blows away pollution and cleans the air. Temperatures during these summer months are normally between 26 and 30° C with an average maximum temperature of approximately 26° C (<http://www.cpnp.co.za/frame.html>).

The Noordhoek valley, together with the rest of the region, has mean temperatures ranging between 20° C and 24° C with a lowest temperature of 6° C during the cold winter months and a highest temperature of 26° C to 30° C during the hot summer months. The mean annual temperature is 7° C (Heinecken, 1985).

The significance of temperature in wetland sedimentation like this should not be discounted. Peat formation in a wetland is directly dependent on temperature and moisture. Temperature tolerance influences vegetation in the same manner as rainfall and therefore changes in vegetation type and cover will affect sediment availability. An organic layer in a sequence forms during warmer and wetter periods of the year. The percentage change in organic sediments will therefore be a reflection of change in temperature and rainfall availability. Finally, diurnal temperature variation influences mechanical weathering of rocks like granite. This variation greatly depends on the daily fluctuation and temperature changes therefore influence the amount of ready-to-transport sediment available in catchments.

### **3.3.3 Hydrology**

Besides the perennial Goede Hoop River that drains the Chapman's Peak range in the north, the entire Noordhoek catchment consist of numerous (poorly defined) non-perennial streams which drains the rest of the surrounding slopes. Runoff from these non-perennial rivers through the catchment (measuring about 31 km<sup>2</sup>) (Figure 3.1 from a 1:50000 Topocadastral Map 3418 AB and AD) seeps down into the valley floor, where its characteristic porous sandy substrate acts as a sponge. The valley bottom consists of wetland with three permanent water bodies (Lake Michelle, Papkuilsvlei and the Wildevoelvlei) with no visible surface connection between them. However, Heinecken (1985) noted that during winter the whole valley becomes flooded with visible surface connections between the vleis.

Within the Noordhoek catchment there are two main aquifers, an upper (0-30m depth) unconfined aquifer and a lower (40-90m depth) confined aquifer (Gassner, 1999). The upper aquifer is associated with the unconsolidated sand of the Bredasdorp Formation and receives salty water via direct vertical surface flow or laterally from the flanks of the valley. The lower aquifer is located at the interface between kaolin and fresh unweathered rock and is recharged by lateral leakage from the TMS (Davies and Gassner, 1999).

### **3.3.4 The wetlands**

Discussion surrounding land use history on two of the Noordhoek vleis (Lake Michelle and Wildevoelvlei) and Groot Rondevlei the sediments of which have been used in this research is given below.

#### **3.3.4.1 Lake Michelle**

Lake Michelle is situated in the central part of the Noordhoek valley (Figure 1.2).

Winterbottom (1960, in Gassner, 1999) described it as a seasonal Salt Pan: always dry in summer and forming a shallow lake during the winter rainy months. Until 1974, this Salt Pan was used for the production of salt by a salt mining company (Heinecken, 1985). Heinecken (1985) noted that during the summer months prior to its dredging in 1974, the hard surface of the pan was being used as an unofficial racetrack. In 1974, as part of a scheme for a marina-type development proposed for the Salt Pan, the pan was dredged. Substantial earthworks followed excavation of the pan floor on the southern end of the pan and stabilisation of its banks by concrete embankments led to the creation of a permanent lake. Day (1985, cited in Gassner, 1999) described the 1.6m deep lake as brackish (average salinity =  $10^0/_{00}$ ) and eutrophic.

In 1995, following the dredging and embankment, phases 1-3 of the proposed marina development, named Lake Michelle Estate, was completed. Lake Michelle in the centre of this development, acts as a "sink" towards which a large portion of the stormwater in the Noordhoek valley is drawn (KFD Wilkinson,

1999). Stormwater entering Lake Michelle enters via the adjacent reed beds in the northeastern corner. Outflow from the lake is through an artificial conduit about 1km long situated at the northwest end of the lake toward Papkuilsvlei.

Prior to the arrival of people in the valley, the Lake used to be linked to the Wildevoelvlei via an estuary. This connection helped raise the salt level in the two wetlands until it was artificially redirected to Papkuilsvlei. As part of the approval process of phases 4 - 7 of Lake Michelle Estate, the developer was to re-establish the connection between Lake Michelle and the Wildevoelvlei by cutting off the artificial outflow between Lake Michelle and Papkuilsvlei (Davies and Gassner, 1999). Redirecting the artificial link between Lake Michelle and Papkuilsvlei is expected to improve the ecological status of Papkuilsvlei as part of the lower marshland which now falls under the Cape Peninsula National Park.

The main vegetation around Lake Michelle today is dense stands of pondweed *Potamogeton pectinatus*. Gassner (1999) reported that local residents in an attempt to control these pondweeds harvested them with a harvesting machine.

#### 3.3.4.2 Wildevoelvlei

Wildevoelvlei a twin water body system located at the southwestern edge of the Noordhoek valley (Figure 1.2) lies on the foothill of the Rooikrans mountain range (Figure 3.1). Wildevoelvleis-literally translated as "wild bird lakes" used to be a seasonal system regulated by rain, runoff and spring tides until 1979 when discharge of treated sewage from a Wastewater treatment plant transformed it into a permanent vlei. Today, the vlei function as an estuary, connecting the Wildevoelvlei with the sea and receiving seawater from the southern backshore lagoon (Heinecken, 1985).

Stormwater from surrounding locations such as Sunnydale, Sun Valley, Capri and Masiphumelele are indirectly discharged into the Wildevoelvlei via the Pick'n Pay reed beds (Gassner, 1999). Discharge from the industrial developments of Heron Park, the Wastewater treatment works on the eastern shore of the vlei and

residential developments on the Imhoff's Gift farm directly enters the Wildevoelvlei typically as runoff.

Dense stands of Sago pondweeds *Potamogeton pectinatus* are the main aquatic vegetation type present around the vlei (Plate 3.2). Toxic algae such as the cyanobacterium, *Microcystis aeruginosa* occasionally colonise the vlei, for example in April and November (summer) of 1998 (Gassner, 1999). Davies and Gasser (1999) blamed the re-occurrence of these algae in the Wildevoelvlei on low-level salinity that has led to a high phosphorous content in the vlei, a condition favourable for their growth. They recommended that estuarine conditions be re-introduced at Wildevoelvlei via Lake Michelle to lower the phosphorous content in the vlei so as to effectively eradicate the green algae. At present there is no surface flow between Lake Michelle and the Wildevoelvlei wetlands. However, vestigial channels that once linked Lake Michelle and the Wildevoelvlei can still be visible from the topography of the area.



Plate 3.2 Vegetation at Wildevoelvlei (photo: E. Akunji)

#### 3.3.4.3 Groot Rondevlei

Located in the Cape of Good Hope Nature Reserve, Groot Rondevlei (Figure 1.2) is a seasonal wetland approximately 5ha and situated about 20 metres away

from the coastline. It was completely dry at the time of our visit in March 2003. During the winter months, we were informed that the vlei is always flooded (Smith, pers.com). Vegetation around the vlei is mainly coastal fynbos (Plate 3.3). However, invasive species such as *A cyclops* (Rooikrans), *A saligna* (Port Jackson) and *A longifolia* (long-leafed wattle) are still visible around the vlei despite recent attempts by the park authority to eradicate it.

The history of human occupation on this Reserve extends back for over 600 000 years with pre-colonial hunter-gatherers and Khoi pastoralists occupying much of the coastal lowlands (Gasson, 1990). During the time of colonial occupation, the "Reserve" was used for crop cultivation, cattle grazing and as a military training site until 1941 when it was officially declared a Nature Reserve (Gasson, 1990). Today the Reserve is used solely for recreation and tourism. Despite the long history of land use in the region, the absence of Kikuyu grass in the vicinity of Groot Rondevlei is an indication of no major human disturbance on the natural system.



Plate3.3 Coastal fynbos at Groot Rondevlei (photo: E. Akunji)

### 3.3.5 Vegetation

#### 3.3.5.1 Regional vegetation types and their distribution

Fynbos vegetation, uniquely characterised by restioids is confined to the nutrient poor soils of the southwestern and southern Cape (Cowling *et al.*, 1995). Fynbos vegetation in the Peninsula forms part of the Cape Floristic Kingdom, recognised worldwide for its endemism. The Cape Floristic Kingdom, one of only six world floral kingdoms, covering less than 90 000 square kilometres of land, is home to about 8500 plants species (Cowling *et al.*, 1995). The extraordinary high number of endemic species, genera and families; about 68% of the species, 20 % of the genera and six families, makes it quite unique from the other floral kingdoms (Cowling *et al.*, 1995). Among the six endemic families present in the peninsula are the Geissolomaceae, Grubbiaceae, Penaeaceae, Retziaceae, Roridulaceae and Stillbaceae, while a seventh member, Bruniaceae, is almost endemic to the region (Cowling *et al.*, 1995). The predominant vegetation type around the study area and the region as a whole is fynbos. Fynbos is distinctively recognised by the presence of heath-like *Ericas* (small leafed shrubs); *Restios* (evergreen, wiry grasses) and *Proteas* (larger, woody shrubs) (Kidd, 1983) (Figure 3.5).

Although fynbos is a dominant vegetation type, contributing more than 80% of the Cape Floristic Kingdom, there are substantial areas of non-fynbos vegetation within the peninsula. These include the rare *renosterveld* grassland; subtropical thicket and the evergreen forest found largely in the moist eastern valleys and sheltered ravines of the Peninsula mountain chain. The hardy *strandveld* (beach vegetation) has evolved to survive in the salty, coastal marine sand. It is generally thought that fynbos is largely confined to the infertile sandy soil derived from quartzites and sandstone, and leached colluvial and dune sands of lowland; non-fynbos vegetation occur on the less sandy and more fertile soils (Cowling, 1992).

Even though some families or genera of the fynbos species are endemic to the Cape Floristic Kingdom, Taylor (1983) remarked that species richness and

disjunct distributions seen in the region maybe related in some way to the past climatic history of this varied and variable corner of South Africa.

The two floristic categories, lowland and mountain fynbos, largely reflect the two major soil types present in the region (Taylor, 1983). Within the mountain fynbos region, precipitation, soil type and topography determine the character of the vegetation. A relatively tall and dense climax community where vegetation is three-layered (the proteoid upper layer, the ericoid middle layer and the third ground layer mainly of Restionaceae) is found on a better drained, slightly sloping parts of the plateau where rainfall is between 500mm and 750mm rainfall per annum.

Coastal or lowland fynbos on the other hand is different from the mountain fynbos in that it comprises a different suite of species. It is similar to mountain fynbos in structure but lower in stature. Growing on the alkaline dune soils, the restioid element, though poorer in species and less conspicuous, still forms the matrix of the ground layer (Taylor, 1983). Many of the shrubs are ericoid or narrow-scleropyll, succulent and broad-leaved shrubby vegetation that is well adapted to the rigours of life in a windy sandy soils near the sea (Kidd, 1983). On these lowlands, there are more grasses, most of which are nutritious and palatable, and hence good for grazing (Taylor, 1983).

Unique in comparison to the mountainous and lowland fynbos in terms of its physiognomy and floristic features, forest vegetation is confined to kloofs and sheltered riversides and remains evergreen with highly polished medium size leaves (Taylor, 1983).

The role of fire in the survival of the fynbos vegetation is important. The existence of fynbos plants can be attributed to the increasing importance of fire over the past few million years (Cowling *et al.*, 1995). Fire is thought by many ecologists to have shaped the fynbos lifestyle. Without fire, the plant species will perish, leaving no offspring and thus confounding the biological imperative to reproduce.

Recurring fires at relatively long intervals in fynbos helps in regenerating the veld and maintaining vigorous cover and species diversity while simultaneously eliminating invasive species from its community (Boucher *et al.*, 1995).

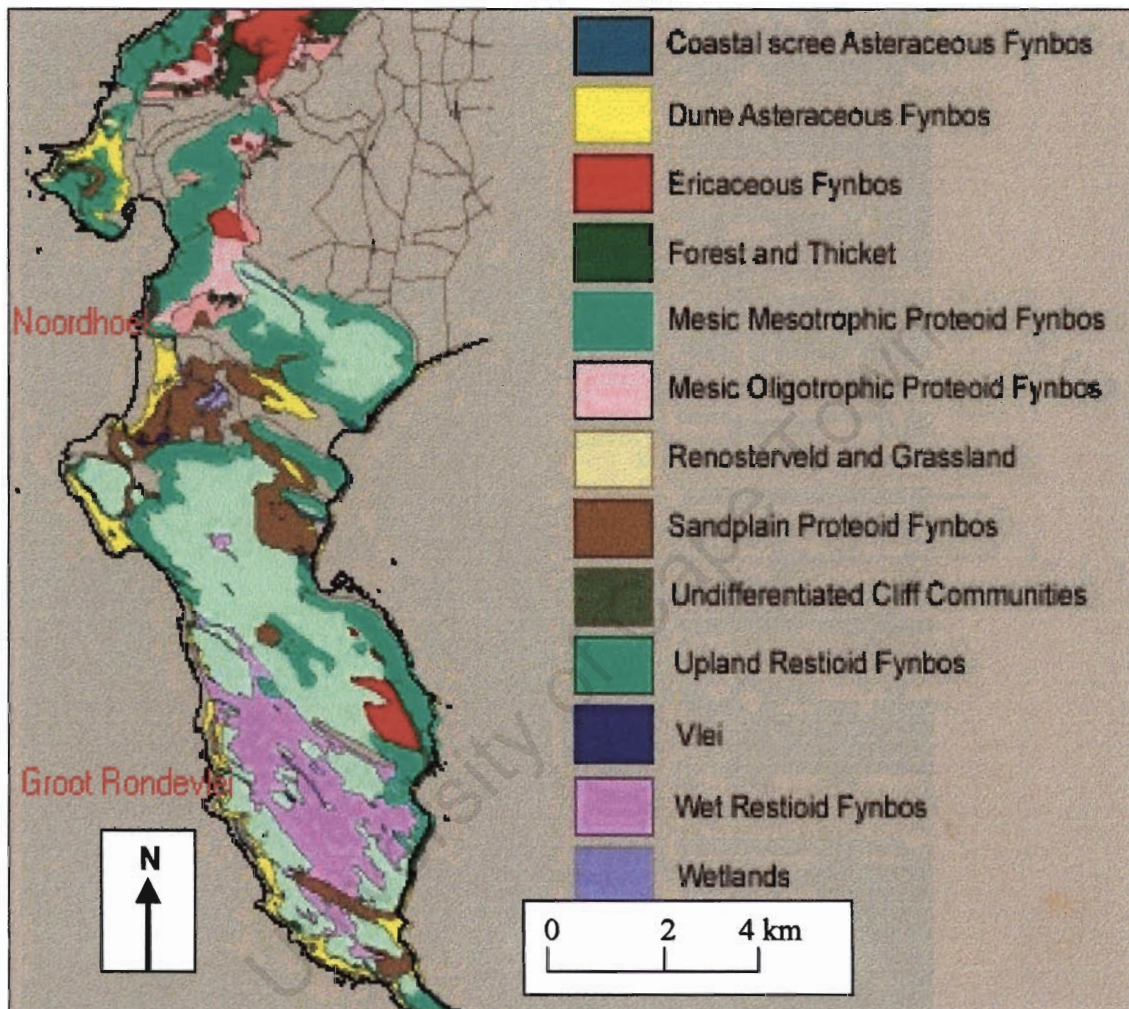

Figure 3.5 Vegetation map for Southern Cape Peninsula (after CPNP)

The fynbos community of southwestern Cape is thought to have developed in isolation from the rest of the world. Its isolation ended when humans intentionally introduced alien species from similar environments into the fynbos community (Cowling *et al.*, 1995). Both plants and animals were introduced into this community and have both made a significant impact on the regime. Since the establishment of the Cape Colony in 1652 by European settlers, fynbos has been invaded by the Australian acacias, which account for the bulk of the alien vegetation and include *Acacia cyclops* (Rooikrans) and *Acacia saligna* (Port

Jackson), although these are by no means the only ones. Pines (*P. radiata* and *P. pinaster*) from the Mediterranean Basin and California, because they are adapted to cope with similar conditions, thrived well among the fynbos community and today are widely present in much of the Peninsula (Cowling, 1992). So too are the magnificent oaks which line many of the older streets of the City (Holmes, pers.com.).

These alien species, apart from out competing the indigenous vegetation play havoc with soil and subterranean water in mountain catchments. These alien species compete with indigenous species for space and water consumption. In their benchmark review, Bosch and Hewlett (1982 cited in Boucher *et al.*, 1995) concluded that afforestation has led to reduction in runoff in most of the catchments in the Western Cape. For this reason, Working for Water has implemented a policy of eradicating alien vegetation from mountain catchments in an effort to increase mountain catchment runoff. For example in the Silvermine river catchment an intensive eradication process was carried in an effort to boost runoff and water supply (Akunji, 2001).

Alien species also add greatly to the biomass and, in the event of the (frequent) fires, which occur in the Peninsula, exacerbate the intensity of the blaze. This in turn increases the water repellency in the soil, resulting in increased overland flow, flooding and soil loss through erosion (Holmes, pers.com).

#### 3.3.5.2 *Vegetation in the Noordhoek Valley*

The Noordhoek valley has four major plant communities as observed by Heineken (1985) and Cowling (1991) (Figure 3.6). These four plant communities include the dune thicket (dune pioneer) a vegetation type that occupies the fore dunes adjacent to the beach. Dominated by herbs and grasses, this community has been heavily invaded by *Acacia cyclops* in the northern sector of the dunes and its thicket composition and structure obviously reflects a history of frequent and intense fires (Cowling, 1991).

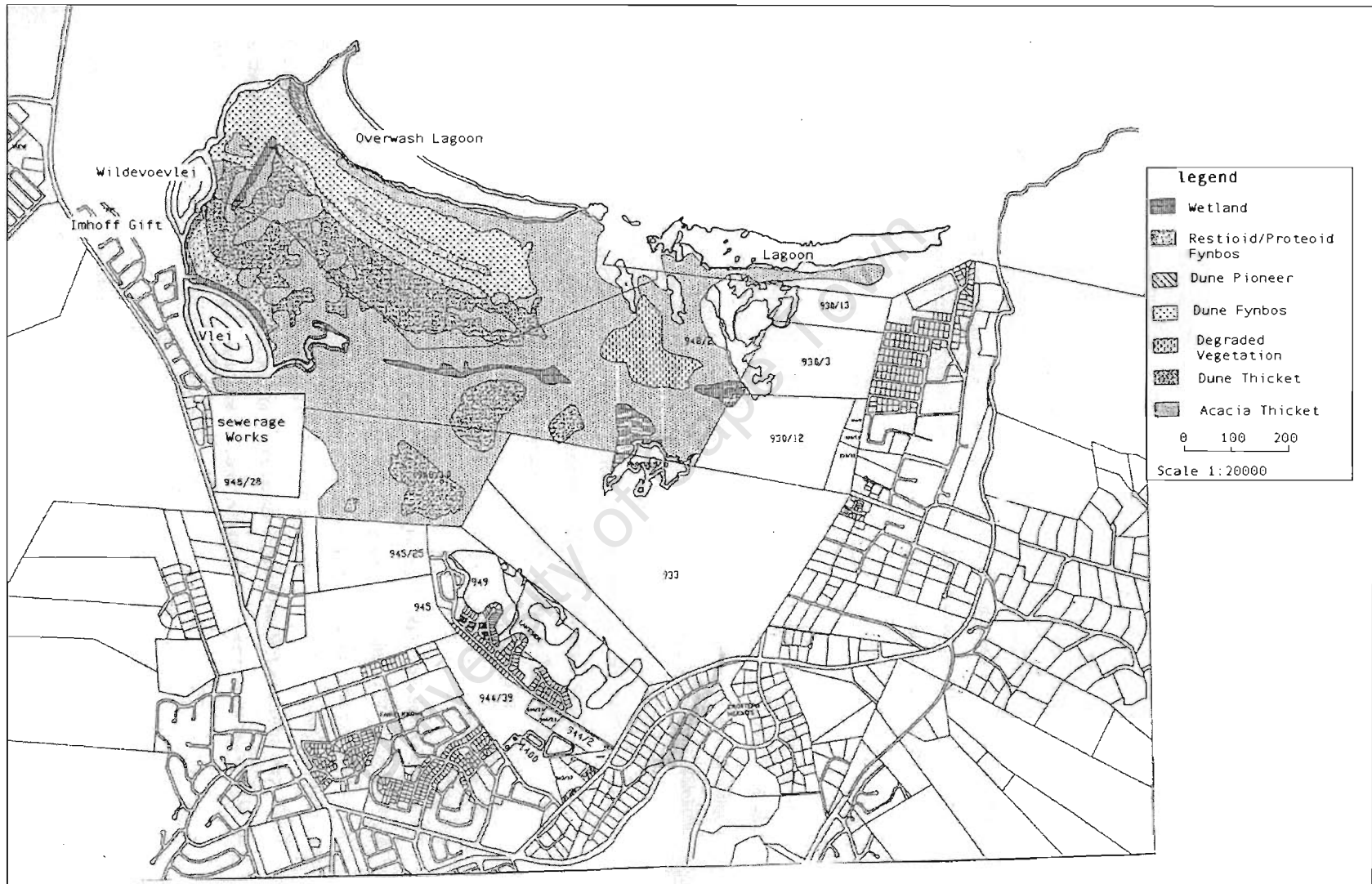

Figure 3.6 Vegetation types of the Noordhoek valley (adapted after Cowling, 1993)

The dune shrub (restioid/ proteoid) community is confined to the younger, alkaline shelly sands and is found on both sides of the vleis occupying about 45ha of the Wildevoelvlei flats. The restioid/ proteoid community is more dominant in the south (Figure 3.6) of the Wildevoelvlei flats and is the last remaining patch of its type within the entire Cape Flats (Ringdahl, 1995).

Finally, terrestrial alien trees such as *A. saligna* located on the older sands and *A. cyclops* found on the younger sands dominates large areas around the Noordhoek wetlands. These alien trees have a significant impact on the hydrology of the valley. Increased invasion has resulted in a significant increase in water utilisation and a related decrease in runoff from the catchment area (Gassner, 1999). Besides impacting on the hydrology, the widely observed increases in these alien species could be detrimental to the survival of indigenous vegetation which they have invaded.

There is thus a clear distinction between the wetland and terrestrial vegetation. The wetland zonation is due mainly to differing water regimes and varying nutrients distribution. The terrestrial zonation, on a larger scale, can be attributed to varying soil types and levels of disturbance.

### **3.4 CONCLUSION**

Soil as well as vegetation types are constantly changing over time in response to environmental factors such as climate. Thus soil and vegetation types can be good indicators of environmental perturbation. The effectiveness of plant cover in erosion control cannot be underestimated and the supply of sediments to a vlei will depend on the catchment vegetation type. Soil type as already discussed above also affects the supply of sediments to vlei environments. Therefore, a change in vegetation cover on the southern Cape Peninsula resulting from changing environmental conditions (natural or human induced) would affect the supply of sediments to its coastal and vlei environments alike.

The study area, like the rest of the Southern Cape region, has experienced dramatic changes in climate in the past. These changes have influenced its contemporary vegetation type and climatic regime. The past 1.5 million years, during which fynbos species proliferated, have been characterised by fluctuating climates (Cowling *et al.*, 1995). Fluctuating climates, causing changes in vegetation cover in the study area may have affected the supply of varying size sediments and organic matter into surrounding vleis. A detailed study on the composition and characteristics of sediments from these vleis may yield clues to past climates as well as changing depositional environments.

To retrieve this vital information, a well thought methodology need to be applied both in the field and in the laboratory. Laboratory and statistical techniques need to be employed to test the usefulness of vlei sediments as a reliable indicator of environmental change and environmental reconstruction at Noordhoek valley. The following chapter is dedicated to the methodology used in acquiring the primary and secondary data used in this research.

University of Cape Town

---

## CHAPTER 4

### METHODOLOGY AND LABORATORY TECHNIQUES

---

#### 4.1 INTRODUCTION

In this chapter a number of techniques used in the field and the laboratory for processing the sediments and a number of inferential statistical methods are introduced. Where need arises, a rationale for the use of a specific approach, method or technique is provided alongside the method or technique in question.

In the first section of this chapter, the strategies used in identifying suitable sites in terms of the primary aim of the research (see section 1.6) are discussed, followed by the actual fieldwork, the laboratory analysis, and the inferential statistical methods.

As already mentioned, the selection of the study sites was guided by the main aims and objective of the research. In order to achieve the aims and objectives of the research, a carefully thought out decision on possible study sites was imperative. The southern Cape Peninsula region is ideally suited to provide sites of relatively low human disturbance that can readily be compared with highly disturbed systems elsewhere and was thus chosen for this study. The primary aim of this research is to assess the extent of human impact on the Noordhoek valley and to a large extent reconstruct its environmental history. This is to be done by establishing a comparative analysis of the characteristics and composition of sediments in the three wetland systems and the land use and land cover changes, particularly in the Noordhoek basin.

Gauging the impact of manipulative human activities, such as agriculture or housing development on wetlands requires having a notion of the unmanipulated condition as a reference point (Latimer *et al.*, 2002). This was the rationale for choosing the Groot Rondevlei wetland in the Cape of Good Hope Nature Reserve as a "control" which, according to documentary and eyewitness (park

officers) accounts, is the most pristine area when compared to the Noordhoek wetlands. An understanding of the reference condition requires knowledge of natural factors influencing erosion and sedimentation processes. A reference location or system is often chosen to make comparisons against a given site or system in order to assess the effects of the stressors. To be useful, Latimer *et al.* (2002) noted that a reference location should share as many common characteristics as possible with the investigated site, while remaining free from the stressors being resolved. In this research, the Groot Rondevlei site met these requirements. In general, the study focuses on the natural physical factors (conditions and processes) that drive the coastal wetland sedimentation of the Noordhoek systems. Thus, the Noordhoek coastal wetlands system that developed under conditions of large-lake hydrology and disturbances imposed at a hierarchy of spatial and temporal scales is considered as a geomorphic archive for environmental change in the Cape Peninsula region.

Having decided upon the study locality and the study sites, field surveys were conducted in order to identify the precise logging and sampling locations on the site. This was done on a more subjective basis- where coring was expected to yield a long and a representative core.

## **4.2 IDENTIFYING STUDY LOCALITIES**

Ideally, the availability of high quality primary historical data should guide palaeosedimentological site selection. Spatially precise documentary information is most necessary when changes in the ecology of lakes with small catchments are considered. In the absence of such historical and detailed documentary information for the site, alternative decisions were made with regard to selecting the suitable study sites.

An initial field investigation of the region was aimed at choosing the study site(s). Two major wetlands (Groot Rondevlei and Skilpadvlei) located within the Cape of Good Hope Nature Reserve were initially visited. Skilpadvlei or Groot Rondevlei was intended to serve as a control that would reveal the "natural" changes e.g.

climate, sea-level changes of the recent geological past. After some initial laboratory analysis and map work, the idea of including Skilpadvlei as a control was discarded as had been used for dumping, in favour of Groot Rondevlei located about 13 km southwest of Noordhoek basin (Figure 1.2). Thereafter, the "best" or the "most representative" depositional sequence at each of the study sites where coring was planned and then conducted were identified and selected. A degree of subjectivity influenced the selection of possible coring sites: the middle of the wetlands with relatively limited surface water was a preferred locality. Lowe and Walker (1984) proposed that coring in the middle of lake basins was likely to provide the longest and least disturbed environmental change record.

### **4.3 CORING TECHNIQUES**

Detailed coring and field logging (Miall, 1977; Lindholm, 1987; Graham, 1988, Baxter, 1997) was then undertaken on the Lake Michelle site and the Wildevoelvlei.

The vibra corer designed by Lanesky *et al.* (1979) is a refined vibracoring tool that can be used both on land and in water. The Lanesky *et al.* (1979) design is superior to previous systems, which used mechanical vibrators or air driven compressors and must have presented difficulty in transporting. Being able to produce a continuous, high frequency vibration (+/- 12 000 vibrations per minute), waves from the core tubes fluidise and reduce the resistance presented by compacted sediments through the process of liquefaction thereby letting the sampling tubes penetrate to a greater depth with minimal disturbance (Baxter, 1997). Initially designed for beach and offshore deposit environments, the equipment has been modified for use in fluvial and deltaic environments (Smith 1984; 1987 summarized in Baxter, 1997), and in an assortment of depositional environments at the Verlorenvlei including fluvial, lacustrine, deltaic, estuarine and marine environment with a wide range of sediment characteristics (Baxter, 1997).

The UCT vibracorer (Appendix A) constitutes a hybrid system that was developed from the original Lanesky *et al.* (1979) design, modified by Baxter in 1997 for sampling efficiency and core recovery over a wide range of saturated unconsolidated sediments. This instrument was used for coring in this research. First used at the Verlorenvlei, Baxter (1997) noted that this adapted technique had the capability to penetrate considerable depths and is advantageous in that the extraction of sediments deep down is done with minimal disturbance. This means maintaining stratigraphic consistency in the sediments.

As seen from the schematic blueprint (Appendix A), the vibracorer is made up of a number of individual components that combine together to facilitate the coring process. These are described below as summarized in Baxter, (1997). The vibrator, also referred to as the poker vibrator, is made up of a flexible transmission shaft housed in a high tensile spring-steel liner and coated with a weathering and abrasion rubber compound. A rotating, precision balanced pendulum supported by a tempered rolling race is attached to the working end of the transmission shaft and also the vibrator head while getting the equipment ready for coring.

A clamping device is used to align and clamp the vibrator head perpendicular to the 6.5cm wide aluminium cores. This is required in order to transmit the high frequency vibrations from the vibrator head to the core tube. Once ready the portable generator is switched on to provide the vibrator with the necessary vibrations that help sink the core down through the substrate. As the coring tube reaches a certain depth in the substrate, it becomes necessary to turn off the generator, loosen the clamps bolts, and move the vibrator head to a new point higher up the core tube until the tube reaches the "desired" depth.

When the coring tube reaches maximum depth, the core needs to be retrieved from the sediment. This necessitates the use of a mechanical leverage device like a sturdy tripod. A manually operated trailer winch is attached to one of the tripod's leg. The winch is fed with a cable from the rotating pulley located at the

apex of the tripod and also attached to support the emerging core. Before turning the winch clockwise the tripod legs are all welded closed with large inflexible plastic dustbin lids and old tyres in some cases to avoid the sinking of the tripod into the surface. The cores are retrieved from beneath the surface by turning the winch clockwise with minimal force and are immediately laid horizontally with the distal end closed to minimize the loss of sediments. These cores are cut into shorter lengths in order for them to fit into the car with each sequence labelled at both ends.

This same procedure was applied for the two corings made on the Noordhoek basin. Brett Smith who had earlier worked in the region provided the core for Groot Rondevlei. The cores were photographed while in the field as well as the process of coring.

Upon collection, cores were immediately transported to the University of Cape Town where they were handled and stored according to standard procedures described by Gardiner and Dackombe (1983) in order to avoid contamination.

#### **4.3.1 Elevations (average mean heights above sea level)**

It was considered necessary to measure the heights above mean sea level at each of the sites. Above mean sea level (amsl) refers to the elevation of the vlei surface relative to the average sea level. By determining the relative position of each site to present mean sea level, an idea of how much sea levels have changed during the period of investigation can be established.

Benchmarks on the M4 around the Noordhoek valley were used as reference points for this exercise. Each of the benchmarks used had its relative height above sea level marked on a tag attached to it. With the aid of Total Station, the elevation above mean sea level at each coring site is determined. This is subtracted from the elevation amsl of the reference points and the difference between was the relative elevation of each vlei site to mean sea level.

## **4.4 LABORATORY ANALYSIS OF SEDIMENTS**

The cores were split open at the University of Cape Town's Environmental Science sedimentological laboratory with an electric handsaw. This procedure is simple and requires the core to be horizontally laid on the core sample tube holder before the sawing proceeds. Cores were evenly split into two halves and were made ready for further analysis. Only one half of the core was used for the routine analysis and the other half stored for future reference and the retrieval of a dateable sample. Cores were visually inspected for bedding, based on Munsell colour, lithology, texture and sedimentary structures in order to assess coring disturbance and sedimentary characteristics. Sub-samples for microscopic, mineralogical and geochemical analysis were taken every 10cm or following major sedimentary changes for a high-resolution analysis.

The purpose of doing this routine analysis was to be able to understand the natural trends in the changing depositional environments and the subsequent changes brought about by human activities in the form of pollution. All the sub-samples from the cores underwent the same preparation and analytical procedure. This routine analytical procedure was conducted in two phases, physical (morphometric) and chemical analysis. Details of these procedures can be found in Tucker (1988), Carver (1971) and Friedman *et al.* (1978).

### **4.4.1 Physical analysis**

In an effort to reconstruct past environments, physical sedimentary attributes such as particle size analysis and particle composition are essential. Changes in grain sizes and sand composition are expected to reflect changing depositional environments within the cores and hence assist in environmental reconstruction. However, as noted by Holmes (1994), such data should not be used too simplistically to infer modes of transport, instead they should be interpreted within the context of the geomorphic setting of each site.

Particle size analysis is one of the most important techniques in describing the physical attributes of the sediment. It is useful in that it helps identify the

processes of transportation and deposition of sediments both in the past and at present. Its importance when studying contemporary processes and palaeo-environments cannot be underestimated (Briggs, 1977). Distribution of particle size in a sediment sample according to Leeder (1982) is a function of the parent material from which the sediments are derived, transportation mode and the processes to which the sediments have been subjected since deposition (diagenesis). With finer sediments, measurement of particle size becomes more difficult especially with sediments that contain an abundance of silt or clay.

Particle size determination was done using the settling column in the Geological Sciences department, University of Cape Town. The procedure used was based on methods described in detail by Akroyd (1957), and Flemming and Thum (1978) and summarised in Appendix B.

#### **4.4.2 Mineralogy**

The mineral composition of the grains was determined with the help of an optical magnification microscope. A mineral such as quartz that makes up much of sandstone was easily identified in the sediments under the microscope.

#### **4.4.3 Munsell Notation**

Using a Munsell chart, each of the samples was assigned a colour code based on the dominant colour of the sediments. The Munsell colour chart provides a colour notation for hue (colours from R-red, and YR-browns and oranges through to Y-yellow), value (lightness and darkness of colour), and chroma (strength of the colour) as well as giving a colour description for each of the sediment samples (Munsell Colour, 1975).

#### **4.4.4 Dating**

Radiometric dating techniques have been widely used in geomorphological and sedimentological studies to assign ages to Quaternary sedimentary deposits. Lowe and Walker (1997) give a summary review of the application of radiometric dating techniques in earth science research. There are a number of radiometric

dating methods that have been developed (Lowe and Walker, 1997), but in this research, only the radiocarbon dating technique was utilized because of limited funds.

The principles underlying  $^{14}\text{C}$  dating have been dealt with in the literature (Lowe and Walker, 1997) and need not be repeated here. In summary, any substance that adsorbed carbon dioxide during genesis can be radiocarbon dated. In this research sediment from Lake Michelle and the Wildevoevlvlei cores, rich in organic sediment, was sub-sampled for the purpose of dating. Radiocarbon dating was undertaken by the Council for Scientific and Industrial Research (CSIR), Pretoria and the dates were given in years before present (BP), that is 1950. These dates were reported in conventional radiocarbon years, that is, using a half-life of 5568 years for  $^{14}\text{C}$ , with ages corrected for variations in isotope fractionation (Holmes, 1998). Calibration of ages for the southern hemisphere using the Pretoria programme, attempts to establish a best estimate of past atmospheric  $^{14}\text{C}$  levels (Talma and Vogel, cited in Holmes 1998).

## **4.5 CHEMICAL ANALYSIS**

### **4.5.1 pH**

By definition pH is the negative logarithm to base 10 of the  $\text{H}^+$  ion activity. The pH values may serve as indicators of diagenetic processes (post depositional processes), which may have resulted in leaching of chemicals from sedimentary units. A pH reading is important in that the soil acidity has important ramifications for rehabilitation, transport of pollutants within soils and the agricultural potential of land. It is therefore seen as a major variable controlling ion exchange, dissolution/ precipitation and reduction/oxidation reactions. pH readings can be done both in KCl and in water. In this research, the KCl readings were favoured because the results varied less between successive samples and were more consistent throughout the process. Using KCl solution in pH analysis is preferred because it has been established that readings in KCl are less influenced by changes in biological and meteorological conditions than water solutions (Peech,

1967 cited in Dewey 1998). The method and procedure utilized to determine pH, as described by McLean (1973) is outlined in Appendix C.

#### **4.5.2 Conductivity**

A conductivity test is important in a sediment sample in that it determines the presence of ionisable salt. Soil conductivity is closely correlated with many soil characteristics including water content, soil texture, soil organic matter, cation exchange capacity (CEC), and salinity. Conductivity tests can help estimate the total quantity of dissolved inorganic salt in the samples. The method used in determining conductivity in sediment samples is outlined in Appendix C.

#### **4.5.3 Total organic fraction**

The total organic fraction in the sediment samples was measured using the ignition weight loss method as used by the Soil and Plant Analysis Council (1974) and summarized by Holmes (1998). The presence of organic matter in a sediment sample indicates a reducing type environment which favours the preservation of organic material. The method used in determining the percentage organic content in sediments samples in this research is outlined in detail in Appendix C.

### **4.6 GEOCHEMICAL ANALYSIS**

Bulk sediments were analysed for trace and major element concentration in the Department of Geological Sciences, University of Cape Town. The analysis was performed using a Perkin Elmer/Sciex Elan 600 Inductively Coupled Plasma Spectrometer (ICP - MS). Approximately 0.5 g of each sample was digested by a standard multi stage acid digestion procedure using ultra-clean concentrated HF Teflon beakers into a 10ml HNO<sub>3</sub> and 5 ml HClO<sub>4</sub> solution. The tightly closed beakers were placed into the holes of the cleaned aluminium trays on the hotplates and were allowed to digest for 48 hours at a temperature of 50 - 60°C. The lids were then removed and the samples were allowed to evaporate to complete dryness. Once the samples dried out, 2ml of concentrated 2-bottled HNO<sub>3</sub> was added to each sample and the closed beakers were left on the hot

plate to dissolve completely. The samples were diluted 5000 times for ICP - MS analysis. They were then analyzed using a Perkin Elmer/Sciex Elan 600 ICP - MS instrument.

As noted in Chapter 1, wetlands have attracted industrial and urban development in all areas around the globe. Over the years, these developments have left their marks in the form of heavy metal inputs into the surrounding vleis, which if dated, may allow a historical reconstruction of the rate and the compositional change in their deposition. Sediment cores from two wetlands in the Noordhoek basin have been analysed for heavy metal inputs to be compared with undisturbed vlei sediments of the Groot Rondevlei, which has been less prone to human activities.

Heavy metals concentrations in sediments from these cores were obtained in the context of historical land use and environmental change. Land use is thought to have a strong impact on the spatial, temporal distribution and abundance of the selected elements. Elements such as copper (Cu), chromium (Cr) lead (Pb), zinc (Zn), iron (Fe), manganese (Mn) and cadmium (Cd) were examined.

The geochemical laboratory in the Geological Sciences department, University of Cape Town, conducted the analyses for trace element concentration for all the cores. Results are presented in parts per million (ppm). It is worth mentioning here that only a few of the elements analysed for in this laboratory have been chosen for further and detailed analysis. Elements chosen for analysis are those most often mentioned in geochemical texts and papers as being the major pollutant elements whose concentration is mainly influenced by anthropogenic activities. These elements include Fe, Mn, Cr, Cu, Zn, Pb, Cd.

Because these elements came from different sites with varying sediments characteristic, variation in metal concentrations between the sites was expected. In a natural environment, variations in sediment characteristics influence metal

concentration. Normalization of all the geochemical data was therefore applied to discern trends in the data for easy interpretation (section 4.8.2).

## **4.7 SPATIAL LAND USE AND LAND COVER CHANGE**

This research addresses spatial land use and land cover changes over a time period of 56 years from 1944 - 2000. The natural landscape (fynbos vegetation) has been impacted by the conversion of the area into primarily built-up and agricultural areas and to a lesser extent, the spread of alien vegetation into former indigenous landscape. The modification of the coastline has also impacted on the natural landscape.

Mapping land use and land cover changes from 1944 to 2000 on the Noordhoek basin with the aim of assessing the trends in the various categories of land cover is imperative. Changes in land use and cover can be detected by visually and statistically comparing the spatial extent of the various land uses over time.

### **4.7.1 Data Acquisition**

Selection of imagery acquisition dates for land use and land cover changes for the study area was based on the availability of the aerial photography. Aerial photographs for the years 1944, 1958, 1989, 1996 and 2000 were obtained from the Directorate of Maps and Survey Mowbray Cape Town and varied in both their scales and the seasons during which they were shot (Table 4.1). Changes in seasons from winter, spring to summer are dealt with during the discussion of the results but the issue of varying scale is addressed with below.

### **4.7.2 Image processing**

The aerial photos were analysed in the department of Environmental and Geographical Science, University of Cape Town. The initial processing was carried out using a stereoscope (Shokkisha MS-27) and magnification. A piece of transparent paper was placed on each of the photographs and the various land uses vegetation (mostly alien), vegetation (mostly fynbos), beach and sand

dunes, built-up (urban), waterbodies (wetlands) and agriculture carefully drawn out. These traced maps were scanned/ digitized and later exported onto a PC with ArcView GIS software capabilities where further analysis was to be done.

Table 4.1 Aerial photographs for Noordhoek basin 1944-2000

| Years /Job No. | Imagery season     | Resolution |
|----------------|--------------------|------------|
| 1944 /203      | N/A                | 1: 8400    |
| 1958 /335      | N/A                | 1: 36000   |
| 1989 / 929     | Spring (September) | 1: 15000   |
| 1996 / 994     | Winter (May)       | 1: 20000   |
| 2000 /1033     | Summer (November)  | 1: 50000   |

Given that the aerial photos used were all in different scales (Table 4.1) and so too were the digitized maps, the need arose for a base map to be used as a reference to correct for the distortions. This was imperative to allow for visual and statistical comparison between the various land uses over the years. Major roads on the base map were used as reference points to which each of the five digitized maps was aligned. This automatically georeferenced the maps and each land use type for each year was drawn separately and joined to make a composite map for the year.

As already mentioned, an additional data layer with vector data (Shapefiles) showing major roads was incorporated into the ArcView GIS Project. This additional layer was added on the land categories layer in ArcView to produce the final hardcopies of the land uses and land cover changes maps for the Noordhoek basin for the years 1944, 1958, 1989, 1996 and 2000.

### 4.7.3 Analysis

Total area occupied by each land use for a particular year was calculated using the ArcView software and was later exported to Excel. Quantitative analysis of the areal extent of each of the land use categories was done using Excel. Graphs

of the total areal coverage for each land use presented in Figures 5.20a-e and 5.21a-e for visual and basic interpretation were produced using statistical.

## **4.8 STATISTICAL TECHNIQUES**

The computer package STATISTICA for Windows was used for the calculation of descriptive statistics reported in the research. Descriptive data analyses (mean, median, and standard deviation) were carried out using Excel. The Principal component analysis was used to compare the systems with one another in order to understand the underlying processes responsible for their structures and compositions (Hewiston, *pers.com*).

### **4.8.1 Principal component analysis**

Principal component analysis, a multivariate technique for examining relationships between several quantitative variables (Hewiston, *pers.com*) was used for summarizing the raw data and for detecting linear relationships between variables. Spearman's rank correlations were calculated for the geochemical data to determine relationships among different metals (Hewiston, *pers.com*). These relationships were explored to shed light on how individual elements were transported and deposited in the wetlands. Fe–Mn compounds (oxides, hydroxides, carbonates, sulphides) and, to a lesser extent organic matter, have the ability to scavenge trace elements from solutions. Therefore, any correlations between these metal oxides (Fe and Mn) and individual metals may highlight their role as enrichment agents for the elements involved.

Elemental concentration in most deposits often show typically high values in the superficial layers, and also in the middle of the core and sometimes at the bottom core, for example, Lake Michelle core (see Chapter 5). Interpretation of changes in concentration of such cores is often constrained by the background noise posed by changes in the properties of the matrix (silt and clay content and textural variability). This noise must be eliminated in order to effectively quantify and differentiate natural and anthropogenic processes influencing element concentration and distribution. To eliminate this noise from the data, the entire

data set for each of the core must be normalized against the potential source of noise.

#### **4.8.2 Normalisation of geochemical data**

Variations in heavy metal concentrations observed within and between the three cores (see Appendix E, G and I), required for the data to be normalised. The abundance and distribution of trace elements in natural wetlands and estuaries is to a large extent determined by grain size and organic carbon content. Silts and clays, because they are finer, tend to adsorb more metals than sand size sediments as these fine sediments have large surface areas for adsorption (Loring *et al.*, 1991). Therefore, grain size and organic fractions known to influential in natural variations in metal concentrations must be corrected in order to understand the degree of pollution and contamination at a particular site. To correct for the natural variability, Liaghati *et al.* (2004) proposed that the geochemical data be normalized. The geochemical data for each sample was normalised against the total weight percent fine ( $<63 \mu\text{m}$ ) present in the sample.

#### **4.9 CONCLUSION**

This chapter has described the various techniques use in acquiring the primary and secondary data sets used in this research. In the following chapter, the results obtained from using these analytical methods are presented.

## CHAPTER 5

### SEDIMENTOLOGY, GEOCHEMISTRY AND SPATIAL LAND USE CHANGE IN THE NOORDHOEK VALLEY

#### 5.1 INTRODUCTION

In the previous chapter (Chapter 4), a detailed analysis of the methodology used in processing the three cores from the Noordhoek valley and Groot Rondevlei was presented. All the cores obtained were processed using a standard range of laboratory techniques (see Chapter 4) for sedimentological attributes (grain size, sand composition, organic matter, pH and conductivity) and for trace element analysis. The results from each of the vleis are presented and described in this chapter and the implications are discussed in Chapter 6.

#### 5.2 SEDIMENTOLOGICAL AND GEOCHEMICAL EVIDENCE

##### 5.2.1 Lake Michelle Core (LM-Core)

The core from Lake Michelle (hereafter abbreviated to LM) had an uncompressed length of 5.42m in the field and after compression it measured just 4.2m, meaning that compression of sediments was approximately 25%. Eight distinct units, varying in composition, texture and length (Table 5.1 & Figure 5.1) were identified and 44 subsamples were taken from this core (Appendix D). The 44 subsamples were grouped into eight distinct units, based on similarity in grain size and composition.

Table 5.1 Lake Michelle: General description of the stratigraphic units

| Units | Depth interval (cm) | Texture        | General description and Munsell Notations                               |
|-------|---------------------|----------------|---|
| 1     | 0-5                 | n.d            | Very dark grey (5YR 3/1) layer rich in plant roots                      |
| 2     | 5-15                | Sandy mud      | Very dark grey (5YR 3/1) organic layer                                  |
| 3     | 15-55               | Slightly muddy | Dark reddish grey (5YR 4/2) sandy Unit                                  |
| 4     | 55-100              | Sandy          | Brown (10YR 4/3) to light grey (5 YR 7/1) sandy Unit                    |
| 5     | 100-345             | Slightly muddy | Grey (5YR 6/1) to pinkish grey (7.5 YR 7/2) with marine shells          |
| 6     | 345-355             | Sandy mud      | Dark grey (5YR 4/1) compact unit, rich in charcoal deposit              |
| 7     | 355-405             | Muddy sand     | Very dark grey (5YR 4/1), to black (5 YR 2.5/1) compacted with charcoal |
| 8     | 405-420             | Sandy mud      | Dark grey (5YR 4/1) sandy Unit rich in marine shells                    |

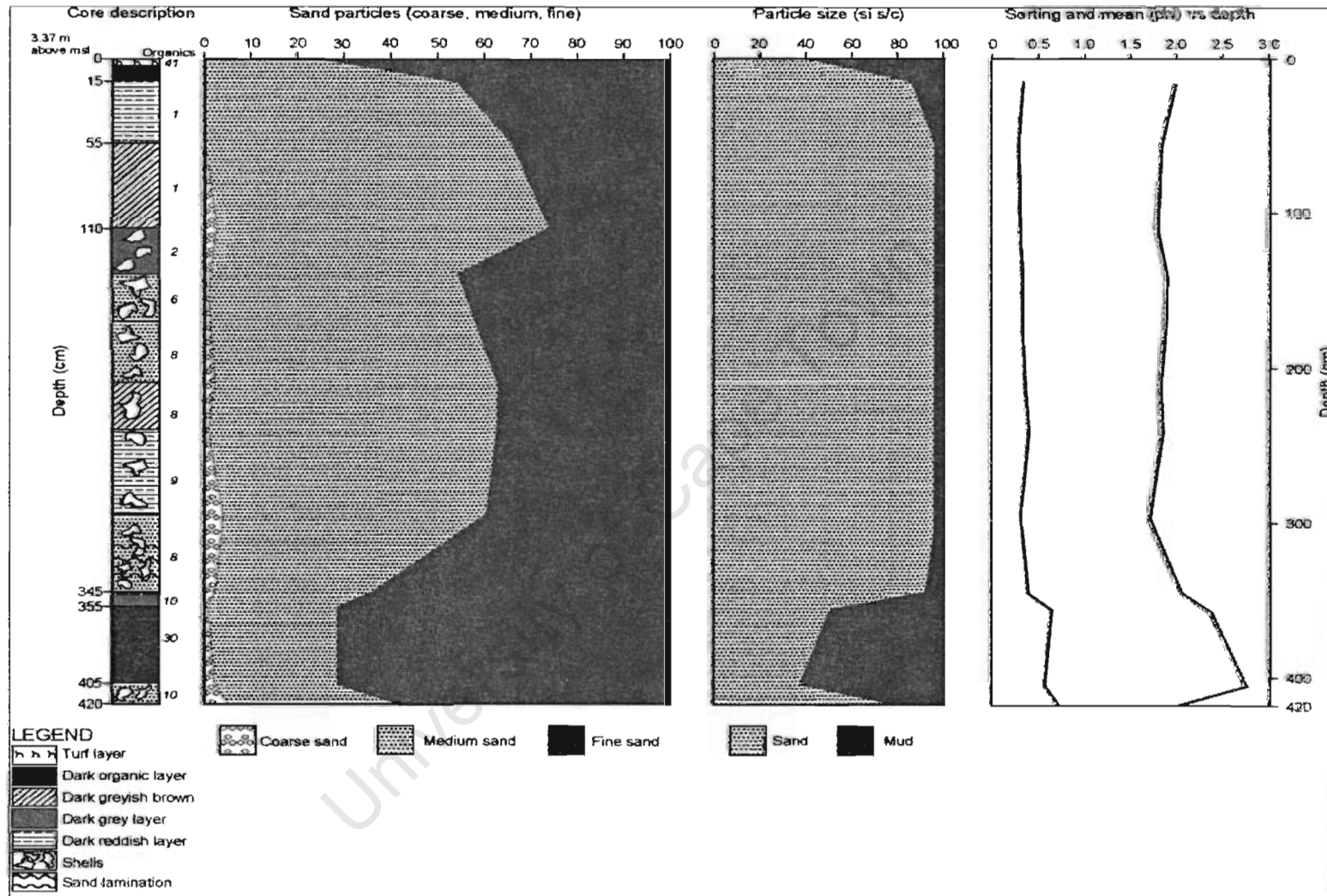

Figure 5.1 LM-Core log and textural analysis

### 5.2.1.1 Particle size analysis

Texturally, sediments in the LM-Core show a relatively high degree of heterogeneity. They range from sandy mud (mS), muddy sand (sM), slightly muddy sand ((m) S) to sand (S), (Table 5.2). The basal Unit 8 differs in composition and texture from the overlying Unit 7, which itself also differs from the overlying Unit 6. Unit 6 is also different from Unit 5 in texture and composition. Units 4 to 2 are also different in composition and texture from the underlying Unit 5. Unit 1 was not analysed for particle size, because it was so organic that the percentage sand retrieved from it was too low to be used in any further analysis. The variation in the proportion of silt and clay across the core facilitates grouping into four sections; the basal Unit 8 with approximately 21% silt, Units 7 and 6 with approximately 50% silt and clay, Units 5 to 3 with the lowest proportion, namely 3% silt and clay and Unit 2 with approximately 13% silt and clay. The Wentworth Grade of the sand ranges from fine to medium sand, showing sand to be coarsening upcore with two distinct “phases” (Tables 5.3 and 5.4), which will be discussed further in the next chapter.

Graphical values show that, upcore, the sand fraction ranges from moderately well sorted (Units 8 to 6), very well sorted to well-sorted (Unit 5 to 2), as shown in Table 5.4. Skewness values are nearly uniform from bottom to top (near symmetrical) with the exception of Units 6 and 2, which are classified as fine, skewed.

Bivariate scattergrams of sand-sized particle statistics such as mean sand size, sorting and skewness were shown by Griffiths (1967) to be hydraulically controlled and were used to characterise depositional environments. Friedman (1961) used scattergrams of skewness and sorting to discriminate between river, beach and dune sand. Briggs (1977) recommended the use of bivariate scattergrams in palaeoenvironmental studies where the aim is to identify various depositional environments. Figure 5.2 presents scatterplots of mean sand size, sorting and skewness for the LM-Core. These scatterplots show the majority of the samples to be composed of sand grains that are well-sorted and symmetrically skewed.

Table 5.2 LM-Core: Textural analysis (values in percentage) (n.d=no determined)

| Units | Depths (cm) | Mean Mud % | Mean sand % | Sediment texture (Folk, 1954) | Sand component       |
|-------|-------------|------------|-------------|-------------------------------|----------------------|
| 1     | 5           | n.d        | n.d         | n.d                           | n.d                  |
| 2     | 15          | 13         | 87          | mS                            | Quartz (qtz)         |
| 3     | 55          | 4 ±1.1     | 96 ±1.2     | (m)S                          | Quartz (qtz)         |
| 4     | 100         | 2 ±1.1     | 98 ±1.3     | S                             | Quartz (qtz)         |
| 5     | 345         | 4 ±1.3     | 96 ±1.3     | (m) S                         | Shell & qtz (~5%)    |
| 6     | 355         | 48         | 52          | mS                            | Charcoal & qtz (~2%) |
| 7     | 405         | 57 ±14     | 43 ±14      | sM                            | Charcoal & qtz (~2%) |
| 8     | 420         | 21         | 79          | mS                            | Shell & qtz (~5%)    |

Table 5.3 LM-Core: Textural description of sand (after Wentworth, 1922)

| Units | Coarse (mean)% | Medium (mean)% | Fine% (mean) | V. Fine (mean)% | Mean (ϕ)   | Mean (ϕ)   | Sand grade |
|-------|----------------|----------------|--------------|-----------------|------------|------------|------------|
| 1     | n.d            | n.d            | n.d          | n.d             | n.d        | n.d        | n.d        |
| 2     | 0              | 54             | 43           | 3               | 1.98       | 1.98       | Medium     |
| 3     | 0              | 70 ± 1.8       | 29 ± 2.5     | 1 ± .81         | 1.85 ± .02 | 1.85 ± .01 | Medium     |
| 4     | 1 ± .5         | 66 ± 4.3       | 32 ± 4.1     | 1 ± .40         | 1.86 ± .03 | 1.86 ± .03 | Medium     |
| 5     | 1 ± .8         | 63 ± 8.9       | 35 ± 8.9     | 1 ± .52         | 1.88 ± .08 | 1.88 ± .08 | Medium     |
| 6     | 1              | 28             | 51           | 20              | 2.24       | 2.24       | Fine       |
| 7     | 2 ± .5         | 18 ± 4.9       | 50 ± 9       | 30 ± 13.5       | 2.6 ± .20  | 2.6 ± .23  | Fine       |
| 8     | 4              | 38             | 55           | 3               | 2.02       | 2.02       | Fine       |

Table 5.4 LM-Core: Graphical statistics of sand fraction (after Folk and Ward, 1953)

| Units | Sorting     | Description            | Skewness     | Description      |
|-------|-------------|------------------------|--------------|------------------|
| 1     | n.d         | n.d                    | n.d          | n.d              |
| 2     | 0.36        | Well sorted            | 0.12         | Fine skewed      |
| 3     | 0.31 ± .009 | Very well sorted       | -0.002 ± .01 | Near symmetrical |
| 4     | 0.31 ± .01  | Very well sorted       | -0.012 ± .01 | Near symmetrical |
| 5     | 0.33 ± .02  | Very well sorted       | -0.01 ± .02  | Near symmetrical |
| 6     | 0.68        | Moderately well sorted | 0.19         | Fine skewed      |
| 7     | 0.7 ± .07   | Moderately sorted      | -0.07 ± .09  | Near symmetrical |
| 8     | 0.55        | Moderately well sorted | -0.09        | Near symmetrical |

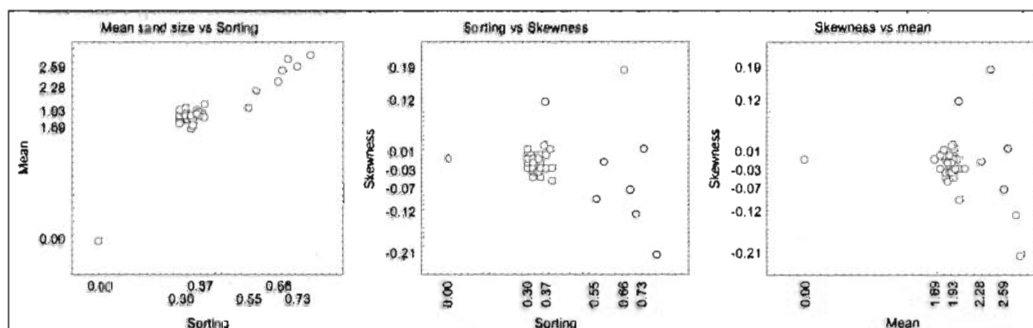

Figure 5.2 LM-Core: Scatterplots of mean sand size, sorting and skewness

## 5.2.1.2 Chemical analysis

### 5.2.1.2.1 pH

Sediment pH values (Table 5.5) range from a maximum of 8 (alkaline) in Unit 8 to a low of 4 (acidic) in Unit 6. Three distinct groups can be identified based on the pH of the sediments. The basal Unit 8 has a distinctively high pH value of 8 in the profile, meaning it is very alkaline compared to the overlying units; Units 7 and 6 form the second group with values ranging between 4 and 5 (very acidic) and Units 5, 4, 3, 2 and 1 form the third group with values ranging from 7 to 7.5 (high alkalinity). Upcore, pH values decrease with an increase in organic matter, attaining a minimum between 405 and 355cm, and from there increase up to a depth of 40cm matched by a decrease in organic matter. From 40cm to the surface, pH values tend toward neutral (7.0), accompanied by an increase in organic matter toward the surface (Figure 5.3). Organic matter content is expected to correlate with a decrease in pH values, that is to say, the higher the organic matter content, the higher the acidity. As expected, pH values showed an inverse relationship with organic matter in most of the core, although the surface fibrous layer anticipated to be the most acidic, tended to be close to neutral (pH =7). Generally, the sandy units were very alkaline (Table 5.5 and Figure 5.3).

### 5.2.1.2.2 Electrical conductivity (EC)

Sediments in this profile have very low values of electrical conductivity. Total salinity (Table 5.5) ranges between 2  $\mu\text{S}/\text{cm}$  (Unit 8) and 45  $\mu\text{S}/\text{cm}$  (Unit 1). From Unit 8, total salinity increases up the core to Unit 6 and then decreases to Unit 4. From Unit 3 it increases to the maximum in Unit 1. Generally, salinity increases up the core showing marked uniformity from the basal unit to approximately 50cm to the surface and above this depth, increases significantly to the surface (Figure 5.3). The elevated surface value may be attributed to the higher organic matter content. However, the extremely low values across the core are indication of the absence of ionisable salts in the sediments.

Table 5.5 LM-Core: pH and conductivity (EC)

| Units | Mean pH | Mean Conductivity (EC) | Mean %Organics |
|-------|---------|------------------------|----------------|
| 1     | 7       | 45                     | 41             |
| 2     | 7.5     | 11                     | 9              |
| 3     | 7.4     | 3                      | 1 ± .5         |
| 4     | 7 ± .06 | 3 ± .35                | 1 ± .41        |
| 5     | 7 ± 2.1 | 3 ± .43                | 7 ± 2.7        |
| 6     | 4       | 5                      | 11             |
| 7     | 5 ± 1.2 | 4 ± .9                 | 23 ± 13.8      |
| 8     | 8       | 2                      | 10             |

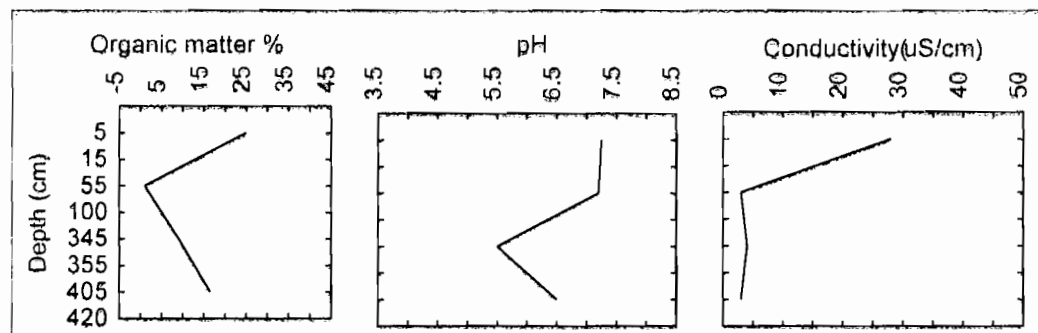

Figure 5.3 LM-Core: Organic, pH and conductivity vertical distribution

#### 5.2.1.2.3 Organic matter

Organic matter concentration in the LM-Core ranges between 1% and 41% (Table 5.15). Organic matter concentration increases from 10% in Unit 8 to 23% in Unit 7 and from there decreases to the lowest value of 1% in Unit 4. Organic percentage again increases from Unit 3 with just 1.4% in composition to 41% in the uppermost Unit 1. The decrease observed in Unit 4 corresponds with the presence of shell fragments which are absent from Units, 5 and 6. Figure 5.3 shows an initial increase in mean organic matter percentages from the basal unit to a depth of 405 cm and from there a decrease to less than 3% up the core and later again an increase from 35cm to the surface.

#### 5.2.1.2.4 Heavy metal distribution and concentration

Heavy metal concentrations and distribution in the sediments of the LM-Core are presented in Appendix E. LM-Core sediments show a marked variation in concentration between the various elements across the profile (Figure 5.4). Geochemically, this core has been subdivided into four distinct zones based on the variability of total element concentration (Figure 5.4 & Table 5.6). These subdivisions seem to reflect and complement the textural variability and divisions seen earlier. From the bottom of the core Zone 4, ranging from 420 to 385cm,

identified as a separate zone, is sandy and very low in total element concentration. On top of this sandy layer is Zone 3, only 40cm thick, which extends from 385 to 345cm, and is rich in silt and clay and also rich in heavy metal concentrations compared to the underlying Zone 4 and the overlying Zone 2 which extends from 345 to 15cm. The sand-dominated Zone 2 has the least concentration in terms of metals, as well as silt and clay content. Finally, the top Zone1, extending from 15cm up to the surface is rich in heavy metals and organic carbon and is characterised by a high silt and clay content.

Considering individual element concentration, Fe is the dominant element in the profile. However, it also shows a marked variation upcore, with a minimum concentration in the basal section of the core. Moving upcore, the concentration increases slightly between 385cm and 345cm as in total element concentration, and decreases between 345cm and 15cm. The top unit (15-0cm) shows a maximum concentration of iron in the profile. With the exception of Cr, that shows marked variability from bottom to the top of the core, all the other elements display a concentration pattern similar to that of Fe (Figure 5.5). This implies that concentration of these elements strongly correlates with silt and clay content. Sediment compositional change is consistent with changes observed in concentration change in the elements.

Correlation analysis was used to determine relationships among the different metals so as to help clarify the various paths by which individual metals are carried and deposited within the wetland and the processes involved. The potential of metal oxides such as iron oxyhydroxides and manganese oxides to act as scavengers for heavy metals, together with organic carbon, has been noted. A correlation matrix (Table 5.7) from a principal component analysis has been used to further evaluate potential relationships between trace element concentrations and silt and clay content (<63  $\mu\text{m}$ ) and organic carbon content. High correlations exist between Cu and Pb, and silt/clay content ( $r = 0.79, 0.75$  respectively). This suggests that these metals are significantly associated with the silt/clay-sized constituents of the sediments. No correlation was observed between the various elements and organic carbon. Interestingly, all these elements except Cr and Cd are negatively correlated with sand particle size in the profile. This probably indicates the inability of sand to adsorb and accumulate ions.

Strong correlations also exist between individual elements, including Mn and Fe ( $r=0.94$ ), Mn and Zn ( $r = 0.91$ ) and Mn and Pb ( $r = 0.72$ ), Fe and Mn ( $r = 0.94$ ), Fe and Cu ( $r = 0.51$ ), Fe and Zn ( $r = 0.98$ ) and Fe and Pb ( $r = 0.72$ ). The strong correlation exhibited by these compounds (Fe and Mn) in the sediments suggest that they are effective scavengers of other elements. Bodur and Ergin (1994) in Baptista *et al.* (2000) highlighted the ability of Fe–Mn compounds (oxides, hydroxides, carbonates, sulphides) to scavenge trace metals from solution, before or during diagenesis. They further suggested that there is a possibility that Fe- and Mn-oxyhydroxides and sulphides, together with organic matter, are involved in redox processes associated with the enrichment of a number of trace metals. However, organic matter, often considered as an element scavenger showed no, or only a weak association with trace elements in this core. These points will be picked up on in the next chapter.

In order to account for the effects of particle grain size on the vertical distribution of the elements and possible anomalies in concentrations, granulometric normalisation was conducted on the data set as described in section 4.6.2 in Chapter 4. For comparative purposes, significant differences can be seen between graphs derived from the raw data (Figure 5.5) and the normalised graphs (Figure 5.6). Generally speaking, concentrations increased upcore, peaking between 200cm and 100cm in both the raw and normalised graphs (Figures 5.5 and 5.6). Graphs of the raw data show differences in concentrations between the various elements in the top surface of the core. While Mn, Cu and Zn increases toward the surface, Cr, Fe, Cd and Pb decreases (Figure 5.5). After normalisation only Cu and Zn peaked toward the surface of the core while the other elements showed a reverse trend. Whether or not the trends in Figures 5.5 and 5.6 are indicative of natural or anthropogenic processes will be taken up in the next chapter.

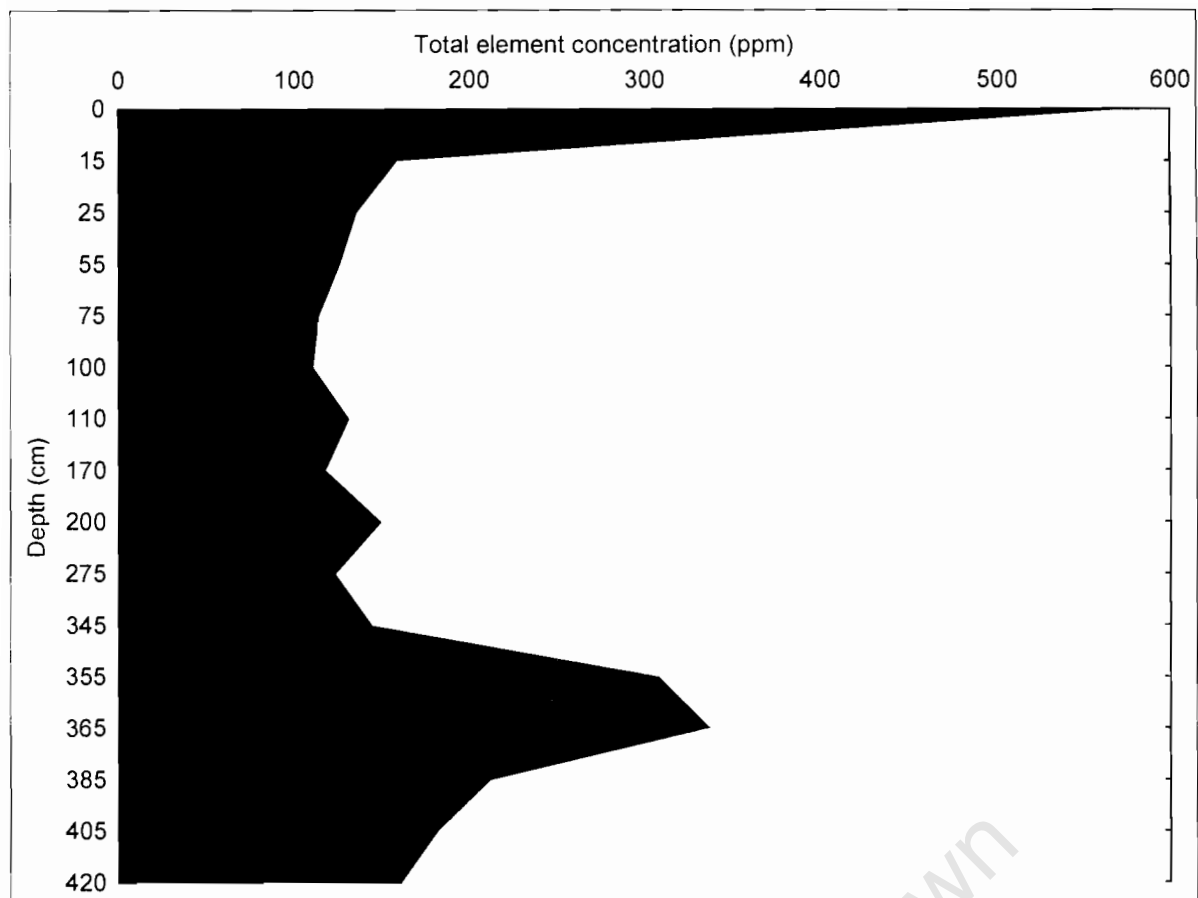

Figure 5.4 LM-Core: Trace elements concentration in parts per million

Table 5.6 LM-Core: Relative percentages of each element into the units

| Zones | Depth   | Cr   | Mn   | Fe    | Cu   | Zn   | Cd    | Pb   |
|-------|---------|------|------|-------|------|------|-------|------|
| 1     | 0-15    | 0.13 | 1.43 | 97.76 | 0.10 | 0.50 | 0.003 | 0.10 |
| 2     | 15-345  | 0.80 | 0.84 | 97.44 | 0.25 | 0.42 | 0.028 | 0.22 |
| 3     | 345-385 | 0.23 | 1.03 | 98.03 | 0.13 | 0.45 | 0.006 | 0.13 |
| 4     | 385-420 | 0.39 | 1.09 | 97.01 | 0.41 | 0.90 | 0.001 | 0.20 |

Table 5.7 LM-Core: Correlation between heavy elements, silt/clay and organics

|           | Cr    | Mn           | Fe           | Cu           | Zn           | Cd    | Pb           | Silt/clay    | Organics | Sand |
|-----------|-------|--------------|--------------|--------------|--------------|-------|--------------|--------------|----------|------|
| Cr        | 1.00  |              |              |              |              |       |              |              |          |      |
| Mn        | -0.21 | 1.00         |              |              |              |       |              |              |          |      |
| Fe        | -0.12 | <b>0.94</b>  | 1.00         |              |              |       |              |              |          |      |
| Cu        | 0.10  | 0.35         | <b>0.51</b>  | 1.00         |              |       |              |              |          |      |
| Zn        | -0.10 | <b>0.91</b>  | <b>0.98</b>  | <b>0.63</b>  | 1.00         |       |              |              |          |      |
| Cd        | 0.06  | 0.33         | 0.37         | 0.19         | 0.34         | 1.00  |              |              |          |      |
| Pb        | -0.05 | <b>0.72</b>  | <b>0.88</b>  | <b>0.72</b>  | <b>0.90</b>  | 0.27  | 1.00         |              |          |      |
| Silt/clay | 0.24  | 0.18         | 0.42         | <b>0.79</b>  | <b>0.51</b>  | 0.10  | <b>0.75</b>  | 1.00         |          |      |
| Organics  | -0.08 | <b>0.73</b>  | <b>0.66</b>  | 0.50         | <b>0.71</b>  | 0.06  | <b>0.64</b>  | 0.47         | 1.00     |      |
| Sand      | 0.04  | <b>-0.86</b> | <b>-0.89</b> | <b>-0.63</b> | <b>-0.92</b> | -0.26 | <b>-0.87</b> | <b>-0.60</b> | -0.36    | 1.00 |

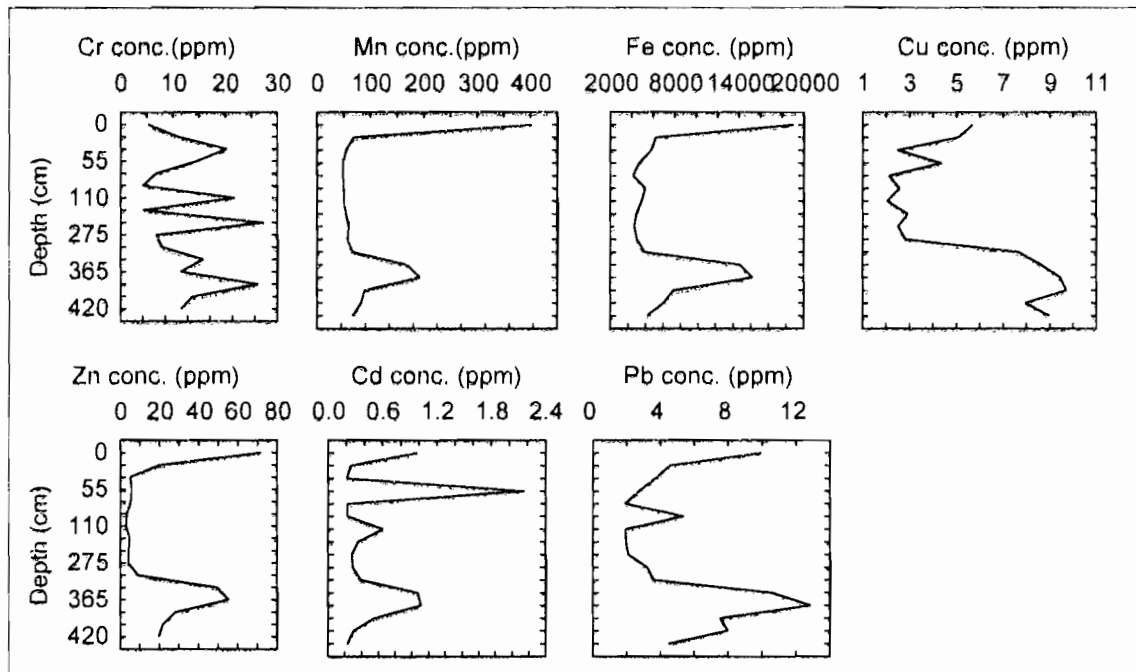

Figure 5.5 LM-Core: Graphs depicting distribution of metals

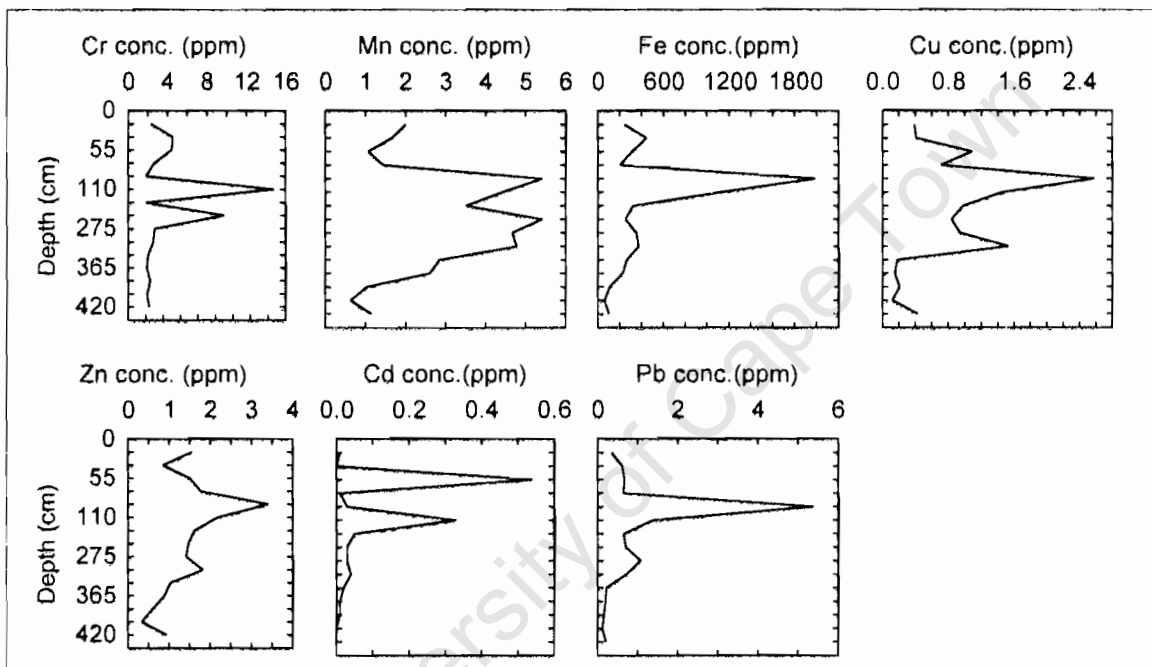

Figure 5.6 LM-Core: Normalised graphs depicting distribution of metals

### 5.2.2 Wildevoelveli Core (WV-Core)

An uncompressed core measuring 1.85 m was recovered from the upper reaches of the Wildevoelveli with the assistance of a vibracorer. After compaction, it measured 1.46m (Figure 5.7) indicating a 20% compaction of its sediments. Attempts to sample deeper than this proved futile. The total length of the core was subdivided

into six distinct units varying in composition, texture and thickness (Table 5.8). The six units in this core determined from the seventeen samples (Appendix F) were also made on the basis of appearance as in the LM-Core. This core appears to be somewhat homogeneous in colour, ranging from dark grey, reddish and pinkish grey to brownish grey (Table 5.8).

Table 5.8 Wildevoevlelei core: General description

| Units | Depth interval (cm) | Texture        | Description  |
|-------|---------------------|----------------|--|
| 1     | 0-8                 | n.d            | Dark grey sediments (humus) (5YR 4/1)  |
| 2     | 8-14                | Slightly muddy | Dark reddish grey sediments (5YR4/2)   |
| 3     | 14-20               | Sandy mud      | Dark greyish sediments (7.5YR 4/1)   |
| 4     | 21-85               | Slightly muddy | Dark reddish (5YR4/2), brown (7.5 YR 5/3) to pinkish grey sediments (7.5 YR 6/2) |
| 5     | 85-130              | Muddy sand     | Dark grey (7.5 YR 4/1) clayish sediments   |
| 6     | 130-146             | Muddy sand     | Grey (7.5 YR 6/1) to brownish (7.5YR 5/2) sediments                              |

### 5.2.2.1 Particle size analysis

Unit 1 of WV-Core was excluded from the particle size analysis for the same reason as Unit 1 was excluded from the LM-Core; the amount of sand retrieved after wet sieving was insufficient for any granulometric analysis. Texturally, there is little variability within the core. Sand dominates the entire core with the minor exception of Units 5 and 6. It is either muddy sand (mS), as in Units 3, 5 and 6, or slightly muddy sand ((m)S), as Unit 2 and 4 (Table 5.9). Quartz sand dominates in the basal section of the core between 146cm and 87cm. Between 87cm and 21cm, the sand-sized component changes from being quartzitic to sand characterised by the occurrence of sponge spicules made up of calcium carbonate. From this depth up to 14cm, quartz again becomes the dominant sand component (Table 5.9). Table 5.10 shows that the entire core is dominated by medium-sized sand.

Graphical values from this core show all samples to be of medium-sized sand, symmetrically skewed and moderately well-sorted, except for Unit 5, which is positively skewed (Table 5.11), although still dominated by medium-sized sand (Figure 5.8).

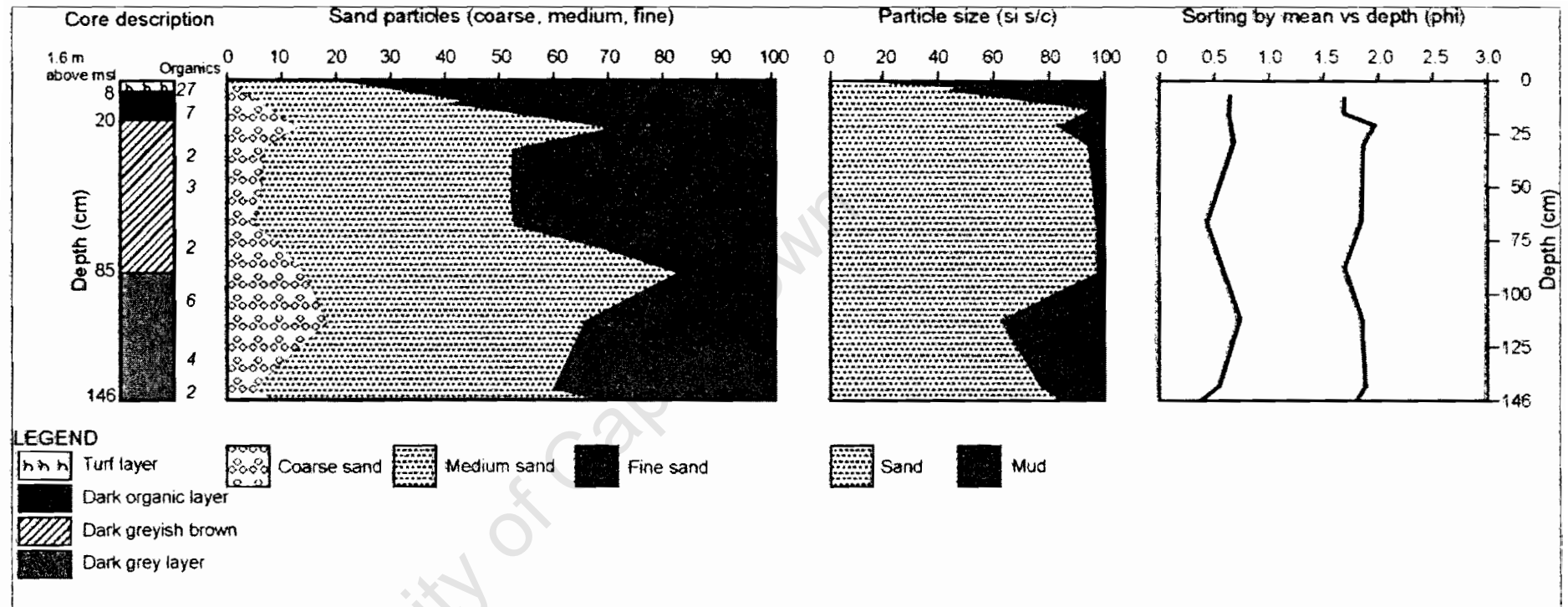

Figure 5.7 WV-Core log and textural analysis

Table 5.9 WV-Core; Textural analysis (values in percentages)

| Units | Depth (cm) | Mud %  | Sand % | Sediment texture (Folk, 1954) | Sand components     |
|-------|------------|--------|--------|-------------------------------|---------------------|
| 1     | 8          | n.d    | n.d    | n.d                           | n.d                 |
| 2     | 14         | 8      | 92     | (m)S                          | Quartz and rootlets |
| 3     | 20         | 18     | 82     | mS                            | Quartz (qtz)        |
| 4     | 85         | 5 ±2   | 95 ±2  | (m)S                          | S. Spicules & (qtz) |
| 5     | 130        | 34 ±10 | 66 ±10 | sM                            | Quartz and rootlets |
| 6     | 146        | 20     | 80     | mS                            | Quartz (qtz)        |

Table 5.10 WV-Core: Textural description of sand (after Wentworth, 1922)

| Units | Coarse % | Medium % | Fine %  | V. Fine % | Sand grade  |
|-------|----------|----------|---------|-----------|-------------|
| 1     | n.d      | n.d      | n.d     | n.d       | n.d         |
| 2     | 13       | 57       | 26      | 4         | Medium sand |
| 3     | 13       | 57       | 25      | 5         | Medium sand |
| 4     | 7 ± 3    | 53 ±6.8  | 35 ±5.6 | 5 ±2.6    | Medium sand |
| 5     | 11 ± 5.7 | 49 ±3.7  | 34 ±6   | 6 ±2.5    | Medium sand |
| 6     | 7        | 55       | 33      | 5         | Medium sand |

Table 5.11 WV-Core; Graphical statistics of sand grains (after Folk and Ward, 1953)

| Units | Mean (Ø) | Median (Ø) | Sorting (Ø) | Description            | Skewness   | Description      |
|-------|----------|------------|-------------|------------------------|------------|------------------|
| 1     | n.d      | n.d        | n.d         | n.d                    | n.d        | n.d              |
| 2     | 1.69     | 1.7        | 0.65        | Moderately well sorted | -0.02      | Near symmetrical |
| 3     | 1.69     | 1.71       | 0.65        | Moderately well sorted | -0.02      | Near symmetrical |
| 4     | 1.8 ±.1  | 1.8 ±.07   | 0.58 ±.08   | Moderately well sorted | -0.07 ±.14 | Near symmetrical |
| 5     | 1.8 ±.16 | 1.8 ±.12   | 0.77 ±.18   | Moderately sorted      | -0.16 ±.22 | Coarse skewed    |
| 6     | 1.8      | 1.81       | 0.53        | Moderately well sorted | -0.07      | Near symmetrical |

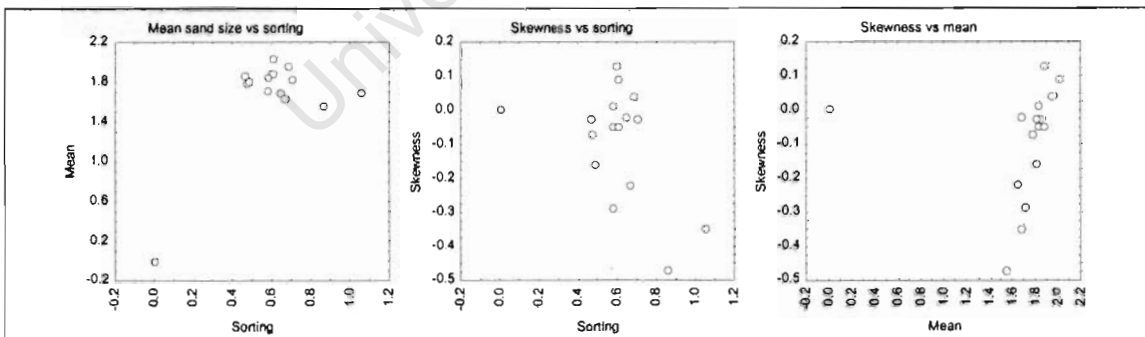

Figure 5.8 WV-Core: Scatterplots of mean size sand, sorting and skewness

## 5.2.2.2. Chemical analysis

### 5.2.2.2.1 pH

Characteristically, the Wildevoevlei sediments are strongly acidic, with values ranging from a minimum of 4.8 (in the slightly muddy Unit 4) to a high of 5.8 (in the

sandy Unit 6). As expected, the top organic unit, where the organic matter content was high, was also highly acidic (Table 5.12 and Figure 5.9).

### 5.2.2.2 Conductivity

Electrical conductivity (EC), a measure of the total dissolved solids, ranges from a minimum of 83  $\mu\text{S}/\text{cm}$  (basal Unit 6) to a maximum of 452  $\mu\text{S}/\text{cm}$  (Unit 4) (Table 5.12). Salinity is higher in the lower Unit 4 characterised by low percentage fines (mud, clay and silt) with organic matter and sand being the major components. Above Unit 4, salinity levels upcore are generally low and less variable in the profile (Figure 5.9). This trend is very different from those portrayed in the other two cores (LM-Core and GR-Core), a matter to be explored in the discussion (Chapter 6).

### 5.2.2.3 Organic matter

Organic matter content fluctuates upcore from the base of the core to the surface (Figure 5.9). Organic matter content increases upcore from 2% in the basal sandy unit to a maximum of 27% in the humifying top Unit 1 (Table 5.12). Decomposing plant remains common in swampy areas may explain the exceptionally high percentage of organic matter toward the surface.

Table 5.12 WV-Core: Organics, pH and conductivity (EC)

| Units | pH            | Conductivity (EC) | Organics %  |
|-------|---------------|-------------------|-------------|
| 1     | 4.90          | 128               | 27          |
| 2     | 5.25          | 119               | 7           |
| 3     | 5.75          | 119               | 8           |
| 4     | $4.8 \pm 1.7$ | $453 \pm 577$     | $2 \pm .96$ |
| 5     | 4.9           | 121               | $5 \pm 1.4$ |
| 6     | 5.8           | 83                | 2           |

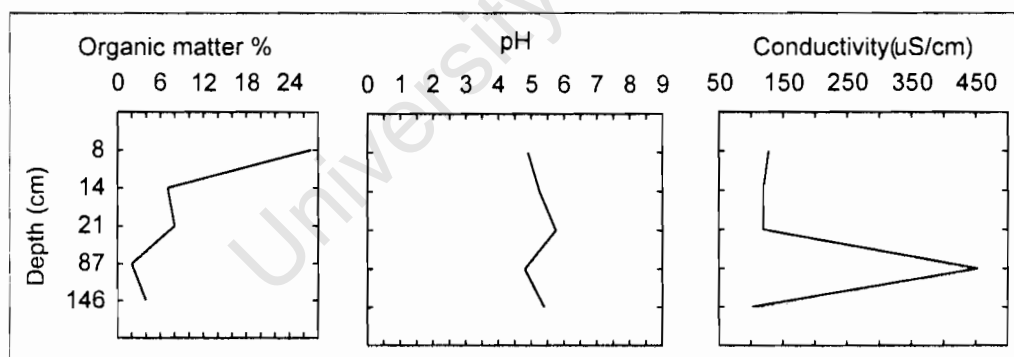

Figure 5.9 WV-Core: Organic, pH and conductivity vertical distribution

#### 5.2.2.2.4 Heavy metal distribution and concentration

Heavy metal concentrations and distribution in the sediments of the WV-Core are presented in Appendix G. As Figure 5.10 and Table 5.13 shows, in respect of the total concentration of Cr, Mn, Fe, Cd, Cu, Pb and Zn present, sediments from the WV-Core are vertically heterogeneous and can be subdivided into four distinct zones. Some of these divisions coincide with textural units discussed above. Basal sediments (146 - 65, Zone 4) consisting mainly of muddy sands are relatively rich in heavy metals. The lowest concentration of metals is seen in the middle section of the core and at depth 65-36cm (Zone 3). Between 36 - 8cm (Zone 2), the concentration of heavy metals increases significantly above that of all the sections of the core. The top 8cm (Zone 1), expected to be dominant in total metal concentration, has less than the underlying layer. This top section, rich in organic matter (27%) (Table 5.13) has low metal concentrations and the organic percentage seems to be negatively correlated to metal concentration. Increased metal concentrations in silty clay sections show a positive correlation between silty clay and heavy metals.

In Figure 5.11, results of individual metal concentrations at each depth are presented. Individually, Cr, Cu, Pb and Zn concentrations are much less varied from depth 146 to 110cm, then simultaneously increase between 110 - 87cm and decrease between 87 - 36cm. These elements attain maximum concentration at a depth of 36 - 14cm like all the other elements in the profile, except cadmium whose distribution upcore is out of phase with the rest of the elements. Mn is less invariable from the basal unit to 36cm, but has its maximum concentration between 36 - 14cm like the other elements. Prior to normalisation, Fe, Cu, Cd and Pb "peak" together in the upper core (Figure 5.11). After normalising the data for granulometric effects, only Cu and Zn peaked in the upper core and all the other elements except Cd, showed a reverse trend in the upper core (Figure 5.12).

Correlation between heavy element concentration and silt/clay content (<63  $\mu\text{m}$ ) shows Cr and Zn ( $r = 0.79, 0.69$ ) (Table 5.14) to be positively correlated, with none of the other elements showing any significant correlation with organic matter content. Textural variability upcore seems to have minimal influence on the distribution and concentration of trace elements as was the case in the LM-Core. Similar to the LM-Core sand negatively correlates with all the elements, although the

correlations are not significant, reinforcing the notion that sand cannot adsorb or accumulate minerals.

Strong correlations (Table 5.14) exist between Fe and Mn, both known to be effective scavengers of other elements, namely, Mn and Fe ( $r = 0.93$ ), Mn and Cu ( $r = 0.85$ ), Mn and Pb ( $r = 0.90$ ), Fe and Cu ( $r = 0.84$ ), Fe and Pb ( $r = 0.93$ ). Also, a strong correlation between Cu and Pb ( $r = 0.86$ ), Zn and Cr ( $r = 0.96$ ), Pb and Cr ( $r = 0.62$ ) and Pb and Zn ( $r = 0.77$ ) might suggest they are from the same source. Cd is the only element in the profile with no affiliation to the others.

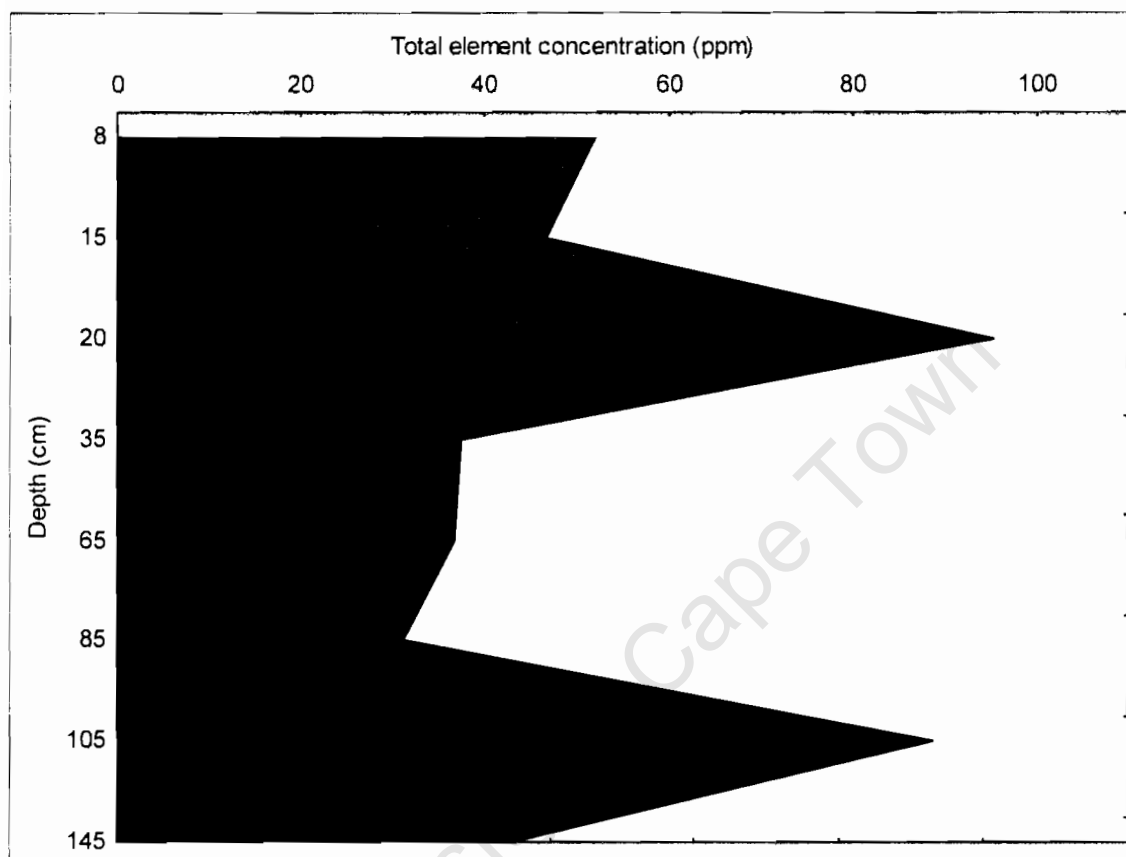

Figure 5.10 WV-Core: Trace elements concentration parts per million

Table 5.13 WV-Core: Zonal distribution of heavy metal

| Zones | Depth (cm) | Cr | Mn | Fe   | Cu | Zn | Cd   | Pb |
|-------|------------|----|----|------|----|----|------|----|
| 1     | 0-8        | 4  | 17 | 5272 | 3  | 13 | 0.06 | 9  |
| 2     | 8-36       | 13 | 43 | 9570 | 4  | 23 | 0.02 | 19 |
| 3     | 36-65      | 3  | 10 | 1304 | 1  | 9  | 0.06 | 3  |
| 4     | 65-146     | 29 | 14 | 5158 | 2  | 35 | 0.01 | 13 |

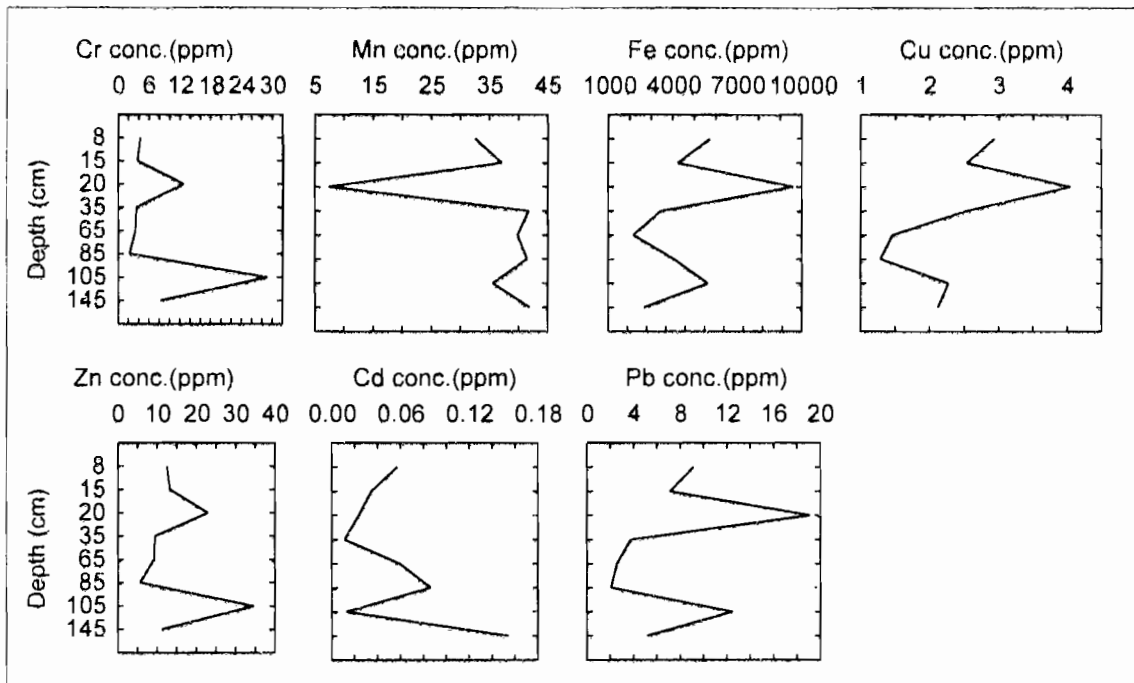

Figure 5.11 WV-Core: Graphs depicting vertical distribution of metals

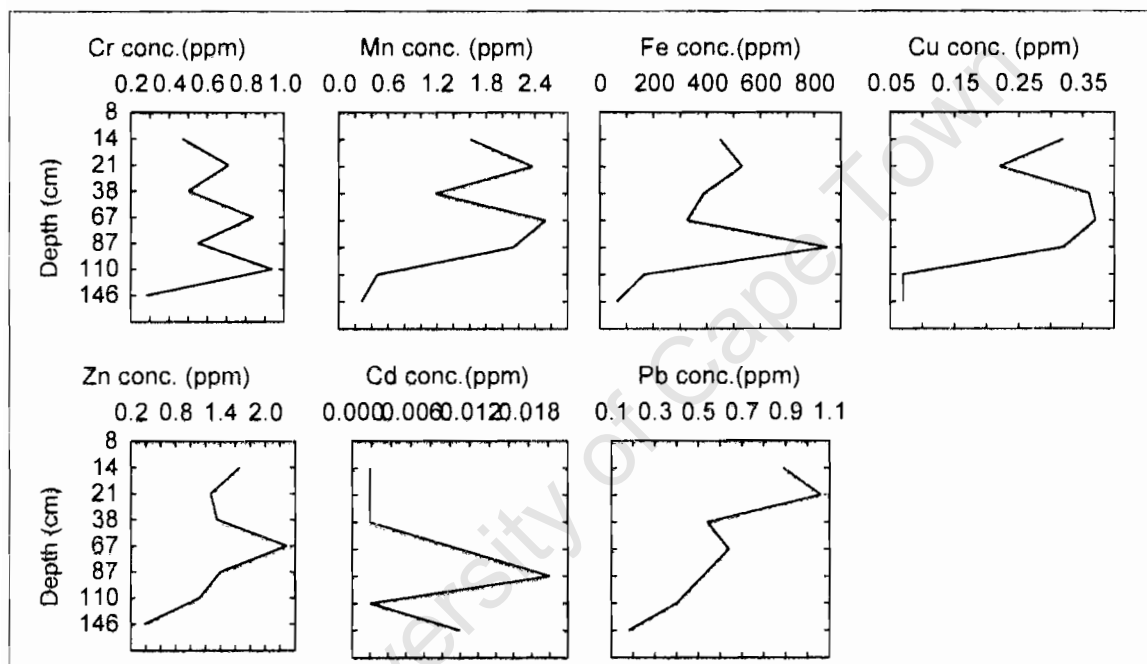

Figure 5.12 WV-Core: Normalised graphs depicting vertical distribution

Table 5.14 WV-Core: Correlation between various metals, sand, silt and organics

|           | Cr    | Mn    | Fe    | Cu    | Zn    | Cd    | Pb    | Silt/clay | Organics | Sand |
|-----------|-------|-------|-------|-------|-------|-------|-------|-----------|----------|------|
| Cr        | 1.00  |       |       |       |       |       |       |           |          |      |
| Mn        | 0.28  | 1.00  |       |       |       |       |       |           |          |      |
| Fe        | 0.42  | 0.93  | 1.00  |       |       |       |       |           |          |      |
| Cu        | 0.23  | 0.85  | 0.84  | 1.00  |       |       |       |           |          |      |
| Zn        | 0.96  | 0.47  | 0.58  | 0.44  | 1.00  |       |       |           |          |      |
| Cd        | -0.31 | -0.37 | -0.46 | -0.42 | -0.48 | 1.00  |       |           |          |      |
| Pb        | 0.62  | 0.90  | 0.93  | 0.86  | 0.77  | -0.43 | 1.00  |           |          |      |
| Silt/clay | 0.79  | 0.14  | 0.17  | 0.16  | 0.69  | 0.17  | 0.43  | 1.00      |          |      |
| Organics  | 0.28  | 0.06  | 0.16  | 0.24  | 0.29  | 0.17  | 0.28  | 0.14      | 1.00     |      |
| Sand      | -0.09 | -0.14 | -0.26 | -0.33 | -0.15 | -0.08 | -0.27 | 0.10      | -0.95    | 1.00 |

### 5.2.3 Groot Rondevlei Core (GR-Core)

A 344 cm deep sediment core retrieved in 2001 by Brett Smith from this vlei shows variation in its sediments across the profile (Figure 5.13). Table 5.15 identifies the seven units of the core categorised according to appearance, sediment composition and sand grade from the 38 samples analysed (Appendix H). A brief description from bottom to top of the core shows basal Unit 7, 10cm thick as a dark greyish brown layer and similar to Unit 6 which also ranges from grey to dark greyish brown. From Unit 5 to 2, sediments are entirely black or dark grey in colour. The uppermost Unit 1 is also black and composed of humus material rich in root and other plant materials, contributing to a very high organic matter content of 76% .

Table 5.15 GR-Core: General description

| Units | Depth (cm) | Texture        | General description and Munsell Notations        |
|-------|------------|----------------|--|
| 1     | 0-4        | n.d            | Black (humus) (7.5YR 2.5/1)                      |
| 2     | 4-24       | Sandy mud      | Black (10YR 2/1)                                 |
| 3     | 24-262     | Slightly muddy | Black (10YR 2/1) to light gray (10YR 7/1)        |
| 4     | 262-281    | Sandy mud      | Black (10YR 2/1) to dark gray (10YR 4/1)         |
| 5     | 281-294    | Slightly muddy | Black (10YR 2/1) to grey (10YR 5/2)              |
| 6     | 294-334    | Sandy          | Grey (10YR 5/2) to dark greyish brown (10YR 4/2) |
| 7     | 334-344    | Slightly muddy | Dark greyish brown (10YR 4/2)                    |

#### 5.2.3.1 Particle size analysis

For the same reason as in the last two cores, Unit 1 of this core was not analysed for sand size particles. Sand is seen to be dominant in the entire core with some units slightly muddy ((m) S) (Units 7, 5 and 3), sandy (S) (Unit 6) or sandy mud (mS) (Units 4 and 2) in texture (Table 5.16). Sand grade upcore is medium sand and composed entirely of quartz sand (Table 5.16). In summary, this core is relatively homogenous in its texture as silt and clay percentages are relatively low compared to the other cores.

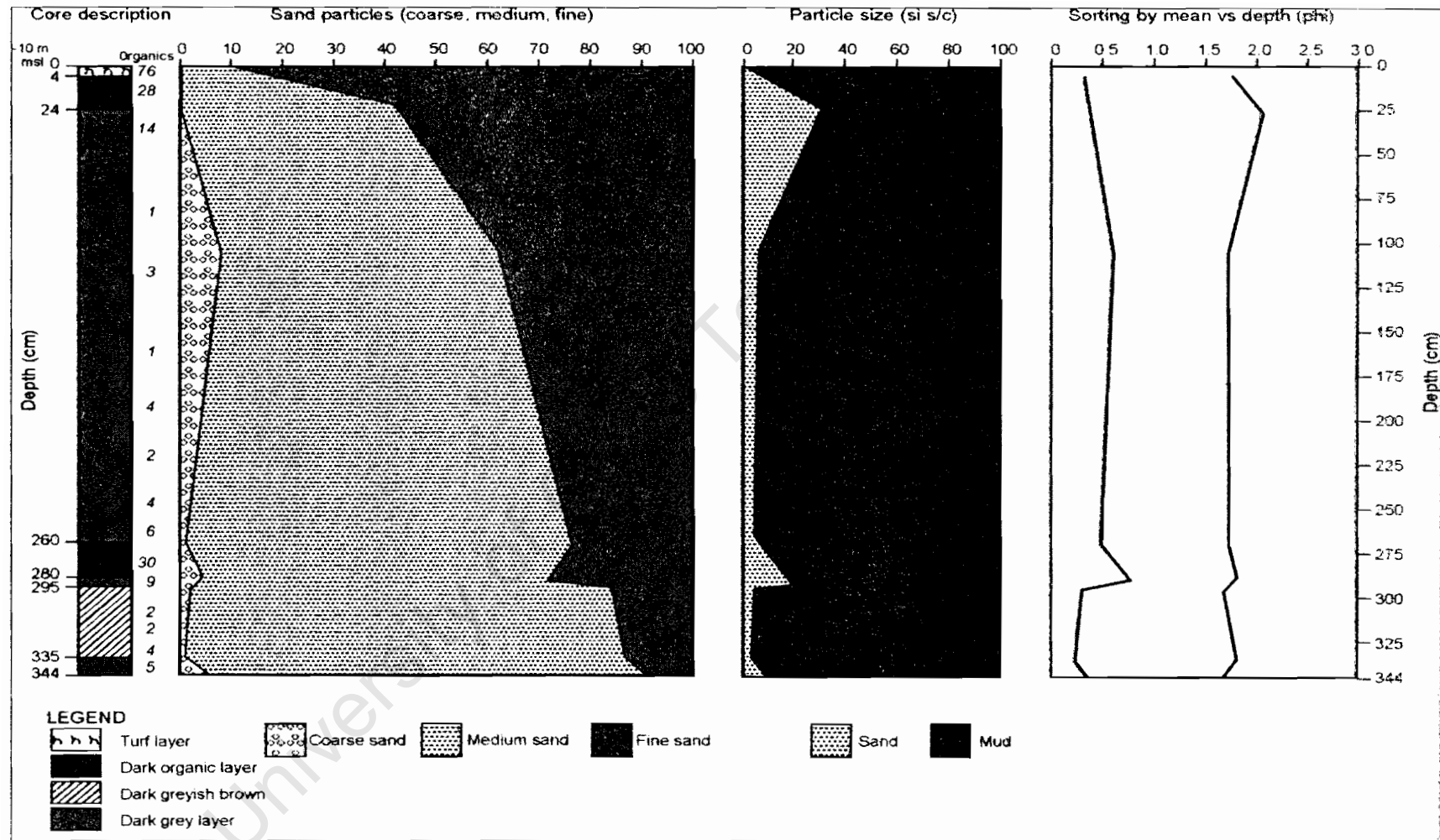

Figure 5.13 GR-Core log and textural analysis

A careful examination of the graphical values (Tables 5.17, 5.18 and Figure 5.13) for the GR-Core shows that most of the samples are made up of medium sand, ranging from very well sorted to well-sorted (Figure 5.14) and symmetrically skewed, with the exception of a few outliers such as Units 7 and 4, which are coarse and finely skewed respectively (Table 5.18). Unit 4 is also moderately well-sorted.

Table 5.16 Groot Rondevlei core: Textural analysis (values in percentage)

| Units | Depth (cm) | Mud %    | Sand%    | Sediment texture (Folk, 1954) | Sand composition |
|-------|------------|----------|----------|-------------------------------|------------------|
| 1     | 4          | n.d      | n.d      | n.d                           | n.d              |
| 2     | 24         | 19 ±10.6 | 81 ±10.4 | mS                            | Quartz (qtz)     |
| 3     | 262        | 6 ±1.4   | 94 ±1.4  | (m) S                         | Quartz (qtz)     |
| 4     | 281        | 14 ±3.5  | 86 ±3.5  | mS                            | Quartz (qtz)     |
| 5     | 294        | 4 ±8.4   | 96 ±8.4  | (m) S                         | Quartz (qtz)     |
| 6     | 334        | 2 ±.81   | 98 ±.81  | S                             | Quartz (qtz)     |
| 7     | 344        | 6        | 94       | (m) S                         | Quartz (qtz)     |

5.17 GR-Core; Textural description of sand (after Wentworth, 1922)

| Units | Depth (cm) | Coarse % | Medium % | Fine %  | V fine % | Sand grade  |
|-------|------------|----------|----------|---------|----------|-------------|
| 1     | 4          | n.d      | n.d      | n.d     | n.d      | n.d         |
| 2     | 24         | 2 ±.7    | 58 ±24.7 | 38 ±24  | 2        | Medium sand |
| 3     | 262        | 5 ±2.6   | 62 ±10.8 | 30 ±10  | 3 ±1.2   | Medium sand |
| 4     | 281        | 4        | 68       | 22      | 6        | Medium sand |
| 5     | 294        | 2 ±1.4   | 83 ±10.6 | 11 ±7.7 | 4 ±1.4   | Medium sand |
| 6     | 334        | 1 ±.57   | 88 ±2    | 9 ±2.6  | 2 ±.57   | Medium sand |
| 7     | 344        | 5        | 82       | 12      | 1        | Medium sand |

Table 5.18 GR-Core; Graphical statistics of sand grain (after Folk and Ward, 1953)

| Units | Mean (phi) | Median (phi) | Sorting    | Description            | Skewness     | Description          |
|-------|------------|--------------|------------|------------------------|--------------|----------------------|
| 1     | n.d        | n.d          | n.d        | n.d                    | n.d          | n.d                  |
| 2     | 1.91 ±.18  | 1.91 ±.19    | 0.35 ±.04  | Well sorted            | -0.045 ±.077 | Near symmetrical     |
| 3     | 1.8 ±.08   | 1.84 ±.08    | 0.45 ±.09  | Well sorted            | -0.01 ±.076  | Near symmetrical     |
| 4     | 1.78 ±.02  | 1.78 ±.02    | 0.61 ±.32  | Moderately well sorted | 0.37 ±.38    | Strongly fine skewed |
| 5     | 1.67 ±.09  | 1.66 ±.09    | 0.33 ±.31  | Very well sorted       | 0.1 ±.31     | Near symmetrical     |
| 6     | 1.64 ±.03  | 1.64 ±.02    | 0.27 ±.008 | Very well sorted       | -0.015 ±.01  | Near symmetrical     |
| 7     | 1.64       | 1.65         | 0.35       | Very well sorted       | -0.12        | Coarse skewed        |

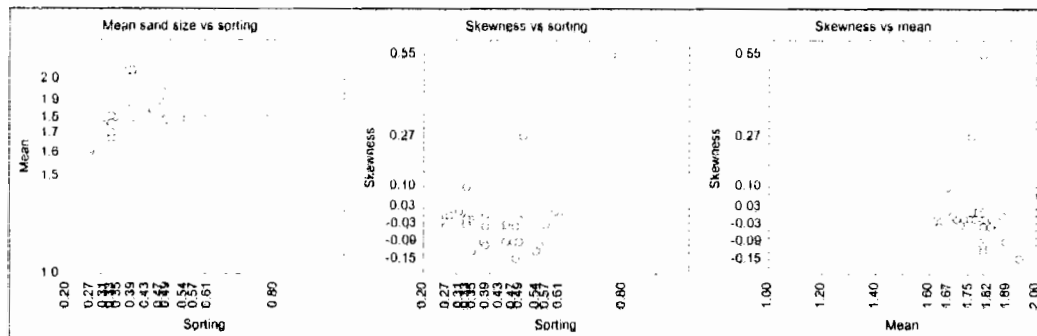

Figure 5.14 GR-Core: Scatterplots of mean size sand, sorting and skewness

### 5.2.3.2 Chemical analysis

#### 5.2.3.2.1 pH

All the sediments in the GR-Core display a high level of acidity with little variability between the units from the bottom to the top of the core (Figure 5.15). Sediment pH ranges from a minimum of 2 (very acidic) in the basal sediments to a maximum of 4 (acidic) in Unit 3 which are both slightly muddy (Table 5.19).

#### 5.2.3.2.2 Conductivity (EC)

Electrical conductivity in the GR-Core shows a high degree of homogeneity across the profile. Compared to the WV-Core, salinity values in this core are low with its basal sediments having a highest value of 119  $\mu\text{S}/\text{cm}$ . EC values remain almost constant from the base of the core up to Unit 2 where they sharply decrease to 55  $\mu\text{S}/\text{cm}$  in the surface unit, with the lowest salinity in the profile (Table 5.19 and Figure 5.15).

#### 5.2.3.2.3 Organic matter

Groot Rondevlei surface sediments are characteristically rich in organic matter compared to the other two cores examined. Organic matter content ranges from a low of 1% (Unit 3) to a maximum of 76% (mass of raw material) (Unit 1). An initial decrease upcore from 5% (Unit 7) to 2% (Unit 6) is punctuated by a steady increase from Units 5 (6%) to 19% in Unit 4 and a low of 1% in Unit 3 (Table 5.19). Overall, there is marked heterogeneity in organic matter composition throughout the core. As with the other cores, the trend in organic matter composition is directly inverse to pH and conductivity (Figure 5.15).

Table 5.19 GR-Core: Organics, pH and conductivity (EC)

| Units | pH     | Conductivity (EC) | Organics % |
|-------|--------|-------------------|------------|
| 1     | 3      | 55                | 76         |
| 2     | 3      | 118               | 19 ±5.6    |
| 3     | 4 ±.79 | 119 ±.35          | 1 ±3.2     |
| 4     | 3      | 116               | 19 ±11.7   |
| 5     | 3      | 119               | 6 ±24.8    |
| 6     | 3      | 118               | 2 ±.72     |
| 7     | 2      | 119               | 5          |

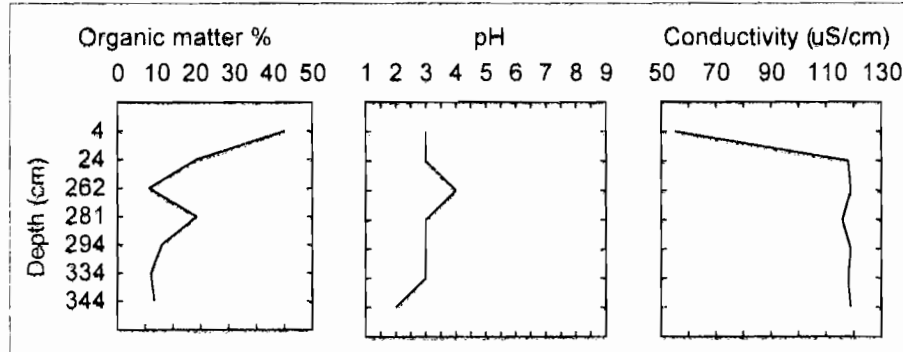

Figure 5.15 GR-Core: Organic, pH and conductivity vertical distribution

#### 5.2.3.2.4 Heavy metal distribution and concentration

Heavy metal concentrations and distribution in the sediments of the GR-Core are provided in Appendix I and also presented in Figure 5.16 below. The Groot Rondevlei site is located in a nature reserve (13km from the Noordhoek valley) and metal concentrations here, as with granulometric results, are used as reference points for the Noordhoek cores.

This core is divided into five zones based on total and individual metal concentrations and distributions (Figure 5.16). As in the LM and WV cores, some of these zones coincide with textural units discussed above. Basal sediments of the core show the highest total metal concentration in the profile, with the top sediments not highly enriched as would be expected. Concentration also increases in the middle of the core between 294 - 52cm with a minimum concentration between 4 - 52cm and 294 - 314 cm (Figure 5.16).

Individually, Fe shows the highest concentration of heavy metals in the profile but together with other elements Cr, Mn, Cu, Zn, Cd and Pb, shows similar distribution and concentration patterns across the core (Figure 5.17). All the element

concentrations seem to peak toward the surface of the core, with the middle of the core displaying a significant composition of most of the elements.

Prior to normalisation, elements such as Cr, Mn, Fe, Cu and Pb increased toward the surface (Figure 5.17). After the granulometric normalisation, these elements were again plotted and the resulting graphs show a steady decrease in concentrations toward the surface by all the elements (Figure 5.18). This trend of decreased concentrations toward the surface of the GR-Core has been observed in some elements in the other two cores examined in this research and its significance is discussed in the following chapter.

Textural variability, in addition to other factors, influences the distribution of trace elements within the sedimentary deposit. Thus, potential relationships between trace element concentration and silt and clay content (<63  $\mu\text{m}$ ) and organic carbon content are explored for this core using a correlation matrix derived from principal component analysis. There is no significant correlation between silt/clay and the major elements but organic matter is positively correlated to two of the major elements, namely Cu ( $r = 0.61$ ) and Pb ( $r = 0.76$ ). As was the case with the other cores, sand was negatively correlated to all the heavy metal concentrations observed (Table 5.20).

Cr, Mn, Cu, Zn and Cd are seen to be strongly correlated to most of the elements and Fe, one of the scavenger elements, is positively correlated only to Cd, (see Table 5.20 for the correlation coefficients).

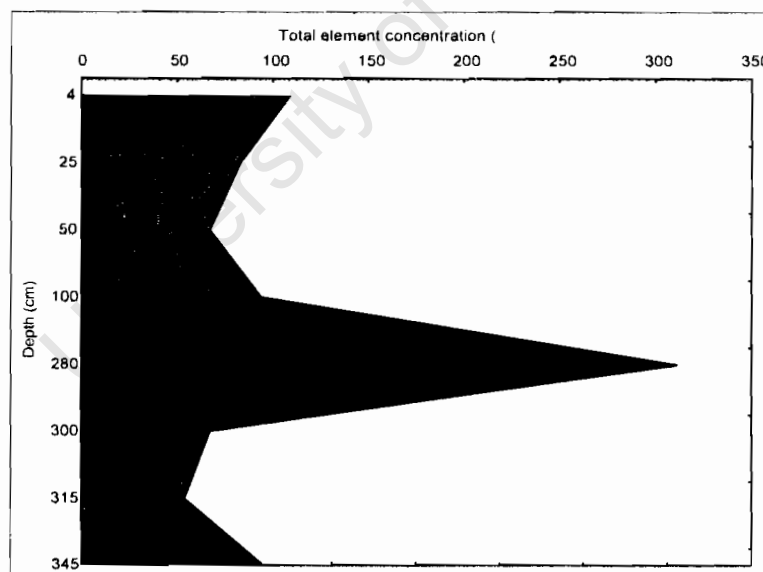

Figure 5.16 GR-Core: Trace elements concentration in parts per million

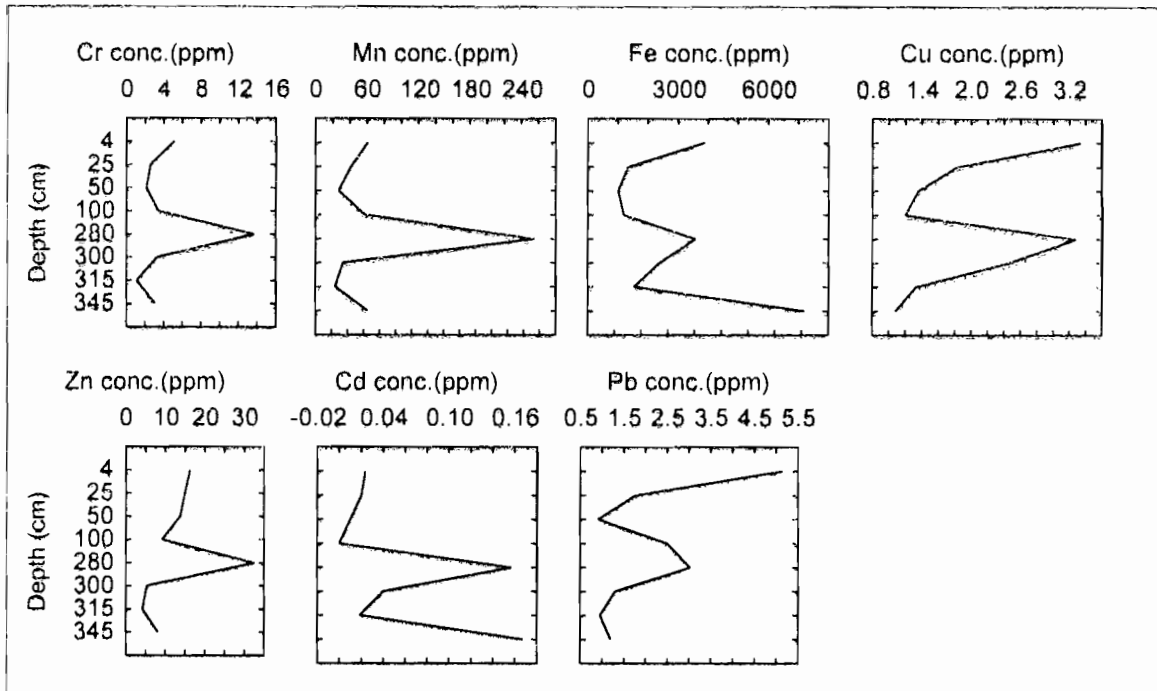

Figure 5.17 GR-Core: Graphs depicting vertical distribution of metals

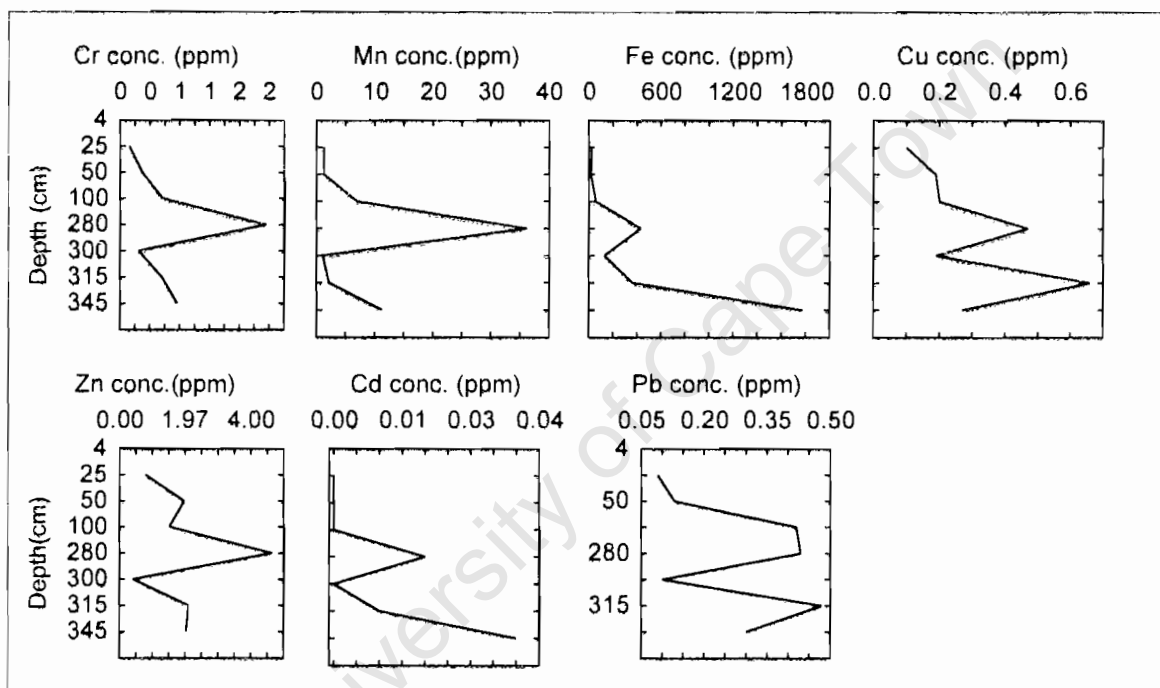

Figure 5.18 GR-Core: Normalised graphs of metal concentrations

Table 5.20 Correlation between the various trace elements, silt and organics

|           | Cr    | Mn    | Fe    | Cu    | Zn    | Cd    | Pb    | Silt/clay | Organics | Sand |
|-----------|-------|-------|-------|-------|-------|-------|-------|-----------|----------|------|
| Cr        | 1.00  |       |       |       |       |       |       |           |          |      |
| Mn        | 0.98  | 1.00  |       |       |       |       |       |           |          |      |
| Fe        | 0.26  | 0.28  | 1.00  |       |       |       |       |           |          |      |
| Cu        | 0.71  | 0.59  | 0.13  | 1.00  |       |       |       |           |          |      |
| Zn        | 0.90  | 0.89  | 0.10  | 0.66  | 1.00  |       |       |           |          |      |
| Cd        | 0.61  | 0.67  | 0.82  | 0.19  | 0.44  | 1.00  |       |           |          |      |
| Pb        | 0.49  | 0.38  | 0.18  | 0.75  | 0.50  | -0.01 | 1.00  |           |          |      |
| Silt/clay | -0.07 | -0.07 | -0.36 | -0.05 | 0.04  | -0.13 | -0.36 | 1.00      |          |      |
| Organics  | 0.00  | -0.15 | 0.08  | 0.61  | 0.13  | -0.29 | 0.76  | -0.13     | 1.00     |      |
| Sand      | -0.08 | 0.06  | -0.16 | -0.63 | -0.16 | 0.22  | -0.85 | 0.33      | -0.97    | 1.00 |

Thus far, combined granulometric and geochemical results in the two disturbed (Lake Michelle and Wildevoevlei) and the undisturbed (Groot Rondevlei) systems have been presented. These results are used in the next chapter to attempt to reconstruct sedimentation rates and processes as well as historical trends in heavy metals inputs into the three systems. Before attempting to do so, a presentation of results of historical land use and land cover changes in the vicinity of the disturbed systems is given to complement an understanding of recent changes in the valley.

### 5.3 TIME SERIES OF SPATIAL LAND USE /COVER CHANGE

#### 5.3.1 INTRODUCTION

In the following paragraphs a spatial analysis of land use and land cover data first catalogued for the Noordhoek basin from 1944 - 1996 by Ringdahl (1995) is re-evaluated and extended to the year 2000. The various land uses were divided into six categories; vegetation (alien dominated), vegetation (fynbos dominated), exposed beach and sand dunes, built-up (urban), waterbodies (wetlands) and agriculture. For a clearer understanding of how land use and land cover has changed since 1944, each of the categories is examined individually from 1944 to 2000.

#### 5.3.2 Patterns in agricultural land use changes

The absence of historical data for land use and land cover change for the southwestern Cape (Biggs *et al.*, 2002) in general, and for the Noordhoek basin in particular, limits the accuracy of land cover reconstruction for the 150 years of intense human occupation. Until the mid-1900s data on agricultural land cover for South Africa can only be estimated from crop production and population numbers using

simple linear regression (Biggs *et al.*, 2002). For the Noordhoek basin, the first aerial photograph available for agricultural land cover analysis is from the year 1944. At that time agricultural land cover accounted for approximately 11% (Table 5.21) of the total area, in spite of the infertile soils and marshy conditions reported by Heinecken (1985). Fourteen years later in 1958, agricultural land cover had increased to 16% (Table 5.21 and Figures 5.19, 5.20a and 5.21a). The major agricultural activities in the valley then were market gardening, dairy farming and cash crop cultivation with animal grazing on the wetland areas during the drier summer months (Heinecken, 1985). After 1958, cultivated land in the Noordhoek basin dropped back to the 1944 level of 11% in 1989 (Table 5.21 and Figures 5.19, 5.20a and 5.21a) and seven years later in 1996 it again increased to 15%, close to the 1958 peak and decreased by 1% to 14% in 2000 (Figures 5.19, 5.20d and 5.19d).

Table 5.21 Relative percentages in land use and land cover over time

| Years | Built-up % | Agriculture % | Beach | Vegetation (alien dominated) % | Vegetation (fynbos dominated) % | Waterbodies % |
|-------|------------|---------------|-------|--------------------------------|---------------------------------|---------------|
| 1944  | 0          | 11            | 17    | 20                             | 49                              | 3             |
| 1958  | 1          | 16            | 10    | 26                             | 45                              | 2             |
| 1989  | 9          | 11            | 9     | 28                             | 41                              | 2             |
| 1996  | 14         | 15            | 5     | 26                             | 37                              | 3             |
| 2000  | 24         | 14            | 8     | 18                             | 32                              | 4             |

### 5.3.3 Patterns in urban land use changes

Changes in local and global biogeochemical cycles, climate, as well as loss of biodiversity through habitat fragmentation and destruction, have not solely been a response to agricultural expansion. The rapid increase in population in the Cape region has resulted in the expansion of urban landscapes into rural areas and previously 'uninhabitable' lands. The Noordhoek basin witnessed initial urban development from around 1958 as the city of Cape Town encroached into its southern suburbs. Conversion of land from rural to urban use (commercial, industrial and residential uses) in the Noordhoek basin increased from 30 hectares in 1958 to approximately 808 hectares in 2000 (Figures 5.20a & f). From 1% in 1958, built-up areas rapidly increased to 24% by the year 2000 (Table 5.21 and Figures 5.19b, 5.20b and 5.21b).

Development of urban settlement began in 1958 in the east of the basin, and is shown in Figure 5.19b and Plate 3.1. The proximity of Fish Hoek Township, which had developed earlier, is thought to have offered infrastructural facilities to this newly

developed town center of Noordhoek. Between 1958 and 1989 (Figures 5.19b and c respectively), the extension of the first urban center alongside the new developments in the northeast and northwest of the basin (previously dominated by agriculture) occurred.

Between 1989 and 2000, (Figure 5.19c-e) other major developments took place, including the completion of the marina-type development (Lake Michelle) around the former Salt Pan. The initial phase of the marina-type development started in 1974 and led to the excavation of the pan floor, earthworks on the southern end of the pan and concrete embankments for stabilising the banks, thereby creating a 1.6m deep lake (Gassner, 1999). Phase 1-3 of the development on the southern shores, completed in 1995, accounts for the increase in urban land use between 1989 and 1996. New developments elsewhere in the valley during this time have had major implications for the spatial reach of the human population in the basin.

#### **5.3.4 Patterns in vegetation (alien dominated) change**

Urbanisation has not been the only aspect of land use/ cover that has changed since the colonisation of the Cape. Since the arrival of Europeans in the Cape region and the establishment of the Cape Colony in 1652, alien plants were intentionally introduced, first to provide for fuel, shelter and later to 'Europeanise' the Cape (Cowling *et al.*, 1995).

Approximately 300 years after these invasive aliens were first introduced, the Noordhoek basin in 1944 had 20% of its land surface covered with alien trees, typically *A. Cyclops* (Table 5.21 & Figures 5.19a, 5.20a and 5.21a.). These alien plants encroached and occupied approximately 28% of the basin by 1989 (Table 5.21 & Figures 5.19b, 5.20b and 5.21b.). From 1989 onward, alien vegetation coverage in the basin and its catchment declined to approximately 26% in 1996 and 18% in 2000 (Table 5.21 and Figures 5.19c,d, 5.20c,d and 5.21c,d).

#### **5.3.5 Patterns in vegetation (fynbos dominated) change**

Humans have, in various ways, altered the fynbos ecosystem since their arrival in the Cape 125 000 years ago. However, European establishments caused irreversible changes on the natural landscape (Cowling *et al.*, 1995). The Noordhoek basin has had its own share of the transformation. From a total area of 1716 hectares occupied by natural fynbos in 1944 (Figure 5.20a), it steadily decreased to 1061 hectares by

2000 (Figure 5.20e). By the year 2000, only about 32% of the total 49% of the coastal and mountain fynbos that had thrived in the basin in 1944 (Table 5.21 and 5.21e) could be seen. By implication, the Noordhoek basin and its catchment lost more than 30% of its natural vegetation within a period of 56 years. However, this loss, as in the rest of the region, has been uneven, with the valleys and coastal lowlands being severely affected whereas the mountain fynbos being less affected.

### **5.3.6 Beach and sand dunes**

Sand deposits that once extended inland from the beach (Figure 5.19a) in 1944 decreased such, that by 2000 (Figure 5.19e), there was only a narrow strip of sand along the present day beach. As with other areas, the Noordhoek beach and dune deposits have undergone some dramatic spatial changes over the years. Occupying approximately 17% of the total land use in 1944 and roughly 10% in 1958 and 1989, beach and sand deposits decreased to only 5% in 1996 (Table 5.21 and Figure 5.21e). Between 1996 and 2000, beach and dune deposits increased by approximately 3% from the low 5% in 1996 to 8% in 2000 (Table 5.21 and Figure 5.21e).

### **5.3.7 Waterbodies**

The basin at the moment consists of three permanent water (wetlands) bodies, namely the Salt Pan, the Wildevoelvlei and Papkuilsvlei (Figure 6.3). Apart from Papkuilsvlei, which only developed after 1944, the other two are noticeable on the 1944 map (Figure 5.19a), indicating that they existed prior to 1944. Although in existence prior to 1944, they were all perennial systems until humans directly interfered with their natural functioning. Between 1944, when the first aerial photograph of the basin was taken and 2000, area coverage of the vlei has fluctuated. It decreased from 3% in 1944 to 2% in 1989. From 1989 to 2000, aerial coverage by waterbodies increased from 2 to 4% (Table 5.21 and Figure 5.21f). The creation of The Lake (Lake Michelle) after 1974 during the early stage of the marina-type development may be the reason for this increase.

There are no equivalent results available on land use changes for the Groot Rondevlei site. The Groot Rondevlei situated in the Cape of Good Hope Nature Reserve has witnessed little or no major changes in its land use since the area was declared a national park in 1941 (Gasson, 1990).

Noordhoek basin from 1944 - 2000

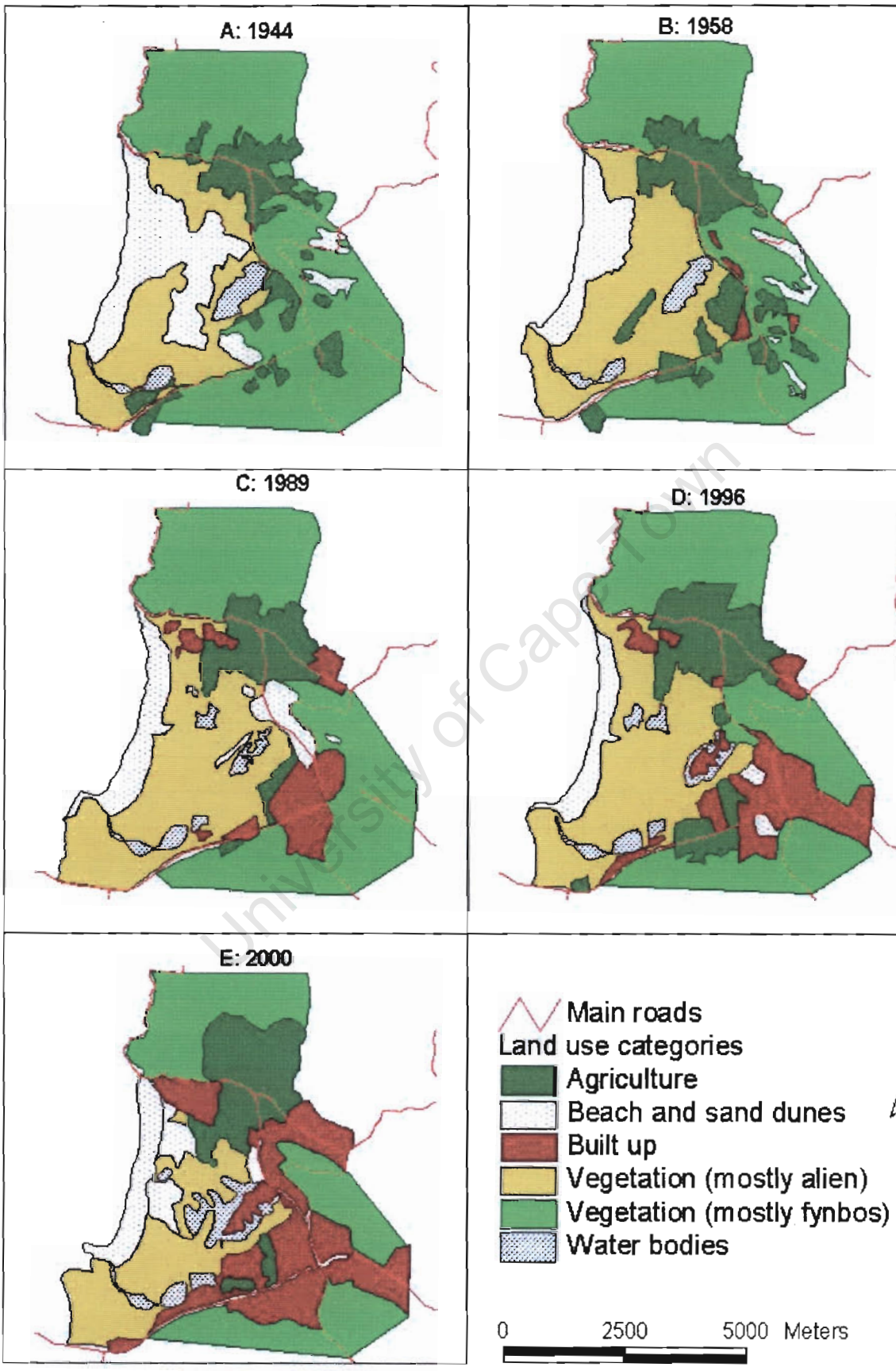

Figure 5.19a-e: Land use changes in the Noordhoek basin (1944-2000)

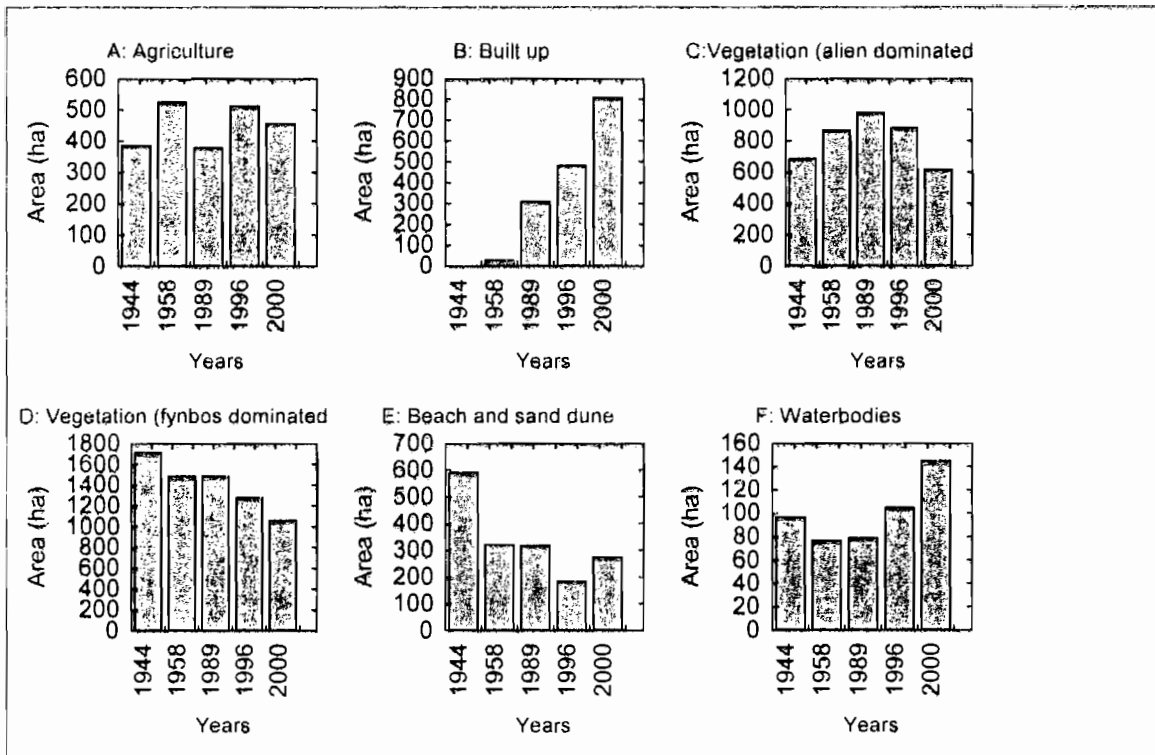

Figure 5.20a-f: Graphs of land use changes in the Noordhoek basin (1944-2000)

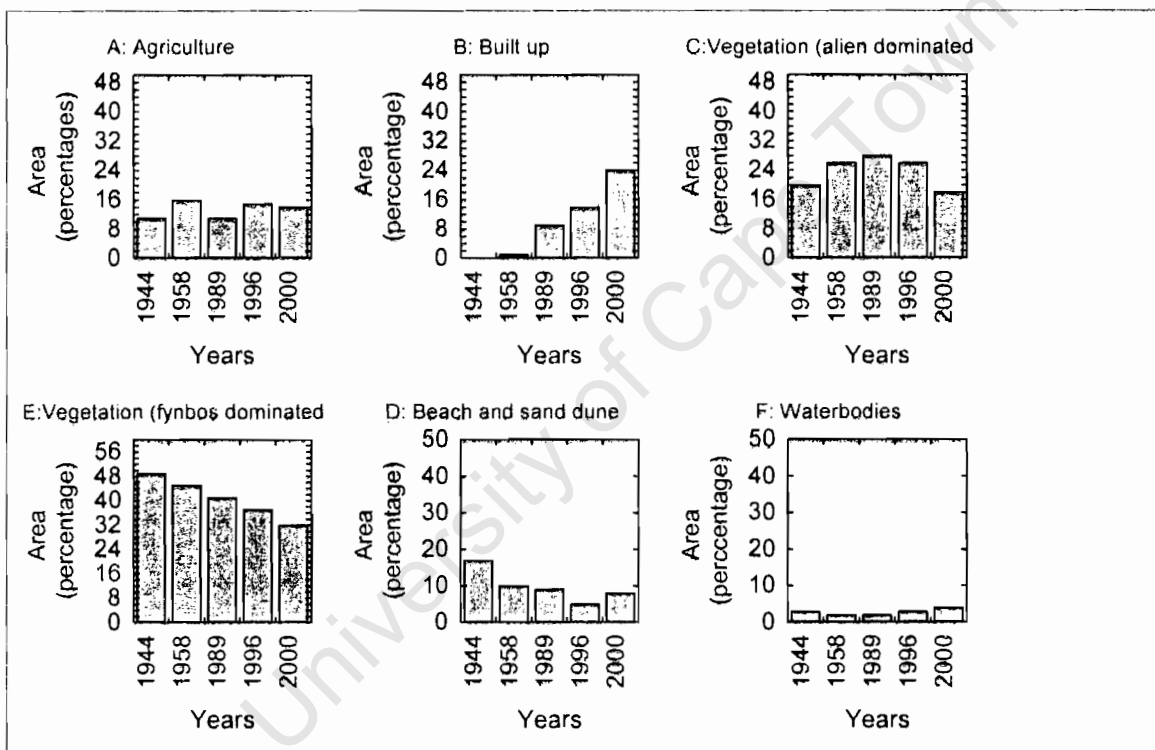

Figure 5.21a-f: Relative percentages of land use changes in the Noordhoek basin (1944-2000)

## 5.4 CONCLUSION

Changes in land cover and land use categories presented thus far for the Noordhoek valley are further discussed in the next chapter, together with results of textural and geochemical examinations of the cores. These results and analysis will help in the interpretation of sedimentation processes in the Noordhoek valley and changing environmental conditions during the recent past.

University of Cape Town

---

## CHAPTER 6

---

### PALAEOENVIRONMENTAL RECONSTRUCTION

---

#### 6.1 INTRODUCTION

This chapter begins by discussing a possible chronology of environmental change for the study site in relation to well-documented chronologies from other sites within the region. It is followed by a discussion on palaeoenvironmental evidence that accumulated in the Noordhoek wetlands as presented in the previous chapter, which is in turn used to summarise environmental changes in the basin during the late Quaternary. It attempts to establish a chronostratigraphy for the basin based on the interpretation of sedimentological evidence and changes in the proportion and distribution of heavy metals in sediments of the two Noordhoek cores, LM-Core and WV-Core. Reference is made to the GR-Core, thought to be a "pristine" core, which is used to compare the degree of human-induced pollution in the Noordhoek wetlands. Interpretation of spatial changes is discussed in order to provide a three-dimensional view of environmental changes in the basin. The chapter concludes with a synthesis of environmental change in the Noordhoek basin from late Pleistocene to the present based on evidence provided by this research.

##### 6.1.1 Regional synthesis

The Noordhoek wetlands have undergone major changes over the last 125k years as a result of fluctuating sea level, climate change and human interference. In the absence of a clear chronology from the sediment cores (LM and WV), the following are the possible scenarios that could have influenced the development of the Noordhoek wetlands, as evidence from elsewhere in the region corroborates.

Fluctuation in sea level from the last interglacial with an initial transgression to about 3 metres of the modern datum around 125k years ago during the rapid warming of the Eemian. This period is known globally as OIS (Oxygen Isotope Stage) 5e (Ramsay *et al.*, 2002) and has received little attention from Quaternary scientists in the region.

Rapid regression in sea level during glaciation, which ended about 21 000 years ago (LGM) marked by cold and moist conditions in most of the winter rainfall region that

favoured the accumulation of peat deposits below most wetlands in the region, for example Verlorenvlei (Meadows *et al.*, 1996 and Baxter and Meadows, 1999). Vlei sediments elsewhere in the region suggest rapid environmental change marked by an abrupt change in climate and change in the depositional environment following the cold and moist climatic conditions of the LGM. This period is known as the Holocene.

The Holocene is effectively divisible into two halves, neither of which have received adequate attention in the winter rainfall region of South Africa (Meadows *et al.*, 1999). Warmer and drier conditions during the first half of the Holocene are associated with sea level rise to within a metre or two of the modern datum at around 8000 BP in the region. Evidence for this is from multiple sites within the region, for example, calibrated radiocarbon analysis on marine shells at Verlorenvlei (Meadows *et al.*, 1999) and oyster-rich bioclastic gravel at Langebaan (Compton, 2001). During the second half of the Holocene (about 3800 BP), sea levels significantly dropped in the region below the sand dunes that had earlier formed (e.g. Meadows *et al.*, 1999, Compton, 2001, Bateman *et al.*, 2004).

Anthropogenic disturbance over the last 300 years ago replaced natural processes such as climate and sea level change as the dominant environmental determinants in the west coast and probably across much of the winter rainfall region, as indeed it would have in most of southern Africa. Deposition of organic and non-calcareous mud sediments mostly below 15cm from the surface indicates the commencement of the contemporary vlei environment. Prior to colonial farming activities that raised sedimentation rates into wetlands with disturbed catchments (e.g. Verlorenvlei), they would have naturally developed by aggradation and progradation. Changes in land use through agriculture, housing and alien infestation and the associated change in natural vegetation cover may have lead to increasing erosion (wind/water) of sandy material from the catchments into the vleis. Verlorenvlei presents a good case of the transition from natural to anthropogenically dominant processes (Meadows and Baxter, 1999).

These scenarios from elsewhere in region could have influenced the development of Noordhoek wetlands. The hypothesis adopted here, as seen in other known sites within the region, is that recent human activities have replaced fluctuating sea level and climate change as the dominant environmental determinants in the Noordhoek valley. The following discussion is based on this assumption.

## 6.2 STRATIGRAPHY AND CHRONOLOGY

Stratigraphy has been used to place sedimentary deposits taken from the Noordhoek cores into a temporal and spatial framework that facilitates a better understanding of change in sedimentary processes over time for the LM and WV-Cores. This has been done using organic, sedimentological and geochemical attributes. Each of these cores is described individually and thereafter a general picture of the changes in the basin is drawn.

Partitioning of each core into the various accumulative phases based on attributes such as upcore distribution and abundance of trace metals, grain sizes and organic matter, complement an understanding of the relative impact of late Quaternary climate change, the role of fluctuating sea levels and the extent of human impact evident in sediments. Changes in depositional environments and climate revealed by these sediments are correlated with other paleoclimatic records from related sites to establish a chronology for the Noordhoek deposits.

### 6.2.1 LM-Core (18° 23' 15"E; 34° 07' 00"S)

The LM-Core is situated 3.37m amsl in relation to the modern datum (Figure 6.1 and Table 6.1). The vertical section of LM-Core deposits shows intercalations of mud, shell-rich and shell-free sand layers (Figure 6.1). Its well-defined stratigraphy seems to reflect changing depositional environments dating back to the late Pleistocene. On the basis of organic, sedimentological and geochemical evidence, four different phases of sedimentation can be distinguished in the LM-Core (Figure 5.1).

- The oldest unit (405 - 420cm) consists of dark grey sandy mud with abundant marine shell and low silt/clay content.
- The second phase (345 - 405cm) consists of dark to very dark, clayey rich material with abundant charcoal remains.
- The third phase (100 - 345cm) is characterised by slightly muddy grey to pinkish grey deposits, rich in marine shells.
- Finally, the upper phase (0 - 100cm) ranges in colour from very dark grey to dark reddish grey and from brown to light sandy grey units.

Sediments deposited in phases III and I are similar but characteristically different from those deposited in phase II, which lies unconformably between the two.

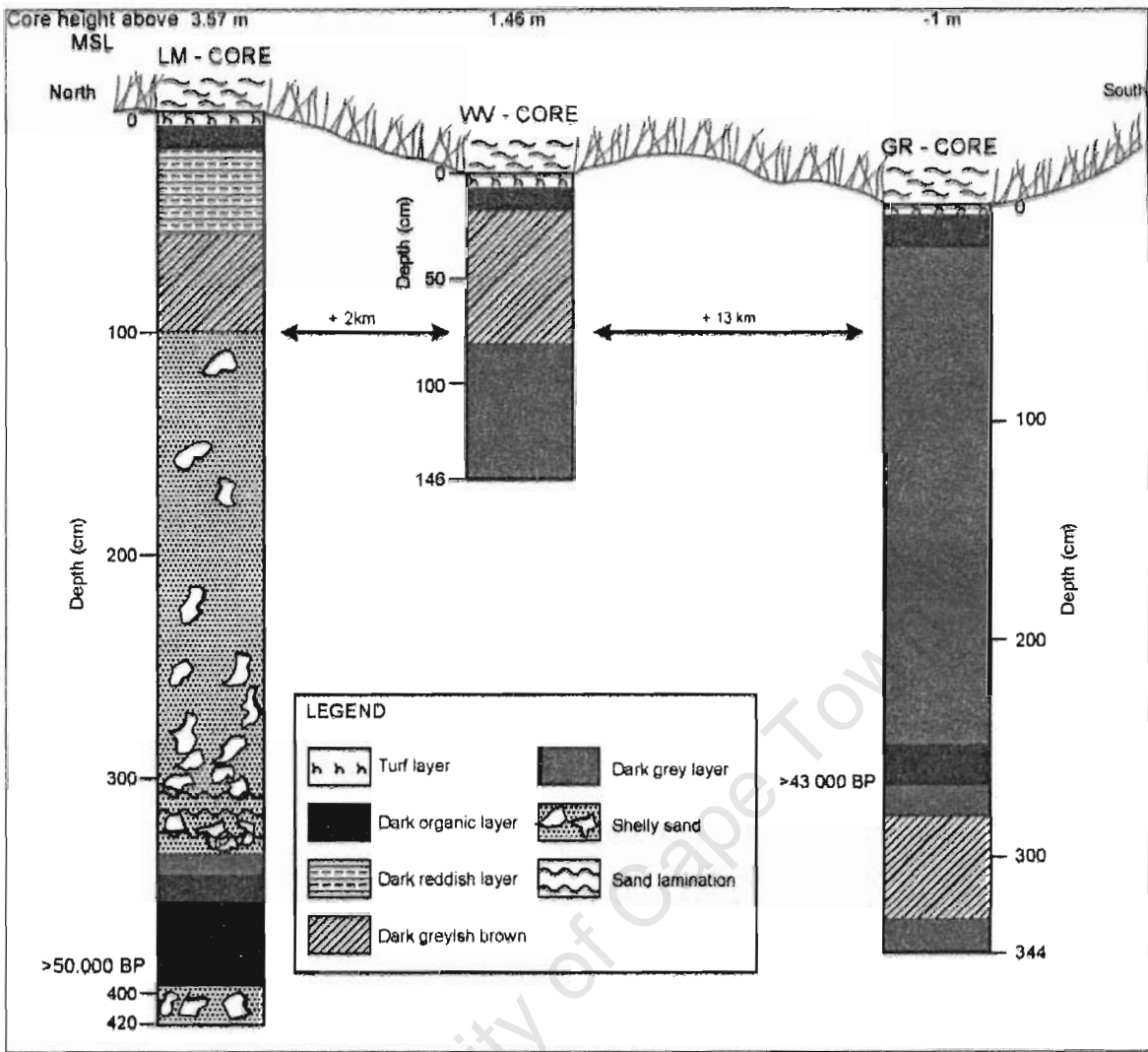

Figure 6.1 Stratigraphy of the Noordhoek and Cape of Good Hope cores

Table 6.1 Elevations, depths and geographic coordinates of core sites

| Cores | Coordinates                 | Elevations (m amsl) | Depth of cores (m) |
|-------|-----------------------------|---------------------|--------------------|
| LM    | 18° 23' 15"E; 34° 07' 00"S  | 3.37                | 4.2                |
| WV    | 18° 21' 45"E; 34° 08' 15"S  | 1.46                | 1.46               |
| GR    | 18° 23' 10" E; 34° 14' 20"S | -1                  | 3.4                |

### 6.2.1.1 Phase I LM-Core

The oldest of these deposits lie between 420 - 405cm and constitute phase I of the deposition. This initial phase of deposition in the LM-Core indicates a marine dominated episode with fine-sediment deposited between 420cm and 405cm. It is dominated by moderately well-sorted fine-sized sand with fragments of marine shells.

The shell rich sandy (80%) layer at LM-Core, as yet undated, may correlate to the dated Agulhas aeolianites (Bateman *et al.*, 2004) and the Wilderness dune cordon (e.g., Illenberger, 1996), both rich in shell fragments. The presence of shells in the matrix of this sand-rich sediment, suggests a marine source for the sand. These unconsolidated sediments, poor in organic content have been noted elsewhere along the southern Cape in the dune systems formed during the Upper Pleistocene within OIS 5e–5b (Bateman *et al.*, 2004). Low organic matter, here as in other upper Pleistocene sand deposits in the region could be a reflection of changes in sediment provenance or post-depositional leaching (Bateman *et al.*, 2004).

Aeolian processes in the past transported these sediments from coastal plains where there were deposited as a result of coastline and sea level fluctuations and emplaced as barrier dunes or aeolianites along most of the southern Cape coastline (Bateman *et al.*, 2004). The influence of fluctuating sea levels in the formation of barrier dunes in the region is discussed below (section 6.4.3).

Geochemically, sediments in this phase are characterised by low Cu, Zn, Pb, Cd, Mn, Fe, Cr concentrations and organic matter compared to the preceding phase where subsequent sedimentation recommenced under somewhat different environmental conditions. This is typical of sandy deposits where textural variability limits metal enrichment in sediments of varying sizes and composition.

#### *6.2.1.2 Phase II LM-Core*

Units 6 and 7 of the LM-Core (405-355 cm) constitute the second phase in the history of sediment accumulation at this site. The deposits contrast in texture and composition with the underlying section over which they rest unconformably. Even though these two phases are dominated by medium-sized sand, grain size parameters alone cannot be used to assign the two phases to a particular environment of deposition. Previous attempts to relate statistical parameters calculated from grain size distributions to different environments of deposition (e.g., Folk and Ward, 1957, Friedman, 1961, Chappell, 1967 Friedman *et al.*, 1978) have had limited success in environmental interpretation (Reineck and Singh, 1973). However, the high proportion of mud and the absence of marine fauna from this phase is indicative of a marine free depositional

environment. Moreover, non-marine flora evident in charcoal and plant roots present in these deposits suggests they were indeed derived sub-aerially.

Marine sediments deposited in coastal lowlands during marine regression, as noted by Illenberger (1996), were rapidly vegetated thereby slowing down the rate of aeolian sand movement in relatively humid areas like the southwestern Cape. This means that abundant plant life would have surrounded the Noordhoek lowlands and phytoplankton would characterise their near surface waters, making these wetland sediments rich in organic matter. This organic matter would have been derived mostly from autochthonous sedimentation and sometimes from debris of vegetation washed down from within the catchment. Thus, accumulation of sediments high in organic matter with plant debris well preserved, possibly under anoxic conditions, led to the development of marshes in the Noordhoek basin. Reineck and Singh (1973) explained that marshes developed under this condition could be preserved as peat layers, perhaps even up to several metres thick.

Cold and moist conditions following the last interglacials and especially the LGM noted in several locations within the winter rainfall region (Meadows *et al.*, 1996, Meadow and Baxter, 1999, Meadows *et al.*, 1996, Irving, 1998) could have favoured the accumulation of this organic layer (Chase, pers.com). The 60cm thick organic layer would have been deposited over a considerable length of time starting from the onset of the cold glaciation phase.

Heavy metal concentrations in these organic deposits increased as the sediment particle size reduced and the percentage of clay increased. Located about 3 metres below the surface, this layer would not have been affected by modern day semi-industrial activities in the basin. Rather, enrichment by parent rocks is another valid explanation over and above the grain-size effect. Surrounding Table Mountain sandstone (Marchant *et al.*, 1978), known to be naturally rich in Fe and Mn could be the main enrichment source for these elements and all others elements that peaked during this phase, as compared to the earlier phase. It is also possible that these wetlands have acted as a good sink (i.e. retainer) of catchment-derived heavy metals.

### 6.2.1.3 Phase III LM-Core

Phase III of this core (345-100cm) has a relatively minor component of mud and is dominated by very well sorted, medium sized sands with well-rounded pebbles-sized rock fragments of about 2cm in diameter, and broken shell fragments. Shell fragments in coastal environments with greater than 95% sand component are indicative of marine deposition under high-energy activities (Friedman *et al.*, 1978). White sandy layers interdigitated with laminated dark units of approximately 5cm thick between 345-300cm probably represent the onset of the Holocene transgression as ice retreated from most of the continental landmass sparked by global increase in temperatures (Meadow and Baxter, 1999). Sediments of this phase accord with what is understood of mid-Holocene transgressive deposits, which have been noted elsewhere in the southwestern Cape region, including Verlorenvlei (Meadows and Baxter 1999), and Langebaan (Compton, 2001). Such sediments comprised of a minor mud component, dominated by very well-sorted sand and abundant marine shells. A mean sea-level highstand of about 2.3m amsl during the mid-Holocene altithermal, during which these deposits accumulated, has been reported elsewhere in the region. For example, there was a mean sea level rise of 0-3m above present level at Langebaan (Compton 2001) and 0–2m amsl at Verlorenvlei (Baxter and Meadows, 1999) between 7000 and 6500 years ago.

Heavy metal concentration in this phase is low compared to the underlying phase II deposits, also indicating the influence of particle grain size on the metal accumulation. Heavy metal concentrations increases as sediment grain size decreases because of the increase of surface area in small grain sediments. This in turn increases the absorption surface. However, the variability in chromium (Cr) concentration toward the surface might suggest otherwise. Chromium unlike the other elements, is not entirely influenced by silt/clay or the organic content but has an erratic distribution upcore displaying a strong affinity for sand and the organic-poor sediments. At some depths, chromium was noted to be below detection limits (Table 5.16).

### 6.2.1.4 Phase IV LM-Core

A marked change in sedimentary texture together with the absence of shell components (Table 5.2) at 2.37m amsl (Figure 6.1) signals a dramatic change in the depositional environment at the Lake Michelle site. Upcore from this depth (100-15cm),

whitish beach sand, well-sorted and ranging from symmetrically skewed to fine skewed dominates the sequence. Deposits in this phase show intercalations of organic-rich sediments and quartz-rich sand that consists of three sub-phases.

Sub-phase (a), >50cm from the surface was deposited during the early part of the phase. It consists of fine sediments ranging in colour from light grey to brown with well-sorted sub-angular medium-sized sand (98%), which is loosely held together by a 2% mud fraction. These sediments lack marine shells and mark a change in sedimentary environment from the previous marine environment to a sub-aerial dune environment. Well-sorted sub-angular medium-sized sand at this depth with no marine deposits in a coastal environment like this, is consistent with the development of a sub-aerial dune system (Friedman, 1961). Sub-aerial dune systems have been noted in several coastal locations in the southwestern Cape and could have formed as the coast prograded during widespread submergence following the mid-Holocene transgression. These dunes have been identified for example, at Verlorenvlei (Meadows and Baxter, 1999) and at Knysna (Illenberger, 1996), deposited following the +/-2m fall in sea level about 6500 BP in South Africa (Ramsay *et al.*, 2002).

Sub-phase (b) below 15cm from the surface consists of mud-rich sediments, dark grey in colour, poor in organic matter and lacking in marine shells like its predecessor. The majority of its sand component is angular in shape and made up of well-sorted, fine skewed medium-sized sand. These physical attributes alone cannot be used in reconstruction of the depositional environment. However, because the distance travelled and the mode of transport affects, for example particle shape (Friedman *et al.*, 1973), it is tempting to suggest that sand present in this deposit was blown in by wind from the surrounding dunes that had formed earlier. This phase accords well with the open marine embayment phase described in the GDN core at Verlorenvlei (Meadows and Baxter, 1999). However, the absence of a radiocarbon age determination means that this can only be speculated upon. If the foregoing argument is true then the non-calcareous organic rich mud present here indicates the initiation of another phase, probably the development of a brackish water wetland. The initiation of brackish water wetland on this prograded coast could have been favoured by wind deposition of silt and water in some of the low-lying areas that were later filled by the contemporary vleis (Davies and Gassner, 1999).

Finally, sub-phase (c), (0-5cm) consists mostly of plant rootlets which burnt out during ignition indicating increased organic matter (43%) in the surface layer. Increased organic matter content together with plant remains is indicative of marshy conditions where marsh grasses have grown and decayed over time (Friedman *et al.*, 1978). This surface layer represents the contemporary vlei environment of Lake Michelle where the growth of salt marsh vegetation has been favoured by the salty water in the vlei (see conductivity level, Table 5.5). Unlike most vegetated salt marshes where sedimentation of fine deposits has increased in surface layers (Mitsch *et al.*, 2000), surface sediments in the LM vlei have low fine deposits. This suggests that the vlei has not been exposed to allochthonous sedimentation but rather to autochthonous sedimentation.

The absence of sand deposits from this surface layer could have been a result of human interference in the catchment. Firstly, the increase in water table following the urbanisation of the catchment could have stabilised the dunes and limited the free movement of sand from nearby dunefields to the vlei. Aeolian activities are dependent on the moisture content of sand particles. The drier the sand, the easier it is to be blown away by wind. Therefore, an increase in the water table following urbanisation would have moistened the sand and limited its movement.

Secondly, dune stabilisation in the area could have limited aeolian activities in the recent past. Sand transportation by wind reduces as vegetation increases on dune formations and urbanisation spreads (housing structures) limiting the free movement of sand as, was the case between Hout Bay and Sandy Bay (Holmes and Luger, 1996). It is also possible that human activities in the vicinity of this vlei have reworked the surface sediments.

Geochemically, phase IV of these deposits, which is the last in the depositional sequence is representative of modern deposits. Sediments of sub-phase (b) and (c) (0 to 15cm), as described above are relatively rich in silt/clay and characterized by higher Cr, Cu, Zn, Pb, Cd, Mn, Fe concentration and organic matter contents than the bottom sub-phase (a). This indicates a textural control on the distribution of these elements. The increase in concentrations of all the above elements between 0 and 15cm probably reflects a coarser fraction in the sediments but in the absence of textural analysis for Unit 1 (Table 5.2) it can only be assumed. Typical high values in sub-phase (c) sediments could be an indication of anthropogenically-induced pollution from

within the catchments. This interpretation is constrained by the fact that higher metal values are also found in some deeper units like phase II. This limitation is based on the fact that changes in textural properties, mineral compositions and the bulk density of sediments upcore affect element concentration. Thus quantifying natural and anthropogenic inputs based on upcore variation in concentration alone could be misleading. However after normalizing the data against total weight % fines (<63  $\mu\text{m}$ ) present in each sample of the core, surface sediments showed increasing trends of some of the elements such as Mn, Zn and Cd while the rest decreased (Figure 5.6). To further quantify for anthropogenic signals, i.e. human-induced pollution, the metal concentration identified from the pristine site should be compared to the apparent elevated concentration in the surface sediments of this core as outlined in section 6.5.1 below. The data used should be normalised for sediment characteristics that control element concentration, this was done in this study.

### **6.2.2 WV-Core (18° 21' 45''E; 34° 08' 15''S)**

The 146cm-long WV-Core (Figure 6.1 and Table 6.1) has been divided into three major depositional phases based on textural variations:

- The lower phase WVI (146 - 85cm) which comprises of dark grey to brown sandy mud with abundant quartz fines.
- The middle phase WVII (85 - 20cm) which has dark reddish brown to pinkish grey, slightly muddy sediments rich in sponge spicules.
- And the upper phase WVIII (20 - 0cm) which is dark grey to dark red, slightly to sandy mud sediments also rich in quartz fines.

Sitting at about 1.46m amsl (Figure 6.1), this core has no marine shells as the previous core did. Considering that the WV-Core is about 1.91m below the LM-Core (Figure 6.1 and Table 6.1), the absence of marine shells from this short core is controversial. However, the presence of sponge spicules is also suggestive of marine influence. Sponge spicules are derived not only from lakes (Harrison, 1988) but also from rivers (Chauvel *et al.*, 1996), bogs and waterlogged soils (Schwandes and Collins, 1994) all cited in Clarke (2003).

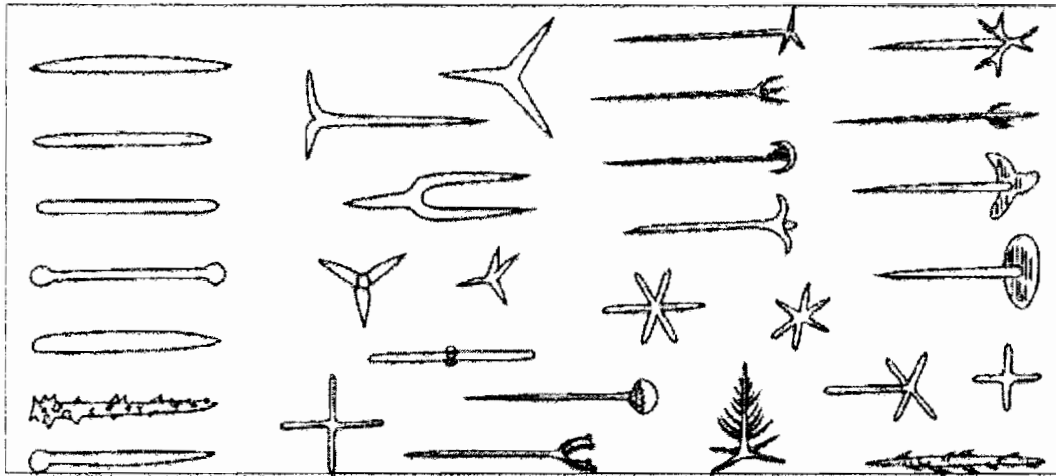

Figure 6.2 Marine and freshwater sponge spicules (after de Laubenfel 1955 in Clarke 2002)

Sponges spicules, (Figure 6.2) normally indicative of marine rather than terrestrial ecosystems can however proliferate and even dominate in freshwater ecosystem as is the case in southern Australia (Clarke, 2003). Gammon *et al.* (2000) explained that this terrestrial proliferation was probably related to a unique confluence of run-off, turbidity, and nutrient conditions. Turner (1985) has used freshwater sponges found in deposits at the Cedar Mountain bog in the southeastern Puget lowland (Washington) to infer water characteristics during the late-glacial period. This study determined that the water was calcareous, aerobic not deficient in  $\text{SiO}_2$ , and within pH range 6.6-8.5.

Even though sponge spicules are good indicators of permanently waterlogged conditions (Clarke, 2003), they have not been fully exploited as palaeoecological tools because of difficulties in taxonomic identification. The occurrence of these sponges in sediments is useful in assisting paleoenvironmental and paleogeographical interpretations. However, the difference between freshwater and marine sponges is that freshwater sponges produce much smaller spicules than marine sponges, typically silt rather than sand-sized and are often missed by researchers looking only at the larger fraction (Clarke, 2003). Therefore, the presence of silt-sized sponges in the WV-Core sediments suggests freshwater conditions during the time of formation.

#### 6.2.2.1 Phase WVI

This phase is characterized by the sedimentation of medium-grained sediment with quartz as the dominant sand component. Sediments of the basal units, between 130-146cm, are composed of medium-sized sand that is moderately well-sorted. On top of

this basal unit is another distinct layer, 85 -130cm, with above 60% sand component (medium to coarse moderately well-sorted) and above 30% mud in its sediments. Although it is rich in mud, the organic matter present is low compared to other units in the profile with lower mud content. Low organic matter at this depth may suggest that the vlei environment during this time lacked potential sources of organic matter such as vegetation, possibly indicating sparse vegetation around the then possibly seasonal vlei. Alternatively, the vlei may have dried out subsequently and the organic matter oxidized. If the former is the case, then increased erosion and sedimentation due to a less vegetated catchment, as well as the mobilization of sand would have been enhanced. The absence of charcoal debris in this sedimentary phase lends further support to the hypothesis of reduced vegetation cover around the Wildevoelvlei during this time.

As the sediments were deposited probably after the Holocene transgression, no marine deposits would be expected and therefore the sediments could only be fluvial, or aeolian deposits derived from within the catchment. Understanding that these are non-point source wetlands, fluvial or alluvial activities as source of sediments in the contemporary vlei would have been minimal if not absent. Reduced vegetation cover means drier conditions. There is evidence for mid-Holocene aridity elsewhere on the southwestern Cape during this time around Verlorenvlei (Meadows *et al.*, 1996).

Geochemically, sediments of this phase with a relatively high mud content also have a high concentration of heavy metals. Clay-rich sediments in this layer absorb reasonable quantities of trace metals. Based on the available evidence in this research, no reference could be made as to the type of climate that prevailed during this sedimentary phase.

#### 6.2.2.2 Phase WVII

The central phase WVII is characterised by moderately well-sorted medium sand with some siliceous sponges spicules within its matrix. As discussed in section 6.2.2, sponge spicules maybe good indicators of permanently waterlogged conditions, albeit with limited application in environmental reconstruction. There is no possibility at this elevation and age that these sponge spicules are of marine origin. The absence of shell fragments in sediments at this depth is consistent with this view, although

perhaps the low pH value (4.8) (Table 5.10) could have resulted in the dissolution of any marine shells. However, the presence of sponges at this depth suggests that a waterlogged depositional environment prevailed at the time of deposition. The presence of orange mottling and plant root remains further supports this argument. Mottling results from post-depositional anaerobic/aerobic processes under seasonally saturated swampy conditions (Holmes, 1998).

Isolated well-rounded pebbles and the unusually high salt concentration in respect to other layers indicates that these sediments were deposited when the Salt Pan (now Lake Michelle) was still linked to Wildevoelviei by an estuary.

Heavy metal concentration in the lower section (87-38cm) of this phase recorded the lowest values in the sequence, although concentrations tended to increase with depth and peaked at 20cm (mainly Fe and Mn) below the surface. High Fe and Mn concentrations indicate the prevalence of waterlogging and peat formation processes (Lowe and Walker, 1984), therefore reinforcing the view that the deposits of this layer were laid down in a waterlogged condition. Textural variability as well as the organic matter concentration favoured heavy metal enrichment at this depth.

### 6.2.2.3 Phase WVIII

Measuring just 21cm in thickness, this final depositional phase is similar to phase WVI in that, as well as being dominated by medium sand, it consists entirely of quartzitic sand. Lying unconformably above the underlying phase, this most recent phase has no sponge spicules and as with the LM-Core, can be divided into three sub-phases. Firstly, sub-phase (a), is a dark grey laminated clay-rich layer relatively high in fines (silt and clay) and a proportional decrease in sand; it is classified as sandy mud. This dark laminated layer lies below the contemporary vlei surface that commenced with the deposition of sub-phase (b).

Sub-phase (b) (8-14cm), unlike its predecessor, is sandier with reddish sand (probably oxidized) and also very rich in plant remains. Sand in these two sub-phases could have come from coastal dunes that were formed during the mid-Holocene highstands about 6000 years ago.

The turf layer occupying the surface from 8cm represents sub-phase (c). Deposits of this phase were excluded from the particle size analysis for the same reason as deposits of phase (c) of the LM-Core. This phase has moderately acidic sediments with low salinity, however mean organic matter peak in sub-phase (c). High-level organic matter derived from plants and vlei vegetation may well have increased as sewerage was emitted into the vlei following the rapid urbanisation.

Geochemically, concentrations of Fe, Cu, Cd and Pb, all of which are markedly influenced by anthropogenic activities, peak together while other elements such as Zn, Cr and Mn decreased (Figure 5.12). With silt and clay content below detection limit, it is tempting to relate these signals to contemporary human activities in the close vicinity of the vleis. Higher Pb, for example, may suggest the anthropogenic input of this element from the use of leaded petrol by cars and machinery. The issue of surface pollution is explored in detail later in the discussion (section 6.5.1) when other factors favouring metal enrichment, besides particle grain sizes will be introduced.

### **6.2.3 GR-Core (18° 23' 10" E; 34° 14' 20" S)**

Located in the Cape Peninsula Nature Reserve less than 50m from the sea (Figure 3.1), this 3.4m core sits at less than 1m amsl of the modern datum (Figure 6.1 and Table 6.1). Due to time constraints, the exact height above sea level could not be measured. A nominally infinite date of +/- 43 000BP from the bottom sediments of this core indicates a long Quaternary record of deposition and sedimentation. Contamination with older sediments while coring in the field and in the laboratory could account for the age discrepancy in this basal sediment (as well as those from the LM-Core with a similar age).

Textural and chemical variations that allow diagnoses of the environments of deposition in the first two cores seem to be lacking in this core. The mud content is generally low with a maximum of 19% in the upper 24cm of the core. Lithologically, it comprises entirely of medium-sized sand, very well sorted (mainly quartz) (Tables 5.17-19), and symmetrically skewed. This suggests that deposits in this core may have a common origin and were deposited under similar environmental conditions.

Organic matter content significantly increases from 28% at about 24cm below the surface to 76% at the surface, and is higher than in the previous cores. The increase in organic matter content in these surface sediments is a response to increased marshland vegetation favoured by abundant water in the vlei.

The study site is close to the sea and even a marginal increase in sea level may cause the entire vlei to be flooded. However, the lack of any marine evidence (e.g. marine shell fragments) raises concern about post depositional activities. It is speculated in this research that the high acidity level in sediments found at this site (Table 5.20), dissolved any evidence of marine shell accumulation. Precipitation of calcium carbonate, the chief component of the skeletons of marine shells, increases in alkaline sediments as oppose to neutral solutions (Friedman, 1961).

Heavy element concentration in this core as in the other cores, is influenced by textural variability (Figure 5.14 and 5.15). After normalizing the data against textural variability, metal concentration is shown to decrease towards the surface (Figures 5.18 and 6.4), as was expected of a "pristine" site. The fact that all the metals after normalisation show a decreasing trend towards the surface means element concentrations at the site is solely controlled by particle size distribution. This suggests that human interference if not minimal, is entirely absent. The observed enrichment in the central deposits at 2.8m below the surface is a response to the relatively high percentage of mud. The geochemical implications of the pattern observed here and in the previous cores are further discussed below.

### **6.3 GEOCHEMICAL IMPLICATIONS**

Tables 5.8, 5.15 and 5.22 illustrate the correlations between the various elements, silt and clay. Strong positive correlation exhibited by compounds such as Fe and Mn, and other elements in the sediments suggests that these compounds are effective scavengers of the other elements. Bodur and Ergin (1994, cited in Baptista *et al.*, 2000) highlighted the ability of Fe and Mn compounds (oxides, hydroxides, carbonates, sulphides) to scavenge trace metals from solution, before or during diagenesis. They further suggested that there is a possibility that Fe and Mn-oxyhydroxides and sulphides, together with organic matter, are involved in redox processes associated with the enrichment of a number of trace metals. Lowe and Walker (1984) also noted

that high concentrations of Fe and Mn mark the prevalence of waterlogging and peat formation processes in a deposit. However, organic matter, which is often considered to be a scavenger element, shows a weak or no association with trace elements in these cores. Individual elements strongly correlate with each other, as noted in Chapter five, suggesting that they have similar or common sources and/or similar enrichment mechanisms (Baptista *et al.*, 2000).

To conclude, the abundance and distribution of elements in the Noordhoek basin as presented by the two cores is to a large extent determined by sediment size and organic carbon content. As a result of both surface and bottom richness in trace elements, it is difficult to conclude that anthropogenic activities alone in the catchment influenced the distribution and the abundance of these elements. Naturally these elements are known to be present in catchment soils (Lowe and Walker 1984), thus making it possible that they could have been deposited together with sediments from natural erosion in the past and with surface concentration due to the accelerated erosion from the catchment following urbanisation. Interpretation of these changes in concentration is constrained by noise from chemical speciation which affects oxidation and mobilisation rates in metals that must be eliminated. These constraints include variation in the mobility of different elements under different conditions besides textural control which has been dealt with above.

## **6.4 DEVELOPMENT OF THE NOORDHOEK COASTAL LANDFORMS**

A summary of the origin and history of the development of the coastal landforms of the Noordhoek basin is given in this section. Sea level fluctuations (regressions and transgressions) from OIS 5e to OIS 5c determined with a limited degree of accuracy, contributed significantly to sand and ultimately the coastal dune deposits on the contemporary beach. Figure 6.3 schematically illustrates the interpreted stages in their evolution.

### **6.4.1 Upper Pleistocene development**

The origin and development of coastal wetlands in the Noordhoek basin can be linked to global scale climatic change and marine transgressions and regressions. Reid *et al.* (1999) noted that the Wildevoelvllei was in the past linked to Lake Michelle (Salt Pan) and the Atlantic Ocean as is evident from the abundant marine shells at the Salt Pan

(LM-core between 405-420cm). With no absolute date obtained from the LM basal deposits, they have been assigned to deposits of OIS 5e and OIS 5c when sea level reached a maximum of approximately 6m amsl.

Pleistocene deposits (from OIS 5d-OIS 2), interpreted in the LM-Core at between 345-405 cm are virtually absent from the WV-Core. Marine regression (expansion of continental ice) following the last interglacial period saw a drop in sea level to approximately -130m amsl (Reid *et al.*, 1999) expanding the Noordhoek coastline and transforming its ecology, climate, pedology, geology and hydrology. Emerging features such as vleis could have provided a new habitat for terrestrial vegetation and animals during glacio-eustatic sea-level lowstands evident from the abundance of charcoal and plant remains in organic-rich deposits at Lake Michelle (Figure 6.1). Sand dunes (with remains of shell deposit), left behind during this regression further separated these vleis from the main sea.

#### **6.4.2 Holocene**

In the southwestern Cape as in the rest of South Africa, the Holocene transgression is recorded in back-barrier estuarine fill sequences (Ramsay *et al.*, 2002). Sedimentation during this transgression resulted in the formation of new layers on the pre-existing submerge shoreline deposits (Ramsay, 1994). Reid *et al* (1999) explained that as sea level dropped to its present position, the barrier complex dunes, berm, foreshore and backshore lagoon prograded seaward. They also cited the wreck of the Kakapo which ran aground on the southern part of the Noordhoek beach in 1900 as the most recent evidence for continuous progradation on the coast.

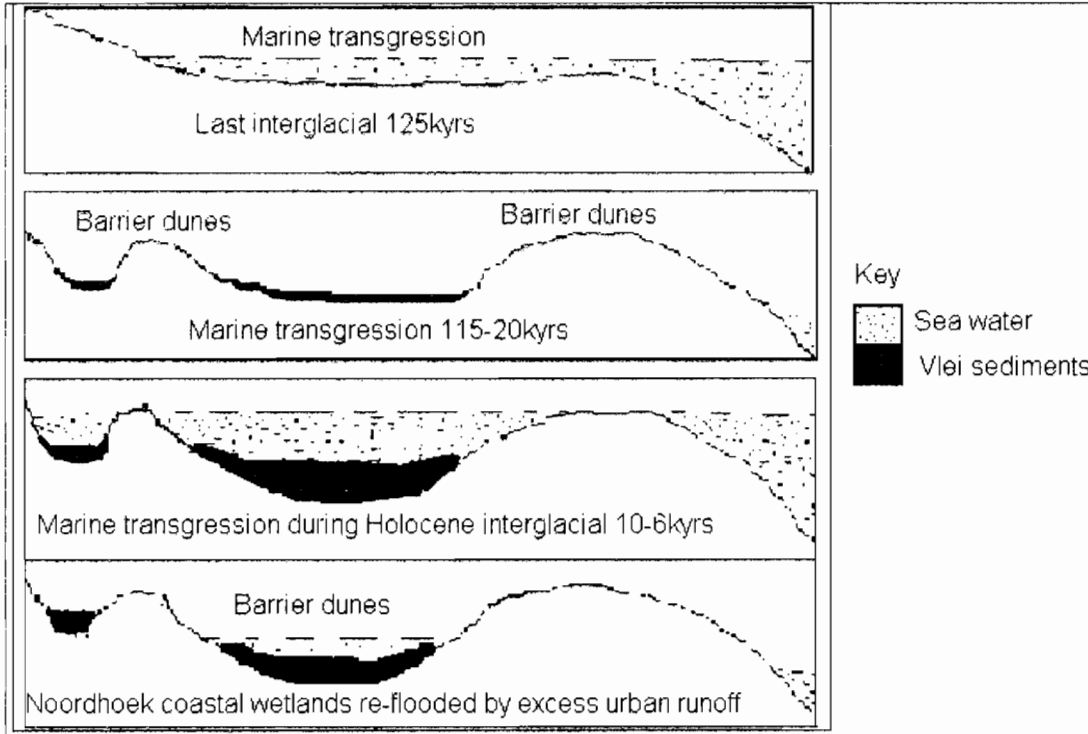

Figure 6.3 Hypothesized development of the coastal Noordhoek landforms

### 6.4.3 Evolution of the Noordhoek wetlands

Deposition and formation of coastal dunes located landward of the present shoreline of the Noordhoek basin resulted from sea level fluctuations (both short and long-term), which in the past influenced the supply of sand to the beach. Long-term fluctuations in sea levels have been established for the coastal Cape region (see e.g., Illenberger, 1996, Shaw *et al.*, 2001 and Bateman *et al.*, 2004). The mid-Holocene transgression reported elsewhere in the region (see Illenberger, 1996 and Meadows *et al.*, 1999) was followed by a marine regression when the coastal zone prograded seaward, leaving behind an extensive marshland (Rogers, pers.com. cited in Davies and Gassner 1999).

Bateman *et al.* (2004) have offered a comprehensive account on the exact association between barrier dune formation on the one hand, and sea level and coastline fluctuations on the other hand. Prior to the Bateman *et al.* (2004) report, previous authors (e.g., Tankard and Schweitzer (1974), Dingle and Rogers (1972a) and Tinley (1985) in Bateman *et al.*, 2004) proposed that during periods of marine regression, the adjacent continental shelf would be exposed to wind deflation, thus encouraging more sediment supply than would have occurred during transgression highstands. On the contrary, Bateman *et al.* (2004), concur with Illenberger (1996) that dunes and

aeolianites were formed in the southern Cape coast from OIS 5e to the OIS 5/4 boundary during marine transgression. It is tentatively suggested by this research that sand deposits, between 420-405cm of the LM-Core, were deposited during this period given that a date of 50 000BP from the preceding layer implies that this shell-rich layer could coincide with the OIS 5/4 boundary.

At the end of the LGM stage OIS2 to OIS1 (Holocene) marked by rapid ice decay from the continental mass, sea levels in South Africa increased by about 110–130 m (e.g. Illenberger, 1996 Ramsay *et al.*, 2002). The sandy phase at between 345 and 100cm in the LM-Core, poor in organic carbon like the dune systems of the Strandveld Formation, (Bateman *et al.*, 2004) is speculated to have formed around the start of the Holocene. These supposedly unconsolidated sediments could have been reworked from coastal dunes into the low-lying marshes (study site) by wind and recent human activities. Predominant southwesterly wind activities on this coast has also favoured the deposition of silt and water in some of the low lying areas that were later occupied permanently by two pans; the Noordhoek Saltpan (Lake Michelle) and the two Wildevoelvlei pan systems (Davies and Gassner, 1999).

Human-induced erosion in the recent past has replaced and now dominates sea level fluctuation as the major source of sediments to these coastal wetlands. Increased lacustrine deposits in the LM-Core, as at Verlorenvlei are associated with colonial occupation of the region some 300 years ago (Meadows *et al.*, 1999). The arrival of people in the Noordhoek valley signaled the transformation of the catchment land surface through mining, agriculture (ploughing), clearing, urbanisation and the introduction of new species that changed sedimentation patterns. From the onset of colonial occupation in the region (Deacon, 1992), increasing human disturbances evident in changes in textural and geochemical composition of surface sediments and the spatial land use noted earlier, are examined below.

## **6.5 ANTHROPOGENIC INFLUENCE ON THE NOORDHOEK VALLEY**

### **6.5.1 Surface pollution**

Elemental concentrations indicate textural control on the geochemistry of sediments which has been adjusted by normalizing the data set against particle size. Elevated values in surface sediments from the Noordhoek sites may indicate recent human

activities through the transformation of the natural land surface due to different land uses. However, these values need to be compared with natural catchments of a similar geology in order to accurately assess the level of anthropogenic input on the studied site. Therefore, it is necessary to compare background signals from the “pristine” core from Groot Rondevlei as a reference point with the two Noordhoek cores. Elevated levels of Fe, Pb, Zn, Mn, Cd and Cu seen in the surface sediments of the LM and WV-Cores are more notable after comparing them with the generally lower concentrations found in surface sediments of the Groot Rondevlei core (Figures 5.18 and 6.4).

Elemental abundance and bulk concentration, apart from human inputs and granulometric controls, vary according to the physical and chemical forms of individual elements, which in turn control their mobility and circulation in the environment. The effect of speciation on the rate of metal oxidation, mobilization and remobilization in different environments is important given that biological toxicity and bioavailability is strongly affected by the redox state and the chemical form of each metal (Ferguson, 1991). Under redox conditions, heavy metals are removed from solution thereby increasing their mobility (Ferguson, 1991). The redox state itself is controlled by the rates of oxidation and reduction. Other conditions, like lowering pH (which can dissolve metal from solid phases) and increasing the concentration of inorganic salt, enhances solubility and consequently the mobility of heavy elements.

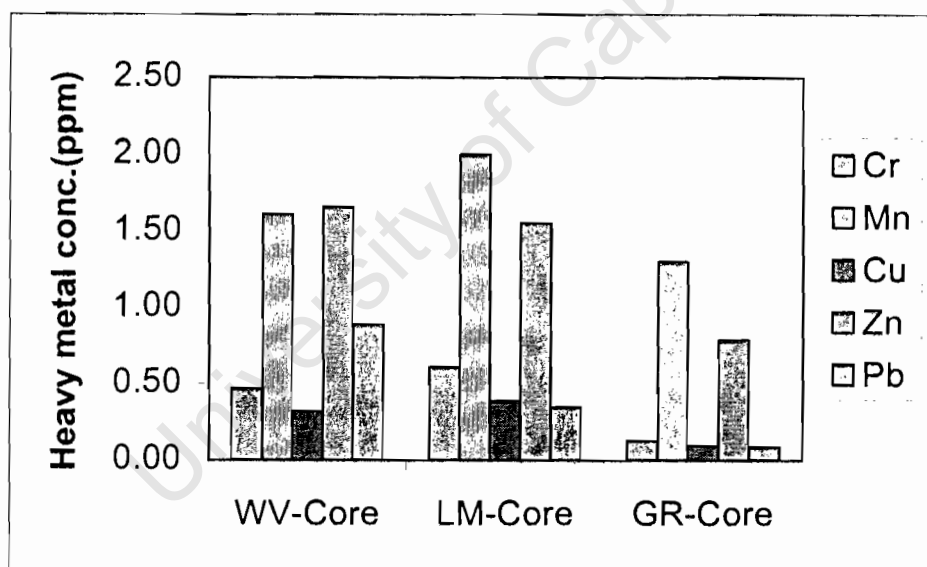

Figure 6.4 Metal concentrations in surface sediments at the three sites

In conclusion, natural processes as well as anthropogenic activities have led to the enrichment of trace elements in the Noordhoek basin, since elements with substantial anthropogenic overprints, such as Pb, Cu, Zn, Cd, show a high concentration in the upper horizons of the sediment (Figure 6.4). However, within the Noordhoek valley, Wildevoelvlei has higher Fe, Cu, Zn and Pb concentrations than Lake Michelle (Figure 6.4). Gassner (1999) reported that, polluted water from the nearby industrial site (Heron Park) enters the Wildevoelvlei through the stormwater outlet pipe, which drains the industrial area and is situated about 20m from the vlei. The absence of major sources of polluting elements in the immediate vicinity of Lake Michelle probably limits the quantity of these elements in its sediments examined. The old municipal waste site next to Lake Michelle, containing wastes ranging from household wastes, agricultural use of sludges, fertilizers and pesticides containing metals like cadmium, could have leached contaminants into the vlei. Burning of fossil fuels (of very limited effect) by cars and Zn and Pb from wearing car tyres are the potential sources of metal enrichment for all the vleis in the valley.

Land transformation and land use changes are thought to have had a strong impact on the spatial and temporal distribution and abundance of the elements mentioned above. Therefore, it is important to understand the pattern and trends in land use changes over the past 56 years.

### **6.5.2 Land use and land cover change**

In section 5.5 of Chapter Five, results of spatial analysis of land use and land cover changes on the Noordhoek basin from 1944 to the year 2000 were described. The patterns and trends observed need to be accounted for. A good understanding of major drivers of the land use and land cover changes is necessary to accurately project future land uses in the basin. The pattern and trends in land use cover at this site, as well as in the rest of South Africa, are related to population growth coupled with cultural, political and economic conditions (Biggs *et al.*, 2002).

In the late 1980s, the Noordhoek population increased from a low base to about 3,000 inhabitants to about 54 370 inhabitants in 2002 (N M & Associate Planners and Designers, 2002). According to the Noordhoek-Sunnydale Structure Plan Report (NSSPR), Noordhoek valley will increase to 72 000 people by 2015. However, growth

and settlement patterns within the valley vary considerably from a low growth rate to a high growth rate. Masiphumelele, meaning, "let us succeed" (in Xhosa) officially established as a permanent settlement in 1990 has a high growth rate (Davies and Gassner, 1999). Purseglove (1998) reported that the 4 495 household in Masiphumelele have a total population of 22 500 people. Increase in population numbers in an informal settlement such as Masiphumelele where sanitation conditions are poor and refuse removal non-existent explains why it has become the highest source of non-point pollution in the valley.

Population growth means increased demand for living space and food resources. Growth patterns which have already impacted on the natural systems within the Noordhoek valley, if not well managed and directed, will exacerbate with increasing population growth rates and will add pressure to the already sensitive wetlands. In summary, increased urbanisation in the Noordhoek basin from 1944 to 2000 was achieved at the expense of other major land cover types. This will be discussed below.

Apart from population growth, economic and political factors influenced land use changes in South Africa prior to the end of Apartheid in 1990. Variability in cultivated land in the former White Group areas after 1960 was probably due to the cultivation of marginal lands resulting from the introduction of agricultural subsidies by the Apartheid government aimed at stimulating domestic production due to economic sanctions (Biggs *et al.*, 2002 pp 423). Between 1996 and 2000, the decline in agricultural land cover in the study area was probably a response to increase urbanisation. Biggs *et al.*, (2002) explained that prior to 1980, increased demand for agricultural product was met through the expansion of the area under cultivation, and after the '80s increased production was achieved through technological innovations that increased yields per hectare.

Spatial coverage of natural vegetation in the catchment decreased markedly during the study period as much of it was colonised by alien species or converted into residential areas. The initial increase in alien vegetation correlates with a steady increase in urbanisation. Use of these alien plants for firewood and as windbreaks against the strong southeasterly winds that blow through the basin during the summer months have been reported in other areas of the western Cape and in the Noordhoek basin. In the coastal lowlands of the southwestern Cape, the invasive Australian acacias *A.*

*cyclops* (Rooikrans) and *A saligna* (Port Jackson willow) introduced around 1850 to stabilize active dunes have naturally spread to other areas and grown to be the most dominant species of alien vegetation in the basin (Heinecken, 1985). In the early 1970's, many of the Cape's nature reserves were being overrun by these alien species and there was a need to eradicate them (Cowling *et al.*, 1995). "Working for Water" is a Department of Water Affairs and Forestry project aimed at the eradication of alien invasive plants that threaten indigenous vegetation and water resources in the region. The decline in coverage by these species from 1989 to 2000 (Figures 5.20 and 5.21) could therefore be attributed to the efforts of the Working for Water project. Clearing acacia for firewood by residents from neighbouring townships could have also contributed to its decline in the valley.

The steady decline in the area occupied by beach and dune sediments could also be attributed to recent human activity such as building and construction, dredging and canalisation of existing wetlands and stabilisation of dunes through the introduction of alien plants. These developments have affected the existence of the corridor sand strait that once linked Noordhoek and Fish Hoek beaches (Heinecken, 1985). This strait or headland bypass system, fed by the free flow of sand between the two beaches has had its source interfered with by urban development and dune stabilisation in the basin. This has occurred in the same way as the drift sand system that once linked Hout Bay and Sandy Bay (Holmes and Luger, 1996) that had its transportation route interfered with by urban encroachment.

As a consequence of population growth, the amount of wastewater effluent and stormwater presumably entering into the existing vleis increased, consequently increasing the waterbodies coverage. The waterside housing development project at Lake Michelle encouraged the dredging of the Salt Pan in 1974 as part of the development scheme. This changed the pan into a permanent vlei. Heinecken (1985) reported that, until dredging, the hard surface of the Salt Pan was used as a racing track in the summer months prior to development. The Wildevoelvlei, which was seasonal, was transformed into a permanent body with the establishment of a permanent sewerage works in 1977 above the wetlands. This treatment plant discharged treated sewage into the wetland, thereby transforming it into a permanent water body. Designed in 1977 with a carrying capacity of only 6.3million l/day, its

capacity was upgraded to 14million l/day as a result of increased population (Davies and Gassner 1999).

Urbanisation has encouraged the conversion of sensitive and agricultural lands into human living space and, if no urgent intervention is made with regards to the projected population in 2015 (NM & Associate Planners and Designers 2002), these impacts may significantly intensify. If more development in the valley such as proposed in the "Noordhoek proposed structural plan" is approved we will see an additional 700 housing units incorporated into the existing 4 495 structures and a school in the Masiphumelele township (southeast of Sunnydale, Figure 6.5) (Davies and Gassner, 1999). Further developments on Sunnydale and the completion of phase 4-9 of Lake Michelle Estate approved in 1999 which is above the 5m amsl contour limit will see a readjustment of the urban edge limit around these places. These proposed developments together with the existing structures will have far-reaching implications on the natural functioning of the valley.

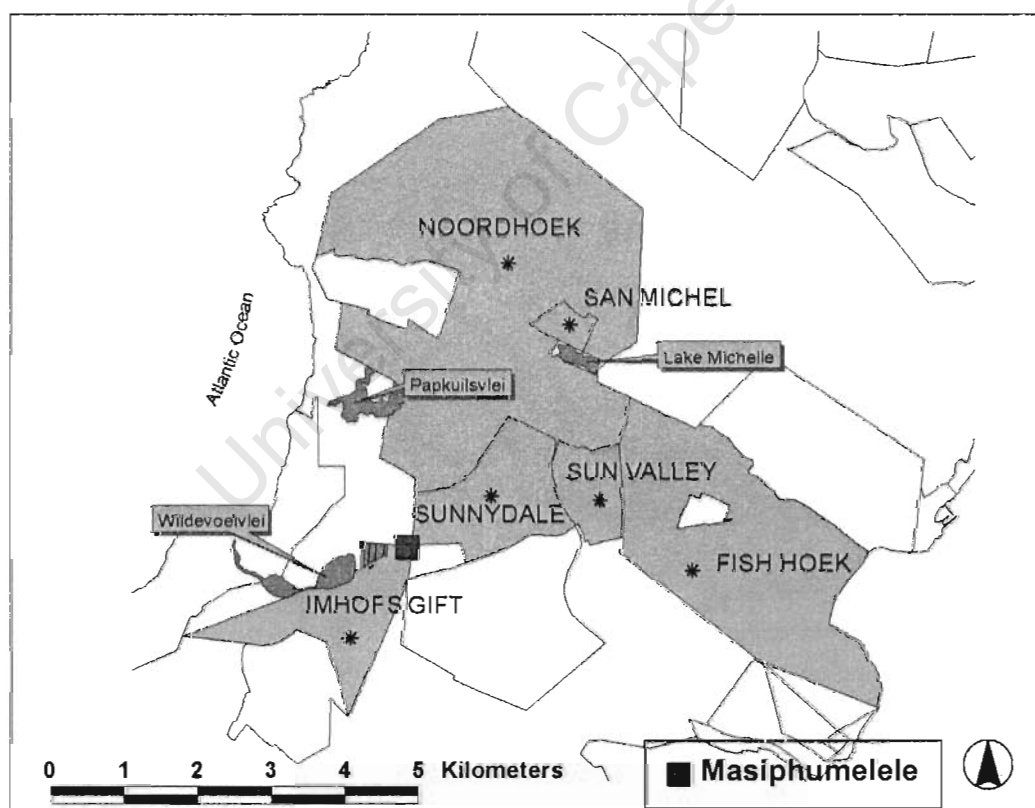

Figure 6.5 Townships in the Noordhoek valley and the environs

Firstly, the proposed increase of the sewer capacity from 14 million l/day to 21million l/day and plans to incorporate newly developed townships and housing into the Wildevoelwei wastewater treatment works will result in increased sewage discharge and further increases in the areal coverage of the waterbodies. Increase in runoff from increased urbanisation, Ringdahl (1995) speculated, would contribute to raising the water table in the basin and so enhance the development of a larger channel between the Wildevoelwei and the sea, thereby increasing the areal coverage of water bodies in the system. This may already be evident given the 2% increase in waterbodies from 1996 to 2000.

Secondly, increased development means more of the natural catchment will be hardened, thereby increasing the amount of runoff and consequently decreasing infiltration and recharge of the two aquifers situated in the valley. Reduced recharge and extraction of groundwater implies an increase in seawater intrusion and the loss of the aquifers.

Urbanisation during the 56 years of investigation consumed a considerable portion of land cover (from 0% in 1944 to 24% in 2000) at the expense of all other land uses with the exception of waterbodies. All the other land uses lost much of their land cover to urbanisation with a record high of 30% lost in indigenous fynbos vegetation. This period witnessed a conversion of land formerly used for agriculture, forestry and recreation at a rate unprecedented in the history of the basin. This rate of conversion has implications for natural resource management and necessitates the need for data on land use and land cover patterns, so as to be able to predict and control future land conversion. Beside population growth, economic and political factors as in the rest of South Africa, have contributed to the observed trend and pattern of land use in the Noordhoek basin.

Urbanisation in the Noordhoek valley has resulted in changes in land use and land cover; erosion has been accelerated, traffic increased, more waste produced, and the amount of domestic wastewater increased significantly (Ringdahl, 1995). Evidence of these changes stored in the adjacent wetlands over time has been used in the previous section to account for the temporal chronology of human disturbance in the recent past.

The upper 15cm of sediments from the Noordhoek cores shows an upcore increase in heavy metal concentration together with organic sedimentation. This upcore trend in inorganic geochemical data indicates pollution and changes in the nature of sedimentation driven by recent land use activities in the catchment. However, the absence of high-resolution absolute ages limits an understanding of the exact chronology. Similar studies have been done elsewhere and show the same pattern. For example, research on Lake Pinto in California and the floodplain wetlands of South Africa both showed that increased pollution and sedimentation in the surface sediments is linked to land use activities and aperiodic flooding (Plater *et al.*, 2003). A chronology, based on high resolution dating, reveals a shift from minerogenic to biological sedimentation and finally to biological productivity in Lake Pinto during the 1950s. In South Africa, recent human activities and changing land use patterns on the Mkuze River catchment have resulted in increased sedimentation in the floodplain wetland since the 1960s (Plater *et al.*, 2003).

Spatial land use changes observed in the Noordhoek basin between 1944 and 2000 are consistent with the chronology established from geochemical examination of cores taken from its wetlands' which saw an upward trend in element concentration and land conversion. This is because the increase in land conversion and intensification of certain land use activities is reflected in the temporal distribution and abundance of trace elements in sediments.

## **6.6 CONCLUSION**

This chapter has reconstructed the environmental changes and step-by-step development of the Noordhoek wetlands and its environs from the late Pleistocene to the year 2000. Sedimentological and geochemical evidence from the three sites and data on spatial land use changes has been used in association with local (Reid *et al.*, 1999) and other regional studies (Baxter *et al.*, 1996, Meadows *et al.*, 1999, Compton, 2001 and Bateman *et al.*, 2004) to infer both local and regional environmental changes driven by natural and anthropogenic forces. The final chapter reviews the aims and objectives of the study, outlines problems encountered during the research and proposes directives for further research in the area.

---

## CHAPTER 7

---

### CONCLUSIONS AND FUTURE RECOMMENDATIONS

---

#### 7.1 INTRODUCTION

In Chapter Six, reconstructing environmental change from the late Pleistocene to the year 2000 was attempted based on the multi-disciplinary forms of evidence presented in Chapter Five. This chapter reviews the aims and objectives of the research outlined in Chapter One and considers if these have been fulfilled. Problems encountered during the research and directions for future work in this area will conclude the chapter.

#### 7.2 REVIEW OF AIMS AND OBJECTIVES

The main aim of this research as stated in Chapter One has been to reconstruct palaeoenvironments and distinguish the relative influence of climate, sea level change and human activities in the late Quaternary on the Noordhoek basin. Human activities during the late Holocene have impacted on the landscape of the Noordhoek basin. Therefore, an appreciation of processes like erosion and sedimentation within the catchment that may have impacted on the development of these wetlands from when human-induced processes replaced natural processes is important. To achieve the goals of this research, specific objectives were designed. These objectives are individually presented and discussed below to assess the achievement of the research.

- I. The first objective was to describe the southern Cape Peninsula wetlands and their respective environments. Chapter 3 was devoted to a discussion of the contemporary environment of the Noordhoek valley with particular attention to its geology, pedology, geomorphology, hydrology and climate. Being coastal lowlands, most sediments are derived from the sea and to a lesser extent from its catchment. In the absence of a major feeding stream, wind is the second major transportation and depositional agent.

Increased runoff and dumping (human action) during the recent past has contributed to the surficial sediment load in the Noordhoek wetlands. The objective of describing the wetlands and the associated catchment has thus been fulfilled.

- II. The second objective was to assess the spatial and temporal changes in the Noordhoek basin and catchment during the recent past. This has been achieved by evaluating spatial land use and land cover changes from 1944 to the year 2000 as presented and discussed in Chapters 5 and 6 respectively. Understanding recent spatial changes was fundamental in establishing the rates and direction of human intervention in the Noordhoek basin. Analysis of these spatial and temporal changes on this catchment complemented chronological analysis of top sediments.
- III. Describing the physical, chemical and geochemical properties of sediments from the LM-Core, WV-Core and GR-Core has been achieved. Relationships between these variables were established and complemented each other in understanding the changing depositional conditions as well as reconstructing past environments and climates in the valley. Sediments from the LM-Core were useful in characterizing changing depositional environments dating back to the late Pleistocene, the LGM and the Holocene.
- IV. Objective four, which required the establishment of stratigraphies from the LM, WV and GR sedimentary cores, has been completed and is presented in Chapter 6. Sedimentary units in each of the cores were described based on grain size, sediment component, organic percentages and colour. Achieving this enabled a better categorisation of the depositional environments and sedimentary sources, and has facilitated direct comparison between and within the cores.

- V. The fifth objective was to establish a chronology for the deposits as well as dating the samples. Chronologies have been established for each of the core using the established stratigraphies and radiocarbon dating. Radiocarbon dating of the basal sediment of the LM and GR cores has not been very successful because respective dates of 50 000BP and 43 000BP are beyond the radiocarbon age limit. Samples from the LM and WV obtained from the middle and the top of the cores may provide a more resolved chronology for the area, although the age determinations are still in progress. Dated chronologies from these cores will allow for direct comparison within and between other sites within the winter rainfall region for a comprehensive understanding of the regional synthesis.
- VI. As for objective six, deducing changing depositional environments from the stratigraphic units has to a limited extent been successful. Based on the LM-Core, depositional conditions are interpreted as having changed from a highstand marine environment (125k years) to a lowstand fluvial environment (115 – 20k years ago) during the LGM. From the LGM, depositional conditions again changed to highstand marine until the late Holocene when wind activities and human modification of the landscape returned the vlei into a relative lowstand depositional environment. In the absence of high-resolution dates for the recent deposits and their strata, little can be said about the annual sedimentation rates as was estimated for the Verlorenvlei (see Meadows and Baxter, 1999).
- VII. Reconstructing the late Quaternary environment of the Noordhoek and southern Peninsula wetlands using sediment deposits has been successful with an attempt to establish the chronologies of events from the sedimentary facies discussed in Chapter Six. However, lack of corresponding dates for most of the layers limits the establishment of a comprehensive reconstruction especially for the late Holocene. The record for this epoch seems to be incomplete due to interruption in sedimentation. From the sedimentary deposits, it is reasonable to

conclude that the Noordhoek basin responded in accordance with the rest of the sub-winter rainfall region during late Quaternary perturbations. However, other evidence such as pollen analysis, needs to be explored and integrated into these findings for a clearer understanding and comparison of events and climate during the late Quaternary in the area and in the rest of the sub region.

VIII. The significance of vlei sediments in environmental reconstruction of the Noordhoek basin has been stated. Characteristic changes in sediment properties and composition reflect environmental changes during the period under investigation. The successful application of sediments *per se* in environmental reconstruction from the Noordhoek wetlands notwithstanding the many limitations posed by this method (see section 2.3.1) gives hope for further application of this Quaternary evidence in future studies in the southwestern Cape where it has thus far not been widely used.

An understanding of the trends and threats posed by humans on the development of the Noordhoek wetlands evident in the geochemical, sedimentary, organic and spatial land use changes have been established. Failure to establish an accurate baseline which management could use to attempt to restore these sensitive features to pre-impact levels was effectively a result of poor age resolution. Understanding past fluctuations alone should guide management in predicting the future in the case of changes in local and global climates. The history of the developments of the wetlands and their present day location at below 5m amsl highlights their sensitivity and thus reiterate the need for proper management based on a clear knowledge of the past. To understand the impact of future change in climate or land use on these wetlands requires an understanding of the natural variability of sea level change, climate and human influence.

### 7.3 FUTURE RESEARCH DIRECTIONS

It is impossible to fully understand environmental changes at any given site by relying solely on a single source of evidence and without considering other independent types of evidence. Therefore there is the need for a multi-disciplinary approach to disentangle the complex signals stored in vleis sediments for late Quaternary environmental change in the Noordhoek valley. Further research into the late Quaternary vegetation history in the Noordhoek basin using pollen analysis will complement the sedimentological results presented so far. The application of a multi-disciplinary approach will help clarify an understanding of the underlying processes and the forcing mechanisms of change.

Research on other vleis in the region needs to be integrated in order to build a complete regional picture. Given that most of these vleis are now located in the Cape Peninsula National Park and therefore should have had minimal interference from human activities may present an undisturbed but complete history of environmental change dating back to late Pleistocene.

Limitations presented by the application of radiocarbon dating to sediments deposited more than 40 000 years ago, as is the case with the LM bottom sediments, require that other suitable radiometric techniques be employed. This will help provide a sequential chronology with which to make meaningful comparison within and between sites outside the winter rainfall region and also between the different proxies. The application of  $^{210}\text{Pb}$  for example, could provide records for decadal, sub-decadal and centennial changes in the surface sediments of the two Noordhoek cores. Application of pollen composition as a proxy for vegetation change in the top sediments can also be employed to distinguish human influence from climatic influences during the late Holocene. Tibby (2003) suggested that increased rates of vegetation change in the late Holocene in the absence of similar rates of independent climate change could be a response to human action. Applied in New Guinea, this approach could be adopted in the study region and South Africa.

## 7.4 CONCLUSION

The Noordhoek wetlands and their catchments have been impacted by major environmental changes before and during the colonial settlement of the southwestern coast of South Africa. Sediment cores and spatial analysis provide records of the origin, processes involved in the formation of these wetlands and the transition from "pristine" environmental conditions driven by natural processes to human induced processes. Recent human activities have combined with natural processes, such as fluctuations in sea level and climate change, as the most prominent agents of environmental change in the Noordhoek basin as shown in the case of Verlorenvlei. Due to the nature of evidence used, it is difficult to distinguish between anthropogenic and natural processes responsible for change in the basin. The absence of high precision dates on the sediments, limits the research from developing a better chronology for the area and the timing of the transition. However punctuated, a sequence of events is apparent from the Noordhoek deposit which adds to the already emerging pattern of late Quaternary environments for the winter rainfall region.

---

## REFERENCES

---

- Agar, MR; 1988: Late Quaternary vegetation history of the fynbos biome: A case study from the Cape of Good Hope Nature Reserve. Unpublished Bsc Honours Thesis, University of Cape Town.
- Akroyd, TNW; 1957: *Laboratory testing in soil engineering and soil mechanics*. London Academic Press.
- Akunji, EU; 2001: The geomorphology and sedimentology of a sand fan in the Silvermine River Valley. Unpublished Honours thesis, University of Cape Town.
- Baptista, JA, Smith, BJ and McAllister JJ; 2000: Heavy metal concentrations in surface sediments in a near shore environment, Jurujuba Sound, Southeast Brazil. *Journal of Environmental Pollution* 109, 1-9.
- Ballantyne, AO; 1956: Reconnaissance soil survey, section 2. Report on soil and land use survey. Copperbelt, Northern Rhodesia, 15-25. Dept. Agric., Lusaka.
- Barber, KE; 1981: *Peat stratigraphy and climatic change*. Balkema, Rotterdam.
- Battarbee, RW; 1999: The importance of palaeolimnology to lake restoration. *Hydrobiologia* 395/396, 149-159.
- Bateman, MD, Holmes, PJ, Carr, AS, Horton, BP and Manoj, MK; 2004: Aeolianite and barrier dune construction spanning the last two glacial-interglacial cycles from the southern Cape coast, South Africa. *Quaternary Science Reviews* 23, 1681-1698.
- Baxter, AJ and Davies, BR; 1994: Palaeoecological insights for the conservation of aquatic ecosystems in dryland environments. A case study of the Verlorenvlei system, South Africa. *Aquatic Conservation; Marine and Freshwater Ecosystems* 4, 225-271.
- Baxter, AJ and Meadows ME; 1994: Palynological evidence for the impact of colonial settlement within lowland fynbos: a high resolution study from the Verlorenvlei, southwestern Cape Province, South Africa. *Historical Biology* 9, 61-70.
- Baxter, AJ; 1997: Late Quaternary palaeoenvironments of the Sandveld, Western Cape Province, South Africa; Unpublished PhD Thesis, University of Cape Town.

- Baxter, AJ and Meadows ME; 1999: Evidence for Holocene sea level change at Verlorenvlei, Western Cape, South Africa. *Quaternary International* 56, 65-79.
- Biggs, R and Scholes, RJ; 2002: Land cover change in South Africa 1911-1993. *South African Journal of Science* 98, 420-424.
- Bottomley, BR; 1998: Mapping Rural Land Use & Land Cover Change. In: Carroll County, Arkansas Utilizing Multi-Temporal Landsat Thematic Mapper Satellite Imagery 1984-1994. Unpublished BA Thesis, University of Arkansas.
- Boucher, C and Marais, C; 1995: *Managing fynbos catchments for water*. Foundation of Research Development Report 24. Proceedings of a workshop at Stellenbosch, South Africa.
- Briggs, D; 1977: *Sediments sources and methods in geography*. Butterworths Press, London.
- Brink, ABA, van Schalkwyk A, Patridge TC, Midgley DC, Ball JM and Geldenhuis 1990: The changing impact of urbanization and mining on the geological environment. *South African Journal of Science* 86, 434-440.
- Brinson, NM; 1993: *Hydrogeomorphic classification of wetlands*. Technical Report WRP-DE-4. US Army of Engineer Waterways Experiment Station, Vicksburg, MS.
- Carver, RE; 1971: *Procedures in sedimentary petrology*. Wiley Interscience, New York.
- Chappell, J; 1967: Recognising fossil strand lines from grain size analysis. *Journal of Sedimentary Petrology* 157-165.
- Chase, TN, Pielke, RA, Kittel, TGF, Nemani, RR. and Running, SW; 1999: Simulated impacts of historical land cover changes on global climate in northern winter. *Climate Dynamics* 16, 93-105.
- Clarke J; 2003: The occurrence and significance of biogenic opal in the regolith. *Earth Science Reviews* 60, 175-194.
- Cockroft, MJ, Wilkinson M.J. and Tyson ED. (1987). The application of a present-day climatic model to late Quaternary southern Africa. *Climate Change* 10, 161-181.

- Coetzee, JM; 1967: Climatic and biological changes in the southwestern Africa during the late Cainozoic. *Palaeoecology of Africa* 10,13-29.
- Compton, JS; 2001: Holocene sea-level fluctuations inferred from the evolution of depositional environments of the southern Langebaan Lagoon salt marsh, South Africa. *Holocene* 11, 395-405.
- Cornell, KJ; 2001: Late Quaternary sediments in the Pakiuius basin, Cederberg, Western Cape, South Africa. Unpublished Bsc Honours Thesis University of Cape Town.
- Cowardin, LM, Carter, V, Golet, FC and La ROE, ET; 1976: *Interim Classification of wetlands and aquatic habitats of the United States*. Fish and Wild life Service.
- Cowardin, LM, Carter, V, Golet, FC and La ROE, ET; 1976; 1979: *Classification of wetlands and deepwater habitats of United States*. US Department of Interior. Fish and Wildlife Services Report FWS/UBS 79-31
- Cowling, RM; 1991: *A preliminary report on the flora and vegetation of the Wildevoevlei flats in the Noordhoek/Kommetjie Basin*. Flora Conservation Report No 91/2. Botanical Society of South Africa, Cape Town.
- Cowling, RM; 1992: *The ecology of fynbos: nutrients, fire and diversity*. Oxford University Press, Cape Town.
- Cowling, RM, Richardson, DM; 1995: *Fynbos: South Africa's unique floral kingdom*. Fernwood Press, Cape Town.
- Cowling, RM, Richardson, DM and Pierce, S; 1997: *Vegetation of southern Africa*. Cambridge University Press.
- Davies B and Gassner, A; 1999: *The ecological status of the wetlands of Noordhoek valley. Toward the development of a catchment management plan for the wetland valley*. Report to the Cape Metropolitan Council.
- Deacon, HJ, Hendy, QB and Lambrechts, JJN (eds); 1983: *Fynbos palaeoecology: a preliminary synthesis*; South African National Scientific Programmes Report 75. Council for Scientific and Industrial Research, Pretoria.
- Deacon, J and Lancaster, N; 1988: *Late Quaternary palaeoenvironments of southern Africa*. Claredon Press, Oxford.

- Deacon, HJ; 1992: Human settlement. In: Cowling, RM; (ed)1992. *The ecology of fynbos: nutrients, fire and diversity*. University Press, Cape Town, pp260-270.
- Dewey, JF; 1988: The sedimentology and palaeoenvironmental significance of vlei sediments on the Winterberg range, South Africa. Unpublished Msc Thesis University of Cape Town.
- Dingle, RV and Rogers, J; 1972a: Pleistocene palaeogeography of the Agulhas bank. *Transaction of the Royal Society of South Africa* 40, 155-165.
- Ferguson, JE; 1991: *The heavy elements; chemistry, environmental impact and health effects*. Pergamon Press University of Canterbury.
- Flemming, BW and Thum, AB; 1978: The settling tube - a hydraulic method for grain size analysis of sand. *Kieler Meeresforschungen* 4, 82-95.
- Folk, RL and Ward, WC; 1957: Brazos River Bar. A study in the significance of grain size parameters. *Journal of Sedimentary Petrology* 27, 3-26.
- Friedman, GM, 1961: Distinction between dune, beach and river sands from their textural characteristics. *Journal of Sedimentary Petrology*, 31, 514-529.
- Friedman, GM and Sanders, JL; 1978: *Principles of geomorphology*. Wiley Press, New York.
- Gammon, PR, James, NP, Bone, Y and Clarke JDA; 2000: Sedimentology and lithostratigraphy of a late Eocene sponge-dominated sequence, south-western Australia. *Journal of Earth Science* 154, 127-163.
- Gasson, B; 1990: *Cape of Good Hope Nature Reserve. Development and management plan*. Report for the Western Cape Regional service council. Cape Town, South Africa.
- Gassner, A; 1999: Geochemical and limnological aspects of phosphorous contamination in the Noordhoek Valley, Cape Peninsula, South Africa. Unpublished Msc thesis, University of Cape Town.
- Gardiner, V and Dackombe, R; 1983: *Geomorphological field manual*. Allen and Unwin Press, London.
- Graham, J; 1988: Collection and analysis of field data. In: ME Tucker (ed) *Techniques in sedimentology*. Oxford, Blackwell Press, pp1-62.

- Griffiths, JC; 1967: *Scientific methods in analysis of sediments*. McGraw -Hill Book New York.
- Hart, RC; 1995: *South African coastal lakes*. In: Cowan, GI; 1995: *Wetlands of South Africa*. Department of Environmental Affairs and Tourism, Pretoria.
- Heineken, TJE; 1985: *Estuaries of the Cape; Wildevoelvtlei/Noordhoek*. Council for Scientific and Industrial Research, Stellenbosch, South Africa.
- Holmes, PJ and Luger, A; 1996: Geomorphic implications of the stabilization of a headland bypass dune system in the Cape Peninsula, South Africa. *Zeitschrift für Geomorphologie Supplement Band 107*, 63-77.
- Holmes, PJ; 1998: Late Quaternary geomorphic palaeoenvironments of some central and marginal Great Karoo Uplands. Unpublished PhD Thesis, University of Cape Town.
- Houghton, RA, Hackler, JL and Lawrence, KT; 1999: The USA carbon budget; contributions from land-use change. *Science* 285, 574–578.
- Illenberger, WK. and Verhagen, BT; 1990. Environmental history and dating of coastal dune fields. *South African Journal of Science* 86, 311–314.
- Illenberger, WK; 1996: The geomorphic evolution of the Wilderness dune cordons, South Africa. *Quaternary International* 33,11–20.
- Irving, S.J., 1998: Late Quaternary palaeoenvironments at Vankervelsvlei, Kynsna, South Africa. Unpublished Msc Thesis, University of Cape Town.
- KFD Wilkinson Consulting Engineers; 1999: *Noordhoek Wetlands Management Plan*: Report to the Cape Metropolitan Council, Cape Town.
- Kidd, MM; 1983: *Cape Peninsula; South Africa wild flower guide 3*. Botanical Society of South Africa.
- King, WB; 1983: Geomorphology of the Cape Peninsula. Unpublished Msc Thesis, University of Cape Town.
- Lanesky, DE, Brown, RG, Logan, BW and Hine, AC; 1979: A new approach to portable vibracoring underwater and on land. *Journal of Sedimentary Petrology* 49, 654-657.
- Latimer, SL, Boothman, WS, Pesch, CE, Chmura, GL, Pospelova, V and Jayaraman, S; 2002: Environmental stress and recovery: the geochemical record of human disturbance in New Bedford Harbor and Apponagansett Bay, Massachusetts. *Science of the Total Environment* 313, 153-176.

- Leeder, MR; 1982: *Sedimentology process and product*. Allen and Unwin Press, London.
- Liaghati, T, Preda, M and Cox, M; 2004: Heavy metal distribution and controlling factors within coastal plain sediments, Bells Creek catchment, southeast Queensland, Australia. *Environment International* 27, 935-948.
- Lindholm, R; 1987: *A practical approach to sedimentology*. Allen and Unwin Press, London.
- Loring, DH; 1991: Normalization of heavy-metal data from estuarine and coastal sediments. *Journal of Marine Science* 48,101–115.
- Lowe, JJ and Walker, MJC; 1984: *Reconstructing Quaternary environments*; Longman Press, London. 1<sup>st</sup> edition.
- Lowe, JJ and Walker, MJC; 1997: *Reconstructing Quaternary environments*; Longman, London. 2<sup>nd</sup> edition.
- Mabbutt, JA; 1952: *The Cape peninsula*. Standard Press, Cape Town.
- Macvicar, CN, DE Villiers, Loxton, JM, Vester, RF, Lambrechts, E, Merryweather, JJN, Le Roux, FE, Van Rooyen, J, Harmse, TH, Von, HJ; 1977: *Soil classification: a binomial system for South Africa*. Science Bulletin 30. Soil and Irrigation Research Institute, Pretoria.
- Marchant, JW, Willis, JP and Duncan, AR; 1978: Geochemistry of the Table Mountain sandstone Group 1: aspects of the origin of the Houtbaai manganese deposits. *Transactions of the Geological Society of South Africa* 81,179-184.
- Marcus, W; 1998: A reconstruction of Quaternary palaeoenvironments in the Fish-Hoek valley. Unpublished Bsc Honours Thesis, University of Cape Town.
- Marker, ME; 1998: New radiocarbon dates from Lesotho. *South African Journal of Science* 94, 239-240.
- Martin, ARH; 1968: Pollen analysis of Groenvlei lake sediments, Knysna, South Africa. *Review of Palaeobotany and Palynology* 7, 107-144.
- McLean, EO; 1973: Soil pH and lime requirements. In: AL Page (ed) *Methods of soil analysis part 2*. Madison Press.
- Meadows, ME; 1987b: Vlei sediments and sedimentology: a tool in the reconstruction of palaeoenvironments of southern Africa. *Palaeoecology of Africa* 19, 249-258.

- Meadows, ME; 1988: Late Quaternary peat accumulation in southern Africa. *Catena* 15, 459-472.
- Meadows, ME; 1999: The nature, extent and significance of land degradation in the Mediterranean-climate region of South Africa. *Petermanns Geographische Mitteilungen* 14, 303-320.
- Meadows ME and Asmal O; 1996: Chronology, sedimentology and geochemistry of sediments at Verlorenvlei as evidence of anthropogenically induced land degradation, *Z Zeitschrift für Geomorphologie* 107, 45-62.
- Meadows, ME and Sudgen, JM; 1990: Late Quaternary vegetation of the Cederberg, southwestern Cape. *Palaeoecology of Africa* 21, 269-281.
- Meadows, ME and Sudgen, JM; 1991: A vegetation history of the last 14,500 years on the Cederberg, SW Cape, *South African Journal of Science* 87, 34-43.
- Meadows, ME, Baxter, AJ and Adams, T; 1994: The late Holocene vegetation of lowland fynbos, Verlorenvlei, southwestern Cape Province, South Africa. *Historical Biology* 9, 47-59.
- Meadows, ME, Baxter, AJ, Parkington, JE; 1996: Late Holocene environments at Verlorenvlei, Cape Province, South Africa. *Quaternary International* 33, 81-95.
- Meadows, ME, and Baxter, AJ; 1999: Late Quaternary palaeoenvironments of the southwestern Cape, South Africa: a regional synthesis. *Quaternary International* 57-8, 193-206.
- Miall, AD; 1977: A review of the braided river depositional environment. *Earth Science Reviews* 13, 1-62.
- Mitsch, WJ and Gosselink, JG; 2000: *Wetlands*. Wiley Press, New York.
- Morel, A; 1998: Soil erosion and land degradation in the Swartland and Sandveld, Cape Province, South Africa: a re-evaluation. Unpublished MA Thesis, University of Cape Town.
- Munsell Soil Colour Charts*; 1975: Kollmorgen Corporation, Baltimore.
- NM and Associates Planners and Designers; 2002: Noordhoek-Sunnydale Structure Plan Review. Southern Peninsula Administration.
- Partridge, TC, Avery, DM, Botha, GA, Brink, JC, Deacon, J, Herbert, RS, Maud, RR, Scholtz, A, Scott, L, Talma, AS, Vogel, JC; 1990: Late Pleistocene and

- Holocene climatic change in southern Africa. *South African Journal of Science* 86, 302-306.
- Partridge, TC, Kerr, SJ, Metcalfe, SE, Scot, L, Talma, AS and Vogel, JC; 1993: The Pretoria Saltpan; A 200 000 year southern African lacustrine sequence. *Palaeogeography, Palaeoclimatology, Palaeoecology* 1001, 317-337.
- Partridge, TC, Demenocal PB, Lorentz, SA, Parker, MJ and Vogel, JC; 1997: Orbital forcing of climate over South Africa. A 2000-year rainfall record from Pretoria Saltpan. *Quaternary Science Review* s16, 1125-1133.
- Partridge, TC, Scott, L and Hamilton, JE; 1999: Synthetic reconstruction of southern African environments during the Last Glacial Maximum (21-18kyr) and the Holocene Althithermal (8-6kyr). *Quaternary International* 57/58, 207-214.
- Plater, AJ, Mayers, C, Turner, S, Boyle, JF and Thompson, A; 2003: A Multidisciplinary approach to dating late Holocene sedimentary records. ([http://www.liv.ac.uk/Geography/Html use/poster/ajp inqua.pdf](http://www.liv.ac.uk/Geography/Html%20use/poster/ajp_inqua.pdf)).
- Purseglove, J; 1998: Noordhoek wetlands management study. Interim environmental scoping report. KFD Wilkinson Consulting Engineers (Cape Town) in association with Mott MacDonald (United kingdom).
- Ramsay, PJ; 1994: Marine geology of the Sodwana Bay shelf, southeast Africa. *Marine Geology* 120, 225-247.
- Ramsay, PJ and Cooper, JAG; 2002: Late Quaternary sea-level change in South Africa. *Quaternary Research* 57, 82-90.
- Reason, CJC; 2002: The wet winter of 2001 over the southwestern Cape, South Africa: potential large-scale influences. *South African Journal of Science* 98, 307-311.
- Reid, DL, Rogers, J, Hartnady, CJ and De Wit, MJ; 1999: Geology of the Cape Peninsula. Unpublished excursion guide, Department of Geological Sciences, University of Cape Town.
- Reineck, HE and Singh, IB; 1980: *Depositional sedimentary environments*. Springer Publisher, Verlag Berlin.
- Ringdahl, B; 1995: The Noordhoek valley; some current and potential impacts. Unpublished Bsc Honours Thesis, University of Cape Town.
- Ruiz, F; 2001: Trace metals in estuarine sediments from southwestern Spanish coast. *Marine Pollution Bulletin* 42, 482-490.

- Schalke, HJWG; 1973: The upper Quaternary of the Cape Flats area, Cape Province, South Africa. *Scripta Geologica* 15, 1-57.
- Scott, L, Anderson, HM and Anderson, JM; 1997: Fynbos. In: Cowling, RM, Richardson, DM and Pierce, SM (ed) *Vegetation of southern Africa*. Cambridge University Press, pp 62-80.
- Shaw, AE., Holmes, PJ. and Rogers, J; 2001: Depositional landforms and environmental change in the headward vicinity of Dias Beach, Cape Point. *South African Journal of Geology* 104, 101–114.
- Soil and Plant Analysis Council 1974: *The handbook on reference methods for soil testing*. The Council on Soil Testing and Plant Analysis, 2400 College Station Road, Georgia, USA.
- Talbot, WJ; 1947: *Swartland and Sandveld*. Oxford University Press, Cape Town.
- Tankard, AJ and Schweitzer, J; 1974: The geology of De Kelders cave and environs: a palaeoenvironmental study. *South African Journal of Science* 70, 365-369.
- Taylor, HC; 1983: The vegetation of the Cape of Good Hope nature reserve. *Bothalia* 14, 3-17.
- Theron, JN; 1984: *The geology of Cape Town and environs*. Geological Survey, South Africa.
- Thomas, MF; 2004: Landscape sensitivity to rapid environmental change-a Quaternary perspective with examples from tropical areas. *Catena* 55, 107-124.
- Tibby, J; 2002: Explaining lake and catchment change using sediment derived and written histories; an Australian perspective. *Science of the Total Environment* 310, 61-71.
- Tolba, MK, El-Kholy, OA; 1992: *The world environment 1972–1992: Two decades of challenge*. Chapman & Hall Publisher, London.
- Tucker, M (ed); 1988: *Techniques in sedimentology*. Blackwell Oxford.
- Turner, J; 1985: Sponge gemmules from lake sediments in the Puget Lowland, Washington. *Quaternary Research* 24, 240-243.
- Tyson, PD, Odada, EO and Partridge, TC; 2001: Late Quaternary environmental change in southern Africa. *South African Journal of Science* 97, 139-155.

Wentworth, CN; 1922: A scale of grade and class terms for clastic sediments.  
*Journal of Geology* 30, 377-392.

University of Cape Town

---

## APPENDICES

---

University of Cape Town

APPENDIX A

BLUEPRINT OF A VIBRACORER (Baxter, 1997)

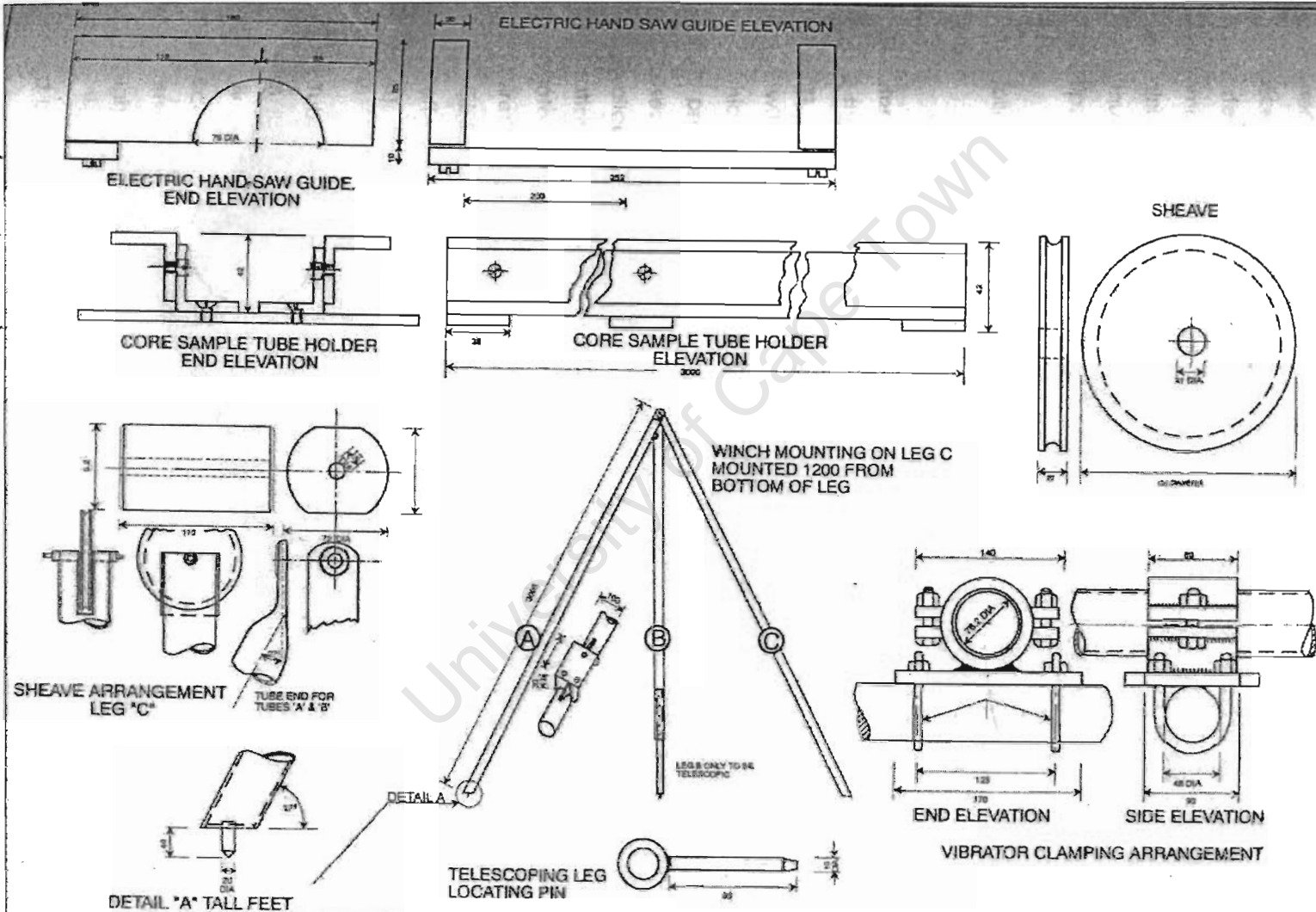

---

## APPENDIX B

### Particle Size Determination Adopted after Holmes (1998)

---

1. Between 1kg and 3kg of each sediment sample was dry sieved through a 2 mm sieve to separate the coarse fraction from the finer fraction.
2. The coarse and the fine fractions were weighed to determine the % mass of material  $>$  and  $<$  2 mm ( $-1\Phi$ ).
3. The finer fraction was air dried for a week and split into  $\sim 50$ g fractions.  $\sim 50$ g of fine fraction was then oven dried at  $50^{\circ}$  C for 24 hours to remove all moistures.
4. The same  $\sim 50$ g of sediments was then weighed and treated with 200 ml of sodium hexametaphosphate solution. This solution was made up by dissolving 35,7 g Na (PO<sub>3</sub>)<sub>6</sub> and 7,9 g Na<sub>2</sub>CO<sub>3</sub> in 1 litre of distilled water. Treatment comprised of agitating the treated samples for 12 hours on a Protea Model SC 201 rotary (dual plane) mechanical agitator. The purpose of this was to deflocculate silt and clay particles but not to alter the size dimensions of sand size particles. Samples were not stirred with an electric stirrer because of the damage this could cause to individual particles.
5. After this mild deflocculation, samples were wet sieved through a 63 $\mu$  sieve to separate the clay and silt fraction from the sand size fraction. The presence of salt in the sample will cause individual samples to stick together and will give false readings when passed through the settling column.
6. The sand fraction received from the sieve was oven dried at  $50^{\circ}$  C for 12 hours. The mass of the sand size fraction was then determined. By subtracting this figure from 50 g, the mass and proportion of silt and clay in each sample was determined by default.
7. The dried sand fraction was then fine split till a sub sample of  $\sim 2.5$ g was obtained. The samples were first passed through a splitter in order to have a representative proportion of each sample.
8. To determine the percentages of coarse, medium and fine sand sized sediment, between 2 to 3 g of each sample was processed in a settling column unit described above (Flemming and Thum, 1978).

---

## APPENDIX C

### Determination of pH, electrical conductivity and total organic fraction

#### Determination of pH (H<sub>2</sub>O)

1. The pH meter was calibrated to a constant temperature with standard buffer solution and was recalibrated hourly to compensate for drift.
2. 5ml of distilled water was added to 2g of sediments sample.
3. The sample was shaken for 5 seconds and allowed to stand for 50 minutes
4. It was then shaken and allowed to stand for 10 minutes before a reading was taken. The pH was determined after 30 seconds with the electrodes positioned in the supernatant.

#### Determination of conductivity

1. The conductivity probe of an M90 multimeter (calibrated in air and in a solution of known conductivity) was immersed in the supernatant.
2. A conductivity reading was taken after 1 hour.

#### Determination of organic matter content

1. The bulk sample was first oven dried for 12 hours at 80° C to eliminate soil moisture.
2. 5g of the oven-dried sample was weighed and heated at 800° C for 12 hours to eliminate organic matter by combustion. A diagram of the placement of crucibles within the furnace was made to avoid confusion because no heat resistant marker was available.
3. The samples were allowed to cool down in a desiccator before recording the post furnace weight to prevent the regaining of hygroscopic moisture prior to reweighing.
4. Percentage organic content was then calculated using the following formula:

$$\text{Organic matter index} = \frac{\text{initial weight of sample (g)} - \text{final weight of sample (g)}}{\text{initial weight of sample}}$$

5. The organic matter index was then multiplied by a hundred to obtain % organic matter in each unit.

APPENDIX D

LMC RAW GRAIN SIZE ANALYSIS DATA

| Sample N | Depth (cm) | Munsell Notation              | Mud         |       | Sediment texture (Folk, 1954) | pH   | Conductivity | Organics | Sand         |          |          |       | V. fine % | Mean (phi) | Median (phi) | Mean size (verbal) | Sorting (phi) | Sorting (verbal) | skewness | Skewness (verbal) |
|----------|------------|-------------------------------|-------------|-------|-------------------------------|------|--------------|----------|--------------|----------|----------|-------|-----------|------------|--------------|--------------------|---------------|------------------|----------|-------------------|
|          |            |                               | Silt & Clay | Sand% |                               |      |              |          | component    | Coarse % | medium % | Fine% |           |            |              |                    |               |                  |          |                   |
| LM1      | 0-5        | 5 YR 3/1 very dark gray       | n.d.        | n.d.  | n.d.                          | 7.40 | 45.00        | 41       | n.d.         | n.d.     | n.d.     | n.d.  | n.d.      | n.d.       | n.d.         | n.d.               | n.d.          | n.d.             | n.d.     | n.d.              |
| LM2      | 5-15       | 5 YR 3/1 very dark gray       | 13          | 87    | mS                            | 7.64 | 11.00        | 9        | Quartz (qtz) | 0        | 54       | 43    | 3         | 1.98       | 1.97         | Medium             | 0.25          | well sorted      | 0.12     | fine skewed       |
| LM3      | 15-25      | 5 YR 4/2 dark reddish gray    | 6           | 94    | (m)S                          | 7.75 | 3.10         | 2        | Quartz (qtz) | 0        | 70       | 28    | 2         | 1.84       | 1.84         | Medium             | 0.32          | well sorted      | 0        | symmetrical       |
| LM4      | 25-35      | 10 YR 4/2 dark grayish brown  | 5           | 95    | (m)S                          |      |              | 1        | Quartz (qtz) | 0        | 71       | 28    | 1         | 1.84       | 1.84         | Medium             | 0.3           | well sorted      | 0        | symmetrical       |
| LM5      | 35-45      | 10 YR 4/2 dark grayish brown  | 4           | 96    | (m)S                          |      |              | 1        | Quartz (qtz) | 0        | 71       | 28    | 1         | 1.84       | 1.84         | Medium             | 0.31          | well sorted      | 0        | symmetrical       |
| LM6      | 45-55      | 5 YR 4/2 dark reddish gray    | 3           | 97    | (m)S                          |      |              | 1        | Quartz (qtz) | 0        | 67       | 33    | 0         | 1.88       | 1.87         | Medium             | 0.3           | well sorted      | -0.02    | near symmetrical  |
| LM7      | 55-58      | 5 YR 4/2 dark reddish gray    | 4           | 96    | (m)S                          | 7.08 | 2.90         | 2        | Quartz (qtz) | 1        | 69       | 29    | 1         | 1.84       | 1.84         | Medium             | 0.33          | well sorted      | 0.01     | near symmetrical  |
| LM8      | 58-68      | 10 YR 4/3 brown               | 2           | 98    | S                             |      |              | 1        | Quartz (qtz) | 1        | 65       | 33    | 1         | 1.87       | 1.87         | Medium             | 0.32          | well sorted      | -0.03    | near symmetrical  |
| LM9      | 68-78      | 10 YR 4/3 brown               | 2           | 98    | S                             | 7    | 2.40         | 1        | Quartz (qtz) | 1        | 65       | 33    | 1         | 1.87       | 1.88         | Medium             | 0.32          | well sorted      | -0.03    | near symmetrical  |
| LM10     | 78-83      | 10 YR 4/3 brown               | 2           | 98    | S                             |      |              | 1        | Quartz (qtz) | 0        | 61       | 38    | 1         | 1.91       | 1.91         | Medium             | 0.31          | well sorted      | -0.01    | near symmetrical  |
| LM11     | 83-93      | 10 YR 4/3 brown               | 1           | 99    | S                             |      |              | 1        | Quartz (qtz) | 1        | 70       | 28    | 1         | 1.83       | 1.83         | Medium             | 0.31          | well sorted      | 0        | symmetrical       |
| LM12     | 93-100     | 10 YR 6/2 light brownish gray | 0           | 100   | S                             |      |              | 10       | Quartz (qtz) | 0        | 73       | 27    | 0         | 1.82       | 1.82         | Medium             | 0.3           | well sorted      | 0.01     | near symmetrical  |
| LM13     | 100-110    | 7.5 YR 4/1 dark gray          | 1           | 99    | S                             | 3.9  | 2.70         | 10       | Shell & qtz  | 1        | 74       | 24    | 1         | 1.8        | 1.8          | Medium             | 0.3           | well sorted      | 0.02     | near symmetrical  |
| LM14     | 110-120    | 7.5 YR 4/1 dark gray          | 2           | 98    | S                             | 3.81 | 2.26         | 200      | Shell & qtz  | 0        | 60       | 39    | 1         | 1.93       | 1.93         | Medium             | 0.3           | well sorted      | -0.02    | near symmetrical  |
| LM15     | 120-130    | 7.5 YR 4/1 dark gray          | 4           | 96    | (m)S                          |      |              | 200      | Shell & qtz  | 0        | 61       | 38    | 1         | 1.91       | 1.92         | Medium             | 0.3           | well sorted      | -0.01    | near symmetrical  |
| LM16     | 130-140    | 7.5 YR 5/1 gray               | 3           | 97    | (m)S                          |      |              | 400      | Shell & qtz  | 1        | 55       | 43    | 1         | 1.96       | 1.97         | Medium             | 0.32          | well sorted      | 0        | symmetrical       |
| LM17     | 140-150    | 7.5 YR 5/1 gray               | 3           | 97    | (m)S                          |      |              | 500      | Shell & qtz  | 0        | 60       | 39    | 1         | 1.93       | 1.93         | Medium             | 0.31          | well sorted      | 0.01     | near symmetrical  |
| LM18     | 150-160    | 7.5 YR 5/1 gray               | 3           | 97    | (m)S                          |      |              | 500      | Shell & qtz  | 1        | 53       | 45    | 1         | 1.98       | 1.98         | Medium             | 0.3           | well sorted      | 0        | symmetrical       |
| LM19     | 160-170    | 7.5 YR 5/1 gray               | 3           | 97    | (m)S                          |      |              | 700      | Shell & qtz  | 1        | 57       | 41    | 1         | 1.94       | 1.94         | Medium             | 0.32          | well sorted      | 0        | symmetrical       |
| LM20     | 170-180    | 5 YR 7/1 light gray           | 3           | 97    | (m)S                          | 7.9  | 2.53         | 900      | Shell & qtz  | 0        | 61       | 38    | 1         | 1.91       | 1.91         | Medium             | 0.32          | well sorted      | -0.01    | near symmetrical  |
| LM21     | 180-190    | 5 YR 7/1 light gray           | 3           | 97    | (m)S                          |      |              | 700      | Shell & qtz  | 1        | 47       | 51    | 1         | 2.01       | 2.01         | Fine               | 0.32          | well sorted      | -0.02    | near symmetrical  |
| LM22     | 190-200    | 5 YR 7/1 light gray           | 3           | 97    | (m)S                          |      |              | 900      | Shell & qtz  | 1        | 58       | 40    | 1         | 1.93       | 1.93         | Medium             | 0.32          | well sorted      | -0.04    | near symmetrical  |
| LM23     | 200-210    | 5 YR 7/1 light gray           | 3           | 97    | (m)S                          | 8.08 | 2.12         | 800      | Shell & qtz  | 2        | 67       | 30    | 1         | 1.84       | 1.84         | Medium             | 0.35          | well sorted      | -0.04    | near symmetrical  |
| LM24     | 210-220    | 7.5 YR 7/2 pinkish gray       | 4           | 96    | (m)S                          |      |              | 800      | Shell & qtz  | 1        | 68       | 30    | 1         | 1.84       | 1.85         | Medium             | 0.33          | well sorted      | -0.03    | near symmetrical  |
| LM25     | 220-230    | 7.5 YR 7/2 pinkish gray       | 3           | 97    | (m)S                          |      |              | 700      | Shell & qtz  | 0        | 63       | 36    | 1         | 1.9        | 1.9          | Medium             | 0.32          | well sorted      | -0.01    | near symmetrical  |
| LM26     | 230-240    | 7.5 YR 7/2 pinkish gray       | 3           | 97    | (m)S                          |      |              | 900      | Shell & qtz  | 1        | 63       | 35    | 1         | 1.88       | 1.89         | Medium             | 0.34          | well sorted      | -0.03    | near symmetrical  |
| LM27     | 240-250    | 5 YR 7/1 light gray           | 2           | 97    | S                             |      |              | 900      | Shell & qtz  | 2        | 55       | 40    | 3         | 1.94       | 1.94         | Medium             | 0.38          | well sorted      | 0.02     | near symmetrical  |
| LM28     | 250-260    | 5 YR 7/1 light gray           | 2           | 98    | S                             |      |              | 800      | Shell & qtz  | 1        | 67       | 31    | 1         | 1.85       | 1.85         | Medium             | 0.35          | well sorted      | -0.01    | near symmetrical  |
| LM29     | 260-269    | 7.5 YR 7/2 pinkish gray       | 3           | 97    | (m)S                          |      |              | 800      | Shell & qtz  | 0        | 60       | 39    | 1         | 1.91       | 1.92         | Medium             | 0.34          | well sorted      | -0.03    | near symmetrical  |
| LM30     | 269-279    | 7.5 YR 7/2 pinkish gray       | 4           | 96    | (m)S                          | 8.23 | 3.35         | 900      | Shell & qtz  | 2        | 73       | 23    | 1         | 1.77       | 1.77         | Medium             | 0.35          | well sorted      | 0.01     | near symmetrical  |
| LM31     | 279-289    | 7.5 YR 7/2 pinkish gray       | 3           | 97    | (m)S                          |      |              | 1000     | Shell & qtz  | 2        | 80       | 18    | 0         | 1.69       | 1.69         | Medium             | 0.34          | well sorted      | 0        | symmetrical       |
| LM32     | 289-297    | 5 YR 7/3 light gray           | 2           | 98    | S                             |      |              | 800      | Shell & qtz  | 2        | 74       | 23    | 1         | 1.76       | 1.76         | Medium             | 0.35          | well sorted      | -0.02    | near symmetrical  |
| LM33     | 297-307    | 5 YR 6/1 gray                 | 5           | 95    | (m)S                          |      |              | 1100     | Shell & qtz  | 3        | 60       | 36    | 1         | 1.87       | 1.89         | Medium             | 0.39          | well sorted      | -0.05    | near symmetrical  |
| LM34     | 307-317    | 5 YR 6/1 gray                 | 4           | 96    | (m)S                          |      |              | 1000     | Shell & qtz  | 2        | 52       | 45    | 1         | 1.96       | 1.96         | Medium             | 0.37          | well sorted      | -0.02    | near symmetrical  |
| LM35     | 317-327    | 5 YR 6/1 gray                 | 5           | 95    | (m)S                          |      |              | 900      | Shell & qtz  | 2        | 61       | 36    | 1         | 1.89       | 1.89         | Medium             | 0.37          | well sorted      | 0.01     | near symmetrical  |
| LM36     | 327-337    | 5 YR 6/1 gray                 | 5           | 95    | (m)S                          |      |              | 800      | Shell & qtz  | 1        | 62       | 35    | 2         | 1.92       | 1.91         | Medium             | 0.36          | well sorted      | 0.03     | near symmetrical  |
| LM37     | 337-347    | 5 YR 6/1 gray                 | 8           | 92    | (m)S                          | 7.78 | 2.42         | 300      | Shell & qtz  | 2        | 38       | 58    | 2         | 2.08       | 2.09         | Fine               | 0.39          | well sorted      | -0.02    | near symmetrical  |
| LM38     | 347-357    | 5 YR 4/1 dark gray            | 48          | 52    | mS                            | 3.7  | 4.9          | 1100     | Charcoal & q | 1        | 28       | 51    | 20        | 2.4        | 2.31         | Fine               | 0.66          | well sorted      | 0.19     | fine skewed       |
| LM39     | 357-367    | 5 YR 4.5/1 very dark gray     | 63          | 37    | sM                            | 3.2  | 4.7          | 1400     | Charcoal & q | 1        | 15       | 46    | 38        | 2.75       | 2.8          | Fine               | 0.7           | well sorted      | -0.12    | coarse skewed     |
| LM40     | 367-377    | 5 YR 2.5/1 black              | 43          | 57    | mS                            |      |              | 1000     | Charcoal & q | 2        | 15       | 37    | 46        | 2.81       | 2.91         | Fine               | 0.78          | mod sorted       | -0.21    | coarse skewed     |
| LM41     | 377-387    | 5 YR 2.5/1 black              | 53          | 47    | sM                            | 4.83 | 3.95         | 1800     | Charcoal & q | 1        | 19       | 49    | 31        | 2.64       | 2.62         | Fine               | 0.73          | mod sorted       | 0.02     | near symmetrical  |
| LM42     | 387-397    | 5 YR 2.5/1 black              | 80          | 20    | sM                            |      |              | 4400     | Charcoal & q | 2        | 17       | 55    | 26        | 2.59       | 2.62         | Fine               | 0.68          | well sorted      | -0.07    | near symmetrical  |
| LM43     | 397-407    | 5 YR 2.5/1 black              | 52          | 48    | sM                            | 5.54 | 2.90         | 300      | Charcoal & q | 2        | 27       | 61    | 10        | 2.28       | 2.29         | Fine               | 0.58          | well sorted      | -0.01    | near symmetrical  |
| LM44     | 407-420    | 5 YR 4/1 dark gray            | 21          | 79    | mS                            | 8.16 | 2.02         | 100      | Shell & qtz  | 4        | 38       | 55    | 3         | 2.02       | 2.05         | Fine               | 0.55          | well sorted      | -0.09    | near symmetrical  |

APPENDIX E  
LM-Core heavy metal concentrations

| Sample | depth (cm) | Sc    | Ti   | V    | Cr    | Mn   | Fe    | Co    | Ni   | Cu   | Zn    | As    | Se   | Rb    | Sr   | Y    | Zr    | Nb   | Mo   | Cd    | Ce   | Ba   | La   | Co    | Hf   | Ta    | W     | Th    | Pb   | Th   | U    |
|--------|------------|-------|------|------|-------|------|-------|-------|------|------|-------|-------|------|-------|------|------|-------|------|------|-------|------|------|------|-------|------|-------|-------|-------|------|------|------|
| LM 1   | 5          | 3.08  | 428  | 4.85 | 1.16  | 397  | 19904 | 2.81  | 10.2 | 5.68 | 71.8  | 2.48  | 0.99 | 8.83  | 721  | 1.76 | 6.43  | 0.77 | 2.23 | 0.88  | 0.44 | 63.1 | 2.67 | 5.71  | 0.16 | 0.077 | 0.17  | 0.20  | 0.96 | 1.25 | 1.84 |
| LM 2   | 15         | 1.51  | 424  | 4.26 | 7.90  | 28.0 | 3178  | 0.75  | 1.59 | 5.08 | 20.1  | 0.94  | 0.31 | 8.99  | 36.7 | 2.20 | 11.8  | 1.78 | 0.82 | 0.097 | 0.84 | 24.5 | 4.06 | 8.62  | 0.40 | 0.21  | 0.21  | 0.15  | 4.57 | 1.79 | 0.74 |
| LM 3   | 25         | 0.81  | 269  | 3.40 | 18.7  | 9.99 | 2964  | 0.40  | 1.29 | 2.47 | 5.07  | 0.46  | 0.32 | 11.17 | 19.2 | 1.41 | 8.24  | 0.84 | 0.29 | 0.02  | 0.71 | 29.2 | 3.34 | 7.23  | 0.23 | 0.066 | 0.16  | 0.12  | 3.70 | 1.54 | 0.99 |
| LM 7   | 60         | 0.69  | 368  | 3.37 | 11.89 | 4.33 | 1257  | 0.17  | 1.80 | 4.38 | 6.01  | 0.56  | 1.29 | 19.4  | 15.3 | 1.54 | 8.29  | 1.53 | 0.74 | 2.15  | 0.51 | 30.8 | 3.71 | 8.06  | 0.26 | 0.11  | 0.16  | 0.10  | 2.72 | 1.90 | 0.79 |
| LM 9   | 80         | 0.033 | 245  | 1.84 | 2.94  | 4.31 | 811   | 0.085 | 1.54 | 2.13 | 5.30  | 0.41  | 0.74 | 7.07  | 11.0 | 1.34 | 7.36  | 0.72 | 0.63 | 0.030 | 0.29 | 20.7 | 3.20 | 7.22  | 0.20 | 0.051 | 0.16  | 0.073 | 1.91 | 1.03 | 0.84 |
| LM 13  | 110        | n.d.  | 149  | 0.94 | n.d.  | 5.42 | 1987  | 0.35  | 0.86 | 2.58 | 3.41  | 1.30  | 0.24 | 8.94  | 10.1 | 1.89 | 7.72  | 0.93 | 1.15 | 0.030 | 0.27 | 21.4 | 3.80 | 8.67  | 0.21 | 0.098 | 0.096 | 0.10  | 5.38 | 1.93 | 0.69 |
| LM 14  | 120        | 0.12  | 175  | 2.71 | 20.6  | 6.19 | 1573  | 0.88  | 2.39 | 2.04 | 3.05  | 0.80  | 0.66 | 7.39  | 38.2 | 8.98 | 7.89  | 0.67 | 0.84 | 0.46  | 0.24 | 27.0 | 7.42 | 18.6  | 0.20 | 0.29  | 0.092 | 0.072 | 1.95 | 1.67 | 1.86 |
| LM 20  | 180        | 0.072 | 209  | 1.30 | n.d.  | 10.5 | 974   | 0.12  | 2.23 | 2.93 | 4.86  | 0.085 | 0.61 | 5.48  | 531  | 4.95 | 4.85  | 0.53 | 0.95 | 0.16  | 0.25 | 25.3 | 3.46 | 7.52  | 0.13 | 0.031 | 0.096 | 0.061 | 1.66 | 1.39 | 1.26 |
| LM 23  | 210        | 1.83  | 308  | 1.89 | 27.0  | 18.3 | 780   | 0.18  | 2.25 | 2.51 | 4.40  | 0.14  | 0.82 | 7.35  | 512  | 3.85 | 5.63  | 1.02 | 0.88 | 0.092 | 0.30 | 23.2 | 2.82 | 5.97  | 0.14 | 0.19  | 0.076 | 0.084 | 2.13 | 0.88 | 0.78 |
| LM 30  | 280        | 1.60  | 238  | 3.17 | 3.01  | 16.0 | 1057  | 0.21  | 1.75 | 2.83 | 4.24  | 0.27  | 0.26 | 19.5  | 553  | 2.63 | 4.02  | 0.46 | 1.25 | 0.093 | 0.48 | 35.0 | 3.59 | 7.29  | 0.11 | 0.025 | 0.14  | 0.11  | 3.23 | 1.26 | 0.50 |
| LM 37  | 345        | 0.96  | 388  | 4.20 | 4.92  | 23.9 | 1876  | 0.31  | 2.50 | 7.63 | 9.12  | 0.80  | 0.28 | 12.8  | 147  | 3.78 | 10.3  | 1.32 | 2.28 | 0.19  | 0.66 | 26.8 | 4.84 | 9.08  | 0.29 | 0.11  | 0.16  | 0.14  | 3.81 | 1.54 | 1.19 |
| LM 38  | 355        | 3.27  | 1417 | 28.7 | 13.5  | 197  | 12774 | 1.88  | 8.77 | 8.62 | 49.5  | 5.74  | 1.83 | 45.4  | 49.0 | 17.1 | 39.7  | 5.41 | 29.6 | 0.87  | 3.26 | 111  | 26.3 | 53.8  | 1.11 | 0.46  | 1.07  | 0.45  | 10.6 | 10.2 | 12.2 |
| LM 39  | 355        | 3.42  | 1837 | 32.1 | 8.45  | 184  | 14190 | 2.12  | 16.5 | 9.45 | 55.5  | 6.31  | 1.96 | 46.8  | 49.6 | 14.9 | 54.6  | 7.08 | 39.7 | 0.91  | 3.87 | 120  | 28.6 | 55.8  | 1.52 | 0.81  | 1.31  | 0.44  | 12.9 | 10.6 | 14.6 |
| LM 41  | 385        | 1.97  | 1273 | 17.8 | 25.8  | 48.8 | 5194  | 1.92  | 4.49 | 9.71 | 28.1  | 2.24  | 0.80 | 23.1  | 45.1 | 8.76 | 51.4  | 4.51 | 2.89 | 0.35  | 2.19 | 73.5 | 15.9 | 34.0  | 1.28 | 0.34  | 0.75  | 0.28  | 7.53 | 6.21 | 2.18 |
| LM 43  | 405        | 2.85  | 1090 | 22.8 | 11.1  | 41.5 | 4097  | 2.37  | 8.14 | 7.94 | 21.8  | 1.62  | 2.68 | 16.4  | 67.3 | 10.3 | 21.8  | 3.78 | 1.75 | 0.11  | 2.23 | 85.3 | 16.1 | 35.2  | 0.95 | 0.29  | 0.62  | 0.28  | 7.96 | 6.82 | 2.54 |
| LM 44  | 420        | 0.77  | 613  | 8.63 | 8.98  | 24.2 | 2134  | 1.05  | 3.43 | 8.98 | 19.89 | 0.52  | 1.10 | 8.82  | 19.5 | 3.56 | 12.38 | 1.75 | 0.34 | 0.03  | 1.02 | 30.1 | 5.80 | 12.95 | 0.38 | 0.12  | 0.28  | 0.10  | 4.47 | 2.78 | 0.74 |

APPENDIX F

WV-Core grain size raw data analysis

| Sample No. | Depth (cm) | Munsell Notation          | Mud, silt clay | Sand % | sediment texture (Folk, 1954) | organic S % | pH   | Conductivity | Sand component       | Coarse sand | Medium sand | Fine sand | V. fine sand | Mean (phi) | Median (phi) | Mean size (verbal) | Sorting (phi) | Sorting (verbal) | skewness | Skewness (verbal)      |
|------------|------------|---------------------------|----------------|--------|-------------------------------|-------------|------|--------------|----------------------|-------------|-------------|-----------|--------------|------------|--------------|--------------------|---------------|------------------|----------|------------------------|
| WV1        | 0-8        | 5YR 4/1 dark grey         | n.d.           | n.d.   | n.d.                          | 27          | 4.90 | 128.00       | n.d.                 | n.d.        | n.d.        | n.d.      | n.d.         | n.d.       | n.d.         | n.d.               | n.d.          | n.d.             | n.d.     | n.d.                   |
| WV2        | 8-014      | 5YR4/2 dark reddish grey  | 8              | 92     | (m)S                          | 7           | 5.25 | 119.00       | Quartz (qtz)         | 13          | 57          | 26        | 4            | 1.69       | 1.7          | medium sand        | 0.65          | d.well sor.      | -0.02    | near symmetrical       |
| WV3        | 14-20      | 7.5YR 4/1 dark grey       | 18             | 82     | mS                            | 8           | 5.75 | 119.00       | Quartz (qtz)         | 13          | 57          | 25        | 5            | 1.69       | 1.71         | medium sand        | 0.65          | d.well sor.      | -0.02    | near symmetrical       |
| WV4        | 20-30      | 5YR 4/2 dark reddish grey | 8              | 92     | (m)S                          | 2.4         |      |              | S. spiracles & (qtz) | 7           | 47          | 37        | 6            | 1.95       | 1.84         | medium sand        | 0.69          | d.well sor.      | -0.04    | near symmetrical       |
| WV5        | 30-35      | 7.5 YR 5/3 brown          | 8              | 94     | (m)S                          | 2           | 5.92 | 1120.00      | S. spiracles & (qtz) | 4           | 49          | 39        | 8            | 1.88       | 1.86         | medium sand        | 0.6           | d.well sor.      | -0.13    | fine skewed            |
| WV6        | 35-45      | 7.5 YR 5/3 brown          | 8              | 97     | (m)S                          | 2           |      |              | S. spiracles & (qtz) | 6           | 47          | 42        | 5            | 1.84       | 1.86         | medium sand        | 0.58          | d.well sor.      | -0.05    | near symmetrical       |
| WV7        | 45-55      | 7.5 YR 5/3 brown          | 3              | 97     | (m)S                          | 2           |      |              | S. spiracles & (qtz) | 11          | 46          | 37        | 4            | 1.63       | 1.66         | medium sand        | 0.67          | d.well sor.      | -0.22    | coarse skewed          |
| WV8        | 55-65      | 7.5 YR 5/3 brown          | 7              | 93     | (m)S                          | 4.6         | 5.66 | 120.00       | S. spiracles & (qtz) | 5           | 59          | 33        | 3            | 1.85       | 1.85         | medium sand        | 0.47          | well sorted      | -0.03    | near symmetrical       |
| WV9        | 65-75      | 7.5 YR 6/2 pinkish grey   | 3              | 97     | (m)S                          | 2           |      |              | S. spiracles & (qtz) | 6           | 62          | 29        | 3            | 1.78       | 1.8          | medium sand        | 0.48          | well sorted      | -0.07    | near symmetrical       |
| WV10       | 75-85      | 7.5 YR 6/2 pinkish grey   | 5              | 95     | (m)S                          | 2           | 2.62 | 121.00       | S. spiracles & (qtz) | 12          | 60          | 26        | 2            | 1.7        | 1.76         | medium sand        | 0.58          | d.well sor.      | -0.29    | coarse skewed          |
| WV11       | 85-90      | 7.5 YR 4/1 dark grey      | 16             | 84     | mS                            | 3.4         |      |              | Quartz               | 18          | 55          | 25        | 2            | 1.56       | 1.71         | medium sand        | 0.96          | mod sorted       | +0.47    | strongly coarse skewed |
| WV12       | 90-100     | 7.5 YR 4/1 dark grey      | 39             | 61     | mS                            | 6           |      |              | Quartz               | 17          | 48          | 30        | 5            | 1.68       | 1.77         | medium sand        | 1.06          | poorly sorted    | +0.25    | strongly coarse skewed |
| WV13       | 100-110    | 7.5 YR 4/1 dark grey      | 38             | 62     | mS                            | 6           | 4.62 | 121.00       | Quartz               | 8           | 47          | 37        | 8            | 1.82       | 1.83         | medium sand        | 0.71          | d.well sor.      | -0.03    | near symmetrical       |
| WV14       | 110-120    | 7.5 YR 8/1 grey           | 40             | 60     | mS                            | 5           |      |              | Quartz               | 5           | 45          | 42        | 8            | 2.02       | 1.99         | fine sand          | 0.61          | d.well sor.      | -0.09    | near symmetrical       |
| WV15       | 120-130    | 7.5 YR 6/1 grey           | 34             | 66     | mS                            | 5           |      |              | Quartz               | 7           | 53          | 35        | 5            | 1.88       | 1.68         | medium sand        | 0.61          | d.well sor.      | -0.05    | near symmetrical       |
| WV16       | 130-140    | 10 YR 6/1 grey            | 22             | 78     | mS                            | 2.4         |      |              | Quartz               | 6           | 50          | 38        | 6            | 1.84       | 1.83         | medium sand        | 0.58          | d.well sor.      | -0.01    | near symmetrical       |
| WV17       | 140-146    | 7.5YR 5/2 brown           | 18             | 82     | mS                            | 2           | 5.87 | 83.00        | Quartz               | 8           | 60          | 29        | 3            | 1.8        | 1.82         | medium sand        | 0.49          | well sorted      | -0.16    | coarse skewed          |

**APPENDIX G**  
**WV-Core heavy metal concentrations**

| Samples | Depth (m) | Sc   | Ti   | V    | Cr   | Mn   | Fe   | Co   | Ni   | Cu   | Zn   | As   | Se   | Rb   | Sr   | Y    | Zr   | Nb   | Mo   | Cd    | Ce   | Ba   | La   | Ce   | Hf   | Ta    | W    | Bi    | Pb   | Th   |
|---------|-----------|------|------|------|------|------|------|------|------|------|------|------|------|------|------|------|------|------|------|-------|------|------|------|------|------|-------|------|-------|------|------|
| WV 1    | 0         | 0.68 | 334  | 8.16 | 4.27 | 17.5 | 5272 | 0.47 | 1.38 | 2.93 | 12.5 | 1.29 | 0.77 | 9.51 | 17.7 | 2.43 | 8.67 | 1.31 | 0.45 | 0.057 | 0.71 | 37.2 | 5.47 | 12.6 | 0.25 | 0.091 | 0.36 | 0.42  | 9.45 | 2.22 |
| WV 2    | 14        | 0.78 | 529  | 6.67 | 3.74 | 12.9 | 3597 | 0.37 | 0.96 | 2.53 | 13.2 | 0.84 | 0.40 | 10.0 | 16.0 | 2.35 | 9.24 | 1.98 | 0.32 | 0.035 | 0.82 | 32.7 | 5.19 | 11.2 | 0.27 | 0.12  | 0.38 | 0.44  | 7.12 | 1.71 |
| WV 3    | 20        | 3.10 | 883  | 18.4 | 12.8 | 42.7 | 9570 | 0.87 | 3.33 | 4.04 | 22.9 | 2.49 | 0.90 | 29.7 | 37.0 | 15.0 | 26.9 | 5.76 | 0.84 | 0.024 | 2.48 | 63.0 | 19.0 | 38.5 | 0.82 | 0.40  | 0.88 | 0.22  | 49.1 | 7.47 |
| WV 5    | 35        | 0.71 | 616  | 4.82 | 3.53 | 8.24 | 2724 | 0.17 | 0.29 | 2.52 | 9.52 | 0.65 | 0.19 | 9.81 | 10.6 | 3.05 | 13.8 | 2.33 | 0.18 | 0.011 | 0.69 | 34.0 | 6.85 | 15.2 | 0.42 | 0.15  | 0.42 | 9.676 | 3.75 | 2.23 |
| WV 8    | 65        | 0.47 | 533  | 3.47 | 3.36 | 10.1 | 1304 | 0.21 | 0.50 | 1.46 | 9.16 | 0.27 | 0.29 | 4.22 | 8.14 | 1.61 | 11.2 | 2.20 | 0.14 | 0.059 | 0.40 | 16.4 | 3.87 | 8.38 | 0.35 | 0.30  | 0.36 | 0.085 | 2.67 | 1.68 |
| WV 10   | 85        | 0.26 | 241  | 2.31 | 2.20 | 8.51 | 3405 | 0.23 | 0.88 | 1.28 | 5.59 | 0.89 | 0.61 | 3.56 | 7.00 | 2.09 | 5.64 | 0.88 | 1.31 | 0.087 | 0.28 | 16.5 | 4.06 | 8.56 | 0.18 | 0.031 | 0.25 | 0.049 | 2.08 | 1.14 |
| WV 13   | 110       | 6.85 | 1130 | 29.1 | 29.1 | 14.4 | 5158 | 2.07 | 8.38 | 2.27 | 34.7 | 2.76 | 0.76 | 33.6 | 24.2 | 7.84 | 35.2 | 5.17 | 1.95 | 0.013 | 3.50 | 99.9 | 13.6 | 33.6 | 1.08 | 0.43  | 1.15 | 0.42  | 12.6 | 10.7 |
| WV 17   | 146       | 2.79 | 644  | 9.58 | 8.26 | 8.07 | 1861 | 0.69 | 2.43 | 2.12 | 11.1 | 0.56 | 0.33 | 15.7 | 12.2 | 5.09 | 15.5 | 2.63 | 0.26 | 0.15  | 1.75 | 45.3 | 11.6 | 27.4 | 0.53 | 0.20  | 0.52 | 0.18  | 5.13 | 5.12 |

APPENDIX H  
GRC GRAIN SIZE ANALYSIS DATA

| Sample No | Depth (cm) | Munsell Notation               | rovd/silt/clay % | %Sand | Sediment texture | Sand composition | pH   | conductivity | % Organics | Coarse % | Medium | Fine % | V fine % | mean (phi) | median (phi) | Description | sorting | Description      | skewness | Description      | kurtosis |
|-----------|------------|--------------------------------|------------------|-------|------------------|------------------|------|--------------|------------|----------|--------|--------|----------|------------|--------------|-------------|---------|------------------|----------|------------------|----------|
| GR1       | 0-4        | 7.5YR 2.5/1 fibrous black soil | n.d              | n.d   | s                | n.d              | 2.97 | 54.50        | 76         |          |        |        |          |            |              |             |         |                  |          |                  |          |
| GR2       | 4-014      | 10YR 2/1 black soil            | 26               | 74    | mS               | Quartz (qtz)     |      |              | 32         | 1        | 76     | 21     | 2        | 1.78       | 1.77         | Medium sand | 0.32    | Very well sorted | 0.01     | Near symmetrical | 1.07     |
| GR3       | 14-24      | 7.5YR 2.5/1 black soil         | 11               | 89    | mS               | Quartz (qtz)     | 3.04 | 117.90       | 24         | 2        | 41     | 55     | 2        | 2.04       | 2.05         | Fine sand   | 0.39    | Well sorted      | -0.1     | Near symmetrical | 1.18     |
| GR4       | 24-32      | 7.5YR 2.5/1 black soil         | 8                | 92    | (m)S             | Quartz (qtz)     |      |              | 14         | 2        | 40     | 56     | 2        | 2.05       | 2.06         | Fine sand   | 0.38    | Well sorted      | -0.09    | Near symmetrical | 1.21     |
| GR5       | 32-42      | 10YR 2/1 black soil            | 6                | 94    | (m)S             | Quartz (qtz)     |      |              | 13         | 2        | 39     | 56     | 3        | 2.05       | 2.07         | Fine sand   | 0.39    | Well sorted      | -0.1     | Near symmetrical | 1.28     |
| GR6       | 42-52      | 7.5YR 4/1 dark gray soil       | 6                | 94    | (m)S             | Quartz (qtz)     | 3.30 | 118.50       | 4          | 4        | 47     | 46     | 3        | 1.94       | 1.98         | Medium sand | 0.48    | Well sorted      | -0.35    | Coarse skewed    | 1.26     |
| GR7       | 52-59      | 10YR 6/1 gray soil             | 5                | 95    | (m)S             | Quartz (qtz)     |      |              | 3          | 6        | 51     | 30     | 3        | 1.81       | 1.82         | Medium sand | 0.49    | Well sorted      | -0.01    | Near symmetrical | 1.34     |
| GR8       | 59-63      | 10YR 7/1 light gray soil       | 5                | 95    | (m)S             | Quartz (qtz)     |      |              | 1          | 4        | 53     | 40     | 3        | 1.89       | 1.92         | Medium sand | 0.47    | Well sorted      | -0.09    | Near symmetrical | 1.21     |
| GR9       | 63-72      | 10YR 6/1 gray soil             | 6                | 94    | (m)S             | Quartz (qtz)     |      |              | 1          | 8        | 54     | 35     | 3        | 1.8        | 1.85         | Medium sand | 0.54    | Mod well sorted  | -0.12    | Coarse skewed    | 1.12     |
| GR10      | 72-82      | 10YR 5/2 grayish brown soil    | 6                | 94    | (m)S             | Quartz (qtz)     |      |              | 1          | 8        | 56     | 33     | 3        | 1.8        | 1.84         | Medium sand | 0.55    | Mod well sorted  | -0.1     | Near symmetrical | 1.23     |
| GR11      | 82-92      | 10YR 6/2 light brown gray soil | 6                | 94    | (m)S             | Quartz (qtz)     |      |              | 1          | 8        | 54     | 34     | 4        | 1.82       | 1.85         | Medium sand | 0.57    | Mod well sorted  | +0.03    | Near symmetrical | 1.24     |
| GR12      | 92-100     | 10YR 6/2 light brown gray soil | 6                | 94    | (m)S             | Quartz (qtz)     | 4.43 | 118          | 1          | 8        | 54     | 33     | 5        | 1.82       | 1.84         | Medium sand | 0.61    | Mod well sorted  | 0        | Near symmetrical | 1.27     |
| GR13      | 100-109    | 10YR 6/2 light brown gray soil | 6                | 94    | (m)S             | Quartz (qtz)     |      |              | 1          | 9        | 59     | 27     | 5        | 1.76       | 1.77         | Medium sand | 0.6     | Mod well sorted  | 0.01     | Near symmetrical | 1.33     |
| GR14      | 109-119    | 10YR 7/1 light gray soil       | 8                | 92    | (m)S             | Quartz (qtz)     |      |              | 0          | 8        | 62     | 26     | 4        | 1.75       | 1.77         | Medium sand | 0.54    | Mod well sorted  | -0.01    | Near symmetrical | 1.35     |
| GR15      | 119-129    | 10YR 5/2 grayish brown soil    | 9                | 91    | (m)S             | Quartz (qtz)     |      |              | 3          | 7        | 61     | 27     | 5        | 1.79       | 1.8          | Medium sand | 0.55    | Mod well sorted  | -0.03    | Near symmetrical | 1.41     |
| GR16      | 129-139    | 10YR 6/1 gray soil             | 10               | 90    | (m)S             | Quartz (qtz)     |      |              | 3          | 4        | 61     | 32     | 3        | 1.84       | 1.86         | Medium sand | 0.45    | Well sorted      | -0.03    | Near symmetrical | 1.3      |
| GR17      | 139-147    | 10YR 4/1 dark gray soil        | 8                | 92    | (m)S             | Quartz (qtz)     |      |              | 3          | 4        | 63     | 30     | 3        | 1.83       | 1.84         | Medium sand | 0.43    | Well sorted      | -0.04    | Near symmetrical | 1.23     |
| GR18      | 147-157    | 10YR 4/1 dark gray soil        | 7                | 93    | (m)S             | Quartz (qtz)     |      |              | 3          | 6        | 65     | 27     | 2        | 1.79       | 1.81         | Medium sand | 0.45    | Well sorted      | -0.09    | Near symmetrical | 1.39     |
| GR19      | 157-164    | 10YR 5/1 gray soil             | 7                | 93    | (m)S             | Quartz (qtz)     |      |              | 2          | 6        | 60     | 30     | 4        | 1.83       | 1.85         | Medium sand | 0.48    | Well sorted      | -0.04    | Near symmetrical | 1.39     |
| GR20      | 164-174    | 10YR 5/1 gray soil             | 6                | 94    | (m)S             | Quartz (qtz)     |      |              | 1          | 7        | 62     | 28     | 3        | 1.79       | 1.81         | Medium sand | 0.49    | Well sorted      | -0.06    | Near symmetrical | 1.39     |
| GR21      | 174-184    | 10YR 5/1 gray soil             | 5                | 95    | (m)S             | Quartz (qtz)     |      |              | 1          | 2        | 62     | 34     | 2        | 1.87       | 1.87         | Medium sand | 0.39    | Well sorted      | 0        | Near symmetrical | 1.25     |
| GR22      | 184-194    | 10YR 5/1 gray soil             | 5                | 95    | (m)S             | Quartz (qtz)     |      |              | 1          | 4        | 68     | 25     | 3        | 1.8        | 1.8          | Medium sand | 0.39    | Well sorted      | -0.04    | Near symmetrical | 1.25     |
| GR23      | 194-204    | 10YR 5/1 gray soil             | 8                | 92    | (m)S             | Quartz (qtz)     |      |              | 4          | 2        | 72     | 24     | 2        | 1.8        | 1.8          | Medium sand | 0.34    | Very well sorted | -0.01    | Near symmetrical | 1.13     |
| GR24      | 204-212    | 10YR 4/1 dark gray soil        | 7                | 93    | (m)S             | Quartz (qtz)     |      |              | 3          | 2        | 71     | 25     | 2        | 1.81       | 1.81         | Medium sand | 0.33    | Very well sorted | -0.01    | Near symmetrical | 1.13     |
| GR25      | 212-222    | 10YR 4/1 dark gray soil        | 6                | 94    | (m)S             | Quartz (qtz)     |      |              | 2          | 2        | 75     | 21     | 2        | 1.77       | 1.77         | Medium sand | 0.33    | Very well sorted | -0.01    | Near symmetrical | 1.13     |
| GR26      | 222-232    | 10YR 6/2 light brown gray soil | 5                | 95    | (m)S             | Quartz (qtz)     |      |              | 2          | 2        | 76     | 21     | 1        | 1.72       | 1.76         | Medium sand | 0.33    | Very well sorted | -0.03    | Near symmetrical | 1.12     |
| GR27      | 232-242    | 10YR 6/2 light brown gray soil | 4                | 96    | (m)S             | Quartz (qtz)     |      |              | 2          | 2        | 80     | 17     | 1        | 1.7        | 1.71         | Medium sand | 0.33    | Very well sorted | -0.01    | Near symmetrical | 1.09     |
| GR28      | 242-252    | 10YR 4/1 dark gray soil        | 5                | 95    | (m)S             | Quartz (qtz)     |      |              | 4          | 2        | 79     | 16     | 1        | 1.73       | 1.73         | Medium sand | 0.33    | Very well sorted | -0.01    | Near symmetrical | 1.09     |
| GR29      | 252-262    | 10YR 3/1 very dark gray soil   | 5                | 95    | (m)S             | Quartz (qtz)     |      |              | 6          | 1        | 75     | 18     | 6        | 1.76       | 1.76         | Medium sand | 0.5     | Well sorted      | 0.27     | Fine skewed      | 2.04     |
| GR30      | 262-271    | 10YR 3/1 very dark gray soil   | 11               | 89    | mS               | Quartz (qtz)     |      |              | 11         |          |        |        |          | 1.76       | 1.76         | Medium sand | 0.31    | Very well sorted | 0.01     | Near symmetrical | 1.06     |
| GR31      | 271-281    | 10YR 2/1 black soil            | 16               | 84    | mS               | Quartz (qtz)     | 2.67 | 116          | 28         | 4        | 68     | 22     | 6        | 1.8        | 1.79         | Medium sand | 0.77    | Mod well sorted  | 0.55     | Fine skewed      | 14.6     |
| GR32      | 281-287    | 10YR 2/1 black soil            | 16               | 84    | mS               | Quartz (qtz)     |      |              | 44         | 4        | 68     | 22     | 6        | 1.8        | 1.79         | Medium sand | 0.77    | Mod well sorted  | 0.55     | Fine skewed      | 14.6     |
| GR33      | 287-294    | 10YR 5/2 gray soil             | 4                | 96    | (m)S             | Quartz (qtz)     | 2.71 | 118.5        | 9          | 2        | 83     | 11     | 4        | 1.67       | 1.66         | Medium sand | 0.23    | Very well sorted | 0.1      | Near symmetrical | 1.2      |
| GR34      | 294-304    | 10YR 5/2 gray soil             | 2                | 98    | s                | Quartz (qtz)     |      |              | 2          | 1        | 90     | 8      | 1        | 1.63       | 1.63         | Medium sand | 0.27    | Very well sorted | 0        | Near symmetrical | 1.04     |
| GR35      | 304-314    | 10YR 6/2 light brown gray soil | 1                | 99    | s                | Quartz (qtz)     | 2.78 | 118.4        | 2          |          |        |        |          | 1.62       | 1.63         | Medium sand | 0.26    | Very well sorted | -0.02    | Near symmetrical | 1.04     |
| GR36      | 314-324    | 10YR 5/2 gray soil             | 2                | 98    | s                | Quartz (qtz)     |      |              | 2          | 2        | 89     | 7      | 2        | 1.64       | 1.64         | Medium sand | 0.27    | Very well sorted | -0.04    | Near symmetrical | 1.08     |
| GR37      | 324-334    | YR 4/2 dark grayish brown s    | 3                | 97    | s                | Quartz (qtz)     |      |              | 4          | 1        | 86     | 12     | 1        | 1.69       | 1.69         | Medium sand | 0.28    | Very well sorted | 0        | Near symmetrical | 1.06     |
| GR38      | 334-344    | YR 4/2 dark grayish brown s    | 6                | 94    | (m)S             | Quartz (qtz)     | 2.43 | 118.7        | 5          | 5        | 82     | 12     | 1        | 1.64       | 1.65         | Medium sand | 0.35    | Very well sorted | -0.12    | Coarse skewed    | 1.18     |

APPENDIX I  
GR-Core heavy metal concentrations

| Sample | Depth (cm) | Sc   | Ti   | V    | Cr   | Mn   | Fe   | Co   | Ni   | Cu   | Zn   | As    | Se   | Rb   | Sr   | Y    | Zr   | Nb   | Mo    | Cd    | Ce    | Ba   | La   | Co   | Hf   | Ta    | W     | Tl    | Pb   | Tb   | U    |
|--------|------------|------|------|------|------|------|------|------|------|------|------|-------|------|------|------|------|------|------|-------|-------|-------|------|------|------|------|-------|-------|-------|------|------|------|
| GR 1   | 1          | 1.56 | 541  | 5.03 | 5.12 | 45.2 | 3361 | 0.92 | 2.13 | 3.34 | 66.3 | 1.61  | 0.40 | 1.81 | 51.1 | 1.78 | 10.5 | 1.69 | 0.31  | 0.024 | 0.18  | 15.5 | 2.81 | 6.08 | 0.25 | 0.13  | 0.30  | 0.079 | 5.14 | 1.40 | 0.37 |
| GR 3   | 24         | 0.89 | 1040 | 3.02 | 2.56 | 24.0 | 503  | 0.84 | 1.17 | 1.82 | 15.0 | 0.33  | 0.50 | 0.58 | 21.7 | 2.05 | 13.0 | 4.19 | 0.17  | 0.020 | 0.078 | 5.37 | 4.03 | 7.99 | 0.36 | 0.27  | 0.86  | 0.028 | 1.77 | 1.05 | 0.49 |
| GR 6   | 50         | 0.33 | 896  | 1.99 | 2.13 | 8.77 | 139  | 0.26 | 0.49 | 1.36 | 13.8 | 0.30  | 0.11 | 0.33 | 3.27 | 2.97 | 86.4 | 2.47 | 0.065 | 0.010 | 0.048 | 3.54 | 2.58 | 5.56 | 3.33 | 0.20  | 0.42  | 0.023 | 0.81 | 0.94 | 0.63 |
| GR 12  | 100        | 0.46 | 547  | 2.43 | 3.41 | 41.4 | 347  | 0.16 | 0.32 | 1.20 | 9.11 | 0.064 | 0.70 | 0.77 | 5.82 | 3.51 | 13.0 | 1.47 | 0.073 | n.d.  | 0.12  | 6.23 | 6.01 | 13.1 | 0.35 | 0.065 | 0.20  | 0.015 | 2.66 | 1.71 | 0.52 |
| GR 31  | 280        | 1.31 | 487  | 16.3 | 13.7 | 253  | 3037 | 1.75 | 6.99 | 3.28 | 32.5 | 1.00  | 6.93 | 0.74 | 18.2 | 9.86 | 11.8 | 1.38 | 0.12  | 0.16  | 0.098 | 1.30 | 6.72 | 13.0 | 0.36 | 0.054 | 0.21  | 0.076 | 3.02 | 1.90 | 10.8 |
| GR 33  | 295        | 0.45 | 149  | 1.82 | 3.31 | 14.6 | 1689 | 0.55 | 1.25 | 2.46 | 5.32 | 0.55  | 0.67 | 0.56 | 3.02 | 3.85 | 7.91 | 0.68 | 0.034 | 0.040 | 0.10  | 3.87 | 3.36 | 7.53 | 0.23 | 0.013 | 0.091 | 0.040 | 1.31 | 0.76 | 0.74 |
| GR 35  | 315        | 0.46 | 101  | 0.51 | 1.12 | 4.26 | 727  | 0.33 | 0.28 | 1.33 | 4.22 | 0.11  | 0.47 | 0.77 | 2.19 | 1.74 | 12.3 | 0.25 | 0.026 | 0.019 | 0.16  | 4.46 | 3.57 | 7.65 | 0.38 | n.d.  | 0.052 | 0.039 | 1.96 | 1.01 | 0.27 |
| GR 38  | 344        | 0.35 | 142  | 1.28 | 3.09 | 45.0 | 7115 | 0.23 | 0.49 | 1.08 | 8.12 | 1.46  | 0.52 | 1.61 | 2.80 | 3.56 | 11.6 | 0.43 | 0.059 | 0.17  | 0.42  | 7.14 | 3.65 | 7.67 | 0.36 | n.d.  | 0.14  | 0.041 | 1.20 | 0.78 | 0.53 |