



**Department of Chemical Engineering**

**Faculty of Engineering and the Built Environment**

**University of Cape Town**

**AN INVESTIGATION INTO THE RELATIONSHIP  
BETWEEN ELECTROCHEMICAL PROPERTIES AND  
FLOTATION OF SULPHIDE MINERALS**

**By**

**Wonder Chimonyo**

**January 2016**

A thesis submitted to the faculty of Engineering and the Built Environment, University of Cape Town in fulfilment of the requirements for the degree of Master of Science in  
Chemical Engineering



The copyright of this thesis vests in the author. No quotation from it or information derived from it is to be published without full acknowledgement of the source. The thesis is to be used for private study or non-commercial research purposes only.

Published by the University of Cape Town (UCT) in terms of the non-exclusive license granted to UCT by the author.

## **DECLARATION**

I declare that this work is my own work. I know the meaning of plagiarism and declare that all the contents in this document, save for that which is properly acknowledged, is my own.

.....

Signed: Wonder Chimonyo

## **ACKNOWLEDGEMENTS**

I would like to extend my deepest appreciation to the following persons and organisations

- Supervisors: Dr Kirsten Corin and Mrs Jenny Wiese for technical support, guidance and the encouragement to keep pushing towards the goal.
- Advisors: Professor Cyril O' Connor for the ideas, advice and technical input.
- Margreth Tadie for being a big sister throughout the journey. Your help will forever be acknowledged especially helping me out learn about electrochemistry and how to use the equipment.
- CMR staff with special mention to Shireen Govender who was always available to attend to any problem in the laboratories
- Colleagues and friends in the chemical engineering department at UCT, with special mention to Dereck Ngoro for all your support.
- My parents for being a pillar of strength and source of my self-belief.
- My wife, Thanks and my daughter, Anotidaishe for standing with me all the way.

## **PRESENTATIONS AND PUBLICATIONS**

**Relating Electrochemistry to Flotation of Sulphide Minerals.** Chimonyo, W., Corin, K.C., Wiese, J.G., O'Connor, C.T.

Presented at the 32nd Minerals Processing annual conference hosted by the Southern African Institute of Mining and Metallurgy (SAIMM), 7 – 8 August 2014, Cape Town, South Africa.

**Relating Electrochemistry to Flotation of Sulphide Minerals.** Chimonyo, W., Corin, K.C., Wiese, J.G., O'Connor, C.T.

Presented at the South African Metals to Minerals Institute (SAMMRI) Workshop, 4 August 2014, Cape Town, South Africa.

**Relating Electrochemistry to Flotation of Sulphide Minerals.** Chimonyo, W., Corin, K.C., Wiese, J.G., O'Connor, C.T.

Presented at the 33rd Minerals Processing annual conference hosted by the Southern African Institute of Mining and Metallurgy (SAIMM), 6 – 7 August 2015, Cape Town, South Africa.

**An investigation into the relationship between electrochemical properties and flotation of sulphide Minerals.** Chimonyo, W., Corin, K.C., Wiese, J.G., O'Connor, C.T. Abstract accepted for the South African Metals to Minerals Institute (SAMMRI) Workshop, 2 – 3 November 2015, Cape Town, South Africa

**Redox potential control during flotation of sulphide minerals.** Chimonyo, W., Corin, K.C., Wiese, J.G., O'Connor, C.T.

Accepted for the proceedings of the MEI's Flotation '15 Conference, 16 – 17 November 2015, Cape Town, South Africa.

## SYNOPSIS

There is a growing importance in the mineral processing industry to find ways which are economic and effective in improving the recovery of minerals in the flotation process. The focus of this study was on the recovery by flotation of minerals found in the Merensky reef, which is one of the major reefs in the Bushveld complex. In that reef, base metal sulphide (BMS) minerals are commonly associated with PGMs and this has an effect on the way in which these minerals are concentrated by flotation (Vermaak et al. 2004; Wiese et al. 2005b; Miller et al. 2005; Schouwstra et al. 2000). A major problem in this process has been reported to be losses of valuable minerals (PGMs) associated with the loss of BMS (Wiese et al. 2005b), during flotation.

The present investigation has focused on studying the relationship between the flotation of sulphide minerals using xanthates as collectors and the electrochemical properties of the flotation system. It is well known that electrochemical mechanisms in flotation systems have a major influence on flotation since the reactions occurring at the mineral/solution interface are of critical importance in the process (Woods, 1971). The aim of this study was to investigate the extent to which there was a relationship between the electrochemical reactions occurring in this ore which could indicate the effectiveness of the flotation process. The electrochemical reactions were studied by determining the redox potential changes occurring when various changes were made. These were the length of the alkyl chain length of the xanthate collector, changing the pH or using various chemical reagents to change the potential of the system.

It was found from the rest potential measurements, that collectors of different chain length have different extents of interaction with mineral surface. A greater interaction, which is indicated by a greater change in the mixed potential after addition of the collector, is considered to be indicative of a greater adsorption of the collector at the mineral surface. It was hypothesized that this stronger adsorption by collectors of longer alkyl chain length would result in improved flotation performance. However, this was not observed to be the case and that was consistent with previous results on the relationship between the recovery of sulphide minerals in the Merensky ore and xanthates of different chain lengths. Thus it was shown that there was no correlation between the interactions between collectors of different alkyl chain lengths as

determined through electrochemical studies and the flotation performance of valuable minerals under the tests conditions used.

When NaClO was used as a potential modifier it was found that it was possible to change the Eh values without any change in pH. This was important since it allowed the effect of Eh alone to be investigated. The measurements of rest potentials of sulphide minerals showed that the addition of NaClO increased these potentials to varying degrees. It was hypothesised that an increase in surface potential would promote collector-mineral interactions and thus possibly the formation of hydrophobic species such as dixanthogen. Depending on whether the potential is greater than a threshold value of between 120 – 150 mV, the formation of dixanthogen would be preferred and that would result in a higher degree of hydrophobicity, and hence a possible improvement in floatability of valuable minerals.

However, from the findings in this study copper recoveries and grades remained largely unchanged at Eh values produced by the addition of NaClO which were in the range from (100 – 200 mV) to (500 – 600 mV) at a pH of 9. At pH 11 the Eh produced by the addition of NaClO was in the range between (0 – 100 mV) and (200 – 300 mV) and similar results for copper were observed in the presence of a collector and/or NaClO. Under all the conditions nickel recoveries and grades were high only in the presence of a collector.

This project has contributed to a further understanding of the effect of changing electrochemical potential by chemical means on the flotation of sulphides. Usually such potentials are changed by changing either the dissolved oxygen content or the pH (as illustrated in Pourbaix diagrams). The actual mechanisms involved when using chemical reagents are still generally not well understood (Chanturiya and Vigdergauz, 2009), and consequently some of the proposed mechanisms are inevitably speculative.

## TABLE OF CONTENTS

<b>DECLARATION</b> .....	i
<b>ACKNOWLEDGEMENTS</b> .....	ii
<b>PRESENTATIONS AND PUBLICATIONS</b> .....	iii
<b>SYNOPSIS</b> .....	iv
<b>TABLE OF CONTENTS</b> .....	vi
<b>LIST OF FIGURES</b> .....	ix
<b>LIST OF TABLES</b> .....	xiii
<b>Chapter 1</b> .....	1
<b>1 Introduction</b> .....	1
1.1 Background .....	1
1.2 Scope of Work .....	3
1.3 Objectives .....	4
<b>Chapter 2</b> .....	5
<b>2 Literature Review</b> .....	5
2.1 Bushveld Igneous Complex .....	5
2.2 Froth flotation .....	9
2.3 Classification of Flotation Reagents .....	9
2.4 Theory of Flotation .....	10
2.4.1 Pulp phase .....	11
2.4.2 Froth Phase .....	11
2.4.3 Flotation Variables .....	12
2.5 Collectors .....	13
2.5.1 Chemistry .....	13
2.5.2 Adsorption .....	16
2.6 Electrochemical potential .....	17
2.7 Importance of pH .....	18
2.8 Electrochemical Techniques .....	21
2.8.1 Rest Potential Measurements .....	21
2.8.2 Cyclic Voltammetry .....	23
2.9 Potential Control in Sulphide Flotation .....	26
2.10 Key Questions .....	29
2.11 Hypotheses .....	29

<b>Chapter 3</b> .....	30
<b>3 Methodology</b> .....	30
3.1 Rest Potential Measurements .....	30
3.1.1 Experimental Setup .....	30
3.1.2 Electrodes.....	31
3.1.3 Reagents .....	32
3.2 Batch Flotation .....	33
3.2.1 Ore preparation .....	33
3.2.2 Flotation Reagents .....	33
3.2.3 Water .....	34
3.2.4 Milling .....	34
3.2.5 Batch Flotation Procedure .....	34
3.2.6 Analysis of flotation performance.....	36
3.2.7 Two phase tests .....	36
3.2.8 Confirmatory Tests .....	36
<b>Chapter 4</b> .....	38
<b>4 Results</b> .....	38
4.1 Introduction .....	38
4.2 Determination of oxidation potentials of collectors .....	38
4.3 Rest potential measurements.....	39
4.3.1 Reproducibility .....	40
4.3.2 Chalcopyrite.....	41
4.3.3 Pentlandite.....	44
4.3.4 Pyrite .....	47
4.3.5 Pyrrhotite .....	48
4.4 Batch Flotation Tests .....	51
4.4.1 Reproducibility .....	51
4.4.2 Preliminary Tests.....	51
4.4.3 Effect of changing potential with NaClO .....	55
4.4.4 Effect of collectors of different chain length .....	71
4.4.5 Comparison of different types of potential modifiers .....	78
4.4.6 Effect of addition of trace amounts of Hydrogen Peroxide (H <sub>2</sub> O <sub>2</sub> ) .....	86
4.5 Effect of Eh on Gangue Recovery.....	91
4.5.1 Talc Recovery.....	91
4.5.2 Rate Constants.....	93

<b>Chapter 5</b> .....	94
<b>5 Discussion</b> .....	94
<b>5.1 Introduction</b> .....	94
5.2 Oxidation Potentials of collectors .....	95
5.3 Effect of collector chain length .....	96
5.4 Effect of pH .....	99
5.5 Effect of oxidizing reagent on rest potentials of sulphide minerals .....	100
5.6 Potential control during the flotation of sulphide minerals .....	102
5.6.1 Preliminary Tests.....	102
5.6.2 Flotation performance.....	103
5.7 Comparison of potential modifiers.....	105
5.8 Effect of Eh on Gangue Recovery.....	107
5.9 Summary.....	108
<b>Chapter 6</b> .....	109
<b>6 Conclusions and Recommendations</b> .....	109
6.1 Conclusions.....	109
6.2 Recommendations .....	111
<b>Chapter 7</b> .....	112
<b>7 References</b> .....	112
<b>Chapter 8</b> .....	117
<b>8 Appendices</b> .....	117
8.1 Appendix A: Rest Potential Results.....	117
8.2 Appendix B: Batch Flotation Raw Data .....	118
8.3 Appendix C: Microflotation .....	124
Collector Surface Coverage Calculations.....	124
Microflotation Test Procedure .....	124

## LIST OF FIGURES

Figure 2-1: The simplified geological map of the Bushveld Complex (Schouwstra et al. 2000). .....	5
Figure 2-2: The map showing the location of the Merensky .....	8
Figure 2-3: Simplified circuit of the metallurgical treatment of the mined Merensky ores (Schouwstra et al. 2000). .....	8
Figure 2-4: Schematic diagram of a mechanical flotation cell (Perry and Green, 1997). .....	10
Figure 2-5: Classes of Collectors (Bulatovic, 2010) .....	13
Figure 2-6: Collector adsorption on a mineral surface (Wills and Napier-munn, 2006) .....	14
Figure 2-7: A mixed potential model for two redox couples (Rand and Woods, 1984) .....	18
Figure 2-8: Eh-pH diagram for H <sub>2</sub> O-O <sub>2</sub> -Cl <sub>2</sub> system .....	19
Figure 2-9: The effect of change in pH on collector adsorption on the mineral surface (Wills and Napier-munn, 2006). .....	20
Figure 2-10: A schematic diagram for a typical rest potential profile as a result of reactions such as oxygen reduction, mineral oxidation and collector oxidation (Tadie, 2015). .....	21
Figure 2-11: Electrode set-up for rest potential measurements (Gamry, 2011). .....	22
Figure 2-12: Electrode set-up for cyclic voltammetry (Gamry, 2011). .....	24
Figure 2-13: Cyclic voltammetry for PtS in the absence and presence of SEX in an aerated solution at pH 9.2 (Tadie et al. 2015) .....	25
Figure 2-14: Recovery versus potential for chalcopyrite, enargite and chalcocite (Smith et al. 2012) .....	27
Figure 2-15: Recovery of pentlandite versus pyrrhotite at pH between 9-9.5 in the presence of sodium isobutyl xanthate 1x 10 <sup>-4</sup> M (Khan and Kelebek, 2004). .....	28
Figure 3-1: Set-up of equipment used for electrochemical measurements .....	30
Figure 4-1: Rest potential measurements to show reproducibility, for chalcopyrite with SEX added as collector after 600s, in a buffer solution at pH 9. .....	40
Figure 4-2: Rest potential measurements to show reproducibility, for pentlandite with PAX added as collector after 600 s in a buffer solution at pH 9. .....	40

Figure 4-3: Rest potential for chalcopyrite in the absence and presence of collectors of different alkyl chain length at pH 9. ....	41
Figure 4-4: Rest potential for chalcopyrite in the absence and presence of collector SEX shown as X at pH 9 and at pH 11.....	42
Figure 4-5: Rest potential for chalcopyrite with NaClO added after 300 s and collector SEX added after 600 s at pH 9 and at pH 11 .....	43
Figure 4-6: Rest potentials for chalcopyrite in absence of collector and in the presence of collector SEX added first at 300 s, NaClO added at 600 s and 900 s at a pH of 11.....	43
Figure 4-7: Rest potentials for pentlandite in the absence and presence of collectors at pH 9.....	44
Figure 4-8: Rest potential for pentlandite in the absence and presence of collector SEX shown as X at pH 9 and at pH 11.....	45
Figure 4-9: Rest potential for pentlandite with NaClO added after 300 s and collector SEX added after 600 s at pH 9 and at pH 11. ....	45
Figure 4-10: Rest potential for pentlandite in absence and presence of collector SEX added at 300 s and NaClO added after 600 s and 900 s at pH 11.....	46
Figure 4-11: Rest potential for pyrite in the absence and presence of collectors at pH 9. ....	47
Figure 4-12: Rest potential for pyrite in the absence and presence of SEX at pH 9 and at pH 11.....	48
Figure 4-13: Rest potential for pyrite with NaClO added after 300 s and collector SEX added after 600 s at pH 9 and at pH 11. ....	48
Figure 4-14: Rest potential for pyrrhotite in the absence and presence of collectors at pH 9.....	48
Figure 4-15: Rest potential for pyrrhotite in the absence and presence of collector SEX shown as X at pH 9 and at pH 11.....	49
Figure 4-16: Rest potentials for pyrrhotite in the presence of SEX with NaClO added after 300 sec, at pH 9 and at pH 11 .....	50
Figure 4-17: Change of Eh using NaClO against pH in slurry, distilled water (DW) and synthetic plant water (SPW).....	52
Figure 4-18: Change of Eh using NaClO against pH in a flotation cell using a slurry of a Merensky ore and NaOH to adjust pH to 11.....	53

Figure 4-19: Water recovered during two phase tests conducted with SPW.....	54
Figure 4-20: Final solids versus water final recoveries during batch flotation tests under different conditions at pH 9 and 11 using a Merensky ore .....	55
Figure 4-21: Solids recovery at pH 9 and 11 during batch flotation tests .....	56
Figure 4-22: Water recovery at the pH 9 and 11 during flotation.....	57
Figure 4-23: Solids recovered as a function of water for different conditions at pH 9. .....	57
Figure 4-24: Solids recovery as a function of water recovery for different conditions at pH 11.....	58
Figure 4-25: Images of froth zone (first concentrate) at pH 9.2 in a) the presence SEX and b) collector and NaClO.....	59
Figure 4-26: The effect of Eh against a) solids and b) water recovered, at pH 9 and pH 11.....	60
Figure 4-27: Final recovery versus final grade for copper and nickel a) pH 9 and b) pH 11.....	61
Figure 4-28: Final a) recovery and b) grade for copper at pH 9 versus pH 11 .....	62
Figure 4-29: Copper grade as a function of copper recovery at pH 9.....	63
Figure 4-30: Copper grade as a function of recovery at pH 11.....	64
Figure 4-31: Flotation rate of copper at the pH 9.....	65
Figure 4-32: Flotation rate of copper at the pH 11.....	66
Figure 4-33: Final a) recovery and b) grade for nickel at pH 9 and pH 11.....	67
Figure 4-34: Cumulative grade recovery curves for nickel at pH a) 9.2 and b) pH 11 .....	68
Figure 4-35: Flotation rate for nickel at pH 9 .....	70
Figure 4-36: Flotation rate for nickel at pH 11 .....	71
Figure 4-37: Final solids and final water recovery in the absence and presence of collectors of different chain length at pH 9. ....	72
Figure 4-38: Solids versus water recovery in the absence and presence of collectors of different chain length at pH 9. ....	73
Figure 4-39: Final recovery and final grade for copper and nickel in the absence and presence of collectors of different chain length at pH 9.....	74
Figure 4-40: Copper grade as a function of copper recovery in the absence and presence of collectors of different chain length at pH 9.....	75

Figure 4-41: Flotation rate of copper at the pH 9.....	76
Figure 4-42: Nickel grade as a function of nickel recovery for nickel in the absence and presence of collectors of different chain length at pH 9.....	77
Figure 4-43: Flotation rate for nickel at pH 9 .....	78
Figure 4-44: Final solids and final water recovery in the absence and presence of collector, SEX and potential modifiers; H <sub>2</sub> O <sub>2</sub> and NaClO at pH 9. ....	79
Figure 4-45: Solids recovery as a function of water recovery in the absence and presence of collector (SEX) potential modifiers; H <sub>2</sub> O <sub>2</sub> and NaClO at pH 9. ....	80
Figure 4-46: Final recovery and final grade for copper and nickel in the absence and presence of collector (SEX) and potential modifiers; H <sub>2</sub> O <sub>2</sub> and NaClO at pH 9. ....	81
Figure 4-47: Copper grade as a function of copper recovery in the absence and presence of collector, (SEX) and potential modifiers; H <sub>2</sub> O <sub>2</sub> and NaClO at pH 9 .....	82
Figure 4-48: Flotation rate of copper at the pH 9.....	83
Figure 4-49: Cumulative nickel grade versus cumulative nickel recovery in the absence and presence of collector, SEX; H <sub>2</sub> O <sub>2</sub> and NaClO.....	84
Figure 4-50: Flotation rate for nickel at pH 9 .....	85
Figure 4-51: Final water and solids recoveries with change of concentration of H <sub>2</sub> O <sub>2</sub> in the presence of SEX at pH 9. ....	86
Figure 4-52: Solids recovery as a function of water recovery with change of concentration of H <sub>2</sub> O <sub>2</sub> in the presence of SEX at pH 9.....	87
Figure 4-53: Final recovery and final grade for copper and nickel obtained at different concentrations of H <sub>2</sub> O <sub>2</sub> at pH 9. ....	87
Figure 4-54: Cumulative copper grade versus cumulative copper recovery obtained at different concentrations of H <sub>2</sub> O <sub>2</sub> at pH 9 for Merensky ore.....	88
Figure 4-55: Cumulative copper grade versus cumulative nickel recovery obtained at different concentrations of H <sub>2</sub> O <sub>2</sub> at pH 9 for Merensky ore. ....	89
Figure 4-56: Flotation rate for copper at pH 9 .....	89
Figure 4-57: Flotation rate for nickel at pH 9 .....	90
Figure 4-58: Talc recovery as function of time under different conditions .....	92
Figure 5-1: The rest potential profiles of sulphide minerals in the presence of collectors, SEX and PAX at pH 9. ....	97
Figure 8-1: Rest potential profiles for a) pyrite in the absence of any reagent at pH 9 and b) pyrrhotite in the absence of any reagent at pH 11.....	117

## LIST OF TABLES

### Chapter 2

Table 2-1: Mineralogical Composition of the Merensky Ore .....	7
Table 2-2: Variables in flotation system (Klimpel, 1984; Bulatovic, 2007) .....	12
Table 2-3 : Structure of the commonly used xanthates .....	15
Table 2-4: Results of rest potentials of various minerals and the surface species on the mineral surface (Allison et al. 1972). .....	22

### Chapter 3

Table 3-1: Purities of reagents .....	32
Table 3-2: The ions concentration of synthetic plant water (SPW).....	34
Table 3-3: Summary of the batch flotation procedure .....	35

### Chapter 4

Table 4-1: The reversible potential of PAX when compared to literature values .....	39
Table 4-2: The rate of flotation (k) and maximum recovery (Rmax) for copper recovery at pH 9.2 at conditions evaluated. ....	65
Table 4-3: The rate of flotation (k) and maximum recovery (Rmax) for copper at pH 11 at conditions evaluated.....	66
Table 4-4: The rate of flotation (k) and maximum recovery (Rmax) for nickel recovery at pH 9 at conditions evaluated. ....	70
Table 4-5: The rate of flotation (k) and maximum recovery (Rmax) for nickel recovery at pH 11 at conditions evaluated. ....	71
Table 4-6: The rate of flotation (k) and maximum recovery (Rmax) for copper recovery at pH 9 under conditions evaluated. ....	76
Table 4-7: The rate of flotation (k) and maximum recovery (Rmax) for nickel recovery at pH 9.2 at shown conditions .....	78
Table 4-8: The rate of flotation (k) and maximum recovery (Rmax) for copper recovery at pH 9 at conditions evaluated. ....	83
Table 4-9: The rate of flotation (k) and maximum recovery (Rmax) for nickel recovery at pH 9 at shown conditions .....	85
Table 4-10: The rate of flotation constants (k) and maximum recovery (Rmax) for copper recovery at pH 9 under conditions of varying concentration for H <sub>2</sub> O <sub>2</sub> . ....	90
Table 4-11: The rate of flotation constants (k) and maximum recovery (Rmax) for nickel recovery at pH 9 under conditions of varying concentration for H <sub>2</sub> O <sub>2</sub> .....	91

Table 4-12: The rate of flotation (k) and maximum recovery (R<sub>max</sub>) for talc recovery  
at pH 9 at shown conditions ..... 93

**Chapter 5**

Table 5-1: The change in rest potentials before and after addition of NaClO at pH 9.  
..... 102

## **Chapter 1**

### **1 Introduction**

This chapter contains the background of this study and highlights previous investigations. The objectives and scope of the study are detailed. The scope describes the focus areas of the research giving emphasis on what has been covered.

#### **1.1 Background**

The Merensky reef is a valuable source of Platinum Group of Minerals (PGMs), and these occur in association with Base Metal Sulphides (BMS). The reef is considered as a complex sulphide ore in terms of the variety of sulphide minerals contained therein, where the total sulphide content has been reported to be approximately less than 1%. The remaining 99% is the non-valuable minerals which include pyroxene, talc, quartz and other non-sulphide gangue minerals.

The association that exists between PGMs and BMs in the Merensky Reef, has been reported to be detrimental to the way these minerals can be concentrated by flotation and the ability to improve on the recovery of base metal sulphides offers economic benefits in terms of revenue to the platinum industry (Wiese et al. 2005b; Biesinger et al. 2007).

Flotation is a widely used separation process during mineral beneficiation and is based on the differences in surface characteristics of minerals to separate them. During flotation, sulphide minerals interact with thiol collectors in an electrochemical manner to form hydrophobic entities at the mineral surface (Rand and Woods, 1984; Yoon & Basilio, 1983). The interaction or reactions involve transfer of electrons and as such, a potential is responsible for driving electrons between reacting species.

The potential can be manipulated by changing the solution chemistry and this study seeks to understand how potential changes can affect overall sulphide mineral recovery. The use of potential as an important parameter to control flotation has been widely mentioned by many investigators (Woods, 2003; Vermaak et al. 2007; Buswell et al. 2002a). Other parameters, in addition to potential, such as dissolved oxygen (DO) and pH are important as they can be used to describe the changes to the general chemical properties of sulphide mineral surfaces during flotation (Fuerstenau et al. 2007). A limitation has been observed with regards to the uncertainties around such

parameters to accurately predict the synergistic effects, if any, in the sulphide mineral recovery when changing solution/pulp chemistry (Heyes and Trahar, 1979).

Rest potential measurements seek to further understand the reactions occurring at sulphide mineral surfaces when interacting with collectors, and other reagents, during flotation, from an electrochemical point of view. These measurements give a fundamental understanding of the mechanisms of the reactions taking place at the mineral surfaces and the possible species being formed (Woods, 2010; Rao, 2004; Leppinen and Hintikka, 1995).

It should be noted though that rest potential values vary depending on the components of the system under investigation. It is also difficult to accurately predict the flotation performance of complex sulphide ores from surface chemistry alone as formation of different oxidation products is possible. However, electrochemical measurements are able to give an indication of the regions of potential in which metallurgical performance may be optimized.

Chemical oxidizing reagents, such as sodium hypochlorite and hydrogen peroxide have been reported as useful for the control of the potential during flotation (Bulatovic, 2007; Rao, 2004). The limited literature available on electrochemically controlled flotation has failed to quantify potential control by chemical means in complex flotation systems. The studies available are restricted to single mineral studies and therefore, the main objective of this work is to understand the action of potential control in regulating the wettability of minerals in a complex sulphide ore and evaluate the subsequent flotation performance.

## **1.2 Scope of Work**

The study focusses on the investigation of electrochemical potential controlled flotation of sulphide minerals. Rest potential measurements were conducted to establish the potentials at which oxidizing conditions can be present in flotation and also predict the kind of typical species that can be formed at a mineral surface. The species present at the mineral surface are important as they may be related to hydrophobic behaviour of valuable minerals.

In this study, the valuable information obtained from open circuit potential measurements was used to develop further understanding on the conditions under which the flotation behaviour of a complex sulphide ore in a flotation process can be optimized. The metallurgical performance was evaluated using results from batch flotation tests by chemically analysing for copper and nickel. The batch flotation tests were conducted using chemical oxidizing reagents as potential modifiers, collectors of different chain length and at different pH values. In the current study, froth characteristics were not analysed and also the dissolved concentration (DO) of the pulp was monitored and not controlled.

### **1.3 Objectives**

The overall objective of the work is to study conditions suitable for increased recovery of sulphide minerals using potential modifiers, collectors of different carbon chain length, and pH variation.

This objective can be further divided into the following sub-objectives.

1. To determine the rest potential profiles of selected sulphide minerals in the absence and presence of either/both oxidizing agent and collector
2. Investigate the use of chemical reagent(s) as Eh modifiers to control potential during flotation
3. Investigate the influence of Eh and pH on the recovery and grade of selected sulphide minerals during flotation

## Chapter 2

### 2 Literature Review

#### 2.1 Bushveld Igneous Complex

South Africa, with its strong mining based economy, features prominently in terms of the world's reserves of mineral commodities, particularly with regards to the platinum group minerals (PGMs). Minerals are a common heritage of all South Africans and in addition to the direct contribution, mining has an indirect multiplier effect on the South African gross domestic product (GDP) of between 15 and 20% (SAMMRI, 2009). South Africa hosts the Bushveld Igneous Complex (BIC) which contributes more than 80% of the world PGM supply and is the largest natural reserve of PGMs (Muzenda et al. 2011; Miller et al. 2005). Therefore the mineral processing of the ore deposits in the BIC is important to the economy of the country.

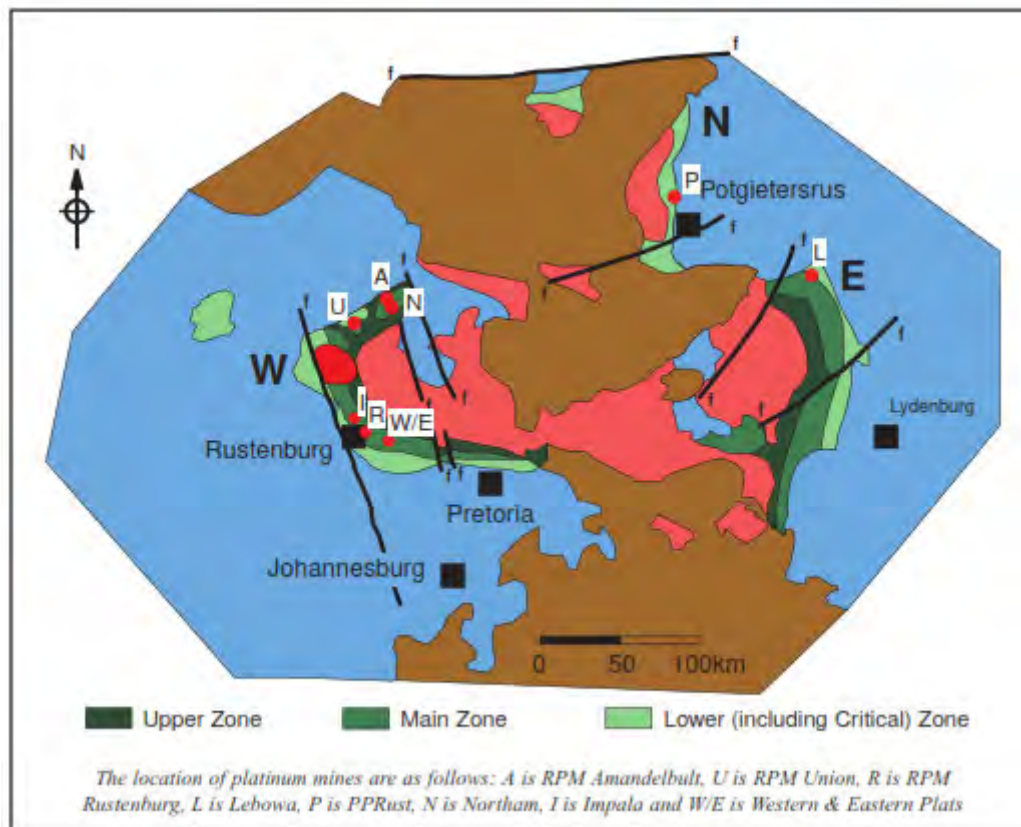

Figure 2-1: The simplified geological map of the Bushveld Complex (Schouwstra et al. 2000).

The geological map of the Bushveld Igneous Complex is shown in Figure 2-1. The green shades represent the Bushveld rocks, the rose shades are the granitic cover rocks, the blue and brown shades represent the pre- and post-Bushveld rocks, respectively. The red circular shape near Rustenburg is the Pilanesberg alkali complex. The complex is a layered igneous intrusion consisting of rocks that cooled from hot molten magma, deep within the earth. The aggregation and crystallization of silicate minerals resulted in the formation of the igneous rocks. It stretches over 65 000 km<sup>2</sup> and is some seven to nine kilometres thick (Schouwstra et al. 2000).

The BIC consists of three major reefs, namely Platreef, Merensky and UG2 reef. Platreef is located in the Northern limb shown as N in Figure 2-1 and it extends for more than 30 km (Cawthorn, 1999). It has been reported to have a complex assemblage of pyroxenites, serpentinites and calc-silicates. Base metal sulphides (BMS) commonly found in the Platreef include pyrrhotite, pentlandite, chalcopyrite and pyrite. PGMs have a high association with the silicate minerals in some areas, and they frequently exist, enclosed in or on the grain boundaries of BMS sulphides (Schouwstra et al. 2000)

The UG2 is another important horizon which occurs in the BIC, and has chalcopyrite and pentlandite as the major BMS whilst pyrrhotite, pyrite, arsenopyrite and galena exist in minor phases (Viljoen and Schurmann, 1998). The main gangue mineral constituent in the UG2 ore is the chromite (60 – 90% by volume) with lesser silicate minerals (5 – 30% pyroxene and 1 – 10% plagioclase. The BMS are within the interstitial silicate and are enclosed with the chromite particles. The PGMs present in the UG2 ore are dominated by BMS and occur in association together (Schouwstra et al. 2000).

This study focuses on the Merensky reef which is located in the Western Limb of the BIC. It has a depth of up to 5 km and stretches over 300 km around the eastern and western limbs. It is a complex sulphide ore in terms of the variety of sulphide minerals contained therein. The total sulphide mineral content is reported to be approximately less than 1% where the remaining 99% can be pyroxene, talc, quartz and any other non-sulphide gangue minerals (Ekmekçi et al. 2005). The distribution of the rock forming silicate minerals is orthopyroxene (~ 60%), plagioclase feldspar (~ 20%),

pyroxene (~ 15%), phlogopite (5%) and rare olivine. The reef contains BMS which include pyrrhotite, pentlandite, chalcopyrite and pyrite associated with PGMs.

Table 2-1 shows the results obtained using XRD at UCT, to determine mineral composition of a typical sample from the Merensky Reef. It can be observed that pyrrhotite is the most abundant sulphide mineral in Merensky Reef.

*Table 2-1: Mineralogical Composition of the Merensky Ore*

<b>Mineral Composition</b>	<b>%</b>
Olivine	0.280
Pentlandite	0.102
Pyrrhotite	0.430
Biotite	0.398
Chalcopyrite	0.355
Chlorite	3.767
Chromite	0.263
Diopside	6.925
Hornblende magesian iron	3.231
Lizardite IT	0.002
Bytownite An85	42.410
Orthopyroxene	0.565
Talc	2.025
Quartz	0.596
Pyrite	0.056
Enstatite	37.190
Epidote	0.633
Calcite	0.772

Secondary minerals such as talc and chlorite have a widespread occurrence and they are generally termed gangue minerals. Talc is known to be naturally floatable and this has a detrimental impact on the flotation performance. It contributes to the inefficiencies of the flotation process and can lead to losses of valuable minerals (Wiese et al. 2005b).

Figure 2-2 shows the geological map of the Merensky Reef mines.

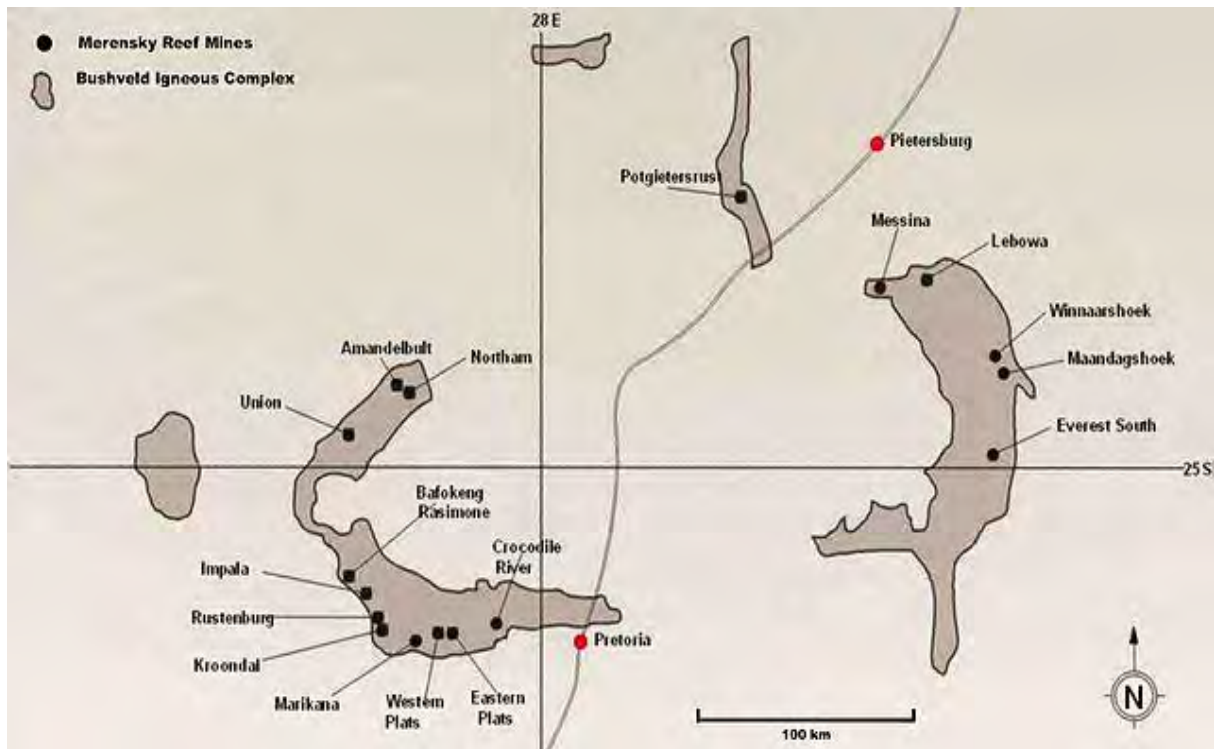

Figure 2-2: The map showing the location of the Merensky Reef Mines ([https://en.wikipedia.org/wiki/Merensky\\_Reef\\_Mines](https://en.wikipedia.org/wiki/Merensky_Reef_Mines))

The flow sheet of the mineral processing operations on the Merensky ore is shown in Figure 2-3.

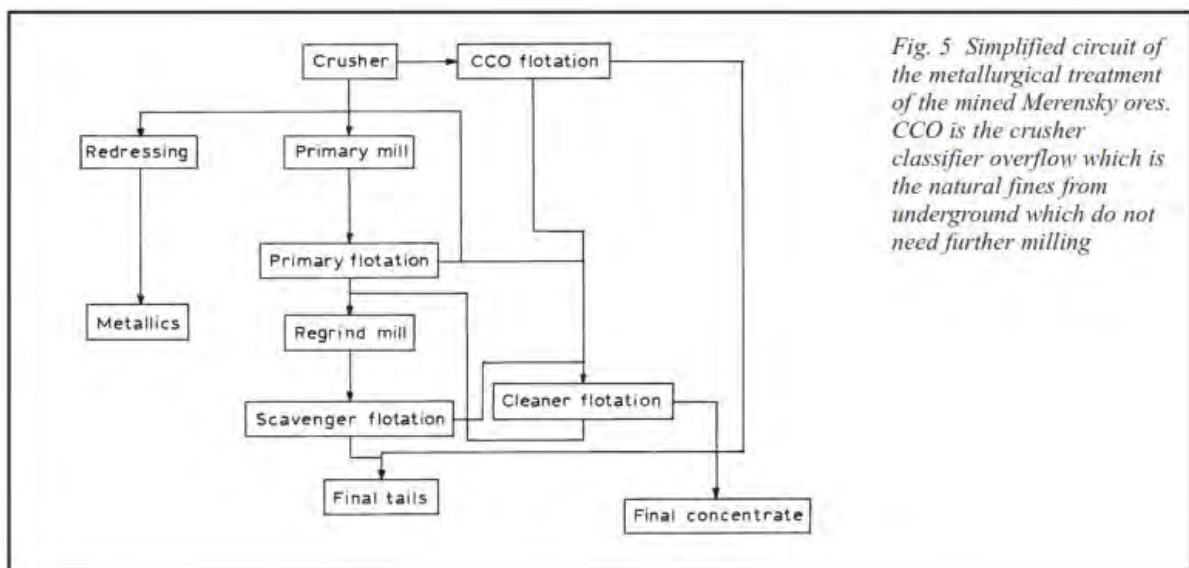

Fig. 5 Simplified circuit of the metallurgical treatment of the mined Merensky ores. CCO is the crusher classifier overflow which is the natural fines from underground which do not need further milling

Figure 2-3: Simplified circuit of the metallurgical treatment of the mined Merensky ores. CCO is the crusher classifier overflow which is the natural fines from underground which do not need further milling (Schouwstra et al. 2000).

## 2.2 Froth flotation

Froth flotation is a technique that is used for concentration or separation of valuable minerals from undesired gangue material by use of differences in the interfacial properties of the solid-liquid-gas system. Fuerstenau et al. (2007), mentioned that the properties which allow separation are created and controlled by various classes of reagents used during the flotation process

## 2.3 Classification of Flotation Reagents

The reagents used in flotation are critical and are generally classified according to performing specific functions at the mineral/solution or air/solution interfaces. Depending on their particular function, reagents are generally divided into collectors, frothers and modifiers.

1. **Collectors** impart hydrophobicity at a mineral surface and the most important prerequisite for increased recovery is the rendering of the valuable minerals' surface hydrophobic; water repellent (Khan and Kelebek, 2004). The mechanism of adsorption has been described in detail in section 2.5.2.
2. **Frothers** reduce the surface tension at the air-water interface to improve bubble formation. This is useful in order to stabilize the air bubbles generating a froth that is stable enough such that the froth product or concentrate can be collected. This should occur before the bubbles burst and release valuable mineral particles back into the pulp. The presence of frothers at the interface increases the strength of the film of the air bubbles such that the attachment of the water repellent particles to the bubbles is enhanced (Bulatovic, 2007)
3. **Modifiers** generally affect the way collectors interact with the mineral surfaces. Their action can be considered as twofold; either increasing the adsorption of collectors onto selected mineral surfaces or preventing the interaction of collectors with selected mineral surfaces (Bulatovic, 2007).

**Modifiers** have a number of functions (Hu et al. 2009);

- a) Activators are used to facilitate mineral-collector interactions for minerals which do not readily interact with collectors; oxidised or altered. For example, copper sulphate has been widely mentioned in literature as applicable in sulphide mineral flotation.

- b) Depressants adsorb on surfaces to prevent or hinder the action of collectors (promote selective flotation of desired minerals). Examples include guar gum and carboxymethyl cellulose (CMC).
- c) pH regulators control the pH of the system; affecting the surface charge of mineral particles and the ionisation/stability of collectors, frothers, depressants, activators. Lime is commonly used in industry as a pH modifier.
- d) Potential (Eh) modifiers adjust the redox potential of the system, influencing the surface properties of the minerals and allowing for electrochemically controlled flotation of sulphide minerals. Sodium hypochlorite (NaClO), Sodium Hydrosulphide (NaSH), Hydrogen peroxide (H<sub>2</sub>O<sub>2</sub>), are examples of Eh modifiers.

## 2.4 Theory of Flotation

The froth flotation process is complex and affected by many sub processes and/or interactions in the three phase system. This has led to incomplete understanding of the theory of flotation and according to Bulatovic (2007) many conclusions have been based on approximations. The froth flotation process consist of two distinct regions in a flotation cell; the froth phase and the pulp phase as shown in Figure 2-4.

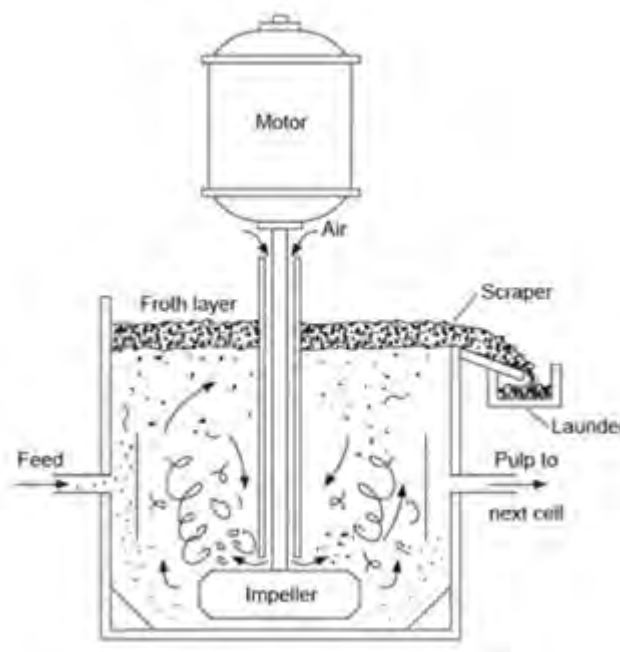

Figure 2-4: Schematic diagram of a mechanical flotation cell (Perry and Green, 1997).

### **2.4.1 Pulp phase**

In the pulp phase the flotation reagents added are responsible for imparting different surface properties to the minerals. A hydrophobic particle should attach to an air bubble and ascend to the top of the flotation cell (froth layer) for recovery. Particles are transported to the froth layer from the pulp phase by either true flotation or entrainment. True flotation is selective and occurs as a result of the differences in the physiochemical properties of various particles. Entrainment is the deportment of hydrophilic minerals in the water layers surrounding bubbles to the concentrate. It is known that some valuable minerals report to the froth phase as a result of entrainment and entrapment but the dominant mechanism is true flotation, while gangue minerals report to the froth phase by entrainment. The impeller in a flotation cell promotes the collision of particles and the bubbles, adsorption and transport in the pulp (Wills and Napier-munn, 2006).

### **2.4.2 Froth Phase**

The froth phase is regarded as the most important phase as it enhances the separation of the valuable mineral from the gangue. This is achieved by allowing the drainage of entrained material and retaining wanted material in the concentrate stream. This determines the performance variables i.e. the grade and recovery of the flotation process. The relationship of these variables is a trade-off which is dependent on froth stability, a measure of the ability of froth to withstand collapse when external forces are exerted on it. Conditions necessary for an optimally stable froth must be achieved otherwise an unstable froth causes the fall back of both solids and water into the pulp (Wills and Napier-munn, 2006), causing a decrease in recovery. According to Zheng et al. (2006) a highly stable froth also has a detrimental effect, for example when the water recovery is high, this increases the entrainment of gangue in a real ore system.

### 2.4.3 Flotation Variables

The froth flotation process is affected by both physical and chemical variables which are shown in Table 2-2. These variables are related such that a change in one variable will result in corresponding changes in other parts of the flotation system (Klimpel, 1984; Bulatovic, 2007).

*Table 2-2: Variables in flotation system (Klimpel, 1984; Bulatovic, 2007)*

	Equipment (Hydrodynamics)	Operation	Chemistry
Variables	<ol style="list-style-type: none"> <li>1. Airflow</li> <li>2. Cell Design</li> <li>3. Agitation</li> <li>4. Solids</li> <li>5. Suspension</li> </ol>	<ol style="list-style-type: none"> <li>1. Feed Rate</li> <li>2. Particle size</li> <li>3. Mineralogy</li> <li>4. Pulp density</li> <li>5. Temperature</li> </ol>	<ol style="list-style-type: none"> <li>1. Collectors</li> <li>2. Frothers</li> <li>3. Activators</li> <li>4. Depressants</li> <li>5. pH Modifiers</li> </ol>

In this study the focus was on the surface chemistry of sulphide minerals to create oxidizing conditions of collectors during flotation. Therefore oxidation products present on the surface of sulphide minerals play a critical role in determining the flotation properties (Hamilton and Woods, 1981).

## 2.5 Collectors

Collectors facilitate the bubble-particle attachment by adsorbing on the mineral surface and rendering the valuable mineral surface hydrophobic or water-repellent (Khan and Kelebek, 2004). Once the mineral surface has been made hydrophobic, this provides conditions favourable for the recovery of such minerals to the froth phase (Bulatovic, 2007).

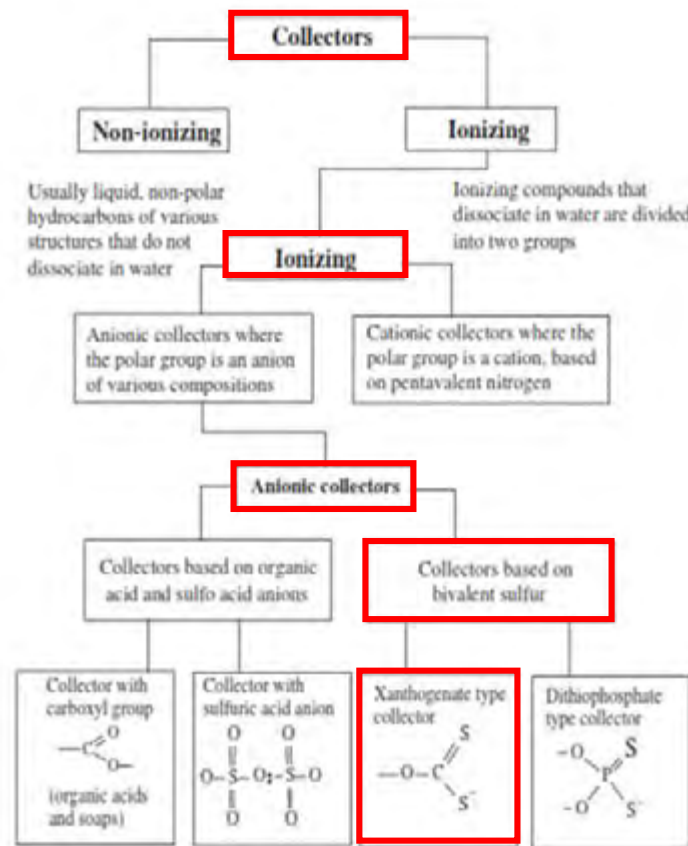

Figure 2-5: Classes of Collectors (Bulatovic, 2007)

Figure 2-5 shows the classes of collectors which are of relevance to this study highlighted in red. The selective hydrophobization of sulphide minerals is normally carried out using thiol-based collectors such as xanthates. Xanthates are cheap and also widely known to be efficient during sulphide mineral and PGMs flotation because of their selectivity and no affinity for gangue minerals (Bulatovic, 2007).

### 2.5.1 Chemistry

Collectors are heteropolar molecules mainly consisting of two parts; a non-polar tail that is attracted to the air bubbles and a polar head that is attracted to the mineral

surface and reacts with water. Figure 2-6 shows the interaction of the collector with a mineral surface.

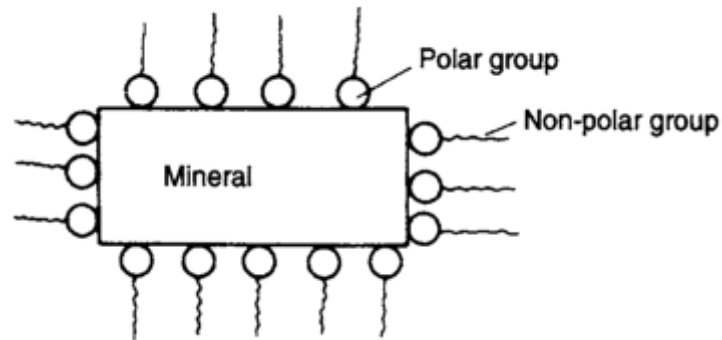

Figure 2-6: Collector adsorption on a mineral surface (Wills and Napier-munn, 2006)

Thiol collectors have a sulfhydryl (-SH) group and are anionic collectors. They are prepared by reacting an alkali hydroxide, an alcohol, and carbon disulphide. The thiol collector formed is RO.CS.SK, where R is the hydrocarbon chain (non-polar) group, as show in reaction (2.1).



The sulphur atoms of the polar group of the collectors have accessible, vacant d-orbitals which accept electrons and form pi bonds with the metal ions in addition to the already present sigma bonds. The d-orbitals make the atom readily polarizable enabling the adsorption of the molecules at the mineral surfaces.

The bonding of the polar group of the collector with the mineral surface depends on

- a) nature of the reaction with the mineral surface
- b) strength of the attachment, and
- c) selectivity,

All these are dependent on the polar group's composition and structure (Bulatovic, 2007). The collector type, the nature and charge of the mineral surface influence the bonding and stability of the species present to cause hydrophobicity (Bradshaw et al. 1998).

The structure of the commonly used xanthates is shown in Table 2-3.

Table 2-3 : Structure of the commonly used xanthates

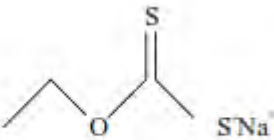
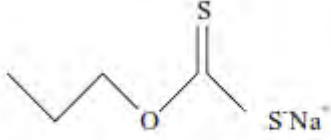
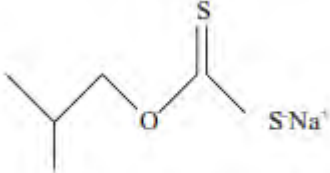
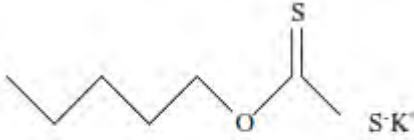
 <p><b>Sodium ethyl xanthate (SEX)</b></p>	 <p><b>Sodium normal propyl xanthate (SNPX)</b></p>
 <p><b>Sodium isobutyl xanthate (SIBX)</b></p>	 <p><b>Potassium amyl xanthate (PAX)</b></p>

Sodium ethyl xanthate (SEX) and potassium amyl xanthate (PAX) are the collectors used in this study. They have different alkyl chain lengths and are stable within the alkaline pH range 8 -13 (Fuerstenau, 1982). The water repellent effect caused by a collector on the mineral surface has been indicated to be directly proportional to the chain length and also structure of the (non-polar) hydrocarbon radical. Finkelstein and Poling (1977), pointed out that the solubility of the collector – metal specie formed at a mineral surface, vary depending on the length and conformation of the alkyl chains of the non-polar portion of the collector. The variation is due to the inductive effects of the hydrocarbon chain affecting the strength and therefore solubility of collector-metal bonds.

A collector of longer chain length results in a more stable and less soluble oxidation product. The presence of such a product at a mineral surface also results in a higher surface coverage than short alkyl chain oxidation product. Wiese et al. (2011) conducted work on a real ore comparing collectors of different chain length; ethyl and butyl xanthates. From their results, they showed no significant difference on the flotation performance of valuable minerals. These results confirm the complexity of a typical flotation system due to various factors affecting the metallurgical performance of an ore.

### 2.5.2 Adsorption

The type of collector adsorption to the mineral surface is highly debated and there are many theories that have been developed. These included ion-exchange, physisorption or chemisorption, however, around the 1980s the interaction of thiol collectors with sulphide mineral surface was reported to be electrochemical in nature (Rand and Woods, 1984). This involves an anodic reaction in which the collector transfers electrons to the mineral surface and a simultaneous cathodic reduction of oxygen in the adsorption process (Yoon and Basilio, 1983; Rao, 2004). Oxygen acts as the electron acceptor although, other oxidizing reagents can undergo cathodic reduction (Chanturiya and Vigdergauz, 2009).



$X_{\text{ads}}$  represents a physically adsorbed xanthate molecule.



The chemisorption reactions shown in 2-3 up to 2-5 are coupled electrochemical and chemical reactions in the adsorption process.

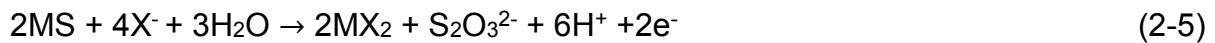
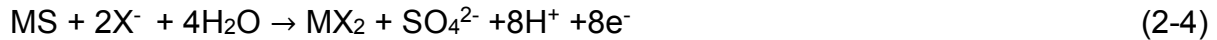

MS represents a sulphide mineral which provides a passage for electrons released by the thiol collector.



Adsorption of collectors, also depends on the electro-catalytic property of the sulphide mineral to drive the reaction and this causes varying flotation responses (Somasundaran, 1987; Woods, 1971)

Metal xanthate is a product that can be formed due to collector oxidation, however, dixanthogen/dithiolate (Reaction 2-7) at the surface or in solution has been considered as a key step in rendering mineral surfaces hydrophobic. Dixanthogen results in a higher degree of hydrophobicity which might lead to better flotation performance (Buswell et al. 2002a; Ekmekçi et al. 2005).



The overall reactions have been presented by Hu et al.(2009) and Rao (2004) as the following;

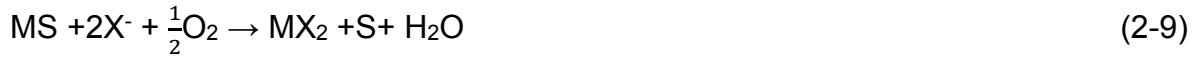

Oxidation constitutes a central part of the electrochemical reactivity of sulphide minerals and from the reactions  $X_{ads}$ ,  $MX_2$ ,  $S$ ,  $X_2$  are the possible entities contributing to hydrophobicity (Hu et al. 2009). It is therefore difficult to know the exact type of species available at a particular instant and their contribution to floatability of minerals.

## 2.6 Electrochemical potential

Sulphide minerals are semi-conductors and their flotation behaviour can be reconciled by an electrochemical approach. When introduced into solution sulphide minerals form a rest or electrochemical potential. The potential is a driving force for the transferring of electrons between a conducting solid and species in solution. The electrons/charge transfer rate,  $K$  can be given by Equation 2- 12 (Bard and Faulkner, 2001):

$$K = K^0 \exp[-\alpha F(E - E^0)/RT] \quad (2-12)$$

Where  $\alpha$  is a transfer coefficient which is normally given as 0,5 and  $K^0$  is the rate constant of charge transfer.

The resulting current reflects the rate at which electrons move across the electrode – solution interface. Changing the potential will influence equilibrium rate constants in an exponential fashion. Positive and negative potentials thus speed up the oxidation and reduction reactions, respectively. When they are large negative potentials, there will be an increased rate of movement of charge in the cathodic direction and also a decrease in charge movement in the anodic direction. This infers that oxidation rate is faster at high potentials than at low potentials (Wang, 2000; Nicol and Lázaro, 2002; Chanturiya and Vigdergauz, 2009).

Anodic reactions such as the oxidation of minerals and collectors occur simultaneously with cathodic reactions which involve reduction of oxidants present, forming redox

couples. The potential at which the sum of the anodic currents equals the cathodic currents is called the “mixed potential” (Rao, 2004). Figure 2-7 shows a representation of a current potential diagram showing the mixed potential model.

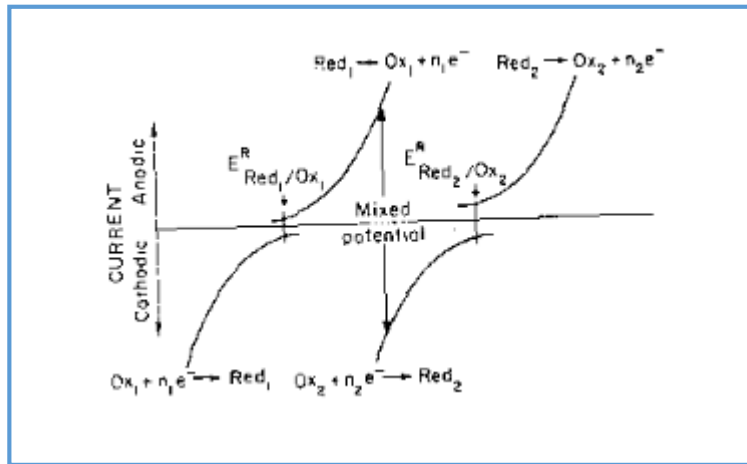

Figure 2-7: A mixed potential model for two redox couples (Rand & Woods, 1984)

The dynamic conditions surrounding a mineral in solution cause chemical complexity due to the different individual reactions taking place. An example is the conditions such as those encountered in a flotation system, this has led to the proposal of the mixed potential theory. According to the theory, the overall current due to the forward and backward reactions is at the mixed potential. There is general agreement in literature that the production of dixanthogen due to oxidation of xanthate, can proceed at only potentials above the mixed potential of a mineral under the particular conditions (Finkelstein and Poling, 1977). As previously discussed the presence of dixanthogen gives increased floatability.

## 2.7 Importance of pH

The pH of a flotation system is known to be an important parameter in electrochemical controlled flotation of sulphide minerals (Hu et al. 2009). A change in pH causes a shift in the mixed potential and this affects the electrochemical reactions taking place at the mineral surface. The relationship between Eh and pH is mostly linear as expressed by the linear Equation 2 – 13, which is an example for oxygen reduction (Mendiratta, 2000).

$$E = 1.23 - 0.059\text{pH (V)} \quad (2-13)$$

E, is the mixed potential and  $E^0 = 1.23 \text{ V}$  is the standard potential.

The relationship between Eh and pH can be used to construct Pourbaix diagrams. These diagrams provide much information on the behaviour of a system as the pH and Eh vary. Figure 2-8 shows the Eh-pH diagram for H<sub>2</sub>O-O<sub>2</sub>-Cl<sub>2</sub> system.

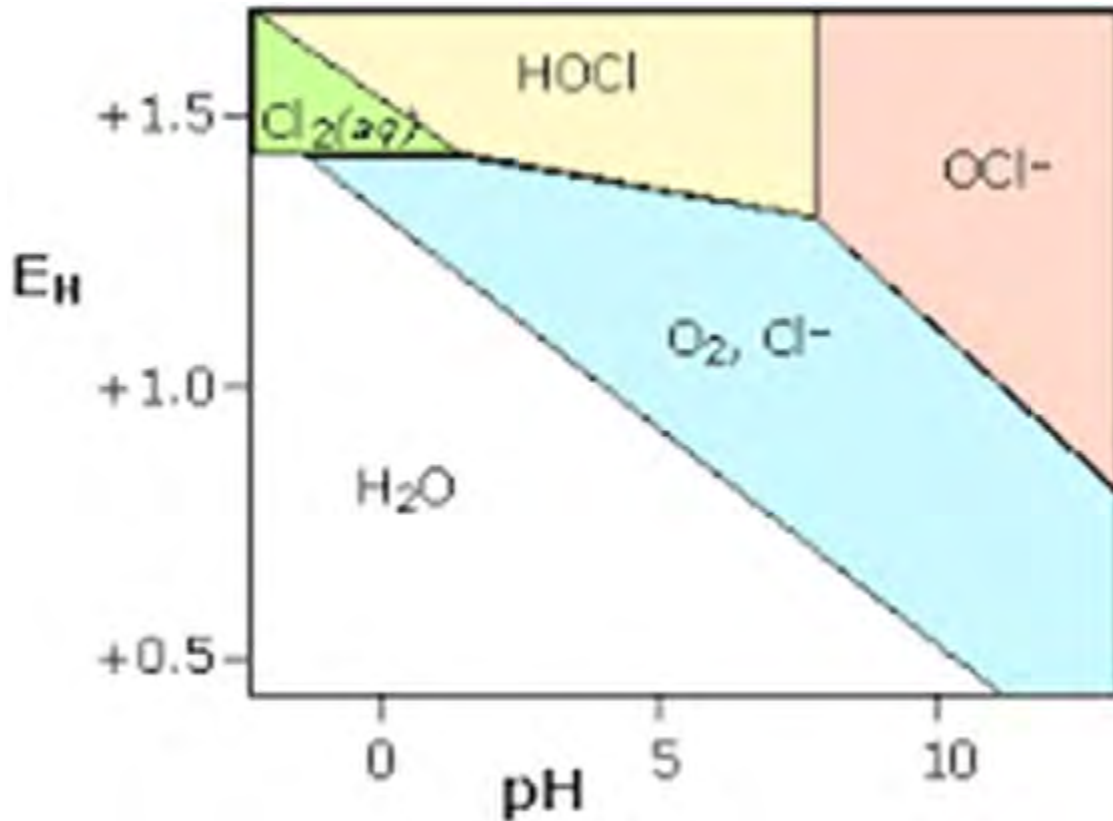

Figure 2-8: Eh-pH diagram for H<sub>2</sub>O-O<sub>2</sub>-Cl<sub>2</sub> system (<http://chemicalmafians.blogspot.co.za/p/electro-chemistry.html>)

The Pourbaix diagrams predict which species will be thermodynamically stable at different conditions. It can be observed that hypochlorite (OCl<sup>-</sup>) is more stable in the alkaline pH range under which most typical flotation processes take place.

The standard free energy,  $\Delta G^\circ$  of the formation of species in solution can be related to the standard electrode potential,  $E^\circ$ , by the following equation (Chanturiya and Vigdergauz, 2009)

$$\Delta G^\circ = nFE^\circ \quad (2-14)$$

This shows the direct relationship between the standard free energy,  $\Delta G^\circ$  and standard potential,  $E^\circ$ . The standard free energy is thus important as it be used in the formulation of the Nernst Equation, and for the given Reaction (2-15), the potential,  $E$  can be predicted (2-16).

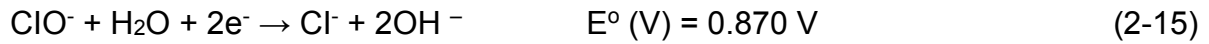

$$E = E^\circ - \left(\frac{0.05916}{n}\right) \log\left(\frac{[\text{Cl}^-][\text{OH}^-]}{[\text{ClO}^-]}\right) \quad (2-16)$$

The Nernst equation is a thermodynamic method that can be used to substantiate experimental data and give information with regards to kinetic factors (Finkelstein and Poling, 1977).

Another important aspect about pH, is that it creates competition at the mineral surface, as a result of the presence of nucleophiles or anions such as anions,  $\text{OH}^-$  and  $\text{X}^-$  (from the collector). As explained earlier, the resultant products formed are dependent on their solubility in solution. The presence of  $\text{OH}^-$  ions at a mineral surface can also affect other properties, such as zeta potential and electrical double layer, by hydrating the surface. Recovery is thus affected by the variation in the balance between hydrophilic and hydrophobic particles.

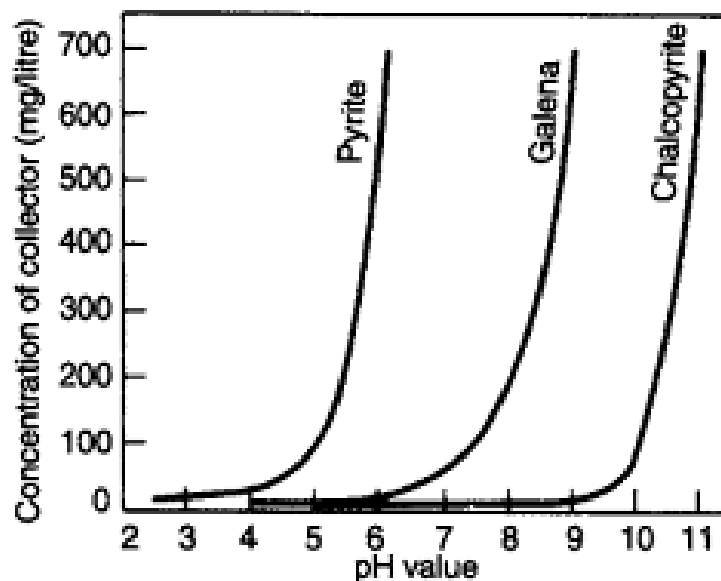

Figure 2-9: The effect of change in pH on collector adsorption on the mineral surface (Wills and Napier-munn, 2006)

The results in Figure 2-9 show that at a certain collector concentration, the manipulation of pH can be used for depressing some minerals and float others, especially in cases where selectivity has to be achieved. Therefore pH is an important parameter, as it can affect mineral hydrophobicity and consequently the recovery.

## 2.8 Electrochemical Techniques

Various methods have been used to study the electrochemical nature of the attachment of collectors to sulphide minerals. These methods include amongst others, rest potential measurements, cyclic voltammetry, and linear sweep voltammetry. (Allison et al. 1972; Khan and Kelebek, 2004; Rand and Woods, 1984). In this study the measurement of rest potentials has been used to predict whether dixanthogen will be formed when a mineral reacts with a xanthate.

### 2.8.1 Rest Potential Measurements

Rest potential measurements provide useful information with regards to possible processes or oxidising/reducing characteristics of sulphide minerals. It is one of the techniques that is used to characterise the electrochemical behaviour of a mineral sample (Ekmekçi et al. 2010).

A schematic diagram in Figure 2-10, shows a typical rest potential profile as a result of reactions such as oxygen reduction, mineral oxidation and collector oxidation.

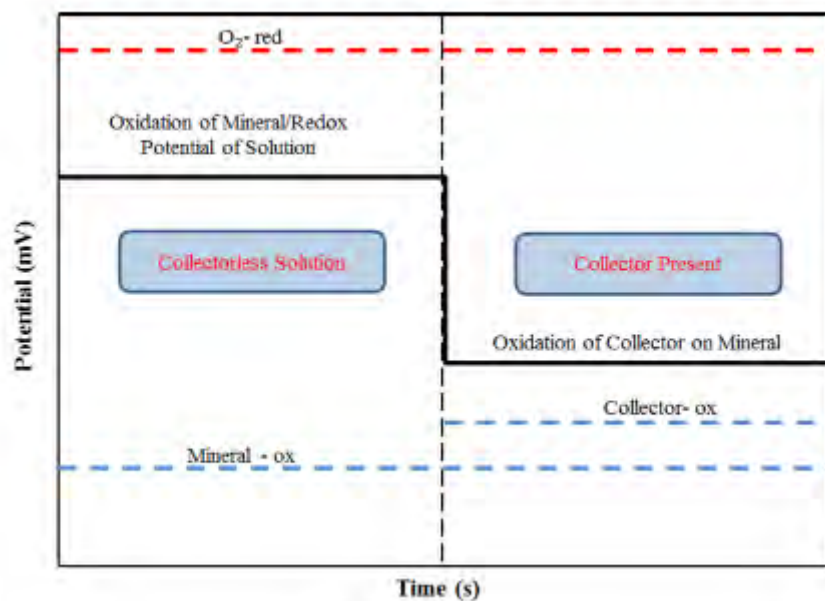

Figure 2-10: A schematic diagram for a typical rest potential profile (Tadie, 2015).

The oxidation of mineral donates electrons which are accepted by oxygen undergoing reduction, in the collectorless solution. The balance of these reactions is the rest/mixed potential. When a collector is present, mineral oxidation and collector oxidation at the mineral surface acts as the supply of electrons to reduce oxygen and the resultant potential is the rest/mixed potential. The potential drop from the original rest potential

prior to collector addition is indicative of the interaction of collector with mineral surface (Buswell et al.2002a).

Rest potential measurements are taken using a 2 electrode system and Figure 2-11 is schematic diagram showing the electrode set-up.

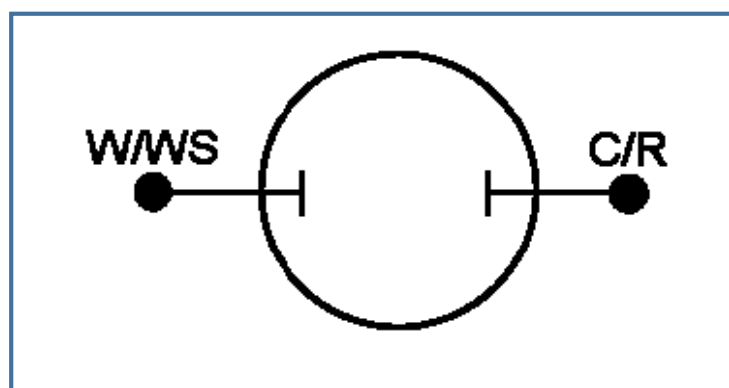

Figure 2-11: Electrode set-up for rest potential measurements (Gamry, 2011)

The mineral electrode is referred to as the working electrode (W/WS). The potentials are measured against a reference electrode (R) and the commonly used reference electrodes are standard calomel electrode (SCE) and the silver/silver chloride electrode (Ag/AgCl). In this study the (Ag/AgCl) was used as the reference electrode.

Various studies have been conducted using rest potentials, including the work of Allison et al. (1972) in which the species being formed at the mineral surface in a solution of  $6 \times 10^{-4}$  M potassium ethyl xanthate were determined.

The results of their study at a pH of 7 are shown in Table 2-4.

Table 2-4: Results of rest potentials of various minerals and the surface species on the mineral surface (Allison et al. 1972).

Minerals	Rest Potential(mV)	Products
Pyrite	220	Dixanthogen
Arsenopyrite	220	Dixanthogen
Pyrrhotite	210	Dixanthogen
Molybdenite	160	Dixanthogen
Chalcopyrite	140	Dixanthogen
Alabandite	150	Dixanthogen
Covellite	50	Dixanthogen

Bornite	60	Metal xanthate
Galena	60	Metal xanthate

The reversible potential for oxidation to dixanthogen was taken as 130 mV and it can be seen that the minerals with rest potential above 130 mV formed dixanthogen except for covellite where cupric xanthate could have decomposed to dixanthogen. In another study by (Finkelstein and Goold, 1972), the rest potential of pyrite was 545 mV and the reversible potential of the collector used, dithiophosphate (DTP) was 448 mV. It was then expected that the dimer form of DTP would be formed at the mineral surface since the DTP oxidation potential was lower than the rest potential of pyrite measured under the conditions investigated. It was concluded that, metal thiolate is the possible specie that can be formed when the collector (DTP) reacts with other minerals with rest potentials less positive than 448 mV.

It should be noted that different experimental conditions result in different values of rest potentials. The results depend on conditions being investigated, the origin and history of the electrode and also the electrode preparation method (Rao 2004; Hu et al. 2009). However, what can be relied on in terms of the rest potential is that it gives a basis to state whether a metal thiolate or dithiolate can be formed or not. This study uses the rest potential measurements to get a fundamental understanding of the reactions that can take place and predict the products formed at the mineral surface when an oxidant such as sodium hypochlorite is added. This can then be used to infer and help interpret the flotation response in a typical flotation system.

### 2.8.2 Cyclic Voltammetry

Cyclic Voltammetry is used to identify the range of potentials over which electrochemical reactions occur by studying the changes in the corresponding anodic and cathodic current peaks. The measurements are made when a complete range of potential is scanned in a short period of time and qualitative information of oxidation/reduction processes can be obtained (Rao, 2004; Chanturiya and Vigdergauz, 2009). It is considered the most useful technique to understand the interaction of collectors with mineral surfaces and help to infer the species present on the mineral surface (Tolley et al. 1996).

The cyclic voltammetry experiments can be conducted in an electrochemical cell which consist of three electrodes as shown in Figure 2-12.

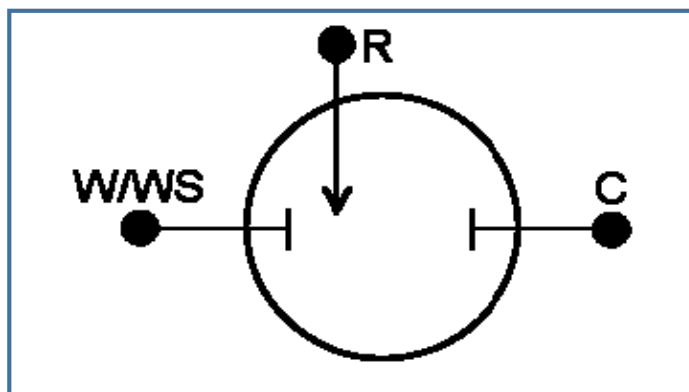

Figure 2-12: Electrode set-up for cyclic voltammetry (Gamry, 2011)

The counter electrode (C) which can also be referred to as the auxiliary acts as the current sink/source. It is the electrode that completes the current path. These are connected to a potentiostat, a programmer and temperature control device. The electrolyte is a buffered solution but this generally depends on the experimental conditions.

When conducting the experiments the scan rates during polarisation can vary between 1 – 1000 mV/s, however, it is important to use medium rates because of the disadvantages associated with too high or too low rates. At high scan rates there is charging of the electrical double layer which might cause a negative impact on results and at low rates, the convection currents of the system may complicate the processes.

More recent results on the usefulness of cyclic voltammetry have been published by Tadie et al. (2015), where they showed interactions between PtS and sodium ethyl xanthate (SEX). This was deemed critical in order to gain an understanding of the role of SEX during flotation, from a fundamental level.

Figure 2-13 shows the cyclic voltammetry for PtS in the absence and presence of SEX in an aerated solution at pH 9.2

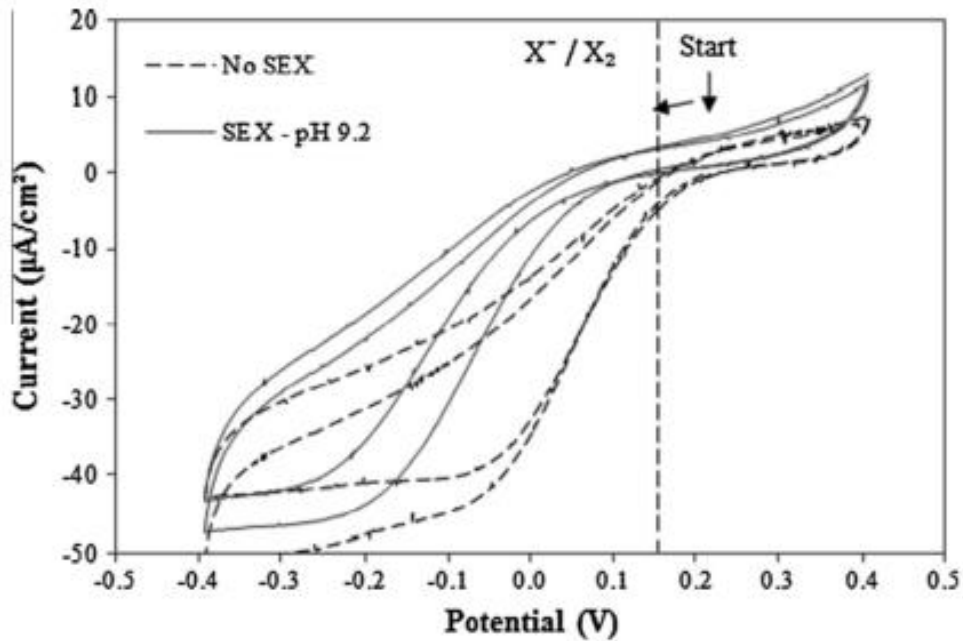
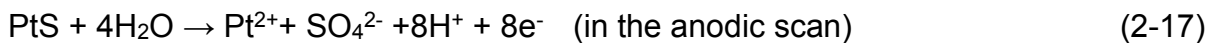

Figure 2-13: Cyclic voltammetry for PtS in the absence and presence of SEX in an aerated solution at pH 9.2 (Tadie et al. 2015)

At 150 mV which is the xanthate/dixanthogen oxidation potential, PtS is expected to start to dissolve into solution and form sulphate and  $\text{Pt}^{2+}$ . On the cathodic scan below potentials around 200 mV the currents formed are due to oxygen reduction.

Some of the reactions proposed according to the voltammograms observed are shown in reactions (2-17) and (2-18).



These studies have shown the importance of cyclic voltammetry as one of the electrochemical studies that can be used to characterise reactions and predict species that are likely to be present at a mineral surface, and relate them to flotation response.

## 2.9 Potential Control in Sulphide Flotation

As discussed earlier base metal sulphides are readily floatable in the presence of thiol collectors. During the flotation process the control of the mixed potential has been widely considered as crucial to enhance the flotation performance. The mixed potential can be called redox potential (Eh) and it varies significantly depending on the conditions investigated. Redox potential measurement will help monitor chemical changes in the sulphide mineral flotation system. There has been general increase in agreement amongst many authors that sulphide mineral flotation is only possible under certain redox environments (Hu et al. 2009).

Factors such as oxygen concentration, pH level, the minerals present, collector alkyl chain length and concentration (Rao, 2004), results in different potential values from sample to sample. In addition to that, the use of different indicator electrodes result in different values of redox potential in the same system. According to Goktepe (2001), these factors contribute to variation and conflicting observations noted in literature of quoted potential range values that are significant to effect efficient flotation of sulphide minerals. However, a relationship exists between potential and recovery in various flotation systems (Leppinen and Hintikka, 1995).

There are many methods that can be used to control potential which include the use of Eh modifiers such as reducing agents to lower the potential and oxidizing agents to increase the potential (Rao, 2004). The flotation response when the redox potential has been controlled by chemical means, has not been previously quantified nor explored for complex ores such as the Merensky ore. Previous studies on use of a chemical reagents to increase potential have been mostly single mineral studies and have fallen short on reliable information on how Eh modifiers control potential.

This limited information available in literature with regards to Eh control in a complex sulphide ore flotation process is a major concern which needs attention. Furthermore, it has also been mentioned that the mechanism of Eh modifiers is not clearly understood (Chanturiya and Vigdergauz, 2009).

As previously mentioned, according to available literature many studies focused on single mineral studies to investigate potential control. These include, the work conducted by Smith et al. (2012), and the results are shown in Figure 2-14. Chalcopyrite recovery was high at potentials over 200 mV. The collector used was potassium ethyl xanthate (KEX) added at concentrations that approximate plant practice. KEX has an oxidation potential of 130 mV, and at the potentials highlighted in red, dixanthogen was expected to be the species present at the mineral surface.

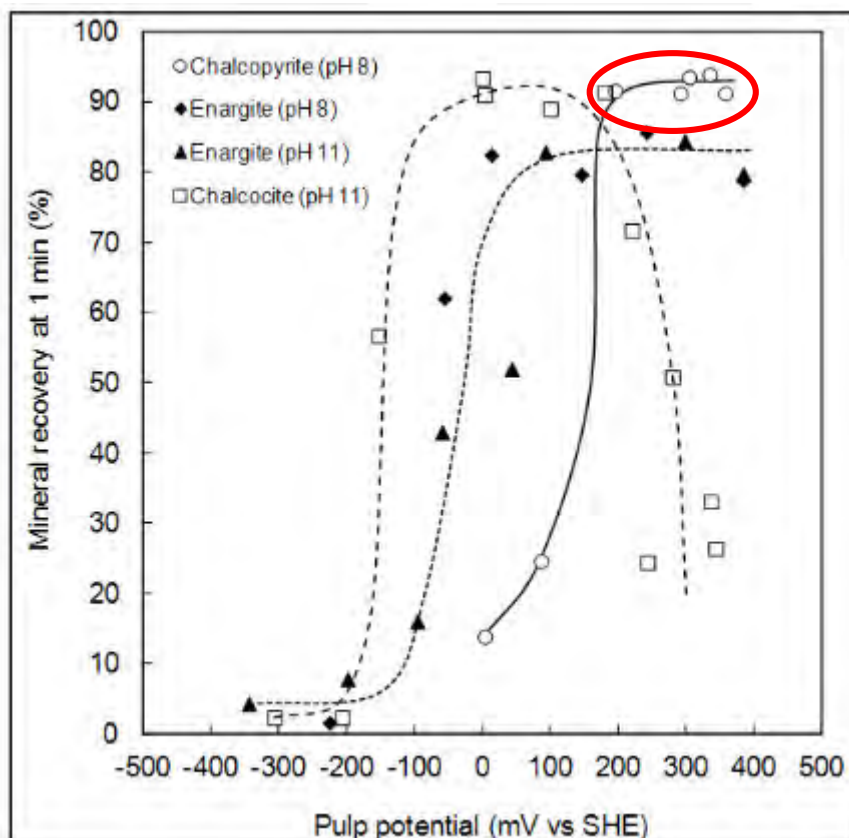

Figure 2-14: Recovery versus potential for chalcopyrite, enargite and chalcocite (Smith et al. 2012)

These results also show that potential can be used to separate minerals (selectivity), due to variation in recovery at different potentials.

In another study by Khan and Kelebek (2004) in which they used potential control to separate pentlandite and pyrrhotite, the results are shown in Figure 2-15. The potential controlled condition was in the absence of air (oxygen) where nitrogen was used to control the potential to low levels between -0.095 V to - 0.005 V. There was higher selectivity as compared to the condition (potential uncontrolled), when air was used to increase the potential to a region between 2.5 V – 3 V.

Figure 2-15 shows the recovery of pentlandite versus pyrrhotite at pH between 9-9.5 in the presence of sodium isobutyl xanthate concentration  $1 \times 10^{-4}$  M.

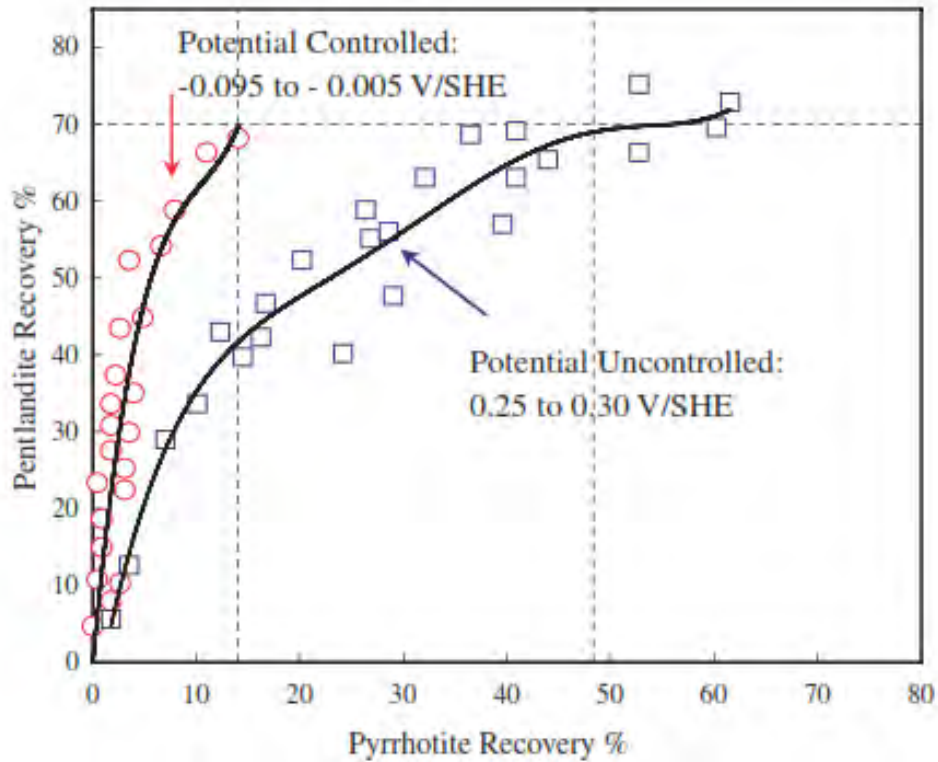

Figure 2-15: Recovery of pentlandite versus pyrrhotite at pH between 9-9.5 in the presence of sodium isobutyl xanthate  $1 \times 10^{-4}$  M (Khan & Kelebek, 2004)

Khan and Kelebek (2004), concluded that higher potential favours pyrrhotite flotation when compared to pentlandite. Furthermore, Plackowski et al. (2014) investigated the effect of increasing potential to +500 mV, using sodium hypochlorite (NaClO), on the flotation of enargite ( $\text{Cu}_3\text{AsS}_4$ ). They discovered a high recovery of 82 % at +500 mV than at lower potentials where recovery was 52% at a potential of +100 mV.

In conclusion, all these findings described on potential control, do not account for the presence of other minerals (galvanic interactions) and other variables during flotation (Bozkurt and Xu, 1998; Woods, 2003). There is much more information about single minerals and responses of minerals in simple idealized solutions with little data available in applying this information to real and more practical systems (Tolley et al. 1996). The approach used in this study was to use open circuit potential measurements of some base metal sulphides to predict species that can be formed under the conditions investigated, and relate the information to floatability. Additionally, there was need to develop the investigation further into a fundamental understanding,

to help explain or interpret some of the flotation responses in a bulk sulphide flotation system.

### **2.10 Key Questions**

The following key questions have been addressed in this study:

- What is the effect of changing the alkyl chain length of the collector on the oxidation potential of collectors in relation to their interactions with sulphide minerals?
- Is there a relationship between the different oxidation potentials observed for these different collectors and the recoveries and grades when they are used in the flotation of the same sulphide minerals?
- What is the effect of changing pH on the rest potentials of sulphide minerals and the subsequent species forming at the mineral surface?
- To what extent can chemical reagents be used to change Eh without changing pH and how do these methods of changing potential affect flotation performance?

### **2.11 Hypotheses**

- A knowledge of the mineral/solution interface potential will indicate the potentials at which successful flotation will occur because a relationship exists between the surface potential and the nature of the species formed when collectors are added, which imparts hydrophobicity on the mineral surface.
- Collectors of longer alkyl chain length results in improved flotation performance in terms of recovery because there is a relationship between the different surface potential measured for these collectors and the hydrophobicity imparted to the surface and hence the flotation performance.
- Instead of changing the Eh by changing the dissolved oxygen concentration and pH it will be preferable to change Eh by using chemical reagents such as NaClO and H<sub>2</sub>O<sub>2</sub> since this will enable the pH to be held constant at varying Eh values and thus improve the flotation performance at a fixed pH.

## Chapter 3

### 3 Methodology

This chapter describes the materials and experimental techniques used in this study. The rest potential measurements are described first followed by batch flotation tests.

#### 3.1 Rest Potential Measurements

Rest potential measurements were obtained using open circuit potentials of the sulphide minerals in an electrochemical cell. Measurements were conducted over 1200 s and depending on the condition under investigation, the first reagent was added after 300 s and the second was added after 600 s.

##### 3.1.1 Experimental Setup

The electrochemical setup for rest potential measurements is shown in Figure 3-1.

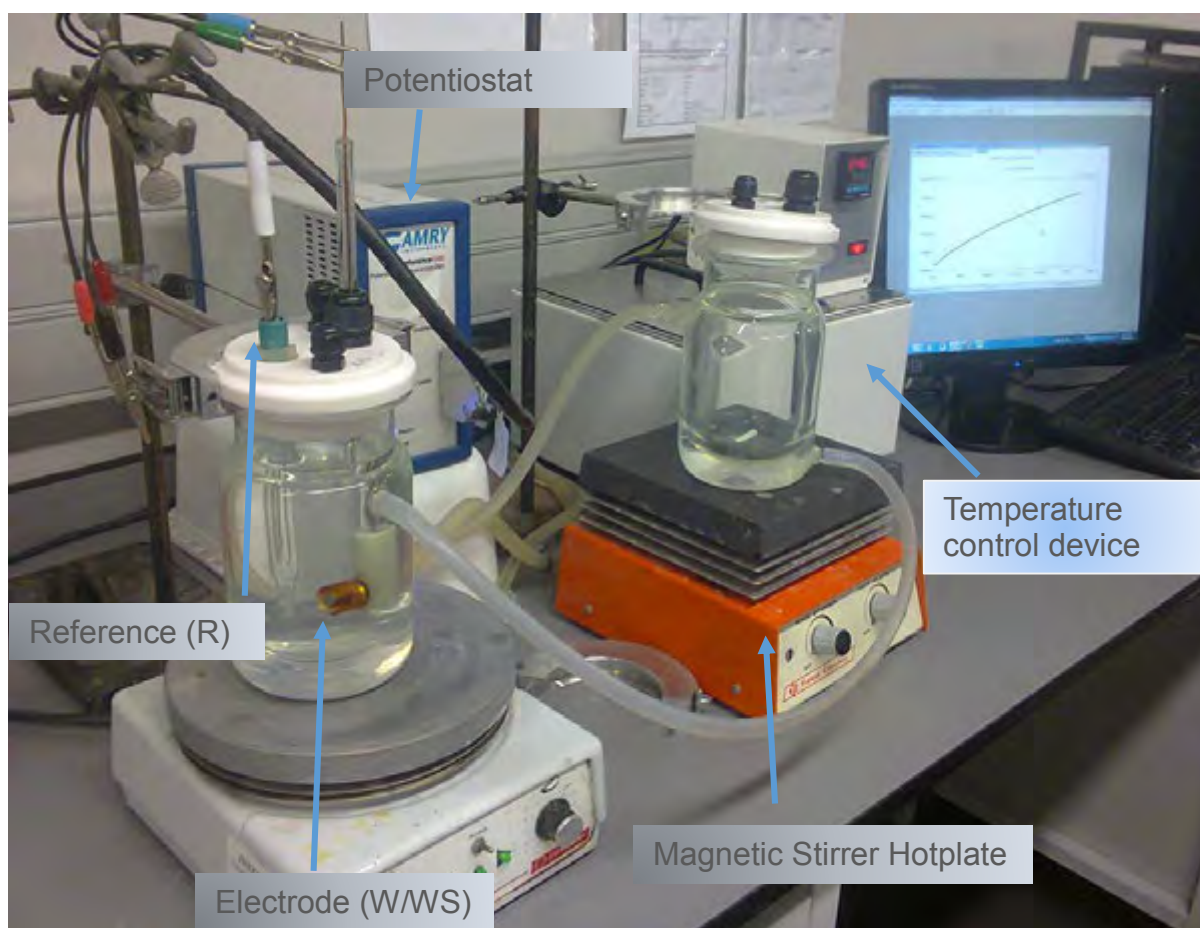

Figure 3-1: Set-up of equipment used for electrochemical measurements

A 500 ml jacketed vessel was used as the electrochemical cell. The vessel was mounted on a Freed Electric magnetic stirrer hotplate and a 15 mm magnetic stirrer bar was used for stirring. Working temperature within the vessel was  $25\pm 1$  °C and was regulated by a water bath using a Shinha DCS Model 300 temperature controller.

A Gamry Instruments Reference 600™ Potentiostat was used for the electrochemical measurements. The potentiostat was interfaced to a computer via USB connection. The user interface coupled with the potentiostat is the Gamry Framework which enables calibration of the instrument, measurement of open circuit and measurement of current. A software called Echem Analyst was used to analyse the results. The software was supplied by Gamry Instruments.

### **3.1.2 Electrodes**

Rest potential measurements were conducted using a 2 electrode system as shown previously in Figure 2-11. The mineral electrode is referred to as the working electrode (WWS). The mineral electrodes were manufactured from pure samples of the selected minerals; chalcopyrite, pentlandite, pyrrhotite and pyrite. These were moulded in epoxy resin and connected to a copper wire (conductive electric wire) encased in a plastic tube. The method of electrode construction has been described by Tadie (2015). Electrodes were cleaned before each measurement by polishing using a 600 grit silicon carbide paper, 1.0  $\mu\text{m}$ , 0.3  $\mu\text{m}$ , and 0.05  $\mu\text{m}$  alumina powders obtained from IMP Scientific and Precision (Pty) Ltd. Rinsing of the electrodes during polishing was done using deionised water (10  $\text{M}\Omega/\text{cm}^2$ ) and then dried by lightly dabbing the surface with a paper towel, before transferring to the electrochemical cell

The potentials were measured against a reference, silver/silver chloride electrode (Ag/AgCl) supplied by Metrohm. Potentials are usually converted to the standard hydrogen electrode (SHE), for example values reported in this study were measured relative to the Ag/AgCl (+0.207 V vs SHE), and 0.207 V was added to potential values in order that they be reported relative to SHE (Ekmekci et al. 2006). The reference electrode was filled with 3 M KCl (potassium chloride) solution which was replenished every 30 days. During the conducting of experiments plastic surgical gloves were used.

### 3.1.3 Reagents

Different reagents were used to make up the electrolyte and deionised water of conductivity  $10\text{M}\Omega/\text{cm}^2$  was used as the solvent. The total volume of electrolyte for each experiment was 450 ml.

0.1 M  $\text{Na}_2\text{SO}_4$ , 0.05 M ( $\text{Na}_2\text{B}_4\text{O}_7$ ) was used to achieve pH 9.

0.1 M  $\text{Na}_2\text{SO}_4$ , 0.05 M ( $\text{Na}_2\text{B}_4\text{O}_7$ ), 1 M NaOH was used to achieve pH 11

A buffer is important to minimise pH changes during measurements.

1 M NaOH used for adjusting the pH level was supplied by Merck and was of analytical grade and used as received. Measurements of pH were done using a calibrated TPS meter. Sodium hypochlorite ( $\text{NaClO}$ ), the oxidizing reagent was supplied from Kimix as a stock solution of 12% and was diluted to 1% for use during the experiments. The concentration of  $\text{NaClO}$  was 0.13 M. The collectors were supplied by Senmin and were obtained in powder form and dissolved to achieve a concentration of  $6.24 \times 10^{-4}$  M.

Table 3-1: Purities of reagents

Reagents	Chemical Formula	Molecular Weight	Purity
Sodium Ethyl Xanthate (SEX)	$\text{C}_2\text{H}_5\text{OCCSSNa}$	144	99.0%
Potassium Amyl Xanthate(PAX)	$\text{C}_5\text{H}_{11}\text{OCSSK}$	170	99.0%
Sodium Sulphate	$\text{Na}_2\text{SO}_4$	142	99.5%
Sodium Tetraborate	$\text{Na}_2\text{B}_4\text{O}_7$	202	99.0%
Sodium Hypochlorite	$\text{NaClO}$	74	96.0%

Table 3-1 shows the purities of the reagents used during the electrochemical measurements. The mass of the active ingredient is used as a measure of purity of reagents. Calculations of concentrations were based on the purity of the reagents.

## **3.2 Batch Flotation**

### **3.2.1 Ore preparation**

A Merensky sample from the Bushveld Igneous Complex in South Africa, which had been crushed, blended, riffled and split using a rotary splitter into 1 kg representative portions was used throughout this study. The average % composition of the base metal sulphides in the ore has been shown earlier in Table 2-1.

### **3.2.2 Flotation Reagents**

The flotation reagents used were chosen based on the known UCT batch flotation procedure described later.

#### **3.2.2.1 Collectors**

In the batch flotation tests the main collector used was sodium ethyl xanthate, (SEX). This collector was considered owing to previous work done by Dimou (1986), where the results available were consistent. The other collector investigated was potassium amyl xanthate, (PAX) which is a collector of longer chain length. The volume added per experimental run was 10 ml, which would be equivalent to a dosage of 100 g/t of collector. A new stock solution of collector was prepared for experiments conducted each day. The purities have been shown earlier in Table 3-1.

#### **3.2.2.2 Frother**

DOW 200 supplied by BetaChem was used as the frother. It is a polyglycol type of frother in liquid form and with purity close to 100%. A volume of 40  $\mu\text{m}$  was added per each test and it is an equivalency of 40 g/t. This dosage was kept constant in all tests.

#### **3.2.2.3 The pH Modifier**

A 0.1 M sodium hydroxide (NaOH) solution was used to adjust pH in the flotation cell from the natural pH of the slurry to pH 11. The NaOH was also supplied by BetaChem.

#### **3.2.2.4 Eh Modifier**

Sodium hypochlorite (NaClO), supplied by Kimix, was used as the main reagent for oxidation-reduction potential (Eh) control. A 1% solution was prepared from a 12% commercial solution using distilled water. The amount of NaClO added was equivalent to 500 g/t.

### 3.2.3 Water

The water used for milling and all the batch flotation experiments was synthetic plant water (SPW), which was prepared using a formulation based on the analysis of ions present in the process water in a Merensky concentrator located on the Western Limb of the Bushveld Igneous Complex. The formulation involves the modification of distilled water through the addition of various chemical salts to achieve specific total dissolved solids (TDS) content. The ions present in the synthetic plant water are shown in the table below (Wiese et al. 2005b).

*Table 3-2: The ions concentration of synthetic plant water (SPW)*

Ion	Ca <sup>2+</sup>	Mg <sup>2+</sup>	Na <sup>+</sup>	Cl <sup>-</sup>	SO <sub>4</sub> <sup>2-</sup>	NO <sub>3</sub> <sup>-</sup>	NO <sub>2</sub> <sup>-</sup>	CO <sub>3</sub> <sup>2-</sup>	TDS
Concentration (ppm)	80	70	153	287	240	176	-	17	1023

### 3.2.4 Milling

A 1kg sample of sulphide ore typical of the Merensky reef ( $\pm 1$  mm) was milled in a laboratory scale Eriez stainless steel rod mill. The milling time was 13 ½ minutes to achieve the required particle size of 60% passing 75  $\mu$ m. The choice of the grind was based on the fact that it matches the rougher grind employed by industrial mining operations processing the Merensky ore (Manono, 2010). The charge was 66% solids and was prepared using 500 ml of synthetic plant water. Collector addition was made to the mill before grinding and this was done throughout all the experiments. A total of 20 stainless steel rods were used as the grinding media and were of the following sizes; 6 x 25 mm, 6 x 20 mm and 8 x 16 mm in diameter and the length of all them was 285 mm. The total weight of rods was measured as 13.40 kg. The rods were periodically checked, and if they have been worn out they were replaced. The dimensions of the mill were; internal diameter of 195 mm and inside length of 295 mm. After milling, the slurry was transferred to a 3 L batch flotation cell and made up to a pulp density of 33% solids by addition of SPW for all the tests.

### 3.2.5 Batch Flotation Procedure

The standard batch flotation procedure developed at the Centre for Minerals Research (CMR), University of Cape Town (UCT) has been found to be effective to investigate the interactions that occur between reagents and minerals during flotation. Any

variations in froth stability can be accounted for and the effect of the presence of naturally floating gangue can also be established. The batch flotation equipment consisted of a modified Leeds flotation machine consisting of Perspex flotation cell with a capacity of 3 L and an impeller. The flotation process was conducted under the open air typical conditions where temperature and atmospheric oxygen were not measured. The air used for the flotation process was controlled by the use of Wilkerson ¼ inch 0-8 bar air regulator. The impeller speed of the flotation cell was set to 1200 rpm and the airflow rate was 7 L/min.

A 50 ml feed sample was collected before each experiment. A total of four concentrates (C1, C2, C3, and C4) were collected by scraping froth off manually every 15 seconds, into pre-weighed dishes. A froth height of 2 cm was maintained manually by constantly adding synthetic plant water (SPW). The total time for each experiment was 20 minutes and at the end of the flotation stage two 50 ml samples of tails were also collected. The amount of water recovered with each of the four concentrates was measured. The feed, concentrates and tails' samples were filtered and put in an oven to dry. All experiments were performed in duplicate for reproducibility.

*Table 3-3: Summary of the batch flotation procedure*

<b>Action</b>	<b>Time (mins)</b>
Milling	13.30
Collector	Added to the Mill
Eh Modifier	Added to the Mill
Frother	0
Air turned on and froth develops	1
C1	3
C2	7
C3	13
C4	21

Addition of reagents to the mill was done to expose freshly formed mineral surfaces for reaction.

### **3.2.6 Analysis of flotation performance**

The dried samples of feeds, concentrates and tailings were weighed before being sent for assays of copper and nickel using Bruker X-ray Fluorescence Analyser. The results obtained for chemical assays were used to calculate grade and recovery. This gave the percentage of the purity and amount of minerals recovered respectively. Copper recoveries in this work were an estimate of chalcopyrite, nickel recoveries were estimates of pentlandite.

Flotation kinetics have also been used to analyse the flotation performance under the various conditions investigated in this study. There are various models available which include Klimpel, Classical and Kelsall. These models can be used to analyse the performance in terms of the slow and fast floating component of the valuable minerals. In addition to that, they can also give information about the affinity of the minerals towards oxidation. This was critical information towards the development of this investigation considering that this study aimed at creating oxidizing conditions and promoting the interaction between the mineral surface and collectors. The model used in this study was the Classical model.

### **3.2.7 Two phase tests**

Two phase batch tests were conducted to investigate the impact of increasing potential on foamability and help in the interpretation of the effect on froth stability when potential had been raised. It is suggested that the two phase (solution-air), can be linked to the observations in three phase (solids-air-water) where the increase in foam stability after an increase in Eh would imply increase in froth stability (Manono et al. 2013). The tests were necessary to help quantify the effect of an increase in potential on water recovery. The same procedure as the 3 phase batch flotation system was used with the exception that in these tests there was no slurry.

### **3.2.8 Confirmatory Tests**

Some added tests were conducted to be able to develop a better understanding of outlying test results. These include the alternative use of hydrogen peroxide ( $H_2O_2$ ) as an oxidizing reagent. Although it should be appreciated that different modifiers give different flotation response even at the same potential (Hu et al. 2009), it was

considered necessary to investigate and see if this was consistent under the conditions used in this study.

The effect of increasing potential on recovery of gangue minerals was investigated. This was conducted in a 250 ml microflotation cell available at UCT. Talc in the particle size distribution of -106 to +38  $\mu\text{m}$  was used. Synthetic plant water (SPW) was used and the pH was measured and maintained at 9. The collector used was SEX. No frother was used as these tests depend on the interactions in the pulp (not on froth characteristics) (See Appendix C for detailed procedure).

## **Chapter 4**

### **4 Results**

#### **4.1 Introduction**

This chapter presents the results obtained from all the experiments conducted in this study. The reduction potentials of the collectors used in this study and the rest potential measurements of the selected sulphide minerals used are presented first.

The batch flotation test results are presented next, and show how the experimental conditions under investigation influenced the metallurgical performance of sulphide minerals. The minerals analysed were chalcopyrite and pentlandite. The batch flotation results showing the effect of increasing Eh using NaClO at pH 9, the natural pH of the system and pH 11 are presented first, followed by the effect of collectors of different chain length. The results from a comparison of potential modifiers and the effect of adding trace amounts of the potential modifier are then presented.

The last section of results are from microflotation tests using talc, which were conducted in an attempt to determine whether the increase in Eh caused activation of gangue using a simple idealized system. This was considered important to be able to support quantitatively if an increase in potential causes an activation of gangue minerals such as talc.

#### **4.2 Determination of oxidation potentials of collectors**

The Nernst equation can be used to calculate the standard potential,  $E^{\circ}$  using the measured potentials from experiments. It is important to be able to compare the calculated values of standard potential to values reported in literature for validation. Assumptions made are that the collectors used, sodium ethyl xanthate (SEX) and potassium amyl xanthate (PAX), follow Nernstian behaviour which implies that, thermodynamically the reactions should be reversible and reach equilibrium. The collectors are of different chain length and the oxidation potential for SEX was 150 mV for a concentration of  $1 \times 10^{-4}$  M (Tadie, 2015).

Table 4-1: The reversible potential of PAX when compared to literature values

	Literature*	Measured
Standard Potential, E° (mV)	-159	-155
Potential E(mV)	89	100

\* (Finkelstein & Poling 1977).

Table 4-1 shows the reversible potential for PAX from experimental results in this study and values obtained from literature. The potential was measured on a Pt electrode and found to be 100 mV and a standard potential, E° of -155 mV was calculated. The value was deemed acceptable as it was close to the standard potential, E° of -159 mV reported in literature (Finkelstein and Poling, 1977). As earlier alluded to, the adsorption mechanism occurs via an electrochemical mechanism which involves either xanthate chemisorption, metal xanthate formation or the catalytic oxidation to dixanthogen which is shown in Equation (4-1):



It should be emphasized that dixanthogen formation also depends on the type of sulphide mineral in terms of its catalytic effect on the reduction of oxygen which is the usual corresponding cathodic process. The mineral has been reported to provide a passage for the transfer of electrons from the site where the collector is oxidized to the site where oxygen is reduced (Yoon and Basilio, 1983). This is possible since sulphide minerals have semi-conducting properties. According to Mendiratta (2000), the role of oxygen can be substituted by other oxidants which can also accept electrons during the electrochemical reactions.

### 4.3 Rest potential measurements

The aim of conducting the rest potential measurements was to determine the kind of species that can be formed under various conditions, and relate these to hydrophobicity at the mineral surface. This was considered important in providing fundamental understanding of the response of the selected sulphide minerals under the conditions investigated.

### 4.3.1 Reproducibility

The rest potential measurements were conducted in duplicate and results were accepted if the measurements obtained between tests differed by less than 20mV.

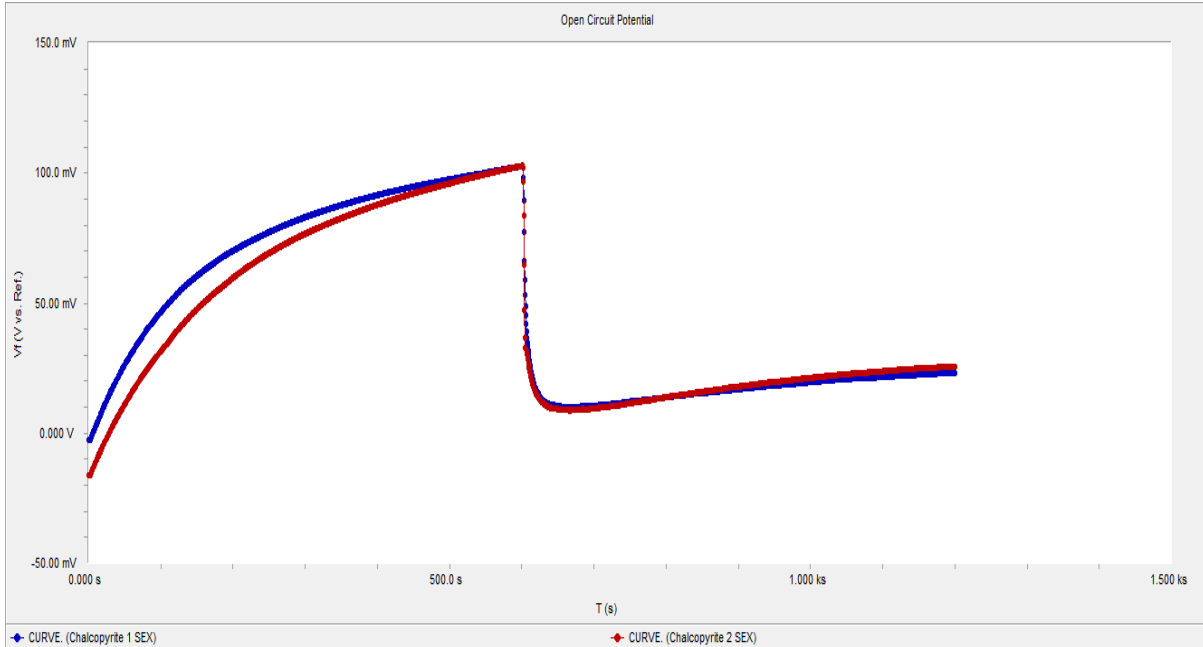

Figure 4-1: Rest potential measurements to show reproducibility, for chalcopyrite with SEX added as collector after 600s, in a buffer solution at pH 9.

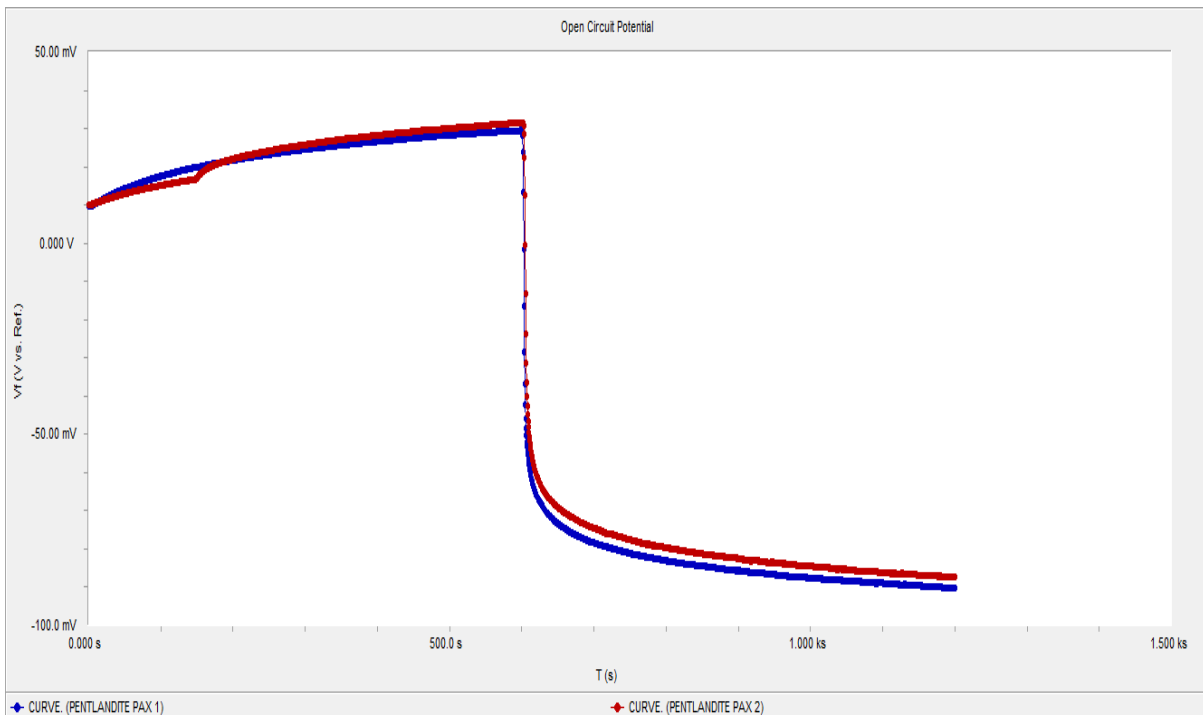

Figure 4-2: Rest potential measurements to show reproducibility, for pentlandite with PAX added as collector after 600 s in a buffer solution at pH 9.

Figure 4-1 shows the rest potential measurements obtained for chalcopyrite in the presence of SEX at pH 9. The results show the potential profiles before and after the addition of collector at 600 s. The curves closely follow each other and the initial and final rest potentials have differences of less than 20 mV. Figure 4-2 shows the results obtained for pentlandite under similar conditions, although in the presence of a collector of different chain length namely PAX. The rest potentials profiles are not significantly different. These results, have shown that the electrochemical technique used in this study was reliable and accurate.

### 4.3.2 Chalcopyrite

Figure 4-3 shows the rest potential profiles for chalcopyrite in the absence and presence of collector.

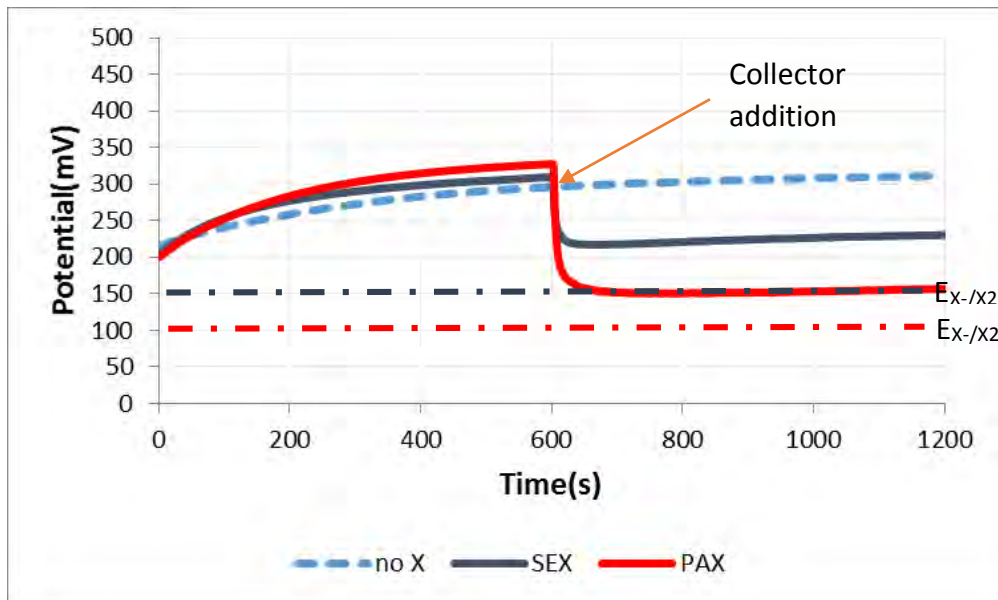

Figure 4-3: Rest potential for chalcopyrite in the absence and presence of collectors of different alkyl chain length at pH 9.

In the absence of collector as denoted by a dashed curve the rest potential for chalcopyrite was estimated to be at an average value of 300 mV. The collector addition was after 600 s and a potential drop at this point is indicative of extent of the interaction with mineral surface. The straight dashed lines show the boundary lines above which the dimer for the respective collectors (SEX and PAX) is expected to be formed. It is widely known that when a mineral's rest potential profile is above the dioxanthogen formation line it is assumed that dioxanthogen is formed at the mineral surface.

Results shown in Figure 4-3 thus imply that dixanthogen is the species that should be formed at the surface of chalcopyrite under all the conditions investigated.

Figure 4-4 shows the rest potentials for chalcopyrite at different pH values.

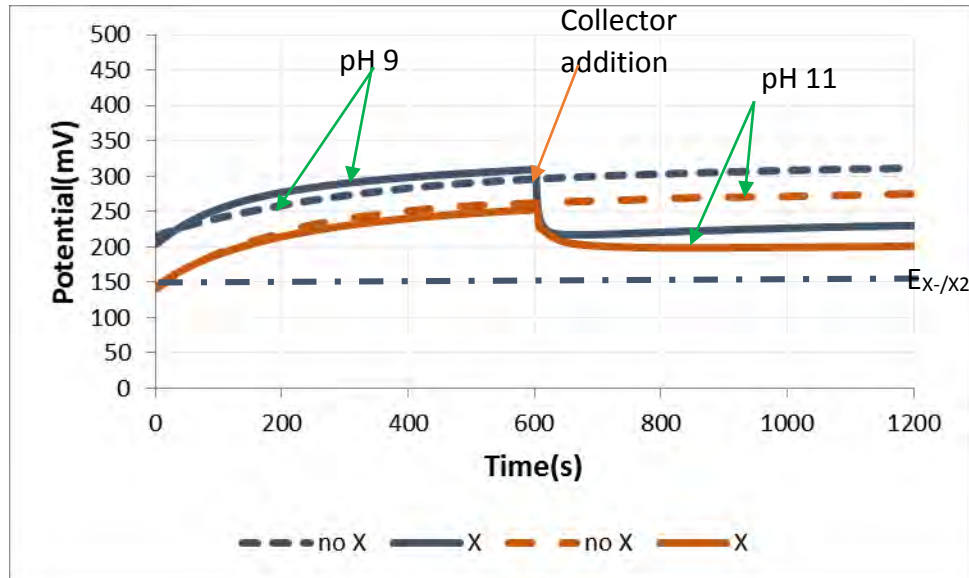

Figure 4-4: Rest potential for chalcopyrite in the absence and presence of collector SEX shown as X at pH 9 and at pH 11

The solid lines show the results obtained for measurements conducted at both pH values with a collector added after 600 s. The dashed lines are the rest potential profiles at pH 9 and pH 11 obtained in the absence of a collector. The addition of collector resulted in interactions with the mineral surface as indicated by the potential drop. The increase of pH to 11, caused a small reduction in the extent of interaction at the surface. In the absence and presence of collectors, all potentials are more positive than 150 mV, the dixanthogen formation line for SEX. This is indicative of thermodynamically favourable conditions for dixanthogen formation at the mineral solution boundary.

Figure 4-5 shows the rest potentials for chalcopyrite at pH 9 and pH 11.

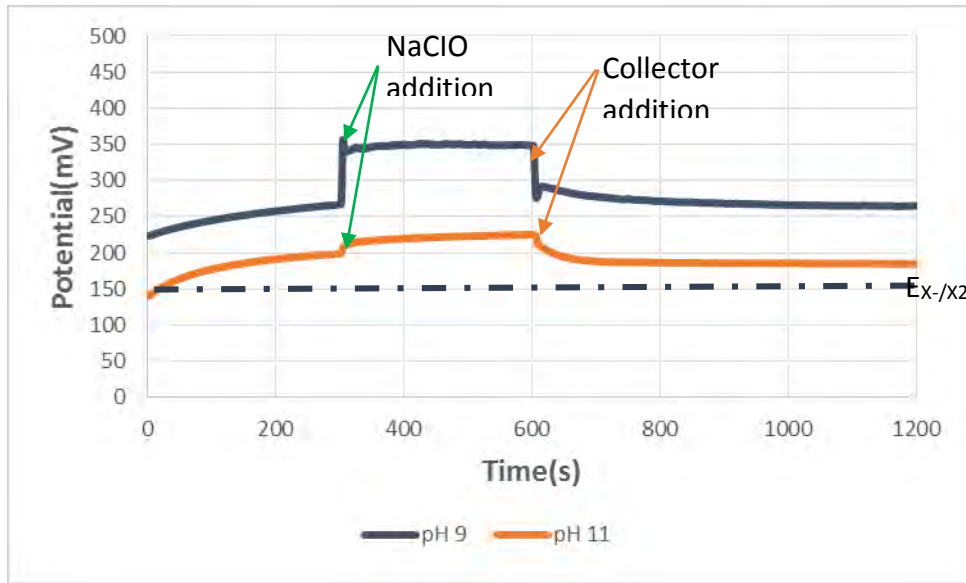

Figure 4-5: Rest potential for chalcopyrite with NaClO added after 300 s and collector SEX added after 600 s at pH 9 and at pH 11

An increase in pH to 11 resulted in a decrease in the starting potential of around 50 mV. The oxidizing effect of NaClO is illustrated by an increase in potential after 300 s, which is less pronounced at the higher pH of 11.

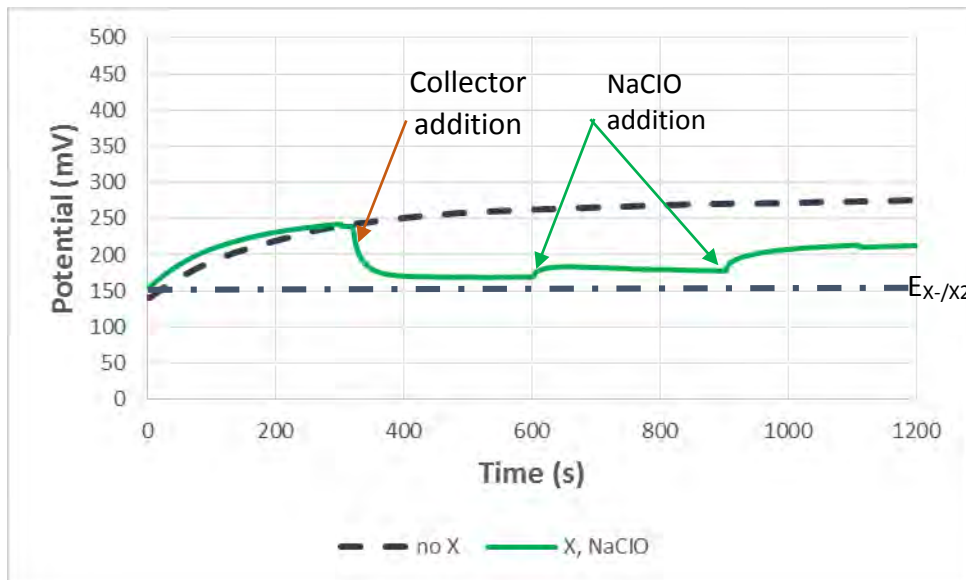

Figure 4-6: Rest potentials for chalcopyrite in absence of collector and in the presence of collector SEX added first at 300 s, NaClO added at 600 s and 900 s at a pH of 11

Figure 4-6, shows the effect of adding the collector before addition of NaClO at pH 11. These results can be compared to the results shown in Figure 4-5 when the collector was added after NaClO. Oxidation at a mineral surface can be observed by an

increase in the rest potential as shown in Figure 4-5, however, from the results shown in Figure 4-6, when the collector, SEX was added first, the effect of NaClO addition was diminished as indicated by the small extent of interaction.

### 4.3.3 Pentlandite

Figure 4-7 shows the rest potentials of pentlandite in the absence and presence of SEX and PAX.

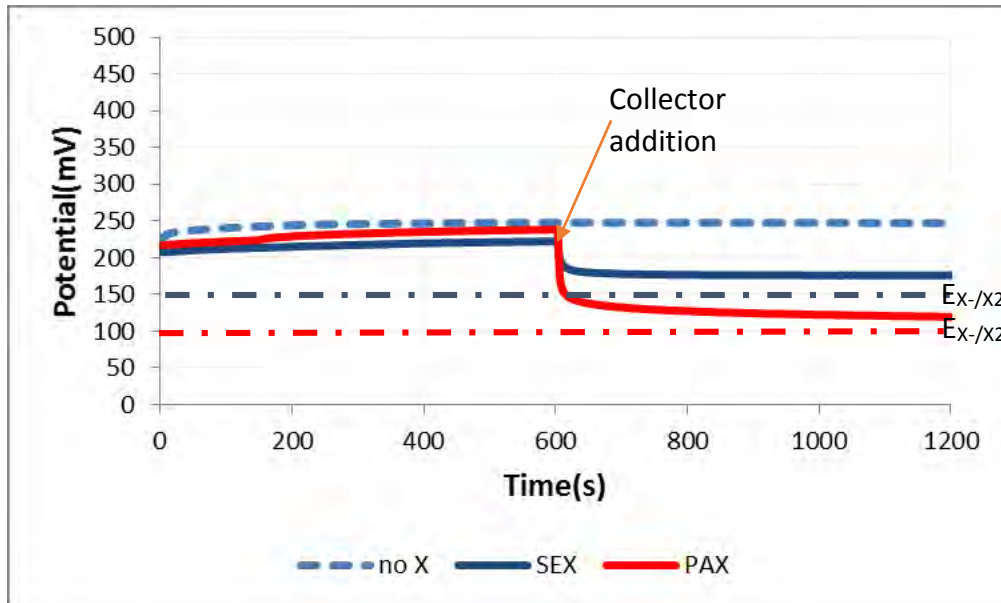

Figure 4-7: Rest potentials for pentlandite in the absence and presence of collectors at pH 9.

The rest potential of pentlandite was an average value of 250 mV as shown in Figure 4-7, obtained in the absence of a collector. As previously shown in the results for chalcopyrite in Figure 4-3, the potential drop on collector addition was greater with PAX than with SEX. This can be interpreted as a greater and stronger interaction with PAX than with SEX at the mineral surface. It can be observed that the respective rest potentials in the presence of the collectors, are above the xanthate – dixanthogen line for both collectors.

Figure 4-8 shows the rest potentials for pentlandite in the absence and presence of collector SEX shown as X at pH 9 and at pH 11.

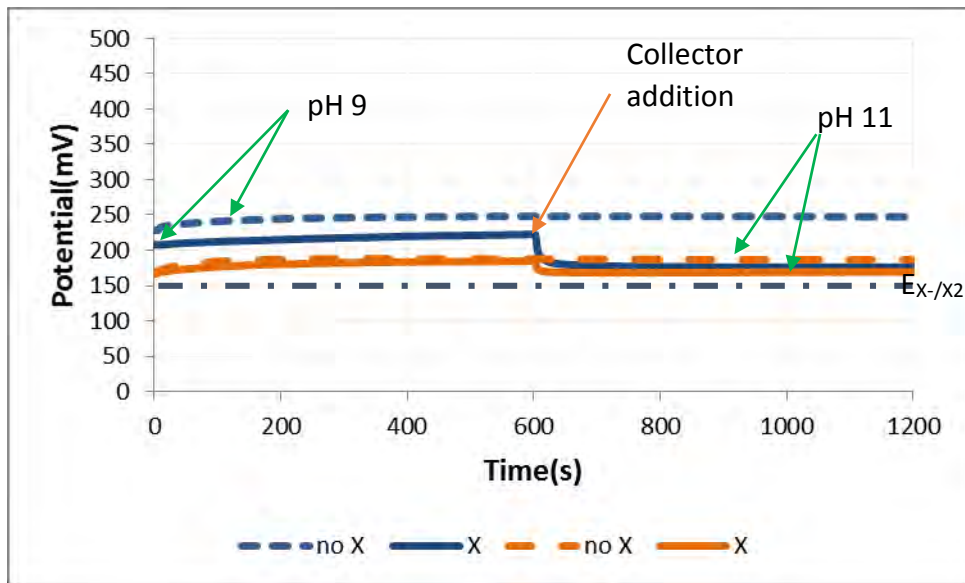

Figure 4-8: Rest potential for pentlandite in the absence and presence of collector SEX shown as X at pH 9 and at pH 11

As previously stated, the solid lines show the results obtained for measurements conducted with a collector added after 600 s for both pH values. Dashed lines are those obtained in the absence of a collector.

Figure 4-9, shows the rest potentials for pentlandite in the presence of NaClO and SEX at different pH values.

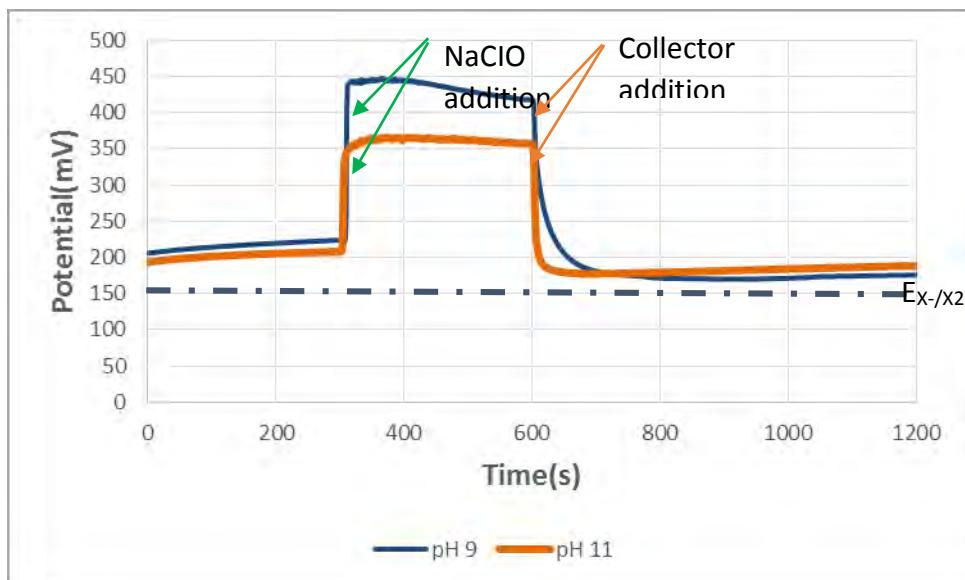

Figure 4-9: Rest potential for pentlandite with NaClO added after 300 s and collector SEX added after 600 s at pH 9 and at pH 11.

After an increase in pH to 11 the mineral developed potentials which were less positive than at pH 9. However, at pH 11 after collector addition dixanthogen is expected to be available to impart hydrophobicity to the mineral surface. The results in Figure 4-9 illustrate the oxidizing effect of NaClO observed by the increase of rest potentials at pH 9 and pH 11. The increase in rest potentials due to NaClO and the potential drop after addition of collector were significantly different, with the change in pH. It was found that the final rest potential values were within 10 mV of each other, all above the dixanthogen equilibrium line.

Rest potentials for pentlandite showing the effect of adding the collector before NaClO at pH 11 are shown in Figure 4-10.

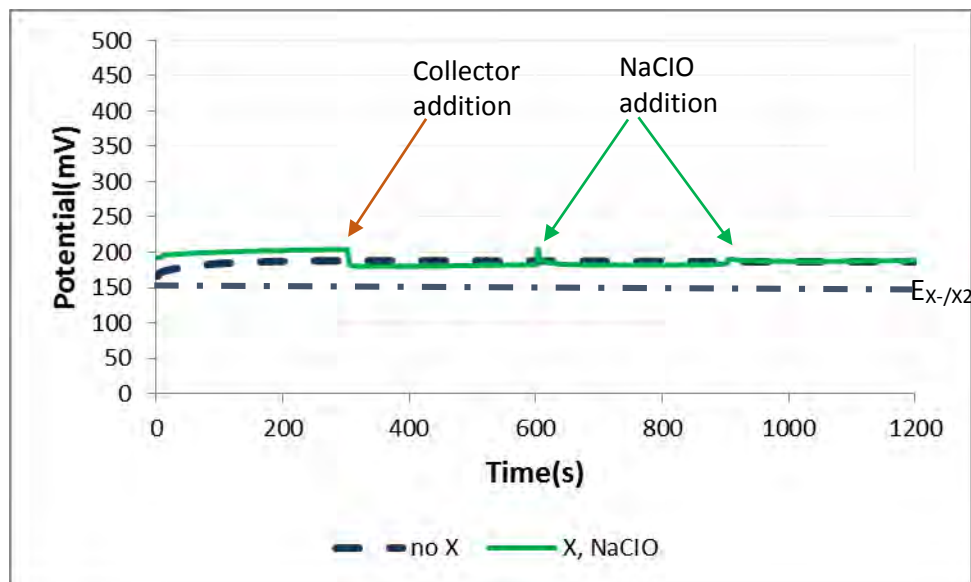

Figure 4-10: Rest potential for pentlandite in absence and presence of collector SEX added at 300 s and NaClO added after 600 s and 900 s at pH 11.

The results illustrate the effect of the addition of collector after 300 s, followed by NaClO at 600 s and 900 s. It can be observed that the oxidizing effect was significantly reduced and the final rest potentials are almost similar with the condition when no collector was present. The rest potential profiles are still within the region in which they are more positive than the dixanthogen formation potential.

### 4.3.4 Pyrite

Figure 4-11 shows the results for the rest potential for pyrite at pH 9.

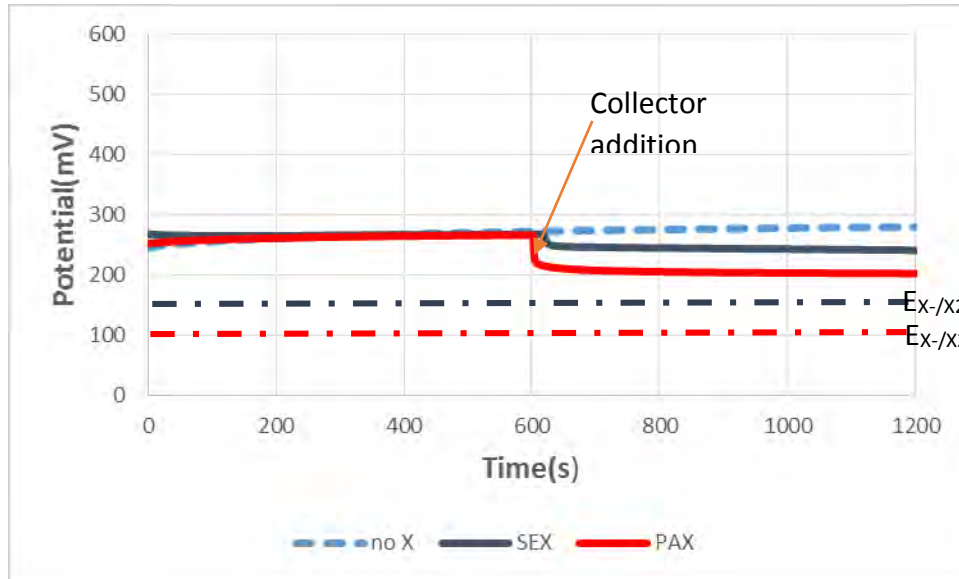

Figure 4-11: Rest potential for pyrite in the absence and presence of collectors at pH 9.

Pyrite had a rest potential of 279 mV in the absence of a collector. The results demonstrate a lesser interaction between pyrite and collectors, when compared to chalcopyrite and pentlandite. This is indicated by the smaller extents of potential drops on collector addition. However, dixanthogen was expected to be the species available at the mineral surface, since the rest potential profiles are all above the equilibrium potential lines for both SEX and PAX.

Figure 4-12 shows the rest potentials for pyrite at different pH values.

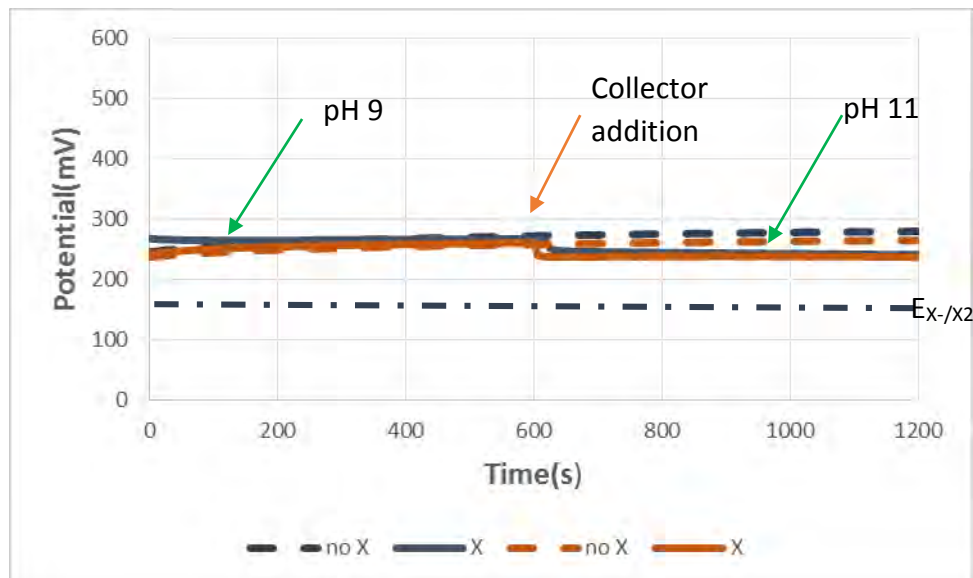

Figure 4-12: Rest potential for pyrite in the absence and presence of SEX at pH 9 and at pH 11. The results for the rest potential profiles of pyrite in the presence of NaClO and SEX at different pH values are shown in Figure 4-13.

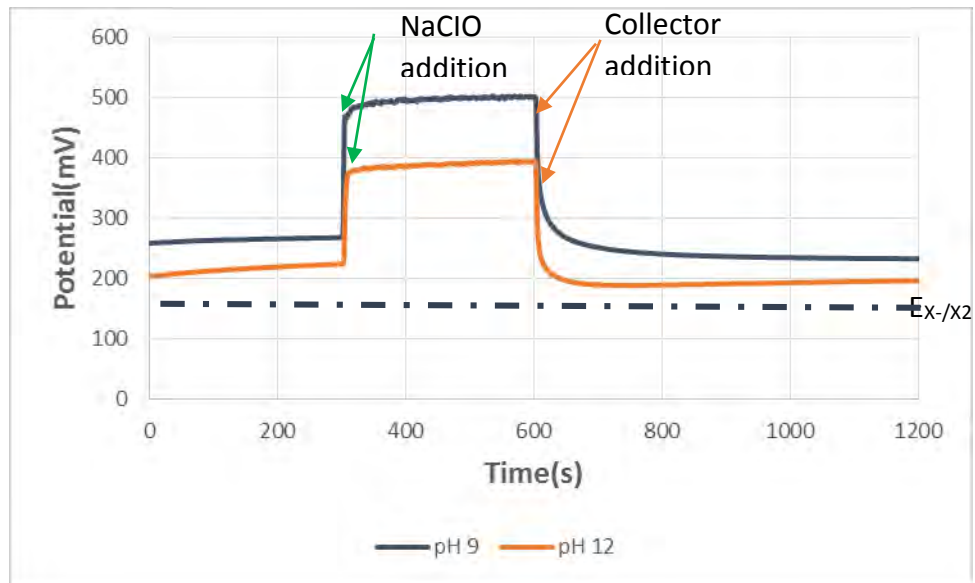

Figure 4-13: Rest potential for pyrite with NaClO added after 300 s and collector SEX added after 600 s at pH 9 and at pH 11.

The difference between starting potentials, when comparing the two pH values is an average value of 60 mV. There was not a pronounced difference in interaction with the reagents at the mineral surface at the different pH conditions.

#### 4.3.5 Pyrrhotite

Figure 4-14 shows the rest potentials of pyrrhotite at pH 9.

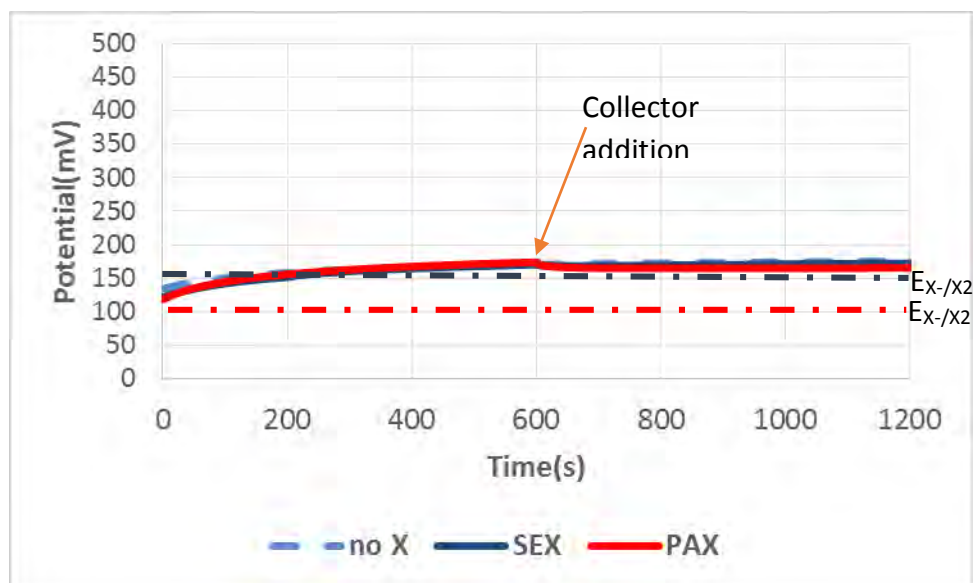

Figure 4-14: Rest potential for pyrrhotite in the absence and presence of collectors at pH 9.

The starting potential was less than 150 mV. The measurements were conducted in the absence and presence of the collectors, SEX and PAX. The mineral showed no significant interaction with the two collectors. The final rest potential in the absence and presence of the collectors was an average of 175 mV. This value is higher than the reversible potentials of the collectors. It should be noted that even if the potential is more positive than the potential for dixanthogen formation it does not necessarily imply that dixanthogen can be formed. It is speculated that other reaction schemes can be present at the mineral surface depending on the rate-determining step and this determines the type of species present at the mineral surface.

The rest potentials for pyrrhotite at different pH values are shown in Figure 4-15.

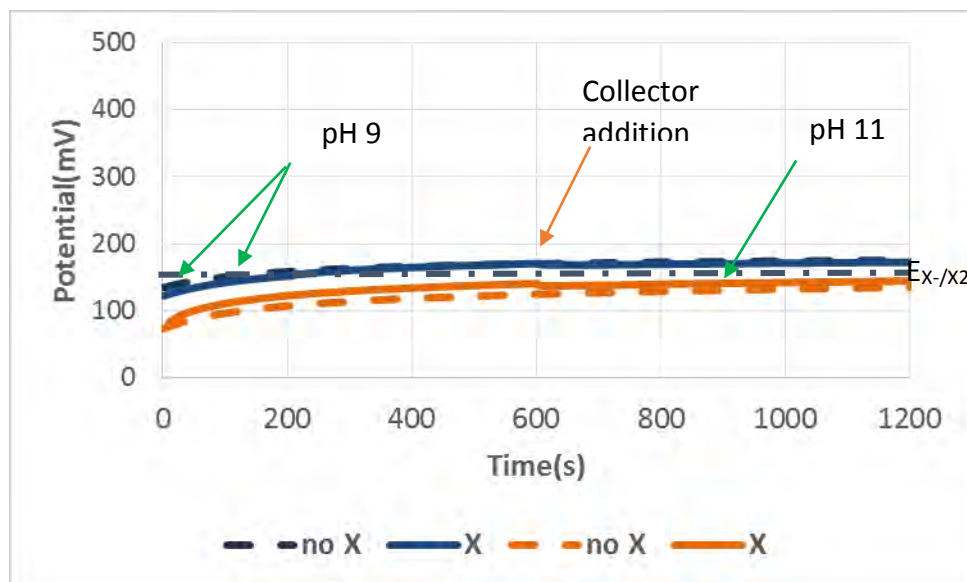

Figure 4-15: Rest potential for pyrrhotite in the absence and presence of collector SEX shown as X at pH 9 and at pH 11

The results obtained for pyrrhotite in the absence and presence of collectors at pH 9 showed an insignificant difference in the rest potentials measured. The same response was observed at a high pH level of 11. The mineral electrode final rest potentials had a difference of 30 mV for pH 9 and 11. The reversible potential for oxidation of ethyl xanthate lie in the region between the final rest potentials for pyrrhotite at the two different pH values.

Figure 4-16 shows the rest potentials for pyrrhotite in the presence of NaClO and SEX at different pH values.

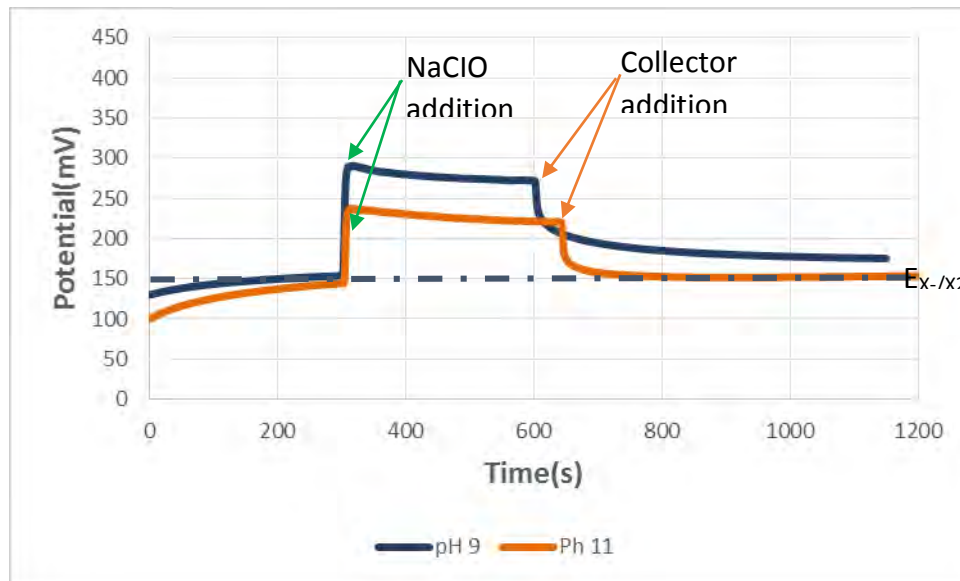

Figure 4-16: Rest potentials for pyrrhotite in the presence of SEX with NaClO added after 300 sec, at pH 9 and at pH 11

The initial potential of pyrrhotite was below 150 mV, the xanthate/dixanthogen couple oxidation potential for SEX. The addition of an redox reagent indicates an oxidizing effect by the increase in potential, this apparently caused a significant interaction with the collector for both pH values. Final potentials in the presence of a collector are very close to 150 mV suggesting that dixanthogen may not be formed. The shape of the profiles at the two pH values looks the same, and this possibly indicates a similar pathway of the reactions taking place. It was however, observed that the reactions occur at different potentials as shown by the different initial and final potentials.

#### **4.4 Batch Flotation Tests**

Batch flotation tests were performed to investigate the effect of redox potential control by chemical means in a bulk sulphide flotation process using Merensky ore. In addition the influence of changing pH and the use of collectors of different alkyl chain length were investigated. The influence of using different potential modifiers was also examined using batch flotation tests.

##### **4.4.1 Reproducibility**

The experiments were conducted in duplicate to minimize the errors associated with experimental results. Solids recovery, water recovery, metal recovery and grade are the variables which were key in determining the reproducibility of the tests. These results have been reported as average values obtained from the duplicate tests. The UCT standard procedure for experimental results requires that the standard error for water recovery not exceed 10 – 12.5% of the total water recovered. The standard error for solids recovery is expected to be below 5% of the total solids recovered. The error bars displayed on figures represent the standard error between the duplicate tests.

##### **4.4.2 Preliminary Tests**

Preliminary tests were conducted to determine how and to what extent potential can be changed using an oxidizing reagent. The potential range achieved was compared with rest potential values and the reduction potential values of the collectors. It was necessary to evaluate the flotation above the natural Eh of the ore, achieved on the addition of sodium hypochlorite, in order to determine whether the changes were significant.

#### 4.4.2.1 Eh versus pH diagrams

The results presented in Figure 4-17 show the changes in Eh as a function of pH in three different solutions.

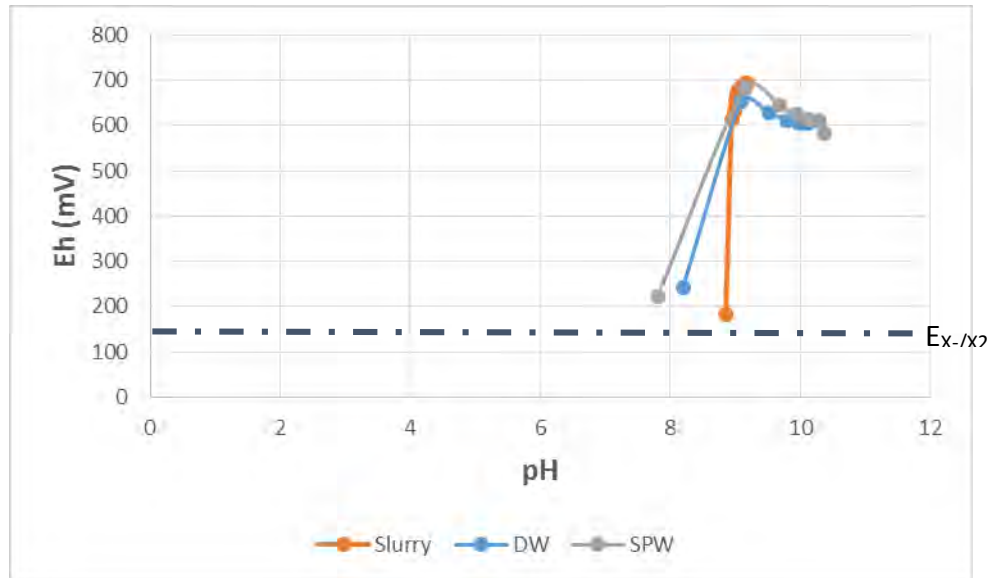

Figure 4-17: Change of Eh using NaClO against pH in slurry, distilled water (DW) and synthetic plant water (SPW)

These tests were conducted to determine whether potential could be raised by addition of NaClO. The NaClO was prepared as a 1% solution which translated to 0.1 M. The first data points shown are before the addition of NaClO and these points were between 100 – 200 mV. The NaClO was added drop wise and upon the first addition the Eh was raised to a region between 500 mV up to 700 mV depending on the solution condition. Subsequent addition of NaClO did not result in changes in the potential range.

The next set of tests were then conducted in a flotation cell and the results from these tests are shown in Figure 4-18.

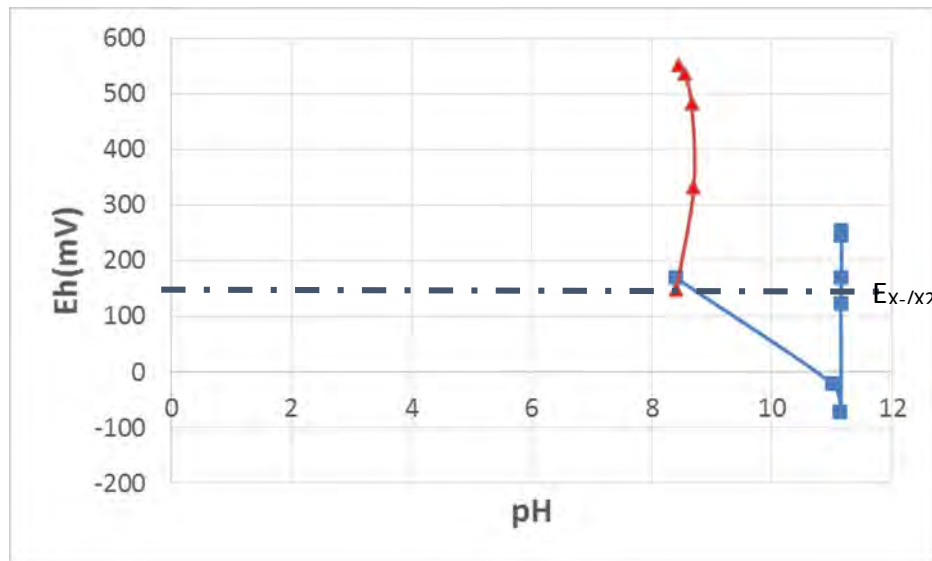

Figure 4-18: Change of Eh using NaClO against pH in a flotation cell using a slurry of a Merensky ore and NaOH to adjust pH to 11.

The dashed line in the figure shows the xanthate - dixanthogen formation line when SEX was used as the collector. As shown in Figure 4-17, the natural Eh of the slurry was found to lie in the potential range of 100 – 200 mV. The increase of Eh in the flotation cell was over a conditioning period of 1 minute raising the potential from the ore's natural Eh value to a higher value in the range between to 500 – 600 mV as shown by the triangles in Figure 4-18.

When pH was increased to a higher value of 11, the Eh decreased to a region between 0 and -100 mV, which is below the equilibrium potential for SEX. The addition of NaClO at pH 11 caused an increase in Eh to a potential range between 200 – 300 mV as shown by squares in Figure 4-18.

#### 4.4.2.2 Two Phase Flotation tests

Two phase batch flotation tests which can be described as consisting of air and liquid (no solids), were conducted to determine whether the addition of NaClO had a direct effect on foam stability.

The water recovered during two phase tests using SPW for the experimental conditions investigated is shown in Figure 4-19.

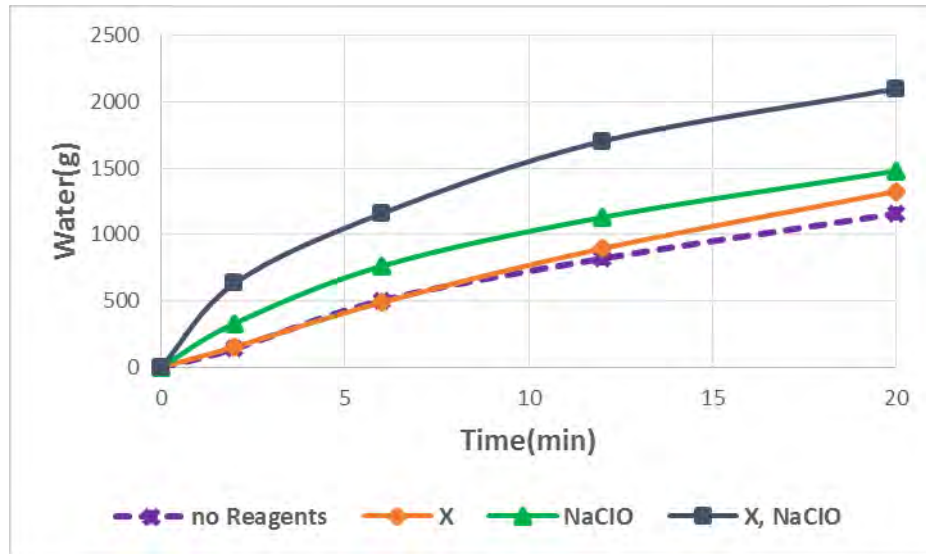

Figure 4-19: Water recovered during two phase tests conducted with SPW.

The pH of SPW is approximately 9. It was observed that the amount of water increased with the increase in Eh due to addition of NaClO. The highest mass was obtained in the presence of both SEX and NaClO. This was 45 % more than in the absence of any reagent, where the lowest amount of water viz. 1154.5 g was recovered.

### 4.4.3 Effect of changing potential with NaClO

The following results were obtained from three Phase Batch Flotation tests, which is a system consisting of solids, water and air. The control of Eh was conducted at pH 9 and pH 11.

#### 4.4.3.1 Solids versus Water Recovery

SEX at a dosage of 100 g/t was added to the mill in tests where a collector was added. The same amount of 1% NaClO solution was added per experimental run as was used in the tests where potential was raised shown in Figure 4-17, Figure 4-18 and Figure 4-19.

Figure 4-20 shows the amount of total solids and water recovered during batch flotation tests at the given conditions.

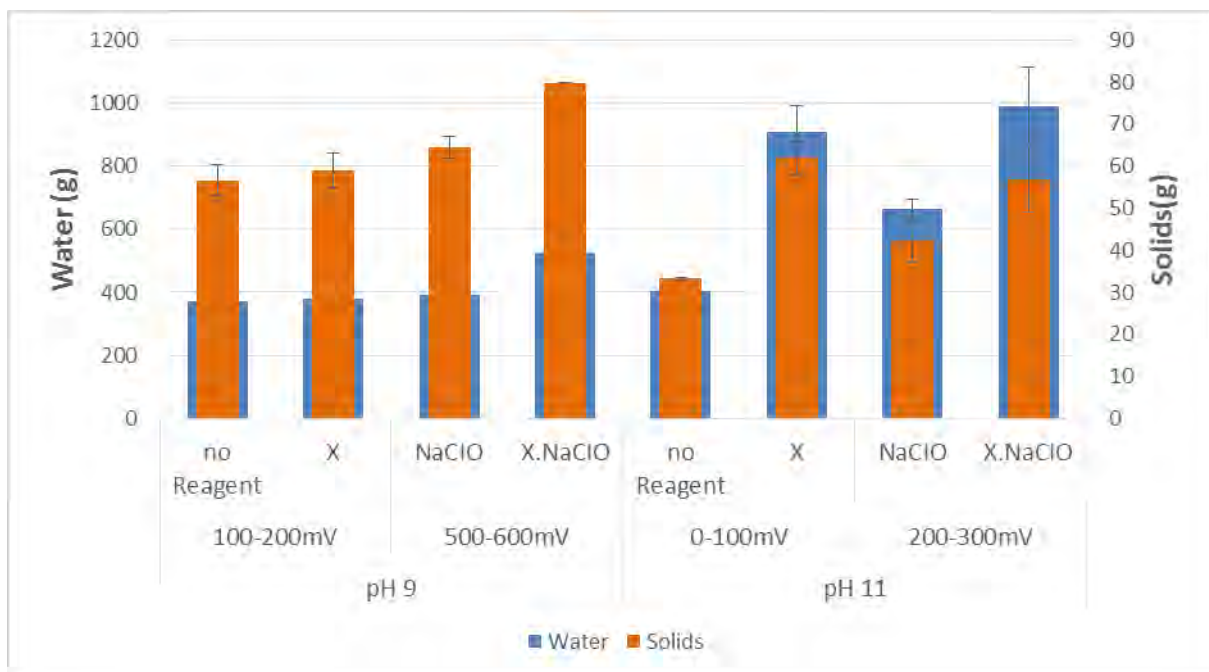

Figure 4-20: Final solids versus water final recoveries during batch flotation tests under different conditions at pH 9 and 11 using a Merensky ore

The figure also shows the baseline data for comparison, i.e, the flotation results without the addition of any reagent. At pH 9 there was a general increase in solids recovery as a result of the increase in potential on NaClO addition. The highest amount of solids obtained was 79.88 g in the presence of collector and NaClO. The amount of water recovered was generally unchanged at pH 9 except when collector was added together with NaClO.

Figure 4-21 compares the amount of solids recovered at the two different pH values.

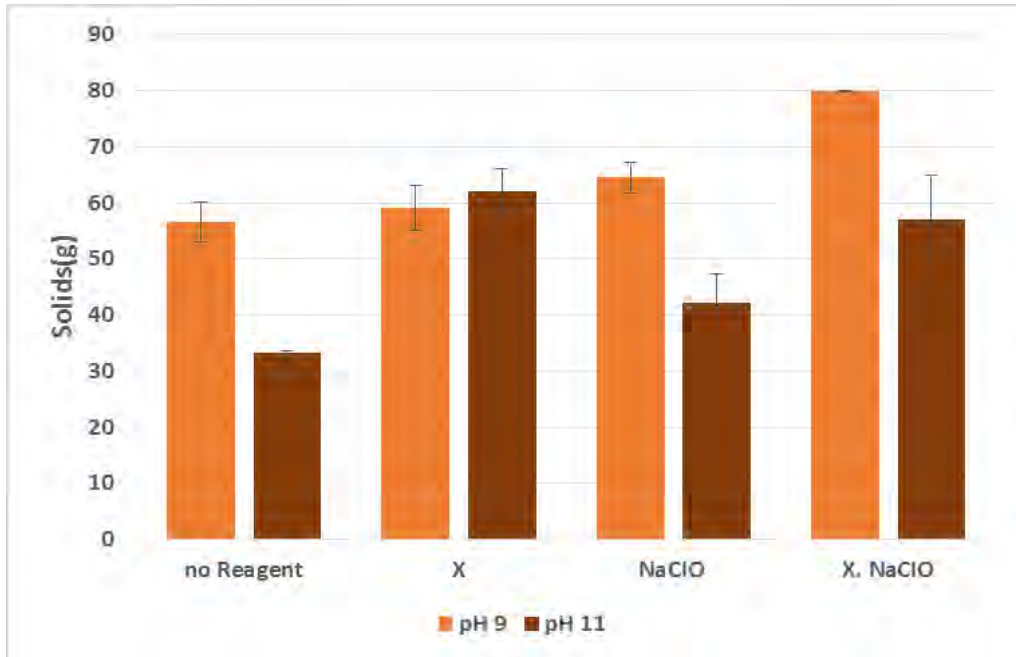

Figure 4-21: Solids recovery at pH 9 and 11 during batch flotation tests

Figure 4-21 also shows the baseline data for comparison, i.e., the flotation results without any reagent. At pH 9 more solids were recovered than at pH 11. It was observed that at pH 11 the differences observed in solids recovery on the addition of collector were more pronounced than those at pH 9.

Figure 4-22 compares the water recoveries obtained at pH 9 and pH 11.

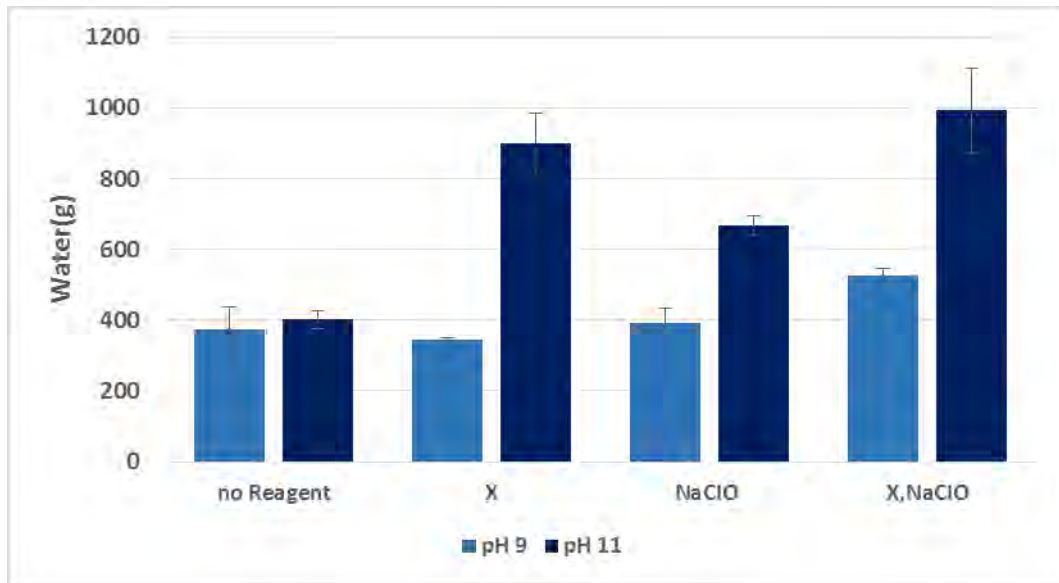

Figure 4-22: Water recovery at the pH 9 and 11 during flotation.

The amount of water at pH 11 in Figure 4-22 was generally higher than that obtained at pH 9 and this is the opposite of what was observed for solids recovery.

Figure 4-23 shows the solids and water recoveries for different conditions at pH 9.

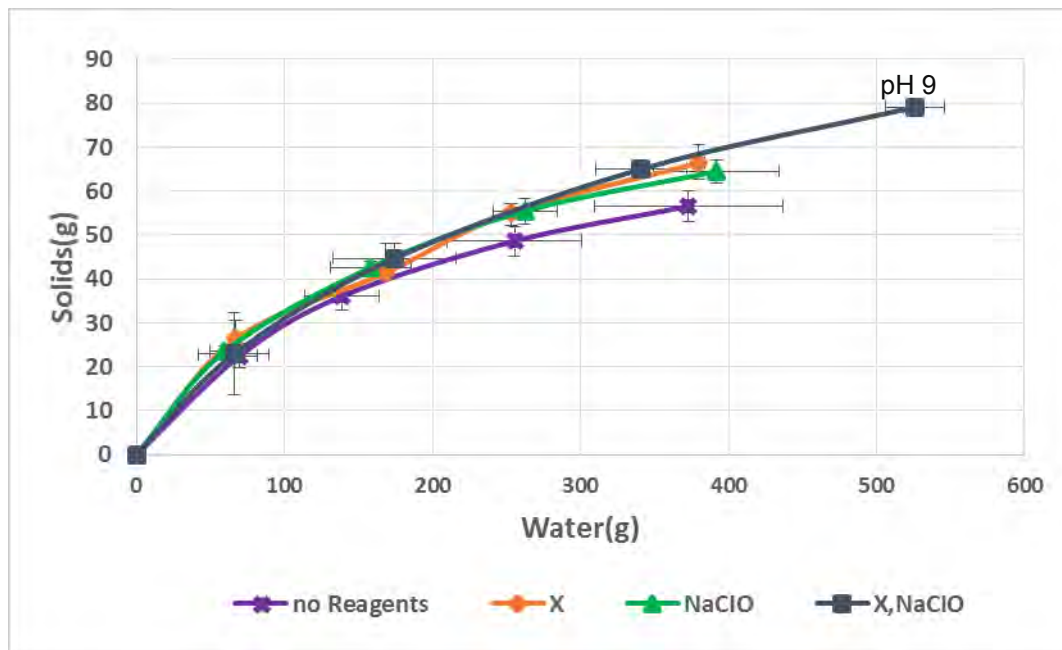

Figure 4-23: Solids recovered as a function of water for different conditions at pH 9.

There are small differences in the solids and water recovery for every concentrate collected as shown in Figure 4-23, except the condition in which the collector and

NaClO were present together. It is also interesting to note, when one compares the presence of a collector against NaClO, the mass of solids recovered was almost identical as shown in Figure 4-23 where the curves are closely following each other.

The solids and water recovery curves at pH 11 are shown in Figure 4-24.

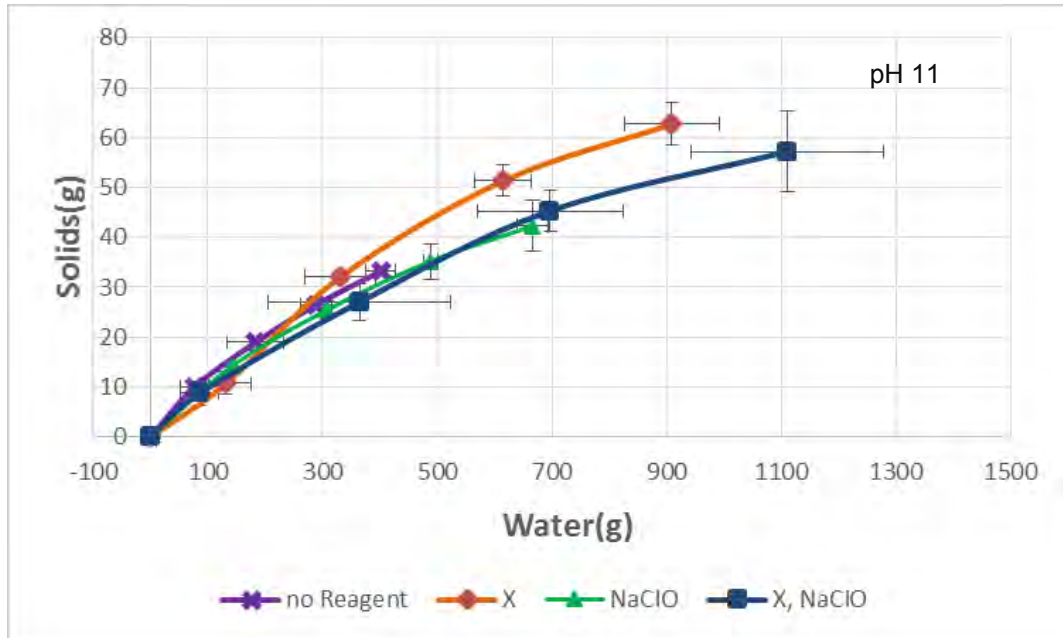

Figure 4-24: Solids recovery as a function of water recovery for different conditions at pH 11.

There is a big difference between the conditions, in terms of solids and water recoveries. As alluded to earlier, the presence of a collector caused more solids to be recovered. It can also be observed that the presence of both a collector and NaClO resulted in the highest amount of water being recovered.

The images in Figure 4-25 (a) and (b) show the colour of the froth and the sizes of the bubbles at the different conditions shown.

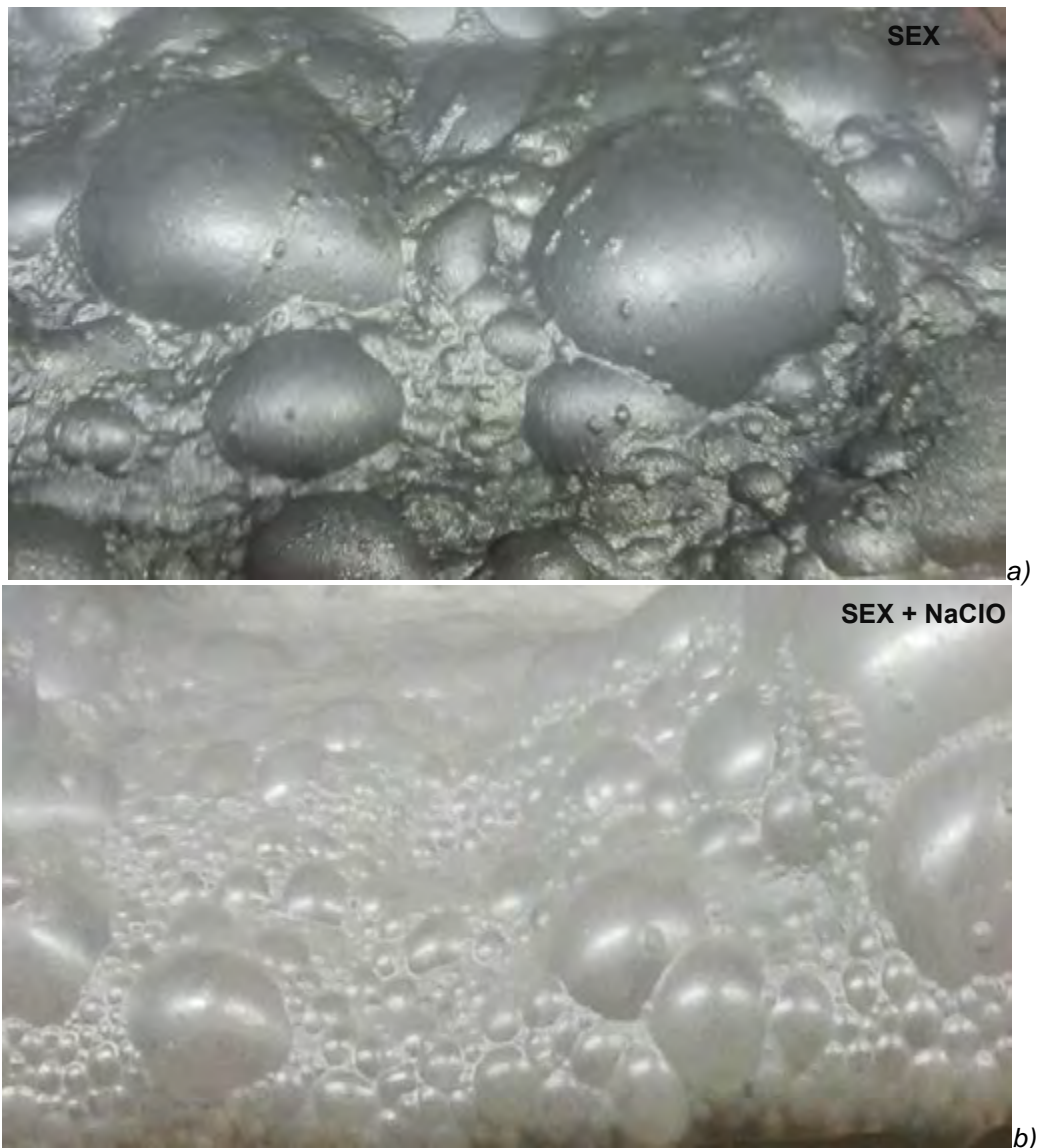

Figure 4-25: Images of froth zone (first concentrate) at pH 9.2 in a) the presence SEX and b) collector and NaClO

Without the addition of NaClO the bubbles are larger and more loaded, than when SEX and NaClO were added. The bubbles shown in Figure 4-25a) are larger which can indicate froth instability. The colour of the froth in Figure 4-25a) was dark greenish which might imply presence of high content of chalcopyrite, whereas Figure 4-25b) was whitish and watery. Considering the size, bubbles shown in Figure 4-25b) are smaller and this is indicative of a more stable froth. This can be attributed to the presence of gangue minerals such as talc. The above images can be related to the

amount of solids and water recovered in the absence and presence of potential controlling reagent.

#### 4.4.3.2 Eh versus solids and water recovery

Figure 4-26 a) and b) show the results obtained when Eh was changed.

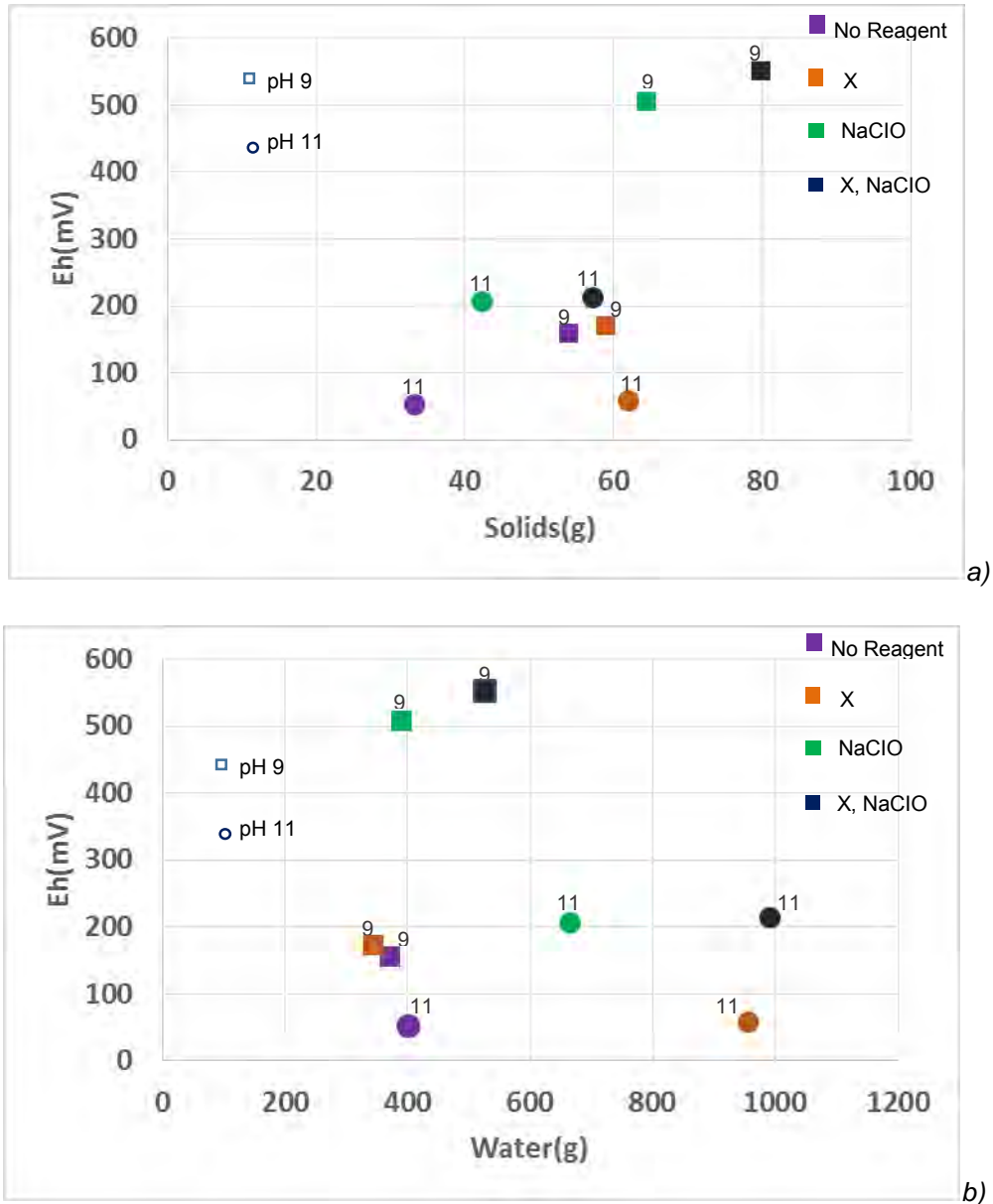

Figure 4-26: The effect of Eh against a) solids and b) water recovered, at pH 9 and pH 11

Upon examination of the results, it is evident that an increase in Eh resulted in an increase in the amount of solids recovered at both pH 9 and pH 11. Figure 4-26 b) shows that water recovery increased with an increase in Eh and that at pH 11 these increases were larger than those obtained at pH 9.

#### 4.4.3.3 Valuable Mineral Recovery and Grade

Figure 4-27a) and b) present the results obtained for final recovery and final grade for copper and nickel at pH 9 and pH 11.

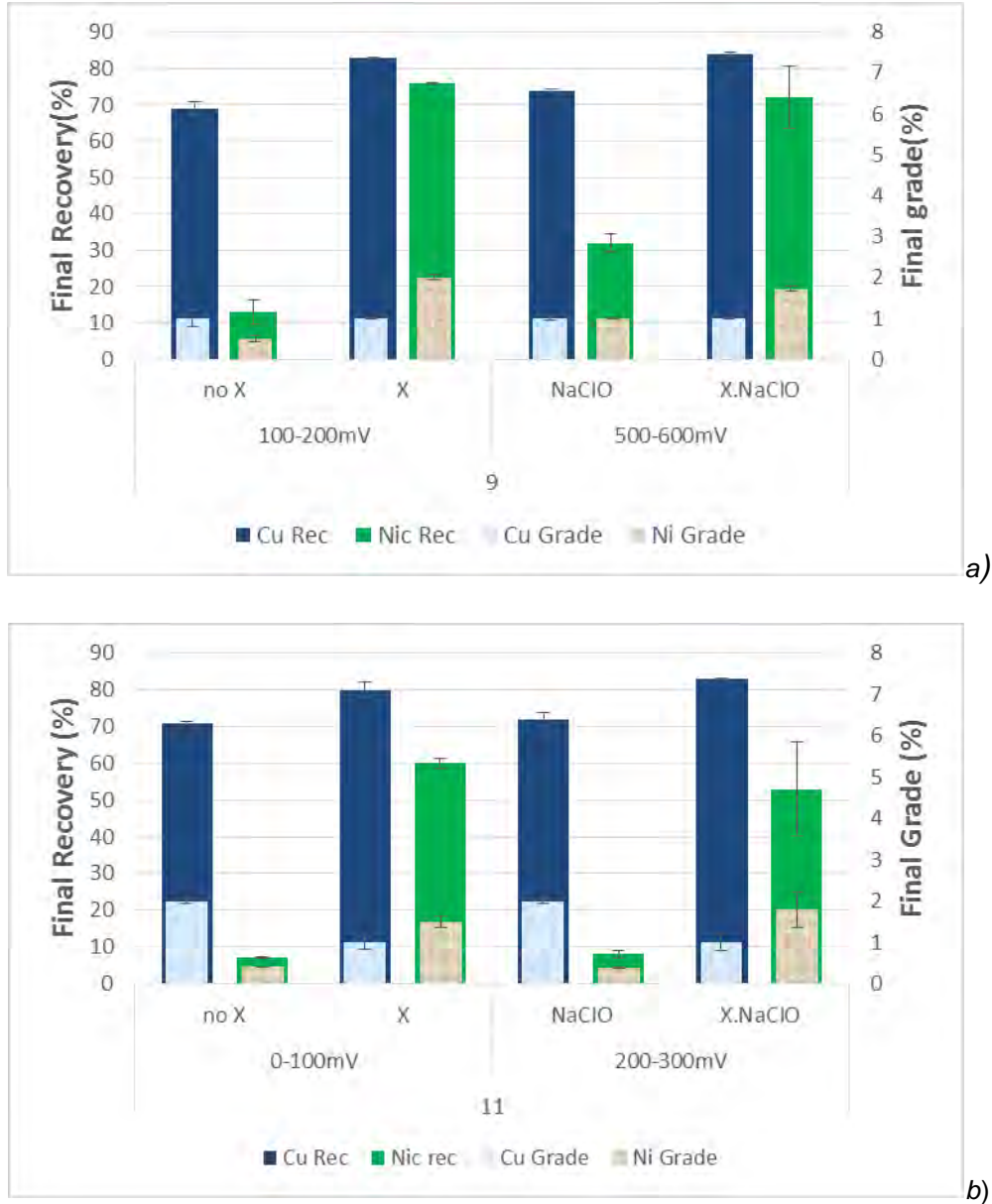

Figure 4-27: Final recovery versus final grade for copper and nickel a) pH 9 and b) pH 11

The results generally show that recoveries for copper were high regardless of the conditions in the batch flotation cell. The highest recoveries for copper viz. 80 – 85% were obtained for tests conducted in the presence of X, X and NaClO at pH 9. Similar results were obtained at pH 11. Copper grade at pH 9 was relatively unchanged for all conditions evaluated, but at pH 11 the lowest grades were obtained from tests conducted in the presence of collector. The recovery of nickel, at both pH values was

affected by the conditions in the batch flotation cell, with tests conducted in the absence of a collector having the lowest recovery. In general recoveries for both copper and nickel were lower at pH 11 than at pH 9.

#### 4.4.3.3.1 Copper Flotation Performance

Figure 4-28 compares a) the final recovery for copper and b) copper grade at the given pH values.

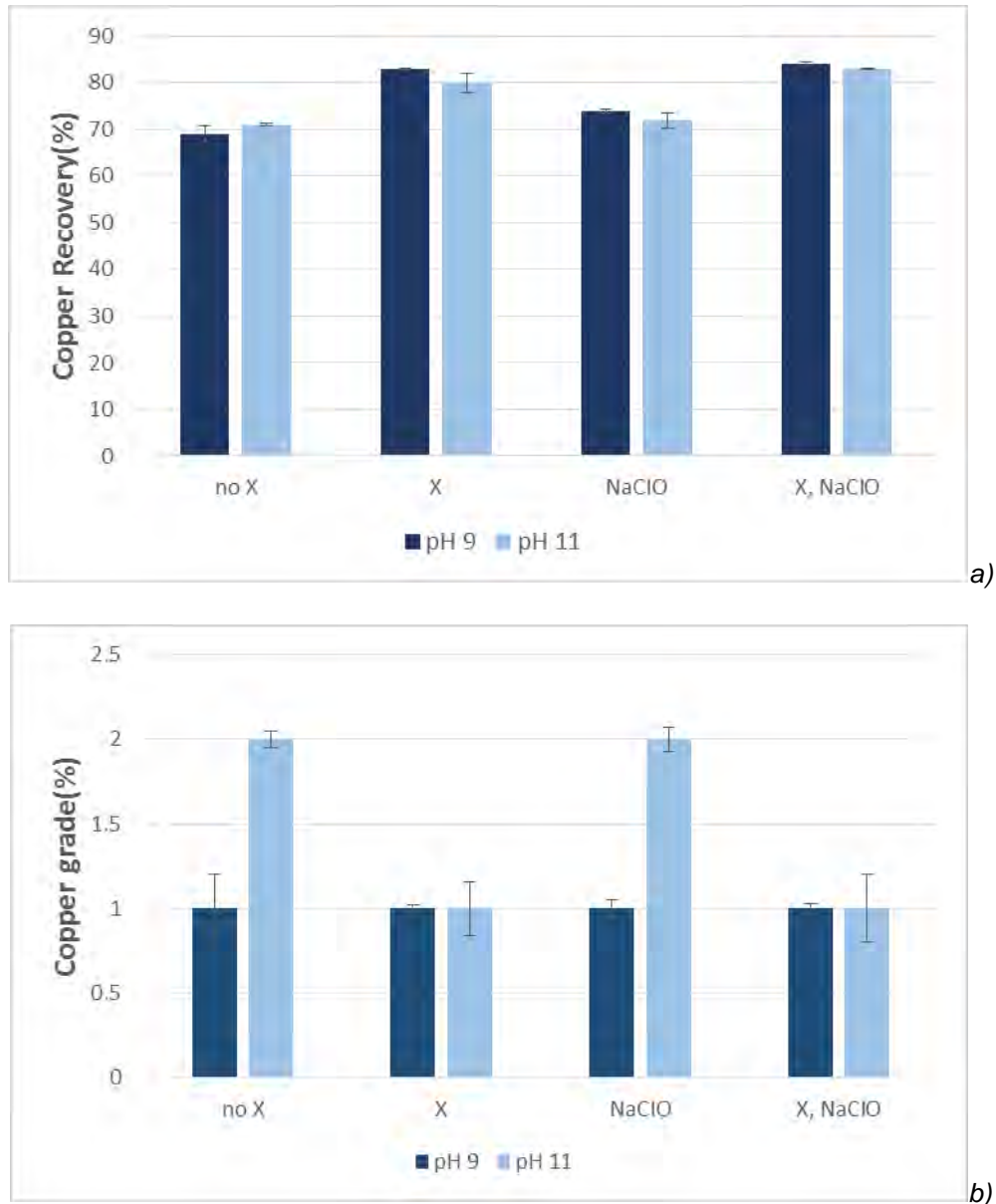

Figure 4-28: Final a) recovery and b) grade for copper at pH 9 versus pH 11

The recovery for copper under all conditions at both pH values was almost the same as shown in Figure 4-28a). The highest recovery was achieved in the presence of NaClO and X, viz. 84% at pH 9 and 83% at pH 11. It may be acceptable that therefore

changing pH had no effect on recovery of copper under all conditions. As shown in Figure 4-28b) copper grade was not affected at pH 9, and at pH 11 it was changed between 1 – 2%. Higher grades were obtained in conditions when no collector was present.

The grade-recovery curves for copper at pH 9 are shown Figure 4-29.

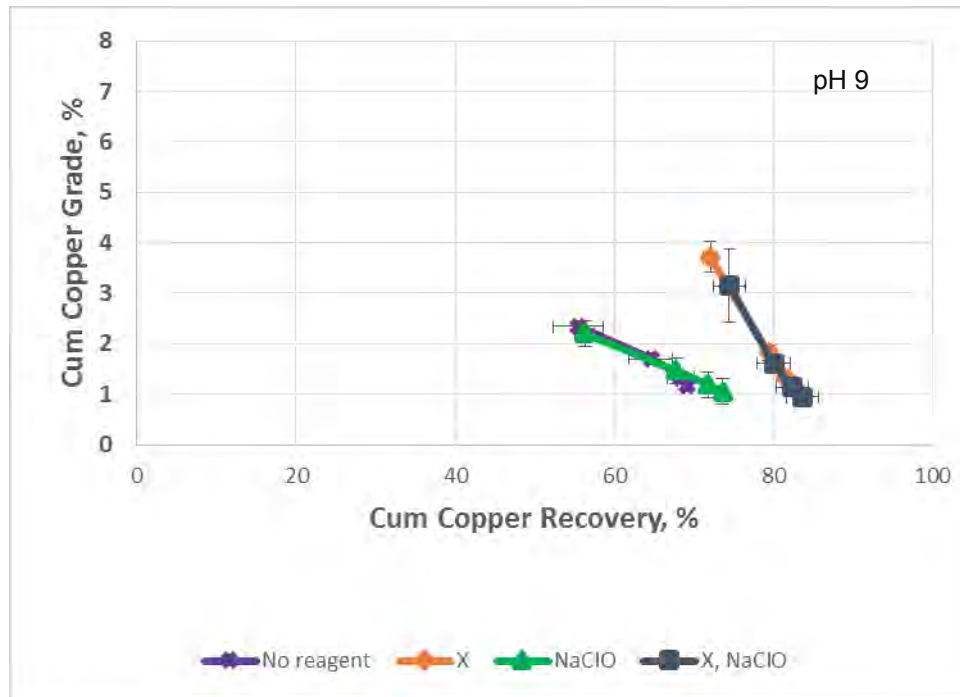

Figure 4-29: Copper grade as a function of copper recovery at pH 9

In the presence of collector at pH 9, the curves follow the same trend in that copper recovery was very similar for the two conditions evaluated. The grade obtained for the test using collector alone was slightly higher, but this small difference may be due to experimental error. In the absence of a collector the curves overlap demonstrating small differences in recovery viz. 69% - 74%.

The grade-recovery curves for copper at pH 11 are shown Figure 4-30.

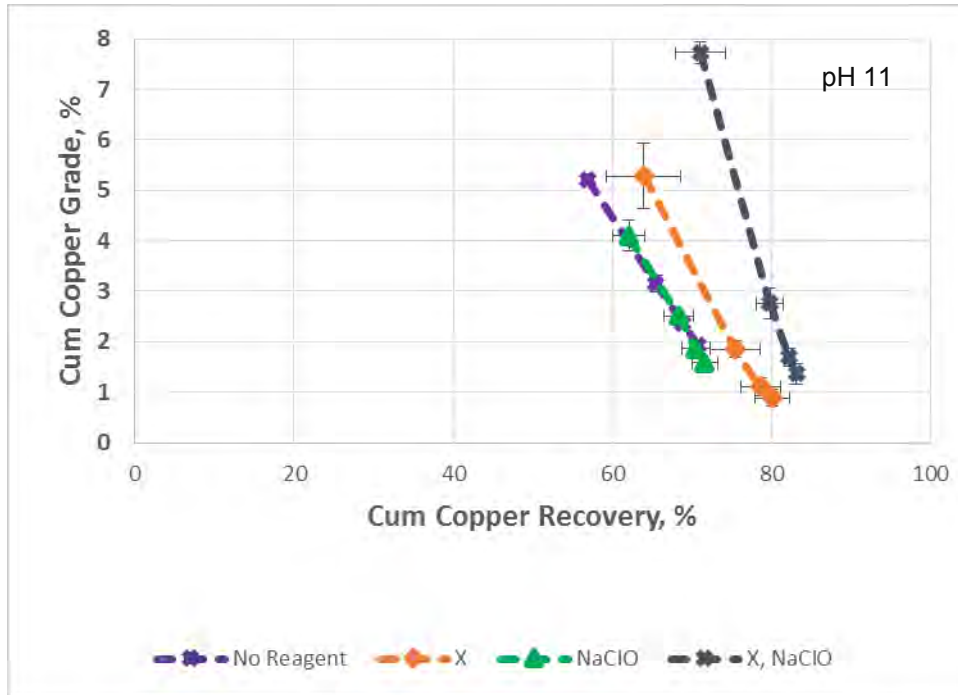

Figure 4-30: Copper grade as a function of recovery at pH 11

As shown in Figure 4-30 in the conditions where no collector was present the grade-recovery curves overlap each other although they have different initial grades and recovery. In the presence of a collector alone recovery is lower, slightly lower than when collector and NaClO were added together. Grades in the absence of NaClO are, however, slightly lower than those obtained in its presence. The final grades at pH 9 were in the range  $\pm 1\%$  which was almost similar to the final grades obtained at pH 11 which were between 1 – 2%. There are no striking differences in the grade for copper at both pH values and under all the conditions specified in the study.

#### 4.4.3.3.2 Flotation kinetics – copper

The flotation rate provides information on the flotation kinetics in terms of which mineral floated at a faster rate in comparison to others under the same conditions.

Figure 4-31 shows the rate of copper recovery as a function of time for the different conditions at pH 9.

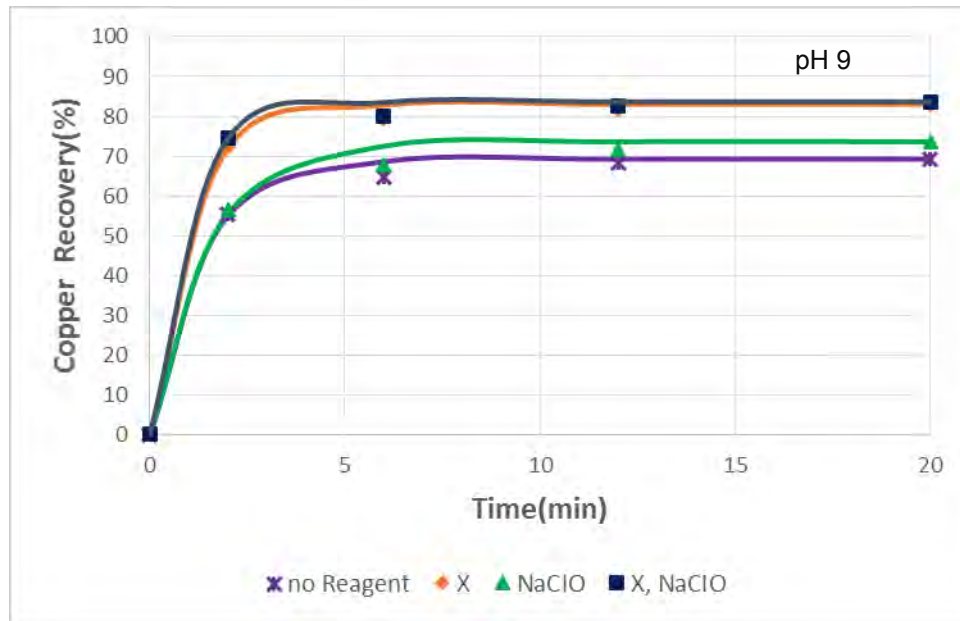

Figure 4-31: Flotation rate of copper at the pH 9

Table 4-2 shows the flotation rate constants and maximum possible recovery for copper at pH 9.

Table 4-2: The rate of flotation ( $k$ ) and maximum recovery ( $R_{max}$ ) for copper recovery at pH 9.2 at conditions evaluated.

Conditions	Classical model constants	
	$k(\text{min}^{-1})$	$R_{max} (\%)$
No reagent	0.79	69
X	1.01	83
NaClO	0.70	74
X, NaClO	1.10	84

The Classical model has been used to analyse flotation rates and establish the flotation performance. The Classic model is represented as:

$$R = R_{max}(1 - e^{-kt})$$

$R$  is the recovery,  $R_{max}$  is maximum possible recovery,  $k$  is the flotation rate constant and  $t$  is flotation time.

In the presence of collector, the highest rate constants were achieved. These correspond to the maximum possible recoveries obtained, with the highest being 84% in the presence of NaClO. In the absence of a collector the rate constants were low at an average of 0.75.

Figure 4-32 show the rate of copper recovery at different conditions and at pH 11.

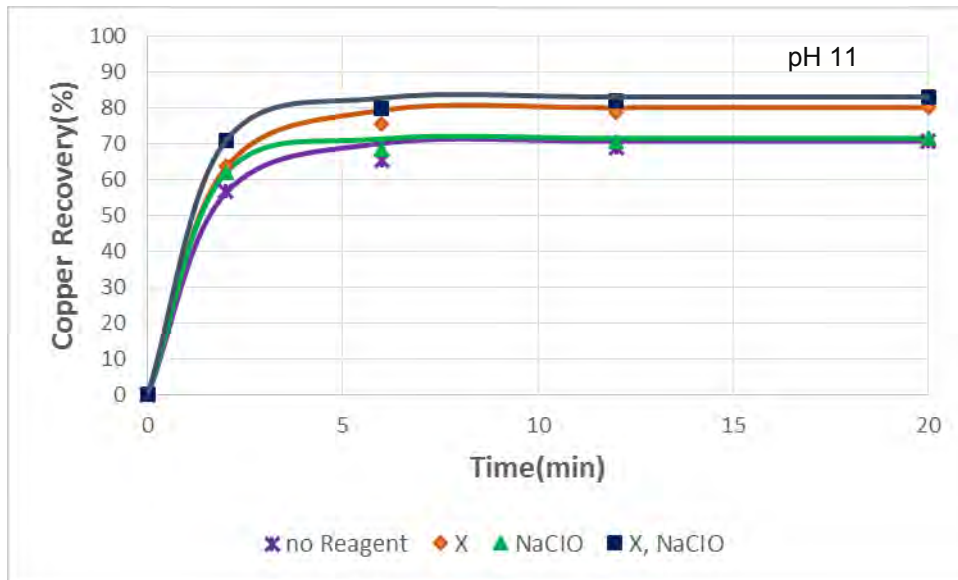

Figure 4-32: Flotation rate of copper at the pH 11

The flotation rate constants,  $k$  values and maximum possible recovery,  $R_{max}$  for copper at pH 11 are shown in Table 4-3.

Table 4-3: The rate of flotation ( $k$ ) and maximum recovery ( $R_{max}$ ) for copper at pH 11 at conditions evaluated.

Conditions	Classical model constants	
	$k(\text{min}^{-1})$	$R_{max}$ (%)
No reagent	0.79	71
X	0.78	80
NaClO	1.00	72
X, NaClO	0.96	83

The highest possible recovery of 83 % was attained in the presence of collector and NaClO. The rate constant is significantly high when compared to values obtained under other conditions. Upon examination of the curves, it can be observed that the rates of flotation were almost identical with no significant changes in recovery from the

second concentrate to the last concentrate. When no collector was present the rates of flotation were close to each other and this behaviour can be attributed to the species available being responsible for imparting hydrophobicity under the different conditions. The model predictions were comparable to the experimental data showing similar trends, with a high rate constant indicating which species float quickly while a low rate constant implies slow flotation. These data give valuable information on the efficiency of the process.

#### 4.4.3.3 Nickel Flotation Performance

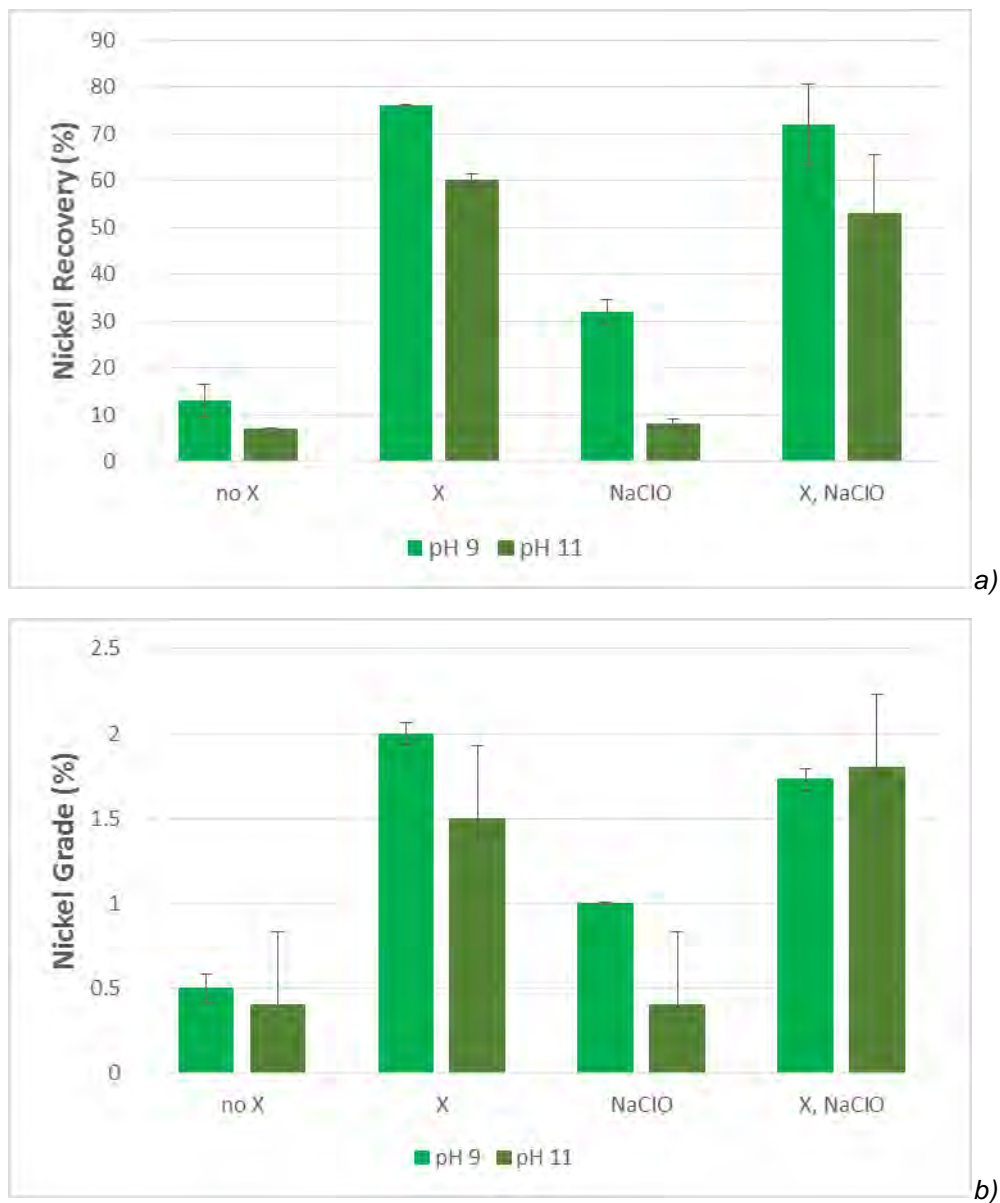

Figure 4-33: Final a) recovery and b) grade for nickel at pH 9 and pH 11

Figure 4-33 a) and b) shows the final recovery and final grade respectively, for nickel at pH 9 and pH 11. In the absence of a collector the recovery of nickel was very low;

at pH 9 the recovery was 13% and at pH 11 it was 7%. The addition of NaClO at pH 9 in the absence of the collector increased the recovery from 13% to 32%, whereas at pH 11 it did not change. Higher recoveries and grades for nickel were obtained in the presence of collector at both pH values, which implies that nickel can effectively be concentrated only in the presence of a collector.

The cumulative grade – recovery curves for nickel at pH 9 and pH 11 are shown in Figure 4-34 a) and b).

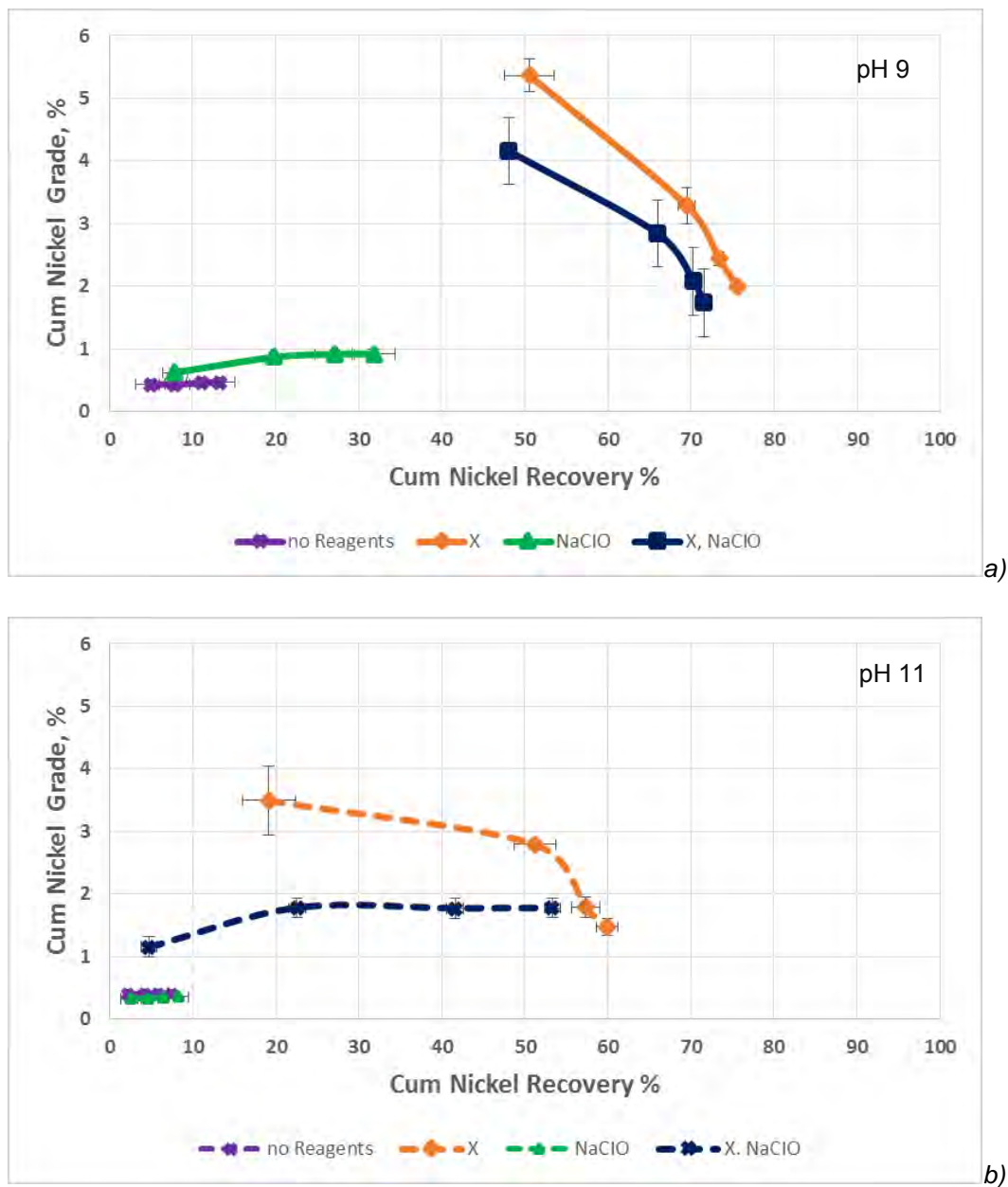

Figure 4-34: Cumulative grade recovery curves for nickel at pH a) 9 and b) pH 11

The results obtained at both pH values shown in Figure 4-34 a) and b) emphasize the variation in behaviour of nickel under different conditions. The lowest recovery and grade were obtained at pH 11 in the presence of NaClO alone, where a final recovery of 7% and final grade of 0.4% were achieved. In the presence of collector the highest initial grade and recovery were achieved at both pH values when compared to the condition when the collector was present with NaClO. At pH 9 in Figure 4-34 a) the highest recovery and grade were achieved as 76% and 2% respectively.

#### 4.4.3.3.4 Flotation kinetics –nickel

Figure 4-35 shows the flotation rate for nickel at pH 9.

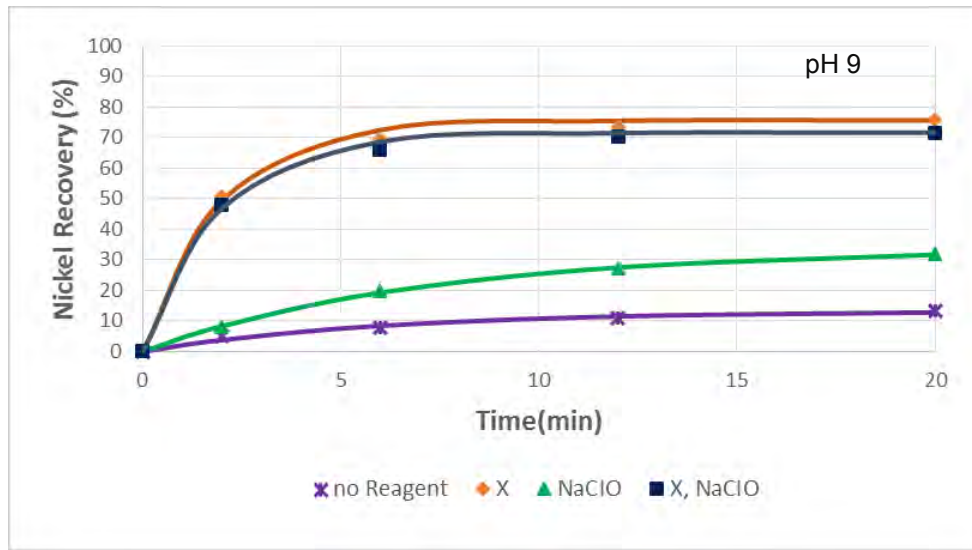

Figure 4-35: Flotation rate for nickel at pH 9

Table 4-4 shows the flotation rate constants,  $k$  values and maximum possible recovery,  $R_{max}$  for nickel at pH 9.

Table 4-4: The rate of flotation ( $k$ ) and maximum recovery ( $R_{max}$ ) for nickel recovery at pH 9 at conditions evaluated.

Conditions	Classical model constants	
	$k(\text{min}^{-1})$	$R_{max}$ (%)
No reagent	0.17	13
X	0.53	76
NaClO	0.14	34
X, NaClO	0.53	72

The highest  $k$  values in Table 4-4 resulted in the highest maximum possible recovery, which correspond to the recovery of nickel obtained during flotation experiments. It is indicative of minimum deviation and accuracy of the data, when the model can closely fit the experimental data.

The results in Figure 4-36 show the flotation rates for nickel at pH 11.

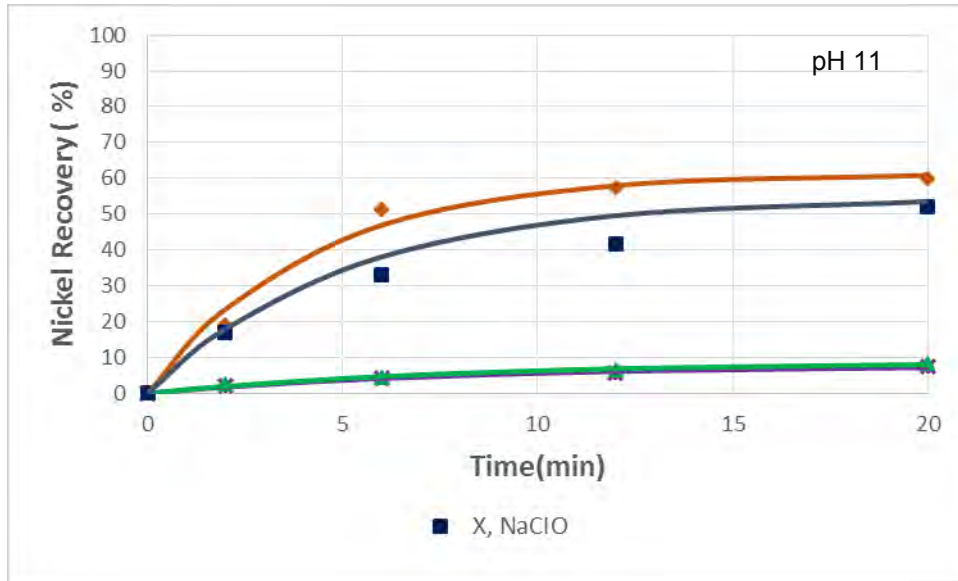

Figure 4-36: Flotation rate for nickel at pH 11

The results confirm that in collectorless flotation the rate of nickel floatability is poor. It can be observed that at both tests conducted at pH 11 in the absence of a collector there was a similar trend in the flotation rate.

Table 4-5 shows the flotation rate constants,  $k$  values and maximum possible recovery,  $R_{max}$  for nickel at pH 11.

Table 4-5: The rate of flotation ( $k$ ) and maximum recovery ( $R_{max}$ ) for nickel recovery at pH 11 at conditions evaluated.

Conditions	Classical model constants	
	$k(\text{min}^{-1})$	$R_{max}$ (%)
No reagent	0.13	8
X	0.24	62
NaClO	0.13	34
X, NaClO	0.20	54

The  $k$  values for nickel at both pH 9 and 11 are less than 0.6. As observed in some tests that the magnitude of the  $k$  value is proportion to the recovery. From the results shown in Table 4-5, the maximum possible recovery for nickel was 62% corresponding to the highest value of  $k$  viz. 0.24.

#### 4.4.4 Effect of collectors of different chain length

Collectors of different chain length were investigated in terms of how they influence the flotation behaviour during a bulk sulphide flotation process. This was critical in

order to be able to identify conditions where recovery and grade could be optimised when potential is controlled during the flotation process.

#### 4.4.4.1 Solids versus Water Recovery

Figure 4-37 shows the results for final solids and final water recovery obtained in the absence and presence of collectors of different chain length at pH 9.

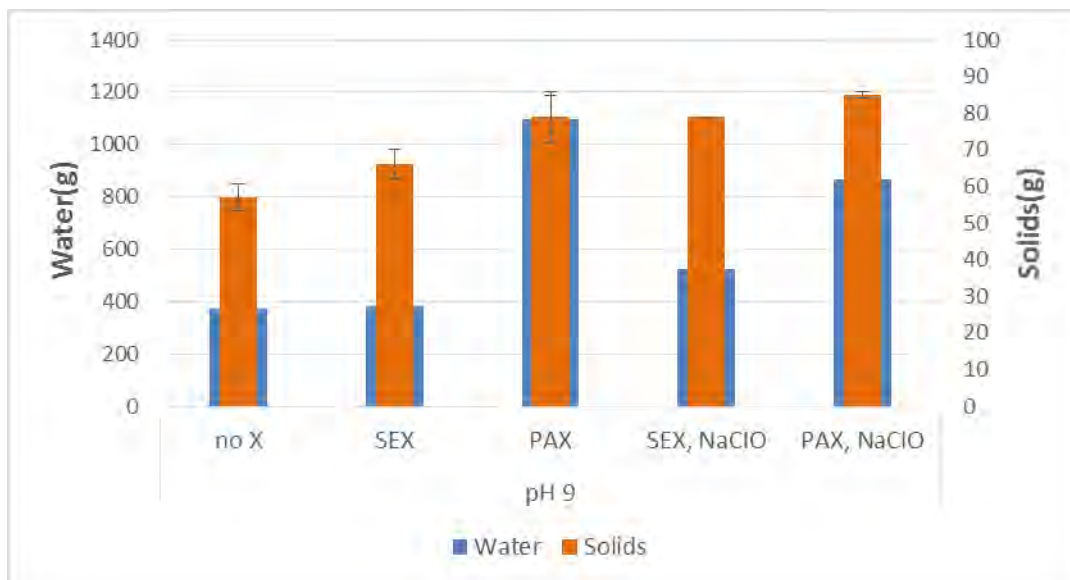

Figure 4-37: Final solids and final water recovery in the absence and presence of collectors of different chain length at pH 9.

The same collector dosage of 100 g/t was added for both collectors (SEX and PAX) and NaClO was added as the potential modifier. The amount of solids and water recovered in the absence of a reagent is slightly different to the the amount of solids and water recovered in the presence of SEX as the collector. The use of PAX as the collector resulted in a large increase in both solids and water recovery. The addition of NaClO resulted in increased solids recovery for both SEX and PAX, but its addition lowered the recovery of water obtained for PAX.

The solids recovery as a function of water recovery curves in the absence and presence of collectors of different chain length are shown in Figure 4-38.

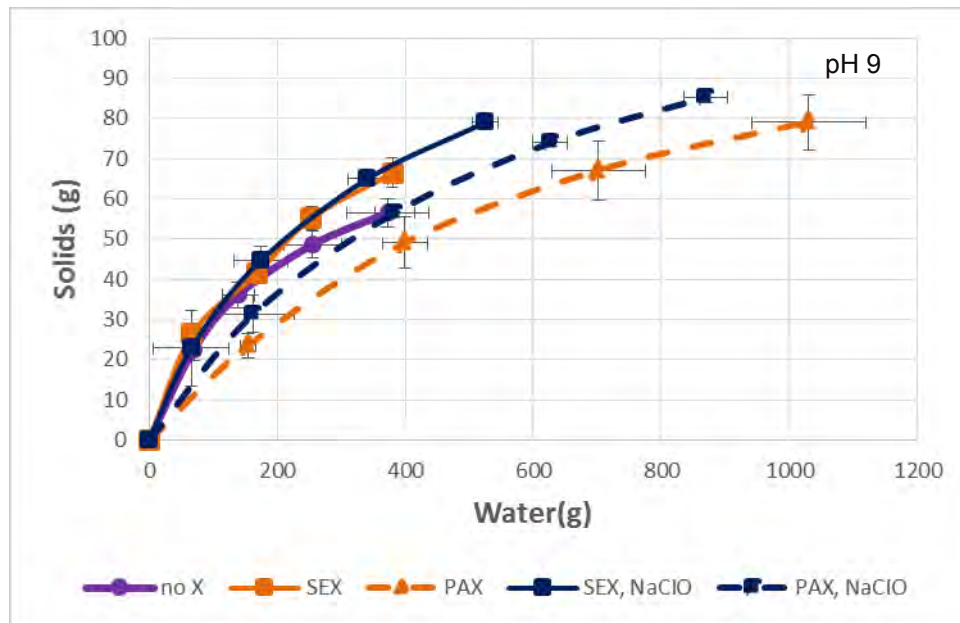

Figure 4-38: Solids versus water recovery in the absence and presence of collectors of different chain length at pH 9.

It can be observed from the results in Figure 4-37 and Figure 4-38 that when the collectors were added without NaClO, the addition of PAX resulted in higher water and solids recoveries than the addition of SEX. The lowest solids and water recoveries were obtained in the absence of any reagent. In the presence of the collector together with NaClO, the highest amount of solids and water obtained was 85 g and 1030 g respectively, in the presence of PAX and NaClO. The expectation was that when a collector of longer chain length was used it could result in destabilised froth due to a higher contact angle with the mineral surface. The results in this study showed otherwise, with the collector of longer chain length resulting in a more stable froth as indicated by the high solids and water recoveries.

#### 4.4.4.2 Valuable Mineral Recovery and Grade

Figure 4-39 shows the results for the final recovery and final grade for copper and nickel in the absence and presence of collectors of different chain length at pH 9.

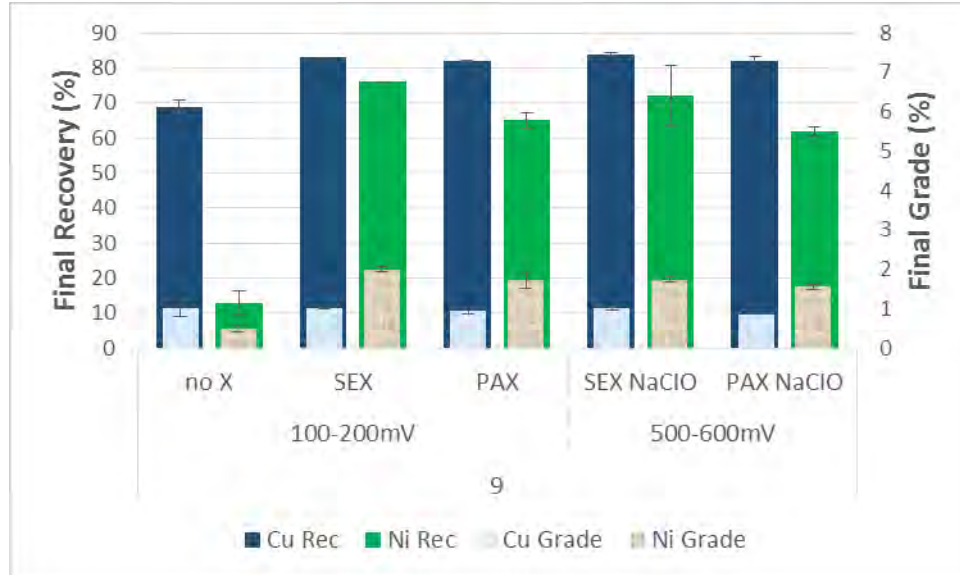

Figure 4-39: Final recovery and final grade for copper and nickel in the absence and presence of collectors of different chain length at pH 9.

The results in Figure 4-39 indicate a very slight drop in both recovery and grade of copper when PAX was used as the collector instead of SEX. It can be assumed that copper flotation performance is not significantly affected by collector chain length. As previously shown in other results for collectorless flotation, the lowest recovery and grade for nickel was obtained in the absence of a collector. The addition of PAX, as collector resulted in a decrease in the recovery of nickel from 76% to 62% when compared with tests in which SEX was used as the collector. In the tests in which NaClO was added, there was a decrease in recovery and grade obtained when PAX was used when compared to SEX.

#### 4.4.4.2.1 Copper Flotation Performance

Figure 4-40 shows the results for cumulative grade as a function of cumulative recovery for copper in the absence and presence of collectors of different chain length at pH 9.

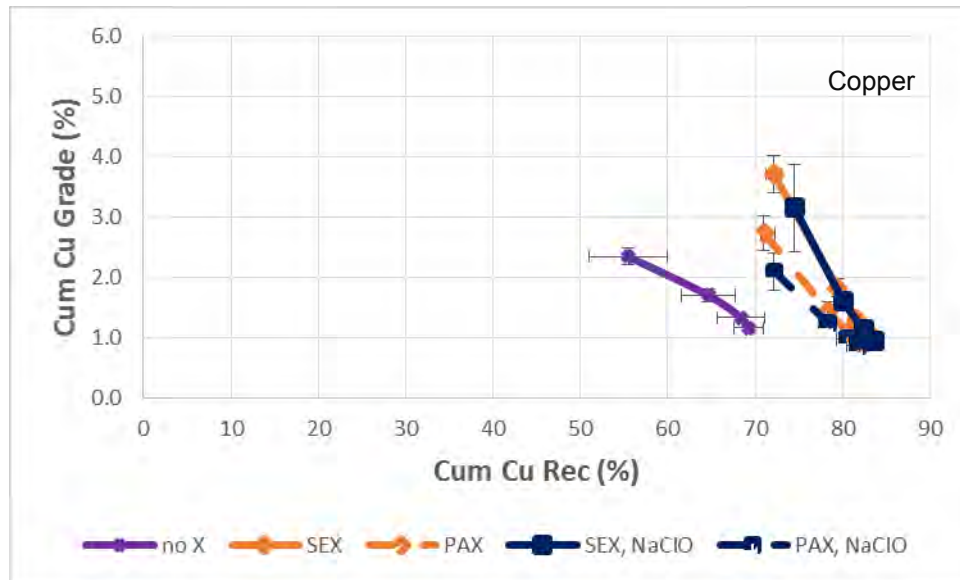

Figure 4-40: Copper grade as a function of copper recovery in the absence and presence of collectors of different chain length at pH 9.

The lowest copper recovery was obtained in the absence of reagents. All other conditions resulted in very little difference in the recovery of copper. The highest grades were obtained from tests in which SEX was used as a collector.

#### 4.4.4.2.2 Flotation kinetics: Copper

Figure 4-41 shows the results obtained from tests on effect of collectors of different chain lengths on the rate of flotation of copper at pH 9.

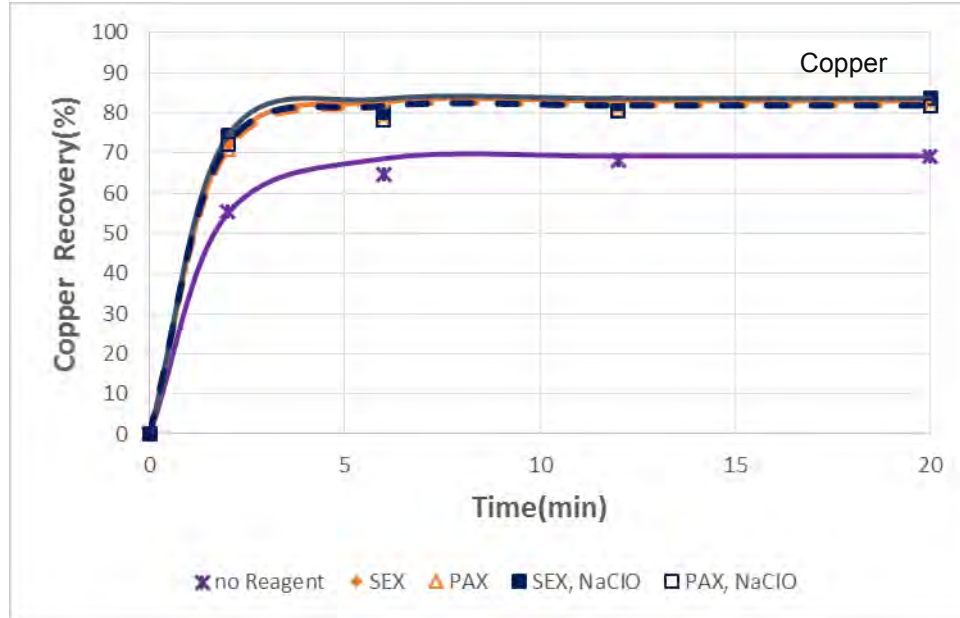

Figure 4-41: Flotation rate of copper at the pH 9

The results in Figure 4-41 show an overlap of the curves of the rate of flotation for copper under conditions in which the collectors were added. This is indicative of the fact that copper recovery was not significantly affected by the collectors.

The flotation rate constants,  $k$  values and the maximum possible recovery,  $R_{max}$  for copper under conditions in which collectors of different chain lengths were used are shown in Table 4-6.

Table 4-6: The rate of flotation ( $k$ ) and maximum recovery ( $R_{max}$ ) for copper recovery at pH 9 under conditions evaluated.

Conditions	Classical model constants	
	$k(\text{min}^{-1})$	$R_{max} (\%)$
No reagent	0.79	69
SEX	1.01	83
PAX	1	82
SEX, NaClO	1.10	84
PAX, NaClO	1.06	82

In Table 4-6, the k values were identical in the presence of collectors. It was observed that the flotation rate constants and the maximum possible recovery, obtained in absence of the collectors were lower than all other conditions tested.

#### 4.4.4.2.3 Nickel Flotation Performance

Figure 4-42 shows cumulative grade as a function of recovery for nickel in the absence and presence of collectors of different chain length at pH 9.

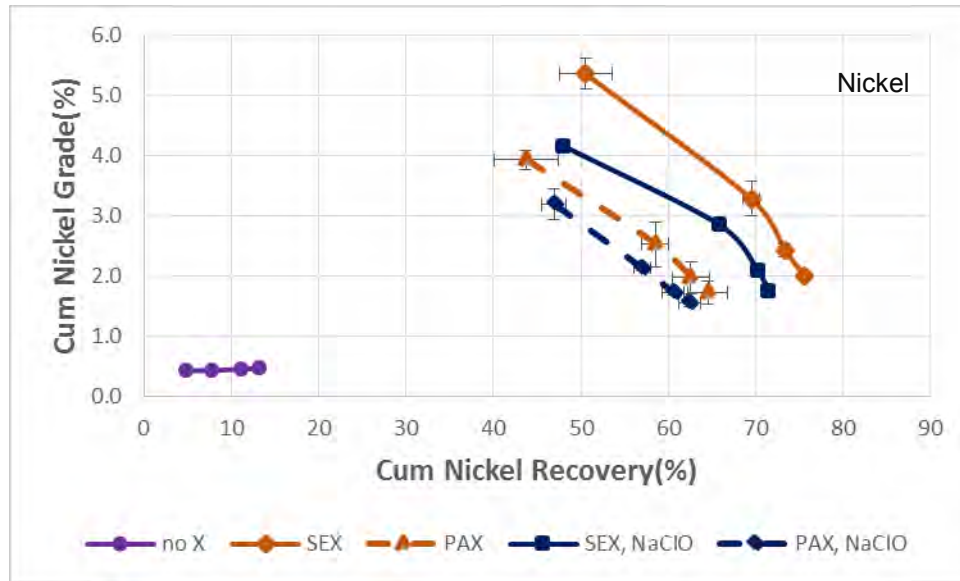

Figure 4-42: Nickel grade as a function of nickel recovery for nickel in the absence and presence of collectors of different chain length at pH 9.

The figure also highlights the large differences in nickel grade and recovery obtained at the various conditions. It is interesting to note that, the highest grade and recovery was obtained in the presence of a collector of shorter chain length (SEX) and the lowest in the absence of a collector.

Figure 4-43 shows results obtained from tests on the effect of collectors of different chain lengths on the rate of flotation of nickel at pH 9.

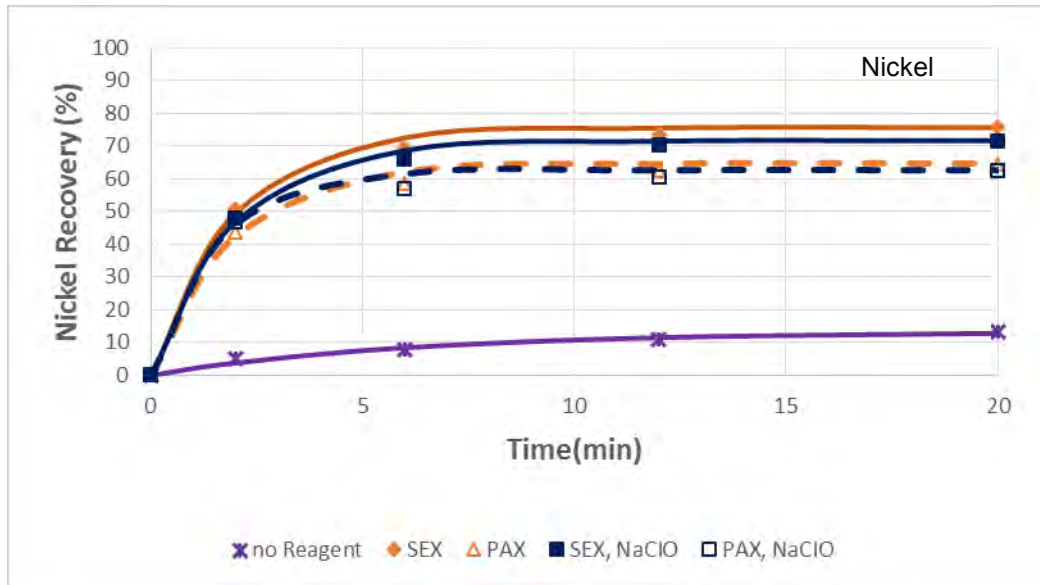

Figure 4-43: Flotation rate for nickel at pH 9

Table 4-7: The rate of flotation ( $k$ ) and maximum recovery ( $R_{max}$ ) for nickel recovery at pH 9.2 at shown conditions

Conditions	Classical model constants	
	$k(\text{min}^{-1})$	$R_{max}$ (%)
No reagent	0.17	13
SEX	0.53	76
PAX	0.54	65
SEX, NaClO	0.53	72
PAX, NaClO	0.67	62

The results in Figure 4-43 and Table 4-7, show that the lowest recovery of nickel was 13% and the best flotation performance was in the presence of SEX. The  $k$  values in the presence of collectors was an average of 0.53 except when PAX was added together with NaClO, in which the  $k$  value calculated was 0.67 and a  $R_{max}$  of 62%. This might imply a high rate of flotation of valuable mineral together with unwanted material.

#### 4.4.5 Comparison of different types of potential modifiers

Potential modifiers have different mechanisms of interaction with sulphide minerals during flotation. The aim of the comparison conducted using two modifiers, hydrogen peroxide ( $\text{H}_2\text{O}_2$ ) and sodium hypochlorite ( $\text{NaClO}$ ) was to determine the flotation behaviour obtained using the two different reagents during batch flotation tests.

H<sub>2</sub>O<sub>2</sub> at the same equimolar ratio as was used in NaClO tests was added. This was based on the 1% solution for NaClO which had a molarity of 0.13 M. The other reagents and the ore were as used previously and the same procedure was followed to conduct the batch flotation tests. The potential region achieved using H<sub>2</sub>O<sub>2</sub> was 300 – 400 mV. This was considered important as the potential range was different from that obtained when NaClO was used and could result in a different flotation response.

#### 4.4.5.1 Solids versus Water Recovery

Figure 4-44 shows the final solids and final water recovery in the absence and presence of collector SEX, and potential modifiers; H<sub>2</sub>O<sub>2</sub> and NaClO at pH 9.

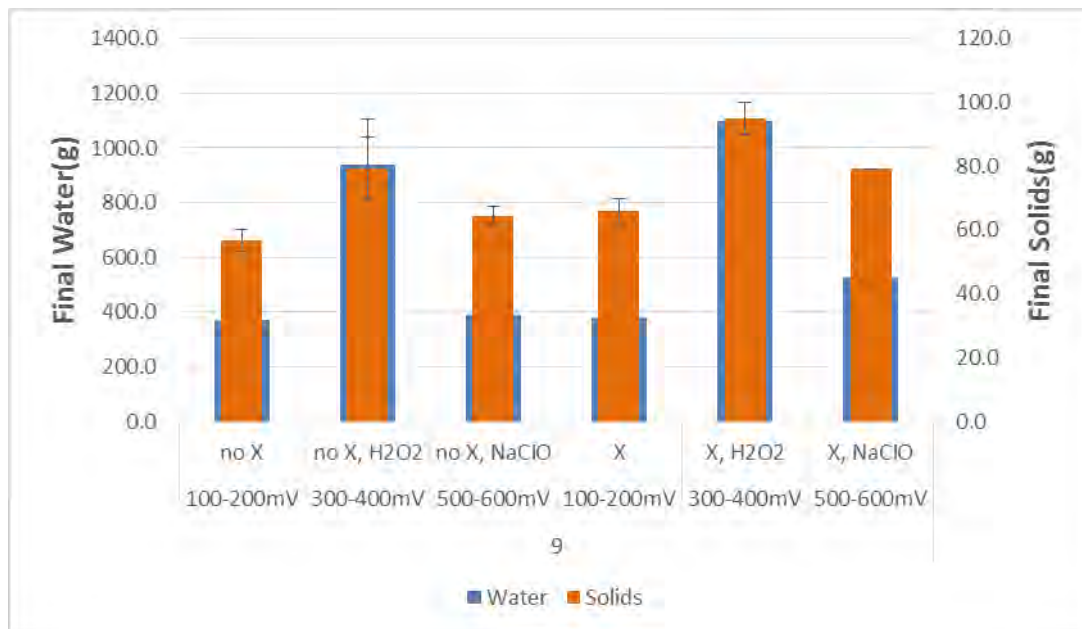

Figure 4-44: Final solids and final water recovery in the absence and presence of collector, SEX and potential modifiers; H<sub>2</sub>O<sub>2</sub> and NaClO at pH 9.

It can be observed that the presence of H<sub>2</sub>O<sub>2</sub>, whether added together with SEX or not, generally resulted in high solids and water recoveries in comparison to that obtained in the presence of NaClO. The highest amounts of solids and water recovered were respectively was 95 g and 1099 g in the presence of H<sub>2</sub>O<sub>2</sub> and SEX.

The solids and water recoveries in the absence and presence of collector, SEX and the different potential modifiers, are shown in Figure 4-45.

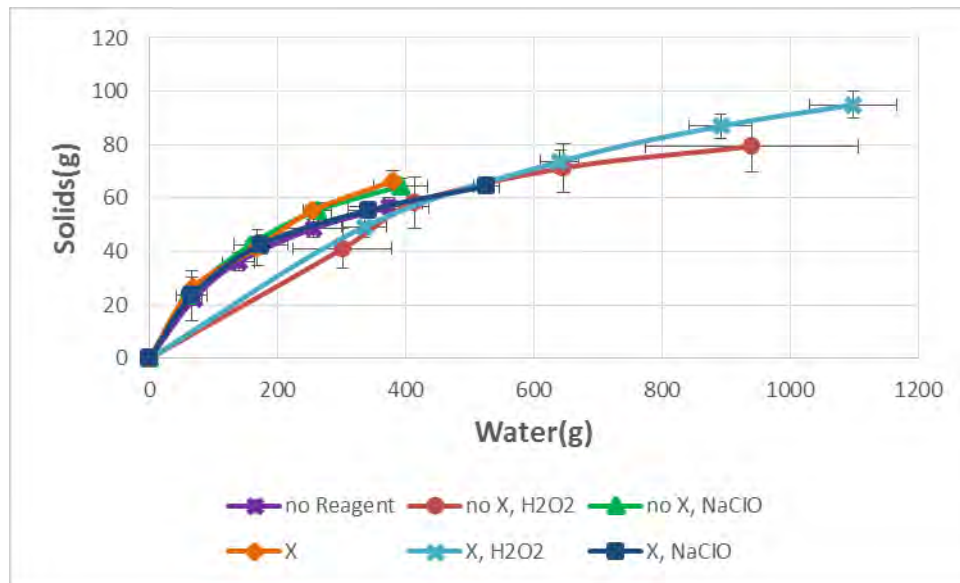

Figure 4-45: Solids recovery as a function of water recovery in the absence and presence of collector (SEX) potential modifiers; H<sub>2</sub>O<sub>2</sub> and NaClO at pH 9.

It can be clearly seen that the presence of H<sub>2</sub>O<sub>2</sub> had a great impact on the solids and water recovery. From the results in Figure 4-44 and Figure 4-45, it can be concluded that in collectorless and in collector induced flotation the amounts of solids and water recovered when using H<sub>2</sub>O<sub>2</sub> were higher than when using NaClO as a potential modifier.

#### 4.4.5.2 Valuable Mineral Recovery and Grade

Figure 4-46 shows the results for final recovery and final grade for copper and nickel in the absence and presence of SEX and the potential modifiers H<sub>2</sub>O<sub>2</sub> and NaClO.

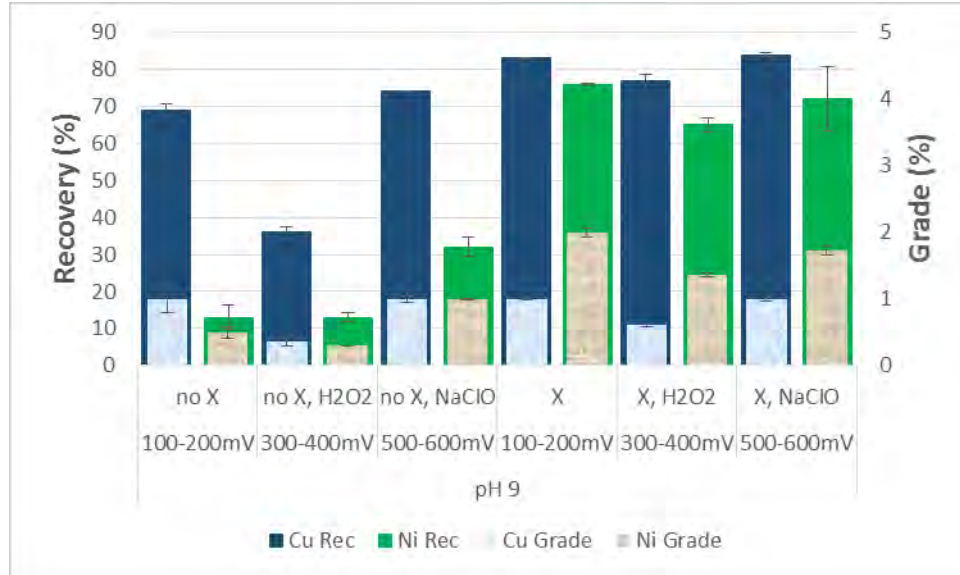

Figure 4-46: Final recovery and final grade for copper and nickel in the absence and presence of collector (SEX) and potential modifiers; H<sub>2</sub>O<sub>2</sub> and NaClO at pH 9.

It is surprising to note that under the oxidizing conditions using H<sub>2</sub>O<sub>2</sub>, the lowest recovery of 36% for copper was obtained. Chalcopyrite is known to be a fast-floating mineral hence the flotation response in collectorless and the presence of H<sub>2</sub>O<sub>2</sub>, was quite unusual. The results in Figure 4-46 also indicate that nickel recovery was very poor in collectorless flotation, regardless of the addition of H<sub>2</sub>O<sub>2</sub> and NaClO, with all the values below 32%.

In collector induced flotation the recoveries for copper decreased from 83% to 77% when H<sub>2</sub>O<sub>2</sub> was added. The addition of NaClO resulted in no significant differences in copper recovery in the presence of collector. The grades for copper were significantly affected by the presence of H<sub>2</sub>O<sub>2</sub> with the lowest grade value of 0.39% obtained in the absence of collector. Nickel showed the same trend as copper in the collector induced experiments. Grade is affected more by the amount of solids recovered and as shown in Figure 4-44, H<sub>2</sub>O<sub>2</sub> addition resulted in recovery of more solids than when NaClO was used.

#### 4.4.5.2.1 Copper Flotation Performance

Results for cumulative copper grade as a function of copper cumulative recovery are shown in Figure 4-47.

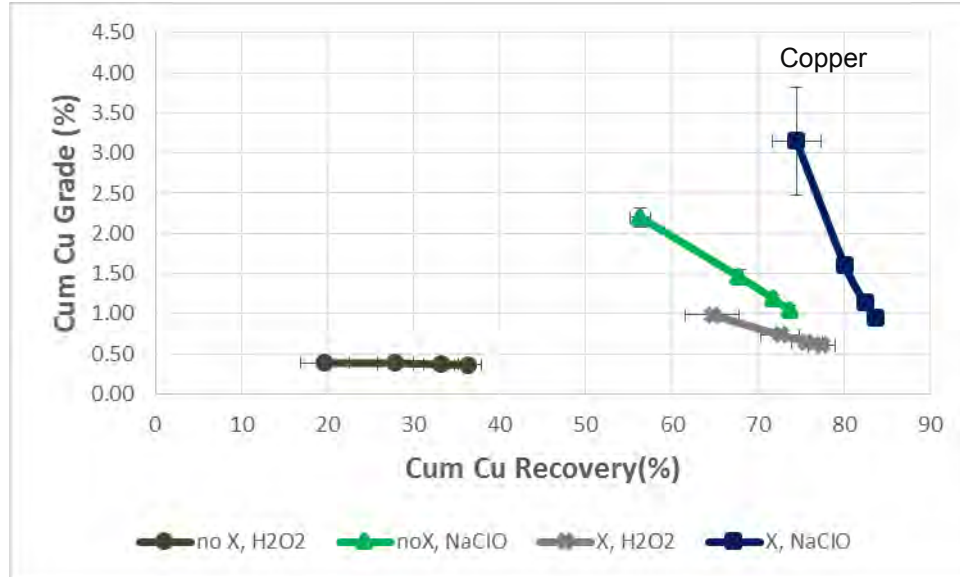

Figure 4-47: Copper grade as a function of copper recovery in the absence and presence of collector, (SEX) and potential modifiers; H<sub>2</sub>O<sub>2</sub> and NaClO at pH 9

The highest copper recoveries and grades were obtained for tests in which a collector together with NaClO were added. When H<sub>2</sub>O<sub>2</sub> was added in the absence of a collector the lowest grades and recoveries were obtained. In comparison of the potential modifiers the sodium hypochlorite exhibited a better flotation performance than hydrogen peroxide at the equimolar dosage used during the tests.

Figure 4-48 shows the recoveries of copper as a function of time in the presence of different types of potential modifiers at pH 9.

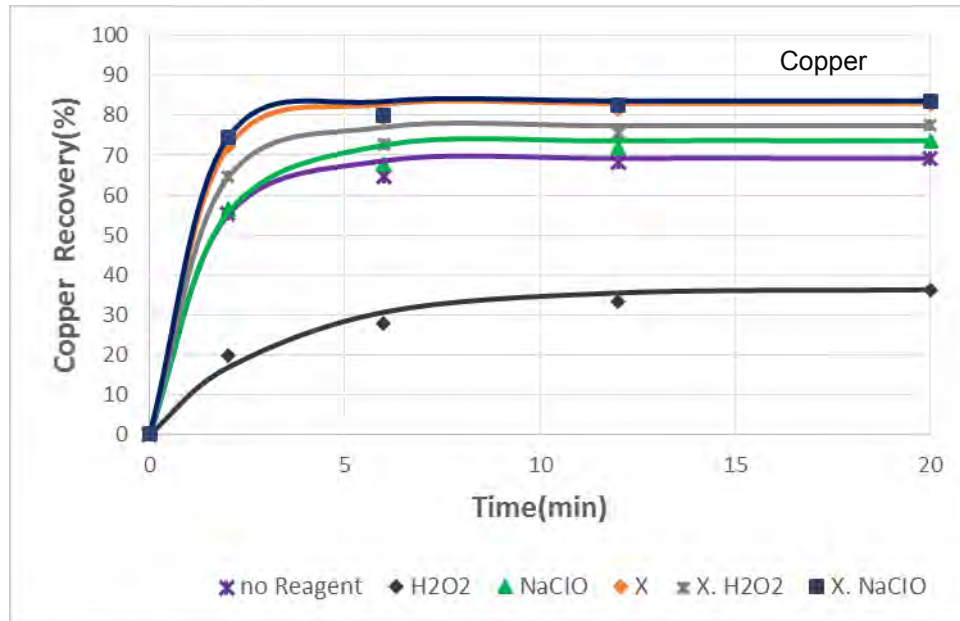

Figure 4-48: Flotation rate of copper at the pH 9

Table 4-8 shows the flotation rate constants,  $k$  values and maximum possible recovery,  $R_{max}$  for copper at pH 9 in the absence and presence of different types of modifiers.

Table 4-8: The rate of flotation ( $k$ ) and maximum recovery ( $R_{max}$ ) for copper recovery at pH 9 at conditions evaluated.

Conditions	Classical model constants	
	$k(\text{min}^{-1})$	$R_{max} (\%)$
No reagent	0.79	69
H <sub>2</sub> O <sub>2</sub>	0.31	36
NaClO	0.70	74
X	1.01	83
X. H <sub>2</sub> O <sub>2</sub>	0.89	77
X. NaClO	1.10	84

The  $k$  values for copper in the absence of a collector were lower than when compared to conditions in which the collector was present. The lowest was 0.31 obtained in the presence of H<sub>2</sub>O<sub>2</sub> where corresponding for copper was 36%. The presence of a collector resulted in generally high  $k$  values and maximum possible recoveries for copper.

#### 4.4.5.2.2 Nickel Flotation Performance

Figure 4-49 show the results for nickel cumulative grade against cumulative recovery.

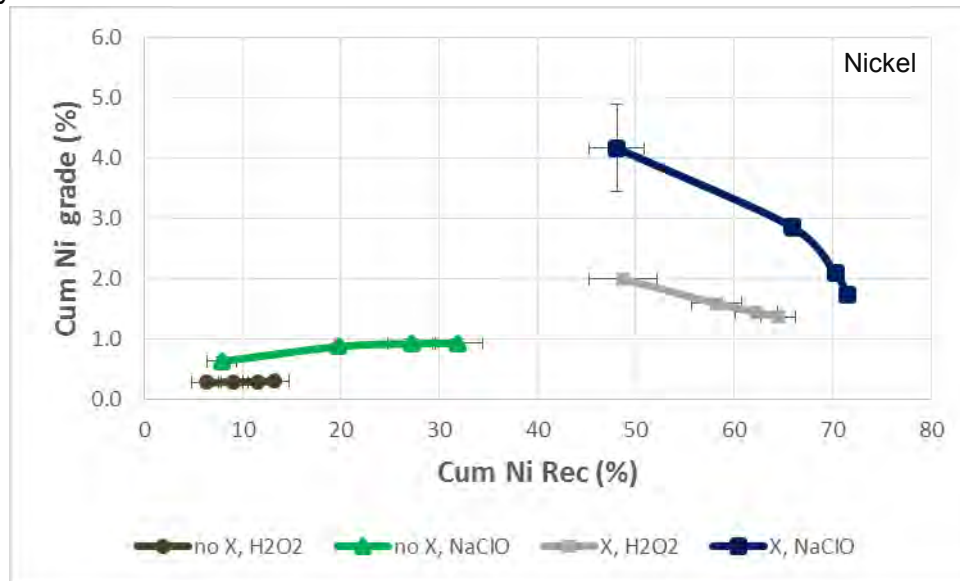

Figure 4-49: Cumulative nickel grade versus cumulative nickel recovery in the absence and presence of collector, SEX and potential modifiers; H<sub>2</sub>O<sub>2</sub> and NaClO at pH 9 for Merensky ore.

The experimental conditions were in the absence and presence of collector, SEX and potential modifiers; H<sub>2</sub>O<sub>2</sub> and NaClO at pH 9 for Merensky ore. It can be observed that the curves for copper in Figure 4-47 are closely following each other, except the condition where there was no collector added and in the presence of H<sub>2</sub>O<sub>2</sub> as modifier. The grade – recovery curves for nickel in Figure 4-49, are more scattered when compared to those for copper. The results in Figure 4-49 supports the previous findings that nickel shows high grades and recoveries only under the conditions when a collector was present.

Figure 4-50 shows the nickel recoveries versus time in the presence of different types of potential modifiers at pH 9.

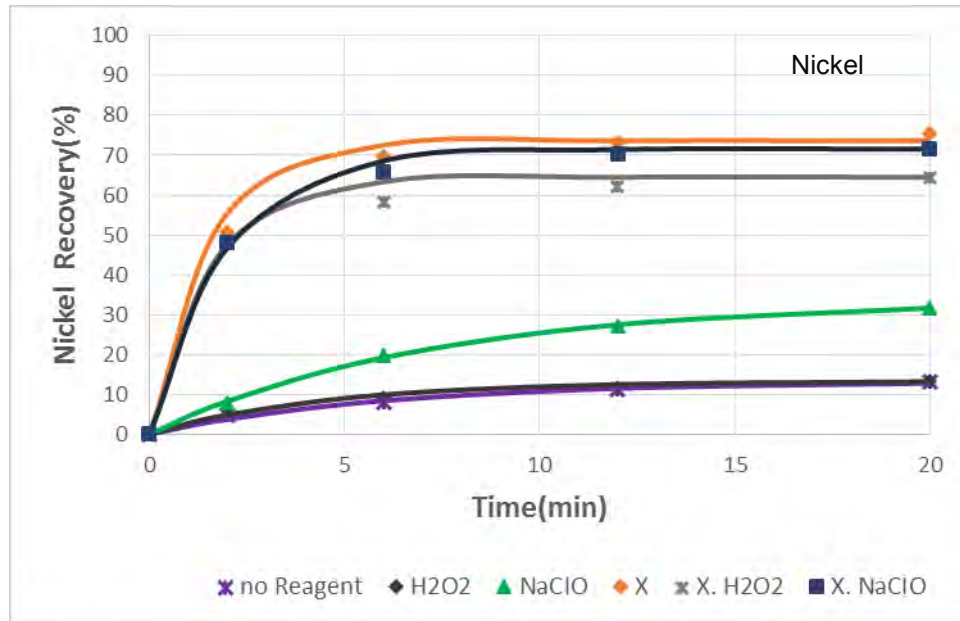

Figure 4-50: Flotation rate for nickel at pH 9

The flotation rate constants, values and maximum possible recovery,  $R_{max}$  for nickel in the presence of different types of potential modifiers at pH 9 are shown in Table 4-9.

Table 4-9: The rate of flotation ( $k$ ) and maximum recovery ( $R_{max}$ ) for nickel recovery at pH 9 at shown conditions

Conditions	Classical model constants	
	$k(\text{min}^{-1})$	$R_{max}$ (%)
No reagent	0.17	13
H <sub>2</sub> O <sub>2</sub>	0.23	13
NaClO	0.14	34
X	0.53	76
X, H <sub>2</sub> O <sub>2</sub>	0.67	65
X, NaClO	0.53	72

The results show higher recoveries in conditions where a collector was present than when it was absent. The potential modifiers did not show any significant impact on the recovery of nickel during the flotation process.

#### 4.4.6 Effect of addition of trace amounts of Hydrogen Peroxide (H<sub>2</sub>O<sub>2</sub>)

There exists anecdotal evidence that the addition of trace amounts of a potential modifier may result in improved flotation performance. Preliminary tests were conducted in which the concentration of H<sub>2</sub>O<sub>2</sub> was changed and the effect on the flotation variables analysed.

##### 4.4.6.1 Solids versus Water Recovery

Shown in Figure 4-51, are the final solids and water recoveries obtained for tests in which the concentration of H<sub>2</sub>O<sub>2</sub> was varied.

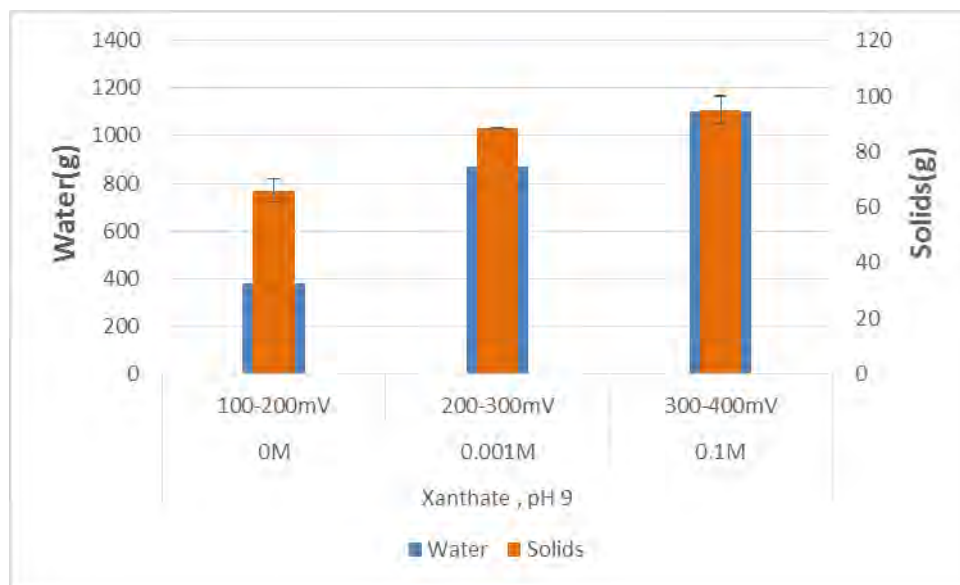

Figure 4-51: Final water and solids recoveries with change of concentration of H<sub>2</sub>O<sub>2</sub> in the presence of SEX at pH 9.

An increase in H<sub>2</sub>O<sub>2</sub> concentration caused an increase in both solids and water recoveries. It can also be observed that a change in H<sub>2</sub>O<sub>2</sub> concentration caused changes to the Eh values, where the Eh at a concentration of 0.1 M resulted in a potential of 300 – 400 mV while at the lower concentration the Eh observed was in the region of 200 – 300 mV. The results in Figure 4-51, are consistent with results shown earlier, where an increase in the Eh resulted in an increase in both the solids and water recovery.

The solids and water recovery curves when the concentration of H<sub>2</sub>O<sub>2</sub> was varied are shown in Figure 4-52.

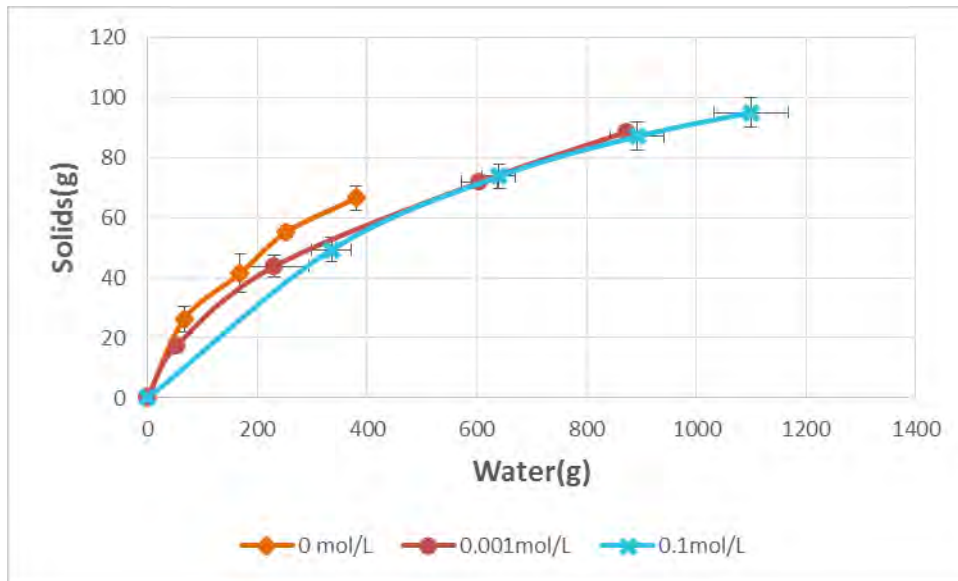

Figure 4-52: Solids recovery as a function of water recovery with change of concentration of H<sub>2</sub>O<sub>2</sub> in the presence of SEX at pH 9.

At a concentration of 0.1 M (H<sub>2</sub>O<sub>2</sub>), the highest amount of solids obtained was 95 g which was 7% more than that obtained at a concentration of 0.001 M. The water recovery was far higher in the presence of the higher concentration of H<sub>2</sub>O<sub>2</sub> with the difference in recovery between the two concentrations being 26%. At the higher concentration the amount of solids and water were high and this can possibly be due to stabilization of the froth phase.

#### 4.4.6.2 Valuable Mineral Recovery and Grade

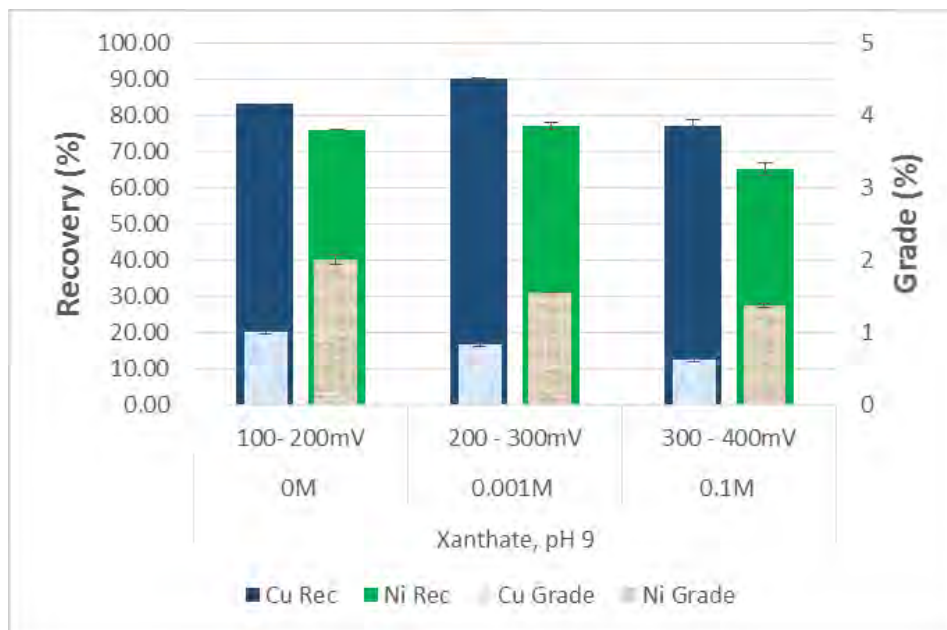

Figure 4-53: Final recovery and final grade for copper and nickel obtained at different concentrations of H<sub>2</sub>O<sub>2</sub> at pH 9.

The results in Figure 4-53 show the final recovery and final grade for copper and nickel in the presence of SEX at different concentrations of  $H_2O_2$  at pH 9. It is shown that there is a decrease in grade for both copper and nickel as the concentration of  $H_2O_2$  is increased. Nickel recovery follows this same decreasing trend, however copper recovery appears to reach a maximum at the intermediate  $H_2O_2$  concentration.

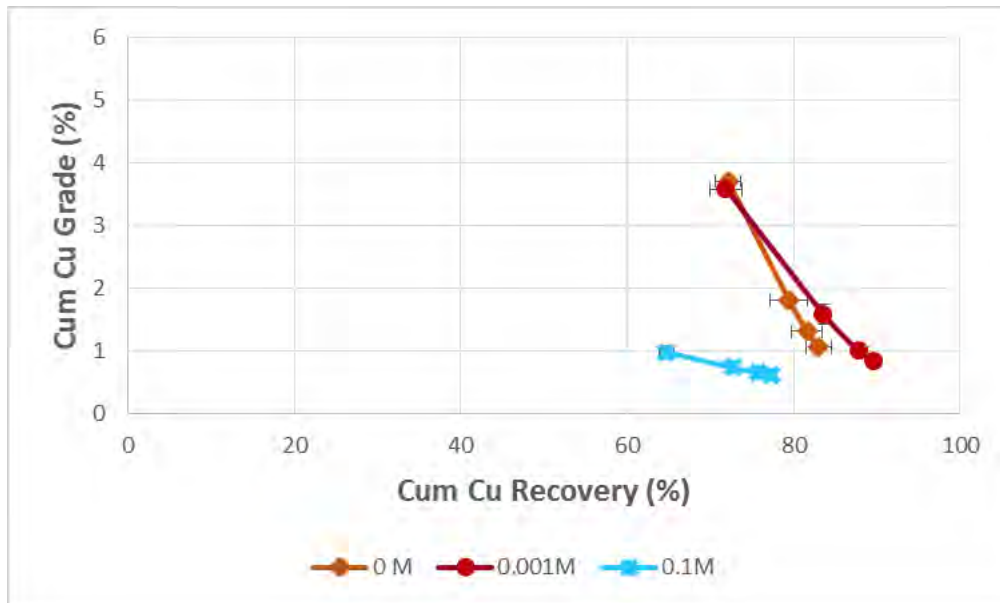

Figure 4-54: Cumulative copper grade versus cumulative copper recovery obtained at different concentrations of  $H_2O_2$  at pH 9 for Merensky ore.

Figure 4-54 are the results for cumulative copper grade as a function of copper cumulative recovery under the conditions evaluated. It is clear that the best recovery is found with the intermediate  $H_2O_2$  concentration, while the best grade is found when no  $H_2O_2$  is added.

Figure 4-55 are the results for cumulative nickel grade as a function of nickel cumulative recovery under the various conditions evaluated. Here it is clear that the best grade is found when no H<sub>2</sub>O<sub>2</sub> is added, while the best recovery is given when only a trace amount, 0.001 M, of H<sub>2</sub>O<sub>2</sub> is added.

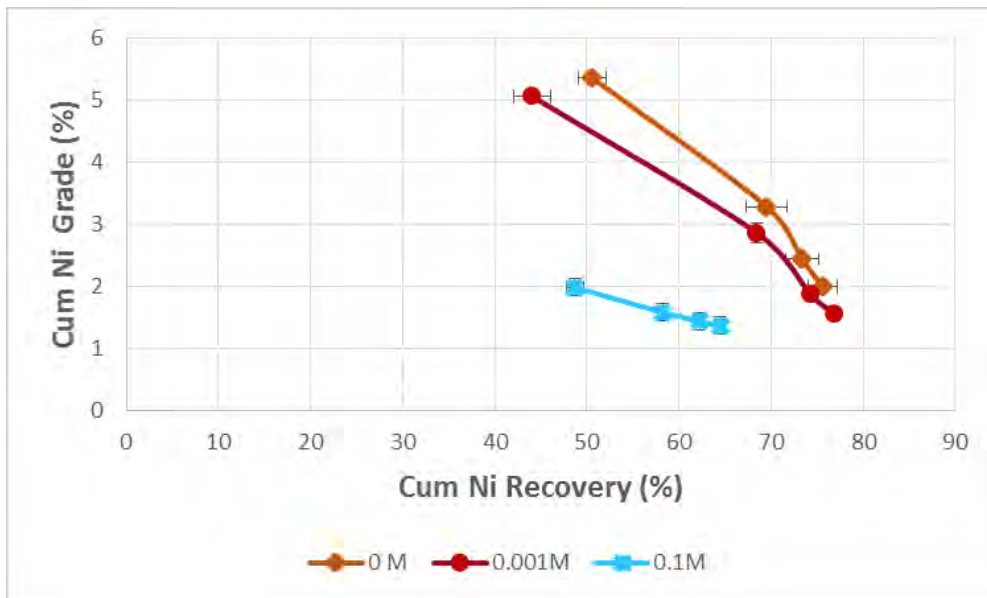

Figure 4-55: Cumulative copper grade versus cumulative nickel recovery obtained at different concentrations of H<sub>2</sub>O<sub>2</sub> at pH 9 for Merensky ore.

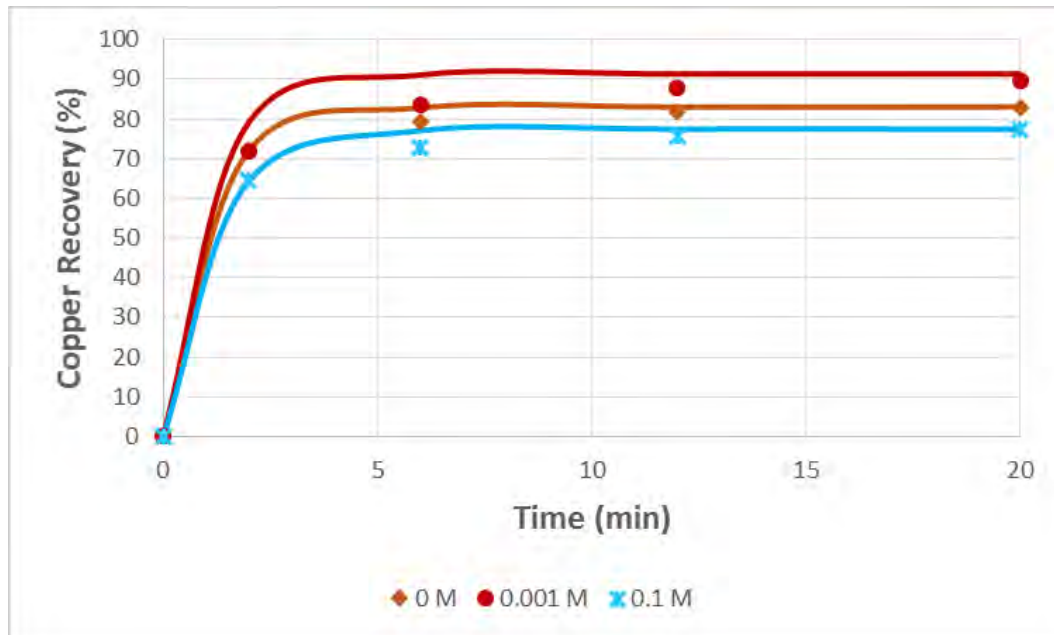

Figure 4-56: Flotation rate for copper at pH 9.

The results for copper recovery as a function of time are shown in Figure 4-56.

The k values and the maximum possible recoveries ( $R_{max}$ ) for copper at pH in varying concentrations of H<sub>2</sub>O<sub>2</sub> are shown in Table 4-10.

Table 4-10: The rate of flotation constants ( $k$ ) and maximum recovery ( $R_{max}$ ) for copper recovery at pH 9 under conditions of varying concentration for  $H_2O_2$ .

Concentration of $H_2O_2$ (M)	Classical model constants	
	$k(\text{min}^{-1})$	$R_{max}$ (%)
0	1.00	83
0.001	1.00	91
0.1	0.89	77

It can be seen from the results in Figure 4-53 and Figure 4-54 that there was a high recovery of copper to 90 % when trace amounts of  $H_2O_2$  were added. Comparing the tests in which there was no potential modifier added (0 M) and 0.001 M  $H_2O_2$ , there was a slight change of grade from 1.06% to 0.83 %. However, under the same conditions the flotation rate constants were similar as shown in Table 4-10. Addition of the small quantity of  $H_2O_2$  (0.001 M), improved the flotation rate, when compared to when 0.1 M was added.

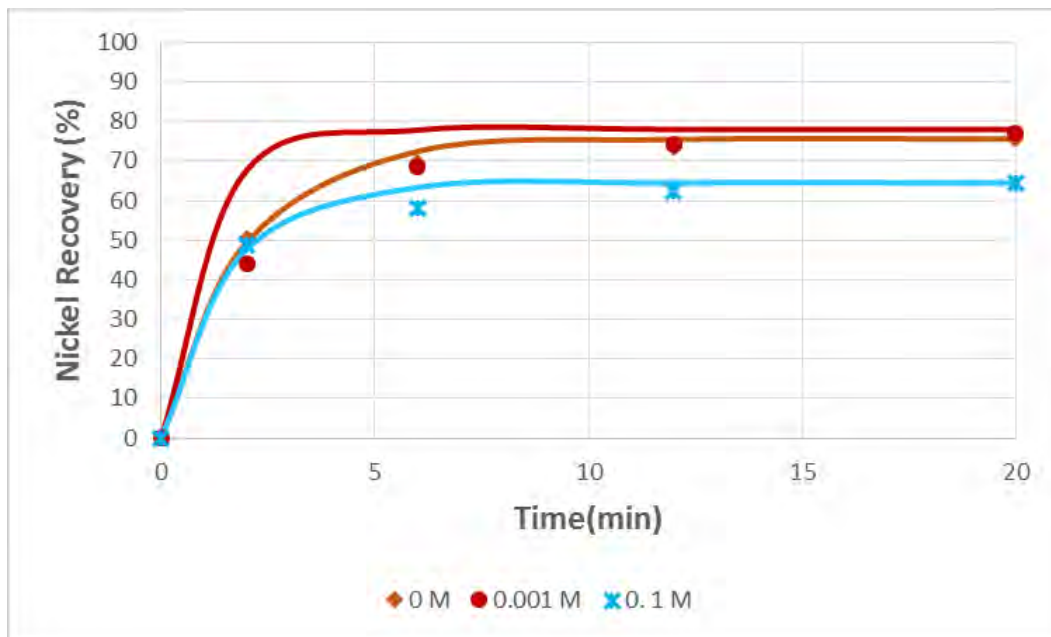

Figure 4-57: Flotation rate for nickel at pH 9

The results for the recovery of nickel as a function of time are shown in Figure 4-57. The  $k$  values and the maximum possible recoveries ( $R_{max}$ ) for nickel at pH in varying concentrations of  $H_2O_2$  are shown in Table 4-11.

*Table 4-11: The rate of flotation constants (k) and maximum recovery (R<sub>max</sub>) for nickel recovery at pH 9 under conditions of varying concentration for H<sub>2</sub>O<sub>2</sub>*

Concentration of H <sub>2</sub> O <sub>2</sub> (M)	Classical model constants	
	k(min <sup>-1</sup> )	R <sub>max</sub> (%)
0	0.53	76
0.001	1.00	78
0.1	0.67	65

The results for nickel flotation performance in Figure 4-53 and Figure 4-55, show that in the presence of SEX alone (0.1 M), the final recovery obtained was 76% and final grade of 2%, and the addition of 0.001 M H<sub>2</sub>O<sub>2</sub> caused a slight increase in the final recovery to 77% and a decrease in the final grade to 1.55%. It was observed that at 0.1 M H<sub>2</sub>O<sub>2</sub> the lowest recovery was obtained.

The addition of H<sub>2</sub>O<sub>2</sub> could lead to the presence of sulphate species at the mineral surface and these have a direct effect on the floatability of the wanted minerals. It is worthwhile to mention that this study was an electrochemical investigation using techniques that predict surface reactions and the likely product species that are formed at the sulphide mineral surface. It however did not characterise the exact type of species that were being formed at the surface which is a phenomena that can be carried out by other techniques such as XPS and FTIR.

#### **4.5 Effect of Eh on Gangue Recovery**

Microflotation tests were conducted to investigate the effect of potential control using NaClO as chemical oxidizing reagent on the recovery of gangue minerals. Since talc is one of the gangue minerals present in Merensky ore, it was chosen as the gangue mineral for the purpose of this investigation. The surface coverage in the condition where a collector was used was 50% coverage and the amount of oxidant (NaClO) added was the same as in the rest potential measurements. The tests were conducted in synthetic plant water at pH 9.

##### **4.5.1 Talc Recovery**

The classical model was fit to the experimental data to investigate the flotation performance of talc. Figure 4-58 shows the results for talc recovery in SPW under different conditions

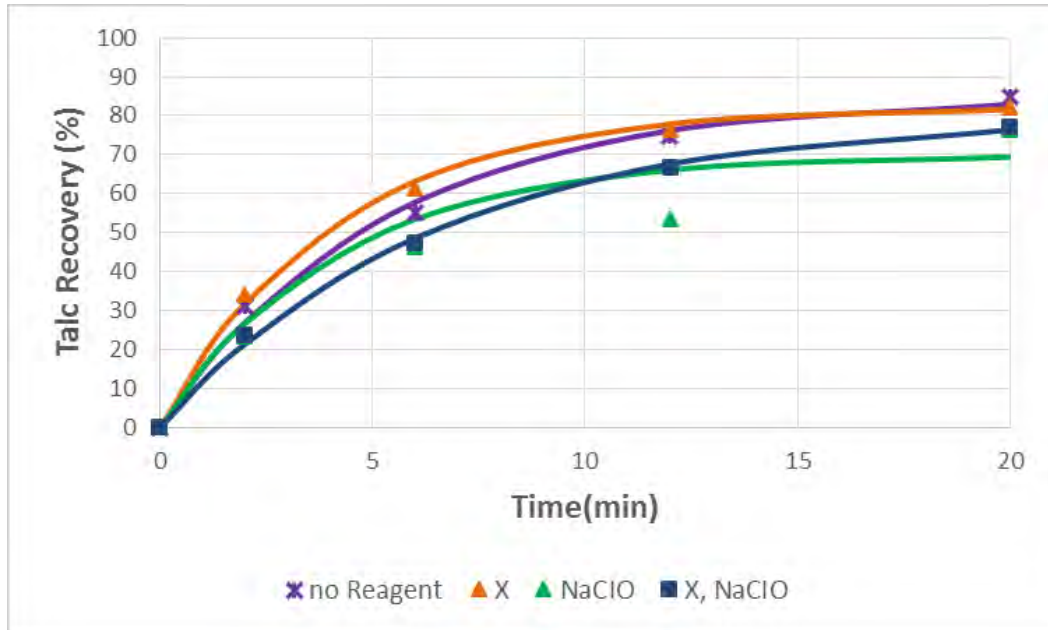

Figure 4-58: Talc recovery as function of time under different conditions

The curves in Figure 4-58 show a similar trend and it is also interesting to note that the oxidizing reagent (NaClO) did not have a significant impact in terms of increasing talc recovery. The highest talc recovery was 85% in the absence of any reagent. According to these results the oxidant might be causing some depressing action of the non-valuable mineral (talc) as indicated by the lowest recovery of 70% obtained in this test.

### 4.5.2 Rate Constants

Table 4-12 shows the flotation rate constants,  $k$  and the maximum possible recovery,  $R_{max}$  as the two parameters of the classical model used to analyse talc recovery under the conditions shown.

*Table 4-12: The rate of flotation ( $k$ ) and maximum recovery ( $R_{max}$ ) for talc recovery at pH 9 at shown conditions*

Conditions	Classical model constants	
	$k(\text{min}^{-1})$	$R_{max}$ (%)
No reagent	0.19	85
X	0.24	82
NaClO	0.24	70
X, NaClO	0.16	80

The rate constants range between 0.1 – 0.3 which is a very low range and the maximum possible recoveries of talc are relatively high if one considers that the values are greater than 50% under the conditions investigated. These results provide an understanding of how talc can readily float, when such low  $k$  values correspond to the high possible recoveries calculated using the model.

## Chapter 5

### 5 Discussion

#### 5.1 Introduction

This study was aimed at relating electrochemical properties to flotation of sulphide minerals. Sulphide minerals when in solution form a potential, hence it is proposed that the mixed potential theory would provide an insight into the changes that would occur when surface potentials are changed by chemical means. The results obtained in this study will be discussed in this Chapter using an electrochemical approach.

During the flotation of sulphide minerals the anodic and cathodic processes which produce the mixed potential involve various species reacting to form different products in a mixed mineral system. The chemical conditions existing in a flotation system at a particular instance will determine the nature of the species present and thus the effectiveness of the process of separation by flotation. As has been alluded to earlier, the most common cathodic process in such a system is the reduction of oxygen at the mineral surface (Equation 5-1).



In addition to oxygen reduction, it is also possible to have other oxidizing agents present which may result in making the minerals more floatable (Somasundaran, 1987; Kocabağ and Güler, 2007). Moreover, additional electrochemical reactions can occur by the addition of such oxidizing or reducing agents. This results in driving reactions in a certain direction and thus possibly influencing the flotation response of the sulphide minerals. Sodium hypochlorite (NaClO) or hydrogen peroxide (H<sub>2</sub>O<sub>2</sub>) are examples of oxidizing reagents that undergo a cathodic reaction and can potentially play a role in promoting the flotation of the minerals. They cause an increase in potential through an over-potential, which is a result of a shift away from the mixed or rest potential value. It is the magnitude of the over-potential which has a direct impact on the rates of the oxidation processes and influences the flotation response of sulphide minerals (Kocabağ and Güler, 2008). The discussion of the results is presented with a view to addressing the key questions set out in this study.

## 5.2 Oxidation Potentials of collectors

The first key question which this study aimed to address was to determine the effect of collector alkyl chain length on the oxidation potential of collectors when they interact with sulphide mineral surfaces.

The validation of the experimental technique used in this study to measure open circuit potentials was the same as that described by Tadie (2015), in which it was shown that the system used and the measurements made are reliable and accurate. In this study, the method used to determine the oxidation potentials for the thiol collectors, viz. sodium ethyl xanthate (SEX) and potassium amyl xanthate (PAX), has already been described in Section 4.2.

The thiol collectors SEX and PAX have different alkyl chain lengths and were compared in terms of their adsorption potentials on interaction with mineral surfaces. SEX has an oxidation potential i.e. 150 mV (Tadie, 2015), and this is higher than that of PAX obtained in this study, viz. 100 mV (Table 4-1). These oxidation potentials are indicative of potentials above which the collectors can undergo dimerization. The differences observed imply that PAX can easily undergo oxidation to the dimer (amyl dithiolate), as this occurs at a lower potential than SEX which forms the dimer (ethyl dithiolate). This result is consistent with literature in which it has been shown that an increase in the number of carbon atoms of the alkyl group results in a decrease in the potential of the xanthate/dixanthogen ( $X^-/X_2$ ) couple (Majima and Takeda, 1968).

A study by Finkelstein and Poling (1977), confirmed that the increase in chain length by the addition of an extra methylene group causes the standard potential to fall by a constant factor. What is of importance is the difference between the oxidation potential of the collector and the rest potential which a sulphide mineral has in solution. Therefore a collector of longer chain length would interact with the sulphide mineral surface at lower potentials than a shorter chain length. The reason for this may be related to the fact that the longer alkyl chain may have a stronger inductive effect which would increase the electron density on the xanthate ligand. A higher electron density on the reacting head of the collector means an increase in the number of electrons participating in the electrochemical reaction of dimerization.

### 5.3 Effect of collector chain length

The second key question addresses the relationship between collectors of different alkyl chain length and the flotation recoveries and grades when they are used in the flotation of the same sulphide minerals.

Rest potential measurements were conducted in the absence and in the presence of collectors with different alkyl chain lengths. This was followed by batch flotation tests to determine whether there was a relationship between chain length and recovery under the conditions evaluated. The results for the rest potential profiles for chalcopyrite in the absence and presence of collectors of different chain length are shown in Figure 4-3. In the absence of a collector chalcopyrite undergoes oxidation, and Equations 5-2 and 5-3, have been proposed to occur under alkaline conditions (Kocabağ and Güler, 2008):

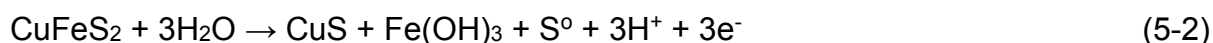

The reaction products such as CuS and elemental S<sup>0</sup> are the species that can impart hydrophobicity, as they are expected to be stable at potentials shown in Figure 4-3. The rest potential profiles in the absence of a collector show oxidation of the mineral, and on xanthate addition there was a decrease in potential. The anodic oxidation of the collector causes the potential to decrease because the oxidation potential of the xanthate-dixanthogen couple which is typically in the region of 150 mV (Allison et al, 1972), is cathodic relative to the rest potential of the mineral since most sulphide minerals have rest potentials greater than about 200 mV (Allison et al, 1972).

The rest potential profiles of sulphide minerals in the presence of SEX and PAX at pH 9 as well as the oxidation potentials for the pure SEX and PAX systems are shown in Figure 5-1. It is important to note the magnitude of potential decrease caused by the different collectors on different mineral surfaces. The results for chalcopyrite (Cp), pentlandite (Pn) and pyrite (Py) all show significant differences in potential as a result of their interactions with SEX and PAX. However in the case of pyrrhotite (Po) there is hardly any decrease in the potential when collectors are added to the system.

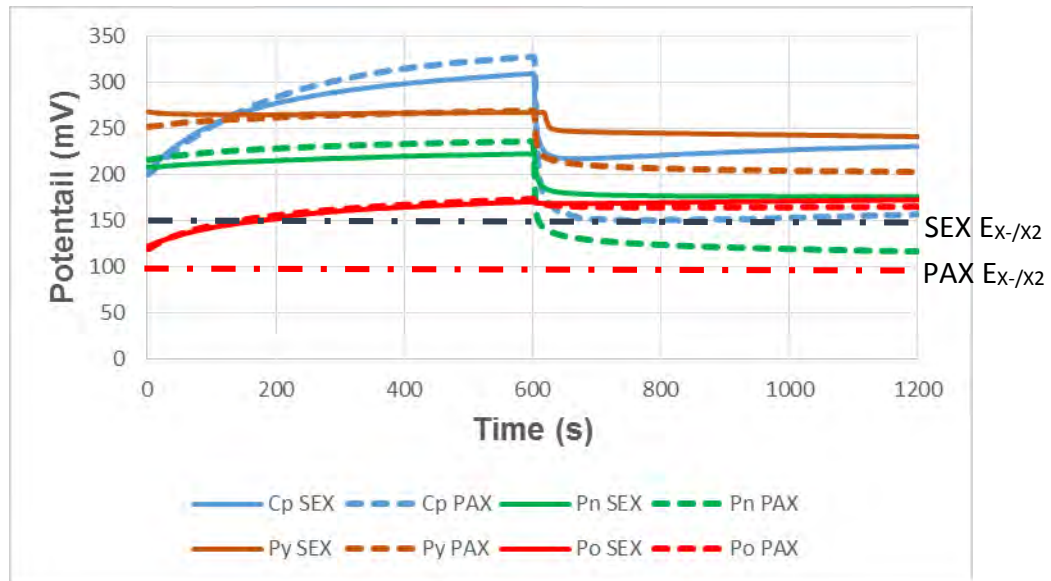

Figure 5-1: The rest potential profiles of sulphide minerals in the presence of collectors, SEX and PAX at pH 9. The oxidation potentials of the collectors are also shown.

The differences in the decrease of the potential at the sulphide mineral surfaces after the addition of either SEX or PAX, were in the following order: chalcopyrite > pentlandite > pyrite > pyrrhotite. The final recoveries for chalcopyrite and pentlandite mirrored this order of the potential decrease on collector interaction. Different species formed at the surface have different adsorption potentials and the solubilities of these products also differ with the type and chain length of the collectors employed (Finkelstein and Poling, 1977).

On all minerals studied with reference to the interaction with PAX, which has already been described as having an oxidation potential of 100 mV, dixanthogen (in this case amyl dithiolate) was likely to form since the rest potentials were always greater than 100 mV, although in the case of pentlandite it is close to 100 mV. Considering SEX, with an oxidation potential of 150 mV, dixanthogen (ethyl dithiolate) is likely to form on chalcopyrite and pyrite. Pentlandite final rest potentials lie below the  $X/X_2$  line for SEX and this observation would infer that metal xanthates could be forming on pentlandite and not dixanthogen.

The likelihood of dimer formation on pyrrhotite was questionable since, although the potential value is greater than the potential associated with dimer formation there was almost no change in potential after the collector was added (Figure 4-14). Pyrrhotite is the least noble mineral of those considered in this study. Its behaviour can be

attributed to the fact that the mineral is not stable and is easily oxidizable forming iron oxy/sulphoxy species which can be present at the surface (Buswell and Nicol, 2002b). In literature it was proposed that, the interaction of the collector and the mineral surface also depends on the electro-catalytic ability of an individual mineral to facilitate the oxygen reduction (Rand and Woods, 1984). Collector oxidation requires a catalyst to drive the reduction reaction of oxygen and these results seem to indicate that pyrrhotite is a poor promoter of oxygen reduction (Equation 5-1).

The use of a collector of a shorter chain length, is generally well known to result in higher recoveries of valuable minerals than a longer alkyl chain length. In the testwork conducted, it was observed that more solids and water were obtained with an increase in chain length from SEX to PAX (Figure 4-37), thus implying that the froth is more stable and this is similar to the observation made by Zheng et al. (2006). In an investigation by Bradshaw et al. (2005), they showed lower solids and water recoveries with the increase in chain length i.e. SEX to Sodium iso-butyl xanthate; (SIBX). In the same study, enhanced recoveries of sulphide minerals were obtained using SEX in comparison to SIBX.

According to the rest potentials observed in this study, PAX was expected to oxidize more easily to the dimer, thus possibly resulting in a higher degree of hydrophobicity and a possible improvement in floatability. However, it was observed in this study (Figure 4-39), that the recoveries and grades for copper were largely unchanged. In the case of nickel the recoveries decreased by an average of 7% and no significant changes to the grades were noted. Other studies on the effect of chain length on sulphide minerals recovery were conducted by Mbonambi (2009), who observed a higher flotation rate with increase in chain length.

In another study by Wiese (2009), no significant effect was found on the recovery of sulphide minerals arising from changes to xanthate alkyl chain length. The difference in flotation responses can also be due to other factors such as froth stability which could be playing a role on the observed final recoveries of the valuable minerals. Froth stability was not investigated in this study. These results thus indicate that it was not possible to infer the floatability of an ore on the basis of its propensity to promote the formation of the xanthate dimer which is generally considered to increase the hydrophobicity of the mineral.

#### 5.4 Effect of pH

The third key question addressed in this study was to investigate the effect of changing pH on the rest potentials of the sulphide minerals and the subsequent species forming at the mineral surface.

A change in pH has an impact on the surface charge properties of minerals thus affecting the behaviour of both hydrophilic and hydrophobic minerals (Wills and Napier-Munn, 2006). In this study, the change of pH from 9 to 11 resulted in a shift of the mixed/rest potentials of all the sulphide minerals in the cathodic direction. It is likely that such a shift might be due to the fact that, a change of pH causes a change of potential as shown in Equation 5-4 (Pourbaix, 1966).

$$E = E^{\circ} - pH \quad (5-4)$$

Where E is the equilibrium potential and  $E^{\circ}$  is the standard potential.

Chalcopyrite rest potential profiles shown in Figure 4-4, at pH 9 and pH 11, have a similar behaviour with the only difference being the initial and final rest potentials in the absence and presence of the collector at the two pH values. It can thus be deduced from such results that similar reactions may be occurring at the chalcopyrite surface in the alkaline pH range. The potentials are above the dixanthogen formation potential line and thus dixanthogen will be the thermodynamically preferred species adsorbing at the mineral surface at the two pH values.

Figure 4-8 shows that an increase of pH from 9 to 11, caused a decrease in the potential of the pentlandite. There was also a decrease in the extent of interaction between the collector and the pentlandite surface as pH increases. This may be due to the formation of a hydroxyl species at higher pH values which would inhibit the collector-mineral interaction and thus lower the minerals hydrophobicity. This observation is similar to that reported by Buswell et al. (2002a).

On the other hand, pyrite showed minimal changes to the final rest potential profiles after collector addition when pH was increased (Figure 4-12). The oxidation of pyrite in alkaline conditions can proceed as in Equation 5-5 or 5-6:

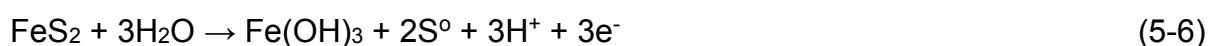

Kocabağ and Güler (2008), suggested that the yield of sulphate in Equation 5-5, can increase with increasing pH with no major changes occurring to the electrochemical behaviour of the pyrite mineral electrode. The potentials occurring in the present case are consistent with the formation of dixanthogen (Equation 5-7).



Yoon and Basilio (1983) have also reported that for the same system at pH 9 dixanthogen is most probably formed.

In the case of pyrrhotite it was observed that the dixanthogen formation line lie between the rest potential profiles of pyrrhotite at pH 9 and pH 11 respectively (Fig. 4-15), although the differences between these potential values were very small. The results have shown that it is unlikely that dixanthogen will form for this system. It can be concluded from these results, that a change in pH causes different variations in the potential responses for different sulphide minerals when in contact with a collector.

### 5.5 Effect of oxidizing reagent on rest potentials of sulphide minerals

The final key question addressed in this study was to determine to what extent the control of potential using chemical means affect the reactions which take place and whether these effects can influence the flotation behaviour.

The effect of using NaClO as an oxidizing reagent was investigated. The potential observed when NaClO is added, is important since that could indicate its influence on flotation behaviour (Gardner and Woods, 1979). NaClO in open circuit at alkaline conditions of pH 9.2 undergoes reduction according to Equation 5-8.



The equilibrium potential  $E$ , was calculated to be 0.327 V. The pH considered was 9.2 and a concentration of 0.1 M  $ClO^-$ .

From a mixed potential perspective, the reduction reactions of NaClO (Eqn. 5-7) and oxygen (Equation 5-1), result in an increase in the rest potential of minerals. In the case of chalcopyrite (Figure 4-5), the addition of NaClO at pH 9 resulted in an increase in the potential from 250 mV to 350 mV and when a collector was added there was a decrease back to the rest potential prior to addition of any reagent. At pH 11, the

addition of NaClO resulted in an increase in the potential from 200 mV to 220 mV. Addition of the collector had a similar effect as at pH 9.

The results in Figure 4-5 can be interpreted as follows:

- (i) The increase in the potential over the first 300 s is due to the oxidation of the mineral as per Equation 5-2 and 5-3.
- (ii) The increase in potential at 300 s after the addition of NaClO is due to the reduction of the NaClO as indicated in Equation 5-8. It is interesting to note that the speciation diagram shown for NaClO in Fig. 2-8 does not indicate whether there is a preferred form of the NaClO species at the pH (9-11) and Eh (~450 mV) measured in this study. The decrease in the potential after the addition of a collector is due to the oxidation of the collector to form dixanthogen (Equation 5-7). The decrease at higher pH was less than at pH 9. This may be due to the presence of some passivating products at the mineral surface such as hydroxyl species.

In the case of pentlandite, pyrite and pyrrhotite (Figure 4-9, Figure 4-13 and Figure 4-16 respectively), similar observations were made. These minerals showed similar behaviour in terms of the extent of the potential increase on addition of NaClO and decrease on addition of collector, which was of similar magnitude for each mineral.

The increase in potential after addition of NaClO is indicative of a reduction reaction which would require a source of electrons. These electrons can only come from the mineral under investigation. In the case of chalcopyrite, Equation 5-2 and 5-3 may be occurring to produce such electrons and thus a redox couple would occur. On collector addition at the potentials observed the formation of dixanthogen is favoured. This is the oxidation reaction which may be causing the potential to decrease.

As explained earlier, sulphide minerals oxidize to varying degrees. From Table 5-1, which shows the increase in rest potentials before and after addition of NaClO at pH 9, it was observed that the oxidizing effect of NaClO was most significant in the case of pentlandite and the least significant in the case of pyrrhotite.

*Table 5-1: The change in rest potentials before and after addition of NaClO at pH 9.*

<b>Mineral Electrode</b>	<b>Before (mV)</b>	<b>After (mV)</b>	<b>Increase in Potential (mV)</b>
Chalcopyrite	200	370	170
Pentlandite	250	450	250
Pyrite	270	490	220
Pyrrhotite	145	290	145

It is interesting to note that, after the increase in potential, the addition of the collector was accompanied by the formation of a white emulsion in the electrochemical cell. This could be a result of the formation of dixanthogen as suggested by Plackowski et al. (2014) who also found a white emulsion forming after polarisation in their electrochemical cell.

The results in Figure 4-6 and Figure 4-10 for chalcopyrite and pentlandite respectively, show tests conducted to determine the effect of the sequence of addition of reagents into the electrochemical cell during rest potential measurements. It was observed that:

- (i) After collector addition the potential decreased probably due to oxidation of xanthate leading to dixanthogen formation (Equation 5-7)
- (ii) After the subsequent addition of NaClO there was minimal change in potential. This indicates that compared to the addition of a collector after NaClO addition, in which it was proposed that the NaClO undergoes reduction (Equation 5-8), this reduction reaction did not appear to occur in the case of this sequence of addition. This may be due to the presence of dixanthogen at the surface which forms after collector addition and that this may inhibit the reduction reaction.

## **5.6 Potential control during the flotation of sulphide minerals**

### **5.6.1 Preliminary Tests**

It is well known that there is a close relationship between changes in redox potential and associated changes in pH as already shown in Equation 5-4. Such a relationship is the basis for Pourbaix diagrams. Any change in pH can in turn affect the surface reactions occurring in sulphide and non-sulphide systems by changing the zeta potential. The important point to be noted from the experimental conditions investigated in this work, is that when the potential is changed by addition of NaClO

no significant change in pH was observed (Figure 4-18). This was considered important since it allowed the effect of changes in redox potential to be studied at a fixed pH. In the context of this study this is of great importance since it facilitated the opportunity to decouple pH and Eh effects.

### 5.6.2 Flotation performance

Although controlling potential using modifiers such as sodium hydrosulphide, NaHS, is widely practiced in the flotation of complex copper ores there is little information available on the effect of using an oxidizing reagent such as NaClO, to control potential in the flotation of sulphide ores and most of the work published has focused on the effect of potential changes using pure mineral systems. In the testwork conducted in this study, when there were no reagents present (baseline data), the lowest recoveries in terms of solids and water were obtained (Figure 4-20). The Eh values were not identical at pH 9 and 11 since it was not possible to achieve this. However, the natural Eh values are both in the region of ~ 100 mV.

The main collector used in this study was SEX and it is the collector described in the rest of this discussion. After collector addition at the same conditions relative to the baseline studies there was little change at pH 9 but the water and solids recoveries increased significantly at pH 11. As expected, the recoveries of chalcopyrite increased i.e. from 69% to 83% and the pentlandite from 13% to 76% at pH 9. The grades of chalcopyrite were similar indicating that the increase in values recovered was matched by an increase in gangue recovered. The constant solids and water recoveries are in consistent with this interpretation. The grades of pentlandite increased from 0.5% to 2%. This is indicative of an increase in selectivity of the collector for this mineral.

As shown in Figure 4-20, the addition of NaClO in the absence of a collector resulted in a higher solids recovery compared to the baseline case. The solids recovery increased significantly after the addition of a collector. The NaClO may be increasing the recovery of gangue minerals and this will be discussed in Section 5.8. When a collector is added simultaneously with NaClO, the solids and water recoveries remain high. In Section 5.5, it was proposed that NaClO addition resulted in the reduction reaction (Equation 5-8) and that this promoted the oxidation of the xanthate to dixanthogen (Equation 5-7). On the contrary, the flotation results did not reflect any increase in the recovery of the values (chalcopyrite and pentlandite) in the presence

of NaClO. Presumably, the formation of dixanthogen was sufficient even in the absence of NaClO to promote recoveries. This indicates that the addition of the potential modifier NaClO did not result in any increase in the recoveries of sulphide minerals even though it may have increased dixanthogen formation.

The relatively high recovery of chalcopyrite observed in collectorless flotation is consistent with findings of other researchers (Ross and Van Deventer, 1985; Hayes et al. 1987) who also noted high recoveries of copper in the absence of a collector. The presence of a collector increased the grade and recovery for nickel at both pH values, whereas in the absence of a collector very low recoveries (less than 35%) were achieved. This poor flotation response in the absence of a collector is attributed to possible formation of sulphate, ferric and nickel hydroxides at the pentlandite mineral surface. These oxidation products are hydrophilic and are responsible for the low recovery of nickel in the absence of a collector (Hodgson and Agar, 1989).

In the presence of a collector it has been proposed that nickel xanthate forms initially and in the second stage, transformation of the chemisorbed xanthate to dixanthogen occurs. This mechanism was supported by many authors (Bozkurt and Xu, 1998; Khan and Kelebek, 2004; Kelebek and Nanthakumar, 2007; Hodgson and Agar, 1989). Likewise, in the present study the potential of pentlandite is indicative of the formation of dixanthogen but it is possible that this is a two-step process as proposed by these afore-mentioned authors. These oxidation reactions are shown in Equations 5-9 and 5-10, in which the xanthate initially forms (5-9) and the product reacts subsequently with another xanthate ion to form a dixanthogen – type species (5-10).



The recovery for nickel obtained at pH 9 in collector-induced flotation was 76% but when both the collector and NaClO were added simultaneously, the recovery was hardly affected. A further increase in potential from the natural Eh of the ore which was in the range 100 – 200 mV, to a potential in the region of 500 – 600 mV using NaClO, was expected to increase the recovery. As shown in the rest potential results where NaClO resulted in an increase in rest potentials of the sulphide minerals, this was expected to subsequently increase the oxidation rates of the collector to dixanthogen. However no increase was observed in the recovery of nickel.

At pH 11 the potential was 0 – 100 mV, which is below the dixanthogen formation potential of 150 mV for SEX. There was little effect on recovery of the valuable minerals, which exhibited recoveries of 80% for copper and 60% for nickel as shown in Figure 4-27. The recoveries could be attributed to the presence of the hydrophobic metal xanthate species at the mineral surface, as these can be formed at potentials less positive than the critical potential (150 mV), above which dixanthogen should be formed. Additionally, in the presence of NaClO and a collector at pH 11, the Eh was in the region 200 – 300 mV and the recovery was 83% for copper and 52% for nickel. These findings also indicate that NaClO addition to change the Eh at constant pH had no significant impact on the flotation performance.

It is moreover, proposed that the use of potential control in flotation is also affected by the surface area of the mineral exposed, although this is subject to verification. The reasoning behind this proposal is that the electrochemical reactions occurring at the mineral surface proceed at different rates. This is when compared to those occurring in cracks or inclusions where reagents may be in contact with the metallic sites, while the larger exposed mineral surface area interacts with reagents in the bulk solution. This possibly results in differences in the rates of reactions, and an effect on the potential values measured at a particular instance. In that regard, it is difficult to maintain the values of Eh constant as the Eh depends on the redox couples present.

### **5.7 Comparison of potential modifiers**

Potential modifiers such as NaClO and H<sub>2</sub>O<sub>2</sub> have different reaction mechanisms when present in a sulphide mineral system (Hu et al. 2009). However, it was considered of interest to understand to what extent different potential modifiers may affect flotation performance. This would also provide evidence of whether there was a chemical effect when different chemicals were used to modify the potential. Tests were conducted using H<sub>2</sub>O<sub>2</sub> as an alternative to NaClO to chemically modify the potential. The addition of an equimolar dosage of H<sub>2</sub>O<sub>2</sub> to that of NaClO resulted in a potential in the range of 300 – 400 mV, which was lower than that observed in the case of NaClO (500 – 600 mV). These potential regions indicate that in both cases dixanthogen can be formed at the mineral surface of sulphide minerals since these potentials are both greater than the critical potential for dixanthogen (~150 mV).

From the solids-recovery data (Figure 4-44), it was observed that, in the absence of a collector, H<sub>2</sub>O<sub>2</sub> generally resulted in more solids recovery, viz. 79 g, than NaClO in which 65 g solids were recovered. Also, in the presence of a collector the same observation was made, viz. more solids and water recoveries were obtained using H<sub>2</sub>O<sub>2</sub> when compared to NaClO. The influence of H<sub>2</sub>O<sub>2</sub> as a potential modifier on the flotation behaviour of the sulphide minerals, was detrimental to the recoveries of valuable minerals compared to NaClO (Figure 4-46). In the absence of a collector and in the presence of H<sub>2</sub>O<sub>2</sub>, it was quite surprising that the recovery of copper was low (around 32%). This was when compared to the condition in which there was no potential modifier in collectorless flotation in which case the recovery was 69%.

From the difference in copper recoveries, it is possible that the presence of H<sub>2</sub>O<sub>2</sub> results in the release of oxygen as per Equation 5-11, which then undergoes reduction (Equation 5-1) forming OH<sup>-</sup> ions (Mielczarski et al. 1998). The OH<sup>-</sup> ions are possibly responsible for depressing the floatability of the chalcopyrite mineral as shown in Equation 5-12:



However, the presence of a collector improved the flotation responses although H<sub>2</sub>O<sub>2</sub> resulted in lower grades and recoveries of valuable minerals when compared to NaClO. The low grades are indicative of a probable activation of gangue minerals which possibly increased the solids recoveries when H<sub>2</sub>O<sub>2</sub> was used. The presence of a powerful oxidant, H<sub>2</sub>O<sub>2</sub>, it is also acknowledged that it is possible that it can oxidise the sulphide mineral surface leading to formation of hydrophilic sulphate species which causes a reduction in floatability of the valuable minerals. This suggestion is hugely supported by the fact that there was no improvement on the recovery of the sulphide minerals except when there was a change to the concentration of H<sub>2</sub>O<sub>2</sub>, as discussed later in this section.

It has been proposed that hydrogen peroxide oxidizes xanthate according to Equation 5-13 (Lipkina and Streltysn, 1970).



On the other hand, the oxidation of xanthate by hypochlorite proceeds as a complex successive – parallel reaction (Chanturiya and Vigdergauz, 2009). In this study, the following overall reaction (Equation 5-14) has been proposed.



From literature, it has also been stated that the addition of hypochlorite should be at equimolar ratio with xanthate and this is consistent with the proposed reaction mechanism in Equation 5-14. According to Chanturiya and Vigdergauz (2009), if the concentration of hypochlorite is excessive then this can lead to decomposition of the dixanthogen. While this may be true, there is no experimental evidence given to support this statement.

Furthermore, it has also been reported in the literature from commercial operations that very low concentrations of  $\text{H}_2\text{O}_2$  can result in increases in copper recovery. Preliminary tests conducted to determine the effect of adding very low concentrations of  $\text{H}_2\text{O}_2$ , clearly indicated that the addition of low concentrations of  $\text{H}_2\text{O}_2$  increased recoveries. Therefore, higher concentrations may result in a detrimental effect to flotation performance.

### **5.8 Effect of Eh on Gangue Recovery**

Tests were carried out to evaluate the effect of using potential modifiers on the recovery of a typical hydrophobic gangue mineral such as talc, to investigate whether the modifiers had any depressant effect. The results in Figure 4-58 show that the highest recovery of talc was obtained in the absence of any reagent viz. 85 %. This is indicative that talc is naturally floatable as shown by the recovery data. It was also found that the addition of NaClO resulted in a decrease in talc recovery to 70%, and from this observation it can be suggested that NaClO had a depressing effect on talc recovery.

## 5.9 Summary

It is known that the control of potential has an influence on the collector species formed and therefore the hydrophobicity of minerals, thus affecting flotation performance. However, it is difficult to determine all species present and their distributions at the surface and as such information regarding surface species is inferred, giving rise to speculation, uncertainty and some contradictions in the literature. To this end, it may be suggested that there is no strong impact observed from the control of potential by chemical means in a complex sulphide ore, as there was no substantial increase in recovery of valuable minerals. Corin et al. (2012) suggested that Eh may be an indicator of fundamental reactions which might also be influenced by dissolved oxygen (DO) concentration and/or the pH. However, from the preliminary tests conducted using low concentrations of H<sub>2</sub>O<sub>2</sub>, there was an indication of possible improvement in the metallurgical performance of the Merensky ore.

## Chapter 6

### 6 Conclusions and Recommendations

#### 6.1 Conclusions

The recovery of PGMs is known to be dependent on the recovery of sulphide minerals during mineral processing of the Merensky ore, since these minerals are closely associated with one another (Schouwstra et al. 2000). It is widely known that the potential at the mineral solution interface is an important parameter which governs the floatability of the sulphide minerals. Therefore, controlling the interactions that occur between sulphide minerals and collectors using potential control was the primary focus of this study.

The rest potential profiles of sulphide minerals were determined with the aim of predicting the potentials at which there is increased probability for the formation of dixanthogen at the mineral surface. Dixanthogen results in a higher degree of hydrophobicity and it is understandable that for flotation to be successful there needs to be hydrophobic species such as dixanthogen present at the mineral surface. Therefore it is important to be able to predict the species that form and the conditions in which hydrophobicity can be imparted. A mixed potential model was used to explain the rest potential results.

The following conclusions are drawn from the present study:

1. The study has shown under the conditions investigated and on the basis of the potentials measured that the reaction product of all sulphide minerals with PAX was amyl dithiolate/dixanthogen. This was because rest potentials of the sulphide minerals were more positive than the oxidation potential of PAX. In the presence of SEX, ethyl dithiolate was expected to form on chalcopyrite and pyrite because the rest potentials were more positive than the critical potential of the xanthate-dixanthogen couple. Metal xanthates were the species predicted to be present on the surface of pentlandite, as the rest potential of pentlandite in the presence of SEX was below the potential of the xanthate-dixanthogen couple. In addition, pyrrhotite showed minimal interaction with both collectors.

2. There was a greater extent of interaction with the mineral surface with PAX, a collector with longer alkyl chain length than with SEX per molecule. This was attributed to their differences in oxidation potentials. Although this would be expected to result in the surface having a greater degree of hydrophobicity with PAX, and hence result in improved flotation performance, it was in fact observed that the lower alkyl chain length collector (SEX) produced higher pentlandite recoveries. There was little change in the recoveries of chalcopyrite which is to be expected given the ease with which chalcopyrite floats. This was consistent with previous findings in literature.
3. Changing dissolved oxygen concentration and changing pH is a common method to vary the Eh in a pulp. In this study NaClO was used as the main chemical modifier, in which it was found it was possible to change Eh while holding the pH fixed. The work has also demonstrated from rest potential measurements that pH significantly changed the rest potential profiles of the sulphide minerals. Increasing the pH from 9 to 11 caused a shift of the rest potentials in the cathodic direction thus reducing the possibility of dixanthogen formation. The rest potential of all the sulphide minerals increased relative to the dixanthogen formation line although the extent to which this occurred varied depending on the particular sulphide mineral being investigated.
4. It was shown that there was no significant increase in the recovery of copper and nickel when changing the Eh to a higher value using NaClO. Copper recoveries and grades were essentially independent of changes to both Eh and pH 9 or 11. However, notable changes were observed on the grades of nickel which were high in the presence of a collector and/or NaClO at both pH 9 and 11.
5. The use of H<sub>2</sub>O<sub>2</sub> in the same amount as NaClO was shown to reduce recoveries of sulphide minerals. At very low concentrations of H<sub>2</sub>O<sub>2</sub> (0.001 M) the recoveries of copper increased significantly and a slight increase of nickel recovery was observed. These results appear to indicate that careful control of the concentration of H<sub>2</sub>O<sub>2</sub> to appropriately low levels can increase the recoveries of sulphide minerals.

## 6.2 Recommendations

1. The Merensky ore has a very low sulphide content and this might have had a bearing on the results obtained in this study. It would be useful to conduct further studies using a typical base metal sulphide.
2. In this study, some preliminary studies were conducted using  $H_2O_2$  as a potential modifier, added in low concentrations during batch flotation tests. Results obtained showed an increase in recovery of copper and nickel. It would be useful to conduct further studies on the effect of concentration of the Eh modifiers on the flotation performance of a sulphide ore.

## Chapter 7

### 7 References

- Allison, S.A., Goold, L.A., Nicol, M.J., Granville, A., 1972. A determination of the products of reaction between various sulfide minerals and aqueous xanthate solution, and a correlation of the products with electrode rest potentials. *Metallurgical Transactions*, 3(10), pp.2613–2618.
- Bard, A.J. & Faulkner, L.R., 2001. *Fundamentals and Applications*, John Wiley & Sons, Inc.
- Biesinger, M.C., Hart, B.R., Polack, R., Kobe, B.A., Smart, R.C., 2007. Analysis of mineral surface chemistry in flotation separation using imaging XPS. *Minerals Engineering*, 20(2), pp.152–162
- Bozkurt, V. and Xu, Z., 1998. Pentlandite / pyrrhotite interaction and xanthate adsorption. *International Journal of Mineral Processing*, 52(4), pp.203–214.
- Bradshaw, D.J., Harris, P.J. and Connor, C.T.O., 1998. Synergistic interactions between reagents in sulphide flotation. *SAIMM*, (May), pp.189–194.
- Bulatovic, S.M., 2007. *Handbook of Flotation Reagents: Chemistry, Theory and Practice*, Elsevier.
- Buswell, A., Bradshaw, D.J., Harris, P.J., Ekmecki, Z., 2002. The use of electrochemical measurements in the flotation of a platinum group minerals (PGM) bearing ore. *Minerals Engineering*, 15(6), pp.395–404.
- Buswell, A.M. and Nicol, M.J., 2002. Some aspects of the electrochemistry of the flotation of pyrrhotite. *Journal of applied electrochemistry*, 32(b), pp.1321–1329.
- Cawthorn, R.G., 1999. The platinum and palladium resources of the Bushveld Complex. *South African Journal of Science*, 11/12(December), pp.481–489.
- Chander, S., 2003. A brief review of pulp potentials in sulfide flotation. *International Journal of Mineral Processing*, 72, pp.141–150.
- Chanturiya, V. A. and Vigdergauz, V.E., 2009. *Electrochemistry of Sulfides. Theory and Practice of Flotation*:
- Corin, K.C., Mishra, J. and Connor, C.T.O., 2012. Investigating the role of pulp chemistry on the floatability of a Cu–Ni sulfide ore. *International Journal of Mineral Processing*, 120, pp.8–14.
- Dimou, A., 1986. *The flotation of pyrite using xanthate collectors*. University of Cape Town. MSc Thesis

- Ekmekci, Z., Bradshaw, D.J., Harris, P.J., Buswell, A.M., 2006. Interactive effects of the type of milling media and CuSO<sub>4</sub> addition on the flotation performance of sulphide minerals from Merensky ore Part II: Froth stability. *International Journal of Mineral Processing*, 78, pp.164–174.
- Ekmekci, Z., Becker, M., and Tekes, E., 2010. The relationship between the electrochemical, mineralogical and flotation characteristics of pyrrhotite samples from different Ni Ores. *Journal of Electroanalytical Chemistry*, 647, pp.133–143.
- Ekmekçi, Z., Buswell, M.A., Bradshaw, D.J., Harris, P.J., 2005. The value and limitations of electrochemical measurements in flotation of precious metal ores. *Minerals Engineering*, 18(8), pp.825–831.
- Finkelstein, N.P. and Poling, G.W., 1977. The role of dithiolates in the flotation of sulphide minerals. *Mineral Sci Eng*, 9(4), pp.177–197.
- Finkelstein, N.P. and Goold, L.A., 1972. The reaction of sulphide minerals with thiol compounds. National Institute of Metallurgy, South Africa. Report, (1439).
- Fuerstenau, M., Jameson, G., and Yoon, R-H, 2007. *Froth Flotation: A Century of Innovation*, SME.
- Gamry, 2011. Two, Three, and Four-Electrode Experiments. , pp.3–5. Available at: [www.gamry.com](http://www.gamry.com).
- Gardner, J.R. and Woods, R., 1979. An electrochemical investigation of the natural flotability of chalcopyrite. *International Journal of Mineral Processing*, 6(1), pp.1–16.
- Goktepe, F., 2001. Effect of pH on Pulp Potential and Sulphide Mineral Flotation. *Turkish Journal of Engineering and Environmental Science*, 26, pp.309–318.
- Hamilton, I.C. and Woods, R., 1981. An investigation of surface oxidation of pyrite and pyrrhotite by linear potential sweep voltammetry. *Journal of Electroanalytical Chemistry and Interfacial Electrochemistry*, 118, pp.327–343.
- Heyes, G.W. and Trahar, W.J., 1979. Oxidation-Reduction effects in the flotation of chalcocite and cuprite. *International Journal of Mineral Processing*, 6(3), pp.229–252.
- Hodgson, M. and Agar, G.E., 1989. Eilectrochemical Investigations into the Flotation Chemistry of Pentlandite and Pyrrhotite: Process Water and Xanthate Interactions. *Canadian Metallurgical Quarterly*, 28(3), pp.189–198.
- Hu, Y., Sun, W. and Wang, D., 2009. Electrochemistry of flotation of sulphide minerals,
- Javadi, A., 2013. Sulphide Mineral Flotation. Lulea University of Technology. Licentiate Thesis

- Kelebek, S. and Nanthakumar, B., 2007. Characterization of stockpile oxidation of pentlandite and pyrrhotite through kinetic analysis of their flotation. *International Journal of Mineral Processing*, 84, pp.69–80.
- Khan, A. and Kelebek, S., 2004. Electrochemical aspects of pyrrhotite and pentlandite in relation to their flotation with xanthate. Part-I: Cyclic voltammetry and rest potential measurements. *Journal of applied electrochemistry*, pp.849–856.
- Klimpel, R. R., 1984. "Froth Flotation: the Kinetic Approach.(Retroactive Coverage)." *MINTEK 50: International Conference on Mineral Science and Technology*. Vol. 1
- Kocabağ, D. and Güler, T., 2008. A comparative evaluation of the response of platinum and mineral electrodes in sulfide mineral pulps. *International Journal of Mineral Processing*, 87(1-2), pp.51–59.
- Kocabağ, D. and Güler, T., 2007. Two-liquid flotation of sulphides: An electrochemical approach. *Minerals Engineering*, 20(13), pp.1246–1254.
- Leppinen, J.O. and Hintikka, V.V., 1995. Potential control in the flotation of sulphide minerals. *Minerals Engineering*, 8(10), pp.1151–1158.
- Lipkina, T.E., and Streltysn, G.S., 1970. Removal of collectors from galena surface with diethyl ether; *Obog.Rud.* No. ½, p. 98
- Majima, H. and Takeda, M., 1968. Electrochemical studies of xanthate -dixanthogen system on pyrite. *Trans. AIME.*, 241(December 1968), pp.431–436.
- Manono, M.S., Corin, K.C. and Wiese, J.G., 2013. The effect of ionic strength of plant water on foam stability: A 2-phase flotation study. *Minerals Engineering*, 40, pp.42–47.
- Manono, S.M., 2010. An investigation into the effect of ionic strength of plant water on valuable mineral and gangue recovery of a platinum bearing ore from the Merensky reef. University of Cape Town. MSc Thesis
- Mbonambi, M. J., 2009. On the Selective Flotation of Pentlandite from Pyrrhotite in Sheba's Ridge Ores. University of Cape Town. MSc Thesis
- Mendiratta, N.K., 2000. Kinetic Studies of Sulfide Mineral Oxidation and Xanthate Adsorption. Virginia Polytechnic Institute and State University. PhD Thesis
- Mielczarski, J. A., Mielczarski, E. and Cases, J.M., 1998. Influence of chain length on adsorption of xanthates on chalcopyrite. *International Journal of Mineral Processing*, 52(4), pp.215–231.
- Miller, J.D., Li, J. and Davidtz, J., 2005. A review of pyrrhotite flotation chemistry in the processing of PGM ores. *Minerals Engineering*, 18(8), pp.855–865.

- Moslemi, H., Shamsi, P. and Alimohammady, M., 2012. Electrochemical properties of pyrite, pyrrhotite, and steel: Effects on grinding and flotation processes. *Journal of the Southern African Institute of Mining and Metallurgy*, 112(May), pp.883–890.
- Muzenda, E., Afolabi, A.S., Abdulkareem, A.S., 2011. Effect of pH on the Recovery and Grade of Base Metal Sulphides (PGMs) by Flotation. In WCECS. pp. 19–22.
- Nicol, M.J. and Lázaro, I., 2002. The role of EH measurements in the interpretation of the kinetics and mechanisms of the oxidation and leaching of sulphide minerals. *Hydrometallurgy*, 63(1), pp.15–22.
- Perry, R.H. and Green, D.W., 1997. *Perry's Chemical Engineers' Handbook 7th Edition*. NY: McGraw-Hill.
- Plackowski, C., Bruckard, W.J. and Nguyen, A. V., 2014. Surface characterisation, collector adsorption and flotation response of enargite in a redox potential controlled environment. *Minerals Engineering*, 65, pp.61–73.
- Pourbaix, M., 1966. *Atlas of Electrochemical Equilibria in Aqueous Solutions*: Pergamon Press, London.
- Rand, D.A.J. and Woods, R., 1984. Eh measurements in sulphide mineral slurries. *International Journal of Mineral Processing*, 13(1), pp.29–42.
- Rao, S.R., 2004. *Surface Chemistry Surface Chemistry of Froth Flotation Volume 2: Reagents and Mechanisms*: Plenum Publishers.
- Ross, V.E. and Van Deventer, J.S.J., 1985. The interactive effects of the sulphite ion, pH, and dissolved oxygen on the flotation of chalcopyrite and galena from Black Mountain ore. *Journal of the South African Institute of Mining and Metallurgy*, pp.13–21.
- SAMMRI REPORT 2009, SAMMRI 2009, Available at: <http://www.sammri.com/> [Accessed April 1, 2014].
- Schouwstra, R.P., Kinloch, E.D. and Lee, C. a., 2000. A Short Geological Review of the Bushveld Complex. *Platinum Metals Review*, 44(1), pp.33–39.
- Shackleton, N.J., 2007. *Surface characterisation and flotation behaviour of the platinum and palladium arsenide, telluride and sulphide mineral species*. University of Cape Town. MSc Thesis
- Smith, L.K., Davey, K.J. and Bruckard, W.J., 2012. The use of pulp potential control to separate copper and arsenic - an overview based on selected case studies. In XXVI IMPC. pp. 5057–5067.
- Somasundaran, P., 1987. *Reagents in Mineral Technology*, CRC Press.

- Tadie, M., 2015. An Electrochemical Investigation of Platinum Group Minerals. University of Cape Town. PhD Thesis
- Tadie, M., Corin, K., Wiese, J., Conoor, C.T.O., 2015. An investigation into electrochemical interactions between platinum group minerals and xanthate : Voltammetric study. *Minerals Engineering*, 70, pp.148–155.
- Tolley, W., Kotlyar, D. and Wagoner, R.V., 1996. Fundamental Electrochemical Studies of Sulphide Mineral Flotation. *Minerals Engineering*, 9(6), pp.603–637.
- Vermaak, M.K.G., Venter, J.A. and Pistorius, P.C., 2004. Electrochemical studies of the interaction of ethyl xanthate with Pd-Bi-Te.pdf. , (October), pp.3–7.
- Viljoen, M. J., and Schürmann, L. W. (1998). Platinum-group metals. The mineral resources of South Africa. Council for Geoscience, Pretoria, 532-568
- Wang, J., 2000. Analytical electrochemistry, Wiley.com.
- Wiese, J., 2009. Investigating Depressant Behaviour in the Flotation of Selected Merensky Ores. University of Cape Town. MSc Thesis
- Wiese, J., Harris, P. and Bradshaw, D., 2011. The effect of the reagent suite on froth stability in laboratory scale batch flotation tests. *Minerals Engineering*, 24(9), pp.995–1003.
- Wiese, J., Harris, P. and Bradshaw, D., 2005. The influence of the reagent suite on the flotation of ores from the Merensky reef. In *Minerals Engineering*. pp. 189–198.
- Wills, B. A. and Napier-munn, T., 2006. *Mineral Processing Technology: An Introduction to the Practical Aspects of Ore Treatment and Mineral Recovery*, Elsevier Science & Technology Books.
- Woods, R., 2003. Electrochemical potential controlling flotation. *International Journal of Mineral Processing*, 72(1-4), pp.151–162.
- Woods, R., 1971. The Oxidation of Ethyl Xanthate on Platinum, Gold, Copper, and Galena electrodes. Relation to the Mechanism of mineral flotation. *Journal of Electroanalytical Chemistry*, 76(9), pp.354–362.
- Yoon, R.-H. and Basilio, C.I., 1983. Adsorption of thiol collectors on sulphide minerals and precious metals - A new perspective. *International Journal of Mineral Processing*, pp.611–617.
- Zheng, X., Franzidis, J.P. and Johnson, N.W., 2006. An evaluation of different models of water recovery in flotation. *Minerals Engineering*, 19(9), pp.871–882.

## Chapter 8

### 8 Appendices

#### 8.1 Appendix A: Rest Potential Results

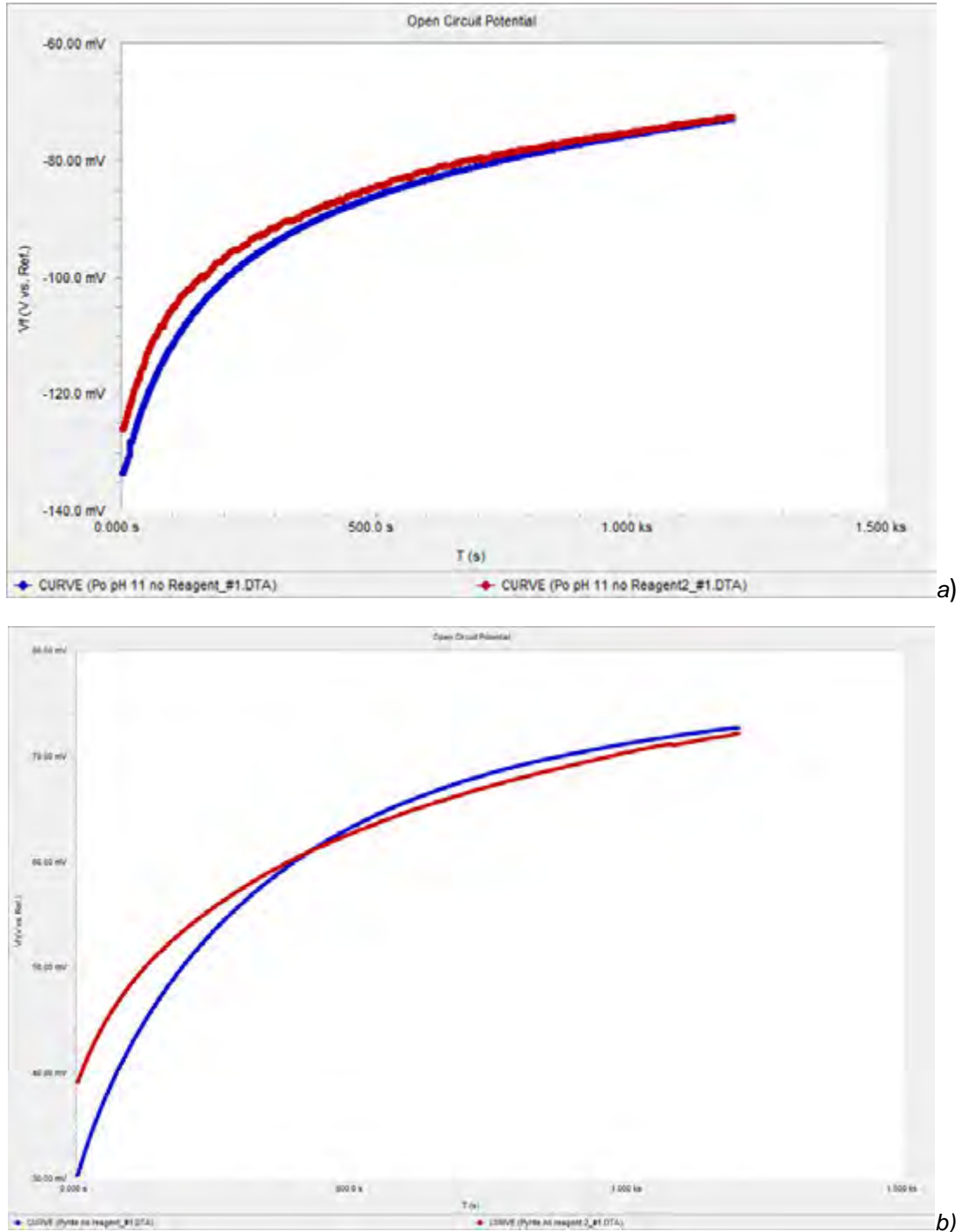

Figure 8-1: Rest potential profiles for a) pyrite in the absence of any reagent at pH 9 and b) pyrrhotite in the absence of any reagent at pH 11. The results illustrates the consistency of the technique as readings were always with 20 mV of each other.

**8.2 Appendix B: Batch Flotation Raw Data**

Test Conditions	Sample ID	Time (mins)	Cum mass (g)	Cum water (g)	Copper Grade (%)	Copper Rec (%)	Nickel Grade (%)	Nickel Rec (%)
pH 9 DOW 200	Cl	2	24.41	68.37	2.25	58.65	0.48	4.49
	C2	4	38.35	137.67	1.63	66.86	0.51	7.75
	C3	6	51.01	257.45	1.29	70.29	0.52	11.32
	C4	20	59.08	375.27	1.11	70.44	0.53	13.63
	Feed		983.31					
	Tails		924.23					
pH 9 DOW 200	Cl	2	20.46	70.89	2.44	52.31	0.38	5.35
	C2	4	33.75	140.01	1.77	62.43	0.36	7.98
	C3	6	46.27	253.67	1.37	66.40	0.39	11.95
	C4	20	54.05	370.95	1.20	68.05	0.41	12.85
	Feed		1025.32					
	Tails		971.27					
pH 9 SEX Dow 200	Cl	2	24.64	64.03	3.49	72.76	5.18	52.66
	C2	4	39.06	163.9	1.71	79.80	3.08	70.19
	C3	6	51.06	254.58	1.28	81.75	2.36	73.52
	C4	20	65.77	378.81	1.05	83.06	1.96	75.64
	Feed		982.65					
	Tails		914.82					
pH 9 SEX Dow 200	Cl	2	28.04	70.04	3.93	71.50	5.55	48.45
	C2	4	43.79	173.11	1.92	79.06	3.49	68.82
	C3	6	59.31	251.87	1.34	81.52	2.51	73.20
	C4	20	67.06	381.19	1.08	82.93	2.05	75.49
	Feed		981.44					
	Tails		916.25					

Test Conditions	Sample ID	Time (mins)	Cum mass (g)	Cum water (g)	Copper Grade (%)	Copper Rec (%)	Nickel Grade (%)	Nickel Rec (%)
pH 9 NaClO DOW 200	C1	2	24.42	61.34	2.28	57.20	0.67	8.97
	C2	4	43.5	159.45	1.53	68.16	0.85	20.12
	C3	6	57.55	263.06	1.22	72.16	0.92	28.84
	C4	20	66.40	397.86	1.08	73.87	0.93	33.63
	Feed Tails		998.04 931.64					
pH 9 NaClO DOW 200	C1	2	22.62	57.83	2.12	55.49	0.57	6.80
	C2	4	41.7	157.06	1.40	67.47	0.89	19.44
	C3	6	53.35	261.64	1.16	71.43	0.91	25.44
	C4	20	62.60	386.01	1.01	73.40	0.92	30.03
	Feed Tails		959.14 896.54					
pH 9 SEX NaClO DOW 200	C1	2	22.45	67.70	3.92	72.50	4.68	37.16
	C2	4	42.17	179.61	1.65	79.51	2.95	60.99
	C3	6	64.16	346.8	1.12	82.08	2.08	65.27
	C4	20	79.01	528.04	0.92	83.31	1.69	65.47
	Feed Tails		1010.57 931.56					
pH 9 SEX NaClO DOW 200	C1	2	23.23	63.84	2.38	76.48	3.64	59.01
	C2	4	47.11	168.84	1.57	80.64	2.74	70.93
	C3	6	65.86	335.21	1.15	82.80	2.08	75.33
	C4	20	79.18	523.71	0.97	83.97	1.78	77.62
	Feed Tails		1008.84 929.66					

Test Conditions	Sample ID	Time (mins)	Cum mass (g)	Cum water (g)	Copper Grade (%)	Copper Rec (%)	Nickel Grade (%)	Nickel Rec (%)
pH 11 DOW 200	C1	2	9.91	81.64	5.18	57.39	0.40	2.14
	C2	4	19.52	186.92	3.02	66.04	0.40	4.21
	C3	6	26.6	279.36	2.32	69.12	0.39	5.71
	C4	20	33.43	399.48	1.90	71.05	0.40	7.29
	Feed		991.96					
	Tails		958.53					
pH 11 DOW 200	C1	2	9.96	70.84	5.23	56.43	0.39	2.18
	C2	4	18.39	179.11	3.27	65.04	0.40	4.08
	C3	6	26.38	297.36	2.41	68.76	0.40	5.94
	C4	20	33.05	403.85	1.97	70.60	0.41	7.59
	Feed		997.76					
	Tails		964.71					
pH 11 SEX Dow 200	C1	2	11.35	131.02	5.93	60.62	3.88	16.87
	C2	4	31.29	325.44	1.73	73.25	2.75	49.45
	C3	6	49.09	617.47	0.98	76.99	1.68	56.10
	C4	20	59.77	901.49	0.78	78.68	1.37	59.00
	Feed		990.41					
	Tails		919.36					
pH 11 SEX Dow 200	C1	2	10.16	133.28	4.63	67.29	3.11	21.37
	C2	4	32.98	338.31	1.97	77.72	2.83	52.96
	C3	6	53.51	612.47	1.24	80.50	1.90	58.51
	C4	20	65.71	917.54	1.00	81.71	1.57	60.86
	Feed		1011.01					
	Tails		941.75					

Test Conditions	Sample ID	Time (mins)	Cum mass (g)	Cum water (g)	Copper Grade (%)	Copper Rec (%)	Nickel Grade (%)	Nickel Rec (%)
pH 11 NaClO DOW 200	Cl	2	14.28	135.17	4.31	63.58	0.32	2.49
	C2	4	26.65	307.4	2.53	69.73	0.33	4.75
	C3	6	37.75	480.11	1.84	71.77	0.34	6.94
	C4	20	45.89	685.10	1.53	72.80	0.37	9.06
	Feed Tails		1006.05 960.16					
pH 11 NaClO DOW 200	Cl	2	14.01	147.01	3.88	60.62	0.33	2.55
	C2	4	24.18	306.68	2.48	67.07	0.33	4.44
	C3	6	32.73	496.82	1.89	69.25	0.34	6.13
	C4	20	38.72	647.28	1.63	70.48	0.35	7.52
	Feed Tails		987.86 949.14					
pH 11 SEX NaClO DOW 200	Cl	2	10.47	83.08	6.64	74.75	0.59	3.59
	C2	4	29.57	366.54	2.55	81.06	0.64	11.09
	C3	6	42.4	700.99	1.81	82.51	1.04	25.85
	C4	20	51.48	1115.58	1.50	83.21	1.47	44.37
	Feed Tails		988.55 937.07					
pH 11 SEX NaClO DOW 200	Cl	2	7.08	88.75	8.82	67.46	1.73	5.81
	C2	4	24.51	362.54	2.97	78.70	2.92	34.00
	C3	6	48.25	692.55	1.57	81.90	2.50	57.35
	C4	20	62.96	1106.2	1.22	83.11	2.08	62.25
	Feed Tails		1001.75 938.79					

Test Conditions	Sample ID	Time (mins)	Cum mass (g)	Cum water (g)	Copper Grade (%)	Copper Rec (%)	Nickel Grade (%)	Nickel Rec (%)
pH 9 PAX DOW 200	Cl	2	22.65	153.28	2.93	70.06	4.04	41.10
	C2	4	50.6	401.96	1.55	77.92	2.80	59.62
	C3	6	64.94	696.54	1.15	80.46	2.16	64.07
	C4	20	80.97	1056.93	0.98	81.69	1.87	66.16
	Feed		982.31					
	Tails		908.18					
pH 9 PAX DOW 200	Cl	2	24.26	155.90	2.52	71.92	3.82	46.289
	C2	4	47.53	397.44	1.32	78.83	2.27	57.424
	C3	6	69.18	707.71	1.01	81.02	1.79	61.087
	C4	20	77.12	1003.65	0.88	82.09	1.59	62.884
	Feed		988.56					
	Tails		904.59					
pH 9 PAX NaClO DOW 200	Cl	2	30.02	155.68	2.31	72.46	3.38	45.99
	C2	4	56.44	378.24	1.25	79.06	2.11	57.71
	C3	6	74.7	625.13	0.97	81.30	1.69	61.41
	C4	20	86.23	862.44	0.86	82.60	1.51	63.33
	Feed		981.42					
	Tails		895.19					
pH 9 PAX NaClO DOW 200	Cl	2	32.69	168.68	1.87	71.83	3.01	47.90
	C2	4	56.73	388.23	1.24	77.60	2.17	56.31
	C3	6	73.5	628.24	0.98	79.69	1.77	59.72
	C4	20	84.44	875.70	0.86	80.85	1.59	61.52
	Feed		1032.11					
	Tails		947.66					

Test Conditions	Sample ID	Time (mins)	Cum mass (g)	Cum water (g)	Copper Grade (%)	Copper Rec (%)	Nickel Grade (%)	Nickel Rec (%)
pH 9 SEX 0.1 M H <sub>2</sub> O <sub>2</sub> DOW 200	Cl	2	50.18	330.4	1.01	66.95	2.03	51.12
	C2	4	75.66	642.28	0.76	74.17	1.62	59.99
	C3	6	87.23	896.37	0.67	76.96	1.46	63.77
	C4	20	98.38	1147.19	0.63	78.50	1.38	65.77
	Feed Tails		1003.89 905.51					
pH 9 SEX 0.1 M H <sub>2</sub> O <sub>2</sub> DOW 200	Cl	2	48.37	339.88	0.96	62.52	1.94	46.28
	C2	4	71.7	639.48	0.71	71.04	1.55	56.39
	C3	6	85.65	887.52	0.63	74.40	1.41	60.71
	C4	20	91.48	1051.23	0.59	76.32	1.35	63.24
	Feed Tails		1005.87 914.39					
pH 9 SEX 0.001 M H <sub>2</sub> O <sub>2</sub> DOW 200	Cl	2	16.85	54.34	3.59	70.55	5.04	41.34
	C2	4	46.38	229.87	1.47	83.43	2.68	67.98
	C3	6	71.47	607.31	0.99	87.58	1.86	73.61
	C4	20	88.18	879.34	0.81	89.57	1.55	76.38
	Feed Tails		962.9 874.72					
pH 9 SEX 0.001 M H <sub>2</sub> O <sub>2</sub> DOW 200	Cl	2	17.74	51.27	3.57	73.30	5.09	46.82
	C2	4	41.22	232.06	1.70	83.84	3.04	68.95
	C3	6	71.93	600.93	1.01	88.13	1.87	74.97
	C4	20	88.72	865.41	0.83	89.82	1.56	77.51
	Feed Tails		961.76 873.04					

### 8.3 Appendix C: Microflotation

#### Collector Surface Coverage Calculations

<b>Xanthate Coverage</b>	<b>Talc</b>
Particle size( $\mu\text{m}$ )	38-106
Mass(g)	2
BET( $\text{m}^2/\text{g}$ )	5.4211
Total mineral area	10.8422
1 X- atom coverage(A)	28.8
Number of molecules per monolayer	3.76465E+19
Moles of Collector	6.2515E-05
moles for 50% coverage	3.12575E-05
Mr (SEX)	149
Mass(g)	0.004657367
Volume added to cell (mL)	1

#### Microflotation Test Procedure

The following procedure was followed for the microflotation tests:

1. Weigh 2 grams of the pure mineral sample of the particle size range (+38-106  $\mu\text{m}$ ).
2. Add the mineral sample to 50 ml of deionised water adjusted to pH 9.
3. Ultra-sonicate the mineral suspension for 5 minutes in a water bath to ensure good dispersion of the mixture.
4. Transfer the mineral suspension to a microflotation cell and fill the cell with deionised water to just below the overflow lip.
5. Turn on the peristaltic pump to circulate the pulp at 90 rpm.
6. For the experimental condition requiring reagent addition, add 1ml and condition for 5 minutes with SEX solution and for 2 minutes with NaClO solution.
7. Top up the volume of the cell to 250  $\text{cm}^3$ , put the cone in place.
8. Introduce the air with a flow rate of 7  $\text{cm}^3/\text{min}$  through the syringe at the base of the cell.
9. Remove the syringe and collect the flotation products at the following times for a total of 20 minutes:

2<sup>nd</sup> minute – 1<sup>st</sup> concentrate

6<sup>th</sup> minute – 2<sup>nd</sup> concentrate

12<sup>th</sup> minute – 3<sup>rd</sup> concentrate

20<sup>th</sup> minute – 4<sup>th</sup> concentrate

10. Collect tailings sample at the end of each run.
11. Filter the products on pre-weighed filter paper and rinse with deionised water at the adjusted pH.
12. Repeat steps 1-11 two times for reproducibility