

The copyright of this thesis vests in the author. No quotation from it or information derived from it is to be published without full acknowledgement of the source. The thesis is to be used for private study or non-commercial research purposes only.

Published by the University of Cape Town (UCT) in terms of the non-exclusive license granted to UCT by the author.



**New synthetic routes to functionalized  
2-C-alkylglucosides, precursors  
of potential inhibitors of  
mycothiol biosynthesis  
in the *Mycobacteria***

---

**Freddy Munyololo Muganza**

**University of Cape Town**

**January 2011**

**New synthetic routes to functionalized  
2-C-alkylglucosides, precursors  
of potential inhibitors of  
mycothiol biosynthesis  
in the *Mycobacteria***

A thesis submitted to the University of Cape Town  
in partial fulfillment of the requirements  
for the degree of Doctor of Philosophy

By

**Freddy Munyololo Muganza**

Supervisor: **Assoc. Professor David W. Gammon**

Department of Chemistry  
University of Cape Town  
Rondebosch, 7701  
Cape Town

**January 2011**

I declare that 'New synthetic routes to functionalized 2-C-alkylglucosides, precursors of potential inhibitors of mycothiol biosynthesis in the *Mycobacteria*' is my own work and that all sources that I have used or quoted have been indicated and acknowledged by means of complete references.

Freddy Munyololo Muganza

University of Cape Town

## DEDICATION

To the following late people:

My father, **Robert Munyololo Mwisimbwa Balelwa**, who after sacrificing a lot for the sake of my education did not wait to reap the fruits of his hard labour, he died a year before my graduation. To my Sister, **Munyololo Katale Esther**, to whom I will always pay respect for her contribution towards my ethics. May your spirits rest in peace knowing that what you sowed behind bore fruits and will always reflect your enormous contribution.

## **ACKNOWLEDGEMENTS**

I would like to thank my creator Almighty God for His blessings and protection throughout these years.

My heartfelt thanks go to my supervisor Assoc. Prof. David William Gammon for his guidance, patience, support and encouragement. Many thanks also to my loving wife, Detty Muganza Kajuru for all her endless support. I would also like to extend my sincere thanks to my kids, Jamie, Linda, Yael and Skyller Muganza for their permanent noise near me every time that I needed to refresh my mind with something different from Chemistry. My great appreciation and thanks to the non-academic staff in Department of Chemistry for their support.

I would like to thank Mr. Noel Hendricks, Mr. Pete Roberts and Mr. Pierro Benincasa (University of Cape Town) for NMR experiments and microanalysis.

It has been a blessing and privilege to occupy the laboratory with great individuals from my group (past and present) and all the best for your future endeavors. Other occupants in the laboratory whom I share both the East and West wing are also acknowledged for creating conducive working environment throughout these years.

Finally, it would not be possible to complete this project without Eric Abrahams Trustee Committee, NRF and University of Cape Town for their financial support.

## ABSTRACT

This thesis was concerned with the design and synthesis of compounds which are either substrate-mimics or inhibitors of MshB, a *N*-deacetylase involved in the biosynthesis of mycothiol in the *Mycobacteria*, including *M. tuberculosis*, the causative agent of TB. Mycothiol is a low molecular weight thiol produced by *Mycobacteria* as a defense against oxidative stress and xenobiotics, and the enzymes involved in its biosynthesis are postulated to be viable drug targets.

The thesis first describes the preparation of a series of 2-deoxy-2-acetamido thioglucosides and evaluation of these as competitive substrates of MshB, and the  $\alpha$ -phenylthioglucoside **1.30** shown to have substrate activity comparable to the natural substrate. This result, combined with earlier results on the use of carbon isosteres of the acetamido group led to this study of synthetic approaches to phenyl-2-*C*-alkylated-1-thio- $\alpha$ -D-glucosides which would be suitable precursors for a range of potential inhibitors of MshB.

A comprehensive literature survey of methods for preparation of sugars branched at *C*-2 was carried out. On the basis of this and previous experience, three approaches were selected for further evaluation. In the first instance, attempts at alkylation of 1,6-2,3-dianhydro-D-glucose derivatives met with limited success. This was followed by preparation of phenyl-2-keto-1-thioglucosides with a view to preparing 2-*C*-alkyl derivatives via

olefination procedures, but these also proved unsuccessful. The use of 1,2-cyclopropanated sugars was then investigated, initially following literature precedents to prepare  $\alpha$ -1,2-cyclopropano-D-glucose followed by iodonium-ion-mediated opening to form 2-C-iodomethylglucose derivatives. However, the iodine in the side chain was found to participate anchimerically to give  $\beta$ -selectivity in subsequent glycosidation reactions instead of the desired  $\alpha$ -selectivity.

Although it was shown that the iodomethyl side-chain could be easily modified by, for example, substituting the iodide azide, cyano and formate groups the limitations of this approach led to exploration of the use of  $\alpha$ -1,2-cyclopropanated glucose having an *exo*-oriented ethoxycarbonyl substituent on the cyclopropane. Iodonium ion-mediated opening of the cyclopropane, followed by reductive removal of the iodo-substituent produced the synthetically useful 2-C-methoxycarbonylmethyl glucosides, with the carboxyl group surprisingly found not to participate significantly in subsequent glycosylation reactions. Attempts at direct Lewis acid mediated nucleophilic opening of the cyclopropane were not successful, but when the ester was reduced and acetylated, the acetoxymethyl derivative underwent Ferrier-type fragmentation-rearrangement with a range of nucleophiles and  $\text{BF}_3 \cdot \text{Et}_2\text{O}$  or  $\text{Al}(\text{OTf})_3$  as catalyst to give 2-C-vinyl glucosides with high  $\alpha$ -selectivity. In contrast, treatment with a combination of  $\text{Al}(\text{OTf})_3$  and acetic acid led to a novel rearrangement resulting from initial Ferrier-type fragmentation followed by interception of the intermediate

oxocarbenium ion by water, elimination of the substituent at C-3, and acid-catalysed ring closure to give a 2-C-formyl-C-glycoside.

Evidence has thus been accumulated to show that these represent efficient, general synthetic approaches to 2-C-alkylated glucosides having functionalized side-chains which will permit further modification.

University of Cape Town

## TABLE OF CONTENTS

|   |     |
|---|-----|
| DEDICATION.....                               | i   |
| ACKNOWLEDGEMENT.....                          | ii  |
| ABSTRACT.....                                 | iii |
| TABLE OF CONTENTS.....                        | vi  |
| LIST OF ABBREVIATIONS.....                    | ix  |
| PUBLICATION AND CONFERENCE PARTICIPATION..... | xii |

### CHAPTER 1: INTRODUCTION

|  |    |
|--|----|
| 1.1 Disease:Tuberculosis.....  | 1  |
| 1.2 TB Chemotherapy.....   | 2  |
| 1.3 Low molecular weight thiols.....   | 4  |
| 1.3.1 Mycothiol synthesis.....   | 6  |
| 1.3.1.1 Whole cell synthesis.....  | 6  |
| 1.3.1.2 Chemical synthesis.....  | 8  |
| 1.4 Carbohydrate-based inhibitors of enzyme<br>involved in MSH biosynthesis..... | 13 |
| 1.5 Aim and Objectives of the project.....                                       | 14 |
| 1.6 REFERENCES.....  | 16 |

### CHAPTER 2: REVIEW ON C-2 ALKYLATION OF GLYCOPY GLYCORANOSIDES

|   |    |
|---|----|
| 2.1 Introduction.....   | 20 |
| 2.2 Compounds with a C-C-H branch (Type 1).....                           | 22 |
| 2.2.1 Via nucleophilic Opening of epoxides on the sugar<br>Skeleton ..... | 22 |
| 2.2.2 Via Radical Alkylation .....  | 30 |

|  |           |
|--|-----------|
| 2.2.2.1 Intramolecular radical alkylation at C-2 of<br>sugars..... | 31        |
| 2.2.2.2 Intermolecular radical alkylation at C-2<br>of sugars..... | 35        |
| 2.2.3 Via Cyclopropanation .....                                   | 51        |
| 2.2.4 Via Formylation of Glucal.....                               | 60        |
| 2.2.5 Via C-2 Lithiation / Trapping.....                           | 62        |
| 2.2.6 Via Metal glycosylidenes.....                                | 64        |
| 2.2.7 Via ketone enolate.....                                      | 66        |
| <b>2.3 Compounds with a C-C-X branch (Type 2)</b> .....            | <b>67</b> |
| 2.3.1 Via Nucleophilic attack at the carbonyl group<br>at C-2..... | 67        |
| <b>2.4 Compound with a C=C branch (Type 3)</b> .....               | <b>68</b> |
| 2.4.1 Via Wittig reaction.....                                     | 68        |
| <b>2.5 Compounds with undefined type</b> .....                     | <b>71</b> |
| 2.5.1 Via 1,2-Lactone opening.....                                 | 71        |
| 2.5.2 Via 1,2-migration.....                                       | 75        |
| <b>2.6 REFERENCES</b> .....  | <b>78</b> |

### **CHAPTER 3: RESULTS AND DISCUSSION**

|  |           |
|--|-----------|
| <b>3.1 Synthesis of thioglucoside analogues of the natural<br/>substrate of MshB</b> .....         | <b>88</b> |
| <b>3.2 Chemical synthesis of phenyl-2-deoxy-2-C-alkyl-1-<br/>thioglucosides</b> .....              | <b>91</b> |
| 3.2.1 Use of 1,6-2,3-anhydromannosides in the<br>attempted synthesis of compound <b>1.33</b> ..... | 92        |
| 3.2.2 Approach to the synthesis of <b>1.33</b> via a 2-<br>uloside.....                            | 95        |
| 3.2.3 Approach to the synthesis of compound <b>1.33</b> via 1,2-                                   |           |

|   |         |
|---|---------|
| cyclopropanated sugars.....   | 98      |
| 3.2.3.1 <i>Via</i> unsubstituted cyclopropanes .....  | 98      |
| 3.2.3.1a Influence of protecting group (OAc) on<br>Thioglycosylation reaction of <i>C</i> -2-iodomethyl-<br>glycosylacetates..... | 99      |
| 3.2.3.1b Influence of neighbouring group on stereo<br>selectivity of thioglycosylation reaction.....                              | 102     |
| 3.2.3.1c Influence of the leaving group on stereo<br>selectivity of thioglycosylation reaction.....                               | 103     |
| 3.2.3.1d Functionalization at <i>C</i> -2' position of <b>1.34</b> .....  | 106     |
| 3.2.3.2 <i>Via</i> substituted 1,2-cyclopropanated sugars.....  | 108     |
| 3.2.3.2a Synthesis of 2- <i>C</i> -vinylglycoside as precu-<br>sor of 2- <i>C</i> -iodomethylglycoside <b>1.33</b> .....          | 108     |
| 3.2.3.2b Synthesis of 2- <i>C</i> -alkoxycarbonylalkylglyco<br>sides.....   | 130     |
| <b>3.3 REFERENCES</b> .....   | 135     |
| <br><b>CHAPTER4: CONCLUSION</b> .....   | <br>141 |
| <br><b>CHAPTER 5: EXPERIMENTAL PROCEDURE</b>  |         |
| <b>5.1 General experimental techniques and<br/>    Instrumentations</b> .....   | <br>144 |
| 5.1.1 Chemicals and Purification of solvents.....   | 144     |
| 5.1.2 Chromatographic separation.....   | 144     |
| 5.1.3 Spectroscopic and physical measurements.....  | 144     |
| 5.1.4 General Procedures and Characterization of<br>Compounds.....  | 145     |
| <b>5.2 REFERENCES</b> .....   | 192     |

### LIST OF ABBREVIATIONS

|                     |  |
|---------------------|--|
| A                   | Acceptor   |
| Ac                  | Acetyl   |
| AIBN                | 2,2'-Azobisisobutyronitrile  |
| All                 | Allyl  |
| Anal.               | Analytical   |
| Aq.                 | Aqueous  |
| Ar                  | Aryl   |
| Bn                  | Benzyl   |
| Bu <sub>3</sub> SnH | Tributyl tinhydride  |
| BuLi                | Butyl Lithium  |
| Calcd               | Calculated   |
| CAN                 | Ceric Ammonium nitrate   |
| D                   | Donor  |
| d                   | Doublet  |
| DCM                 | Dichloromethane  |
| dd                  | Doublet of doublets  |
| ddd                 | Doublet of doublet of doublet (in NMR)   |
| DMAP                | 4-Dimethylaminopyridine  |
| DMF                 | <i>N,N</i> -Dimethylformamide  |
| DMSO                | Dimethyl sulfoxide   |
| dt                  | Doublet of triplets  |
| Equiv.              | Equivalent(s)  |
| Et                  | Ethyl  |
| EtOAc               | Ethyl Acetate  |
| g                   | Gram(s)  |
| GlcNAc              | 2-Acetamido-2-deoxyglucose   |
| HATU                | <i>O</i> -(7-Azabenzotriazol-1-yl)- <i>N,N,N',N'</i> -tetramethyluronium hexafluorophosphate |
| HOAt                | 1-Hydroxy-7-azabenzotriazole   |

---

---

*List of Abbreviations*

---

---

|                  |  |
|------------------|--|
| Hz               | Hertz                                  |
| IR               | Infrared                               |
| <i>J</i>         | Coupling constant                      |
| LAH              | Lithium Aluminium Hydride              |
| m                | Multiplet                              |
| M <sup>+</sup>   | Molecular ion                          |
| m-CPBA           | <i>meta</i> -Perchlorobenzoic acid     |
| Me               | Methyl                                 |
| MHz              | Mega Hertz                             |
| MIC              | Minimum Inhibition concentration       |
| min              | Minute(s)                              |
| ml               | Millilitre                             |
| mmol             | Millimole                              |
| mp               | Melting Point                          |
| MS               | Mass Spectrometry                      |
| Multi            | Multiciplity                           |
| NBS              | <i>N</i> -Bromosuccinimide             |
| NIS              | <i>N</i> -Iodosuccinimide              |
| NMR              | Nuclear magnetic resonance             |
| PG               | Protecting group                       |
| Ph               | Phenyl                                 |
| ppm              | Parts per million                      |
| q                | Quartet(s)                             |
| rt               | Room temperature                       |
| s                | Singlet(s)                             |
| S <sub>N</sub> 1 | Unimolecular nucleophilic substitution |
| S <sub>N</sub> 2 | Bimolecular nucleophilic substitution  |
| t                | Triplet(s)                             |
| TB               | Tuberculosis                           |
| TBAI             | Tetrabutyl ammonium iodide             |

---

---

*List of Abbreviations*

---

---

|             |   |
|-------------|---|
| TBDMS       | Tributyldimethylsilyl                   |
| td          | triplet of doublets                     |
| TEA         | Triethyl amine                          |
| <i>Tert</i> | Tertiary                                |
| Tf          | trifluoromethanesulphonyl               |
| TFA         | Trifluoroacetic acid                    |
| THF         | Tetrahydrofuran                         |
| TLC         | Thin Layer Chromatography               |
| TMS         | Trimethylsilyl                          |
| TMSOTf      | Trimethylsilyltrifluoromethanesulfonate |
| WHO         | World Health Organisation               |
| X           | Halide(s)                               |
| $\delta$    | Chemical shift                          |

### PUBLICATION

David W. Gammon, Daniel J. Steenkamp, Vuyo Mavumengwana, Mohlopheni J. Marakalala, Theophilus T. Mudzunga, Roger Hunter, **Muganza Munyololo**, *Bioorg. Med. Chem.*, **2010**, *18*, 2501-2514

### CONFERENCES

**Muganza Munyololo**, Gammon, D.W., "Approaches to the stereoselective installation of alkyl side-chains at C-2 of glucose" at the SACI-GDCh, *Bio-National Organic Chemistry Conference*, **January 2010**, University of Pietermaritzburg, South Africa, **Poster**

**Muganza Munyololo**, Gammon, D.W., "Approaches to the stereoselective preparation of 2-deoxy-2-C-alkylglucosides as potential enzyme inhibitors" (poster) at the SACI-GDCh, *Bio-National Organic Chemistry Conference*, **September 2008**, Berg-en-Dal, Kruger National Park, South Africa, **Poster**

**Muganza Munyololo**, Gammon, D.W., "Development of synthetic methods for C-2 alkylation of glucose: towards the preparation of potential inhibitors of enzymes involved in the biosynthesis of mycothiol" at South African Chemical Institute-Mini Symposium, **2007**, University of Western Cape, Cape Town- South Africa, **Oral Presentation**

# CHAPTER 1

## INTRODUCTION

### 1.1 DISEASE: TUBERCULOSIS

**T**uberculosis (TB) is one of the major health-threatening diseases in the world. The World Health Organisation (WHO) estimated that over nine million new cases of TB occurred in 2007. India, China, Indonesia, Nigeria and South Africa rank first to fifth in terms of total number of cases. Asia (the South-East Asia and Western Pacific regions) accounts for 55% of global cases and the African region for 31%; the other three regions (the American, European and Eastern Mediterranean regions) account for small fractions of global cases. Among the 15 countries with the highest estimated TB incidence rates, 13 are in Africa.<sup>1,2</sup>

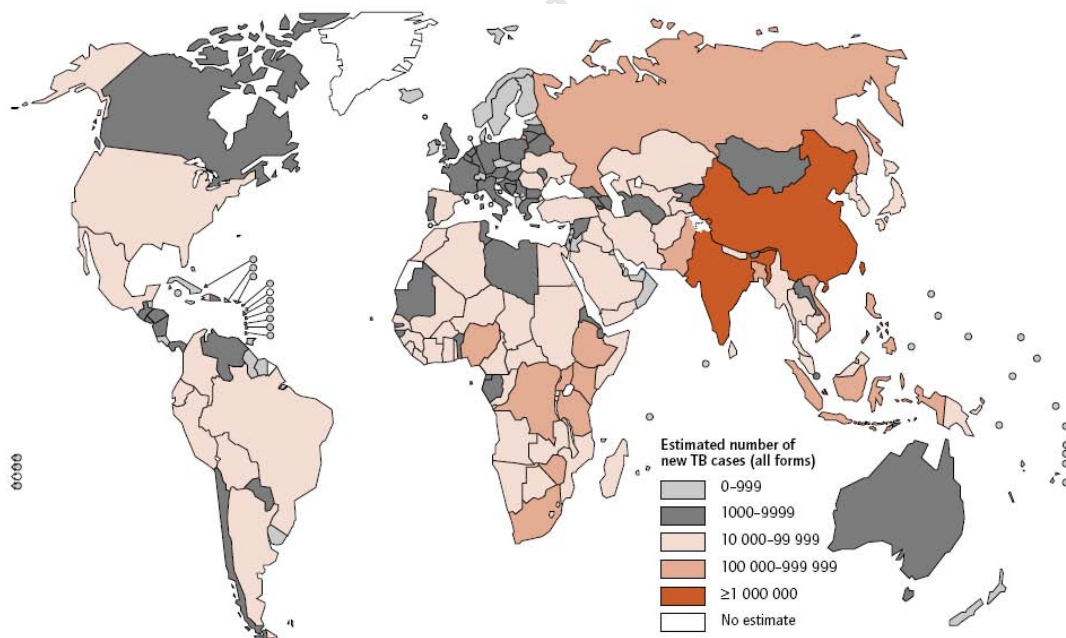

**Figure 1.1:** Estimated number of new TB cases in the World, 2007.<sup>2</sup>

It has been reported that the number of newly infected TB patients has increased in Africa in 2007 and 80% of all TB patients presently live in sub-Saharan Africa and Asia.<sup>2</sup>

In addition, the rate of newly infected TB patients in sub-Saharan and Asian countries has increased due to several factors including poverty, overcrowding, development of drug resistant strains, and synergy between Human Immunodeficiency Virus (HIV) and TB. The prolonged exposure to the drugs by lengthy treatment regimens results in an increased possibility of drug resistance, and this has emerged as a major problem in drug development. The increasing problem of multidrug-resistance and the persistence of *M.tuberculosis* have been driving the development of drugs that are not only active against multidrug-resistant bacteria but that also shorten the drug therapy period required.<sup>3,4,5</sup>

## 1.2 TB CHEMOTHERAPY

There are drugs that are currently used to treat TB. First-line TB drugs<sup>6</sup> include Isoniazid, Rifampin, Pyrazinamide and Ethambutol and second-line TB drugs are *Para*-amino-salicylate, Kanamycin, Fluoroquinolones, Capreomycin, Ethionamide and Cycloserine.

These currently prescribed drugs were developed over 40 years ago, and they have different targets in the metabolic pathways of *Mycobacterium tuberculosis*. Table 1.1 shows current drugs, their mechanisms of action and their respective targets in the tubercle lifecycle:

**Table 1.1:** Current TB drugs, their mechanisms of action and their targets.<sup>3</sup>

| Drugs            | MIC (microgram/ml)      | Mechanism of action                                    | Targets   |
|------------------|-------------------------|--|---|
| Isoniazid        | 0.01-0.20               | Inhibition of cell wall mycolic acid synthesis         | Enoyl acyl carrier protein reductase (InhA)     |
| Rifampin         | 0.05-0.50               | Inhibition of RNA synthesis                            | RNA polymerase, beta subunit                    |
| Pyrazinamide     | 20-1009 (pH 5.5 or 6.0) | Depletion of membrane energy                           | Membrane energy metabolism                      |
| Ethambutol       | 1-5                     | Inhibition of cell wall arabinogalactan synthesis      | Arabinosyl transferase                          |
| Streptomycin     | 2-8                     | Inhibition of protein synthesis                        | Ribosomal S12 protein and 16S rRNA              |
| Kanamycin        | 1-8                     | Inhibition of protein synthesis                        | 16S rRNA  |
| Capreomycin      | 4                       | Inhibition of protein synthesis                        | 16S rRNA, 50S ribosome, rRNA, methyltransferase |
| Fluoroquinolones | 0.2-4.0                 | Inhibition of DNA synthesis                            | DNA gyrase                                      |
| Ethionamide      | 0.6-2.5                 | Inhibition of mycolic acid synthesis                   | Acyl carrier protein reductase (InhA)           |
| PAS              | 1-8                     | Inhibition of folate pathway and mycobactin synthesis? | Thymidylate synthase (ThyA)?                    |

From the Table 1.1, it is notable that current TB drugs inhibit a diverse range of targets in DNA synthesis, RNA

synthesis, protein synthesis, and cell wall synthesis and the energy metabolism pathway. Other enzymes in these metabolic pathways which are not inhibited by current TB drugs could also be targets as could be enzymes involved in the pathogenesis of the disease process, like the enzymes involved in the liquefaction from necrotic lesion to the cavity formation<sup>7,8,9</sup> and the protective system of the bacterium against reactive species.<sup>10,11</sup>

Despite the specificity of the current drugs to different sites of action, these drugs still face remarkable resistance from the bacteria. Multi-drug resistance (MDR) has been observed in most of the current TB-drugs.<sup>12</sup> Consequently, the search for anti-TB treatment has been a challenge and attracted researchers from all over the world. One of the approaches has been to try to develop potential therapeutic agents that inhibit the biosynthesis of its defensive agents, typically low molecular weight thiols.

### 1.3 Low molecular weight thiols

Low molecular weight thiols play a significant role in human systems. Thiols are essential for the maintenance of redox homeostasis as well as for the protection of cells against reactive species including reactive oxygen and nitrogen species.<sup>10,11</sup> Low molecular weight thiols also participate in a number of important biological functions as redox buffers, reducing cofactors and in xenobiotic detoxification.<sup>13</sup>

The tripeptide glutathione (GSH) is the major thiol in eukaryotes and most Gram-negative bacteria and also in cyanobacteria and the purple bacteria.<sup>14</sup> Not all organisms use GSH as their major thiol. The halobacteria use  $\gamma$ -L-glutamyl-L-cysteine,<sup>15</sup> while the pathogenic protozoa of the genera *Trypanosoma* and *Leishmania* use trypanothione ( $N^1, N^8$ -bis(glutathionyl) spermidine)<sup>16</sup> and the *Actinomycetales*

bacteria use mycothiol (1-D-*myo*-inositol-2-(*N*-acetyl-L-cysteinyl)amido-2-deoxy- $\alpha$ -D-glucopyranoside),<sup>17</sup> the most well studied of all the intracellular thiols. Mycothiol (MSH) is a low-molecular weight thiol equivalent of glutathione in *Mycobacterium*.<sup>17</sup>

The metabolic function of MSH in mycobacteria has been the subject of many studies to date. The emerging importance of MSH for *Mycobacterium tuberculosis* growth<sup>8,18,19</sup> has subsequently gained attention, and it is hypothesised that MSH analogues could be potential lead drugs for the treatment of TB.

The thiol was first isolated as a disulfide (MSSM) from *Streptomyces* sp. Strain AJ9463 by Sakuda and co-workers<sup>20a</sup> and the MSSM was given a trivial name mycothione by Blanchard<sup>20b</sup> though Newton and co-workers<sup>20c</sup> opposed this nomenclature. Later Steenkamp and Spies<sup>20d</sup> isolated and identified the thiol from *Mycobacterium bovis* and gave it the trivial name mycothiol (MSH). Newton *et al.* also managed to isolate mycothiol as the bimane derivative (MSmB) from *Streptomyces clavuligerus*.<sup>20e</sup> MSH is obtained exclusively in actinomycetes and is present in high levels in *Mycobacterium tuberculosis*, suggesting that *Mycobacterium tuberculosis* is highly dependent on mycothiol for antioxidant and alkylating processes.

The majority of the studies of MSH biosynthesis and pertinent MSH-dependent processes relevant to oxidative stress management and xenobiotic detoxification have been elucidated in *M. smegmatis* (as a model organism) and *M. tuberculosis* (as a therapeutically relevant pathogen).<sup>13</sup>

### 1.3.1 Mycothiol synthesis

#### 1.3.1.1 Whole cell synthesis

The pathway for MSH biosynthesis (Scheme 1.1) starts with L-*myo*-inositol-1-phosphate, which is obtained from glucose-6-phosphate by the action of the inositol-1-phosphate synthase (Ino-1). The MSH biosynthetic pathway has been elaborated in the *Mycobacteria* and involves five enzymatic steps (Scheme 1.1). It was originally proposed that MshA catalyses the first step from which *N*-Acetylglucosaminylinositol (GlcNAc-Ins) is formed, using *myo*-inositol as an acceptor substrate. However the activity of GlcNAc-transferase was never observed when using *myo*-inositol as the acceptor substrate with either crude *M.smegmatis* cell lysates<sup>21</sup> or purified *M.tuberculosis* recombinant MshA.<sup>22</sup> It was only later that the acceptor for MshA was identified to be 1-L-*myo*-inositol-1-phosphate.<sup>23</sup>

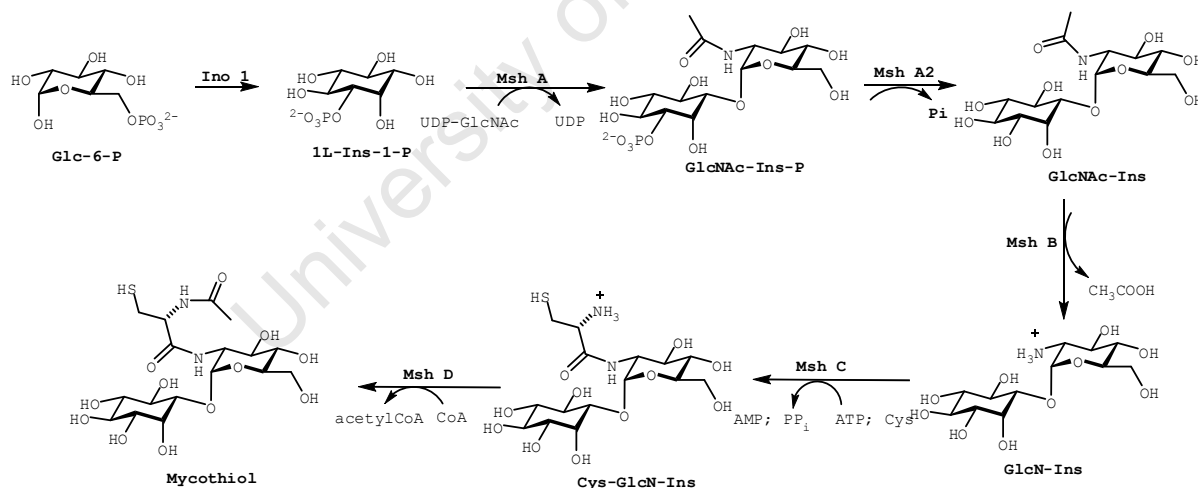

**Scheme 1.1:** Mycothiol biosynthesis pathway<sup>24</sup>

The structural basis for the selectivity of the acceptor was identified from the structure of *C.glutamicum* MshA, which had been resolved with both UDP and 1-L-*myo*-Inositol-1-phosphate bound in the active site.<sup>25</sup> The known role that MshA plays in the biosynthesis of mycothiol is as a glycosyl-transferase,

generating GlcNAc-Ins. In this reaction UDP-*N*-acetylglucosamine serves as the *N*-acetylglucosamine donor and 1-*L*-*myo*-Inositol-1-phosphate serves as the acceptor.<sup>26</sup>

The second step is presumed to be undertaken by a phosphatase (designated MshA2) which hydrolyses the enzymatic product of MshA, though the genes have yet to be identified. Other carbohydrate phosphatase superfamily genes such as *suh B* (Rv2701c),<sup>27</sup> Rv3137c,<sup>28</sup> *imp A* and *cysQ* from the *M. tuberculosis* genome are already known to exhibit inositol monophosphatase activity.<sup>29,30</sup>

The third step involves MshB, a zinc metalloprotein that catalyses hydrolysis of the acetamide formed by MshA in the first step, to give rise to the glycoside of glucosamine, GlcN-Ins.<sup>21</sup> The activity of this protein is lost in the presence of a metal chelator<sup>31</sup> or in proximity of an *N*-terminal Hist-tag to the active site, as in the case of Hexahistidine-tagged recombinant MshB, which strips the metal ion from the active site.

A fourth step involves an MSH ligase, MshC, which catalyses the coupling of cysteine to the C-2-amino group of GlcN-Ins.<sup>32</sup> The final step is catalysed by the mycothiol synthase, MshD which mediates the acetyl-CoA-dependent *N*-acetylation of Cys-GlcN-Ins.<sup>33</sup>

The inhibition of one or more of these enzymes could bring about inhibition of MSH production and therefore be potential drug targets. The evaluation of the enzymes of MSH metabolism as suitable potential drug targets depends on several criteria<sup>34</sup> such as exhibition of the drugability of the target,<sup>35,36</sup> essentiality for growth and whether inhibition of the enzyme is effective against latent or dormant states of *M.*

tuberculosis.<sup>37</sup> Studies have now shown that these enzymes are potential targets for the inhibition of production of MSH.<sup>24</sup>

### 1.3.1.2 Chemical synthesis

The first preparation of mycothiol was a semi-synthetic approach (Scheme 1.2).<sup>38,39</sup> Here silver triflate-mediated coupling of penta-*O*-acetyl-1-*D*-myo-Inositol **1.1** with the glycosyl bromide **1.2**, derived from a 2,4-dinitrophenyl (DNP)-protected glucosamine, gave inosityl-glycoside **1.3** as a 1:1 anomeric mixture, separable by column chromatography. Full deprotection of **1.3** produced **1.4**, with this route applied to both the DL racemate<sup>38</sup> and the *D*-stereoisomer<sup>39</sup> of **1.1**. Coupling of **1.4** with undialysed, cell-free extract from *M. smegmatis* gave a 4:1 product mixture of MSH and *N*-desacetylmucothiol (DAM) in 40% conversion.

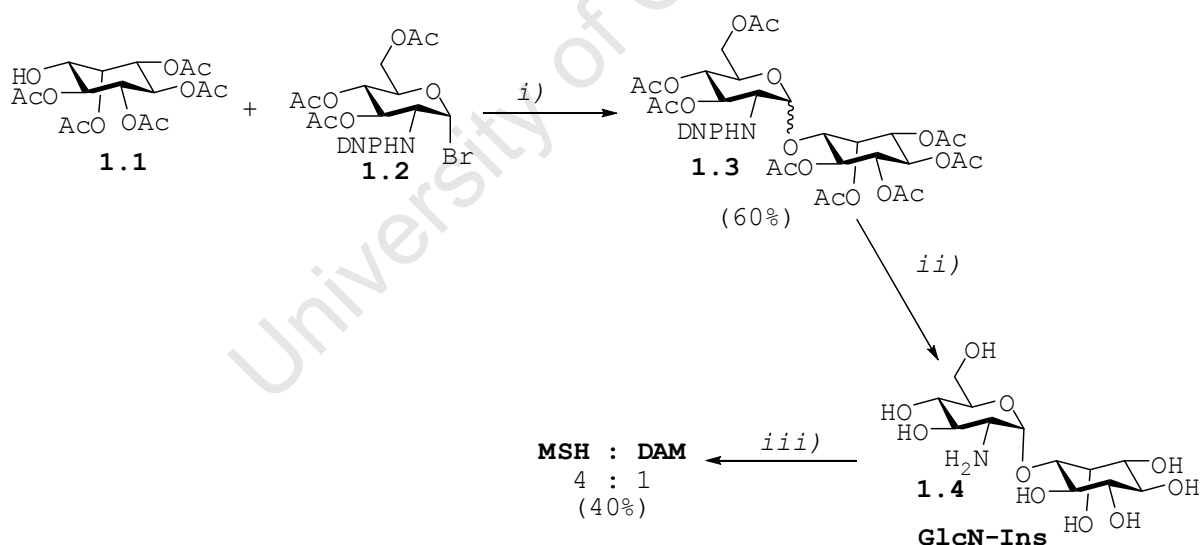

**Scheme 1.2** Reagents and conditions: *i*)  $\text{CF}_3\text{SO}_3\text{Ag}$ , 2,6-di-*tert*-butylpyridine,  $\text{CH}_2\text{Cl}_2$ , 60%; *ii*) Amberlite IR400 (OH); *iii*) *M. smegmatis* undialysed cell extract.

In another approach, trichloroacetimidate **1.5** was reacted with **1.1** to give glycoside **1.6** in 45% yield in a 9:1  $\alpha$ : $\beta$  product ratio.<sup>40</sup> The most selective  $\alpha$ -glycosylation was achieved using TMSOTf-promoted coupling of **1.1** with **1.5** to afford **1.6**. Azide

reduction followed by coupling of **1.7** with CysNAc-SAc using carbodiimide reagents (DCC or EDCI) resulted in racemisation of the Cys sidechain.<sup>41</sup>

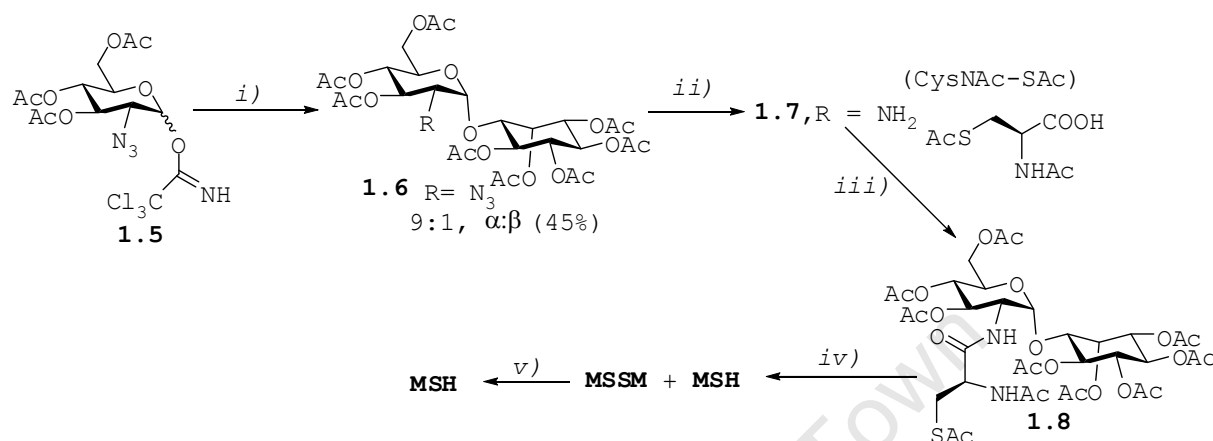

**Scheme 1.3** Reagents and conditions: *i)*  $\text{CF}_3\text{SO}_3\text{SiMe}_3$ , **1.1**, MS,  $\text{CH}_2\text{Cl}_2$ , 56%; *ii)* Pd/C,  $\text{H}_2$ , EtOAc, HCl, 81%; *iii)* HATU, HOAt, collidine, DMF, 25%; *iv)*  $\text{Mg}(\text{OMe})_2$ , MeOH, 69%; *v)* BMS,  $\text{H}_2\text{O}$ , 100%

However, using HATU/HOAt and collidine at  $0^\circ\text{C}$  provided diastereomerically pure **1.8** in 25% yields. Global deprotection of **1.8** under basic conditions gave a mixture of MSH and its symmetrical disulfide MSSM which was cleanly reduced to MSH by treatment with a 6-fold excess of bis(2-mercaptoethyl)sulfone (BMS). MSH was obtained in pure form after removing unconsumed and oxidised BMS by ethyl acetate extraction. Apart from that, other multi-step synthetic preparations of MSH have been accomplished but in low overall yields and on a small scale.<sup>40,42</sup>

An alternative route to MSH was explored involving cyclisation of glucosamine-*S*-CysNAc- $\beta$ -thioglycoside **1.9** to form a fused bicyclic thioglycoside **1.10** as a potentially  $\alpha$ -selective *N*-cysteinyl glucosamine donor.<sup>43</sup> This route was unsuccessful as the cyclic thioglycoside **1.10** proved too unreactive, and conditions could not be found to achieve the desired single

step opening and glycosylation to give the desired protected MSH **1.11** and eventually to MSH.

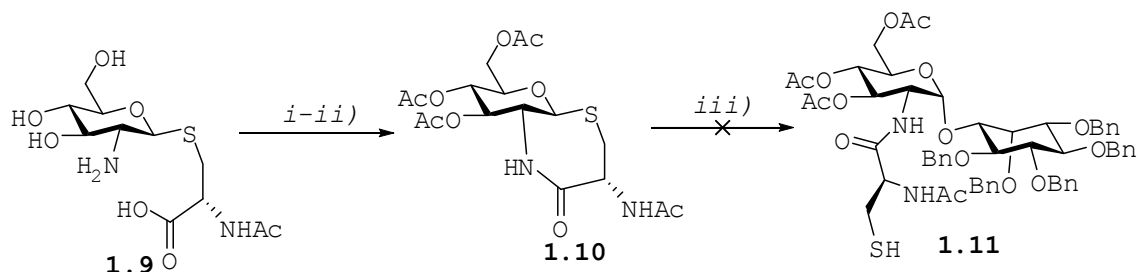

**Scheme 1.4** Reagents and conditions: *i*) EDCI, HOBT, DMF *ii*)  $\text{Ac}_2\text{O}$ , pyridine, 50% *iii*) Thiophilic promoter (*N*-iodosuccinimide/ $\text{CF}_3\text{SO}_3\text{Ag}$  or dimethylsulfonium triflate or  $\text{CF}_3\text{SO}_3\text{CH}_3$ ), pentabenzylated *myo*-inositol (**1.12**)

Recently, a new route for MSH synthesis was developed by Knapp *et al.*<sup>44</sup> involving a key intramolecular glycosidation step. The methylthiomethyl ether **1.13**<sup>45</sup> was synthesised from pentabenzylated *myo*-inositol **1.12**<sup>46</sup> to provide an inositol derivative which could be tethered to the glycosyl donor.

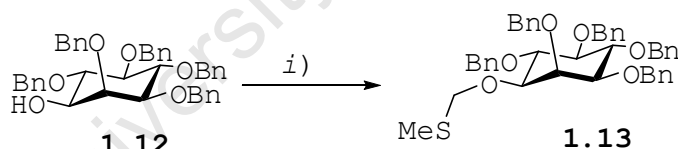

**Scheme 1.5:** *i*)  $\text{MeSCH}_2\text{Cl}$ , NaI, NaH, THF, 8h, 74%

To prepare the glycosyl donor, 1,3,4,6-Tetra-*O*-acetyl- $\beta$ -D-glucosamine **1.14**<sup>47</sup> (Scheme **1.6**) was transformed<sup>48</sup> to the 2-naphthalenesulfonamide **1.15** and afterwards to the *p*-tolyl thioglycoside **1.16**. Phosphazene base 2-*tert*-butylimino-2-diethylamino-1,3-dimethylperhydro-1,3,2-diazaphosphorine (BEMP) mediated coupling of **1.16** with protected inositol **1.13** produced glycoside **1.17** having the glycosyl acceptor tethered via the amine. Activation of this thioglycoside using  $\text{PhSeCl}$  with catalytic  $\text{AgOTf}$  then gave the desired  $\alpha$ -glucoside **1.18** in

high yield after the quench. Careful selective reductive cleavage of the *N*-sulfonyl protecting group and deprotection of the acetates were performed in the presence of five *O*-benzyl ethers under NaOMe/MeOH conditions and led to the amino triol **1.19**, and hydrogenolysis gave the 2-amino glycoside **1.20** as its hydrochloride salt. Subsequent coupling with *N*-Boc-*S*-acetylcysteine **1.21**<sup>49</sup> resulted in amide **1.22** which was deprotected by treatment with trifluoroacetic acid. Neutralization of the resulting ammonium trifluoroacetate salt induced *S* to *N* vicinal migration of the acetyl group, to give the natural product MSH **1.23**.

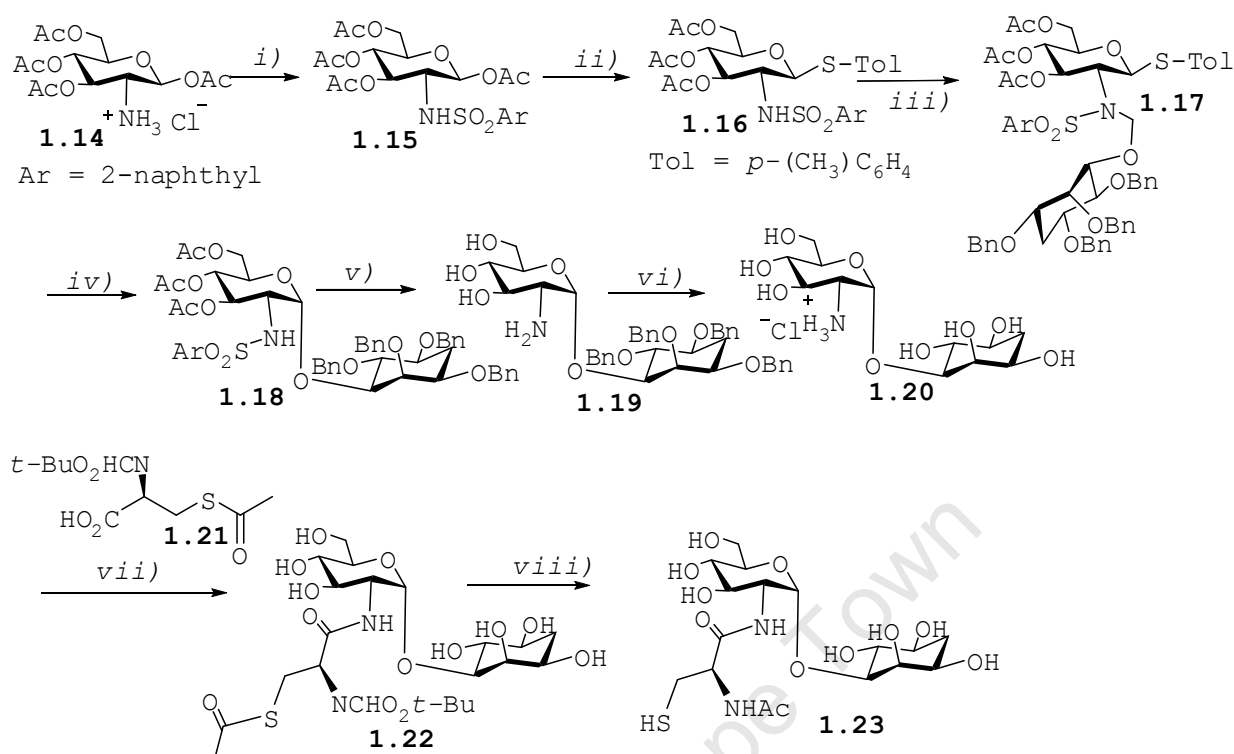

**Scheme 1.6:** Reaction conditions: *i*) ArSO<sub>2</sub>Cl, Et<sub>3</sub>N, CH<sub>2</sub>Cl<sub>2</sub>, 95%; *ii*) Tol-SH, BF<sub>3</sub>·OEt<sub>2</sub>, CH<sub>2</sub>Cl<sub>2</sub>, 93%, (9:1, β/α); *iii*) BEMP, THF, 4 Å MS, 0°C, 96%; *iv*) PhSeCl, AgOTf, CH<sub>2</sub>Cl<sub>2</sub>, CHCN, 78°C to -20°C, 98%; *v*) (a) NaOMe, MeOH, (b) Na(Hg), Na<sub>2</sub>HPO<sub>4</sub>, MeOH, 15 min., 74%, *v*) H<sub>2</sub>, Pd(OH)<sub>2</sub>, HCl, aq. *t*-BuOH 6h, 98% *vii*) HATU, *i*-Pr<sub>2</sub>EtN, DMF, 0 to 23°C, 12h, 77%; *viii*) (a) TFA, CH<sub>2</sub>Cl<sub>2</sub>, (b) Pyridine, (c) concentrate, 100% overall

Notwithstanding the success of these procedures for MSH chemical synthesis, MSH can still only be generated on a small scale.<sup>13</sup> The whole-cell synthesis remains the most economic route to milligram quantities of MSH. Nevertheless, many mycothiol derivatives have been successfully synthesised in excellent yields and tested against enzymes involved in the biosynthesis of MSH.<sup>13</sup>

## 1.4 Carbohydrate-based inhibitors of enzymes involved in MSH biosynthesis

The rise in the number of MDR-TB strains has opened a new approach for the discovery of new TB drugs. The earliest work on carbohydrate-based inhibitors of enzymes involved in MSH biosynthesis was done by Patel and Blanchard where they synthesised the natural substrate Des-*myo*-inositol-MSH disulfide (MSSM) **1.24** and investigated its potential as a possible inhibitor of the mycothione reductase.<sup>50</sup> The result showed that though it lacks the *myo*-inositol units, it provides sufficient features to act as an active analogue of MSH.

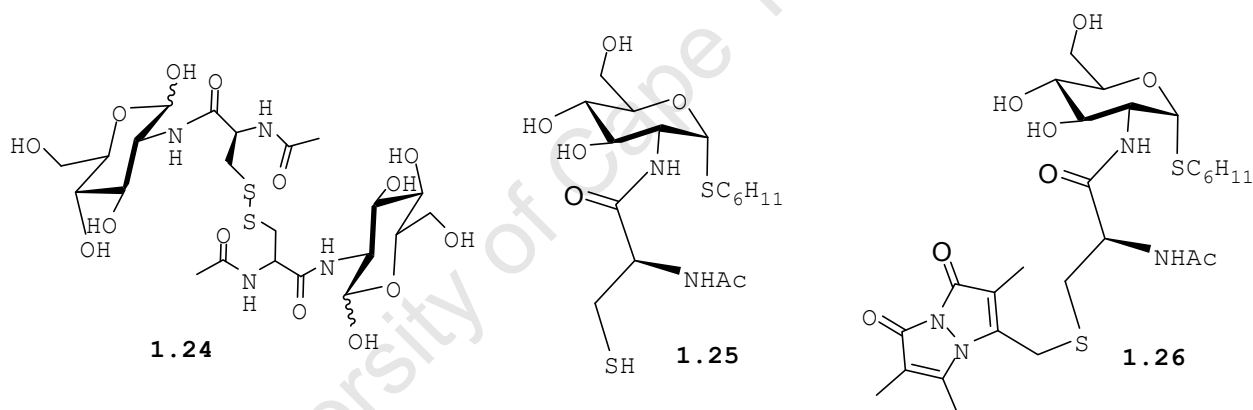

**Figure 1.2:** Des-*myo*-inositol-mycothiolsulfide **1.24**, cyclohexyl thioglycoside **1.25**, and its bimane derivative **1.26**.

Knapp *et al.* also reported the synthesis of a cyclohexyl thioglycoside analogue **1.25** of MSH which in order to evaluate its potential substrate ability for *M. tuberculosis* MSH *S*-conjugate amidase was converted to its bimane derivative **1.26**. The bimane derivative **1.26** was found to be a good substrate for Mca.<sup>13</sup> This suggested that neither the glycosidic linking atom nor the inositol hydroxyls play a major role in enzyme binding.

Gammon *et al.*<sup>51</sup> reported the synthesis of a number of C-2 modified isosteres of GlcNAc-Ins among which the 2-C-modified inositol glucosides **1.27**, and **1.28**, and the cyclohexyl 2-C-allyl glucopyranoside **1.29** were tested for their biological activity. Although they did not inhibit the growth of *M. smegmatis in vitro*, a pronounced inhibition of incorporation of [<sup>3</sup>H] inositol by whole cells into inositol containing metabolites was observed. This result suggested that MSH analogues can indeed inhibit the biosynthesis of mycothiol, thereby potentially paving the way for the design of new TB drugs.

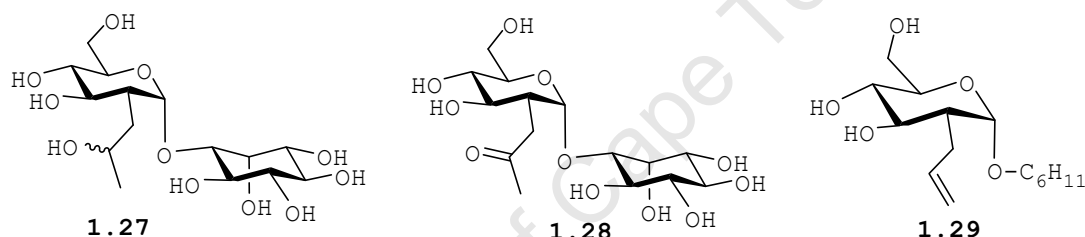

**Figure 1.3:** Mycothiol inhibitors

From the abovementioned investigations and findings there is some evidence that synthetic analogues of the natural substrates can inhibit the enzymes involved in the biosynthesis or detoxification process of MSH and that preparation of larger numbers of carefully designed analogues is needed. The analogues modified at C-2 position of the sugar unit remain an important target, and justified the development of new methodologies for synthesis and manipulation of the 2-deoxy sugar.

### 1.5 AIM AND OBJECTIVES OF THE PROJECT

The aims of this project were as follows: (a) to synthesise and evaluate a number of thioglycosides of 2-acetamidoglucose (compounds **1.30–1.32**) as alternative substrates of MshB, in order to establish whether simple thio-aryl or thiobenzyl

aglycones can be tolerated by the enzyme active site, and (b) to design and synthesise potential substrate-based inhibitors of MshB, with metabolically stable modifiable alkyl chains at the C-2 position that will allow easy functionalization at that position.

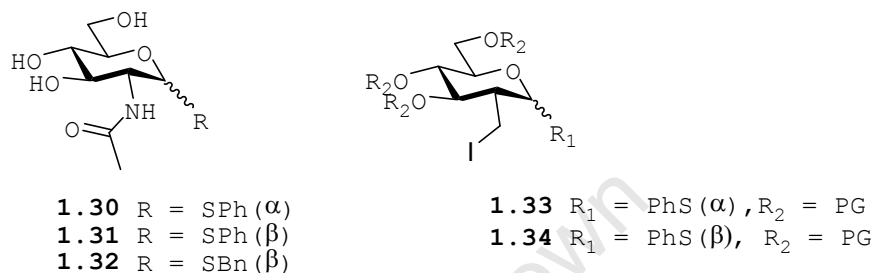

**Figure 1. 4:** Potential substrates **1.30-1.32** and inhibitor **1.33** and **1.34** of enzymes involved in mycothiol biosynthesis

The molecules of the type **1.33** or **1.34** would serve as starting materials to generate more derivatives. Based on the above aims, the objectives of this project are as follows:

- To stereoselectively synthesise thioglycosides of 2-acetamidoglucose **1.30-1.32**
- To develop and optimize general and stereoselective synthetic strategies for preparation of 2-deoxy-2-C-alkylglucosides **1.33** or **1.34**, having aglycones R<sub>1</sub> which are suitable surrogates for D-*myo*-inositol, and functionalized side-chains R which permit generation of a wide variety of side-chain-modified analogues of MSH and its biosynthetic precursors.

---

**1.6 REFERENCES**

- 
- [1] Dye; C. *et al.* *JAMA*, **1999**, *282*, 677-686
- [2] WHO Report, **2009**, Global tuberculosis control: epidemiology, strategy and financing, visited 23 March 2010.
- [3] *Global Alliance for Tuberculosis Drug Development (2001) Executive Summary of the Scientific Blueprint for TB Drug Development. Tuberculosis (Edinb.)* 81 (Suppl.), 1-52
- [4] O'Brien, R.J.; Nunn; P.P. *Am.J. Respir. Crit. Care Med.*, **2001**, *163*, 1055-1058
- [5] Zhang; Y. *Annu. Rev. Pharmacol. Toxicol.*, **2005**, *45*, 529-564
- [6] Blumberg, H.M *et al.* *Am.J. Respir. Crit. Care Med.*, **2003**, *163*, 603-662
- [7] Dannenber, A.M., Jr *Immunology*, **1994**, *191*, 461-473
- [8] Grosset, J. *Antimicrob. Agents. Chemother.*, **2003**, *47*, 833-836
- [9] Lamichhane, G. *et al.*, *Proc. Natl. Acad. Sci. USA*, **2003**, *100*, 7213-7218
- [10] Fahey, R.C. *Ann. Rev. Microbiol.*, **2001**, *55*, 333-356
- [11] Hand, C.E.; Honek, J.F. *J. Nat. Prod.*, **2005**, *62*, 293-308
- [12] WHO, *Global Project on Anti-tuberculosis Drug Resistance Surveillance WHO Report 2008*. World Health Organization Document, 2008. WHO/HTM/TB/2008.394.
- [13] Jothivasan, V.K.; Hamilton, C.J. *Nat. Prod. Rep.*, **2008**, *25*, 1091-1117
- [14] Newton, G.L.; Fahey, R.C. *Meth. Enzymol.*, **1995**, *251*, 148-166
- [15] Newton, G.L.; Javor, B. *J. Bacteriol.*, **1985**, *161*, 438-441
- [16] Fairlamb, A.H.; Blackburn, P.; Ulrich, P.; Chait, B. T.; Cerami, A. *Science*, **1985**, *227*, 1485-1487

- [17] Newton, G.L.; Arnold, K.; Price, M.S.; Sherrill, S.B.; Delcardayre, Y.; Aharonowitz, G.; Cohen, J.; Fahey, R.C.; Davis, C. *J. Bacteriol.*, **1996**, *178*, 1990-1995
- [18] Rothstein, D.M. *et al. Expert Opin. Investig. Drugs*, **2003**, *12*, 255-271
- [19] Gerald, L.N.; Philong, T.; Bzymek, K.P.; Fahey, R.C. *J. Biol. Chem.*, **2006**, *281*, 33910-33920
- [20] (a) Sakuda, S.; Zhou, Z.Y.; Yamada, Y. *Biosci. Biochem.*, **1994**, *58*, 1347-1348, (b) Patel, M.P.; Blanchard, J.S. *Biochem.*, **1999**, *38*, 11827-11833, (c) Newton, G.L.; Fahey, R.C. *Arch. Microbiol.*, **2002**, *178*, 388-394, (d) Spies, H.S.; Steenkamp, D.J. *Eur. J. Biochem.*, **1994**, *224*, 203-213, Newton, C.A.; Bewley, T.J.; Dwyer, R.; Horn, Y.; Aharonowitz, G.; Cohen, G.; Davis, J.; Faulkner, D.J.; Fahey, R.C. *Eur. J. Biochem.* **1995**, *230*, 821-825
- [21] Newton, G.L.; Av-Gay, Y.; Fahey, R.C. *J. Bacteriol.*, **2000**, *182*, 6958-6963
- [22] Newton, G.L.; Koledin, T.; Gorovitz, B.; Rawat, M.; Fahey, R.C.; Av-Gay, Y. *J. Bacteriol.*, **2003**, *185*, 3476-3479
- [23] Campbell, J.A.; Davies, G.J.; Bulone, V.; Henrissat, B. *Biochem. J.*; **1997**; *326*; 929-939
- [24] Newton, G.L.; Buchmeier, N.; Fahey, R.C.; *Mycrobiol. and Molec. Biol. Rev.*; **2008**; *72*; 471-494
- [25] Vetting, M.W.; Frantom, P.A.; Blanchard, J.S. *J. Biol. Chem.*; **2008**, *283*; 15834-15844
- [26] Newton, G.L.; Ta, P.; Bzymek, K.P.; Fahey, R.C. *J. Biol. Chem.*, **2006**, *281*, 33910-33920
- [27] Nigou, J.; Dover, L.G.; Besra, G.S. *Biochem.*, **2002**, *41*, 4392-4398.

- [28] Bone, R.; Frank, L.; Springer, J.P.; Pollack, S.J.; Osborne, S.; Atack, J.R.; Knowles, M.R.; McAllister, G.; Ragan, C.I.; Broughton, H.B.; Baker, R.; Fletcher, S.R. *Biochem.*, **1994**, *33*, 9460–9467.
- [29] Gu, X.; Chen, M.; Shen, H.; Jiang, X.; Huang, Y.; Wang, H. *Biochem. Biophys. Res. Commun.*, **2006**, *339*, 897–904.
- [30] Morgan, A.J.; Wang, Y.K.; Roberts, M.F.; Miller, S.J. *J. Am.Chem.Soc.*, **2004**, *126*, 15370–15371.
- [31] Newton, G.L.; Ko, M.; Ta, P.L.; Av-Gay, Y.; Fahey, R.C. *Prot.Expr. Purif.*, **2006**; *47*; 542–550.
- [32] Sareen, D.; Steffek, M.; Newton, G.L.; Fahey, R.C. *Biochem.*, **2002**, *41*, 6885–6890.
- [33] Koledin, T.; Newton, G.L.; Fahey, R.C. *Arch. Microbiol.*, **2002**, *178*, 331–337
- [34] Payne, D.J., Gwynn, M.N.; Holmes, D.J.; Pompliano, D.L. *Nat.Rev. Drug Discov.*, **2007**, *6*, 29–40.
- [35] Lipinski, C.A., *J. Pharmacol. Toxicol. Methods* , **2000**, *44*, 235–249.
- [36] Schneider, M., **2004**, *Arch. Pharm. (Weinheim)*, *337*, 625–633.
- [37] Barry, C.E.; Duncan, K.; *Drug Disc.Today*, **2004**, *1*, 491–496.
- [38] Bornemann, C.; Jardine, M.A.; Spies, H.S.C.; Steenkamp, D.J. *Biochem.J.*, **1997**, *325*, 623–629.
- [39] Jardine, M.A.; Spies, H.S.C.; Nkambule, C.M.; Gammon, D.W.; Steenkamp, D.J. *Bioorg. Med. Chem.*, **2002**, *10*, 875–881.
- [40] Lee, S.; Rosazza, J.P.N. *Org. Lett.*, **2004**, *6*, 365–368.
- [41] Jothivasan, V.K.; Hamilton, C.J. *Nat. Prod. Rep.*, **2008**, *25*, 1091–1117

- [42] Nicholas, G.M.; Kovac, P.; Bewley, C.A. *J. Am. Chem. Soc.*, **2002**, *124*, 3492-3493.
- [43] Slattegard, R.; Gammon, D.W.; Oscarson, S. *Carbohydr. Res.*, **2007**, *342*, 1943-1946.
- [44] Ajayi, K.; Thakur, V.V.; Lapo, R.C.; Knapp, S. *Org. Lett.*, **2010**, *12*, 2630-2633
- [45] Corey, E.J.; Bock, M.G. *Tetrahedron Lett.* **1975**, *16*, 3269-3270.
- [46] Massy, D.J.R.; Wyss, P. *Helv. Chim. Acta* **1990**, *73*, 1037-1057. Baker, G.R.; Billington, D.C.; Gani, D. *Tetrahedron* **1991**, *47*, 3895-3908. Koto, S.; Hirooka, M.; Yoshida, T.; Takenaka, K.; Asai, C.; Nagamitsu, T.; Sakuma, H.; Sakurai, M.; Masuzawa, S.; Komiya, M.; Sato, T.; Zen, S.; Yago, K.; Tomonaga, F. *Bull. Chem. Soc. Jpn.* **2000**, *73*, 2521-2529.
- [47] Bergmann, M.; Zervas, L. *Chem. Ber.* **1931**, *64*, 973-980.
- [48] Nyasse, B.; Grehn, L.; Maia, H.L.S.; Monteiro, L.S.; Ragnarsson, U. *J. Org. Chem.* **1999**, *64*, 7135-7139.
- [49] Knapp, S.; Gonzalez, S.; Myers, D.S.; Eckman, L.L.; Bewley, C.A. *Org. Lett.* **2002**, *4*, 4337-4339.
- [50] Patel, M.P.; Blanchard, J.S., *J. Am. Chem. Soc.*, **1998**, *120*, 11538-11539
- [51] Gammon, D.W.; Hunter, R.; Steenkamp, D.J.; Mudzunga, T. *Bioorg. Med. Chem.*, **2003**, *13*, 2045-2049

## CHAPTER 2

### REVIEW ON C-2 ALKYLATION OF GLYCOPYRANOSIDES

#### 2.1 Introduction

**B**ranch ed-chain carbohydrates are defined as sugar molecules with alkyl, alkenyl or alkynyl substituents directly attached to the carbon skeleton. The occurrence of branched-chain carbohydrates in nature has encouraged interest in the syntheses of these complex structures and there is continuing interest in the preparation of analogues for evaluation of biological activity. Accordingly, new methods for their construction continue to be devised<sup>1</sup> stimulated by the availability of sugars as cheap, chiral starting materials with arrays of hydroxylated carbon atoms disposed for further reactions.

A classification of branched-chain sugars has been proposed<sup>2</sup> and a modification of this is used in this review of methods for preparing C-2-branched sugars (Fig. 2.1): C-C-H bonds (type 1), C-C-X bonds (type 2), C=C bonds (type 3), geminal doubly branched-chain sugar (type 4) and vicinal doubly branched-sugars (type 5) at any position of the sugar molecule.

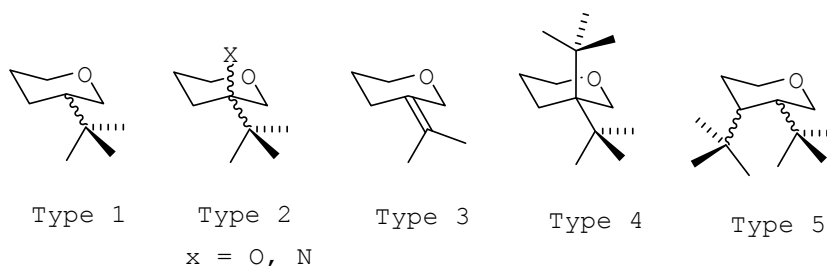
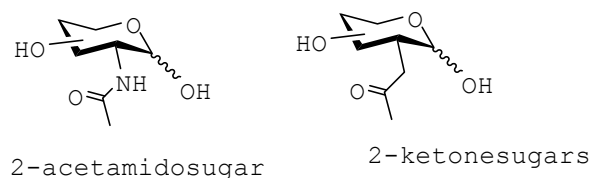

Figure 2.1: C-2-alkylated pyranosides, following Stephen's classification.<sup>2</sup>



**Figure 2.1: 2-acetamidoglucopyranose and its C-2 isostere**

There has recently been renewed interest in the 2-C-alkylated sugars as mimics of the biologically-significant 2-acetamidoglucopyranose (Fig. 2.2),<sup>3</sup> *N*-acetylglucosamine (GlcNAc) and *N*-acetylgalactosamine (GalNAc). These occur widely in glycoproteins, proteoglycans and glycolipids, so that their C-2-modified derivatives (Fig. 2.2) are attractive targets for metabolic engineering. It is known that GlcNAc and GalNAc are converted within cells to their UDP-activated analogues via salvage pathways,<sup>4</sup> and it is therefore considered that unnatural GlcNAc and GalNAc derivatives could be substrates for metabolic glycoproteins.<sup>3</sup> The 2-ketoglucopyranose, which are isosteres of the 2-acetamidoglucopyranose permit exogenous chemical cell surface targeting<sup>5</sup> and they are believed to be transformed into glycoconjugate-bound sialosides by human cells.<sup>6</sup>

Another recent application of the isosteres of 2-acetamidoglucopyranose is their demonstrated activity as substrate-based inhibitors of the amidases implicated in the biosynthesis of mycothiol. Glycosides of 2-ketoglucopyranose and other 2-C-alkylated sugars have been shown to be metabolically stable competitive inhibitors of MshB. There is thus an ongoing interest in developing methodologies for efficient, stereoselective construction of 2-C-alkylated sugars, and recent developments in this regard are discussed here.

From an examination of the literature on C-2 branched sugars, types 1-3 (Fig. 2.1) are most common and the focus of this review will therefore reflect this.

## 2.2 Compounds with a C-C-H branch (Type 1)

### 2.2.1 Via nucleophilic Opening of epoxides on the sugar

#### skeleton

Epoxides (or oxiranes) are important building blocks in organic synthesis and polymer science<sup>7</sup> due to the reactivity associated with ring strain in the three-membered ring system. Fusion of oxiranes with the pyran ring allows for regioselective introduction of a nucleophile onto the pyranoside ring, with selectivity dictated by factors such as the preference for a *trans*-diaxial transition state in the substitution pattern<sup>8</sup> or the influence of the electrophilic anomeric centre.

Inch and Lewis<sup>9</sup> confirmed the limited reactivity of some 2,3-anhydro sugars with several Grignard and alkyl-(or aryl)-lithium reagents, and reported their tendency to afford reduction or elimination by-products. However, Kelly *et al.*<sup>10</sup> have reported efficient copper-catalysed ring opening of oxiranes by Grignard reagents. Though it was not covered by the author, it is equally possible that a transmetallation occurs and the reaction proceeds simply *via* an organocuprate without catalysis. For example, the 1,6:2,3 dianhydro-2-tosyloxy derivative **2.1**, on treatment with allylmagnesium chloride **2.2** in the presence of a catalytic amount of cuprous iodide, gave exclusively the 2-C-allyl derivative **2.3**. Beau *et al.*<sup>12</sup> have also successfully opened 2,3-epoxide **2.4** with Grignard reagent **2.5** using CuI as a catalyst at -30°C to give 2-C-alkylated derivative **2.6** (Scheme 2.4). The stereo- and regiospecific outcomes in both the above cases are as predicted by the Furst-Plattner rule<sup>11</sup>, which states that cyclohexene epoxides undergo ring opening with nucleophiles to give diaxial product.

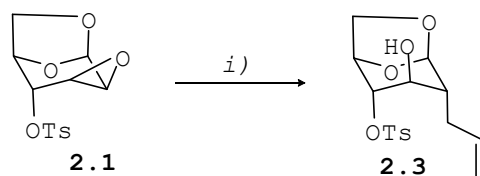

**Scheme 2.1** Reaction conditions: *i*)  $\text{CH}_2=\text{CHCH}_2\text{MgCl}$  (**2.2**), CuI, THF, 20 h, 88%

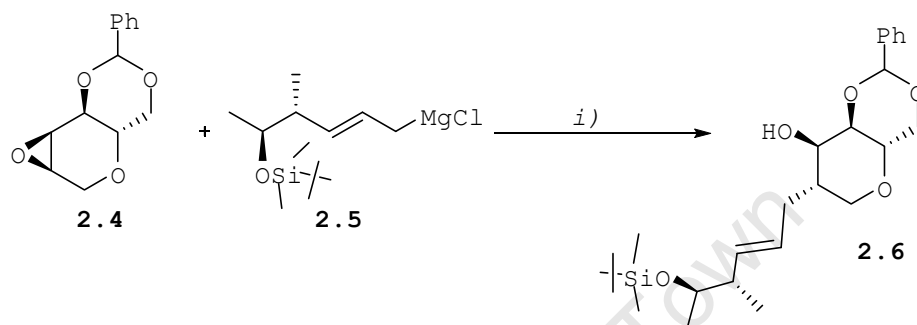

**Scheme 2.2** Reaction conditions: *i*) CuI, THF,  $-30\text{ }^\circ\text{C}$ , 43%

Nucleophilic opening of the oxirane ring of 4,6-*O*-benzylidene-1,5:2,3-dianhydro-D-allitol **2.4** was achieved with good regio- and stereoselectively with the Grignard reagent **2.5** in the presence of catalytic amount of CuI.<sup>12</sup> However, compound **2.7**, the analogue of **2.4** with the epoxide on the  $\alpha$ -face, required a large excess of  $\text{Me}_2\text{CuLi}$  to give **2.8** in 64% yield. Corriu *et al.*<sup>13</sup> attempted to open the oxirane ring in **2.7** with functionalised carbon chains using the homocuprates prepared in the usual way<sup>14</sup> from allyl-lithium, vinyl-lithium, or 1-(trimethylsilyl)prop-1-enyl-lithium, and failed even with the higher order mixed cuprates<sup>15</sup>,  $\text{R}_2\text{Cu}(\text{CN})\text{Li}_2$  ( $\text{R}_2$ =allyl or vinyl). However, the reaction went smoothly with allylmagnesium chloride in THF at  $-30\text{ }^\circ\text{C}$  to give the 2-*C*-allyl compound **2.9** in 80-88% yield with ~5% of **2.10** as byproduct.

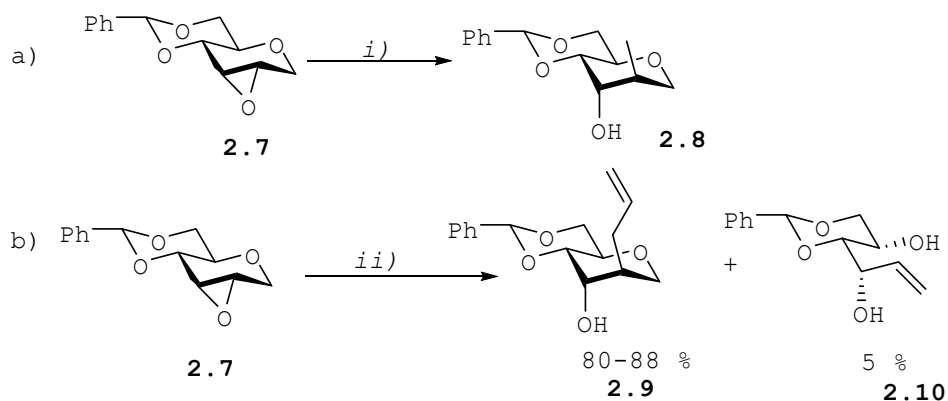

**Scheme 2.3** Reaction conditions: i)  $\text{Me}_2\text{CuLi}$ ; ii)  $\text{CuI}$ , **2.2**, THF,  $-30^\circ\text{C}$

By contrast, addition of **2.7** to a solution of allylmagnesium bromide **2.11** and  $\text{CuI}$  (10 mol %) in THF at  $-30^\circ\text{C}$  gave only the bromohydrin **2.12** in 90% yield. The formation of **2.12** was rationalized as involving a Lewis acid-catalysed scission of the oxirane ring since **2.7** also reacted rapidly with anhydrous  $\text{MgBr}_2$  in THF at  $-30^\circ\text{C}$  to give **2.12** in 90% yield.<sup>16</sup>

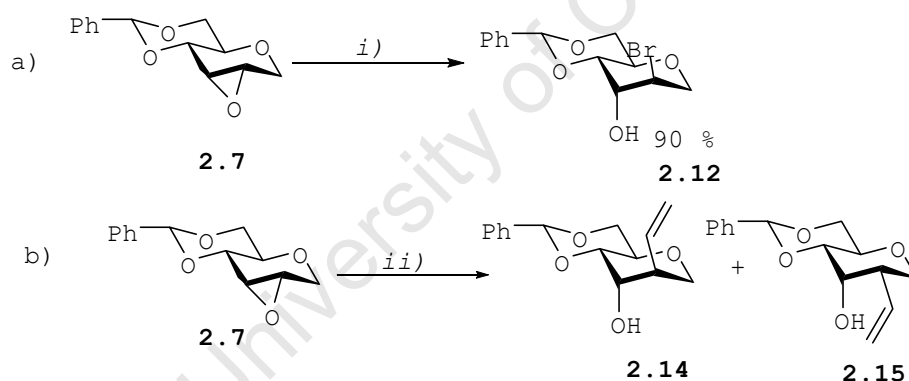

**Scheme 2.4** Reaction conditions: i) 10 mole%  $\text{CuI}$ ,  $\text{C}_3\text{H}_5\text{MgBr}$  (**2.11**), THF,  $-30^\circ\text{C}$   
 ii) 10 mole%  $\text{CuI}$ ,  $\text{C}_2\text{H}_3\text{MgBr}$  (**2.13**), THF,  $-30^\circ\text{C}$ , 75%

However, when **2.7** was treated with vinylmagnesium bromide **2.13** and 10 mol%  $\text{CuI}$  in THF at  $-30^\circ\text{C}$  two isomeric products **2.14** and **2.15** were obtained in a combined yield of 75%. They observed that the proportions of **2.14** and **2.15** depended on the age of the Grignard reagent: freshly prepared Grignard reagent gave a 1:1 mixture, whereas week-old Grignard reagent, stored at  $-40^\circ\text{C}$ , gave a 3:1 mixture of **2.14** and **2.15**, respectively.<sup>16</sup>

Isomer **2.14** was presumed to be the product of normal *trans*-diaxial ring scission with inversion of configuration at C-2 whereas isomer **2.15** was probably the result of a two-step mechanism in which competing MgBr<sub>2</sub>-catalysed scission of the oxirane ring gave the bromohydrin **2.12** from which a second copper-catalysed displacement at C-2 by the vinyl group occurred with inversion of configuration, resulting in overall retention of configuration. The variation in product ratio was thus attributed to the amount of MgBr<sub>2</sub> accumulated in solution, with a considerable amount of MgBr<sub>2</sub> accumulating during storage of the reagent.<sup>16</sup> This mechanism was proven by initial reaction of the oxirane with MgBr<sub>2</sub> to give alkoxy magnesium bromide **2.16** which was then added to vinylmagnesium bromide-CuI in THF at -30 °C to obtain exclusively *cis*-vinylic compound **2.15** in 59% yield without traces of the *trans*- isomer **2.14** (Scheme 2.5).

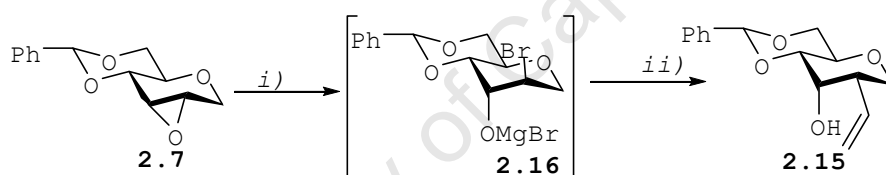

**Scheme 2.5** Reaction conditions: i) MgBr<sub>2</sub>, THF, -30°C;  
ii) CuI-**2.13**, THF, -30°C

The catalysed ring opening of oxiranes by Grignard reagents was applied in the synthesis of the antibiotic, erythronolide A.<sup>17</sup> The precursor **2.20** to this antibiotic was made from epoxide **2.17** which on treatment with Me<sub>2</sub>CuLi in ether opened regioselectively to give **2.18** with the secondary alcohol at C-3 and methyl group at C-2 in a 1,2-*trans* relationship. The oxidation of the secondary alcohol **2.18** followed by treatment of the ketone with base resulted in epimerisation to give the more stable C-2 epimer **2.20** in 85% yield (Scheme 2.6). This was then processed through further steps to give Erythronolide A.

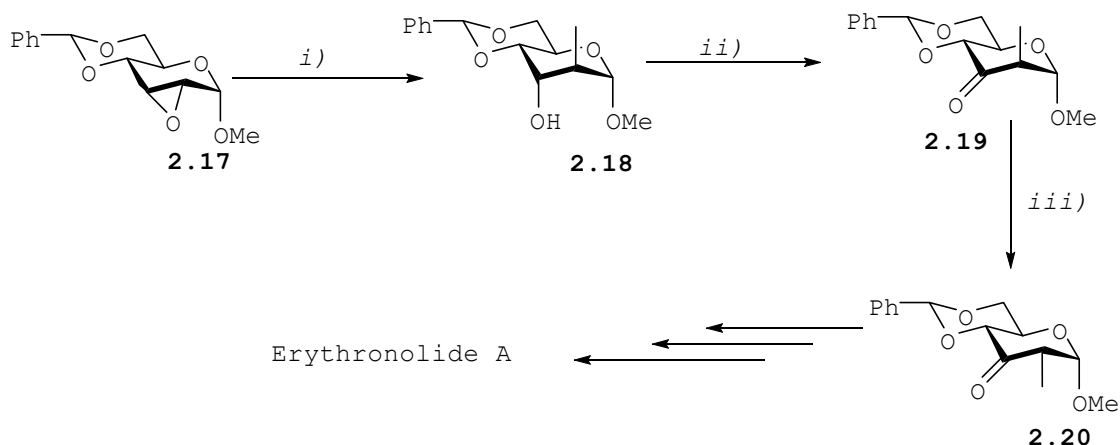

**Scheme 2.6** Reaction conditions: i)  $\text{Me}_2\text{CuLi}$ , Ether; ii)  $\text{DMSO-Ac}_2\text{O}$   
iii)  $\text{NaOMe}$ ,  $\text{MeOH}$

This type of epimerisation was also used in the work of Wood *et al.*<sup>18</sup> They first reacted methyl 2,3-anhydro-4,6-O-benzylidene- $\alpha$ -D-allopyranoside **2.17** separately with either allylmagnesium chloride or methallylmagnesium chloride in THF to obtain **2.21** (86% yield) or **2.22** (92% yield). Swern oxidation of each alcohol then gave the corresponding ketones **2.23** and **2.24** and treatment of these with  $\text{Et}_3\text{N}$  in DMF afforded the epimerised, more stable equatorial products **2.25** and **2.26** in 56% and 84% yields respectively (Scheme 2.7). This classic epimerisation was not observed when D-arabino- and D-ribo-3-ulosides (**2.27** and **2.28**) were allylated under radical conditions (Scheme 2.8).<sup>19</sup> Both isomers gave the same product **2.23** which suggested that they react by a common intermediate as observed previously in related radical reactions as described by Redlich *et al.*<sup>20a</sup> and Blattner and Ferrier.<sup>20b</sup> This lack of epimerisation is not surprising given the absence of base in the case of the radical reaction.

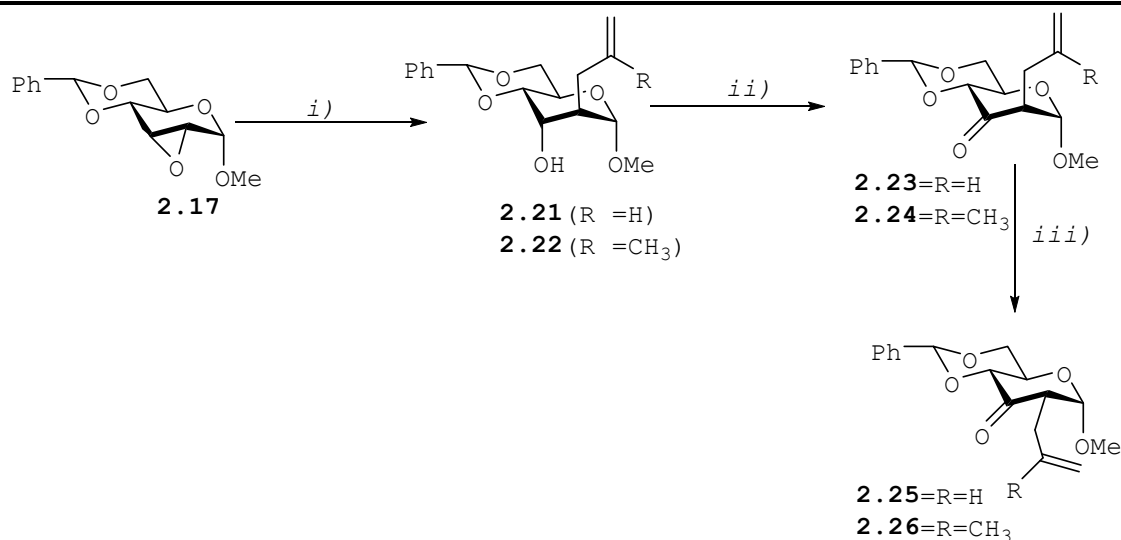

**Scheme 2.7** Reaction conditions: *i*) CH<sub>2</sub>CRCH<sub>2</sub>MgCl, THF, reflux,  
*ii*) Swern oxidation; *iii*) Et<sub>3</sub>N, DMF

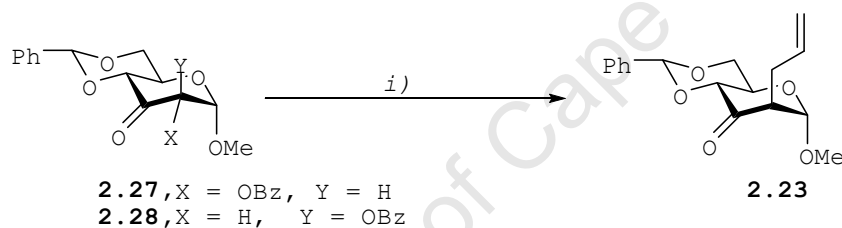

**Scheme 2.8** Reaction conditions: *i*) AIBN, Bu<sub>3</sub>SnCH<sub>2</sub>CH=CH<sub>2</sub>, **2.29**  
 Benzene, reflux

Kazmi *et al.*,<sup>21</sup> reported the oxirane ring-opening of the same 2,3-anhydro glycoside **2.17** in moderate yields, by using cyanotrimethylsilane and a catalytic amount of aluminium chloride. These results were later investigated by Magione *et al.*,<sup>8</sup> who found similar axial attack at C-2, but accompanied by opening of the benzylidene protecting group when treated with Et<sub>2</sub>AlCN (Scheme 2.9). The reaction afforded the β-cyanohydrin **2.30** as the minor component in a mixture of products, the others arising from competing opening of the benzylidene acetal caused by attack of ethyl or cyano groups. The reason for the competitive reaction products that was given by Inch and Lewis<sup>9</sup> and elsewhere<sup>21,22,23</sup> is that the carbon-oxygen bonds in the ring and the methoxy group are β to the cyano group and

therefore labile to base. And the regioselectivity was explained by the presence of multiple coordinating sites in the substrate. The Al co-ordinates to O-4 and O-3 (as shown in Fig 2.3), causing the benzylidene acetal to be opened and the oxocarbenium ion is then "trapped" by the CN or ethyl nucleophile. The results suggested that chelation of the aluminium centre of the alkoxide with O-4 plays an important role in promoting nucleophilic attack on the benzylic carbon and determining the regiochemistry of the ring cleavage and also the spatial disposition of O-4 encourages the affinity of Lewis acid for this site.

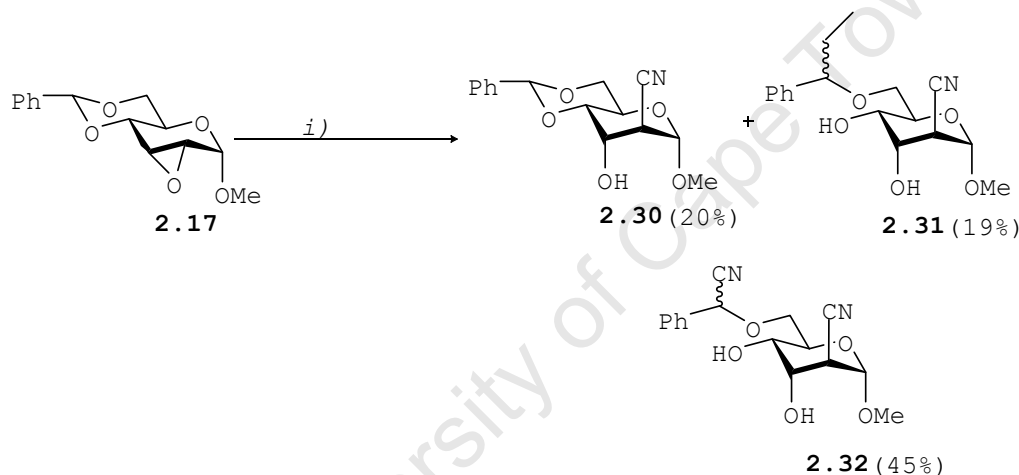

**Scheme 2.11** Reaction conditions: i)  $\text{EtAlCN}$ ,  $\text{CH}_2\text{Cl}_2$ , r.t.

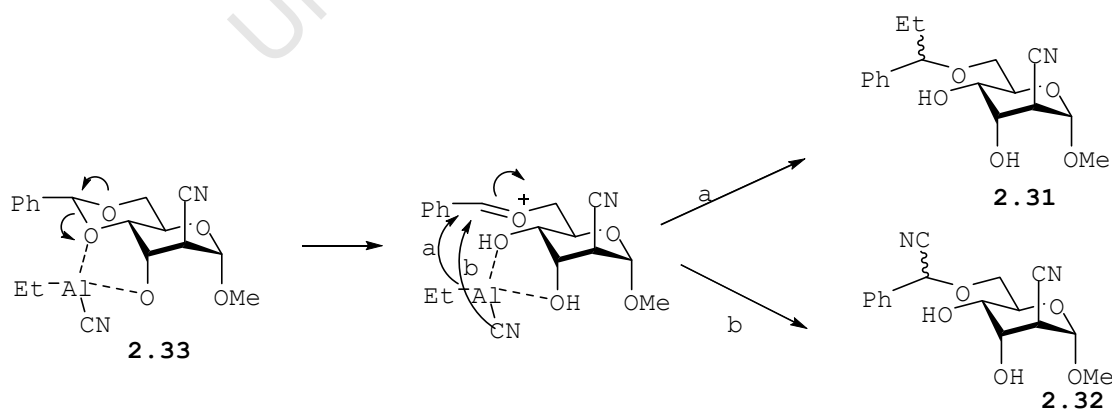

**Figure 2.3:** Reaction mechanism for formation of **2.31** and **2.32**

Challenger and Procter<sup>24a</sup> and Procter and Genin,<sup>24b</sup> used 1,6:2,3-dianhydro-4-O-benzyl-β-D-mannopyranoside **2.34**, readily

obtained from 1,6-anhydro- $\beta$ -D-mannopyranoside, to obtain **2.36** by reaction with allylmagnesium chloride in ether (Scheme 2.10). The selectivity is presumed to originate from the locking of the 1,6-anhydro- $\beta$ -D-hexopyranose into the  ${}^1C_4$  conformation, and the preference for 1,2-*trans* opening of the epoxide directing attack of the nucleophile from the  $\beta$ -face at C-2. Methanolysis of the product **2.36** gave methyl-2-C-allyl-4-O-benzyl-2-deoxy- $\alpha$ -D-glucopyranoside **2.37** in excellent yield (96%). However, when **2.34** was treated with the Grignard reagent in an alternative solvent, THF, chlorohydrins **2.35** were obtained in 76% yield (Scheme 2.10). This alteration of the reaction pathway with change in solvent was attributed to the different positions of the Schlenk equilibrium (Scheme 2.11)<sup>25</sup> in ether and THF.

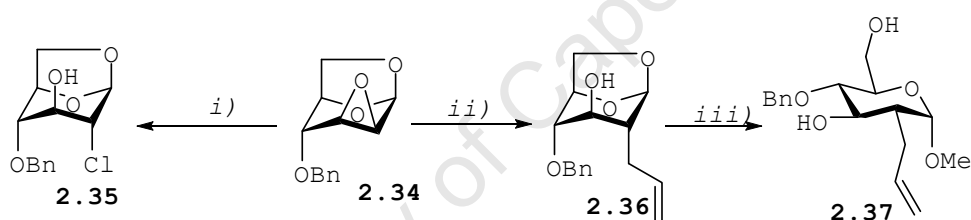

**Scheme 2.10** Reaction conditions: i)  $\text{AllylMgCl}$ , THF; ii)  $\text{AllylMgCl}$ ,  $\text{Et}_2\text{O}$ ; iii)  $\text{MeOH}$ ,  $\text{HCl}$

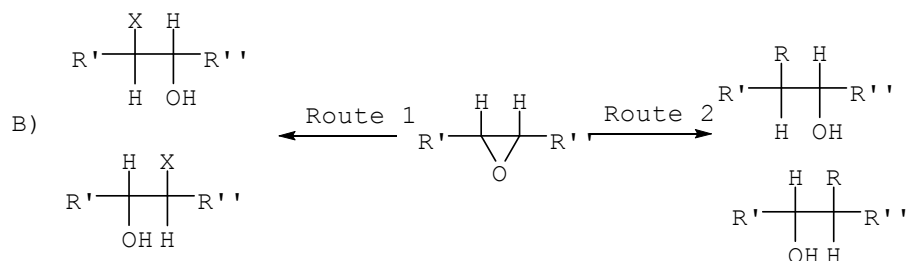
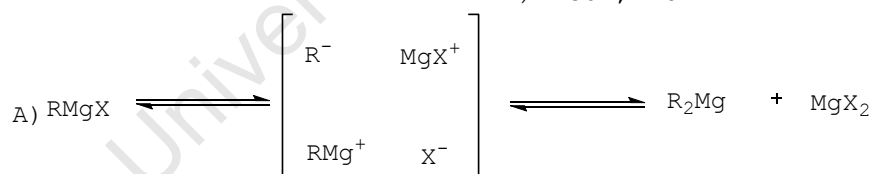

**Scheme 2.11:** A) Schlenk equilibrium equation; B) Possible results from Schlenk equilibrium equation

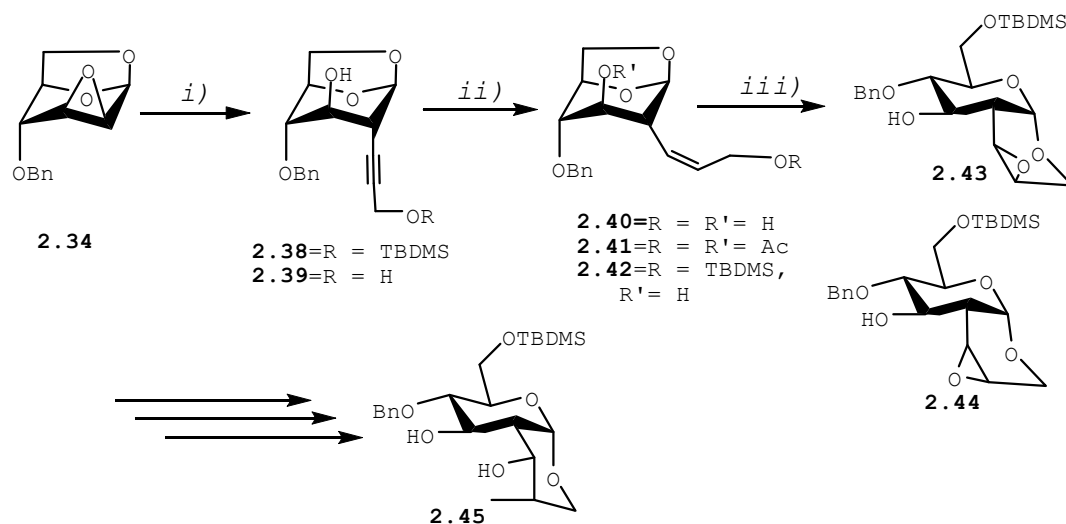

**Scheme 2.12** Reaction conditions: *i)*  $\text{HCCCH}_2\text{OTBDMS}$ ,  $\text{BuLi}$ ,  $\text{Et}_2\text{AlCl}$ ,  $\text{PhCH}_3$ ,  $80^\circ\text{C}$ , quant.; *ii)*  $\text{Pd}$ ,  $\text{CaCO}_3$ ,  $\text{PbO}_2$ , quant.; *iii)* (a)  $\text{CF}_3\text{COOH}$ , TEA, (b) *m*-CPBA

The foregoing methodology has found application in the synthesis of precursors for molecules containing multiple contiguous chiral centres such as the ansa chain of rifamycin S and streptovaricin A.<sup>26</sup> The 2-C-alkynylglucosides **2.38** and **2.39** were prepared by opening the epoxide **2.34** with propargylic anions (Scheme 2.12) in quantitative yield, and this was followed by Lindlar reduction to give *Z*-olefin **2.40**, with further manipulation of protecting groups yielding compounds **2.41** and **2.42**. Reaction of **2.40** with neat trifluoroacetic acid and quenching with  $\text{Et}_3\text{N}$  led to the unsaturated fused bicyclic sugar, which, when treated with *m*-perchlorobenzoic acid gave a mixture of the *endo*- and *exo*-epoxides (**2.43** and **2.44**) in good to excellent yield. After several further steps, rifamycin precursor **2.45** was obtained.

### 2.2.2 Via Radical alkylation

The construction of carbon-carbon bonds using radical-mediated chemistry is a well-established strategy in organic synthesis.<sup>27</sup>

A number of radical-mediated protocols have also been applied to the synthesis of branched-chain sugars and synthetically

interesting annulated sugars.<sup>28</sup> These are conveniently divided into intramolecular and intermolecular approaches.

### 2.2.2.1 Intramolecular radical alkylation at C-2 of sugars

An efficient method to make C-2 branched carbohydrates was developed<sup>29</sup> where the precursor 2-iodomannosides **2.49** and **2.50** were prepared by reacting the glucals **2.46** and **2.47** with  $\alpha$ -phenyl allyl alcohol and *N*-iodosuccinimide in acetonitrile (Scheme 2.14). This iodoetherification reaction leads to an allylated product, which is cleaved by ozonolysis and reductive work-up to furnish only the 1,2-diaxial products **2.49** and **2.50** as a 1:1 diastereomeric mixture at the allylic centres of the glucosides, with separation unnecessary since the chiral centre was lost in the subsequent radical cyclization. When **2.49** and **2.50** were treated with tributyl tin hydride in the presence of AIBN a radical cyclization/fragmentation occurred to give the C-2 branched glucopyranosides **2.51** and **2.52** in 50% and 84% yields respectively.

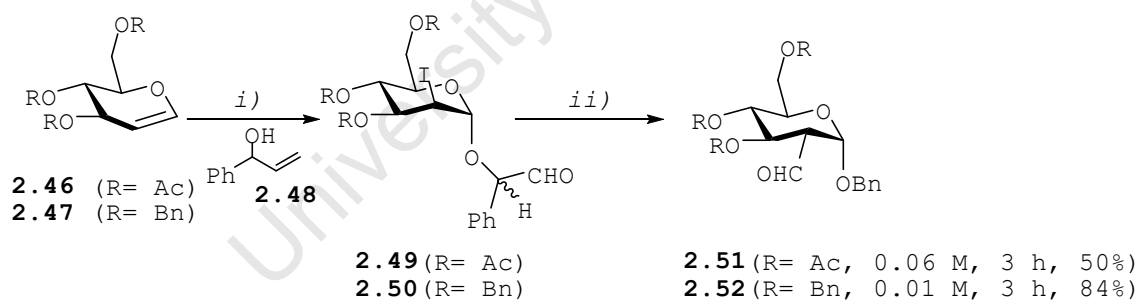

**Scheme 2.14** Reaction conditions: i) a) NIS, **2.48** b) O<sub>3</sub>, DMS;  
ii) Bu<sub>3</sub>SnH, AIBN, PhH, heat

When the  $\alpha$ -gem-dimethyl aldehydes (**2.53**, **2.54**) were treated with Bu<sub>3</sub>SnH/AIBN (Scheme 2.15), the corresponding C-2 carbaldehydes **2.56** and **2.57** were obtained, but accompanied by a range of other products, including fused-ring products **2.58**–**2.60**, resulting from trapping of the intermediate in the intramolecular radical reaction, glycals **2.62**, **2.63** which are products of  $\beta$ -elimination of the anomeric substituent, and

unexpected products such as furanoside **2.61**, products of reductive de-iodination **2.64** and **2.65**, and the inverted fused-ring product **2.66**. This demonstrated that the driving force of producing a benzyl radical (Scheme 2.14) caused the fragmentation to occur more efficiently, leading to higher yields of the desired 2-C-formyl glucopyranosides.

The formation of the 2-C-formyl sugars arises from initial formation of a secondary alkyl radical at the iodinated C-2, and this adds intramolecularly to the aldehyde tethered at C-1 of the sugar to give the highly reactive alkoxy radical. This radical intermediate then undergoes  $\beta$ -scission to produce an  $\alpha$ -isopropoxy radical, which after reduction gives the 2-C-formyl glycosides **2.56** and **2.57**. A conceptually similar process was previously reported by Tsang *et al.*,<sup>30</sup> where an aldehyde group was transposed upon  $\beta$ -scission onto the side-chains of carbohydrates. The furanoside product was presumed to result from a tributyltin iodide-promoted rearrangement of the radical intermediate (Scheme 2.16), while the other by-products appear to arise from an incomplete radical addition/fragmentation sequence, although this is not explicitly proposed by the authors.<sup>29</sup>

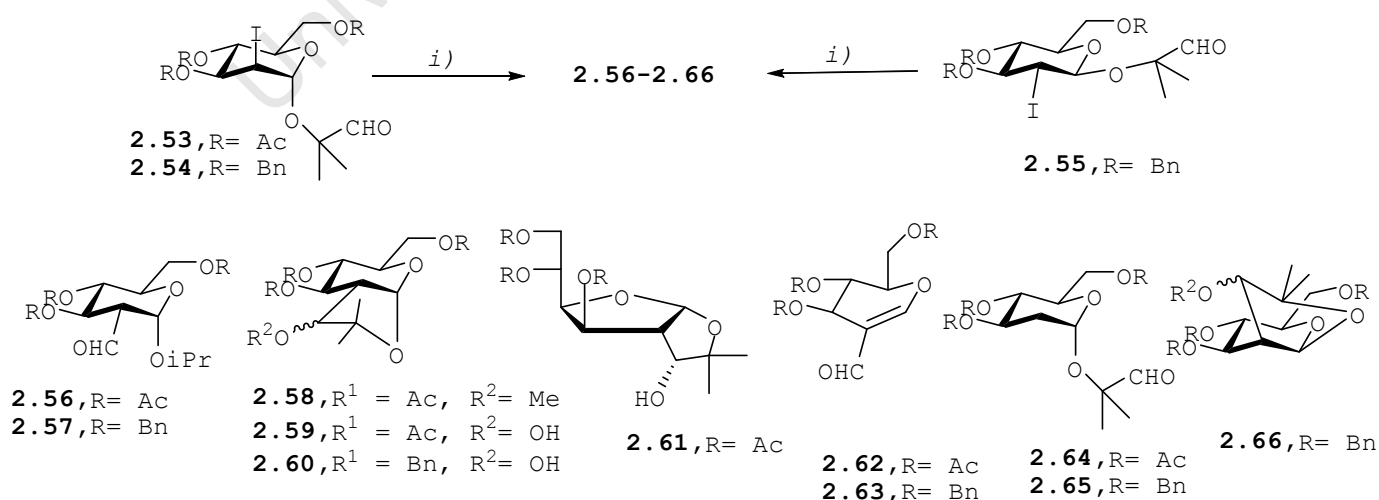

**Scheme 2.15** Reaction conditions: *i)* Bu<sub>3</sub>SnH, AIBN, PhH, heat

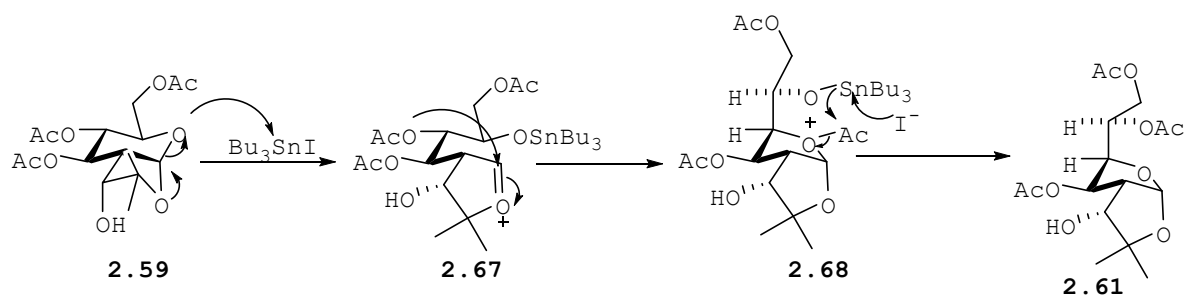

**Scheme 2.16:** Proposed mechanistic pathway for the formation of **2.61**

After formation of the fused molecule **2.59**,  $\text{Bu}_3\text{SnI}$  attacks the six-membered ring sugar which results in its opening in an oxocarbenium-like intermediate **2.67** with tributyl tin bound to the free oxygen on the opened molecule. The oxocarbenium ion would then be attacked by the C-4 acetate group followed by intermolecular acetate transfer to yield the furanoside **2.61**.

The two step-reactions to iodoaldehyde were also applied to obtain galactosides **2.71**. The radical reaction of galactoside using  $\text{Bu}_3\text{SnH}$  conditions successfully produced the desired formyl-transfer product **2.71** in 50% yield along with an inseparable mixture of what appeared to be the bicyclic alcohol **2.72** and the furanoside **2.73** for which the structures were not confirmed.

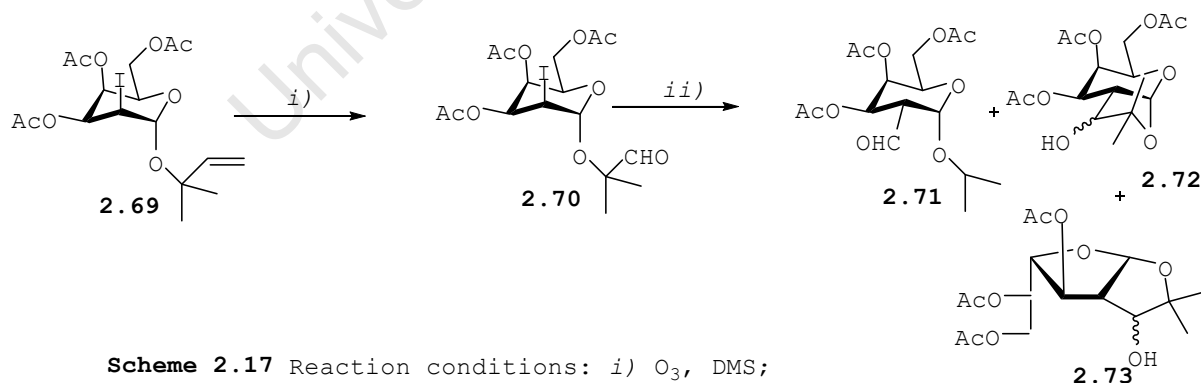

**Scheme 2.17** Reaction conditions: i)  $\text{O}_3$ , DMS;  
ii)  $\text{Bu}_3\text{SnH}$ , AIBN, PhH

Olivier Jarreton *et al.*, have used the formyl-transfer reaction protocol via benzylic radical intermediates at C-3 (compound **2.74** and **2.75**) to introduce axial formyl groups at C-2 in good yield.<sup>31</sup> These axial formyl glycopyranosides **2.77**

and **2.78** were eventually used to make C-oligosaccharides with the Man( $\alpha$ -1,2)Man linkage **2.80** and **2.81**.

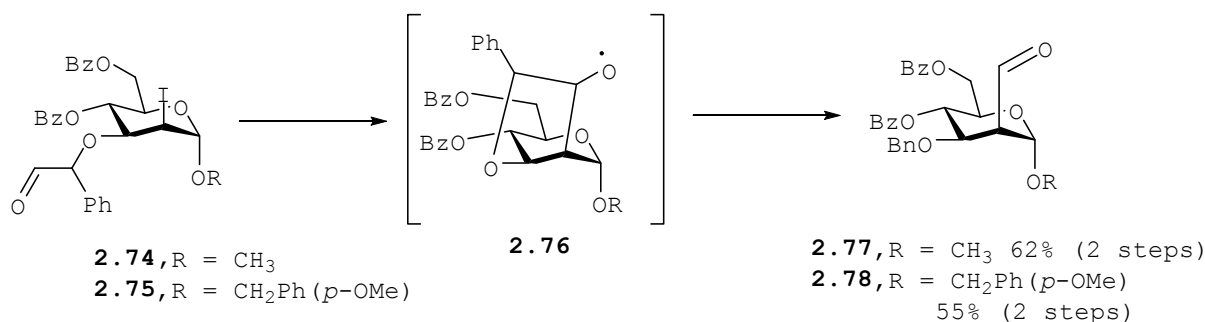

**Scheme 2.18** Radical mechanism for the aldehydes **2.77** and **2.78** synthesis

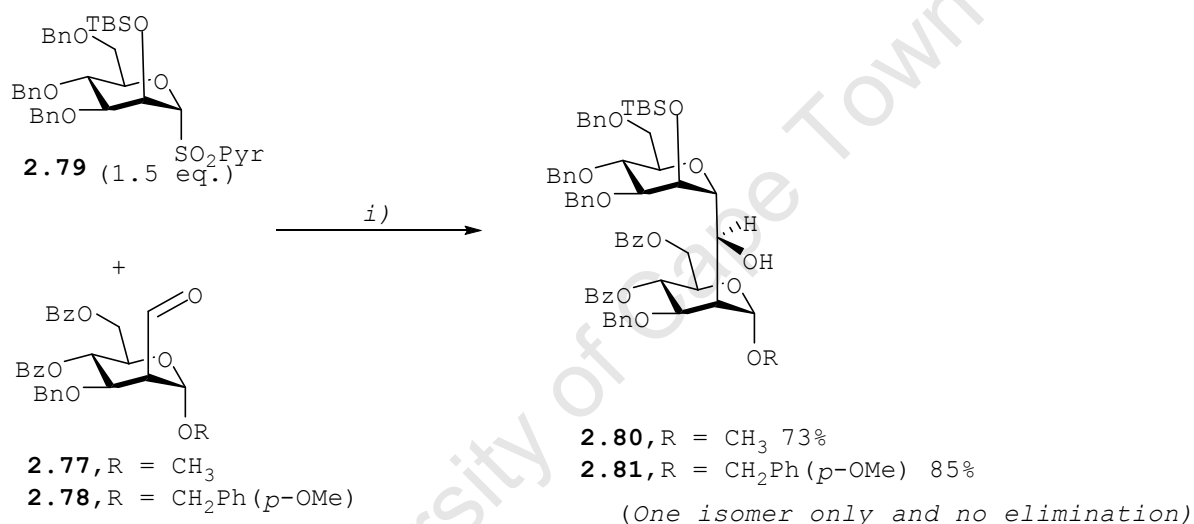

**Scheme 2.19** Reaction conditions: *i*) SmI<sub>2</sub> (3 eq.), THF, 20°C

This radical fragmentation process was further extended to nitrile-transfer reactions following the work of Curran and Seong who demonstrated the nitrile-transfer reaction on non-carbohydrate systems.<sup>32</sup> Addition of 2-cyano-2-methylpropanol to glucals **2.46** or **2.47** led to the 2-iodomannosides **2.82** and **2.83** in 42% and 82% yield respectively. When these were each treated with Bu<sub>3</sub>SnH and AIBN in toluene under reflux the acetylated derivative **2.82** gave 2-cyanoglucoside **2.84** in 30% yield, whereas the benzylated derivative **2.83** decomposed under the described conditions.

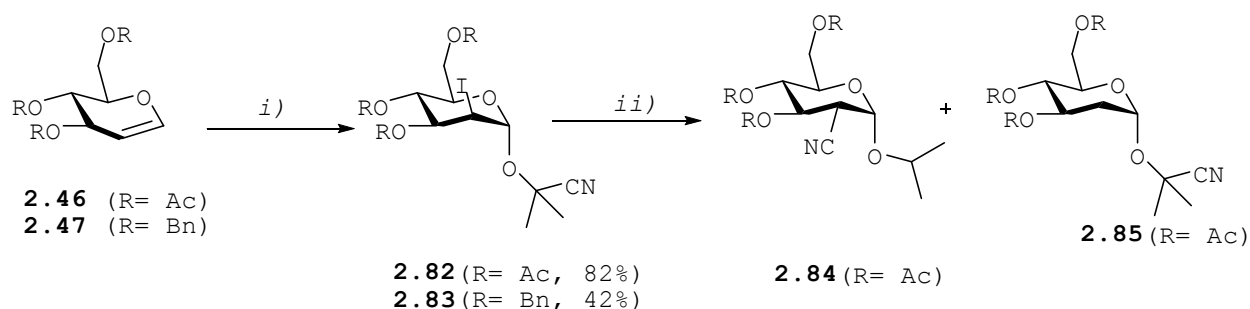

**Scheme 2.20** Reaction conditions: *i*)  $\text{HO}(\text{CH}_3)_2\text{CN}$ , NIS; *ii*)  $\text{Bu}_3\text{SnH}$ , AIBN, PhH, heat

### 2.2.2.2. Intermolecular radical alkylation at C-2 of sugars

An intermolecular radical reaction strategy was used to introduce an allyl group at C-2 of a methyl glucoside as a precursor to a 2-C-carboxymethyl carbohydrate.<sup>33</sup> The radical precursor was prepared by treating the known glucals **2.46** and **2.47** with iodine in methanol to give methyl-2-iodo- $\alpha$ -mannoside **2.86a** and **2.86b**, respectively.<sup>34</sup> Treatment of these with Allyl tributyltin gave a mixture of **2.87** and **2.89** in 64% combined yield and a 1:1.5, gluco:manno ratio and for **2.88** and **2.90** in 92% yield, each of which eventually produced acid-based carbohydrate *via* cleavage of the double bond followed by oxidation to yield acid-based carbohydrate **2.91-2.92**. It was discovered that<sup>34</sup> the observed selectivity toward the *manno* products was due to the greater accessibility of the  $\beta$ -face by the radical nucleophile (allyl radical) due to the presence of the  $\alpha$ -methoxy group at C-1.

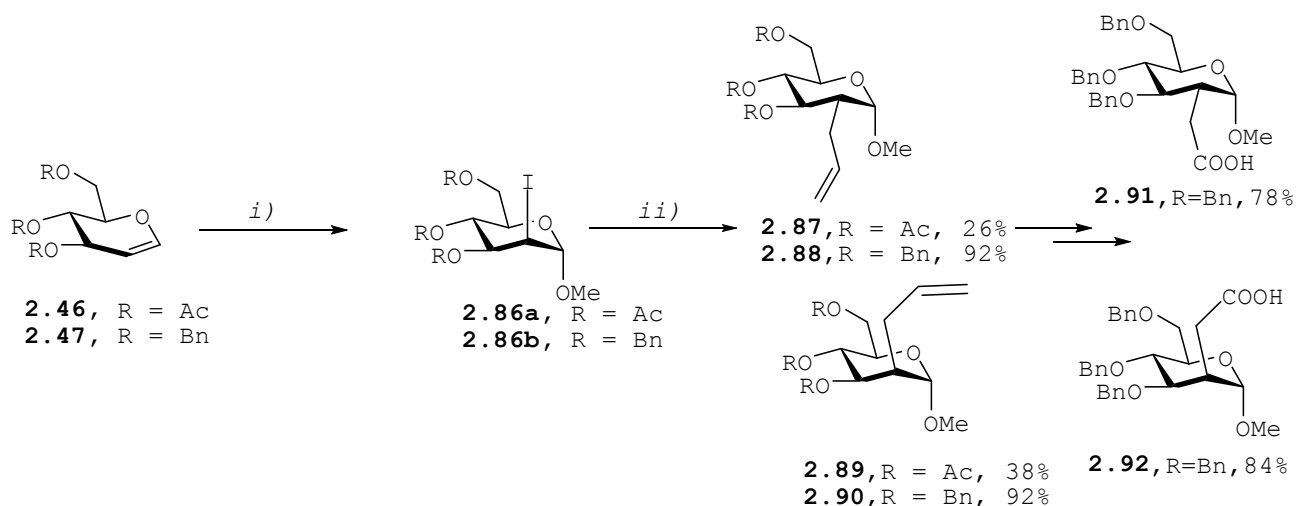

**Scheme 2.21** Reaction conditions: *i*)  $\text{I}_2$ , MeOH, 85%; *ii*)  $\text{Bu}_3\text{SnAlI}$ , AIBN, THF

In similar work, Bertozzi *et al.*<sup>35</sup> introduced the methallyl group at C-2 using Keck radical coupling<sup>36</sup> of methallyltributyltin with 2-iodosugars **2.93** (galacto- or gluco-configurations) to afford 2-methallylpyranosides **2.94** as the major products (6:1 and 7:1 equatorial:axial methallylation, respectively) (Scheme 2.22).

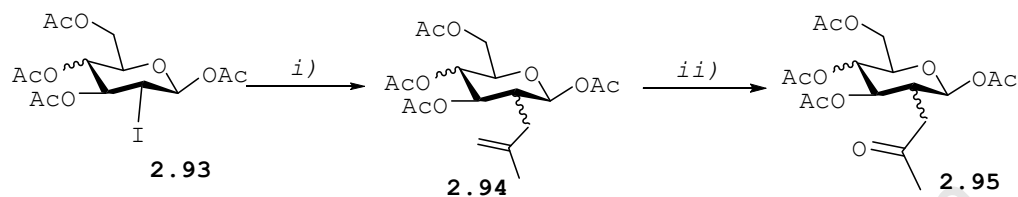

**Scheme 2.22** Reaction conditions: i) methallyltributyltin, AIBN, Benzene, reflux 65-70%; ii) a) O<sub>3</sub>, -78°C, CH<sub>2</sub>Cl:CH<sub>3</sub>OH(10:1), b) DMS, -78 °C-r.t, 85-90%

The predominance of the equatorial over the axial isomer is in accordance with the work reported by Giese and co-workers.<sup>37</sup> The methallylated compounds were later converted to 2-ketonesugars by ozonolysis followed by reduction.

The synthesis of 2-C-alkylated sugars by addition of malonates **2.97** to glycals **2.96** in the presence of CAN or Mn(OAc)<sub>3</sub> has been extensively studied.<sup>38</sup> The reactions are mediated by manganese(III) or cerium(IV) and proceed *via* intermediate malonyl radicals. Acetylated derivatives of glucal, galactal, xylal and arabinal were used and all additions exhibit a very high degree of regioselectivity, but widely varying degrees of stereoselectivity.

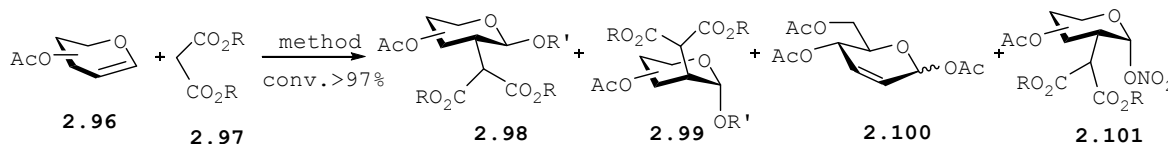

**Scheme 2.23** Reaction conditions: Method A: 2-4 equiv of Mn(OAc)<sub>3</sub>·2H<sub>2</sub>O, HOAc, 95°C; Method B: 3-6 equiv of CAN, MeOH, 0°C

The regioselectivity observed is based on favourable orbital interactions between the SOMO of the malonyl radical **2.102** and the HOMO of the double bond.

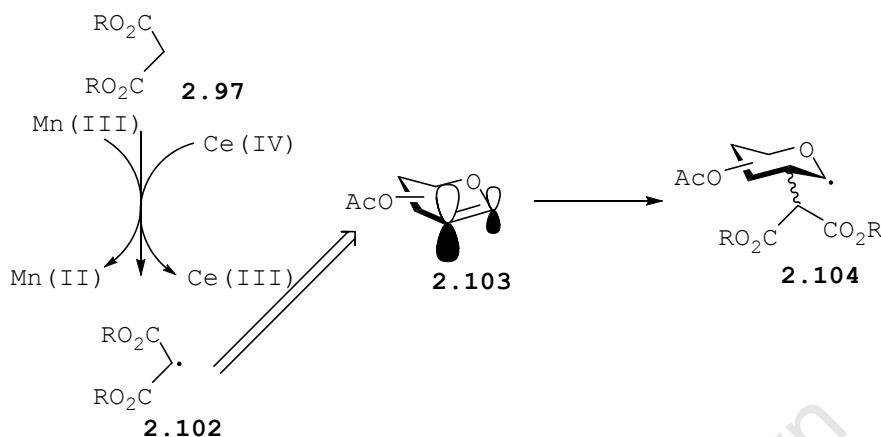

**Scheme 2.24** Mechanistic path for the radical formation

Acceptor-substituted radicals are characterised by low energy of the SOMO and their electrophilic character.<sup>39</sup> Thus, the interaction with the HOMO of the double bond becomes predominant, and this has the largest coefficient at the 2-position of glycals. This explains the high regioselectivity found when malonates **2.97** were added to afford the adduct radicals **2.105** (Scheme 2.25) and also reveals the importance of orbital interactions in radical reactions, since for steric reasons, attack at the 1-position should be favoured.

Linker *et al.* have demonstrated that variation of the steric demand of the malonate or the glycal allows the stereoselectivities to be increased up to >98%.<sup>38</sup> They also discovered that the highest selectivities were obtained with tri-*O*-acetyl-D-galactal and di-*O*-acetyl-D-arabinal, where the attack occurs exclusively from the  $\alpha$ -face of the carbohydrate as the protecting group on the axial substituent at the 3- or 4-position hinders the  $\beta$ -face of the glycal. Methyl glycosides **2.107** are formed as main products in 73-89% yield.

Beside the desired products, strong evidence was found for a ligand transfer rather than electron transfer during the formation of carbohydrate 1-nitrates, which sheds light on the

mechanism of transition metal-mediated radical reactions depicted below.

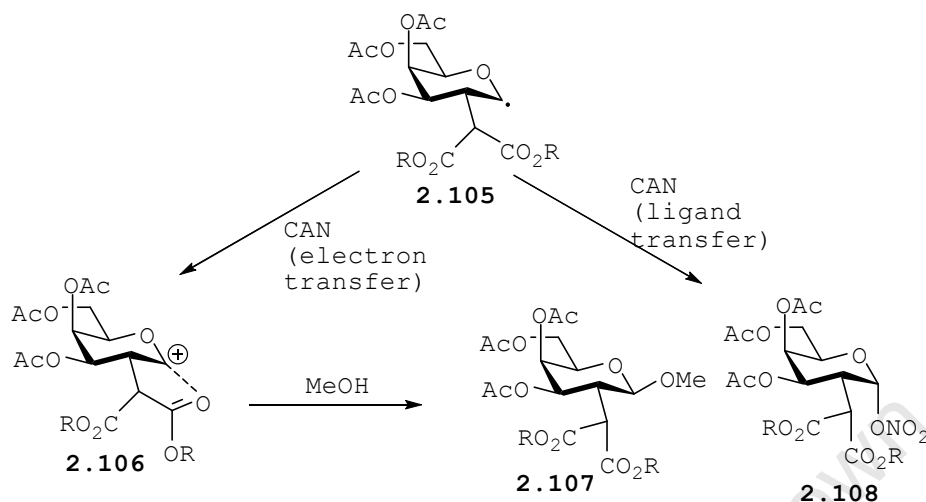

**Scheme 2.25** Mechanism for a neighboring group participation of the malonyl substituent

It was found that the nitrates **2.108** were exclusively obtained as  $\alpha$ -anomers and could not be formed via the intermediate **2.106**.<sup>38</sup> Instead, a direct ligand transfer from CAN without participation of cations was more likely to occur, thus explaining the high stereoselectivity, since carbohydrate radicals like **2.105** are preferentially trapped from the  $\alpha$ -face.<sup>40</sup>

In the process of investigating the stereoselectivity of malonate addition on glycols, different substituents at the 1-position of the glycol were investigated<sup>41</sup> and it was shown that the product distribution was strongly dependent on the oxidation potential of the intermediate substituted anomeric radical (Scheme 2.27).

Gyóllai *et al.* demonstrated that when a nitrile group is attached at C-1 (compound **2.109d**) the oxidation potential is remarkably increased, and the oxidation by CAN ( $E^\circ = +1.37$  V versus SCE) is suppressed.<sup>41</sup> Furthermore, the captodative substitution pattern at the anomeric centre was found to stabilise the radical<sup>42</sup> and therefore give rise to a

competitive reaction of an intramolecular attack at the carbonyl carbon (pathway B in Scheme 2.27).

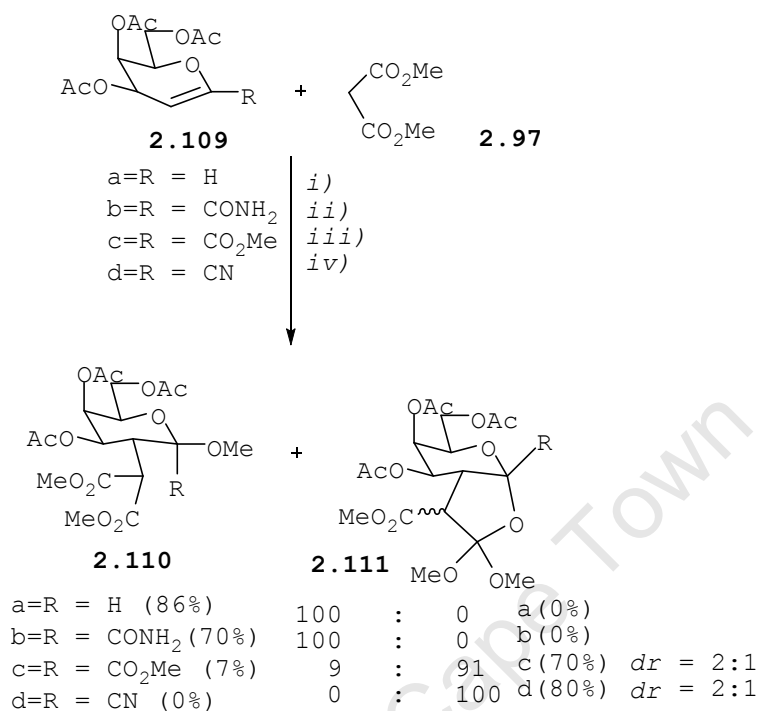

**Scheme 2.26** Reactions conditions: *i*)CAN (4 equiv.), MeOH; *ii*)CAN (2 equiv.), MeOH  
*iii*)CAN (4 equiv.), MeOH; *iv*)CAN (4 equiv.), MeOH

Due to the two alkoxy substituents, the resulting radical **2.114** is now easily oxidized by cerium(IV) ammonium nitrate to afford the ortho esters **2.111** after trapping with the solvent methanol. For the unsubstituted glycol **2.109a**, the intermediate is oxidized immediately by CAN to afford the carbenium ion **2.113** since the CAN oxidation potential is higher. Glycoside **2.110** is eventually formed after trapping of intermediate **2.105** with methanol.

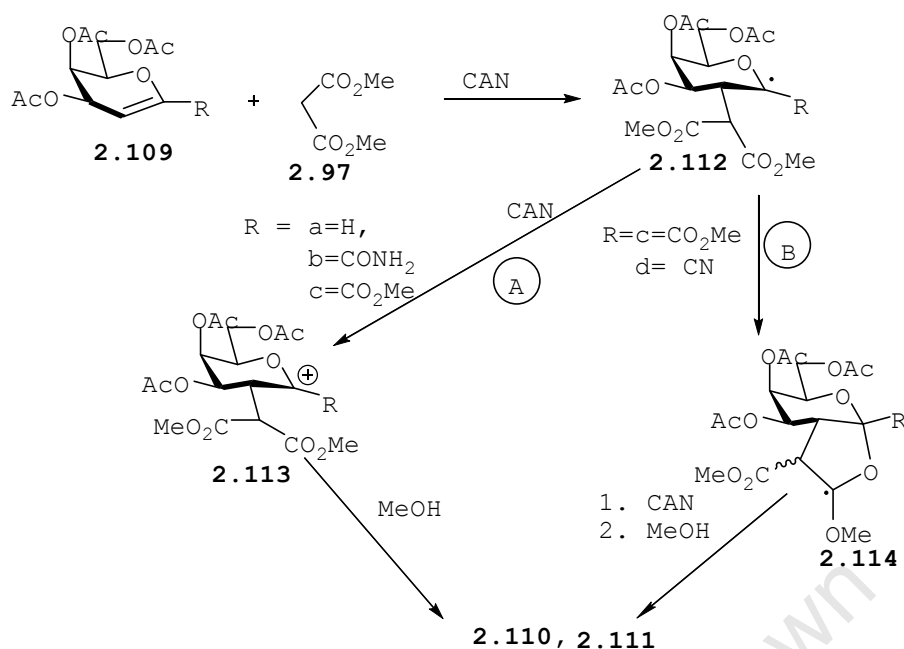

**Scheme 2.29** Influence of the substituents R on the product distribution

The radical intermediate **2.112c** (R= COOMe) was found to be at the borderline where it forms both methyl glycoside and ortho ester and this suggested that the oxidation potential of **2.112c** lies between the values for **2.112b** and **2.112d**, with pathways A and B therefore competing with each other.

Having established what influences the stereochemistry of the radical reaction product, further intensive and extensive work has been conducted to establish optimum conditions for C-2 alkylation.<sup>43</sup> Various glycols (**2.46**, **2.109a**, **2.115-2.118**) were subjected to react with dimethyl malonate **2.97** in the presence of cerium(IV) ammonium nitrate.<sup>41,44</sup> The reactions exhibited high degrees of diastereoselectivity, and the malonate derivatives (**2.110a**, **2.119-2.123**) were obtained in good to high yields in analytical pure form (Scheme 2.28).

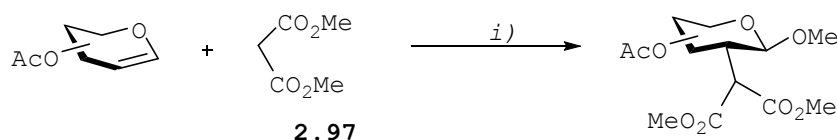

|  |                     |
|--|---------------------|
| tri- <i>O</i> -acetyl-D-glucal ( <b>2.46</b> )     | <b>2.119</b> , 68%  |
| tri- <i>O</i> -acetyl-D-galactal ( <b>2.109a</b> ) | <b>2.110a</b> , 78% |
| tri- <i>O</i> -acetyl-D-xylal ( <b>2.115</b> )     | <b>2.120</b> , 81%  |
| tri- <i>O</i> -acetyl-D-arabinal ( <b>2.116</b> )  | <b>2.121</b> , 89%  |
| tri- <i>O</i> -acetyl-D-maltanal ( <b>2.117</b> )  | <b>2.122</b> , 83%  |
| tri- <i>O</i> -acetyl-D-lactal ( <b>2.118</b> )    | <b>2.123</b> , 80%  |

**Scheme 2.28** Reaction conditions: i) CAN (3 equiv), MeOH, 0°C

To obtain C-2 branched glyco acetic acid, these malonate derivatives were subjected to decarboxylation reaction conditions (Scheme 2.29) which afforded the C-2 branched esters **2.124**; subsequent treatment of **2.124** with lithium hydroxide in DMSO as depicted in table 2.1 afforded the deprotected C-2 branched acetic acids **2.125** in good to excellent yields.<sup>43</sup>

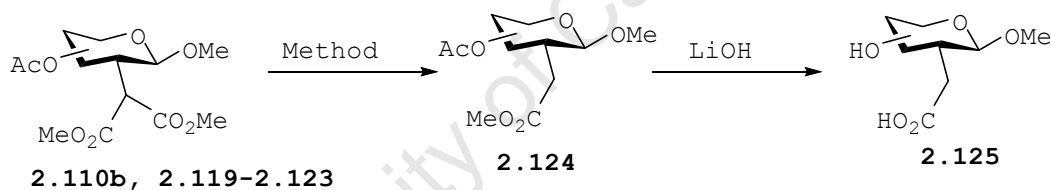

**Scheme 2.29** Demethoxycarbonylation of the carbohydrate C-analogs

**Table 2.1**

| Entry | Malonate      | Configu-<br>ration | Method   | Time/h | Yield (%)    |              |
|-------|---------------|--------------------|----------|--------|--------------|--------------|
|       |               |                    |          |        | <b>2.124</b> | <b>2.125</b> |
| 1     | <b>2.119</b>  | <i>gluco</i>       | <b>A</b> | 6      | –            | –            |
| 2     | <b>2.119</b>  | <i>gluco</i>       | <b>B</b> | 24     | –            | –            |
| 3     | <b>2.119</b>  | <i>gluco</i>       | <b>C</b> | 6      | 34           | –            |
| 4     | <b>2.119</b>  | <i>gluco</i>       | <b>D</b> | 4.5    | 92           | >95          |
| 5     | <b>2.119</b>  | <i>gluco</i>       | <b>E</b> | 5 min  | 97           | >95          |
| 6     | <b>2.110a</b> | <i>galacto</i>     | <b>D</b> | 4.5    | 81           | >95          |
| 7     | <b>2.120</b>  | <i>xylo</i>        | <b>D</b> | 5      | 81           | >95          |
| 8     | <b>2.121</b>  | <i>arabino</i>     | <b>D</b> | 5.5    | 79           | >95          |
| 9     | <b>2.122</b>  | <i>malto</i>       | <b>D</b> | 6      | 73           | >95          |
| 10    | <b>2.123</b>  | <i>lacto</i>       | <b>D</b> | 6      | 72           | >95          |

Method A: (i) H<sub>2</sub>O, cat. LiOH; (ii) HCl, 95 °C. Method B: DMSO, 2 equiv. H<sub>2</sub>O, 180 °C.  
 Method C: DMSO, 1.5 equiv. NaCl, 180 °C. Method D: DMSO, 1.5 equiv. LiI, 180 °C.  
 Method E: DMSO, 1.5 equiv. LiI, 200W, 10 bar, 100 °C.

The sensitivity of the acetyl protecting group in the methyl esters **2.124** toward basic reaction conditions suggested the introduction of the protecting group that are stable during the saponification stage and would allow further transformations of the carbon side chain. The benzyl protecting group was the obvious choice but had limitations in that it is known to be unstable toward Lewis acids<sup>45</sup> and prone to fast Ferrier rearrange to the 2,3-unsaturated derivatives.<sup>46</sup> The latter could be suppressed by addition of sodium bicarbonate in the reaction mixture, an additive which is known to facilitate the formation of dimethyl malonate radical with CAN.<sup>47</sup>

Using these conditions (Scheme 2.30) an easily separable mixture of the *gluco* and *manno*-isomers was prepared, and the *gluco*-isomer underwent clean demethoxycarbonylation to give methyl ester **2.128** in 92% yield.

The base-stability of the protecting group allowed further transformations and provided access to C-2-functionalised carbohydrate analogues. The free acid analogue **2.129** was synthesised in quantitative yield, and reductions to alcohol **2.130** and aldehyde **2.131** progressed smoothly in good yields.

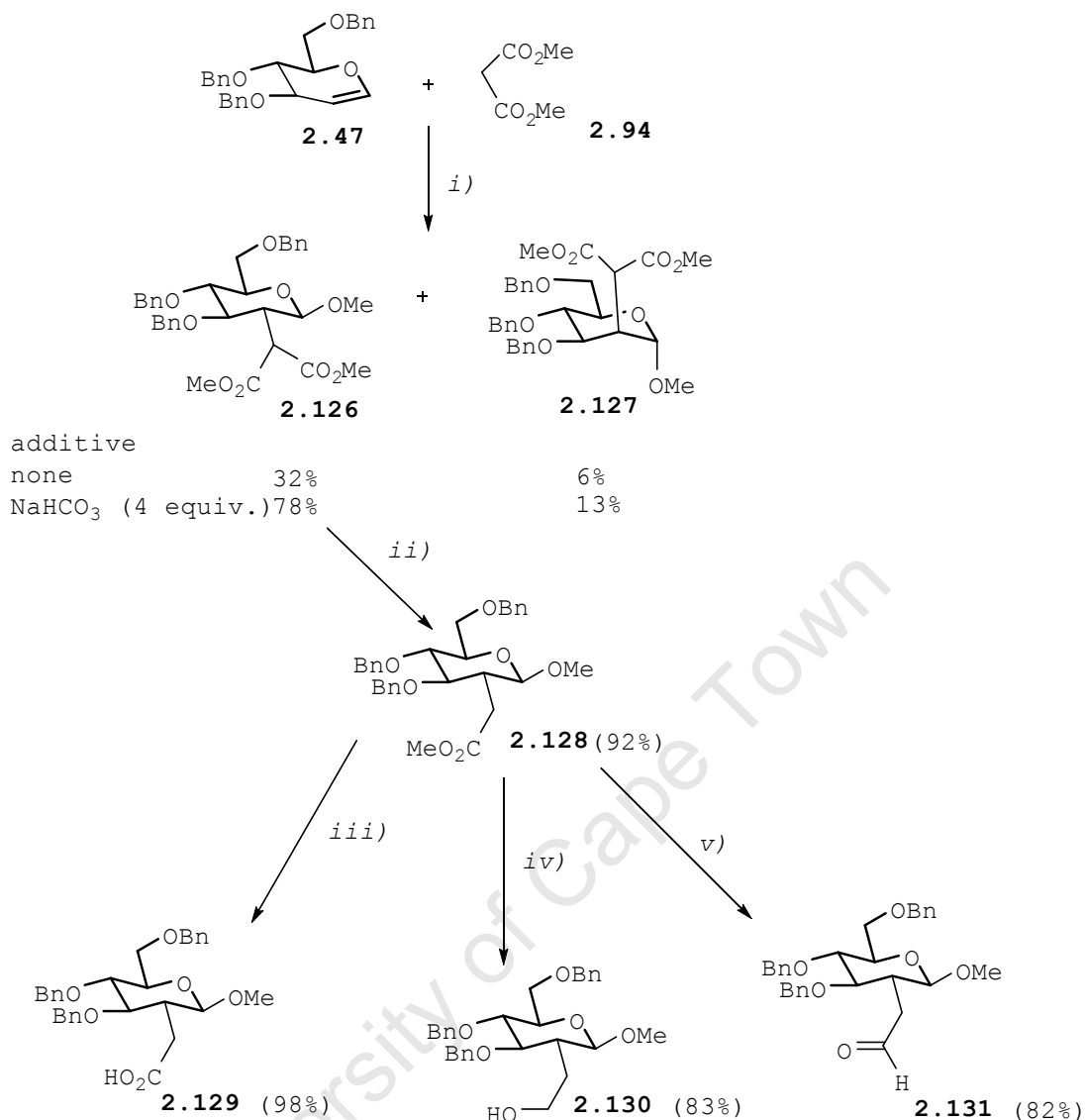

**Scheme 2.30** Reaction conditions: *i*) CAN (4 equiv.), MeOH, 0°C; *ii*) LiI, DMSO, microwave, 200W, 10 bar, 100°C; *iii*) LiOH; *iv*) LAH; *v*) *i*-Bu<sub>2</sub>AlH

The extension of this malonate radical reaction to allow introduction of different nucleophiles at the anomeric position was pursued and improved by Elamparuthi *et al.*<sup>48</sup> (Scheme 2.32). Anhydrous CAN was used to avoid the formation of anomeric nitrate **2.101**, but formation of unsaturated carbohydrates **2.138–2.139** was unavoidable for some cases.

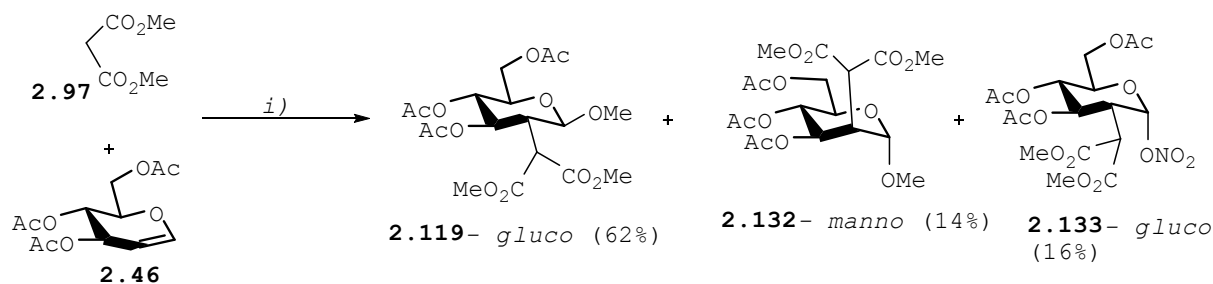

**Scheme 2.31** Reaction conditions: *i*) CAN (10 equiv.), MeOH, 0°C

These unsaturated carbohydrates were presumed to arise from the slow reaction of the intermediate due to low concentrations of nucleophile. Deprotonation at the C-2 position thus competes, followed by elimination to form the unsaturated carbohydrate (Scheme 2.33).

The neighbouring group of malonyl side-chain was responsible for the exclusive formation of  $\beta$ -glucosides **2.119** (Scheme 2.28) and **2.126** (Scheme 2.30) or  $\alpha$ -mannosides **2.132** (Scheme 2.31) and **2.127** (Scheme 2.30).

After exploring malonates as radical precursors, ethyl nitroacetate **2.141**<sup>48</sup> and nitromethane **2.160**<sup>49</sup> were also used under the same reaction conditions. Ethyl nitroacetate gave a mixture of products **2.145** due to generation of three contiguous stereogenic centres as depicted in Scheme 2.36.

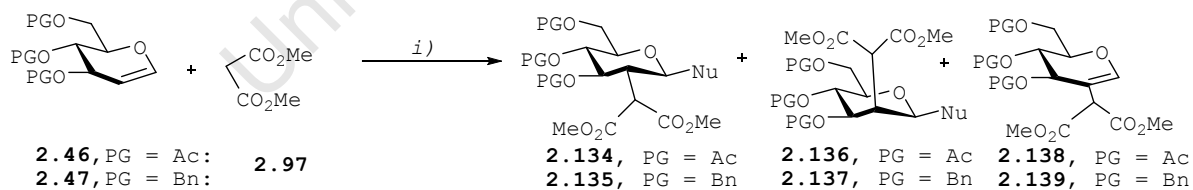

**Scheme 2.32** Reaction conditions : *i*) CAN, solvent, 0°C, Nu<sup>⊖</sup>

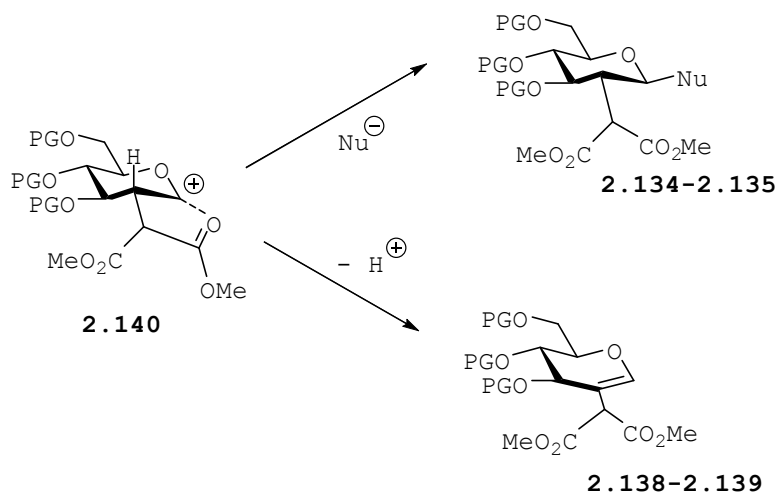

**Scheme 2.33** Formation of the unsaturated carbohydrates **2.138/2.139**

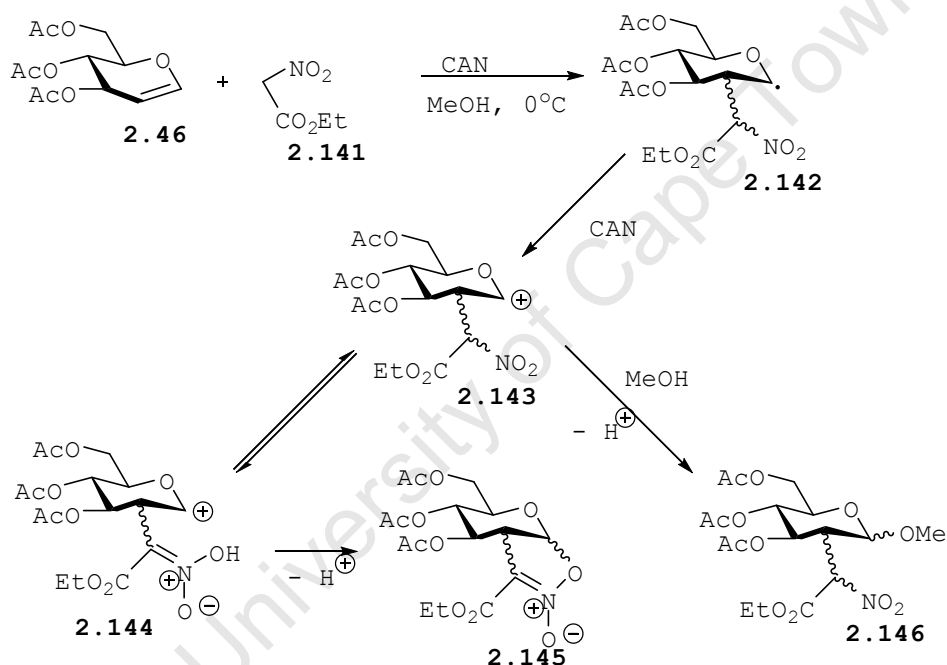

**Scheme 2.34** Formation of the unsaturated carbohydrates **2.145/2.146**

However, to suppress the formation of this mixture which renders the separation process difficult to accomplish, the use of a non-nucleophilic solvent was recommended with *N,N*-Dimethylformamide the best choice. The intermediate, isoxazoline *N*-oxides **2.151-2.158** which are presumed to be formed *via* tautomers **2.144** of the acid, were isolated in moderate yields in analytically pure form. The  $\alpha$ -form was reduced and generated C-glycosylated amino acids, while the



the isoxazoline, irrespective of the configuration of the carbohydrate. And in the case of arabino **2.158**, having C-2 substituent axial, the reduction was exclusively from the *Si*-face which resulted in *R*-configured amino acid (Fig. 2.4).

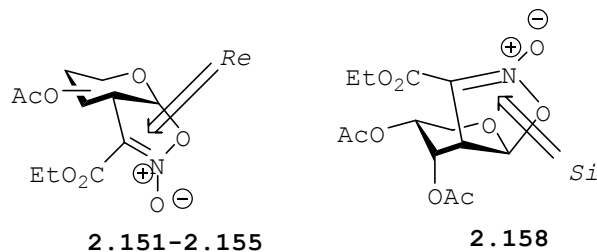

**Figure 2.4** Facial selective hydrogenation of isoxazoline *N*-oxides **2.151-2.155** and **2.158**.

In a radical pathway, both CH acidic precursors **2.141** and **2.159** would cyclise. However, in similar work Elamparuthi *et al.* observed no cyclisation when nitromethane **2.159** was used.<sup>49</sup> The reason given for this was the presence of the ester group in ethyl nitroacetate which stabilises the intermediate **2.144**, and is absent in nitromethane, resulting in formation of isoxazoline *N*-oxides **2.145**<sup>49</sup>. During the addition of nitromethane **2.159** this tautomeric form **2.144** is less favoured, and thus a cyclisation could not compete with the intramolecular reaction with the solvent methanol, affording exclusively methyl glycosides **2.165-2.170** and **2.171-2.176**. The methyl glycosides are formed by CAN oxidation of the adduct radicals **2.157** to cations **2.158** and trapping with the solvent, exhibiting excellent 1,2-*trans* selectivity. The mechanism for methyl glycosides formation is depicted in Scheme 2.38.

In another related work,<sup>48</sup> potassium hydroxide was added to the CAN radical reaction reagents due to the known low CH acidity character of nitromethane compared to ethyl nitroacetate and malonate.

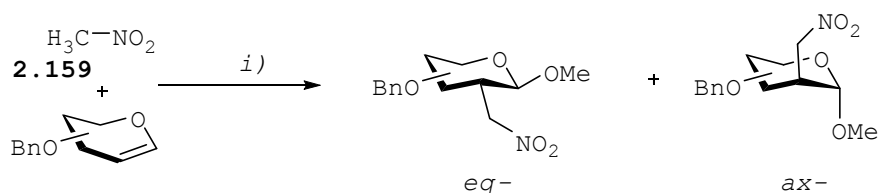

tri-*O*-benzyl-D-glucal-**2.47**    *gluco*-**2.165** (59%)    *manno*-**2.171** (12%)  
 tri-*O*-benzyl-D-galactal-**2.160**    *galacto*-**2.166** (55%)    *talo*-**2.172** (10%)  
 di-*O*-benzyl-D-xylal-**2.161**    *xylo*-**2.167** (28%)    *lyxo*-**2.173** (20%)  
 di-*O*-benzyl-D-arabinal-**2.162**    *ribo*-**2.168** (8%)    *arabino*-**2.174** (31%)  
 hexa-*O*-benzyl-D-maltal-**2.163**    *malto*-**2.169** (58%)    *epi-malto*-**2.175** (12%)  
 hexa-*O*-benzyl-D-lactal-**2.164**    *lacto*-**2.170** (59%)    *epi-lacto*-**2.176** (9%)

**Scheme 2.37** Reaction conditions: *i)* CAN, KOH, MeOH, 0°C

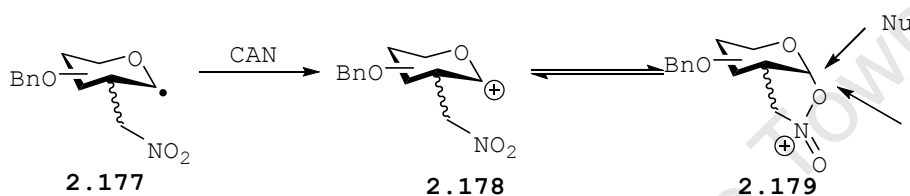

**Scheme 2.38** Mechanism for the formation of the Methyl Glycosides **2.179** via Radicals **2.177** and Cations **2.178**

The reduction followed by acetylation of C-2 nitromethyl pyranosides **2.165–2.170** was used to furnish C-2 glycosamines **2.180–2.185**.<sup>49</sup>

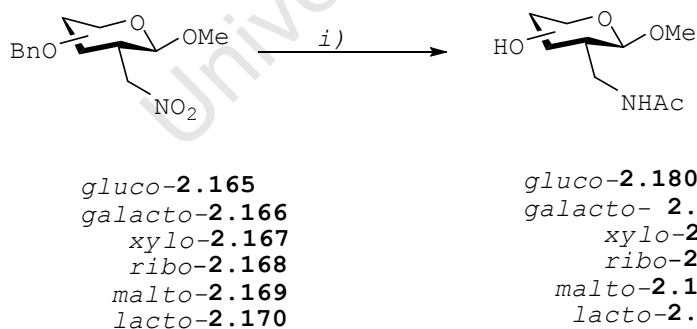

**Scheme 2.39** Reaction conditions: *i)* a) H<sub>2</sub> (40 bar), Pd/C, b) Ac<sub>2</sub>O

C-2-glycoamino acids **2.191** and **2.192** were synthesised successfully<sup>44c</sup> from both malonate and nitroester radical reaction products **2.186** and **2.187–2.190**, respectively, by catalytic hydrogenation followed by *N*-acetylation using acetic

anhydride and pyridine. Pd(OH)<sub>2</sub> catalyst was amongst the successful catalyst used for the catalytic hydrogenation step.

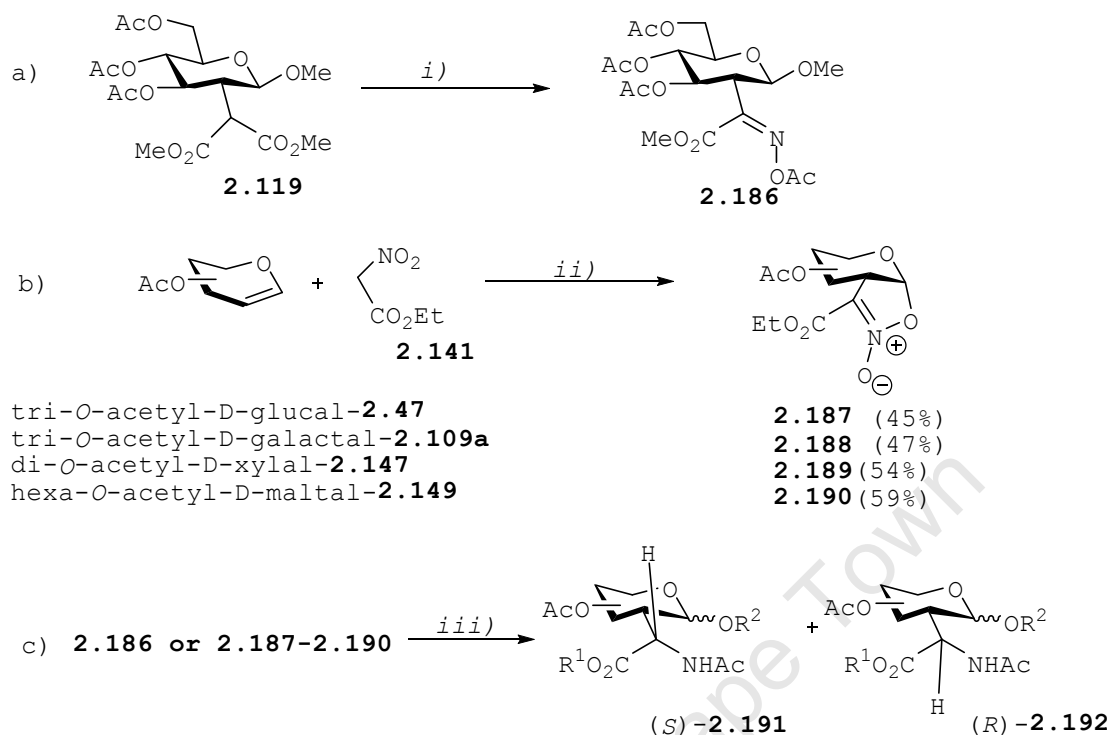

**Scheme 2.40** Reaction conditions: *i*) a) isoamyl nitrite, NaOMe, MeOH; b) Ac<sub>2</sub>O / pyridine, 94%; *ii*) CAN (5 equiv.), DMF, 0 °C; *iii*) a) H<sub>2</sub>, Pd(OH)<sub>2</sub>, 40 bar, b) Ac<sub>2</sub>O / pyridine

The formation of the preferred depicted diastereomers **2.191** and **2.192** can be rationalised by an *anti* attack of the radicals to the 3-*O*-acetyl group, in accordance with the mechanism of malonates addition.<sup>41,44a,b,50</sup>

In the same manner as for other CH-acidic compounds to glycols<sup>44a,c,51</sup> the reaction of benzylated glucal **2.194** with dimethyl phosphite **2.193** in the presence of CAN afforded the 2-phosponates **2.195** and **2.196**<sup>52</sup> in high yield, and these were used to form a C-C bond at the 2-position of the glucal. The reaction to form phosphonates **2.195** is presumed to proceed via phosphenyl radicals generated from dimethyl phosphite **2.193** and CAN. Linker *et al.* have demonstrated that orbital control is responsible for the regioselective attack at the 2-position of the glycols and the methyl glycosides are formed by

oxidation of the anomeric centre to a cation and subsequent trapping by methanol.<sup>38</sup>

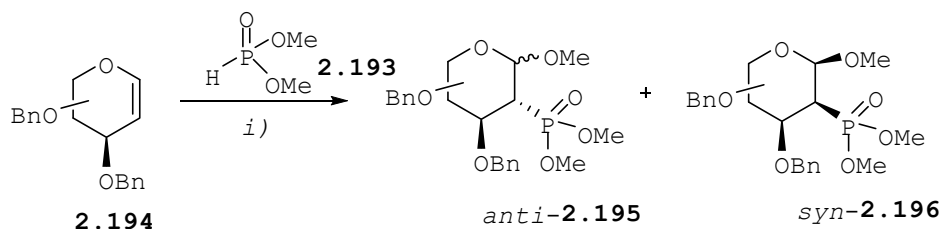

**Scheme 2.41** Reaction conditions: *i)* CAN, MeOH, 0°C

The benzylated glycal **2.194** (Scheme 2.41) is among one of many examples of glycals that were used in application of this new route to C-C bond formation at C-2 position of glycals. The phosphonates were subjected to Horner-Emmons reaction conditions to generate dienes **2.200** to **2.203** in excellent yields, with an *E/Z* ratio of the exo-alkene of 75:13 in the case of the *gluco*-isomer.

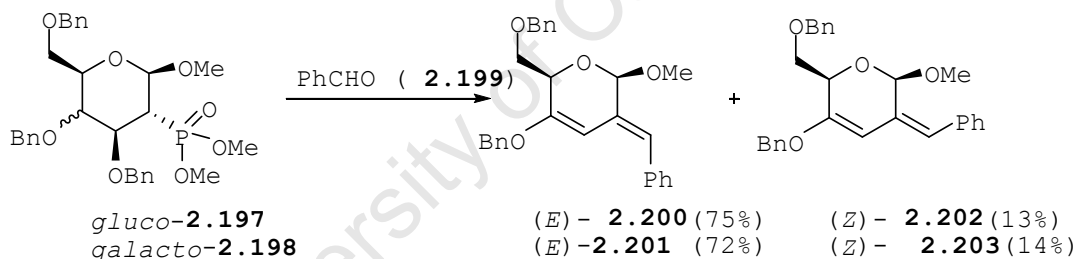

**Scheme 2.42** Reaction conditions: *i)* NaH, THF, 0°C

Sodium hydride proved to be the best base for this procedure, with other bases leading to the decomposition of the products as a result of the lability of the carbohydrate. Use of DBU in the Horner-Emmons reactions as previously described by Junker *et al.*<sup>53</sup> was unsuccessful.

As illustrated for the *xylo*-derivative (Scheme 2.43) the diene products are a result of initial fast elimination of the benzyloxy group at the 3-position followed by deprotonation at the 4-position by sodium hydride to give a resulting stabilised carbanion at C-2. The latter reacts with an aldehyde in the Horner-Emmons reaction.

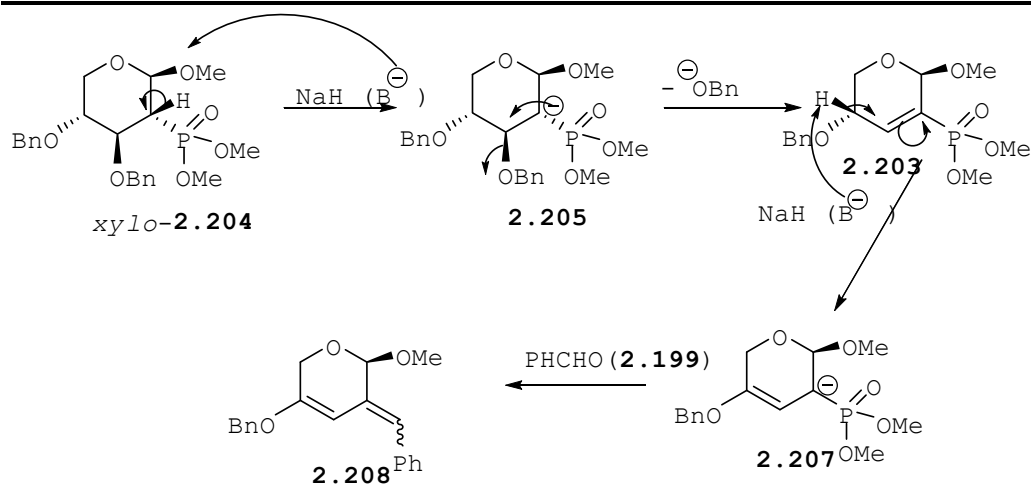

**Scheme 2.43** Proposed mechanism of the elimination during the Horner-Emmons reaction (shown for xylo-**2.204**).

In attempts to prevent elimination of the benzyloxy group during the Horner-Emmons reaction,<sup>52</sup> the protecting group on **2.204** was removed and the product subjected to the same reaction conditions (Scheme 2.42), but this resulted in decomposition of the products. This decomposition was explained by the fact that the tetra-anion is poorly soluble in organic solvents and the excess of base required in the reaction mixture.

### 2.2.3 Via Cyclopropanation

The synthesis and reactivity of donor-acceptor (DA) cyclopropanes have been widely studied and reviewed,<sup>54</sup> and they have been recognised as important building blocks in modern organic synthesis.<sup>55</sup> Although unactivated cyclopropanes have been directly employed for certain useful chemical transformations<sup>56</sup> most of the cyclopropane based synthetic methodologies have relied on activation from additional functional groups.

Cyclopropanes substituted with electron accepting groups can react as homo Michael acceptors in nucleophilic ring opening reactions (Scheme 2.44a), while donor substituted cyclopropanes can be cleaved by electrophiles to afford cation equivalents for further transformations (Scheme 2.44b).<sup>57</sup>

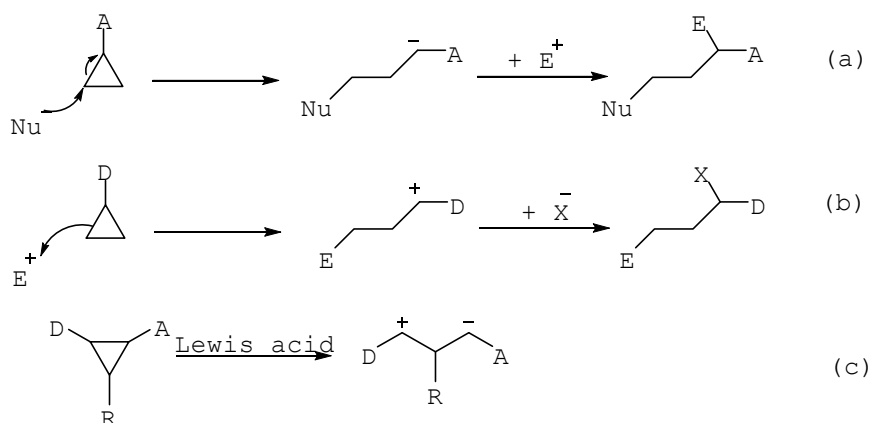

A = Electron acceptor:  $\text{CO}_2\text{R}$ ,  $\text{C}(\text{O})\text{R}$ ,  $\text{CN}$ , etc

D = Electron donor:  $\text{OR}$ ,  $\text{OSiR}_3$ ,  $\text{NR}^1\text{R}^2$ ,  $\text{SR}$ , etc

**Scheme 2.44** Reactivity of cyclopropane

Vicinal donor-acceptor (DA) cyclopropanes are particularly useful synthetic building blocks because the reactivity imparted to the cyclopropane by the substituents is amplified by a synergistic electron 'push-pull' relationship.<sup>54</sup> Under Lewis acidic conditions, the doubly activated cyclopropanes undergo formal retro-aldol rearrangement to 1,3-zwitterionic intermediates that can be considered as 1,3-dipole equivalents (Scheme 2.44c).

In carbohydrate chemistry the cyclopropanation of glycals affords unique bicyclic structures combining the high reactivity of cyclopropanes together with the optical purity and functional density associated with sugars.<sup>58</sup> The electron donating effect from the pyran ring oxygen directs the cyclopropane reactivity towards accessing C-2 carbon-branched glycosides as illustrated in Scheme 2.45 where the generalised 1,2-cyclopropanated carbohydrate **2.208** is converted to C-2 branched glycosides **2.211**. The reaction normally proceeds (pathway A, Scheme 2.45) through electrophilic cyclopropane methylene activation by an electron deficient species that leads directly to formation of the oxocarbenium ion intermediate **2.210**. However, an alternative pathway (pathway B, Scheme 2.45) involves a Ferrier rearrangement to give 7-

membered ring intermediate **2.213**, which is trapped by a nucleophile to give **2.214**.<sup>59</sup>

An example of electrophilic cyclopropane ring-opening was demonstrated on the pyran-derived substrate **2.215**, involving mercury(II) salt activation (Scheme 2.46).<sup>60</sup> The regioselectivity was thought to originate from partial cation charge stabilisation by the pyran oxygen.

This strategy was later adapted by Scott to access C-2 methyl glucal **2.220**.<sup>61</sup> Treatment of **2.218** with mercury (II) trifluoroacetate in the presence of water afforded hemiacetal **2.219**, which after subsequent  $\text{Bu}_3\text{SnH}$  reduction and elimination provided glucal **2.220**.

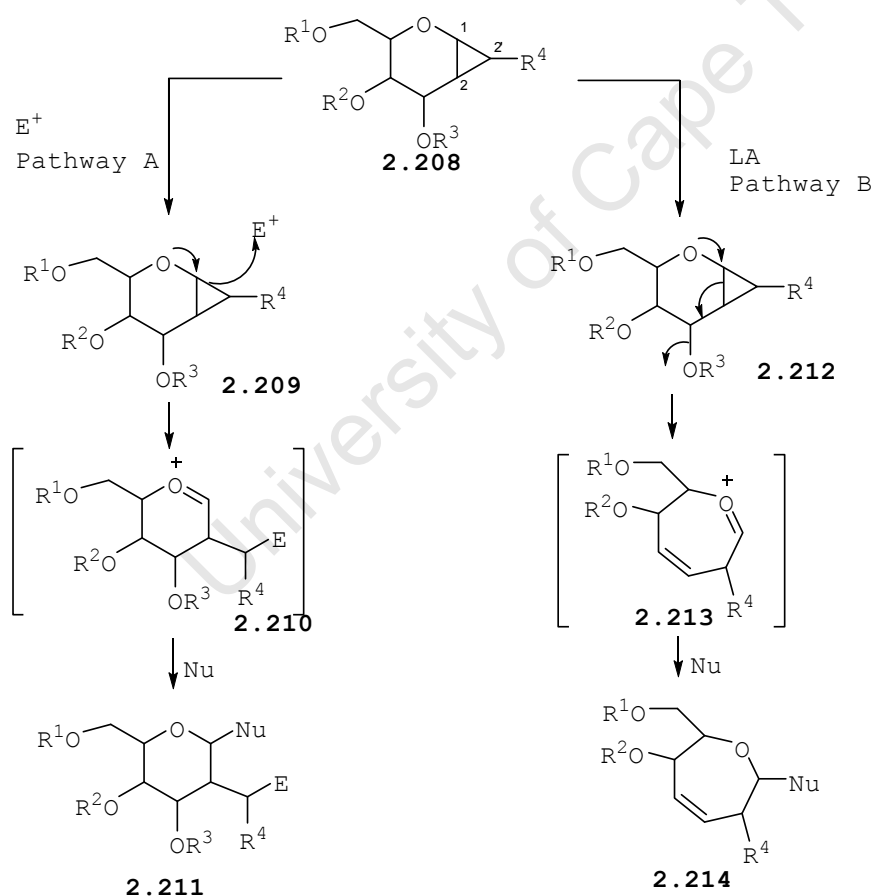

**Scheme 2.45** Electrophilic C-1-C-2' cyclopropane ring cleavage and ring expansion

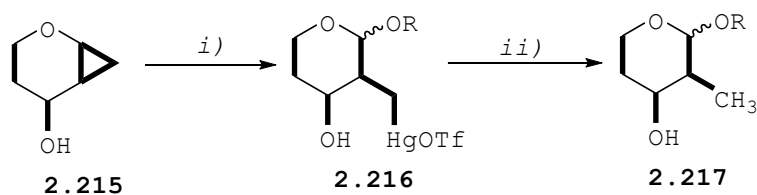

**Scheme 2.46** Reaction conditions: *i)* Hg(OR)<sub>2</sub>, NaCl; *ii)* LiAlH<sub>4</sub> (64% overall)

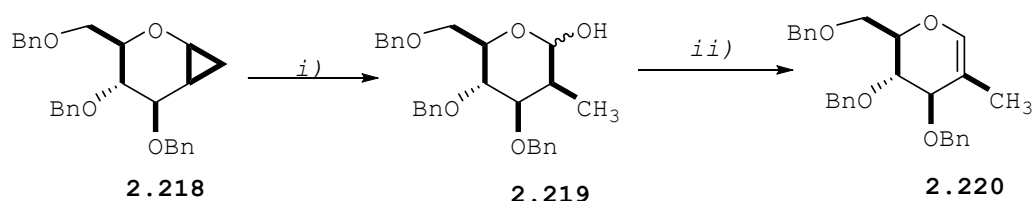

**Scheme 2.47** Reaction conditions: *i) a)* Hg(O<sub>2</sub>CCF<sub>3</sub>)<sub>2</sub>, H<sub>2</sub>O, NaCl; *b)* Bu<sub>3</sub>SnH, AIBN, 81%; *ii)* Ms<sub>2</sub>O, Et<sub>3</sub>N, 84%

A conceptually equivalent transformation was developed by Meng and co-workers using *N*-iodosuccinimide (NIS) to access the geminal methyl groups in the synthesis of cytotoxic agents epothilone A and B.<sup>62, 63</sup>

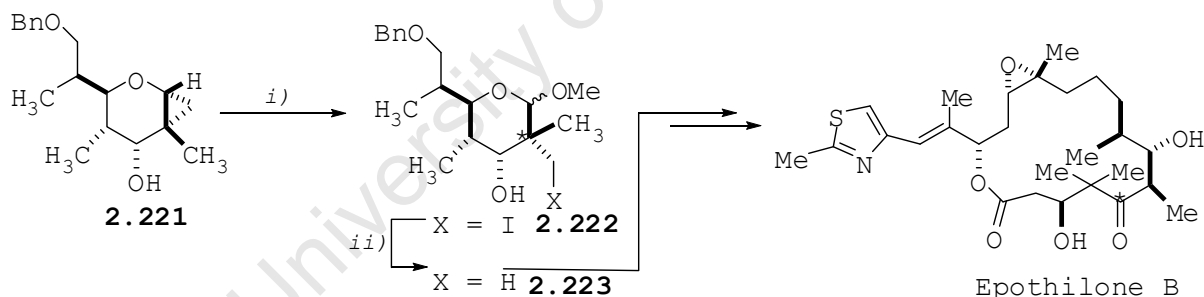

**Scheme 2.48** Reaction conditions: *i)* NIS(excess), MeOH; *ii)* Bu<sub>3</sub>SnH, AIBN, 80% (two steps)

Importantly, the high efficiency observed in the preparation of the intermediate **2.222** using NIS activation eradicated the need for highly toxic mercury salts. Several applications of, and modifications to, the intriguing NIS strategy have been reported.<sup>64</sup> Nagarajan and co-workers<sup>64b-c</sup> have discovered sharply different cyclopropane reactivity between diastereomers **2.224** and **2.226**. Reaction of  $\alpha$ -cyclopropane **2.224** with either NIS or NBS occurred rapidly and provided an anomeric mixture of **2.225**

in ~90% yield. By contrast, reaction under otherwise identical conditions with  $\beta$ -cyclopropane **2.226** results in slower formation of **2.227** with pronounced anomeric selectivity. The same tendency in reactivity was also observed on diastereomeric substrates **2.228** and **2.230** in which the free C-6 hydroxyl is available to participate in an intramolecular nucleophilic attack. The differences in reactivity were attributed to steric hindrance on the  $\beta$ -cyclopropanes **2.228** and **2.230** toward the approaching electrophilic activator. The most reactive  $\alpha$ -cyclopropane **2.228** not only has the benefit of the least C-3 steric hindrance, but is equipped with a free hydroxyl ideally positioned for  $S_N2$ -like participation. The  $\beta$ -cyclopropane **2.230** is not predisposed for direct substitution and is blocked from the electrophilic activators.

In similar work, Gammon *et al.*<sup>65</sup> have used  $NH_4I$  or  $NH_4Br$ , 50%aq. $H_2O_2$  and  $Ac_2O/AcOH$  in acetonitrile at low temperatures and achieved efficient and highly stereoselective haloacetoxylated **2.225**.

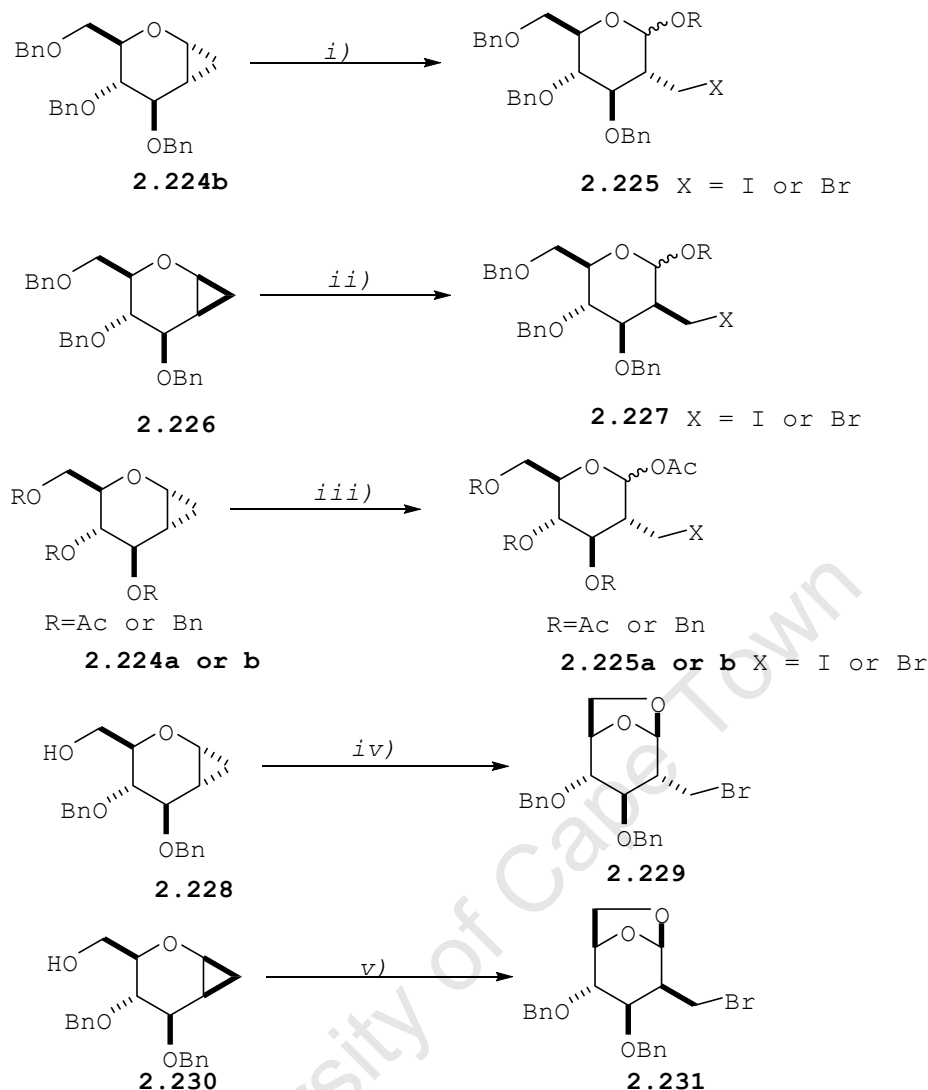

**Scheme 2.49** Reaction conditions: i) NIS or NBS, ROH, up to 91%; ii) NIS or NBS, ROH, 40–70%; iii)  $\text{NH}_4\text{I}$  or  $\text{NH}_4\text{Br}$ , 50% aq.  $\text{H}_2\text{O}_2$ ,  $\text{Ac}_2\text{O}/\text{AcOH}$ ,  $\text{CH}_3\text{CN}$ , up to 100%; iv) NBS,  $\text{CH}_3\text{CN}$ , 4 A MS, 5 h, 71%; v) NBS,  $\text{CH}_3\text{CN}$ , 4 A MS, 36 h, 35%

In addition to investigations on 1,2-disubstituted cyclopropanes, the electrophilic ring cleavage strategy was applied to substrates **2.232** prepared through diazo ester cyclopropanation.<sup>66</sup>

In an early example reported by Hoberg *et al.*,<sup>67</sup> the 1-bromopyran derivative **2.233** was prepared in moderate yield (38%) by treating **2.232** with 30% HBr in acetic acid, but the reaction was inevitably accompanied with C-3 'S<sub>N</sub>2-like'

substitution by bromide (Scheme 2.50a). In a similar example by Henry, the carboxylate substitution on **2.234** was advantageously used in a highly selective cyclopropylcarbinyl-homoallyl rearrangement (Scheme 2.50b).<sup>68</sup> Ester reduction by lithium aluminum hydride (LiAlH<sub>4</sub>) on **2.234** followed by standard Mitsunobu manipulation employing benzoic acid as the nucleophile gave 66-90% yield of 2-deoxy-2-vinyl glycols **2.236** as anomeric mixtures.

In related work, Sridhar *et al* have used carboxylated cyclopropopane **2.237**, derived from benzylated glucal, to synthesise C-2 branched glycoamino acids **2.239** (Scheme 2.50c).<sup>69</sup> Carboxylated cyclopropane **2.237** was opened as suggested by Ramana *et al*<sup>70</sup> to form iodo compound **2.238** which after several steps generated **2.239**.

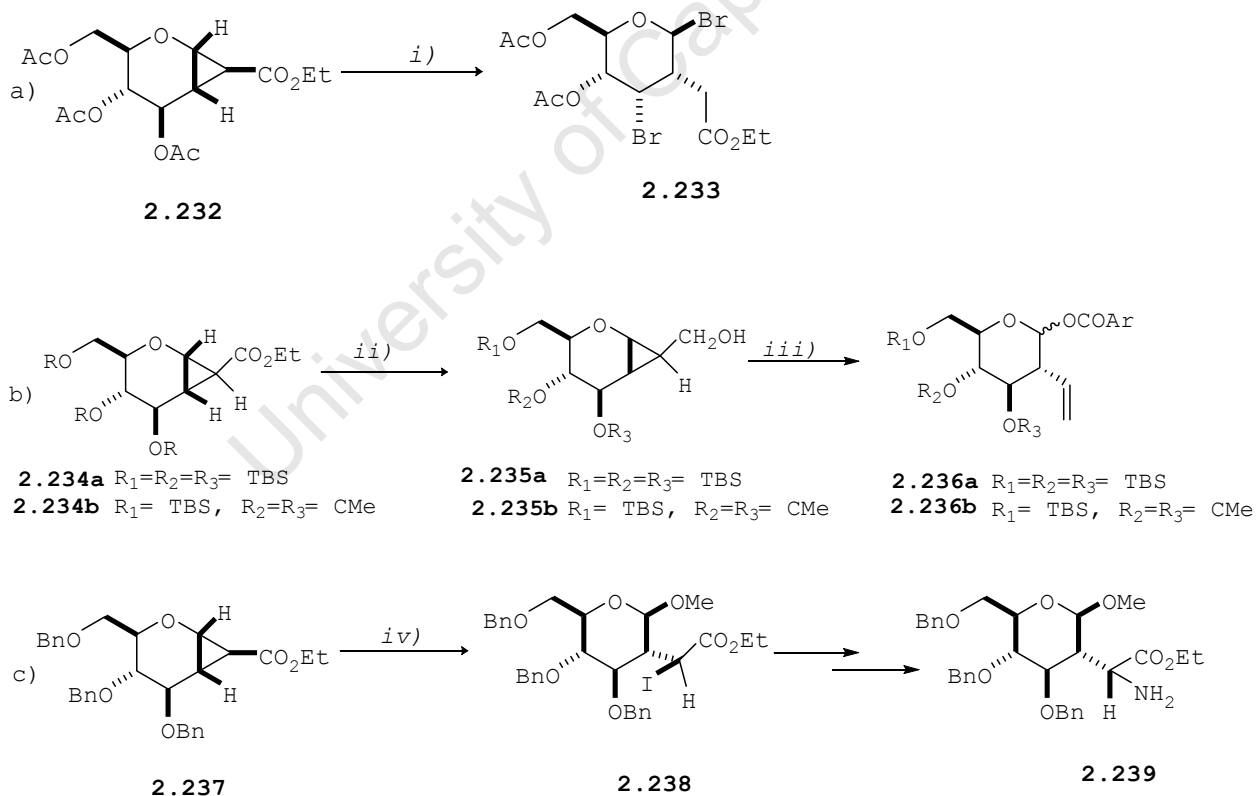

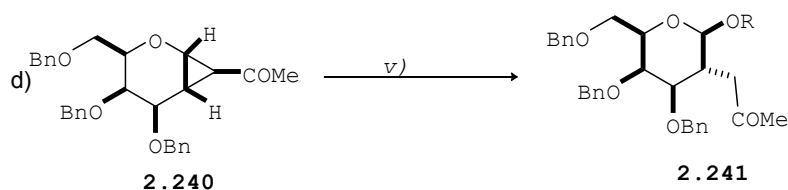

R = monosaccharides, amino acids, alcohols

**Scheme 2.50** Reaction conditions: i) 30% HBr (AcOH), 38%; ii) LiAlH<sub>4</sub>; iii) Ph<sub>3</sub>P, DEAD, ArCOOH, 66-90%; iv) NIS, MeOH, 75%; v) BF<sub>3</sub>·Et<sub>2</sub>O or TMSOTf, ROH, CH<sub>2</sub>Cl<sub>2</sub>, MS 4A

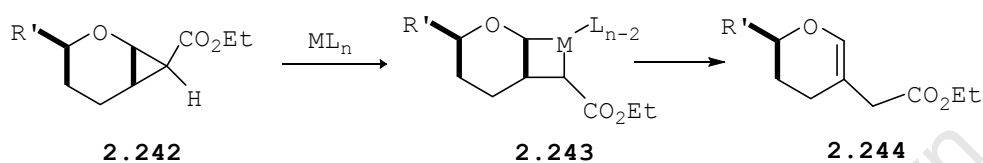

**Scheme 2.51** Mechanistic path for C-2-glycoside formation using a metal

Transition metal catalysed rearrangements of DA cyclopropanes to give (or regenerate) enol ether products are well established and were also used in the ring opening reaction of donor-acceptor cyclopropanes.<sup>71</sup>

A broad range of transition metals such as rhodium(I) ([Rh(CO)<sub>2</sub>Cl]<sub>2</sub>), ruthenium(II) ([Ru(CO)<sub>3</sub>Cl<sub>2</sub>]<sub>2</sub>), platinum(II) (PtCl<sub>2</sub>·2PhCN), copper bronze and CuCl were reported to be efficient catalysts for this transformation, which is thought to proceed by a regioselective oxidative addition to produce a metallacyclobutane intermediate **2.243**. Subsequent β-elimination and reductive elimination affords the vinyl ether products, which have shown little penchant for C=C bond migration.

Using Ziese's dimer in alcoholic solvent, Beyer *et al.* extended this transformation to glycol-derived cyclopropane substrates **2.224** as a means to access C-2 branched glycosides.<sup>72</sup>

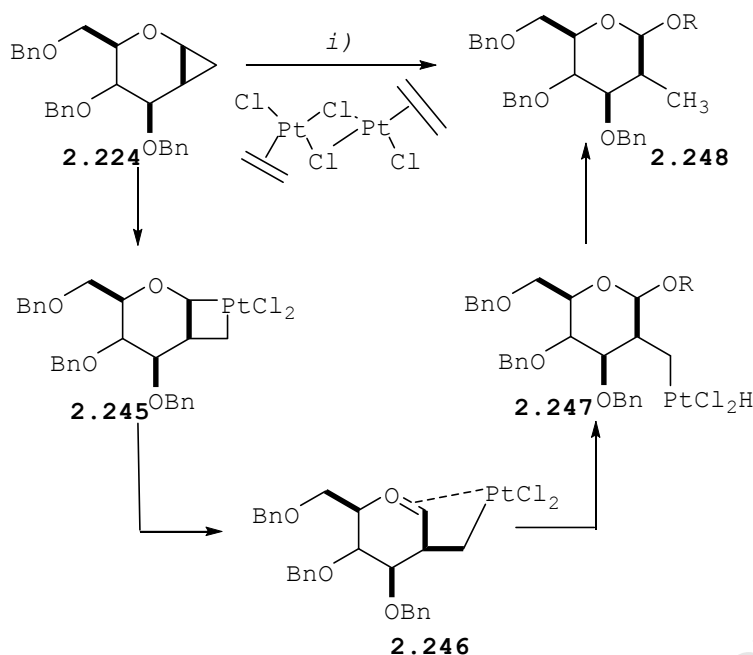

**Scheme 2.52** Reaction conditions: i) ROH, CH<sub>2</sub>Cl<sub>2</sub>, 50-97%

Interestingly, the platinumacyclobutane intermediate gained enough lifetime for competitive C-1-Pt bond dissociation before  $\beta$ -elimination to afford the glycoside products **2.248**. Even when challenged with substrates bearing a carboxylate group, the same reaction pathway was observed (Scheme 2.52).

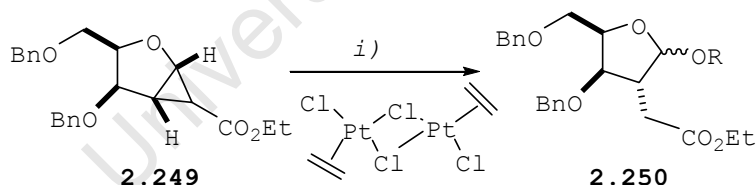

**Scheme 2.53** Reaction conditions: i) ROH, CH<sub>2</sub>Cl<sub>2</sub>, 59-75%

Nagarajan *et al.*<sup>70</sup> have also reported cyclopropane ring opening using iodonium bis(*s*-collidine) perchlorate in dioxane-water (Scheme 2.54). This reaction leads to the formation of  $\alpha$ -methylidenevalerolactone **2.253** from cyclopropane sugars **2.251** in acceptable yields. The reaction was shown to proceed through iodomethyl intermediates **2.252**, which subsequently undergo elimination and oxidation. These products **2.253** are good precursors for C-2 alkyl glycosides.

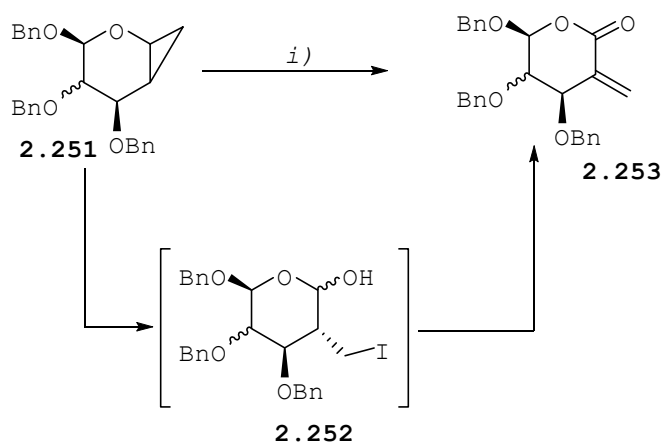

**Scheme 2.54** Reaction conditions: *i)* Dioxane-H<sub>2</sub>O, [s-collidine]<sub>2</sub>I<sup>+</sup>ClO<sub>4</sub><sup>-</sup> 41-82%

#### 2.2.4 Via Formylation of Glucal

C-2 formylations of carbohydrates have been described by Ramesh and Booma<sup>73</sup> under Vilsmeier-Haack conditions and C-2-acetylations were realized by Priebe *et al.*<sup>74</sup> using acetic anhydride in the presence of Lewis acids (Scheme 2.55). Protected glycals under Vilsmeier-Haack conditions afforded 2-C-formylglycals **2.255**,<sup>73a</sup> which after reduction and acetylation gave acetoxymethyl derivative **2.257** which could be converted to C-2-methylene-O-glycosides **2.258** using a Ferrier rearrangement protocol under BF<sub>3</sub>·Et<sub>2</sub>O catalysis. This rearrangement takes place readily in the glucal as well as in the galactal series. The utility and generality of the reaction were established by examining use of different catalysts and nucleophiles.<sup>75</sup>

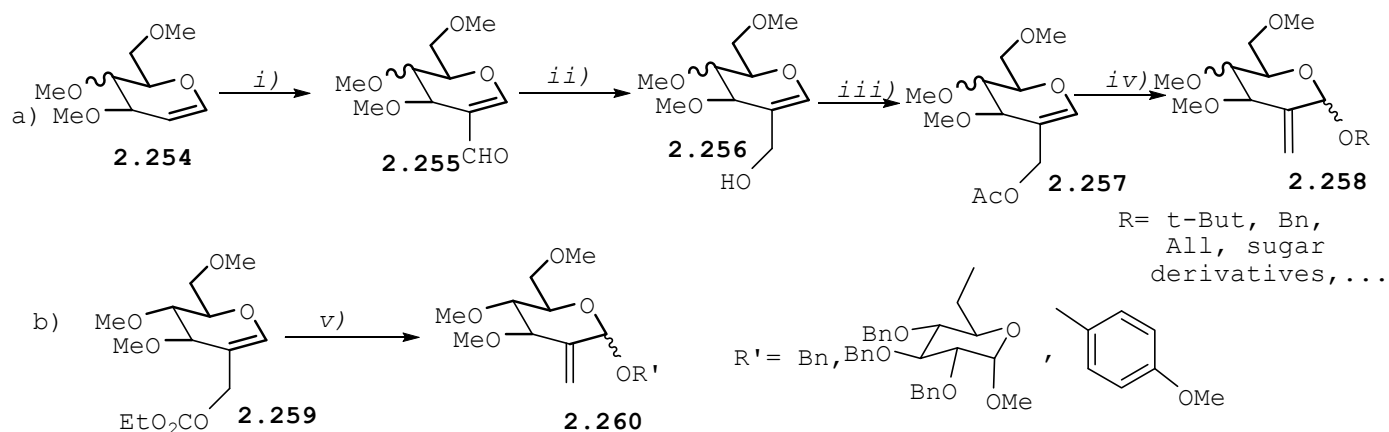

**Scheme 2.55** Reaction conditions: i) DMF, POCl<sub>3</sub>, 0-r.t; ii) NaBH<sub>4</sub>, MeOH, 70%; iii) Ac<sub>2</sub>O, pyridine, cat. DMAP, CH<sub>2</sub>Cl<sub>2</sub>, 85%; iv) ROH, BF<sub>3</sub>-Et<sub>2</sub>O, 0 °C, CH<sub>2</sub>Cl<sub>2</sub>, 55-75%; v) Pd(PPh<sub>3</sub>)<sub>4</sub>, R'OH, THF, reflux

Palladium catalysed reactions with an allylic carbonate instead of allylic acetate (scheme 2.55b), resulted in glucosides instead of mannosides as previously demonstrated in Scheme 2.55a. The reversed stereochemistry is explained by the fact that since these glycosides was  $\alpha$  in nature: it is believed that the formation of the  $\pi$ -allyl complex occurs from  $\beta$ -face followed by the attack of nucleophiles from  $\alpha$  side (Fig. 2.5).

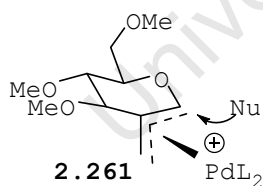

**Figure 2.5** Mechanism of the  $\pi$ -allyl complex **2.261** and attack of nucleophiles from  $\alpha$  side.

Kashyap *et al.*<sup>76</sup> extended this work by reducing benzylated 2-C-formylglucal **2.63** and propargylating the alcohol using NaH/propargyl bromide in the presence of  $n\text{-Bu}_4\text{N}^+\text{I}^-$  to give enyne **2.262**, which was then subjected to AuCl<sub>3</sub>-mediated S<sub>N</sub>2' addition

in methanol at 0°C-rt. Exomethylene compound **2.263** was obtained in 63%.

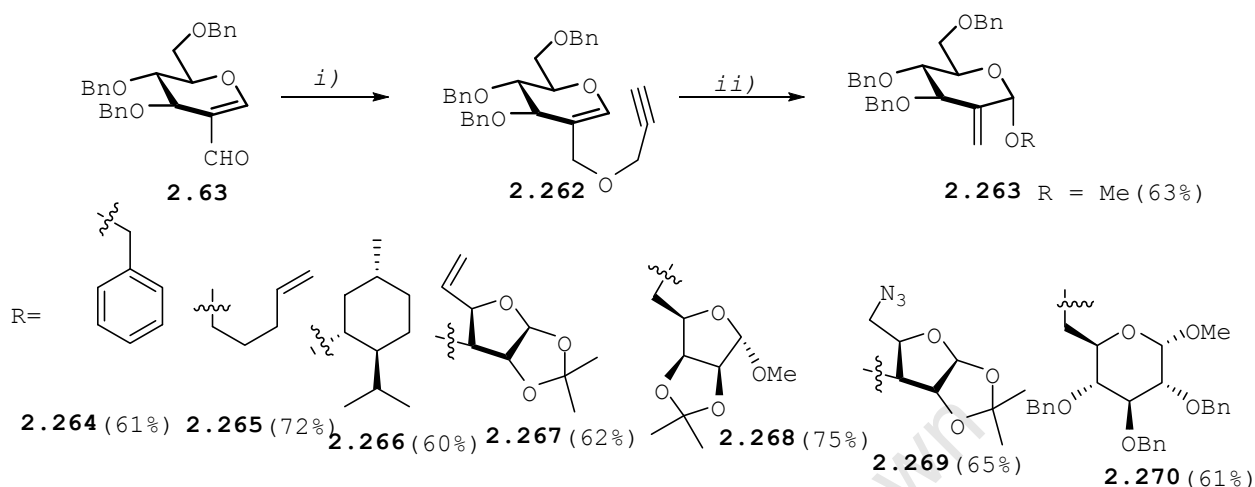

**Scheme 2.56** Reagents and conditions: i) a) NaBH<sub>4</sub>, MeOH, 0°C-r.t, 85%; b) NaH, DMF, nBu<sub>4</sub>NI, Propagylbromide, 0°C-r.t, 87%; ii) AuCl<sub>3</sub>, ROH, Acetonitrile, 0°C-r.t, 61-75%

Various aglycones comprising aromatic, aliphatic, alicyclic and carbohydrate-derived alcohols were used to test the general applicability of this AuCl<sub>3</sub>-mediated S<sub>N</sub>2' addition reaction. And it was shown that the conditions were tolerant of functional groups such as olefins, isopropylidene, azide and ethers, and that the stereoselective formation of α-glycosides could be attributed to the anomeric effect, though a thorough mechanistic investigation was not done.

### 2.2.5 Via C-2 Lithiation / Trapping

Direct lithiation at the α-vinyllic position of functionalised acrylates has become a versatile tool in organic synthesis because of the compatibility of the vinyl lithium intermediate with a variety of other substituents. The ease of availability of phenylsulfinyl analogue **2.272** of the α-alkoxy acrylate **2.271** allowed its use in the synthesis of C-2 branched sugars derived from glucose.<sup>77</sup>

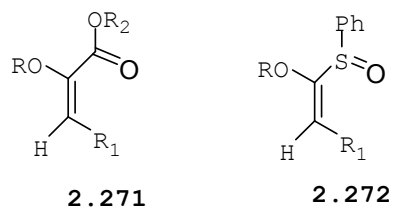

**Figure 2.6**  $\alpha$ -alkoxy acrylate **2.271** and phenylsulfinyl analogue **2.272**

The required glucal derivatives were obtained from phenyl tetra-*O*-benzyl-1-thio- $\beta$ -D-glucopyranoside **2.273**. Oxidation with *m*-CPBA afforded the desired sulfoxide **2.274** as a substrate for the lithiation conditions. Treating this sulfoxide with 2.0 equivalent of LDA achieved both elimination and lithiation of the sulfoxide derivative.

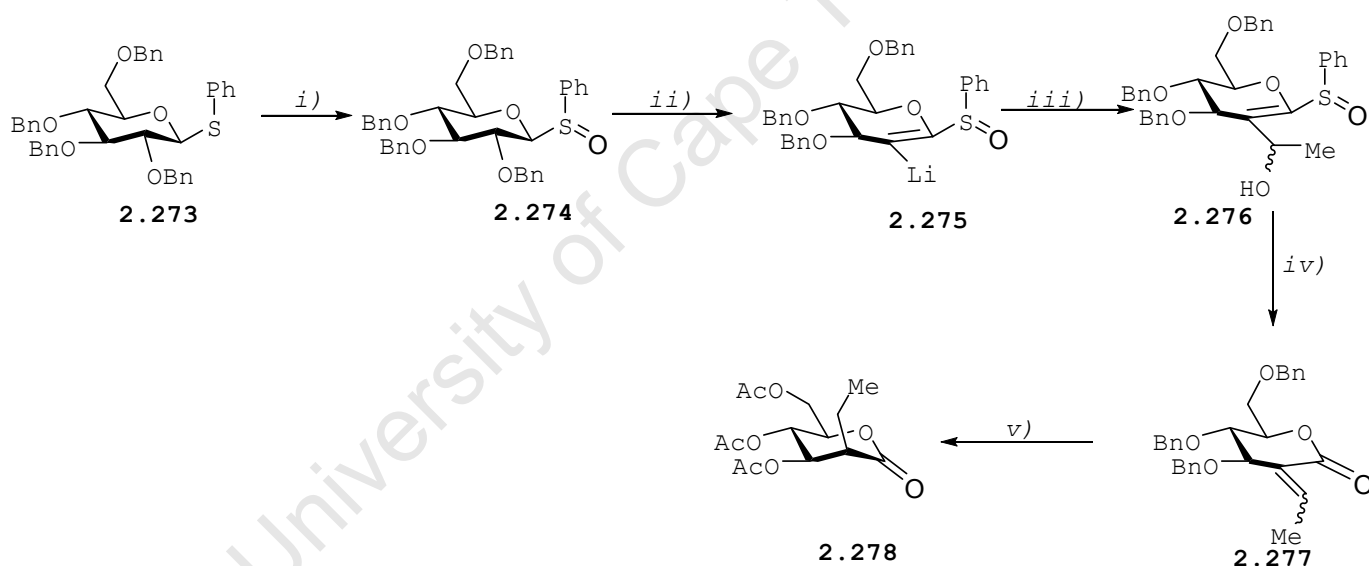

**Scheme 2.57** Reaction conditions: *i*) *m*-CPBA; *ii*) LDA,  $-80^{\circ}\text{C}$ , 80%;  
*iii*)  $\text{CH}_3\text{CHO}$ , LDA,  $-80^{\circ}\text{C}$ , 48%; *iv*)  $\text{H}^+$ , 81%;  
*v*) a) Pd/C,  $\text{H}_2$ , b)  $\text{Ac}_2\text{O}$ , Pyridine

Reaction with aldehyde ( $\text{MeCHO}$ ) then gave a mixture of diastereomers **2.276** in good yield, and the formation of 2-alkylidene lactone **2.277** was achieved by acid-catalysed hydroxyl group migration to C-1 followed by phenylsulfenic acid elimination. Subsequent hydrogenation of ethylidene lactone with Pd/C as a catalyst occurred exclusively from the less hindered face. Debenzylation followed by acetylation

afforded the 2-ethyl-branched lactone **2.278** with *manno* configuration.

### 2.2.6 Via Metal glycosylidenes

Different synthetic methodologies have been developed for the introduction of the 'Fischer-type carbene functionality' into a carbohydrate skeleton. The  $K_2M(CO)_5$ - 'dianion' approach ( $M=Cr, Mo, W$ ) provides access to metal iminoglycosylidenes. Sugar-derived propynols have been applied to the synthesis of vinylcarbene complexes, which undergo stereoselective C-glycosidation and C-C bond formation in the carbohydrate backbone. The reaction of 1-lithioglucals<sup>78</sup> **2.280** and **2.281**, prepared *via* transmetalation of the corresponding 1-stannylated glucals **2.278** and **2.279**, with Group 6 metal carbonyls is controlled by the substitution pattern of the carbonyl complexes (Scheme 2.58).<sup>79</sup>

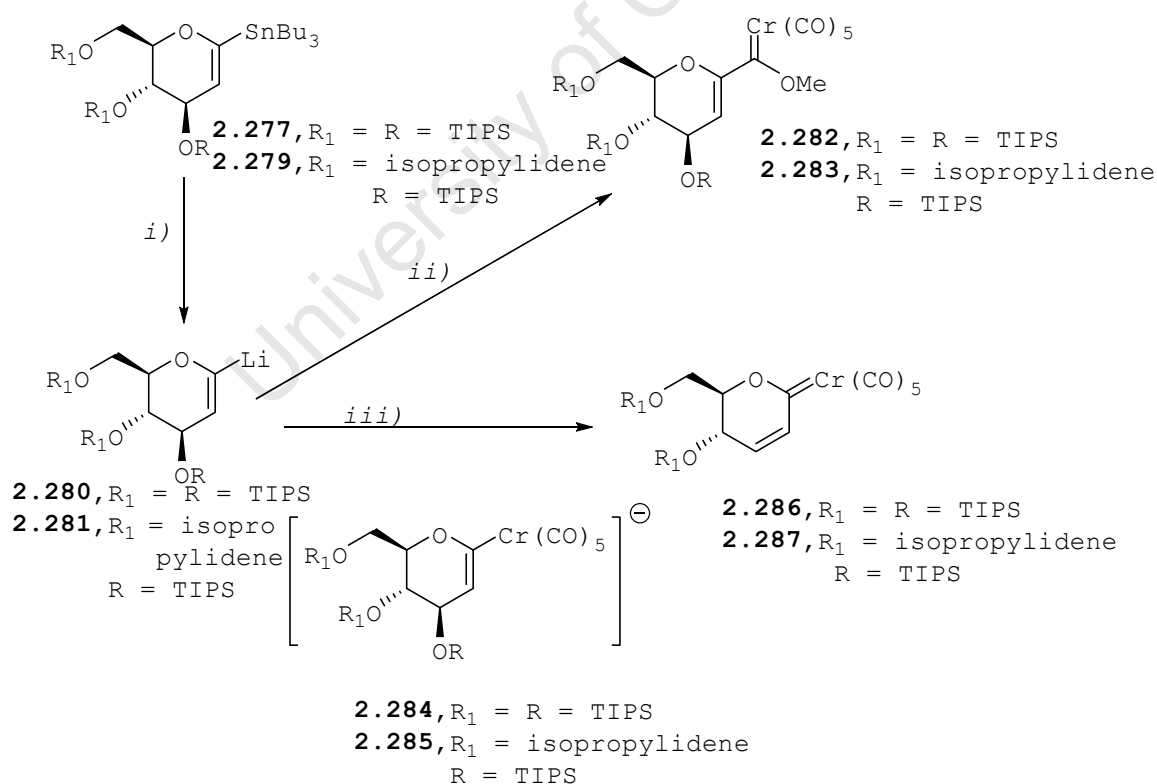

**Scheme 2.58** Reaction conditions: *i*)  $n\text{-BuLi}$ ,  $-78^\circ\text{C}$ ; *ii*) a)  $\text{Cr(CO)}_6$   
 b)  $\text{Me}_3\text{O}^+\text{BF}_4^-$ ; *iii*) a)  $\text{Cr(CO)}_5$ , THF;  
 b) Heat

According to the classical Fischer-route for the synthesis of carbene complexes,<sup>80</sup> the addition of the lithiated glycal to hexacarbonyl chromium occurs at the carbonyl carbon yielding  $\alpha,\beta$ -unsaturated carbene complexes **2.282**, **2.283** after methylation of the acylchromate intermediate.<sup>81</sup> However with a ligand combining good leaving group and good donor properties such as triphenylphosphine or tetrahydrofuran, the lithioglucal adds at the metal to generate vinyl chromates **2.284**, **2.285** which correspond to enolate-type pentacarbonyl chromium intermediates (Scheme 2.58).<sup>82</sup> Alkylation with allyl iodide resulted in the formation of 2-C-allyl complexes **2.289** and **2.290** in good yield and with excellent diastereoselectivity (Scheme 2.59).<sup>83</sup>

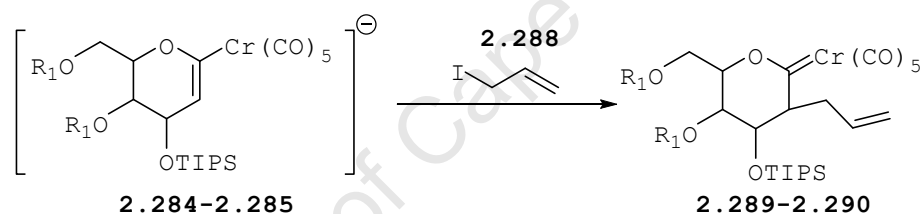

**Scheme 2.59** Alkylation of **2.284-2.285** with allyl bromide

### 2.2.7 Via ketone enolate

Chapleur<sup>84</sup> reported the alkylation of a ketone lithioenolate derived from D-mannose. The lithium enolate **2.292**, readily obtained from the D-mannose-derived ketone **2.291** at low temperature with butyllithium,<sup>85</sup> reacted with electrophilic reagents in a tetrahydrofuran-hexamethylphosphoric triamide mixture, providing a short route to 2-C-alkyl sugars **2.293**, **2.294** in low yields ranging from 38% to 55%. A second alkylation was done on these molecules by the same procedure with yields of **2.295-2.297** in the range 28% to 44%. The stereochemistry at the C-2 position reflects the preferred electrophilic attack from the less hindered  $\beta$ -face of the enolate.

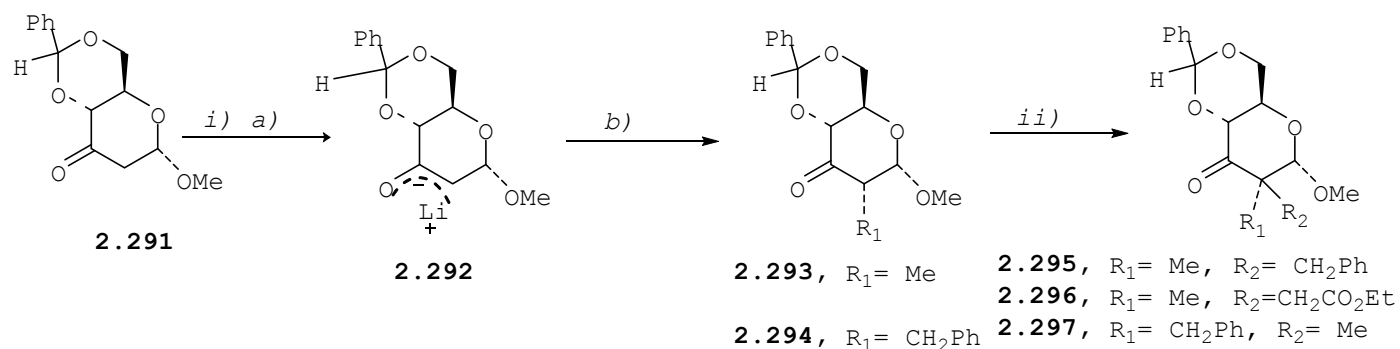

**Scheme 2.60** Reaction conditions: i) a) BuLi, THF,  $-30^\circ\text{C}$ ; b)  $R_1\text{Br}$ , HMPA, THF,  $-30^\circ\text{C}$ ; ii) a) LDA, THF; b)  $R_2\text{Br}$ , HMPA, THF,  $-20^\circ\text{C}$

Another enolate-type reaction developed by Chapleur *et al.* involves the reaction of aldehydes with the keto-sugar.<sup>86</sup> The enolate **2.292**<sup>85</sup> underwent *in situ* aldolisation with acetaldehyde and propionaldehyde to give aldols **2.298** and **2.299** as mixtures of isomers in 70% and 80% yield, respectively.

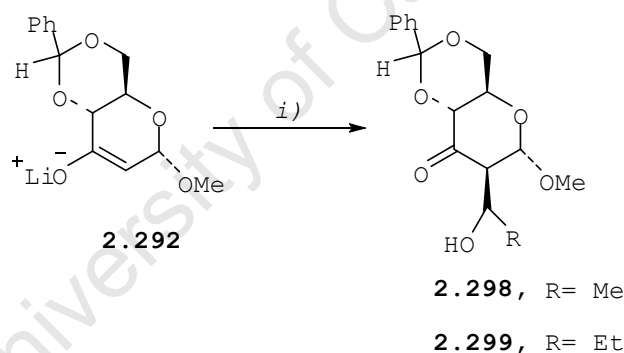

**Scheme 2.61** Reaction conditions: i) RCHO, THF,  $-30^\circ\text{C}$

The same protocol described above has been applied by Samb *et al.* in the synthesis of a branched-chain ulose.<sup>87</sup> Compound **2.291** (Scheme 2.62) underwent condensation with *N,N*-dimethylformamide dimethylacetal to yield **2.300** in 81% yield and this was then used to make pyrazole-annulated pyranoside **2.301**. Pyrazole were used for peptidomimetic design.

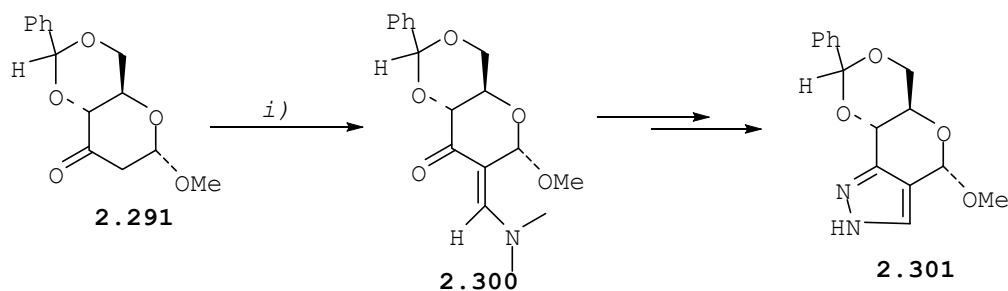

**Scheme 2.62** Reaction conditions: *i)*  $\text{HCNMe}_2(\text{OMe})_2$ ,  $\text{CH}_2\text{Cl}_2$

## 2.3 Compounds with a C-C-X branch (Type 2)

### 2.3.1 Via Nucleophilic attack at the carbonyl group at C-2

A wide variety of nucleophilic reagents have been used to add to a carbohydrate having a carbonyl group at C-2, as a way of synthesizing branched-chain sugars.<sup>88</sup> Treatment of ketone **2.302** with benzyloxymethyl lithium, derived from benzyloxy methyltrimethyl tin and *n*-BuLi in THF, gave 2-C-alkylated glucoside **2.303** in good yield.<sup>88a</sup> Here the stereoselectivity is believed to be strongly influenced by the axial methoxyl group at the anomeric position.

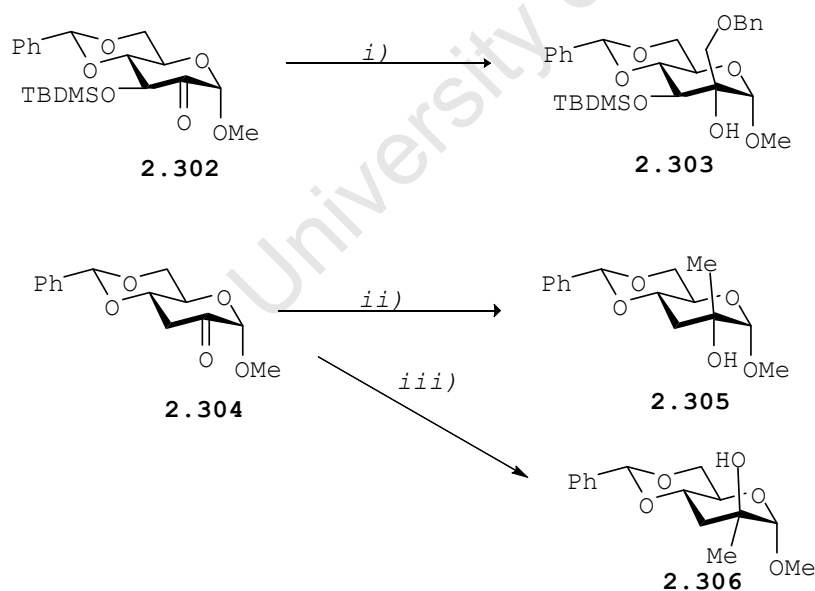

**Scheme 2.63** Reaction conditions: *i)*  $\text{Bu}_3\text{SnCH}_2\text{OBn}$ , *n*-BuLi, THF, 72%;  
*ii)*  $\text{MeMgI}$ ,  $\text{Et}_2\text{O}$ , 73%; *iii)*  $\text{MeLi}$ ,  
 $\text{Et}_2\text{O}$

Similarly, treatment of ketone **2.304** with  $\text{MeMgI}$  gave exclusively the glucoside **2.305**; however, reaction of **2.304**

with methyllithium was much less selective, giving a 3:2 ratio of **2.305** and **2.306**.

## 2.4 Compounds with a C=C branch (Type 3)

### 2.4.1 Via Wittig reaction

The Wittig reaction is a very important tool in synthetic organic chemistry since it generates a carbon-carbon double bond normally with a high level of regioselectivity.<sup>89</sup> It allows the preparation of an alkene by the reaction of an aldehyde or ketone with an ylide generated from a phosphonium salt. Different modifications of the Wittig reaction have been developed including the Wittig-Horner reaction,<sup>90</sup> and Horner-Wadsworth-Emmons reaction<sup>91</sup> which are more versatile than the initial reaction.

The Wittig and related reactions have found wide use in carbohydrate synthesis where they have the potential either to extend the carbohydrate chain or cause a branching of the chain.<sup>92</sup>

Wittig reactions were used in the total synthesis of macrolide lasonolide A.<sup>93</sup> The top half of the macrolide (C<sub>18</sub>-C<sub>23</sub>) was elongated by using Wittig chain elongation method on the 2-position of pyranose subunit. Compound **2.307** was synthesized as precursor to the top half of the macrolide<sup>94</sup> and subsequent oxidation using (CF<sub>3</sub>CO)<sub>2</sub>O/DMSO led to the 2-ulose derivative which was subjected to Wittig reaction conditions to generate **2.308** (Scheme 2.64). Reduction of **2.308** with LiAlH<sub>4</sub> in ether at 0°C provided the allylic alcohol **2.309**.

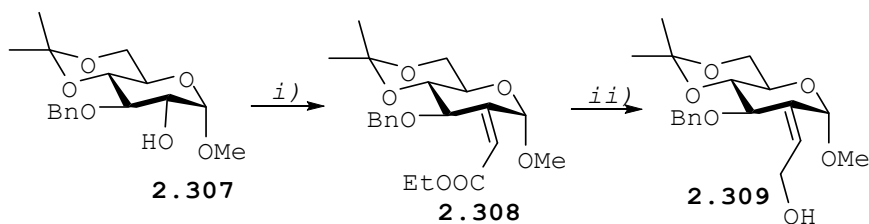

**Schem 2.64** Reaction conditions: i) (a) TFAA, DMSO, Et<sub>3</sub>N, DCM, -78°C; b) Ph<sub>3</sub>P=CHCOEt, CH<sub>3</sub>CN, reflux (overall yield 67 %); ii) LAH, 0°C, ether, 0.5 h, 86%

In similar work by Wood *et al.* directed towards synthesis of the pyranoside subunit a fused-butyrolactone, ketones **2.313** and **2.314** were prepared by a sequence involving mono-protection of diol **2.310** to give separable mixture of the alcohols **2.311** and **2.312** and followed by oxidation.<sup>95</sup>

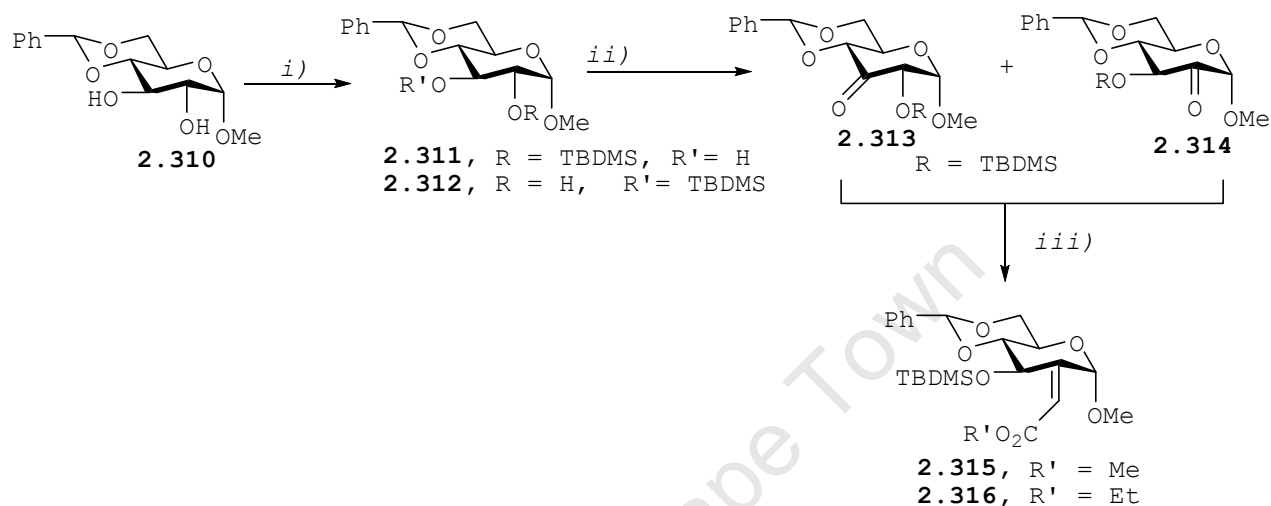

**Scheme 2.65** Reaction conditions: *i)* TBDMSCl, pyr.; *ii)* PCC, CH<sub>2</sub>Cl<sub>2</sub>; *iii)* Ph<sub>3</sub>P=CHCO<sub>2</sub>R', MeCN, reflux

Separate treatment of **2.313** and **2.314** with a Wittig reagent as shown in scheme 2.65 afforded exclusively the same C-2 olefin **2.315**. Changing reagent from Ph<sub>3</sub>P=CHCOOMe to Ph<sub>3</sub>P=CHCOOEt under the same conditions afforded the same unexpected result, with olefin **2.316** arising from both **2.313** and **2.314**.

The explanation provided by Wood *et al.* was that the ketones **2.313** and **2.314** equilibrate under the basic conditions of the Wittig reaction, and that the C-2 ketone **2.314** was the major component of the mixture.<sup>95</sup> As proof of this, when silyl ether **2.311** was treated with triethylamine in acetonitrile at reflux, **2.313** was found to be the major component of the mixture, being present in 4:1 ratio with **2.314**. Thus, under the conditions of the Wittig reaction, equilibrium between **2.313** and **2.314** is established with **2.315** as the major component. However, the less-hindered ketone **2.314** reacts with the Wittig reagent at a faster rate than **2.313**.<sup>95</sup>

In a similar investigation, the benzylidene derivative of a 2-ketothioglucoside **2.317** was subjected to Wittig conditions with an ylide reagent generated *in situ* (Scheme 2.66) and gave the alkene **2.318** in low yield.<sup>96</sup>

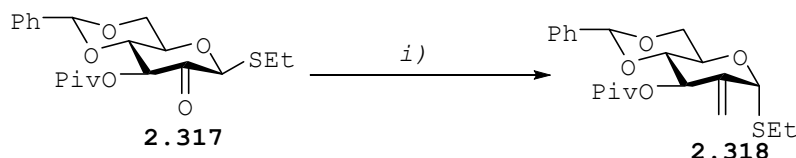

**Scheme 2.66** Reaction conditions: i)  $\text{MePh}_3\text{PBr}$ ,  $\text{NaNH}_2$ , THF, reflux, 48%

The  $\alpha$ -anomeric stereochemistry was confirmed by a large positive  $[\alpha]_D$  (+160.0), the characteristic coupling constant for  $H$ -3/ $H$ -4 of 10.0 Hz and an x-ray crystal structure of compound **2.318**.<sup>96</sup> The epimerisation of the anomeric centre observed was presumed to be a result of the instant ylide reagent mediating the ketone-enol tautomerism process under refluxing conditions.

## 2.5 Compounds with undefined type

### 2.5.1 Via 1,2-Lactone opening

Lactones represent an important group of organic compounds, are industrial intermediates, and can be synthesized by different methods.<sup>97</sup> Their interest is further emphasised due to their easy opening by nucleophiles.<sup>98</sup> The formation of 1,2-fused lactone derivatives of carbohydrates such as **2.319** have not attracted a great deal of attention despite the ease of accessibility to C-2 branched saccharides by reaction with nucleophiles at the anomeric centre; and have only recently been described in the literature.<sup>99</sup>

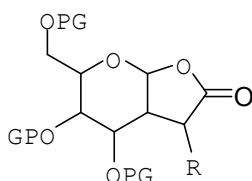

PG = Ac, Bn

**2.319** (R = H)

**2.320** (R = I, NHAr)

**Figure 2.7** Typical lactone ring

Lactone **2.319** was obtained by thermolysis of malonic acid derivative **2.321**, obtained from benzylated glucal **2.47** via malonate ester **2.126**. The diacid **2.321** underwent lactonisation and decarboxylation in toluene at 110°C to give **2.322** in good yield.

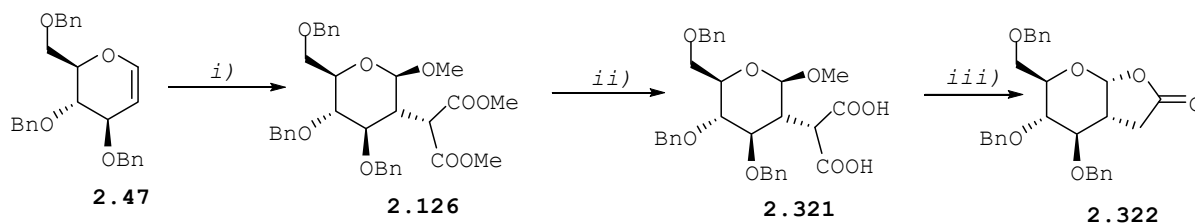

**Scheme 2.69** Reaction Conditions: *i)* CAN, Dimethyl Malonate, MeOH, 0°C, 32-78%;  
*ii)* LiOH, IR-120, >98%; *iii)* Toluene, 110°C, 89%

It is believed that the release of carbon dioxide and methanol from the reaction provides the driving force of the reaction, which favours the lactonization entropically.<sup>99</sup> Lactone **2.322** was synthesised using this route and eventually opened with different nucleophiles to give a variety of 2-C-carboxymethyl glycosides in yields ranging from 30 to 95%.

Table 2.3. Opening of the lactone **2.322** with nucleophiles

| Entry | Nucleophiles  | Products (%)   |
|-------|---|--|
| 1     | MeOH  | <br><b>2.323</b> (92%)                           |
| 2     | <i>i</i> PrOH   | <br><b>2.324</b> (78%) ( $\alpha:\beta$ , 75:25) |
| 3     | <i>t</i> ButOH  | <br><b>2.325</b> (65%)                           |
| 4     | AllOH   | <br><b>2.326</b> (78%)                          |
| 5     | OctOH   | <br><b>2.327</b> (60%)                         |
| 6     |  | <br><b>2.328</b> (53%)                         |
| 7     |  | <br><b>3.329</b> (30%)                          |
| 8     | 25%NH <sub>3</sub> /H <sub>2</sub> O  | <br><b>3.330</b> (95%)                          |

Table 2.4. Opening of the Lactone **2.322** with nucleophiles (Cont.)

| Entry | Nucleophiles              | Products (%)   |
|-------|---------------------------|--|
| 9     | $\text{Me}_3\text{SiN}_3$ | <br><b>2.331</b> (75%) |
| 10    | EtSH                      | <br><b>2.332</b> (82%) |
| 11    | $\text{Et}_3\text{SiH}$   | <br><b>2.333</b> (78%) |

Table 2.5 Opening of the lactone **2.322** with C-nucleophiles

| Entry | Nucleophiles  | Products (%)   |
|-------|---|--|
| 1     | $\text{Me}_3\text{SiCN}$  | <br><b>2.334</b> (90%) |
| 2     | $\text{AllSiMe}_3$  | <br><b>2.335</b> (83%) |
| 3     |  | <br><b>2.336</b> (85%) |
| 4     |  | <br><b>2.337</b> (67%) |
| 5     |  | <br><b>2.338</b> (77%) |

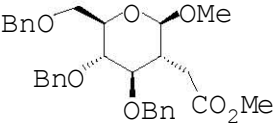
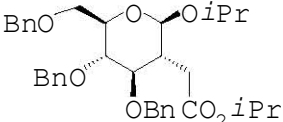
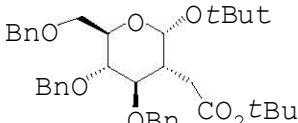
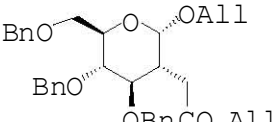
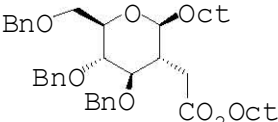
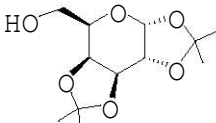
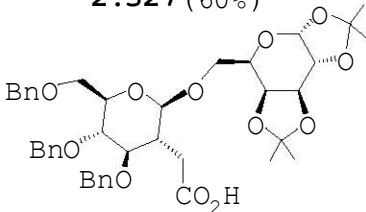
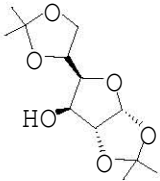
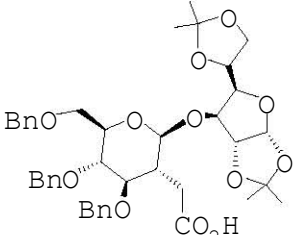
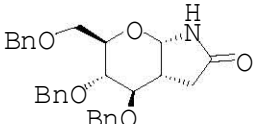
This method by Jian Yin and Torsten Linker<sup>99</sup> has demonstrated an easy entry to 2-C-functionalised glucosides *via* lactone ring opening and offers the versatility of introducing hetero and carbon substituents at the anomeric position. The  $\alpha/\beta$  selectivities are believed to be strongly dependent on the nucleophile and the reaction times. Thus, it was observed that<sup>99</sup> methanol (table 2.3, entry 1) afforded the  $\beta$ -methyl glucoside **2.323** after 30 min in excellent yield, whereas an epimerization to the  $\alpha$ -anomer occurred after 4 h. For the opening of the lactone **2.322** with C-nucleophiles (table 2.5), for all reactions the opening proceeds stereoselectively to  $\beta$ -anomers, since subsequent epimerisation is not possible.

### 2.5.2 Via 1,2-migration

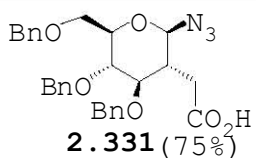
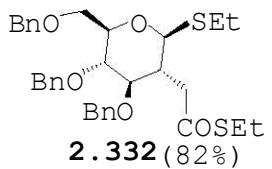
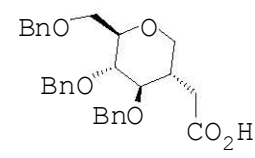
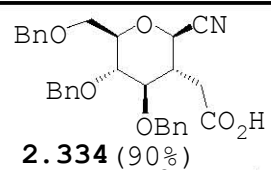
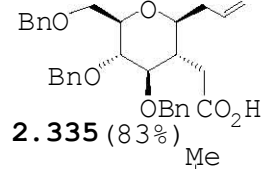
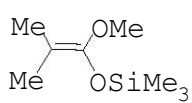
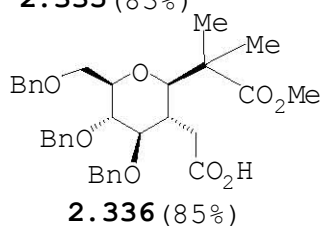
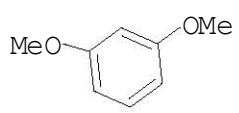
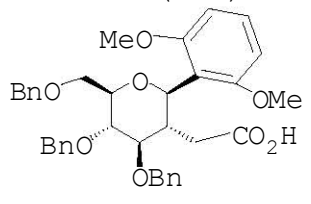
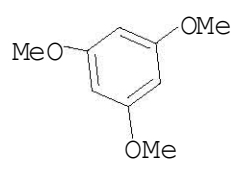
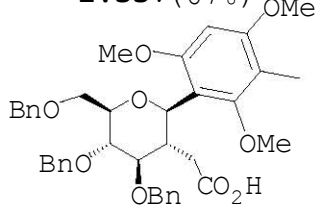
Shao *et al* have developed a method for C-2 alkylation by migration of substituents from C-1 to C-2.<sup>100</sup> Treatment of mannosyl C-glycosides **2.339** and **2.340**, having an acyl substituent at C-1 and a mesylate or tosylate group at C-2, with base resulted in 1,2-cyclopropanation *via* an intramolecular S<sub>N</sub>2 reaction due to their 1,2-*trans*-*di*axial configurations. The 1,2-cyclopropanated sugars **2.341** and **2.342** were reacted with various alcohols, thiols, and sodium azide to produce 2-C-branched O- and S-glycosides and glycosyl azides in good to excellent yields. The example depicted below (Scheme 2.68) is one among many of the reaction studies.

For ketone migration the intermediate **2.343** was isolated and the yield was in the range 80-95%.

The ring opening of 1,2-cyclopropanated sugars by various nucleophiles (alcohols, thiols, and azide) resulted in the concomitant formation of C-2-branched O-, S- $\beta$ -glycosides and glycosyl azides. The results also confirm that the 1,2-cyclopropanation requires the 1,2-*trans*-*di*axial configuration, otherwise  $\beta$ -elimination dominates. Due to the epimerisation at

C-2 under basic conditions this method can only be applied to prepare 1,2-*trans*-C-2-branched  $\beta$ -glycosides.

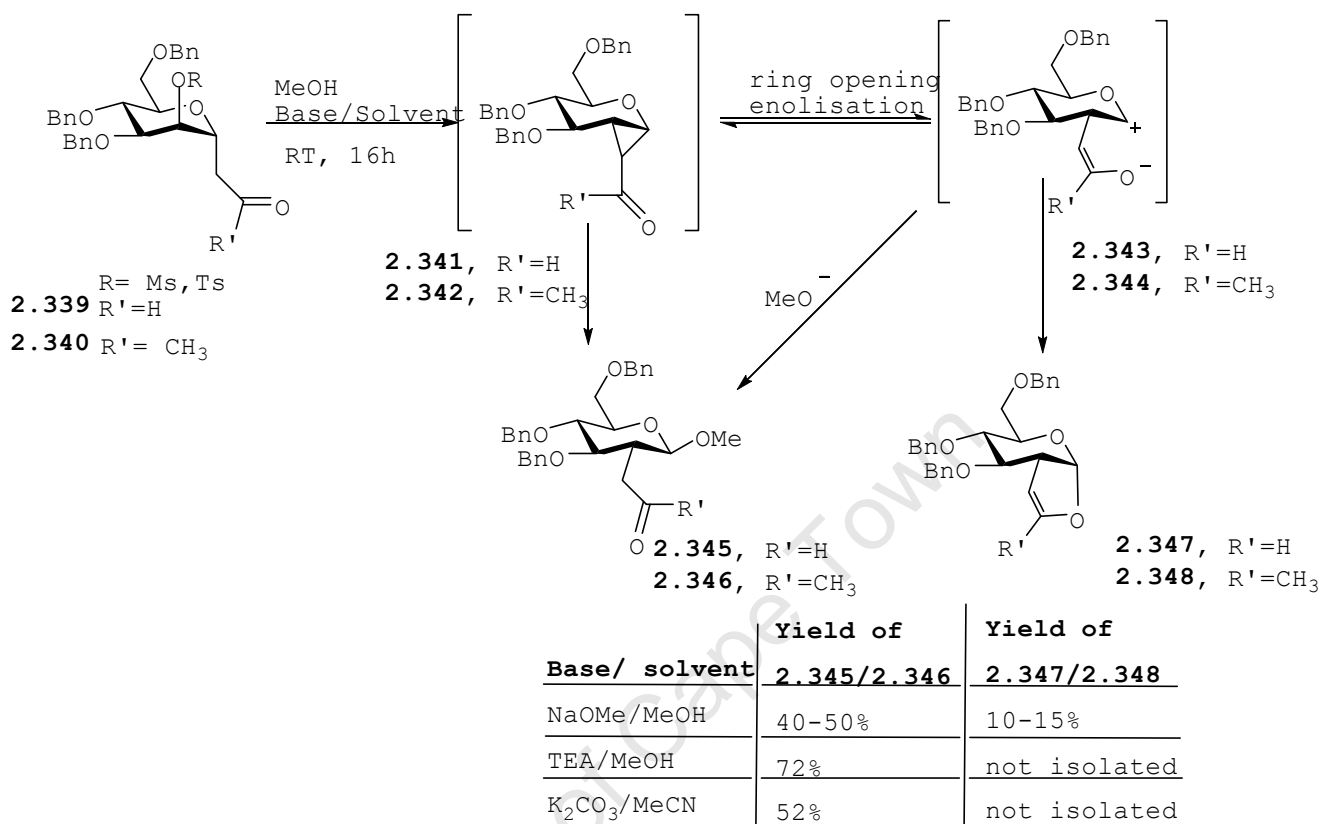

**Scheme 2.68** 1,2-Migration of the Formylmethyl group

Later Shao *et al.* have used 1,2-cyclopropaneacetyl galactoside to generate 2-C-acetyl-2-Deoxy-D-Galactosides.<sup>101</sup> The glycosylation favours  $\beta$ -anomeric products under BF<sub>3</sub>·OEt<sub>2</sub> while TMSOTf-catalysed glycosylation prefers  $\alpha$ -anomers.

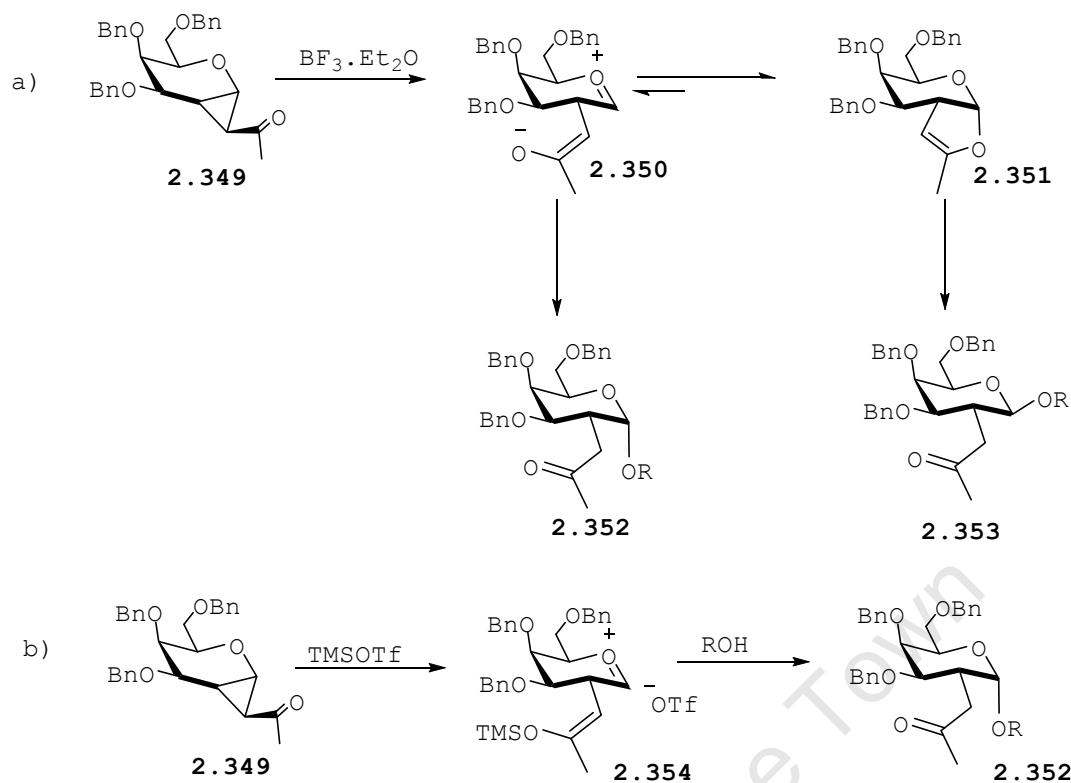

**Scheme 2.69** Proposed Mechanism for the  $\text{BF}_3 \cdot \text{Et}_2\text{O}$  and TMSOTf catalyzed Ring Opening of 1,2-Cyclopropaneacetylated Sugar

The reaction condition under  $\text{BF}_3 \cdot \text{Et}_2\text{O}$  (Scheme 2.69a) is believed to go more *via* the formation of the five-membered ring **2.351**. This is encouraged by the intramolecular neighbouring group participation rather than compound **2.350**, followed by Lewis acid induced nucleophilic attack by the glycosyl acceptor from  $\beta$ -face to form compound of the type **2.353**. A small amount of **2.350** remained in the enol ether form since the reaction is not in equilibrium and generated compounds of type **2.352** ( $\alpha$ -glycosides). As for predominantly  $\alpha$ -glycoside products, the tight coordination of the oxygen atom of the carbonyl with TMSOTf produced oxocarbenium triflate intermediate **2.354** with a 2-C-branched trimethylsilyl enol ether, which has no neighbouring group participation. Thus, nucleophilic attack by an acceptor alcohol at the anomeric carbon would afford compound of the type **2.352**.

It is clear from the foregoing discussions that a wide range of approaches to 2-branched carbohydrates has been investigated, but that no single method provides these with the desired selectivity. This therefore justifies the present study of alternative methodologies.

**2.6 REFERENCES**

- [1] Yoshimura, J. *Adv. Carbohydr. Chem. Biochem.*, **1984**, 42, 69
- [2] Stephen, H. *In Preparative Carbohydrate Chemistry*, Marcel Dekker, INC., Yves Chapleur and François Chrétien, New York, **1996**; pp 207-252
- [3] Varki, A.; Cummings, R.; Esko, J.; Freeze, H.; Hart, G.; Marth, J. *Essentials of Glycobiology*; Cold Spring Harbor Laboratory Press: Cold Spring Harbor, **1999**.
- [4] Varki, A. *FASEB J.* **1991**, 5, 226.
- [5] (a) Yarema, K.J.; Mahal, L.K.; Bruehl, R.E.; Rodriguez, E.C.; Bertozzi, C.R. *J. Biol. Chem.* **1998**, 273, 31168. (b) Lee, J.H.; Baker, T.J.; Mahal, L.K.; Zabner, J.; Bertozzi, C.R.; Wiemer, D.F.; Welsh, M.J. *J. Biol. Chem.* **1999**, 274, 21878. (c) Lemieux, G.A.; Yarema, K.J.; Jacobs, C.L.; Bertozzi, C. R. *J. Am. Chem. Soc.* **1999**, 121, 4278.
- [6] Mahal, L.K.; Yarema, K.J.; Bertozzi, C.R. *Science* **1997**, 276, 1125
- [7] (a) Ko, S.Y.; Lee, A.W.M.; Masamune, S.; Reed, L.A., III; Sharpless, K.B.; Walker, F.J. *Science* **1983**, 220, 949; (b) Nicolaou, K.C.; Winssinger, N.; Pastor, J.; Ninkovic, S.; Sarabria, F.; He, Y.; Vourloumis, D.; Yang, Z.; Li, T.; Giannakakou, P.; Hamel, E. *Nature* **1997**, 387, 268; (c) Gagnon, S.D. *In Encyclopedia of Polymer Science and Engineering*; Mark, H.F.; Bikales, N.M.; Overberger, C.G.; Menges, G.; Kroschwitz, J. I., Eds.; John Wiley & Sons: New York, **1985**; Vol. 6, pp 273-307; (d) Darensbourg, D.J.; Mackiewicz, R.M.; Phelps, A.L.; Billodeaux, D.R. *Acc. Chem. Res.* **2004**, 37, 836.
- [8] Mangione, M.I.; Suárez, A.G.; Spanevello, R.A. *Carbohydr. Res.*, **2003**, 338, 2177- 2183
- [9] Inch, T.D.; Lewis, G. *J. Carbohydr. Res.* **1970**, 15, 1-10.

- [10] Kelly, A.G.; Roberts, J.S. *J.Chem.Soc., Chem. Commun.*, **1980**, 228-229; Edwards, M.P.; Ley, S.V.; Lister, S.G.; Palmer, B.D. *ibid.*, **1983**, 630.
- [11] Fürst, A.; Plattner, P. A., *Helv.Chim.Acta*, **1949**, 32, 275.
- [12] Beau, J.M.; Aburaki, S.; Pougny, J.; Sinay, P. *J.Am.Chem.Soc.* **1983**, 105, 622-624
- [13] Corriu, R.J.P.; Guerin, C.; M'Boula, J. *Tetrahedron Lett.*, **1981**, 22, 2985.
- [14] Posner, G.H. *Org.React.*, **1975**, 22, 253.
- [15] Lipshutz, B.H.; Kozlowski, J.; Wilhelm, R.S. *J.Am.Chem.Soc.*, **1982**, 22, 2985.
- [16] Brockway, C.; KocienSki, P.; Pant, C. *J.Chem Soc.Perkin Trans. I* **1984**
- [17] Stephen, H.; Rancourt, G. *Pure & Appl.Chem.*, 49, 1201-1214. Pergamon Press, **1977**
- [18] Wood, A.J.; Holt, D.J.; Dominguez, M.; Jenkins, P.R. *J.Org.Chem.*, **1998**, 63, 8522-8529
- [19] Ferrier, R.J.; Leeb, C.; Wood, T.A. *J.Chem.Soc., Comm.*, **1991**, 690 -691
- [20] a) Redlich, H.; Neumann, H.J.; Paulsen, H. *Chem.Ber.*, **1977**, 110, 2911; b) Blattner, R.; Ferrier, R.J.; *J.Chem.Soc. Perkin Trans. I*, **1980**,
- [21] Kazmi, S.N.H.; Ahmed, Z.; Khan, A.Q.; Malik, A. *Synth.Comm.* **1988**, 18, 151-156.
- [22] (a) Hall, R.H.; Bischofberger, K.; Brink, A.J.; de Villiers, O.G.; Jordaan, A. *J.Chem.Soc., Perkin Trans. 1*, **1979**, 781-786; (b) Mubarak, A.; Fraser-Reid, B. *J.Org.Chem.*, **1980**, 47, 4265-4268.
- [23] De las Heras, F.; San Felix, A.; Calvo-Mateo, A.; Fernandez-Resa, P. *Tetrahedron*, **1985**, 41, 3867-3873.
- [24] a) Challenger, S.; Procter, G. *Tetrahedron Lett.*, **1986**, 27, 391-394. b) Procter, G.; Genin, D. *Carbohydr. Res.*, **1990**, 202, 81-92

- [25] (a) Kharasch, M.S.; Reinmuth, O. *Grignard Reactions of Nonmetallic Substances*, Constable, London, **1954**;  
(b) Gaylord, N.G.; Becker, E.I. *Chem.Rev.*, **1951**, 49, 413.
- [26] Fraser-Reid, B.; Magdzinski, L.; Molino, B.F.; Mootoo, D.R. *J. Org. Chem.* **1987**, 52, 4495-4504
- [27] a) Giese B., *Radicals in Organic Synthesis: Formation of Carbon-Carbon Bonds*, Pergamon Press, Oxford, **1986**. b) Giese B., Kopping B.; Göbel T.; Dickhaut J.; Thoma G.; Kulicke K.J.; Trach, F. *Org.React.* **1996**, 48, 301. c) Curran, D.P.; *Synthesis*, **1988**, 417, 489; d) Motherwell M.B., Crich D., *Free Radical Chain Reactions in Organic Synthesis*, Academic Press, London, **1991**.
- [28] Marco-Contelles, J.; Alhambra, C.; Martínez-Grau A.; *Synlett*, **1998**, 693.
- [29] Choe, S.W.T.; Jung, M.E. *Carbohydr.Res.*, **2000**, 29, 731-744
- [30] (a) Tsang, R.; Dickson, J.K.; Pak, H.; Walton, R.; Fraser-Reid, B. *J.Am.Chem.Soc.*, **1987**, 109, 3484-3486. (b) Tsang, R.; Fraser-Reid, B. *J.Am.Chem.Soc.*, **1986**, 108, 2116-2117. (c) Fraser-Reid, B.; Vite, G.D.; Yeung, B.W.A.; Tsang, R. *Tetrahedron Lett.*, **1988**, 29, 1645-1648.
- [31] Jarreton, O., Skrydstrup, T., Espinosa, J-F., Jiménez-Barbero, J., Beau, J-M. *Chem. Eur. J.*; **1999**, 5, 429-441
- [32] Curran, D.P.; Seong, C.M.; *Tetrahedron*, **1992**, 48, 2175-2190.
- [33] Postema, M.H.D.; Piper, J.L.; Liu, L.; Shen, J.; Faust, M.; Andreana, P. *J.Org.Chem.* **2003**, 68, 4748-4754
- [34] Chen, S.H.; Horvath, R.F.; Joglar, J.; Fisher, M.J.; Danishefsky, S. J. *J.Org.Chem.* **1991**, 56, 5834-5845
- [35] Hang, H.C.; Bertozzi, C.R. *J.Am.Chem.Soc.* **2001**, 123, 1242-1243
- [36] Keck, G.E.; Enholm, E.J.; Yates, J.B.; Wiley, M.R. *Tetrahedron*, **1985**, 41, 4079.

- [37] (a) Giese, B. *Radicals in Organic Synthesis: Formation of Carbon-Carbon Bonds*; Pergamon Press: Elmsford, 1986. (b) Korth, H.G.; Sustmann, R.; Giese, B.; Ruckert, K.S.; Groninger, K.S. *Chem.Ber.* **1990**, *123*, 1891.
- [38] Linker, T.; Sommermann, T.; Kahlenberg, F. *J.Am.Chem.Soc.* **1997**, *119*, 9377-9384
- [39] (a) Baciocchi, E.; Giese, B.; Farshchi, H.; Ruzziconi, R. *J.Org.Chem.*, **1990**, *55*, 5688-5691; (b) Giese, B. *Angew.Chem., Int.Ed.Engl.* **1983**, *22*, 753-764. (c) Giese, B. *Angew. Chem., Int. Ed. Engl.* **1985**, *24*, 553-565.
- [40] (a) Giese, B.; Dupuis, J. *Angew.Chem., Int.Ed.Engl.* **1983**, *22*, 622-623. (b) Giese, B. *Radicals in Organic Synthesis: Formation of Carbon-Carbon Bonds*; Pergamon Press: Oxford, **1986**; pp 60-66. (c) Curran, D. P.; Porter, N. A.; Giese, B. *Stereochemistry of Radical Reactions*; VCH: Weinheim, **1996**; pp 132-135.
- [41] Gyóllai, V.; Schanzenbach, D.; Somsák, L.; Linker, T. *Chem. Comm.*, **2002**, 1294-1295
- [42] Sustmann, R.; Korth, H.G. *Adv.Phys.Org.Chem.*, **1990**, *26*, 131; Welle, F.M.; Verevkin, S.P.; Beckhaus, H.D.; Rüchardt, C. *Liebigs Ann.Chem.*, **1997**, 155; Welle, F.M.; Beckhaus, H.D.; Rüchardt, C. *J.Org.Chem.*, **1997**, *62*, 552; Korth, H.G.; Praly, J.P.; Somsák, L.; Sustmann, R. *Chem. Ber.*, **1990**, *123*, 1155.
- [43] Yin, J.; Spindler, J.; Linker, T. *Chem.Commun.*, **2007**, 2712-2713
- [44] (a) Linker, T.; Hartmann, K.; Sommermann, T.; Scheutzow, D.; Ruckdeschel, E. *Angew.Chem., Int.Ed. Engl.*, **1996**, *35*, 1730; (b) Linker, T.; Sommermann, T.; Kahlenberg, F. *J.Am.Chem. Soc.*, **1997**, *119*, 9377; (c) Sommermann, T.; Kim, B.G.; Peters, K.; Peters, E.M.; Linker, T. *Chem.Commun.*, **2004**, 2624.
- [45] *Greene's Protective Groups in Organic Synthesis*, ed.

- Wuts, P. G. M.; Greene, T. W. Wiley, New Jersey, 4th edn, **2007**.
- [46] Ferrier, R. J.; Prasad, N. *J.Chem.Soc. C*, **1969**, 581.
- [47] (a) Linker, U.; Kersten, B.; Linker, T. *Tetrahedron*, **1995**, 51, 9917; (b) Linker, T.; Linker, U. *Angew.Chem., Int.Ed.*, **2000**, 39, 902; (c) Linker, T. *J.Organomet.Chem.*, **2002**, 661, 159; (d) Kim, B.G.; Schilde, U.; Linker, T. *Synthesis*, **2005**, 1507.
- [48] Elamparuthi, E.; Kim, B.G.; Yin, J.; Maurer, M.; Linker, T. *Tetrahedron*, **2008**, 64, 11925-11937
- [49] Elamparuthi, E.; Linker, T. *Org. Lett.*, **2008**, 10, 1361-1364
- [50] Linker, T. *J.Organomet.Chem.*, **2002**, 661, 159-167.
- [51] Linker, T.; Schanzenbach, D.; Elamparuthi, E.; Sommermann, T.; Fudickar, W.; Gyo'llai, V.; Soms\_k, L.; Demuth, W.; Schmittel, M. *J.Am.Chem.Soc.* **2008**, 130, 16003-16010
- [52] Elamparuthi, E.; Linker, T. *Angew.Chem.Int.Ed.* **2009**, 48, 1853-1855
- [53] Junker, H.D.; Phung, N.; Fessner, W.D. *Tetrahedron Lett.* **1999**, 40, 7063-7066.
- [54] (a) Reissig, H.U.; Zimmer, R. *Chem.Rev.* **2003**, 103, 1151-1196. (b) von Angerer, S. In de Meijere, A., Ed.; Carbocyclic Three- and Four-membered Ring Compounds. Methods of Organic Chemistry (Houben-Weyl); Verlag: New York, **1997**; Vol. E17c, pp 2121-2153. (c) Reissig, H.U. *Top.Curr.Chem.*, **1988**, 144, 73-135 (d) Wenkert, E. *Acc. Chem. Res.* **1980**, 13, 27-31.
- [55] (a) Paquette, L.A. *Chem.Rev.* **1986**, 86, 733-750. (b) Reissig, H.U. In The Chemistry of the Cyclopropyl Group; Rappoport, Z., Ed.; Wiley: Chichester, **1987**; Chapter 8, pp 375-443. (c) Wong, H.N.C.; Hon, M.Y.; Tse, C.W.; Yip, Y.C.; Tanko, J.; Hudlicky, T. *Chem. Rev.* **1989**, 89, 165-198. (d) Kulinkovich, O.G. *Pol.J.Chem.* **1997**, 849-

- 882.(e) Salaün, J. *Top.Curr.Chem.* **2000**, 207,1-67.(f) de Meijere, A.; Kozhushkov, S.I.; Khlebnikov, A. F. *Top.Curr.Chem.* **2000**, 207, 89-147. (g) de Meijere, A.; Kozhushkov, S.I.; Hadjiarapoglou, L.P. *Top.Curr.Chem.* **2000**, 207, 149-227.
- [56] (a) Patai, S.; Rappoport, Z. *The Chemistry of the Cyclopropyl Group*; Wiley: New York, **1987**. (b) Houben-Weyl *Methods of Organic Chemistry*. Thieme: Stuttgart, **1997**; Vol. E17c. (c) de Meijere, A. *Small Ring Compounds in Organic Synthesis VI*; Springer: Berlin, **2000**; Vol 207. (d) Lebel, H.; Marcoux, J.F.; Molinaro, C.; Charetter, A. *Chem.Rev.* **2003**, 103, 977-1050.
- [57] Salaün, J.R.Y. *Top.Curr.Chem.* **1988**, 144, 4-71.
- [58] Cousins, G.S.; Hoberg, J. O., *Chem.Soc. Rev.* **2000**, 29, 165-174.
- [59] Hoberg, J.O.; *J.Org.Chem.*, **1997**, 62, 6615-6618
- [60] a) Collum, D.B.; Mohamadi, F.; Hallock, J.S. *J.Am.Chem.Soc.* **1983**, 105, 6882-6889. (b) Collum, D.B.; Still, W.C.; Mohamadi, F. *J.Am.Chem.Soc.* **1986**, 108, 2094-2096.
- [61] Scott, R.W.; Heathcock, C.M. *Carbohydr. Res.* **1996**, 291, 205-208.
- [62] Meng, D.; Bertinato, P.; Balog, A.; Su, D.S.; Kamenecka, T.; Sorensen, E.J.; Danishefsky, S.J. *J.Am.Chem.Soc.* **1997**, 119, 10073-10092
- [63] Bertinato, P.; Sorensen, E.J.; Meng, D.; Danishefsky, S.J. *J.Org.Chem.* **1996**, 61, 8000-8001.
- [64] a) Fernandez-Megia, E.; Gourlaouen, S.; Ley, S.V.; Rowlands, G.J. *Synlett* **1998**, 991-994. b) Ramana, C.; Nagarajan, M. *Synlett* **1997**, 763-764. c) Ramana, C.; Nagarajan, M. *Carbohydr. Lett.* **1998**, 3, 117-119. d) Boechman, R.; Charette, A.; Asberom, T.; Johnston, B. *J.Am.Chem.Soc.* **1991**, 113, 5337-5353.
- [65] Gammon, D.W.; Kinfel, H.H.; De Vos, D.E.; Jacobs, P.A.;

- Sels, B.F. *J. Carbohydr.Chem.*, **2007**, *26*,141-157
- [66] Timmers, C.M.; Leeuwenburgh, M.A.; Verheijen, J.C.; van der Marel, G.A.; van Boom, J.H., *Tetrahedron: Asymmetry*, **1996**, *7*, 49-52.
- [67] Hoberg, J.O.; Claffey, D.J. *Tetrahedron Lett.* **1996**, *37*, 2533-2536.
- [68] Henry, K.J.; Fraser-Reid, B. *Tetrahedron Lett.* **1995**, *36*, 8901-8904.
- [69] Sridhar, P.R.; Ashalu, K.C.; Chandrasekaran, S. *Org.Lett.* **2004**, *6*, 1777-1779.
- [70] Ramana, C.; Nagarajan, M. *Synlett*, **1997**, 763-764
- [71] (a) Hall, P.W.; Puddephatt, R.J.; Tipper, C.F.H. *J.organomet. Chem.* **1974**, *71*, 145-151. (b) Al-Essa, R.J.; Ling, S.S.M.; Puddephatt, R. *J.Organometallics*, **1987**, *6*, 951-959. (c) Al-Essa, R.J.; Puddephatt, R.J.; Thompson, P.J.; Tipper, C.F.H. *J.Am.Chem.Soc.* **1980**, *102*, 7546-7553. (d) Puddephatt, R. *J.Coord.Chem.Rev.* **1980**, *33*, 149-194. (e) Crabtree, R.H. *Chem.Rev.* **1985**, *85*,245-269. (f) Jennings, P.W.; Johnson, L.L. *Chem.Rev.* **1994**, *94*, 2241-2290. (g) Doyle, M.P.; Van Leusen, D. *J.Am.Chem Soc.* **1981**, *103*, 5917-5919. (h) Doyle, M.P.; Van Leusen, D. *J.Org.Chem.* **1982**, *47*, 5326-5338. (i) Danishefsky, S. *Acc.Chem.Res.* **1979**, *12*, 66-72. (j)Wenkert, E. *Acc.Chem.Res.* **1980**, *13*, 27-31.
- [72] Beyer, J.; Madsen, R. *J.Am.Chem.Soc.* **1998**, *120*, 12137-12138.
- [73] a) Ramesh, N.G.; Balasubramanian, K.K. *Tetrahedron Lett.* **1991**, *32*,3875-3878; b) Booma, C.; Balasubramanian, K.K. *J.Chem.Soc., Chem.Commun.* **1993**, 1394-1395.
- [74] Priebe, W.; Gryniewicz, G.; Nemati, N. *Tetrahedron Lett.* **1992**, *33*, 7681-7684.
- [75] a) Gupta, A.; Vankar, Y.D.; *Tetrahedron*, **2000**, *56*, 8525-8531; b) Ghosh, R.; Chakraborty, A.; Maitia, D.K.; Puranik, V.G. *Tetrahedron Lett.*, **2005**, *46*, 8047-8051

- [76] Kashyap, S.; Rao Vidadala, S.; Hotha, S. *Tetrahedron Lett.*, **2007**, 48, 8960-8962
- [77] Schmidt, R.R.; Kast, J. *Tetrahedron Lett.*, **1986**, 27, 4007-4010
- [78] (a) Stephen, H.; Martin, M.; Desai, R.C. *J.Chem.Soc., Chem.Comm.* **1986**, 926; (b) Bearder, J.R.; Dewis, M.L.; Whiting, D.A. *J.Chem.Soc.Perkin Trans. 1* **1995**, 227.
- [79] Dötz, K.H.; Ehlenz, R.; Paetsch, D. *Angew.Chem.* **1997**, 109, 2473; *Angew.Chem.Int. Ed.Engl.* **1997**, 36, 2376.
- [80] Fischer, E.O.; Maasböl, A. *Angew.Chem.* **1964**, 76, 645; *Angew.Chem.Int.Ed Engl.* **1964**, 3, 580.
- [81] Ehlenz, R. Dissertation, **1996**, Universität Bonn.
- [82] (a) Cooper, N.J.; Lee, I. *J.Am.Chem.Soc.* **1995**, **115**, 4389. (b) Knochel, P.; Stadmuller, H. *Organometallics*, **1995**, 14, 3163
- [83] Jäkel, C.; Dötz, K.H. *Tetrahedron* **2000**, 56, 2167.
- [84] Chapleur, Y. *Chem.Comm.* **1983**, 3, 141-142
- [85] Klemer, A.; Rodmeyer, G. *Chem.Ber.*, **1974**, 107, 2612; Horton, D.; Weckerle, W. *Carbohydr.Res.*, **1975**, 44, 227.
- [86] Chapleur, Y.; Euvrard, M.N. *Chem.Comm.* **1987**, 12, 884-885.
- [87] Samb, I.; Pellegrini-Moïse, N.; Chapleur, Y. *Tetrahedron Lett.*, **2007**, 48, 7978-7981
- [88] a) Wong, G.; Fraser-Reid, B. *Can. J. Chem.*; **1994**, 72, 69-74; b) Jarosz, S.; Hicks, D. R.; Fraser-Reid, B.; *J. Org. Chem.*; **1982**, 47, 935-940; c) Sato, K. I.; Sekiguchi, T.; Akai, S.; *Tetrahedron Lett.*, **2001**, 42, 3625-3628. d) Nakamura, T.; Shiozaki, M.; *Tetrahedron*; **2002**, 58, 8779-8791
- [89] (a) Maerckar, A. *Org.React.* **1965**, 14, 270-490. (b) Maryanoff, B.E.; Reitz, A.B. *Chem. Rev.* **1989**, 89, 863-927. (c) Kolodiazhnyi, O.I. *Phosphorus Ylides, Chemistry*

- and Application in Organic Synthesis; Wiley-VCH: Weinheim, Germany, **1999**.
- [90] a) Horner, L.; Hoffmann, H.M.R.; Wippel, H.G. *Ber.* **1958**, 91, 61-63. b) Horner, L.; Hoffmann, H.M.R.; Wippel, H.G.; Klahre, G. *Ber.* **1959**, 92, 2499-2505.
- [91] a) Wadsworth, W.S.Jr.; Emmons, W.D. *J. Am. Chem. Soc.*, **1961**, 83, 1733; b) Wadsworth, W.S.Jr.; Emmons, W.D. *Organic Synthesis*, **1965**, 45, 44; **1973**, 5, 547.
- [92] Schmidt, R.R., *Pure Appl. Chem.*, **1989**, 61, 1257; b) Sinaÿ, P. *Pure Appl. Chem.*, **1991**, 63, 519; c) Schmidt, R.R., Synthesis of glycosides, in *Comprehensive Organic Synthesis*, Trost, B.M. and Fleming, I. Eds, vol. 6, Pergamon, Oxford, pp. 33; d) Lockhoff, O.; Acetale als anomere zentren von kohlenhydraten (hal/O- und O/O-acetale), in *Methoden der organischen chemie* (Houben-Weyl) E14a/3, Thieme, Stuttgart, p. 621.
- [93] Gurjar, M.K.; Kumar, P.; Venkateswara Rao, B. *Tetrahedron Lett.*, **1996**, 37, 8617-8620
- [94] Koto, S.; Takabe, Y. And Zen, S. *Bull. Chem. Soc. Jpn.*, **1972**, 45, 291-293
- [95] Wood, W.W.; Rashid, A. *Tetrahedron Lett.*, **1987**, 28, 1933-1937
- [96] Michael, G.B.D; Ennis, S.C.; Gridley, J.J.; Osborn, H.M.I.; Spackman, D.G. *Tetrahedron*, **2001**, 57, 7919-7937
- [97] a) H. Krçper in Houben-Weyl, *Methoden der Organischen Chemie*, Vol. VI/2 (Ed.: E. Müller), Thieme, Stuttgart, 1963, pp. 561 -852; b) Grieco, P. A. *Synthesis*, **1975**, 67-82; c) Ogliaruso, M.A.; Wolfe, J.F.; Synthesis of Lactones and Lactams, Wiley, New York, 1993; d) Seitz, M.; Reiser, O. *Curr. Opin. Chem. Biol.* **2005**, 9, 285-292; e) Burstein, C.; Tschan, S.; Xie, X.; Glorius, F. *Synthesis* **2006**, 2418-2439; f) Chapleur, Y.; Moufid, N. *J. Chem.*

- Soc. Chem. Commun.* **1989**, 39-40; g) Moufid, N.; Chapleur, Y.; Mayon, P. *J. Chem. Soc. Perkin Trans. 1*, **1992**, 991-998; h) Veitch, G.E.; Beckmann, E.; Burke, B.J.; Boyer, A.; Maslen, S.L.; Ley, S.V. *Angew. Chem.* **2007**, *119*, 7773-7776; *Angew. Chem. Int. Ed.* **2007**, *46*, 7629-7632. i) Jimenez, O.; de La Rosa, G.; Lavilla, R. *Angew. Chem.* **2005**, *117*, 6679-6683; *Angew. Chem. Int. Ed.* **2005**, *44*, 6521-6525; j) Haveli, S.D.; Sridhar, P.R.; Suguna, P.; Chandrasekaran, S. *Org. Lett.* **2007**, *9*, 1331-1334.
- [98] a) Gaertzen, O.; Misske, A.M.; Wolbers, P.; Hoffmann, H.M.R. *Synlett* **1999**, 1041-1044; b) Gaertzen, O.; Misske, A.M.; Wolbers, P.; Hoffmann, H.M.R. *Tetrahedron Lett.* **1999**, *40*, 6359 - 6363; c) Poláková, M.; Pitt, N.; Tosin, M.; Murphy, P.V. *Angew. Chem.* **2004**, *116*, 2572-2575; *Angew. Chem. Int. Ed.* **2004**, *43*, 2518-2521; d) Rat, S.; David, M.; Michaud, P.; Kovensky, J.; Wadouachi, A. *Tetrahedron* **2007**, *63*, 12424-12428; e) O'Brien, C.; Poláková, M.; Pitt, N.; Tosin, M.; Murphy, P.V. *Chem. Eur. J.* **2007**, *13*, 902-909.
- [99] Yin, J.; Linker, T. *Chem. Eur. J.* **2009**, *15*, 49-52
- [100] Shao, H.; Ekthawatchai, S.; Chen, C.; Wu, S.; Zou, W. *J. Org. Chem.* **2005**, *70*, 4726-4734
- [101] Tian, Q.; Xu, L.; Ma, X.; Zou, W.; Shao, H. *Org. Lett.*, **2010**, *12*, 540-543

## CHAPTER 3

### RESULTS AND DISCUSSION

#### 3.1. Synthesis of thioglucoside analogues of the natural substrate of MshB

Compounds **1.30**, **1.31**, and **1.32** (Scheme 3.1), which are thioglycosides of 2-acetamidoglucose, were synthesised as analogues of the natural substrate of MshB, and were designed to evaluate (a) whether the inositol aglycone is really required for substrate activity, and (b) how crucial the anomeric configuration is for substrate activity.

The synthesis of the  $\alpha$ -phenylthioglucoiside **1.30** commenced from commercially available glucosamine hydrochloride **3.1** (Scheme 3.1). The formation of the 2-azido derivative of **3.1** was achieved by azide transfer, and subsequent acetylation provided the 2-azido glucoiside **3.2a**<sup>1</sup> in good yield (Scheme 3.1). Treatment of this with thiophenol in the presence of  $\text{BF}_3 \cdot \text{Et}_2\text{O}$ ,<sup>2</sup> and subsequent reduction of the azide followed by acetylation gave the protected thioglucoiside **3.2d**.<sup>3</sup> De-*O*-acetylation of compound **3.2d** using catalytic NaOMe in  $\text{CH}_3\text{OH}$  produced the desired  $\alpha$ -phenylthioglucoiside **1.30** (Scheme 3.1).<sup>3</sup>

This compound **1.30** has been reported and the analytical data obtained were identical to that found in the literature. However, the value of  $J_{1,2}$  (5.1 Hz)<sup>4</sup> in the  $^1\text{H}$  NMR spectrum, consistent with the  $\alpha$ -configuration at C-1, was not reported in the original paper.<sup>3</sup>

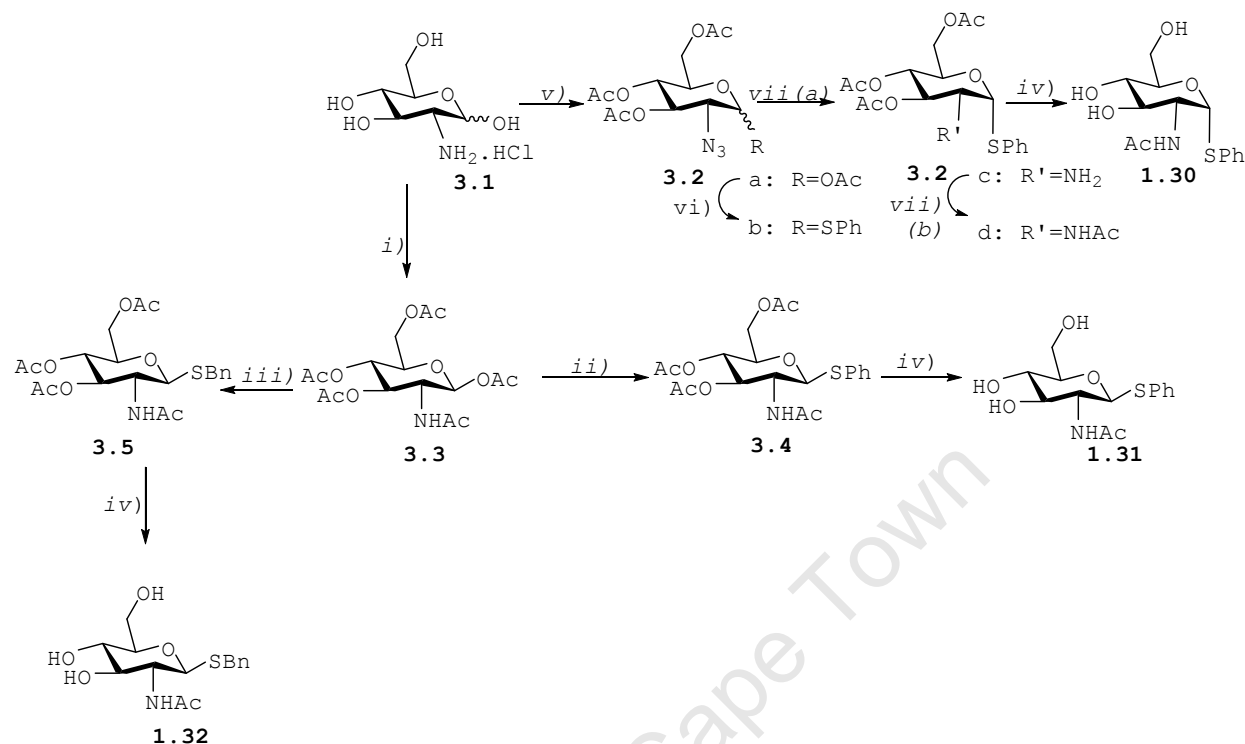

**Scheme 3.1:** Reaction conditions: *i)*  $\text{ZnCl}_2$ ,  $\text{Ac}_2\text{O}$ , 40–50°C, 4h, 70%; *ii)*  $\text{SnCl}_4$ , SPh, DCM reflux, 24h, 75%; *iii)* Thiourea, BnBr,  $\text{Et}_3\text{N}$ ,  $\text{CH}_3\text{CN}$ , 80°C, 70%; *iv)* NaOMe,  $\text{CH}_3\text{OH}$ , 25°C, 10min., 90–95%; *v)* (a)  $\text{TFN}_3$ ,  $\text{CuSO}_4$ ,  $\text{NaHSO}_4$ , Toluene/ $\text{MeOH}/\text{H}_2\text{O}$ , 14h, rt; (b)  $\text{Ac}_2\text{O}$ , pyridine, 24h, *vi)*  $\text{PhSH}$ ,  $\text{BF}_3 \cdot \text{Et}_2\text{O}$ , 55°C, 12h, 61%; *vii)* (a)  $\text{H}_2$ , Pd/C, rt, 5h, 93%; (b)  $\text{Ac}_2\text{O}$ , pyridine, 88%

The synthesis of β-phenylthioglucoside **1.31** and β-benzylthioglucoside **1.32** proceeded from known β-glucosylacetate **3.3**, prepared by acetylation of glucosamine **3.1** using zinc chloride and acetic anhydride.

Treatment of **3.3** with thiophenol in dichloromethane in the presence of tin tetrachloride ( $\text{SnCl}_4$ ) led stereoselectively to β-glucoside **3.4**.<sup>5</sup> The benzylthioglucoside **3.5** was synthesised in good yield by an alternative strategy, involving refluxing of **3.3** with thiourea<sup>6</sup> and benzyl bromide.<sup>7</sup> Deprotection of the acetylated derivatives **3.4** and **3.5** using NaOMe in methanol produced the 2-acetamido-β-thioglucosides **1.31** and **1.32**. The assigned structures were evident from the  $^1\text{H}$  NMR spectra which showed the absence of singlets for O-acetyl groups but

presence of singlets for the acetamido methyl groups at  $\delta$  1.95 and 2.00 ppm respectively. The observed singlet at  $\delta$  8.36 ppm in each spectrum integrating for one hydrogen atom was assigned to the NH- group in the respective compounds.

The  $^{13}\text{C}$  NMR spectrum of **1.31** and **1.32** showed only one signal for a carbonyl carbon at 171.1 ppm and 172.5 ppm respectively, with corresponding signals at  $\delta$  21.5 and 21.3 ppm for the acetamido methyl groups.<sup>3,7,8</sup>

Compounds **1.30**, **1.31**, and **1.32** were tested as substrates of MshB and also for inhibitory activity against Mca at the Chemical Pathology laboratory at the University of Cape Town. Out of these three compounds, **1.30** was found to be a competitive substrate for MshB (Table 3.2).<sup>9</sup>

**Table 3.2:** Inhibition of Mca and MshB by thioglycosides

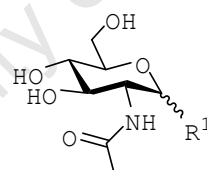

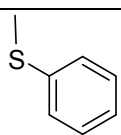
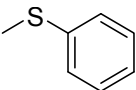
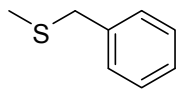
| Compounds                           | R <sub>1</sub>  | Mca (%) <sup>a</sup> | MshB (%) <sup>a</sup> | Substrate    |
|-------------------------------------|---|----------------------|-----------------------|--------------|
| <b>1.30</b><br>( $\alpha$ -linkage) |  |                      | 27                    | Yes          |
| <b>1.31</b><br>( $\beta$ -linkage)  |  | 0                    | 15.1                  | Not measured |
| <b>1.32</b><br>( $\beta$ -linkage)  |  | 0                    | 13.3                  | Not measured |

a: percentage inhibition of Mca and MshB at 250 $\mu\text{M}$  and 500 $\mu\text{M}$ , respectively.

These results suggest that the D-myoinositol unit in the natural substrate **3.7** of MshB is not an absolute requirement

for substrate activity but the anomeric configuration is crucial. This has important implications for the design and synthesis of substrate-like inhibitors, in that the phenylthioglycosides are easier to assemble than the more complex inositol glycosides, where additional steps are required to prepare and resolve the partially-protected *myo*-inositol units and then couple these to suitable glycosyl donors. This is illustrated in previously reported work on preparation and evaluation of 2-oxopropylglycoside **3.6** as an inhibitor of MshB.<sup>10</sup>

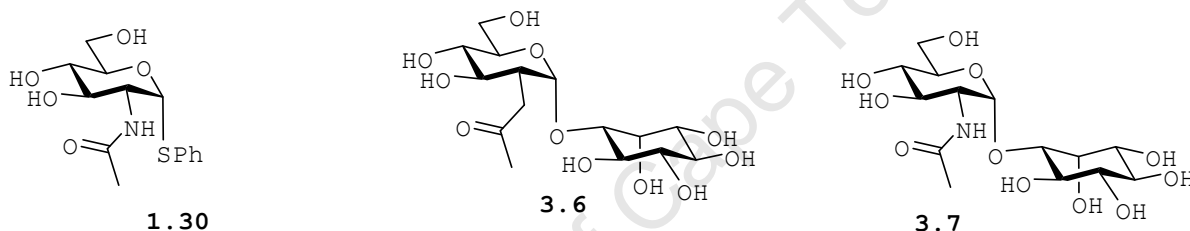

These findings therefore suggest that structures of the type **1.33**, which incorporate a phenylthio group in  $\alpha$ -position at C-1 and a substituted methylene group at C-2 may be envisaged as useful building blocks for the synthesis of potential inhibitors of MshB and other enzymes involved in the biosynthesis and further processing of mycothiol.

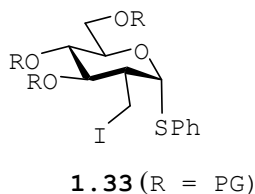

### 3.2 Chemical synthesis of phenyl-2-deoxy-2-C-alkyl-1-thioglycosides

Three approaches to the synthesis of structures **1.33**, were evaluated, with an emphasis on addressing the key challenges of (a) achieving a high degree of regio- and stereoselectivity

in introduction of the alkyl group at C-2, (b) ensuring that a suitable functionalized side-chain is attached, allowing for further elaboration and (c) achieving good stereoselectivity in glycoside formation. These approaches were as follows:

1. The use of 1,6-2,3-anhydromannosides in order to direct nucleophilic alkyl groups to C-2 from the  $\alpha$ -face (see 3.2.1) and potentially achieve  $\alpha$ -selective glycosylation in opening of the 1,6-anhydro ring.
2. the preparation and subsequent olefination of 2-keto sugars,<sup>11</sup> followed by anti-Markovnikov addition to prepare C-2 branched glucosides with functionalized side-chains (see 3.2.2).
3. the preparation of  $\alpha$ -1,2-cyclopropanated sugars, with subsequent opening of the cyclopropyl group at the electrophilic C-1 position to give C-2 branched, C-1 functionalized sugar derivatives (see 3.2.3).

### **3.2.1 Use of 1,6-2,3-anhydromannosides in the attempted synthesis of compound 1.33**

Based on the considerations outlined above, one key synthetic intermediate identified was the C-2-vinylglycoside **3.9**. The proposed synthetic route (Scheme 3.2A) is conceptually similar to that published by Kelly *et al.*<sup>12</sup> and later on by Challenger *et al.*<sup>13</sup> but with a vinyl group instead of allyl at C-2 and a thiophenyl group instead of methoxy at C-1. The vinyl group was selected as a versatile side-chain easily converted to functionalized C<sub>1</sub>, C<sub>2</sub>, or C<sub>n</sub> side-chains. For example, a one-carbon side-chain would result from ozonolysis to obtain aldehyde **3.10**. The two-carbon vinyl group can itself be modified further, by, for example, converting it via

hydroboration-oxidation to C<sub>2</sub>-primary alcohol **3.12** and other derivatives **3.15**. Oxidation of the alcohol would generate the aldehyde **3.13**, from which side-chain-extended compounds **3.16** could be obtained via a Grignard/oxidation sequence (Scheme 3.2B).

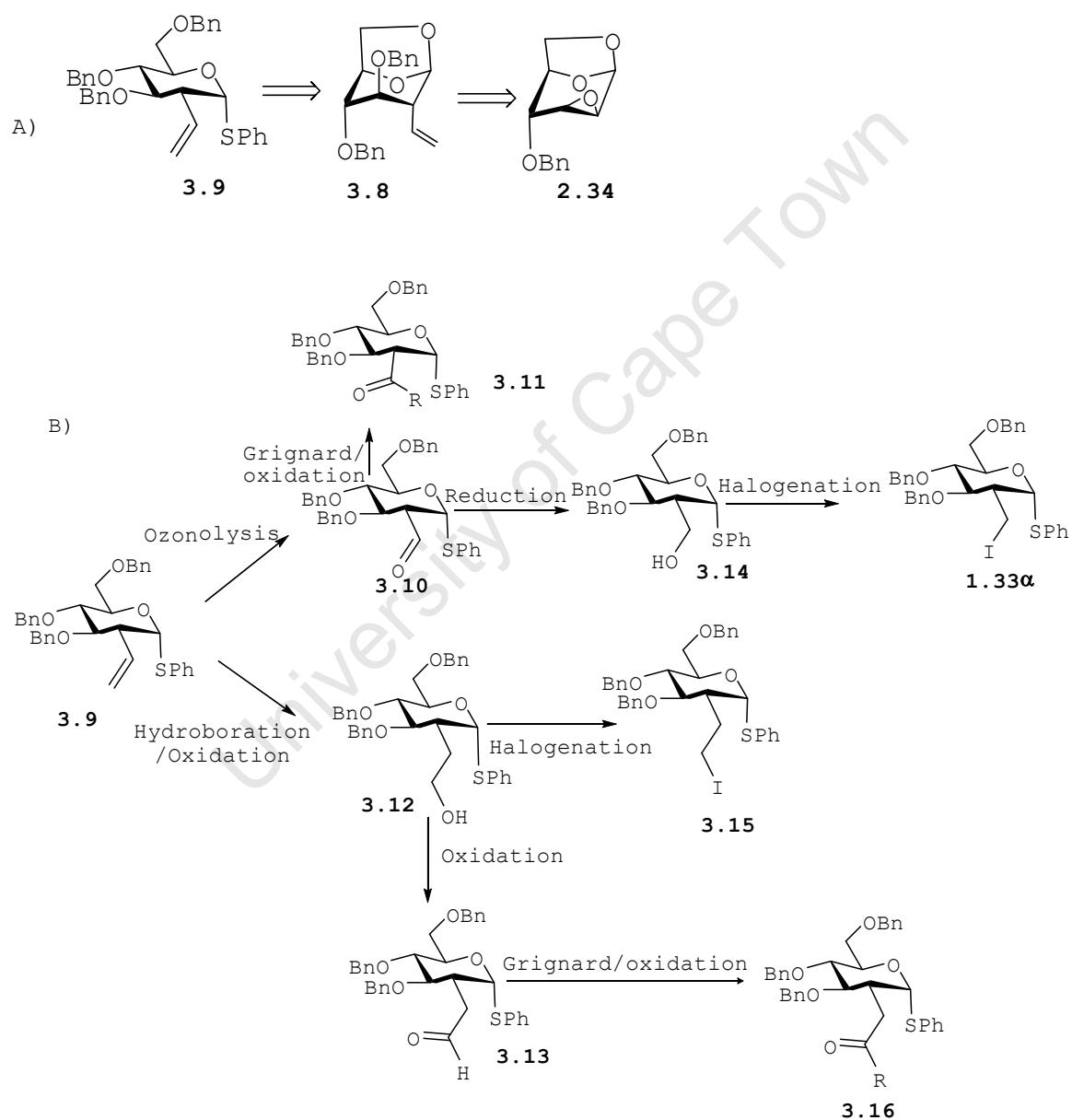

**Scheme 3.2:** Examples of possible modifications of a vinyl group at 2-C-vinylglucosides

The 2-*C*-vinylglycoside **3.9** could be obtained from 1,6-anhydrohexopyranose **3.8** via selective opening of the 1,6-anhydro group to regenerate the sugar in its  ${}^4C_1$  conformation. The 1,6-anhydro sugar is in turn readily available by a known sequence of reactions.<sup>14</sup> The non-participatory character of the vinyl group at *C*-2 of **3.8** would be anticipated to give  $\alpha$ -selective glycosylation. Efforts to bring this strategy to fruition are shown in Scheme 3.3.

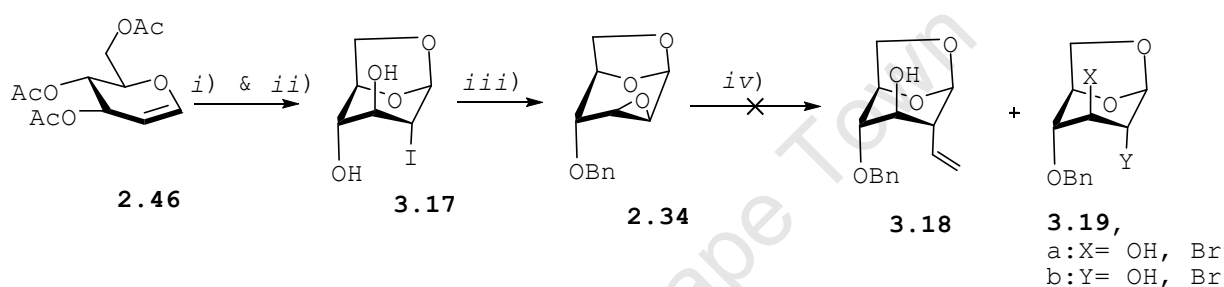

**Scheme 3.3.** Reaction conditions: *i*)  $\text{Et}_3\text{N}-\text{CH}_3\text{OH}-\text{H}_2\text{O}$ , rt, 5h *ii*) MS  $3\text{\AA}$ ,  $(n\text{-Bu}_3\text{Sn})_2\text{O}$  at reflux,  $\text{I}_2$  at  $5^\circ\text{C}$  to rt,  $\text{CH}_3\text{CN}$ , 2h30, 43%, *iii*)  $\text{BnBr}$ ,  $\text{NaH}$  (60% in mineral oil),  $\text{DMF}$ ,  $-20^\circ\text{C}$  to rt, 2h, 81%, *iv*)  $\text{VinylMgBr}$ ,  $\text{THF}$ , reflux, 24h.

Our synthetic venture began with the transformation of protected glucal **2.46** to the 2-deoxy-2-iodo-1,6-anhydrohexopyranoside **3.17** in 43% yield using a reported procedure which involves deacetylation followed by *O*-stannyl-mediated iodo-cyclization (Scheme 3.3).<sup>14</sup> Treatment of **3.17** with benzyl bromide and sodium hydride afforded the desired epoxide **2.34** in 81% yield.<sup>15</sup> It was anticipated that the 1,6-anhydrohexopyranoside bridge in conjunction with the 2,3- $\beta$ -epoxide would direct a vinyl nucleophile to attack from the  $\alpha$ -face of the molecule as demonstrated in Scheme 2.12, with preferential attack at the 2-position via the favoured *trans*-diaxial orientation of substituents in the transition state. Unfortunately, a Grignard reaction with vinyl magnesium bromide did not yield the desired alcohol **3.8**, even when the reaction was heated at reflux in tetrahydrofuran, and/or a

catalytic amount of CuI was added, in all cases, the starting material were recovered. However, the addition of considerable amount of CuI did give rise to a complex mixture which could not be identified by  $^1\text{H}$  NMR. Inch and Lewis<sup>16</sup> have studied the reaction of epoxides with Grignard reagents and found that alkylmagnesium iodides and bromides do not give rise to branched-chain but to halohydrins. Later, Brockway *et al*<sup>17</sup> did manage to open the oxirane ring and extend the side chain (Scheme 2.6). In our case, with a substrate different from that of Inch and Lewis, and Brockway *et al* a complex mixture was observed on TLC. The presence of a 4,6-benzylidene acetal in previous successful reactions may be the major factor influencing the reactivity of the substrate. Maybe this group renders the molecule rigid and more reactive for opening. One is tempted to say that the alkylation at C-2 via oxirane opening depends on substrate; the substrate used was not suitable to be opened by alkylmagnesium bromide. This synthetic approach was abandoned.

### 3.2.2 Approach to the synthesis of 1.33 via a 2-uloside

The difficulties encountered in achieving efficient addition of a Grignard reagent to the 1,6-2,3-anhydro sugars prompted us to pursue the second approach, involving preparation of 2-keto glycosides ("ulosides") (Fig. 3.1) with potential for further modification at C-2 using Wittig or related olefination reactions. This type of compound has a history of being used in the synthesis of C-2 branched-chain sugars<sup>18,19</sup> and under olefination reaction conditions the ulosides can epimerise to provide  $\alpha$ -glycosides (Scheme 2.68).<sup>11</sup>

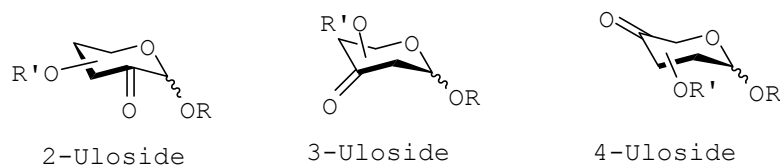

**Figure 3.1:** Types of ulosides

The olefin **3.22** was identified as a key intermediate for the synthesis of compounds like **1.33**, which would readily be obtained by, for example, hydroboration-iodination sequence<sup>20</sup> or direct anti-Markovnikov halogenations. The alkene **3.22** would be obtained by Wittig or related methylenation of ketone **3.21** which in turn is obtainable by sequence of published procedures.<sup>21,22</sup>

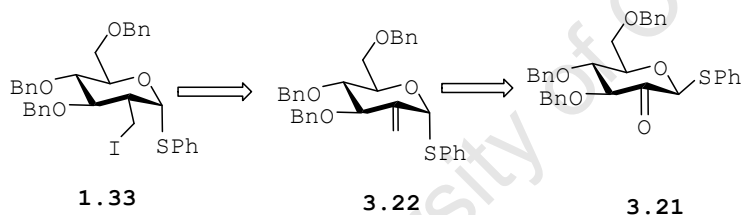

**Scheme 3.4:** Retrosynthetic route to compound **1.33** and derivatives via 2-uloglycoside

The synthetic process started with benzylated glucal **2.47** (Scheme 3.5),<sup>23</sup> which was converted to the epoxide **3.23** in 98% yield<sup>24</sup> and then further to the thioglucoside **3.20**, albeit in low yield (41%). An alternative approach to thioglucoside **3.20** involved preparation of the 1,2-di-*O*-acetyl glucose derivative **3.24** via the 1,2-dihydroxylated analogue,<sup>25</sup> and subsequent treatment with thiophenol using  $\text{BF}_3 \cdot \text{Et}_2\text{O}$  as promoter, which led selectively to the  $\beta$ -glucoside **3.25**.

The anomeric stereochemistry was confirmed by  $^1\text{H}$  NMR, with the observation of coupling constant of 10.0 Hz indicating a vicinal diaxial coupling between *H*-1 and *H*-2. Deacetylation of

**3.25** gave alcohol **3.20** (Scheme 3.4). This alternative approach proved to be more efficient as it is resulted in 64% overall yield. Subsequent oxidation<sup>26</sup> of **3.25** afforded 2-uloside **3.21**.

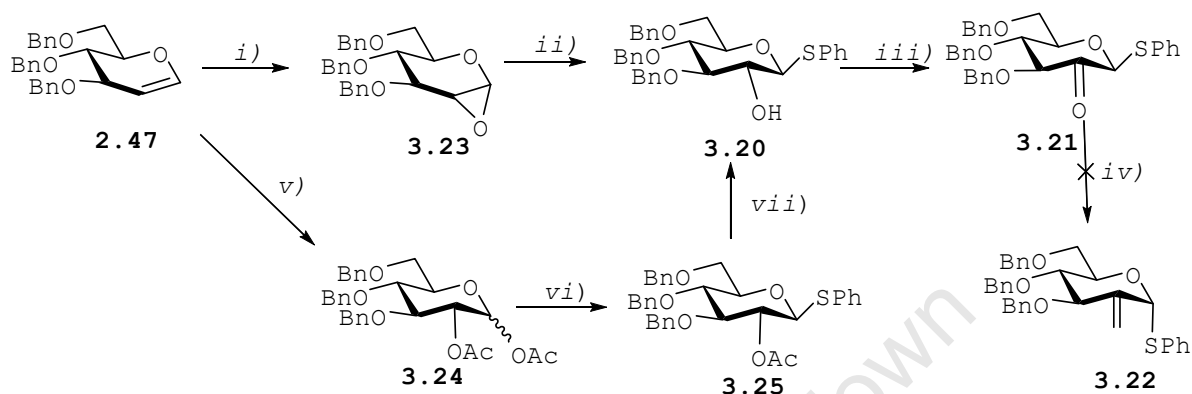

**Scheme 3.5** Reaction conditions: *i*) Oxone, Acetone, NaHCO<sub>3</sub>(sat.), DCM, 4h, 0–25°C, 98%, *ii*) NaH, PhSH, DMSO:THF, 41% *iii*) DMSO, DCC, Pyridine, Acetic anhydride, 50°C, 95% *iv*) Wittig, Peterson, HWE *v*) (a) Oxone, Acetone:H<sub>2</sub>O (4:1), NaHCO<sub>3</sub>(sat.), 4h, 25°C, 98%; (b) Ac<sub>2</sub>O, DMAP, TEA, THF, 30min., 100%; *vi*) PhSH, BF<sub>3</sub>·Et<sub>2</sub>O, DCM, -10°C, 75%; *vii*) NaOMe, MeOH, DCM, rt, 87%

The stage was now set for the crucial olefination reaction. Several olefination methods were attempted, such as Wittig, Peterson<sup>27</sup> and Horner Wadsworth-Emmons (HWE)<sup>28</sup> but in each case no reaction was observed and only the starting material was recovered. The reason for the poor reactivity of this ketone is not clear. In a previous report of successful olefination of a 2-keto sugar the substrate was a methyl glycoside incorporating a 4,6-benzylidene acetal<sup>29</sup> and this suggests that conformational factors and the nature of the anomeric substituent may have an impact on the approach of the reagent and the steric requirements of the intermediates.

### 3.2.3 Approach to the synthesis of compound **1.33** via 1,2-cyclopropanated sugars

#### 3.2.3.1 Via unsubstituted cyclopropanes

The failure to achieve the desired olefination of the phenylthio-2-uloside led to consideration of an alternative approach to **1.33** (Scheme 3.6). The synthesis of **2.225** via a cyclopropanated sugar has been published,<sup>30</sup> but this was re-investigated with particular attention to the stereoselectivity in the thioglycosylation step. The key issue was whether  $\alpha$ -selectivity could be achieved on the assumption that the iodomethyl substituent at C-2 would not be a "participating group" (offer anchimeric assistance), although this was later found not to be the case.

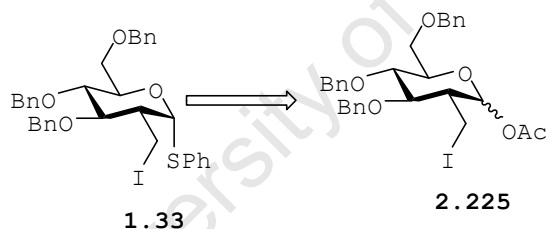

**Scheme 3.6:** Retrosynthetic analysis to compound **1.33**

The synthesis started with conversion of **2.47**<sup>31</sup> to the dichlorocyclopropanated sugar **3.26** (Scheme 3.7).<sup>28</sup> Treatment with lithium aluminium hydride (LAH) afforded cyclopropanated sugar **2.224b** in 71% yield. Exposing **2.224b** to ammonium iodide, acetic anhydride and hydrogen peroxide in a solvent mixture of acetic acid and acetonitrile (1:1) afforded the iodoacetoxy compound **2.225**<sup>30</sup> in 60% as a mixture of anomers (1:2,  $\alpha$ : $\beta$ ).

Treatment of **2.225** with thiophenol (PhSH) and  $\text{BF}_3 \cdot \text{Et}_2\text{O}$  in dry dichloromethane afforded compound **1.33** and **1.34** in 75% yield (1:5,  $\alpha$ : $\beta$ -mixture), with a small portion of **1.34** crystallizing

from ethanol. The structure of the mixture was established with the help of NMR spectroscopy. The downfield signals at  $\delta$  5.71 and 4.66 ppm with coupling constants of 4.6 Hz and 9.9 Hz were assigned to *H*-1 of the  $\alpha$ - and  $\beta$ -isomers<sup>30</sup> respectively.

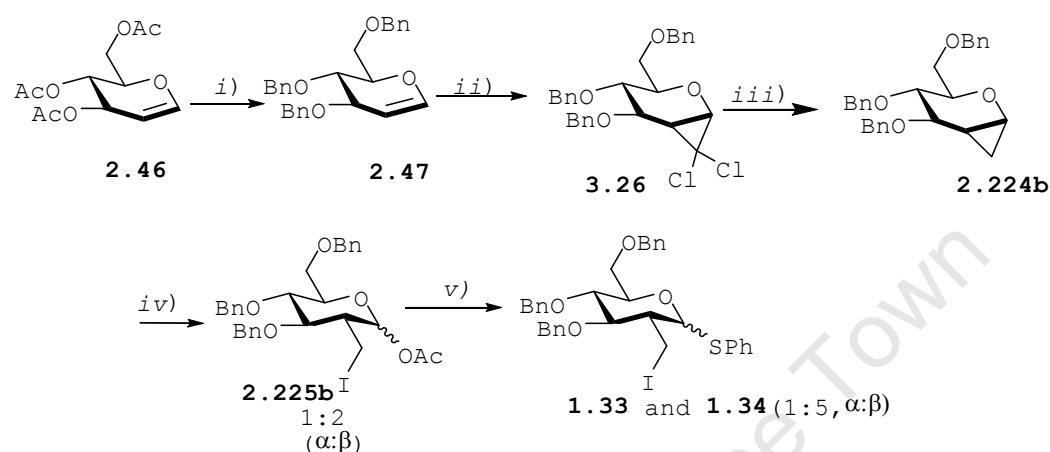

**Scheme 3.7** Reagents and conditions: i) BnBr, TBAI, NaOH, RT, 4h, 85%; ii) CHCl<sub>3</sub>, NaOH aq., BTEAC, 24h, 85%; iii) LiAlH<sub>4</sub>, THF, rt, 8days, 71%; iv) AcOH-CH<sub>3</sub>CN, NH<sub>4</sub>I, Ac<sub>2</sub>O, H<sub>2</sub>O<sub>2</sub>, -10°C, 1h, 60% mixture; v) BF<sub>3</sub>·Et<sub>2</sub>O, PhSH, DCM, -10°C, 1h, 75% mixture

The observation of high  $\beta$ -selectivity in the glycosidation reaction was somewhat unexpected. Stereoselectivity in glycoside formation is known to be dependent on factors which include the presence or absence of a participating group at C-2, and the influence of the protecting groups on the reactivity at the anomeric centre.<sup>32</sup> These factors were thus investigated further.

### 3.2.3.1a Influence of protecting group (OAc) on Thioglycosylation reaction of C-2-iodomethyl-glycosylacetates

The effect of substituents on the reactivity at the anomeric center has long been recognized.<sup>33</sup> Glycosyl donors with ester protecting groups go through glycosylation reactions much more slowly than do the corresponding donors with ether protection.

A modified approach utilizing ester protecting group was evaluated. The sequence started from benzylated cyclopropanated sugar **2.224b** instead of acetylated glucal **2.46**, with subsequent debenzylation and acetylation to give the acetylated cyclopropanated sugar. This was necessary because the reaction conditions used in the synthesis of the cyclopropanated sugar involved basic medium (Scheme 3.7, (ii)) which would lead to deacetylation and lead to inefficient cyclopropanation. The synthesis of 2-C-iodomethyl thioglucoside **3.27** and **3.28** in 75% yield (1:1,  $\alpha:\beta$ ) required to follow the procedures for the synthesis of the corresponding benzylated 2-C-iodomethyl thioglucoside (Scheme 3.7) but at higher temperature (60°C).

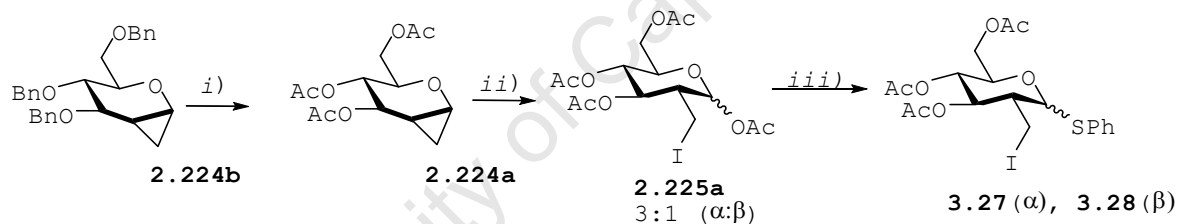

**Scheme 3.8:** Reagents and conditions: i) Pd/C, H<sub>2</sub>, THF, 2h, 100%; ii) AcOH-CH<sub>3</sub>CN, NH<sub>4</sub>I, Ac<sub>2</sub>O, H<sub>2</sub>O<sub>2</sub>, -10°C to 60°C, 24h, 70% mixture; iii) BF<sub>3</sub>.Et<sub>2</sub>O, PhSH, DCM, 25°C, 1h, 75% mixture (1:1;  $\alpha:\beta$ )

The structures of these isomers were established with the help of <sup>1</sup>H NMR spectroscopy. The anomeric hydrogen atoms of **3.27**, **3.28** resonated at  $\delta$  5.74 ppm and 4.69 ppm, respectively. All other spectroscopic data confirmed that both compounds **3.27** and **3.28** were synthesised. The products **3.27** and **3.28** were only obtained after increasing the temperature to room temperature whereas the benzylated thioglucosides **1.33** and **1.34** were obtained at low temperature (-10 °C). Presumably, in the case of the benzylated derivative the oxocarbenium intermediate forms readily at lower temperatures as it is stabilised both by the electron-donating character of the

benzyl groups and by participation of the iodomethyl substituent at C-2, resulting in preferential formation of the  $\beta$ -glycoside. In contrast, the formation of the oxocarbenium ion from the acetylated sugar requires higher temperatures due to the destabilizing electron-withdrawing character of the acetoxy substituents, and these higher temperatures allow for equilibration and formation of the thermodynamic  $\alpha$ -product. The acetyl (EWG) protecting groups do thus have an indirect influence on the stereoselectivity of thioglycoside formation from 2-C-iodomethylglycosylacetates.

On the basis of the above observations, the iodomethyl group at the C-2 position<sup>34</sup> appears to offer anchimeric assistance as shown in Scheme 3.9. Coordination of the oxygen atom of acetyl with  $\text{BF}_3 \cdot \text{Et}_2\text{O}$  of **2.225b** followed by the release of the leaving group produces the highly reactive oxocarbenium **I** which is in equilibrium with **II**. The oxocarbenium **I** could react with a nucleophile from both face since it is a flat molecule giving rise to 1,2-*trans* glycoside **1.34** and 1,2-*trans* glycoside **1.33**. Alternatively, **I** might be equilibrating to iodonium **II** and the equilibrium is assumed to preferentially shift to the iodonium intermediate which is more favoured over oxocarbenium intermediate due to the electron donating character of the benzyl ether protecting group.<sup>35</sup> Thus, the nucleophile would attack from the  $\beta$ -face to afford 1,2-*trans*  $\beta$ -glycoside **1.34**, predominantly if not exclusively. In contrast, the electron withdrawing character of acetyl protecting groups would favour the formation of oxocarbenium over iodonium intermediate. Thus, the reaction of **2.225a** with thiophenol in the presence of  $\text{BF}_3 \cdot \text{Et}_2\text{O}$ , resulted in 1:1,  $\alpha$ : $\beta$  ratio of **3.27** and **3.28**.

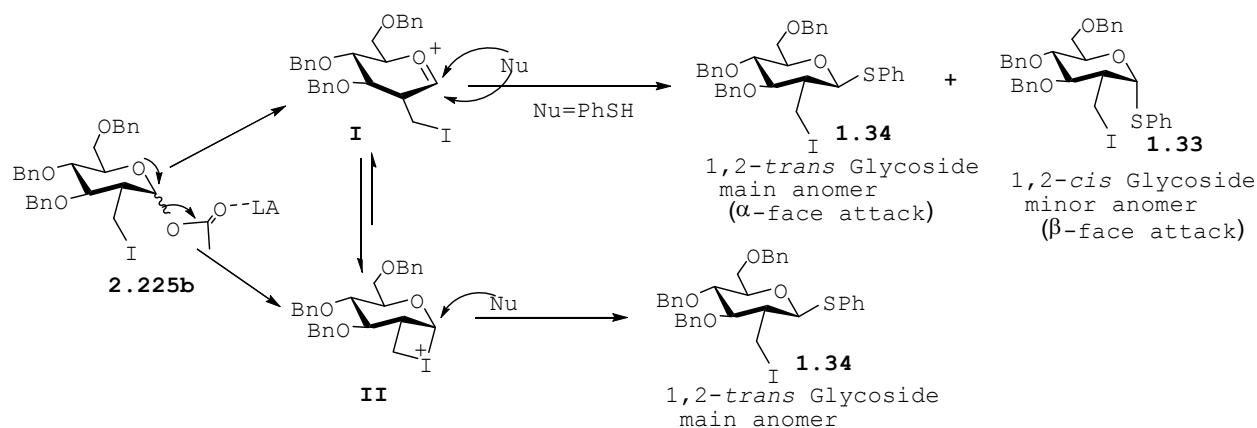

**Scheme 3.9:** Possible Mechanism for predominantly  $\beta$ -product as opposed to  $\alpha$ -product

### 3.2.3.1b Influence of neighbouring group on stereoselectivity of thioglycosylation reaction

The apparent participation of the iodo group at C-2' was investigated further by replacing it with an azido group. Treatment of **2.225b** with sodium azide in dimethylsulfoxide afforded the C-2-azidomethyl glucosyl acetate **3.29** (Scheme 3.10). Subjecting the latter to glycosylation reaction conditions with thiophenol resulted in an inseparable mixture of isomers of 2-C-azidomethyl phenylthioglycoside **3.30** and **3.31** in 66% yield in an  $\alpha$ : $\beta$  ratio of 2:1. The structure was confirmed by the presence of signals in the aromatic region of the  $^1\text{H}$  NMR spectrum and an  $\text{N}_3$  stretch at  $2102\text{ cm}^{-1}$  in the IR spectrum. The predominance of the  $\alpha$ -anomer in this case is consistent with the non-participatory character of the azidomethyl group, and contrasts with the  $\beta$ -selectivity observed with the iodomethyl group at C-2.

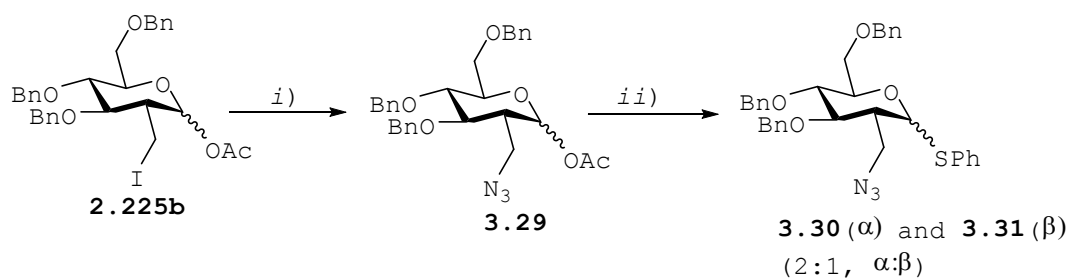

**Scheme 3.10** Reaction conditions: *i)*  $\text{NaN}_3$ , DMSO, rt, 1 h, 100%;  
*ii)* PhSH, DCM,  $-10^\circ\text{C}$ , 1 h, 66%

An interesting further contribution to this investigation arose in later work, but is presented here for comparison. The 2-ethoxycarbonyl methyl derivative **3.32** for which synthesis is described later, was subjected to thioglycosylation reaction conditions (see Scheme 3.7), and gave phenylthioglycoside **3.33** with the  $\alpha$ -anomer predominating (Scheme 3.11). This suggests that the ester is not participating in the glycosidation. Beyer, J. *et al.*<sup>36</sup> have also observed in their search for convenient synthesis of C-2 branched carbohydrates that ester groups on the C-2 branch do not participate in the glycosidation reaction.

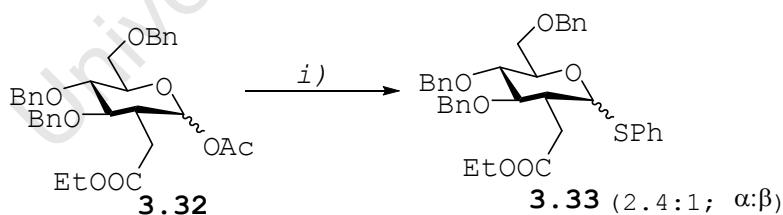

**Scheme 3.11:** Reaction conditions: *i)* PhSH,  $\text{BF}_3 \cdot \text{Et}_2\text{O}$ , DCM, 5h,  $-10^\circ\text{C}$

### 3.2.3.1c Influence of the leaving group on stereoselectivity of thioglycosylation reaction

On the basis of these findings, alternative strategies to activate the anomeric position were investigated. The objective was to use an  $\alpha$ -directing anomeric substituent in the glycosyl donor; with glycosyl halides favoured based on the well established principle of halide ion-assisted  $\alpha$ -

glycosylations.<sup>37,38,39,40,41</sup> In particular the possibility of utilizing glycosyl iodides for this purpose seemed attractive, with recent reports suggesting these reactive species can be prepared and handled efficiently.<sup>42,43,44</sup>

We embarked on a route to synthesise glycoside halide which will be used to direct the stereoselectivity through halide ion-assisted  $\alpha$ -glycosylations reaction condition. The possibility of direct preparation of glycosyl iodides from cyclopropanated sugar **2.224b** was investigated. It was thus exposed to a mixture of molecular iodine and thiolacetic acid in chloroform; conditions known to generate hydrogen iodide *in situ* for subsequent addition to an alkene as outlined in Scheme 3.12.<sup>45</sup> As cyclopropane reactivity is known to be similar to that of alkenes, the assumption was that once the hydrogen iodide was generated it could add to the cyclopropane to generate glycosyl iodide **3.39** via the stabilized oxocarbenium ion **3.39** (Scheme 3.13).

However, all attempts at this reaction either at room temperature or elevated temperatures failed although the starting material appeared to decompose during the process. The failure of this reaction suggested that it is possible that the concentration of HI is not sufficient to undertake such a route and perhaps a more reactive species like  $I_3^-$  could be a better option to obtain the desired compound. Unfortunately, there were no literature procedures that described the reaction of triiodide with cyclopropane or alkene.

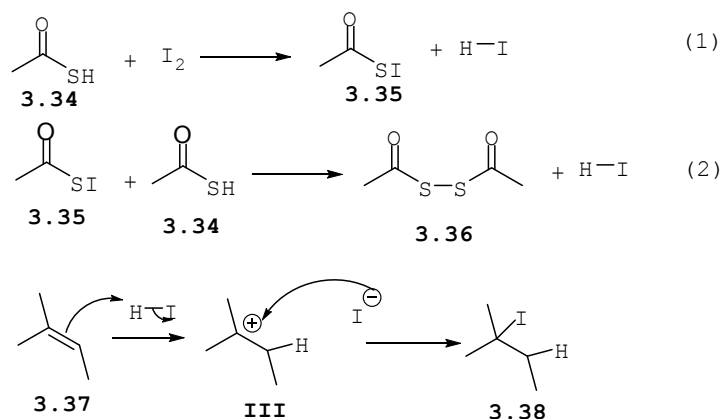

Scheme 3.12: Possible intended mechanism of HI on alkene

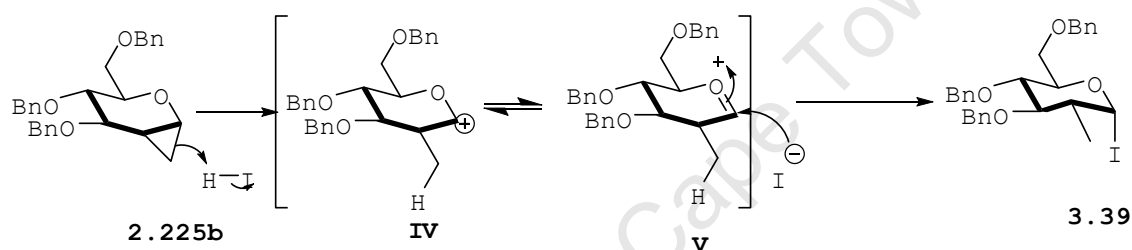

Scheme 3.13: Possible intended mechanism for HI on cyclopropane

An alternative strategy was to exploit the ease of preparation of the  $\beta$ -thioglycosides, and to investigate their anomerization to  $\alpha$ -thioglycosides. In the first instance this was investigated using azidomethylphenylthioglycoside **3.31** obtained from **1.34** in 90% yield as shown in Scheme 3.14. It was expected that the reaction of **3.31** with methyl iodide would give a sulfonium ion intermediate **3.40** which would in the presence of an activator and a nucleophile give rise to  $\alpha$ -glycoside. Similar work was done by Geert-Jan Boons *et al.*<sup>46</sup> and it was observed that  $\beta$ -sulfonium ion intermediates improve  $\alpha$ -anomeric selectivity. Although, Cook *et al.*<sup>47</sup> have synthesised a sulfonium salt of thiacyclohexane with methyl iodide, we thought using the same reaction condition would yield sulfonium salt of our sugar molecule **3.31**. This attempt did not succeed as viewed by TLC (as a salt **3.40** is expected

to be on the baseline of the TLC), and the starting material was recovered.

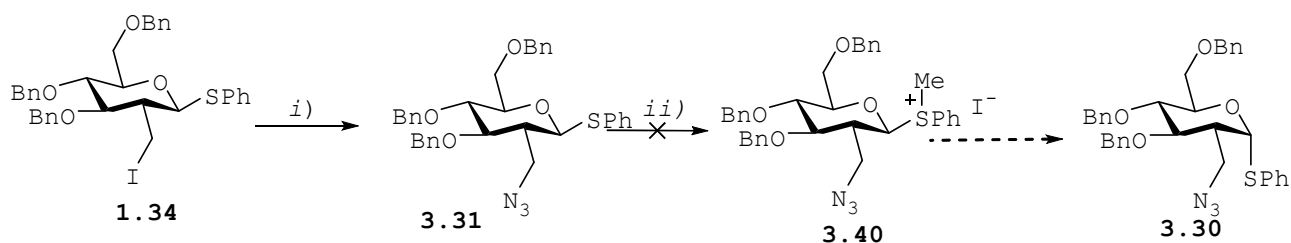

**Scheme 3.14** :Reaction conditions:*i)*  $\text{NaN}_3$ , DMSO,  $25^\circ\text{C}$ , 1h, 90% *ii)* MeI, reflux, 24h.

### 3.2.3.1d Functionalization at C-2' position of 1.34

Failure to activate and epimerize the phenylthioglycoside resulted in attention turning to the second objective of the project: the investigation of a range of options to functionalise the C-2' position of **1.34**.

The cyano derivative **3.41** was synthesised following a published protocol.<sup>48</sup> Treatment of **1.34** with four equivalents of NaCN in DMSO at  $100^\circ\text{C}$  for 24 hours resulted in compound **3.41** in 70% yield (Scheme 3.15).  $^{13}\text{C}$  NMR spectrum showed a peak at 114 ppm indicating the presence of a cyano carbon atom substituting iodine at C-2' of the thioglycoside **1.34**. Under the same conditions,  $\text{NaN}_3$  was used instead of NaCN and compound **3.31** was obtained in 90% yield (Scheme 3.14).

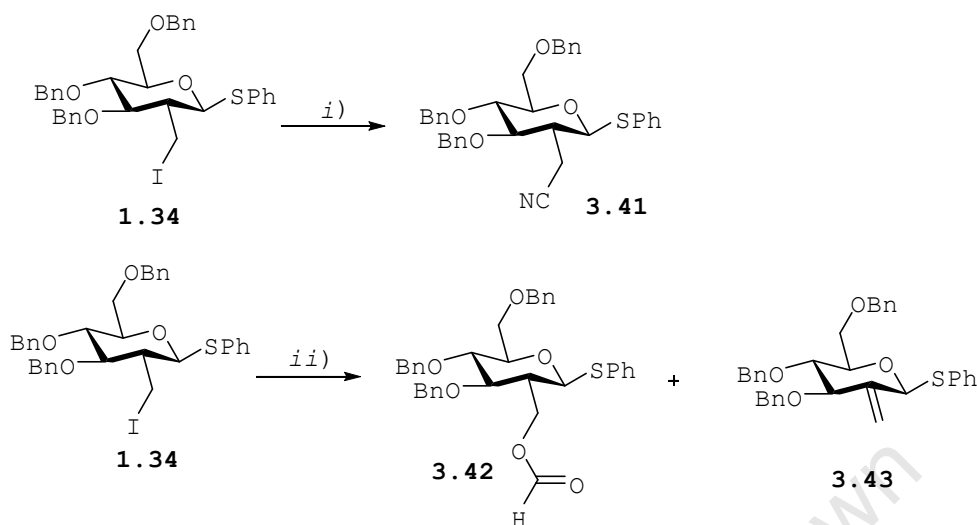

**Scheme 3.15** Reaction conditions: i) DMSO, NaCN, 100<sup>o</sup>C, 24h, 70%,  
ii) Formic acid, TEA, THF, rt, 3h (**3.42**, 75% and **3.43**, 20%)

The absorbance (IR) value of the azido group was observed at 2102 cm<sup>-1</sup>, which is the characteristic stretch for azide.

Direct hydrolysis of **1.34** was attempted using NaOH in THF; this reaction was unsuccessful even when refluxing. An alternative route was envisaged via the formate<sup>49</sup> which can be hydrolysed to a hydroxyl group. The reaction of compound **1.34** with formic acid and triethyl amine in THF generated successfully the formate **3.42** accompanied by 20% of the elimination product **3.43** (Scheme 3.15). Reaction conditions were then evaluated for conversion of iodide **1.34** to Grignard or other similar organometallic species. The successful synthesis of the Grignard intermediate followed by subsequent C-C bond formation would allow for a range of electrophiles to be added to **1.34** at C-2'. This could be one way of elongating the C-2' position of **1.34** to C<sub>2</sub>, C<sub>3</sub> and C<sub>n</sub> side-chains, therefore generating analogues of mycothiol. In a first approach the formation of organozinc intermediates was envisaged, followed by quenching with active electrophiles such as acid chloride. The 2-C-iodomethyl **1.34** was therefore

treated with activated zinc in dry THF followed acetyl chloride with intention of obtaining ketone **3.44**. This led only to decomposition of the starting material. However, quenching with water instead of acetyl chloride led to C-2-methyl glucoside **3.45** together with its partially deprotected counterpart **3.46**. While these results served to confirm the formation of organozinc intermediate **VI**, they suggest either that acetyl chloride is not sufficiently reactive to react further, or that the environment of the anion is too sterically congested due to the adjacent substituted carbohydrate and the large zinc cation, or the zinc is chelated to sulphur to give a very unreactive organometallic species.

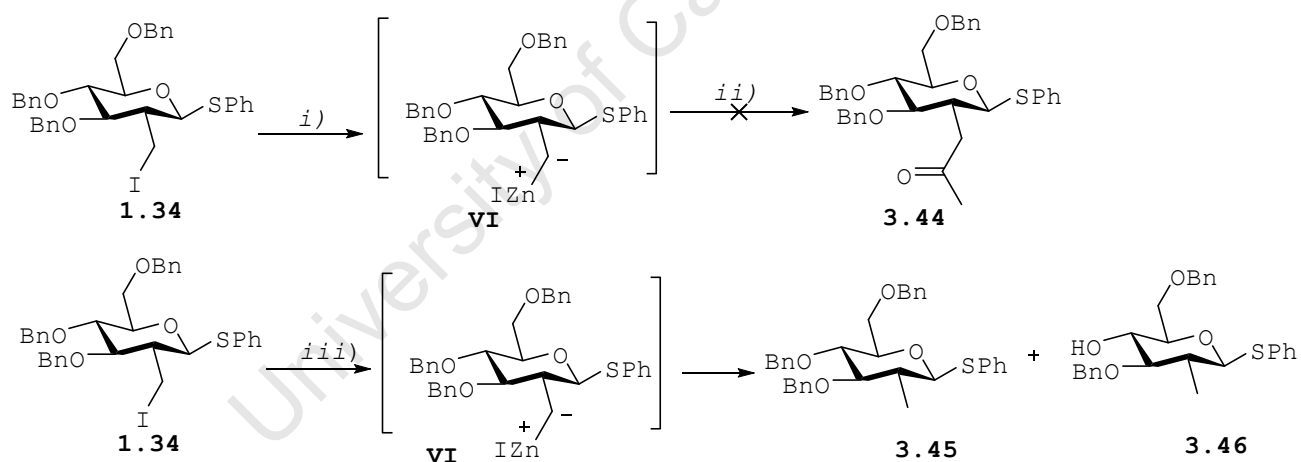

**Scheme 3.16:** Reaction conditions i) Zn, THF,  $-78^\circ\text{C}$  to  $25^\circ\text{C}$ , 1h ii)  $\text{CH}_3\text{COCl}$ , iii) Zn, TMSCl,  $\text{CH}_3\text{I}$ , 12h, **3.45** (16%) and **3.46** (49%)

### 3.2.3.2 Via substituted 1,2-cyclopropanated sugars

#### 3.2.3.2a Synthesis of 2-C-vinylglycoside as precursor of

##### 2-C-iodomethylglycoside **1.33**

The work described above confirmed the limitations of an approach based on simple 1,2-cyclopropanated sugars, and a

modified approach was thus evaluated based on substituted cyclopropanated sugars. Electrophilic or Lewis-acid mediated fragmentation of these would lead to direct installation of higher order carbon fragments at C-2, as demonstrated by Henry *et al.*<sup>50</sup>

As noted earlier the vinyl group was recognized as a suitable functionality for modifying and extending the side chain<sup>51</sup> and would also act as a non-participating group in glycosidation reactions. It therefore seemed appropriate to investigate more general methodology for the Henry fragmentation-elimination which would allow for direct introduction of a variety of nucleophiles at C-1, as outlined in Scheme 3.18.

The key step envisaged was the formation of 2-C-vinylglycosides **3.48** via an *exo*-Ferrier rearrangement of cyclopropylcarbonyl acetate **3.47** obtained by reduction and acetylation of ester **2.237** (Scheme 3.19).

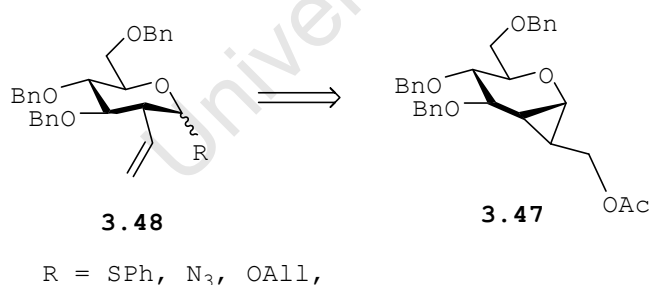

Scheme 3.18: Retrosynthetic analysis for generalized approach to 2-C-vinyl glycosides

Carboxylated cyclopropopane **2.237** was thus synthesised by reported methods.<sup>52</sup> LAH reduction and acetylation of this ester then afforded acetate **3.47** in 71% yield over the two steps (Scheme 3.19).

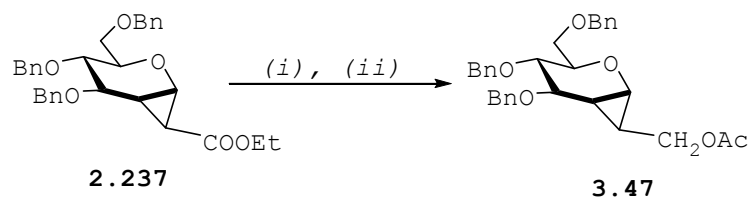

**Scheme 3.19** Reaction conditions: i) a) LAH, Et<sub>2</sub>O, 1h; b) Ac<sub>2</sub>O, DMAP, TEA, THF, 30min.

The structure of **3.47** was evident from the NMR data. Replacement of the ester group on **2.237** by an acetoxymethyl group caused the signal for *H*-2' to shift upfield from  $\delta$  2.02 ppm to 1.45 ppm, where it appears as a complex multiplet as it is coupled to an additional -CH<sub>2</sub>- (Table 3.1).

**Table 3.1:** NMR data of compounds **2.237** and **3.47**

|              | <sup>1</sup> H NMR | <sup>13</sup> C NMR |                 |
|--------------|--------------------|---------------------|-----------------|
|              | H-2'               | C-2'                | CH <sub>3</sub> |
| <b>2.237</b> | 2.02               | 24.5                | 14.2            |
| <b>3.47</b>  | 1.45               | 20.7                | 23.0            |

Similarly, the <sup>13</sup>C NMR spectrum showed a signal at  $\delta$  20.7 ppm for C-2' of the cyclopropylcarbinyl acetate **3.47**, shifted upfield from its position at  $\delta$  24.5 ppm in carboxylated cyclopropopane **2.237**. The signal for the acetate methyl group appears at  $\delta$  23.0 ppm (Table 3.1).

The possibility of a Lewis acid-catalyzed Ferrier-type rearrangement **3.47** was then explored, using benzyl alcohol as nucleophile and a range of Lewis acids similar to those used in the classic Ferrier reactions (Table 3.2). The Ferrier rearrangement of glycals is mediated by Lewis acids such as BF<sub>3</sub> etherate and titanium(IV) chloride<sup>53,54</sup> but a wide range of

alternative catalysts has also been used successfully, including indium (III) halides,<sup>55</sup> montmorillonite K10,<sup>56</sup> 2,3-dichloro-5,6-dicyano-*p*-benzoquinone,<sup>57</sup> trimethylsilyl triflate,<sup>58</sup> gold trichloride<sup>59</sup> and trichloroacetimidate.<sup>60</sup> More recently, the effectiveness of zeolites as heterogeneous Lewis acids in Ferrier rearrangement has been demonstrated by Levecque *et al.*<sup>61</sup> Only a few examples of *exo*-Ferrier rearrangements have been reported in the literature. For example, glycosides and glycoconjugates were synthesised from *exo*-glycals by Ferrier-type rearrangement using  $\text{BF}_3 \cdot \text{Et}_2\text{O}$  as catalyst,<sup>62</sup> 2-*C*-methylene glycosides were synthesised from 2-*C*-propargyloxymethyl glycals in a stereoselective manner using a catalytic quantity of gold trichloride,<sup>59</sup> and also from 2-*C*-acetoxymethyl glycals using Nafion-H, montmorillonite K-10 or  $\text{LiClO}_4$  in dichloromethane,  $\text{Pd}(\text{PPh}_3)_4$  or  $\text{BF}_3$  etherate as catalysts.<sup>63a</sup> In similar work, 2-*C*-acetoxymethyl glycals derivatives were treated with aliphatic alcohols in the presence of indium trichloride to synthesise corresponding 2-*C*-methylene glycosides.

We initiated our investigation using  $\text{BF}_3 \cdot \text{Et}_2\text{O}$  as well as  $\text{Al}(\text{OTf})_3$ , not hitherto used in this type of reaction but recently reported to be a practical, efficient, alternative Lewis acid.<sup>64</sup> Scheme 3.20 summarizes the reaction conditions and outcome of the reaction investigated.

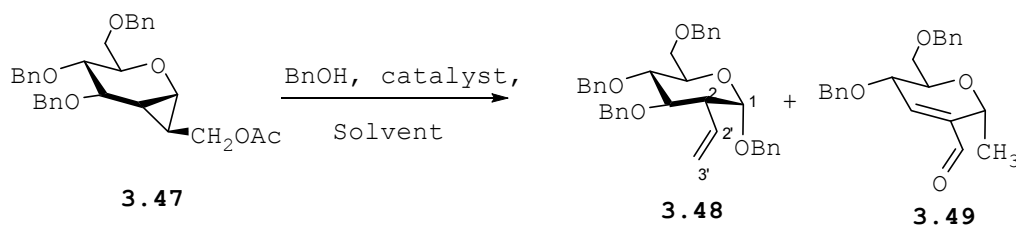

**Scheme 3.20:** Products of *exo*-Ferrier-type rearrangement reaction on cyclopropylcarbinylacetate **3.47**

**Table 3.2:** Lewis Acid-catalyzed *exo*-Ferrier-type rearrangement of cyclopropylcarbinyllacetate **3.47**

| Entry  | Catalyst                           | Solvent            | Temperature | Yield of <b>3.48</b><br>(stereochemistry<br>at C-1) | Yield of<br><b>3.49</b> , |
|--|------------------------------------|--------------------|-------------|---|---------------------------|
| 1 <sup>a</sup>   | Zeolite                            | DCM                | 25°C        | trace   | -                         |
| 2 <sup>b</sup>   | BF <sub>3</sub> .Et <sub>2</sub> O | DCM                | 5°C         | 23% ( $\alpha$ )                                    | trace                     |
| 3 <sup>b</sup>   | BF <sub>3</sub> .Et <sub>2</sub> O | CH <sub>3</sub> CN | 5-40°C      | 41% ( $\alpha$ )                                    | trace                     |
| 4 <sup>c</sup>   | Al(OTf) <sub>3</sub>               | DCM                | 25°C        | trace   | -                         |
| 5 <sup>d</sup>   | Al(OTf) <sub>3</sub>               | DCM                | 40°C        | 54% ( $\alpha$ )                                    | 7%                        |
| 6 <sup>d,e</sup>   | Al(OTf) <sub>3</sub>               | DCM                | 40°C        | 57% ( $\alpha$ )                                    | -                         |
| a: After 4 days only an estimated 25% conversion had been achieved<br>b: after 12h the starting material was fully consumed.<br>c: After 12h with 0.35 equiv. of the Lewis acid the starting material was fully consumed.<br>d: After 1h of refluxing the starting material was fully consumed.<br>e: with molecular sieves (4Å) |                                    |                    |             |   |                           |

In the first attempts, a mixture of **3.47** and BF<sub>3</sub>.Et<sub>2</sub>O was treated with benzyl alcohol in dichloromethane at 5°C under an inert atmosphere, giving rise to a major and minor product. The major product was identified as the predicted 2-C-vinyl glycoside **3.48**, exclusively as the  $\alpha$ -anomer, and the minor product was identified as the dihydropyranyl carbaldehyde **3.49** (Table 3.2, entry 2). The structures of these products were determined by NMR spectroscopy. The <sup>1</sup>H NMR spectrum of **3.48** showed a triplet of doublets at  $\delta$  5.93 ppm for the vinylmethine hydrogen including couplings of 9.5 Hz and 17.1

Hz which is a result of *cis-trans* hydrogen coupling between  $H-2-H-2'$  and  $H-2'-H-3'a$ . The terminal hydrogen atoms on the double bond appeared at  $\delta$  5.28 and 5.23 ppm for  $H-3'a$  and  $H-3'b$  as both doublet of doublets and with coupling constants of 1.5 Hz and 17.2 Hz for  $H-3'a$  and 1.9 Hz and 10.2 Hz for  $H-3'b$ . The  $H-1$  appeared at  $\delta$  4.88 ppm as a doublet with a coupling constant of 3.4 Hz which is consistent with an  $\alpha$ -*gluco* isomer. The coupling constant of 3.4 Hz for  $H-1$  results from equatorial-axial coupling between  $H-1_{\text{equatorial}}$  and  $H-2_{\text{axial}}$  which implies that the vinyl group at C-2 is equatorial. The structure of unexpected compound **3.49** was obtained by careful analysis of the proton and carbon spectra, with the aid of 2D NMR experiments. It was evident from a preliminary analysis of the  $^1\text{H}$  and  $^{13}\text{C}$  NMR (Fig 3.2 & 3.3 and APT spectra (Fig 3.8) that only two benzyl groups were present and a total of three  $\text{CH}_2$  carbons, two CH carbons downfield from the aromatic region and five CH carbons upfield of the aromatic region.

The singlet at  $\delta_{\text{H}}$  9.40 ppm and its corresponding carbon atom at  $\delta_{\text{C}}$  191.9 ppm (HSQC, Fig. 3.5), confirmed the presence of an aldehyde group attached to a quaternary carbon. The long-range coupling (HMBC, Fig. 3.7) between the olefinic CH ( $\delta_{\text{H}}$  6.8 ppm) and aldehyde carbon ( $\delta_{\text{C}}$  191.8 ppm), and between the aldehyde CH ( $\delta_{\text{H}}$  9.40 ppm) and the fully-substituted olefinic carbon ( $\delta_{\text{C}}$  147.4 ppm) combine to suggest the presence of an  $\alpha,\beta$ -disubstituted- $\alpha,\beta$ -unsaturated aldehyde.

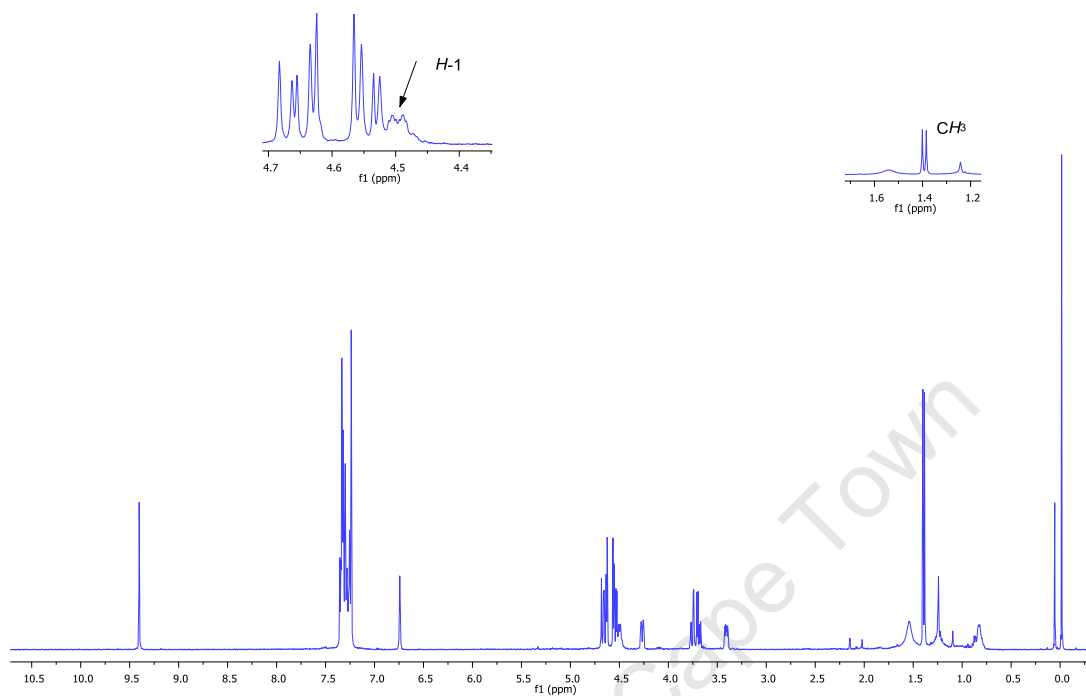

**Figure 3.2:** Proton NMR of **3.49**

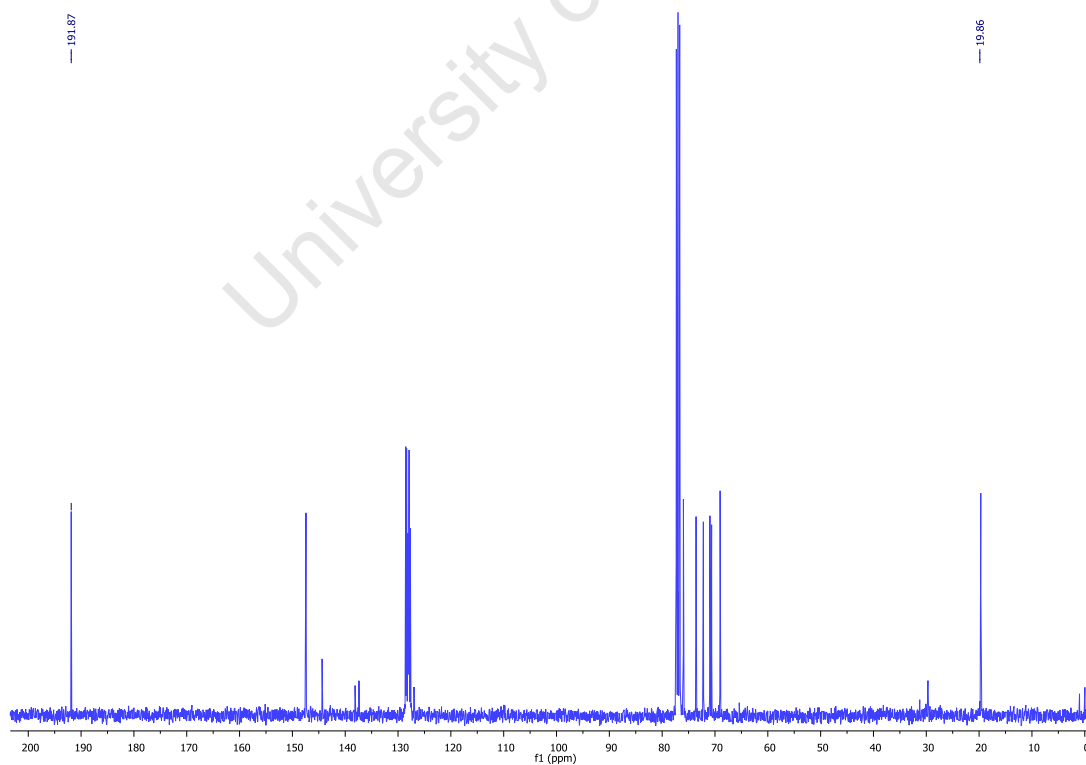

**Figure 3.3:** Carbon NMR spectrum of **3.49**

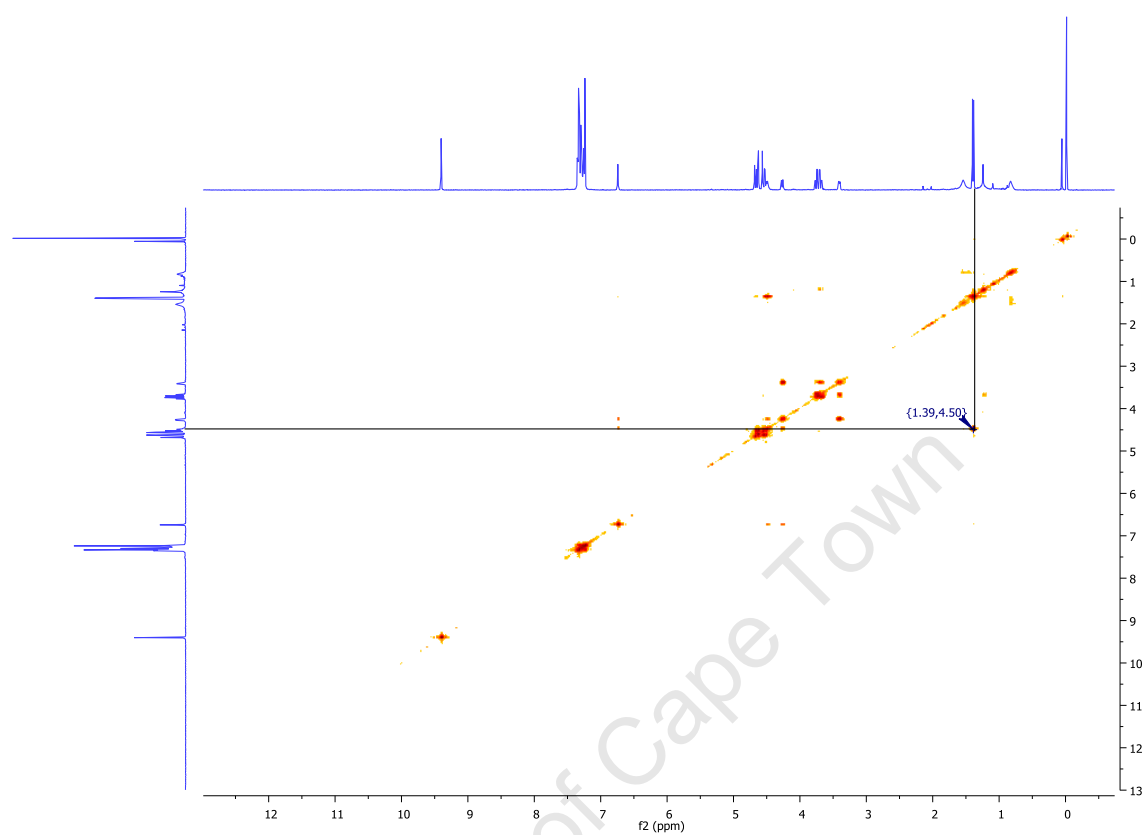

Figure 3.4: Cosy NMR of **3.49**

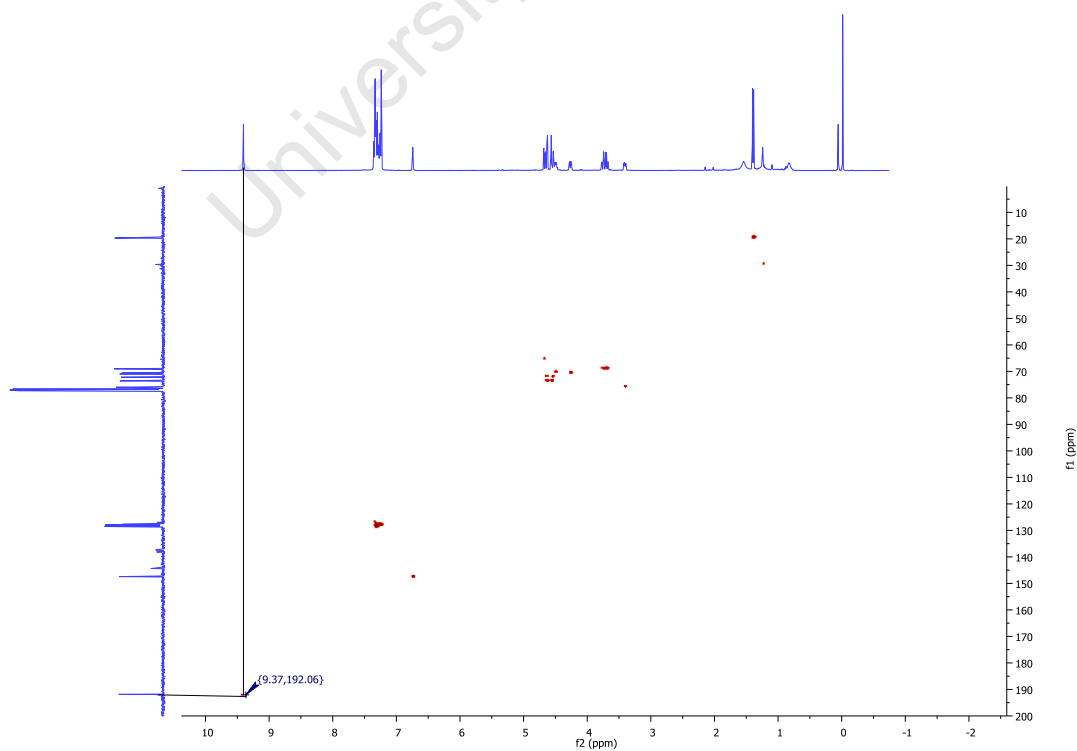

Figure 3.5: HSQC NMR Spectrum of **3.49**

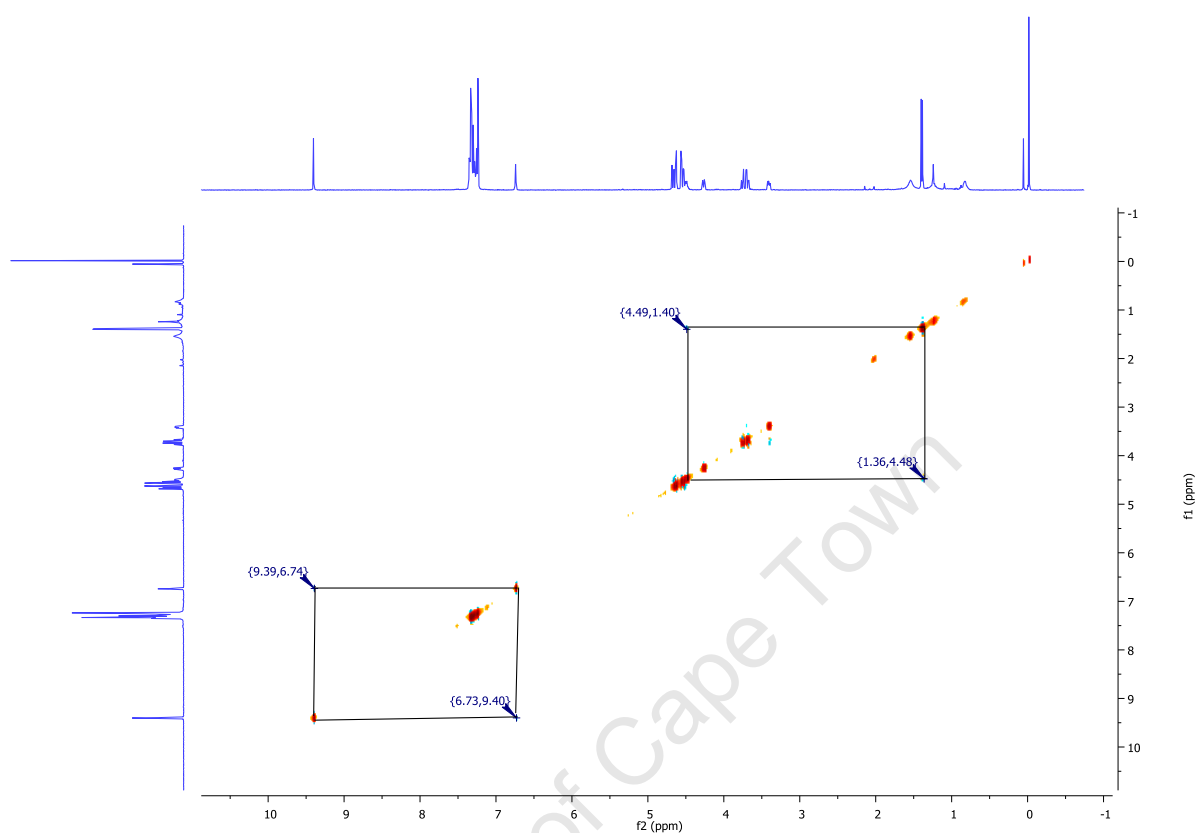

Figure 3.6: NOESY NMR Spectrum of 3.49

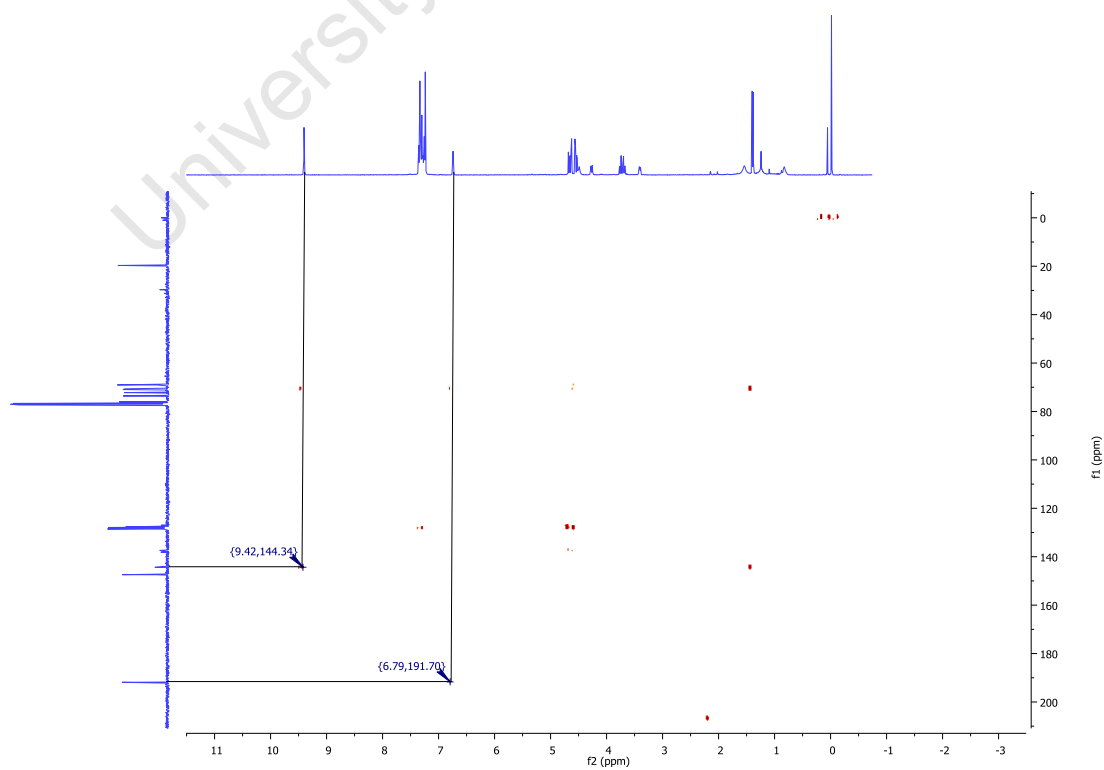
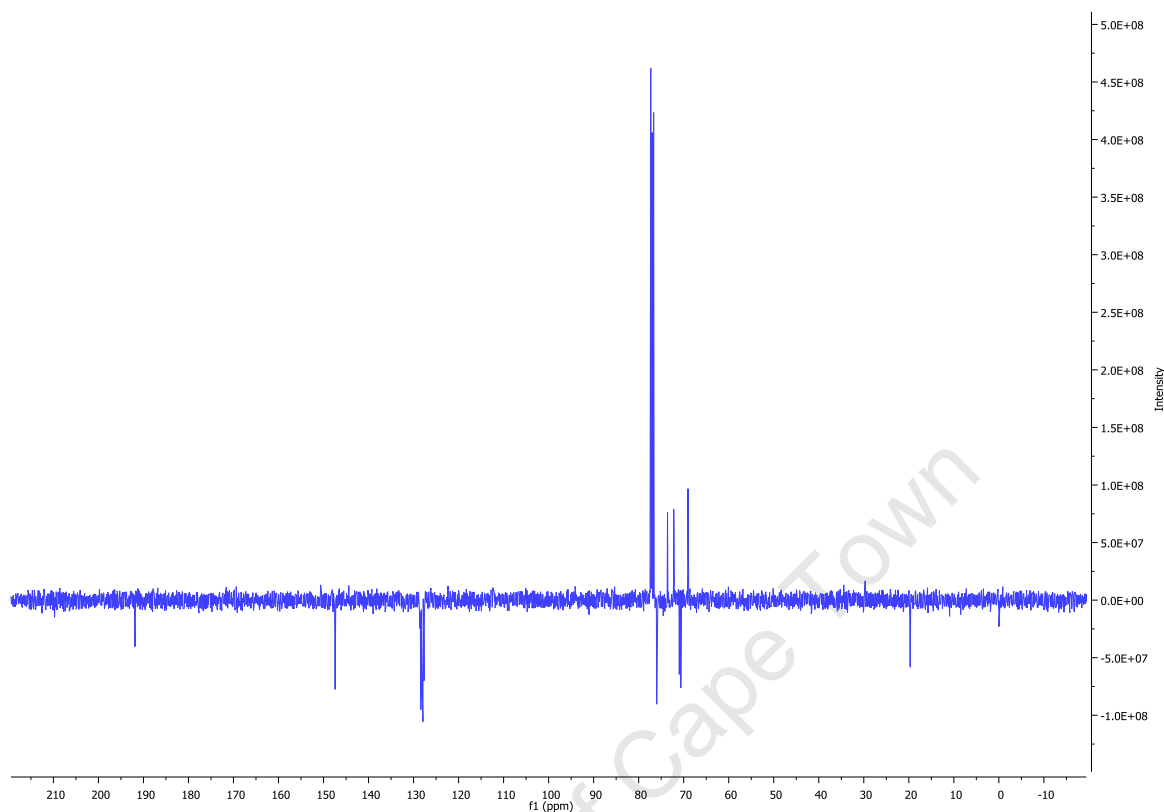

Figure 3.7: HMBC NMR Spectrum of 3.49

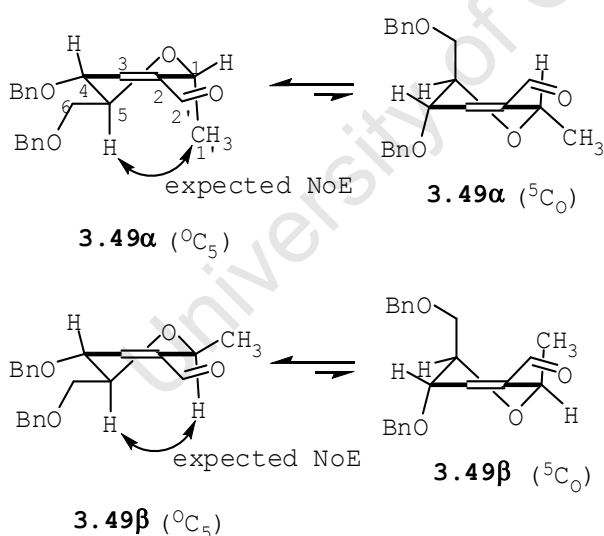

**Figure 3.8:** APT NMR Spectrum of **3.49**

In addition, a three-proton doublet at  $\delta_{\text{H}}$  1.40 ppm with  $J = 6.6$  Hz attached (HSQC) to the carbon resonating at  $\delta_{\text{C}}$  19.6 ppm, indicated the presence of a  $-\text{CHCH}_3$  group, with the COSY spectrum (Fig.3.4) confirming coupling to the proton resonating as a doublet of doublet of doublet ( $J$  1.8, 2.5 & 6.5 Hz) at  $\delta_{\text{H}}$  4.52 ppm. The long-range coupling (HMBC, Fig. 3.7) between the methyl carbon ( $\delta_{\text{C}}$  19.6 ppm) and  $H-1$  ( $\delta_{\text{H}}$  4.52 ppm) and also between aldehyde hydrogen ( $\delta_{\text{H}}$  9.40 ppm) and  $C-1$  ( $\delta_{\text{C}}$  70.6 ppm) confirmed the presence of hydrogen atom at  $C-1$ .

The foregoing information led to the proposed structure **3.49**. Although the stereochemistry at  $C-1$  was still uncertain, a search of the literature revealed that the  $\alpha$ -anomer **3.49** had been prepared previously by Cossy *et al.*<sup>65</sup> from 2- $C$ -formyl glycal by nucleophilic addition of methylcopper (MeCu) in the presence of  $\text{BF}_3 \cdot \text{Et}_2\text{O}$  in  $\text{Et}_2\text{O}$  at  $-30^\circ\text{C}$ . The spectroscopic data

for **3.49** is identical to that reported by Cossy *et al.*, where they had assigned the stereochemistry at C-1 on the basis of an observed NoE. Our analysis of the predicted preferred conformations of the two anomers **3.50** and **3.51** is shown in Figure 3.9. It is assumed that in both cases the  ${}^{\circ}C_5$  half-chair conformation is preferred due to the substituents adopting a *pseudo-equatorial* orientation. This would suggest that an observable NoE between H-5 and the CH<sub>3</sub> group would confirm the presence of  $\alpha$ -anomer **3.50** while an observable NoE between H-5 and H-1 would confirm the presence of  $\beta$ -anomer **3.51**. However, the NOESY spectrum of **3.49** did not show any of the predicted NoE's, and the C-1 stereochemistry is therefore provisionally assigned as  $\alpha$ - since **3.49** has identical analytical data with the compound prepared by Cossy *et al.*



**Figure 3.9:** Possible conformations of anomers of **3.49** illustrating predicted NoE's

Having identified the products, attempts were made to establish conditions for selectively obtaining one product or the other. Repeating the reaction in dichloromethane at higher temperatures resulted in formation of many more products as shown by TLC. Changing to acetonitrile as solvent improved the

yield of **3.48** to 41% as major product after 12 hours at 40 °C, although it was still accompanied by traces of **3.49** (Table 3.2, entry 3). When  $\text{BF}_3 \cdot \text{Et}_2\text{O}$  was replaced with zeolite H-USY CBV720 under an inert atmosphere, only traces of 2-C-vinylglycoside **3.48** were observed by TLC after 4 days at room temperature (Table 3.2, entry 1). With  $\text{Al}(\text{OTf})_3$  as catalyst in dichloromethane, only traces of the desired product were observed by TLC after 12 hours at room temperature. However, increasing the temperature to reflux resulted in full conversion of the starting material after 1 hour with formation of **3.48** (54% yield) and **3.49** (7% yield). Furthermore, when the reaction medium was kept strictly anhydrous, no formation of the aldehyde **3.49** was observed, which suggested a key role for water in formation of this product.

The unexpected formation of dihydropyranyl carbaldehyde **3.49** was of interest in that it represented an unusual fragmentation/rearrangement of cyclopropanated sugars, and a potentially useful route to 2-C-alkylated-C-glycosides. This led to a brief investigation of conditions which might favour formation of this product. Deliberate addition of acetic acid to a solution of **3.47** and  $\text{Al}(\text{OTf})_3$  in DCM and heating at reflux resulted in exclusive formation of the aldehyde **3.49** (59%). This result and our earlier observations on the role of water in the reaction contributed to a proposed mechanism for the formation of **3.49**, illustrated in Scheme 3.21. The challenges in rationalizing the formation of **3.49** were to provide an explanation for the elimination of the benzyloxy group at C-3, and the apparent interchange of the carbaldehyde and the vinyl unit. The 2-C-vinyl oxocarbenium ion **VII** is presumably formed in the initial Lewis-acid-mediated Ferrier-type fragmentation. Interception by a nucleophile in pathway A then gives rise to

the 2-C-vinylglycosides. However, an alternative pathway B results if oxocarbenium ion **VII** is intercepted by water to give hemiacetal **VIII** which would be in equilibrium with aldehyde **IX**. Elimination of the benzyloxy group at C-3 is possible *via* E1<sub>CB</sub> mechanism, since it would be driven by potential formation of an enolate in a cyclic coordinated complex **XII**. The apparent preferred attack from the top face, with the result that the methyl group ends up in the  $\alpha$ -orientation will provide the thermodynamically more stable anomer due to the anomeric effect.

This appears therefore to be a novel variation of the Ferrier rearrangement of substituted cyclopropanated sugars, dependent on the presence of some water in addition to the Lewis acid catalyst, and enhanced by the presence of some Brønsted acid.

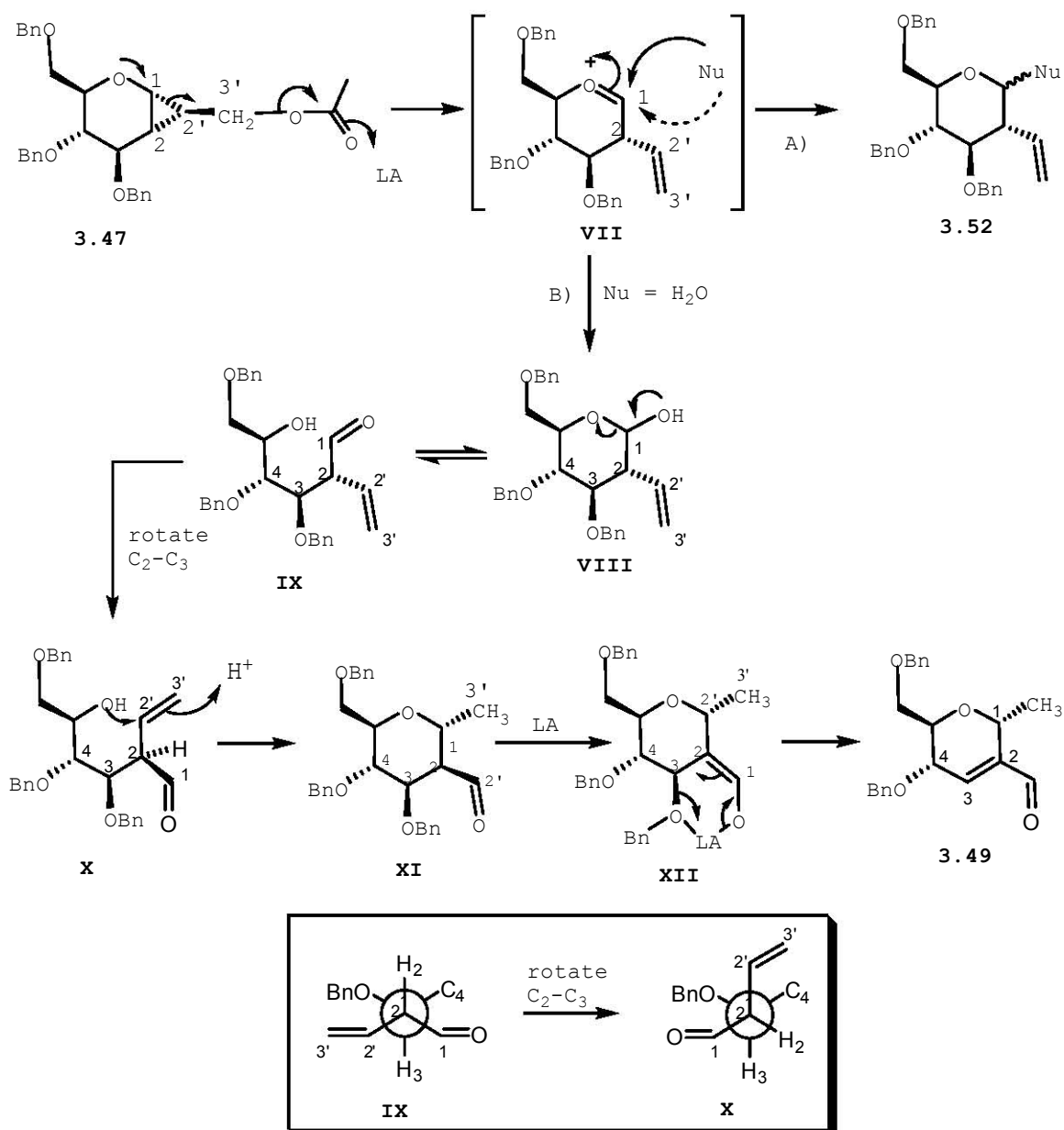

**Scheme 3.21:** Proposed mechanisms for alternative pathways in the Lewis-acid mediated fragmentation-rearrangement of cyclopropanated sugar **3.47**. Key intermediates IX and X are also shown in Newman projection along C2-C3.

Returning to the conditions favouring formation of the 2-C-vinyl glycosides, the results show that  $\text{BF}_3 \cdot \text{OEt}_2$  and  $\text{Al}(\text{OTf})_3$  are comparable in activity, with both selectively catalysing this *exo*-Ferrier-type rearrangement reaction, albeit in

moderate yields and as long as water is rigorously excluded. These catalysts and optimum conditions (Scheme 3.22) were therefore used to explore the scope of this approach for generating a range of 2-*C*-vinylglycosides (Table 3.3) using a variety of nucleophiles, including thiophenol (PhSH), allyl alcohol (AllOH) and trimethylsilylazide (TMSN<sub>3</sub>). With PhSH and TMS azide as nucleophile, comparable results (good yield of mixture of anomers) were obtained with either BF<sub>3</sub>.Et<sub>2</sub>O or Al(OTf)<sub>3</sub> as catalyst. However, with allyl alcohol as nucleophile, the allyl-2-*C*-vinyl glucoside was formed in high  $\alpha$ -selectivity in good yield (74%) using Al(OTf)<sub>3</sub>, but poor yield (30%) with BF<sub>3</sub>.Et<sub>2</sub>O as catalyst.

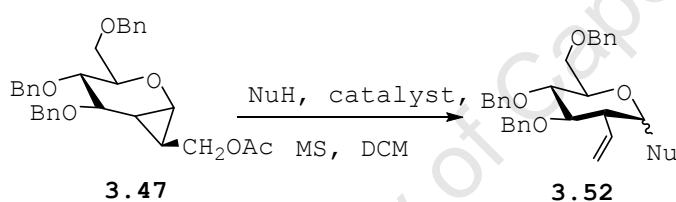

**Scheme 3.22:** General scheme for the selective synthesis of **3.52**

**Table 3.3:** *Exo*-Ferrier-type rearrangement on cyclopropyl carbinylacetate using *O*-, *N*- and *S*-nucleophiles, and Al(OTf)<sub>3</sub> or BF<sub>3</sub>.Et<sub>2</sub>O as promoters.

| entry          | nucleophiles<br>(Nu) | Catalysts                          | vinyl glycosides<br><b>3.52</b> | yield<br>( $\alpha$ : $\beta$ ) |
|----------------|----------------------|------------------------------------|---------------------------------|---------------------------------|
| 1 <sup>a</sup> | PhSH                 | BF <sub>3</sub> .Et <sub>2</sub> O |                                 | 72%<br>(1:1)                    |
| 2 <sup>b</sup> | PhSH                 | Al(OTf) <sub>3</sub>               |                                 | 80%<br>(1.2:1)                  |

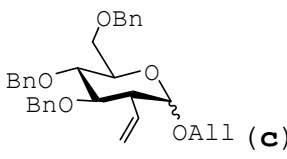
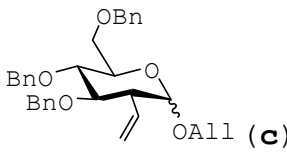
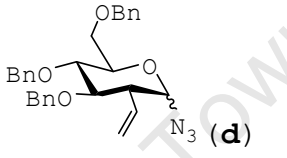
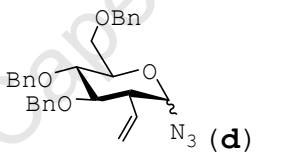
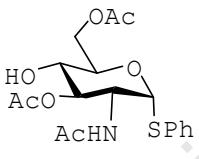
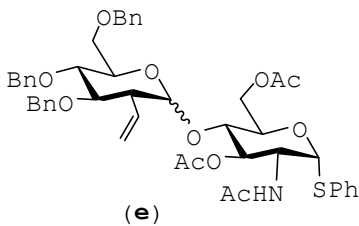
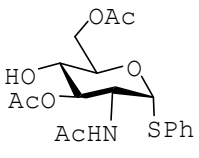
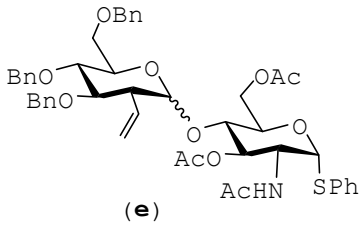
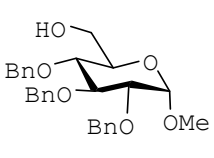
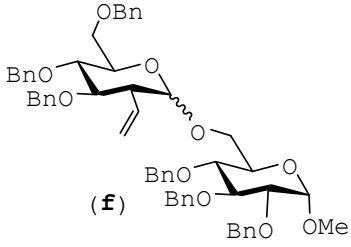
|                |   |                                    |  |                |
|----------------|---|------------------------------------|--|----------------|
| 3 <sup>a</sup> | Al1OH   | BF <sub>3</sub> .Et <sub>2</sub> O |    | 30%<br>(1:0)   |
| 4 <sup>b</sup> | Al1OH   | Al(OTf) <sub>3</sub>               |    | 74%<br>(1:0)   |
| 5 <sup>a</sup> | TMSN <sub>3</sub>   | BF <sub>3</sub> .Et <sub>2</sub> O |    | 80%<br>(2:1)   |
| 6 <sup>b</sup> | TMSN <sub>3</sub>   | Al(OTf) <sub>3</sub>               |   | 78%<br>(2.2:1) |
| 7 <sup>a</sup> |  | BF <sub>3</sub> .Et <sub>2</sub> O |  | no<br>reaction |
| 8 <sup>b</sup> |  | Al(OTf) <sub>3</sub>               |  | no<br>reaction |
| 9 <sup>a</sup> |  | BF <sub>3</sub> .Et <sub>2</sub> O |  | no<br>reaction |

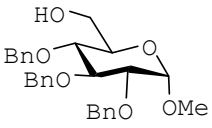
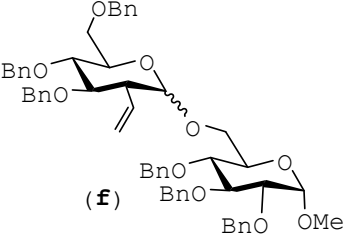
|                 |   |                      |  |             |
|-----------------|---|----------------------|--|-------------|
| 10 <sup>b</sup> |  | Al(OTf) <sub>3</sub> | <br>( <b>f</b> ) | no reaction |
|-----------------|---|----------------------|--|-------------|

The structures of products obtained were confirmed by <sup>1</sup>H NMR and HRMS. In the case where anomeric mixtures were obtained, the vinyl methine hydrogen atom appeared between δ 5.90 ppm and 5.61 ppm with a coupling constant similar to that of **3.48**. The terminal hydrogen atoms on the double bond appear between δ 5.30 ppm and 5.26 ppm. The H-1 signal appeared as a doublet at δ 5.47 ppm with a coupling constant of 5.0 Hz which suggests the axial-equatorial coupling of H-1<sub>α</sub>-H-2 and at δ 4.64 ppm with coupling constant of 7.5 Hz suggesting the diaxial coupling of H-1<sub>β</sub>-H-2. None of the above synthesised vinylglycosides presented evidence for the vinyl group to be axial at C-2. The rest of the analytical data were in agreement with the drawn structures and their masses were suitably allocated to their corresponding structure.

In an attempt to extend this methodology to the formation of modified disaccharides, cyclopropylcarbonylacetate **3.47** was reacted with a selectively unprotected monosaccharide alcohol (Table 3.2, entry 7-10) under conditions similar to those for preparation of the simple glycosides. The starting material did not react. These results were consistent with the observations of Shao *et al*<sup>66</sup> that substituted cyclopropanes with 'gluco' configuration were unreactive with sugar nucleophiles, presumably due to their weaker nucleophilicity or steric demand or both.

However, the success of the fragmentation-rearrangement using simple nucleophiles suggested a further investigation of the synthetic utility of this method for installing more complex side chains at C-2 of glucosides. It was envisaged that it should be possible to prepare modified acetates **B** (Scheme 3.23) by hydrolysis of the ester **2.237** followed by conversion of the acid to the Weinreb amide **3.54** and subjection of this to Grignard or other carbanionic reagents and followed by reduction and acetylation. This would then be set up for the Ferrier-type fragmentation leading to 2-C-modified glycosides **C**.

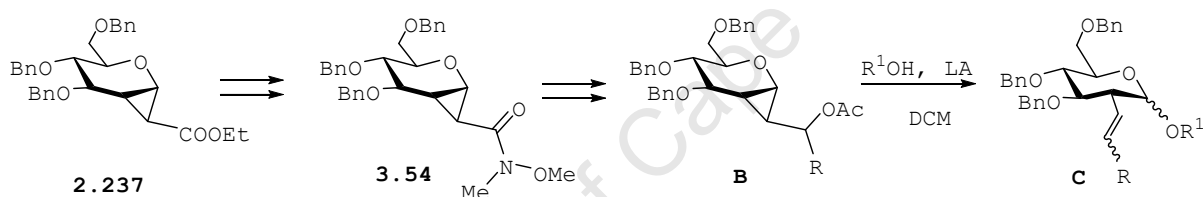

**Scheme 3.23.** Proposed route to glucosides having extended alkylidene side chains at C-2

The ester **2.237** was duly hydrolysed and converted in good overall yield to the Weinreb amide **3.54**<sup>67,68</sup>. The <sup>1</sup>H NMR spectrum of the amide showed the expected singlets  $\delta$  3.65 ppm and 3.16 ppm accounting for the N-OCH<sub>3</sub> and N-CH<sub>3</sub>, respectively. Their corresponding carbon atoms on the <sup>13</sup>C NMR appeared at  $\delta_c$  61.6 and 32.5 ppm.

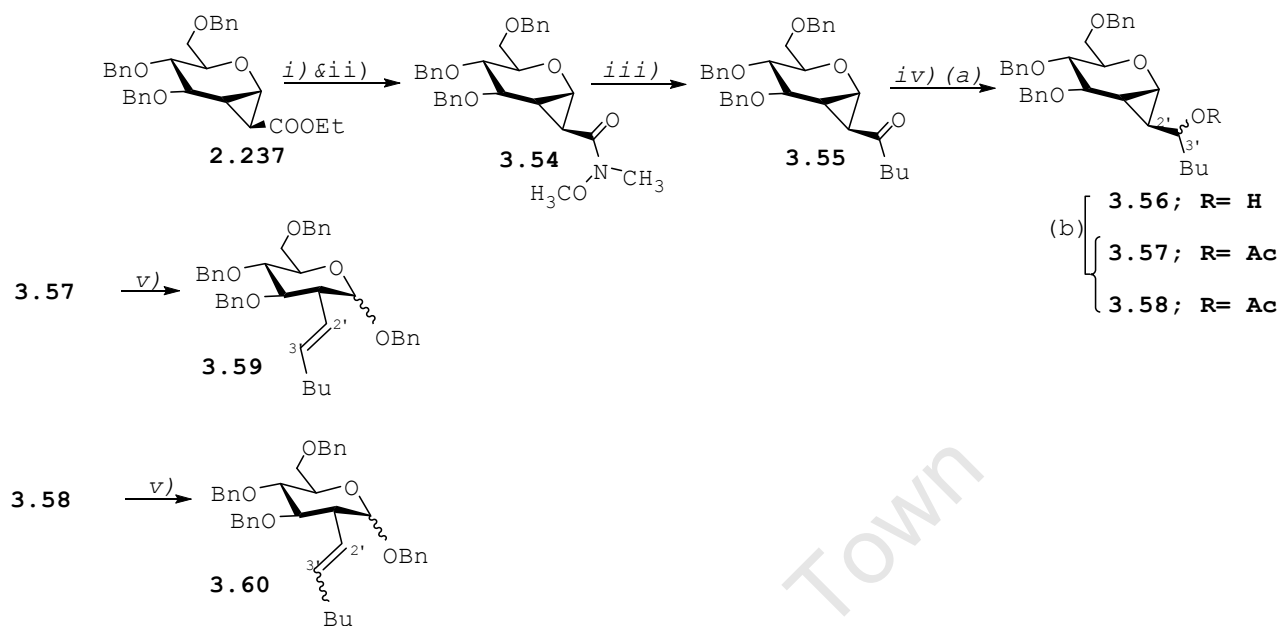

**Scheme 3.24** Reaction conditions: *i*) KOH, EtOH, reflux, 1h, quant., **3.53**; *ii*) CDMT, NMM, MeNH-Ome.HCl, overnight; *iii*) *n*-BuLi, THF, -78°C, 30 min.; *iv*) a) LiAlH<sub>4</sub>, Et<sub>2</sub>O, 1h; b) Ac<sub>2</sub>O, DMAP, TEA, THF, 30min.; *v*) BnOH, Al(OTf)<sub>3</sub>, DCM, 40°C, 1h,

Amide **3.54** was then treated with *n*-butyl lithium at -78 °C following the procedure of Catherine *et al*<sup>69</sup> to form ketone **3.55** which was envisaged as a simple substrate for the subsequent fragmentation reaction. The <sup>1</sup>H NMR spectrum of ketone **3.55** showed disappearance of signals for N-OCH<sub>3</sub> and N-CH<sub>3</sub> and appearance of new signals in the region between δ 2.49 and 1.30 ppm corresponding to butyl hydrogen atoms. The <sup>13</sup>C NMR spectrum showed a signal at δ 207.4 ppm for the ketone carbon and these and other data confirmed the formation ketone **3.55**. Reduction of **3.55** followed by acetylation gave a mixture of diastereomeric acetates **3.57** and **3.58** in a 2:1 ratio and 72% yield over the two steps. The presence of methyl acetate hydrogen atom as singlets in their <sup>1</sup>H NMR spectra at δ 2.07 ppm and their corresponding carbon atoms in the <sup>13</sup>C NMR spectra at δ 21.1 ppm confirmed that the carbonyl group was reduced to

alcohols and afterward acetylated. These two isomers were not easily distinguishable as *R*- or *S*-isomers due to the complexity of their  $^1\text{H}$  NMR signal multiplicity for *H*-3'. However, the *S*-isomer was predicted to be the major product from an analysis of the preferred orientation of the carbonyl group and the preferred attack of the hydride ion from the least-hindered face of the  $\text{C}=\text{O}$  group as predicted by the Felkin-Anh model (Scheme 3.25).

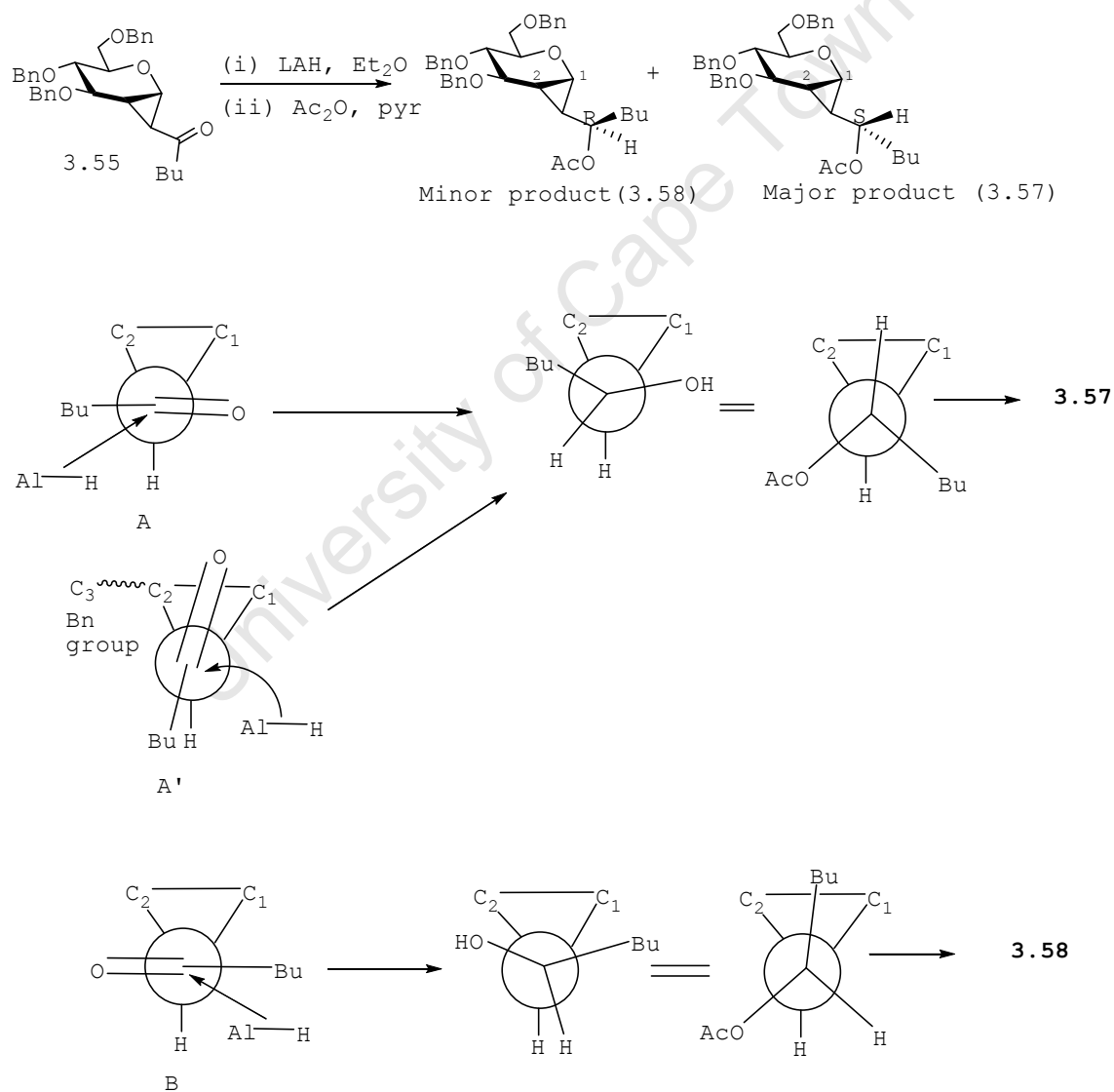

**Scheme 3.25:** Products for reduction of 3.55 followed by acetylation

The major product **3.57** was subjected to *exo*-Ferrier type rearrangement reaction conditions, using benzyl alcohol as nucleophile, and gave compound **3.59** (Scheme 3.24) in 67% yield in an  $\alpha:\beta$  ratio of 100:1 as estimated by  $^1\text{H}$  NMR and in single geometric isomer. The stereochemistry of the alkene was assigned as *E* on the basis of the observed large coupling constant between *H*-2' and *H*-3'. A coupling constant of 15.3 Hz was observed between the protons resonating at  $\delta$  5.65 ppm and  $\delta$  5.50 ppm. Hence, only the *trans*-isomer was observed. The formation of a single geometric isomer in this elimination suggests that an E2 elimination occurred, and this would require the acetoxy group to be *anti*-periplanar to the  $\text{C}_1\text{-C}_2$  bond. Newman projections of the two isomers (Fig 3.10) shows that the *S*-isomer (A) allows for this to occur in a stable staggered conformation, whereas the *R*-isomer (B) can only adopt this conformation by having the butyl substituent in an unfavourable sterically demanding orientation towards the cyclopropyl group. This therefore suggests that the major isomer **3.57** has the *S* geometry.

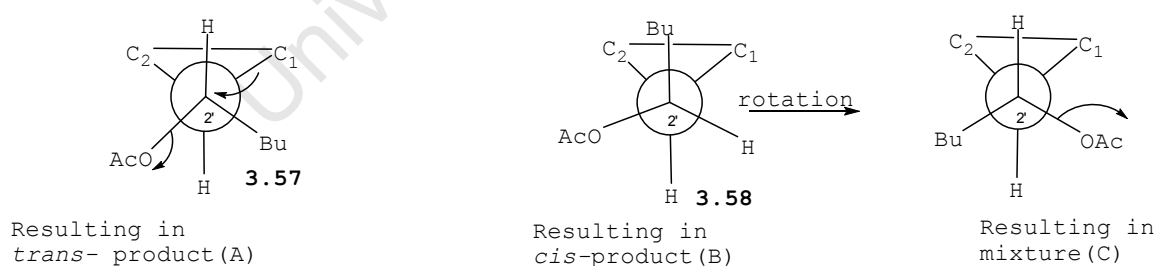

**Figure 3.10.** Newman projection for *cis-trans* isomers formation

In contrast, subjecting **3.58** to the same conditions afforded a complex mixture of products **3.60**, in an overall yield of 86%. The products were predominantly  $\alpha$  in 100:3 ratio, but existed as an inseparable 1:1 mixture of *cis* and *trans* isomers. As described above this result suggests that **3.58** was the *R*-isomer which, as shown in Fig 3.10B, cannot adopt the

necessary conformation for E2 elimination, and probably rather undergoes an E1 elimination to give the mixture of geometric isomers. The stereochemistry is also explained by the Newman projection, butyl group is eclipsing with cyclopropane ring which makes it into a constrained position (Fig. 3.10B). Thus, the front bond rotates to the most favourable conformation. This rotation disturbs the setup for E2-elimination; but encourages E1-elimination where a carbocation is first formed and then the nucleophile will attack (Fig. 3.10C). But in this case, the carbocation is stabilised by resonance and generates the reactive oxocarbenium intermediate from which *O*-glycoside was formed (Scheme 3.26).

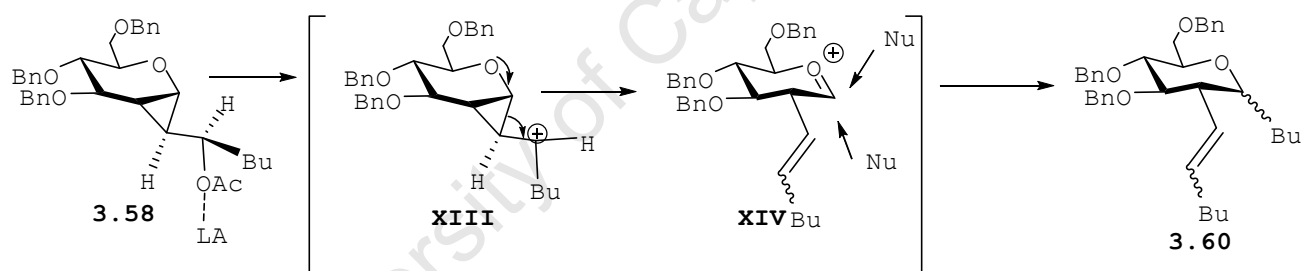

**Scheme 3.26:** Mechanism for *cis-trans* isomers formation of **3.60**

All the spectroscopic data obtained were in agreement with the predicted structure **3.60**.

In conclusion, the synthesis of 2-*C*-vinyl glucoside has revealed a new method for *C*-2 alkylation of a pyran ring via a substituted cyclopropanated sugar, which under catalytic condition gives stereoselective *C*-2-alkene glycoside. The glycosylation favours the  $\alpha$ -product more and these novel glycosides may be used as starting materials for more complex carboglycosides with potential enzymes inhibition. Furthermore, changing the substrate to acetic acid under the same conditions resulted into the formation of an aldehyde;

this appeared to be a novel route to C-glycoside. Due to the time constraint, 2-C-vinyl glucoside **3.52b** was not further transformed to the intended main starting material as mentioned earlier.

### 3.2.3.2b Synthesis of 2-C-alkoxycarbonylalkyl glycosides

The substituted cyclopropane sugar was also used to synthesise 2-deoxy-2-C-alkoxycarbonylalkyl glycosides, with the recognition that an ester group at C-2 would also serve as a useful precursor to C<sub>2</sub>, C<sub>3</sub> and C<sub>n</sub> side-chains, as noted earlier for the vinyl group (see page 93).

The synthesis of these esters was previously achieved in two steps (see page 43). The NIS- and NBS-mediated openings of cyclopropanes in the presence of simple alcohols have been reported,<sup>30,31,70,71</sup> but the direct preparation of the equivalent iodinated 2-deoxy-alkoxycarbonylalkyl glycosyl acetates has not.

The precursor carboxylated cyclopropopane **2.237** was obtained as explained above (see page 56). Treatment of **2.237** with ammonium iodide, hydrogen peroxide and acetic anhydride in a solvent mixture of acetonitrile-acetic acid (1:1) for 18 hours at room temperature<sup>30</sup> resulted in ring opening of the cyclopropylcarbonyl ethylester to give an isomeric mixtures (1:5,  $\alpha$ : $\beta$ ) of iodinated 2-deoxy-alkoxycarbonylalkyl glycosyl acetates **3.61** in 60% yield (Scheme 3.28). The <sup>1</sup>H NMR spectrum of **3.61** showed multiplets at  $\delta$  4.82-4.79 ppm which were allocated to H-2' $\beta$  of the ester glycoside. However, the overlap of the H-2' of the  $\beta$ -isomer peak with the peaks of benzylidene hydrogen atoms made the H-2' of the  $\beta$ -isomer appear as a complex multiplet. The doublet at  $\delta$  4.28 ppm with a coupling constant of 10.2 Hz was assigned to H-2' of the  $\alpha$ -isomer. This coupling constant resulted from a coupling between H-2 of the  $\alpha$ -isomer and H-2' of the  $\alpha$ -isomer suggests

that these two hydrogen atoms have a trans-diaxial relationship and the iodine was added from the top face of the cyclopropane. This would be consistent with both Newman projection A or B (Fig. 3.11) since both representation put  $H-2$  and  $H-2'$  at  $180^\circ$  (dihedral angle) from each other. Representation A arises from attack by  $I^+$  from lower-face (or *endo* attack) and B arises from attack from upper face (*exo* attack).

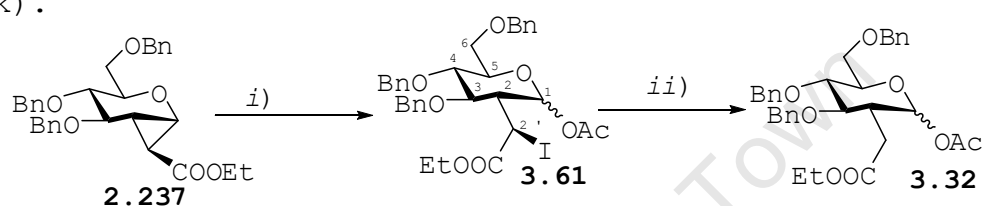

**Scheme 3.27:** Reaction conditions: i)  $NH_4I$ ,  $H_2O_2$ ,  $AcOH-CH_3CN(1:1)$ ,  $AcO_2$ ,  $0-25^\circ C$ , 18 h ii)  $FeCl_3$ ,  $NaBH_4$ ,  $CH_3CN$ , 3 h, rt

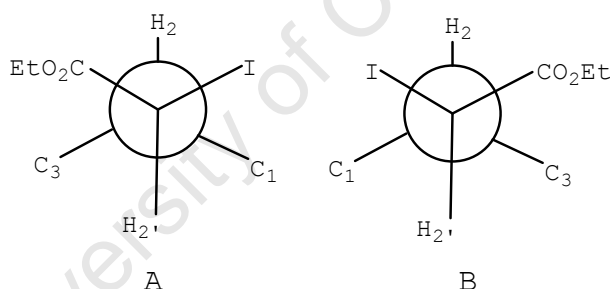

**Figure 3.11:** Newman projection of **3.61**

The anomeric hydrogen atoms for both  $\alpha$ - and  $\beta$ -isomers were found at  $\delta$  6.48 ppm and 5.64 ppm, respectively and with coupling constants of 3.2 Hz and 8.6 Hz as a result of axial-equatorial and diaxial coupling, respectively.

The acetyl hydrogen atoms appeared at  $\delta$  2.18 ppm and 2.17 ppm for  $\alpha$ - and  $\beta$ -isomers, respectively. The  $^{13}C$  NMR spectrum showed signals for  $C-2'$  of the  $\alpha$ -isomer and  $C-2'$  of the  $\beta$ -isomer carbons at  $\delta$  74.9 ppm and 74.7 ppm respectively and  $C-2$  of the  $\alpha$ -isomer and  $C-2$  of the  $\beta$ -isomer carbons at 45.7 and 48.8 ppm. The anomeric carbons for  $\alpha$ - and  $\beta$ -isomers appeared at  $\delta$  94.2 ppm and 96.0 ppm, respectively. No other signals were detected

on both  $^1\text{H}$  and  $^{13}\text{C}$  NMR. This confirms that only  $\alpha$  and  $\beta$ -isomers were formed.

Attempts to dehalogenate the iodinated ester using the conventional radical-mediated method of Danishefsky *et al.*<sup>72</sup> resulted in decomposition of the starting material as observed on TLC. However, when an alternative dehalogenation procedure was attempted, using ferric chloride with  $\text{NaBH}_4$  in  $\text{CH}_3\text{CN}$  at room temperature the deiodinated compound **3.32** was obtained after 3 hours in 82% yield (1:2; $\alpha$ : $\beta$ ) (Scheme 3.27).

The  $^1\text{H}$  NMR spectrum of **3.32** showed a multiplet at  $\delta$  2.58–2.44 ppm allocated to the hydrogen atoms  $H-2$  and  $H-2'$  of the  $\alpha$ -isomer, and that was accounting for 0.5 H (1x0.17 H for  $H-2\alpha$  and 2x0.17 H for  $H-2'\alpha$ ). The  $H-2$  and  $H-2'$  of the  $\beta$ -isomer signals appeared also as multiplet at  $\delta$  2.40–2.30 ppm accounted for 2.5 H (1x0.83 H for  $H-2\beta$  and 2x0.83 H for  $H-2'\beta$ ). The presence of two hydrogen atoms at  $C-2'$  of **3.32** as opposed to one hydrogen atom observed on **3.61** (see page 131) confirmed the removal of the iodine at that position. The other spectroscopic data including the mass spectroscopy were in agreement with the designated structure **3.32**.

These results therefore represent a simple entry to useful glycosyl donors, incorporating a synthetically useful alkoxy-carbonylalkyl substituent at the  $C-2$  position. As a model study, the glycosyl acetate **3.32** was treated with thiophenol and  $\text{BF}_3 \cdot \text{Et}_2\text{O}$  in  $\text{CH}_2\text{Cl}_2$   $5^\circ\text{C}$  for 5 h (Scheme 3.28).

Phenylthioglycoside **3.33** was obtained in 87% yield with the  $\alpha$ -isomer predominating ( $\alpha$ : $\beta$  = 2.4:1).

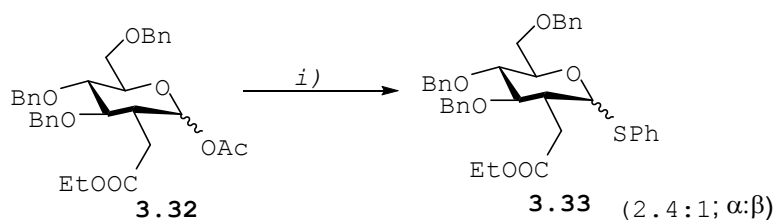

**Scheme 3.28:** Reaction conditions: *i)* PhSH,  $\text{BF}_3 \cdot \text{Et}_2\text{O}$ , DCM, 5h, 0 °C

The structure of **3.33** was evident from the  $^1\text{H}$  NMR spectrum which showed disappearance of the singlet for the acetate at around  $\delta$  2.08–2.09 ppm and appearance of signals for the aromatic hydrogen atoms in the thiophenyl group at  $\delta$  7.59–7.50 ppm. The anomeric hydrogen resonated at  $\delta$  5.75 ppm and 4.91 ppm for  $\alpha$  and  $\beta$  isomers, respectively. The  $^{13}\text{C}$  NMR spectrum showed a peak at  $\delta$  170 ppm allocated to the carbonyl carbon of the ethyl ester and was the only signal in that region, suggesting that the acetoxy group ( $-\text{OAc}$ ) at the anomeric centre had been replaced.

The fact that  $\alpha$ -isomer predominated suggested that the ester carbonyl does significantly offer anchimeric assistance ("participation") in the glycosylation reaction, but maybe this reaction is reversible and provides the thermodynamically more stable products due to the anomeric effect.

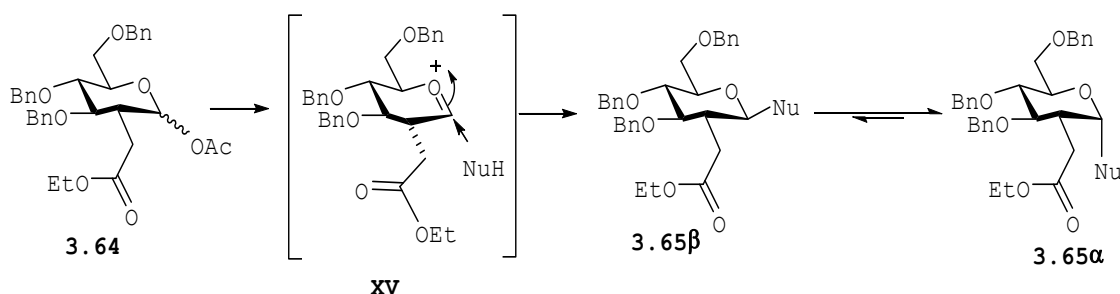

**Scheme 3.29:** Possible formation of more of **3.65 $\alpha$**  than **3.65 $\beta$**

**3.2 REFERENCES**

- [1] a) Vasella, A.; Witzig, C.; Chiara, J.L.; Martin-Lomas, M. *Helv. Chim. Acta* **1991**, *74*, 2073-2077; b) Titz, A.; Radic, Z.; Schwarzt, O. and Ernst, B. *Tetrahedron Lett.* **2006**, *47*, 2383-2385.
- [2] a) Yan, L.; Kahne, D. *J. Am. Chem. Soc.* **1996**, *118*, 9239-9248. b) Martin-Lomas, M; Flores-Mosquera, M.; Chiara, J.L. *Eur. J. Org. Chem.* **2000**, 1547-1562.
- [3] Pocsi, I.; Kiss, L.; Zsoldos-Mady, V.; Pinter, I. *Biochim. et Biophys. Acta, Protein Structure and Molecular Enzymology* **1990**, *1039*, 119-122.
- [4] Proton-proton coupling constants:  $J = 0-6$  Hz for axial-equatorial coupling and  $J = 8-10$  Hz for axial-axial coupling.
- [5] Gilbert, B.; Davis, N.J.; Pearce, M.; Aplin, R.T.; Flitch, S.L. *Tetrahedron: Asymmetry* **1994**, *5*, 2163-2178.
- [6] a) Tiwari, P.; Agnihotri, G.; Misra, A. K. *J. Carbohydr. Chem.* **2005**, *24*, 723; b) Matta, L. L.; Johnson, E. A. Z.; Girotra, R. N.; Barlow, J. *J. Carbohydr. Res.* **1973**, *30*, 414-417.
- [7] Matta, L.L.; Johnson, E.A.Z.; Girotra, R.N.; Barlow, J.J. *Carbohydr. Res.* **1973**, *30*, 414-417.
- [8] Buskas, T.; Garegg, P.J.; Konradsson, P.; Maloisel, J.L. *Tetrahedron: Asymmetry* **1994**, *5*, 2187-2194.
- [9] Gammon, D.W.; Steenkamp, D.J.; Mavumengwana, V.; Marakalala, M.J. Mudzunga, T.T.; Hunter, R.; Munyololo, M. *Bioorg. Med. Chem.* **2010**, *18*, 2501-2514.
- [10] Gammon, D.W.; Hunter, R.; Steenkamp, D.J.; Mudzunga, T.T. *Bioorg. Med. Chem. Lett.* **2003**, *13*, 2045-2049.
- [11] Drew, M.G.B.; Ennis, S.C.; Gridley, J.J.; Osborn, H.M.I.; Sparkman, D. G. *Tetrahedron* **2001**, *57*, 7919-7937.

- [12] Kelly, A.G.; Roberts, J.S. *J. Chem. Soc., Chem. Commun.* **1980**, 228-229; Edwards, M.P.; Ley, S.V.; Lister, S.G.; Palmer, B.D. *ibid.* **1983**, 630.
- [13] a) Challenger, S.; Procter, G. *Tetrahedron Lett.* **1986**, 27, 391-394. b) Procter, G.; Genin, D. *Carbohydr. Res.* **1990**, 202, 81-92.
- [14] Leteux, C.; Veyrières, A.; Robert, F. *Carbohydr. Res.* **1993**, 243, 119-130.
- [15] Arndt, S.; Hsieh-Wilson, L. C. *Org. Lett.* **2003**, 5, 4179-4182.
- [16] Inch, T. D.; Lewis, G. *J. Carbohydr. Res.* **1970**, 15, 1-10.
- [17] Brockway, C.; KocienSki, P.; Pant, C. *J. Chem Soc. Perkin Trans. I* **1984**
- [18] Sato, K.; Bokura, M.; Moriyaman, H.; Igarashi, T. *Chem. Lett.* **1994**, 1, 37-40.
- [19] Fairbanks, A.J.; Sinaÿ, P. *Tetrahedron Lett.* **1995**, 36, 893-896.
- [20] Morrison, H.; Kleopfer, R. *J. Am. Chem. Soc.* **1968**, 90, 5037-5038
- [21] Cox, D.J.; Fairbanks, A.J. *Tetrahedron: Asymmetry* , **2009**, 20, 773-780
- [22] Lichtenthaler, F.W.; Schneider-Adams, T., *J. Org. Chem.* **1994**, 59, 6728-6734
- [23] Madhusudan, S.K.; Agnihotri, G.; Negi, D.S.; Misra, A.K. *Carbohydr. Res.* **2005**, 340, 1373-1377.
- [24] Cheshev, P.; Marra, A.; Dondoni, A. *Carbohydr. Res.* **2006**, 341, 2714-2716.
- [25] Rani, S.; Vankar, Y.D. *Tetrahedron Letters* **2003**, 44, 907-909.
- [26] Pfitzner, K.E.; Moffatt, J.G. *J. Am. Chem. Soc.* **1965**, 87, 5661- 5670.

- [27] Frances van Staden, L.; Gravestock, D.; Ager, D.J. *Chem. Soc. Rev.* **2002**, *31*, 195-200.
- [28] Muthiah, C.; Kumar, K.P.; Kumaraswamy, S.; Swamy, K.C.K. *Tetrahedron* **1998**, *54*, 4315-14326.
- [29] Michael, G.B.D; Ennis, S.C.; Gridley, J.J.; Osborn, H.M.I.; Spackman, D.G. *Tetrahedron*, **2001**, *57*, 7919-7937
- [30] Gammon, D. W.; Kinf, H. H. De Vos, D. E.; Jacobs, P. A.; Sels, B. F. *J. Carbohyd. Chem.* **2007**, *26*, 141-157.
- [31] Ramana, C.V.; Murali, R.; Nagarajan, M., *J. Org. Chem.* **1997**, *62*, 7694-7703.
- [32] Zhang, Z.; Ollmann, I.R.; Ye, X.; Wischnat, R.; Baasov, T.; Wong, C. *J. Am. Chem. Soc.* **1999**, *121*, 734-753.
- [33] (a) Feather, M.S.; Harris, J.F. *J.Org.Chem.* **1965**, *30*, 153-157. (b)Capon, B. *Chem. Rev.* **1969**, *69*, 407-498 (d)Fraser-Reid, B.; Boctor, B. *Can.J. Chem.* **1969**, *47*, 393-401.(e)Paulsen, H.; Richter, A.; Sinnwell, H.; Stenzel,W. *Carbohydr. Res.* **1974**, *38*, 312-315.
- [34] Hou, D.; Lowary, T.L., *Carbohydr.Res.* **2009**, *344*, 1911-1940.
- [35] Li, Z.; Gildersleeve, J.C. *Tetrahedron Lett.* **2007**, *48*, 559-562.
- [36] Beyer, J., Skaanderup, P.R.; Madsen, R. *J. Am. Chem. Soc.* **2000**, *122*, 9575-9583.
- [37] Andersson, F.; Fugedi, P.; Garegg, P.J.; Nashed, M. *Tetrahedron Lett.* **1986**, *27*, 3919-3922.
- [38] Kihlberg, J.O.; Leigh, D.A.; Bundle, D.R. *J.Org.Chem.*; **1990**; *55*; 2860-2868.
- [39] Garegg, P.J.; Oscarson, S., Szonyi, M.; *Carbohyd. Res.* **1990**, *205*, 125-132.
- [40] Vermeer, H.J.; van Dijk, C.M.; Kamerling, J.P.; Vliegthart, J.F.G. *Eur. J.Org.Chem.* **2001**, 193-203.
- [41] Hadd. M.J.; Gervay, J. *Carbohyd. Res.* **1999**, *320*, 61-69.

- [42] Lemieux, R.U.; Hendricks, K.B.; Stick, R.V.; James, K.J. *Am. Chem. Soc.* **1975**, *97*, 4056-4062.
- [43] Higashi, K.; Nakayama, K.; Soga, T.; Shioya, E.; Uoto, K.; Kusama, T. *Chem. Pharm. Bull.* **1990**, *38*, 3280-3282.
- [44] Gervay, J.; Ngunyen, T.N.; Hadd, M.J. *Carbohydrate Research.*, **1997**, *300*, 119-125.
- [45] Chervin, S.M.; Abada, P.; Koreeda, M. *Org. Lett.* **2000**, *2*, 369-372.
- [46] Jin Park, Sameer Kawatkar, Jin-Hwan Kim, and Geert-Jan Boons *Org. Lett.* **2007**, *9*, 1959-1962.
- [47] Cook, M.J., Dorn, H, Katritzky, A.R. *J. Chem. Soc. (B)* **1968**, *396*, 1467-1470.
- [48] Van Driessche, B.; Van Brabandt, W.; D'hooghe, M.; Dejaegher, Y.; De Kimpe, N. *Tetrahedron* **2006**, *62*, 6882-6892.
- [49] Alexander, J.; Renyer, M.L.; Vecrapanane, H. *Synth. Comm.* **1995**, *25*, 3875-3881.
- [50] Henry, K.J.; Fraser-Reid, B. *Tetrahedron Lett.* **1995**, *36*, 8901-8904.
- [51] Praly, J.P.; Chen, G.R.; Gola, J.; Hetzer, G.; Raphoz, C. *Tetrahedron Lett.* **1997**, *38*, 8185-8188.
- [52] Timmers, C.M.; Leeuwenburgh, M.A.; Verheijen, J.C.; van der Marel, G.A.; van Boom, J.H., *Tetrahedron: Asymmetry*, **1996**, *7*, 49-52.
- [53] (a) Ferrier, R.J. *J. Chem. Soc. (C)* **1964**, 5443-5449; (b) Ferrier, R.J.; Ciment, D.M. *J. Chem. Soc. (C)* **1966**, 441-445; (c) Ferrier, R.J.; Prasad, N. *J. Chem. Soc. (C)* **1969**, 570-574; (d) Ferrier, R.J.; Prasad, N. *J. Chem. Soc. (C)* **1969**, 581-586.
- [54] Danishefsky, S.; Keerwin, J.F. *J. Org. Chem.* **1982**, *47*, 3803-3805.
- [55] (a) Ghosh, R.; De, D.; Shown, B.; Maiti, S.B. *Carbohydr.*

- Res. **1999**, 321, 1-3 and references cited therein; (b) Yadav, J.S.; Reddy, B.V.S.; Raman, J.V.; Niranjana, N.; Kumar, S.K.; Kunwar, A.C. *Tetrahedron Lett.* **2002**, 43, 2095-2098; (c) Yadav, J.S.; Reddy, B.V.S. *Synthesis* **2002**, 511-514.
- [56] Toshima, K.; Miyamoto, N.; Matsuo, G.; Nakata, M.; Matsumura, S. *Chem. Commun.* **1996**, 1379-1380.
- [57] Toshima, K.; Ishizuka, T.; Matsuo, G.; Nakata, M. *Chem. Lett.* **1993**, 2013-2016.
- [58] Dawe, R.D.; Fraser-Reid, B. *J. Chem. Soc., Chem. Commun.* **1981**, 1180-1181.
- [59] Kashyap, S.; Vidadala, S.R.; Hotha, S.; *Tetrahedron Lett.* **2007**, 48, 8960-8962.
- [60] Schmidt, R. R.; Hoffman, M. *Tetrahedron Lett.* **1982**, 23, 409-412.
- [61] Levecque, P.; Gammon, D.W.; Jacobs, P.; De Vos, P.; Sels, B. *Green Chem.*, **2010**, 12, 828-835.
- [62] Lin, H.C.; Yang, W.B.; Gu, Y.F.; Chen, C.Y.; Wu, C.Y.; Lin, C.H., *Org. Lett.*, **2003**, 5, 1087-1089
- [63] a) Gupta, A.; Vankar, Y.D.; *Tetrahedron* **2000**, 56, 8525-8531; b) Ghosh, R.; Chakraborty, A.; Maitia, D.K.; Puranik, V.G., *Tetrahedron Lett.* **2005**, 46, 8047-8051.
- [64] Williams, D.G.B; Simelane, S.B; Lawton, M.; Kinfe, H.H.; *Tetrahedron*, **2010**, 66, 4573-4576
- [65] Cossy, J.; Rakotoarisoa, H. *Synlett*, **2000**, 5, 734-736
- [66] a) Shao, H.W.; Ekthawatchai, S.; Wu, S.H.; Zou, W. *Org. Lett.* **2004**, 6, 3497-3499; b) Shao, H.W.; Ekthawatchai, S.; Chen, C.S.; Wu, S.H.; Zou, W. *J. Org. Chem.* **2005**, 70, 4726-4734.
- [67] Ilka, M; Gammon, D.W. Unpublished, 2010

- [68] Lidia De Luca, Giacomelli, G.; Taddei, M. *J. Org. Chem.* **2001**, *66*, 2534-2537
- [69] Catherine, T.; Véronique, B.; Christophe, M.; Janine, C. *Org. Lett.*, **2004**, *6*, 2145-2147
- [70] Ramana, C.; Nagarajan, M. *Synlett* **1997**, 763-764.
- [71] Sridhar, P.R.; Ashalu, K.C.; Chandrasekaran, S. *Org. Lett.* **2004**, *6*, 1777-1779.
- [72] Meng, D.; Bertinato, P.; Balog, A.; Su, D.; Kamenecka, T.; Sorensen, E. J.; Danishefsky, S. J. *J. Am. Chem. Soc.* **1997**, *119*, 10073-10092.

## CHAPTER 4

### CONCLUSION

This project aimed to synthesise and evaluate selected thioglycosides as competitive substrates of the *N*-deacetylase MshB in the *Mycobacteria*, and to use this as a basis for the design and synthesis of potential inhibitors of MshB. The phenyl-2-acetamido-1-thio- $\alpha$ -D-glucoside **1.30** was found to be a competitive substrate for MshB thus demonstrating that the inositol unit may not be necessary for binding to the active site of the enzyme. These findings led to the design and synthesis of  $\alpha$ -phenylthioglycosides **1.33** having modified alkyl groups at C-2 as potential inhibitors of MshB.

After initial unsuccessful attempts to prepare compounds **1.33** via selective alkylation at C-2 of 1,6-anhydroglucosides, or via olefination of the 2-uloses, the use of 1,2-cyclopropanated sugars was fully explored. In the first set of experiments the 2-C-iodomethyl-glucosyl acetates prepared from the 1,2-cyclopropanated glucose was found to undergo preferential  $\beta$ -thioglycoside formation through anchimeric assistance of the iodo group at the C-2 position. The iodomethyl group at C-2 was readily transformed to the corresponding azide, cyanide and formate.

The preparation and fragmentation of 1,2-cyclopropanated sugars bearing an ethyloxycarbonyl-substituent on the cyclopropane was then explored more fully. 2-C-vinyl glycosides were prepared by first converting the ester to an acetoxy group by reduction and acetylation, and then treating this with Lewis acids ( $\text{BF}_3 \cdot \text{Et}_2\text{O}$  and  $\text{Al}(\text{OTf})_3$ ) in the presence of nucleophiles under anhydrous conditions. The reaction is an example of an *exo*-Ferrier-type rearrangement, and favours

formation of the  $\alpha$ -gluco products with nucleophiles such as azide, thiophenol, allyl alcohol and benzyl alcohol. However, the sugar alcohols could not be introduced using this method, so that it could not be extended to the formation of disaccharides. The presence of traces of water in these reactions produced a rearranged C-glycoside **3.49**, thought to arise from interception of the oxocarbenium ion intermediate by water to form the glucose, and subsequent ring-opening and further rearrangement. This compound could be selectively formed by deliberate addition of acetic acid to the Lewis acid.

The ethoxycarbonylated cyclopropane **2.237** was readily opened by electrophilic iodine species to give, after reductive removal of the iodine, the 2-C-ethoxycarbonyloxymethyl glycoside **3.32**. Reaction with thiophenol as glycosyl acceptor in the presence of  $\text{BF}_3 \cdot \text{Et}_2\text{O}$  gave thioglucoside **3.33** in an  $\alpha:\beta$  anomeric ratio of 2.4:1. This result suggested that the ester group in **3.32** does not offer substantial anchimeric assistance in the glycosylation reaction.

This work has extended the methodologies for C-2 alkylation of glucose to provide synthetic intermediates which may be used towards the successful synthesis of inhibitors of the enzymes involved in the biosynthesis of mycothiol. The substituted cyclopropanated sugars have proved to be useful precursors for is a feasible pathway for the selective preparation of 2-C-vinyl- $\alpha$ -glycosides with the vinyl substituent presumably readily modifiable to give a variety of side-chain modified glycosides. However, the direct formation of **3.32** having the ester in the side-chain at C-2, and the  $\alpha$ -selectivity observed in subsequent glycosidation reactions suggest that this is a more efficient approach to the desired 2-C-alkylated glycosides: hydrolysis to the acid would allow for subsequent

chain-extension through amide chemistry, while reduction of the ester would generate an alcohol, allowing for a range of further functionalizations.

---

---

## CHAPTER 5

### EXPERIMENTAL PROCEDURES

#### 5.1 General experimental techniques and Instrumentations

##### 5.1.1 Chemicals and Purification of solvents

All commercially available chemicals were purchased from either Sigma-Aldrich or Merck. All solvents were dried by appropriate techniques. Unless otherwise stated, all other solvents used were analytical reagent grade. The solvents used for silica gel chromatography were pre-distilled using purification documented procedures.

##### 5.1.2 Chromatographic separation

All commercially available reagents were used as received. Air- and moisture-sensitive reactions were performed under nitrogen atmosphere. The progresses of all reactions were monitored by thin layer chromatography on a pre-coated silica gel 60 F254 plates of thickness 0.25mm (Merck) and were visualized by ultraviolet light. Silica gel chromatography was performed using Merck kieselgel 60:70-230 mesh for gravity columns and 230-400 mesh for flash chromatography.

##### 5.1.3 Spectroscopic and physical measurements

NMR spectra were recorded on a Varian Mercury-300 ( $^1\text{H}$  300.13,  $^{13}\text{C}$  75.5 MHz), a Varian Unity-400 ( $^1\text{H}$  400.13;  $^{13}\text{C}$  100.6 MHz) or Bruker spectrometer in mostly  $\text{CDCl}_3$  or otherwise stated with  $(\text{CH}_3)_4\text{Si}$  as an internal standard for  $^1\text{H}$  NMR and solvent signals as internal standard for  $^{13}\text{C}$  NMR spectra.  $^1\text{H}$  NMR chemical

shifts and coupling constants  $J$  are given in ppm (relative to  $(\text{CH}_3)_4\text{Si}$ ) and Hz, respectively. Mass spectrometry analysis was carried out at the Department of Chemistry, University of Stellenbosch. Melting points were recorded on a Kofler hotstage microscope (Reichant Thermovar) and are uncorrected. Microanalysis data were obtained using a Thermo Flash EA1112 CHNS-O elemental analyzer. Infrared spectra were recorded on a Perkin-Elmer Paragon 1000 FT-IR spectrometer using chloroform as solvent.

#### 5.1.4 General Procedures and Characterization of compounds

##### Phenyl-2-deoxy-2-acetamido-2-deoxy-1-thio- $\alpha$ -D-glucopyranoside (1.30)

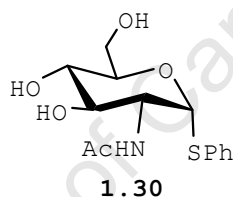

A suspension of **3.2d** (30 mg, 0.07 mmol) in methanol (2 mL) was treated with a catalytic amount of sodium methoxide in methanol at room temperature. The reaction was complete after two hours, whereupon the solution was treated with methanol-washed amberlite  $\text{H}^+$  resin, then filtered and the filtrate concentrated under vacuum to give **1.30** as a white solid (22 mg, 98%).

m.p. 220-222°C (lit.<sup>7</sup> m.p. 230°C);  $[\alpha]_{\text{D}} = +108.6$  ( $c = 0.5$ , MeOH) (lit.<sup>7</sup>  $[\alpha]_{\text{D}} = +5.7$  ( $c = 0.51$ , MeOH));  $^1\text{H}$  NMR (400 MHz,  $\text{CD}_3\text{OD}$ ):  $\delta_{\text{H}}$  7.52-7.22 (5H, *m*, Ph-H), 5.68 (1H, *d*,  $J$  5.3 Hz, H-1), 4.15-3.99 (2H, *m*), 3.77 (2H, *dq*,  $J$  11.9 & 3.7 Hz), 3.64 (1H, *dd*,  $J$  11.0 & 8.7 Hz), 3.43 (1H, *dd*,  $J$  9.8 & 8.7 Hz), 3.36-3.18 (1H, *m*), 3.36-3.07 (1H, *m*), 2.00 (3H, *s*, 1x-COCH<sub>3</sub>);  $^{13}\text{C}$  NMR (100 MHz,  $\text{CD}_3\text{OD}$ ):  $\delta_{\text{C}}$  172.5 (C=O), 134.8, 131.9, 131.0, 128.6, 127.2, 88.2 (C-1), 73.8, 71.5, 71.2, 61.2, 55.0, 21.3. Anal. calcd.

for  $C_{14}H_{19}NO_5S$ : C 53.66, H 6.11, N 4.47, S 10.23; found: C 52.72, H 5.98, N 4.28, S 9.90.  $[M+H]$  calcd. for  $C_{14}H_{19}NO_5S$ : 314.1062; found: 314.1085.

### Phenyl-2-deoxy-2-acetamido-1-thio- $\beta$ -D-Glucopyranoside **1.31**

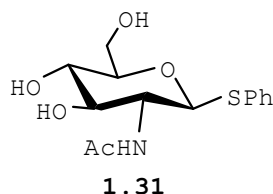

0.2 M NaOMe in MeOH (10 mL) was added to a suspension of **3.4** (0.4 g, 0.911 mmol) in methanol (20 mL) with stirring at room temperature. TLC showed complete conversion to a single more polar product within 10 min. The reaction mixture was then stirred with resin (Dowex-50WX-200(H<sup>+</sup>)), then the resin removed by filtration, and the filtrate concentrated under reduced pressure. The product **1.31** was obtained as white powder (260 mg, 91%); m.p. 231–234°C (lit.<sup>8</sup> 222°C; lit.<sup>1</sup> 196–199°C); <sup>1</sup>H NMR (400 MHz, D<sub>2</sub>O):  $\delta_H$  8.36 (1H, s, NH), 7.44 (2H, dd,  $J$  1.7&7.8 Hz, Ph-H), 7.34–7.29 (3H, m, Ph-H), 4.80 (1H, d,  $J$  10.4 Hz, H-1), 3.82 (1H, d,  $J$  12.0 Hz, H-6a), 3.71–3.66 (1H, m, H-5&6b), 3.51 (1H, t,  $J$  9.3 Hz, H-4), 3.41–3.36 (2H, m, H-2&3), 1.95 (3H, s, CH<sub>3</sub>); <sup>13</sup>C NMR (100 MHz, CDCl<sub>3</sub>):  $\delta_C$  171.1 (C=O), 132, 130 (2xC), 128 (2xC), 127, 87 (C-1), 81, 76, 71, 61.5, 53.7, 21.5 (-CH<sub>3</sub>).  $[M+H]$  calcd for  $C_{14}H_{19}NO_5S$ : 314.1062; found for  $C_{14}H_{19}NO_5S$ : 314.1079.

### Benzyl 2-deoxy-2-acetamido-1-thio- $\beta$ -D-Glucopyranoside **1.32**

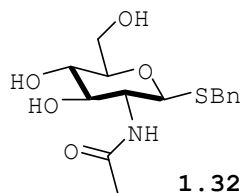

0.2 M NaOMe in MeOH (10 ml) was added to a suspension of **3.5** (0.4 g, 0.911 mmol) in methanol (20 ml) with stirring at room

temperature. TLC showed complete conversion to a single more polar product within 10 min. The reaction mixture was then stirred with resin (Dowex-50WX-200(H+), then the resin removed by filtration, and the filtrate concentrated under reduced pressure to give **1.32** as white powder (0.27 g, 89%).

m.p. 125–127°C (lit.<sup>9</sup> 225–227°C); <sup>1</sup>H NMR (400 MHz, D<sub>2</sub>O): δ<sub>H</sub> 8.36 (1H, s, NH), 7.7–7.6 (5H, m, Ph-H), 4.25 (1H, d, *J* 10.2 Hz, H-1), 3.9 (1H, d, *J* 12.2 Hz, H-6a), 3.8 (2H, m, Ph-CH<sub>2</sub>-), 3.65–3.60 (2H, m, H-5&6b), 3.5–3.48 (2 H, m, H-3&4), 3.41–3.40 (2H, m, H-2&3), 3.3–3.28 (1H, m, H-2), 2.22 (3H, s, CH<sub>3</sub>); <sup>13</sup>C NMR (100 MHz, CDCl<sub>3</sub>): δ<sub>C</sub> 172.5 (C=O), 137, 128 (2xC), 127.7 (2xC), 126, 82 (C-1), 79, 74, 68, 59, 53.5, 23 (CH<sub>2</sub>-), 21.5 (-CH<sub>3</sub>), Elemental Anal. Calcd for C<sub>15</sub>H<sub>21</sub>NO<sub>5</sub>S: C 55.03, H 6.47, N 4.28, S 9.79; Found: C 53.66, H 6.11, N 4.47, S 10.23. [M+H] calcd for C<sub>15</sub>H<sub>21</sub>NO<sub>5</sub>S: 328.1219; found for C<sub>15</sub>H<sub>21</sub>NO<sub>5</sub>S: 328.1214.

**Phenyl 3,4,6-Tri-O-benzyl-2-deoxy-2-C-Iodomethyl-1-thio- $\alpha/\beta$ -D-Glucopyranoside 1.33 and 1.34**

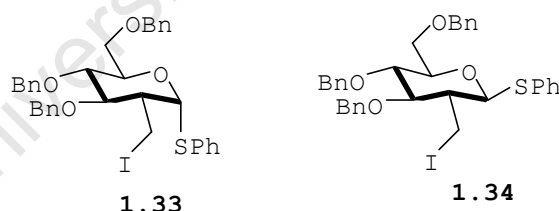

To a solution of acetyl 3,4,6-TriO-benzyl-2-deoxy 2-C-Iodomethyl- $\alpha,\beta$ -D-Glucopyranoside **2.225b** (4.3 g, 6.97 mmol) in DCM (50 ml) at  $\sim -10^\circ\text{C}$  was added thiophenol (1.69 ml, 13.94 mmol) and boron trifluoride-diethylether (3.84 ml, 31.36 mmol). The reaction mixture was stirred for 45 min. After TLC had shown the completion of the reaction, the reaction mixture was diluted with DCM, washed with NaCl, and dried over Na<sub>2</sub>SO<sub>4</sub>. Silica gel column chromatography (EtOAc:Petroleum ether, 2:8) was used to purify the sugar thioglucoside obtained as

compounds **1.33** and **1.34** (3.60 g, 78%) in 1:5 ratio. Crystallisation from ethanol gave pure **1.34** in low yield as white crystals and **1.33** remained in solution as a mixture which was carefully purified to obtain oil by preparative thin layer chromatography (EtOAc:Petroleum ether, 1:9) for characterisation purposes.

**1.33**; oil;  $^1\text{H}$  NMR (400 MHz,  $\text{CDCl}_3$ ):  $\delta_{\text{H}}$  7.58–7.56 (2H, m, Ar-H), 7.35–7.22 (18H, m, Ar-H), 5.72 (1H, d,  $J$  4.67 Hz, H-1), 4.93 (1H, d,  $J$  11.12 Hz, Ph-CH), 4.82 (1H, d,  $J$  10.9 Hz, Ph-CH), 4.66 (1H, d,  $J$  10.7 Hz, Ph-CH), 4.65 (1H, d,  $J$  9.9 Hz, Ph-CH), 4.59 (1H, d,  $J$  10.9 Hz, Ph-CH), 4.49 (1H, d,  $J$  12.0 Hz, Ph-CH), 4.46–4.39 (1H, m, H-6a), 3.86 (1H, dd,  $J$  3.8 & 10.8 Hz, H-6b), 3.76–3.64 (3H, m, H-2'a, 4, 5), 3.57 (1H, dd,  $J$  8.8 & 11.1 Hz, H-3), 3.03 (1H, dd,  $J$  9.8 & 12.0 Hz, H-2'b), 2.51 (1H, m, H-2);  $^{13}\text{C}$  NMR (100 MHz,  $\text{CDCl}_3$ ):  $\delta_{\text{C}}$  138.0, 137.8, 133.8, 132.7, 129.0, 128.6, 128.4, 128.3, 128.0, 127.84, 127.81, 127.7, 127.6, 91.2 (C-1), 81.5, 79.4, 77.3, 76.7, 75.5, 73.5, 72.4, 68.7, 49.1 (C-2), 4.28 (C-2'); Elemental Anal. calcd for  $\text{C}_{34}\text{H}_{35}\text{ISO}_4$ : C, 61.26; H, 5.29; S, 4.81, Found: C, 61.20 ; H, 5.27; S, 4.73; [M+Na] calcd for  $\text{C}_{34}\text{H}_{35}\text{INaO}_4\text{S}$ : 689.1199 found for  $\text{C}_{34}\text{H}_{35}\text{INaO}_4\text{S}$ : 689.1194

**1.34**; m.p. 77–79°C;  $^1\text{H}$  NMR (400 MHz,  $\text{CDCl}_3$ ):  $\delta_{\text{H}}$  7.58–7.56 (2H, m, Ar-H), 7.35–7.22 (18H, m, Ar-H), 4.97 (1H, d,  $J$  10.72, Ph-CH), 4.82 (1H, d,  $J$  10.7, Ph-CH), 4.79 (1H, d,  $J$  10.72, Ph-CH), 4.66 (1H, d,  $J$  10.0, H-1); 4.64 (1H, d,  $J$  10.7, Ph-CH), 4.64 (2H, d,  $J$  10.7, Ph-CH), 4.55 (1H, d,  $J$  12.0, Ph-CH), 3.78 (2H, m, H-4&5), 3.74 (2H, m, H-3&6a), 3.66 (1H, dd,  $J$  2.5 & 10.2 Hz, H-2'a), 3.59 (1H, dd,  $J$  2.9 & 10.2 Hz, H-2'b), 3.52 (1H, td,  $J$  3.2 & 9.3, H-6b), 1.30 (1H, tt,  $J$  2.86 & 9.75 Hz, H-2);  $^{13}\text{C}$  NMR (100 MHz,  $\text{CDCl}_3$ ):  $\delta_{\text{C}}$  138.2, 138.00 133.1, 128.8, 128.5, 128.4, 128.3, 127.9, 127.87, 127.84, 127.8, 127.6, 127.5, 88.3, 82.7, 79.3, 79.2, 75.7, 74.8, 73.4, 69.0, 44.7 (C-2), 9.2 (C-2'); Elemental Anal. calcd for  $\text{C}_{34}\text{H}_{35}\text{ISO}_4$ : C, 61.26;

H, 5.29; S, 4.81, Found: C, 61.20; H, 5.27; S, 4.73; [M+Na] calcd for C<sub>34</sub>H<sub>35</sub>INaO<sub>4</sub>S: 689.1199 found for C<sub>34</sub>H<sub>35</sub>INaO<sub>4</sub>S: 689.1199

### 1,6, 2,3-Dianhydro- $\beta$ -D-mannopyranose **2.34**

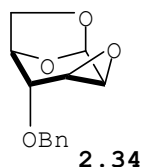

The iodide compound **3.17** (0.2g, 0.73 mmol) was dissolved in anhydrous DMF (20 ml) and cooled to  $-20^{\circ}\text{C}$ . Benzyl bromide (0.301g, 0.209 ml, 1.76 mmol) and NaH 60% in mineral oil (0.0588g, 1.47 mmol) were added. The mixture was stirred for 2 hours at  $-20^{\circ}\text{C}$  to room temperature. Water was added carefully and the mixture was diluted with Et<sub>2</sub>O. The combined organic layers were washed with brine, dried with MgSO<sub>4</sub>, filtered and the solvent was evaporated in vacuo. Column chromatography on silica gel (EtOAc-Pet.Ether 1:1) afforded **2.34** in 75% yields as brownish oil product.

<sup>1</sup>H NMR (400 MHz, CDCl<sub>3</sub>):  $\delta_{\text{H}}$  7.42–7.32 (5H, m, Ar-H), 5.72 (1H, d,  $J$  3.2 Hz, H-1), 4.75 (2H, s, Ph-CH<sub>2</sub>-), 4.54–4.48 (1H, m, H-5), 3.73–3.66 (3H, m, H-4 & 6a,b), 3.46–3.43 (1H, ddd,  $J$  0.8, 3.15 & 3.8 Hz, H-2), 3.21–3.18 (1H, ddd,  $J$  0.6, 1.5 & 3.8 Hz, H-3); <sup>13</sup>C NMR (100 MHz, CDCl<sub>3</sub>):  $\delta_{\text{C}}$  137.2, 128.6, 128.5, 127.8, 127.6, 126.9, 97.6(C-1), 73.8, 72.1, 71.6, 65.8, 54.4, 47.8. The spectroscopic data were consistent with the published data.<sup>2</sup>

### 3,4,6-Tri-O-benzyl-D-glucal **2.47**

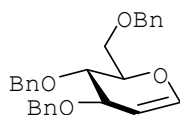

To a solution of 3,4,6-Tri-O-acetyl-D-glucal **2.46** (10.0g, 36.73 mmol) in THF (80 ml) were added powdered NaOH (20.0g,

500 mmol), TBAI (2.72g, 7.35 mmol) and benzyl bromide (41 ml, 341.9 mmol) successively and the reaction mixture was allowed to stir briskly for 4 h at room temperature. After completion as monitored by TLC; the mixture was poured into water and extracted with CH<sub>2</sub>Cl<sub>2</sub>. The organic layer was washed with water and dried (Na<sub>2</sub>SO<sub>4</sub>), and concentrated. The crude was purified by column chromatography (EtOAc: Pet.Ether, 1:9) to yield pure 3,4,6-Tri-*O*-benzyl-*D*-glucal **2.47** (13 g, 85%).

<sup>1</sup>H NMR (400 MHz, CDCl<sub>3</sub>): δ<sub>H</sub> 7.34–7.24 (15H, m, Ar-*H*), 6.44 (1H, dd, *J* 1.2&6.2 Hz, *H*-1), 4.89 (1H, dd, *J* 2.7 & 6.0 Hz, *H*-2), 4.85 (1H, d, *J* 11.3 Hz, Ph-CH<sub>2</sub>-), 4.67–4.54 (5H, m, Ph-CH<sub>2</sub>-), 4.23–4.21 (1H, m, *H*-3), 4.09–4.05 (1H, m, *H*-4), 3.89–3.81 (1H, m, *H*-5), 3.80–3.75 (2H, m, *H*-6a,b); <sup>13</sup>C NMR (100 MHz, CDCl<sub>3</sub>): δ<sub>C</sub> 144.7(C-1), 138.4, 138.2, 138.0, 128.4, 128.38, 128.36, 127.8, 127.76, 127.72, 127.70, 127.6, 99.9(C-2), 77.3, 76.8, 76.7, 75.7, 74.4, 73.7, 73.5, 70.4, 68.6. The spectroscopic data were consistent with the published data.<sup>3</sup>

**3,4,6-Tri-*O*-acetyl-1,5-anhydro-2-deoxy-1,2-*C*-methylene-*D*-glycero-*D*-gulo-hexitol 2.224a**

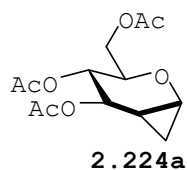

1.5 g (3.49 mmol) of 3,4,6-Tri-*O*-benzyl-1,5-anhydro-2-deoxy-1,2-*C*-methylene-*D*-Glycerol-*D*-gulo-hexitol **2.224b** was dissolved in THF (30 ml) and 0.5 g of Pd/C (10%) was added to the solution, under H<sub>2</sub> at 1.5 atm for 2 h. When TLC has shown the completion of the reaction, the reaction mixture was filtered through a celite layer and dried under rota-evaporator. The tri-alcohol compound was obtained in 100% (0.560 g) as oil. Without further purification, the tri-alcohol was subjected to

acetylation following the usual procedure.<sup>14</sup> Compound **2.224a** was obtained after 30 min. in 90% yield (0.902 g) after column chromatography (EtOAc: Pet. Ether, 3:7).

<sup>1</sup>H NMR (300 MHz, CDCl<sub>3</sub>): δ<sub>H</sub> 4.95 (1H, dd, *J* 3.0 & 6.3 Hz, *H*-3), 4.81 (1H, dd, *J* 4.5 & 6.3 Hz, *H*-4), 4.51 (1H, dd, *J* 7.5 & 12.0 Hz, *H*-6a), 4.14 (1H, dd, *J* 4.1 & 6.3 Hz, *H*-6b), 3.88–3.83 (1H, m, *H*-5), 3.62 (1H, dt, *J* 3.0 & 6.0 Hz, *H*-1), 2.09, 2.08, 2.05 (9H, 3s, 3xCH<sub>3</sub>COO), 1.01–0.92 (1H, m, *H*-2), 0.85 (2H, tdd, *J* 4.5, 10.1 & 12.3 Hz, *H*-2'a&b); <sup>13</sup>C NMR (75 MHz, CDCl<sub>3</sub>): δ<sub>C</sub> 170.5, 169.7, 169.6, 73.7, 70.2, 69.6, 62.4, 48.7(*C*-1), 21.0, 20.8, 20.7(3xCH<sub>3</sub>COO), 13.7(*C*-2), 11.0(*C*-2'). The spectroscopic data were consistent with the published data.<sup>4</sup>

**3,4,6-Tri-*O*-benzyl-1,5-anhydro-2-deoxy-1,2-*C*-methylene-*D*-Glycerol-*D*-gulo-hexitol 2.224b**

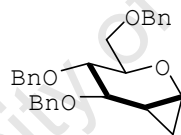

**2.224b**

To a stirred suspension of LiAlH<sub>4</sub> (8.0 g, 200.5 mmol) in dry THF (60 ml) was added a solution of dichlorocyclopropane **3.26** (11.0 g, 22.0 mmol) in THF (40 ml). The reaction mixture was monitored by <sup>1</sup>H NMR which confirmed the total reduction of the starting material to the desired product after 8 days of stirring at 25°C. The reaction mixture was diluted with ether and cooled to 0°C and quenched\* by careful and slow addition of 8 ml of water after which 8 ml of 15% aqueous solution of NaOH. 24 ml of water was again added and the mixture was left to warm up to room temperature for 15 min. Sodium magnesium sulphate was added as a drying agent and stirred again for 15 min, the mixture was decanted to remove the salts formed.

After column chromatography (EtOAc:Petroleum ether, 1:19) The solvent was removed to yield 3,4,6-Tri-*O*-benzyl-1,5-anhydro-2-deoxy-1,2-*C*-methylene-*D*-Glycerol-*D*-gulo-hexitol **2.224b** was obtained as a syrup (6.78 g, 71%).

$^1\text{H}$  NMR (400 MHz,  $\text{CDCl}_3$ ):  $\delta_{\text{H}}$  7.49–7.2 (15H, m, Ar-*H*), 4.85 (2H, d,  $J$  11.4 Hz, Ph-*CH*), 4.71–4.55 (5H, m, 4xPh-*CH* & *H*-1), 3.90–3.81 (1H, m, *H*-5), 3.75 (1H, dd,  $J$  6.1 & 10.4 Hz, *H*-6a), 3.69 (1 H, dd,  $J$  3.6 & 7.5 Hz, *H*-6b), 3.67–3.60 (2H, m, *H*-3&4), 1.04–0.96 (1H, m, *H*-2), 0.82–0.73 (2H, m, *H*-2'*a*&*b*);  $^{13}\text{C}$  NMR (100 MHz,  $\text{CDCl}_3$ ):  $\delta_{\text{C}}$  138.8, 138.6, 138.50, 128.52, 128.4, 128.0, 127.8, 80.2 (*C*-1), 77.2, 76.9, 73.5, 73.4, 71.2, 70.2, 49.8, 15.0, 11.6 (*C*-2'). The spectroscopic data were consistent with the published data.<sup>17</sup>

**1,3,4,6-Tetra-*O*-acetyl-2-deoxy-2-*C*-iodomethyl- $\alpha/\beta$ -*D*-glucopyranoses 2.225a**

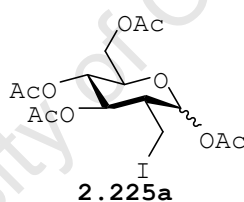

To a solution of 3,4,6-Tri-*O*-acetyl-1,5-anhydro-2-deoxy-1,2-*C*-methylene-*D*-glycero-*D*-gulo-hexitol **2.224a** (0.1 g, 0.399 mmol) in AcOH/ $\text{CH}_3\text{CN}$  (1:1, 6 ml) was added  $\text{NH}_4\text{I}$  (0.071 g, 0.489 mmol), and  $\text{Ac}_2\text{O}$  (0.5 ml) and the resulting cooled to 0 °C.  $\text{H}_2\text{O}_2$  (0.0142 ml of a 50% aqueous solution in water, 0.489 mmol) was added and the solution stirred for 24 h at 60 °C. When the TLC showed the reaction was complete a 0.1 M solution of  $\text{Na}_2\text{S}_2\text{O}_3$  was then added until the brownish colour disappeared, and the solution was cooled in an ice-water bath before adding cold 10% aqueous NaOH until the solution became slightly basic. The resultant mixture was extracted with ethyl acetate, and the combined organic phases washed once with brine, then dried ( $\text{MgSO}_4$ ) and concentrated. The column chromatography

(EtOAc:Petroleum ether, 3:7) gave a mixture of inseparable iodomethylacetate glucoside **2.225 $\alpha/\beta$**  (0.105 g, 64%) in 3/1 ratio.

$^1\text{H}$  NMR (300 MHz  $\text{CDCl}_3$ ):  $\delta_{\text{H}}$  6.40 (0.75H, d,  $J$  3.4 Hz,  $H-1\alpha$ ), 5.65 (0.25H, d,  $J$  8.7 Hz,  $H-1\beta$ ), 5.28-5.16 (1H, m,  $H-3$ ), 5.12-4.98 (1H, m,  $H-4$ ), 4.34-4.23 (1H, m,  $H-6a$ ), 4.11-3.95 (1.25 H, m,  $H-5\alpha\&6b$ ), 3.86-3.77 (0.75H, m,  $H-5\beta$ ), 3.22 (0.75H, dd,  $J$  3.3 & 10.9 Hz,  $H-2'a\beta$ ), 3.16-3.07 (1H, m,  $H-2'b\beta$  &  $H-2'a\alpha$ ), 2.87 (0.25H, t,  $J$  10.6 Hz,  $H-2'b\alpha$ ), 2.40 (0.25H, tt,  $J$  3.8 & 11.0 Hz,  $H-2\alpha$ ), 2.16, 2.15, 2.07, 2.06, 2.02, 2.01 (12H, 6s,  $\text{CH}_3\text{COO}$ ), 1.85-1.75 (0.75H, m,  $H-2\beta$ );  $^{13}\text{C}$  NMR (100 MHz,  $\text{CDCl}_3$ ):  $\delta_{\text{C}}$  170.6, 170.58, 170.5, 169.8, 169.6, 169.5, 168.4, 168.3, 94.7 ( $C-1\beta$ ), 92.9 ( $C-1\alpha$ ), 72.8, 72.4, 72.0, 69.8, 69.0, 68.3, 61.7, 45.4, 43.4, 20.8, 20.7, 20.6, 20.5, 0.43 ( $C-2'\beta$ ), -2.0 ( $C-2'\alpha$ ). The spectroscopic data were consistent with the published data.<sup>4</sup>

**Acetyl 3,4,6-Tri-O-benzyl-2-deoxy-2-C-iodomethyl- $\alpha/\beta$ -D-Glucopyranoside 2.225b**

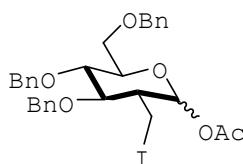

**2.225b**

To a solution of 3,4,6-Tri-O-benzyl-1,5-anhydro-2-deoxy-1,2-C-methylene-D- Glycerol-D-gulo-hexitol **2.224b** (6.0 g, 13.99 mmol) in AcOH/ $\text{CH}_3\text{CN}$  (1:1, 90 ml) was added  $\text{NH}_4\text{I}$  (2.84 g, 19.5 mmol), and  $\text{Ac}_2\text{O}$  (18 ml) and the resulting cooled to  $0^\circ\text{C}$ .  $\text{H}_2\text{O}_2$  (1.11 ml of a 50% aqueous solution in water, 19.59 mmol) was added and the solution stirred for 25 min at room temperature. When the TLC showed the reaction was complete a 0.1 M solution of  $\text{Na}_2\text{S}_2\text{O}_3$  was then added until the brownish colour disappeared, and the solution was cooled in an ice-water bath

before adding cold 10% aqueous NaOH until the solution became slightly basic. The resultant mixture was extracted with ethyl acetate, and the combined organic phases washed once with brine, then dried ( $\text{MgSO}_4$ ) and concentrated. After column chromatography (EtOAc:Petroleum ether, 1:9) iodomethylacetate glucoside **2.225b $\alpha$ / $\beta$**  was obtained as inseparable mixture (5.1 g, 60%) in 1/2 ratio.

$^1\text{H}$  NMR (400 MHz,  $\text{CDCl}_3$ ):  $\delta_{\text{H}}$  7.42–7.17 (15H, m, Ar-H), 6.37 (0.33H, d,  $J$  3.29 Hz, H-1 $\alpha$ ), 5.61 (0.66H, d,  $J$  8.61 Hz, H-1 $\beta$ ), 4.99 (0.66H, d,  $J$  11.0 Hz, H- $\beta$ ), 4.95 (0.33H, d,  $J$  12.4 Hz, H- $\alpha$ ), 4.84–4.57 (4H, m), 4.50 (1H, dd,  $J$  3.2 & 12.0 Hz), 3.89–3.65 (3.3H, m), 3.60 (0.33 H, ddd,  $J$  2.13, 3.29 & 9.71 Hz, H $\alpha$ ), 3.54 (0.66H, dd,  $J$  2.80 & 10.39 Hz, H- $\beta$ ), 3.46 (0.33H, dd,  $J$  3.5 & 9.9 Hz, H $\alpha$ ), 3.27 (0.66H, dd,  $J$  2.9 & 10.4 Hz, H- $\beta$ ), 2.85 (0.33H, dd,  $J$  10.0 & 10.9 Hz, H- $\alpha$ ), 2.24 (0.33H, td,  $J$  3.4 & 11.0 Hz, H-2 $\alpha$ ), 2.14 (1.98H, s,  $\text{CH}_3\text{CO}_2$ - $\beta$ ), 2.10 (0.99H, s,  $\text{CH}_3\text{CO}_2$ - $\alpha$ ), 1.55–1.47 (0.66H, m, H-2 $\beta$ );  $^{13}\text{C}$  NMR (100 MHz,  $\text{CDCl}_3$ ):  $\delta_{\text{C}}$  168.8, 138.0, 127.7(Ph), 94.9(C-1 $\beta$ ), 93.7(C-1 $\alpha$ ), 81.3, 80.8, 78.9, 78.5, 75.6, 75.5, 74.9, 74.7, 73.6, 73.5, 73.4, 68.2, 46.7, 45.0, 20.9( $\text{CH}_3$ - $\alpha$ & $\beta$ ), 4.2(C-2' $\alpha$ ), 0.7(C-2' $\beta$ ). The spectroscopic data were consistent with the published data.<sup>4</sup>

**(1S,3S,4S,5R,6R)-ethyl 4,5-bis(benzyloxy)-3-(benzyloxymethyl)-2-oxabicyclo[4.1.0]heptane-7-carboxylate 2.237**

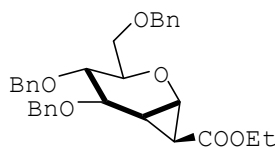

**2.237**

To a stirred suspension of tri-*O*-benzyl-D-glucal **2.47** (10 g, 24 mmol) and  $\text{Rh}_2(\text{OAc})_4$  (32 mg, 0.072 mmol) in anhydrous  $\text{CH}_2\text{Cl}_2$  (40 mL) was added dropwise, over a period of 1 h, a solution

of ethyl diazoacetate (10 mL, 93.7 mmol) in  $\text{CH}_2\text{Cl}_2$  (10 mL). After cessation of the nitrogen evolution (5-10 minutes), the reaction mixture was left to stir for 3 hours and then concentrated *in vacuo* and the remaining residue was purified by silica gel column chromatography (EtOAc/petroleum ether 1:9) to give the desired 1,2-cyclopropyl adduct **2.237** as an oil (2.7 g, 62%) and recovered starting material (6.4 g).

$^1\text{H}$  NMR (400 MHz,  $\text{CDCl}_3$ ):  $\delta_{\text{H}}$  7.36-7.28 (15H, m, Ar-H), 4.75 (2H, d,  $J$  11.7 Hz, Ph- $\text{CH}_2$ ), 4.62 (2H, d,  $J$  11.5 Hz, Ph- $\text{CH}_2$ ), 4.60-4.56 (2H, m, Ph- $\text{CH}_2$ ), 4.16 (2H, q,  $J$  7.1 Hz,  $-\text{CH}_2-\text{CH}_3$ ), 3.98 (1H, dd,  $J$  2.0 & 7.3 Hz, H-1), 3.81 (1H, dd,  $J$  1.9 & 6.3 Hz, H-3), 3.74-3.71 (2H, m, H-6a&b), 3.65-3.60 (2H, m, H-4&5), 2.02 (1H, dd,  $J$  2.0 & 5.6 Hz, H-2'), 1.84-1.80 (1H, m, H-2), 1.29 (1H, t,  $J$  7.1 Hz,  $\text{CH}_2-\text{CH}_3$ );  $^{13}\text{C}$  NMR (100 MHz,  $\text{CDCl}_3$ )  $\delta_{\text{C}}$  171.5 (COOEt), 138.16, 138.13, 137.8, 128.5, 128.4, 127.9, 127.8, 127.75, 127.73, 127.6, 76.6, 75.4, 74.5, 73.4, 73.3, 71.5, 69.3, 60.7 ( $\text{CH}_2-\text{CH}_3$ ), 57.6 (C-1), 24.5 (2XC, C-2&2'), 14.2 ( $\text{CH}_3$ ). The spectroscopic data were consistent with the published data.<sup>5</sup>

**Phenyl 3,4,6-tri-O-acetyl-2-deoxy-2-azido-1-thio- $\alpha$ -D-glucopyranoside (3.2b)**

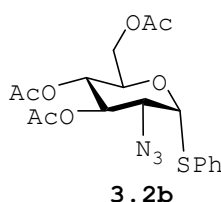

$\text{BF}_3 \cdot \text{OEt}_2$  (2.6 ml, 18.1 mmol) was added to a solution of **3.2a**<sup>6</sup> (1.5 g, 4.0 mmol) and thiophenol (0.862 ml, 8.0 mmol) in  $\text{CH}_2\text{Cl}_2$  (30 ml) at  $0^\circ\text{C}$ . The reaction mixture was stirred at  $55^\circ\text{C}$  for 12 h. On completion, the reaction mixture was diluted with  $\text{CH}_2\text{Cl}_2$ , washed with brine and the organic layer separated. The aqueous layer was extracted with  $\text{CH}_2\text{Cl}_2$ . The combined organic layers

were dried over  $\text{MgSO}_4$  and concentrated under reduced pressure. Silica gel chromatography (EtOAc/petroleum ether 1:9) of the crude mixture afforded **3.2b** as an  $\alpha/\beta$  mixture (1.03 g, 61%). The  $\alpha$ -anomer was obtained as white crystals by crystallization from absolute ethanol.

m.p. 93–97°C;  $^1\text{H}$  NMR (400 MHz,  $\text{CDCl}_3$ ):  $\delta_{\text{H}}$  7.51–7.47 (2H, m, Ph-H), 7.34–7.29 (3H, m, Ph-H), 5.61 (1H, d,  $J$  5.6 Hz, H-1), 5.31 (1H, dd,  $J$  9.2 & 10.5 Hz, H-3), 5.01 (1H, dd,  $J$  9.2 & 10.3 Hz, H-4), 4.56 (1H, ddd,  $J$  2.3, 5.1 & 10.3 Hz, H-5), 4.26 (1H, dd,  $J$  5.1 & 12.4 Hz, H-6a), 4.04 (1H, dd,  $J$  6.1 & 11.1 Hz, H-6b), 2.07 (3H, s, 1x-COCH<sub>3</sub>), 2.02 (3H, s, 1x-COCH<sub>3</sub>), 1.99 (3H, s, 1x-COCH<sub>3</sub>);  $^{13}\text{C}$  NMR (100 MHz,  $\text{CDCl}_3$ ):  $\delta_{\text{C}}$  170.4, 169.7, 132.4, 132.2, 129.2, 128.0, 86.5 (C-1), 76.6, 72.0, 68.7, 68.5, 61.9, 61.5, 20.6, 20.5; Anal. calcd. for  $\text{C}_{18}\text{H}_{21}\text{N}_3\text{O}_7\text{S}$ : C 51.06, H 5.19, N 9.92, S 7.57; found: C 51.64, H 5.11, N 9.94, S 7.23.

**Phenyl-3,4,6-tri-O-acetyl-2-deoxy-2-amino-1-thio- $\alpha$ -D-glucopyranoside (3.2c)**

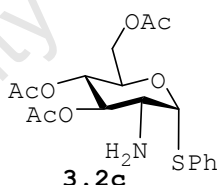

A suspension of **3.2b** (0.844 g, 2.0 mmol) and palladium on carbon (0.424 g) in ethanol (48 ml) was stirred under hydrogen (1atm.) for 5 hours at room temperature. The reaction mixture was then filtered through celite and further purified by silica column chromatography (EtOAc/petroleum ether 6:4) to yield **3.2c** as a white solid (0.739 g, 93%).

m.p. 83–85°C.  $^1\text{H}$  NMR (400 MHz,  $\text{CDCl}_3$ ):  $\delta_{\text{H}}$  7.42–7.23 (5H, m, Ph-H), 5.56 (1H, d,  $J$  5.2 Hz, H-1), 5.05 (2H, dd,  $J$  2.2 & 10.3 Hz, H-4&6a), 4.6 (1H, m, H-5), 4.32 (1H, dd,  $J$  5.1 & 12.3 Hz, H-2), 4.07 (1H, dd,  $J$  2.3 & 12.3 Hz, H-3), 3.32 (1H, dd,  $J$  5.2 & 10.2 Hz, H-6b), 2.1 (3H, s, 1x-COCH<sub>3</sub>), 2.04 (6H, s, 2x-COCH<sub>3</sub>).

$^{13}\text{C}$  NMR (100 MHz,  $\text{CDCl}_3$ ):  $\delta_{\text{C}}$  170.7, 170.5, 169.7, 133.5, 131.8, 129.1, 127.7, 91.2 (C-1), 74.7, 69.0, 62.3, 55.1, 20.6. [M+H] calcd for  $\text{C}_{18}\text{H}_{23}\text{NO}_7\text{S}$ : 398.1268; found 398.1283.

**Phenyl-2-deoxy-2-acetamido-3,4,6-tri-O-acetyl-2-deoxy-1-thio- $\alpha$ -D-glucopyranoside (3.2d)**

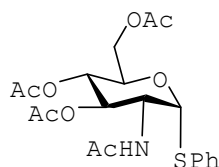

**3.2d**

A solution of **3.2c** (37 mg, 0.093 mmol) in pyridine (2 mL) was treated at room temperature with acetic anhydride (0.9 mL, 9.52 mmol) for two hours. The reaction mixture was then diluted with  $\text{CH}_2\text{Cl}_2$  (10 mL), then the organic phase washed with 1M HCl (2 X 10 mL), aq.  $\text{NaHCO}_3$  (2 x 10 mL) and brine (10 mL), before drying over  $\text{MgSO}_4$ . Compound **3.2d** was obtained as a white solid (36 mg, 88%).

m.p. 124–126°C (lit.<sup>7</sup> m.p. 204–205°C);  $[\alpha]_{\text{D}} = +160.1$  ( $c = 1.25$ ,  $\text{CHCl}_3$ ); lit.<sup>7</sup>  $[\alpha]_{\text{D}} = -22.1$  ( $c = 1.26$ ,  $\text{CHCl}_3$ );  $^1\text{H}$  NMR (400 MHz,  $\text{CDCl}_3$ ):  $\delta_{\text{H}}$  7.44–7.42 (5H, m, Ph-H), 5.88 (1H, d,  $J$  8.79, N-H), 5.69 (1H, d,  $J$  5.13 Hz, H-1), 5.15 (2H, m, H-3, H-4), 4.59 (1H, m, H-2), 4.50 (1H, ddd,  $J$  5.1, 7.3 & 12.5 Hz, H-5), 4.27 (1H, dd,  $J$  2.6 & 12.5 Hz, H-6a), 4.08 (1H, dd,  $J$  2.6 & 12.5 Hz, H-6b), 2.05, 2.04, 1.98 (12H, s, 4x- $\text{COCH}_3$ ).  $^{13}\text{C}$  NMR (100 MHz,  $\text{CDCl}_3$ ):  $\delta_{\text{C}}$  170.9, 170.5, 169.5, 166.3, 131.7 (2xC), 129.8 (2xC), 127.8 (2xC), 87.6 (C-1), 71.2, 68.9, 68.3, 62.0, 52.6, 22.9, 21.9, 20.6, 20.5. [M+H] calcd for  $\text{C}_{20}\text{H}_{25}\text{NO}_8\text{S}$ : 440.1374; found: 440.1393.

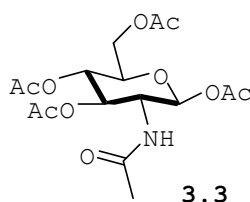
**1,3,4,6-Tetra-O-Acetyl-2-deoxy-2-acetamido- $\beta$ -D-Glucopyranoside****3.3**

Compound **3.1** (5.0 g, 23 mmol) was added slowly to a suspension of  $\text{ZnCl}_2$  (4.15 g, 30 mmol) in  $\text{Ac}_2\text{O}$  (26.5 ml) under Nitrogen, with temperature kept between 40–50°C during the addition. When the starting material had all dissolved, the solution was poured into ice-water (30 ml) with stirring, then NaOH (16 g in 50 ml water, used from the 50 ml was 30 ml) was slowly added. The solution was kept at a low temperature to encourage crystallisation of the product. The product was washed several times with water, and dried with  $\text{P}_2\text{O}_5$ . The yield of product as a mixture obtained was of 70% as white powder.

(400 MHz,  $\text{CDCl}_3$ ):  $\delta_{\text{H}}$  5.71 (1H, d,  $J$  8.8 Hz, H-1), 5.54 (1H, d,  $J$  9.6 Hz, NH-), 5.14 (2H, m, H-3&5), 4.30 (2H, m, H-2&6a), 4.14 (1H, dd,  $J$  2.1 & 12.4 Hz, H-6b), 3.81 (1H, ddd,  $J$  2.3, 4.6 & 8.9 Hz, H-4), 2.13 (3H, s,  $\text{CH}_3$ -), 2.1 (3H, s,  $\text{CH}_3$ -), 2.05 (6H, s,  $\text{CH}_3$ -), 1.94 (3H, s,  $\text{CH}_3$ -);  $^{13}\text{C}$  NMR (100 MHz,  $\text{CDCl}_3$ ):  $\delta_{\text{C}}$  171.1, 170.5, 170.1, 169.5, 169.2, 92.6 (C-1), 73.1, 72.6, 67.8, 61.7, 53.1, 23.1 ( $\text{CH}_3$ -), 20.8 ( $\text{CH}_3$ -), 20.7 ( $\text{CH}_3$ -), 20.6 ( $\text{CH}_3$ -), 20.5 ( $\text{CH}_3$ -).

**Phenyl 3, 4, 6-Tri-O-Acetyl-2-deoxy-2-acetamido- $\beta$ -Thio-D-Glucopyranoside 3.4**

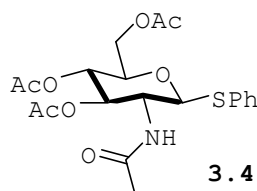

Thiophenol (0.208 ml, 2.14 mmol) and  $\text{SnCl}_4$  (1.25 ml, 1.25 mmol) were added to a stirred solution of **3.3** (1.0 g, 1.79 mmol) in  $\text{CH}_2\text{Cl}_2$  (20 ml). The reaction mixture was heated at reflux for

24 h, cooled to room temperature and quenched by addition of saturated aqueous NaHCO<sub>3</sub>. The aqueous layer was separated and extracted with DCM. The combined organic layers were washed with brine, dried over Na<sub>2</sub>SO<sub>4</sub> and concentrated under reduced pressure, and the solid residue was recrystallised from Et<sub>2</sub>O-Hexane (10:1) to give **3.4** (0.59 g, 75%).

m.p. 186–187°C (lit.<sup>8</sup> 199°C); [α]<sub>D</sub> 24.9 (c 1.0, CHCl<sub>3</sub>), lit.<sup>8</sup> [α]<sub>D</sub> 20.4 (c 1.0, CHCl<sub>3</sub>); <sup>1</sup>H NMR (400 MHz, CDCl<sub>3</sub>): δ<sub>H</sub> 7.52–7.50 (2H, m, Ph-H), 7.32–7.30 (3H, m, Ph-H), 5.60 (1H, d, *J* 9.3 Hz, NH), 5.23 (1H, t, *J* 9.8 Hz, H-3), 5.06 (1H, t, *J* 9.7 Hz, H-4), 4.87 (1H, d, *J* 10.3 Hz, H-1), 4.20 (1H, dq, *J* 4.2 & 12.2 Hz, H-6a & b), 4.04 (1H, m, H-2), 3.73 (1H, ddd, *J* 2.5, 5.2 & 10.0 Hz, H-5), 2.08 (3H, s, CH<sub>3</sub>), 2.03 (3H, s, CH<sub>3</sub>), 2.02 (3H, s, CH<sub>3</sub>), 1.99 (3H, s, CH<sub>3</sub>); <sup>13</sup>C NMR (100 MHz, CDCl<sub>3</sub>): δ<sub>C</sub> 170.9, 170.5, 169.9, 169.2, 132.4 (2xC), 128.8 (2xC), 128 (2xC), 86.6 (C-1), 75.7, 73.7, 68.4, 62.3, 53.3, 23.2, 20.68, 20.62, 20.5. Anal. calcd for C<sub>20</sub>H<sub>25</sub>NO<sub>8</sub>S: C 54.66; H 5.73; N 3.19; S 7.30; found: C 54.30; H 5.74; N 2.71; S 6.89. [M+H] calcd for C<sub>20</sub>H<sub>25</sub>NO<sub>8</sub>S: 440.1379; found: 440.1396.

**Benzyl-3,4,6-tri-O-acetyl-2-deoxy-2-acetamido-1-thio-β-D-Glucopyranoside 3.5**

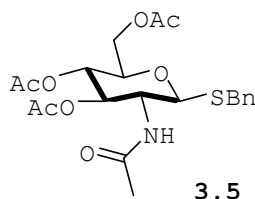

BF<sub>3</sub>·Et<sub>2</sub>O (0.16 ml, 1.34 mmol) was added in one portion to a cold suspension of **3.3** (0.5 g, 0.895 mmol). An exothermic reaction was immediately observed and the reaction mixture was allowed to stir for 50 min when TLC showed complete consumption of **3.3**. Anhydrous CH<sub>3</sub>CN (20 ml) was then added followed by thiourea (0.136 g, 1.79 mmol) and the reaction mixture placed on a preheated oil bath at 80°C for 15 min. with

constant stirring. After full consumption of the starting material as judged by TLC, the reaction mixture was cooled to room temperature and BnBr (0.458 g, 0.318 ml, 1.34 mmol) and Et<sub>3</sub>N (0.89 ml, 6.44 mmol) were added in succession and the reaction allowed to stir for 3 h at ambient temperature. After standard workup, the crude product was purified by flash column chromatography (EtOAc as eluent) to give **3.5** as a white powder (0.31g, 75%).

m.p. 178-179°C (lit.<sup>9</sup> 199-202°C). <sup>1</sup>H NMR (400 MHz, CDCl<sub>3</sub>): δ<sub>H</sub> 7.33-7.28 (5H, m, Ph-H); 5.32 (1H, d, *J* 9.3 Hz, NH), 5.10 (1H, t, *J* 9.6 Hz, CH-Ph), 5.02 (1H, t, *J* 9.5 Hz, CH-Ph), 4.28-4.15 (4 H, m, H-1,2,3&4), 3.96 (1H, d, *J* 13.1 Hz, H-6a), 3.96 (1H, d, *J* 13.1 Hz, H-6b), 3.57 (1H, ddd, *J* 2.3, 4.9 & 9.6 Hz, H-5), 2.08 (3H, s, CH<sub>3</sub>), 1.98 (3H, s, CH<sub>3</sub>), 1.97 (3H, s, CH<sub>3</sub>), 1.87 (3H, s, CH<sub>3</sub>); <sup>13</sup>C NMR (100 MHz, CDCl<sub>3</sub>): δ<sub>C</sub> 171 (C=O), 170.9 (C=O), 170 (C=O), 169.5 (C=O), 137, 129 (2xC), 128.6 (2xC), 127, 83 (C-1), 76, 74.1, 68.2, 62.1, 53.2, 34.2 (Ph-CH<sub>2</sub>-S), 23.2, 20.68, 20.62, 20.5. Anal. Calcd for C<sub>21</sub>H<sub>27</sub>NO<sub>8</sub>S : C 55.62; H 6.00; N 3.09; S 7.07; found: C 55.74; H 5.90; N 2.36; S 7.01. [M+H] calcd for C<sub>21</sub>H<sub>27</sub>NO<sub>8</sub>S: 454.1536; found: 454.1556.

### 1,6-Anhydro-2-deoxy-2-iodo-β-D-Glucopyranose **3.17**

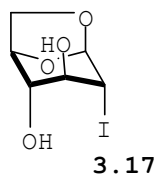

A solution of tri-*O*-acetyl-D-glucal **2.46** (11.7 g, 43.0 mmol) in 1:10:10 Et<sub>3</sub>NH-MeOH-H<sub>2</sub>O (6-60-60 ml) was stirred for 5 h at room temperature, and then concentrated. The residue was dried under vacuum in the presence of P<sub>2</sub>O<sub>5</sub>. The syrup D-glucal (8.4 g, 57.4 mmol) was treated with bis(tributyltin) oxide (17.8 g,

15.2 ml, 29.9 mmol) and activated powdered 3 Å molecular sieves (23.4 g) in refluxing dry acetonitrile (50 ml) for 3 h. The mixture was cooled to 5°C in an ice-water bath under nitrogen. Iodine (22.68 g, 89.5 mmol) was thereafter added in one portion. The dark-brown mixture was stirred for 15 min. at 5°C, then for 2 h at room temperature. Upon completion confirmed by TLC, the mixture was filtered through celite and concentrated. Saturated aqueous sodium thiosulphate and hexane were added to the residue, and stirred vigorously for 3 h. The product was extracted with EtOAc and dried by MgSO<sub>4</sub>. Flash chromatography on silica gel (EtOAc-Hexane 1:1) of the residue gave **3.17** (7.05 g, 43%) as light brown crystals.

<sup>1</sup>H NMR (400 MHz, DMSO): δ<sub>H</sub> 5.61 (1H, s, H-1), 5.47 (1H, d, *J* 4.2 Hz, OH-3), 5.14 (1H, d, *J* 4.0 Hz, OH-4), 4.42 (1H, d, *J* 4.9 Hz, H-5), 4.01 (1H, d, *J* 7.0 Hz, H-6a), 3.93 (1H, s, H-3), 3.82 (1H, m, H-2), 3.52 (1H, dd, *J* 6.0 & 6.8 Hz, H-6b), 3.45 (1H, s, H-4); <sup>13</sup>C NMR (100 MHz, DMSO): δ<sub>C</sub> 102.6 (C-1), 76.2, 74.6, 71.9, 65.2, 30.2. The spectroscopic data were consistent with the published data.<sup>10</sup>

### Phenyl 3,4,6-Tri-O-benzyl-1-thio-α-D-Glucopyranoside **3.20**

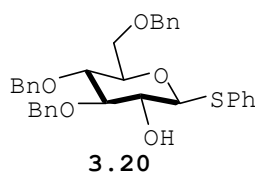

Compound **3.23** (0.4 g, 0.94 mmol) was treated with thiophenol (0.0637 g, 59 μl, 0.561 mmol) and NaH (0.0134 g, 0.56 mmol) as base in DMSO (10 ml). After 20 h the reaction was completed as observed by TLC, water was added to the mixture and extracted with DCM. The crude was subjected to a silica gel chromatography (EtOAc:Petroleum ether, 3:7) to give compound **3.20** in 41% yield.

**From Phenyl 3,4,6-tri-O-benzyl-2-acetoxy-1-thio- $\beta$ -D-glucopyranose 3.25**

0.2 M NaOMe in MeOH (3.6 ml) was added to a suspension of **3.25** (0.260 g, 0.44 mmol) in dichloromethane (10 ml) with stirring at room temperature. TLC showed complete conversion to a single more polar product within 10 min. The reaction mixture was then stirred with resin (Dowex-50WX-200(H+)), then the resin removed by filtration, and the filtrate concentrated under reduced pressure to give **3.20** as white powder (0.207 g, 87%).

$^1\text{H}$  NMR (400 MHz,  $\text{CDCl}_3$ ):  $\delta_{\text{H}}$  7.62–7.58 (2H, dd,  $J$  2 & 7.6, Ar-H), 7.31–7.22 (18H, m, Ar-H), 4.9 (1H, d,  $J$  11 Hz, Ph-CH), 4.87 (1H, d,  $J$  11 Hz, Ph-CH), 4.86 (1H, d,  $J$  10.9 Hz, Ph-CH), 4.62 (1H, d,  $J$  12.0 Hz, Ph-CH), 4.58 (1H, d,  $J$  12.0 Hz, Ph-CH), 4.54 (1H, d,  $J$  9.5 Hz, H-1), 4.52 (1H, d,  $J$  10.9 Hz, Ph-CH), 3.83 (1H, dd,  $J$  1.9 & 11 Hz, H-6a), 3.77 (1H, dd,  $J$  4.3 & 11 Hz, H-6b), 3.64–3.61 (2H, m, H-3&H-4), 3.58–3.51 (2H, m, H-2&5), 2.52 (1H, br. s, OH);  $^{13}\text{C}$  NMR (100 MHz,  $\text{CDCl}_3$ ):  $\delta_{\text{C}}$  138.5, 138.3, 138.1, 132.9, 131.9, 128.9, 128.5, 128.4, 128.3, 128.1, 128.0, 127.9, 127.8, 127.7, 127.6, 88(C-1), 86.1, 79.0, 75.3, 75.1, 73.4, 72.6, 69.1. The spectroscopic data were consistent with the published data.<sup>11</sup>

**Phenyl 3, 4, 6-Tri-O-benzyl-2-keto-1-thio- $\beta$ -D-Glucopyranoside**

**3.21**

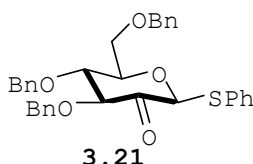

DMSO (5.5 ml), DCC (1.08 g), pyridine (0.142 ml) and acetic anhydride (0.172 ml) were added to compound **3.20** (0.3 g, 0.55 mmol) and stirred for 3 h at 50°C. Upon completion the mixture

was diluted with Et<sub>2</sub>O, washed with H<sub>2</sub>O, Na<sub>2</sub>CO<sub>3</sub> and brine successively; dried over Na<sub>2</sub>SO<sub>4</sub>. After column chromatography (EtOAc/petroleum ether 2:8), compound **3.21** was obtained in 95% yield.

m.p.: 90–93°C (lit.<sup>12</sup> 94–96°C); (400 MHz, CDCl<sub>3</sub>): δ<sub>H</sub> 7.60–7.51 (2H, m, Ph-H), 7.35–7.20 (18H, m, Ph-H), 5.29 (1H, s, H-1), 5.04 (1H, d, *J* 10.9 Hz), 4.81 (1H, d, *J* 11.3 Hz, Ph-CH), 4.54 (4H, m), 4.24 (1H, d, *J* 8.0 Hz), 3.90 (1H, dd, *J* 8.0, 9.3 Hz), 3.86 (1H, m), 3.71 (1H, dd, *J* 4.9 & 10.7 Hz); <sup>13</sup>C NMR (100 MHz, CDCl<sub>3</sub>): δ<sub>C</sub> 197.2 (C=O), 138.25, 138.2, 137.9, 128.8, 128.3, 128.0, 127.8, 127.7, 127.6, 127.5, 89.1 (C-1), 86.2, 80.1, 79.4, 74.9, 73.6, 73.5, 68.9. The spectroscopic data were consistent with the published data.<sup>12</sup>

### 1,2-Anhydro-3,4,6-Tri-*O*-benzyl- $\alpha$ -*D*-Glucopyranoside **3.23**

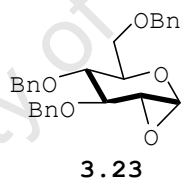

To a vigorously stirred, cooled (ice bath) biphasic solution of tri-*O*-benzyl-glucal **2.47** (3.0 g, 7.21 mmol) in DCM (30 ml), acetone (3 ml) and satd aq NaHCO<sub>3</sub> (50 ml), a solution of Oxone (8.87 g, 14.45 mmol) in water (35 ml) was added dropwise over 15 min. The mixture was vigorously stirred at 0°C for 30 min. and then at room temperature for an additional 2 h. The organic phase was separated and the aq. phase extracted with DCM. The combined organic phases were dried and concentrated to afford **3.23** (3.0 g, 98%) as a white solid.

<sup>1</sup>H NMR (CDCl<sub>3</sub>, 300 MHz) δ<sub>H</sub> 7.42–7.23 (15H, m, Ar-H), 5.01 (1H, br. d, *J* 2.0 Hz, H-1), 4.87–4.84 (2H, d, *J* 11 Hz, Ph-CH), 4.85–4.83 (2H, d, *J* 11.6 Hz, Ph-CH), 4.74 (2H, d, *J* 11.6 Hz,

Ph-CH), 4.68-4.65 (2H, d,  $J$  12.0 Hz, Ph-CH), 4.66-4.63 (2H, d,  $J$  11.0 Hz, Ph-CH), 4.60-4.56 (2H, d,  $J$  12.0 Hz, Ph-CH), 4.03 (1H, dd,  $J$  1.0 & 7.8 Hz, H-3), 3.83-3.77 (2H, m, H-5&6a), 3.73-3.66 (2H, m, H-4 & 6b), 3.14 (1H, d,  $J$  2.3 Hz, H-2);  $^{13}\text{C}$  NMR (75 MHz,  $\text{CDCl}_3$ ):  $\delta_{\text{C}}$  138.2, 138.1, 137.6, 128.6, 128.4, 128.3, 128.1, 127.9, 127.8, 127.7, 79.1(C-1), 74.5, 72.3, 69.5, 68.3, 52.6. The spectroscopic data were consistent with the published data.<sup>13</sup>

### 1,2-Di-O-acetyl-3,4,6-tri-O-benzyl- $\alpha/\beta$ -D-glucopyranose **3.24**

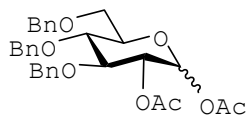

**3.24**

To a solution of tribenzyl glucal **2.47** (19.5 g, 46.92 mmol) in 391 mL of an acetone-water(2:0.5) mixture, was added a mixture of Oxone (86.41 g, 586.5 mol) and  $\text{NaHCO}_3$  (23.65 g, 1173 mmol) slowly at 20-25°C in small portions over a period of 30-60 min in a stoppered flask with continuous stirring. After the reaction was complete (TLC monitoring), acetone was evaporated and the remaining semi-solid mass was filtered and washed with EtOAc (3x150 ml). The organic layer was washed with water (2x150 ml), and brine (150 ml) and dried over  $\text{Na}_2\text{SO}_4$ . Evaporation of solvent gave the diol which was purified by column chromatography. Acetylation of the diol was done in the usual manner<sup>14</sup> to give **3.24** in 60% yields over two steps.

$^1\text{H}$  NMR (400 MHz,  $\text{CDCl}_3$ ):  $\delta_{\text{H}}$  7.37-7.27 (15H, m, Ph-H), 6.32 (0.56H, d,  $J$  3.6 Hz, H-1 $\alpha$ ), 5.64 (0.44H, d,  $J$  8.2 Hz, H-1 $\beta$ ), 5.13 (0.54H, dd,  $J$  8.2 & 9.2 Hz, H-2 $\beta$ ), 5.07 (0.44H, dd,  $J$  3.6 & 10.0 Hz, H-2 $\alpha$ ), 4.86-4.50 (6H, m, Ph-CH- $\alpha$ & $\beta$ ), 4.03-3.73 (5H, m, H-3,4,5&6a&b), 2.12, 2.09, 1.98, 1.95 (12H, 4s, 4x $\text{CH}_3\text{COO}$ );  $^{13}\text{C}$  NMR ( $\text{CDCl}_3$ , 75 MHz):  $\delta_{\text{C}}$  169.1, 166.1, 138.1, 137.8, 137.69, 137.64, 128.25, 128.22, 128.1, 128.0, 127.9, 127.8, 127.7, 127.68, 127.62, 127.5, 127.3, 92.0(C-1 $\beta$ ), 89.7(C-1 $\alpha$ ), 82.5,

79.7, 76.4, 75.6, 75.17, 75.13, 74.9, 74.8, 73.38, 73.04, 71.9, 71.7, 67.9, 21.9, 20.7, 20.5, 20.4. The spectroscopic data were consistent with the published data.<sup>15,16</sup>

### Phenyl 3,4,6-tri-*O*-benzyl-2-acetoxy-1-thio- $\beta$ -D-glucopyranose

#### 3.25

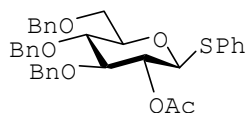

#### 3.25

To a solution of 1,2-Di-*O*-acetyl-3,4,6-tri-*O*-benzyl- $\alpha/\beta$ -D-glucopyranose **3.24** (6.23 g, 11.65 mmol) in DCM (15 ml) at  $\sim -10^\circ\text{C}$  was added thiophenol (3 ml, 13.94 mmol) and boron trifluoride-diethylether (3.56 ml, 28.94 mmol). The reaction mixture was stirred for 1 h at  $-10^\circ\text{C}$  and at  $30^\circ\text{C}$  for one more hour. After TLC had shown the completion of the reaction, the reaction mixture was diluted with DCM, washed with NaCl, and dried over  $\text{Na}_2\text{SO}_4$ . Silica gel column chromatography (EtOAc:Pet. ether, 2:8) was used to purify and only **3.25** was obtained in 78% yield.

$^1\text{H}$  NMR (400 MHz,  $\text{CDCl}_3$ ):  $\delta_{\text{H}}$  7.54–7.51 (2H, m, SPh-H), 7.35–7.20 (18H, m, Ar-H), 5.06–5.01 (1H, m, H-2), 4.81 (2H, dd,  $J$  2.7&11.2 Hz, Ph- $\text{CH}_2$ ), 4.69 (1H, d,  $J$  11.4 Hz, Ph-CH-), 4.64 (1H, d,  $J$  10.0 Hz, H-1), 4.61 (1H, d,  $J$  11.7 Hz, Ph-CH-), 4.60 (1H, d,  $J$  10.9 Hz, Ph-CH-), 4.58 (1H, d,  $J$  11.0 Hz, Ph-CH-), 3.81 (1H, dd,  $J$  2.0 & 11.0 Hz, H-6a), 3.75–3.68 (3H, m, H-3,4&6b), 3.56 (1H, ddd,  $J$  2.0, 5.0 & 9.6 Hz, H-5), 2.01 (3H, s,  $\text{CH}_3\text{COO}$ );  $^{13}\text{C}$  NMR (75 MHz,  $\text{CDCl}_3$ ):  $\delta_{\text{C}}$  169.4, 138.2, 138.1, 137.9, 133.0, 132.3 (2xC), 128.8 (2xC), 128.4 (3xC), 128.3 (2xC), 128.0 (2xC), 127.87, 128.84 (2xC), 127.7, 127.6 (2xC), 127.5, 86.0 (C-1), 84.4, 79.4, 77.8, 75.2, 75.0, 73.5, 71.9, 20.9 ( $\text{CH}_3\text{COO}$ ). The spectroscopic data were consistent with the published data.<sup>11</sup>

**3,4,6-Tri-*O*-benzyl-1,5-anhydro-2-deoxy-1,2-*C*-  
(dichloromethylene)-*D*-glycero-*D*-gulo-hexitol 3.26**

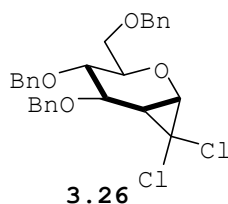

Aqueous NaOH (28.1 g/56.2 ml H<sub>2</sub>O) was added to a vigorously stirred solution of 3,4,6-tri-*O*-benzyl-*D*-glucal **2.47** (9.0 g; 21.59 mmol) in chloroform (62.5 ml) containing benzyltriethylammonium chloride (113 mg). The reaction mixture was stirred at 35°C overnight and then diluted with water and extracted with CH<sub>2</sub>Cl<sub>2</sub>. The combined extracts were dried and concentrated (Na<sub>2</sub>SO<sub>4</sub>), and the residue was purified by chromatography (EtOAc:Petroleum ether, 1:9) to furnish 3,4,6-Tri-*O*-benzyl-1,5-anhydro-2-deoxy-1,2-*C*-(dichloromethylene)-*D*-glycero-*D*-gulo-hexitol **3.26** (9.22 g, 85%).

m.p. 60–62°C; <sup>1</sup>H NMR (400 MHz, CDCl<sub>3</sub>): δ<sub>H</sub> 7.44–7.23 (15H, m, Ar-*H*), 4.93 (1H, d, *J* 11.4 Hz, Ph-CH), 4.85 (1H, d, *J* 11.8 Hz, Ph-CH), 4.74 (1H, d, *J* 11.8 Hz, Ph-CH), 4.66–4.57 (2H, m, Ph-CH), 4.51 (1H, d, *J* 12.1 Hz, Ph-CH), 3.96 (1H, d, *J* 7.8 Hz, H-1), 3.94–3.89 (1H, m, H-5), 3.87–3.82 (2H, m, H-3&4), 3.66–3.57 (2H, m, H-6a&b), 1.81–1.78 (1H, dd, *J* 4.5 & 8.0 Hz, H-2); <sup>13</sup>C NMR (100 MHz, CDCl<sub>3</sub>): δ<sub>C</sub> 138.2, 138.0, 137.7, 128.5, 128.4, 128.3, 128.1, 127.9, 127.8, 127.76, 127.73, 127.6, 79.9, 75.2, 74.5, 73.3, 71.8, 70.2, 61.5, 58.9, 34.3. The spectroscopic data were consistent with the published data.<sup>17</sup>

**Phenyl 3,4,6-Tri-O-acetyl-2-deoxy-2-C-Iodomethyl-1-thio- $\alpha/\beta$ -D-Glucopyranoside 3.27( $\alpha$ ) and 3.28( $\beta$ )**

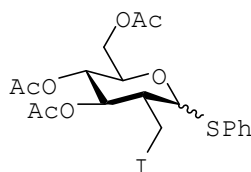

**3.27 and 3.28**

To a solution of 1,3,4,6-Tetra-O-acetyl-2-deoxy-2-C-iodomethyl- $\alpha/\beta$ -D-glucopyranoses **2.225a** (4.3 g, 6.97 mmol) in DCM (50 ml) at  $\sim -10$  °C was added thiophenol (1.69 ml, 13.94 mmol) and boron trifluoride-diethylether (3.84 ml, 31.36 mmol). The reaction mixture was stirred for 45 min. After TLC had shown the completion of the reaction, the reaction mixture was diluted with DCM, washed with NaCl, and dried over Na<sub>2</sub>SO<sub>4</sub>. Silica gel column chromatography (EtOAc:Pet.Ether, 2:8) was used to purify the sugar thioglucoside obtained as compounds **3.27** and **3.28** (3.60 g, 78%) in 2:1,  $\alpha:\beta$  ratio.

<sup>1</sup>H NMR (300 MHz, CDCl<sub>3</sub>):  $\delta_{\text{H}}$  7.61-7.54 (2H, m, SPh-H), 7.43-7.31 (3H, m, SPh-H), 5.74 (0.66H, d,  $J$  3.4 Hz, H-1 $\alpha$ ), 5.29-5.14 (1H, m, H-3), 5.1-4.95 (1H, m, H-4), 4.69 (0.33H, d,  $J$  10.1 Hz, H-1 $\beta$ ), 4.61 (0.66H, ddd,  $J$  2.1, 5.1 & 10.0 Hz, H-5 $\alpha$ ), 4.32 (0.66H, dd,  $J$  5.1 & 12.3 Hz, H-6 $\alpha\alpha$ ), 4.25 (0.33H, dd,  $J$  5.3 & 12.2 Hz, H-6 $\alpha\beta$ ), 4.14 (0.33H, dd,  $J$  4.7 & 11.9 Hz, H-6 $\beta\beta$ ), 4.14 (0.33H, dd,  $J$  4.7 & 11.9 Hz, H-6 $\beta\alpha$ ), 4.06 (0.66H, dd,  $J$  2.3 & 12.3 Hz, H-6 $\beta\alpha$ ), 3.70 (0.33H, ddd,  $J$  2.4, 5.3 & 10.1 Hz, H-5 $\beta$ ), 3.56 (0.33H, dd,  $J$  3.2 & 10.8 Hz, H-2'a $\beta$ ), 3.56 (0.33H, dd,  $J$  3.2 & 10.8 Hz, H-2'a $\alpha$ ), 3.28 (0.33H, dd,  $J$  4.2 & 10.3 Hz, H-2'b $\beta$ ), 3.24 (0.66H, dd,  $J$  2.1 & 11.0 Hz, H-2'a $\alpha$ ), 3.10 (0.66H, dd,  $J$  10.3 & 11.4 Hz, H-2'b $\alpha$ ), 2.60 (0.66H, m, H-2), 2.07, 2.06, 2.049, 2.04, 2.02, 2.01 (9H, s, CH<sub>3</sub>COO), 1.25 (0.33H, dt,  $J$  4.5 & 7.1 Hz, H-2 $\beta$ ); <sup>13</sup>C NMR (100 MHz, CDCl<sub>3</sub>):  $\delta_{\text{C}}$  170.7, 170.1, 170.09, 170.07, 169.9, 169.7, 133.6, 132.8, 131.5, 129.1, 128.0, 127.8, 90.5(C-1 $\beta$ ), 88.7(C-1 $\alpha$ ), 75.4,

73.8, 71.6, 69.7, 69.5, 62.7, 62.4, 53.5, 47.5, 42.9, 29.6, 20.9, 20.7, 20.65, 20.60, 20.4, 18.5, 18.4, 12.4, 5.6; Anal. Calcd for C<sub>19</sub>H<sub>23</sub>IO<sub>7</sub>S: C, 43.69; H, 4.44; S, 6.14 Found: C, 43.53; H, 4.64, S, 6.12.

**1-O-Acetyl-3,4,6-tri-O-benzyl-2-deoxy-2-C-azidomethyl- $\alpha/\beta$ -D-glucopyranose 3.29**

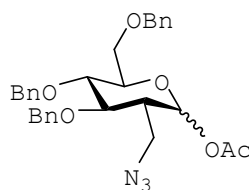

**3.29**

1-O-Acetyl-3,4,6-Tri-O-benzyl-2-deoxy-2-C-iodomethyl- $\alpha/\beta$ -D-Glucopyranoside **2.225b** (1.04 g, 1.68 mmol) was dissolved in DMSO (20 ml). To this solution NaN<sub>3</sub> (0.438 g, 6.75 mmol) was carefully added. This mixture was stirred at room temperature for 1 h and when tlc showed the completion of the reaction. The mixture was poured into water and extracted with EtOAc. The combined organic extracts were washed with water, brine successively and then dried over MgSO<sub>4</sub>. After column chromatography (EtOAc/petroleum ether 1:9), compound **3.29** was obtained in 100% yield (0.89 g).

<sup>1</sup>H NMR (300 MHz, CDCl<sub>3</sub>):  $\delta_{\text{H}}$  7.46–7.07 (15H, m, Ar-H), 6.27 (0.33H, d,  $J$  3.4 Hz, H-1 $\alpha$ ), 5.63 (0.67H, d,  $J$  9.4 Hz, H-1 $\beta$ ), 4.97–4.90 (1H, m, Ph-CH<sub>2</sub>), 4.85–4.75 (1H, m, Ph-CH<sub>2</sub>), 4.69–4.46 (4H, m, Ph-CH<sub>2</sub>), 3.85–3.58 (5.33H, m, H-3, H-2'a $\alpha$ , 2'b $\beta$ , 4,5 $\alpha$ , 6a,b), 3.54 (0.67H, ddd,  $J$  2.0, 3.2 & 9.4 Hz, H-5 $\beta$ ), 3.45 (0.67H, dd,  $J$  2.8 & 12.4 Hz, H-2'a $\beta$ ), 3.17 (0.33H, dd,  $J$  9.6 & 12.4 Hz, H-2'b $\alpha$ ), 2.28–2.18 (0.33H, m, H-2 $\alpha$ ), 2.14 (2.01H, s, CH<sub>3</sub>COO- $\beta$ ), 2.11 (0.99H, s, CH<sub>3</sub>COO- $\alpha$ ), 1.99–1.93 (0.67H, m, H-2 $\beta$ ); <sup>13</sup>C NMR (100 MHz, CDCl<sub>3</sub>):  $\delta_{\text{C}}$  169.3, 138.3, 138.2, 138.1, 128.7, 128.6, 128.2, 128.1, 128.0, 127.9, 92.4

(C-1 $\beta$ ), 91.9(C-1 $\alpha$ ), 79.3, 79.2, 78.6, 75.8, 75.5, 75.4, 75.2, 74.9, 73.9, 73.8, 70.9, 68.5, 49.4(C-2' $\alpha$ ), 47.6(C-2' $\beta$ ), 46.0(C-2 $\alpha$ ), 45.0(C-2 $\alpha$ ), 21.2, 21.1(CH<sub>3</sub>COO); Elemental Anal. calcd for C<sub>30</sub>H<sub>33</sub>N<sub>3</sub>O<sub>6</sub>: C, 67.78; H, 6.26; N, 7.90, Found: C, 67.20; H, 6.27; N, 7.73. [M+Na] calcd for C<sub>30</sub>H<sub>33</sub>N<sub>3</sub>NaO<sub>6</sub>: 554.2267 found for C<sub>30</sub>H<sub>33</sub>N<sub>3</sub>NaO<sub>6</sub>: 554.2270

**Phenyl 3,4,6-Tri-O-benzyl-2-deoxy-2-C-azidomethyl-1-thio- $\alpha/\beta$ -D-glucopyranoside 3.30 ( $\alpha$ ) and 3.31 ( $\beta$ )**

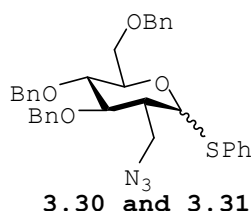

To a solution of 1-O-acetyl-3,4,6-Tri-O-benzyl-2-deoxy-2-C-azidomethyl- $\alpha/\beta$ -D-glucopyranoses **3.29** (0.360 g, 0.676 mmol) in DCM (10 ml) at  $\sim -10^\circ\text{C}$  was added thiophenol (0.14 ml, 1.32 mmol) and boron trifluoride-diethylether (0.37 ml, 3.0 mmol). The reaction mixture was stirred for 1 h. After TLC had shown the completion of the reaction, the reaction mixture was diluted with DCM, washed with NaCl, and dried over Na<sub>2</sub>SO<sub>4</sub>. Silica gel column chromatography (EtOAc:Pet.Ether, 2:8) was used to purify the sugar thioglucoside obtained as compound **3.30** and **3.31** (0.260 g, 66%) in 2:1,  $\alpha:\beta$  ratio.

$\nu_{\text{max}}$  (CHCl<sub>3</sub> /cm<sup>-1</sup>) 2104 (N<sub>3</sub>); <sup>1</sup>H NMR (300 MHz, CDCl<sub>3</sub>):  $\delta_{\text{H}}$  7.53-7.45 (2H, m, SPh-H), 7.31-7.16 (18H, m, Ar-H), 5.55 (0.68H, d, *J* 4.8 Hz, H-1 $\alpha$ ), 4.86 (1H, dd, *J* 11.1 & 13.2 Hz, Ph-CH), 4.75 (1H, dd, *J* 2.1 & 10.9 Hz, H-), 4.66 (0.32H, d, *J* 10.5 Hz, H-1 $\beta$ ), 4.59 (1H, d, *J* 11.6 Hz, H-), 4.55 (1H, d, *J* 11.1 Hz, H-), 4.55 (1H, d, *J* 11.1 Hz, H-), 4.50 (1H, d, *J* 9.8 Hz, H-), 4.43 (1H, d, *J* 12.1 Hz, H-), 4.33 (0.67H, ddd, *J* 1.8, 3.7 & 9.8 Hz, H-5 $\alpha$ ), 3.81-3.54 (5.33H, m, H-2' $\alpha\alpha$ , 2' $\beta\beta$ , 3,4,5 $\beta$ &6a&b), 3.43 (0.67H, dd, *J* 10.7&12.1 Hz, H-2' $\beta\alpha$ ), 3.32 (0.33H, m, H-2' $\alpha\beta$ ),

2.40 (0.67H, tt,  $J$  4.3 & 10.7 Hz,  $H-2\alpha$ ), 1.81 (0.33H, m,  $H-2\beta$ );  $^{13}\text{C}$  NMR (100 MHz,  $\text{CDCl}_3$ ):  $\delta_{\text{C}}$  138.5, 138.3, 138.27, 138.21, 138.1, 134.3, 132.9, 132.8, 132.3, 129.2, 129.1, 128.79, 128.75, 128.6, 128.58, 128.56, 128.2, 128.15, 128.1, 128.06, 128.0, 127.9, 127.8, 127.76, 127.72, 88.1( $C-1\alpha$ ), 85.0( $C-1\beta$ ), 82.9, 80.5, 80.1, 79.7, 79.5, 79.2, 75.7, 75.4, 75.1, 75.0, 73.7, 73.6, 72.4, 69.3, 68.9, 50.8( $C-2'\alpha$ ), 49.3( $C-2'\beta$ ), 47.1( $C-2\alpha$ ), 46.3( $C-2\beta$ ); Elemental Anal. calcd for  $\text{C}_{34}\text{H}_{35}\text{N}_3\text{O}_4\text{S}$ : C, 70.20; H, 6.06; S, 5.51, Found: C, 69.90; H, 6.27; S, 5.73;  $[\text{M}+\text{Na}]$  calcd for  $\text{C}_{34}\text{H}_{35}\text{N}_3\text{NaO}_4\text{S}$ : 604.2246 found for  $\text{C}_{34}\text{H}_{35}\text{N}_3\text{NaO}_4\text{S}$ : 604.2256

**Phenyl 2-azidomethyl-2-deoxy-3,4,6-Tri-O-benzyl-1-thio- $\beta$ -D-glucopyranoside 3.31**

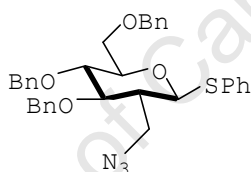

**3.31**

Phenyl 3,4,6-Tri-O-benzyl-2-deoxy-2-C-Iodomethyl-1-thio- $\alpha$ -D-glucopyranoside **1.34** (0.394 g, 0.59 mmol) was dissolved in DMSO (20 ml). To this solution, sodium azide (0.154 g, 2.37 mmol) was added carefully. This mixture was stirred at room temperature for 2 h and then stopped when TLC showed the completion of the reaction. The reaction mixture was cooled, poured into water and extracted with Ethyl Acetate. The combined organic extracts were washed with water, brine successively and then dried over  $\text{MgSO}_4$ . After column chromatography (EtOAc:Petroleum ether, 2:8) compound **3.31** was generated as a syrup (0.272 g, 79%).

$\nu_{\text{max}}$  ( $\text{CHCl}_3$  / $\text{cm}^{-1}$ ) 2102 ( $\text{N}_3$ );  $^1\text{H}$  NMR (400 MHz,  $\text{CDCl}_3$ ):  $\delta_{\text{H}}$  7.37-7.27 (15H, m, Ar-H), 4.86 (1H, dd,  $J$  11.1 & 13.2 Hz, Ph-CH), 4.75 (1H, dd,  $J$  2.1 & 10.9 Hz, H-), 4.66 (1H, d,  $J$  10.5 Hz, H-

1 $\beta$ ), 4.59 (1H, d,  $J$  11.6 Hz,  $H^-$ ), 4.55 (1H, d,  $J$  11.1 Hz,  $H^-$ ), 4.55 (1H, d,  $J$  11.1 Hz,  $H^-$ ), 4.50 (1H, d,  $J$  9.8 Hz,  $H^-$ ), 4.43 (1H, d,  $J$  12.1 Hz,  $H^-$ ), 3.82–3.54 (5H, m,  $H-3,4,5,6a,b$ ), 1.0–0.92 (1H, m,  $H-2$ ), 0.78–0.68 (2H, m,  $H-2'$ );  $^{13}\text{C}$  NMR (100 MHz,  $\text{CDCl}_3$ ):  $\delta_{\text{C}}$  138.8, 138.6, 138.5, 128.5, 128.4, 128.0, 127.8, 80.2, 77.2, 76.9, 73.5, 73.4, 71.2, 70.2, 49.8 ( $C-2'\beta$ ), 46.3 ( $C-2\beta$ ). Elemental Analysis: Calcd for  $\text{C}_{34}\text{H}_{36}\text{SO}_6$ : C, 70.20; H, 6.06; N, 7.22; S, 5.51, Found: C, 69.51; H, 6.0; N, 6.64; S, 5.43;  $[\text{M}+\text{Na}]$  calcd for  $\text{C}_{34}\text{H}_{35}\text{N}_3\text{NaO}_4\text{S}$ : 604.2246 found for  $\text{C}_{34}\text{H}_{35}\text{N}_3\text{NaO}_4\text{S}$ : 604.2242

**1-*O*-acetyl 3,4,6-Tri-*O*-benzyl-2-deoxy-2-*C*-methylEthylacetate)- $\alpha/\beta$ -*D*-glucopyranoside 3.32**

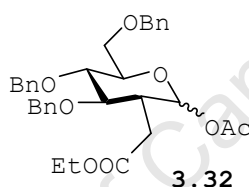

To a solution of Acetyl 3,4,6-Tri-*O*-benzyl-2-deoxy-2-*C*- (IodomethylEthylacetate)- $\alpha,\beta$ -*D*-Glucopyranoside **3.61** (100 mg, 0.145 mmol) in acetonitrile was added  $\text{NaBH}_4$  followed by catalytic amount of  $\text{FeCl}_3$  (2.3 mg, 0.0145 mmol). The reaction was stirred for 3 hours at room temperature. After completion observed by TLC, the reaction mixture was washed with concentrated solution of  $\text{NH}_4\text{Cl}$ , extracted with  $\text{EtOAc}$  and dried with  $\text{MgSO}_4$ . Column chromatography yielded ( $\text{EtOAc}$ :Petroleum ether, 2:8) an inseparable mixture of 1-*O*-Acetyl 3,4,6-Tri-*O*-benzyl-2-deoxy-2-*C*- (methylEthylacetate)- $\alpha,\beta$ -*D*-glucopyranoside **3.32**. The product was obtained as an oil (0.067 g, 82%) in 1:5 ratio of  $\alpha$  and  $\beta$ , respectively.

IR ( $\text{CHCl}_3/\text{cm}^{-1}$ ) 1755, 1727, 1455, 1366 ( $\text{OAc}$ );  $^1\text{H}$  NMR (300 MHz,  $\text{CDCl}_3$ ):  $\delta_{\text{H}}$  7.34–7.27 (13H, m, Ph- $H$ ), 7.17–7.15 (2H, m, Ph- $H$ ), 6.24 (0.166H, d,  $J$  3.2 Hz,  $H-1\alpha$ ), 5.60 (0.833H, d,  $J$  8.8 Hz,  $H-1\beta$ ), 4.96 (0.166H, d,  $J$  11.1 Hz, Ph- $\text{CH}-\alpha$ ), 4.93 (0.833H, d,  $J$

11.1 Hz, Ph-CH- $\beta$ ), 4.79 (0.166H, d,  $J$  10.7 Hz, Ph-CH- $\alpha$ ), 4.77 (0.833H, d,  $J$  10.9 Hz, Ph-CH- $\beta$ ), 4.66 (0.166H, d,  $J$  11.1 Hz, Ph-CH- $\alpha$ ), 4.65 (0.833H, d,  $J$  12.3 Hz, Ph-CH- $\beta$ ), 4.64 (0.166H, d,  $J$  11.1 Hz, Ph-CH- $\alpha$ ), 4.59 (0.166H, d,  $J$  10.7 Hz, Ph-CH- $\alpha$ ), 4.58 (0.833H, d,  $J$  10.9 Hz, Ph-CH- $\beta$ ), 4.51 (0.166 H, d,  $J$  12.1 Hz, Ph-CH- $\alpha$ ), 4.50 (0.833H, d,  $J$  12.1 Hz, Ph-CH- $\beta$ ), 4.04 (1.666H, q,  $J$  7.2 Hz, O-CH<sub>2</sub>-CH<sub>3</sub>- $\beta$ ), 4.04 (0.333H, q,  $J$  7.1 Hz, O-CH<sub>2</sub>-CH<sub>3</sub>- $\alpha$ ), 3.83-3.54 (6H, m, H-3,4,5&6a,b), 2.58-2.44 (0.498H, m, H-2 $\alpha$ &2' $\alpha$ ), 2.40-2.30 (2.499H, m, H-2 $\beta$ &2' $\beta$ ), 2.09 (2.49H, s, CH<sub>3</sub>- $\beta$ ), 2.08 (0.5H, s, CH<sub>3</sub>- $\alpha$ ), 1.20 (3H, t,  $J$  7.1Hz, CH<sub>2</sub>-CH<sub>3</sub>); <sup>13</sup>C (100 MHz, CDCl<sub>3</sub>):  $\delta_c$  171.5(COOEt- $\beta$ ), 171.4(COOEt- $\alpha$ ), 169(O=CCH<sub>3</sub>), 138.1, 138, 128.4, 128.3, 127.9, 127.8, 127.7, 127.5, 93.9 (C-1 $\beta$ ), 92.6(C-1 $\alpha$ ), 81.6(C- $\beta$ ), 80.3(C- $\alpha$ ), 79.1(C- $\beta$ ), 75.8(C- $\beta$ ), 75.2(C- $\alpha$ ), 74.9(C- $\beta$ ), 74.7(C- $\beta$ ), 73.6(C- $\alpha$ ), 73.5(C- $\beta$ ), 68.4(C- $\beta$ ), 60.7(C- $\alpha$ ), 60.5(C- $\alpha$ ), 43.5(C-2 $\beta$ ), 41.8(C-2 $\alpha$ ), 32.6(C-2' $\alpha$ ), 31.7(C-2' $\beta$ ), 20.9(CO-CH<sub>3</sub>- $\alpha$ & $\beta$ ), 14.1(CH<sub>2</sub>-CH<sub>3</sub>- $\alpha$ & $\beta$ ); Elemental Anal. calcd for C<sub>33</sub>H<sub>38</sub>O<sub>8</sub>: C, 70.44; H, 6.81; Found: C, 70.04; H, 6.54; [M+Na] calcd for C<sub>33</sub>H<sub>38</sub>O<sub>8</sub>: 585.2464 found for C<sub>33</sub>H<sub>38</sub>O<sub>8</sub>: 585.2479

**Phenyl 3,4,6-tri-O-benzyl-2-deoxy-2-C-(methylEthylacetate)-1-thio- $\alpha/\beta$ -D-glucopyranoside 3.33**

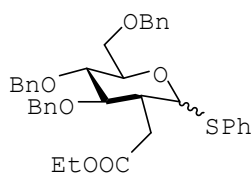

To a solution of 1-O-Acetyl 3,4,6-Tri-O-benzyl-2-deoxy-2-C-(methylEthylacetate)- $\alpha,\beta$ -D-Glucopyranoside **3.32** (106 mg, 0.188 mmol) DCM (5 ml) at 0°C was added thiophenol (0.0116 ml, 0.094 mmol) and boron trifluoride-diethylether (0.2 ml, 1.8 mmol). The reaction mixture was stirred for 5 hours. After TLC had

shown the completion of the reaction, the reaction mixture was diluted with DCM, washed with NaCl, and dried over Na<sub>2</sub>SO<sub>4</sub>. Silica gel column chromatography (EtOAc/petroleum ether 2:8) was used to purify the sugar thioglycoside **3.33**. The product was obtained as oil (0.100 g, 87%) in 2.4:1 ratio of  $\alpha$  and  $\beta$ , respectively.

<sup>1</sup>H NMR (400 MHz, CDCl<sub>3</sub>):  $\delta_H$  7.59 (0.58H, dd,  $J$  3.2&6.5 Hz, Ph- $H-\beta$ ), 7.50 (1.42H, dd,  $J$  2.0&7.4 Hz, Ph- $H-\alpha$ ), 7.38-7.20 (15H, m, Ar- $H$ ), 5.75 (0.71H, d,  $J$  4.4 Hz,  $H-1\alpha$ ), 4.97 (0.71H, d,  $J$  11 Hz, Ph- $CH-\alpha$ ), 4.94 (0.29H, d,  $J$  13.4 Hz, Ph- $CH-\beta$ ), 4.91 (0.29H, d,  $J$  10.7 Hz,  $H-1\beta$ ), 4.83 (0.71H, d,  $J$  11.0 Hz, Ph- $CH-\alpha$ ), 4.82 (0.29H, d,  $J$  11.0 Hz, Ph- $CH-\beta$ ), 4.68 (0.71H, d,  $J$  10.9, Ph- $CH-\alpha$ ), 4.67 (0.29H, d,  $J$  12.1 Hz, Ph- $CH-\beta$ ), 4.64 (0.29H, d,  $J$  13.9 Hz, Ph- $CH-\beta$ ), 4.61 (0.71H, d,  $J$  10.84 Hz, Ph- $CH-\alpha$ ), 4.59 (0.29H, d,  $J$  11.9 Hz, Ph- $CH-\beta$ ), 4.51 (1H, d,  $J$  12.0 Hz, Ph- $CH-\alpha$ ), 4.41 (1H, ddd,  $J$  1.6, 3.4 & 9.6 Hz,  $H-5$ ), 4.12-4.0 (2H, m, O-CH<sub>2</sub>-CH<sub>3</sub>), 3.9-3.6 (3H, m,  $H-3,4,6a$  &  $6b$ ), 2.8-2.78 (1H, m,  $H-2\alpha$ ), 2.67 (1H, dd,  $J$  4.9 & 16.6 Hz,  $H-2'\beta$ ), 2.50 (1H, dd,  $J$  10.3 & 17.7 Hz,  $H-2'\alpha$ ), 2.28-2.22 (1H, m,  $H-2\beta$ ), 1.22 (3H, t,  $J$  7.1 Hz, O-CH<sub>2</sub>-CH<sub>3</sub>- $\beta$ ), 1.18 (3H, t,  $J$  7.1 Hz, O-CH<sub>2</sub>-CH<sub>3</sub>- $\alpha$ ); <sup>13</sup>C NMR (100 MHz, CDCl<sub>3</sub>):  $\delta_C$  171.55(COOEt), 138.02(C- $\beta$ ), 138 (C- $\beta$ ), 137.94(C- $\alpha,\beta$ ), 137.9 (C- $\alpha$ ), 137.8(C- $\alpha$ ), 134.32(C- $\beta$ ), 133, 132(C- $\beta$ ), 131.6(C- $\alpha$ ), 128.7(C- $\alpha$ ), 127.6(C- $\beta$ ), 128.2, 128.1, 127.7, 127.6, 127.5, 127.47, 127.43, 127.39, 127.32, 127, 88.7(C-1 $\alpha$ ), 86.4(C-1 $\beta$ ), 82.8(C- $\beta$ ), 80.9(C- $\alpha$ ), 79.8(C- $\alpha$ ), 79.5(C- $\beta$ ), 79.1(C- $\beta$ ), 75(C- $\alpha$ ), 74.8(C- $\beta$ ), 74.7(C- $\alpha$ ), 74.5(C- $\beta$ ), 73.2(C- $\alpha$ ), 72(C- $\alpha$ ), 69(C- $\beta$ ), 68.6(C- $\alpha$ ), 60.3(C- $\alpha$ ), 60.2(C- $\beta$ ), 43.5(C-2 $\beta$ ), 43.4(C-2 $\alpha$ ), 34.5(C-2' $\alpha$ ), 32.9(C-2' $\beta$ ), 13.9(CH<sub>2</sub>-CH<sub>3</sub>- $\alpha$ & $\beta$ ); Elemental Anal. calcd for C<sub>37</sub>H<sub>40</sub>O<sub>6</sub>S : C, 72.52; H, 6.58; S, 5.23; Found: C, 72.92; H, 6.73; S, 4.99; [M+Na] calcd for C<sub>37</sub>H<sub>40</sub>O<sub>6</sub>S: 635.2443 found for C<sub>37</sub>H<sub>40</sub>O<sub>6</sub>S: 635.2437

**Phenyl 3,4,6-Tri-O-benzyl-2-deoxy-2-C-cyanomethyl-1-thio-β-D-Glucopyranoside 3.41**

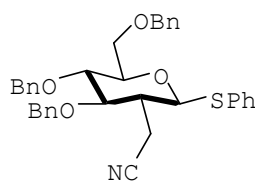

**3.41**

Phenyl 3,4,6-Tri-O-benzyl-2-deoxy-2-C-Iodomethyl-1-thio-α-D-glucopyranoside **1.34** (0.3g, 0.451 mmol) was dissolved in DMSO (20 ml). To this solution, sodium cyanide (0.088 g, 1.80 mmol) was added carefully. This mixture was stirred at reflux for 24 h and then stopped when TLC showed the completion of the reaction. The reaction mixture was cooled, poured into water and extracted with Ethyl Acetate. The combined organic extracts were washed with water, brine successively and then dried over MgSO<sub>4</sub>. After column chromatography a powdered product **3.41** was generated in 70% yield.

$\nu_{\max}$  (CHCl<sub>3</sub>/cm<sup>-1</sup>) 2242 (CN); mp: 92-95°C; (400 MHz, CDCl<sub>3</sub>):  $\delta_{\text{H}}$  7.63-7.52 (2H, m, Ar-H), 7.42-7.23 (18H, m, Ar-H), 5.01 (1H, d,  $J$  11.1 Hz, Ph-CH), 4.81 (1H, d,  $J$  11.0 Hz, Ph-CH), 4.72 (1H, d,  $J$  10.9 Hz, Ph-CH), 4.68 (1H, d,  $J$  11.2 Hz, Ph-H); 4.678 (1H, d,  $J$  6.8 Hz, H-1), 4.67 (1H, d,  $J$  12.0, Ph-H), 4.5 (1H, d,  $J$  11.9 Hz, Ph-CH), 3.82-3.81 (2H, m, H-6a,b), 3.73-3.70 (2H, m, H-3&5), 3.57-3.54 (1H, m, H-4), 2.82-2.73 (2H, m, H-2'a,b), 2.01-1.94 (1H, m, H-2); <sup>13</sup>C NMR (100 MHz, CDCl<sub>3</sub>):  $\delta_{\text{C}}$  138, 137.9, 137.6, 133, 131.6, 129, 128.6, 128.5, 128.38, 128.31, 128.1, 127.9, 127.87, 127.80, 127.7, 127.68, 127.61, 117.1 (CN), 85.5 (C-1), 82.2, 79.3, 79.2, 75.7, 74.7, 73.4, 68.8, 42.5 (C-2), 17.1 (C-2'); Elemental Anal. calcd for C<sub>35</sub>H<sub>35</sub>NO<sub>4</sub>S: C, 74.31; H, 6.24; S, 5.56 Found: C, 71.97; H, 6.00; S, 4.37; [M+H] calcd for C<sub>35</sub>H<sub>36</sub>NO<sub>4</sub>S: 588.2184 found for C<sub>35</sub>H<sub>36</sub>NO<sub>4</sub>S: 588.2

**Phenyl 3,4,6-Tri-O-benzyl-2-deoxy-2-C-formylmethyl-1-thio-β-D-Glucopyranoside 3.42**

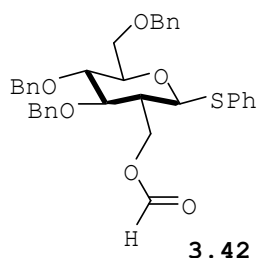

To a mixture of **1.34** (100 mg, 0.150 mmol) and formic acid (13.8 mg, 0.30 mmol) cooled in an ice-bath, TEA (34.3 mg, 0.34 mmol) was added dropwise with stirring in the course of 15 min. The cooling bath was removed and the reaction mixture was stirred at 50°C for 2 h. Upon completion the reaction mixture was diluted with brine and extracted with EtOAc. The organic layer was washed with water, 1 M HCl, aqueous NaHCO<sub>3</sub>, water and brine. The extract was dried over NaSO<sub>4</sub> and evaporated. The residue was chromatograph (EtOAc:Petroleum ether, 1:98) to afford **3.42** in 75% and **3.43** in 20 % yield both as white powder.

**3.42**,  $\nu_{\max}$  (CHCl<sub>3</sub>/cm<sup>-1</sup>) 1721, 1212(OCOH); mp: 70–73°C; <sup>1</sup>H NMR (400 MHz, CDCl<sub>3</sub>):  $\delta_{\text{H}}$  8.1 (1H, s, OCOH), 7.48–7.46 (2H, m, Ar-H), 7.33–7.22 (18H, m, Ar-H), 4.94 (1H, d, *J* 10.6 Hz, Ph-CH), 4.79 (1H, d, *J* 11.0 Hz, Ph-CH), 4.72 (1H, d, *J* 11.0 Hz, Ph-CH), 4.58 (1H, d, *J* 11.8 Hz, Ph-H); 4.53 (1H, d, *J* 6.8 Hz, H-1), 4.51 (1H, d, *J* 12.0, Ph-CH), 4.48 (1H, d, *J* 11.0 Hz, Ph-CH), 4.38 (1H, br.d, *J* 11.6 Hz, H-2'a), 4.28 (1H, br.d, *J* 12.1, H-2'b), 3.72–3.61 (4H, m, H-3,5,6a,b), 3.53 (1H, t, *J* 9.0 Hz, H-4), 1.9 (1H, br.t, *J* 10.6 Hz, H-2); <sup>13</sup>C NMR (100 MHz, CDCl<sub>3</sub>):  $\delta_{\text{C}}$  162 (C=O), 139, 138.8, 138.7, 133.8, 131, 129.6, 128.9, 128.8, 128.5, 128.4, 128.4, 128.3, 128.2, 128.1, 127.9, 84.1 (C-1), 80, 79.8, 78.6, 74.8, 74.5, 72.9, 69.5, 60.5(C-2'), 46.1(C-2). Elemental Analysis: Calcd for C<sub>34</sub>H<sub>36</sub>SO<sub>6</sub>: C, 71.89; H, 6.21;

S, 5.48, Found: C, 71.66; H, 6.22; S, 5.23; [M+Na] calcd for C<sub>34</sub>H<sub>36</sub>NaO<sub>6</sub>S: 607.2130 found for C<sub>34</sub>H<sub>36</sub>NaO<sub>6</sub>S: 607.2130

**Phenyl 3,4,6-Tri-O-benzyl-2-deoxy-2-methylene-1-thio-β-D-Glucopyranoside 3.43**

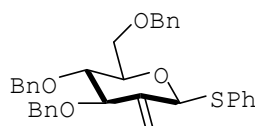

**3.43**

**3.43** (20% yields from formylation reaction conditions, see page 107), mp: 50-52°C; <sup>1</sup>H NMR (400 MHz, CDCl<sub>3</sub>): δ<sub>H</sub> 7.58-7.56 (2H, m, Ar-H), 7.32-7.20 (18H, m, Ar-H), 5.5 (1H, s, H-2'a), 5.4 (1H, d, J 1.5, H-2'b), 5.3 (1H, s, H-1), 4.8 (1H, d, J 11.2 Hz, Ph-CH), 4.7 (1H, d, J 11.5 Hz, Ph-CH), 4.6 (1H, d, J 11.6 Hz, Ph-CH), 4.55-4.51 (3H, m, Ph-H); 4.1 (1H, td, J 1.5 & 6.8 Hz, H-3), 3.79-3.59 (4H, m, H-4,5,6a,b); <sup>13</sup>C NMR (100 MHz, CDCl<sub>3</sub>): δ<sub>C</sub> 141.0, 138.4, 138.0, 137.9, 134.0, 131.0, 130.0, 129.1, 128.4, 128.3, 128.2, 128, 127.9, 127.83, 127.8, 127.78, 127.72, 127.6, 127.5, 127.4, 127.1, 112.4 (C=CH<sub>2</sub>), 85.7 (C-1), 83, 79.5, 79, 74, 73, 72, 69.8; Elemental Anal. calcd for C<sub>34</sub>H<sub>34</sub>O<sub>4</sub>S: C, 75.81; H, 6.36, S, 5.95 Found: C, 75.96; H, 6.37; S, 5.53; [M+Na] calcd for C<sub>34</sub>H<sub>34</sub>NaO<sub>4</sub>S: 561.2076 found for C<sub>34</sub>H<sub>34</sub>NaO<sub>4</sub>S: 561.2083

**Phenyl 3,4,6-O-benzyl-2-deoxy-2-C-methyl-1-thio-α-D-glucopyranoside 3.45 and Phenyl 3,6-O-benzyl-2-deoxy-2-C-methyl-1-thio-α-D-glucopyranoside 3.46**

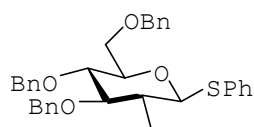

**3.45**

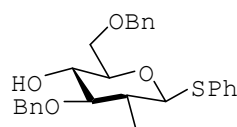

**3.46**

Zinc powder (54.21 mg, 0.83 mmol) was weighed into a 50 ml two-necked Round-bottom flask which had been carefully dried

and flushed with nitrogen. Dry tetrahydrofuran (1 ml) and chlorotrimethylsilane (0.01 ml, 0.08 mmol) were added to the zinc dust and the resulting mixture stirred for 30 min at room temperature. Alkyl iodide (186 mg, 0.28 mmol) was dissolved in dry tetrahydrofuran (9 ml) under nitrogen. Phenyl 3,4,6-Tri-O-benzyl-2-deoxy-2-C-Iodomethyl-1-thio- $\alpha$ -D-Glucopyranoside **1.34** was transferred *via* syringe to the zinc mixture at  $-78^{\circ}\text{C}$  and allowed to warm to ambient temperature with stirring. After 1 hour of stirring the starting material was fully consumed, the mixture was exposed to air. The reaction was then diluted with ethyl acetate (50 ml) and extracted. The organic fractions were washed with brine, dried over sodium sulphate and concentrated under vacuum. The purification by preparative TLC (EtOAc:Petroleum ether, 1:20) afforded **3.45** in 16% and **3.46** in 49% as both colourless oils.

**3.45:**  $^1\text{H}$  NMR (400 MHz,  $\text{CDCl}_3$ )  $\delta_{\text{H}}$  7.66–7.61 (2H, m, SPh-H), 7.40–7.22 (18H, m, SPh-H&Ph-H), 4.92 (1H, d,  $J$  10.9 Hz, Ph-CH-), 4.84 (1H, d,  $J$  10.9 Hz, Ph-CH-), 4.69–4.56 (4H, m, Ph-CH-), 4.46 (1H, d,  $J$  10.5 Hz, H-1), 3.83 (1H, dd,  $J$  2.0 & 10.8 Hz, H-6a), 3.78 (1H, dd,  $J$  4.7 & 10.9 Hz, H-6b), 3.66–3.60 (1H, m, H-4), 3.57–3.51 (1H, m, H-5), 3.33–3.26 (1H, m, H-3), 1.98–1.84 (1H, m, H-2), 1.20 (3H, d,  $J$  6.55 Hz,  $\text{CH}_3$ -);  $^{13}\text{C}$  NMR (100 MHz,  $\text{CDCl}_3$ )  $\delta_{\text{C}}$  138.4–127.2 (3xPh), 88.9 (C-1), 86.6, 79.4, 79.2, 75.5, 74.7, 73.4, 69.3, 42.0, 14.8 ( $\text{CH}_3$ -); Elemental Anal. calcd for  $\text{C}_{34}\text{H}_{36}\text{O}_4\text{S}$  : C, 75.52; H, 6.71; S, 5.93, Found: C, 75.45; H, 6.50; S, 6.10.

**3.46:**  $^1\text{H}$  NMR (400 MHz,  $\text{CDCl}_3$ )  $\delta_{\text{H}}$  7.60–7.54 (2H, m, SPh-H), 7.36–7.21 (13H, m, SPh-H&Ph-H), 4.80 (1H, d,  $J$  11.5 Hz, Ph-CH-), 4.62–4.51 (3H, m, Ph-CH-), 4.44 (1H,  $J$  10.5 Hz, H-1), 3.77 (1H, dd,  $J$  2.0 & 10.9 Hz, H-6a), 3.71 (1H, dd,  $J$  4.6 & 10.9 Hz, H-6b), 3.51–3.39 (3H, m, H-3,4&5), 1.86–1.73 (1H, m, H-2), 1.14 (3H, d,  $J$  6.6 Hz,  $\text{CH}_3$ -);  $^{13}\text{C}$  NMR (100 MHz,  $\text{CDCl}_3$ )  $\delta_{\text{C}}$  138.5–127.2 (3xPh), 88.6 (C-1), 79.7, 79.5, 79.3, 74.6, 73.3, 69.5,

43.0, 15.3(CH<sub>3</sub>-); Elemental Anal. calcd for C<sub>27</sub>H<sub>30</sub>O<sub>4</sub>S : C, 71.97; H, 6.71; S, 7.12, Found: C, 71.70; H, 6.30; S, 7.01.

**3,4,6-tri-O-benzyl-1,5-anhydro-2-deoxy-1,2-cyclopropylcarbinyl**

**acetate-D-Glycerol-D-gulo-hexitol 3.47**

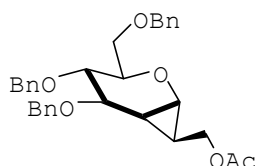

**3.47**

To a stirred suspension of LiAlH<sub>4</sub> (2.03 g, 5.37 mmol) in dry Et<sub>2</sub>O (40 ml) was added slowly a solution of 3,4,6-Tri-O-benzyl-1,5-anhydro-2-deoxy-1,2-cyclopropylcarbinyl-D-Glycerol-D-gulo-hexitol Ethyl Ester **2.237** (2.7 g, 5.37 mmol) in Et<sub>2</sub>O (10 ml). The reaction mixture was stirred for 1 hour at 25°C when TLC showed the reaction was complete. The reaction mixture was then diluted with ether, cooled to 0°C and quenched by careful and slow addition of water (8 ml) and 15% aqueous NaOH (8 ml). A further portion of water (24 ml) was added and the mixture was left to warm up to room temperature for 15 min. Magnesium Sulphate was added as a drying agent and the slurry stirred again for 15 min, the mixture was decanted to remove the salts formed since the use of frit was difficult due to its blockage by the salt. The solvent was removed to yield cyclopropylcarbinol **3.52a** (1.63 g, 3.5 mmol). This was immediately acetylated, without further purification, by dissolving in THF (20 ml) and adding Ac<sub>2</sub>O (1.92 ml, 20.4 mmol), DMAP (41.4 mg, 0.34 mmol) and TEA (1.87 ml, 13.6 mmol) in THF (20 ml). The reaction was complete after 30 minutes of stirring at room temperature as monitor by TLC. The reaction mixture was diluted in dichloromethane and poured in iced water with stirring. The organic layer was separated and washed successively with water and brine, dried over MgSO<sub>4</sub>,

filtered and then concentrated on rotary evaporator. The crude was purified by column chromatography on silica gel (EtOAc/petroleum ether 2:8). And the product **3.47** was obtained as oil (1.26 g, 71% over two steps).

IR (CHCl<sub>3</sub>/cm<sup>-1</sup>) 1734, 1452, 1364; <sup>1</sup>H NMR (400 MHz, CDCl<sub>3</sub>): δ<sub>H</sub> 7.38-7.27 (15H, m, Ar-H), 4.77 (2H, 2d, *J* 10.7 Hz & 11.5 Hz, Ph-CH<sub>2</sub>-), 4.63 (1H, d, *J* 11.8 Hz, Ph-CH-), 4.58 (1H, d, *J* 11.6 Hz, Ph-CH-), 4.56 (1H, d, *J* 12.0 Hz, Ph-CH-), 4.55 (1H, d, *J* 11.1 Hz, Ph-CH-), 3.90 (2H, d, *J* 7.5 Hz, H-3'), 3.79 (1H, dt, *J* 3.7 & 6.0 Hz, H-6a), 3.7-3.66 (2H, m, H-3&4), 3.58-3.52 (3H, m, H-1,5&6b), 2.07 (3H, s, COCH<sub>3</sub>), 1.46-1.43 (1H, m, H-2'), 1.04-1.01 (1H, m, H-2); <sup>13</sup>C NMR (100 MHz, CDCl<sub>3</sub>): δ<sub>C</sub> 170.8 (C=O), 138.2, 137.9, 128.2, 128.1, 127.7, 127.5, 127.4, 127.3, 78.4, 76.6 (C-1), 76.1, 73.2, 73.1, 70.9, 69.6, 64.4 (C-3'), 53.9, 23.0 (CH<sub>3</sub>), 20.7 (C-2'), 20.2 (C-2); Found: C, 73.39 ; H, 6.54 calcd for C<sub>31</sub>H<sub>34</sub>O<sub>6</sub>: C, 74.08; H, 6.82; [M+Na] calcd for C<sub>31</sub>H<sub>34</sub>NaO<sub>6</sub>: 525.2253 found for C<sub>31</sub>H<sub>34</sub>NaO<sub>6</sub>: 525.2244

**General Reaction Protocols for C-2 alkylation of Tri-O-benzyl-1,5-anhydro-2-deoxy-1,2-Cyclopropylcarbinyllacetate-D-Glycerol-D-gulo-hexitol 3.47**

**General procedure for BF<sub>3</sub>.OEt<sub>2</sub>-catalyzed Ferrier-type rearrangement reaction with Tri-O-benzyl-1,5-anhydro-2-deoxy-1,2-Cyclopropylcarbinyllacetate-D-Glycerol-D-gulo-hexitol donor 3.47**

Method A:

To a solution of 3,4,6-Tri-O-benzyl-1,5-anhydro-2-deoxy-1,2-Cyclopropylcarbinyllacetate-D-Glycerol-D-gulo-hexitol **3.47** (0.2 g, 0.397 mmol, 1.0eq.) in CH<sub>2</sub>Cl<sub>2</sub> (5 ml) at 0°C was added the acceptor (1.19 mmol, 3.0 eq.) and boron trifluoride diethyl etherate triflate (2.02 mmol, 5.1 eq.). The reaction mixture was stirred for 1 hour at 40°C. After TLC had shown completion

of the reaction, the reaction mixture was diluted with EtOAc, and then the EtOAc phase washed with aq. NaCl, separated from the aqueous phase, dried over Na<sub>2</sub>SO<sub>4</sub> and the solvent under vacuum. The residue was purified by silica gel column chromatography (EtOAc/petroleum ether 2:8) to give the corresponding product.

**General procedure for Al(OTf)<sub>3</sub>-catalyzed Ferrier-type rearrangement reaction with Tri-*O*-benzyl-1,5-anhydro-2-deoxy-1,2-Cyclopropylcarbinyllacetate-*D*-Glycerol-*D*-gulo-hexitol donor 3.47**

Method B:

To a solution of 3,4,6-Tri-*O*-benzyl-1,5-anhydro-2-deoxy-1,2-Cyclopropylcarbinyllacetate-*D*-Glycerol-*D*-gulo-hexitol **3.47** (0.2 g, 0.397 mmol, 1.0 eq.) in CH<sub>3</sub>CN (5 ml) at 25°C was added the acceptor (1.19 mmol, 3.0 eq.) and aluminium triflate (2.02 mmol, 5.1 eq.). The reaction mixture was stirred for 1 hour at 40°C. After TLC had shown completion of the reaction, the reaction mixture was diluted with EtOAc, and then the EtOAc phase washed with aq. NaCl, separated from the aqueous phase, dried over Na<sub>2</sub>SO<sub>4</sub> and the solvent removed under vacuum. The residue was purified by silica gel column chromatography (EtOAc/petroleum ether 2:8) to give the corresponding product.

**1,3,4,6-tetra-*O*-benzyl-2-deoxy-2-*C*-vinyl- $\alpha$ -*D*-glucopyranoside**

**3.48**

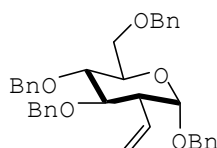

**3.48**

**3.47** (0.2 g, 0.397 mmol) was treated with benzyl alcohol (0.123 ml, 1.19mmol) using Method B provided the crude

product, which was purified by silica gel column chromatography, to give the  $\alpha$ -isomer of the vinyl glycoside **3.48** as an oil (0.117 g, 54%).

$^1\text{H}$  NMR (400 MHz,  $\text{CDCl}_3$ ):  $\delta_{\text{H}}$  7.42–7.26 (18H, m, Ph-H), 7.21 (2H, m, Ph-H), 5.93 (1H, td,  $J$  9.5 & 17.1 Hz, H-2'), 5.28 (1H, dd,  $J$  1.5 & 17.2 Hz, H-3'a), 5.23 (1H, dd,  $J$  1.9 & 10.2 Hz, H-3'b), 4.88 (1H, d,  $J$  3.6 Hz, H-1), 4.87 (1H, d,  $J$  10.6 Hz, Ph-CH-), 4.74 (1H, d,  $J$  11.4 Hz, Ph-CH-), 4.72 (1H, d,  $J$  10.4 Hz, Ph-CH-), 4.71 (1H, d,  $J$  10.6 Hz, Ph-CH-), 4.69 (1H, d,  $J$  12.1 Hz, Ph-CH-), 4.56 (1H, d,  $J$  12.8 Hz, Ph-CH-), 4.56 (1H, d,  $J$  10.1 Hz, Ph-CH-), 4.50 (1H, d,  $J$  12.0 Hz, Ph-CH-), 3.94 (2H, m, H-3&6a), 3.81 (1H, dd,  $J$  3.9 & 10.6 Hz, H-6b), 3.71 (2H, m, H-4&5), 2.64 (1H, m, H-2);  $^{13}\text{C}$  NMR (75 MHz,  $\text{CDCl}_3$ ):  $\delta_{\text{C}}$  138.4, 138.3, 138, 137.5, 135.1 (C-2'), 128.2, 128.12, 128.1, 127.8, 127.6, 127.5, 127.4, 118.6 (C-3'), 99.8 (C-1), 80.5, 78.6, 74.8, 74.6, 73.3, 71, 69, 67.7, 52.5 (C-2); Elemental Anal. calcd for  $\text{C}_{36}\text{H}_{38}\text{O}_5$ : C, 78.52; H, 6.96; Found: C, 78.88; H, 6.34; [M+Na] calcd for  $\text{C}_{35}\text{H}_{38}\text{NaO}_5$ : 573.2617 found for  $\text{C}_{35}\text{H}_{38}\text{NaO}_5$ : 573.2634

**(2R,5S)-5-(benzyloxy)-6-(benzyloxymethyl)-2-methyl-5,6-dihydro-2H-pyran-3-carbaldehyde 3.49**

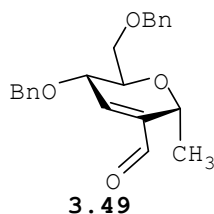

**3.47** (0.1 g, 0.198 mmol) with acetic acid (0.3 ml, 5.24 mmol) by using Method B with  $\text{Al}(\text{OTf})_3$  (0.02 g, 0.058 mmol) in DCM (5 ml) provided the crude product, which was purified by silica gel column chromatography (EtOAc:Petroleum ether, 2:8), to give the  $\alpha$ -isomer of the glycoside **3.49** as an oil (0.054 g, 59%).

$^1\text{H}$  NMR (400 MHz,  $\text{CDCl}_3$ ):  $\delta_{\text{H}}$  9.40 (1H, s, CHO), 7.35–7.23 (10H, m, Ar-H), 6.74 (1H, s, H-3), 4.67 (1H, d,  $J$  11.4 Hz, Ph-CH), 4.63 (1H, d,  $J$  12.3 Hz, Ph-CH), 4.56 (1H, d,  $J$  12.3 Hz, Ph-CH), 4.53 (1H, d,  $J$  11.3 Hz, Ph-CH), 4.5 (1H, ddd,  $J$  1.8, 2.5 & 6.5 Hz, H-1), 4.26 (1H, dt,  $J$  2.0 & 8.6 Hz, H-4), 3.75 (2H, dd,  $J$  2.0 & 10.8 Hz, H-6a&b), 3.45–3.40 (1H, ddd,  $J$  2.0, 4.6 & 8.7 Hz, H-5), 1.39 (3H, d,  $J$  6.6 Hz,  $\text{CH}_3$ );  $^{13}\text{C}$  NMR (100 MHz,  $\text{CDCl}_3$ ):  $\delta_{\text{C}}$  191.8 (CHO), 147.4 (C-3), 144.3 (C-2), 138.1, 137.3, 128.5, 128.3, 128.1, 128.0, 127.9, 127.6, 75.9, 73.5, 72.1; 70.9, 70.6 (C-1), 69.0, 19.6 ( $\text{CH}_3$ ). The spectroscopic data were consistent with the published data.<sup>18</sup>

**Phenyl 3,4,6-tri-*O*-benzyl-2-deoxy-1-thio-2-*C*-vinyl- $\alpha/\beta$ -*D*-glucopyranoside 3.52b**

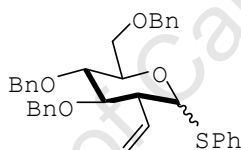

**3.52b**

**3.47** (250 mg, 0.397 mmol) was treated with thiophenol (0.2 ml, 1.69 mmol) using Method B provided the crude product, which was purified by silica gel column chromatography, to give the vinyl thioglycoside **3.52b**. The product was obtained as crystal (0.157 g, 72%) in 1:1 ratio of  $\alpha$  and  $\beta$ , respectively.

$^1\text{H}$  NMR (400 MHz,  $\text{CDCl}_3$ ):  $\delta_{\text{H}}$  7.57–7.55 (0.918H, m, SPh-H- $\beta$ ), 7.51–7.49 (1.08H, m, SPh-H- $\alpha$ ), 7.36–7.28 (8.10H, m, Ph-H- $\alpha$ ), 7.27–7.24 (8.10H, m, Ph-H- $\beta$ ), 5.90 (0.541H, td,  $J$  9.6 & 16.9 Hz, H-2' $\alpha$ ), 5.68 (0.459H, td,  $J$  9.6 Hz & 16.9 Hz, H-2' $\beta$ ), 5.47 (0.541H, d,  $J$  5.0 Hz, H-1 $\alpha$ ), 5.30 (2H, m, H-3' $\alpha$ & $\beta$ ), 4.87 (0.459H, d,  $J$  10.9 Hz, Ph-CH- $\beta$ ), 4.86 (0.541H, d,  $J$  11.0 Hz, Ph-CH- $\alpha$ ), 4.74 (1H, d,  $J$  16.1 Hz, Ph-CH- $\alpha,\beta$ ), 4.73 (1H, d,  $J$  16.3 Hz, Ph-CH- $\alpha,\beta$ ), 4.64 (0.541H, d,  $J$  12.0 Hz, Ph-CH- $\beta$ ), 4.64 (0.459H, d,  $J$  7.5 Hz, H-1 $\beta$ ), 4.63 (0.541H, d,  $J$  11.4 Hz, Ph-CH- $\beta$ ), 4.58 (0.459H, d,  $J$  10.8 Hz, Ph-CH- $\beta$ ), 4.57 (0.541H,

d,  $J$  11.9 Hz, Ph-CH- $\alpha$ ), 4.48 (0.541H, d,  $J$  11.9 Hz, Ph-CH- $\alpha$ ), 3.87-3.48 (5H, m, H-3,4,5,6a&6b $\alpha,\beta$ ), 2.99 (0.541H, ddd,  $J$  4.8, 9.4 & 10.5 Hz, H-2 $\alpha$ );  $^{13}\text{C}$  NMR (75 MHz,  $\text{CDCl}_3$ ):  $\delta_{\text{C}}$  138.4, 138.38, 138.3, 138.2, 138.1, 138.09, 135.1(C-2' $\alpha$ ), 134.2(C-2' $\beta$ ), 132, 131, 128.8, 128.7, 128.4, 128.4, 128.34, 128.3, 128, 127.9, 127.8, 127.7, 127.67, 127.6, 127.5, 127.3, 127, 119.6(C-3' $\beta$ ), 119.3(C-3' $\alpha$ ), 89.6(C-1 $\alpha$ ), 85.7, 84.3, 80.9, 79.5, 78.9, 78.4, 75.2, 75, 74.9, 74.7, 73.4(C-1 $\beta$ ), 72, 69.4, 68.8, 53(C-2 $\alpha$ ), 52.7(C-2 $\beta$ ); Elemental Anal. calcd for  $\text{C}_{35}\text{H}_{36}\text{O}_4\text{S}$ : C, 76.06; H, 6.56; S, 5.80; Found: C, 76.51; H, 6.73; S, 5.50; [M+Na] calcd for  $\text{C}_{35}\text{H}_{36}\text{NaO}_4\text{S}$ : 575.2232 found for  $\text{C}_{35}\text{H}_{36}\text{NaO}_4\text{S}$ : 575.2250.

**1-O-Allyl 3,4,6-tri-O-benzyl-2-deoxy-2-C-vinyl- $\alpha$ -D-glucopyranoside 3.52c**

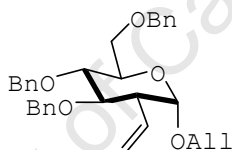

**3.52c**

**3.47** (0.2 g, 0.397 mmol) was treated with allyl alcohol (0.125 ml, 2.52 mmol) using Method B provided the crude product, which was purified by silica gel column chromatography, to give the  $\alpha$ -isomer of the vinylallylglycoside **3.52c**. The product was obtained as oil (0.352 g, 74%).

$^1\text{H}$  NMR (400 MHz,  $\text{CDCl}_3$ ):  $\delta_{\text{H}}$  7.36-7.16 (15H, m, Ph-H), 5.95-5.80 (2H, m, H-2' &  $\text{OCH}_2\text{CHCH}_2$ ), 5.31-5.13 (4H, m, H-3' &  $\text{OCH}_2\text{CHCH}_2$ ), 4.83 (1H, d,  $J$  10.8 Hz, Ph-CH-), 4.77 (1H, d,  $J$  3.3 Hz, H-1), 4.69-4.62 (3H, m, Ph- $\text{CH}_2$ - & Ph-CH-), 4.51 (2H, d,  $J$  11.7 Hz, Ph- $\text{CH}_2$ -), 4.16 (1H, tdd,  $J$  1.5, 5.1 & 13.2 Hz, H-6a), 3.94 (1H, tdd,  $J$  1.4, 5.8 & 13.1 Hz, H-6b), 3.86 (2H, m, H-3&5), 3.78 (1H, dd,  $J$  3.9 & 10.6 Hz, H-4) 3.68 (2H, dd,  $J$  1.7 & 10.5 Hz,  $\text{OCH}_2\text{CHCH}_2$ ), 2.58 (1H, m, H-2);  $^{13}\text{C}$  NMR ( $\text{CDCl}_3$ , 75 MHz):  $\delta_{\text{C}}$  138.5, 138.4, 138.1, 135.3(C-2'), 134( $\text{OCH}_2\text{CHCH}_2$ ), 128.3, 128.2,

128, 127.8, 127.6, 118.7(C-3'), 116.8(OCH<sub>2</sub>CHCH<sub>2</sub>), 99.7(C-1), 80.6, 78.7, 74.9, 74.8, 73.4, 71, 69.9, 67.9, 52.6(C-2); Elemental Anal. calcd for C<sub>32</sub>H<sub>36</sub>O<sub>5</sub>: C, 78.53; H, 7.04; Found: C, 78.05; H, 6.87; [M+Na] calcd for C<sub>32</sub>H<sub>36</sub>NaO<sub>5</sub>: 523.2460 found for C<sub>32</sub>H<sub>36</sub>NaO<sub>5</sub>: 523.2480

**Azido 3,4,6-Tri-O-benzyl-2-deoxy-2-C-vinyl- $\alpha/\beta$ -D-glucopyranoside 3.52d**

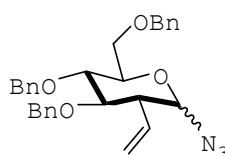

**3.52d**

**3.47** (0.2 g, 0.397 mmol) was treated with TMSN<sub>3</sub> (0.18 ml, 1.78 mmol) using Method B provided the crude product, which was purified by silica gel chromatography, to give the vinyl Azidoglycoside **3.52d**. The product was obtained as oil (0.150 g, 78%) in 2:1 ratio of  $\alpha$  and  $\beta$ , respectively.

IR (CHCl<sub>3</sub>/cm<sup>-1</sup>) 2114(N<sub>3</sub>); <sup>1</sup>H NMR (400 MHz, CDCl<sub>3</sub>):  $\delta$ <sub>H</sub> 7.38–7.20 (15H, m, Ph-H), 5.75–5.61 (1H, m, H-2' $\alpha/\beta$ ), 5.42–5.26 (1.66H, m, H-1 $\alpha$ &3' $\alpha,\beta$ ), 4.85 (1H, d, *J* 11.0 Hz, Ph-CH-), 4.73 (1H, d, *J* 10.8 Hz, Ph-CH-), 4.67 (1H, d, *J* 12.4 Hz, Ph-CH-), 4.62 (1H, d, *J* 10.9 Hz, Ph-CH-), 4.60 (1H, d, *J* 12.3 Hz, Ph-CH-), 4.56 (1H, d, *J* 10.9 Hz, Ph-CH-), 4.55 (1H, d, *J* 12.1 Hz, Ph-CH-), 4.50 (0.33H, d, *J* 9.6 Hz, H-1 $\beta$ ), 4.03–3.96 (0.66H, m, H-4 $\alpha$ ), 3.86–3.65 (3.63H, m, H-3 $\alpha,5\alpha,\beta,6\alpha,a,b,6\beta,a,b$ ), 3.61–3.55 (0.33H, m, H-4 $\beta$ ), 3.55–3.47 (0.33H, m, H-3 $\beta$ ), 2.69–2.59 (0.66H, m, H-2 $\alpha$ ), 2.53–2.42 (0.33H, m, H-2 $\beta$ ); <sup>13</sup>C NMR (75 MHz, CDCl<sub>3</sub>):  $\delta$ <sub>C</sub> 138.2, 138, 137.9, 134(C-2' $\alpha$ ), 133(C-2' $\beta$ ), 128, 127.8, 127.7, 127.69, 127.64, 120.6(C-3' $\alpha$ ), 120.1(C-3' $\beta$ ), 91.4(C-1 $\alpha$ ), 89(C- $\beta$ ), 79.9, 76.7, 78.1, 77.9, 77.5, 75, 74.9, 73.6, 73.5, 73.3, 68.7, 68.5, 53(C- $\alpha$ ), 51.5(C-2 $\beta$ ); Elemental Anal. calcd for C<sub>29</sub>H<sub>31</sub>N<sub>3</sub>O<sub>4</sub>: C, 71.73; H, 6.43; N, 8.65; Found: C, 71.26; H,

6.48; S, 8.18; [M+Na] calcd for  $C_{29}H_{31}N_3NaO_4$ : 508.2212 found for  $C_{29}H_{31}N_3NaO_4$ : 508.2216

**(1S, 3S, 4S, 5R, 6R)-4,5-bis(benzyloxy)-3-(benzyloxymethyl)-2-oxabicyclo[4.1.0]heptane-7-carboxylic acid, 3.53**

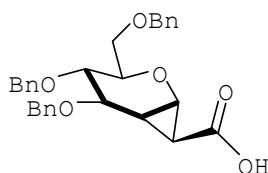

**3.53**

To a stirred solution of **2.237** (0.286 g, 0.570 mmol) in ethanol (5 ml) was added aqueous KOH (3 M, 2 ml). The reaction mixture was gently refluxed for 1 h and then cooled to 0 °C and made slightly acidic by the addition of aqueous HCl (2 M) with stirring; it was then extracted with EtOAc. The combined extracts were washed with brine, dried (MgSO<sub>4</sub>) and evaporated. Filtration of the residue through a short silica gel column (2:8, EtOAc:Petroleum ether) gave the acid **3.53** in quantitative yield.

mp: 71–73 °C; IR (CHCl<sub>3</sub>/cm<sup>-1</sup>) 1760 (C=O); <sup>1</sup>H NMR (400 MHz, CDCl<sub>3</sub>): δ<sub>H</sub> 7.31–7.20 (15H, m, Ar-H), 4.71 (2H, d, *J* 11.6 Hz, 2x Coincident benzylic CH- in AB system), 4.61–4.50 (4H, m, 2x benzylic CH<sub>2</sub>-), 4.00 (1H, dd, *J* 2.1 & 7.3 Hz, H-1), 3.78 (1H, dd, *J* 2.7 & 6.2 Hz, H-3), 3.72–3.66 (2H, m, H-4&6a), 3.60 (2H, dd, *J* 5.3 & 7.5 Hz, H-5&6b), 1.99 (1H, dd, *J* 2.0 & 5.5 Hz, H-2'), 1.83 (1H, ddd, *J* 2.1, 5.6 & 7.5 Hz, H-2), <sup>13</sup>C NMR (100 MHz, CDCl<sub>3</sub>): δ<sub>C</sub> 176.4 (C=O), 138.0, 128.4, 128.3, 127.8, 127.7, 127.69, 127.63, 76.2, 75.19, 74.4, 73.4, 73.3, 71.5, 69.2, 58.2 (C-1), 25.4 (C-2), 24.1 (C-2'); Found: C, 73.55; H, 7.06 calcd for C<sub>29</sub>H<sub>30</sub>O<sub>6</sub>: C, 73.40; H, 6.37; [M+Na] calcd for C<sub>29</sub>H<sub>30</sub>O<sub>6</sub>: 497.1940 found for C<sub>29</sub>H<sub>30</sub>NaO<sub>6</sub>: 497.1954

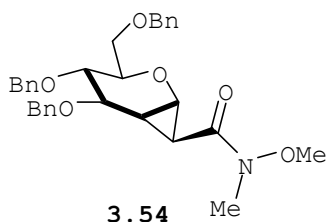
**(1S,3S,4S,5R,6R)-4,5-bis(benzyloxy)-3-(benzyloxymethyl)-N-methoxy-N-methyl-2-oxabicyclo[4.1.0]heptane-7-carboxamide 3.54**

To a solution of the acid **3.53** (0.650 g, 1.37 mmol) in THF (8 mL), at room temperature, were added 2-chloro-4,6-dimethoxy-[1,3,5]triazine (0.288 g, 1.644 mmol) and N-methylmorpholine (0.382 mL, 4.110 mmol). A white precipitate was formed during stirring for 1 h, and then N,O-dimethylhydroxylamine hydrochloride (0.133 g, 1.37 mmol) was added. The mixture was stirred overnight and then quenched with 15 mL of H<sub>2</sub>O and extracted two times with 7 mL of diethyl ether. The combined organic phases were washed two times with 15 mL of a saturated solution of Na<sub>2</sub>CO<sub>3</sub>, followed by 15 mL of a solution 1N HCl and brine. The organic layer was dried over anhydrous Na<sub>2</sub>SO<sub>4</sub> to give, after evaporation of solvent; the amide **3.54** was isolated pure without other purifications (0.682 mg, 96%): mp: 87–89 °C; IR (CHCl<sub>3</sub>/cm<sup>-1</sup>) 1660, 1450, 1415; <sup>1</sup>H NMR (400 MHz, CDCl<sub>3</sub>): δ<sub>H</sub> 7.34–7.27 (15H, m, Ar-H), 4.72 (1H, d, *J* 11.7 Hz, Ph-CH-), 4.68 (1H, d, *J* 11.3 Hz, Ph-CH-), 4.57–4.50 (4H, m, 2xPh-CH<sub>2</sub>-), 3.90 (1H, dd, *J* 2.1 & 7.2 Hz, H-1), 3.81–3.74 (2H, m, H-3&4), 3.71 (1H, dd, *J* 6.0 & 10.3 Hz, H-6a), 3.65 (3H, s, OCH<sub>3</sub>-), 3.61–3.55 (2H, m, H-5&6b), 3.16 (3H, s, CH<sub>3</sub>-), 2.54–2.43 (1H, br.s, H-2'), 1.86 (1H, ddd, *J* 2.1, 5.8 & 7.5 Hz, H-2); <sup>13</sup>C NMR (100 MHz, CDCl<sub>3</sub>): δ<sub>C</sub> 171.7 (C=ON(OCH<sub>3</sub>)(CH<sub>3</sub>)), 138.2, 138.1, 137.9, 128.4, 128.35, 128.32, 127.8, 127.65, 127.61, 76.2, 75.6, 74.6, 73.43, 73.1, 71.2, 69.3, 61.6 (N-OCH<sub>3</sub>), 57.6 (C-1), 32.5 (N-CH<sub>3</sub>), 23.9 (C-2), 22.2 (C-2'); Found: C, 72.46; H, 6.50; N, 2.14 calcd for C<sub>31</sub>H<sub>35</sub>NO<sub>6</sub>: C, 71.93; H, 6.82;

N, 2.71; [M+Na] calcd for  $C_{31}H_{35}NNaO_6$ : 540.2344 found for  $C_{31}H_{35}NNaO_6$ : 540.2344

**1-((1S,3S,4S,5R,6R)-4,5-bis(benzyloxy)-3-(benzyloxymethyl)-2-oxabicyclo[4.1.0]heptan-7-yl)pentan-1-one 3.55**

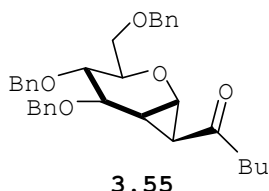

To a solution of **3.54** (0.100 g, 0.193 mmol) in dry THF (5 ml) at  $-78^{\circ}\text{C}$  was added a solution of *n*-BuLi 2.5 M (0.716 ml, mmol). After 1 hour at  $-78^{\circ}\text{C}$  the amide was fully consumed. The reaction was stopped and diluted with diethylether. Water was then added and the aqueous layer was extracted. The combined organic extracts were dried over  $\text{MgSO}_4$ , filtered and concentrated in vacuo. Purification of the crude by column chromatography (100% Petroleum ether and then 1:9, Ethyl acetate: Petroleum ether) afforded **3.55** (0.0728 mg, 74%) as an oil.

IR ( $\text{CHCl}_3/\text{cm}^{-1}$ ) 1690 (C=O);  $^1\text{H}$  NMR (400 MHz,  $\text{CDCl}_3$ ):  $\delta_{\text{H}}$  7.33–7.18 (15H, m, Ar-H), 4.68 (1H, d,  $J$  8.1 Hz, Ph-CH-), 4.65 (1H, d,  $J$  8.4 Hz, Ph-CH-), 4.56–4.47 (4H, m, 2xPh-CH<sub>2</sub>-), 3.82 (1H, dd,  $J$  1.9 & 7.1 Hz, H-1), 3.72 (2H, td,  $J$  2.9, 6.1 & 6.2 Hz, H-3&4), 3.66 (1H, dd,  $J$  6.0 & 10.3 Hz, H-6a), 3.65 (2H, dt,  $J$  4.8, 4.8 & 8.8 Hz, H-5&6b), 2.49 (2H, dd,  $J$  7.6 & 15.2, -CH<sub>2</sub>CH<sub>2</sub>CH<sub>2</sub>CH<sub>3</sub>), 2.28 (1H, dd,  $J$  1.9 & 5.6 Hz, H-2'), 1.95–1.90 (1H, m, H-2), 1.59–1.49 (2H, m, -CH<sub>2</sub>CH<sub>2</sub>CH<sub>3</sub>), 1.30 (2H, dd,  $J$  7.4&14.9 Hz, -CH<sub>2</sub>CH<sub>3</sub>), 0.88 (3H, t,  $J$  7.3 Hz, -CH<sub>3</sub>);  $^{13}\text{C}$  NMR (100 MHz,  $\text{CDCl}_3$ ):  $\delta_{\text{C}}$  207.4 (C=O), 138.2, 138.1, 137.9, 128.4, 128.3, 127.8, 127.79, 127.73, 127.6, 76.1, 75.4, 74.5, 73.4, 73.2, 71.3, 69.2, 60.3 (C-1), 43.7 (-CH<sub>2</sub>CH<sub>2</sub>CH<sub>2</sub>CH<sub>3</sub>), 32.3 (C-2'), 26.3 (C-2), 26.1 (-CH<sub>2</sub>CH<sub>2</sub>CH<sub>3</sub>), 22.3 (-CH<sub>2</sub>CH<sub>3</sub>), 13.8 (CH<sub>3</sub>-); Found:

C, 77.06; H, 7.43 calcd for  $C_{33}H_{38}O_5$ : C, 77.01; H, 7.44; [M+Na] calcd for  $C_{33}H_{38}NaO_5$ : 537.2617 found for  $C_{33}H_{38}NaO_5$ : 537.2592

**(1S)-1-((1R,4S,5R,6R,7R)-4,5-bis(benzyloxy)-3-(benzyloxymethyl)-2-oxabicyclo[4.1.0]heptan-7-yl)pentyl acetate 3.57(S) & 3.58(R)**

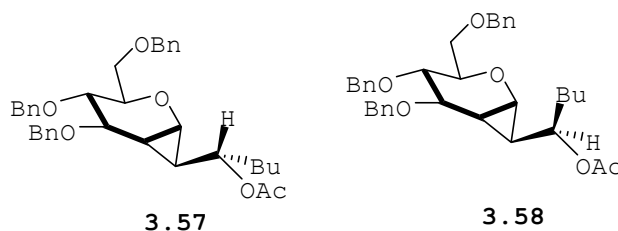

To a stirred suspension of  $LiAlH_4$  (0.00641 g, 0.169 mmol) in dry  $Et_2O$  (5 ml) was added slowly a solution of **3.55** (0.0728 g, 0.141 mmol) in  $Et_2O$  (5 ml). The reaction mixture was stirred for 1 hour at  $25^\circ C$  when TLC showed the reaction was complete. The reaction mixture was then diluted with ether, cooled to  $0^\circ C$  and quenched by careful and slow addition of water (5 ml) and 15% aqueous NaOH (5 ml). A further portion of water (15 ml) was added and the mixture was left to warm up to room temperature for 15 min. Magnesium Sulphate was added as a drying agent and the slurry stirred again for 15 min, the mixture was decanted to remove the salts formed since the use of frit was difficult due to its blockage by the salt. The solvent was removed to yield alcohol derivative **3.56** (0.0644 g, 0.115 mmol). This was immediately acetylated, without further purification, by dissolving in THF (10 ml) and adding  $Ac_2O$  (0.0744 ml, 0.69 mmol), DMAP (1.61 mg, 0.0115 mmol) and TEA (0.0728 ml, 0.46 mmol) in THF (10 ml). The reaction was complete after 30 minutes of stirring at room temperature as monitor by TLC. The reaction mixture was diluted in dichloromethane and poured in iced water with stirring. The organic layer was separated and washed successively with water and brine, dried over  $MgSO_4$ , filtered and then concentrated on

rotary evaporator. The crude was purified by column chromatography on silica gel (EtOAc/petroleum ether 2:8). And two isomers were obtained in 72% yield over two steps. **3.57** (0.044 mg, 48%) and **3.58** (0.020 mg, 24%).

**3.57:** IR ( $\text{CHCl}_3/\text{cm}^{-1}$ ) 1743 (C=O), 1270, 1048;  $^1\text{H}$  NMR (400 MHz,  $\text{CDCl}_3$ ):  $\delta_{\text{H}}$  7.38–7.26 (15H, m, Ar-H), 4.79 (1H, d,  $J$  11.6 Hz, Ph-CH-), 4.78 (1H, d,  $J$  11.8 Hz, Ph-CH-), 4.59–4.50 (4H, m, 4xPh-CH-), 4.35 (1H, td,  $J$  6.5 & 9.1 Hz, H-1), 3.77 (1H, td,  $J$  3.50, 5.99 & 6.01, H-5), 3.68 (1H, dd,  $J$  6.1 & 10.4 Hz, H-6a), 3.61 (1H, dd,  $J$  3.6 & 7.5 Hz, H-3), 3.56–3.50 (4H, m, H-3', 4&6b), 2.07 (3H, s,  $-\text{COCH}_3$ ), 1.73–1.66 (2H, m, H-2' & 6'a), 1.38–1.26 (5H, m, H-2, 4'a&b, 5'a&6'b), 1.20–1.16 (1H, m, H-5'b), 0.93 (3H, t,  $J$  7.1 Hz,  $-\text{CH}_3$ );  $^{13}\text{C}$  NMR (100 MHz,  $\text{CDCl}_3$ ):  $\delta_{\text{C}}$  170.7 (C=O), 138.4, 138.1 (2xC), 128.4, 128.3, 128.2, 127.9, 127.67, 128.61, 78.7, 77.1, 76.4, 75.1, 73.4 (C-1), 73.2, 70.5, 69.8, 54.1, 34.1, 29.0, 27.4, 22.5, 21.1, 20.53 ( $-\text{COCH}_3$ ), 13.8 ( $-\text{CH}_2-\text{CH}_3$ ); Found: C, 75.57; H, 7.93 calcd for  $\text{C}_{35}\text{H}_{42}\text{O}_6$ : C, 75.24; H, 7.58;  $[\text{M}+\text{Na}]$  calcd for  $\text{C}_{35}\text{H}_{42}\text{NaO}_6$ : 581.2879 found for  $\text{C}_{35}\text{H}_{42}\text{NaO}_6$ : 581.2872

**3.58:** IR ( $\text{CHCl}_3/\text{cm}^{-1}$ ) 1744 (C=O), 1270, 1048;  $^1\text{H}$  NMR (400 MHz,  $\text{CDCl}_3$ ):  $\delta_{\text{H}}$  7.38–7.26 (15H, m, Ar-H), 4.77 (1H, d,  $J$  11.6 Hz, Ph-CH-), 4.76 (1H, d,  $J$  11.8 Hz, Ph-CH-), 4.64–4.52 (4H, m, 4xPh-CH-), 4.39 (1H, ddd,  $J$  5.4, 7.4 & 8.4 Hz, H-1), 3.81 (1H, dt,  $J$  3.8 & 6.0, H-5), 3.71–3.67 (2H, m, H-4&6a), 3.63 (1H, dd,  $J$  2.4 & 7.2 Hz, H-3), 3.57–3.54 (2H, m, H-3' & 6b), 2.07 (3H, s,  $-\text{COCH}_3$ ), 1.67–1.62 (2H, m, H-2' & 6'a), 1.38–1.29 (5H, m, H-2, 4'a&b, 5'a&6'b), 1.01–0.96 (1H, m, H-5'b), 0.94 (3H, t,  $J$  7.1 Hz,  $-\text{CH}_3$ );  $^{13}\text{C}$  NMR (100 MHz,  $\text{CDCl}_3$ ):  $\delta_{\text{C}}$  170.7 (C=O), 138.4, 138.18, 138.14, 128.4, 128.36, 128.32, 127.9, 127.7, 128.6, 78.4, 76.46, 76.42, 73.8, 73.36 (C-1), 73.33, 71.3, 69.7, 53.3, 33.6, 28.1, 27.4, 22.5, 21.1, 20.35 ( $-\text{COCH}_3$ ), 13.9 ( $-\text{CH}_2-\text{CH}_3$ ); Found: C, 75.12; H, 7.20 calcd for  $\text{C}_{34}\text{H}_{40}\text{O}_5$ : C, 75.24; H,

7.58; [M+Na] calcd for C<sub>35</sub>H<sub>42</sub>NaO<sub>6</sub>: 581.2879 found for C<sub>35</sub>H<sub>42</sub>NaO<sub>6</sub>: 581.2872

**1,3,4,6-Tetra-O-benzyl-2-deoxy-2-C-cis/trans-hexenyl- $\alpha/\beta$ -D-Glucopyranoside 3.59**

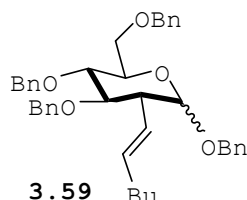

Compound **3.57** (0.04 g, 0.0714 mmol) was treated with BnOH (0.022 ml, 0.214 mmol) using Method B provided the crude product, which was purified by silica gel chromatography, to give the *trans*-alkene. The product **3.59** was obtained as oil (0.0295 g, 67%) in 100:1 ratio of  $\alpha$  and  $\beta$ , respectively and only *trans*-isomer.

<sup>1</sup>H NMR (400 MHz, CDCl<sub>3</sub>):  $\delta_{\text{H}}$  7.39–7.26 (20H, m, Ar-H), 5.65 (1H, td, *J* 6.6&15.4 Hz, H-3'), 5.50 (1H, tdd, *J* 1.2, 9.1&15.3 Hz, H-2'), 4.86 (1H, d, *J* 10.9 Hz, Ph-CH-), 4.81 (1H, d, *J* 3.4 Hz, H-1), 4.74–4.63 (4H, m, 4xPh-CH-), 4.57–4.48 (3H, m, 3xPh-CH-), 3.93–3.64 (5H, m, H-3,4,5&6a&b), 2.57 (1H, ddd, *J* 3.4, 9.2 & 10.6 Hz, H-2), 2.09–2.04 (2H, m, H-4'a&b), 1.37–1.29 (4H, m, H-5'a&b, H-6'a&b), 0.91 (3H, t, *J* 7.1 Hz, -CH<sub>3</sub>); <sup>13</sup>C NMR (100 MHz, CDCl<sub>3</sub>):  $\delta_{\text{C}}$  138.7, 138.5, 138.2, 137.9, 134.8 (C-3'), 128.3, 128.2, 127.7, 127.84, 127.80, 127.6, 127.56, 127.51, 126.6 (C-2'), 100.3 (C-1), 81.0, 78.8, 74.9, 74.8, 73.4, 71.2, 69.08, 69.01, 51.6 (C-2), 32.3, 31.4, 22.2, 13.9 (-CH<sub>3</sub>); Found: C, 78.90; H, 7.40 calcd for C<sub>40</sub>H<sub>46</sub>O<sub>5</sub>: C, 79.18; H, 7.64; [M+Na] calcd for C<sub>40</sub>H<sub>46</sub>NaO<sub>5</sub>: 629.3243 found for C<sub>40</sub>H<sub>46</sub>NaO<sub>5</sub>: 629.3234

**1,3,4,6-Tetra-O-benzyl-2-deoxy-2-C-cis/trans-hexenyl- $\alpha/\beta$ -D-Glucopyranoside 3.60**

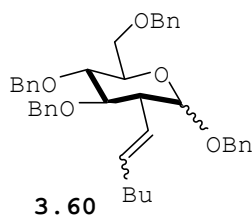

Compound **3.58** (0.02 g, 0.0357 mmol) was treated with BnOH (0.011 ml, 0.107 mmol) using Method B provided the crude product, which was purified by silica gel chromatography, to give an inseparable mixture of alkenes according to the NMR. The product **3.60** was obtained as oil (0.0189 g, 86%) in 100:3 ratio of  $\alpha$  and  $\beta$ , respectively and *cis:trans*-isomers (1:1).

$^1\text{H}$  NMR (400 MHz,  $\text{CDCl}_3$ ):  $\delta_{\text{H}}$  7.39–7.26 (20H, m, Ar-H), 5.67–5.59 (1H, m, H-3'), 5.53 (1H, tt,  $J$  1.2&7.8 Hz, H-2'), 4.86 (1H, d,  $J$  10.9 Hz, Ph-CH-), 4.82 (0.5H, d,  $J$  3.5 Hz, H-1-*cis*), 4.79 (0.5H, d,  $J$  3.5 Hz, H-1-*trans*), 4.74–4.63 (4H, m, 4xPh-CH-), 4.57–4.48 (3H, m, 3xPh-CH-), 3.93–3.64 (5H, m, H-3,4,5&6a&b), 2.98 (0.5H, dt,  $J$  3.3 & 10.1 Hz, H-2-*cis*), 2.57 (1H, ddd,  $J$  3.4, 9.2 & 10.6 Hz, H-2-*trans*), 2.09–2.04 (2H, m, H-4a&b), 1.37–1.29 (4H, m, H-5'a&b, H-6'a&b), 0.91 (1.5H, t,  $J$  7.1 Hz, -CH<sub>3</sub>-*cis*), 0.88 (1.5H, t,  $J$  5.3 Hz, -CH<sub>3</sub>-*trans*);  $^{13}\text{C}$  NMR (100 MHz,  $\text{CDCl}_3$ ):  $\delta_{\text{C}}$  138.8(C-*cis*), 138.7(C-*trans*), 138.55(C-*cis*), 138.51(C-*trans*), 138.2(C-*trans*), 138.1(C-*cis*), 137.9(C-*trans*), 137.8(C-*cis*), 134.8(C-3'*trans*), 133.8(C-*cis*), 128.3, 128.2, 128.1, 127.94, 127.91, 127.85, 127.80, 127.68, 127.68, 127.62, 127.56, 127.52, 127.4, 126.6(C-2'*trans*), 126.2(C-2'*cis*), 100.3(C-1-*trans*), 99.6(C-1-*cis*), 81.5(C-*cis*), 81.0(C-*trans*), 78.87(C-*cis*), 78.81(C-*trans*), 74.95(C-*trans*), 74.91(C-*cis*), 74.8(C-*trans*), 74.5(C-*cis*), 73.5(C-*cis*), 73.4(C-*trans*), 71.2(C-*trans*), 71.1(C-*cis*) 69.2(C-*cis*), 69.08(C-*trans*), 69.01(C-*trans*), 68.9(C-*cis*) 51.6(C-2-*trans*), 45.8(C-2-*cis*), 32.3(C-*trans*), 31.9(C-*cis*) 31.4(C-*trans*), 27.5(C-*cis*), 22.3(C-*cis*), 22.2(C-*trans*), 13.95(-CH<sub>3</sub>-*cis*) 13.9(-CH<sub>3</sub>-*trans*); Found:

C, 78.80; H, 7.20 calcd for  $C_{40}H_{46}O_5$ : C, 79.18; H, 7.64;  $[M+Na]$  calcd for  $C_{40}H_{46}NaO_5$ : 629.3243 found for  $C_{40}H_{46}NaO_5$ : 629.3217

**1-O-acetyl 3,4,6-Tri-O-benzyl-2-deoxy-2-C-iodomethylethylacetate- $\alpha/\beta$ -D-glucopyranoside 3.61**

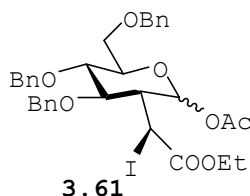

To a solution of **2.237** (1.0 g, 1.98 mmol) in AcOH/CH<sub>3</sub>CN (1:1, 20ml) was added NH<sub>4</sub>I (0.403 g, 2.78 mmol), and Ac<sub>2</sub>O (0.3 ml) and the resulting cooled to 0 °C. H<sub>2</sub>O<sub>2</sub> (2.0 ml of a 50% aqueous solution in water, 68.7 mmol) was added and the solution stirred for 18 hours at room temperature. When the TLC showed the reaction was complete a 0.1 M solution of Na<sub>2</sub>S<sub>2</sub>O<sub>3</sub> was then added until the brownish colour disappeared, and the solution was cooled in an ice-water bath before adding cold 10% aqueous NaOH until the solution became slightly basic. The resultant mixture was extracted with ethyl acetate, and the combined organic phases washed once with brine, then dried (MgSO<sub>4</sub>) and concentrated. The column chromatography gave a mixture of inseparable iodomethylethylacetate glucoside **3.61**. The product was obtained as oil (0.981 g, 72%) in 1:5 ratio of  $\alpha$  and  $\beta$ , respectively.

IR (CHCl<sub>3</sub>/cm<sup>-1</sup>) 1750, 1723, 1450, 1362(OAc)<sup>1</sup>H NMR (400 MHz, CDCl<sub>3</sub>):  $\delta_H$  7.37-7.26 (13H, m, Ph-H), 7.17-7.15 (0.33H, m, Ph-H- $\alpha$ ) 7.11-7.079 (1.7H, m, Ph-H- $\beta$ ), 6.48 (0.17H, d,  $J$  3.1 Hz, H-1 $\alpha$ ), 5.64 (0.83H, d,  $J$  8.6 Hz, H-1 $\beta$ ), 5.03 (0.33H, d,  $J$  11.0 Hz, Ph-CH- $\alpha$ ), 4.96 (0.83H, d,  $J$  10.8 Hz, Ph-CH- $\beta$ ), 4.82-4.79 (1.83H, m, Ph-CH- $\alpha$ & $\beta$ , 2' $\beta$ ), 4.73 (1H, d,  $J$  10.8 Hz, Ph-CH- $\alpha$ & $\beta$ ), 4.68 (1H, d,  $J$  12.0 Hz, Ph-CH- $\alpha$ & $\beta$ ), 4.66 (1H, d,  $J$  12.0 Hz, Ph-CH-  $\alpha$ & $\beta$ ), 4.60 (1H, d,  $J$  10.9 Hz, Ph-CH- $\alpha$ & $\beta$ ), 4.58 (1H, d,  $J$  10.68 Hz, Ph-CH- $\alpha$ & $\beta$ ), 4.53 (0.83H, d,  $J$  11.9 Hz, Ph-CH- $\alpha$ ), 4.52 (0.83H, d,  $J$  12.01 Hz, Ph-CH- $\beta$ ), 4.28 (0.17H, d,  $J$  10.2

Hz,  $H-2'\alpha$ ), 3.96-3.60 (7H, m,  $H-3,4,5,6a,b$  &  $CH_2-CH_3-\alpha$  &  $\beta$ ), 2.71 (0.17H, dt,  $J$  3.2 & 10.2 Hz,  $H-2\alpha$ ), 2.24 (0.83H, m,  $H-2\beta$ ), 2.18 (2.49H, s,  $CH_3-\beta$ ), 2.17 (0.5H, s,  $CH_3-\alpha$ ), 1.10 (2.49H, t,  $J$  7.2 Hz,  $CH_2-CH_3-\beta$ ), 1.06 (0.5H, t,  $J$  7.2 Hz,  $CH_2-CH_3-\alpha$ );  $^{13}C$  NMR (100 MHz,  $CDCl_3$ ):  $\delta_c$  168.8 (COOEt), 167 (O=CCH<sub>3</sub>), 138, 137.8, 137.7, 128.4, 128.2, 128.1, 128, 127.9, 127.8, 127.7, 127.5, 127.4, 127, 96.0 (C-1 $\beta$ ), 94.2 (C-1 $\alpha$ ), 81.4 (C- $\beta$ ), 80.7 (C- $\alpha$ ), 79.1 (C- $\beta$ ), 78.7 (C- $\alpha$ ), 75.6 (C- $\beta$ ), 75.1 (C- $\alpha$ ), 74.9 (C-2' $\alpha$ ), 74.75 (C-2' $\beta$ ), 74.7 (C- $\beta$ ), 73.7 (C- $\alpha$ ), .6 (C- $\beta$ ), 68.1 (C- $\beta$ ), 62.8 (C- $\beta$ ), 61.7 (C- $\alpha$ ), 48.8 (C-2 $\beta$ ), 45.7 (C-2 $\alpha$ ), 30.8 (C- $\alpha$ ), 25.7 (C- $\beta$ ), 21.5 (C- $\alpha$ ), 21 (C- $\beta$ ), 20.9 (C- $\alpha$ ), 13.8 (CH<sub>3</sub>); Elemental Anal. calcd for  $C_{33}H_{37}IO_8$ : C, 57.56; H, 5.42; Found: C, 57.40; H, 5.20; [M+Na] calcd for  $C_{33}H_{37}IO_8$ : 711.1431 found for  $C_{33}H_{37}IO_8$ : 711.1447.

---

**5.2 REFERENCES**

---

- [1] Buskas, T.; Garegg, P.J.; Konradsson, P.; Maloisel, J.L. *Tetrahedron: Asymmetry* **1994**, *5*, 2187
- [2] Xue, J.; Guo, Z., *Tetrahedron Letters*, **2001**, *42*, 6487-6489
- [3] Madhusudan, S.K.; Agnihotri, G.; Negi, D.S.; Misra, A.K.; *Carbohydr. Res.*, **2005**, *340*, 1373-1377
- [4] Gammon, D.W.; Kinfe, H.H.; De Vos, D.E.; Jacobs, P.A.; Sels, P.A. *J. Carbohydr. Chem.*, **2007**, *26*, 141-157
- [5] Timmers, C.M.; Leeuwenburgh, M.A.; Verheijen, J.C.; van der Marel, G.A.; van Boom, J.H. *Tetrahedron: Asymmetry*, **1996**, *7*, 49-52
- [6] a) Vasella, A.; Witzig, C.; Chiara, J.L.; Martin-Lomas, M. *Helv. Chim. Acta* **1991**, *74*, 2073; b) Titz, A.; Radic, Z.; Schwardt, O.; Ernst, B. *Tetrahedron Lett.* **2006**, *47*, 2383.
- [7] Pocsi, I.; Kiss, L.; Zsoldos-Mady, V.; Pinter, I. *Biochim. Biophys. Acta, Protein Struct. Mol. Enzymol.* **1990**, *1039*, 119.
- [8] Gilbert, B.; Davis, N.J.; Pearce, M.; Aplin, R.T.; Flitch, S.L. *Tetrahedron: Asymmetry* **1994**, *5*, 2163.
- [9] Matta, L.L.; Johnson, E.A.Z.; Girotra, R.N.; Barlow, J. *J. Carbohydr. Res.* **1973**, *30*, 414.
- [10] Leteux, C.; Veyrières, A.; Robert, F. *Carbohydr. Res.* **1993**, *242*, 119-130.
- [11] Cox, D.J.; Fairbanks, A.J. *Tetrahedron: Asymmetry* , **2009**, *20*, 773-780
- [12] Lichtenthaler, F.W.; Schneider-Adams, T., *J. Org. Chem.* **1994**, *59*, 6728-6734
- [13] Halcomb, R.L.; Danishefsky, S.J. *J. Am. Chem. Soc.* **1989**, *111*, 6661-6666.
- [14] Bouilllot, A.; Khac, D.D.; Fetizon, M.; Guir, F.; Memoria,

- 
- 
- Y., *Synth.comm.* **1993**, *23*, 2071-2081
- [15] Tiwari, P.; Misra, A.K. *J. Org. Chem.* **2006**, *71*, 2911-2913
- [16] Rani, S.; Vankar, Y.D., *Tetrahedron Letters* **2003**, *44*, 907-909
- [17] Ramana, C.V.; Murali, R.; Nagarajan, M., *J. Org. Chem.*, **1997**, *62*, 7694-7703.
- [18] Cossy, J.; Rakotoarisoa, H. *Synlett*, **2000**, *5*, 734-736

University of Cape Town