

**POWER SECTOR REFORMS AND REGULATION IN  
SELECTED COUNTRIES OF Central AND SOUTHERN AFRICA**

---

Masauko Mula

Submitted to the University of Cape Town  
in partial Fulfilment of the requirements for the degree of  
Masters of Engineering (Energy Studies)

August 2002  
Energy and Development Research Centre  
University of Cape Town

The copyright of this thesis vests in the author. No quotation from it or information derived from it is to be published without full acknowledgement of the source. The thesis is to be used for private study or non-commercial research purposes only.

Published by the University of Cape Town (UCT) in terms of the non-exclusive license granted to UCT by the author.

## Declaration

I, Masauko Mula, submit this dissertation to the University of Cape Town in partial fulfilment of the requirement for the degree of Master of Science in engineering. I declare that this is my own original work and that it has not been submitted before in this or similar form for any degree at any University.

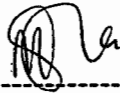

-----  
M. Mula

30<sup>th</sup> day of August 2002

## **Acknowledgement**

My sincere thanks are due to Prof. Anton Eberhard for his personal guidance, support and supervision of this thesis. I would also like to thank Prof. O.R. Davidson for his valuable comments throughout the entire period of study at the University of Cape Town.

I would like to acknowledge the following people: Judi Konz (SAD-ELEC), Dr. C. Kafumba, Dr. A. Chiwaya and A. Mandambwe (Malawi), M.B. Mandava (Mozambique), H.S. Hibajene and R. Mwala (Zambia) and K. Mashange and M. Mapako (Zimbabwe) for their co-operation and assistance in supplying most of the data that was used to compile this thesis.

I am grateful to AFREPREN/FWD for the financial assistance and to the management of ESCOM (Malawi) for their support.

The support of the International Energy Initiative is gratefully acknowledged.

Finally I would like to thank my family and friends for the encouragement and support throughout my period of study.

# Table of Contents

Acknowledgements.....	i
Table of contents .....	ii
<b>Chapter One</b>	
<b>Introduction .....</b>	<b>1</b>
1.1 Objectives of the study .....	1
1.2 The research questions.....	2
1.3 The rationale of the thesis.....	3
1.4 Research methodology.....	5
1.5 Thesis outline.....	6
<b>Chapter Two</b>	
<b>Power sector reforms and regulation: Literature review.....</b>	<b>7</b>
2.1 Introduction.....	7
2.2 The nature of the electricity supply industry.....	7
2.2.1 Generation.....	7
2.2.2 Transmission.....	8
2.2.3 Distribution.....	8
2.2.4 Retailing.....	9
2.3 Electricity supply in selected SADC countries.....	9
2.5 Need for reforms and privatisation .....	9
2.6 Reform paths and restructuring of the ESI.....	12
<b>Chapter Three</b>	
<b>Lesotho .....</b>	<b>17</b>
3.1 Location and demography .....	17
3.2 Economy.....	17
3.3 Energy sector .....	18
3.3.1 Biomass .....	19
3.3.2 Hydropower.....	19
3.3.3 Petroleum products.....	20
3.3.4 New and renewable energy sources.....	20
3.4 The power sector.....	20

3.4.1 Background.....	20
3.4.2 Existing institutional arrangements.....	20
3.4.3 Electricity supply.....	21
3.4.3.1 Generation.....	21
3.4.3.2 Transmission and distribution system.....	23
3.4.3.3 Power system losses.....	24
3.4.4 Demand.....	25
3.4.5 Electrification.....	26
3.4.6 Tariff structure.....	28
3.4.7 Financial performance of the LEC.....	30
3.4.8 Power sector reforms.....	30
3.4.8.1 Main driving forces for power sector reforms in Lesotho.....	31
3.4.8.2 Characteristics of the reforms.....	31
3.4.8.3 Privatisation.....	31
3.4.9 Regulatory framework.....	32

## **Chapter Four**

<b>Malawi.....</b>	<b>34</b>
4.1 Location and demography .....	34
4.2 Economy.....	35
4.3 Energy sector .....	36
4.3.1 Biomass .....	37
4.3.2 Coal.....	37
4.3.3 Hydropower.....	37
4.3.4 Petroleum .....	38
4.3.5 Solar energy.....	38
4.3.6 Nuclear.....	38
4.4 The power sector.....	38
4.4.1 Background.....	38
4.4.2 Existing institutional arrangements.....	39
4.4.3 Electricity supply.....	40
4.4.3.1 Generation.....	40
4.4.3.2 Transmission and distribution system.....	43
4.4.3.3 Power system losses.....	44
4.4.4 Demand.....	45
4.4.5 Electrification.....	45
4.4.6 Tariff structure.....	48

4.4.7 Financial performance of the Escom.....	49
4.4.8 Electricity sector reforms.....	50
4.4.8.1 Main driving forces behind the reforms.....	50
4.4.8.2 Main characteristics of the reforms.....	51
4.4.8.3 Privatisation.....	51
4.4.9 Regulatory framework.....	52

## **Chapter Five**

<b>Mozambique .....</b>	<b>54</b>
5.1 Location and demography .....	54
5.2 Economy.....	54
5.3 Energy sector .....	56
5.3.1 Biomass .....	56
5.3.2 Hydropower.....	56
5.3.3 Coal.....	56
5.3.4 Natural gas.....	56
5.3.5 Renewable sources of energy .....	57
5.4 The power sector.....	57
5.4.1 Background.....	57
5.4.2 Existing institutional arrangements.....	57
5.4.3 Electricity supply.....	58
5.4.3.1 Generation.....	58
5.4.3.2 Transmission and distribution system.....	62
5.4.3.3 Power system losses.....	63
5.4.4 Demand.....	63
5.4.5 Electrification.....	64
5.4.6 Tariff structure.....	65
5.4.7 Financial performance of EDM.....	67
5.4.8 Power sector reforms.....	68
5.4.8.1 Main driving forces behind the reforms.....	69
5.4.8.2 Main characteristics of the reforms.....	69
5.4.8.3 Privatisation.....	70
5.4.9 Regulatory framework.....	71

## **Chapter Six**

<b>South Africa.....</b>	<b>73</b>
6.1 Location and demography .....	73
6.2 Economy.....	73
6.3 The energy sector .....	74
6.3.1 Coal.....	75
6.3.2 Hydropower.....	75
6.3.3 Oil and gas.....	75
6.3.4 Nuclear energy.....	76
6.3.5 Biomass.....	76
6.3.6 New and renewable energy.....	76
6.4 The power sector.....	77
6.4.1 Background.....	77
6.4.2 Existing institutional arrangements.....	77
6.4.3 Electricity supply.....	79
6.4.3.1 Generation.....	79
6.4.3.2 Transmission and distribution system.....	82
6.4.3.3 Power system losses.....	82
6.4.4 Demand.....	83
6.4.5 Electrification.....	84
6.4.6 Tariffs.....	87
6.4.7 Financial performance of Eskom.....	88
6.4.8 Electricity sector reforms.....	89
6.4.8.1 Main drivers for the reforms.....	89
6.4.8.2 Main characteristics of the reforms.....	90
6.4.9 Regulatory framework.....	92

## **Chapter Seven**

<b>Zambia.....</b>	<b>94</b>
7.1 Location and demography .....	94
7.2 Economy.....	94
7.3 The energy sector .....	95
7.3.1 Wood fuel.....	95
7.3.2 Hydropower.....	96
7.3.3 Coal.....	96
7.3.4 Petroleum.....	96

7.4 The power sector.....	96
7.4.1 Background.....	96
7.4.2 Existing institutional arrangements.....	97
7.4.3 Electricity supply.....	99
7.4.3.1 Generation.....	99
7.4.3.2 Transmission and distribution system.....	102
7.4.3.3 Power system losses.....	103
7.4.4 Demand.....	103
7.4.5 Electrification.....	104
7.4.6 Tariff structure.....	105
7.4.7 Financial performance of Zesco.....	106
7.4.8 Power sector reforms.....	108
7.4.8.1 Main driving forces of the ESI reforms.....	108
7.4.8.2 Main characteristics of the reforms.....	108
7.4.8.3 Privatisation.....	109
7.4.9 Regulatory framework.....	110

## **Chapter Eight**

<b>Zimbabwe.....</b>	<b>112</b>
8.1 Location and demography.....	112
8.2 Economy.....	112
8.3 Energy sector .....	113
8.3.1 Coal.....	113
8.3.2 Hydropower.....	114
8.3.3 Petroleum products.....	114
8.3.4 Biomass and new and renewable sources of energy.....	114
8.4 The power sector.....	114
8.4.1 Background.....	114
8.4.2 Existing institutional arrangements.....	115
8.4.3 Electricity supply.....	116
8.4.3.1 Generation.....	116
8.4.3.2 Transmission and distribution system.....	119
8.4.3.3 Power system losses.....	120
8.4.4 Demand.....	120
8.4.5 Electrification.....	121
8.4.6 Tariff structure.....	123
8.4.7 Financial performance of Zesa.....	123

8.4.8 Electricity sector reforms.....	124
8.4.8.1 Main driving forces behind the reforms.....	124
8.4.8.2 Main characteristics of the reforms.....	125
8.4.8.3 Privatisation.....	127
8.4.9 Regulatory framework.....	128
<b>Chapter Nine</b>	
<b>Comparative study.....</b>	<b>130</b>
9.1 Introduction.....	130
9.2 Current economic situation and prospects.....	131
9.3 Resource potentials for electricity generation.....	133
9.4 Electricity supply.....	134
9.4.1 Generation.....	134
9.4.2 Peak demand and electricity sales .....	137
9.4.3 Financial performance .....	142
9.4.4 Other performance indicators .....	145
9.4.5 Electrification .....	148
9.5 The reforms .....	149
9.5.1 Drives for power sector reforms.....	149
9.5.2 Objectives of the power sector reforms.....	150
9.5.3 Reform paths/strategies.....	151
9.5.4 Changing of laws/enabling legislation.....	154
9.5.4.1 Commercialisation and corporatisation.....	155
9.5.4.2 Private sector participation.....	156
9.5.4.3 Restructuring.....	156
9.5.4.4 Unbundling.....	158
9.5.4.5 Regulatory framework.....	158
9.6 Social and economic impacts of power sector reforms.....	160
9.6.1 Impacts on electricity tariffs.....	160
9.6.2 Impacts on employment.....	160
9.6.3 Government fiscal resources.....	161
9.6.4 Rural electrification.....	161
9.7 Conclusion.....	162
References.....	164

# Introduction

## 1.1 Objectives of the Study

Electricity Supply Industries (ESI) in most African countries, in general, and in the Southern African Development community (SADC) region in particular, are made up of small networks. The only exception to this is the South African electricity industry which is huge. Financial institutions such as the World Bank, the International Monetary Fund (IMF), the African Development Bank (ADB) and other donor nations help to finance the development of the electricity industry in most African countries, with the central government acting as a guarantor to all the loans. The power utilities are owned by the states, and they are highly involved in the day-to-day running of the organisations. In some countries governments are also involved in setting the price of electricity and in appointing people to influential positions in the utilities' structures. The electricity prices, on the whole, are kept low with a view to attracting potential investors and to improving the socio-economic status of the people through enabling small-scale businesses such as welding shops and farming by irrigation.

As is becoming increasingly evident, such government interventions have a negative effect on the performance of the utilities, with the result that the utilities are now experiencing significant technical and financial problems. Consequently, they are finding it difficult to service the loans. Frequently this means that governments must rescue the utilities with funds obtained from the central treasury. The loans held by the utilities are thus becoming a burden to the governments. This has now led several countries to look at various options of power sector reforms in order to improve the performance of their power sector. Restructuring and reforms with regard to the power sector fall into the following five main categories, namely:

- i. corporatisation and commercialisation (sometimes involving management contract);
- ii. structural reforms (vertical and horizontal unbundling of the utility) to introduce competition;
- iii. privatisation;
- iv. regulatory reform; and
- v. the introduction of electricity trading.

These processes need to be properly understood in order to evaluate the best options that can be implemented in the power utility according to a country's set of circumstances.

## 1.2 The Research Questions

This report will attempt to answer four main questions that will guide the focus of the study and the analysis of the research results.

### Question One

*What is the status of Electricity Supply Industry (ESI), its performance, reform and regulation in countries under examination?*

The present ESI structures and current policies governing the electricity industry need to be known in order to have a wider view of the present status of the utilities in the region in terms of restructuring and regulation. In addition, analysis of the technical and financial performance of the utilities as well as their electrification achievement levels may also help to assess the weaknesses in the industry. The answer to the question will reveal the progress made so far by the selected countries in reforming their power sectors. The term “reform” refers to changes in the organisational structure in the electricity industry following the implementation of new policies, as well as ownership changes and various forms of regulation. The structure of the electric utilities and their ownership patterns are currently shifting to the private sector. This implies that the policies governing the energy sector have, over the years, also undergone several changes. The poor state of the public utilities, when compared to the good performance of the utilities in countries that have reformed their ESIs, prompts most governments to undertake power sector reforms in order to improve their performances. The term “regulation” may be defined as the act of controlling specific activities that affect, in this regard, the power sector. The sector requires a set of guidelines or rules that must direct suppliers on how to conduct their businesses and improve their performances. In the past, regulation of the electricity industry was the responsibility of the government as the owner of the power utilities.

### Question Two

*What are the main forces and the objectives behind the reforms?*

Historically, power utilities play a commendable role in boosting the socio-economic welfare of society. The provision of the services, including electricity, required worldwide that governments become involved to make sure that the services were offered at affordable rates. Most governments tended to become involved in such economic activities due to perception that the private sector could not provide such services at low costs because of the monopolistic tendencies of the industry. The governments therefore developed most power utilities. The performance of the utilities in many countries was, however, hampered by financial difficulties that led to an overall poor performance of the utilities. In the 1990s some developed countries such as the United Kingdom (UK) embarked on power sector reforms in

order to improve its performance. Their good results proved it wrong to say that only government utilities can provide electricity at affordable rates for socio-economic development. The major power sector reforms that occurred in developed countries caused some countries to examine their power sectors to see if any improvement could be achieved through such reforms. This paper will also examine the driving forces behind ESI reforms in the selected countries and observe whether the present technical and financial performance of the utilities are some of the contributing factors.

### **Question Three**

*Why have particular countries taken particular reform paths?*

There are two broad reform paths which the restructuring process follows. One involves physical changes in the organisational set-up, called the “structure reform path”, and the other involves transfer of ownership, termed “ownership reform path” (Chiwaya in Bhagavan, 1999: 36). The structural reforms involve the unbundling of the vertically integrated monopoly utility structure into separate generation, transmission, distribution and supply entities without subjecting any part of the industry to ownership changes. Generation and distribution can further be unbundled into different units, while transmission is left intact since it is considered a natural monopoly. When this separation is achieved, each entity is expected to operate independently with its own account. Ideally this is done to facilitate competition and efficiency improvements. This can allow participation by the private sector, especially in the generation side of the industry.

The ownership reforms involve change of ownership and control of the power utilities. This relieves the government from being in the forefront of conducting commercial business. This form of power sector reform may involve the sale of assets, especially in areas where competition can be achieved. Another important aspect of this reform process is the change in government attitude towards the control of the utilities. For instance, in some cases the management of the specific utilities should be given the autonomy to run their organisations in a commercial manner. As will become clear from the discussion, countries adopt different approaches to the reforms in order to address specific problems pertaining to their respective countries.

### **1.3 The Rationale of the Thesis**

The challenges facing developing countries in Africa with regard to expanding their respective power sectors are enormous. Substantial investments are necessary. The utilities’ performance is, however, plagued by many other problems: low revenues due to low tariffs, poor revenue collection, unreliable supplies, monopolistic structure of the industry, and lack of regulatory policies. The utilities cannot raise enough funds to implement their projects and are therefore not able to expand their services. These are the

major driving forces behind the restructuring and reform of the power sector, both in the African countries discussed herein, as well as in the rest of the developing world. The reforms are expected to overcome the problems referred to above and to assist the respective governments in relieving the financial debt burden, and to direct their resources into other areas of poverty alleviation (education, health and the provision of other services that are essential for development).

Some of the selected countries in the region are, increasingly, facing international pressure to change their policies governing the ESI so that some of the industry's problems can be addressed. This calls for reforms to introduce competition and privatisation of part of the utilities in order to reduce the role of the government in the running of the utilities.

Several organisations have carried out studies to evaluate the performance and efficiency of the power sector in most of the SADC countries. These include the UNDP/World Bank under the Energy Sector Management Assistance Programme (ESMAP), the Southern African Development through Electricity (SAD-ELEC) and the African Energy Policy Research Network (AFREPREN). The present study differs from all the other studies in the following respects:

- i. It identifies specific driving forces behind the reforms in the selected countries.
- ii. It has carried out in-depth research of the utilities supplying electricity in the region. Enough statistical data for the ESIs in the selected countries have been compiled and these can assist in drawing conclusions. The research has paid particular attention to power sector performance for the case study period 1990 to 2000, and the areas that require particular attention have been noted.
- iii. This study includes issues of electrification and other public benefits and discusses how the government proposes to address these.
- iv. It ascertains and examines the reasons why the countries in the region are taking different approaches to power sector reforms, and compares (the countries) to one another.

The study is relevant because it intends to provide both the government and the utilities with a better understanding of the importance of organisational reforms and regulation. The research is also significant because it can provide comparative information to other countries as to why restructuring and reforms are necessary in the region, and because it highlights the lessons that the countries can learn from one another, as they are in a more or less similar environment.

## **1.4 Research Methodology**

Electricity supply utilities of six countries were researched, namely: Lesotho, Malawi, Mozambique, South Africa, Zambia and Zimbabwe<sup>1</sup>. The initial information regarding the ESI reform processes was gathered from the Internet and from available documents on these countries. This information was presented in summary form and sent to the power sector institutions of the countries concerned for confirmation. In addition, a relevant questionnaire was developed and sent to the utilities and institutions. Energy sector policy reports of various countries were also examined, with particular emphasis placed on how the ESI is currently being governed, and how it expects to be governed in the future.

The utilities and other institutions, such as regulatory authorities, governments' Departments of Energy and Afrepren offices/Afrepren principal researchers were contacted in order to gather further information. In addition to this, oral interviews regarding power sector reforms and regulations were conducted in Malawi and with the officials of the National Electricity Regulator (NER) of South Africa and the chairman of the Regional Electricity Regulatory Association (RERA) at the NER offices in Pretoria. A one-week visit was undertaken to some of the institutions in South Africa, such as the ESKOM library, the SAD-ELEC offices and the NER in order to obtain further published material. Other information placed on the Internet by the World Bank and other agencies provided useful guidelines in preparing this thesis.

The institutions to which the summary sheets had been sent, were requested to provide both quantitative and qualitative data. The quantitative data comprised information such as the existing demand and supply situations, future demand forecasts, electricity tariffs, technical and non-technical losses and staffing levels. The qualitative data was mainly a descriptive analysis of the utility organisation's structure, legal and regulatory frameworks, current reform efforts and methods of privatisation within the utility. A brief report was then compiled with regard to each country. This is contained in chapters three to eight of this report.

### ***Limitations of the Study***

The main problem that was encountered during the study was on data collection. Apart from little data that was obtained internally at the ESKOM library and SAD-ELEC offices, a major part of the data had to be obtained from outside South Africa. Due to financial difficulties, visits to selected countries to get the required primary data were not made. In order to obtain the data, contacts with people working in utilities and government departments or regulatory boards had to be established through written correspondence. Those who responded sent utilities' annual reports or statistical reports in which most of the data was captured. Historical data for some countries is missing because old annual reports are not available and

---

<sup>1</sup> A parallel Masters study is looking at the remaining southern African countries

were therefore not sent. The second problem is that some utilities have not yet published their 2000 annual reports and as such, the data comparisons could not be based on one particular year, the year 2000, as was initially intended. It should also be pointed out here that the study concentrated on publicly owned utilities since they are the ones which will be greatly affected by the reforms. The third problem is that the area of study is very dynamic. There are so many changes taking place as the countries are attempting to implement the reforms. Some of the information presented here might have changed by now. However, this may affect isolated cases and the changes may not be major.

## **1.5 Thesis Outline**

This report is divided into nine chapters. Chapter one introduces the thesis. Chapter two describes the concepts of reforms and regulation and provides a literature review. It presents the general characteristics of and the driving forces behind the reforms of the power sector on the international scene, and highlights the regulation of the electricity industry. Chapters three to nine cover the energy sectors in the selected countries. Each of these chapters consists of five main sections. Section one briefly describes the country's location and demography. Section two discusses the current economic policies to see whether they are favourable to foreign investments. Section three outlines the various sources of energy supply available in the specific country, with the emphasis being on the primary energy sources that contribute to electricity production. Section four is a general presentation of the performance of ESI in the particular country. Finally, section five describes the issues surrounding regulation and reform in that country. Furthermore, a detailed analysis of the current reforms and regulatory frameworks is provided and the expected structures of the respective ESIs are presented. Chapter nine offers a comparative analysis of the key elements of the various reform programmes. The emphasis is on the structures of the reforms, explaining why the reforms took different paths. This chapter also presents the conclusions of the study.

## **Chapter Two**

---

# **Power Sector Reforms and Regulation: Literature Review**

## **2.1 Introduction**

From the early 1990s both developed and developing countries started to reform their Electricity Supply Industries (ESIs) with a view to fulfilling a number of objectives. The most notable and successful reforms have occurred in the United Kingdom, the Nordic countries, Australia and Argentina (Energy Information Administration, 1997). Each of the approaches followed by these countries in the restructuring and reform of their ESIs was different, although their main goal was the same, i.e. to improve the poor performance of their power sectors. The Southern African Development Community (SADC) countries in Africa have not remained idle in undertaking such reforms. Although the SADC countries, with the exception of South Africa, have smaller ESIs in terms of their generating capacity they face numerous problems. In an effort to find solutions to these problems, almost all the countries in the region have embarked on the same program of reforming their power sectors. The models being followed do, of course, differ from country to country because of the different sizes of their respective ESIs and the unique problems faced by each country. However, ESI structures are modelled (probably with minor modifications) on those used in the developed countries, which have already successfully reformed their electricity industries. The general nature of the electricity industry needs to be understood in order to gain a clearer picture of the reforms and regulation currently being implemented in the power sector.

## **2.2 The Nature of the Electricity Supply Industry**

Electricity production involves four main stages: Generation, transmission, distribution and retailing. As these stages are interlinked, the whole electricity sector was for many years' thought of as a "natural" monopoly industry, where a single provider would provide all the services. Historically most power utilities have been established by the state or were under the control of the state because of the central role these utilities play in the economic development of a country.

### **2.2.1 Generation**

Electricity is generated from primary energy sources such as coal, oil, natural gas, hydropower, nuclear, biomass and geothermal by using turbines. It can also be generated from wind and solar power, although this tends to be in small quantities, and does not produce enough power to be used for major processes that require heavy current. Most developed and developing countries use fossil fuels (coal, oil, natural gas) and nuclear to generate electricity. Tropical countries and a few communities in Europe (such as Norway) do, however, rely on hydropower.

The cost of generating electricity from these primary energy sources differs substantially, depending on the primary source of energy used. Electricity production from fossil fuels is often more expensive than that generated from hydropower. Electricity from the new and renewable energy sources such as solar and wind is even more expensive, and usually unaffordable to the poor, except for specific high value uses.

A country may have one or more power stations owned either by the state or a private company. When electricity is generated, it cannot be stored. It has to be transmitted to the country's load centres through transmission lines and then distributed to end-users.

### **2.2.2 Transmission**

Transmission lines provide the link between the generators and the distribution centres. The voltage generated at the power stations is stepped up and transmitted at various high voltage levels to distribution centres. The lines are commonly operated at voltages between 132 kV and 765 kV in most countries, as in, for example, South Africa (ESKOM Annual Report, 2001: 130). Thereafter the voltage is stepped down at major transforming stations in distribution centres, before it is distributed to consumers through distribution lines.

Some countries are not self sufficient in their electricity requirements and have to meet the excess demand through electricity imports from other countries, either at transmission or distribution level. The transmission lines can be constructed to operate at different voltages, depending on power needs. Countries with a high enough capacity, such as, for example, South Africa, use their transmission interconnectors mainly to export power and, to some extent, to import power, basically for load management purposes.

### **2.2.3 Distribution**

The distribution network forms the link between the transmission system and the customers. The distribution voltages of, for example, 11 kV and 33 kV, are stepped down to voltages that are supplied to consumers, namely 6.6 kV, 3.3 kV and 400 V. The distribution networks are vast in any system because the lines pass through all the main areas that require electricity. When the distributed voltage is stepped down, the medium voltage lines (the so-called reticulation system) are connected to each and every customer.

Most countries, in the past, met their electricity requirements from publicly owned power utilities that exercise a monopoly in the areas of generation, transmission, distribution and supply of electricity to consumers.

#### **2.2.4 Retailing**

The retailing function does not require heavy construction, unlike the other electricity supply functions discussed above. It mainly involves metering and billing, and it also provides demand management services. In addition, retailing also arranges for supplies of power from generators, and in most cases distribution and retailing are viewed as integrated functions (Millan et al, 2001: 6). Retailers are able to choose which generator they buy power from, once competition is allowed in the electricity market.

### **2.3 Electricity Supply in Selected SADC Countries**

The Electricity Supply Industries (ESIs) in the SADC region, especially in the selected countries under study herein, differ in terms of their generation capacities, as well as their primary energy sources. With regard to the former, the countries can be grouped into three categories: The first group consists of countries with capacities of more than 10,000 MW; the second group has capacities between 1,000 MW and 10,000 MW; and the last group has a generation capacity of less than 1,000 MW. South Africa has the largest generating capacity of about 43,000 MW and is the only country in category one. The countries which fall in the second category include Zimbabwe, Zambia and Mozambique. Malawi and Lesotho belong in the third category. With regard to primary energy sources, South Africa and Zimbabwe rely heavily on thermal generation from coal, while the rest of the countries depend primarily on hydroelectric production and to a limited extent, other sources.

The financial performance of the utilities, with the exception of South Africa, is poor. Most utilities fail to pay back their loans. In general, access to electricity in the entire region is still low because the utilities cannot raise enough funds for the necessary generation projects and to extend their grid networks.

### **2.5 Need for Reforms and Privatisation**

The importance of the electricity industry in the economy of a country cannot be over-emphasised. More electricity is actually required, if the objectives of SADC to develop the region are to be met. The deteriorating condition of their respective electricity industries is a source of grave concern to the governments in the region. In order to boost the efficiency and effectiveness of the sector, most governments are now responding to the challenges faced by their utilities by embarking on restructuring programmes, either in readiness for privatisation (change of ownership) or private sector participation. Some governments are pressurised to reform their utilities by lending institutions such as the World Bank, but others, like South Africa, would like to introduce the reforms in order to broaden economic empowerment and position the industry to meet the future challenges.

The reformation and liberalisation of electricity sectors is not a new idea. Electricity industries of some countries have already been reformed and many countries in the world are at present going through the

same process. In many cases these reforms are being driven by a number of factors, which include the following (Bacon et al, 2001: 1), each of which will be discussed in more detail hereunder:

- i) Poor performance of the state-run electricity sectors in terms of high costs and inadequate expansion of services to the majority of the population;
- ii) Financing needs with regard to new investments and / or maintenance of existing utilities;
- iii) The need to remove subsidies to the sector.

Eberhard (2000) further points out four other important driving forces, which include the following:

- iv) The desire to improve allocative and productive efficiencies;
- v) The need for technological changes;
- vi) Environmental pressures; and
- vii) Country specific needs.

### ***Poor Performance of State-Owned Power Utilities***

The performance of most state-run utilities is poor because they lack the funds to develop their systems and improve their operations. The relevant governments tend to approve low electricity prices in an effort to encourage industrialisation and to meet their obligations of social development, i.e. to keep electricity affordable for the many poor citizens of their countries. In the process, however, the performance of their utilities is negatively affected. Furthermore, because the utility cannot raise enough money to maintain the system, the system becomes unreliable, with many facilities being out of order and system losses occurring regularly. In conclusion, the system is not able to expand, resulting in low access to electricity.

### ***Financing Needs with regard to New Investments***

Poor decisions regarding new investments in the power system in many SADC countries have resulted in the misallocation of funds and resources. Some countries even have excess capacity. This is because more stations were constructed than were necessary. The costs of poor investment decisions are reflected in the pricing system, thereby effectively transferring the burden to the consumers. In a competitive environment, there would be incentives for the investors, managers and employees to operate efficiently (i.e. to make least cost investment decisions). Since it is not acceptable to pass on the burden of the inefficient allocation of resources to consumers, investors tend to bear a more than equitable share of the risk.

Many nations borrowed money from financial institutions or other governments to finance the development of their power sectors. The utilities are, however, unable to service these foreign loans because of their poor financial performances. This puts pressure on the respective governments to service

the foreign debts on their behalf. In order to reduce the burden of foreign debt and to generate revenue for selected development activities, many nations have embarked on the privatisation of some assets in the electricity sector (Energy Information Administration, 1997).

### ***The Need to Remove Subsidies***

Most governments of developing countries intervene in electricity tariff settings. Probably every country in Sub-Saharan Africa (including all the countries in the SADC region) subsidises electricity to users, especially in the residential sector, by charging low prices (UNDP / World Bank, 1996: 102). If these subsidies are not properly implemented, electricity may be sold at a price that is below the cost of production. In many SADC countries, particularly where the electrification level is low, subsidies, in fact, only benefit wealthier households in that they have access to electricity and can afford electrical appliances. The majority of the population does not benefit from the electricity subsidies. In these cases, it is necessary for the government to remove the subsidies and focus their revenues on the more pressing social needs of the majority of the population, such as health and education.

### ***To Improve Allocative and Productive Efficiencies***

Allocative and operational inefficiencies normally occur in the traditional vertically bundled ESI. Due to monopolistic behaviours of publicly owned power utilities, poor allocation of resources and low quality of services are common. Poor investment decisions leading to installation of excess capacity have been a common phenomenon in the ESI because of the option of passing the burden to the consumers in the form of increased tariffs. Van Horen (cited by Eberhard, 2001) notes that during the 1980s ESKOM invested significantly in new generation plants that resulted in over-capacity that would only be fully utilised after 2007. This, in principle, is a misallocation of resources. On the other hand, efficiencies in State-Owned Enterprises (SOEs) are low because they are not profit oriented and as a result fail to raise funds for operational costs and development projects. These inefficiencies are reflected in increased power losses and poor service delivery. The situation may improve if more players are introduced in to the sector to disrupt the monopolistic nature of the ESI.

### ***Technological Changes***

The traditional vertically integrated electricity supply industry was believed to be a natural monopoly. With recent technological changes and market reforms, however, it is accepted that the generation and supply (retail) elements of the industry are no longer natural monopolies as competition can be introduced. Technological advancements and changes in industrial structures also make it possible for competition to be introduced in the ESI. The traditional vertical structure is unbundled, so that generation, transmission, distribution, supply and auxiliary services are separated. Competition is introduced in the generation and the supply sectors by encouraging additional players to provide these

services (Eberhard, 2000: 4). Information and communication technologies, combined with the development of the new electricity generation technologies (such as the Combined Cycle Gas Turbine (CCGT) and the mini hydro, etc. have encouraged new competitors to enter the ESI. At first, it was not possible (or too costly) for these to enter the ESI, because of technological constraints.

### ***Environmental Pressures***

Currently electricity production by many utilities in the world is derived primarily from the burning of fossil fuels such as coal and oil. The increasing concern about the impact of such electricity generation technologies on the global environment and ensuing climate changes has slowed down investments in large nuclear and coal-fired plants (Eberhard, 2000: 4). Electricity production from cleaner fuels such as natural gas and renewable energy sources is now increasingly encouraged worldwide. Most countries are furthermore introducing institutional reforms in their electricity sectors with a view to allowing private investors to promote electricity production from cleaner fuels.

Apart from the general issues listed above, many countries in both the developed and the developing world are reforming their ESI in response to a number of specific needs, as listed in the subsequent chapters hereunder for each particular case study.

## **2.6 Reform Paths and Restructuring of the ESI**

The reform and/or restructuring processes are divided into the following five categories, as listed by Eberhard (2000), which are discussed in more detail hereunder:

- i. Commercialisation and corporatisation;
- ii. Restructuring to allow / encourage competition;
- iii. Creation of an electricity trading market;
- iv. Increased private sector participation; and
- v. Modernisation of the regulatory framework.

### ***i) Commercialisation and Corporatisation***

Commercialisation and corporatisation of the national power sector, as stated in the UNDP / World Bank Report No. 182/96 (1996), is the least radical reform that can be implemented in order to increase efficiency in the electricity generation, transmission, distribution and supply sectors without change of ownership in utility assets. The utility should ideally operate like any other business entity and is liable to pay taxes and dividends. Commercialisation and corporatisation also prepares the ground for competition in the ESI, which can easily be encouraged if monopolistic utilities are restructured.

### ***ii) Restructuring to allow and encourage Competition***

The recent ESI policy objectives of the countries in the SADC region encompass, among other things, the provision of low electricity prices, reduced debts, wider economic ownership and electrification. Under the present monopolistic structures of the ESI in this region, however, it is not plausible to effectively achieve these outlined government policy goals. The structures need to be reformed, thereby establishing competitive practices in the generation and supply sides of the industry, whilst regulating the remaining, naturally monopolistic sector of transmission and distribution.

In phase one, the monopolistic power utilities must be vertically unbundled; that is, generation must be separated from transmission and distribution so that these become independent entities. Thus the potentially competitive part of the business (generation) is separated from the natural monopoly components (transmission and distribution wires).

The second phase of the restructuring process involves horizontal unbundling of the generation and supply aspects of the industry. This removes market power and forces generators to compete against one another.

The third and final phase introduces competition with regard to the generation and supply sectors. The competing generating companies would then be privatised, as was the case in the UK, where the power utility CEGB was first unbundled before it was sold (International Energy Agency, 1994: 39).

### ***iii) Creation of an Electricity Trading Market***

When competition is introduced in the ESI, i.e. specifically in the areas of generation and supply, it is necessary that a proper electricity market, or a set of trading mechanisms, be established. In this regard, Eberhard (2000) discusses two broad market models in which sellers and buyers of electricity interact, namely the power pool model and the multi-market model where a range of electricity trading mechanisms is employed.

### ***iv) Increased Private Sector Participation and Privatisation***

The other category of reform is to allow the private sector to build new generating plants and to sell their electricity either directly to customers or to the main utility through power purchase agreements. The UNDP / World Bank Report No. 182/96 (1996) describes the most radical approach, which is to allow the private sector to own the existing assets either through a long-term concession or through changes of ownership. In this regard private investors will be responsible for supplying electricity in a competitive manner and for developing new investments.

Despite the above, the restructuring of the ESI does not necessarily mean privatisation. Many countries have restructured and introduced competition in the electricity sector while still retaining ownership of a major part of the utility. The countries whose utilities have undergone significant structural changes although the state has to a large extent retained ownership of the utilities, include Denmark, Norway and Canada (International Energy Agency, 1994: 34). The presence of the private sector in these countries is small. On the other hand, in other countries, such as the UK, the private sector dominates the electricity industry. The UK has privatised part of its power utilities after the restructuring of its ESI, and the period between 1995 and 1997 has seen several mergers and changes of ownership in the UK electricity industry, with the American firms taking an active part in bidding for ownership (Energy Information Administration, 1997). When the ESI is reformed in such a way, Independent Power Producers (IPPs) are encouraged to increase their investments, especially in electricity generation, thus easing the pressure on governments to do so. The growth of IPPs has been remarkable in the UK since the reforms began. The IEA stated in 1997 that between the 1990/1991 and 1995/1996 fiscal years the IPPs' generation capacity increased from roughly 1 % to 15 %, and was further expected to increase the UK's generation capacity to 21 % by the fiscal year 2000/2001 (International Energy Administration, 1997).

#### ***v) Modernisation of the Regulatory Framework***

James Hodge (2002) has defined regulation as the administrative control by economic agents over certain factors, such as price, entry into/exit out of the industry, quality and quantity of supply, etc. Where competition exists, regulation may not be necessary. Regulation is, in fact, only required when there is a monopoly. The rationale behind this is that social benefits in a monopolistic industry, if the same is left unregulated, will not be maximised. As with other industries that involved networks (for example, telecommunication and natural gas distribution networks), the ESI was regarded as a natural monopoly and therefore requiring regulation. Ergas et al (2001) mentions two types of regulation, namely price caps (incentive) regulations, and rate of return (RoR) regulations. According to Ergas et al (2001), the rate of return regulation originated in the USA, while the price cap regulation was developed in the UK. When the power utilities of these two countries were restructured and competition introduced in the generation and supply sectors, they followed the type of regulation that had already been developed in their respective countries. There are several reasons, which call for the regulation of the ESI. Bradburd, R (1992: 2) outlined some of the reasons as follows:

- i. To reduce the extent of allocative inefficiency: The utility can easily make wrong decisions in the allocation of its resources. This mainly occurs if the utility operates as a monopoly. For example, the utility may over-invest in generation, and thereafter it may increase its electricity tariffs in order to recover the costs. In this regard then, regulation is required to limit unnecessary increases in electricity prices, and to ensure that the utility allocates and invests its resources in a sensible manner.

- ii. To restrain the utilities from making unnecessary profits: With good electricity prices, consumers are able to increase their own savings, which they can use for other purposes. Thus, in an indirect manner, income redistribution can be achieved in the society through regulation of the electricity market.
- iii. To create confidence in the stability of the economic environment, which is necessary to encourage business activities.

In a properly regulated market, it is expected that the utilities will be compensated for the capital invested, that additional capital can be attracted and that utilities can meet their obligations to supply electricity according to the rules that are laid down by the regulators.

These developments are in line with what Professor Adilson de Oliveira stated in 1991 when he pointed out that the regulatory regime of the ESIs in developing countries is outdated and requires substantial review. According to De Oliveira, electricity industry regulation should not be in government hands but should be monitored by a strong and independent regulator who should operate in terms of government policy guidelines.

Changes in the role of regulators are inevitable, as the market is reformed. As markets change, it is necessary to introduce new regulatory regimes that will enable regulatory authorities to efficiently meet the needs of the future competitive electricity market. Due to such changes, the electricity regulators should be geared to conduct the following functions:

- to monitor the transmission and distribution elements of the industry;
- to ensure that the bidding process for new generating capacity is competitive;
- to come up with incentives for efficient generation by independent power producers;
- to establish performance standards, both related to quality of supply and service; and
- to make sure that regulation is in line with the changing market structure and includes regional power trading.

In addition to these roles, the Electricity Sector Regulators should perform the following broad functions:

- i. to set, review and adjust electricity prices for all the suppliers and distributors;
- ii. to investigate the tariff structures;
- iii. to enforce environmental, technical and safety standards;
- iv. to investigate complaints made by parties with grievances and to help settle their disputes;
- v. to approve electric power purchase contracts between generators and customers;

- vi. to co-ordinate with other state regulatory authorities in order to ensure the consistent and effective development and enforcement of standards; and
- vii. to collect information and statistics, publish reports and disseminate information relating to the performance of the electricity market.

### Lesotho

#### 3.1 Location and Demography

The Kingdom of Lesotho is a land-locked country located in Southern Africa. It occupies a land area of 30,355 square kilometres; it is about the size of Belgium in Western Europe and is completely surrounded by South Africa. It is mountainous and is the only country in the world to have all its territory situated at more than 1,000 metres above sea level. It is known variously as '*the roof of Africa*' and '*the Switzerland of Africa*'. Only 25 percent of the area is considered lowland. The lowest point is at 1,388 meters and the highest point is at 3,500 metres in the Maluti mountain range (The Official SADC Trade, Industry and Investment Review, 2001).

Lesotho has a continental climate with four main seasons of spring, summer, autumn and winter. Spring is from August to October. Summer months, from November to January, are hot and wet. Autumn begins in February and ends in April, whereas the winter months, from May to July, are dry but very cold during the night. It also snows in winter (ibid.).

The population of Lesotho is estimated at 2.0 million, with an annual population growth rate of 1.8 %. Life expectancy at birth is estimated at 44 years. The majority of people live in the lowlands around the capital city, Maseru. The settlement in rural areas is scattered and most of land is mountainous. The rural population is estimated at 72 % while the rest, 28 %, lives in urban areas (World Bank, 2002).

#### 3.2 Economy

Lesotho is one of the least developed countries in the world. Much of the economy of the country is dependent on subsistence agriculture which contributes about 16.9 % of the GDP (World Bank, 2002), and livestock farming is the main source of income. Of late, especially in 2001, agricultural activity has decreased due to frequent droughts. Apart from agriculture, the household income for many people comes from the migrant labour force working in South African gold mines and, according to the World Bank estimates, the migrant labour contributes about 30 % of the country's GNP (cited by International Finance Center, 2001). However, the number of migrant workers is declining steadily because South Africa's gold mining activity is on a downward trend as a result of increasing costs and less attractive gold prices.

Apart from agriculture, the Lesotho economy relies on the industrial, service and the manufacturing sectors. Although the industrial sector is small, its contribution to the GDP is significant. Out of the

country's GDP of US\$ 0.9 billion in 2000, the industrial sector contributed about 43.8 %. This was followed by the service industry sector that contributed about 39.3 % of the GDP. Given the annual average GDP growth rate of 3.8 % and inflation of only 8 %, the economy of Lesotho is on track when compared to other countries in the SADC region (World Bank, 2002).

The country enjoyed an economic boom in the early 1990s up to the end of 1997. Three factors contributed to this economic boom: the construction of the Lesotho Highland Water Project (LHWP), increased manufacturing production and the increase of export products. The combination of sound economic policies and economic integration with South Africa resulted in decreasing inflation in the 1990s. The situation, however, changed in the late 1990s, as the economy of the country started to perform badly. This came about because the water project was coming to an end, there was a decline in the manufacturing sector and the remittances by mine workers from South Africa decreased further (IMF, 2001).

The present government does not want to engage directly in business activities. It, instead, plans to expand the country's economic base by developing policies that can assist increased private sector contribution to the economic development of the country and that can attend to the needs of all the citizens of Lesotho (The Official SADC Trade, Industry and Investment Review, 2001).

Currently, among other things, the government has embarked on a programme of restructuring some of the state-owned enterprises. Implementations of the reforms in various sectors including financial, agriculture, trade and utilities sectors were started in 2000. In the utilities sector, the restructuring of the Lesotho Electricity Corporation (LEC) will lead to eventual privatisation (ibid.). In order to encourage private sector investment by local and foreign companies, the government has introduced a number of financial incentives. Some of these include the free repatriation of profits and unimpeded access to foreign exchange. Although the investment code does not exist at present, the incentives are set out in the legislation and their rights are protected by the constitution of Lesotho (ibid.). In addition, foreign investors have access to the international jurisdiction of the International Centre for Settlement Disputes (ICSD) in the case of legal disputes regarding investments in Lesotho.

### **3.3 Energy Sector**

The comprehensive energy policy of Lesotho is incorporated in the Lesotho Energy Master Plan that was approved by government in 1988. The policy of the government is to supply energy to all sectors of the economy with minimum cost. In order to achieve this, it is necessary to improve efficiency levels where the energy resources are used. The policy also aimed at reducing the country's dependence on energy imports from other countries. The country used to import almost all commercial energy resources,

including electricity, from South Africa. This policy of self-reliance encouraged Lesotho to build its hydropower plant at Muela so that it could reduce electricity imports from South Africa.

The government started to revise its energy policy from March 1999. The new energy policy is expected in 2002 (Launch of the Lesotho Utilities Project, May 21 – 22, 2001) and the main policy objectives are:

- i. Contributing towards the improvement of livelihoods. Energy is considered as an engine for economic growth. It is, therefore, expected that energy supply to all areas will help create income-generating activities and reduce poverty.
- ii. Contributing towards the protection of the environment. The energy resources will be developed and used in a sustainable and environmentally friendly manner.
- iii. Contributing towards economic growth and investment. The sector will be developed so as to create employment opportunities for the people. The participation of the private sector in production and delivery of services will also be encouraged.
- iv. Ensuring access to basic energy technologies and services. Currently, access to modern energy is low. In order to increase access, a number of energy technologies will be introduced and made available on the market.

To achieve these policy objectives, most of the energy resources will still have to be imported since the country is poor in energy resources. The primary energy sources available in the country are biomass and hydropower.

### **3.3.1 Biomass**

The main energy source in Lesotho is biomass, which comes in the form of firewood, shrubs, dung and agricultural residue. Of these, firewood is also imported. Biomass supplies about 77 % of the country's total energy consumption requirements (Khalema in Ranganathan, 1992: 147). This energy source is mainly used in rural areas. However, because of low electrification levels in urban areas, use of firewood is common there too.

### **3.3.2 Hydropower**

Hydropower is the main source of electrical energy. The potential for hydro electricity is estimated to be as high as 1,000 MW (SAD-ELEC & MEPC, 1996: 139). Out of this a mere 72 MW has already been developed at Muela hydropower station, although this is usually sufficient for Lesotho's needs. The commissioning of the Muela station made Lesotho more self-reliant in electrical power requirements. Initially electricity was mostly imported from ESKOM, South Africa (Financial Times, October 2000: 8).

### **3.3.3 Petroleum Products**

Lesotho does not have oil reserves. Petroleum products are imported and are used mostly in the transport sector. In the power sector, diesel is used to generate electricity from the standby diesel plants owned and operated by the LEC.

### **3.3.4 New and Renewable Energy Sources**

Solar, wind and biogas as alternative sources for electricity contribute marginally.

## **3.4 The Power Sector**

### **3.4.1 Background**

The Lesotho Electricity Corporation (LEC) generates its electricity from four mini hydro stations and several small diesel machines. Its installed generation capacity amounts to about 4 MW. The organisation that complements the role of LEC is the Lesotho Highland Development Authority (LHDA), which operates the Muela hydropower station with an installed capacity of 72 MW. The LHDA sells all its electricity to the LEC under Power Purchase Agreements (PPA). Any excess demand during periods of low generation in the country is met by electricity imported from ESKOM of South Africa. The country was entirely dependent on electricity imports before the commissioning of the Muela hydropower plant in December 1998.

The transmission system operates at various voltages of 132 kV and lower. Electricity reaches the consumers through distribution lines. All transmission lines, including those that were constructed as part of the Lesotho Highland Water Project (LHWP), are operated and maintained by the LEC. As the LEC's transmission system is interconnected with the South African ESKOM system at 132 kV, it is an automatic operating member of the Southern African Power Pool (SAPP).

The distribution network is concentrated in the lowland areas. To increase electricity access, the network needs to be extended to other parts of the country, including the highlands. This, however, poses a challenge to the corporation. In order for the LEC to extend electricity services to far more people, it has to address its financial and operational problems. The other factor that affects the performance of the LEC is that the electricity tariffs do not cover costs of supply and that the tariffs take too long to be adjusted upwards.

### **3.4.2 Existing Institutional Arrangements**

The Department of Energy (DoE), which falls under the Ministry of Natural Resources, is responsible for the power sector's policy formulation. It also supervises the operations of the Lesotho Electricity Corporation (LEC) and the Lesotho Highland Development Authority (LHDA) which was constructed to

facilitate the transfer of water from the Orange River basin in Lesotho to the Vaal River basin in South Africa. The amount of electricity generated is dependent, therefore, on water deliveries to South Africa (SADC-REPN, 2001: 8).

The LEC is a statutory corporation responsible for the production, transmission, distribution and supply of electricity in Lesotho. The LEC owns four mini hydropower plants and small diesel plants, which generate less than 10% of the country's power requirements. The LEC thus purchases most of its requirements from the LHDA and relies on electricity imports from ESKOM, South Africa, during emergencies (SAD-ELEC, 2000: 42). Currently a Johannesburg consultancy, SAD-ELEC, has been given a management contract for the LEC.

The LEC is a member of the Southern African Power Pool and is interconnected with ESKOM at 132 kV.

The LEC is the sole operator of all the electricity transmission and distribution systems in the country and is responsible for supplying all the customers in Lesotho with electricity.

**Figure 3.1: Lesotho ESI Current Structure**

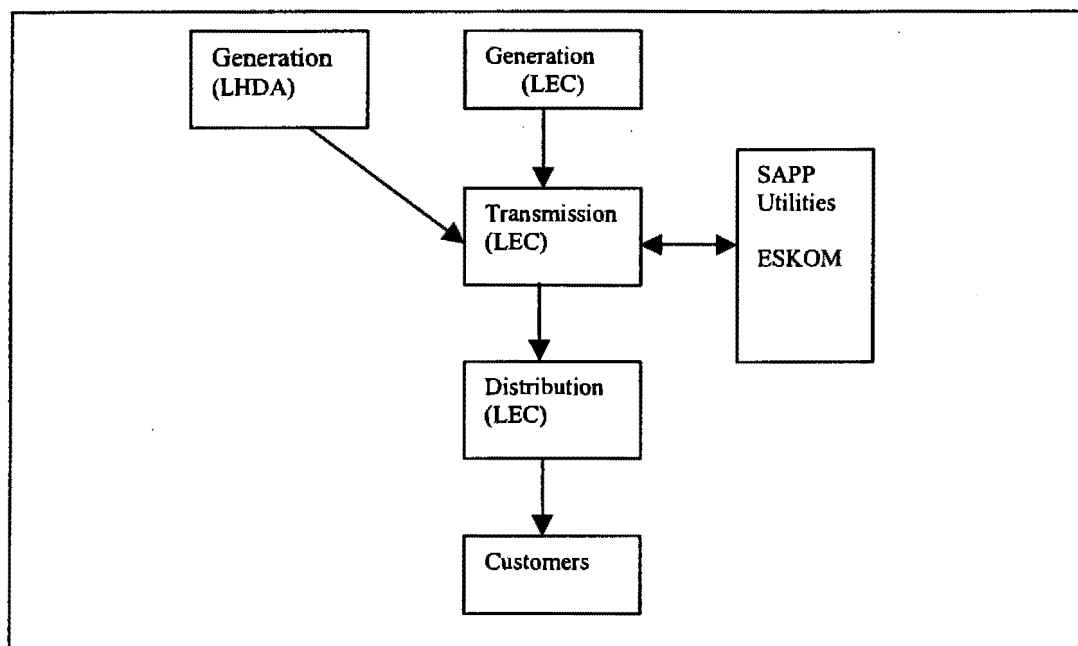

Source: SAD-ELEC, 2000: 39

### 3.4.3 Electricity Supply

#### 3.4.3.1 Generation

The total generation capacity of the Muela hydropower station, which belongs to the LHDA, stands at 72 MW. The LEC produces only a total of 4 MW from the mini hydro stations and standby diesel sets. The

recent information from the SAD-ELEC Inception Report that was submitted to the Privatisation Unit of the Lesotho Government indicates that the installed generating capacity of the LEC is as shown in Table 3.1 below.

**Table 3.1: LEC's Installed Capacity**

Source of power		Installed Capacity (MW)	Total (MW)	Year Commissioned
Mantsonyane	Hydro	1*0.5, 1*1.5	2.00	1989
Semonkong	Hydro	1*0.180	0.180	1988
Tsoelike	Hydro	1*0.275, 1*0.125	0.40	1990
Tlokoeng	Hydro	1*0.460, 1*0.210	0.670	1990
<b>Total Hydro</b>			<b>3.25</b>	
Semonkong	Diesel	0.12	0.12	1988
Tsoelike	Diesel	0.52	0.52	1990
Tlokoeng	Diesel	0.20	0.20	1990
<b>Total Diesel</b>			<b>0.84 MVA</b>	

Source: SAD-ELEC, 2001

All the hydro stations, except for Mantsonyane, have standby diesel generators. Further, Semonkong and Tlokoeng are isolated from the main grid whereas the other stations are connected to the grid. The hydro plants operate mainly during the rainy season, while the diesel generators are used primarily during the dry months. The total units generated by the hydroelectric stations have decreased, firstly because the reservoirs have silted up and have resulted in less water flow along the river. Secondly, generating equipment technical faults take too long to be repaired.

The historical statistics of units generated by the LEC's own plants are not up to date. Records of only four years were available, i.e. from 1992 to 1994 and more recently from March 2001 to April 2002. The units generated between 1992 and 1994 show a steady downward trend.

**Table 3.2: LEC's Generation Statistics from 1990 to 1997**

	1990	1991	1992	1993	1994	1995	1996	1997
<b>Installed Capacity</b>								
Hydro plant (MW)	3.270	3.268	--	3.268	3.268	3.268	3.268	3.25
Thermal plant (MW)	1.593	1.378	--	1.56	1.56	1.56	1.56	1.512
<b>Total</b>	<b>4.863</b>	<b>4.646</b>	<b>--</b>	<b>4.828</b>	<b>4.828</b>	<b>4.828</b>	<b>4.828</b>	<b>4.762</b>
Units Generated (GWh)	--	--	2.88	2.59	2.71	--	--	--
Units Sold (GWh)	168.4	175.70	191.3	221.36	242.03	259.2	302.6	272.6
Max Demand (MW)	48.6	47.8	50.07	65.00	66.00	71.5	80.02	73.5

Source: LEC Annual Report 1993/94, ESKOM Statistical Year books 1990--96

When SAD-ELEC took over the management of the LEC, it was found that the total cost of generation for the LEC hydro and diesel-generating plants had previously been calculated at three Maloti per kWh in March 2001. This is extremely high when compared with other supply options, particularly the costs of

importing power from South Africa (SAD-ELEC, 2001: 14). This poses a major financial challenge for the LEC. Subsequent to these findings, thorough assessments of the condition of the hydro plants were carried out during 2002, and the LEC Board approved the following recommendations:

- i. Tsoelike to be mothballed (with a view to possible sell-off in the future).
- ii. Tlokoeng to be mothballed (with a view to possible sell-off in the future) as soon as a grid supply is available.
- iii. Mantsonyane to be retained in service in its current operating regime.
- iv. Semonkong's ownership and operation to be transferred to the local community.

### ***Future Generation Potential***

SAPP statistical and planning data (SAPP Annual Report, 2001: 20) indicate that the maximum power demands for Lesotho will double by 2010. This means that if Lesotho wants to continue to be self-reliant with regard to electricity supply, it will have to build additional power stations. The country has the potential to increase its installed capacity. For instance, Muela power station can be extended by an additional capacity of 100-120 MW. This capacity could be commissioned between 2005 and 2010 (SAD-ELEC & MEPC, 1996: 139). As a privatisation programme is already in process, it is likely that independent private investors will be encouraged to build any additional generating capacity.

### ***Electricity Imports***

Before the construction of Muela in 1998, Lesotho depended on electricity imports from ESKOM, as summarised in Table 3.3 below. From the Table it is observed that imports reduced drastically from 1998. LEC now imports power from Muela during periods of low generation and for emergency supplies.

**Table 3.3: Lesotho's Electricity Imports from South Africa**

	1990	1991	1992	1993	1994	1995	1996	1997	1998	1999	2000	2001
Imports GWh	--	--	241	281	310	324	335	318	209	55	12	40

Source: ESKOM Annual Reports 2000 and 2001

As Lesotho is already interconnected with ESKOM, the extension of the Muela power station can be delayed, if it is found that its power imports through the SAPP are a cheaper or 'least cost' option.

### **3.4.3.2 Transmission and Distribution System**

Lesotho's transmission and sub-transmission system consists of 132 kV, 88 kV, 66 kV, 33 kV and 11 kV overhead lines. The main transmission lines of 132 kV and 66 kV are radial, while the 33 kV distribution

lines are in ring in the major city of Maseru (SAD-ELEC & MEPC 1996: 136). The development of both transmission and distribution networks from 1990 to 1997 has been slow. The transmission system has been extended by 7.61% during the period 1990-1997, while the distribution system during the same period has only increased by 2.41%. By March 1997, the transmission and distribution network covered about 2,062 km of High Voltage overhead transmission line and about 602 MVA of total installed transformer capacity. (Refer to Table 3.4 below).

**Table 3.4: Transmission and Distribution Line lengths, 1990--1996**

Transmission lines (Km)	86	166	230	328	308	328	360
Distribution lines (Km)	1398.7	1500	1511	1585	1466	1553	1702
Transformers (MVA)	601	415	253	461	519	582	602
System losses %		10.4	8.1	11.8			

Source: LEC Annual Report 1993/94, ESKOM Statistical Yearbooks 1990--96

Since 2001, considerable system strengthening has been in progress to support renewed mining activity in Letseng, with textile works in Maseru's industrial area requiring some 19 MW, as well as to support some 9,000 new domestic connections currently being undertaken.

The LEC system is interconnected, except for three networks that are supplied from the mini hydro plants. The interconnection with South Africa is at 132 kV double circuits at Maseru, 88 kV at Hololo and 11 kV at Peka (SAD-ELEC & MEPC 1996: 136).

### 3.4.3.3 Power System Losses

From the transmission/distribution statistics, it appears that the losses on the system network are very high, ranging from 10.4 % in 1989 to 20.3 % in 1996. These include both technical and non-technical losses. The calculated losses in 2001/02 indicate that the losses are still high at an average value of 21.5 percent in the year as seen in Table 3.5 below.

**Table 3.5: The calculated losses on LEC System**

Month	Purchases	Own supply	Total supply	Credit billing	Pre-payment	Total sales	Global losses	Losses (in %)
Mar - 01	29 180	343	29 523	21 466	4 202	25 668	3 855	13.1%
Apr - 01	30 441	485	30 926	20 183	4 258	24 441	6 485	21.0%
May - 01	37 390	979	38 369	22 950	4 977	27 927	10 442	27.2%
June - 01	36 286	1 946	38 232	22 629	5 652	28 281	9 951	26.0%
July - 01	42 760	412	43 172	25 410	5 694	31 105	12 067	28.0%
Aug - 01	41 648	147	41 795	26 164	5 873	32 037	9 758	23.0%
Sept - 01	40 369	911	41 280	22 122	5 635	27 757	13 523	32.8%
Oct - 01	30 217	515	30 732	18 233	6.631	24 864	5 868	19.1%
Nov - 01	29 920	1 160	31 080	16 098	6 297	22 395	8 685	28.0%
Dec - 01	25 922	963	26 885	15 969	8 826	24 795	2 090	7.8%
Jan - 02	26 879	576	27 455	13 043	8 049	21 092	6 363	23.2%
Feb - 02	25 760	512	26 272	12 906	8 172	21 078	5 194	19.8%
Mar - 02	27 294	325	27 619	11 000	12 021	23 021	4 598	16.6%
April-02	30 298	359	30 657	16.457	9 568	26 025	4 632	15.1%

Source: SAD-ELEC, 2002

### 3.4.4 Demand

The LEC has a weak customer base. Most of the customers come from the domestic sector. Between 1990 and 1996, electricity sales were highest in the domestic sector, followed in decreasing order by the commercial, industrial and general sectors of the economy. The total maximum demand increased from 48.6 MW in 1989 to 73.5 MW in 1996 and in 2001 it was 92 MW. Table 3.6 below shows the breakdown of the LEC's sales per customer category.

**Table 3.6: Lesotho's Electricity Consumption by Sector, 1990-1996**

	1990	1991	1992	1993	1994	1995	1996	1997 to 2000
Domestic	57.9		54.73	48.6	52.8	72.9	64.4	Information Not available
Commerce	42.2		45.81	51.3	44.3	45.4	51.4	
Industrial	31.6		61.7	39.9	41.7	51.6	50.7	
General Purpose	43.9		36.4	42.3	35.8	47.7	40.8	
LHDA			22.7	60.0	84.6	85.2	65.3	

Source: LEC Annual Report 1993/94, ESKOM Statistical Yearbooks 1990-96

In 1997 the billing system collapsed and information about customers was no longer available (SAD-ELEC, 2001: 13). As part of the contract entered into between Lesotho and SAD-ELEC, the latter was required to establish the existing number of customers and reintroduce sound commercial practices. A customer meter survey was carried out in 2001 to identify the existing customers (ibid.). The survey found that the LEC at that time had a total of 21,708 customers. This contradicted the LEC's records, which claimed there were 38,000 customers as of June 2001. The customers comprised 356 large power

users on maximum demand meters, 7,493 single-phase and three-phase credit meters, 2,191 Plessey prepayment meters, and 9,524 EML/CashPower prepayment meters. The customer database has been reconciled now. By January 2002 a total of 3,500 new customers had been connected to the system, bringing the total customers to about 25,200.

The government plans to increase the electrification levels to 13 % by 2010 (SAD-ELEC & MEPC, 1996: 131). In view of these intentions, and considering other development programmes in other sectors, e.g. renewed mining activity and increased manufacturing such as textiles, the demand for electricity is likely to increase.

### **3.4.5 Electrification**

Between 2-3 % of the country's population has access to electricity. Electrification of both urban and rural areas is the responsibility of the LEC. Low electrification levels are attributed to the following factors:

- High connection fees;
- Very high price / cost of electricity;
- Scattered settlement patterns in the rural areas;
- The geographical nature of the country as it is so mountainous; and
- The inability by LEC to meet backlogs in the demand for connections.

The LEC's electrification projects are generally concentrated in urban centres because the utility considers these to be financially viable. Connections to new customers were made as and when funds were available, either from donor funding in the form of loans and grants, or from the LEC's own resources. One such project for electrification was the M80 joint Swedish/Norwegian funded project for phase 1 of the network development project in the Central and Southern regions of Lesotho. The project aimed to improve the reliability and quality of supply so that more people could be connected (LEC Annual Report, 1993/94: 7).

To improve access to electricity, the World Bank and the African Development Bank are currently supporting an ongoing electrification programme, which is expected to result in the completion of at least 9,600 new connections by end-October 2002. SAD-ELEC is expected to make 8,000 new connections, while the LEC will be responsible for the remaining 1,600 connections (SAD-ELEC, 2001: 21 - 22).

The electrification exercise is progressing well, although it is doubtful that the target of 9,600 connections will be reached during the SAD-ELEC contract period, which was supposed to end in July 2002. The

extension of the contract by 6 months will probably enable SAD-ELEC to meet the targeted new connections. The new connections, sorted by customer group, from April 2001 to April 2002 are shown in Table 3.7 below.

**Table 3.7: New connections per customer group**

Month	Domestic	General Purpose	Commercial	Industrial	Total connections in the month	Running total from April 2001 to April 2002
April-01	29	3	0	0	32	32
May-01	166	26	0	0	192	224
June-01	533	40	0	1	574	798
July-01	353	6	3	3	365	1 163
Aug-01	332	37	0	0	369	1 532
Sep-01	317	28	0	2	347	1 879
Oct-01	559	30	0	1	590	2 469
Nov-01	501	29	0	0	530	2 999
Dec-01	386	21	0	0	407	3 406
Jan-02	119	4	0	1	124	3 530
Feb-02	103	16	0	1	120	3 650
March-02	143	40	0	0	183	3 833
April-02	157	29	0	0	186	4 019
<b>Total</b>	<b>3 698</b>	<b>309</b>	<b>3</b>	<b>9</b>		

Source: SAD-ELEC, 2002

The government believes that participation by private investors will improve future electrification levels both in urban and rural areas.

### ***Rural Electrification***

The extension of the distribution system to supply the peri-urban and rural areas is the responsibility of the LEC. At present, the electrification level in rural areas is low when compared to that in urban areas. The LEC finds it expensive to extend the distribution network to these areas because of the low demand. In an effort to increase the economic activities and access to electricity in the rural areas, the corporation proposed to encourage the communities in the various villages and townships to come together and form themselves into schemes which could apply for electrification. In this way it was hoped that the corporation would assist the communities in financing the schemes through investment programmes (LEC Annual Report 1993/94: 6), but so far the response has been very low, probably due to the very low income levels of the rural population.

It is envisaged that, when the LEC is privatised after the expiry of the current management contract, the government will assume the responsibility for electrifying the rural areas. In order to achieve meaningful electrification levels, it intends to:

- Establish a rural electrification fund; and
- Investigate possibilities of establishing a rural electricity advisory committee for designing and implementing rural electrification projects.

One of the government objectives for the LEC management contract was that electricity coverage should be extended to as many households as possible. A study has been conducted to find out how the services can be extended to rural areas. Two recommendations for implementations have been made (SAD-ELEC, 2001: 25):

- i. Rural electrification projects should be implemented via concession approaches; and
- ii. Private investors should be encouraged to supply the areas, which are presently still isolated from the grid, through building diesel machines or using renewable technologies.

The study further recommended that for the LEC to make profits its services should be limited to the lowland areas of the country.

#### **3.4.6 Tariff Structure**

The DoE is responsible for approving tariff increases. In 1994 the average price per unit supplied by the LEC was about 7.5 US cents/kWh (SAD-ELEC & MEPC, 1996: 131). This was the time when Lesotho relied on electricity imports from South Africa. Although ESKOM increased its tariff to Lesotho in 1994 and 1995, Lesotho's tariff itself was not revised. This definitely had a negative impact on the financial performance of the utility.

When the LHDA completed the construction of the 72 MW Muela power plants in 1998, the LEC commenced buying electricity from within Lesotho, as part of an agreement with the government, and reduced imports to emergency supplies only. Buying electricity from the LHDA, however, had a negative impact on the LEC's financial performance, because the LHDA's tariff was very high compared to the import tariff.

### ***LEC's Schedule of Tariffs and Charges***

The LEC's current schedule of tariffs and charges is organised into the following five scales:

- i. Prepayment tariff
- ii. Domestic tariff
- iii. General purpose tariff
- iv. Commercial maximum demand tariff
- v. Industrial maximum demand tariff

The prepayment tariff is divided into seven parts, with different charges ranging from Maloti 0.31/kWh for domestic to Maloti 0.654/kWh for general purpose, which includes a surcharge.

The domestic tariff for premises used solely for private residential purposes and for primary and secondary schools is divided into fourteen levels. The fixed monthly demand charge per kVA is 4.51 Maloti and customers pay an additional flat energy charge of 0.28 Maloti per kWh.

The general-purpose tariff applies to all installations other than private residences/schools, which have a demand of less than 50 kW per month for commercial purposes and less than 25 kW for industrial purposes. This category of consumers pay a fixed monthly demand charge of 7.73 Maloti per kVA in addition to the flat energy charge of 0.41 Maloti per kWh. The tariff charges are also organised in fourteen levels.

The commercial maximum demand tariff applies to consumers who use electricity predominantly for commercial purposes other than industrial, and regularly have a maximum demand of 50 kW measured during any 30 minute period in the course of a meter reading period. The tariffs and charges are in two parts and each part in turn has two tariff levels and charges.

The industrial maximum demand tariff applies to industrial consumers with a regular maximum demand in excess of 25 kW measured during any 30 minute period of a meter reading period. The tariff levels are in two parts, as for the above category, but the charges are different. It also includes an off-peak tariff.

According to SAD-ELEC, a tariff study for the introduction of cost reflective tariffs was carried out and was completed in May 2002. Its recommendations were submitted to government for consideration.

### **3.4.7 Financial Performance of the LEC**

The prices of electricity from the LHDA to the LEC and the LEC's tariffs were initially intended to ensure that the ESI operates in a financially viable manner. Although the financial situation of the ESI as a whole looks promising, the LEC faces two key problems: the high cost of power from Muela which has not been offset by increases in the LEC's tariffs, and poor revenue collection. During the past decade the LEC had a large proportion of outstanding payments from customers. The connection fees charged to new customers during the same period were very low (SAD-ELEC & MEPC 1996: 133). The other reason for the LEC's continued poor financial performance is that it is failing to increase its customer base. If the backlog of outstanding applications for connections were cleared, the customer base would increase.

One of the tasks of the current SAD-ELEC contract during 2001/02 is to reverse the weakening performance of the LEC in particular with regard to financial losses. To achieve this objective, they agreed at the beginning of the contract period to replace all domestic and general-purpose customer credit meters with prepayment meters. The aim of this meter replacement exercise is to improve revenue collection (Central Bank of Lesotho, May 2001).

According to the report prepared by the Privatisation Unit of the Lesotho Government (11 January 2002) SAD-ELEC has made significant progress in improving the operating efficiency and financial performance of the LEC. It is expected that privatisation will continue this process of performance improvement.

Apart from the collapse of the billing system in 1997 as mentioned above, the utility's annual accounts for the financial years ending 31 March 1997, 1998, 1999, 2000 and 2001 have not been published. SAD-ELEC is also expected to update the accounts (SAD-ELEC, 2001: 10). Because of this, the historical financial statistics for the LEC are not available.

### **3.4.8 Power Sector Reforms**

To improve service delivery, the Lesotho Government embarked on a Utilities Sector Reform Project (LURP), supported by credits from the International Development Association (IDA – a member of the World Bank group) and the African Development Bank. The LURP was established in support of the privatisation process in order to ensure efficient and reliably functioning utilities. A key element of the Lesotho Government's initiative was the appointment of the current SAD-ELEC consultants to run the LEC.

### **3.4.8.1 Main Driving Forces for Power Sector Reforms in Lesotho**

The various countries in both developed and developing countries that embarked on reforming their electricity supply industries did so for different reasons. According to the Lesotho Government (Ministry of Natural Resources, 2001) the reforms in its power sector are driven by the following main problems faced by the LEC:

- i. Inefficient commercial operations;
- ii. Inability to meet demand and the connections backlog. (The LEC was failing to increase the electricity connection and as a result the electrification level for the country is low.)
- iii. High operational costs characterised by high staffing levels;
- iv. Poor financial management;
- v. High tariffs; and
- vi. Inability to service loan commitments.

### **3.4.8.2 Characteristics of the Reforms**

The LEC is undergoing reforms under the public utilities reform project. Currently no changes have been made to the present ESI structure shown in Figure 3.1 above. Thus the LEC is still operating as a vertically integrated organisation.

The restructuring of the LEC involves turning the enterprise into a commercially viable entity that will in the end be privatised. In order to address the LEC's financial, operational and managerial problems, the government recruited a management firm to run it. The LEC is now under a management contract, which is expected to end in July 2002.

### **3.4.8.3 Privatisation**

The government is looking for a strategic partner to purchase a majority stake in the LEC (Financial Times, October 2000: 8) in order to allow for the entry of new investors in the sector and to ensure proper business management. The government's Sales Advisory Group commenced its work in December 2001. The LEC is expected to be privatised as a whole because of its small size. This means that the LEC's vertically integrated structure is likely to remain intact. However, the whole ESI structure may change with the entry of new players, (e.g. operators in rural areas or Independent Power Producers (IPP) if Muela should be sold or extended), as well as the introduction of the regulatory authority, as shown in Figure 3.2 below.

**Figure 3.2: Lesotho's Assumed New ESI Market Structure**

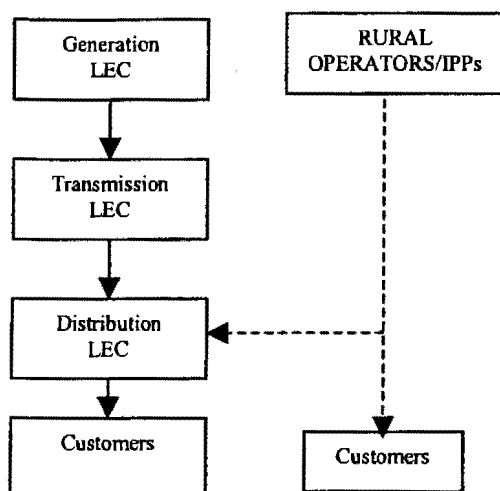

### ***Expected Benefits of Privatisation***

The government's privatisation policy aims to encourage the Basotho's ownership of the LEC. To achieve this goal, the government has adopted a policy of reserving a portion of the shares for the Basotho. With this arrangement, it is expected that the managerial and operational efficiency of the organisation will improve and will in turn improve the financial performance of the organisation.

The second expected benefit of the reforms is the increase in investments by foreign organisations. In a reformed electricity market, the electricity prices will be competitive in relation to those in the region and are likely to decrease. Low electricity prices will thus encourage foreign investments in industrial and manufacturing sectors.

Access to electricity is also likely to increase in the reformed electricity market because the companies will need to connect as many customers as possible in order to make high profits (Central Bank of Lesotho, May 2001).

### **3.4.9 Regulatory Framework**

The regulatory framework of the Electricity Act, No.7 of 1969, governs the ESI (SAD-ELEC, 2000: 43). According to the rules set out in the Act, only the LEC is allowed to generate, transmit and distribute electricity in Lesotho. Generation of electricity is, however, dominated by the LHDA, which generates virtually all the electricity in Lesotho. Any other organisation wishing to embark on the business of electricity production, transmission and distribution has to be licensed by the LEC.

All issues concerning the ESI and its management are the responsibility of the Directorate of Energy in the Ministry of Natural Resources. In line with the programme of privatising the state utilities, the

government intends to introduce two major institutional reforms. The first is to replace the existing power sector policy committee, which at present is dominated by government representatives, with a new Electricity Forum representing a broad range of stakeholders. The second is to establish a regulatory authority to oversee all the electricity regulatory functions and to issue licences (London Economics, 1999: 4).

Presently the Lesotho Government, through its Privatisation Unit (PU) signed a contract with the Barents Group of KPMG Consulting of Virginia (USA), for advisory services required to prepare for the divestiture of LEC (The Privatisation Unit of Lesotho Government Report, January 2002).

### ***ESI Regulation in Lesotho***

Currently, Lesotho does not have an Independent Electricity Regulator. The Department of Energy in the Ministry of Natural Resources carries out all the ESI regulatory functions. In view of the reforms being implemented in the power sector, the government intends to establish a regulatory board to regulate the sector. An independent power regulator will be part of a multi-sectoral regulator covering all the utilities and is expected to become operational during 2003 (SAD-ELEC, 2001: 7). The expected functions of the utilities regulatory board, as indicated in the speech by the Minister of Natural Resources during the launch of the Lesotho Utilities project include:

- i. To regulate electricity tariffs;
- ii. To protect the interests of consumers while ensuring the financial viability of the utility companies;
- iii. To ensure that there is competition in supplying electricity to consumers in order to foster new private investments;
- iv. To provide incentives and efficiency improvements on the part of the licensees so as to enable all reasonable demands for electricity to be met in accordance with current government policy; and
- v. To regulate licences.

## Chapter Four

---

### Malawi

#### 4.1 Location and Demography

Malawi, the former British protectorate of Nyasaland, is a land-locked country located in Southern Central Africa. Mozambique borders it to the east, south and west, Zambia to the west and Tanzania to the north and east. The country covers a total area of 118,480 square kilometers, of which 94,080 square kilometers are covered by land while 24,400 square kilometers are covered by water (CIA World Factbook, 2001). Lake Malawi covers a large proportion of the water area. The lake has one outlet, the Shire River. This river flows out of the southern end of the lake and joins the Zambezi River in Mozambique. All the main hydropower stations are located in cascades in the middle section of the Shire River.

The country is divided into three regions: Southern, Central and Northern. The Southern Region has two main cities, namely Blantyre (the commercial center) and Zomba, the former capital. The capital city for the entire country is Lilongwe and lies in the Central Region, while Mzuzu is the main city in the Northern Region.

Malawi has a subtropical climate. There are two distinct seasons: the dry season from May to November and the rainy season from November to May. The latter is the planting season for most of the crops. Rainfalls are heaviest in December and January. Most rivers are full during this period. Since the catchment area of the Shire River has been deforested through bad forestry management, a lot of sediments flows along the river. These sediments reduce the water flow and the dams' capacity at the power stations intakes. As a result electricity generation is negatively affected during the rainy season, though theoretically, with the larger volumes of water, it would be able to generate more electricity.

In 2000 the population of the country was estimated to be 10.3 million. The annual population growth rate is 2.1 %, and total life expectancy is 39. It is estimated that 15 % of the population lives in urban areas and the remaining 85 % lives in rural areas (World Bank, 2002).

The country's natural resources include limestone, hydropower, and coal and, as yet, not exploited deposits of uranium and bauxite.

## 4.2 Economy

Malawi's main economic base is agricultural. The main cash crops are tobacco, tea and sugar. It is estimated that agriculture contributes about 41.6 % of the country's GDP. The contributions of the other sectors to the GDP are as follows: industry (19.1 %), manufacturing (13.8 %) and services (39.4 %) (World Bank, 2002). The economy has historically been relatively healthy, but poor agricultural output contributes to reduced economic growth. Frequent droughts, and in some years, heavy flooding have contributed to poor farm productivity. The recent food crisis in late 2001 and early 2002 was a result of heavy flooding during the previous year. The lack of agricultural inputs, mostly fertiliser, also leads to poor maize harvests in most rural areas. Currently, the government plans to improve food production through free distribution of farm inputs to poor families in rural areas.

The substantial part of Malawi's economy depends on inflows of economic assistance from the IMF, the World Bank and individual donor nations. In 2000 the estimated Gross National Income (GNI) per capita was US\$170 with the GDP's real growth rate of 1.7 %, while the rate of inflation was about 24.5 % (World Bank, 2002).

After Independence in 1966, the government established a number of state-owned enterprises (SOEs) in order to create employment and improve service deliveries. The SOEs operated in most sectors of the economy and enjoyed a monopoly status. The combined effects of good agricultural output and good performances by the enterprises had a positive impact on economic growth of the country up to 1979, when the economy went into recession for a period of three years. The government then started to change its economic development policies in order to bring the economy back on track. Among other things, the government liberalised foreign exchange, overhauled the monetary and tax system and improved the incentives for local and foreign investors (The Official SADC Trade, Industry and Investment Review, 2001).

The government started to follow a market determined exchange regime in 1994. Before the changes in exchange policy, the government followed a flexible exchange rate. The companies that have invested in the country are allowed to operate a foreign currency account with any of the authorised commercial banks. The companies are also allowed to sell their services in foreign currency, although payment is made in local currency, depending on the exchange rate of that particular time. Thus the prices are adjusted automatically, depending on the depreciation and appreciation of the local currency. Inflation and interest rates are, however, very high.

The government is also changing its fiscal policies in many sectors of the economy in order to stimulate employment and economic growth. It intends to broaden the ownership base of the state enterprises in the infrastructure industries, such as transport, telecommunication and energy, by privatising them. This

privatisation programme was initiated in 1998 under the technical assistance of the World Bank (IMF, 1998). This is being done with the aim of achieving a stable economic performance. To accelerate this programme the government established a privatisation commission to oversee the selling of state-owned enterprises. In the power sector, the power utility ESCOM is to be restructured and private sector participation to be encouraged. The implementation of the restructuring process in the power utility has so far been a success.

### **4.3 Energy Sector**

The final draft for the Energy Policy White Paper of Malawi was produced in October 2001. Previously the policy guidelines and strategies for the various energy sub-sectors of electricity, liquid fuels, biomass and coal were scattered over a number of documents. According to the Malawi Energy Policy White Paper (2001: 26), the government's main objectives for the energy sector are:

- i. **Improving technical and economic efficiency of the commercial energy supply industry.** The government proposes to undertake major reforms of the commercial energy sector in order to ensure improved technical and economic efficiency in supply of energy services. Participation of the private sector will be facilitated in order to promote competition.
- ii. **Increasing security and reliability of energy supply systems.** The reliability of supply of commercial energy is affected by several bottlenecks in the energy sub-sectors. The government will ensure all the sub-sectors operate efficiently through policy measures that are designed to strengthen the existing energy supply systems and promote inter-regional trade.
- iii. **Increasing access to affordable modern energy services.** Access to modern energy services is currently limited. Modern energy only accounts for 7 % of the total energy consumption at present. The government aims to increase the accessibility of the energy services to the majority of the people by promoting the use of low-cost quality technologies.
- iv. **Stimulating economic development and rural transformation for poverty reduction.** The energy sector will contribute towards economic growth of the rural areas through encouraging industrialisation and modernisation of agriculture so that the available commercial energy resources can be used to prepare land for farming and increase agricultural production.
- v. **Improving energy sector governance.** The sector is currently weak and lacks proper co-ordination between the sub-sectors. The government proposes to reform the sector in order to improve operational efficiency.
- vi. **Managing energy related environmental, health and safety impacts.** Energy is the major cause of environmental degradation and in this regard the government plans are that all energy development programmes should be implemented in line with the provisions of the environmental Act.

The various sources of energy available in Malawi include biomass, coal, solar, energy, uranium and hydropower. The Malawi government Energy Policy White Paper attempts to address various issues in these energy sub-sectors.

#### **4.3.1 Biomass**

The main energy source in Malawi is biomass, which is mainly used in the form of firewood and charcoal. These fuels are mostly used in traditional stoves that have efficiencies ranging from 15 to 20 % (Davidson, 1992: 375). The Malawi Energy Policy White Paper (2001: 30), states that biomass supplies about 91 % of Malawi's total energy consumption. This over-reliance on wood fuel has increased the rate of deforestation to an alarming degree, as most of the wood fuel comes from the natural forests. Energy policy formulation is therefore required in the country in order to halt the depletion of natural forests.

Malawi also produces ethanol from molasses, obtained from two local sugar factories. The ethanol produced is mainly blended with petrol and is thus used in the transport sector. Baggase, the residue from the sugar cane crushing process, is used as fuel for electricity production. This is inevitably seasonal, though, and the factories themselves normally use the electricity generated. Other forms of biomass such as animal waste, by-products of agricultural activities and municipal waste are also used to provide energy, albeit in a minor way.

#### **4.3.2 Coal**

Malawi has proven coal reserves estimated at 1 billion metric tonnes, of which about 22 million tonnes are of bituminous type (Malawi Energy Policy White Paper, 2001: 84). These reserves are found in the northern and southern parts of the country. Both coalfields are, however, very far from industrial/commercial centres. At present, very little coal is mined in the Northern Region. The potential for thermal generation of electricity, using coal on site at these coalfields, is regarded as one of the options of generating electricity in Malawi in order to meet the future power needs of the country, as well as for the export market (Chiwaya in Bhagavan, 1999: 30).

#### **4.3.3 Hydropower**

Malawi has many perennial rivers in all three regions of the country. The Shire River, which is the only outlet of Lake Malawi, is the largest river in the country. The potential for hydropower from the Shire River alone is estimated at 600 MW (Chiwaya in Bhagavan, 1999: 26). In 1999, 47 % of this potential had already been developed. The hydropower development studies that were carried out by Lahmeyer International and Knight Piesold consultants together with ESCOM, indicated that the total untapped hydro resources stand at about 7,000 Gwh per annum (Lahmeyer International, Knight Piesold & ESCOM, 1998: 10). This potential can be developed from twelve possible sites. According to the studies,

however, only three potential sites, two on the Shire River and another one on lower Fufu River in the north can be developed economically.

#### **4.3.4 Petroleum**

There are no proven oil reserves in Malawi, and thus the country relies on imports of petroleum products. Most of the imported petrol and diesel are used in the transport sector/industry. ESCOM used to operate a number of diesel generators for electricity production in some isolated places and main cities. Since all the major towns and districts are now supplied from the main grid, these diesel generators are mainly used during peak hours, for voltage boosting and, in some cases, limited standby in Lilongwe, Karonga and Chitipa districts. However, the plants are rarely operational because they are not in good condition. Some major companies have also installed diesel generators on their premises for standby purposes; as the supply of electricity from the ESCOM grid is not reliable due to frequent power failures.

#### **4.3.5 Solar Energy**

The use of solar power as an energy source is not yet developed. Currently there is a project funded by Danish International Development Agency (DANIDA), which is promoting the use of solar photovoltaics in rural areas. The government of Malawi requested aid from DANIDA, UNDP and other donors to set up a revolving renewable energy fund so that rural people could get loans to access renewable energy services (UNDP Report, March 1999: 22). The large-scale development of this energy source is, however, very unlikely, since the income of the rural people is very low.

#### **4.3.6 Nuclear**

Malawi has proven reserves of uranium of about 0.063 million tonnes which may be mined for export in the future (Malawi Energy Policy White Paper, 2001: 89). These deposits are found in the northern part of the country. The Government has, at the moment, no plans to use this primary energy source for electricity production.

### **4.4 The Power Sector**

#### **4.4.1 Background**

The Electricity Supply Industry in Malawi is dominated by the vertically integrated power utility called the Electricity Supply Corporation of Malawi (ESCOM). This utility is responsible for the supply of electricity in Malawi, and it generates, transmits, distributes and sells electricity to its customers. ESCOM has a total installed capacity of 306 MW; of this 285 MW is hydro-generated and 21 MW is thermal. Generation is concentrated along the middle section of the Shire River, an outlet of Lake Malawi. Currently, ESCOM is able to meet its national electricity requirements. In 2000 ESCOM commissioned

its 64 MW hydropower plants, on Shire River, at Kapichira and phase II of similar capacity is planned for commissioning in the year 2010.

Electricity is supplied to the three main regional centers through 132 kV and 66 kV transmission lines. These transmission voltages are stepped down to distribution voltage level in transformation stations, which are scattered all over the country. The distribution system is demarcated into three areas, corresponding to the geographical regions of the country. The network coverage is only high in urban areas. The current efforts by the government to increase electrification levels in rural areas and to improve agricultural productivity through irrigation will increase both the network coverage and the demand for electricity.

#### **4.4.2 Existing Institutional Arrangements**

ESCOM reports to the Ministry of Natural Resources and Environmental Affairs through its Department of Energy. The Director of Energy is responsible for the formulation of policies on the Electricity Supply Industry (ESI). Due to recent reforms taking place in the power sector, the National Electricity Council (NECO) now regulates the ESI. The Directorate of Energy previously carried out this function. The NECO was established in 1998 after a new Electricity Act was passed by Parliament the same year, in June 1998 (SAD-ELEC, 2000: 44). According to Chiwaya in Bhagavan (1999: 54), the other government departments involved in the current electricity industry set-up include the following:

- i. The Ministry of Water and Irrigation, which is responsible for the management of water resources;
- ii. The Ministry of Finance; and
- iii. The Ministry of Statutory Corporations, which is responsible for the supervision of public enterprises.

Due to the reform process, ESI in Malawi is changing from the current vertically integrated structure shown in Figure 4.1 to a new market structure elaborated later in Figure 4.2 in section 4.4.8.3, in order to allow participation by private investors. As part of this process, the utility, ESCOM, has been unbundled into generation, transmission and distribution entities.

ESCOM is a member of the Southern African Power Pool (SAPP) but its transmission network is not connected to any of the neighbouring countries. This makes it impossible to import power at high voltage from other SAPP member countries, and as a result the country experiences power shortages during periods of low generation.

Self-generation for own purposes, using diesel generators and bagasse, is an important part of the ESI in the country and constitutes about 51.3 MW (Malawi Energy Policy White Paper, 2001: 65). Co-

generation is done primarily in the two main sugar factories at Dwangwa in the Central Region and Nchalo in the Southern Region of the country. Electricity generation is carried out in these industries in order to meet part of their power requirements. With the opening up of the electricity market, the sugar companies may increase their generation capacity, so that they can sell the surplus to either ESCOM or directly to consumers in their immediate surroundings.

The current ESI structure in Malawi is illustrated in Figure 4.1 below.

**Figure 4.1: Current ESI Structure in Malawi**

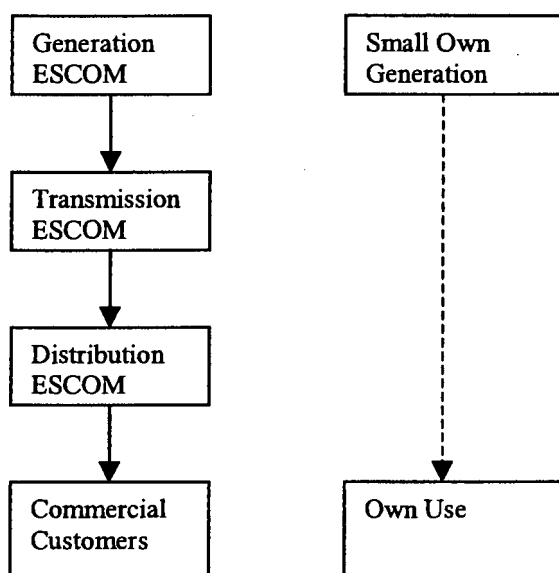

Source: Malawi Energy Policy White Paper (Draft)

### 4.4.3 Electricity Supply

#### 4.4.3.1 Generation

The total generation capacity of ESCOM stands at 306.1 MW, of which 21.4 MW is thermal and 284.7 MW is hydro-generated. The generation development by ESCOM is indicated in Table 4.1 below.

**Table 4.1: ESCOM's Generation Development**

STATION	Year	INSTALLED CAPACITY (MW)	Generation Type
Zomba	1953	0.3	Hydro
Zomba	1954	0.3	Hydro
Nkula 'A'	1966	16	Hydro
Nkula 'A'	1967	8	Hydro
Lilongwe 'A'	1972	3	Thermal
Tedzani 1	1973	20	Hydro
Blantyre GT	1975	15	Thermal
Tedzani 2	1976	10	Hydro
Tedzani 2	1977	10	Hydro
Lilongwe 'A'	1980	1.3	Thermal
Mzuzu	1980	1.1	Thermal
Nkula "B"	1980	40	Hydro
Nkula "B"	1981	20	Hydro
Mzuzu	1983	0.7	Thermal
Nkula "B"	1986	20	Hydro
Chitipa	1988	0.3	Thermal
Nkula "B"	1992	20	Hydro
Wovwe	1995	4.5	Hydro
Tedzani 3	1995	51.6	Hydro
Kapichira	2000	64	Hydro

Source: ESCOM Annual Report, 1999/2000 Unpublished.

Expansion in the area of electricity generation to meet demand in the country has been rapid and has been done in small phases within a short period of time. This is as a result of the small sizes of the plants that were constructed.

Electricity generation in Malawi is predominantly hydroelectric, and is generated at the three main stations: Nkula, Tedzani and Kapichira. The thermal power plants are used for standby purposes or during peak demand hours. These old diesel plants also inflate the country's reserve margin (UNDP/World Bank Report no. 182/96: 47). In the past five years the availability of these units has been very low because of numerous breakdowns and lack of spare parts (ESCOM Annual Reports, 1995-1999). The performance of the hydropower plants, however, has been effective, and ESCOM has been able to meet the country's demand. Moreover, the units generated show an upward trend. For instance, from 1991 to 2000 the units have actually increased by 40 %. Most of the units are sent out to transmission systems, and the load factor is generally good. Refer to Table 4.2, below, for further detailed generation statistics.

**Table 4.2: ESCOM's Generation Statistics**

	1990	1991	1992	1993	1994	1995	1996	1997	1998	1999	2000
Installed Capacity											
Hydro plant (MW)	144.60	144.60	144.60	164.60	164.60	164.60	219.10	220.70	220.70	220.70	284.10
Thermal plant (MW)	23.70	23.70	23.70	25.20	25.115	24.555	24.555	22.475	21.40	21.40	21.40
Total	168.30	168.30	168.30	189.155	189.155	189.155	243.655	243.10	242.10	242.10	305.50
Units (GWh) Generated	792.41	707.08	772.80	784.72	831.88	859.90	857.65	891.73	977.39	1,031.76	1,071.50
Station Units (GWh)	3.2	3.69	2.67	6.39	5.31	11.62	9.32	11.05	3.15	4.27	12.95
Units Transmitted (GWh)	789.21	703.39	770.13	778.33	826.57	848.28	848.33	880.68	974.24	1027.49	1,058.55
Load factor	--	67.39	65.70	--	67.30	66.52	64.52	61.10	61.30	61.92	61.95

Source: ESCOM Annual Reports 1990/91 - 1993/4 and 1995/96 - 2000

Private generators produce their electricity from a number of small generating units installed on their premises. The total generating capacity for own use by private generators amounts to 14.4 % of the total national generating capacity.

### ***Future Generation Potential***

The extension to the Kapichira hydropower station by 64 MW was supposed to have been completed by 2003, according to initial building plans. The Malawi power system development study recommended extending the Kapichira power station after the interconnection of the transmission line with Mozambique. According to the recommendations, the line will be designed to allow power imports of up to 200 MW. This would delay the commissioning of Kapichira phase two to around 2010. Generally this is not a good plan. If ESCOM could secure sufficient funding to complete Kapichira before 2010, it might stand a chance of exporting its excess electricity to other countries in the region, as this would be a source of considerable foreign revenue. The future electricity demand will be met after implementing the following proposed projects:

**Table 4.3: Malawi's Future Generation Potential**

Forecast	Low	DSM	Base	High
170 m <sup>3</sup> /s-Pumping station at Mangochi	2001	2001	2001	2001
200 MW Interconnection to Mozambique	2002	2002	2002	2002
64 MW-Kapichira	2012	2010	2010	2006
33 MW- Gas Turbine Lilongwe		2014	2012	2008
33 MW- Gas Turbine Mapanga		2015	2014	2010
33 MW- Gas Turbine Mzuzu			2015	2011
90 MW-Lower Fufu (hydro)				2012
33 MW- Gas Turbine Lilongwe				2013
33 MW- Gas Turbine Mapanga				2014
33 MW- Gas Turbine Mzuzu				2015

Source: Malawi-Power System and Operational Study, Lahmeyer International , Knight Piesold & ESCOM 1998: 23

The total estimated costs for the new generation projects listed above amounts to US\$ 63.7 million. Since the electricity industry is liberalized, the IPPs are expected to invest in some of the projects.

### ***Electricity Imports and Exports***

As has been pointed out earlier in section 4.4.2 above, Malawi is not interconnected with any of the countries in the region and as such it does not import power from any country. As a result, the country, although it is a member of the SAPP, does not enjoy the main benefits that are offered by the association as the other operating member countries do. Some of the benefits of SAPP-membership are:

- i. Electricity trading within the region. Power can be exported to other countries during periods of excess capacity and can be imported when there is inadequate generation.
- ii. It helps to defer investments.

The development of power stations at the proposed sites (as per the list in Table 4.3 above) requires huge investments, which ESCOM unfortunately cannot meet on its own without foreign financing. Currently, the least-cost power development projects include the establishment of a transmission link between Malawi and Mozambique. The commissioning of this line will automatically incorporate ESCOM as an operating member of the SAPP.

The country does, however, already export electricity to the border districts of Mozambique and Zambia.

#### **4.4.3.2 Transmission and Distribution System**

Power throughout the country is transmitted at two voltages, namely 132 kV and 66 kV. The 132 kV lines originate at the power stations themselves, while the 66 kV transmission lines either come from power stations or from 132/66 kV step-down substations. Refer to Table 4.4, below, which shows the transmission and distribution network development in Malawi as from 1991.

**Table 4.4: Transmission and Distribution Line Lengths (1991 – 2000)**

	1991	1992	1993	1994	1995	1996	1997	1998	1999	2000
132 kV (km)	416	416	--	952	952	952	960	960	960	960
66 kV (km)	1,018	1,018	--	820	820	820	820	820	820	820
33 kV (km)	1,574	1,647	--	1,867	--	1,918	1,958	1,985	2,042	2,061
11 kV (km)	1,837	1,884	--	2,071	--	2,168	2,227	2,293	2,322	2,331

ESCOM Annual Reports 1990/1991 – 1993/1994, 1995/1996–2000

All the transmission lines supplying the central and northern parts of the country originate from the one area, the middle section of the Shire River, where the power stations are concentrated. The lines are very long and contribute substantially to high losses in the system. The long distribution lines in all three regions further compound this problem. Procuring appropriate compensating equipment to reduce voltage collapse and energy losses in order to solve this problem has not yet been done due to lack of finance.

The distribution system operates at two voltages of 11 kV and 33 kV and covers about 4,392 km of line length. The reticulation or medium voltage system of 400 volts that connects the majority of the consumers, is also huge. It covers 3,942 km of line length and has installed transformer capacities of 70,021 kVA (ESCOM, 2001). This installed transformer capacity indicates that ESCOM can easily increase its access to electricity without much investment in areas where under-utilised transformers are already installed.

#### 4.4.3.3 Power System Losses

The transmission and distribution system lacks metering facilities to monitor technical losses of the power system in the transformation stations. The units that are generated and sent to transmission are metered in all the power stations. However, the units used in substations, in most staff houses and units sent to distribution networks, are not metered<sup>2</sup>. Lack of metering equipment makes it difficult for the utility to demarcate the technical losses that occur in transmission and distribution system. This has unfortunately led to improper decisions being made in implementing reinforcement projects to address the problem of technical losses in the system. Major reinforcement projects undertaken by the utility concentrated on upgrading the transmission substations, whereas very little work has been carried out in the distribution network. Lack of metering facilities in staff residential houses and some utility office buildings further encourages electricity wastage, and the chances of abuse by staff cannot be ruled out. Lack of metering in houses rented by staff can also lead to substantial losses, most especially when staff members rent and vacate the house again within a short period of time. If all the houses were to be metered and monitored properly, losses could be dramatically reduced. The total system losses (technical and non-technical) from 1990 to 2000 varied from 14.8 % to 17.7 %, as indicated in Table 4.5 below. It is imperative to take appropriate measures to reduce these losses.

**Table 4.5: ESCOM's Power System Losses**

	1991	1992	1993	1994	1995	1996	1997	1998	1999	2000
Total System Losses (%)	15.0	15.8	15.8	15.0	14.8	14.5	15.8	17.7	16.9	14.8

Source: ESCOM Annual Report 1999/2000 (Unpublished)

#### 4.4.4 Demand

Electricity is the main source of energy for industry and commerce, as well as for the urban population. The system's maximum demand (peak load) for electricity in 2000 was 196.90 MW (see Table 4.6 below). This compares very favourably with the dependable capacity of 285 MW.

**Table 4.6: Electricity Sales by Consumer Category (GWh) in Malawi from 1990—2000**

Category	1991	1992	1993	1994	1995	1996	1997	1998	1999	2000
Industry (MV)	162.146	216.345	--	286.496	296.860	272.300	249.311	270.823	274.941	289.543
Industrial (LV)	238.588	211.911	--	154.210	155.321	162.657	166.757	176.134	186.922	193.767
General	92.870	103.445	--	118.970	121.299	120.837	127.409	126.775	129.463	139.110
Domestic	106.285	118.429	--	143.942	157.925	170.354	196.683	225.810	252.322	276.587
Export	--	0.609	--	0.826	1.044	1.647	2.337	2.849	2.961	3.196
Grand Total	599.889	650.739	654.98	704.444	732.449	727.795	742.497	802.391	846.610	902.203
Max Demand (MW)	119.40	133.40	138.70	140.20	145.40	149.40	164.10	179.90	190.20	196.90

Source: ESCOM Annual Reports 1990/91 – 1993/94, 1995/96–2000

Electricity consumption by sector from 1990 to 2000, with the exception of industrial (LV) category, has grown substantially, as illustrated by the transmission/distribution statistics in Table 4.6 above. In 1999 the pattern of consumption by customer category was approximately one third residential, one third large industrial and the remainder commercial and small industrial. The growth of demand in the residential sector has been rapid, whereas the other sectors growth has only been little. According to ESCOM's Central Planning Department, the demand for electricity is expected to double by the year 2015.

#### 4.4.5 Electrification

Throughout its existence ESCOM has carried out electrification projects both in urban and in rural areas, once the utility, through of its Planning Department, had identified the areas to be electrified. The electrification rate is higher in urban than in rural areas, and at present the country's electrification rate stands at 4 % (30 % of urban population and 0.5 % of rural population) (Malawi Energy Policy White Paper, 2001: 57). Shortfalls in delivering power are common because of inadequacies in the transmission and distribution networks in both urban and rural areas. Currently electrification of urban areas is undertaken by ESCOM, while rural electrification is now the responsibility of the government. These changes were made after the government allowed the commercialisation of the utility.

<sup>2</sup> Personal experience as employee of ESCOM (Malawi)

### ***Urban Electrification***

ESCOM carries out electrification of the urban areas, the main reason being that the urban areas are more financially viable than the rural areas. The Distribution Planning Department of ESCOM identifies the areas to be electrified. If a project requires large capital equipment, the utility seeks donor funding, which may come in the form of a loan or a grant. If the backbone equipment is already in place, ESCOM requests the consumers to contribute towards the construction and connection of the services. In view of the ESI reforms taking place in the country, the government does not as yet have any special programme put in place to assist with the electrification of urban areas. The government expects the Distribution Business Units will continue to expand the distribution network in the urban areas in order to increase their customer base.

### ***Rural Electrification***

The government, as part of its poverty reduction efforts, wants to improve access to electricity supplies among its peri-urban and rural population. Rural electrification projects were thus carried out by ESCOM with substantial funding from the government. Since the commercialisation of ESCOM, the rural electrification projects have been wholly funded by the government from the levies it collects from petroleum products and from foreign donations (grants). ESCOM merely carries out the projects as a contractor to the government in view of its technical competence and expertise. There have so far been no tenders offered for rural electrification projects. This is likely to change in the near future once other technical organisations capable of competing with ESCOM have been established.

In order to have a good financial base for these rural electrification programmes, the government proposes that additional financial resources be obtained from the following areas (Malawi Energy Policy White Paper, 2001: 68):

- i. Levy on electricity sales;
- ii. Levy on petroleum sales;
- iii. Proceeds from privatisation;
- iv. Proceeds from the Highly Indebted Poor Countries (HIPC) programme; and
- v. Donations from local and international partners.

Despite the above efforts, rural electrification may only be economically viable in very few areas in the country. The main problem is that rural households and settlements are generally far from the existing national grid and are more scattered than urban settlements, as is the case in most African countries (Eberhard and Van Horen, 1995: 140). As it is expensive to construct networks to rural areas, access to electricity in these places is also likely to be provided using the solar photovoltaics being promoted by DANIDA.

### ***Subsidies for Rural Electrification***

The majority of rural people depend on subsistence farming, and as such their income is very low. The priority target areas for rural electrification in the short term may, therefore, not be the domestic sector. The areas to be targeted instead are the trading centres, government institutions (for example, schools, clinics, etc). Electricity may also assist in boosting agricultural activities through irrigation.

Private investors are not likely to be attracted to rural electrification because of the expected low returns. The government is aware of this problem and consequently has indicated that, once the ESI has been reformed, it intends to extend electricity services to rural areas by providing subsidies for plant and equipment for rural electrification (Malawi Energy Policy White Paper, 2001: 69). The Policy Paper, however, is not clear on the extent of these subsidies. If the government's social policy objective of poverty reduction and rural transformation is to be met, the subsidies will need to include some electrical appliances and agricultural machinery which can help to boost economic activities.

### ***Other Public Benefits***

The government proposes to play a part in promoting Integrated Resource Planning, Demand Side Management (DSM) and Research and Development as discussed below.

### ***Integrated Resource Planning***

The government proposes to guide the planning activities of the energy sector, while the utilities are expected to take an active part by following government policies and regulatory mechanisms. The utilities will need to keep track of government's plans where electricity industry projects are concerned. This means that certain functions, such as Load Forecasting and Power System Planning, should take into account all the developments in the ESI.

### ***Demand Side Management***

Demand Side Management (DSM) may be defined as optimising the utilisation of existing installed capacity through, *inter alia*, the use of more efficient electrical appliances or shifting the time of use for industrial applications. The DSM aims to save energy while upholding the required benefits of using it. A benefit of DSM is the reduction of household energy expenditure, and it can also help to increase electricity access without excessive investment in additional capacity. The government intends to promote DSM, as stated in its Policy Paper (Ibid.), by means of the following approaches:

- i. Promoting energy efficiency awareness programmes amongst industry, commerce and households;
- ii. Establishing and enforcing building standards; and
- iii. Promoting appliance labelling and use of efficient appliances.

## ***Research and Development***

Most of the projects to improve access to electricity currently involve extension of the existing distribution networks to the target areas. Other remote places, scattered over wide areas, are not likely to have grid connection in the immediate future, and the only option for them is to use an alternative, more cost-effective solution. Alternative energy sources such as solar power do exist, but are not yet extensively exploited. The potential for mini or micro hydropower generation also exists. The government has already taken a leading role in the use of solar PVs. Both private generators and the government are likely to develop these technologies in order to increase the rural electrification programme.

### **4.4.6 Tariff Structure**

In 2001 ESCOM's tariff schedule was organised in six categories: Domestic tariff, General tariff, Maximum demand tariff for low voltage consumers, Maximum demand tariff for medium voltage consumers, Maximum Demand (Off-peak) (at consumer's option) and Export tariff, as indicated below.

<b>Domestic Tariff</b>	<b>MK</b>
a) Fixed charge per month	72.9549
b) For each kWh of the first 30kWh per month	1.5652
c) For each kWh in excess of 30kWh but less than 750kWh	2.2901
d) For each kWh in excess of 750kWh per month	3.2468
<b>General Tariff</b>	<b>MK</b>
a) Fixed charge for single phase supply per month	239.2088
b) Fixed charge for three phase supply per month	333.4469
c) Charge per kWh per month	4.2923
<b>Maximum Demand Tariff</b>	<b>MK</b>
a) Fixed charge per month	882.8261
b) Maximum demand charge per kVA per month	798.0681
c) Charge per kWh per month	1.3254
<b>Maximum Demand Tariff (Medium Voltage Consumer)</b>	<b>MK</b>
a) Fixed charge per month	851.2279
b) Maximum demand charge per kVA per month	749.4507
c) Charge per kWh per month	1.2567
<b>Maximum Demand (Off-peak) (at consumer's option)</b>	<b>MK</b>
a) Fixed charge per kVA per month	851.2279

b) On-peak demand charge, per kVA per month	374.7253
c) Charge per kWh for non-peak units consumed	1.2567

<b>Export Tariff (Medium Voltage)</b>	<b>US\$</b>
a) Fixed charge per kVA per month	N/A
b) Demand charge per kVA per month	18.3600
c) Energy charge per kWh per month	0.0140

#### 4.4.7 Financial Performance of ESCOM

Financing for ESCOM project investments comes largely from loans obtained from foreign financial institutions, the government and local commercial banks. Most of the foreign loans are paid back in US dollars. Consequently, the depreciation of the local currency against the US dollar and European major currencies in the last few years has put pressure on ESCOM with regard to its loan repayments.

Despite this, ESCOM's financial performance profitability throughout the past decade has been good. The organisation's profit margin (profit before tax over the total sales) has been over 30 % from 1991 to 1994. Between the 1995 and 1999 financial years, however, the profit margins have been low and unstable. The lowest profit margin recorded was 9 % in 1995 and from 1997 to 1999. The profits started to pick up again in the year 2000. Refer to Table 4.7, below, for detailed information on the financial performance of ESCOM.

**Table 4.7: Some Financial Performance Indicators of ESCOM**

Year	Total asset Value (Historical) (MK million)	Annual revenue (MK million)	Net profit before tax (MK million)	Avg. price electricity generated	Avg. price electricity sold	Debtor's period (Days)	Return on assets % before tax
1991	348.70	76	26.65	7.84	12.48	66	11
1992	548.50	89.62	38.71	7.77	12.80	79	15
1993	909.71	114.2	43.88	9.27	19.83	61	12
1994	1206.07	142.4	44.44	9.24	21.08	60	19
1995	2040.42	217.4	19.58	15.22	29.68	89	12.8
1996	2556.17	354.6	120.96	25.85	48.87	63	18.1
1997	3474.95	458.9	96.31	36.33	61.80	76	7.10
1998	4781.33	674.1	63.69	61.74	84.06	76	4.9
1999	8882.87	1130.3	96.44	101.28	133.50	65	5.5
2000	--	1641.92	623.93	94.00	182.00	118	--

**Table 4.7 Continued**

Year	Debt/equity ratio	Interest cover	Number of Customers	Total Employees	Customers per Employee	GWh Sold per Employee	Exchange Rate
1991	1.20	2.7	43,339	2,190	20	0.274	
1992	0.93	4.7	45,712	2,251	20	0.289	3.6033
1993	0.81	5.0	51,000	2,372	22	0.276	4.4028
1994	0.54	2.5	52,293	2,421	22	0.291	8.7364
1995	0.26	0.7	57,270	2,494	24	0.294	15.2837
1996	0.28	4.5	61,482	2,414	25	0.301	15.3085
1997	0.27	1.8	65,786	2,319	28	0.320	16.4442
1998	0.22	0.4	71,990	2,318	31	0.346	31.0727
1999	0.28	0.3	77,383	2,222	35	0.381	44.0881
2000	0.34	2.1	82,792	2,218	37	0.407	59.5438

Source: ESCOM Annual Reports: 1991 to 2000

As can be seen from the above, the utility is able to service its debts from the profits it makes. These profits are, however, not enough for the utility to finance its own projects.

Revenue collection is the one of the challenges facing the utility in its attempts to improve its financial performance. ESCOM would be able to make tremendous profits if billing procedures and revenue collection was enhanced. Currently, the processing of bills for new customers can take over three months, and the collection of revenue from older customers is generally not good. ESCOM's poor debt collection records, together with other financial performance indicators, are summarised in Table 4.7 above.

#### **4.4.8 Electricity Sector Reforms**

##### **4.4.8.1 Main Driving Forces behind the Reforms**

ESCOM faces many challenges in having to generate, transmit and distribute electricity. The financial performance is weak, the utility fails to pay back loans on time and the system is unreliable due to lack of maintenance and low plant availability. The government in its energy policy white paper (Malawi Energy Policy White Paper, 2001: 58) outlines some of the main driving forces behind the ESI reforms in Malawi, which can be summarised as follows:

- i. Supply side inefficiencies;
- ii. Poor financial performance of the present power utility;
- iii. Lack of an efficient, independent and transparent regulatory system;
- iv. Lack of management autonomy; and
- v. Problem of environmental degradation.

#### **4.4.8.2 Main Characteristics of the Reforms**

ESI reforms in Malawi began after the passing of the Electricity Act of 1998. The main reason for repealing the previous Act was to improve the performance of and enhance competition in the ESI. In order to achieve this objective, the government initiated the restructuring of the public power utility with the aim of bringing an end to its monopolistic structure. According to ESCOM's Annual Report for 1999, the company was partially deleted from the list of state enterprises and registered instead as a limited liability company, with the government owning majority shares of 99 % and the Malawi Development Corporation (MDC) owning minority shares of 1 %. The third step of the restructuring process saw the unbundling of the vertical structure of the utility into three separate entities of Generation, Transmission and Distribution. These three entities now operate as separate Business Units under a holding company, ESCOM Limited. The Distribution Business Unit was further unbundled into three sub-units as per the three geographical regions of the country. Currently ESCOM is under a two-year Management Consultancy Services contract that was awarded to ESKOM Enterprises of South Africa. The contract was put in place in order to improve ESCOM's financial performance and power supply quality and to increase the electrification level.

#### **4.4.8.3 Privatisation**

The privatisation of state enterprises in Malawi started in 1996 in accordance with the assistance of the World Bank and the International Monetary Fund (IMF). Among the companies listed, which were to be privatised, was the power utility company, ESCOM (Daily Mail and Guardian, April 20, 2000). Outright privatisation of the utility is not expected in the near future. However, in order to prepare ESCOM for privatisation, some of the laws which govern the ESI have had to be repealed and new laws applicable to the proposed new electricity market have been introduced.

#### ***The Expected Final ESI Structure in Malawi***

Malawi plans to adopt a single buyer model, which will operate as follows:

- i. The existing generation assets will be held and operated by a publicly owned company, the National Generation Company. The ownership of the company may change at a later date. In future, the existing four power stations of Nkula, Tedzani, Kapichira and Wovwe are likely to separate and operate independently. They will have to compete to sell their power to the Transmission Company. This may be done in accordance with an internal arrangement to prepare them for sale so that no single generator will dominate the market.
- ii. The IPPs will be allowed to build their own generation plants and sell either to large customers or to the National Transmission Company in a competitive and regulated market. This will also apply to the isolated mini-grid at Wovwe.

- iii. Transmission (66 kV and above) will remain as a natural monopoly with all its assets owned by the government and will operate under the new company, National Transmission/Dispatch. The company will be buying power from the generators through Power Purchase Agreements (PPAs) and will in turn sell electricity in bulk to the three Independent Power Distributors (IPD). It will also be responsible for importing/exporting electricity through participation in the SAPP electricity market
- iv. Distribution will also be retained by the government but will be divided into three independent Distribution Companies; management of the network will, however, be transferred to a private operator under a long-term concession of up to 20 years. The concessions will be based as per the three sub-distribution business units.

To date (2002), ESCOM has undergone structural changes so that it will fit into the expected final ESI structure shown in Figure 4.2 below.

**Figure 4.2: The Expected ESI Structure in Malawi**

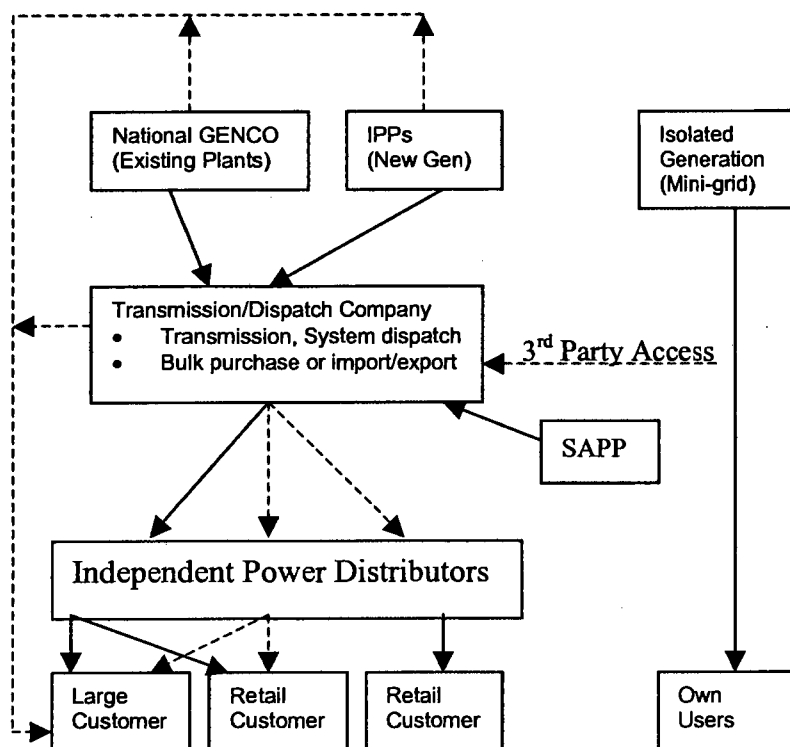

Source: Malawi Energy Policy White Paper, 2001: 61

#### 4.4.9 Regulatory Framework

In the past, ESCOM operated as a monopoly organisation in delivering power. No one was allowed to generate, transmit and distribute electricity without being licensed by ESCOM. In recent years, however, the government reviewed some of the laws governing the electricity supply industry to encourage

participation of other players. As a result, three Acts of Parliament with regard to the ESI were approved in 1998. These were:

- i. The Electricity Act No. 19 of 1998;
- ii. The ESCOM Act No. 20 of 1998. This has since been repealed, pending the formulation of a comprehensive Energy Policy which is now in its final stages;
- iii. ESCOM Amendment Act No. 20

The first Act was meant to liberalise the power sector with a view to allowing the private sector to participate in electricity generation, transmission and distribution. In order to remove the monopolistic tendencies of ESCOM, a regulatory authority known as the National Electricity Council (NECO) was established in the same year, 1998, and became operational in 1999.

The second Act allowed the commercialisation of ESCOM. In terms of this Act, ESCOM was registered as a private company under the Companies Act of 1984 in 1999 (ESCOM Annual Report, 1999: 22). The Third Act made provisions for the transfer of any properties, funds, obligations, agreements, assets and liabilities from ESCOM as a public company to ESCOM as a commercial company.

### ***Regulation of ESI in Malawi***

Regulation of the ESI in Malawi is currently the responsibility of the National Electricity Council (NECO). Previously, either the government or the public utility, ESCOM, had regulated the industry. The government reviewed the legal and the regulatory framework governing the ESI as part of the reforms. Malawi became the third country in the SADC region to establish an independent electricity regulator. All the regulatory functions that had been undertaken by the utility and the government now resort under NECO. The main functions of NECO as spelt out in the Electricity Act No. 19 are:

- i. To issue licences for the generation, transmission and distribution of electricity;
- ii. To approve electricity prices and tariffs and to decide how a licensee may supply electricity;
- iii. To assist in settling disputes between suppliers or between suppliers and consumers if requested by either party;
- iv. To collect all necessary information from undertakers and consumers;
- v. To ensure that all electrical installations are made and maintained according to set standards and specifications;
- vi. To advise the minister on any matters relating to the ESI; and
- vii. To be adequately empowered to pass by-laws relating to the smooth running of the ESI.

# Mozambique

## 5.1 Location and Demography

Mozambique is located on the East Coast of Southern Africa. It shares borders with Malawi, South Africa, Swaziland, Tanzania, Zambia and Zimbabwe. The country has a total area of 799,380 square kilometres and the coastline stretches about 2,575 kilometres. There are a number of rivers, including two major African rivers, the Zambezi and the Limpopo, which flow through the country (The official SADC Trade, Industry and Investment Review, 2001). The major dam for hydroelectric production is located on the Zambezi River.

The country has a tropical and subtropical climate, which is affected by the monsoon winds from the Indian Ocean and the warm current from the Mozambique Channel. The country is divided into three different climatic regions. The region north of the Zambezi River experiences two seasons. The hot and rainy season is from November to April while the cool and dry season is from May to October. The region south of the Zambezi River has two seasons as well, but a shorter rainy season. The interior highland region has a temperate climate, which is influenced by the altitude (ibid.).

The population of the country was estimated at 17.7 million in 2000, with a growth rate of 2.3 %. The majority of the people (about 60 %) live in rural areas and depend on subsistence farming (World Bank, 2002).

## 5.2 Economy

Mozambique's economy was greatly hampered by war and civil strife. In 1992, the country was rated as the poorest in the world. It had a per capita GDP of US\$80 and the inflation rate reached as high as 50 % (Miller et al, 2001). In contrast, by 2000 the World Bank estimated that Mozambique had a Gross National Income (GNI) of US\$210 and inflation as low as 11.7 % which is a dramatic improvement. In order to stimulate the economy, the government has undertaken a series of economic reform programmes that include the privatisation of state enterprises. According to the IMF, the country had privatised or restructured about 1,200 state enterprises by 1999 (IMF, 1999). A policy dealing with the remaining 11 wholly owned public enterprises and the 22 companies with government majority shares is at present still being formulated by the government. In the energy sector the government would like to increase electricity exports, to promote competition in generation and distribution and to increase access to electricity. The growth of the economy is now very admirable, particularly given the history of the country (recent wars, etc.). Mozambique, in fact, registered an economic growth rate of over 6.4 % of

GDP in 1990-2000. Recent economic performance has, however, suffered as a result of several natural disasters, including floods.

Mozambique's economy is heavily dependent on the services sector which contribute about 50.5 % of the country's GDP, estimated at US\$3.8 billion (World Bank, 2002). The other rapidly growing sectors of the economy are those of industry and agriculture. These sectors contribute about 25.1 % and 24.4 % to the country's GDP. The building of the aluminium smelting plant that became operational towards 2000 will increase the economic growth further.

The government wants to improve the utilisation of the energy resource base and increase access to the energy services as a way of fostering economic and social development. To achieve this objective, the following priority goals for the energy sector have been outlined (SAD-ELEC, 1998: 5):

- a) The rehabilitation of the supply network from Cahora Bassa in support of revenue and employment creation and to ensure reliable and low-cost electricity supply for Mozambique;
- b) The continued expansion of the national electricity grid to ensure that all provincial capitals and other important load centres is supplied from the grid;
- c) The promotion of high voltage electrical interconnection with the neighbouring countries of Zimbabwe, Malawi, Swaziland, and South Africa, to facilitate the utilisation and further development of hydropower resources on the Zambezi river;
- d) The implementation of new legislation in the energy sector to stimulate private sector involvement (both national and foreign) as a means to further the government's objectives of improving access to electricity.

The government created a special fiscal regime by developing the concept of economic zones in order to attract investment in different areas. The two notable zones are the Zambezi River basin and the Maputo development corridor zones. There are many opportunities for investments, especially in the Zambezi River basin zone. The major projects in the power sector, encouraged to be developed in this zone by the private sector, include the extension of Cahora Bassa Dam and the development of a new hydropower station on the Zambezi River at a site known as Mepanda Uncua.

Mozambique is following a fiscal policy aimed at stabilising the prices and modernising the financial system. In 2000 inflation was reduced to 11.7 % (World Bank, 2002). The local currency has also appreciated against the major currencies due to a stable macroeconomic environment and high levels of foreign aid.

## **5.3 Energy Sector**

Mozambique has a wide range of primary energy sources, which includes biomass, hydropower, natural gas, coal and new and renewable energy sources. The majority of the people live in rural areas and rely on biomass for their energy needs since the other sources are developed to supply mainly the urban areas.

### **5.3.1 Biomass**

Mozambique relies heavily on biomass as a source of energy. It accounts for about 83 % of the total energy consumption and 60 % of urban households rely on either charcoal or firewood. Some industries also depend on woodfuel for their energy needs (Directorate of National Energy, 1999: 1). Electricity, petroleum products, and coal contribute the remaining 17 % of the total energy consumption. Many areas are not settled and as a result vast tracts of land are still covered by natural forests; there is thus no danger that this energy source will be scarce in the near future.

### **5.3.2 Hydropower**

Mozambique has substantial hydropower potential from the Zambezi River at Cahora Bassa and Mepanda Uncua. Other sites with small power potential are also available on other rivers that run across the country. The total potential annual generating capacity from hydropower is estimated at 14,000 MW, of which 2,388 MW has already been developed by Hydroelectrica de Cahora Bassa (HCB) and EDM (Directorate of National Energy, 1999). According to SAD-ELEC (March 2000: 55) two main sites for hydroelectricity generation were identified by the power development study that was conducted in 1996, namely: Cahorra Bassa Northern Extension (550 MW) and the Mepanda Uncua site (2,400 MW). These sites are yet to be developed by any potential investors.

### **5.3.3 Coal**

Mozambique has large coal reserves in the Tete-Moatize region west of the country. The reserves are estimated at 3 billion metric tonnes (Directorate of National Energy, 1999: 2). Coal mining in the area is done on a small scale and a major part of it is exported to Malawi.

### **5.3.4 Natural Gas**

Exploration surveys have revealed that Mozambique has a large sedimentary basin of natural gas. Currently, three gas reserves have been discovered on-shore in Inhambane, Bizi and Sofala provinces. The reserves are estimated to be as high as 25 trillion cubic feet (ibid.). The gas can be used for heating, cooking and, most importantly, for generating electricity. Minor generation of electricity of 660 kW from the Pande gas field is already taking place at the small towns Vilankulo and Inhasson.

### **5.3.5 Renewable Sources of Energy**

Electricity from renewable sources of energy, such as solar and wind power, could be used for lighting and water pumping on a small scale to supplement the national grid. However, the use of this energy source has not yet been developed in the country.

## **5.4 The Power Sector**

### **5.4.1 Background**

Electricidade de Mozambique (EDM) is responsible for power generation, transmission, distribution and retail of electricity in Mozambique. Its power system is divided into three independent parts: the northern system, the central system and the southern system, and many small generating stations are scattered in all three regions.

The other supplier is Hydroelectrica de Cahora Bassa (HCB) which has an installed capacity of 2,075 MW. HCB is a private company, with 81.2 % Portuguese interests and 18.8 % Mozambique interests (SAD-ELEC, March 2000: 50). The power produced by HCB is sold to South Africa through long-term Power Purchase Agreements. Mozambique, therefore, has to import power that is produced in its own country from South Africa.

The national utility, EDM, cannot meet all the electricity demands of the country. Electricity purchases from HCB and imports from ESKOM of South Africa meet the excess demand, which amounts to over 70 % of the total electricity supplied in Mozambique. The other challenges facing EDM include improving its financial performance; reducing technical and non-technical losses in its system and increasing electricity access to the majority of the people.

Electricity reaches end-users through the transmission and distribution system. The transmission system covers various voltages from 60 kV to 400 kV, while the distribution system operates at 33 kV and lower voltages. Part of the transmission system is owned by the HCB. The transmission network is interconnected with Swaziland, South Africa and Zimbabwe.

### **5.4.2 Existing Institutional Arrangements**

The responsibility of the electricity sub-sector development is under the control of the Directorate of National Energy (DNE) in the Ministry of Mineral Resources and Energy. Thus the DNE is responsible for policy formulation and regulation of the Electricity Supply Industry (ESI). The department also undertakes functions of rural electrification and a supervisory role of the public utility, EDM.

EDM is the main utility that supplies electricity in Mozambique. It was established as a state enterprise in 1977 and became a public company in 1995. This was done in order to increase the utility's sphere of operations after commercialisation was introduced in the organisation.

EDM is an operating member of the Southern African Power Pool (SAPP) and is interconnected with other systems of SAPP member countries of South Africa, Zimbabwe and Swaziland. It has a contractual relationship with ESKOM (SA) to purchase power, and with ZESA (Zimbabwe) to transport the electricity that is exported by HCB.

HCB and private isolated systems are also important components of the Mozambican ESI. The structure of the ESI in Mozambique is shown below:

**Figure 5.1: Current ESI Structure in Mozambique**

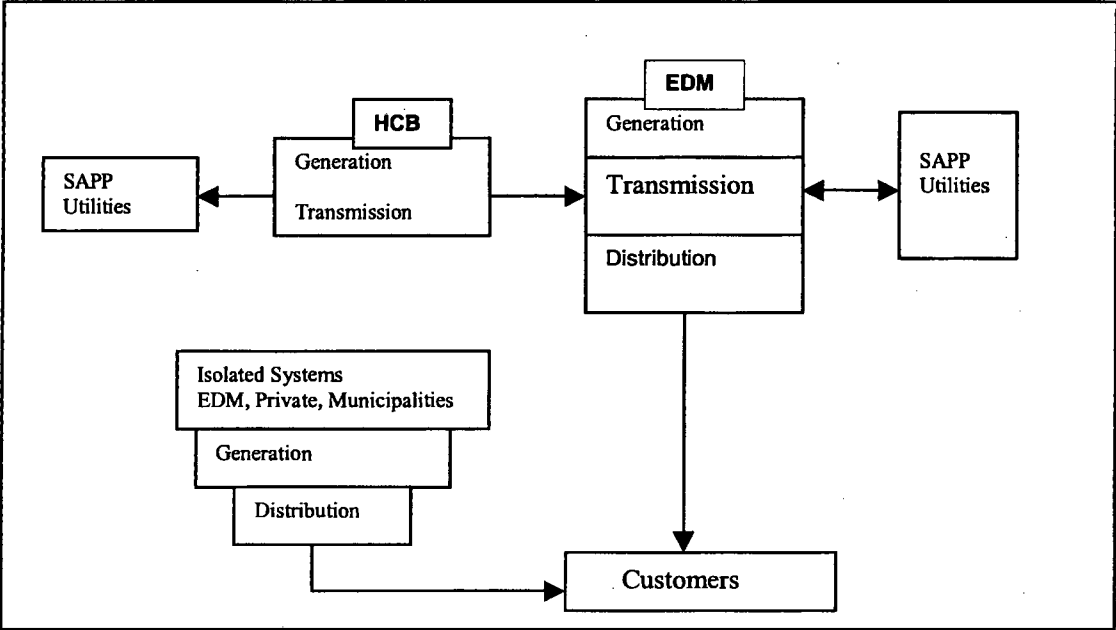

Source: SAD-ELEC, March 2000: 51

**5.4.3 Electricity Supply**

**5.4.3.1 Generation**

The total installed generating capacity stands at about 2,388.5 MW. This includes 2,075 MW, which is produced at Cahora Bassa Hydropower Station owned by HCB. Generation from EDM's power plants totals 307.7 MW. However, the recent results of the power plant operations indicate that only 176.6 MW can actually be produced. This is due to the fact that most of the thermal diesel generators are out of order, whereas the hydropower plants are generating at their maximum installed capacities. Major rehabilitation is required for the plants to produce 307.7 MW.

The major power stations are interconnected, but other areas are supplied by diesel plants and operate as isolated systems. The installed and theoretically available generating capacity of EDM is shown in Table 5.1 (below).

**Table 5.1: EDM's Hydroelectric and Thermal Power Stations as at 31 December 2000**

Power Station	Unit	Generator Manufacture	Year Installed	Nominal Capacity (MW)	Available Capacity (MW)	Comments
<b>1. HYDRO</b>						
Mavuzi	1	Charilles/BBC	1955	5	4.5	Operational
	2	Charilles/BBC	1955	5	4.5	Operational
	3	Neyrpic/Siemens	1967	14	12	Operational
	4	Neyrpic/Siemens	1957	14	12	Operational
	5	Neyrpic/Siemens	1957	14	0	Out-of-order
Chicamba	1	Voith/SECRON	1968	19.2	17	Operational
	2	Voith/SECRON	1968	19.2	17	Operational
Corumana	1	Undenas/ABB	1990	8.3	7.0	Operational
	2	Undenas/ABB	1990	8.3	7.0	Operational
Cuamba	1	Soerumsand/NEBB	1989	0.545	0.5	Operational
	2	Soerumsand/NEBB	1989	0.545	0.5	Operational
Lichinga	1	Soerumsand/NEBB	1984	0.75	0.6	Operational
<b>Total Hydro</b>				<b>108.90</b>	<b>82.60</b>	
<b>THERMAL GENERATOR</b>						
Angoche	1-Diesel	Deutz/REM	1970	0.69	0.55	Operational
	2-Diesel	Bergen/NEBB	1979	0.51	0.0	Out-of-order
Beira	1	ABB/Stal	1988	12	12	Operational
Inhambane	1-Diesel	Deutz/REM	1969	0.4	0.0	Out-of-order
Central Velha	2-Diesel	Caterpillar	1969	0.52	0.0	Out-of-order
	3-Diesel	Deutz/REM	1962	0.4	0.0	Out-of-order
	4-Diesel	GM/ELLIOT	1970	1.00	0.0	Out-of-order
	5-Diesel	GM/ELLIOT	1970	1.00	0.0	Out-of-order
	6-Diesel	MAN(Movel)	1987	0.56	0.0	Out-of-order
Central Nova	7-Diesel	DORMAN	1994	0.4	0.0	Out-of-order
	1-Diesel	CAT35116DITA	1999	1.46	1.25	Operational
Lichinga	2-Diesel	CAT35116DITA	1999	1.46	1.25	Operational
	1-Diesel	Deutz/REM	1969	0.4	0.0	Out-of-order
	2-Diesel	MirrIBlackston	1975	0.56	0.35	Operational
	3-Diesel	MirrIBlackston	1975	0.56	0.35	Operational
	4-Diesel	Bergen	1979	0.52	0.42	Operational
	5-Diesel	Cumming	1980	0.57	0.0	Out-of-order
	Lionde	1-Diesel	English Electric	1965	0.49	0
2-Diesel		Bergen	1979	0.52	0.45	Operational
3-Diesel		English Electric	1965	0.49	0	Out-of-order
4-Diesel		Pielstick	1970	0.45	0.3	Operational

	5-Diesel	Mirlees	1974	1.48	1.0	Operational
	6-Diesel	Bergen	1979	0.52	0.45	Operational
Maputo	1-Steam	Combustion/Brush	1951	6.25	0.0	Out-of-order
	2-Steam	Engineering/Brush	1951	6.25	0.0	Out-of-order
	3-Steam	Sulzer/BBC	1961	15.0	0.0	Out-of-order
	4-Steam	Sulzer/BBC	1962	15.0	0.0	Out-of-order
	5-Steam	Mague/BBC	1968	15.0	0.0	Out-of-order
	6-Gas	Rolls Royce	1968	17.5	0.0	Out-of-order
	7-Gas	BBC	1973	36.0	29.0	Operational
	8-Gas	Alsthom	1991	25.0	23.0	Operational
Tete	1-Diesel	Deutz	--	0.41	0.3	Operational
Mocuba	1-Diesel	Bergen	1979	0.42	0.35	Operational
	2-Diesel	Bergen	1979	0.42	0.0	Out-of-order
Cuamba	1-Diesel	Berger	N.D	0.42	0.36	Operational
Nacala	1-Diesel	Sulzer	1966	1.5	1.2	Operational
	2-Diesel	Sulzer	1966	1.5	0	Out-of-order
	3-Diesel	Sulzer	1967	1.5	0	Out-of-order
	4-Diesel	SWD	1980	2.7	0	Out-of-order
	5-Diesel	Storkwerks	1965	2.7	2.2	Operational
Nampula	1-Diesel	Deutz	1965	1.20	0.7	Operational
	2-Diesel	Deutz	1965	1.20	0.9	Operational
	3-Diesel	MAN	1971	2.00	1.6	Operational
	4-Diesel	MAN	1971	2.00	1.8	Operational
Pemba	1-Diesel	Mirlees	1985	2.56	2.15	Operational
	2-Diesel	Mirlees	1985	2.56	2.15	Operational
	3-Diesel	Deutz	1971	1.00	0.92	Operational
	4-Diesel	Lister	1964	0.46	0.3	Operational
	5-Diesel	Lister	1964	0.46	0.3	Operational
	6-Diesel	Deutz	1964	1.00	0.0	Out-of-order
Quelimane	1-Fuel oil	Mirlees	1980	3.44	3.2	Operational
	2-Fuel oil	Mirlees	1980	3.44	3.2	Operational
	3-Diesel	Cummins/ AUX	1980	0.27	0.25	Operational
Xai-Xai	1-Diesel	Blackstone	1965	0.2	0	Out-of-order
	2-Diesel	National	1963	0.52	0.4	Operational
	3-Diesel	National	1963	0.52	0.4	Operational
	4-Diesel	Mirlees	1972	1.43	1.0	Operational
Massingir	1-Diesel	N.D	N.D	N.D	N.D	Operational
Bela Vista	1-Diesel	N.D	N.D	N.D	N.D	Operational
<b>Total Thermal</b>				<b>198.80</b>	<b>94.10</b>	
<b>TOTAL HYDRO + THERMAL (1 + 2)</b>				<b>307.70</b>	<b>176.70</b>	

Source: EDM Annual Statistical Report 2000: 56

The total units generated by EDM in 2000 were 296.2 GWh; the major part (254.6 GWh) came from hydro generation, whereas only 41.6 GWh came from thermal generation (EDM, 2000: 32). During the past decade EDM's plants only managed to generate over 300 GWh, the lowest output being in 1994 when the plants generated only 200.4 GWh. The electricity consumption during the same period has, however, increased at an annual average rate of 8.9 %. Most of the demand is accordingly met by electricity purchases and imports as reflected in Table 5.2 below.

**Table 5.2: EDM's Electricity Generation, Imports and Purchases**

	1990	1991	1992	1993	1994	1995	1996	1997	1998	1999	2000
Generation	322.1	325.7	273.8	223.6	200.4	212.1	238.8	219.0	243.8	302.8	296.2
Imports	321.8	373.2	436.3	510.9	566.9	601.4	598.6	686.0	343.0	72.8	244.7
Purchases	94.2	98.7	95.0	118.1	141.00	151.7	185.5	207.1	615.3	952.5	854.0
<b>Tot. EDM</b>	<b>738.1</b>	<b>797.6</b>	<b>805.1</b>	<b>852.6</b>	<b>908.3</b>	<b>965.2</b>	<b>1022.9</b>	<b>1112.1</b>	<b>1202.0</b>	<b>1328.0</b>	<b>1394.9</b>

Source: EDM Annual Statistical Report 2000: 11

### ***Forecasted Generation***

The studies that have been conducted in the past indicate that Mozambique's future power generation will rely on both hydro and thermal. Whereas current thermal generation relies on diesel, in the future it will depend on coal and natural gas. Some suitable sites have already been identified for both thermal and hydro generation at Moatize and Uncua respectively. The immediate plans are to develop the Uncua Dam on the Zambezi River in order to generate about 2,000 MW from five generating units of 400 MW each (SAPP Annual Report, 1999: 30). The feasibility studies on the extension of Cahora Bassa concluded that a further 550 MW could also be developed there (SAD-ELEC, 2000: 55). As already pointed out in Section 5.3.3 above, Mozambique has adequate coal reserves at Moatize which, if mined, could be used to generate up to 1,000 MW electricity. The gas that has already been discovered will further boost electricity generation in the country.

### ***Electricity Imports and Exports***

Mozambique's generating capacity is very high in comparison to the country's actual power demand. Most of the power generated at Cahora Bassa is exported to South Africa and Zimbabwe under contract and only a small portion is used to supply the central system of Mozambique. Some of the country's border areas also import electricity from Malawi at distribution level, since the national grid does not supply all areas.

Electricity is imported and exported through transmission and distribution lines. Table 5.3, below, provides a summary of Mozambique's power exports and imports to and from SAPP member countries

from 1990 to date. The exports to South Africa and Zimbabwe are from the HCB and they pass through the EDM transmission system.

**Table 5.3: EDM's Power Exports and Imports (GWh) to and from SAPP countries, 1990–2000**

	1990	1991	1992	1993	1994	1995	1996	1997	1998	1999	2000
<b>Exports</b>											
South Africa	--	--	--	--	--	--	--	--	--	--	93.722
Zimbabwe	--	26.0	86.75	1.394	--	--	1.956	239.477	3,459.503	3,503.186	3,493.037
<b>IMPORTS</b>											
Malawi	--	--	0.609	0.760	N/A	1.710	2.089	2.777	2.976	2.970	3.058
South Africa	322	383	436	506	559	560	596.3	682.9	339.4	70.9	241.3
Zimbabwe				0.13	N/A	0.19	0.54	0.39	0.61	0.81	0.28

Source: EDM Annual Statistical Reports 1993 – 2000, ESKOM Statistical Yearbook 1991 – 1992, ESKOM Annual Report 1998 & ESCOM Annual Report 1991/92

#### 5.4.3.2 Transmission and Distribution System

There are two transmission systems in Mozambique. One system belongs to HCB. The other network belongs to EDM. EDM's system comprises three independently operated systems: the northern system, the central system and the southern system. The power is transmitted at four voltages: 110 kV DC, 220 kV ac, 275 kV ac and 400-330 kV ac. The sub-transmission system covers 60/66 kV. The total transmission line length as at December 2000 was 3,254.5 km (EDM Annual Statistical Report, 2000: 58). The development of the system has been slow, as can be observed in Table 5.4. Between the year 1993 and 2000 the 275 kV lines have been extended by 17 km while the extension of 60/66 kV lines was only 79.5 km.

**Table 5.4: EDM's Transmission and Distribution Line Lengths (1990 – 2000)**

kV	1993	1994	1995	1996	1997	1998	1999	2000
400 – 330	--	--	--	--	252.0	252.0	252.0	252.0
275	85	85	85	85	85.0	85	102.0	102.0
220	1756	1316	1316	1316.0	1316.0	1316.0	1316.0	1316.0
110	1158	1158	1158	1158.0	1163.5	1163.5	1163.5	1237.5
60/66	268	268	268	271.5	300.4	300.4	347.5	347.5
33	--	1341	1341	1481.0	1481.0	1481.0	1689.0	1689.0
22	--	293	293	293	367.8	367.8	367.8	367.8
11	--	127	127	141.4	141.4	141.4	141.4	141.4
6.6	--	353	353	353	353.0	353.0	353.0	353
5.5	--	6.2	6.2	6.2	6.2	6.2	6.2	6.2
0.4	--	2284.6	2284.6	2284.6	2284.6	2284.6	2284.6	2284.6

Source: EDM Annual Statistical Reports 1993 - 2000

The distribution network comprises lines operating at 33 kV, 22 kV and 11 kV. By the year 2000 it covered a total line length of 2,198.2 km of overhead lines. The secondary distribution system operates at 6.6 kV and lower voltages. It covers a total of 2,643.8 km of overhead lines.

#### 5.4.3.3 Power System Losses

All the power that is sent out to the transmission system does not reach the end users. Some of it is used in transmission and distribution transformation stations, while the rest is lost along the way, due to technical losses in the system. EDM is able to compute all the power losses in each of the sectors of the system and it is noted that many of the losses occur in the distribution system. The combined total power system losses during the past decade ranged from 18.6 % to 33.4 %. Refer to Table 5.5, below, for a summary of the losses in each particular year.

**Table 5.5: EDM's Power System Losses**

	1993	1994	1995	1996	1997	1998	1999	2000
Total Energy (GWh)	852.6	908.3	965.3	1023.2	1112.1	1202	1328	1394.9
Transmission Losses %	4.4	5.4	5.8	4.7	6.8	5.0	4.0	7
P. Station Losses %	4.1	2.7	1.9	2.0	2.5	5.0	7.0	6
Distribution Losses %	10.1	21.8	20.2	26.7	17.6	13.0	12.0	12
Total Losses %	18.6	29.9	27.8	33.4	26.9	24.0	22.0	19

Source: EDM Annual Statistical Reports 1993 to 2000

#### 5.4.4 Demand

Table 5.6 below indicates the development of four different categories of consumers in the past eleven years. In 2000, the demand was 1013.0 GWh compared to 592.4 GWh in 1990. This represents an increase of 41.52 %. The increase in demand in all consumer categories has been fairly steady. The largest increase was registered in the Medium and High Voltage consumer categories. The consumption growth in the domestic sector has been significant as well. The evolution of electricity consumption in the LV consumer category is not steady, though, reflecting the fact that the economic activities in the commercial sector have not been positive.

The demand for electricity is expected to increase once certain development projects, which are still in the planning stages, are actually implemented. The other increase in demand is expected to come from exports to neighbouring countries.

**Table 5.6: EDM's Electricity Sales by Consumer Category 1990--2000**

	1990	1991	1992	1993	1994	1995	1996	1997	1998	1999	2000
Invoiced Energy (GWh)											
LV-Commercial	93.10	126.00	131.20	133.20	125.20	146.50	126.30	90.7	104.4	123.7	119.70
LV- Big consumers									48.20	58.20	56.90
LV-Domestic	222.40	257.70	252.2	285.40	259.10	271.60	268.90	305.60	348.60	404.80	391.90
MV – HV	276.90	311.00	291.70	265.60	244.10	260.60	262.40	334.60	375.10	409.20	444.40
Total Invoiced	592.40	694.70	675.10	684.20	628.40	678.70	660.60	779.10	882.80	996.20	1013.00

Source: EDM Annual Statistical Reports 1993, 94, 95, 96, 99 and 2000

### 5.4.5 Electrification

Mozambique has a total of 91 principal cities, towns and large villages where around 40 % of the population lives. The remaining 60 % of the population lives in rural areas. The three independent EDM systems of the south, the centre and the north do not cover all the principal cities in each region and consequently some towns are not connected to the regional grid. In a survey that was carried out by the Directorate of National Energy (DNE) in 1996, it was found that out of the 129 districts of ten provinces, only about 57 headquarters were electrified. In 2000 electricity from the main grid reached a mere 4.2 % of the population (EDM Annual Statistical Report, 2000: 46). Access to electricity during the other years is shown in Table 5.7 below.

**Table 5.7: Electricity Access in Mozambique**

	1993	1994	1995	1996	1997	1998	1999	2000
Access	3.3	3.6	3.7	4.0	4.1	4.1	4.1	4.2

Source: EDM Annual Statistical Report, 2000: 46

### *Urban Electrification*

Either EDM or private suppliers can carry out electrification. Since EDM's grid covers a large area, they also do most of the new connections. The utility faces the daunting task of connecting new consumers despite an average of 8,300 new connections in a year, as of 2000. The majority of these connections occur in urban areas, which EDM assumes are financially viable. All new connections are made when full reticulation costs are paid.

Private producers and distributors supply the other urban communities where there is no grid connection. This came about as a result of the de-monopolisation of EDM in 1997. So far the private sector has participated in the electrification of two coastal towns in Mozambique under the Urban Household Energy Project funded by the World Bank (Sakairi, 2001). Under this project about 400 households/industries have been connected with supplies.

### ***Rural Electrification***

Access to electricity in the rural areas is very low, as the distribution network is concentrated in urban areas. To increase the network coverage, the national grid must either be extended to the rural areas, or alternatively mini hydro or diesel generators should be built in remote places.

The government, following its 15-year strategy plan to electrify all the district headquarters by 2015, undertook the rural electrification projects on a priority basis. In view of the ESI reforms which are taking place now, the government proposes to speed up rural electrification by:

- i. Funding from the licensing of energy-related activities. This fund shall be applicable to all forms of energy and will be managed by a Rural Energy Fund which is still to be established.
- ii. Encouraging the private sector to participate in electrification of off-grid areas.
- iii. Encouraging municipalities and local districts to take part in the electrification of their cities and districts.

### **5.4.6 Tariff Structure**

EDM has a tariff structure with two major tariff categories:

- i. High Voltage, Medium Voltage and Low Voltage (big consumers) tariff.
- ii. Low voltage tariff. This is in two parts: Domestic tariff and commercial tariff.

#### ***Category 1***

The tariffs in category 1 are divided into three levels. Level 1 consists of consumers with a load above 45 kVA. Level 2 applies to consumers with a load between 1 kVA and 45 kVA, while level 3 is for consumers with loads of less than 1 kVA. Each tariff subcategory has different rates depending on utilisation level (load factor), referred to as short-term use, medium-term use and long-term use. Consumers in this category are free to choose the utilisation level at which they want to be billed.

**Table 5.8: EDM's Electricity Tariffs as of December 2000**

#### **Category 1**

<b>Consumer Category</b>	<b>Energy Charge</b>	<b>Demand Charge</b>
<b>LV-Big Consumers</b>	<b>(MT/kW)</b>	<b>(MT/kWh)</b>
Short-term use	67,040	835
Medium-term use	81,625	582
Long-term use	96,598	436

<b>Medium Voltage</b>		
Short-term use	64,364	830
Medium-term use	78,395	569
Long-term use	92,763	418
<b>High Voltage</b>		
Short-term use	56,319	712
Medium-term use	68,599	481
Long-term use	81,137	371

### Category 2: Low Voltage EDM's Step Tariff

<b>Registered Consumption (kWh)</b>	<b>Domestic Tariff Price (Mt/kWh)</b>	<b>Commercial Tariff Price (Mt/kWh)</b>	<b>Tax (Mt)</b>
From 0 to 50 (social tariff)	602	--	0
0 to 85	652	848	38,618
86 to 165	1,196	1,555	38,618
166 to 330	1,401	1,821	38,618
331 to 495	1,534	1,994	38,618
496 to 990	1,547	2,011	38,618
991 to 1481	1,623	2,109	38,618
1482 to 1980	1,669	2,169	38,618
1981 to 2475	1,684	2,189	38,618
Up to 2476	1,739	2,261	38,618
<b>LV Pre-Payment Current (Amp)</b>	<b>Domestic tariff Price (Mt/kWh)</b>	<b>Commercial Tariff Price (Mt/kWh)</b>	<b>Tax (Mt)</b>
10	970	1,261	--
30	1,048	1,362	--
45	1,131	1,471	--
60	1,222	1,588	--
75	1,320	1,716	--
Up to 75	1,425	1,853	--

Source: EDM Annual Statistical Report, 2000: 38 & 39

Exchange Rates: Meticals per US dollar – 15,199.8 (2000), 12,775.1 (1999), 11,874.6 (1998), 11,543.6 (1997), 11,293.8 (1996), 9,024.3 (1995), 6,038.6 (1994), 3,834.2 (1993) & 2,516.5 (1992)

## ***Category 2***

The tariff in this category, according to the London Economics consultants' report (1997: 10), applies to consumers with loads of less than 19.8 kVA. There are ten different levels in this category and the tariff covers only the demand charge.

The tariff is set by the utility after considering the consumer price index and fluctuation of the local currency against the South African currency. Tariff adjustments are not automatically sensitive to increases in inflation and are implemented only after government approval. The tariffs indicated in Table 5.8 above were adjusted in December 2000. The tariffs for power supplied to other customers from isolated systems are different from those supplied from the national grid.

EDM's tariffs are uniform for all its consumers in the country as part of cross-subsidisation, as is the case with most public utilities. This may be good politically but unfortunately does not cover all the costs in some regions. This causes the utility in general to have a poor financial performance.

### **5.4.7 Financial Performance of EDM**

The EDM invested quite a lot in the generation, transmission and distribution of electricity in order to cope with demand and to contribute to the expected economic development of the country. These investments have become a huge financial burden to the EDM. The high level of non-technical losses and the depreciation of the currency also compounded this problem. These caused large increases in the domestic currency equivalent to service debt obligations (SAD-ELEC and MEPC, 1996: 153).

In addition the transmission and distribution networks were severely damaged during the civil war. This continues to hamper the technical and financial performance of the utility. According to the study carried out in 1997 by London Economics consultants on the reforms and regulation of the power sector, it concluded that the utility couldn't make significant returns on its assets unless tariffs were increased by large amounts. The EDM simply cannot service all its debts. Table 5.9 depicts the financial performance of the EDM.

**Table 5.9: Some Financial Performance Indicators of EDM**

	1992	1993	1994	1995	1996	1997	1998	1999	2000
Annual Revenue (MT million)	120,250	162,943	220,550	79,883	507,195	648,639	784,818	854,265	1,023,332
Net Profit before Tax (MT million)	(405,888)	(1,005,400)	1,667,067	(53,502)	(302,015)	(155,155)	31,370	24,120	(138,475)
Avg. Price Elec sold (Mt/kWh)	--	--	34.64	54.56	76.80	86.968	88.50	87.39	102.73
Avg. cost Elec generat (Mt/kWh)	--	--	46.34	60.4	121.3	127.2	103.3	93.90	117.50
Utility Employees	3,086	2,839	2,889	2,895	2,895	2,728	2,799	2,860	2,774
Number of Customers	132,412	136,327	151,480	159,169	171,066	177,793	186,208	189,569	202,001
Customers per Employee	43	48	52	55	59	65	67	66	73
GWh sold per Employee	0.219	0.241	0.218	0.234	0.228	0.286	0.315	0.348	0.365

**Source: EDM Annual Statistical Reports 1993 - 2000**

Over the years the average cost of electricity generated is higher than the average selling price of electricity. The other factor that hinders the financial performance of EDM is that revenue collection is poor. In some years, the debtors' collection period is as high as four months.

EDM registered an increase in the number of consumers from 132,412 in 1992 to 202,001 in 2000. The number of customers had almost doubled. The increase in the MV and HV categories can be mainly attributed to the growth of industrial customers; the other reason for the substantial increase in the number of customers is that the government had initiated more electrification projects. This is reflected by the increases in electricity access levels.

EDM is able to meet its operational costs from electricity sales to its consumers. The utility's performance is dependent on a number of capable and efficient employees and the good customer base. During the period under review, the number of customers per employee increased, while the number of utility employees decreased over the same period. Because of the increase in electricity consumption, the electricity sold per employee on average also increased.

#### **5.4.8 Power Sector Reforms**

The government initiated power sector reforms in 1997. The reforms are to fulfil the government's objective of developing the power sector in an efficient and profitable manner so as to encourage economic development in the country.

#### **5.4.8.1 Main Driving Forces behind the Reforms**

EDM faces a lot of challenges in the fulfilment of its objectives. As the utility's financial position is weak, it cannot finance any project and, as such, access to electricity remains low. The other problem which EDM is currently facing, is the maintenance of its generating equipment. Out of the total installed capacity of 307.7 MW only about 57 % was available in 2000. In order to improve EDM's performance and the management of the ESI as a whole, the government started to reform the power sector. It is clear from the general policy contained in Article 5 of the Electricity Laws, that the main driving forces behind the reforms are:

- i. To improve financial performance of the ESI through charging electricity prices that reflect the actual costs of production;
- ii. To improve the power sector's efficiency;
- iii. To increase access to electricity for the majority of Mozambicans; and
- iv. To attract private investment participation in the development of the power sector.

#### **5.4.8.2 Main Characteristics of the Reforms**

EDM is still a vertically integrated utility. The major change that took place after the passing of the Electricity Act of 1997 was that EDM was commercialised. EDM is now a public company operating on a commercial basis, the same as any other company. It is, however, still 100 % owned by the government. No other change has since taken place. If the government considers implementing the recommendations that were made under the reform and regulation of power sector study then the restructuring of EDM will proceed as follows:

- i. The vertically integrated structure will be separated into different business units of generation, transmission and distribution, each with its own account. The generation and distribution business units will later be further unbundled horizontally into sub-business units. When all the players are considered, the expected ESI structure will be represented by Figure 5.2, below.
- ii. The generation business unit will be separated into two units. i.e. thermal and hydro. The thermal generators will be a part of the transmission business unit. The hydro generators will then have to compete with the HCB and other IPPs. The ownership of generation may change at a later date through concession.
- iii. Transmission including power procurement are to be controlled by one publicly owned company which should be responsible for operating and developing the system, purchasing power from generators under power purchase agreements and selling in bulk to distributors, large customers and external customers.

- iv. Distribution will also have to be unbundled horizontally into a number of businesses. These businesses will have to be demarcated so that they are all financially viable. Participation by the private sector is expected through lease or concession contracts.
- v. Private sector participation will be introduced by:
  - Selling part of the existing hydro generation plants and introducing Independent Power Producers (IPPs) in new generation projects;
  - Implementing management contracts for the distribution business units followed by lease/concession contracts;
  - Outsourcing of non-core business units;
  - Continuing to allow IPPs, in addition to HCB, to generate and sell electricity, as they are already doing.

The strategy for the reforms in the electricity industry sector is also currently under the control of MIREME. As a review of sector laws and regulations is still under way, implementation of the above changes may take some years.

#### 5.4.8.3 Privatisation

The government does not regard the privatisation or a change of ownership of EDM as a priority. In this regard, it believes that the proposed reforms, if well implemented, will meet its objectives.

**Figure 5.2: The Expected Final ESI Structure in Mozambique**

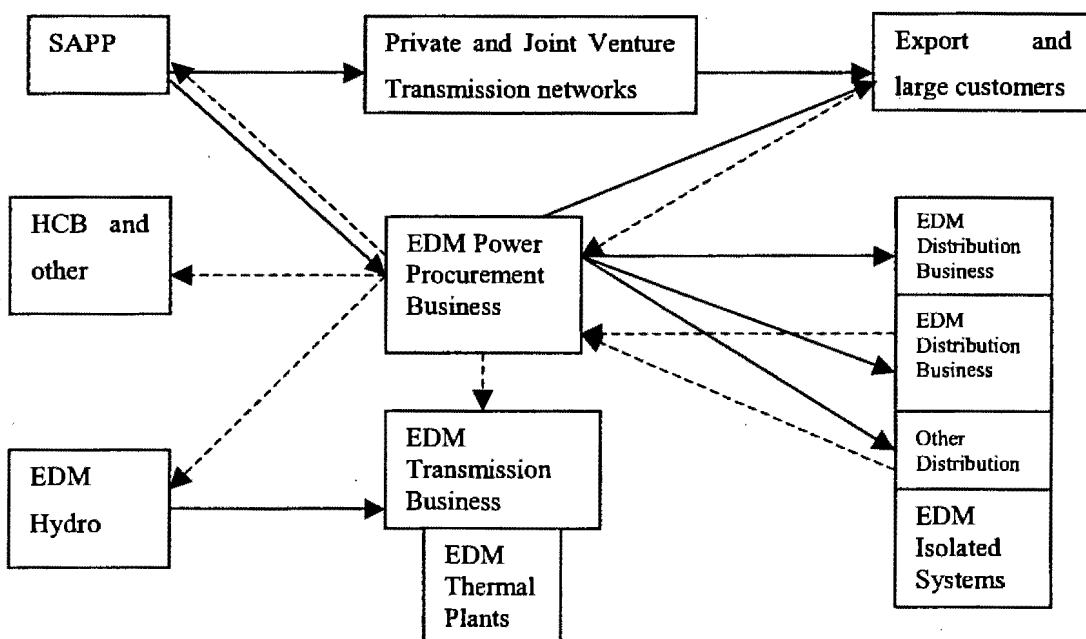

Source: London Economics Report, 1997

#### **5.4.9 Regulatory Framework**

The power supply industry is governed by the regulatory framework, which was approved by an Act of Parliament in 1997 (SAD-ELEC, 2000: 54). The Act provides the legal framework for the production, transmission, distribution and supply of electricity in the country. It also lays down the procedures of allowing private suppliers into the system.

Mozambique does not have an independent electricity regulator at present. The government partly takes on this role through the Council of Ministers and also partly through the National Electricity Council (CNELEC), a body that was created in 1997. Article 6 of the Electricity Law of Mozambique stipulates the powers and authorities of the Council of Ministers. It empowers the council to approve any new electricity supply projects of equal to or in excess of 100 MVA. It also defines the powers and authorities concerning the customers' rights in respect of the supply of electricity. According to the Electricity Law, however, CNELEC also carries out regulatory functions. The role of the Council among other things is to arbitrate between customers and suppliers as well as between concessionaires, to issue advisory opinions on proposals for new projects and to draft proposals for extension of the grid coverage (Mozambique Electricity Law pages 6 and 8).

The government instituted a study to develop the regulatory framework for the power sector. The London Economics Consultants undertook the study in 1997, which in short recommended the following:

- i. To revise the existing legislation;
- ii. To fill the gaps by current legislation;
- iii. To rename the CNELEC so that it can reflect the changes in the energy sector. The establishment of the Energy Regulatory Authority of Mozambique (ERAM) was proposed.

#### ***Regulation of ESI in Mozambique***

Mozambique does not have an independent electricity regulator. The government carries out all regulatory functions. Due to reforms taking place in the power sector, the government gave the London Economics consultants the task of developing a framework for power regulation. The consultants' report proposed that all functions of CNELEC be transferred to ERAM, which should then have the following revised functions:

- i. To review and set electricity prices;
- ii. To enforce technical and safety standards;
- iii. To regulate investments where necessary;
- iv. To promote competition in the electricity sector;
- v. To provide information on industry performance;

- vi. To assist in supervising and evaluating concession tender;
- vii. To resolve disputes between parties in the ESI; and
- viii. To provide advice to the Government on policies and development taking place in the ESI.

### South Africa

#### 6.1 Location and Demography

South Africa covers a total land area of 1,219,912 square kilometres and has a semi-arid and sub-tropical climate. The country is thus largely dry and very few large rivers run through it. It is located at the southern tip of the African continent (CIA World Factbook, 2001). Botswana, Lesotho, Mozambique, Namibia, Swaziland and Zimbabwe border South Africa to the north.

In 2000 the country's population was estimated to be 42.8 million; population growth was only 1.9 % and life expectancy was 48 years. About 55 % of the people live in urban areas and the rest lives in rural areas (World Bank, 2002).

#### 6.2 Economy

The South African economy is highly dependent on the service industry and on the industrial as well as agricultural sectors. In the industrial sector, mining is the main economic base. The country is blessed with vast resources of gold, chromium, antimony, coal, iron ore, manganese, nickel, phosphate, tin, uranium, gem diamonds, platinum, copper, vanadium, salt and natural gas. The total GDP contributions of the industrial and service sectors to the economy amount to 30.9 % and 65.9 % respectively (World Bank, 2002). In the agriculture sector, various crops are grown on commercial farms that rely heavily on irrigation. The main food crops produced are bananas, barley, maize, potatoes, rice, soya beans, sugar cane and wheat. Poultry farming is also practised on many farms. The World Bank estimates that the agriculture sector contributes about 3.2 % of the GDP.

South Africa's Gross Domestic Income (GNI) per capita was at US\$ 3,020 in 2000 but there are wide irregularities in income distribution. The GDP real growth rate was 3.1 in 2000 (ibid.). Besides the country's huge mineral resources, it also has well-developed financial and legal sectors.

Although the country's economy is well developed, the government nonetheless aims to promote its growth further and to redistribute it evenly to the majority of the people. By promoting economic growth, the government's main objective is to create more jobs for the people, thereby reducing poverty which still affects large communities, especially in rural areas.

Following the policy of social and economic reform, the government embarked on restructuring and privatising state enterprises. In the power sector, the main electricity supply company, ESKOM, will be restructured with the aim of partially privatising it in future.

### **6.3 The Energy Sector**

South Africa is a country which has huge energy resources in the SADC region. The government is committed to having a vibrant energy sector so that it can contribute to the economic growth of the country. This commitment was shown in 1998, when it published its new White Paper on Energy Policy. Five main policy objectives are outlined in this document (White Paper on Energy Policy, 1998: 8) and include the following:

- i. Increasing access to affordable energy services. The majority of people do not have access to affordable modern energy services to meet their basic energy needs. The government's policy is to promote access to affordable energy services to all the people so that its objectives of socio-economic development are achieved.
- ii. Improving energy governance. The operations of institutions that govern the various energy sub-sectors are to be strengthened and the development of any new policies will have to be carried out in a consultative approach with the stakeholders.
- iii. Stimulating economic development. The energy sector will contribute towards economic growth by encouraging competition within the energy markets. The sector will be properly regulated to ensure proper pricing and delivery of services.
- iv. Managing energy-related environmental impacts. The policy promotes access to basic energy services for poor households in order to reduce health risks associated with air pollution resulting from the burning of coal and fuelwood. The policy also ensures that energy consumption does not impact significantly on the environment.
- v. Securing supply of energy services through diversity. Energy security will be achieved by means of the least cost development of local primary energy sources and through energy trading with other countries.

South Africa's primary energy base consists of coal, hydropower, uranium, biomass and new and renewable sources of energy. The energy supply system to industry, commerce and urban households is well developed in the country.

### **6.3.1 Coal**

South Africa has proven coal reserves totalling approximately 121 billion tonnes, of which about 55 billion can be recovered economically (White Paper on Energy Policy, 1998: 67). Of the large quantities of coal that are produced within the country, most are used for synfuels production by Sasol and for electricity production by ESKOM. Out of ESKOM's total installed generation capacity of 42,011 MW, coal-fired stations generated 37,678 MW (89.7 %) of electricity in 2001 (ESKOM Annual Report, 2001: 128). One of the resources of coal, which remains untapped at present, is coal-bed methane. The gas is at the moment still allowed to escape into the atmosphere during mining. The exploitation and use of this gas could, however, help to reduce the release of greenhouse gases into the atmosphere (White Paper on Energy Policy, 1998: 68). Due to environmental concerns about greenhouse gas emissions from coal production, the development of electricity generation from coal will have to depend on improved technologies which will limit emissions.

### **6.3.2 Hydropower**

South Africa generally receives little rain compared to countries in the tropical regions. The country also does not have many large rivers and as such has limited potential for hydropower. The estimated hydropower potential is about 8,360 MW (Trollip, 1996: 4-71). ESKOM has installed capacity of 600 MW and 1,400 MW from hydroelectric stations and pumped water storage schemes respectively (ESKOM Annual Report, 2001: 128). The plans to develop the remaining untapped hydro potential may not be realised in the immediate future due to the frequent droughts experienced by the country. Some of the presently undeveloped sites, which are in off-grid areas, could probably be developed as mini-hydro power stations to assist in the programme of rural electrification.

### **6.3.3 Oil and Gas**

Oil and gas exploration in South Africa is undertaken by Petro SA which is a subsidiary of Central Energy (Pty) Limited. The company has carried out extensive exploration and appraisal programmes in the country that have resulted in the discovery of 20 gas and 9 oil fields within the Bredasdorp Basin (Trollip, 1996: 4-13). One gas field, F-A, which is now in production, converts gas into liquid fuels at the rate of 25,000 barrels per day.

Another important element in the South African oil and gas industry is the production of synfuel products (petrol, diesel, paraffin, LPG, solvent gas and a variety of chemical feedstock) from coal. Trollip (1996: 4 - 25) estimated that about 150,000 barrels of crude oil equivalent were produced in a day.

South Africa's petroleum product requirements cannot be met from internal sources only. Large amounts of oil are consequently imported in crude form and refined within the country. In the electricity sector, gas turbines use diesel to generate electricity. The current installed gas turbine capacity for ESKOM is

342 MW (ESKOM Annual Report, 2001: 128). The plants are, however, rarely run, being used for standby purposes only. Electricity generation from oil and gas in the foreseeable future is expected to come from the natural gas that has been discovered in the neighbouring countries of Mozambique (Pande gas field) and Namibia (Kudu gas field). The gas from these fields could be piped into the country and part of it could be used for electricity generation. Alternatively, electricity generation could take place near the gas fields themselves after which the power could be transmitted through transmission lines from these sites into already existing transmission lines in these countries.

#### **6.3.4 Nuclear Energy**

South Africa produces uranium as a by-product of gold mining. Part of the uranium is exported as oxide. Its contribution to the total South African primary energy supply is, however, very small. It is estimated that nuclear energy provides between 1 % (DMEA 1995) and 2.6 % (IEA 1996) (cited by Trollip, 1996: 4-56). ESKOM uses enriched uranium to produce electricity from the two nuclear power plants at the Koeberg power station outside Cape Town. Currently the plants provide a base-load of about 1860 MW. Further development of nuclear power in the reformed electricity market, which is expected soon, is doubtful because of the high costs associated with its production and the environmental concerns arising from the radioactive waste materials. However, if other options of electricity generation and supply are found to be too expensive in relative terms, then new-generation nuclear power production, such as the pebble-bed modular Reactor, could be developed.

#### **6.3.5 Biomass**

Biomass, in the form of firewood, wood waste, dung and charcoal, is the main source of energy in rural households and some urban settlements. It constitutes about 10 % of the national energy requirements and 60 % of the household energy needs (White Paper on Energy Policy, 1998: 70). Most of the wood fuel is used in the rural households. The government's main concern with regard to this source of fuel is that it is used in an unsustainable manner in many areas. Increased electrification programmes, which the government embarked on in 1994, will enable rural people to use electricity, thereby reducing the rate of deforestation which results from cutting down trees for wood fuel.

#### **6.3.6 New and Renewable Energy**

The potential for the use of new and renewable energy technologies from solar and from wind exists in South Africa. The fact that most parts of the country are basically hot and dry favours the use of solar photovoltaics (PVs). These are commonly used in communication (off-grid areas), domestic houses and water pumping, while solar water heaters are also used in domestic, commercial, industrial and agricultural sectors (Trollip, 1996: 4-71). In some areas wind power is used to pump water, but this is limited to those areas of the country where wind speed is high, for example, in coastal areas where wind speed is at an average of 4 m/s. The use of solar and the wind as a source of energy is not popular

because of the following limitations: Firstly, solar PVs and wind turbines have a limited generation capacity; and secondly, many people cannot afford their costs. The development of these systems is essential in increasing electricity access and could play a far greater role in the economic growth of the rural population.

## **6.4 The Power Sector**

### **6.4.1 Background**

The Electricity Supply Industry (ESI) in South Africa is dominated by the public utility ESKOM. Although the company does not have a monopoly over generation and distribution, because of its huge generation capacity it makes other generators uncompetitive. Private generators and major municipalities also generate electricity for their own use and to sell to customers. Electricity generated by these producers is insignificant compared to that generated by ESKOM. ESKOM has an installed over-capacity such that the country may not need any new generation until after 2007, when demand is expected to exceed the present generation capacity (White Paper on Energy Policy, 1998: 28). In 2001, the total installed capacity of ESKOM was 42,011 MW while the peak demand on the integrated ESKOM system amounted to 30,599 MW. ESKOM is one of the major utilities in the world. It is ranked seventh in terms of generation capacity and ninth in terms of sales (ESKOM Annual Report, 2001: 124).

Power is transmitted from the generating stations to major load centres, municipalities and large customers through the national transmission grid, which is owned by ESKOM. The distribution network is slightly fragmented. There are about 400 distributors currently involved in the supply of electricity (White Paper on Energy Policy, 1998: 28), and this poses a major challenge to the financial and technical efficiency of the ESI.

### **6.4.2 Existing Institutional Arrangements**

The South African government wholly owns ESKOM. The Department of Minerals and Energy formulates policies for the electricity sector. Functionally, ESKOM reports to the Ministry of Public Enterprises. The governance of ESKOM changed after the implementation of the ESKOM Conversion Act, No.13 of 2001, under which ESKOM was converted into a public company that will be governed by the Companies Act of 1973 (Business Day, Monday, July 1 2002).

ESKOM is a vertically integrated utility and supplies about 96 % of South Africa's electricity requirements, while the municipalities supply the rest. It has a monopoly over the high voltage transmission grid which, with the exception of the Motraco line to Mozambique, is jointly owned by the utilities of Swaziland and Mozambique (Eberhard, 2001: 1). ESKOM, municipalities and private distributors together undertake electricity distribution.

ESKOM is a member of the Southern Africa Power Pool (SAPP) and its transmission network is interconnected with those of all its the neighbouring countries. These transmission lines are used either for power exports or imports. Although ESKOM has an installed over-capacity, it purchases power from Hydroelectrica de Cahora Bassa (HCB) of Mozambique under long-term power purchase agreements. The purchased power is mainly used for peak load management purposes.

Figure 6.1 below shows the details of the current ESI structure in South Africa.

**Figure 6.1: Current ESI Structure in South Africa**

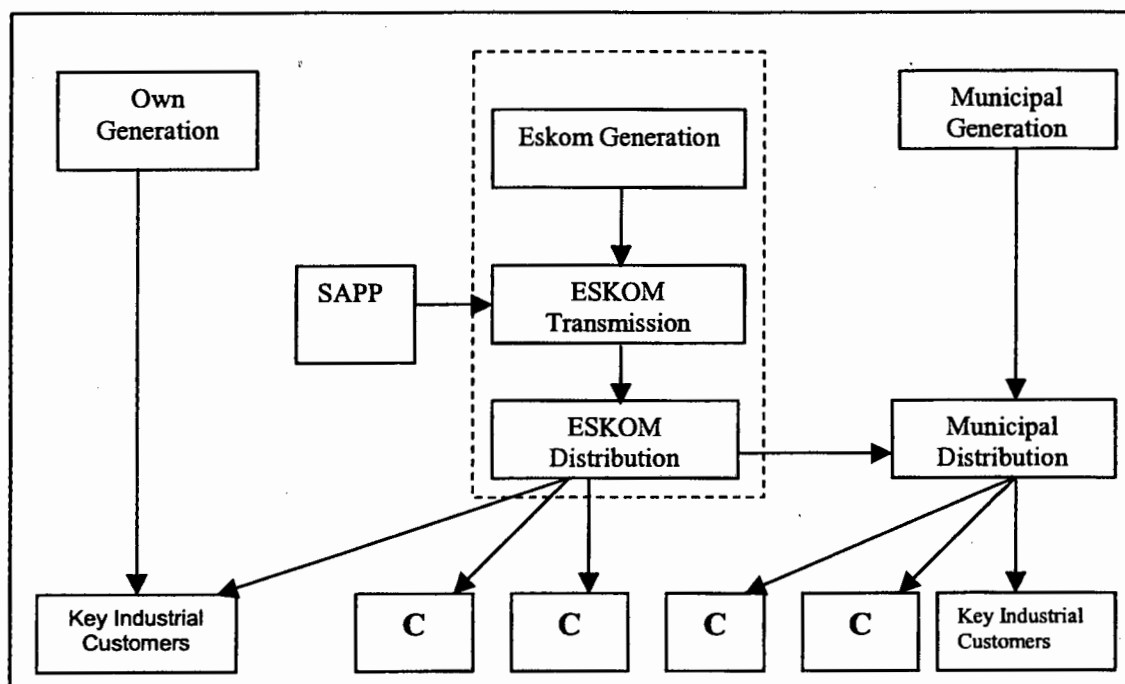

Source: Conrad Barberton, EDRC Report Series 2000: 2

## 6.4.3 Electricity Supply

### 6.4.3.1 Generation

The total generating capacity of ESKOM by the end of 2001 was 42,011 MW, most of which came from coal (89.7 %). Installed nuclear capacity accounts for 4.6 %, hydroelectric and pumped storage schemes contributed about 4.9 % and the remaining 0.8 % is the installed capacity of gas turbines. Refer to Table 6.1 for the historical data on ESKOM's installed generating capacities from 1990.

**Table 6.1: ESKOM's Installed Generating Capacity, 1990 – 2001**

Year	Coal-fired (MW)	Gas Turbine & Diesel (MW)	Hydro-electric (MW)	Pumped Storage (MW)	Nuclear Power (MW)	Total Installed Capacity (MW)	Net Maximum Capacity (MW)	Units Generated (GWh)
1990	31413	390	540	1400	1930	35673	33843	146047
1991	34136	390	540	1400	1930	38396	36228	148671
1992	34822	368	540	1400	1930	39060	36846	148207
1993	35508	368	540	1400	1930	39746	37636	154260
1994	33568	342	600	1400	1930	37840	35926	160293
1995	33568	342	600	1400	1930	37840	35951	164834
1996	34225	342	600	1400	1930	38497	36563	178855
1997	34882	342	600	1400	1930	39154	37175	187811
1998	35539	342	661	1400	1930	39872	37848	183093
1999	36252	342	661	1400	1930	40585	38517	181818
2000	36965	342	661	1400	1930	41298	39186	189307
2001	37678	342	661	1400	1930	42011	39810	189590

Source: ESKOM Annual Reports 1990, 1991, 1992, 1993, 1994, 1995, 1996, 1997, 1998, 1999 & 2000

Table 6.2, below, provides details of ESKOM's power stations as at December 2001. The total number of power stations is 24, of which 13 are coal-fired, 2 gas turbines, 6 hydroelectric, 2 pumped storage and 1 a nuclear power station (ESKOM Annual Report, 2001: 128). The power is mainly generated from ten coal-fired stations and one nuclear power station. These provide the base load. The other stations are used for peak or emergency load.

The municipalities and private generators produce their electricity from a number of small generating units. The municipalities alone have a total of 22 small generating stations and back-up gas turbines, which constitute only 5 % of the national generating capacity, while the private installed capacity constitutes 2 % of the total capacity (Eberhard, 2001: 2).

**Table 6.2: ESKOM's Power Stations at 31 December 2001**

Name of Station	Location	Number and capacity of generator sets (MW)	Total nominal capacity MW	Total net maximum capacity (MW)	Generators in reserve storage. Total rating		Other generation. Total rating (MW)
					Number	(MW)	
<b>Coal-fired Stations</b>							
Arnot	Middelburg Mpumalanga	6*350	2,100	1,980	--	--	--
Candem	Ermelo	8*200	1,600	--	8	1,520	--
Duvha	Witbank	6*600	3,600	3,450	--	--	--
Grootvlei	Balfour	6*200	1,200	--	6	1,130	--
Hendrina	Hendrina	10*200	2,000	1,895	--	--	--
Kendal	Witbank	6*686	4,116	3,840	--	--	--
Komat	Middelburg Mpumalanga	5*100 4*125	1,000	--	9	891	--
Kriel	Bethal	6*500	3,000	2,850	--	--	--
Lethabo	Sasolburg	6*618	3,708	3,558	--	--	--
Majuba	Volksrust	3*657;3*713	4,110	3,843	--	--	--
Matimba	Ellisras	6*665	3,990	3,690	--	--	--
Matla	Bethal	6*600	3,600	3,450	--	--	--
Tutuka	Standerton	6*609	3,654	3,510	--	--	--
<b>Subtotal of Coal-fired Stations (13)</b>			<b>37,678</b>	<b>32,066</b>	<b>23</b>	<b>3,541</b>	<b>--</b>
<b>Gas Turbine Stations</b>							
Acacia	Cape Town	3*57	171	171	--	--	--
Port Rex	East London	3*57	171	171	--	--	--
<b>Subtotal gas turbine stations (2)</b>			<b>342</b>	<b>342</b>	<b>--</b>	<b>--</b>	<b>--</b>
<b>Hydroelectric Stations</b>							
Collev Wobbles	Mbashe River	3*14	42	--	--	--	42
First Falls	Umtata River	2*3	6	--	--	--	--
Gariep	Norvalspont	4*90	360	360	--	--	--
Ncora	Ncora River	2*0.4;1*1,3	2	--	--	--	2
Second Falls	Umtata River	2*5.5	11	--	--	--	11
Vanderkloof	Petrusville	2*120	240	240	--	--	--
<b>Subtotal Hydroelectric Stations (6)</b>			<b>661</b>	<b>600</b>	<b>--</b>	<b>--</b>	<b>61</b>
<b>Pumped storage schemes</b>							
Drakensberg	Bergville	4*250	1,000	1,000	--	--	--
Palmiet	Grabouw	2*200	400	400	--	--	--
<b>Subtotal Pumped Storage (2)</b>			<b>1400</b>	<b>1400</b>	<b>--</b>	<b>--</b>	<b>--</b>
<b>Nuclear power station</b>							
Koeberg	Cape Town	2*965	1930	1,800	--	--	--
<b>Total ESKOM Stations in Commission (24)</b>			<b>42,011</b>	<b>36,208</b>	<b>23</b>	<b>3,541</b>	<b>61</b>

Source: ESKOM Annual Report, 2001: 128

### ***Future Generation Potential***

South Africa has a number of options with regard to meeting its future electricity demand. Additional coal-fired or nuclear power stations could be built within the country, although there are concerns from the public regarding environmental and safety issues. Such concerns could, however, be addressed by new technological designs. The other option to meet the estimated future demand would be by importing electricity from other SAPP Member Countries. If the development of Grand Inga materialises in the Democratic Republic of Congo (DRC), it could be the main source of power imports. The discovery of natural gas in Namibia and Mozambique is another blessing to the region, as far as electricity generation is concerned. Due to the reforms that are taking place in the power sectors in the whole region, electricity markets will be increasingly liberalised, and thus ESKOM could invest in electricity generation in those other countries that have cleaner resources of electricity generation.

### ***Electricity Imports and Exports***

Although ESKOM's installed capacity can at present meet all of South Africa's electricity demand, the utility nevertheless imports power from Mozambique, the DRC, and Zambia, for peak load management (Eberhard, 2001: 2). Importing electricity from the above-mentioned countries is generally cheaper than it would cost for ESKOM to run its own gas turbines.

South Africa exports electricity to its neighbouring countries of Botswana, Mozambique, Namibia, Zimbabwe, Lesotho and Swaziland, even though it has to import too, as explained above. Table 6.3, below, shows ESKOM's electricity exports to neighbouring countries from 1990 until 2000.

**Table 6.3: ESKOM's Electricity Exports (GWh)**

<b>Country</b>	<b>1990</b>	<b>1991</b>	<b>1992</b>	<b>1993</b>	<b>1994</b>	<b>1995</b>	<b>1996</b>	<b>1997</b>	<b>1998</b>	<b>1999</b>	<b>2000</b>
Botswana	84	106	100	121	205	340	685	748	689	934	986
Mozambique	322	383	436	510	559	600	596	680	385	68	1331
Namibia	586	823	457	999	813	950	1100	1295	602	562	640
Zimbabwe	13	6	14	149	164	154	2267	2790	1521	1564	788
Lesotho	192	206	241	281	310	324	335	318	209	55	12
Swaziland	410	356	657	530	577	618	571	608	687	701	115

Source: ESKOM Annual Report, 2001: 126, 2000: 124, & 1998: 80

As can be seen from the above Table, Lesotho reduced its power imports after the commissioning of its hydropower plant in 1999. Presently, Lesotho imports power for emergency purposes only.

### 6.4.3.2 Transmission and Distribution System

Electricity generated from power stations is transmitted to internal load centres and neighbouring countries through lines which operate at different voltages. ESKOM's transmission lines operate between 132 kV and 765 kV. The total transmission line length for the national grid is 26,912 km (ESKOM Annual Report, 2001: 130).

The distribution system consists of lines operating at voltages between 33 kV and 132 kV and has the total line length of 41,825 km. The secondary distribution system, i.e. the reticulation system, is very vast. It operates at 22 kV and lower voltages and consists of 247,897 km. The total line length of the national grid, therefore, comes to 316,634 km. Customers are served from the 79,855 MVA installed transformer capacities that are part of the distribution and reticulation systems. Refer to Table 6.4, below, which indicates the development of ESKOM's transmission and distribution lines from 1990 to 2000.

**Table 6.4: ESKOM's Transmission and Distribution Line Lengths (1990 to 2000)**

kV	1990	1991	1992	1993	1994	1995	1996	1997	1998	1999	2000
765	871	871	871	1,153	1,153	1,153	1,153	1,153	870	870	870
533	1,030	1,030	1,030	1,031	1,031	1,031	1,035	1,035	1,035	1,031	1,031
400	12,344	13,187	13,782	13,848	13,930	13,981	14,216	14,614	15,187	15,039	15,397
275	6,994	6,992	7,199	7,167	7,220	7,148	7,130	7,267	7,409	7,298	7,505
220	1,239	1,239	1,243	1,186	1,243	1,243	1,239	1,239	1,239	1,239	1,239
132		491	–	371	604	632	653	757	703	984	984
165 – 132	16,358	17,011	16,910	17,102	17,483	16,632	18,730	19,123	19,583	19,884	20,147
88 – 33	20,996	21,063	21,099	20,953	20,639	20,230	20,597	20,695	20,816	20,822	20,936
22	160,280	165,424	170,484	176,153	176,154	179,752	190,992	201,717	214,168	227,158	238,015
<b>Total</b>	<b>220,112</b>	<b>226,817</b>	<b>233,109</b>	<b>238,964</b>	<b>239,457</b>	<b>241,802</b>	<b>255,745</b>	<b>267,600</b>	<b>281,010</b>	<b>294,325</b>	<b>306,124</b>

Source: ESKOM Annual Reports 1991: 46, 1992: 51, 1994: 57, 1996: 72, 1998: 83 & 2000: 126

### 6.4.3.3 Power System Losses

The losses in ESKOM's transmission and distribution lines range from 5.0 % to 7.4 % as indicated in Table 6.5 below. The low losses incurred show that most of the electricity that is generated is sold to consumers. In the power system, major losses occur in the distribution network due to non-technical losses, for instance, from electricity theft by meter bypassing, unmetered sales, defective metering equipment and billing errors. In this regard, ESKOM's system stands a chance to reflect low power losses because it is not involved with the major part of the distribution system. ESKOM sells most of its electricity in bulk to distributors.

**Table 6.5: Power System Losses in ESKOM Network**

	1990	1991	1992	1993	1994	1995	1996	1997	1998	1999	2000
Line Losses (%)	5.0	5.0	5.6	5.7	5.6	5.9	5.9	6.4	5.9	6.2	7.4

Source: ESKOM Annual Reports 1999: 93 & 2000: 124

#### 6.4.4 Demand

The Electricity Sales statistics data summarised in Table 6.6, below, shows the total energy sold by ESKOM and the maximum demand on the ESKOM integrated system from 1990 up to 2001. From the data available, the overall growth in electricity demand in the last twelve years is about 22 %. Bulk redistributors, residential/street lighting, and commercial customers registered increases in consumption every year, except in 2001, when bulk distributors' consumption decreased slightly. Electricity demand in the mining and industrial sectors stagnated over the same period.

**Table 6.6: ESKOM's Electricity Sales by Consumer Category**

	1990	1991	1992	1993	1994	1995	1996	1997	1998	1999	2000	2001
Bulk (GWh)	59,076	62,482	63,193	63,591	64,584	66,421	69,905	68,109	68,666	69,374	71,580	72,189
Domestic (GWh)	1,081	1,138	1,604	2,778	3,660	3,906	4,753	5,494	5,989	6,057	6,476	7,301
Commercial (GWh)	340	344	379	493	478	579	654	979	801	768	817	6,407
Industrial (GWh)	34,152	35,470	34,034	37,467 <sup>a</sup>	40,394 <sup>a</sup>	42,244	47,451	52,236	53,683	54,240	55,953	48,664
Mining (GWh)	33,363	31,366	30,840	30,998	31,619	31,293	31,188	33,077	31,645	31,505	31,403	31,923
Rural (GWh)	3,641	3,711	4,038	3,149 <sup>b</sup>	3,255	3,383	3,239	3,402	3,725	3,890	3,816	4,224
Traction (GWh)	3,958	3,685	3,568	3,365	3,494	3,522	3,458	3,406	3,439	3,180	3,330	3,481
International (GWh)	—	—	—	1,565	1,583	1,832	4,441	5,513	3,197	4,099	4,549	6,996
Own Use (GWh)	557	491	470	394	376	367	281	334	309	309	268	326
Total (GWh)	136,168	138,687	138,126	143,800	149,443	153,547	165,370	172,550	171,454	173,422	178,192	181,511
Maximum Demand (MW)	21,863	22,342	22,640	22,169	24,798	25,133	27,967	28,329	27,803	27,813	29,188	30,599
No of Customers	242592	278033	541866	872505	1207049	1567789	1877265	2244403	2563652	2855838	3054435	3274863
Employees	50,000	46,637	42,223	40,128	39,760	39,952	39,857	39,241	37,311	34,027	32,832	29,969
Customers per Employee	5	6	13	22	30	39	47	57	69	84	93	109
GWh Sold per Employee	2.723	2.974	3.271	3.584	3.759	3.843	4.149	4.397	4.595	5.096	5.427	6.057

Source: ESKOM Annual Reports 1991, 1992, 1994, 1996, 1998, 2000, 2001

ESKOM's profits are mainly derived from sales of electricity to its three main customers: bulk redistributors, industry and mining. Although the number of customers in the residential sector has increased tremendously, relatively speaking, electricity consumption in this sector still remains low. Most utilities actually incur losses in the residential sector because this is also where more non-technical losses occur due to electricity theft and meter tampering. The supply to most rural households also becomes expensive, because operational costs tend to be higher than the revenue collected.

In the SADC region, South Africa has achieved higher electrification levels than any other country. As a result, the demand in the residential sector is expected to grow significantly.

#### 6.4.5 Electrification

In the past the electrification of both urban and rural areas was the responsibility of electricity distributors. The distributors had their own electrification programmes. In 1991, ESKOM initiated the programme of extending electricity services to communities that were prepared to pay for it. Ideally ESKOM undertook the programme of increasing access to electricity with the view to stimulating economic growth and improving people's quality of life (ESKOM Annual Report, 1990: 6). The Reconstruction and Development Programme (RDP) that was undertaken by the ANC government boosted ESKOM's efforts in 1994. Under the RDP the government wanted the electricity connections to be extended to about 2.5 million households by the year 2000 (Energy and Development Group, 1995: R-2). Out of the targeted 2.5 million households, ESKOM committed itself to electrifying 1,750,000 homes by the year 2000 (ESKOM Annual Report, 1994: 6). The rest were to be electrified by the other distributors. Table 6.7, below, shows details of yearly connections carried out by ESKOM and other distributors from 1991 to 2000.

**Table 6.7: Connections Completed by ESKOM and Local Government, 1991 – 2000**

	1991	1992	1993	1994	1995	1996	1997	1998	1999	2000
<b>ESKOM</b>	31,035	145,522	208,801	254,383	313,179	307,047	274,345	280,977	293,006	250,801
<b>Local Government</b>	51,435	74,335	107,034	164,535	150,454	137,534	213,768	136,074	144,043	139,780
<b>Farm Workers</b>	0	12,698	16,074	16,838	15,134	9,414	11,198	10,375	6,241	6,438
<b>Total</b>	82,470	232,555	331,909	435,756	478,767	453,995	499,311	427,426	443,290	
<b>% Total</b>	—	—	—	—	50	55	60	63	66	63

Source: National Electricity Regulator, 1999: 19 & 2001: 17

#### *Urban Electrification*

Both ESKOM and the government Local Authorities (Distributors) implement electrification in urban areas. Since the inception of the electrification programmes in 1994, many low-income urban households that had previously not been connected to the national grid, have been electrified. ESKOM financed the electrification exercise in its demarcated distribution areas from its own financial earnings and loans

(ESKOM Annual Report, 1994: 10). In order to increase the electrification rate in many places, the barriers that had previously hindered household connections were overcome and at the same time electricity use had to be encouraged. In this regard, ESKOM developed a tariff system that was specifically designed to encourage use of electricity. The minimum connection fee was abolished and all the connection costs were to be recovered from the tariff. The tariff only included the energy charge (Energy and Development Group, 1995: R-3). The electrification costs were further lowered through the use of appropriate technologies such as Redi-board, prepayment meters, Aerial Bundled Conductors (ABC), pole-mounted transformers and single phase transformers. However, electricity consumption by low-income households was low.

The Local Authorities are also active in extending electricity connection in their demarcated areas of distribution. However, because of the financial problems encountered by some of the Local Authorities, the progress of the RDP electrification exercise was fairly slow. ESKOM assisted by funding their electrification programmes through the National Electricity Regulator (ESKOM Annual Report, 1998: 17).

### ***Rural Electrification***

The distributors, as well as the government, embarked on a rural electrification programme. The distributors concentrated in those areas where it was feasible to extend the grid connections, whereas the government assisted in funding non-grid connections. The areas that benefit from the rural electrification programme are the farms and commercial centres which are close to the distribution network, such as clinics, schools and other institutions. Since it is not financially viable to extend the network to all the areas, electricity access to some centres was increased through the use of solar photovoltaics (PVs). The government undertook this solar power initiative, and its priority is to electrify as many schools and clinics as possible. The off-grid electrification programme using the PVs progressed well too. By 1999 PV cell installations totalled 5.0 MW. Half of these were used in telecommunication application and the rest were installed in schools, clinics and households. A total number of 1,500 schools and 500 rural health clinics had benefited from the PV systems by 1999 (African Energy Journal, April-May 1999: 28). ESKOM supported the government's solar programmes through its own involvement in installations and finances. Some of ESKOM's projects were financed by grants. In 1998, for example, ESKOM electrified 90 non-grid schools from a grant received from the Netherlands (ESKOM, 2002).

South Africa's electrification programme is progressing well. To date, the target of bringing electricity to 2.5 million households has been exceeded. ESKOM has done quite a lot to make the programme a success, as reflected in Table 6.7 above. The country's electrification rate was around 63 % by the year 2000 (National Electricity Regulator, 2001: 17).

Under the restructured electricity supply industry, rural electrification will be the responsibility of the government. The National Electrification Fund (NEF) that was established in 2000 will help to finance the programme and it is likely that targets will be negotiated with the utilities.

### ***Other Public Benefits***

The government recognises the importance of other public benefits in the ESI, such as Integrated Resource Planning (IRP), Demand Side Management (DSM) and Research and Development and intends to address them as follows:

### ***Integrated Resource Planning***

ESKOM and other distributors are currently involved in the planning of electricity supplies in the country. ESKOM took the investment decisions in the generation and transmission of electricity in order to ensure security of supply. Once the ESI has been reformed, the government hopes that the electricity suppliers and service providers will continue to undertake IRP. The NER is currently overseeing the preparation of a national IRP. The NER is expected to enforce this through the licensing of the new facilities (White Paper on Energy Policy, 1998: 75).

### ***Demand Side Management***

The government is aware of the importance of demand side management in the power sector. In the expected new ESI structure, elaborated in Figure 6.2, it is possible that suppliers might not promote the efficient use of electricity, as their aim will be to make high profits. This means that if energy efficiency on the demand side will not be promoted, poor households will suffer due to high electricity bills, which is clearly not in line with the government's wishes. Currently ESKOM promotes Demand Side Management (DSM) through the 'time of use' tariffs as part of its peak load management programme. Once the ESI has been restructured, the government intends to promote DSM through awareness programmes amongst consumers and through the deployment of incentives to encourage energy efficiency measures. The government will also enforce manufacturing standards and labelling of electrical equipment so that consumers can make an informed choice on the type of equipment they will be purchasing (White Paper on Energy Policy, 1998: 77 & 78). Presently the NER is developing an energy efficiency and DSM policy.

### ***Research and Development***

Research projects in the ESI are conducted mostly by ESKOM. The government expects the current trend to continue in the future. The electricity suppliers will have to carry on with research to develop their systems, so that they can supply and meet electricity demand more efficiently. In its Energy Policy White Paper (White Paper on Energy Policy, 1998: 87), the government indicates that it will support research

programmes and projects that focus on the development of national policy. It also intends to assist institutions that are involved in meeting the energy needs of people through the use of renewable energy technologies and energy efficient applications. The question arises as to what will happen to the substantial Research and Development capacity in ESKOM once it is restructured.

#### 6.4.6 Tariffs

Electricity tariffs in South Africa are set by the suppliers and approved by the National Electricity Regulator (NER). Currently, the main suppliers are ESKOM and about 400 local government distributors that have been licensed by the NER to distribute electricity to end-use customers (National Electricity Regulator Annual Report, 2000 / 2001: 9). Since the electricity distribution industry is so highly fragmented, there are several tariffs, which are charged by the different suppliers. In 1996, Trollip (1996: 4-48) estimated that there were more than 2,000 electricity tariffs.

ESKOM's tariffs fall into different categories depending on electricity use (consumption), type of consumer, time of use and flexibility of consumption. In 2001 the total number of tariff categories was 15 (ESKOM Tariffs and Charges 2001). In the past 13 years, the tariffs were adjusted slightly below the inflation rate as indicated in Table 6.8 below.

**Table 6.8: ESKOM's Average Tariff Increases for the last 13 years**

Year	Average tariff increase	Inflation rate (CPI)
Jan 1989	10.00%	14.70%
Jan 1990	14.00%	14.40%
Jan 1991	8.00%	15.30%
Jan 1992	9.00%	14.00%
Jan 1993	8.00%	9.80%
Jan 1994	7.00%	8.90%
Jan 1995	4.00%	8.70%
Jan 1996	4.00%	7.40%
Jan 1997	5.00%	8.60%
Jan 1998	5.00%	6.90%
Jan 1999	4.50%	5.20%
Jan 2000	4.50%	6.20%
Jan 2001	5.20%	6.20%

Source: ESKOM Tariffs and Charges for 2001

The existence of so many different tariffs by different suppliers leads to the conclusion that some suppliers, in fact, charge tariffs which do not reflect the cost of supplies. Some distributors are likely to

charge high electricity prices with the aim of achieving other goals from electricity profits, whereas others may be making a loss. In view of the coming ESI restructuring, the NER will have to make sure that electricity prices provide efficient market signals by accurately reflecting the cost of supply and that a general price level is set that ensures the financial viability of the electricity utilities (White Paper on Energy Policy, 1998: 39).

#### 6.4.7 Financial Performance of ESKOM

Eskom's financial performance for the last decade has been sound. The available financial indicators are shown in Table 6.9 below. The Table indicates that ESKOM has been making a profit. A number of factors contributed to this good financial performance, the first of which is the higher percentage of electricity generation from the coal-fired stations using low cost coal. The price of coal is generally low and most of the power stations are conveniently situated next to coal mines (Trollip, 1996: 4-46).

The second factor with regard to ESKOM's good financial performance is its financial policy of recovering the real cost of supplying electricity to its consumers every year (ESKOM, 2002). ESKOM ensures that it recovers costs of supply through selling electricity at adequate tariff levels. In the past 13 years, the tariffs were adjusted slightly below the inflation rate, as indicated in Table 6.8 above. Although the tariff increases were generally lower than the inflation rate, ESKOM was able to meet its operating and maintenance costs from its own financial resources and also earned a real return on its assets because of its good financial position.

**Table 6.9: Some Financial Performance Indicators of ESKOM**

Year	Total asset Value (Rm)	Annual revenue (Rm)	Net profit before tax (Rm)	Average cost electricity sold (c/kWh)	Average price electricity sold (c/kWh)	Return on assets (%)	Debt/equity ratio (Rm)	Interest cover (Rm)	Exchange Rate
1990	--	10,736	845	--	7.88	10.71	2.74	1.26	--
1991	--	11,726	988	--	8.46	10.51	2.55	1.3	--
1992	--	12,649	1,489	--	9.16	10.54	2.27	1.5	2.8497
1993	--	13,793	1,646	8.45	9.59	10.80	2.03	1.52	3.2636
1994	52,761	15,417	2,268	8.82	10.32	11.52	1.73	1.71	3.5490
1995	57,498	17,114	2,716	9.40	11.15	11.45	1.45	1.88	3.6266
1996	60,215	18,687	3,072	9.46	11.30	11.65	1.25	1.96	4.29935
1997	65,283	20,488	3,083	10.08	11.85	11.30	1.08	1.92	4.60796
1998	75,085	21,074	2,474	10.70	12.29	9.69	0.89	1.74	5.52828
1999	71,383	21,568	2,062	11.27	12.44	8.26	0.89	1.69	6.10948
2000	73,353	23,569	3,213	11.44	13.23	9.95	0.68	2.1	6.93983
2001	74,709	24,983	3,426	11.90	13.76	10.10	0.50	2.24	7.6

Source: ESKOM Annual Reports 1991, 1992, 1994, 1996, 1997-- 2001

The third reason is ESKOM's good revenue collection. ESKOM basically uses two types of metering equipment on customers' premises: prepayment metering and conventional metering (ESKOM, January 2001). Prepayment metering has the advantage of reducing operational costs. Customers pay up-front, in contrast to conventional metering, where monthly meter reading has to be done. The revenue collection of ESKOM in the past decade has generally been efficient. The annual revenue has been on the increase from R10, 736 million in 1990 to R24, 983 million in 2001 (Refer to Table 6.9 Financial indicators - for further details). This high increase was achieved as a result of increases in sales. The net profit before taxation has also been good and has shown a positive growth. The net profit was slightly reduced in 1998 and 1999, but picked up again in the year 2000. The utility's debt has, in fact, been reducing since 1990, to such a degree that the debt-equity ratio in 2001 was only 0.5. Accordingly, its financial costs have fallen drastically.

The financial viability of the other smaller distributors depends on the customer base and electricity consumption. The municipalities, such as Cape Town, Johannesburg, Pretoria and Durban, are likely to make far larger profits than other local authorities.

#### **6.4.8 Electricity Sector Reforms**

Almost all the countries in the SADC region have started to reform their ESI's, following the current trend in many developed and developing countries. South Africa, too, has not remained immune to these developments.

##### **6.4.8.1 Main Drivers for the Reforms**

The ESKOM supply system is very reliable and electricity is delivered to customers very efficiently. So far, ESKOM's financial performance has been very good and encouraging. In order to ensure continued performance and to meet future challenges, the government plans to reform the electricity sector based on the following reasons as stated by Eberhard (2001: 7) in his paper presented to the Trade and Industrial Policy Strategies Annual Forum in Pretoria.

i. ***To ensure that investment (allocative) and productive efficiencies result in a lower price.***

Introduction of competition in the generation and establishment of competitive markets can result in efficiency gains. The generators can compete against each other. For the companies to survive, they will try to sell their product and reduce the costs. Again, any new investments to be made will depend on sound technologies with very good efficiencies. Thus the investors will try to make least cost investments. In the current industry structure, poor investment decisions can result in high prices that are simply passed on to the customers.

- ii. ***To unlock economic value.*** The government receives very little financial returns from the assets invested in ESKOM. The utility did not pay tax to the government in the past. Restructuring ESKOM will enable the government to receive financial returns that can assist in paying off the country's foreign debt and for funding the rural electrification programme.
- iii. ***To widen economic ownership.*** The country needs to broaden the participation of the majority of the people in the economy. This can be achieved through the transfer of equities and share ownership to the citizens, granting share ownership to employees, and motivating management to help in efficiency improvements.
- iv. ***To attract direct foreign investment.*** Restructuring the utility will open competition in both generation and distribution sectors. This will attract private foreign companies to invest in the sector and hence improve fixed domestic investments to support economic growth. The increase in foreign capital inflows can then improve the country's foreign reserves.
- v. ***To contribute to the New Partnership for African Development (NEPAD).*** For ESKOM to contribute to the NEPAD, it has to be restructured so that it can compete effectively in the electricity market in the SADC region and in Africa as a whole. This is possible if it can experience competitive forces within the country.

#### **6.4.8.2 Main Characteristics of the Reforms**

The initiative to restructure ESKOM started many years ago in 1992; the main focus then was on increasing electrification levels and restructuring the distribution part of the industry.

Restructuring of ESKOM is progressing at a slow pace. However, the passing of the ESKOM Conversion Bill in 2001, which replaced the old ESKOM Act of 1987, was the first major step in this process. The government's commitment to restructuring and partially privatising ESKOM was again emphasised on 1 July 2002, when it converted ESKOM from a public enterprise, led by an electricity council, into a public company with share capital. A board of directors appointed by the Minister has now replaced the electricity council (*Business Day*, Monday, July 1 2002: 12). The utility name is now known as ESKOM Holdings Ltd. This means that ESKOM holdings will be operating as any other company liable to pay taxes to the government and dividends to share holders.

Further restructuring of ESKOM is expected to proceed as follows:

- i. Unbundling of the vertically integrated structure into separate business units of generation, transmission and distribution, while operating under ESKOM Holdings Limited. Unbundling of the current ESKOM structure means that ESKOM's natural monopoly in electricity generation

will cease and that other private companies are likely to begin playing a greater role in the market.

- ii. Generation stations will be clustered into competing units, with the view to establishing the necessary conditions and capacity for competitive markets, before introducing other players in the generation sector. Currently, ESKOM has grouped the generators and has run them competitively. This horizontal unbundling of generation will create a number of generating companies, which will initially be under the control of the Generation Business Unit. The private sector will be introduced after privatising some of the generating companies under ESKOM holdings. By privatising a part of the generation division, the government will fulfil its objective of widening economic ownership through the sale of shares to the public or to employees and management. Privatisation of generation assets will also encourage competition and attract private sector companies to invest in new electricity generation plants.
- iii. When competition is introduced in generation and new entrants are allowed, transmission would be restructured to create a “wires and systems operator” business as well as an independent market operator, that will ensure that electricity trading between generators, traders and power purchasers is conducted in a competitive and transparent manner. According to an ESKOM Annual Report (2001: 26), an ESKOM internal pool was arranged in 2001 to test this wholesale electricity pricing system. Thus, it is clear that ESKOM is positioning itself for the new market structure. Transmission will thus either remain in the hands of the state or operate as an independent company.
- iv. The electricity distribution industry in South Africa is highly fragmented at present. As part of the reforms taking place now, the government intends to establish a maximum number of six financially viable independent Regional Electricity Distributors (REDS). These REDS will initially be owned by the government and controlled by a board of directors (White Paper on Energy Policy, 1998: 32). According to an NER Annual Report (2000/2001: 12) the government prefers to have the REDS operated under a national holdings company model for the time being. The government recognises, however, that the REDS can be more efficient if they operate as independent companies. In this regard, the government’s control over the REDS will only be a transitional arrangement as the Energy White Paper puts it. When the transfer of distribution assets has been finalised, the REDS would become independent. At this stage the REDS would also be able to choose from which generators they wish to purchase electricity.

From the above, it is clear that ESKOM will be unbundled both vertically and horizontally with regard to the generation and distribution sectors of the industry. The utility as a whole will be operating as any other company, which is registered under the Companies Act of 1973.

According to the government energy policy, the most likely ESI market structure for South Africa is indicated in Figure 6.2.

**Figure 6.2: Expected ESI Structure in South Africa**

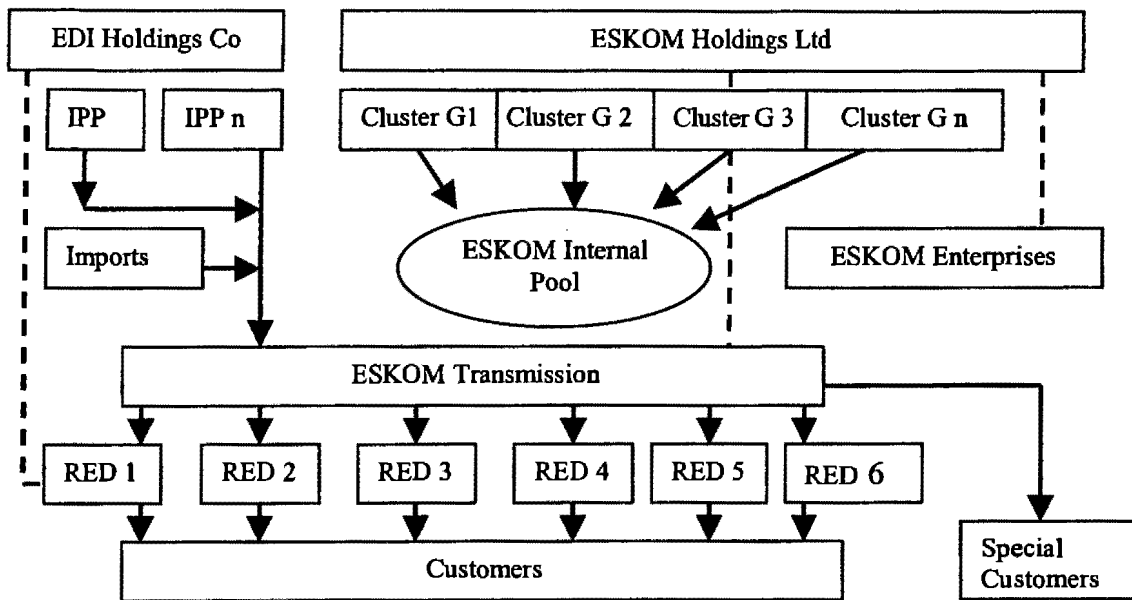

Source: Competition and Regulation in the Electricity Industry in South Africa (Eberhard, 2001: 18)

#### 6.4.9 Regulatory Framework

The Electricity Supply Commission (ESKOM) was established by the Electricity Act of 1922 with the objective of meeting South Africa’s electricity demand. The utility began to generate electricity in 1925. In order to broaden its capacity as a national supplier, ESKOM took over the control of the Victoria Falls Transvaal Power Company Limited; the company that was mining coal and operating power stations in 1948. ESKOM became a corporate organisation in 1985 after undergoing restructuring (ESKOM Annual Report, 1990: 3).

The principal Acts governing the industry are the Electricity Act of 1987 and its amendments, and the ESKOM Conversion Act of 2001, which completed the corporatisation of ESKOM as a tax and dividend paying company.

#### *The Regulation of the ESI in South Africa*

South Africa was the first country in the SADC region to establish an independent and autonomous regulatory body, the National Electricity Regulator (NER), responsible for regulating the Electricity Supply Industry (ESI). In the new reformed electricity market, the government intends to consolidate the powers and functions of the NER through a clear legislative mandate and by strengthening its capacity to

achieve its mandate (White Paper on Energy Policy, 1998: 45). The main functions of the NER as indicated in its 2000/2001 Annual Report are:

- i. to collect information and statistics and to publish reports, all of which will form a national database for the ESI. This information will assist in decision making;
- ii. to co-ordinate with players in the ESI and the South African Bureau of Standards (SABS) to ensure the effective development and enforcement of standards;
- iii. to ensure and supervise the development of long-term capacity plans for the ESI by means of integrated resource planning (IRP) techniques;
- iv. to set, review and adjust electricity prices for all suppliers and distributors;
- v. to assist in settling disputes between any parties with grievances in the ESI;
- vi. to issue licences for the generation, transmission, distribution and supply of electricity within South Africa, and for electricity imports and exports outside South Africa; and
- vii. to advise the Department of Minerals and Energy (DME) on matters relating to the developments taking place in the ESI.

## Chapter Seven

---

### Zambia

#### 7.1 The Location and Demography

Zambia, the former British protectorate of Northern Rhodesia, is a landlocked country in southern Africa. It adopted the name Zambia when it became independent in 1964. The country covers a total land area of 752,614 square kilometres, of which 740,724 square kilometres is land and 11,890 square kilometres is covered by water (CIA World Factbook, 2001). Zambia shares its borders with Angola, the Democratic Republic of Congo, Malawi, Mozambique, Namibia, Tanzania and Zimbabwe. The country sits on a plateau with combined vegetation of woodland and savannah and has many rivers, lakes, hills, swamps and plains. The most spectacular geographical feature, found on the southern border with Zimbabwe, are the Victoria Falls which is one of the natural wonders of the world (The Official SADC Trade, Industry and Investment Review, 2001).

Zambia has a tropical climate with three main seasons: The hot, dry season from September to October, the warm, wet season from November to April, and the cold, dry season from May to August (ibid.).

In 2000, the population of the country was estimated at 10.1 million and about 55 % of the people lived in rural areas. The population growth rate was at 2.4 % with a total life expectancy at birth of 38 years (World Bank, 2002).

#### 7.2 Economy

The economy of Zambia is highly dependent on the mining and manufacturing sectors. The main minerals are copper, cobalt and zinc and contribute about 75 % of the country's export earnings (International Finance Center, 2001). The other natural resources that contribute to economic growth include lead, coal, emeralds, gold, silver, uranium and hydropower.

The climatic conditions of Zambia also make it an agricultural country. The main crops are maize, sugar cane, sunflower and beans. In addition to these the country also grows bananas, barley, coffee, potatoes, rice, soya beans, tobacco and cotton. Farming, though not practised on a commercial basis in many areas, contributes about 27.3 % of the total GDP which was at US\$2.9 billion in 2000.

The government continues to implement economic policies that are intended to stimulate the improvement of the economy. The policies include an attractive package of incentives for both local and foreign investors. These incentives include a reduction on exercise duty on electricity from 10 % to 7 %,

profit repatriation of 100 %, unrestricted controls on foreign exchange and protection against compulsory acquisition of property (The Official SADC Trade, Industry and Investment Review, 2001). In respect of the power sector, the government further launched a special framework and package of incentives in order to encourage private sector participation in hydropower generation and transmission development. An office for promoting private investment was also established to evaluate the proposals, negotiations and award of contracts and implement power purchase agreements (Hibajene, 2002: 2).

The government further believes that the economic structure of the country can be changed for the better by encouraging the private sector to be the engine for economic growth. In line with this the government embarked on the privatisation of parastatal organisations. One of the state enterprises listed by the Zambia Privatisation Agency (ZPA) is the Zambia Electricity Supply Corporation (ZESCO). ZESCO has already been restructured and is now waiting to be privatised.

### **7.3 The Energy Sector**

The current national energy policy for Zambia was published in 1994. Its main objective is to promote optimum supply and utilisation of energy resources in order to accelerate the socio-economic development of the country (Zambia National Energy Policy, 1994: 19).

The primary energy sources available in Zambia include woodfuel, hydropower and coal. Further, all petroleum products are imported into the country. New and renewable energy sources are also important elements in the energy sector.

#### **7.3.1 Wood fuel**

Wood fuel, in the form of firewood and charcoal, is the dominant energy source in Zambia. The majority of the population relies on this energy source. Charcoal, made from burning wood, is usually a source of income for some rural households, and is mostly used in urban households for cooking purposes. In rural areas, firewood is collected from dead trees, but in other areas live trees are cut down for firewood. The cutting down of trees in such areas is, however, done in an unsustainable manner and, to curb the situation, the government is taking certain measures to ensure effective management of this resource. (SADC-REPN Task Force, March 2001: 5). Wood fuel is also used in other sectors of the economy, such as agriculture, commerce, industry and mining.

### **7.3.2 Hydropower**

Zambia has substantial hydropower resources from the rivers, which run across the country. The total potential stands at 8,435 MW and out of this 1,670 MW have already been developed at Kafue Gorge, Kariba North, Victoria Falls, Mulungushi and Lunsemfwa. The development of the remaining potential will increase electricity exports to other countries within the Southern Africa Power Pool (SAPP) and will also play a greater role in the national economic growth. In view of power sector restructuring that was initiated in 1998, private investors are likely to be interested in developing this clean energy source, especially for exports to countries which do not have adequate capacities like Zimbabwe, Malawi and Tanzania.

### **7.3.3 Coal**

Zambia has estimated coal reserves of about 30 million tonnes. These reserves are found in the Zambezi Valley at Luano, Lukusashi and Luangwa (Mbewe in Ranganathan, 1992: 21). The mining of coal already takes place in the country. The major coal users at present are the copper mines and cement companies. The potential for thermal generation of electricity using coal has not yet been considered as one of the options of generating electricity to meet future domestic and export demands.

### **7.3.4 Petroleum**

Zambia does not have proven oil reserves, thus it imports crude oil from other countries through the port of Dar-es-salaam in Tanzania. The crude oil is transported by pipeline from the port to the refinery in Ndola (Mbewe in Ranganathan, 1992: 21). The petroleum products are mostly used in the transport sector. In the power sector, either gas turbines or diesel generators are used for electricity generation. Electricity generation from these plants is at present only done in small quantities in isolated areas.

### **7.3.5 New and Renewable Sources of Energy**

The use of solar energy technologies in the form of solar heaters and solar photovoltaics (PVs) is growing in off-grid areas and helps to increase access to modern energy.

## **7.4 The Power Sector**

### **7.4.1 Background**

The Electricity Supply Industry (ESI) in Zambia is dominated by the Zambia Electricity Supply Corporation (ZESCO), which was formed by an Act of Parliament in 1971. The company was formed after amalgamating the three main utilities that were supplying electricity in the country: the Central Electricity Supply, the Northern Electricity Supply and the Victoria Falls Power Board. The only power company that was not taken over by ZESCO was the Power Division of the Zambia Consolidated Copper Mines (ZCCM), now privatised with its power stations being run by two companies. The ZESCO Act of

1971 gave ZESCO monopoly powers in the generation, transmission, distribution and supply of electricity. Although the Act has been repealed and the electricity market liberalised, ZESCO still dominates the ESI in Zambia.

The major power stations of Kariba North Bank (KNB), Victoria Falls and Kafue Gorge are interconnected by a transmission network, which is operated at 330 kV and 220 kV. The national transmission grid is also interconnected with other power utilities' transmission systems, namely those of the DRC, Botswana and Zimbabwe. Power reaches the end-users through a distribution system operating at 132 kV and lower voltages. The distribution system is currently divided into the following four regions: ZESCO North, Lusaka, ZESCO South and the Copperbelt region. The transmission network coverage is low and the distribution system is concentrated in urban areas only. Although the country has an excess generating capacity, only 18 % of the population actually have access to electricity. The government, therefore, faces the challenge of increasing access, but in order to do so, it first needs to address the financial problems experienced by ZESCO.

#### **7.4.2 Existing Institutional Arrangements**

The Department of Energy under the Ministry of Energy and Water Development takes the responsibility for policy formulation in the power sector, energy planning and research. After writing the new energy policy document for Zambia in 1994, the operations of the energy sector were streamlined and the body to regulate the energy sub-sectors and advise the ministry on all issues relating to energy developments in the sector, the Energy Regulation Board, was created.

ZESCO is a state-owned, vertically integrated utility and is the major player in the Zambian Electricity Supply Industry (ESI). It operates the two hydropower stations of Kafue Gorge and Victoria Falls. It also operates mini hydropower stations and a number of diesel generators in isolated systems as shown in Table 7.1. The Kariba North power station was separated from ZESCO and it operates independently as a result of an order that was issued by the Government in 1999 (Hibajene, 2002: 4). The other players involved in the ESI are the Copperbelt Energy Corporation (CEC) and Lusefwa Hydro Power Company (LHPC).

ZESCO is a member of the Southern Africa Power Pool (SAPP). Its power system is interconnected with that of Zimbabwe at 330 kV at Kariba and is also connected to the CEC's 220 kV transmission network which is interconnected with SNEL's system belonging to the DRC.

The CEC is a privately owned power company that was formed after a part of the ZCCM power division was privatised. The company owns and operates the 80 MW gas turbines and is responsible for supplying

power to the copper mine areas. It also owns part of the transmission system and the entire distribution system in the copperbelt area.

The two hydropower stations, including its associated transmission and distribution network in Kabwe, which formed the remaining part of ZCCM power division, were also privatised. An IPP, Lusefwa Hydro Power Company, composed of a local management buy-out and ESKOM, operates the power station. The transmission and distribution network may be sold to ZESCO (Ibid.).

The Zambezi River Authority (ZRA), which reports to both the Zambian and Zimbabwean governments, is responsible for maintaining the Kariba Dam's and any further hydroelectric development projects at the site.

The current structure of the ESI in Zambia is illustrated in Figure 7.1 below:

**Figure 7.1: Existing Utilities in the Zambian Electricity Industry**

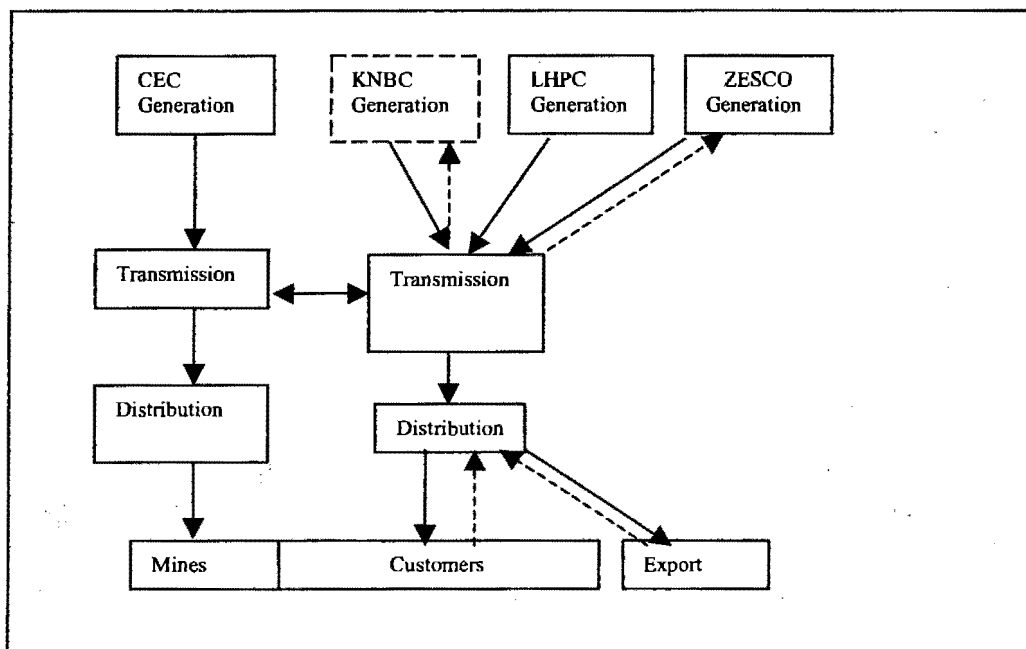

**Source: Improving Electricity Distribution Through Restructuring: Case of Zambia (Hibajene, 2002: 5)**

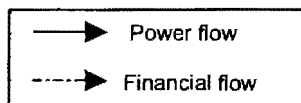

## 7.4.3 Electricity Supply

### 7.4.3.1 Generation

Hydropower plants dominate existing electricity generation. The thermal stations are mostly used in isolated places where there is no national grid, and where there are grid connections, they are used only for standby purposes.

ZESCO's main hydro plants are at Kafue Gorge (900 MW) and Victoria Falls (108 MW). In addition to the two main stations, ZESCO has four smaller hydro stations with a total installed capacity of 23.75 MW in its northern system. The Kariba North Bank has an installed capacity of 600 MW. The small diesel stations are scattered over different parts of the country and serve isolated systems. Half of these stations are, however, currently not available, as illustrated in Table 7.1a below.

**Table 7.1a: ZESCO's Installed Generating Capacity**

Station	Year	Machine Type	Installed capacity (kW)	Available capacity
Kafue Gorge	1972	Hydro	4*150= 600,000	600,000
	1976		2*150= 300,000	300,000
Kariba North	1976	Hydro	4*150= 600,000	600,000
Victoria Falls	1936	Hydro	8,000	8,000
	1968		60,000	60,000
	1972		40,000	40,000
Sub - Total			1,608,000	1,608,000
Lusiwasi		Hydro	12,000	12,000
Musonda Falls		Hydro	5,000	5,000
Chishimba Falls		Hydro	6,000	6,000
Lunzua River		Hydro	750	750
Sub-Total			23,750	23,750

#### Isolated System

Musonda		Diesel	427	Not - in - use
Mbala		Diesel	250	Not - in - use
Chipata		Diesel	1,258	Not - in - use
Mwinilunga		Diesel	750	750
Kasempa		Diesel	795	795
Kabompo		Diesel	750	750
Zambezi		Diesel	750	750
Mpika		Diesel	725	Not - in - use
Kaoma		Diesel	789	789
Luangwa		Diesel	348	348
Lukulu		Diesel	680	680
Lundazi		Diesel	680	680

Chinsali		Diesel	775	Not - in - use
Isoka		Diesel	420	Not - in - use
Nakonde		Diesel	350	Not - in - use
SUB - TOTAL		Diesel	9,747	5,542
GRAND TOTAL			1,641,497	1,637,292

Source: ZESCO Annual Report, 1998/99: 34

The other utilities have a total installed capacity of 118 MW. The CEC has a total installed capacity of 80 MW standby generators using gas turbines while the Lusenfwa Hydro Power Company (LHPC) has an installed capacity of 38 MW, as indicated in Table 7.1b below.

**Table 7.1b: Private Installed Generating Capacity in Zambia**

Station	Year	Machine Type	Installed capacity (kW)	Available capacity (kW)	Owner
Mulungushi	1944	Hydro	20,000	20,000	IPP (LHPC)
Lusenfwa	1944	Hydro	18,000	18,000	IPP (LHPC)
Bancroft		Gas Turbine	20,000	20,000	CEC
Luano		Gas Turbine	40,000	40,000	CEC
Luanshya		Gas Turbine	10,000	10,000	CEC
Mufulira		Gas Turbine	10,000	10,000	CEC
Nkana		Waste heat plant	20,000	20,000	Mines
TOTAL			138,000	138,000	

Source: ZESCO Annual Report 1998/99: 34, Department of Energy

The total units generated by both the interconnected and the isolated systems vary from year to year, without indicating a steady increase in units generated. The units generated in 1990/91 are actually higher than the units generated in 1998/99. Refer to Table 7.2 for a summary of generation statistics in Zambia.

**Table 7.2: Units Generated on ZESCO's Interconnected System and Isolated System Sent out (GWh)**

Year	Interconnected System			Isolated System (Sent out)	
	Kariba North	Kafue Gorge	Victoria Falls	Hydro	Diesel
1999	2,176	4,760	668	39	14
1998	1,642	5,481	693	35	17
1997	1,669	4,716	650	39	15
1996	2,405	4,721	643	41	14
1995	2,004	5,386	647	65	13
1994	2,335	5,052	614	69	12
1993	2,545	3,216	651	93	13
1992	3,348	4,955	496	107	11
1991	2,872	4,127	669	125	10
1990	4,694	841	644	113	10

Source: ZESCO Annual Report 1998/99: 36 & 38

The only problem that affects power generation is the shortage of water during the dry months of the year. This problem, if severe, at times forces ZESCO to ration power (Panafrican News Agency, October 11, 2000).

### ***Future Hydropower Potential***

Zambia has untapped power that can be developed to meet any increase in demand from the following sites:

**Table 7.3: Zambia's Future Hydropower Potential**

Basin	Description	Possible Capacity (MW)	Possible Output (GWh)	Comments
Kafue River	Kafue Gorge (lower)	450	2500	
	Itezhi-Tezhi	80	510	
Zambezi River	Kariba North	300	700	
	Mpata Gorge	1200	6100	Shared with Zimbabwe
	Devil's Gorge	1600	8500	Shared with Zimbabwe
	Batoka Gorge	1600	9200	Shared with Zimbabwe
	Victoria Falls extension	140	90	
	Chavuma Falls	10 - 20		
Luapula River	Mumbotula Gorge and Mambilima Falls	1188	6700	
	Lumangwe Falls	60	220	
	Kabwelume Falls	54	180	
Luangwa River	Lusiwasi Extension	40	150	
Luakela River	Sachibonda	0.2		
Kabompo River	Chakata Falls	0.3		
	Kabompo Gorge	30		
	Kabempe	2 - 3		
West Lunga River	Mwinilunga	0.4		

Source: ZESCO (1993) & (1985) cited by National Energy Policy, 1994: 5

### ***Electricity Imports and Exports***

Zambia's installed and generating capacity is greater than its demand and, as a result, it exports some of its power to Zimbabwe, Botswana, Tanzania, Namibia, South Africa and the DRC (Panafrican News Agency, October 11, 2000). The exports are achieved through the high voltage interconnections with the two border countries of the DRC and Zimbabwe. The exports to northern Botswana, Namibia and Tanzania occur at lower voltage levels. Currently a power transmission line to interconnect Zambia with Tanzania is being constructed by a private investor. This line will help Tanzania to meet its excess demand through power imports from either Zambia or other SAPP member countries.

Zambia imports very minimal amounts of power. The country imports power for Lundazi, the border district adjacent to Malawi. The link between Zambia and Malawi is at a lower voltage level of 33 kV and the line was commissioned in January 2001.

Power export statistics in the 1990's from Zambia to the above-mentioned SADC countries are shown in Table 7.4 below.

**Table 7.4: Zambia - Power Exports to SADC Countries, (MWh) 1990 - 2000**

Year	Zimbabwe (HV)	Botswana (LV)	DRC (HV)	Tanzania (LV)	Namibia (LV)	South Africa (HV)	Zimbabwe (LV)	Total
1990/91	985,501.00	--	301,650.00	--	--	--	--	1,260,151
1991/92	2,107,851.00	45,344.50	289,512.00	--	--	--	--	2,442,707.5
1992/93	95,437.00	3,725.96	11,265.00	2,021.95	8,036.68	--	1,673.87	122,160.46
1993/94	855,414.00	5,541.26	637.00	3,163.30	8,277.07	--	2,218.10	875,250.73
1994/95	1,066,524.00	74,162.00	913.00	2,936.00	9,632.00	--		1,154,167
1995/96	1,397,371.00	6,563.38	85.00	2,722.37	10,869.33	--	2,978.86	1,420,589.94
1996/97	816,428.00	N/a	25,870.00			--		25,870
1997/98	694,650.00	9,065.26	113,152.00	4,145.96	16,704.00	--	3,350.50	841,067.72
1998/99	257,091.00	9,065.26	136,002.00	4,145.96	16,704.00	272,666.24	3,350.50	699,024.96
TOTAL	7,386,267	153,467.62	879,086	19,135.54	70,223.08	272,666.24	13,571.83	

Source: ZESCO Annual Report 1992/93, 93/94, 94/95, 95/96, 97/98, 98/99

#### 7.4.3.2 Transmission and Distribution System

The power transmission system is owned and operated by two utilities, ZESCO and CEC. ZESCO owns most of the system because the CEC network is basically in the Copperbelt area. The high voltage transmission system, which uses two voltage levels of 330kV and 220 kV, is operated by ZESCO. The two main power stations, Kafue Gorge and Kariba North Bank, are interconnected by a 330 kV line. The 220 kV line that originates from the Victoria Falls power station feeds into these 330 kV systems. Major substations were constructed along the main transmission lines to step down the voltage so that it can be distributed by the distribution system.

Zambia's transmission system is interconnected with the ZESA system at 330 kV and the DRC's SNEL system by means of a CEC 220 kV transmission line. ZESCO also intends to interconnect with Tanzania Electricity Supply Corporation (TANESCO) of Tanzania and Malawi at transmission voltages of 330 kV and 132 kV respectively in the near future.

The distribution system consists of 132 kV, 88 kV, 66 kV, 33 kV, 11 kV and lower voltages. The 132 kV, 88kV and 66 kV voltages are regarded as sub-transmission voltages and 33 kV and 11 kV are taken

as actual distribution voltages. The distribution lines originate from the transforming stations and carry power to load centres. ZESCO's distribution system is divided into four zones, namely, North, Lusaka, South and Copperbelt zones. These zones are concentrated along the railway line from the Southern province town of Livingstone to Copperbelt province (Hibajene, 2001: 6). Part of the distribution system is very old and overloaded, especially in the main cities of Lusaka, Ndola and Livingstone and as a result, the system is unreliable and power failures are frequent. To improve the system's reliability, ZESCO is considering rehabilitating the distribution system (ZESCO Annual Report, 1998/99: 9).

#### 7.4.3.3 Power System Losses

Zambia's transmission system operates at high standards. The technical losses on the high voltage transmission system ranged from 2.1 % to 3.8 % during the past nine years. By comparison, the distribution losses, within the same period, ranged from 13.2 % to 21.6 %. This includes both technical and non-technical losses. In many cases the non-technical losses are high. The combined total power system losses are less than 10 %, ranging from 6.7 % to 8.9 %. Refer to Table 7.5, below, for the detailed statistics in respect of the losses incurred by the ZESCO system.

**Table 7.5: ZESCO's Transmission, Distribution and System Losses**

Year	Net Generation (MWh)	Bulk Delivery (MWh)	High Voltage Losses %	Supplies to ZESCO (MWh)	Retailed to ZESCO (MWh)	ZESC ODist. Losses %	Total Zambia Consumption (MWh)	Total system Consumption (MWh)	Zambia systems Losses %
1990/91	7,791,707	7,533,192	3.3	2,296,529	1,969,925	14.2	6,221,087	7,206,588	7.5
1991/92	8,939,558	8,601,338	3.8	2,383,624	2,069,915	13.2	6,164,778	8,272,629	7.5
1992/93	7,904,799	7,652,986	3.2	2,491,269	2,154,519	13.5	6,393,580	7,316,236	7.4
1993/94	9,203,721	8,859,806	3.7	2,634,605	2,108,398	20.0	6,420,925	8,333,599	9.5
1994/95	9,006,840	8,727,004	3.1	2,707,495	2,122,060	21.6	6,264,872	8,177,546	9.2
1995/96	9,338,879	9,119,732	2.3	2,647,198	2,238,385	15.4	6,361,850	8,710,919	6.7
1996/97	8,438,053	8,201,439	2.8	2,833,252	2,401,655	15.2	6,550,229	7,862,772	6.8
1997/98	8,332,368	8,153,538	2.1	2,920,100	2,383,792	18.4	6,430,481	7,733,650	7.2
1998/99	7,925,572	7,714,283	2.7	3,065,019	2,603,435	15.1	6,482,019	7,024,099	8.9

Source: ZESCO Annual Report, 1998/99: 51

#### 7.4.4 Demand

ZESCO generally meets all the electricity requirements of the country. During drought periods and times of low generation, however, the country experiences power shortages. Power shedding becomes the order of the day almost every year when the rains have stopped. The breakdown of electricity consumption by sector is shown in a more detailed form in Table 7.6 below.

**Table 7.6: ZESCO's Electricity Sales by Consumer Category, (MWh) 1990–1999**

Sector	1990	1991	1992	1993	1994	1995	1996	1997	1998	1999
Agriculture and Forestry	179164	175687	250734	184752	201179	205550	177553	199,964	116,783	-
Mining quarries	50073	39577	40675	40012	46202	40572	69248	60,849	50,736	-
Mining (ZCCM)	4289371	2245671	4094863	4239061	4312527	4142812	4123465	4,148,574	4,046,689	-
Manufacturing	347294	381040	354896	370542	304123	266302	205276	207,700	274,667	-
Transport	8962	9907	9635	14126	14319	9470	9976	9,573	7,436	-
Services	324946	342937	309232	334129	366174	365463	364894	404,758	389,718	-
Commerce	278387	250871	247776	292366	272763	272951	293354	257,300	298,113	-
Construction	11270	9687	8674	9743	7611	7418	3508	3,275	4,099	-
Domestic	573421	626545	711945	721966	801849	844447	1002816	1,161,397	1,154,289	-
Other	86286	139165	181348	186883	149541	94984	111761	96,838	87,951	-
<b>Total</b>	<b>6149174</b>	<b>6221087</b>	<b>6209778</b>	<b>6393580</b>	<b>6476288</b>	<b>6249969</b>	<b>6361851</b>	<b>65502228</b>	<b>6131763</b>	<b>7042281</b>
Exports	148263	1260151	2442708	122160	875251	1154167	1420590	25870	841067	699025
<b>Grand Total</b>	<b>6297437</b>	<b>7481238</b>	<b>8652486</b>	<b>6515740</b>	<b>7351539</b>	<b>7404136</b>	<b>7782441</b>	<b>6576098</b>	<b>6972830</b>	<b>7741306</b>

**Source: ZESCO Annual Reports 1992/93: 36 & 97/98: 55**

The above Table demonstrates that there is growth in electricity consumption in all the sectors. The annual growth rate is particularly high in the domestic sector, followed by the commercial and agricultural sectors. Growth in the mining sector was, however, very small from 1990 to 1994. In 1995, consumption was reduced only in the mining sector. This may be due to reduction in the worldwide demand for copper, which is the main mineral produced in the area.

According to ZESCO's planning department, the demand for electricity is expected to increase at an average growth rate of 1.5 % per annum for the period 1995-2000 and 2.2 % for the period between 2000 and 2015 (SAD-ELEC & MEPC, 1996: 225). To meet this increase in demand, it is imperative to strengthen the generation, transmission and distribution systems.

#### **7.4.5 Electrification**

Various electrification projects are carried out by ZESCO. The funding for these projects is obtained partly from an electricity levy of 10 % on all ZESCO bills (Department of Energy, Ministry of Energy and Water Development 2000: 30). Initially the levy was at 3 %, but it increased to 10 % in 1995. The government collects the funds which first go to its central treasury. The energy fund from the electricity levy has assisted in increasing household access to grid electricity from 11 % in 1995 (SAD-ELEC & MEPC 1996: 224) to as high as 18 % in 2001 (Swedpower News, 2001). It is expected that the privatisation of ZESCO's distribution system will further increase the electrification level from the

present 18 % in the country, as it seems to be rather low when compared to the size of the utility and its actual capacity.

### ***Urban Electrification***

Electrification in urban areas is in most cases considered financially viable. These projects are carried out by ZESCO and although the funding for the project initially comes from ZESCO's internal sources, it is later refunded through customers' capital contributions. If the project involves high capital costs such as the building of a major substation and the construction of long transmission/distribution lines, funding is usually obtained from donors or loans. Customers do, however, still make capital contributions for the supplies in the local areas. Electrification levels in urban areas are higher than in rural areas.

### ***Rural Electrification***

Development of the rural areas can be encouraged by improving or expanding the existing social services and facilities, improving the tourism industry, promoting agricultural activities and encouraging small-scale industries. This can be achieved by a reliable supply of energy sources. In most rural areas of Zambia the main energy source is wood fuel. The use of commercial fuels such as diesel, petrol and paraffin is not common, because these fuels are expensive due to high transportation costs. The other alternatives for meeting rural energy needs, which is necessary for development, is by either extending the electricity grid or by building isolated generation systems. Currently most areas in Zambia are electrified by ZESCO. The government or ZESCO may identify the areas still to be electrified. Since there are many centres requiring electricity, the sites are prioritised depending on the importance of their needs. Funding for these projects comes from the central government or from donor agencies, and ZESCO implements the projects as a contractor (Mbewe in Ranganathan, 1992: 27). The areas selected for rural electrification can either be supplied by extending the grid or by using of diesel generators. Currently electrification levels in the rural areas are very low.

Zambia is currently reforming its ESI, and as such the government will have to look at alternative ways of improving electricity access in rural areas. ZESCO will not be able to continue with this program, as it is not financially viable. To ensure that electricity services are extended to reach as many people as possible, the government will probably maintain the 10 % rural electrification levy on electricity bills.

#### **7.4.6 Tariff Structure**

ZESCO's tariff is basically divided into four categories: domestic, commercial, industrial and social services. Tariff adjustments are proposed by the utilities and approved by the Energy Regulation Board before implementation. The tariffs that were implemented by ZESCO from 1998 to April 2000 are indicated in Table 7.7 below.

**Table 7.7: ZESCO's Electricity Tariffs**

Consumer Category	Tariff	Description	Unit	Effective Date			
				01- Jan 1998	01- Oct 1998	01- April 1999	01-April 2000
Residential	L1	Consumption of up to 2.5 amps (for lighting only)	K/kWh	4,200	4,200	4,200	4,200
	L2	Consumption of above 2.5 amps	K/kWh	15,200	15,200	15,200	15,200
	R1	Consumption of up to 50 kWh	K/kWh	23	58	58	75
	R2	Consumption of between 50 and 700 kWh	K/kWh	46	58	58	75
	R3	Consumption of above 700 kWh	K/kWh	65	82	82	120
	R	Fixed charge	K/month		5,000	5,000	5,000
Commercial	C1	Consumption of up to 1000 kWh	K/kWh	61	80	90	112
	C2	Consumption of above 1000 kWh	K/kWh	82	80	90	112
	C	Fixed charge	K/month		20,000	20,000	20,000
Maximum Demand	MD1	Capacity up to 300 kVA	K/kVA/month	6,122	4,000	4,420	5,015
		Energy Charge	K/kWh	49	55	61	73
		Fixed charge	K/month	0	50,000	50,000	50,000
	MD2	Capacity between 300 and 2000 kVA	K/kVA/month	7,483	7,483	8,269	9,551
		Energy Charge	K/kWh	43	48	53	63
		Fixed charge	K/month	0	100,000	100	000
	MD3	Capacity between 2000 and 7500 kVA	K/kVA/month	11,283	11,283	12,468	14,402
		Energy Charge	K/kWh	30	35	39	46
		Fixed charge	K/month	0	20,000	20,000	20,000
	MD4	Capacity above 7500 kVA	K/kVA/month	11,661	11,661	12,885	14,882
		Energy Charge	K/kWh	23	30	33	39
		Fixed charge	K/month	0	40,000	40,000	40,000
Social Services	W1	Water and Sewage	K/kWh	59	71	80	100
	H1	Hospitals, Schools	K/kWh	59	71	80	100
	SL1	Street lighting	K/kWh	43	71	80	100
	S	Fixed charge	K/month	0	200,000	200,000	200,000

Source: Zambia Energy Statistics Bulletin, 2000: 31

#### 7.4.7 Financial Performance of ZESCO

The development of the ESI requires huge capital investments. The initial development projects of power generation, transmission and distribution in Zambia depended on multilateral lending from institutions, which require loan repayments in foreign currency, mostly US dollars. Large amounts of money are also needed for the operation, maintenance and expansion of the system. This money is supposed to be generated by the utility itself.

The accounting reports of ZESCO indicate that the utility has been operating at a loss in most years as indicated in Table 7.8 below.

**Table 7.8: Some Financial Performance Indicators of ZESCO**

Year	Annual revenue (K000, 000's)	Net profit before tax (K 000,000's)	Avg price electr sold ZK/kWh)	Number of Customers	Total Employees	Customers per Employee	GWh Sold per Employee	Exchange Rate end of Year
1989/90	923	-(415)	--	120,505	5,259	23	1.20	--
1990/91	1,929	-(1,268)	--	122,890	5,067	24	1.48	--
1991/92	5,526	-(561)	--	126,949	5,189	24	1.67	156.25
1992/93	18,382	-(13,588)	--	126,933	5,197	24	1.25	434.78
1993/94	65,107	1483	8.40	133,572	5,121	26	1.44	769.23
1994/95	82,147	-(5,563)	13.35	143,169	4,788	30	1.55	833.33
1995/96	123,359	9,250	18.86	151,701	4,377	35	1.78	1,207.90
1996/97	159,653	-(56,203)	--	165,860	4,246	39	1.55	1,314.50
1997/98	226,534	-(78,483)	--	171,194	4,133	41	1.69	1,862.07
1998/99	324,142	92,264	41.87	188,434	4,025	47	1.92	2,388.02

Source: ZESCO Annual Reports 1989/90 to 1998/99 & CIA

To remedy the situation, some key recommendations were implemented in 1995 (SAD-ELEC & MEPC, 1996: 223), including the following:

- i. Introduction of a financial and operational reporting system to track down ZESCO's performance;
- ii. Control of stock, purchasing and credit management;
- iii. Installation of a new customer billing and debtor management system; and
- iv. Enhancement of the cost accounting functions.

The above measures resulted in ZESCO making a big profit in 1996. Nevertheless, the utility still experiences difficulties in raising enough revenue, mainly for the following two reasons: Firstly, the depreciation of the local currency against major foreign currencies and secondly, inadequate metering infrastructure and electricity theft. Most of the residential consumers in the unmetered category are supposed to have current limiters. This, however, does not happen in practice. The other challenge faced by ZESCO is to reduce the illegal connections of electricity, which is a common occurrence (Hibajene, 2002: 9). As a result of these two problems, the utility cannot account for the power supplied and hence its financial performance is affected.

### **7.4.8 Power Sector Reforms**

Energy reforms in Zambia started many years ago in 1994 after the government formulated a new energy policy. The government continues to implement its energy policy objectives as outlined in its policy document. One of the government's goals is to restructure the electricity industry so that service delivery can be improved (Zambia National Energy Policy, 1994: 24). The government hoped to achieve this through liberalising the electricity market by permitting other companies to participate in the ESI. With ZESCO being the dominant utility in the ESI and considering the financial difficulties it faces, the government felt that its operations should be commercialised in the short term and that the distribution function should be privatised.

In 1999 the ERB requested the government to consider the restructuring of the electricity market in Zambia in order to fulfil the government's goals as outlined in its policy paper. The government gave the ERB the go-ahead to propose a methodology for realising the new electricity market. The proposal has since been developed by means of a consultative process with stakeholders, and the ERB is presently in the process of submitting the proposal to the government (Hibajene, 2002: 10 & 12). One of the stakeholders who came up with a proposal for unbundling ZESCO and preparing it for concessions and privatisation, was the Zambia Privatisation Agency (ZPA). The ZPA obtained funding of US\$ 0.800 million from USAID through the government (USAID African Trade and Investment Program, 2000).

#### **7.4.8.1 The Major Driving Forces of the ESI Reforms**

Most developed and developing countries are restructuring and reforming their Electricity Supply Industries (ESIs) for different reasons. In Zambia, it is clear from the government energy policy that the major driving forces behind the reforms are:

- i. To improve reliability and security of supply;
- ii. To improve access to electricity by the majority of the Zambian population by extending the national electricity network.

#### **7.4.8.2 Main Characteristics of the Reforms**

The reform of ZESCO started in the mid-1990's with the assistance from the World Bank reform programme. The organisation was restructured and the three core business entities of generation, transmission and distribution were created. In order to accelerate the reform process, each Business Unit of ZESCO opened its own banking account.

The current efforts by the ERB to restructure the ESI recommends that the model indicated in Figure 7.2, below, should be implemented. This model was developed, based on the standard model from the literature but modified to suit the Zambian situation. Once the government has granted its approval for the

proposed new ESI structure, which is to be submitted by the ERB, the restructuring of ZESCO and other utilities currently involved in the ESI is expected to proceed, as per the proposed model, as follows:

- i. ZESCO will be unbundled vertically into separate units for generation, transmission and distribution/supply. This process may not be difficult in practice, since the three units are already operating their own accounts. The Generation Business Unit is to be further unbundled into separate generation companies. The existing power stations will either continue operating as individual companies, or will be combined to form companies. The IPPs will be encouraged to establish new generation companies (Hibajene, 2002: 18).
- ii. The existing ZESCO transmission assets would form a single transmission company. The model does, however, allow other players to build their own transmission system. Thus CEC transmission can continue to develop their network to other areas. Since several players will be involved in transmission and wholesale market, Zambia proposes to establish the office of an Independent System Operator (ISO). The ISO would own the existing assets of ZESCO's National Control Centre and Regional Control Centres to facilitate power exchanges and settlements in the wholesale market.
- iii. The proposal to restructure the ESI has focused mainly on the area of distribution and supply. This is where the designers of the new ESI structure believe that meaningful improvements in extending electricity services can be achieved, so that the majority of Zambian citizens can enjoy the huge investments that was made in generation and its associated transmission and distribution system. It is proposed that when the restructuring of ZESCO commences, the Distribution Business Unit will be unbundled horizontally into four distribution/supply companies (DISCOs). Each DISCO will cover both viable and non-viable areas, in view of accelerating the grid network expansion. The DISCOs will be operating as independent companies either under public ownership, private management or concession (ibid. 21). The recommendations further propose that the distribution and supply licenses that shall be issued to the DISCOs will not provide the utilities with a monopoly over the electricity supply in their designated areas. This is designed to allow private investors to build distribution networks in uncovered areas. The operation of the lines will, however, be the responsibility of the DISCOs, because the ERB will be checking the performance of the DISCOs and not of private distributors.

#### **7.4.8.3 Privatisation**

In line with the government's policy of liberalising state enterprises, the power utility ZESCO was added to Zambia Privatisation Agency list of companies to be privatised (IMF, 1999).

Zambia is likely to have the wholesale competition model shown in Figure 7.2, below, when the ESI is fully reformed and privatised.

**Figure 7.2: Zambia's Expected ESI Structure**

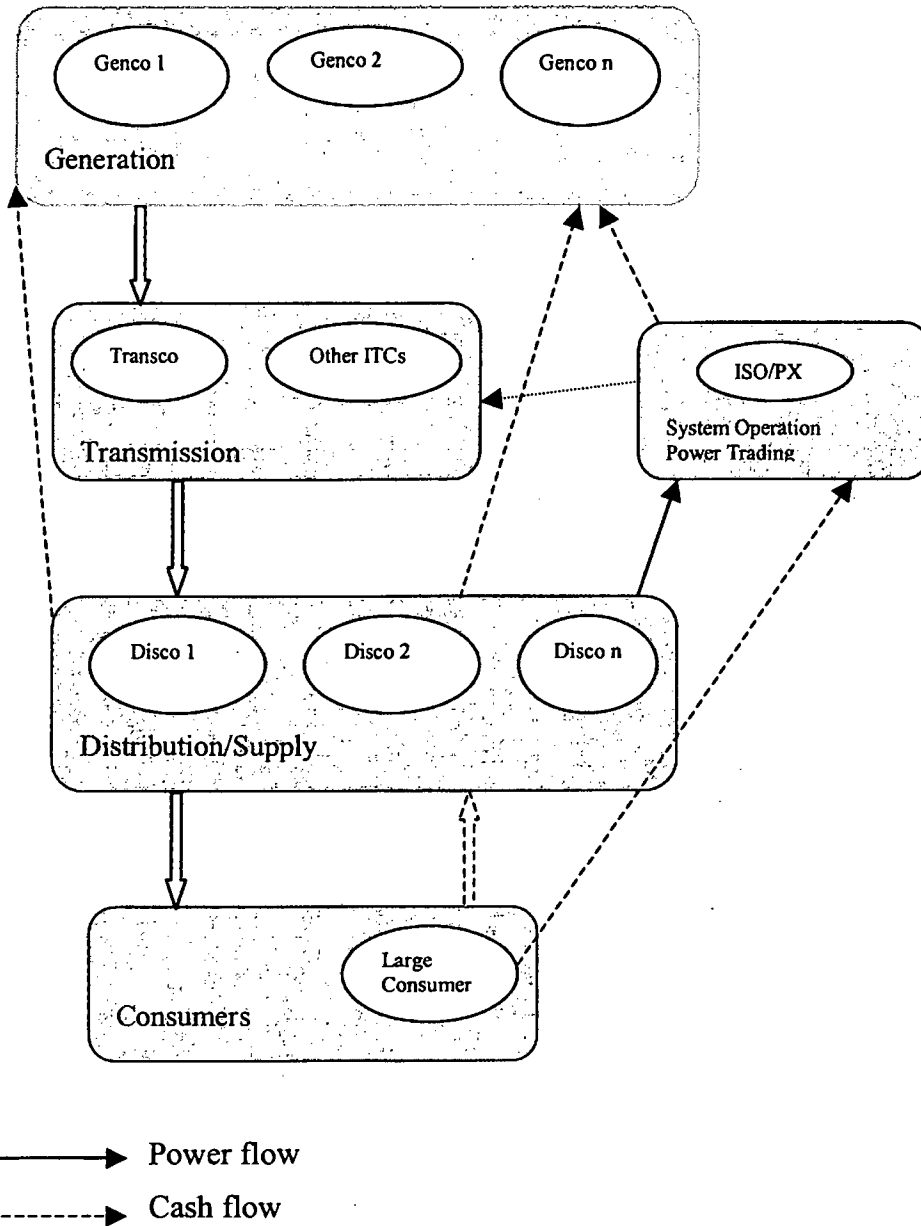

#### 7.4.9 Regulatory Framework

After the elections in 1991, the Ministry of Energy and Water Development was created to deal with all aspects of energy planning, research and policy formulation. The ministry introduced a new energy policy in 1994. In the electricity sector the measures included: restructuring of the industry, improving accessibility to electricity, promoting electrification and developing the hydropower potential (Zambia National Energy Policy, 1994: 23). In line with this policy, the Electricity Act, Chapter 811 of the laws of

Zambia was repealed and a new Electricity Act, No.15 of 1995 was passed by Parliament in order to achieve the stated government objectives. According to SAD-ELEC (SAD-ELEC, 2000: 87) the Energy Regulation Act, No. 16 of 1995, responsible for the establishment of the Energy Regulation Board (ERB), was also passed.

### ***The Regulation of the ESI in Zambia***

Zambia was the second country in the SADC region to establish an independent regulatory body, the ERB, responsible for regulating the activities in the energy sector. Unlike in South Africa, where the electricity regulatory board is industry specific, Zambia has a multi-sectoral energy regulator. The Zambian energy policy (Zambia National Energy Policy, 1994: 41) outlines the functions of the ERB as follows:

- i. To receive opinions from consumers and other interested parties on energy price adjustments and levels;
- ii. To make sure that utilities have adequate grounds to allow them to adjust their energy prices;
- iii. To ensure energy services are provided according to set standards and as such, ERB receives complaints from individuals and institutions not happy with the services provided by any energy company;
- iv. To settle disputes between various stakeholders with grievances in the energy sector in general and to protect the interests of energy users and the public;
- v. To regulate against monopolistic tendencies of the energy companies;
- vi. To advise the ministry on all matters and developments taking place in the energy sector.

# Zimbabwe

## 8.1 Location and Demography

Zimbabwe is a landlocked country situated in Southern Africa and is bordered by South Africa, Mozambique, Zambia and Botswana. It has a total land area of 390,580 square kilometres, of which 386,670 square kilometres is land and 3,910 square kilometres is water (CIA World Factbook, 2001). The country lies within the tropics, and thus has a tropical climate. The rainfall season is in summer, which begins in November and ends in March. Droughts occur frequently. In the year 2000, the country's population was estimated at 12.6 million; the population has a life expectancy of about 40 years and a growth rate of only 1.9 (World Bank, 2002).

## 8.2 Economy

Zimbabwe's economy is predominantly based on both agricultural and mineral products. In the agricultural sector the main cash crops include tobacco, cotton and sugar. The country also grows a lot of maize, which is its main staple food. Some of the agricultural products are exported unprocessed while others are processed within the country (International Finance Centre, 2002). According to the World Bank development indicators for 2002, in 2000, the contribution of agriculture to the country's total GDP (then at US\$7.4 billion) was 18.5 %. The country's industrial sector is better developed compared to other countries within the region. Mining contributes substantially to the economic growth in the industry sector. The main minerals are coal, gold, copper, tin and nickel (Mbendi, 2002).

Zimbabwe adopted a centralised economic policy after independence. It took control of some areas of production and intervened in price controls and subsidies. This worked well initially but of late the approach has been modified as a result of increasing globalisation in order to allow for the participation of private enterprises in the economy. The market-oriented economy, which the governments wanted to develop with support from the International Monetary Fund (IMF), was not progressing well because of the economic problems facing the country. Some of the factors contributing to this include the recent drought that reduced agricultural output and meant delays by the IMF to release the funds because the government had failed to meet its budgetary goals. Inflation in the country is also increasing. It rose from 32 % in 1998 to 59 % in 1999 (CIA World Factbook, 2001). To reduce inflation and restore economic stability in the country, the government designed the Millennium Economic Recovery Programme (MERP) which aims to create an environment conducive to economic growth and development. The programme's target is to boost the role of the business sector and to accelerate the privatisation of state

enterprises. The recent reforms in the ESI have opened the electricity market to the private sector (The Official SADC Trade, Industry and Economic Review, 2001).

The government has created a very good environment for investments, having put in place a number of incentives for both local and foreign private investors. These include favourable taxes, capital transfers, recruitment and engagement of expatriate personnel, and there are no restrictions on local borrowing. Foreign investors are further assured of getting returns from their businesses because the government signed bilateral investment protection agreements with multilateral treaties like the Multilateral Investment Guarantee Agency, the Overseas Private Investment Corporation and the International Centre for the Settlement of Investment Disputes (*ibid.*).

### **8.3 Energy Sector**

The national energy policy of Zimbabwe was published in 2000 and the objectives of the energy policy as outlined in the document (Zimbabwe National Energy Policy, 2000: 4), are:

- i. To ensure accelerated economic development. Proper exploitation and utilisation of the energy resources will contribute to economic growth. This requires making a proper choice of which energy sources to use in meeting the energy demand.
- ii. To facilitate rural development. The provision of commercial energy such as coal and electricity to rural areas will promote economic growth and reduce environmental degradation caused by deforestation.
- iii. To ensure environmentally friendly energy development. In this regard the policy will promote energy efficiency and minimise effects on the environment.
- iv. To promote small-scale enterprises.
- v. To ensure efficient utilisation of energy resources.

The country is not self-sufficient with regard to its energy resources and thus has to import part of its energy needs. The main energy resources in Zimbabwe are coal, hydropower, petroleum products, biomass and solar and wind energy.

#### **8.3.1 Coal**

Zimbabwe has large reserves of coal estimated at 30 billion metric tonnes of bituminous type (Dube in Bhagavan, 1999: 214). The main coal mine is at Hwange. The coal that is produced is mostly used by ZESA for power generation. The other sectors of the economy, which use high quality coal, are the industrial, agricultural and mining sectors, and also households to a small extent (Zimbabwe National

Energy Policy, 2000: 2). The potential for electricity generation from coal also exists at Sengwa, the second largest mine.

### **8.3.2 Hydropower**

Hydropower potential exists in Zimbabwe. An analysis of the studies that were carried out along the Zambezi River indicated that the potential of about 4,200 MW from Batoka Gorge, Devil's Gorge, Mupata Gorge and Kariba South could be developed jointly with Zambia. Out of this potential, only 750 MW have to date been developed at Kariba Dam on the Zambezi River (Dube in Bhagavan, 1999: 214).

The hydropower potential that can be developed from other smaller rivers inside the country amounts to some 3,500 MW.

### **8.3.3 Petroleum Products**

Zimbabwe does not have any proven oil reserves and thus the country relies on imports for all of its petroleum product requirements. The oil is pumped into the country through pipelines from Beira in Mozambique (SADC-REPN Task Force, 2001: 2). About one third of the total oil imports is transported into the country by railroad from South Africa. Most of the petroleum products are used in the transport sector. If the proposals to build two gas turbines to generate 200 MW each by 2008 (ibid.) materialise, then there will be an increase in the use of petroleum products, especially diesel, in the electricity sector.

### **8.3.4 Biomass and New and Renewable Sources of Energy**

Biomass is the main source of energy for households. It is used in the form of charcoal and firewood. Wood fuel provides for about 80 % of energy services in rural areas. High-density urban areas also depend on it as their main energy source (Zimbabwe National Energy Policy, 2000: 2). Wood fuel is likely to remain the dominant energy source since electrification levels in the rural areas are still low.

Some areas of the country use new and renewable sources of energy, mostly solar photovoltaics (PVs), to meet their energy needs. The use of solar PVs is limited and solar panels are expensive, therefore most ordinary Zimbabweans cannot afford them.

## **8.4 The Power Sector**

### **8.4.1 Background**

Zimbabwe's electrical power is supplied by the public utility, the Zimbabwe Electricity Supply Authority (ZESA). ZESA is charged with the responsibility of electricity generation, transmission, distribution and supply in the country.

Electricity generated in the country is not sufficient to meet the national demand whose peak was at 2034.1 MW in 1999. The excess demand is, therefore, supplied by imports from the Democratic Republic of Congo (DRC), Mozambique, South Africa and Zambia. The other challenge facing ZESA is that of improving its financial performance and increasing access to electricity. Although electricity tariffs are adjusted towards Long Run Marginal Cost (LRMC), inflation is very high; as a result ZESA experiences problems with regard to servicing foreign debts and imports payments.

Privatisation of state-owned enterprises in Zimbabwe started in the early 1990s under the Economic Structural Adjustment Programme (ESAP). The programme in general was, however, a failure. Another programme known as the Zimbabwe Programme for Economic and Social Transformation (ZIMPREST) was initiated towards the end of the 1990s. Under this programme the government proposes to commercialise, privatise and reform public enterprises in order to promote and improve efficiency, to reduce monopolies, to empower Zimbabweans economically and to improve the country's economy in general by involving the private sector. The Privatisation Agency of Zimbabwe (PAZ) was established in 1999 to accelerate and supervise the privatisation process. Under the ZIMPREST programme, ZESA was earmarked as one of the enterprises to be reformed.

#### **8.4.2 Existing Institutional Arrangements**

The Ministry of Mines and Energy is responsible for co-ordinating energy matters and operations in the electricity sector. The Department of Energy formulates the policy for the ESI and monitors the operations of ZESA, while the Department of Mines oversees operations of the other energy sub-sectors such as coal. The Ministry of Finance and Economic Development approves all investment decisions in the energy sector (Zimbabwe National Energy Policy, 2000: 3).

The Zambezi River Authority (ZRA) is responsible for water management along the Zambezi River. It reports to both the Zimbabwean and the Zambian governments. The body is also responsible for the maintenance of the Kariba Dam and further development of any new hydroelectric projects at the site.

ZESA is a public power utility responsible for the generation, transmission, distribution and supply of electricity. It owns five power stations and has a total installed capacity of 2,045 MW, of which 1,295 MW is thermal (from coal-fired plants) and 750 MW is hydro. ZESA also purchases its power from the DRC, Mozambique, South Africa and Zambia.

The sugar estates and one private generator have a total installed capacity of 68.75 MW and are an important component of the country's ESI. The sugar estates generate about 68 MW for their own consumption, while the private generator operates a mini-hydro plant of 750 kW.

ZESA is a member of the Southern Africa Power Pool (SAPP) and is interconnected with other (SAPP) operating member utilities, namely Mozambique, South Africa, Zambia and Botswana.

The present structure of the ESI in Zimbabwe is shown in Figure 8.1 below.

**Figure 8.1: Current ESI Structure in Zimbabwe**

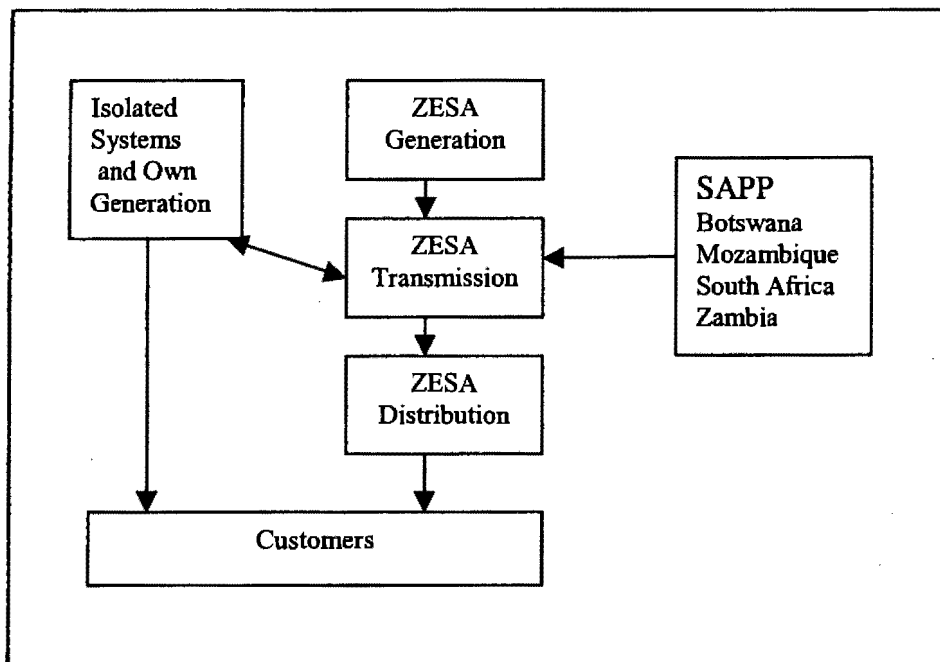

Source: SAD-ELEC, 2000: 89

### 8.4.3 Electricity Supply

#### 8.4.3.1 Generation

ZESA's installed generating capacity from the five power stations at present stands at 2,045 MW as indicated in Table 8.1 below. The power stations at Hwange, Harare, Munyati and Bulawayo are thermal (coal-fired) and constitute 63.3 % of the total installed capacity. The only hydropower station in Zimbabwe is located at Kariba and has a total installed capacity of 750 MW. Initially this power station had an installed capacity of 666 MW, but this was increased to 750 MW when the plants were rehabilitated (ZESA Annual Report, 1999: 13). The net maximum capacity for the thermal power stations is, however, low, suggesting that if the stations were to be rehabilitated, a considerable amount of power could be made available. The other players involved in generation are the sugar estates (68 MW) and one private generator with an installed capacity of a mere 750 kW. This brings the country's total installed capacity to 2,113.75 MW. Generation data for the sugar estates and the private generator is not available, as the study mainly focused on the main utility, ZESA.

**Table 8.1: ZESA's Installed and Available Capacity**

Name of plant	No. of Units	Year commissioned	Type	Installed capacity (MW)	Available capacity (MW)
Hwange	(4*120 MW)	1983	Thermal	480	
	(2*220 MW)	1987	Thermal	440	830 (total)
Harare	(1*135 MW)	---	Thermal	135	80
Munyati	(1*120 MW)	---	Thermal	120	40
Bulawayo	(1*120 MW)	---	Thermal	120	90
Kariba	(6*125 MW)	---	Hydro	750	750
<b>Total</b>				<b>2045</b>	<b>1596</b>

Source: ZESA Annual Report, 1992: 4; SAD-ELEC & MEPC, 1996

ZESA has added 84 MW to its generation capacity through the rehabilitation and upgrading project of the Kariba hydropower plants, which was completed in 2001. The total internal generation sent out from the power stations has declined from 9,361.4 GWh in 1990 to 7,090.772 GWh in 1999. During the same period, the peak demand increased from 1,537.9 MW in 1990 to 2,030 MW in 2000. Refer to Table 8.2 (below) for a summary of the generation statistics.

**Table 8.2: ZESA's Generation Statistics**

	1990	1991	1992	1993	1994	1995	1996	1997	1998	1999
Hydro (MW)	666.0	666.0	666.0	666.0	666.0	666.0	666.0	666.0	666.0	666.0
Thermal (MW)	1299.5	1299.5	1299.5	1299.5	1295.0	1295.0	1295.0	1295.0	1295.0	1295.0
Total (MW)	1965.5	1965.5	1965.5	1965.5	1961.0	1961.0	1961.0	1961.0	1961.0	1961.0
Generation sent out (GWh)	9361.4	8924.2	8237.0	7468.0	7535.0	7810.9	7323.2	7297.7	6607.1	7090.8
Imports (GWh)	332.4	1143.8	2026.9	1213.9	2008.5	2311.6	3171.5	4012.9	5149.2	5274.7
Max Demand (MW)	1537.9	1575.7	1607.7	1478.3	1553.6	1615.8	1744.0	1828.0	1905.0	2034.1

Source: ZESA Annual Reports, 1992, 93, 96, 97, 98 and 99; ESKOM Statistical Year Books, 1990–96

### ***Future Generation Potential***

The SAPP generation and statistics planning data (SAPP Annual Report, 1999: 30) indicates that Zimbabwe has proposed to develop both hydro and thermal power from the identified potential sites as shown in Table 8.3 below. The proposed projects are medium and long term and may be executed as per ZESA's system development plan. ZESA intends to increase its generation capacity from 2,045 MW to 3,000 MW in order to meet the rising future demand before the expiry of the present import contracts it has with South Africa and Mozambique in 2002/2003 (ZESA, 2000). The project to build a 1,400 MW thermal power station at Sengwa was commenced with the aim of commissioning it by 2002/2003. This project was, however, suspended in 1999 and no further work has been done since. Neither ZESA nor the government can finance the building of the proposed power station. Due to the reform process currently

taking place in the Zimbabwe power sector, it is likely that independent power producers (IPPs) will be encouraged to build some of the additional generating capacity.

**Table 8.3: Zimbabwe's Future Generation Potential**

Year	Power station	No. of units	Units size (MW)	Total added (MW)	Type
2001	Hwange upgrade	1	84	84	Thermal
2001	Hwange 7	1	330	330	Thermal
2003	Hwange 8	1	330	330	Thermal
2004	Gokwe North	3	350	1050	Thermal
2006	Gokwe North	1	350	350	Thermal
2008	Batoka	1	200	200	Hydro
2010	Batoka	1	200	200	Hydro
2010	Batoka	1	200	200	Hydro
2012	Batoka	1	200	200	Hydro
2013	Kariba South	1	150	150	Hydro
2014	Kariba South	1	150	150	Hydro

Source: SAPP Annual Report, 1999: 30

### *Electricity Imports*

As ZESA cannot meet the country's domestic demand, electricity is imported from other power utilities in the SAPP region. Initially Zimbabwe relied on power imports from Zambia and the DRC as indicated in Table 8.4 below.

**Table 8.4: Zimbabwe's Electricity Imports in (GWh)**

	1990/91	1991/92	1992/93	1993/94	1994/95	1995/96	1996/97	1998	1999
Zambia	1,331.9	1,757.1	189.3	949.4	1,093.0	1,345.1	805.2	766.1	62.5
DRC	--	261.8	911.0	913.2	1,055.8	729.7	591.3	297.4	115.6
Mozambique	--	--	--	--	--	--	--	3,813.5	3,526.3
South Africa	--	--	--	--	--	1,093.6	2,615.2	2,578.4	1,567.1
Other	12.0	8.0	113.6	145.9	162.8	3.1	1.2	5.2	3.2
Total	1,143.9	2,026.9	1,213.9	2,008.5	2,311.6	3,171.5	4,012.9	7,460.5	5,274.7

Source: ZESA Annual Report, 1999: 52

Currently power is mainly imported from Mozambique and South Africa. Zambia and the DRC provide emergency supplies only when the need arises (ZESA Mega Watt Bulletin, 2002). Since the generating capacity is not expanding, electricity imports are on the increase. In 1990 the country imported 332.4 GWh and in 1999 it imported 5,274.7 GWh, an increase of about 93.7 %.

### 8.4.3.2 Transmission and Distribution System

The transmission system operates between 220 kV and 400 kV. Power is supplied to various load centres at sub-transmission voltages consisting of 66 kV, 88 kV and 132 kV. The system is further strengthened by interconnections with other power systems in the region to facilitate power transfers and imports as shown in Table 8.5 below

**Table 8.5: Transmission Interconnectors in Zimbabwe**

Country	Voltage
Zambia/DRC	2*330 kV
South Africa (Marimba)	1*420 kV
South Africa (Messina)	1*132
Mozambique (Chikamba)	1*110 kV
Mozambique (Cahora Bassa)	1*420 kV
Botswana	1*220 kV

Source: *Reforming the power sector in Africa, 1999: 219*

Some of the transmission lines are now old and require refurbishment. ZESA carried out a study of its transmission system to identify which lines should be upgraded. The analysis concluded that most of the 330 kV lines that had been built between 1958 and 1980, and between 1980 and 1988 could be upgraded to 400 kV (ZESA Annual Report, 1999: 14). Apart from upgrading the existing transmission lines, additional lines, as indicated in Table 8.6 below, will also be required to transfer power from the proposed power stations which have been earmarked to be completed by 2006 (Refer to Table 8.3 above).

**Table 8.6: Internal Transmission Strengthening in Zimbabwe**

Year	Substation From	Substation To	Voltage kV	Length Km	Thermal rating MVA
2002	Gokwe North	Chakari	400	198	1750
2004	Gokwe North	Sherwood	400	225	1750
2004	Chakari	Dema	400	148	1750

Source: *SAPP Annual Report, 1999: 32*

The distribution system is divided into four regions: Southern, Western, Northern and Eastern. There are proposals to re-demarcate the regions into five as part of the general ESI reform process. The system operates at 11 kV and 33 kV and the majority of the consumers are supplied from 380-400 V. The network is expanding rapidly as a result of the progress of the electrification programme.

### 8.4.3.3 Power System Losses

Some of the power sent out via the transmission and distribution systems is lost before reaching its consumers. The losses in the transmission system are mostly technical, while the losses in the distribution system are as a result of both technical and non-technical reasons. The total system losses range from 8.7 % to 12.8 % as indicated in Table 8.7 below.

**Table 8.7 ZESA's System Losses (1990 – 1999)**

	1990	1991	1992	1993	1994	1995	1996	1997	1998	1999
System losses %	8.7	10.7	9.9	11.0	11.9	10.7	10.8	10.8	11.3	12.3

Source: ZESA Annual Report, 1999: 52

### 8.4.4 Demand

Electricity is the main source of energy for industry, mining, commerce and agriculture. Zimbabwe cannot meet its own electricity demand and as such has to import electricity from power utilities in Mozambique, South Africa, Democratic Republic of Congo (DRC) and Zambia. In 1999, the imports accounted for 42.7 % of the total demand (ZESA Annual Report, 1999: 13). Imports are supplied under contractual agreements.

**Table 8.8: ZESA Electricity Sales by Consumer Category (GWh), and Other Statistics (1990 – 1999)**

	1990	1991	1992	1993	1994	1995	1996	1997	1998	1999
Consumption by sector GWh										
Mining	1473.9	1518.5	1549.7	1306.0	1441.0	1571.0	1579.1	1662.8	1646.7	-
Industrial	4278.0	4052.7	4146.5	3079.0	3296.0	3507.1	3951.8	3946.9	3625.5	-
Farming	750.6	834.1	809.8	593.0	805.0	902.7	690.5	899.6	1023.7	-
Commerce and lighting	900.1	1044.2	1141.4	1036.0	1198.0	1382.9	1385.9	1645.9	1862.0	-
Domestic	1449.2	1542.9	1600.6	1717.0	1672.0	1658.1	1734.2	1911.2	2040.5	-
ZESA own use						13.87	23.37	21.63	14.48	
Grand Total	8924.9	9020.8	9266.7	7731.0	8412.0	9035.9	9364.9	10088.	10213	10,779.1
No. Customers	309423	319357	332784	339732	356395	368687	387593	410782	437888	473,244
No. Utility employees	7,615	7,674	7,603	7,531	7,975	7,903	7,655	7,273	7,128	6,846
No. Customers per employee	41	42	44	45	45	47	51	56	61	69
Electricity sales per employee	1.172	1.176	1.219	1.027	1.055	1.142	1.220	1.384	1.431	1.575
Exports	73.08	28.42	18.75	--	--	--	--	--	--	--

Source: ZESA Annual Report 1991— 99; ESKOM Statistical Yearbooks 1990 – 96

Table 8.8, above, indicates that electricity sales have increased tremendously from 8,924.9 GWh in 1990 to 10,779.1 GWh in 1999. On average, electricity consumption reflects an increase almost every year in all sectors except for the industrial sector, where the demand fluctuates. The number of new customer connections has been more than 20,000 every year as from 1996. The majority of these are in the domestic category, leading to increased electrification levels. Since more connections are made every year, the total number of customers per employee, especially after the 1995 financial year, has been increasing. This is also true for electricity sales per employee. ZESA's maintenance of a low number of employees in its establishments could be a contributing factor.

The government has embarked on a rural electrification programme with the objective of extending electricity services to all Zimbabweans and empowering rural people economically. This electrification programme and other development programmes in other sectors, such as industry and mining, are likely to increase the demand for electricity.

#### **8.4.5 Electrification**

ZESA is no longer the only organisation mandated to supply electricity in Zimbabwe and, consequently, the electrification of both urban and rural areas in the country can be undertaken by other interested organisations. At present ZESA is, however, still the main utility carrying out the electrification projects.

##### ***Urban Electrification***

The backbone for the electricity supply in the main urban centres is carried out by ZESA through projects, which are financed by loans obtained from either the government or from foreign institutions. The reticulation system and small extensions of the distribution network are financed from ZESA's internal sources, but are partly refunded through capital contributions by customers. The planning department first evaluates the electricity needs in the areas to be targeted, and then prioritises these depending on their financial viability. Once ZESA has been restructured and unbundled as per the government's reform programme, it is expected that the distributors will continue to increase access to electricity in the urban areas.

##### ***Rural Electrification***

ZESA also carries out household electrification in rural areas. Extending the grid to peri-urban and rural areas is however capital-intensive, and ZESA does not have sufficient financial resources of its own to do this. The government has thus established a special fund to assist in the rural electrification programme. Funds come from the 1 % electrification levy on electricity sales (Electricity White Paper, April 2000: iv). The areas that have been covered so far are mainly the commercial centres. The electrification rate

has been higher in urban areas than in rural areas, primarily because of differences in settlement patterns. See Table 8.9, below, which shows the progress of electrification in Zimbabwe.

**Table 8.9: Zimbabwe' Electrification Levels (1990 – 2000)**

Year	1990	1991	1992	1993	1994	1995	1996	1997	1998	1999	2000
Urban electrification	-	-	69.0	67.0	69.0	72.0	70.0	74.0	78.0	80.0	84
Rural electrification	-	-	11.0	14.0	15.0	14.0	17.0	16.0	15.0	18.0	18
<b>Total</b>	<b>20</b>	<b>20</b>	<b>28.0</b>	<b>29.4</b>	<b>30.8</b>	<b>32.2</b>	<b>33.6</b>	<b>35.0</b>	<b>37.5</b>	<b>39.0</b>	<b>40</b>

**Source: ZESA corporate performance statistics (cited by Kayo, 2001: 50)**

Zimbabwe is making great strides in the electrification process when compared to other countries in the SADC region. It is actually second only to South Africa in achieving such high electrification levels. This increase in access to electricity is supported by the increase in number of new customers as can be observed in Table 8.8. Nevertheless, despite these achievements ZESA will no longer carry out the rural electrification projects once the proposed reforms have been implemented. According to the Zimbabwe government's legislative package on the reform programme, a Rural Electrification Fund Bill provides for the following:

- i. The establishment of a rural electrification fund, which will be managed by a board;
- ii. The establishment of the Rural Electrification Fund Agency which will embark on the expanded rural electrification programme; and
- iii. The operations of the Rural Electrification Agency, which will be financed by
  - A rural electrification levy on electricity sales;
  - Donor funding; and
  - Government funding.

The passing of this Act in February 2002 will enable Zimbabwe to increase its electrification levels. Currently the government is seeking 24 billion Zimbabwe Dollars for rural electrification purposes (Financial Gazette, February 7 - 13, 2002). According to the paper, the government has already raised \$ZM 2b for the programme and has engaged foreign banks for the possibility of getting loans.

### ***Rural Electrification Subsidies***

Under the Rural Electrification Programme, the government intends to extend the grid to rural communities. Since grid extension to remote areas is capital intensive and electrical equipment is unaffordable due to their high costs, the programme is designed to have substantial subsidies (Financial Gazette, February 7 – 13, 2002):

- i. The projects that will serve entire communities, such as education and health institutions, government offices, community-based schemes and resettlement schemes under the government land reform exercise, will receive a 100 % electrification capital subsidy.
- ii. Capital equipment, which can support the economic empowerment of the rural communities, will be purchased by the fund and individuals will be able to access it by means of soft loans. The loan can be repaid over a period of three to five years at a fixed subsidised interest rate of 17 %.
- iii. Projects initiated by communities and individuals, which fall outside the 100 % capital subsidy, will be carried out on condition that 50 % of the costs will be borne by the communities or individuals themselves and that no interest shall be charged on any remaining balances.

#### **8.4.6 Tariff Structure**

Tariffs are set by the utility and approved by the government. The tariffs are normally adjusted towards Long Run Marginal Costs (LRMC), but the depreciation of the local currency and the rising inflation has had a negative impact on tariff levels. This problem is compounded by the delays in adjusting the tariff to reflect real terms. This has meant that electricity prices have been very low in US dollar terms compared to other SADC countries. Since tariffs are not based on LRMC, the possibilities for ZESA to service foreign debts are very low.

ZESA's tariff system is divided into five categories: -

- i. Domestic category
- ii. Public lighting
- iii. Mining and industry
- iv. Commerce
- v. Agricultural and large consumers

#### **8.4.7 Financial Performance of ZESA**

ZESA was operating at a loss before 1993. A very successful performance improvement programme that was implemented by the utility brought about increased profits from 1994 to 1997, as reflected in Table 8.10 below. One of the areas that contributed to this turn-around was improved revenue collection. The financial statistics in Table 8.10 indicate that the debtors' days were reduced from 99 in 1994 to 32 in 1998. The financial performance, however, started to decline again from the 1998 fiscal year, thereby reversing the net surplus position that had been achieved every year since 1993. The main explanation for this might be that tariffs are not automatically adjusted in line with inflation and depreciation of the local currency.

**Table 8.10: Some Financial Performance Indicators of ZESA**

Year	Total asset value (SZM 000's)	Annual revenue (SZM 000's)	Net profit before tax (SZM 000's)	Avg. cost electricity generated C/kWh	Avg. price electricity sold C/kWh	Debtor collection period (Days)	Return on assets (%)	Interest cover	Exchange rate
1990	1,862,208	525,196	-1,724	--	--	72	8.4	1.0	--
1991	2,136,703	657,109	-63,517	--	--	74	8.3	0.7	--
1992	3,028,074	989,145	-73,055	--	--	85	13.3	1.8	5.0942
1993	3,772,329	1,464,533	36,822	--	--	99	12.5	1.8	6.4725
1994	4,866,239	2,139,596	84,954	15.1	23.8	61	12.9	1.2	8.1500
1995	6,240,676	2,436,098	83,566	17.3	24.8	50	11.1	1.2	8.6580
1996	7,491,578	3,050,357	95,697	22.0	30.5	56	8.25	1.18	9.9206
1997	22,473,022	3,858,123	104,817	27.3	36	32	3.96	1.13	11.8906
1998	29,248,817	8,253,290	-2,340,503*	60.1	52.6	25	(0.26)	(0.03)	21.4133
1999	32,155,114	9,756,792	-282,285	76.1	87.1	32	4.84	0.85	38.3142

Source: ZESA Annual Reports, 1999: 6 & 50, 1998: 6, 1997: 6 & 1996: 6, CIA

\* Net before tax profit for 18 months

The poor performance of the utility greatly affected the maintenance of power plants and its bulk power purchases. As the utility could not maintain its power plants adequately, two generators at Hwange power station were lost for some time. The station's generating capacity was consequently reduced from 920 MW to 200 MW (*Financial Gazette*, February 7 – 13, 2002). This resulted in frequent power cuts, and ZESA was forced to buy emergency power from ESKOM. The depreciation of the currency against the US dollar and the shortage of foreign currency have further made it necessary for ZESA to postpone its loan repayments and the power purchase payments.

#### 8.4.8 Electricity Sector Reforms

Zimbabwe's position regarding the restructuring and reform of its utility is in line with its economic structural adjustment programme. In fact, the government submitted a draft White Paper containing guidelines for the privatisation of ZESA in March 2000 (Mbendi, August 2001). According to Mbendi the White Paper proposed both horizontal and vertical unbundling of the utility and the privatisation of power stations in a phased programme over a six-year period. Ahead of the expected full sector reforms, the government currently allows private participation in electricity production.

##### 8.4.8.1 Main Driving Forces behind the Reforms

Economic development in many countries depends on the strength of their Electricity Supply Industry. In Zimbabwe, the power utility ZESA dominates the ESI. ZESA is currently plagued by many problems such as an increase in the number of blackouts, failure to increase the generating capacity of its plants, and poor financial performance. In order to achieve the objective of economic development and improve

power sector performance, the government initiated certain electricity sector reforms. The main driving forces for the reforms, as the government indicates in its Electricity White Paper (2000), are:

- i. To attract the public sector and multilateral agencies to finance the expansion and rehabilitation of the system.
- ii. To improve the reliability of supplies and meet customers' expectations for safe, environmentally friendly and cost-effective electricity supplies. The quality of supply service declined due to a lack of preventive maintenance.
- iii. To attract both foreign and domestic investment in the power sector. The government would like to increase its power generation capacity by developing the potential sites at Hwange 7 and 8, Gokwe North, Batoka and Kariba South. The power plant and associated transmission investment required is substantial. Clearly, neither the government nor local institutions alone will be able to finance it. It would therefore require borrowing from external financial institutions, which now require sector reforms as one of their preconditions before agreeing to finance the projects.
- iv. To accelerate the pace of electrification. The government intends to increase access to electricity in order to promote economic growth and improve the lives of its citizens. Under current conditions it is difficult to achieve higher electrification levels because the country simply does not have adequate internal electricity capacity.

#### **8.4.8.2 Main Characteristics of the Reforms**

The ESI in Zimbabwe is dominated by ZESA. Other players such as the sugar estates, private companies and off-grid renewables play an insignificant role. To achieve the objectives described above in section 8.4.8.1, the government, in its draft Electricity White Paper (2000: 4), plans to approach the reforms as outlined below:

- i. Unbundling ZESA from its present vertically integrated structure into separate business operations of generation, transmission, distribution and supplies. The aim of unbundling the existing ESI monopolistic structure is to attract private investors into the electricity sector. In fact, the government has already approved the new company structure to be known as ZESA Holdings Limited. Under the new company structure, ZESA will initially have three subsidiary companies responsible for power generation, transmission and distribution respectively. Generation will be under the control of the Zimbabwe Power Company. The names for the transmission and distribution subsidiaries have not yet been finalised (Financial Gazette, February 7 – 13, 2002).
- ii. The establishment of an independent regulatory commission. The independent regulator is to be established soon after the enactment of the Electricity Act in January 2002. The regulator is

expected to promote competition and level the playing field for stakeholders. At this stage all the operations of ESI will be monitored by the ZERC.

- iii. The next stage will be characterised by the horizontal unbundling of the Generation and Distribution Business Units. The power stations will operate separately as sub-generation business units, initially under the Zimbabwe Power Company (ZPC) which was established in 1996 as an investment vehicle in the power sector (Financial Gazette, February 7 – 13, 2002). The Distribution Business Unit is expected to be unbundled into five sub-business units.
- iv. The fourth stage of the reforms will be the commercialisation phase. The business units, though wholly owned by the government, will be operating on a commercial basis and electricity prices shall be approved by the ZERC.
- v. The privatisation of ZESA's subsidiary companies. Government ownership of the commercialised business units will either cease completely or will be diluted through the sale of ZESA assets.

Step one is being implemented at present, paving way for a good transition to other subsequent steps. This will involve changing the structure of the ESI from its present form to an interim structure, as shown in Figure 8.2 below.

**Figure 8.2: Zimbabwe's Transition/Interim Structure**

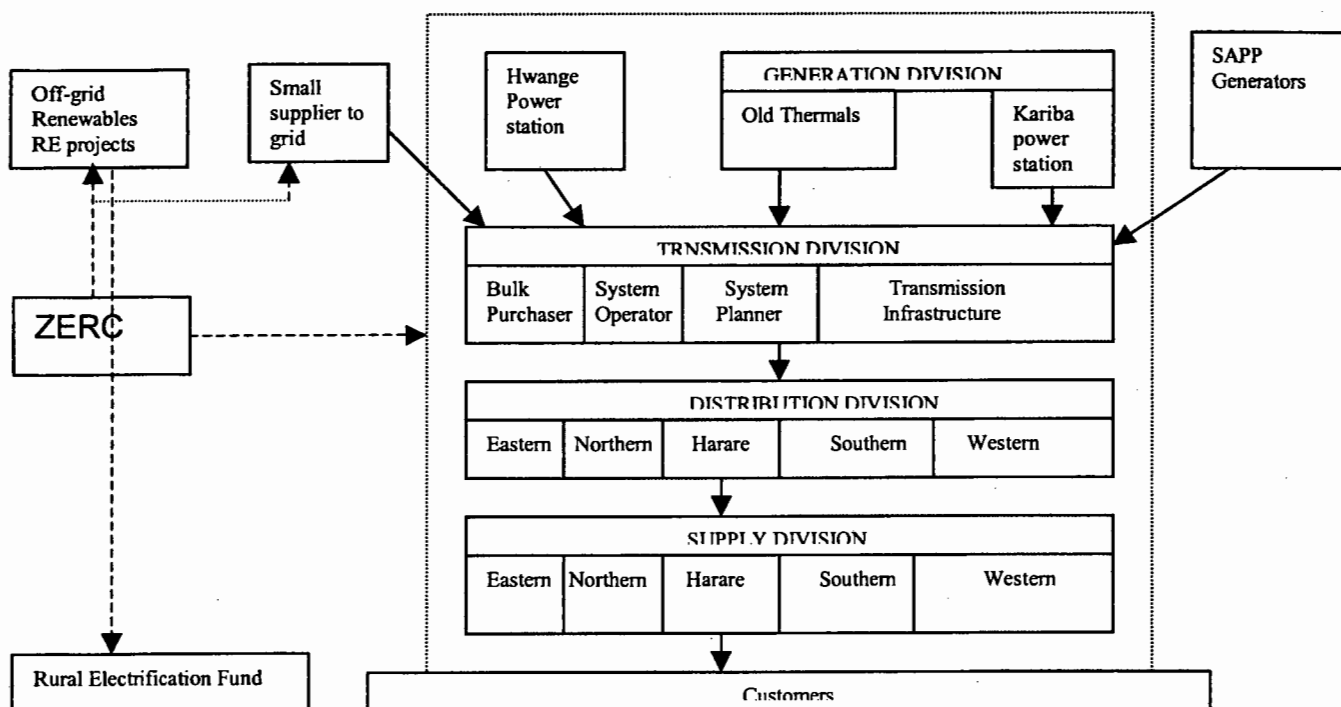

Source: Electricity White Paper: Electricity Sector Reform in Zimbabwe, April 2000: 6

### **8.4.8.3 Privatisation**

The Zimbabwe Government, in its draft Electricity White Paper, proposed to privatise ZESA's Generation and Distribution business entities. Presently, the privatisation of ZESA's assets is no longer on the agenda: Thus, ZESA will merely be unbundled into separate generation, transmission and distribution units. None of these units will be privatised, but will remain 100 % owned by the government as subsidiaries of ZESA Holdings. The initial proposal was that once all the commercial business units are in place, the Generation Business Unit would be privatised.

Hwange was earmarked as the first station to be privatised. The privatisation of other power stations would have taken place in a phased programme over a period of six years, as indicated by Mbendi (Mbendi, August 2001). However, this is no longer happening. According to the initial plan the Electricity White Paper (2000) gives three main reasons for the privatisation of the station and these are:

- i. The privatisation of Hwange has the potential to reduce the national debt;
- ii. It will improve the performance and reliability of the power sector;
- iii. It will attract foreign investment in the electricity generation sector.

Privatisation on of the other generating stations and the distribution business would have gone ahead, depending on the lessons that would have been learnt from the privatisation of Hwange power station. Ahead of the expected full sector reforms, the government currently allows private participation in electricity production.

The Electricity White Paper further points out that the second stage of the reform process will take place after the establishment of ZERC, after identifying financially viable distribution entities and after reviewing the tariff. It is therefore expected that the final proposed ESI structure illustrated in Figure 8.3, below, would be implemented in Zimbabwe.

**Figure 8.3 Zimbabwe's Expected Final ESI Structure**

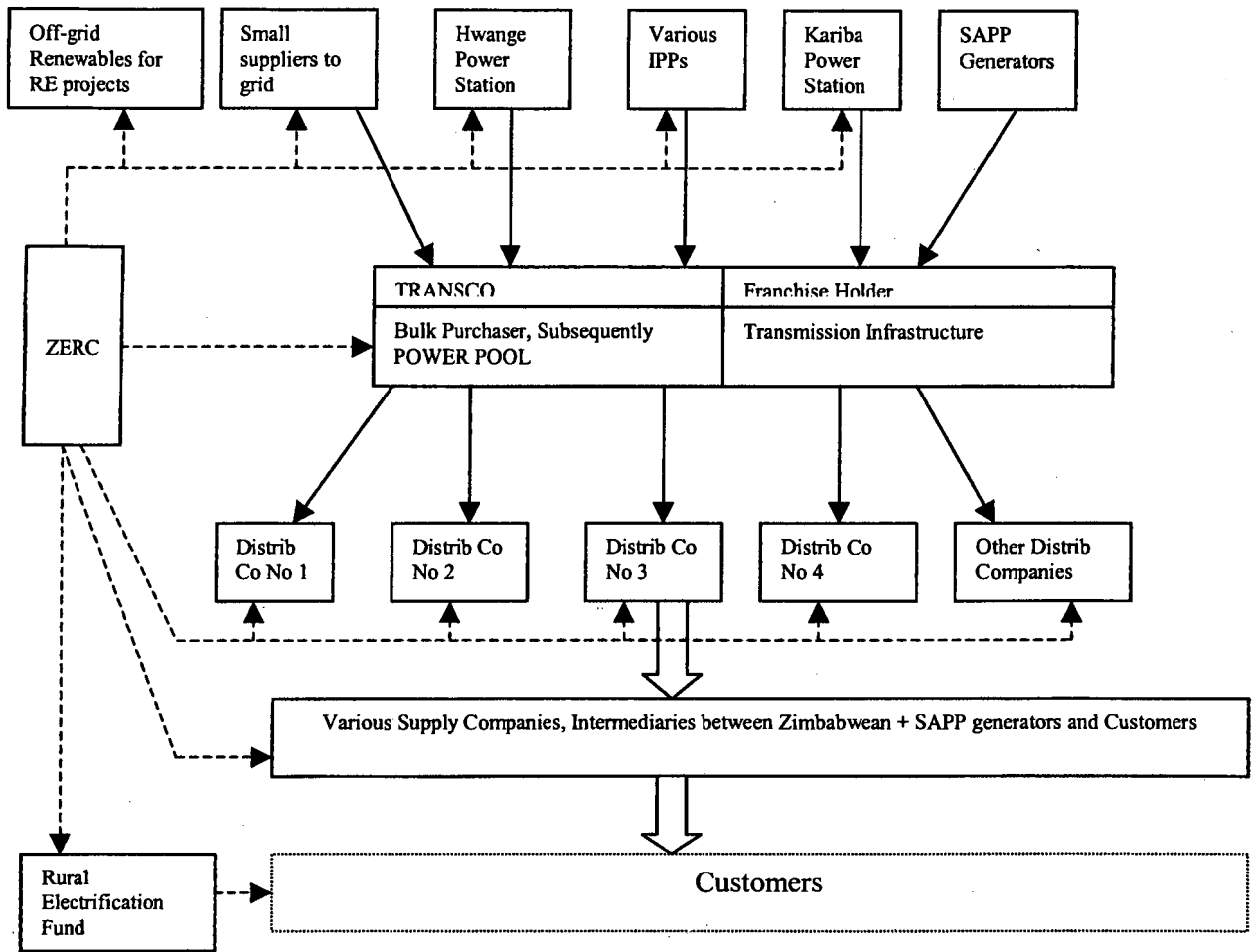

Source: Electricity White Paper: Electricity Sector Reform in Zimbabwe, April 2000: 6

### 8.4.9 Regulatory Framework

Zimbabwe's power sector was governed by the Electricity Act of 1992 before it was amended in 1995 (SAD-ELEC, 2000: 92). The amended Act defined a number of requirements to be carried out by ZESA and clarified the conditions of acquiring power from private suppliers. Due to the current ESI reform process, the amended Electricity Act of 1995 was repealed. Three major Acts of Parliament will now govern the ESI, namely:

- i. The Electricity Act of 2001
- ii. The ZESA Commercialisation Act
- iii. The Rural Electrification Fund Act of 2002

The new Electricity Act is designed to liberalise the power sector in order to allow and encourage the participation of the private sector in electricity generation, transmission, distribution and supply. The new Act further provides for the establishment of an independent regulatory commission, the Zimbabwe

Electricity Regulatory Commission (ZERC), which will be given the powers to carry out functions relating to the licensing and regulation of the electricity industry. According to the Zimbabwe Financial Gazette Newspaper of February 7 – 13, 2002, the new Electricity Act was passed by Parliament in 2001 and was ratified on January 30, 2002.

The second Act is the ZESA Commercialisation Act. This Act will allow ZESA to operate as a commercial company. This, therefore, means that assets and liabilities of the old Zimbabwe Electricity Authority (ZESA) will be transferred to a new successor company, ZESA Holdings Limited (Financial Gazette, February 7 – 13, 2002).

The third Act, the Rural Electrification Fund Act, was ratified on January 23, 2002 (Financial Gazette, February 7 – 13, 2002). The Act provides for the establishment of the Rural Electrification Agency, which will implement rural electrification and the programmes dealing with renewable energy resources (Electricity White Paper, April 2000: 12).

### ***ESI Regulation in Zimbabwe***

Currently the government and ZESA itself are carrying out ESI regulation. In view of the changes taking place at the moment, all the regulatory functions will, in the immediate future, resort under the Zimbabwe Electricity Regulatory Commission (ZERC). The government, in its electricity White Paper (April 2000: 11), proposes that the main functions of the ZERC be:

- i. To issue licences;
- ii. To set and approve electricity tariffs;
- iii. To establish appropriate technical standards in order to ensure security, reliability and quality of electricity supply;
- iv. To advise the government and other players on matters concerning the operations of the electricity sector;
- v. To settle disputes between licensees and between licensees and customers; and
- vi. To promote competition in the industry.

### Comparative Study

#### 9.1 Introduction

This chapter compares the Electricity Supply Industries (ESIs) reforms of the six countries in the SADC region selected for this study. The power sectors of these countries have already been discussed from chapters three to eight of this thesis. The second and third sections of this chapter look at the selected countries' economic indicators and primary energy resources in order to provide the relevant background information on the various countries' economies and development and to examine how these relate to the development of the power sector. The fourth section analyses and evaluates various sets of utilities data with a view to ascertain whether the data supports the respective governments' reasons for power sector reforms in response to their poor performance. The fifth section looks at the key elements of the various reform programmes and also examines whether the expected new ESI structures will address the existing problems facing the industry. The sixth section explains the socio-economic impacts of the ESI reforms. Lastly, the conclusions of the study have been presented.

The countries have been divided into three categories in terms of their generation capacity in order to simplify comparisons in some instances:

- i. Countries with greater than 10,000 MW installed capacity: South Africa
- ii. Countries with greater than 1,000 MW but less than 10,000 MW installed capacity: Mozambique, Zambia and Zimbabwe
- iii. Countries with less than 1,000 MW installed capacity: Lesotho and Malawi

Due to the reforms taking place in the power sector, some countries have already changed their energy policies while others are still in the process of formulating new ones. The main common issue in all the current energy policies is the de-monopolising of the power sector industry, which is dominated by the public utilities. All the countries plan to increase private sector participation in electricity generation and delivery services in order to improve reliability of supply and increase electricity access for the majority of the people. These changes necessitate new legislation to govern the sector and to establish regulatory regimes that are capable of monitoring the industry's standards, introducing competition and approving appropriate tariffs for the utility. So far, progress has been made in Malawi, South Africa and Zimbabwe towards corporatisation of the utilities. The reforms generally aim to improve the electricity sector performance and stimulate economic growth. No country in the region has fully implemented the reforms and, as such, their impact is not yet known. Some speculation on possible impact has been included at the end of this study.

## 9.2 Current Economic situation and Prospects

The current economic environment and demographic situation have an impact on the development of the power sectors in the countries under study. Major investment in some of the countries seems to be favourable. Some information on the economic and demographic characteristics such as the Gross Domestic Product (GDP), GDP per capita, GDP annual growth rate, annual inflation population and agricultural contribution to economic growth will create understanding for the countries' economic situation and how that relates to the performance of the power utilities.

The economic performance of the countries varies from one to another. South Africa has a huge Gross Domestic Product of US\$ 125.9 billion while the rest of the countries have a GDP of less than US\$ 8 billion, as indicated in Table 9.1 below. In economic terms, South Africa is one of the upper middle income countries in the world, whereas the other countries are low income, with Malawi being classified among the poorest countries in the world. Generally, electricity consumption in countries with a high GDP is also higher when compared with countries that have a low GDP. This is not the case with Mozambique, however. This country has a higher GDP than Zambia but its electricity consumption is lower than that of that country (refer to Table 9.3 below). Mozambique's electricity consumption is low because of low industrial development and electrification levels (see Chapter Five). The economies of most of the countries under examination, with the exception of South Africa, rely on agriculture. This is reflected by the contribution of agriculture to the total GDP of the country. For example, Table 9.1 indicates that the economy of Malawi is highly dependent on agriculture. This is partly due to insignificant mineral resources in the country. The economic contribution of agriculture for the other countries such as Lesotho, Zimbabwe, Mozambique and Zambia is also fairly large. The frequent droughts experienced in the region have a detrimental effect on current economic conditions and consequently also on electricity sales, which in turn affect the financial performance of the utilities.

**Table 9.1: Some Population and Economic Indicators of the Countries (2000)**

Country	Population Total	(%) Rural Population	Population Growth rate (Annual %)	Total GDP (US\$ Billion)	GDP Annual Growth rate (Annual %)	GDP per Capita (US\$)
Lesotho	2.0	72	1.5	0.9	3.8	450
Malawi	10.3	85	2.1	1.7	1.7	165
Mozambique	17.7	60	2.2	3.8	1.6	215
South Africa	42.8	45	1.9	125.9	3.1	2940
Zambia	10.1	55	2.1	2.9	3.5	280
Zimbabwe	12.6	65	1.9	7.4	-4.9	590

Source: World Development Indicator Database 2002

**Table 9.1: Continued**

Country	1990 – 2000 Average GDP Growth	Agriculture Contribution to GDP (%)	Inflation, GDP deflator (Annual %)
Lesotho	4.1	16.9	8.0
Malawi	3.8	41.6	24.5
Mozambique	6.4	24.4	11.7
South Africa	2.0	3.2	6.5
Zambia	0.5	27.3	18.1
Zimbabwe	2.5	18.5	59.9

The economic growth rate also varies from country to country. The average annual growth in the GDP rate for Lesotho, Zambia and South Africa in 2000 was higher than the population growth rate while the per capita income of these countries also reflected a positive growth. The GDP per capita during the same period for Malawi, Mozambique and Zambia were lower than those for the other three countries.

**Figure 9.1: GDP per Capita (2000)**

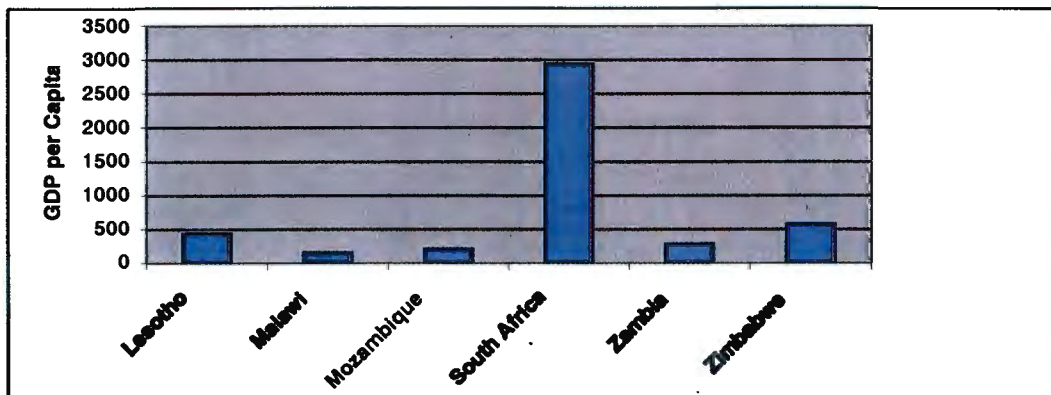

The other factors that affect the financial performance of the utilities are the high inflation rates and the depreciation of local currencies against major convertible currencies. Only two countries, South Africa and Lesotho, have single-digit inflation rate figures, which is impressive in the context of the general SADC region. The annual inflation rate in other countries during the same year (2000) was more than 10 %, with Zimbabwe having the highest rate of 59.9 % (see Table 9.1 above). Such high inflation clearly has a negative effect on the electricity tariffs. The tariffs in most of these countries are not automatically adjusted to accommodate the level of inflation and the depreciation of the currency and, as a result, the utilities' electricity prices do not reflect the cost of production, which means that they, in turn, cannot make enough of a profit. Furthermore, because of the high inflation, the interest rates of commercial banks are also high, making it difficult for investors to borrow money for any major investment.

Table 9.1 above further shows that the total population in the countries ranges from 2.0 million for Lesotho to 42.8 million for South Africa in 2000. It also indicates that the annual population growth rate in some countries is over 2 %: for example, in Malawi and Zambia it is 2.1 %, and in Mozambique it is 2.2 %. It can further be observed that those countries with a high population growth rate (e.g. Malawi and Mozambique) also have low per capita income. These low incomes constrain people from using electricity or getting electricity connections and, as a result, access to electricity remains very low.

The utilities in these countries face a common problem: that of extending electricity connections to the residential sector since the majority of the population lives in rural areas. According to the World Development Indicators statistics, the proportion of the population living in rural areas, in the year 2000, were as follows: South Africa (45 %), Zambia (65 %), Mozambique (60 %), Zimbabwe (65 %), Lesotho (72 %) and Malawi (85 %) (World Bank, 2002). Most of the settlements in rural areas are scattered and population densities are low (less than 100 people per square kilometre in all of these countries). This requires the construction of long distribution lines to serve the very few people who can afford electricity.

**Figure 9.2: Rural Population (2000)**

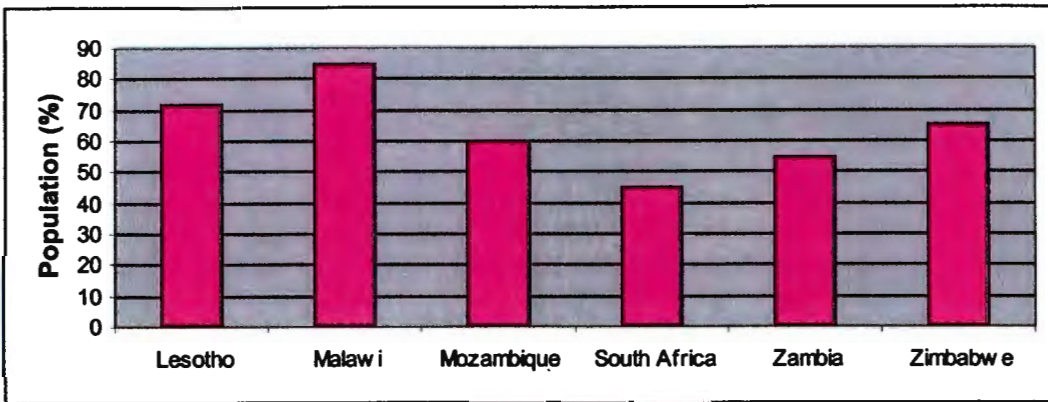

### 9.3 Resource Potentials for Electricity Generation

The countries under study have various forms of primary energy, which can be developed for electricity generation. Electricity is basically produced from three main energy sources in this region: hydropower, coal and nuclear. Zambia, Mozambique, Malawi and Lesotho rely heavily on hydro generation, while South Africa and Zimbabwe depend on thermal generation from coal. Further, South Africa is the only country in the region that generates electricity from nuclear energy. The future generation potential of Zimbabwe and Mozambique will depend on both hydro and thermal power, and South Africa will depend on electricity production from nuclear and coal-fired power plants. Zambia and Malawi will have to develop their hydro potentials. The availability of these resources varies from country to country, as indicated in Table 9.2 below, illustrating the potential energy sources.

**Table 9.2 Potential Energy Sources (2000)**

Country	Hydro (MW)	Proven Reserves Coal (tonnes billion)	Gas (tcf)	Geo-thermal (MW)	Oil tonnes Million	Total Primary energy supply (TPES) In Mtoe	TPES per Population (Toe per capita)
Lesotho	1,072	--	--	--	--	--	--
Malawi	2018.5	1	--	--	--	--	--
Mozambique	14,000	3	25	--	--	6.98	0.40
South Africa	8,360	121	--	--	--	109.33	2.60
Zambia	8,435.65	0.030	--	--	--	6.19	0.63
Zimbabwe	7,700	30	--	--	--	10.17	0.85

**Notes:**

1.Mtoe: Metric tonnes oil equivalent

2. Toe: Tonnes oil equivalent

From this Table, it can be observed that out of the six countries, Mozambique is the only country which has natural gas reserves. At the moment, however, this gas is not exploited to a significant extent either for commercial purposes or electricity generation.

## 9.4 Electricity Supply

### 9.4.1 Generation

Electricity in these countries is generated from two dominant sources of primary energy as shown in Table 9.3 below. From the Table it is seen that Lesotho, Malawi, Mozambique and Zambia depend on hydropower, while South Africa and Zimbabwe rely on thermal generation from coal. Part of the electricity demand in Lesotho, Mozambique and Zimbabwe is met from imports from either South Africa or Zambia.

**Table 9.3: Internal Generation and Imports (2000)**

Country	Existing Installed Generating Capacity (MW)					Total Capacity (MW)	Total Generation (GWh)	Imports (GWh)	Imports (%)	Total System Energy (GWh)
	Hydro & Pumped Storage	Coal	Diesel	Nuclear	Geo-thermal					
Lesotho	75	-	0.84			76	366	38	10.4	403
Malawi	284	-	21	-	-	305	1072			1072
Mozambique	2184	-	199	-	-	2383	296	1,099	78.8	1395
South Africa	2,061	37,678	342	1930	-	42,011	189,590	5,294	2.7	194,601
Zambia	1,632	-	9.75	-	-	1,642	7661	-		7661
Zimbabwe	750	1,295	-	-	-	2,045	7091	5,275	42.7	12,366

## Notes

1. *Lesotho: Data from March 2001 to February 2002. Hydro installed capacity includes Muela, 72 MW and LEC, 3.25 MW.*
2. *Mozambique existing installed capacity is for both EDM and HCB but purchases from HCB are treated as imports.*
3. *The rest of the countries' installed capacities are for the public utilities only.*
4. *Data for Zambia and Zimbabwe is for 1999.*

In addition to the main generating plants, all the countries have a number of diesel generators, which are either used for standby purposes or to supply isolated areas. In Malawi and Mozambique these generators tend to inflate the installed capacities, as most of them are out-of-order and require rehabilitation.

## Installed Capacity

The total installed capacity of the utilities in the selected countries, including that of independent producers, amounts to 49,552 MW. South Africa alone has a total installed capacity of 43,100 MW and this is about 6.7 times the combined capacity of the rest of the five countries. The second category of countries has more or less the following installed capacities: Mozambique (2,383 MW), Zambia (1,642 MW) and Zimbabwe (2,046 MW). The third category of countries, Lesotho and Malawi, have small power systems with installed capacities of 76 MW and 305 MW respectively. South Africa's installed capacity is, in fact, comparable to that of many developed countries.

**Figure 9.4: Total Installed Generating Capacity**

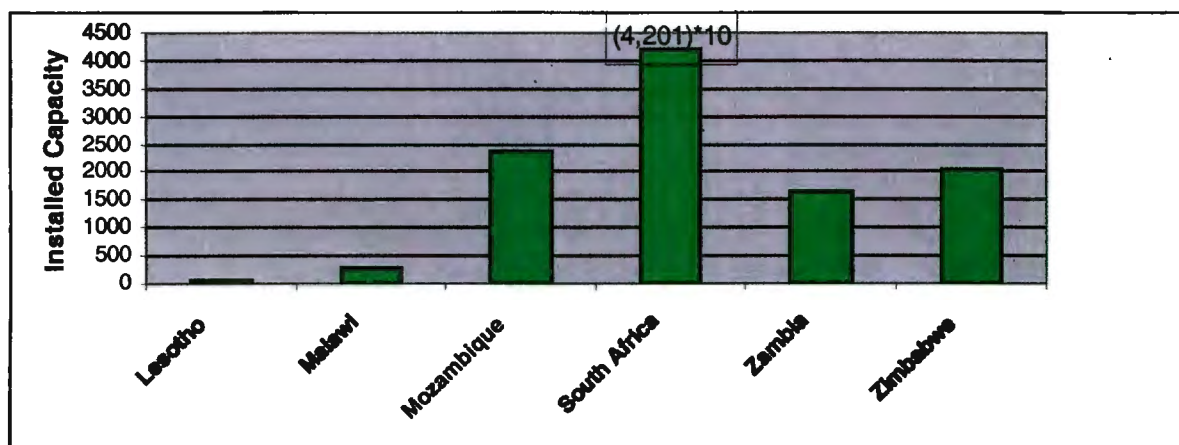

It should be noted here that the independent producer, Hydroelectrica de Cahora Bassa (HCB), accounts for 87.06 % of Mozambique's installed capacity. Electricity that is generated by HCB is exported to other countries in the region on contractual agreements, and as a result Mozambique meets its excess demand from electricity purchases from HCB and imports from South Africa. Although Lesotho and Malawi have just enough capacities to meet their existing respective demands, they both face energy shortfalls during

peak load periods and generation equipment outages. In contrast, Mozambique, South Africa and Zambia have over-installed capacities and can export their power to other countries in the region.

### Units Generated

The units generated from the power plants are different depending on the availability and sizes of the plants. The main hydro-based countries indicate that their utility performances meet their demands. As is clear from Figure 9.5, below, South Africa dominates electricity generation. The utilities of Mozambique (private, HCB) and Zambia (ZESCO), apart from satisfying their domestic market, export electricity to neighbouring countries. Units generated by the power utility of Zimbabwe, ZESA, are lower than the installed capacity because most of the old thermal-generating power stations require rehabilitation.

The units generated by public utilities of Lesotho, Mozambique and Mozambique could not meet their countries electricity needs due to a number factors. Lesotho and Mozambique public utilities have very little installed generating capacities and as such rely on electricity purchases from independent utilities within the countries. ZESA's inadequate generation is, however, because of poor generation performance from its power stations.

**Figure 9. 5: Internal Generation and Imports**

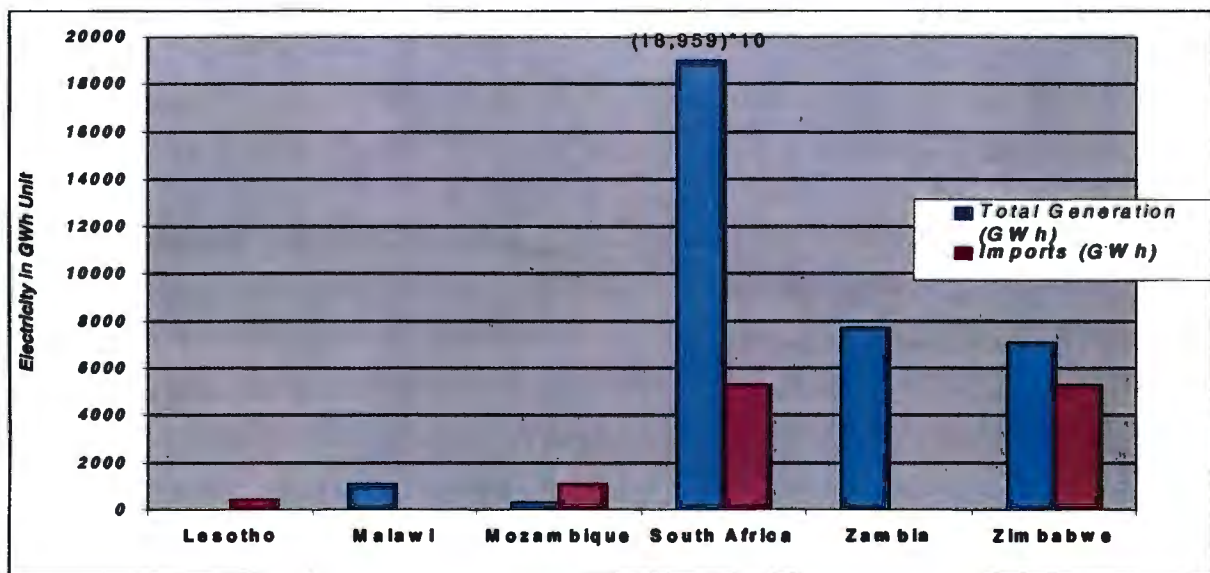

**Note:**

Total generation for South Africa should be multiplied by the factor of 10

### ***Imports***

Electricity imports depend on installed generation capacities and transmission and distribution bottlenecks in meeting demand. The major electricity importers, as indicated in the graph above, are Zimbabwe, South Africa and Mozambique. Malawi is the only country that is not interconnected with any other transmission system in the region and, as such, does not import electricity.

Since ZESA's total installed capacity was as high as 2045 MW in the early 1990s when its peak demand was 1538 MW, it could meet Zimbabwe's electricity demand. Internal electricity generation is hampered by frequent failure of old power stations and reduced water allocation from the Zambezi River Authority during drought periods. These factors influenced Zimbabwe to import electricity from other countries.

ESKOM of South Africa imports electricity from other utilities for peak load management and emergencies only since it is cheaper to import than to run some of its power stations.

#### **9.4.2 Peak Demand and Electricity Sales**

The peak demand indicated in Table 9.4, below, takes into account the total electricity supplied into the country's interconnected system. This includes internal generation and imports from other systems. If imports are excluded, it can be noted that the Zimbabwe Electricity Supply Authority (ZESA), Electricidade de Mozambique (EDM) and the Lesotho Electricity Corporation have insufficient generation capacity to meet their countries' electricity demand.

The EDM and LEC meet demand from electricity purchases from local producers – Hydroelectrica de Cahora Bassa (HCB) and the Lesotho Highland Development Authority (LHDA), respectively – and from imports from ESKOM (South Africa). In the case of ZESA, additional demand is met from imports from HCB, SNEL (DRC), Zambia Electricity Supply Corporation (ZESCO) and ESKOM. The supply system of ESCOM of Malawi is not interconnected with systems of neighbouring countries and as such it does not import electricity. Load shedding has thus become the norm during periods of power shortages. In addition to the inability of utilities to meet the domestic demand, the power systems are unstable and unreliable. The major reason being lack of maintenance/rehabilitation and vandalism on transmission towers. These problems sometimes result in power blackouts. Notable examples are the blackouts that occurred in Zimbabwe on 14 November 1997, 4 May 1998 and 5 August 1998. Two of these blackouts happened as a result of a loss of machines at Kafue Gorge in Zambia and one was due to a bush fire (ZESA Annual Report 1998: 15).

**Table 9.4: Electricity Sales and Exports (2000)**

Country	Electricity Sales (GWh)			Peak Demand (MW)	No. of Customers	Sales per Capita kWh/person	Sales per GDP
	Domestic	Export	Total				
Lesotho	311.44	-	311.44	92.0	25,200	156	0.35
Malawi	899.01	3.58	902.59	196.9	82,792	88	0.53
Mozambique	1013.0	-	1013.0	224.6	202,001	57	0.27
South Africa	174,320	3,872	178,192	29,188	3,054,435	4,152	1.41
Zambia	7042.28	62.208	7660	1126	270,604*	758	2.64
Zimbabwe	10778.3	0.8	10779.1	2034	502,462*	855	1.46

Source: \* SAPP Annual Report, 2001

The maximum demand for the countries relates to the sizes of the various power systems. South Africa has the highest demand in the region as shown in figure 9.6 below. The demand for Zimbabwe, Zambia and Mozambique is also higher than that of the smaller systems of Lesotho and Malawi.

**Figure 9.6: Countries' Peak Demand (2000)**

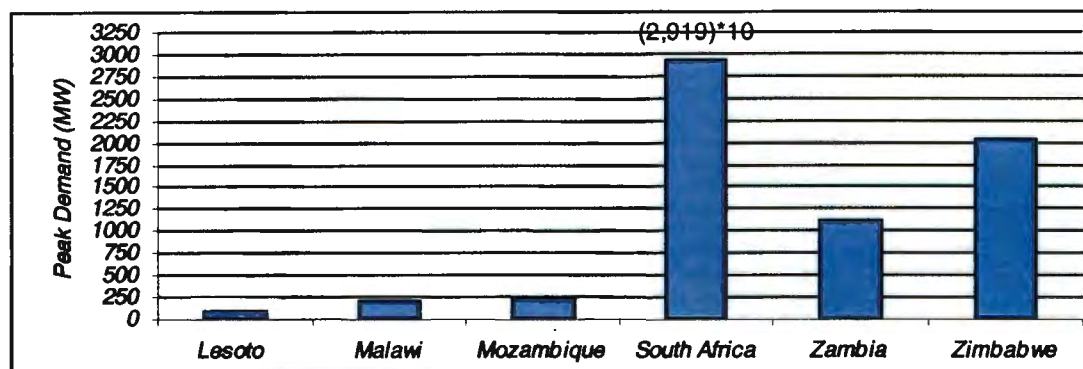

**Note:**

*Demand for South Africa should be multiplied by the factor of 10.*

### **Electricity Exports**

Zambia and South Africa export electricity at high voltage to other countries in the region. Zambia exports to South Africa, Botswana and Zimbabwe, while South Africa also exports to Botswana, Mozambique, Namibia, Zimbabwe, Lesotho and Swaziland. All power trading in the region is done under the umbrella of the Southern Africa Power Pool (SAPP). Although South Africa exports electricity to a number of countries, it is, of late, generally a net importer of electricity. The reason that South Africa imports power is to lower expenses by not running additional generating plants during peak hours.

**Table 9.5: Electricity Sales and Customers Growth (1990 – 2000)**

		1992	1993	1994	1995	1996	1997	1998	1999	2000
Malawi	Sales	651	655	704	732	727	743	803	847	902
	Sales growth %		0.61	6.96	3.83	-0.68	2.15	7.47	5.19	6.10
	Customers	45712	51000	52293	57270	61482	65786	71990	77383	82792
	% increase		10.37	2.47	8.69	6.85	6.54	8.62	6.97	6.53
Mozambique	Sales	675	684	628	679	661	779	883	996	1013
	Sales growth %		1.32	-8.92	7.51	-2.72	15.15	11.79	11.35	1.68
	Customers	132412	136327	151480	159169	171066	177793	186208	189569	202001
	% increase		2.87	10.00	4.83	6.95	3.78	4.52	1.77	6.15
South Africa	Sales	138126	143800	149443	153547	165370	172550	171457	173422	178193
	Sales growth %		3.95	3.78	2.67	7.15	4.16	-0.64	1.13	2.68
	Customers	541866	872509	1207053	1567793	1877269	2244407	2563656	2855844	3054435
	% increase		37.4	27.72	23.01	16.49	16.36	12.45	10.23	6.50
Zambia	Sales	8652	6516	7352	7404	7782	6576	6973	7741	--
	Sales growth %		-0.005	11.37	0.70	4.86	-0.18	5.69	9.92	--
	Customers	126949	126933	133572	143169	151701	165860	171194	188434	--
	% increase		-0.013	4.97	6.70	5.62	8.54	3.12	9.15	--
Zimbabwe	Sales	9248	7731	8412	9036	9365	10088	10213	10779	--
	Sales growth %		-19.62	8.10	6.91	3.51	7.17	1.22	5.25	--
	Customers	332784	339732	356395	368687	387593	410782	437888	473244	--
	% increase		2.05	4.68	3.33	4.88	5.65	6.19	7.47	--

Table 9.5, above, shows the overall trend of electricity sales of the six utilities in the countries under study from 1990 to 2000. On the domestic market electricity sales rely on different categories of customers. Thus, for example, ESKOM (South Africa) sells mainly in bulk to distributors, followed by industrial customers. Residential sales come fourth after mining. This utility has a larger customer base than any other utility in the region. The other SADC countries, Zambia, Zimbabwe, Malawi and Mozambique, have high sales from industrial customers, followed by residential customers.

The increase in electricity sales comes as a result of the increase in the utilities' customer base. All the utilities have, in fact, tremendously increased their number of customers over the past decade. The percentage increase in electricity sales is, however, lower than the percentage increase in number of customers (see Table 9.5 above). In 2000 electricity sales for ESKOM was very high, as seen from Figure 9.7 below. ESKOM was followed by ZESA while the Lesotho Electricity Corporation made the smallest sales.

**Figure 9.7: Electricity Sales (2000)**

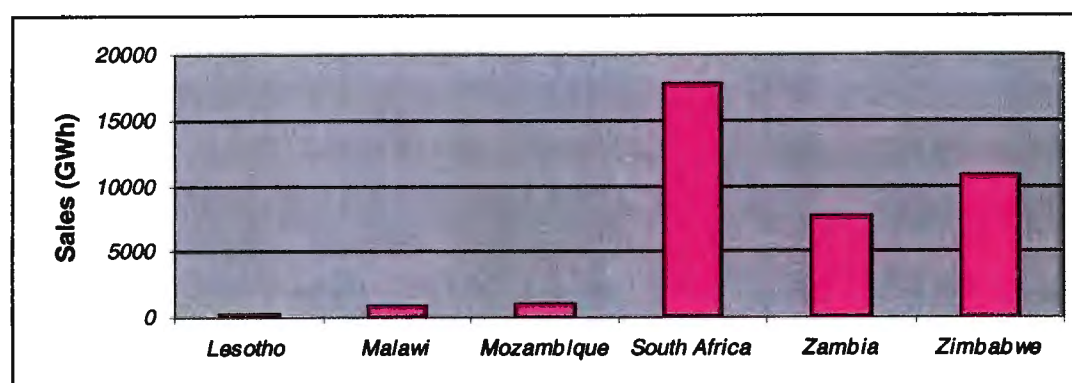

*Note: Electricity Sales for South Africa should be multiplied by the factor of 10*

**Figure 9.8: GDP per Capita and Electricity Sales per Capita**

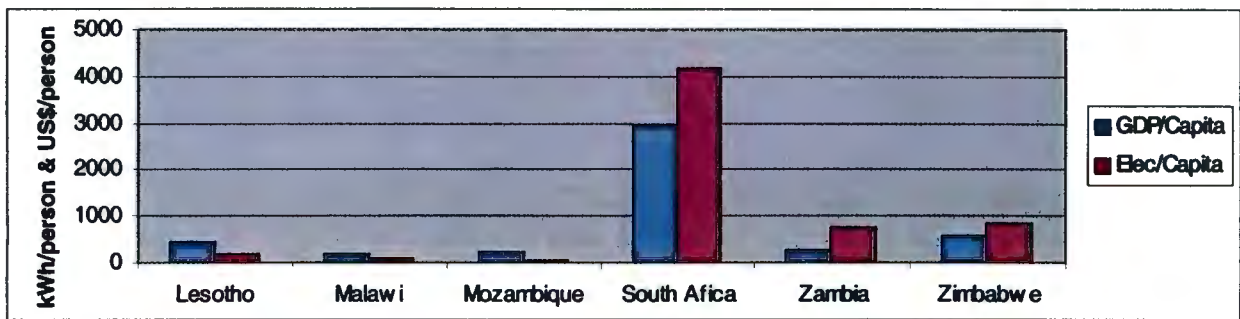

The growth of electricity sales seems to be in line with the GDP per capita growth rate, as indicated in Figure 9.8 above. The Figure shows three countries (Lesotho, Malawi and Mozambique) with low electricity sales per capita and a high GDP per capita whereas the other three countries (South Africa, Zambia and Zimbabwe) have high electricity sales per capita and a lower GDP per capita. In any case, when the GDP decreases, electricity consumption also decreases. Furthermore, one factor in common among the countries with low electricity sales per capita is that their power utilities have a comparatively low industrial customer base.

Since 1990 the growth of electricity sales in the countries has been increasing, as indicated in Figures 9.9a and 9.9b below. The electricity sales in Malawi and Mozambique are relatively good compared to the sizes of their power systems and economies.

**Figure 9.9a: Electricity Sales Growth (1990 – 2000)**

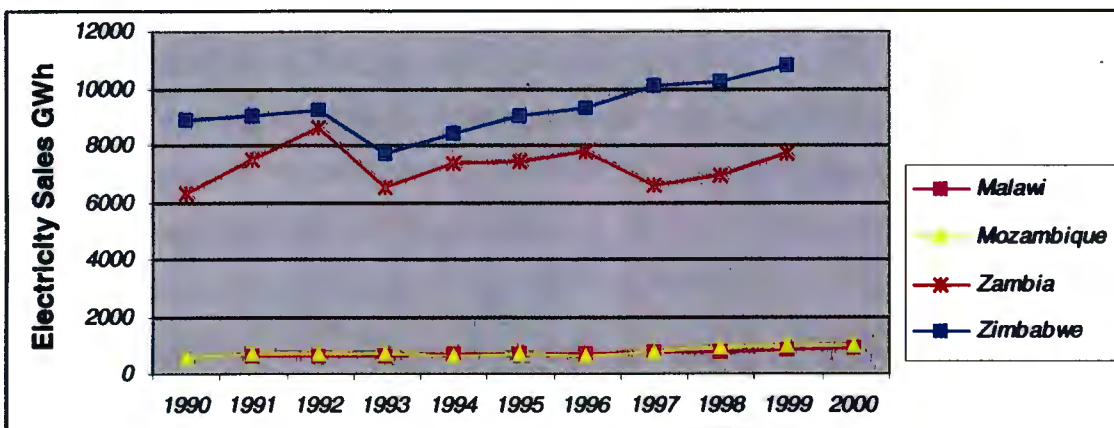

**Figure 9.9b: Electricity Sales Growth for South Africa (1990 – 2000)**

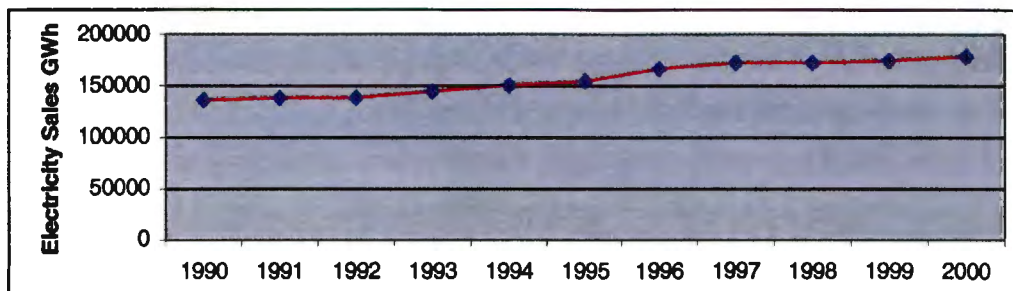

It can further be observed from Figure 9.9a that the growth of electricity sales for ZESA and ZESCO declined in 1992. The ZESA sales during this period were affected by the decline in electricity sales to the farming sector, which was affected by poor rainfall (ZESA 1992: 22). In the case of Zambia, the sales decreased due to low generation as a result of restricted generation from Kafue Gorge power station. Two units of total capacity of 300 MW, at this station, were undergoing major restoration work (ZESCO, 1991/92: 5). In 1996, Zambia further experienced the worst drought in the region, and this consequently affected electricity generation output (ZESCO, 1995/96: 8).

### *Number of Customers*

Electricity produced by the utilities is either sold in bulk to large customers such as distributors or in small quantities to small customers. In the countries under study, only ESKOM sells some of its electricity in bulk to redistributors, which then sell the same to their customers. The growth of customers indicated in Figure 9.10b for ESKOM, therefore, excludes the customers of redistributors.

Although Mozambique is second after South Africa in respect of country size and population, it has fewer customers than Zimbabwe. The rate of customer growth in the five countries is also low when compared to South Africa and this consequently results in low demand as well. It is observed, from Figure 9.10b below, that ESKOM increased its number of customers more than any other utility over the past 11 years. The other utility that has also increased its customers significantly is ZESA (see Figure 9.10a). The main reason for such increases in numbers of customers is the electrification programmes which these two embarked on from the early 1990s.

**Figure 9.10a: Customers Growth (1990 – 2000)**

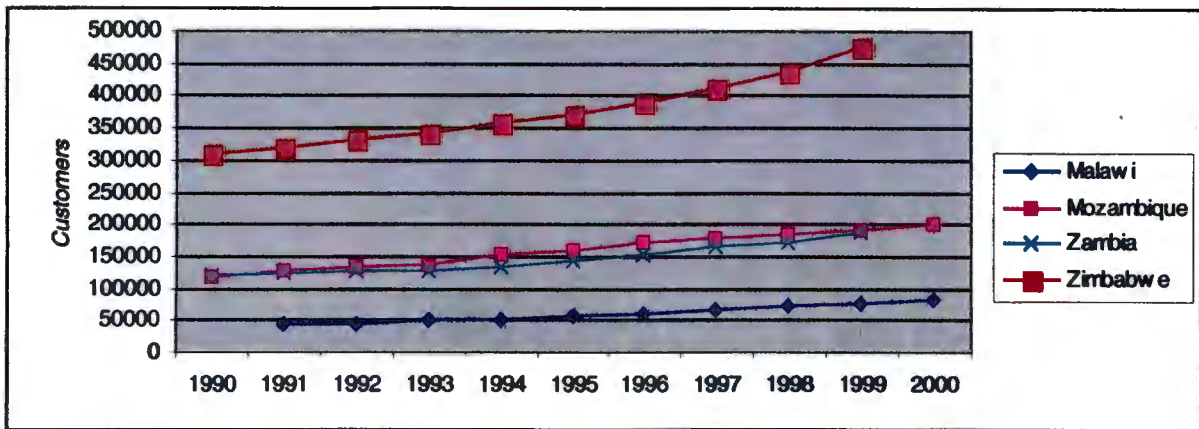

**Figure 9.10b: Customers Growth for South Africa (1990 – 2000)**

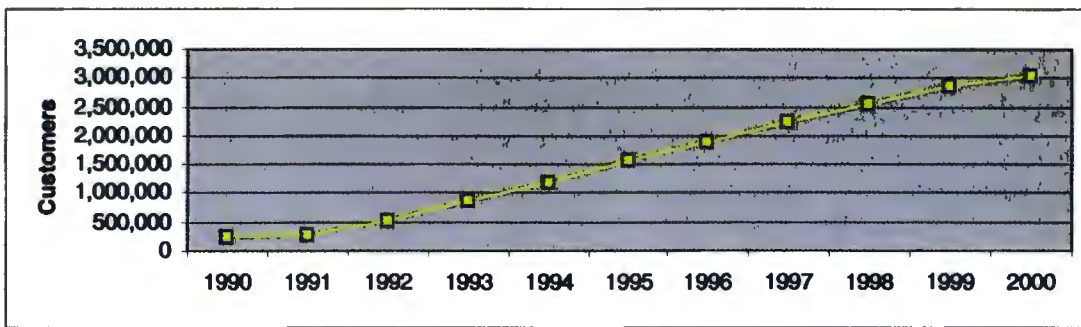

### 9.4.3 Financial Performance

The utilities' financial performance can be measured by means of the indicators listed in Table 9.6 below.

**Table 9.6: Some Financial Performance Indicators (2000)**

	Malawi	Mozambique	South Africa	Zambia	Zimbabwe
Avg price electricity generated US\$ /kWh	0.016	0.077	.016	-	0.018
Avg price electricity sold US\$ /kWh	0.031	0.068	.020	-	0.020
Total asset value US\$ (million)	162	2,380.215	10,689	565	743
Net profit US\$ (million)		-9.406	462.968	29.659	71.917
Return on assets %	2.16	0.87	9.79	2.8	4.84
Debt/equity ratio	0.34	-	0.71	0.4	4.46
Interest cover ratio	2.1	-	2.10	3.25	0.85
Exchange rate	59.54	15,199.8	6.94	3,110.84	43.29

The asset values of the utilities depend on the size of the utility. The utilities with large systems such as those of South Africa, Zimbabwe and Zambia obviously have more assets than the utilities with smaller systems as in Malawi and Mozambique. Since the electricity industry is capital-intensive, most utilities borrow money from financial institutions to build their systems, with the government acting as a

guarantor. The loans are returned with interest to the lenders. The debt/equity and interest cover ratios for these utilities in 2000 are shown in Table 9.6 above.

### Electricity Costs

The price of electricity generated and the price of electricity sold are other factors against which financial performance can be measured. It is seen from Figure 9.11 that the selling price per unit of electricity is higher in Mozambique than in the rest of the countries. The major problem hindering the good financial performance of some of the utilities is poor revenue collection. Thus the debt collection period is very high. In Mozambique, for example, debt collection reached a peak of over 120 days in some years.

Figure 9.11: Average Price of Electricity Sold (2000)

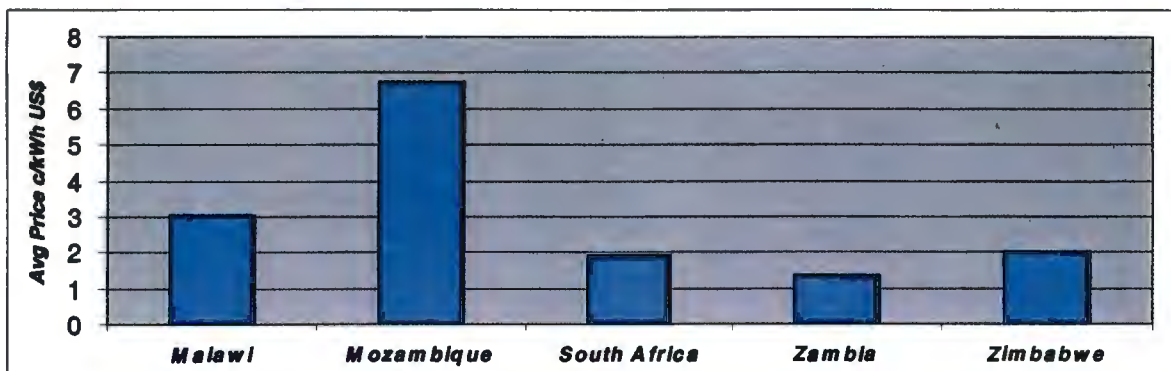
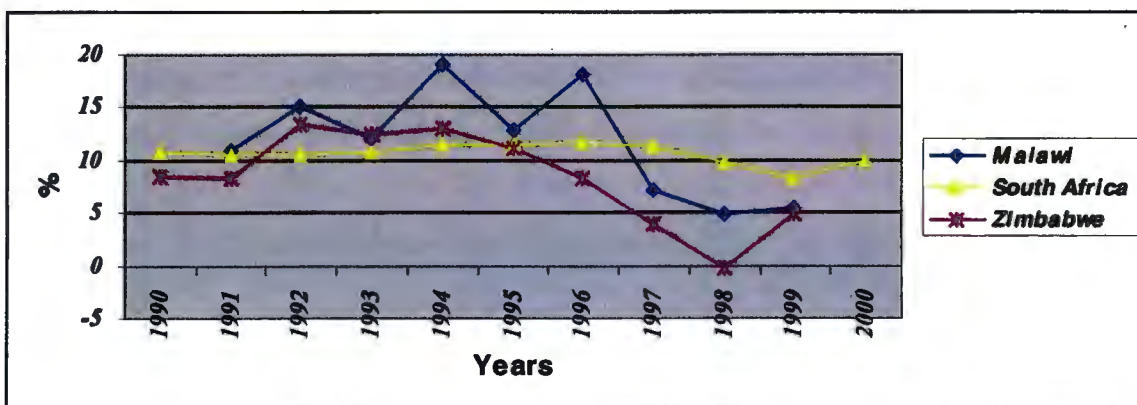

Figure 9.12: Return on Assets (1990 – 2000)



### Return on Assets

The return on assets for three utilities where data was available indicates that the utilities have a positive return on their assets. ZESA's return on assets had been declining from 1994 till 1998 when it posted a negative return of -0.26 %. This trend changed in 1999 when ZESA reported a positive return on its assets, as can be seen from figure 9.12 above. From this Figure it is also seen that only ESKOM has been

reporting an almost consistent trend on its assets. The trend for ESCOM (Malawi) is positive, but varies widely almost every year.

### ***Electricity Tariff***

Electricity tariffs vary from country to country. The tariff adjustment aims at covering the costs of supply in the countries so that the utilities can perform well financially. Currently governments approve tariff adjustments in countries that do not have independent regulators such as Mozambique and Zimbabwe. However, in Malawi, South Africa and Zambia, regulators do approve tariff adjustments as opposed to governments

### ***Net Profit before Tax***

Figures 9.13a and 9.13b, below, show the net profit/loss for the utilities for the past decade. It is observed that over the years the utilities' net profits before tax show that Eskom (SA)'s performance is the best by far. The other utility that has managed to maintain consistently considerable profits was ESCOM (Malawi). The profits are, however, small as can be seen from the Figure 9.13a. Up to 1998 when it started making losses, ZESA's profits show a similar trend of profits as those of ESCOM. In other countries the utilities were either making profits or losses in some years. The EDM (Mozambique) has been operating at a loss, because the selling prices of electricity are less than their production costs. Electricity production from hydropower is considered to be cheaper than from other generation sources. Low profitability levels experienced by the utilities with hydro-based systems, such as ZESCO, thus generally relate to poor commercial practices and not because hydro is inherently expensive. In contrast, South Africa, despite relying on thermal generation from coal, which is fairly expensive, still makes profits and, in addition, has lower tariffs.

**Figure 9.13a: Net Profit/Loss before Tax (1992 – 2000)**

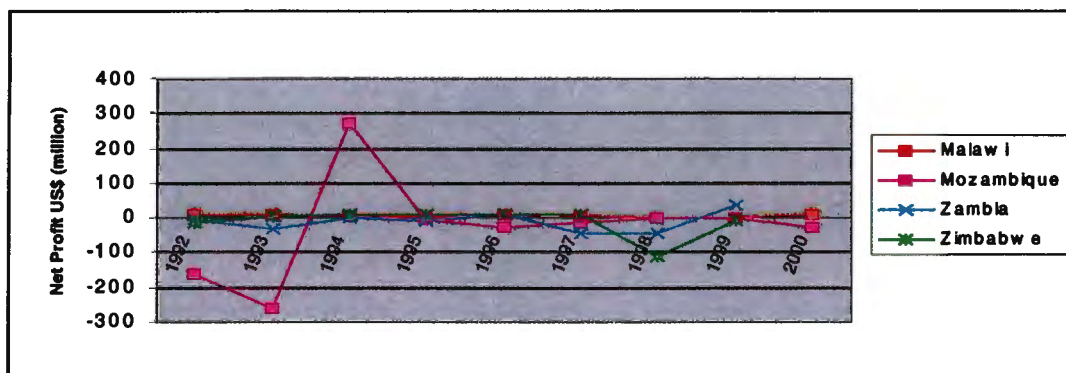

**Figure 9.13b: Net Profit before Tax for South Africa (1992 – 2000)**

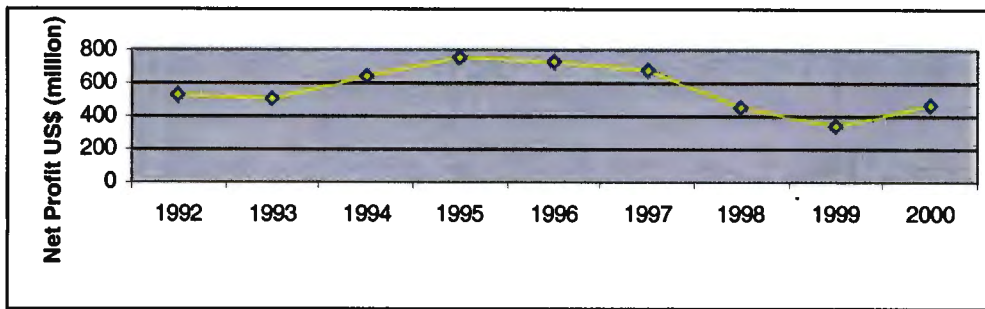

#### 9.4.4 Other Performance Indicators

Table 9.7, below, illustrates other data that can also help to evaluate the performance of the utilities in addition to the other indicators already discussed in previous sections.

**Table 9.7: Other Performance Indicators**

Indicators	Lesotho	Malawi	Mozambique	South Africa	Zambia	Zimbabwe
Number of Employees	444	2,218	2,774	32,8312	4,025	6,846
Customers per Employee	57	37	73	95	-	69
GWh sold per Employee	0.701	0.406	0.365	5,427	0.994	1.576
System Losses (%)	22.4	14.8	24.9	7.4	8.9	12.8
Access to Electricity (%)	3	4	4.2	70	18	40

#### Notes

1. Lesotho data is for 2001
2. Data for Zambia and Zimbabwe is for 1999 with exception of access to electricity which is for 2000
3. Utility employees for Zambia – Figure obtained from SAPP Annual Report
4. South Africa's system losses exclude distribution losses.

#### *Sales per Employee*

Electricity sales per employee roughly indicate how the utilities are manned. South Africa's ESKOM had the highest sales per employee at 5,427 GWh in 2000 and Mozambique's EDM had the lowest sales per employee at 0.365 GWh as can be seen from Figure 9.14 below. Taking the World Bank benchmark of 0.602 GWh per employee as the standard (The UNDP/World Bank, 1996: 53), only ESKOM is performing well in the region. The figure for South Africa, however, is somewhat misleading, as it does not include municipal distributors' employees.

**Figure 9.14: Sales per Employee**

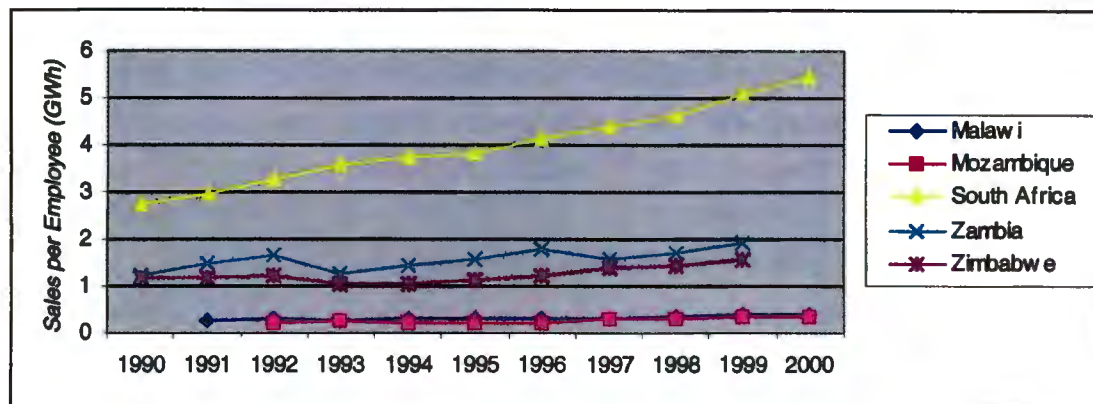

**Number of Employees**

Another area in which the performance of the utilities can be compared is with regard to labour productivity. The utilities in all the countries, for instance, have different numbers of employees. In general, countries with greater installed capacities also have higher numbers of employees. Thus, South Africa, with its huge capacity and customer base, had 32,832 employees in 2000 (ESKOM Annual Report, 2000: 124). The two utilities with more or less similar capacities, that is Zambia and Zimbabwe, follow a similar pattern. ESCOM (Malawi) and EDM (Mozambique) have an almost similar installed capacity and their numbers of employees are also small. Analysis from the case studies of the countries indicates that all the utilities have been reducing staff over the past years in order to increase their profit margins.

**Figure 9.15a: Utility Employees (1990 – 2000)**

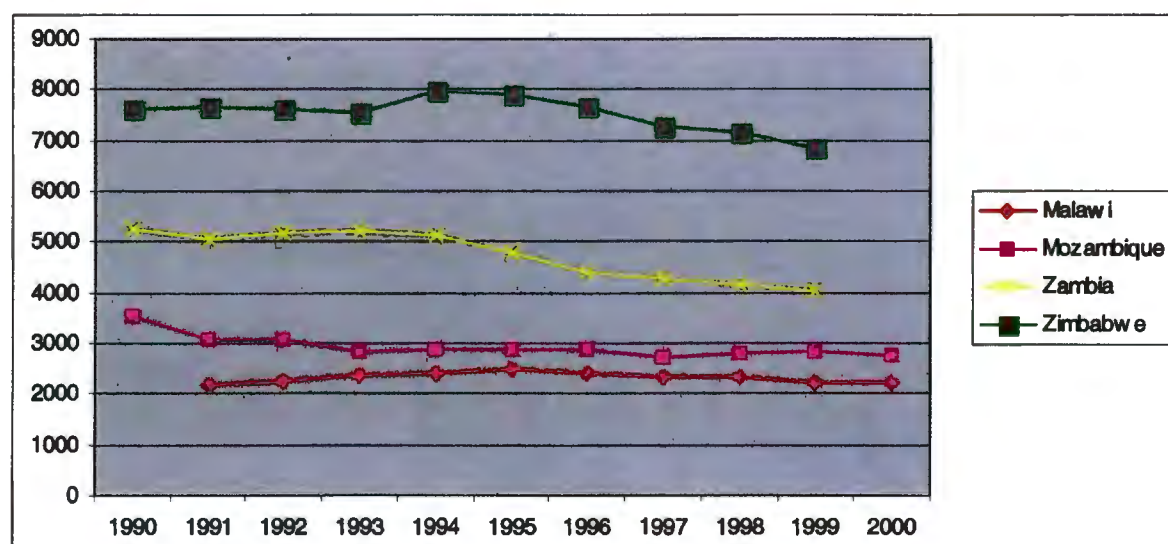

**Figure 9.15b: Utility Employees for ESKOM (1990 – 2000)**

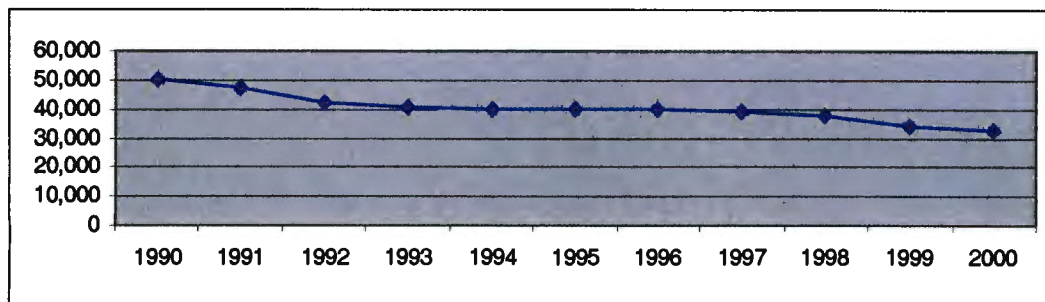

***Number of Customers per Employee***

In 2000, ESKOM (South Africa) had the highest number of customers per employee, namely 95, followed by Mozambique with 73 customers per employee as indicated in Figure 9.16 below. The Figure shows an increasing trend in the number of customers per employee for all the utilities. The ratio of customer per employee, however, varies from country to country. If productivity of the utility were only measured by customer per employee ratio, then all the utilities in the selected countries display low productivity, using the World Bank standard of 104 customers per employee. Malawi is the least with only 37 customers per employee. The main contributing factor to the low ratio of customer to employee is the low access to electricity in the countries. The main contributing factor to South Africa’s high ratio is the increase in electricity access as from 1992.

**Figure 9.16: Customers per Employee (1990 – 2000)**

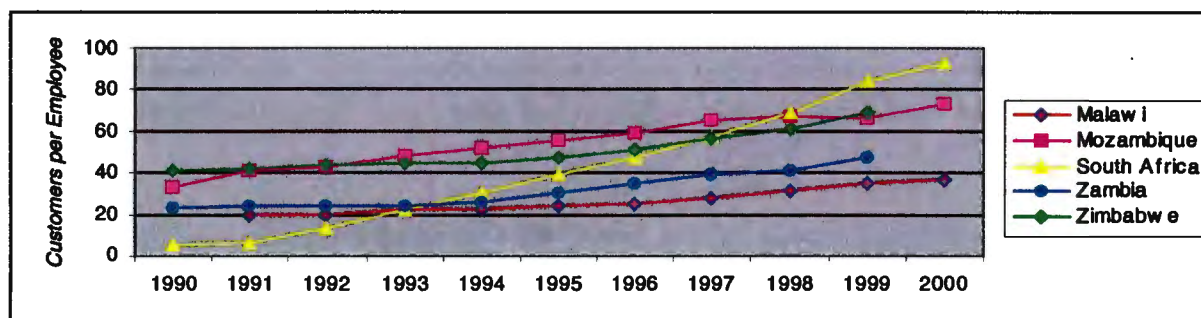

***Power System Losses***

The difference between the energy sent out to the transmission and distribution system and the energy that is ultimately metered at consumers’ premises indicates the total power system losses. The power losses vary from one utility to another, ranging from 5 % for South Africa to 33.4 % for Mozambique (see Figure 9.17 below). The South African system’s losses are low because the distribution system that incurs a large

proportion of these losses is part of the municipal redistributors. The losses in the non-ESKOM distribution system are thus not included in this study.

**Figure 9.17: Power System Losses**

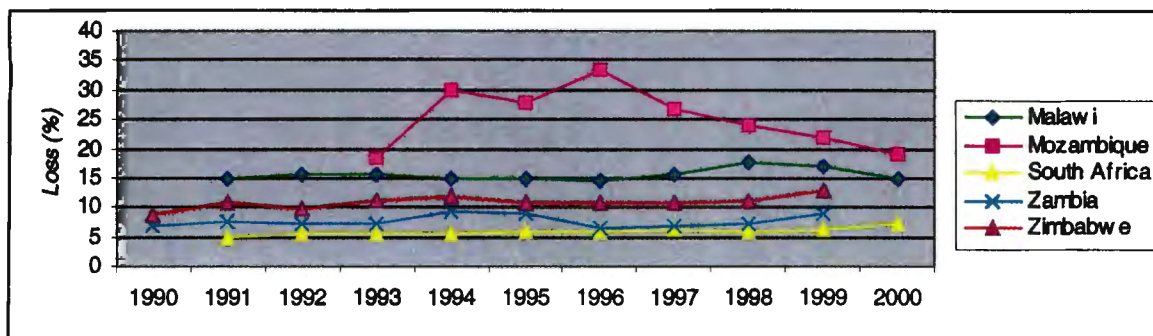

Generally, Lesotho and Mozambique have the highest power losses compared to other countries. In Mozambique more losses occur in the distribution system, and this could be due to non-technical losses. Nevertheless, the utility has managed to reduce the losses from 33.4 % in 1996 to 19 % in 2000. This is a tremendous improvement.

The technical data of some countries does not distinguish between transmission and distribution losses, or between technical and non-technical losses. Lack of metering equipment is the main reason for not separating the transmission and the distribution losses. If the countries can, however, reduce these losses, system performances can improve and then an improved financial performance can also be achieved due to higher revenue collection.

### 9.4.5 Electrification

Electrification levels still remain low in the countries, with the exception of South Africa. Efforts to increase electricity access were hampered by the poor financial performance of most of the utilities. The utilities concentrated on providing services to urban upper and middle-income earners, while the urban low-income earners and the majority of the rural poor continue to rely on traditional energy sources from biomass. South Africa had the highest electrification level (63 %) in 2000, followed by Zimbabwe (40 %) (See chapters 6 and 8 respectively). Access to electricity in Zambia was 18 % (see chapter 7) while the rest of the countries had less than 7 %. The lowest was that of Lesotho at about 3 %, as mentioned in chapter 3. The countries that achieved high electrification levels had committed themselves to electrification programmes that were financed by the utilities themselves, as well as from grants, loans from donors, and in some countries, electricity levies. The only countries that have had tremendous achievements so far are South Africa and Zimbabwe.

**Figure 9.18: Electrification Levels (Access to Electricity)**

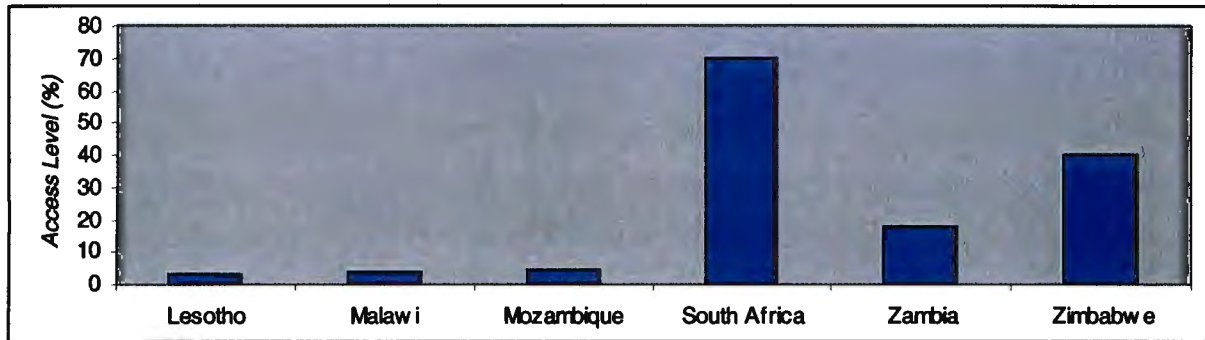

One of the main objectives of the reforms is to increase access to electricity. Most governments have realised that electrification projects to rural areas are not financially viable and thus have designed various mechanisms to finance such projects, as part of their ESI reforms.

## 9.5 The Reforms

Power sector reforms were started as far back as the 1990s by both developed and middle income countries. Currently, many countries in the world are reforming their electricity industries. The countries in the SADC region, which have been selected for the current study, have followed the same trend. Although each of these countries has specific driving forces for opening up their electricity markets, some of the drives are common to all the countries.

### 9.5.1 Drives for Power Sector Reforms

Reforms in the various countries of this region are driven by the need to improve the poor technical and financial performance of the publicly owned utilities. These utilities, with the exception of ESKOM of South Africa, had performed badly in the last decade, recording huge financial losses or marginal profits in most of the years as illustrated in Figure 9.13. The utilities failed to finance system expansion projects in their respective countries and inadequate maintenance resulted in poor service provision. According to the energy policies and other government documents of Lesotho, Malawi, Mozambique, South Africa, Zambia and Zimbabwe, the following reasons<sup>1</sup> had been identified as the main driving forces behind these changes:

- i. poor financial performance of the present utility (Lesotho, Malawi, Mozambique and Zambia)

<sup>1</sup> Government of Zambia, National Energy Policy, Mozambique: Reform and regulation of power sector (London Economics, South Africa Government, White Paper on Energy Policy, Energy Policy of the Government of Lesotho, Government of Malawi, Energy Policy White Paper, Government of Zimbabwe, Electricity White Paper

- ii. supply-side inefficiency, i.e. unreliability of supply, poor plant maintenance, high system losses, etc. (Malawi, Mozambique, Zambia and Zimbabwe)
- iii. problem of environmental degradation (Malawi and Zimbabwe)
- iv. failure of the present utilities to increase access to electricity (Lesotho, Mozambique, Malawi, Zambia and Zimbabwe)
- v. to attract private investment participation in the development of the power sector (Mozambique, South Africa, Zambia and Zimbabwe)
- vi. inability to service loans (Lesotho)
- vii. high tariffs (Lesotho)
- viii. inefficient commercial operation of the utility (Lesotho)
- ix. high operational costs characterised by high staffing levels (Lesotho)
- x. lack of an efficient and independent regulatory system (Malawi)
- xi. lack of management autonomy (Malawi)
- xii. to ensure that investment and productive efficiency result in a lower cost of electricity (South Africa)
- xiii. to unlock economic value (South Africa)
- xiv. to widen economic ownership (South Africa)
- xv. to contribute to the New Partnership for African Development (South Africa)

### **9.5.2 Objectives of the Power Sector Reforms**

Power sector reforms are aimed at improving the operational efficiencies of the utilities in order to reduce electricity prices and extend electricity services to the majority of the people. After reviewing the objectives of the governments in the selected countries of study, as outlined in their energy policy documents or Electricity White Paper, it is clear that different governments have some common objectives as well as country-specific objectives for reforming their power sectors. The objectives identified are:

- i. To make the sector financially viable and eliminate direct and indirect subsidies from the government budget (Lesotho, Malawi and Zimbabwe)
- ii. To create an enabling environment for private sector participation in order to expand the electricity sector (Lesotho, Malawi, Mozambique, South Africa, Zambia and Zimbabwe)
- iii. To make sure consumers pay a service connection charge based on the expected average cost for the new connections to the network (Lesotho)
- iv. To promote competition in the segments of generation and supply to ensure that customers' choices and expectations for safe, secure and reliable electricity are met (Zambia and Zimbabwe)
- v. To promote use of solar and other renewable energy sources (Malawi)

- vi. To attract and retain competent employees (South Africa)
- vii. To improve the reliability and quality of service and supply (Malawi and South Africa)
- viii. To improve efficiency in the electricity industry (Malawi and Zambia)
- ix. To ensure that electricity tariff structures and prices are based on sound economic principles (Lesotho and South Africa)
- x. To provide low-cost electricity (Malawi and South Africa)
- xi. To protect the environment (Malawi and Zimbabwe)
- xii. To increase the capacity to meet the growing demand (Malawi)
- xiii. To increase the number of customers from 4 % to 10 % of the population by 2010 (Malawi)

### **9.5.3 Reform Paths/Strategies**

The reform programs in the selected countries were developed at different times during the last decade and can be traced back to 1994. Zambia first showed its intention of restructuring ZESCO's distribution industry in its national energy policy document in 1994 (Ministry of Energy and Water Development, 1994). Later the other governments showed their willingness to reform their power sectors. These governments framed the strategies for adoption in their energy or electricity policy documents or White Papers. The implementation of these strategies should enable the governments to realise the power sector reform policy objectives outlined above. The governments employ consultants to assist either in developing the regulatory framework or in restructuring of the utility. The consultants are engaged in order to advise the government on how best to implement the reforms so that the transition from the current state to a liberalised electricity markets is smooth.

The elements of electricity market reforms being discussed include commercialisation/corporatisation, unbundling of the organisations, increased private sector participation, and review of laws governing the electricity sector. The selected countries have attempted to implement some of the reform elements and are at different stages in the reform process. In Lesotho, Malawi and South Africa, the reforms are at an advanced stage, whereas in Mozambique, Zambia and Zimbabwe the progress is slow. Unlike reforms in industrialised countries which took place speedily, the reforms in these countries are approached consciously and carefully. Firstly, the laws that governed the electricity sector needed to be revised and regulatory boards established. Secondly, the lack of resources in most of the countries meant that progress would not be rapid. Some countries such as Malawi, Lesotho and Zambia had to receive financial assistance from the World Bank or other agencies. Thirdly, the governments seemed uncertain as to whether the reforms would bring about the expected benefits and as a result there have been some delays in the implementation of the programme.

Different approaches to the reform process have been undertaken by the countries in order to address some of the common issues affecting the utilities, as well as some country-specific objectives. The initial step before embarking on the reforms was to agree on the objectives of the electricity sector reforms. The challenges facing the sector were identified and the tentative reform programme for implementation had to be drawn up.

Zambia produced its Energy Policy Paper in 1994 and all the reforms are occurring in accordance with what was outlined in that document. Thus it started by establishing the office of the energy regulator, which plays a major role in implementing government objectives. The other institution that has been active in reforming the Zambia Electricity Supply Corporation is the Zambia Privatisation Agency (ZPA). The ZPA was founded because of the government plans to restructure and privatise state-owned enterprises. The main aim of the Zambian government is to restructure the distribution system so that it becomes efficient. The Energy Regulatory Board and the government are the key players in these reforms. The regulator developed the expected new ESI structure through a consultative process with stakeholders. The existing ZESCO structure will be vertically unbundled into generation, transmission, and distribution and supply functions. The new structure will allow room for the participation of private investors and independent power producers. Thus, a number of generation and distribution companies will be formed from ZESCO. Once the government accepts the methodology adopted by the regulator to restructure the electricity industry, it is expected that the subsequent reform processes will follow.

The case for South Africa is similar to that of Zambia, but there are some differences. South Africa is also basing its reforms on the government's plan as outlined in its national energy policy. The new Electricity Act, which governs the sector, was passed in 1994/5. Thus the legislation was reformed first. After the enactment of the new Electricity Act, an independent regulatory body, the National Electricity Regulator (NER) was set up. The restructuring of the power sector and the public utility then followed. The process of designing the utility structure was also developed through a consultative process. The design of the new ESI structure allows sales of generation assets with the main objective of increasing black economic empowerment. Consultants have been involved in restructuring the distribution industry. Currently, ESKOM has been corporatised and will operate as any other commercial entity. The remaining reform processes will follow after all utility structures have been completed and agreed upon.

The reform strategies for the other countries are quite different. Malawi, for example, started reforming its electricity sector without a new national energy policy document being in place. Initially laws governing electricity supply were changed. After revising the laws, an independent electricity sector regulator was established and the utility was corporatised. The process of producing the national energy policy occurred in parallel with the utility reforms. The policy document which outlines the government's objectives regarding the reform of the electricity sector, is currently in its final stages. A consultant from

ESKOM, RSA was involved in restructuring the utility (ESCOM Annual Report, 1999:9). The present vertically integrated utility structure will be unbundled into separate generation, transmission and distribution units and will allow private sector participation in the generation function of the ESI. The government intends to implement a single buyer model as the final ESI structure in Malawi. The size of the ESI in Malawi is basically small, hence the single buyer model proposal.

The power sector reforms in Lesotho were initiated by the government and were funded by the World Bank. Lesotho's approach has been different to those of the other countries, in that the government intends to privatise the utility as a whole. Thus the utility's present structure is not expected to change. Due to the poor financial performance of the utility, radical changes were thought to be necessary. Initially a management contract was put in place so that the consultant could improve its financial performance and prepare it for privatisation. The new legislation will be in force soon and a regulator is to be established.

The reform strategies for Zimbabwe and Mozambique have been the same. The two governments have designed the ESI structures before establishing an independent regulator. The model for Zimbabwe is to some extent similar to that of South Africa. Zimbabwe's initial proposal was to privatise a part of generation assets. This is, however, on hold now. The proposal for the new ESI structure, however, remains. Thus the vertically integrated ZESA structure will be unbundled into generation, transmission, distribution and supply functions. The generation and distribution will further be horizontally unbundled into different companies. Currently the Electricity Act which allows ZESA to be commercialised and the regulatory authority to be established, has been approved by parliament. Further reforms are expected to proceed following the designed ESI structures.

The reforms that have already taken place and those that are underway in the selected countries are illustrated in Table 9.8 below.

**Table 9.8: Status of the Reforms**

	Lesotho	Malawi	Mozambique	South Africa	Zambia	Zimbabwe
Energy Policy	2002	2002		1998	1994	2000
Reform Policy/Strategy						
Reform Legislation		1998	1997			
Regulator Legislation	2001	1998		1995		2002
Corporatisation		1998		2002		2002
<b>Commercialisation</b>						
- Management Contract	2001	2001				
- Unbundling (separation of Accounts)		2001				
<b>Physical Vertical Unbundling</b>						
- Gen/Trans/ Distr				2003?		
- Gen&Tran/Distribution						
- Generation/Tran & Dist.						
<b>Horizontal Unbundling</b>				2003?		
- Gen/Gen/Gen						
- Dist/Dist/Dist						
- Distribution Rationalisation						
Generation Monopoly		Yes			ZESCO	ZESA
IPPS					Two	Small IPPs
- Competition Possible						
- Competition Actual						
Generation Market Power			By IPP	ESKOM		
Single Buyer						
Wholesale Competition						
Electricity Trading						
<b>Privatisation</b>						
- Generation					One hydro	
- Transmission						
- Distribution						
Independent Regulator	2003	1998			1995	

**Note**

?: means proposal

**9.5.4 Changing of Laws/Enabling Legislation**

The ESIs in the selected countries operate under various Acts passed by their parliaments. These Acts specify how electricity production and supply should be carried out, and prescribe the structure of the industry and its regulatory system. Since the ESI was a monopoly for many years, the governments felt that it was their obligation to ensure that electricity is supplied at low cost in order to improve socio-economic development. As a result, the governments of these countries established public power utilities rather than encourage private sector participation. The thinking was that, should the ESI be left entirely in the hands of the private sector, electricity prices would be too high and, to be cost-effective, the utilities

might only concentrate on already developed areas, and hence the governments' development objectives would not be achieved. Consequently the laws which governed the industry restricted the right to the generation and supply of electricity to the public utilities and prevented private sector involvement. This is the reason for the dominance of the publicly owned utilities in the ESI, as seen in Chapters Three to Eight. The utilities, however, face numerous challenges in delivering reliable electricity services. The efforts to solve the problems facing the utilities have brought about the liberalisation of the electricity industry. This then requires reforming the role of the public and private sectors, institutional arrangements and the regulatory system. Effecting these changes require new laws which will allow private sector participation in the industry, provide a legal basis for public utility restructuring and facilitate ESI regulation.

It is clear from Table 9.8, above, that almost all the countries discussed have reviewed the laws governing the power sector and that new legislation has been passed. The last country to implement new legislation to allow new entrants into the power sector will be Lesotho. In this regard, the drafting of the legal, regulatory and other documentation required for the execution of the new legal and regulatory framework was awarded to Barents Group of KPMG Consultants in December 2001 (The Privatisation Unit of Lesotho, 11 January 2002). The other countries reformed their electricity legislation much earlier. For instance, Zambia was the first country to change its legislation in 1995 and its ESI is now governed by a new Electricity Act, No. 15 of 1995. Mozambique's new Electricity Act was approved by Parliament in August 1997. It allows other players to generate and supply electricity in Mozambique. Malawi and South Africa reformed their respective electricity legislation almost at the same time in 1998. The Electricity Act No. 19 of 1998 liberalised the power sector in Malawi. The liberalisation of the power sector took place in Zimbabwe after its Parliament passed the new Electricity Act in 2001. The restructuring of the public utilities forms part of the reform processes.

#### **9.5.4.1 Commercialisation and Corporatisation**

The governments, as the first step towards reforming the public utility, have used commercialisation as a tool. This enables the utility to be detached from the government ministry. The idea is to let the utility be customer driven and accountable for its operations. The utility is required to operate on commercial principles and becomes liable to pay taxes and dividends. Three countries have so far corporatised their utilities. The power utility of Malawi was the first to be corporatised, followed by Zimbabwe, and recently, South Africa. Separate Generation, Transmission and Distribution Business Units have been created and fall under a holding company. Generation and distribution have been further unbundled into sub-business units, pending complete separation into different generation and distribution companies in future. Corporatisation in the other countries is pending. The Electricity Supply Corporation of Malawi separated the accounts of generation, transmission and distribution departments in order to monitor the financial performance of each core business unit.

### ***Management Contracts***

Generally management contracts are forms of participation where the operation of the utility or part of the core function of the utility is contracted to an external operator. As part of power sector reforms, two utilities are currently under management contract in the selected countries under study. The Lesotho government hired SAD-ELEC to manage the Lesotho Electricity Corporation initially for a period of eighteen months, from February 2001 to July 2002. The contract period has now been extended for another six months. Under the contract SAD-ELEC is supposed to prepare the LEC for privatisation. ESCOM of Malawi is also being managed by ESKOM Enterprises of South Africa, under what is known as a management consultancy contract. These contracts were primarily established with the objective of introducing commercial discipline and improving both technical and financial performance of the utilities.

#### **9.5.4.2 Private Sector Participation**

The introduction of the reforms has opened up the electricity market for private sector participation in generation, transmission and distribution. The actual level of participation differs from country to country. Lesotho and Malawi are the only countries which do not have independent power producers or any private participant in both transmission and distribution. However, private sector participation in the other countries is still limited. The countries where other players are already involved are South Africa, Zimbabwe, Mozambique and Zambia. One private operator who has come as a result of the reforms is the independent producer in Zambia, Lusenfwa Hydro Power Company, who now owns the 38 MW hydro plant at Mulungushi after the government allowed the privatisation of these assets. The generation capacities of the independent power producers in these countries, with the exception of Mozambique, are also very small. This means that real competition is not possible at this moment within the countries. The situation will only change after implementation of the new ESI structures, i.e. after privatisation of some assets in generation. The only country where IPP production is huge is Mozambique. Lack of alternative sources of primary energy that can be used for electricity generation is one of the factors hampering the emergence of independent producers. The second factor is demand. In some countries, such as Malawi and Lesotho, demand for electricity is currently fairly low.

#### **9.5.4.3 Restructuring**

Restructuring involves changing the structure of the organisation. This is achieved through unbundling the current organisational structures in order to create an enabling environment for competition.

#### ***The Current ESI Structure and Ownership***

The Electricity Supply Industry (ESI) in the region shows wide-ranging characteristics in terms of generation capacities, transmission, distribution sizes, demand and financial performances. The utilities' present structures are still monopolistic and vertically integrated. Nevertheless, participation of other

players at one or two stages of the different functions of generation, transmission and distribution does already exist to a small degree in some countries, as illustrated in Figure 9.19 below.

1. The supply system in Malawi maintains a high degree of integration. No other player is involved in the sector. Small generation by large electricity users, basically for own consumption, is, however, available.
2. The Lesotho Highland Development Authority (LHDA), which owns a major part of the generating plant, is a state-owned enterprise that is responsible for water delivery and hydropower projects in Lesotho. The Lesotho Electricity Corporation owns and operates a small part of the generation, transmission and distribution systems.
3. The public utility ZESA and other private companies, which own a small part of generation, dominate the current ESI structure in Zimbabwe. The private generators basically generate electricity for their own consumption, but also sell any surplus to ZESA. Transmission and distribution is wholly owned by the public utility.
4. Zambia's ESI structure shows a high degree of participation in all line functions of the electricity industry. The industry is, however, dominated by the public utility, ZESCO. An IPP is currently involved in generation after taking ownership of a 38 MW hydropower plant that was privatised. The CEC also owns part of the transmission and distribution system.
5. The structure of the ESI in Mozambique is different from those of the other countries in the region, but it has one common feature with that of Lesotho in that a major part of the generation sector is owned by an IPP. Mozambique also has several isolated systems, which are owned by the EDM, municipalities and private suppliers, unlike the situation in Zambia, where all the isolated systems are owned and operated by ZESCO.
6. The ESI in South Africa is dominated by a vertically integrated public utility, ESKOM. There is a small degree of participation in generation by municipalities and private generators. ESKOM and the municipal generators carry out both distribution and supply, but transmission is wholly owned and operated by ESKOM.

**Figure 9.19: Current ESI Structures (Excluding self-generation and isolated systems)**

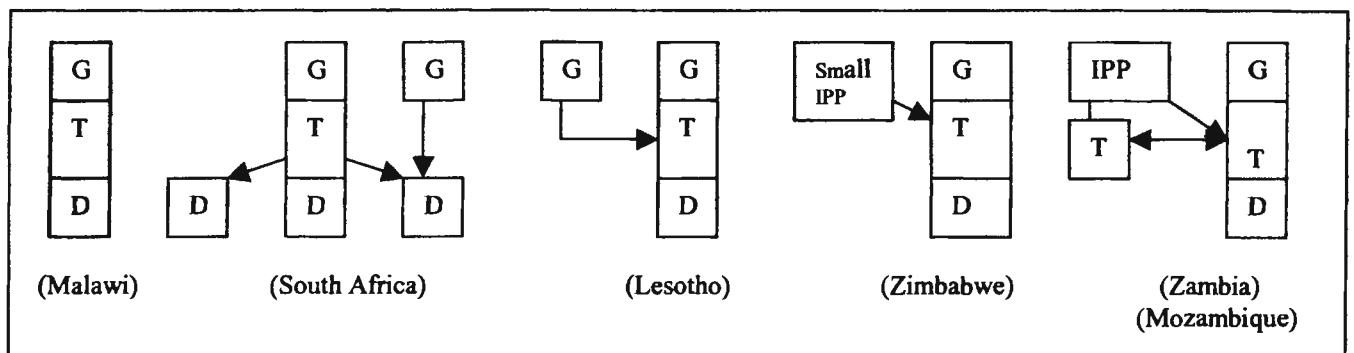

#### 9.5.4.4 Unbundling

The restructuring of electricity industries currently undertaken by the governments is moving from the traditional vertically integrated structure to two main models illustrated in Figure 9.20 below.

**Figure 9.20: Expected New Structure**

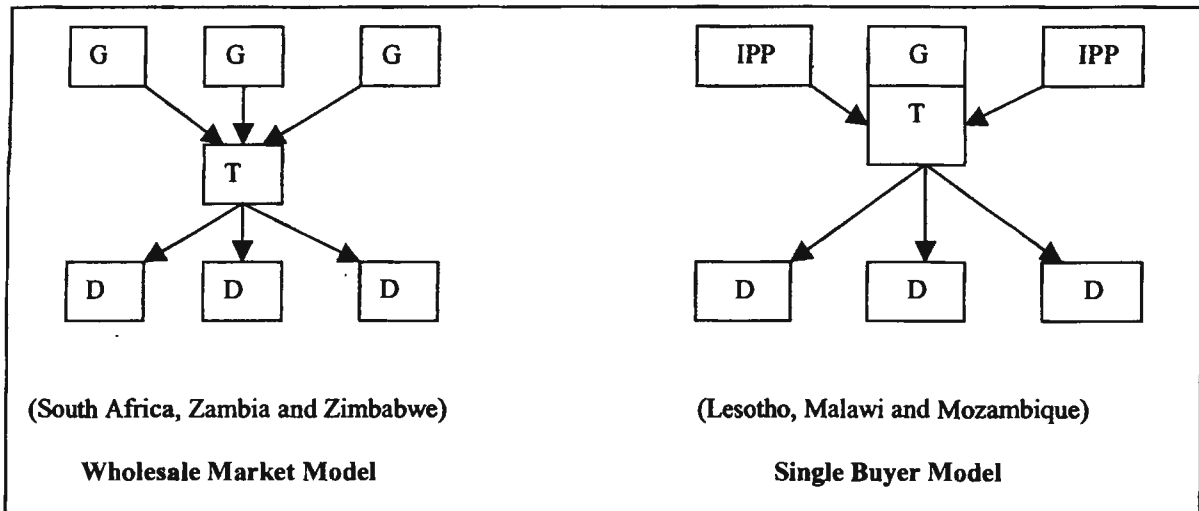

The restructuring of the Electricity industry in South Africa, Zambia and Zimbabwe is thus following the World Bank Standard Reform Model (the wholesale market model) while Lesotho, Malawi and Mozambique propose to have a single buyer model.

The wholesale competition model involves unbundling the utility into several companies. The utility can be dismantled vertically according to electricity supply functions of generation, transmission and distribution. These units can form companies completely independent from each other. Generation and distribution can further be unbundled to create different generation and distribution companies. Competition in these segments can now be introduced. Due to a multiplicity of players in generation and distribution, it is normal to establish an independent system operator, often linking to the Transmission Company, to be responsible for system operations, short-term power trading and settlements of payments in the market.

The single buyer model allows partial unbundling of the existing utility. In this model the generation and transmission functions are separated from distribution, and Independent Power Producers are allowed to compete in electricity generation. This may be regarded as the initial stage of moving to a wholesale model.

#### 9.5.4.5 Regulatory Framework

Electricity Acts that were passed by the parliaments in the particular countries under study govern their respective ESIs. These Acts further provide a legal framework for the supply of electricity and the

operations of the power sector. In terms of the issuing of licences and tariff approvals, there are differences between countries that have established independent regulators and those that have not. In this particular regard Malawi, South Africa and Zambia have regulatory bodies that issue licences in order for any one to gain access to the ESI. The tariffs in these countries have to be approved by the regulators. In other countries like Lesotho, Zimbabwe and Mozambique, both the government and the utilities themselves currently handle the regulatory issues. Licensing in Lesotho is currently the responsibility of the Lesotho Electricity Corporation. The tariffs in countries without regulators are also set by the utilities, but are approved by the government. In Mozambique, the government does both licensing and tariff approval. Lesotho and Mozambique are currently reviewing some of the laws governing their power sectors and Lesotho intends to establish a regulatory authority, which will oversee some of the current functions undertaken by the government. Recently, on 30 January 2002, the Zimbabwe parliament passed the Electricity Act 2001 that is set to introduce comprehensive reforms in the electricity industry. The Act allows the establishment of the Zimbabwe Electricity Regulatory Commission (ZERC). Until ZERC is established and operational, any investors in the electricity sector need to obtain the consent of both ZESA and the government in order to gain access to the sector. Similarly, the tariffs are still approved by the government until ZERC is operational.

The new electricity legislation enabled the establishment of regulators in Zambia, South Africa and Malawi. Zambia established a multi-sectoral regulator, which covers both the energy and water sectors. In contrast, the regulatory bodies in Malawi and South Africa are industry specific. They are only concerned with regulating the electricity sector. The functions of the regulatory bodies already established seem to differ slightly. The National Electricity Regulator (NER) of South Africa is very active compared to the other two regulators of Malawi and Zambia in terms of its involvement in rural electrification and ensuring that the utilities provide published data and annual reports on time. The major changes in legal and regulatory framework deal with issues of licensing and tariff approval. Previously these issues were under the responsibility of the ministry while currently it is the responsibility of the regulatory agencies wherever there is one. The settling of electricity industrial disputes which the law courts initially handled has also been transferred to regulators. This means that the regulator does the administration of the electricity industry and the government role is merely reduced to policy making.

The reforms currently taking place in the region have necessitated that the SADC member countries form a Regional Electricity Regulatory Association (RERA). The establishment of RERA will help to facilitate regulation of the electricity industry among the power utilities at a regional level. Proper regulation of the electricity industry will also require establishment of a Regional Electricity Regulator which will undertake some of the current responsibilities of SAPP, such as enforcing standards and monitoring the power system performance. In addition the Regional Electricity Regulator will have to take responsibility for issuing inter-regional transmission licenses in conjunction with the individual countries' regulators.

International power trading is not only taking place within the SADC region. Other regions on the African continent also conduct electricity trading at a regional level. As more and more countries are becoming interconnected, the association of African Utility Regulators (AFUR) will need to have adequate capacity so that it is conversant with the power sector regulation within the African Union.

## **9.6 Social and Economic Impacts of Power Sector Reforms**

This section attempts to explain the socio-economic impacts of the ESI reforms with regard to the industry/organisation, the broader economy of the country and domestic households. The impacts are either direct or indirect, depending on how and where they occur.

### **9.6.1 Impacts on Electricity Tariffs**

The study on electricity prices in Southern and Eastern Africa that was conducted by SAD-ELEC in 2001 (SAD-ELEC 2001: 5) indicates that cross-subsidies exist both between and within utilities' tariff classes. The domestic and rural customers are the main beneficiaries of these subsidies. The reforms will require the utilities to restructure their tariffs to reflect the cost of supply. The need to remove the subsidies in the pricing system will become inevitable. The immediate impact of the reforms, therefore, is the high electricity tariffs to the subsidised group of customers and this will negatively affect the lower income earners. In countries where competition is possible, such as South Africa and to a small extent Zambia, Zimbabwe and Mozambique, the electricity tariffs may be lower in the long run if anti-competitive practices will be properly checked by the regulators. In countries with smaller power systems, such as Lesotho and Malawi, competition in electricity generation and supply is very unlikely. However, benefits can come from commercialisation and corporatisation. The regulatory bodies in these countries will need to monitor utility activities closely and allow tariff adjustments when really inevitable. On the other hand the category of customers which are currently subsidising the others will have lower tariffs. If the industries are currently subsidising the other customers, then after removing the subsidies, lower prices of goods on the market can be expected, as production costs will be reduced.

### **9.6.2 Impacts on Employment**

It is observed that the ratios of utility customers to employees and the total sales to employees are below the World Bank benchmark. This means that most utilities are, in fact, over-staffed. The immediate impact of the restructuring and/or privatisation of the utilities will, therefore, be a loss of jobs by many people. Many people currently execute a job that can be executed by a single worker. This has led to the existing lower labour productivity in the utilities. The other reason for job losses will be attributed to the installation of new technologies, such as computers and modern power plants that might require new skills and fewer people. On the other hand, since the policy reforms have opened access to the ESI, more

investors will be attracted into the industry, thereby creating more jobs. This, however, will depend on establishment of independent power producers and growth of the electricity industry, especially at distribution level.

### **9.6.3 Government Fiscal Resources**

The capital invested by the government in power utilities is huge. If private investors had developed the ESI, this money could have provided other social services such as education and health and would have improved the social welfare of the people. The reform of the utilities up to the privatisation level, will enable governments to obtain additional funds to either provide the necessary social services or to service public debts. If the reform process stops after allowing the utilities to operate on commercial principles, the governments may still benefit from the dividends, which will enable them to provide the other services.

Foreign Direct Investment (FDI) is also expected as a result of the ESI reforms. This, however, requires the existing monopolistic public structures to be dismantled in order to give confidence to potential investors.

### **9.6.4 Rural Electrification**

The governments in the countries under study realise that extending electricity services to rural communities is not financially viable for the utilities and as such have taken an initiative to implement rural electrification programmes when the utilities are reformed. Currently the funding for rural electrification programmes is inadequate, hence the low access to electricity in most of these countries. The power sector reforms have enabled governments to identify other options of funding rural electrification programmes. The most reliable means of funding is by means of electricity levies. It is expected that access to electricity will increase as a result of rural electrification programmes. This will enable basic human needs such as lighting, portable water, education and primary health care to be more easily available to communities. Furthermore, it will facilitate different economic activities, which will in turn provide employment and income for many people. Due to increased economic activities in rural areas, rural-urban migration will be reduced and development will become more widespread. Availability of electricity to the majority of the people will also reduce their dependence on biomass as a source of energy and hence reduce environmental degradation.

## 9.7 Conclusion

It has been observed that power sector reforms are taking place in the selected countries of the SADC region. The countries have implemented the reforms in various ways and to differing degrees, and are currently at different stages of implementation. The legal and regulatory frameworks governing the sector are still in the process of being changed and the public utilities are being restructured as part of the reform programmes.

The main utilities, which are responsible for power generation and supply in the countries, are wholly owned by the national governments. It is evident from the studies that the utilities of the five countries Lesotho, Malawi, Mozambique, Zambia and Zimbabwe performed badly in the last decade and lacked effective commercial principles, while ESKOM of South Africa performed exceptionally well.

Thorough analyses of data obtained from the utilities of these countries reveal that most of the utilities faced both financial and technical hardships. The utilities, instead of assisting the governments with their development objectives, continued to drain government resources. Only two utilities, namely those of South Africa and Malawi, made consistent profits. The profits by the Malawi utility were, however, small and thus it could not finance many of its development projects. Apart from the technical problems that contributed to low generation, the power system losses have been high, especially in Lesotho, Mozambique and Malawi. Moreover, production and supply of electricity were unreliable and inadequate in some countries such as Malawi due to a lack of raw materials, spares and proper maintenance. This was also due to lack of funds, and consequently the reinforcement and maintenance work, which are necessary to improve the quality of supply in the distribution system, were not carried out. Unfortunately these problems were not addressed in time. If these problems had been properly addressed, electricity generation might have been more efficient and the supply might have been made available to many people in both rural and urban areas.

The worsening performance of the utilities and additional pressure from financial lending institutions have in some cases led certain governments to follow either the World Bank power sector reform programmes or to follow their own reform programmes after learning about the achievements of other countries. The focus of most governments has been on energy policies, reforming the legislation and restructuring the utilities.

So far, the main reforms that have been implemented are with regard to the legislation that governs the sector and, to some extent, the commercialisation of the utilities. Since opening up access to the industry, very little investment has been made by private investors in generation where competition is considered to be possible. The process from one stage to the next also seems to take an unusually long time to be

implemented. As a result it is possible that investors may be uncertain whether electricity trading could be conducted in a transparent manner.

Two major strategies have been followed in implementing the reforms. In countries with small power systems, as for example those of Lesotho and Malawi, the focus has been on improving supply efficiency and financial performance and encouraging private sector participation in electricity generation. The utilities in these countries have maintained their vertically integrated structures because competition was considered to be impossible. However, slight differences exist in the design of the final structures to be implemented. This is because the governments have different objectives of the reforms in terms of ownership. While Malawi intends to retain the ownership of the utility, privatisation in Lesotho is the top priority on the government's agenda.

The countries with larger power systems aim to increase competition through restructuring and through privatisation of existing assets or private sector participation in new generation and distribution. This is the case in Mozambique, South Africa, Zambia and Zimbabwe. From a microeconomic point of view, competition in the electricity market provides incentives to firms in the industry to improve on their efficiency level, which is reflected in lower prices. This being the case, the strategy of these countries is to reform and/or privatise their utilities to fully reap the advantages of competitive ESI markets. The vertically integrated utilities will be unbundled into separate generation, transmission and distribution functions (see models on page 158). Competition will be introduced in generation, whereas transmission and distribution will remain monopolies. In order to achieve the objective of competition in the ESI, environments that allow fair competition need to be established.

The expected benefits of power sector reforms in the countries are attracting heated debates because of the uncertainties of their impact. However, in the long run, ESI reforms will improve the technical and financial performance of the utilities and hopefully lower electricity prices due to competition. There would also be increased employment opportunities from the expansion of the industry. Governments stand a chance to benefit through collection of taxes and dividends. Major competition within particular countries such as Mozambique, Zambia and Zimbabwe may not come in the near future. Competition in electricity trading will be initiated in the South African market and then largely come at a regional level from the SAPP. A major benefit from the power sector reforms in the long term will be increased investment and economic development in the region.

## References

- Bacon, R.W. and Besant-Jones, J. 2001. *Global Electric Power Reform, Privatisation and Liberalization of the Electric Power Industry in Developing Countries*. Washington, DC: World Bank.
- Barberton, C. 2000. *Exploring the Possible Impact of Electricity Supply Industry Restructuring on Demand-Side Management*. Energy & Development Research Centre. University of Cape Town.
- Bhagavan, M.R.(Ed.). 1999. *Reforming the Power Sector in Africa*. London: Zed Books Ltd.
- Bradburd, R. 1992. *Privatisation of Natural Monopoly Public Enterprises: Regulation Issue*. Washington, DC: U.S.A.
- Central Bank of Lesotho. May 2001. *Government Officially Launches the Lesotho Utilities Sector Reforms*. available: [http://www.centralbank.org.ls/publications/ereview05\\_01.htm](http://www.centralbank.org.ls/publications/ereview05_01.htm). Date accessed: 21/01/2002.
- Central Intelligence Agency (CIA). 2001. Available: <http://www.odci.gov/cia/publications/factbook.html>. Date accessed: 08/04/2002.
- Davidson, O.R. 1992. *Energy Issues in Sub-Saharan Africa: Future Directions*. Unpublished paper. University Research and Development Services Bureau, University of Sierra Leone, Freetown, Sierra Leone.
- De Oliveira, A. 1991. *Electrification and Social and Economic Development. Senior Expert Symposium on Electricity and the Environment*. Helsinki, Finland, 13 – 17 May 1991.
- Department of Energy. April 2000. *Electricity White Paper: Electricity Sector Reform in Zimbabwe*. Harare: Department of Energy.
- Department of Minerals and Energy. 1998. *White Paper on Energy Policy*. Pretoria: Department of Minerals and Energy.
- Directorate of National Energy. 1999. *Rural Electrification Strategy Plan for Mozambique*. Maputo, Mozambique.
- Eberhard, A. 2000. *Competition and Regulation in the Electricity Supply Industry in South Africa*. Prepared for the Competition Commission South Africa. University of Cape Town.
- Eberhard, A. 2001. *Competition and Regulation in the Electricity Supply Industry in South Africa*. Graduate School of Business, University of Cape Town-Paper presented to the Trade and Industry Policy Strategies Annual Forum, Pretoria, 10 – 12 September 2001.
- Eberhard, A. and Van Horen, C. 1995. *Poverty and Power: Energy and the South African State*. University of Cape Town, Cape Town, South Africa.
- EDM. 1993,1994,1995,1996,1997,1998,1999,2000. *Annual Statistical Reports*. Maputo: Electricidade de Mocambique – Planning Division.

- Energy & Development Group. 1995. *CIDA assistance project: Access to Electricity in Southern Africa. Review of the status quo and Identification of Opportunities to increase access*. Cape Town, South Africa.
- Energy Information Administration. 1997. *Electricity Reform Abroad and U.S Investment*. Washington, DC. Available: <http://www.eia.doe.gov/emeu/pgem/electric/contents.html>. Date accessed: 12/02/2002.
- Ergas, H. and Small, J. 2001. *Price Caps and rate of return Regulation*. Available: <http://www.necg.com.au/pappub/papers-ergas-org-may01.pdf>. Date accessed: 06/11/2001.
- ESCOM. 1991/92, 1993/94, 1995/96, 1996/97, 1997/98 and 1999. *Annual Reports*. Blantyre: Electricity Supply Corporation of Malawi Ltd.
- ESCOM. 1999/2000. *Annual Report*. Unpublished. Blantyre: Electricity Supply Corporation of Malawi Ltd.
- ESKOM. 1990, 1991, 1992, 1993, 1994, 1995, 1996, 1997, 1998, 1999, 2000 and 2001. *Annual Reports*. Johannesburg: Electricity Supply Commission.
- ESKOM. 1990, 1991, 1992, 1993, 1994, 1995 and 1996. *Statistical Yearbooks*. Johannesburg: Electricity Supply Commission.
- ESKOM. 2000. *Alternative energy sources*. Available: <http://www.eskom.co.za/alternative.html>. Date accessed: 24/04/2002.
- ESKOM. 2001. *Annual Report*. Johannesburg: Electricity Supply Commission.
- ESKOM. 2002. *Finance*. Available: <http://www.eskom.co.za/finance.html>. Date accessed: 24/04/2002.
- ESKOM. 2001. *ESKOM Tariffs and Charges 2001*. Available: <http://www.eskom.co.za/tariffs>. Date accessed: 24/04/2002.
- Hibajene, H. 2002. *Improving Electricity Distribution through Restructuring: Case of Zambia*. Paper presented at the Sub-Saharan Power Conference, Mid Rand, South Africa, 19 – 21 February 2002.
- IMF. 1998. *Malawi--Enhanced Structural Adjustment Facility Policy Framework Paper, 1998/99 – 2000/01*. Available: <http://www.imf.org/external/NP/PFP/malawi/tables.htm>. Date accessed: 14/03/2002.
- IMF. 1999. *Republic of Mozambique--Enhanced Structural Adjustment Facility Policy Framework Paper for April 1999 – March 2002*. Available: <http://www.imf.org/external/NP/PFP/1999/mozam/index.htm>. Date accessed: 09/04/2002.
- IMF. 1999. *Zambia--Enhanced Structural Adjustment Facility Policy Framework Paper, 1999- 2001*. Available: <http://www.imf.org/external/NP/PFP/1999/zambia/>. Date accessed: 19/12/2001.
- IMF. 2001. *Lesotho: Memorandum on Economic and Financial Policies*. Available: <http://www.imf.org/external/NP/L01/2001/Iso/01/INDEX.HTM>. Date accessed: 09/04/2002.
- International Energy Agency. 1994. *Electricity Supply Industry Structure, Ownership and Regulation in OECD countries*. Paris.
- International Finance Center. 2001. Available: <http://biz.yahoo.com/ifc>. Date accessed: 02/04/2002.

- James, H. 2002. *Theory of Natural Monopoly, Market and Regulation*. Handout – Prepared for Infrastructure Reform and Regulation Programme. University of Cape Town, 3 – 8 March, 2002.
- Kayo, D. 2001. *Power Sector Reform in Zimbabwe*. Proceedings of a Regional Policy Seminar, Nairobi, Kenya, 24 – 25 April 2001.
- Lahmeyer International, Knight Piesold and ESCOM. 1998. *Malawi-Power System and Operational Study*. Blantyre, Malawi.
- LEC. 1993/94. *Annual Report*. Maseru: Lesotho Electricity Corporation Ltd.
- London Economics. 1997. *Mozambique: Reform and Regulation of the Power Sector – Final Report*.
- London Economics. 1997. *Reform and Regulation of the Power Sector – Final Report*.
- London Economics. 1999. *Lesotho - Water and Electricity Sector's Legal and Regulatory Framework (draft report)*.
- Lori, P. 2000. *Power Shedding Haunts Zambian Consumers*. Available: <http://www.saep.org/sadc/country/zambia/ZAMBIApowerpan0001.htm>. Date accessed: 28/12/2001.
- Mbendi. 2001. *Zimbabwe: Electrical Power*. Available: <http://www.mbendi.com>. Date accessed: 14/08/2001.
- Millan, J.; Lora, E. and Mico, A. 2001. *Sustainability of the Sector Reforms in Latin America*. Seminar on Towards Competitiveness: The Institutional Path. Inter-American Development Bank.
- Miller Esselaar and Associates. November 2001. *A country ICT Survey for Mozambique – Final Report*. Available: <http://www.sida.se/>. Date accessed: 19/02/2002.
- Ministry of Energy and Water Development. 1994. *Zambia National Energy Policy*. Lusaka: Department of Energy.
- Ministry of Energy and Water Development. 2000. *Zambia Energy Statistics Bulletin (1980 – 1999)*. Lusaka: Department of Energy.
- Ministry of Natural Resources. 2001. *Management objectives of the Lesotho Electricity Corporation (LEC)*. Available: <http://www.lesotho.gov.ls/lec/objectives.htm>. Date accessed: 01/04/2002.
- Ministry of Natural Resources. 2001. *Launch of the Lesotho Utilities Project*. Available: <http://www.lesotho.gov.ls>. Date accessed: 01/04/2002.
- Ministry of Natural Resources and Environmental Affairs. 2001. *Malawi Energy Policy White Paper*. Lilongwe: Department of Energy Affairs.
- Mozambique Electricity Law. 1997. Maputo. Government Gazette 1st Series, NO. 40 – 3<sup>rd</sup>.
- National Electricity Regulator (NER). 1999. *Electricity Supply Statistics for South Africa*. Sandton. NER.
- National Electricity Regulator (NER). 2000/2001. *Annual Report*. Sandton: NER Corporate Communications.
- National Electricity Regulator (NER). 2001. *Lighting Up South Africa*. Pretoria: NER Information Resources Management Department.

- Privatisation on track in Malawi. 2000. *Daily Mail and Guardian*. Johannesburg, South Africa, April 2000. Available: <http://www.mg.co.za/mg/news/2000apr2/20apr-malawi.html>. Date accessed: 14/03/2002.
- Privatisation Unit of the Lesotho government. January 2002. The Privatisation Unit Appoints Consultants for Privatisation of the Lesotho Electricity Corporation (LEC). Available: <http://www.lesotho.gov.ls/articles/2002/PU%20Appoints%20Consultants%20for%20Pri>. Date accessed: 27/03/2002.
- Ranganathan, V (Ed.). 1992. *Rural Electrification in Africa*. London: Zed Books Ltd.
- Ranganathan, V (Ed.). 1998. *Planning and Management in the African Power Sector*. London: Zed Books Ltd.
- Robyn, C. 2002. ESKOM to be converted into a tax-paying public company today. *Business Day*, Monday, July 1 2002, p12.
- Ruffini, A. 1999. The Sun & SA's electrification programme. *African Energy Journal: Power for Africa's Future*. April – May 1999. Vol. 1 NO. 2.
- SAD-ELEC. 1998. *Strategic Plan for the Mozambique Energy Sector (first draft)*. Johannesburg: Southern African Development through Electricity (Pty) Ltd.
- SAD-ELEC. 2000. *Overview of Electricity Supply Industry (ESI) Developments in Southern and Eastern African Countries*. Regional Workshop on Regulatory co-operation. Gaborone, Botswana, 27 – 28 March 2000.
- SAD-ELEC. 2001. *Interim Management Task Force (IMTF) – Lesotho Electricity Corporation (LEC): Inception Report*. Rivonia: Southern African Development through Electricity (Pty) Ltd.
- SAD-ELEC. 2002. The Calculated Losses on LEC System, New Connections per Customer Group. Handout. Rivonia: Southern African Development through Electricity (Pty) Ltd.
- SAD-ELEC and MEPC. 1996. *Electricity in Southern Africa: Investment Opportunities in an Emerging Regional Market*. London: Pearson Professional Ltd.
- SADC-REPN Task Force. 2001. *Regional Energy Planning Network: Energy Infrastructure Survey*. Lesotho: SADC Energy Commission Technical Unit.
- SADC-REPN Task Force. 2001. *Regional Energy Planning Network: Energy Infrastructure Survey*. Zambia: SADC Energy Commission Technical Unit.
- SADC-REPN Task Force. 2001. *Regional Energy Planning Network: Energy Infrastructure Survey*. Zimbabwe: SADC Energy Commission Technical Unit.
- Sakairi, Y. 2001. *Mozambique: Private Participation in Isolated Electrical Grids*. Available: <http://www.worldbank.org/afr/findings/infobeng/infob62.htm>. Date accessed: 27/03/2002.
- SAPP. 2001. *Annual Report*. Harare: Southern African Power Pool.
- Swedpower News. 2001. *New Assignment in Zambia*. Available: [http://swedpower.se/swpsite/swpages/bar/news/news\\_up\\_date.html](http://swedpower.se/swpsite/swpages/bar/news/news_up_date.html). Date accessed: 28/12/2001.
- The Financial Gazette, 2002. Power sector reform gets green light. *The Financial Gazette*, 7 – 13 February 2002. Harare. Sovereign Publishers (Pvt.) Ltd.

- The Official SADC Trade, Industry and Investment Review. 2001. Available:  
<http://www.sadcreview.com/countryprofiles2001.htm>. Date accessed: 13/06/2002.
- Trollip, H. 1996. *Overview of the South African Energy Sector*. Energy & Development Research Centre. University of Cape Town, Cape Town, South Africa.
- UNDP. March 1999. *Renewable Energy Programme in Malawi*. Lilongwe, Malawi.
- UNDP/World Bank. 1996. *Symposium on Power Sector Reform and Efficiency Improvement in Sub-Saharan Africa*. Johannesburg, 5 – 8 December 1995.
- USAID. 2000. *US Agency for International Development: Office of Sustainable Development, Economic Growth Activities*. Available:  
<http://www.af.sd.org/EconomicGrowth/EconomicGrowthActivities.htm>. Date accessed: 19/12/2001.
- ZESA. 1990, 1991, 1992, 1993, 1995, 1996, 1997, 1998 and 1999. *Annual Reports and Accounts*. Harare: Zimbabwe Electricity Supply Authority.
- ZESA. 2000. *Company profile*. Available: <http://www.zesa.co.za/profile.htm>. Date accessed: 08/02/2002.
- ZESA. 2002. *The megawatt Bulletin Issue No. 20*. Power Imports from Cahora Bassa Begins. Available:  
<http://www.zesa.co.zw/megawatt/current/index.html>. Date accessed: 08/02/2002.
- ZESCO. 1990/91, 1991/92, 1992/93, 1993/94, 1995/96, 1997/98 and 1998/99. *Annual Reports*. Lusaka: Zambia Electricity Supply Corporation.
- World Bank. 2002. *World Development Indicators*. CD-ROM, World Bank.

**Power sector reforms and regulation in selected  
countries of Central and Southern Africa**

**Masauko Mula**

**Submitted to the University of Cape Town  
in partial fulfilment of the requirements for the degree of  
Masters of Engineering (Energy Studies)**

**University of Cape Town  
August 2000**