

The copyright of this thesis vests in the author. No quotation from it or information derived from it is to be published without full acknowledgement of the source. The thesis is to be used for private study or non-commercial research purposes only.

Published by the University of Cape Town (UCT) in terms of the non-exclusive license granted to UCT by the author.

7

**APPROACHES TOWARD THE ENANTIOSELECTIVE  
TOTAL SYNTHESIS OF AMAROGENIN**

**BY**

**ANNE THERESE STEVENS**

**Thesis Presented for the Degree of  
DOCTOR OF PHILOSOPHY**

**In the Department of Chemistry  
UNIVERSITY OF CAPE TOWN**

**September 2001**

**Supervisors: Prof. J.R. Bull  
Dr K. Chibale**

## ABSTRACT

Three different, but complementary strategies for the enantioselective synthesis of the secoiridoid core of amarogentin were evaluated. The first is based on the enantioselective desymmetrisation of *meso*-anhydrides using titanium TADDOLates. 1,2,4,6-Tetrahydrophthalic anhydride was desymmetrised and chemoselectively reduced to give (3*aR*, 7*aS*)-3*a*,4,7,7*a*-Tetrahydro-3*H*-isobenzofuran-1-one. Further development of this route was performed on a racemic model. A 14-step sequence to the secoiridoid glycosidation precursor from *cis*-3*a*,4,7,7*a*-Tetrahydro-3*H*-isobenzofuran-1-one has been achieved. Key features of this synthesis include two one-carbon homologation steps, the oxidative cleavage *via* ozonolysis of the cyclohexenyl olefin with chemoselective differentiation of the termini at a later stage, and the chemoselective ring closure of a dialdehyde intermediate to give the requisite dihydropyran ring.

For the second approach, three homochiral silyloxymethyl-5*H*-furan-2-ones (butenolides) were accessed from the chiral pool. The thermal and Lewis acid catalysed Diels-Alder reactions between butadiene and the butenolides have been investigated. Further transformations toward the target were made on the optimised cycloaddition product (3*S*, 3*aS*, 7*aR*)-3-*t*-butyldiphenylsilyloxymethyl-3*a*,4,7,7*a*-tetrahydro-3*H*-isobenzofuran-1-one. Successful methodologies to perform the reduction of the carboxyl group in the butenolide residue to the requisite carbonyl moiety, followed by ring opening and oxidative cleavage of the cyclohexene moiety have been identified.

Lastly, a model synthesis based on levoglucosenone was investigated. An impurity that arose during the thermal cycloaddition of levoglucosenone to butadiene was identified as the C-7 epimer of (1*S*, 2*S*, 7*R*, 9*R*)-10,12-Dioxatricyclo[7.2.1.0<sup>2,7</sup>]dodec-4-en-8-one, the major cycloadduct. Molecular modelling results predicting the relative energies and proportions of these epimers are reported as is an X-ray crystal structure of the alcohol obtained by hydroboration of the methylenated cycloadduct. Extensive one carbon-homologation studies and elaboration to the required carboxyl group were performed. Successful ozonolysis-reduction of the cyclohexene, acetal trapping, and oxidative cleavage of the exposed glycol moiety are also reported.

I declare that '*Approaches Toward the Enantioselective Total Synthesis of Amarogentin*' is my own work and that all sources that I have used or quoted have been indicated and acknowledged by means of complete references.

signature removed

Anne Therese Stevens

University of Cape Town

## **ACKNOWLEDGEMENTS**

I would like to thank the following people for their contributions to the preparation of this thesis:

Professor James R. Bull for his constant guidance, enthusiasm and patience throughout the course of my PhD studies;

Dr Kelly Chibale for introducing me to amarogentin, and for all his support and advice during the project;

All my past and present colleagues in the Department of Chemistry, particularly those in the Organic Synthesis laboratories;

Dr David Gammon and Prof. Roger Hunter for their helpful discussions and Dr Eugene Sickle for his mammoth proofreading effort on this thesis;

Dr Kevin Naidoo and Jeff Chen for their assistance in the computational aspects of this work;

Piero Benincasa, Dr Phillip Boshoff, Dr Krassi Dimitrova, Noel Hendricks and Pete Roberts for their analytical services, Dr John Bacsa for performing the X-ray crystal structure determination and Naziem George for all his technical support;

The National Research Foundation for financial assistance;

Finally I would like to thank my husband, parents, family and friends for their constant support and encouragement during the ups and downs that this period has been filled with. Without them this might not have been!

# CONTENTS

<b>1.</b>	<b>INTRODUCTION</b>	<b>1</b>
<b>2.</b>	<b>DESYMMETRISATION BASED STRATEGY</b>	<b>13</b>
2.1	Background and Objectives	13
2.2	Synthesis of (3a <i>R</i> , 7a <i>S</i> )-3a,4,7,7a-Tetrahydro-3 <i>H</i> -isobenzofuran-1-one	17
<b>3.</b>	<b>RACEMIC MODEL SYNTHESIS</b>	<b>20</b>
3.1	Background and Objectives	20
3.2	Results and Discussion	22
3.3	Revised Synthetic Strategy	46
3.4	Conclusion	56
<b>4.</b>	<b>ENANTIOSELECTIVE SYNTHESIS USING CHIRAL POOL INTERMEDIATES</b>	<b>58</b>
4.1	Cycloaddition with a Chiral Cyclopentenone	58
4.2	Cycloaddition with a Chiral Butenolide	61
4.3	Results and Discussion	65
4.4	Closing Remarks on the Butenolide Approach	76
<b>5.</b>	<b>MODEL SYNTHESIS BASED ON LEVOGLUCOSENONE</b>	<b>77</b>
5.1	Introduction	77
5.2	Results and Discussion	81
5.3	Conclusion	102
<b>6.</b>	<b>EXPERIMENTAL</b>	<b>103</b>
	<b>REFERENCES</b>	<b>176</b>

# CHAPTER 1

## INTRODUCTION

### 1.1 BACKGROUND

The leishmaniases are a globally widespread group of parasitic diseases. They are transmitted by the bite of a female phlebotomine sandfly that has been infected with a species of flagellate protozoa belonging to the *Leishmania* genus. Four different forms of the leishmaniases present themselves in humans. Visceral leishmaniasis (VL), for which *Leishmania donovani* is the causative agent, is the most severe. It is characterised by irregular bouts of fever, weight loss, swelling of the spleen and liver, and anaemia. If left untreated, the disease has an almost 100% mortality rate.

The geographical distribution of leishmaniasis is limited by the distribution of the sandfly, which is predominantly found in tropical and subtropical zones. It is estimated that worldwide, 12 million people suffer from leishmaniasis. Of the 500 000 new cases of VL reported annually, 90% are in Bangladesh, Brazil, India, Nepal and Sudan.<sup>1</sup>

VL/HIV coinfection is emerging as a serious new disease. Persons who are immunosuppressed are more likely to develop the disease after being bitten by an infected sandfly. VL then accelerates the onset of AIDS. Coinfected patients harbour a high number *Leishmania* in their blood, and there is a risk of them becoming reservoirs for the disease, and consequently, the risk of epidemics has increased. The leishmania/HIV coinfection has ensured that the spread of the disease is no longer limited to the endemic areas. Of the 1700 cases reported to the World Health Organisation (WHO) up till 1998, 1440 were from Spain, Portugal, Italy and France.<sup>1</sup>

The treatment of visceral leishmaniasis has been the subject of a recent review.<sup>2</sup> Although the development of a vaccine has been given high priority, success has not been achieved to date since the pathogens of leishmaniasis change their membrane surface structure frequently and the structure recognition that is required for vaccine efficacy is absent. The usual form of treatment is an intravenous therapy using formulations of highly toxic pentavalent antimony compounds based on stibonic acid 1. In areas where the disease is endemic, up to 40% of cases are resistant to this treatment. It also has serious side effects: mortality in 2—5% of patients and toxicity in 10—15%.

The second line treatment, pentamidine 2, causes 7–9% mortality and 60% toxicity, sometimes with irreversible damage such as diabetes. The most effective treatment, Amphotericin B 3, is also toxic and difficult to administer. Its cost also puts it out of the reach of 95% of patients.<sup>3</sup> In 1992 the first oral treatment of VL in mice, with hexadecylphosphocholine, (or miltefosine) 4,<sup>4</sup> was reported. A phase II clinical trial conducted in India in 1999 reported a 97% cure rate with orally administered 4.<sup>5</sup> However, gastrointestinal side effects were frequent (62%).

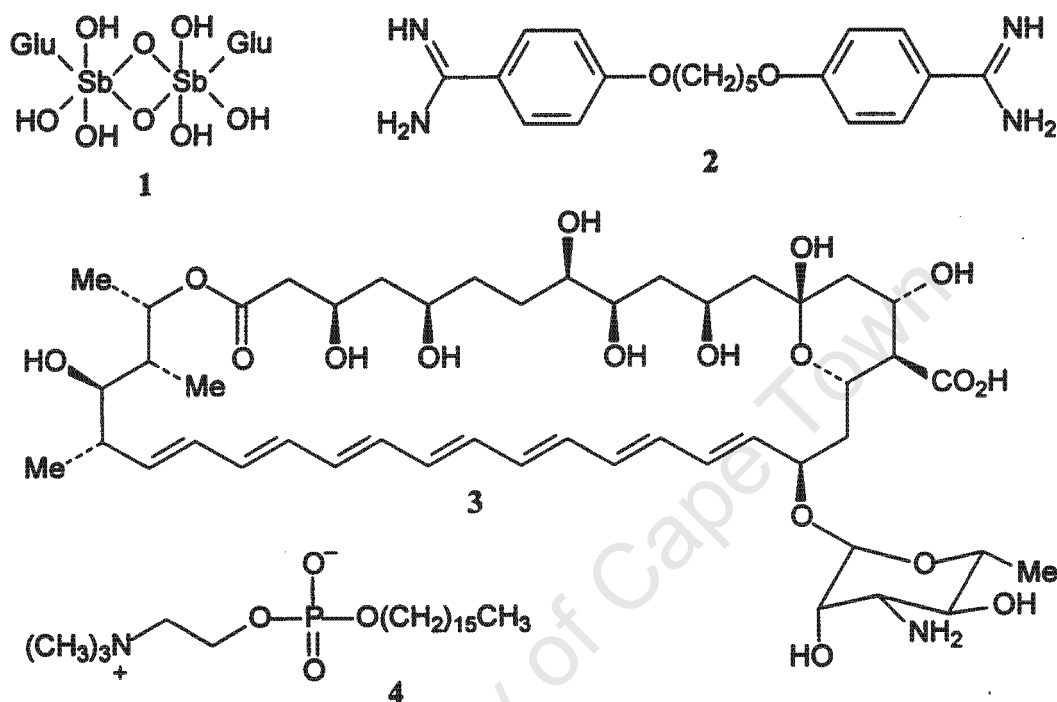

Although miltefosine has heralded a vast improvement in treatments available for VL, the situation is far from ideal. Resistance is likely to emerge and more molecules that could provide the same degree of efficacy *via* oral administration, and without toxic side effects, are still being sought. The secoiridoid glycoside, amarogentin 5 has been targeted as a potential lead compound in this search.

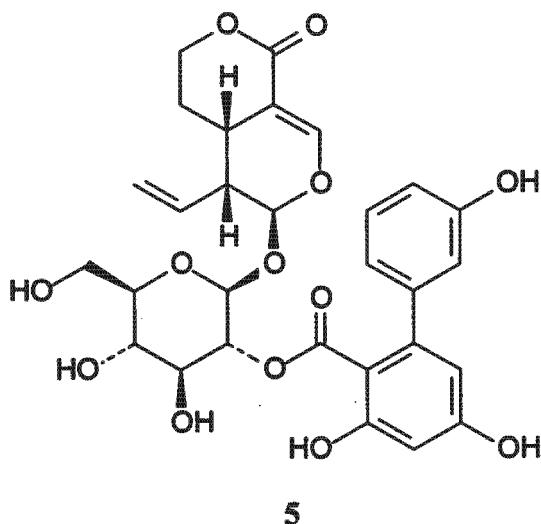

Amarogentin has been recognised as an inhibitor of the DNA topoisomerase I enzyme isolated from *L.donovani*.<sup>6</sup> The separation of complementary polynucleotide strands is essential during DNA replication and is facilitated by a relaxation in the supercoiling of the double helix. The topoisomerases are enzymes that control the supercoiling (or topology) of DNA. Type I topoisomerases, also called nicking-closing enzymes, operate by cutting a single strand of DNA and allowing a loop to pass through the gap before resealing it. In the case of type II topoisomerase (or DNA gyrase) activity, both strands are cut. Amarogentin exerts its antileishmanial activity by binding to topoisomerase I, which is thus prevented from forming binary complexes with DNA, and replication is inhibited. The *in vivo* activity of amarogentin in a hamster model has recently been evaluated, with positive results.<sup>7</sup> These results have reinforced the notion that amarogentin is worthy of attention in a medicinal programme. Whereas investigations into the efficacy of amarogentin have been documented, no structure activity studies in the aforementioned enzyme system have been noted to date. The variety of functionality borne by amarogentin, which includes biaryl,  $\beta$ -glucoside,  $\delta$ -lactone, dihydropyran and olefin moieties, indicates that a vast number of analogues will be required to complete these aspects of a medicinal programme. Although the development of synthetic routes toward amarogentin was the primary aim of this work, the position of the total synthesis in a medicinal chemistry programme was a consideration. The facilitation of analogue synthesis using the methodology applied here is an important theme that will recur in the ensuing discussions.

## 1.2 AMAROGENTIN

The isolation of amarogentin from *Swertia chirata* was first described in 1955.<sup>8</sup> This annual herb is a member of the Gentianaceae, which occurs in the temperate Himalayas of Northern India and Nepal. It has a number of therapeutic uses in Indian medicine, mostly dealing with gastrointestinal disorders. The structure elucidation of **5** was published after it was isolated from another plant species of the Swertia genus, *S. japonica*.<sup>9, 10</sup> The NMR assignments in that work were made from 1D spectra recorded at 60 and 100 MHz and overlapping signals resulted in some false assignments. The unambiguous assignments of the  $^1\text{H}$  and  $^{13}\text{C}$  signals, made on the basis of high field (500 MHz) spectroscopy, including 2D techniques have been published.<sup>11</sup> Amarogentin also holds the distinction of being the bitterest substance known, a characteristic that has found it occasionally used as an alternative bittering agent to quinine in soft drinks. Supplies of the herb still rely on wild sources and amarogentin content ranges from 0.15 to 0.3% dry weight for both of the above species. Prompted by the commercial application, attempts have been made to produce

5, a secondary metabolite, in root cultures of *S. chirata*. Although this has been achieved, the process was not economically viable.<sup>12</sup>

### 1.3 RETROSYNTHETIC ANALYSIS OF AMAROAGENTIN

Application of the two obvious disconnections on amarogentin, firstly, that of the glycosidic linkage and secondly the ester (Scheme 1.1) allowed the identification of three major fragments: (i) the secoiridoid core 6, (ii) a suitably functionalised glucose derivative 7 and (iii) the biphenyl moiety 8. Approaches to the synthesis of 6, which form the topic for this thesis, are outlined later in this chapter. The synthesis of the minor fragments 7 and 8 was not undertaken as part of this work, but the planned synthetic routes as well as the background information supporting these intentions are briefly discussed below.

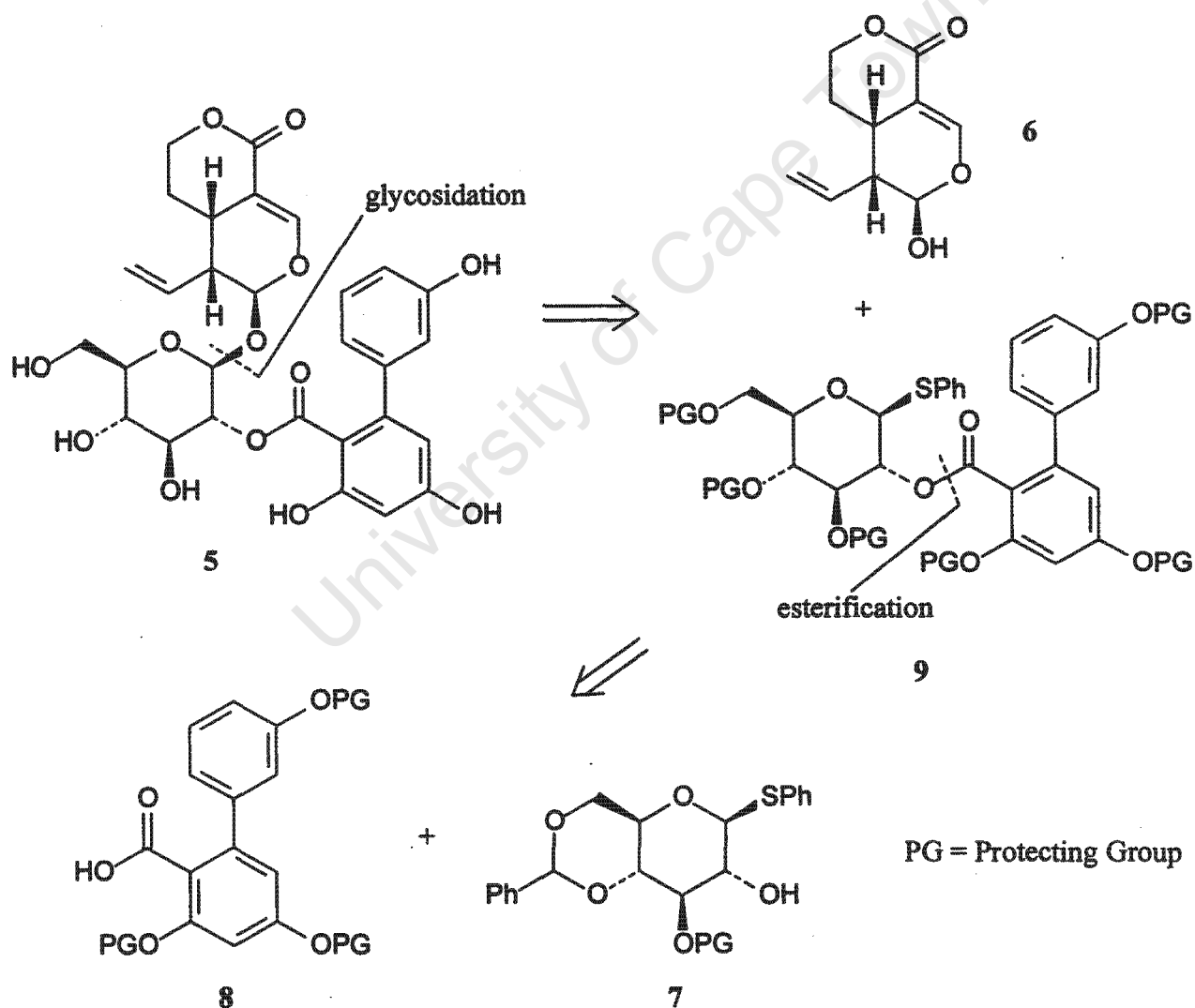

Scheme 1.1 Major disconnections of amarogentin

The esterification of **7** with **8** using an acyl transfer reagent in the presence of a dehydrating reagent (e.g. DCC–DMAP) was expected to be straightforward. The use of solid-phase reagents for esterification during the synthesis of compound libraries has been developed,<sup>13</sup> and could be applied in advanced studies. The replacement of the benzylidene protection in **7** with alternative hydroxyl group protection in the glycosidation precursor **9** has been proposed because benzylidene deprotection in the presence of the glycosidic and vinyl functionalities was expected to present chemoselectivity problems. The thioglycoside moiety was selected as a glycosyl donor because of (i) its stability to a wide variety of reaction conditions which may be encountered in producing **9** from glucose, (ii) the wide variety of methodology associated with activation of thioglycosides for reaction with the glycosyl acceptor and (iii) the ease with which it can be converted into the more reactive glycosyl fluoride, which allows glycosidation to occur under milder conditions, should this be required. These glycosidation methodologies have been reviewed<sup>14</sup> and their application to combinatorial synthesis has since been reported.<sup>15</sup> The presence of a participating group (the ester) at C-2 on the sugar residue in **9** was expected to ensure the formation of the desired  $\beta$ -glycoside.

### 1.3.1 Retrosynthesis of glucose residue **7**

The disconnections for the known synthesis of **7** from glucose pentaacetate **10** are summarised in Scheme 1.2. Formation of the thioglycoside followed by acetate hydrolysis gives **11**, which was selectively protected to give **7**.

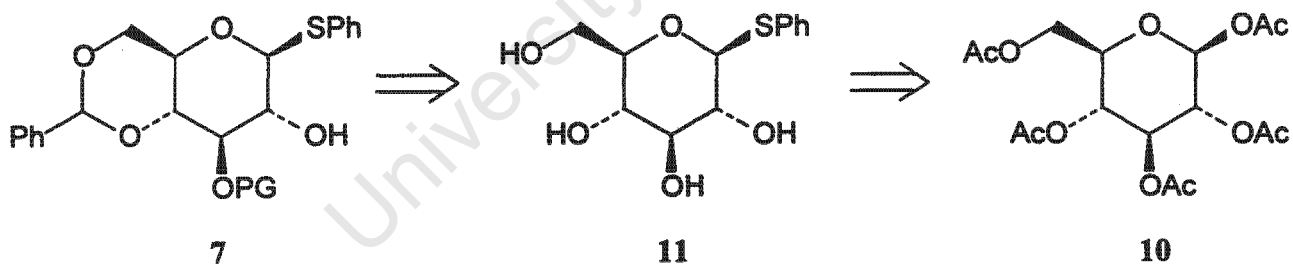

**Scheme 1.2**

Scheme 1.3 shows the conditions applied to this synthesis, and the intermediates that were formed. The conversion of glucose pentaacetate to a thioacetal and then to the 4,6-*O*-benzylidene derivative **12** has been frequently described,<sup>16-18</sup> whilst the selective protection of the 3-OH on **12** is more problematic. The use of a stannylene acetal intermediate to give the 3-acetoxy derivative **13** was used in a recent synthesis of vancomycin.<sup>19</sup> Standard silylation conditions have given selective reaction at 3-OH affording **14**, which has been utilised in branched oligosaccharide synthesis.<sup>18</sup> For our application, **14** was preferred since selective hydroxyl deprotection in the presence of the biphenyl ester was envisaged post glycosidation.

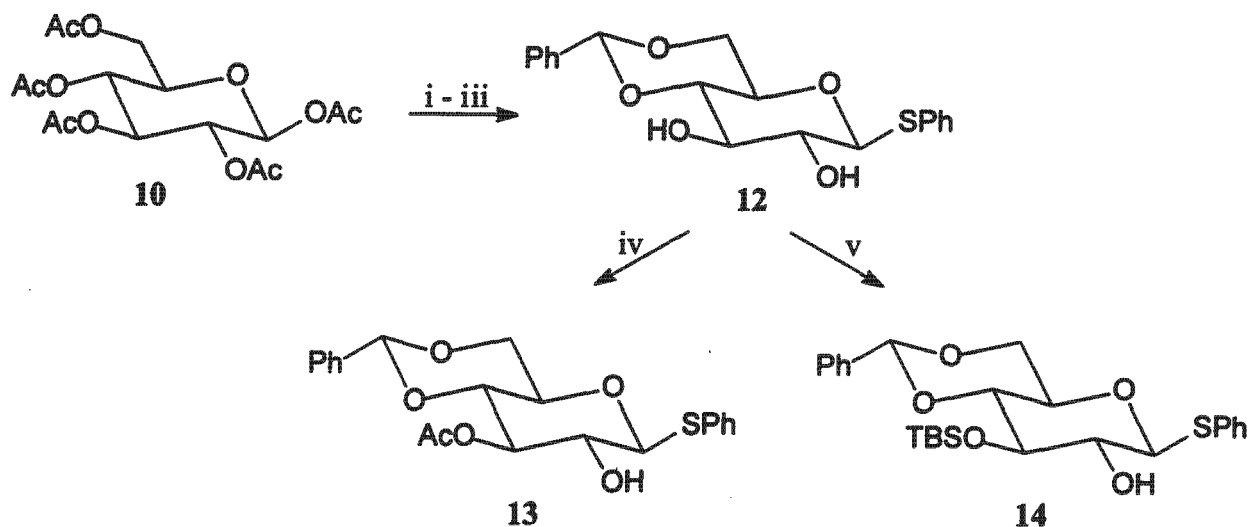

**Scheme 1.3** Reagents and conditions: (i) PhSH, SnCl<sub>4</sub>, CH<sub>2</sub>Cl<sub>2</sub>, 0 °C, (ii) K<sub>2</sub>CO<sub>3</sub>, THF-MeOH, (iii) PhCH(OMe)<sub>2</sub>, CSA, benzene, reflux, (iv) Bu<sub>2</sub>SnO, benzene, reflux, then AcCl, CH<sub>2</sub>Cl<sub>2</sub>, 0 °C, (v) TBSCl, imidazole, DMF, 0 °C

### 1.3.2 Retrosynthesis of 3,3',5-trihydroxybiphenyl-2-carboxylic acid derivative, 8

The palladium-mediated Suzuki cross-coupling reaction<sup>20</sup> was selected for the formation of the aryl-aryl bond (Scheme 1.4).

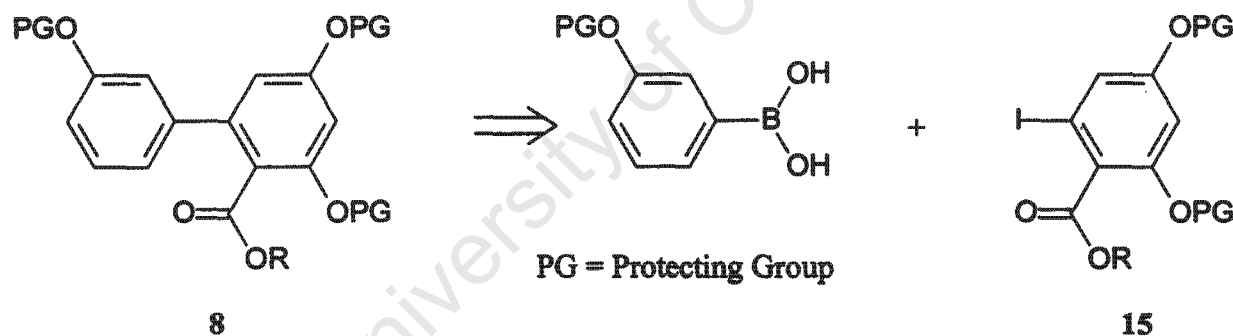

**Scheme 1.4** Proposed Suzuki coupling to give 8

The methodology tolerates a broad range of functionality, which makes it suitable for the synthesis of compound libraries. Small biaryl libraries have been produced in a liquid-phase synthesis on a poly(ethylene glycol) (PEG) support in which the aryl iodide was attached to PEG *via* an ester linkage. The carboxyl functionality on 15 makes it an ideal candidate for such methodology.<sup>21</sup> The use of the Suzuki, Heck and Stille reactions for C-C bond formation on solid support has recently been reviewed.<sup>22</sup> Although modern palladium chemistry is attractive for the synthesis of analogues, a biaryl moiety bearing the desired substitution pattern for fragment 8 using this methodology has not been reported. However, the synthesis of  $\beta$ -resorcylic esters using condensation of diketene with 1,3-dicarbonyl compounds has been reported<sup>23</sup> and was recently applied to give the ethyl ester

16 (Scheme 1.5).<sup>24</sup> Appropriate deprotection and protection of the phenolic residues followed by deprotection of the ester should give 8.

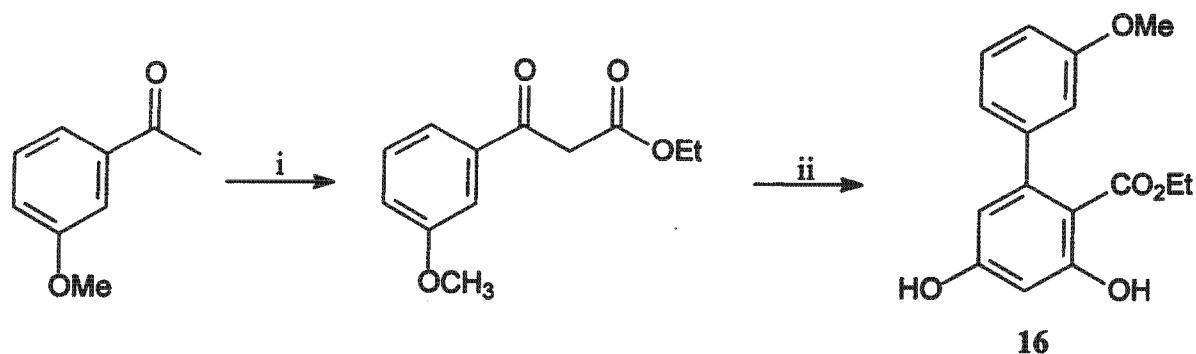

**Scheme 1.5** Reagents and conditions: (i) NaH, diethyl carbonate, benzene, reflux,  
(ii) diketene, NaH, THF, 0 °C to room temperature

## 1.4 APPROACHES TO THE SECOIRIDOID FRAGMENT

Prior to discussing our approaches to 6, the literature relevant to these discussions will be briefly reviewed.

### 1.4.1 Background

The secoiridoid aglycone fragment 6 is also the aglycone of a more frequently reported secoiridoid, sweroside 17.<sup>25</sup> Radioactivity labelling experiments have shown that the biosynthetic pathway for secoiridoid formation (Scheme 1.6) begins with mevalonolactone 18, which is converted into loganic acid 19, secologanic acid 20 and finally sweroside.<sup>26,27</sup>

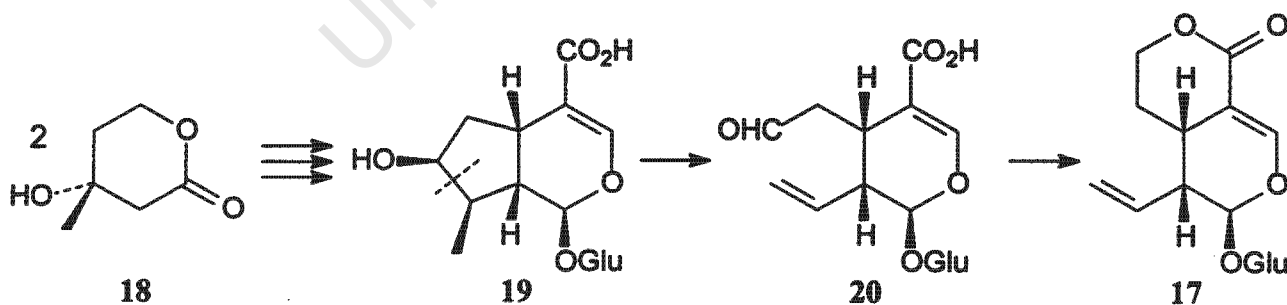

**Scheme 1.6** The biosynthesis of sweroside

The first synthesis of secoiridoids by Tietze (Scheme 1.7) used a racemic precursor analogous to 19, which was converted into secologanic aglycone-*O*-methyl ether *via* a base-mediated Grob-type

fragmentation. The secologanin was reduced to give sweroside aglycone-*O*-methyl ether **21**, as a racemate.<sup>28</sup>

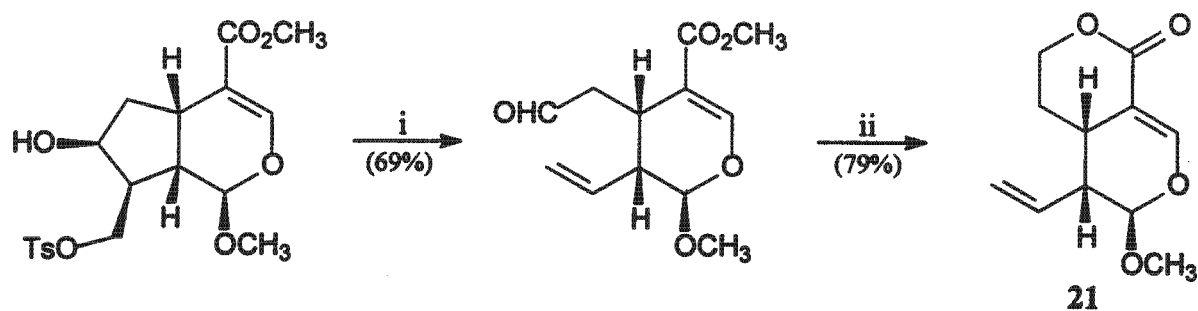

**Scheme 1.7** Reagents and conditions: (i)  $\text{CH}_3\text{S}(\text{O})\text{CH}_2^-\text{Na}^+$ , DMSO, (ii)  $\text{NaBH}_4$ , MeOH

Hutchinson *et al.* reported another racemic total synthesis of **21** in 1978 (Scheme 1.8).<sup>29</sup> A [2+2] photocycloaddition of 1,4-cyclohexadiene and methyl diformylacetate, followed by acid-catalysed ring expansion gave the *cis*-fused bicyclic intermediate **22**. The methyl acetal **23** was ozonised and a reductive work-up followed by treatment with acid gave lactone **24**. Elimination *via* the phenylselenide afforded **21**.

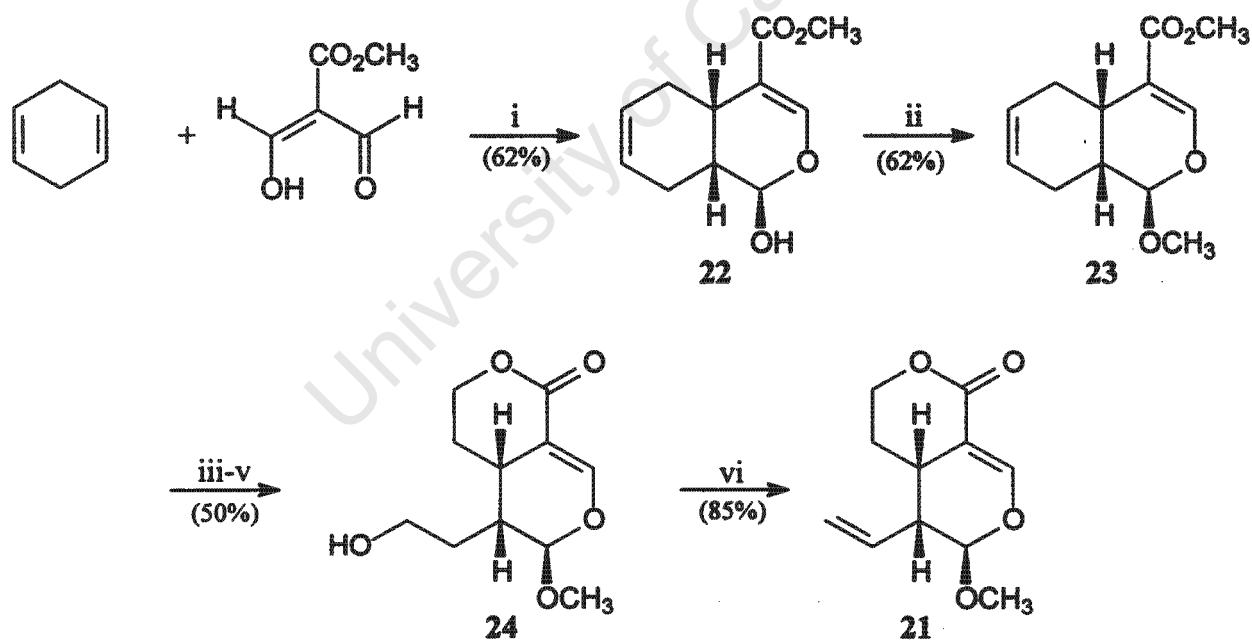

**Scheme 1.8** Reagents and conditions: (i)  $h\nu$ , (ii) MeOH,  $\text{H}^+$ , (iii)  $\text{O}_3$ , MeOH,  $-78^\circ\text{C}$ , (iv)  $\text{NaBH}_4$ , MeOH,  $-78^\circ\text{C}$ , (v) benzene,  $\Delta$ , (vi) *o*- $\text{NO}_2$ -PhSe,  $\text{Ph}_3\text{P}$ , pyr, then  $\text{H}_2\text{O}_2$

The only enantioselective total synthesis of a sweroside derivative reported to date employed an enantioselective synthesis of **22** followed by the steps shown in Scheme 1.6.<sup>30</sup> The enantioselectivity was imparted by the use of homochiral bicyclic starting material in the form of

lactone **25** (Scheme 1.9). Literature procedures for the production of **25** have been tabulated at the beginning the following chapter in this thesis (Table 2.1).

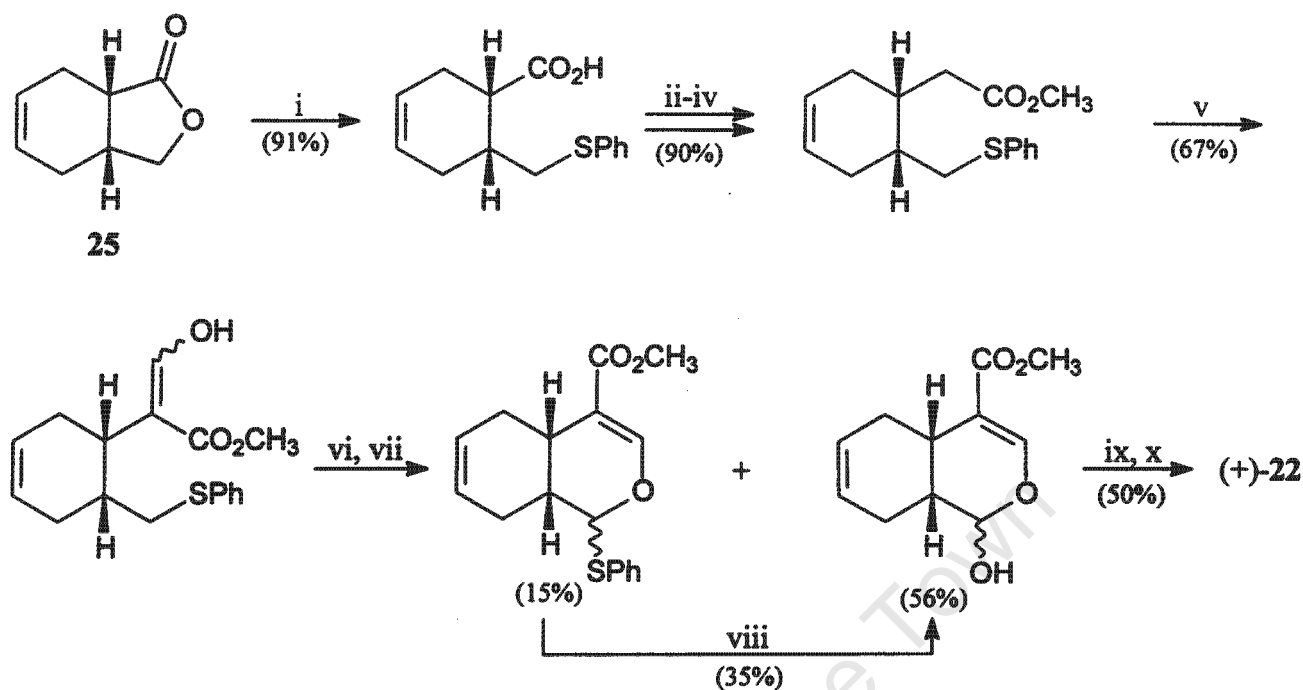

**Scheme 1.9** Reagents and conditions: (i)  $\text{LiSPH}$ , DMF, reflux, (ii)  $(\text{COCl})_2$ , benzene, (iii)  $\text{CH}_2\text{N}_2$ ,  $\text{Et}_2\text{O}$ , (iv)  $\text{Ag}_2\text{O}$  (cat.), MeOH, reflux, (v) LDA, THF,  $-50^\circ\text{C}$ , then  $\text{HCO}_2\text{Et}$ , (vi)  $\text{NaIO}_4$ , MeOH-THF- $\text{H}_2\text{O}$  (6:3:4), (vii) 2,6-lutidine, TFAA,  $\text{CH}_3\text{CN}$ ,  $-15$  to  $0^\circ\text{C}$ , (viii)  $\text{HgCl}_2$ ,  $\text{CH}_3\text{CN}-\text{H}_2\text{O}$  (3:1), reflux, (ix),  $\text{BF}_3\cdot\text{OEt}_2$ , MeOH, (x) Allyl-OTMS, TMSOTf,  $\text{CH}_2\text{Cl}_2$ ,  $-20$  to  $0^\circ\text{C}$

Most published syntheses of complex secoiridoids rely on an advanced secoiridoid precursor as a starting point. This is exemplified by the synthesis of bakankosin<sup>31</sup> **26** and huntereoside<sup>32</sup> **27**, which were both derived from the natural product secologanin **28**.

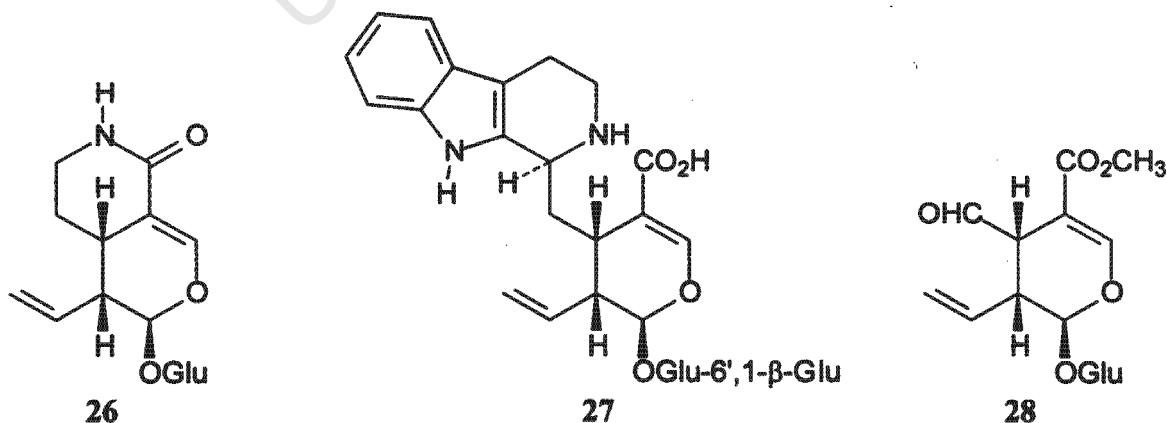

A major thrust of the structure-activity work planned for this programme was the preparation and evaluation of analogues of amarogentin in which both the carbohydrate and the biphenyl moieties

were varied. The susceptibility of the hemiacetal in sweroside aglycone **6** to epimerisation to give the thermodynamically favoured *trans*-isomer has frequently been reported, particularly upon de- and reglycosidation.<sup>29, 30, 33, 34</sup> This precluded the use of readily available sweroside or secologanin as starting materials. An enantioselective total synthesis was thus required.

#### 1.4.2 Retrosynthetic analysis of **6**

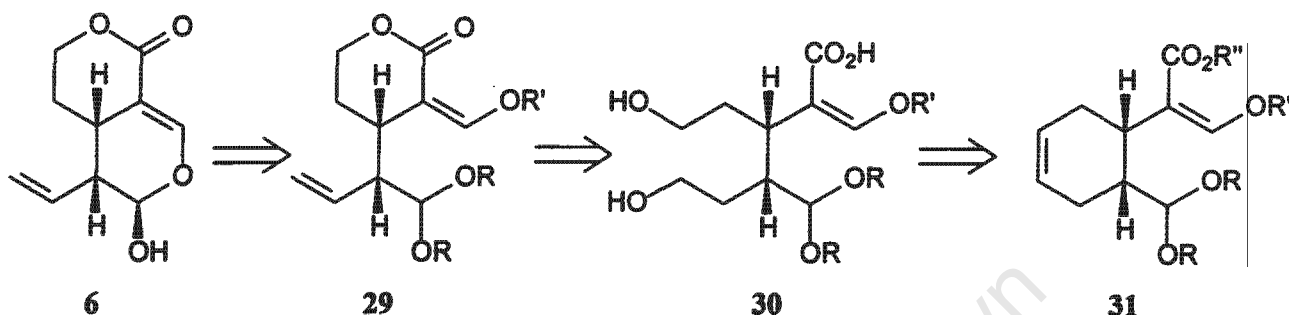

Scheme 1.10 Major disconnections on the secoiridoid core

In a major departure from the Hutchinson synthesis, dismantling of the acetal to **29** was the first disconnection chosen. Because of the labile nature of the hemiacetal, glycosidation must take place immediately after closure to the dihydropyranose system, as such protecting the hemiacetal. The parallel synthesis of compound libraries with varying glycosyl donors would be greatly facilitated if the glycosidation step took place late in the synthesis. It thus followed that the acetal formation must take place late, thus rendering the Hutchinson procedure obsolete for our purposes.

Lactonisation and olefin formation would both utilise the primary hydroxyethyl functionalities present in **30**, which are most conveniently derived from the oxidative cleavage of the cyclohexene **31**. The obvious route to a cyclohexene moiety bearing substituents at positions 4 and 5, and which are configured *syn* to each other, is *via* a Diels-Alder reaction between butadiene and a functionalised dienophile (Scheme 1.11). Diels-Alder methodology was also attractive because substitution on the diene would allow for the synthesis of analogues whilst the functionality associated with the dienophile, to be exploited during secoiridoid construction, could be retained.

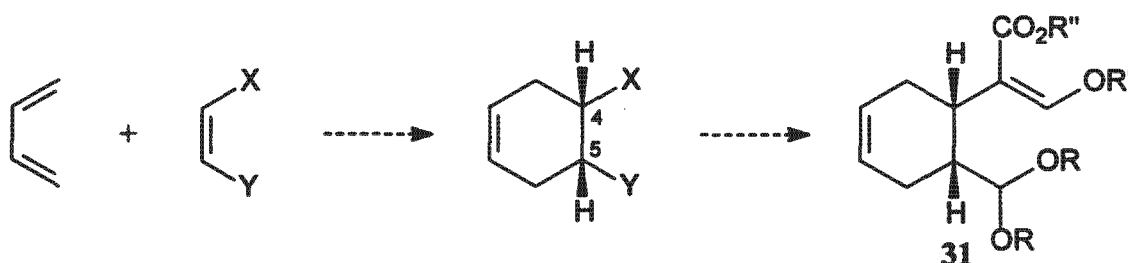

Scheme 1.11

Synthesis of a single enantiomer of the secoiridoid could arise from either the enantioselective synthesis of the cyclohexenyl precursor to **31**, or a resolution step performed during the synthesis of the aglycone from a racemic precursor. The latter option was not attractive because firstly, a successful resolution could not be guaranteed and secondly, only half of the material would be useful in the total synthesis. For the former approach, a number of strategies could be applied to producing the cyclohexenyl precursor as a single enantiomer:

(i) Enantioselective cycloaddition employing a chiral catalyst

A number of enantioselective cycloadditions employing chiral metal catalysts has been reported.<sup>35</sup> In the absence of an immediately obvious system, a brief exploratory investigation into this option has been made previously,<sup>36</sup> but the development of this theme would constitute a methodological study in itself, which was considered outside the scope of this dissertation.

(ii) Diastereoselective cycloaddition employing a chiral dienophile.

The planar nature of a  $\pi$ -system means that an expression of chirality elsewhere in a molecule containing an olefin can render one face of the olefin more sterically hindered than the other. This is particularly true in cyclic systems where rotation of the vinyl substituents is restricted. The reaction of the diene at only the available face of the dienophile affords a single diastereomer in enantiomerically pure form. (Figure 1.1)

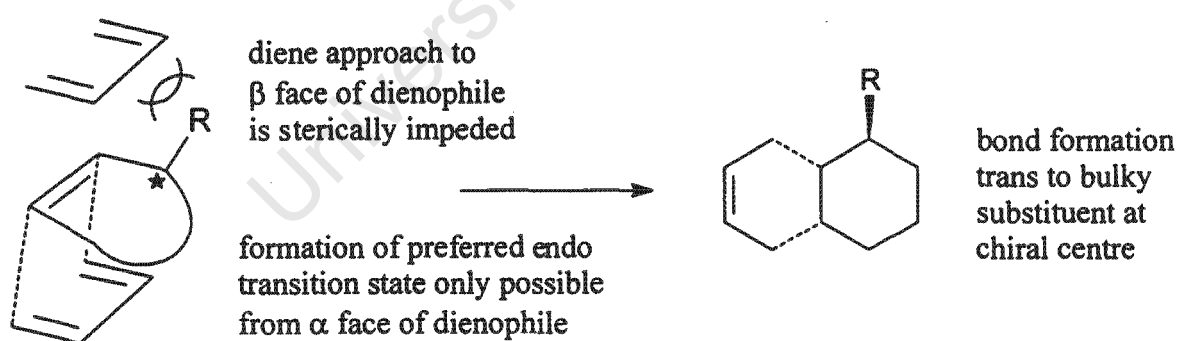

**Figure 1.1** Diastereoselective Diels-Alder cycloaddition using a chiral dienophile

Several chiral dienophiles originating in the chiral pool have been demonstrated to impart a high degree of face selectivity during the reaction with achiral dienes.<sup>37</sup> Two such dienophiles, **32** and **33** were selected for further investigation during this study. The background information behind these choices has been included in Chapter 4. The steric access to the olefin in levoglucosenone,<sup>34</sup> is such that the absolute configuration of the bridgehead protons in the cycloadduct is opposite to

what is required here. *ent*-Levoglucosenone is however available synthetically and **34** was used as a model compound to evaluate this approach. This work has been included in Chapter 5.

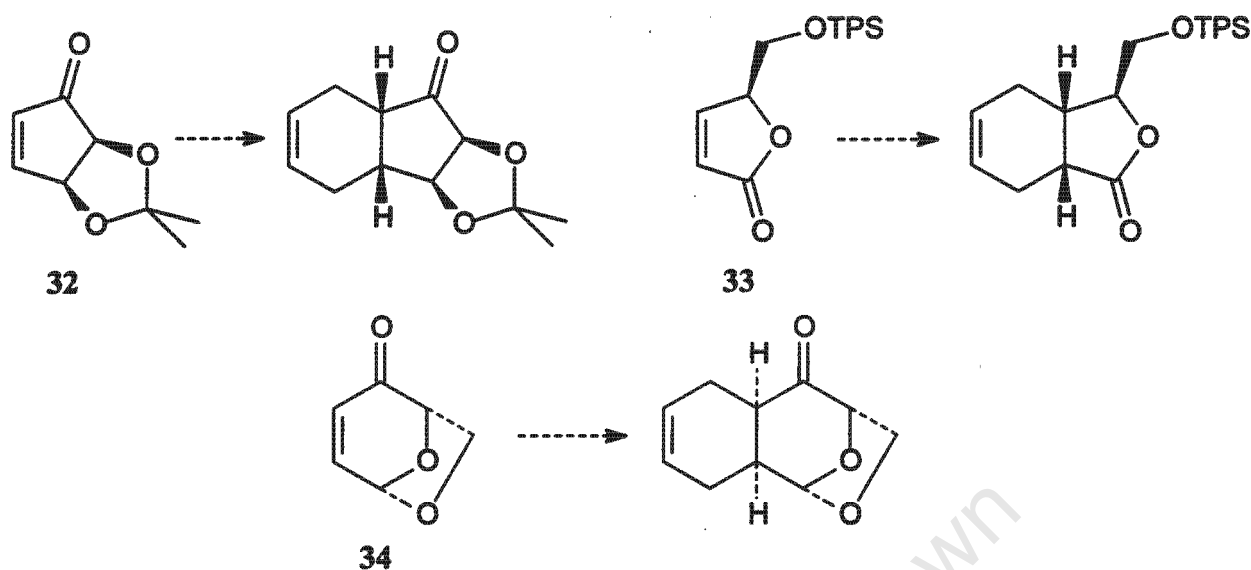

**Scheme 1.12** Proposed cycloaddition of chiral dienophiles originating in the chiral pool with butadiene

(iii) Desymmetrisation of a *meso*-cycloadduct

A *meso*-cycloadduct arises from the reaction of butadiene with a dienophile that contains a plane of symmetry bisecting its double bond (*i.e.*  $X = Y$  in Scheme 1.9). The *meso* product arising from the cycloaddition of maleic anhydride with butadiene, *cis*-1,2,4,6-tetrahydrophthalic anhydride **35** was selected as the starting point for an investigation of a desymmetrisation approach. The enantioselective conversion of **35**, a *meso* compound, to lactone **25** (Scheme 1.13), which no longer bears the aforementioned symmetry, is well known. These procedures are discussed and evaluated in the following chapter.

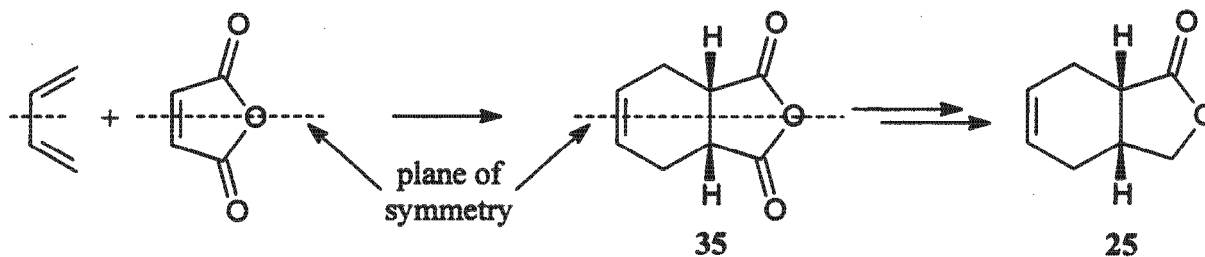

**Scheme 1.13**

Whilst the methodology for the enantioselective formation of **25** was being explored, the synthetic methodology to be employed in this approach to amarogentin was concurrently investigated using racemic starting material. This chemistry has been discussed in Chapter 3.

## CHAPTER 2

## DESYMMETRISATION BASED STRATEGY

## 2.1 BACKGROUND AND OBJECTIVES

This approach was based on the enantioselective desymmetrisation of *cis*-1,2,4,6-tetrahydrophthalic anhydride **35**. The anhydride is readily available at reasonable cost, is stable, and provides no handling difficulties when used in bulk processes. In addition, the wide variety of methods available for converting the anhydride into the homochiral lactone **25** in high enantioselectivity (see Table 2.1 below) make this an attractive starting point. In many cases, these methods can be applied to give either enantiomer of the lactone. The development of chiral drugs must include, for regulatory reasons, extensive medicinal studies that detail the pharmacological activity of the unwanted enantiomer.<sup>38</sup> Access to *ent*-sweroside aglycone using the methodology optimised for the natural enantiomer would thus eventually be required in this project.

Lactone **25** was also selected as an intermediate because it bears chemodifferentiated substituents on the cyclohexene ring, both of which are suitably functionalised to allow conversion to the target functionality using known methodology. Unravelling of sweroside aglycone **6** identifies an aliphatic core skeleton of the target (Fig 2.1). The transformations required on the starting lactone to give this product have been indicated diagrammatically below. The functional group management required in order to achieve these transformations, and the attendant ring closures are discussed in Chapter 3 where the development of a racemic synthetic route is described.

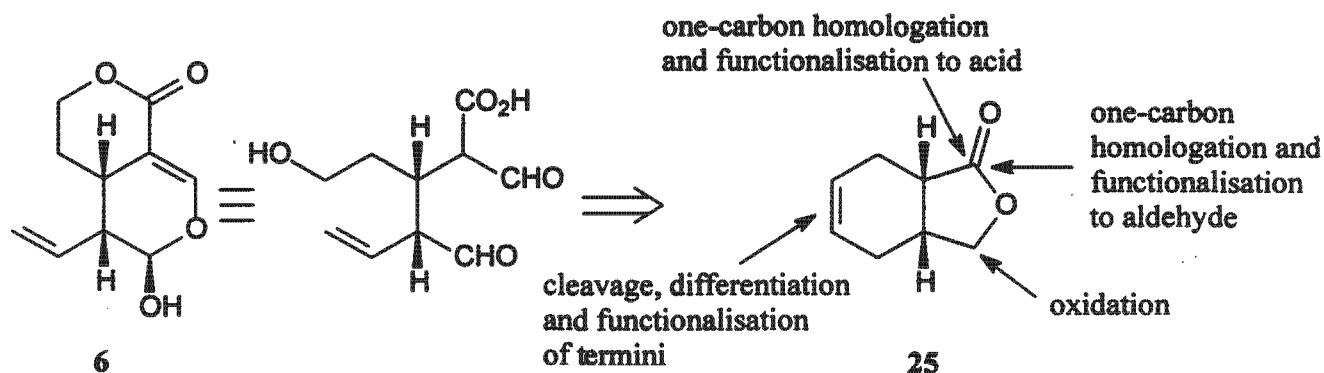
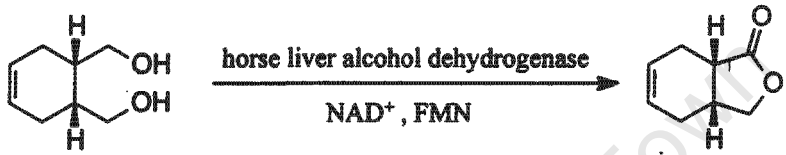
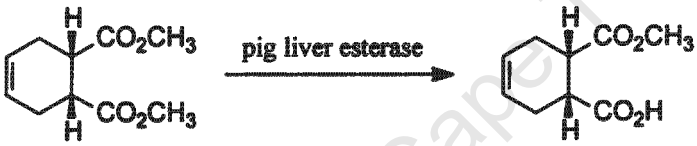
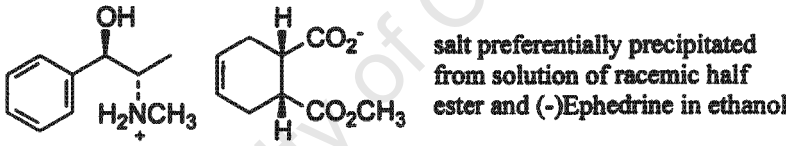
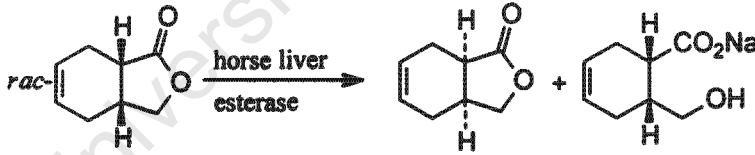
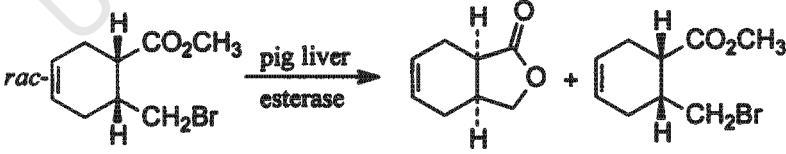
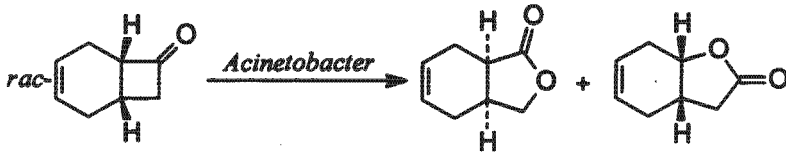
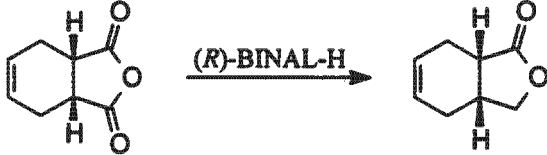

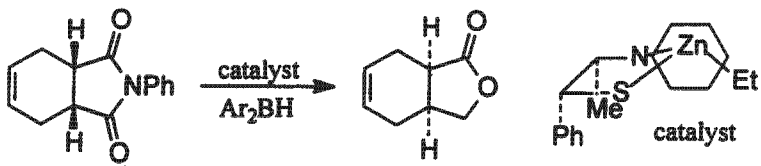
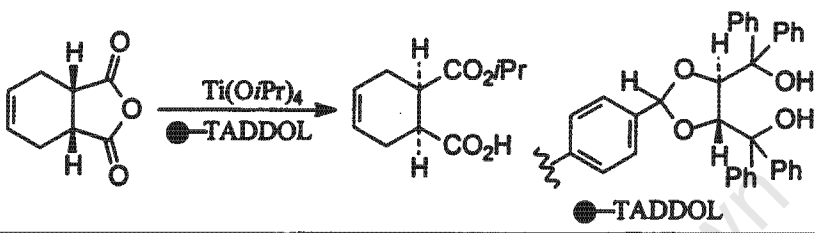
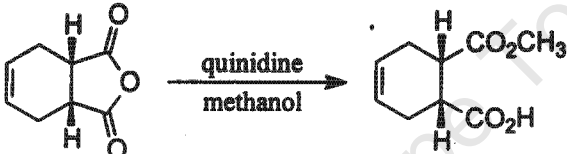

Figure 2.1 An outline of the transformations required on lactone **25** to give sweroside aglycone **6**

As a starting point for this total synthesis, the methodologies available for producing the starting lactone as a single enantiomer were reviewed. The most successful methods have been tabulated in Table 2.1. The criteria applied in selecting a procedure were that both enantiomers be available, the number of transformations on the starting anhydride and to produce the lactone after the chiral induction be minimised, and that scaling up the procedure in our laboratory environment be viable. The cost and availability of the homochiral reagents was also considered.

Table 2.1: Enantioselective methodology towards the homochiral lactone 25

Process Type	Enantioselective Transformation	ee(%)	Ref.
Enzymatic oxidation		>99	39
Enzymatic desymmetrisation		>99	40, 41
Classical resolution		>99	40, 41
Enzymatic resolution		95	42
Enzymatic resolution		97	43
Microbial oxidation		>95	44
Enantioselective reduction		78	45

Process Type	Enantioselective Transformation	ee(%)	Ref.
Microbial oxidation		>99	46
Asymmetric catalytic reduction		96	47
Asymmetric desymmetrisation		>90	48
Asymmetric desymmetrisation		95	49

Although the resolution methods theoretically give both enantiomers, they seldom both afford useful enantiomeric excesses, and the processes become inherently wasteful. The methods that afford a half ester are appealing because, using the selective reductions illustrated in Scheme 2.1, both enantiomers of the bicyclic lactone can be prepared from a single precursor.<sup>40</sup>

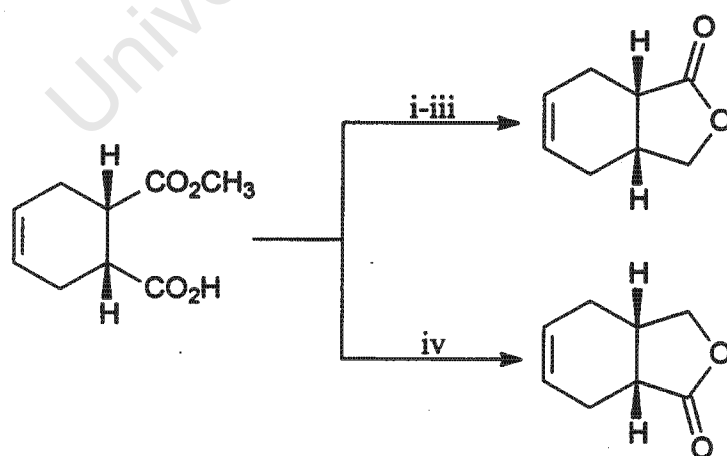

**Scheme 2.1** Reagents and conditions: (i)  $(\text{COCl})_2$ ,  $\text{CH}_2\text{Cl}_2$ ,  $0\text{ }^\circ\text{C}$ , (ii)  $\text{NaBH}_4$ ,  $\text{EtOH-THF}$ ,  $-40\text{ }^\circ\text{C}$ , (iii)  $\text{CSA}$ , toluene, (iv)  $\text{LiEt}_3\text{H}$ ,  $\text{THF}$ ,  $0\text{ }^\circ\text{C}$

Of the methods listed, that using the most readily available and cost effective reagent for chiral induction on a large scale appeared to be the desymmetrisation using tartaric acid derived  $\alpha,\alpha',\alpha',\alpha'$ -tetraaryl-1,3-dioxolane-4,5-dimethanols (TADDOLS). These chiral ligands are easily prepared by the reaction of tartrate acetals with aryl Grignard reagents, and their application in enantioselective synthetic methodologies has been widespread. Seebach, who has pioneered much of the TADDOL-derived methodology, has used the ligands to give chiral titanates (Ti-TADDOLates) (Scheme 2.2) that have been successfully employed as Lewis acid catalysts in the addition of carbon nucleophiles to aldehydes, [2+2] cycloadditions and Diels-Alder cycloadditions.<sup>50</sup> He has also recognised the presence of a nucleophilic moiety in addition to the Lewis acidic functionality in the Ti-TADDOLates. This provides the opportunity to deliver an alkoxide moiety from the chiral ligand sphere of the complex to a substrate with which it forms a Lewis acid-base pair.

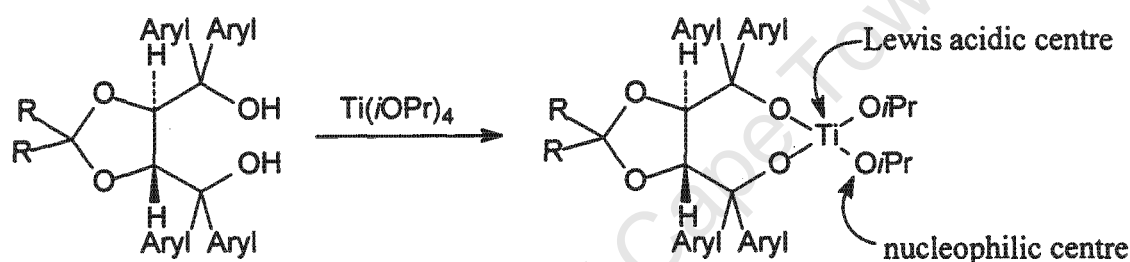

Scheme 2.2

This was first applied to the enantioselective opening of *meso*-*N*-(methylsulfonyl)dicarboximides to give sulfonylimido isopropyl esters,<sup>51</sup> and was followed by a report on the successful opening of cyclic  $C_2$ -symmetric anhydrides (Scheme 2.3).<sup>52</sup> The procedure was optimised using stoichiometric quantities of the Ti-TADDOLate. In most cases, the enantioselectivity was compromised when substoichiometric quantities were used in the presence of stoichiometric  $Ti(OiPr)_4$  or  $Al(OiPr)_3$ .

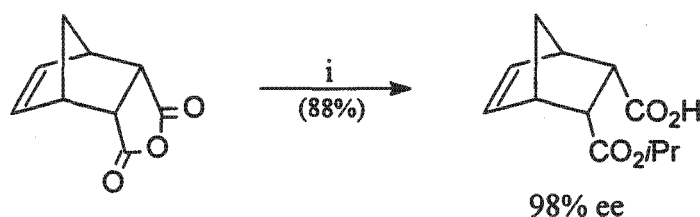

Scheme 2.3 Reagents and conditions: (i)  $Ti[TADDOL (R=CH_3, \text{Aryl}=\beta\text{-naphthyl})](OiPr)_2$ , THF,  $-30\text{ }^\circ\text{C}$

Although a number of bicyclic anhydrides was included in the Seebach study, the desymmetrisation of *cis*-1,2,4,6-tetrahydrophthalic anhydride was not included. However, this transformation has been reported when it was performed using a polymer bound Ti-TADDOLate, as referenced in

Table 2.1,<sup>48</sup> which gave products whose enantiomeric excesses were below those reported for similar anhydrides in the initial methodological study.<sup>52</sup> This phase of the work was thus started by investigating the desymmetrisation of *cis*-1,2,4,6-tetrahydrophthalic anhydride using solution phase Ti-TADDOLates.

## 2.2 SYNTHESIS OF (3*aR*, 7*aS*)-3*a*,4,7,7*a*-Tetrahydro-3*H*-isobenzofuran-1-one 25

### 2.2.1 Preparation of TADDOLS

TADDOLS 36, 37 and 38 were prepared from D-tartaric acid according to literature procedures,<sup>53-55</sup> with 37 and 38 being the ligands that produced optimum results in the Seebach desymmetrisation study.<sup>52</sup> The purification of 37 and 38 was not trivial. Both ligands were recrystallised as alcohol solvates. The literature procedures then describe azeotropic removal of the recrystallisation solvent, followed by precipitation (37) or drying (38) to give a crystalline product. Ligand 37 behaved as described, but in our hands 38 was obtained as a foam and despite repeated attempts to purify it as the solvate, it remained as such and was used in that form.

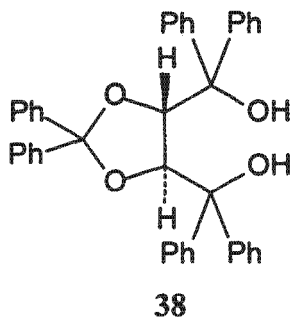
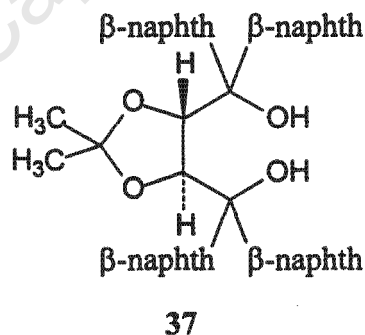
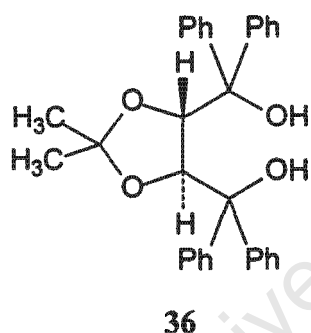

### 2.2.2 Desymmetrisation studies

The described reaction procedure<sup>52</sup> was followed. The isopropyl half ester 39 was isolated, along with unreacted starting material. The recovery of the TADDOL used was also quantified. The enantioselectivity of the reactions was evaluated after reduction of the isopropyl half ester to 25 (Scheme 2.4). The enantiomers of 25 were separated by gas chromatography on a chiral stationary

phase. The absolute configuration of the product was confirmed to be opposite to that of the Seebach half ester (obtained using TADDOLS derived from L-tartaric acid) by comparison of the direction of optical rotation.

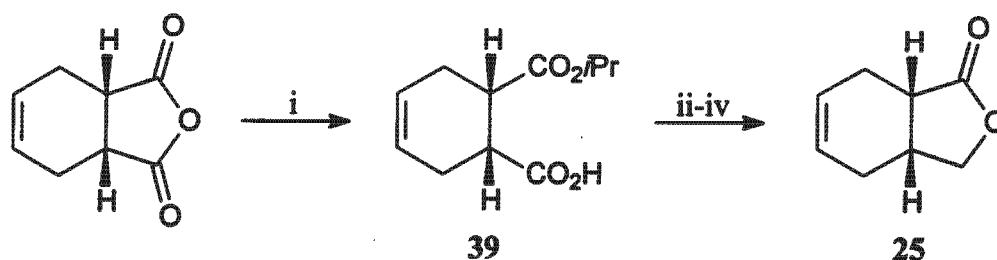

**Scheme 2.4** Reagents and conditions: (i)  $\text{Ti}(\text{TADDOL})(\text{OiPr})_2$ , THF,  $-15$  or  $-20$  °C, (ii)  $(\text{COCl})_2$ ,  $\text{CH}_2\text{Cl}_2$ ,  $0$  °C, (iii)  $\text{NaBH}_4$ , EtOH-THF,  $-40$  °C, (iv) *p*TsOH, toluene

The results of the desymmetrisation experiments performed are presented in Table 2.2.

**Table 2.2** Results for the Ti-TADDOLate-mediated desymmetrisation of tetrahydrophthalic anhydride 35

Exp. No	TADDOL	Scale (mmol)	Temp. (°C)	Time (d)	TADDOL recovered (%)	Yield 39 (%)	Anhydride recovered (%)	Enantiomer ratio
1	36	4.0	-15	7	96	72	—	8.1 : 91.9
2	37	4.0	-15	7	85	90	—	5.6 : 94.4
3	38	4.0	-15	7	97	58	—	3.1 : 96.9
4	36	4.0	-20	7	98	40	33	2.8 : 97.2
5	36	30.0	-20	7	61	75	20	8.0 : 92.0
6	38	30.0	-15	7	93	89	—	4.3 : 95.6
7	36	30.0	-20	10	50	63	—	7.4 : 92.6

The enantioselectivity of the initial reaction using 36 was, as expected from the Seebach work, lower than that for the reactions using 37 and 38 (entries 1,2 and 3). Since the preparation and purification of 36 was the most cost and time effective, an attempt was made to apply the temperature dependence noted by Seebach to enhance the enantioselectivity achieved at  $-15$  °C (entry 1). At a reaction temperature of  $-20$  °C the lactone was obtained in  $>94\%$  ee (entry 4). A loss of enantioselectivity was however observed on scaling up the reaction (entries 5 and 7). The reason for this was not obvious. The reaction was started by the addition of a solution of the TiTADDOLate in THF to a solution of 35 in THF. The heats of mixing of these two solutions may

have been such that an increase in temperature was experienced. In a large scale reaction, temperature dissipation to the immediate environment could be expected to be slower, thus increasing the effective reaction temperature. These entries also show that the enantioselectivity was not compromised by increasing the duration of the reaction to 10 days, which allowed complete consumption of the starting anhydride. The performance of **37** and **38** were both encouraging on a small scale. For larger scale experiments, the cost of producing **37** was considered to be prohibitive (2-bromonaphthalene is expensive, relative to the alternative bromobenzene) and the hexaphenyl ligand, **38**, was thus persevered with. The enantiomeric excess was slightly lower for the larger scale experiment (92% as opposed to 94%, entries 6 and 3), but remained the optimum result.

Although further experimentation is required to optimise both the synthesis of **38** and the desymmetrisation reaction in our laboratories, the knowledge that sufficient starting lactone for a multi-step sequence could be produced in acceptable enantiomeric excess allowed us to embark on the total synthesis. Rather than developing a synthetic route using homochiral **25**, a racemic model was adopted. That is, the racemate of **25**, which is easier to access in bulk, was used as the starting material for a proposed diastereoselective synthesis of sweroside aglycone. In combination with the positive desymmetrisation results, this would constitute a formal enantioselective total synthesis.

## CHAPTER 3

## RACEMIC MODEL SYNTHESIS

## 3.1 BACKGROUND AND OBJECTIVES

The transformations of the functionality present in **25** required to give overall conversion into sweroside aglycone **6** were identified and noted in the previous chapter (Figure 2.1). A schematic representation is repeated here for the purposes of this discussion.

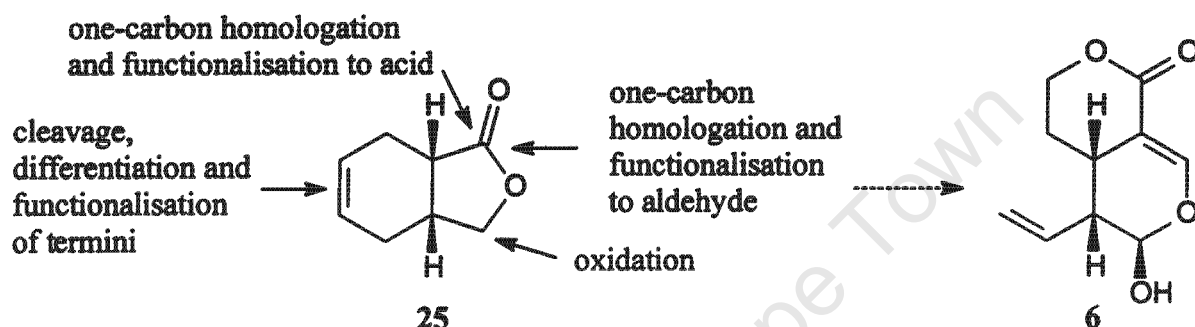
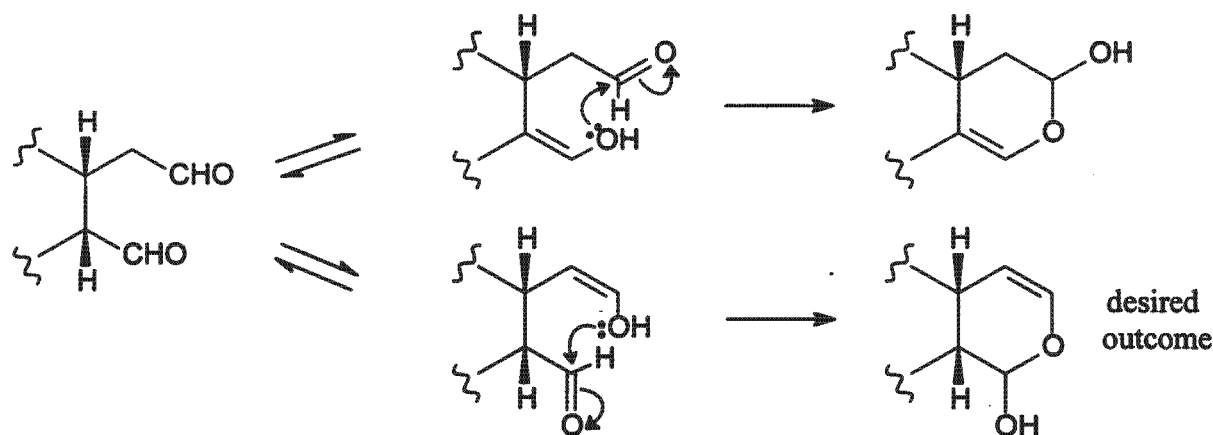

Figure 3.1 Planned transformations on the starting lactone **25**

The aim of the work described in this chapter was to devise a synthetic route using a racemic model, to achieve these transformations efficiently and without compromising the absolute configuration of the chiral centres. Prior to planning a route, the following constraints were identified:

- (i) The carboxyl moiety should be in place prior to attempted closure of the dihydropyranoid ring. As shown in Scheme 3.1, enolisation of either one of the aldehyde moieties results in the formation of two different hemiacetals, one of which compromises a chiral centre.



Scheme 3.1

Formation of the desired hemiacetal would be facilitated if the 'northern' aldehyde were present as its enol tautomer. Conjugation of the carboxyl C=O bond with the enol C=C bond should provide stability of this enol tautomer and ensure its existence in preference to the keto (aldo) form (Scheme 3.2).

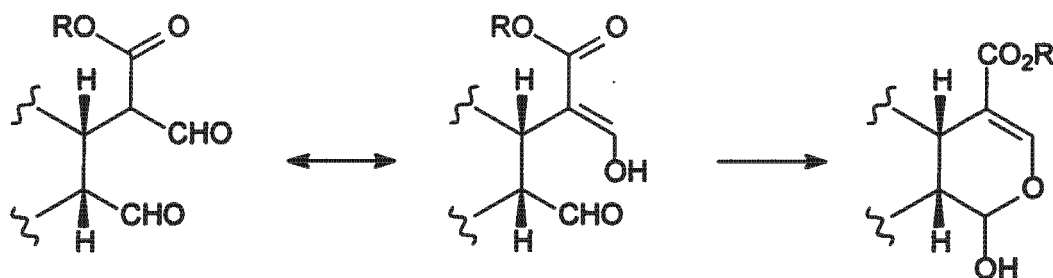

**Scheme 3.2**

(ii) Chemodifferentiation of the hydroxyethyl moieties formed after oxidative cleavage of the cyclohexene motif would be facilitated if the carboxyl was in place prior to diol formation.  $\delta$ -Lactone formation would thus provide the required chemodifferentiation step (Scheme 3.3).

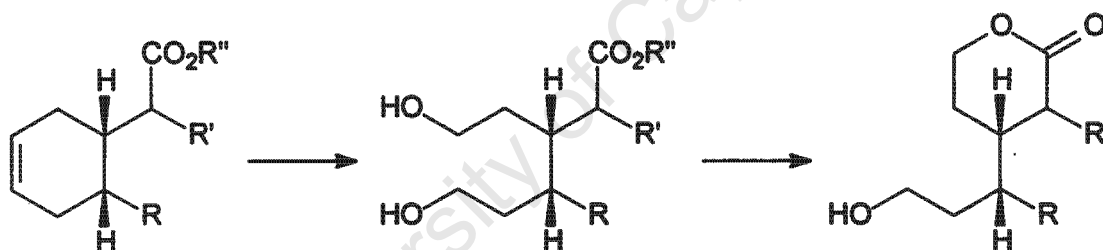

**Scheme 3.3** Chemodifferentiation of hydroxyethyl moieties *via* lactone formation

(iii) As stated in Chapter 1, in order to accommodate analogue synthesis, dihydropyran ring closure and acetal protection should be the last steps in the synthesis.

A retrosynthetic scheme observing these requirements was devised and is outlined in Scheme 3.4. What follows here is a brief discussion on the processes constituting transformations (a) through (f) in Scheme 3.4. The specific methodologies identified to achieve these conversions are introduced at the appropriate point in the discussions on the actual syntheses performed. Transformation (a) consisted of: firstly, deprotection of the enolic moiety; followed by acetal deprotection and concomitant ring closure to give the dihydropyran. Elimination of the primary hydroxyl group constituted step (b), whilst oxidative cleavage of the endocyclic olefin, and reduction of the termini to hydroxyl groups, followed by lactonisation was planned at (c). An enolate-mediated process was

planned for the C-C bond formation step (d), so utilising the carbonyl functionality available at that point. The aldehyde would be protected as an enol ether after the homologation process. Transformation (e) comprised firstly, acetal formation, followed by regioselective functionalisation of the exocyclic olefin to install the requisite carbonyl group. For process (f), opening of the heterocyclic moiety was required first, to allow access to both termini. Homologative olefination and oxidation of the 'northern' and 'southern' termini respectively completed this step.

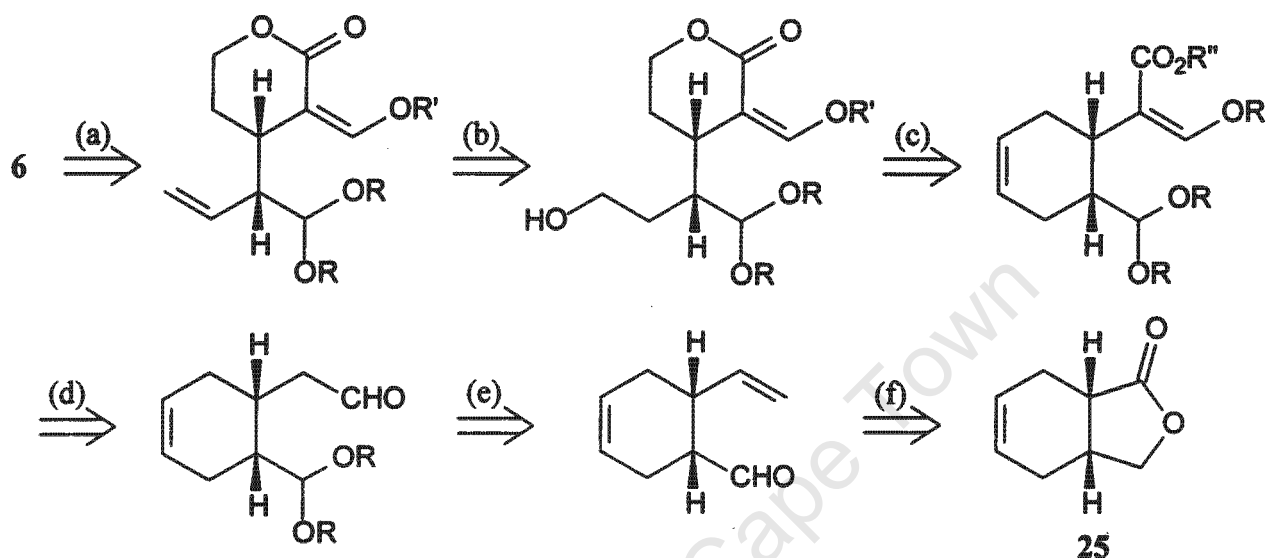

**Scheme 3.4** Synthetic plan for the racemic synthesis of sweroside aglycone

## 3.2 RESULTS AND DISCUSSION

### 3.2.1 Synthesis of *cis*-3a,4,7,7a-Tetrahydro-3*H*-isobenzofuran-1-one 25

Various protocols for this reduction were applied. Methanolysis of 35 in the presence of diisopropylamine provided the novel salt 40. Following a procedure described by Zwanenberg *et al.*,<sup>56</sup> the salt was treated with *i*-butyl chloroformate to give a mixed anhydride. Filtration followed by reduction with sodium borohydride ( $\text{NaBH}_4$ ) using the conditions described led largely to the diol 41, the product of over-reduction (Scheme 3.5).

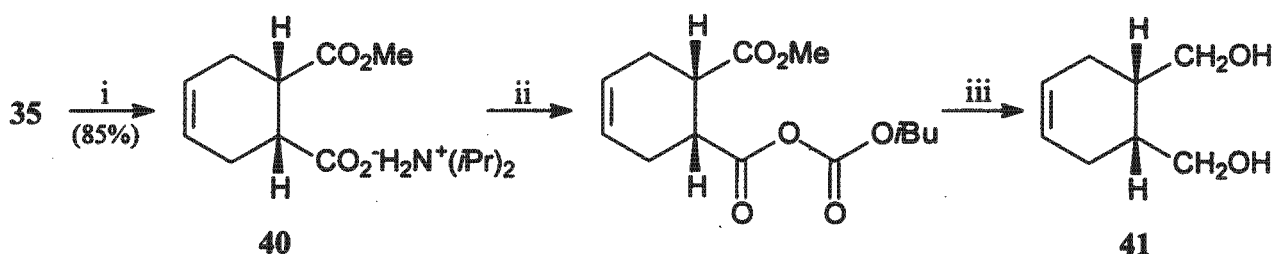

**Scheme 3.5** Reagents and conditions: (i)  $\text{HN}(\text{iPr})_2$ , MeOH, (ii)  $i\text{BuOCOC}\text{Cl}$ ,  $\text{CH}_2\text{Cl}_2$ , 0–25 °C then filter, (iii)  $\text{NaBH}_4$ ,  $\text{CH}_2\text{Cl}_2$ – $\text{H}_2\text{O}$ , 0 °C

The methyl half ester of *cis*-1,2,4,6-tetrahydrophthalic anhydride, **35** was produced by simple methanolysis and, more efficiently, by acidifying an aqueous solution of **40** followed by extraction of **42** (Scheme 3.6).

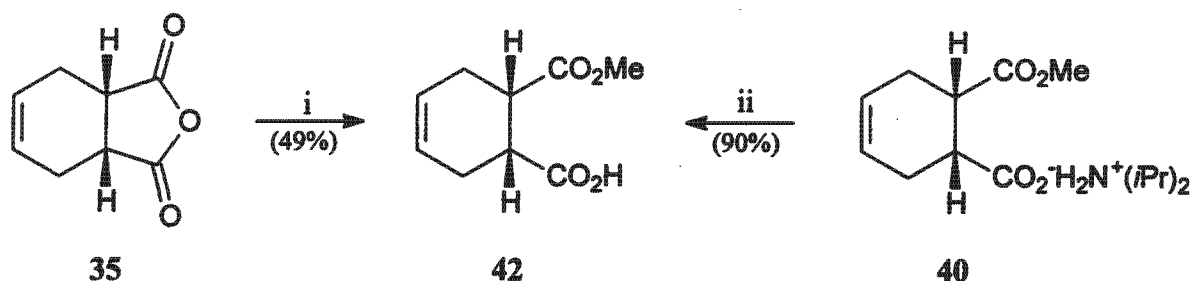

**Scheme 3.6** Reagents and conditions: (i)  $K_2CO_3$ , MeOH, (ii) HCl, EtOAc-H<sub>2</sub>O

Selective borohydride reduction of **42** via acid chloride formation requires careful control of both stoichiometry and temperature to avoid over-reduction. The simplest reduction proved to be a literature procedure<sup>57</sup> in which the anhydride was directly reduced with  $NaBH_4$  in cold dimethylformamide (DMF) to give the lactone as a single product which could be purified by vacuum distillation (Scheme 3.7).

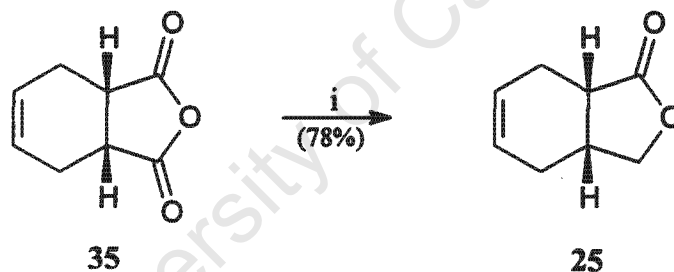

**Scheme 3.7** Reagents and conditions: (i)  $NaBH_4$ , DMF, 0 °C

### 3.2.2 Homologation studies

Both stepwise<sup>58</sup> and one pot procedures<sup>59</sup> have been described for the diisobutylaluminium hydride (DIBAH) reduction of **25** to lactol **43**, followed by a Wittig reaction with a methylphosphorane to give the homologated olefin **44** (Scheme 3.8).

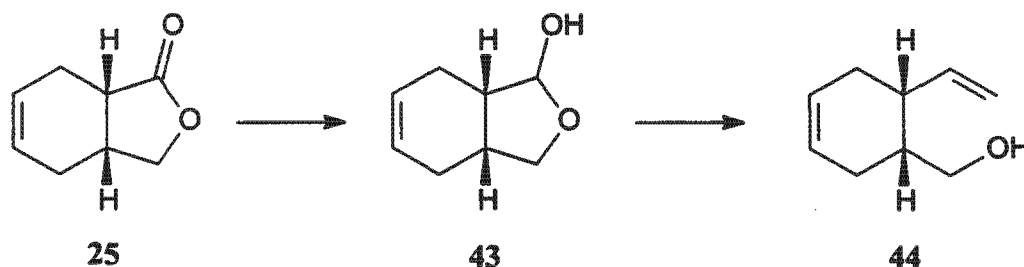

**Scheme 3.8** Known one-carbon homologation of **25**

This procedure was selected because, in addition to one-carbon homologation, it provided a ring opened intermediate in which the cyclohexenyl substituents were clearly chemodifferentiated. The hydroxyl group in **44** would be accessible for oxidation to the required aldehyde level. The olefin is ideally primed for further functionalisation since it is monosubstituted. It is thus chemodifferentiated from the endocyclic double bond and as well as providing an opportunity for regioselective hydroboration.

In the event, the reduction procedure was found to be less selective than that described and reduction of the product lactol to diol **41** was observed prior to complete consumption of starting lactone. The reaction of **25** with 1.5 equivalents of DIBAH showed complete consumption of starting material and a 3:1 distribution of products **43** and **41** (Scheme 3.9). Alternative reduction methodology affording **43** in 88% yield has been described.<sup>60</sup> In that work, **25** was reacted with stoichiometric polymethylhydrosiloxane in the presence of catalytic titanocene difluoride to give a silylated lactol which was deprotected to **43** during an aqueous work-up at basic pH. This methodology was not required here since it was later noted that very fast addition of DIBAH to a rapidly stirring solution of **25** minimised over-reduction and stoichiometric hydride could be used to give **43** in 92% yield.

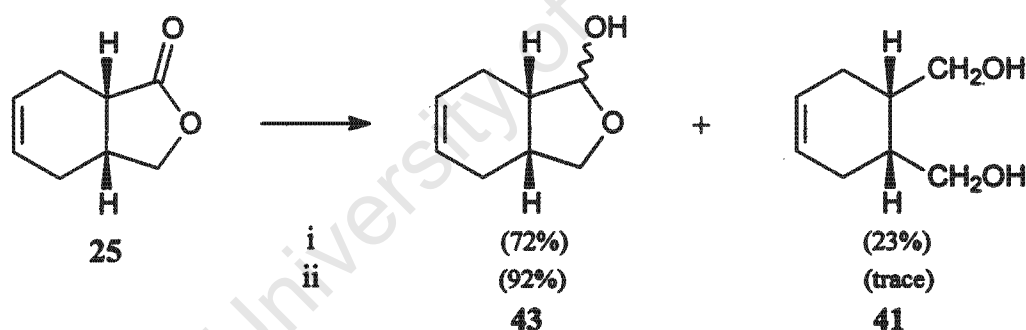

**Scheme 3.9** Reagents and conditions: (i) DIBAH (1.5 mol. equiv., slow addition), toluene,  $-78\text{ }^{\circ}\text{C}$   
(ii) DIBAH (1.1 mol. equiv., fast addition), toluene,  $-78\text{ }^{\circ}\text{C}$

The synthesis of **44** was most efficiently achieved when two discrete steps were used, as opposed to the one-pot procedure (Scheme 3.10). The oxidation of the exposed hydroxyl group using chromium trioxide–pyridine has been reported,<sup>58</sup> but in a poor yield (55%). This oxidation proved to be problematic for two reasons; (i) the epimerisable nature of the bridgehead position  $\alpha$  to the aldehyde carbonyl in the product and (ii) the volatile nature of the aldehyde. Epimerisation was noted in the oxidation with pyridinium chlorochromate–alumina where a mixture of inseparable products, **45** and **46** was recovered in proportions that varied from 9:1 to 4:6 depending on the reaction conditions (Scheme 3.10). Swern oxidation<sup>61</sup> as well as oxidation with Ley's

tetrapropylammonium perruthenate (TPAP)<sup>62</sup> provided only the desired *cis* diastereomer **45**. In all cases the recovery of **45** was less than 50%. This was assumed to be due to evaporation of the aldehyde during isolation. One of the work-up procedures recommended for the TPAP oxidation,<sup>62</sup> is a non-aqueous procedure involving flash chromatography of the reaction mixture to give the aldehyde. This protocol was followed using dichloromethane as the elution solvent to give a solution of the aldehyde in dichloromethane, which provided the reaction medium for the protection of **45** as an acetal, thus minimising the handling and losses due to evaporation. Cyclic acetal formation was achieved, but the recovery of the dioxanyl derivative **47** was only 23% over the two steps. Signals at  $\delta$  4.27 (doublet) and  $\delta$  104.1 in the <sup>1</sup>H and <sup>13</sup>C NMR spectra respectively confirmed the presence of an acetal moiety in **47**.

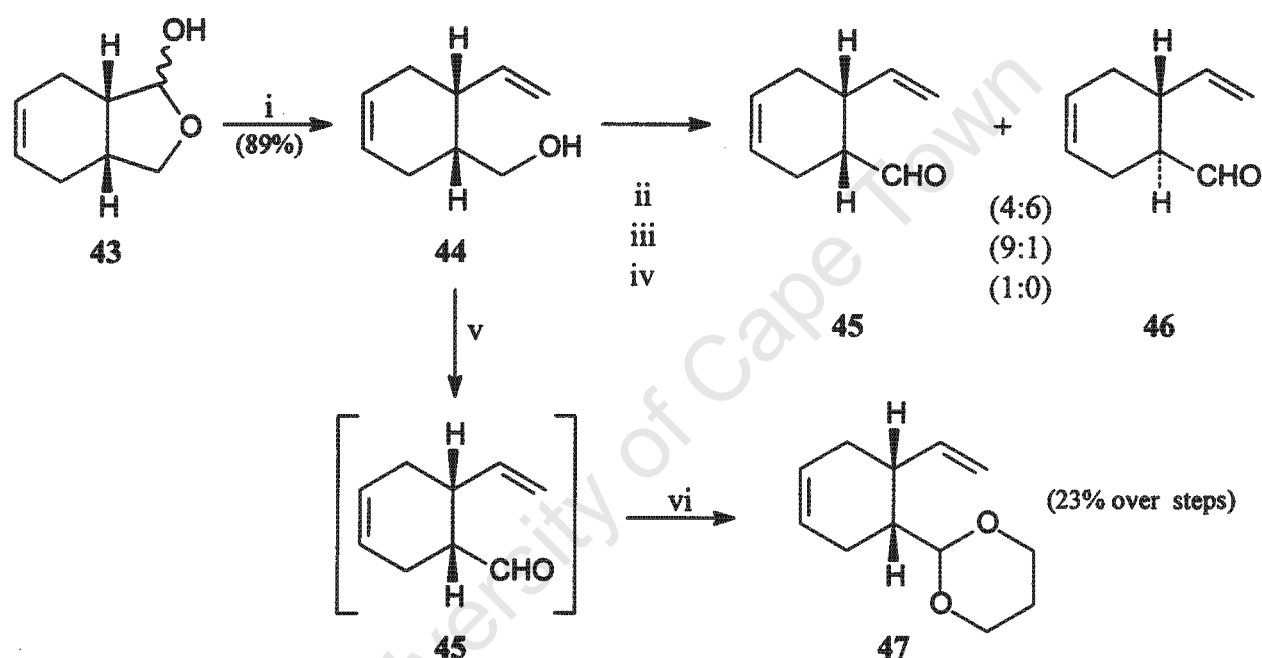

**Scheme 3.10** Reagents and conditions: (i)  $\text{Ph}_3\text{P}^+\text{CH}_3\text{I}^-$ , *n*BuLi, THF, 0—25 °C (ii) PCC-alumina,  $\text{CH}_2\text{Cl}_2$  (0.58M), (iii) PCC-alumina,  $\text{CH}_2\text{Cl}_2$  (0.04M), (iv)  $(\text{COCl})_2$ , DMSO,  $\text{CH}_2\text{Cl}_2$ , -78 °C, then  $\text{Et}_3\text{N}$ , -78—25 °C, (v) TPAP, NMO, 4Å mol. sieve,  $\text{CH}_2\text{Cl}_2$ , (vi) propane-1,3-diol,  $\text{HC}(\text{OCH}_3)_3$ , *p*TsOH

In order to confirm the assumption that the single isomer isolated (*i.e.* **47**) was indeed the *cis* diastereomer, the peak width for the 5-H signal in the <sup>1</sup>H NMR spectrum was examined. Unfortunately other proton signals were not useful since they overlapped, and the lack of resolution in the H-5 signal precluded the identification of specific *J* values. In the *trans* diastereomer, the cyclohexene ring would be expected to exist primarily in the conformation in which both substituents are equatorial. Figure 3.2 shows that in this conformation, two of the vicinal coupling partners of 5-H on the ring adopt an antiperiplanar relationship with 5-H and each thus contributes large *J* values. The vinyl substituent in a *s-trans* configuration would also contribute a coupling partner in an antiperiplanar relationship. These three large couplings could not account for the

observed half height peak width  $W_{1/2}$  18 Hz. For the *cis* diastereomer, shown in the conformation inferred by examining conformational energies ('A' values), the coupling would comprise three small gauche interactions and a single large interaction with the vinyl proton and the observed peak width is feasible. In 44, the analogous signal was identical in appearance and width to that in 47, which provided a further indicator that no epimerisation had occurred over the transformation

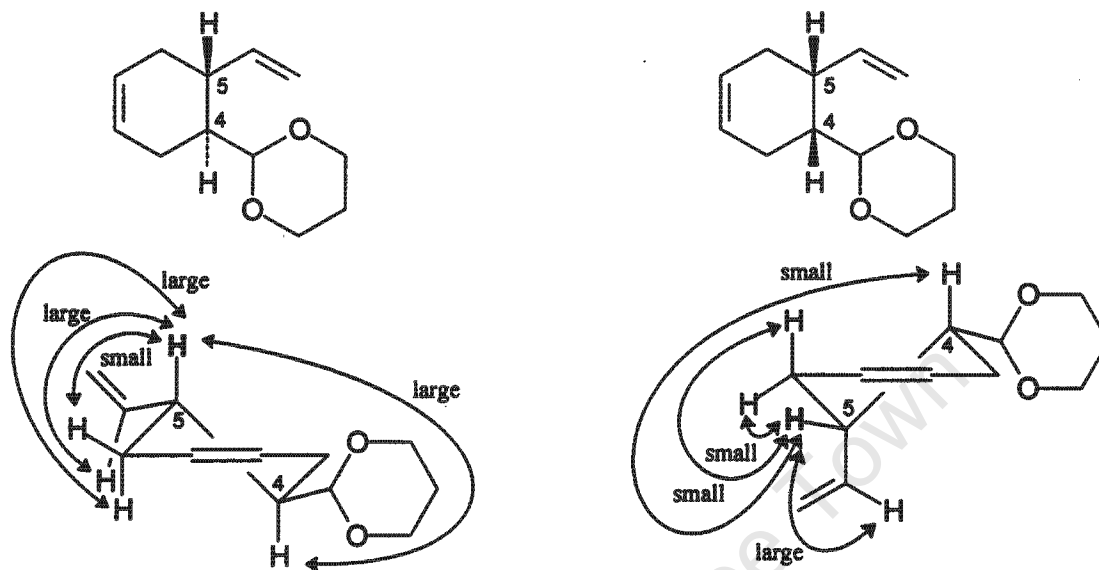

**Figure 3.2** Expected coupling for 5-H in the *trans* and *cis* diastereomers of the disubstituted cyclohexene 47

In order to eliminate the losses caused by handling 45, the synthetic plan was altered. The conversion of the alcohol into the desired aldehyde oxidation state was delayed until later in the synthesis when the intermediates were expected to be less volatile. The hydroxyl group in 44 was thus silylated to give 48. The *t*-butyldiphenylsilyl (TPS) ether was selected because of its robust nature and likely ability to survive a wide variety of reaction conditions. Hydroboration-oxidation using 9-borabicyclononane (9-BBN- $H_2O_2$ ) provided a single product showing the expected chemo- and regioselectivity, 49 (Scheme 3.11). The  $^1H$  NMR spectrum included signals in the olefinic region, which integrated for only two protons and could thus not be assigned to the terminal olefin, indicating the chemoselectivity of the reaction. A signal at  $\delta$  1.38–1.54 integrating for two protons was assigned to 1''- $H_2$  and confirmed that the primary hydroxyl group was present.

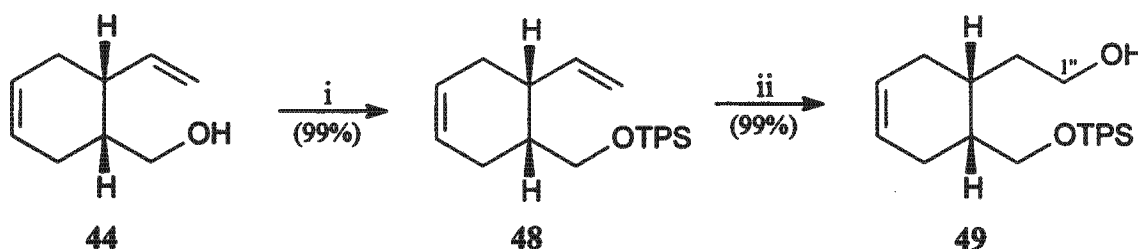

**Scheme 3.11** Reagents and conditions: (i) TPSCl, imidazole, DMF (ii) 9-BBN, THF, then 1M NaOH,  $H_2O_2$

The selection of the oxidation level into which the hydroxyl group in **49** should be converted was dependent on the second one-carbon homologation strategy to be applied. Oxidation to an aldehyde followed by base-mediated enolate formation and carboxylation of the enolate would give the desired intermediate **50** (Scheme 3.12 PATH A). Similarly, oxidation to an acid followed by ester formation, deprotonation and formylation of the enolate would lead to the same intermediate (Scheme 3.12 PATH B).

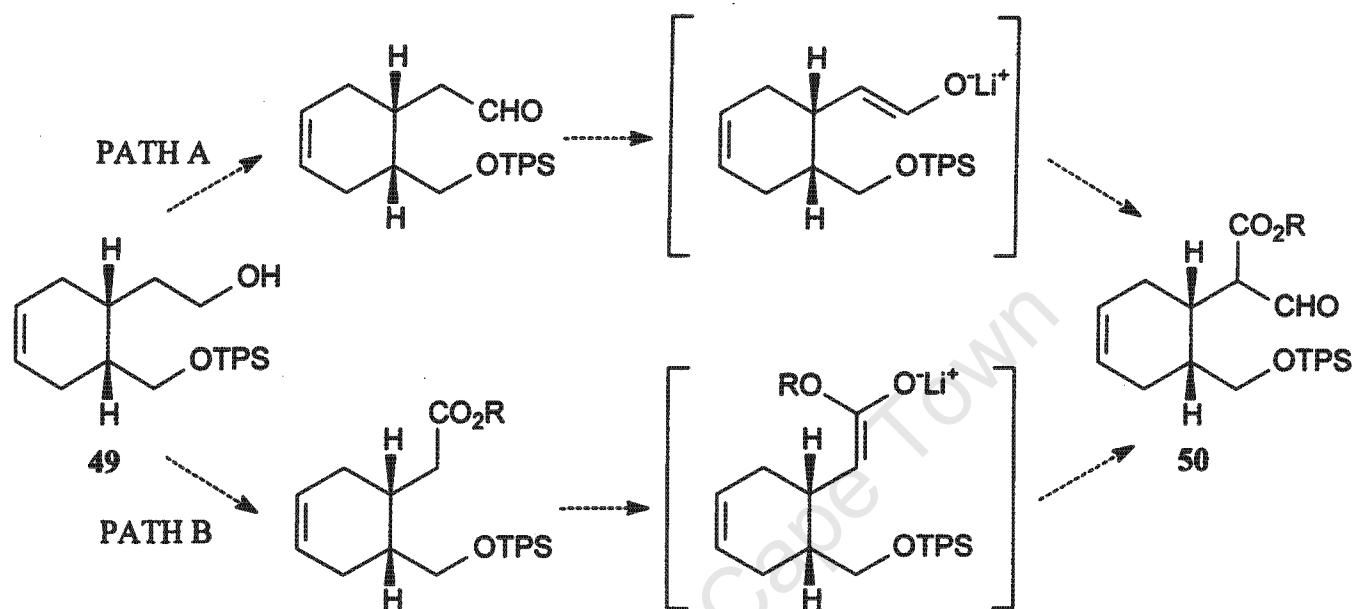

Scheme 3.12 Enolate-mediated routes to **50**

The selection of PATH A as the first option attempted was made firstly, because the aldehyde should be accessible in a single step using mild conditions (Swern or Dess-Martin oxidation procedures) and secondly, to avoid complications that could arise from the ambident nature of enolate anions. In terms of the HASAB (Hard and Soft Acids and Bases) principle, the enolate possesses a hard oxygen and a soft carbon end, both of which are nucleophilic and can participate in alkylation and acylation reactions.<sup>63</sup> *O*-Acylation is the most serious side reaction experienced during the attempted *C*-acylation (as proposed in PATH B) of alkali metal enolates of simple aldehydes and ketones.<sup>64</sup> Although the quenching of lithium enolates with CO<sub>2</sub> provides the desired *C*-carboxylated product, yields are usually poor. Methyl cyanofomate has been shown to give the desired regioselectivity forming β-ketoesters during reactions with preformed lithium enolates of ketones<sup>65</sup>. This reagent was thus applied to the carboxylation of an aldehyde precursor.

The oxidation of **49** using 1,1,1-trifluoro-1,1-dihydro-1,2-benziodoxol-3(1*H*)-one, also known as Dess-Martin periodinane,<sup>66</sup> to aldehyde **51** proceeded as expected. Spectroscopic data were consistent with the assigned structure. Treatment of **51** with lithium diisopropylamide (LDA)

followed by methyl cyanofornate gave a complex mixture of products. When the enolate was treated with methyl chloroformate or carbon dioxide, mixtures dominated by unreacted starting material were produced. A carboxylation using the *in situ* formation of a magnesium carbonate species similar to the Stiles reagent (magnesium methyl carbonate)<sup>67</sup> also gave unsatisfactory results (Scheme 3.13).

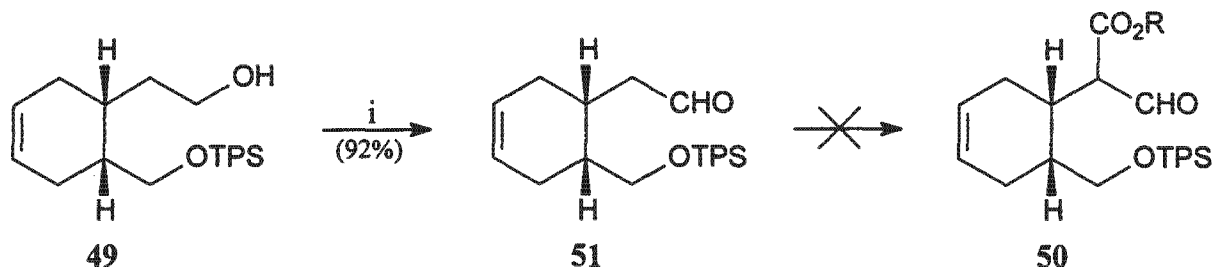

**Scheme 3.13** Reagents and conditions: (i) Periodinane,  $\text{CH}_2\text{Cl}_2$

At this point, the nature of the enolates involved was examined. Although the  $pK_a$  of the aldehyde  $\alpha$ -protons is similar to that of ketones ( $\sim 19$ ),<sup>68</sup> the propensity of aldehyde enolates to condense with a protonated species in an aldol condensation is far higher. It has been shown that this unwanted reactivity can be minimised by rapid, quantitative deprotonation with a stronger base like potassium hydride,<sup>69</sup> or by using an indirect method whereby the aldehyde is derivatised, frequently to an enamine, and acylated in that form.<sup>70</sup> In preference to these options, the formylation of an ester was considered. The  $pK_a$  of the ester  $\alpha$ -CH protons is higher ( $\sim 24$ ),<sup>68</sup> and deprotonation with LDA can thus be expected to be slower than that of aldehydes. The Claisen self-condensation is however not as rapid as the aldol equivalent and lithium enolates of esters are thus useful reactive intermediates. Mixed Claisen reactions usually deliver four possible products. Ethyl formate, however, bears no hydrogens  $\alpha$  to the carbonyl and can thus only react as the electrophile under these conditions, giving an overall  $\alpha$ -formylation product in these reactions (Scheme 3.14).

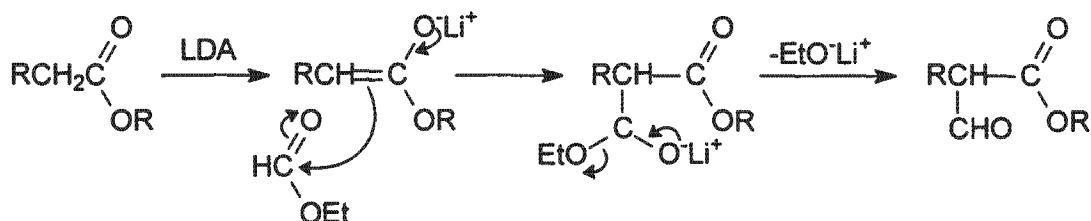

**Scheme 3.14** Formylation of an ester enolate using Claisen condensation methodology

The alternative homologation sequence (PATH B) was thus attempted. The ester was prepared by a Jones oxidation of 49 to give acid 52. The reaction was performed at low temperature ( $-16\text{ }^\circ\text{C}$ ) to

preclude any silyl deprotection under the strongly acidic conditions. The acid was converted into its methyl ester **53** that was successfully formylated by enolate formation with LDA followed by treatment with ethyl formate. The formyl product **54** was present in solution as a mixture of the two formyl diastereomers and the two enolic diastereomers as depicted (Scheme 3.15).

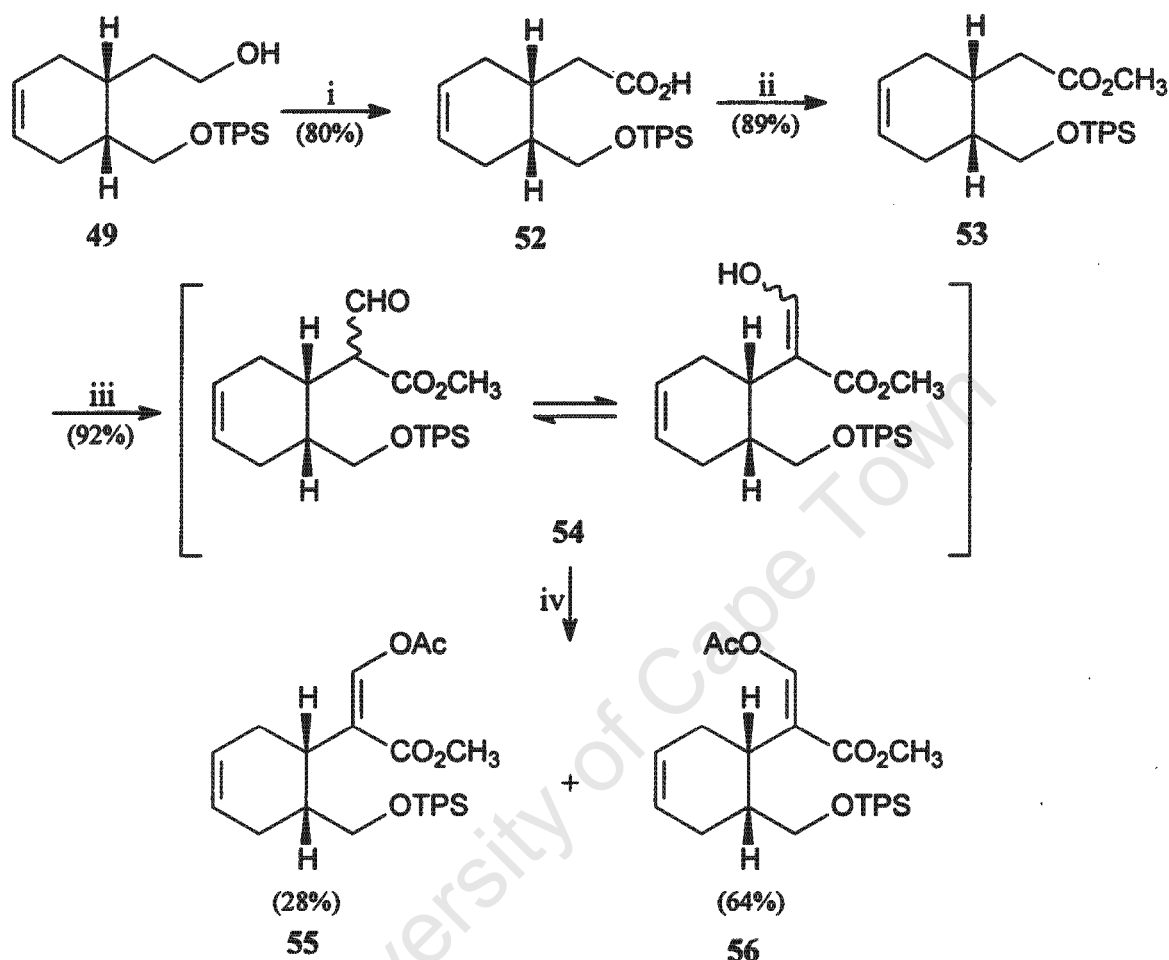

**Scheme 3.15** Reagents and conditions: (i) 8M CrO<sub>3</sub>, acetone, -16 °C (ii) MeI, K<sub>2</sub>CO<sub>3</sub>, DMF, 0–25 °C, (iii) LDA, HCO<sub>2</sub>Et, THF, -78–-40 °C, (iv) Ac<sub>2</sub>O, pyr, DMAP, CH<sub>2</sub>Cl<sub>2</sub>

The <sup>1</sup>H NMR spectrum showed two doublets at δ 9.60 and δ 9.68 that were assigned to the aldehyde protons and two doublets at δ 7.00 and δ 7.04 which confirmed the presence of the vinyl proton of the enol tautomers. The overlapping spectra were too complex to be fully assigned and **54** was thus derivatised to allow characterisation. The enol acetates **55** and **56** were formed under standard acetylation conditions (Scheme 3.15).

The assignment of **55** and **56** as the *Z* and *E* geometrical isomers respectively was made on the basis of nOe difference NMR experiments. Irradiation of 3-H of **55** displayed a significant enhancement of signals for protons at positions 1' (12%), 2' (7%), 3' and 4' (7%) and 5' (10%), all of

which are associated with the cyclohexene moiety. The two cyclohexene half-chair conformations **A** and **B** for the *E* and *Z* isomers are depicted in Figure 3.3. Of these, only conformation **B** for the *Z* isomer can account for all of the observed enhancements as rotation about the C-2 – C-1' bond brings 3-H into the proximity of the protons highlighted. This structure was thus assigned to **55**.

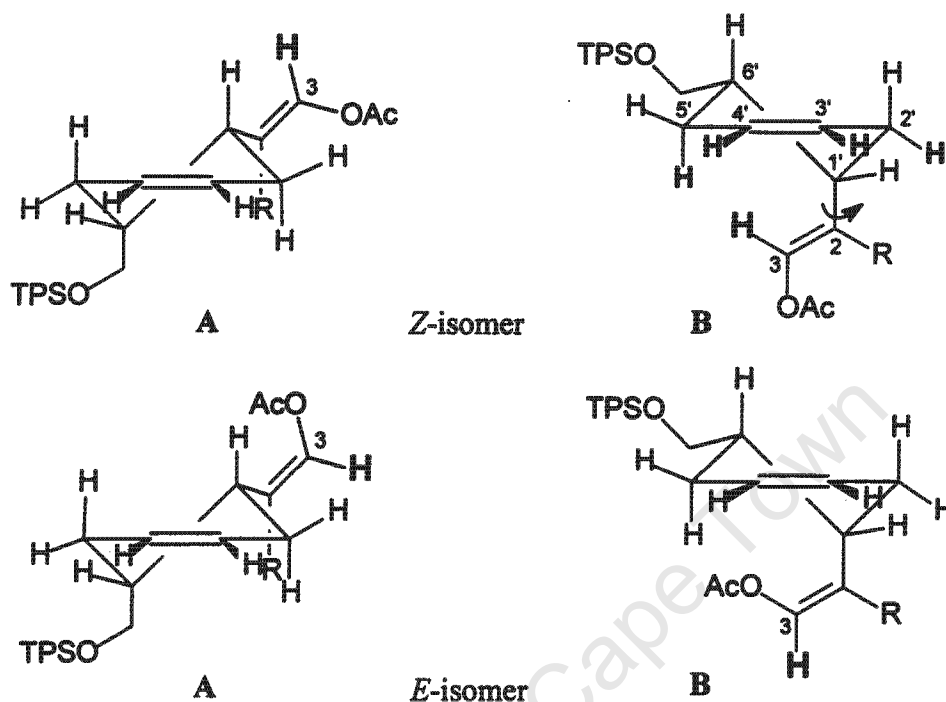
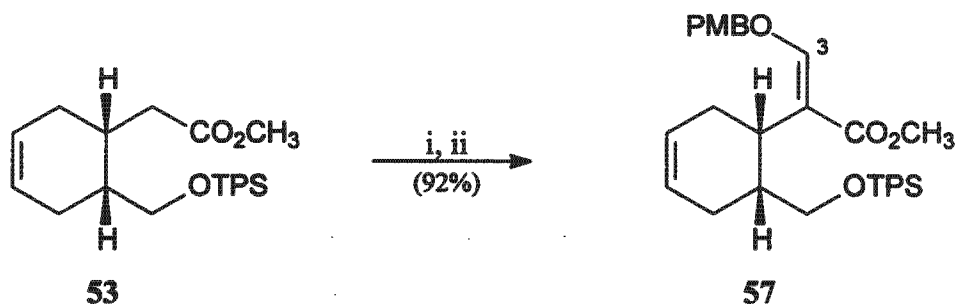

Figure 3.3 Possible Conformers of the enol acetate **55**

To avoid the cumbersome task of characterising two isomers in further steps in the synthesis, an attempt to enhance the *E*-selectivity of the protection reaction was made by forming the *p*-methoxybenzyl (PMB) ether, which is more sterically demanding than the acetate. The PMB ether was also selected because of the variety of conditions that could be applied if selective deprotection was required.<sup>71</sup> A single isomer was isolated in good yield (Scheme 3.16). Spectroscopic data were consistent with the assigned structure, **57**. Irradiation of 3-H in **57** gave no *n*Oe enhancements of protons on the cyclohexene ring and, whilst this is not conclusive, in combination with the argument above, assignment of **57** as the *E* isomer is reasonable.



Scheme 3.16 Reagents and conditions: (i) LDA, HCO<sub>2</sub>Et, THF, -78 to -40 °C, (ii) NaH, PMBCl, DMF

### 3.2.3 Oxidative cleavage

In comparing **57** to the required 'skeleton of functionality' described earlier, it can be noted that the carbon framework was in place and only the oxidation state at the olefin termini and the alcohol required alteration (Figure. 3.4).

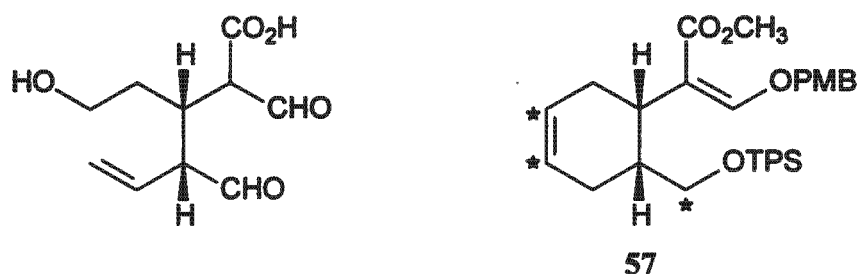
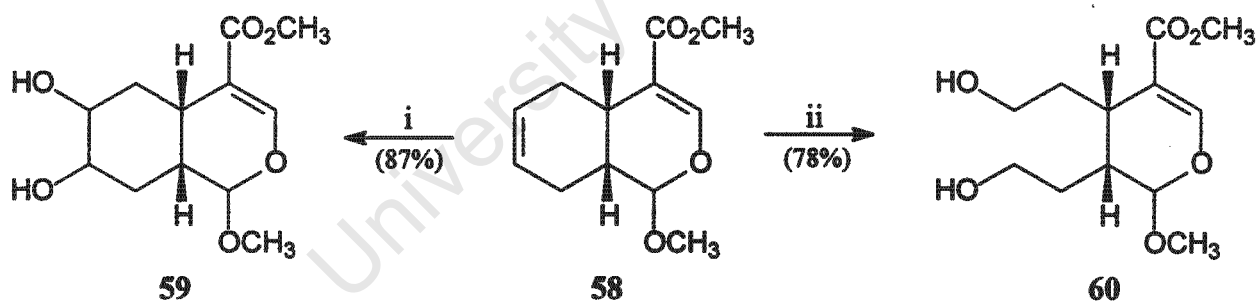

Figure 3.4 Comparison of **57** to the required aliphatic skeleton

Although two olefinic moieties are present in **57**, it was hoped that the enolic olefin would be less susceptible to oxidative cleavage due to the presence of electron withdrawing functionality in the carboxy substituent. The desired chemoselectivity has been demonstrated by Hutchinson<sup>29</sup> where *cis*-dihydroxylation of the sweroside aglycone precursor **58** gave the periodate cleavage precursor, glycol **59**, in 87% yield. The chemoselectivity of ozonolysis was also demonstrated when **60** was furnished in 78% yield (Scheme 3.17).



Scheme 3.17 Reagents and conditions: (i) OsO<sub>4</sub>, NMO, acetone-H<sub>2</sub>O, (ii) O<sub>3</sub>, MeOH, -78 °C, then NaBH<sub>4</sub>, -78 °C

The reaction of **57** with stoichiometric osmium tetroxide (OsO<sub>4</sub>) in pyridine furnished equal quantities of the glycol **61** and *p*-methoxybenzyl alcohol (Scheme 3.18), which indicated that unexpected deprotection of the vinyl alcohol had occurred. Other reaction products were detected using TLC but these were extremely polar and were not isolated.

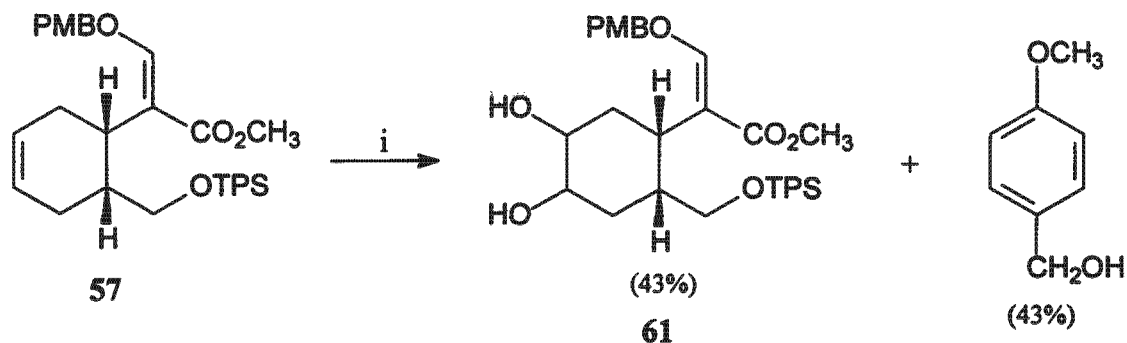

**Scheme 3.18** Reagents and conditions: (i) OsO<sub>4</sub>, pyr

An oxidative procedure, typically with 2,3-dichloro-5,6-dicyanobenzoquinone (DDQ), is frequently used for the deprotection of PMB ethers. This proceeds *via* the formation of a charge transfer complex between the electron donating aromatic ring and electron accepting DDQ and is followed by benzylic dehydrogenation. In the presence of water, the oxidation affords an alcohol and anisaldehyde (Scheme 3.19).<sup>72</sup>

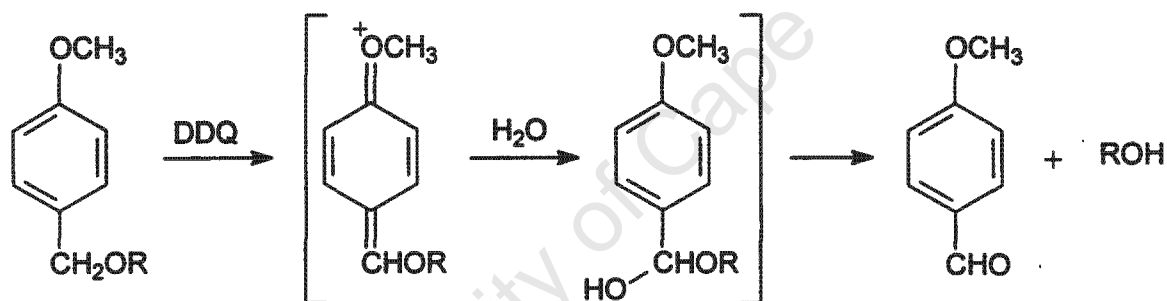

**Scheme 3.19** Mechanism of oxidative deprotection of PMB ethers

The interaction of high-valent transition-metal oxo compounds (like OsO<sub>4</sub>) with benzyl and other ethers has been described for potassium permanganate<sup>73</sup> and ruthenium tetroxide.<sup>74</sup> In the mechanism proposed for these interactions (illustrated for ruthenium tetroxide in Scheme 3.20), the first step is that of hydride transfer to the metal oxide, followed by further interaction of the oxycarbenium and metal species to give the product of benzylic oxidation.

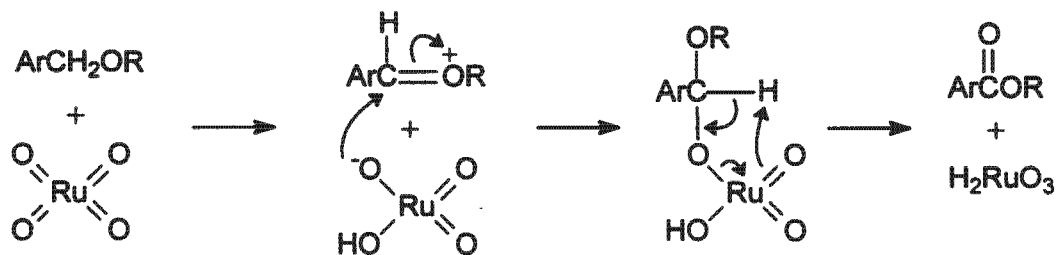

**Scheme 3.20** Mechanism for the oxidation of ethers by ruthenium tetroxide

Based on this observation, the interaction between  $\text{OsO}_4$  and **57** should not lead to the benzylic dehydrogenation observed in the reaction of PMB ethers with DDQ. If any direct interaction between the reagent and **57** were predicted, it would be benzylic oxidation, which has been observed with ruthenium tetroxide. Literature precedent also indicates that PMB ethers are stable to  $\text{OsO}_4$  dihydroxylation conditions.<sup>75</sup> In this case however, the ether was vinylic and the deprotection could be rationalised by invoking the interaction of  $\text{OsO}_4$  with the enolic double bond to give a cyclic osmate ester, which, upon hydrolysis would be expected to give the deprotection result in addition to dihydroxylating the species. Since stoichiometric  $\text{OsO}_4$  was used, the equal proportions of **61** and benzyl alcohol recovered give the surprising observation that no chemoselectivity was displayed by this reaction. The structure of the Hutchinson dihydroxylation precursor **58**, and that of **57** were closely compared in an attempt to rationalise the difference in chemoselectivity in their reaction with  $\text{OsO}_4$ . The olefin in **58** is embedded in a 6-membered ring *cis*-fused to another, and thus bears a small degree of ring strain. This factor would, however, result in faster osmylation of the enolic olefin in **58** than **57**, which is the opposite outcome to that which was observed. A tenuous steric argument could be invoked in that, although the PMB ether is a bulky substituent, the position  $\beta$  to the olefin in **57** is secondary whereas the equivalent position in **58** is tertiary, and thus more likely to limit reagent access to the olefinic bond (Figure 3.5).

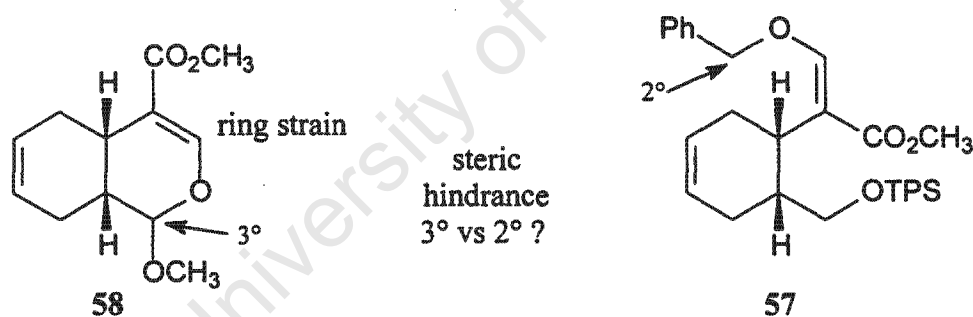
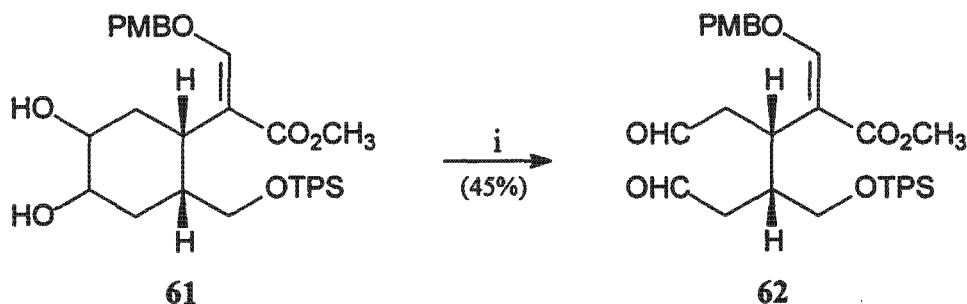

**Figure 3.5** Structural comparison of dihydroxylation substrates **57** and **58**

In his osmylation of **58**, Hutchinson used catalytic  $\text{OsO}_4$  with *N*-methylmorpholine-*N*-oxide as a co-oxidant in acetone–water. On **57**, stoichiometric  $\text{OsO}_4$  in pyridine was used. In the latter reaction, the significant rate enhancement of the osmate ester formation experienced in the presence of pyridine<sup>76</sup> may have been such that the subtle differences in the rates of reaction of the two olefins in **57** became insignificant. The dihydroxylation step was not investigated further due to the outcome of the glycol cleavage experiment described below.

The glycol **61** was successfully cleaved with lead tetraacetate in toluene. The NMR spectra of the product showed two peaks at  $\delta$  9.43 and  $\delta$  9.55 ( $^1\text{H}$ ), as well as two at  $\delta$  202.0 and  $\delta$  202.3 ( $^{13}\text{C}$ )

confirming that the dialdehyde **62** had been formed. The product was extremely unstable and decomposed during isolation and chromatography resulting in a poor yield of 45% (Scheme 3.21).



**Scheme 3.21** Reagents and conditions: (i)  $\text{Pb}(\text{OAc})_4$ , toluene

Ozonolysis of **57** followed by  $\text{NaBH}_4$  reduction of the ozonide resulted in a complex mixture of products. This result, as well as the lack of stability demonstrated by the glycol cleavage product, required that the synthetic route that had been designed around the existing literature precedent be altered. The oxidative cleavage was thus attempted prior to the second homologation step, *i.e.* on **53**.

Ozonolysis of **53** followed by a reductive work-up of the ozonide with sodium borohydride was attempted, but again, a complex mixture of products was observed by TLC. Ozonolysis of **53** followed by the addition of dimethyl sulfide furnished a single product (by TLC). Surprisingly, the dialdehyde **63** could be purified by flash chromatography (Scheme 3.22) but it decomposed rapidly once isolated, and during further reactions. The attempted borohydride reduction of **63** gave a complex mixture from which only 35% of the lactone **64** could be recovered (Scheme 3.22).

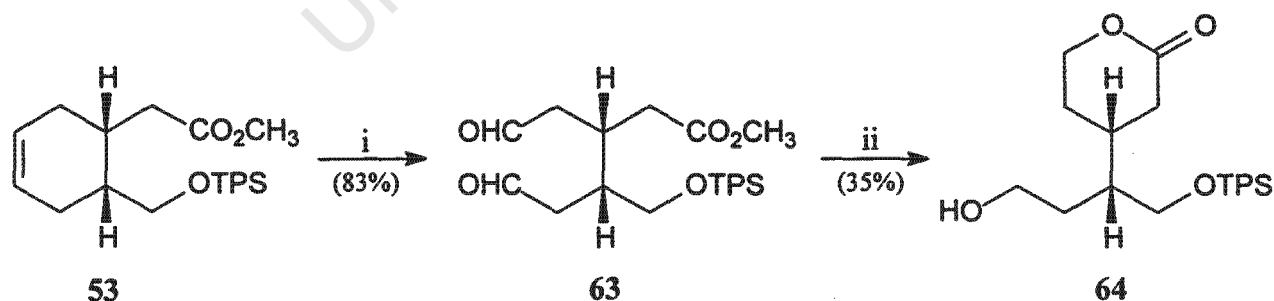

**Scheme 3.22** Reagents and conditions: (i)  $\text{O}_3$ , MeOH,  $-78^\circ\text{C}$ , then  $\text{Me}_2\text{S}$  (ii)  $\text{NaBH}_4$ , MeOH

The presence of a single exchangeable proton, as indicated by  $^1\text{H}$  NMR in the presence of  $\text{D}_2\text{O}$ , and the absence of the typical methyl ester peak at  $\delta \sim 3.6$  from the  $^1\text{H}$  NMR spectrum indicated that spontaneous lactonisation of the diol reduction product to give **64** had occurred. Whilst the use of a more reactive reducing agent like lithium aluminium hydride would reduce the lifetime of the

aldehyde moieties in solution and thus minimise decomposition, the presence of ester functionality in the molecule precluded the use of this reagent. As **63** would also be the product of the dihydroxylation-glycol cleavage methodology, this was not attempted.

Flippin *et al.*<sup>77</sup> have developed a procedure for the reduction of ozonides to alcohols using borane-dimethyl sulfide complex. Employed at room temperature, this reagent is tolerant to ester functionality. On the ozonide of **53**, yields of **64** improved, but could only be optimised at 67% (Scheme 3.23). In each case, a mixture of decomposition products accompanied **64** in the crude reaction extract.

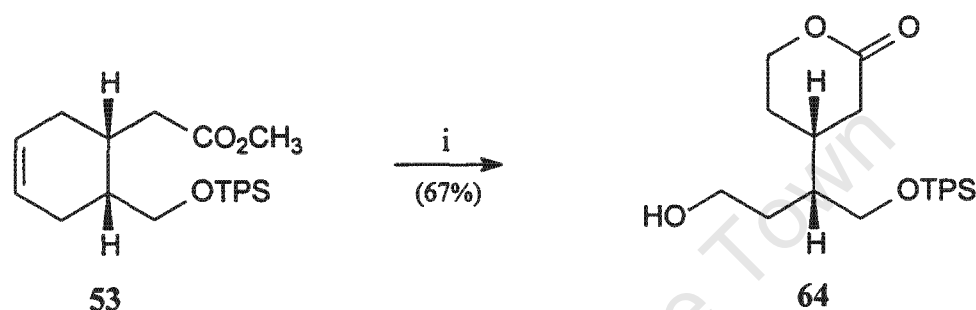

**Scheme 3.23** Reagents and conditions: (i)  $O_3$ ,  $CH_2Cl_2$ ,  $-78\text{ }^\circ\text{C}$ , then  $BH_3 \cdot Me_2S$ ,  $25\text{ }^\circ\text{C}$

The decomposition that occurred during the reductions was ascribed to the reactivity of aldehyde intermediates. Schreiber<sup>78</sup> has described a procedure whereby the termini of an ozonide are differentiated. In the presence of alcohols, the ozonolysis of cyclohexenes affords a chain bearing an aldehyde and an  $\alpha$ -alkoxy hydroperoxide at the termini. The addition of acid to the reaction medium promotes acetal formation at the aldehyde terminus, which is then protected from reductive work-up conditions, whilst the hydroperoxide is reduced to an ester or an aldehyde (Scheme 3.24).

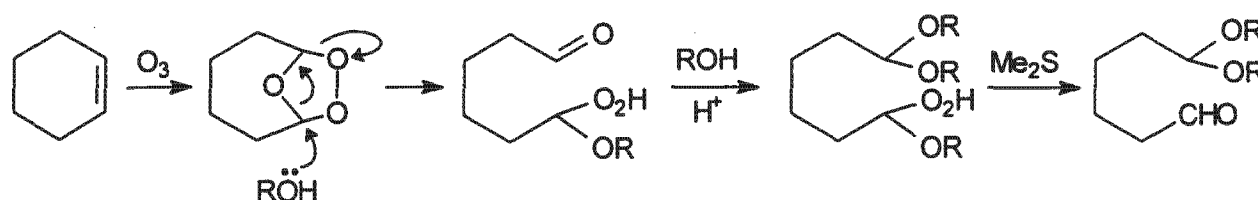

**Scheme 3.24** The Schreiber procedure for differentiating the termini of an ozonide

In this procedure a dialdehyde species is not encountered and the reduction occurs in the presence of a single reactive terminus, thus minimising the opportunity for side reactions. Neither the Schreiber work nor extensions of this methodology by Hon<sup>79</sup> describe the isolation of an acetal-alcohol. An adaptation of the Schreiber procedure was performed on **53**, using  $NaBH_4$  as the

reductant, and gave a vastly improved recovery (86%) of a 1:1 mixture of products **65** and **66** which arise from acetal formation at opposite termini of the parent olefin (Scheme 3.25). In order to obtain a regioselective reaction, the difference in the electrophilicity of the carbon atoms forming the termini of the ozonide must be sufficient to promote nucleophilic attack by the alcohol at one of these positions. In **53**, the absence of strongly electron withdrawing or releasing substituents on the ring does not create this situation and hence no selectivity was observed.

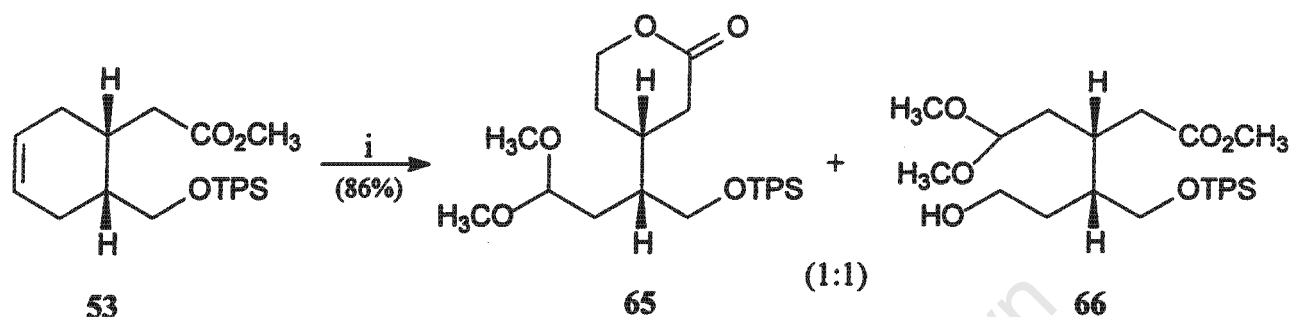

**Scheme 3.25** Reagents and conditions: (i)  $O_3$ , MeOH,  $-78\text{ }^\circ\text{C}$ , then  $p\text{TsOH}$ ,  $25\text{ }^\circ\text{C}$ , followed by  $\text{NaBH}_4$ ,  $0\text{ }^\circ\text{C}$

The separation of **65** and **66** was difficult and partial separation allowed the isolation of analytical samples of each which gave spectroscopic data consistent with the assigned structures. Acetal hydrolysis of the mixture followed by reduction of the exposed aldehyde to an alcohol, and lactonisation where appropriate, would allow these two products to converge as **64**. Unfortunately, all efforts to achieve these transformations gave mixtures from which the required lactone could not be isolated in acceptable yield or purity.

### 3.2.4 Pyrolytic *syn*-Elimination

Treatment of **64** with *p*-toluenesulfonyl chloride and triethylamine afforded the *p*-toluenesulfonate ester **67** (Scheme 3.26). A variety of conditions to induce the elimination of the tosylate were applied. No reaction was observed after refluxing the starting material in benzene, acetonitrile or DMF, in the presence of bases DBN or DBU, for extended periods. The mesylate, which was not isolated and characterised, was similarly unreactive and **68** could not be accessed from **67**.

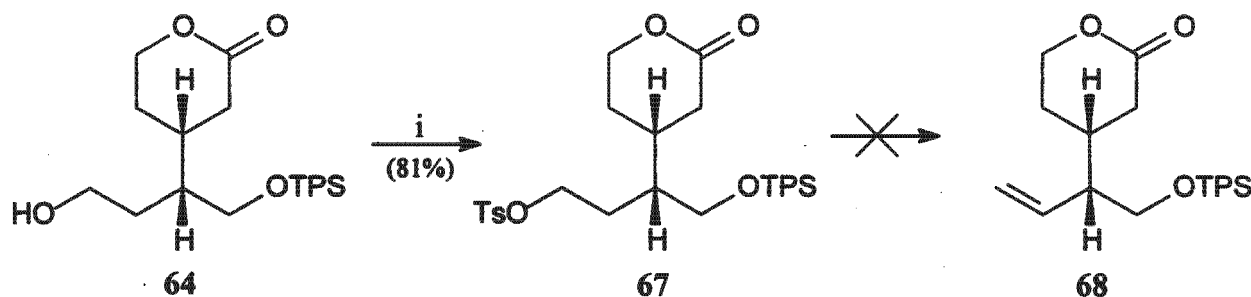

**Scheme 3.26** Reagents and conditions: (i)  $p\text{TsCl}$ ,  $\text{Et}_3\text{N}$ ,  $\text{CH}_2\text{Cl}_2$

The pyrolytic *syn*-elimination of sulfoxides having a  $\beta$ -hydrogen is well known.<sup>80</sup> The sulfoxide precursor, phenylthioether **69** was readily prepared in 87% yield from **64** by treatment with diphenyldisulfide and *n*-tributylphosphine (Scheme 3.27). NMR spectra and the observation of the parent molecular ion in the mass spectrum confirmed the sulfide structure of **69**.

The oxidation of sulfides to sulfoxides is complicated by the competing oxidation of sulfoxides to sulfones; a difficulty that is indicated by the wide variety of methods developed to perform this transformation.<sup>81</sup> These methods usually rely on stoichiometric and thermal control to affect selective oxidation with the reagent in question. The oxidation of **69** with stoichiometric Oxone®<sup>82</sup> was not selective and both the sulfoxide **70** and the sulfone **71** were recovered. The oxidation with 1 equivalent of *m*-chloroperbenzoic acid also furnished both oxidation levels. The oxidation to **70** was optimised using sodium periodate in the presence of tetra-*n*-butylammonium iodide as a phase transfer reagent and a yield of 77% was achieved (Scheme 3.27). The chiral nature of sulfur in sulfoxide groups meant that **70** was presented as a mixture of diastereomers that gave rise to duplicated signals in the NMR spectra. The infrared spectrum of **70** showed a strong absorption at  $\nu$  1039  $\text{cm}^{-1}$  which is characteristic of the S=O stretch in sulfoxides. In **71** the S=O signals were observed, also characteristically, at  $\nu$  1146 and 1310  $\text{cm}^{-1}$ .

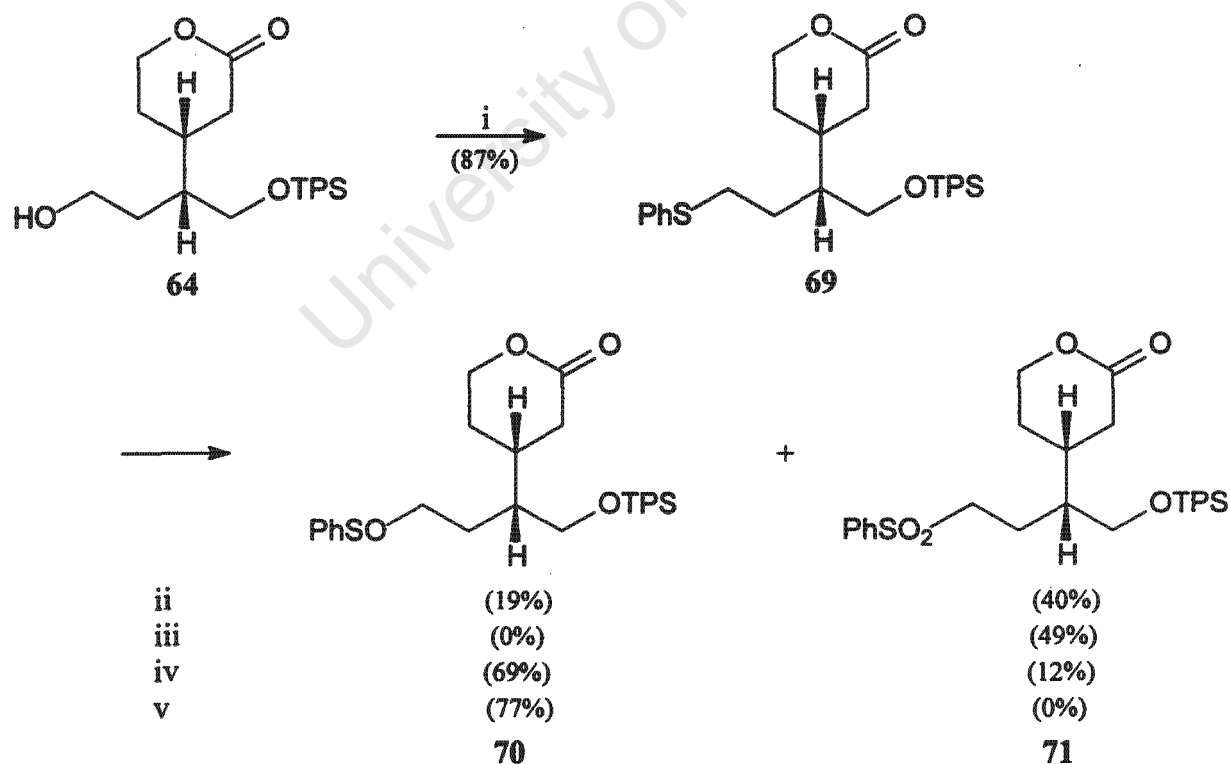

**Scheme 3.27** Reagents and conditions: (i) PhSSPh, *n*Bu<sub>3</sub>P, benzene, (ii) Oxone®, wet alumina, CH<sub>2</sub>Cl<sub>2</sub>, reflux, (iii) *m*CPBA (2.0 mol. equiv.), CH<sub>2</sub>Cl<sub>2</sub>, -78 °C, (iv) *m*CPBA (1.0 mol. equiv.), CH<sub>2</sub>Cl<sub>2</sub>, -78 °C, (v) NaIO<sub>4</sub>, (*n*Bu)<sub>4</sub>NBr, MeOH-H<sub>2</sub>O

When **70** was subjected to the standard elimination conditions of heating in toluene, no reaction was observed even upon refluxing for extended periods. The rate of sulfoxide elimination is accelerated by alkyl substitution  $\alpha$  to the sulfoxide, whereas  $\beta$ -substituents retard the rate.<sup>83</sup> In this primary sulfoxide, which bears no substitution at the  $\alpha$  position, no elimination was possible at the reaction temperatures used. The analogous but reactive selenoxide has frequently been used to introduce terminal olefins during the synthesis of natural products.<sup>84</sup>

Reaction of **64** with phenylselenocyanate using the Grieco conditions<sup>85</sup> afforded the primary selenide **72**. A number of oxidising agents, among them hydrogen peroxide ( $\text{H}_2\text{O}_2$ ), *m*CPBA,  $\text{NaIO}_4$  and ozone, can be used to form the selenoxide.<sup>86</sup> Warming the oxidation reaction medium to room temperature is usually sufficient to induce elimination. For the reaction of **72**, treatment with  $\text{H}_2\text{O}_2$  followed by warming gave a 60% yield of the elimination product **68**. The slow elimination to give terminal olefins is often hampered by side reactions with the selenium by-products of the reaction. Re-addition of the phenylselenenic acid produced in the reaction to the olefin means that incomplete reaction is often observed if the rate difference between elimination and re-addition is not sufficient. Furthermore, the phenylselenenic acid gives rise to phenylseleninic acid, either by oxidation with excess oxidising agent, or by a disproportionation reaction.<sup>86</sup> Under neutral or acidic conditions this side product reacts with olefins to yield  $\beta$ -hydroxy selenides.<sup>87</sup> These side reactions can be avoided by performing the elimination as a distinct step from the oxidation in the presence of tertiary amines that remove phenylselenenic acid from the reaction medium.<sup>87</sup> Following  $\text{NaIO}_4$  promoted formation of the selenoxide, the latter was subjected to heating in the presence of triethylamine and benzene and the pyrolytic elimination was optimised at 89% (Scheme 3.28).

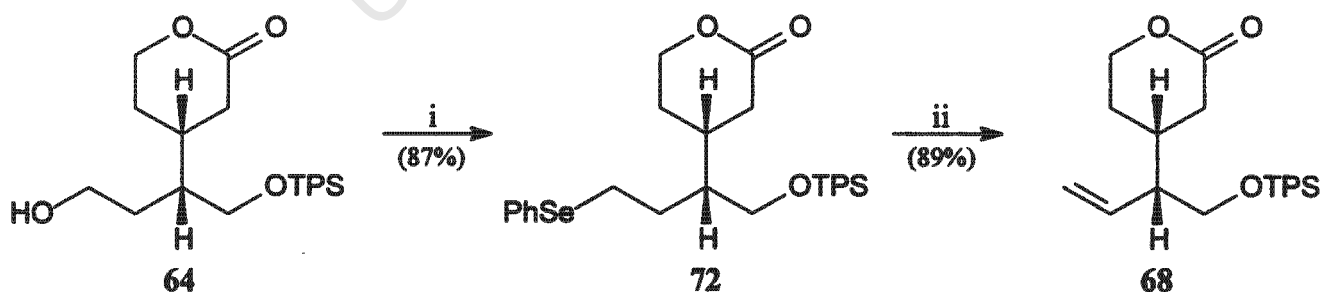

**Scheme 3.28** Reagents and conditions: (i) PhSeCN, *n*Bu<sub>3</sub>P, THF,  
(ii)  $\text{NaIO}_4$ , MeOH-H<sub>2</sub>O, then Et<sub>3</sub>N-benzene, reflux

Three single proton signals in the <sup>1</sup>H NMR spectrum of **68**, at  $\delta$  5.05, 5.14 and 5.66 respectively, accounted for the three vinyl protons of the terminal olefin. The <sup>1</sup>H and <sup>13</sup>C spectra were fully assigned with the aid of 2D spectra.

The elimination of primary selenoxides is accelerated by the presence of electron withdrawing substituents on the phenyl ring, and the *o*-nitrophenyl variant of the selenoxide, which eliminates under milder conditions than the phenylselenoxide is frequently used.<sup>88</sup> Attempts to introduce the *o*-nitrophenylselenium onto **64** using the Grieco methodology resulted in incomplete reaction and the recovery of the diaryldiselenide along with the desired product **73** (Scheme 3.29). Alteration of the reaction conditions (concentration, rate of addition, order of reagent addition and stoichiometry) did not improve the recovery and a significant proportion of starting material was isolated after each reaction.

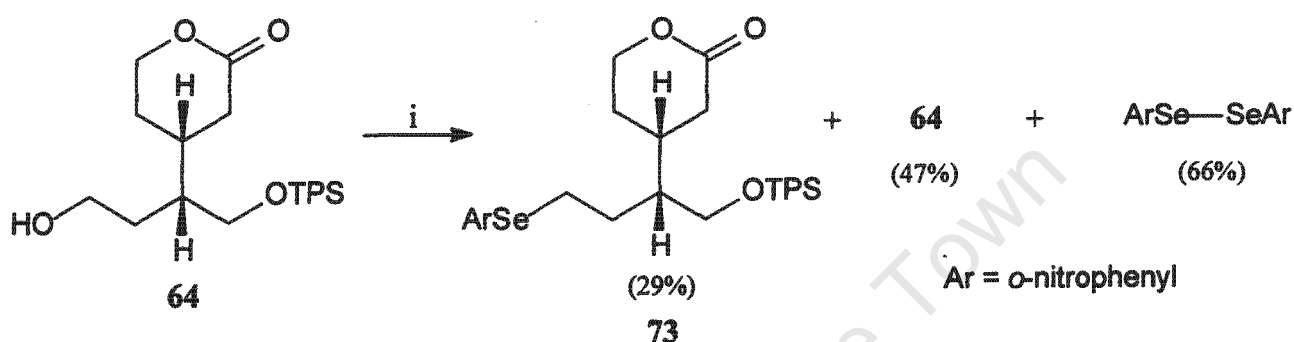

**Scheme 3.29** Reagents and conditions: (i) ArSeCN, *n*Bu<sub>3</sub>P, THF

### 3.2.5 One-carbon homologation revisited

The enolate-mediated formylation reaction that had been delayed until after successful oxidative cleavage could now be employed. The protocol that was used to formylate the ester **53** (LDA/ethyl formate, Scheme 3.15) was applied to the lactone **68**. Although formylation was achieved, a minimum of 50% starting material was recovered from each reaction. Increased ratios of reagents, increased reaction times and increased reaction temperatures did not improve this reactivity. *t*-Butoxybis(dimethylamino)methane, or Brederick's reagent, is used to introduce one-carbon units to a wide variety of compound classes bearing CH- or CH<sub>2</sub>-acidic positions.<sup>89</sup> Brederick's reagent offers a mild and neutral introduction of enamine or aldehyde functionality and has been successfully employed during a solid phase synthesis of 5-aminopyrazoles.<sup>90</sup> The primary reaction product is an enamine, which may be hydrolysed upon work-up to give formyl functionality (Scheme 3.30).

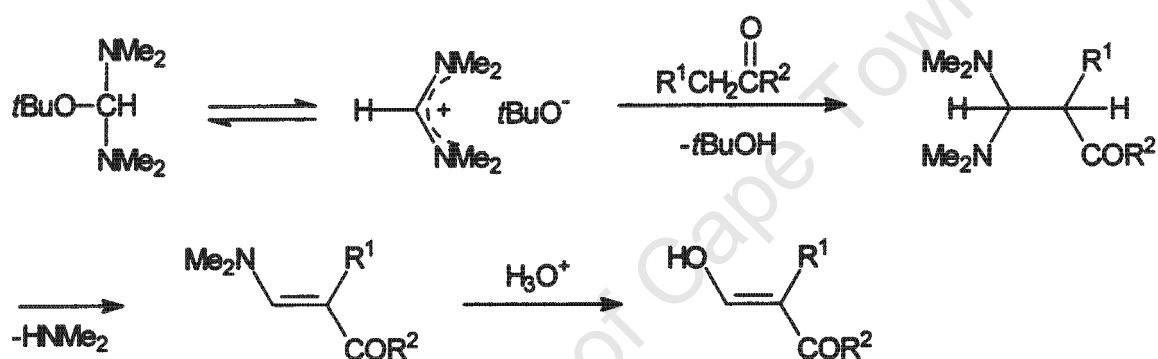

**Scheme 3.30** Reaction of Brederick's reagent with a carbonyl compound

Treatment of **68** with neat Brederick's reagent at 80 °C produced a single product (by TLC) which was treated with cold HCl–methanol to give the formyl product **74**. The formation of the formyl adduct was confirmed by microanalytical and mass spectral data. The NMR spectra were again complicated by the presence of tautomers. Benzoylation of **74** provided a single enol benzoate **75**.

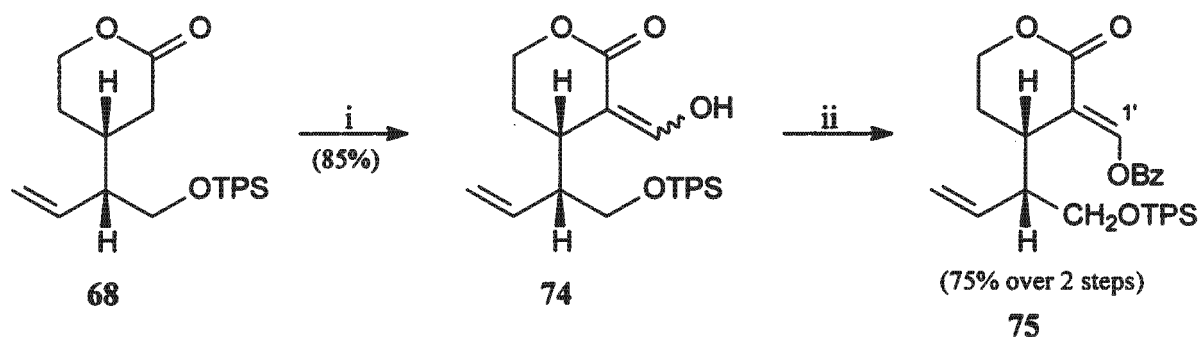

**Scheme 3.31** Reagents and conditions: (i) Brederick's reagent, 80 °C, (ii) BzCl, pyr

The designated connectivities on **75** were confirmed using COSY and HSQC spectra. The assignment of **75** as the *E*-isomer was made on the basis of the chemical shift of the vinyl proton 1'-H. The magnetic anisotropy of the conjugated double bonds present in these systems exerts a deshielding effect on the proton signal in the *E*-isomers, and the signal for the vinyl proton is detected further downfield than that in the corresponding *Z*-isomer. In this case, **75** was formed diastereoselectively, and no comparative chemical shift data were available. These data were however available for the analogous tetrahydropyranones illustrated below (Fig. 3.6).<sup>91</sup> The chemical shift of the vinyl proton on the *E*-isomer ( $\delta$  8.64) was similar that that in **75** ( $\delta$  8.48) whilst that on the *Z*-isomer ( $\delta$  7.79) was not in this range. It was thus possible to assign the *E* geometry to **75**.

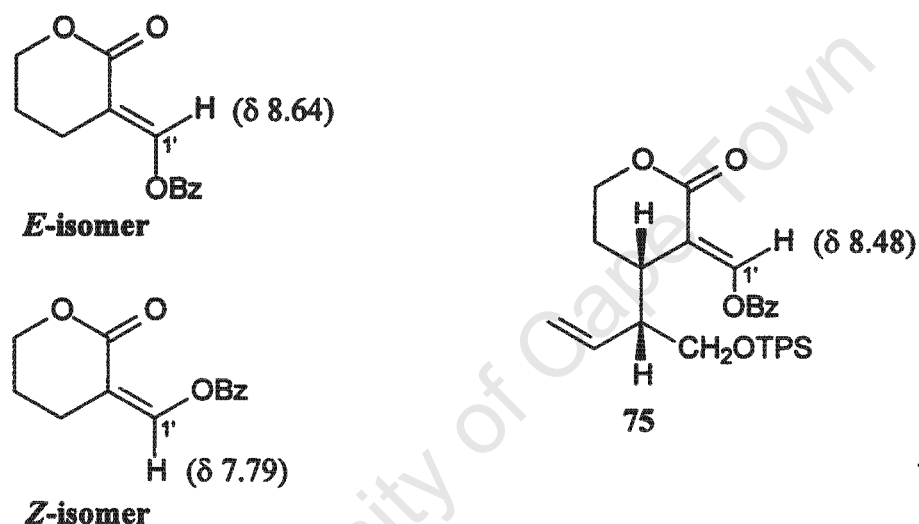
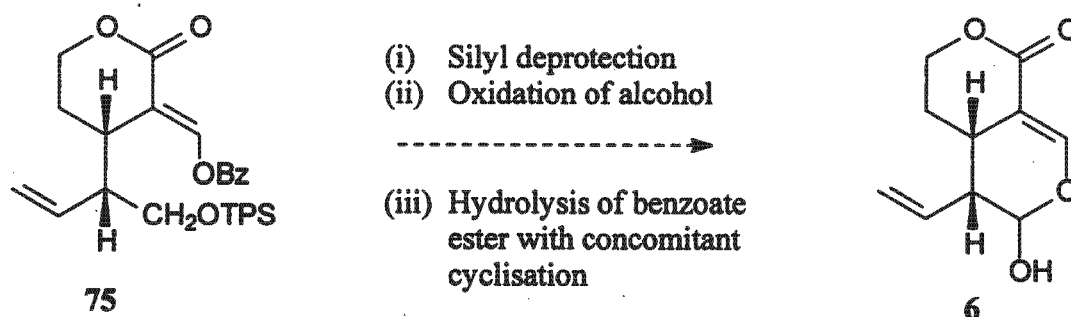

Figure 3.6 *E/Z* isomerism in 3-oxymethylene substituted tetrahydropyranones

### 3.2.6 Approaches to chemoselective differentiation

A comparison of **75** to sweroside aglycone **6** highlights, as illustrated in Scheme 3.32, the three steps required to complete the synthesis of the aglycone.



Scheme 3.32

The robust nature of TPS as a protecting group for alcohols proved to be a problem in the required deprotection step. Treatment of **75** with tetrabutylammonium fluoride (TBAF) in THF at 25 °C was slow and multiple products were formed. The alternative fluoride source routinely used for silyl deprotections, hydrogen fluoride (HF), was also unreactive and concentrated mixtures were required to achieve deprotection, which was again accompanied by decomposition. Since the strongly basic (TBAF) and acidic (HF) conditions could induce hydrolysis of the benzoate ester as well as desilylation, the ester was replaced with an ether protecting group in an attempt to achieve selectivity during the TBAF deprotection. Reaction of **74** with methoxyethoxymethyl chloride and diisopropylamine furnished the MEM ether **76** (Scheme 3.33). The spectral assignments were analogous to those made on **75**, and a significant upfield shift in the 1'-H resonance (from  $\delta$  8.48 in **75** to  $\delta$  7.56 in **76**) was noted and ascribed to the absence of deshielding by the ester carbonyl that was present in **76**. In the light of the earlier discussion on geometrical isomerism in these systems, the possibility of the presence of the *Z*-isomer could not be discounted. No comparative data were available for the MEM protected system, and the geometry thus remains unassigned. The TBAF deprotection afforded an approximately 1:1 mixture of pyrano-pyranones **77** and **78**, which were partially separable and multiple chromatographic steps furnished analytical samples of each (Scheme 3.33).

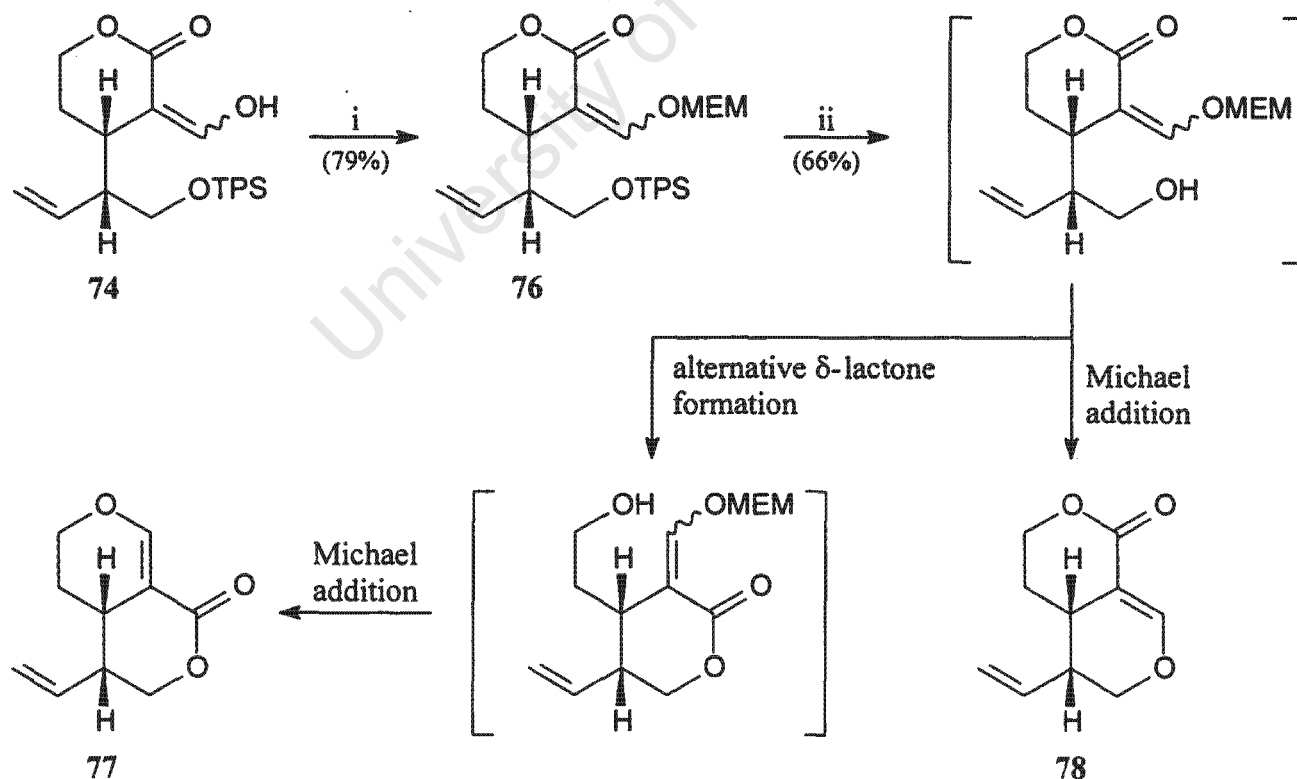

**Scheme 3.33** Reagents and conditions: (i) MEMCl, EtN(*i*Pr)<sub>2</sub>, CH<sub>2</sub>Cl<sub>2</sub>, (ii) TBAF, THF, 0–25 °C

These unexpected products were the result of Michael addition of a free hydroxyl group to the terminus of the  $\alpha,\beta$ -unsaturated system, followed by  $\beta$ -elimination of the methoxyethoxymethyl moiety. In the case of **78** the Michael donor was the hydroxyl group revealed by the deprotection step. For the formation of **77**, however, the deprotected hydroxyl group had successfully competed for  $\delta$ -lactone formation, leaving the newly released alcohol to perform the Michael reaction sequence (Scheme 3.33).

The intramolecular Michael reaction using an oxygen donor is frequently used in the synthesis of oxygen heterocycles.<sup>92</sup> The ring closure observed here, in which  $\beta$ -elimination to give a dihydropyran was facilitated by the presence of a leaving group on the Michael acceptor, has seldom been exploited. In a recent example where the  $\alpha,\beta$ -unsaturated system and the nucleophilic oxygen were suitably tethered, this reaction has been used during a novel approach to dihydropyranones (Scheme 3.34).<sup>93</sup>

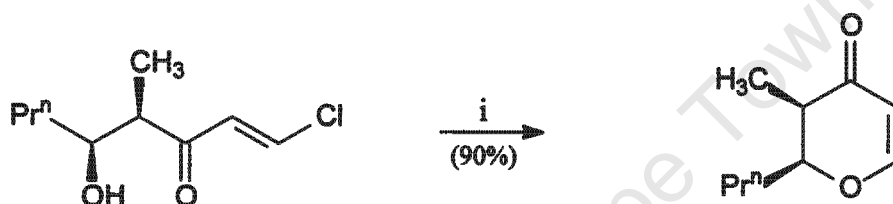

**Scheme 3.34** Reagents and conditions: (i) TMSOTf, *i*Pr<sub>2</sub>Net, -78—-15 °C

The structure elucidation of **77** and **78** proved to be non-trivial. NMR spectra indicated the absence of the MEM ether in both of the products. Neither infrared spectra nor <sup>1</sup>H NMR spectra in the presence of D<sub>2</sub>O showed any evidence of free hydroxyl functionality in either product. The mass spectral analysis of the samples delivered identical parent molecular ions with *M*<sup>+</sup> 180. <sup>13</sup>C, DEPT, COSY and HSQC spectra established the C-H and C-C connectivities, although the connectivities across the heteroatoms in the rings could not be confirmed using these techniques, *i.e.* the two isomers could not be distinguished. The chemical shifts of the methylene protons at the heterosubstituted positions were compared (Fig. 3.7).

Proton	77 ( $\delta$ , ppm)	78 ( $\delta$ , ppm)
A	3.97—4.08	4.13—4.32
	4.30—4.40	4.41
B	4.33 and 4.44	4.13—4.32

**Figure 3.7** Chemical shifts of hydroxymethylene protons in **77** and **78**

The protons at position A on **77** were, on average, slightly less deshielded than those at the similar position in **78**, and the converse was true at position B. Whilst the degree of deshielding through the heteroatom for a carbonyl is expected to be higher than for a vinyl substituent, these effects are muted in this case by the fact that the carbonyl and olefin form part of an  $\alpha,\beta$  unsaturated system. As shown in Figure 3.8(a), resonance through the system renders the carbonyl carbon less deshielded than if it was isolated, and the terminus of the olefin becomes more deshielded. The use of the subtle shift differences observed thus only allowed a tenuous assignment of the structures as indicated. The assignments were finally confirmed by long range couplings observed in HMQC spectra for the samples. In both spectra, a cross peak corresponding to 3-bond coupling between C-6 and 8-H was observed as shown in Figure 3.8(b). These couplings are only possible if the pyran and pyranone rings are arranged as shown.

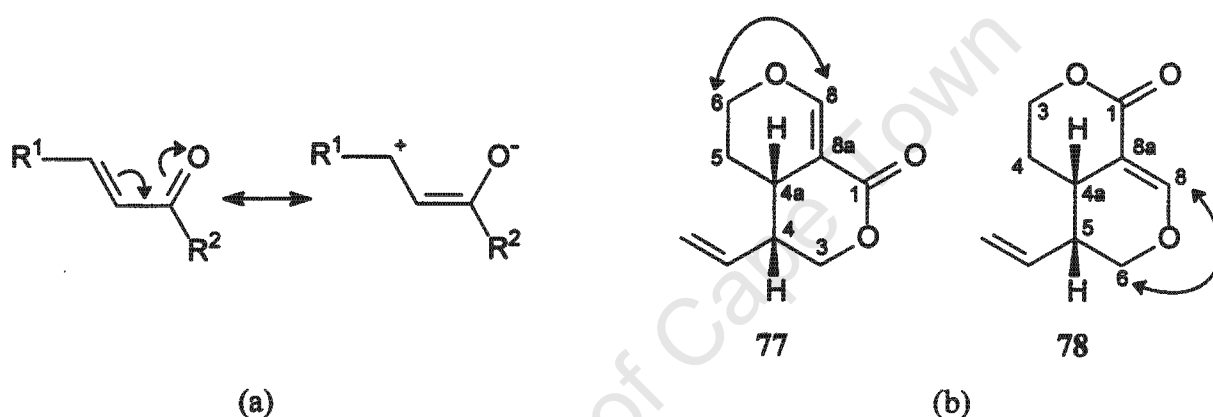

**Figure 3.8** (a) Resonance structures in  $\alpha,\beta$ -unsaturated carbonyls (b) observed long range couplings in **77** and **78**

Whilst the unwanted Michael reactivity could be avoided by protecting the formyl group as an acetal, the equilibration between the two possible  $\delta$ -lactones would be more difficult to control. To ascertain whether this equilibration was restricted to the system described above, **72** was subjected to TBAF deprotection conditions. The result was a 69% yield of an inseparable mixture of alcohols **79** and **80**. The mixture was acetylated using acetic anhydride and DMAP in pyridine, to give the acetylated products, **81** and **82**, which were partially separable (Scheme 3.35). The similarity of the spectroscopic data for these compounds once again indicated that they were isomers. Although all the NMR signals were assigned using COSY and HSQC spectra, the two  $\delta$ -lactones could not be distinguished. HMBC provided the necessary information when cross peaks signifying 4 bond couplings between the acetate methyl protons and C-2' in **81**, and C-1' in **82** were detected.

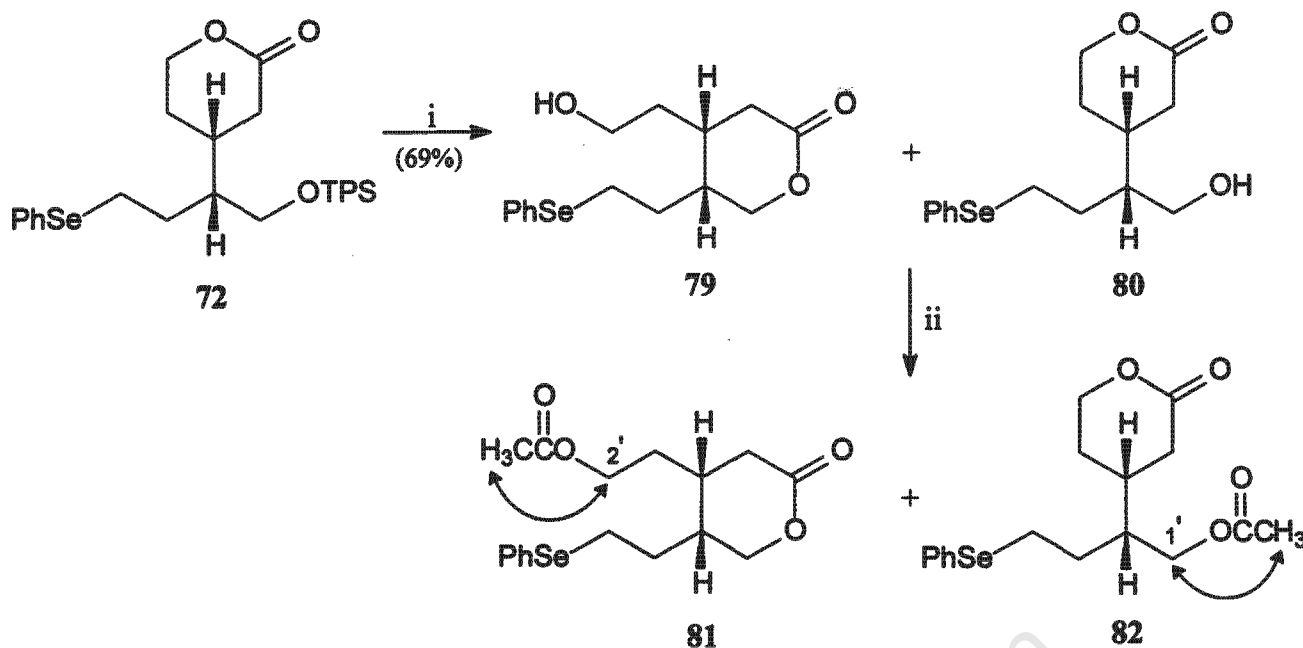

**Scheme 3.35** Reagents and conditions: (i) TBAF, THF, 0 °C, (ii) Ac<sub>2</sub>O, DMAP, pyr

The Michael reactivity and the lactone equilibration that were experienced upon exposure of the primary alcohol were serious flaws in the initial synthetic route. Although neither was expected, the intermediates formed did not have any features predisposing them to this reactivity and, with hindsight, both reactions could have been avoided. The information gathered in reaching this point in the synthesis were thus collated and reviewed so that a renewed synthetic plan could be established. The points to be considered were:

- (i) As stated earlier, an overall requirement was that the acetal closure and protection should occur as late as possible in the synthesis.
- (ii) Oxidative cleavage of the cyclohexenyl moiety should be performed prior to the formation of any enol functionality.
- (iii) The carboxyl functionality should be in place prior to any attempts at acetal formation, to ensure that the desired aldehyde was enolised and that acetal closure is chemoselective.
- (iv) Lactonisation should take place after the aldehyde functionality has been installed at the proposed acetal carbon, so avoiding the formation of competing  $\delta$ -lactones.
- (v) The complex arrangement of oxygen functionality close to the endpoints precludes the use of any strongly acidic or basic reaction conditions. Protecting groups should be selected accordingly.
- (vi) Since epimerisation  $\alpha$  to the hemiacetal in sweroside aglycone is known to occur during attempts to modify the hemiacetal hydroxyl group,<sup>33</sup> the acidity of the proton in question should be minimised. Once the olefin is in place, this proton is allylic and thus more acidic. The elimination step should be delayed until after acetal formation and protection.

### 3.3 REVISED SYNTHETIC STRATEGY

An outline that identifies the major intermediates for the revised synthesis of protected sweroside aglycone is depicted in Scheme 3.36. The starting point for this synthesis, the monoprotected diol has previously been synthesised as **49** ( $R^1 = \text{TPS}$ ).

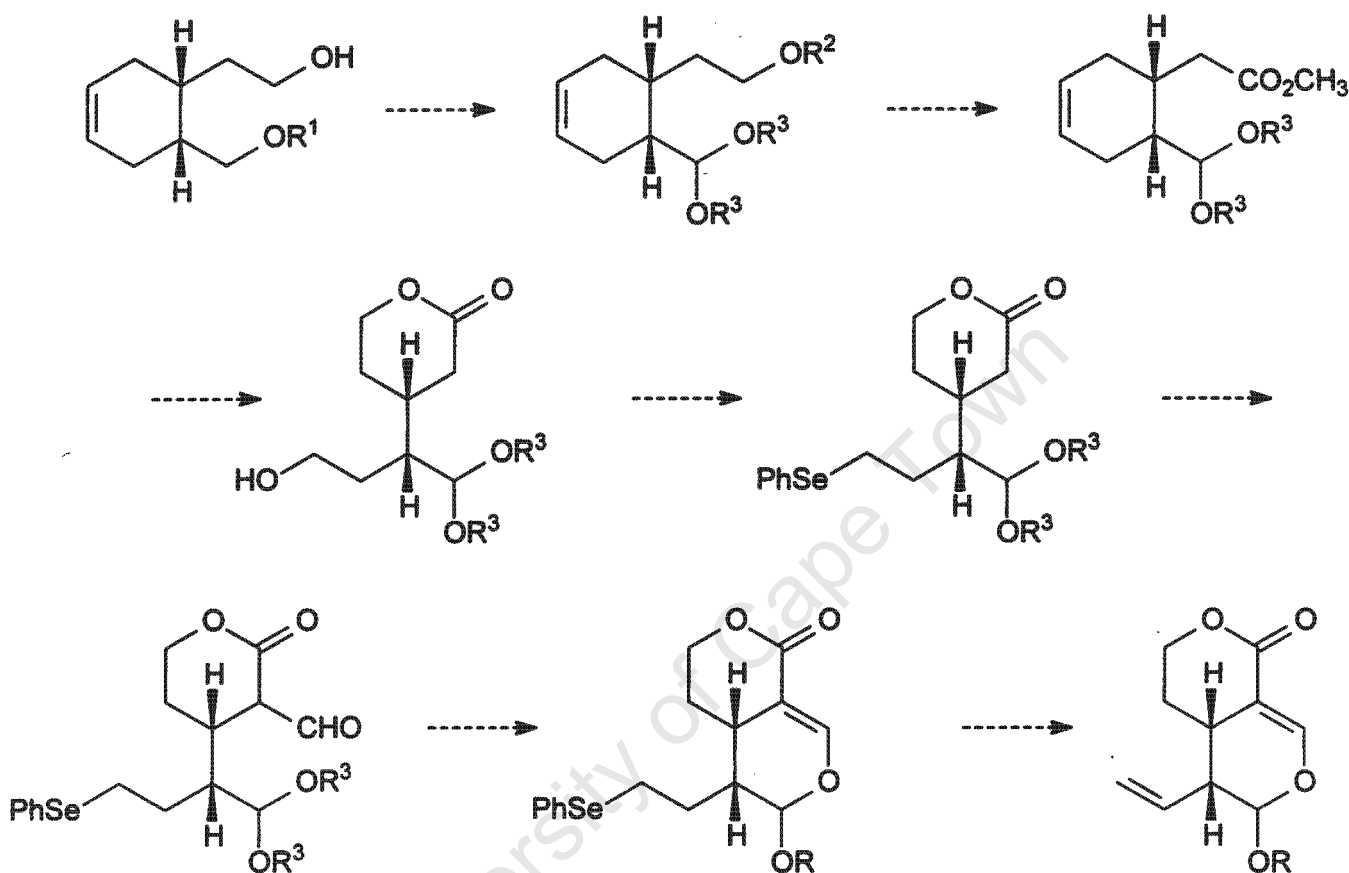

**Scheme 3.36** Renewed synthetic outline for the synthesis of sweroside aglycone

Bearing in mind the difficulty experienced in deprotecting a TPS ether, an attempt was made to protect the alcohol as a benzyl ether. This could be deprotected reductively, as required. Treatment of **44** with sodium hydride and benzyl bromide afforded **83** in 91% yield. Hydroboration-oxidation with the 9-BBN- $\text{H}_2\text{O}_2$  system afforded the alcohol **84**, albeit in poor yield (Scheme 3.37). The reaction with thexyl borane prepared *in situ* was also poor.

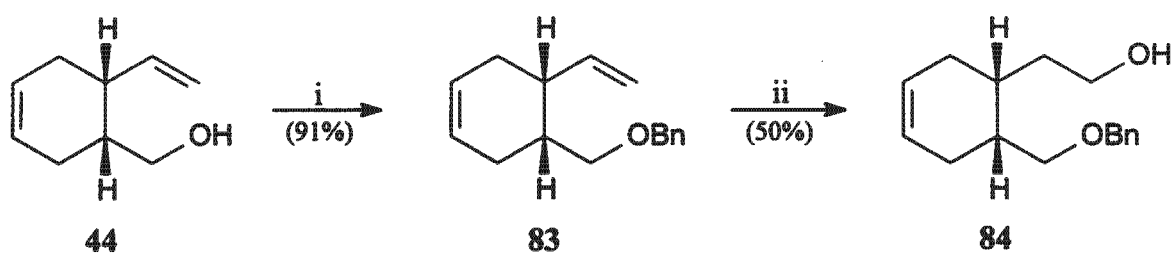

**Scheme 3.37** Reagents and conditions: (i) NaH, BnBr, THF, (ii) 9-BBN, THF

Since 49, the TPS protected analogue of 84 was already available, and the planned TPS deprotection was imminent, its use was evaluated prior to experimenting with other protecting groups. Treatment of 49 with pivaloyl chloride in pyridine afforded the pivaloate ester 85. The desilylation was chemoselective, leaving the pivaloate ester intact, to give 86. TLC monitoring of the Dess Martin and Swern oxidations of 86 indicated the formation of a single product. NMR spectra of the crude extracts from these reactions verified the presence of a single diastereomer. The  $^1\text{H}$  NMR spectrum contained a doublet at  $\delta$  9.67 that, along with a resonance at  $\delta$  204.3 in the  $^{13}\text{C}$  NMR spectrum confirmed the presence of the aldehyde 87. Previous experience had highlighted the epimerisable nature of the aldehyde  $\alpha$ -proton to give a *trans*-ring junction, and crude 87 was thus protected without purification and further characterisation. The mild acetal formation procedure developed by Noyori<sup>94</sup> was applied and provided the dioxane derivative, 88 as a single diastereomer. Over two steps the procedure using the Dess Martin oxidation delivered 69% of 88, whilst the Swern oxidation afforded 91%. Epimerisation was noted (by NMR) if the aldehyde protection reaction temperature exceeded  $-78$  °C. The characteristic acetal resonance at  $\delta$  4.39 and  $\delta$  103.4 in the  $^1\text{H}$  and  $^{13}\text{C}$  NMR spectra respectively provided positive evidence for the assigned structure. The NMR spectra were fully assigned using 2D spectra (Scheme 3.38).

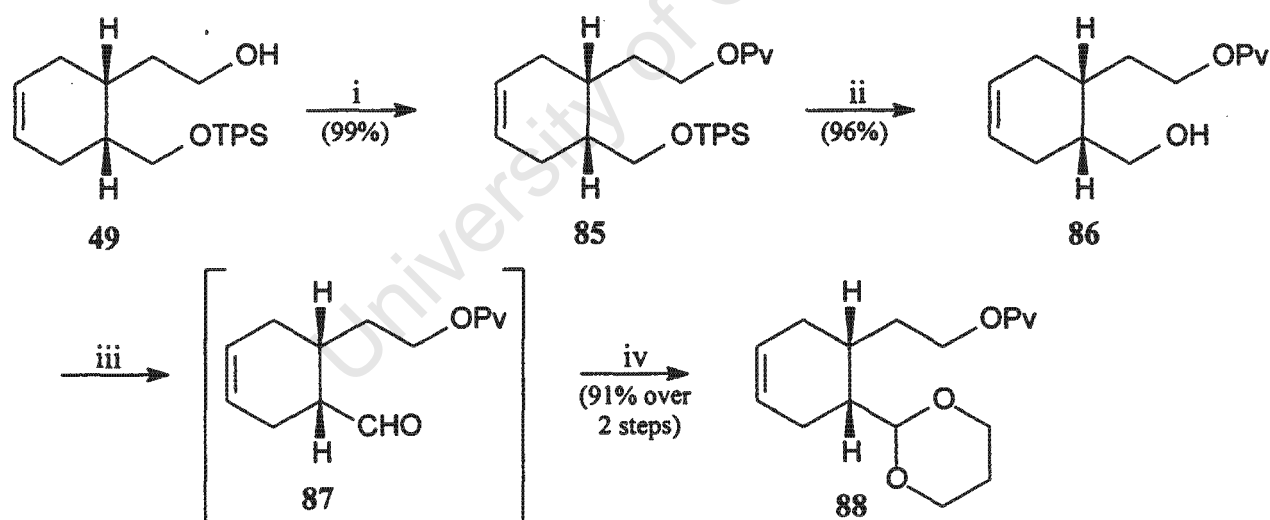

**Scheme 3.38** Reagents and conditions: (i) PvCl, DMAP, pyr, (ii) TBAF, THF, (iii)  $(\text{COCl})_2$ , DMSO,  $\text{CH}_2\text{Cl}_2$ ,  $-78$  °C, then  $\text{Et}_3\text{N}$ ,  $0$  °C, (iv)  $\text{TMSO}(\text{CH}_2)_3\text{OTMS}$ ,  $\text{TMSOTf}$ ,  $-78$  °C

The selection of a dioxane acetal as opposed to the dioxolane variant usually formed using Noyori methodology<sup>95</sup> was to provide stability toward ozone during the oxidative cleavage step. The oxidation of acetals by ozone to give an ester has been described by Deslongchamps *et al.* (Scheme 3.39).<sup>96</sup> The data included below show that the oxidation rates vary markedly with the nature of the acetal. Whilst the dimethyl acetal shows the slowest reaction with ozone, its extremely labile

nature in acidic media makes it too fragile for this synthesis. Of the more robust cyclic acetals, the dioxane version displays the slower reaction with ozone and was thus selected.

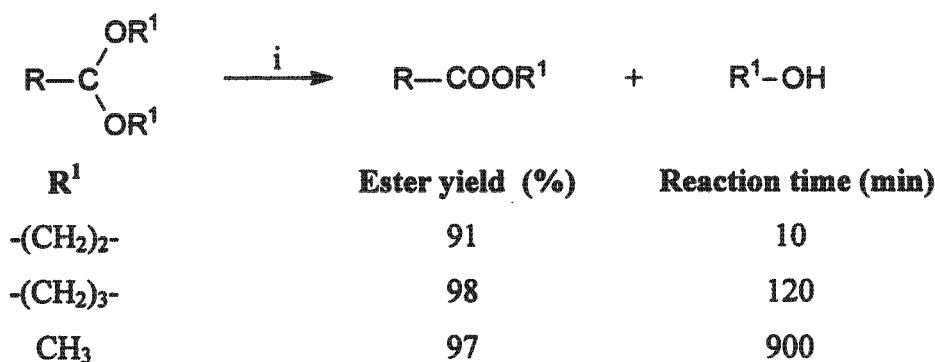

**Scheme 3.39** Reagents and conditions: (i) O<sub>3</sub> (1 mmol.min<sup>-1</sup>), EtOAc, -78 °C, 10 mmol start. mat.

Unfortunately, the argument that was used to confirm the relative configuration of the cyclohexenyl substituents in **47** could not be applied here because the signals for both bridgehead protons were overlapping with other signals. However, since the *trans* diastereomer would be thermodynamically most stable, it was reasonable to assume that it was the diastereomer being formed when the Noyori protection was performed at higher temperature. The diastereomerically pure material isolated from the reaction at -78 °C was thus assigned as the *cis* product as shown.

Treatment of **88** with an excess of LAH in THF at 0 °C delivered the alcohol **89**. Oxidation of the alcohol to acid **90** was achieved using a Jones oxidation at 0 °C, but was accompanied by considerable decomposition, presumed to be due to hydrolysis of the acetal in the harshly acidic reaction conditions (Scheme 3.40). Ruthenium tetroxide oxidation also produced mixtures, presumably due to interaction between the reagent and the cyclohexenyl olefin. The oxidation was thus delayed until after cleavage of this olefin, when chemoselective reaction could be assured.

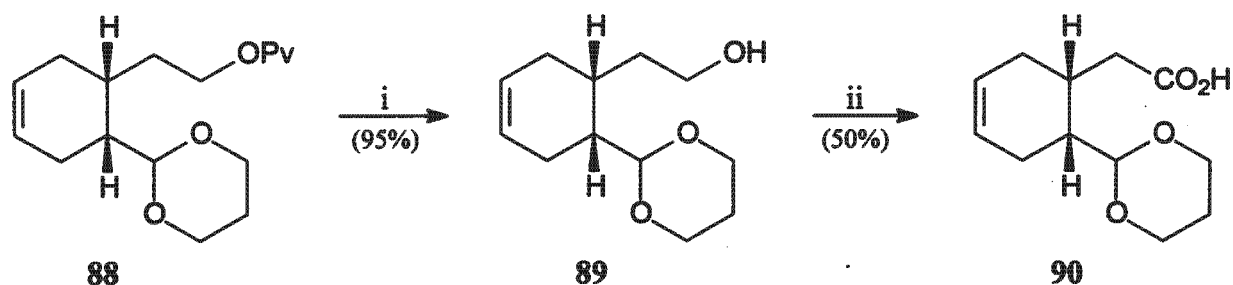

**Scheme 3.40** Reagents and conditions: (i) LAH, THF, 0 °C, (ii) 8M CrO<sub>3</sub>, acetone, 0 °C

Ozonolysis of **88** in methanol at  $-78\text{ }^{\circ}\text{C}$  followed by reduction with excess  $\text{NaBH}_4$  gave diol **91**. The high polarity of **91** made purification on silica gel difficult and the crude material was therefore silylated to give **92** (Scheme 3.41). The  $^1\text{H}$  NMR spectrum confirmed that (i) the acetal protection was still intact (doublet,  $\delta$  4.44), (ii) no vinyl protons were present and (iii) the product was bis-silylated (singlets,  $\delta$  0.03, 0.04, 0.88 and 0.89). The  $^1\text{H}$  and  $^{13}\text{C}$  spectra were fully assigned using COSY and HSQC data.

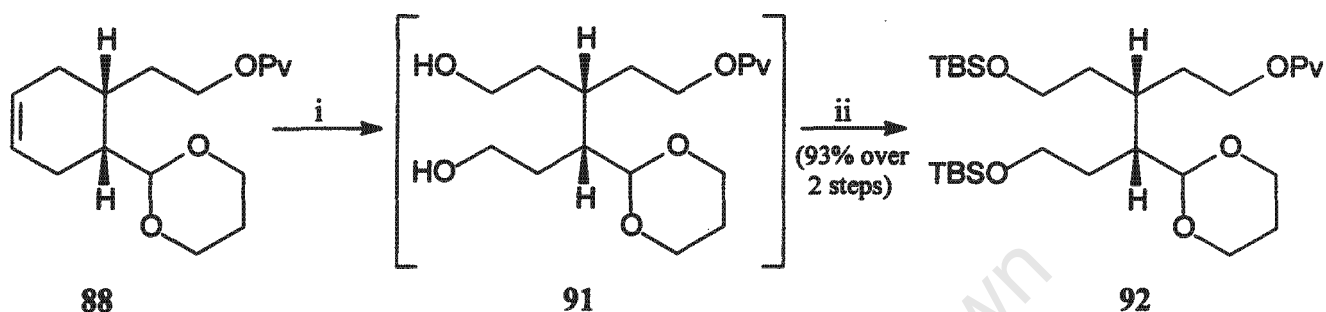

**Scheme 3.41** Reagents and conditions: (i)  $\text{O}_3$ , MeOH,  $-78\text{ }^{\circ}\text{C}$ , then  $\text{NaBH}_4$ ,  $25\text{ }^{\circ}\text{C}$  (ii) TBSCl, imidazole, MeCN

Pivaloate ester **92** underwent deprotection with LAH as before to give **93**. Oxidation with ruthenium tetroxide, prepared *in situ* using catalytic ruthenium dioxide with sodium periodate as the co-oxidant,<sup>97</sup> gave a carboxylic acid which was converted into its methyl ester **94** and then characterised (Scheme 3.42). When the oxidation was performed at ambient temperatures, as described, TLC showed evidence of numerous side reactions. The optimum reaction temperature was found to be  $0\text{ }^{\circ}\text{C}$ . Spectroscopic and analytical data confirmed the assigned structure.

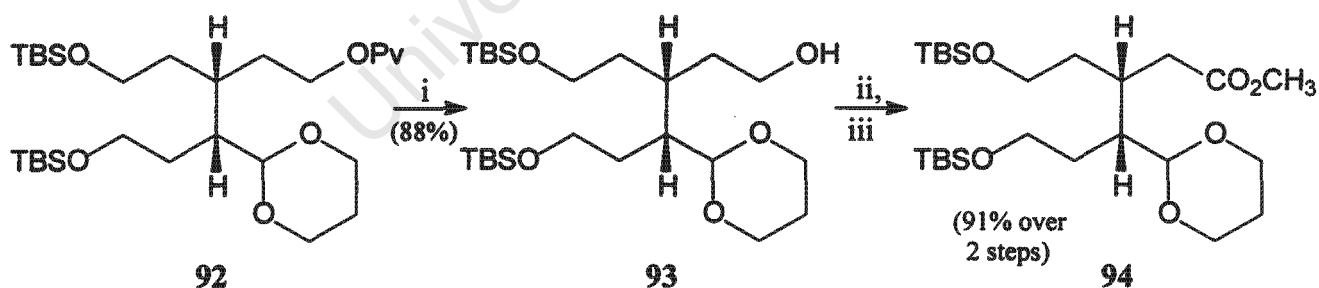

**Scheme 3.42** Reagents and conditions: (i) LAH, THF,  $0\text{ }^{\circ}\text{C}$ , (ii)  $\text{RuO}_2$  (cat.),  $\text{NaIO}_4$ ,  $\text{CCl}_4$ -MeCN- $\text{H}_2\text{O}$ ,  $0\text{ }^{\circ}\text{C}$ , (iii) MeI,  $\text{K}_2\text{CO}_3$ , DMF, MeCN

Chemoselective deprotection of the silyl ethers was more difficult than had been anticipated. Treatment of **94** with TBAF at  $0\text{ }^{\circ}\text{C}$  showed a single polar product on TLC. The  $^1\text{H}$  NMR spectrum of the product post chromatography was dominated by four signals ( $\delta$   $\sim$ 0.96, 1.36, 1.65 and 3.45) which indicated the presence of a tetra-*n*-butylammonium species. The absence of a resonance relating to the ester methoxy protons indicated that hydrolysis of the ester may have accompanied

silyl deprotection and that the resulting acid was isolated as an ammonium salt. Buffering the TBAF with an equimolar amount of acetic acid<sup>98,99</sup> gave the same result. Attempts to isolate a free acid or a lactonised species resulted in decomposition. Deprotection using HF·pyr gave multiple products. A procedure using trimethylsilyltrifluoromethane sulfonate for the chemoselective desilylation of TBS ethers under mild conditions has recently been reported.<sup>100</sup> Application of those conditions to our system gave multiple products, from which the major product, **95**, was isolated (Scheme 3.43).

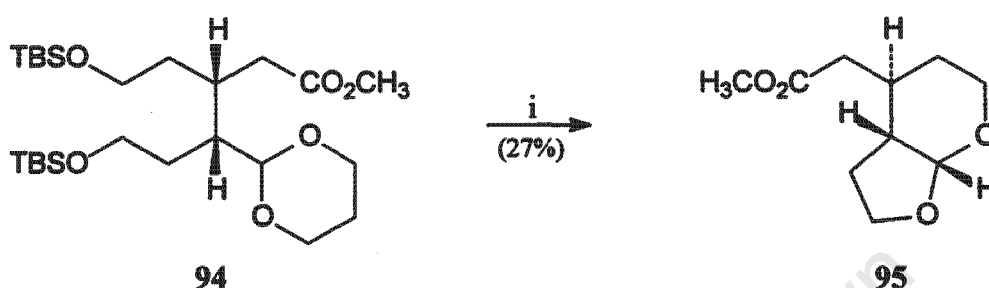

**Scheme 3.43** Reagents and conditions: (i) TMSOTf (3.0 mol. equiv.),  $\text{CH}_2\text{Cl}_2$ ,  $-78^\circ\text{C}$ , then MeOH (xs),  $-78^\circ\text{C}$  followed by  $\text{NaHCO}_3$  (aq)

The  $^1\text{H}$  NMR spectrum of the product carried a signal implying the presence of an acetal moiety (doublet,  $\delta$  5.12), but the absence of any methylene signals relating to propanediol showed that the starting acetal was no longer present. The IR and  $^1\text{H}$  NMR spectra contained no evidence of hydroxyl functionality and FAB-MS results proposed a parent molecular ion with  $m/z$  200. All of these data confirm the assigned structure. The *cis* stereochemistry at the ring junction is proposed on the basis of the observed coupling of the acetal proton that, at 3.6 Hz, implied a gauche relationship with its partner. In hydrindane-like systems, relationship of the bridgehead protons in a *trans* system would be antiperiplanar and a larger coupling than that observed would be expected [Fig. 3.9 (a)]. As shown in Fig 3.9 (b), the small coupling observed was likely in the *cis* isomer.

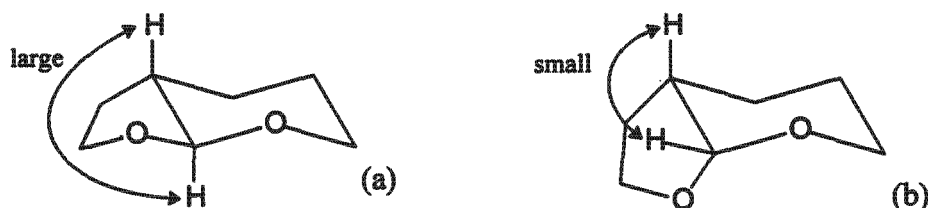

**Figure 3.9** Expected coupling at bridgehead protons in *trans* (a) and *cis* (b) hydrindane-like systems

Since **94** was treated with TMSOTf under aprotic conditions, and the addition of methanol, followed by aqueous sodium bicarbonate ten minutes later took place at  $-78\text{ }^{\circ}\text{C}$ , a straightforward hydrolytic cleavage of the acetal moiety, followed by internal acetal formation was unlikely. In addition, examples cited in the original work showed isopropylidene ketal protecting groups to be stable to these reagents at  $-40\text{ }^{\circ}\text{C}$ .<sup>100</sup> Although a difference in the rates of hydrolysis of these moieties could be expected, this degree of selectivity was unlikely. A mechanism for this reaction has been proposed, but in the absence of suitable experimental work to confirm the presence of the intermediates formed, it remains speculative. The proposed reaction mechanism invokes silylation of acetal oxygen by TMSOTf, leading to an oxycarbenium intermediate as illustrated in Scheme 3.44. In this form, the acetal is potentiated towards attack by a nucleophilic silyloxy moiety. Following silyl exchange, a further oxycarbenium intermediate intercepts the second silyloxy function, resulting in formation of the internal acetal.

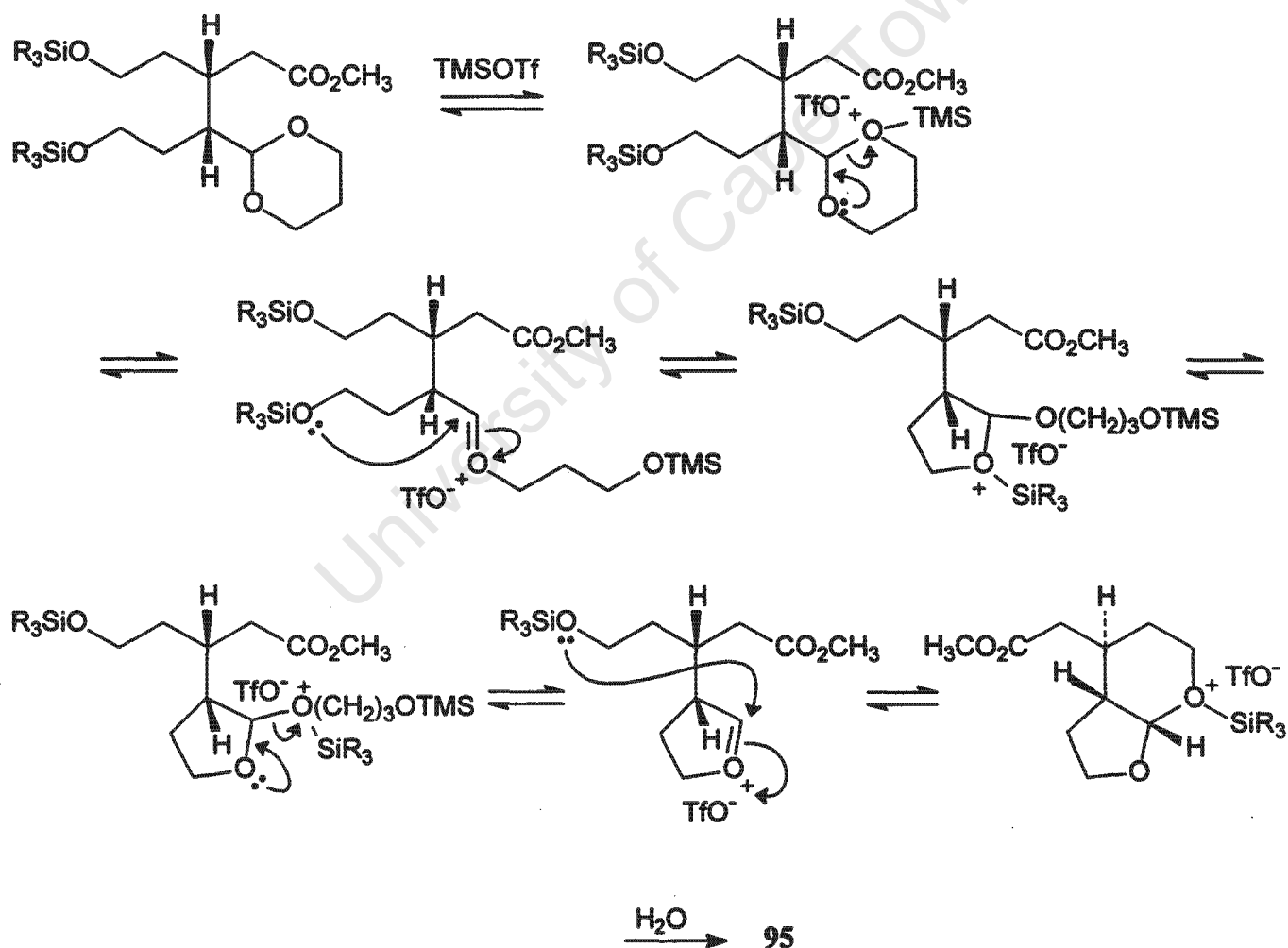

Scheme 3.44

The mild, water stable Lewis acid, scandium triflate, has been used catalytically to cleave TBS ethers at ambient temperatures.<sup>101</sup> Treatment of **94** with 0.5 mol %  $\text{Sc}(\text{OTf})_3$  in the presence of an excess of water, in acetonitrile delivered a 70% yield of **95**. TLC monitoring of this reaction indicated that **95** was formed *via* a polar species assumed to be the desired diol with the acetal still intact. Under these reaction conditions, acetal hydrolysis catalysed by the Lewis acid, followed by internal acetal formation with the desilylated alcohols to give **95** is feasible (Scheme 3.45).

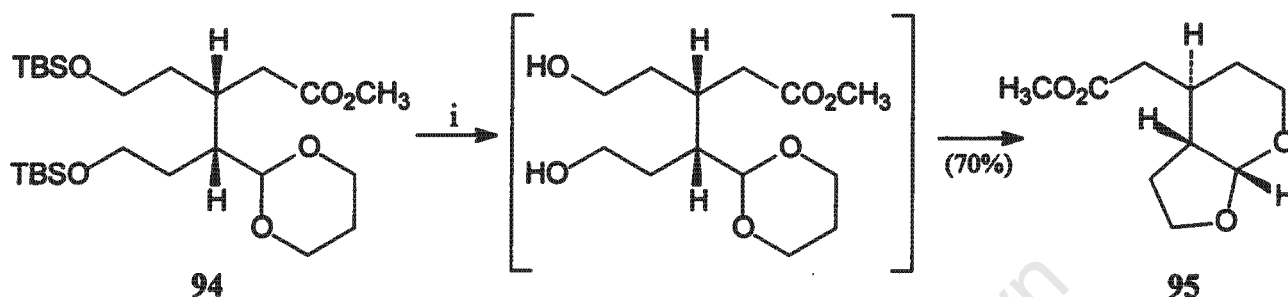

**Scheme 3.45** Reagents and conditions: (i)  $\text{Sc}(\text{OTf})_3$ ,  $\text{H}_2\text{O}$ , MeCN, 25 °C

At 0 °C, complete reaction to the polar material could be achieved prior to formation of **95**. Spontaneous lactonisation of the diol intermediate provided **96**, which was isolated in 94% yield (Scheme 3.46).

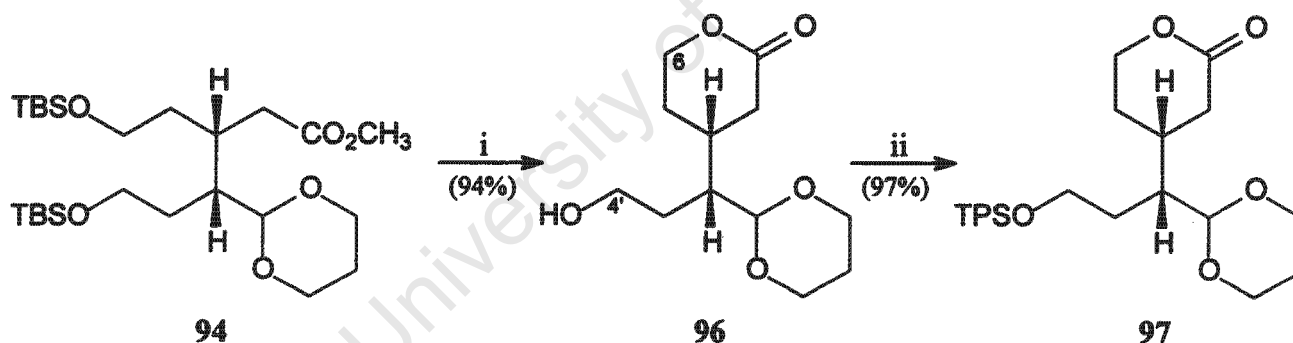

**Scheme 3.46** Reagents and conditions: (i)  $\text{Sc}(\text{OTf})_3$ ,  $\text{H}_2\text{O}$ , MeCN, 0 °C (ii) TPSCl, imidazole, MeCN

The loss of the ester methoxy group was indicated by the <sup>1</sup>H NMR spectrum of **96**. The carbonyl band at 1731 cm<sup>-1</sup> in the IR spectrum was as expected for a δ-lactone. If hydrolysis of the ester had occurred, the carbonyl group would be expected to give a peak at 1700–1720 cm<sup>-1</sup> in the IR spectrum. The <sup>1</sup>H and <sup>13</sup>C NMR spectra were assigned using 2D spectra. The chemical shifts assigned to the methylene protons α to oxygen were examined, and those for 6-H (δ 4.37 and 4.54) were noted to be more deshielded than that for 4'-H<sub>2</sub> (δ 3.51–3.56). The evident deshielding at C-6 confirmed that the δ-lactone had been formed preferentially to the alternative γ-lactone. The structure of **96** was confirmed by reacting it with TPSCl and imidazole in acetonitrile to give the product of monosilylation, **97**.

The primary alcohol **96** was converted into the selenide **98** by reaction with phenylselenocyanate and tri-*n*-butylphosphine<sup>85</sup> (Scheme 3.47). The one-carbon homologation step was performed using Brederick's reagent. On this occasion, the hydrolysis of the enamine intermediate was carefully controlled to avoid competing hydrolysis of the acetal protecting group. The formylated product, **99**, was present as a mixture of tautomers for which the NMR spectra were too complex to be easily assigned. The formation of **99** was however confirmed by the detection of the parent molecular ion in the mass spectrum. For complete characterisation, **99** was benzoylated to give the enoate ester **100** (Scheme 3.47). The <sup>1</sup>H NMR chemical shift for 1'-H ( $\delta$  8.36) was used to assign **100** as the *E*-isomer on the basis of the literature analogy<sup>91</sup> that was invoked in earlier discussions on similar systems (see section 3.2.5).

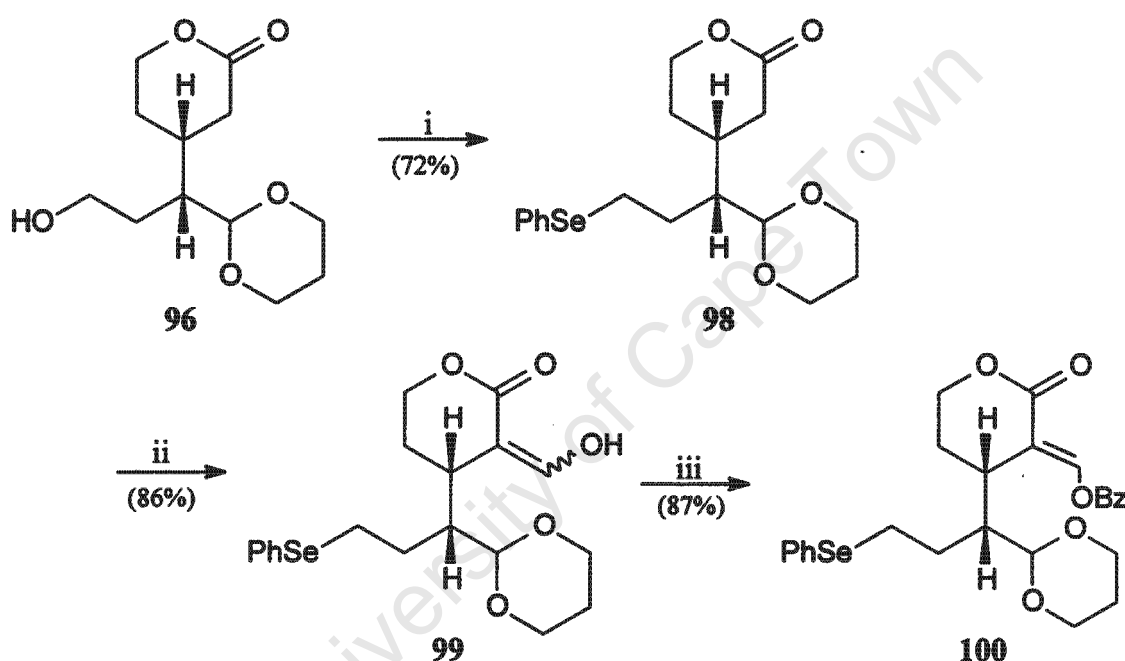

**Scheme 3.47** Reagents and conditions: (i) PhSeCN, *n*Bu<sub>3</sub>P, THF, (ii) Brederick's reagent, THF, reflux, (iii) BzCl, pyr, CH<sub>2</sub>Cl<sub>2</sub>

Deprotection of the acetal moiety in **99** accompanied by the closure to the dihydropyran ring was required to provide the glycosidation precursor **101**. Owing to the sensitive nature of the chiral centre  $\alpha$  to the carbonyl group to be exposed, conventional acid hydrolysis was not considered for the deprotection reaction.<sup>102</sup> Instead, a procedure employing catalytic ceric ammonium nitrate in a buffered medium<sup>103</sup> was used. The major product from this reaction proved to be unstable, and decomposition was observed during chromatography on silica gel. However, the NMR spectra of a sample obtained by flash chromatography allowed it to be identified as **101**, for which the connectivities depicted were confirmed by 2D spectroscopy (Scheme 3.48). The absence of signals associated with the methylene groups of the dioxane moiety in both the <sup>1</sup>H and <sup>13</sup>C spectra

confirmed that deprotection had occurred. Table 3.1 contains a comparison of several signals from the NMR spectra of **101** to the equivalent signals for sweroside aglycone **6**.<sup>33</sup>

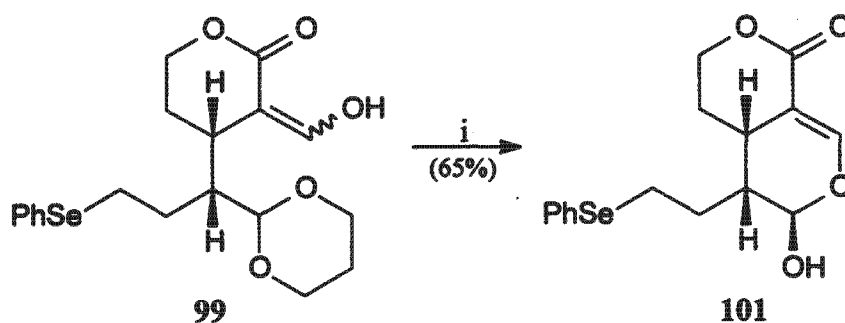

**Scheme 3.48** Reagents and conditions: (i) CAN (0.1 mol. equiv.), MeCN, HCl–borate buffer (pH 8), 60 °C

**Table 3.1** Comparative NMR signals for the hemiacetal **101** and sweroside aglycone **6**

Nucleus	Signal (CDCl <sub>3</sub> , ppm)	
	<b>101</b>	<b>6</b> <sup>33</sup>
4a-H	2.70—3.20 (m)	2.70(m)
5-H	2.06—2.18 (m)	2.02—2.11 (m)
6-H	5.46 (d, <i>J</i> 1.8 Hz)	5.44 (br.s.)
8-H	7.55 (d, <i>J</i> 2.2 Hz)	7.63 (d, <i>J</i> 2.1 Hz)
C-1	166.3	166.3
C-4a	27.8	28.5
C-5	36.9	46.9
C-6	94.1	94.4
C-8	153.3	153.6
C-8a	103.5	—

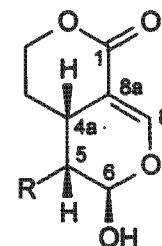

**101** R = CH<sub>2</sub>CH<sub>2</sub>SePh  
**6** R = CH=CH<sub>2</sub>

It was recognised that the different two-carbon substituents at C-5 in **101** and **6** could affect the magnetic behaviour of some nuclei in these compounds. However, these substituents are remote from the nuclei under consideration (other than C-5) and were thus unlikely to have influenced the aforementioned NMR signals. In addition, the signals for **101** were assigned independently of those for **6** using COSY and HSQC spectra, thus ensuring a genuine comparison. The correlation between these signals provide strong evidence for the structure assigned to **101**. The upfield shift observed in the signal for C-5 in **101** was ascribed to the absence of the deshielding vinyl substituent. Although no signal was observed for the quaternary centre C-8a in **6**, the signal observed at  $\delta$  103.5 in **101** compares favourably with that for sweroside itself,  $\delta$  106.0 (spectrum recorded in CD<sub>3</sub>OD).<sup>33</sup>

Drewes *et al.*<sup>33</sup> have rationalised the small coupling observed in the signal for H-6 (*i.e.*  $J_{5,6}$ ) on the basis of the *trans* diequatorial relationship between these protons in secoiridoids belonging to this series. This relationship has been confirmed crystallographically.<sup>104</sup> During the acetylation of **6**, they observed epimerisation at C-5, which was reflected in a  $J_{5,6}$  of 9.3 Hz. This was ascribed to a *trans* diaxial relationship between 5-H and 6-H and was also confirmed by an X-ray crystal structure. Although  $J_{5,6}$  was not resolved in the signal for H-6 in **6**, the observed  $J_{5,6}$  of 1.8 Hz in **101** provides further evidence that the deprotection reaction and concomitant ring closure were achieved without epimerisation at C-5.

The planned glycosidation (and hence protection) of **101** with a suitable carbohydrate glycosyl donor was not appropriate here because **101** was available as a racemate and the formation of diastereomeric glycosides was expected to complicate the reaction. The preparation of a possible crystalline intermediate in the form of the 4-nitrobenzoate ester **102** was thus attempted with the available material. In the light of the literature evidence for epimerisation at C-5 in **6** under standard basic esterification conditions,<sup>33</sup> an alternative preparation was considered. The activation of acid chlorides with polymer-supported (PS) DMAP has been utilised in amide and ester formation.<sup>105</sup> In esterification reactions, DMAP is usually used catalytically as an acyl transfer reagent, in the presence of a base. The use of stoichiometric PS-DMAP was selected here because of the convenience with which the acid could be activated and the active form purified prior to reaction with **101**, thus ensuring that the starting material was not exposed to an excess of either reagent. In addition, for this small scale reaction, the simplified isolation of reaction products was attractive. Unfortunately, no reaction was observed when **101** was treated with the activated acid. (Scheme 3.49).

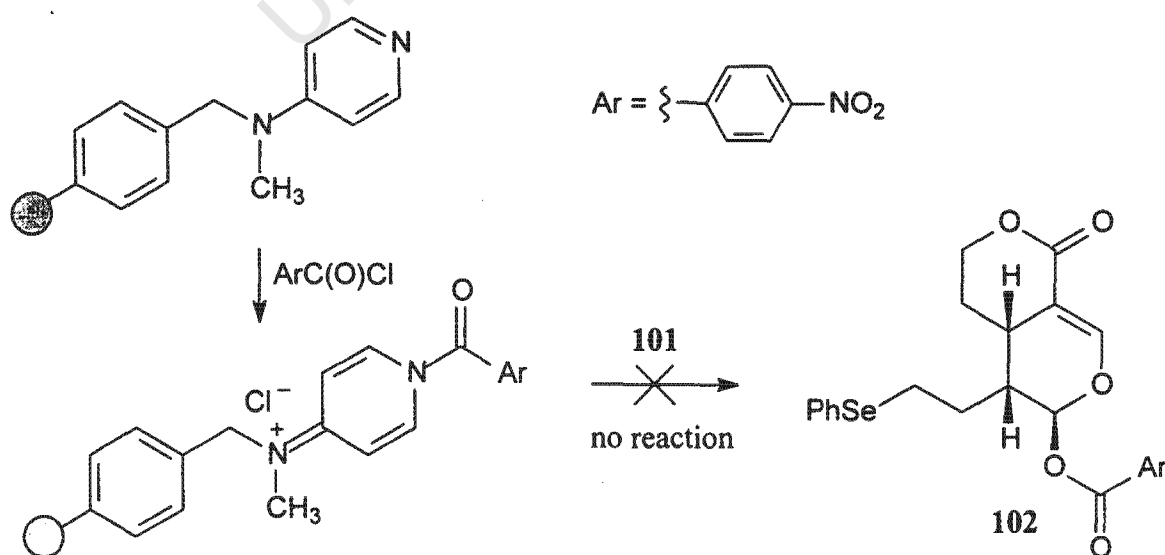

Scheme 3.49 Failed esterification of **101** using polymer-supported DMAP

The absence of reactivity was ascribed to the poor nucleophilicity of the hemiacetal hydroxyl group, and a more electrophilic reagent for the derivatisation was thus sought. The adduct formed by the reaction between *N,N*-dimethylformamide (DMF) and phenyl chloroformate has been reported to react with alcohols at 0 °C to give, after decarboxylation under the reaction conditions, a phenyl ether (Scheme 3.50).<sup>106</sup>

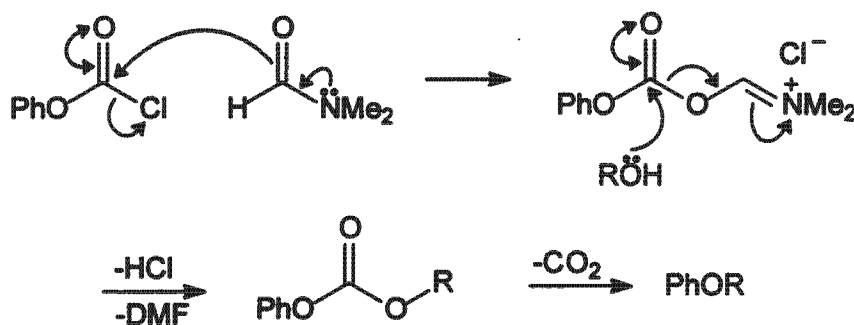

**Scheme 3.50** Derivatisation of an alcohol to a phenyl ether under mild conditions<sup>106</sup>

The enhanced electrophilicity of this reagent system has been demonstrated in a positive reaction with the poorly nucleophilic amino group in aniline.<sup>106</sup> In the reaction with **101**, however, the formation of multiple products was observed and no suitable derivatives could be isolated.

### 3.4 CONCLUSION

In combination with the enantioselective desymmetrisation described in Chapter 2, the synthesis of **101** as a single enantiomer is feasible and the proposed conversion into amarogentin **5** can be envisaged (Scheme 3.51).

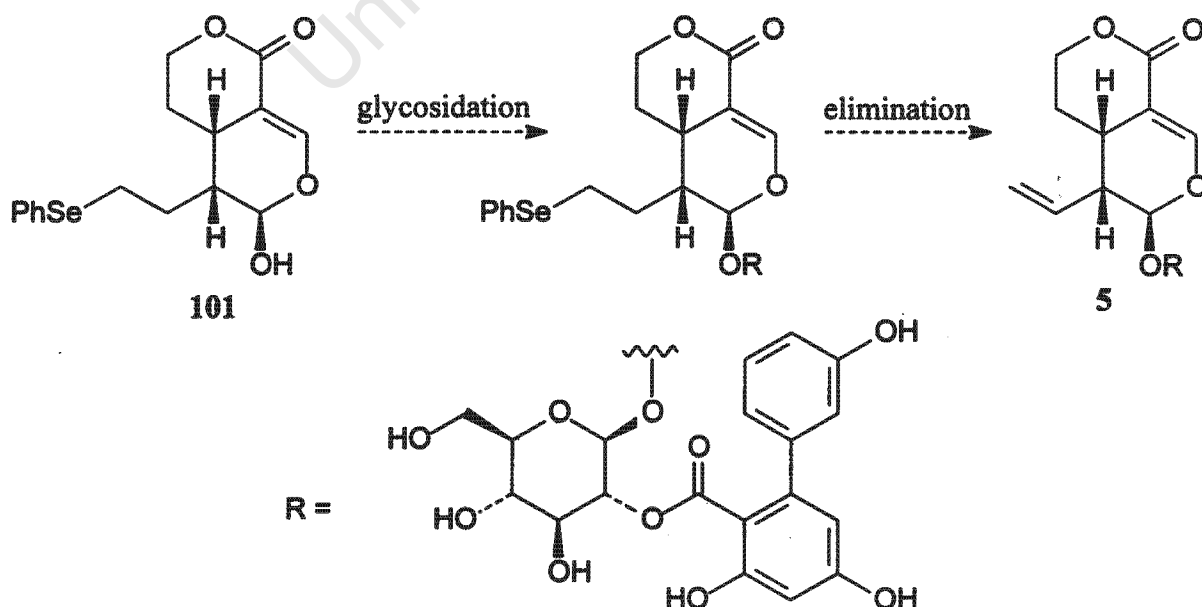

**Scheme 3.51** Proposed conversion of **101** into the target molecule, amarogentin **5**

The synthesis of the glycosidation precursor **101** thus represented the successful completion of this phase of the total synthesis. Although the formation and characterisation of **101** have not been optimised here, the aim of the racemic model synthesis, *i.e.* the development of a diastereoselective route to the secoiridoid portion of amarogentin has been achieved. In light of the sensitive nature of the hemiacetal in **101**, the development of an efficient glycosidation protocol was expected to be complex and was unfortunately not within the time constraints of this individual project.

In addition to the obvious contribution towards the total synthesis of amarogentin, the work described in this chapter has highlighted the chemoselectivity problems associated with highly functionalised systems of this type and identified suitable reaction and protection protocols for application to these intermediates.

University of Cape Town

## CHAPTER 4

## ENANTIOSELECTIVE SYNTHESIS USING CHIRAL POOL INTERMEDIATES

### 4.1 CYCLOADDITION WITH A CHIRAL CYCLOPENTENONE

The utility of cyclopentenone **32** as a chiral dienophile has been demonstrated during the enantioselective total synthesis of (-)-methyl jasmonate **103** (Scheme 4.1),<sup>107</sup> in which a lithium perchlorate catalysed reaction between **32** and 2-methoxybutadiene gave Diels-Alder adduct **104**. A 5-step sequence from **104**, which included an epimerisation at the bridgehead position  $\alpha$  to C=O, afforded **103**. The Diels-Alder cycloaddition reaction between racemic **32** and Dane's diene **105** has also been achieved (Scheme 4.2).<sup>108</sup>

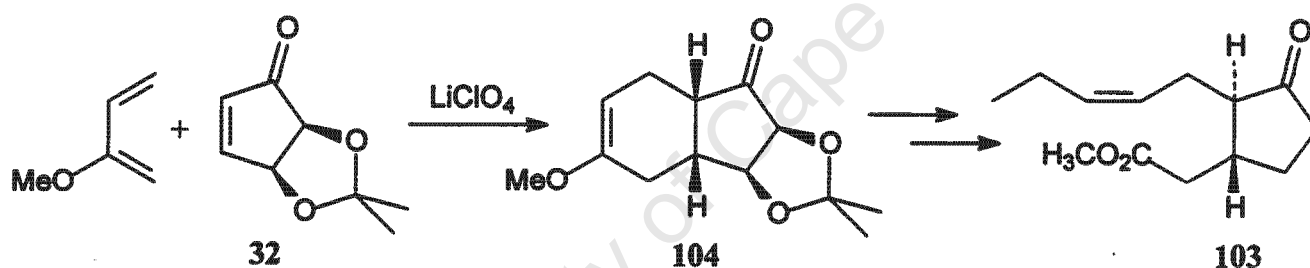

Scheme 4.1 Diels-Alder cycloaddition-mediated synthesis of methyl epijasmonate **s1**

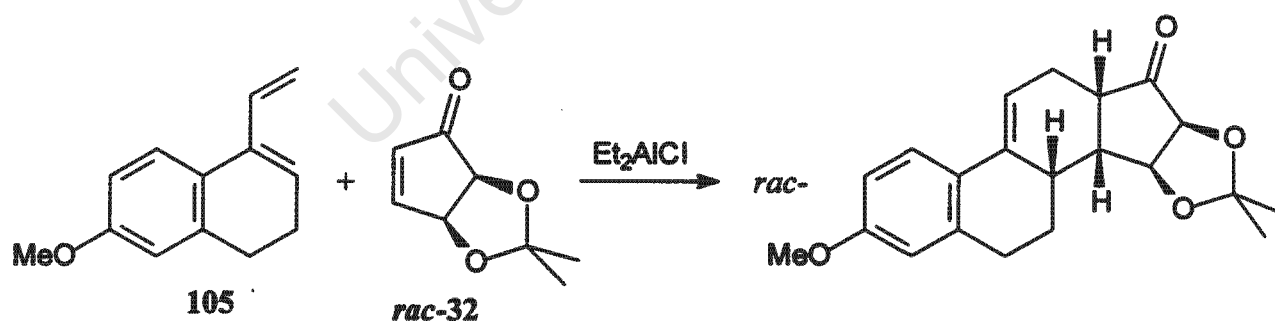

Scheme 4.2 Diels-Alder cycloaddition of **32** with Dane's diene **s3**

Complete diastereofacial selectivity has been demonstrated during the zinc chloride catalysed cycloaddition of **32** with cyclopentadiene.<sup>109</sup> Although an equivalent reaction with butadiene does not appear to have been reported to date, in the light of the aforementioned literature precedent, the concept was considered worthy of further investigation. Furthermore, the functionality on the expected cycloadduct **106** is exceptionally well positioned for conversion into sweroside aglycone

6, as shown by the four major transformations (a)—(c) which were identified during the retrosynthetic analysis\* of 6 (Scheme 4.3).

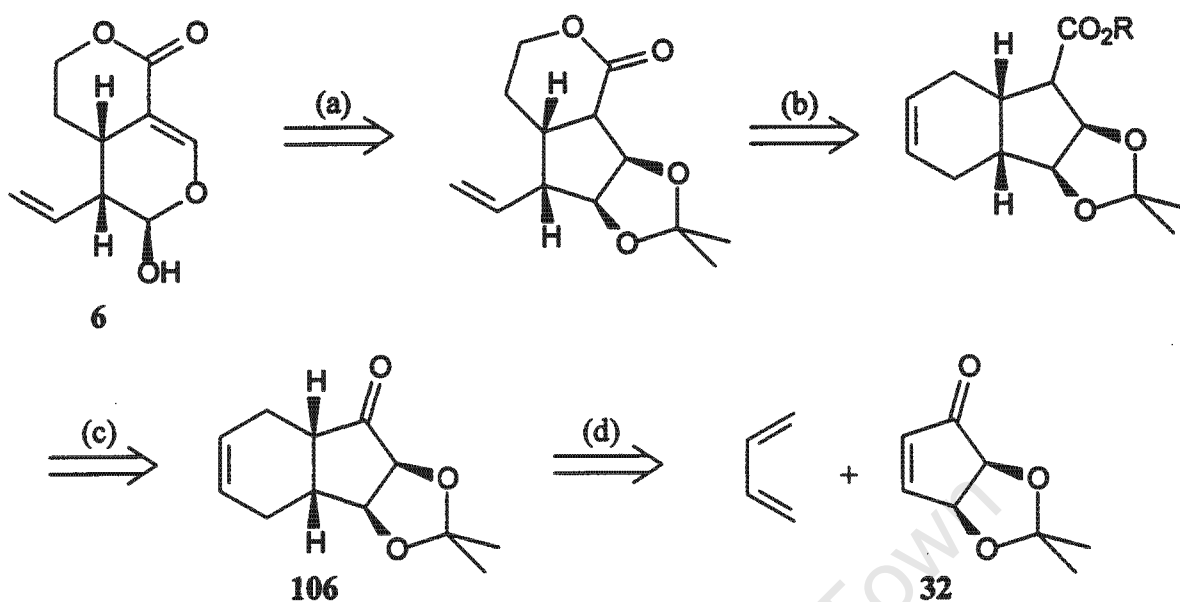

**Scheme 4.3** Retrosynthetic analysis for the conversion of 32 into 6

In step (a) acetonide deprotection, followed by glycol cleavage to a bis aldehyde intermediate that would cyclise to give the desired dihydropyran was envisaged. This methodology has been successfully employed to achieve the analogous transformation in the synthesis of the iridoid loganin.<sup>110</sup> The next key transformation that was identified, step (b), was an oxidative cleavage of the olefin. Ozonolysis followed by a reductive work-up was planned, after which lactonisation would allow chemodifferentiation of the hydroxyethyl moieties so formed. Elimination of the remaining primary hydroxyl group formed the last part of this step. In step (c) exploitation of the carbonyl functionality to perform a one-carbon homologation followed by functionalisation to give a carboxyl group was required. The aforementioned cycloaddition constituted step (d).

The dienophile 32 has been synthesised from D-ribonolactone<sup>111</sup> and D-ribose.<sup>112</sup> Its cyclohexylidene analogue has been accessed from D-mannose.<sup>113</sup> Classical resolution of *rac*-32 synthesised from cyclopentadiene has also been reported.<sup>114</sup> Recently, both enantiomers of 32 have been produced by the use of lipase-mediated kinetic resolution as the enantiodifferentiating step.<sup>115</sup> Only the synthesis from D-ribose was considered in this project because of its cost effectiveness

\* It should be noted that all of the initial retrosynthetic analyses described in this thesis were performed early in the project. The analyses described in Chapters 4 and 5 were thus devised without the insights gained during the racemic model synthesis and are reported as such.

(vs. D-ribonolactone) and efficiency (vs. resolution). The synthesis from D-ribose is a four-step procedure (Scheme 4.4). In our hands, the conversions to give **107** and **108** were achieved in similar yields to those shown in Scheme 4.4. However, the final step proved to be capricious and recoveries of **32** ranged from 0 to 31%. This observation has also been reported by Roberts *et al.* where an optimum yield of 38% was achieved for this conversion.<sup>116</sup>

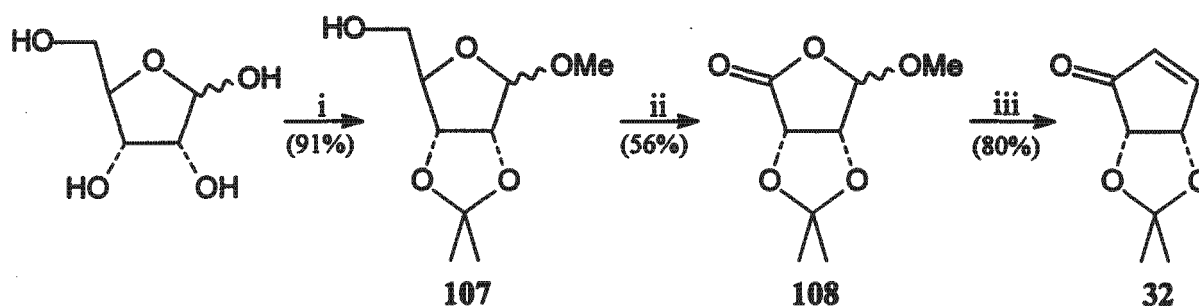

Scheme 4.4 Borchardt synthesis of **32** from D-ribose<sup>112</sup>

Reagents and conditions: (i) DMP, MeOH, HClO<sub>4</sub>, (ii) PCC, benzene, (iii) (MeO)<sub>2</sub>P(O)Me, *n*BuLi, -78 °C

In the light of the inability to produce sufficient quantities of **32** for the development of a synthetic route, the effort in this project was concentrated on the application of the more accessible chiral pool dienophiles **33** and **34** (identified in Chapter 1) to this synthesis. It is however recognised that on paper, cycloadduct **106** should provide the most efficient route to sweroside aglycone **6**. A diastereoselective synthesis on a racemic model should be undertaken in order to evaluate the potential of this intermediate, after which an informed decision could be made on the degree of investment warranted in the production of **32**.

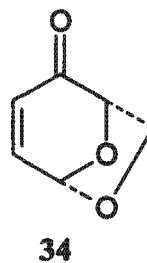
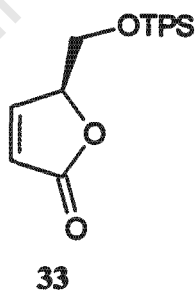

## 4.2 CYCLOADDITION WITH A CHIRAL BUTENOLIDE

Chiral  $\alpha,\beta$ -butenolides (or 2-5(*H*)-furanones) such as **109** have frequently been utilised as chiral synthons in the enantioselective synthesis of natural products. Recent examples include the synthesis of an aflatoxin<sup>117</sup> and the preparation of the ABC ring of paclitaxol (Taxol<sup>TM</sup>).<sup>118</sup> Although the use of acrylic acid derivatives as dienophiles in enantioselective Diels-Alder cycloadditions has been extensively explored,<sup>119</sup> that of butenolides (as cyclic acrylate equivalents as shown in Figure 4.1) is limited. The high degree of stereoselectivity imparted by Diels-Alder methodology combined with the high density of functionality associated with butenolides make this an attractive option.

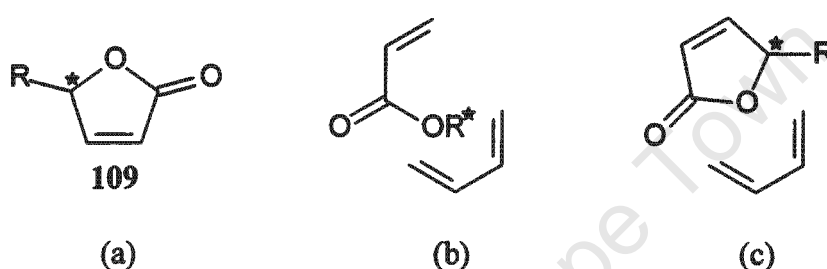

**Figure 4.1:** (a) Chiral  $\alpha,\beta$ -butenolide (b) Cycloaddition with a chiral acrylate (c) Butenolide as an acrylate equivalent

Recently, Jauch has utilised an intramolecular Diels-Alder reaction with Feringa's butenolide<sup>120</sup> tethered to a substituted diene (Scheme 4.5).<sup>121</sup> The cycloaddition reaction was performed under thermal conditions (xylene/160 °C) to deliver the product as a single diastereomer. The complex cycloadduct formed an advanced intermediate in the synthesis of a series of sesquiterpenoid natural products, the mniopetals.<sup>122, 123</sup>

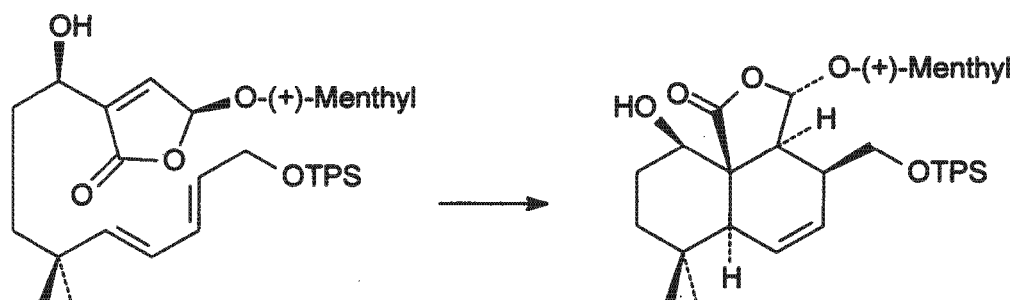

**Scheme 4.5** Intramolecular Diels-Alder reaction using a tethered butenolide

For this synthesis, the cycloadduct obtained from the reaction of 4-*t*-butyldiphenylsilyloxymethyl substituted butenolide **33** with butadiene was identified as a suitable chiral intermediate. Key structures identified during the retrosynthetic analysis have been noted in Scheme 4.6 below.

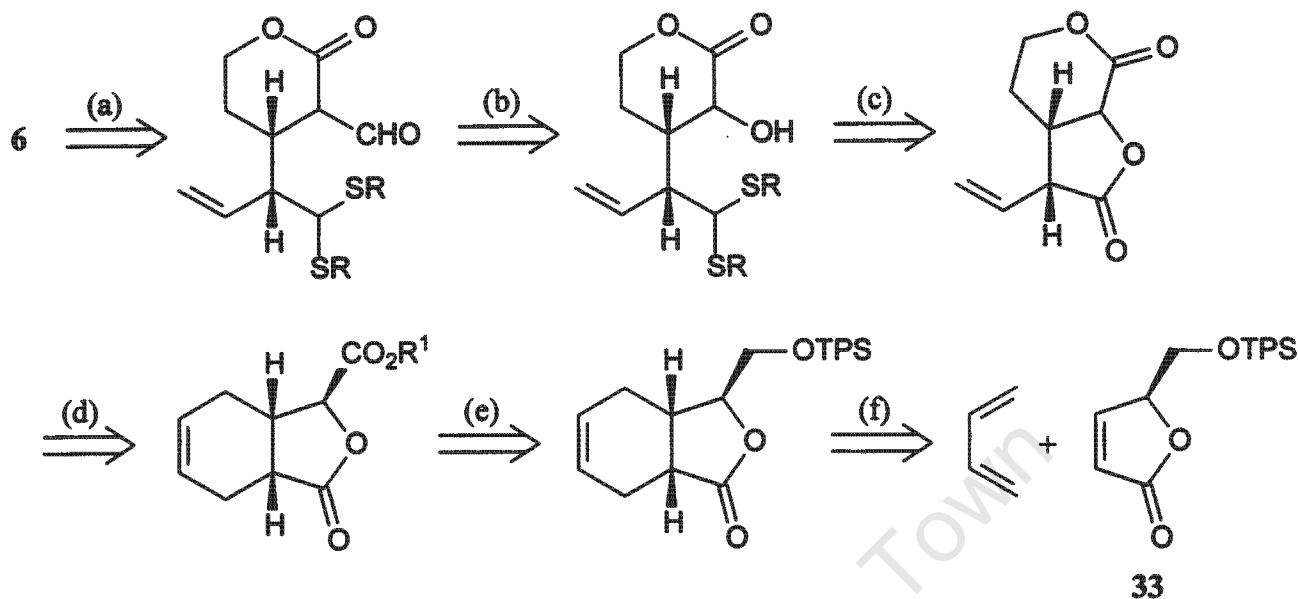

**Scheme 4.6** Retrosynthetic steps identified for the synthesis of **6** from **33**

Deprotection of the thioacetal with concomitant ring closure to form the dihydropyran moiety [step (a)] would deliver the target, sweroside aglycone **6**. The one-carbon homologation represented in step (b) is an overall conversion of hydroxyl functionality into a formyl group. Two possible processes were identified for this transformation: firstly, oxidation of the hydroxyl group to a carbonyl group followed by methylenation with a suitably functionalised reagent and secondly, removal of the alcohol using a radical deoxygenation process, followed by enolate-mediated formylation. In step (c) ring opening of the butenolide residue was planned, by reducing the lactone to a lactol, followed by aldehyde trapping to give the thioacetal-alcohol intermediate. Oxidative cleavage of the cyclohexene ring, followed by lactonisation and elimination at the termini comprised step (d). Oxidation of the hydroxymethyl moiety obtained by desilylation of the cycloadduct, as shown in step (e), would deliver the carboxyl group that was required for the chemoselective lactone formation proposed at step (d). The cycloaddition reaction (f) is known for **33** and a number of butenolides in this series (*i.e.* where protection other than TBS is present). These have been discussed later in this introductory section.

Many enantioselective syntheses of the hydroxymethyl butenolides **110**, from which **33** can be accessed in a simple silylation step, are known. These are based on (i) transformation of intermediates from the chiral pool, and (ii) asymmetric transformations on achiral starting

materials. From the chiral pool, the desired (4*S*)-enantiomer has been synthesised from (*S*)-glutamic acid,<sup>124</sup> D-ribonolactone<sup>125, 126</sup> and D-mannitol.<sup>127, 128</sup> The latter procedure (outlined in Scheme 4.7) was selected for this work because it is well described and the starting material is inexpensive.

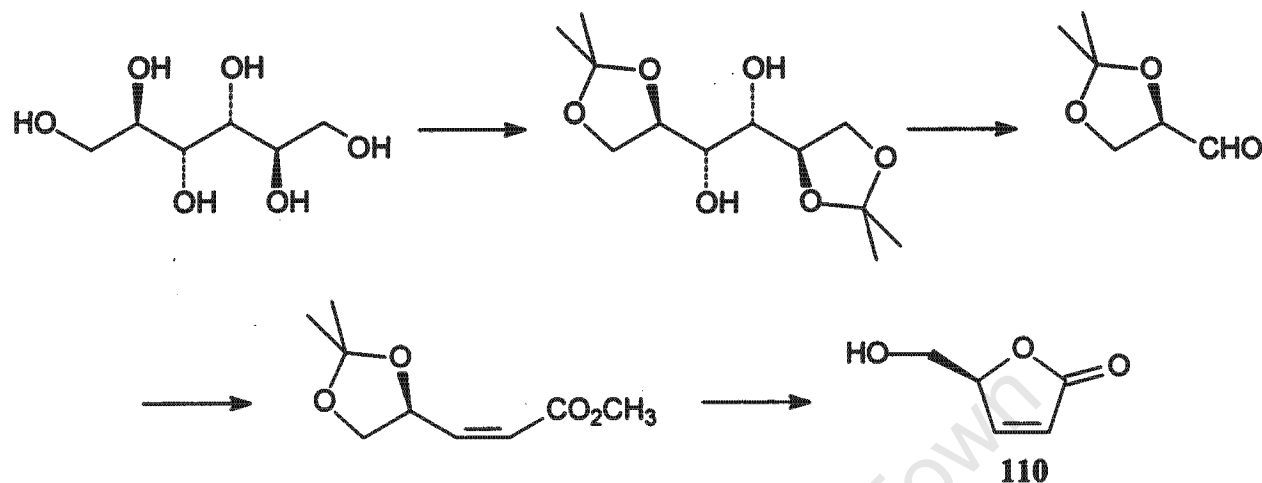

**Scheme 4.7** Conversion of D-mannitol into butenolide 110<sup>127, 128</sup>

The opposite enantiomer *ent*-110 has been accessed from L-ascorbic acid in 33% overall yield.<sup>129</sup> As mentioned previously, access to both enantiomers is important in order to complete structure-activity studies.

The asymmetric synthesis of the TBS protected butenolide 111 in a two-step procedure from an achiral  $\beta,\gamma$ -unsaturated ester has been published (Scheme 4.8).<sup>130</sup> It relies on a Sharpless dihydroxylation with concomitant lactonisation as the enantioselective process, followed by an elimination step to give 111 in acceptable (~92%) enantiomeric excess. Desilylation of 111 has been demonstrated in 85% yield,<sup>130</sup> thus potentially providing access to both enantiomers of butenolides bearing alternative hydroxymethyl protection.

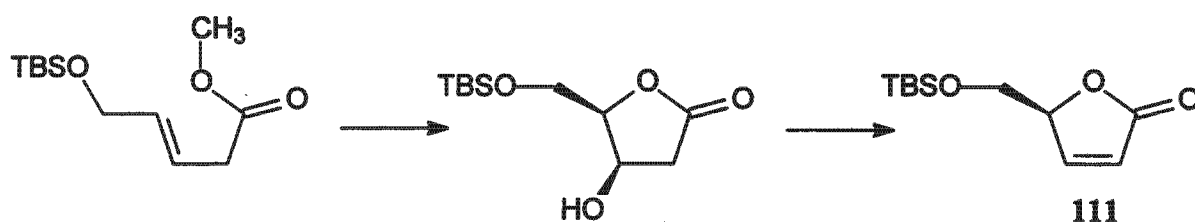

**Scheme 4.8** Asymmetric synthesis of TBS protected butenolide 111

The Diels-Alder adduct arising from the reaction between 33 and butadiene was first reported by Mann *et al.*<sup>126</sup> who performed a Lewis acid catalysed cycloaddition to give 112 in 76% yield (Scheme 4.9). The product was then used in the enantioselective synthesis of a prostaglandin analogue.<sup>131</sup>

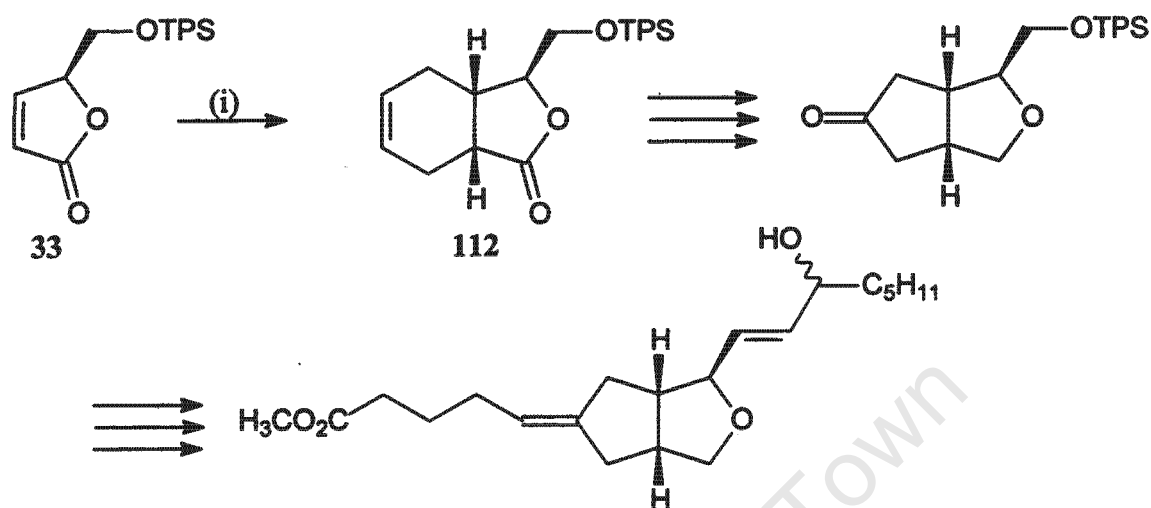

**Scheme 4.9** Reagents and conditions: (i) butadiene,  $\text{AlCl}_3$ ,  $\text{CH}_2\text{Cl}_2$ , 55–60 °C, 7d

The Mann report prompted a publication by Ortuño *et al.*<sup>132</sup> in which a series of thermal cycloadditions with analogues of 33 were reported (Scheme 4.10). Further work by this group includes studies on the regio- and endo/exo-selectivities of the reactions of these butenolides with isoprene and cyclopentadiene.<sup>133, 134</sup> The latter diene results in polyfunctional norbornene-type derivatives that have been used in synthesis of several biologically active compounds.<sup>135</sup>

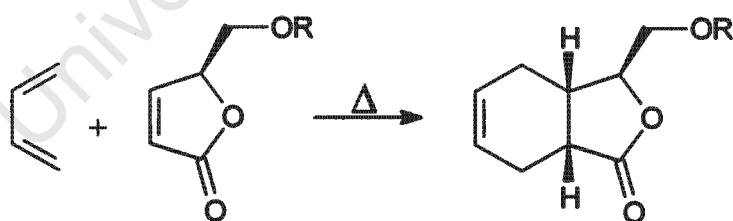

R	% Yield
H	65
CH <sub>3</sub>	70
CH <sub>2</sub> OH	32
CH <sub>2</sub> OAc	53
CH <sub>2</sub> OMe	77
CH <sub>2</sub> OBn	80
CH <sub>2</sub> SPh	66

**Scheme 4.10**

Of the hydroxymethyl protecting groups utilised in the cycloaddition reactions cited above, a silylated version was selected as a starting point for this synthesis. The facility with which chemoselective desilylation can be achieved using the fluoride ion under conditions that are compatible with most functional groups,<sup>136</sup> was an important consideration. To date the TPS butenolide **33** appears to be the only silylated analogue utilised as a dienophile in these cycloadditions. The ability to modulate the stability of silyl ethers by varying the substituents on silicon is a major reason for their widespread application in organic synthesis.<sup>136</sup> In order to increase the scope for applying chemoselective differentiation of similar functionality should this be required later, an investigation of the Diels-Alder reaction of butadiene with butenolides bearing alternative silyl groups was planned. The relative stability of the more common silyl groups towards acid and base hydrolysis has been listed:<sup>95</sup>

Acid: TMS (1) < TES (64) < TBS ( $2 \times 10^4$ ) < TIPS ( $7 \times 10^5$ ) < TPS ( $5 \times 10^6$ )

Base: TMS (1) < TES (10—100) < TBS ~ TPS ( $2 \times 10^4$ ) < TIPS ( $1 \times 10^5$ )

The order of stability for acidic and basic fluoride reagents (e.g. TBAF and HF-MeCN respectively) parallels that for acid and base hydrolyses.<sup>136</sup> The more robust examples of commonly used silyl protecting groups, TIPS and TBS were thus included with TPS in the investigation.

### 4.3 RESULTS AND DISCUSSION

#### 4.3.1 Butenolide Preparation

The hydroxy butenolide **110** was routinely prepared on a 10g scale from D-mannitol.<sup>127, 128</sup> Silylation under standard conditions afforded the butenolides **33**, **111** and **113** (Scheme 4.11).

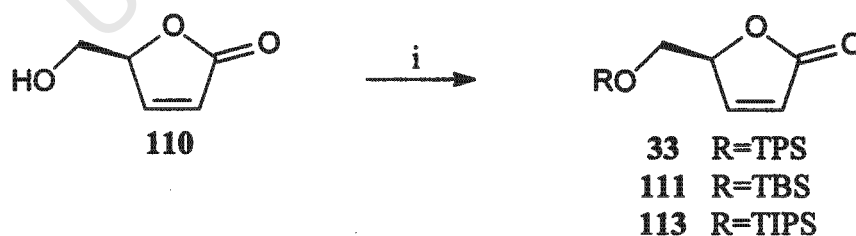

**Scheme 4.11** Reagents and conditions: (i) RCl, imidazole, CH<sub>2</sub>Cl<sub>2</sub>

#### 4.3.2 Cycloaddition Studies

Earlier attempts to reproduce the catalytic efficiency of the aluminium trichloride catalysed cycloaddition between **33** and butadiene as described by Mann<sup>126</sup> provided erratic results.<sup>137</sup> An alternative aluminium based Lewis acid catalyst, ethylaluminium dichloride was used in the

reaction with 33 to deliver 112 (Scheme 4.12). The successful outcome of this reaction was reproducible, but was however followed by less encouraging results with 113 and 111 (Scheme 4.12).

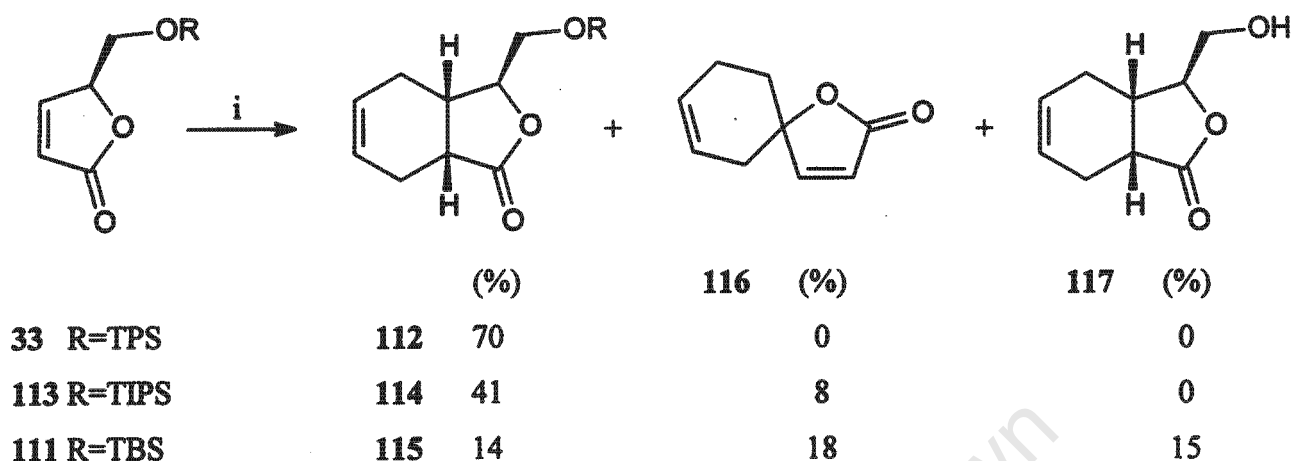

**Scheme 4.12** Reagents and conditions: (i) butadiene, EtAlCl<sub>2</sub> (0.3 mol. equiv.), CH<sub>2</sub>Cl<sub>2</sub>, 55 °C, 7 d

The NMR data for 112 coincided with those described<sup>126</sup> although some of the assignments (made here on the basis of COSY and HETCOR spectra) differed (Table 4.1).

**Table 4.1** A comparison of selected assignments of the NMR data for cycloadduct 112

Nucleus	Chemical shift (CDCl <sub>3</sub> , ppm)	
	Present Study	Mann <sup>126</sup>
4-H <sub>2</sub>	1.88—1.98 and 2.22—2.28	2.20—2.45
7-H <sub>2</sub>	2.22—2.28	1.88—1.94 and 2.20—2.45
C-5 and C-6	125.6 and 126.5	135.5 and 135.6

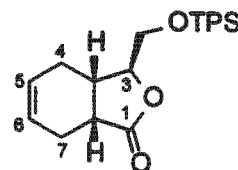

Spectroscopic and analytical evidence confirmed the structures of 114 and 115. The use of TPS as a protecting group in the original work<sup>126</sup> was based on the desire to maximise facial differentiation on the dienophile during the cycloaddition. The steric bulk of the TPS group was thus selected in order to maximise the steric hindrance at one face of the butenolide. Although the yields of cycloadducts 114 and 115 obtained here are poor, they were the only diastereomers detected. This study has thus given no evidence that using less sterically demanding derivatives compromised the diastereofacial selectivity of the cycloaddition. Although the yield of 112 was as expected, the lability of the TIPS and TBS ethers under these conditions was confirmed by the poor recoveries of 114 and 115 as well as the presence of the spiro-lactone 116 and deprotected cycloadduct 117. The spiro-lactone has been isolated previously from the thermal cycloaddition of 110 and its acetate to

butadiene.<sup>132</sup> Its presence was attributed to the formation of protoanemonin **118** from the butenolide under the conditions described, followed by the cycloaddition of butadiene to the exocyclic double bond (Scheme 4.13). Since this site selectivity is claimed to be contrary to that predicted by FMO theory,<sup>138</sup> Ortuño *et al.* have performed extensive experimental and computational studies on the thermal reaction to prove that the reaction mechanism operating is not a concerted one but rather a two-step process. Both steps are believed to proceed *via* a biradical mechanism, to produce the 1,4-adduct.<sup>139</sup> Whilst it is reasonable to assume that **118** is an obligatory intermediate in the formation of **116** under conditions of Lewis acid catalysis, proposal of a mechanism for this transformation would require further investigation.

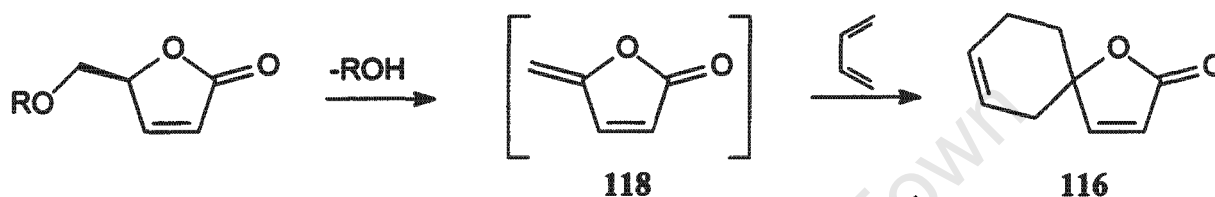

Scheme 4.13

The complexity of the product mixtures containing **114** and **115** render this option unattractive for the preparation of these cycloadducts as starting materials. The thermal cycloaddition of these butenolides with butadiene was thus investigated. These reactions provided the desired cycloadducts exclusively and no decomposition products were detected. However, isolation of the products was difficult due to extensive butadiene polymerisation under thermal conditions and careful chromatography using large proportions of silica gel was required in order to isolate clean (as indicated by 200MHz <sup>1</sup>H NMR) cycloadducts (Scheme 4.14).

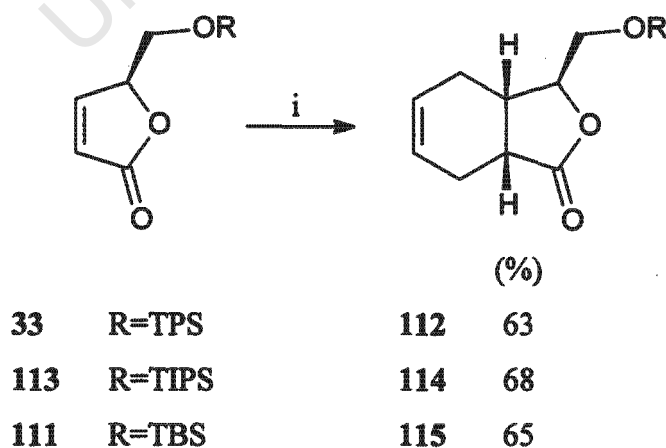

Scheme 4.14 Reagents and conditions: (i) butadiene, 210 °C

The addition of hydroquinone, as described by Ortuño<sup>132</sup> did not inhibit polymerisation. This is probably attributable to the higher dilutions of the butenolide in butadiene used in that study. This dilution was considered excessive for the preparative scale conditions sought. Owing to the problems encountered during the isolation of products and the safety problems associated with the use of butadiene under thermal conditions, this approach was not considered suitable for the production of multigram quantities of the cycloadducts. The modified Mann procedure was thus used to react 5g quantities of the TPS protected parent butenolide and further work towards the synthesis of sweroside aglycone **6** was made on the cycloadduct **112**.

### 4.3.3 Further Transformations on **112**

Further chemistry performed on **112** concentrated on the identification and management of methodologies suitable for its conversion into sweroside aglycone **6** as illustrated in Figure 4.2.

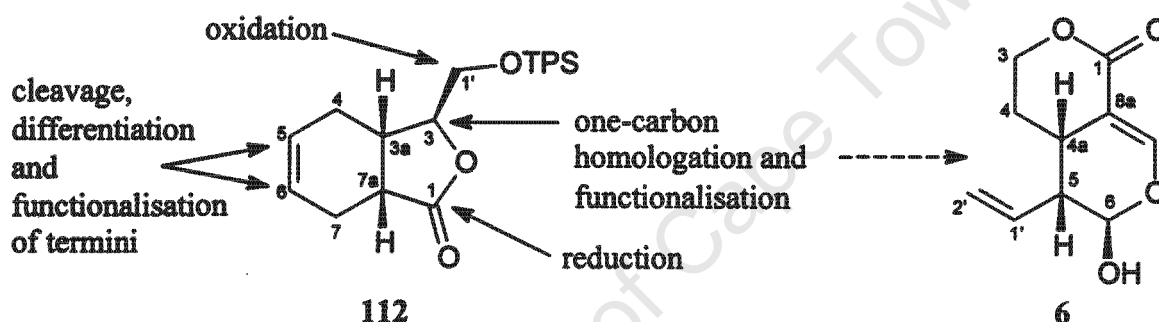

Figure 4.2 Transformations required to convert butenolide cycloadduct **112** into **6**

Although the retrosynthetic analysis (Scheme 4.6) highlighted a number of proposed intermediates for this total synthesis, results obtained early in this work indicated that the order in which the required transformations could be performed was dependent on the ability to apply chemoselective procedures to the densely functionalised intermediates. What follows is a description of the progress made toward **6** with each of a variety of starting transformations.

#### Desilylation

The oxidation process at C-1' in **112** was required to give either the formyl or the carboxylic acid level (to become C-8 or C-1 respectively in **6**). In either case desilylation was a prerequisite. Treatment of **112** with tetrabutylammonium fluoride (TBAF) at room temperature gave an inseparable 85:15 (by NMR) mixture of **117**, and an unidentified by-product. Based on the duplication of signals in the NMR spectra of the mixture, the by-product was assumed to be the *trans* diastereomer of **117**, which had resulted from epimerisation  $\alpha$  to the carbonyl group, *via* enolisation under the basic reaction conditions to give **119** (Scheme 4.15). Although this

observation was unexpected, literature precedent for the abstraction of  $\alpha$ -acidic protons in this reaction medium does exist.<sup>140</sup>

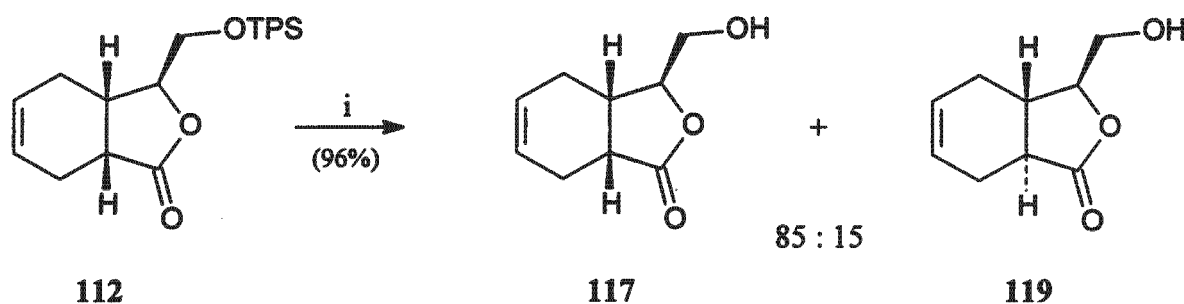

**Scheme 4.15** Reagents and conditions: (i) TBAF, 22 °C

Reaction at 0 and -15 °C gave a similar diastereomeric mixture. Maintaining the temperature of the reaction mixture at -20 to -30 °C provided a single diastereomer, but the reaction was slow. In order to temper the basicity of TBAF, buffering of the reaction medium with acetic acid has been reported.<sup>141</sup> The reaction of 112 with equimolar quantities of TBAF and acetic acid at 10 °C provided a single diastereomer, but 117 could only be recovered in 78% yield (Scheme 4.16). Hydrogen fluoride was also used as a fluoride source for deprotection, although large excesses of HF were required in order to achieve complete reaction. After 20 min at 40 °C, 55% of the desired product was recovered. This was improved to 75% by decreasing the reaction temperature to 25 °C for 24 h (Scheme 4.16). At 0 °C, no reaction was observed.

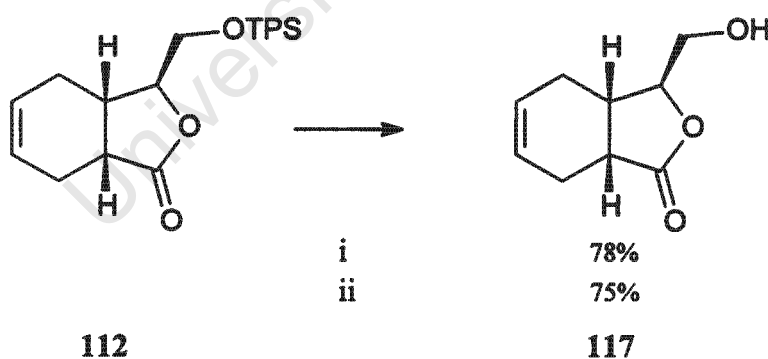

**Scheme 4.16** Reagents and conditions: (i) TBAF-HOAc, THF, 10 °C, (ii) HF-MeCN, MeCN, 25 °C

Reaction to give 117 had thus been achieved diastereoselectively but the yields obtained were inferior to that for the TBAF deprotection shown in Scheme 4.16, *i.e.* 96%. Although this appeared to be the superior system for TPS deprotection, its use needed to be postponed to a point in the synthesis at which the functionality at C-1 was deactivated, to prevent  $\alpha$ -deprotonation.

### Reduction at C-1

The relative ease with which C-7a had been deprotonated during deprotection of **112** indicated that reduction of the lactone moiety was required prior to deprotection. The formyl level of oxidation was required in any event, so **112** was reduced with DIBAH at low temperature to the diastereomeric lactol mixture **120** (Scheme 4.17). The  $^1\text{H}$  NMR spectrum gave diagnostic signals for the hemiacetal protons 1-H at  $\delta$  5.05 and 5.07 (minor and major diastereomer respectively). Similarly,  $^{13}\text{C}$  NMR signals  $\delta$  103.0 and 104.2 indicated an acetal at C-1 and an IR absorption band at  $3450\text{ cm}^{-1}$  confirmed the presence of a hydroxyl group. Trapping of the aldehyde as a dithiolane, by treatment with ethanedithiol in the presence of titanium tetrachloride ( $\text{TiCl}_4$ ) gave **121** (Scheme 4.17). The  $^1\text{H}$  NMR spectrum displayed a distinctive doublet at  $\delta$  5.00, which was ascribed to the thioacetal proton, and the thioacetal carbon resonated characteristically at  $\delta$  58.4.

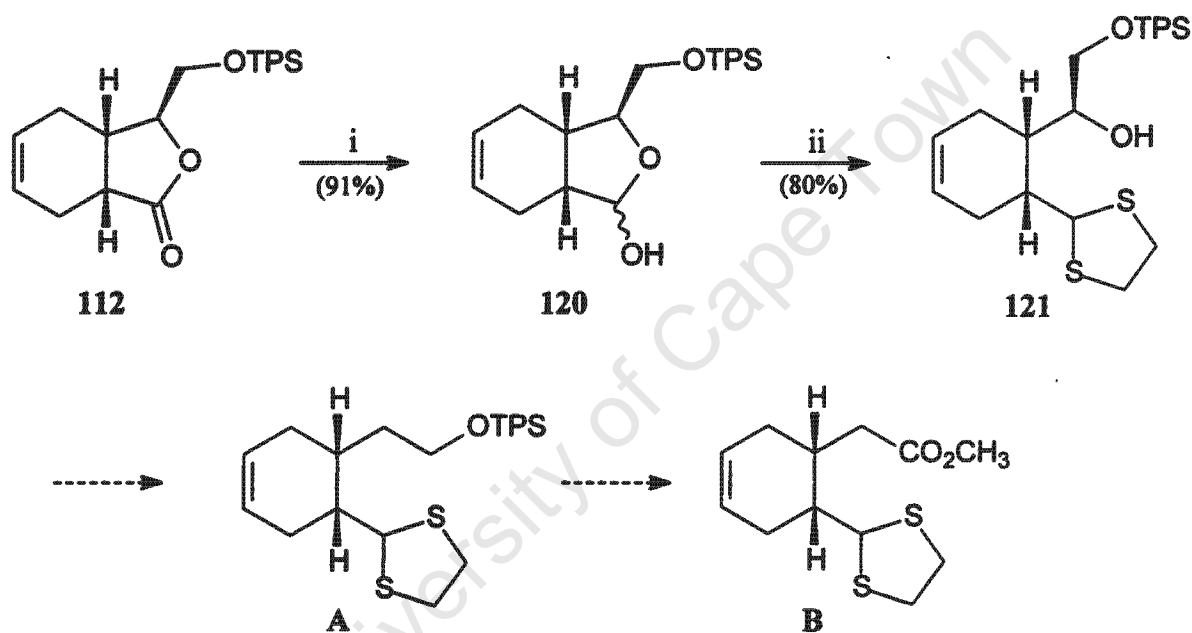

**Scheme 4.17** Reagents and conditions: (i) DIBAH, toluene,  $-78\text{ }^\circ\text{C}$ , (ii) ethanedithiol,  $\text{TiCl}_4$ ,  $\text{CH}_2\text{Cl}_2$ ,  $-78\text{ }^\circ\text{C}$

A radical deoxygenation process on **121** to give **A** had been envisaged, which after conversion into **B**, would allow an enolate-mediated one-carbon homologation step, as was applied in the racemic synthesis. All attempts to produce a radical deoxygenation precursor (xanthate ester, thiocarbonyl imidazole or phenoxythiocarbonyl)<sup>142</sup> failed, possibly due to limited reagent access to the hydroxyl which was  $\alpha$  to a tertiary carbon and  $\beta$  to the bulky TPS moiety.

The exhaustive reduction of **112** to **122** with  $\text{LiBH}_4$ <sup>126</sup> was followed by the selective protection of the primary hydroxyl group as a triisopropyl silyl ether **123** (Scheme 4.18). In this instance, tosylation of the secondary hydroxyl group to **A** was planned, followed by an  $\text{S}_{\text{N}}2$  substitution with  $\text{CN}^-$ <sup>143</sup> to give **B**, in which the nitrile, after hydrolysis at an appropriate point, would provide the desired carboxyl moiety at C-1 in sweroside aglycone. Once again, no reaction occurred at the free hydroxyl group under standard tosylation conditions.

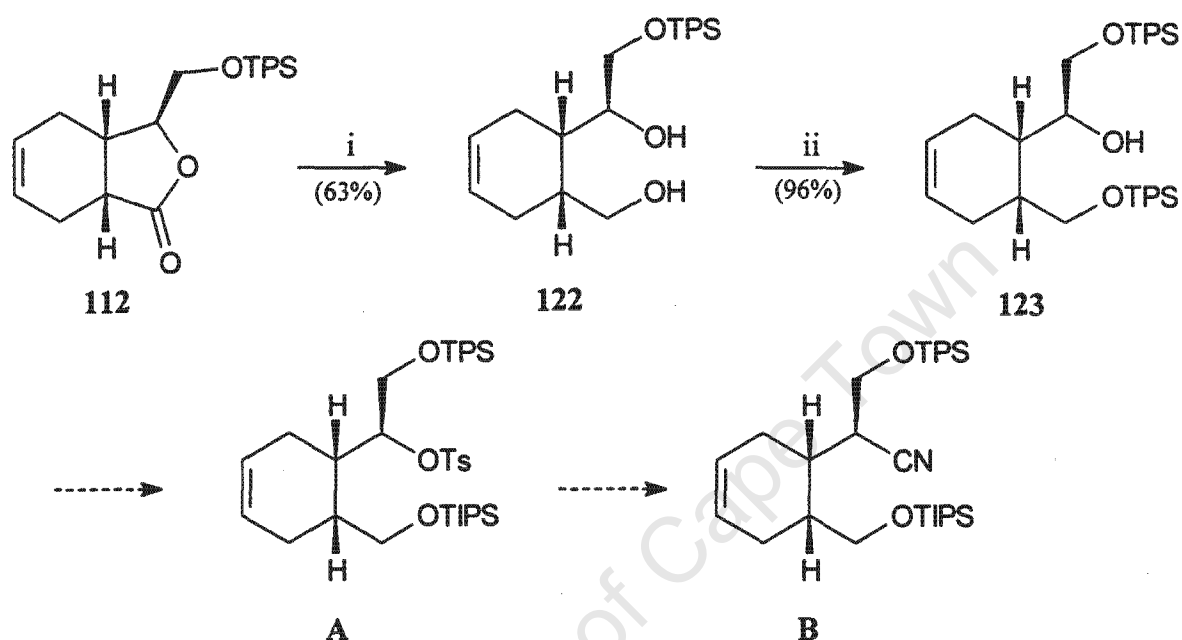

**Scheme 4.18** Reagents and conditions: (i)  $\text{LiBH}_4$ , THF, RT, 85 h, (ii) TIPS-Cl, imidazole, MeCN

When the reduction of **112** to **122** was attempted with  $\text{NaBH}_4$ , DIBALH, or LAH, silyl deprotection accompanied reduction. An excess of LAH in refluxing ether for 60 min provided complete conversion into a single product (by TLC) that was assumed to be the triol **124**. Because the extraction and purification of **124** were hampered by its polarity, the 1,2-diol moiety in the crude reduction product was subjected to acetonide formation conditions<sup>144</sup> to give **125** (Scheme 4.19).

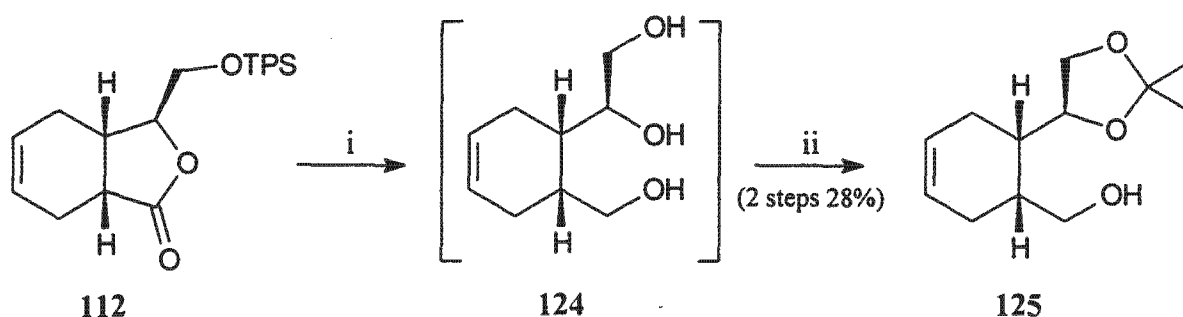

**Scheme 4.19** Reagents and conditions: (i) LAH,  $\text{Et}_2\text{O}$ , reflux, 1 h, (ii) Acetone, *p*-TsOH,  $\text{CuSO}_4$  (anhydrous), reflux

However, the yield of **125** was too low to be useful in a total synthesis and, despite numerous attempts using different work-up and extraction procedures for the reduction, it could not be optimised.

### Ring Opening

Although the reduction-aldehyde trapping sequence applied above was successful, its timing in the synthetic route is problematic owing to the susceptibility of sulfur to oxidation under the conditions for oxidative cleavage of the olefin. Another possibility examined was the opening of the lactone to the Weinreb amide **126**. Chemoselective reduction of the Weinreb amide to an aldehyde (as is targeted) in an excess of DIBAL is well known.<sup>145</sup> Treatment of **112** with Weinreb's salt and dimethylaluminium chloride gave complete reaction to a single product (TLC). The amide appeared to relactonise during work up, chromatography, and in  $\text{CDCl}_3$ , and could not be isolated and characterised (Scheme 4.20). A  $^1\text{H}$  NMR spectrum of a sample produced by flash chromatography showed singlets at  $\delta$  3.18 and 3.74, each integrating for three protons which were indicative of the presence of the methyl and methoxy groups associated with the amide. Silylation of the alcohol in **126** was attempted on the crude isolate but lactonisation occurred preferentially under the protection conditions (TPSCl, imidazole) and only **112** was recovered.

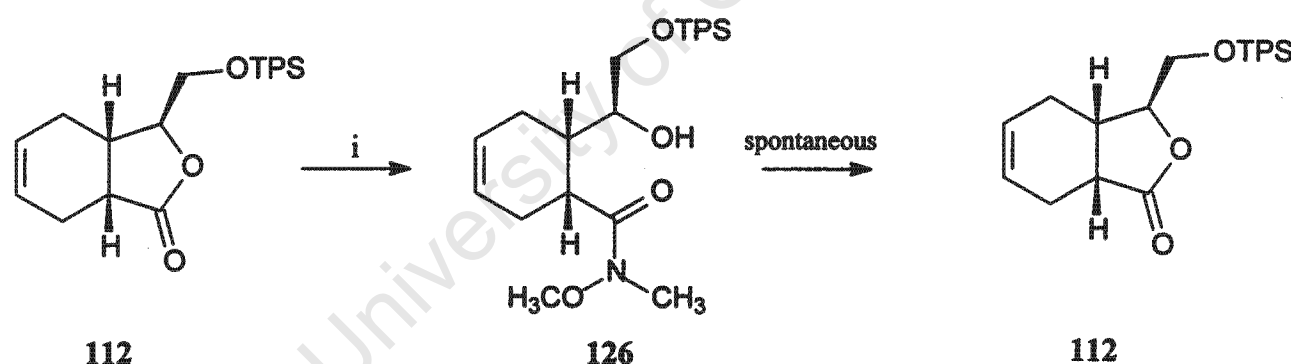

Scheme 4.20 Reagents and conditions: (i)  $\text{MeONHMe}\cdot\text{HCl}$ ,  $\text{Me}_2\text{AlCl}$ ,  $\text{CH}_2\text{Cl}_2$

### Oxidative Cleavage

Ozonolysis of **112** followed by a reductive work up with  $\text{NaBH}_4$  proceeded efficiently to give diol **127** (Scheme 4.21). Its  $^1\text{H}$  NMR spectrum showed no olefinic signals, whilst a signal at  $\delta$  3.61–3.92 which integrated for six protons provided evidence for the existence of three  $\text{CH}_2\text{OH}$  moieties. The  $^{13}\text{C}$  spectrum similarly showed an absence of olefinic signals and resonances at 60.4, 61.1 and 64.5 verified the deductions made from the proton spectrum. A broad IR absorption band at  $3437\text{cm}^{-1}$  supported the presence of hydroxyl functionality. The analytical and spectral data gathered could not preclude the possibility of formation of the alternative  $\gamma$ -lactone, **128** or the

$\delta$ -lactone, **129**. The diol **127** was thus bis-esterified with 3,5-dinitrobenzoyl chloride in pyridine to give **130** (Scheme 4.21).

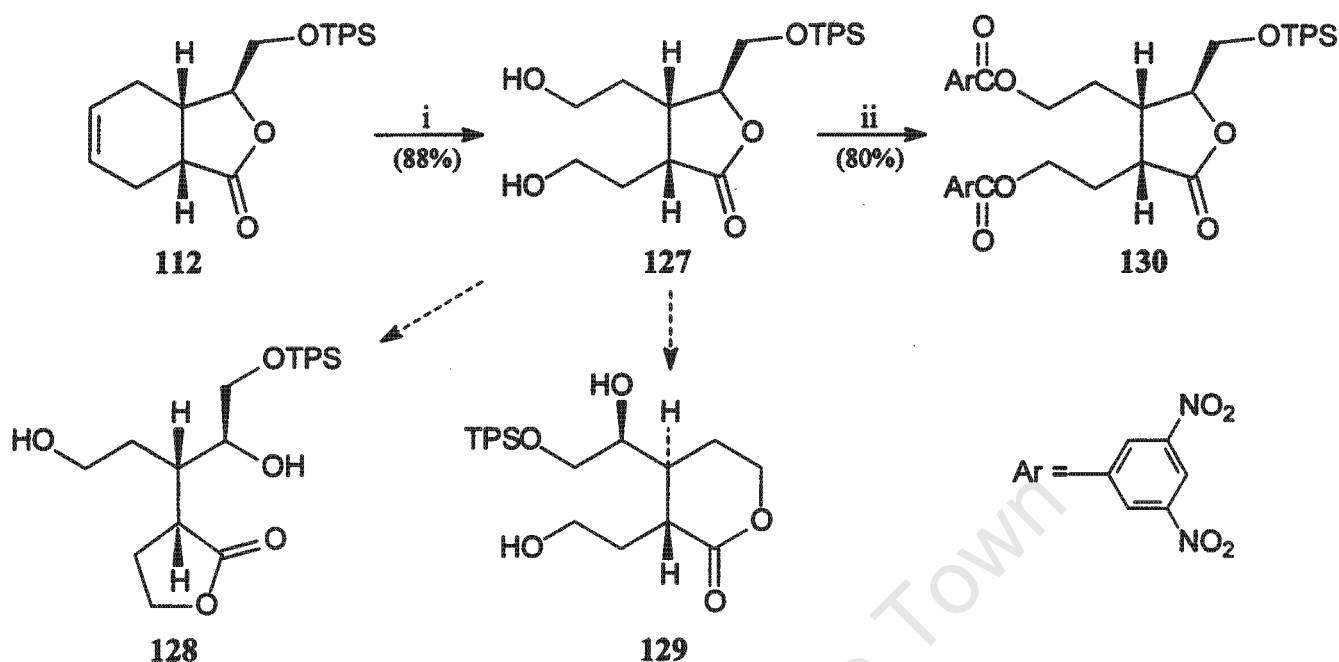

**Scheme 4.21** Reagents and conditions: (i)  $O_3$ , MeOH,  $-78\text{ }^\circ\text{C}$ , then  $NaBH_4$ , RT, (ii)  $ArC(O)Cl$ , pyr

The NMR spectra of the product **130** were fully assigned and compared to those of the diol. Selected diagnostic signals have been listed in Table 4.2.

**Table 4.2** Selected NMR data from the spectra of **127** and **130**

Nucleus	Chemical shift (ppm)	
	127 (R=H)	130 (R=3,5-DNB-CO)
5-H	4.36	4.40
2'-H <sub>2</sub>	3.61—3.92	4.60—4.77
2''-H <sub>2</sub>	3.61—3.92	4.53
C-5	83.0	81.9
C-2'	61.1	64.6
C-2''	60.4	64.1

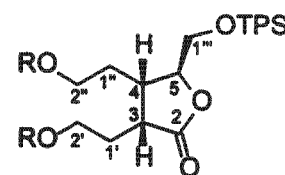

The downfield shift evident in the  $^1H$  and  $^{13}C$  resonances for 2'-H<sub>2</sub>, 2''-H<sub>2</sub>, C-2' and C-2'' in the acylated product confirms the additional deshielding provided by the electron withdrawing carbonyl moiety. H-5 and C-5, by contrast, show very little change in chemical shift. These data confirm that C-2' and C-2'' both bore free hydroxyl groups which were acylated, thereby excluding a possible alternative lactone structure.

### Reduction and ring opening revisited

With the oxidative cleavage product in hand, the reduction-aldehyde trapping sequence was attempted. The unprotected diol **127** in toluene at  $-78\text{ }^{\circ}\text{C}$  was treated with 3 equivalents of DIBAH. The product was extremely polar and full characterisation was hampered by a minor co-eluting impurity. Although signals in the  $^1\text{H}$  ( $\delta$  5.71) and  $^{13}\text{C}$  NMR ( $\delta$  108.4) spectra indicated acetal presence, they did not coincide closely with those obtained for hemiacetal **120** ( $\delta$  5.07 and 103.0 for the major diastereomer). The absence of signal duplication was noted, indicating the presence of a single diastereomer in the product. Furthermore, inspection of the  $^1\text{H}$  NMR spectrum run in the presence of  $\text{D}_2\text{O}$  indicated a single exchangeable proton. Acetylation provided a product displaying a single acetal moiety. The product was assigned as the internal acetal **131**. NMR spectra were assigned with the assistance of COSY and HETCOR spectra. The connectivities shown were confirmed by an HMBC spectrum which showed three bond correlations between (i) the acetate carbonyl carbon and  $2''\text{-H}_2$ , (ii) C-2 and 6a-H, and (iii) C-5 and 6a-H which are uniquely assignable to the given structure (Scheme 4.22)

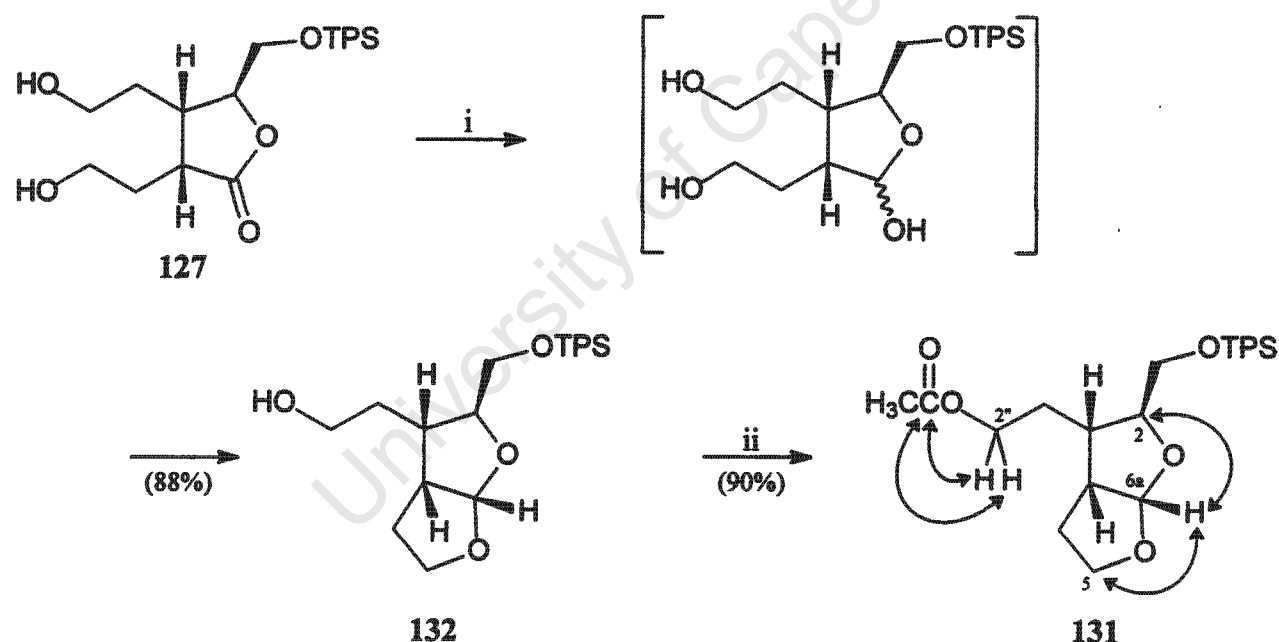

**Scheme 4.22** Reagents and conditions: (i) DIBAH, toluene,  $-78\text{ }^{\circ}\text{C}$ , (ii)  $\text{Ac}_2\text{O}$ , DMAP, pyr

The formation of **132** was easily rationalised as a dehydration of the reduced product under the acidic work up conditions. Although the formation of *trans*-fused oxabicyclo[3.3.0]octanes is possible, it requires considerable deformation of the five-membered rings, and the *cis* fusion is far less demanding. In the parent hydrocarbon, the enthalpy of formation for the *trans* isomer is about  $25\text{ kJ/mol}$  higher<sup>146</sup> than that for the *cis* isomer. The bridgehead proton in **131**,  $6a\text{-H}$  showed a 5 Hz coupling to its neighbour. This coupling is not possible in the *trans* isomer where, as is shown

schematically in Fig. 4.3(a), the bridgehead protons take on an antiperiplanar relationship. In the *cis* isomer shown in Fig. 4.3(b), the relationship is approaching gauche and the 5 Hz coupling is feasible.



**Figure 4.3** (a) *trans*-1,7-dioxabicyclo[3.3.0]octane (b) *cis*-1,7-dioxabicyclo[3.3.0]octane

The bis-tetrahydrofuranoid moiety is present in a number of natural products, in particular the aflatoxins. Although dehydrative cyclisation onto a preformed tetrahydrofuran ring has been used in the total synthesis of aflatoxins,<sup>147, 148</sup> this result produces a useful synthon, easily derived from the chiral pool for the enantioselective synthesis of similar systems.

In order to prevent the observed dehydration, the free hydroxyl groups in 127 were protected as methoxyethoxymethyl (MEM) ethers to give 133. The DIBAH reduction of 133 produced a diastereomeric mixture of the hemiacetals represented by 134. Treatment of 134 with ethanedithiol and  $\text{TiCl}_4$  gave a very poor yield of the dithiolane 135 (Scheme 4.23).

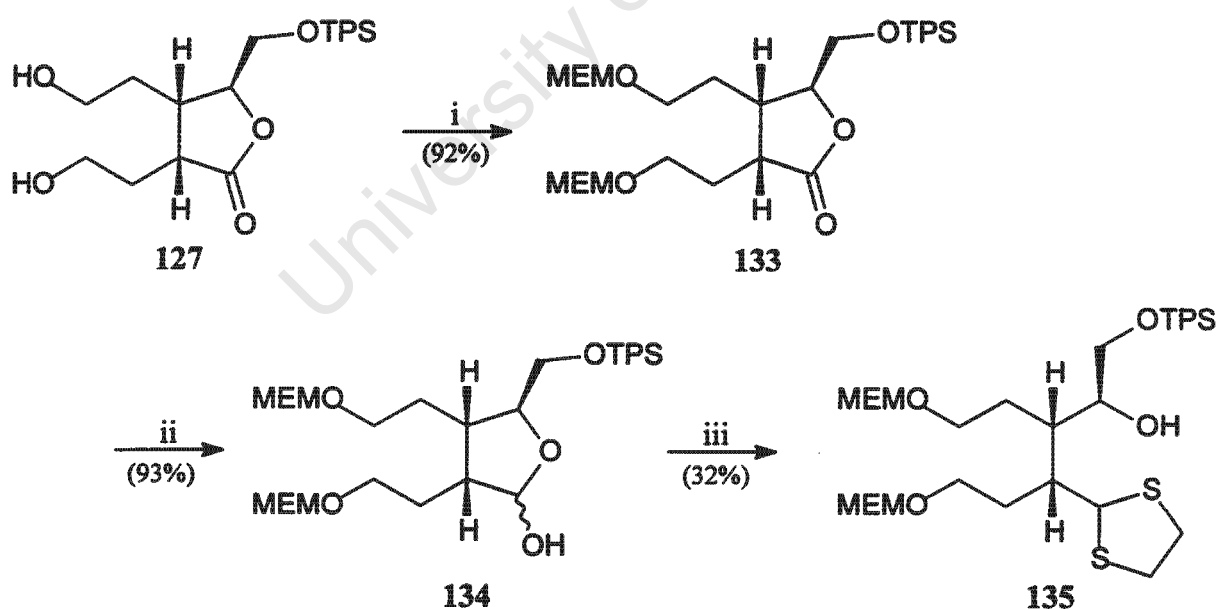

**Scheme 4.23** Reagents and conditions: (i) MEMCl,  $i\text{Pr}_2\text{NEt}$ ,  $\text{CH}_2\text{Cl}_2$  (ii) DIBAH, toluene,  $-78^\circ\text{C}$ , (iii) ethanedithiol,  $\text{TiCl}_4$ ,  $\text{CH}_2\text{Cl}_2$ ,  $-84^\circ\text{C}$

The MEM protection was selected because it would allow chemoselective TBAF-mediated deprotection of the TPS moiety in a more advanced intermediate. Although the labile nature of MEM acetals in Lewis acidic conditions was recognised,<sup>149</sup> it was believed that they would be stable at the low reaction temperature (-84 °C) used. The TLC plates of the reaction mixture showed a high proportion of extremely polar material in addition to the desired product, which indicated that deprotection to give diol, and possibly triol products had probably occurred.

#### 4.4 CLOSING REMARKS ON THE BUTENOLIDE APPROACH

The exploratory work described in this chapter has shown that cycloadducts like 112 could become useful intermediates for secoiridoid synthesis. A number of the required transformations were achieved:

- (i) oxidative cleavage of the olefin with installation of the appropriate hydroxyl functionality at the termini
- (ii) reduction of the lactone carboxyl group to give the formyl functionality required at C-6 in 6
- (iii) ring opening of the butenolide residue, to give an intermediate bearing a thioacetal protected version of the sensitive formyl group and the free hydroxy alcohol

The TPS moiety proved to be a poor choice of protection for two reasons: Firstly, chemoselective deprotection on the starting cycloadduct could not be optimised, and secondly, access to the hydroxyl group  $\alpha$  to the silyloxy moiety appeared to be hampered by steric crowding, partly due to the bulk associated with the TPS moiety. Precursors for the planned one-carbon homologation step could thus not be synthesised. Further, TPS protection would have been preferred to the MEM groups used in the transformations shown in Scheme 4.23, because they are more stable to Lewis acids, but these could not be used because chemodifferentiation of the three primary hydroxyl groups present was required. The use of less sterically demanding protection in the starting butenolide (for example a benzyl ether) could be considered. This would also offer the opportunity for chemoselective deprotection later in the synthesis, whilst silyl protection could be employed elsewhere on the molecule.

The work described in this chapter forms one of three approaches toward the total synthesis of amarogentin that was evaluated. It was not within the time constraints of this individual project to bring all three routes to the secoiridoid target. Since it was felt that the butenolide approach would be best served by altering the initial chiral dienophile, completion of the synthesis was not feasible here and attention was diverted towards the two alternative approaches.

## CHAPTER 5

## MODEL SYNTHESIS BASED ON LEVOGLUCOSENONE

## 5.1 INTRODUCTION

Levoglucosenone has been used as a chiral template in natural product synthesis and its chemistry has been extensively explored and documented.<sup>150</sup> It was selected from the chiral pool as a useful dienophile for the synthesis at hand because the cycloadduct **136**, obtained from the Diels-Alder reaction with butadiene, is highly functionalised. If the internal acetal moiety is unravelled, the conversion of **136** into the enantiomer of the desired hydrocarbon skeleton can be envisaged (Fig 5.1). Levoglucosenone could thus provide access to the *ent*- series of secoiridoid intermediates, thus expanding the scope for biological testing, whilst also providing a model for the synthesis of the natural secoiridoid series, starting from *ent*-levoglucosenone which is available synthetically.

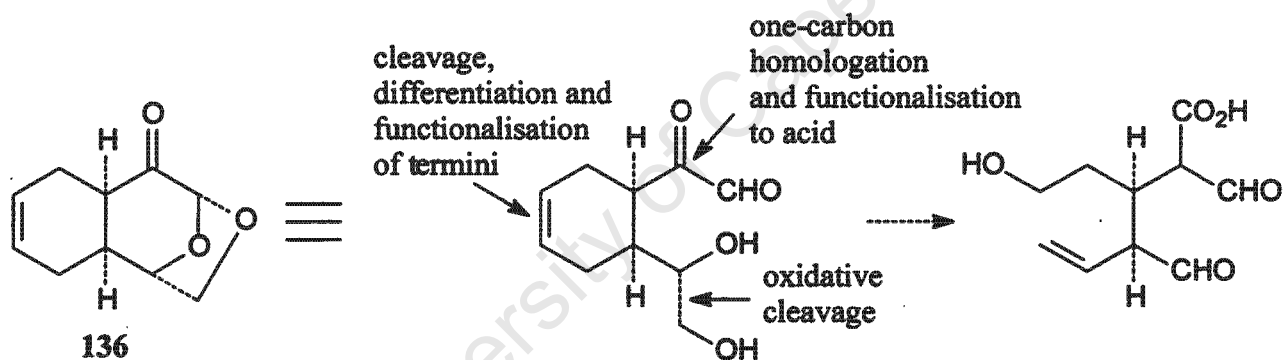
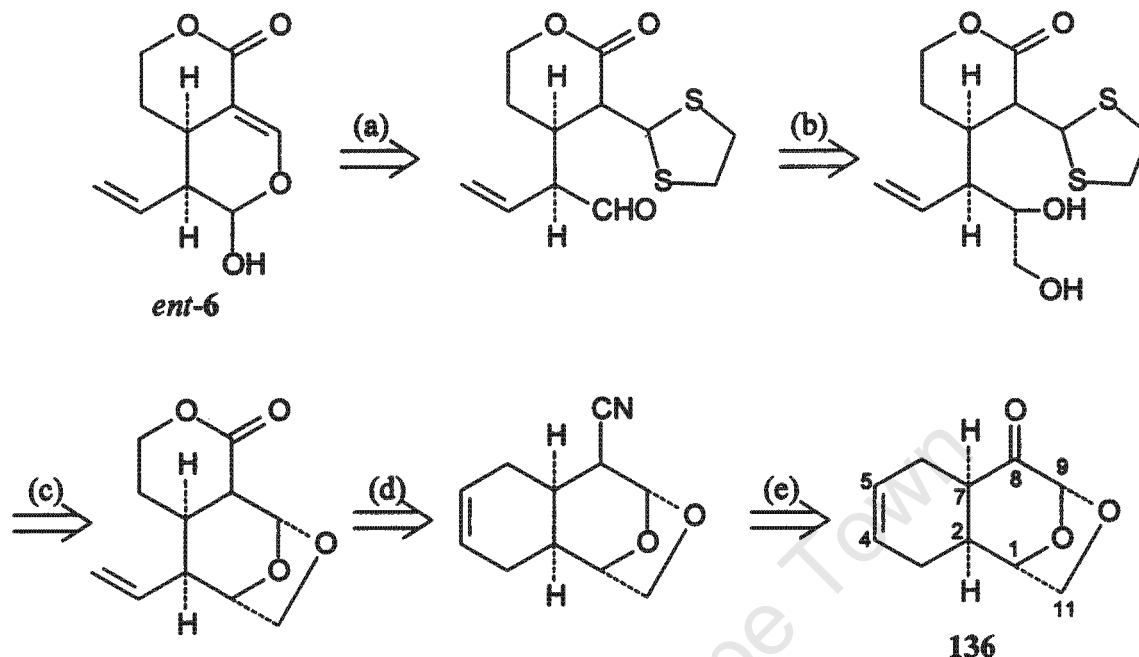

Figure 5.1 Envisaged transformations on the parent cycloadduct **136**

A retrosynthetic analysis of the proposed model synthesis is illustrated in Scheme 5.1. Deprotection of the thioacetal in step (a) would provide the enolic participant for the formation of the dihydropyran moiety in *ent*-sweroside aglycone, whilst the electrophilic carbonyl participant would be expected to arise from oxidative cleavage of the vicinal diol as shown in step (b). Access to the glycol moiety of levoglucosenone derivatives by trapping of the carbonyl group as a cyclic thioacetal [step (c)] has been described.<sup>151</sup> In step (d) oxidative cleavage of the cyclohexenyl olefin followed by reduction of the termini to give hydroxyethyl groups was envisaged. Hydrolysis of the nitrile moiety to give a carboxyl group, followed by chemoselective  $\delta$ -lactone formation would allow selective functionalisation of the remaining hydroxyl group to give the required terminal olefin. Step (d) represents a one-carbon homologation at C-8 on **136**. The presence of carbonyl

functionality provides wide scope for one-carbon homologation. The scope for direct carboxylation is limited so the introduction of a nitrile group, from which the carboxyl functionality could be revealed by acid hydrolysis at an appropriate stage, was planned.



**Scheme 5.1** Retrosynthetic plan for the synthesis of *ent-6* from the known cycloadduct **136**\*

Levoglucosenone **34** was first identified as a minor product in the tar obtained from the pyrolysis of cellulose.<sup>152</sup> It is formed by the dehydration of levoglucosan **137**, which itself arises from a transglycosidation reaction of cellulose under pyrolytic conditions (Scheme 5.2). The conversion of **137** into **34** has been optimised by impregnating the sample with an acid catalyst.<sup>153</sup> The acid catalysed pyrolysis of newsprint paper was also demonstrated to be a useful procedure for the synthesis of **34**.

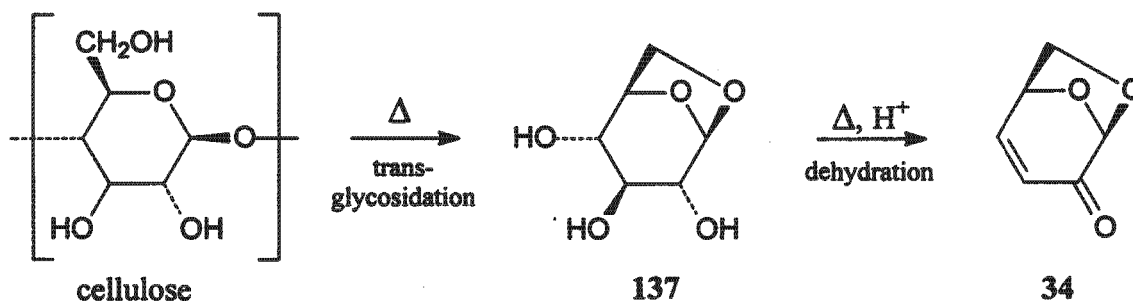

**Scheme 5.2** The preparation of levoglucosenone from cellulose

\* Numbered according to von Baeyer nomenclature

An alternative route to levoglucosenone is available from D-galactose<sup>154</sup> but this was not considered to be cost effective in comparison to the preparation from newspaper. *ent*-Levoglucosenone 138 has also been accessed in 9 steps and 28% overall yield from D-galactose.<sup>155</sup> However, the most convenient route to either enantiomer appears to be that of Ogasawara,<sup>156</sup> which employs asymmetric dihydroxylation of a prochiral precursor to introduce the desired stereochemistry (Scheme 5.3).

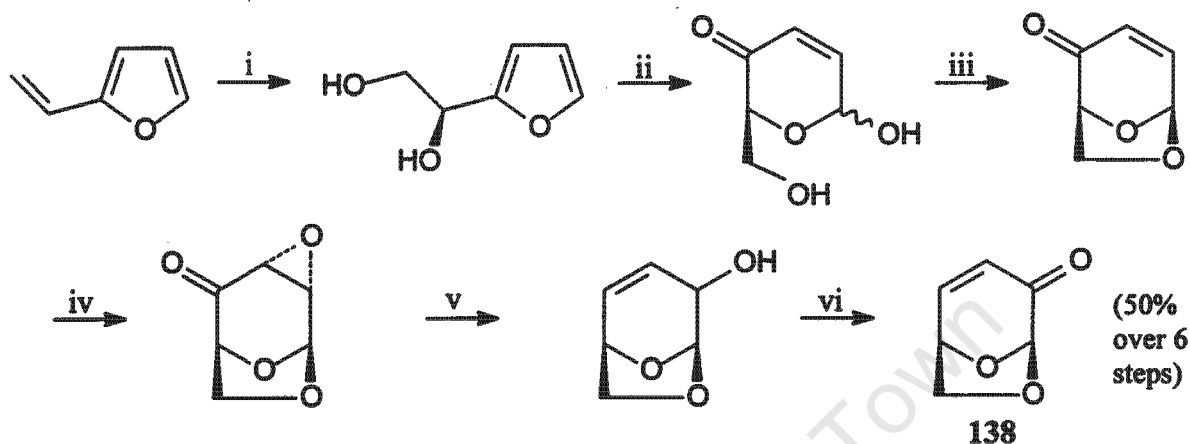

**Scheme 5.3** The Ogasawara synthesis of *ent*-levoglucosenone 138<sup>156</sup>

*Reagents and conditions:* (i) AD-mix- $\beta$ ,  $\text{Me}_2\text{SO}_2\text{NH}_2$ ,  $\text{H}_2\text{O}$ -*t*BuOH, (ii) *m*CPBA,  $\text{CH}_2\text{Cl}_2$ , (iii) *p*TsOH, benzene, reflux/ $\text{NaBH}_4$ , (iv) 30%  $\text{H}_2\text{O}_2$ , 0.5M NaOH, THF, (v)  $\text{NH}_2\text{NH}_2 \cdot \text{H}_2\text{O}$ , AcOH, MeOH, (vi)  $\text{MnO}_2$ ,  $\text{CH}_2\text{Cl}_2$

The use of carbohydrate templates for Diels-Alder methodology has been reviewed by Ferrier.<sup>37</sup> Although the work of Fraser-Reid is described as providing the impetus for the development of pyranoside carbohydrate dienophiles, the methodology using levoglucosenone in cycloadditions was developed concurrently. The results of cycloaddition reactions of 34 with butadiene and various cyclic dienes were reported in 1981.<sup>157</sup> This work has been extended to higher butadiene analogues such as 1-acetoxy-1,3-butadiene<sup>158</sup> and 2-methyl-1,3-butadiene<sup>159</sup>. The cycloadduct of interest here, 136, was obtained in 95% yield upon heating of 34 in neat butadiene at 160 °C for 3 hours<sup>157</sup> (Scheme 5.4).

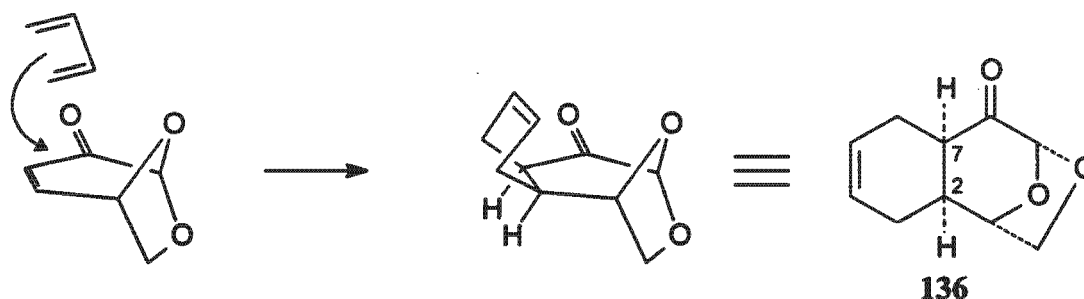

**Scheme 5.4** Addition of butadiene to the less hindered exo face of 34 to give 136

The stereochemistry depicted for 136 was confirmed by conversion the cycloadduct into allo-yohimbane.<sup>160</sup> As would be expected, preferential approach of the diene took place from the sterically less demanding exo face of the bicyclic dienophile to give 136. As is depicted in Scheme 5.5(a), addition of butadiene to 34 from the endo face would have provided 139, the ring junction diastereomer of 136 which exhibits the required stereochemistry at C-2 and C-7. Since this reaction does not occur, the cycloaddition of butadiene to the exo face of *ent*-levoglucosenone 138 [Scheme 5.5(b)] would be required to give the enantiomer of the cycloadduct in hand, 140.

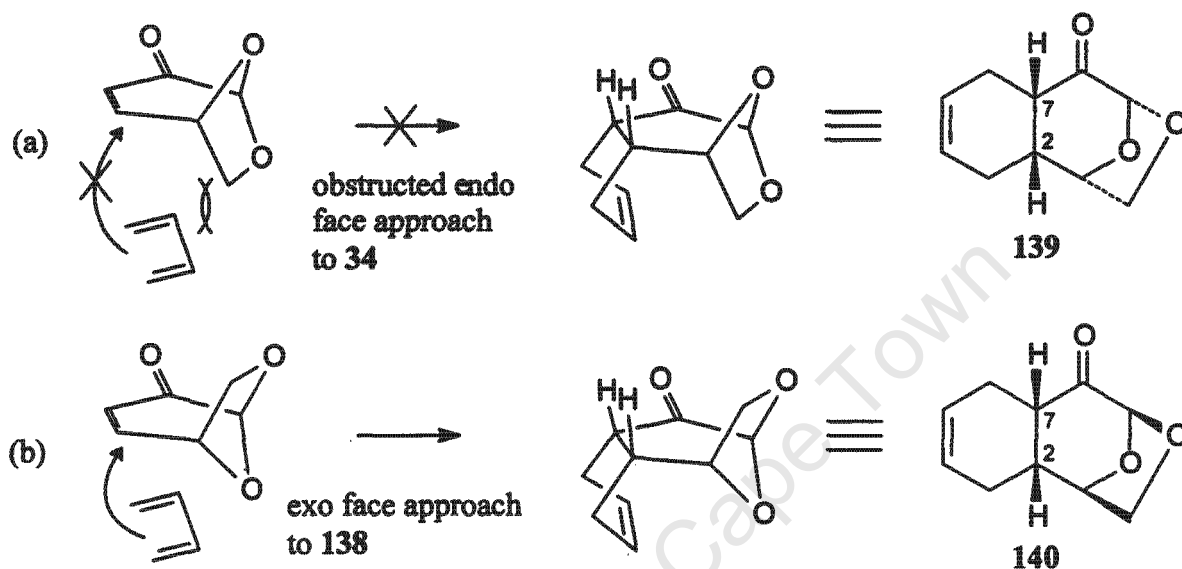

**Scheme 5.5** Addition of butadiene to (a) the endo face of levoglucosenone 34 and, (b) the exo face of *ent*-levoglucosenone 138

Apart from the aforementioned conversion of 136 into allo-yohimbane, only the adduct 141 obtained from reaction of 34 with 1-acetoxy butadiene, has been used in targeted syntheses. Approaches toward the indole alkaloid reserpine 142<sup>158</sup> and the puffer fish food toxin tetrodotoxin 143<sup>161</sup> have been published (Scheme 5.6).

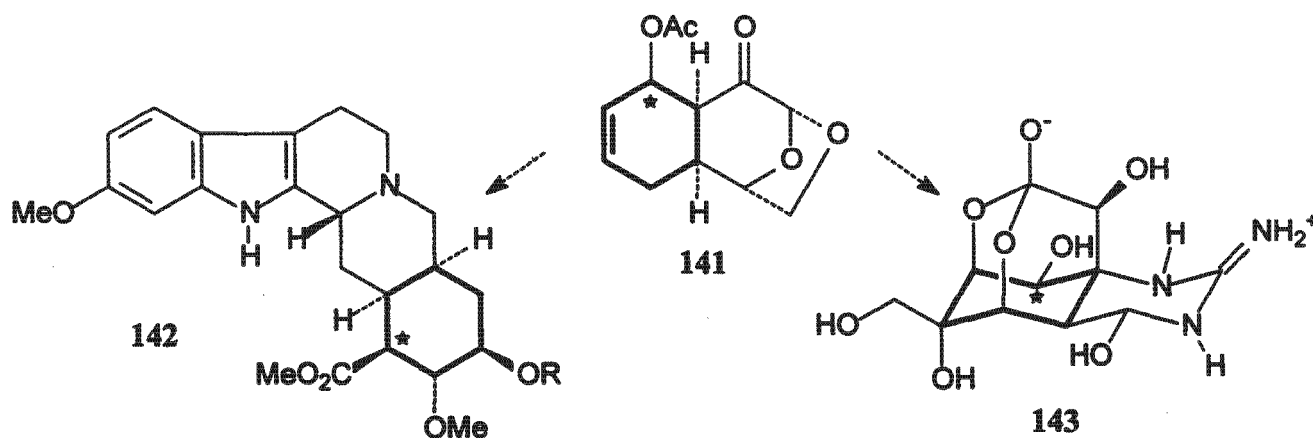

**Scheme 5.6** Targets for which 141 has been identified as an intermediate

The work described in this chapter includes the synthesis and isolation of levoglucosenone, optimisation of the cycloaddition reaction in our laboratories, and efforts toward the *ent*-sweroside aglycone target as described in the retrosynthetic analysis (Scheme 5.1).

## 5.2 RESULTS AND DISCUSSION

### 5.2.1 Preparation of levoglucosenone

Printed newspaper was used as the source of cellulose for producing levoglucosenone. The paper was treated as described in a recent procedure (Scheme 5.7).<sup>162</sup> The recovery of **34** was variable and averaged 0.8%.

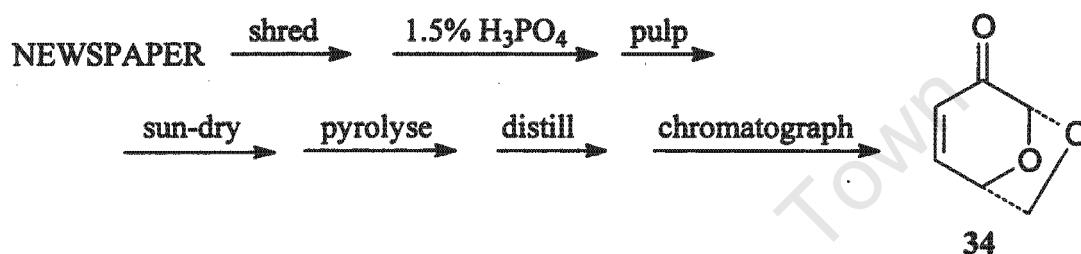

Scheme 5.7 Outline of the procedure adopted to prepare **34**

### 5.2.2 Thermal cycloaddition with butadiene

Following literature procedures,<sup>157</sup> the thermal cycloaddition of levoglucosenone was performed at 160 °C for 3 h to give after chromatography a product (72%) that was assigned as the expected cycloadduct **136** (Scheme 5.8). NMR spectroscopy of the chromatographically homogenous material revealed the presence of a minor contaminant (~5%) which was eliminated after one recrystallisation. The contaminant was assumed to be an isomer of **136** on the basis of an earlier report that claimed that the reaction of butadiene with **34** at 120 °C gave a 3:2 mixture of isomers.<sup>157</sup>

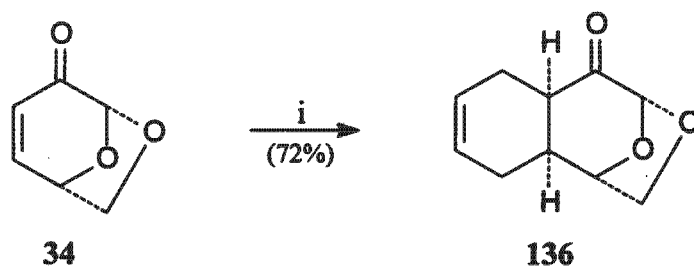

Scheme 5.8 Reagents and conditions: (i) butadiene, 160 °C

Unfortunately overlapping signals in the <sup>1</sup>H NMR spectrum of the isomeric mixture meant that no further information on the orientation of the protons at the ring junctions could be derived. We speculated that the minor isomer could be the alternative cycloadduct **139** formed by the addition of

butadiene from the more hindered endo face as shown in Scheme 5.5(a). Whilst **139** would be useful in this synthesis because the absolute configuration at the bridgehead carbons is as desired, the formation of the other possible diastereomer *i.e.* the *trans*-fused isomer **144** cannot be discounted. This could arise from an epimerisation *via* an enol at the new bridgehead carbon  $\alpha$  to the carbonyl group (Scheme 5.9).

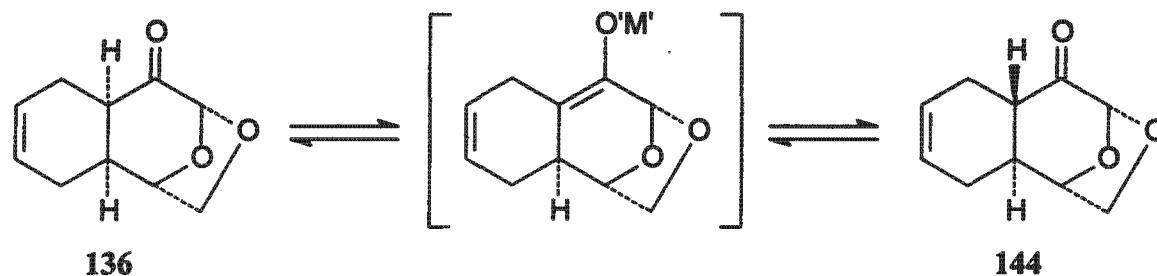

**Scheme 5.9** Equilibration of **136** *via* an enolic species (where 'M' = H or Lewis acid, for example)

The formation of a *trans* ring junction in decalin-type systems is usually favoured unless there are over-riding additional structural features that destabilise it. Models of **144** showed that the rigidity imparted by the oxymethylene bridge in the levoglucosenone residue means that the oxacyclohexanone ring is constrained to adopt a boat conformation, thus compromising the energy advantage associated with a *trans* ring junction in the oxadecalin sub-structure. In order to ascertain whether the *trans*-fused product **144** was energetically favoured over **136**, a molecular modelling study was carried out. *Ab initio*\* calculations were used to obtain the coordinates of the minimum energy conformations of **144** and **136**. In order to ensure that an absolute minimum was identified for each compound, the energy minimisation calculations were performed on a number of starting conformations that were selected as feasible local minimum and maximum conformers for each structure. The single point energies (*i.e.* the sum of the electronic energy and nuclear repulsion energy of the molecule in a specified configuration) of the local minima so obtained were calculated and compared (Tables 5.1 and 5.2).

**Table 5.1** Results of energy minimisation calculations on **144**

	Input Conformation		Minimised Conformation		Single point energy at minimum (Hartree)
	Ring A	Ring B	Ring A	Ring B	
	<sup>7</sup> H <sub>2</sub>	<sup>10</sup> B <sup>7</sup>	<sup>7</sup> H <sub>2</sub>	<sup>10</sup> B <sup>7</sup>	-602.6105445
	<sup>3</sup> B <sup>6</sup>	<sup>10</sup> B <sup>7</sup>	<sup>7</sup> H <sub>2</sub>	<sup>10</sup> B <sup>7</sup>	-602.6105445
	<sup>3</sup> B <sub>6</sub>	<sup>10</sup> B <sup>7</sup>	<sup>7</sup> H <sub>2</sub>	<sup>10</sup> B <sup>7</sup>	-602.6105445

\* Computational details are given in Chapter 6

Table 5.2 Results of energy minimisation calculations on 136

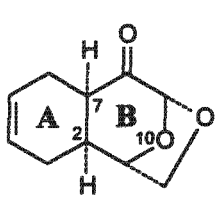

Input Conformation		Minimised Conformation		Single point energy at minimum (Hartree)
Ring A	Ring B	Ring A	Ring B	
${}^7\text{H}_2$	${}^7\text{C}^{10}$	${}^7\text{H}_2$	${}^7\text{C}^{10}$	-602.6121642
${}^3\text{B}^6$	${}^7\text{C}^{10}$	${}^7\text{H}_2$	${}^7\text{C}^{10}$	-602.6121642
${}^3\text{B}^6$	${}^7\text{C}^{10}$	${}^7\text{H}_2$	${}^7\text{C}^{10}$	-602.6121642
${}^7\text{H}^2$	${}^7\text{B}^{10}$	${}^7\text{H}^2$	${}^7\text{B}^{10}$	-602.6053115
${}^3\text{B}^6$	${}^7\text{B}^{10}$	${}^7\text{H}^2$	${}^7\text{B}^{10}$	-602.6053115
${}^3\text{B}^6$	${}^7\text{B}^{10}$	${}^7\text{H}^2$	${}^7\text{B}^{10}$	-602.6053115

The unit of energy that was quoted in the computational output, the Hartree, is an atomic quantity. Whilst the values given here are not significant in themselves, the differences between these values are of interest and are converted into SI units using the factor 1 Hartree = 2625.50 kJ.mol<sup>-1</sup>. It should be noted that these energies are approximate and have not accounted for the effects of molecular vibration, translation or rotation at ambient temperatures.<sup>163</sup>

For 144, a single minimum conformer was obtained, which has been represented in Figure 5.2(a). For 136, two minima with an energy difference of 18 kJ.mol<sup>-1</sup> were detected. The lower energy conformer of the two, *i.e.* that having a chair conformation in ring B, was assigned as the absolute minimum conformation for 136 [Figure 5.2(b)].

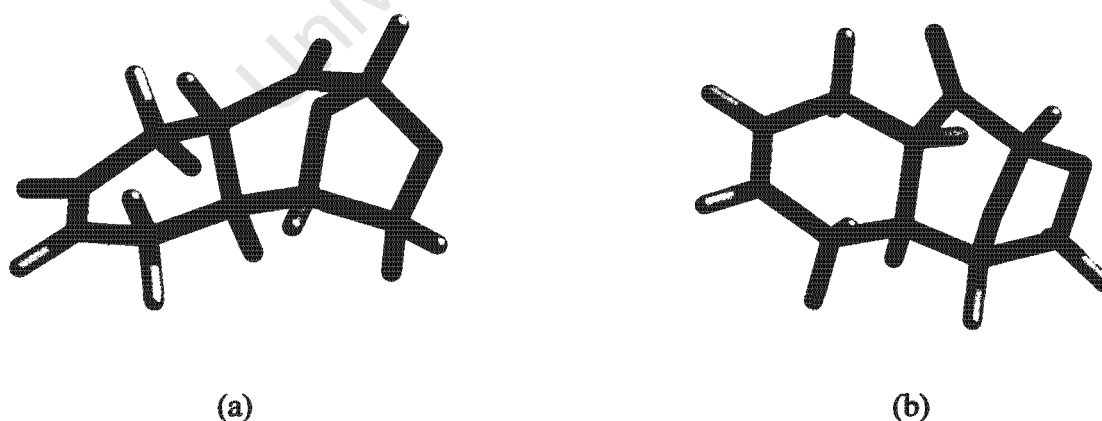
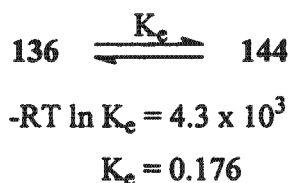

Figure 5.2 Minimum energy geometries for (a) 144 and (b) its C-7 epimer 136

The single point energies that were calculated for these minima indicate that the *cis*-cycloadduct 136 is preferred by 4.3 kJ.mol<sup>-1</sup>. This value can be used to give an approximation of the equilibrium constant for the epimerisation at 25 °C:



This constant translates to a 136:144 ratio of ~6:1 at equilibrium. These results indicated that the possibility of the minor isomer being 144 could not be eliminated on the basis of thermodynamic preference for 136. An epimerisation experiment was thus undertaken in order to ascertain firstly, whether the minor isomer was 144 and secondly, whether the calculated equilibrium ratio was a valid approximation. Two samples with different proportions of 136 and the contaminant isomer were treated with 0.1 molar equivalents of potassium *t*-butoxide for 24 h at 25 °C. The ratios of 136:impurity in the starting materials, and the crude reaction products were determined by <sup>1</sup>H NMR (Table 5.3).

**Table 5.3** Epimerisation studies on mixtures of the cycloadduct 136 and its unidentified isomer

Sample	Ratio before (136:isomer)	Ratio after (136:isomer)
Primary cycloaddition product	16.5:1	8.5:1
Mother liquor from 136 recrystallisation	3.5:1	4.7:1

The ratios shown in Table 5.3 indicate that under the conditions of base-mediated epimerisation, the relative proportions of the two species were altered. The <sup>1</sup>H NMR spectra of the crude reaction products indicated that no new species had been formed during the reactions. The altered proportions of the isomers were thus due to interconversion of the two species. From these observations, it was deduced that the cycloaddition impurity was indeed 144. Although the ratios were converging in the epimerisation experiments, the disparity between them showed that equilibrium had not been reached under the reaction conditions used. In addition, the ratio of 6:1 which was approximated from molecular modelling results was feasible. The presence of 144 in the primary cycloaddition extract indicated that adventitious isomerisation was occurring under the thermal conditions used.

The experimental and computational data presented above show that the 3:2 ratio of isomers obtained from the reaction at 120 °C<sup>157</sup> was unlikely for 136 and 144. Several attempts were made to emulate the reported procedure because of the useful role 139 could play in this synthetic study. Experiments conducted at 120 °C failed to give a mixture in these or similar proportions, nor have they been reported by other laboratories, and the possibility that this is a spurious result should be considered.

The cycloaddition reactions carried out under thermal conditions were complicated by the familiar problem of butadiene polymerisation, which interfered with the isolation of products, particularly in large-scale reactions. Safety concerns also led to the application of Lewis acid catalysis to this cycloaddition. Ethylaluminium dichloride was the first Lewis acid selected because of the success that had been achieved with it in similar cycloaddition reactions (Section 4.2.2). At 0 °C, the reaction was complete after 60 min giving an isomer ratio of 33:1 in the crude material, from which 136 was isolated in 64% yield (Scheme 5.10). In view of the satisfactory result obtained, this aspect of catalysis was not investigated further.

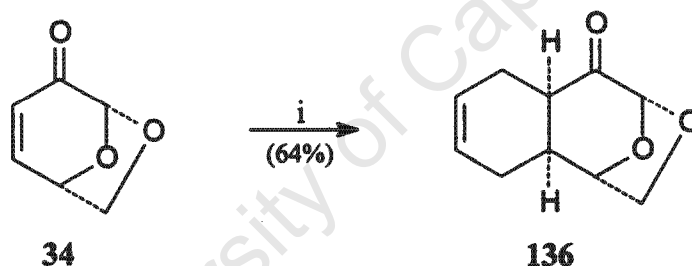

**Scheme 5.10** Reagents and conditions: (i) butadiene, EtAlCl<sub>2</sub> (0.3 mol. equiv.), CH<sub>2</sub>Cl<sub>2</sub>, 0 °C

In their conformational analysis of 136, Ward and Shafizadeh acknowledge the flexible nature of the cyclohexenoid portion of the tricyclic system.<sup>157</sup> Further, they argue that owing to the nature of the bond formation in this reaction the cyclohexenoid ring must take up a boat configuration. The modelling studies described here have shown that the energy minimised conformer [Fig 5.2(b)], has a <sup>7</sup>H<sub>2</sub> cyclohexenoid ring. Although the energy of the inversion barrier has not been quantified here, it seems unlikely that this system should behave contrary to accepted cyclohexenoid conformational behaviour, and remain in the boat conformation that was adopted during bond formation.<sup>164</sup>

### 5.2.3 Reduction studies

During the course of exploratory studies designed to probe conformational properties, and to prepare intermediates for possible 8-homologation studies, hydride-mediated reduction of **136** was attempted. The reaction with sodium borohydride afforded the diastereomeric alcohols **145** and **146** in 65 and 19% yields respectively. A more sterically demanding reducing agent was used in an attempt to improve the diastereoselectivity of the reduction. Reduction with L-Selectride in THF at  $-78\text{ }^{\circ}\text{C}$  afforded only **145** in 93% yield (Scheme 5.11).

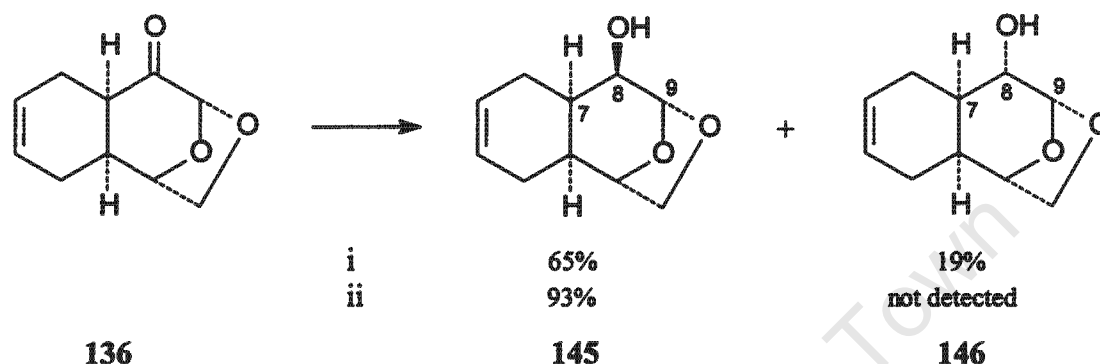

**Scheme 5.11** Reagents and conditions: (i)  $\text{NaBH}_4$ , MeOH,  $0\text{ }^{\circ}\text{C}$ , (ii) L-Selectride, THF,  $-78\text{ }^{\circ}\text{C}$

The structural assignments of **145** and **146** were based on the observed coupling for 8-H in the  $^1\text{H}$  NMR spectra. Relevant data have been reproduced below (Table 5.4).

**Table 5.4** Selected data from the  $^1\text{H}$  NMR spectra for the epimeric alcohols **145** and **146**

Proton	<b>145</b>	<b>146</b>
8-H	$\delta$ 3.40 brs, $W_{1/2}$ 8.4 Hz	$\delta$ 3.38 dd, $J$ 9.7 and 1.3 Hz
9-H	$\delta$ 5.33 d, $J$ 2.2 Hz	$\delta$ 5.32 d, $J$ 1.3 Hz

The data reported in Table 5.4 were recorded from spectra run in  $\text{CDCl}_3\text{-D}_2\text{O}$  and the coupling that was observed in 8-H was ascribed to its vicinal coupling partners 7-H and 9-H. In both cases, the signal for 7-H was obscured, but that for 9-H was clearly resolved and  $J_{8,9}$  was established. In **146**, the large coupling constant (9.7 Hz) was thus assigned as  $J_{7,8}$ . In **145**,  $J_{7,8}$  could not be extracted due to lack of resolution in the 8-H signal, but was estimated at  $\sim 6.2$  Hz ( $W_{1/2} - J_{8,9}$ ). The minimum energy conformers of the 8-H epimers was identified by molecular modelling and the relationship

between 8-H and its vicinal coupling partners was examined. As expected from computational work on 136, the  ${}^7\text{H}_2 - {}^7\text{C}^{10}$  conformer was identified as the most stable for each epimer. In 145, 8-H is equatorial and has a synclinal relationship to the bridgehead proton 7-H as well as 9-H. Two smaller couplings were thus expected, and were observed (Figure 5.3). In 146, 8-H is axial and thus antiperiplanar to 7-H and gauche to 9-H, which was reflected in the signals as one large and one small coupling (9.7 and 1.3 Hz respectively) (Figure 5.3).

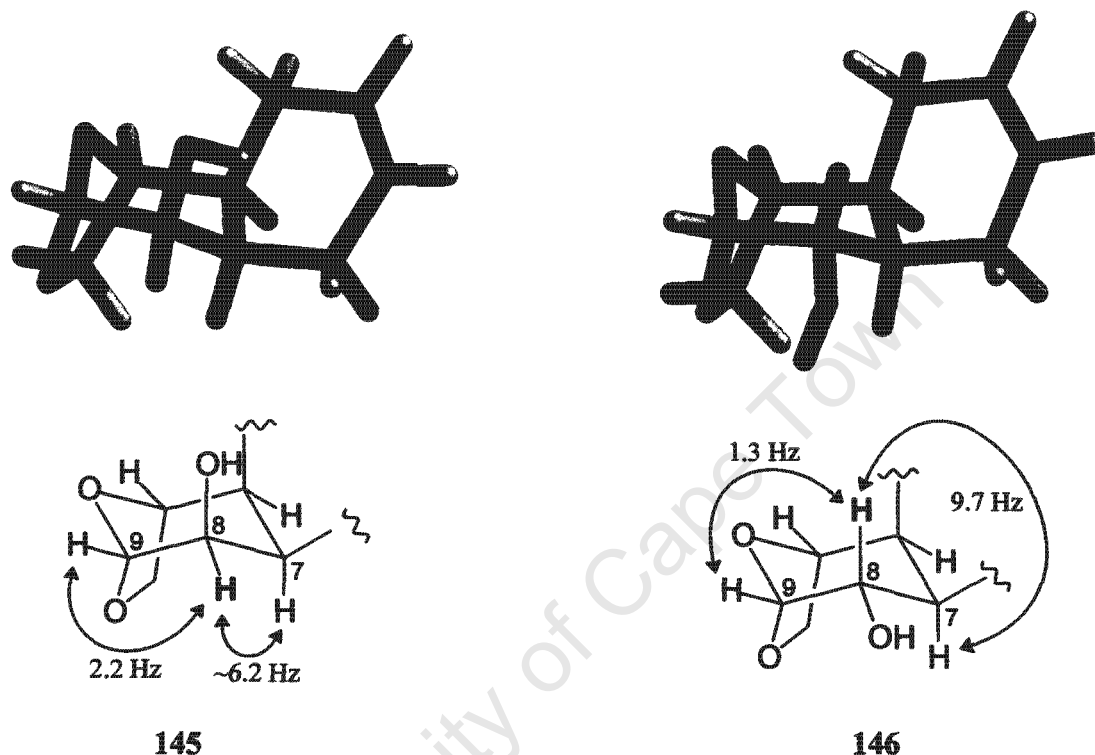

**Figure 5.3** Minimum energy conformations of 145 and 146, highlighting the spatial relationship between 8-H and its coupling partners

The rationalisation of the stereochemical outcome of this reaction requires insight into the conformation of the starting material 136. It has been shown that the oxacyclohexanone ring adopts a chair-like conformation [Figure 5.2(b)]. Ignoring pendant functionality, stereoelectronic control analogous to that demonstrated in cyclohexanone could be expected, where the hydride is delivered from the exo face leading to an equatorial hydroxy substituent on the endo face of the oxacyclohexanoid ring.<sup>165</sup> On this basis, 146 should have been the favoured alcohol (Figure 5.4). However, the presence of the cyclohexenoid ring introduces a steric factor to this reduction. The minimum energy conformation of 136 shows the C-2 – C-3 bond as a 1,3-diaxial substituent to the ketone, thus providing a classical feature for inverting stereoelectronic delivery of the hydride (Figure 5.4).<sup>166</sup> The hydride was preferentially delivered from the  $\alpha$ -face, which is less sterically hindered, thus resulting in the axially substituted hydroxyl group on the  $\beta$ -face that was observed in

the major product, 145. This argument is supported by the fact that the stereoselectivity improved when hydride delivery took place from the more sterically demanding reducing agent L-Selectride.

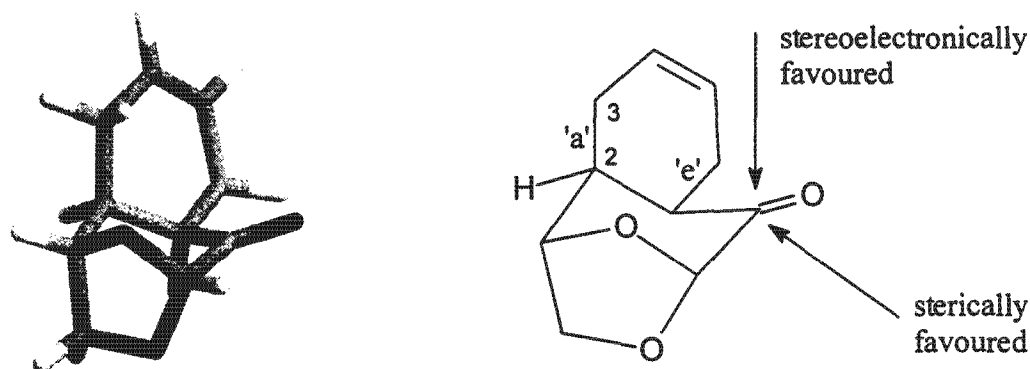
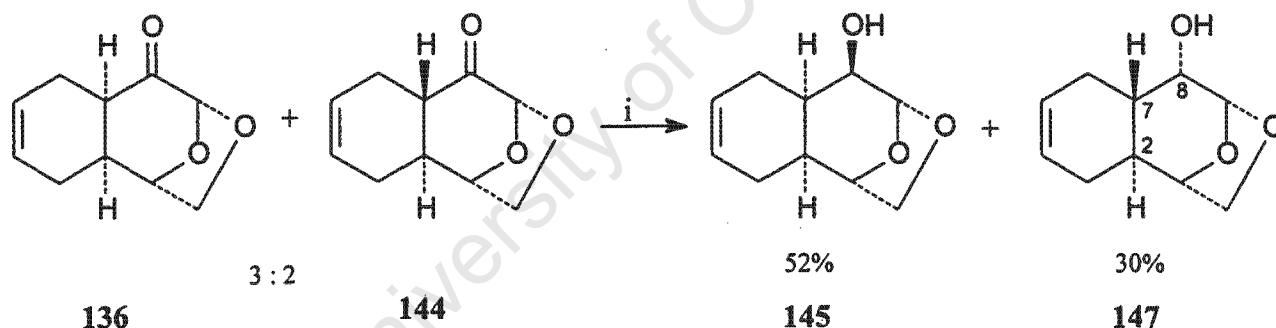

Figure 5.4 Hydride approach to the 8-keto group of 136

The mother liquors from the recrystallisation of 136 provided a mixture of cycloadducts which was enriched in 144 relative to the crude material (136:144 ~3:2 by NMR). Reduction of this mixture with sodium borohydride afforded a mixture of the alcohols 145 and 147 which were present in the same proportions as the starting materials, as well as trace amounts of 146 (Scheme 5.12).



Scheme 5.12 Reagents and conditions: (i) NaBH<sub>4</sub>, MeOH, 0 °C

The <sup>1</sup>H NMR spectrum of 147 provided further evidence for the *trans* ring junction. Relevant signals are listed below (Table 5.5).

Table 5.5 Selected data from the <sup>1</sup>H NMR spectrum for the alcohol 147

Proton	δ (ppm)	mult	J (Hz)
2-H	1.50	tdd	2 x 11.5, 5.6 and 1.8
7-H	1.60	tt	2 x 11.5 and 2 x 4.9
8-H	3.87	t	2 x 5.6
9-H	5.59	d	5.6

The new signal, that for 8-H, showed two intermediate couplings (5.6 Hz) which could have been assigned to a number of structural options. In this spectrum, however, the signals for the bridgehead protons 2-H and 7-H were resolved and their connectivities were established using 2D spectra. The magnitude of the correlations proved to be decisive. Both signals included two large (11.5 Hz) couplings. Models of the reduction products showed that the *trans* ring junction provided a unique solution for the observed coupling. An antiperiplanar relationship between the bridgehead protons themselves, and between 2-H and 3-H, and 6-H and 7-H respectively accounts for the magnitude of the observed couplings (Figure 5.5). The assignment of the stereochemistry at the newly formed chiral centre, C-8, was made on the basis of information obtained from the signal for 8-H. If 8-OH were present on the  $\beta$ -face, 8-H would form a further antiperiplanar coupling partner with 7-H and a large coupling would be expected in the signal for 8-H. This was not observed and the stereochemistry was assigned as depicted below.

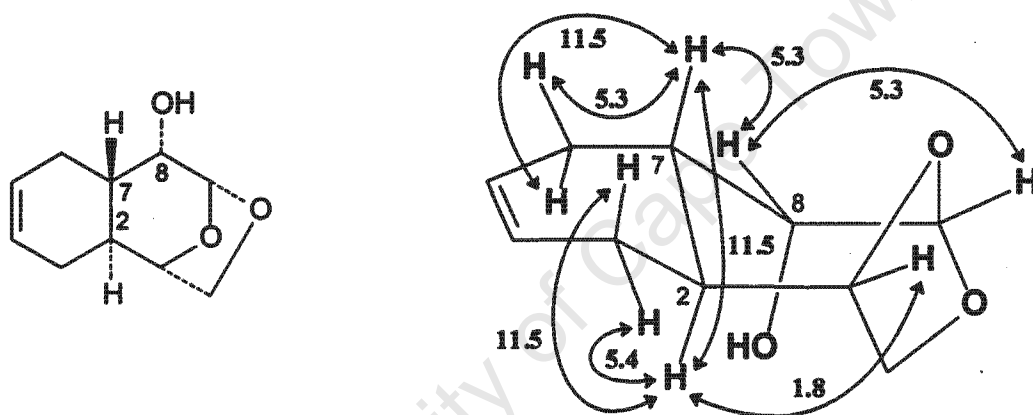
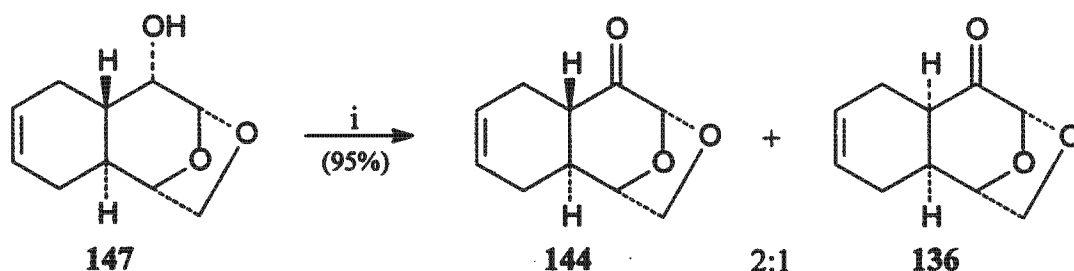

Figure 5.5 Diagnostic coupling constants (Hz) in 147

Oxidation of 147 was attempted in order to isolate and characterise 144. Dess Martin oxidation of an analytically pure sample of the alcohol afforded, after work-up a 2:1 mixture of the carbonyl compounds 144 and 136 respectively (Scheme 5.13). Although the epimerisation at C-7 had been demonstrated previously, the facility with which it occurred under the weakly acidic to neutral Dess Martin oxidation conditions was unexpected.



Scheme 5.13 Reagents and conditions: (i) periodinane,  $\text{CH}_2\text{Cl}_2$

### 5.2.4 One-carbon homologation

Although the carbonyl functionality at C-8 in **136** provided a functional handle for one-carbon homologation, a suitable method for the direct conversion of the carbonyl group into a carboxylic acid was not obvious.<sup>167, 168</sup> However, the one-step conversion of ketones into nitriles in a reductive cyanation reaction with tosylmethyl isocyanide (TosMIC) is known.<sup>169</sup> The conversion of a nitrile group to a carboxylic acid is a facile hydrolytic step, and nitriles are thus frequently utilised as 'masked' forms of carboxylic acid functionality.<sup>170</sup> The proposed sequence has been represented in Scheme 5.14.

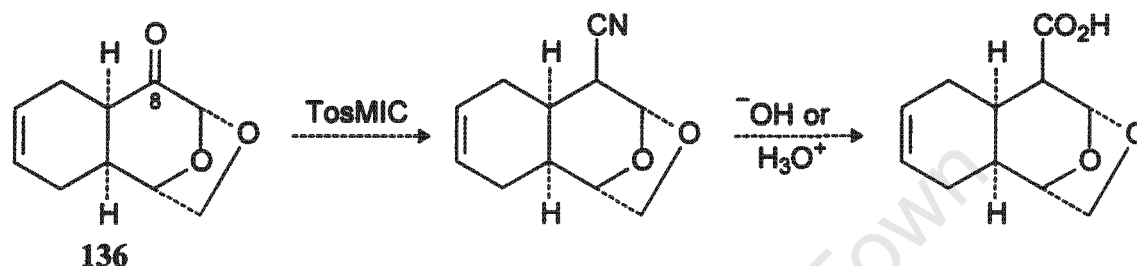

**Scheme 5.14.** Proposed sequence for the introduction of carboxyl functionality at C-8 in **136**

In the reaction with TosMIC, the active TosMIC anion is generated by treatment of the reagent with base. The conditions required for further reaction are dependent on the reactivity of the ketone. Sterically hindered ketones frequently require elevated temperatures in order to achieve reaction<sup>171</sup> but under these conditions, self-destruction of the reagent in competitive processes has been observed.<sup>172</sup> Successful reaction at a hindered ketone in a steroid starting material has been achieved by the adoption of a reaction protocol of slow reverse addition of the reagent to a mixture of the starting material and base (*t*BuOK), thereby minimising the opportunity for reagent self-destruction.<sup>172</sup> The conditions described<sup>172</sup> were applied to the reductive cyanation of **136**, and produced a mixture so complex that neither starting material nor any single product could be isolated from it. A similar scenario was encountered when the traditional reaction conditions of van Leusen<sup>169, 171</sup> were used. The reaction outcome could not be improved despite extensive efforts using varying rates of reagent addition and reaction temperatures.

In the light of the failure of the reductive cyanation reaction, displacement chemistry was considered for the introduction of the nitrile group. The alcohol **145** was available in high yield from the stereoselective reduction of **136** that was described in Section 5.2.3. Although the hydroxyl moiety on the oxacyclohexane in **145** ring is axial, which is the preferred orientation for leaving groups in S<sub>N</sub>2 reactions, it was recognised that the approach trajectory of the nucleophile would be *syn* to the oxymethylene bridge and steric hindrance could compromise the substitution

reactivity. Several procedures utilising  $S_N2$  methodology have been developed for the introduction of cyanide.<sup>173</sup> The most common of these is the displacement of sulfonic acid esters by the cyanide anion. A non-aqueous cyanation procedure using lithium cyanide has been described to be more reactive than the traditional sodium and potassium variants that frequently require the use of phase transfer catalysts and extreme temperatures to achieve reaction.<sup>143</sup> The hydroxyl group in **145** was converted into the tosylate in **148**, to act as a more electrophilic partner. Heating of **148** at 80 °C in the presence of LiCN in DMF produced a single product. Instead of substitution, the competing elimination reaction had occurred exclusively to give the olefin **149** (Scheme 5.15). The  $^1\text{H}$  NMR spectrum confirmed that the internal acetal was still intact, ( $\delta$  5.49, doublet) whilst the total of three vinyl protons ( $\delta$  5.59—5.80) confirmed that an additional trisubstituted olefinic bond was present. Carbon resonances at  $\delta$  120.2, 125.4, 126.4 and 137.3 for the termini of the olefins provided further confirmation of this assignment, as did the detection of the parent molecular ion with  $m/z$  164 in the mass spectrum.

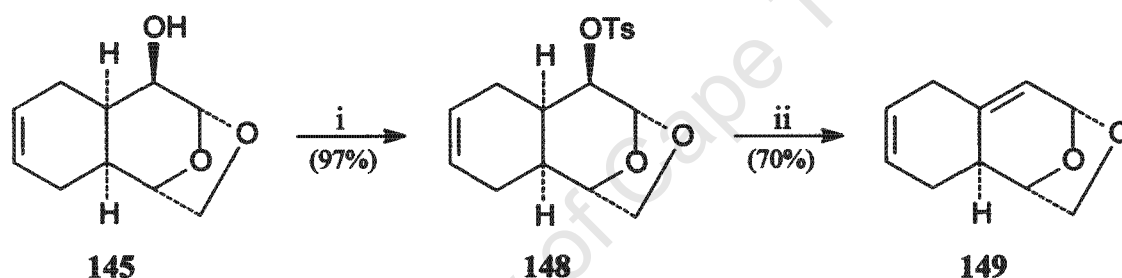

**Scheme 5.15** Reagents and conditions: (i) *p*TsCl, DMAP, pyr, (ii) LiCN, DMF, 80 °C

In addition to the aforementioned steric considerations, elimination could also have been facilitated by stereoelectronic factors. Elimination takes place most readily when the hydrogen atom and the leaving group are in an antiperiplanar relationship.<sup>80</sup> The minimised structure modelled for **145** showed this arrangement for 8-OH and 7-H (Figure 5.6). The arrangement in the tosylate, **148** should be identical, thus contributing to the propensity of this material to undergo elimination.

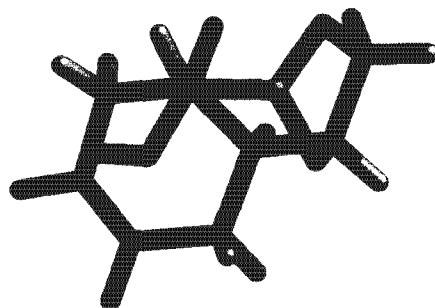

**Figure 5.6** Alcohol **145** viewed down the C-8 – C-7 bond. The antiperiplanar arrangement of 8-OH and 7-H is evident.

Alternative procedures for this substitution, which make use of NaCN and KCN in the presence of crown ethers or phase transfer catalysts are used for this transformation,<sup>173</sup> but in the light of the facility with which elimination appears to have occurred in **148**, these were not considered. Mitsunobu-type reactions have been used to substitute hydroxyl groups with cyanide,<sup>174</sup> but this class of reactions generally results in poor yields when performed on hindered secondary alcohols.<sup>175</sup> In **145**, the hydroxyl moiety is flanked by two tertiary centres, and of particular importance, the 1,3-diaxial relationship between the hydroxyl group and the C-2 – C-3 bond in the cyclohexenyl moiety would further limit the access of bulky reagents. In the light of these factors, alternative homologation procedures were investigated preferentially.

The addition of cyanide to a carbonyl group to give a cyanohydrin was first reported in 1832<sup>176</sup> and numerous efficient procedures for this transformation have since been developed.<sup>177</sup> Reaction conditions whereby the cyanohydrin hydroxyl group is trapped as a phosphate ester<sup>178, 179</sup> to give a cyanohydrin *O,O'*-diethyl phosphate (cyanophosphate) were attractive here because there is literature precedent for the reductive elimination of the phosphate group to give a nitrile.<sup>180</sup> The reaction of **136** with diethylchlorophosphate and lithium cyanide<sup>179</sup> afforded cyanophosphate **150** as a single diastereomer (Scheme 5.16). In the absence of further evidence it was reasonable to assume that the cyanide anion followed the same approach trajectory to the carbonyl group as the hindered hydride (Section 5.2.3), to give the stereochemical outcome depicted for **150**. The numerous applications of samarium diiodide ( $\text{SmI}_2$ ) as a one-electron reducing agent have been reviewed by Molander,<sup>181</sup> and these include the conversion of cyanophosphate groups into nitriles in a reductive cleavage process.<sup>182</sup> Surprisingly, the treatment of **150** with  $\text{SmI}_2$  in the presence of *t*-butyl alcohol gave **151** as the major product (Scheme 5.16).

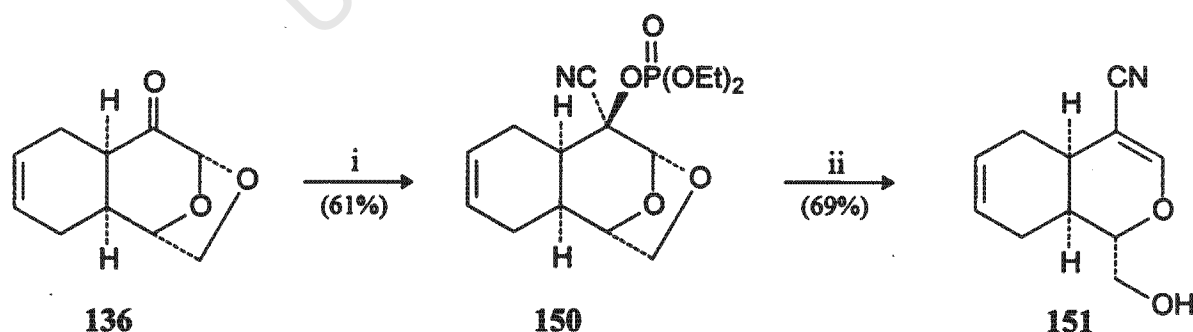

**Scheme 5.16** Reagents and conditions: (i) LiCN,  $(\text{EtO})_2\text{P}(\text{O})\text{Cl}$ , DMF–THF, (ii)  $\text{SmI}_2$ , HMPA, *t*BuOH, THF

The continued presence of the nitrile group was confirmed by an infrared absorption at  $2212\text{ cm}^{-1}$  as well as the characteristic  $^{13}\text{C}$  resonance at  $\delta\ 118.4$ , whereas the absence of the acetal moiety was

obvious from both the  $^1\text{H}$  and  $^{13}\text{C}$  NMR. A singlet at  $\delta$  7.10 that integrated for one proton and a  $^{13}\text{C}$  signal at  $\delta$  155.6 were indicative of a trisubstituted enolic olefin. HSQC and COSY spectra confirmed the depicted connectivities, and the identification of the parent molecular ion in a mass spectrum of **151** provided further confirmation of the structure.

The conversion of **150** into **151** appears to be one of overall  $\beta$ -elimination as opposed to reductive elimination. However, the accepted mechanism<sup>181</sup> for the reductive elimination of cyanophosphates (Scheme 5.17) does not allow for this outcome.

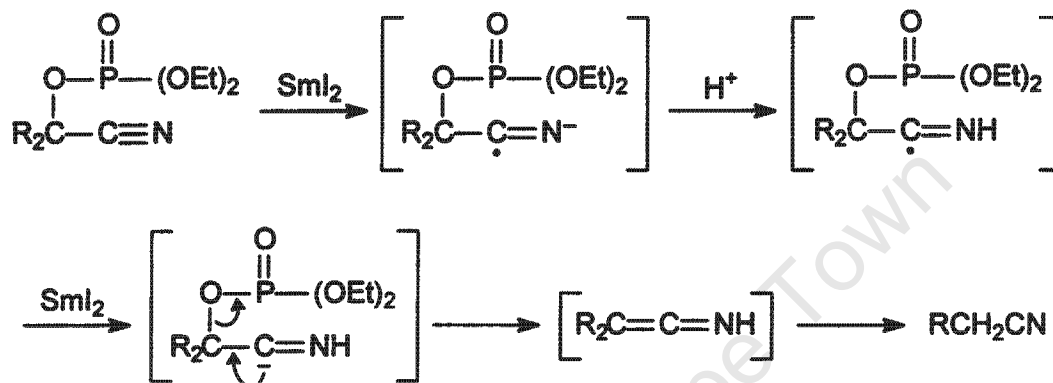

**Scheme 5.17** Mechanism for the  $\text{SmI}_2$ -mediated reductive elimination in cyanophosphates

The reductive cleavage illustrated is analogous to a large class of reactions, the reductive cleavage of  $\alpha$ -heterosubstituted carbonyl compounds. Two mechanisms for this class of reactions have been proposed.<sup>183</sup> The first is similar to the cyanophosphate mechanism (Scheme 5.17), where the first electron transfer would be to the carbonyl as opposed to the nitrile. This generates a ketyl that reacts immediately with a proton source to generate an  $\alpha$ -hydroxy radical. Reduction of the radical followed by  $\beta$ -elimination gives the reductive elimination product. In the second mechanism (Scheme 5.18), there is initial dissociative electron transfer to an easily reducible  $\alpha$ -substituent. Subsequent reduction by a second equivalent of  $\text{SmI}_2$  generates an enolate that becomes protonated to give the carbonyl product. The mechanism followed in these processes appears to be substrate dependent, with the latter being confirmed in the case of  $\alpha$ -halo esters.

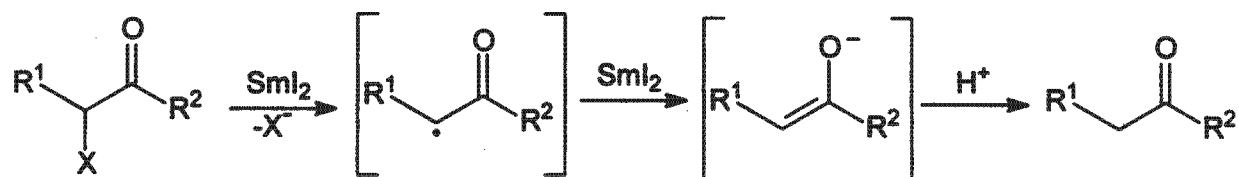

**Scheme 5.18** Mechanism observed for  $\text{SmI}_2$ -mediated reductive elimination in  $\alpha$ -haloesters

( $\text{R}^1$  = alkyl,  $\text{R}^2$  = alkoxy,  $\text{X}$  = halogen)

In some substrates, particularly  $\alpha,\beta$ -diheterosubstituted lactones [eg  $R^1 = \text{CH}(\text{R})\text{OAc}$  in Scheme 5.18] the enolate intermediate undergoes  $\beta$ -elimination prior to protonation in the final step, leading to an overall  $\beta$ -elimination product [*i.e.* if  $R^1 = \text{CH}(\text{R})\text{OAc}$ , elimination of the acetoxy group occurs to give an olefin]. It is speculated here that when **150** interacts with  $\text{SmI}_2$ , the reaction proceeds along a path similar to that shown in Scheme 5.18 to produce the product of  $\beta$ -elimination as illustrated in Scheme 5.19. Although **151** was not the expected product, it does contain a dihydropyran ring as well as the masked carboxyl group in the form of a nitrile. Hydrolytic cleavage of the enol ether in **151**, thereby releasing the vicinal diol for oxidative cleavage, followed by reclosure of the dihydropyran moiety *via* hemiacetal formation, could be envisaged. This line of experimentation was not followed here, but the possible utility of **151** as an intermediate in this synthesis should not be discounted.

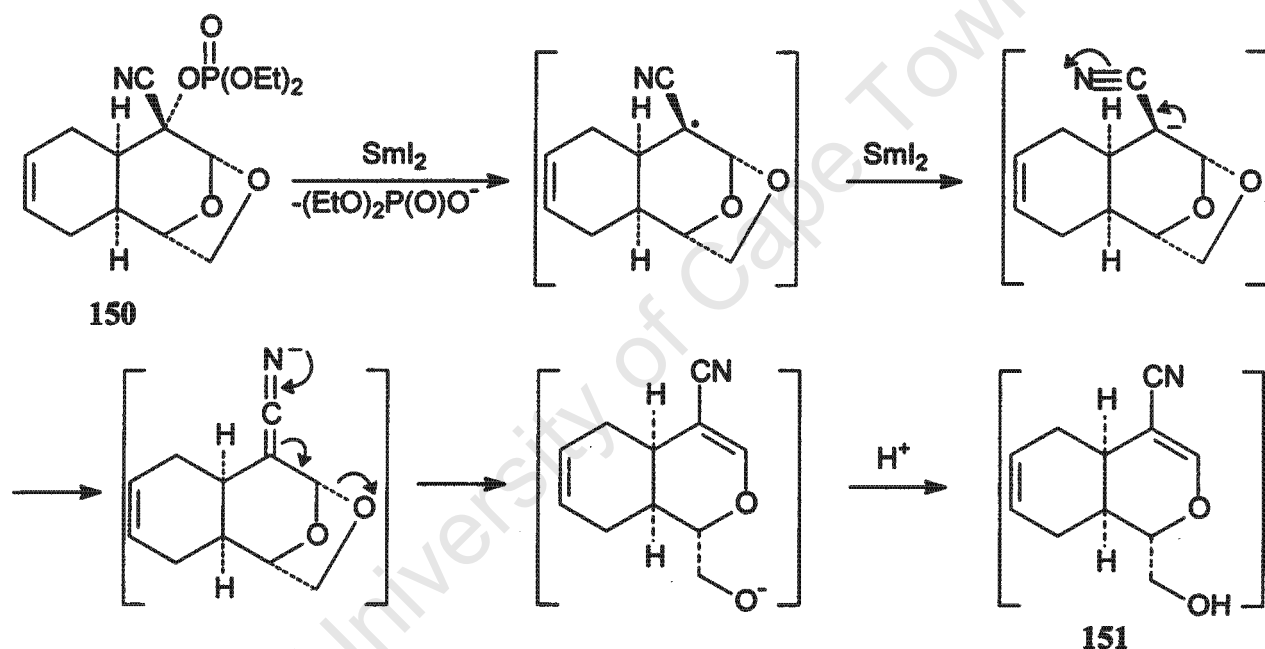

Scheme 5.19 Proposed mechanism for the conversion of **150** into **151**

As an alternative, the obvious option of Wittig olefination methodology was applied to the conversion of the carbonyl group in **136** into a chain-extended carboxyl moiety. A stepwise approach of methylenation, followed by further functionalisation was adopted. The methylenated product **152** was afforded by the reaction of **136** with the methyltriphenylphosphorane (Scheme 5.20). Spectral and analytical data were consistent with the assigned structure. Hydroboration was performed with 9-BBN because of the expectation that the reagent would attack the terminal olefin in **152** regio- and chemoselectively. Further, the product obtained from the treatment of **152** with 9-BBN- $\text{H}_2\text{O}_2$ , **153**, confirmed the expectation that 9-BBN would attack from the least hindered face of the olefin (Scheme 5.20).

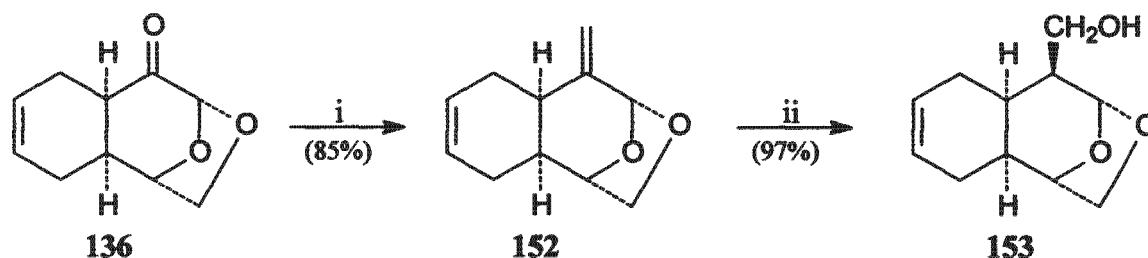

**Scheme 5.20** Reagents and conditions: (i)  $\text{Ph}_3\text{PCH}_2\text{I}$ ,  $n\text{BuLi}$ , THF, 0–25 °C,  
(ii) 9-BBN, THF, then 1M NaOH,  $\text{H}_2\text{O}_2$

The crystalline nature of this alcohol provided an opportunity for crystal structure determination. A search of the Cambridge Crystal Database<sup>184</sup> showed that no compounds bearing the levoglucosenone cycloadduct motif had been registered. The crystal structure obtained (Figure 5.7) confirmed the absolute configuration at the bridgehead positions C-2 and C-7, thus confirming the diastereoselectivity that had been assumed for the cycloaddition reaction. The configuration at C-8, where the hydroxymethyl substituent was axially orientated on the  $\alpha$ -face of the oxacyclohexane ring, confirmed the deduction (argued for the hydride reduction of 136) that reactions at C-8 were under steric rather than stereoelectronic control. In addition, the conformations exhibited by the cyclohexene and oxacyclohexane ring moieties in the structure of 153 were in close agreement with the geometries exhibited by the minimum energy conformers of other compounds in the series that were obtained computationally, *i.e.* the  ${}^7\text{H}_2 - {}_7\text{C}^{10}$  conformation was being adopted in these rings.

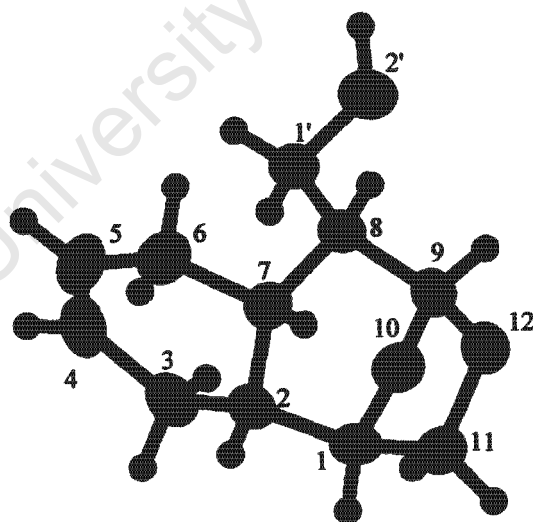

**Figure 5.7** X-Ray crystal structure of 153

In order to proceed to the required carboxyl level of oxidation at C-1', Jones oxidation of 153 was investigated. In a reaction carried out at  $-4$  °C the aldehyde 154 proved to be a discrete and isolable intermediate.<sup>185</sup> However under the prolonged reaction times required to achieve complete consumption of the aldehyde, extensive decomposition intervened, as evidenced by TLC

monitoring, and yields of **155** were poor (Scheme 5.21). This behaviour was presumed to be due to the acid-labile nature of the internal acetal functionality. Other methods of achieving direct oxidation of the primary alcohol, including reactions with pyridinium dichromate and ruthenium tetroxide were attempted, but in both cases chemoselective reaction could not be achieved owing to the presence of the acetal and olefin moieties respectively.

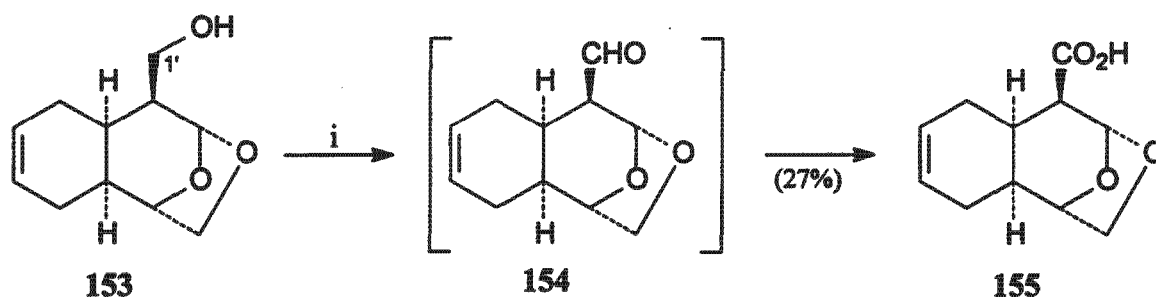

**Scheme 5.21** Reagents and conditions: (i) 8M CrO<sub>3</sub>, acetone, -4 °C

The conversion of **153** into the aldehyde **154** was most efficiently achieved using Swern oxidation conditions (Scheme 5.22). However, the oxidation of **154** with sodium chlorite gave a complex mixture from which the carboxylic acid could not be isolated.

The use of ozone to achieve the desired oxidation state was also attempted. The oxidation of acetals to esters by ozone<sup>96</sup> has been discussed in Chapter 3 (Scheme 3.39). The most reactive acetal species, the dioxolanyl acetal was selected in the hope that chemoselective oxidation could be achieved in the presence of the internal acetal. Treatment of **154** with ethylene glycol and tosic acid in the presence of trimethyl orthoformate provided an inseparable mixture of what appeared in <sup>1</sup>H and <sup>13</sup>C NMR spectra to be C-8 epimers of the cyclic acetal (Scheme 5.22).

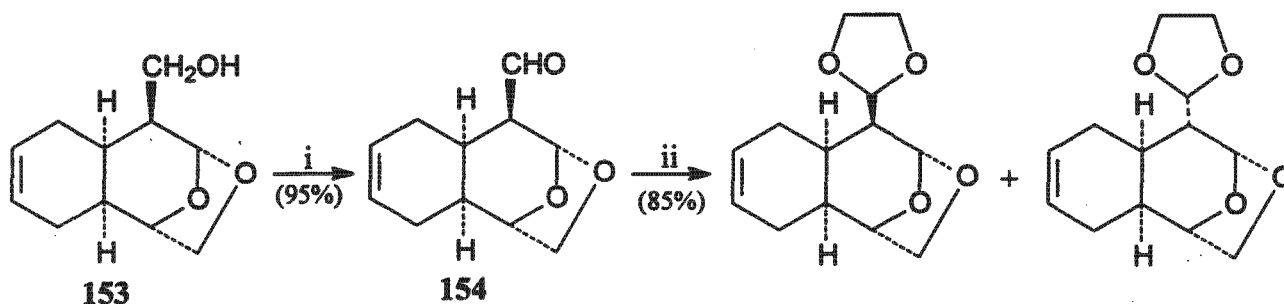

**Scheme 5.22** Reagents and conditions: (i) (COCl)<sub>2</sub>, DMSO, CH<sub>2</sub>Cl<sub>2</sub>, -78 °C, then Et<sub>3</sub>N, -78—25 °C,  
(ii) (CH<sub>2</sub>OH)<sub>2</sub>, HC(OMe)<sub>3</sub>, CH<sub>2</sub>Cl<sub>2</sub>, *p*TsOH, 25 °C

The enolisable nature of the carbonyl group in the starting material necessitated the use of a milder acetal formation procedure. The conversion of **154** into **156** by a reaction with bis-

trimethylsilylated ethylene glycol in the presence of a catalytic amount of TMSOTf at  $-78\text{ }^{\circ}\text{C}$ <sup>94</sup> was successful (Scheme 5.23). The spectroscopic data for **156** were consistent with the assigned structure. It was hoped that treatment of **156** with ozone would result in the simultaneous cleavage of the olefinic bond and oxidation of the acetal to give, after a chemoselective reductive work-up, **157**, which would be converted into **158** by lactonisation (Scheme 5.23). A solution of **156** in ethyl acetate was subjected to a stream of ozone at  $-78\text{ }^{\circ}\text{C}$  for varying lengths of time (10 min to 60 min). After a reductive work-up with sodium borohydride, TLC showed the presence of complex mixtures in all cases. When the work-up was performed immediately after the appearance of the first blue colour in the ozonolysis reaction mixture, an extremely polar product was observed. NMR spectra of the crude isolate showed two acetal signals ( $\delta_{\text{H}}$  5.64 and 4.88,  $\delta_{\text{C}}$  103.7 and 102.3). No signals relating to the presence of a vinyl species were detected, and on this basis, the substance was assumed to be **159** (Scheme 5.23). The polar nature of this material made purification difficult and it was not further characterised. A methanolic solution of the diol was exposed to ozone. After 2 h most of the starting material had been consumed but a mixture of products had been produced. Despite varying the reaction temperature and ozone flow rate, no improvement could be made to this reaction outcome.

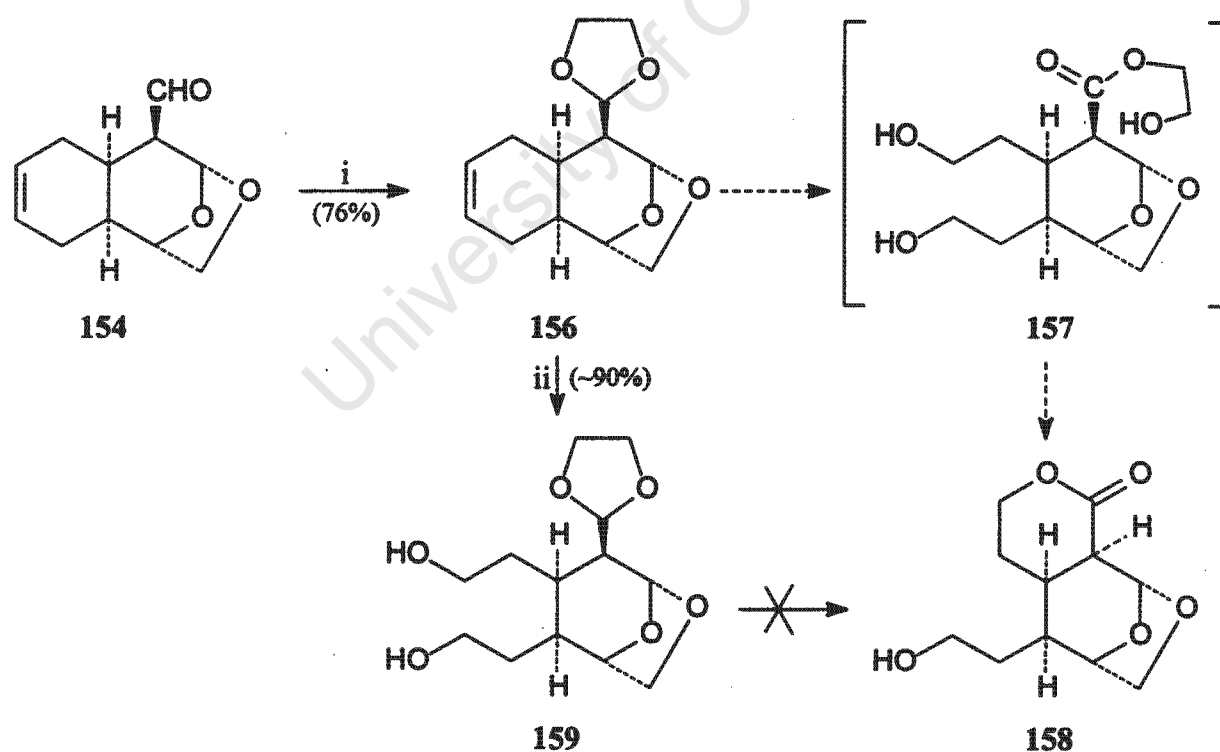

**Scheme 5.23** Reagents and conditions: (i)  $(\text{CH}_2\text{OTMS})_2$ , TMSOTf,  $\text{CH}_2\text{Cl}_2$ ,  $-78\text{ }^{\circ}\text{C}$ ,

(ii)  $\text{O}_3$ , MeOH,  $-78\text{ }^{\circ}\text{C}$ , then  $\text{NaBH}_4$ ,  $25\text{ }^{\circ}\text{C}$

In the light of the chemoselectivity problems associated with the application of oxidation methodology to **153** and **154**, it was decided to protect the 1'-OH group in **153** and cleave the olefinic bond prior to oxidation at C-1'. The benzyl group was selected for protection purposes because it provided scope for later chemoselective differentiation. The benzyl ether **160** was produced in 92% yield using standard benzylation conditions (Scheme 5.24).

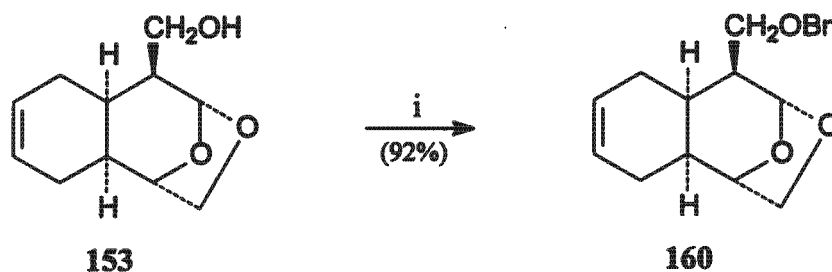

**Scheme 5.24** Reagents and conditions: (i) NaH, BnCl, THF

University of Cape Town

### 5.2.5 Oxidative cleavage and aldehyde trapping

Ozonolysis of **160** followed by a reductive work-up with sodium borohydride afforded a very polar product (TLC) that was subjected to silylation conditions in the hope of producing a more manageable intermediate for characterisation. TPS protection was selected because of the stability of this group to Lewis acids that would be used later during the aldehyde trapping procedure on the acetal. An inseparable mixture (~2:1 by NMR) of two products was obtained from the ozonolysis-reduction-silylation reaction sequence. The complexity of the  $^1\text{H}$  and  $^{13}\text{C}$  NMR spectra made identification of the components difficult. Accordingly, this characterisation was deferred whilst the acetal moiety was subjected to a cleavage-trapping procedure which gave a partially separable mixture of **161** and **162** (Scheme 5.25). The absence of the characteristic signal for the benzyl protons in the  $^1\text{H}$  NMR spectrum of **162**, which was observed at  $\delta$  4.52 in **161**, indicated that benzylic oxidation had been effected by ozone. Further evidence for this oxidation was provided by a unique resonance at  $\delta$  166.6 in the  $^{13}\text{C}$  NMR spectrum of **162**, which was assigned to the carboxyl carbon of the benzoyl moiety. Diagnostic signals confirming the presence of the thioacetal moieties were observed at  $\delta_{\text{H}}$  4.79 and 4.82 ( $2''$ -H) and  $\delta_{\text{C}}$  54.3 and 54.8 (C- $2'''$ ) in **161** and **162** respectively. The presence of two hydroxyl groups in each compound was evident from  $^1\text{H}$  NMR  $\text{D}_2\text{O}$  exchange experiments. The spectra for **161** and **162** were fully assigned using spectra from COSY and HSQC experiments.

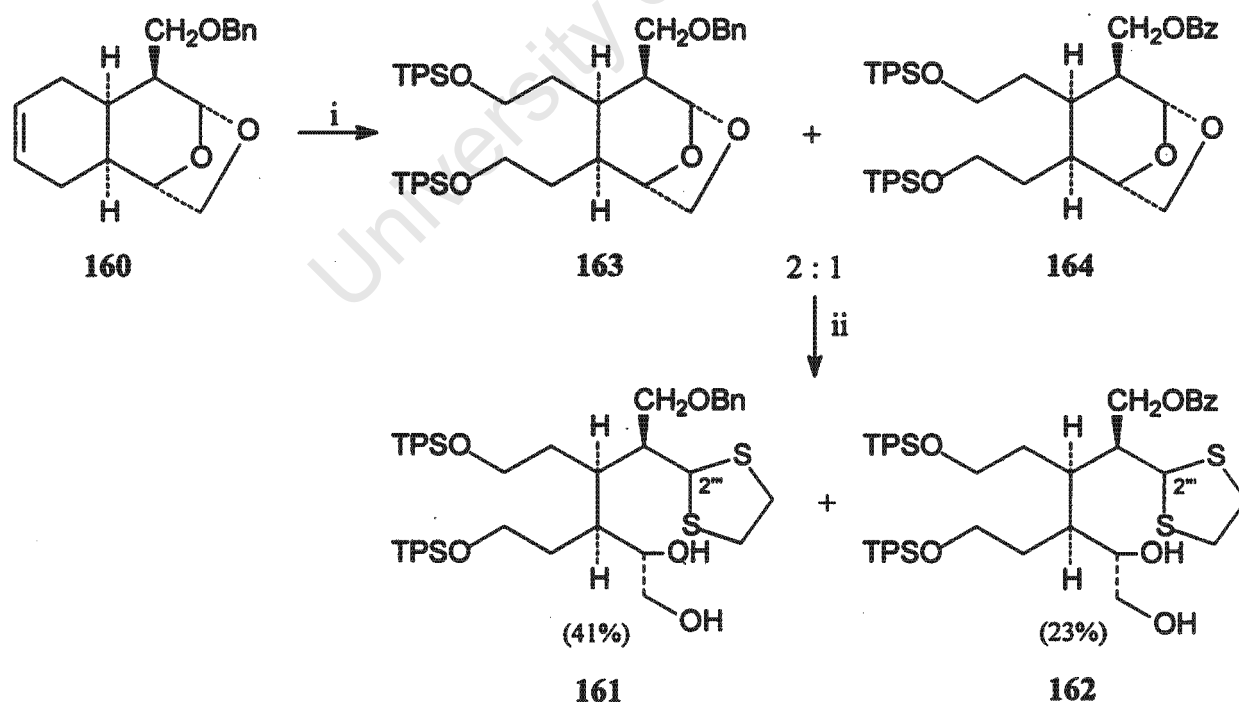

**Scheme 5.25** Reagents and conditions: (i)  $\text{O}_3$ , MeOH,  $-78^\circ\text{C}$ , then  $\text{NaBH}_4$ ,  $25^\circ\text{C}$  followed by  $\text{TPSCl}$ , imidazole, DMF,  $\text{CH}_2\text{Cl}_2$ , (iii) ethanedithiol,  $\text{BF}_3\cdot\text{OEt}_2$ ,  $\text{CH}_2\text{Cl}_2$ ,  $0^\circ\text{C}$

Although the oxidation of benzyl ethers to benzoate esters with ozone is known,<sup>186</sup> it was expected that the greater reactivity of an olefinic bond with ozone would give rise to chemoselective oxidation. This expectation was based on a briefly described literature precedent.<sup>187</sup> Despite shorter reaction times, lower reaction temperatures and varying flow rates of ozone, conditions for this reaction could not be optimised to the extent that benzylic oxidation was eliminated.

The reaction scheme was thus reconsidered, and instead of benzylating, the hydroxymethyl group in **153** was pivaloylated, to give the ester **165** (Scheme 5.26). The ozonolysis-reduction-silylation sequence reported for the benzyl ether was repeated and gave **166** in excellent yield (Scheme 5.26). Spectral data were fully assigned and agreed with the depicted structure. The acetal trapping was however beset by a deprotection problem that had been evident to a smaller extent during the earlier reactions. The poor yield of thioacetal **167** (Scheme 5.26) was accompanied by the recovery of TPSOH. This indicated that, although TPS ethers are reported to be stable to  $\text{BF}_3 \cdot \text{OEt}_2$  in dichloromethane at room temperature,<sup>188</sup> silyl cleavage had been induced under the reaction conditions applied here. A chemoselective transformation could not be achieved by varying the temperature or concentration of the reaction. The diagnostic spectral data for **167** concurred with those obtained for **161** and **162**, and NMR spectra were fully assigned with the aid of 2D NMR experiments.

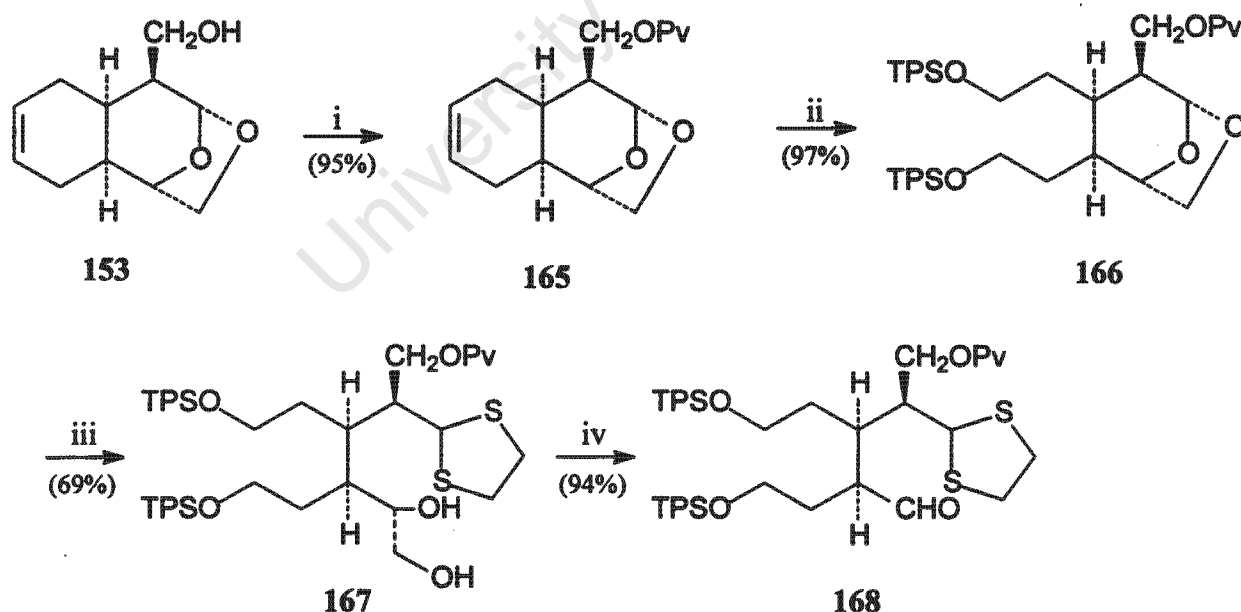

**Scheme 5.26** Reagents and conditions: (i)  $\text{PvCl}$ ,  $\text{Et}_3\text{N}$ ,  $\text{CH}_2\text{Cl}_2$  (ii)  $\text{O}_3$ ,  $\text{MeOH}$ ,  $-78^\circ\text{C}$ , then  $\text{NaBH}_4$ ,  $25^\circ\text{C}$  followed by  $\text{TPSCl}$ , imidazole,  $\text{DMF}$ ,  $\text{CH}_2\text{Cl}_2$ , (iii) ethanedithiol,  $\text{BF}_3 \cdot \text{OEt}_2$ ,  $\text{CH}_2\text{Cl}_2$ ,  $0^\circ\text{C}$

Despite the poor yield of the thioacetal, and the attendant necessity to improve these steps for a practical synthesis, the available material sufficed to demonstrate the oxidative cleavage of the glycol moiety. Treatment of **167** with lead tetraacetate afforded a cleavage product that was purified by flash chromatography to give the aldehyde **168** in excellent yield (Scheme 5.27). No epimerisation  $\alpha$  to the aldehyde carbonyl group could be detected in the NMR spectra of **168**. The aldehyde proton resonated characteristically as a doublet at  $\delta_{\text{H}}$  9.66 and the carbonyl carbon was detected at  $\delta_{\text{C}}$  204.2. Other spectral data confirmed the structure assignment.

In the light of the observed instability of the TPS ethers in **166**, an alternative approach to this portion of the synthesis was embarked on. The pivaloate protection on **166** was removed by reduction with LAH to give the alcohol **169**. The alcohol was treated with ruthenium tetroxide to give the carboxylic acid **170**, which was characterised as its methyl ester **171** (Scheme 5.27).

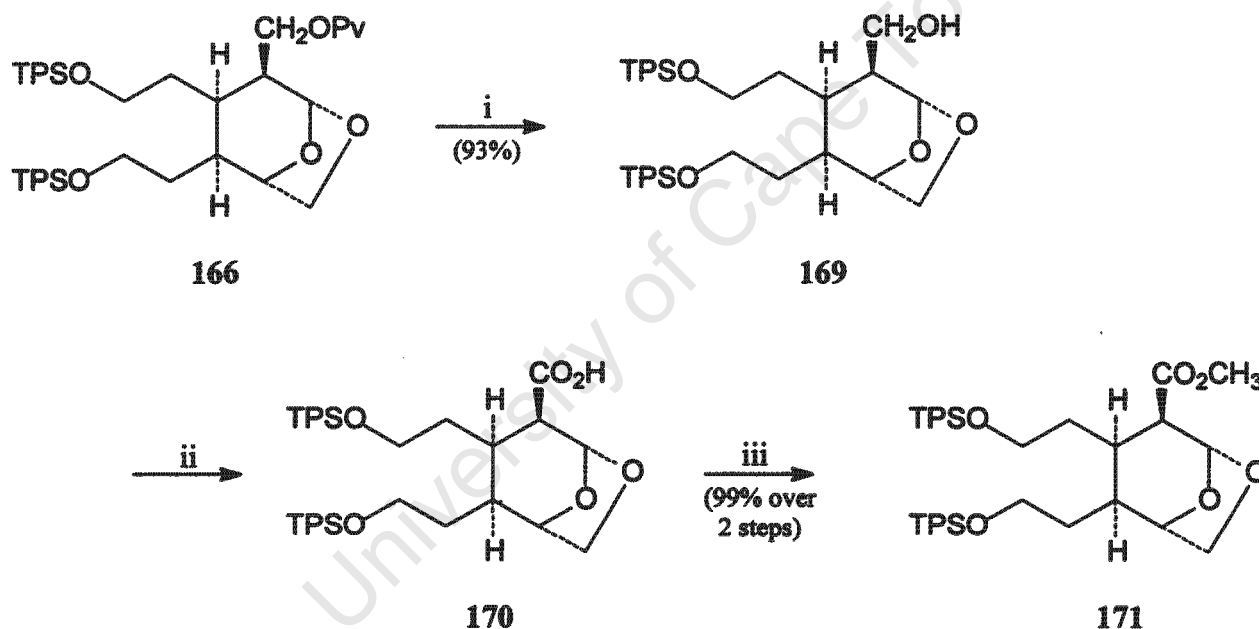

**Scheme 5.27** Reagents and conditions: (i) LAH, THF, 0 °C, (ii)  $\text{RuO}_2$  (cat.),  $\text{NaIO}_4$ ,  $\text{CCl}_4$ -MeCN- $\text{H}_2\text{O}$ , 0 °C, (iii) MeI,  $\text{K}_2\text{CO}_3$ , DMF, 0 °C

Since the completion of this synthesis from levoglucosenone was not within the timescale of this particular project, the synthetic effort was suspended at **171**. This was deemed to be an appropriate intermediate at which to end this particular investigation as it represented the successful culmination of extensive efforts to perform the one-carbon homologation with attendant functionalisation to give the required carboxylic acid.

### 5.3 CONCLUSION

The contribution towards the synthesis of *ent*-sweroside aglycone from **136** that has been described in this work is best demonstrated by considering the required transformations that were identified in the introductory paragraphs to this chapter:

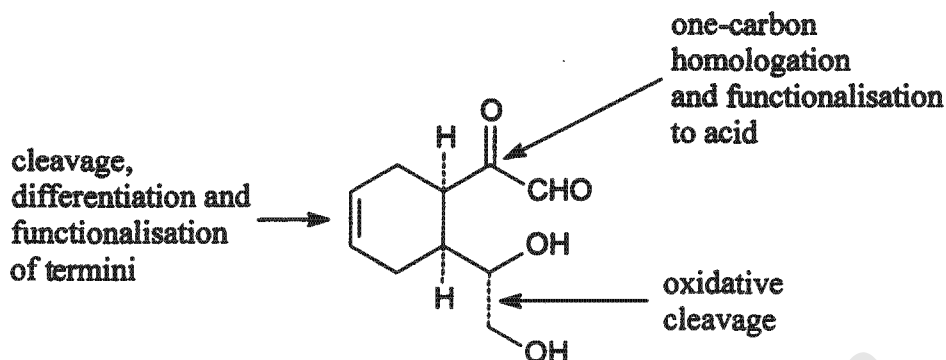

The oxidative cleavage and functionalisation of the termini to hydroxyl groups has been achieved in high yields. One-carbon homologation and functionalisation to a carboxylic acid were achieved in a stepwise, but efficient process. The opening of the internal acetal to reveal the vicinal diol, and the oxidative cleavage of that diol to give the required aldehyde functionality have also been successfully demonstrated. Considerable progress has been made in determining the sequence in which these methodologies should be applied in the final synthetic route, as well as in the identification of protecting groups that complement these chemoselective processes.

In addition, the reduction and molecular modelling studies have provided extensive insight into the conformational behaviour and reactivity of the tricyclic cycloadduct **136**, and allowed the identification of an artifact from the cycloaddition reaction as a *trans* epimer of the primary cycloadduct. Further, the X-ray crystal structure of **153** has provided the first structural evidence confirming the diastereoselectivity of the cycloaddition procedure, and of further transformations at C-8 in **136**.

## CHAPTER 6

## EXPERIMENTAL

## 6.1 GENERAL PROCEDURES

**Preparative** Reactions were monitored by thin layer chromatography using Merck F254 aluminium-backed precoated silica gel plates. Developed plates were visualised with a combination of ultraviolet, iodine vapour and either anisaldehyde or ceric ammonium sulfate solutions. Work-up typically involved threefold extraction with an organic solvent. The extracts were combined to give the organic phase. Column chromatography was performed using Merck Kieselgel 60: 70—230 mesh for gravity columns and 230—400 mesh for flash chromatography. Cycloadditions were performed in purpose made thick walled glass tubes fitted with a pressure valve and surrounded by a steel sheath during reactions. Diethyl ether and tetrahydrofuran (THF) were distilled from sodium-benzophenone ketyl, dichloromethane from phosphorous pentoxide and toluene from sodium. Other reagents and solvents were purified according to standard procedures.<sup>189</sup>

**Analytical** Melting points were determined using a Reichert-Jung Thermovar hot-stage microscope and are uncorrected. Optical rotations were measured on a Perkin-Elmer 141 Polarimeter using chloroform solutions. Infrared spectra were recorded as solutions in chloroform on a Paragon 1000 FT-IR Spectrometer. <sup>1</sup>H NMR spectra were recorded on a Varian VXR-200 at 200 MHz, Varian Mercury 300 MHz or Varian Unity spectrometer at 400 MHz. <sup>13</sup>C spectra were recorded on the same instruments operating at 50, 75 and 100 MHz respectively. All spectra were recorded in deuteriochloroform, using CHCl<sub>3</sub>,  $\delta$  7.26 as an internal standard. All chemical shifts are reported in ppm. H<sub>A</sub> and H<sub>B</sub> have been used arbitrarily in the NMR assignments to distinguish diastereotopic protons. Elemental analyses were recorded using a Fison's Instruments Elemental Analyser EA1108. Mass spectra were recorded on a VG micromass 16F spectrometer. In the absence of elemental analyses on oils and gums, accurate mass determinations were performed on a Kratos Limited MS9/50 spectrometer. All mass spectral data were obtained using Electron Impact techniques unless otherwise stated.

Where a name other than that preferred by IUPAC is used, it has been for the continuity of numbering, and the preferred IUPAC alternative has been included beneath the relevant experiment.

## 6.2 ENANTIOSELECTIVE DESYMMETRISATION

### Preparation of TADDOLs

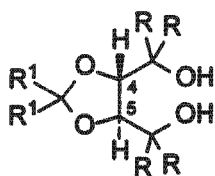

- 36 R=Ph, R<sup>1</sup>=Me  
 37 R=2-naphthyl, R<sup>1</sup>=Me  
 38 R=Ph, R<sup>1</sup>=Ph

#### (4*S*, 5*S*)-2,2-Dimethyl- $\alpha,\alpha,\alpha',\alpha'$ -tetraphenyl-1,3-dioxolane-4,5-dimethanol 36

(4*S*, 5*S*)-2,2-Dimethyl-1,3-dioxolane-4,5-dicarboxylic acid dimethyl ester<sup>190</sup> (5.00 g, 22.9 mmol) was reacted with phenyl magnesium bromide (183 mmol, 4.4 g magnesium, 19.3 cm<sup>3</sup> bromobenzene) according to the described procedure.<sup>53</sup> Work-up and recrystallisation from carbon tetrachloride, followed by digestion in pentane yielded the tetraphenyl TADDOL 36 (5.21 g, 49%), mp 191—193 °C;  $[\alpha]_D$  64 (*c* 1.0 in CHCl<sub>3</sub>), (lit.,<sup>53</sup> 190—192 °C;  $[\alpha]_D$  (4*R*, 5*R*)-enantiomer; -68.5);  $\delta_H$  (200 MHz, CDCl<sub>3</sub>), 1.03 (6H, s, 2 x CH<sub>3</sub>), 4.09 (2H, s, 2 x OH), 4.59 (2H, s, 4-H and 5-H) and 7.15—7.62 (20H, m, Ar-H). These data correspond with those reported previously.<sup>53</sup>

#### (4*S*, 5*S*)-2,2-Dimethyl- $\alpha,\alpha,\alpha',\alpha'$ -tetra(naphth-2-yl)-1,3-dioxolane-4,5-dimethanol 37

(4*S*, 5*S*)-2,2-Dimethyl-1,3-dioxolane-4,5-dicarboxylic acid dimethyl ester<sup>190</sup> (2.40 g, 11.0 mmol) was reacted with 2-naphthyl magnesium bromide (48 mmol, 1.2 g magnesium, 10.0 g 2-bromonaphthalene) according to the described procedure.<sup>54</sup> Work-up, chromatography, and recrystallisation as an ethanol solvate, followed by precipitation from toluene with hexane afforded the tetra- $\beta$ -naphthyl TADDOL 37 (4.02 g, 55%), mp 203—204 °C;  $[\alpha]_D$  113.3 (*c* 1.0 in EtOAc) (lit.,<sup>54</sup> 204—208 °C;  $[\alpha]_D$  (4*R*, 5*R*)-enantiomer; -115.4);  $\delta_H$  (200 MHz, CDCl<sub>3</sub>), 1.20 (6H, s, 2 x CH<sub>3</sub>), 2.39 (2H, s, 2 x OH), 5.00 (2H, s, 4-H and 5-H) and 7.17—7.99 (28H, m, Ar-H). These data correspond with those reported previously.<sup>54</sup>

#### (4*S*, 5*S*)- $\alpha,\alpha,\alpha',\alpha'$ -2,2-Hexaphenyl-1,3-dioxolane-4,5-dimethanol 38

(4*S*, 5*S*)-Dimethyltartrate (5.0 g, 28 mmol) was reacted with dimethoxydiphenylmethane (9.6 g, 42 mmol, produced by the reaction of benzophenone, excess trimethyl orthoformate and catalytic toluene-*p*-sulfonic acid in methanol) in benzene (50 cm<sup>3</sup>) in the presence of toluene-*p*-sulfonic acid (400 mg, 2.1 mmol). Azeotropic removal of methanol and the described isolation<sup>55</sup> procedure gave the transacetylation product (4*S*, 5*S*)-2,2-diphenyl-1,3-dioxolane-4,5-dicarboxylic acid dimethyl

ester (9.95 g) as a white solid. Treatment of the diphenyl acetal (9.90 g, 29 mmol) with phenyl magnesium bromide (173 mmol, 4.2g magnesium, 18.2 cm<sup>3</sup> bromobenzene) followed by the described work-up procedure<sup>55</sup> produced the crude TADDOL (17.99 g). Column chromatography, followed by crystallisation as a 2-propanol solvate and finally azeotropic removal of the solvent produced the hexaphenyl ligand, **38**, as a foam (8.02 g, 47%), [ $\alpha$ ]<sub>D</sub> -175 (c 0.5 in CHCl<sub>3</sub>) (lit.,<sup>55</sup> [ $\alpha$ ]<sub>D</sub> (4*R*, 5*R*)-enantiomer; 187.5);  $\delta$ <sub>H</sub> (200 MHz, CDCl<sub>3</sub>), 2.06 (2H, s, OH), 5.54 (2H, s, 4-H and 5-H) and 6.90—7.58 (30H, m, Ar-H). These data correspond with those reported previously.<sup>55</sup>

### General Procedure for desymmetrisation reactions

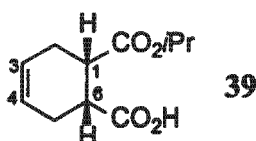

Titanium tetraisopropoxide (1.2eq) was added dropwise to a solution of the TADDOL (1.25eq) in diethyl ether (~8 cm<sup>3</sup>/mmol TADDOL) under nitrogen and the mixture was stirred for 3 h at 25 °C. The solvent was removed under reduced pressure and the Ti-TADDOLate was dried under high vacuum for 30 min. The residue was dissolved in tetrahydrofuran (~4 cm<sup>3</sup>/mmol) and cooled to -30 °C under argon. A cooled (-30 °C) solution of *cis*-1,2,4,6-tetrahydrophthalic anhydride (1.0eq) in tetrahydrofuran (~4 cm<sup>3</sup>/mmol) was added. The reaction temperature, duration, work-up and isolation procedures are detailed for each reaction below. 200 MHz <sup>1</sup>H NMR spectra of the recovered TADDOLs were run in each case and corresponded to those described above. The identity of the isopropyl half ester **39** was confirmed by 200 MHz <sup>1</sup>H NMR for each experiment.

### General Procedure for reduction of the half ester **39**

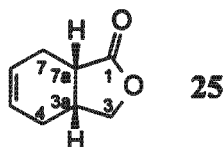

Oxalyl chloride (1.4eq) was added in a dropwise fashion to a solution of **39** (1.0eq) in dichloromethane (~2.5 cm<sup>3</sup>/mmol) at 0 °C. The reaction was warmed to 25 °C and stirred for 3 h after which the solvent was removed and the resulting acid chloride was dried under high vacuum. Sodium borohydride (2.0eq) was added to a stirred solution of the acid chloride in absolute ethanol (~2.5 cm<sup>3</sup>/mmol) at -40 °C. The mixture was stirred at -40 °C for 3 h after which water was added (~2.5 cm<sup>3</sup>/mmol) and it was acidified (pH 2) with 1 M HCl. The mixture was extracted with ethyl acetate and the organic phase was washed with water, dried (MgSO<sub>4</sub>) and the solvent was

removed to give a residue which was dissolved in toluene ( $\sim 2.5 \text{ cm}^3/\text{mmol}$ ) and stirred with toluene-*p*-sulfonic acid ( $\sim 0.1 \text{ eq}$ ) for between 5 and 16 h. The solvent was removed in vacuo to give a residue which was chromatographed on silica gel (50g/1g residue) using ethyl acetate–hexane (3:7) to give the enantiomerically enriched lactone **25**. In all cases the 200 MHz  $^1\text{H}$  NMR spectrum was run and coincided with that described later for **25**:  $\delta_{\text{H}}$  (200 MHz,  $\text{CDCl}_3$ ) 1.70–1.95 (1H, m, 3a-H), 2.15–2.70 (4H, m, 4-H<sub>2</sub> and 7-H<sub>2</sub>), 2.70–2.83 (1H, m, 7a-H), 4.00 (1H, dd,  $J$  8.9 and 2.2 Hz, 3-H<sub>A</sub>) 4.30 (1H, dd,  $J$  8.9 and 5.1 Hz, 3-H<sub>B</sub>) and 5.63–5.83 (2H, m, 5-H and 6-H);  $\delta_{\text{C}}$  (50 MHz,  $\text{CDCl}_3$ ) 22.0 (C-4), 24.7 (C-7), 31.9 (C-3a), 37.2 (C-7a), 72.7 (C-3), 124.8, 125.1 (C-5 and C-6) and 179.0 (C=O)

The enantiomer ratios of **25** were determined by gas chromatography on a Carlo Erba Vega 6200 instrument using the following conditions:

Stationary phase: Heptakis-2,3-di-*O*-acetyl-6-*O*-TBS- $\beta$ -CD (30m x 0.2mm i.d. manufactured at the University of Stellenbosch)

Carrier: H<sub>2</sub>; 56 kPa

Injector temperature: 200 °C

Temperature programme: 38 °C 10 min

38–150 °C at 2.1 °C/min

150–160 °C at 0.5 °C/min

Detection: FID, Temperature 240 °C

#### Desymmetrisations using dimethyl-tetraphenyl TADDOL **36**

a) *cis*-1,2,4,6-Tetrahydrophthalic anhydride (690 mg, 4.0 mmol) was reacted at  $-20 \text{ }^\circ\text{C}$  for 7 days after which the solution was acidified with 1 M HCl, warmed to  $25 \text{ }^\circ\text{C}$  and concentrated under reduced pressure. Water was added to the aqueous slurry and it was extracted with ethyl acetate. The organic phase was dried ( $\text{MgSO}_4$ ) and the solvent was removed under reduced pressure to give a residue (3.85 g) which was chromatographed on silica gel (55 g) using ethyl acetate–hexane (1:9) as eluent to recover **36**. Further elution with ethyl acetate–hexane (2:3) afforded isopropyl hydrogen (1*S*, 2*R*)-cyclohex-4-ene-1,2-dicarboxylate **39** (369 mg, 40%),  $\delta_{\text{H}}$  (200 MHz,  $\text{CDCl}_3$ ) 1.20 [6H, d,  $J$  6.2 Hz,  $\text{CH}(\text{CH}_3)_2$ ], 2.23–2.65 (4H, m, 2-H<sub>2</sub> and 5-H<sub>2</sub>), 2.94–3.10 (2H, m, 1-H and 6-H), 5.03 [1H, sept, 6 x 6.1 Hz,  $\text{CH}(\text{CH}_3)_2$ ] and 5.58–5.75 (2H, m, 3-H and 4-H).  $^1\text{H}$  NMR data correspond with literature data.<sup>48</sup> Following this, elution with ethyl acetate yielded unreacted anhydride (185 mg, 30%).

Reduction and lactonisation of **39** (360 mg, 1.70 mmol) gave (3*a*R, 7*a*S)-3*a*,4,7,7*a*-Tetrahydro-3*H*-isobenzofuran-1-one **25** (199 mg, 85%) with e.r. 97.2:2.8.

b) *cis*-1,2,4,6-Tetrahydrophthalic anhydride (690 mg, 4.0 mmol) was reacted at -15 °C for 7 days after which the solution worked up as in (a) to give a residue (2.63 g) which was chromatographed on silica gel (100 g) using ethyl acetate-hexane (1:9) as eluent to recover **36** (2.01, 85%). Further elution with ethyl acetate-hexane (2:3) afforded **39** (552 mg, 90%).

Reduction and lactonisation of **39** (150 mg, 0.71 mmol) gave **25** (69 mg, 71%) with e.r. 91.9:8.1.

c) *cis*-1,2,4,6-Tetrahydrophthalic anhydride (4.56 mg, 30.0 mmol) was reacted at -20 °C for 7 days after which the solution was poured into 0.5 M NaOH (500 cm<sup>3</sup>), warmed to 25 °C and extracted with diethyl ether. The organic phase was dried (MgSO<sub>4</sub>) and the solvent was removed under reduced pressure to give a residue (10.67 g) which was chromatographed on silica gel (100 g) using ethyl acetate-hexane (1:9) as eluent to recover **36** (10.30 g, 59%). The aqueous phase was acidified with 1 M HCl (pH 2), extracted with ethyl acetate and the organic phase was dried (MgSO<sub>4</sub>). Removal of the solvent under reduced pressure gave a crude mixture (6.67 g) which was chromatographed on silica gel (100 g) using ethyl acetate-hexane (2:3) as eluent to give **39** (4.79 g, 75%) Further elution with ethyl acetate yielded unreacted anhydride (907 mg, 20%).

Reduction and lactonisation of **39** (1.06 mg, 5.0 mmol) gave **25** (560 mg, 82%) with e.r. 92.0:8.0.

d) *cis*-1,2,4,6-Tetrahydrophthalic anhydride (3.80 g, 25.0 mmol) was reacted at -20 °C for 10 days after which the solution was poured into 0.5 M NaOH (500 cm<sup>3</sup>), warmed to 25 °C and extracted with dichloromethane. The organic phase was dried (MgSO<sub>4</sub>) and the solvent was removed under reduced pressure to give a residue (11.47) which was chromatographed on silica gel (240 g) using ethyl acetate-hexane (1:9) as eluent to recover **36** (7.36 g, 50%) Further elution with ethyl acetate-hexane (2:3) gave **39** (765 mg, 14%). The aqueous phase was acidified with 1 M HCl (pH 2), extracted with dichloromethane and the organic extract was dried (MgSO<sub>4</sub>). Removal of the solvent under reduced pressure gave a crude mixture (3.70 g) which was chromatographed on silica gel (100 g) using ethyl acetate-hexane (2:3) as eluent to yield **39** (2.49, 47%). No starting material was detected (TLC) in the crude mixtures.

Reduction and lactonisation of **39** (1.00 g, 4.7 mmol) gave **25** (502 mg, 77%) with e.r. 92.6:7.4.

#### **Desymmetrisation using dimethyl-tetra(2-naphthyl) TADDOL **37****

a) *cis*-1,2,4,6-Tetrahydrophthalic anhydride (690 mg, 4.0 mmol) was reacted at -15 °C for 7 days after which the solution was acidified with 1 M HCl, warmed to 25 °C and concentrated under reduced pressure. Water was added to the aqueous slurry and it was extracted with ethyl acetate. The organic phase was dried (MgSO<sub>4</sub>) and the solvent was removed under reduced pressure to give

a residue (4.10 g) which was chromatographed on silica gel (60 g) using ethyl acetate–hexane (1:9) as eluent to recover **37** (3.21 g, 85%). Further elution with ethyl acetate–hexane (2:3) afforded **39** (760 mg, 90%).

Reduction and lactonisation of **39** (470 mg, 2.22 mmol) gave **25** (300 mg, 98%) with e.r. 94.4:5.6.

#### **Desymmetrisations using hexaphenyl TADDOL **38****

a) *cis*-1,2,4,6-Tetrahydrophthalic anhydride (690 mg, 4.0 mmol) was reacted at  $-15\text{ }^{\circ}\text{C}$  for 7 days after which the solution was acidified with 1 M HCl, warmed to  $25\text{ }^{\circ}\text{C}$  and concentrated under reduced pressure. Water was added to the aqueous slurry and it was extracted with ethyl acetate. The organic phase was dried ( $\text{MgSO}_4$ ) and the solvent was removed under reduced pressure to give a residue (3.59 g) which was chromatographed on silica gel (150 g) using ethyl acetate–hexane (1:9) as eluent to recover **38** (2.87 g, 97%). Further elution with ethyl acetate–hexane (2:3) afforded **39** (492 mg, 58%).

Reduction and lactonisation of **39** (460 mg, 2.17 mmol) gave **25** (115 mg, 38%) with e.r. 96.9:3.1.

b) *cis*-1,2,4,6-Tetrahydrophthalic anhydride (4.56 g, 30.0 mmol) was reacted at  $-20\text{ }^{\circ}\text{C}$  for 7 days after which the solution was poured into 0.5 M NaOH (500  $\text{cm}^3$ ), warmed to  $25\text{ }^{\circ}\text{C}$  and extracted with dichloromethane. The organic phase was dried ( $\text{MgSO}_4$ ) and the solvent was removed under reduced pressure to give a residue (20.62) which was chromatographed on silica gel (100 g) using ethyl acetate–hexane (1:9) as eluent to recover **38** (20.01 g, 90%)–hexane (2:3). The aqueous phase was acidified with 1 M HCl (pH 2), extracted with dichloromethane and the organic extract was dried ( $\text{MgSO}_4$ ). Removal of the solvent under reduced pressure gave a crude mixture (5.80 g) which was chromatographed on silica gel (150 g) using ethyl acetate–hexane (2:3) as eluent to give **39** (5.63 g, 89%).

Reduction and lactonisation of **39** (3.07 g, 14.5 mmol) gave **25** (1.68 mg, 84%) with e.r. 95.6:4.3.

## 6.3 RACEMIC MODEL SYNTHESIS

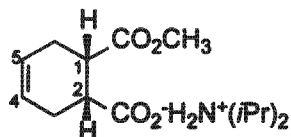
Methyl diisopropylammonium (1*S*\*, 2*R*\*)-cyclohex-4-ene-1,2-dicarboxylate 40

Diisopropylamine (6.0 cm<sup>3</sup>, 42.8 mmol) was added to a stirred solution of *cis*-1,2,4,6-tetrahydrophthalic anhydride **35** (6.08 g, 40.0 mmol) in methanol (200 cm<sup>3</sup>). The resulting solution was stirred at 25 °C for 90 min. The solvent was removed *in vacuo* to give a solid residue (11.5 g). Recrystallisation from ethyl acetate–hexane yielded the *ammonium salt* **40** (9.70 g, 85%), mp 81–83 °C;  $\nu_{\max}(\text{CHCl}_3)/\text{cm}^{-1}$  3025 (NH<sub>2</sub><sup>+</sup>), 1726 (CO ester), 1556 (CO carboxylate);  $\delta_{\text{H}}$  (200 MHz, CDCl<sub>3</sub>) 1.22 [12H, d, *J* 6.5 Hz, 2 x CH(CH<sub>3</sub>)<sub>2</sub>], 2.15–2.70 (4H, m, 3-H<sub>2</sub> and 6-H<sub>2</sub>), 2.72–3.00 (2H, m, 1-H and 2-H), 3.13 [2H, sept, *J* 6 x 6.5 Hz, 2 x CH(CH<sub>3</sub>)<sub>2</sub>], 3.60 (3H, s, CO<sub>2</sub>CH<sub>3</sub>), 5.50–5.72 (2H, m, 4-H and 5-H) and 8.17 (2H, br. s, NH<sub>2</sub><sup>+</sup>);  $\delta_{\text{C}}$  (50 MHz, CDCl<sub>3</sub>) 19.2 (CH(CH<sub>3</sub>)<sub>2</sub>), 25.8 and 27.7 (C-3 and C-6), 40.2 and 41.7 (C-1 and C-2), 45.9 (CO<sub>2</sub>CH<sub>3</sub>), 51.1 (CH(CH<sub>3</sub>)<sub>2</sub>), 125.1 and 126.4 (C-4 and C-5), 175.3 and 178.1 (CO<sub>2</sub><sup>-</sup> and CO<sub>2</sub>CH<sub>3</sub>) (Found: C, 63.0; H, 9.8; N, 4.8. Calc. for C<sub>15</sub>H<sub>27</sub>N<sub>2</sub>O<sub>4</sub>: C, 63.0; H, 9.5; N, 4.9%).

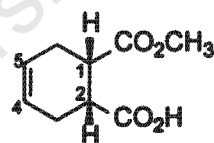
Methyl hydrogen (1*S*\*, 2*R*\*)-cyclohex-4-ene-1,2-dicarboxylate 42

a) The salt **40** (6.30 g, 22.1 mmol) was added to a stirred mixture of ethyl acetate–water (50:50). 1 M HCl was added dropwise until pH 3 was reached. The aqueous phase was extracted with ethyl acetate, dried (MgSO<sub>4</sub>) and the solvent was removed under reduced pressure to give a residue (3.91 g). Recrystallisation from acetone–hexane furnished the half ester **42** (3.66 g, 90%), mp 81–83 °C (lit.,<sup>191</sup> 81.2–83.1 °C);  $\nu_{\max}(\text{CHCl}_3)/\text{cm}^{-1}$  1736 (CO ester), 1714 (CO acid);  $\delta_{\text{H}}$  (200 MHz, CDCl<sub>3</sub>) 2.20–2.68 (4H, m, 3-H<sub>2</sub> and 6-H<sub>2</sub>), 2.98–3.07 (2H, m, 1-H and 2-H), 3.69 (3H, s, CO<sub>2</sub>CH<sub>3</sub>) and 5.54–5.78 (2H, s, 4-H and 5-H).

b) Potassium carbonate (0.70 g, 5.1 mmol) was added to a stirred solution of *cis*-1,2,4,6-tetrahydrophthalic anhydride (1.52 g, 10.0 mmol) in methanol (60 cm<sup>3</sup>). The resulting mixture was stirred at 25 °C for 16 h. The solvent was removed under reduced pressure and the resulting oil was dissolved in ethyl acetate (100 cm<sup>3</sup>). This solution was acidified to pH 4 with 1 M HCl and the

aqueous phase was extracted with ethyl acetate. The organic extract was washed with brine, dried ( $\text{MgSO}_4$ ) and the solvent was removed under reduced pressure to give a residue (0.98 g). Recrystallisation from acetone–hexane gave 42 (0.90 g, 49%), mp 82–83 °C.

**(3a*R*\*, 7a*S*\*)-3a,4,7,7a-Tetrahydro-3*H*-isobenzofuran-1-one 25**

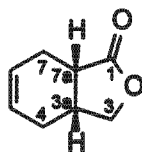

A solution of *cis*-1,2,4,6-tetrahydrophthalic anhydride 35 (15.2 g, 100 mmol) in dry *N,N*-dimethylformamide (50 cm<sup>3</sup>) was added dropwise over a period of 2 h to a stirred solution of sodium borohydride (3.0 g, 80 mmol) in dry *N,N*-dimethylformamide (50 cm<sup>3</sup>) at 0 °C. Water (5 cm<sup>3</sup>) was added and the solvent was removed under reduced pressure. The residue was treated with 2 M  $\text{H}_2\text{SO}_4$  (200 cm<sup>3</sup>) and, after standing for 16 h, was extracted with ethyl acetate. The extract was dried ( $\text{MgSO}_4$ ), and the solvent was removed under reduced pressure. The residue was purified by vacuum distillation to give the lactone 25 (7.7 g, 56%), bp 76–78 °C at 0.1 mm Hg (lit.,<sup>57</sup> 128–130 °C at 2.8 mm Hg);  $\nu_{\text{max}}(\text{CHCl}_3)/\text{cm}^{-1}$  1771 (CO);  $\delta_{\text{H}}$  (200 MHz,  $\text{CDCl}_3$ ) 1.70–1.95 (1H, m, 3a-H), 2.15–2.70 (4H, m, 4-H<sub>2</sub> and 7-H<sub>2</sub>), 2.70–2.83 (1H, m, 7a-H), 4.00 (1H, dd, *J* 8.9 and 2.2 Hz, 3-H<sub>A</sub>) 4.30 (1H, dd, *J* 8.9 and 5.1 Hz, 3-H<sub>B</sub>) and 5.63–5.83 (2H, m, 5-H and 6-H);  $\delta_{\text{C}}$  (50 MHz,  $\text{CDCl}_3$ ) 22.0 (C-4), 24.7 (C-7), 31.9 (C-3a), 37.2 (C-7a), 72.7 (C-3), 124.8, 125.1 (C-5 and C-6) and 179.0 (C=O).

Flash chromatography of the distillation residue on silica gel (150 g) using ethyl acetate–hexane (2:3) afforded a further 3.0 g (22%) of 25.

**(3a*R*\*, 7a*S*\*)-3a,4,7,7a-Tetrahydro-3*H*-isobenzofuran-1-ol 43**

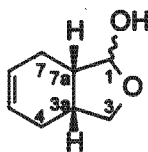

a) Diisobutylaluminium hydride (1.5 M solution in toluene, 5.3 cm<sup>3</sup>, 8.0 mmol) was added in one portion to a stirred solution of the lactone 25 (1.00 g, 7.2 mmol) in dry toluene (30 cm<sup>3</sup>) at –78 °C and the resulting solution was stirred for 1 h at –78 °C. Then HCl (3 M, 2 cm<sup>3</sup>) was added to the reaction mixture which was subsequently acidified to pH 2 by further addition of 1 M HCl. The aqueous phase was extracted with ethyl acetate, the organic extract was dried ( $\text{MgSO}_4$ ) and the solvent was removed under reduced pressure. The resulting oil (1.12 g) was chromatographed on

silica gel (400 g) using ethyl acetate–hexane (1:3) as eluent afforded the lactol **43** (0.93 g, 92%), as an inseparable mixture (~8:1 by NMR) of diastereomers,  $\nu_{\max}(\text{CHCl}_3)/\text{cm}^{-1}$  3601 (OH);  $\delta_{\text{H}}$  (200 MHz,  $\text{CDCl}_3$ ) *major* 1.64–2.09 (1H, m, 3a-H), 2.10–2.70 (4H, m, 4-H<sub>2</sub> and 7-H<sub>2</sub>), 2.55–2.75 (1H, m, 7a-H), 4.00 (1H, dd,  $J$  8.9 and 2.2 Hz, 3-H<sub>A</sub>) 4.30 (1H, dd,  $J$  8.9 and 5.1 Hz, 3-H<sub>B</sub>) and 5.72 (2H, m, 5-H, 6-H);  $\delta_{\text{C}}$  (50 MHz,  $\text{CDCl}_3$ ) 22.9 (C-4), 23.2 (C-7), 32.8 (C-3a), 41.3 (C-7a), 72.2 (C-3), 103.4 (C-1), 124.6 and 124.7 (C-5 and C-6). These data correspond to literature values.<sup>60</sup>

b) Diisobutylaluminium hydride (1.5 M solution in toluene, 80 cm<sup>3</sup>, 120 mmol) was slowly added to a stirred solution of the lactone **25** (11.10 g, 80 mmol) in dry toluene (300 cm<sup>3</sup>) at –78 °C and the resulting solution was stirred for 1 h at –78 °C. The reaction was quenched with 3 M HCl (20 cm<sup>3</sup>) and the aqueous phase was adjusted to pH 2 by the addition of 1 M HCl. The aqueous phase was extracted with ethyl acetate, the combined organic extract was dried ( $\text{MgSO}_4$ ) and the solvent was removed under reduced pressure. Chromatography of the residue (13.50 g) on silica gel (400 g) using ethyl acetate–hexane (1:3) as eluent afforded the lactol **43** (8.10 g, 72%). Further elution with ethyl acetate yielded diol (4*R*\*, 5*S*\*)-4,5-di(hydroxymethyl)cyclohexene **41** (2.61 g, 23%),  $\delta_{\text{H}}$  (200 MHz,  $\text{CDCl}_3$ ) 1.80–2.20 (6H, m, 3-H<sub>2</sub>, 4-H, 5-H and 6-H<sub>2</sub>), 3.45–3.68 (4H, m, 2 x  $\text{CH}_2\text{OH}$ ), 3.95–4.35 (2H, br.s, 2 x  $\text{CH}_2\text{OH}$ ), 5.47–5.60 (2H, m, 1-H and 2-H). These data correspond to literature values.<sup>192</sup>

#### (4*R*\*, 5*R*\*)-4-Hydroxymethyl-5-vinylcyclohexene **44**

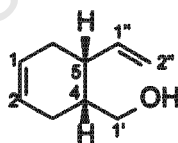

*n*-Butyllithium (2.5 M solution in hexane, 8.6 cm<sup>3</sup>) was added to a stirred slurry of methyltriphenylphosphonium iodide (8.65 g, 21.4 mmol) in tetrahydrofuran (40 cm<sup>3</sup>) at 0 °C. The resulting solution was warmed to 25 °C and stirred for 2 h. A solution of lactol **43** (0.93 g, 6.6 mmol) in tetrahydrofuran (20 cm<sup>3</sup>) was slowly added and the mixture was stirred for 30 min at 25 °C. 1 M HCl (100 cm<sup>3</sup>) was added and the mixture was extracted with ethyl acetate. The organic extract was dried ( $\text{MgSO}_4$ ) and the solvent was removed under reduced pressure to give a yellow residue (1.02 g). Chromatography on silica gel (100 g) using ethyl acetate–hexane (1:4) as eluent yielded the vinyl alcohol **44** (0.81 g, 89%),  $\nu_{\max}(\text{CHCl}_3)/\text{cm}^{-1}$  3620 (OH);  $\delta_{\text{H}}$  (300 MHz,  $\text{CDCl}_3$ ) 1.66 (1H, br.s, OH), 1.79–2.12 (4H, m, 3-H<sub>2</sub>, 4-H and 6-H<sub>A</sub>), 2.23–2.33 (1H, m, 6-H<sub>B</sub>), 2.54–2.63 (1H, m, 5-H) 3.48 (1H, dd,  $J$  10.6 and 6.5 Hz, 1'-H<sub>A</sub>), 3.56 (1H, dd,  $J$  10.6 and 6.8 Hz, 1'-H<sub>B</sub>), 5.04 (1H, ddd,  $J$  10.3, 2.1 and 0.9 Hz, 2'-H<sub>A</sub>), 5.08 (1H, ddd,  $J$  17.2, 2.1 and 1.2 Hz, 2'-H<sub>B</sub>),

5.60—75.71 (2H, m, 1-H and 2-H) and 5.87 (1H, ddd,  $J$  17.2, 10.3 and 8.5 Hz, 1''-H);  $\delta_C$  (75 MHz,  $\text{CDCl}_3$ ) 25.6 (C-3), 30.1 (C-6), 38.2 (C-5), 39.2 (C-4), 64.8 (C-1'), 115.2 (C-2''), 125.4 and 125.6 (C-1 and C-2) and 139.3 (C-1'').  $^1\text{H}$  NMR data correspond to literature values.<sup>58</sup>

**(1*R*\*, 6*R*\*)-6-Vinyl-3-cyclohexene-1-carbaldehyde 45**

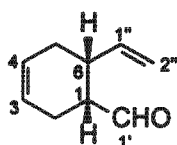

Dimethyl sulfoxide (0.33  $\text{cm}^3$ , 0.36 g, 4.64 mmol) was added to a stirred solution of oxalyl chloride (0.20  $\text{cm}^3$ , 0.29 g, 2.32 mmol) in dichloromethane (3  $\text{cm}^3$ ) at  $-78^\circ\text{C}$ . After 10 min a solution of 44 (320 mg, 2.32 mmol) in dichloromethane (2  $\text{cm}^3$ ) was added and the solution was stirred for 30 min. Triethylamine (38  $\text{cm}^3$ , 1.48 g, 14.6 mmol) was added and the mixture was stirred for 45 min then warmed to  $25^\circ\text{C}$ . Saturated aqueous ammonium chloride was added and the mixture was extracted with dichloromethane. The organic extract was washed with brine, dried ( $\text{MgSO}_4$ ) and the solvent was removed under reduced pressure to give a liquid (351 mg). Flash chromatography on silica gel (30 g) using ethyl acetate–hexane (1:9) as eluent afforded the aldehyde 45 (116 mg, 37%),  $\delta_H$  (400 MHz,  $\text{CDCl}_3$ ), 2.02—2.70 (4H, m, 1-H, 2- $\text{H}_2$ , and 5- $\text{H}_A$ ), 2.55—2.70 (1H, m, 5- $\text{H}_B$ ), 2.84—2.99 (1H, m, 6-H) 5.08 (2H, m, 2''- $\text{H}_2$ ), 5.60—75.71 (2H, m, 3-H and 4-H), 5.90 (1H, ddd,  $J$  17.1, 10.5 and 7.6 Hz, 1''-H) and 9.69 (1H, d,  $J$  1.2 Hz, 1'-H).  $^1\text{H}$  NMR data correspond to literature values.<sup>58</sup>

**(4*R*\*, 5*R*\*)-4-(1,3-Dioxan-2-yl)-5-vinylcyclohexene 47**

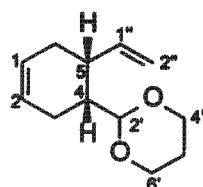

Tetrapropylammonium perruthenate (17 mg, 0.05 mmol), *N*-methylmorpholine-*N*-oxide (826 mg, 7.06 mmol) and powdered 4Å molecular sieve (1.2 g) were added to 44 (650 mg, 4.71 mmol) in dichloromethane (10  $\text{cm}^3$ ) at  $25^\circ\text{C}$  under nitrogen. After 2.5 h the reaction mixture was loaded directly onto a silica column (70 g) and eluted under pressure with dichloromethane. Product fractions were collected and pooled to give a 200  $\text{cm}^3$  solution in dichloromethane to which trimethyl orthoformate (2.6  $\text{cm}^3$ , 23.6 mmol), propan-1,3-diol (4.0  $\text{cm}^3$ , 55.7 mmol) and toluene-*p*-sulfonic acid (60 mg, 0.32 mmol) were added and the resulting mixture was stirred for 40 h.

Aqueous saturated sodium hydrogen carbonate was added and the resulting mixture was extracted with dichloromethane. The combined organic phase was dried ( $\text{MgSO}_4$ ) and the solvent was removed under reduced pressure to give an oily product (1.03 g). Chromatography on silica gel (70 g) using ethyl acetate–hexane (1:9) as eluent yielded the *vinyl acetal* 47 (210 mg, 23%) as an oil,  $\delta_{\text{H}}$  (300 MHz,  $\text{CDCl}_3$ ) 1.28–1.36 (1H, m, 5'- $\text{H}_A$ ) 1.71–2.19 (5H, m, 3- $\text{H}_2$ , 4-H, 5'- $\text{H}_B$  and 6- $\text{H}_A$ ), 2.25–2.37 (1H, m, 6- $\text{H}_B$ ), 2.69–2.77 (1H, m, 5-H), 3.68 (1H, dd,  $J$  12.2 and 2.4 Hz, 4'- $\text{H}_A$  or 6'- $\text{H}_A$ ), 3.73 (1H, dd,  $J$  12.2 and 2.5 Hz, 4'- $\text{H}_A$  or 6'- $\text{H}_A$ ), 4.05–4.16 (2H, m, 4'- $\text{H}_B$  and 6'- $\text{H}_B$ ), 4.27 (1H, d,  $J$  7.7 Hz, 2'-H), 5.02 (1H, dd,  $J$  10.5 and 2.3 Hz, 2''- $\text{H}_A$ ), 5.06 (1H, dd,  $J$  17.1, 2.3 and 0.9 Hz, 2''- $\text{H}_B$ ), 5.57–5.70 (2H, m, 1-H and 2-H) and 5.86 (1H, ddd,  $J$  17.1, 10.5 and 8.9 Hz, 1''-H);  $\delta_{\text{C}}$  (75 MHz,  $\text{CDCl}_3$ ) 23.9 (C-3), 26.3 (C-5'), 31.3 (C-6), 36.6 (C-5), 41.9 (C-4), 66.6 and 66.8 (C-4' and C-6'), 104.1 (C-2'), 115.3 (C-2''), 125.3 and 126.3 (C-1 and C-2) and 139.1 (C-1'') (Found:  $\text{M}^+$ , 194.1322. Calc. for  $\text{C}_{12}\text{H}_{18}\text{O}_2$ :  $M$ , 194.1307).

**(4*R*\*, 5*R*\*)-4-*t*-Butyldiphenylsilyloxymethyl-5-vinylcyclohexene 48**

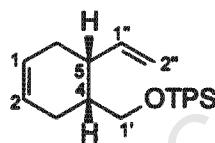

Alcohol 44 (1.10 g, 8.0 mmol) in dry *N,N*-dimethylformamide (15  $\text{cm}^3$ ) and *t*-butyldiphenylsilyl chloride (2.3  $\text{cm}^3$ , 8.8 mmol) were added sequentially to a stirred solution of imidazole (0.65 g, 9.6 mmol) in dry *N,N*-dimethylformamide (20  $\text{cm}^3$ ). The reaction was stirred at 25 °C for 16 h after which it was diluted with diethyl ether (100  $\text{cm}^3$ ) and washed with water. The organic phase was dried ( $\text{MgSO}_4$ ) and the solvent was removed under reduced pressure. The residue was chromatographed on silica gel (100 g) using ethyl acetate–hexane (1:9) as eluent to give the *silyl ether* 48 (2.97 g, 99%) as an oil,  $\delta_{\text{H}}$  (400 MHz,  $\text{CDCl}_3$ ) 1.07 [9H, s,  $\text{C}(\text{CH}_3)_3$ ], 1.78–1.91 (1H, m, 3- $\text{H}_A$ ), 1.92–2.03 (1H, m, 6- $\text{H}_A$ ), 2.02–2.21 (2H, m, 3- $\text{H}_B$  and 4-H), 2.26–2.40 (1H, m, 6- $\text{H}_B$ ), 2.65–2.79 (1H, m, 5-H) 3.53 (1H, dd,  $J$  9.9 and 6.8 Hz, 1'- $\text{H}_A$ ), 3.59 (1H, dd,  $J$  9.9 and 7.2 Hz, 1'- $\text{H}_B$ ), 4.99 (1H, dd,  $J$  10.3 and 2.1 Hz, 2''- $\text{H}_A$ ), 5.05 (1H, ddd,  $J$  17.2, 2.1 and 1.1 Hz, 2''- $\text{H}_B$ ), 5.61–5.72 (2H, m, 1-H and 2-H), 5.79 (1H, ddd,  $J$  17.2, 10.3 and 8.3 Hz, 1''-H), 7.35–7.48 (6H, m, Ar-H) and 7.66–7.78 (4H, m, Ar-H);  $\delta_{\text{C}}$  (100 MHz,  $\text{CDCl}_3$ ) 19.2 [ $\text{C}(\text{CH}_3)_3$ ], 25.4 (C-3), 26.8 [ $\text{C}(\text{CH}_3)_3$ ], 30.3 (C-6), 37.6 (C-5), 39.3 (C-4), 65.4 (C-1'), 115.1 (C-2''), 125.4 and 125.8 (C-1 and C-2), 127.5, 129.4(3) and 129.4(4), 134.0(2) and 134.0(5), 135.5(2) and 135.5(5) (Ar-C\*) and 138.8 (C-1'') (Found:  $\text{M}^+$ , 376.2208. Calc. for  $\text{C}_{25}\text{H}_{32}\text{OSi}$ :  $M$ , 376.2220).

\* Note: The diastereotopic nature of the two phenyl substituents of TPS is reflected by the duplication of signals.

Where these have been resolved, the relevant figures for both signals have been included.

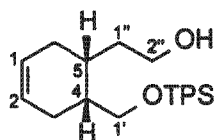
**(4*R*\*, 5*R*\*)-4-*t*-Butyldiphenylsilyloxymethyl-5-(1-hydroxyethyl)cyclohexene 49**

9-Borabicyclo[3.3.1]nonane (0.65 g, 5.3 mmol) was added to a stirred solution of **48** (1.00 g, 2.7 mmol) in tetrahydrofuran (50 cm<sup>3</sup>). After 2 h of stirring at 25 °C 1 M NaOH (25 cm<sup>3</sup>) was slowly added, followed by 30% hydrogen peroxide (10 cm<sup>3</sup>) and the resulting mixture was stirred for 14 h. The mixture was diluted with water (100 cm<sup>3</sup>) and extracted with ethyl acetate. The extract was dried (MgSO<sub>4</sub>), and the solvent was removed under reduced pressure. The residue (3.01 g) was adsorbed onto silica gel (6 g) and chromatographed on silica (150 g) using ethyl acetate–toluene (1:9) as eluent to yield the *alcohol* **49** (1.04 g, 99%) as an oil,  $\nu_{\max}(\text{CHCl}_3)/\text{cm}^{-1}$  3620 (OH);  $\delta_{\text{H}}$  (400 MHz, CDCl<sub>3</sub>) 1.08 [9H, s, C(CH<sub>3</sub>)<sub>3</sub>], 1.38–1.54 (2H, m, 1''-H<sub>2</sub>), 1.78–1.87 (1H, m, 6-H<sub>A</sub>), 1.92–2.10 (5H, m, 3-H<sub>2</sub>, 4-H, 5-H and 6-H<sub>B</sub>), 3.50–3.70 (4H, m, 1'-H<sub>2</sub> and 2''-H<sub>2</sub>), 5.57–5.70 (2H, m, 1-H and 2-H), 7.38–7.48 (6H, m, Ar-H) and 7.67–7.73 (4H, m Ar-H);  $\delta_{\text{C}}$  (100 MHz, CDCl<sub>3</sub>) 19.2 [C(CH<sub>3</sub>)<sub>3</sub>] 26.2 (C-3), 26.9 [C(CH<sub>3</sub>)<sub>3</sub>], 29.5 (C-6), 30.2 (C-5), 32.7 (C-1''), 38.7 (C-4), 61.6 (C-2''), 64.2 (C-1'), 125.5 and 125.8 (C-1 and C-2), 127.5(9) and 127.6(0), 129.5(3) and 129.5(5), 133.8(4) and 133.8(7), 135.5(6) and 135.5(8) (Ar-C) (Found: M<sup>+</sup>, 394.2333. Calc. for C<sub>25</sub>H<sub>34</sub>O<sub>2</sub>Si: M, 394.2325).

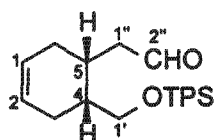
**(4*R*\*, 5*R*\*)-4-*t*-Butyldiphenylsilyloxymethyl-5-formylmethylcyclohexene 51**

Dess-Martin periodinane (1.30 g, 3.07 mmol) was added to a solution of **49** (1.00 g, 2.54 mmol) in dichloromethane (50 cm<sup>3</sup>). The mixture was stirred for 2.5 h at 25 °C after which it was diluted with ether (100 cm<sup>3</sup>), washed with 0.1 M sodium thiosulfate, sodium hydrogen carbonate (sat.) and water. The organic phase was dried (MgSO<sub>4</sub>) and the solvent was removed under reduced pressure to give an oil (1.23 g). Chromatography on silica gel (100 g) using ethyl acetate–hexane (1:9) as eluent afforded the *aldehyde* **51** (920 mg, 92%) as an oil,  $\nu_{\max}(\text{CHCl}_3)/\text{cm}^{-1}$  1721 (CO);  $\delta_{\text{H}}$  (400 MHz, CDCl<sub>3</sub>) 1.07 [9H, s, C(CH<sub>3</sub>)<sub>3</sub>], 1.72–1.86 (2H, m, 3-H<sub>A</sub> and 6-H<sub>A</sub>), 2.00–2.12 (2H, m, 3-H<sub>B</sub> and 4-H), 2.15–2.26 (1H, m, 6-H<sub>B</sub>), 2.25–2.40 (2H, m, 1''-H<sub>2</sub>), 2.55–2.68 (1H, br.s, 5-H), 3.55 (1H, dd, *J* 10.4 and 7.3 Hz, 1'-H<sub>A</sub>), 3.61 (1H, dd, *J* 10.4 and 6.3 Hz, 1'-H<sub>B</sub>), 5.52–5.70 (2H, m, 1-H and 2-H), 7.35–7.44 (6H, m, Ar-H), 7.62–7.67 (4H, m Ar-H) and 9.71 (1H, dd, *J* 2.4 and 1.6 Hz,

2''-H);  $\delta_C$  (100 MHz,  $CDCl_3$ ) 19.2 [ $C(CH_3)_3$ ] 25.6 (C-3), 26.8 [ $C(CH_3)_3$ ], 27.5 (C-5), 29.8 (C-6), 38.5 (C-4), 43.5 (C-1''), 64.6 (C-1'), 124.9 and 125.6 (C-1 and C-2), 127.6(1) and 127.6(4), 129.5(9) and 129.6(4), 133.6, 135.5(0) and 135.5(5) (Ar-C) and 202.8 (C-2'') (Found:  $M^+$ , 392.2177. Calc. for  $C_{25}H_{32}O_2Si$ :  $M$ , 392.2169).

**(4*R*\*, 5*R*\*)-4-*t*-Butyldiphenylsilyloxymethyl-5-carboxymethylcyclohexene\* 52**

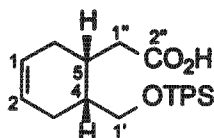

An excess of 8 M  $CrO_3$  was added to a stirred solution of 49 (715 mg, 1.81 mmol) in acetone (30  $cm^3$ ) at  $-30^\circ C$ . The solution was left at  $-16^\circ C$  for 14 h after which the excess reagent was consumed by the addition of propan-2-ol (10  $cm^3$ ). The solution was diluted with ether (100  $cm^3$ ) and washed with water (2 x 100  $cm^3$ ). The organic phase was dried ( $MgSO_4$ ) and the solvent was removed under reduced pressure to give an oil (760 mg). Chromatography on silica gel (60 g) using ethyl acetate-hexane (1:9) as eluent afforded the acid 52 (591 mg, 80%),  $\nu_{max}(CHCl_3)/cm^{-1}$  3512 (OH), 1706 (C=O);  $\delta_H$  (400 MHz,  $CDCl_3$ ) 1.07 [9H, s,  $C(CH_3)_3$ ], 1.78—1.96 (2H, m, 3- $H_A$  and 6- $H_A$ ), 2.02—2.14 (2H, m, 3- $H_B$  and 4-H), 2.16—2.21 (1H, m, 6- $H_B$ ), 2.23 (1H, dd,  $J$  15.4 and 10.3 Hz, 1''- $H_A$ ), 2.33 (1H, dd,  $J$  15.5 and 4.2 Hz, 1''- $H_B$ ), 2.48—2.57 (1H, m, 5-H), 3.58 (2H, d,  $J$  6.4 Hz, 1'- $H_2$ ), 5.54—5.70 (2H, m, 1-H and 2-H), 7.36—7.42 (6H, m, Ar-H) and 7.64—7.70 (4H, m Ar-H);  $\delta_C$  (100 MHz,  $CDCl_3$ ) 19.2 [ $C(CH_3)_3$ ] 25.8 (C-3), 26.8 [ $C(CH_3)_3$ ], 29.6 (C-6), 30.1 (C-5), 34.0 (C-1''), 38.5 (C-4), 64.7 (C-1'), 125.0, 125.6 (C-1 and C-2), 127.5(9) and 127.6(1), 129.5(4) and 129.6(0), 133.6(0) and 133.6(6), 135.5(1) and 135.5(6) (Ar-C) and 179.4 (C-2'') (Found:  $M^+$ , 408.2124. Calc. for  $C_{25}H_{32}O_3Si$ :  $M$ , 408.2120).

\* IUPAC preferred name: (1*R*\*, 6*R*\*)-(6-*t*-Butyldiphenylsilyloxymethylcyclohex-3-en-1-yl)-acetic acid

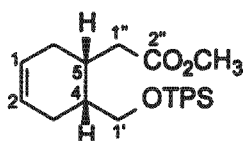
**(4*R*\*, 5*R*\*)-4-*t*-butyldiphenylsilyloxyethylmethyl-5-(methoxycarbonyl)methylcyclohexene\* 53**

Potassium carbonate (182 mg, 1.32 mmol) and iodomethane (0.11 cm<sup>3</sup>, 1.76 mmol) were added to a solution of acid **52** (360 mg, 0.88 mmol) in *N,N*-dimethylformamide (10 cm<sup>3</sup>) at 0 °C. The solution was stirred at 0 °C for 30 min and allowed to warm to 25 °C over 1 h. Dichloromethane (50 cm<sup>3</sup>) was added and the resulting mixture was washed with water and brine, dried (MgSO<sub>4</sub>) and the solvent was removed under reduced pressure to give an oil (1.50 g). Chromatography on silica gel (100 g) using ethyl acetate–hexane (1:19) as eluent afforded the *ester* **53** (330 mg, 89%) as an oil,  $\nu_{\max}(\text{CHCl}_3)/\text{cm}^{-1}$  1730 (CO);  $\delta_{\text{H}}$  (400 MHz, CDCl<sub>3</sub>) 1.06 [9H, s, C(CH<sub>3</sub>)<sub>3</sub>], 1.78–1.92 (2H, m, 3-H<sub>A</sub> and 6-H<sub>A</sub>), 2.02–2.14 (2H, m, 3-H<sub>B</sub> and 4-H), 2.14–2.22 (1H, m, 6-H<sub>B</sub>), 2.20 (1H, dd, *J* 15.3 and 10.2 Hz, 1''-H<sub>A</sub>), 2.28 (1H, dd, *J* 15.3 and 4.3 Hz, 1''-H<sub>B</sub>), 2.45–2.54 (1H, m, 5-H), 3.57 (1H, dd, *J* 10.4 and 6.8 Hz, 1'-H<sub>A</sub>), 3.60 (1H, dd, *J* 10.4 and 6.7 Hz, 1'-H<sub>B</sub>), 3.65 (3H, s, CO<sub>2</sub>CH<sub>3</sub>), 5.52–5.68 (2H, m, 1-H and 2-H), 7.35–7.49 (6H, m, Ar-H) and 7.64–7.70 (4H, m Ar-H);  $\delta_{\text{C}}$  (100 MHz, CDCl<sub>3</sub>) 19.2 [C(CH<sub>3</sub>)<sub>3</sub>], 25.9 (C-3), 26.8 [C(CH<sub>3</sub>)<sub>3</sub>], 29.7 (C-6), 30.4 (C-5), 34.1 (C-1''), 38.7 (C-4), 51.4 (CO<sub>2</sub>CH<sub>3</sub>), 64.7 (C-1'), 125.1, 125.6 (C-1 and C-2), 127.6, 129.5(2) and 129.5(5), 133.7(0) and 133.7(4), 135.5(2) and 135.5(6) (Ar-C) and 173.9 (C-2'') (Found: *M*<sup>+</sup>, 422.2268. Calc. for C<sub>26</sub>H<sub>34</sub>O<sub>3</sub>Si: *M*, 422.2275).

\* IUPAC preferred name: Methyl (1*R*\*, 6*R*\*)-(6-*t*-Butyldiphenylsilyloxyethylmethylcyclohex-3-en-1-yl)acetate

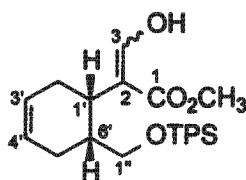
**Formylation of ester 53**

*n*-Butyllithium (2.5 M solution in hexane, 0.48 cm<sup>3</sup>) was added to a stirred solution of diisopropylamine (0.17 cm<sup>3</sup>, 1.20 mmol) in tetrahydrofuran (3 cm<sup>3</sup>) at –78 °C. After 30 min stirring at –78 °C, a solution of **53** (422 mg, 1.00 mmol) in tetrahydrofuran (3 cm<sup>3</sup>) was added and the resulting solution was stirred for 60 min. Ethyl formate (0.12 cm<sup>3</sup>, 1.53 mmol) was added and the solution was warmed over 60 min to –40 °C where the temperature was maintained for a further 60 min. The reaction was acidified with 5% H<sub>3</sub>PO<sub>4</sub> and the volatile media were removed *in vacuo*.

The resulting mixture was extracted with diethyl ether and the organic phase was washed with brine and dried ( $\text{MgSO}_4$ ). Removal of the solvent under reduced pressure gave a residue (497 mg) which was further purified by chromatography on silica gel (50 g) using ethyl acetate–hexane (1:19) as eluent to yield **54** (415 mg, 92%) as an inseparable mixture of the geometrical isomers methyl (1'S\*,2E,6'R\*)- and methyl (1'S\*,2Z,6'R\*)-3-hydroxy-2-(6-*t*-butyldiphenylsilyloxy)methylcyclohex-3-en-1-yl)acrylate.

#### Acetylation of the formylation mixture **54**

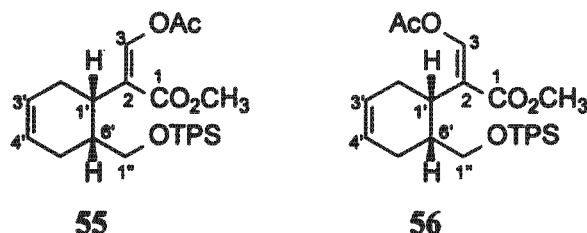

Acetic anhydride (0.23 cm<sup>3</sup>, 2.4mmol), pyridine (0.04 cm<sup>3</sup>, 0.5 mmol) and 4-dimethylaminopyridine (20 mg, 0.16 mmol) were added to a solution of **54** (110 mg, 0.24 mmol) in dichloromethane (5 cm<sup>3</sup>). The resulting solution was stirred for 15 h at 25 °C. Water (5 cm<sup>3</sup>) was added the mixture was stirred for 20 min. The organic phase was washed with water followed by cold 1 M HCl, dried ( $\text{MgSO}_4$ ) and the solvent was removed under reduced pressure to yield the acetylated mixture (120 mg). Chromatography on silica gel (15 g) using ethyl acetate–hexane (1:9) as eluent yielded *Methyl (1'S\*,2Z,6'R\*)-3-acetoxy-2-(6-*t*-butyldiphenylsilyloxy)methylcyclohex-3-en-1-yl) acrylate* **55** (33 mg, 28%) as an oil,  $\nu_{\text{max}}(\text{CHCl}_3)/\text{cm}^{-1}$  1719 and 1761 (CO);  $\delta_{\text{H}}$  (400 MHz,  $\text{CDCl}_3$ ) 1.03 [9H, s,  $\text{C}(\text{CH}_3)_3$ ], 2.03–2.15 (4H, m, 2'-H<sub>A</sub>, 5'-H<sub>2</sub> and 6'-H), 2.15 (3H, s, 3-OCOCH<sub>3</sub>), 2.17–2.27 (1H, m, 2'-H<sub>B</sub>), 3.08–3.14 (1H, m, 1'-H), 3.48 (1H, dd,  $J$  10.1 and 7.8 Hz, 1''-H<sub>A</sub>), 3.61 (1H, dd,  $J$  10.1 and 6.0 Hz, 1''-H<sub>B</sub>), 3.68 (3H, s, 1-OCH<sub>3</sub>), 5.61–5.72 (2H, m, 3'-H and 4'-H), 7.29 (1H, d,  $J$  1.5 Hz, 3-H) 7.33–7.44 (6H, m, Ar-H) and 7.59–7.66 (4H, m Ar-H);  $\delta_{\text{C}}$  (100 MHz,  $\text{CDCl}_3$ ) 19.2 [ $\text{C}(\text{CH}_3)_3$ ] 20.6 (3-OCOCH<sub>3</sub>), 25.9 (C-5'), 26.8 [ $\text{C}(\text{CH}_3)_3$ ], 28.1 (C-2'), 34.0 (C-1'), 38.3 (C-6'), 51.7 (1-OCH<sub>3</sub>), 63.8 (C-1''), 119.5 (C-2), 125.5, 126.1 (C-3' and C-4'), 127.5, 129.4(0) and 129.4(3), 133.8, 135.5 (Ar-C), 137.7 (C-3), 167.1 and 167.3 (C-1 and 3-OCOCH<sub>3</sub>) (Found:  $M^+$ , 492.2317. Calc. for  $\text{C}_{29}\text{H}_{36}\text{O}_5\text{Si}$ :  $M$ , 492.2323).

Further elution afforded *Methyl (1'S\*,2E,6'R\*)-3-acetoxy-2-(6-*t*-butyldiphenylsilyloxy)methylcyclohex-3-en-1-yl)acrylate* **56** (77 mg, 64%),  $\nu_{\text{max}}(\text{CHCl}_3)/\text{cm}^{-1}$  1711, 1771 (CO);  $\delta_{\text{H}}$  (200 MHz,  $\text{CDCl}_3$ ) 1.02 [9H, s,  $\text{C}(\text{CH}_3)_3$ ], 1.89 (3H, s, COCH<sub>3</sub>), 2.00–2.70 (5H, m, 2'-H<sub>2</sub>, 5'-H<sub>2</sub> and 6'-H), 3.15 (1H, ddd,  $J$  11.8, 5.5 and 3.3 Hz, 1'-H), 3.50–3.70 (2H, m, 1''-H<sub>2</sub>), 3.68 (3H, s, 1-OCH<sub>3</sub>),

5.52—5.73 (2H, m, 3'-H and 4'-H), 7.30—7.47 (6H, m, Ar-H), 7.54—7.65 (4H, m Ar-H) and 8.12 (1H, s, 3-H) (Found:  $M^+$ , 492.2330. Calc. for  $C_{29}H_{36}O_5Si$ :  $M$ , 492.2323).

**Methyl (1'S\*,2E,6'R\*)-2-(6-*t*-butyldiphenylsilyloxy)methylcyclohex-3-en-1-yl)-3-*p*-methoxybenzyloxyacrylate 57**

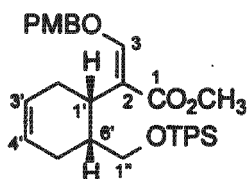

*n*-Butyllithium (10 M solution in hexane, 0.14 cm<sup>3</sup>, 1.40 mmol) was added to a stirred solution of diisopropylamine (0.20 cm<sup>3</sup>, 1.41 mmol) in tetrahydrofuran (4 cm<sup>3</sup>) at -78 °C. After 30 min stirring at -78 °C, a solution of 53 (500 mg, 1.18 mmol) in tetrahydrofuran (4 cm<sup>3</sup>) was added and the resulting solution was stirred for 60 min. Ethyl formate (0.14 cm<sup>3</sup>, 1.78 mmol) was added and the solution was warmed over 60 min to -40 °C where the temperature was maintained for a further 60 min. The reaction was acidified with 5% H<sub>3</sub>PO<sub>4</sub> and the volatile media were removed *in vacuo*. The resulting mixture was extracted with diethyl ether and the organic extract was washed with brine and dried (MgSO<sub>4</sub>). Removal of the solvent under reduced pressure gave an oil (730 mg) which was dissolved in dry dimethylformamide (20 cm<sup>3</sup>). Sodium hydride (60% dispersion in oil, 40 mg, 1.00 mmol) was added and the mixture was stirred at 25 °C for 60 min after which *p*-methoxybenzyl chloride (0.36 cm<sup>3</sup>, 2.65 mmol) was added. After 4 h stirring, the reaction mixture was diluted with dichloromethane, washed with water and dried (MgSO<sub>4</sub>). Removal of the solvent under reduced pressure gave a residue (1.073 g) which was chromatographed on silica gel (100 g) using ethyl acetate-hexane (1:9) as eluent to yield the *aryl enol* 57 (620 mg, 92%) as an oil,  $\nu_{\max}(\text{CHCl}_3)/\text{cm}^{-1}$  1699 (CO);  $\delta_{\text{H}}$  (400 MHz, CDCl<sub>3</sub>) 1.02 [9H, s, C(CH<sub>3</sub>)<sub>3</sub>], 1.72—1.82 (1H, m, 2'-H<sub>A</sub>), 2.03—2.11 (1H, m, 6'-H), 2.19—2.30 (1H, m, 5'-H<sub>A</sub>), 2.43—2.53 (1H, m, 5'-H<sub>B</sub>), 2.60—2.72 (1H, m, 2'-H<sub>B</sub>), 3.07 (1H, ddd,  $J$  12.6, 5.4 and 3.3 Hz, 1'-H), 3.63 (3H, s, 1-OCH<sub>3</sub>), 3.64—3.78 (2H, m, 1''-H<sub>2</sub>), 3.77 (3H, s, Ar-OCH<sub>3</sub>), 4.52 (1H, d,  $J$  11.7 Hz, Ar-CH<sub>A</sub>-O), 4.58 (1H, d,  $J$  11.7 Hz, Ar-CH<sub>B</sub>-O), 5.52—5.68 (2H, m, 3'-H and 4'-H), 6.70—6.75 (2H, m, PMB Ar-H), 6.95—7.02 (2H, m, PMB Ar-H), 7.22—7.45 (7H, m, 3-H and TPS Ar-H) and 7.56—7.65 (4H, m TPS Ar-H);  $\delta_{\text{C}}$  (100 MHz, CDCl<sub>3</sub>) 19.3 [C(CH<sub>3</sub>)<sub>3</sub>] 24.8 (C-2'), 27.0 [C(CH<sub>3</sub>)<sub>3</sub>], 27.6 (C-5'), 34.4 (C-1'), 40.0 (C-6'), 51.5 (1-OCH<sub>3</sub>), 55.5 (Ar-OCH<sub>3</sub>), 63.1 (C-1''), 75.8 (Ar-CH<sub>2</sub>-O), 112.7 (C-2), 114.6 (PMB Ar-C), 125.2, 127.8 (C-3' and C-4'), 127.7, 129.8 (PMB Ar-C), 128.0(8) and 128.1(6), 129.9(7) and 129.9(9), 135.0(2) and 135.1(3), 136.3(2) and 136.4(0) (TPS Ar-C), 159.0 (C-3), 160.5 (PMB Ar-C) and 170.0 (C-1) (Found:  $M^+$ , 570.2780. Calc. for  $C_{35}H_{42}O_5Si$ :  $M$ , 570.2791).

**Methyl (2*E*,1'*S*\*,2'*R*\*)-2-(2-*t*-butyldiphenylsilanyloxymethyl-4ξ-5ξ-dihydroxycyclohexan-1-yl)-3-*p*-methoxybenzyloxyacrylate 61**

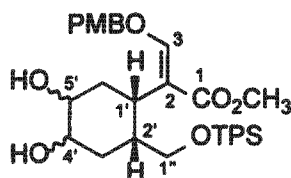

Osmium tetroxide (152 mg, 0.60 mmol) was added to a stirred solution of **57** (285 mg, 0.5 mmol) in dry pyridine (10 cm<sup>3</sup>) and the solution was stirred at 25 °C for 60 min. Saturated aqueous sodium metabisulfite was added and the solution was stirred for 2 h after which it was acidified with 1 M HCl and extracted with ethyl acetate. The extract was dried (MgSO<sub>4</sub>), and the solvent was removed to give a solid residue (300 mg). Chromatography on silica gel (50 g) using ethyl acetate–hexane (1:1) as eluent afforded the *cyclohexanediol* **61** (130 mg, 43%), mp 141–142 °C (from toluene);  $\nu_{\max}(\text{CHCl}_3)/\text{cm}^{-1}$  3611 (OH);  $\delta_{\text{H}}$  (400 MHz, CDCl<sub>3</sub>) 1.02 [9H, s, C(CH<sub>3</sub>)<sub>3</sub>], 1.60 (1H, br.s, -OH), 1.61 (1H, dt,  $J$  14.3 and 2 x 4.1 Hz, 6'-H<sub>A</sub>), 1.75 (1H, td,  $J$  2 x 13.1 and 4.5 Hz, 3'-H<sub>A</sub>), 2.07 (1H, br.s, -OH), 2.08–2.17 (2H, m, 2'-H and 3'-H<sub>B</sub>), 2.22 (1H, td,  $J$  2 x 14.3 and 2.7 Hz, 6'-H<sub>B</sub>), 3.28 (1H, dt,  $J$  9.9 and 2 x 4.1 Hz, 1'-H), 3.50–3.61 (2H, m, 1''-H<sub>A</sub> and 4'-H), 3.61 (3H, s, 1-OCH<sub>3</sub>), 3.67 (1H, t,  $J$  2 x 10.3 Hz, 1''-H<sub>B</sub>), 3.78 (3H, s, Ar-OCH<sub>3</sub>), 3.88–3.92 (1H, m, 5'-H), 4.65 (2H, s, Ar-CH<sub>2</sub>-O), 6.72–6.78 (2H, m, PMB Ar-H), 7.00–7.06 (2H, m, PMB Ar-H), 7.28–7.45 (7H, m, 3-H and TPS Ar-H) and 7.56–7.65 (4H, m TPS Ar-H);  $\delta_{\text{C}}$  (100 MHz, CDCl<sub>3</sub>) 19.2 [C(CH<sub>3</sub>)<sub>3</sub>], 26.9 [C(CH<sub>3</sub>)<sub>3</sub>], 29.2 (C-3'), 29.7 (C-1'), 30.4 (C-6'), 40.5 (C-2'), 51.2 (1-OCH<sub>3</sub>), 55.3 (Ar-OCH<sub>3</sub>), 62.1 (C-1''), 67.4 (C-4'), 69.4 (C-5'), 75.5 (Ar-CH<sub>2</sub>-O), 111.2 (C-2), 114.0, 127.8, 129.2 (PMB Ar-C), 127.4(9) and 127.5(6), 129.4 (7) and 129.5(1), 133.9(6) and 134.1(1), 135.6 (TPS Ar-C), 158.5 (C-3), 160.0 (PMB Ar-C) and 168.9 (C-1) (Found: C, 69.2; H, 7.4%, M<sup>+</sup>-C<sub>4</sub>H<sub>9</sub>, 547.2133. Calc. for C<sub>35</sub>H<sub>44</sub>O<sub>7</sub>Si: C, 69.5; H, 7.4%, C<sub>31</sub>H<sub>35</sub>O<sub>7</sub>Si: M, 547.2143).

**Methyl (2*E*,3*S*\*,4*R*\*)-4-*t*-butyldiphenylsilanyloxymethyl-3-formylmethyl-2-*p*-methoxybenzyl-oxymethylene-6-oxohexanoate 62**

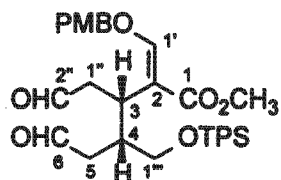

Lead tetraacetate (150 mg, 0.34 mmol) was added over a 30 min period to a stirred solution of **61** (160 mg, 0.26 mmol) in toluene (5 cm<sup>3</sup>). The solution was stirred at 25 °C for a further 30 min after which ethylene glycol (2 drops) was added and the solution was stirred for 10 min. The

resulting mixture was filtered through Celite and the solvent was removed to give an oily residue (200 mg). Chromatography on silica gel (20 g) using ethyl acetate–hexane (1:9) as eluent afforded the unstable *dialdehyde* **62** (70 mg, 45%) as an oil,  $\nu_{\max}(\text{CHCl}_3)/\text{cm}^{-1}$  1722 (CO);  $\delta_{\text{H}}$  (400 MHz,  $\text{CDCl}_3$ ) 1.04 [9H, s,  $\text{C}(\text{CH}_3)_3$ ], 2.28 (1H, ddd,  $J$  17.0, 4.3 and 2.1 Hz, 5- $\text{H}_A$ ), 2.34 (1H, ddd,  $J$  16.2, 4.3 and 1.3 Hz, 1''- $\text{H}_A$ ), 2.45 (1H, ddd,  $J$  17.0, 8.2 and 2.1 Hz, 5- $\text{H}_B$ ), 2.52–2.62 (1H, m, 4-H), 2.70 (1H, ddd,  $J$  16.2, 10.6 and 3.3 Hz, 1''- $\text{H}_B$ ), 3.43–3.52 (1H, m, 3-H), 3.58 (1H, dd,  $J$  5.3 and 10.8 Hz, 1'''- $\text{H}_A$ ), 3.66 (3H, s, 1-OCH<sub>3</sub>), 3.70 (1H, dd,  $J$  10.8 and 3.2 Hz, 1'''- $\text{H}_B$ ), 3.81 (3H, s, Ar-OCH<sub>3</sub>), 4.91 (2H, s, Ar-CH<sub>2</sub>-O), 6.86–6.96 (2H, m, PMB Ar-H), 7.20–7.24 (2H, m, PMB Ar-H), 7.35–7.46 (6H, m, TPS Ar-H), 7.51 (1H, s, 1'-H) 7.58–7.70 (4H, m TPS Ar-H), 9.43 (1H, dd,  $J$  3.3 and 1.3 Hz, 2''-H) and 9.55 (1H, t,  $J$  2 x 2.1 Hz, 6-H);  $\delta_{\text{C}}$  (100 MHz,  $\text{CDCl}_3$ ) 19.2 [ $\text{C}(\text{CH}_3)_3$ ], 26.8 [ $\text{C}(\text{CH}_3)_3$ ], 30.7 (C-3), 38.0 (C-4), 44.6 (C-1''), 44.8 (C-5), 51.3 (1-OCH<sub>3</sub>), 55.3 (Ar-OCH<sub>3</sub>), 64.1 (C-1'''), 75.5 (Ar-CH<sub>2</sub>-O), 110.1 (C-2), 114.2, 127.5 and 129.6 (PMB Ar-C), 127.7(2) and 127.7(5), 129.7(8) and 129.8(4), 133.0, 135.5(9) and 135.6(3) (TPS Ar-C), 159.3 (C-2'), 160.0 (PMB Ar-C), 167.7 (C-1), 202.0 (C-2'') and 202.3 (C-6) (Found:  $M^+$  602.2678. Calc. for  $\text{C}_{35}\text{H}_{42}\text{O}_7\text{Si}$ :  $M$ , 602.2689).

#### Methyl (3*R*\*,4*R*\*)-4-*t*-butyldiphenylsilanyloxymethyl-3-formylmethyl-6-oxohexanoate **63**

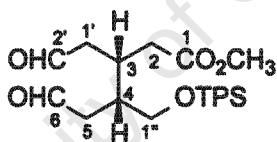

Ozone was bubbled through a solution of **53** (320 mg, 0.76 mmol) in methanol (15 cm<sup>3</sup>) at -78 °C for 5 min. The solution was placed under positive nitrogen pressure and dimethyl sulfide (0.09 cm<sup>3</sup>, 1.23 mmol) was added. The resulting solution was warmed to 25 °C and stirred for 3 h. The solvent was removed *in vacuo* to give an oily residue (390 mg). Flash chromatography on silica gel (20 g) using ethyl acetate–hexane (2:3) as eluent yielded the unstable *dialdehyde* **63** (0.50 mg, 83%) as an oil,  $\nu_{\max}(\text{CHCl}_3)/\text{cm}^{-1}$  1727 (CO);  $\delta_{\text{H}}$  (400 MHz,  $\text{CDCl}_3$ ) 1.04 [9H, s,  $\text{C}(\text{CH}_3)_3$ ], 2.22 (1H, dd,  $J$  15.7 and 8.3 Hz, 1'- $\text{H}_A$ ), 2.30–2.50 (6H, m, 2- $\text{H}_2$ , 1'- $\text{H}_B$ , 4-H, 5- $\text{H}_2$ ) 2.65 (1H, m, 3-H), 3.53–3.64 (2H, m, 1''- $\text{H}_2$ ), 3.63 (3H, s, 1-OCH<sub>3</sub>), 7.34–7.45 (6H, m, Ar-H), 7.57–7.65 (4H, m Ar-H), 9.65–9.70 (2H, m, 2'-H and 6-H);  $\delta_{\text{C}}$  (100 MHz,  $\text{CDCl}_3$ ) 19.1 [ $\text{C}(\text{CH}_3)_3$ ], 26.8 [ $\text{C}(\text{CH}_3)_3$ ], 30.6 (C-3), 36.0 (C-1'), 38.2 (C-4), 43.2 (C-5), 45.7 (C-2), 51.7 (1-OCH<sub>3</sub>), 64.4 (C-1''), 127.8, 129.9, 132.8(1) and 132.8(5), 135.5(3) and 135.5(6) (TPS Ar-C), 167.7 (C-1), 200.8 and 201.0 (C-2' and C-6) (Found:  $M^+$ - $\text{C}_4\text{H}_9$ , 397.1471. Calc. for  $\text{C}_{22}\text{H}_{25}\text{O}_5\text{Si}$ :  $M$ , 397.1463).

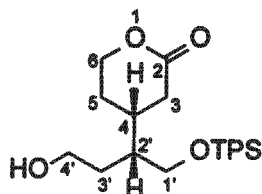
**(2'R\*,4R\*)-4-(1-*t*-Butyldiphenylsilynyloxy-4-hydroxybutan-2-yl)tetrahydropyran-2-one 64**

Ozone was bubbled through a solution of **53** (200 mg, 0.47 mmol) in dichloromethane (10 cm<sup>3</sup>) at -78 °C until a faint blue colour appeared. Nitrogen was bubbled through the solution for 10 min and borane dimethylsulfide complex (1.0 M solution in dichloromethane, 1.9 cm<sup>3</sup>) was added. The solution was warmed to 25 °C and stirred for 18 h. The reaction was acidified with 1 M HCl (0.5 cm<sup>3</sup>) and the solution was stirred vigorously for 2 h. Solid sodium carbonate was added until the pH of the aqueous portion reached 10. Magnesium sulfate was added to dry the solution and the mixture was filtered through a sintered glass funnel and rinsed with dichloromethane. The filtrate and rinsings were combined and the solvent was removed under reduced pressure to give a crude product (210 mg). Chromatography on silica gel (25 g) using ethyl acetate-hexane (3:2) as eluent yielded the *lactone* **64** (135 mg, 67%) as an oil,  $\nu_{\max}(\text{CHCl}_3)/\text{cm}^{-1}$  1731 (CO);  $\delta_{\text{H}}$  (400 MHz, CDCl<sub>3</sub>) 1.06 [9H, s, C(CH<sub>3</sub>)<sub>3</sub>], 1.46–1.68 (4H, m, 5-H<sub>A</sub>, 3'-H<sub>2</sub> and 2'-H), 1.68–1.77 (1H, m, 5-H<sub>B</sub>), 1.85 (1H, br.s, OH), 2.07–2.25 (2H, m, 3-H<sub>A</sub> and 4-H), 2.59 (1H, ddd,  $J$  16.7, 5.5 and 1.8 Hz, 3-H<sub>B</sub>), 3.54–3.66 (4H, m, 1'-H<sub>2</sub> and 4'-H<sub>2</sub>), 4.13 (1H, td,  $J$  2 x 11.3 and 3.6 Hz, 6-H<sub>A</sub>), 4.31 (1H, ddd,  $J$  11.3, 4.9 and 3.6 Hz, 6-H<sub>B</sub>), 7.34–7.50 (6H, m, Ar-H) and 7.58–7.67 (4H, m Ar-H);  $\delta_{\text{C}}$  (100 MHz, CDCl<sub>3</sub>) 19.2 [C(CH<sub>3</sub>)<sub>3</sub>], 26.5 (C-5), 26.9 [C(CH<sub>3</sub>)<sub>3</sub>], 31.2 (C-3'), 32.8 (C-4), 33.9 (C-3), 41.8 (C-2'), 60.7 and 63.7 (C-1' and C-4'), 68.6 (C-6), 127.7(3) and 127.8(1), 130.0, 132.9(2) and 132.9(8), 135.5(6) and 135.5(9) (Ar-C) and 171.5 (C-2) (Found:  $M^+$ , 426.2216. Calc. for C<sub>25</sub>H<sub>34</sub>O<sub>4</sub>Si:  $M$ , 426.2224).

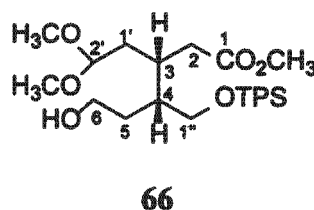
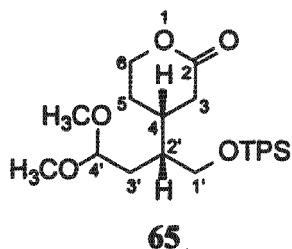
**Ozonolysis-trapping of cyclohexene 53**

Ozone was passed through a solution of **53** (1.00 g, 2.4 mmol) in methanol (150 cm<sup>3</sup>) at -78 °C until the solution turned blue. Argon was bubbled through the solution for 20 min after which toluene-*p*-sulfonic acid monohydrate (100 mg, 0.5 mmol) was added and the solution was warmed

to 25 °C and stirred for 2 h. The solution was cooled to 0 °C and sodium borohydride (350 mg, 9.5 mmol) was added. After 5 min water was added and the mixture was acidified (1 M HCl). The volatile media were removed under reduced pressure and the resulting mixture was extracted with ethyl acetate. The organic phase was washed with brine to yield the crude mixture (1.43 g) which was chromatographed on silica gel (70 g) using ethyl acetate–hexane (3:7) as eluent to yield a 1:1 mixture of **65** and **66** (994 mg, 86% based on a 1:1 distribution of products).

A portion (397 mg) of the mixture was chromatographed on silica (50 g) using ethyl acetate–hexane (3:7) as eluent to give (2'R\*,4R\*)-4-(1-*t*-Butyldiphenylsilyloxy-4,4-dimethoxybutan-2-yl)tetrahydropyran-2-one **65** (42 mg),  $\nu_{\max}(\text{CHCl}_3)/\text{cm}^{-1}$  1731 (CO);  $\delta_{\text{H}}$  (400 MHz, CDCl<sub>3</sub>) 1.07 [9H, s, C(CH<sub>3</sub>)<sub>3</sub>], 1.53–1.73 (4H, m, 5-H<sub>A</sub>, 3'-H<sub>2</sub> and 2'-H), 1.76–1.86 (1H, m, 5-H<sub>B</sub>), 2.18–2.39 (2H, m, 3-H<sub>A</sub> and 4-H), 2.61–2.69 (1H, m, 3-H<sub>B</sub>), 3.24 (3H, s, 4'-OCH<sub>3</sub>), 3.26 (3H, s, 4'-OCH<sub>3</sub>), 3.57–3.64 (1H, m, 1'-H<sub>A</sub>), 3.65–3.72 (1H, m, 1'-H<sub>B</sub>), 4.17 (1H, td,  $J$  2 x 11.0 and 3.7 Hz, 6-H<sub>A</sub>), 4.28–4.32 (1H, m, 4'-H), 4.36 (1H, ddd,  $J$  11.4, 4.7 and 3.6 Hz, 6-H<sub>B</sub>), 7.37–7.47 (6H, m, Ar-H) and 7.59–7.67 (4H, m, Ar-H);  $\delta_{\text{C}}$  (100 MHz, CDCl<sub>3</sub>) 19.2 [C(CH<sub>3</sub>)<sub>3</sub>], 26.8 (C-5), 26.9 [C(CH<sub>3</sub>)<sub>3</sub>], 30.7 (C-3'), 32.8 (C-4), 33.9 (C-3), 40.6 (C-2'), 52.1 (OCH<sub>3</sub>), 53.1 (OCH<sub>3</sub>), 63.3 (C-1'), 68.7 (C-6), 103.3 (C-4'), 127.7(7) and 127.7(9), 129.8(6) and 129.8(7), 133.2(1) and 133.2(9), 135.5(9) and 135.6(4) (Ar-C) and 171.5 (C-2) (Found: M<sup>+</sup>-C<sub>4</sub>H<sub>9</sub>, 413.1784. Calc. for C<sub>23</sub>H<sub>29</sub>O<sub>5</sub>Si:  $M$ , 413.1796).

Further elution gave mixed fractions (182 mg), followed by Methyl (3R\*,4R\*)-4-*t*-butyldiphenylsilyloxymethyl-3-(2,2-dimethoxyethan-1-yl)-6-hydroxyhexanoate **66**

$\nu_{\max}(\text{CHCl}_3)/\text{cm}^{-1}$  1730 (CO);  $\delta_{\text{H}}$  (400 MHz, CDCl<sub>3</sub>) 1.07 [9H, s, C(CH<sub>3</sub>)<sub>3</sub>], 1.44–1.59 (3H, m, 1'-H<sub>A</sub> and 5-H<sub>2</sub>), 1.60–1.72 (2H, m, 1'-H<sub>B</sub> and OH), 1.85–1.94 (1H, m, 4-H), 2.23–2.38 (2H, m, 2-H<sub>A</sub> and 3-H), 2.42 (1H, dd,  $J$  14.4 and 5.6 Hz, 2-H<sub>B</sub>), 3.29 (3H, s, 2'-OCH<sub>3</sub>), 3.31 (3H, s, 2'-OCH<sub>3</sub>), 3.59 (1H, dd,  $J$  6.4 and 1.6 Hz, 1''-H<sub>A</sub>), 3.66 (3H, s, 1-OCH<sub>3</sub>), 3.56–3.72 (2H, m, 1''-H<sub>B</sub> and 6-H<sub>2</sub>), 4.39 (1H, t,  $J$  2 x 5.6 Hz, 2'-H), 7.35–7.46 (6H, m, Ar-H) and 7.60–7.68 (4H, m, Ar-H);  $\delta_{\text{C}}$  (100 MHz, CDCl<sub>3</sub>) 19.1 [C(CH<sub>3</sub>)<sub>3</sub>], 26.8 [C(CH<sub>3</sub>)<sub>3</sub>], 31.7 (C-5), 32.3 (C-3), 33.7 (C-1'), 36.3 (C-2), 40.2 (C-4), 51.5 (1-OCH<sub>3</sub>), 52.6 (2'-OCH<sub>3</sub>), 53.0 (2'-OCH<sub>3</sub>), 61.2 (C-6), 65.5 (C-1''), 103.3 (C-2'), 127.7, 129.7(6) and 129.7(8), 133.2(3) and 133.2(7), 135.5(9) and 135.6(4) (Ar-C) and 174.0 (C-1) (Found: M<sup>+</sup>-C<sub>4</sub>H<sub>9</sub>, 445.2046. Calc. for C<sub>24</sub>H<sub>33</sub>O<sub>6</sub>Si:  $M$ , 445.2063).

**(2'*R*\*,4*R*\*)-4-[1-*t*-Butyldiphenylsilynyloxy-4-(4-toluenesulfonyloxy)butan-2-yl]tetrahydropyran-2-one 67**

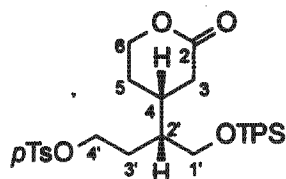

Lactone **64** (260 mg, 0.61 mmol) was dissolved in dry dichloromethane (20 cm<sup>3</sup>). Toluene-*p*-sulfonyl chloride (350 mg, 1.84 mmol) was added, followed by triethylamine (1.50 cm<sup>3</sup>, 10.82 mmol) and the reaction was stirred for 48 h. The reaction mixture was washed with aqueous ammonium chloride and dried (MgSO<sub>4</sub>). The solvent was removed under reduced pressure to give a residue (590 mg). Chromatography on silica gel (50 g) using ethyl acetate–hexane (1:4 followed 2:3) as eluent, yielded the *tosylate* **67** (286 mg, 81%) as a gum,  $\nu_{\max}(\text{CHCl}_3)/\text{cm}^{-1}$  1732 (CO), 1362 and 1175 (SO<sub>2</sub>);  $\delta_{\text{H}}$  (400 MHz, CDCl<sub>3</sub>) 1.02 [9H, s, C(CH<sub>3</sub>)<sub>3</sub>], 1.35–1.75 (5H, m, 5-H<sub>2</sub>, 3'-H<sub>2</sub> and 2'-H), 1.98–2.18 (2H, m, 3-H<sub>A</sub> and 4-H), 2.43 (3H, s, Ar-CH<sub>3</sub>), 2.52 (1H, ddd, *J* 16.9, 5.2 and 1.6 Hz, 3-H<sub>B</sub>), 3.53 (1H, dd, *J* 11.0 and 4.4 Hz, 1'-H<sub>A</sub>), 3.58 (1H, dd, *J* 11.0 and 4.2 Hz, 1'-H<sub>B</sub>), 3.94 (1H, dt, *J* 10.1 and 2 x 6.7 Hz, 4'-H<sub>A</sub>), 4.05–4.12 (1H, m, 4'-H<sub>B</sub> and 6-H<sub>A</sub>), 4.28 (1H, ddd, *J* 11.2, 4.9 and 3.7 Hz, 6-H<sub>B</sub>), 7.28–7.33 (2H, m, *p*Ts Ar-H), 7.35–7.46 (6H, m, TPS Ar-H), 7.55–7.60 (4H, m TPS Ar-H), 7.70–7.75 (2H, m, *p*Ts Ar-H);  $\delta_{\text{C}}$  (100 MHz, CDCl<sub>3</sub>) 19.2 [C(CH<sub>3</sub>)<sub>3</sub>], 21.6 (Ar-CH<sub>3</sub>), 26.5 (C-5), 26.9 [C(CH<sub>3</sub>)<sub>3</sub>], 27.3 (C-3'), 32.5 (C-4), 34.0 (C-3), 41.0 (C-2'), 62.4 (C-1'), 68.4 and 68.5 (C-6 and C-4'), 127.8, 129.9(9) and 130.0(0), 132.9(4) and 133.0(1), 135.5(2) and 135.5(4) (TPS Ar-C), 127.8, 129.9, 132.8 and 144.9 (*p*Ts Ar-C) and 171.0 (C-2) (Found:  $\text{M}^+ - \text{C}_4\text{H}_9$ : 523.1580. Calc. for C<sub>28</sub>H<sub>31</sub>O<sub>6</sub>SSi: *M*, 523.1591).

**(2'*R*\*,4*R*\*)-4-(1-*t*-Butyldiphenylsilynyloxy-4-phenylsufanylbutan-2-yl)tetrahydropyran-2-one 69**

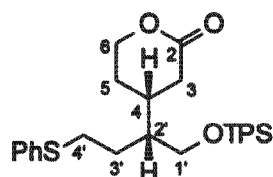

Tri-*n*-butylphosphine (1.05 cm<sup>3</sup>, 4.24 mmol) was added to a solution of diphenyl disulfide (690 mg, 3.17 mmol) in dry benzene (15 cm<sup>3</sup>) and the solution was stirred at 25 °C for 3 h. A solution of lactone **64** (450 mg, 1.06 mmol) in dry benzene (5 cm<sup>3</sup>) was added and the resulting solution was stirred for 18 h. The reaction mixture was diluted with diethyl ether (100 cm<sup>3</sup>), washed with 5% NaOH and brine, and dried (MgSO<sub>4</sub>). The solvent was removed *in vacuo* to give an oil (560 mg)

which was further purified by chromatography on silica gel (50 g) using ethyl acetate–hexane (3:7) as eluent to yield the *sulfide* **69** (478 mg, 87%) as an oil,  $\nu_{\max}(\text{CHCl}_3)/\text{cm}^{-1}$  1737 (CO);  $\delta_{\text{H}}$  (400 MHz,  $\text{CDCl}_3$ ) 1.06 [9H, s,  $\text{C}(\text{CH}_3)_3$ ], 1.42–1.80 (5H, m, 5-H<sub>2</sub>, 3'-H<sub>2</sub> and 2'-H), 2.09–2.22 (2H, m, 3-H<sub>A</sub> and 4-H), 2.59 (1H, m, 3-H<sub>B</sub>), 2.70 (1H, dt,  $J$  12.8 and 2 x 7.4 Hz, 4'-H<sub>A</sub>), 2.90 (1H, ddd,  $J$  12.8, 8.3 and 5.2 Hz, 4'-H<sub>B</sub>) 3.62 (1H, dd,  $J$  10.9 and 4.8 Hz, 1'-H<sub>A</sub>), 3.66 (1H, dd,  $J$  10.9 and 4.1 Hz, 1'-H<sub>B</sub>), 4.13 (1H, td,  $J$  2 x 11.2 and 3.6 Hz, 6-H<sub>A</sub>), 4.31 (1H, ddd,  $J$  11.2, 4.9 and 3.8 Hz, 6-H<sub>B</sub>), 7.15–7.22 (1H, m, PhS Ar-H), 7.24–7.29 (4H, m, PhS Ar-H), 7.35–7.48 (6H, m, TPS Ar-H), 7.60–7.65 (4H, m TPS Ar-H);  $\delta_{\text{C}}$  (100 MHz,  $\text{CDCl}_3$ ) 19.2 [ $\text{C}(\text{CH}_3)_3$ ], 26.6 (C-5), 26.9 [ $\text{C}(\text{CH}_3)_3$ ], 27.1 (C-3'), 31.6 (C-4'), 32.7 (C-4), 34.0 (C-3), 43.6 (C-2'), 62.6 (C-1'), 68.6 (C-6), 127.7(9) and 127.8(0), 129.8(9) and 129.9(1), 133.0(4) and 133.1(2), 135.5(5) and 135.5(7) (TPSAr-C), 126.1, 128.9, 129.3, 136.0 (PhS Ar-C) and 171.3 (C-2) (Found:  $M^+$ , 518.2311. Calc. for  $\text{C}_{31}\text{H}_{38}\text{O}_3\text{SSi}$ :  $M$ , 518.2309).

**(2'*R*\*,4*R*')-4-(1-*t*-Butyldiphenylsilynyloxy-4-phenylsufinylbut-2-yl)tetrahydropyran-2-one**

**70**

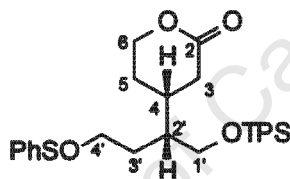

A solution of **69** (127 mg, 0.25 mmol) in methanol (8 cm<sup>3</sup>) was cooled to –5 °C. A solution of sodium metaperiodate (126 mg, 0.58 mmol) in water (4 cm<sup>3</sup>) was added dropwise followed by tetra-*n*-butylammonium bromide (93 mg, 0.29 mmol). The solution was warmed to 25 °C and stirred for 16 h. The reaction mixture was filtered through Celite and the solvent was evaporated under reduced pressure. The residue was extracted into ethyl acetate, dried ( $\text{MgSO}_4$ ) and the solvent removed under reduced pressure to give an oily residue (255 mg) which was purified by chromatography on silica gel (25 g) using ethyl acetate–hexane (3:2) as eluent to give the *sulfoxide* **70** (103 mg, 77%) as a mixture of diastereomers,  $\nu_{\max}(\text{CHCl}_3)/\text{cm}^{-1}$  1730 (CO) and 1039 (SO);  $\delta_{\text{H}}$  (400 MHz,  $\text{CDCl}_3$ ) 0.99 and 1.00 [9H, s,  $\text{C}(\text{CH}_3)_3$ ], 1.35–1.90 (5H, m, 5-H<sub>2</sub>, 2'-H and 3'-H<sub>2</sub>) 2.00–2.32 (2H, m, 4-H and 3-H<sub>A</sub>), 2.51–2.78 (3H, m, 3-H<sub>B</sub> and 4'-H<sub>2</sub>), 3.52–3.63 (2H, m, 1'-H<sub>2</sub>), 4.05–4.15 (1H, m, 6-H<sub>A</sub>), 4.25–4.35 (1H, m, 6-H<sub>B</sub>) and 7.25–7.60 (15H, m, Ar-H);  $\delta_{\text{C}}$  (100 MHz,  $\text{CDCl}_3$ ) 19.1 [ $\text{C}(\text{CH}_3)_3$ ], 19.8 and 21.1 (C-3'), 26.5 and 26.4 (C-5), 26.9 [ $\text{C}(\text{CH}_3)_3$ ], 32.9 (C-4), 33.9 and 34.1 (C-3), 43.6 and 44.1 (C-2'), 54.2 and 55.0 (C-4'), 62.7 and 62.8 (C-1'), 68.5 (C-6), 127.8(1) and 127.8(4), 130.0, 130.9(7) and 131.0(9), 135.5 (TPS Ar-C), 123.9, 129.2, 132.9,

136.0 (PhS Ar-C) and 171.3 (C-2) (Found:  $M^+ - C_4H_9$  477.1542. Calc. for  $C_{27}H_{29}O_4SSi$ :  $M$ , 477.1548).

**(2'*R*',4*R*')-4-(1-*t*-Butyldiphenylsilyanyloxy-4-phenylsulfonylbutan-2-yl)tetrahydropyran-2-one 71**

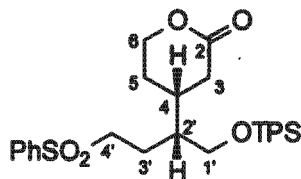

A solution of **69** (210 mg, 0.41 mmol) in dichloromethane (3 cm<sup>3</sup>) was added to a stirred solution of *m*-chloroperbenzoic acid (80%, 178 mg, 0.82 mmol) in dichloromethane (5 cm<sup>3</sup>) at -78 °C. The solution was stirred for 1 h, diluted with dichloromethane (20 cm<sup>3</sup>) and washed with aqueous sodium thiosulphate, aqueous saturated sodium hydrogen carbonate, water and brine after which the organic phase was dried (MgSO<sub>4</sub>) and the solvent evaporated to give an oil (180 mg). Chromatography on silica gel (20 g) using ethyl acetate-hexane (2:3) as eluent afforded *sulfone* **71** (110 mg, 49%) as an oil,  $\nu_{max}(\text{CHCl}_3)/\text{cm}^{-1}$  1737 (CO), 1146 and 1310 (SO<sub>2</sub>);  $\delta_H$  (400 MHz, CDCl<sub>3</sub>) 0.98 [9H, s, C(CH<sub>3</sub>)<sub>3</sub>], 1.40—1.51 (2H, m, 5-H<sub>A</sub> and 2'-H), 1.64—1.88 (3H, m, 3'-H<sub>2</sub> and 5-H<sub>B</sub>) 2.00—2.09 (1H, m, 4-H), 2.15 (1H, dd,  $J$  17.1 and 11.3 Hz, 3-H<sub>A</sub>), 2.55 (1H, ddd,  $J$  17.1, 5.7 and 1.8 Hz, 3-H<sub>B</sub>), 2.93 (1H, ddd,  $J$  14.0, 10.3 and 5.6 Hz, 4'-H<sub>A</sub>), 3.04 (1H, ddd,  $J$  14.0, 10.5 and 5.6 Hz, 4'-H<sub>B</sub>) 3.56 (2H, d,  $J$  4.5 Hz, 1'-H<sub>2</sub>), 4.07 (1H, td,  $J$  2 x 11.3 and 3.7 Hz, 6-H<sub>A</sub>), 4.28 (1H, ddd,  $J$  11.3, 4.8 and 3.8 Hz, 6-H<sub>B</sub>) and 7.20—7.82 (15H, m, Ar-H);  $\delta_C$  (100 MHz, CDCl<sub>3</sub>) 19.2 [C(CH<sub>3</sub>)<sub>3</sub>], 21.3 (C-3'), 26.5 (C-5), 26.9 [C(CH<sub>3</sub>)<sub>3</sub>], 32.9 (C-4), 34.1 (C-3), 43.5 (C-2'), 54.2 (C-4'), 62.5 (C-1'), 68.4 (C-6), 127.9(3) and 127.9(8), 130.0(6) and 130.0(8), 132.7(0) and 132.8(1), 135.5(4) and 135.5(6) (TPS Ar-C), 128.0, 129.3, 133.8, 139.0 (PhS Ar-C) and 170.8 (C-2) (Found:  $M^+ - C_4H_9$  493.1485. Calc. for  $C_{27}H_{29}O_5SSi$ :  $M$ , 493.1498).

**(2'*R*',4*R*')-4-(1-*t*-Butyldiphenylsilyanyloxy-4-phenylselenanylbutan-2-yl)tetrahydropyran-2-one 72**

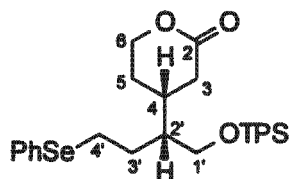

Phenylselenocyanate (538 mg, 2.95 mmol) in tetrahydrofuran (5 cm<sup>3</sup>) and tri-*n*-butylphosphine (0.98 cm<sup>3</sup>, 3.94 mmol) were added sequentially to a stirred solution of **64** (840 mg, 1.97 mmol) in

tetrahydrofuran (15 cm<sup>3</sup>). The resulting solution was stirred at 25 °C for 30 min after which the solvent was removed under reduced pressure to give a crude mixture which was chromatographed directly on silica gel (60 g) using ethyl acetate–hexane (2:3) as eluent to yield *phenyl selenide 72* (970 mg, 87%) as an oil,  $\nu_{\max}(\text{CHCl}_3)/\text{cm}^{-1}$  1730 (CO);  $\delta_{\text{H}}$  (400 MHz, CDCl<sub>3</sub>) 1.03 [9H, s, C(CH<sub>3</sub>)<sub>3</sub>], 1.42–1.79 (5H, m, 5-H<sub>2</sub>, 3'-H<sub>2</sub> and 2'-H), 2.06–2.21 (2H, m, 3-H<sub>A</sub> and 4-H), 2.51–2.58 (1H, m, 3-H<sub>B</sub>), 2.65 (1H, ddd,  $J$  12.1, 8.5 and 7.3 Hz, 4'-H<sub>A</sub>), 2.84 (1H, ddd,  $J$  12.1, 8.8 and 5.2 Hz, 4'-H<sub>B</sub>) 3.58 (1H, dd,  $J$  10.9 and 5.0 Hz, 1'-H<sub>A</sub>), 3.62 (1H, dd,  $J$  10.9 and 4.2 Hz, 1'-H<sub>B</sub>), 4.06–4.14 (1H, m, 6-H<sub>A</sub>), 4.29 (1H, ddd,  $J$  11.3, 4.7 and 3.8 Hz, 6-H<sub>B</sub>), 7.15–7.25 (4H, m, Ar-H), 7.32–7.45 (7H, m, Ar-H) and 7.55–7.66 (4H, m, Ar-H);  $\delta_{\text{C}}$  (100 MHz, CDCl<sub>3</sub>) 19.2 [C(CH<sub>3</sub>)<sub>3</sub>], 25.6 (C-5), 26.6 (C-3'), 27.0 [C(CH<sub>3</sub>)<sub>3</sub>], 28.1 (C-4'), 32.7 (C-4), 34.1 (C-3), 44.6 (C-2'), 62.6 (C-1'), 68.7 (C-6), 127.8(3) and 127.8(4), 129.9(2) and 129.9(5), 133.1(1) and 133.1(8), 135.6(0) and 135.6(2) (TPS Ar-C), 127.1, 129.1, 129.8, 132.8 (PhSe Ar-C) and 171.3 (C-2) (Found: M<sup>+</sup>–C<sub>4</sub>H<sub>9</sub>, 509.1032. Calc. for C<sub>27</sub>H<sub>29</sub>O<sub>3</sub><sup>80</sup>SeSi:  $M$ , 509.1043).

**(2'R\*,4R\*)-4-(1-*t*-Butyldiphenylsilynyloxy-but-3-en-2-yl)tetrahydropyran-2-one 68**

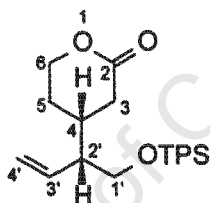

Water (30 cm<sup>3</sup>) and sodium periodate (2.40 g, 11.2 mmol) were added to a stirred solution of **72** (1.10 g, 1.95 mmol) in methanol (100 cm<sup>3</sup>). The resulting mixture was stirred at 25 °C for 20 min, poured into dichloromethane, washed with brine (200 cm<sup>3</sup>) and dried (MgSO<sub>4</sub>). The solvent was evaporated to give the selenoxide (1.20 g) which was dissolved in benzene–triethylamine (1:1) (100 cm<sup>3</sup>), refluxed for 10 min, and cooled. The solution was poured into an aqueous saturated sodium hydrogen carbonate solution (300 cm<sup>3</sup>), extracted with diethyl ether and the organic extract dried (MgSO<sub>4</sub>). The solvent was removed under reduced pressure to give an oil (1.01 g) which was purified by flash chromatography on silica gel (40 g) using ethyl acetate–hexane (1:9) as eluent to give the *olefin 68* (707 mg, 89%) as an oil,  $\nu_{\max}(\text{CHCl}_3)/\text{cm}^{-1}$  1732 (CO);  $\delta_{\text{H}}$  (400 MHz, CDCl<sub>3</sub>) 1.04 [9H, s, C(CH<sub>3</sub>)<sub>3</sub>], 1.48–1.58 (1H, m, 5-H<sub>A</sub>), 1.77–1.85 (1H, m, 5-H<sub>B</sub>), 2.02–2.12 (1H, m, 2'-H), 2.17 (1H, dd,  $J$  16.6 and 10.7 Hz, 3-H<sub>A</sub>), 2.20–2.31 (1H, m, 4-H), 2.57 (1H, ddd,  $J$  16.6, 5.3 and 1.7 Hz, 3-H<sub>B</sub>), 3.65 (1H, dd,  $J$  10.3 and 5.6 Hz, 1'-H<sub>A</sub>), 3.69 (1H, dd,  $J$  10.3 and 5.1 Hz, 1'-H<sub>B</sub>), 4.17 (1H, td,  $J$  2 x 11.2 and 3.7 Hz, 6-H<sub>A</sub>), 4.32 (1H, ddd,  $J$  11.2, 4.7 and 4.2 Hz, 6-H<sub>B</sub>), 5.05 (1H, dd,  $J$  17.2 and 1.8 Hz, 4'-H<sub>A</sub>), 5.14 (1H, dd,  $J$  10.3 and 1.8 Hz, 4'-H<sub>B</sub>) 5.66 (1H, ddd,  $J$  17.2, 10.3 and 9.2 Hz, 3'-H), 7.35–7.49 (6H, m, Ar-H) and 7.59–7.65 (4H, m, Ar-H);  $\delta_{\text{C}}$  (100 MHz, CDCl<sub>3</sub>)

19.3 [C(CH<sub>3</sub>)<sub>3</sub>], 26.9 [C(CH<sub>3</sub>)<sub>3</sub>], 27.1 (C-5), 31.4 (C-4), 33.7 (C-3), 51.0 (C-2'), 64.5 (C-1'), 68.4 (C-6), 118.5 (C-4'), 127.8, 129.8, 133.3, 135.5(8) and 135.6(1) (Ar-C), 136.0 (C-3') and 171.6 (C-2) (Found: M<sup>+</sup>-C<sub>4</sub>H<sub>9</sub>, 351.1415. Calc. for C<sub>21</sub>H<sub>23</sub>O<sub>3</sub>Si: M, 351.1414).

**(2'R\*,4R\*)-4-(1-*t*-Butyldiphenylsilyloxy-4-(2-nitrophenyl)selanylbut-2-yl)tetrahydropyran-2-one 73**

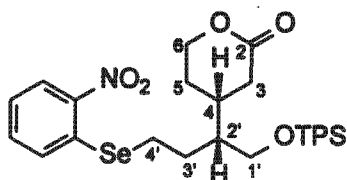

A solution of 2-nitrophenylselanyl cyanide (341 mg, 1.50 mmol) in tetrahydrofuran (5 cm<sup>3</sup>) and tri-*n*-butylphosphine (0.42 cm<sup>3</sup>, 1.68 mmol) were added sequentially to a stirred solution of **64** (500 mg, 1.17 mmol) in tetrahydrofuran (15 cm<sup>3</sup>). The resulting solution was stirred at 25 °C for 2 h after which the solvent was removed under reduced pressure to give a crude mixture which was chromatographed directly on silica gel (50 g) using ethyl acetate-hexane (2:3) as eluent to give the *selenide* **73** (210 mg, 29%) as a yellow oil,  $\nu_{\max}(\text{CHCl}_3)/\text{cm}^{-1}$  1731 (CO);  $\delta_{\text{H}}$  (400 MHz, CDCl<sub>3</sub>) 1.08 [9H, s, C(CH<sub>3</sub>)<sub>3</sub>], 1.50—1.66 (2H, m, 5-H<sub>A</sub> and 2'-H), 1.70—1.94 (3H, m, 3'-H<sub>2</sub> and 5-H<sub>B</sub>), 2.14—2.32 (2H, m, 3-H<sub>A</sub> and 4-H), 2.60—2.75 (2H, m, 3-H<sub>B</sub> and 4'-H<sub>A</sub>), 2.84 (1H, ddd, *J* 11.5, 9.3 and 5.3 Hz, 4'-H<sub>B</sub>) 3.71 (1H, dd, *J* 11.0 and 4.4 Hz, 1'-H<sub>A</sub>), 3.75 (1H, dd, *J* 10.9 and 4.4 Hz, 1'-H<sub>B</sub>), 4.16 (1H, m, 6-H<sub>A</sub>), 4.35 (1H, ddd, *J* 11.5, 4.8 and 3.7 Hz, 6-H<sub>B</sub>), 7.35—7.50 (9H, m, Ar-H), 7.60—7.67 (4H, m, Ar-H) and 8.28 (1H, dd, *J* 8.2 and 1.5 Hz, Ar-H);  $\delta_{\text{C}}$  (100 MHz, CDCl<sub>3</sub>) 19.2 [C(CH<sub>3</sub>)<sub>3</sub>], 23.9 (C-4'), 25.6 and 26.6 (C-5 and C-3'), 27.0 [C(CH<sub>3</sub>)<sub>3</sub>], 32.9 (C-4), 34.1 (C-3), 45.1 (C-2'), 62.6 (C-1'), 68.5 (C-6), 125.5, 126.5, 129.0, 133.0, 133.5, 147.0 (ArSe Ar-C), 127.8(6) and 127.8(8), 129.9(8) and 130.0(0), 133.0(2) and 133.0(8), 135.5(9) and 135.6(2) (TPS Ar-C) and 171.1 (C-2) (Found: M<sup>+</sup>-C<sub>4</sub>H<sub>9</sub>, 554.0908. Calc. for C<sub>27</sub>H<sub>28</sub>NO<sub>5</sub><sup>80</sup>SeSi: M, 554.0902).

**(2'R\*,4S\*)-4-(1-*t*-Butyldiphenylsilyloxy-but-3-en-2-yl)-3-formyltetrahydropyran-2-one 74**

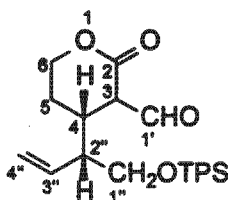

*t*-Butoxybis(dimethylamino)methane (2.58 cm<sup>3</sup>, 12.5 mmol) was added to a flask containing lactone **68** (512 mg, 1.25 mmol) fitted with a condenser and N<sub>2</sub> inlet. The resulting mixture was stirred for 15 h at 82 °C. The solution was cooled and poured into a rapidly stirring solution of

methanol (50 cm<sup>3</sup>) and 3 M HCl (12 cm<sup>3</sup>). The mixture was warmed to 25 °C with stirring and the volatile media were removed under reduced pressure. The residue was extracted with ethyl acetate, the organic extract was dried (MgSO<sub>4</sub>) and the solvent was removed *in vacuo* to give a solid residue (606 mg). The material was chromatographed on silica gel (40 g) using ethyl acetate–hexane (1:4) as eluent to give the *formyl lactone* 74 (462 mg, 85%), m.p. 109–112 °C (from ethyl acetate–hexane),  $\nu_{\max}(\text{CHCl}_3)/\text{cm}^{-1}$  1658 and 1702 (CO) (Found: C, 71.5; H, 7.4%,  $M^+$ –C<sub>4</sub>H<sub>9</sub>, 379.1363. Calc. for C<sub>26</sub>H<sub>32</sub>O<sub>4</sub>Si: C, 72.2; H, 7.3%,  $M$ , 379.1369).

**(2'*R*\*, 3*E*, 4*S*\*)-4-(1-*t*-Butyldiphenylsilyloxy-but-3-en-2-yl)-3-benzoyloxymethylene-tetrahydropyran-2-one 75**

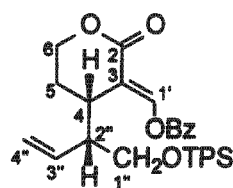

Lactone 68 (300 mg, 0.74 mmol) was formylated as described above. The unpurified formyl lactone 74 (423 mg) was dissolved in dry pyridine (5 cm<sup>3</sup>). Benzoyl chloride (0.2 cm<sup>3</sup>, 240 mg, 1.72 mmol) was added and the solution was stirred at 25 °C for 30 min. The pyridine was removed under reduced pressure by azeotrope formation with toluene (3 x 30 cm<sup>3</sup>). The resulting material was dissolved in dichloromethane, washed with brine and the aqueous phase extracted with dichloromethane. The organic extract was dried (MgSO<sub>4</sub>) to give the benzoylated product (492 mg) which was purified by chromatography on silica gel (70 g) using ethyl acetate–hexane (1:9) to elute excess benzoyl chloride followed by elution with ethyl acetate–hexane (2:3) to yield the *enol benzoate* 75 (298 mg, 75% over 2 steps),  $\nu_{\max}(\text{CHCl}_3)/\text{cm}^{-1}$  1713 and 1749 (CO);  $\delta_{\text{H}}$  (400 MHz, CDCl<sub>3</sub>) 1.08 [9H, s, C(CH<sub>3</sub>)<sub>3</sub>], 1.89–2.10 (2H, m, 5-H<sub>2</sub>), 2.36–2.47 (1H, m, 2''-H), 3.47 (1H, dd,  $J$  13.1 and 5.9 Hz, 4-H), 3.77 (1H, dd,  $J$  10.4 and 5.3 Hz, 1''-H<sub>A</sub>), 3.82 (1H, dd,  $J$  10.4 and 4.6 Hz, 1''-H<sub>B</sub>), 4.15–4.23 (1H, m, 6-H<sub>A</sub>), 4.33–4.41 (1H, ddd,  $J$  11.7, 9.2 and 3.9 Hz, 6-H<sub>B</sub>), 5.00–5.07 (2H, m, 4''-H<sub>2</sub>), 5.94 (1H, ddd,  $J$  16.9, 10.4 and 9.2 Hz, 3''-H), 7.30–8.12 (15H, m, Ar-H) and 8.48 (1H, d,  $J$  1.1 Hz, 1'-H);  $\delta_{\text{C}}$  (100 MHz, CDCl<sub>3</sub>) 19.5 [C(CH<sub>3</sub>)<sub>3</sub>], 25.6 (C-5), 27.1 [C(CH<sub>3</sub>)<sub>3</sub>], 33.1 (C-4), 49.6 (C-2''), 65.2 (C-1''), 66.1 (C-6), 115.6 (C-3), 118.0 (C-4''), 127.9(8) and 128.1(4), 127.9, 129.1, 130.0(2) and 130.0(9), 130.4, 133.4(5) and 133.5(1), 134.5, 135.8(1) (Ar-C), 136.0 (C-3''), 145.3 (C-1'), 162.2 (Ar-C=O) and 166.5 (C-2) (Found:  $M^+$ –C<sub>4</sub>H<sub>9</sub>, 483.1633. Calc. for C<sub>21</sub>H<sub>23</sub>O<sub>3</sub>Si:  $M$ , 483.1628).

**(2'R\*,4S\*)-4-(1-*t*-Butyldiphenylsilynyloxy-but-3-en-2-yl)-3-methoxyethoxymethoxy-methylene-tetrahydropyran-2-one 76**

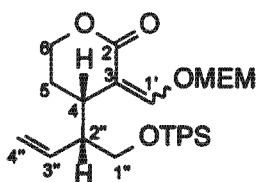

Formyl lactone 74 (220 mg, 0.50 mmol) was dissolved in dry dichloromethane (10 cm<sup>3</sup>). Methoxyethoxymethyl chloride (0.07 cm<sup>3</sup>, 76 mg, 0.61 mmol) was added, followed by diisopropylethylamine (0.11 cm<sup>3</sup>, 82 mg, 0.63 mmol). The mixture was stirred at 25 °C for 16 h after which water (10 cm<sup>3</sup>) was added and the aqueous phase was extracted with dichloromethane. The organic phase was dried (MgSO<sub>4</sub>) and the solvent was removed under reduced pressure to give an oil (272 mg). Chromatography on silica gel (25 g) using ethyl acetate–hexane (3:7) as eluent, furnished the *enol ether* 76 (207 mg, 79%) as an oil,  $\nu_{\max}(\text{CHCl}_3)/\text{cm}^{-1}$  1698 (CO);  $\delta_{\text{H}}$  (400 MHz, CDCl<sub>3</sub>) 1.05 [9H, s, C(CH<sub>3</sub>)<sub>3</sub>], 1.78–1.88 (1H, m, 5-H<sub>A</sub>), 1.89–2.00 (1H, m, 5-H<sub>B</sub>), 2.38–2.48 (1H, m, 2"-H), 3.17 (1H, dd, *J* 12.1 and 6.1 Hz, 4-H), 3.35 (3H, s, OCH<sub>3</sub>), 3.46–3.57 and 3.62–3.67 (4H, m, OCH<sub>2</sub>CH<sub>2</sub>O), 3.67 (1H, dd, *J* 10.3 and 5.9 Hz, 1"-H<sub>A</sub>), 3.72 (1H, dd, *J* 10.3 and 5.1 Hz, 1"-H<sub>B</sub>), 4.05–4.15 (1H, m, 6-H<sub>A</sub>), 4.32 (1H, ddd, *J* 11.3, 9.2 and 3.7 Hz, 6-H<sub>B</sub>), 4.95–5.06 (4H, m, 4"-H<sub>2</sub> and OCH<sub>2</sub>O), 5.69–5.81 (1H, m, 3"-H), 7.34–7.45 (6H, m, Ar-H), 7.56 (1H, s, 1'-H) and 7.61–7.67 (4H, m, Ar-H);  $\delta_{\text{C}}$  (100 MHz, CDCl<sub>3</sub>) 19.3 [C(CH<sub>3</sub>)<sub>3</sub>], 25.9 (C-5), 26.8 [C(CH<sub>3</sub>)<sub>3</sub>], 32.1 (C-4), 49.8 (C-2"), 59.1 (OCH<sub>3</sub>), 65.5 (C-6), 65.7 (C-1"), 68.5 and 71.3 (OCH<sub>2</sub>CH<sub>2</sub>O), 97.1 (OCH<sub>2</sub>O) 109.3 (C-3), 117.1 (C-4"), 127.6(4) and 127.6(7), 129.7, 133.5(4) and 133.6(1), 135.6 (Ar-C), 137.9 (C-3"), 155.9 (C-1') and 167.7 (C-2) (Found: M<sup>+</sup>-C<sub>4</sub>H<sub>9</sub>, 467.1889. Calc. for C<sub>21</sub>H<sub>23</sub>O<sub>3</sub>Si: *M*, 467.1890).

**Desilylation of 76**

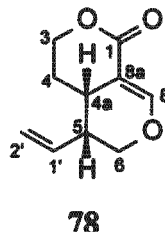
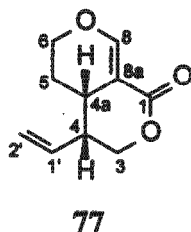

Tetrabutylammonium fluoride (1 M in THF, 0.62 cm<sup>3</sup>, 0.62 mmol) was added to a stirred solution of 76 (524 mg, 0.31 mmol) in tetrahydrofuran (5 cm<sup>3</sup>) at 0 °C. The solution was warmed to 25 °C. After stirring for 16 h reaction was complete (TLC). Water (10 cm<sup>3</sup>) was added and the mixture was extracted with ethyl acetate. The organic extract was dried (MgSO<sub>4</sub>) and the solvent was

removed under reduced pressure to give a crude mixture (168 mg). Chromatography on silica gel (20 g) using ethyl acetate–hexane (2:3) as eluent yielded (*4R*\*,*4aS*\*)-4-vinyl-4,4a,5,6-tetrahydro-3H-pyrano[3,4-c]pyran-1-one **77** (12 mg, 22%) as an oil,  $\nu_{\max}(\text{CHCl}_3)/\text{cm}^{-1}$  1708 (CO) and 1611 (C=C conj.);  $\delta_{\text{H}}$  (300 MHz,  $\text{CDCl}_3$ ) 1.60–1.89 (2H, m, 5-H<sub>2</sub>), 2.52–2.59 (1H, m, 4-H), 2.80–2.89 (1H, m, 4a-H), 3.97–4.08 (1H, m, 6-H<sub>A</sub>), 4.30–4.40 (1H, m, and 6-H<sub>B</sub>), 4.33 (1H, dd, *J* 11.1 and 2.5 Hz, 3-H<sub>A</sub>), 4.44 (1H, dd, *J* 11.1 and 2.0 Hz, 3-H<sub>B</sub>) 5.22–5.30 (2H, m, 2'-H<sub>2</sub>), 5.73–5.88 (1H, m, 1'-H) and 7.73–7.76 (1H, br.d, 8-H);  $\delta_{\text{C}}$  (75 MHz,  $\text{CDCl}_3$ ) 24.9 (C-5), 33.2 (C-4a), 40.5 (C-4), 66.8 (C-6), 72.7 (C-3), 102.4 (C-8a) 119.4 (C-2'), 132.7 (C-1'), 157.9 (C-8) and 165.4 (C-1), (Found:  $M^+$ , 180.0790. Calc. for  $\text{C}_{10}\text{H}_{12}\text{O}_3$ : *M*, 180.0786) followed by mixed fractions (25 mg, 44%) which were combined and rechromatographed on silica gel (10 g) using ethyl acetate–hexane (3:7). Partial separation gave further **77** (5 mg) followed by mixed fractions (5 mg) and (*4aS*\*,*5R*\*)-5-vinyl-4,4a,5,6-tetrahydro-3H-pyrano[3,4-c]pyran-1-one **78** (14 mg),  $\nu_{\max}(\text{CHCl}_3)/\text{cm}^{-1}$  1703 (CO) and 1612 (C=C conj.);  $\delta_{\text{H}}$  (300 MHz,  $\text{CDCl}_3$ ) 1.58–1.83 (2H, m, 4-H<sub>2</sub>), 2.55–2.63 (1H, m, 5-H), 2.85 (1H, dtd, *J* 11.8, 2 x 5.3 and 2.4 Hz, 4a-H), 4.13–4.32 (3H, m, 3-H<sub>A</sub> and 6-H<sub>2</sub>), 4.41 (1H, ddd, *J* 11.3, 4.4 and 2.4 Hz, 3-H<sub>B</sub>), 5.20–5.30 (2H, m, 2'-H<sub>2</sub>), 5.74 (1H, ddd, *J* 9.3, 10.3 and 17.0 Hz, 1'-H) and 7.73–7.76 (1H, br.d, 8-H);  $\delta_{\text{C}}$  (75 MHz,  $\text{CDCl}_3$ ) 26.4 (C-4), 33.1 (C-4a), 38.9 (C-5), 67.7 (C-3), 71.8 (C-6), 102.5 (C-8a) 118.7 (C-1'), 133.2 (C-2'), 156.2 (C-8) and 166.0 (C-1) (Found  $M^+$ , 180.0785. Calc. for  $\text{C}_{10}\text{H}_{12}\text{O}_3$ : *M*, 180.0786).

#### Deprotection of silyl ether **72**

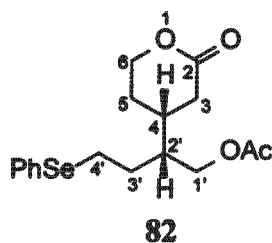
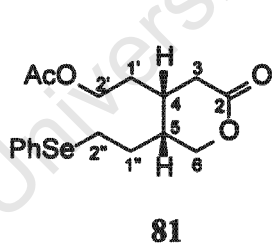

Tetrabutylammonium fluoride (1.0 M solution in THF, 2.0 cm<sup>3</sup>, 2.0 mmol) was added to a stirred solution of silyl ether **72** (565 mg, 1.00 mmol) in 10 cm<sup>3</sup> tetrahydrofuran at 0 °C. After 90 min water (10 cm<sup>3</sup>) was added and the resulting mixture was extracted with ethyl acetate, dried ( $\text{MgSO}_4$ ) and the solvent was removed under reduced pressure to give a residue (603 mg). Chromatography on silica gel (50 g) using ethyl acetate–hexane (3:2) as eluent yielded an inseparable mixture of alcohols **79** and **80** (224 mg, 69%). The mixture (220 mg, 0.67 mmol) in pyridine (10 cm<sup>3</sup>) was treated with acetic anhydride (0.32 cm<sup>3</sup>, 3.36 mmol) and dimethylaminopyridine (20 mg, 0.16 mmol) and then stirred at 25 °C for 16 h. Toluene was added (30 cm<sup>3</sup>) and the mixture was concentrated under reduced pressure (3x), resulting in an oil (320

mg) which was chromatographed on silica gel (30 g) using ethyl acetate–hexane (3:7) as eluent to give *(4R\*,5R\*)-4-acetoxyethyl-5-phenylselanylethyl-3,4,5,6-tetrahydropyran-2-one* **81** (36 mg, 14%)  $\nu_{\max}(\text{CHCl}_3)/\text{cm}^{-1}$  1732 (CO);  $\delta_{\text{H}}$  (300 MHz,  $\text{CDCl}_3$ ), 1.44–1.54 (1H, m, 1'-H<sub>A</sub>), 1.60–1.75 (3H, m, 1'-H<sub>B</sub>, 1''-H<sub>2</sub>), 2.03 (3H, s, CO<sub>2</sub>CH<sub>3</sub>), 2.06–2.22 (2H, m, 4-H, 5-H), 2.32 (1H, dd,  $J$  18.1 and 8.5 Hz, 3-H<sub>A</sub>), 2.60 (1H, dd,  $J$  18.1 and 6.2 Hz, 3-H<sub>B</sub>) 2.85 (1H, dt,  $J$  12.4 and 2 x 7.6 Hz, 2''-H<sub>A</sub>), 3.03 (1H, ddd,  $J$  12.4, 7.6 and 5.9 Hz, 2''-H<sub>B</sub>), 4.00–4.12 (2H, m, 2'-H<sub>2</sub>), 4.25 (2H, d,  $J$  4.8 Hz, 6-H<sub>2</sub>), 7.23–7.29 (3H, m, Ar-H) and 7.44–7.51 (2H, m, Ar-H);  $\delta_{\text{C}}$  (75 MHz,  $\text{CDCl}_3$ ) 20.9 (CO<sub>2</sub>CH<sub>3</sub>), 24.9 (C-1''), 25.0 (C-2''), 29.4 (C-1'), 31.8 (C-4), 34.1 (C-3), 35.2 (C-5), 61.6 (C-2'), 70.8 (C-6), 127.3, 129.2, 132.8 (Ar-C), 169.7 (CO<sub>2</sub>CH<sub>3</sub>) and 170.8 (C-2) (Found:  $M^+$ , 370.0667. Calc. for C<sub>17</sub>H<sub>22</sub>O<sub>4</sub><sup>80</sup>Se:  $M$ , 370.0683) followed by mixed fractions (97 mg, 39%) and *(2'R\*,4R\*)-3-(1'-acetoxy-4-phenylselanylbut-2-yl)pentan-5-olide* **82** (25 mg, 10%) as an oil,  $\nu_{\max}(\text{CHCl}_3)/\text{cm}^{-1}$  1735 (CO);  $\delta_{\text{H}}$  (300 MHz,  $\text{CDCl}_3$ ) 1.58 (1H, dtd,  $J$  14.0, 2 x 10.7 and 4.9 Hz, 5-H<sub>A</sub>), 1.67–1.93 (4H, m, 2'-H, 3'-H<sub>2</sub> and 5-H<sub>B</sub>), 2.03 (3H, s, CO<sub>2</sub>CH<sub>3</sub>), 2.00–2.14 (1H, m, 4-H) 2.23 (1H, dd,  $J$  17.0 and 11.0 Hz, 3-H<sub>A</sub>), 2.59 (1H, ddd,  $J$  17.0, 6.0 and 1.8 Hz, 3-H<sub>B</sub>), 2.84 (1H, dt,  $J$  2 x 7.8 and 12.3 Hz, 4'-H<sub>A</sub>), 3.00 (1H, ddd,  $J$  12.3, 6.9 and 5.4 Hz, 4'-H<sub>B</sub>) 4.07 (1H, d,  $J$  4.9, 1'-H<sub>2</sub>), 4.18 (1H, td,  $J$  2 x 11.4 and 3.6 Hz, 6-H<sub>A</sub>), 4.37 (1H, ddd,  $J$  11.4, 4.9 and 3.6 Hz, 6-H<sub>B</sub>), 7.23–7.38 (3H, m, Ar-H) and 7.44–7.52 (2H, m, Ar-H);  $\delta_{\text{C}}$  (75 MHz,  $\text{CDCl}_3$ ) 20.8 (CO<sub>2</sub>CH<sub>3</sub>), 25.2 (C-4'), 26.3 (C-5), 28.4 (C-3'), 32.9 (C-4), 33.8 (C-3), 41.5 (C-2'), 63.4 (C-1'), 68.3 (C-6), 127.3, 129.2, 129.4, 133.0 (Ar-C), 170.1 and 170.1 (C-2 and CO<sub>2</sub>CH<sub>3</sub>) (Found:  $M^+$ , 370.0665. Calc. for C<sub>17</sub>H<sub>22</sub>O<sub>4</sub><sup>80</sup>Se:  $M$ , 370.0683).

**(4R\*,5R\*)-4-Benzylloxymethyl-5-vinylcyclohexene 83**

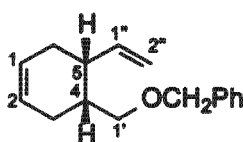

Sodium hydride (60% dispersion in oil, 290 mg, 7.25 mmol) was washed with hexane, dried under N<sub>2</sub> and tetrahydrofuran (10 cm<sup>3</sup>) was added, followed by **44** (500 mg, 3.62 mmol). The resulting mixture was stirred for 90 min after which benzyl bromide (0.47 cm<sup>3</sup>, 4.3 mmol) was added and the solution was stirred for 14 h. Methanol was added and the mixture was concentrated under reduced pressure. Saturated aqueous ammonium chloride was added and the mixture was extracted with ethyl acetate. The organic phase was washed with brine, dried (MgSO<sub>4</sub>) and the solvent was removed under reduced pressure. The product (880 mg) was purified by chromatography on silica gel (80 g) using ethyl acetate–hexane (1:19) as eluent, to give the *benzyl ether* **83** (741 mg, 91%) as an oil,  $\delta_{\text{H}}$  (300 MHz,  $\text{CDCl}_3$ ) 1.74–2.21 (4H, m, 3-H<sub>2</sub>, 4-H and 6-H<sub>A</sub>), 2.22–2.36 (1H, m, 6-H<sub>B</sub>),

2.57—2.69 (1H, m, 5-H), 3.33 (1H, dd,  $J$  9.1 and 6.8 Hz, 1'-H<sub>A</sub>), 3.40 (1H, dd,  $J$  9.1 and 6.9 Hz, 1'-H<sub>B</sub>), 4.49 (2H, s, OCH<sub>2</sub>Ph), 5.00—5.09 (2H, m, 2''-H<sub>2</sub>), 5.61—5.71 (2H, m, 1-H and 2-H), 5.84 (1H, ddd,  $J$  16.9, 10.6 and 8.4 Hz, 1''-H) and 7.21—7.42 (Ar-H);  $\delta_c$  (75 MHz, CDCl<sub>3</sub>) 25.9 (C-3), 30.1 (C-6), 36.8 (C-4), 38.0 (C-5), 72.3 (C-1'), 73.1 (OCH<sub>2</sub>Ph), 115.2 (C-2''), 125.4 and 125.8 (C-1 and C-2), 127.4, 127.6, 128.3, and 138.7 (Ar-C) and 138.9 (C-1'') (Found  $M^+$ , 228.1515. Calc. for C<sub>16</sub>H<sub>20</sub>O:  $M$ , 228.1514).

**(4*R*\*,5*R*\*)-4-Benzylloxymethyl-5-hydroxyethylcyclohexene 84**

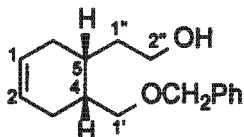

9-Borabicyclo[3.3.1]nonane (288 mg, 2.36 mmol) was added to a stirred solution of 83 (170 mg, 0.75 mmol) in tetrahydrofuran (5 cm<sup>3</sup>). The reaction was stirred until consumption of starting material was complete (TLC). Sodium hydroxide (1 M, 2 cm<sup>3</sup>) and 30% hydrogen peroxide (2 cm<sup>3</sup>) were added and the solution was stirred for 30 min. The mixture was extracted with ethyl acetate, dried (MgSO<sub>4</sub>) and the solvent was removed under reduced pressure to give a residue (500 mg) which was chromatographed on silica gel (50 g) using ethyl acetate–hexane (3:7) as eluent to yield the *alcohol* 84 (92 mg, 50%) as an oil,  $\nu_{\max}$ (CHCl<sub>3</sub>)/cm<sup>-1</sup> 3619 (OH);  $\delta_H$  (300 MHz, CDCl<sub>3</sub>) 1.42—1.68 (3H, m, 1''-H<sub>2</sub>, OH), 1.76—2.22 (6H, m, 3-H<sub>2</sub>, 4-H, 5-H and 6-H<sub>2</sub>), 3.38 (1H, dd,  $J$  9.3 and 7.1 Hz, 1'-H<sub>A</sub>), 3.48 (1H, dd,  $J$  9.3 and 6.9 Hz, 1'-H<sub>B</sub>), 3.65 (1H, ddd,  $J$  10.5, 7.4 and 6.5 Hz, 2''-H<sub>A</sub>), 3.71 (1H, ddd,  $J$  10.5, 7.1 and 5.8 Hz, 2''-H<sub>B</sub>), 4.50 (2H, s, OCH<sub>2</sub>Ph), 5.58—5.63 (2H, m, 1-H and 2-H) and 7.20—7.38 (Ar-H);  $\delta_c$  (75 MHz, CDCl<sub>3</sub>) 26.9 (C-3), 29.4 (C-6), 30.7 (C-5), 33.1 (C-1''), 36.3 (C-4), 61.6 (C-2''), 71.0 (C-1'), 73.1 (OCH<sub>2</sub>Ph), 125.6 and 125.7 (C-1 and C-2), 127.5, 127.6, 128.4, and 138.5 (Ar-C) (Found:  $M^+$ , 246.1628. Calc. for C<sub>16</sub>H<sub>22</sub>O<sub>2</sub>:  $M$ , 246.1620).

**(4*R*\*,5*R*\*)-4-*t*-Butyldiphenylsilyloxymethyl-5-pivaloyloxyethylcyclohexene 85**

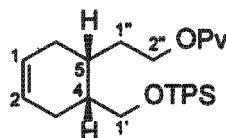

4-Dimethylaminopyridine (75 mg, 0.63 mmol) and pivaloyl chloride (1.50 cm<sup>3</sup>, 1.47 g, 12.18 mmol) were added to a stirred solution of 49 (2.50 g, 6.34 mmol) in pyridine (50 cm<sup>3</sup>). The resulting solution was stirred at 25 °C for 16 h. Toluene (2 x 100 cm<sup>3</sup>) was added and the solvents were removed under reduced pressure. The resulting oil was extracted with dichloromethane, dried

(MgSO<sub>4</sub>) and the solvent was removed *in vacuo* to give an oil (3.62 g). Chromatography on silica gel (150 g) using ethyl acetate–hexane (1:9) as eluent yielded the *pivaloate ester* **85** (3.02 g, 99%) as an oil,  $\nu_{\max}(\text{CHCl}_3)/\text{cm}^{-1}$  1718 (CO);  $\delta_{\text{H}}$  (300 MHz, CDCl<sub>3</sub>) 1.06 [9H, s, SiC(CH<sub>3</sub>)<sub>3</sub>], 1.16 [9H, s, COC(CH<sub>3</sub>)<sub>3</sub>], 1.39–1.65 (2H, m, 1''-H<sub>2</sub>), 1.77–2.15 (6H, m, 3-H<sub>2</sub>, 4-H, 5-H and 6-H<sub>2</sub>), 3.57 (1H, dd, *J* 10.1 and 5.9 Hz, 1'-H<sub>A</sub>), 3.64 (1H, dd, *J* 10.1 and 6.8 Hz, 1'-H<sub>B</sub>), 3.97–4.12 (2H, m, 2''-H<sub>2</sub>), 5.55–5.70 (2H, m, 1-H and 2-H), 7.32–7.45 (6H, m, Ar-H) and 7.62–7.70 (4H, m Ar-H);  $\delta_{\text{C}}$  (75 MHz, CDCl<sub>3</sub>) 19.2 [SiC(CH<sub>3</sub>)<sub>3</sub>] 26.4 (C-3), 26.8 and 27.2 [SiC(CH<sub>3</sub>)<sub>3</sub> and COC(CH<sub>3</sub>)<sub>3</sub>], 28.7 (C-1''), 29.2 (C-6), 31.0 (C-5), 38.7 [COC(CH<sub>3</sub>)<sub>3</sub>], 38.8 (C-4), 63.3 (C-2''), 64.3 (C-1'), 125.5, 125.9 (C-1 and C-2), 127.6, 129.5(4) and 129.5(7), 133.9, 135.6 (Ar-C) and 178.6 (C=O) (Found (FAB): M<sup>+</sup>-C<sub>4</sub>H<sub>9</sub>, 421.2211. Calc. for C<sub>26</sub>H<sub>33</sub>O<sub>3</sub>Si: *M*, 421.2199).

**(4*R*\*, 5*R*\*)-4-Hydroxymethyl-5-pivaloyloxyethylcyclohexene **86****

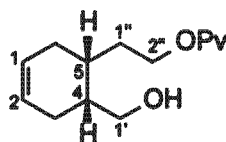

Tetrabutylammonium fluoride (1.0 M in tetrahydrofuran, 38 cm<sup>3</sup>, 38 mmol) was added to a stirred solution of silyl ether **85** (15.31 g, 32 mmol) in tetrahydrofuran (200 cm<sup>3</sup>) at 0 °C. The resulting solution was warmed to 25 °C and stirred for 2 h after which the solvent was removed under reduced pressure. Saturated aqueous ammonium chloride was added and the aqueous phase was extracted with dichloromethane. The organic phase was washed with brine, dried (MgSO<sub>4</sub>) and the solvent was removed under reduced pressure to give a crude mixture (17.06 g) which was chromatographed on silica gel (150 g) using ethyl acetate–hexane (3:7) as eluent to give the *alcohol* **86** (7.37 g, 96%) as an oil,  $\nu_{\max}(\text{CHCl}_3)/\text{cm}^{-1}$  1718 (CO) and 3484 (OH);  $\delta_{\text{H}}$  (400 MHz, CDCl<sub>3</sub>) 1.16 [9H, s, C(CH<sub>3</sub>)<sub>3</sub>], 1.52 (1H, ddt, *J* 13.9, 8.8 and 2 x 6.4 Hz, 1''-H<sub>A</sub>), 1.59–1.70 (1H, m, 1''-H<sub>B</sub>), 1.77–2.14 (7H, m, 3-H<sub>2</sub>, 4-H, 5-H, 6-H<sub>2</sub> and OH), 3.51 (1H, dd, *J* 10.4 and 7.2 Hz, 1'-H<sub>A</sub>), 3.60 (1H, dd, *J* 10.4 and 6.0 Hz, 1'-H<sub>B</sub>), 4.03–4.12 (2H, m, 2''-H<sub>2</sub>) and 5.54–5.65 (2H, m, 1-H and 2-H);  $\delta_{\text{C}}$  (100 MHz, CDCl<sub>3</sub>) 26.2 (C-3), 27.2 [C(CH<sub>3</sub>)<sub>3</sub>], 28.7 (C-1''), 29.2 (C-6), 30.7 (C-5), 38.7 [C(CH<sub>3</sub>)<sub>3</sub>], 38.9 (C-4), 63.2 and 63.2 (C-1' and C-2''), 125.6 and 125.6 (C-1 and C-2) and 178.7 (C=O) (Found (FAB): M<sup>+</sup>+H, 241.1814. Calc. for C<sub>14</sub>H<sub>25</sub>O<sub>3</sub>: *M*, 241.1804).

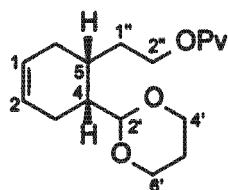
**(4*R*\*, 5*R*\*)-4-(1,3-Dioxan-2-yl)-5-pivaloyloxyethylcyclohexene 88**

Dimethyl sulfoxide (9.5 cm<sup>3</sup>, 10.41 g, 134 mmol) was added to a stirred solution of oxalyl chloride (5.8 cm<sup>3</sup>, 67 mmol) in dichloromethane (240 cm<sup>3</sup>) at -78 °C. After 10 min a solution of **86** (13.2 g, 55 mmol) in dichloromethane (240 cm<sup>3</sup>) was added and the solution was stirred for 5 min. Triethylamine (38 cm<sup>3</sup>, 28.13 g, 278 mmol) was added and the reaction flask was placed in an ice bath for 5 min after which the reaction was quenched with saturated aqueous ammonium chloride and the mixture was extracted with dichloromethane. The organic extract was washed with 1 M HCl-ice followed by cold brine, dried (MgSO<sub>4</sub>) and the solvent was removed under reduced pressure to give the aldehyde **87** (17.3 g) which was dried under high vacuum for 10 min. The aldehyde was dissolved in dichloromethane (250 cm<sup>3</sup>) and cooled to -78 °C. 1,2-Bis(trimethylsilyloxy)ethane (18.35 g, 83.4 mmol) was added followed by trimethylsilyl-trifluoromethanesulfonate (1.0 cm<sup>3</sup>, 1.24 g, 5.6 mmol). After 3 h at -78 °C the reaction was quenched with triethylamine (5 drops), poured into aqueous sodium hydrogen carbonate and extracted with dichloromethane. The organic phase was washed with brine, dried (MgSO<sub>4</sub>) and the solvent was removed under reduced pressure to give an oil (22.3 g) which was purified by chromatography on silica gel (800 g) using ethyl acetate-hexane (1:4) as eluent to yield the *cyclic acetal* **88** (14.9 g, 91%),  $\nu_{\max}(\text{CHCl}_3)/\text{cm}^{-1}$  1718 (CO),  $\delta_{\text{H}}$  (300 MHz, CDCl<sub>3</sub>) 1.19 [9H, s, C(CH<sub>3</sub>)<sub>3</sub>], 1.29—1.37 (1H, m, 5'-H<sub>A</sub>), 1.46—1.60 (1H, m, 1''-H<sub>A</sub>), 1.65—1.78 (1H, m, 1''-H<sub>B</sub>), 1.80—2.19 (7H, m, 3-H<sub>2</sub>, 4-H, 5-H, 6-H<sub>2</sub> and 5'-H<sub>B</sub>), 3.73 (2H, td,  $J$  2 x 12.0 and 2.6 Hz, 4'-H<sub>A</sub> and 6'-H<sub>A</sub>), 4.02—4.17 (4H, m, 2''-H<sub>2</sub>, 4'-H<sub>B</sub> and 6'-H<sub>B</sub>), 4.39 (1H, d,  $J$  7.1 Hz, 2'-H) and 5.51—5.69 (2H, m, 1-H and 2-H),  $\delta_{\text{C}}$  (75 MHz, CDCl<sub>3</sub>) 23.8 (C-3), 26.0 (C-5'), 26.8 (C-1''), 27.2 [C(CH<sub>3</sub>)<sub>3</sub>], 28.4 (C-5), 29.4 (C-6), 38.7 [C(CH<sub>3</sub>)<sub>3</sub>], 41.5 (C-4), 63.2 (C-2''), 66.9 and 67.0 (C-4' and C-6'), 103.4 (C-2'), 125.0 and 126.0 (C-1 and C-2) and 178.6 (C=O) (Found (FAB):  $M^+$ +Rb, 381.1176. Calc. for C<sub>17</sub>H<sub>28</sub>O<sub>4</sub>Rb:  $M$ , 381.1106).

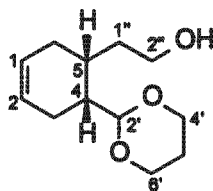
**(4*R*\*, 5*R*\*)-4-(1,3-Dioxan-2-yl)-5-hydroxyethylcyclohexene 89**

Lithium aluminium hydride (31 mg, 0.81 mmol) was added to a solution of **88** (200 mg, 0.68 mmol) in tetrahydrofuran (5 cm<sup>3</sup>) at 0 °C. After 30 min, 1 M sodium hydroxide was added dropwise until pH 11 was reached. The mixture was added to ethyl acetate–water, extracted with ethyl acetate, dried (MgSO<sub>4</sub>) and the solvent was removed *in vacuo* to give the an oily residue (157 mg). Chromatography on silica gel (20 g) using ethyl acetate–hexane (2:3) as eluent afforded the *alcohol* **89** (136 mg, 95%) as an oil,  $\nu_{\max}(\text{CHCl}_3)/\text{cm}^{-1}$  3468 (OH);  $\delta_{\text{H}}$  (400 MHz, CDCl<sub>3</sub>) 1.30–1.37 (1H, m, 5'-H<sub>A</sub>), 1.44–1.55 (1H, m, 1''-H<sub>A</sub>), 1.61–1.73 (2H, m, 1''-H<sub>B</sub> and OH), 1.85–1.98 (3H, m, 4-H, 3-H<sub>A</sub> and 6-H<sub>A</sub>), 2.00–2.19 (4H, m, 3-H<sub>B</sub>, 5-H, 6-H<sub>B</sub> and 5'-H<sub>B</sub>), 3.58–3.78 (4H, m, 4'-H<sub>A</sub>, 6'-H<sub>A</sub> and 2''-H<sub>2</sub>), 4.08–4.15 (2H, m, 4'-H<sub>B</sub> and 6'-H<sub>B</sub>), 4.42 (1H, d, *J* 7.2 Hz, 2'-H) and 5.52–5.68 (2H, m, 1-H and 2-H);  $\delta_{\text{C}}$  (100 MHz, CDCl<sub>3</sub>) 24.0 (C-3), 25.9 (C-5'), 28.4 (C-5), 30.1 (C-6), 31.4 (C-1''), 41.3 (C-4), 61.9 (C-2''), 66.9 and 67.0 (C-4' and C-6'), 103.6 (C-1'), 125.0 and 126.0 (C-1 and C-2) (Found: *M*<sup>+</sup>, 212.1411. Calc. for C<sub>12</sub>H<sub>20</sub>O<sub>3</sub>: *M*, 212.1412).

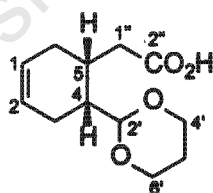
**(4*R*\*, 5*R*\*)-4-Carboxymethyl-5-(1,3-dioxan-2-yl)cyclohexene 90**

An excess of 8 M CrO<sub>3</sub> was added to a stirred solution of **89** (100 mg, 0.47 mmol) in acetone (5 cm<sup>3</sup>) at 0 °C. The solution was left at 0 °C for 10 min after which the excess reagent was consumed by the addition of propan-2-ol (1 cm<sup>3</sup>). The solvents were removed under reduced pressure, water was added and the mixture was extracted with dichloromethane. The organic phase was dried (MgSO<sub>4</sub>) and the solvent was removed under reduced pressure to give a green residue (120 mg). Chromatography on silica gel (12 g) using ethyl acetate–hexane (2:3) as eluent afforded the *acid* **90** (53 mg, 50%), mp 121–123 °C (from ethyl acetate–hexane),  $\nu_{\max}(\text{CHCl}_3)/\text{cm}^{-1}$  1706 (CO);  $\delta_{\text{H}}$  (300 MHz, CDCl<sub>3</sub>) 1.28–1.38 (1H, m, 5''-H<sub>A</sub>), 1.88–2.37 (7H, m, 3-H<sub>2</sub>, 5-H, 6-H<sub>2</sub> and 5''-H<sub>B</sub>), 2.30 (1H, dd, *J* 16.6 and 10.5 Hz, 1'-H<sub>A</sub>), 2.50–2.61 (2H, m, 4-H and 1'-H<sub>B</sub>), 3.65–3.78 (2H, m, 4''-H<sub>A</sub> and 6''-H<sub>A</sub>), 4.05–4.16 (2H, m, 4''-H<sub>B</sub> and 6''-H<sub>B</sub>), 4.43 (1H, d, *J* 5.9 Hz, 2''-H) and

5.52—5.71 (2H, m, 1-H and 2-H);  $\delta_C$  (75 MHz,  $CDCl_3$ ) 23.5 (C-6), 25.9 (C-5''), 29.0 (C-4), 30.6 (C-3), 34.0 (C-1'), 40.9 (C-5), 66.9 and 66.9 (C-4' and C-6'), 103.4 (C-2'), 124.7 and 125.9 (C-1 and C-2) and 179.2 (C-4<sup>2</sup>), (Found: C, 63.6, H, 7.9%,  $M^+$ , 226. Calc. for  $C_{12}H_{18}O_4$ : C, 63.7, H, 8.0%.  $M$ , 226).

**(3*S*\*, 4*R*\*)-6-(*t*-Butyldimethylsilyloxy)-3-(2-*t*-butyldimethylsilyloxyethyl)-4-(1,3-dioxan-2-yl)hexan-1-yl pivaloate 92**

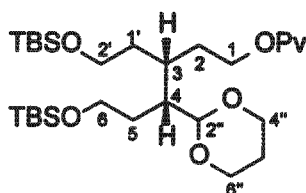

Ozone was bubbled through a solution of **88** (5.20 g, 17.6 mmol) in methanol (300 cm<sup>3</sup>) at -78 °C until the solution turned blue. The ozone was replaced by nitrogen until the solution was colourless after which sodium borohydride (3.34 g, 87.8 mmol) was added in portions and the solution was warmed to 25 °C with stirring. The reaction was quenched with aqueous ammonium chloride and the volatile material was removed under reduced pressure. The resulting mixture was thoroughly extracted with chloroform, dried ( $MgSO_4$ ) and the solvent was removed to give the crude diol (9.02 g) which was dissolved in acetonitrile (200 cm<sup>3</sup>). Imidazole (3.58 g, 52.7 mmol) and *t*-butyldimethylsilylchloride (5.83 g, 38.6 mmol) were added and the mixture was stirred for 16 h. The solvent was removed under reduced pressure and the concentrate was added to brine and extracted with dichloromethane. The organic extract was dried ( $MgSO_4$ ) and the solvent was removed under reduced pressure. The residue (12.62 g) was chromatographed on silica gel (150 g) using ethyl acetate-hexane (1:9) as eluent to yield the *bis-silyl ether* **92** (9.13 g, 93%) as an oil,  $\nu_{max}(CHCl_3)/cm^{-1}$  1717 (CO);  $\delta_H$  (300 MHz,  $CDCl_3$ ) 0.03 (6H, s,  $Si(CH_3)_2$ ), 0.04 [6H, s,  $Si(CH_3)_2$ ], 0.88 [9H, s,  $SiC(CH_3)_3$ ], 0.89 [9H, s,  $SiC(CH_3)_3$ ], 1.19 [9H, s,  $COC(CH_3)_3$ ], 2.02 (1H, qt,  $J$  3 x 12.7 and 2 x 5.0 Hz, 5''-H<sub>A</sub>), 1.36—1.74 (6H, m, 2-H<sub>A</sub>, 4-H, 5-H<sub>2</sub> and 1'-H<sub>2</sub>), 1.75—1.90 (2H, m, 2-H<sub>B</sub>, 3-H), 2.02 (1H, m, 5''-H<sub>B</sub>), 3.51—3.81 (6H, m, 6-H<sub>2</sub>, 2'-H<sub>2</sub>, 4''-H<sub>A</sub> and 6''-H<sub>A</sub>), 3.98—4.13 (4H, m, 1-H<sub>2</sub>, 4''-H<sub>B</sub> and 6''-H<sub>B</sub>) and 4.44 (1H, d, 4.5 Hz, 2''-H);  $\delta_C$  (75 MHz,  $CDCl_3$ ) -5.3 and -5.2 [2 x  $Si(CH_3)_2$ ], 18.3 and 18.4 [2 x  $SiC(CH_3)_3$ ], 25.9 (C-5''), 26.0 and 26.0 [2 x  $SiC(CH_3)_3$ ], 27.2 [ $COC(CH_3)_3$ ], 29.6 (C-1' or C-5), 30.2 (C-2), 31.6 (C-3), 35.1 (C-1' or C-5), 38.7 [ $COC(CH_3)_3$ ], 41.6 (C-4), 61.7 and 62.9 (C-2' and C-6), 63.4 (C-1), 66.8 (C-4'' and C-6''), 104.3 (C-2'') and 178.5 (C=O) (Found (FAB):  $M^+$ +Rb, 645.3034. Calc. for  $C_{29}H_{60}O_6Si_2Rb$ :  $M$ , 645.3047).

**(3*S*\*, 4*R*\*)-6-(*t*-Butyldimethylsilanyloxy)-3-(2-*t*-butyldimethylsilanyloxyethyl)-4-(1,3-dioxan-2-yl)hexan-1-ol 93**

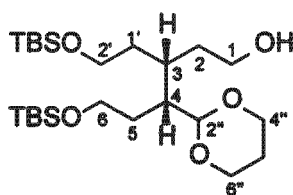

To a stirred solution of the pivaloate **92** (880 mg, 1.57 mmol) in tetrahydrofuran (20 cm<sup>3</sup>) at 0 °C was added lithium aluminium hydride (78 mg, 2.04 mmol). After 30 min the reaction was quenched with 1 M NaOH, water was added and the aqueous phase was extracted with ethyl acetate. The organic extract was dried (MgSO<sub>4</sub>) and the solvent was removed under reduced pressure to give an oil (786 mg) which was purified by chromatography on silica gel (70 g) using ethyl acetate–hexane (3:7) as eluent to yield *alcohol* **93** (655 mg, 88%) as an oil,  $\nu_{\max}(\text{CHCl}_3)/\text{cm}^{-1}$  3446 (OH);  $\delta_{\text{H}}$  (300 MHz, CDCl<sub>3</sub>) 0.04 [12H, s, 2 x Si(CH<sub>3</sub>)<sub>2</sub>], 0.89 [18H, s, 2 x SiC(CH<sub>3</sub>)<sub>3</sub>], 1.23–1.34 (1H, m, 5''-H<sub>A</sub>), 1.34–1.79 (7H, m, 2-H<sub>2</sub>, 4-H, 5-H<sub>2</sub> and 1'-H<sub>2</sub>), 1.86–2.12 (3H, m, 3-H, 5''-H<sub>B</sub> and OH), 3.53–3.81 (8H, m, 1-H<sub>2</sub>, 6-H<sub>2</sub>, 2'-H<sub>2</sub>, 4''-H<sub>A</sub> and 6''-H<sub>A</sub>), 4.04–4.12 (2H, m, 4''-H<sub>B</sub> and OH) and 4.46 (1H, d, 4.5 Hz, 2''-H);  $\delta_{\text{C}}$  (75 MHz, CDCl<sub>3</sub>) –5.3 and –5.3 [2 x Si(CH<sub>3</sub>)<sub>2</sub>], 18.3 and 18.4 [2 x SiC(CH<sub>3</sub>)<sub>3</sub>], 25.8 (C-5''), 26.0 and 26.0 [2 x SiC(CH<sub>3</sub>)<sub>3</sub>], 29.7 (C-1' or C-5), 31.2 (C-2), 34.2 (C-3), 35.7 (C-1' or C-5), 42.2 (C-4), 61.9 (C-1), 61.9 and 62.8 (C-2' and C-6), 66.9 (C-4'' and C-6'') and 104.5 (C-2'') (Found (FAB): M<sup>+</sup>+Na 499.3236. Calc. for C<sub>24</sub>H<sub>52</sub>O<sub>5</sub>Si<sub>2</sub>Na: *M*, 499.3251).

**Methyl (3*R*\*, 4*R*\*)-6-(*t*-butyldimethylsilanyloxy)-3-(2-*t*-butyldimethylsilanyloxyethyl)-4-(1,3-dioxan-2-yl)hexanoate 94**

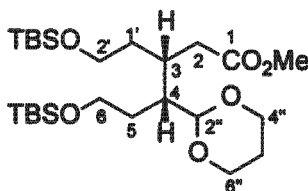

Sodium metaperiodate (10% solution in water, 100 cm<sup>3</sup>) and ruthenium dioxide (60 mg, 0.5 mmol) were added sequentially to a vigorously stirred solution of **93** (21.32 g, 44.8 mmol) in carbon tetrachloride–acetonitrile (1:1) (100 cm<sup>3</sup>) at 0 °C. Stirring was continued at this temperature for 18 h. The resulting mixture was poured into dichloromethane–water (1:1) (1000 cm<sup>3</sup>) and the aqueous layer was extracted with dichloromethane. The organic phase was dried (MgSO<sub>4</sub>) and the solvent was removed under reduced pressure to give the acid (27.21 g) which was dissolved in acetonitrile

(400 cm<sup>3</sup>). *N,N*-Dimethylformamide (50 cm<sup>3</sup>) was added, followed by potassium carbonate (12.36 g, 89.6 mmol) and iodomethane (3.3 cm<sup>3</sup>, 53.8 mmol). The mixture was stirred at 25 °C for 16 h. The mixture was concentrated under reduced pressure and the residual aqueous slurry was added to ethyl acetate (800 cm<sup>3</sup>). The organic phase was washed with water and brine, dried (MgSO<sub>4</sub>) and the solvent was removed under reduced pressure to give a residue (29.32 g) which was purified by chromatography on silica gel (800 g) using ethyl acetate–hexane (1:9) as eluent, to yield the *ester* **94** (20.54 g, 91%) as a gum,  $\nu_{\max}(\text{CHCl}_3)/\text{cm}^{-1}$  1729 (CO);  $\delta_{\text{H}}$  (400 MHz, CDCl<sub>3</sub>) 0.02 [6H, s, Si(CH<sub>3</sub>)<sub>2</sub>], 0.04 (6H, s, Si(CH<sub>3</sub>)<sub>2</sub>), 0.87 [9H, s, SiC(CH<sub>3</sub>)<sub>3</sub>], 0.88 [9H, s, SiC(CH<sub>3</sub>)<sub>3</sub>], 1.23–1.31 (1H, m, 5''-H<sub>A</sub>), 1.38–1.80 (5H, m, 4-H, 5-H<sub>2</sub> and 1'-H<sub>2</sub>), 1.93–2.07 (1H, m, 5''-H<sub>B</sub>), 2.16 (1H, dd, *J* 15.6 and 7.9 Hz, 2-H<sub>A</sub>), 2.25–2.37 (1H, m, 3-H), 2.57 (1H, dd, *J* 15.6 and 5.7 Hz, 2-H<sub>B</sub>), 3.63 (3H, s, OCH<sub>3</sub>), 3.55–3.79 (6H, m, 6-H<sub>2</sub>, 2'-H<sub>2</sub>, 4''-H<sub>A</sub> and 6''-H<sub>A</sub>), 4.00–4.10 (2H, m, 4''-H<sub>B</sub> and 6''-H<sub>B</sub>) and 4.45 (1H, d, 3.9 Hz, 2''-H);  $\delta_{\text{C}}$  (100 MHz, CDCl<sub>3</sub>) –5.1 and –5.1 [2 x Si(CH<sub>3</sub>)<sub>2</sub>], 18.4 and 18.5 [2 x SiC(CH<sub>3</sub>)<sub>3</sub>], 26.0 (C-5''), 26.1 and 26.2 [2 x SiC(CH<sub>3</sub>)<sub>3</sub>], 29.4 (C-1' or C-5), 32.6 (C-3), 35.7 (C-1' or C-5), 36.8 (C-2), 42.1 (C-4), 51.5 (OCH<sub>3</sub>), 61.8 and 62.9 (C-2' and C-6), 66.9 and 67.0 (C-4'' and C-6''), 104.4 (C-2'') and 174.2 (C-1) (Found: *M*<sup>+</sup>, 504.3268. Calc. for C<sub>25</sub>H<sub>52</sub>O<sub>6</sub>Si<sub>2</sub>: *M*, 504.3303).

**Methyl (4'*S*\*, 4'*aR*\*, 7'*aR*\*)-(hexahydrofuro[2,3-*b*]pyran-4-yl)acetate **95****

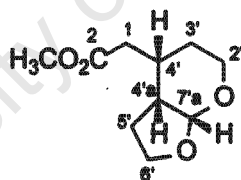

Water (0.22 cm<sup>3</sup>, 12.6 mmol) followed by a solution of scandium trifluoromethanesulfonate (6.2 mg, 0.013 mmol) in acetonitrile (5 cm<sup>3</sup>) were added to a stirred solution of **94** (1.27 g, 2.52 mmol) in acetonitrile (20 cm<sup>3</sup>). The reaction was stirred for 40 min at 25 °C after which saturated aqueous ammonium chloride was added. The resulting mixture was extracted with dichloromethane, dried (MgSO<sub>4</sub>), and the solvent was removed *in vacuo*. Chromatography of the residue (750 mg) on silica gel (70 g) using ethyl acetate–hexane (3:7) as eluent, yielded the *acetal* **95** (354 mg, 70%) as an oil,  $\nu_{\max}(\text{CHCl}_3)/\text{cm}^{-1}$  1732 (CO);  $\delta_{\text{H}}$  (300 MHz, CDCl<sub>3</sub>) 1.26 (1H, dtd, *J* 13.7, 2 x 8.3 and 3.6 Hz, 3'-H<sub>A</sub>), 1.70–1.91 (3H, m, 3'-H<sub>B</sub>, 4'-a-H and 5'-H<sub>A</sub>), 1.96 (1H, dtd, *J* 12.1, 8.3 and 2 x 7.2 Hz, 5'-H<sub>B</sub>), 2.04–2.16 (1H, m, 4'-H), 2.26 (1H, dd, *J* 15.1 and 8.8 Hz, 2-H<sub>A</sub>), 2.47 (1H, dd, *J* 15.1 and 5.4 Hz, 2-H<sub>B</sub>) 3.60 (1H, ddd, *J* 11.6, 6.2 and 3.6 Hz, 2'-H<sub>A</sub>), 3.65 (3H, s, OCH<sub>3</sub>), 3.76 (1H, ddd, *J* 11.6, 8.3 and 3.5 Hz, 2'-H<sub>B</sub>), 3.83 (1H, td, *J* 2 x 8.0 and 5.2 Hz, 6'-H<sub>A</sub>), 4.02 (1H, q, *J* 3 x 8.0 Hz, 6'-H<sub>B</sub>) and 5.12 (1H, d, 3.6 Hz, 7'-a-H);  $\delta_{\text{C}}$  (75 MHz, CDCl<sub>3</sub>) 27.4 (C-3'), 27.8 (C-5'), 31.2 (C-4'),

39.2 (C-2), 41.1 (C-4'a), 51.5 (OCH<sub>3</sub>), 60.2 (C-2'), 65.6 (C-6'), 100.2 (C-7'a) and 172.1 (C-1) (Found: M<sup>+</sup>, 200.1061. Calc. for C<sub>10</sub>H<sub>16</sub>O<sub>4</sub>: M, 200.1049).

**(2'R\*,4R\*)-4-[4-Hydroxy-1-(propan-1,3-dioxy)butan-2-yl]tetrahydropyran-2-one 96**

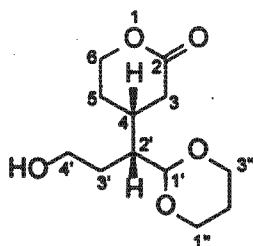

Water (0.9 cm<sup>3</sup>, 50.0 mmol) and a solution of scandium trifluoromethanesulfonate (24.6 mg, 0.05 mmol) in acetonitrile (10 cm<sup>3</sup>) were added to a solution of **94** (5.04 g, 10.0 mmol) in acetonitrile (75 cm<sup>3</sup>) at -10 °C. The reaction was stirred for 6 h at -10 °C after which it was poured into aqueous ammonium chloride-ice, extracted with dichloromethane, dried (MgSO<sub>4</sub>) and the solvent was removed under reduced pressure to give an oil (2.49 g). Chromatography on silica gel (120 g) using ethyl acetate as eluent afforded the *lactone* **96** (2.29 g, 94%),  $\nu_{\max}(\text{CHCl}_3)/\text{cm}^{-1}$  3448 (OH) and 1731 (CO);  $\delta_{\text{H}}$  (300 MHz, CDCl<sub>3</sub>) 1.29—1.39 (1H, m, 2''-H<sub>A</sub>), 1.50—1.63 (1H, m, 5-H<sub>A</sub>), 1.63—1.79 (4H, m, 5-H<sub>B</sub>, 2'-H and 3'-H<sub>A</sub>), 1.80—1.92 (1H, m, 3'-H<sub>B</sub>), 2.04 (1H, dtt, *J* 13.5, 2 x 12.6 and 2 x 5.1 Hz, 2''-H<sub>B</sub>), 2.22—2.41 (2H, m, 3-H<sub>A</sub> and 4-H), 2.43—2.57 (1H, br.s, OH), 2.59—2.74 (1H, m, 3-H<sub>B</sub>), 3.51—3.56 (4H, m, 4'-H<sub>2</sub>, 1''-H<sub>A</sub> and 3''-H<sub>A</sub>), 4.05—4.14 (2H, m, 1''-H<sub>B</sub> and 3''-H<sub>B</sub>), 4.20 (1H, td, *J* 2 x 11.0 and 3.7 Hz, 6-H<sub>A</sub>), 4.37 (1H, ddd, *J* 11.0, 4.8 and 3.7 Hz, 6-H<sub>B</sub>) and 4.54 (1H, d, *J* 3.4 Hz, 1'-H);  $\delta_{\text{C}}$  (75 MHz, CDCl<sub>3</sub>) 25.6 (C-2''), 26.9 (C-3''), 28.7 (C-5), 32.1 (C-4), 33.7 (C-3), 44.0 (C-2'), 61.3 (C-4'), 66.9 and 67.0 (C-1'' and C-3'') 68.6 (C-6), 102.7 (C-1') and 171.7 (C-2) (Found M<sup>+</sup>, 243.1241. Calc. for C<sub>12</sub>H<sub>19</sub>O<sub>5</sub>: M, 243.1233).

**(2'R\*,4R\*)-4-[4-*t*-Butyldiphenylsilyloxy-1-(propan-1,3-dioxy)butan-2-yl]tetrahydropyran-2-one 97**

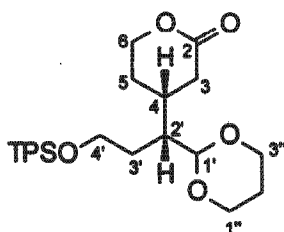

*t*-Butyldiphenylsilyl chloride (0.13 cm<sup>3</sup>, 0.49 mmol) and imidazole (33 mg, 0.49 mmol) were added to a stirred solution of **96** (40 mg, 0.16 mmol) in acetonitrile. The solution was stirred for 2 h, diluted with dichloromethane, washed with water, dried (MgSO<sub>4</sub>) and the solvent was removed to

give the crude product (280 mg). Chromatography on silica gel (20 g) using ethyl acetate–hexane (3:7) as eluent afforded the *silyl ether* **97** (75 mg, 97%),  $\nu_{\max}(\text{CHCl}_3)/\text{cm}^{-1}$  1731 (CO);  $\delta_{\text{H}}$  (400 MHz,  $\text{CDCl}_3$ ) 1.05 [9H, s,  $\text{C}(\text{CH}_3)_3$ ], 1.24–1.31 (1H, m, 2''-H<sub>A</sub>), 1.46–1.58 (1H, m, 3'-H<sub>A</sub>), 1.60–1.81 (4H, m, 5-H<sub>2</sub>, 2'-H and 3'-H<sub>B</sub>), 1.97 (1H, qt,  $J$  3 x 12.6 and 2 x 4.9 Hz, 2''-H<sub>B</sub>), 2.26–2.40 (2H, m, 3-H<sub>A</sub> and 4-H), 2.61–2.73 (1H, m, 3-H<sub>B</sub>), 3.54–3.73 (3H, m, 4'-H<sub>A</sub>, 1''-H<sub>A</sub> and 3''-H<sub>A</sub>), 3.74–3.83 (1H, m, 4'-H<sub>B</sub>), 3.98–4.07 (2H, m, 1''-H<sub>B</sub> and 3''-H<sub>B</sub>), 4.15 (1H, td,  $J$  2 x 11.1 and 3.7 Hz, 6-H<sub>A</sub>), 4.32 (1H, ddd,  $J$  11.1, 4.8 and 3.7 Hz, 6-H<sub>B</sub>), 4.43 (1H, d,  $J$  3.5 Hz, 1'-H), 7.33–7.45 (6H, m, Ar-H) and 7.63–7.70 (4H, m Ar-H);  $\delta_{\text{C}}$  (100 MHz,  $\text{CDCl}_3$ ) 17.1 [ $\text{C}(\text{CH}_3)_3$ ], 23.7 (C-2''), 24.9 [ $\text{C}(\text{CH}_3)_3$ ], 25.0 (C-3'), 26.7 (C-5), 29.2 (C-4), 31.8 (C-3), 40.9 (C-2'), 60.5 (C-4'), 64.9 and 64.9 (C-1'' and C-3'') 66.7 (C-6), 100.9 (C-1'), 125.6(0) and 125.6(2), 127.6, 131.7(6) and 131.8(1), 133.5(4) and 133.5(9) (Ar-C) and 170.0 (C-2) (Found (FAB):  $\text{M}^+ + \text{Na}$ , 505.2372. Calc. for  $\text{C}_{12}\text{H}_{19}\text{O}_5\text{Na}$ :  $M$ , 505.2386).

**(2'R\*,4R\*)-4-[4-Phenylselanyl-1-(propan-1,3-dioxy)butan-2-yl]tetrahydropyran-2-one 98**

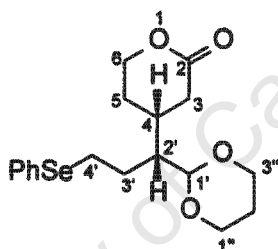

Phenylselenocyanate (284 mg, 1.56 mmol) in tetrahydrofuran (2 cm<sup>3</sup>) and tri-*n*-butylphosphine (0.40 cm<sup>3</sup>, 1.60 mmol) were added sequentially to a stirred solution of **96** (190 mg, 0.78 mmol) in tetrahydrofuran (5 cm<sup>3</sup>). The resulting solution was stirred at 25 °C for 20 min after which the solvent was removed under reduced pressure to give a crude mixture which was chromatographed directly on silica gel (50 g) using ethyl acetate–hexane (2:3) as eluent to yield *phenyl selenide* **98** (215 mg, 72%) as an oil,  $\nu_{\max}(\text{CHCl}_3)/\text{cm}^{-1}$  1730 (CO);  $\delta_{\text{H}}$  (400 MHz,  $\text{CDCl}_3$ ) 1.30–1.37 (1H, m, 2''-H<sub>A</sub>), 1.55–1.86 (4H, m, 5-H<sub>2</sub>, 2'-H and 3'-H<sub>A</sub>), 1.88–2.10 (2H, m, 3'-H<sub>B</sub> and 2''-H<sub>B</sub>), 2.23–2.39 (2H, m, 3-H<sub>A</sub> and 4-H), 2.57–2.70 (1H, m, 3-H<sub>B</sub>), 2.90 (1H, ddd,  $J$  12.1, 9.1 and 7.1 Hz, 4'-H<sub>A</sub>), 3.10 (1H, ddd,  $J$  12.1, 9.3 and 5.1 Hz, 4'-H<sub>B</sub>), 3.62–3.75 (2H, m, 1''-H<sub>A</sub> and 3''-H<sub>A</sub>), 4.04–4.12 (2H, m, 1''-H<sub>B</sub> and 3''-H<sub>B</sub>), 4.17 (1H, td,  $J$  2 x 11.1 and 3.7 Hz, 6-H<sub>A</sub>), 4.33 (1H, ddd,  $J$  11.1, 4.8 and 3.7 Hz, 6-H<sub>B</sub>), 4.51 (1H, d,  $J$  3.8 Hz, 1'-H), 7.20–7.29 (3H, m, Ar-H), 7.45–7.51 (2H, m, Ar-H);  $\delta_{\text{C}}$  (100 MHz,  $\text{CDCl}_3$ ) 25.7 (C-2''), 26.4 (C-4'), 26.8 and 26.9 (C-5 and C-3'), 31.5 (C-4), 33.8 (C-3), 46.4 (C-2'), 66.9 and 67.0 (C-1'' and C-3''), 68.6 (C-6), 102.7 (C-1'), 126.8, 129.0, 130.1, 132.4 (Ar-C) and 171.6 (C-2) (Found:  $M$ , 384.0847. Calc. for  $\text{C}_{18}\text{H}_{24}\text{O}_4^{80}\text{Se}$ :  $M$ , 384.0840).

**(2'R\*,4S\*)-4-[4-Phenylselanyl-1-(propan-1,3-dioxy)butan-2-yl]-3-formyltetrahydropyran-2-one 99**

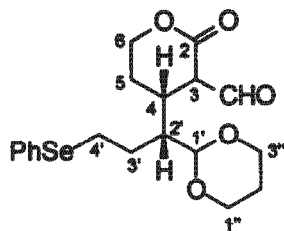

*t*-Butoxybis(dimethylamino)methane (0.45 cm<sup>3</sup>, 2.20 mmol) was added to a solution of **98** (210 mg, 0.55 mmol) in tetrahydrofuran (2 cm<sup>3</sup>). The solution was refluxed under nitrogen for 3 h after which it was cooled to 0 °C and methanol (3 cm<sup>3</sup>) was added. The solution was acidified to pH 3 by the addition of 1M HCl. Water (3 cm<sup>3</sup>) was added and the resulting mixture was stirred at 0 °C for 30 min. The mixture was extracted with ethyl acetate, the organic extract was dried (MgSO<sub>4</sub>) and the solvent was removed *in vacuo* to give an oil (320 mg). The material was chromatographed on silica gel (10 g) using ethyl acetate–hexane (3:2) as eluent to give the *formyl lactone 99* (195 mg, 86%), (Found: *M*<sup>+</sup>, 412.0784. Calc. for C<sub>19</sub>H<sub>24</sub>O<sub>5</sub><sup>80</sup>Se: *M*, 412.0789).

**(2'R\*,3E,4S\*)-4-[4-Phenylselanyl-1-(propan-1,3-dioxy)butan-2-yl]-3-benzoyloxymethylene-tetrahydropyran-2-one 100**

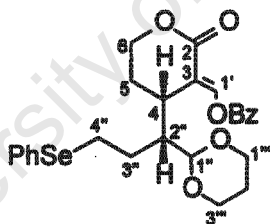

Formyl lactone **99** (80 mg, 0.19 mmol) was dissolved in dichloromethane–pyridine (2:1, 3 cm<sup>3</sup>). Benzoyl chloride (0.05 cm<sup>3</sup>, 0.43 mmol) was added and the solution was stirred at 25 °C for 90 min. The pyridine was removed under reduced pressure by azeotrope formation with toluene (3 x 30 cm<sup>3</sup>). The resulting material was dissolved in dichloromethane, washed with brine and the aqueous phase was extracted with dichloromethane. The organic extract was dried (MgSO<sub>4</sub>) to give the benzoylated product (270 mg) which was purified by chromatography on silica gel (20 g) using ethyl acetate–hexane (1:9) to elute excess benzoyl chloride followed by elution with ethyl acetate–hexane (3:2) to yield the *enol benzoate 100* (85 mg, 86%),  $\nu_{\max}(\text{CHCl}_3)/\text{cm}^{-1}$  1715 and 1749 (CO);  $\delta_{\text{H}}$  (400 MHz, CDCl<sub>3</sub>) 1.27–1.34 (1H, m, 2'''-H<sub>A</sub>), 1.68–1.79 (1H, m, 3'''-H<sub>A</sub>), 1.83–1.93 (1H, m, 5-H<sub>A</sub>), 2.02 (1H, qt, *J* 3 x 12.4 and 2 x 5.0 Hz, 2'''-H<sub>B</sub>), 2.09–2.24 (2H, m, 5-H<sub>B</sub> and 3'''-H<sub>B</sub>), 2.24–2.33 (1H, m, 2''-H), 2.98–3.13 (2H, m, 4''-H<sub>2</sub>), 3.32–3.41 (1H, m, 4-H), 3.63–3.74 (2H, m, 1'''-H<sub>A</sub> and 3'''-H<sub>A</sub>), 4.02–4.13 (3H, m, 6-H<sub>A</sub>, 1'''-H<sub>B</sub> and 3'''-H<sub>B</sub>), 4.39 (1H,

ddd,  $J$  11.3, 6.2 and 3.9 Hz, 6-H<sub>B</sub>), 4.57 (1H, d,  $J$  3.3 Hz, 1''-H), 7.16—8.14 (10H, m, Ar-H) and 8.36 (1H, d,  $J$  1.7 Hz, 1'-H);  $\delta_C$  (100 MHz, CDCl<sub>3</sub>) 24.3 (C-5), 25.6 (C-2'''), 26.6 (C-4''), 28.6 (C-3'''), 33.0 (C-4), 45.1 (C-2''), 66.4 (C-6), 66.8 and 66.9 (C-1''' and C-3'''), 102.5 (C-1''), 116.7 (C-3), 126.8, 127.8, 128.4, 128.8, 129.0, 130.1, 130.2, 130.3, 132.5, 133.5 and 134.2 (Ar-C), 144.1 (C-1'), 162.0 (Ar-C=O) and 167.4 (C-2) (Found:  $M^+$ , 516.1053. Calc. for C<sub>26</sub>H<sub>28</sub>O<sub>6</sub><sup>80</sup>Se:  $M$ , 516.1051).

**(4a*S*\*,5*R*\*,6*R*\*)-6-Hydroxy-5-(2-phenylselanylethyl)-4,4a,5,6-tetrahydro-3*H*-pyrano[3,4-*c*]-pyran-1-one 101**

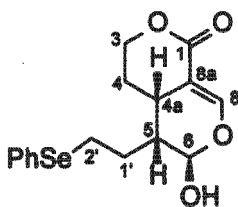

A borate-HCl buffer (pH 8, 2 cm<sup>3</sup>) followed by ceric ammonium nitrate (18mg, 0.03 mmol) were added to a stirred solution of **99** (150 mg, 0.36 mmol) in acetonitrile (2 cm<sup>3</sup>). The resulting mixture was stirred at 60 °C for 24 h and then cooled and diluted with dichloromethane (10 cm<sup>3</sup>). The aqueous phase was extracted with dichloromethane, the combined organic phases were dried (MgSO<sub>4</sub>) and the solvent was removed under reduced pressure to give an oil (140 mg). Flash chromatography on silica gel (12 g) using ethyl acetate-hexane (1:1) as eluent afforded the *hemiacetal* **101** (82 mg, 65%),  $\delta_H$  (400 MHz, CDCl<sub>3</sub>) 1.34—1.55 (1H, m, 1'-H<sub>A</sub>), 1.56—1.82 (3H, m, 4-H<sub>2</sub> and 1'-H<sub>B</sub>), 2.06—2.18 (1H, m, 5-H), 2.70—3.20 (3H, m, 4a-H and 2'-H<sub>2</sub>), 4.18—4.32 (1H, m, 3-H<sub>A</sub>), 4.35—4.47 (1H, m, 3-H<sub>B</sub>), 5.46 (1H, d,  $J$  1.8 Hz, 6-H), 7.20—7.29 (3H, m, Ar-H), 7.43—7.50 (2H, m, Ar-H) and 7.55 (1H, d,  $J$  2.2 Hz, 8-H);  $\delta_C$  (75 MHz, CDCl<sub>3</sub>) 24.2 (C-4), 25.1 (C-1'), 25.6 (C-2'), 27.8 (C-4a), 36.9 (C-5), 68.2 (C-3), 94.1 (C-6), 103.5 (C-8a) 127.2, 129.2 and 132.9 (Ar-C), 153.3 (C-8) and 166.3 (C-1)

## 6.4 CHIRAL POOL DERIVED ENANTIOSELECTIVE SYNTHESIS

## General procedure for dienophile preparation



110	R=OH
33	R=TPS
113	R=TIPS
111	R=TBS

(*S*)-5-Hydroxymethylfuran-2(5*H*)-one **110**<sup>127, 128</sup> (4–10 mmol) and imidazole (~1.2 equivalents), were dissolved in dry dichloromethane (to give ~1 M solution). The silyl chloride (~1.1 equivalents) was added and the reaction was stirred at 25 °C until the consumption of starting material was complete (TLC). Water was added and the resulting mixture was extracted with dichloromethane. The organic phase was dried (MgSO<sub>4</sub>) and the solvent was removed under reduced pressure to give a residue which chromatographed on silica gel using ethyl acetate–hexane in varying proportions.

(*S*)-(5-*O*-*t*-Butyldiphenylsilyloxymethyl)furan-2(5*H*)-one **33**, (68%), mp 79–82 °C (from ether–hexane) (lit.,<sup>126</sup> mp 79–80 °C);  $\delta_{\text{H}}$  (200 MHz, CDCl<sub>3</sub>) 1.03 [s, 9H, C(CH<sub>3</sub>)<sub>3</sub>], 3.89 (2H, dd, *J* 4.4 and 2.1 Hz, 5-H<sub>2</sub>), 5.03–5.10 (1H, m, 4-H), 6.16 (1H, dd, *J* 5.8 and 2.0 Hz, 2-H) and 7.20–7.70 (11H, m, Ar-H and 3-H). <sup>1</sup>H NMR data correspond with those previously reported.<sup>126</sup>

(*S*)-(5-*O*-Triisopropylsilyloxymethyl)furan-2(5*H*)-one **113**, (65%) as an oil,  $\alpha_{\text{D}}$  –133.7 (*c* 1 in CHCl<sub>3</sub>);  $\nu_{\text{max}}$ (CHCl<sub>3</sub>)/cm<sup>-1</sup> 1756 (CO);  $\delta_{\text{H}}$  (400 MHz, CDCl<sub>3</sub>) 0.98–1.08 [21H, m, 3 x CH(CH<sub>3</sub>)<sub>2</sub>], 3.87 (1H, dd, *J* 10.4 and 5.7 Hz, 5-H<sub>A</sub>), 4.06 (1H, dd, *J* 10.4 and 4.6 Hz, 5-H<sub>B</sub>), 5.05–5.10 (1H, m, 4-H), 6.16 (1H, dd, *J* 5.7 and 2.0 Hz, 2-H) and 7.54 (1H, dd, *J* 5.7 and 1.5 Hz, 3-H);  $\delta_{\text{C}}$  (100 MHz, CDCl<sub>3</sub>) 11.9 [3 x CH(CH<sub>3</sub>)<sub>2</sub>], 17.8 [3 x CH(CH<sub>3</sub>)<sub>2</sub>], 63.5 (C-5), 83.3 (C-4), 122.4 (C-2), 154.5 (C-3) and 172.8 (C-1), (Found:  $M^+$ –C<sub>3</sub>H<sub>7</sub>, 227.1117. Calc. for C<sub>11</sub>H<sub>19</sub>O<sub>3</sub>Si: *M*, 227.1104).

(*S*)-(5-*O*-*t*-Butyldimethylsilyloxymethyl)furan-2(5*H*)-one **111**, (96%), mp 30–32 °C (crude) (lit.,<sup>127</sup> mp 31 °C crude);  $\delta_{\text{H}}$  (300 MHz; CDCl<sub>3</sub>) 0.05 and 0.06 (6H, 2 x s, 2 x CH<sub>3</sub>), 0.86 (9H, s, C(CH<sub>3</sub>)<sub>3</sub>), 3.79 (1H, dd, *J* 10.7 and 5.4 Hz, 5-H<sub>A</sub>), 3.92 (1H, dd, *J* 10.7 and 4.5 Hz, 5-H<sub>B</sub>), 4.99–5.07 (1H, m, 4-H), 6.15 (1H, dd, *J* 5.7 and 1.9 Hz, 2-H) and 7.48 (1H, dd, *J* 5.7 and 1.6 Hz, 3-H). <sup>1</sup>H NMR data correspond with those previously reported.<sup>127</sup>

### General procedure for cycloadditions of furanones 33, 111 and 113 with butadiene (a) Lewis acid catalysed cycloadditions

The butenolide was dissolved in dichloromethane ( $\sim 2 \text{ cm}^3/\text{mmol}$  butenolide) under nitrogen. Ethylaluminium dichloride (1.0 M solution in hexanes,  $\sim 0.4$  equivalents) was added and the resulting mixture was added to cooled ( $-78 \text{ }^\circ\text{C}$ ) butadiene ( $\sim 2 \text{ cm}^3/\text{mmol}$  butenolide) in a pressure tube which was sealed and heated at  $60 \text{ }^\circ\text{C}$  for 168 h. (CAUTION-explosion risk) The tube was cooled to  $-78 \text{ }^\circ\text{C}$  and aqueous saturated sodium hydrogen carbonate was added. The mixture was extracted with dichloromethane and the organic extract was dried ( $\text{MgSO}_4$ ). The solvent was removed *in vacuo* to give the cycloadduct which was purified by chromatography on silica gel using ethyl acetate–hexane.

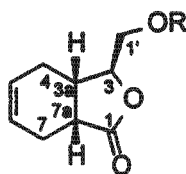

112 R=TPS

114 R=TIPS

115 R=TBS

117 R=OH

a) The reaction of 33 (2.00 g, 5.7 mmol) gave a solid mass (3.25 g) after work-up. Chromatography on silica gel (250 g) using ethyl acetate–hexane (1:9) as eluent afforded (3*S*, 3*aS*, 7*aR*)-3-*t*-butyldiphenylsilyloxymethyl-3*a*,4,7,7*a*-tetrahydro-3*H*-isobenzofuran-1-one 112 (1.61 g, 70%); mp  $71\text{--}74 \text{ }^\circ\text{C}$  (from hexane);  $[\alpha]_{\text{D}} +19.0$  ( $c$  9.7 in  $\text{CHCl}_3$ ) (lit.,<sup>126</sup> mp  $73\text{--}74 \text{ }^\circ\text{C}$ ;  $[\alpha]_{\text{D}} +19.6$ );  $\delta_{\text{H}}$  (400 MHz,  $\text{CDCl}_3$ ) 1.07 [9H, s,  $\text{C}(\text{CH}_3)_3$ ], 1.88–1.98 (1H, br d, 4- $\text{H}_{\text{A}}$ ), 2.22–2.48 (3H, m, 4- $\text{H}_{\text{B}}$ , 7- $\text{H}_2$ ), 2.66–2.75 (1H, m, 3*a*-H), 3.00 (1H, td,  $J$  2 x 10.4 and 4.4 Hz, 7*a*-H), 3.77 (1H, dd,  $J$  11.4 and 3.8 Hz, 1'- $\text{H}_{\text{A}}$ ), 3.88 (1H, dd,  $J$  11.4 and 3.8 Hz, 1'- $\text{H}_{\text{B}}$ ), 4.16 (1H, q,  $J$  3 x 3.8 Hz, 3-H), 5.76–5.90 (2H, m, 5-H and 6-H), 7.30–7.49 (6H, m, Ar-H) and 7.61–7.67 (4H, m, Ar-H);  $\delta_{\text{C}}$  (100 MHz,  $\text{CDCl}_3$ ) 19.2 [ $\text{C}(\text{CH}_3)_3$ ], 22.6 (C-7), 25.5 (C-4), 26.8 [ $\text{C}(\text{CH}_3)_3$ ], 34.1 (C-3*a*), 37.4 (C-7*a*) 64.3 (C-1'), 84.8 (C-3), 125.6 and 126.5 (C-5 and C-6), 127.9, 129.9, 132.6(4) and 132.9(3), 135.5(5) and 135.6(4) (Ar-C), 179.4 (C-1).

b) The reaction of 113 (1.40 g, 5.19 mmol) gave a residue (1.66 g) after work-up. Chromatography on silica gel (160 g) using ethyl acetate–hexane (1:19) as eluent afforded (3*S*, 3*aS*, 7*aR*)-3-triisopropylsilyloxymethyl-3*a*,4,7,7*a*-tetrahydro-3*H*-isobenzofuran-1-one 114 (689 mg, 41%) as an oil,  $[\alpha]_{\text{D}} +3.8$  ( $c$  3.3 in  $\text{CHCl}_3$ );  $\nu_{\text{max}}(\text{CHCl}_3)/\text{cm}^{-1}$  1766 (CO);  $\delta_{\text{H}}$  (400 MHz,  $\text{CDCl}_3$ ) 1.06 [21H, m, 3 x  $\text{CH}(\text{CH}_3)_2$ ], 1.92–2.02 (1H, m, 4- $\text{H}_{\text{A}}$ ), 2.24–2.45 (3H, m, 4- $\text{H}_{\text{B}}$ , 7- $\text{H}_2$ ), 2.70 (1H, m, 3*a*-H), 3.01 (1H, td,  $J$  2 x 8.6 and 4.4 Hz, 7*a*-H), 3.86 (1H, dd,  $J$  11.0 and 3.3 Hz, 1'- $\text{H}_{\text{A}}$ ),

3.94 (1H, dd,  $J$  11.0 and 4.0 Hz, 1'-H<sub>B</sub>), 4.13 (1H, q,  $J$  3 x 3.7 Hz, 3-H) and 5.65 (2H, m, 5-H and 6-H);  $\delta_C$  (100 MHz, CDCl<sub>3</sub>) 11.9 [3 x CH(CH<sub>3</sub>)<sub>2</sub>] 17.9 [3 x CH(CH<sub>3</sub>)<sub>2</sub>], 22.5 (C-7), 25.7 (C-4), 34.1 (C-3a), 37.4 (C-7a) 64.2 (C-1'), 85.1 (C-3), 125.7 and 126.5 (C-5 and C-6) and 179.4 (C-1) (Found:  $M^+$  324.2126. Calc. for C<sub>18</sub>H<sub>32</sub>O<sub>3</sub>Si:  $M$ , 324.2121).

Further elution with ethyl acetate–hexane (1:9) yielded 1-Oxa-spiro[4.5]deca-3,7-dien-2-one 116 (63 mg, 8%); mp 64–65 °C (from ethyl acetate–hexane) (lit.,<sup>193</sup> mp 66–67 °C);  $\delta_H$  (400 MHz; CDCl<sub>3</sub>) 1.75–1.84 (1H, m, 10-H<sub>A</sub>), 1.90–1.98 (1H, m, 10-H<sub>B</sub>), 2.13–2.45 (4H, m, 6-H<sub>2</sub> and 9-H<sub>2</sub>), 5.64–5.71 (1H, m, 7-H or 8-H), 5.78–5.85 (1H, m, 7-H or 8-H), 6.05 (1H, d,  $J$  5.5 Hz, 3-H) and 7.50 (1H, d,  $J$  5.5 Hz, 4-H). <sup>1</sup>H NMR data correspond with those previously reported.<sup>138</sup>

c) The reaction of 111 (1.41 g, 6.18 mmol) gave a residue (1.25 g) after work-up. Chromatography on silica gel (160 g) using ethyl acetate–hexane (1:9) as eluent afforded (3*S*, 3*aS*, 7*aR*)-3-*t*-butyldimethylsilyloxymethyl-3*a*,4,7,7*a*-tetrahydro-3*H*-isobenzofuran-1-one 115 (238 mg, 14%) as an oil,  $[\alpha]_D +3.1$  ( $c$  1.4 in CHCl<sub>3</sub>);  $\nu_{max}$ (CHCl<sub>3</sub>)/cm<sup>-1</sup> 1766 (CO);  $\delta_H$  (400 MHz, CDCl<sub>3</sub>) 0.07 and 0.08 (6H, 2 x s, 2 x CH<sub>3</sub>), 0.90 [9H, s, C(CH<sub>3</sub>)<sub>3</sub>], 1.92–2.10 (1H, m, 4-H<sub>A</sub>), 2.24–2.45 (3H, m, 4-H<sub>B</sub>, 7-H<sub>2</sub>), 2.60–2.71 (1H, m, 3*a*-H), 2.99 (1H, td,  $J$  2 x 8.5 and 4.6 Hz, 7*a*-H), 3.76 (1H, dd,  $J$  11.4 and 3.3 Hz, 1'-H<sub>A</sub>), 3.85 (1H, dd,  $J$  11.4 and 3.9 Hz, 1'-H<sub>B</sub>), 4.13 (1H, q,  $J$  3 x 3.9 Hz, 3-H) and 5.65 (2H, m, 5-H and 6-H);  $\delta_C$  (100 MHz, CDCl<sub>3</sub>) 5.3 and 5.4 (2 x CH<sub>3</sub>) 18.4 [C(CH<sub>3</sub>)<sub>3</sub>], 22.7 (C-7), 25.8 (C-4), 25.9 [CH(CH<sub>3</sub>)<sub>3</sub>], 34.3 (C-3*a*), 37.6 (C-7*a*) 64.0 (C-1'), 85.1 (C-3), 125.8 and 126.6 (C-5 and C-6) and 179.6 (C-1) (Found:  $M^+$  282.1640. Calc. for C<sub>15</sub>H<sub>26</sub>O<sub>3</sub>Si:  $M$ , 282.1651).

Elution with ethyl acetate–hexane (2:3) yielded spiro-adduct 116 (170 mg, 18%) and further elution with ethyl acetate–hexane (7:3) gave (3*S*, 3*aS*, 7*aR*)-3-hydroxymethyl-3*a*,4,7,7*a*-tetrahydro-3*H*-isobenzofuran-1-one 117 (155 mg, 15%),  $\delta_H$  (400 MHz; CDCl<sub>3</sub>) 1.92–2.01 (1H, br.d, 4-H<sub>A</sub>), 2.26–2.34 (1H, br.d, 4-H<sub>B</sub>), 2.34–2.40 (2H, m, 7-H<sub>2</sub>), 2.63–2.71 (1H, m, 3*a*-H), 2.91–2.98 (1H, m, 7*a*-H), 3.72 (1H, dd,  $J$  12.4 and 4.8 Hz, 1'-H<sub>A</sub>), 3.90 (1H, dd,  $J$  12.4 and 3.2 Hz, 1'-H<sub>B</sub>), 4.21 (1H, dt,  $J$  2 x 4.9 and 3.2 Hz, 3-H) and 5.75–5.88 (2H, m, 5-H and 6-H). <sup>1</sup>H NMR data correspond to those reported previously.<sup>134</sup>

**General procedure for cycloadditions of furanones 33, 111 and 113 with butadiene (b)**

#### **Thermally induced cycloadditions**

The butenolide (1–6 mmol) and hydroquinone (5 mg) were weighed into a pressure tube. Butadiene (~2.5 cm<sup>3</sup>/mmol butenolide) was condensed into the tube which was sealed and the mixture was heated at 210 °C for 16 h. (CAUTION-explosion risk) The tube was cooled to –40 °C and opened.

The mixture was warmed to 25 °C and the excess butadiene was evaporated to leave a rubbery residue which was dissolved in dichloromethane and slurried with silica gel (~5g/g residue). The solvent was evaporated to leave the adsorbed residue which was slurried in ethyl acetate–hexane (1:9) and loaded onto a column of silica gel (~20g/g residue). Elution with ethyl acetate–hexane (1:9) afforded the cycloadduct.

a) The reaction of **33** (2.00 g, 5.7 mmol) afforded (3*S*, 3*aS*, 7*aR*)-3-*t*-butyldiphenylsilyloxy-methyl-3*a*,4,7,7*a*-tetrahydro-3*H*-isobenzofuran-1-one **112** (1.45 g, 63%)

b) The reaction of **113** (504 mg, 1.87 mmol) afforded (3*S*, 3*aS*, 7*aR*)-3-triisopropylsilyloxy-methyl-3*a*,4,7,7*a*-tetrahydro-3*H*-isobenzofuran-1-one **114** (412 mg, 68%)

c) The reaction of **111** (610 mg, 2.68 mmol) afforded (3*S*, 3*aS*, 7*aR*)-3-*t*-butyldimethylsilyloxy-methyl-3*a*,4,7,7*a*-tetrahydro-3*H*-isobenzofuran-1-one **115** (492 mg, 65%)

#### Desilylation of cycloadduct **112**

a) Acetic acid (1.0 M solution in THF, 1.1 cm<sup>3</sup>, 1.10 mmol) and tetrabutylammonium fluoride (1.0 M solution in THF, 1.1 cm<sup>3</sup>, 1.10 mmol) were added to a stirred solution of silyl ether **112** (406 mg, 1.00 mmol) in 5 cm<sup>3</sup> tetrahydrofuran at 0 °C. The solution was warmed to 10 °C and stirred for 1 h. Saturated aqueous ammonium chloride (10 cm<sup>3</sup>) was added and the mixture was concentrated under reduced pressure. The aqueous slurry was extracted with ethyl acetate, dried (MgSO<sub>4</sub>) and the solvent was removed *in vacuo* to give a residue (430 mg). Column chromatography on silica gel (15 g) using ethyl acetate–hexane (3:2) as eluent afforded the alcohol **117** (131 mg, 78%).

b) Hydrogen fluoride [40% HF–MeCN (40:60), 6 cm<sup>3</sup>, 8.00 mmol] was added to a stirred solution of **112** (1.00 g, 2.50 mmol) in acetonitrile (10 cm<sup>3</sup>). The mixture was stirred at 25 °C for 24 h after which saturated aqueous sodium carbonate was added and the resulting mixture was extracted with ethyl acetate. The organic phase was dried (MgSO<sub>4</sub>) and the solvent was removed under reduced pressure to give an oily residue (992 mg). Column chromatography on silica gel (50 g) using ethyl acetate–hexane (3:2) as eluent afforded the alcohol **117** (315 mg, 75%).

c) Tetrabutylammonium fluoride (1.0 M solution in THF, 1.2 cm<sup>3</sup>, 1.20 mmol) was added to a stirred solution of silyl ether **112** (406 mg, 1.00 mmol) in 5 cm<sup>3</sup> tetrahydrofuran at 0 °C. The solution was warmed to 25 °C and stirred until the consumption of starting material was complete

(TLC). Saturated aqueous ammonium chloride (10 cm<sup>3</sup>) was added and the mixture was concentrated under reduced pressure. The aqueous slurry was extracted with ethyl acetate, dried (MgSO<sub>4</sub>) and the solvent was removed *in vacuo* to give a residue (539 mg). Chromatography on silica gel (50 g) using ethyl acetate–hexane (3:2) as eluent yielded an inseparable mixture of **117** and a minor product, **119** (162 mg, 96%),  $\delta_{\text{H}}$  (400 MHz; CDCl<sub>3</sub>) *major* 2.63–2.71 (1H, m, 3a-H), 2.91–2.98 (1H, m, 7a-H), 3.90 (1H, dd, *J* 12.4 and 3.2 Hz, 1'-H<sub>A</sub>), 4.21 (1H, dt, *J* 2 x 4.9 and 3.2 Hz, 3-H), *minor* 3.47–3.53 (1H, m, 7a-H), 3.96 (1H, dd, *J* 12.4 and 3.2 Hz, 1'-H<sub>A</sub>), 4.25 (1H, ddd, *J* 9.9, 4.7 and 2.7 Hz, 3-H) and *mixed* 1.92–2.55, 3.65–3.75 and 5.69–5.87.

**(3S, 3aS, 7aR)-3-*t*-Butyldiphenylsilyloxymethyl-3a,4,7,7a-tetrahydro-3H-isobenzofuran-1-ol 120**

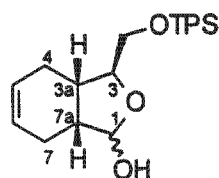

Diisobutylaluminium hydride (1.5 M in toluene, 0.40 cm<sup>3</sup>, 0.60 mmol) was slowly added to a stirred solution of **112** (200 mg, 0.49 mmol) in toluene (4 cm<sup>3</sup>) at –78 °C. After 20 min the reaction was quenched with 1 M HCl and warmed to 25 °C. The mixture was extracted with ethyl acetate and the organic extract was dried (MgSO<sub>4</sub>). The solvent was removed under reduced pressure to give a residue (230 mg). Chromatography on silica gel (20 g) using ethyl acetate–hexane (3:7) as eluent, afforded *lactol 120* (183 mg, 91%) as a mixture (~2:1 by NMR) of diastereomers,  $[\alpha]_{\text{D}} -11.1$  (*c* 1.0 in CHCl<sub>3</sub>);  $\nu_{\text{max}}$ (CHCl<sub>3</sub>)/cm<sup>-1</sup> 3450 (OH);  $\delta_{\text{H}}$  (400 MHz, CDCl<sub>3</sub>) *major* 1.08 [9H, s, C(CH<sub>3</sub>)<sub>3</sub>], 2.66–2.76 (1H, m, 1-H), 5.07 (1H, s, 9-H), *minor* 1.06 [9H, s, C(CH<sub>3</sub>)<sub>3</sub>], 2.42–2.53 (1H, m, 1-H), 5.05 (1H, s, 9-H), *mixed* 1.75–2.35 (5H, m, 2-H<sub>2</sub>, 5-H<sub>2</sub> and 6-H), 3.43–3.90 (3H, m, 7-H and 10-H<sub>2</sub>), 5.52–5.75 (2H, m, 3-H and 4-H), 7.30–7.48 (6H, m, Ar-H) and 7.61–7.67 (4H, m, Ar-H);  $\delta_{\text{C}}$  (100 MHz, CDCl<sub>3</sub>) *major* 19.2 [C(CH<sub>3</sub>)<sub>3</sub>], 22.8 (C-2), 23.3 (C-5), 26.8 [C(CH<sub>3</sub>)<sub>3</sub>], 32.1 (C-6), 41.7 (C-1) 64.5 (C-10), 83.4 (C-7), 103.0 (C-9), 123.9 and 125.2 (C-3 and C-4), *minor* 19.2 [C(CH<sub>3</sub>)<sub>3</sub>], 23.1 (C-2), 23.1 (C-5), 26.8 [C(CH<sub>3</sub>)<sub>3</sub>], 34.8 (C-6), 40.2 (C-1) 66.7 (C-10), 83.1 (C-7), 104.1 (C-9), 124.3 and 124.9 (C-3 and C-4), *mixed* 127.5(6), 127.6(0) and 127.7(1), 129.5(4), 129.5(6), 129.7(4) and 129.8(0), 132.9(5) and 133.0(7), 135.5(5), 135.5(9) and 135.6(4) (Ar-C) [Found (FAB): M<sup>+</sup>–OH, 391.2079. Calc. for C<sub>25</sub>H<sub>31</sub>O<sub>2</sub>Si: *M*, 391.2085].

(4*S*, 5*R*)-4-[(*S*)-2-*t*-Butyldiphenylsilyloxy-1-hydroxyethyl]-5-(1,3-dithiolan-2-yl) cyclohexene  
121

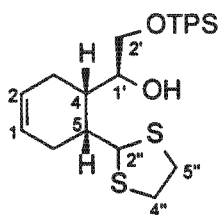

1,2-Ethanediol (0.04 cm<sup>3</sup>, 0.04 mg, 0.48 mmol) and titanium tetrachloride (1.0 M in CH<sub>2</sub>Cl<sub>2</sub>, 0.10 cm<sup>3</sup>, 0.10 mmol) were added sequentially to a solution of 120 (148 mg, 0.36 mmol) in dichloromethane (4 cm<sup>3</sup>) at -78 °C. After 15 min at -78 °C, aqueous saturated sodium hydrogen carbonate was added and the resulting mixture was warmed to room temperature. The mixture was extracted with dichloromethane, the organic extract was dried (MgSO<sub>4</sub>) and the solvent was removed under reduced pressure to give a residue (178 mg). Purified by chromatography on silica gel (20 g) using ethyl acetate-hexane (1:9) as eluent gave the *thioacetal* 121 (140 mg, 80%) as a gum, [α]<sub>D</sub> -3.6 (c 3.4 in CHCl<sub>3</sub>); ν<sub>max</sub>(CHCl<sub>3</sub>)/cm<sup>-1</sup> 3557 (OH); δ<sub>H</sub> (400 MHz, CDCl<sub>3</sub>), 1.07 [9H, s, C(CH<sub>3</sub>)<sub>3</sub>], 1.57 (1H, br.s, -OH), 1.67—1.77 (1H, m, 3-H<sub>A</sub>), 1.98—2.18 (3H, m, 3-H<sub>B</sub>, 6-H<sub>A</sub> and 5-H), 2.26—2.33 (1H, m, 4-H), 2.34—2.42 (1H, m, 6-H<sub>B</sub>), 3.13—3.25 (4H, m, 4''-H<sub>2</sub> and 5''-H<sub>2</sub>), 3.57 (1H, dd, *J* 10.1 and 6.4 Hz, 2'-H<sub>A</sub>), 3.72 (1H, dd, *J* 10.1 and 2.9 Hz, 2'-H<sub>B</sub>), 3.79—3.85 (1H, m, 1'-H), 5.00 (1H, d, *J* 9.8 Hz, 2''-H), 5.40—5.49 (1H, m, 2-H), 5.57—5.65 (1H, m, 1-H), 7.37—7.49 (6H, m, Ar-H) and 7.63—7.70 (4H, m, Ar-H); δ<sub>C</sub> (100 MHz, CDCl<sub>3</sub>), 19.2 [C(CH<sub>3</sub>)<sub>3</sub>], 26.8 [C(CH<sub>3</sub>)<sub>3</sub>], 28.1 (C-3), 29.4 (C-6), 38.0 (C-4'' and C-5''), 38.3 (C-5), 45.3 (C-4), 58.4 (C-2''), 66.9 (C-2'), 70.8 (C-1'), 124.7 (C-2), 126.7 (C-1), 127.8, 129.8, 133.0, 135.5(2) and 135.5(5) (Ar-C) (Found: M<sup>+</sup>-C<sub>4</sub>H<sub>9</sub>, 427.1227. Calc. for C<sub>23</sub>H<sub>37</sub>O<sub>2</sub>S<sub>2</sub>Si: *M*, 427.1219)

(4*S*, 5*R*)-4-[(*S*)-2-*t*-Butyldiphenylsilyloxy-1-hydroxyethyl]-5-hydroxymethylcyclohexene 122

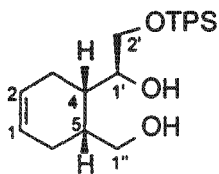

Lithium borohydride (62 mg, 3.4 mmol) was added to a solution of 112 (400 mg, 0.99 mmol) in tetrahydrofuran (20 cm<sup>3</sup>). The resulting mixture was stirred at 25 °C for 85 h. The reaction mixture was diluted with water, extracted with dichloromethane and the organic phase was dried (MgSO<sub>4</sub>). The solvent was removed under reduced pressure to give a residue (440 mg) which was purified by column chromatography on silica gel (40 g) using ethyl acetate-hexane (1:4) as eluent

to give the diol **122** (259 mg, 63%) as an oil,  $[\alpha]_D +14.4$  ( $c$  2.2 in  $\text{CHCl}_3$ );  $\delta_H$  (400 MHz,  $\text{CDCl}_3$ ); 1.09 [9H, s,  $\text{C}(\text{CH}_3)_3$ ], 1.81—2.28 (6H, m, 3-H<sub>2</sub>, 4-H, 5-H, 6-H<sub>2</sub>), 3.05 (2H, br.s, 2 x OH), 3.52 (1H, dd,  $J$  11.1 and 4.8 Hz, 1''-H<sub>A</sub>), 3.62—3.69 (1H, m, 2'-H<sub>A</sub>), 3.73—3.82 (3H, m, 1'-H, 2'-H<sub>B</sub>, 1''-H<sub>B</sub>), 5.50—5.65 (2H, m, 1-H, 2-H), 7.38—7.49 (6H, m, Ar-H) and 7.66—7.70 (4H, m, Ar-H);  $\delta_C$  (100 MHz,  $\text{CDCl}_3$ ), 19.2 [ $\text{C}(\text{CH}_3)_3$ ], 25.9 (C-3 or C-6), 26.9 [ $\text{C}(\text{CH}_3)_3$ ], 28.2 (C-3 or C-6), 35.7 (C-5), 37.8 (C-4), 63.3 (C-1''), 66.8 (C-2'), 72.6 (C-1'), 125.3 and 125.8 (C-1 and C-2), 127.8, 129.9, 133.1(0) and 133.1(3), 135.5(2) and 135.5(4) (Ar-C).  $^1\text{H}$  NMR data correspond with those previously reported.<sup>126</sup>

**(4*S*, 5*R*)-4-[(*S*)-2-*t*-Butyldiphenylsilyloxy-1-hydroxyethyl]-5-triisopropylsilyloxymethylcyclohexene **123****

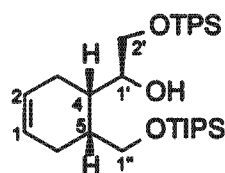

Triisopropylsilyl chloride (0.63 cm<sup>3</sup>, 2.95 mmol) and imidazole (219 mg, 3.21 mmol) were added to a stirred solution of **122** (1.10 g, 2.68 mmol) in acetonitrile (100 cm<sup>3</sup>). After 5 h at 25 °C, the solvent was removed under reduced pressure and water was added. The mixture was extracted with dichloromethane, the organic phase was dried ( $\text{MgSO}_4$ ) and the solvent was removed under reduced pressure to give an oil (2.53 g). Chromatography on silica gel (150 g) using ethyl acetate-hexane (1:19) as eluent furnished the *1''*-triisopropylsilyl ether **123** (1.454 g, 96%) as an oil,  $[\alpha]_D +1.3$  ( $c$  1.7 in  $\text{CHCl}_3$ );  $\nu_{\text{max}}(\text{CHCl}_3)/\text{cm}^{-1}$  3329 (OH);  $\delta_H$  (400 MHz,  $\text{CDCl}_3$ ), 0.98—1.20 [30H, m, 3 x  $\text{CH}(\text{CH}_3)_2$  and  $\text{C}(\text{CH}_3)_3$ ], 1.63 (1H, br.s, OH), 1.78—2.15 (4H, m, 3-H<sub>2</sub>, 4-H, 6-H<sub>A</sub>), 2.16—2.29 (1H, m, 6-H<sub>B</sub>), 2.29—2.40 (1H, m, 5-H), 3.52 (1H, dd,  $J$  10.0 and 5.6 Hz, 1''-H<sub>A</sub>), 3.62—3.80 (3H, m, 1'-H and 2'-H<sub>2</sub>), 3.85 (1H, dd,  $J$  10.0 and 8.1 Hz, 1''-H<sub>B</sub>), 5.50—5.60 (2H, m, 1-H, 2-H), 7.33—7.47 (6H, m, Ar-H) and 7.64—7.72 (4H, m, Ar-H);  $\delta_C$  (100 MHz,  $\text{CDCl}_3$ ), 11.9 (3 x  $\text{CH}(\text{CH}_3)_2$ ), 18.0 (3 x  $\text{CH}(\text{CH}_3)_2$ ), 19.2 [ $\text{C}(\text{CH}_3)_3$ ], 25.4 (C-3), 26.9 [ $\text{C}(\text{CH}_3)_3$ ], 29.2 (C-6), 34.3 (C-5), 37.8 (C-4), 63.5 (C-1''), 66.4 (C-2'), 73.3 (C-1'), 125.3 and 126.0 (C-1 and C-2), 127.6(5) and 127.6(6), 129.6, 133.6 and 135.6 (Ar-C). (Found:  $M^+$ , 566.3612. Calc. for  $\text{C}_{34}\text{H}_{54}\text{O}_3\text{Si}_2$ :  $M$ , 566.3627).

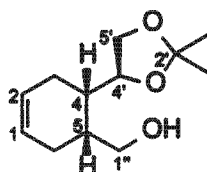
**(4*S*, 5*R*)- 4-[(*S*)-2,2-Dimethyl-1,3-dioxolan-4-yl]-5-hydroxymethyl-cyclohexene 125**

Cycloadduct 112 (408 mg, 1.00 mmol) was added to a stirred suspension of lithium aluminium hydride (160 mg, 4.20 mmol) in diethyl ether (20 cm<sup>3</sup>) and the mixture was refluxed for 60 min. Saturated aqueous sodium sulfate was added dropwise until flocculation occurred and the resulting mixture was stirred for 60 min. The mixture was filtered through layers of Celite and MgSO<sub>4</sub> which were rinsed with hot methanol–chloroform (50:50). The combined filtrate was evaporated under reduced pressure to give the crude triol 124 which was dissolved in acetone (5 cm<sup>3</sup>) and toluene-*p*-sulfonic acid (10 mg) was added. After stirring for 16 h at 25 °C, anhydrous copper sulfate (200 mg) was added and the mixture refluxed for 5 h. Triethylamine (2 cm<sup>3</sup>) was added, and the mixture was filtered through a Celite pad, which was washed with ethyl acetate. Removal of the solvent under reduced pressure gave a residue (570 mg) which was loaded onto a silica column (50 g) and eluted with ethyl acetate–hexane (1:4) to give the *acetone* 125 (60 mg, 28%) as an oil,  $[\alpha]_D +13.9$  (*c* 3.6 in CHCl<sub>3</sub>);  $\nu_{\max}(\text{CHCl}_3)/\text{cm}^{-1}$  3442 (OH);  $\delta_H$  (400 MHz, CDCl<sub>3</sub>) 1.35 (3H, s, CH<sub>3</sub>), 1.40 (3H, s, CH<sub>3</sub>), 1.69–1.80 (1H, m, 3-H<sub>A</sub>), 1.90–2.01 (1H, m, 4-H), 2.02–2.30 (4H, m, 3-H<sub>B</sub>, 5-H, 6-H<sub>2</sub>), 2.81 (1H, br.s, OH), 3.58 (1H, t, *J* 2 x 7.9 Hz, 5'-H<sub>A</sub>), 3.50–3.83 (2H, m, 1''-H<sub>2</sub>), 4.04 (1H, dd, *J* 7.9 and 5.9 Hz, 5'-H<sub>B</sub>), 4.13 (1H, ddd, *J* 9.7, 7.9 and 5.9 Hz, 4'-H), 5.52–5.62 (1H, m, 1-H), 5.64–5.72 (1H, m, 2-H);  $\delta_C$  (100 MHz, CDCl<sub>3</sub>) 25.7 (CH<sub>3</sub>), 25.9 (C-6), 26.8 (CH<sub>3</sub>), 27.2 (C-3), 37.6 (C-5), 38.9 (C-4), 64.4 (C-1''), 69.4 (C-5'), 75.5 (C-4'), 109.0 (C-2'), 124.3 (C-2), 126.5 (C-1) (Found:  $M^+$ , 212.1421. Calc. for C<sub>12</sub>H<sub>20</sub>O<sub>3</sub>: *M*, 212.1412)

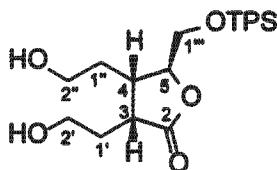
**(3*R*, 4*S*)-5-[(*S*)-*t*-Butyldiphenylsilanyloxymethyl]-3,4-bis(2-hydroxyethyl)-dihydrofuran-2-one 127**

Ozone was bubbled through a solution of 112 (1.10 g, 2.71 mmol) in methanol (100 cm<sup>3</sup>) at –78 °C until the solution turned blue. Nitrogen was then bubbled through the solution as it was warmed to 25 °C. Sodium borohydride (450 mg, 12.16 mmol) was added and the solution was stirred for 15 min. Water was added and the volatile media removed under reduced pressure. The mixture was

extracted with dichloromethane, the organic phase was dried ( $\text{MgSO}_4$ ) and the solvent was removed under reduced pressure to give the crude diol (1.35 g). Column chromatography on silica gel (75 g) using ethyl acetate–hexane (4:1) as eluent afforded the *diol* 127 (1.01 g, 88%) as an oil,  $[\alpha]_D +17.2$  ( $c$  1.5 in  $\text{CHCl}_3$ );  $\nu_{\text{max}}(\text{CHCl}_3)/\text{cm}^{-1}$  3437 (OH) and 1760 (CO);  $\delta_{\text{H}}$  (400 MHz,  $\text{CDCl}_3$ ) 1.07 [9H, s,  $\text{C}(\text{CH}_3)_3$ ], 1.45–1.56 (1H, m,  $1''\text{-H}_A$ ), 1.67 (1H, br.s, OH), 1.74–1.92 (3H, m,  $1'\text{-H}_2$  and  $1''\text{-H}_B$ ), 2.52 (1H, br.s, OH), 2.66–2.76 (1H, m, 4-H), 3.11 (1H, td,  $J$  2 x 8.6 and 6.4 Hz, 3-H), 3.61–3.92 (6H, m,  $2'\text{-H}_2$ ,  $2''\text{-H}_2$  and  $1'''\text{-H}_2$ ), 4.36 (1H, dd,  $J$  7.5 and 3.6 Hz, 5-H), 7.38–7.48 (6H, m, Ar-H), 7.63–7.72 (4H, m, Ar-H);  $\delta_{\text{C}}$  (100 MHz,  $\text{CDCl}_3$ ) 19.2 [ $\text{C}(\text{CH}_3)_3$ ], 26.8 [ $\text{C}(\text{CH}_3)_3$ ], 28.4 (C-1'), 30.4 (C-1''), 37.2 (C-4), 40.6 (C-3), 60.4 (C-2''), 61.1 (C-2'), 64.5 (C-1'''), 83.0 (C-5), 127.9, 130.0, 132.5(7) and 132.8(2), 135.5(7) and 135.6(3) (Ar-C), 179.7 (C-1) (Found:  $\text{M}^+ - \text{C}_4\text{H}_9$ , 385.1477. Calc. for  $\text{C}_{21}\text{H}_{25}\text{O}_5\text{Si}$ :  $M$  385.1471)

**(3*R*, 4*S*)-5-[(*S*)-*t*-Butyldiphenylsilyloxyethyl]-3,4-bis[2-(3,5-dinitrobenzoyl)ethyl]-dihydrofuran-2-one 130**

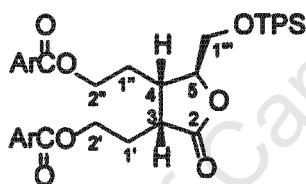

4-Dimethylaminopyridine (20 mg, 0.16 mmol) and freshly prepared 3,5-dinitrobenzoyl chloride (1.54 g, 6.66 mmol) were added to a stirred solution of 127 (400 mg, 0.90 mmol) in dry pyridine ( $10 \text{ cm}^3$ ). After stirring the mixture for 3 h at  $25^\circ\text{C}$ , toluene was added and the mixture was concentrated under reduced pressure. Water was added to the remaining residue and it was extracted with ethyl acetate. The organic extract was washed with saturated aqueous ammonium chloride and brine, dried ( $\text{MgSO}_4$ ) and the solvent was removed under reduced pressure to give an oil (1.62 g). Purification by column chromatography on silica gel (750 g) using ethyl acetate–hexane (1:4) as eluent yielded the *bis*(3,5-dinitrobenzoate) 130 (604 mg, 80%) as an oil,  $[\alpha]_D +7.1$  ( $c$  1.4 in  $\text{CHCl}_3$ );  $\nu_{\text{max}}(\text{CHCl}_3)/\text{cm}^{-1}$  1734 and 1773 (CO);  $\delta_{\text{H}}$  (400 MHz,  $\text{CDCl}_3$ ) 1.00 [9H, s,  $\text{C}(\text{CH}_3)_3$ ], 1.84–1.96 (1H, m,  $1''\text{-H}_A$ ), 2.07–2.22 (2H, m,  $1'\text{-H}_A$  and  $1''\text{-H}_B$ ), 2.24 (1H, m,  $1'\text{-H}_B$ ), 2.73–2.83 (1H, m, 4-H), 3.14 (1H, dd,  $J$  15.2 and 8.2 Hz, 3-H), 3.82 (1H, dd,  $J$  11.5 and 3.1 Hz,  $1'''\text{-H}_A$ ), 3.95 (1H, dd,  $J$  11.5 and 4.2 Hz,  $1'''\text{-H}_B$ ), 4.40 (1H, dd,  $J$  7.0 and 3.2 Hz, 5-H), 4.53 (2H, t,  $J$  2 x 6.8 Hz,  $2''\text{-H}_2$ ), 4.60–4.77 (2H, m,  $2'\text{-H}_2$ ), 7.32–7.48 (6H, m, TPS Ar-H), 7.55–7.65 (4H, m, TPS Ar-H), 9.10 (4H, t,  $J$  2 x 2.0 Hz, DNP Ar-H) and 9.21 (2H, dt,  $J$  8.6 and 2 x 2.0 Hz, DNP Ar-H);  $\delta_{\text{C}}$  (100 MHz,  $\text{CDCl}_3$ ) 19.2 [ $\text{C}(\text{CH}_3)_3$ ], 25.0 (C-1'), 26.8 [ $\text{C}(\text{CH}_3)_3$ ], 27.2 (C-1''), 37.0 (C-4), 39.3 (C-3), 64.1 (C-2''), 64.4 (C-1'''), 64.6 (C-2'), 81.9 (C-5), 122.5(0) and 122.6(5), 127.9(1) and

127.9(3), 129.3(6) and 129.3(9), 130.1(1) and 130.1(5), 132.1(3) and 132.5(4), 133.2(7) and 133.5(4), 135.3(5) and 135.4(9), 148.7(1) and 148.7(6) (Ar-C), 2 x 162.5 [2 x OC(O)Ar] and 177.0 (C-2) [Found (FAB):  $M^+$ -C<sub>4</sub>H<sub>9</sub>, 773.1372. Calc. for C<sub>35</sub>H<sub>29</sub>N<sub>4</sub>O<sub>15</sub>Si: *M*, 773.1399]

### Hydride reduction of 127

Diisobutylaluminium hydride (1.5 M in toluene, 1.66 cm<sup>3</sup>, 2.49 mmol) was added to a stirred solution of 127 (275 mg, 0.62 mmol) in toluene (20 cm<sup>3</sup>) at -78 °C. After 5 min 1 M HCl was added until pH 1 was reached and the mixture was warmed to 25 °C. The toluene was removed under reduced pressure and the mixture was extracted with ethyl acetate. The organic phase was dried (MgSO<sub>4</sub>) and the solvent was removed under reduced pressure to give a residue (274 mg) which was further purified by column chromatography on silica gel (12 g) using ethyl acetate as eluent to give crude 132 (242 mg, ~88%) which required derivatisation to allow complete characterisation.

### (3a*R*, 6a*S*)-2-[(*S*)-*t*-Butyldiphenylsilyloxymethyl]-3-[(*S*)-2-acetoxyethyl]hexahydrofuro[2,3-*b*]furan 131

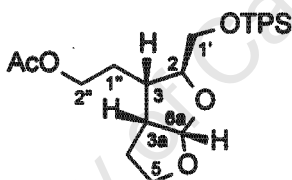

Acetic anhydride (0.41 cm<sup>3</sup>, 443 mg, 4.34 mmol) and 4-dimethylaminopyridine (20 mg, 0.16 mmol) were added sequentially to a stirred solution of 132 (480 mg, 1.08 mmol) in dry pyridine (10 cm<sup>3</sup>). After stirring for 1 h at 25 °C toluene was added and the volume was reduced under reduced pressure. The resultant slurry was dissolved in ethyl acetate, washed with water and brine, dried (MgSO<sub>4</sub>) and the solvent was removed under reduced pressure. The residue (497 mg) was purified by column chromatography on silica gel (50 g) using ethyl acetate-hexane (3:7) an eluent to give the *acetate* 131 (456 mg, 90%) as an oil, [ $\alpha$ ]<sub>D</sub> +16.9 (*c* 2.0 in CHCl<sub>3</sub>);  $\nu_{\max}$ (CHCl<sub>3</sub>)/cm<sup>-1</sup> 1733 (CO);  $\delta_{\text{H}}$  (400 MHz, CDCl<sub>3</sub>) 1.06 [9H, s, C(CH<sub>3</sub>)<sub>3</sub>], 1.59—1.74 (1H, m, 1''-H<sub>A</sub>), 1.76—1.98 (3H, m, 4-H<sub>2</sub> and 1''-H<sub>B</sub>), 2.03 [3H, s, C(O)CH<sub>3</sub>], 2.39—2.50 (1H, m, 3-H), 2.87—2.96 (1H, m, 3a-H), 3.63—3.78 (2H, m, 2-H, 1'-H<sub>A</sub>), 3.80—3.98 (2H, m, 5-H<sub>2</sub> and 1'-H<sub>B</sub>), 4.03—4.19 (2H, m, 2''-H<sub>2</sub>), 5.75 (1H, d, *J* 5.0 Hz, 6a-H), 7.35—7.43 (6H, m, Ar-H), 7.62—7.75 (4H, m, Ar-H);  $\delta_{\text{C}}$  (100 MHz, CDCl<sub>3</sub>) 19.5 [C(CH<sub>3</sub>)<sub>3</sub>], 21.1 [C(O)CH<sub>3</sub>], 25.4 (C-4), 26.8 (C-1''), 27.0 [C(CH<sub>3</sub>)<sub>3</sub>], 39.9 (C-3), 46.1 (C-3a), 63.4 (C-2''), 64.2 (C-1'), 68.9 (C-5), 83.4 (C-2), 108.7 (C-6a), 127.9(0) and 127.9(3), 129.8(9) and 129.9(1), 133.4(8) and 133.7(0), 135.8(1) and 135.9(0) (Ar-C) and 171.2 [C(O)CH<sub>3</sub>] (Found:  $M^+$ -C<sub>4</sub>H<sub>9</sub>, 411.1642. Calc. for C<sub>23</sub>H<sub>27</sub>O<sub>5</sub>Si: *M*, 411.1628)

**(3*R*, 4*S*)-5-[(*S*)-*t*-Butyldiphenylsilyloxymethyl]-3,4-bis(2-methoxyethoxymethoxyethyl)-dihydrofuran-2-one 133**

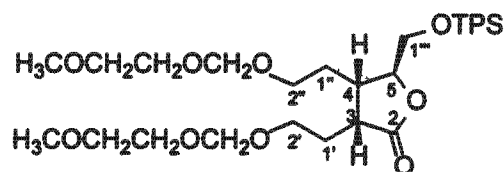

Methoxyethoxymethylchloride (0.15 cm<sup>3</sup>, 164 mg, 1.31 mmol) and diisopropylethylamine (0.24 cm<sup>3</sup>, 178 mg, 1.38 mmol) were added to diol 127 (200 mg, 0.45 mmol) in dichloromethane (3 cm<sup>3</sup>) and stirred at 25 °C for 16 h. Then saturated aqueous ammonium chloride was added and the mixture was extracted with dichloromethane. The organic extract was dried (MgSO<sub>4</sub>) and the solvent was removed under reduced pressure to give an oil (340 mg). Chromatography on silica gel (20 g) using ethyl acetate–hexane (3:2) as eluent, afforded 133 (257 mg, 92%) as an oil, [α]<sub>D</sub> +10.5 (*c* 1.9 in CHCl<sub>3</sub>); ν<sub>max</sub>(CHCl<sub>3</sub>)/cm<sup>-1</sup> 1771 (CO); δ<sub>H</sub> (400 MHz, CDCl<sub>3</sub>) 1.05 [9H, s, C(CH<sub>3</sub>)<sub>3</sub>], 1.48–1.60 (1H, m, 1''-H<sub>A</sub>), 1.76–1.87 (2H, m, 1'-H<sub>A</sub> and 1''-H<sub>B</sub>), 1.93–2.04 (1H, m, 1'-H<sub>B</sub>), 2.63–2.73 (1H, m, 4-H), 3.15 (1H, q, *J* 3 x 8.0 Hz, 3-H), 3.35 (3H, s, OCH<sub>3</sub>), 3.38 (3H, s, OCH<sub>3</sub>), 3.47–3.76 (13H, m, 2'-H<sub>2</sub>, 2''-H<sub>2</sub>, 1'''-H<sub>A</sub>, 2 x OCH<sub>2</sub>CH<sub>2</sub>O), 3.87 (1H, dd, *J* 11.4 and 3.5 Hz, 1'''-H<sub>B</sub>), 4.32 (1H, q, *J* 3 x 3.5 Hz, 5-H), 4.64 (2H, d, *J* 1.5 Hz, OCH<sub>2</sub>O), 4.69 (2H, s, OCH<sub>2</sub>O), 7.35–7.46 (6H, m, Ar-H) and 7.62–7.65 (4H, m, Ar-H); δ<sub>C</sub> (100 MHz, CDCl<sub>3</sub>) 19.2 [C(CH<sub>3</sub>)<sub>3</sub>], 25.8 (C-1'), 26.7 [C(CH<sub>3</sub>)<sub>3</sub>], 27.9 (C-1''), 37.3 (C-4), 39.4 (C-3), 59.0 (2 x OCH<sub>3</sub>), 64.9, 65.4 and 65.4 (C-2', C-2'' and C-1'''), 66.8, 66.9, 71.7 and 71.8 (2 x OCH<sub>2</sub>CH<sub>2</sub>O), 82.3 (C-5), 95.4 and 95.5 (2 x OCH<sub>2</sub>O), 127.8, 129.9, 132.5(3) and 132.8(8), 135.5(5) and 135.6(2) (Ar-C) and 178.6 (C-2) (Found: M<sup>+</sup>-C<sub>4</sub>H<sub>9</sub>, 561.2507. Calc. for C<sub>29</sub>H<sub>41</sub>O<sub>9</sub>Si: *M*, 561.2520).

**(3*R*, 4*S*)-5-[(*S*)-*t*-Butyldiphenylsilyloxymethyl]-3,4-bis(2-methoxyethoxymethoxyethyl)-dihydrofuran-2-ol 134**

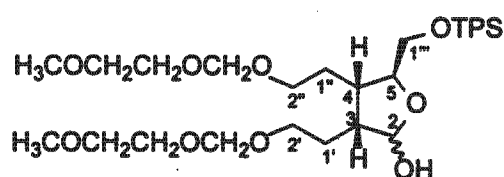

Diisobutylaluminium hydride (1.5 M in toluene, 1.30 cm<sup>3</sup>, 1.95 mmol) was added to a stirred solution of 133 (1.00 g, 1.62 mmol) in toluene (100 cm<sup>3</sup>) at -78 °C. After 10 min the solution was acidified (pH 1) with 3 M HCl and the mixture was warmed to room temperature. Water was added and the mixture extracted with ethyl acetate. The organic extract was washed with water, dried (MgSO<sub>4</sub>) and the solvent was removed under reduced pressure to give the lactol (1.23 g) which was further purified by column chromatography on silica gel (30 g) using ethyl acetate as eluent to give

the *lactol* 134 (0.94 g, 93%) as a mixture (~4:1 by NMR) of diastereomers,  $[\alpha]_D +6.6$  ( $c$  1.4 in  $\text{CHCl}_3$ );  $\nu_{\max}(\text{CHCl}_3)/\text{cm}^{-1}$  3440 (OH);  $\delta_H$  (400 MHz,  $\text{CDCl}_3$ ) *major* 1.07 [9H, s,  $\text{C}(\text{CH}_3)_3$ ], 2.57—2.69 (1H, m, 4-H), 3.77—3.83 (1H, m, 5-H), 5.23 (1H, d,  $J$  5.1 Hz, 2-H), *minor* 1.05 [9H, s,  $\text{C}(\text{CH}_3)_3$ ], 2.30—2.40 (1H, m, 4-H), 2.82 (1H, br.s, OH), 4.12—4.17 (1H, m, 5-H), 5.40 (1H, d,  $J$  4.4 Hz, 2-H), *mixed* 1.33—1.45 and 1.46—1.92 (5H, m, 1''-H<sub>2</sub>, 1'-H<sub>2</sub> and OH), 2.17—2.26 (1H, m, 3-H), 3.15—3.75 (20H, m, 2'-H<sub>2</sub>, 2''-H<sub>2</sub>, 1'''-H<sub>2</sub>, 2 x  $\text{OCH}_2\text{CH}_2\text{O}$  and 2 x  $\text{OCH}_3$ ), 4.58—4.80 (4H, m, 2 x  $\text{OCH}_2\text{O}$ ), 7.33—7.46 (6H, m, Ar-H) and 7.64—7.72 (4H, m, Ar-H);  $\delta_C$  (100 MHz,  $\text{CDCl}_3$ ) *major* 19.4 [ $\text{C}(\text{CH}_3)_3$ ], 26.1 (C-1'), 27.0 [ $\text{C}(\text{CH}_3)_3$ ], 27.7 (C-1''), 36.6 (C-4), 46.3 (C-3), 59.1 (2 x  $\text{OCH}_3$ ), 84.0 (C-5), *minor* 19.4 [ $\text{C}(\text{CH}_3)_3$ ], 25.5 (C-1'), 27.7 [ $\text{C}(\text{CH}_3)_3$ ], 30.5 (C-1''), 38.2 (C-4), 43.7 (C-3), 59.1 (2 x  $\text{OCH}_3$ ), 84.7 (C-5), *mixed* 65.2, 66.4, 66.5, 66.6 and 67.0 (C-2', C-2'' and C-1'''), 67.0(2), 67.0(4), 67.1(0), 67.1(6), 72.0(1) and 72.0(5) (2 x  $\text{OCH}_2\text{CH}_2\text{O}$ ), 95.6(1), 95.6(4), and 95.6(8) (2 x  $\text{OCH}_2\text{O}$ ), 99.7 and 101.7 (C-2) and 127.8, 128.0, 129.9, 130.0, 130.1, 133.1, 133.7, 133.8, 135.3, 135.5 and 135.9 (Ar-C) [Found (FAB):  $M^+ + ^{85}\text{Rb}$ , 705. Calc. for  $\text{C}_{33}\text{H}_{52}\text{O}_9\text{Si}^{85}\text{Rb}$ :  $M$ , 705].

**(2*S*, 3*S*, 4*R*)-1-*t*-Butyldiphenylsilyloxy-4-(1,3-dithiolan-2-yl)-6-methoxyethoxymethoxy-3-(methoxyethoxymethoxyethan-2-yl)hexan-2-ol 135**

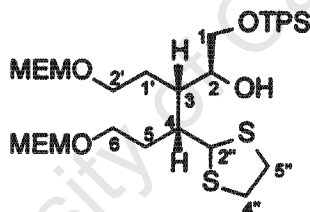

1,2-Ethanedithiol (0.04 cm<sup>3</sup>, 45 mg, 0.48 mmol) and titanium tetrachloride (1.0 M in  $\text{CH}_2\text{Cl}_2$ , 0.37 cm<sup>3</sup>, 0.37 mmol) were added sequentially to a stirred solution of 134 (200 mg, 0.32 mmol) in dichloromethane (5 cm<sup>3</sup>) at  $-84$  °C. After 5 min, the reaction was quenched with saturated aqueous sodium hydrogen carbonate and the resultant mixture was extracted with dichloromethane. The organic phase was dried ( $\text{MgSO}_4$ ) and the solvent was removed under reduced pressure to give a residue (320 mg) which was chromatographed on silica gel (20 g) using ethyl acetate–hexane (2:3) as eluent to give the *thioacetal* 135 (71 mg, 32%) as a glassy solid,  $[\alpha]_D -34.5$  ( $c$  1.25 in  $\text{CHCl}_3$ );  $\nu_{\max}(\text{CHCl}_3)/\text{cm}^{-1}$  3498 (OH);  $\delta_H$  (300 MHz,  $\text{CDCl}_3$ ) 1.06 [9H, s,  $\text{C}(\text{CH}_3)_3$ ], 1.50—1.82 (4H, m, 5-H<sub>2</sub> and 1'-H<sub>2</sub>), 1.94 (1H, br.s, OH), 2.23—2.35 (1H, m, 4-H), 2.38—2.51 (1H, m, 3-H), 2.63—3.00 (4H, m, 4''-H<sub>2</sub> and 5''-H<sub>2</sub>), 3.36 (3H, s,  $\text{OCH}_3$ ), 3.38 (3H, s,  $\text{OCH}_3$ ), 3.45—3.77 (14H, m, 1-H<sub>2</sub>, 6-H<sub>2</sub>, 2'-H<sub>2</sub>, 2 x  $\text{OCH}_2\text{CH}_2\text{O}$ ), 3.86—3.94 (1H, m, 2-H), 4.64 (2H, s,  $\text{OCH}_2\text{O}$ ), 4.70 (2H, s,  $\text{OCH}_2\text{O}$ ), 5.10 (1H, d,  $J$  4.1 Hz, 2''-H), 7.34—7.46 (6H, m, Ar-H) and 7.65—7.70 (4H, m, Ar-H);  $\delta_C$  (75 MHz,  $\text{CDCl}_3$ ) 19.2 [ $\text{C}(\text{CH}_3)_3$ ], 25.3 (C-4'' or C-5''), 26.8 [ $\text{C}(\text{CH}_3)_3$ ], 27.0 and 27.4 (C-1' and

C-5), 35.4 (C-4" or C-5"), 40.0 (C-3), 45.0 (C-4), 58.9 and 59.0 (2 x OCH<sub>3</sub>), 66.1, 66.2, 66.4, 66.7 and 66.8 (C-1, C-6, C-2' and 2 x OCH<sub>2</sub>CH<sub>2</sub>O), 71.7 and 71.8 (2 x 'OCH<sub>2</sub>CH<sub>2</sub>O), 84.9 (C-2), 88.5 (C-2"), 95.3 and 95.4 (2 x OCH<sub>2</sub>O), 127.7, 129.6(3) and 129.6(5), 133.4 and 135.6 (Ar-C) [Found (FAB): M<sup>+</sup>+<sup>85</sup>Rb, 781. Calc. for C<sub>35</sub>H<sub>56</sub>O<sub>8</sub>S<sub>2</sub>Si<sup>85</sup>Rb: M, 781].

University of Cape Town

## 6.5 MODEL SYNTHESIS FROM LEVOGLUCOSENONE

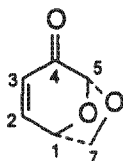
**(1*S*, 5*R*)-6,8-Dioxabicyclo[3.2.1]oct-2-en-4-one 34**

Finely shredded newspaper was soaked in 1.5%  $\text{H}_3\text{PO}_4$  for 24 h after which the mixture was stirred with an overhead stirrer. The resulting pulp was removed from the acid solution, spread out, and dried to give a fibrous residue (1.450 kg). The dry paper were stuffed into a glass tube (50 cm x 5 cm) and placed into a tube furnace. The top of the tube was fitted with an argon inlet and the bottom was attached to a 2-necked flask fitted with an argon outlet. The flask contained chloroform–water (1:1,  $\sim 2 \text{ dm}^3$ ) and was immersed in an ice bath. The tube was heated to 300 °C where the temperature was maintained until the drip rate slowed ( $\sim 20$  min). The pyrolysis experiment was repeated nineteen times after which the combined solvents were placed in a separating funnel and the aqueous phase was extracted with chloroform. The organic extract was dried ( $\text{MgSO}_4$ ) and the solvent was removed under reduced pressure to give the crude pyrolysate (102 g). Distillation through a vigreux column gave a forerun of furfural followed by a levoglucosenone fraction (32 g, 75–85 °C/0.8 mm Hg) which was further purified by chromatography on silica gel (400 g) using ethyl acetate–hexane (3:7) as eluent to give levoglucosenone 34 (12.4 g, 0.9%),  $\delta_{\text{H}}$  (200 MHz,  $\text{CDCl}_3$ ), 3.99–4.09 (1H, m, 7- $\text{H}_A$ ), 4.19 (1H, d,  $J$  7.6, 7- $\text{H}_B$ ), 4.50 (1H, d,  $J$  5.2 Hz, 1-H), 5.13 (1H, s, 5-H), 5.87 (1H, d,  $J$  11.0 Hz, 2-H) and 6.51 (1H, d,  $J$  11.0 Hz, 3-H).  $^1\text{H}$  NMR data agree with those previously reported.<sup>155</sup>

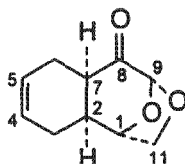
**(1*S*, 2*S*, 7*R*, 9*R*)-10,12-Dioxatricyclo[7.2.1.0<sup>2,7</sup>]dodec-4-en-8-one 136**

a) Butadiene ( $\sim 5 \text{ cm}^3$ ) was condensed into a pressure tube which held levoglucosenone (270 mg, 2.14 mmol). The tube was sealed, mildly agitated, and slowly heated to 160 °C (CAUTION–explosion risk). After 3 h the mixture was cooled to 25 °C, diluted with dichloromethane and slurried with silica gel (6 g). The solvent was evaporated and the adsorbed mixture was

chromatographed on silica gel (20 g) using ethyl acetate–hexane (2:3) as eluent to give cycloadduct **136** (276 mg, 72%), mp 63–66 °C (from dichloromethane–hexane) (lit.,<sup>157</sup> 62–63 °C);  $[\alpha]_D -55$  (*c* 1.1 in CHCl<sub>3</sub>) (lit.,<sup>158</sup>  $[\alpha]_D -55.2$ );  $\nu_{\max}(\text{CHCl}_3)/\text{cm}^{-1}$  1737 (CO),  $\delta_{\text{H}}$  (400 MHz, CDCl<sub>3</sub>), 1.98–2.11 (2H, m, 3-H<sub>2</sub>), 2.33–2.52 (2H, m, 6-H<sub>2</sub>), 2.67–2.75 (1H, br.d, 2-H), 3.18 (1H, t, *J* 2 x 7.2 Hz, 7-H), 4.03 (1H, dd, *J* 7.6 and 4.8 Hz, 11-H<sub>A</sub>), 4.19 (1H, dd, *J* 7.6 and 0.4 Hz, 11-H<sub>B</sub>), 4.46 (1H, dd, *J* 4.8 and 1.6 Hz, 1-H), 5.13 (1H, s, 9-H) and 5.60–5.69 (2H, m, 4-H and 5-H);  $\delta_{\text{C}}$  (100 MHz, CDCl<sub>3</sub>), 20.4 (C-3), 24.2 (C-6), 38.1 (C-2), 40.7 (C-7), 67.3 (C-11), 77.3 (C-1), 101.8 (C-9), 124.1 (C-4), 124.6 (C-5) and 201.8 (C-8). <sup>1</sup>H- and <sup>13</sup>C NMR data agree with those previously reported.<sup>157</sup>

The combined mother liquors were concentrated to give a mixture of **136** and **144**, (~3:2 by NMR);  $\delta_{\text{H}}$  (200 MHz, CDCl<sub>3</sub>) 3.18 (1H, t, *J* 2 x 7.0 Hz, 7-H), 3.99 (1H, dd, *J* 7.6 and 5.0 Hz, 11-H<sub>A</sub>), 4.18 (1H, d, *J* 7.6 Hz, 11-H<sub>B</sub>), 5.07 (1H, s, 9-H), *minor* 3.60–3.74 (2H, m, 11-H<sub>2</sub>) 5.13 (1H, s, 9-H), *mixed* 1.40–2.75 (5H, m, 2-H, 3-H<sub>2</sub>, 6-H<sub>2</sub>, and *minor* 7-H) and 5.50–5.81 (2H, m, 4-H and 5-H);  $\delta_{\text{C}}$  (50 MHz, CDCl<sub>3</sub>), *major* 20.3 (C-3), 24.0 (C-6), 38.0 (C-2), 40.5 (C-7), 67.2 (C-11), 77.2 (C-1), 101.5 (C-9), 123.9 (C-4), 124.5 (C-5) and 202.0 (C-8), *minor* 24.6 (C-3), 32.6 (C-6), 38.0 (C-2), 41.1 (C-7), 70.8 (C-11), 76.7 (C-1), 98.8 (C-9), 125.9 (C-4), 126.4 (C-5) and 205.9 (C-8).

b) Ethylaluminium dichloride (1.0 M solution in hexanes, 11.9 cm<sup>3</sup>, 11.9 mmol) was added to a solution of levoglucosenone (5.0 g, 39.7 mmol) in dichloromethane (20 cm<sup>3</sup>) under nitrogen. The resulting mixture was added to butadiene (~7 cm<sup>3</sup>) in a pressure tube at –78 °C. The tube was sealed and warmed to 0 °C. After 60 min at 0 °C the tube was cooled to –78 °C, opened and water (2 cm<sup>3</sup>) and 1 M HCl (2 cm<sup>3</sup>) were added. The mixture was warmed to 25 °C, extracted with dichloromethane and the organic extract was dried (MgSO<sub>4</sub>). The solvent was removed *in vacuo* to give the cycloadduct (5.70 g). Chromatography on silica gel (250 g) using ethyl acetate–hexane (3:7) as eluent furnished **136** (4.59 g, 64%).

### Reduction of cycloadduct **136**

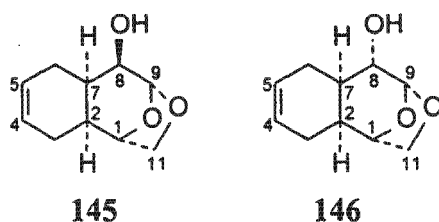

a) L-Selectride (1.0 M in tetrahydrofuran, 2.7 cm<sup>3</sup>) was added to a stirred solution of **136** (400 mg, 2.22 mmol) in toluene (100 cm<sup>3</sup>) at –78 °C. After 2 h at –78 °C, saturated aqueous ammonium chloride was added and the mixture was warmed to 25 °C with stirring. Sodium hydroxide (1 M, 50

cm<sup>3</sup>) was added, followed by hydrogen peroxide (30%, 50 cm<sup>3</sup>) and the mixture was stirred for 60 min. The aqueous phase was extracted with dichloromethane, the organic extract was washed with aqueous saturated sodium hydrogen carbonate and brine, dried (MgSO<sub>4</sub>) and the solvent was removed under reduced pressure to give a residue (507 mg) which was chromatographed on silica gel (50 g) using ethyl acetate–hexane (3:17) as eluent, to give (*1S*, *2S*, *7R*, *8R*, *9R*)-*10,12-dioxatricyclo[7.2.1.0<sup>2,7</sup>]dodec-4-en-8-ol* **145** (376 mg, 93%), [ $\alpha$ ]<sub>D</sub> -9.3 (*c* 1.0 in CHCl<sub>3</sub>);  $\nu_{\max}(\text{CHCl}_3)/\text{cm}^{-1}$  3525 (OH);  $\delta_{\text{H}}$  (400 MHz, CDCl<sub>3</sub>), 1.78—1.89 (2H, m, OH and 2-H), 2.01—2.10 (1H, m, 6-H<sub>A</sub>), 2.11—2.21 (1H, m, 3-H<sub>A</sub>), 2.27—2.43 (2H, m, 6-H<sub>B</sub> and 7-H), 2.43—2.55 (1H, m, 3-H<sub>B</sub>), 3.40 (1H, br.s, 8-H), 3.85 (1H, dd, *J* 7.2 and 5.2 Hz, 11-H<sub>A</sub>), 3.93 (1H, dd, *J* 7.2 and 1.2 Hz, 11-H<sub>B</sub>), 4.33 (1H, m, 1-H), 5.33 (1H, d, *J* 2.2 Hz, 9-H) and 5.78 (2H, m, 4-H and 5-H);  $\delta_{\text{C}}$  (100 MHz, CDCl<sub>3</sub>), 26.0 and 26.1 (C-3 and C-6), 26.9 (C-7), 34.4 (C-2), 67.0 (C-11), 72.6 (C-8), 76.5 (C-1), 103.1 (C-9), 125.7 and 126.3 (C-4 and C-5) (Found:  $M^+$  182.0964. Calc. for C<sub>10</sub>H<sub>14</sub>O<sub>3</sub>: *M*, 182.0943).

a) Sodium borohydride (90 mg, 2.44 mmol) was added to a stirred solution of **136** (400 mg, 2.22 mmol) in methanol (10 cm<sup>3</sup>) at 0 °C. The mixture was stirred at 0 °C for 1 h after which saturated ammonium chloride was added and the volatile material was removed under reduced pressure. The aqueous residue was extracted with ethyl acetate, dried (MgSO<sub>4</sub>) and the solvent was removed under reduced pressure to give a mixture of the alcohols (500 mg). Chromatography on silica gel (50 g) using ethyl acetate–hexane (3:17) as eluent afforded **145** (262 mg, 65%), followed by (*1S*, *2S*, *7R*, *8S*, *9R*)-*8-hydroxy-10,12-dioxatricyclo[7.2.1.0<sup>2,7</sup>]dodec-4-ene* **146** (78 mg, 19%), mp 92—93 °C (from ethyl acetate–hexane); [ $\alpha$ ]<sub>D</sub> -82.4 (*c* 0.4 in CHCl<sub>3</sub>);  $\nu_{\max}(\text{CHCl}_3)/\text{cm}^{-1}$  3574 (OH);  $\delta_{\text{H}}$  (400 MHz, CDCl<sub>3</sub>), 1.61 (1H, br.d, OH), 1.87—2.60 (3H, m, 2-H, 3-H<sub>A</sub>, 7-H), 2.09—2.20 (1H, m, 6-H<sub>A</sub>), 2.30—2.45 (2H, m, 3-H<sub>B</sub>, 6-H<sub>B</sub>), 3.38 (1H, dd, *J* 9.7 and 1.3 Hz, 8-H), 3.85 (1H, dd, *J* 7.2 and 4.8 Hz, 11-H<sub>A</sub>), 3.90 (1H, dd, *J* 7.2 and 0.8 Hz, 11-H<sub>B</sub>), 4.29 (1H, d, *J* 5.2 Hz, 1-H), 5.32 (1H, d, *J* 1.3 Hz, 9-H), 5.55—5.63 (1H, m, 5-H) and 5.65—5.75 (1H, m, 4-H);  $\delta_{\text{C}}$  (100 MHz, CDCl<sub>3</sub>), 23.8 (C-6), 24.2 (C-3), 33.7 (C-7), 35.7 (C-2), 67.9 (C-11), 70.1 (C-8), 77.3 (C-1), 103.0 (C-9), 123.8 (C-5) and 125.0 (C-4) (Found: C, 65.9, H, 7.7%,  $M^+$  182. Calc. for C<sub>10</sub>H<sub>14</sub>O<sub>3</sub>: C, 65.5, H, 7.8%, *M*, 182).

## Reduction of cycloadduct mixture 136 and 144

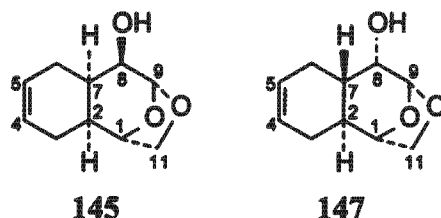

Sodium borohydride (45 mg, 1.22 mmol) was added to a stirred solution of 136 and 144 (~3:2 from the mother liquors of recrystallisation of 136 (200 mg, 1.11 mmol) in methanol (10 cm<sup>3</sup>) at 0 °C. The mixture was stirred at 0 °C for 1 h after which saturated aqueous ammonium chloride was added and the volatile material was removed *in vacuo*. The aqueous residue was extracted with ethyl acetate, the organic extract was dried (MgSO<sub>4</sub>) and the solvent was removed under reduced pressure to give a residue (231 mg). Chromatography on silica gel (24 g) using ethyl acetate–hexane (3:7) as eluent afforded (1*S*, 2*R*, 7*S*, 8*S*, 9*R*)-8-Hydroxy-10,12-dioxatricyclo[7.2.1.0<sup>2,7</sup>]dodec-4-ene 147 (60 mg, 30%) as an oil,  $[\alpha]_D^{25} +15.7$  (*c* 2.3 in CHCl<sub>3</sub>);  $\nu_{\max}(\text{CHCl}_3)/\text{cm}^{-1}$  3588 (OH);  $\delta_{\text{H}}$  (400 MHz, CDCl<sub>3</sub>), 1.50 (1H, tdd, *J* 2 x 11.5, 5.6 and 1.8 Hz, 2-H), 1.60 (1H, tt, 2 x 11.5 and 2 x 4.9 Hz, 7-H), 1.95–2.04 (1H, m, 3-H<sub>A</sub>), 2.08–2.29 (3H, m, 3-H<sub>B</sub>, 6-H<sub>2</sub>), 2.57 (1H, br.s, OH), 3.63–3.69 (2H, m, 11-H<sub>2</sub>), 3.87 (1H, t, *J* 2 x 5.6 Hz, 8-H), 4.15 (1H, m, 1-H), 5.59 (1H, d, *J* 5.6 Hz, 9-H), 5.57–5.63 (1H, m, 5-H) and 5.75–5.79 (1H, m, 4-H);  $\delta_{\text{C}}$  (100 MHz, CDCl<sub>3</sub>), 25.9 (C-3), 32.7 (C-6), 33.8 (C-7), 37.6 (C-2), 68.7 (C-8), 70.8 (C-11), 77.3 (C-1), 99.1 (C-9), 124.9 (C-5) and 128.0 (C-4), (Found: *M*<sup>+</sup> 182.0920. Calc. for C<sub>10</sub>H<sub>14</sub>O<sub>3</sub>: *M*, 182.0943) followed by 145 (105 mg, 52%) and 146 (trace).

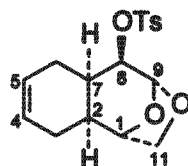
(1*S*, 2*S*, 7*R*, 8*R*, 9*R*)-10,12-dioxatricyclo[7.2.1.0<sup>2,7</sup>]dodec-4-en-8-yl-toluene-*p*-sulfone 148

Toluene-*p*-sulfonyl chloride (3.70 g, 19.40 mmol) and 4-dimethylaminopyridine (20 mg, 0.16 mmol) were added to a solution of 145 (360 mg, 1.98 mmol) in dry pyridine (25 cm<sup>3</sup>). The solution was stirred at 25 °C for 18 h after which toluene was added and the volatile material was removed under reduced pressure. Water was added to the residue and the mixture was extracted with ethyl acetate, washed with saturated ammonium chloride and brine, dried (MgSO<sub>4</sub>) and the solvent was removed under reduced pressure. The residue (872 mg) was chromatographed on silica gel (60 g) using ethyl acetate–hexane (1:4) as eluent to give the *tosylate* 148 (648 mg, 97%), mp 164–166 °C (from ethyl acetate–hexane);  $[\alpha]_D^{25} +25.9$  (*c* 1.7 in CHCl<sub>3</sub>);  $\nu_{\max}(\text{CHCl}_3)/\text{cm}^{-1}$  1039, 1176 and 1362

(SO<sub>2</sub>);  $\delta_{\text{H}}$  (400 MHz, CDCl<sub>3</sub>), 1.61 (1H, m, 6-H<sub>A</sub>), 1.70—1.78 (1H, m, 2-H), 1.91—2.00 (1H, m, 3-H<sub>A</sub>), 2.15—2.28 (1H, m, 6-H<sub>B</sub>), 2.40 (1H, dd,  $J$  8.8 and 4.4 Hz, 7-H) 2.43 (3H, s, Ar-CH<sub>3</sub>), 2.48—2.59 (1H, m, 3-H<sub>B</sub>), 3.80 (1H, dd,  $J$  7.6 and 5.2 Hz, 11-H<sub>A</sub>), 3.88 (1H, dd,  $J$  7.6 and 0.8 Hz, 11-H<sub>B</sub>), 4.27 (1H, dd,  $J$  4.4 and 2.4 Hz, 8-H), 4.32 (1H, dd,  $J$  5.2 and 2.4 Hz, 1-H), 5.31 (1H, d,  $J$  2.4 Hz, 9-H), 5.44—5.51 (1H, m, 5-H), 5.67—5.71 (1H, m, 4-H), 7.31 (2H, br.d, Ar-*m*-H) and 7.77 (2H, br.d, Ar-*o*-H);  $\delta_{\text{C}}$  (100 MHz, CDCl<sub>3</sub>), 21.6 (Ar-CH<sub>3</sub>), 25.1 (C-3), 25.6 (C-6), 26.3 (C-7), 34.5 (C-2), 67.2 (C-11), 76.5 (C-8), 79.0 (C-1), 100.0 (C-9), 124.0 (C-5), 125.6 (C-4), 125.6, 127.8, 129.7 and 144.7 (Ar-C) (Found: C, 60.6, H, 5.9, S, 9.4%,  $M^+$ , 336. Calc. for C<sub>17</sub>H<sub>20</sub>O<sub>5</sub>S: C, 60.7, H, 6.0, S, 9.5%,  $M$ , 336).

**(1S, 2S, 9R)-10,12-Dioxatricyclo[7.2.1.0<sup>2,7</sup>]dodeca-4,7-diene 149**

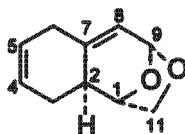

Lithium cyanide (0.5 M in *N,N*-dimethylformamide, 7.5 cm<sup>3</sup>) was added to a solution of 148 (250 mg, 0.74 mmol) in *N,N*-dimethylformamide and heated at 80°C for 15 h. The solution was cooled, diluted with diethyl ether, washed with water, dried (MgSO<sub>4</sub>), and the solvent was removed under reduced pressure to give a solid residue (107 mg) which was purified by chromatography on silica gel (10 g) using ethyl acetate–hexane (1:9) as eluent to yield the *olefin* 149 (85 mg, 70%);  $\delta_{\text{H}}$  (400 MHz, CDCl<sub>3</sub>), 2.08 (1H, ddd,  $J$  5.2, 4.8 and 1.2 Hz, 3-H<sub>A</sub>), 2.20–2.31 (1H, m, 2-H), 2.47 (1H, ttd,  $J$  14.2, 2 x 4.5 and 2 x 2.4 Hz, 3-H<sub>B</sub>), 2.55—2.65 (1H, m, 6-H<sub>A</sub>), 2.84—2.94 (1H, m, 6-H<sub>B</sub>), 3.70 (1H, dd,  $J$  7.2 and 2.0 Hz, 11-H<sub>A</sub>), 3.98 (1H, dd,  $J$  7.2 and 6.0 Hz, 11-H<sub>B</sub>), 4.39 (1H, dt,  $J$  6.0 and 2 x 0.8 Hz, 1-H), 5.49 (1H, d,  $J$  3.2 Hz, 9-H), 5.59—5.67 (1H, m, 8-H) and 5.68—5.80 (2H, m, 4-H and 5-H);  $\delta_{\text{C}}$  (100 MHz, CDCl<sub>3</sub>), 30.4 (C-3), 32.9 (C-6), 42.4 (C-2), 68.0 (C-11), 75.0 (C-8), 96.3 (C-9), 120.2 (C-8), 125.4 and 126.5 (C-4 and C-5) and 137.3 (C-7) (Found  $M^+$  164, C<sub>10</sub>H<sub>12</sub>O<sub>2</sub> requires  $M$ , 164)

**(1*S*, 2*S*, 7*R*, 8*S*, 9*R*)-8-Hydroxy-10,12-dioxatricyclo[7.2.1.0<sup>2,7</sup>]dodec-4-en-8-carbonitrile-diethylphosphate 150**

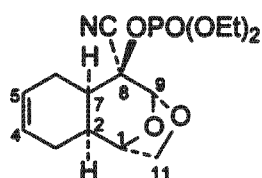

Diethyl chlorophosphate (1.12 cm<sup>3</sup>, 1.34 g, 7.75 mmol) and lithium cyanide (0.5 M in *N,N*-dimethylformamide, 22.0 cm<sup>3</sup>) were added to a stirred solution of 136 (1.00 g, 5.56 mmol) in tetrahydrofuran (30 cm<sup>3</sup>). After stirring at 25 °C for 60 min, water was added and the mixture was concentrated under reduced pressure. The aqueous residue was extracted with ethyl acetate, the organic extract was washed with water and brine, dried (MgSO<sub>4</sub>), and the solvent was removed under reduced pressure to give a solid residue (1.02 g). Chromatography on silica gel (100 g) using ethyl acetate–hexane (1:1) as eluent afforded the *cyanophosphate* 150 (1.17 g, 61%), mp 85–86 °C (from ethyl acetate–hexane); [α]<sub>D</sub> –37.8 (*c* 1.3 in CHCl<sub>3</sub>); ν<sub>max</sub>(CHCl<sub>3</sub>)/cm<sup>–1</sup> 1273 (PO); δ<sub>H</sub> (400 MHz, CDCl<sub>3</sub>), 1.30–1.37 (6H, m, 2 x OCH<sub>2</sub>CH<sub>3</sub>), 1.84–1.93 (1H, m, 2-H), 1.97–2.07 (1H, m, 3-H<sub>A</sub>), 2.24–2.34 (1H, m, 6-H<sub>A</sub>), 2.41–2.54 (2H, m, 3-H<sub>B</sub> and 6-H<sub>B</sub>), 2.60–2.68 (1H, m, 7-H), 3.92 (1H, dd, *J* 7.6 and 5.0 Hz, 11-H<sub>A</sub>), 4.01 (1H, dd, *J* 7.6 and 0.8 Hz, 11-H<sub>B</sub>), 4.09–4.20 (4H, m, 2 x OCH<sub>2</sub>CH<sub>3</sub>), 4.42 (1H, dd, *J* 4.4 and 0.8 Hz, 1-H), 5.52–5.55 (2H, m, 4-H and 5-H) and 5.95 (1H, s, 9-H); δ<sub>C</sub> (100 MHz, CDCl<sub>3</sub>), 15.9 (d, *J* 6.0 Hz, OCH<sub>2</sub>CH<sub>3</sub>), 16.0 (d, *J* 9.2 Hz, OCH<sub>2</sub>CH<sub>3</sub>), 24.8 and 25.1 (C-3 and C-6), 32.7 (C-7), 34.1 (C-2), 64.5 (d, *J* 24 Hz, OCH<sub>2</sub>CH<sub>3</sub>), 64.8 (d, *J* 24 Hz, OCH<sub>2</sub>CH<sub>3</sub>), 67.8 (C-11), 75.8 (C-8), 76.7 (C-1), 100.0 (C-9), 116.8 (CN), 124.0 and 125.1 (C-4 and C-5) (Found: C, 52.6, H, 6.6, N, 4.0%, M<sup>+</sup>, 343. Calc. for C<sub>15</sub>H<sub>22</sub>NO<sub>6</sub>P: C, 52.5, H, 6.5, N, 4.1%, M, 343).

**(1*S*, 4*aR*, 8*aS*)-1-Hydroxymethyl-4*a*,5,8*a*-tetrahydro-1*H*-isochromene-4-carbonitrile 151**

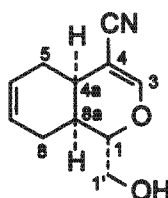

1,2-Diiodoethane (564 mg, 2.0 mmol) in tetrahydrofuran (20 cm<sup>3</sup>) was slowly added to samarium (451 mg, 3.0 mmol) with rapid stirring. The solution was refluxed until a deep blue colour developed (~60 min) after which it was cooled and hexamethylphosphoramide (0.01 cm<sup>3</sup>, 0.06 mmol) was added. To this was added a solution of 150 (200 mg, 0.58 mmol) and *t*-butyl alcohol

(43 mg, 0.58 mmol) in tetrahydrofuran (6 cm<sup>3</sup>). After stirring at 25 °C for 4 h, 1 M HCl was added (till pH 2 was reached). The mixture was diluted with ethyl acetate, washed with aqueous sodium thiosulfate (1 M), dried (MgSO<sub>4</sub>), and the solvent was removed under reduced pressure to give an oily residue (140 mg). Chromatography on silica gel (15 g) using ethyl acetate–hexane (2:3) as eluent yielded the *carbonitrile* 151 as a colourless oil (76 mg, 69%), [ $\alpha$ ]<sub>D</sub> +18.6 (*c* 1.3 in CHCl<sub>3</sub>);  $\nu_{\max}$ (CHCl<sub>3</sub>)/cm<sup>-1</sup> 3425 (OH), 2212 (CN);  $\delta_{\text{H}}$  (400 MHz, CDCl<sub>3</sub>), 1.80 (1H, br.s, OH), 1.99–2.13 (2H, m, 5-H<sub>A</sub> and 8-H<sub>A</sub>), 2.16–2.31 (2H, m, 8a-H and 8-H<sub>B</sub>), 2.42–2.51 (1H, m, 5-H<sub>B</sub>), 2.52–2.59 (1H, m, 4a-H), 3.74 (1H, dd, *J* 12.4 and 5.6 Hz, 1'-H<sub>A</sub>), 3.80 (1H, dd, *J* 12.4 and 3.4 Hz, 1'-H<sub>B</sub>), 4.08 (1H, ddd, *J* 7.6, 5.6 and 3.4 Hz, 1-H), 5.59–5.62 (2H, m, 6-H and 7-H) and 7.10 (1H, s, 3-H);  $\delta_{\text{C}}$  (100 MHz, CDCl<sub>3</sub>), 24.4 (C-8), 27.9 (C-4a), 28.3 (C-5), 29.0 (C-8a), 62.7 (C-1'), 78.6 (C-1), 92.5 (C-4), 118.4 (CN), 123.2 and 124.3 (C-6 and C-7) and 155.6 (C-3) (Found: *M*<sup>+</sup>, 191.0948. Calc. for C<sub>11</sub>H<sub>13</sub>NO<sub>2</sub>: *M*, 191.0946)

**(1*S*, 2*S*, 7*R*, 9*R*)-8-Methylene-10,12-dioxatricyclo[7.2.1.0<sup>2,7</sup>]dodec-4-ene 152**

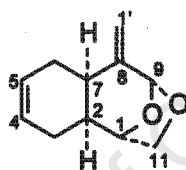

*n*-Butyllithium (10 M solution in hexane, 2.40 cm<sup>3</sup>) was added to a stirred slurry of methyltriphenylphosphonium iodide (9.42 g, 23.3 mmol) in tetrahydrofuran (50 cm<sup>3</sup>) at 0 °C. The resulting solution was warmed to 25 °C and stirred for 2 h. The solution was cooled to 0 °C and a solution of 136 (2.10 g, 11.7 mmol) in tetrahydrofuran (20 cm<sup>3</sup>) was slowly added. The reaction was warmed to 25 °C and stirred for 18 h. The mixture was acidified with 1 M HCl and concentrated. The aqueous residue was extracted with dichloromethane, the organic extract was dried (MgSO<sub>4</sub>) and the solvent was removed under reduced pressure. The yellow residue (10.90 g) was adsorbed onto silica gel (25 g) and then chromatographed on silica gel (200 g) using ethyl acetate–hexane (1:9) as eluent to yield *olefin* 152 (1.77 g, 85%), mp 88–90 °C (from hexane); [ $\alpha$ ]<sub>D</sub> 32.9 (*c* 1.0 in CHCl<sub>3</sub>);  $\delta_{\text{H}}$  (400 MHz, CDCl<sub>3</sub>), 1.92–1.96 (1H, m, 3-H<sub>A</sub>), 1.97–2.06 (1H, m, 2-H), 2.22–2.33 (2H, m, 6-H<sub>2</sub>), 2.34–2.49 (1H, m, 3-H<sub>B</sub>), 2.93–3.00 (1H, m, 7-H), 3.89 (1H, dd, *J* 7.2 and 4.9 Hz, 11-H<sub>A</sub>), 4.06 (1H, dd, *J* 7.2 and 0.8 Hz, 11-H<sub>B</sub>), 4.35 (1H, dd, *J* 4.9 and 2.1 Hz, 1-H), 4.70 (1H, d, *J* 2.3 Hz, 1'-H<sub>A</sub>), 4.96 (1H, d, *J* 2.3 Hz, 1'-H<sub>B</sub>), 5.53 (1H, s, 9-H) and 5.58–5.66 (2H, m, 4-H and 5-H);  $\delta_{\text{C}}$  (100 MHz, CDCl<sub>3</sub>), 23.7 (C-3), 24.4 (C-6), 30.2 (C-7), 38.4 (C-2), 67.7 (C-11), 77.2 (C-1), 105.0 (C-9), 107.6 (C-1'), 123.2 and 125.0 (C-4 and C-5) and 146.4 (C-8) (Found: C, 73.9, H, 8.0%, *M*<sup>+</sup> 178. Calc. for C<sub>11</sub>H<sub>14</sub>O<sub>2</sub>: C, 65.5, H, 7.8%, *M*, 178).

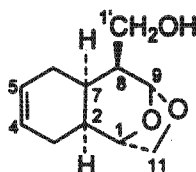
**(1S, 2S, 7R, 8S, 9R)-8-Hydroxymethyl-10,12-dioxatricyclo[7.2.1.0<sup>2,7</sup>]dodec-4-ene 153**

9-Borabicyclo[3.3.1]nonane (4.93 g, 40.4 mmol) was added to a stirred solution of **152** (3.60 g, 20.2 mmol) in tetrahydrofuran (100 cm<sup>3</sup>). After 6 h of stirring at 25 °C 1 M NaOH (50 cm<sup>3</sup>) was slowly added, followed by hydrogen peroxide (30%, 50 cm<sup>3</sup>). The mixture was diluted with water and extracted with ethyl acetate. The extract was dried (MgSO<sub>4</sub>), and the solvent was removed under reduced pressure. The residue (6.72 g) was chromatographed on silica gel (100 g) using ethyl acetate–hexane (4:1) as eluent to yield the *alcohol* **153** (3.83 g, 97%), mp 80–82 °C (from ethyl acetate–hexane); [α]<sub>D</sub> 67.4 (*c* 1.0 in CHCl<sub>3</sub>); ν<sub>max</sub>(CHCl<sub>3</sub>)/cm<sup>-1</sup> 3626 (OH); δ<sub>H</sub> (400 MHz, CDCl<sub>3</sub>), 1.65–1.95 (4H, m, 2-H, 6-H<sub>A</sub>, 8-H and OH), 2.00–2.12 (1H, m, 3-H<sub>A</sub>), 2.24–2.39 (2H, m, 3-H<sub>B</sub> and 6-H<sub>B</sub>), 2.50–2.59 (1H, m, 7-H), 3.64 (1H, dd, *J* 10.5 and 4.4 Hz, 1'-H<sub>A</sub>), 3.76 (1H, t, *J* 2 x 10.5 Hz, 1'-H<sub>B</sub>), 3.83 (1H, dd, *J* 7.0 and 5.3 Hz, 11-H<sub>A</sub>), 3.97 (1H, dd, *J* 7.0 and 0.7 Hz, 11-H<sub>B</sub>), 4.30 (1H, dd, *J* 5.3 and 0.7 Hz, 1-H) and 5.62–5.75 (3H, m, 4-H, 5-H and 9-H); δ<sub>C</sub> (100 MHz, CDCl<sub>3</sub>), 24.7 (C-7), 26.2 (C-3), 27.0 (C-6), 35.1 (C-2), 48.3 (C-8), 61.3 (C-1'), 67.8 (C-11), 77.1 (C-1), 103.2 (C-9), 125.5 and 126.2 (C-4 and C-5) (Found: C, 67.1, H, 8.3%, M<sup>+</sup> 196. Calc. for C<sub>11</sub>H<sub>16</sub>O<sub>3</sub>: C, 67.3, H, 8.2%, M, 196).

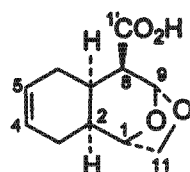
**(1S, 2S, 7R, 8R, 9R)-10,12-Dioxatricyclo[7.2.1.0<sup>2,7</sup>]dodec-4-ene-8-carboxylic acid 155**

CrO<sub>3</sub> (8 M, 5 cm<sup>3</sup>) was added to a solution of **153** (421 mg, 2.15 mmol) in acetone (15 cm<sup>3</sup>) at 0°C. The resulting mixture was kept at -4°C for 15 h after which excess isopropyl alcohol was added and the volume was reduced *in vacuo*. Ethyl acetate was added to the aqueous slurry and the resulting mixture was washed with water, dried (MgSO<sub>4</sub>) and the solvent was removed under reduced pressure to give a green residue (360 mg). Chromatography on silica gel (45 g) using ethyl acetate–hexane (3:7 to 3:2 gradient), gave *acid* **155** (122 mg, 27%), mp 82–85°C (from ethyl acetate), δ<sub>H</sub> (300 MHz, CDCl<sub>3</sub>), 1.79–1.90 (1H, m, 2-H), 1.96–2.09 (1H, m, 6-H<sub>A</sub>), 2.19–2.42 (2H, m, 3-H<sub>2</sub>), 2.49–2.67 (2H, m, 6-H<sub>B</sub> and 8-H), 2.66–2.76 (1H, m, 7-H), 3.85 (1H, dd, *J* 7.1 and 5.4 Hz, 11-H<sub>A</sub>), 4.00 (1H, dd, *J* 7.1 and 0.6 Hz, 11-H<sub>B</sub>), 4.37–4.45 (1H, m, 1-H) and

5.62—5.66 (3H, m, 4-H, 5-H and 9-H);  $\delta_C$  (75 MHz,  $CDCl_3$ ), 24.6 (C-7), 25.9 and 26.5 (C-3 and C-6), 35.4 (C-2), 48.2 (C-8), 67.9 (C-11), 76.9 (C-1), 100.6 (C-9), 124.5 and 126.6 (C-4 and C-5) (Found:  $M^+$ , 210.0892. Calc. for  $C_{11}H_{14}O_4$ :  $M$ , 210.0907).

(1*S*, 2*S*, 7*R*, 8*S*, 9*R*)-10,12-Dioxatricyclo[7.2.1.0<sup>2,7</sup>]dodec-4-ene-8-carbaldehyde 154

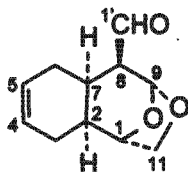

Dimethyl sulfoxide (0.17 cm<sup>3</sup>, 187 mg, 2.4 mmol) was added to a stirred solution of oxalyl chloride (0.11 cm<sup>3</sup>, 152 mg, 1.2 mmol) in dichloromethane (5 cm<sup>3</sup>) at -78 °C. After 10 min a solution of 153 (196 mg, 1.0 mmol) in dichloromethane (2 cm<sup>3</sup>) was added and the solution was stirred for 15 min. Triethylamine (0.5 cm<sup>3</sup>, 363 mg, 3.5 mmol) was added and the reaction was stirred at -78 °C for 30 min then warmed to 0 °C over 10 min. Cold saturated aqueous ammonium chloride was added and the mixture was extracted with dichloromethane. The organic extract was washed with cold 0.5 M HCl followed by cold aqueous saturated sodium hydrogen carbonate, dried ( $MgSO_4$ ) and the solvent was removed under reduced pressure to give a residue (262 mg) which was chromatographed on silica gel (25 g) using ethyl acetate-hexane (1:9) as eluent to give the *carbaldehyde* 154 (185 mg, 95%), mp 72—75 °C (from dichloromethane-hexane);  $[\alpha]_D$  125.4 ( $c$  1.0 in  $CHCl_3$ );  $\nu_{max}(CHCl_3)/cm^{-1}$  1712 (OH);  $\delta_H$  (400 MHz,  $CDCl_3$ ), 1.89—1.97 (1H, m, 2-H), 1.98—2.07 (1H, m, 6-H<sub>A</sub>), 2.13—2.24 (1H, m, 3-H<sub>A</sub>), 2.29—2.40 (1H, m, 3-H<sub>B</sub>), 2.40—2.46 (1H, m, 8-H), 2.46—2.52 (1H, m, 6-H<sub>B</sub>), 2.75 (1H, q,  $J$  3 x 6.5 Hz, 7-H), 3.88 (1H, dd,  $J$  7.3 and 5.3 Hz, 11-H<sub>A</sub>), 4.03 (1H, dd,  $J$  7.3 and 0.7 Hz, 11-H<sub>B</sub>), 4.43 (1H, dd,  $J$  5.3 and 1.2 Hz, 1-H), 5.62—5.75 (3H, m, 4-H, 5-H and 9-H) and 9.71 (1H, d,  $J$  3.3 Hz, 1'-H<sub>A</sub>);  $\delta_C$  (100 MHz,  $CDCl_3$ ), 25.0 (C-3), 26.3 (C-7), 26.9 (C-6), 35.1 (C-2), 58.9 (C-8), 68.0 (C-11), 77.3 (C-1), 101.0 (C-9), 125.5 and 126.0 (C-4 and C-5) and 203.3 (C-1'), (Found: C, 67.8, H, 7.4%,  $M^+$  194. Calc. for  $C_{11}H_{14}O_3$ : C, 68.0, H, 7.3%,  $M$ , 194).

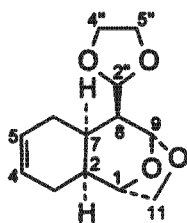
**(1*R*, 2*S*, 7*R*, 8*S*, 9*R*)-8-(1,3-Dioxolan-2-yl)-10,12-dioxatricyclo[7.2.1.0<sup>2,7</sup>]dodec-4-ene 156**

1,2-Bis(trimethylsilyloxy)ethane (0.21 cm<sup>3</sup>, 0.89 mmol) and trimethylsilyltrifluoromethane sulfonate (10% v/v solution in dichloromethane, 0.1 cm<sup>3</sup>, 0.06 mmol) were added sequentially to a stirred solution of **154** (115 mg, 0.59 mmol) in dichloromethane (10 cm<sup>3</sup>) at -78 °C. The reaction was stirred at -78 °C for 4 h and then quenched with triethylamine (0.1 cm<sup>3</sup>). The mixture was poured into aqueous saturated sodium hydrogen carbonate, extracted with dichloromethane, dried (MgSO<sub>4</sub>) and the solvent was removed under reduced pressure. Chromatography of the solid residue (301 mg) on silica gel (25 g) using ethyl acetate-hexane (1:4) as eluent afforded the *acetal* **156** (107 mg, 76%), mp 67–69 °C (from ethyl acetate-hexane); [α]<sub>D</sub> +22.9 (*c* 0.9 in CHCl<sub>3</sub>); δ<sub>H</sub> (300 MHz, CDCl<sub>3</sub>), 1.71–1.85 (2H, m, 2-H and 8-H), 2.01–2.14 (1H, m, 3-H<sub>A</sub>) 2.15–2.32 (2H, m, 6-H<sub>2</sub>), 2.32–2.47 (1H, m, 3-H<sub>B</sub>), 2.47–2.58 (1H, m, 7-H), 3.68–3.90 (5H, m, 11-H<sub>A</sub>, 4'-H<sub>2</sub> and 5'-H<sub>2</sub>), 3.93 (1H, dd, *J* 6.9 and 0.8 Hz, 11-H<sub>B</sub>), 4.29–4.34 (1H, m, 1-H), 4.84 (1H, d, *J* 7.8 Hz, 2'-H) and 5.56–5.74 (3H, m, 4-H, 5-H and 9-H); δ<sub>C</sub> (75 MHz, CDCl<sub>3</sub>), 24.5 (C-7), 25.7 (C-3), 26.4 (C-6), 35.4 (C-2), 49.7 (C-8), 63.9 and 64.6 (C-4' and C-5'), 67.8 (C-11), 77.4 (C-1), 102.8 (C-9), 103.7 (C-2'), 123.9 and 127.0 (C-4 and C-5) (Found: C, 65.7, H, 7.4%, *M*<sup>+</sup>, 238. Calc. for C<sub>13</sub>H<sub>18</sub>O<sub>4</sub>: C, 65.5, H, 7.6%, *M*, 238).

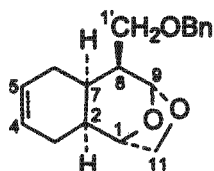
**(1*S*, 2*S*, 7*R*, 8*S*, 9*R*)-8-Benzoyloxymethyl-10,12-dioxatricyclo[7.2.1.0<sup>2,7</sup>]dodec-4-ene 160**

Sodium hydride (60% dispersion in mineral oil, 166 mg, ~4.1 mmol) was rinsed with dry hexane and suspended in tetrahydrofuran (5 cm<sup>3</sup>). Alcohol **153** (270 mg, 1.38 mmol) was added and the resulting mixture was refluxed for 60 min after which it was cooled to 25 °C. Benzyl bromide (0.42 cm<sup>3</sup>, 4.14 mmol) was added and the solution was stirred for 48 h. Methanol was added and the mixture was concentrated under reduced pressure. Water was added to the residue and the mixture was extracted with ethyl acetate, dried (MgSO<sub>4</sub>) and the solvent was removed to give an oil (1.03 g) which was chromatographed on silica (100 g) using ethyl acetate-hexane (9:1) as eluent to

yield the *benzyl ether 160* (362 mg, 92%) as an oil,  $[\alpha]_D +41.8$  (c 1.4 in  $\text{CHCl}_3$ );  $\delta_H$  (400 MHz,  $\text{CDCl}_3$ ), 1.72—1.78 (1H, m, 2-H), 1.85—1.94 (1H, m, 8-H), 1.95—2.12 (2H, m, 3- $\text{H}_A$  and 6- $\text{H}_A$ ), 2.25—2.39 (2H, m, 3- $\text{H}_B$  and 6- $\text{H}_B$ ), 2.56 (1H, dd,  $J$  13.4 and 6.3 Hz, 7-H), 3.47 (1H, dd,  $J$  9.5 and 4.2 Hz, 1'- $\text{H}_A$ ), 3.64 (1H, t,  $J$  2 x 9.5 Hz, 1'- $\text{H}_B$ ), 3.83 (1H, dd,  $J$  7.0 and 5.2 Hz, 11- $\text{H}_A$ ), 3.97 (1H, dd,  $J$  7.0 and 0.7 Hz, 11- $\text{H}_B$ ), 4.29 (1H, d,  $J$  4.4 Hz, 1-H), 4.47 (2H, s,  $\text{CH}_2\text{Ph}$ ), 5.60—5.68 (3H, m, 4-H, 5-H and 9-H) and 7.24—7.37 (5H, m, Ar-H);  $\delta_C$  (100 MHz,  $\text{CDCl}_3$ ), 24.6 (C-7), 26.2 (C-3), 27.0 (C-6), 35.1 (C-2), 46.0 (C-8), 67.8 (C-11), 69.2 (C-1'), 73.2 ( $\text{CH}_2\text{Ph}$ ), 77.1 (C-1), 103.5 (C-9), 125.6 and 125.9 (C-4 and C-5), 127.4, 128.3 and 138.6 (Ar-C) (Found:  $M^+$ , 286.1562. Calc. for  $\text{C}_{18}\text{H}_{22}\text{O}_3$ :  $M$ , 286.1569).

### Oxidative cleavage of 160

Ozone was bubbled through a solution of **160** (490 mg, 1.73 mmol) in methanol ( $20 \text{ cm}^3$ ), at  $-78^\circ\text{C}$  until the solution turned blue. The ozone was replaced by nitrogen which was bubbled for 10 min after which sodium borohydride (317 mg, 8.3 mmol) was added. The reaction mixture was warmed to  $25^\circ\text{C}$  and then quenched with aqueous saturated ammonium chloride. The volatile material was removed under reduced pressure and the remaining mixture was extracted with ethyl acetate, dried ( $\text{MgSO}_4$ ) and the solvent was removed to give a crude mixture (575 mg) which was dissolved in dichloromethane ( $20 \text{ cm}^3$ ). *N,N*-Dimethylformamide ( $1 \text{ cm}^3$ ) followed by imidazole (353 mg, 5.19 mmol) and *t*-butyldiphenylsilyl chloride ( $1.08 \text{ cm}^3$ , 4.15 mmol) were added and the solution was stirred for 14 h. Water was added and the mixture was extracted with dichloromethane, dried ( $\text{MgSO}_4$ ) and the solvent was removed under reduced pressure. The residue (1.92 g) was chromatographed on silica gel (100 g) using ethyl acetate–hexane (1:19) as eluent to give an inseparable mixture of silyl alcohols **163** and **164**

### Thioacetal trapping of 163 and 164

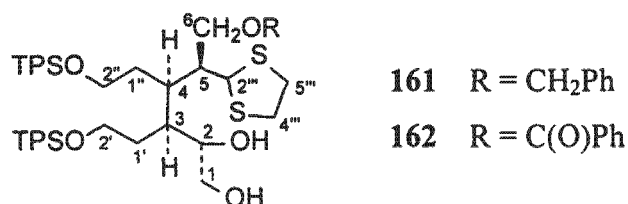

Ethanedithiol ( $0.05 \text{ cm}^3$ , 0.57 mmol) followed by titanium tetrachloride (1.0 M in dichloromethane,  $0.57 \text{ cm}^3$ ) were added to a stirred solution of **163** and **164** (~2:1 by NMR, 300 mg, 0.38 mmol) in dichloromethane ( $10 \text{ cm}^3$ ) at  $0^\circ\text{C}$ . After 45 min aqueous saturated sodium hydrogen carbonate was added and the resulting mixture was extracted with chloroform, dried ( $\text{MgSO}_4$ ) and the solvent was removed under reduced pressure. The mixture (362 mg) was chromatographed on silica (40 g)

using ethyl acetate–hexane (1:9 to 3:7) to give (2*S*, 3*S*, 4*R*, 5*S*)-3,4-bis[2-*t*-butyldiphenylsilanyloxy]ethyl]-5-(1,3-dithiolan-2-yl)-6-benzoyloxyhexan-1,2-diol **161** (140 mg, 41%),  $[\alpha]_D -8.7$  (*c* 1.1 in CHCl<sub>3</sub>);  $\nu_{\max}(\text{CHCl}_3)/\text{cm}^{-1}$  3402 (OH);  $\delta_{\text{H}}$  (300 MHz, CDCl<sub>3</sub>), 1.08 [18H, s, 2 x C(CH<sub>3</sub>)<sub>3</sub>], 1.32–1.55 (2H, m, 1'-H<sub>2</sub>), 1.56 (2H, s, 2 x OH), 1.65–1.88 (2H, m, 1''-H<sub>2</sub>), 1.89–2.09 (2H, m, 3-H and 4-H), 2.36–2.45 (1H, m, 5-H), 3.07–3.30 (5H, m, 1-H<sub>A</sub>, 4'''-H<sub>2</sub> and 5'''-H<sub>2</sub>), 3.40–4.50 (1H, m, 2-H), 3.51–3.76 (6H, m, 1-H<sub>B</sub>, 6-H<sub>A</sub>, 2'-H<sub>2</sub> and 2''-H<sub>2</sub>), 3.89 (1H, dd, *J* 9.3 and 1.8 Hz, 6-H<sub>B</sub>), 4.52 (2H, d, *J* 3.0 Hz, CH<sub>2</sub>Ph), 4.79 (1H, d, *J* 3.3 Hz, 2'''-H), 7.29–7.48 (17H, m, Ar-H) and 7.65–7.73 (8H, m, Ar-H);  $\delta_{\text{C}}$  (75 MHz, CDCl<sub>3</sub>), 19.1 [2 x C(CH<sub>3</sub>)<sub>3</sub>], 26.9 and 26.9 [2 x C(CH<sub>3</sub>)<sub>3</sub>], 32.2 and 32.2 (C-1' and C-1''), 37.3 (C-3), 38.3 (C-4), 38.4 and 39.2 (C-4''' and C-5'''), 46.2 (C-5), 54.8 (C-2'''), 62.2 and 63.0 (C-2' and C-2''), 66.0 (C-1), 71.2 (C-6), 73.5 (CH<sub>2</sub>Ph), 73.6 (C-2), 127.6(6) and 127.6(8), 128.0(4) and 128.0(6), 128.5(1), 129.6(0) and 129.6(6), 133.6(2), 133.7(2) and 133.7(5), 135.5(7) and 135.6(2), and 137.0(4) (Ar-C), (Found:  $M^+$ +Na, 915.3960. Calc. for C<sub>52</sub>H<sub>68</sub>O<sub>5</sub>S<sub>2</sub>Si<sub>2</sub>Na: *M*, 915.3945), followed (2*S*, 3*S*, 4*R*, 5*S*)-3,4-bis[2-(*t*-butyldiphenylsilanyloxy)ethyl]-5-(1,3-dithiolan-2-yl)-6-benzoyloxyhexan-1,2-diol **162** (80 mg, 23%),  $[\alpha]_D -6.4$  (*c* 1.0 in CHCl<sub>3</sub>);  $\nu_{\max}(\text{CHCl}_3)/\text{cm}^{-1}$  1715 (CO), 3430 (OH);  $\delta_{\text{H}}$  (300 MHz, CDCl<sub>3</sub>), 1.01 [9H, s, C(CH<sub>3</sub>)<sub>3</sub>], 1.02 [9H, s, C(CH<sub>3</sub>)<sub>3</sub>], 1.48–1.64 (3H, m, 1'-H<sub>2</sub> and 1''-H<sub>A</sub>), 1.75–1.94 (2H, m, 3-H and 1''-H<sub>B</sub>), 2.05–2.30 (3H, m, 4-H and 2 x OH), 2.70–2.79 (1H, m, 5-H), 3.01–3.29 (4H, m, 4'''-H<sub>2</sub> and 5'''-H<sub>2</sub>), 3.41–3.75 (7H, m, 1-H<sub>2</sub>, 2-H, 2'-H<sub>2</sub> and 2''-H<sub>2</sub>), 4.48 (1H, dd, *J* 11.5 and 7.0 Hz, 6-H<sub>A</sub>), 4.64 (1H, dd, *J* 11.5 and 3.8 Hz, 6-H<sub>B</sub>), 4.82 (1H, d, *J* 3.4 Hz, 2'''-H), 7.27–7.44 (13H, m, Ar-H), 7.49–7.56 (1H, m, Ar-H), 7.58–7.68 (9H, m, Ar-H) and 7.99–8.05 (2H, m, Ar-H);  $\delta_{\text{C}}$  (75 MHz, CDCl<sub>3</sub>), 19.1 [2 x C(CH<sub>3</sub>)<sub>3</sub>], 26.8 and 26.9 [2 x C(CH<sub>3</sub>)<sub>3</sub>], 31.2 and 31.4 (C-1' and C-1''), 36.7 (C-4), 38.0 (C-3), 38.1 and 39.5 (C-4''' and C-5'''), 44.3 (C-5), 54.3 (C-2'''), 62.4 and 62.8 (C-2' and C-2''), 65.3 (C-1), 65.4 (C-6), 73.2 (C-2), 127.6(4) and 127.6(8), 128.3(2), 129.5(8) and 129.6(6), 130.3(5), 132.7(9), 133.4(2) and 133.4(4), 133.6(1) and 133.6(6), 135.5(1), 135.5(5) and 135.5(8) (Ar-C) and 166.6 (C=O) (Found:  $M^+$ +Na, 929.3730. Calc. for C<sub>52</sub>H<sub>66</sub>O<sub>6</sub>S<sub>2</sub>Si<sub>2</sub>Na: *M*, 929.3737).

**(1*S*, 2*S*, 7*R*, 8*S*, 9*R*)-8-Pivaloyloxymethyl-10,12-dioxatricyclo[7.2.1.0<sup>2,7</sup>]dodec-4-ene **165****

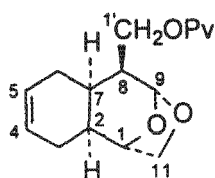

Triethylamine (5.0 cm<sup>3</sup>, 3.63 g, 35.9 mmol) and pivaloyl chloride (1.0 cm<sup>3</sup>, 0.98 g, 8.1 mmol) were added to a solution of the alcohol **153** in dichloromethane (20 cm<sup>3</sup>). The resulting mixture was

stirred for 3 h after which it was acidified with 1 M HCl and extracted with dichloromethane. The organic phase was washed with brine, dried ( $\text{MgSO}_4$ ) and the solvent was removed under reduced pressure. The residue (2.09 g) was chromatographed on silica gel (100 g) using ethyl acetate–hexane (1:9) as eluent to give the *pivaloate* **165** (1.79 g, 95%) as an oil,  $[\alpha]_D +52.3$  ( $c$  1.7 in  $\text{CHCl}_3$ );  $\nu_{\text{max}}(\text{CHCl}_3)/\text{cm}^{-1}$  1719 (CO);  $\delta_{\text{H}}$  (400 MHz,  $\text{CDCl}_3$ ), 1.10 (9H, s,  $\text{C}(\text{CH}_3)_3$ ), 1.67–1.79 (1H, m, 2-H), 1.81–1.95 (2H, m, 6- $\text{H}_A$  and 8-H), 1.96–2.10 (1H, m, 3- $\text{H}_A$ ), 2.20–2.37 (2H, m, 3- $\text{H}_B$  and 6- $\text{H}_B$ ), 2.47–2.56 (1H, m, 7-H), 3.76 (1H, dd,  $J$  7.0 and 5.2 Hz, 11- $\text{H}_A$ ), 3.91 (1H, d,  $J$  7.0 Hz, 11- $\text{H}_B$ ), 3.98 (1H, t,  $J$  3 x 11.2 Hz, 1'- $\text{H}_A$ ), 4.12 (1H, dd,  $J$  11.2 and 4.1 Hz, 1'- $\text{H}_B$ ), 4.24 (1H, d,  $J$  5.1 Hz, 1-H), 5.44 (1H, s, 9-H) and 5.57–5.67 (2H, m, 4-H and 5-H);  $\delta_{\text{C}}$  (100 MHz,  $\text{CDCl}_3$ ), 24.7 (C-7), 26.0 (C-6), 26.8 (C-3), 27.1 [ $\text{C}(\text{CH}_3)_3$ ], 34.9 (C-2), 38.7 [ $\text{C}(\text{CH}_3)_3$ ], 45.2 (C-8), 63.1 (C-1'), 67.9 (C-11), 77.1 (C-1), 102.9 (C-9), 125.4 and 126.0 (C-4 and C-5) and 178.2 (C=O) (Found (FAB):  $\text{M}^+\text{Rb}$ , 365.0812. Calc. for  $\text{C}_{16}\text{H}_{24}\text{O}_4\text{Rb}$ :  $M$ , 365.0793).

**(1S, 2S, 3R, 4S, 5R)-2,3-Bis(2-*t*-butyldiphenylsilyloxyethyl)-4-pivaloyloxymethyl-6,8-dioxabicyclo[3.2.1]octane 166**

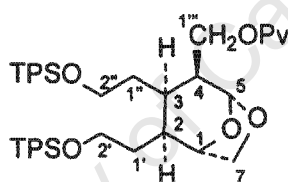

Ozone was bubbled through a solution of **165** (140 mg, 0.50 mmol) in methanol ( $8 \text{ cm}^3$ ), at  $-78^\circ\text{C}$  until the solution turned blue. The ozone was replaced by oxygen which until the solution became colourless after which sodium borohydride (95 mg, 2.5 mmol) was added. The reaction mixture was warmed to  $25^\circ\text{C}$  and then quenched with aqueous saturated ammonium chloride. The volatile material was removed under reduced pressure and the remaining mixture was extracted with chloroform, dried ( $\text{MgSO}_4$ ) and the solvent was removed to give the diol (161 mg) which was dissolved in acetonitrile ( $10 \text{ cm}^3$ ). Imidazole (102 mg, 1.5 mmol) and *t*-butyldiphenylsilyl chloride ( $0.29 \text{ cm}^3$ , 1.1 mmol) were added and the solution was stirred for 60 min. The mixture was concentrated under reduced pressure and water was added to the residue. The aqueous mixture was extracted with dichloromethane, the organic extract was dried ( $\text{MgSO}_4$ ) and the solvent was removed under reduced pressure. The residue (550 mg) was chromatographed on silica gel (50 g) using ethyl acetate–hexane (1:9) as eluent to give the *bissilyl ether* **166** (385 mg, 97%) as an oil,  $[\alpha]_D -10.4$  ( $c$  1.0 in  $\text{CHCl}_3$ );  $\nu_{\text{max}}(\text{CHCl}_3)/\text{cm}^{-1}$  1719 (CO);  $\delta_{\text{H}}$  (300 MHz,  $\text{CDCl}_3$ ), 1.03 [9H, s,  $\text{TPS-C}(\text{CH}_3)_3$ ], 1.05 [9H, s,  $\text{TPS-C}(\text{CH}_3)_3$ ], 1.16 [9H, s,  $\text{Pv-C}(\text{CH}_3)_3$ ], 1.35–1.73 (5H, m, 2-H, 1'- $\text{H}_2$  and 1''- $\text{H}_2$ ), 1.80–1.91 (1H, m, 4-H), 2.50–2.64 (1H, m, 3-H), 3.55–3.82 (6H, m, 7- $\text{H}_2$ ,

2'-H<sub>2</sub> and 2''-H<sub>2</sub>), 3.92—4.17 (2H, m, 1'''-H<sub>2</sub>), 4.28 (1H, d, *J* 5.0 Hz, 1-H), 5.46 (1H, d, *J* 1.2 Hz, 5-H), 7.30—7.46 (12H, m, Ar-H) and 7.58—7.64 (8H, m, Ar-H); δ<sub>C</sub> (75 MHz, CDCl<sub>3</sub>), 19.1 and 19.2 [2 x TPS-C(CH<sub>3</sub>)<sub>3</sub>], 26.8 and 26.9 [2 x TPS-C(CH<sub>3</sub>)<sub>3</sub>], 27.2 [Pv-C(CH<sub>3</sub>)<sub>3</sub>], 27.3 (C-3), 29.4 and 32.0 (C-1' and C-1''), 37.5 (C-2), 38.7 [Pv-C(CH<sub>3</sub>)<sub>3</sub>], 42.7 (C-4), 61.0 and 62.2 (C-2' and C-2''), 62.4 (C-1'''), 68.1 (C-7), 75.5 (C-1), 102.1 (C-5), 127.6(7) and 127.6(9), 129.6(2) and 129.6(9), 133.6(5), 133.6(9), 133.7(2) and 133.7(6), 135.5(3), 135.5(6) and 135.5(8) (Ar-C) and 178.2 (C=O) (Found (FAB): M<sup>+</sup>+Rb, 877.3369. Calc. for C<sub>48</sub>H<sub>64</sub>O<sub>6</sub>Si<sub>2</sub>Rb: *M*, 877.3360).

**(2*S*, 3*S*, 4*R*, 5*S*)-3,4-Bis[2-(*t*-butyldiphenylsilyloxy)ethyl]-5-(1,3-dithiolan-2-yl)-6-pivaloyloxyhexane-1,2-diol 167**

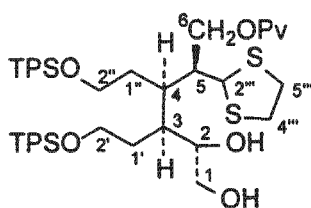

Ethanedithiol (0.40 cm<sup>3</sup>, 4.8 mmol) followed by titanium tetrachloride (1.0 M in dichloromethane, 2.8 cm<sup>3</sup>, 2.8 mmol) were added to a stirred solution of **166** (2.80 g, 3.5 mmol) in dichloromethane (60 cm<sup>3</sup>) at 0 °C. The reaction was stirred at this temperature for 4 h and then quenched with aqueous saturated sodium hydrogen carbonate, extracted with dichloromethane, dried (MgSO<sub>4</sub>) and the solvent was removed under reduced pressure. The residue (3.80 g) was chromatographed on silica (150 g) using ethyl acetate–hexane (1:9 to 3:7) to give the *thioacetal* **167**, (2.17 g, 69%), [α]<sub>D</sub> –11.6 (*c* 1.6 in CHCl<sub>3</sub>); ν<sub>max</sub>(CHCl<sub>3</sub>)/cm<sup>-1</sup> 1718 (CO), 3566 (OH); δ<sub>H</sub> (300 MHz, CDCl<sub>3</sub>), 1.02 [9H, s, TPS-C(CH<sub>3</sub>)<sub>3</sub>], 1.03 [9H, s, TPS-C(CH<sub>3</sub>)<sub>3</sub>], 1.16 [9H, s, Pv-C(CH<sub>3</sub>)<sub>3</sub>], 1.49—1.66 (3H, m, 1'-H<sub>2</sub> and 1''-H<sub>A</sub>), 1.73—1.90 (2H, m, 3-H and 1''-H<sub>B</sub>), 1.94—2.12 (2H, m, 4-H and OH), 2.47—2.57 (1H, m, 5-H), 2.62—2.70 (1H, br.d, OH), 2.98—3.27 (4H, m, 4'''-H<sub>2</sub> and 5'''-H<sub>2</sub>), 3.45—3.75 (7H, m, 1-H<sub>2</sub>, 2-H, 2'-H<sub>2</sub> and 2''-H<sub>2</sub>), 4.21 (1H, dd, *J* 11.7 and 7.0 Hz, 6-H<sub>A</sub>), 4.36 (1H, dd, *J* 11.7 and 3.6 Hz, 6-H<sub>B</sub>), 4.73 (1H, d, *J* 3.8 Hz, 2'''-H), 7.30—7.45 (12H, m, Ar-H) and 7.60—7.70 (8H, m, Ar-H); δ<sub>C</sub> (75 MHz, CDCl<sub>3</sub>), 19.0 [2 x TPS-C(CH<sub>3</sub>)<sub>3</sub>], 26.8 [2 x TPS-C(CH<sub>3</sub>)<sub>3</sub>], 27.1 [Pv-C(CH<sub>3</sub>)<sub>3</sub>], 31.2 and 31.3 (C-1' and C-1''), 37.0 (C-3), 38.0 and 39.3 (C-4''' and C-5'''), 38.6 (C-4), 44.4 (C-5), 54.2 (C-2'''), 62.4 and 62.9 (C-2' and C-2''), 65.1 (C-1), 65.2 (C-6), 73.1 (C-2), 127.5(8) and 127.6(4), 129.5(3) and 129.6(4), 133.2(9), 135.4(7) and 135.5(0) (Ar-C), and 178.2 (C=O) (Found (FAB): M<sup>+</sup>+Rb, 971.3257. Calc. for C<sub>50</sub>H<sub>70</sub>O<sub>6</sub>S<sub>2</sub>Si<sub>2</sub>Rb: *M*, 971.3270).

**(2*S*, 3*R*, 4*S*)-2,3-Bis[2-(*t*-butyldiphenylsilyloxy)ethyl]-4-(1,3-dithiolan-2-yl)-5-pivaloyloxy-pentanal 168**

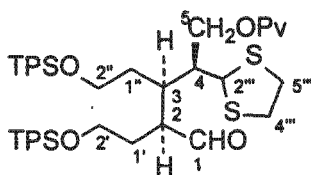

Lead tetraacetate (0.90 g, 2.03 mmol) was added to a solution of **167** (1.50 g, 1.70 mmol) in toluene (100 cm<sup>3</sup>) at 25 °C. After 15 min, ethylene glycol (5 drops) was added and the mixture was stirred for 10 min, then filtered through Celite and MgSO<sub>4</sub> layers and concentrated to give an oil (1.97 g). Flash chromatography on silica gel (100 g) using ethyl acetate–hexane (1:9) as eluent afforded the aldehyde **168** (1.37 g, 94%), [α]<sub>D</sub> 4.4 (*c* 1.5 in CHCl<sub>3</sub>); ν<sub>max</sub>(CHCl<sub>3</sub>)/cm<sup>-1</sup> 1722 (CO); δ<sub>H</sub> (300 MHz, CDCl<sub>3</sub>), 1.04 [18H, s, 2 x TPS-C(CH<sub>3</sub>)<sub>3</sub>], 1.17 [9H, s, Pv-C(CH<sub>3</sub>)<sub>3</sub>], 1.47–1.63 (1H, m, 1'-H<sub>A</sub>), 1.64–1.86 (2H, m, 1''-H<sub>2</sub>), 1.96–2.12 (1H, m, 1'-H<sub>B</sub>), 2.12–2.24 (1H, m, 4-H), 2.30–2.43 (1H, m, 3-H), 2.89–2.99 (1H, m, 2-H), 3.04–3.25 (4H, m, 4'''-H<sub>2</sub> and 5'''-H<sub>2</sub>), 3.54–3.80 (4H, m, 2'-H<sub>2</sub> and 2''-H<sub>2</sub>), 4.27 (2H, d, *J* 4.7 Hz, 5-H<sub>2</sub>), 4.73 (1H, d, *J* 7.4 Hz, 2'''-H), 7.28–7.45 (12H, m, Ar-H), 7.57–7.70 (8H, m, Ar-H) and 9.66 (1H, d, *J* 1.9 Hz, 1-H); δ<sub>C</sub> (75 MHz, CDCl<sub>3</sub>), 19.0 [2 x TPS-C(CH<sub>3</sub>)<sub>3</sub>], 26.8 [2 x TPS-C(CH<sub>3</sub>)<sub>3</sub>], 27.1 [Pv-C(CH<sub>3</sub>)<sub>3</sub>], 31.4 and 32.0 (C-1' and C-1''), 38.1 and 38.8 (C-4''' and C-5'''), 38.4 (C-4), 38.6 [Pv-C(CH<sub>3</sub>)<sub>3</sub>], 46.1 (C-3), 48.1 (C-2), 54.3 (C-2'''), 61.5 and 61.8 (C-2' and C-2''), 63.9 (C-5), 127.5, 129.5, 133.5, 135.4(4) and 135.4(8) (Ar-C), 178.7 (C=O) and 204.2 (C-1) (Found (FAB): M<sup>+</sup>+Rb, 939.3021. Calc. for C<sub>49</sub>H<sub>66</sub>O<sub>5</sub>S<sub>2</sub>Si<sub>2</sub>Rb: *M*, 939.3008).

**(1*S*, 2*S*, 3*R*, 4*S*, 5*R*)-2,3-Bis(2-(*t*-butyldiphenylsilyloxyethyl)-4-hydroxymethyl-6,8-dioxabicyclo[3.2.1]octane 169**

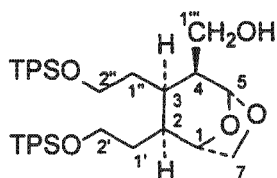

Lithium aluminium hydride (134 mg, 3.5 mmol) was added to a solution of **166** (2.53 g, 3.2 mmol) in tetrahydrofuran (250 cm<sup>3</sup>) at 0 °C. After 10 min, the reaction was quenched with water and the solvent removed under reduced pressure. The aqueous slurry was diluted with 1 M sodium hydroxide, extracted with chloroform, the organic extract was dried (MgSO<sub>4</sub>) and the solvent was removed *in vacuo* to give the an oily residue (2.70 g). Chromatography on silica gel (250 g) using ethyl acetate–hexane (2:3) as eluent afforded the alcohol **169** (2.09 g, 93%) as an oil, [α]<sub>D</sub> -18.7 (*c* 1.0 in CHCl<sub>3</sub>); ν<sub>max</sub>(CHCl<sub>3</sub>)/cm<sup>-1</sup> 3450 (OH); δ<sub>H</sub> (300 MHz, CDCl<sub>3</sub>), 1.04 [9H, s, C(CH<sub>3</sub>)<sub>3</sub>], 1.06

[9H, s, C(CH<sub>3</sub>)<sub>3</sub>], 1.32—1.66 (6H, m, 2-H, 1'-H<sub>2</sub>, 1''-H<sub>2</sub> and OH), 1.66—1.76 (1H, m, 4-H), 2.43—2.64 (1H, m, 3-H), 3.50—3.74 (7H, m, 7-H<sub>A</sub>, 2'-H<sub>2</sub>, 2''-H<sub>2</sub> and 1'''-H<sub>2</sub>), 3.79 (1H, d, *J* 7.6 Hz, 7-H<sub>B</sub>), 4.27 (1H, d, *J* 5.2 Hz, 1-H), 5.56 (1H, d, *J* 1.2 Hz, 5-H), 7.31—7.46 (12H, m, Ar-H) and 7.59—7.68 (8H, m, Ar-H); δ<sub>C</sub> (75 MHz, CDCl<sub>3</sub>), 19.2 [2 x C(CH<sub>3</sub>)<sub>3</sub>], 26.9 and 26.9 [2 x C(CH<sub>3</sub>)<sub>3</sub>], 27.6 (C-3), 29.5 and 32.1 (C-1' and C-1''), 37.7 (C-2), 45.8 (C-4), 60.4 (C-1'''), 61.5 and 62.3 (C-2' and C-2''), 68.0 (C-7), 75.5 (C-1), 102.5 (C-5), 127.7, 129.7, 133.7 and 135.6 (Ar-C) (Found: M<sup>+</sup>-C<sub>4</sub>H<sub>9</sub>, 651.2975. Calc. for C<sub>39</sub>H<sub>47</sub>O<sub>5</sub>Si<sub>2</sub>: *M*, 651.2962).

**Methyl (1*S*, 2*S*, 3*R*, 4*R*, 5*R*)-2,3-bis(2-*t*-butyldiphenylsilyloxyethyl)-6,8-dioxabicyclo[3.2.1]-octane-4-carboxylate 171**

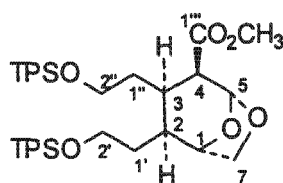

Sodium metaperiodate (10% solution in water, 12 cm<sup>3</sup>) and ruthenium dioxide (19 mg, 0.14 mmol) were added sequentially to a vigorously stirred solution of **169** (1.00 g, 1.41 mmol) in carbon tetrachloride–acetonitrile (1:1) (100 cm<sup>3</sup>) at 0 °C. Stirring was continued at this temperature for 18 h. The resulting mixture was poured into ethyl acetate–water and the aqueous layer was extracted with ethyl acetate. The organic phase was dried (MgSO<sub>4</sub>) and the solvent was removed under reduced pressure to give the acid (1.10 g) which was dissolved in *N,N*-dimethylformamide (10 cm<sup>3</sup>). Potassium carbonate (390 mg, 2.82 mmol) and iodomethane (0.11 cm<sup>3</sup>, 1.83 mmol) were added and the mixture was stirred at 0 °C for 2 h. The mixture was diluted with ethyl acetate (200 cm<sup>3</sup>). The organic phase was washed twice with water, dried (MgSO<sub>4</sub>) and the solvent removed under reduced pressure to give a residue (2.30 g) which was purified by chromatography on silica gel (50 g) using ethyl acetate–hexane (1:9) as eluent, to yield the *ester* **171** (1.03 g, 99%) as a gum, [α]<sub>D</sub> -11.3 (*c* 1.5 in CHCl<sub>3</sub>); ν<sub>max</sub>(CHCl<sub>3</sub>)/cm<sup>-1</sup> 1740 (CO); δ<sub>H</sub> (400 MHz, CDCl<sub>3</sub>), 1.04 [9H, s, C(CH<sub>3</sub>)<sub>3</sub>], 1.06 [9H, s, C(CH<sub>3</sub>)<sub>3</sub>], 1.55 (1H, s, 2-H), 1.59—1.92 (4H, m, 1'-H<sub>2</sub> and 1''-H<sub>2</sub>), 2.59—2.69 (2H, m, 3-H and 4-H), 3.61 (3H, s, OCH<sub>3</sub>), 3.63—3.78 (5H, m, 7-H<sub>A</sub>, 2'-H<sub>2</sub> and 2''-H<sub>2</sub>), 3.81 (1H, d, *J* 7.1 Hz, 7-H<sub>B</sub>), 4.37 (1H, d, *J* 5.7 Hz, 1-H), 5.67—5.72 (1H, br.s, 5-H), 7.32—7.45 (12H, m, Ar-H) and 7.60—7.67 (8H, m, Ar-H); δ<sub>C</sub> (100 MHz, CDCl<sub>3</sub>), 19.1 [2 x C(CH<sub>3</sub>)<sub>3</sub>], 26.9 and 26.9 [2 x C(CH<sub>3</sub>)<sub>3</sub>], 27.5 (C-3), 28.7 and 32.4 (C-1' and C-1''), 37.6 (C-2), 48.6 (C-4), 51.2 (OCH<sub>3</sub>), 61.3 and 62.1 (C-2' and C-2''), 68.4 (C-7), 75.6 (C-1), 100.5 (C-5), 127.6, 129.6, 133.8(0) and 133.8(2), 135.5(0), 135.5(3) and 135.5(6) (Ar-C) and 170.8 (C-1''') (Found: M<sup>+</sup>-CH<sub>3</sub>, 721.3387. Calc. for C<sub>43</sub>H<sub>53</sub>O<sub>6</sub>Si<sub>2</sub>: *M*, 721.3381).

## 6.6 MOLECULAR MODELLING

GAUSSIAN98<sup>194</sup> was used for all *ab initio* calculations. Both geometrical minimisations and single point energy calculations were made at the Hartree-Fock level with the STO-3G basis set.

## 6.7 CRYSTAL STRUCTURE DETERMINATION OF 153

Data were collected at 295 K using a Nonius Kappa CCD with 1.5 kW graphite monochromated Mo radiation. The strategy for the data collection was evaluated using *COLLECT*<sup>195</sup>. The detector to crystal distance was 40 mm. Exposure times of 40 s per frame and scan widths of 1° were used throughout the data collection. Three sets of data were collected: a 182°  $\phi$ -scan and two  $\omega$ -scans. The data were scaled and reduced using *DENZO-SMN*<sup>196</sup>. Unit cell dimensions were refined on 1291 strong, well-measured reflections in the  $\theta$ -range 1.02° to 27.5° (resolution between 20.00 Å and 0.77 Å). The chiral space group P2<sub>1</sub>2<sub>1</sub>2<sub>1</sub> was chosen on the basis of the systematic absences. The structure was solved and refined using *SHELX97*.<sup>197, 198</sup> Hydrogen atoms were placed in calculated positions and refined as riding atoms. Molecular graphics were generated using *X-SEED*.<sup>199</sup>

Details of the data collection and refinement are given in Table 6.1.

Atomic coordinates for non-hydrogen atoms are listed in Table 6.2.

Selected bond lengths are listed in Table 6.3, and torsion angles in Table 6.4.

Table 6.1 Crystal data and structure refinement for 153

Empirical formula	$C_{11}H_{16}O_3$	
Formula weight	196.24	
Temperature	295(2) K	
Wavelength	0.71073 Å	
Crystal system	Orthorhombic	
Space group	$P2_12_1$	
Unit cell dimensions	$a = 7.475(1)$ Å	$\alpha = 90^\circ$
	$b = 8.234(1)$ Å	$\beta = 90^\circ$
	$c = 16.061(2)$ Å	$\gamma = 90^\circ$
Volume	$988.5(2)$ Å <sup>3</sup>	
Z	4	
Density (calculated)	1.319 Mg/m <sup>3</sup>	
Absorption coefficient	0.095 mm <sup>-1</sup>	
F(000)	424	
Crystal size	0.45 x 0.24 x 0.17 mm <sup>3</sup>	
$\theta$ range for data collection	2.78 to 27.48°	
Index ranges	$-9 \leq h \leq 9, -10 \leq k \leq 10, -13 \leq l \leq 20$	
Reflections collected	4919	
Independent reflections	2160 [R(int) = 0.0211]	
Completeness to $\theta = 27.48^\circ$	99.3%	
Max. and min. transmission	0.9841 and 0.9586	
Refinement method	Full-matrix least-squares on $F^2$	
Data / restraints / parameters	2160 / 1 / 148	
Goodness-of-fit on $F^2$	1.088	
Final R indices [ $I > 2\sigma(I)$ ]	$R1 = 0.0370, wR2 = 0.0713$	
R indices (all data)	$R1 = 0.0559, wR2 = 0.0779$	
Absolute structure parameter	0.6(12)	
Extinction coefficient	0.013(3)	
Largest diff. peak and hole	0.156 and -0.133 e.Å <sup>-3</sup>	

**Table 6.2** Atomic coordinates ( $\times 10^4$ ) and equivalent isotropic displacement parameters ( $\text{\AA}^2 \times 10^3$ ) for 153.  $U(\text{eq})$  is defined as one third of the trace of the orthogonalized  $U^{ij}$  tensor

	x	y	z	$U(\text{eq})$
O(10)	-1711(1)	2653(1)	833(1)	43(1)
O(12)	-2969(1)	2964(1)	2105(1)	49(1)
O(2')	1850(2)	417(1)	1782(1)	53(1)
C(7)	-3204(2)	-289(2)	1507(1)	35(1)
C(1')	275(2)	-261(2)	1413(1)	40(1)
C(2)	-3852(2)	472(2)	685(1)	37(1)
C(8)	-1407(2)	435(2)	1805(1)	35(1)
C(3)	-2965(2)	-228(2)	-93(1)	48(1)
C(6)	-3238(2)	-2156(2)	1471(1)	48(1)
C(1)	-3594(2)	2304(2)	721(1)	40(1)
C(9)	-1464(2)	2268(2)	1679(1)	39(1)
C(11)	-4383(2)	3098(2)	1493(1)	47(1)
C(5)	-2613(2)	-2831(2)	664(1)	55(1)
C(4)	-2505(2)	-1994(2)	-24(1)	53(1)

Table 6.3 Selected bond lengths for 153

Bond	Length (Å)	Bond	Length (Å)
O(10)-C(9)	1.407(2)	C(1')-C(8)	1.518(2)
O(10)-C(1)	1.4472(19)	C(2)-C(1)	1.522(2)
O(12)-C(9)	1.4353(19)	C(2)-C(3)	1.527(2)
O(12)-C(11)	1.4475(19)	C(8)-C(9)	1.524(2)
O(2')-C(1')	1.431(2)	C(3)-C(4)	1.499(3)
C(7)-C(6)	1.539(2)	C(6)-C(5)	1.486(3)
C(7)-C(2)	1.540(2)	C(1)-C(11)	1.520(2)
C(7)-C(8)	1.546(2)	C(5)-C(4)	1.305(3)

Table 6.4 Selected torsion angles for 153

Bonds	Angle (°)	Bonds	Angle (°)
C(9)-O(10)-C(1)	101.69(12)	C(1')-C(8)-C(9)	110.01(13)
C(9)-O(12)-C(11)	106.22(12)	C(1')-C(8)-C(7)	116.49(13)
C(6)-C(7)-C(2)	111.67(13)	C(9)-C(8)-C(7)	108.46(13)
C(6)-C(7)-C(8)	114.30(13)	C(4)-C(3)-C(2)	113.93(15)
C(2)-C(7)-C(8)	112.45(13)	C(5)-C(6)-C(7)	113.62(14)
O(2')-C(1')-C(8)	111.24(14)	O(10)-C(1)-C(11)	101.00(13)
C(1)-C(2)-C(3)	110.52(14)	O(10)-C(1)-C(2)	108.96(12)
C(1)-C(2)-C(7)	109.26(13)	C(11)-C(1)-C(2)	114.14(15)
C(3)-C(2)-C(7)	114.30(13)	O(10)-C(9)-O(12)	105.48(12)

## REFERENCES

1. The leishmaniases and *leishmania*/HIV coinfections, Fact Sheet No 116, World Health Organisation, Geneva, 2000 (available at <http://www.who.int/inf-fs/en/fact116.html>).
2. H.W. Murray, *Int. J. Infect. Dis.*, 2000, 4, 158.
3. N. Mattock, Public/private partnership: developing an oral treatment for Visceral leishmaniasis., TDR News Release No. 60, World Health Organisation, Geneva, 2001 (available at <http://www.who.int/tdr/publications/tdrnews/news60/miltefosine.htm>).
4. A. Kuhlencord, T. Maniera, H. Eibl, and C. Unger, *Antimicrob. Agents Chemother.*, 1992, 36, 1630.
5. T.K. Jha, S. Sundar, C.P. Thakur, P. Bachmann, J. Karbwang, C. Fischer, A. Voss, and J. Berman, *N. Engl. J. Med.*, 1999, 341, 1795.
6. S. Ray, H.K. Majumder, A.K. Chakraborty, S. Mukhopadhyay, R.R. Gil, and G.A. Cordell, *J. Nat. Prod.*, 1996, 59, 27.
7. S. Medda, S. Mukhopadhyay, and M.K. Basu, *J. Antimicrob. Chemother.*, 1999, 44, 791.
8. F. Korte, *Chem. Ber.*, 1955, 88, 704.
9. H. Inouye and Y. Nakamura, *Tetrahedron Lett.*, 1968, 47, 4919.
10. H. Inouye and Y. Nakamura, *Tetrahedron*, 1971, 27, 1951.
11. P.K. Chaudhuri and W.M. Daniewski, *Polish J. Chem.*, 1995, 69, 1514.
12. M. Keil, B. Härtle, A. Guillaume, and M. Psiorz, *Planta Med.*, 2000, 66, 452.
13. S.V. Ley, I.R. Baxendale, R.N. Bream, P.S. Jackson, A.G. Leach, D.A. Longbottom, M. Nesi, J.S. Scott, R.I. Storer, and S.J. Taylor, *J. Chem. Soc., Perkin Trans. 1*, 2000, 3815, and references cited therein.
14. K.C. Nicolaou and H. Ueno, in *Preparative Carbohydrate Chemistry*, ed. S. Hanessian, Marcel Dekker, New York, 1997, p. 313.
15. K.C. Nicolaou and H.J. Mitchell, *Angew. Chem., Int. Ed.*, 2001, 40, 1576, and references cited therein.
16. A. Liptak, I. Jodal, J. Harangi, and P. Nanasi, *Acta Chim. Hung.*, 1983, 113, 415.
17. M.S. Motiawa, C.E. Olsen, K. Enevoldsen, J. Marcussen, and B.L. Møller, *Carbohydr. Res.*, 1995, 277, 109.
18. K.C. Nicolaou, N. Winssinger, J. Pastor, and F. DeRoose, *J. Am. Chem. Soc.*, 1997, 119, 449.
19. C. Thompson, M. Ge, and D. Kahne, *J. Am. Chem. Soc.*, 1999, 121, 1237.
20. A. Suzuki, *J. Organomet. Chem.*, 1999, 576, 147.
21. C.G. Blettner, W.A. König, W. Stenzel, and T. Schotten, *Synlett*, 1998, 295.

22. R. Franzen, *Can. J. Chem.*, 2000, **78**, 957.
23. J. Nakano, N. Katagiri, and T. Kato, *Chem. Pharm. Bull.*, 1982, **36**, 2590.
24. C.-Z. Wang, U.H. Maier, and M.H. Zenk, *J. Nat. Prod.*, 2000, **63**, 371.
25. H. Inouye, S. Ueda, and Y. Nakamura, *Tetrahedron Lett.*, 1966, **43**, 5229.
26. H. Inouye, S. Ueda, and Y. Nakamura, *Tetrahedron Lett.*, 1967, **33**, 3221.
27. R. Guarnaccia, L. Botta, and C.J. Coscia, *J. Am. Chem. Soc.*, 1974, **96**, 7079.
28. L.-F. Tietze and G. Kinast, *Chem. Ber.*, 1976, **109**, 3626.
29. C.R. Hutchinson, K.C. Mattes, M. Nakane, J.J. Partridge, and M.R. Uskokovic, *Helv. Chim. Acta*, 1978, **61**, 1221.
30. C.R. Hutchinson and T. Ikeda, *J. Org. Chem.*, 1984, **49**, 2837.
31. L.-F. Tietze and C. Bärtels, *Tetrahedron*, 1989, **45**, 681.
32. O. Ohmori, H. Takayama, and N. Aimi, *Tetrahedron Lett.*, 1999, **40**, 5039.
33. S.E. Drewes, M.M. Horn, N.J. Brown, O.Q. Munro, J.J.M. Meyer, and A.D.M. Mathekga, *Phytochemistry*, 2001, **57**, 51.
34. T. Ikeda and C.R. Hutchinson, *Tetrahedron Lett.*, 1984, **25**, 2427.
35. J. Jurkzack, T. Bauer, and C. Chaphuis, in *Stereoselective Synthesis*, ed. G. Helmchen, R. W. Hoffman, J. Mulzer, and E. Schaumann, Georg Thieme Verlag, Stuttgart, 1996, p. 2856.
36. A. Kroger, Steps Toward the Synthesis of a Natural Product Fragment, Post Doctoral Report, University of Cape Town, 1997.
37. R.J. Ferrier and S. Middleton, *Chem. Rev.*, 1993, **93**, 2779.
38. FDA's Policy Statement for the Development of New Stereoisomeric Drugs, Centre for Drug Evaluation and Research, U.S. Food and Drug Administration, 1992, updated 1998 (available at <http://www.fda.gov/cder/guidance.stereo.htm>).
39. I.J. Jacovac, H.B. Goodbrand, K.P. Lok, and J.B. Jones, *J. Am. Chem. Soc.*, 1982, **104**, 4659.
40. H.-J. Gais and K.L. Lukas, *Angew. Chem., Int. Ed.*, 1984, **23**, 142.
41. H.-J. Gais, K.L. Lukas, W.A. Ball, S. Braun, and H.J. Lindner, *Liebigs. Ann. Chem.*, 1986, 687.
42. E. Guibé-Jampel, G. Rousseau, and L. Blanco, *Tetrahedron Lett.*, 1989, **30**, 67.
43. E.J. Toone and J.B. Jones, *Tetrahedron: Asymmetry*, 1991, **2**, 207.
44. V. Alphand and R. Furstoss, *J. Org. Chem.*, 1992, **57**, 1306.
45. K. Matsuki, H. Inoue, A. Ishida, M. Takeda, M. Nakagawa, and T. Hino, *Chem. Pharm. Bull.*, 1994, **42**, 9.
46. H. Luna, K. Prasad, and O. Repic, *Tetrahedron: Asymmetry*, 1994, **5**, 303.

47. J. Kang, J.W. Lee, J.I. Kim, and C. Pyun, *Tetrahedron Lett.*, 1995, **36**, 4265.
48. D. Seebach, R.E. Marti, and T. Hintermann, *Helv. Chim. Acta*, 1996, **79**, 1710.
49. C. Bolm, A. Gerlach, and C.L. Dinter, *Synlett*, 1999, 195.
50. D. Seebach, A.K. Beck, and A. Heckel, *Angew. Chem., Int. Ed.*, 2001, **40**, 92.
51. G. Guillena, D.J. Ramón and D. Seebach, *Helv. Chim. Acta*, 1996, **79**, 875.
52. G. Jaeschke and D. Seebach, *J. Org. Chem.*, 1998, **63**, 1190.
53. D. Seebach, A.K. Beck, R. Imwinkelreid, S. Roggo, and A. Wonnacott, *Helv. Chim. Acta*, 1987, **70**, 954.
54. L. La Vecchia, A.K. Beck, P. Gysi, and D. Seebach, *Org. Synth.*, 1999, **76**, 12.
55. J. Irrure, A. Alvarez-Larena and J.F. Pinniella *Tetrahedron: Asymmetry*, 1992, **3**, 1591.
56. B. Zwanenberg, G.H.L. Nefkens, and J.W.J.F. Thuring, *Synthesis*, 1997, 290.
57. B. Belleau and J. Puranen, *Can. J. Chem.*, 1965, **43**, 2551.
58. L. Jaenicke and F.-J. Marnier, *Chem. Ber.*, 1975, **108**, 2202.
59. D. Borland and H.F. Getrest, *Helv. Chim. Acta*, 1985, **68**, 2063.
60. S.L. Buchwald, X. Verdaguer, M.C. Hansen, and S.C. Berk, *J. Org. Chem.*, 1997, **62**, 8522.
61. K. Omura and D. Swern, *Tetrahedron*, 1978, **34**, 1651.
62. S.V. Ley, J. Norman, W.P. Griffith, and S.P. Marsden, *Synthesis*, 1994, 639.
63. T.-L. Ho, *Chem. Rev.*, 1975, **75**, 1.
64. H.O. House, in *Modern Synthetic Reactions*, ed. R. Breslow, W A Benjamin, Menlo Park, 1972, p. 763.
65. L.N. Mander and S.P. Sethi, *Tetrahedron Lett.*, 1983, **24**, 5425.
66. D.B. Dess and J.C. Martin, *J. Am. Chem. Soc.*, 1991, **113**, 7277.
67. R.E. Tirpak, R.S. Olsen, and M.W. Rathke, *J. Org. Chem.*, 1985, **50**, 4877.
68. J. March, *Advanced Organic Chemistry*, John Wiley & Sons, New York, 1992, p. 250.
69. P. Groenewegen, H. Kallenberg, and A. Van der Gen, *Tetrahedron Lett.*, 1978, **5**, 491.
70. G. Stork, H. Brizzolara, J. Landesman, J. Szmuszkowicz, and R. Terrel, *J. Am. Chem. Soc.*, 1963, **85**, 207.
71. T.W. Greene and P.G.M. Wuts, *Protective Groups in Organic Synthesis*, John Wiley & Sons, New York, 1999, p. 86.
72. K. Horita, T. Yoshioka, T. Tanaka, Y. Oikawa, and O. Yonemitsu, *Tetrahedron*, 1986, **42**, 3021.
73. K.N. Rankin, D.G. Lee, Q. Liu, J. Hendry, H. Yee, and N.A. Noureldin, *Tetrahedron Lett.*, 1998, **39**, 1095.
74. D.G. Lee and M. van dan Engh, *Can. J. Chem.*, 1972, **50**, 3129.

75. A.G.M. Barrett, D.C. Braddock, P.D. de Koning, A.J.P. White, and D.J. Williams, *J. Org. Chem.*, 2000, **65**, 375.
76. M. Schröder, *Chem. Rev.*, 1980, **80**, 187.
77. L.A. Flippin, D.W. Gallagher, and K. Jalali-Araghi, *J. Org. Chem.*, 1989, **54**, 1430.
78. S.L. Schreiber, R.E. Claus and J. Reagan, *Tetrahedron Lett.*, 1982, **38**, 3867.
79. Y.-S. Hon and J.-L. Yan, *Tetrahedron*, 1997, **53**, 5217.
80. W. Carruthers, in *Some Modern Methods of Organic Synthesis.*, Cambridge University Press, Cambridge, USA, 1990, p. 115.
81. M. Hudlický, *Oxidations in Organic Chemistry*, American Chemical Society, Washington DC, 1990
82. R.P. Greenhalgh, *Synlett*, 1992, 235.
83. D.W. Emerson, A.P. Craig, and I.W.J. Potts, *J. Am. Chem. Soc.*, 1967, **32**, 102.
84. K.C. Nicolaou and N.A. Petasis, *Selenium in Natural Products Synthesis*, CIS, Philadelphia, 1984, p. 128.
85. P.A. Grieco, S. Gilman, and M. Nishizawa, *J. Org. Chem.*, 1976, **41**, 1485.
86. D.L.J. Clive, *Tetrahedron*, 1978, **34**, 1049, and references cited therein.
87. H.J. Reich, S. Wollowitz, J.E. Trend, F. Chow, and D.F. Wendelborn, *J. Org. Chem.*, 1978, **43**, 1697.
88. K.B. Sharpless and M.W. Young, *J. Org. Chem.*, 1975, **40**, 947.
89. W. Kantlehner, in *Encyclopaedia of Reagents for Organic Synthesis*, ed. L. Paquette, John Wiley & Sons, Chichester, 1995, p. 828.
90. R.D. Wilson, S.P. Watson, and S.A. Richards, *Tetrahedron Lett.*, 1998, **39**, 2827.
91. C. Mazal and J. Jonas, *Collect. Czech. Chem. Commun.*, 1993, **58**, 1607.
92. R.D. Little, M.R. Masjedizadeh, O. Wallquist, and J.I. McLoughlin, *Organic Reactions*, 1995, **47**, 315.
93. I. Paterson and S. Osborne, *Tetrahedron Lett.*, 1990, **31**, 2213.
94. R. Noyori, M. Suzuki, and T. Tsunoda, *Tetrahedron Lett.*, 1980, **21**, 1357.
95. T.W. Greene and P.G.M. Wuts, *Protective Groups in Organic Synthesis*, John Wiley & Sons, New York, 1999, p. 114.
96. P. Deslongchamps, P. Atlani, D. Fréhel, A. Malaval, and C. Moreau, *Can. J. Chem.*, 1974, **52**, 3651.
97. V.S. Martin, P.H.J. Carlsen, T. Katsuki, and K.B. Sharpless, *J. Org. Chem.*, 1981, **46**, 3936.
98. D.L. Boger, R.M. Borzilleri, S. Nukui, and R.T. Beresis, *J. Org. Chem.*, 1997, **62**, 4721.
99. R. Rodebaugh, J.S. Debenham, and B. Fraser-Reid, *J. Org. Chem.*, 1997, **62**, 4591.
100. R. Hunter, W. Hinz, and P. Richards, *Tetrahedron Lett.*, 1999, **40**, 3643.

101. T. Oriyama, Y. Kobayashi, and K. Noda, *Synlett*, 1998, 1047.
102. T.W. Greene and P.G.M. Wuts, *Protective Groups in Organic Synthesis*, John Wiley & Sons, New York, 1999, p. 317.
103. I.E. Marko, A. Gautier, A. Ates, and B. Leroy, *Angew. Chem., Int. Ed.*, 1999, **38**, 3207.
104. W.G. Van der Sluis and R.P. Labadie, *Planta Med.*, 1981, **41**, 150.
105. Y. Shai, K.A. Jacobson, and A. Patchornik, *J. Am. Chem. Soc.*, 1985, **107**, 4249.
106. R.R. Koganty, M.B. Shambhu, and G.A. Digenis, *Tetrahedron Lett.*, 1973, **45**, 4511.
107. G.J. Roth, S. Kirschbaum, and H.J. Bestmann, *Synlett*, 1997, 618.
108. K. Tanaka, H. Nakashima, T. Taniguchi, and K. Ogasawara, *Organic Letters*, 2000, **2**, 1915.
109. P.P.M.A. Dols, A.J.H. Klunder, and B. Zwanenburg, *Tetrahedron*, 1994, **50**, 8515.
110. K. Kon and S. Isoe, *Helv. Chim. Acta*, 1983, **66**, 755.
111. P. Bélanger and P. Prasit, *Tetrahedron Lett.*, 1988, **29**, 5521.
112. S.M. Ali, K. Ramesh, and R. Borchardt, *Tetrahedron Lett.*, 1990, **31**, 1509.
113. D.R. Borcharding, S.A. Scholtz, and R.T. Borchardt, *J. Org. Chem.*, 1987, **52**, 5457.
114. C.R. Johnson and C.D. Penning, *J. Am. Chem. Soc.*, 1986, **108**, 5655.
115. H. Nakashima, M. Sato, T. Taniguchi, and K. Ogasawara, *Synthesis*, 2000, 817.
116. J.M. Hill, E.J. Hutchinson, D.M. Le Grand, S.M. Roberts, A.J. Thorpe, and N.J. Turner, *J. Chem. Soc., Perkin Trans. 1*, 1994, 1483.
117. B.M. Trost and F.D. Toste, *J. Am. Chem. Soc.*, 1999, **121**, 3543.
118. G. Stork, K. Manabe, and L. Liu, *J. Am. Chem. Soc.*, 1998, **120**, 1337.
119. W. Oppolzer, *Angew. Chem., Int. Ed.*, 1984, **23**, 876.
120. B.L. Feringa and J.C. de Jong, *Bull. Soc. Chim. Belg.*, 1992, **101**, 627.
121. U. Reiser, J. Jauch, and E. Herdtweck, *Tetrahedron: Asymmetry*, 2000, **11**, 3345.
122. J. Jauch, *Eur. J. Org. Chem.*, 2001, 473.
123. J. Jauch, *Synlett*, 2001, 87.
124. K. Tomioka, T. Ishiguro, Iitaka, Y., and K. Koga, *Tetrahedron*, 1984, **40**, 1303.
125. P. Camps, J. Cardellach, J. Font, R.M. Ortuño, and O. Ponsatí, *Tetrahedron*, 1982, **38**, 2395.
126. M.G.B. Drew, J. Mann, and A. Thomas, *J. Chem. Soc., Perkin Trans. 1*, 1986, 2279.
127. J. Mann and A.C. Weymouth-Wilson, *Org. Synth.*, 1998, **75**, 139.
128. C.R. Schmid and J.D. Bryant, *Org. Synth.*, 1995, **72**, 6.
129. C. Huberschwerlen, *Synthesis*, 1986, 962.
130. C. Harcken and R. Bruckner, *Angew. Chem., Int. Ed.*, 1997, **36**, 2750.
131. J. Mann and A. Thomas, *J. Chem. Soc., Perkin Trans. 1*, 1986, 2287.
132. R.M. Ortuño, J. Font, and J. Corbera, *Tetrahedron Lett.*, 1986, **27**, 1081.

133. R. Batllori, J. Font, M. Monsalvatje, R.M. Ortuño, and F. Sanchez-Ferrando, *Tetrahedron*, 1989, **45**, 1833.
134. R.M. Ortuño, M. Ballesteros, J. Corbera, F. Sanchez-Ferrando, and J. Font, *Tetrahedron*, 1988, **44**, 1711.
135. R. Casas, J. Ibarzo, J.M. Jiménez, and R.M. Ortuño, *Tetrahedron: Asymmetry*, 1993, **4**, 669.
136. P.J. Kocienski, *Protecting Groups*, Georg Thieme Verlag, Stuttgart, 1994, p. 28.
137. G. Arnott, Cycloaddition Mediated Approaches to the Synthesis of Amarogentin, B.Sc. (Hons) Project, University of Cape Town, 1998.
138. D. Alonso, J. Orti, V. Branchadell, A. Oliva, R.M. Ortuño, J. Bertrán, and J. Font, *J. Org. Chem.*, 1990, **55**, 3060.
139. V. Branchadell, J. Font, A.G. Moglioni, C. Ochoa de Echagüen, A. Oliva, R.M. Ortuño, J. Veciana, and J. Vidal-Gancedo, *J. Am. Chem. Soc.*, 1997, **119**, 9992.
140. L.A. Paquette, A.M. Doherty, and C.M. Rayner, *J. Am. Chem. Soc.*, 1992, **114**, 3910.
141. D.L. Boger, R.M. Borzilleri, S. Nukui, and R.T. Beresis, *J. Org. Chem.*, 1997, **62**, 4721.
142. W. Hartwig, *Tetrahedron*, 1983, **39**, 2609, and references cited therein.
143. S. Harusawa, R. Yoneda, Y. Omori, and T. Kurihara, *Tetrahedron Lett.*, 1987, **28**, 4189.
144. P. Kocienski, *Protecting Groups*, Georg Thieme Verlag, Stuttgart, 1994, p. 104.
145. S. Nahm and S.M. Weinreb, *Tetrahedron Lett.*, 1981, **22**, 3815.
146. D. Nasipuri, *Stereochemistry of Organic Compounds*, Wiley Eastern Limited, New Delhi, 1991, p. 316.
147. A.J. Castellino and H. Rapoport, *J. Org. Chem.*, 1986, **51**, 1006.
148. E.R. Civitello and H. Rapoport, *J. Org. Chem.*, 1994, **59**, 3775.
149. T.W. Greene and P.G.M. Wuts, *Protective Groups in Organic Synthesis*, John Wiley & Sons, New York, 1999, p. 41.
150. *Levoglucosenone and Levoglocosans: Chemistry and Applications*, ed. Z. J. Witczak, A T L Pr. Scientific Pub., Washington DC, 1996.
151. K. Mori, M. Mori, T. Chuman, and K. Kato, *Tetrahedron Lett.*, 1982, **23**, 4593.
152. Y. Halpern, R. Riffer, and A. Broido, *J. Org. Chem.*, 1973, **38**, 204.
153. F. Shafizadeh, R.H. Furneaux, and T.T. Stevenson, *Carbohydr. Res.*, 1979, **71**, 169.
154. M. Shibagaki, K. Takahashi, H. Kuno, I. Honda, and H. Matsushita, *Chem. Lett.*, 1990, 307.
155. Z.J. Witczak and R. Mielgaj, *Synlett*, 1996, 108.
156. M. Takeuchi, T. Taniguchi, and K. Ogasawara, *Synthesis*, 1999, 341.
157. D.D. Ward and F. Shafizadeh, *Carbohydr. Res.*, 1981, **95**, 155.
158. M. Isobe, N. Fukami, T. Nishikawa, and T. Goto, *Heterocycles*, 1987, **25**, 521.
159. S. Yamada, H. Ishikawa, and M. Matsumoto, *J. Chem. Soc., Chem. Commun.*, 1994, 2155.

160. M. Isobe, N. Fukami, and T. Goto, *Chem. Lett.*, 1985, 71.
161. M. Isobe, T. Nishikawa, S. Pikul, and T. Goto, *Tetrahedron Lett.*, 1987, 28, 6485.
162. J.S. Swenton, J.N. Freskos, P. Dalidowicz, and M.L. Kerns, *J. Org. Chem.*, 1996, 61, 459.
163. J.B. Foresman and A. Frisch, *Exploring Chemistry with Electronic Structure Methods*, Gaussian, Inc., Pittsburgh, 1996, p. 68.
164. E.I. Eliel and S.H. Wilen, *Stereochemistry of Organic Compounds*, John Wiley & Sons, 1994, p. 726.
165. J. Seyden-Penne, *Reductions by the Alumino- and Borohydrides in Organic Synthesis*, VCH Publishers, New York, 1991, p. 47.
166. M. Nogradi, *Stereoselective Synthesis*, VCH Publishers, Weinheim, 1995, p. 100.
167. M.A. Ogliaruso and J.F. Wolfe, in *Comprehensive Organic Functional Group Transformations*, ed. A. R. Katritzky, O. Meth-Cohn, and C. W. Rees, Elsevier, Oxford, 1995, p. 23.
168. R.C. Larock, *Comprehensive Organic Transformations*, VCH Publishers, New York, 1989, p. 864.
169. O.H. Oldenziel and A.M. van Leusen, *Synth. Commun.*, 1972, 2, 281.
170. J. March, *Advanced Organic Chemistry*, John Wiley & Sons, New York, 1992, p. 887.
171. O.H. Oldenziel, D. van Leusen, and A.M. van Leusen, *J. Org. Chem.*, 1977, 42, 3114.
172. J.R. Bull and A. Tuinman, *Tetrahedron*, 1975, 31, 2151.
173. M. North, in *Comprehensive Organic Functional Group Transformations*, ed. A. R. Katritzky, O. Meth-Cohn, and C. W. Rees, Elsevier, Oxford, 1995, p. 612.
174. B.K. Wilk, *Synth. Commun.*, 1993, 23, 2481.
175. J.A. Dodge, J.S. Nissen, and M. Presnell, *Org. Synth.*, 1996, 73, 110.
176. F.W. Winkler, *Liebigs. Ann. Chem.*, 1832, 4, 246.
177. M. North, in *Comprehensive Organic Functional Group Transformations*, ed. A. R. Katritzky, O. Meth-Cohn, and C. W. Rees, Elsevier, Oxford, 1995, p. 615.
178. R. Yoneda, S. Harusawa, T. Kurihara, Y. Hamada, and T. Shioiri, *Tetrahedron Lett.*, 1984, 25, 427.
179. I. Micó and C. Nájera, *Tetrahedron*, 1993, 49, 4327.
180. R. Yoneda, S. Harusawa, and T. Kurihara, *J. Org. Chem.*, 1991, 56, 1827.
181. G.A. Molander, *Organic Reactions*, 1994, 46, 211.
182. R. Yoneda, S. Harusawa, and T. Kurihara, *Tetrahedron Lett.*, 1989, 30, 3681.
183. G.A. Molander and G. Hahn, *J. Org. Chem.*, 1986, 51, 1135.

184. Cambridge Structural Database and Cambridge Structural Database System, Version 5.21, Cambridge Crystallographic Data Centre, University Chemical Laboratory, Cambridge, April 2001.
185. S. Wilson, Chiral Pool Intermediates in the Total Synthesis of Amarogentin, B.Sc. (Hons) Project, University of Cape Town, 1999.
186. M. Hirama and M. Shimizu, *Synth. Commun.*, 1983, 13, 781.
187. M. Hirama and M. Uei, *J. Am. Chem. Soc.*, 1982, 104, 4251.
188. T.W. Greene and P.G.M. Wuts, *Protective Groups in Organic Synthesis*, John Wiley & Sons, New York, 1999, p. 139.
189. D.D. Perrin and W.L.F. Armarego, *Purification of Laboratory Chemicals*, Pergamon Press, Oxford, 1988.
190. M. Carmack and C.J. Kelley, *J. Org. Chem.*, 1968, 33, 2171.
191. R.V. White and P.S. Landis, *J. Org. Chem.*, 1956, 21, 279.
192. P. O'Brien and J. Tournayre, *Tetrahedron*, 1997, 53, 17527.
193. R. Tanikaga, Y. Nozaki, K. Tanaka, and A. Kaji, *Chem. Lett.*, 1982, 1703.
194. M.J. Frisch, G.W. Trucks, H.V. Schlegel, G.E. Scuseria, M.A. Robb, A.R. Cheeseman, V.G. Zakrzewski, J.A.J. Montgomery, R.E. Stratmann, J.C. Burant, J.M. Millam, A.D. Daniels, K.N. Kudin, M.C. Strain, O. Farkas, J. Tomasi, V. Barone, M. Cossi, R. Cammi, B. Mennucci, C. Pomelli, C. Adamo, C. Clifford, J. Ochterski, G.A. Petersson, P.Y. Ayala, Q.K. Cui, K. Morokuma, D.K. Malick, A.D. Rabuck, K. Raghavachari, J.B. Foresman, J. Cioslowski, J.V. Ortiz, B.B. Stefanov, G. Liu, A. Liashenko, P. Piskorz, I. Komaromi, R. Gomperts, R.L. Martin, D.J. Fox, T. Keith, M.A. Al-Laham, C.Y. Peng, A. Nanayakkara, C. Gonzalez, M. Challacombe, P.M.W. Gill, B. Johnson, W. Chen, M.W. Wong, J.L. Andres, C. Gonzalez, M. Head-Gordon, E.S. Replogle, and J.A. Pople, GAUSSIAN 98, Revision A.6, Gaussian, Inc., Pittsburgh, 1998.
195. COLLECT, Data Collection Software, Nonius B.V., Delft, 2000.
196. Z. Otwinowski and W. Minor, *Methods in Enzymology*, 1997, 276, 307.
197. G.M. Sheldrick, SHELXS97, Program for Solving Crystal Structures, University of Göttingen, 1997.
198. G.M. Sheldrick, SHELXL97, Program for the Refinement of Crystal Structures, University of Göttingen, 1997.
199. L.J. Barbour, X-SEED, A Graphical Interface to Shelx, University of Missouri, Columbia, 1999.