

A STUDY OF THE NATURE AND
ORIGIN OF THE MINIALBUMINS
TO BE FOUND IN CADMIUM-
POISONED ANIMALS .

Thesis presented for the degree of
Doctor of Philosophy of the
University of Cape Town

by

ELIZABETH MARY SUTHERLAND, B.Sc. (Hons) (Rand)

October, 1967

The copyright of this thesis vests in the author. No quotation from it or information derived from it is to be published without full acknowledgement of the source. The thesis is to be used for private study or non-commercial research purposes only.

Published by the University of Cape Town (UCT) in terms of the non-exclusive license granted to UCT by the author.

A C K N O W L E D G E M E N T S .

The candidate gratefully wishes to express indebtedness to the following persons:-

Professor J.E. Kench without whose invaluable supervision, guidance and continuous encouragement this investigation could not have been carried out.

Dr. G.M. Potgieter and Dr. M.C. Berman for helpful discussion and advice with technical problems.

Professor A. Kipps who kindly made available facilities for our animals in the animal house and for generous help from the Virus Research Unit, of which he is Director.

Dr. A. Polson who performed the ultracentrifugal analyses and molecular weight determinations.

Professor J.H. Low for providing the facilities of the Department of Cardiac Surgical Research, and Dr. M. Barnard who performed the surgical procedures.

Dr. A. Timme of the Department of Pathology for his interest in the histological changes in the tissues of our poisoned animals.

Dr. G. Hardie kindly made the statistical analyses of the data on amino acid composition of the various albumins.

Miss E.F. Hall and Mr. R.A. Carreyett for operation of the Beckman Spinco amino acid analyser.

Mr. A. Kooij and the staff of the animal house for maintenance of the experimental animals.

Mrs. P. de Gouveia for typing the manuscript.

The work was carried out during the tenure of a C.S.I.R. Scientific Assistantship in the C.S.I.R./U.C.T. Protein Research Unit, Department of Chemical Pathology, University of Cape Town, under the directorship of Professor J.E. Kench.

TABLE OF CONTENTS

PART I

INTRODUCTION AND HISTORICAL REVIEW

| | Page |
|--|------|
| I 1. Properties of cadmium and its salts | 1 |
| I 2. Cadmium poisoning in industry | 2 |
| I 3. Tissue injury in cadmium poisoning | 4 |
| I 4. The effect of cadmium on metabolism | 7 |
| I 5. The effect of cadmium on enzymes | 8 |
| I 6. Proteinuria in cadmium poisoning | 10 |
| I 7. Objectives of the present study | 15 |
| I 8. Contributions of this investigation | 15 |

PART II

EXPERIMENTAL AND RESULTS

| | |
|-----------------------------------|----|
| II 1. Experimental animals | 18 |
| (i) Maintenance | 18 |
| (ii) Collection of specimens | 19 |
| (iii) Intoxication of the animals | 21 |

| | Page |
|--|------|
| II 2. General biochemical investigations | 24 |
| (i) On serum | 24 |
| (ii) On urine | 30 |
| II 3. Determination of cadmium | 34 |
| (i) In urine | 36 |
| (ii) On albumin | 37 |
| (iii) In the tissues | 38 |
| II 4. Preparation of albumins | 41 |
| (i) Trichloroacetic acid-ethanol method | 41 |
| (ii) Hydrochloric acid-ethanol method | 42 |
| (iii) Zone electrophoresis on inert cellulose | 43 |
| (iv) Polyethylene glycol method | 45 |
| (v) Purity of the prepared albumins | 47 |
| II 5. Experiments with visking cellophane tubing | 48 |
| II 6. Separation of albumins of differing molecular weight | 51 |
| (i) Use of cross-linked dextran gel (Sephadex) | 51 |
| (ii) Packing of Sephadex columns | 52 |
| (iii) Estimation of molecular weight by gel filtration | 53 |
| II 7. The direct effects of cadmium | 56 |
| (i) On blood | 56 |
| (ii) On serum | 56 |
| (iii) On serum albumin | 57 |
| II 8. The origin of minialbumin | 58 |
| (i) Peritoneal dialysis of monkeys | 58 |
| (ii) The production of serum minialbumin | 62 |
| (iii) Appearance of minialbumin in the urine | 63 |
| (iv) Correlation between urinary cadmium and minialbumin | 64 |

| | Page |
|--|------|
| II 9. Studies to ascertain whether minialbumin was an artefact | 66 |
| (i) The effect of anticoagulant | 66 |
| (ii) Possibility of degradation on Sephadex columns | 67 |
| (iii) Tests for production of minialbumin by proteolysis of normal serum albumin | 69 |
| II 10. Preliminary study of the effect of cadmium on globulins | 71 |
| II 11. Acute cadmium poisoning in rats | 75 |
| (i) Investigation of the serum | 75 |
| (ii) Investigation of albumins in tissues | 76 |
| (iii) Investigation of the urine | 77 |
| (iv) Characterisation of rat minialbumin | 78 |
| II 12. Characterisation of the albumins of cadmium poisoning | 83 |
| (i) Electrophoresis on cellulose acetate | 83 |
| (ii) Aggregation-disaggregation phenomena | 84 |
| (iii) Amino acid analyses | 88 |
| (iv) Analyses for tryptophan | 99 |
| (a) By alkaline hydrolysis | 99 |
| (b) By para dimethyl-amino benzaldehyde colour method | 102 |
| (c) Tests for validity of the analysis | 107 |
| (d) The tryptophan content of albumins | 112 |
| (v) Systematic search for a missing peptide | 114 |
| (vi) Immunological studies | 119 |
| (a) Preparation of antisera | 119 |
| (b) Immuno-electrophoresis | 122 |
| (c) Ouchterlony technique | 125 |
| (vii) Ultracentrifugal studies | 126 |
| (a) Determination of sedimentation coefficients | 128 |
| (b) Determination of diffusion coefficients | |
| (c) Molecular weight determination | 131 |
| (viii) High voltage paper electrophoresis | 132 |
| (ix) Polyacrylamide gel electrophoresis | 135 |
| (x) Starch gel electrophoresis | 139 |
| (xi) Tryptic digestion and peptide mapping. | 142 |

P A R T III

145

DISCUSSION

P A R T IV

173

SUMMARY AND CONCLUSIONS

P A R T V

178

BIBLIOGRAPHY

P A R T VI

198

ADDENDA

PART I

INTRODUCTION AND HISTORICAL
REVIEW

Cadmium, one of the trace metals, has, in the last two to three decades, become increasingly important in both industrial and biological fields.

The recognition of cadmium as a serious health hazard⁽¹⁾ has led to a closer examination of its properties and biochemical effects.

I 1. The Properties of Cadmium

Cadmium, an element of atomic number 48, atomic weight 112.41 and valency 2, is a soft white lustrous metal belonging to the second sub-group of the Periodic Table.

It has a boiling point of 768°C, melting point of 321°C, is remarkably volatile for a heavy metal, and exists naturally as a mixture of eight isotopes, constituting $2 \times 10^{-5}\%$ of the earth's crust. Extraction of cadmium is by distillation from zinc ores.

The electron configuration of cadmium is $4d^{10}5s^2$, and it forms simple bivalent cations only. There are no ligand field stabilization effects in cadmium ions, and the stereochemistry is, therefore, determined solely by size and electrostatic and covalent bonding forces. Cadmium chloride shows octahedral co-ordination.

The metal is used in electroplating, in bearing metals,

in fusible alloys and as a neutron absorber in nuclear reactors.

Cadmium forms numerous isomorphous salts, pure preparations of the sulphate and chloride being readily available commercially. The cadmium halides appear to be weak electrolytes and form complex ions in concentration solutions. The oxy salts are formed on burning and are soluble in water. Cadmium sulphide can be produced by action of hydrogen sulphide on the chloride in aqueous solution, and forms the yellow-red pigments used in the paint industry^(2,3).

I 2. Cadmium Poisoning in Industry

Cadmium was first recognised as a toxic metal in the alkaline battery factories in Sweden (Friberg, 1950)⁽⁴⁾, when workers suffered from ill health and even died from exposure to cadmium oxide dust. Cadmium oxide fume evolved in factories making copper-cadmium alloys and cadmium sulphide in the paint industry are equally potent. Ingestion of cadmium caused symptoms of food-poisoning such as vomiting and diarrhoea⁽⁵⁾.

Bonnell, Kazantzis and King (1959)⁽⁶⁾ observed that the first signs of cadmium poisoning can occur after a long latent period, and that once started, the disease progresses in the absence or presence of cadmium.

Clinically, the symptoms of chronic poisoning from inhalation of cadmium oxide fume were generally manifested as tiredness,

nerviness, shortness of breath, palpitations, coughing, impaired olfactory sense and dyspnoea. Blood pressures were, for the most part, normal and radiological pictures showed nothing unusual^(4,5). Many of the affected men had lung emphysema and examination of the urine showed the presence of proteinuria in 65% of the workers. This proteinuria - not the type usually found in connection with renal disease - can be regarded as a diagnostic feature and will be discussed again in detail.

Examination of the blood showed lowish values for haemoglobin and red corpuscle count, while the erythrocyte sedimentation rate was raised. Minor displacements between the protein fractions, with an increase in the concentration of γ globulins (Olhagen, 1945⁽⁷⁾, Kekwick, 1955⁽⁸⁾), were found on electrophoresis of serum proteins.

Changes in liver function tests occurred occasionally which could account for the raised γ globulin concentrations.

A number of investigators have remarked on evidence of renal damage, both glomerular and tubular, although reports are often conflicting as regards severity of the renal lesions. Inulin clearance was diminished and the concentrating capacity was low⁽⁴⁾. Clarkson and Kench (1956)⁽⁹⁾ showed that the total concentration of amino acids in the urine was raised. There was a remarkable increase in the excretion of serine

and threonine, and it was suggested that a common pathway for the reabsorption of these two amino acids was easily blocked by cadmium. This amino aciduria was generally accompanied by glycosuria and in some cases traces of reducing sugars were found in the urine (Smith, Wells and Kench, 1961)⁽¹⁰⁾. Apparently cadmium ions were removed by glomerular filtration, since excretion of the metal increased proportionally with creatinine clearance (Smith and Kench, 1957)⁽¹¹⁾. This mode of renal clearance would allow the cadmium ions to become attached to the tubular epithelial cells and thereby impair reabsorption of glucose, amino acids and even proteins from the glomerular filtrate.

More recent work by Bonnell (1965)⁽⁵⁾, Holden (1965)⁽¹²⁾ and Potts (1965)⁽¹³⁾ on cadmium-poisoned factory workers is in agreement with all these earlier findings.

I 3. Tissue Injury in Cadmium Poisoning

Histologically, signs of cadmium poisoning are clearly evident. In poisoned workmen in industry, the respiratory tract was perhaps most affected - this generally being the most dangerous route of entry. Usually, widespread emphysema with a fibrous exudate, signs of acute bronchitis and the presence of bullae were characteristic in the lung tissue^(4,5,12,13). Bronchi underwent inflammatory changes with infiltration of

lymphocytes and plasma cells⁽¹⁴⁾.

Also notable was the effect on the kidney, an organ noted for its natural ability to accumulate and store cadmium (Gunn and Gould, 1957⁽¹⁵⁾ and Bonnell, Ross and King, 1960⁽¹⁶⁾). This appeared to be in keeping with the discovery and work on metallothionein by Margoshes and Vallee (1957)⁽¹⁷⁾ and Kagi and Vallee (1961)^(18,19). This protein, which can readily be prepared from kidney tissue, has a molecular weight of 10,000 and contains 5.9% cadmium.

In the kidneys of chronically poisoned men there was an initial blurring of the cortical pattern, followed by dilation and atrophy of the tubules, and finally contractions and crowding of the glomeruli^(4,16). Renal calculi have also been found⁽⁴⁾. However, in some cases, often after death due to emphysema, no signs of kidney necrosis were evident.

Renal damage in rabbits and rats⁽¹⁶⁾ after experimental poisoning apparently followed a similar pattern to that in man (Kench, Wells and Smith, 1962⁽²¹⁾ and Axelsson and Piscator, 1966⁽²²⁾). Definite degenerative changes have been seen in the kidneys of chronically poisoned monkeys (Timme, 1966)⁽²⁰⁾. The cells of the proximal convoluted tubules were often pale, swollen and vacuolated and some showed frank necrosis. Hyaline droplet degeneration was

seen in a few tubules.

Livers of cadmium-poisoned men were congested, with areas of focal necrosis^(14,20,23) with some lipochrome deposition and fatty degeneration⁽²³⁾; one case had a calcifying leiomyoma in the oesophagus wall⁽¹⁴⁾.

There was occasionally hypertrophy and fatty degeneration of the myocardium, diffuse suppurative prostatitis and glandular atrophy of the corpus mucosa⁽²³⁾.

Skeletal changes, osteoporosis and pseudo fractures have also been described as a result of cadmium poisoning⁽²⁴⁾. Friberg, 1950⁽⁴⁾ noted the presence of minor accretions only on the vertebrae. Yellowing of the teeth at the alveolar margin was often noticed^(25,26) in men exposed for longer than two years.

Baum and Worthen (1967)⁽²⁷⁾ have reported the presence of amyloidosis in poisoned rabbits. It occurred only in animals exposed for a long time and was mainly renal, but with infiltration into the spleen and liver. This has never been noticed in men or monkeys and may be due to a species difference.

Experimental poisoning in rats has shown that severe testicular damage with regressive changes of spermatogenic epithelium are caused by cadmium. No morphological lesions

in the ovaries of female rats have been observed⁽²⁸⁾. The metal has even been incriminated as an aetiological factor in human toxæmia of pregnancy, but there is little available evidence to support this suggestion⁽³⁰⁾.

Some workers have tentatively suggested cadmium as a carcinogenic agent because of the high incidence of malignant disease in cadmium workers^(12,13). Kazantzis, Flynn and Spowage and Trott (1963)⁽²⁹⁾ have produced tumours in rats following injections of cadmium compounds.

I 4. The effect of cadmium on metabolism

Cadmium has widespread effects in experimental poisoning.

Lawford (1961)⁽³¹⁾ found that rats suffered rapid and severe anaemia with a rise in serum transferrin. Hypoalbuminaemia, hyperglobulinaemia, and the presence of an extra serum protein component were evident. This could be the result of aberrant biosynthesis of proteins under the influence of cadmium.

Rats fed with cadmium became hypertensive^(32,33,34). This was associated with neurological and vestibular disturbances, bleaching of the incisor teeth, cardiac hypertrophy and considerably shortened life.

The interrelationship between the effect of mercury

and cadmium on aortic vasoconstriction indicate that cadmium is an adrenergic blocker⁽³⁵⁾. Intra-arterial cadmium also had acute pressor effects⁽³⁶⁾.

Gabbiani (1966)⁽³⁷⁾ demonstrated a severe and rapid effect of cadmium on sensory ganglia in rats, hamsters and guinea pigs. It has also been shown that cadmium has an effect on nervous conduction⁽³⁸⁾.

Cattle were adversely affected by dietary intake of cadmium. Growth rate, food consumption, water intake, general appearance and testicle development decreased progressively with intake of cadmium. Removal of cadmium from the diet reversed these effects to some extent⁽³⁹⁾.

Cadmium has also been reported to enhance renal proximal tubular reabsorption of sodium⁽⁴⁰⁾.

I 5. The effect of cadmium on enzymes

Cadmium is known to both stimulate and inhibit various enzyme actions.

Oxidative phosphorylation was uncoupled at extremely low concentrations of cadmium. This effect could be reversed by addition of dithiols (e.g. dimercaptopropional) and ethylene diamine tetra acetic acid, but not by monothiols such as glutathione^(41,42). Succinic dehydrogenase was most sensitive^(43,44),

but other dithiol systems such as α ketoglutarate and lipamide dehydrogenases were also affected. Hexokinase, purified phosphatase and cytochrome oxidase were relatively uninhibited. Cadmium also uncoupled the phosphate esterification associated with the oxidation of citrate. The cadmium was firmly bound to the mitochondria and was thought to act by displacing other cations essential for phosphorylation, or by blocking the active site. The action was thought to be through a disulphide group, probably with the formation of mercaptides. Cadmium in metallothionein⁽¹⁸⁾ is known to be associated with large amounts of sulphur - from cysteine residues - in the protein, and reversal of inhibition by sulphur compounds seems to indicate participation of -SH groups in the reaction.

Na^+ , K^+ -stimulated activity of adenine triphosphatase was inhibited to a fair degree by cadmium and this action is also thought to be through sulphydryl groups⁽⁴⁵⁾.

Several peptidases were affected by cadmium. Prolidase, which hydrolyses peptides containing proline and hydroxyproline, was strongly inhibited⁽⁴⁶⁾ and could be differentiated from prolinase which was activated by cadmium ions⁽⁴⁷⁾. Aminotripeptidase⁽⁴⁸⁾, carnosinase, leucine aminopeptidase, and glycylopeptidase from pig liver were all inhibited by cadmium, whereas Berman and Kench (1967)⁽⁴⁹⁾ have demonstrated slight activation of leucine amino peptidase from rat liver supernatant by cadmium ions.

Cadmium ions had a marked inhibitory effect on the esterase activity in developing bones and teeth⁽⁵⁰⁾ but they stimulated the activity of yeast arginase⁽⁵¹⁾, tryptophan pyrrolase, phosphopyruvate hydratase, pyruvate decarboxylase and oxaloacetic decarboxylase⁽⁵²⁾. Most of these enzymes were also activated by a number of other divalent ions such as Mn^{++} , Zn^{++} , Mg^{++} , Co^{++} , Ca^{++} and Fe^{++} .

It has been suggested that cadmium may be an antimetabolite for zinc because of similar responses⁽⁵³⁾. The enzyme, zinc carboxypeptidase A, exhibited both esterase and peptidase activity. This dual specificity was sensitive to minor alterations in the structure of the enzyme and if the zinc was replaced by either cadmium or mercury, the esterase activity was enhanced while the peptidase activity was lost⁽⁵⁴⁾. Kagi and Vallee (1961)⁽⁵²⁾ have shown competition between zinc and cadmium for binding sites on metallothionein.

However, in spite of the very widespread action of cadmium in living organisms there is apparently no homeostatic control^(55,56).

I 6. Proteinuria in Cadmium Poisoning

The proteinuria of chronic poisoning was unlike that of normal renal tubular disease in that both the distribution of proteins and the overall molecular weight of urinary proteins were different.

When traces of protein were found in the urine of cadmium poisoned men, only α_2 and β globulins could be identified. Later albumin appeared, and the electrophoretic pattern in severe cases was similar to that of serum though α_1 and α_2 globulins were not distinguishable. There were also far greater amounts of globulin than albumin (Smith, Wells and Kench, 1961)⁽¹⁰⁾. On ultracentrifugation, these urinary proteins sedimented as a single component of molecular weight 20,000 to 30,000 (Kekwick, 1955)⁽⁸⁾ and Pedersen - findings published in Friberg's monograph⁽⁴⁾). These facts seemed to indicate that the proteinuria of cadmium poisoning was a specific lesion.

Other workers have maintained that the proteinuria was no different from that occurring in any renal tubular dysfunction and suggested that the damage caused by cadmium was mainly tubular (Creeth, Kekwick, Flynn, Harris and Robson, 1963)⁽⁵⁷⁾). Undoubtedly renal tubular damage does occur in chronic cadmium poisoning. This is evident from the amino aciduria and glycosuria demonstrated by Clarkson and Kench (1956)⁽⁹⁾ as well as from renal function tests carried out on poisoned men by Friberg⁽⁴⁾ and renal lesion described by Bonnell, Ross and King (1960)⁽¹⁶⁾ and Axelsson and Piscator (1966)⁽²²⁾.

That the proteinuria resulted from a direct action of

cadmium on the kidney tubules is unlikely as histologically the renal lesions did not appear severe enough^(20,21).

There was also no evidence of catalasuria or alkaline phosphaturia - the most sensitive signs of severe renal damage (Dounce, Roberts and Wills, 1949)⁽⁵⁸⁾. In addition to this the excretion of cadmium was glomerular⁽¹¹⁾ and the proteinuria may well have arisen from changes in this part of the kidney.

Both Rowe (1957)⁽⁵⁹⁾ and Smith et al (1961)⁽¹⁰⁾ have found the albumin excreted by nephrotic and nephritic patients to have a sedimentation constant similar to normal serum albumin (i.e. ± 4.04) as opposed to the sedimentation value of 2.2 - 2.8 described by Creeth et al (1963)⁽⁵⁷⁾ for the proteins excreted during tubular malfunction.

Smith and Wells (1960)⁽⁶⁰⁾ have described proteinuria in three workmen suffering from metallic mercury poisoning - an unusual occurrence - in which the excreted albumin was indistinguishable from serum albumin.

The albumin excreted by normal persons has been shown by Webb, Rose and Sehon (1958a)⁽⁶¹⁾ to be indistinguishable from normal serum albumin while Merler, Remington, Finland and Gitlin (1962)⁽⁶²⁾ have evidence for the presence of albumin with a sedimentation constant of 2.6 ± 0.2 which is equivalent

to a molecular weight of about 30,000. However, this was only excreted in very small quantities.

An investigation of the proteinuria displayed by workers was carried out by Smith, Kench and Lane (1955)⁽⁶³⁾ and verified and extended Friberg's⁽⁴⁾ findings. They demonstrated that the incidence of proteinuria in cadmium workers was much higher than in any other group, and that the excreted protein varied independently of urinary cadmium. 1.0 to 3.2 g./l. of protein was excreted daily by the poisoned men while normal adults excrete an average of 133 mg./day (Webb et al, 1958b⁽⁶⁴⁾).

Proteinuria, as a result of cadmium poisoning, was not unique to men. Rabbits and dogs exhibited a similar pattern. (Kench, Wells and Smith, 1962⁽²¹⁾). However, unlike the men, albumin of normal size ($S_{20}^w = 4.07$) was excreted together with the low molecular weight fraction ($S_{20}^w = 1.99$). Studies on the total urinary albumins showed similar amino acid composition and antigenic behaviour to normal serum albumin while radioactive isotope studies indicated a more rapid metabolism for the low molecular weight urinary albumin than for normal serum proteins.

The advent of dextran gel filtration methods facilitated the separation of the normal and low molecular albumins. Once separated this low molecular albumin, termed minialbumin because of its similarity to normal albumin, could be further

characterized. It was isolated from the urine of monkeys, dogs and rabbits experimentally poisoned with cadmium (Gain and Kench, 1965⁽⁶⁵⁾ and Gain, 1966⁽⁶⁶⁾) and found to behave like a normal serum albumin with respect to electrophoretic mobility (on paper and etholanized cellulose columns) and titration curves. The amino acid composition of the minialbumin had a deficit in its content of lysine and cysteine but was otherwise very similar to normal serum albumin. Antigenically this urinary low molecular albumin, found by ultracentrifugal studies to be 20,000 in molecular weight, was identical with serum albumin. Incorporation of radioactive amino acids indicated that minialbumin had a higher metabolic turnover than its normal serum counterpart, and that injected minialbumin was rapidly removed from the circulation by excretion through the kidneys. Infusions of haemoglobin increased the excretion of minialbumin in a poisoned monkey, but the reasons for this are not yet clear.

The origin of this low molecular albumin was apparently not renal in nature as intravenous injections of cadmium chloride increased the amount of minialbumin recovered from the peritoneal dialysates of a nephrectomized monkey. It was, therefore, suggested that the minialbumin, because of its rapid synthesis and excretion, was produced in the liver and its urinary clearance enhanced by secondary renal tubular damage (Gain and Kench, 1965⁽⁶⁵⁾ and Gain, 1966⁽⁶⁶⁾).

I 7. Objectives of the present study

The present study was undertaken in order, if possible, to ascertain the nature and origin of this minialbumin which occurs in cadmium poisoning. The source of the minialbumin and the mechanism by which it arises are important to an understanding of the proteinuria of cadmium poisoning, but in addition we hoped might provide information on the metabolism of serum albumin in normal animals. The quantities of low molecular weight albumin to be found in both the serum and urine of monkeys after the initial and each successive dose of cadmium should provide some indication as to the tissues of origin of the protein. Should low molecular albumin be found circulating it would be necessary to establish whether this was in fact similar to the urinary minialbumin. To this end, we embarked upon studies involving electrophoretic mobility, exact amino acid composition, molecular weight and antigenic behaviour of all the albumins that could be isolated from cadmium-poisoned monkeys.

I 8. Contributions of this investigation

As a result of this investigation the following facts have been established:

- (i) Cadmium-poisoned monkeys produced a circulating minialbumin, which occurred in a variety of

molecular size ranging from 5,000 to aggregates of 170,000.

- (ii) Circulating minialbumin was identical with urinary minialbumin in amino acid composition, molecular weight, electrophoretic and antigenic behaviour.
- (iii) Timing studies indicated that the minialbumin did not arise by direct action of cadmium on the kidney, and was probably excreted only after renal tubular damage had occurred.
- (iv) The phenomenon of a partially reversible aggregation and disaggregation of the low molecular albumins at neutral pH values, by non-covalent and sulphydryl bonding has been established. Polymerization of albumins is known to occur at low pH but has not hitherto been reported in normal pH ranges. A higher proportion of aggregated albumin was found in the serum than in the urine, and made a substantial contribution to serum albumin of normal molecular weight in cadmium-poisoned animals.
- (v) Minialbumin was a complete antigen even though it lacked tryptophan and some lysine and cysteine,

i.e. the antigenic sites in normal albumin have been retained intact in the smaller molecule.

- (vi) On the available evidence, the most rational explanation of the action of cadmium appears to be that it suspends proteolysis during the catabolism of albumin by inhibiting further breakdown of the fragments. Cadmium is known to inhibit the activity of endopeptidase and carboxypeptidase as well as some of the di and tripeptidases. Such an action would result in a mixture of polypeptides, which apparently have a marked propensity to aggregate together. It is suggested that a similar process could lead to microheterogeneity in the albumin molecule, around a structure based on a single genetic code.

Some of the investigations described here have been published: the reprints form the addendum to the thesis.

PART II

EXPERIMENTAL AND RESULTS

II 1. EXPERIMENTAL ANIMALS

II 1. (i) Experimental animals and their maintenance

(a) Monkeys: The species of monkey studied was *Cercopithecus aethiops* (Fig. 1A). Animals were captured in their wild state and allowed to settle down for 2 to 3 months in their new environment before being poisoned. Only healthy young males showing stationary weight and presumably, therefore, in nitrogen balance were employed for the investigation.

The experimental animals were kept singly in metabolic cages, of measurement 20" x 24" x 20", made of galvanized iron rods. The cages were fitted with an internal sliding door to facilitate handling, so that the monkey could be held still at one end. The side wall of the cage at this end had apertures through which the tail and hind limb could be extended (Fig. 1B). The cages were raised and stood in stainless steel trays.

The animals were fed between 12 and 3 p.m. daily, with a mixed diet consisting of carrots, pumpkin, sweet potatoes, cabbage, oranges and dried maize and nuts. The monkeys were not given extra water, the fruit in the diet providing sufficient fluid for their needs (Gain, 1966⁽⁶⁶⁾).

(b) Rabbits: Rabbits were used for the production of antiserum. They were a ~~from~~ a locally bred (mixed) variety. Male animals weighing three to four kg. were selected and maintained

FIG. 1

A. EXPERIMENTAL MONKEY.



B. MONKEY AS FOR INJECTION.



in metabolic cages of dimensions 20" x 16" x 16". They were fed daily between 12 p.m. and 3 p.m. on cabbage, carrots and rabbit biscuits containing a mixed enriched protein concentrate. Fresh drinking water was provided daily.

(c) Rats. These animals were used only in short-term experiments and were a locally bred albino variety. They were housed in metabolic cages measuring 12" x 10" x 8". Rat biscuits, consisting of a mixed protein concentrate, and fresh drinking water, renewed twice daily, was the only nourishment provided. The animals were not starved prior to the experiments.

II 1. (ii) Collection of specimens

(a) Blood

- (i) Monkeys - Blood was withdrawn into a syringe, in the absence of anti-coagulant, from the saphenous vein of the lower hind limb.
- (ii) Rabbits were bled from the marginal ear vein by nicking it and allowing the blood to drip into a container.
- (iii) Rats - As it was very difficult to

obtain a large enough sample by puncture of the caudal veins (the recognised method), rats were killed by stunning and blood taken immediately from the aorta and hepatic portal vein.

All blood samples were allowed to clot at room temperature before separation of the serum by centrifugation.

(b) Urine

- (i) Monkeys - Urine was collected in the stainless steel trays in which the cages stood, and kept free from stools and food debris by a $\frac{1}{2}$ " wire mesh and muslin covering which formed a floor to the cage.
- (ii) Rats were supported on perforated porcelain discs inside glass containers for the duration of the experiments. In this way urine could easily be collected.

All urines were filtered through Whatman No. 1 filter paper in the presence of kieselguhr, and then dialysed for 36 - 48 hrs. against running tap water, and then for 12 - 16 hrs. against

distilled water, before proteins contained therein were precipitated.

II 1. (iii) Intoxication of the animals

(a) Monkeys: Cadmium, as the chloride ($\text{Cd} \cdot \text{Cl}_2 \cdot 2\frac{1}{2} \text{H}_2\text{O}$) was administered intravenously in dosages of not more than 2.0 mg. cadmium per kilogram body weight per week⁽²¹⁾. As the animals weighed on the average 6 - 7 kg., this was normally given as two pulse doses of 6 mg. cadmium twice weekly. The solution could not be injected directly as its low pH (4 to 5) caused haemolysis, thrombosis and tissue necrosis. The procedure was as follows. Six ml. of blood was withdrawn from the saphenous vein of the lower hind limb into an heparinized all-glass Leurlock syringe. The needle, type 21G and 1-1 $\frac{1}{2}$ " , was left in the vein and a two-way Leur stopcock attached, while the blood was mixed immediately with approximately 0.5 ml. heparin (5000 I.U./ml.) in a small beaker. Three ml. of a cadmium chloride solution containing 2 mg. cadmium per ml., and a calculated amount of sodium chloride to make the chloride level physiological, was added dropwise to this with continuous mixing to prevent precipitation of the blood proteins. The mixture was then drawn up into the syringe which was fitted to the tap, and the cadmium slowly injected over a period of 1 to 2 min. Bleeding was stopped by application of Hibitane antiseptic cream (ICI) and adhesive plaster. If the

animals did not themselves remove the bandages, they were taken off the following day. Hind limbs were used alternatively.

All the instruments and solutions required for this procedure were autoclaved before use at a pressure of 15 lb./sq. inch for 15 min. A fresh solution of cadmium was prepared every 4 weeks.

Overdosage led to nausea and lethargy in the monkeys. It was found that animals were far more tolerant to cadmium in the early stages of poisoning. Severely poisoned animals showed agglutination and darkening of the blood, and in such cases dosages very often had to be reduced to two thirds or half the usual amount.

As the poisoning progressed, the animals tended to become very aggressive. Loss of pigment on the face was also noted in chronically poisoned animals.

(b) Rats: Owing to the difficulty of withdrawing and re-injecting blood from the caudal veins of the rat, cadmium was administered intraperitoneally rather than intravenously.

Dosages of 1 mg. cadmium per kilogram body weight, as advocated and used by Lawford (1961)⁽³¹⁾ were tried, but found to be rather too small for acute poisoning experiments. It was found by trial that the dosage could be increased up to 15 mg. cadmium per kilogram body weight without killing the animals.

However, the rats were very lethargic after such doses.

The cadmium was administered as a 1%(w/v) solution of cadmium chloride ($\text{Cd} \cdot \text{Cl}_2 \cdot 2\frac{1}{2} \text{H}_2\text{O}$) in 0.85%(w/v) sodium chloride.

The rats were lightly anaesthetized with ether and the cadmium given intraperitoneally over one to two min., using a disposable syringe and 21G needle. Control animals were given an equivalent volume of physiological saline in the same way.

II 2. GENERAL BIOCHEMICAL INVESTIGATIONS

Blood and urine samples were collected from normal and experimental monkeys at regular intervals for routine analysis. This provided a check on the metabolic state of the animals and could be an index to the onset of any metabolic disturbances occurring in the poisoned animals.

As rabbits were used for antiserum production only, and experiments on rats were short-term, routine investigation on these animals was deemed unnecessary.

II 2. (i) General investigations on sera included the following and the results are summarized in Table 1.

- (a) The albumin-globulin ratio: This was measured by the biuret method on the total protein and the albumin fraction following precipitation with sodium sulphite according to the method of Wolfson, Cohn, Calvary and Ichiba (1948)⁽⁶⁷⁾. There was a tendency for the concentrations of albumin and globulin to decrease on prolonged poisoning (Table 1).
- (b) Na⁺ and K⁺: These were measured by the methods of Spencer (1950)⁽⁶⁸⁾ and Brealey and Ross (1951)⁽⁶⁹⁾ using a Baird flame photometer (Atomic Model KY-1).

TABLE 1.

General biochemical investigations on serum
of normal and of cadmium-poisoned monkeys

| Test | Units | Normal monkey | Poisoned monkey (a) | Poisoned monkey (b) |
|----------------------|--------------|---------------|---------------------|---------------------|
| Albumin | g./100 g. | 3.9 | 3.9 | 3.7 |
| Globulin | g./100 g. | 2.7 | 3.0 | 2.4 |
| Na ⁺ | meq./l. | 146 | 153 | 160 |
| K ⁺ | meq./l. | 4.8 | 5.2 | 5.9 |
| Cl ⁻ | meq./l. | 96 | 107 | 110 |
| Urea | mg./100 ml. | 10 | 20 | 33 |
| Total Bilirubin | mg./100 ml. | < 0.5 | < 0.5 | < 0.5 |
| Conjugated Bilirubin | mg./100 ml. | 0.0 | 0.0 | 0.0 |
| S.G.O.T. | Karmen units | 30 | 28 | 83 |
| Cholesterol | mg./100 ml. | 120 | 112 | 115 |
| Alkaline phosphatase | units | 5 | 6 | 5 |
| Amylase | units | 510 | 230 | 158 |
| Thymol turbidity | units | 0 | 1 | 0 |
| Zinc turbidity | units | 3 | 4 | 2 |
| Glucose | mg./100 ml. | 109 | 92 | 89 |

(a) Mean of determinations on three monkeys in early stages of poisoning.

(b) Mean of determinations on three monkeys chronically poisoned with cadmium.

- (c) Cl⁻: Glasstone's (1955)⁽⁷⁰⁾ method was employed and adapted to measure the fall in electrical conductivity of the solution containing the chloride ions on addition of silver nitrate.
- (d) Urea: determined colorimetrically with diacetyl monoxime reagent in a Technicon auto-analyser according to the method of Skeggs (1957)⁽⁷¹⁾ modified by Marsh, Fingerhut and Kirsch (1957)⁽⁷²⁾.
- (e) Bilirubin: The methods of Michaelsson (1961)⁽⁷³⁾ and Nosslin (1960)⁽⁷⁴⁾ were used, and the bilirubin determined as total and conjugated.
- (f) Serum glutamic oxaloacetic transaminase (S.G.O.T.): This was determined spectrophotometrically by following the decrease in optical density - a result of the oxidation of reduced nicotinamide adenine dinucleotide - according to the procedure described by Karmen (1955)⁽⁷⁵⁾ and Henry et al (1960)⁽⁷⁶⁾.
- (g) Cholesterol: colour development with the Liebermann-Buchard reaction, according to the method of Pearson, Stern and McGarack (1953)⁽⁷⁷⁾, was used.
- (h) Alkaline phosphatase: The method, measurement of the enzyme action on the substrate phenyldisodium orthophosphate, was adopted for use on the auto-analyser by Marsh (1959)⁽⁷⁸⁾ from a modification of the King-Armstrong procedure⁽⁷⁹⁾.

- (i) Amylase: The activity was determined as a function of the colour intensity of the starch-iodine complex formed by residual substrate after the action of the enzyme. The procedure was as described by Pimstone (1964)⁽⁸⁰⁾.

Amylase activity in the serum and urine of a monkey was determined during a course of injections of cadmium. The results in Table 1A show a significant rise in serum amylase activity after administration of 12 - 18 mg. cadmium over a period of 18 days. Levels in the urine increased concurrently.

TABLE 1A.

Amylase activity in the serum and urine of a newly poisoned monkey T

| Amount Cd given | Days after injection | Amylase activity (modified Somogyi units) | |
|-----------------|----------------------|---|-------|
| | | Serum | Urine |
| 6 mg. | 0 | 370 | - |
| | 1 | 400 | 69 |
| | 4 | 310 | - |
| 3 mg. | 0 | 320 | - |
| | 1 | 400 | - |
| | 2 | 460 | 90 |
| 3 mg. | 1 | 460 | - |
| | 2 | 572 | 720 |
| 6 mg. | 1 | 870 | 620 |

- (j) Thymol turbidity: According to Maclagan's (1944)⁽⁸¹⁾ method.
- (k) Zinc turbidity: By the method of Kunkel (1947)⁽⁸²⁾.
- (l) Glucose: This was determined on whole blood by a modification of the Hoffman (1937)⁽⁸³⁾ procedure, using a Technicon auto-analyser.
- (m) Electrophoresis^(84,85): This was performed with a Beckman Model LB analytrol with a microzone electrophoresis cell and membranes⁽⁸⁶⁾. Cellulose acetate was used as the supporting medium, and the method was standardized as regards potential gradient, buffer flow, sample size, humidity, buffer level and duration of separation.

The microzone cell consisted of a vessel divided into two buffer compartments by a bridge onto which the supporting membrane was fitted. The ends of the membrane extended freely into the buffer solution. A cell cover was applied directly over the suspended membrane.

The membrane was a homogeneous, inert, cellulose acetate material, 130 microns thick and with a uniform pore size of less than 2 microns in diameter. Membranes were impregnated with buffer

before the samples were spotted with an applicator which was standardized to give repeatable deliveries.

The electrodes contained a pH 8.6 barbital buffer of ionic strength 0.075 and the run was continued at 250 V for 20 min. The membrane was then immersed in the fixative-dye (containing 0.2% (w/v) Ponceau-S, 3.0% (w/v) TCA and 3.0% (w/v) salicylsulphonic acid) for 7 - 10 min. It was then rinsed in 5% (v/v) acetic acid and cleared in an acetic acid-alcohol mixture before drying.

The membranes, in a protective envelope, were then passed through a scanning attachment at 520 m μ , and the patterns quantitatively assessed in terms of colour intensity, using saw tooth counts under the protein peaks as an index.

Sera from normal and poisoned monkeys were electrophoresed under these conditions and compared. As can be seen from the typical patterns in Fig. 2, and the values in Table 2, there was a decrease in the amount of albumin and of γ globulins while the other fractions remain unchanged.

FIG. 2

SCANS OF ELECTROPHORESIS
PATTERNS.

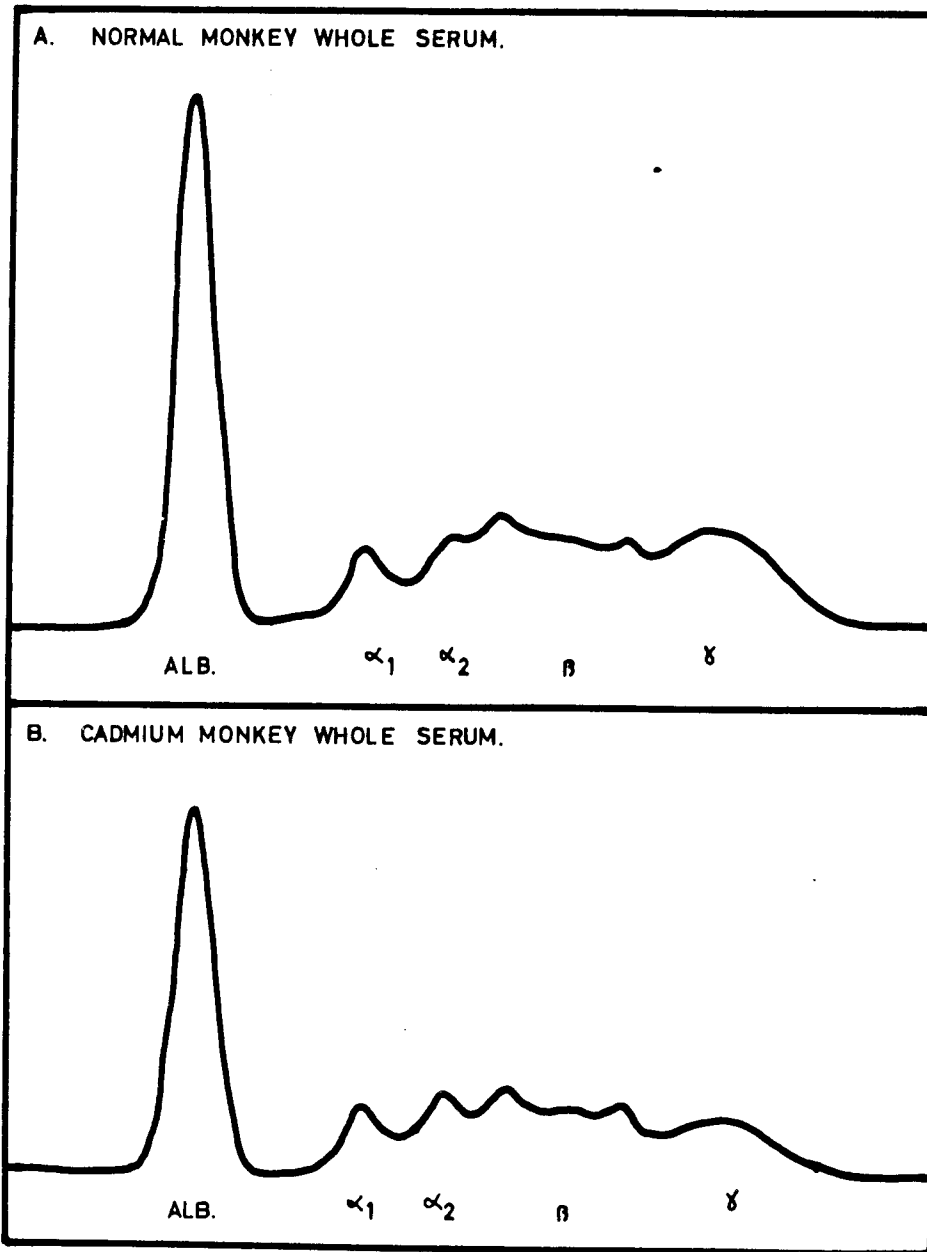

TABLE 2.

Concentration of serum protein constituents
in normal and poisoned monkeys.

| Fraction | g. per 100 ml. | |
|---------------------|----------------|----------|
| | Normal | Poisoned |
| Total protein | 8.2 | 7.4 |
| Albumin | 3.0 | 2.9 |
| Globulin α_1 | 0.7 | 0.5 |
| α_2 | 0.6 | 0.7 |
| β | 2.0 | 2.0 |
| γ | 1.9 | 1.3 |

II 2. (ii) Urinary investigations

Specimens of urine were filtered till clear before carrying out investigations on them, especial care being taken in this precautionary measure in the case of the tests for proteinuria. Results are presented in Table 3, for the following constituents.

(a) Proteinuria: This was checked daily by three

different methods viz. heat coagulation, treatment with an equal volume of 10% (w/v) trichloroacetic acid; and treatment with an equal volume of 0.2% (w/v) salicyl sulphonic acid. Opalescence and precipitation were indicative of the presence of protein.

- (b) Total Protein: Once the animals became proteinuric, the total protein excreted daily was determined by the Fines method⁽⁸⁷⁾, which involves a biuret reaction on the TCA-precipitated proteins.
- (c) Ketonuria: Acetone and acetoacetic acid were detected by Rothera's (1908)⁽⁸⁸⁾ test, when if present they give a purple colour in the presence of ammonium sulphate, sodium nitroprusside and ammonium hydroxide. Acetoacetic acid was further tested for by Gerhardt's reagent⁽⁸⁹⁾, which is a less sensitive procedure than Rothera's test and becomes positive (violet coloured product) only with severer grades of ketonuria.
- (d) Urea: Is measured in terms of nitrogen which is liberated on addition of hypobromide and sodium hydroxide to the urine.

- (e) Titratable acidity: Measured on freshly collected urine by the method of Henderson and Palmer (1914)⁽⁹⁰⁾ using neutral red as an indicator.

- (f) Glucose: tested for qualitatively by glucose oxidase (testape)^(91,92) and quantitatively with Benedict's reagent⁽⁹³⁾.

- (g) Bilirubin: Fouchet's reagent⁽⁹⁴⁾ gives a blue-green colour (biliverdin) on oxidation of bilirubin, adsorbed to the precipitate of barium sulphate and phosphate formed on addition of barium chloride solution to the urine.

- (h) Urobilin: Detected by the method of Decomps⁽⁹⁵⁾ as a green fluorescent zinc complex on addition of saturated alcoholic zinc acetate (Schlesinger's reagent).

- (i) Specific Gravity: Determined by weighing an appropriate volume of urine and comparing its weight with that of an equal volume of water.

- (j) Na⁺ and K⁺: Measured on the Baird flame photometer employing lithium as the internal standard^(68,69).

- (k) Cl⁻: Measured as for serum.

TABLE 3.

General biochemical investigations on urine of
normal monkeys and on monkeys poisoned by cadmium

| Test | Units | Normal monkey | Poisoned monkey (a) | Poisoned monkey (b) |
|------------------------------|------------|------------------|------------------------|------------------------|
| Proteinuria: | | | | |
| heat coagulation | + or - | - | - | + |
| TCA | + or - | - | - | +++ |
| salicyl sulphonic acid. | + or - | - | - | +++ |
| Total Protein | g./100 ml. | 0.003 | 0.004 | 0.063 |
| Ketonuria: | | | | |
| Rothera's test | + or - | - | - | - |
| Gerhardt's test | + or - | - | - | - |
| Urinary urea | mg./24 hr. | 1010 | 1372 | 1460 |
| Titrateable acidity | meq. NaOH | 0.0 | 0.0 | 0.0 |
| Glucose: | | | | |
| glucose oxidase (testape) | + or - | - | - | - |
| Benedicts | g./100 ml. | <0.1 | <0.1 | <0.1 |
| Bilirubin | + or - | - | - | - |
| Urobilin | + or - | - | - | - |
| Specific gravity | | 1.016 | 1.027 | 1.031 |
| Na ⁺ | meq./l. | 22 | 24 | 20 |
| K ⁺ | meq./l. | 106 | 115 | 94 |
| Cl ⁻ | meq./l. | 27 | 52 | 49 |

- (a) Mean of determinations on three monkeys in the early stages of poisoning.
- (b) Mean of determinations on three monkeys chronically poisoned with cadmium.

II 3. DETERMINATION OF CADMIUM

It seemed important to establish the quantity of cadmium excreted by poisoned animals, how much was attached to the albumins and the amount present in the tissues.

The method employed for cadmium determination was that of Smith, Kench and Lane (1955)⁽⁶³⁾. It was essentially designed for urinary estimations but was adapted for use with tissues⁽⁹⁶⁾.

Fifty ml. of urine was transferred quantitatively to 100 ml. Pyrex erlenmeyer flask, and evaporated gently to dryness on a sand bath. After cooling 5 ml. of concentrated nitric acid was added and the flask warmed until no more brown fumes were given off. Five ml. of concentrated sulphuric acid were then added and the flask heated strongly until the nitric acid had evaporated. The cooled digest was treated with 0.5 ml. hydrogen peroxide (100 vols.) and gently warmed. This was repeated until the digest remained clear after strong heating. The digest was then cooled to room temperature, diluted to 10 ml. with distilled water and treated with 1 g. of sodium citrate (to prevent precipitation of calcium phosphate) before being rendered alkaline by addition of concentrated ammonia (S.G. 0.88). The cooled neutralized digest was then quantitatively transferred with the aid of two five-ml. portions of 1.0% (v/v) nitric acid to a separating funnel, and

5 ml. of a 1.5% (w/v) ammonia solution, 10 ml. chloroform and 10 drops ammoniacal dithizone (prepared by dissolving \pm 0.1 g. diphenylthiocarbazon in 10 ml. chloroform, extracting with 20 ml. of 1.5% (w/v) ammonia solution and discarding the chloroform layer) were added. After shaking well, more dithizone was added until the chloroform layer was dark blue. This coloured extract was run into a second funnel containing 25 ml. of 1% (v/v) nitric acid. Further similar extractions were made. The pooled chloroform extracts were then shaken with the acid and the chloroform layer discarded. Five ml. of chloroform was then gently run through (without shaking) to remove traces of dithizonate.* Next the aqueous layer was made alkaline by the addition of 5 ml. 40% (w/v) sodium hydroxide, 0.05% (w/v) potassium cyanide and 2 ml. of 25% (w/v) sodium-potassium-tartrate, and 10 ml. chloroform and 5 drops of the dithizone added. After continuous shaking for one min., the phases were allowed to settle. If the aqueous layer was colourless or pale yellow, more dithizone was added. The chloroform layer was run off into a third funnel containing 25 ml. of 1% (v/v) nitric acid. Three to 4 more 10 ml. portions of chloroform were used to

* This operation was performed out of bright sunlight, since in the light there is a great danger from oxidation of chloroform by nitric acid with formation of toxic quantities of phosgene(97).

extract the contents of the second funnel. The third funnel was shaken gently and the chloroform layer discarded. Traces of dithizone were again removed by running through 5 ml. of chloroform. Five ml. of 40% (w/v) sodium hydroxide - 1%(w/v) potassium cyanide, 5 ml. of chloroform and 3 drops of dithizone were added and the funnel well-shaken for 1 min. The pink chloroform layer containing the cadmium was run into a calibrated tube and the extraction repeated with a further 5 ml. of chloroform. The volume in the tube was brought to 10 ml. and the tube stoppered and allowed to stand (the cadmium complex is photostable) before measurement at 506 m μ - the point of maximum absorption.

Standard curves were drawn from determinations on standard amounts of cadmium ranging from 0 - 100 μ g of cadmium. Such a curve is shown in Fig. 3. The concentration of cadmium in the urine and tissues was then estimated by reference to these standard graphs.

II 3. (i) Excretion of cadmium

The urinary determinations were carried out exactly as described above. However, as severely poisoned animals excreted large amounts of cadmium, it was possible to obtain easily determinable values from 20 ml. of urine,

FIG. 3

CADMIUM DETERMINATION.
STANDARD GRAPH.

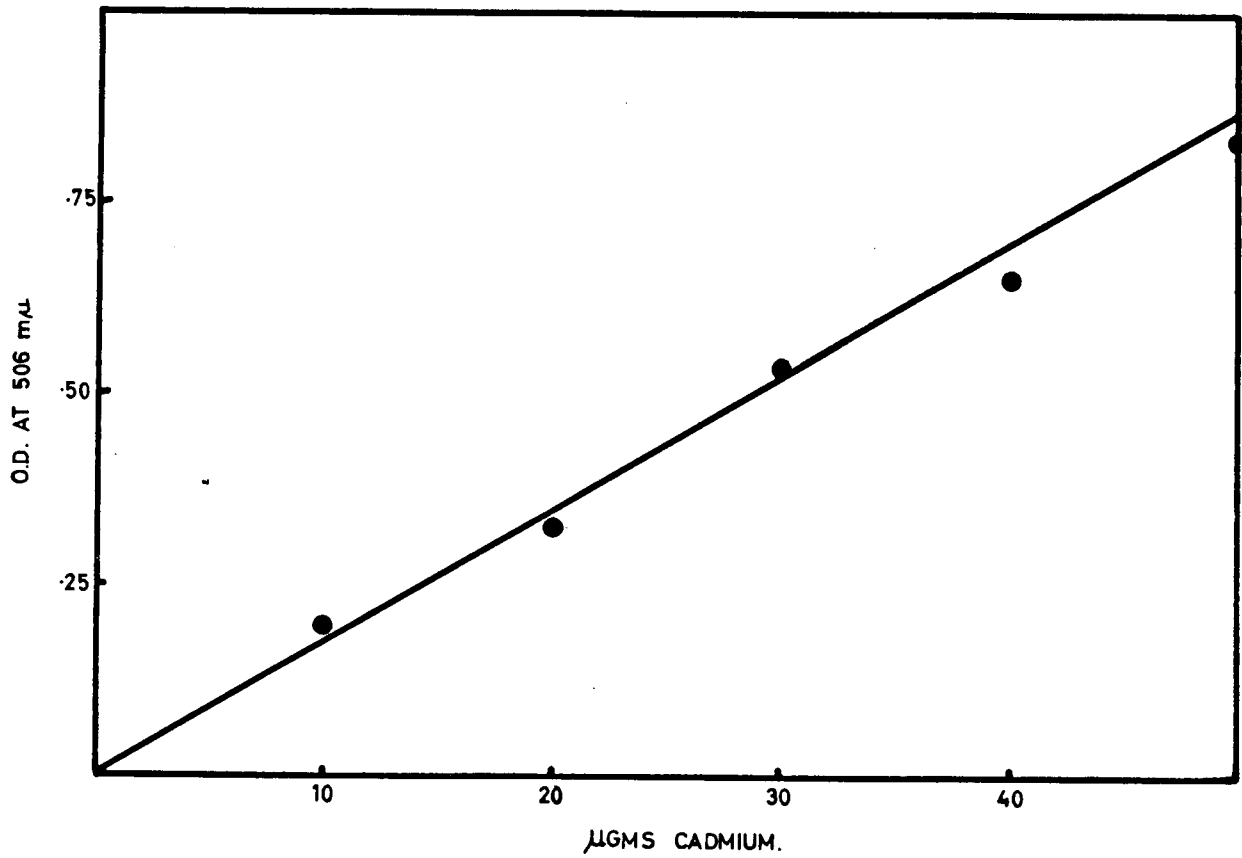

and this procedure was therefore adopted. Table 4 shows the amounts of cadmium excreted daily by chronically poisoned animals. There is a wide variation dependent on the degree of poisoning of the animal and the time lapse between injection of the cadmium and collection of the specimen.

TABLE 4.

Excretion of cadmium by poisoned monkeys

| Monkey | $\mu\text{g Cd}^*$ excreted daily |
|--------|-----------------------------------|
| M | 50, 62, 117, 94, 108 |
| P | 40, 45, 65, 72, 40 |
| L | 135, 297, 180, 88, 211 |

* The values are a mean of duplicate determinations on the same sample.

II 3. (ii) Attachment of cadmium to serum albumin

The amount of cadmium attached to the serum albumin of chronically poisoned animals was determined by dissolving a known weight of the protein in distilled water and thereafter treating it in the same fashion as for the urines. Samples of albumin from a normal monkey were treated simultaneously. Table 5 shows the results.

TABLE 5.

Determination of the amount of cadmium attached to serum albumin of normal and cadmium-poisoned monkeys

| Sample of 25 mg. | * $\mu\text{g.}$ Cadmium |
|-----------------------------------|--------------------------|
| Serum albumin of normal monkey. | 2.12 |
| Serum albumin of poisoned monkey. | 6.37 |

* Values are a mean of three determinations. There is, therefore, a nett difference of 4.25 $\mu\text{g.}$ of cadmium per 25 mg. of protein.

For practical purposes the amount of cadmium attached to the protein was taken to be 0.2 $\mu\text{g.}$ per mg.

II 3. (iii) Distribution of cadmium in the tissues.

Cadmium in the tissues was expressed in terms of wet weight. Varying amounts of tissue were processed, depending on the size of the organ. The tissue, after weighing, was cut into minute pieces and quantitatively transferred to a digestion flask with distilled water. On complete evaporation of the water, the tissues were digested in nitric

and sulphuric acid in the usual way. Thereafter, the determination was exactly as described for urine.

Table 6 shows the values obtained for the monkey and those found in man⁽⁹⁶⁾ and rabbits⁽²¹⁾. The data show a similar pattern in all cases; in the cadmium worker and in rabbits, however, there was a greater divergence between the concentrations of cadmium present in the liver and kidneys (richest sources of cadmium) and in the remaining tissues than was observed in a chronically-poisoned monkey.

TABLE 6.

Distribution of cadmium in tissues

| Tissue | µg. cadmium/g. of tissue (wet weight) | | | |
|--------------------------------|---------------------------------------|------------------------|------------------------|----------|
| | Worker ⁽⁹⁶⁾ | Normal ⁽⁹⁶⁾ | Rabbit ⁽²¹⁾ | Monkey * |
| Adrenals | 24 | 0.42 | 4.4 | - |
| Artery (aorta) | - | - | 1.9 | 29.3 |
| Brain | 3.5 | 0.12 | 0.2 | 8.2 |
| Bone marrow | 4.1 | 0.31 | - | - |
| Colon | 20.0 | 0.29 | 2.4 | 10.6 |
| Epididymus and vas deferens | 54.0 | 0.63 | 1.0 | 10.9 |
| Gall-bladder | 21.0 | 0.62 | 21.7 | 29.2 |
| Bile | 24.0 | - | - | - |
| Heart | 11.0 | - | 4.7 | 12.4 |
| Kidney cortex | 150.0 | 14.0 | - | 38.0 |
| Kidney medulla | 130.0 | 12.5 | 30.3 | 20.0 |
| Liver | 160.0 | 2.0 | 84.0 | 38.7 |
| Lung | 13.0 | 0.62 | 7.6 | 16.2 |
| Mesenteric fat | 11.5 | - | - | 13.2 |
| Skeletal muscle | 7.1 | 0.09 | 0.07 | 18.6 |
| Pancreas | 84.0 | - | 9.0 | 24.0 |
| Prostate | 37.0 | 0.17 | - | - |
| Skin | 4.0 | 0.16 | - | 3.8 |
| Spleen | 55.0 | 0.35 | 3.2 | 12.5 |
| Stomach | 32.0 | 0.30 | 4.7 | 15.0 |
| Testis | 38.0 | 0.16 | 1.5 | 2.8 |
| Tongue | 11.0 | 0.21 | - | 22.2 |
| Urinary bladder | 30.0 | 0.31 | 6.7 | 22.0 |
| Vena cava | - | 1.2 | - | 29.0 |

* Present investigation.

II 4. PREPARATION OF ALBUMINS

Several methods were tried and compared to ensure that the prepared proteins were not artefacts of the experimental procedure.

II 4. (i) The trichloroacetic acid method of Vallance-Owen, Dennes and Campbell (1958)⁽⁹⁸⁾

This was a modified form of the procedure set out by Debro, Tarner and Korner (1957)⁽⁹⁹⁾ and involved initial precipitation of the total protein in the specimen with an equal volume of 10% (w/v) aqueous trichloroacetic acid (TCA). The precipitate was then washed twice with 5% (w/v) aqueous TCA and the supernatants discarded in each case. A 96% (v/v) ethanol : 1% (w/v) TCA solution (3 times the volume of the original sample) was used to dissolve the albumin⁽¹⁰⁰⁾. The denatured globulins were easily removed by centrifugation. The supernatant was subsequently dialysed against several changes of distilled water until completely free of ethanol and then lyophilized. On prolonged dialysis a precipitate, which formed initially, redissolved. The whole procedure was carried out in the cold. On the average recoveries of 55-65% were obtained.

It was found that replacement of the ethanol with acetone gave better preparations in many instances, especially

where lipaemic sera were involved. As the pH of the TCA-ethanol or TCA-acetone mixture was extremely low (\pm 2.0 - 3.5) and in the range where albumin molecules are known to dimerize⁽¹⁰¹⁾ it was advantageous to start the dialysis with 0.066 M potassium phosphate buffer, pH 7.0 and then revert to distilled water.

Visking cellophane tubing had to be boiled for 30 - 40 min. in distilled water prior to use in order to remove extraneous substances and reduce the pore size, thus preventing the loss of low molecular weight protein. The tubing was found to contain a contaminating substance. This will be discussed at a later stage of the thesis.

II 4. (ii) The hydrochloric acid - ethanol method of Fernandez, Sobel and Goldenberg (1966)⁽¹⁰²⁾

This procedure was originally designed for the quantitative estimation of the concentrations of albumin and globulin in sera, but as the albumin remained undenatured, the method served as an excellent one for its preparation. The procedure was completed within 2 - 3 hr., gave a 80 - 90% recovery and had the advantage of being performed at room temperature.

0.5 ml. of serum was diluted to 2.5 ml. with physiological

saline (0.85% w/v) in a 50 ml. centrifuge tube. 22.5 ml. of an HCl-ethanol mixture (1 ml. conc. HCl plus 600 ml. absolute ethanol) was added dropwise from a burette with constant shaking. The mixture was left to stand for 30 min. at room temperature to allow complete precipitation of the globulins which were subsequently centrifuged off and discarded. The supernatant, containing the albumin, was treated with 2.5 to 3.0 ml. of 0.2 M sodium acetate in absolute ethanol, and left at room temperature for 10 - 20 min. before the precipitate was centrifuged down. This albumin precipitate was then washed with Bloor's reagent (3 volumes ethanol plus 1 volume ether) to remove traces of lipid, and finally dissolved in buffer for immediate use or in distilled water and lyophilized.

This method was preferred as it eliminated the need for Visking tubing but was not suitable for specimens of urine or peritoneal dialysates where large volumes were involved. The presence of excessive amounts of heparin in the plasma also invalidated the fractionation as it caused precipitation of all the proteins in the first step, a technical drawback, not normally encountered.

II 4. (iii) Zone electrophoresis

Zone electrophoresis originally described by

Tiselius and Flodin (1953)⁽¹⁰³⁾, was also employed for the preparation of albumin as this method did not involve the use of organic liquids or extremes of pH.

An inert supporting medium, in this case ethanolized cellulose, was used in column form and after application of the sample a potential difference was applied. The different proteins were separated according to their electric charge, and were then eluted from the column and collected.

Ethanolized cellulose was prepared by the method of Campbell and Stone (1957)⁽¹⁰⁴⁾. Approximately 300 g. of pure absorbant cotton wool was torn into small pieces and refluxed with 4875 ml. ethanol and 375 ml. acetyl chloride. After about 16 hr. the cotton wool suddenly disintegrated to give a white powdery mass. The mixture was then refluxed for a further 4 hr. The ethanolized cellulose so obtained was washed several times in ethanol and then in distilled water before being dried in an oven at 80° to a fine white powder.

A column 26 x 2 cm. was used and 2 ml. dialysed serum applied. The sample was run in to a depth of 2 - 3 cm. before current was applied. The running conditions simulated those of Flodin and Porath (1954)⁽¹⁰⁵⁾ and Porath (1954)⁽¹⁰⁶⁾ in which a borate-phosphate buffer, (0.115 M

$\text{Na}_2\text{B}_4\text{O}_7$ and $0.0155 \text{ M NaH}_2\text{PO}_4$), pH 8.6 and ionic strength 0.05 was used for both suspension of the column and in the electrode chambers. The electrodes were a silver/silver chloride combination prepared by running a current of 40 - 50MA through coils of silver wire connected to an anodal pole, and placed in a 2M potassium chloride, 0.1M hydrochloric acid mixture. A platinum electrode was used for the cathode. A potential difference of 160V was applied to the cellulose column for approximately 40 hr. (Fig. 5). The proteins were eluted at 12 ml./hr. with the same buffer, and the eluate monitored through an ultraviolet absorptiometer (LKB Uvicord) set at 262 m μ (Fig. 6A). Albumin being the most electro-negative protein in serum - with the possible exception of the prealbumin orosomucoid - migrated farthest in the electrical field and was, therefore, the first protein to be eluted. The peaks were dialysed and lyophilized.

II 4. (iv) Polyethylene glycol method

Another method used to check the albumin samples prepared by the TCA-ethanol or HCl-ethanol procedures was that described by Potgieter and Hines (1963)⁽¹⁰⁷⁾ and Potgieter (1964)⁽¹⁰⁸⁾.

FIG. 5

ZONE ELECTROPHORESIS.
APPARATUS.

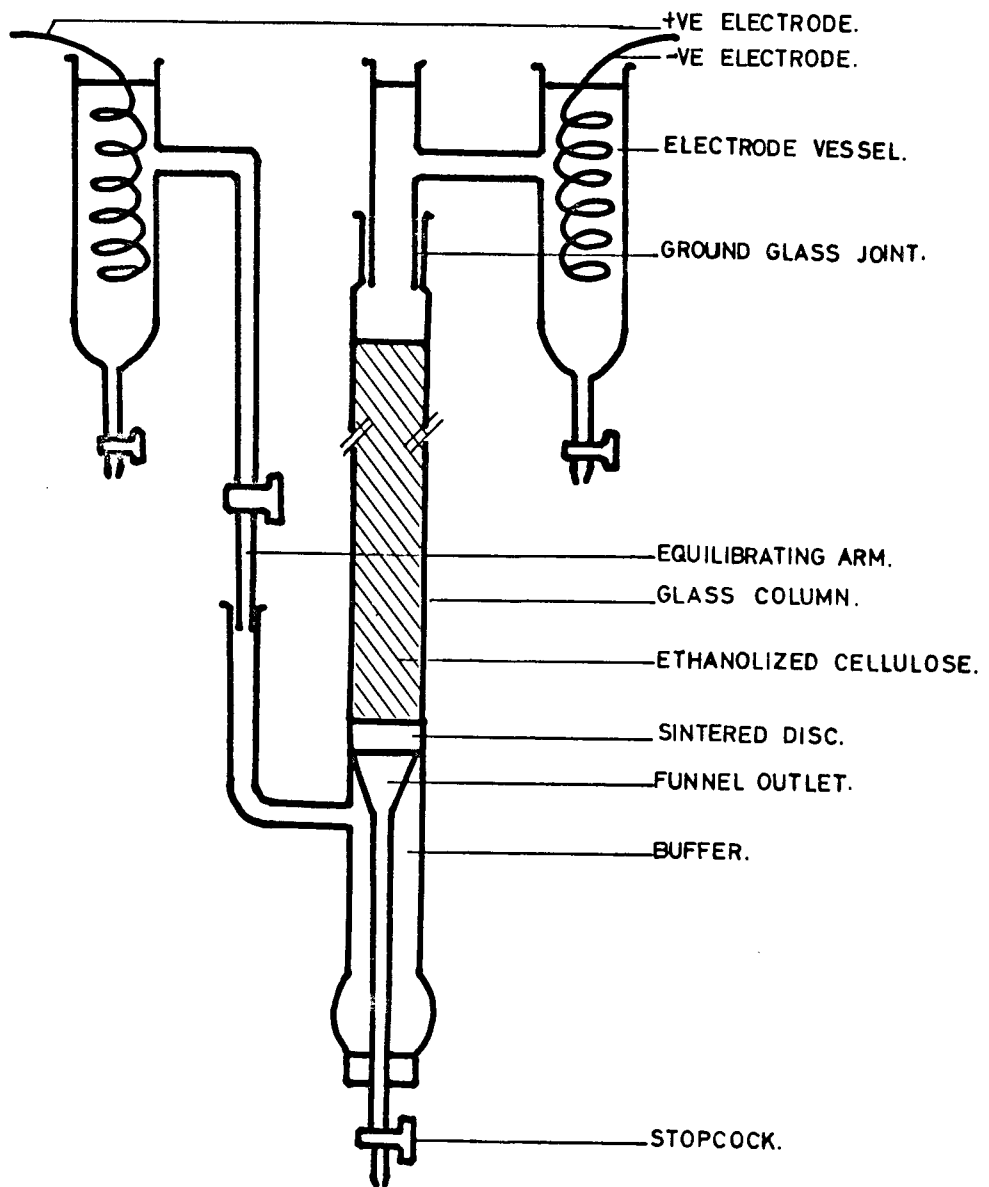

Serum was diluted to a protein concentration of 2% (w/v) with 0.2M phosphate buffer, pH 7.0, and the γ globulins and some α and β globulins removed by precipitation with an equal volume of 28% (w/v in the above buffer) polyethylene glycol (P.E.G.). The supernatant was adjusted to pH 5.9 with 0.5N acetic acid, thus precipitating the remaining α and β globulins. PEG was then added to the supernatant to give a final concentration of 20% (w/v) and 0.5N acetic acid added until the pH reached 5.0. This caused precipitation of the remaining proteins (albumin and α_2 globulins), which, after removal of the supernatant, were dissolved in the starting buffer, and chromatographed on carboxymethyl cellulose*. On gradient elution, the albumin could be separated from the contaminating proteins. The starting buffer was 0.08M sodium acetate, pH 4.25, while the limiting buffer was 0.15M sodium acetate, pH 5.25. A 150 ml. mixing chamber was employed. The column was run at 15 ml. per hour, and the eluate monitored through an LKB Uvicord with attached recorder. The albumin peak (Fig. 6B) was dialysed against

* The C.M. cellulose was prepared for use by standing it for 30 min. in 0.5N NaOH, washing with water to pH 8.0 and then allowing it to stand in 0.5N HCl. After washing with water (to pH 4.0) and several volumes of starting buffer, the column was packed and allowed to equilibrate with the starting buffer overnight.

FIG. 6

PREPARATION OF ALBUMIN.

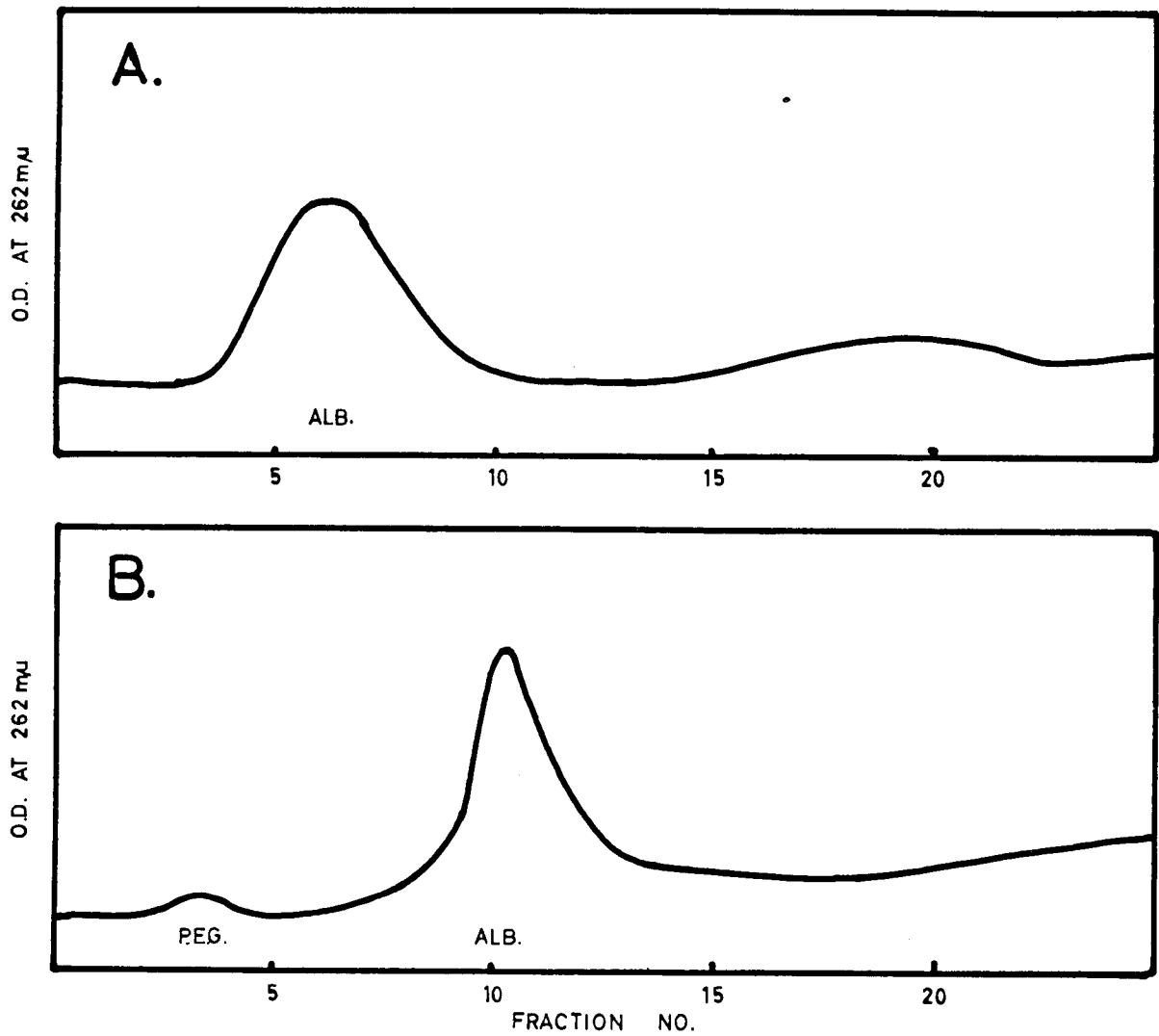

A. ZONE ELECTROPHORESIS. TRACE OF COLUMN EFFLUENT.

B. CARBOXY METHYL CELLULOSE. TRACE OF COLUMN EFFLUENT.

distilled water in the cold room (1°).

II 4. (v) Purity of the albumin preparations was checked before any further studies were carried out. This was done by the following two methods (these will be described in detail in a later section).

(a) Electrophoresis on cellulose acetate at pH 8.6⁽¹⁰⁹⁾. Preparations showing only a single band as in Fig. 7A were considered pure.

(b) Immunoelectrophoresis on agar gel at pH 8.4, using a polyvalent antiserum⁽¹¹⁰⁾. Fig. 7B shows the single precipitin arc of purified albumin.

Michael (1962)⁽¹¹¹⁾ described the antigenic and physico-chemical properties of albumin prepared by organic solvents and found them to be unchanged. On this basis, the specialized studies carried out on the albumins prepared as described above and the conclusions drawn were considered to be legitimate.

FIG. 7

TESTS FOR ALBUMIN PURITY.

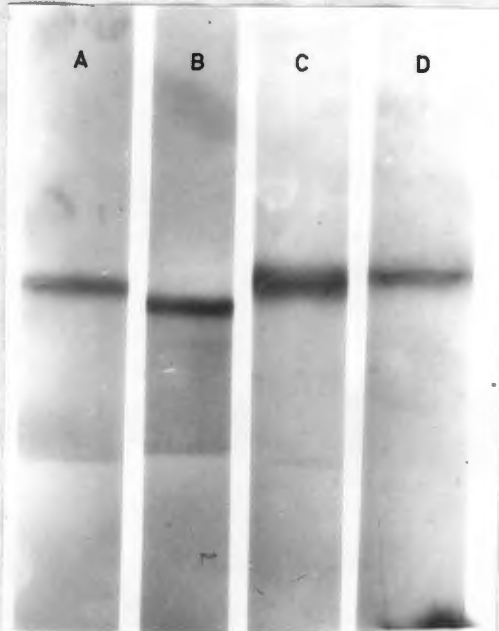

CELLULOSE ACETATE ELECTROPHORESIS.

- A. TCA ETHANOL METHOD.
- B. HCl ETHANOL METHOD.
- C. ZONE ELECTROPHORETIC METHOD.
- D. PEG. - CM CELLULOSE METHOD.

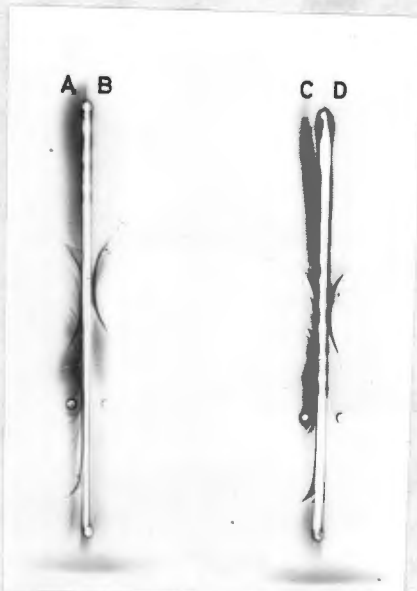

IMMUNOELECTROPHORESIS.

- A. NORMAL MONKEY WHOLE SERUM.
- B. TCA ETHANOL ALBUMIN.
- C. NORMAL MONKEY WHOLE SERUM.
- D. HCl ETHANOL ALBUMIN.

II 5. EXPERIMENTS WITH VISKING TUBING

During the early course of the study of the purified albumins on dextran gels (cf. Fig. 16) a contaminating substance, having a molecular weight ranging widely about 5,000 was frequently found. This material which was biuret positive and absorptive at 280 m μ (Fig. 8A) was finally traced to the Visking cellophane dialysis tubing.

It was important to remove this material from preparations as it could interfere with the studies on minialbumin. It was easily extractable on boiling with 1% (w/v) sodium carbonate (Fig. 8B) which is normally used to remove fatty acids. Soaking the tubing in bile salts, which emulsify fats and lipids, had the same effect. 1% (w/v) solutions of sodium deoxycholate and sodium taurocholate were used (Fig. 8C and 8D respectively). Ethanol and acetone, employed in the preparation of albumin, and ether were, therefore, tested and were also effective in removing some of this material, as seen in Fig. 9. Ethanol was not as good a solvent for the contaminant as acetone and, thereafter, was preferred for albumin preparation.

In all cases equal weights of tubing and equal volumes of diffusate were compared. The internal and external surfaces were compared and it was shown that more of this material could be removed from the external surface.

FIG. 8

SPECTRA OF VISKING
TUBE EXTRACTS.

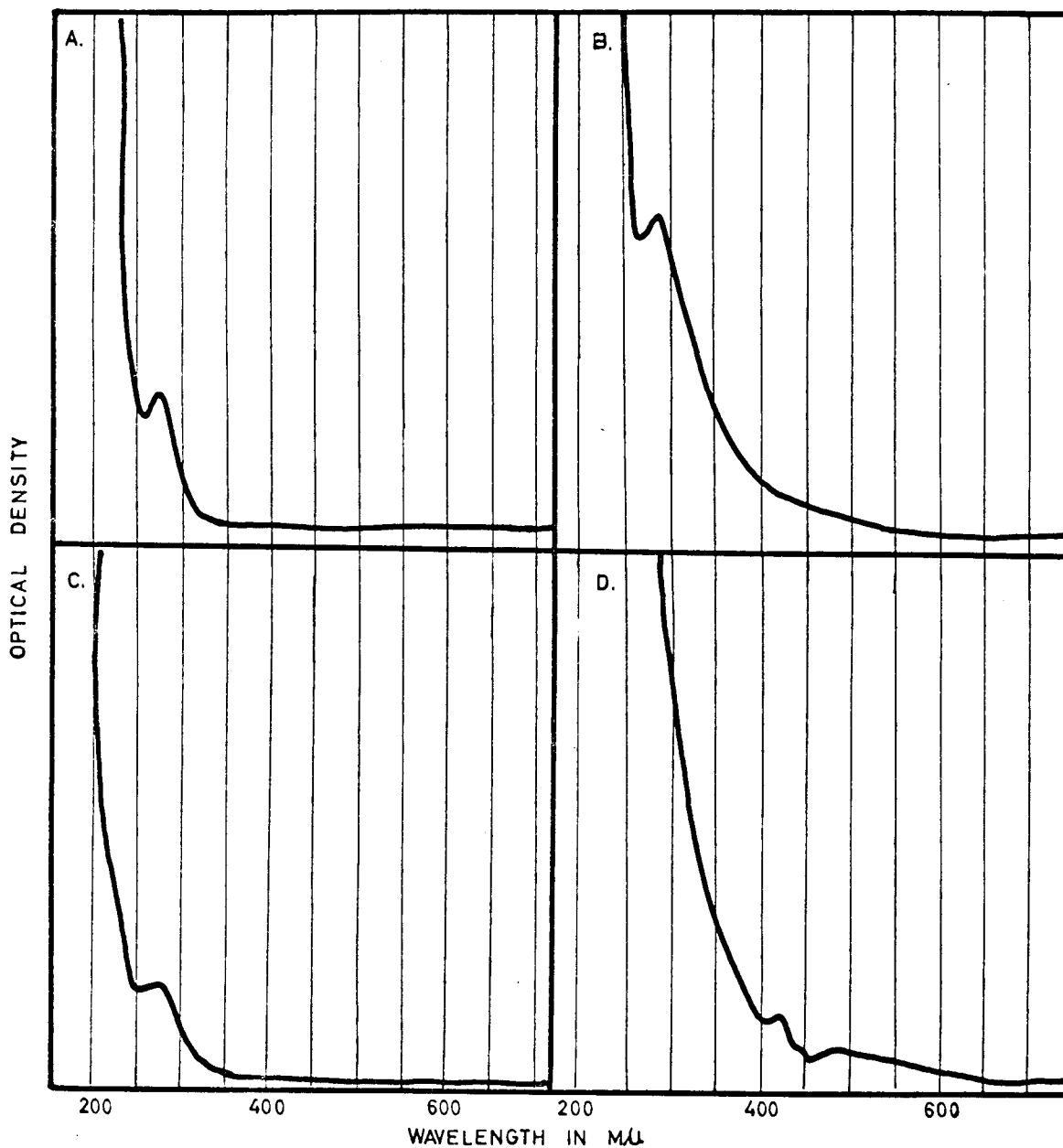

- A. EXTRACT WITH TCA ACETONE REAGENT.
- B. EXTRACT WITH Na_2CO_3
- C. EXTRACT WITH Na-DEOXYCHOLATE
- D. EXTRACT WITH Na-TAUROCHOLATE

FIG. 9

SPECTRA OF VISKING
TUBE EXTRACTS.

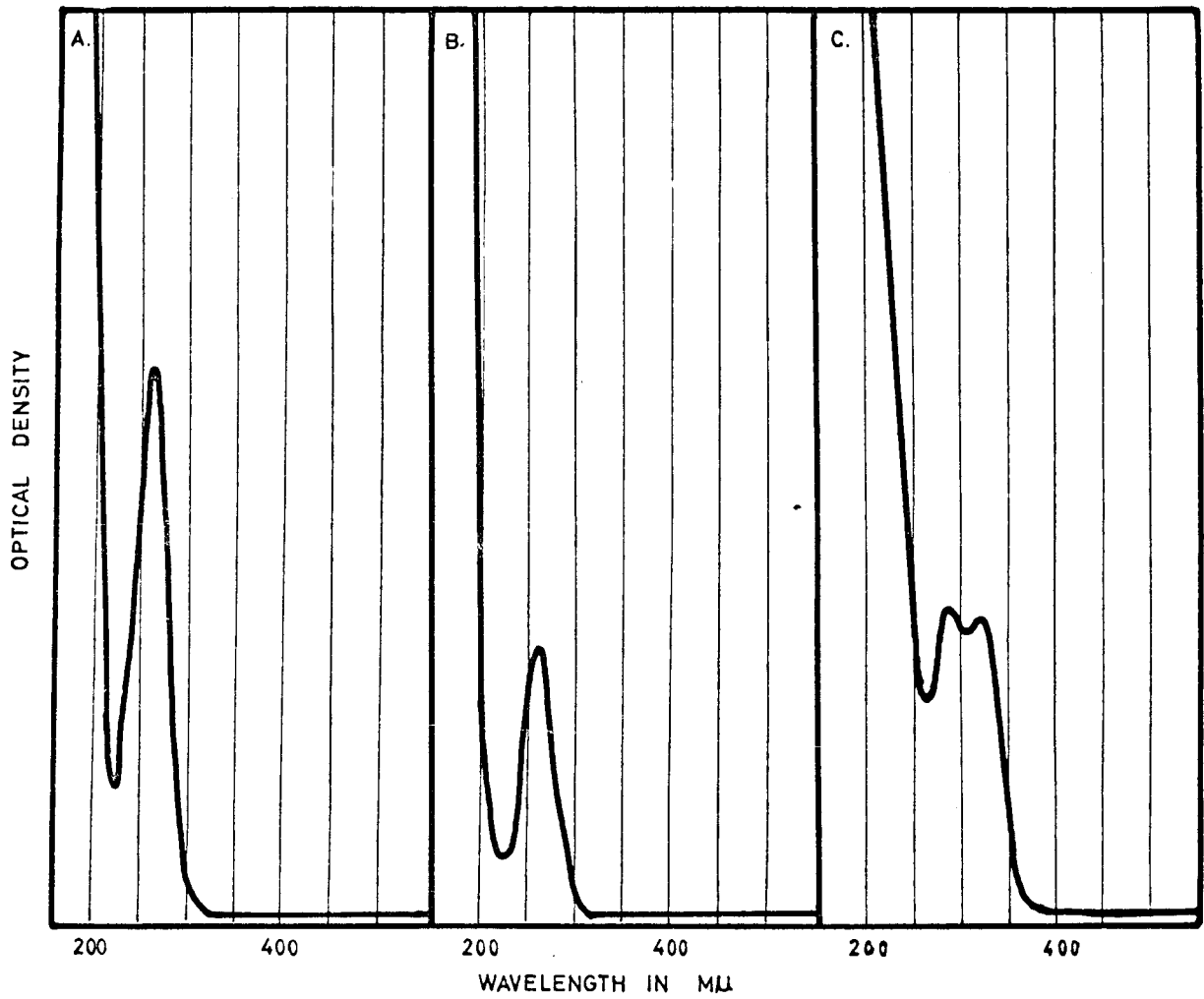

- A. EXTRACTION WITH ACETONE.
- B. EXTRACTION WITH ETHANOL.
- C. EXTRACTION WITH ETHER.

Just as the removal of this contaminant was important to our work, so was the effect it had on the pore size of the tubing if we were not to lose minialbumin through dialysis. Lysozyme, which between pH 5.0 and 9.0 occurs almost exclusively as a dimer of M.W. $29,000 \pm 100$ ⁽¹¹²⁾, was used to check the pore size. A lysozyme solution in 0.1M phosphate buffer, pH 6.24 was placed inside the treated visking tubings and dialysed against the same buffer overnight at 0°C. Aliquots of the diffusate were then tested for activity by following the rate of lysis of *Micrococcus lysodickticus* spectrophotometrically. The assay method used was that of Shugar (1952)⁽¹¹³⁾. Fig. 10A shows a typical example of an assay on the diffusate surrounding treated tubing, which indicated an increased pore size. Untreated, unboiled tubing, and tubing boiled for 45 min. in distilled water did not allow the passage of lysozyme into the surrounding medium (Fig. 10B and C respectively). However, tubing boiled in water after treatment, with Na_2CO_3 or bile salts was still porous to the lysozyme dimer. This led to the conclusion that the materials removed by the various treatments described above were actually part of the structure of the sac. This observation was substantiated by fluorescent studies on the sac, and the solvents, before and after treatment. There was a gradual decrease in fluorescence of the sac, on successive extractions, while the extracts retained a fairly consistent

FIG. 10

POROSITY OF VISKING
TUBING.

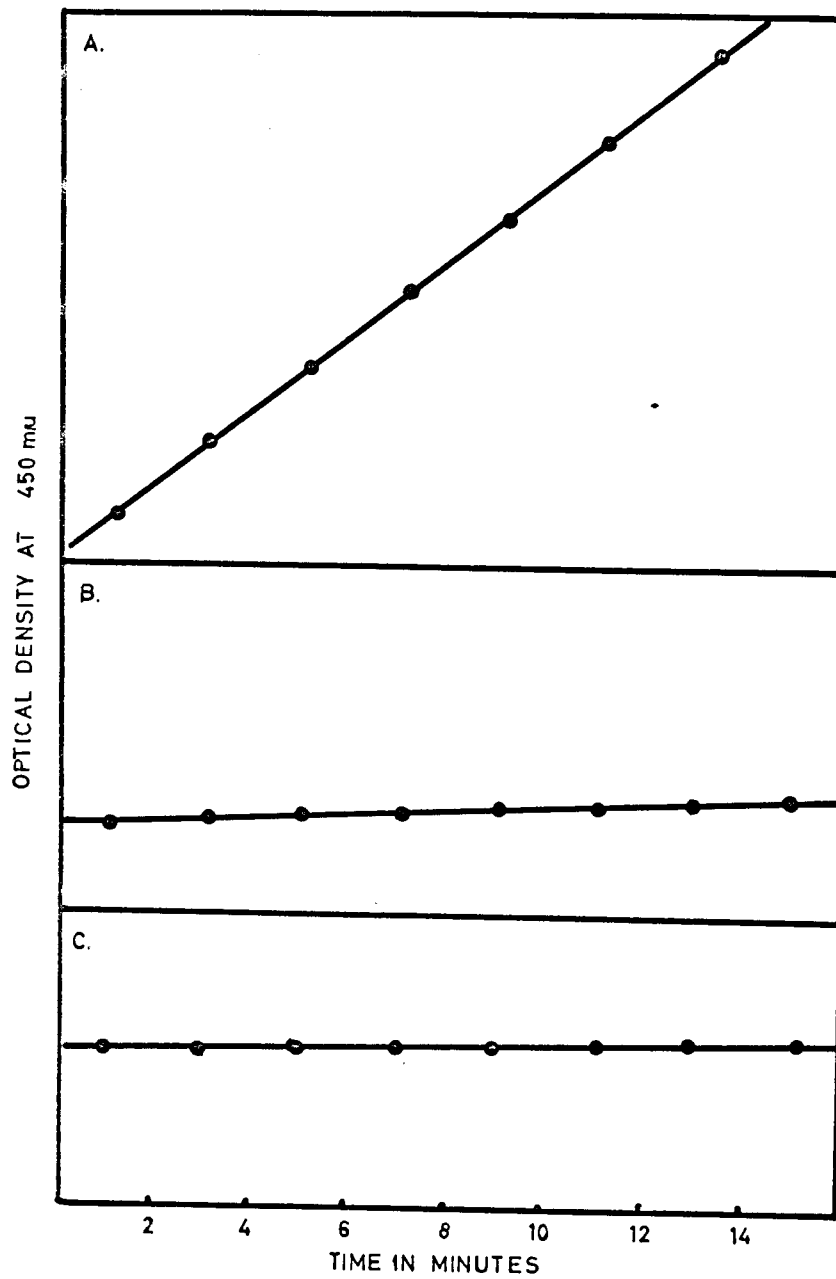

- A. LYSOSYME ACTIVITY OF DIALYSING FLUID - TREATED SAC.
- B. LYSOSYME ACTIVITY OF DIALYSING FLUID - UNTREATED SAC.
- C. LYSOSYME ACTIVITY OF DIALYSING FLUID - H₂O BOILED SAC.

fluorescent value.

In the light of these findings dialysis tubing was avoided as much as possible. Where there was no alternative only tubing that had been boiled in distilled water for 30 - 40 min. was employed.

II 6. SEPARATION OF ALBUMINS OF DIFFERING MOLECULAR WEIGHT

With the advent of dextran gels, albumins of differing molecular size, which had previously only been detectable by ultracentrifugation^(10,21), could readily be separated from one another.

II 6. (i) The cross-linked dextran gels behave as a molecular sieve, their porosity (a function of the degree of cross-linkage) determining the degree of separation of different sized molecules. Larger molecules that cannot enter the gel pores, pass through the dextran bed more rapidly than their smaller counterparts which are trapped and thus retarded. This technique of gel filtration was first introduced in Uppsala, Sweden, by Porath and Flodin⁽¹¹⁴⁾ in 1959, when they used this dextran, termed Sephadex, to separate ammonium sulphate from serum albumin.

A wide range of Sephadex is available and is graded according to its degree of cross-linkages. Sephadex G75, with an approximate exclusion limit of 50,000 M.W., was the most suitable for our purposes. Normal serum albumin of M.W. 66,000 would be excluded, while albumin of a lower molecular weight would be retained and separated from it. Haemoglobin (M.W. 67,000) is well separated from myoglobin

(M.W. 17,000) on such a column (Berman and Kench, 1963⁽¹¹⁵⁾).

II 6. (ii) Packing of the column

It was essential that the gel was uniformly packed as the separation volume was small when compared with the bed volume. Packing was effected in the following manner. Sephadex G75 (bead form) was allowed to swell for 24 hr. in a large volume of distilled water. The water was then decanted and replaced by 0.066M potassium phosphate buffer, pH 7.0 containing 0.2M sodium chloride. The gel was washed several times in large volumes of this buffer. A glass column, fitted with a sintered glass disc at the base, and free from all traces of dust or grease, was then almost filled with a weak slurry of the gel. A funnel was attached to the top of the column and also filled with the gel suspension, which was then continuously agitated with a mechanical stirrer (Fig. 11). After approximately 1" to 1½" of gel had settled on the bottom, the outlet was opened and the column allowed to drip at a slow rate (not more than 10 ml./hr.) until completely packed. Several bed volumes of buffer were pumped through the column to equilibrate it before use. It was found that columns drawn sharply to a narrow outlet tube gave best results as there was little or no mixing of the eluate.

FIG. 11

METHOD OF POURING
SEPHADEX COULMNS.

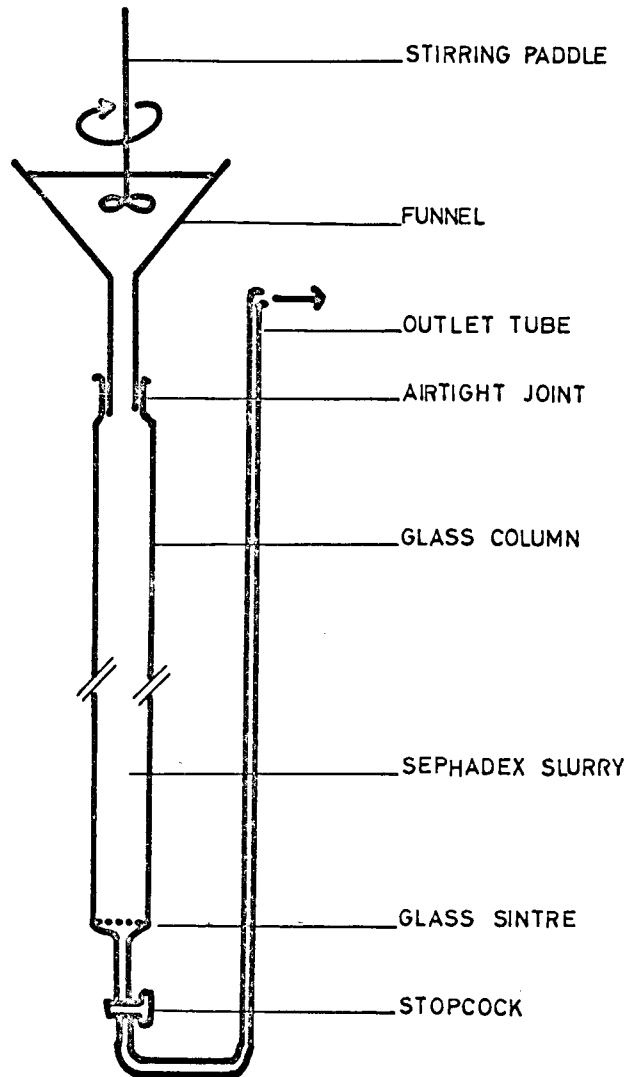

Further details of column dimensions and running procedures will be described under individual separations. Once it became apparent that the salt concentration in the Sephadex column played a major role in the "aggregation phenomenon of minialbumin" (described in detail in a later section) it was kept constant at 0.2M NaCl. For the same reason, urea was incorporated into the column buffers during the latter period of the study.

II 6. (iii) Estimation of the molecular weights of the albumins by gel filtration.

The molecular size of proteins can be estimated from the rate at which they are able to pass through the dextran gel. This principle was first demonstrated by Flodin (1962)⁽¹¹⁶⁾ and later by Whitaker (1963)⁽¹¹⁷⁾ who showed that there is a linear correlation between the logarithm of the molecular weight of a protein and the ratio of its elution volume (V_e = the volume at which the particular protein is eluted) to the void volume (V_o = the elution volume of a solute known to be completely excluded from the gel grains), i.e. $\log M.W. \propto V_o/V_e$.

This formula appeared to apply irrespective of the concentration of the protein or column size, and need only be

disregarded when there is complex formation between the actual gel and the protein.

It was, therefore, possible to 'mark' a column of Sephadex with substances of known molecular weight, and from this approximate the size of unknown molecules. This was necessary where the albumin of cadmium-poisoned animals was concerned, as molecules of different size were found. It was carried out essentially according to the method of Andrews (1964)⁽¹¹⁸⁾.

A column of Sephadex G75, 42.0 x 1.8 cm., prepared and packed as described earlier, was used. The buffer system was 0.066M potassium phosphate, pH 7.0 containing 0.2M sodium chloride, and the markers employed were normal human serum albumin (Mol. wt. 66,000), lysozyme dimer (Mol. wt. 29,000), cytochrome c (Mol. wt. 13,000) and coproporphyrin (Mol. wt. 500 - 600).

The freeze-dried samples, dissolved in a small volume of the column buffer, were loaded by careful layering onto the just damp surface of the column, and allowed to run in. The column surface was then washed twice with 1.0 ml. of buffer, before a head of pressure was applied and pumping begun. Buffer was pumped through at an even rate of 13.5 ml. per hr. and the effluent was monitored through an ultraviolet absorptiometer set at 262 m μ (LKB Uvicord) and

automatically recorded. Fractions were collected, and the volume at which the marker first made its appearance carefully noted. Each marker was run separately. Figure 12 shows the graph obtained when the logarithm of the molecular weight was plotted against the elution volume.

Albumins, isolated from the sera and urine of cadmium-poisoned animals, were separated under similar conditions, and their molecular weights estimated from the above graph. The large molecules were found to be no different from human albumin in size, while the small molecules - minialbumin - occurred in a range of molecular weights varying from about 5,000 to 20,000. Sera showed a predominance of a 10,000 size molecule, while the 20,000 M.W. fragment occurred almost exclusively in the urine.

Figure 13 illustrates the separation of the serum albumins prepared by the different methods described and Figure 14 shows a similar pattern for urinary albumins.

FIG. 12

DETERMINATION OF MOLECULAR
WEIGHT WITH SEPHADEX.

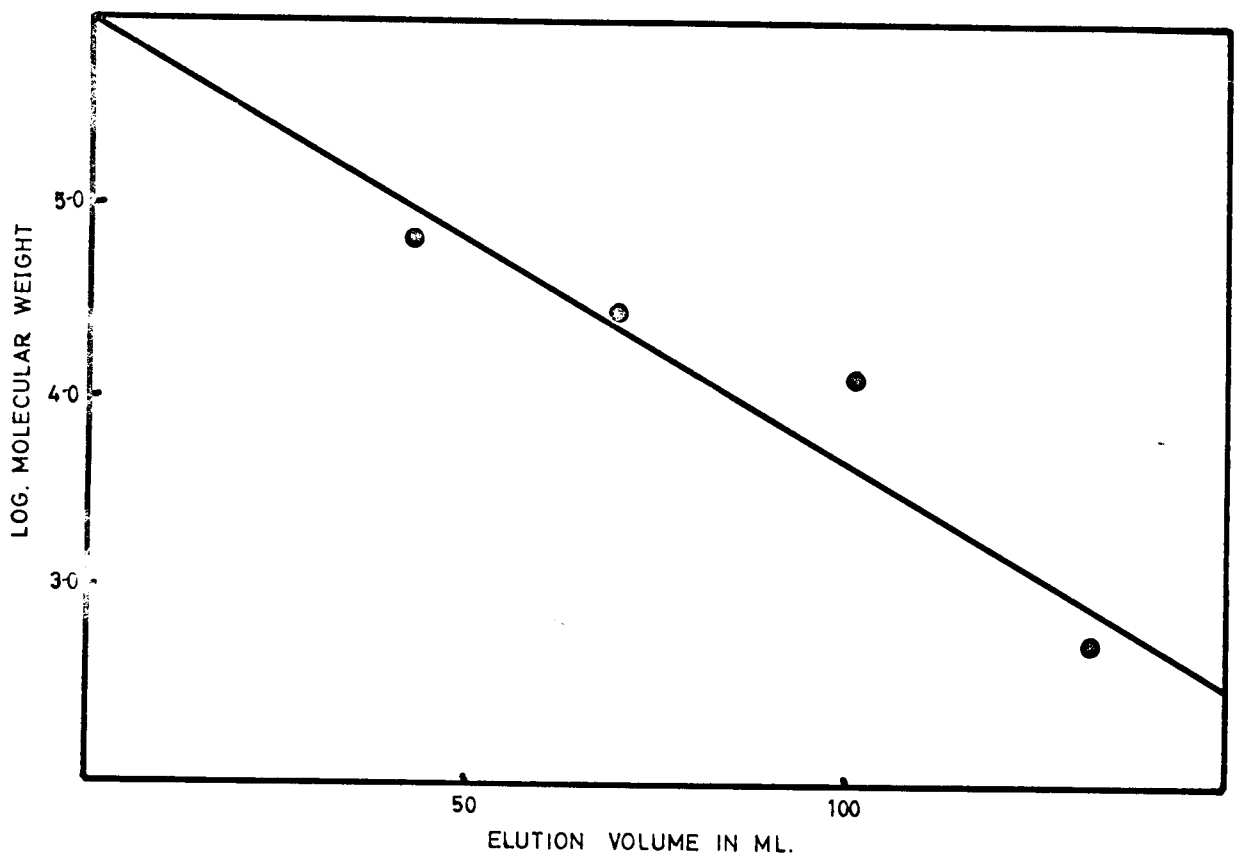
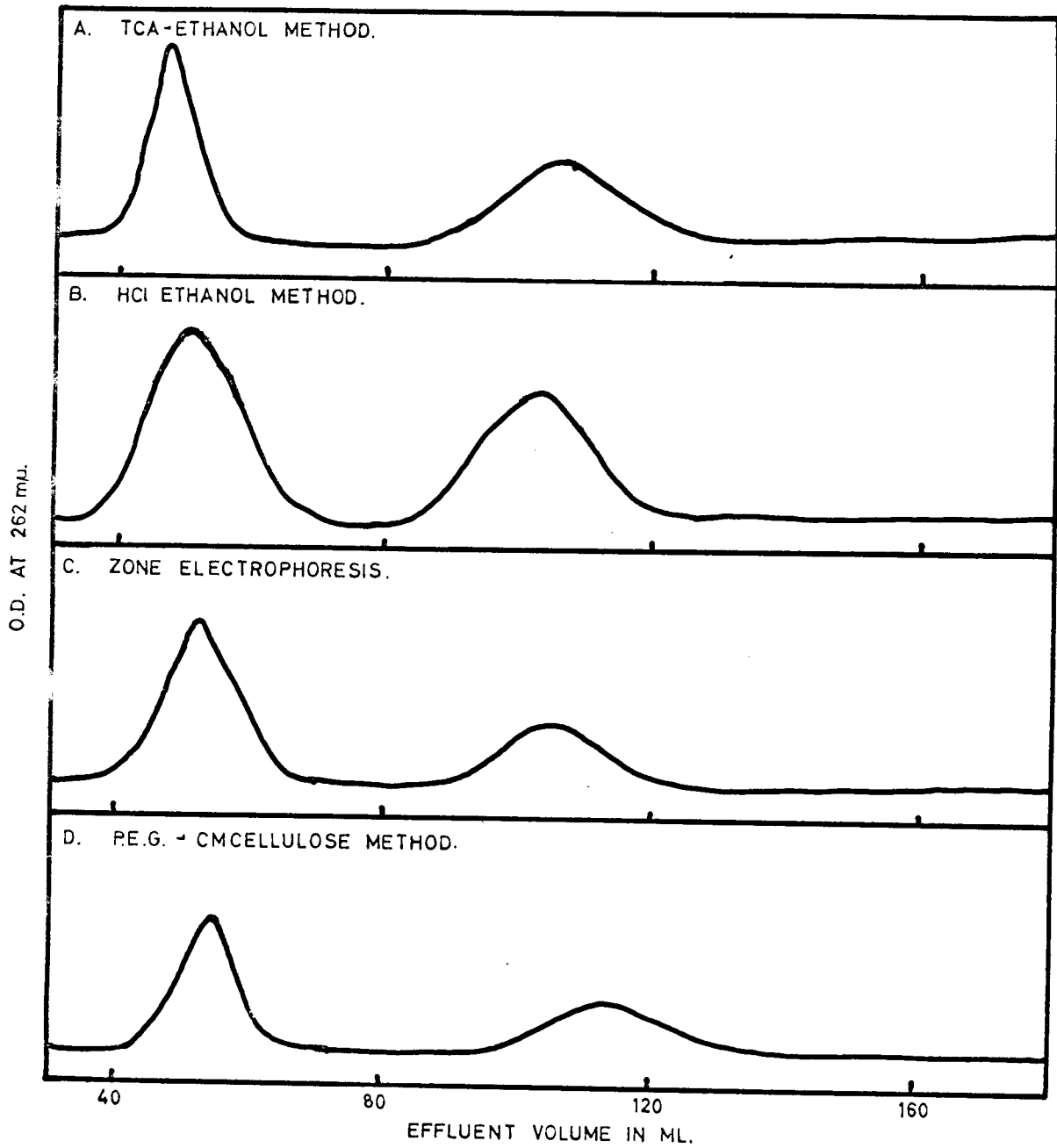

FIG. 13

SEPARATION OF SERUM ALBUMINS
ON SEPHADEX G75.



COLUMN = 42 X 1.8 CMS.

BUFFER = 0.066M PHOSPHATE pH 7.0 + 0.2M NaCl

FLOW RATE = 15 ML. PER HOUR.

FIG. 14

SEPARATION OF URINARY ALBUMINS
ON SEPHADEX G75.

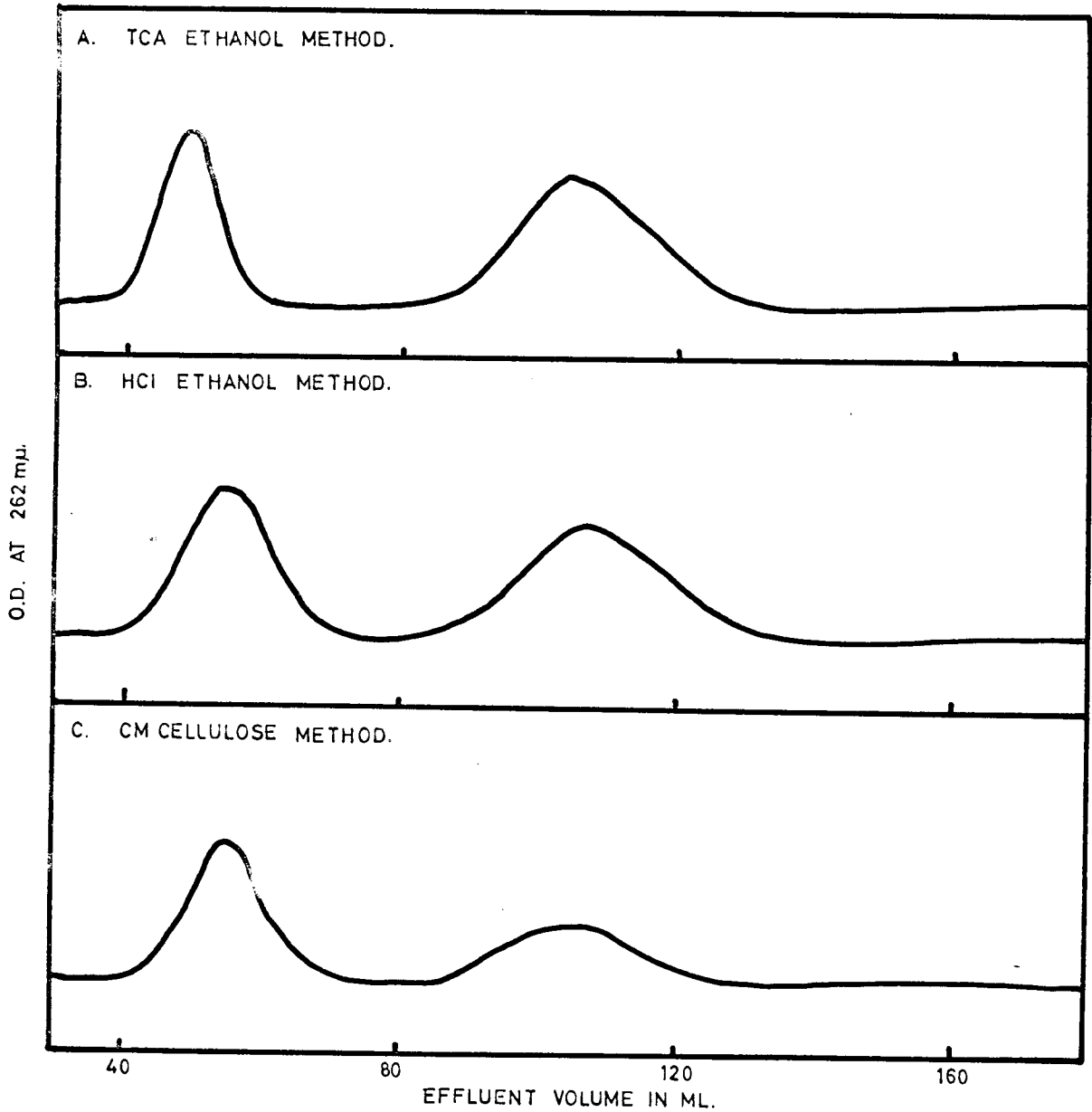

COLUMN = 42 X 1.8 CMS.

BUFFER = 0.066M PHOSPHATE pH 7.0 + 0.2M NaCl

FLOW RATE = 15 ML. PER HOUR.

II 7. THE DIRECT EFFECT OF CADMIUM ON BLOOD, SERUM
AND SERUM ALBUMIN OF THE MONKEY

Considering the toxicity of cadmium and its acidity in solution, it was not inconceivable that such a metal could have a direct hydrolysing effect on proteins. However, the following experiments proved this was not the case.

II 7. (i) Direct effect of cadmium on blood

Six ml. of blood were withdrawn from the saphenous vein of a normal unpoisoned monkey and mixed with 0.5 ml. of heparin. Three ml. of cadmium chloride solution, containing 2 mg. cadmium/ml. were added dropwise with constant mixing (i.e. the same concentrations as for the injection). The mixture was then incubated in a water bath at 37° with gentle agitation for 60 min. Thereafter, the cells were removed by centrifugation and the plasma albumin prepared by the TCA-acetone method of Vallance-Owen (1958)⁽⁹⁸⁾. This albumin was run through a Sephadex G75 column as described earlier. The trace obtained is shown in Figure 15A. It is evident that no minialbumin was present.

II 7. (ii) Direct effect of cadmium on serum

Blood was withdrawn from a normal unpoisoned

monkey in the usual manner and immediately centrifuged to remove the cells. Three ml. of the serum so obtained was sterilized by passage through a millipore filter (as described for the preparation of antisera) and transferred into each of 2 sterile containers. To one was added 7.5 μ g. cadmium in physiological saline (the approximate concentration of cadmium in the serum following a normal dose) and an equal volume of physiological saline was added to the other which served as a control. The samples were incubated in a water bath at 37° for 48 hr. with constant gentle agitation. Thereafter, albumin was prepared from both by the TCA-acetone method⁽⁹⁸⁾ and monitored through the Sephadex G75 column. The records (Fig. 15 B and C) show a complete absence of minialbumin.

II 7. (iii) Direct effect of cadmium on serum albumin

This was done in exactly the same way as for the whole serum, using an albumin solution of 40 mg./ml. (i.e., the concentration of albumin in serum). Again no traces of minialbumin could be detected (Fig. 15D).

FIG. 15

THE DIRECT EFFECT OF CADMIUM.

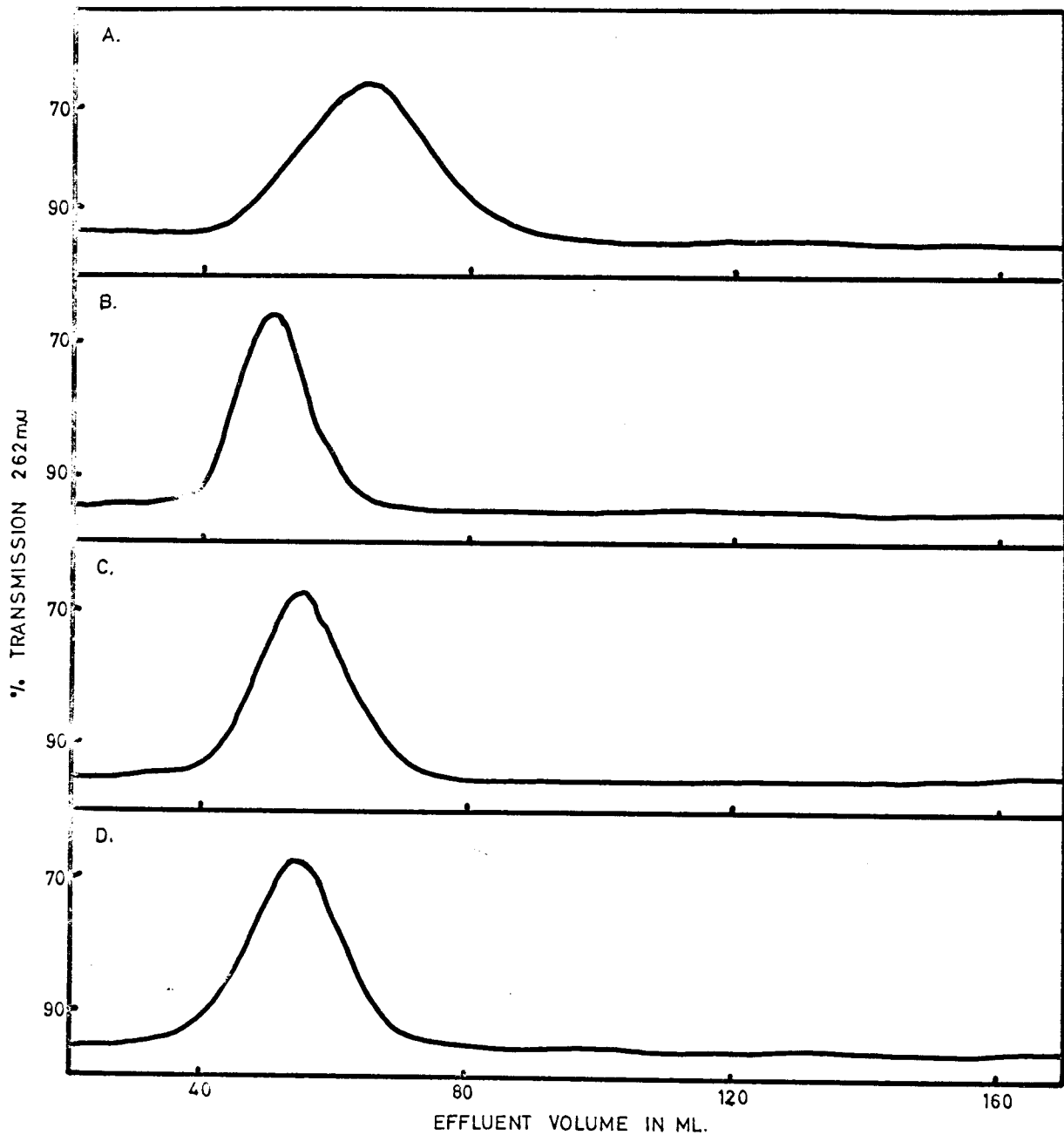

- A. INCUBATION OF CADMIUM WITH WHOLE BLOOD.
 - B. INCUBATION OF SALINE WITH SERUM.
 - C. INCUBATION OF CADMIUM WITH SERUM.
 - D. INCUBATION OF CADMIUM WITH ALBUMIN
- SEPHADEX G 75 IN 0.066M PHOSPHATE pH 7.0 + 0.2M NaCl.
COLUMN = 42 x 1.8 CMS. FLOW RATE = 15 ML. PER HOUR.

II 8. THE ORIGIN OF MINIALBUMIN

II 8. (i) Peritoneal dialysis of the monkeys

Previous work (Gain and Kench, 1965⁽¹¹⁹⁾ and Gain, 1966⁽⁶⁶⁾) in this laboratory indicated that the minialbumin of cadmium poisoning arose in the liver. This was demonstrated by a rise in the amounts of circulating minialbumin following booster doses of cadmium in an animal which had undergone bilateral nephrectomy. Experiments, designed to show the presence of minialbumin in the circulatory system of an animal with intact liver and kidneys before its appearance in the urine, were deemed necessary to substantiate this evidence.

Peritoneal dialysis afforded an excellent means of detecting the circulating albumins and was conducted in the following way. Indwelling teflon catheters were surgically inserted into the peritoneal cavity of the monkeys while under pentothal anaesthesia (2 ml. of 2.5% aqueous sodium pentothal given intravenously). The dialysis fluid used was sterile, non-pyrogenic lactate Ringer's solution containing 130 meq. Na^+ /l., 4.0 meq. K^+ /l., 2.7 meq. Ca^{++} /l., 109 meq. Cl^- /l., 28 meq. lactate/l., 1 mg. bisulphide/l. and 15% (w/v) glucose. The fluid was run in and out of the peritoneal space under gravitational influence. In most cases the dialysis was continued for 30 to 45 min.

periods, and was performed under strictly sterile conditions.

Dialysates were immediately centrifuged in the cold to remove cells, and aliquots taken for the determination of electrolyte concentration. It was found that sodium and chloride values were reduced (50 - 120 meq./l. and 30 - 80 meq./l. respectively) while that of potassium was elevated (7 - 10 meq./l.). The pH of the outflowing fluid, collected anaerobically in sealed capillary tubes, was measured immediately and after exposure to the atmosphere. The Astrup⁽¹²⁰⁾ technique was used, and the average value for the initial measurement was pH 6.98. This dropped to an average value of 6.87 after standing exposed to the air for approximately 10 min. The fall of pH due to glycolysis was not such as to vitiate our further studies of the albumins present.

Preparation of albumin from the dialysate was essentially by the method of Vallance-Owen et al (1958)⁽⁹⁸⁾. However, because of the large volumes, the initial precipitation was with 50% (w/v) aqueous TCA to give a final concentration of 5% (w/v) TCA. Thereafter, the procedure was unchanged. The isolated albumins were then monitored through a Sephadex G75 column.

Animals were dialysed after the initial and each successive dose of cadmium to check for the presence of circulating minialbumin. At the same time urine was tested daily for

protein. It was consistently found in several different monkeys that circulating minialbumin appeared after the animals had received 25 - 30 mg. cadmium (i.e. 10 - 12 mg. weekly for 2 to 3 weeks) while minialbuminuria only became apparent 6 to 7 weeks after initiation (i.e. after 60 - 90 mg. of cadmium had been injected). This sequence of events is assured, however, only if the poisoning regime is steadily maintained.

The dialysates of normal unpoisoned animals contained albumin of molecular weight 66,000 only, whilst in those of cadmium-poisoned animals albumins of molecular weight 10,000 to 20,000 were also present (Fig. 16).

In an attempt to determine the peak of minialbumin production following a cadmium dose, an all day dialysis was programmed. Six mg. of cadmium was given intravenously prior to catheterization and dialysis was started 30 min. after the injection. 500 ml. volumes of fluid were used and these were exchanged at half-hourly intervals for the first two hr. and at hourly intervals for the following four hr. The animal was kept under very light anaesthesia and maintained on a 5%(w/v) glucose drip throughout the course of the experiment.

Albumins were prepared from the dialysates⁽⁹⁸⁾ and run through Sephadex columns to separate them. Figure 17 shows

FIG. 16

ALBUMINS IN THE PERITONEAL DIALYSATES.

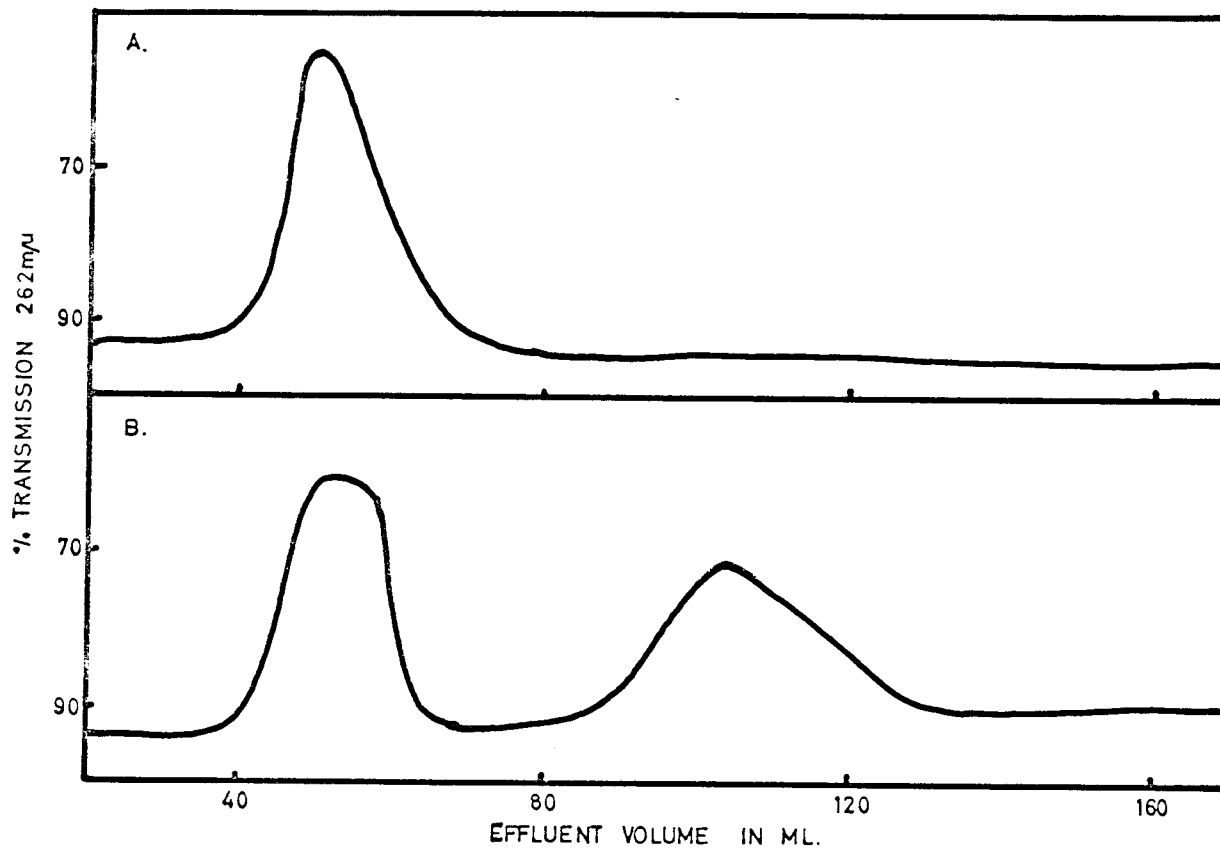

A. NORMAL MONKEY.
B. CADMIUM POISONED MONKEY - AFTER 39 MGS. CADMIUM.
SEPARATION ON SEPHADEX G75 IN 0.066M PHOSPHATE pH 7.0 + 0.5M NaCl.
COLUMN 42 x 1.8 CMS. FLOW RATE = 15 ML. PER HOUR

the peak of minialbumin production to be $1\frac{1}{2}$ to 2 hr. after the cadmium injection. After 6 - 7 hr. this level of circulating minialbumin had dropped to practically nothing.

It was considered necessary to ascertain whether or not cadmium had a direct effect on the peritoneum. Animals were, therefore, dialysed prior to and following on a cadmium dose. Monkey K received 6 doses of 6 mg. cadmium each at 3 - 4 day intervals and was then allowed to rest for 7 days before the start of this experiment.

The animal was initially dialysed with 500 ml. of fluid for a 30 min. interval. Fifteen min. after the commencement of the dialysis, a 5 ml. sample of blood was withdrawn from the left leg vein. On completion of the dialysis a 6 mg. dose of cadmium was administered intravenously into the right leg of the animal. Forty-five min. later the second dialysis was commenced and again a blood sample was taken from the left leg after 15 min.

The samples collected were immediately treated by the TCA-ethanol method⁽⁹⁸⁾ and the albumins monitored through Sephadex G75. It can be seen (Fig. 18A and C) that there was a small quantity of circulating minialbumin present following a long resting period which suggested that the cadmium has a 'real' rather than temporary direct effect. The booster dose increased the amount of this minialbumin several fold (Fig. 18B and D).

FIG. 17

ALL DAY PERITONEAL DIALYSIS
OF MONKEY.

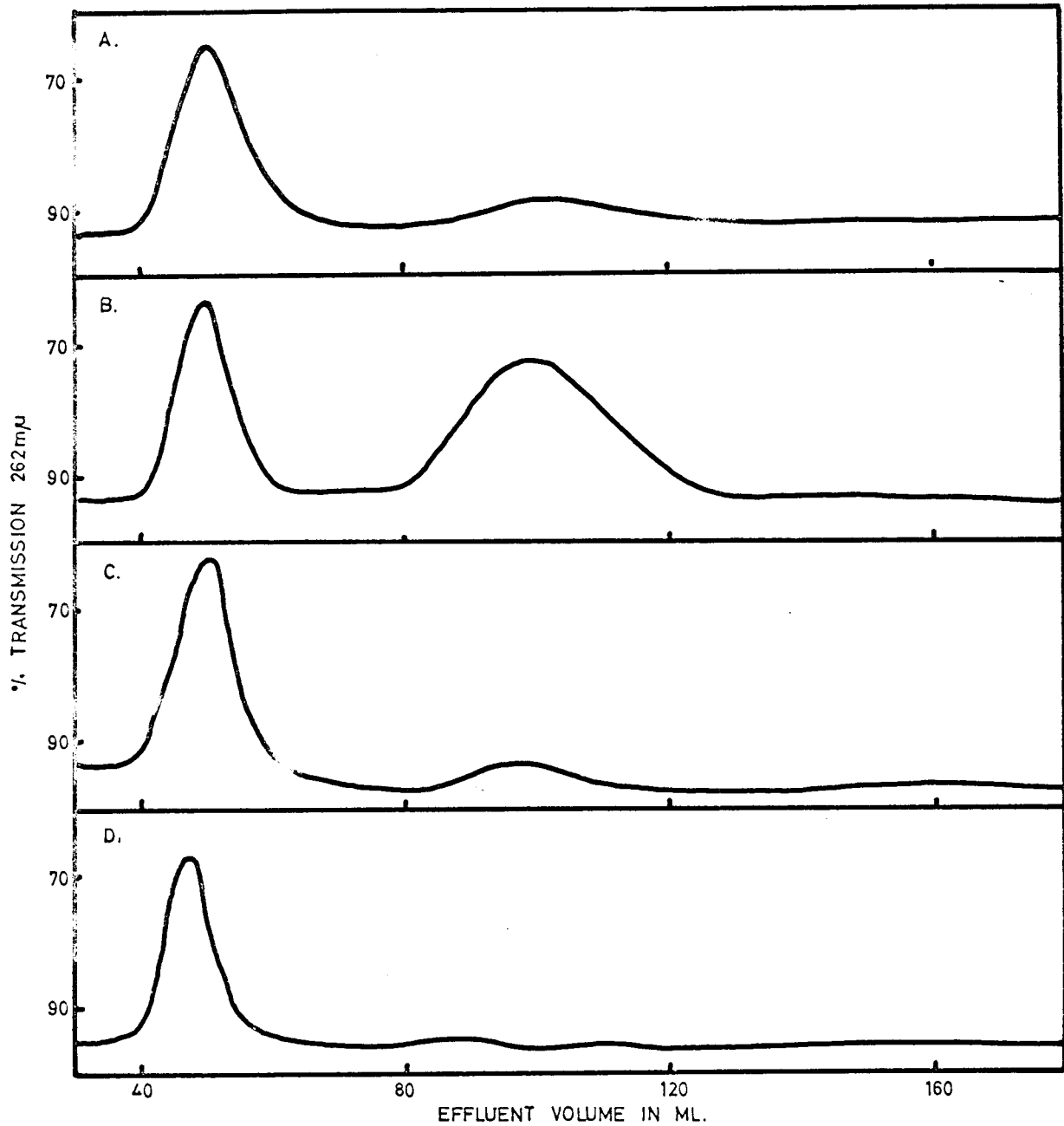

A. DIALYSATE TAKEN AT 30MINS.

B. DIALYSATE TAKEN AT 90 MINS.

C. DIALYSATE TAKEN AT 4 HOURS.

D. DIALYSATE TAKEN AT 6 HOURS.

SEPHADEX G 75 IN 0.066M PHOSPHATE pH 7.0 + 0.2M NaCl.

COLUMN = 42 x 1.8 CMS. FLOW RATE = 15 ML. PER HOUR.

FIG. 18

DIRECT EFFECT OF CADMIUM
ON THE PERITONEUM.

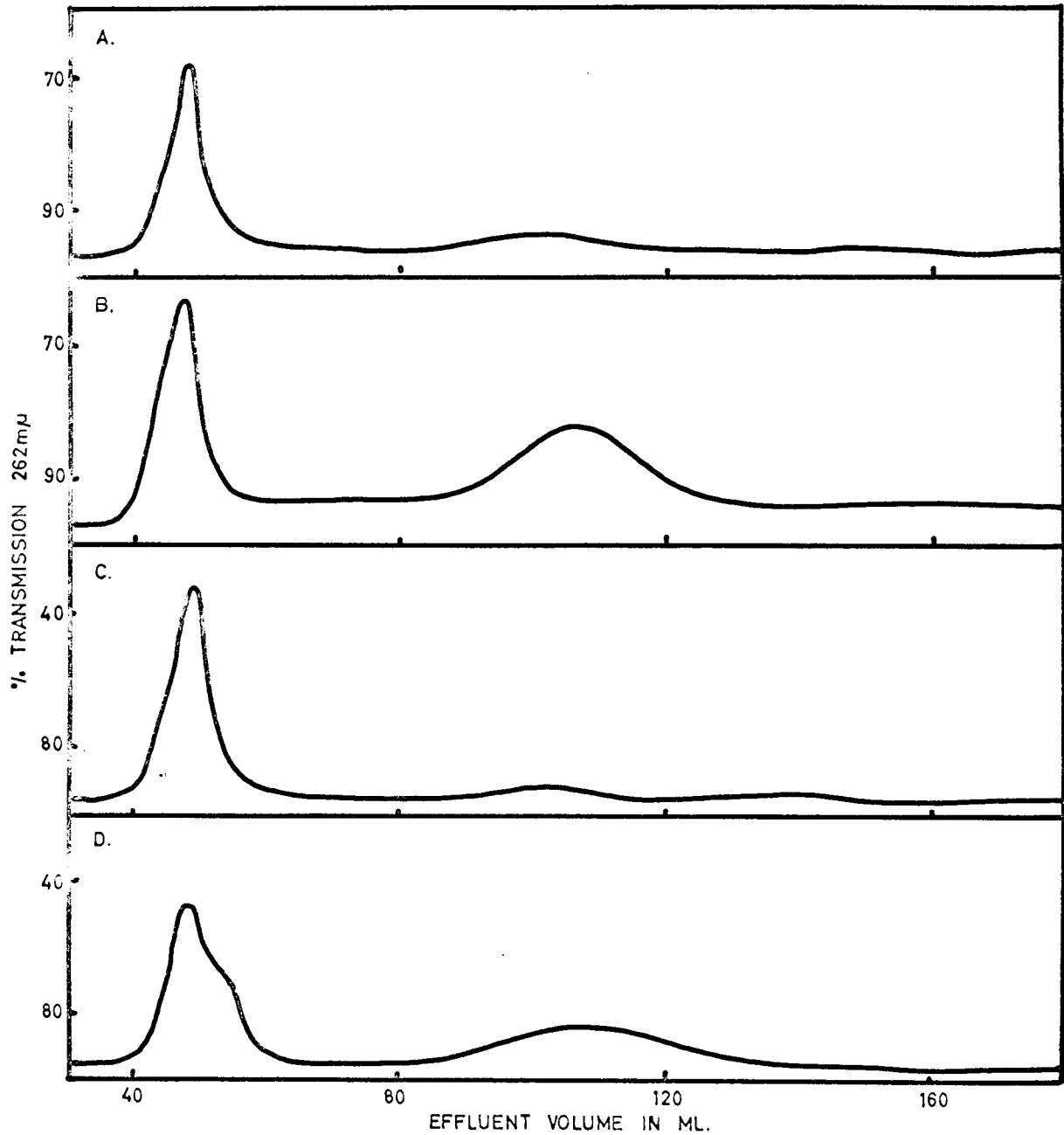

A. SERUM TAKEN BEFORE Cd⁺⁺ DOSE B. SERUM TAKEN AFTER Cd⁺⁺ DOSE.
C. DIALYSATE BEFORE Cd⁺⁺ DOSE. D. DIALYSATE AFTER Cd⁺⁺ DOSE.

SEPHADEX G 75 IN 0.066M PHOSPHATE pH 7.0 + 0.2M NaCl.
COLUMN = 42 x 1.8 CMS. FLOW RATE = 15 ML. PER HOUR.

Once the animals became proteinuric this technique was abandoned as then most of the minialbumin disappeared from the circulation, being presumably lost by renal clearance. However, a small amount of minialbumin is apparently always present in the circulating blood of poisoned animals. The work described in this section has already been published (Kench and Sutherland, 1966⁽¹²¹⁾).

II 8. (ii) The production of serum minialbumin

The production of serum minialbumin in a monkey, newly poisoned with cadmium but not proteinuric, was also followed by withdrawal of blood from the saphenous vein of the lower limb at intervals varying from $\frac{1}{2}$ to 5 hr. after a dose of 6 mg. of cadmium. Four ml. blood samples were taken and allowed to clot. Albumin was prepared from the serum by the HCl-ethanol method⁽¹⁰²⁾ and an equal quantity of protein from each sample cycled through a Sephadex G75 column (42 x 1.8 cm.), in 0.066M phosphate buffer, pH 7.0 and 0.2M NaCl. The quantity of protein under the curves was estimated spectrophotometrically by the Warburg and Christian method⁽¹²²⁾, and minialbumin expressed as percentage of the total albumin. The graph in Fig. 19 shows an initial sharp rise to a steady plateau followed by a gradual decline.

FIG. 19

CLEARANCE OF SERUM
MINIALBUMIN.

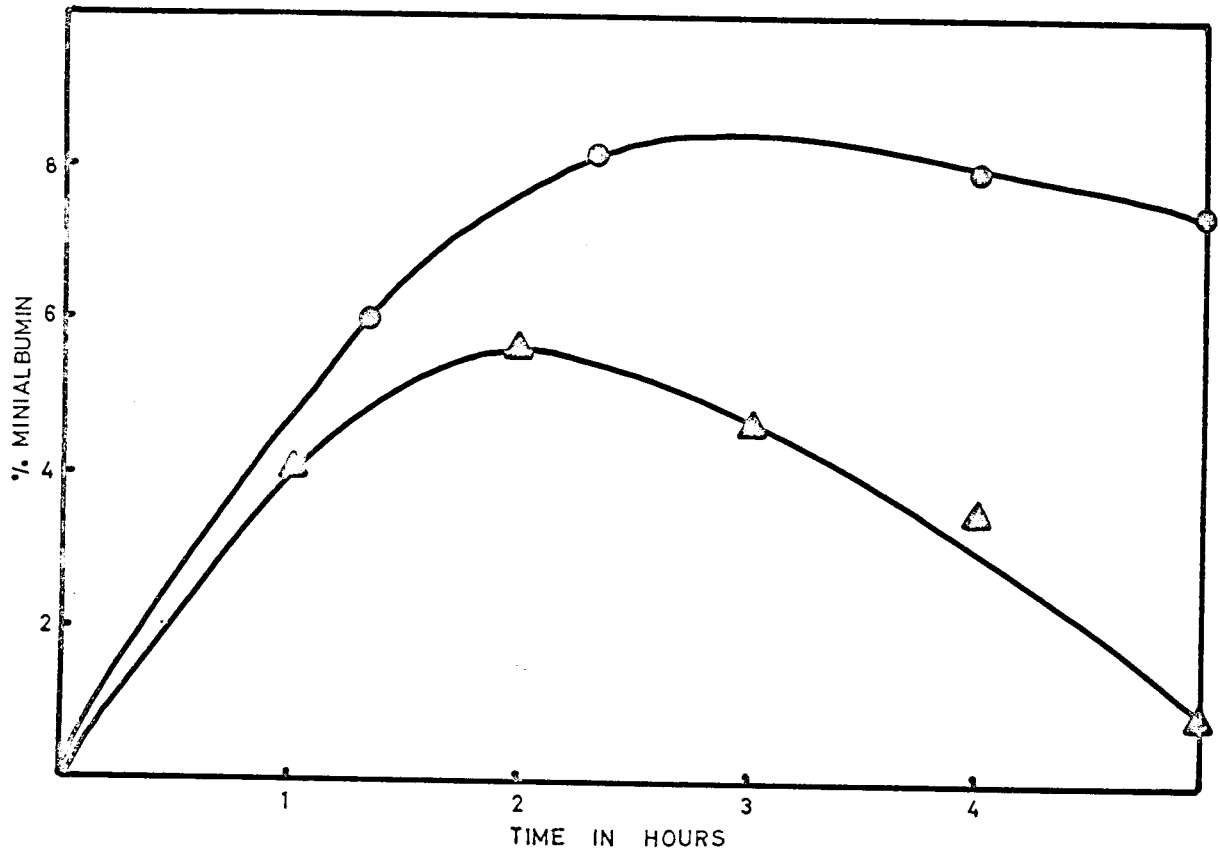

- NEWLY POISONED ANIMAL: NON-PROTEINURIC.
- ▲ CHRONICALLY POISONED ANIMAL: PROTEINURIC.

If a chronically poisoned animal was used, the fall in circulating minialbumin was much sharper and occurred sooner (Fig. 19).

II 8. (iii) Appearance of minialbumin in the urine

Minialbumin was first detected in the urine 3 - 4 weeks following its appearance in the circulatory system as described earlier. However, it appeared concurrently with albumin of normal size which was not the case with cadmium-poisoned men⁽¹⁰⁾. At the onset of detectable proteinuria there was a far greater amount of the smaller protein (Fig. 20A), while chronically poisoned animals exhibited a larger percentage of normal size albumin (Fig. 20B). The quantity of albumin in the urine on 5 successive days following a pulse dose of cadmium fell steadily, but not so rapidly as in the serum. Figure 21 shows the effect.

Proteinuria could be abolished during its very early stages by stopping the cadmium injections. However, once the animal became chronically poisoned, small amounts of minialbumin were excreted even in the absence of regular dosages of cadmium.

In all cases urinary albumin was isolated as described earlier in the text.

FIG. 20

APPEARANCE OF MINIALBUMIN
IN THE URINE.

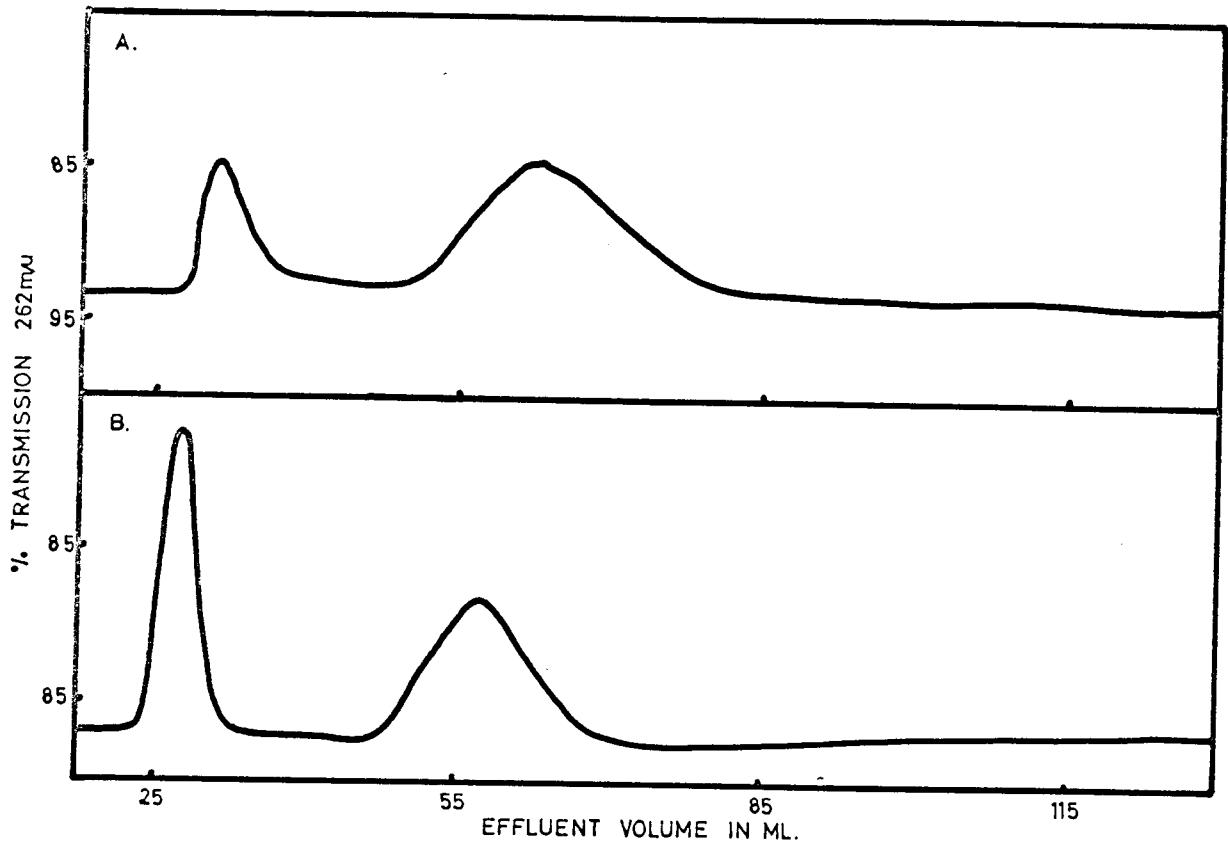

A. ONSET OF PROTEINURIA.
B. CHRONICALLY POISONED ANIMAL.

SEPHADEX G 75 IN 0.066M PHOSPHATE pH 7.0 + 0.5M NaCl.
COLUMN = 26 x 2.0 CMS. FLOW RATE = 15 ML. PER HOUR.

FIG. 21

FALL OFF IN THE EXCRETION
OF URINARY MINIALBUMIN.

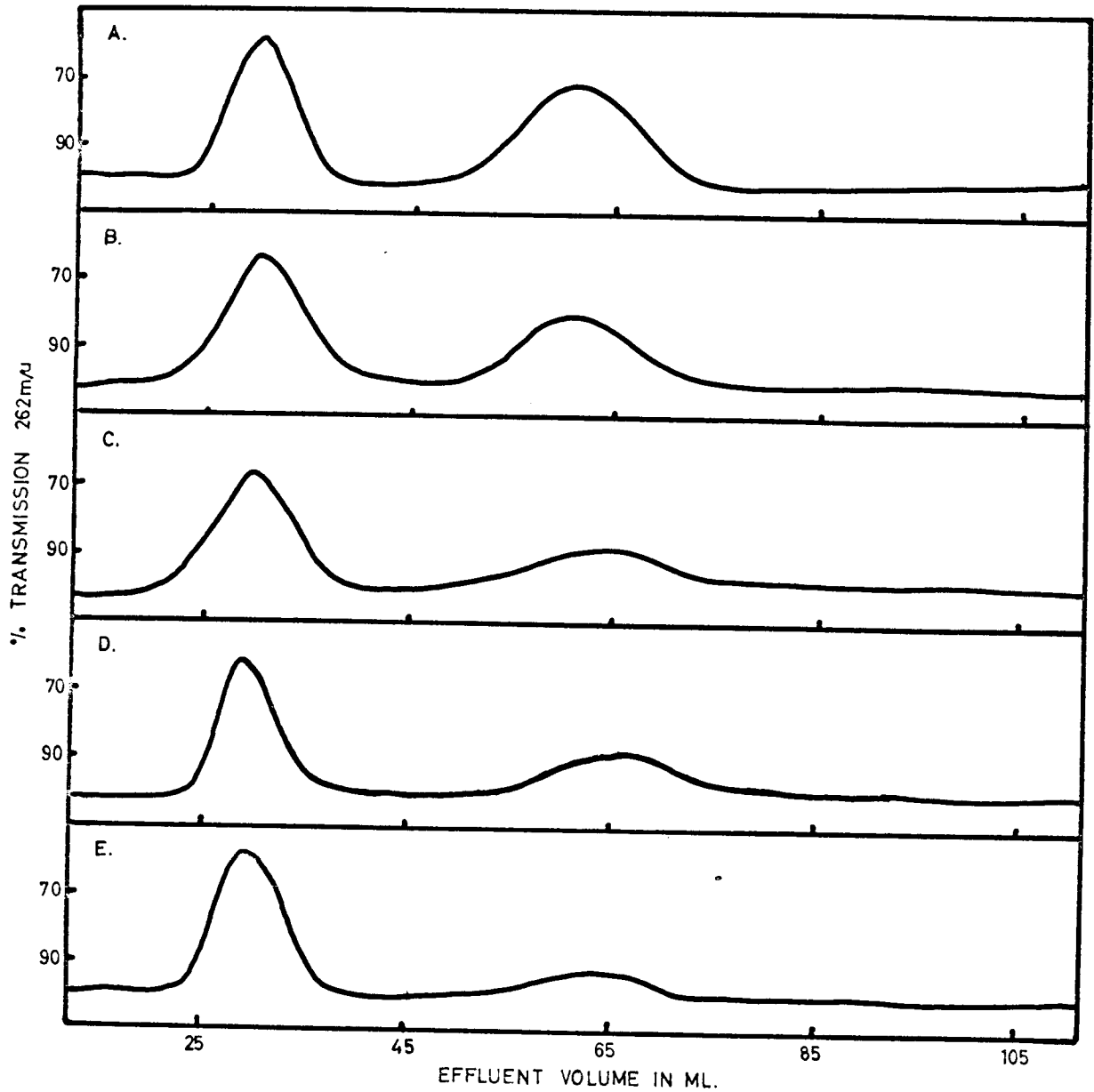

A-E = 1-5 DAYS FOLLOWING A CADMIUM DOSE.

SEPHADEX G 75 IN 0.066M PHOSPHATE pH 7.0 + 0.2M NaCl.

COLUMN = 42 x 1.8 CMS. FLOW RATE = 15 ML. PER HOUR.

II 8. (iv) Correlation between excretion of minialbumin
and excretion of cadmium

Smith, Kench and Lane⁽⁶³⁾ found that the cadmium and total excreted protein in the urine of industrial workers exposed to cadmium varied independently. The urinary excretion of cadmium was proportional to creatinine excretion, which implied glomerular filtration as mechanism for elimination of the metal (Smith and Kench, 1957⁽¹¹⁾). More recently, Axelsson and Piscator (1966)⁽³³⁾ claim to have shown that the excretion of cadmium in the urine of rabbits was significantly correlated with the function of the proximal tubules.

In order to discover whether there was any correlation between the excretion of cadmium and albumin in chronically poisoned monkeys, the quantities of cadmium and minialbumin excreted daily, following a pulse dose of 6 mg. cadmium, were measured and compared.

Cadmium was determined by the method of Smith et al (1955)⁽⁶³⁾ as described, and the albumins were prepared by the Vallance-Owen et al (1958)⁽⁹⁸⁾ method. Identical conditions for the isolation of the albumin were used for each sample and similar total percentage recoveries were assumed. The minialbumin was separated from that of normal size on columns of dextran gel.

Figure 4 shows the fall off in cadmium excretion to be hyperbolic, while that in minialbumin excretion is linear.

FIG. 4

EXCRETION OF MINIALBUMIN
AND CADMIUM.

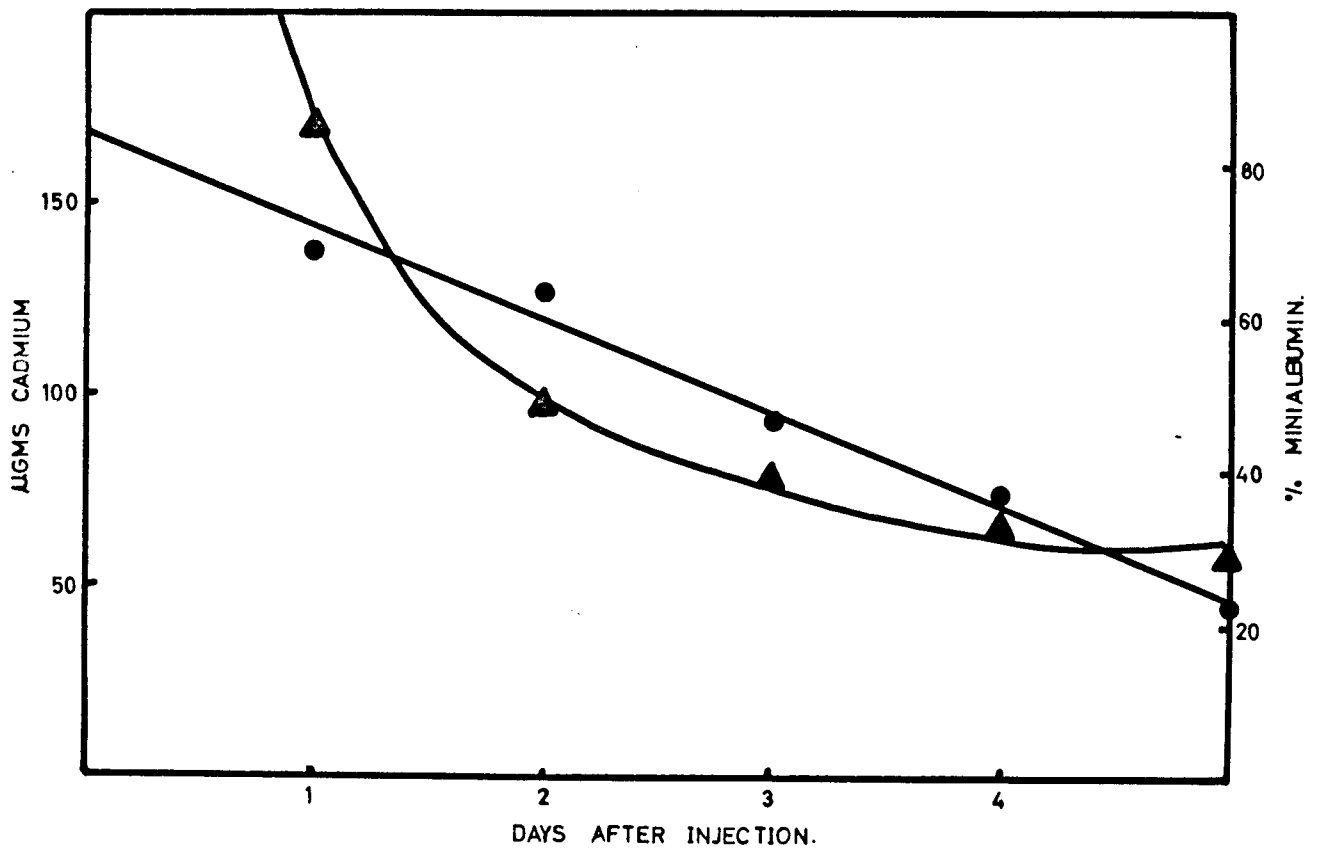

II 9. STUDIES TO ASCERTAIN WHETHER MINIALBUMIN WAS
AN ARTEFACT

II 9. (i) Effects of anticoagulant on minialbumin production

Heparin, a highly sulphated mucopolysaccharide⁽¹²³⁾, similar to chondroitin sulphate, and used as the anticoagulant in the administration of the cadmium, could conceivably play a role in minialbumin production and had, therefore, to be tested.

Its "in vitro" effect was checked by incubating isolated serum albumin, obtained from a normal monkey, with a volume of heparin equivalent to the amount normally injected. This was done under sterile conditions at 37° for 16 hr. This albumin, cycled through a Sephadex G75 column, showed no small molecules.

An "in vivo" effect was eliminated by injecting heparin alone and by using different anticoagulants. Heparin (0.5 ml. 5,000 I.U./ml.) on its own did not induce a rise in the circulating minialbumin. The alternative anticoagulants, sodium citrate and ethylene diamine-tetracetic acid (EDTA) gave results indicating that heparin was not responsible for production of minialbumin. 0.5 ml. of a 3.8% (w/v) solution of the monobasic sodium citrate salt was used, while 0.94 mg. EDTA was added per ml. of serum - this being the amount calculated for total chelation of the calcium, lead and cadmium ions present.

During this study it was noticed that EDTA apparently gave

rise to relatively larger quantities of minialbumin. This phenomenon was further investigated and will be discussed under 'Aggregation' studies.

II 9. (ii) The possibility of degradation on Sephadex columns

It was necessary to be sure that the smaller albumin was not being produced by fragmentation on the actual Sephadex column. Successive recycling of normal monkey albumin on the same column was the most effective test. This was initially done by collecting the protein peak, dialysing it against distilled water, freeze-drying it, and then running it again through the column. This procedure was repeated 3 to 4 times on the same protein sample. It was partially through this that the contamination from the Visking tubing - as described earlier - was discovered. Subsequently, salts were removed by fractionation on a Sephadex G10 column (42 x 1.8 cm.) , packed and equilibrated (in distilled water) as described in the earlier section.

The presence of salts in the effluent was tested for as follows:

- (a) Chloride. The aqueous solution was acidified with dilute nitric acid. The formation of a white precipitate on the addition of

silver nitrate to this is indicative of the presence of chloride⁽¹²⁴⁾.

- (b) Phosphate. This formed a yellow granular precipitate on slight heating in the presence of an excess of ammonium molybdate and nitric acid⁽¹²⁵⁾. These tests were not carried out quantitatively.

Figure 22 shows the separation of protein from inorganic ions on a Sephadex G10 column. The Sephadex fractionation was effective and successfully eliminated any contact with dialysis tubing. When it was done, no small molecular weight substances were found (Fig. 23), showing that minialbumin was not a column effect.

Columns run at 0° and 20° gave identical patterns indicating that temperature did not play any part.

Minialbumin was likewise treated as described above. Again desalting was performed on a G10 column. The records in Fig. 24 show that some normal size albumin appeared with each successive run. In each case only the small-sized albumin was recycled. This phenomenon inexplicable at the time the experiment was conducted, can now be accounted for in terms of aggregation of the minialbumin and will be discussed later in the thesis.

FIG. 22

DESALTING OF PROTEINS.

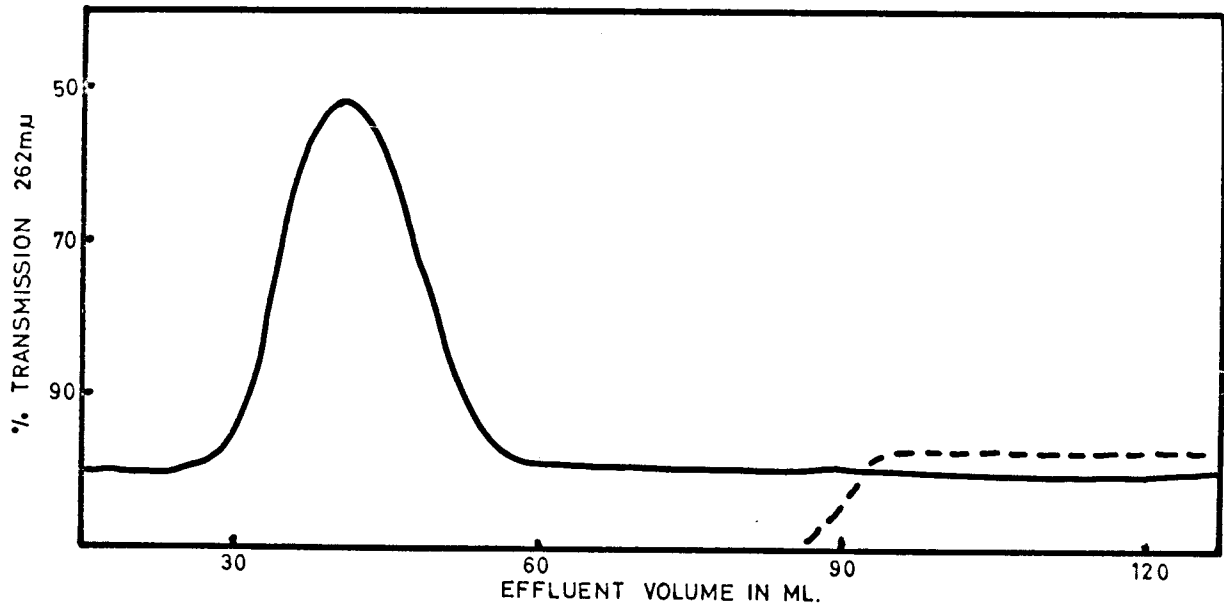

--- PRESENCE OF SALTS (NON QUANTITATIVE)
SEPHADEX G 10 IN DISTILLED WATER.
COLUMN = 42 x 1.8 CMS. FLOW RATE = 15 ML. PER HOUR.

FIG. 23

RECYCLING OF NORMAL ALBUMIN
ON SEPHADEX.

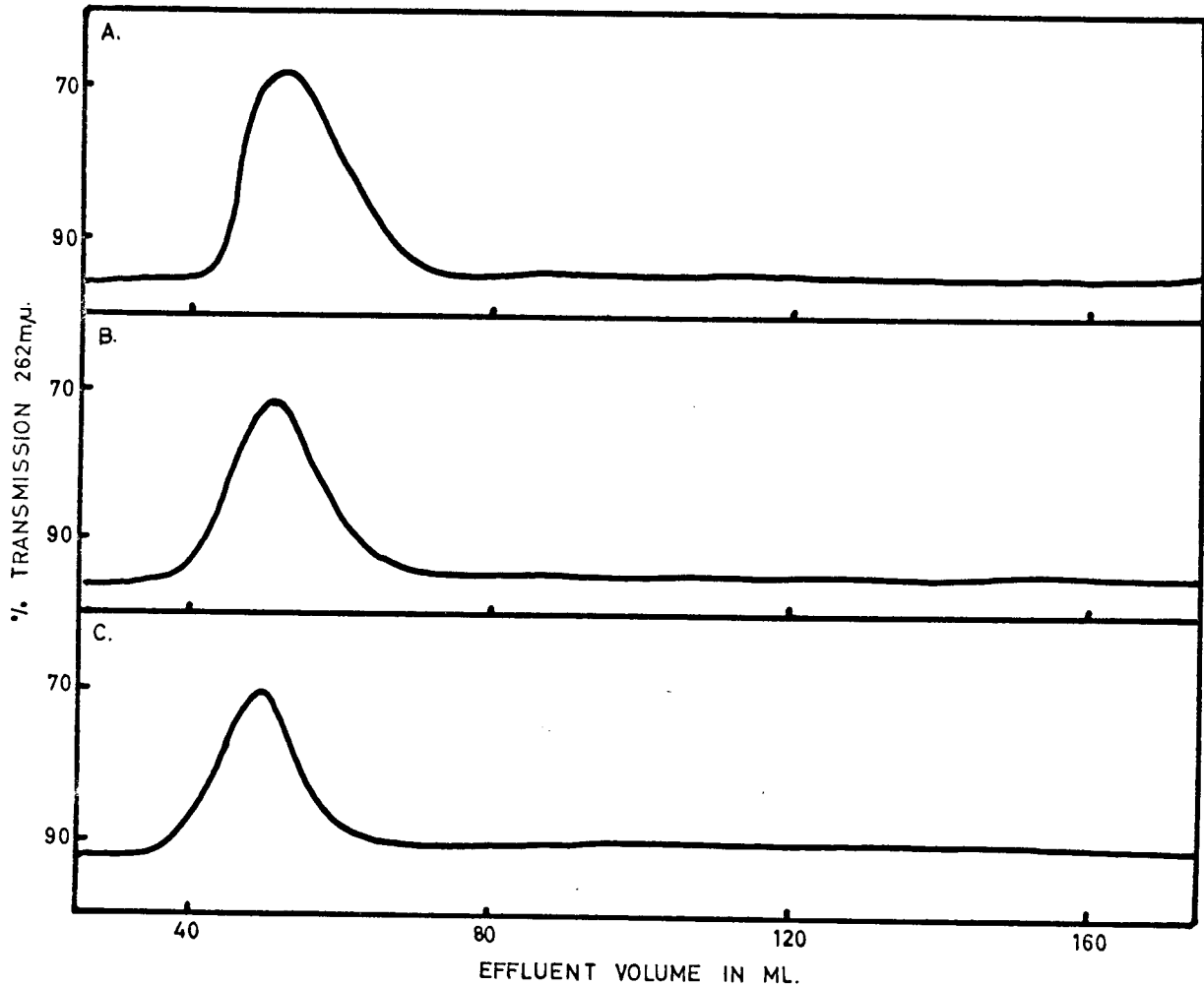

A,B,C. SUCCESSIVE RUNS OF THE SAME ALBUMIN FRACTION.
SEPHADEX G75 IN 0.066M PHOSPHATE pH 7.0 + 0.2M NaCl.
COLUMN = 42 x 18 CMS. FLOW RATE = 15 ML PER HOUR.

FIG. 24

RECYCLING OF MINIALBUMIN
ON SEPHADEX.

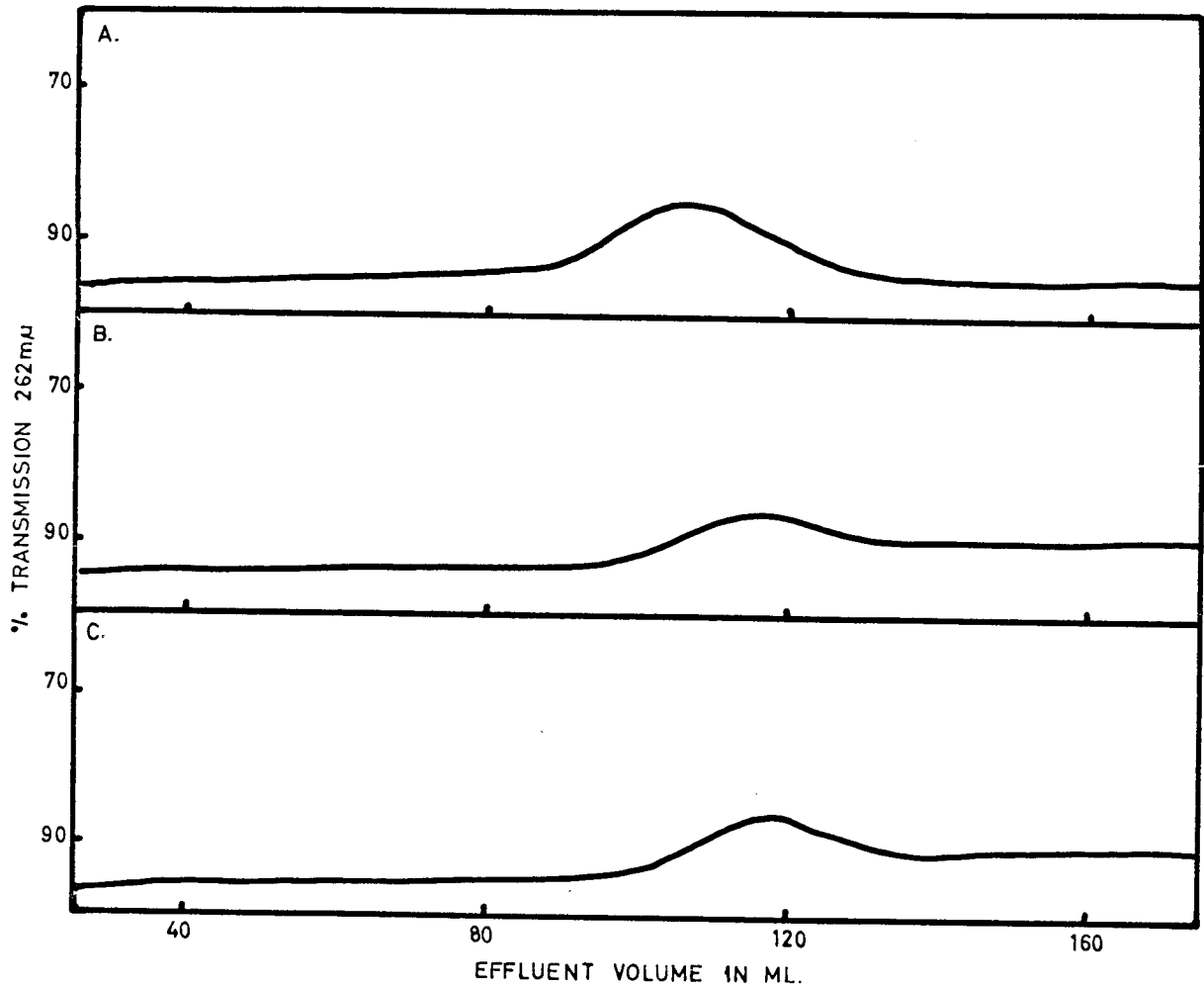

A,B,C. SUCCESSIVE RUNS OF THE SAME ALBUMIN FRACTION.

SEPHADEX G 75 IN 0.066M PHOSPHATE pH 7.0 + 0.2M NaCl.

COLUMN = 42 x 1.8 CMS. FLOW RATE = 15 ML. PER HOUR.

II 9. (iii) Tests for production of minialbumin by proteolysis of normal serum albumin

The possibility that hydrolytic processes, occurring during the isolation and purification of the albumin samples, were responsible for the presence of the small molecular weight moiety could not be overlooked. At the pH used in these experiments, trypsin was the most likely enzyme to be active. Hence, the use of trypsin inhibitor to check this.

Samples of serum, obtained from both a normal monkey and a poisoned monkey were divided into two. In each case, one of the two was treated with trypsin inhibitor (obtained from Soybeans, Seravac Laboratories, Cape Town) in concentrations of 3 $\mu\text{g./ml. serum}$ ⁽¹²⁶⁾. Albumins were then prepared by the HCl-ethanol method⁽¹⁰²⁾ and cycled through Sephadex G75. Figure 25 shows the records. It is evident that there was no difference between them, and that minialbumin was not the result of tryptic breakdown.

As a further method of checking, ϵ amino caproic acid, which has been shown to be a suitable stabilizer against spontaneous proteolysis⁽¹²⁷⁾ was used. Its effect^(128,129) in concentrations of not less than 0.06M was to inhibit non-competitively the proteolytic action shown by plasmin or trypsin. It also exhibits no toxic or noxious effects.

Addition of \leq amino caproic acid had no measurable effect on the formation of minialbumin.

On the basis of these results it was very unlikely that minialbumin arose by proteolytic breakdown during isolation of the albumin fraction.

FIG. 25

THE EFFECT OF TRYPSIN INHIBITOR.

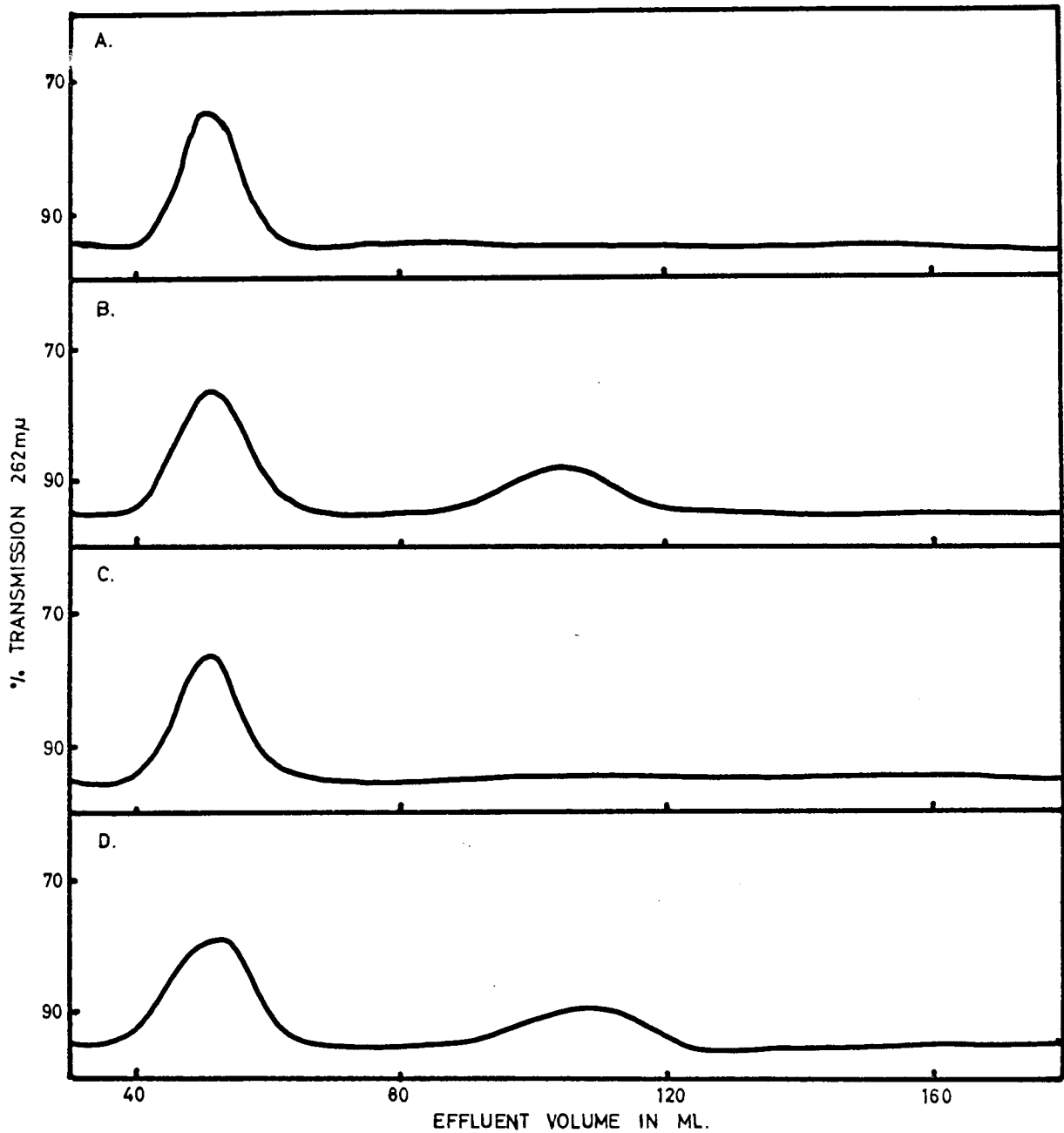

- A. NORMAL MONKEY ALBUMIN. B. CADMIUM POISONED MONKEY ALBUMIN.
C. NDRMAL MONKEY ALBUMIN WITH TRYPSIN INHIBITOR.
D. CADMIUM MONKEY ALBUMIN WITH TRYPSIN INHIBITOR.

SEPHADEX G 75 IN 0.066M PHOSPHATE pH 7.0 + 0.2M NaCl.
COLUMN = 42 x 1.8CMS. FLOW RATE = 15 ML. PER HOUR.

II 10. PRELIMINARY STUDY OF THE EFFECT OF CADMIUM
ON GLOBULINS

Electrophoretic studies on the serum proteins of cadmium-poisoned monkeys, as compared with normal monkeys (as described earlier in the test) showed a decreased γ globulin concentration. Preliminary studies were made on this effect.

II 10. (i) Serum. γ globulins were separated from the sera of normal and cadmium-poisoned animals by the rivanol method⁽¹³⁰⁾. This procedure involved selective precipitation of the serum proteins with aqueous rivanol (2 ethoxy 2,9 diamino acridine lactate) and subsequent removal of the rivanol with activated charcoal. The method, modified by Kistler, Nitschmann, Wyttenbach, Studer, Niederost and Mauerhofer (1960)⁽¹³¹⁾, was carried out according to the following steps:

- (a) The pH of the serum was adjusted to 9.4 with 0.1N NaOH.
- (b) 3.5 ml. of a 0.4% (w/v) aqueous rivanol solution was added dropwise, with constant mixing, for every 1 ml. of serum.
- (c) The pH was adjusted again to 9.4 with 0.1N NaOH.

- (d) The mixture was allowed to stand for 1 hr. during which time precipitation occurred.
- (e) The clear supernatant, containing the γ globulins, was removed by decantation after centrifugation. Activated charcoal was added to the supernatant, with constant stirring until the rivanol was completely adsorbed. (An excess of charcoal will greatly reduce the yield of γ globulin).
- (f) The charcoal was subsequently removed by filtration, using Whatman No. 1 paper, and well washed with 0.9% (w/v) saline. This washed off only the adsorbed protein. The filtrates were combined and lyophilized.

The purity of the product was checked by electrophoresis on cellulose acetate⁽¹⁰⁹⁾, which showed the γ globulin fraction to be contaminated with transferrin. This, being of large enough molecular weight (90,000) not to interfere with the present studies, was not removed.

This method, certainly not the best for the preparation of γ globulin, was chosen because of its simplicity and the rapidity with which it could be completed. Other more precise procedures involved ion exchange chromatography and the use of dialysis tubing.

The isolated γ globulins were cycled through Sephadex G75 columns, containing 0.2M sodium chloride and 2% (w/v) urea, to check for the presence of molecules of 20,000 Mol. wt. and less. There was some small molecular weight material present, but it was common to both the normal and poisoned monkeys. Further studies on this small molecular weight fraction were not undertaken.

II 10. (ii) Urine. γ globulins were also isolated from the urine of chronically poisoned, proteinuric animals. This was done by initial precipitation with ammonium sulphate to 50% saturation at 0°. The precipitate was dialysed free of salt with successive changes of cold distilled water and then freeze-dried. Subsequent purification was on diethylaminoethyl cellulose (DE 32 microgranular form) with elution chromatography using a salt gradient.

The cellulose was prepared by washing successively in 0.5N hydrochloric acid in 96% (v/v) aqueous ethanol, with water to pH 4, in 0.5N sodium hydroxide, and in water to

pH 8.0. The cellulose was then washed in several volumes of starting buffer before being packed into a column using the funnel method. The column was equilibrated and the sample was dialysed against the starting buffer overnight.

A starting buffer of 0.01N tris-HCl, pH 8.0, and a limiting buffer of 0.30N tris-HCl, pH 8.0⁽¹³²⁾ with a linear gradient and a total volume of 1l. over 16 hr. were employed. The effluent was passed through a Beckman Spectrochrom analyser model 135, and the optical density at 260, 280 and 410 m μ automatically recorded. The peaks identified as γ globulin on cellulose acetate electrophoresis were combined and rechromatographed on Sephadex gel G75. There was apparently a range of molecular sizes present, and the results were decidedly inconclusive.

II 11. ACUTE CADMIUM POISONING IN RATS

Short term experiments to examine the in vivo effects of cadmium on albumin metabolism were carried out, by acutely poisoning rats⁽¹²¹⁾. The method of administration of the cadmium has already been described.

Rats were killed at 0, 40, 90, 180 and 1440 min. intervals after a single intraperitoneal injection. Control animals, injected with saline, were killed at 60 min. Killing was performed by holding a heavy rod against the neck of the animals, and then strongly jerking the animal upwards by the tail, thus breaking the neck. Blood was withdrawn immediately from the aorta and hepatic portal vein with a syringe; and the liver and kidneys dissected as quickly as possible and placed in cold physiological saline (0.85% w/v). The effects of cadmium on the serum and tissues are discussed below.

II 11. (i) Serum.

After clotting, serum was isolated by centrifugation and albumin prepared from it by both the TCA-ethanol⁽⁹⁸⁾ and the HCl-ethanol⁽¹⁰²⁾ methods. The purified albumins were passed through Sephadex G75, and Fig. 26 shows the records obtained. A peak of minialbumin appeared an hour and a half after the cadmium dose. This seemed to indicate that cadmium

FIG. 26

PREPARATION OF RAT SERUM ALBUMINS.

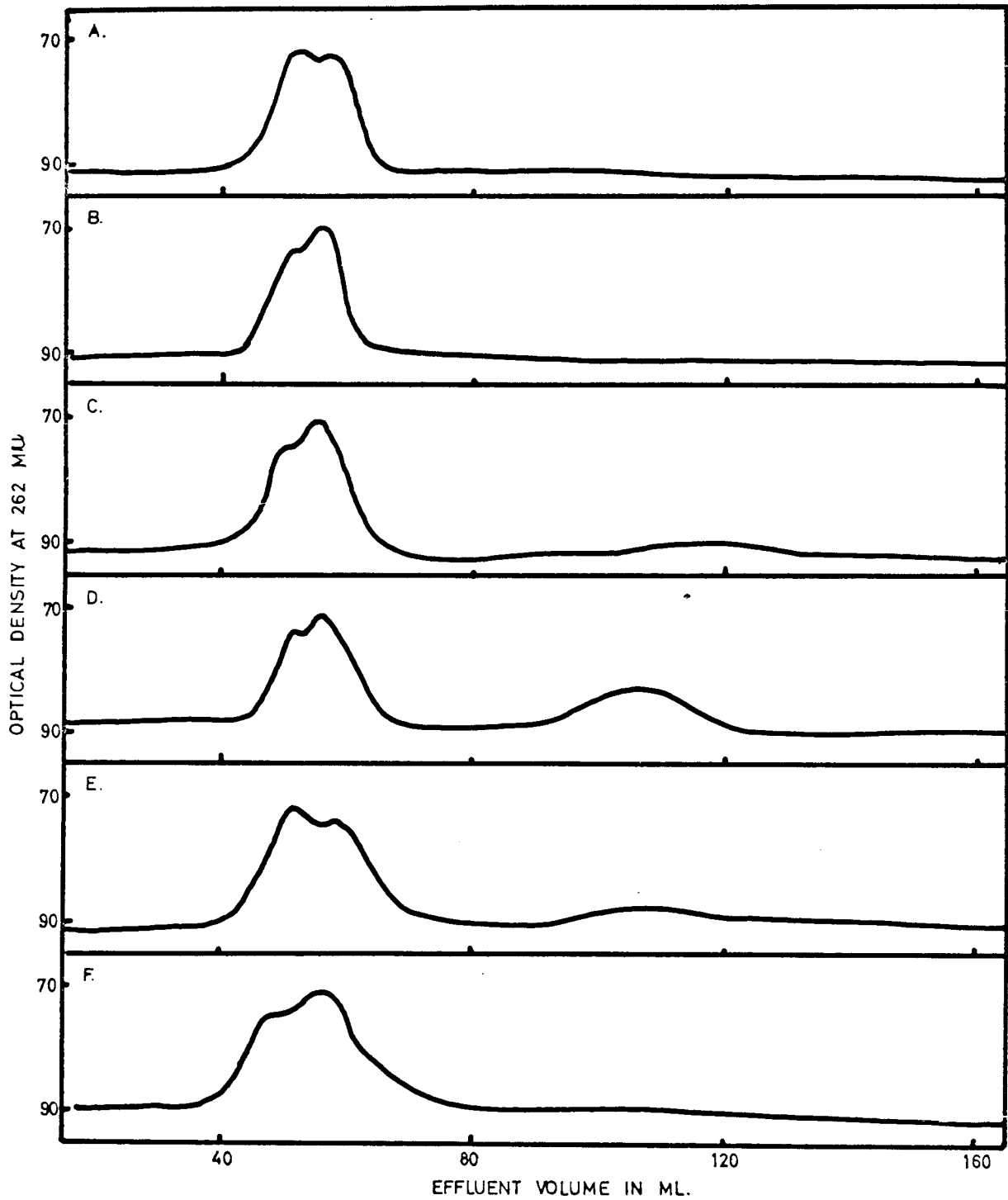

A. CONTROL. B-F. ANIMALS KILLED AT 0, 40, 90, 180, 1440 MINUTES.

SEPHADEX G 75 IN 0.066M PHOSPHATE pH 7.0 + 0.2M NaCl.
COLUMN = 42 x 1.8 CMS. FLOW RATE = 15 ML. PER HOUR.

somehow interfered with the synthetic process, or with the newly formed and liberated albumin. After 24 hr. there was a complete absence of minialbumin suggesting that the effect of cadmium in acute poisoning was in fact short-lived.

The whole sera, obtained at the various time intervals, were electrophoresed on the Analytrol⁽⁸⁶⁾ machine as described under general biochemical investigations.

The scans of the electrophoretic patterns are shown in Fig. 27. A distinct pre-albumin fraction was evident at 90 min., but had markedly fallen 180 min. after the injection. As this pre-albumin appeared and disappeared concurrently with the minialbumin, it was decided to determine whether or not they were the same protein. However, the difficulty of isolating enough of this material led to inconclusive results on this issue. It was also notable that the electrophoretic spread of animals poisoned with cadmium was markedly less than the normal.

II 11. (ii) Tissues.

Tissues were washed initially several times in cold physiological saline and then fractionated essentially by the method of Wust and Novelli (1964)⁽¹³³⁾. As

FIG. 27

ELECTROPHORESIS OF POISONED
RAT SERUM.

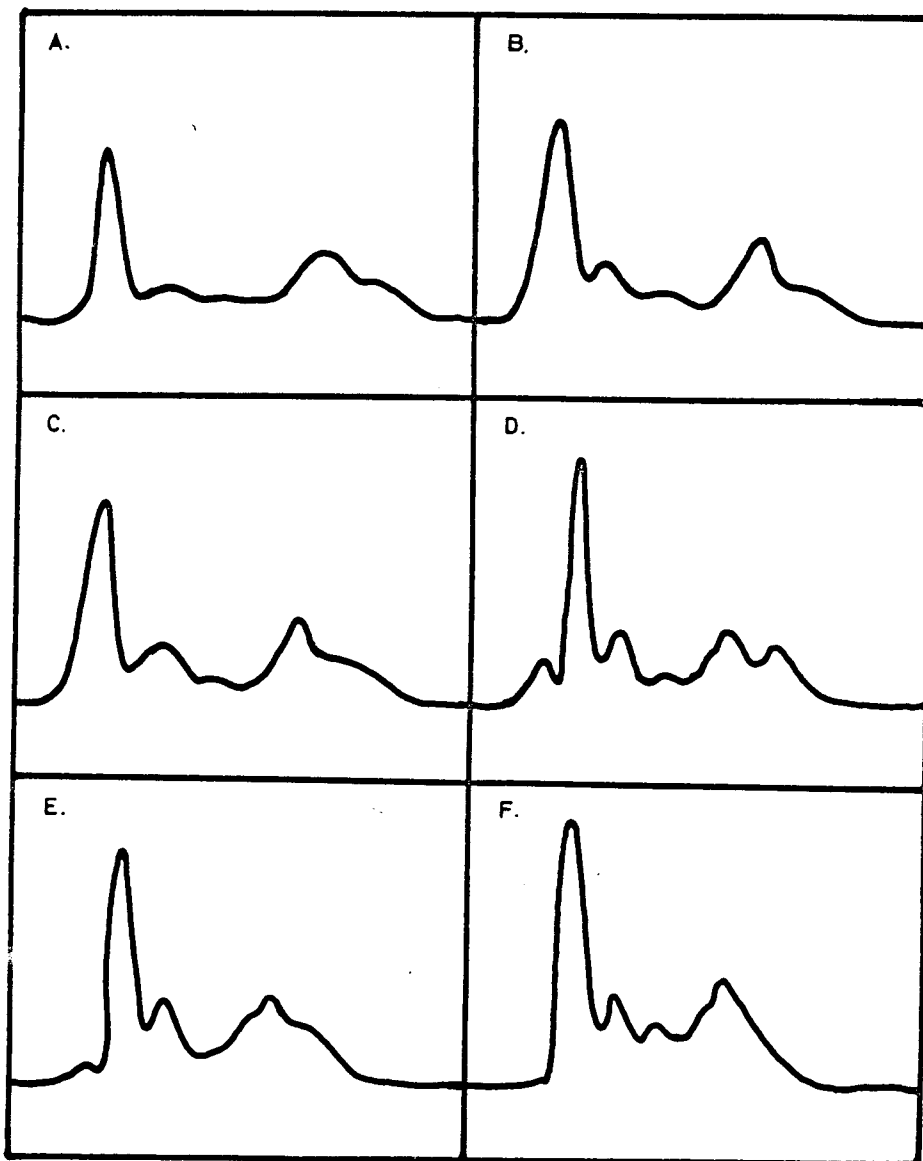

A. CONTROL - SALINE.
C. KILLED AT 40 MINS.
E. KILLED AT 180 MINS.

B. KILLED AT 0 MINS.
D. KILLED AT 90 MINS.
F. KILLED AT 1440 MINS.

active microsomes were not required, a 0.066 M phosphate buffer at pH 7.0 and containing 0.2M sodium chloride was the chosen medium. The tissues, cut into small pieces, were suspended in the above buffer, and homogenized in a Potter Elvehjorth glass homogenizer. Centrifugation at 10,000 g. for 20 min. removed the cell debris, while continuing for 90 min. at 105,000 g. removed membranes, mitochondria and ribosomes.

The clear supernatant - the soluble fraction of the cell - was treated by the TCA-ethanol⁽⁹⁸⁾ and HCl ethanol methods⁽¹⁰²⁾ for the preparation of albumin. The isolated proteins were fractionated on Sephadex gel G75 in the normal fashion. Figs. 28 and 29 show the record for liver and kidney albumins respectively.

It was of especial interest to note the presence of minialbumin in the tissues of normal animals. Injection of cadmium caused an increase in this minialbumin, most marked at 90 min., and a slight proportional decrease in the albumin of normal size. The effect in the kidney appeared to outlast that in the liver.

II 11. (iii) Urine.

The only specimen of urine large enough for

FIG. 28

PREPARATION OF RAT LIVER ALBUMINS.

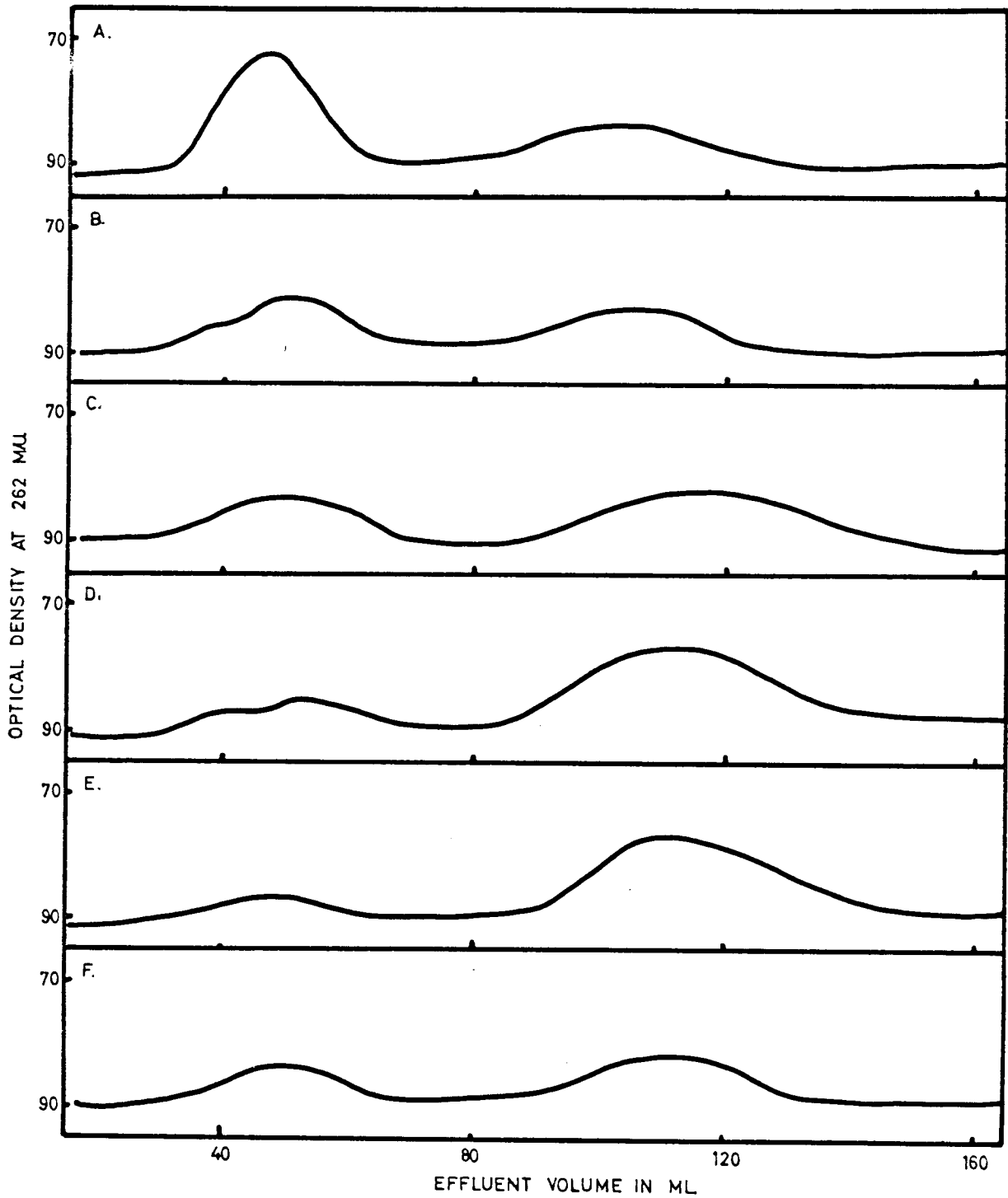

A. CONTROL. B - F ANIMALS KILLED AT 0, 40, 90, 180, 1440 MINUTES.

SEPHADEX G 75 IN 0.066M PHOSPHATE pH 7.0 + 0.2M NaCl.
COLUMN = 42 x 1.8 CMS. FLOW RATE = 15 ML. PER HOUR.

FIG. 29

PREPARATION OF RAT KIDNEY ALBUMINS.

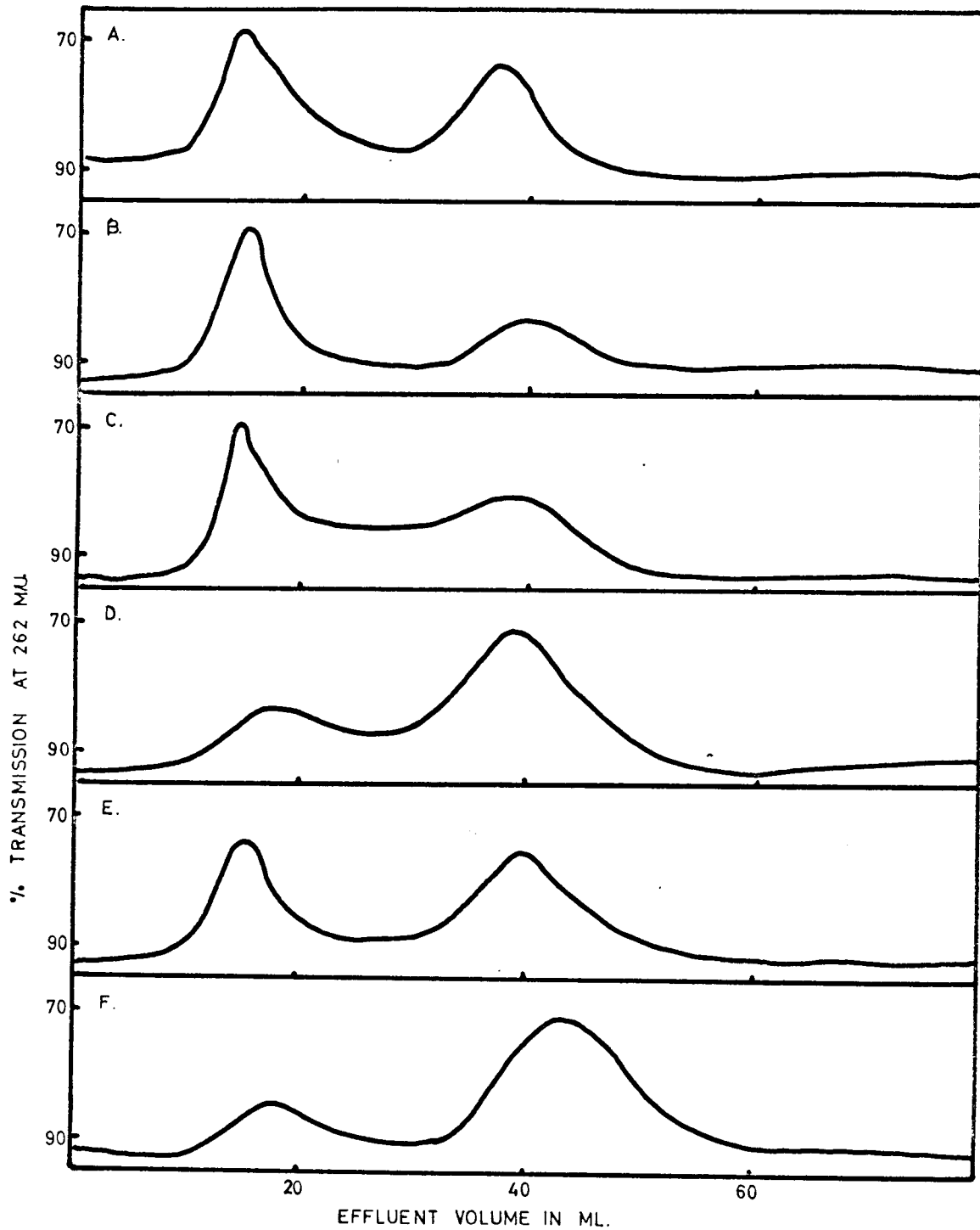

A. CONTROL. B-F ANIMALS KILLED AT 0, 40, 90, 180, 1440 MINUTES.

SEPHADEX G 75 IN 0.066M PHOSPHATE pH 7.0 + 0.2M NaCl.
COLUMN = 16 x 1.6 CMS. FLOW RATE=18 ML. PER HOUR.

analysis was that obtained for the series of rats killed at 24 hr. The urine collected was filtered and then tested for proteinuria with TCA, salicyl sulphonic acid, and by boiling as described earlier. These were all found to be negative, indicating that a single dose of cadmium did not have such immediate direct effects on tissues as to give rise to proteinuria.

II 11. (iv) Characterization of rat minialbumin

(a) Antigenic studies: Both the immunoelectrophoretic and double diffusion techniques performed exactly as described (II 12. (vi)) were used. The minialbumins of serum, liver and kidney had similar mobility and antigenicity to normal rat serum albumin on electrophoresis and immunodiffusion with a polyvalent antiserum⁽¹¹⁰⁾ (Fig. 30A). On Ouchterlony⁽¹³⁴⁾ plates the minialbumins displayed a reaction of identity with normal serum albumin (Fig. 30B). Only multivalent antiserum was used and this was prepared and tested for titre as described (under II 12.(vi)).

(b) Amino acid analysis: The techniques involved were those described (II 12.(iii)). The overall composition of normal rat serum albumin was found to correspond closely with values obtained by other workers^(135,136,137) as is shown in Table 7.

FIG. 30

CHARACTERIZATION OF RAT ALBUMINS.

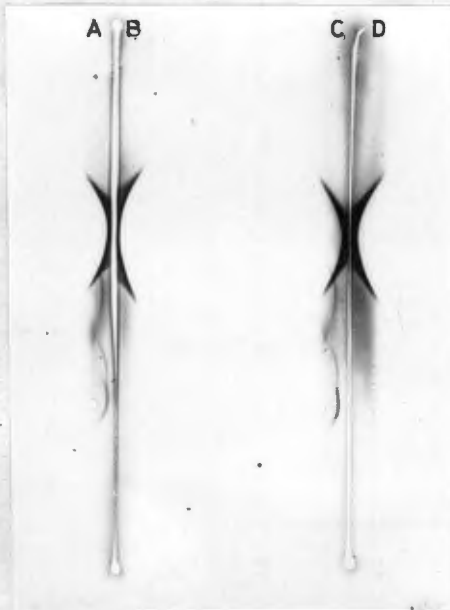

IMMUNOELECTROPHORESIS.

- A. NORMAL RAT WHOLE SERUM.
- B. CADMIUM RAT NORMAL ALBUMIN.
- C. NORMAL RAT WHOLE SERUM.
- D. CADMIUM RAT MINIALBUMIN.

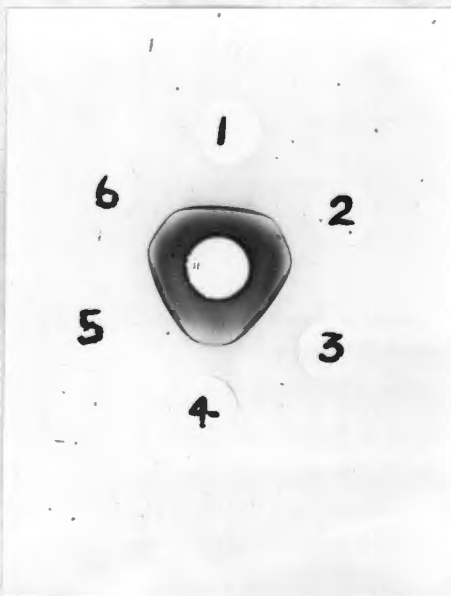

OUCHTERLONY PLATE.

- 1. Cd RAT SERUM NORMAL ALBUMIN.
- 2. Cd RAT SERUM MINIALBUMIN.
- 3. Cd RAT LIVER NORMAL ALBUMIN.
- 4. Cd RAT LIVER MINIALBUMIN.
- 5. Cd RAT KIDNEY NORMAL ALBUMIN.
- 6. Cd RAT KIDNEY MINIALBUMIN.

TABLE 7.Amino acid composition of rat serum albumin

| Amino acid | Residues/mole serum albumin | | | |
|-----------------------|-----------------------------|----|----|----|
| | A | B | C | D |
| Lysine | 50 | 51 | 49 | 52 |
| Histidine | 14 | 14 | 14 | 15 |
| Arginine | 23 | 22 | 22 | 22 |
| Aspartic acid | 50 | 50 | 52 | 52 |
| Threonine | 31 | 32 | 30 | 29 |
| Serine | 23 | 24 | 20 | 22 |
| Glutamic acid | 77 | 83 | 86 | 82 |
| Proline | 29 | 30 | 31 | 28 |
| Glycine | 17 | 18 | 17 | 17 |
| Alanine | 58 | 63 | 61 | 60 |
| $\frac{1}{2}$ Cystine | 30 | 37 | 32 | 29 |
| Valine | 33 | 32 | 34 | 34 |
| Methionine | 6 | 6 | 6 | 6 |
| Iso-leucine | 13 | 14 | 14 | 14 |
| Leucine | 53 | 55 | 59 | 55 |
| Tyrosine | 22 | 19 | 21 | 19 |
| Phenylalanine | 23 | 24 | 26 | 25 |

- A Peters (1962)⁽¹³⁵⁾
 B Jungblut and Turba (1963)⁽¹³⁶⁾
 C Sargent and Campbell (1965)⁽¹³⁷⁾
 D Present work

Only serum and liver albumins were analysed, and the amino acid composition of these albumins is shown in Table 8. The residues are expressed in g. amino acid/100 g. protein, to allow for any variations in the molecular size of the minialbumins. The values given are a mean of three or four determinations. Kidney albumins were not investigated as insufficient material was available.

As was found with the monkey albumins, the mini counterparts were deficient in lysine and cystine content. In addition, there was apparently less proline in the minialbumins of rat serum and liver and an increased amount of methionine. The histograms in Figs. 31 and 32 show these differences more clearly.

(c) The tryptophan content of the rat albumins: This was determined by the pDMAB colour method (II 12. (iv)). Table 9 shows that, as with the monkey minialbumin, the mini-albumin found in rats was devoid of tryptophan. Normal size albumin was shown to contain only one residue of tryptophan in its amino acid chain. This was in accord with the findings of Peters (1962)⁽¹³⁵⁾.

TABLE 8.Amino acid composition of rat serum and liver albumins

| Amino acid | g. residues/100 g. protein | | | | |
|-----------------------|----------------------------|--------|--------|--------|--------|
| | NRNSA | CdRNSA | CdRMSA | CdRNLA | CdRMLA |
| Lysine | 11.07 | 10.02 | 10.19 | 11.17 | 9.52 |
| Histidine | 3.33 | 3.20 | 3.19 | 3.39 | 2.59 |
| Ammonia | 1.58 | 1.62 | 2.22 | 2.13 | 2.43 |
| Arginine | 5.81 | 6.18 | 5.26 | 5.98 | 4.45 |
| Aspartic acid | 8.10 | 8.53 | 9.39 | 8.41 | 10.33 |
| Threonine | 4.22 | 4.43 | 4.50 | 4.11 | 4.85 |
| Serine | 2.67 | 2.87 | 3.34 | 3.00 | 3.76 |
| Glutamic acid | 14.89 | 15.62 | 14.51 | 14.54 | 14.95 |
| Proline | 3.72 | 3.81 | 0.35 | 4.04 | 1.39 |
| Glycine | 1.37 | 1.43 | 2.52 | 1.60 | 3.57 |
| Alanine | 5.92 | 6.19 | 5.85 | 5.80 | 5.86 |
| $\frac{1}{2}$ Cystine | 3.28 | 2.55 | 0.76 | 1.66 | 0.78 |
| Valine | 4.71 | 4.83 | 4.91 | 4.55 | 5.17 |
| Methionine | 0.98 | 0.99 | 3.82 | 0.75 | 1.98 |
| Iso-leucine | 2.16 | 2.23 | 2.82 | 2.21 | 3.22 |
| Leucine | 8.65 | 8.97 | 8.47 | 8.60 | 8.16 |
| Tyrosine | 4.28 | 4.32 | 3.74 | 3.81 | 4.04 |
| Phenylalanine | 5.13 | 5.32 | 5.02 | 4.96 | 4.75 |
| Totals | 91.87 | 93.11 | 90.86 | 90.71 | 91.10 |

NRNSA = Normal rat normal serum albumin

CdRNSA = Cadmium rat normal size serum albumin

CdRMSA = Cadmium rat mini serum albumin

CdRNLA = Cadmium rat normal size liver albumin

FIG. 31

AMINO ACID COMPOSITION OF
RAT SERUM ALBUMINS.

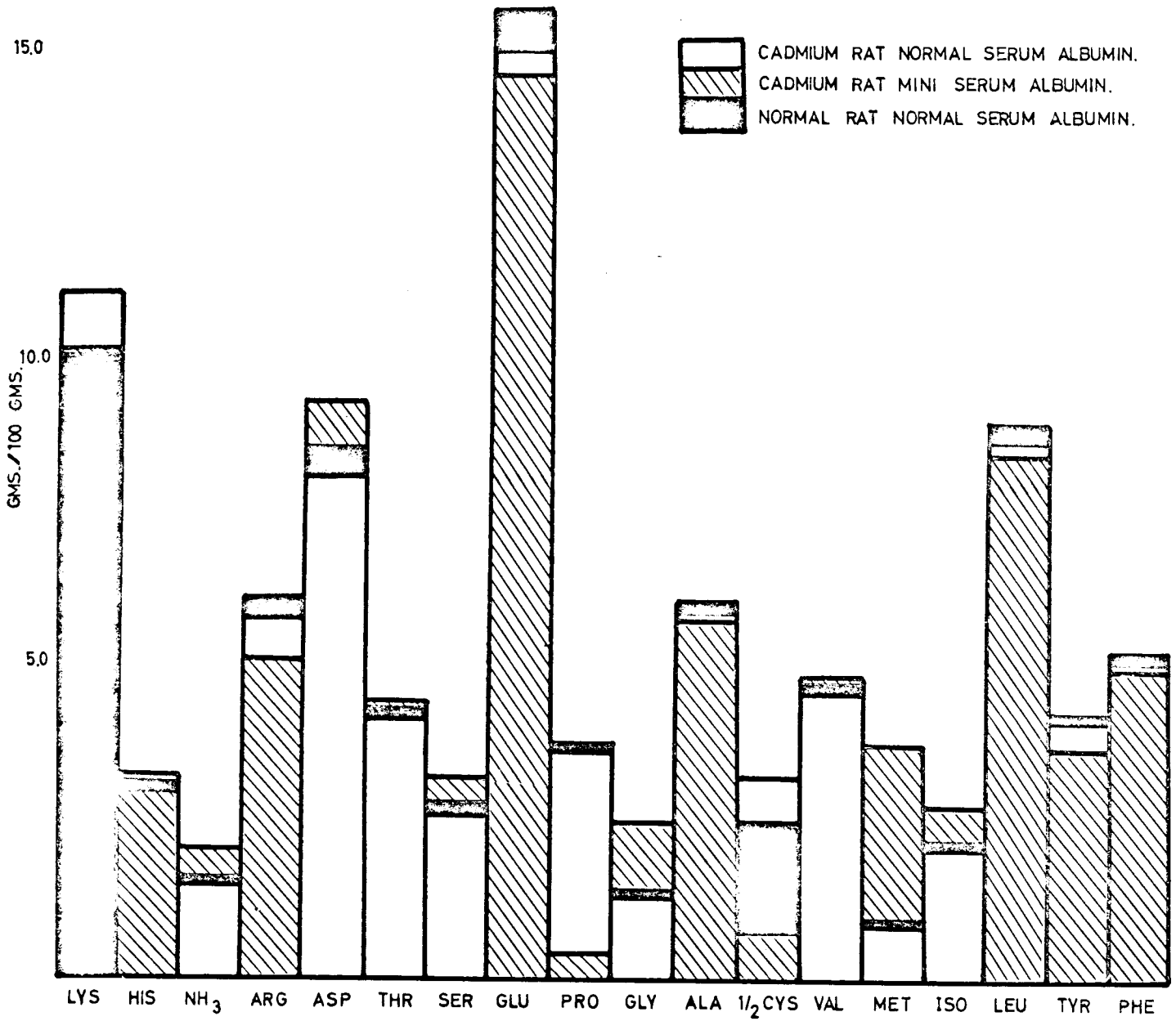

FIG. 32

AMINO ACID COMPOSITION OF
RAT LIVER ALBUMINS.

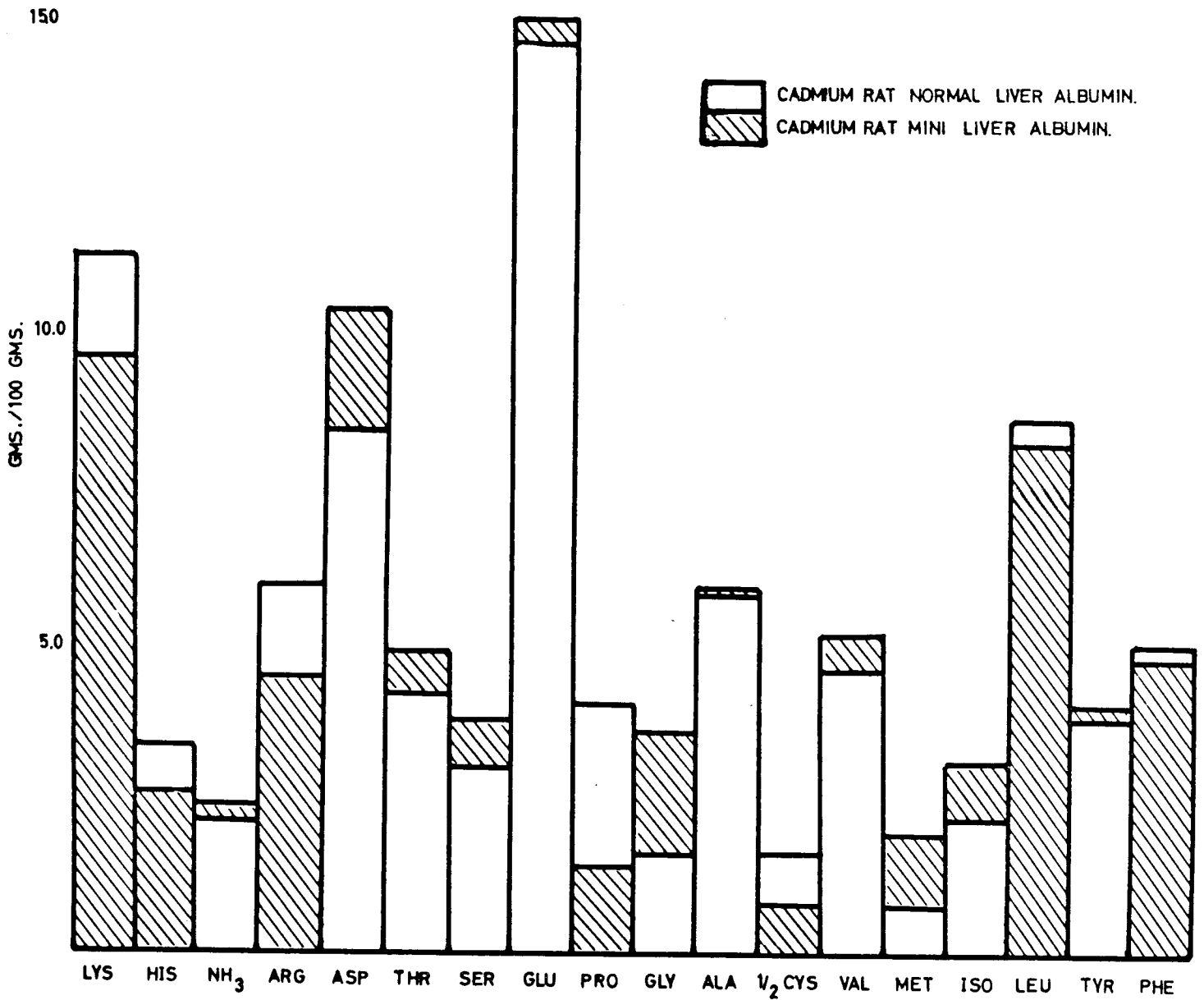

TABLE 9.

Tryptophan content of albumins of rat serum, liver
and kidney

| Sample | Residues tryptophan per mole albumin |
|--|---|
| Normal rat serum normal albumin | 0.81 |
| Cadmium rat serum normal size albumin | 0.93 |
| Cadmium rat serum minialbumin | 0.00 |
| Cadmium rat liver normal albumin | 0.72 |
| Cadmium rat liver minialbumin | 0.00 |
| Cadmium rat kidney normal albumin | 0.67 |
| Cadmium rat kidney minialbumin | 0.00 |

II 12. CHARACTERIZATION OF THE ALBUMINS OF CADMIUM POISONING

II 12. (i) Cellulose acetate electrophoresis

The introduction of cellulose acetate as a supporting medium for electrophoresis was of great value as it afforded superior separation and resolution of protein mixtures than did the older paper method. Kohn (1957)⁽¹³⁸⁾ first described the principle and advocated the use of cellulose acetate because it is microporous, homogeneous and chemically relatively pure as well as showing minimal absorption effects and thus eliminating 'tailing'. It has further advantages in that separation is rapid and only very small quantities of protein are required.

The actual procedure followed was that outlined by Kohn (1960)⁽¹⁰⁹⁾. Oxoid electrophoresis strips, 18 x 5 cm., were impregnated with the tank buffer, which was a sodium barbitone-barbitone mixture of ionic strength 0.01 and at pH 8.6. The sample was spotted, with the aid of an applicator, to the just moist strip (which had been gently blotted with filter) 11 cm. from one end. The strips were then placed in the tank making sure of a good contact with the wicks (Whatman No. 1 filter paper) (Fig. 33). Electrophoresis in a horizontal plane, was continued at a potential difference of 25 V/strip for 90 min. On completion of the

FIG. 33

CELLULOSE ACETATE ELECTROPHORESIS.
APPARATUS.

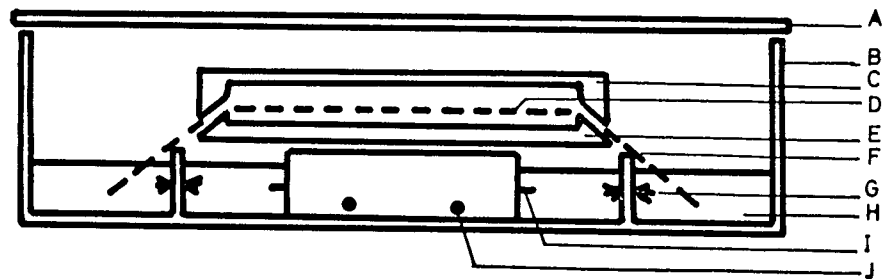

- A. AIRTIGHT COVER
- B. PERSPEX TANK
- C. BAR FOR KEEPING STRIPS TAUT
- D. CELLULOSE ACETATE STRIP
- E. SUPPORT FOR STRIPS
- F. WHATMANS NO.1 WICK
- G. COTTON WICK
- H. BUFFER
- I. TERMINAL
- J. ELECTRODE

run the strips were removed and the protein band simultaneously fixed and stained with a 0.975% (w/v) aqueous lissamine green (G.T. Gurr) solution containing 1.5% (w/v) salicylsulphonic acid as the protein precipitating agent. Staining was complete within 10 - 15 min. and the backgrounds were then cleared with aqueous 1% (v/v) acetic acid. At all stages, the strips were handled with forceps to prevent finger-marking. Strips were then allowed to dry on the bench, and pressed between filter paper pads till flat.

It was necessary to dilute whole serum to one-quarter of its concentration (1 vol. serum + 3 vol. buffer), while purified samples were generally run as 1% (w/v) protein solutions. Fig. 34 shows the results obtained with the various fractions, and the purity of the isolated albumins is established by the complete absence of any other serum or urinary components. This particular method was used as a test for purity of the albumins to be studied further.

II 12. (ii) Studies on the aggregation-disaggregation phenomenon of minialbumin

During the course of the work, it was observed that variation in the ionic strength of the buffer employed in the gel columns gave rise to varying amounts of minialbumin

FIG. 34

CELLULOSE ACETATE ELECTROPHORESIS.

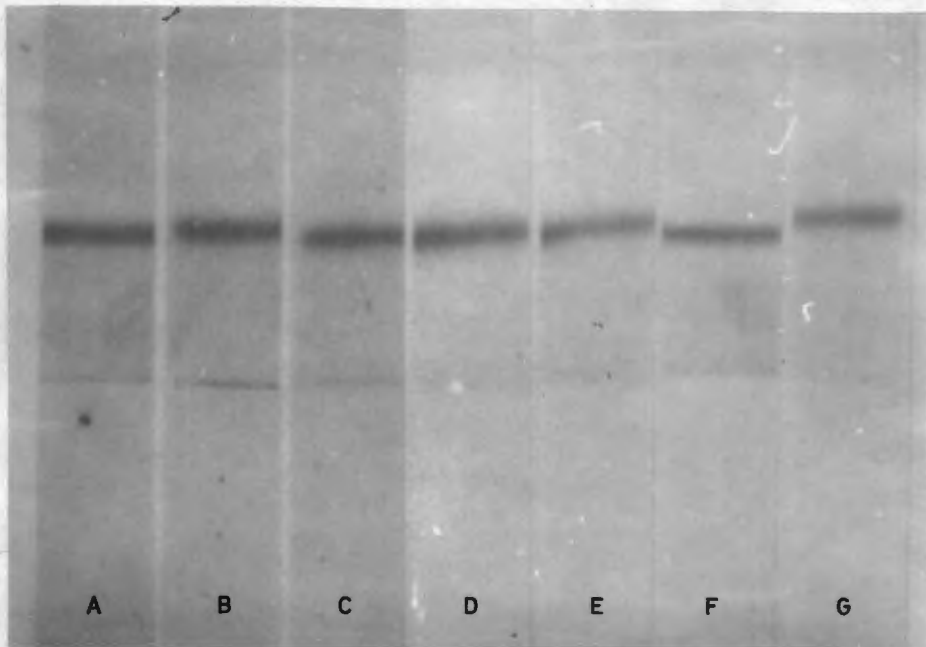

- A. NORMAL MONKEY NORMAL SERUM ALBUMIN.
- B. CADMIUM MONKEY NORMAL SERUM ALBUMIN.
- C. CADMIUM MONKEY MINI SERUM ALBUMIN.
- D. CADMIUM MONKEY URINARY NORMAL ALBUMIN.
- E. CADMIUM MONKEY URINARY MINIALBUMIN.
- F. PERITONEAL DIALYSATE - NORMAL ALBUMIN.
- G. PERITONEAL DIALYSATE - MINIALBUMIN.

from the same sample. Further experiments led to the conclusion that in low salt concentrations, minialbumin readily aggregates to form molecules of various sizes up to 70,000 molecular weight and larger⁽¹²¹⁾.

At first, sodium chloride in concentrations of 0.2M or more was used in all the buffer systems, as this appeared to prevent aggregation of the minialbumin to a considerable extent. Such an effect suggested that hydrogen ion bonding or non-covalent bonding (of some type) was partially responsible for the aggregation. Minialbumin, dialysed free of all traces of salt, lyophilized and passed through a dextran gel column containing no salt, emerged almost entirely as the large size molecule (Figs. 35 and 36A). If this peak of aggregated minialbumin was then passed through the same column, now equilibrated with 0.2M NaCl, some, but not all, reappeared in the small molecular weight form (i. e. 5,000 - 10,000) (Figs. 35 and 36B).

It was also noticed that urinary minialbumin was less susceptible to aggregation than was serum minialbumin. This immediately suggested that urea, which reaches a concentration of about 2% (w/v) in the urine, was helping to prevent aggregation. Hence, 2% (w/v) urea was introduced into the Sephadex column buffers and was found to be effective to some extent. Minialbumin, which remained aggregated

in the presence of 0.2M salt, was next cycled through a column containing both salt and urea. Figs. 35 and 36C show the appearance of some more of the smaller molecules. Urea was apparently more effective in this experiment in dissociating the aggregated molecules than 0.2M alone.

As it was clear that salt and urea could not accomplish complete dissociation of the aggregated minialbumin, it was thought that sulphhydryl interactions must be partially responsible. As minialbumin contains only 12 - 15 sulphhydryl groups, the linking together of small units by disulphide bridges could only account for a small part of the aggregation.

The sulphhydryl groups of the minialbumin, undissociated in the presence of salt and urea, were therefore reduced and alkylated. This was done essentially by the method of Fahey (1963)⁽¹³⁹⁾ which is a modification of Porter's technique⁽¹⁴⁰⁾. The protein was dissolved in 0.5M, pH 8.2 tris-HCl buffer in a concentration of 5 mg./ml., and treated with 0.05M (redistilled) β mercapto-ethanol for 1 hr. at room temperature with continuous shaking. Reduction was stopped by addition of an equal volume of 0.05M iodacetamide in the same buffer. After an hour at 0° the mixture was dialysed against several changes of cold distilled water until free of the reducing and alkylating agents. The protein was then lyophilized and passed through a Sephadex column containing both salt and urea. It

can be seen (Figs. 35 and 36D) that only a trace of aggregated material remains after such treatment.

These findings seemed to indicate that both electrostatic forces and sulphydryl bonds are involved in the production of aggregates. It is also possible that cadmium ions, known to attach readily to albumin, may link the small molecules together. We obtained some evidence for this from experiments done with ethylenediaminetetracetic acid (EDTA).

Serum obtained from monkeys 1 - 2 hr. after a dose of 6 mg. cadmium, was divided into two parts, one of which was immediately treated with solid EDTA to give a final concentration of 0.02M. This concentration was calculated to be more than sufficient to chelate all the calcium, lead and cadmium ions present. Albumin was then prepared from both the treated and untreated sera using the TCA-ethanol⁽⁹⁸⁾ and HCl-ethanol⁽¹⁰²⁾ methods. The purified albumins were then cycled through a Sephadex column in the normal fashion. Fig. 37 A - D shows a comparison of the treated and untreated samples by both methods of preparation. As larger quantities of minialbumin appeared in the presence of EDTA, it seemed that it prevented some linking together of small molecules by divalent ions. Incubation of normal serum albumin with EDTA did not result in the formation of small molecular weight albumin.

FIG. 35

SERUM MINIALBUMIN - AGGREGATION
STUDIES.

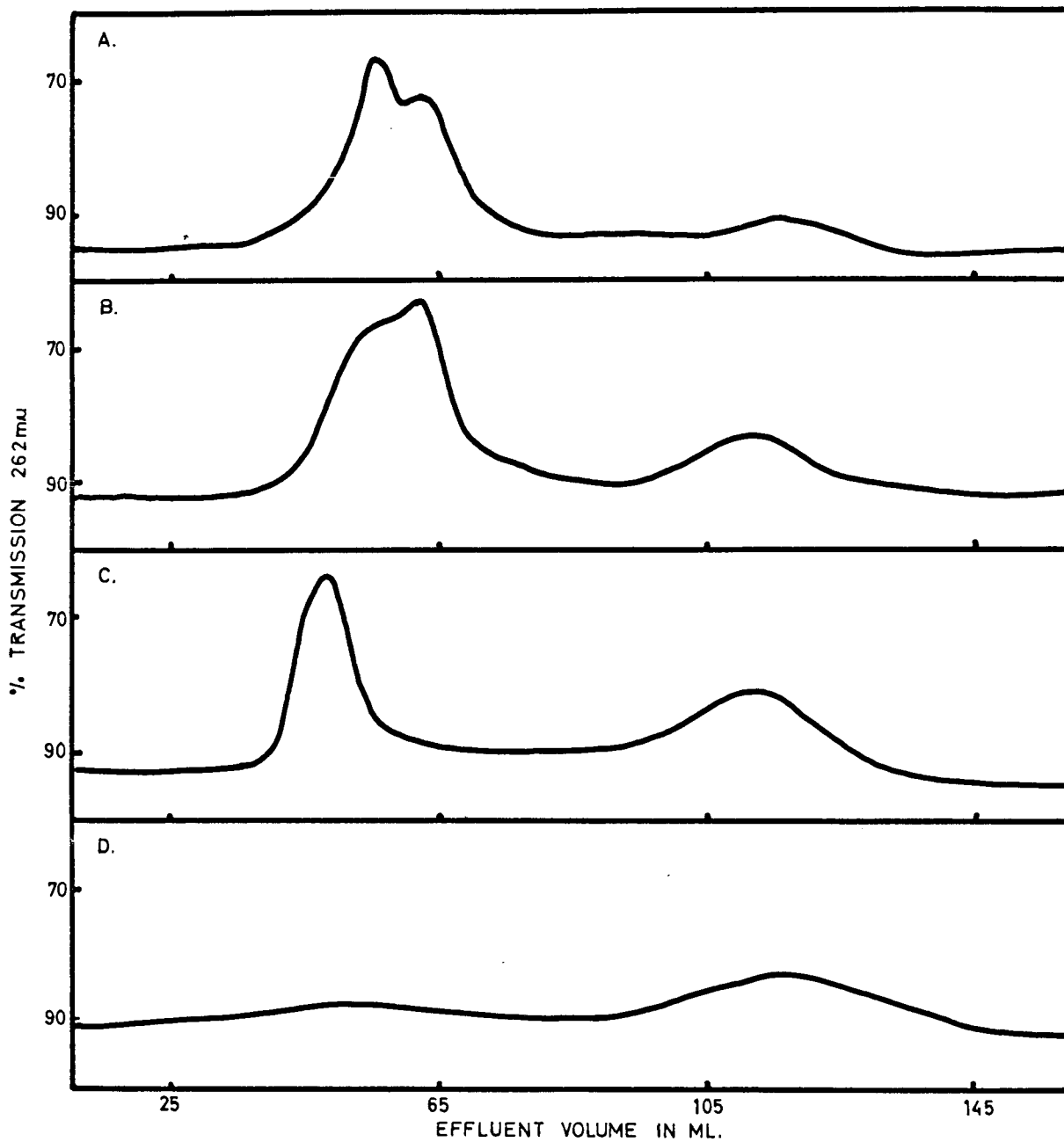

SEPHADEX G75; COLUMN = 42x1.8 CMS.; FLOW RATE = 15 ML. PER HOUR.
A. BUFFER ONLY - 0.066M pH 7.0 PHOSPHATE.
B. BUFFER + 0.2M NaCl.
C. BUFFER + 0.2M NaCl + 2% UREA
D. BUFFER + 0.2M NaCl + 2% UREA - PROTEIN REDUCED AND ALKYLATED.

FIG. 36

URINARY MINIALBUMIN - AGGREGATION
STUDIES.

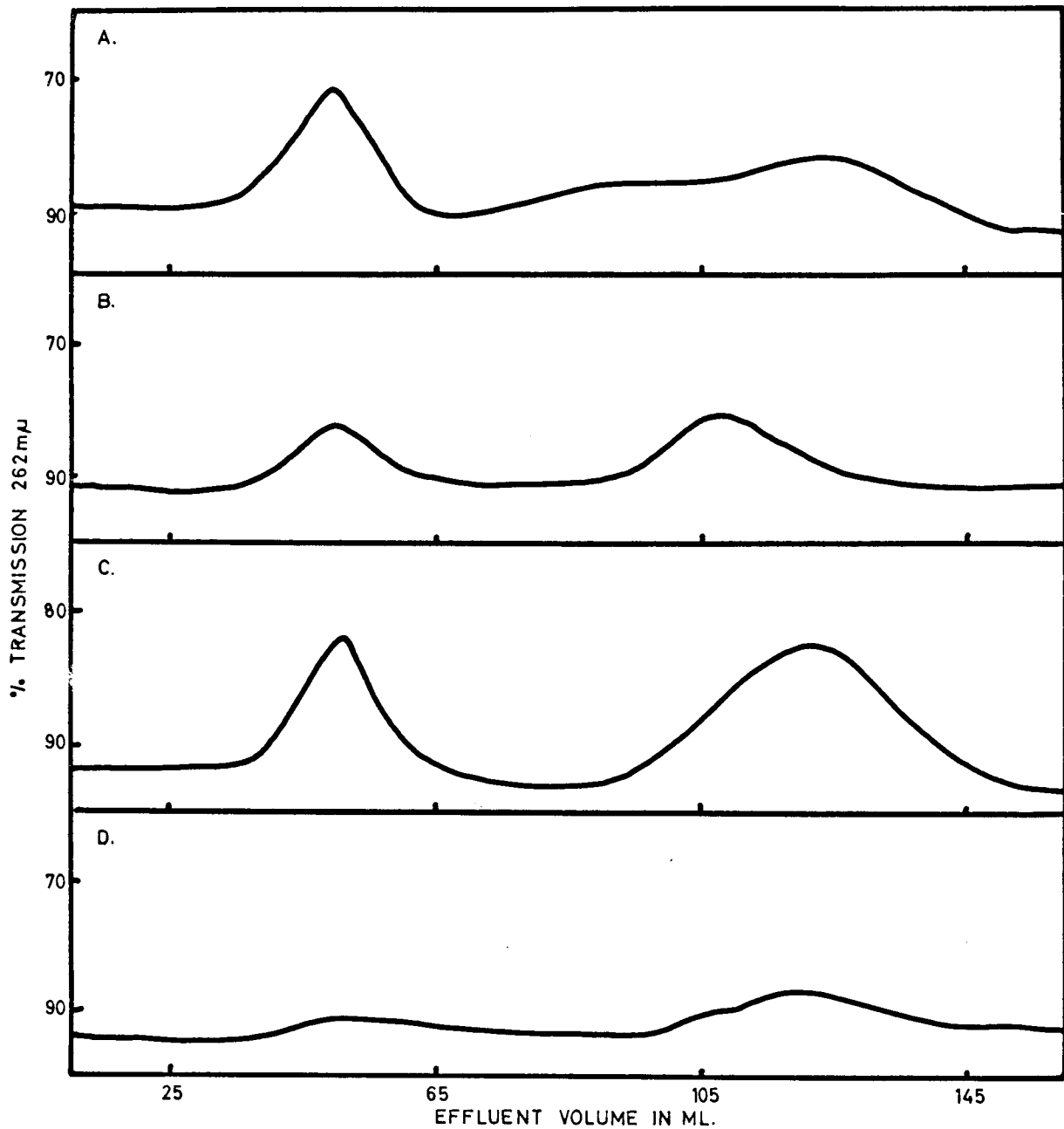

SEPHADEX G 75; COLUMN = 42 x 1.8 CMS; FLOW RATE = 15 ML. PER HOUR.

A. BUFFER ONLY - 0.066M pH 7.0 PHOSPHATE.

B. BUFFER + 0.2M NaCl.

C. BUFFER + 0.2M NaCl + 2% UREA.

D. BUFFER + 0.2M NaCl + 2% UREA - PROTEIN REDUCED AND ALKYLATED.

FIG. 37

DISAGGREGATION EFFECTS OF EDTA.

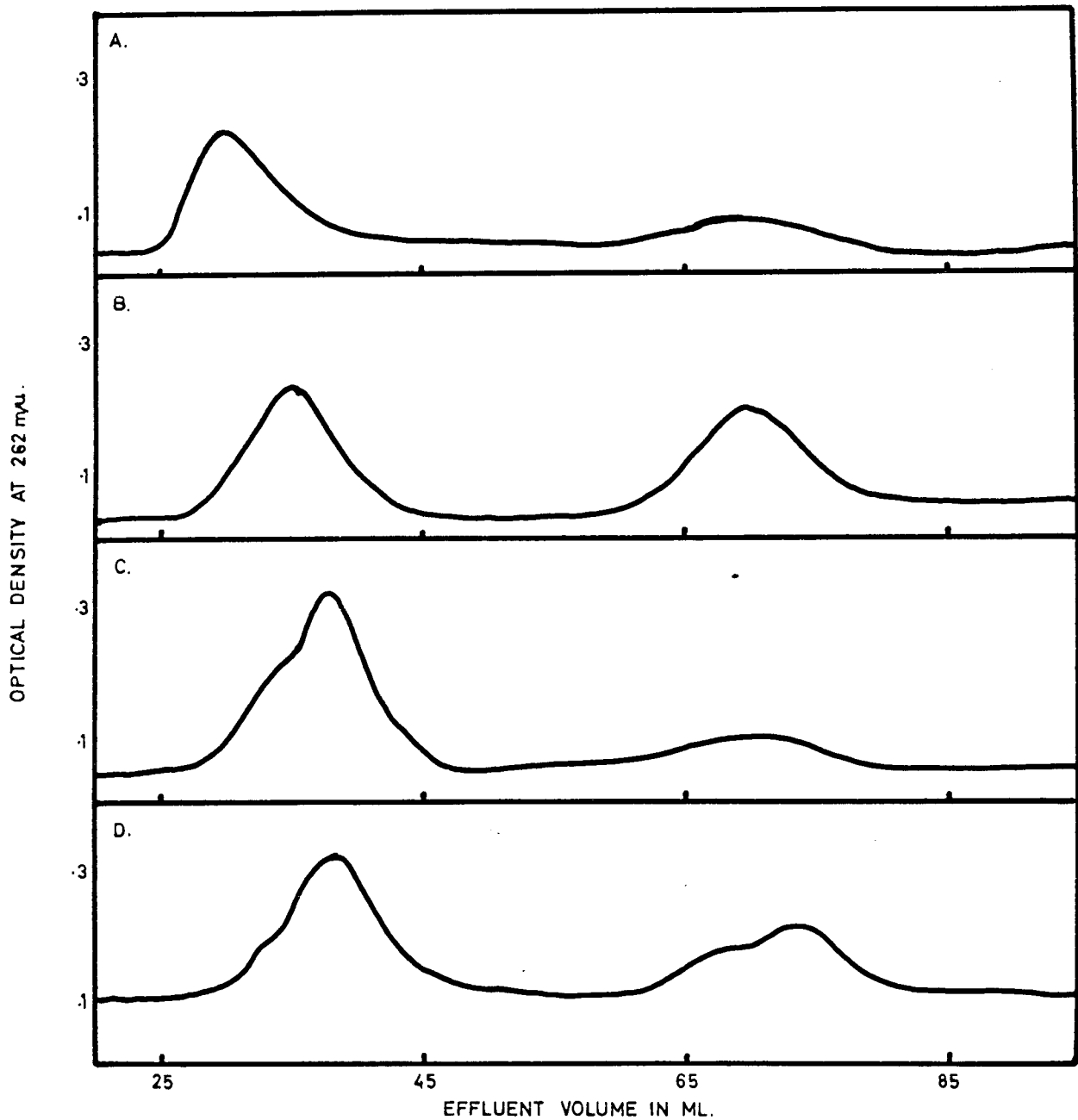

A. HCl METHOD - UNTREATED. C. TCA METHOD - UNTREATED.
B. HCl METHOD WITH E.D.T.A. D. TCA METHOD WITH E.D.T.A.
SEPHADEX G75 IN 0.066M PHOSPHATE + 0.2M NaCl.
COLUMN 26x2 CMS. O.D. AT 262mμ. FLOW RATE = 15 ML PER HOUR.

II 12. (iii) Amino acid analysis of albumins

The overall amino acid composition was considered a valuable way of characterizing the minialbumin with respect to the normal size albumin, and was therefore determined⁽¹²¹⁾. Acid hydrolysis was chosen as the most suitable means of liberating the free amino acids, and the method generally followed was that of Hirs, Moore and Stein (1954)⁽¹⁴¹⁾.

Heavy-walled pyrex glass tubes, 12 x 150 mm., were cleaned by washing in concentrated hydrochloric acid and distilled water, and then rinsed in 1N HCl before being oven dried. Five mg. of the salt-free, lyophilized protein was weighed into the tube and dissolved in 1 ml. 6N HCl, three times glass-distilled at constant boiling temperature. The neck of the tube was first constricted, and then after frequent alternate evacuations and flushings with nitrogen to remove all traces of air, the tube was sealed under vacuum. Hydrolysis was conducted in an oil bath at $110^{\circ} \pm 1^{\circ}$ for 22 hr.

It was imperative that the temperature be kept constant during hydrolysis if the results were to be extrapolated to zero time for correction for the labile amino acids. It has been found that serine and threonine decompose at varying rates during acid hydrolysis while the presence of sulphate ions leads to the formation of sulphoserine which emerges in the same position as cysteic acid. If any air was left in the tubes, oxidation

could occur with the formation of cysteic acid, methionine sulphoxide and chlorotyrosine⁽¹⁴²⁾.

Work in this laboratory on normal human albumin has shown that 22 and 72 hr. hydrolysates gave results which could be extrapolated to zero time (Potgieter and Hall, 1966⁽¹⁴³⁾). As there was insufficient material available for numerous trials at both these time intervals, a 22 hr. hydrolysis period was selected as giving the best overall hydrolysis and recovery.

Once hydrolysis was complete, the seals were broken and the contents of the tubes transferred quantitatively to a small flask with 2 to 3 portions of distilled water. After lyophilization, the residues were redissolved in sodium citrate buffer and analysed on a Beckman Model 120B automatic amino acid analyser according to the method of Spackman, Stein and Moore (1958)⁽¹⁴⁴⁾. This involved elution chromatography from buffered columns of ion exchange resin followed by colorimetric determination of the separated amino acids by the ninhydrin reaction.

The machine operated along the following lines⁽¹⁴⁵⁾. One pump drove buffer through the ion exchange column, while a second pump delivered ninhydrin reagent into the effluent from the column. The mixture then flowed slowly through a 90 ft. Teflon coil which was immersed in a boiling water bath.

During this heating period the amino acids combined with the ninhydrin (Fig. 38) to form blue coloured products for α amino acids and yellowish colours for proline and hydroxyproline. The resulting solution passed through a colorimeter containing 3 separate photometer units, each of which consisted of a light source, lens, interference filter and photovoltaic cell. The extinctions at 570 m μ and 440 m μ were recorded automatically on a chart, which revolved at 6 in./hr., by a dot pen adjusted to print at 2 second intervals. The entire procedure was carried out on a continuously flowing stream. The operating temperature was 52 $^{\circ}$ and the flow rates of buffers and ninhydrin were 40 and 20 ml. per hr., respectively.

The composition, degree of cross linkage, particle size and packing of the resin; the pH, ionic strength and flow rate of the buffer and the temperature of operation could all affect the resolution^(144,146). It was, therefore, necessary to take these factors into account when selecting a resin. For use in the 120B Model, Beckman provided a sulphonated styrene - 8% divinyl benzene copolymer in 3 different grades for the 3 different columns, each of uniform particle size. Uniform particle size was obtained by fractionation with the hydraulic system of Hamilton (1958)⁽¹⁴⁷⁾. Resin 150A of particle size 31 - 41 microns was used for the

FIG. 38

THE NINHYDRIN REACTION.

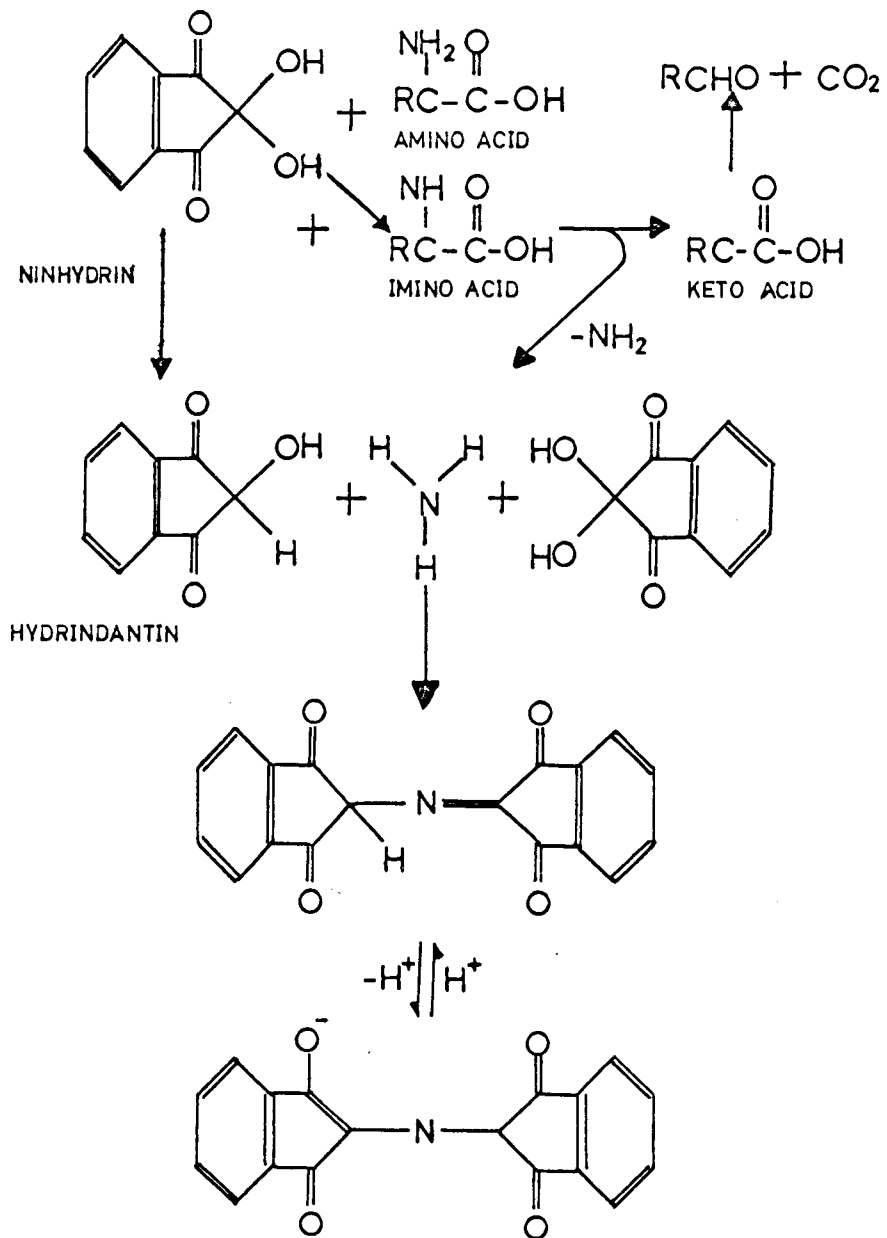

ANION OF DIKETOHYDRINDYLIDINE DIKETOHYDRINAMINE (DYDA)

neutral and acidic amino acids, while type 15A, 19 - 25 micron particles, was employed for the basic column. The columns were packed in sections from a 2 : 1 buffer : resin slurry from which fines had previously been removed. It was necessary to regenerate the column with 0.2N NaOH (containing BRLJ) and equilibrate with the appropriate buffer before use.

Sodium citrate buffers were used and contained pentachlorophenol as an antibacterial agent. Their composition was that shown in Table 10.

TABLE 10.

Composition of buffers for amino acid analysis

| Purpose of buffer pH | Sample dilutor | Acidic and neutral amino acids starting | Acidic and neutral amino acids change over | Basic amino acids |
|----------------------------------|-------------------|--|---|----------------------|
| | 2.2 ± 0.03 | 3.28 ± 0.01 | 4.25 ± 0.02 | 5.28 ± 0.02 |
| Sodium concentration | 0.20 N | 0.20 N | 0.20 N | 0.35 N |
| Sodium citrate 2H ₂ O | 19.6 g. | 784.3 g. | 784.3 g. | 1372.6 g. |
| Concentrated HCl | 16.5 ml. | 493 ml. | 335 ml. | 260 ml. |
| Thiodiglycol | 20 ml. | 200 ml. | 200 ml. | - |
| Brij-35 solution | 2 ml. | 80 ml. | 80 ml. | 80 ml. |
| Pentachlorophenol | 0.1 ml. | 4 ml. | 4 ml. | 4 ml. |
| Final volume | 1 l. | 40 l. | 40 l. | 40 l. |

The ninhydrin reagent was a 2% (w/v) solution dissolved in a mixture comprising 75% (v/v) peroxide-free methyl cello-solve and 25% (v/v) 4N sodium acetate buffer, pH 5.51. The ninhydrin was dissolved by magnetic stirring and under nitrogen. Stannous chloride, a reducing agent, was then added to give a final concentration of 0.04% (w/v).

Using the conditions just described, good resolution and reproducible results were obtained. The percentage recovery from the column was 103% as checked by additions of standard quantities of nor-leucine. Fig. 39 shows a typical elution pattern of the amino acids found in albumin.

Both normal-size albumin and minialbumin from the serum and urine of poisoned animals were analysed and compared with the serum albumin of a normal unpoisoned monkey. The results are given in Tables 11 and 12 and are presented as g. of amino acid per 100 g. of protein, rather than as residues/mole because of the inherent difficulty of selecting a single molecular weight for the minialbumin which exists in a range of sizes. The results are a mean of 5 to 6 separate determinations, and standard deviations are given⁽¹⁴⁸⁾.

It can be seen that amino acid composition was almost identical for the various albumins. Statistical analysis, using the t-test showed the following:-

- (a) The difference between lysine of normal serum

FIG. 39

TRACE OF ELUATE FROM
AMINO ACID ANALYSER.

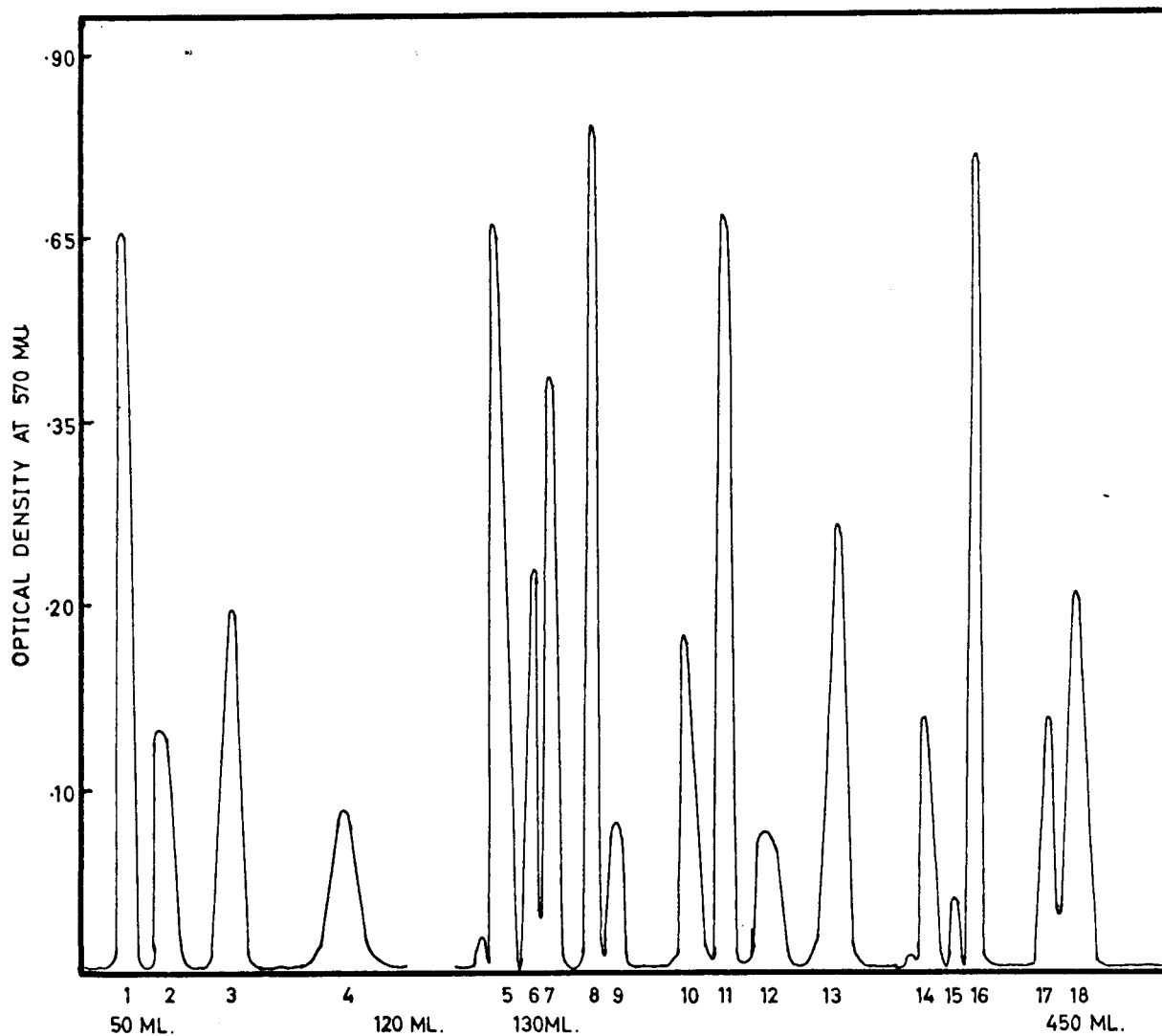

- | | | |
|------------------|------------------|-------------------|
| 1. LYSINE | 7. SERINE | 13. VALINE |
| 2. HISTIDINE | 8. GLUTAMIC ACID | 14. METHIONINE |
| 3. AMMONIA | 9. PROLINE | 15. ISOLEUCINE |
| 4. ARGININE | 10. GLYCINE | 16. LEUCINE |
| 5. ASPARTIC ACID | 11. ALANINE | 17. TYROSINE |
| 6. THREONINE | 12. 1/2 CYSTINE | 18. PHENYLALANINE |

albumin and mini serum albumin was significant. $p = 0.05$.

- (b) The difference between $\frac{1}{2}$ cystine of normal serum albumin and mini serum albumin was very highly significant. $p = 0.001$.
- (c) The difference between isoleucine of normal serum albumin and mini serum albumin was very highly significant. $p = 0.001$.
- (d) There was no significant difference between normal serum albumin and the serum albumin of normal size from poisoned monkeys for the three amino acids mentioned above.
- (e) No values have been obtained for the differences between urinary albumin of normal size and mini urinary albumin. Determination of the amino acid composition of the latter was performed by Gain (1966)⁽⁶⁾ and insufficient data was available for statistical analysis.
- (f) However, significant differences between $\frac{1}{2}$ cystine and isoleucine in normal serum albumin and urinary albumin of normal size from poisoned

monkeys do occur, the values being $p = 0.001$
and $p = 0.05$ respectively.

The differences are more clearly shown in the histograms
(Figs. 40 and 41).

Of interest too, was the close similarity between the
composition of these monkey serum albumins and that of man,
dog, ox and rat. The values are given in Table 13.

In the course of this study it was found that cadmium
ions affected the reaction of ninhydrin with free amino acids
to a noteworthy extent. This was shown by a comparison of
the absorption spectra in the presence and absence of cadmium.
A typical example is presented in Fig. 42. Because of this
it was necessary to test the effect of cadmium ions on an amino
acid analysis. It was done by adding to normal unhydrolysed
serum albumin the amount of cadmium usually found attached in
a chronically poisoned animal (i.e. 1 μ g. cadmium/5 mg. serum
albumin), and then carrying out the standard analytical proce-
dure. The amino acid composition of the normal albumin in
the presence and absence of cadmium is set out in Table 14.
It is evident that though cadmium caused changes in the actual
ninhydrin reaction, it did not affect the overall hydrolysis
and analysis.

TABLE 11.

Amino acid composition of serum albumins of
normal and cadmium-poisoned monkeys

| Amino acid | g./100 g. protein | | |
|---------------|-------------------|--------------|--------------|
| | NMNSA | CdMNSA | CdMMSA |
| Lysine | 11.25 ± 0.03 | 11.37 ± 0.06 | 9.99 ± 0.39 |
| Histidine | 3.46 ± 0.11 | 3.16 ± 0.21 | 3.09 ± 0.35 |
| Ammonia | 1.07 ± 0.06 | 1.42 ± 0.26 | 2.27 ± 0.72 |
| Arginine | 4.68 ± 0.12 | 4.75 ± 0.18 | 4.58 ± 0.37 |
| Aspartic acid | 9.05 ± 0.08 | 8.85 ± 0.17 | 8.77 ± 0.67 |
| Threonine | 3.42 ± 0.22 | 3.23 ± 0.07 | 3.62 ± 0.28 |
| Serine | 3.00 ± 0.11 | 2.83 ± 0.04 | 3.55 ± 0.53 |
| Glutamic acid | 16.22 ± 0.15 | 15.56 ± 0.52 | 15.15 ± 0.98 |
| Proline | 3.47 ± 0.34 | 3.45 ± 0.10 | 3.72 ± 0.77 |
| Glycine | 1.22 ± 0.11 | 1.23 ± 0.28 | 1.69 ± 0.35 |
| Alanine | 7.21 ± 0.07 | 7.03 ± 0.23 | 6.73 ± 0.86 |
| ½ Cystine | 4.32 ± 0.54 | 4.10 ± 0.65 | 2.37 ± 0.92 |
| Valine | 6.24 ± 0.06 | 6.16 ± 0.37 | 5.79 ± 0.12 |
| Methionine | 1.56 ± 0.08 | 1.55 ± 0.10 | 1.32 ± 0.57 |
| Iso-leucine | 0.43 ± 0.08 | 0.52 ± 0.10 | 1.11 ± 0.23 |
| Leucine | 10.69 ± 0.10 | 10.33 ± 0.35 | 8.61 ± 0.83 |
| Tyrosine | 4.23 ± 0.16 | 4.04 ± 0.15 | 4.16 ± 0.26 |
| Phenylalanine | 6.55 ± 0.12 | 6.80 ± 0.85 | 6.27 ± 0.76 |
| Totals | 97.77 | 96.38 | 92.79 |

NMNSA = Normal monkey normal serum albumin

CdMNSA = Cadmium monkey normal size serum albumin

CdMMSA = Cadmium monkey mini serum albumin

FIG. 40

AMINO ACID COMPOSITION OF
SERUM ALBUMINS.

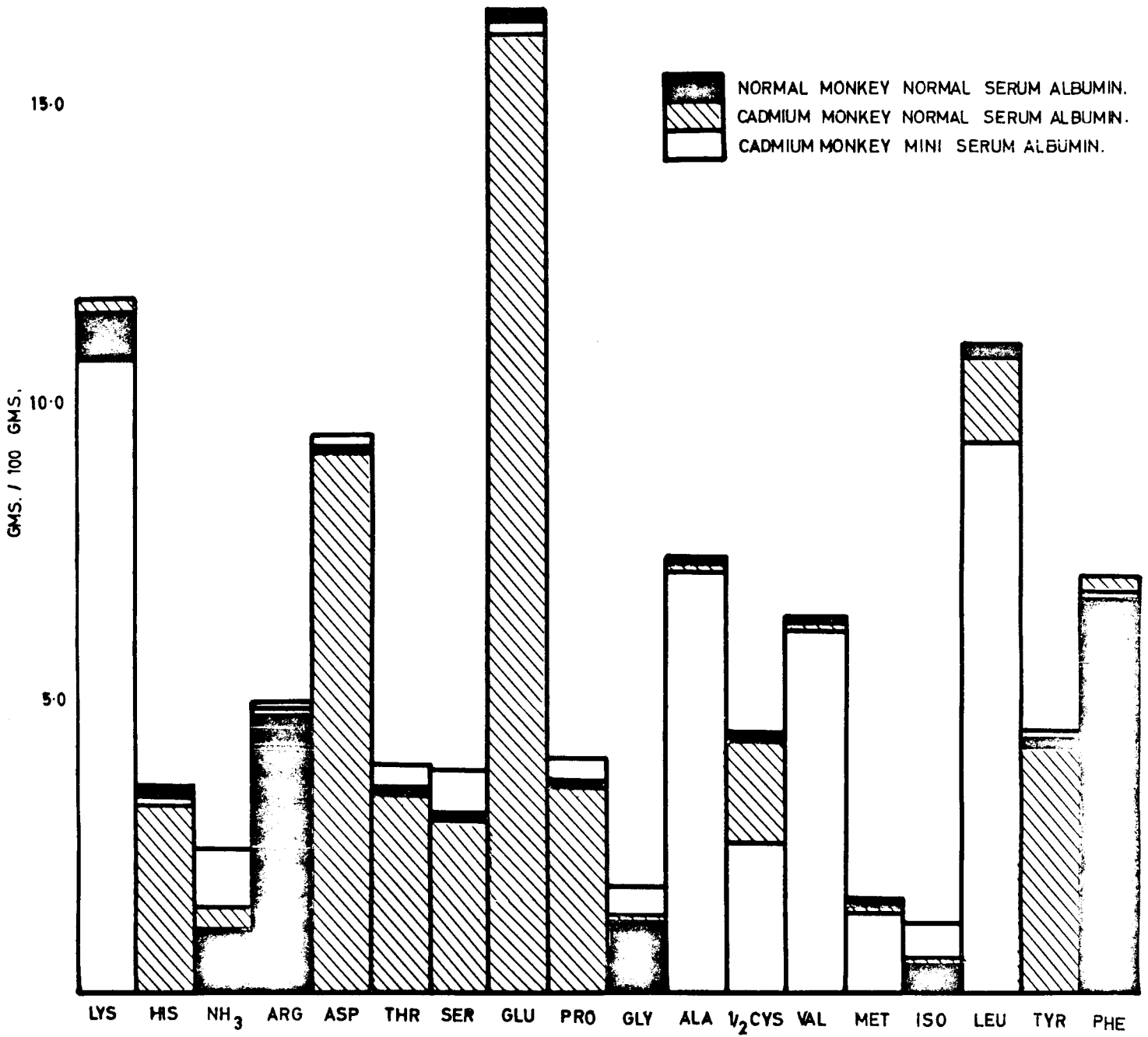

TABLE 12.

Amino acid composition of urinary albumins of
normal and cadmium-poisoned monkeys.

| Amino acid | g./100 g. protein | | |
|-----------------------|-------------------|------------------|---------|
| | NMNSA | CdMNUA | CdMMUA* |
| Lysine | 11.25 \pm 0.03 | 10.82 \pm 0.82 | 10.1 |
| Histidine | 3.46 \pm 0.11 | 3.22 \pm 0.03 | 3.0 |
| Ammonia | 1.07 \pm 0.06 | 1.61 \pm 0.56 | 1.1 |
| Arginine | 4.68 \pm 0.12 | 5.25 \pm 0.83 | 5.6 |
| Aspartic acid | 9.05 \pm 0.08 | 9.37 \pm 0.62 | 10.7 |
| Threonine | 3.42 \pm 0.22 | 4.11 \pm 0.86 | 4.6 |
| Serine | 3.00 \pm 0.11 | 3.54 \pm 0.02 | 3.0 |
| Glutamic acid | 16.22 \pm 0.15 | 16.13 \pm 0.23 | 16.0 |
| Proline | 3.47 \pm 0.34 | 3.00 \pm 0.74 | 4.8 |
| Glycine | 1.22 \pm 0.11 | 1.68 \pm 0.02 | 1.7 |
| Alanine | 7.21 \pm 0.07 | 7.61 \pm 0.03 | 8.7 |
| $\frac{1}{2}$ Cystine | 4.32 \pm 0.54 | 2.48 \pm 0.84 | 3.9 |
| Valine | 6.24 \pm 0.06 | 6.66 \pm 0.03 | 7.5 |
| Methionine | 1.56 \pm 0.08 | 1.04 \pm 0.54 | 1.1 |
| Iso-leucine | 0.43 \pm 0.08 | 1.14 \pm 0.49 | 1.6 |
| Leucine | 10.69 \pm 0.10 | 10.75 \pm 0.15 | 10.4 |
| Tyrosine | 4.23 \pm 0.16 | 4.15 \pm 0.42 | 4.3 |
| Phenylalanine | 6.55 \pm 0.12 | 7.51 \pm 0.95 | 6.7 |
| Totals | 97.77 | 100.07 | 104.8 |

NMNSA = Normal monkey normal serum albumin

CdMNUA = Cadmium monkey normal size urinary albumin

CdMMUA = Cadmium monkey mini urinary albumin

* Gain (1966)⁽⁶⁶⁾.

FIG. 41

AMINO ACID COMPOSITION OF
URINARY ALBUMINS.

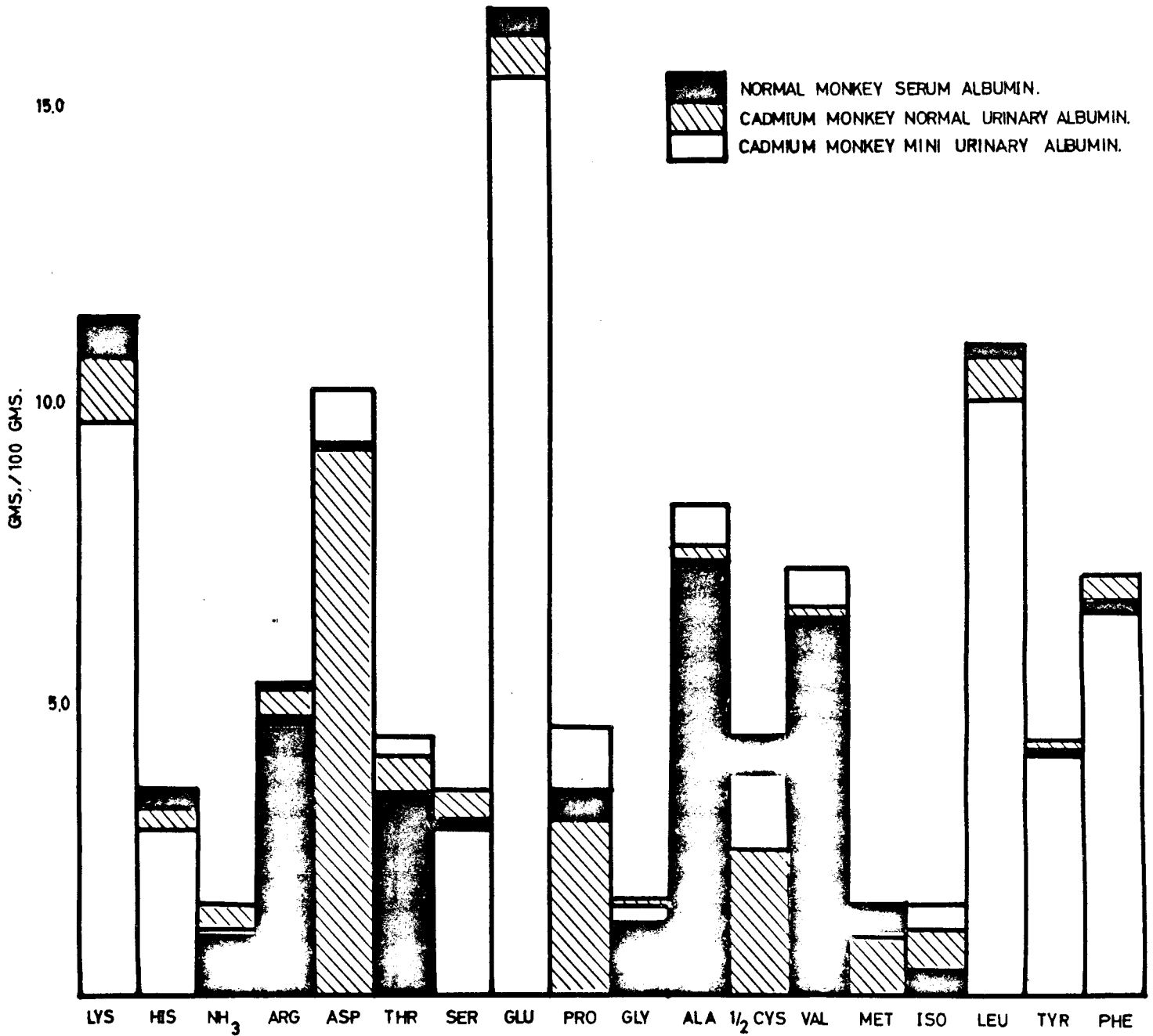

TABLE 13.

Comparison of the amino acid composition of
serum albumin of various animals

| Amino acid | g./100 g. protein | | | | |
|-----------------------|----------------------|---------|---------------------|----------------------|----------------------|
| | Man ⁽¹⁴⁹⁾ | Monkey* | Ox ⁽¹⁵⁰⁾ | Dog ⁽¹⁵¹⁾ | Rat ⁽¹³⁵⁾ |
| Lysine | 10.78 | 11.25 | 11.25 | 11.30 | 9.77 |
| Histidine | 3.09 | 3.46 | 3.54 | 2.50 | 2.87 |
| Ammonia | - | 1.07 | - | - | - |
| Arginine | 5.51 | 4.68 | 5.29 | 5.34 | 5.42 |
| Aspartic acid | 8.99 | 9.05 | 9.43 | 8.95 | 8.71 |
| Threonine | 4.24 | 3.42 | 4.95 | 3.55 | 4.85 |
| Serine | 3.06 | 3.00 | 3.50 | 3.36 | 3.12 |
| Glutamic acid | 15.27 | 16.22 | 14.48 | 16.17 | 15.32 |
| Proline | 4.30 | 3.47 | 4.01 | 4.51 | 4.33 |
| Glycine | 1.22 | 1.22 | 1.38 | 1.99 | 1.49 |
| Alanine | 6.56 | 7.21 | 4.99 | 6.50 | 6.30 |
| $\frac{1}{2}$ Cystine | 4.74 | 4.32 | 5.02 | 5.12 | 4.89 |
| Valine | 6.51 | 6.24 | 5.01 | 6.11 | 4.95 |
| Methionine | 1.12 | 1.56 | 0.71 | 0.78 | 1.16 |
| Iso-leucine | 1.47 | 0.43 | 2.25 | 0.99 | 2.28 |
| Leucine | 10.27 | 10.69 | 10.59 | 10.96 | 9.24 |
| Tyrosine | 4.20 | 4.23 | 4.56 | 5.26 | 5.40 |
| Phenylalanine | 6.95 | 6.55 | 5.87 | 6.68 | 5.18 |
| Totals | 92.59 | 97.77 | 97.36 | 100.60 | 95.60 |

* Present study

TABLE 14.

The amino acid composition of normal serum albumin
in the presence or absence of cadmium

| Amino acid | Residues amino acid/mole albumin | |
|-----------------------|----------------------------------|-----------------------|
| | NMNSA | NMNSA + added cadmium |
| Lysine | * 58 | ** 58 |
| Histidine | 16 | 17 |
| Ammonia | - | - |
| Arginine | 20 | 20 |
| Aspartic acid | 52 | 49 |
| Threonine | 22 | 23 |
| Serine | 23 | 23 |
| Glutamic acid | 83 | 82 |
| Proline | 24 | 25 |
| Glycine | 14 | 16 |
| Alanine | 67 | 68 |
| $\frac{1}{2}$ Cystine | 28 | 28 |
| Valine | 42 | 42 |
| Methionine | 8 | 8 |
| Iso-leucine | 3 | 3 |
| Leucine | 62 | 62 |
| Tyrosine | 17 | 18 |
| Phenylalanine | 30 | 29 |
| Totals | 569 | 571 |

NMNSA = Normal monkey normal serum albumin

* Values given are a mean of six separate determinations

** Values given are a mean of three separate determinations

FIG. 42

EFFECT OF Cd⁺⁺ ON THE
NINHYDRIN REACTION.

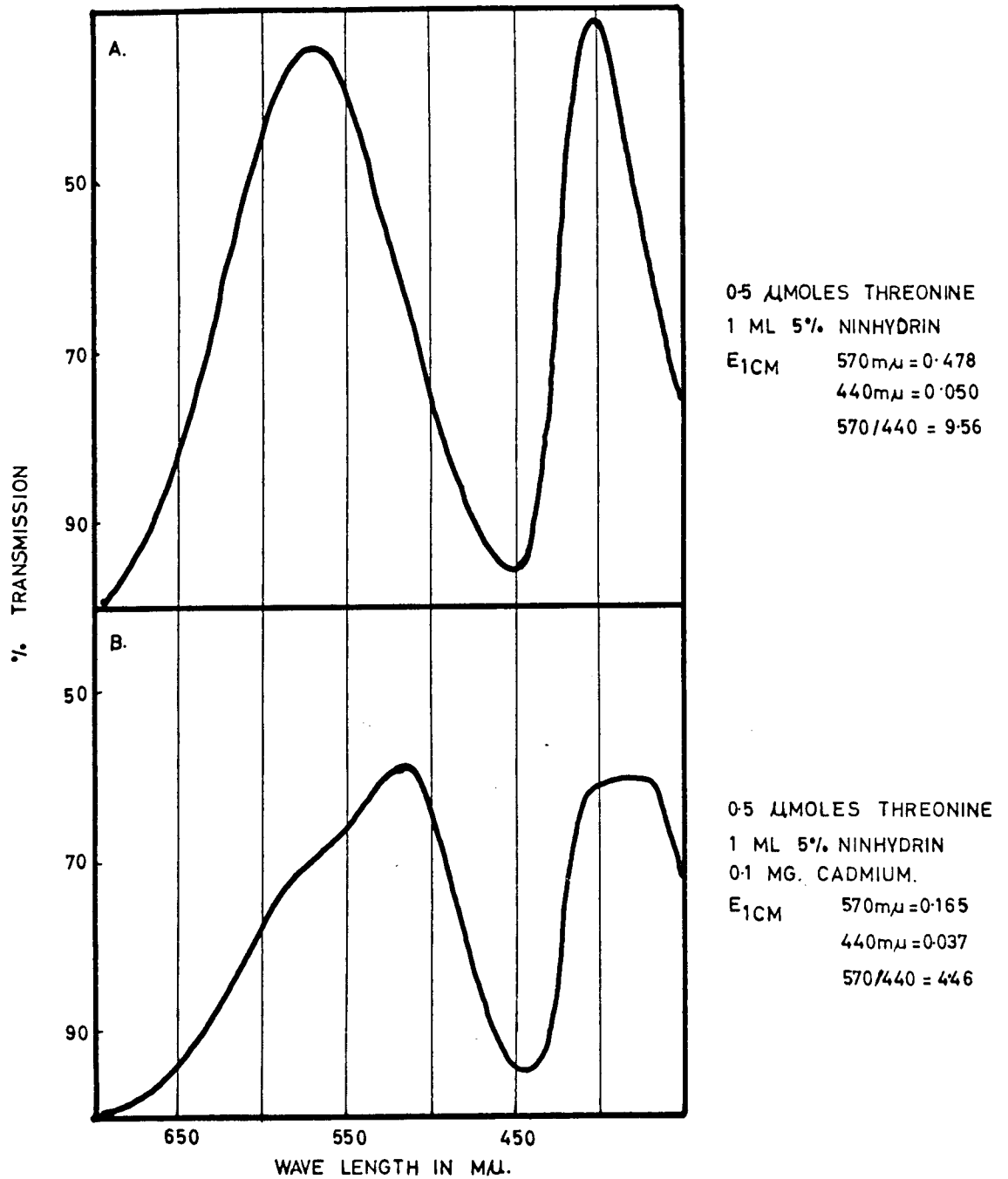

II 12. (iv) The determination of tryptophan

As normal albumin consists of a single chain containing approximately 575 amino acid residues⁽¹⁵²⁾ and only one or two residues of tryptophan, a comparative study of the tryptophan content of the different albumin species was carried out in order to seek further clarification of the relationship between them.

(a) Alkaline hydrolysis with barium hydroxide

The method followed was essentially that of Noltmann, Mahowald and Kuby (1962)⁽¹⁵³⁾. The sample of protein (5 - 10 mg.) was weighed into pyrex test-tubes (12 x 150 mm. rimless) which had been cleaned in concentrated hydrochloric acid and distilled water and oven-dried. Approximately 1 ml. of distilled water was then added and the protein dissolved. Solid barium hydroxide ($\text{Ba}(\text{OH})_2 \cdot 8\text{H}_2\text{O}$) and distilled water were then added to give final concentrations of 1N to 4N $\text{Ba}(\text{OH})_2 \cdot 8\text{H}_2\text{O}$ in a final calculated volume of 0.2 ml./mg. protein. The concentration of $\text{Ba}(\text{OH})_2 \cdot 8\text{H}_2\text{O}$ was found to be critical and this later aspect of the experiment is discussed in detail. The tubes were then alternately evacuated and flushed with nitrogen until all traces of air had been removed. They were subsequently sealed under vacuum.

Hydrolysis was conducted under oil at $110^{\circ} \pm 1^{\circ}$ for a 70 hr. period as advocated⁽¹⁵³⁾. On completion of hydrolysis the seal was broken and the contents of the tube quantitatively transferred to a centrifuge tube with the aid of several small aliquots of near-boiling distilled water. A stream of carbon dioxide, liberated from dry ice, was directed on to the surface of the sample whilst shaking continuously for 10 min. The precipitate of BaCO_3 so obtained was centrifuged off and washed three times with distilled water. The first supernatant and the washings were filtered through a medium sintre and then lyophilized. The dried amino acids were dissolved in 5 ml. of 0.2M sodium citrate buffer, pH 2.2, and analysed on a Beckman Spinco Model 120B amino acid analyser, according to the method of Spackman et al⁽¹⁴⁴⁾ (Fig. 43). It was necessary to carry out acid hydrolysis of the same samples to estimate the quantity of leucine.

Tryptophan and leucine were the only amino acids, present in the proteins, which were not degraded under the conditions of alkaline hydrolysis as just described. Leucine, unlike tryptophan, was also stable during acid hydrolysis, and could, therefore, serve as a reference standard by which tryptophan could be related to the other amino acids, all of which were measurable following acid hydrolysis. The height-width

FIG. 43

ELUTION OF TRYPTOPHAN FROM AMINO
ACID ANALYSER.

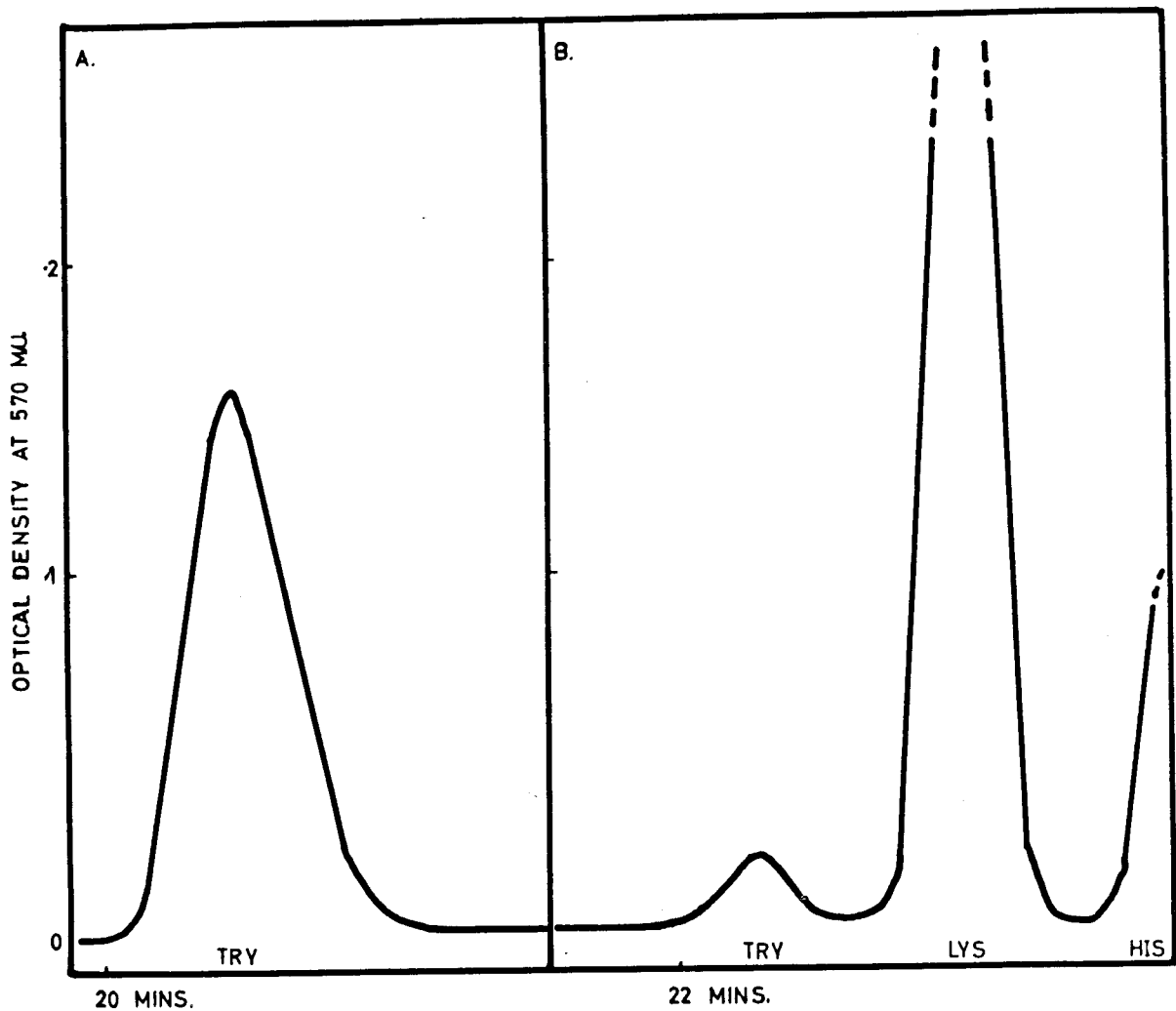

A. TRYPTOPHAN STANDARD OF 1 μMOLE
B. ALKALINE HYDROLYSATE FOR ANALYSIS.

constants for leucine were determined after both acid and alkaline hydrolysis, and by use of these constants, the quantities of all the amino acids in the alkaline hydrolysate could be calculated. From these data, the content of tryptophan as a percentage of total protein was easily derived.

(i) Determination of the optimum barium hydroxide concentration.

Owing to the variability and lack of reproducibility of some results, it was decided to investigate the effect of the barium hydroxide concentration.

Samples of normal monkey serum albumin were utilized. To half of these, 1 μ g. cadmium/5 mg. protein was added (i.e. the amount of cadmium found attached to circulating albumin in a chronically poisoned monkey). $\text{Ba}(\text{OH})_2 \cdot 8\text{H}_2\text{O}$ was added to give final concentrations of 1N, 2N, 3N and 4N in the normal and cadmium-containing samples respectively. The hydrolysis and tryptophan determination were carried out exactly as described above. Results show that the normal monkey serum albumin gave maximum and reproducible results with 1N $\text{Ba}(\text{OH})_2 \cdot 8\text{H}_2\text{O}$, whilst in the presence of cadmium, a higher concentration of $\text{Ba}(\text{OH})_2 \cdot 8\text{H}_2\text{O}$, viz. 2N, was found to be most suitable. Fig. 44 demonstrates this point.

FIG. 44

CONCENTRATION OF BARIUM
HYDROXIDE. OPTIMUMS.

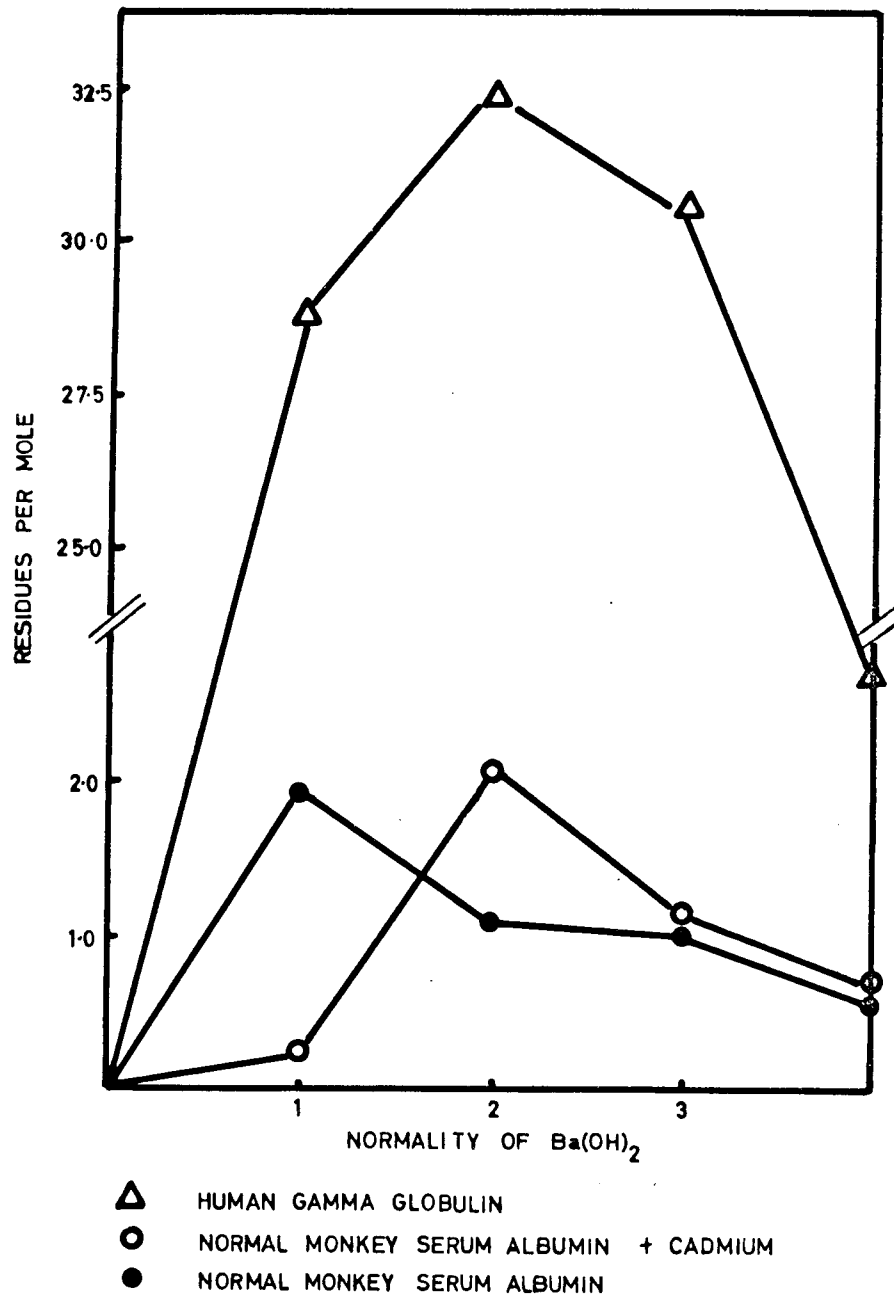

Gamma globulin, used to check recoveries as later described, also showed anomalies with high concentration of $\text{Ba}(\text{OH})_2 \cdot 8\text{H}_2\text{O}$. A concentration of 4N almost completely destroyed the tryptophan, 3N and 1N gave fair results, while 2N gave good reproducible yields and was therefore selected for this work (Fig. 44).

Recoveries of leucine were also impaired by high concentrations of barium hydroxide.

(b) Colorimetric method using p-dimethylaminobenzaldehyde

During alkaline hydrolysis tryptophan may be destroyed by various other naturally occurring amino acids such as cysteine, cystine, lysine, serine and threonine⁽¹⁵⁴⁾. It was, therefore, desirable to estimate tryptophan in unhydrolysed protein where the above-mentioned amino acids had no effect. Spies and Chambers (1948)⁽¹⁵⁵⁾, (1949)⁽¹⁵⁴⁾, have set down a method.

Essentially, free or protein-bound tryptophan was combined with p-dimethylaminobenzaldehyde (pDMAB) in a strongly acid medium and allowed to incubate in the dark before a blue colour was developed by coupled oxidation with sodium nitrite.

It was necessary to establish the optimum conditions under which the reactions take place to obtain maximum colour yields.

Free tryptophan on condensation with pDMAB gave a maximum colour in 12 - 13N H_2SO_4 , while the tryptophan measured in intact protein gave best results with 19N H_2SO_4 ⁽¹⁵⁴⁾. Spies and Chambers⁽¹⁵⁵⁾ also showed that 30 mg. of pDMAB and 0.1 ml. of 0.045% $NaNO_2$ per test were ideal concentrations.

The time required to complete the initial reaction in which the pDMAB condensed with tryptophan, showed a variable optimum depending on the protein in question. To determine this for albumin, a series of tryptophan standards containing 0 - 50 $\mu g.$, and 10 mg. samples of normal monkey serum albumin and cadmium-poisoned monkey serum albumin of normal size were incubated for periods of 3, 6, 9, 12, 18 and 21 hr. before stopping the reaction by the addition of sodium nitrite. Fig. 45 shows the maximum colour for the albumins to be at 15 hr. This incubation time was, therefore, used for all subsequent determinations.

The second reaction, the colour formation with $NaNO_2$, was a far more rapid one and was followed from zero time to 100 min. Readings were taken at min. intervals for the first 10 min., at 2.5 min. intervals for the next 20 min., and thereafter every 5 min. The graph in Fig. 46

FIG. 45

TRYPTOPHAN DETERMINATION
REACTION 1. OPTIMUM.

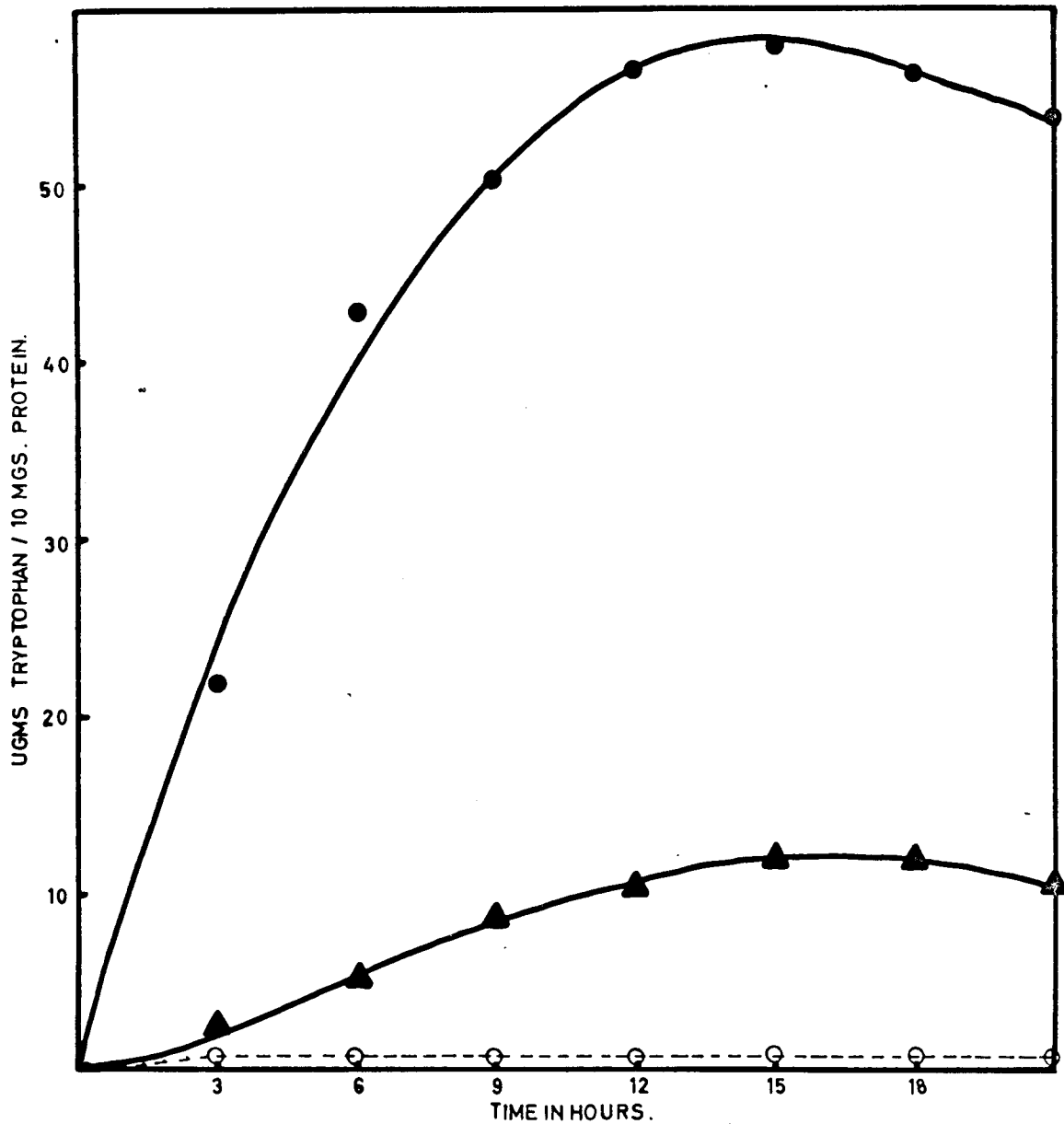

- NORMAL MONKEY SERUM ALBUMIN.
- ▲ CADMIUM MONKEY NORMAL SERUM ALBUMIN.
- CADMIUM MONKEY MINI SERUM ALBUMIN.

FIG. 46

TRYPTOPHAN DETERMINATION
REACTION 2. OPTIMUM.

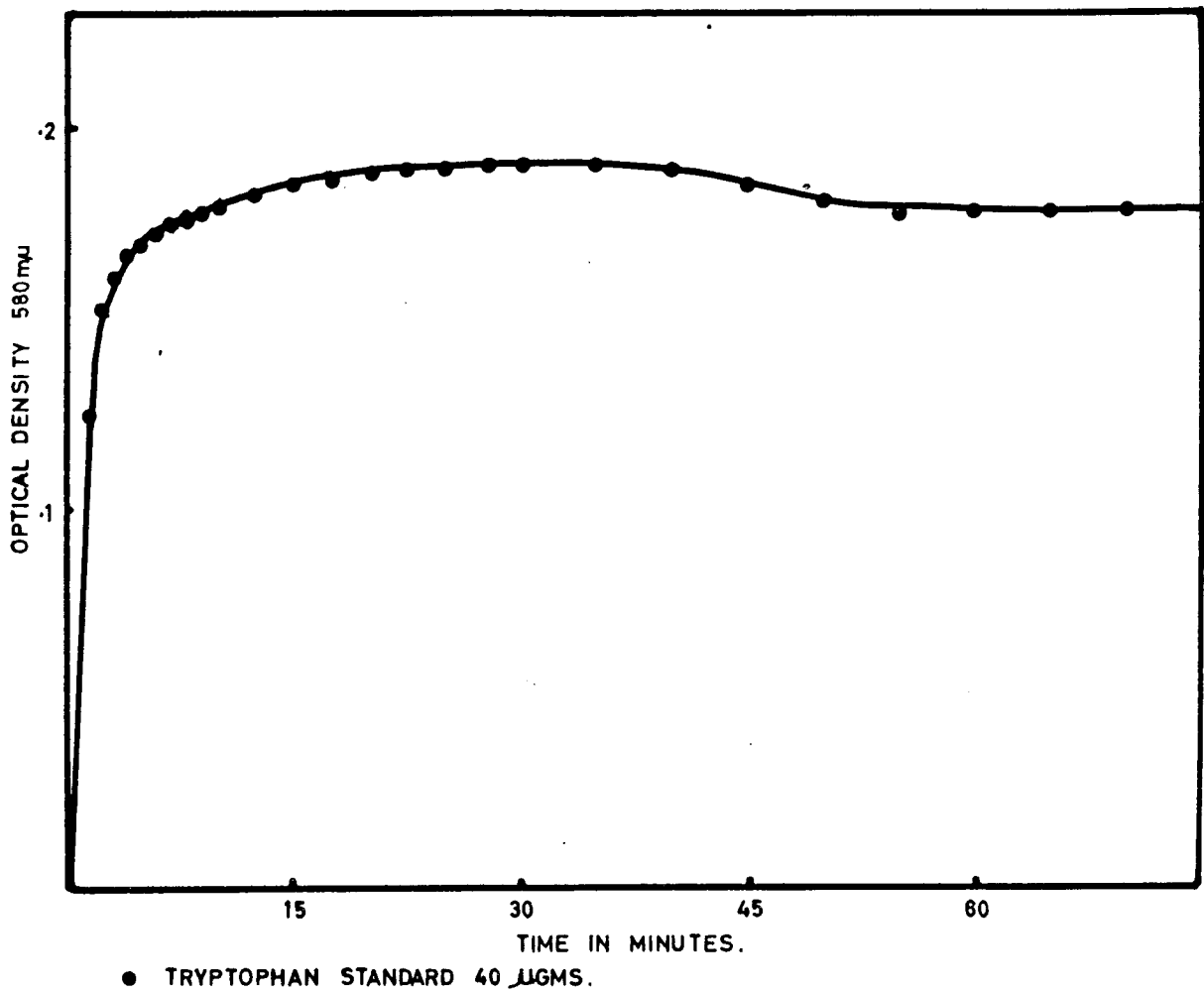

shows that most of the colour was formed in the first 5 min. A peak value was reached after 25 - 30 min. and the colour remained constant until 45 min., after which time there is a slight fall.

Both the first and second reactions must be carried out in the dark. The wavelength chosen, that at which maximum absorption occurred, was 590 m μ . A scan from 700 m μ to the ultraviolet region showed a high plateau from 600 - 580 m μ (Fig. 47) and it was decided to choose the midpoint of this.

The solutions were checked for optical clarity by centrifuging them at 10,000 rev./min. for 8 - 10 min., and then reading the extinction value again. As the colour was stable between 30 and 45 min., any change in extinction could be attributed to the removal of particles by the centrifugation. Table 15 indicates that losses in colour intensity were negligible, and it was therefore assumed that the results obtained were 'real'.

FIG. 47

ABSORPTION CURVE FOR
TRYPTOPHAN COMPLEX.

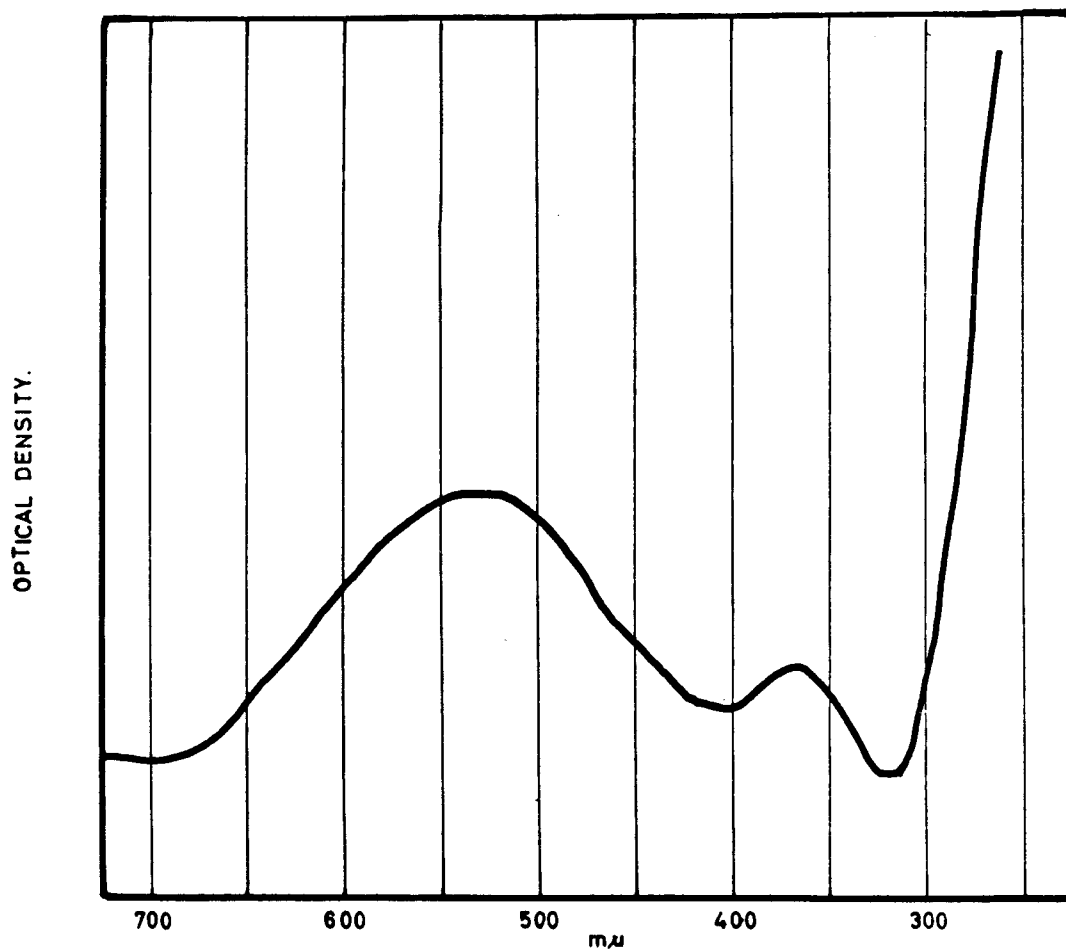

TABLE 15.

The determination of optical clarity of the
tryptophan test solutions

| Sample | Extinction before centrifuga- tion | Extinction after centrifuga- tion | Difference in extinction |
|-------------------------------|---|--|--------------------------------|
| Reagent Blank | 0.000 | 0.000 | 0.00 |
| Protein Blank | 0.006 | 0.004 | 0.002 |
| Tryptophan Std. 10 μ g. | 0.033 | 0.032 | 0.001 |
| " " 20 μ g. | 0.071 | 0.069 | 0.002 |
| " " 30 μ g. | 0.104 | 0.105 | 0.001 |
| " " 40 μ g. | 0.146 | 0.145 | 0.001 |
| " " 50 μ g. | 0.155 | 0.154 | 0.001 |
| Normal monkey normal albumin | 0.206 | 0.208 | 0.002 |
| Cadmium monkey normal albumin | 0.045 | 0.045 | 0.000 |
| Cadmium monkey minialbumin | 0.003 | 0.003 | 0.000 |

Temperature evidently had very little influence as reactions carried out at 20° and 0° gave similar or identical results.

Blanks of two types were always run concurrently. These were a reagent blank containing everything save tryptophan, and a protein blank containing all the reagents but read at zero time.

The reagents used throughout the procedure were Analar grade and were freshly prepared for each determination. They were all dried in vacuo over sodium hydroxide pellets before being used.

The reaction tubes were well washed in tap and distilled water, and then rinsed with 1N sulphuric acid before being oven-dried.

The protein samples were all salt free (by extensive dialysis), lyophilized preparations, and were accurately weighed on a Sartorius micro-torsion balance.

The individual steps of the method may be summarised as follows:

- (i) Protein or free tryptophan was dissolved in 19N H₂SO₄ and brought to a final volume of 9 ml.
- (ii) 1 ml. of a pDMAB solution containing 30 mg./ml. 19N H₂SO₄ was added and the tubes well shaken.

- (iii) Tubes were allowed to stand in the dark for 15 hr.
- (iv) 0.1 ml. of 0.045% (w/v) aqueous NaNO_2 solution was added and the tubes well shaken.
- (v) Tubes were allowed to stand in the dark for 30 min.
- (vi) Extinction was read at 590 m μ .

Standard curves were obtained by using quantities of free tryptophan varying from 0 - 200 μg . per test, and the above conditions. Fig. 48 is illustrative of such a curve. Protein samples were handled in an identical fashion and their tryptophan content estimated by reference to the standard graph.

(c) Experiments designed to test the validity of the tryptophan analyses.

(i) Percentage recovery. This was checked by the use of gamma globulin prepared from normal human serum by precipitation with solid ammonium sulphate brought to 50% saturation, and subsequent chromatography of the dialysed, freeze-dried residue on DEAE-Sephadex A50⁽¹⁵⁶⁾. The preparation was judged to be pure by immunoelectrophoresis on agar gel⁽¹¹⁰⁾ using a 'Hylands' polyvalent anti-human serum. Gamma globulin

FIG. 48

TRYPTOPHAN DETERMINATION.
STANDARD GRAPH.

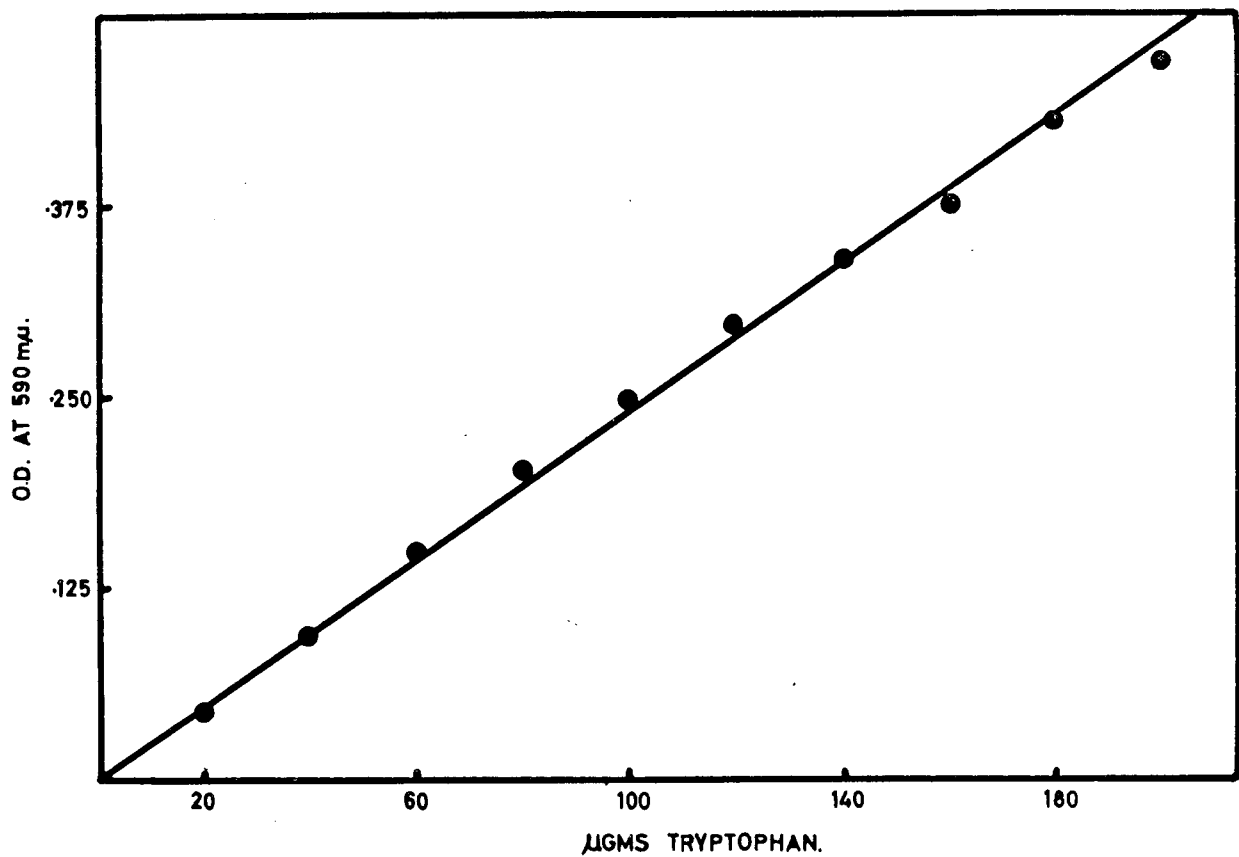

was selected because it is rich in tryptophan and the number of residues per molecule is well established⁽¹⁵⁷⁾. Table 16 shows the results obtained with both methods of analysis and gives the percentage recoveries and standard deviations.

TABLE 16.

Determination of percentage recovery of tryptophan

| Method of analysis | Number residues tryptophan/mole γ globulin | % Recovery* | Standard deviation |
|---------------------|---|-------------|--------------------|
| Alkaline hydrolysis | 33, 27, 34, 28, 29 | 91.51 | 3.11 |
| pDMAB colour method | 30, 32, 30, 31, 33, 31 | 93.97 | 1.41 |

* Human γ globulin has 33 residues/mole⁽¹⁵⁷⁾

Normal human serum albumin was also analysed and was found to contain 1 residue of tryptophan per mole. This is in agreement with the work of several other investigators^(158,159).

(ii) Percentage recovery of added tryptophan

This was measured by adding tryptophan to serum albumin and to the serum before preparation of the albumin.

To check the recovery in the presence of albumin, tryptophan was added to the protein before the determination, and the results compared with a standard containing the same quantity of tryptophan and with protein with no added amino acid. The pDMAB colour method was used.

TABLE 17.

Determination of percentage recovery of tryptophan
added to albumin

| Sample | Tryptophan added | Total tryptophan recovered | % recovery | Standard deviation |
|-----------------------------|------------------|---|-------------------------|--------------------|
| Tryptophan Std. | 50 μ g. | 50 μ g. | 100 | - |
| 5 mg. normal monkey albumin | Nil | 27 μ g. 28 μ g. 27 μ g. | - | - |
| 5 mg. normal monkey albumin | 50 μ g. | 62.5 μ g. 65.1 μ g. 65.5 μ g. | 81.2) 83.4) 85.0) | 1.90 |

Table 17 shows that most of the added tryptophan was recovered.

In order to ascertain whether free tryptophan present in the serum might become adsorbed on albumin during the preparative procedure, and thereby vitiate the observations, varying quantities of tryptophan were added to the serum before albumin

was prepared from it. Poisoned monkey serum, and the pDMAB colour method were used. As shown in Table 18, added tryptophan had no significant effect on the quantity of the amino acid found in the protein.

TABLE 18.

Measurement of tryptophan adsorbed by albumin
during preparation from serum

| Tryptophan added (moles/mole albumin) | Tryptophan found* (residues/mole albumin) |
|--|--|
| 0 | 0.91 |
| 1 | 0.93 |
| 2 | 0.91 |
| 5 | 0.95 |

* Each test was run in duplicate and the results given are a mean of the two values obtained.

(iii) The direct effect of cadmium on the analysis
for tryptophan

This was studied by addition of cadmium chloride to the serum of a normal monkey before albumin preparation,

in the concentration that was found in a monkey immediately following intravenous injection of 6 mg. of cadmium (i.e., 24 μ g. cadmium per ml. of serum). Measurements were made by the pDMAB method and the results are presented in Table 19.

TABLE 19.

The effect of added cadmium on the analysis
for tryptophan.

| Sample | Residues tryptophan per mole |
|--|------------------------------|
| Normal monkey serum albumin | 1.73, 1.78 |
| Normal monkey serum albumin with added cadmium | 1.71, 1.68 |

As these values are not significantly different, it is evident that cadmium ions had no direct effect on the analytical procedure.

(iv) The "in vivo" effect of cadmium on analysis for tryptophan

This was assessed by measuring the quantity of tryptophan to be found in the total albumin fraction of sera

taken from poisoned animals at various times after a booster dose of 6 mg. cadmium. It is evident from Table 20 that there was little or no change in tryptophan concentration.

TABLE 20.

The "in vivo" effect of cadmium on analysis
for tryptophan

| Experimental animal | Time after injection | Residues tryptophan per mole albumin |
|---------------------|----------------------|--------------------------------------|
| Monkey M | 2 hr. | 1.07 |
| Monkey L | 2 hr. | 1.55 |
| Monkey P | 2 hr. | 1.06 |
| Monkey M | 4 days | 0.71 |
| Monkey L | 4 days | 1.00 |
| Monkey P | 4 days | 0.98 |
| Monkey M | 7 days | 0.94 |
| Monkey L | 7 days | 0.97 |
| Monkey P | 7 days | 1.02 |

(d) Estimation of the amount of tryptophan to be found
in the various albumins.

Bearing in mind all the aforementioned investigations, purified albumins isolated from sera and urine of normal and chronically poisoned animals were analysed for their tryptophan content by both methods. The values obtained are presented in Table 21, and each figure given is a mean of three

to six determinations on each of three normal and three poisoned monkeys. Recoveries have been corrected for according to the data in Table 16. In the case of albumins prepared from cadmium-poisoned monkeys, normal and mini refer to the molecular size only.

TABLE 21.

Determination of tryptophan in albumin of normal and poisoned monkeys.

| Type of albumin | Residues tryptophan per mole (alkaline hydrolysis) | Residues tryptophan per mole (DMAB colour method) |
|--|--|---|
| Normal monkey serum normal albumin | 2.11 | 1.95 |
| Poisoned monkey serum normal albumin | 1.32 | 0.99 |
| Poisoned monkey serum minialbumin | 0.00 | 0.00 |
| Poisoned monkey urinary normal albumin | 1.65 | 1.69 |
| Poisoned monkey urinary minialbumin | 0.00 | 0.00 |

From the results obtained, normal monkey albumin, like bovine serum albumin⁽¹⁵⁸⁾, and canine plasma albumin⁽¹⁶⁰⁾ appeared to have two residues of tryptophan per molecule of albumin. In this respect it is unlike human albumin, shown

to have only one residue per mole^(158,159,161). The minialbumins in both serum and urine were totally lacking in tryptophan.

(An account of this section of the work is in proof, Kench and Sutherland (1967)⁽¹⁶²⁾).

II 12. (v) Systematic search for a missing peptide

The complete absence of tryptophan, and decreased amounts of lysine and cysteine in the minialbumins of cadmium-poisoned animals suggested loss of these amino acids, either metabolically by an in vivo mechanism under the influence of cadmium ions, or technically during the preparation of albumin.

It was considered possible that the missing amino acids might occur together in a single peptide, and this concept was investigated. It was not possible to look for a peptide in vivo, but a systematic search for it at the different stages in the preparation of albumin by both the TCA-ethanol⁽⁹⁸⁾ and the HCl-ethanol⁽¹⁰²⁾ methods was carried out.

Serum was obtained from a normal and a poisoned monkey, and albumin prepared in the usual way from both. At each stage, supernatants or precipitates normally discarded were kept and treated as follows:-

The TCA-ethanol method⁽⁹⁸⁾

- (a) The initial supernatant and 5% TCA washings were combined and dialysed against distilled water overnight. Both the dialysis residue and diffusate were concentrated by lyophilization. *
- (b) The globulin precipitate was dissolved in a few ml. distilled water and dialysed against distilled water overnight. The dialysis residue and diffusate were both lyophilized.
- (c) The diffusates used to remove the ethanol and TCA from the final preparation were combined and dried.

The HCl-ethanol method⁽¹⁰²⁾

- (a) The initial globulin precipitate was dissolved in a few ml. of distilled water and dialysed overnight against distilled water. Both the dialysis residue and diffusate were kept and dried.

* Dialysis residue means non-diffusible components remaining inside the dialysis sac. Diffusate means components which have diffused through the membrane into the surrounding medium.

Nomenclature is according to that recommended by the Biochemical Society (1967)⁽¹⁶³⁾.

- (b) The albumin preparation was dialysed overnight against distilled water which was then taken to dryness.
- (c) The final ethanol-sodium acetate supernatant was brought to pH 7.5 by addition of 0.1N sodium hydroxide and then evaporated to dryness in vacuo over sodium hydroxide pellets. This fraction was also optically scanned to detect any protein.

All the tubing employed was preboiled in distilled water. The residues in each case were taken up in a small volume of veronal buffer, ionic strength 0.01 and pH 8.6 and electrophoresed on cellulose acetate.

Figures 49 and 50 show that a number of the fractions normally discarded still contain some albumin. These were the initial TCA supernatant, the TCA globulin precipitate and the HCl globulin precipitate. These fractions containing albumin were pooled separately for the normal and cadmium-poisoned sera. The albumin was then separated from the other contaminating substances by ion exchange chromatography on carboxymethyl (CM) cellulose as follows:-

The new microgranular form (CM32) of cellulose was prepared by cycling in 0.5N sodium hydroxide, water to pH 8.0, in 0.5N HCl, and finally in water till neutral. The cellulose

FIG. 49

MISSING PEPTIDE - ELECTROPHORESIS. PREPARATIONS FROM NORMAL MONKEY.

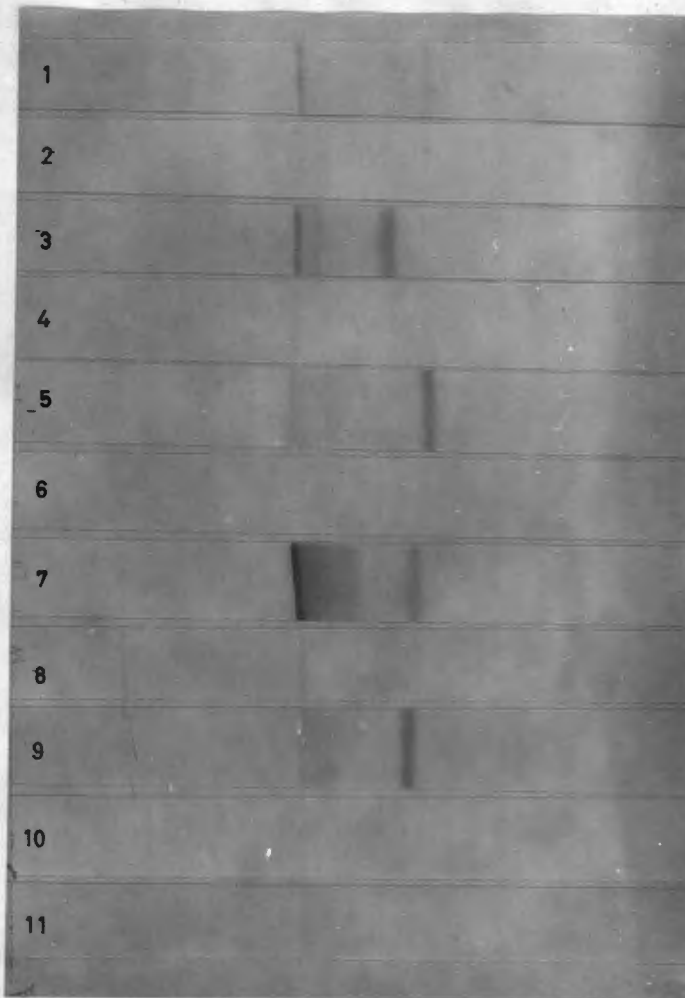

TCA ETHANOL METHOD

1. SUPERNATANT AND WASHINGS.
2. DIALYSIS FLUID FROM 1.
3. GLOBULIN PRECIPITATE.
4. DIALYSIS FLUID FROM 3.
5. PURIFIED ALBUMIN.
6. DIALYSIS FLUID FROM 5.

HCl ETHANOL METHOD

7. GLOBULIN PRECIPITATE.
8. DIALYSIS FLUID FROM 7.
9. PURIFIED ALBUMIN.
10. DIALYSIS FLUID FROM 9.
11. FINAL SUPERNATANT.

FIG. 50

MISSING PEPTIDE - ELECTROPHORESIS. PREPARATIONS FROM CADMIUM MONKEY.

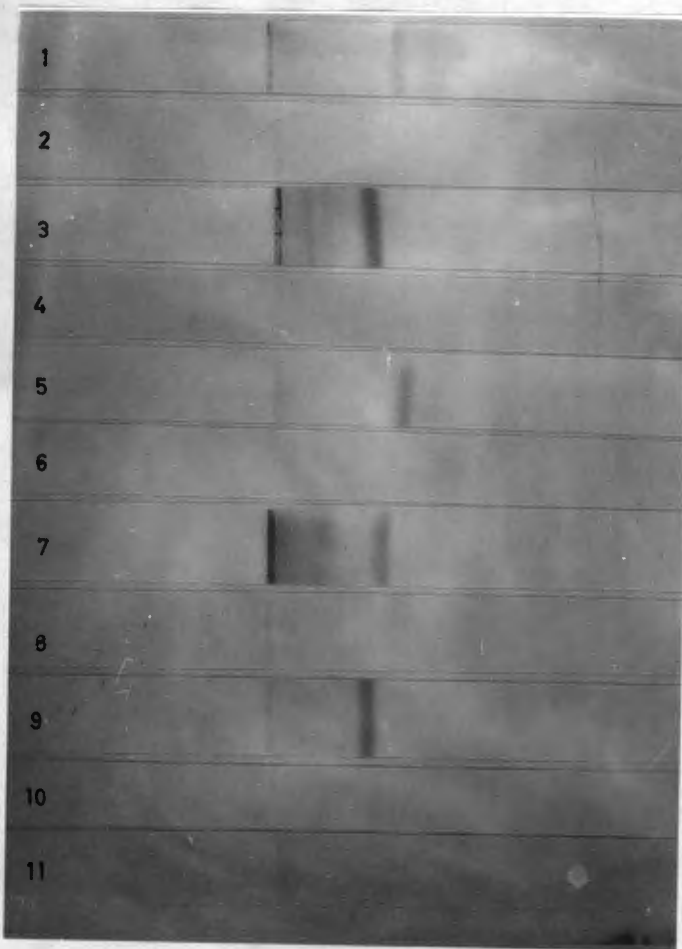

TCA ETHANOL METHOD.

1. SUPERNATANT AND WASHINGS.
2. DIALYSIS FLUID FROM 1.
3. GLOBULIN PRECIPITATE.
4. DIALYSIS FLUID FROM 3.
5. PURIFIED ALBUMIN.
6. DIALYSIS FLUID FROM 5.

HCl ETHANOL METHOD.

7. GLOBULIN PRECIPITATE.
8. DIALYSIS FLUID FROM 7.
9. PURIFIED ALBUMIN.
10. DIALYSIS FLUID FROM 9.
11. FINAL SUPERNATANT.

was then washed with several volumes of starting buffer. This whole operation was carried out in a Buchner funnel. Packing of the column was by the funnel method as described for Sephadex. The column was equilibrated by pumping through starting buffer overnight, and the samples to be chromatographed dialysed against the same buffer.

The buffers and gradient used were those advocated by Potgieter (1964)⁽¹⁰⁸⁾. Elution was started with 0.08M sodium acetate - acetic acid at pH 4.25 and completed with 0.15M sodium acetate - acetic acid at pH 5.25. The gradient was linear and the mixing chamber contained 150 ml. The column (25 x 1.7 cm.) was run at 15 ml./hr. The eluate was monitored through an LKB Uvicord, set at 262 m μ , and recorded (Fig. 51A and B). Albumin, which was the first protein to emerge, was collected, dialysed till free of buffer salts and freeze-dried.

Albumins were then monitored through a Sephadex G75 column in the usual way to check the size. Figs. 52A and B show the records for the albumin from normal and poisoned monkeys.

It is evident that any albumin lost from normal serum during its preparation was of normal size. However, that lost from the serum of cadmium-poisoned animals was mainly the small variety. This was not an unexpected finding as Adiga, Rao, Hussa and Winnick (1966)⁽¹⁶⁴⁾ have shown that low concentrations of TCA may lead to loss of peptides and small proteins such as ACTH due to their solubility. A major

FIG. 51

LOST PEPTIDE - PREPARATION
OF ALBUMIN.

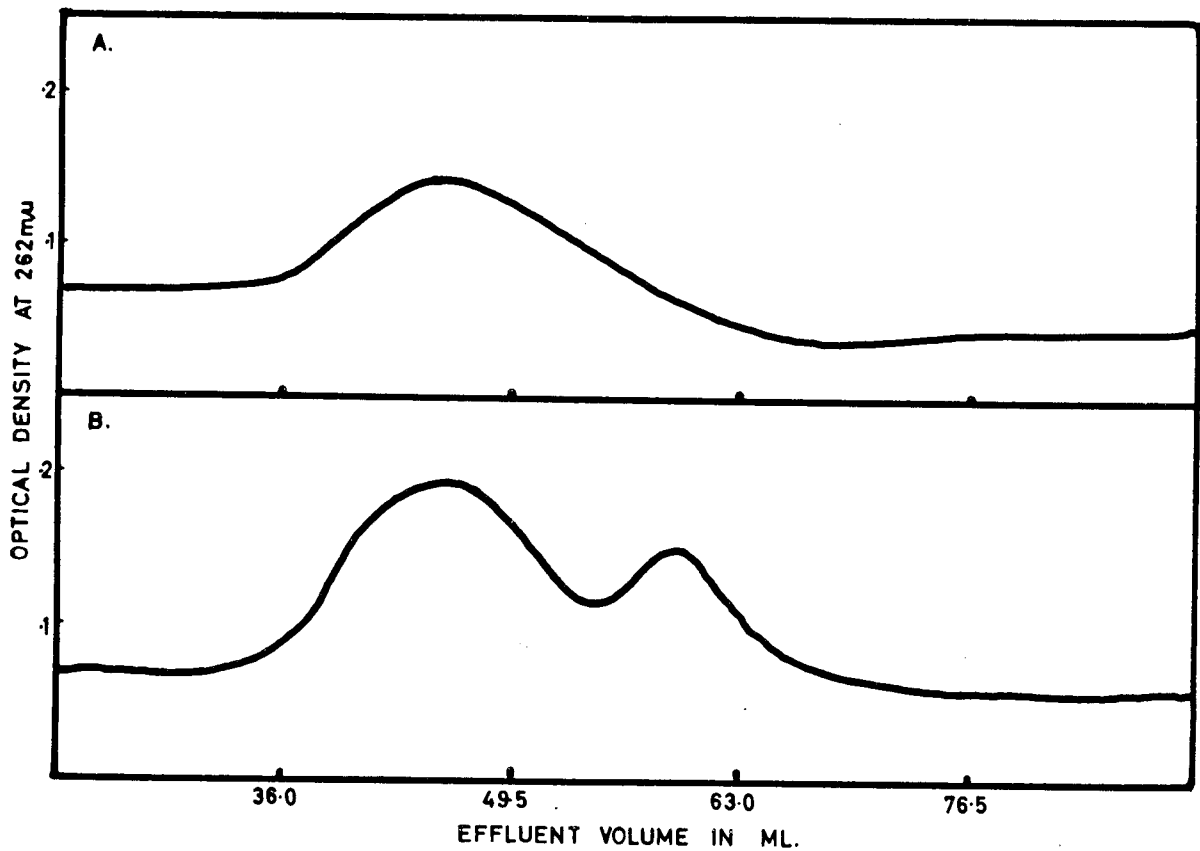

- A. NORMAL MONKEY. TRACE FROM CM CELLULOSE.
B. CADMIUM POISONED MONKEY. TRACE FROM CM CELLULOSE.

FIG. 52

LOST PEPTIDE - SEPARATION
OF ALBUMINS.

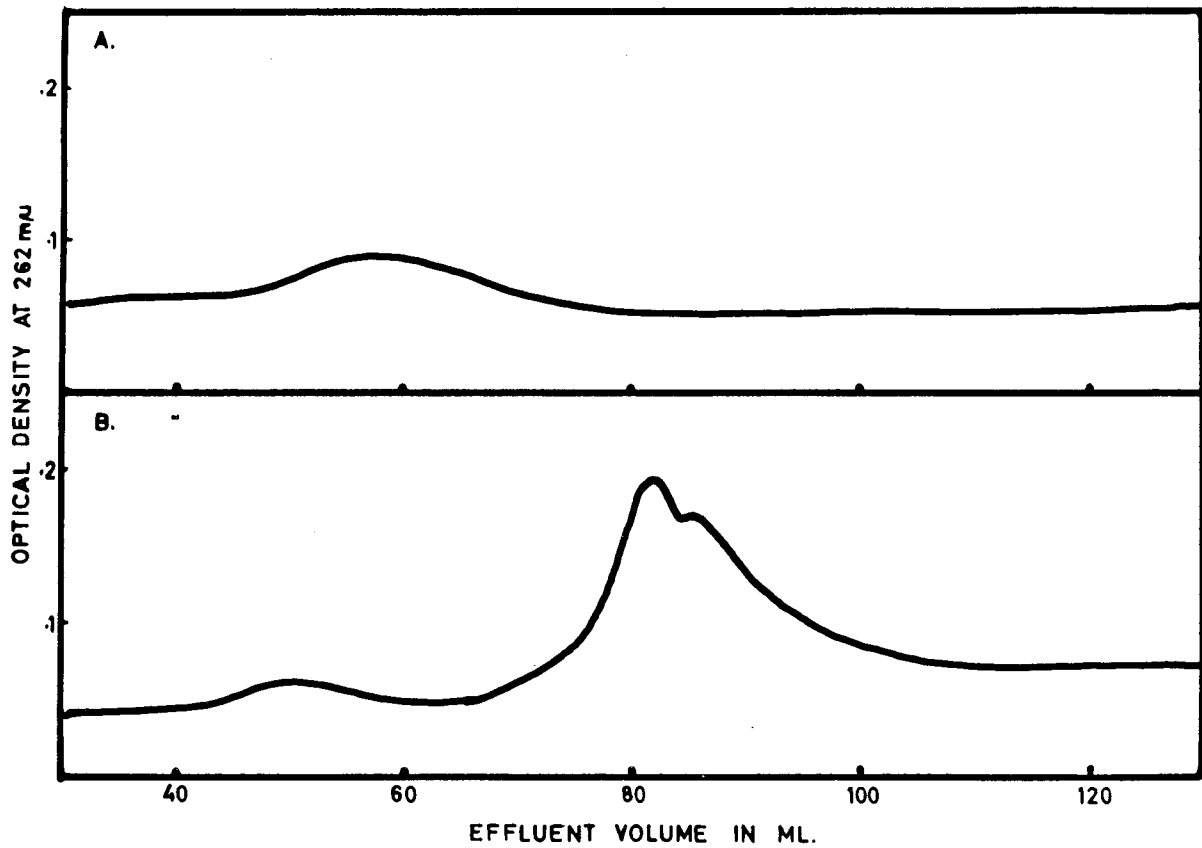

- A. NORMAL MONKEY ALBUMIN ON SEPHADEX G75.
- B. CADMIUM POISONED MONKEY ALBUMIN ON SEPHADEX G75.

part of the minialbumin could escape precipitation by the concentrations of TCA used in the procedure.

Such albumin might be the usual minialbumin, lost through dialysis or by the lack of precipitation. On the other hand, if it contained the "missing peptide" it should contain the two tryptophan residues. Lost albumin after dialysis in boiled tubing and lyophilization was, therefore, analysed for tryptophan by the pDMAB method as described earlier.

Table 22 shows that there was complete absence of tryptophan in this fraction which could, therefore, be assumed to be minialbumin which was discarded during the usual preparative procedure.

TABLE 22.

Determination of tryptophan in the "lost peptide"

| Sample | * Extinction at 580 m μ |
|------------------|------------------------------|
| Tryptophan Stds. | |
| 10 μ g | 0.041 |
| 20 μ g | 0.083 |
| 30 μ g | 0.129 |
| 40 μ g | 0.180 |
| 50 μ g | 0.235 |
| Albumin fraction | 0.002 |
| (5.7 mg. protein | $\bar{=} 0.03$ residues/mole |

* Values have been corrected for blank readings.

II 12. (vi) Immunological studies

The characterization, by immunological tests, of the anomalous albumins produced by cadmium poisoning, was pertinent to this study because of the high degree of specificity and sensitivity afforded by these methods.

Both immunoelectrophoretic and double diffusion techniques involving the use of uni and polyvalent antisera were employed. (Reported⁽¹²¹⁾).

(a) Preparation of antisera

As antisera suitable for these antigenic studies were not readily available commercially, they had to be prepared. Both antisera to whole serum and to the isolated albumins were prepared.

The polyvalent antiserum was made essentially by the method of Mandy, Rivers and Nisonoff (1961)⁽¹⁶⁵⁾ in which rabbits were given 1 ml. of a 1% (w/v) protein solution in physiological saline (0.85% w/v) two to three times weekly for a period of 5 to 6 weeks. The antigen was introduced into the marginal ear vein using a 21 gauge needle and disposable syringe. Inoculations were given alternately into the left and right ears. After a resting period of one week, the animals were test bled by withdrawing 5 ml. blood from the ear vein with a syringe, and then given a further

1 ml. of the antigen. Subsequent bleeding (performed by nicking the ear vein with a razor blade and allowing the blood to flow into a collecting vessel) and inoculation was carried out at 1 to 2 weekly intervals. In each instance, blood was allowed to clot before separation and examination of antigenic activity by reaction with 1% (v/v) whole serum in physiological saline (0.85% w/v). Antisera of high titre were obtained and pooled.

Antisera to the discrete albumin fractions (normal size and minialbumin from the serum) was prepared by the method of Fahey and McLaughlin (1963)⁽¹⁶⁶⁾. Only pure albumin fractions, i.e. preparations showing a single precipitin line against polyvalent antiserum, were used. Three mg. of the dried protein solution was dissolved in 1 ml. physiological saline (0.85% w/v) and emulsified with an equal volume of complete Freund's adjuvant. This was injected intramuscularly into the inner side of the thigh of a hind limb of the rabbit. Five weeks following this a further injection using the same amount of protein but incomplete Freund's adjuvant was given intramuscularly into the other hind limb. After a 3 to 4 week interval the animal was test bled from the marginal ear vein. Subsequent immunization, preceded by bleeding, was by intramuscular injection of 2.5 mg. protein in adjuvant at 4 weekly intervals. The blood collected was allowed to

clot and the separated serum tested for potency by reaction with the appropriate albumin and specificity by reaction with whole serum.

Sterilization of the proteins used for antiserum production was effected by passage through a sterile millipore filter adapter containing a GS filter pad of pore size 0.22 μ . The apparatus was autoclaved at 15 lb. pressure for 15 min. before use.

The titre of the antisera produced was tested by the method of doubling dilutions⁽¹⁶⁷⁾. 0.1 ml. of doubling dilutions of the antiserum from 1 - 1/64 were carefully layered onto 0.1 ml. of the antigen (a 1% (w/v) protein solution) in Dreyer tubes. A ring of precipitate at the interface was indicative of activity. When precipitation was obtained with dilutions up to 1/16 - 1/32, the titre was considered high enough. Usually the higher concentrations of antiserum formed a precipitin ring within an hour while the more dilute ones were allowed to react overnight. The polyvalent rabbit antiserum had good titres against the serum globulins as well as against albumin, and was therefore suitable for testing the purity of preparations. The univalent antiserum was used in specific tests and in cross reactions to determine whether or not identity and complete antigenic activity existed between the large and small molecules of albumin.

(b) Immunelectrophoresis

Since Grabar and Williams (1955)⁽¹¹⁰⁾ introduced this technique it has been widely applied because of its precision and sensitivity. For our purposes, it provided not only an excellent method for identifying proteins, but also one for determining their degree of purity, since antibodies have been shown to have a very high specificity for their homologous antigens⁽¹⁶⁸⁾.

The principle involved an initial electrophoresis in agar gel, followed by immuno-diffusion which was performed by applying antiserum in strips parallel to the electrophoretic run, and then incubating. Both the antiserum and the proteins diffused laterally, and where the antibody encountered its specifically combining antigen in zones of optimal proportions, mutual precipitation occurred.

The supporting medium of agar was of paramount importance. Agarose (Seravac Laboratories, S.A.), a neutral galactose polymer consisting of alternate residues of 3,6 anhydro-L-galactose and galactose was found to be a more suitable product than Ionagar (a mixture of agaropectin and agarose) discussed and used by Wunderly (1959)⁽¹⁶⁹⁾. This was by virtue of its lack of charged particles, which lead to poor resolution owing to endosmotic effects. Due to its low protein nitrogen content, agarose exhibited much less background staining - a further advantage.

A 1% (w/v) gel was ideal, and this was prepared in 0.05M tris-(hydroxy-methyl) amino methane-HCl (tris) buffer at pH 8.4, containing 500 mg. of sodium azide per litre. Sodium azide was used as the antiseptic because it does not ionise to any extent, does not combine with the proteins and is efficient⁽¹⁷⁰⁾. The agar was prepared by boiling with the buffer until completely translucent. Loss of water by evaporation was made good. The solution was plated onto levelled glass slides (7.5 x 5 cm. and precleaned in ethanol and flamed) by means of a plastic syringe to give a gel 1 - 2 mm. thick. Gelling occurred almost immediately and plates were ready for use within 1 hr. Off-centre wells were punched out of the gel with the aid of a flat-tipped pasteur pipette, and the canals for antiserum were made by punching out small wells at either end of a slit cut with a sharp scalpel blade. The wells and the canals were 1 mm. in diameter and 2.5 - 3 mm. apart.

A perspex tank with the buffer compartments and electro-phoretic chamber separated from each other was used. The actual chamber had a built-in cooling system which minimized condensation, and an airtight cover which largely reduced convection currents and maintained a constant degree of saturation (Fig. 53).

The tank buffer selected was 0.1M tris-HCl at pH 8.4⁽¹⁷¹⁾, containing 500 mg. of sodium azide per l. Phosphate and

FIG. 53

IMMUNO - ELECTROPHORESIS.
APPARATUS.

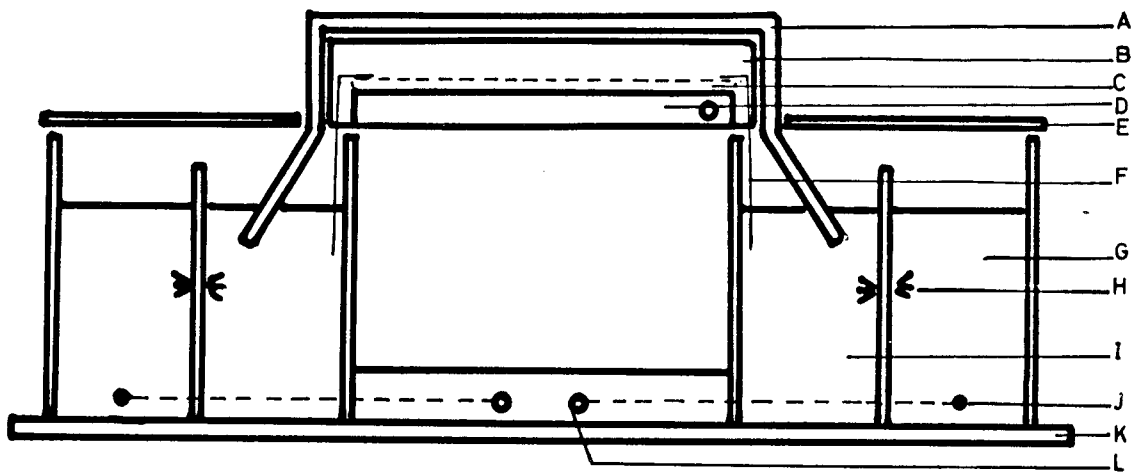

- A. CHAMBER COVER.
- B. COVER SUPPORT.
- C. AGAR PLATE.
- D. COOLING CHAMBER.
- E. TANK COVER PLATE.
- F. WHATMANS NO 1 WICK.
- G. ELECTRODE CHAMBER.
- H. COTTON WICK.
- I. BUFFER TANK.
- J. ELECTRODE.
- K. PERSPEX TANK.
- L. ELECTRODE TERMINAL.

barbitone buffers were also tested but gave poorer results at this pH. Whatman No. 1 filter paper strips were used as wicks and the plates were allowed to equilibrate in the tank for a short while before application of the samples.

The samples freed of salt, as this caused shrinking and swelling of the gel, were run into the wells with a micro-pasteur pipette. Phenol red (G.T. Gurr) was used as a marker as it ran slightly ahead of albumin under these conditions. A potential difference of 300V was applied and the run was completed in 20 - 30 min.

Antiserum was then introduced into the canals with a micro-pasteur pipette and the plates incubated in a moist airtight chamber at 0° for about 16 hr. Unprecipitated protein and antiserum were then removed by dialysis against several changes of cold physiological saline. The plates were now ready for staining. The precipitin arcs were fixed by standing the plate in an ethanol-acetic acid-water mixture (70 : 5 : 25, v/v/v) for 30 min., and then stained in 0.02% (w/v) aqueous nigrosin (G.T. Gurr) for 1 - 2 hr. The background was cleared by washing with 5% (v/v) acetic acid. Plates were air-dried under cover. It was unnecessary to dry the plates before staining, as advocated by some workers.

Fig. 54 shows normal and minialbumin as compared with

FIG. 54

IMMUNOELECTROPHORETIC PATTERNS.

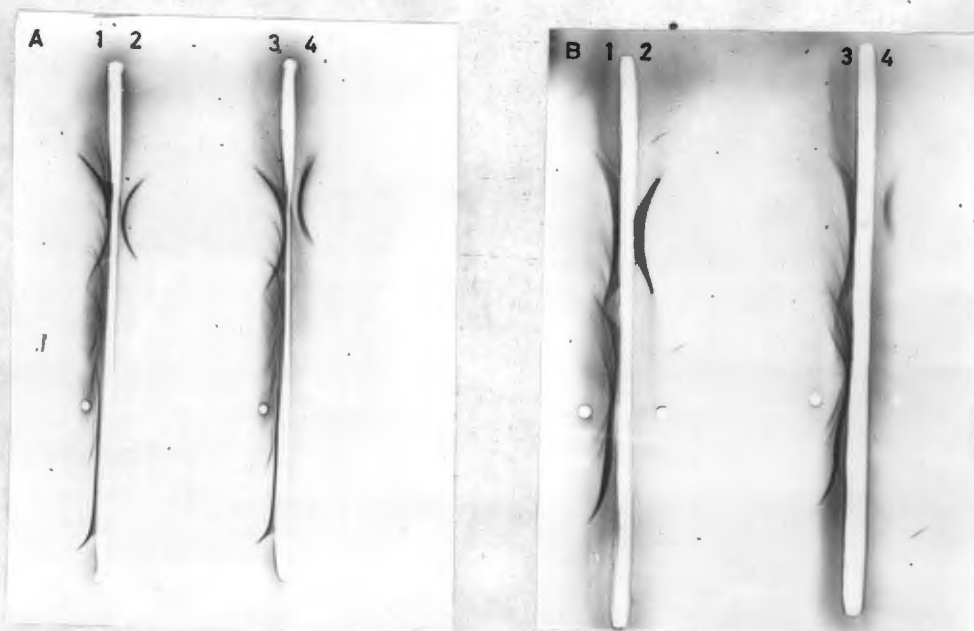

- A1. NORMAL MONKEY WHOLE SERUM.
 2. CADMIUM MONKEY NORMAL SERUM ALBUMIN.
 3. NORMAL MONKEY WHOLE SERUM.
 4. CADMIUM MONKEY MINI SERUM ALBUMIN.
-
- B1. NORMAL MONKEY WHOLE SERUM.
 2. CADMIUM MONKEY NORMAL URINARY ALBUMIN.
 3. NORMAL MONKEY WHOLE SERUM.
 4. CADMIUM MONKEY MINI URINARY ALBUMIN.

A & B ANTI WHOLE NORMAL SERUM ANTISERUM.

FIG. 55

IMMUNOELECTROPHORETIC PATTERNS.

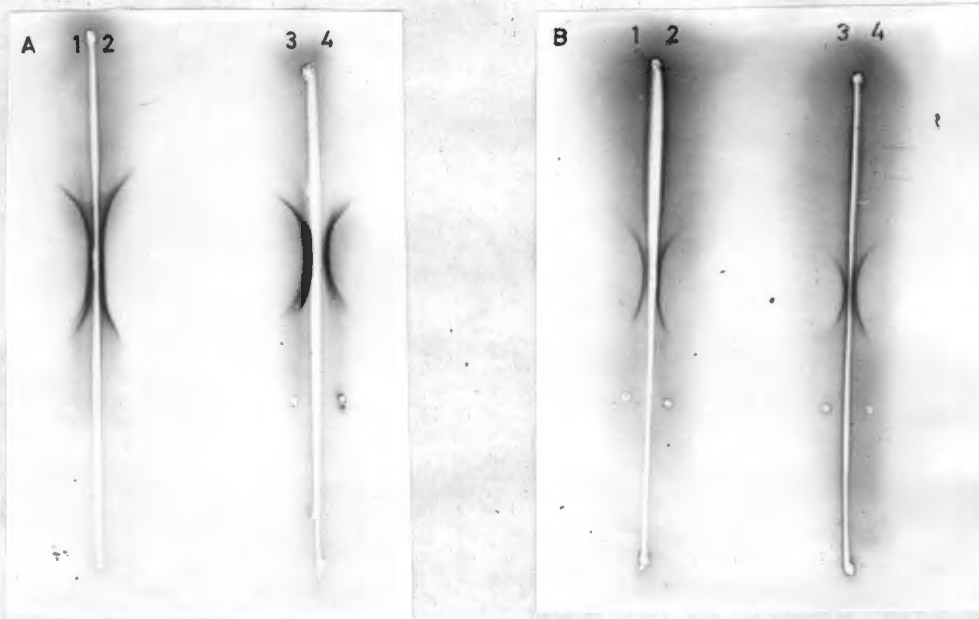

A1 & B1. NORMAL MONKEY SERUM ALBUMIN.
A2 & B2. CADMIUM MONKEY NORMAL SERUM ALBUMIN.
A3 & B3. NORMAL MONKEY SERUM ALBUMIN.
A4 & B4. CADMIUM MONKEY MINI SERUM ALBUMIN.

A. ANTI NORMAL ALBUMIN ANTISERUM.
B. ANTI MINIALBUMIN ANTISERUM.

whole serum. The single precipitin arcs were indicative of pure preparations. The specificity of the isolated albumins is demonstrated in Fig. 55 where antialbumin antisera have been used. It can be seen that the electrophoretic mobility and antigenic reaction of the albumins, both large and small, from normal and cadmium-poisoned animals were closely similar. Minialbumin tended to run a little faster than the normal size albumin.

(c) Ouchterlony Technique

This technique described⁽¹³⁴⁾ and later revised⁽¹⁷²⁾ by Ouchterlony was designed to recognise antigenic identity between proteins, and was therefore very useful to us.

Agarose plates were prepared in a fashion identical with that described for immunoelectrophoresis. A template, consisting of a central punching tube, surrounded by six symmetrically spaced tubes of equal diameter was used to cut the wells.

Antiserum was usually placed in the centre well, while the proteins to be tested filled the encircling hexagonal set of wells. Immunodiffusion was allowed to proceed overnight (or longer if necessary) in a moist airtight chamber at 0°. Thereafter, the washing and staining techniques were those described under immunoelectrophoresis.

FIG. 56

OUCHTERLONY PLATES.



- A1. NORMAL MONKEY SERUM ALBUMIN.
- 2. Cd MONKEY NORMAL SERUM ALBUMIN.
- 3. Cd MONKEY MINI SERUM ALBUMIN.
- 4. NORMAL MONKEY SERUM ALBUMIN.
- 5. Cd MONKEY URINARY NORMAL ALBUMIN.
- 6. Cd MONKEY URINARY MINIALBUMIN.

ANTI NORMAL ALBUMIN ANTISERUM.



- B1. PERITONEAL DIAL. NORMAL ALBUMIN.
- 2. PERITONEAL DIAL. MINIALBUMIN (DILUTE).
- 3. PERITONEAL DIAL. NORMAL ALBUMIN.
- 4. PERITONEAL DIAL. MINIALBUMIN (CONC).
- 5. Cd MONKEY SERUM NORMAL ALBUMIN.
- 6. NORMAL MONKEY SERUM ALBUMIN.

ANTI NORMAL ALBUMIN ANTISERUM.

FIG. 57

OUCHTERLONY PLATES.

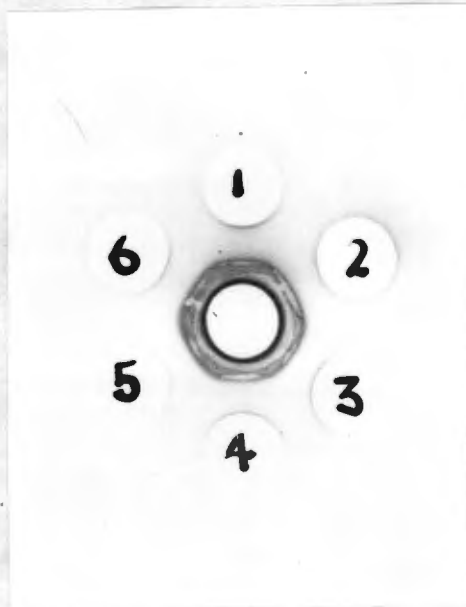

1. NORMAL MONKEY SERUM ALBUMIN.
2. CADMIUM MONKEY MINI SERUM ALBUMIN.
3. CADMIUM MONKEY NDRMAL SERUM ALBUMIN.
4. CADMIUM MONKEY MINI SERUM ALBUMIN.
5. CADMIUM MONKEY NORMAL URINARY ALBUMIN.
6. CADMIUM MONKEY MINI URINARY ALBUMIN.

ANTI MINIALBUMIN ANTISERUM.

It is evident from the absence of spur formation (Fig. 56) that the different size albumins, irrespective of their source (viz. serum or urine) are antigenically identical and indistinguishable.

Fig. 57 shows plates where the antiserum used was prepared against minialbumin, i.e. it was anti-minialbumin. Precipitin lines accrued when normal monkey albumin was the antigen, showing that minialbumin itself can function as a complete antigen.

II 12. (vii) Ultracentrifugal studies and determination of molecular weight *

Although approximate values for the molecular weights of the albumins occurring in cadmium-poisoned animals could be derived from the gel filtration studies, it was highly desirable to know their precise molecular weights.

* This section of the thesis has been included for the sake of completeness. We are indebted to Dr. A. Polson for the specialized information here, and for his kind co-operation. In this context, we wish to put on record our appreciation of the earlier determinations made for us by Dr. R.A. Kekwick, of the Lister Institute, London, which indirectly contributed much to the present work.

From a knowledge of the sedimentation and diffusion coefficients of the protein in question, the molecular weight could be derived from the following formula^(173,174).

$$M = (1 - \bar{v}\rho) W^2 x = f \frac{dv}{dt}$$

where M is the molecular weight, \bar{v} is the partial specific volume, and f is the molar frictional coefficient. However, f can be determined from the diffusion constant (D) because

$$f = \frac{RT}{D}$$

and since the sedimentation constant

$$S = \frac{dx/dt}{w^2 x}$$

the equation can be reduced to the following form

$$M = \frac{RTS}{D(1 - \bar{v}\rho)}$$

The symbols have the following designation:

M, \bar{v} , D and S - as above

R = gas constant

T = absolute temperature

ρ = density of the medium.

(a) Determination of the sedimentation coefficients

The sedimentation constants were measured with a Beckman Spinco Model E analytical ultracentrifuge^(175,176). The concentration gradient curve in the cell was directly observed by a suitable optical system and light of a wavelength such that it was absorbed by the sedimenting substance. A direct method of photography involving refraction, and developed by Philpot (1938)⁽¹⁷⁷⁾ and Andersson (1939)⁽¹⁷⁸⁾, was used. This gave a diagram relating the refractive index gradient with height in the column of solution.

As centrifugation proceeded, the sedimenting boundary was gradually lowered. The change in refractive index at the boundary could be observed, and from this the rate of movement of the boundary downwards was followed. The Schlieren system of lenses was used and projected the boundary as a peak because the rate of change of refractive index was greatest at the centre of the sedimenting boundary, and deviation of light rays was directly proportional to the change in refractive index. Hence, by measuring this rate of sedimentation (by following the movement of the peak), and plotting it against time, a straight line, whose slope was indicative of the sedimentation velocity, was obtained^(179,180).

The calculation of the sedimentation coefficient involved the sedimentation velocity and data regarding angular spin (ω) and time (t); and could be represented by the following equation.

$$S = \frac{2.303 d \log x/dt}{t x w^2}$$

A synthetic boundary cell was used and the albumins analysed were 0.6% (w/v) solutions of protein in 0.9% (w/v) sodium chloride. A speed of 56,100 rev./min. was employed and photographs of the peak were taken at intervals of 16 min.

Fig. 58 shows the ultracentrifugal patterns for disaggregated mini, normal albumin and high molecular weight aggregates of albumin from a cadmium-poisoned monkey. In Fig. 58A the bulk of the material (approximately 60%) had a sedimentation coefficient of less than 1 Svedberg unit (minialbumin), but on account of its inhomogeneity, no accurate sedimentation constant could be calculated. The rest of the protein travelled as a peak for which the sedimentation coefficient was calculated as $S_{20,w} = 4.75$. Within the limits of error of the experiment, this coefficient corresponds to that of normal serum albumin. This same preparation, previously run in higher salt concentrations appeared to consist only of molecules less than 10,000 in molecular weight. Serum minialbumin isolated from another monkey, and run in the higher salt concentration (0.2M NaCl) also showed a preponderance of molecules of Mol. wt. 10,000, but contained larger and smaller molecules as well. Such results are in keeping with the aggregation phenomenon discussed. (Reported⁽¹²¹⁾).

The normal size albumin from cadmium poisoned animals was the only fraction homogeneous on ultracentrifugation (Fig. 58B). The sedimentation coefficient was calculated as $S_{20,w} = 4.23 \times 10^{-13}$ (Fig. 59 shows the graph from which this was determined as an example).

A fraction containing larger aggregates which separated completely from the normal size albumins, was resolved into 3 components which passed through a column of dextran gel (65 x 3.5 cm. and a flow rate of 15 ml./hr.) on centrifugation (Fig. 58C). These had the following sedimentation coefficients:

$$\begin{aligned} S_{20,w} &= 3.47 \\ S_{20,w} &= 7.07 \\ S_{20,w} &= 8.77 \text{ (trace)} \end{aligned}$$

The smallest of these had obviously undergone disaggregation after separation on the Sephadex column, as it is smaller in size than normal albumin, eluted behind it.

(b) Determination of the diffusion coefficients

Diffusion coefficients, dependent on the molecular size and shape of the substance in question can be measured satisfactorily by the method of Cohen and Bruins (1923)⁽¹⁸¹⁾. This procedure, modified by Lamm and Polson (1936)⁽¹⁸²⁾,

FIG. 58

ULTRACENTRIFUGAL PATTERNS.

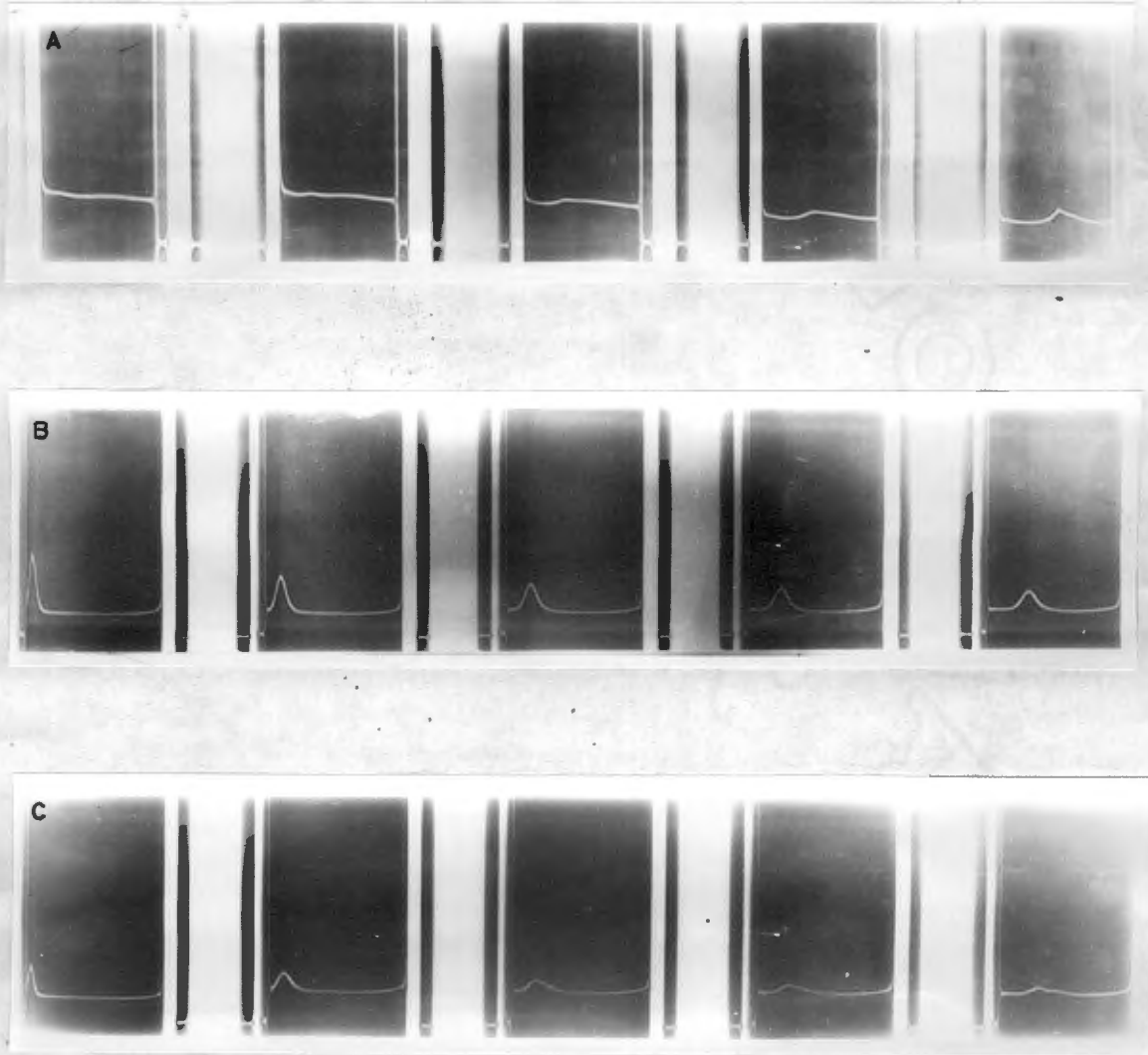

- A. MINIALBUMIN.
- B. NORMAL SIZE ALBUMIN.
- C. AGGREGATED ALBUMIN.

FIG. 59

DETERMINATION OF SEDIMENTATION
COEFFICIENT.

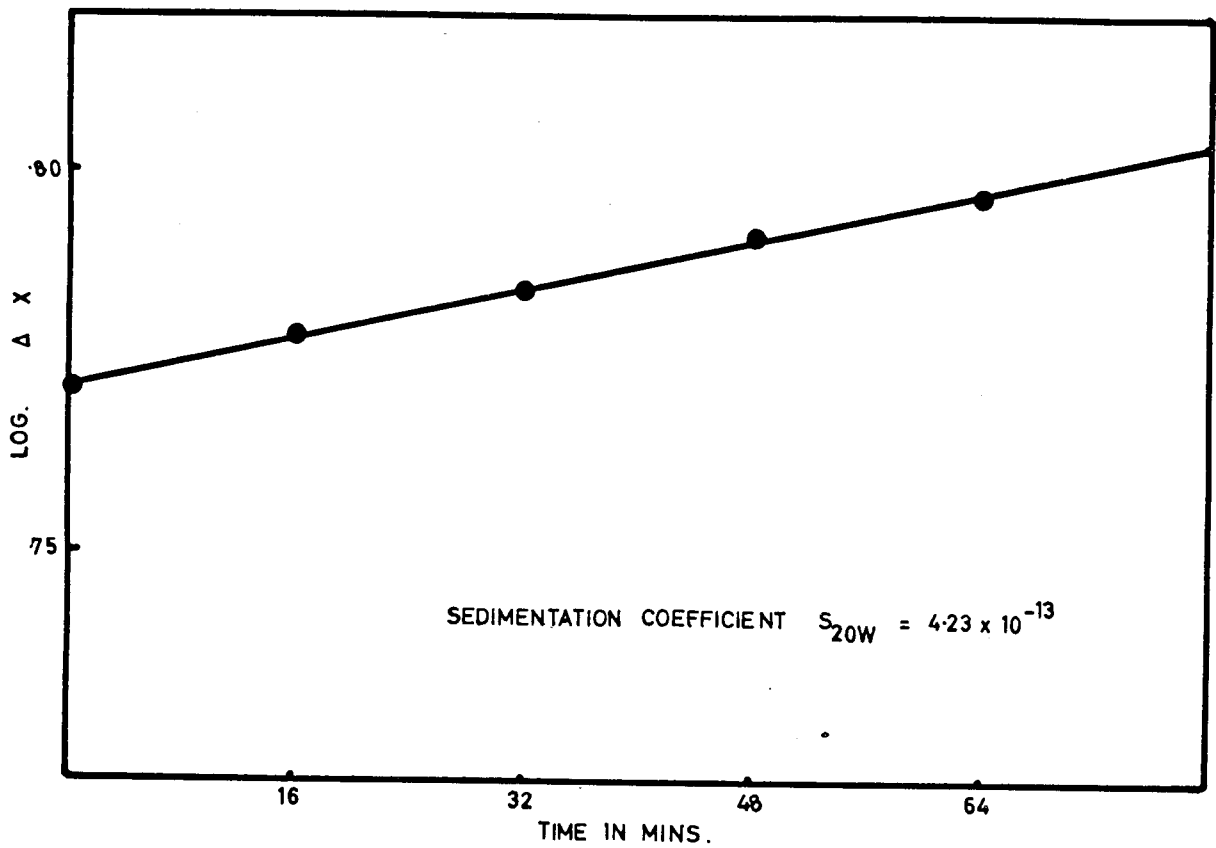

involved photography of a vertical uniform transparent scale. through the cell, in which protein in solution had been allowed to diffuse by exposing it to the solvent. The refractive index gradient at the diffusion boundary produces a distorted image of the scale by deviation of the light rays. As refractive index was a linear function of the concentration, the scale line displacement was proportional to the concentration gradient. From such readings diffusion constants could be calculated.

Diffusion constants for the albumins in question were not actually determined because of the anomalies in molecular weight of the aggregating fractions. However, the diffusion constant for normal serum albumin is known, and that of urinary minialbumin has been determined as $10.61 \times 10^{-7} \text{ cm}^2/\text{sec}$. (Gain and Kench, 1965⁽⁶⁵⁾).

The partial specific volumes have been assumed to be the same as those of normal albumin because of the similarity in amino acid composition.

(c) Determination of molecular weight

From the above parameters the molecular weights of the albumins found in cadmium-poisoned animals could be calculated.

Both the serum and urine of such animals contained a

series of albumin molecules ranging in molecular weights from 5,000 to 170,000. Serum minialbumin comprised mainly molecules of Mol. wt. 5,000 and 10,000, while the major portion of the urinary albumin had a Mol. wt. of 20,000.

The molecules of 140,000 are possible dimers of the normal size albumin (67,000), while the 170,000 particles may arise as polymers of the smaller aggregating units.

II 12. (viii) High voltage electrophoresis

In view of the aggregation-disaggregation phenomena, an attempt was made to separate the small molecules (\pm 5,000 M.W.) thought to be the combining units. As the albumin molecule is a single polypeptide chain with no repeating unit, fragmentation would be expected to give rise to a series of differently charged peptides, separable by high voltage electrophoresis. If minialbumin consisted of such a mixture of peptides formed by partial proteolysis of serum albumin, high voltage electrophoresis should be effective in separating a number of components.

Electrophoresis of the isolated albumins in agar and on cellulose acetate revealed them as single entities with the same electrophoretic mobility as normal albumin obtained from unpoisoned animals.

A "Pherograph Original Frankfurt" unit was subsequently used in which the electrophoretic chamber, supplied with a voltage multiplier, high voltage leads and platinum electrodes, was kept at constant temperature with thermostatically controlled cooling coils of tinned copper, arranged in series⁽¹⁸³⁾.

The buffers used must possess a certain degree of conductivity and capacity. However, most buffers suitable for work with active proteins have low capacity. A veronal buffer, containing 12 g. of barbituric acid/l. and initially dissolved in 23 ml. of hot 2N sodium hydroxide and adjusted to pH 8.6 with 2N NaOH after cooling, was used⁽¹⁸⁴⁾. Urea, in a final concentration of 2M could be incorporated into the buffer with no apparent upset to the running conditions.

The paper, 40 x 37 cm., was soaked in the buffer and then placed on filter paper and pressed with a roller in one direction only, to remove excess moisture. The paper was then transferred to the tank and rolled onto the dry plate glass surface - from the inside outwards, thus expelling all air bubbles. Thicker strips, moist with the same buffer, were placed across the ends, and the platinum electrodes, encased in plastic, positioned on these. Contact between the paper and electrodes was uniform throughout.

It was usual to pencil in a starting line before soaking the paper. This was positioned according to the pH of the buffer and the electric charges on the substances to be run.

Thus at pH 8.6, albumins would be negatively charged and were therefore spotted closer to the cathode end. The sample was applied 1 to 3 times with a very fine tipped bulb pipette either in spots or strips using a ruler as a guide. Phenol red, with practically the same mobility as albumin, was used as a marker. The electrophoresis chamber was covered by plate glass to maintain a constant environment, and the voltage desired was selected. Current should not exceed 120 mA at the chosen voltage. Using the pH 8.6 veronal buffer, electrophoresis was continued for 2 hr. at a potential difference of 1200 V and a current of 20 mA. Higher voltage could not be used because the buffer volatilized too rapidly and this led to overheating.

After electrophoresis, the paper was oven-dried and then stained with lissamine green (0.975% (w/v) in 1.5% (w/v) salicylsulphonic acid) and cleared with 2% (v/v) acetic acid. Alternatively, amido black (a saturated solution in 7% (v/v) acetic acid) could be used. Under the above conditions disappointing results were obtained. The albumins moved as apparently single, but trailing bands (Fig. 60).

It was, therefore, decided to run the albumins in a less volatile buffer at lower pH. The buffer selected was a pyridine-acetic acid-water (10 : 0.4 : 90, v/v/v)

FIG. 60

HIGH VOLTAGE ELECTROPHORESIS
AT pH 8.6

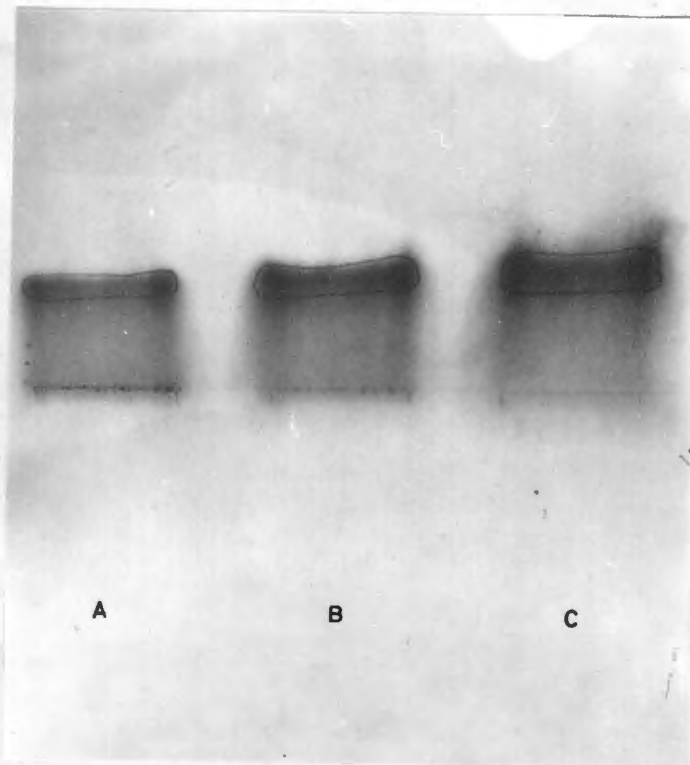

- A. NORMAL MONKEY SERUM ALBUMIN.
- B. CADMIUM MONKEY NORMAL SERUM ALBUMIN.
- C. CADMIUM MONKEY MINI SERUM ALBUMIN.

FIG. 61

HIGH VOLTAGE ELECTROPHORESIS

AT pH 6.5

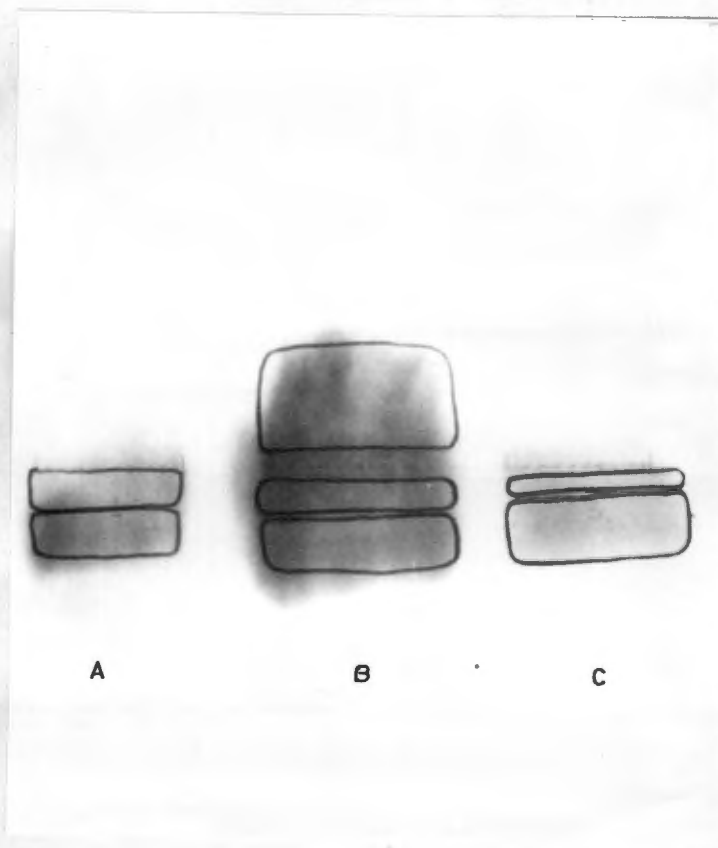

- A. NORMAL MONKEY SERUM ALBUMIN.
- B. CADMIUM MONKEY NORMAL SERUM ALBUMIN.
- C. CADMIUM MONKEY MINI SERUM ALBUMIN.

mixture at pH 6.5 as described for separation of peptides. Potential differences of 1,500 V to 3,000 V were employed for periods ranging from 1 to 2 hr. Duplicate strips were stained for protein with lissamine green as above, and for peptides with ninhydrin. These runs were somewhat more successful, but still did not clearly demarcate a number of fragments. However, it was evident that albumin from cadmium-poisoned animals contained more than one component. Fig. 61 shows a typical pattern.

II 12. (ix) Polyacrylamide electrophoresis

This technique was also tried in a further attempt to separate the peptides which may constitute the minialbumins of poisoned animals, as it could be operated in the presence or absence of urea.

An "Acrylophor" (Pleuger) kit was used. The apparatus and running principles involved were those described by Bloemendal^(185,186), Bloemendal et al (1962)¹⁸⁷ and Aronson and Grönwall (1957)⁽¹⁸⁸⁾. The tank consisted of a cover plate, connected with a circular platinum electrode, an upper electrode vessel with o-rings, and a lower circular platinum electrode attached to the lower electrode vessel (Fig. 62). A Pleuger type V-80 power pack with constant voltage was attached with banana plugs.

FIG. 62

POLYACRYLAMIDE ELECTROPHORESIS.
APPARATUS.

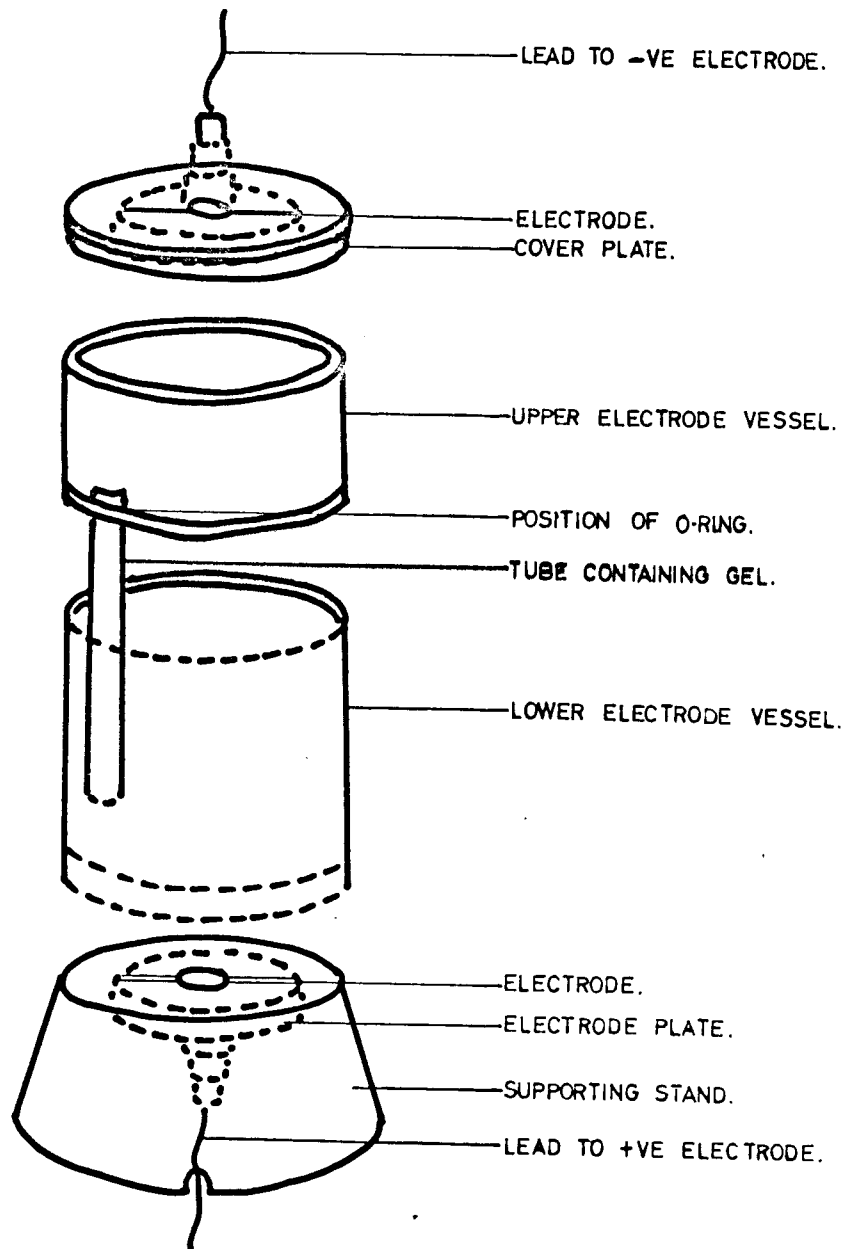

The gel was prepared by mixing together equal volumes of the following four reagents in the order given.

- (i) 30 g. acrylamide + 0.8 g. N N'methylene-bisacrylamide in a final volume of 100 ml.
(store in a dark bottle).
- (ii) 1.6% (w/v) dimethylaminopropionitril in the electrode buffer.
- (iii) 0.3% (w/v) potassium ferricyanide.
- (iv) 0.48% (w/v) ammonium persulfate.

All the solutions were prepared in doubly distilled water, and could be kept at 0° for 3 to 4 weeks. However, they had to be warmed to room temperature for the gel preparation. Gels were allowed to stand at room temperature for 45 min. while polymerization occurred, after which the unpolymerized layer was discarded and the top of the gel washed twice with buffer. The empty part of the tubes was then filled with buffer and the sample (mixed with sucrose) layered onto the buffer-gel interface with a micro-cap.

The tubes were then inserted into the upper electrode vessel and placed in the tank. Any air trapped at the base of the tube was removed with a bent pasteur pipette. The buffer used in both the upper and lower electrode vessels was a tris-glycine mixture at pH 8.5 containing 3 g. tris-

(hydroxymethyl) amino methane and 14.4 g. glycine per 100 ml. doubly distilled water, and diluted 10 times before use. A few drops of bromophenol blue marker were added to the upper vessel.

A potential difference of 80V was applied for the first 45 min. This was stepped up to 160V for a subsequent 15 min. Progress was gauged by the marker, some of which attached itself to the albumin, and some ran slightly ahead of it as a thin blue band of free indicator.

On completion of a run the buffer was decanted, the tubes detached from the electrode vessel, and the gels removed by injection of water from a blunt needle and syringe inserted between the tube wall and the gel surface.

Staining was continued for at least 30 min. with a saturated solution of amido black in 7% (v/v) acetic acid. Gels were decolourized by washing with 7% (v/v) acetic acid initially and then transferring them to constricted tubes and subjecting them to a potential difference of 80V, using 7% (v/v) acetic acid in both electrode vessels. The decolourized gels can be stored in the acetic acid without loss of colour for several months.

Where urea was incorporated into the gels, solid urea was added to the mixed, but unpolymerized gel, to give a final concentration of 2% (w/v). It apparently had no effect

on the gelling process.

This technique provided valuable information on the interrelationships between normal size and minialbumins from cadmium-poisoned monkeys. Electrophoretic patterns of whole sera, both with and without urea, appeared to be identical for both normal and poisoned animals (Fig. 63 and 64). However, isolated large size albumins from cadmium monkeys shown to be homogeneous on ultracentrifugation as already described separated into two or three bands on electrophoresis in polyacrylamide gel. Minialbumin from the same animals exhibited four and sometimes five bands. These were slightly more pronounced in the urea gels (Fig. 63 and 64). All these albumins, however, gave only a single precipitin arc as for albumin with a multivalent antiserum. The results seem indicative of the presence, within the albumin molecule, of fragments or polymers with slightly different electrical charges. These findings lend to support the hypothesis that minialbumin contains a number of polypeptides, the overall amino composition of which, as we have already seen, closely resembles that of normal serum albumin.

FIG. 63

POLYACRYLAMIDE ELECTROPHORESIS.

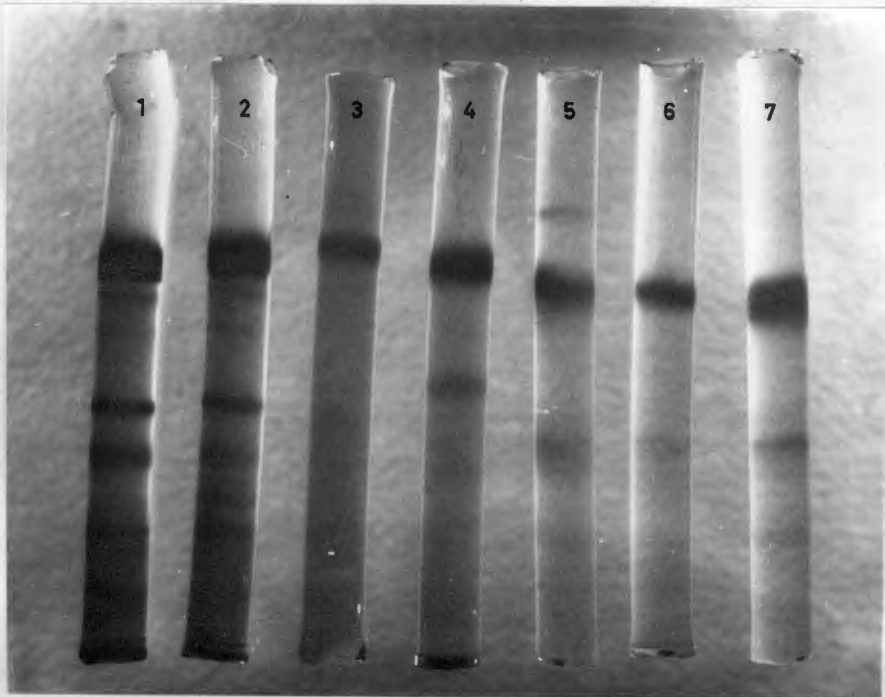

1. NORMAL MONKEY WHOLE SERUM.
2. CADMIUM MONKEY WHOLE SERUM.
3. NORMAL MONKEY SERUM ALBUMIN.
4. CADMIUM MONKEY NORMAL SERUM ALBUMIN.
5. CADMIUM MONKEY MINI SERUM ALBUMIN.
6. CADMIUM MONKEY NORMAL URINARY ALBUMIN.
7. CADMIUM MONKEY MINI URINARY ALBUMIN.

FIG. 64

POLYACRYLAMIDE ELECTROPHORESIS IN 2% UREA.

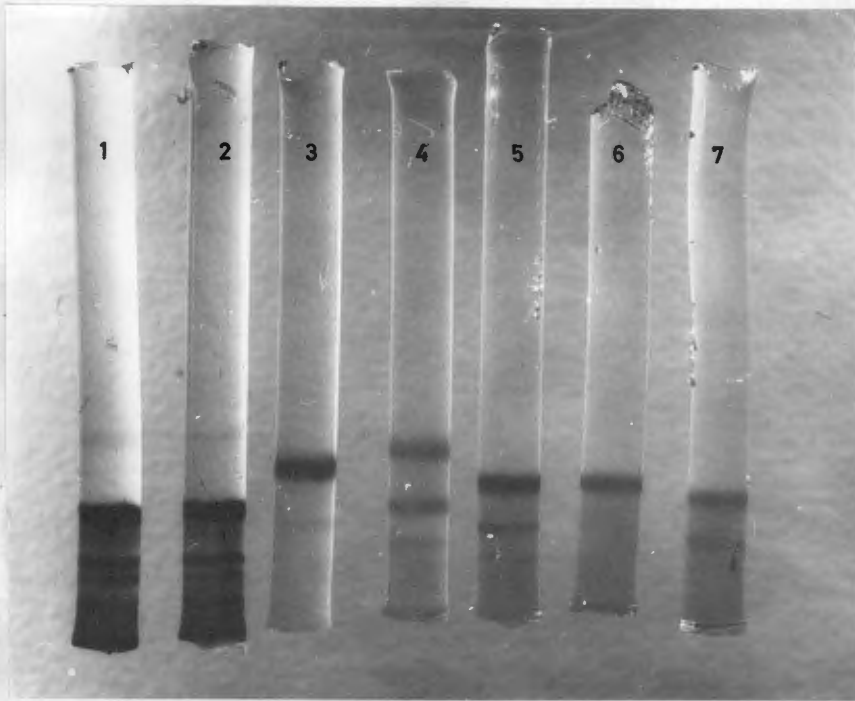

1. NORMAL MONKEY WHOLE SERUM.
2. CADMIUM MONKEY WHOLE SERUM.
3. NORMAL MONKEY SERUM ALBUMIN.
4. CADMIUM MONKEY NORMAL SERUM ALBUMIN.
5. CADMIUM MONKEY MINI SERUM ALBUMIN.
6. CADMIUM MONKEY NORMAL URINARY ALBUMIN.
7. CADMIUM MONKEY MINI URINARY ALBUMIN.

II 12. (x) Starch urea gel electrophoresis

In 1961, Edelman and Poulik⁽¹⁸⁹⁾ employed a starch-urea gel for the separation of the chains of γ globulins. In view of the fact that urea had proved to be useful to some extent in the prevention of aggregation of the minialbumin, it was thought that starch-urea gel electrophoresis might reveal some of the peptides thought to constitute the albumin from cadmium-poisoned monkeys.

62 g. of hydrolysed starch (Connaught Laboratories, Toronto) and 240 g. of urea were mixed together dry. The final concentration of urea was 8M. Aliquots of this mixture were gradually transferred to a litre beaker containing 250 ml. of formate buffer, pH 2.9 - 3.0 (0.05M formic acid and 0.04M sodium hydroxide), with continuous stirring. The mixture was heated in a water bath at 70° until completely dissolved. It was necessary to stir all the time. The transparent gel was then poured into a prepared, levelled tray, and the lid, greased with liquid paraffin, gently lowered till all air bubbles were expelled. The lid was weighted down, and the gel left to set for 24 hr. before being used.

When ready, the lid was gently removed by gradual lifting from the edges inwards, and the gel covered with a layer of parafilm (a plastic waterproof material) to within $\frac{1}{2}$ - 1"

of the slots. Application of the samples was effected with a micro pasteur pipette and the exposed gel surface then covered with molten vaseline to form an airtight seal.

Electrophoresis was carried out in the vertical plane using a formate buffer and silver-silver chloride electrodes prepared as described under zone electrophoresis on cellulose. The buffer, 0.2M formic acid and 0.08M sodium hydroxide, was used in both cathode buffer tank chambers, while the anode was housed in 10% (w/v) sodium chloride. Whatman No. 4 filter paper served as wicks and electrophoresis was carried out for 16 hr. under a potential difference of 5 V/cm. (Fig. 65).

On completion of the run, the vaseline and parafilm were removed and the gel placed in the cold for 15 min. to facilitate slicing. After removal of the end sections, the gel was cut across the spotting line and transferred to a cutting plate in two sections where it was sliced into two longitudinally by means of a wire cutter. One section was stained with a saturated solution of amido black in a methanol-acetic acid-water mixture (5 : 5 : 1, v/v/v)⁽¹⁹⁰⁾ for 5 to 6 min. and then washed in the same solvent for several hr. The stained gel could be kept in the solvent for long periods without deterioration. The remaining section was cut into strips, and the protein eluted.

FIG. 65

STARCH GEL ELECTROPHORESIS.
APPARATUS.

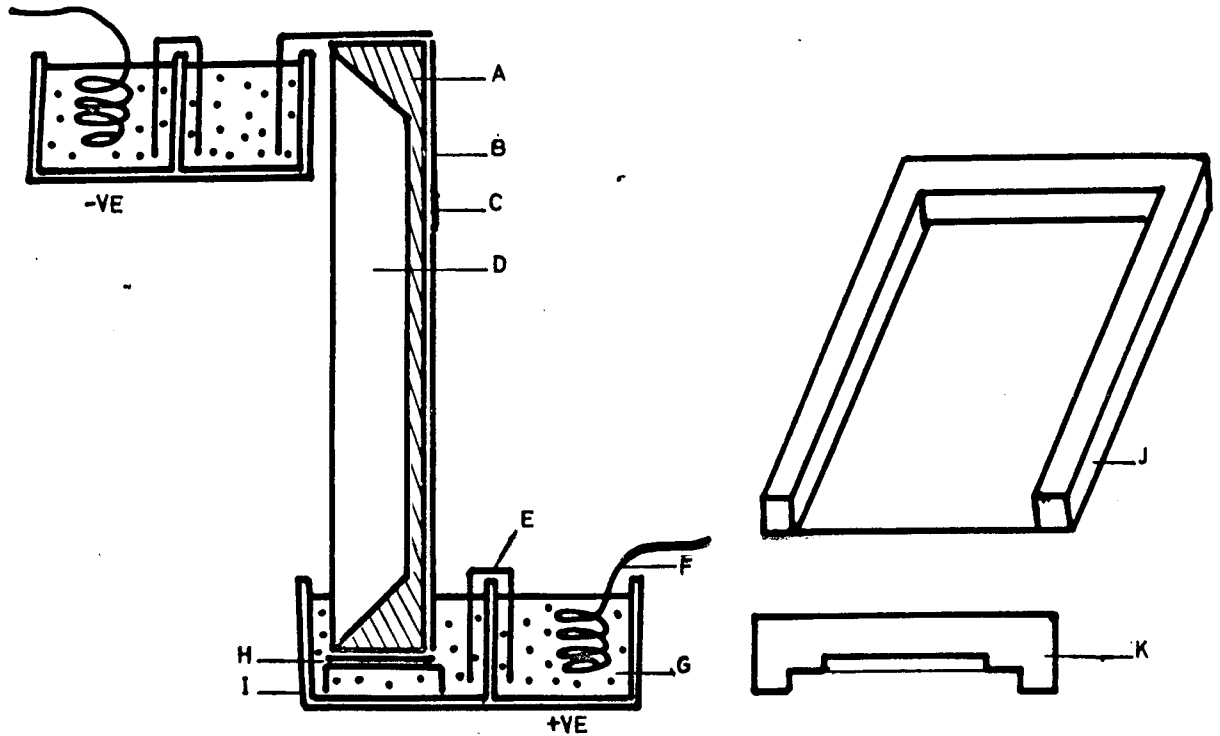

- A. STARCH GEL.
- B. PARAFILM SHEET.
- C. VASELINE COVERING SAMPLE SLOTS.
- D. SUPPORTING TRAY FOR GEL.
- E. WHATMANS NO 4 WICK.
- F. ELECTRODE.
- G. 10% NaCl
- H. ELECTRODE BUFFER.
- I. ELECTRODE TROUGH.
- J. SLICING TRAY FOR GEL.
- K. WIRE CUTTER.

Fig. 66 shows the electrophoretic patterns of the various isolated albumins. Aggregated albumin from a poisoned monkey clearly showed a number of bands. However, under these conditions normal albumin, homogeneous on ultracentrifugation and giving only one precipitin arc against a polyvalent antiserum, also showed more than one band. The additional bands may be polymers⁽¹⁹¹⁾. The disaggregated 5,000 to 10,000 molecular weight minialbumins gave only 2 to 3 bands, corresponding in position to some of the bands derived from larger albumin molecules of the same animals.

In case the low pH and high urea concentration present in the former experiment was causing fragmentation of the molecules in the gel, it was decided to subject these same albumin samples to electrophoresis in a gel at a higher pH and with a lower concentration of urea.

The buffer systems chosen for the starch and for the electrode chambers were those recommended by Smithies⁽¹⁹²⁾ for use in ordinary starch gel electrophoresis. The gel buffer was a 0.027M boric acid : 0.0108M sodium hydroxide mixture at pH 8.6, while the electrode buffer at the same pH was 0.3M in H_2BO_3 and 0.06M in NaOH.

Fig. 67 shows that under these conditions there was more than one band of protein in the albumin fractions.

FIG. 66

STARCH UREA GEL ELECTROPHORESIS
AT pH 2.9

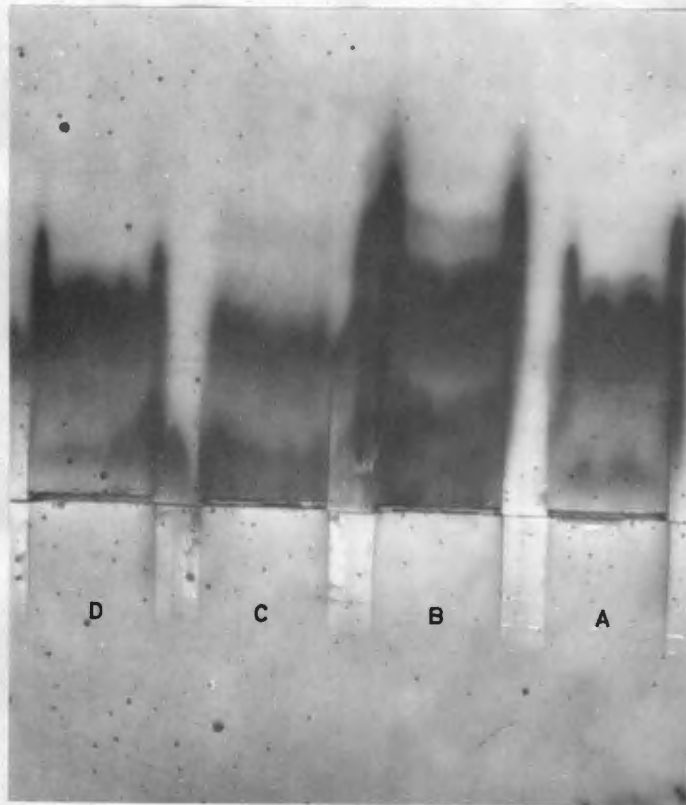

- A. NORMAL MONKEY NORMAL SERUM ALBUMIN.
- B. CADMIUM MONKEY TOTAL SERUM ALBUMINS.
- C. CADMIUM MONKEY SERUM MINIALBUMIN.
- D. CADMIUM MONKEY URINARY MINIALBUMIN.

FIG. 67

STARCH UREA GEL ELECTROPHORESIS
AT pH 8.6

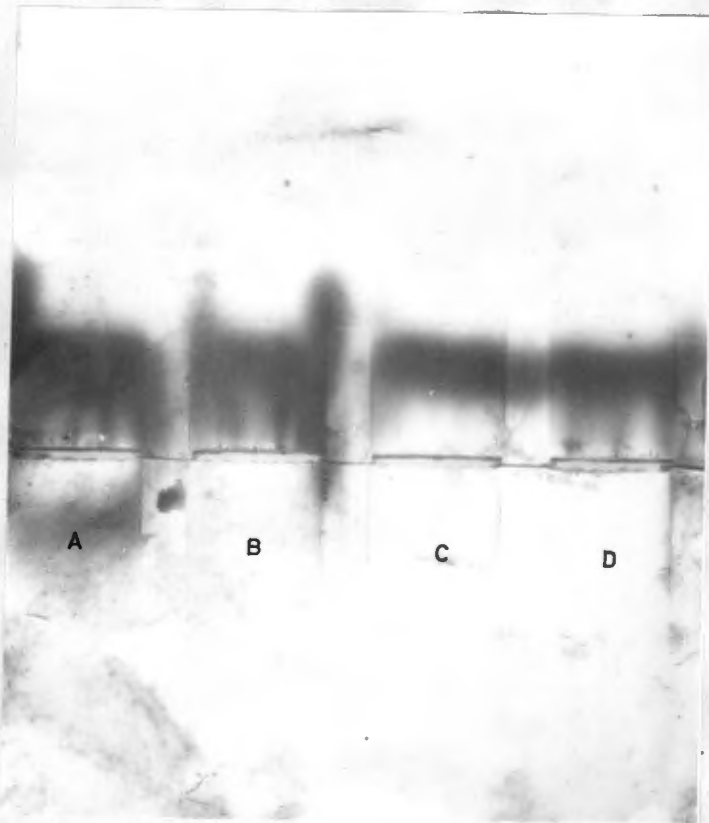

- A. NORMAL MONKEY NORMAL SERUM ALBUMIN.
- B. CADMIUM MONKEY TOTAL SERUM ALBUMINS.
- C. CADMIUM MONKEY SERUM MINIALBUMIN.
- D. CADMIUM MONKEY URINARY MINIALBUMIN.

However, there were fewer than in the original gels indicating that the high urea and low pH may have hydrolysed the albumin to some extent.

II 12. (xi) Peptide mapping

A complete knowledge of the amino acid structure of the serum and urinary albumins of normal and cadmium-poisoned monkeys is a necessary prerequisite to a thorough understanding of the biochemical lesion caused by cadmium. This would involve finger-printing, peptide mapping and N- and C-terminal analysis. Owing to shortage of time and material such a study could not, at present, be undertaken. However, it was thought that comparison of the peptides arising by tryptic digestion could possibly elicit interesting differences.

The procedure essentially followed was that of Poortmans, van Fraechem and Segers (1966)⁽¹⁹³⁾. The protein (usually 10 mg.) was dissolved in 5 ml. of 0.05M tris-(hydroxy methyl)amino methane-HCl buffer, pH 8.0 and reduced with 0.1 equivalents/l. of mercaptoethanol for 2 hr. at room temperature with intermittent shaking. Alkylation, with 0.2 equivalents/l. of iodacetamide, stopped the reduction. The mixtures were then dialysed free of excess reducing and alkylating agents and lyophilized. The dried protein, dissolved in 0.01M tris-HCl, pH 8.0, was then

digested with trypsin (0.5 mg. trypsin 1 : 250 - Difco to 10 mg. protein) for 18 hr. at 37°. The trypsin activity was then destroyed by addition of 1M HCl to pH 2.2, and the residues lyophilized. Separation of the peptides was in two dimensions. The initial step was electrophoresis in a pyridine-acetic acid-water (10 : 0.4 : 90, v/v/v) buffer, pH 6.5, and was carried out in the high voltage electrophoresis unit for 60 min. with a potential difference of 50 V/cm. A test electrophoretic strip was always run with the experimental strip. This was followed by ascending chromatography in butanol-acetic acid-water (3 : 1 : 1, v/v/v) for 16 - 18 hr. The paper was oven-dried after each dimension. Peptides were located by spraying with a ninhydrin solution⁽¹⁹⁴⁾ and heating with care. Spots were circled with pencil lines as the colours tended to fade fairly rapidly. Fig. 68A and B are typical examples of the maps obtained from normal sized albumins from normal and cadmium monkeys.

Fig. 69 shows the patterns for the various albumins superimposed on one another to facilitate a comparison between them. It is clear that one of the positively charged fragments is missing from the digests obtained from albumins of cadmium-poisoned animals. This immediately suggested a check of the quantities of tryptophan in the various peptides to discover whether or not this was the one supposedly lost

FIG. 68

PEPTIDE MAPS OF SERUM ALBUMINS.

A. NORMAL MONKEY.

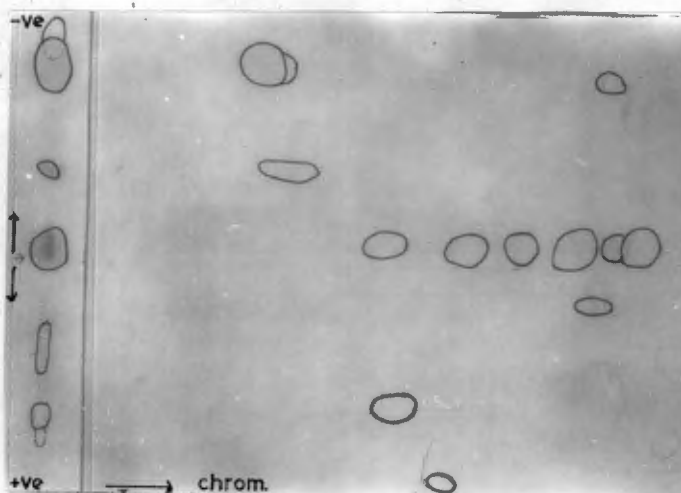

B. CADMIUM MONKEY.

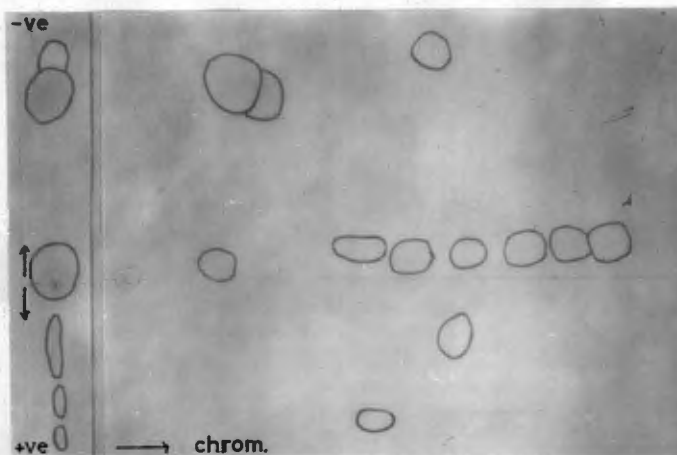
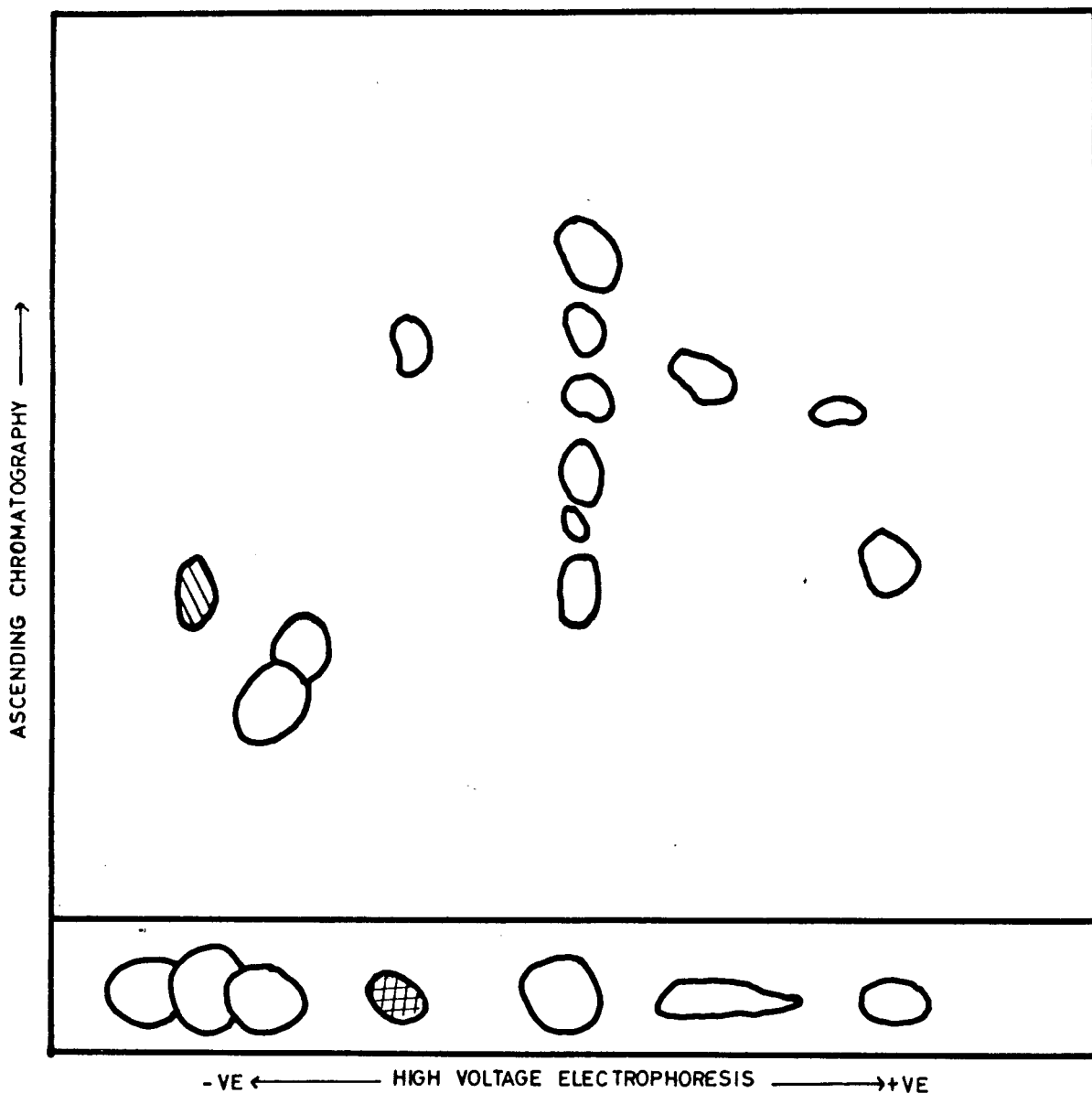

FIG. 69

PEPTIDE MAPPING - COMPARATIVE PLAN.



PEPTIDES COMMON TO ALL DIGESTS.
PEPTIDE SOMETIMES PRESENT IN MINIALBUMIN.
PEPTIDE ABSENT IN MINIALBUMIN, VERY SMALL AMOUNTS IN NORMAL SIZE ALBUMIN FROM POISONED ANIMALS.

under the influence of cadmium ions.

To do this, tryptic digests of the serum albumin from both normal and cadmium-poisoned monkeys were prepared. Separation of the peptides was done only in the first dimension, i.e. electrophoresis. The digest was spotted across the entire width of the paper and run for 60 min. at 50 V/cm. A narrow strip was cut from the edge of the dried paper and stained with ninhydrin to determine the position of the spots. The remainder was then cut into strips and the peptides eluted by shaking vigorously in the same buffer. The dissolved peptides were separated by filtering and the strips washed again. The filtrate and washings were taken to dryness in vacuo, the residues dissolved in 19N H₂SO₄ and treated for tryptophan by the pDMAB colour method. A blank prepared by elution from an equal sized strip of background was run concurrently. Tryptophan was not detected in any of the fractions. This was probably due to a dearth of material or the method of elution.

The untreated, but pure, isolated albumins from both normal and poisoned animals were then compared with the tryptic digests to see if any of the naturally occurring fragments had counterparts in the digests.

They were electrophoresed under the conditions described above and straightaway stained with ninhydrin. As can be seen from Fig. 70 there was evidence of one similar moiety.

FIG. 70

COMPARATIVE ELECTROPHORESIS OF
ALBUMINS AND TRYPTIC DIGESTS.

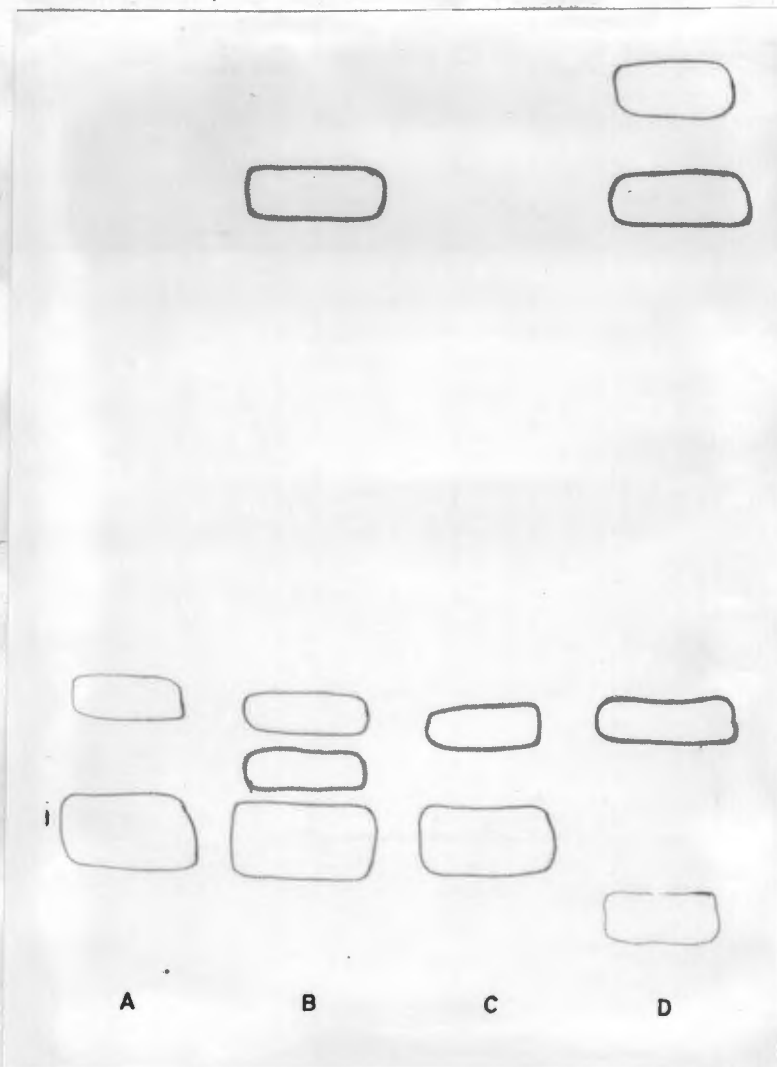

- A. NORMAL MONKEY NORMAL SERUM ALBUMIN.
- B. CADMIUM MONKEY NORMAL SERUM ALBUMIN.
- C. CADMIUM MONKEY MINI SERUM ALBUMIN.
- D. TRYPTIC DIGEST OF B.

PART III

DISCUSSION

The experiments described were designed and carried out in an attempt to clarify both the origin and nature of the albumin produced in cadmium poisoning. Although a fair amount of information has been obtained and the balance of evidence points to interference by cadmium in the catabolism rather than the synthesis of albumin, it is still not known exactly at what level, and in what manner cadmium affects albumin metabolism.

The signs of cadmium poisoning were influenced by the route of entry of the metal ion. Men who inhaled fume and dust containing cadmium oxide suffered from respiratory tract disorders usually culminating in acute emphysema, whilst ingestion of cadmium resulted in severe gastro-enteritis^(4,23,14). These were the local lesions⁽²³⁾. However, common to all types of prolonged cadmium poisoning was the presence of proteinuria; and more specifically the excretion of albumin of low molecular weight^(4,8,10). This was discovered on closer examination of the proteinuria and we believe this protein constitutes a characteristic of cadmium poisoning - arising as a systemic disturbance due to excessive quantities of the metal in the tissues. There is some controversy concerning the pattern of proteinuria; other workers in the field consider that the lesion caused by cadmium is not specific and the sedimentation properties of the urinary proteins of patients with chronic cadmium poisoning are no different from those of

patients with known tubular dysfunction^(29,57). On the other hand, albumin from the serum and urine of nephrotic patients has been shown by Rowe⁽⁵⁹⁾ to have the same molecular weight as normal serum albumin. Similarly, we have found that urinary albumin of patients with nephrotic syndrome, chronic nephritis, de Toni-Fanconi's syndrome and Kinnear-Wilson disease is of normal size (Kench, Gain and Sutherland, 1965⁽¹⁹⁵⁾).

The electrophoretic profile of the urinary proteins of cadmium poisoning was similar to that of serum, but the relative distribution was different - albumin being a minor instead of a major component⁽¹⁰⁾. The distribution could also be distinguished from that observed in nephritic and nephrotic patients^(21,29).

Besides being instrumental in producing this low molecular albumin, termed minialbumin, cadmium has numerous other known deleterious effects on the metabolic processes in living organisms. The general metabolism of the monkeys poisoned by cadmium in the afore-mentioned experiments, was not markedly upset in most respects, but some changes were consistently seen. There was a considerable rise in activity of serum glutamic oxaloacetate transaminase in chronically poisoned monkeys which could be due to hepatic necrosis. In fact, evidence for areas of focal necrosis in the liver has been obtained from both biopsies and postmortem⁽²⁰⁾.

Injected cadmium was rapidly cleared from the blood stream and deposited in the tissues or excreted. The kidney and liver apparently had a predilection for cadmium, and histologically those organs had undergone most change. This could account for the above-mentioned biochemical lesions. There was usually an overall concentration of about 0.5 mg. cadmium per 100 g. of tissue when minimal albumin first appeared in the urine. In chronically-poisoned animals, the liver and kidney contained up to eight times this concentration of cadmium. The remaining tissues of the animal all contained cadmium but in somewhat smaller amounts. In this context, the protean and sometimes bizarre clinical effects which have been ascribed to cadmium - hypertension, eclamptic toxemia, anosmia, testicular atrophy - are intriguing. Our experimental studies did not appear to shed any light on these possible manifestations of cadmium intoxication. One overall effect however, that has been consistently observed in the experimental studies on rabbits, dogs and monkeys, worthy of mention, since it does not appear to happen in man, is a kind of thalamic syndrome. All these animals when severely poisoned by cadmium became temperamentally most irritable and aggressive. Even the rabbits, mild in outlook at the beginning, became furry furies after prolonged cadmium intoxication. It is well known that cells of the thalamus constitute an important target for other heavy metals (e.g. manganese in Moroccan mine workers,

copper in hepatolenticular degeneration).

In the few animals studied, serum amylase rose markedly 2 - 3 weeks after the initiation of cadmium poisoning, which suggested that there was some degree of acute pancreatitis. Later with more prolonged intoxication, activity of the enzyme in serum and urine fell. This could be ascribed to the loss of secretory tissue, but it is impossible to make categorical statements on the few observations which have so far been made. The observation of a pancreatitic lesion raised the issue as to whether serum trypsin, which has measurable activity in man⁽¹⁹⁶⁾, could under the circumstances of cadmium poisoning bring about some degradation of circulating albumin. This possibility was later excluded. Tryptic digestion of serum albumin did not give rise to minialbumin in our experiments, and the polypeptide fragments derived by Press and Porter⁽¹⁹⁷⁾ are quite unlike minialbumin in amino acid composition, immunological and electrophoretic behaviour.

During the course of prolonged cadmium poisoning - over 1 - 2 years - monkeys gradually lost about 20% of their original weight which probably was mainly due to advent of listlessness and loss of appetite. The urinary excretion of urea actually rose, an observation which would need much more study before it could be understood. Increased dietary protein or gluconeogenesis were hardly likely causes, and invokation of some inhibition of bacterial urease⁽¹⁹⁸⁾ far-

fetched. The finding seemed to exclude significant diminution of urea clearance in our chronically poisoned monkeys.

Observations on the serum proteins of animals intoxicated by cadmium have provided variable data. Kekwick in 1955⁽⁸⁾ noted divergence from normal electrophoretic distribution in the serum proteins of patients suffering from cadmium poisoning, although no characteristic deviation appeared consistently. Axelsson and Piscator⁽¹⁹⁹⁾ found, in cadmium-poisoned rabbits, that there was an initial reduction in albumin content and an increase in α and β globulins, followed by an increase in the γ globulins and a striking fall in α_2 globulin concentration. This latter was attributed to removal of haptoglobins as part of a haemolytic process and suggested that in the poisoned rabbit there might be a connection between deposition of haemosiderin in the tubules and kidney damage. No such lesion was observed in monkeys, and no definite trend was observed in serum protein patterns of the monkeys in the present study.

Bonnell, Ross and King (1960)⁽¹⁶⁾ found that residual cadmium circulating in the blood was attached to the red blood corpuscles, rather than present in the plasma. However, albumin isolated from the sera of chronically poisoned monkeys was found to contain approximately 1 μ g. of cadmium per 5 mg. of protein. This relationship meant that only 10% of the albumin molecules have a cadmium atom attached, and suggested that albumin

was not the carrier for cadmium, but rather adsorbed an overflow. The other serum proteins have not as yet been investigated for a role in transport of cadmium. It is our intention to prosecute a systematic search for a protein with the role of cadmium transport analogous to the transferrins. As cadmium has the greatest affinity for free sulphhydryl groups, a protein rich in such groups, e.g. metallothionein described by Kagi and Vallee^(18,19) might function as a carrier. Cadmium would, however, probably attach to various other groups such as carboxyl as well.

It was unlikely that the cadmium that was excreted was transported solely on the urinary minialbumin as there was no stoichiometric relationship between the quantity of minialbumin in the urine and the amount of cadmium excreted. This was clear from a comparison of the fall in the amount of metal and protein excreted following a pulse dose of cadmium. The decrease in the output of minialbumin is linear while that of cadmium had a hyperbolic curve. On the other hand, cadmium, which by creatinine clearance tests was known to be eliminated by glomerular filtration⁽⁹⁾, must be protein-bound as at the operative pH (about 7.4) it would be basic, non-ionised and insoluble. Generally, about one third of the weekly dose of cadmium was excreted and the remainder deposited in the tissues.

Investigation of the albumins found in cadmium-poisoned animals involved their initial isolation and purification. Four different methods of preparation gave similar albumins, judged to be pure by electrophoretic and immunological criteria. The methods with organic solvents were most efficient and therefore adopted. The hydrochloric acid-ethanol method was considered most suitable for serum studies because it eliminated the use of Visking cellophane tubing; while the trichloroacetic acid-ethanol method was deemed best for dialysates and specimens of urine where large volumes were processed.

Impurities in the Visking tubing became a major problem as far as characterization of minialbumin was concerned, because of the similarity in molecular size. This could be circumvented by use of certain precautions or an alternative method of albumin preparation. The substance from the membrane was thought to be a peptide as it formed complexes with the copper of biuret reagent⁽²⁰⁰⁾; exhibited ultra-violet absorption in the tyrosine - tryptophan range; and fluoresced blue white at 210 m μ . Immunologically it had no activity. The cellulose nitrate - which comprised the major portion of the tubing material - was apparently contaminated with peptides, fatty acids and other substances which were included during its manufacture, but which could be extracted from the finished product by various solvents. This idea was supported by the

fact that removal of the contaminant irreversibly enlarged the pore size of the tubing. Unextracted but boiled membranes were normally impermeable to lysozyme (Mol. wt. 29,000) but after treatment with organic solvents, cellophane sacs were freely permeable to the enzyme.

Separation of the albumins of differing molecular size was equally important. Dextran gel (Sephadex G75) proved to be a satisfactory molecular sieve and was also used as an index of molecular size. The values could not be taken as being accurate because elution volumes also depend on the overall shape of the molecule. The normal size albumin was well separated from the smaller molecules which ranged from 5,000 to 20,000 in molecular weight, depending on the salt concentration in the medium.

The possibility that minialbumin was an artefact of the experimental procedures was eliminated since cadmium did not give rise to the protein by direct action on the blood, serum or albumin. The anticoagulant was not responsible for minialbumin production, nor was there any evidence for its formation by proteolysis of normal albumin during preparation. Successive recycling of both normal and minialbumin on Sephadex showed that the minialbumin was not formed in the column as a result of disruption of the normal albumin. This all pointed to an active 'in vivo' process for minialbumin synthesis.

As mentioned earlier, the origin of the minialbumin cannot yet be categorically located, but evidence points to the liver rather than the kidney as the most likely source. The presence of increased quantities of minialbumin in the peritoneal dialysates of a nephrectomized poisoned monkey, following a pulse dose of cadmium (Gain and Kench, 1965⁽⁶⁵⁾); the appearance of minialbumin in the circulation before its detection in the urine; and the accumulation of a high concentration of cadmium in the liver pointed to this organ as being the one where cadmium was exerting its biochemical effect. The peak of minialbumin in the serum occurred after $1\frac{1}{2}$ to 2 hr. This time interval suggested an 'in vivo' process, it being of the same order of magnitude as that required for labelled amino acids, administered to rabbits, to appear in serum proteins in the circulating blood (Henriques, Henriques and Neuberger, 1955⁽²⁰¹⁾). The metabolic turnover of minialbumin has been observed by Kench et al⁽²¹⁾ to be rather more rapid than that of normal albumin; and this would also suggest an active process in the liver rather than origin by non-specific injury to the renal tubular epithelium cells. The clearance of minialbumin from the circulating serum was much more rapid in chronically poisoned animals than in newly poisoned ones, which suggested that renal involvement was of a

secondary nature and that impairment of tubular reabsorption only occurred after a certain amount of cadmium had been deposited in the kidney.

The excretion of minialbumin was, therefore, apparently associated with impaired function of the renal tubular cells as a secondary phenomenon. Hardwicke⁽²⁰²⁾ has shown that following infusions of albumin, tubular reabsorption of the serum proteins was non-selective - this could also apply to the situation in cadmium poisoning. Glomeruli were relatively undamaged as Rowe⁽⁵⁹⁾ has shown that even during heavy proteinuria, the nephrotic kidney retained most of its selectivity in molecular filtration. If this were so, circulating minialbumin was probably filtered through the glomerulus, and then reabsorbed or excreted depending on the activity of the tubular cells, which in turn, was impaired according to the degree of intoxication of the animal. Infusions of haemoglobin caused a rise in the excretion of minialbumin (Gain and Kench, 1965⁽⁶⁵⁾) and this may have been due to overload of the reabsorptive mechanisms in the renal tubular cells. In the early stages of proteinuria, there was a relatively high proportion of minialbumin present. Once proteinuria became gross, normal size albumin and larger aggregates were predominant. In monkeys and rabbits the excretion in the urine of normal size albumin and of minialbumin proceeded simultaneously, whereas cadmium-poisoned

workmen initially excreted only the low molecular weight albumins. With time the men did excrete albumin of normal molecular weight, and this was attributed to renal damage. A relatively high proportion of the normal size albumin excreted by monkeys has been shown in the present work, by tryptophan and disaggregation studies, to be an aggregated form of the minialbumin, and it now appears likely that some, at least, of what appeared to be normal serum albumin in the urine of poisoned men and rabbits was, in fact, aggregated minialbumin. Aggregation could occur in the glomerular filtrate, in the urine, or during the preparative procedures.

Experiments with acutely poisoned rats, carried out in an attempt to clarify the action of cadmium on albumin metabolism, did not fulfil their expectation. Although several points, such as amino acid anomalies, antigenic behaviour, and peak production of minialbumin, emerged as similar for both rats and monkeys, it was not possible to evaluate what was occurring, especially in the kidneys of the rats. It was possible that species differences were responsible, and it will be necessary to poison rats chronically and demonstrate the presence of minialbumin in their urine before any conclusions can be drawn. Male rats at puberty are known to have a natural proteinuria⁽²⁰³⁾, and for this reason the rat is not a good experimental subject

for the study of the biochemical effects of cadmium.

Characterization of the low molecular weight fraction by various methods proved that it comprised a mixture of polypeptide chains, the sum of which behaved in a manner very similar to that of normal albumin. The most notable characteristic of this protean molecule - minialbumin - was its ability to aggregate and disaggregate. An equilibrium between the small and large molecules apparently exists, and it has so far been impossible to prepare one form totally free from the other. The equilibrium appeared to lie in the direction of the aggregated product. This association of the small molecules has been attributed to non-covalent bonding, disulphide linkages, and bridging by the divalent cadmium ions, and was first noticed as a result of varying the salt concentration during the isolation of the minialbumin. Under physiological condition of pH and salt concentration the minialbumin readily aggregated to form molecules of normal size or larger. Concentrations of 0.2M and upwards, largely prevented the minialbumin from reaching a size larger than 10,000 to 20,000 in molecular weight. Urea was equally, if not more, effective in preventing the aggregation and for this reason it was incorporated into the media during later preparative and electrophoretic studies. That sulphydryl groups play a role seemed likely and as there was only one free sulphydryl group in normal albumin, we surmised that cadmium perhaps attacked

the collateral disulphide bridges causing disruption of the molecule and leaving such groups free to reform in the same or a different manner. Experiments with EDTA indicated that cadmium was operative in linking molecules together. This hypothesis will have to be tested further by adding, to the disaggregated minialbumin, isolated in high salt concentration on dextran gel, stoichiometric amounts of cadmium and seeing whether or not large molecules result. Aggregation of minialbumin could also depend on the concentration of the protein - increasing concentration of minialbumin leading to increased proportion of aggregates due to a higher incidence of likely orientations between molecules. This could occur readily until the molecule reached a certain size - for example the 20,000 to 30,000 molecular weight fraction excreted by men and monkeys - and thereafter proceed more slowly. Measurement of the sedimentation coefficients of the various albumins established the size range of the albumin molecules and substantiated the evidence that molecular size was, to a certain extent, a function of the salt concentration. It was evident that minialbumin would reach an equilibrium with its aggregates within the micro cell of the ultracentrifuge during the course of a run. The range from 5,000 molecular weight - the smallest unit - to 170,000 molecular weight - the largest detected molecule - was wide and this seemed to indicate that there was no limiting mechanism to prevent its further aggregation once the

molecule had reached the size of its normal counterpart.

Other examples of the influence of ionic concentration on molecular aggregation are well known. Ku and Romani (1966)⁽²⁰⁴⁾ showed that the dissociation of pear ribosomes into smaller subunits was augmented by lowering the magnesium ion concentration, whilst Bresnick, Thompson and Lyman (1966)⁽²⁰⁵⁾ found that in dilute solution the enzyme, deoxythymidine kinase, occurred in an aggregated form, but in the presence of salt (0.2M KCl and sucrose 0.15M) it could be isolated in the disaggregated form which is approximately six times smaller. Glycine, in high concentrations prevented aggregation of γ globulins by protein-protein interactions⁽¹²⁶⁾. That dimerization of normal albumin could occur - at pH values between 2.5 and 4.0 - has been known for some time⁽¹⁰¹⁾. Furthermore, treatment of albumin with organic solvents and oxidising agents produced disulphide-liked dimers^(206,207,208), which could be converted to the monomer by use of β mercaptoethanol. On the other hand, Gutter, Peterson and Sober (1957)⁽²⁰⁹⁾ reported that high concentrations of urea permitted slow, and initially reversible, polymerization of normal albumin molecules. Evidence obtained by Hartley, Peterson and Sober (1962)⁽²¹⁰⁾ pointed to at least two types of dimerization, only one of which required free sulphhydryl groups. The very large molecules that we have obtained from cadmium-poisoned animals - of molecular weight 140,000 to 170,000 by ultracentrifugation -

are possibly dimers and polymers of smaller units linked together by cadmium ions. Polymers of normal human and bovine albumins have been described⁽²⁰⁷⁾ but occur in lesser proportions than we observed in the cadmium-poisoned animals. Whatever the mechanism, it seems apparent that there is a strong tendency for the albumins produced in cadmium-poisoning to aggregate.

The minialbumin excreted by men did not apparently exist in the aggregated form - an observation not entirely reconciled by the above statements, but may be due to a species difference. However, human urinary minialbumin did aggregate under the appropriate conditions of low salt concentration. The molecular weights of the urinary proteins from two cadmium workmen (Finch and 7108) when measured by Dr. Kekwick⁽²¹¹⁾ in the ultracentrifuge in a phosphate-NaCl buffer, pH 8.10, and total ionic strength 0.35, were 20,000 to 30,000 (sedimentation coefficients $S_{20,w}$ of a 1% solution of protein 1.96 and 1.99 respectively). Similar lyophilized preparations from the same source when re-examined in 1965 in a low-salt concentration passed through dextran gel (Sephadex G75) contained a preponderance of albumin of normal molecular weight (Kench, Gain and Sutherland, 1965⁽¹⁹⁵⁾). This anomalous finding, at first inexplicable, provided the clue to the importance of salt concentration and ionic strength in relation to the molecular size of the albumins we were studying, and

made us aware of the underlying aggregation-disaggregation equilibrium as the cause of a number of other unexpected or inconsistent experimental results. Thus, the observation that only labelled albumin of normal size was found in the serum of a normal receptor monkey after injection of a large dose of ^{14}C -labelled minialbumin (Kench, Gain and Sutherland⁽¹⁹⁵⁾), could be explained by aggregation rather than by the suggestion that it was metabolized into normal albumin, and in fact, this experimental finding provided valuable evidence in support of the idea that 'in vivo' aggregation did occur. The molecules of minialbumin which remained small were rapidly excreted by the normal monkey, but a large single intravenous load of minialbumin was given in this experiment. It is hoped that further studies will throw light on the exact mechanism and the preferential order, if any, by which such aggregation occurs.

The amino acid compositions of normal albumin and of minialbumin were very similar. The only significant differences were a deficiency of lysine and cysteine in the minialbumin, and an increased number of isoleucine residues in the albumins of poisoned monkeys. Smith et al⁽¹⁰⁾ found the urinary albumin of cadmium-poisoned men to be richer in its content of glycine and serine than normal serum albumin, but no significant differences have been observed with monkeys as regards these amino acids. As serum albumin consists of a

single long chain which contains only one or two tryptophan residues, depending on the species, and because proteolytic degradation^(197,212,213) produces fragments varying widely from the overall molecule in the amino acid composition there can be no repeating unit in serum albumin. The close similarity of amino acid composition suggested that the only feasible relationship between minialbumin and normal serum albumin was that the former was a representative mixture of peptides formed by breakdown of the latter, with the proviso that observed differences of amino acid composition would be accountable in terms of a lost or deleted peptide. Cadmium in high concentrations apparently interfered with accurate amino acid determinations, but, in practice, the quantity attached to the proteins being analysed was small enough not to impair the accuracy of the method.

Specific analysis for tryptophan revealed two residues per mole in normal monkey albumin; and its complete absence in the minialbumin of both serum and urine. Intermediate values obtained for the albumin of the conventional size in the serum and urine of poisoned monkeys substantiated the thought that part of the so-called normal albumin was actually aggregated material. Working on this basis, there was evidently a lower proportion of aggregates in the urine. The serum albumin of large molecular weight (66,000 to 130,000) of poisoned animals appeared to be a mixture of approximately

equal numbers of normal molecules and of molecules formed by aggregation of minialbumin. Its counterpart in the urine contained fewer molecules ($\pm 13\%$) which were aggregates. This difference in behaviour seemed inexplicable except in terms of the presence of urea in the urine and its above-mentioned ability to cause dissociation. Somehow, the tryptophan moiety had been irretrievably lost, possibly as a peptide containing also the missing lysine and cysteine, either metabolically under the influence of cadmium ions, or technically during minialbumin preparation. Such a peptide was most likely to be missing from the central portion of the albumin chain as Peters and Hawn (1967)⁽²¹⁴⁾ have isolated and examined N and C terminal peptides and found them both devoid of tryptophan, and the N terminal also contained no cysteine.

An attempt to find such a peptide led to the conclusion that it was apparently not lost during the preparative procedures. If the missing amino acids were eliminated metabolically as individuals or as di or tri-peptides they could disappear into the general metabolic pool. The possibility remained that the peptide as such was rapidly metabolised but with a fair chance that it would be excreted very early in an episode of acute poisoning. It is planned to search for such a tryptophan-rich peptide in daily collections of urine of monkeys from the commencement of the poisoning regime.

Immunological studies have served to characterise minialbumin further and to support the idea that it is indeed a true albumin. It gave a reaction of complete identity with normal albumin on Ouchterlony⁽¹³⁴⁾ plates when polyvalent and specific anti-albumin antisera were used. Conversely, normal albumin and minialbumin exhibited activity and complete identity against antiserum specific to minialbumin. On immunoelectrophoresis, patterns for normal albumin and minialbumin were identical save that the minialbumin tended to move at a slightly faster rate. This could be a reflection of its size rather than of net electric charge, although in the low salt media employed for immunological studies we expected that nearly all the minialbumin would be in the aggregated form. The albumins examined in these studies were evidently uncontaminated, since on challenge with polyvalent antiserum only a single precipitin arc developed. Antigenically, there was, therefore, apparently no difference between normal albumin and minialbumin. Nevertheless, it should be noted that within stated time periods for immunization of rabbits, titres obtained for antinormal albumin were greater than for antiminialbumin. This could mean that minialbumin was a weaker antigen, or alternatively that some of the minialbumin may have been excreted in the urine soon after administration owing to its smaller size. Obviously, the locale of tryptophan was not involved in the antigenic behaviour

of the molecule as there were no significant differences detectable between normal albumin containing two residues and the minialbumin with none. The antigenic sites on the various peptides comprising minialbumin were apparently unharmed by cadmium, and their disposition in the normal or aggregated molecule was not of primary importance. Once a suitable method can be devised for separating the peptides of minialbumin, the antisera may be selectively absorbed by these and in this way we hope to locate the actual antigenic site within a circumscribed region of the molecule.

The various forms of electrophoresis did not separate the twelve or so peptides which together were thought to comprise minialbumin. At this stage it was not certain whether this could be attributed wholly to poor technique or whether it was due to several of the fragments having similar electrophoretic mobilities at the pH values employed. Normal albumin did not appear as a single homogenous band in starch or polyacrylamide gels, and the additional bands have been said to be polymers^(191,215). In addition to these bands displayed by normal albumin, one to three extra ones were visible on electrophoresis of the albumins of cadmium-poisoned monkeys. The zones corresponding to normal albumin were believed to be due to its presence, while it was surmised that the others were aggregates of minialbumin. Ideally, the electrophoresed gel should be inserted into an agar block

containing anti-albumin antiserum for immunodiffusion to take place⁽²¹⁶⁾. Precipitation at the position of each zone would have provided a specific test for ensuring that all were in fact due to albumin. On the other hand, the individual fragments could be incomplete antigens and give anomalous results. One of these electrophoretic zones corresponded to that of one formed on tryptic digestion of albumin, of whatever type. Amino acid analysis of the various entities must needs be performed before any conclusions as to their identity can be drawn. Other than this, there was no evidence that the fragments comprising mini-albumin were in any way similar to the polypeptides which arose from proteolytic degradation of serum albumin^(197,212).

Tryptic digestion of albumins from normal and from poisoned monkeys gave rise to a number of peptides. The peptide patterns from both serum and urinary albumins of cadmium-poisoned monkeys were very similar to that from normal serum albumin; a finding unlike that of Merler, Remington, Finland and Gitlin (1962)⁽⁶²⁾ who reported that the peptides derived from normal urinary albumin were not similar to those from serum albumin. One noteworthy difference between the tryptic digests of normal albumin and that of cadmium-poisoned monkeys, however, was observed, namely the absence (or presence in quantities too small to detect) of one peptide from the mini-albumin. Analysis of the peptides for tryptophan led to

inconclusive results as it was not detected in any of the spots. This could be because the quantities of peptides examined were too small, or the tryptophan was destroyed during the course of elution of the peptides. Should the missing spot, by some chance, be the peptide presumably deleted by the action of cadmium ions on albumin, it would have to be analysed for lysine and cysteine as well, and experiments are continuing along these lines. Trypsin is known to catalyse the hydrolysis of peptide bonds involving the carboxyl groups of the basic amino acids⁽²¹⁷⁾. The short-fall in lysine in the minialbumin of poisoned animals might be due to the fact that the albumin molecule has already been broken at one or more of the positions where trypsin would normally act and one of the portions set free by cadmium was similar in electrophoretic mobility to one liberated by trypsin. It seemed reasonable to expect a number of differences in the detailed composition of peptide patterns which should provide valuable information on minialbumin structure.

The question as to the exact mechanism of cadmium ions, which led to the production of low molecular weight albumins, still remains unanswered in the light of the aforementioned experiments. The findings nevertheless suggest some possibilities for its action, and open up new lines for experimental investigation.

The observation that minialbumin had the overall amino acid composition and antigenic behaviour of normal serum albumin suggested that it originated by disintegration of the molecular chain into a number of polypeptide fragments. This view rested mainly on the detailed experimental observations we have made on poisoned monkeys, but appeared to be equally valid for the rat - similar amino acid composition and antigenic behaviour and complete lack of tryptophan in the small albumin molecules. The liver was regarded as an organ where the action could occur as it has been shown to be the major site for albumin synthesis^(218,219,220), while the kidney, though capable of some protein synthesis, apparently does not actively synthesize albumin⁽¹⁰⁴⁾. This did not exclude the possibility that the kidney, under the influence of cadmium ions, could also produce minialbumin from circulating normal serum albumin, but the nephrectomised monkey retained its capacity to form minialbumin in response to cadmium injections (Gain and Kench, 1965⁽⁶⁵⁾). Cadmium could, theoretically, act at any of three sites where albumin may occur intracellularly⁽²²¹⁾. It could act on albumin, newly formed and released from the microsomes, before it was secreted by the cell into the circulatory system. Peters (1962)⁽²²¹⁾, using radioactive carbon has shown that although the actual synthesis of the protein is very rapid, there is a delay of 20 min. before the protein is released from the microsomes. This time interval

may be the point at which cadmium exerts its influence. Albumin, sessile within the cells was a possible target. In addition, albumin newly returned to the liver, from the circulatory system, to undergo catabolism might also be vulnerable. It is presently envisaged that minialbumin is formed by the 'in vivo' action of some enzyme - activated by cadmium - which does not behave like trypsin, chymotrypsin or pepsin. Alternatively, cadmium could inhibit the action of an enzyme active in catabolism of albumin or naturally occurring fragments of it, to smaller peptides or free amino acids. The effect on such enzymes would result in a mixture such as the minialbumin described.

The protective action of sulphur compounds, such as cystine or dithiopropanol against intoxication by cadmium⁽²²²⁾, implies a participation of sulphhydryl and disulphide groups in the action of cadmium. The metal could chelate with the sulphur in such groups and this could influence neighbouring bonds and cause disruption of the molecule, with the possible loss of cysteine, lysine and tryptophan in one or more small peptides.

A structural model for albumin consisting of globular parts linked by sections of flexible peptide chain has been proposed by Bloomfield (1966)⁽²²³⁾. Electrostatic repulsion between the globular segments keeps them apart, and it is thought that hydrolytic enzymes preferentially attack the

linking amino acid chains⁽²¹²⁾. If this model is truly representative, cadmium might facilitate an initial attack on the exposed peptide chain, followed by breakdown of the separated globular moieties as occurs with the hydrolytic enzymes.

If cadmium interfered with synthesis of albumin, it could do so at some point along messenger RNA. Since growth of the albumin molecule proceeds from the amino to the carboxy terminal end only, a block could produce a minialbumin electrophoretically homogeneous and with only one type of carboxy and amino terminal amino acid. Experiments to determine these end amino acids are to be carried out to clarify this issue. For the minialbumin, so formed, to have an amino acid composition closely similar to that of the complete albumin molecule would require that the latter should be homogeneous throughout its length, although not necessarily the same primary arrangement of amino acids. In as much as complete albumin includes only one or two tryptophan residues, this in conjunction with the data of Foster et al⁽¹⁰¹⁾ do not favour this explanation for the origin of minialbumin. Moreover, localization of the antigenic activity in a relatively small portion of the molecule is not in keeping with generally accepted concepts of immunological behaviour. The balance of evidence points towards some form of catabolic hold-up as the mechanism for minialbumin formation.

A number of other possible loci for cadmium action deserve mention although none of them appears to meet the situation as adequately as the "impeded catabolism" hypothesis. A random disruption by the metal of the RNA-coded synthesis of albumin seems to be excluded by the homogeneity in molecular size of minialbumin. The idea that the albumin molecule is formed by the assembly of a number of polypeptides, separately synthesized in close proximity within a polysome structure has had the support of a number of investigators. If this is true, cadmium might cause disruption of the polysomes and thus prevent the constituent peptides from joining together. This model is in keeping with the structure and behaviour of minialbumin.

The mixture of polypeptides, which minialbumin appears to be, is able to reassemble 'in vivo' without the need for a messenger code. Whether this occurs at random, or in a specific order is so far undecided. Re-orientation of certain parts of the molecule could result in the exposure of different active groups and a process such as this could account for microheterogeneity in serum albumin, based on a single DNA code. Microheterogeneity has been described by Foster and his colleagues^(224,225,226).

The overall experimental evidence appears to support the concept that the primary biochemical lesion of cadmium is on the catabolic pathway of serum albumin, rather than

an inhibition of synthesis. The action of cadmium may be within or in conjunction with the lysosomes, known to contain hydrolytic enzymes involved in protein breakdown. Isolation of this organelle and work with it involving radioactive tracers may resolve the problem.

The possibility that other proteins such as the γ globulins are likewise affected must also be considered. Pernis (1966)⁽²²⁷⁾ has suggested that cadmium could interfere with γ globulin synthesis by inhibiting the linking of the heavy and light chains through disulphide bridges. This aspect of cadmium poisoning is complicated by the fact that globulins of smaller molecular weight than those found in the serum occur normally in the urine and in those suffering from renal disease^(57,59). It would, therefore, be necessary to distinguish between these and any small molecules arising as a result of cadmium intoxication. Berggard (1961)⁽²²⁸⁾ has demonstrated the presence in serum of a γ globulin of low molecular weight similar to that previously identified in normal urine; while the ultracentrifugal studies of Porath and Ui (1964)⁽¹²⁶⁾ have characterized γ globulin sub-fractions in normal human serum, two of which had a sedimentation coefficient of less than 7S (normally the major component). Piscator (1966)⁽¹⁹⁹⁾, studying cadmium-poisoned rabbits, has detected in the serum, several low-molecular weight proteins, the counterparts of those occurring in the urine, and suggested that they had been overlooked

in earlier studies because of their low concentrations. Lawford (1961)⁽³¹⁾ has detected the appearance, after 24 hr., of abnormal protein in the serum of cadmium-poisoned rats. The protein could also be induced by a number of other heavy metals such as mercury (more effective than cadmium), zinc, copper, beryllium and manganese. The marked increase in viscosity of the blood of cadmium-poisoned rabbits, often observed, should be mentioned in this context (Kench, Wells and Smith, 1962⁽²¹⁾).

The ability of the minialbumin to bind metal ions and other small molecules, as does normal albumin, is also to be investigated. Evidence of a thyroxine binding pre-albumin, very rich in tryptophan, but with only one binding site, has emerged⁽²²⁹⁾ and it would be of interest to determine whether or not minialbumin also had the property of transporting thyroxine.

Future investigations will be directed towards an elucidation of the relationship between cadmium ions and the intermediary metabolism of albumin, especially as regards its size, structure and antigenic behaviour. It is our earnest hope that this enquiry will also contribute to knowledge and understanding of the many factors which normally control and modify the metabolism of protein in living systems, in which cadmium itself may play an important role.

PART IV

SUMMARY AND CONCLUSIONS

1. Monkeys chronically poisoned by intravenous injection of cadmium chloride produced a low molecular weight albumin, termed minialbumin, which at first was found in the blood but was later excreted in the urine when a proteinuric state developed.
2. General biochemical investigations indicated that metabolism was not greatly impaired by cadmium ions, except perhaps in the liver and pancreas.
3. The excretion of cadmium was dependent on the degree of poisoning and was not directly correlated with the excretion of minialbumin, though both decreased with time following cadmium administration.
4. Some of the circulating cadmium was attached to albumin, but it seemed unlikely that this was the carrier molecule.
5. The cadmium absorbed by the body was found mainly in the liver and kidneys, but was also distributed in lower concentrations amongst the remaining body tissues.
6. Visking cellophane dialysis tubing was found to contain an easily extractable, biuret positive, and ultraviolet absorptive contaminating material, with a molecular weight ranging

widely round 5,000. Removal of this substance irreversibly enlarged the pore size.

7. The low molecular weight albumins (5,000 - 20,000 molecular weight) produced by cadmium poisoning were separated from normal albumin (66,000 molecular weight) on dextran gel (Sephadex G75) columns.

8. The minialbumin did not arise by breakdown on the gel columns, by proteolytic degradation, or as a result of a direct effect of cadmium or anticoagulant on whole blood, serum or serum albumin.

9. Minialbumin was found in the circulation before the animals exhibit any proteinuria, and was therefore thought to arise in extra-renal tissues.

10. The peak in minialbumin production occurred one and a half to two hours following a dose of cadmium. The fall-off in circulating minialbumin was gradual in newly poisoned animals, but very much more rapid in chronically poisoned animals, where it was probably cleared by the kidneys.

11. Excretion of minialbumin began three to five weeks following its initial appearance in the serum. In early

proteinuria, mainly low molecular weight albumin was excreted, whereas in the later stages large quantities of normal albumin also appeared in the urine.

12. Acute poisoning in rats gave rise to a pre-albumin on electrophoresis of the serum. Minialbumin appeared in the serum, and in increased amounts in the liver and kidney about ninety minutes after injection of cadmium dose.

13. The minialbumins, irrespective of their source, had the same electrophoretic mobility as normal albumin on cellulose acetate.

14. Minialbumin has been shown to aggregate readily to molecules of normal size, and larger, in the absence of salt. This phenomenon was partially reversible in the presence of salt, urea, EDTA and disulphide bridge inhibitors (mercapto ethanol), which implied that more than one mechanism was operative in joining the small molecules together. An equilibrium existed between aggregated and disaggregated molecules.

15. The amino acid composition of minialbumin was very similar to that of normal albumin. There was, however, a deficit of lysine and cystine, and an increased proportion of isoleucine in the minialbumin. Cadmium in high concentrations has been

shown to influence the ninhydrin reaction, but in the concentrations found attached to albumin, amino acid analysis was unaffected.

16. Tryptophan analysis revealed that whereas there were 2 residues of this amino acid in the normal albumin molecule, it was completely absent from minialbumin. Normal size albumins consisting partially of aggregates had intermediate values. The proportion of aggregates in the urine was lower than in the serum. The tryptophan-containing moiety was irreversibly lost, possibly as a peptide with the other missing amino acids.

17. The peptide thought to contain the deficient amino acids was apparently deleted metabolically and not during preparative procedures.

18. Immunologically, normal and minialbumins reacted similarly against anti-whole normal serum, antinormal albumin and anti-minialbumin antisera, showing that minialbumins are complete antigens. The tryptophan site was obviously not involved in the antigenic behaviour of albumin.

19. Sedimentation coefficients of minialbumin indicated it to be in the molecular weight range 5,000 to 20,000, whilst aggregates of up to 170,000 in molecular weight could occur.

20. Electrophoresis in polyacrylamide and starch gels in the presence of urea revealed two to three extra bands, probably due to association of subunits.

21. On tryptic digestion and mapping of the resulting peptides, there was apparently one lacking from minialbumin. So far, any possible relationship to the missing tryptophan, lysine and cysteine, has not been elucidated.

22. Cadmium ions appear to bring about fragmentation of the albumin molecule either during synthesis or more likely during catabolism by some intracellular enzymic process. The resulting peptides have the ability to reassemble, with the loss of a small portion or portions, either in the original or in a different sequence, to form a molecule similar to normal albumin in both amino acid composition and antigenic behaviour. In the light of these findings, cadmium may play an important role in the control of albumin metabolism.

23. Work is continuing in an attempt to clarify the proposed relationship between cadmium and albumin metabolism, and special attention is being paid to the action of cadmium at the cellular level, particularly the effect on microsomes and lysosomes.

PART V

BIBLIOGRAPHY

1. Medical Research Council - Sub-Committee for Chronic Cadmium Poisoning (1959).
2. Cotton, F.A. and Wilkinson, G. (1962) "Advanced Inorganic Chemistry". Interscience Publishers.
3. Heslop, R.B. and Robinson, P.L. (1960) "Inorganic Chemistry". Elsevier.
4. Friberg, L. (1950) Acta Med. Scand., 138 Suppl. 240.
5. Bonnell, J.A. (1965) Ann. Occup. Hyg. 8 45.
6. Bonnell, J.A., Kazantzis, G. and King, E. (1959) Brit. J. Industr. Med. 16 135.
7. Olhagen, B. (1945) Acta Med. Scand. Suppl. 162.
8. Kekwick, R.A. (1955) Brit. J. Industr. Med. 12 196.
9. Clarkson, T.W. and Kench, J.E. (1956) Biochem. J. 62 361.
10. Smith, J.C., Wells, A.R. and Kench, J.E. (1961) Brit. J. Industr. Med. 18 70.
11. Smith, J.C. and Kench, J.E. (1957) Brit. J. Industr. Med. 14 240.
12. Holden, H. (1965) Ann. Occup. Hyg. 8 51.
13. Potts, C.L. (1965) Ann. Occup. Hyg. 8 55.

14. Smith, J.C., Kench, J.E. and Smith, J.P. (1957) Brit.
J. Industr. Med. 14 246.
15. Gunn, S.A. and Gould, T.C. (1957) Proc. Soc. Exp. Biol.
Med. 96 820.
16. Bonnell, J.A., Ross, J.H. and King, E. (1960) Brit. J.
Industr. Med. 17 69.
17. Margoshes, M. and Vallee, B.L. (1957) J. Amer. Chem.
Soc. 79 4813.
18. Kagi, J.H.R. and Vallee, B.L. (1960) J. Biol. Chem.
235 3460.
19. Kagi, J.H.R. and Vallee, B.L. (1961) J. Biol. Chem.
236 2435.
20. Timme, A. (1966) Addendum. Ph.D. Thesis of Gain, A.C.
(1966).
21. Kench, J.E., Wells, A.R. and Smith, J.C. (1962) S. Afr.
med. J. 36 390.
22. Piscator, M. (1966) Arch. Environ. Health 12 335.
23. Lane, R.E. and Campbell, A.C.P. (1954) Brit. J. Industr.
Med. 11 118.
24. Nicaud, P., Lafitte, A. and Gros, A. (1942) Arch. Mal.
Prof. 4 192.

25. Barthelemy, P. and Moline, R. (1946) Paris Med. 36 7.
26. Princi, F. (1947) Industr. Hyg. 29 129.
27. Baum, J. and Worthen, H.G. (1967) Nature 213 1040.
28. Parizer, J. and Zahor, Z. (1956) Nature 177 1036.
29. Kazantzis, C., Flynn, F.V., Spowage, J.S. and Trott, D.C.
(1963) Quart. J. Med. 32 165.
30. Parizek, J. (1965) J. Reprod. and Fertil. 9 111.
31. Lawford, D.J. (1961) Biochem. Pharmacol. 7 109.
32. Schroeder, H.A., Balassa, J.J. and Vinton, W.H.(Jr.) (1965)
J. Nutr. 86 51.
33. Schroeder, H.A. and Vinton, W.H. (jr.) (1962) Amer. J.
Physiol. 202 515.
34. Schroeder, H.A., Kroll, S.S., Little, J.W., Livingstone, P.O.
and Myers, M.A.G. (1966) Arch. Environ. Health 13 788.
35. Perry, H.M. (Jr.), Schoepfle, E. and Bourgoignie, J. (1967)
Proc. Soc. Exp. Biol. and Med. 124 485.
36. Perry, H.M. and Yunice, A. (1965) Proc. Soc. Exp. Biol. and
Med. 120 805.
37. Gabbiani, G. (1966) Experientia 22 261.

38. Kostojanc, Ch.S. (1954) *Physiologica bohemoslov.*
3 382.
39. Powell, G.W., Miller, W.J., Morton, J.D. and Clifton, C.M.
(1964) *J. Nutr.* 84 205.
40. Vander, A.J. (1962) *Amer. J. Physiol.* 203 1005.
41. Jacobs, E.E., Jacob, M., Sanadi, D.R. and Bradley, L.B. (1956)
J. Biol. Chem. 223 147.
42. Fletcher, M.J., Fluharty, A.L. and Sanadi, D.R. (1962)
Biochem. Biophys. Acta. 60 425.
43. Simon, F.P., Potts, A.M. and Gerard, R.W. (1947) *Arch.*
Biochem. 12 283.
44. Barron, E.S. and Kalnitsky, G. (1947) *Biochem. J.* 41 346.
45. Rifkin, R.J. (1965) *Proc. Soc. Exp. Biol. Med.* 120 802.
46. Adams, E. and Smith, E.L. (1952) *J. Biol. Chem.* 198 671.
47. Neuman, R.E. and Smith, E.L. (1951) *J. Biol. Chem.* 193 97.
48. Fruton, J.S., Smith, V.A. and Driscall, P.E. (1948) *J. Biol.*
Chem. 173 459.
49. Berman, M.C. and Kench, J.E. (1967) *Personal communication.*
50. Burstone, M.S. (1957) *Arch. of Path.* 63 164.

51. Edlbacher, S. and Baur, H. (1938) Z. Physiol. Chem.
254 275.
52. Dixon, M. and Webb, E.C. (1964) "Enzymes" p 423.
2nd Edition, Longmans.
53. Cotzias, G.C., Borg, D.C. and Selleck, B.H. (1961) Amer.
J. Physiol. 201 63.
54. Sarabhai, A.S., Stretton, A.O.W., Brenner, S. and Bolle, A.
(1964) Nature 201 13.
55. Cotzias, G.C. and Selleck, B.H. (1960) Fed. Proc. 19 249.
56. Cotzias, G.C., Borg, D.C. and Selleck, B.H. (1961) Amer. J.
Physiol. 201 927.
57. Creeth, J.M., Kekwick, R.A., Flynn, F.V., Harris, H. and
Robson, E.B. (1963) Clin. Chim. Acta 8 406.
58. Dounce, A.L., Roberts, E. and Wills, J.H. (1949) "Pharmacology
and Toxicology of Uranium Compounds". Edited by Vøegtlin, C.
and Hodge, H.C., N.Y.
59. Rowe, D.S. (1957) Biochem. J. 67 435.
60. Smith, J.C. and Wells, A.R. (1960) Brit. J. Industr. Med.
17 205.
61. Webb, T., Rose, B. and Schon, A.H. (1958a) Canad. J.
Biochem. 36 1167.

62. Merler, E., Remington, J.S., Finland, M. and Gitlin, D.
(1962) Nature 196 1207.
63. Smith, J.C., Kench, J.E. and Lane, R.E. (1955) Biochem.
J. 61 698.
64. Webb, T., Rose, B. and Schon, A.H. (1958b) Canad. J.
Biochem. 36 1159.
65. Gain, A.C. and Kench, J.E. (1965) S. Afr. J. Lab. Clin.
Med. 11 77.
66. Gain, A.C. (1966) Ph.D. Thesis, University of Cape Town.
67. Wolfson, W.A., Cohn, C., Calvary, E. and Ichiba, F. (1948)
Amer. J. Clin. Path. 18 773.
68. Spencer, A.G. (1950) Lancet 2 623.
69. Brealey, L. and Ross, R.E. (1951) Analyst 76 334.
70. Glasstone, S. (1955) "Elements of Physical Chemistry".
Macmillan, London.
71. Skeggs, L.T. (1957) Amer. J. Clin. Path. 28 311.
72. Marsh, W.H., Fingerhut, B. and Kirsch, E. (1957) Amer.
J. Clin. Path. 28 681.
73. Michaelsson, M. (1961) Scand. J. Clin. Lab. Invest. 13
Suppl. 56.

74. Nosslin, D. (1960) Scand. J. Clin. Lab. Invest. 12
Suppl. 49.
75. Karmen, A. (1955) J. Clin. Invest. 34 131.
76. Henry, R.J., Chiamori, N., Golub, O.J. and Berkman, S.
(1960) Am. J. Clin. Path. 34 381.
77. Pearson, S., Stern, S. and McGarack, T.H. (1953) Anal.
Chem. 25 813.
78. Marsh, W.H., Fingerhut, B. and Kirsch, E. (1959) Clin.
Chem. 5 119.
79. Powell, M.E.A. and Smith, M.J.H. (1954) J. Clin. Path.
7 245.
80. Pimstone, N.R. (1964) Clin. Chem. 10 891.
81. MacLagan, N.F. (1944) Brit. J. Exp. Path. 25 234.
82. Kunkel, H.G. (1947) Proc. Soc. Exp. Biol. Med. 66 217.
83. Hoffman, W.S. (1937) J. Biol. Chem. 120 51.
84. Block, R.J., Durrum, E.L. and Zweig, G. (1957) "A Manual
of Paper Chromatography and Paper Electrophoresis".
2nd Ed. Academic Press, New York.
85. Lederer, M. (1955) "An Introduction to Paper Electrophoresis
and Related Methods". Elsevier Press.

86. Beckman Instruction Manual RM-IM-3 August, 1965.
87. Fine, J. (1935) Biochem. J. 29 799.
88. Rothera, A.C.H. (1908) J. Physiol. 37 491.
89. Gerhardt, C. (1865) Wein. Med. Pr. 6 672.
90. Henderson, L.J. and Palmer, W.W. (1914) J. Biol. Chem.
17 305.
91. Seltzer, H.S. (1956) J. Am. Med. Assoc. 162 1234.
92. Comer, J.P. (1956) Anal. Chem. 28 1748.
93. Benedicts, S.R. (1911) J. Am. Med. Assoc. 57 1194.
94. Fouchet, A. (1918) J. Pharm. Chim. 18 19.
95. Decomps, P. (1924) J. Pharm. Chim. 30 97.
96. Smith, J.C., Kench, J.E. and Smith, J.P. (1957) Brit.
J. Industr. Med. 14 246.
97. Kench, J.E. (1952) Personal experience.
98. Vallance-Owen, J., Dennes, E. and Campbell, P.N. (1958)
Lancet 2 336.
99. Debro, J.R., Turner, H. and Korner, A. (1957) J. Lab.
Clin. Med. 50 728.

100. Levine, S. (1954) Arch. Biochem. 50 515.
101. Foster, J.F. (1960) "The Plasma Proteins" 1 179.
Edited by Putnam.
102. Fernandez, A., Sobel, C. and Goldenberg, H. (1966)
Clin. Chem. 12 194.
103. Tiselius, A. and Flodin, P. (1953) Advances in Protein
Chemistry 8 461.
104. Campbell, P.N. and Stone, N.E. (1957) Biochem. J. 66 19.
105. Flodin, P. and Porath, J. (1954) Biochem. Biophys. Acta.
13 175.
106. Porath, J. (1954) Acta Chem. Scand. 8 1813.
107. Potgieter, G.M. and Hines, M. (1963) S. Afr. J. Lab. Clin.
Med. 9 138.
108. Potgieter, G.M. (1964) Ph.D. Thesis, University of Cape
Town.
109. Kohn, J. (1960) "Chromatographic and Electrophoretic
Techniques" 2 56. Edited by I. Smith.
110. Grabar, P. and Williams, C.A. (Jr.) (1955) Biochem.
Biophys. Acta 17 67.
111. Michael, S.E. (1962) Biochem. J. 82 212.

112. Fevold, H.L. and Alderton, G. (1949) "Biochemical Preparations" 1 67. Edited by C.S. Vestling, London.
113. Shugar, D. (1952) Biochim. Biophys. Acta 8 302.
114. Porath, J. and Flodin, P. (1959) Nature 183 1657.
115. Berman, M.C. and Kench, J.E. (1963) J. Clin. Path. 16 385.
116. Flodin, P. (1962) Dissertation, Uppsala. Dextran Gels and their Applications.
117. Whitaker, J.R. (1963) Anal. Chem. 35 1950.
118. Andrews, P. (1964) Biochem. J. 91 222.
119. Gain, A.C. and Kench, J.E. Path. Convergence, Cape Town, July, 1965.
120. Astrup, P. (1961) Clin. Chem. 7 1.
121. Kench, J.E. and Sutherland, E.M. (1966) S. Afr. Med. J. 40 1109.
122. Warburg, O. and Christian, W. (1941) Biochem. Z. 310 354.
123. Jorpes, J.E. (1946) "Heparin in the Treatment of Thrombosis". 2nd Edition, Oxford Medical Publications.

124. Vogel, A.I. (1961) "A Text Book of Quantitative Inorganic Analysis" p 406. 3rd Edition, Longmans.
125. Vogel, A.I. (1961) "A Text Book of Quantitative Inorganic Analysis" p 574. 3rd Edition, Longmans.
126. Porath, J. and Ui, N. (1964) Biochem. Biophys. Acta 90 324.
127. Skvaril, F. and Grünberger, D. (1962) Nature 196 481.
128. Alkjaersig, N., Fletcher, A.P. and Sherry, S. (1959) J. Biol. Chem. 234 832.
129. Sjoerdsma, A. and Nilsson, I.M. (1960) Proc. Soc. Exp. Biol. Med. 103 533.
130. Horejsi, J. and Smetana, R. (1956) Acta Med. Scand. 155 65.
131. Kistler, P., Nitschmann, H., Wyttenbach, A., Studer, M., Niederöst, Ch. and Mauerhofer, M. (1960) Vox Sanguinis 5 403.
132. Potgieter, G.M. (1967) Personal communication.
133. Wust, C.J. and Novelli, G.D. (1964) Arch. Biochem. Biophys. 104 185.

134. Ouchterlony, O. (1949) Acta. Path. Microbiol. Scand.
26 507.
135. Peters, T. (1962) J. Biol. Chem. 237 2182.
136. Jungblut, P.W. and Turba, F. (1963) Biochem. Z. 337
88.
137. Sargent, J.R. and Campbell, P.N. (1965) Biochem. J.
96 134.
138. Kohn, J. (1957) Biochem. J. 65 9.
139. Fahey, J.L. (1963) J. Immunol. 91 448.
140. Porter, R.R. (1962) Arch. Biochem. Suppl. 1 174.
141. Hirs, C.H.W., Moore, S. and Stein, W.H. (1954) J.
Biol. Chem. 211 941.
142. Moore, S. and Stein, W.H. (1963) "Methods in Enzymology"
6 819. Edited by Colowick and Kaplan, Academic
Press, New York.
143. Potgieter, G.M. and Hall, E.F. (1966) S. Afr. Med. J.
40 988.
144. Spackman, D.H., Stein, W.H. and Moore, S. (1958) Anal.
Chem. 30 1190.

145. Spackman, D.H. "Serum Proteins and the Dysproteinaemias"
p 116. Edited by Sunderman and Sunderman.
146. Moore, S., Spackman, D.H. and Stein, W.H. (1958) Anal.
Chem. 30 1185.
147. Hamilton, P.B. (1958) Anal. Chem. 30 914.
148. Bernstein, L.L. and Weatherall, M. (1952) "Statistics
for Medical and Other Biological Students" p 59,
Edinburgh.
149. Phelps, R.A. and Putnam, F.W. (1960) "The Plasma Proteins"
1 143. Academic Press, N.Y.
150. Moore, S. and Stein, W.H. (1949) J. Biol. Chem. 178
79.
151. Allerton, S.E., Elwyn, D., Edsall, J.T. and Spahr, P.F.
(1962) J. Biol. Chem. 237 85.
152. Potgieter, G.M., Hines, M. and Kench, J.E. (1967) Clin.
Chim. Acta (in press).
153. Noltmann, E.A., Mahowald, T.A. and Kuby, S.A. (1962) J.
Biol. Chem. 237 1146.
154. Spies, J.R. and Chambers, D.C. (1949) J. Anal. Chem.
21 1249.

155. Spies, J.R. and Chambers, D.C. (1948) J. Anal. Chem.
20 30.
156. Baumstark, J.S., Laffin, R.J. and Bardawil, W.A. (1964)
Arch. Biochem. Biophys. 108 515.
157. Heimbürger, N., Heide, K., Haupt, H. and Schultze, H.E.
(1964) Clin. Chim. Acta 10 293.
158. Ramachandran, L.K. and Witkop, B. (1959) J. Amer. Chem.
Soc. 81 4028.
159. Spahr, P.F. and Edsall, J.T. (1964) J. Biol. Chem.
239 850.
160. Tristram, G.R. and Smith, R.H. (1963) "Advances in
Protein Chemistry" 18 227.
161. Beaven, G.H. and Holiday, E.R. (1952) "Advances in
Protein Chemistry" 7 319.
162. Kench, J.E. and Sutherland, E.M. (1967) Brit. J. Industr.
Med. (in press).
163. The Biochemical Journal (1967) Policy of the Journal
and Instructions to Authors 102 1.
164. Adiga, P.R., Rao, P.M., Hussa, R.O. and Winnick, T. (1966)
Biochem. 5 3850.
165. Mandy, W.J., Rivers, M.M. and Nisonoff, A. (1961) J.
Biol. Chem. 236 3221.

166. Fahey, J.L. and McLaughlin, C. (1963) J. Immunol.
91 484.
167. Humphrey, J.H. and White, R.G. (1964) "Immunology
for Students of Medicine". 2nd Edition, p 202.
168. Burtin, P. (1954) Bull. Soc. Clin. Biol. 36 1027.
169. Wunderly, C. (1959) Clin. Chim. Acta 4 754.
170. Bodman, J. (1960) "Chromatographic and Electrophoretic
Techniques" 2 109. Edited by I. Smith.
171. Wunderly, C. (1961) "Immuno-electrophoresis" in Adv.
in Clin. Chem. 4.
172. Ouchterlony, O. (1962) Progr. Allergy 6 30.
173. Svedberg, T. Kolloidchemie (Leipzig).
174. Svedberg, T. (1925) Kolloid Z. Ergänzung 36 53.
175. Svedberg, T. and Pederson, K.O. (1940) "The Ultracentrifuge".
Clarendon Press, Oxford.
176. Lamm, O. (1929) Z. Für Physikal. Chemie 143 177.
177. Philpot, L. (1938) Nature 141 283.
178. Andersson, K.J.I. (1939) Nature 143 720.
179. Harrington, W.F. and Schachman, H.K. (1953) J. Amer.
Chem. Soc. 75 3533.

180. Kegeles, G. and Gutter, F.J. (1951) J. Amer. Chem. Soc. 73 3770.
181. Cohen, E. and Bruins, H.R. (1923) Hoppe-Seylers Z. Physiol. Chem. 103 349.
182. Lamm, D. and Polson, A. (1936) Biochem. J. 30 528.
183. Crestfield, A.M. and Allen, F.W. (1955) Anal. Chem. 27 422.
184. Pfleiderer, G. and Jeckel, D. (1957) Biochem. Zeitschrift 329 370.
185. Bloemendal, H. (1963) "Zone Electrophoresis in Blocks and Columns - a Monograph". Elsevier.
186. Bloemendal, H., Jongkind, J.F. and Wisse, J.H. (1962) Chemisch Weekblad 58 501.
187. Bloemendal, H. (1963) Chemisch Weekblad 59 281.
188. Aronsson, T. and Grönwall, A. (1957) Scand. J. Clin. Lab. Invest. 9 338.
189. Edelman, G.M. and Poulik, M.D. (1961) J. Exp. Med. 113 863.
190. Pert, J.H., Engle, R.E. (Jr.), Woods, K.R. and Sleichenger, M.H. (1959) J. Lab. Clin. Med. 54 572.

191. Saifer, A., Robin, M. and Ventrice, M. (1961) Arch.
Biochem. Biophys. 92 409.
192. Smithies, O. (1959) Biochem. J. 71 585.
193. Poortmans, J., van Fraechem. J. and Segers, M. (1966)
Biochim. Biophys. Acta 127 380.
194. Jones, K. and Heathcote, J.G. (1966) J. Chrom. 24 106.
195. Kench, J.E., Gain, A.C. and Sutherland, E.M. (1965) S.
Afr. Med. J. 39 1191.
196. Megel, H., Strauss, R., Ho, R. and Bester, M. (1964) Arch.
Biochem. 108 193.
197. Press, E.M. and Porter, R.R. (1962) Biochem. J. 83 172.
198. Regoeczi, E., Irons, L., Koj, A. and McFarlane, A.S. (1965)
Biochem. J. 95 521.
199. Axelsson, B. and Piscator, M. (1966) Arch. Environ. Health
12 374.
200. Perkins, D.J. (1952) Biochem. J. 51 487.
201. Henriques, O.B., Henriques, S.B. and Neuberger, A. (1955)
Biochem. J. 60 409.
202. Hardwicke, J. (1965) Clin. Chim. Acta 12 89.

203. Oliver, J., McDowell, M. and Lee, Y.C. (1954) J. Exp. Med. 99 589.
204. Ku, L. and Romani, R.J. (1966) Science 154 408.
205. Bresnick, E., Thompson, U.B. and Lyman, K. (1966) Arch. Biochem. Biophys. 114 352.
206. Straessle, R. (1954) J. Amer. Chem. Soc. 76 3138.
207. King, T.P., Yphantis, D.A. and Craig, L.C. (1960) J. Amer. Chem. Soc. 82 3350.
208. Therriault, D.G. and Taylor, J.F. (1960) Biochem. Biophys. Res. Commun. 3 560.
209. Gutter, F.J., Peterson, E.A. and Sober, H.A. (1957) Arch. Biochem. Biophys. 72 194.
210. Hartley, R.W., Peterson, E.A. and Sober, H.A. (1962) Biochem. 1 60.
211. Kekwick, R.A. (1958) Personal communications to Dr. J.E. Kench (June).
212. Weber, G. and Young, L.B. (1964) J. Biol. Chem. 239 1415.
213. Weber, G. and Young, L.B. (1964) J. Biol. Chem. 239 1424.
214. Peters, T. (Jr.) and Hawn, C. (1967) J. Biol. Chem. 242 1566.

215. Sogami, M. and Foster, J.F. (1962) J. Biol. Chem.
237 2514.
216. Bednarik, T. (1967) Clin. Chim. Acta 17 132.
217. Dixon, M. and Webb, E.C. (1964) "Enzymes" p 243,
2nd Edition, Longmans.
218. Warren, W.A. and Peters, T. (Jr.) (1965) J. Biol.
Chem. 240 3009.
219. Peters, T. (Jr.) (1962) J. Biol. Chem. 237 1181.
220. Peters, T. (Jr.) (1962) J. Biol. Chem. 237 1186.
221. Gordon, A.H. and Humphrey, J.H. (1961) Biochem. J.
78 551.
222. Gunn, S.A., Gould, T.C. and Anderson, W.A.D. (1966)
Proc. Soc. Exp. Biol. 122 1036.
223. Bloomfield, V. (1966) Biochem. 5 684.
224. Petersen, H.A. and Foster, J.F. (1965) J. Biol. Chem.
240 3858.
225. Foster, J.F., Sogami, M., Peterson, H.A. and Leonard, W.J. (Jr.)
(1965) J. Biol. Chem. 240 2495.
226. Leonard, W.J. and Foster, J.F. (1961) J. Biol. Chem.
236 2662.

227. Pernis, B. Quoted Piscator, M. (1966) Arch. Environ.
Health 12 335.
228. Berggard, I. (1961) Clin. Chim. Acta 6 545.
229. Oppenheimer, J.H., Surks, M.I., Crispin-Smith, J. and
Squef, R. (1965) J. Biol. Chem. 240 173.
-

P A R T VI

A D D E N D A

Reprinted from the "S.A. Medical Journal", Vol. 39, 25 December 1965, pages 1191 - 1199

**A BIOCHEMICAL STUDY OF THE MINIALBUMIN TO BE FOUND IN THE URINE OF
MEN AND ANIMALS POISONED BY CADMIUM***

**J. E. KENCH, M.B., D.Sc., Ph.D., F.R.I.C., A. C. GAIN, B.Sc., AND ELIZABETH M. SUTHERLAND, B.Sc. (HONS.);
*CSIR/UCT Protein Research Unit, Department of Chemical Pathology, University of Cape Town***

A BIOCHEMICAL STUDY OF THE MINIALBUMIN TO BE FOUND IN THE URINE OF MEN AND ANIMALS POISONED BY CADMIUM*

J. E. KENCH, M.B., D.Sc., Ph.D., F.R.I.C., A. C. GAIN, B.Sc., AND ELIZABETH M. SUTHERLAND, B.Sc. (HONS.);
CSIR/UCT Protein Research Unit, Department of Chemical Pathology, University of Cape Town

The early observations of Friberg (1950)¹ stimulated much of the subsequent interest in cadmium poisoning. He noted a high incidence of proteinuria in workers in the alkaline battery industry under his care. Pedersen (findings published in Friberg's monograph, page 37) examined the protein and found it to have a molecular weight of 25-30,000. The protein has been found consistently since then in the urine of men and animals poisoned by cadmium, by inhalation or parenteral route.

Smith, Kench and Lane² carried out a series of investigations in Manchester on the incidence and degree of proteinuria in industrial workers exposed to cadmium, which have confirmed and extended the observations of Friberg. They determined the incidence and degree of proteinuria in relation to cadmium exposure and excretion. Urinary cadmium and excreted protein appeared to vary independently of one another in the series of 95 workmen exposed to the hazard, but the individual who worked in the most heavily contaminated atmosphere consistently excreted most cadmium and protein in his urine. The quantity of urinary protein was 1.0-3.2 G/l.³—which is much in excess of the average value of 133 mg./24 hr. found by Webb and his co-workers⁴ in young, normal, adult males.

As regards the nature of the urinary protein, Friberg described it as having the electrophoretic mobility of α_2 - β -globulins. The proteinuria could not unequivocally be demonstrated by the heat coagulation test, but complete precipitation was effected by addition of 10% w/v aqueous trichloroacetic acid (TCA) (1 vol. TCA to 1 vol. urine).^{5,6} Olhagen (p. 36 of Friberg's monograph) observed that the urinary protein was precipitated when the urine was fully saturated with ammonium sulphate, but not on 50% saturation. The sequence of events, as observed by the Manchester workers, was the initial appearance of α_2 -globulins, soon followed by a β -globulin fraction. Later, protein fractions appeared, migrating as serum albumin and γ -globulins, until eventually the urinary protein pattern was similar to that of serum. Kekwick⁶ observed that, even when the pattern was complex in this way, the urinary proteins all sedimented in the ultracentrifuge in the range 20-30,000.

These observations may be compared with those made on normal urine or on the urinary proteins of patients suffering from renal or other diseases. The small quantity of protein present in normal urine includes γ -globulins of low molecular weight, 10,600,⁷ while the α_2 , β - and other globulins excreted normally⁴ or in conditions of renal tubular necrosis⁷ have molecular weights similar to those found in cadmium poisoning. Creeth and his colleagues are, therefore, convinced that the proteinuria of cadmium poisoning comprises a mixture of globulins which is

typical of any non-specific renal tubular defect or necrosis, as obtains in the Fanconi syndrome, in hepatolenticular degeneration or in galactosaemia. The proteinuria of cadmium poisoning is, in their view, neither specific nor unique, and it also appears that they regard the first urinary peak as probably an α_1 -globulin. As regards the albumin found in normal urine, Webb *et al.*⁴ were unable to distinguish between it and normal serum although, more recently, Merler *et al.*⁸ have reported that normal human urinary albumin has, in fact, a smaller molecular weight, $S_{20,w}$ of 2.6 S as compared with 4.2 S for crystalline serum albumin. The mobility of serum albumin and of other serum proteins is also somewhat augmented in urine,⁹ an effect ascribed to adsorbed urinary pigments. The albumin excreted in the urine of nephritic and of nephrotic patients,^{8,10} as of a person poisoned with metallic mercury,¹¹ is indistinguishable from normal serum albumin in molecular size.

On the basis of the close similarity in amino acid structure and electrophoretic mobility of the urinary and serum albumins of workmen and of animals poisoned by cadmium, and of the low molecular weight of the urinary proteins, Kench and his colleagues^{3,12} have postulated that the special feature of cadmium intoxication is the excretion of an albumin of low molecular weight. Cadmium-poisoned workpeople so far examined have excreted only low molecular albumin unless renal disease from other causes was coexistent. Cadmium-poisoned rabbits¹² excrete both albumins of low and of normal molecular weight in the urine. The metabolic turnover of the low molecular species appeared to be more rapid than that of normal albumin, and, on intravenous injection of the C¹⁴-labelled urinary proteins into normal rabbits, much more activity was recovered in the urine as protein than when C¹⁴-labelled serum proteins were similarly injected. The question of renal permeability to serum proteins of different molecular weights is very pertinent to this situation. Thus, Hardwicke¹³ has demonstrated, both by immunological procedures and by use of gel filtration through Sephadex G 200, that renal clearances of serum proteins increase steadily with diminishing molecular weight.

The experimental evidence in support of the concept of a specific biochemical lesion, caused by cadmium ions, leading to the excretion of a low molecular albumin,¹² was only tentative in kind, since techniques for separating albumin molecules on the basis of difference in molecular size (*cf.* myoglobin and haemoglobin¹⁴) were not available to us. The present paper is an account of biochemical studies designed to separate and characterize, with greater exactitude than was previously possible, the urinary albumins of cadmium-poisoned animals, as a necessary prerequisite to a study of its tissue source and the mechanism of its formation.

Apart from its molecular weight—in its behaviour variously in trichloroacetic acid-acetone, on immunoelectrophoresis and Ouchterlony plates and in its amino acid

*Much of this work was presented at the Annual Conference of the South African Society of Pathologists held in Cape Town, April 1965; most of it is embodied in a thesis submitted by A. C. Gain for the Ph.D. degree, University of Cape Town, December 1965. Full experimental details are available in the thesis and will be presented elsewhere.

composition (established earlier)—the low-molecular protein in the albumin fraction of the urine of cadmium workers was similar to normal human serum albumin. We, therefore, now refer to it as minialbumin.

No minialbumin could be detected in the urine of patients suffering from non-specific renal tubular damage, as for example, in an advanced case of hepatolenticular degeneration, Fanconi syndrome, acute tubular necrosis or nephrotic syndrome. Rabbits, dogs and monkeys have been chronically poisoned by intravenous injection of cadmium chloride, and, after some months, these animals, too, excrete minialbumins closely similar in all the respects already mentioned with their own normal serum albumins and the normal molecular albumin also found in the urine. If it is assumed that all the minialbumin formed in the cadmium-poisoned monkey is excreted in the urine, then the number of such diminutive molecules would correspond to approximately 26% of the number of normal serum albumin molecules being synthesized in the liver. In cadmium workers the corresponding figure is approximately 53%.

The over-all data support the view that cadmium ions may provide a valuable tool in the study of the relationships between chemical structure, antigenic behaviour, and metabolism of serum albumin and perhaps of other proteins in man and animals.

EXPERIMENTAL OBSERVATIONS AND RESULTS

Experimental Animals and their Maintenance

Male vervet monkeys (*Cercopithecus aethiops*), which had been captured in the wild state, were the experimental subjects. Young full-grown individuals of steady weight (about 5 kg.) and, therefore, in nitrogen balance, were chosen. They were kept in stainless steel metabolic cages with floors of $\frac{1}{2}$ inch wire mesh which allowed urine to pass through but held back most of the stools and food debris. The cages were placed over stainless steel trays which were covered with mosquito netting to filter the urine free from residual contaminants.

The animals were fed daily between 11 a.m. and 3 p.m. on carrots, cabbage, sweet potatoes, oranges and dried maize. They do not drink water and none was provided.

Poisoning of the Animals

The technique employed was similar to that developed by Kench *et al.*¹² for cadmium intoxication of rabbits. Blood was withdrawn from the saphenous vein in the lower hind leg using an all-glass 10 ml. Luer-Lock syringe with off-centre attachment and $1\frac{1}{2}$ inch 21-gauge needles. The needle, previously heparinized, was left in the vein and the blood flow halted by closing the Luer-Lock stopcock. The blood was then displaced from the syringe into a beaker containing 0.5 ml. heparin, with which it was well mixed. Cadmium chloride ($\text{CdCl}_2 \cdot 2\frac{1}{2}\text{H}_2\text{O}$) solution, containing 2 mg. Cd^{++} per ml. and sodium chloride added to a final concentration of 0.55% w/v Cl, was then stirred gently into the heparinized blood—a manoeuvre which allows the acidic cadmium chloride solution to be fully buffered by the blood without the occurrence of precipitation. The mixture was then sucked up into the same syringe, which was reattached to the needle in the vein, and the injection given over a period of about 2 minutes.

The needle was finally removed and stasis achieved by placing a piece of cottonwool plus Hibertane ointment over the wound, which was secured with Elastoplast.

Injections were made twice weekly at an approximate dosage of 2 mg. cadmium per kilogram body-weight.

During the first 2-3 months period of intoxication, 15-18 mg. of cadmium were injected weekly. When severe poisoning had occurred with gross proteinuria; dyspnoea and agitation of the animal, the dose was lowered to 6-8 mg. of cadmium weekly.

Quantitation of Proteins in Serum and Urine of Poisoned Animals

The protein concentrations of specimens of serum and urine were measured daily during the intoxicating period by a modified biuret procedure,¹⁵ using a known pure bovine albumin preparation, standardized by the micro-Kjeldahl procedure.¹⁶ Serum albumin-globulin fractionation was performed using 23% w/v Na_2SO_4 solution.¹⁷

Urinary proteins rose steadily in amount in the cadmium-poisoned monkey during the process of poisoning, until an average of nearly 200 mg. was being excreted daily. The concentrations of serum proteins—albumin 3.5-4.0 G/100 ml. and globulins 2.0-3.0 G/100 ml.—remained unaltered during high-dosage administration of cadmium chloride as during the state of chronic intoxication.

Special Investigations of Urinary Proteins

1. Separation of Albumin Fraction

Urinary albumins have, in the course of this study, been separated from globulins present in the urine by a number of procedures.

(i) Zone electrophoresis on ethylated cellulose according to the method of Porath and Flodin,¹⁸ as adapted by Campbell and Stone.¹⁹

(ii) Separation on columns of the cationic ion-exchange resin, carboxy methyl cellulose (CMC), using salt and pH gradients.²⁰

(iii) The trichloroacetic acid procedure described by Vallance-Owen *et al.*²¹ based on the solubility of serum albumin in acid-alcohol mixtures. This technique has been critically appraised by Michael²² who could detect no changes in physico-chemical or antigenic properties of albumin as a result of the fractionation procedures. This has also been our experience.

All three procedures provided homogeneous albumin fractions when electrophoresed in a Durrum-type tank, the protein migrating as a single compact band. However, the excellent recoveries and the relative simplicity and reproducibility of the trichloroacetic acid method were important advantages for our particular work, and after preliminary trials with all 3 procedures, it was thereafter employed for all subsequent experiments on serum, urine or peritoneal dialysate.

In brief, the preparation was performed as follows: The urinary proteins were first precipitated en masse with a 10% w/v aqueous solution of trichloroacetic acid (TCA) which was added in a volume equal to that of the urine, which had already been concentrated 3-4 times by dialysis and per-vaporation alternately.* The precipitated proteins were then centrifuged at 2,000 r.p.m. for 10 minutes at 0°C in a MSE major refrigerated centrifuge with a swing-out head and the supernatant solution discarded. The precipitate was then washed with 5% w/v aqueous TCA. To the washed precipitate, 1% TCA in 96% aqueous ethanol was added and the albumin thereby extracted. After extraction and centrifugation, the

*The urinary specimens were first dialysed against running tap-water overnight, and, later, against cold distilled water. All dialysis tubing was boiled for at least 30 minutes in distilled water before use, to decrease the pore size, a necessary precaution to prevent escape of any low-molecular albumins.

supernatant fluid (SNF) was removed and dialysed in visking sacs at 0°C for 24 hours in a refrigerator, against several changes of distilled water to remove the alcohol and excess TCA. The protein at first precipitated during dialysis but later redissolved. It was found that if the earlier treatment of the total protein precipitate was with 1% TCA in 96% aqueous acetone instead of in ethanol, albumin remained in solution throughout the whole period of removal of the TCA-acetone solvent. In this manner a pure aqueous solution of albumin was obtained, as judged by a single symmetrical peak on paper electrophoresis (Fig. 1).

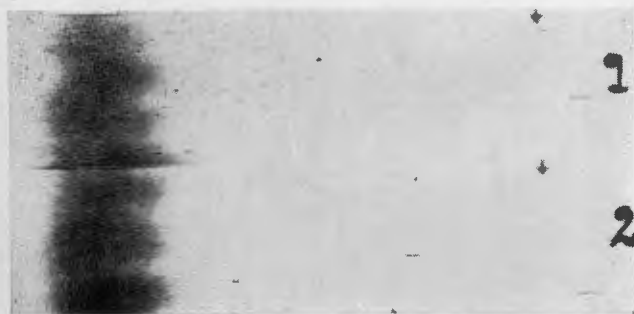

Fig. 1. Homogeneity of albumin fraction prepared by the TCA method. 1 = Urinary albumin of cadmium-poisoned monkey F, 2 = Serum albumin of normal monkey.

2. Separation of Urinary Albumins of Differing Molecular Weights

This was achieved by gel filtration²³ using the cross-linked dextran gel, Sephadex G 75, which allowed ready separation of molecules of the sizes of the albumins with which we were concerned. The aqueous solution of albumin, as prepared above, was applied carefully to the top of a column (40 x 1.8 cm.) of the gel, and allowed to run into the gel. On complete entry, a phosphate-sodium chloride buffer (M/15 phosphate buffer pH 7.0 and 0.5 M NaCl) was pumped through the column at a rate of 15 ml. per hour. The eluate from the column was monitored at 262 m μ . by a LKB Uvicord ultraviolet absorptiometer with a recorder, and then collected in 5 ml. fractions. The solution of the urinary albumins from a cadmium-poisoned monkey (F), produced a trace with two distinct peaks, indicating that there were two proteins of differing molecular weights in the albumin preparation (Fig. 2). The same twin peaks were given on Sephadex chromatography

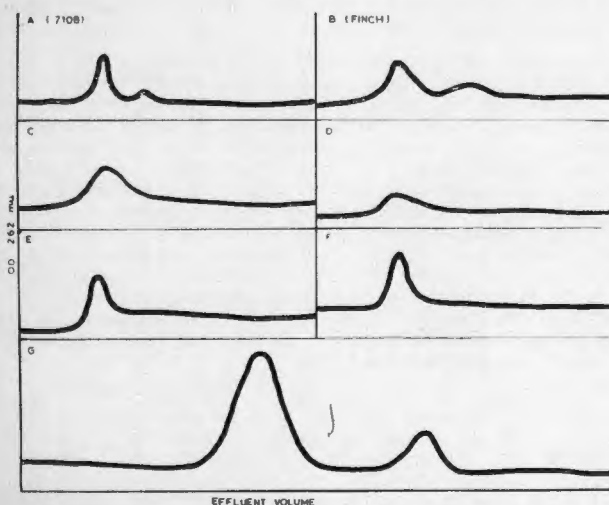

Fig. 2. Separation of urinary albumins of normal and of low molecular weight on dextran gel (Sephadex G 75). A = Cadmium worker 7108, B = Cadmium worker Finch, C = Acute renal failure, D = Hepatolenticular degeneration, E = De Toni-Fanconi syndrome, F = Chronic glomerulonephritis, G = Cadmium-poisoned monkey F.

whether the albumin fraction had been prepared on CM cellulose, by zone electrophoresis on ethylated cellulose, or by the preferred TCA method.

If, before running on Sephadex, the urinary albumin solution was enriched with a solution of normal monkey serum albumin, then the graphic recording of the Uvicord-monitored column effluent had a similar pattern to the urinary albumins alone; but the protein peak first to emerge, i.e. the protein with the greater molecular weight, was augmented, with a greater area under the curve. This pointed to an albumin in the urine with a molecular weight similar to that of normal serum albumin, 66,000, as well as an albumin with a lower molecular weight.

A number of other similar separations are shown in Fig. 2. Finch and 7108 refer to lyophilized urinary albumin from cadmium-poisoned workmen, prepared in Manchester in 1957. Until they were analysed this year, the specimens had stood at room temperature in small sealed bottles. Some denaturation had evidently taken place, since some of the protein remained insoluble in TCA-acetone. The albumin which dissolved was separable into two components, corresponding in size to normal serum albumin and to minialbumin. The presence of normal serum albumin was an unexpected finding, since the sedimentation coefficients of other specimens from the same individuals in May 1958 (kindly determined by Dr. R. A. Kekwick) were respectively 1.96 and 1.99, values which correspond to a molecular weight of approximately 20,000.

Albumin prepared from the urine of patients suffering from various renal disturbances have been examined as follows: acute nephritis (1 case), acute renal failure (4), De Toni-Fanconi syndrome (1) and hepatolenticular degeneration (1). In each instance, molecular separation on Sephadex G 75 showed only one distinct peak appearing in the region and at the effluent volume associated with albumin of a normal molecular weight. No albumin of lower molecular weight was detectable.

3. Characteristics of the Urinary Minialbumin of Cadmium Poisoning

(i) *Sedimentation and diffusion coefficients and molecular weight.* These parameters of minialbumin were measured in the UCT/CSIR Virus Research Unit, either by Dr. A. Polson himself or under his supervision. The sedimentation coefficient was determined using a Beckman Spinco analytical ultracentrifuge, model E, in which the concentration gradient curve is directly observed throughout the run by suitable optical equipment. The ultracentrifugal patterns of the urinary minialbumin of the cadmium-poisoned monkey (F) are presented in Fig. 3, alongside those for the serum albumins of a normal monkey and a normal rabbit.

The sedimentation constant of the minialbumin $S_{20, w}$ was calculated to be 2.2×10^{-13} cm./sec./dyne (2.2 S).

The diffusion constant of the minialbumin was measured by the method of Cohen and Bruins²⁴ as modified by Lamm and Polson.²⁵ The minialbumin was prepared in 0.9% w/v sodium chloride solution at a concentration of 0.6 G/100 ml. From the experimental observations, the calculated diffusion constant $D = 10.61 \times 10^{-7}$ sq. cm./sec.

The molecular weight of the minialbumin was calculated from the sedimentation and diffusion coefficients according to the equation of Svedberg²⁶ and assuming that the partial specific volume of minialbumin is the same as that of normal serum albumin, their amino acid compositions being so similar.

The molecular weight of minialbumin, thus derived, = 20,060.

(ii) *Amino acid composition.* The amino acid composition of normal monkey serum albumin has been compared with the values for the urinary albumins of the cadmium-poisoned monkey (F). The albumins were prepared in the usual manner by TCA-acetone fractionation, and 1 ml. of a solution of each containing 2-3 mg. protein was hydrolysed in 6 N HCl in a sealed pyrex tube according to the procedure of Hirs *et al.*²⁷ Hydrolysis was carried out for 22 hours or for 70 hours. The hydrolysate was subsequently analysed by the ion-exchange chromatographic method of Moore, Spackman and

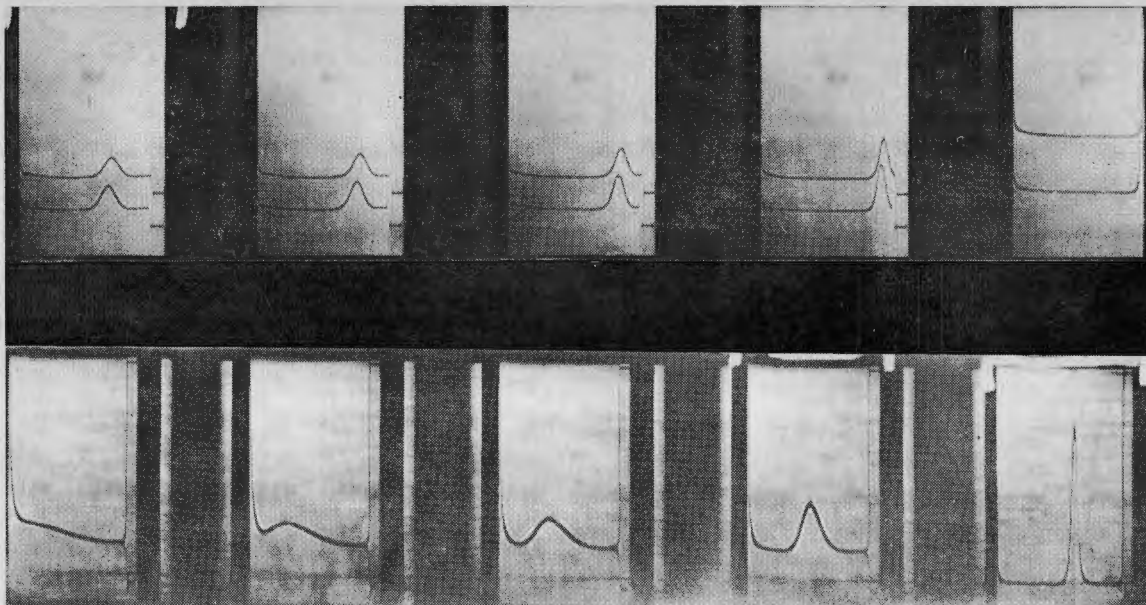

Fig. 3. Ultracentrifugal patterns of albumins. *Above.* Normal monkey serum albumin, normal rabbit serum albumin. *Below.* Urinary minialbumin of cadmium-poisoned monkey F.

Observations were made using a Beckman Spinco analytical ultracentrifuge, model E. Minialbumin was examined as a 0.66% w/v solution in 0.5% w/v aqueous sodium chloride in a synthetic boundary cell at a centrifuge speed of 56,100 r.p.m. The temperature was 24.7°C and photographs were taken of the peak at intervals of 32 minutes. Photographs of the larger serum albumins of rabbit and of monkey were taken at 16-minute intervals.

Stein,²⁸ a known quantity of nor-leucine being added to each protein preparation before hydrolysis in order to check the recoveries in the over-all analytical procedure. From the percentage amino acid composition of the albumins (G each amino acid/100 G protein), the numbers of the individual amino acid residues in each albumin expressed per gram molecular weight (66,000) of normal serum albumin have been computed and presented as histograms in Fig. 4.

With the possible exception of lysine and of cysteine, which apparently represent a relatively lower proportion of the minialbumin molecule, the proportions of amino acids in the urinary albumins of the cadmium-poisoned monkey were not significantly different from one another or from normal monkey serum albumin.

In other experiments, likewise, no significant differences were observed with regard to the quantities of bound hexose and sialic acid associated with the amino acids in the various albumin molecules.

(iii) *Metabolic turnover studies of the albumins in the cadmium-poisoned monkey.* Two aspects were investigated, the metabolic turnover of minialbumin in the poisoned animal, and the fate of minialbumin injected intravenously into a normal monkey.

In the first experiment, 1 mC L-lysine-^{C¹⁴} (generally labelled) was injected intravenously into the cadmium-poisoned monkey F, as a single pulse-dose. Blood and urinary specimens were collected thereafter; 5 carefully-timed collections were made during the first 24 hours and less frequently in the following days, for a period of 3 weeks. In all, 26 blood specimens and 27 samples of urine were obtained from the animal.

The radioactivity of serum albumin was measured on dried protein prepared as follows: The albumin was prepared by the TCA-acetone method and then precipitated from aqueous solution with 10% TCA. The precipitate was washed twice in a centrifuge tube with 5% w/v TCA and then with 95% v/v ethanol followed by a mixture of ethanol, ether and chloroform (2:2:1 v/v/v) to dehydrate the protein adequately. The precipitate was then suspended in pure diethyl ether and plated onto a small filter paper disc (Whatman 541) in a modified Buchner funnel, and the protein thoroughly air-dried. The filter paper discs were then transferred to small stainless steel or plastic planchettes (1.5 cm. diameter), in which the protein

could be weighed to 5 decimal places. The radioactivity was measured in an end-window Geiger-Müller counter at infinite thickness.

The urinary albumins were counted in solution in the Packard Tri-carb Scintillating Counter, Model 314 EX, standardized initially and daily with a Tri-carb standard containing ^{C¹⁴} in toluene. Each vial was individually assayed at maximum efficiency, with recounting of protein preparations from day to day to check for fluctuation in the readings. The aqueous solutions of urinary normal and minialbumins, as collected from the column of dextran gel (Sephadex G 75), were concentrated by pervaporation in visking tubing. The protein concentration of each urinary albumin sample was determined by both the biuret and the micro-Kjeldahl techniques and carefully measured aliquots taken for scintillation counting. Quantities of protein were taken such that optimal counts were obtained throughout the assay.

The results of the experiment are presented in Fig. 5. The rates of logarithmic decay, as portrayed by the linear decline of specific activity of the individual albumins, indicate a greater rate of turnover of minialbumin as compared with the albumins of normal size in serum and urine. The curves are functions of the loss of ^{C¹⁴} label—particularly of ^{C¹⁴} lysine—from the albumin molecules by degradation and by dilution of radioactive molecules by newly synthesized unlabelled albumin. Urinary albumin appears to have a slightly greater rate of turnover than has the albumin in the serum. The lower peak value of specific activity of minialbumin, as compared with the larger albumins, may be accounted for in part by the fact that the relative proportion of lysine is less, and the possible maximum radioactivity by incorporation of ^{C¹⁴} lysine could be diminished accordingly.

Interpretation of the findings is rendered difficult by a number of unknown factors such as the rates of renal clearance of the urinary albumins, of metabolic interconversions, if any, between minialbumin and the other albumins, and the relative importance to the individual proteins of recycled ^{C¹⁴} lysine or other labelled amino acid. The available evidence, though tentative, points to a somewhat greater turnover rate for minialbumin and a corresponding shorter biological half-life, when judged by the radioactivity of the excreted protein.

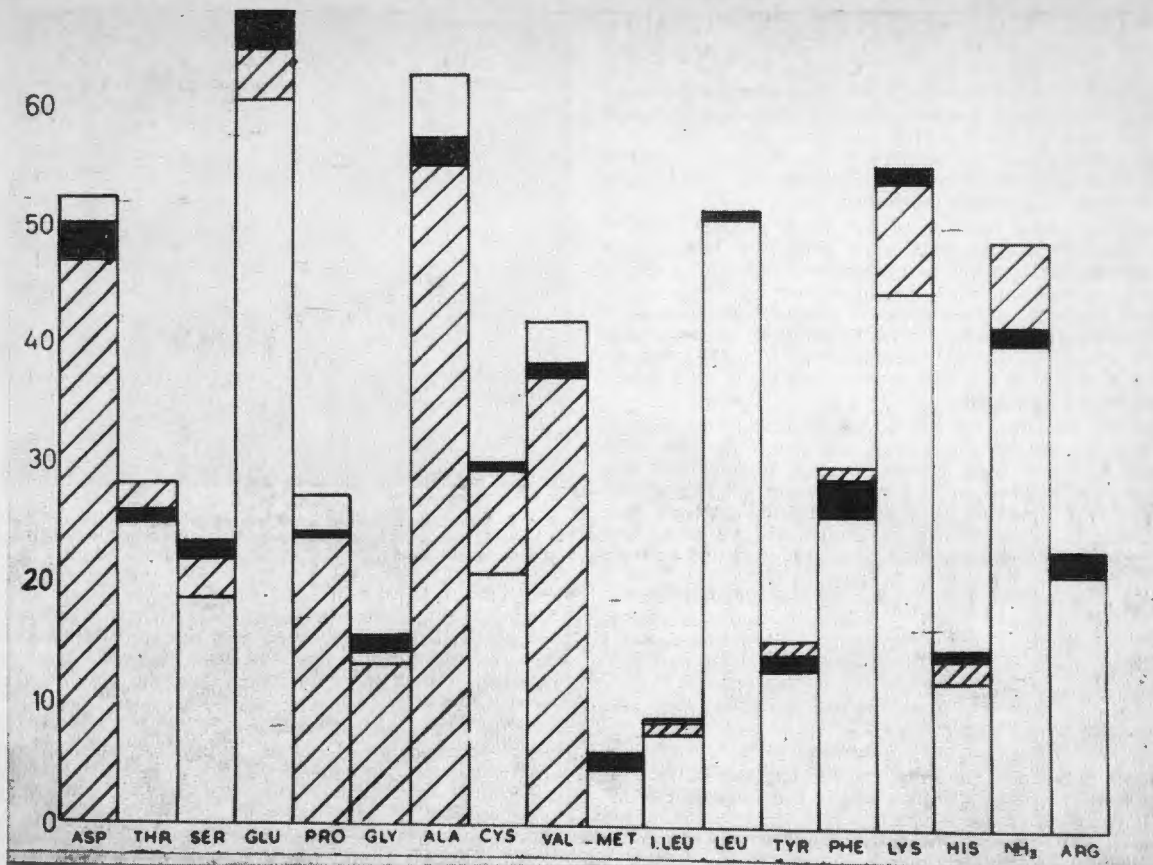

Fig. 4. Amino acid composition of monkey serum and urinary albumins. The ordinate represents numbers of amino acid residues per gram molecular weight of normal serum albumin (66,000).

Normal serum albumin Urinary normal albumin Urinary minialbumin.

The metabolic fate of infused C^{14} minialbumin was studied in order to gain further insight into the metabolic interrelationships of the albumins. A total of 79.7 mg. C^{14} -labelled minialbumin was available from the previous experiment and this was dissolved in 4 ml. sterile isotonic saline, and injected

intravenously into a normal monkey (R). The monkey showed no signs of anaphylactic shock or other reaction after the injection. Blood and urinary specimens were collected following the injection, fractionated in the usual manner, and the specific radioactivity of the albumins measured. No minialbumin could be detected in the serum of the animal at any time,

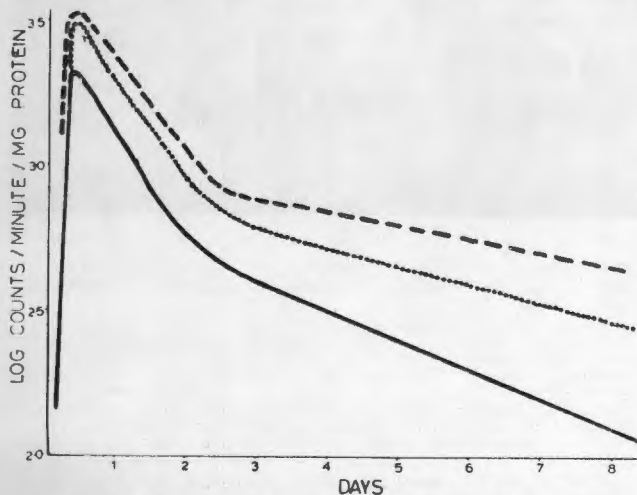

Fig. 5. Metabolic turnover of serum albumin and urinary albumins of cadmium-poisoned monkey F. Specific radioactivity of serum albumin (—); of urinary normal albumin (.....); and of urinary minialbumin (---).

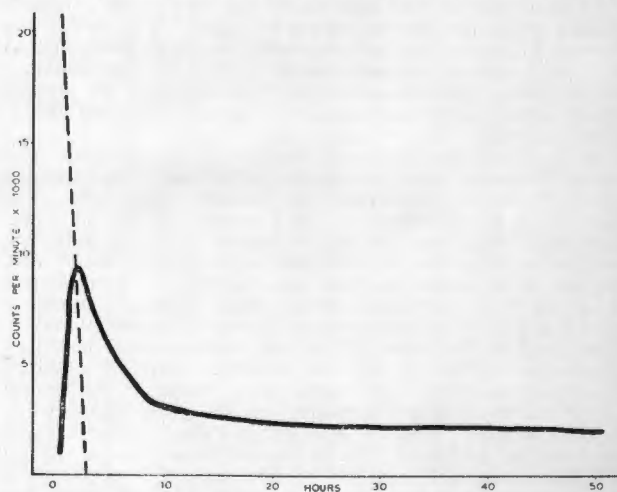

Fig. 6. Fate of C^{14} -minialbumin injected intravenously into a normal monkey R. Specific radioactivity of normal serum albumin (—) and of urinary minialbumin (---).

but serum albumin became rapidly labelled with a peak of radioactivity at 2 hours (Fig. 6). There were no counts incorporated into the serum globulin fraction. Of the injected C^{14} -minialbumin, 40 mg. appeared in the first urinary specimen which could be collected, 3 hours after the injection. This was the only specimen of urine which contained radioactive protein. Slight radioactivity was detected in the urine at 23 hours, but no protein was detectable, and presumably these were labelled products of albumin catabolism.

The apparent rapid transfer of C^{14} from minialbumin to normal serum albumin suggests some precursor relationship between the smaller and the larger albumin molecules. Such an important conclusion must be supported by much more experimental evidence, and a number of alternative mechanisms excluded before acceptance of this hypothesis. One obvious explanation could be that C^{14} minialbumin was adsorbed to normal serum albumin, but this seemed less likely as a result of the following experiment:

2.5 mg. C^{14} -minialbumin was added to a solution containing 7.5 mg. unlabelled normal monkey serum albumin. The individual solutions were counted before mixing, and the mixture was allowed to stand for 5 hours in a waterbath at 37°C . The two albumins were then separated on Sephadex G 75, collected, concentrated in boiled dialysis sacs, and again counted. The experimental data are presented below:

| | Counts before mixing | Counts after separation from mixture |
|-----------------------------|----------------------|--------------------------------------|
| C^{14} -minialbumin | 8,432 | >8,452 |
| Normal monkey serum albumin | 1,723 | 1,637 |
| Background count | was 1,717 c.p.m. | |

This simple experiment does not exclude the possibility that, *in vivo*, a firmer type of complex might exist between minialbumin and normal serum albumin, which might account for the radioactivity in serum albumin, as one of the metabolic fates of the infused C^{14} -minialbumin in addition to the large proportion (50%) rapidly excreted unchanged into the urine.

(iv) *Antigenic behaviour of minialbumin.* The antigenic properties of minialbumin have been examined in two ways, by immunoelectrophoresis²⁹ and on Ouchterlony³⁰ plates. The gel for both techniques was 1% agarose (purchased from Seravac Laboratories S.A. Ltd., Cape Town) in 0.05 M tris (hydroxy methyl) amino methane-HCl buffer, pH 8.4.

Electrophoresis was performed in perspex tanks, with a PD of 300 V for approximately 20 minutes, progress being judged by the movement of a phenol-red marker. After removal of the plates from the electrophoresis tank, antiserum was placed in the longitudinal slot separating the two runs. Antigen-antibody reactions leading to lines of precipitation within the gel, were allowed to proceed overnight, the plates being housed in petri-dishes kept moist with damp filter paper. The immunoelectrophoretic patterns were then photographed by contact printing before or, more usually, after staining with 0.02% aqueous nigrosine.

Fig. 7 shows the immunoelectrophoretic precipitation patterns of the urinary mini- and normal albumins of the cadmium workman, Finch, separated as already described. The antiserum in the middle well was Coombs anti-human serum (Burroughs Wellcome). In each instance there is only one precipitin band to be seen, bands being closely paired with regard to their positions in the gel. No globulin contaminant was revealed on immunoelectrophoresis, although the antiserum had high titres against a wide range of serum globulins.

The antigenic behaviour of various albumins were tested by the two-dimensional gel diffusion procedure first described by Ouchterlony in 1948. The antibody was placed in the central well of the agarose gel deposited on the glass slides, while the antigens to be examined were put into the 6 circumferential wells, as seen in Fig. 8. The proteins diffuse through the gel and, on meeting, antibody and specific antigen form precipitin bands. The reaction was usually complete after 24 hours, but with antigens or antibodies of weak titre, 48 hours were needed for development of the precipitates. Precipitin bands



Fig. 7. Immunoelectrophoretic pattern of urinary albumins of cadmium-poisoned workman Finch. Above. Urinary normal albumin. Below. Urinary minialbumin.

were visible to the naked eye as white lines at varying distances from the central well. The plates were sometimes photographed unstained by contact printing, but more usually after the precipitin bands had been stained. The plates in Fig. 8 are almost self-explanatory, but the important features are as follows:

Plate I. Coombs anti-human serum in the central well has given the reaction of identity between urinary normal albumin and minialbumin of the cadmium worker (Finch), alternating in wells 2-5, and at increasing concentrations of antigen. The precipitin bands fuse without intersection or formation of spurs. In contrast, normal monkey albumin and normal bovine albumin give no clear-cut precipitin bands.

Plate II. There is reaction of identity between the urinary albumin of a cadmium worker (7108) and normal human serum albumin (wells 1 and 2).

Apart from normal albumin and minialbumin in the TCA-acetone preparation, no protein could be detected from

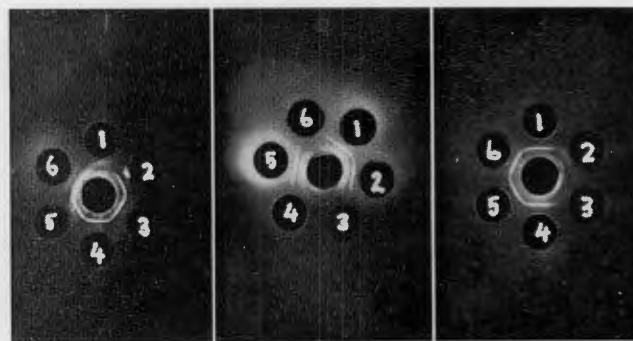

Fig. 8

Plate I

Plate II

Plate III

Fig. 8. Antigenic behaviour on Ouchterlony plates of various albumin preparations.

Plate I. Coombs anti-human serum in central well. 1 = Serum albumin normal monkey, 2 = Urinary albumin cadmium worker Finch, 3 = Urinary minialbumin cadmium worker Finch, 4 = Urinary normal albumin Finch, 5 = Urinary minialbumin Finch, 6 = Normal bovine serum albumin.

Plate II. Coombs anti-human serum in central well. 1 = Normal human serum albumin, 2 = Urinary normal albumin cadmium worker 7108, 3 = Pre-albumin peak, 4 = Pre-albumin peak, 5 = Urinary minialbumin cadmium worker 7108, 6 = Post-minialbumin peak.

Plate III. Rabbit anti-normal monkey albumin in central well. 1 = Normal monkey serum albumin, 2 = Urinary normal albumin cadmium-poisoned monkey F, 3 = Urinary minialbumin monkey F, 4 = Urinary normal albumin monkey F (concentrated 10 x), 5 = Urinary minialbumin monkey F (concentrated 10 x), 6 = Urinary normal albumin monkey F (concentrated 10 x).

the urine of the cadmium worker 7108 (material forming minor peaks in the eluate from the dextran gel column, Sephadex G 75, were placed in wells 3, 4 and 6).

Plate III. The central well contains rabbit anti-normal monkey serum albumin, prepared by 6 weekly intramuscular injections into an adult rabbit, of 5-10 mg. monkey albumin in 1 ml. water, emulsified with 1 ml. oil adjuvant.

Wells 1, 4, 5 and 6 show reaction of identity with one another: the preparations in wells 2 and 3 were too dilute to give clear lines of precipitation.

The Origin of Minialbumin

A detailed report on investigations relating to the origin of minialbumin will be published shortly. One aspect only of this problem will be considered in the present paper, namely, whether any fragmentation of serum albumin can occur during the initial mixing of cadmium chloride with whole blood.

Whole normal monkey blood (6 ml.) was mixed with 6 mg. Cd (as CdCl₂) in the usual manner as for intravenous injection. Thereafter, serum albumin was prepared by the TCA-acetone procedure and fractionated by gel filtration. No minialbumin could be detected, only the single peak of normal serum albumin being present (Fig. 9), and we can safely conclude that minialbumin is produced either in the circulating blood or at some tissue site in the body.

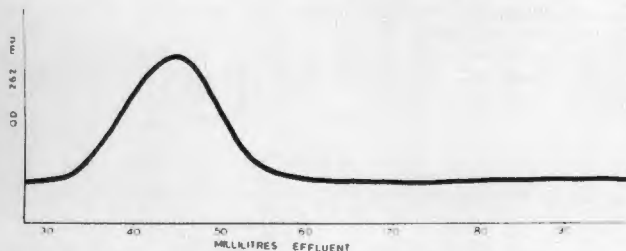

Fig. 9. Gel filtration of serum albumin prepared from whole monkey blood treated with cadmium chloride—6 ml. whole normal monkey blood mixed with 6 mg. Cd (as CdCl₂) as for IV injection. Serum albumin prepared and fractionated in the normal way.

DISCUSSION

Workmen exposed to cadmium oxide dust or fume suffer clinically from an incapacitating emphysema,³¹ the main cause of the morbidity and mortality of men poisoned by cadmium in industry. Proteinuria is commonly found in such affected persons, but the incidence and quantity is not closely associated with the severity of the lung lesion. Cadmium administered intravenously to rabbits,¹² dogs and monkeys gives rise to proteinuria without causing lung damage. On the other hand, much evidence pointing to disturbances in renal function or to histological changes in the kidney has been accumulated from patients and experimental animals. Thus Bonnell and his associates³² have described renal lesions consisting essentially of tubular atrophy and interstitial fibrosis in chronically poisoned rats, although Kench *et al.*³³ observed only minimal changes at postmortem examination of experimental rabbits. In an addendum to this paper Dr. Timme reports definite degenerative changes in the proximal tubules of the cadmium-poisoned monkey F, with occasional frank necrosis. Aminoaciduria is a frequent finding in poisoned workmen, progressing from the appearance alone of the hydroxy amino acids, serine and threonine, in mildest

intoxication to a generalized aminoaciduria in severe poisoning.³³ Glycosuria may accompany the proteinuria and aminoaciduria. A fine intralobular cirrhosis of the liver was observed in poisoned rabbits; and occasional areas of focal necrosis, but without evidence of cirrhosis, were noted in the monkey liver.

As regards the proteinuria itself, the present study has demonstrated unequivocally the presence of a minialbumin as well as normal albumin in the urine of the cadmium-poisoned monkey. Poisoned monkeys, dogs and rabbits, excrete less minialbumin relatively to normal serum albumin when compared with man. The number of minialbumin molecules formed in the cadmium-poisoned monkey is equal approximately to 26% of the number of albumin molecules of normal molecular weight being synthesized in the liver, whereas the corresponding figure for poisoned workmen is 53%.

The minialbumin appears to have a somewhat greater turnover rate than have serum and urinary albumins of normal molecular weight in the cadmium-poisoned monkey. In high doses about 50% of minialbumin passed through the kidney of a normal monkey, but the quantity injected in 2 minutes (80 mg.) corresponds roughly to the quantity presented to the kidneys of severely poisoned monkeys in 24 hours. Of the 40 mg. retained, much of the C¹⁴ of minialbumin appeared in the albumin fraction in a form inseparable by gel filtration. The relatively large metabolic load of minialbumin which can be retained by the normal monkey kidney suggests that a certain degree of renal damage must occur before the protein can pass into the urine. Perhaps the onset of the proteinuria is delayed by the presence, in normal renal cortical tissue, of the cadmium-binding protein metallothionein,³⁴ but, at present, we have no useful information on this question. We have been unable to detect minialbumin in the urine of a small series of patients suffering from non-specific renal tubular defects, but this aspect of the problem also deserves further investigation.

The other characteristics of minialbumin are of great interest. Its molecular weight (20,000) is rather more than one-quarter of that of normal serum albumin, but we have found that, with the possible exception of its content of cysteine and of lysine, its amino acid composition is indistinguishable from that of normal serum albumin. Press and Porter,³⁵ in their studies on the degradation of human serum albumin with α -chymotrypsin, have separated 4 serologically active components, ranging in molecular weight from 7,000 to 23,400. The smallest component did not precipitate antibody but partially inhibited precipitation. Its amino acid composition differed greatly from that of the whole molecule, containing fewer residues of arginine and proline and entirely lacking serine and tyrosine. The minialbumin of cadmium poisoning appears to be quite a different entity from any fragment prepared by Press and Porter, and it precipitated antibody in a manner indistinguishable from that of normal serum albumin. The close similarity in antigenicity and amino acid composition between minialbumin and normal serum albumin suggests that the smaller molecule could arise as a result of the inhibitive action of cadmium ions at some stage in the synthesis or breakdown of normal albumin. For such a mechanism to operate implies the presence of a segment,

identical with minialbumin, within the long polypeptide chain which constitutes the normal serum albumin molecule. The close similarity in amino acid composition between minialbumin and the serum albumin molecule as a whole would, in this context, mean that the remainder of the albumin molecule should have a similar amino acid composition, although not necessarily the same primary arrangement of amino acid residues. It is possible that the small albumin encountered in cadmium poisoning may be formed entirely independently of normal serum albumin metabolism. If this were true, it would resolve the apparent anomalies between the amino acid composition and antigenic behaviour of the peptides prepared from serum albumin by tryptic digestion³⁵ and the corresponding characteristics of the minialbumin of cadmium poisoning.

Whatever the true mechanism, the evidence has already convinced us that cadmium ions will provide an important tool in the investigation of the synthesis of albumin and perhaps of other body proteins, and of the relationship between the size and structure of albumins and their antigenic behaviour.

SUMMARY AND CONCLUSIONS

1. Lyophilized preparations of urinary proteins of cadmium workers have been fractionated by the trichloroacetic acid-acetone method and the albumin fraction subsequently separated into normal and low-molecular species by filtration through a column of dextran gel.

2. The low molecular protein migrated electrophoretically on paper as does serum albumin, and in TCA-acetone, on immunoelectrophoresis, in Ouchterlony plates, and in its amino acid composition was indistinguishable from human serum albumin. Only in its smaller molecular weight (approximately 25,000) did it differ from serum albumin and hence it has been named minialbumin.

3. No minialbumin could be detected in the urine of a small series of patients suffering from non-specific renal tubular damage, as for example, an advanced case of hepatolenticular degeneration, Fanconi syndrome, acute tubular necrosis or nephrotic syndrome.

4. Dogs and monkeys have been chronically poisoned by repeated intravenous injections of cadmium chloride, and after some months these animals, too, were found to excrete a minialbumin closely similar in all the respects already mentioned, with their own serum albumins and the normal molecular albumin found with them in the urine.

5. Diffusion-constant determinations and ultracentrifugation for the sedimentation constant proved the molecular weight of monkey minialbumin to be approximately 20,000.

6. Whole monkey blood when mixed with cadmium chloride in the usual manner, as for intravenous injection, did not give rise to any detectable minialbumin, only the single peak of normal serum albumin being present.

7. Monkey minialbumin had a somewhat higher metabolic turnover rate than its normal serum counterpart as shown by incorporation of C¹⁴-lysine and radioactive decay of the serum and urinary albumin molecules.

8. The minialbumins of the various species differed antigenically from one another, as did their normal proto-

types: Coombs anti-human serum did not give a precipitin reaction with monkey albumins, and a rabbit anti-monkey albumin preparation likewise was inactive against human albumin. No cross-reactions have been observed.

9. When 80 mg. C¹⁴-minialbumin was injected intravenously into a normal monkey, about 50% of the protein appeared in the urine within 3 hours and the remainder was retained in the body. Much of the C¹⁴ was detected in the serum albumin fraction and was inseparable on gel filtration.

10. This appears to be the first recognized example of a simple chemical agent capable of bringing about a reproducible aberration *in vivo* in the molecular size of a protein. The possible biochemical mechanisms by which cadmium ions might lead to the *in vivo* formation of minialbumin have been discussed, and the hope expressed that cadmium may prove to be an important tool in the study of structure, metabolism and immunological behaviour of proteins.

We wish to express our gratitude to the following colleagues whose cooperation made this work possible: Dr. G. M. Potgieter for valuable advice and guidance on immunological techniques; Prof. A. Kipps for making available to us the facilities of the UCT/CSIR Virus Research Unit; Dr. A. Polson for determinations of the molecular weight of our proteins; Dr. M. C. Berman for stimulating discussion; Dr. A. H. Timme, Department of Pathology, for the histological studies and report; and Drs. W. P. U. Jackson, F. Harris and R. McDonald who kindly helped in our search for patients. We wish to thank Dr. Frances Ames in particular for her interest and for making it possible for us to investigate her patient suffering from hepatolenticular degeneration.

ADDENDUM

A Report on the Histology of the Cadmium-poisoned Monkey F

by Dr. A. H. Timme,

Department of Pathology, University of Cape Town

A systematic investigation has been undertaken of the histological changes observed in the tissues of cadmium-intoxicated animals. A detailed report on liver and kidney tissues from biopsies and at postmortem examination is included in A. C. Gain's Ph.D. thesis. In the kidney biopsy definite degenerative changes were evident in the proximal tubules, with occasional frank necrosis, while attempts at regeneration on the part of the epithelial cells were minimal. The liver biopsy showed no evidence of cirrhosis. Occasional areas of focal necrosis were present. At postmortem examination, both the liver and kidney showed evidence of damage which could be attributed to the cadmium intoxication. In the kidney the changes were unmistakable, but those in the liver were less impressive and their significance much less certain. The fact that the post-mortem specimen of liver showed more severe changes than are seen in the biopsy may be due to the metabolic disturbances following the nephrectomies (which were performed following the experiments described in the foregoing paper).

REFERENCES

1. Friberg, L. (1950): *Acta med scand.*, **138**, suppl. 240.
2. Smith, J. C., Kench, J. E. and Lane, R. E. (1955): *Biochem. J.*, **61**, 698.
3. Smith, J. C., Wells, A. R. and Kench, J. E. (1961): *Brit. J. Industr. Med.*, **18**, 70.
4. Webb, R., Rose, B. and Sehon, A. H. (1958): *Canad. J. Biochem.*, **36**, 1159.
5. Bonnell, J. A., Kazantis, G. and King, E. (1959): *Brit. J. Industr. Med.*, **16**, 135.
6. Kekwick, R. A. (1955): *Ibid.*, **12**, 196.
7. Creeth, J. M., Kekwick, R. A., Flynn, F. V., Harris, H. and Robson, E. B. (1963): *Clin. chim. Acta*, **8**, 406.
8. Merler, E., Remington, J. S., Finland, M. and Gitlin, D. (1962): *Nature (Lond.)*, **196**, 1207.

9. Poortmans, J. and Van Fraechem, J. (1965): *Clin. chim. Acta*, **12**, 114.
10. Rowe, D. S. (1957): *Biochem. J.*, **67**, 435.
11. Smith, J. C. and Wells, A. R. (1960): *Brit. J. Industr. Med.*, **17**, 205.
12. Kench, J. E., Wells, A. R. and Smith, J. C. (1962): *S. Afr. Med. J.*, **36**, 390.
13. Hardwicke, J. (1965): *Clin. chim. Acta*, **12**, 89.
14. Berman, M. C. and Kench, J. E. (1963): *J. Clin. Path.*, **16**, 385.
15. Fine, L. (1935): *Biochem. J.*, **29**, 799.
16. Fleck, A. and Munro, H. N. (1965): *Clin. chim. Acta*, **11**, 2.
17. Weichselbaum, T. E. (1946): *Amer. J. Clin. Path.*, **16**, 40.
18. Porath, T. and Flodin, P. (1954): *Biochim. biophys. Acta (Amst.)*, **13**, 175.
19. Campbell, P. N. and Stone, N. F. (1957): *Biochem. J.*, **66**, 19.
20. Potgieter, G. M. and Hines, M. (1963): *S. Afr. J. Lab. Clin. Med.*, **9**, 138.
21. Vallance-Owen, J., Dennes, E. and Campbell, P. N. (1958): *Lancet*, **2**, 336.
22. Michael, S. E. (1962): *Biochem. J.*, **82**, 212.
23. Porath, J. and Flodin, P. (1959): *Nature (Lond.)*, **183**, 1657.
24. Cohen, E. and Bruins, H. R. (1923): *Hoppe-Seylers Z. physiol. Chem.*, **103**, 349.
25. Lamm, D. and Polson, A. (1936): *Biochem. J.*, **30**, 528.
26. Svedberg, T. (1929): *Nature (Lond.)*, **123**, 871.
27. Hirs, C. H. W., Moore, S. and Stein, W. H. (1954): *J. Biol. Chem.*, **211**, 941.
28. Moore, S., Spackman, D. H. and Stein, W. H. (1958): *Analyt. Chem.*, **30**, 1185.
29. Grabar, P. and Williams, C. A. jnr. (1955): *Biochim. biophys. Acta (Amst.)*, **17**, 67.
30. Ouchterlony, O. (1962): *Progr. Allergy*, **6**, 30.
31. Smith, J. C., Kench, J. E. and Smith, J. P. (1957): *Brit. J. Industr. Med.*, **14**, 246.
32. Bonnell, J. A., Ross, J. H. and King, E. (1960): *Ibid.*, **17**, 69.
33. Clarkson, T. W. and Kench, J. E. (1956): *Biochem. J.*, **62**, 361.
34. Kägi, J. H. K. and Vallee, B. L. (1961): *J. Biol. Chem.*, **236**, 2435.
35. Press, E. M. and Porter, R. R. (1962): *Biochem. J.*, **83**, 172.

Reprinted from the "S.A. Medical Journal", Vol. 40, 24 December 1966, pages 1109 - 1116

THE NATURE AND ORIGIN OF THE MINIALBUMIN FOUND IN
CADMIUM-POISONED ANIMALS

J. E. KENCH AND ELIZABETH M. SUTHERLAND, *CSIR/UCT Protein Research Unit, Department of Chemical Pathology, University of Cape Town*

THE NATURE AND ORIGIN OF THE MINIALBUMIN FOUND IN CADMIUM-POISONED ANIMALS

J. E. KENCH AND ELIZABETH M. SUTHERLAND, CSIR/UCT Protein Research Unit, Department of Chemical Pathology, University of Cape Town

In a recent report,¹ we described the isolation and characterization of low-molecular albumins in the urine of dogs and monkeys poisoned chronically with cadmium chloride, given by repeated intravenous injections. The present paper describes experiments designed to provide more information on the origin and mechanism of formation of the minialbumins. Such knowledge would be important in relation to the possible role of cadmium ions in the regulation of albumin metabolism, and would also help to resolve uncertainty with regard to the tissues most affected by the metal. The evidence that cadmium can be a nephrotoxic agent is well reviewed by Bonnell.²

Amino-aciduria³ and glycosuria, hypercalciuria and other defects of both proximal and distal tubular function⁴ appear to be indicative of a Fanconi type of renal tubular disorder. Abnormal renal function tests have been demonstrated in a number of cases⁵ but, on the contrary, the kidneys of poisoned workmen who have died after years of persistent proteinuria may show no histological evidence of tubular necrosis.⁶ Our own view that the proteinuria of cadmium intoxication is a specific entity^{1,7} is not favoured by other investigators. Creeth *et al.*⁸ consider the mixture of urinary proteins observed in cadmium poisoning to be that typical of any non-specific renal tubular defect. Our earlier publications have included data which do not appear to support this concept, and the present work provides, we believe, further evidence in support of the view that the low-molecular albumin, found in the urine of men and animals poisoned by cadmium, arises as a result of a characteristic biochemical lesion.

The pattern of urinary globulins may be associated with the Fanconi type of renal tubular syndrome, but it has transpired from our work that the urinary minialbumin probably comprises a mixture of polypeptides formed by fragmentation of the serum albumin molecule, mainly within the liver cells. The smallest fragments which have been recognized are all approximately similar in size (MW 5,000), and it is presumed they have widely diverse amino-acid composition. The over-all composition of the mixture, nevertheless, closely simulates that of the parent molecule. The peptides have a remarkable tendency to aggregate to form molecules whose molecular weight may be 10,000, 20,000 or even that of normal serum albumin (67,000). Urinary minialbumin, we regard, as the component MW 20,000 in this series which passes into the urine when reabsorption of the protein from the glomerular filtrate is impaired by cadmium ions.

For purposes of discussion, all mixtures of polypeptides, whose amino-acid composition, electrophoretic mobility, antigenic behaviour and stability in acid-ethanol are closely similar to these characteristics in normal serum albumin, are referred to, throughout, as minialbumins, regardless of whether found in urine, peritoneal dialysate, serum or tissues.

EXPERIMENTAL OBSERVATIONS AND RESULTS

Experimental animals and their maintenance. Male vervet monkeys (*Cercopithecus aethiops*) were housed and fed, and

specimens collected, as already described.¹ The rats used were normal adult female albino animals, locally bred and weighing 240-300 G. The animals were maintained on a normal diet and were not starved before the experiments. The rats were supported on a perforated porcelain disc inside a glass container and the urine could thus be easily collected.

The rabbits employed for the production of antisera were normal healthy males, locally bred, and each weighed approximately 2 kg. They were fed on a standard mixed diet.

Poisoning of the animals. Poisoning of monkeys was performed according to the method of Kench *et al.*¹ Cadmium was administered to the rats as a 1% w/v solution of cadmium chloride in 0.9% w/v sodium chloride, at a dosage level of 15 mg. cadmium/kg. body-weight. An equivalent volume of physiological saline was given to the control animals. The animals were lightly anaesthetized and the cadmium chloride or saline injected intraperitoneally over a few minutes.

Peritoneal dialysis. This procedure was performed on monkeys only. Indwelling teflon catheters were surgically inserted into the peritoneal cavity of monkeys, anaesthetized by intravenous injection of sodium pentothal solution (2 ml. of 2.5% aqueous solution). The dialysis fluid was sterile, non-pyrogenic Ringer's lactate, peritoneal dialysis solution (Dianeal), which was warmed before infusion. The solution contained Na⁺, Mg²⁺, Ca²⁺, Cl⁻, lactate and 15% glucose, with 1 mg./l. bisulphite. The fluid was run in and out of the peritoneal space of the animal, under gravity, for 30-min. periods.

Collection and preparation of sera and tissue extracts. Serum was employed throughout for preparation of albumin, as heparin interfered with the precipitation procedure. Blood was withdrawn from the saphenous vein of the lower hind legs of the monkeys and allowed to clot. Blood from the rats was obtained from the aorta and from the hepatic portal vein immediately after killing the animals.

Clear supernatant extracts of liver and kidney tissues were prepared as follows: the tissues were homogenized in M/15 phosphate buffer pH 7.0 and then centrifuged at 105,000 g. for 100 min.

SPECIAL INVESTIGATIONS OF ALBUMINS

Separation of Albumin Fraction

Albumin was prepared in many instances by the trichloroacetic acid (TCA)-acetone method of Vallance-Owen *et al.*,⁹ which is particularly suited to handling of voluminous specimens such as dialysates and urine. Trichloroacetic acid and acetone were removed from the albumin solution by dialysis in Visking cellophane sacs against M/15 phosphate buffer pH 7.0. The dialysed solution of albumin was freeze-dried and redissolved in column buffer. The albumin obtained was found to be free of globulins by either cellulose acetate or immunoelectrophoretic techniques. One unfortunate complication we discovered was an interfering substance being extracted from the sacs by the acetone, or by ethanol if this was used as the solvent.

The contaminant from the Visking dialysis tubing was biuret positive, absorptive at 280 m μ , and had a molecular weight ranging widely around 5,000. It could be extracted from the sacs by boiling with dilute sodium carbonate solution or in the presence of bile salts, but this treatment irreversibly increased the porosity, so that, afterwards, lysozyme (MW 14,500) diffused freely through the membranes. Thus, both untreated and treated membranes were for

different reasons equally unsuitable for our purpose.

Alternatively, the HCl-ethanol method of Fernandez *et al.*¹⁰ was employed, as it did not require contact of cellophane membranes with organic solvents. The method was found to be quite satisfactory. In this procedure, globulins are first precipitated by addition of an HCl-ethanol mixture, and the resulting supernatant fluid separated and treated with sodium acetate to precipitate the albumin. This could be collected by centrifugation and then dissolved in sodium chloride solution (0.2 M or more) for passage through cross-linked dextran gel Sephadex G 75. The pore size of this gel permitted good separation of the different types of albumin under investigation. Details of column dimensions, buffer systems and flow rates are given individually with the illustrations, as these factors varied according to the experiment. Invariably, eluates from the column were monitored at 262 μ by a LKB Uvicord ultraviolet absorptiometer and recorder.

Protein preparations were preserved by lyophilization after removal of salt by dialysis in boiled cellophane sacs. Buffers for all albumin preparations contained 500 mg. sodium azide per litre as preservative. The pH of the albumin solution during the TCA procedure fell to approximately 2.5, whereas it did not fall below 4.5 in the HCl-ethanol method. Both techniques gave closely similar results as judged by quantities of normal and minialbumins present, and in the characteristics of the individual albumins.

Specimens of urine were dialysed for 24 hours against running water and then for 1-2 hrs. against distilled water before precipitation and fractionation of the proteins. Dialysates were treated likewise.

An investigation on the albumins present in peritoneal dialysates of the monkey F is presented in Fig. 1. Many

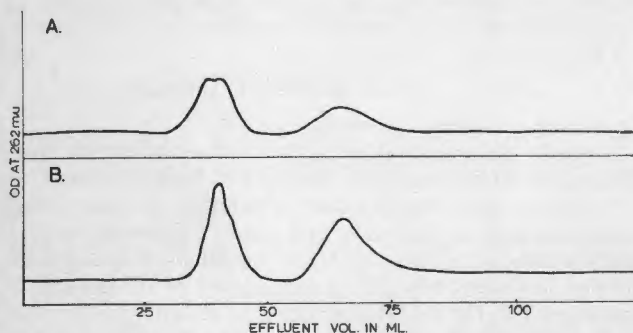

Fig. 1. Albumins in the peritoneal dialysates of a cadmium-poisoned monkey F, following bilateral nephrectomy. A = peritoneal dialysate 1 day after nephrectomy; B = peritoneal dialysate 6 days after nephrectomy and 10 hrs. after a pulse dose of 6 mg. cadmium given intravenously as cadmium chloride. Albumins prepared from the dialysate by the TCA-acetone method, and separated on Sephadex G 75 M/15 phosphate buffer, pH 7.0, containing 0.5 M sodium chloride. Column = 25 x 2 cm. Flow rate 20 ml./hr. Optical density (OD) recorded at 262 μ . Normal albumin is eluted first from the column and minialbumin later, reading from left to right on the optical density tracing.

experiments on this animal were described in our previous communication.¹ He had been chronically poisoned with cadmium for several months, and then, in two stages, underwent bilateral nephrectomy. The animal appeared to withstand the operation well and was sitting up in his cage on the 1st postoperative day. Following nephrectomy,

peritoneal dialysis was performed on the 2nd, 4th and 6th postoperative days. A single dose of 6 mg. cadmium (as cadmium chloride) was administered intravenously at 10 p.m. on the 5th postoperative day, and he was dialysed 10 hours later. Unfortunately, the monkey died unexpectedly 2 hours later.

Minialbumin was found to be present in all peritoneal dialysates, and the quantity did not appear to fall during the 6 days following complete nephrectomy. Moreover, after the booster dose of cadmium on the 5th day, there was a marked rise in output of minialbumin in the peritoneal dialysate collected 10 hours later; the rise in concentration was from 110 to 180 mg./100 ml. dialysis fluid.

In subsequent experiments, we have been unable to detect minialbumin in the peritoneal dialysates of normal monkeys, but the appearance of minialbumins in sera and peritoneal dialysates following intravenous injection of cadmium chloride can regularly be demonstrated (Fig. 2).

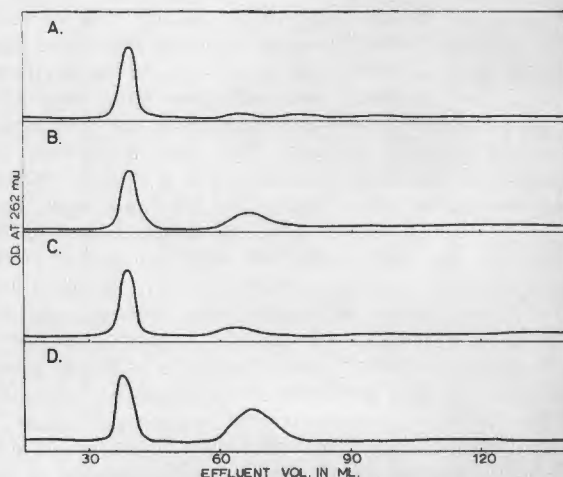

Fig. 2. Albumins in the sera and peritoneal dialysates of a chronically-poisoned monkey K, given pulse doses of cadmium. A and C = peritoneal dialysate and serum respectively 168 hrs. after previous cadmium injection; B and D = peritoneal dialysate and serum respectively 1½ hrs. after pulse dose of 6 mg. cadmium given intravenously as cadmium chloride. Albumins prepared and separated as in Fig. 1. Column = 40 x 1.8 cm. Flow rate 15 ml./hr. Optical density (OD) recorded at 262 μ . Some sac contaminant can be seen as a small peak in A following just behind minialbumin.

The rise in the peak of circulating minialbumin is especially marked 90 mins. following a pulse dose of 6 mg. cadmium, but in the chronically-poisoned monkey there is always some minialbumin present. There is a steady fall in the urinary excretion of minialbumins following a single booster dose of cadmium in monkeys chronically poisoned by cadmium (Fig. 3). The usual timing of events in chronic poisoning, as observed consistently in the 6 monkeys we have studied, is the appearance of minialbumins in the serum after intravenous injection of 25-30 mg. cadmium (10-12 mg. weekly for 2-3 weeks) and minialbuminuria becomes evident after 60-90 mg. cadmium and 6-7 weeks of poisoning, provided the poisoning regime is steadily maintained. Thus, passage of minialbumin into the urine usually begins 4 weeks after its first appearance in the serum. If the injections are stopped in these short-term intoxication studies, the gravity of the biochemical lesion falls away in a few days, as seen in Figs. 2 and 3.

Antigenic Behaviour of the Albumin Preparations

The antigenic behaviour of the various minialbumins was compared with that of normal serum albumin by the technique of Ouchterlony¹¹ and by immunoelectrophoresis.

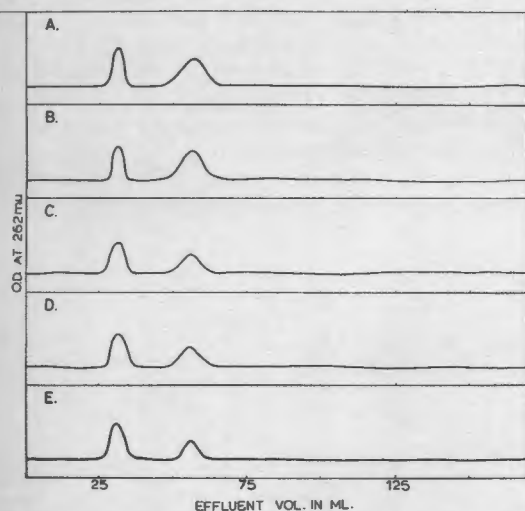

Fig. 3. Urinary albumins of the cadmium-poisoned monkey G, following a pulse dose of 6 mg. cadmium given intravenously. A - E = 1 - 5 days respectively after the dose. Albumins prepared and separated as in Fig. 1. Column 25 x 2.5 cm. Flow rate = 18 ml./hr. OD recorded at 262 m μ .

For these purposes, antisera to normal monkey albumin, to normal monkey serum and to normal rat serum was produced. This was done according to the method of Mandy *et al.*¹² Normal healthy rabbits each weighing approximately 2 kg. and fed on a balanced diet were employed. A 1% solution of the appropriate antigen in physiological saline was sterilized by passage through millipore filters (porosity 0.5 - 0.22 μ) and injected intravenously 2 or 3 times weekly. The animals were test bled from the ear after 5 - 6 weeks and after a 5-day resting period. Subsequently, bleeding and inoculations were carried out every 2 - 3 weeks.

Immunoelectrophoresis¹³ was performed in 1% agarose gel (Seravac Laboratories, Cape Town) prepared in 0.05 M tris (hydroxymethyl) amino methane (tris)-HCl buffer pH 8.4, in a perspex tank, over a period of 25 - 30 minutes with potential difference of 300 V. Phenol red, which runs slightly ahead of albumin, was employed as a marker. The antigen-antibody precipitin reaction was allowed to proceed overnight in a moist chamber at the ambient temperature. After dialysing out excess antiserum, the precipitin lines were fixed with an ethanol-acetic acid-water mixture, stained with 1% aqueous nigrosin solution, and finally cleared with 5% w/v acetic acid. The dried plate could then be photographed.

Ouchterlony plates were prepared with 1% agarose gel in 0.05 M tris-HCl buffer pH 8.4. Diffusion and precipitation was allowed to proceed overnight. The fixing and staining procedures thereafter were as described above for immunoelectrophoresis.

All buffer solutions used in these studies of antigenicity contained 500 mg. sodium azide/litre, as preservative. We have collected together a number of immunoelectrophoretic patterns in Fig. 4 which illustrates the close similarity

in electrophoretic mobility and antigenic behaviour between serum albumin of normal monkeys and minialbumins from sera, peritoneal dialysates and urine of chronically-poisoned animals. Figs. 4 and 5 are representative of consistent observations on 6 poisoned monkeys (F, K, G, O, B, M).

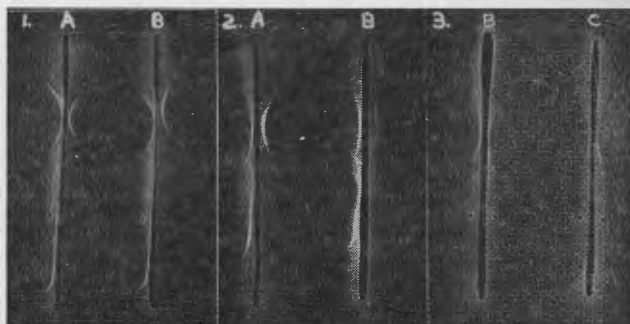

Fig. 4. Immunoelectrophoresis of albumins prepared from normal and cadmium-poisoned monkeys. 1A, 1B, 2A, 2B—left hand side of well = whole normal monkey serum. 1A right, 1B left = serum normal albumin from poisoned monkey. 1B, 3B right = serum minialbumin from poisoned monkey. 2A and 2B right = normal and minialbumin respectively from peritoneal dialysate of poisoned monkey. 3C left and right = urinary normal and minialbumin from poisoned monkey. Antiserum in central well: Plates 1 and 2—rabbit anti-whole normal monkey serum; plate 3—rabbit anti-normal serum albumin from normal monkey.

As seen in plates 1 and 2, the rabbit antiserum had good titres against a wide variety of serum globulins, but no trace of globulin contaminant can be seen in the albumin preparations. Minialbumins from serum or peritoneal dialysate of poisoned animals moved slightly faster than the corresponding normal albumin. With a specific antiserum prepared against normal monkey serum albumin (plates 3B, 3C), serum and urinary normal albumins and minialbumins are indistinguishable from one another on the plates.

Fig. 5 is a photograph of two Ouchterlony plates, in which rabbit anti-whole normal monkey serum was placed in the central well, and various albumin preparations in the peripheral wells numbered 1 - 6. The plates show clearly continuous fusion of all the precipitin bands around

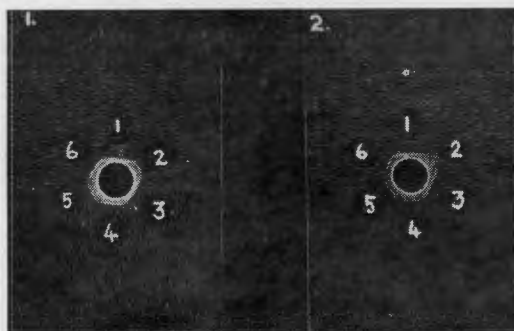

Fig. 5. Ouchterlony plates showing the antigenic behaviour of albumins from serum, peritoneal dialysates or urine of cadmium-poisoned monkeys. Plate 1: 1 and 3 = serum normal albumin from poisoned monkey, 2 = serum minialbumin from poisoned monkey, 4 and 6 = urinary normal albumin from poisoned monkey, 5 = urinary minialbumin from poisoned monkey. Plate 2: 1 and 3 = normal albumin from peritoneal dialysate of poisoned monkey, 2 and 4 = minialbumin from peritoneal dialysate of poisoned monkey, 5 = serum normal albumin of poisoned monkey, 6 = serum normal albumin of normal monkey. Antiserum used: rabbit anti-whole normal monkey serum.

the central well, without intersection or formation of spurs (the minialbumin in well 2 of plate 2 was too dilute to give a precipitin reaction). In brief, all albumins—whether normal or miniature in size, from serum of normal monkeys or from sera, peritoneal dialysates or urine of the 6 cadmium-poisoned monkeys we have studied—gave the reaction of identity in this test and were antigenically indistinguishable against this antiserum.

Amino-Acid Composition

The amino-acid composition of each electrophoretically-pure albumin was determined. The proteins were hydrolysed according to the method of Moore and Stein,¹⁴ in 6 N HCl in sealed, oxygen-free, evacuated pyrex tubes, for 22 hours at 110°C. The resulting mixture of amino acids was dried by lyophilization, and analysed in a Beckman Spinco amino-acid analyser, Model 120 B, according to the method of Spackman *et al.*¹⁵ Data on serum normal albumin and minialbumin of the cadmium-poisoned monkey M are presented in Table I and in the form of histograms in

TABLE I. AMINO-ACID COMPOSITION OF THE ALBUMINS OF THE CHRONICALLY-POISONED MONKEY M

| Aminoacid | Serum normal albumin | | Serum minialbumin | |
|---------------|----------------------|----------|-------------------|----------|
| | G residues /100 G | Residues | G residues /100 G | Residues |
| Lysine | 11.98 | 63 | 10.40 | 54 |
| Histidine | 3.24 | 16 | 3.18 | 16 |
| Ammonia | 1.03 | — | 2.98 | — |
| Arginine | 4.70 | 20 | 4.37 | 19 |
| Aspartic acid | 9.25 | 54 | 9.66 | 56 |
| Threonine | 3.26 | 22 | 3.93 | 26 |
| Serine | 2.90 | 22 | 3.57 | 27 |
| Glutamic acid | 16.48 | 86 | 15.95 | 83 |
| Proline | 3.45 | 24 | 3.44 | 24 |
| Glycine | 1.13 | 13 | 1.95 | 23 |
| Alanine | 7.46 | 70 | 7.22 | 68 |
| ½-cystine | 4.76 | 31 | 3.13 | 21 |
| Valine | 6.85 | 46 | 6.22 | 42 |
| Methionine | 1.71 | 9 | 1.52 | 8 |
| Iso-leucine | 0.40 | 2 | 1.07 | 6 |
| Leucine | 10.90 | 65 | 10.35 | 61 |
| Tyrosine | 4.34 | 18 | 4.56 | 19 |
| Phenylalanine | 6.67 | 30 | 6.42 | 29 |
| Totals | 100.51 | 591 | 99.88 | 582 |

The number of residues has been calculated on the basis of a molecular weight of 67,000 for albumin in both cases. This albumin was prepared by the method of Fernandez *et al.* Albumin prepared by the TCA method of Vallance-Owen *et al.* gave similar results.

Fig. 6. With the exception of the lower proportions of lysine and ½-cystine in minialbumin, there is a close similarity between the amino-acid composition of the two proteins. We are unable to make a firm statement as to whether the smaller differences, seen in threonine, serine, glycine, valine and isoleucine, are significant or within experimental error. Similar findings have already been reported by us for monkey F, and we have so far found low values of lysine and ½-cystine in the minialbumins of all 3 monkeys we have investigated, but, in other respects, the amino-acid compositions of normal serum albumin and minialbumins are remarkably alike.

Sedimentation and Diffusion Coefficients and Molecular Weight of the Minialbumins

These parameters were kindly determined on a number

of our preparations by Dr. A. Polson, as described previously. His report on one preparation of serum minialbumin from the monkey M is as follows: 'The synthetic boundary cell was used, and a 0.6% solution of protein in 0.9% w/v NaCl was run in the Beckman Spinco analytical ultracentrifuge, Model E. The bulk of the material (approximately 60%) had a sedimentation constant less than 1 Svedberg unit, but, on account of its inhomogeneity, no accurate sedimentation constant could be calculated. The rest of the protein travelled as a peak for which the sedimentation constant was calculated as $S_{20,w}=4.75$. Within the limits of error of the experiment, this coefficient corresponds to that of normal serum albumin.'

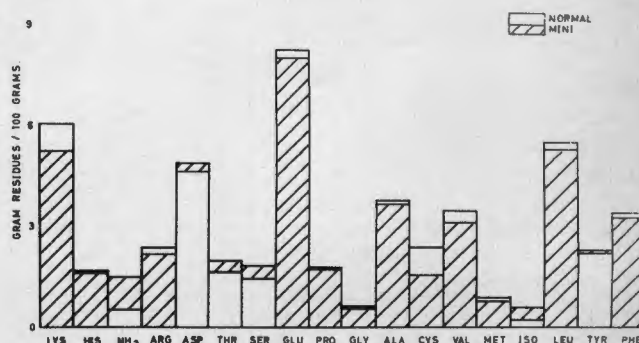

Fig. 6. Amino-acid composition of normal albumin and minialbumin obtained from the serum of the cadmium-poisoned monkey M. In the histogram the amino acids are expressed as gram residues per 100 G albumin, rather than as the number of residues per molecule of albumin, because of the heterogeneity of the small albumin.

This same preparation run previously in higher salt concentration appeared to consist only of molecules of weight less than 10,000. Serum minialbumin prepared from monkey K (Fig. 2) and kindly examined in the ultracentrifuge

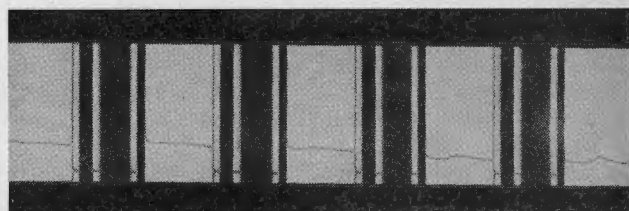

Fig. 7. Ultracentrifugal pattern of serum minialbumin prepared from the cadmium-poisoned monkey M. Observations were made using a Beckman Spinco analytical ultracentrifuge, Model E. The protein was examined as a 0.6% solution in 0.9% w/v aqueous sodium chloride in a synthetic boundary cell at a centrifuge speed of 56,100 r.p.m. Photographs were taken of the peak at intervals of 32 minutes.

by Dr. T. H. Mead, contained mainly protein of MW 10,000, but greater and smaller components were also present.

These observations are in line with those previously reported for the urinary albumins of cadmium workers. In some mysterious manner, the minialbumins had apparently grown in molecular size during storage. The effect was almost certainly due to the fact that the preparations were ultracentrifuged in a lower salt concentration (0.9% NaCl) in Cape Town as compared with that used by Dr. R. A. Kekwick in London (phosphate-sodium chloride buffer total ionic strength 0.35).

Minialbumin Formation in Rats Acutely Poisoned with Cadmium

A series of rats were killed at varying intervals of time after a single intraperitoneal injection of cadmium, and the albumins in the serum separated on dextran gel, Sephadex G 75. A good response was elicited 90 mins. after the

tion is evident at 90 mins., but it has fallen markedly 180 mins. after the injection. It is proposed to study this change in more detail in further experiments.

Fig. 10 presents observations on the albumins present in the liver of normal rats, and in animals during acute cad-

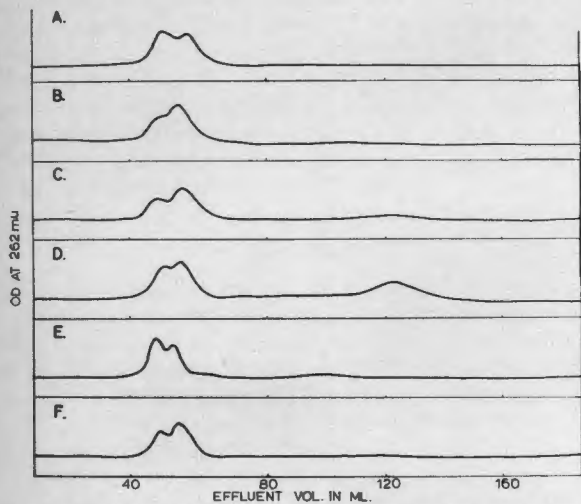

Fig. 8. Albumins prepared from sera of rats acutely poisoned with cadmium. A = control—equal volume of saline injected and animal killed after 60 mins. B - F = 15 mg. cadmium/kg. body-weight injected intraperitoneally, and the animals killed at 0, 40, 90, 180 and 1,440 mins. respectively. Albumins prepared by HCl-ethanol method and separated on Sephadex G 75 in M/15 phosphate buffer, pH 7.0 containing 0.2 M NaCl. Column 42 x 1.8 cm. Flow rate 12.5 ml./hr. OD recorded at 262 mμ.

injection (Fig. 8). Concurrently with the appearance of minialbumin in the serum, a pre-albumin fraction arose in the electrophoretogram. The sera were applied to cellulose acetate strips and electrophoresis carried out for 20 mins. in a perspex tank, in veronal buffer pH 8.6, ionic strength 0.75, at a potential difference of 120 V and current of 3.5 - 4.5 ma. The strip was fixed and stained in a fixative-dye solution containing Ponceau S, trichloroacetic and sulphosalicylic acids. The plates were cleared and dried and scanned in the 500 - 520 mμ range in the analytrol. The records are shown in Fig. 9. A distinct pre-albumin frac-

mium poisoning. Two features of especial interest are the presence of minialbumin in normal rat liver, and the greatly increased concentration of minialbumin in the tissue 90 and 180 mins. after a single intraperitoneal injection of cadmium. It is also noteworthy that there is a decline in the numbers of normal albumin molecules present after 2 hours of intoxication.

Similar extracts of the kidneys of poisoned rats were prepared and the changes in albumin fractions are shown in Fig. 11. A gel column of smaller capacity was employed

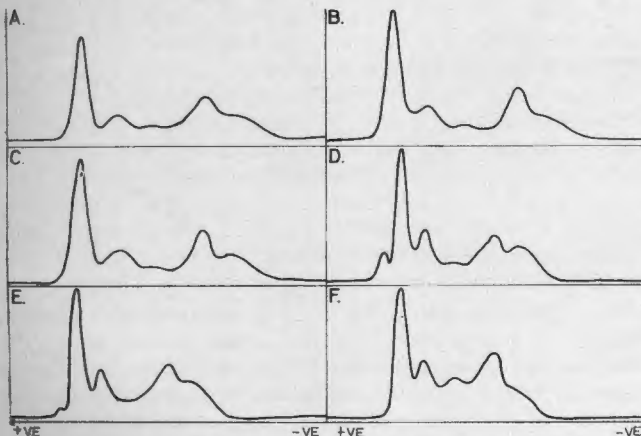

Fig. 9. Electrophoretic studies on the sera obtained from rats acutely poisoned with cadmium. A = control animal—saline—killed at 60 mins. B - F = sera from animals killed at 0, 40, 90, 180 and 1,440 mins. respectively after intraperitoneal injection of 15 mg. cadmium/kg. body-weight.

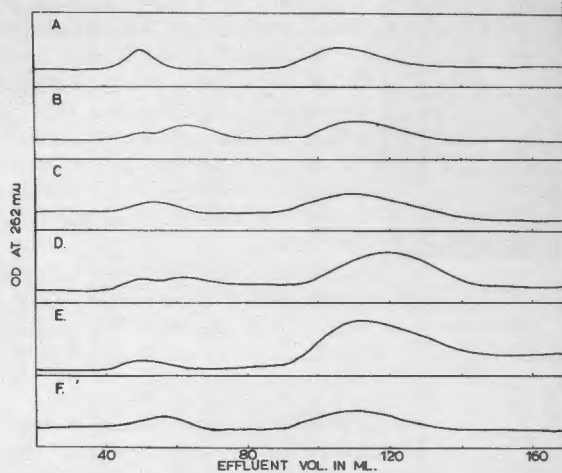

Fig. 10. Albumins prepared from the liver extracts of rats acutely poisoned with cadmium. A = control—saline—killed at 60 mins. B - F = extracts from animals killed at 0, 40, 90, 180 and 1,440 mins. respectively after intraperitoneal injection of 15 mg. cadmium/kg. body-weight. Albumins prepared and separated as in Fig. 8.

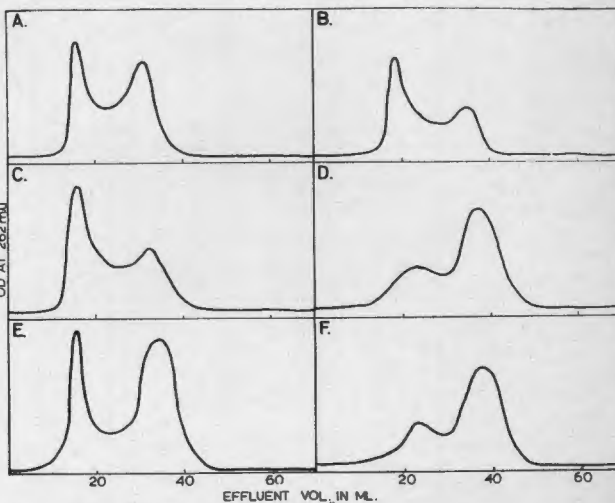

Fig. 11. Albumins prepared from kidney extracts of acutely poisoned rats. A = control—saline—killed at 60 mins. B - F = extracts from animals killed at 0, 40, 90, 180 and 1,440 mins. respectively after intraperitoneal injection of 15 mg. cadmium/kg. body-weight. Albumin prepared and separated as in Fig. 8. Column 16 x 1.6 cm. Flow rate 18 ml./hr. OD recorded at 262 mμ.

in this experiment, and the albumins overlap. There appears to be a considerable quantity of minialbumin before administration of cadmium. Following poisoning, still more minialbumin was found in the renal tissues and the effect appeared to outlast that in the liver. Whether all the minialbumin to be found in the kidney comes from the liver is an extremely important question apropos the origin of the urinary minialbumin of men and animals poisoned with cadmium. We hope to be able soon to publish decisive evidence on this problem.

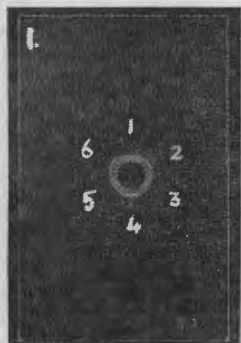

Fig. 12. Antigenic behaviour of albumins found in the serum, liver and kidney of cadmium-poisoned rats. 1=serum normal albumin from acutely poisoned rat, 2=serum minialbumin from acutely poisoned rat, 3=liver normal albumin from acutely poisoned rat, 4=liver minialbumin from acutely poisoned rat, 5=kidney normal albumin from acutely poisoned rat, 6=kidney minialbumin from acutely poisoned rat. Anti-serum—rabbit anti-whole normal rat serum.

The albumins in these tissue extracts behaved antigenically as do the albumins we have already found in sera, peritoneal dialysates and urine (Fig. 12).

Possible Direct Chemical Action of Cadmium Ions on Normal Albumin Present in Blood or Serum

It was important to establish whether minialbumin can be formed by the direct chemical action of cadmium ions on normal serum albumin present in blood or serum. To test this possibility, 2 mg. Cd (as CdCl₂) was added drop by drop with continuous stirring to 6 ml. venous blood of a normal monkey, containing 0.5 ml. heparin as anticoagulant. The mixture was allowed to stand for 2 hours at room temperature, after which the red blood cells were removed by centrifugation and the albumins prepared from the plasma by the TCA-acetone method and passed through a Sephadex G 75 column (Fig. 13A).

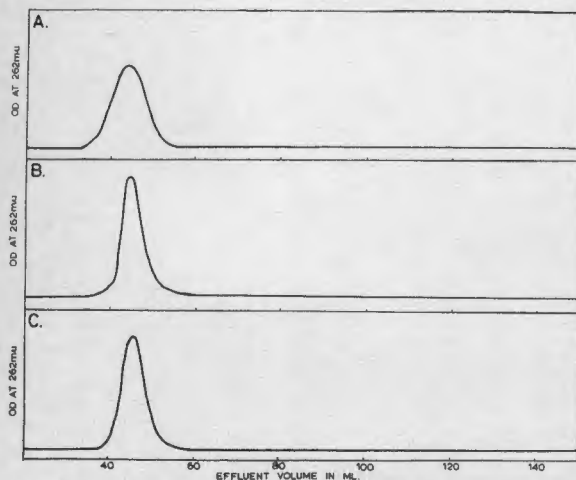

Fig. 13. Incubation of cadmium chloride with normal monkey serum or blood. A = albumins prepared from normal monkey blood after incubation with CdCl₂, B = albumins of normal monkey serum incubated with physiological saline (control), C = albumins of normal monkey serum after incubation with CdCl₂. In each experiment albumin in M/15 phosphate buffer, pH 7.0 and 0.5 M NaCl was passed through a Sephadex G 75 column 40 x 1.8 cm. Flow rate 15 ml./hr. OD was recorded at 262 m μ .

To examine the action on albumin in serum, 3 ml. of normal monkey serum was added to each of 2 containers, which were then treated as follows:

1. Control, 0.01 ml. physiological saline added.
2. 2 mg. Cd (as CdCl₂) added in physiological saline.

This is equivalent to the dosage of cadmium employed to cause acute poisoning in monkeys. The solutions were well mixed, passed through millipore filters into flamed sterile tubes, and then incubated at 37°C in a water bath, with gentle agitation, for 48 hours. Albumin was prepared from the two sera by the TCA-acetone procedure and fractionated on Sephadex G 75 gel (Figs. 13 B and C). No minialbumin was detected in any of the experiments. We can safely conclude that it does not arise by a direct action of cadmium on normal serum albumin.

DISCUSSION

We have been concerned, in this and in earlier studies of the biochemical effects of cadmium, to elucidate the mechanisms which lead, in cadmium-poisoned men and animals, to the appearance of a low-molecular albumin in their urine. Other workers^{5,8} have reported evidence supporting the view that this protein originates as a result of non-specific injury to the renal tubular epithelium cells. The experimental observations presented here appear to indicate, rather, that the urinary minialbumin arises, probably to a major extent, from a primary action of cadmium on the liver cells. The excretion of the protein in the urine occurs only after a period of weeks following the appearance of minialbumins in the circulating blood. The concentration of these compounds fell consistently with the onset of urinary excretion of minialbumin. On the other hand, the level of circulating minialbumins as seen in peritoneal dialysates, was maintained relatively unchanged for 6 days following bilateral nephrectomy, quite out of keeping with the observed high rate of metabolic turnover of minialbumin.²

Maintenance of the circulating blood level of minialbumin in the nephrectomized monkey implies a major source other than renal tissues. We have not, however, excluded the possibility that kidney tissue may be able to produce minialbumins from serum albumin on addition of cadmium ions, and experiments are presently being performed on this aspect of the problem. The presence of such minialbumin in the liver of untreated rats implies that small quantities must be present normally in the circulation, being filtered by the renal glomeruli and reabsorbed by the tubular cells. Whether cadmium ions play a role in the regulation of the production and concentration of these intermediates in normal animals remains to be seen. The effect of cadmium is certainly on intracellular enzymic systems—we have never been able to detect the formation of low-molecular products from albumin, from the direct action of cadmium on serum or blood.

As regards the nature of urinary minialbumin itself, its amino-acid composition is closely similar to that of serum albumin of molecular weight 67,000 and to the low-molecular albumins found in the serum of cadmium-poisoned animals. In the three analyses so far performed, however, the minialbumins show a deficit of lysine and $\frac{1}{2}$ -cystine, which, again, makes it possible to link together the circulating and excretory forms of the protein.

Both urinary and serum minialbumins show reaction of identity with normal serum albumin in Ouchterlony plates. Although the peaks of normal and low-molecular albumins were invariably well separated from one another in the eluates from columns of dextran gel, we were concerned lest some normal albumin might be present and responsible for this antigenic behaviour of the minialbumin fraction, although not for its amino-acid composition. This possibility was dismissed when it was found that two separate preparations of low-molecular albumins from serum, when centrifuged inadvertently in high salt concentration, contained no component with molecular weight greater than 10,000. On the other hand, we became aware of the fact that unless the proteins are in a salt concentration, 0.2 M or greater, there is a probability that some aggregation of minialbumin will take place and such aggregates will be found in the normal albumin fraction. Ready aggregation of minialbumin molecules under physiological conditions of pH and salt concentration gave the impression at first—until the critical influence of salt concentration on molecular size was appreciated—that we were dealing with a protean molecule. Separated on inert columns of dextran gels in sodium chloride solutions of 0.2 M or more, the minialbumin migrates as an entity of molecules of weight 10,000, sometimes with a lesser quantity of smaller molecules of MW 5,000. Lowering the sodium chloride concentration to 0.9% leads to aggregation, and a range of molecules up to the size of normal serum albumin is produced. In salt-free media, as employed for Ouchterlony immunological plates, minialbumin preparations diffuse and react as fully-constituted serum albumin molecules, and give the reaction of identity with it.

It is imperative in handling this protein, therefore, that the concentration of salt should be lowered to a safe level before the solution is dialysed, since the lower molecular species otherwise may rapidly escape. Boiled tubing of reduced porosity must be used. On the other hand, 0.9% sodium chloride or lesser concentration will facilitate rapid aggregation of minialbumin molecules, and it may be thought that normal albumin is a contaminant in the preparation. This certainly explains the anomalous behaviour of the urinary albumin from two cadmium-poisoned workmen, discussed in our earlier paper.¹ Dr. Kekwick determined the sedimentation coefficients of these albumins as 1.96 and 1.99, which correspond to a molecular weight of approximately 20,000.

Since the single chain of albumin includes only one tryptophan residue, and peptides of very different composition are obtainable on proteolytic degradation,¹⁰ the possibility of a repeating unit appears to be excluded. The closeness of fit of the primary amino-acid composition of all the albumins is therefore inexplicable in terms of a disorder in RNA-coded synthesis of albumin. One can, however, readily envisage how such products could arise during catabolism of normal serum albumin. Disintegration of the molecular chains into large polypeptide fragments, of approximately equal size, may occur after release from the liver microsomes of the fully-formed albumin molecules, and before they pass from the cell into the blood stream. A complete mixture of such polypeptides would have an amino-acid composition identical with its parent molecule. Alternatively, such products could arise during

catabolism of circulating serum albumin returning to the liver, since the liver plays an important role in albumin breakdown. Activation of proteinases concerned with this type of fragmentation, or inhibition of enzymes active in further breakdown would raise the concentration of mixtures, such as the minialbumins we now describe. The deficit of lysine and cystine in minialbumins might be due to attack by cadmium ions on one or more of the numerous disulphide bridges, which occur throughout the length of the molecular chain of serum albumin, with subsequent loss of one or more peptides, rich in lysine and cystine. Administration of thiol compounds such as cysteine or dithiopropanol has been observed to be protective against the vascular injuries caused by cadmium.¹⁷ It is also possible that a small peptide, rich in lysine and cystine, may have been lost at some point in the fractionation procedure. We were unable to detect any direct effects on serum albumin prepared, following incubation of cadmium with either whole blood or serum.

It appears remarkable that the peptides in the mixture are able to reassociate to form one or more intact albumins of normal molecular weight (67,000), giving a reaction of identity on Ouchterlony plates with normal serum albumin. This phenomenon implies that the antigenic sites have been preserved intact on individual peptides, whose disposition in the albumin molecule is of secondary importance. We have not so far, owing to dearth of material, been able to test whether these albumins are antigenically complete as compared with normal serum albumin. Since definite quantities of minialbumin are normally present in the liver, it is possible that some reassembly could actually occur *in vivo* without the need for a specific RNA code. This is a heretical concept, perhaps, but such a process could contribute to the micro-heterogeneity of serum albumin, as is well documented by Foster and his colleagues.^{18,19} In this event, cadmium may prove to play a vital role in the physiological control of albumin metabolism.

We hope that our further investigations will shed light on these various possibilities, and on the more intimate relationships between cadmium ions and the intermediary metabolism of albumin.

SUMMARY AND CONCLUSIONS

A low-molecular albumin (MW 10,000) has been demonstrated in the sera and in the peritoneal dialysates of monkeys chronically poisoned with cadmium, and, in one monkey, this minialbumin was found in the peritoneal dialysis fluid, 6 days after bilateral nephrectomy.

The protein was immunologically indistinguishable from albumin of normal size by precipitin techniques.

In all 6 monkeys studied, a minialbumin was detected, in the blood, 3-5 weeks before its appearance in the urine. In addition, in some preparations a component of MW approximately 5,000 could be seen. Previous work has shown that the urinary minialbumin has a molecular weight of approximately 20,000. In earlier experiments, described here, the quantity of this smallest component was exaggerated falsely by the presence of chromogenic material extracted from cellophane sacs by acetone. The excretion of urinary minialbumin fell away rapidly in 4 or 5 days following intravenous pulse doses of cadmium—in these experiments, the biochemical action of cadmium was relatively shortlived.

The serum minialbumins showed the reaction of identity with full-sized albumin by immunoelectrophoresis and Ouchterlony techniques. Amino-acid analysis of serum minialbumin prepared separately from 3 monkeys provided evidence of close agreement in composition between one another and

normal serum albumin, except that in each case the values for lysine and $\frac{1}{2}$ -cystine were lower in the smaller variant.

The minialbumins were clearly separated from molecules of normal size on Sephadex G 75 as long as the concentration of sodium chloride was 0.2 M or more, without the appearance of proteins of intermediate size. At lesser salt concentrations, as for example in 0.9% sodium chloride solution, aggregation occurs with the development of a grossly inhomogeneous mixture containing approximately 40% of albumin of MW 70,000 and 60% of smaller fragments down to peptides of MW 5,000.

Minialbumin which, from its elution volume from Sephadex G 75 columns appears to have a MW of 10,000, has been demonstrated to be present in the liver and kidney of normal rats. In acute cadmium poisoning, the proportion of minialbumin in the rat liver rose rapidly to a maximum at 90 minutes, when it then appeared in the circulating blood. The changes in the kidney were similar in trend but more prolonged. Simultaneously with minialbumin, a pre-albumin fraction made its appearance on electrophoresis in cellulose acetate strips.

Minialbumins are not formed by direct contact of cadmium ions with normal albumin in serum or blood; they must arise as the result of the action of the metal on some intracellular enzymic process.

The significance of these findings in relation to the origin of urinary minialbumin and the biochemical actions of cadmium are discussed.

We wish to express our thanks to a number of colleagues whose cooperation made this work possible: Prof. A. Kipps kindly allowed us the facilities of the Virus Research Unit, and we are especially indebted to Dr. A. Polson for his interest in this programme, for stimulating discussion and for the molecular weight determinations; Dr. G. M. Potgieter gave us valuable advice on immunological techniques, and both he and Dr. M. C. Berman gave us generous help with the literature

and in discussion of our problem; Prof. J. H. Louw provided facilities in his department, and we are most grateful for the skill and infectious enthusiasm of Drs. M. Barnard and J. Ackermann, of the Department of Cardiac Surgery, who performed nephrectomy and peritoneal dialysis on our experimental animals. We are glad to acknowledge the expertise of Miss E. Hall in performing the amino-acid analyses on the Beckman Spinco amino-acid analyser, Model 120 B, which was purchased from funds provided to the Protein Research Unit by the CSIR; and we should also like to thank Mrs. P. de Gouveia for secretarial assistance.

REFERENCES

1. Kench, J. E., Gain, A. C. and Sutherland, E. M. (1965): *S. Afr. Med. J.*, **39**, 1191.
2. Bonnell, J. A. (1965): *Ann. Occup. Hyg.*, **8**, 45.
3. Clarkson, T. W. and Kench, J. E. (1956): *Biochem. J.*, **62**, 361.
4. Kazantzis, G. (1965): *Ann. Occup. Hyg.*, **8**, 59.
5. Bonnell, J. A., Ross, J. H. and King, E. (1960): *Brit. J. Industr. Med.*, **17**, 69.
6. Potts, C. L. (1965): *Ann. Occup. Hyg.*, **8**, 55.
7. Kench, J. E., Wells, A. R. and Smith, J. C. (1962): *S. Afr. Med. J.*, **36**, 390.
8. Creeth, J. M., Kekwick, R. A., Flynn, F. V., Harris, H. and Robson, E. B. (1963): *Clin. chim. Acta*, **8**, 406.
9. Vallance-Owen, J., Dennes, E. and Campbell, P. N. (1958): *Lancet*, **2**, 336.
10. Fernandez, A., Sobel, C. and Goldenberg, H. (1966): *Clin. chim. Acta*, **12**, 194.
11. Ouchterlony, O. (1962): *Progr. Allergy*, **6**, 30.
12. Mandy, W. J., Rivers, M. M. and Nisonoff, A. (1961): *J. Biol. Chem.*, **236**, 3221.
13. Grabar, P. and Williams, C. A. jnr. (1955): *Biochim. biophys. Acta (Amst.)*, **17**, 67.
14. Moore, S. and Stein, W. H. in Colowick and Kaplan, eds. (1963): *Methods in Enzymology*, vol. 6, p. 819. New York: Academic Press.
15. Spackman, D. H., Stein, W. H. and Moore, S. (1958): *Analyt. Chem.*, **30**, 1190.
16. Press, E. M. and Porter, R. R. (1962): *Biochem. J.*, **83**, 172.
17. Gunn, S. A., Gould, T. C. and Anderson, W. A. D. (1966): *Proc. Soc. Exp. Biol. (N.Y.)*, **122**, 1036.
18. Foster, J. F., Soganin, M., Petersen, H. A. and Leonard, W. J. jnr. (1965): *J. Biol. Chem.*, **240**, 2495.
19. Petersen, H. A. and Foster, J. F. (1965): *Ibid.*, **240**, 2503.