

The copyright of this thesis vests in the author. No quotation from it or information derived from it is to be published without full acknowledgement of the source. The thesis is to be used for private study or non-commercial research purposes only.

Published by the University of Cape Town (UCT) in terms of the non-exclusive license granted to UCT by the author.

**A SYSTEM OF PROFOUND KNOWLEDGE  
TO VARIATION MANAGEMENT**

***MASTERS THESIS FOR  
MANUFACTURING MANAGEMENT  
DEVELOPMENT PROGRAMME***

**UNIVERSITY OF CAPE TOWN**

**COMPILED BY:**

**B. PRETORIUS**

**JANUARY 2000**

## **PREFACE**

The aim of this thesis is the transformation of thinking about variation and the management of variation in a manufacturing environment. The main contributor to quality, cost and delivery is variation from its different sources. This thesis will try and establish the mindset of understanding, as well as to develop a model for effective problem solving on the shop floor.

Management must be able to predict outcomes, but if the processes are not under statistical control then prediction and improvement is not possible.

Deming's profound system of knowledge will be used to achieve the aim as well as many other authors who did work and research on the effect of variation.

## **ABOUT THE AUTOR**

B. PRETORIUS is currently the process manager of Nissan South Africa's Paint Shop. The responsibilities, amongst others, include the quality of all incoming material, process control in the total plant, cost control of all the processes as well as improvement activities.

Considering all the possible variability's and statistical process control, this study is vital for control, problem solving and improvement activities.

## TABLE OF CONTENTS

		<u>PAGE NO.</u>
<u>CHAPTER ONE</u>	: <u>ABSTRACT</u>	
1.1	Introduction	1
1.2	Current situation and problem overview	1
1.3	Concerns	3
1.4	Questions	3
1.5	Possible answers	4
1.6	Rationale	5
1.7	Summary	5
<u>CHAPTER TWO</u>	: <u>PROBLEM FORMULATION</u>	
2.1	Introduction	7
2.2	Understand the systems at play	11
2.3	Knowledge of variation	12
2.4	Theory of knowledge	14
2.5	Psychology	14
2.6	Problem formulation claim	15
2.7	Summary	15
<u>CHAPTER THREE</u>	: <u>SYSTEM OF PROFOUND KNOWLEDGE</u>	
3.1	<u>UNDERSTANDING THE ORGANIZATION AS A SYSTEM</u>	
3.1	Chapter introduction	17
3.1.1	Introduction	17
3.1.2	What is a system	18
3.1.3	Sociological systems thinking	21
3.1.4	Process improvements through systems	23
3.1.5	Viable systems	27
3.1.6	Viable systems and requisite variety	32
3.1.7	Total systems interventions	35
3.1.8	Summary	37
3.2	<u>KNOWLEDGE ABOUT VARIATION</u>	
3.2.1	Introduction	38
3.2.2	Variation and its sources	38
3.2.3	Cost of quality and variation	42
3.2.4	Deming's 14 points on management	44

3.2.5	Variety engineering	45
3.2.6	Summary	47

### 3.3 THEORY OF KNOWLEDGE

3.3.1	Introduction	47
3.3.2	Knowledge and prediction	48
3.3.3	Knowledge as scientific method	51
3.3.4	The pursuit of inquiry	57
3.3.5	Summary	61

### 3.4 PSYCHOLOGY

3.4.1	Introduction	62
3.4.2	Psychology and management	62
3.4.3	Peoples management	66
3.4.4	Summary	68
	Chapter summary	69

## CHAPTER FOUR : SYNTHESIS AND FRAMEWORK

4.1	Introduction	70
4.2	Scientific method and improvement.	71
4.3	The cycle of improvement	73
4.4	Changing the system	73
4.5	Improving a process	74
4.6	'Metanormal' business model	77
4.7	Soft systems methodology	78
4.8	The QC story approach to problem solving	83
4.9	Rules for data presentation	87
4.10	Model	90
4.11	Summary	91

## CHAPTER FIVE : REFLECTION ON CASE STUDY

5.1	Introduction	93
5.2	Problem situation	95
5.3	Theory and analysis	95
5.4	Plan activities	95
5.5	Do activities	96
5.6	Measure activities	98
5.7	Evaluation	101
5.8	Summary	102

<b><u>CHAPTER SIX</u></b>	:	<b><u>CONCLUSION AND RECOMMENDATIONS</u></b>	
	6.1	Introduction	103
	6.2	Conclusion	103
	6.3	Recommendations	105
<b><u>BIBLIOGRAPHY</u></b>	:	<b><u>REFERENCES</u></b>	106
ANNEXURE A			108
ANNEXURE B			122

## CHAPTER ONE

### ABSTRACT

#### 1.1 INTRODUCTION:

In this chapter the background and the context of the problem statement will be discussed. The problem or situation, which does not yield the required results, will be viewed in the context of the current system, the performance implications on the bigger systems and a general overview. Some possible explanations for the current behavior will be discussed and certain remedial action will be suggested.

The SCQARE review approach, as illustrated by Tom Ryan (1995), will be used to set the problem background and come up with probable answers to the solution to the problem. This is an important stage in the total process, for a problem well defined and understood is a problem half solved already.

#### 1.2 CURRENT SITUATION AND PROBLEM OVERVIEW:

The success of any manufacturing division can be measured by the ability of the different processes to produce the products right the first time. If the products do not conform to the required quality levels by first intend then the products must be reworked or in some cases totally rejected, All of-standard work or additional rework processes obviously means added cost to the initial manufacturing value of the product.

The build-in quality concept in a manufacturing process is thus of vital importance, to be able to deliver the right quality product at the right price in the shortest time. With the above statement in mind, one word that immediately comes to mind is variation. Variation is the main source for non-conformance to specification, whether it is design variation, parts variation, build variation, inspection variation or any other sources of variation. In turn,

it is probably Management's biggest task and objective to reduce variation as far as possible, not only on the shop floor but also variation in systems, information, training and human behaviour, in the manufacturing context.

The situation in focus, which is the testing of complete build up vehicles through the water test facility at Nissan's plant in Rosslyn, Pretoria, will be used for this thesis, is one where the first time straight through ratio through the water test area is unacceptably low, especially with certain models. The ideal is to have a straight through ratio of at least 80 percent on 'old' models and at least 90 percent on new models. The straight through ratio is the measurement of vehicles that conforms to the required specification by first intent.

The following graph will illustrate the percentage straight through as an average for all models:

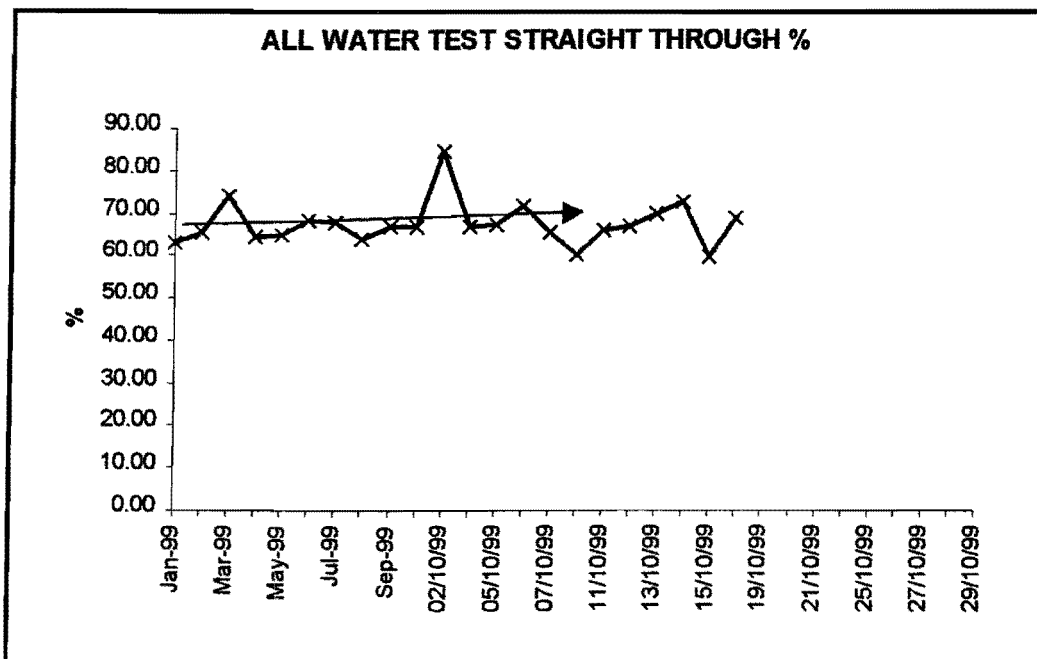

**GRAPH NO 1 PERCENTAGE AVERAGE STRAIGHT THROUGH RATIO**

The average on the graph for the period since January is running at 66.8 % which is unacceptably low.

### **1.3 CONCERNS**

The following will be considered under concerns:

- 1) Why did previous quality intervention activities not have the desired results on the performance of the water test area, and what should the next approach be to try and solve the quality problems?
- 2) What are the implications of the current status quo, and should an attempt be made to improve the situation or not, in relation to cost of quality, volume requirement and throughput success through the specific area?

The implications of the current situation is a huge on-cost to quality in the sense that the poor performance of the area results in a bottle neck situation where overtime and extra labour must be employed to clear the area, of rejected units, after normal working hours and during weekends.

Volume requirement will increase in the near future and this area will become a major bottleneck due to the poor performance and low straight through ratio. Vehicles that are rejected for water leaks must be repaired and returned to the facility for retesting, and it happens that some units are retest 4 to 5 times before final quality acceptance.

### **1.4 QUESTIONS**

The following questions must be asked in order to plan an intervention methodology:

1. Is the facility giving the required test conditions or is the testing too strict?

2. The actions taken up to now do not have the required impact in the majority of the cases and it is a discipline or learning problem.
3. The process capability of the different processes affecting the water test performance in the different assembly stages cannot produce a 'water leak free' vehicle because the build variation is too wide.
4. The current systems in place, both on a micro and macro scale, are not supporting the final result in this area.
5. The vehicle design is of such a nature that the vehicles will leak water despite all efforts to build – in quality.

### **1.5 POSSIBLE ANSWERS**

When viewing the graph under paragraph 1.2 it is clear that there is a big variation in performance. When the monthly performance is considered, the variation is large, but the daily variation performance shows that all the critical processes concerning the water test quality is totally out of statistical control.

From the above the following conclusions or possible answers can be derived:

- 1) The different build procedures are not adhered to.
- 2) The operator that build the vehicle is not aware of the impact of his 'poor work' in the down stream processes.
- 3) The vehicle must be build in a 'certain way' or method to reduce the change of a leaking condition and the current engineering specification does not contain this method.
- 4) Other variations influence the build condition; hence the fact that similar vehicles leak and others do not leak.

## **1.6 RATIONALE**

In order to improve the current condition the following activities are envisaged:

- 1) A physical audit of the current situation should be conducted to observe and learn from previous attempts to improve the straight through ratio in this area.
- 2) The build process and engineering build parameters must be investigated in order to understand the build process and to verify any special 'skills' or methods needed.
- 3) In order to 'learn' the defects and how to solve them, practical training and on the job repair must be done by the investigating team.
- 4) Information from other manufacturing plants, in relation with the problem, must be obtained and studied.

In summary, Demings system of profound knowledge must be applied to understand the systems at play, the variation and it's effect on the process, the acquiring of knowledge on the defects and the human psychology at work.

## **1.7 SUMMARY**

In this chapter the situation under investigation was described in relation to its context and the urgent need for improvement on the straight through ratio in this area is obvious. The possible answers that were listed are not confirmed and through the Deming methodology the problems and solutions will be investigated and in chapter five, the reflection stage will confirm the relative success of this study.

Once reviewed, the background situation in this chapter, it is clear that the day-to-day as well as monthly variation and build condition plays a major role in the problem and in the solution to the problem.

In chapter two it will be a priority to formulate the real cause of the problem in order to understand the problem and to recommend effective solutions to the problem.

## CHAPTER TWO

### PROBLEM FORMULATION

#### 2.1 INTRODUCTION

In the previous chapter the background information of the problem was investigated and the 'conclusion' was suggested to be a variation problem, in the actual build stage as well as variation in the other disciplines such as information, systems, parts supplied and audit procedures. In order to understand the magnitude of the problem better it is important to look at the variation in performance of the individual vehicle models. The following graphs will illustrate the performance per model derivative:

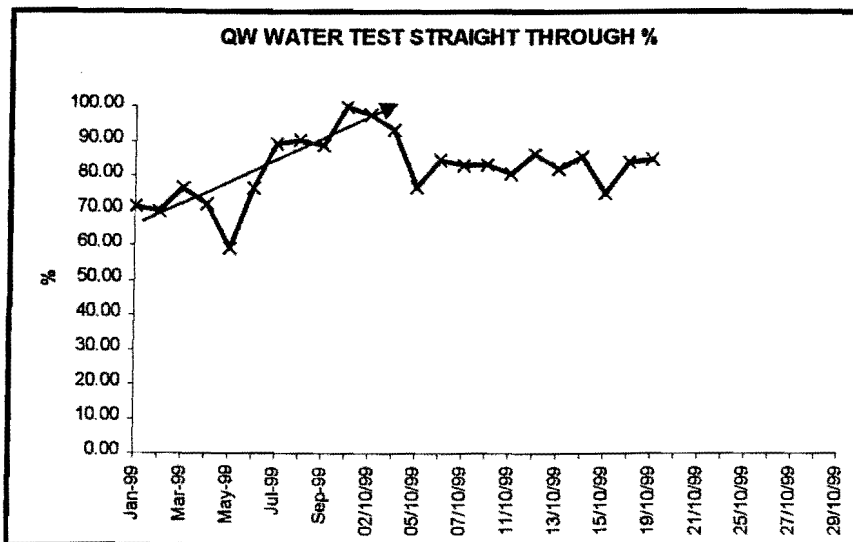

**GRAPH NO 1 QW MODEL STRAIGHT THROUGH PERFORMANCE**

It is clear that the performance of this model has improved over the last nine months from an average of 70 percent to just below the 90 percent mark. This model is the latest model and the target must be more than 90 percent straight through. This model is considered as the 'model line' and the quality is the focus point.

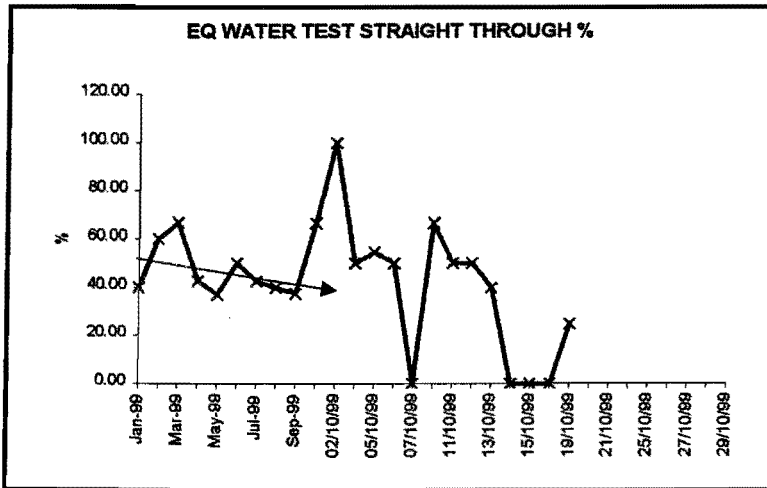

**GRAPH NO. 2 EQ MODEL STRAIGHT THROUGH PERFORMANCE**

This is the second latest model but the performance is very poor. What is not supporting the performance is the amount of units that are tested per day. On average about six to nine units are tested and if one is rejected it results in a great impact on the overall performance. This is however also a new model and the target must be more than 90 percent.

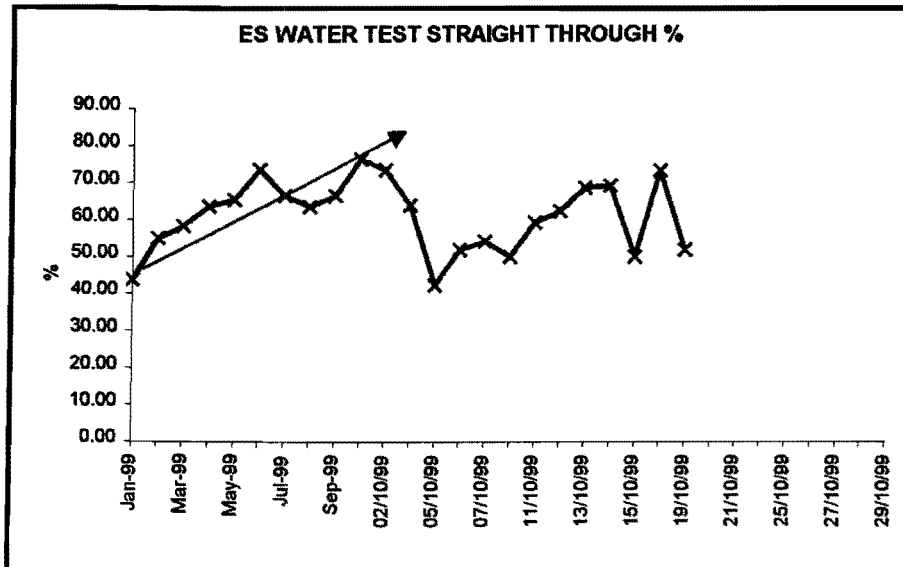

**GRAPH NO. 3 ES MODEL STRAIGHT THROUGH PERFORMANCE**

This model is of average age and the target should be between 80 and 90 percent straight through performance. It is clear that the performance did improve a lot since January month but there is no evidence that this trend will continue, since the data for the next month shows a downward trend already.

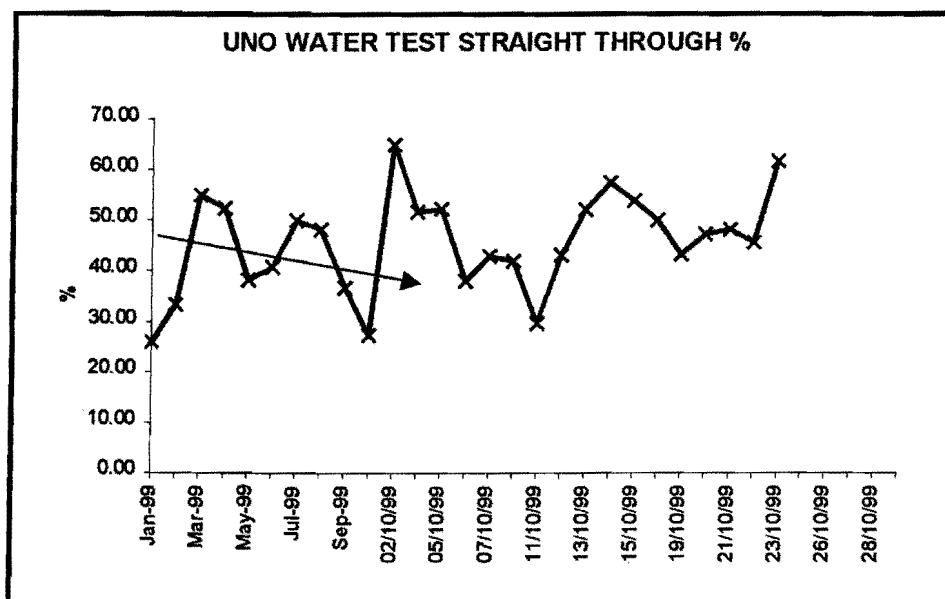

**GRAPH NO. 4 UNO MODEL STRAIGHT THROUGH PERCENTAGE**

This model is an old model and the target should be between 80 and 90 percent straight through performance. The general observation is that there are certain 'build in' problems with this model and to solve the problems will take a different type of quality and performance intervention.

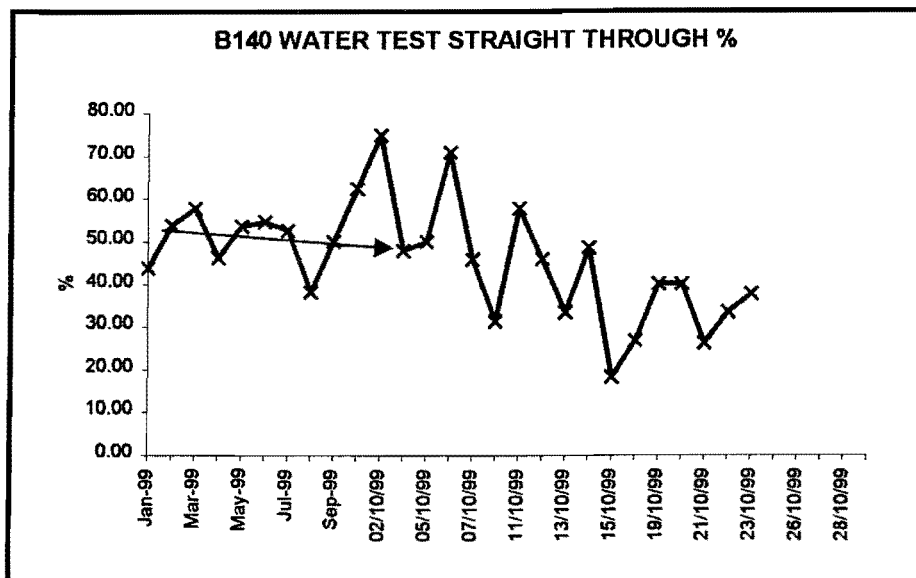

**GRAPH NO. 5 B140 MODEL STRAIGHT THROUGH PERCENTAGE**

This is the oldest model in manufacturing and the target should also be 80 to 90 percent. There are also certain inherent water leak problems within this model's design criteria and the same will apply as with model UNO in relation with quality interventions.

In this chapter the formulation of the problem will be done according to current experience and observations made on the different products and processes. The formulation stage is vital to understand the intervention methodology that must be used to improve or solve the concerns. In order to describe the problem. Deming's system of profound knowledge principles and SSM evaluation methodology will be used to do this function.

A complete SSM study was done in this area of concern by the Author in a previous paper during 1999. Refer to 'Quality improvement intervention through SSM methodology and Action Research Principles'.

(Refer to annexure A)

## **2.2 UNDERSTAND THE SYSTEMS AT PLAY**

The different systems at play in the concerned area are:

- 1) The engineering, prescribe build, system that demonstrates how the vehicle must be build to specification. These systems contain engineering parts and methods as well as build sequence in some cases.
- 2) The actual build system according to standard operation sheets that simplifies the task to the operator. This sheet explains the concept of building the different components or sealer application into a vehicle to different specification requirements.
- 3) The inspection buy – off system that checks different quality aspects of the vehicle before quality buy off. This system does not automatically focus on water leak items unless specified on the buy - off standards.
- 4) The water testing system, which is prescribed by the engineering division, based on acceptable standards. This system must ensure that the vehicle is inspected to such a standard that the Customer will not have a vehicle that leaks water.
- 5) The inspection system at the testing facility which is sometimes subjected to human error or judgment. The standard on defect allowance is zero defects per unit, which in itself is a very strict target to achieve. Some defects are minute but the vehicle is still rejected.

- 6) The repair system where the different parts of the vehicle must be stripped off in order to get to the cause of the defect. The repair methods are off standard and the repair is never as good as the initial build quality. In repairing the water leak defect the operator can easily cause another defect further down the process.

After repair, the units must be retest until a defect free unit can be guaranteed.

If the above systems do not work together and there is no proper interrelationship between them then the target or goal will not be achieved. If the build system does not prescribe critical focus activities to prevent water leaks then the vehicle will probably leak water, if the inspection and buy-off system does not focus on the critical areas then the build process cannot be inspected for correct specification. The water test inspection and repair system must identify real water test defects while the repair system must ensure a proper repair, which will not affect other quality items.

### **2.3 KNOWLEDGE OF VARIATION:**

From the graphs in chapter two the biggest obvious characteristic is the variation on the test results. The daily variation is totally out of control and this is a direct reflection on the off-standard build process. With this type of daily variation no prediction is possible, the next day could be a disaster or an excellent day for straight through performance.

The first step in any situation will be to get the different processes under statistical control, followed by step-by-step improvements to reduce the failure incidences. In order to reduce the variation one should do a careful study to determine the real sources of the variation and then counter the sources to build stability into the various areas.

Possible variation sources could be due to:

- 1) **Incoming parts consistency**, for example the ES door rubber has two distinct quality levels. The one level has a stiff rubber corner mould area whereas the other level has a 'floppy' corner mould.
  
- 2) **Build variation**, this is probably the biggest source of variation. The operator build consistency is not acceptable, operators get rotated around in the various operations and the area management does not understand the impact of the critical processes.  
  
Absenteeism of trained operators is also a major problem. If the dedicated operator is absent for the day or there is non- standard working hours, like on Saturdays, any operators performs the build process with expected poor results.
  
- 3) **Information variation**, standard operating instructions do not illustrate the critical operations clearly. The feedback to the variation source area is not constant and the operator performing the build task is not aware of his build implications further down the line.
  
- 4) **Defect detection variation**, is also a problem in the sense that the inspector at the water test area indicate the possible defect origin on the buy-off sheets. This is normally not the true defect as repaired by the actual repairman. The inspector's data are recorded as the actual defect and this 'wrong' information gives a distorted picture of what the real problems are.
  
- 5) **Repair variation**, is a concern because the repairmen do not always repair the defective unit the first time right. The unit gets retest and it might fail again due to 'poor work'.

## **2.4 THEORY OF KNOWLEDGE**

The ability to understand the true cause of the defect origin and remedial action can only be gained through knowledge. The operator that builds the vehicle must understand the implications of his actions and the rest of the system must support the activities on the shop floor.

The only way to achieve this is through an in-depth study of all the parameters that have an influence on the final product and its results. Knowledge must be obtained through actual trials on affected units as well as experience in other automotive plants. Engineering drawings etc. must also be used to determine if any special requirements is necessary during the build process.

The moment one can start to predict the results out of the water test area then the assumption can be made that the system and the knowledge is at a standard that is suitable for the whole process.

## **2.5 PSHYCOLOGY**

This section of control has to do with the management of the people and the understanding of the need of the people. If the operator and his supervision are not involved in the process of problem solving and understanding the implications of their actions then the expectation of solving the problems is low.

The operator should be given the responsibility and accountability for his work and must feel 'important' in the chain of events. Regular feedback systems should be put in place in order for him to measure his success.

Multi-skilling must be introduced to the extent that in the event of sickness and absenteeism another operator, who is trained properly, can perform the

task with good results. This discipline must be introduced and enforced by the direct line management.

## 2.6 PROBLEM FORMULATION CLAIM

Out of the arguments in this chapter the following claim can be constructed:

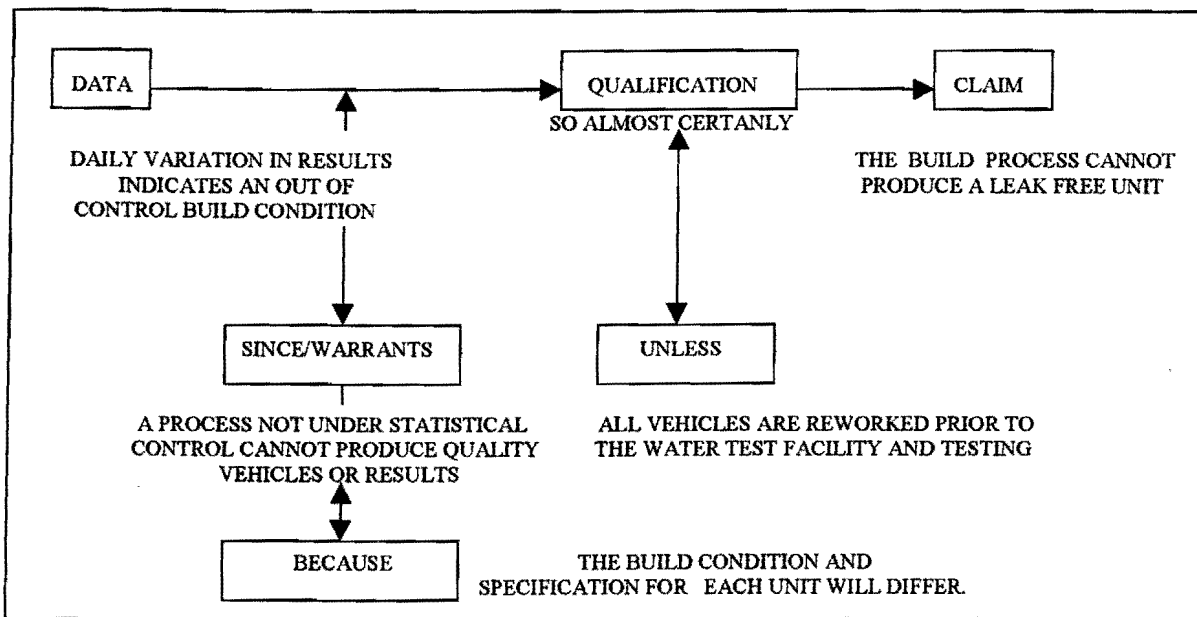

Mitroff (1997) claimed that “the person who controls the definition of a problem controls its solution”, “ a problem well put is a problem half solved”

## 2.7 SUMMARY

In this chapter the basic requirements were laid out as to what the shortcomings in the current process are. The SSM methodology and Deming’s system of profound knowledge were used as a guide and platform to focus on key items. At the end of the chapter a model of the problem was constructed according to the argument mapping principle.

The evidence of variation was confirmed to be the focus activity for this problem and the variation in the systems in process as well as other variations

were discussed. It is clear that the process is not under statistical control in the current state and unless this is true, any effort to rectify the problem will not be successful in the medium to long term.

In order to act on this problem a sound theoretical background is essential and in the next chapter the theory behind Deming's philosophy will be discussed in detail to understand the process better and to plan the required intervention or problem solving methodology.

## **CHAPTER THREE**

### **CHAPTER INTRODUCTION**

In the previous chapter the problem was formulated as a process variation problem. The variation is not only in one specific area but over the total spectrum of events that can influence the quality of the finished vehicle, once it arrives at the water testing facility.

In this chapter the theory, according to Demming, will be evaluated and studied to see how it can compliment the practice and which remedial action can be taken, based on the theory.

The four disciplines that will be studied are: Understanding the organization as a system, Knowledge of variation, Theory of knowledge and Psychology.

### **3.1 UNDERSTANDING THE ORGANIZATION AS A SYSTEM**

#### **3.1.1 INTRODUCTION:**

In this section the organization as a system will be investigated and explained. Systems in an organization will be defined and the interrelationships between the different sub- systems will be focused on.

The importance of the interrelationships between the sub- systems cannot be over emphasized, as the working together to achieve common goals is solely dependent on these interrelationships.

Sociological systems thinking will be investigated and process improvements through systems thinking will be described.

Viable systems and requisite variety will explain management's role in dealing with variety and variation, and finally a total systems intervention methodology will be drafted as a sure way to solve problems through systems approach in organizations.

### **3.1.2 WHAT IS A SYSTEM?**

According to Deming (1994) a system is a network of interdependent components that work together to try and accomplish the aim of the system. A system must therefore have a well-defined aim, because without an aim there could be no system, and if there are a system it must be managed.

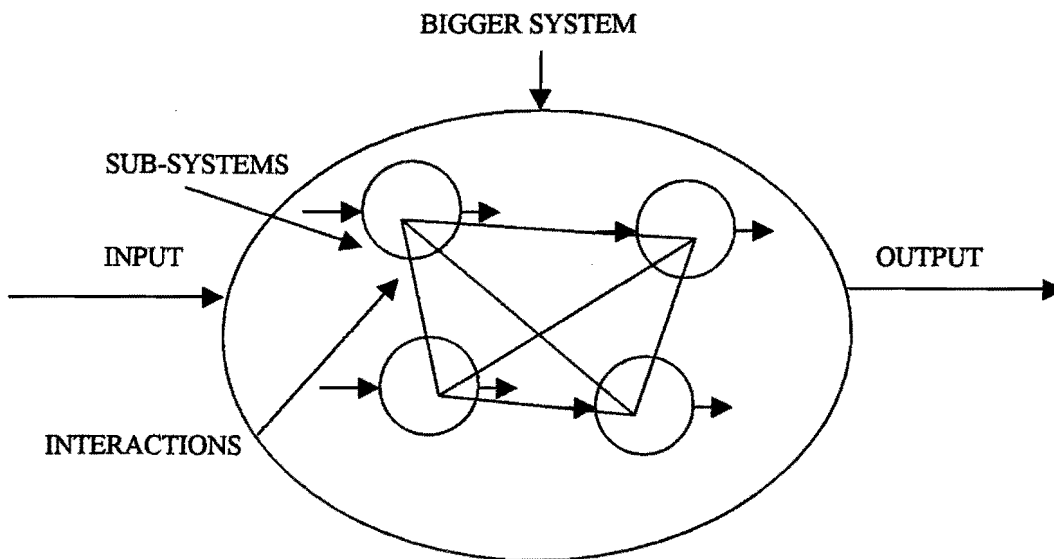
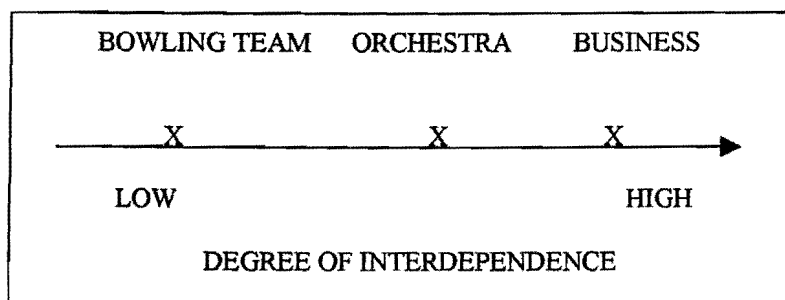

**FIGURE 3.1 SYSTEMS EXPLANATION (AFTER BEER 1981)**

The figure illustrates four smaller sub-systems that function in a bigger system. The bigger system then functions in an even bigger system and so on. Each system is characterized by an input and an output with a transformation process in-between. The following rules apply when systems are investigated:

- 1) The output of the bigger system is not a sum total of the outputs of the smaller sub-systems, but a function of the product of the interrelationships between the sub-systems.
- 2) Any sub-system can be allowed to change as long as it does not affect the output of the bigger system.
- 3) If a change to one of the sub-systems influence another sub-system, but it does not affect the bigger system, then it can proceed to change with the approval of the other sub-system.
- 4) If one of the sub-systems wants to change but it hasn't got the resources from it can negotiate the help from another sub-system at lower management level.

The greater the interdependence between the components in the system the greater will be the need for communication between them. The greater the interdependence the greater will be the need to manage the system. The following figure illustrated the interdependence between certain systems:



**FIGURE 3.2 INTERDEPENDENCE FROM LOW TO HIGH (AFTER DEMING 1994)**

The individual components of a system must support each other to achieve a common goal and try and achieve individual goals, if not one system can kill off another component of the system, which will result in total system failure.

A system is judged by the outcome produced by the system as a whole and not the individual component achievements.

A classical example of a system which is not balanced is where the Purchasing department save cost by purchasing a cheaper product, but the cheaper product cause heavy production losses down stream which result in the non achievement of productivity targets. The Purchasing department did achieve their internal cost reduction target but the system as a whole failed by not producing the required amount of goods.

Negotiation in a system should always be on the basis of best for everyone. The impact of the negotiation in a system will loose it's effect if one or more of the components of system functions drops out of the process to negotiate the aim, function, structure or any other facet of the system.

Jenkins (1969) classified systems in the corporate environment as mostly complex systems. The following are characteristics of complex systems:

- 1) Complex systems are self-stabilizing.
- 2) They are purpose full and have meaning.
- 3) They use feedback to modify their transformation processes.
- 4) Complex systems can modify themselves.
- 5) They are capable of maintaining, reorganizing and repairing themselves.

If the above characteristics are deemed important then it is essential to identify the system you are dealing with and to understand the working of the system properly before changes or new systems are designed.

To derive a systems model the UCT group (1997) outcome will be adopted. Certain drivers will result in certain outcomes, which are

applicable to systems management. The following figure illustrate the drivers and outcomes:

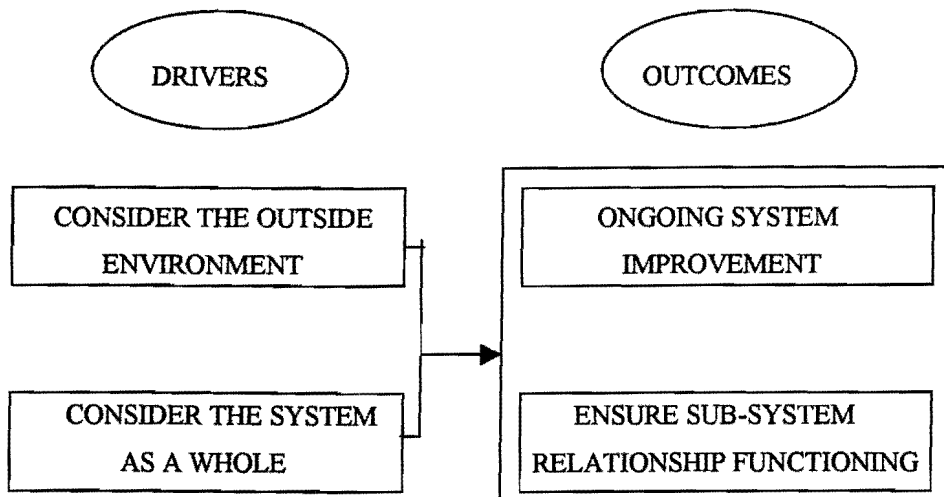

**FIGURE 3.2 SYSTEMS MODEL. (AFTER UCT GROUP 1997)**

### **3.1.3 SOCIOLOGICAL SYSTEMS THINKING**

Jackson (1993) saw organizations as being complex systems made up of parts in mutual interaction. They may exhibit surface change, but deep down, they are in a state of unchanged equilibrium. The important factor to understand is the factors that might cause personal dis-equilibrium amongst workers. Management must understand how they should sustain organizations in equilibrium by the careful manipulation of inducements to stakeholders.

Barnard (1993) sees organizations as “cooperative systems”. When an individual tries to do something, he is subjected to strict physical and biological constraints that determine what is possible to achieve. In order to realize major tasks, therefore, individuals have to cooperate, and this gives rise to the birth of cooperative systems.

Cooperative systems will persist as long as they are effective and efficient. Barnard (1993) links effectiveness to the success of the organization in accomplishing its purpose. Efficiency relates to the need to provide, to individuals who cooperate, a surplus of satisfaction over dissatisfaction. Unless these individuals receive such a surfeit they will not continue to remain as members of the organization. Effectiveness and efficiency are achieved through the interactions among people as managed by both formal and informal structures of the enterprise.

The formal structures are the consciously coordinated activities that define a common purpose, reward members, and put individuals in communication with one another. The informal structures are those that arise without common coordinated purpose.

From the above Barnard (1993) derived his conclusions of what executives should do in order to manage the cooperation as well as the people.

- 1) Organizational communication must be maintained by creating a proper structure for the enterprise, selecting suitable people for the executive role, and securing an informal organization that backs up and supports the formal.
- 2) Essential services must be secured from appropriate individuals by making them aware of the organization, bringing them into cooperative relationship with it, and making sure they are motivated to work for or with the organization by offering them sufficient inducements in return for their contributions.
- 3) The organizational objectives should be formulated and the idea of a common purpose inculcated at all levels of the enterprise.

Parson (1957) derived four functional imperatives that must be adequately fulfilled for a system by its sub-systems if that system is to continue to exist. The well known AGIL mnemonic can be employed to analyze and link the various levels of system right through from the individual personality system to the social system.

The meaning of the terms that make up AGIL is as follows:

- A: Adaptation - the system has to establish relationships between itself and its external environment.
- G: Goal attainment – goals have to be defined and resources mobilized and managed in pursuit of those goals.
- I: Integration – the system has to have a means of coordinating its efforts.
- L: Latency – (or pattern maintenance) – the first three requisites for organizational survival have to be solved with the minimum of strain and tension by ensuring that organizational “actors” are motivated to act in the appropriate manner.

### **3.1.4 PROCESS IMPROVEMENTS THROUGH SYSTEMS FOCUS.**

Variation and bad quality is a result of a process that is out of control. According to David and Sarah Kerridge (1998), there is not one way to improve a process, but many. These are not alternatives. Used with understanding, all contribute to the continual improvement of the particular process, related processes, and the whole system. Each makes other methods more effective, and so they should be used together. To

illustrate this, we concentrate on the practical problems of using the Deming cycle, and show how other actions help it work.

Deming (1994) argued that a unified approach to improvement will be much preferred over separate techniques, the secret lies in a systems approach. Any one action taken might produce dramatic results on its own, but the result of the whole system might not be affected at all. More often it is the interaction between components and their results that affects the systems outcome, what is more, we must see the investigation into one process as an integral part of the transformation of the whole organization. Without this transformation it is hard to improve an individual process, and the improvement, even if we achieve it, seldom lasts. But working on a process can make some of the ideas of overall transformation more concrete, and fix them in everyone's minds. The first question is always "what is the aim"? The following points illustrates the improvement process as well as the questions that we must ask:

- 1) Study the customers needs. Is the output of our process the most helpful that could be given to them? Is it causing problems in a later process? There is no point in improving a process until you know what a good result really means.
- 2) Flow-chart the process. Are there unnecessary stages? Have you identified all the internal and external customers and suppliers? Do you listen to them?
- 3) Improve the training of the process operators. Introduce Operational Definitions, and make sure they work.
- 4) Study ways to measure inputs and outputs. What measures are most relevant to success of the process? Check that the

measurement process is under statistical control before attempting to use the measurements to study the process.

- 5) Reduce variability of the inputs. The inputs include every way in which the rest of the system affects the process. Can you reduce the numbers of internal, and external suppliers to the process? Do the suppliers understand your process?
- 6) Study the outputs and inputs of the process using control charts. Remove special causes. Eliminate tampering.
- 7) Collect suggestions for improving the process, and test them using the Deming cycle.

There are more ways to improve a process, including various special experimental designs. However the listed seven are enough to improve any process. The less variation in a process the clearer will be the results of any improvement. The following figure illustrates a typical Deming cycle:

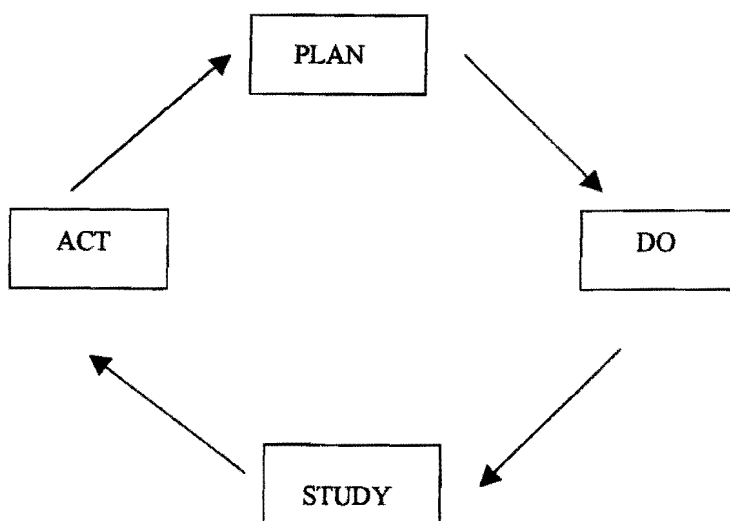

**FIGURE 3.3 THE DEMING IMPROVEMENT CYCLE**

Plan	Decide what to try and predict the changes which will result.
Do	Carry out the plan, preferably on a small scale.
Study	Observe the results, and study them carefully.
Act	Apply the lessons learned to the whole system.

Rules when applying the Deming cycle are:

- 1) Observations and theories must satisfy the rules of operation meaning.
- 2) Final judgment on the accuracy of prediction must wait until the thing we are predicting (not necessarily the whole system) has reached a state of statistical control.

Both these rules contribute to stability. Operational meaning makes sure that different people will observe the same thing and make the same predictions under the same circumstances. This ensures stability from one observer to another. Statistical control ensures that the prediction will be stable over time, and so continue to work in future.

The most important changes are such as new technologies, new product, large changes, etc. but when considering an existing process them small improvement changes are yielding the best results. This is because the system soon returns to a state of statistical control after a small change, but may take a long time to recover from a large change.

Another reasons for making changes in small steps, when we can is that failure costs money. On a laboratory scale total failure does not influence the company that much but when the same failure happens during production the cost could be very high.

In management we actually want to change the system. Every change that makes the organization less chaotic is not only an improvement in itself, but makes problem solving and the PDCA cycle work better.

Learning with the aid of theory makes us see things we would rather not see, and ask questions we would rather not ask. Only if we genuinely want improvement will we dare to use it consistently.

### 3.1.5 VIABLE SYSTEMS

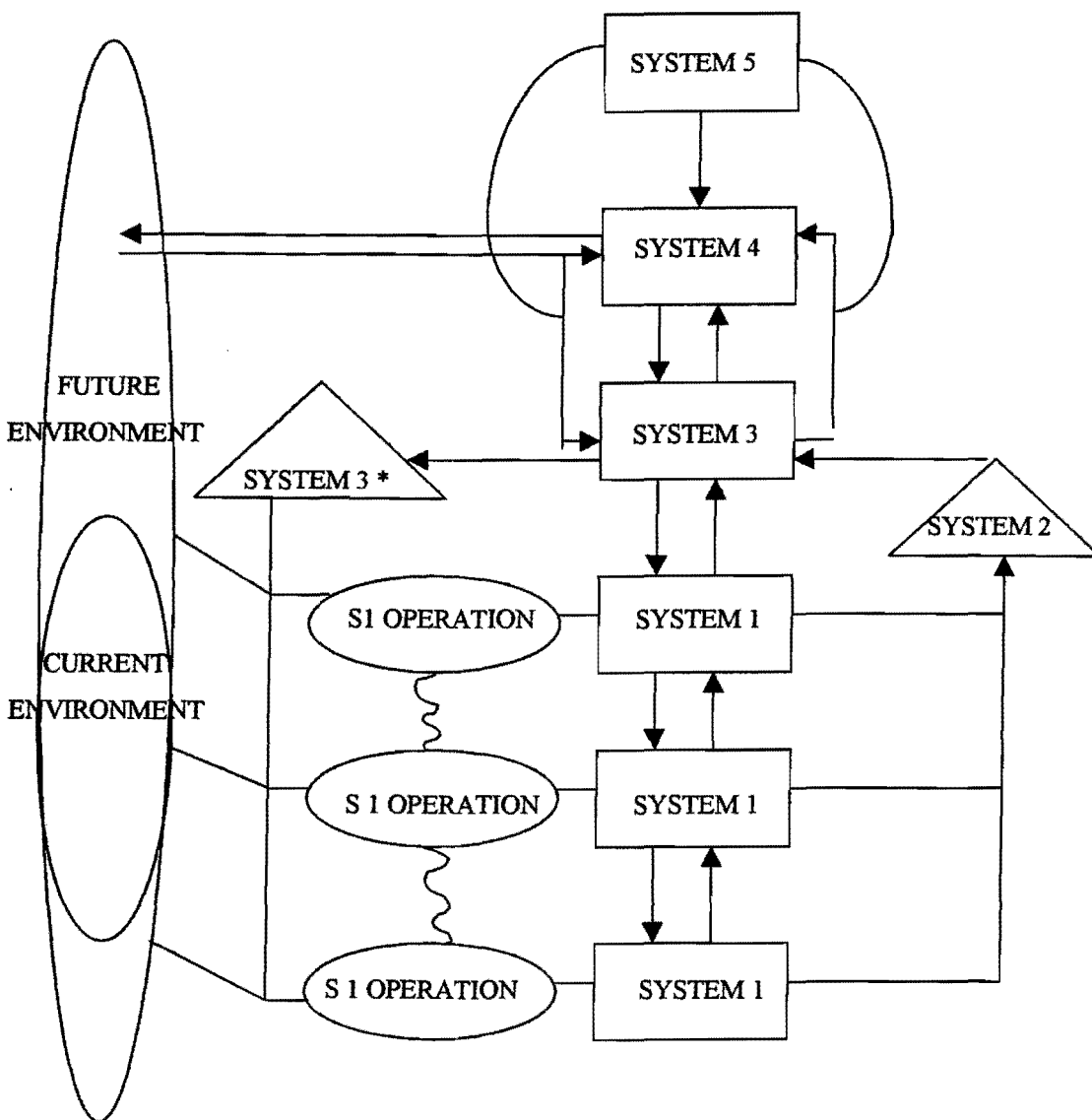

**FIG. 3.4 COMPLETE VIABLE SYSTEMS MODEL SHOWING ALL FIVE FUNCTIONS AFTER BEER, (1981)**

According to Beer (1981), a system is viable if it is capable of responding to environmental changes even if those changes could not have been foreseen at the time the system was designed. In order to become or remain viable, a system has to achieve requisite variety with the complex environment with which it is faced. It must be able to respond appropriately to the various threats and opportunities presented by the environment. The exact level at which the balance of varieties should be achieved is determined by the purpose that the system is pursuing.

Beer sets out a number of strategies that can be used by managers to balance the variety equations for organizations in a satisfactory way. These involve variety engineering and are designed to fulfill two requirements:

- 1) The organization should have the best possible model of the environment relative to its purpose.
- 2) The organization's structure and information flows should reflect the nature of that environment so that the organization is responsive to it.

With the above in mind the VSM, or viable systems model, according to Beer will have the following functions embedded: implementation, coordination, control, development and policy. The different functions will be summarized as follows:

#### **1) System one (S1)**

This system is concerned with implementation, with carrying out the task that the organization is supposed to do. The function has its own relations with the outside world, interacts with other subsidiaries, and has its own localized management. S1 is

connected to the wider management structures by a vertical command axis. In order to make the parts of system one autonomous they must all be viable systems designed in accordance with the VSM. Local management must accept and implement instructions from higher management, use negative feedback to maintain performance, and report back.

System one must also accept coordination and control by Systems two (S2) and three (S3), which are designed to facilitate the effective interaction and performance of all the divisions

## **2) System two (S2)**

System two is a coordination function. Under normal circumstances, compatible instructions from higher management should ensure that the various parts of S1 of an organization act in harmony. A few direct functions of S2 will involve: problem solving, process evaluation, process flow, product and facility design, scheduling, standardization, inventory control, materials, etc.

## **3) System three (S3)**

System three is a control function. It does not initiate policy but interprets it in the light of internal data from system two and system three\*, and external data from system four. It is responsible for passing a coordinated plan down the line to system one. It must oversee the effective implementation of policy and distribute resources to the parts of system one to achieve this. It has to monitor the performance of system one. Three kinds of information systems converge on system three:

- 1) S3 is on the vertical command axis as part of corporate management. It transmits detailed interpretations of policy downward, and S1 information upwards. It acts to send vital information upward extremely quickly.
- 2) It receives and acts upon information from system two. It might send instructions downward or consult upwards based on this information.
- 3) It respond to information received from system three\* advising on the fate of particular subsidiaries.

A few direct functions of S3 will involve: objective measure control, capacity management, OPS-Management, quality and cost management, people and methods management, resource management, performance measurement, etc.

#### **4) System three\* (S3\*)**

This is the audit channel, it is their to give system three direct access to the state of affairs in the operational elements. Through this channel, system three can get immediate information, rather than relying on information passed to it by the localized management. of the subsidiaries. System three might want to check directly on quality, or on employee morale, or to see that maintenance procedures are being followed. Only system three, with information provided to it by system four, can know how essential any subsidiary is to the whole enterprise and therefore take action affecting its future; hence its need for direct access. System three\* is a vital function in any viable system.

## 5) System four (S4)

This is the development function of the organization and has two main tasks:

- 1) It acts as the biggest “switch” in the organization. It switches instructions down from the thinking chamber of the organization, which is system five, to the lower level systems. And it switches upward from systems one to three, information required by system five to take major strategic decisions. System four must filter the information given to system five to prevent “overloading” of system five.
- 2) It must capture all relevant information for the organization about its total environment. If the organization is to be viable and, which it finds itself. To do this it must have a model of the environment that enables predictions to be made about the likely future state of the environment and allows the organization to respond in time. System four must provide the organization with this model.

Relevant environmental opportunities and threats must be identified and given through to system three for quick response and to system five for strategic planning.

System four must have its main focus on the environment, the Customer, the product and the people. A few direct functions will include: corporate planning, market research, operational research, research and development, and public relations. Beer proposed that system four becomes the “operations room” of the enterprise, a “real environment of decision” in which all senior meeting are held.

## **6) System five S(5)**

System five is responsible for the direction of the whole enterprise. It is the thinking part of the organization, formulating policy on the basis of all the information passed to it by system four and communicating the policy downward to system three for implementation by sub-systems. One of the most difficult tasks is balancing the sometimes-conflicting internal and external demands placed on the organization.

The internal demands are represented by the commitment of autonomic management to optimizing ongoing operations. Whereas the external demands are represented by system four, which with its links to the environment tends to be outward and future orientated. Typical functions will include: human policy, strategic change, policy generation, remuneration, human resources policy, etc.

Beer recommended that system five be arranged as an elaborate, inter active assembly of managers-a "multinode".

This is the basic structure of the VSM and the relevant processes as described by Beer (1981).

### **3.1.6 VIABLE SYSTEMS AND REQUISITE VARIETY**

The following figure illustrates a viable system within its environment with management within the viable system. Management also has certain mental models.



We are therefore faced with imbalances of varieties of management, the organization and its environment. Of all the environment variety, only part of it will be relevant to the viable system in focus, that is the part that will disturb the viability of the system and the same relationship will apply between management and the viable system.

It is impossible to accept and digest all information generated by the environment and therefore there will always be some form of filter between the environment and operation and between operation and management. Likewise there will always be some sort of amplifier between management and the organization and between the organization and environment. The following figure illustrates the filter and amplifying principle:

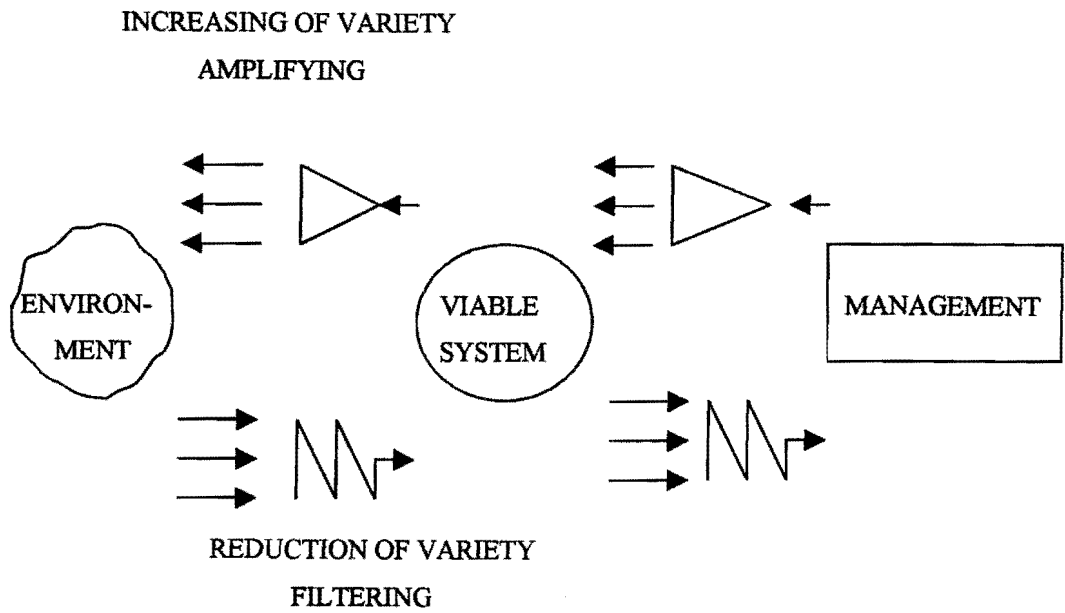

**FIGURE 3.7 FILTERING AND AMPLIFYING VARIETY (AFTER BEER 1981)**

### **3.1.7 TOTAL SYSTEMS INTERVENTIONS.**

Total systems interventions (TSI) as described by Jackson (1991) represents a new approach to planning, designing, “problem solving” and evaluation. The process employs a range of metaphors to encourage creative thinking about organizations and the difficult issues that managers have to confront. These metaphors are linked through a framework, the “system of systems methodologies”, to various system approaches, so that once informed agreement is reached about which metaphors most thoroughly expose an organization’s concerns, an appropriate system based intervention methodology can be employed.

Choice of an appropriate systems methodology will guide “problem solving” in a way that ensures that it addresses what are found to be the main concerns of the particular organization involved.

The philosophy underpinning TSI is “critical systems thinking” Critical systems thinking can be seen as making its stand on three positions. These are “complementarism”, “social awareness”, and the promotion of “human well – being and emancipation”.

TSI consists of three phases, which are labeled: “creativity”, “choice” and “implementation” The following table will summarize the TSI process:

**TABLE 3.1 THE THREE PHASE METHODOLOGY (AFTER FLOOD AND JACKSON 1991)**

<u>CREATIVITY</u>	
TASK	TO HIGHLIGHT AIMS, CONCERNS AND PROBLEMS
TOOLS	SYSTEM METAPHORS
OUTCOME	"DOMINANT" AND "DEPENDANT" METAPHORS HIGHLIGHTING THE MAJOR ISSUES
<u>CHOICE</u>	
TASK	TO CHOOSE AN APPROPRIATE SYSTEM BASED INTERVENTION METHODOLOGY
TOOLS	THE "SYSTEM OF SYSTEM METHODOLOGIES": THE RELATIONSHIP BETWEEN METAPHORS AND METHODOLOGIES.
OUTCOME	"DOMINANT" AND "DEPENDANT" METHODOLOGIES CHOSEN FOR USE
<u>IMPLEMENTATION</u>	
TASK	TO ARRIVE AT AND IMPLIMENT SPECIFIC CHANGE PROPOSALS.
TOOLS	SYSTEM METHODOLOGIES EMPLOYED ACCORDING TO THE LOGIC OF TSM.
OUTCOME	HIGHLY RELEVANT AND CO-ORDINATED INTERVENTION.

There are seven principles embedded in the three phases of TSI, these are:

- 1) Organizations are too complicated to understand using one management "model" and ether problems too complex to tackle with the "quick fix"
- 2) Organizations, their strategies and the difficulties they face should be investigated using a range of systems metaphors.
- 3) Systems metaphors, which seem appropriate for highlighting organizational strategies and problems, can be linked to appropriate systems methodologies to guide intervention.
- 4) Different system metaphors and methodologies can be used in a complimentary way to address different aspects of organizations

and the difficulties they confront.

- 5) It is possible to appreciate the strengths and weaknesses of different systems methodologies and to relate each to organizational and business concerns.
- 6) TSI sets out a system cycle of inquiry with iteration back and forth between the three phases.
- 7) Facilitators, clients and others are engaged at all stages of the TSI process.

The process of total systems intervention will be illustrated according to the following figure:

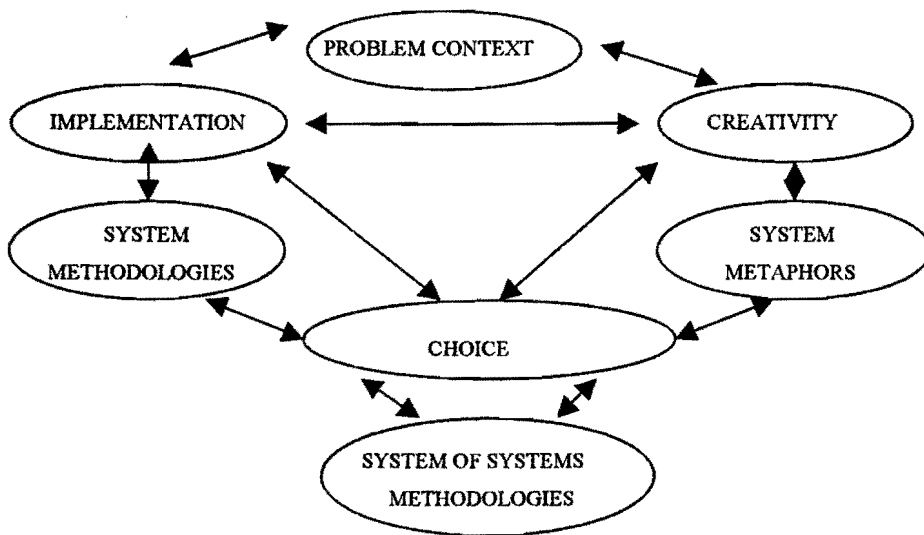

**FIGURE 3.8 THE PROCESS OF TOTAL SYSTEMS INTERVENTION (AFTER FLOOD 1991)**

### **3.1.8 SUMMARY**

The importance of systems and the interrelationships between the different sub- systems as well as improvement through systems methology was

discussed and it is obvious that systems make out a major foundation in any company.

In order to react on variety the system selected and under control must be able to react to the variety in order to stay viable, on the other hand the system must be able to reduce requisite variety in order to focus on the important issues and not let the variety damage the operations.

In the following section the issue of variation will be considered and ways of handling variation will be discussed.

## **3.2 KNOWLEDGE ABOUT VARIATION**

### **3.2.1 INTRODUCTION**

From chapter one it is proven that variation in any form must be managed and controlled. Variation on the shop floor results in non-conformance to the specification which in turn results in rework, which means added cost to the product. Variation can also originate from the environment in the form of new products or information; this variation must be managed through sound management principles and must be minimized to a controllable level.

In this chapter the variation sources will be discussed as well as means to manage variety.

### **3.2.2 VARIATION AND ITS SOURCES**

According to Deming (1994) *life is variation*. There will always be variation between people, in services, in products, in processes. The obvious opposite of variation is stability.

When do data indicate that a process is stable, that the distribution of the output is **predictable**? Once a process has been brought into statistical

control, it has definable capability. A process that is not in statistical control has not a definable capability: its performance cannot be predicted.

There are **common causes and special causes for variation**. Common causes of variation produce points on a control chart that over a long period all fall inside the control limits. Common causes of variation stay the same from day to day and sample to sample.

A special cause of variation is something special, not part of the system of common causes; it is detected by a point that falls outside the control limits. The following figure illustrate common and special causes

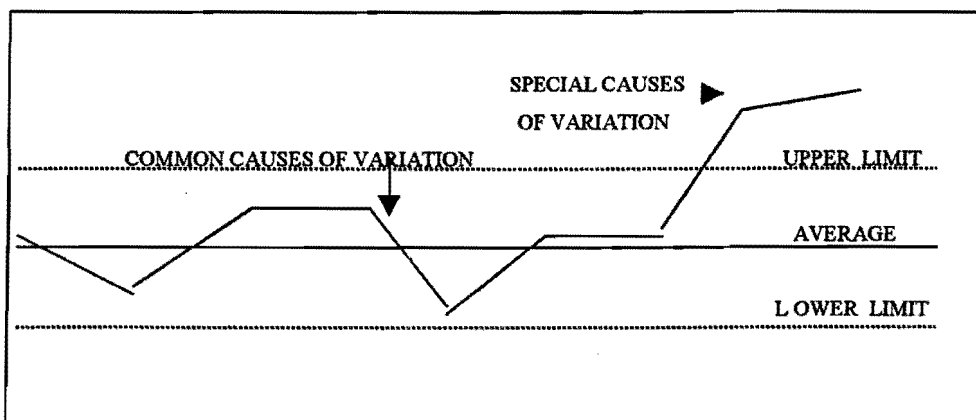

**FIGURE 3.9 COMMON AND SPECIAL CAUSES OF VARIATION (AFTER WHEELER 1993):**

A point outside the control limits is a signal of a special or assignable cause, which indicates the need for action. The cause of the out of control situation must be identified and eliminated as far as possible to prevent reoccurrence

There are usually **two mistakes** that are made in attempts to improve results, both costly (Out of the crises, p 318).

Mistake no. 1 to react to an outcome as if it came from a special cause, when actually it came from common causes of variation.

Mistake no. 2 to treat an outcome as if it came from common causes of variation, when actually it came from a special cause.

Unfortunately it is not possible to reduce both mistakes to zero. It is better to make mistake no. 1 now and then and mistake no. 2 now and then in order to try and minimize the net economic loss from both mistakes.

The ultimate aim is to reduce variation to such an extent that the result or the outcome of the system can be **predicted**. When the control chart display all points inside the control limits and no points outside these limits then the process are in statistical control and the outcome of that process can be predicted. The quality, quantity and cost of the system are predictable and 'just in time' begins to take on meaning. In the absence of statistical control, no prediction is possible and the process is in chaos.

The **capability of the process** can be determined once the process is in statistical control. The capability of the process to meet the specification can be predicted and calculated.

Once the process is in statistical control for a long period of time the next step is to **improve the process**. This may require some capital investment or not, but in any case the economical advantage of the improved process will dictate if it is necessary or not. There are two ways of improving the system: either to narrower the variation or to move the average to the optimum.

It is of vital importance to realize that **specification limits are not the control limits**. Control limits must be calculated from the data gathered. A process can be in statistical control but produce defective goods. The control limits indicates the capability of the process at the time, and it might not satisfy the specification. If there are points or result outside the

specification then the good must be separated from the bad by means of inspection or sorting, if there are points outside the control limits the action required is to bring the process back within the control limits and not the specification.

Variation can come from many sources. Activities within the operation management system can disrupt standard work flow, as can the actions of such groups as marketing, engineering, purchasing etc. Managers can categorize all variances as either controlled or uncontrolled. A controlled variance is a variation from a standard process that an operator can correct or manage whilst an uncontrolled variance is a variation from a standard process due to the impact of some factor outside the control of the employee or operator. The following examples can be listed as sources of variation on the shop floor:

Man	instability in effort, knowledge, commitment, etc.
Material	instability in quality, delivery, availability, etc.
Method	variation in methods, no standardization, etc.
Machine	variation in accuracy, wear and tear, etc.

Under man, the following important factors must be listed:

- **Training** levels of operators must be to such a standard that the control limits of the process can be satisfied.
- **Absentees** on critical operations must be controlled to prevent variation from a new 'untrained' operator.
- **Motivation** of the operators must be constant to produce a constant result
- **Working environment** must be created to stimulate performance.
- **Constant** feedback to the shop floor to display performance and achievements.

Under material the following important factors must be listed:

- **Quality** of raw material or parts to be constant.
- **Availability or delivery** of material must be on time.

Under method the following important points must be listed:

- **Proven methods** to be developed and implemented
- **Standardization** of methods to ensure low variety.
- **Training of operators** to these methods.

Under machine the following important points must be listed:

- Accurate **machine settings** to satisfy specification.
- Well **maintained** equipment and machines.
- **Standardization** on machines and settings.
- 

### 3.2.3 COST OF QUALITY AND VARIATION

Variation in the process will lead to product or goods that do not conform to a specification and as a result the quality of the product will be bad and the product could be rejected or must be reworked to a satisfactory level.

Juran (1980) suggested that quality must be defined as fitness for use. This broad definition accommodates variation in levels of quality, so it does not force the same level of quality for every situation. Fitness for use result from five major product trails: quality of design, quality of conformance, availability, safety and field use. To make a product with these five traits, managers must carefully control quality and variation over the entire product life cycle from concept to design to prototype to production to

phase out or renewal. With this statement in mind both Deming and Juran advocated an appropriate statistical tool for each quality trait.

In order to understand the impact of bad quality or variation in the process it is better to express it as a cost factor. It attracts top management's attention immediately and certain support for the problem will be the resultant action from the top. Cost of quality is an accounting system that states all the cost associated with defective product in rands and cents. These include the cost of making, finding, repairing, of avoiding defects. To simplify data analysis, Juran divided all costs among four categories:

- *Internal failure cost*: Cost that result from detection of quality defects in products prior to shipment to customers, including scrap, salvage, rework, excess inventory, and inspection.
- *External failure cost*: Cost that result from identifying defects in products after they have reached the customer, including complaint adjustment, loss of goodwill, returned material, and field service or repairs.
- *Appraisal cost*: Cost that *result* from examinations to access products' quality levels, including incoming material inspection, product and process inspections, inspection staff, and maintenance of test equipment.
- *Prevention cost*: Cost that results from efforts to prevent defects and limit failure and appraisal costs, including quality planning, new product reviews, training, process control, periodic improvement projects, and continuous improvements.

The cost of poor quality, captured by the sum of the internal and external failure cost, often becomes surprisingly large, sometimes accounting for 50 to 80 percent of the overall cost of quality. Measurements of the COQ also provide guidelines for investment in prevention.

### **3.2.4 DEMINGS 14 POINTS ON MANAGEMENT**

Deming (1903) derived 14 points that summarized his views on management and its relationship with quality. Altogether, these guidelines describe a fundamental basis for an organization's culture. They define a process by which managers actively seek out bad habits and practices and replace them with better, more effective and more stable practices. The 14 points are as follows:

- 1) Create consistency of purpose for continual improvement of product and service.
- 2) Adopt the new philosophy for economic stability.
- 3) Cease dependency on inspection to achieve quality.
- 4) End the practice of awarding business on price tag alone.
- 5) Improve constantly and forever the system of production and service.
- 6) Institute training on the job.
- 7) Adopt and institute modern methods of supervision and leadership.
- 8) Drive out fear.
- 9) Break down barriers between departments and individuals.
- 10) Eliminate the use of slogans, posters and exhortations.
- 11) Eliminate work standards and numerical quotas.
- 12) Remove barriers that rob the hourly worker of the right in pride in workmanship.
- 13) Institute a vigorous program of education and training.
- 14) Define top management's permanent commitment to ever-improving quality and productivity.

### 3.2.5 VARIETY ENGINEERING

Managers are unable to make accurate predictions either about the organizations they manage or the environments within those organizations. They are continually confronted by unexpected occurrences that they and their organizations must have the capacity to respond to if those organizations are going to be successful. They have to learn to live with probabilistic systems. Ashby (1956) defined the variety of a system as the number of possible states it is capable of exhibiting. It is, therefore, a measure of complexity. Obviously, variety is a subjective concept depending on the observer.

The problem for managers, as Ashby's "law of requisite variety" has it, is that only variety can destroy variety. In order to control a system, we need to have as much variety available to us as the system itself exhibits. So, if a machine has twenty ways of breaking down, we need to be able to respond in twenty different ways to be in control of the machine.

The answer is that we must either reduce the variety of the system we are confronting (variety reduction) or increase our own variety (variety amplification). This process of balancing varieties is known as "variety engineering" (Beer 1979).

Managers have to learn how to use variety reducers, filtering out the vast complexity of operational and environmental variety and capturing only that of relevance to themselves and the organization. And they have to learn how to use variety amplifiers, amplifying their own variety vis-à-vis the operation and the organization variety vis-à-vis its environment. The following figure illustrates the variety engineering principle:

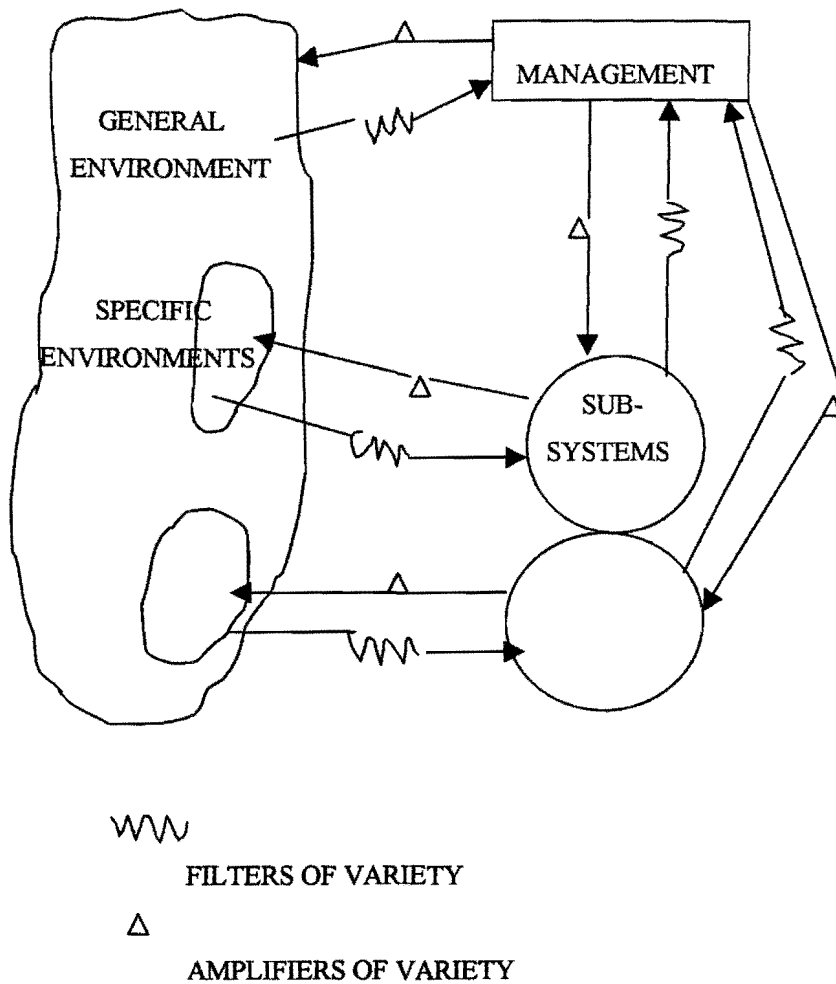

**FIGURE 3.10 MANAGERIAL VARIETY ENGINEERING (AFTER ESPEJO, 1997)**

Beer (1981) mentioned some techniques that managers can employ to reduce external variety of both kinds (operational and environmental) and amplify their own variety. In reducing the external variety confronting them, managers can use the following methods:

- 1) **Structural** (e.g. divisionalization, functionalization, massive delegation)
- 2) **Planning** (e.g. setting priorities)
- 3) **Operational** (e.g. management by exception)

In amplifying their own variety, managers can employ the following methods:

- 1) **Structural** (e.g. integrated teamwork)
- 2) **Augmentation** (e.g. recruit experts, employ consultants)
- 3) **Informational** (e.g. management information systems)

Variety engineering forms part of the three building blocks of cybernetics, which are: the black box technique, feedback and variety engineering.

### **3.2.5 SUMMARY**

Out of this section it is clear that variation is the main focus requirement to produce quality products. Processes must be under statistical control in order to build consistent products and improve on the current working methods. Variation cost money and the impact is normally huge in relation to build- in quality the first time.

Deming suggested certain rules on variety management and it is management's task to focus on the elimination of variety and variation in the work place in order to 'make' money and ensure a viable organization. The next section will discuss knowledge and the acquiring of knowledge to empower management to make the right decisions

## **3.3. THEORY OF KNOWLEDGE**

### **3.2.1 INTRODUCTION.**

In this section the principles of knowledge will be discussed. Knowledge about the process and product will enable management to predict the

future, and once one can start predicting the outcome of certain activities the road to success is much easier.

Gaining knowledge is not about doing something someone else did already, but it is about actual learning. Management must ensure a 'learning environment' and must allow people to make mistakes through which knowledge is gained. The learner or inquirer must pursue the problem to acquire the right knowledge, and these principles and techniques will be laid out in this chapter.

### **3.3.2 KNOWLEDGE AND PREDICTION**

Deming (1994) stated that management is prediction. The theory of knowledge helps us to understand that management in any form is prediction.

**Knowledge** is built on theory. The theory of knowledge teaches us that that a statement, if it conveys knowledge, predicts future outcome, with risk of being wrong, and that it fits without failure observations of the past.

Rational prediction requires theory and builds knowledge through systematic revision and extension of the theory based on comparison of prediction with observation.

**Theory** is required to build knowledge. It is extension of application that discloses inadequacy of a theory, and need for revision, or even a new theory. Again without theory there is nothing to revise. Without theory, experience has no meaning. Without theory there is no question to be asked, hence no learning can take place. Theory is a window, it leads to prediction, and without prediction experience and examples means

nothing. To copy an example of success without understanding it with the aid of a theory may lead to disaster.

**Data** needs prediction, a result of an experiment or trial requires interpretation in order to predict the outcome under real conditions. This prediction largely depends on knowledge about the subject matter. A clear distinction must be made between information and knowledge. Information is available in a dictionary but it is not knowledge.

There is a definite need to distinguish between data, information and knowledge according to Earl (1989). Knowledge is considered as a strategic resource. It is however important to distinguish between knowledge and intelligence, the two concepts are connected in the sense that intelligence is required to produce knowledge and in turn knowledge provides a foundation upon which intelligence can be applied. One source of knowledge is science, science can be described the gathering and presentation of information through methods that turn the data into knowledge. If you can use data to measure, judge and make decisions from then you have knowledge. Experience on the other hand has value and experience is untapped knowledge.

Three levels of knowledge do exist: science, judgement and experience. Out of this two models for knowledge can be postulated: The First is a hierarchy of knowledge where each ascending level represents an increasing amount of structure, certainty and validation. Each level also represents a degree or category of learning. Experience requires action and memory, judgement requires analysis and sensing, whilst science requires formulation and consensus.

**MODEL 1: LEVELS OF KNOWLEDGE (AFTER EARL 1992)**

METHAPHOR	KNOWLEDGE STATE	TYPICAL COMPONENTS
SCIENCE	ACCEPTED KNOWLEDGE	LAWS, THEORIMS AND PROCEDURES
JUDGEMENT	WORKABLEKNOWLEDGE	POLICYRULES,PROBALISTICPARAMETERS AND HEURISTIC
EXPERIENCE	POTENTIAL KNOWLEDGE	TRANSACTIONS, HISTORY AND OBSERVATION

This classification could be argued to be synonymous with the distinction between data, information and knowledge. The lowest level is the equivalent of transaction data and transaction processing systems. The middle level is the equivalent of information in the classical sense of reducing uncertainty to make decisions and thus equivalent also of decision support system. The highest level is knowledge where use is constrained only by its availability or the intellect to exploited and thus approximate to the classical expert system or what some call intelligent knowledge based system.

The second model attempts to describe the difference between data, information and knowledge:

**MODEL 2: KNOWLEDGE AS STRATEGY (AFTER EARL 1992)**

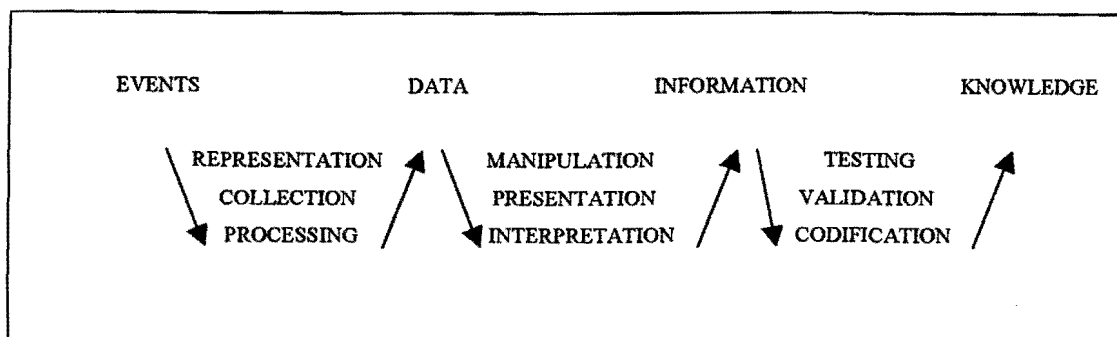

Out of the discussion is clear that knowledge is a strategic advantage. Knowledge is also described as a science.

### **3.3.3 KNOWLEDGE AS SCIENTIFIC METHOD**

Knowledge and prediction goes hand in hand. The reason why *we want to know* is to be able to predict what is going to happen. Scientific method depends on the continual and systematic improvement of prediction. It applies whenever prediction is possible, regardless of the subject. Once a theory has been developed we check it in several ways to determine its ability to predict. The final test for any theory is the accuracy of the prediction it makes.

Although scientific method is used in different ways in different subjects, David and Sarah Kerridge ( 1998), argued that it always depends on the same theory of knowledge, and the same basic principles. These four steps which we must take before prediction is useful.

- 1) Clarify what is to be predicted.
- 2) Improve the measurement process.
- 3) Make sure that the thing to be predicted is stable.
- 4) Define and test the limits within which the prediction rule works.

Number one and four depend on the concept of Operation meaning. The other two depend on establishing a state of statistical control, not necessarily for the whole system, but at least for the things we want to predict. If we follow the steps these steps, the prediction remains accurate and useful, even if the explanation later proves wrong.

The management of science is no different from preventive medicine, ecology or other similar subjects, which all deal with large and complex

subjects. The system studied such as a factory is far more easily changed to bring them under statistical control and make the scientific method work better. One way of looking at the fourteen points of Deming (1994), and the Deming philosophy as a whole, is that it creates the right conditions for scientific method to work effectively.

Those who say that scientific method will not work in their business is probably right: it cannot work in a state of chaos. Nor can it work if people are afraid to report what really happens. In fact skepticism about the use of scientific method outside the laboratory is often justified, given the way it is misunderstood and misused... David and Sarah Kerridge (1998)

In management we look at whole systems, and each system is unique in some way. Because we are involved in rapid change and in creating new situations, we must understand how to use theory and practice effectively. Of course, we use what is known from basic theory and subject knowledge, but we regularly meet problems needing new knowledge. The problems are less "fundamental" than those of pure science, but scientific method is still the best way to solve them.

In industry mistakes are very expensive, and in untransformed organizations they will usually be covered up, instead of welcomed as an opportunity to learn. The old belief was that practice was the only way to gain information and the solution for the problem was basically handled through the following three ways of thinking:

**1) Reason**

By using facts about the world, which seemed obviously true, from these, by strict logic, alone they build up systems to solve problems.

2) **Authority**

By quoting someone else that instead of understanding their methods and reasoning. This is only mental laziness, why waste time arguing over a point if you can quote someone else.

3) **Experience**

The practical approach. Experience seems to be all we can rely on when a situation is too new or too little understood, to have any guiding principles.

These ways are being used every day, and most people never use any other. Why should they when these are good enough? The answer is that what can be done by these methods has in most cases already been done. This is no longer good enough any more and we must strive to perfection in all directions.

The new and powerful way of learning, which is called the scientific method, combines the three previous methods and ways of thinking, so that they help each other rather than compete.

*Logic is used to state a theory clearly, and find its consequences, in the form of predictions. Then experience, in the form of careful observation, or designed experiment, is used to check on the theory, so that when it fails, it can be improved. Finally the body of fully tested theory takes the place of authority, in the older systems.* It can always be revised but most of the time we can safely accept its conclusion, just because it has been thoroughly questioned already.

The following scientific rules must be followed strictly and then there will be nothing to fear, and every thing to gain:

- 1) *A scientific theory is a rule for predicting the future.* It may be a simple "rule of thumb", or expressed as a mathematical equation.

If it predicts accurately, it is a good theory, if it does not it is bad. Whether it is “true” in any other sense is usually both meaningless and irrelevant. Even a false theory can be useful, if we use it scientifically: that is, as a guide to experiment and exploration, not as something to be trusted blindly. Most new knowledge has come from using false theories in this way.

- 2) *A good theory, in this sense, is a summary of experience*, and is easier to use, to learn, and to explain than a disorganized mass of observations. Other things being equal, a simple theory is better than a complicated one, and a general theory is better than a special theory. Failing other compelling reasons, an existing theory is better than a new one. We already know that it works reasonably well.
- 3) *However accurate the predictions from a theory, they never prove it true*, since we can not know what will be observed in the future. But one definitely established wrong prediction proves it false. Every time succeed in disproving a theory, we make a great step forward in knowledge. This leads to a third rule for preferring one theory to another: a theory, which could be more easily disproved, if false, it is better than one which could explain anything. This is usually the same as choosing the simpler theory.
- 4) *In the strict sense, no theory can be completely false, if it ever made useful predictions*. What happens is that its limitations are more and more clearly understood, or that it is replaced by a theory that is more accurate, more widely applicable, or easier to use. Most of the theories of physics are now seen to be “wrong”, but most are still in use. It is safe to use them because their limitations are understood. No one uses General Relativity to build a house.

The emphasis on prediction shows how well suited scientific method is to management. Managers must make plans, which depend on prediction. Even if their rule is to do what worked last time, this uses the unspoken prediction that tomorrow will be much like yesterday.

In order to put scientific method to work the following rules by David and Sarah Kerridge (1998) is not absolutely essential but they speed up learning from experience:

- 1) Prediction is the key to scientific method, so the first priority is to ***get the system under statistical control***. Until we do this, prediction is impossible, as the system is chaotic. The second priority is to ***reduce variability***, since this enables us to predict more accurately.
- 2) Make sure you know ***what theory you are using***: otherwise you cannot improve it. If you think you are relying on “experience”, find out the rules by which you classify situations as similar. You do not know what theory you are using until it has been stated in the form of a prediction that can be checked by observation.
- 3) ***You cannot afford to question every theory each time you use it***. Use generally accepted theories to make predictions, but never use it blindly. Take every opportunity to check on the accuracy of your predictions, certainly by monitoring processes, and where possible by well designed experiment.
- 4) ***Never rely on general impressions, or memory, when you can measure***. But never ignore what you cannot measure: only the purest scientist can afford this luxury.

- 5) ***Never keep a theory for yourself.*** The very act of explaining it helps to clarify it. What is more, others will more easily see the faults in a theory you have postulated than you will yourself. You must not get too attached to “your” theory, or feel disappointed when it is proven false. ***Proving theories false is the only way to make progress.***
  
- 6) ***Experiment to find the range of applicability of a theory,*** by choosing extreme conditions. But it is a waste of time to perform refined experiments on a system that is not under statistical control. Learn all you can from monitoring things as they are before designing experiments.
  
- 7) ***Use logic reasoning, whether mathematical or otherwise,*** to make predictions that are as remote from the original circumstances as possible. Occasionally the predictions are so obviously absurd that no actual observation is needed. In any case, extremes of all kinds are an aid to understanding. However, a theory does not become useless because it fails in extreme cases: we still use Newtonian gravitation in spite of Theory of Relativity. To misquote the statistician John Tukey “ the more we know about what is wrong with a theory, the more useful it becomes.
  
- 8) ***Statistical thinking is an essential part of scientific method,*** since the agreement between prediction and observation has to be judged statistically. Statistical thinking includes, but not as a major part, the use of correct statistical analysis. Operational definitions, applying the concept of statistical control to the process under study, and the measuring systems used to study it, are of higher priority.

- 9) One of the important things a theory tells us is *which situations should be grouped together for analysis*. In other words, it predicts that certain factors are irrelevant. Testing predictions of this kind, by analysing the effect of these factors, is a most important check on theory.

If the selected theory fails there are no automatic rules to select another theory; the new theory must be “developed” through speculation, teamwork and discussion. Another fact to remember is that the problem cannot be broken down in small segments and solved as individual elements, no, a problem is part of a system and must be handled as such.

### **3.3.4 THE PERSUIT OF ENQUIRY**

Enquiry and the urge to gain knowledge must be interdisciplinary; in other words, at the heart of inquiring mind there must be an urge to go beyond the safety of one’s trained enclosure or comfort zone. To be a good inquirer, therefore, takes effort and the inquirer must realize that expression is open ended and that existence is tied to action. Enquiry can therefore be seen as art.

An important part of inquiry is to be able to understand other experiences, once this art is perfected it can be seen as a hallmark of maturity and the understanding will be objective and not subjective. An objective understanding of other’s experience is the basic building block for the philosophical inquirer. Inquiry into experience need not employ one simple methodology or be circumscribed by one definition, the process is rather dynamic and cannot be dictated by a simple procedure.

Experience and knowledge can be related to one another but can also be very far apart, so as the behavior of certain situations and experiences. The

experiences could be different even though the behavior is the same: this is normally referred to as *the inverted spectrum dilemma*.

The “fabulist” or pragmatic inquirer, is one who must face different hypotheses about a problem and choose. The warranted assumption is that there is a correlation between behavior and experience in creatures like us.

A good inquirer will make himself vulnerable by challenging the very beliefs they argue for. It is this vulnerability that marks the quest for objectivity more than making a case persuading. The inquirer will ultimately have to make a claim after the knowledge gained through the inquiry. The most general feature of what one does when making an objective claim is giving a plausible story. One states one’s belief, (or those likely to be challenged), and the reasons for the beliefs, making a case for their viability by persuading an audience of the merits of the claim and subjecting the beliefs to criticism.

What is persuasive or warranted varies to the subject matter. In one case prediction may be the persuasive factor, in another, it may be the perspicuous analysis of a text. In both cases, what makes it objective, is that it can be criticized, tested or challenged in some form. The inquirer makes a case or claim to which the community can respond.

Prediction of behavior or a situation is possible without referring to experience, but when working with humans or animals one wants knowledge or experience. We must understand other being’s ways of experience, pain and joy, only then can we begin to understand the way they will react or respond to certain information or changes. The analysis of experience, in philosophical terms, is often analyzed in terms of the “what and the how”. What do people experience and how do they experience it. For example, to travel to another country gives us a taste what it is to be somewhere else but also someone else.

Intelligence is taken to mean thinking through an issue or proving an explanation via the rules of thought, the actual inferences made, and the successful strategies displayed. Intelligence is strongly linked to the art of problem solving.

Rationality is, on the other hand, concerned with intelligence action, the claim here is that rationality is aimed at the 'good life', at a wisely lived life, though not necessarily successful. Rationality may lack facility at predicting the future, but it involved the consideration of ends worth pursuing because they enhance the quality of life and promote the art of 'living well'.

There are four essential features of rationality:

- 1) Recognizing other minds while maintaining a healthy respect for the plurality of perspectives they exhibit.
- 2) Trying to legitimate one's views in a public forum.
- 3) Showing fairness to others.
- 4) Appreciating and interpreting the values inherent in things.

The main thesis is that intelligence has to do with problem solving, while rationality has to do with wisdom. The distinction is important, because cultural advancement depends upon being rational or wise: *one can be smart and barbaric, but not wise and barbaric.*

The more intelligent the animal (being) the greater the intentional competence, in other words to bridge intelligence and rationality. This intentional competence is crucial for leadership i.e. The more socially intelligent, the more intentional, thus the greater the possibility for rationality. Features that figure in the evolution of a person's rationality are:

- 1) Others must be taken into account, one's view is one among others, the 'better' perspective may lie elsewhere.
- 2) The legitimization of one's view requires a public social world. The public cannot be shut off.
- 3) People are more just, when they distribute goods and when they consider the perspectives of others, -justice as fairness.
- 4) The destructive capabilities are partially avoided by coming to recognize the value of others.

Thoughts express the essence of mind – one's freedom and what is most distinctly human. Thought and freedom are considered essential human attributes. According to some, this is what makes us different from animals. Losing reason, then is a bit like falling from grace. Reason lies within one, passion does not. Passive render images seemingly true through magical delusional moments. Reason uncovers truth by looking inside – to its own source and free from imposed passion.

Emotions are embedded in thoughts tied to problem solving and making sense of things. There are pure emotions. Inquiry helps to distil the sources of emotion and thought and helps to encourage action based on them.

Inquiry helps us to arrive at sound judgements in a muddled world. Nothing is pure: expressed in the language of epistemology, certainty is rarely to be found.

When an expectation is broken the inquirer is left uncomfortable. At first there is denial of the problem, the inquirer tenaciously holds onto the old beliefs, but finally he acquiesces and confronts the problem. All of us are linked to a 'public' by a means. No one can be without a public linked to test the ideas and to approve or reject them. The role of the leader is thus to guide the inquirers in our institution. Inquirers do what they are told; they do what needs to be done. The leader often decides about the research and areas to inquire into and which tools to use.

Sometimes the growth of knowledge can also be demoralizing as the limitations of the leader and research viewpoints become clearer. Leaders and frameworks, however, come and go, knowledge seems to accrue and discovery of truth, through frail continuous.

### **3.3.5 SUMMARY**

In this section it was demonstrated that *prediction is management*. In order to predict accurately variation must be kept to the minimum through knowledge about the process. Scientific methods is not only for clinic studies but also a powerful principle in problem solving and management of variation.

Variety engineering reduce the variety feeding into the organization to a manageable level in order not to cause variation in product and quality levels.

The next step in managing variation is the psychology block in Demings system of profound knowledge. People plays an important role in the manufacturing process and this is usually the biggest source of variation in a company, the principle will be discussed in the next section.

## 3.4 PSYCHOLOGY

### 3.4.1 INTRODUCTION

In this chapter the management of people will be discussed. Managing people is usually the more difficult task and if the supervision of the people do not understand the first principles of psychology the efforts to improve will be in vain.

People need to know the task and the consequences and that they will have the support to do their best under the given circumstances. The manager of the people has the task to motivate and drive the people to achieve the desired results and a lot of attention on this issue will be given in this chapter.

### 3.4.2 PSYCHOLOGY AND MANAGEMENT

Psychology helps us to **understand people**, interaction between people and circumstances, interaction between customer and supplier and between systems of management. Deming (1994 p 108) stated that people are different from one another and a key objective of management must be to understand the differences and react differently when dealing with different people in different situations. People learn in different ways and at different speeds.

In order to **motivate people** to the fullest the understanding of people is the most important factor. There are intrinsic sources of motivation in the fact that people are born with the will to learn, as well as the need to be wanted and appreciated. Rewarding by acknowledging performance and effort build on intrinsic behavior.

Extrinsic motivation lies in the material rewarding of work done by means of money, etc. Extrinsic motivation in the extreme crushes intrinsic motivation.

Overjustification when someone is rewarded through money for an act that was performed out of sheer pleasure will also affect the overall motivation of individuals. A show of appreciation to someone may mean far more to him than monetary reward.

Hertzberg (1966) investigated the question: "what do people want from their job?"

According to him workers will be motivated to work harder only through intrinsic motivation. Extrinsic factors, including physical working conditions, will only move people to do something and will motivate people to either stay or leave their current job. External monetary rewards usually move people to do something for a limited time period.

Robins (1993) defines hygiene factors as: those factors - such as company policy and administration, supervision and salary - that when adequate in a job, placate workers. When these factors are adequate, people will not be dissatisfied.

According to Deming (1993), after transformation, the manager of people will have the following fourteen roles:

- 1) The manager understands and conveys the meaning of a system. He explains the aim of the system, he teaches his people to understand how the work of the group supports these aims.
- 2) He helps his people to see themselves as components of the system. To work in cooperation with preceding stages and with following stages toward optimization of the efforts of all stages toward achievement of the aim.

- 3) He recognizes and accommodates individual differences.  
He tries to create for everybody interest and challenge, and joy in work. He tries to optimize the family background, education, skills, hopes and abilities of everyone. This is not ranking people. It is, instead recognition of differences between people, and an attempt to put everybody in position for development.
- 4) He encourages his people to study and grow.  
He provides, when possible and feasible, seminars and courses for advancement of learning. He encourages continued education in college or university for people that are so inclined.
- 5) He is a couch and counsel, not a judge.
- 6) He understands the interaction between people and circumstances that they work in  
He understands that the performance of anyone that can learn a skill will come to a stable state – upon which further lessons will not bring improvement of performance. A manager of people knows that in this stable state it is distracting to tell the worker about a mistake.
- 7) He has three sources of power:
  - 7.1 Authority of office.
  - 7.2 Knowledge
  - 7.3 Personality and persuasive power: tact

A successful manager of people develops nos. 2 and 3 and does not rely on no. 1. He has nevertheless obligation to use no.1, as this source of power enables him to change the process – equipment,

material, methods – to bring improvement, such as to reduce variation in output.

He who is strong in authority, but lacking knowledge or personality, must depend on his formal power. He unconsciously fills a void in his qualifications by making it clear to everybody that he is in position of authority. His will be done.

8) He will study results with the aim to improve his performance as manager of people.

9) He will try to discover whom, if anybody is outside the system, in need of help.

This can be accomplished with simple calculations, if there be individual figures on production or on failures. Special help may be only simple rearrangement of work. It might be more complicated. He in need of special help is not in the bottom 5 percent of the distribution of others: he is clean outside that distribution.

10) He created an environment that encourages trust (freedom and innovation)

11) He does not expect perfection.

12) He listens and learns without passing judgement on him that he listens to.

13) He will hold spontaneous meetings, at least once per year, with all his people to establish their aims, hopes and fears.

The purpose would be development of understanding of his people, their aims, hopes and fears.

- 14) He understands the benefits of, and losses from competition between people and groups.

### 3.4.3 PEOPLES MANAGEMENT.

The following example by Beer (1994) can be use to illustrate this section. Suppose that symbols A, B, C, etc. are representing the separate abilities of the people in a company. What benefit does the company receive from its people? The full capability of the people in the company working together, working with and for each other, may be expressed as:

Individuals	$A + B + C + D + \dots$
Interactions	$+ (AB) + (AC) + (AD) + \dots$ $\quad + (BC) + (BD) + \dots$ $\quad \quad + (CD) + \dots$ $+ (ABC) + (ABD) + (BCD) + \dots$ $+ (ABCD) + \dots$

The top line is the sum of the individual abilities of the people in a company. Parentheses denote interactions between people, helping or hurting each other in pairs, triplets, etc. in teams, platforms, chimneys, divisions, departments. An interaction may be:

- Negative
- Zero
- Positive

Why is it that a company as a whole may be less than the sum of the individual abilities  $A + b + C + D + \dots$ ?

One possible answer is that failure of managers to make the best use of the diverse abilities, capabilities, family background, experience and hopes of employees detracts from the possible contribution in the top line.

Another reason could be negative interactions. Why does the company hamper itself with negative interactions? What causes them? One cause may be the merit system, ranking of people, competitive measures, in other words: competition.

One of management's main responsibilities is to know about the existence of interactions to perceive how they originate, then to change negative and zero interactions into positive interactions.

Why is it that someone that leaves our company to go to another one contributes more to the new company than he contributed in ours? The answer lies in the management of people or rather, the mismanagement of people, by which the people in the company do not work together as a system.

***The effect of grading and ranking people are humiliation of those that do not receive top rank. The effect of humiliation is demoralizing of the individual. Even he that receives top grades or top rank is demoralized.***

All the qualities that have been traditionally and erroneously applied to competition actually apply better to cooperation. Cooperation builds character, it is basic human nature, and makes learning more enjoyable and productive.

The following figure illustrates fear, competition, motivation, etc.

**FIG. 3.11 THE FORCES OF DESTRUCTION.**

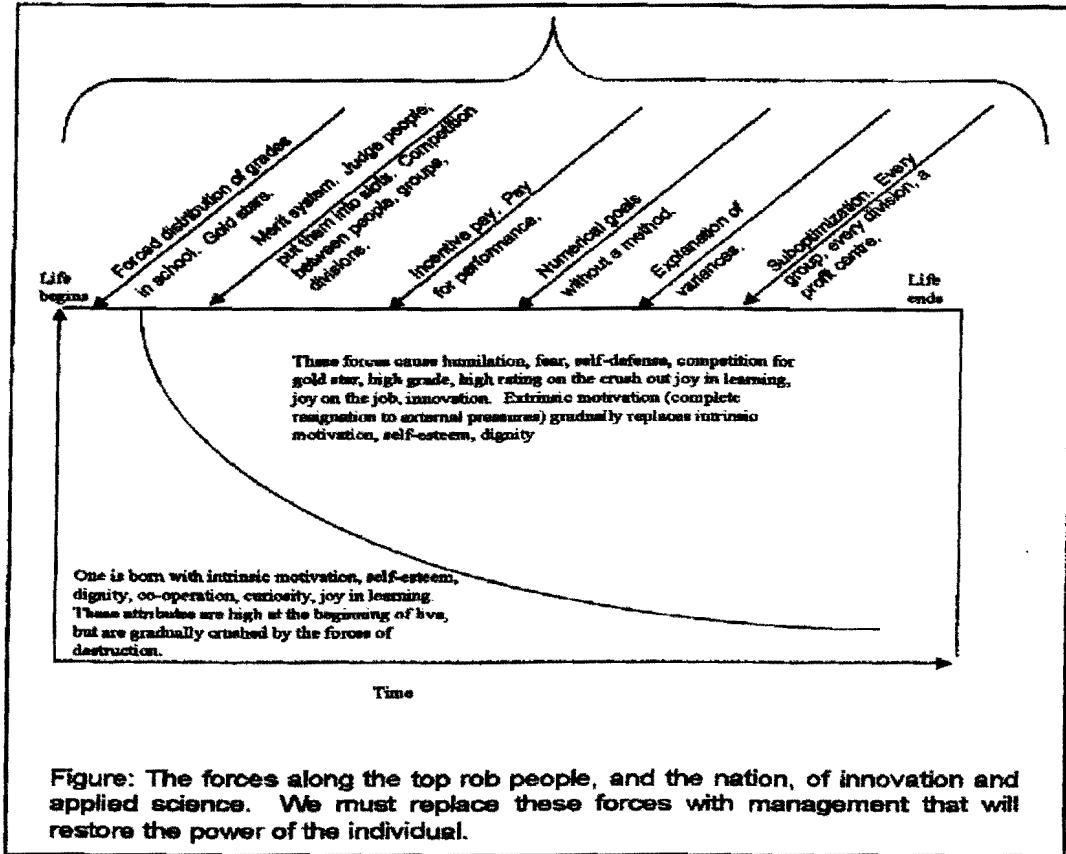

Figure: The forces along the top rob people, and the nation, of innovation and applied science. We must replace these forces with management that will restore the power of the individual.

**FIG. 3.11 THE FORCES OF DESTRUCTION (AFTER DEMING 1994)**

**3.4.4 SUMMARY**

In this section the motivation of the people and the role of the manager were the main focus topic. A motivated workforce is easy to manage and the manager will achieve the desired results, but if the workforce is not motivated the manager will have to apply the skills and principles, discussed in this section, to achieve success. People's management is usually neglected or ignored whilst it is usually the most important item.

## CHAPTER SUMMARY

In this chapter the four principles of Demming's profound system of knowledge were discussed. The theory does compliment the practice very clearly and as a result intervention activities based on the theory must be taken.

The organization as a system clearly displays the need for a viable system to be in place with all the relevant sub-systems in harmony towards the goal. The variety from the environment must be filtered through the system and variation must be kept to a minimum inside the organization in order to produce goods of equal and constant quality.

Variation must be understood and managed through the acquiring of knowledge whilst the peoples factor need strong and fair management in order to motivate and control the workforce and supporting functions.

After this theory study and the previous practical investigations a synthesis excersise is needed to build the knowledge into a sort of model that will help management to solve the problems they encounter on a daily basis as well as non standard problems. In the next chapter the synthesis and framework will be done to combine the knowledge, gathered up to now.

## CHAPTER FOUR

### SYNTHESIS AND FRAMEWORK

#### 4.1 INTRODUCTION:

In chapter three the four Deming principles regarding the system of profound knowledge were discussed, the aim of this chapter will be to synthesize the principles into a model which will give the manager the required tools on variation understanding and problem solving skills.

Schematically the four principles can be illustrated as follows:

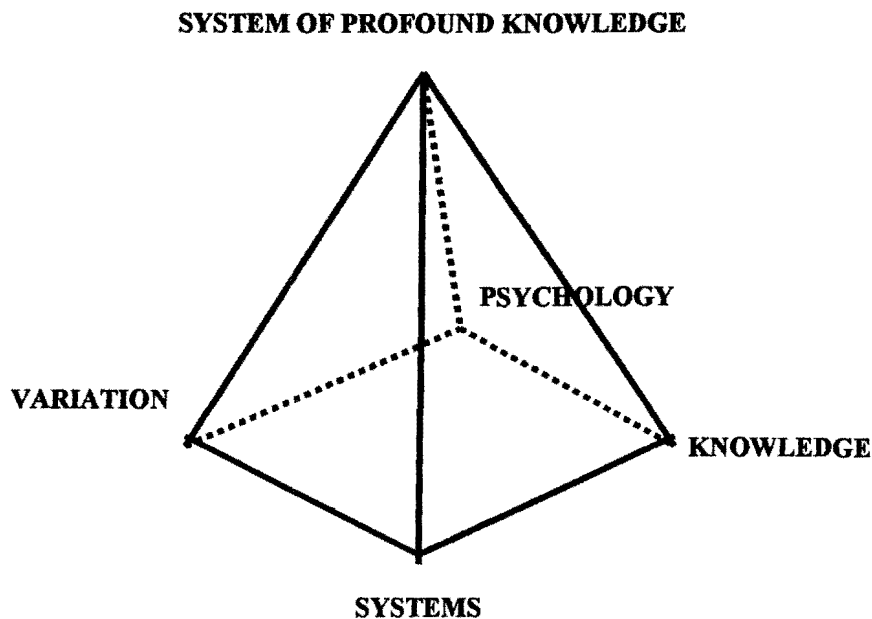

**FIG. 4.1 ILLUSTRATION OF DEMINGS SYSTEM OF PROFOUND KNOWLEDGE**

The Deming system dictates that a specific problem will always have the four 'pillars' as part of the solution to the problem, hence the necessity to build a model that will involve all four of the knowledge principles. Any given problem will fall in a three dimensional spot within the tetrahedron depending on the nature of the problem.

Variation will lean heavily towards the variation pillar, and depending on the other sources, the problem will position itself in the tetrahedron.

Various problem solving models could be derived but each problem will require its own remedial model.

In this chapter the work up to now will be synthesized and various problem solving techniques will be discussed. At the end of the chapter a variation problem solving model will be suggested to solve similar problems.

#### **4.2 SCIENTIFIC METHOD AND CONTINUAL IMPROVEMENT**

Scientific method is the only way to learn from experience. It uses theory, but continually tests and improves it. This is the exact opposite of blind faith. The basic rules of science are always the same, but human systems, such as those in management, can not be dealt with as simply as those in subjects like physics. This is why many people think that scientific method does not apply to management, but it does, provided that we take extra care. This involves:

- 1) Repeated and cautious experiments using Deming Cycle.
- 2) Careful definition of observation and measurement using the concept of operational meaning.
- 3) Stabilization of systems and measurements, by understanding variation and using control charts.
- 4) A unified approach to improvement not confined to one method or just one process at a time, but embracing the whole system.

Practical benefits of the scientific method includes:

- 1) Makes us reject wrong ideas, even though they seem to work.
- 2) Leads to continual improvement of thing that do work.
- 2) Show the way to successful innovation.

#### 4.3 THE CYCLE OF IMPROVEMENT.

The strategy for learning in pure science has three stages:

- 1) **Observe :** Gather facts about the problem as widely as possible.
- 3) **Predict:** Turn the “theoretical” explanation of these facts into a definite rule for predicting the future. It must, of course, agree with what we already know.
- 3) **Explore:** :Check the rule by actively trying to find situations in which it either predicts wrongly, or makes no definite prediction.

Every time we prove the rule wrong, or find a “new” situation, we have new information, and improve our prediction capability. This produces a cycle of ever increasing knowledge, which is not just abstract knowledge, but tells us what will happen if we change things. So we take action with greater confidence, and to a greater effect. This is the cycle, which we use to improve a general theory.

The following figure illustrates the cycle:

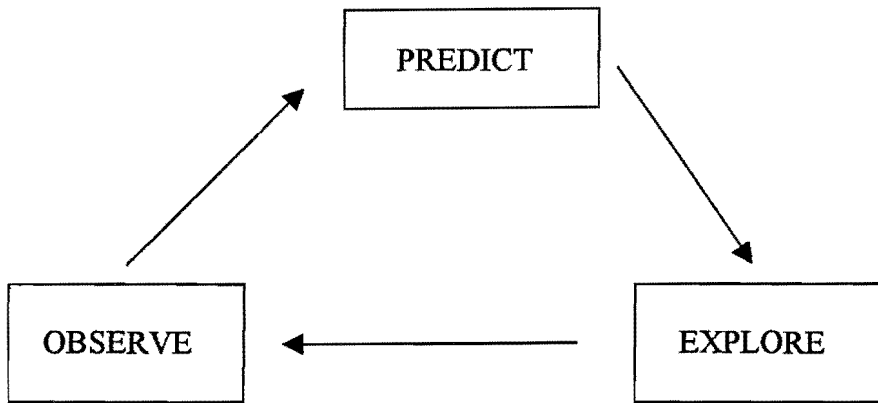

**FIGURE 4.2 IMPROVEMENT CYCLE (AFTER KERRIDGE 1998)**

We can join the cycle at any point, often starting with vague and ill defined ideas, but we must keep going around it in the right direction. Many improvements are small refinements, which do not change the basic idea. Others are more radical. But this approach works with any “fundamental” theory, that holds at all times and places.

#### **4.4 CHANGING THE SYSTEM**

It sounds like if the improvement of management is more difficult than other applications of scientific method, but in many ways it is easier. Pure scientists must not change the nature of systems they are studying. They want to be able to predict how it will work when they are not looking at it.

In management we actually want to change the system. Every change that makes an organization less chaotic is not only an improvement in itself, but makes the PDCA cycle works better. The same applies to all the other changes brought about by applying the Deming philosophy of management. One of the bonuses we get when we apply the 14 points in an organization is it makes learning easier.

The problem of learning are also different because we are dealing with a specific process or system, not a general scientific law. In one way this makes things more difficult, because we can never assume that what works elsewhere will necessarily work in our system. Each system is in some way unique. What is more, we can not assume that what used to work well, will work equally well for ever. Systems change, quite apart from the changes we make deliberately, in the course of continual improvement.

If we are studying a familiar system, with which we have been working for some time, there will be store of accumulated knowledge. This usually means that there will be plenty of suggestions for improvement.

Many of these suggestions will be wrong, but used correctly, even wrong ideas help us to learn.

#### **4.5 IMPROVING A PROCESS**

According to David and Sarah Kerridge (1998), there is no one way to improve a process, but many. These are not alternatives. Used with understanding, all contribute to the continual improvement of the particular process, related processes, and the whole system. Each makes other methods more effective, and so they should be used together.

To illustrate this, we concentrate on the practical problems of using the Deming Cycle, and show how other actions help it work.

**The unified approach** prescribes that a system approach should be used instead of improvement through individual techniques. This is how anything complicated should be tackled. You do not expect a car to perform well if you only fill up the fuel tank now and then, no, the electrical system, the mechanical parts and other functions must all function in harmony for the car to have a good performance level.

The following are listed as different ways to improve any process, always starting with the question: "What is the aim?"

- 1) Study the customers' needs. Is the output of our process the most helpful that could be given to them? Is it causing problems in a later process? There is no point in improving a process until you know what a good result really means.
- 2) Flow-chart the process. Are there unnecessary stages? Have you identified all the internal and external customers and suppliers? Do you listen to them?
- 3) Improve the training of the process operators. Introduce Operational Definitions, and make sure they work.
- 4) Study ways to measure outputs and inputs. What measures are most relevant to success of the process? Check that the measurement processes are under statistical control before attempting to use the measurements to study the process.
- 5) Reduce variability of the inputs. The inputs include every way in which the rest of the system affects the process. Can you reduce the numbers of internal or external suppliers to the process? Do the suppliers understand your process?
- 6) Study the outputs and inputs of the process using control charts. Remove special causes. Eliminate tampering.
- 7) Collect suggestions for improving the process, and test them using the Deming Cycle.

There are more ways to improve a process, including various special experimental designs. However the seven listed ideas are enough to make the point of process improvements. The Deming Cycle relies on checking the results of such a change, using measurement. When the process itself varies less, and the measurement on it is more reliable, it is easier to see the effect of the change.

**The question of what do we do first** can be followed according to the seven listed points, but the priorities will depend on the actual circumstances. This does not mean that we must finish one activity before going on to the next activity: we usually do several at the same time.

Even if the process suffers from a major problem, which must be “fixed” never neglect methods, which improve the overall system. There is a good reason for this. If the cause of the problem had been obvious, such as something broken, it would have been put right immediately. So we expect the investigation to take some time. Occasionally a problem disappears, still unexplained, as part of the overall improvement. Almost always the cause is easier to trace when we improve the system as a whole.

We usually test one change at a time (unless we use advanced experimental design) so if there are too many suggestions, we need ways to choose between them. Some useful questions are listed below:

- 1) Can it be tested on small scale?
- 2) Will the effect be seen reasonably quickly?
- 3) Will the effect be easy to measure?

- 4) Will the types of measurement on the process, which are routinely plotted on control charts, be sufficient to show the effect?
- 5) Has the measurement already been studied and shown to be stable?
- 6) Is the test simple and inexpensive?
- 7) Can the test be done without disturbing the ordinary running of the process?

These questions concentrate on whether a change is easy to try, rather than whether it seems important, or likely to make a big improvement. This is we do not want an inexperienced team to meet many technical difficulties at its first attempt.

The more “yes” answers on the previous questions gives a crude measure of the ease of applying the Deming Cycle.

Once a choice of action has been selected, make sure not to waste any of the information from the experiment Keep systematic records of each stage, especially all the things that did not work at the time.

If an idea does not appear to work, it does not mean that the suggestion should be forgotten. When variation has been reduced by other means, it may be possible to show that the suggestion does work, after all.

**All learning comes from a living partnership between creativity and imagination, on the one hand, and patience, caution and discipline on the other.**

#### **4.6 ‘METANORMAL’ BUSINESS MODEL**

The following figure, after Demings chain reaction theory, shows that the key activities for success are the reduction of waste whilst simultaneously adding value. The two leftmost boxes shows that effort for process

improvement is not enough, that management must also work to remove barriers that prevents people from learning, co-operating, being creative and doing a good job for those that depend on them.

This requires a whole different mindset from the 'common sense' approach to management and brings us back to the business model, which was adopted by Yorkshire Brick. This model is based on Deming's System of Profound Knowledge. We call it the Tetrad.

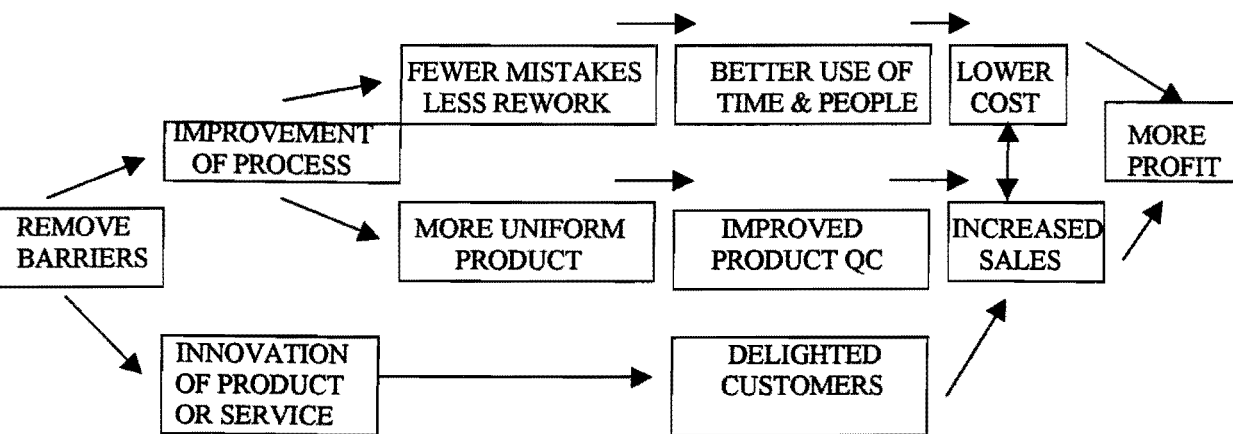

**FIGURE 4.3 'METANORMAL' BUSINESS MODEL (TETRAD) (AFTER DEMING 1992)**

**4.7 SOFT SYSTEMS METHODOLOGY**

The soft systems methodology, or SSM, is a structured method to understand a problem and to put the problem in perspective. Once the problem is analyzed from a bigger perspective right down to the finer detail the problem will be much clearer and 'easier' to solve. The following figure will present a flow of the SSM methodology.

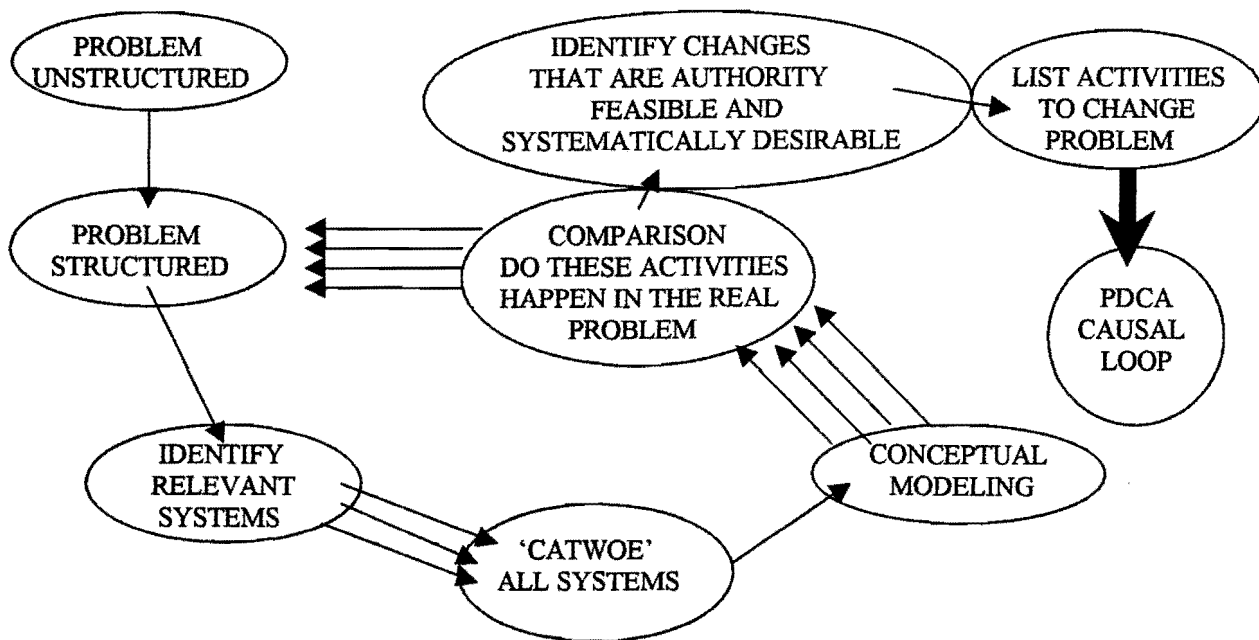

**FIGURE 4.4 SSM PROGRESS CHART (NAUGHTON AND TEAM 1990)**

A brief description of each stage are as follows:

**Problem situation unstructured:**

This is the problem in the 'raw' state, the problem must be tackled from a total open ended view, time needs to be spend with the problem in order to gather information about the situation up to a stage that a 'rich picture' can be drawn on the information in order to structure the information.

What must be avoided at all cost is other peoples opinions based on their past 'experience'. What could be dealing with is a system of interrelated problems or systems that do not work or function at the optimum level.

People involved in the problem will also have their respective views on the cause of the problem which could be misleading at the end. As a soft analyst, you are obliged to take this very seriously indeed, for you are operating on the premise that difference in perceptions may be a determining feature of the situation.

In this stage the following will apply:

- 1) You will have your first encounter with the problem situation.
- 2) Resists attempts-whether by yourself or others-to impose a particular structure on the situation.
- 3) Recognise that if you decide to become involved, you become part of the situation.
- 4) Clarify your own objectives, and your reasons for wishing to become involved.
- 5) Do some thinking about the roles of client, problem - solver and problem – owner in the particular situation.

**Problem situation structured:**

To structure the information from stage one you need some efficient, economical and illuminating way of summarising or representing the situation in all its complexity. You do this by building a cartoon type representation of, which is called, in the jargon of the approach, a *Rich Picture*.

This picture is a way of summarising everything that you know about the situation. It will contain two types of information.

- 1) It contains 'hard' information, by which the factual date is explained – the departments, people, individuals, etc.

- 2) It contains 'soft' information, like subjective interpretations of aspects of the situation. This involves both hunches and guesses about aspects of the situation for which no hard information exists and summaries of the perceptions of the actors involved in the situation.

### **Relevant systems and their root definitions.**

The next stage is to identify the relevant systems in play to understand the complexity of the bigger system in focus. The systems must be relevant to the problem situation in the sense that it will yield insight into the situation when the system is described more fully. Examples of relevant systems could be the inspection system, the data analysis system, the repair system, etc. in a particular situation.

### **Catwoe the systems**

The next step is to Catwoe the systems in play, which stands for:

- C The customers of each system,
- A The actors in each system,
- T The transformation that takes place in each system,
- W The world view of each system,
- O The owners of each system and
- E The environment each system functions in.

The justification for Catwoe - and the source of its power - is that it forces the analyst to ask searching questions about the definition you have drafted.

## **Conceptual modelling.**

Conceptual modelling needs to be done on the systems that have a influence on the system in focus Through conceptual modelling each prominent system could be understood better and subsequent actions will be the best solutions possible. The relevant systems have been identified and we know what the systems are, but it has to be stated what the relevant systems do. This is done by building an activity model of the system, a model of the activities or processes which, logically must go on if the system is to be the one described in the root definition.

The model must be a model of human activity systems. Its elements are therefore activities, and will be represented on paper as verbs. Thus, if your Root definition describes ‘ a system to transform raw material into finished product’, that implies – logically – at least two activities: ‘ obtain raw materials’ and ‘transform into finished product’

## **Comparison**

During this stage the conceptual models must be compared to the rich picture or the real problem to see if they really exist in the situation. The analyst is leaving the abstract world of systems thinking, and bringing the developed relevant systems back into the real world.

The comparison stage involves overlaying, as it were, your abstract model on the problem situation as you have represented it, and drawing some inferences from the comparison between the two.

In general terms one expect to find some similarities and a lot of apparent differences.

## **Implementation of agreed changes**

The proposed changes that will solve the problem situation must be authority feasible and systematically desirable. The changes that will be identified will be 'as observed or analysed', but before the activity plan can be implemented the theoretical background needs to be exploited in order to take justifiable decisions based on proven history.

Typical changes that can come up after a soft systems study are the following:

- 1) Changes in structure: organisation groupings, reporting structures, functional responsibility, etc.
- 2) Changes in procedures: different way of doing things.
- 3) Changes in policy: goals and strategies of the human activity systems being investigated.
- 4) Change in attitude.

## **4.8 THE QC - STORY APPROACH TO PROBLEM SOLVING**

The QC – Story approach to problem solving is another method of structuring problem situations in the workplace. In finding solutions to problems of the workplace a verification type approach based on data has been found effective. Solving a problem and its essence is a step – by – step procedure. Meticulous implementation of each step in turn brings about the quick, positive and effective solution to problems.

Workplace management means creating a workplace in which the main tasks are meticulously carried out in the prescribed way, the five main tasks are: maintain and improve quality, reduce the cost of inputs, reach production goals and maintain delivery schedules, assure safety and improve interpersonal relationships to create a pleasant working environment.

There are ten rules for the QC approach to problem solving:

- 1) Saying there is no problem is a cop-out. There are always problems.
- 2) Get correct and accurate data from all viewpoints. Observe the workplace and situation carefully and use data to get an accurate grasp of what is going on.
- 3) One can't win empty handed. Study the QC techniques carefully, and implement them effectively and thoroughly.
- 4) Skill is important. Acquire specialised techniques and expertise to hone your skills.
- 5) A quick once over will not work. You must proceed methodically through each problem-solving step.
- 6) Don't get carried away with countermeasures. Only take action after you have analysed causes in detail and identified the root problem.
- 7) Computers cannot produce ideas. Aim for ingenuity.
- 8) If you don't proceed logically you will come to a dead end. As you go along, apply QC approach thinking.

- 9) It's no use to urge your subordinates on to greater efforts. You must tackle difficulties yourself.
- 10) Don't give up. Keep your spirits up and fight on to the end.

The QC approach comprises out of seven basic elements and those will be displayed in the following table:

PRO- CEDURE	BASIC STEP	THINGS TO DO
1	SELECTING A THEME	IDENTIFY THE PROBLEM DECIDE A THEME
2	2 UNDERSTANDING THE CURRENT SITUATION, AND SETTING TARGETS	COLLECT FACTS DECIDE WHAT TO ATTACK DECIDE TARGETS
3	3 CREATE A PLAN OF ACTION	DECIDE WHAT TO IMPLEMENT DECIDE SCHEDULES, ROLES, ETC.
4	4 ANALYZING THE FACTORS	INVESTIGATE CHARACTERISTICS VALUES AND CURRENT SITUATION LIST FACTORS ANALYZE FACTORS DECIDE COUNTERMEASURES
5	5 DEVELOP AND IMPLEMENT COUNTERM.	PROPOSE IDEAS THINK ABOUT COUNTERMEASURES IMPLEMENT COUNTERMEASURE
6	6 CONFIRMING EFFECT	CONFIRM COUNTERMEASURE RESULTS COMPARE WITH TARGETS IDENTIFY RESULTS (CONCRETE AND ABSTRACT)
7	7 STANDARDISE AND ESTABLISH CONTROL	ESTABLISH AND IMPROVE STANDARDS DECIDE CONTROL METHODOLOGY EDUCATE SUPERVISORS

The following techniques can be used in the QC approach to problem solving:

<b><i>Activity</i></b>	<b><i>Method and tools</i></b>
<b>Selecting a theme</b>	Pareto Diagrams Cause and effect diagrams Graphs Relation ship diagrams
<b>Understanding the Current situation.</b>	Graphs Pareto Diagrams Control Charts Affinity Diagrams
<b>Setting targets</b>	Graphs Pareto Diagrams Histograms
<b>Creating a plan of Action</b>	Graphs Arrow Diagrams
<b>Investigate causes and Effects</b>	Cause and effect Diagrams System Diagrams Scatter Diagrams
<b>Investigate past and Current situation</b>	Graphs Check sheet Histograms Control Charts
<b>Try stratification</b>	Histograms Scatter plots Control Charts Matrix Diagrams
<b>Look at change over time</b>	Control Charts Graphs
<b>Look at interrelationships</b>	Scatter Diagram Pareto Diagrams Relation Diagrams Matrix Diagrams
<b>Developing and Implementing Countermeasure</b>	Cause and effect Diagrams System Diagrams PDPC Method Affinity Diagrams

<b>Confirming effectiveness</b>	Histograms Control Charts Pareto analysis Graphs
<b>Standardisation and Establishing control</b>	Check sheets Control Charts Histograms Graphs

#### **4.9 RULES FOR DATA PRESENTATION**

Wheeler (1993) suggested that there are two basic rules when data is presented:

- 1) *Data should always be presented in such a way that preserves the evidence in the data for all the predictions that might be made from these data.*

This rule suggests the following: a table of the data on a graph should always be presented with the graph, a table of the values is not sufficient to convey the big picture. We are visually orientated, and tables of data are visually boring, the context for the data should be completely and fully described. This would include the data collector's identity, where the data was collected, how the data was collected and when the data was collected.

Data cannot be divorced from their context without the danger of distorting the data.

- 2) *Whenever an average, range, or histogram is used to summarise data, the summary should not mislead the user into taking any action that the user would not take if the data were presented in a time series.*

Averages, ranges and histograms all obscure the time-order for the data. If the time-order for the data shows some sort of definite pattern, then the obscuring of this pattern by the use of averages, ranges or histograms can mislead the user. Since all data occur in time, virtually all data will have a time-order. In most cases this time-order is the essential context which must be preserved in the presentation.

Out of these two rules the first principle for understanding data is derived:

<p style="text-align: center;">NO DATA HAVE MEANING APART FROM THEIR CONTEXT</p>
--

Three consequences of this first principle are:

- 1) Trust no one who cannot, or will not, provide the context for their figures.
- 2) Stop reporting comparisons between pairs of values except as part of a broader comparison.
- 3) Start using graphs to present current values in context.

**What should one do, starting tomorrow with reference to data?**

- 1) **Begin to collect the right data.**  
Both the data one collect and the data that is reported need to be useful, correct and undistorted by artificial boundaries. Data, which describe the activity, are better than data, which describe

side effects of the process. Data, which concerns things, which the manager can control, are more useful than mere report card data.

**2) Insist upon interpreting data within their context**

This will immediately require, among other things, a transformation of the monthly management report.

**3) Filter out the noise before interpreting any value as a potential signal.**

The failure to do so is a mark of numerical illiteracy, and the illiterate is fair game for the con-artist.

**4) Cease for ask for explanations of noise.**

In the absence of an identifiable signal, the current value cannot be said to differ from the preceding values. In the absence of a detectable signal no amount of explanation however well worded and reasoned, can be supported by the data.

**5) Understand that no matter how the results may stack up against the specification, a process, which displays statistical control, is performing as consistently as possible.**

**6) Always distinguish between the voice of the process and the voice of the customer.**

One cannot begin to get these two voices into alignment until one understands how they differ.

**7) Help others take action on assignable causes.**

Knowing the assignable cause is only the first step. Detrimental assignable causes need to be eliminated. Beneficial ones need to be made part of the process.

**4.10 MODEL**

It is obvious that there is not one way to improve a situation or problem, but many. The method selected will depend on the actual problem, the magnitude of the problem, the people involved in the problem and the circumstances of the problem. What is clear is that by using the best tools any problem can be solved or understood better.

The basic model that will be constructed out of these theories corresponds with the Deming approach.

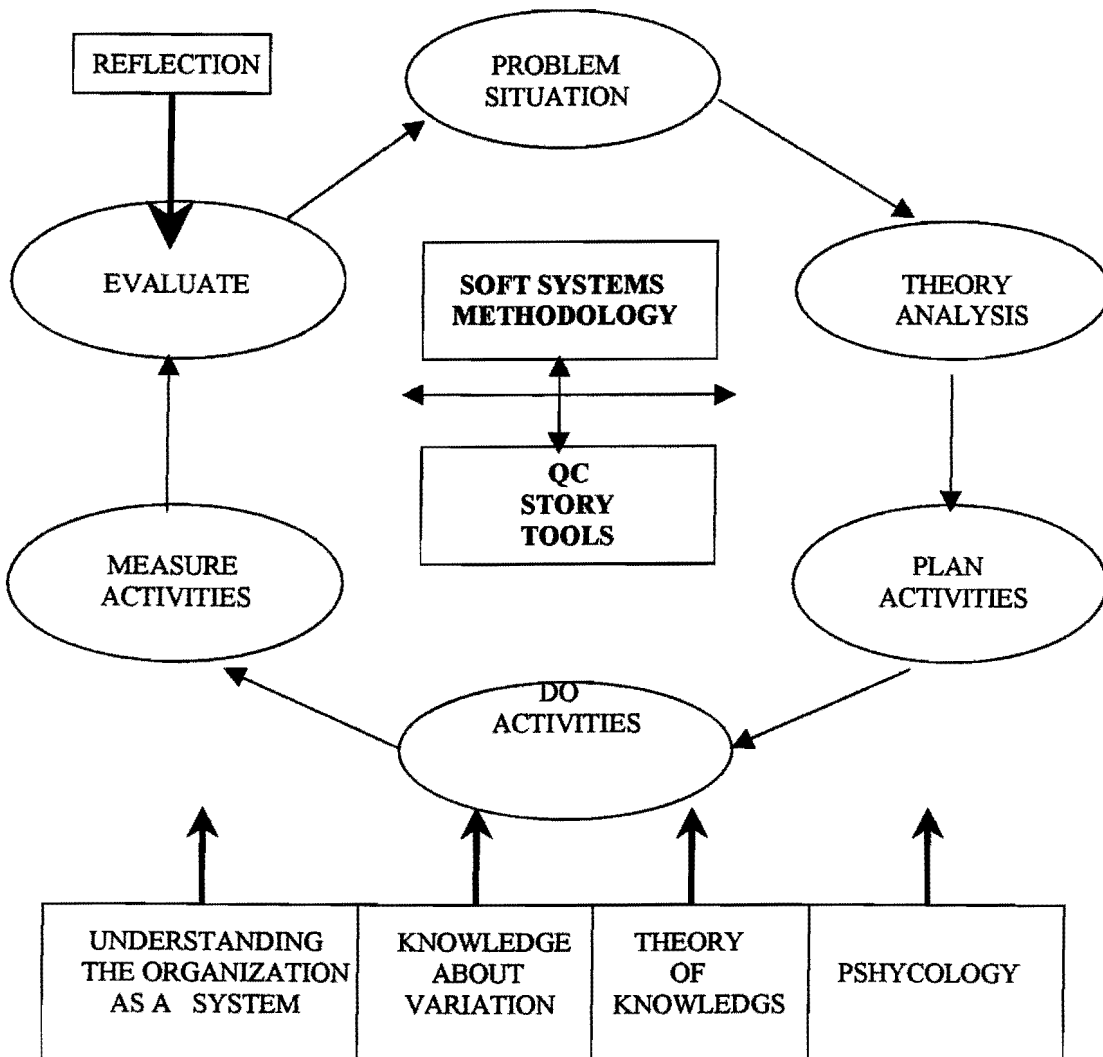

**FIG. 4.5 PROBLEM SOLVING MODEL.**

The model illustrates the basic Deming improvement cycle with the SSM and QC tools as supporting methodologies to understand, measure, analyse and solve the problem.

The model is supported by Demings system of profound knowledge. We must understand that there will be a different model for different situations in the organisational system. Small technical problems can be solved by a simple QC story approach, whereas bigger problems might need a systems approach. The problem or situation and the level in the organisation where the problem exists will determine the model to be used.

Large variations on the shop floor will require a systems approach because of the various variation sources, it might be a supplier part problem that is causing the variation or a human resource problem that is at fault or a process variation problem. The supervision or manager must access the problem or situation and decide the methodology to be used.

#### 4.11 SUMMARY

Various methods and ways of problem solving and improvements have been discussed in this chapter and a model has been derived to guide the manager towards a successful result. It is clear that each situation must be evaluated and a methodology selected to solve the problem effectively. The model also dictates that the most important factor is the evaluation stage, where the countermeasure is evaluated for success. Many problems are solved just to reappear a while later, therefore it is important to solve a problem permanently.

Effective problem solving relies heavy on knowledge. As stated previously: '*a problem well defined is a problem half solved*' If one understands the problem the majority of the work has already been done.

The model clearly illustrates the reflection stage, where the problem solver stands back and assesses the success of the actions taken.

In the next chapter, the reflection stage will be done to see if the model as well as the theory portion did have an impact on the problem as defined in chapter two.

## CHAPTER FIVE

### REFLECTION ON CASE STUDY

#### 5.1 INTRODUCTION

In chapter four a problem solving model was derived for a generic variation problem in the water test area, this model can be used for 'any' variation related issue. Chapter five will reflect on the case study, which was done by the writer in 1999 on the water test area. Refer to the project 'QUALITY IMPROVEMENT INTERVENTION THROUGH S.S.M. METHODOLOGY AND ACTION RESEARCH PRINCIPLES' (Refer to annexure A)

An evaluation will be done, according to the model derived, to see if the application of the model gave the resultant improvement on the straight through ratio at the water test area.

During this comparison the different stages of the problem solving model will be highlighted and discussed according to the actions that were taken.

The different stages of the problem solving model can be summarized as follows:

- Stage 1: Problem situation stage where the actual concern or problem is selected.
- Stage 2: Theory and analysis stage where theories about the problem are constructed together with an analysis of the problem supported by relevant data.
- Stage 3: The planning stage to determine what actions or corrective steps should be taken to solve the problem.
- Stage 4: The 'do' stage where the corrective steps are implemented.

Stage 5: The measuring stage where the results are measured against the targets to confirm the resultant effect of the actions.

Stage 6: The evaluation and reflection stage to determine the new situation.

The different stages can be illustrated by the following figure:

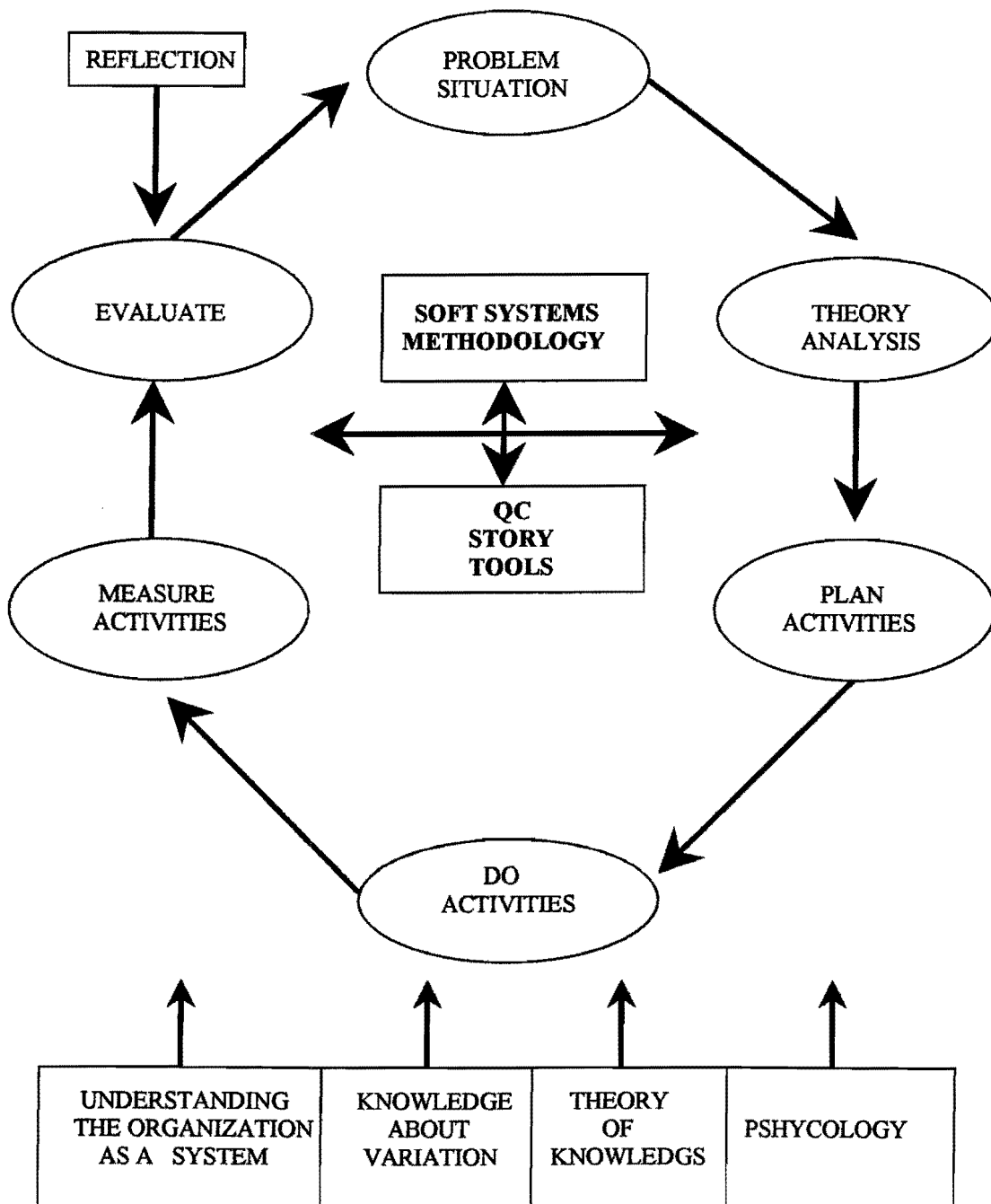

**FIG. 5.1 PROBLEM SOLVING MODEL.**

## **5.2 PROBLEM SITUATION**

The problem situation was established through data gathering from the water testing facility on the straight through ratio of the vehicles being tested. In chapter one the total scenario was described as well as the reasons why this straight through ratio needs to be improved. Pareto analysis were used to illustrate the performance of the water test area.

## **5.3 THEORY AND ANALYSIS**

The theory of why this area was not performing well was described in chapter one as well as in chapter two by using the problem solving model as well as the S.S.M. analysis. Physical observation and studying the area were used.

The analysis of the concerned areas per model derivative were as follows:

**TABLE 5.1 IMPROVEMENT ITEMS PER MODEL**

MODEL	DESCRIPTION	Q1 PERFORMANCE	Q4 PERFORMANCE
B140	DOOR FRAME	67.3 %	81.0 %
	DOOR PLASTIC	71.8 %	97.2 %
QW	DRIP RAIL	47.1 %	98.5 %
	BACK PANEL	65.1 %	97.9 %
ES	DOOR RUBBER	55.1 %	91.1 %
	BOOT FLANGE	64.1 %	88.1 %
EQ	DOOR PLASTIC	67.1 %	97.2 %
	TAIL LIGHTS	54.8 %	86.9 %

## **5.4 PLAN ACTIVITIES**

The following points or shortcomings were highlighted by the SSM study that was done in the area:

- 1) Awareness of operator activities and the resultant influence

- 2) Accurate working hours which includes stop- and start up.
- 3) Introduction of proper and proven repair material and equipment.
- 4) Standardisation of work, which includes build and repair processes
- 5) Accurate defect reporting system, and feedback to defect source area.
- 6) Explicit defect description for accurate action.
- 7) Information accuracy.
- 8) Operator discipline.

## **5.5 DO ACTIVITIES**

The following activity plan was developed and implemented as a result of the SSM study:

- 1) Information session to inform all involved of the intentional activity and the expectations as well as the targets.
- 2) Develop data- and control sheets for measure and tracking of success.
- 3) Implement the changes visually on the production lines.
- 4) Do actual investigations on defects to understand the countermeasure needed to solve the problem.
- 5) Conduct I.E. study to calculate volume capacity.
- 6) Upgrade repair equipment.
- 7) Investigate repair material and test material for suitability.
- 8) Develop written standards for repair work and material.
- 9) Introduce accurate defect description system.
- 10) Audit and check information for reporting system.
- 11) Continuous training of operators on rework and repair standards.
- 12) Introduce repair method in the actual production line.
- 13) Monitor success rate and countermeasures.

To assist the operator to build consistent vehicles with minimum variation with 'no' water leaks, the following information was developed and visually displayed at the actual working station.

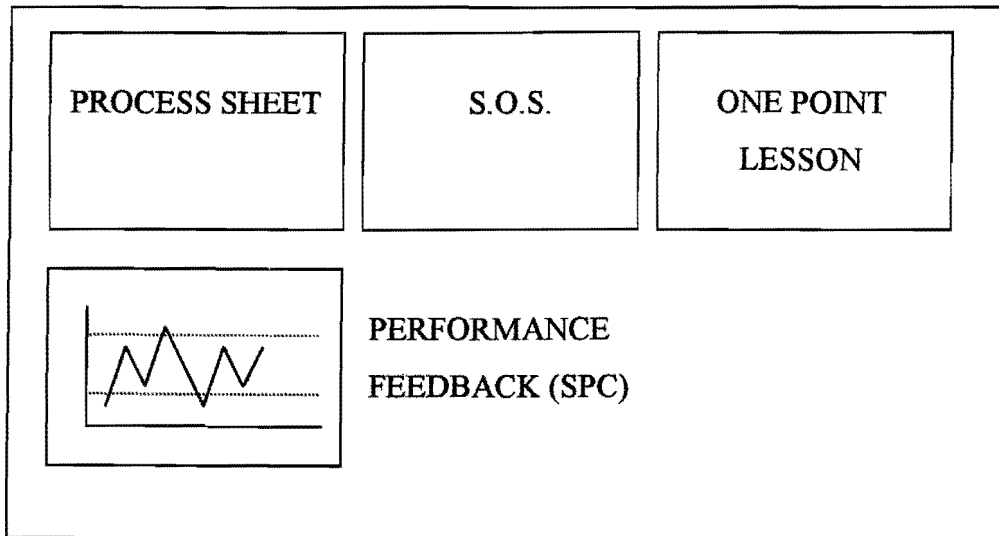

**1) Process sheet**

This is the Engineering document that explains the build procedure and the key points for build specification. All the focus defect items were properly investigated and the process sheets were revised to give the instructions to the production people as accurate as possible.

**2) S.O.S.**

This is the standard operation sheet that is drafted by the line foreman, from the process sheet. All the S.O.S illustrations were revised to illustrate the best build method to the operator on the line to ensure 'no water leak' build method.

### 3) One point lesson

This is a document that illustrates a key point operation to the operator. Additional skill or method requirements will be displayed on this sheet, if required.

### 4) Performance graph on SPC method

This graph illustrates the straight through ratio at the water test area. The graph gets updated every day so that the operator can visually see his build performance. If there has been an operator doing the activity, which was not fully trained up, to do the job, the graph and feedback will illustrate an increase in reject rate. The foreman can then easily see which operator produce poor work.

## 5.6 MEASURE ACTIVITIES

The following results were obtained through the intervention activity:

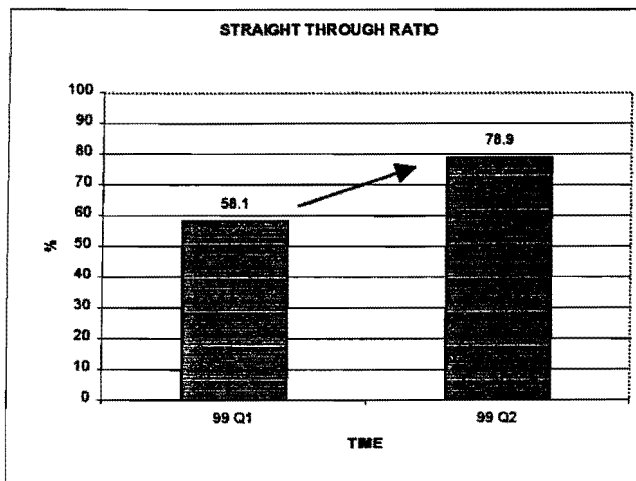

**FIG. 5.2 AVERAGE STRAIGHT THROUGH RATIO FOR 4 MODELS**

As the graph illustrate the average straight through ratio in the first quarter of 1999 was 58.1 % compared to a straight through ratio of 78.9 % in the

fourth quarter of 1999. This improvement is as a direct result of the intervention activities.

Statistical process control graphs showed an improvement in the overall performance but the process must be improved further.

One of the main contributing factors were the rotation of operators in key assembly areas. Fully trained operators on critical water test processes were rotated to other assembly functions which resulted in 'non-trained' operators in the key areas. The variation in assemble consistency resulted in water leaks, hence the limited performance improvements.

The following graphs will illustrate the improvements made per model derivative.

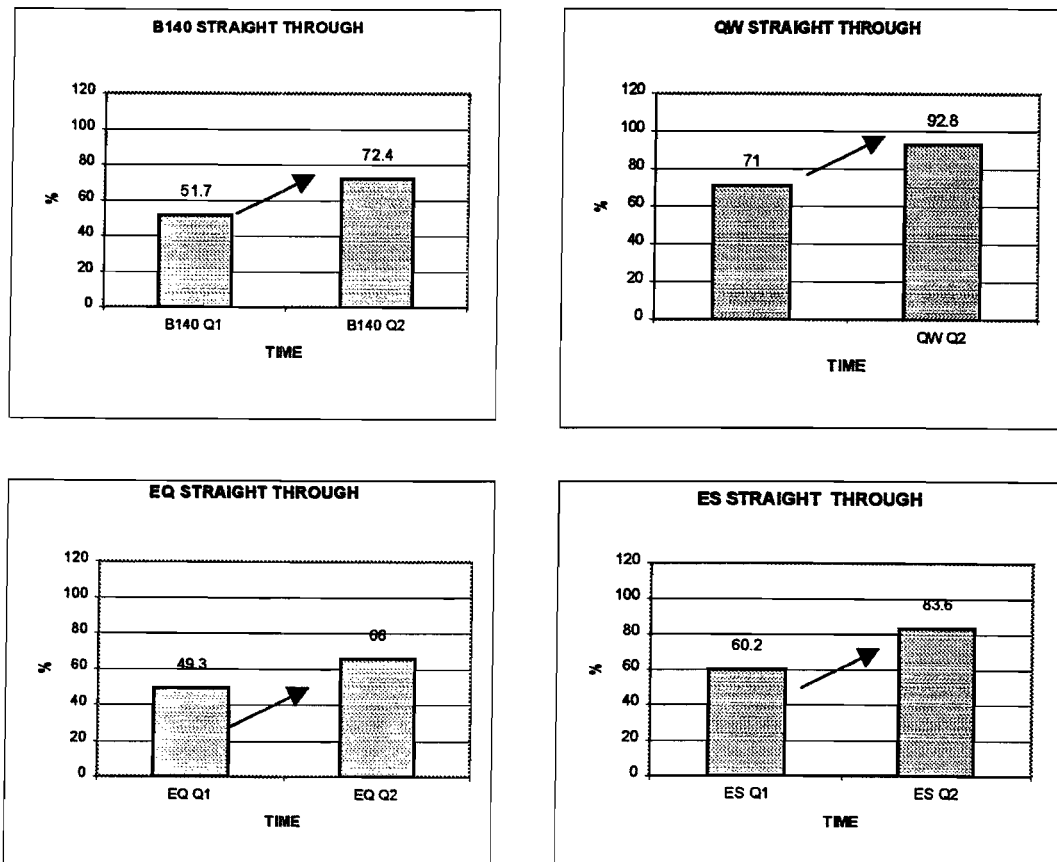

**FIG. 5.2 STRAIGHT THROUGH RATIO PER MODEL DERIVATIVE.**

The graphs illustrate the improvement per mode derivative. Some models have improved more than others have but on average there was a 28.3 % improvement.

Depending on the nature of the build variation some problems were easier to solve than others. On model QW the two selected problems were coming from one area with two operators executing the tasks, the operators were trained and the information supplied was upgraded. The effect was effective and showed excellent results within the same day.

On other models the selected problems were from various areas and the total assembly process must be controlled to limit the defects.

The following table will illustrate the improvement items per model derivative:

**TABLE 5.1 IMPROVEMENT ITEMS PER MODEL**

MODEL	DESCRIPTION	Q1 PERFORMANCE	Q4 PERFORMANCE
B140	DOOR FRAME	67.3 %	81.0 %
	DOOR PLASTIC	71.8 %	97.2 %
QW	DRIP RAIL	47.1 %	98.5 %
	BACK PANEL	65.1 %	97.9 %
ES	DOOR RUBBER	55.1 %	91.1 %
	BOOT FLANGE	64.1 %	88.1 %
EQ	DOOR PLASTIC	67.1 %	97.2 %
	TAIL LIGHTS	54.8 %	86.9 %

As illustrated by the table, some items showed an excellent improvement while others showed a more moderate improvement. The next step is now to understand the improvement methodology on the various items in order to change the direction or to keep the current activity.

## 5.7 EVALUATION

If the activities that were taken in this study are compared to the model that was derived in chapter four the following applies:

- 1) The basic QC story approach was followed in the problem statement, the initial analysis of the problem, the actions that were taken and the reflection stage. The problem layout was not fully done to the QC story format.
- 2) The SSM methodology was done to the full extend because the problem is a system as well as knowledge concern. The recommendations that were put in place were a direct result of the SSM study.
- 3) Deming's system of profound knowledge in relation to systems, variation, knowledge and psychology were adhered to during the activities. The operator to supervision levels was notified of the activities and the targets were clearly discussed, and the feedback on the graphs illustrates the build performance to the operator on an almost real time basis.
- 4) Extensive knowledge was gained through 'self repairing' of the defects and actions taken to solve the problems were very effective.
- 5) The only concern at this stage is the discipline on the shop floor. The training as well as the 'tools' were all given to the operator and supervision of the various build areas but there are still water leak problems, it was demonstrated on various occasions that the countermeasures, if adhered to, will be able to guarantee a defect free unit at the water test are and the straight through ratio can be much higher.

The current straight through ratio of 79 percent is a great improvement on the previous performance but it must still be improved to at least 90 percent average performance.

## **5.8 SUMMARY**

The summary out of this chapter is that the model, illustrated in chapter four, is a very powerful model. The model demonstrated its effectiveness through analysis of the problem situation, and effective countermeasures implemented to solve or improve the problem.

The extend of the problem will determine if the QC story alone will be effective enough or that the SSM methodology must be used as well. By applying the QC story 'tools' the results and information can be evaluated properly and the data will be able to tell its own story.

The next step will be to focus on the psychology pillar of Deming's system to enforce the discipline on the shop floor and to adhere to the countermeasures that were put in place in order to improve the straight through ratio to the optimum level.

## CHAPTER SIX

### CONCLUSION AND RECOMMENDATIONS

#### 6.1 INTRODUCTION

The aim of this chapter will be to draw a final thesis conclusion based on the information discussed in the different chapters and to identify certain recommendations that must be taken to improve the process and its performance to the optimum level.

#### 6.2 CONCLUSIONS

The real problem was identified in chapter two with the problem identification model as a variation problem. The problem formulation statement clearly indicates that variation is the main concern, because of the variation in the build process the quality of the vehicles will vary from vehicle to vehicle. This phenomenon is common amongst assembly and manufacturing plants, and it is the task of management to contain variation to the minimum.

During the study at the water test area the following variations were identified:

**Variation in build quality** was identified as the major concern area. The variation is generated when the build procedures are not adhering to and the 'quality' of the operators also plays a major role.

**Variation in Engineering and Inspection standards** is another concern in the sense that the instructions to the shop floor could be unclear or misleading. Engineering and Inspection standards must be accurate and relevant to critical processes.

**Variation in feedback** is the result of wrong information being gathered. If the right information does not get to the concerned areas in a presentable form the operator or supervision could be misinformed and will react in the wrong way to solve a certain problem.

**Variation in labour** is the inability of supervision to control the workforce. A critical operation should always be manned with a trained operator to ensure build-in quality.

The flow and activities during the thesis did compliment the process in the sense that an improvement of almost 30 % was achieved.

The problem definition in chapter two led the investigation in the right direction. Variation was highlighted as the major concern and the various variation sources were investigated and controls were put in place to minimise the variation.

In chapter three the theoretical study brought about a clear understanding of the theory behind the profound system of knowledge. Out of this theory it is evident that one of the major focus areas in any manufacturing company is the psychological pillar of the system. People make things happen and people cause or control variation. A motivated and well-trained workforce will result in very few operator-related defects, if the other sources of variation are under control.

Chapter four synthesised the theory and problem solving methodologies into an understandable and usable model. The model derived is able to assist the manager in finding the real cause of the problem and lead him through a logical process of solving the right problem effectively.

Each problem will have its own approach, depending on the circumstances and company profile. In some instances a more technical approach must be used whilst in other a more psychological approach will be more effective.

As figure 4.1 in chapter four illustrates, the system of profound knowledge rests on four pillars. A given problem will lean to one of the pillars depending on the nature and the cause of the problem. It is therefore of utmost importance to formulate the problem accurately in order to understand and formulate the approach to the problem.

The reflection on the relative success of the intervention activity is discussed in chapter five. Out of the results obtained the claim can be made that the model did yield good results, although not the required zero defect rejection rate at the water test area. Operator variation will have to be the next extensive area of study to improve the straight through ratio further.

### **6.3 RECOMMENDATIONS**

The following recommendations must be made to improve the situation to the optimum performance level:

- 1) Eliminate parts related variation by an inspection function prior to the assembly process. The parts that do not conform to specification must either be reworked or rejected and not be allowed on the assembly lines.
- 2) Eliminate variation in labour by having dedicated operators for water test sensitive processes. The operators must be fully trained and daily feedback must be reported back to them based on their performance from the water test area.
- 3) Eliminate variation in the feedback system by focusing on the repairmen data from the water test area, the data from the inspectors is misleading. The information should be displayed at the workstations and the line supervision must conduct regular audits to ensure that the right process and procedures are followed.
- 4) Eliminate variation in the different standards. Accurate Engineering and Inspection standards must be developed and maintained.

**Once these recommendations have been implemented the prediction is that the straight through ratio at the Nissan water test facility will improve beyond 90 %.**

## **BIBLIOGRAPHY**

Karen E. Fletcher and Anne Sigismund Huff (1989). Strategic Argument Mapping: A Study of Strategic Reformulation at AT & T.

David and Sarah Kerridge (1998). Scientific Method in Management.

David and Sarah Kerridge (1998). Scientific Method and Continual Improvement.

Katsuya Hosotani (Fact Sheets). The QC Approach to Problem Solving

Donald J. Wheeler (1993). Understanding Variation. The key to managing chaos.

Edward W. Deming (Second edition). The New Economics.

Edward W. Deming (1989). A System of Profound Knowledge.

Edward W. Deming (1990). Variation Management.

Bruce Kogut and Udo Zander (1992). Knowledge of the Firm, Combinative Capabilities, and the Replication of Technology.

John Naughton and course Team (1990). Soft System Analysis: An Introductory Guide

Tom Ryan (1998). Making sense of Literature.

Michael C. Jackson (1993). Systems Methodology for the Management Sciences.

Jay Schulkin (1989). The Pursuit of Enquiry.

Robert L. Flood and Michael C. Jackson. (1991). Creative Problem Solving.

Steven A. Melnyk and David R. Denzler (1995). Operations Management

Pretorius B (1999). Quality Improvement Intervention Through SSM Methodology and Action Research Principles.

Mitroff I (1997). Smart Thinking for Crazy Times

## ANNEXURE A

The attached document displays the S.S.M. methodology study that was done at the water test area in the initial stages of the investigation into the performance of this area.

It was important to study the system on a holistic scale to understand all the sub-systems at play and how they function together to support the goal of the bigger system.

This study serves as background material to understand the methodology used and its effect on the thesis.

# SOFT SYSTEMS METHODOLOGY (SSM)

## PROBLEM INVESTIGATION AT WATER TEST AREA

### 1.1 INTRODUCTION

The soft system methodology (SSM) will be used to structure the water test investigation and to propose certain solutions to the problems.

To summarize the SSM flowchart consider the following:

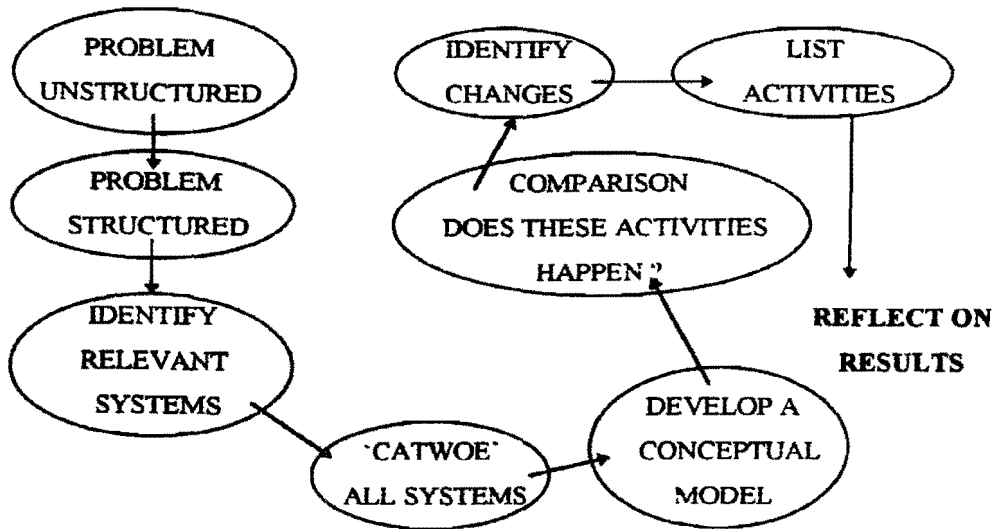

**FIG. 1.1 SSM FLOW CHART**

### 1.2 PROBLEM UNSTRUCTURED

At this point in time the following questions were asked which led the investigation into the SSM process, why are the vehicles leaking water? where are the vehicles leaking, when are the vehicles leaking and can the existing data, as shown in chapter one, be used to analyze the defects ?.

In order to answer these questions a period of three days was set aside to do observations in the area to observe the flow of events and the different

activities that exist in the area in order to establish the customers, actors, the transformation process, the world view, the owners of the system and the environment the everything takes place in.

The resultant information was used to draw a 'rich picture' of the events to structure the information.

### **1.3 PROBLEM STRUCTURED**

#### Process flow

The following information applies to the 'rich picture' that was drawn based on the initial observations:

The incoming quality from the assembly lines varied a lot with reference to water tightness. On some units certain parts were not fitted, on some units certain parts were not fitted properly, on some units sealer skips from the paint shop were evident to name but a few.

The units would then be driven through the water test booths by drivers and left on the other side of the booths for inspection. There are three drivers in total.

Two inspectors would then inspect the vehicles for evidence of water leaks and indicate on the job card where the water was found. On their inspection sheets the vehicle job number and water test defect was again noted for data capturing purposes.

If a vehicle is leak free the vehicle would proceed towards final line. One driver is responsible for this activity.

If a vehicle was rejected for water leaks the vehicle would be side tracked into one of the repair bays where a repairman will attend to the defect. There are four repairmen.

The tools and equipment to the repairmen's disposal was totally inadequate, only one air line was available to 'blow dry' the vehicles after been repaired, hand tools were not suitable and repair material consists of a non-curing gray sealer.

The repairmen would 'repair' a vehicle according to the inspector's comments or according to his experience. New repairmen have a big problem in finding the actual cause of the problem whilst experienced repairmen know where to look for the defect.

After the repair to the vehicle was done the vehicle had to return to the testing booth to verify the success of the repair. Numerous repairs would fail the test again because of the repairmen's ability or a 'new' water leak was detected all of a sudden. If the rejected vehicle was eventually accepted it will also proceed to final line.

#### Information flow

The two quality inspectors in the front of the test booths generated the water test quality and buy off information. A clerk would gather the

information and send it through to the QA department where a daily report is generated on buy-off and reject reasons.

This information would be used to generate priority investigation lists for the Engineers to focus on and the Manager in charge would display this information on his business plan graphs and would be judged accordingly.

During the initial investigation stages it was found that the data available was suspect for the following reasons:

The inspector that had to judge the water leak did not do a proper first fine investigation to determine the cause of the leak and sometimes he would not be able to do so because of the defect origin. The repairmen

had therefore limited information as to where the defect is and they would then have to search for themselves.

The real cause of the defect was not corrected on the information sheet and therefore the question on the data.

The clerk that gathered the data and send it through to QA sometimes makes counting errors when determining the buy-off rates. This could be considered as negligible but when only five EQ's were produced and **either three or four** were rejected it has a great influence on the results.

#### Mental model of actors

The relationship between the inspectors and the repairmen was not healthy, the repairmen could reject the vehicle for 'water leaks' to generate work, or could give the 'wrong location' of the water leak to name a few.

On the other hand the repairmen knew where the actual defects were and how to repair them but the inspectors data were used instead. The repairmen felt that their quality of work was good but they do not have the authority to sign off their own workmanship.

The repairs that were done on the vehicles were not 'permanent' solutions and when units from the stockyard were retested they would sometimes leak again.

### 1.4 IDENTIFY THE RELEVANT SYSTEMS

The next step in the SSM is to identify the relevant systems at play to understand the complexity of the bigger system in focus. If the transformation process is considered the following illustration applies:

**FIG. 2.2 WATER TEST SYSTEM FOCUS**

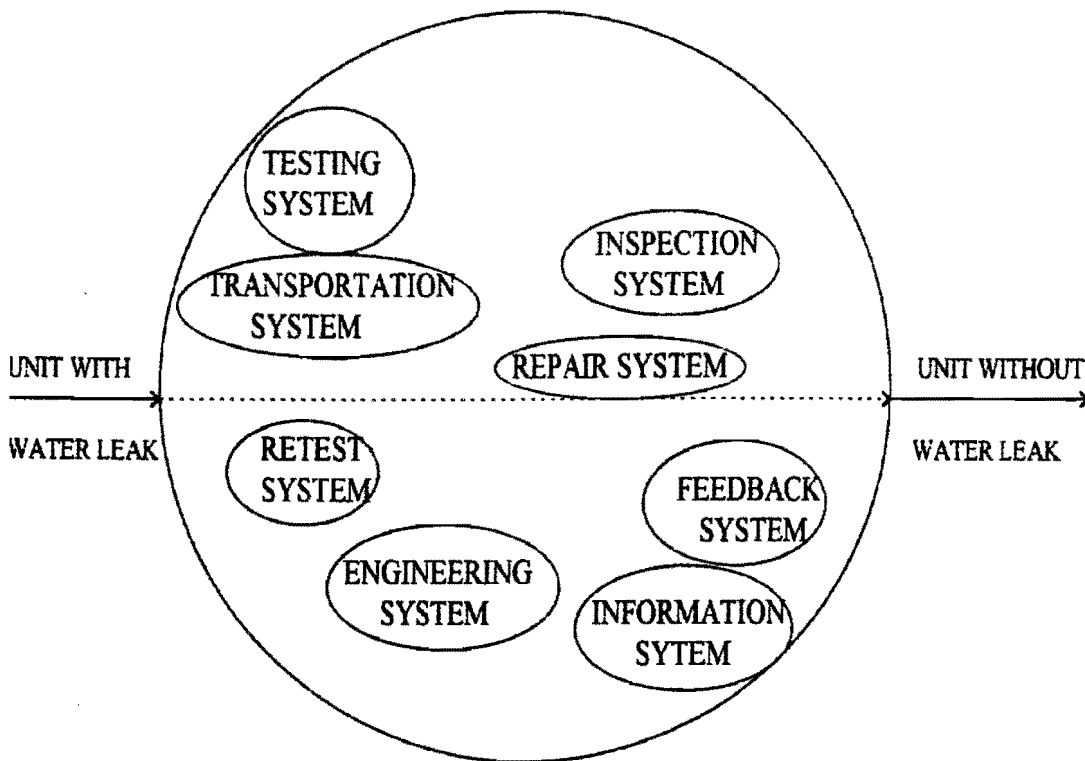

**FIG 1.2 WATER TEST SYSTEM FOCUS**

**System One – Testing system**

The testing system is a system that tests the vehicles to ensure that water leaks would be detected. The system refers to the testing booth and the relevant pressures and water flow.

**System Two – Transportation system**

The transportation system is a system that moves the vehicles through the water test area and through to final line as well as the movement of the vehicles to the repair areas and back to the test booths for retesting.

**System Three – Inspection system**

The inspection system is a system that allows for the visual inspection of the units and a note of where the problem might be. The system also allows for the retesting of rejecting units.

#### **System Four – Repair system**

The repair system is a system that transforms the water leak into a leak free area by means of sealer application in the affected area.

#### **System Five – Retest system**

The retest system is a system that force the repaired unit through the test booth again to verify the repair that was done on the vehicle. The inspection system applies upon retesting of the vehicle.

#### **System Six – Feedback system**

The feedback system is a system that compiles the inspector's data and transforms it into a report that illustrates buy-off percentages as well as defects per unit.

#### **System Seven – Engineering system**

The engineering system is a system that investigates results and come up with temporary and permanent counter measures. This system is dependent on information supplied.

#### **System Eight – Information system**

The information system is a system that generates information through random audits or through customer surveys, the information is channeled back to the QA department that distributes it to the responsible areas.

### **1.5 CATWOE THE SYSTEMS**

The next step in the SSM is to distinguish between the customers of the systems, the actors in the systems, the transformation that takes place, the worldview of the systems, the owners of the systems and the environment the system function in. The abbreviation of the different steps is CATWOE.

**TABLE 1.1 SYSTEM CATWOE**

CATWOE SYTEM	C	A	T	W	O	E
TESTING SYSTEM	ENGINEERING PRODUCTION	INSPECTORS (QA)	UNKNOWN INSPECT KNOWN	LEAK FREE UNITS	QA	TESTING EVALUATION
TRANSP. SYSTEM	PRODUCTION	QA	UNIT FOR TEST INTO BOOTH READY TO INSPECT	QUICK MOVEMENT	QA	TESTING FACILITY
INSPC SYTEM	PRODUCTION ENGINEERING CAR OWNER	INSPECTORS (QA)	LEAK UN-KNOWN KNOWN LEAK	ACCURATE	QA	REPAIR AREA
REPAIR SYSTEM	QA CAR OWNER	PRODUCTION	LEAK SEALING NO LEAK	NO LEAK	PRODUCTION ENGINEERING	REPAIR AREA
RETEST SYSTEM	ENGINEERING PRODUCTION	QA	REPAIRED-UNIT RETEST CONFIRM	GOOD REPAIR	QA	TESTING AREA
FEEDBACK SYSTEM	ENGINEERING PRODUCTION	QA	DATA REPORT ISSUE	ACCURATE FEEDBACK	QA	OFFICE
ENGINEER SYTIME	PRODUCTION QA	ENGINEERING	LEAK ON UNIT COUNTER-MEASURE LEAK FREE	QUICK RESPONSE	ENGINEERING	PRESSURE FROM PRODUCTION
INFO. SYSTEM	ENGINEERING PRODUCTION	QA	RAW DATA STRUCTURER EPORT	ACCURATE	QA	SUSPECT DATA

The table illustrates a brief overview on all the systems in place. The most important systems must be investigated in order to understand the influence on the bigger systems.

The most important systems can be summarized as follows:

- **Transport system**

The reason for importance is the fact that QA is responsible for the throughput through the facility but Production is measured on delivery, considering this fact then Production do not have control over their destiny.

- **Repair system**

The repair system is high importance because if the repairmen do a poor repair the unit will be rejected again and the cycle time for repairing units will escalate. A poor repair can also influence the downstream quality as well as the performance in the field.

- **Feedback system**

The feedback system is probably the most important one. If the right information is not fed back to the right area on time then the time between a quality problem and the subsequent counter measure is too long.

A paint shop related problem could be fed back to the assembly lines and as a result valuable time is lost, which influences quality delivery and cost.

- **Engineering system**

The engineering system is the one, which should bring about stability in the process. Firstly to find good counter measures for water leaks and then audit the activities on a regular basis to ensure adherence to the processes.

The other system is also important but the listed systems are the ones in focus.

## **1.6 CONCEPTUAL MODELING**

Conceptual modeling needs to be done on the systems that have an influence on the system in focus. Through conceptual modeling each prominent system could be understood better and subsequent actions would be the best solutions possible.

Considering the systems of importance listed in 1.4 the following models can be derived:

**1.6.1 Transport system**

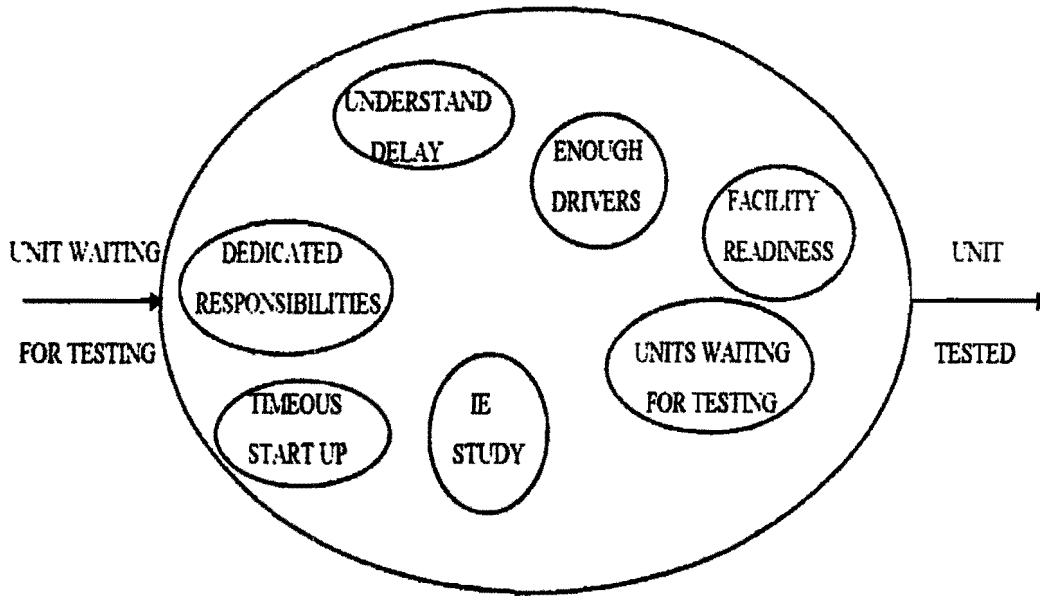

**1.6.2 Repair system**

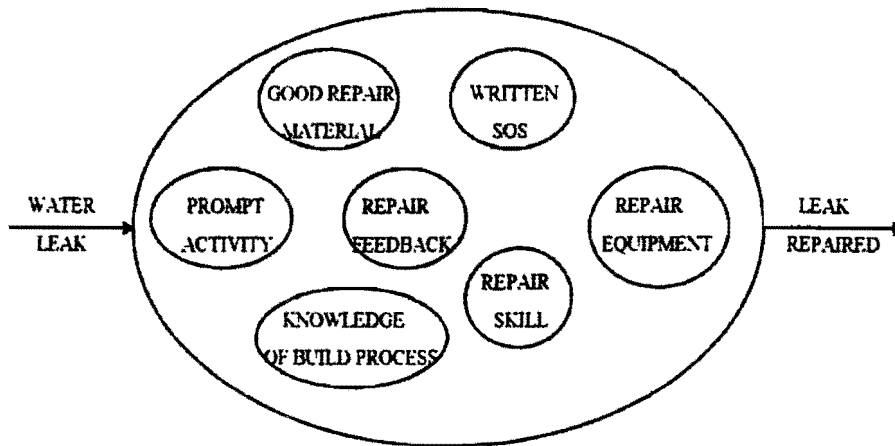

### 1.6.3 Feedback system

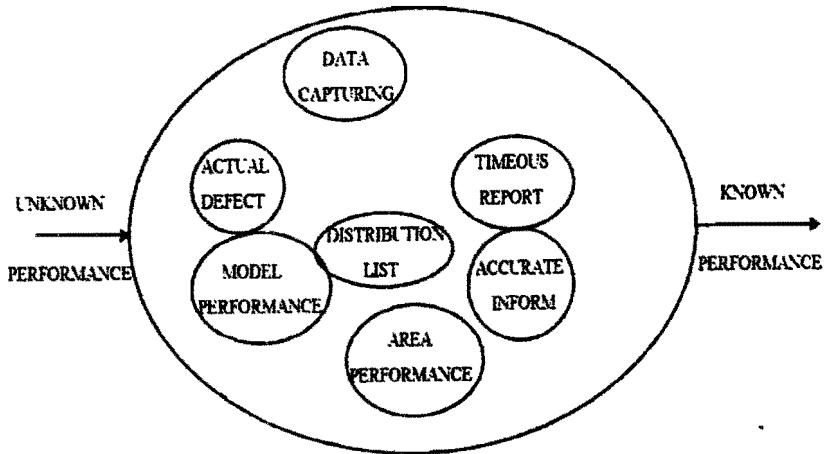

### 1.6.4 Engineering system

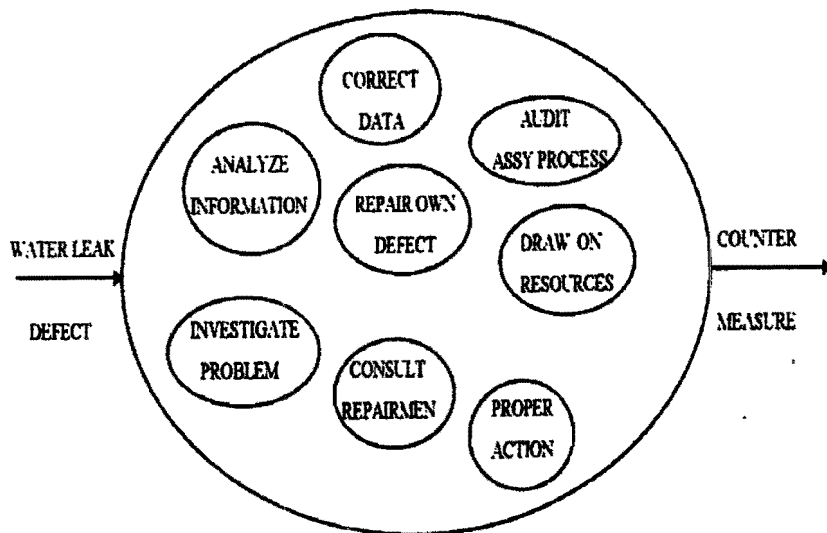

## 1.7 COMPARISON

During the comparison stage the conceptual models will be compared to the real problem as described in the rich picture.

The importance lies in the understanding of the models comparing in the real live situation, the question will be asked if the conceptual model activities happens in the area of focus or not:



The proposed changes must be authority feasible and systematically desirable. The changes that will be identified will be 'as observed or analyzed', but before the activity plan can be implemented the theoretical background needs to be exploited in order to take justifiable decisions based on proven theory.

Based on the comparison that was done in 1.7 the following items need to be changed in order to improve the water test area:

- The drivers and operators at the test area need to be fully aware of the result of their actions. If a bottle neck situation exists the rest of the final line system suffers and it also has an impact on the company as a whole. The key lies in discipline from the foremen active in this area.
- Start up in the morning and after breaks should be timeous and no delay should be tolerated. Discipline is again the key word.
- Proper repair material that is tested should be used for repairs to vehicles with water leaks. The quality of the material not only ensures a proper repair but also influence the total quality of the vehicles.
- Official standards and instructions should be drafted for the repairmen. Some repairmen are working in that area for over 10 years but others are new and do not know how to repair the different leaks on the different models.  
Standards will act as training documents as well as audit information.
- The repair equipment of the area is very poor. There is for example only one air point to dry the interior of the units after inspection while there are 4 repairmen. Air tools are also limited. The equipment itself forms a bottleneck in the area.
- The defects reported on the audit sheets are those of the inspector and not the repairmen. The inspector gives an indication of the origin of the water leak but the repairmen knows the actual defect.

- The data capturing is that of the inspector on his audit sheet. There is no official system to capture the repairmen information.
  
- Because of the general defect description the area of origin cannot be explained, for example a tail light leak could not be a paint shop sealer skip or trim line butyl tape poor fitment or a part problem.
  
- Information accuracy is of vital importance for the obvious reasons. The current system is not accurate enough and many investigations or decisions are made according to the information.

## **1.9 SUMMARY**

In this chapter the SSM methodology was used to define the problem areas and to investigate all the facts in order to understand the bigger picture and how the water test process fits into the whole system.

## ANNEXURE B

The attached document displays a typical QC- story activity that was done on the sealer line in the Paint Shop.

The sealing of the units is done to water proof the units as well as to prevent the panel edges from rusting. It was found during the analysis stage that the sealing operation, which is a complete manual operation, was out of control and it was the cause of many water leaks.

The problem solving model without the S.S.M. analysis was used and the results that was achieved is excellent. The straight through ratio improved by almost 50 % on sealing related concerns.

The QC- story display the techniques that were used to analyze the situation, setting a target, plan the activities, do the activities and evaluate the outcome of the actions.

# WATER TEST IMPROVEMENT ACTIVITY - PAINT SHOP

## PREVIOUS CONDITION

1) Straight through ratio at water test area (1999)

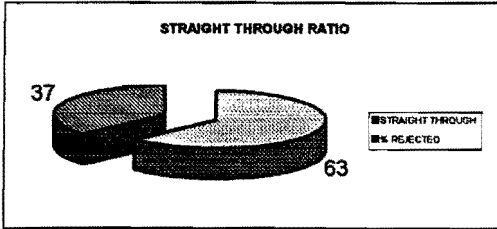

2) Rejects due to Paint Shop sealer process. (1999)

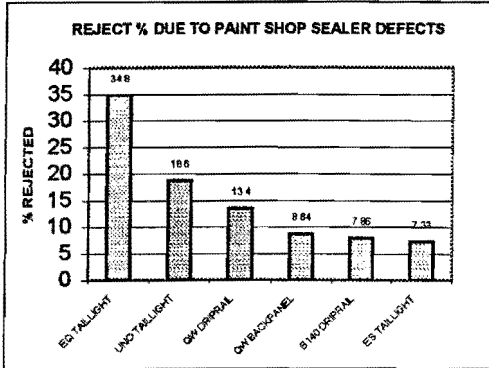

## ANALYSIS

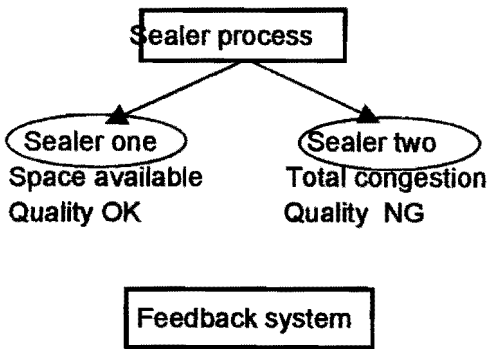

Limited information back to source  
Operator not informed and not measured  
Not involved when solving problems, limited two way communication.

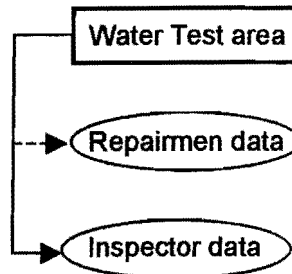

Repairmen data is accurate  
Inspector data is misleading

## TARGET SETTING

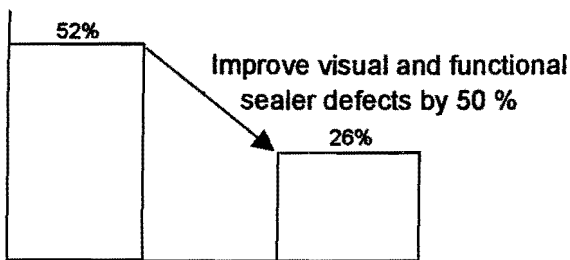

## PLAN

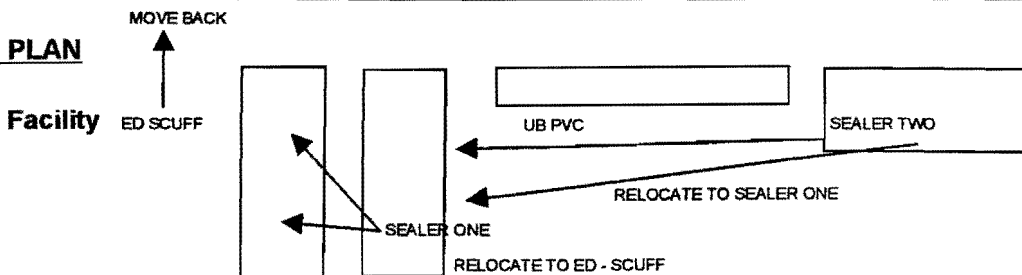

### Feedback system

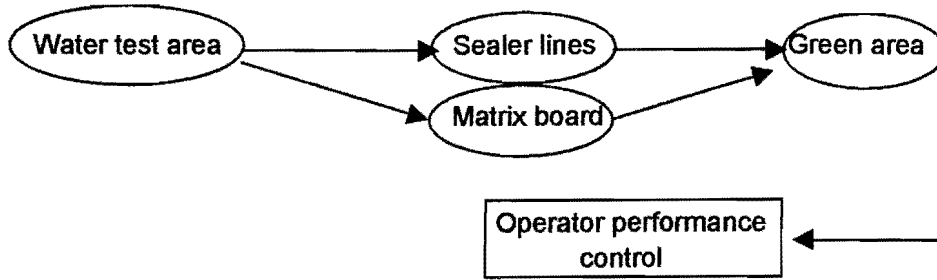

### Defect Analysis

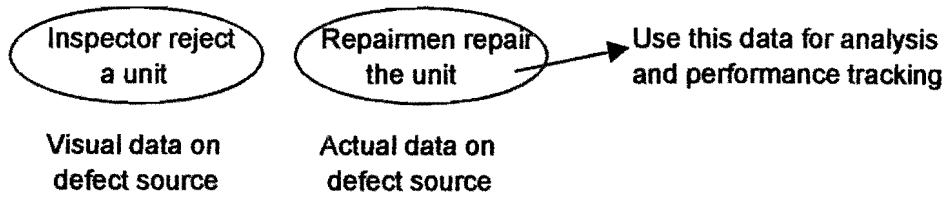

## RESULTS

