

**University of Cape Town**  
**Faculty of Education**  
**Department of Adult Education and Extra-Mural Studies**

**A study of the**  
**Building Industries Federation of South Africa**  
**training model of skill development**  
**for the purpose of considering its**  
**appropriateness as a model for large-scale**  
**Adult Basic Education provision.**

**A dissertation submitted in partial fulfillment of the requirements of a**  
**Master of Philosophy**  
**by**

**Kathleen Anne Watters**

**Supervisor: Mastin Prinsloo**

**15 March 1993**

The copyright of this thesis vests in the author. No quotation from it or information derived from it is to be published without full acknowledgement of the source. The thesis is to be used for private study or non-commercial research purposes only.

Published by the University of Cape Town (UCT) in terms of the non-exclusive license granted to UCT by the author.

## **Declaration**

I declare that this research is my own unaided work. It is being submitted as partial fulfillment for the degree of Master of Philosophy at the University of Cape Town. It has not been submitted before for any degree or examination at any other university.

Signed by candidate

Signature Removed

**Kathleen Anne Watters**

**15 March 1993.**

# CONTENTS PAGE

---

## **CHAPTER 1 : INTRODUCTION**

- 1.1. Introduction
- 1.2. The current context
- 1.3. What this research sets out to do
- 1.4. Methodology
- 1.5. Motivation for using the building industry

## **CHAPTER 2 : REVIEW OF KEY ISSUES IN ADULT BASIC EDUCATION AND COMPETENCY-BASED EDUCATION AND TRAINING**

- 2.1. Adult Basic Education
  - 2.1.1. Historical Perspective of ABE
  - 2.1.2. Theoretical views of literacy
- 2.2. Competency-Based education and training
  - 2.2.1. Historical Perspective of CB
  - 2.2.2. Characteristics of CB
  - 2.2.3. Critique of CB
- 2.3. Relevant current debates in South African education and vocational training provision
  - 2.3.1. Knowledge and skills
  - 2.3.2. Academic versus vocational education
  - 2.3.3. Economic and political concerns
- 2.4. Conclusion

## **CHAPTER 3: A CONTEXTUALISED STUDY OF OLD AND NEW TRAINING IN THE BUILDING INDUSTRY.**

- 3.1. Introduction
- 3.2. Institutional makeup of the building industry
- 3.3. A brief description of the old training programme

- 3.4. Analysis and review of the requirements by the building industry training of the new training programme
  - 3.4.1. Lack of employer commitment to training
  - 3.4.2. Training programme not meeting needs of new kinds of operators
  - 3.4.3. Certification
  - 3.4.4. Technological, political and social changes
  - 3.4.5. Conclusion
- 3.5. Description and preliminary analysis of the new training programme for the building industry
  - 3.5.1. Historical perspective
  - 3.5.2. The framework of the new building industry training programme
  - 3.5.3. A closer look at the new training system
- 3.6. Conclusion

#### **CHAPTER 4: ANALYSIS OF COMPETENCY-BASED EDUCATION**

- 4.1. Introduction
- 4.2. Analysis of the new training programme of the building industry
  - 4.2.1. To what extent has the new programme avoided the pitfalls of the old training programme
  - 4.2.2. To what extent is the CB format suited to the building industry
  - 4.2.3. Conclusion
- 4.3. Assessment of a CB driven ABE for the building industry
  - 4.3.1. General issues
  - 4.3.2. Language and literacy issues
- 4.4. Assessment of CB for large scale ABE
- 4.5. Conclusion

#### **CHAPTER 5: CONCLUSION**

#### **BIBLIOGRAPHY**

#### **APPENDICES**

- A - Institutional make-up of the construction industry
- B - Formal education levels in the building industry
- C - Diagramme of the building industry training programme
- D - Flow diagramme of the carpentry training programme

## **ABBREVIATIONS USED IN THIS REPORT**

ABE	-	Adult Basic Education
ALBSU	-	Adult Literacy and Basic Skills Unit
BIFSA	-	Building Industries Federation of South Africa
BITB	-	Building Industry Training Board
BITS	-	Building Industry Training Scheme
CAWU	-	Construction and Allied Workers Union
CB	-	Competency-based Education
Cosatu	-	Congress of South African Trade Unions
ERS	-	Education Renewal Strategy
MBA	-	Master Builders Association
NVQ	-	National Vocational Qualification
PPC	-	Production Performance Criterion
SBA	-	Small Builders Association
TPC	-	Training Performance Criterion

## **CHAPTER 1 INTRODUCTION**

---

**1.1. INTRODUCTION**

**1.2. THE CURRENT CONTEXT**

**1.3. WHAT THIS RESEARCH SETS OUT TO DO**

**1.4. METHODOLOGY**

**1.5. MOTIVATION FOR USING THE BUILDING INDUSTRY**

## 1.1. INTRODUCTION

The National Education Policy Investigation (NEPI), an initiative of the National Education Crisis Committee (NECC), described basic education for adults in South Africa as being small-scale and inefficient.<sup>1</sup> Van Heerden estimates that less than 1% of the population requiring Adult Basic Education attend classes.<sup>2</sup> The changing political climate of the last few years has resulted in a variety of new social and economic policy options being developed. Some of these policy options will impact on Adult Basic Education (ABE) possibly providing it with a new and more substantial role. Although none of the policy options are near the implementation stage, the fact that they exist has already started to influence the way in which practitioners and researchers think of ABE.

Running parallel to these internal changes are international influences. Education and vocational training particularly, have undergone fairly dramatic reorganisation in most of the western world with the notion of Competency-Based Education (CB) gaining considerable credibility.<sup>3</sup> The change has also been in evidence in South Africa. A competency-based system is now being considered by many key stakeholders, specifically Cosatu, for ABE provision. This research will critically analyse the competency-based option for ABE provision in terms of currently perceived needs.

In order to ground the research an example of an existing training programme, that of the building industry, will be used. The choice of the building industry is felt to be appropriate because it uses CB and is considering including ABE in the existing training framework. The programme is also provided on a national level and provides a training programme linked to a career path.

These terms, concepts and premises will now be expanded before continuing with a research outline.

## 1.2. THE CURRENT CONTEXT

President FW de Klerk's speech in February 1990 boosted the current process of **political** change.<sup>4</sup> This resulted in the possibility of more democratic structures being put in place and acted as a catalyst for a rethink of the potential roles of the large population of adult illiterates. A perceived need for these new voters to be more literate in order to be able to participate more fully in civil society is an example of this kind of thinking. It is also much more likely that many of the political parties, who will be contesting for power in future elections will be addressing the issue of equity, and improved provision of ABE could become part of a campaign pledge. The African National Congress and Cosatu have already committed themselves to such a position.<sup>5</sup> Their policies will be discussed in more detail in the following chapter.

**Economic** policies for reforming the South African economy vary considerably. The view discussed below presents a particular version. The version was selected as it impacts significantly on the future role of ABE and has substantial legitimacy. The current economic problems are believed to be the result of

"an excessive concentration on mineral exports; an inefficient, capital intensive, import-substituting manufacturing sector; a dependence on foreign technology, and the poor performance of manufacturers in world markets."<sup>6</sup>

Analysis by economists such as Gelb suggest that there is a need to promote the exportation of manufactured goods thereby reducing the reliance on primary commodity exports and promoting inward industrialisation strategies.<sup>7</sup>

This strategy requires improved education and training programmes and is described as an active labour policy requiring a **high-participation, high skill strategy**.

The HRD:NEPI Research Group define this as having a high degree of state and employer involvement in education and training, a low level of social stratification, 'active' labour market policies which seek continuous skill formation for all workers, and high levels of educational attainment. This is contrasted with a low-participation, low skill strategy in which nations are characterised as having high levels of social stratification, minimal state and employer support for education and training, highly segmented labour markets fractured along class, race and gender lines, and low levels of educational attainment.<sup>8</sup> According to the NEPI

report countries following a high-participation, high skill model have a good track record as exporters, while the low-skill, low participation countries have been 'singularly unsuccessful' as exporters of manufactured goods. The proposed policies of the ANC and Cosatu are closest to the former while the current state and private sector policies are closer to the latter, i.e., low-skill, low participation.

There will be a significant impact on education and vocational training irrespective of which of these policies is implemented.

In addition and linked to the preceding arguments, the **world of work** has changed. In industry in general, but particularly in the manufacturing sector production, technology has seen rapid change. The advent of the computer and robotics have resulted in a dramatic change in industry which in the past tended to be based on Fordist lines.<sup>9</sup> Long production lines producing one product as cheaply as possible, or an economy of scale, was what made a business profitable. Today, the business able to provide a variety of products quickly with a high standard of quality, or an economy of scope, will win the export tender.<sup>10</sup>

These changes require a different kind of work force. One which is multi-skilled, both technically and socially as workers now need to see themselves as team members, be flexible, and have a broad, holistic understanding of the production process.<sup>11</sup> In conjunction with technology change there has been a change in the organisation of work. Concepts such as "just-in-time" and "quality circles" have appeared. Most of these changes are attempts to improve production quality and efficiency by involving workers in the organisation of their work. Again these innovations require an educated and trained workforce.

In South Africa these changes have tended to be overdramatised and can really only be found in multi-nationals and manufacturers targeted as potential exporters. However, it is believed by advocates of the high-participation, high-skill strategy that if South Africa is to become at all competitive these changes will need to become more commonplace.

In most of the Western world the changes in the economy and the work place have been paralleled by **changes in education and vocational training**. Current researchers describe a closer relationship between education and the world of work and a change in the relationship between "education for personal development" and "education for employment".<sup>12</sup>

Wexler describes this as a process in which the content of education has been redefined as 'specific skill learning'. In this process words such as 'competency', 'effectiveness' and 'performance' have displaced earlier educational terms such as 'knowledge', 'understanding', and 'development'.<sup>13</sup> In this research report this new kind of learning will be referred to as Competency Based Education and training (CB) .

CB started to find its way into the world of school during the 60's under the influence of both vocational training and the psychological school of Behaviourism. More recently CB has been found in Adult Basic Education. This development in ABE happened in the eighties in Britain<sup>14</sup>, but only in the last couple of years in South Africa.<sup>15</sup>

One of the key developments for this research is that in the proposals of Cosatu, Adult Basic Education is included in the education system.<sup>16</sup> Cosatu advocates a national system which links up with other educational and training opportunities. In the Cosatu proposals the goal for ABE is to provide people with a general basic education and the knowledge and skills needed for governance. This indicates, that for the first time, ABE is not the poor relation of education, but is an integral part of an education and training system. The immediate consequence of <sup>it</sup> is that if the proposals are to be implemented, it will be the first time that ABE will need to be provided on a large scale. A CB system is one possible option.

Adult Basic Education has many definitions. In this document the term is used to encompass basic reading, writing and numeracy skills in the mother tongue as well as in English if this is not the mother tongue. Also included are general education and a variety of basic life skills to enable the adult to function effectively in his/her community.

### **1.3. WHAT THIS RESEARCH SETS OUT TO DO**

Proponents of CB claim that the system can provide an effective and efficient framework for a large scale national ABE programme which articulates with national education and vocational training systems. This framework provides a particular kind of answer to the 'literacy for what' question. The emphasis is on development. In this research, this view is contrasted with a version of literacy which gives a different answer to the 'literacy for what' question. Researchers such as Street and Wagner and many of the Non-government organisations affiliated to the National Literacy Co-operative prefer to view literacy as a free standing programme concentrating on individual and local needs. These contrasting positions will be used to consider the relative strengths and weaknesses of CB for ABE. While the possibility of using a CB system for the ABE programme in the building industry will be considered, the research will also consider the opportunity of CB beyond the specific needs of the building industry.

### **1.4. METHODOLOGY**

Information was obtained by the researcher from both primary and secondary sources. Primary sourcing includes discussions with the following sources: Literacy researchers and workers in the ABE field; building industry employers, trainers and trainees; trainers using CB and visits to building sites and the BIFSA training centre. The information was obtained through open-ended, face to face interviews. A list of these interviews follows:

#### *Key stakeholders - organisations*

Representatives of Master Builders Association, Cape Peninsula, 18 July 1991.

Representatives of Master Builders Association, Paarl, 22 July 1991.

Representatives of Small Builders Association, 18 July 1991.

Representatives of Co-ordinating Union, 17 July 1991.

Representatives of Construction and Allied Workers Union (CAWU), 3 August.

Small Builders Forum, Khayelitsha, 16 July 1991.

Officials of Building Industrial Council - Western Cape, a number of meetings during period May-November 1991.

Employees of Dura Construction. 5 August 1991.

#### *Meetings with individuals*

Neil Fraser, Director BIFSA, a number of meetings.

Bert Parker, Principal, BIFSA Training Centre, Belhar, 28 June 1991.

Warren Krafchik, Economics Department, University of Cape Town, a number of meetings.

Bob Hindle, Lecturer, Department of Construction Economics and Building Management, University of Cape Town.

Bruce Boaden, Head of Construction Economics and Building Management, University of Cape Town, 9 July 1991.

Tony Keal, Industrial Relations Manager, Murray and Roberts

Andrew Merrifield, Researcher, University of Natal.

Jeff Sessions, Stocks and Stocks, telephone call, July 1991.

Mr Khakaza, Chairman, Western Cape Black Builders Association, 22 July 1991.

The researcher originally planned to observe training in process and interview trainees who had attended the BIFSA training programme. This was not possible because at the time of the research the new building industry training programme was not operating. Some of the findings of the research are therefore based on an analysis of the training manuals and interviews with other researchers. This is recognised as a limitation of the research.

## **1.5 MOTIVATION FOR USING THE BUILDING INDUSTRY**

The building industry contributes 3,6% to the GDP and employs about 6% of those employed in the formal sector. It is seen as having a significant role in the current scenario because it is labour intensive and has strong linkages with the industrial and other sectors.<sup>17</sup> There has also been a strong move by a number of groupings to particularly target the industry as part of the change process. The most obvious reason being the huge housing shortage. The construction industry has a double role in redress in that it provides employment as well as housing. The building industry was also one of the first industries to establish a national training board. The implementation, under the auspices of this board, of a national training programme offering career pathing also placed the industry in the forefront of training innovation in South Africa.

## CHAPTER 1 - INTRODUCTION - FOOTNOTES

1. ABE:NEPI. 1992. p3.
2. Van Heerden G. 1992. p17.
3. See Spours K. and Young M. 1988. and Wexler P. 1987.
4. President FW. de Klerk watershed speech, Cape Times 3/2/90
5. Refer to Cosatu 1991 and ANC 1990.
6. HRD:NEPI. 1992. p9.
7. Gelb S. 1991. Chapter 1.
8. For a full discussion read HRD:NEPI and Kraak A. 1991c.
9. Fanaroff B. 1991.
10. Kraak A. 1991b.
11. HRD: NEPI, 1992. p6
12. SCANS Report,1991.and Spours and Young,1988, p5.
13. Wexler P. 1987. p70.
14. Mainly found in the work of the Adult Basic skills unit(ALBSU).
15. There are a few examples in South Africa of industry based literacy programmes currently using CB. One of these is Facts Management. However, it was the proposals of Cosatu which resulted in CB gaining some recognition in South Africa.
16. Cosatu's main proposition on ABE
  - 1 The state has a duty to play an active role in ending illiteracy. The state and employers must provide resources for ABE programmes.
  - 2 Cosatu need to negotiate with employers and the state for a nationwide ABE programme open to workers and the wider community.
  - 3 There must be one national system of ABE.
  - 4 ABE courses must link up with other educational and training opportunities, and job creation projects.
  - 5 ABE courses must provide a general basic education and equip people with the knowledge and skills needed for governance.
  - 6 Workers must have the right to paid time off for education and training.
17. Bridgman. 1992. p60.

**CHAPTER 2**  
**REVIEW OF KEY ISSUES IN ADULT BASIC EDUCATION AND**  
**COMPETENCY-BASED EDUCATION AND TRAINING**

---

**2.1. INTRODUCTION**

**2.2 ADULT BASIC EDUCATION**

**2.2.1. Historical Perspective of ABE**

**2.2.2. Theoretical views of literacy**

**2.3. COMPETENCY-BASED EDUCATION AND TRAINING**

**2.3.1. Historical Perspective of CB**

**2.3.2. Characteristics of CB**

**2.3.3. Critique of CB**

**2.4. RELEVANT CURRENT DEBATES IN SOUTH AFRICAN EDUCATION**  
**AND VOCATIONAL TRAINING PROVISION**

**2.4.1. Knowledge and skills**

**2.4.2. Academic versus vocational education**

**2.4.3. Economic and political concerns**

**2.5. CONCLUSION**

## **2.1. INTRODUCTION**

The two main areas discussed in this review are: Adult Basic Education and Competency-based education and training. The discussion gives a historical perspective, outlines the main characteristics of Adult Basic Education and Competency-based education and training and reviews relevant current theoretical debates.

The review will show that literacy theorists argue that there are a number of theoretical concerns specific to the learning of reading, writing and languages, which a system of ABE provision must consider. The views of these theorists are by no means clear cut. The review of ABE focuses on two complimentary views as a starting point from which to consider the Competency-based(CB) option. In the section on competency-based education and training the review focuses on curriculum, the learning event and assessment. These three parameters are used to outline the learning concerns of CB.

In the final section a broad sweep is made of related debates currently circulating in South Africa. The focus is on options facing future educational policy makers with specific reference to those issues which concern ABE provision.

## **2.2. ADULT BASIC EDUCATION**

### **2.2.1. Historical Perspective**

Research on Education in South Africa(RESA) divides the history of literacy provision in South Africa into three periods.<sup>1</sup> Each period has had a different answer to the 'literacy for what' question. These periods as described by RESA are:

Prior to 1976 only the mining houses ran literacy programmes and these were run essentially for recreational purposes. These programmes ran for a short time with limited success. The second period, running from 1976-1983 can be characterised as being the education and training period in which outside experts were called in to solve problems relating to skill shortages. None of these programmes which were initiated exist today. They were abandoned because of numerous problems mainly concerned with implementation and curriculum

design.<sup>2</sup> The third period, 1983-1987, is described in RESA as the "social responsibility" period where employers embarked on programmes due more to concerns with political instability than to improve the skill shortage.<sup>3</sup>

French describes these interventions during all three periods as typically being management initiated, implemented and controlled. Worker involvement in these programmes was limited to participation and possibly representation in an advisory capacity on the management committee. Lack of learner motivation under these conditions proved a real stumbling block to success. Management seems to have always opted for the "quick-fix" approaches and this particularly has led to failure at both process and product levels. Unfortunately this usually resulted in programmes being abandoned rather than altered.<sup>4</sup>

The situation has changed in the nineties and the start of the fourth period of literacy provision. This is mainly as the result of the entrance of Cosatu into the literacy field. Cosatu has put education and particularly basic education on the agenda of the negotiating table. Their proposals involve joint participation of worker and management to set up a nationally standardised and certificated programme. This is linked to skills training and leads to job mobility. The programme as proposed by Cosatu will be discussed in more detail later in the chapter.

### **2.2.2 Theoretical views of literacy**

The programmes in the first three periods in South African history of literacy provision would all be described by Brian Street, a United Kingdom based researcher as embodying an approach to literacy he terms '**autonomous**'.<sup>5</sup> In using this term he would imply that literacy is being seen as an independent variable, which if implemented successfully, can result in dramatic changes for the individual or a society, in this case, an industry. Street contrasts this view of literacy and the kind of programmes which result in what he calls an '**ideological**' model of literacy.

Brian Street outlines this view of literacy by describing six characteristics. These are:

- 1 An assumption that the meaning of literacy depends upon the social institutions in which it is embedded.
- 2 Literacy can only be known to us in forms which already have political and ideological significance and it cannot, therefore, be helpfully separated from that significance and treated as though it were an autonomous thing.
- 3 The particular practices of reading and writing that are taught in any context depend upon aspects of social structure such as stratification [eg where certain social groups only may be taught to read] and the role of educational institutions.
- 4 The processes whereby reading and writing are learnt are what constructs the meaning of it for particular practitioners
- 5 It is probably more appropriate to refer to 'literacies' than to any single 'literacy'.
- 6 Writers who tend towards this model and away from the 'autonomous' model recognise as problematic the relationship between the analysis of any 'autonomous', isolatable qualities of literacy and the analysis of the ideological and political nature of literacy practice.<sup>6</sup>

Advocates of an "ideological" model of literacy programmes emphasize the context in which literacy is acquired. i.e., what kind of literacy does a particular individual need in terms of his/her place in society and how should the learning of this literacy be constructed. This is a considerable move away from the "one solution fits all" kind of literacy programme.

This view emphasizing the "context" is supported by Wagner who stresses the need to focus, not only on classifying different levels of literacy, but also on the kind of literacy required by a particular society.<sup>7</sup>

Kinds of literacy include pragmatic, cultural, conventional, functional, survival, or marginal. Griffin et al point out that these terms are associated with an individual's ability to **perform** something rather than to just know it. The terms also imply that kinds of literacy such as 'non-functional' or 'non-survival' must also exist.<sup>8</sup>

Scribner and Cole have also focused on the role of different contexts and describe literacy as a set of socially organised practices in which writing is used.<sup>9</sup> For clarification they describe 'practice' as a "recurrent, goal directed sequence of activities using a particular technology and particular systems of knowledge" i.e., literacy is not merely knowing how to read and write, but applying knowledge for specific purposes in specific contexts of use. The unit of analysis is not the individual, but the practice or the activity itself which can be analysed in terms of a number of factors. Scribner and Cole identify three dimensions which they feel are important. These are technology, function and social meaning.

The concepts are described as follows:

**technology** - a graphic symbol system which provides a means of producing and distributing in which the individual is technically engaged, if directly involved, in decoding or encoding written messages.

**function** - the individual is involved functionally with the functions of reading and writing i.e., who uses the script?, what functions are served?, what the consequences of reading/writing or not reading/writing are? Children learn technology skills before they are expected to use the written word functionally.

**social meaning** - This was first recognised by Szwed and is viewed as complex as it includes social values and affective reactions. Szwed believes that it is the role of social meaning which often determines an individual's interest in acquiring literacy skills and the subsequent use or lack of use of these newly acquired skills.<sup>10</sup>

A recent document from Wider Opportunities for Women(WOW), which is based in the United States of America is an example of this theoretical position put into practice. The document focuses on 'learning centred education' and 'teaching literacy in context' as ways of conducting 'Best Practices for any adult literacy programme design.' The document argues that teaching in context is not only more effective, but also more motivating for the learner, than teaching isolated skills and techniques.<sup>11</sup>

Researchers and programmers who follow this line of thinking believe that it is no longer appropriate or necessary to search for the best method of teaching adults to read and write. The search instead focuses on what is most appropriate to a particular situation or the context of a particular individual. There is also an implication that literacy and language learning is a complex process and should not be dealt with in an ad hoc way.

While this focus on individual and societal contexts has many virtues it has also introduced a number of new concerns. A possible consequence is that interventions may become "paralysed" and never start operating because they fear that they have not fully understood the "context".

One could also take this concern for individual and societal contexts to its natural conclusion and conclude that literacy ought to be "deschooled" and unsystemized.

Focusing on individual contexts also has financial implications.

When designing new programmes which take seriously this issue of the "context" both the direct and indirect costs will have to be measured against the benefits. The challenge for South African planners will be to find a way of incorporating the above concerns in designing a large-scale programme and not to be tempted to ignore these concerns as impractical or too costly.

In contrast with the view outlined above, is a position which maintains that literacy will have more value to the individual if it is part of a uniform educational package offering standards and accreditation.

A number of new literacy initiatives follow this line of thinking, for example, the UK-based Adult Basic Skills Unit (ALBSU) programme. ALBSU emphasizes a system of standards and accreditation as the "mechanism through which a national qualification can be provided."<sup>12</sup> The Standards follow the structure of National Vocational Qualifications in function and linguistic format.

"Many of the Standards can be used to demonstrate the underpinning core skills of communication and numeracy on which competent performance in NVQs rests."<sup>13</sup>

In the ALBSU programme validation comes largely from this link to an outside accreditation system. The accreditation system (NVQ) is in the business of providing trainees with marketable skills. As the above quote indicates the ALBSU programme prepares trainees to enter the NVQ programme and thus also acquire marketable skills.

In addition to the accreditation system, ALBSU uses a competency-based framework which they maintain is relevant to students and trainees regardless of where they are learning or why they wish to learn.<sup>14</sup>

"Standards are benchmarks for competent performance. Competence is about the outcomes of a learning experience, not the process of learning. By focusing on the outcomes recognition is given to the achievement of a particular activity and not how or where they achieved it. But to be competent, individuals require knowledge and understanding. Knowledge and understanding may not always be assessable by observing outcomes only. So, within Standards, the knowledge and understanding required by students and trainees is also specified."<sup>15</sup>

The emphasis of ALBSU on knowledge and understanding place them in a 'softliner' version of CB.<sup>16</sup> However even with this proviso the equally strong emphasis on accreditation could result in the programme, as interpreted by individual tutors, being assessment driven.

The policy for ABE as outlined by Cosatu is similarly concerned with accreditation, national standards and articulation with education and training systems. BE is seen as an essential part of an integrated education and training system which has the objective of the development of "skills and knowledge needed to help shape and develop economic policies, run industries, build a democratic state and strengthen job creation projects."<sup>17</sup>

Cosatu hopes that by proposing a national system it will be able ensure portability of qualifications and equity in the provision of ABE. Wagner, director of the only federally appointed national literacy research centre in the United States(NCAL), and an advocate of designing literacy programmes to meet the demands of individual consumers, recently said.

"One of the greatest failures of adult literacy comes from allowing the nation state to determine what is best for adult learners."<sup>18</sup>

While acknowledging that it was unwise to import findings for use in local conditions, he felt that in the US research indicated that far more could be gained from "keeping an eye on the consumer" and in trying to meet his/her needs than by focusing on national needs.

The tension between emphasizing the context in which ABE is acquired versus accepting a more decontextualised system which emphasizes that marketable skills are acquired forms the basic parameters of this research. In the following discussion this tension will be explored by focusing on the following three areas:

- \* *Differences in individuals*
- \* *The role of the situation in which literacy is acquired.*
- \* *Different levels of literacy*
  
- \* *Differences in individuals*

The work that is being currently carried out in this area examines the influence of past social and cultural experiences in determining learning potential. The work that is of interest does not work on a cognitive deficit model, but rather attempts to explain why some learners will find learning easier than others and uses social and cultural factors as the departure point.

For example Wagner argues that the experience of a literate environment, such as could be experienced by children who are read to by their parents, will influence the learning potential of a person. In other research he found that race and class structure were indicators of motivational levels.<sup>19</sup>

This relates to the work of Vygotsky who developed the theory that although individuals have an innate cognitive ability to become competent in a skill, this

ability is affected by the social and institutional contexts within which the person functions.<sup>20</sup>

Using Vygotsky's theories, Miller argues that these mediating agents can result in some adults being under or over prepared for certain kinds of learning experiences. These adults have to relearn or unlearn skills or "untie the knots of previous experiences to make space for the new".<sup>21</sup>

In support of these concerns, Morphet argues that the illiterate person like any other adult attempting to change the central terms of his/her understanding of the world, will need to develop a completely new set of skills in order to become literate. This involves risk and programme developers need to incorporate this concern in their planning.<sup>22</sup>

Alant claims that the language skills of the learner are also indicators of learning potential. She argues that in order to become literate one needs to be able process language on two levels. These are at the level of semantics, phonology and syntax and the more sophisticated level of metalinguistics, discourse analysis and pragmatics.<sup>23</sup>

The significance of these concepts to literacy work, according to these theorists, is that it is not appropriate to assume that all learners enter the learning environment equally. It is necessary to take into account social and cultural backgrounds when developing programmes.

The contrasting theoretical position would argue that although it is important to consider the individual, it is more important for the programme to be capable of running on a large scale and to be able to provide the learner with marketable skills.

\* *The role of the situation in which literacy is acquired.*

Street building on concepts used by sociologists such as Giroux maintains that the situation in which knowledge is imparted often reinforces the power structures of the ruling class. He maintains that even in classes in which the imparter of knowledge is claiming to be open and rational, his/her values and ideals are still reflected in their classes by the kind of choices they make in respect of curriculum, style of imparting knowledge, etc. Proponents of the kind of literacy

programme which Street refers to as "autonomous" tend to create a programme which concentrates on the technical skills involved in reading. In Street's view these programmes generally assume that increased literacy skills will result in greater job opportunities and social mobility and as a result are more likely to reinforce current power structures. i.e., because only technical skills are taught learners are given no skills to help them to change existing social structures.<sup>24</sup>

Greene describes this as seeing "curriculum as fact" in which a prescribed body of knowledge has to be acquired as opposed to seeing "curriculum as practice" in which the focus shifts from learners being required to replicate knowledge to learners being required to synthesize and generate knowledge.<sup>25</sup>

Scribner and Cole in discussing the role in which literacy skills are required maintain that different kinds of skills are acquired if the skills are acquired informally as opposed to formally. They feel that it may be useful to look at the kinds of skills that are acquired informally and how this happens when developing literacy programmes.<sup>26</sup>

\* *Different levels of literacy*

Finally in looking at methodological issues this report looks at recognising differing levels of literacy skills. The writer is referring, not to different kinds of literacy skills, such as "essay" type versus technical, but to different levels of mastery.

Scribner and Cole believe that there is a universal pattern of skill development.<sup>27</sup> Griffin also works within this universal pattern of skill development and uses two concepts to talk about different levels of literacy. These are "basic" and "required". "**Basic**" refers to acquiring a set of basic skills which will enable the individual to gain access to a culture. This could also be described as the level of skill necessary for self-sustained development. "**Required**" encompasses a set of skills necessary for a given social context which may change over time. For example, if a person moved into a particular social situation such as work, then the person might need more specific competencies.<sup>28</sup>

Griffin et al see these kinds of literacies developing along a continuum. The skills are acquired following a structure, very much like that of a pyramid, with skills above being based on those below. The pyramid analogy is also maintained as

fewer people will have these higher skills. Withers disagrees with the view of the description of literacy as a series of discrete units which are acquired in a universally correct continuum.<sup>29</sup> Using this concept there is also the problem of identifying the critical point at which the person becomes literate. The concept of seeing literacy as a series of tasks has also been criticised as there is the danger of tasks becoming so specific that the learner is unable to generalise the learning to other contexts.<sup>30</sup>

The discussion is of particular relevance to this research because of the structure of the CB framework which breaks learning tasks into discrete units. Further discussion on the varying views on the implications of this will be reviewed later in this chapter after the section on CB

In **summary**, key issues for literacy provision identified thus far include a concern for the context in which literacy is acquired, the level and kind of literacy to be acquired and a concern for individual differences in people acquiring the literacy. In addition to these concerns which revolve around meeting individual needs in particular contexts is a concern that the programme has an accreditation system, maintains national standards and articulates with the education and training systems.

Another way of describing this tension is to view an ABE programme as either free-standing or part of an overall national system. Although not a necessary characteristic, free-standing literacy programmes seem to inevitably focus on meeting individual needs while programmes which articulate with other systems tend to focus on national needs. Arnove argues that it is possible to avoid an either/or situation by running parallel systems. A parallel system could include a strong enabling state which formulates policy, but utilises local initiatives, in the form of NGOs, to do the provision.<sup>31</sup>

The challenge for developers of a new programme for South Africa will be to develop a programme which is able to hold the concerns of the contrasting positions in such a way that learners and the nation get the best of both worlds.

## **2.3. COMPETENCY-BASED EDUCATION AND TRAINING**

This section details Competency-Based methodology (CB). The discussion covers the following four areas: Historical background of CB; Characteristics of CB; Critique of CB and Relevant current debates in South African education and vocational training provision. The first two sections will give a descriptive account of the competency-based training programme framework. This is to form the background and basis for critical analysis which is the third section. In the last part of this section some relevant current debates in South African education and vocational training provision will be reviewed. This review will contextualise possible options for education, particularly ABE, from an economic and political perspective.

### **2.3.1. Historical background of Competency-based Education**

Apprenticeship training has for a long time been associated with behavioural objectives. The link was the result of the need for apprentices to learn to master specific tasks, although it is unlikely that the tasks to be mastered were initially written down or even described in formal behavioural objective terms. Franklin Bobbitt at the turn of the 19th century started the process of describing tasks in behavioural objective terms. He translated his observations of adults carrying out tasks successfully into specific and itemized lists of objectives. Although CB was developed for mastering tasks in adult training schemes the system was soon found in schools. The process was refined in 1923 by WW Charters and by Tyler in 1949, but only became more common in the 1960s and 1970s with the work of Mager, Popham and others.<sup>32</sup>

For example RB Miller, working in the American Airforce in the sixties, found that technology was advancing faster than personnel could be trained. Miller changed the training system by developing criterion performance requirements. This involved analysing the tasks in order to determine the behaviours essential to the jobs. These were turned into behavioural objectives for the training programme.<sup>33</sup>

This change in the concept of training is the inevitable result of the introduction of Taylorism to the production process. The manufacture of motor cars by Henry Ford in which the procedure was broken up into small manageable chunks to be carried out by people with limited skills is a prime example of this move to Taylorism.

Critics of the CB approach at the time queried what happened when personnel were placed in positions where they were required to think rather than follow set procedures. Miller maintained that thinking should not be necessary if the procedures were adequate. This attitude still exists today amongst some of the 'hardline' advocates of CB.<sup>34</sup>

The position taken by 'hardliners' is the first example given in this review of the kind of concerns traditional educationalists often have regarding the CB system. The hardliner position highlights that tensions exist between views on knowledge and skills and education and training. Many advocates of a CB framework would ignore or at least blur the distinctions. This attitude contrasts with the 'softliner' position who acknowledge a distinction.

For example, Macdonald-Ross, a 'softliner' feels it is necessary to distinguish between knowledge and skills in order to deal with the idea that 'knowledge' consists of meaningful ideas linked to form a coherent view of world and that 'skill' cannot be used in this way. Also one cannot apply directly notions of truth and coherence to skill as one can to knowledge. Macdonald-Ross limits 'skill' to behaviours performed to given standards which can become refined, repeatable, predictable and eventually may be performed subconsciously. Having a skill is to have the ability to execute useful tasks to publicly agreed standards of performance.<sup>35</sup>

The above discussion has identified that there are at least two versions of CB, namely softliner and hardliner. This is important in terms of the current research as CB tends to be viewed as a 'monolithic beast'.<sup>36</sup>

### **2.3.2. Characteristics of CB**

CB is distinguished from other kinds of training by two features. These are the notions of "**competency**" and "**modular**". Obviously the two concepts are not unique, but the combination and the way they are used is distinctive.

Advocates of CB use "**competency**" to describe an ability that an individual has acquired either through training or development to the extent that it becomes a characteristic of the individual. Depending on one's interpretation of ability, in this

context, this could include only overt behaviours or be looser and include behaviours such as knowledge, critical thinking and attitudes.<sup>37</sup>

Competencies can also be called **mastery learning**, a term developed by Bloom.<sup>38</sup> In mastery learning, as in competency training, students are told that they will only be graded on their final performance and that this assessment will be in terms of predetermined standards and will not be in relation to the performance of their peers. This is known as 'criterion referenced testing' as opposed to 'norm referenced testing'. In the latter the results are graded so that they follow the normal distribution curve. In the competency-based system there is an assumption that all students will eventually master the task, but that some will take longer than others.<sup>39</sup>

Competency-based training programmes comprise a set of learning or performance objectives which have been clearly and specifically defined in such a way that they can only be achieved if the behaviour specified is carried out. Objectives are also known as **intended learning outcomes**.<sup>40</sup>

The individual learner is held responsible for the successful mastery of a performance or skills objective, while the trainer manipulates and uses external conditions to attempt to ensure that the learner obtains the required level of mastery. All target behaviours function as independent units and have a definite beginning and end. There are usually three elements. These are: the practical action the learner is to carry out; the condition under which action has to be carried out and the criteria or standards with which the learner has to comply before s/he can be regarded as being competent to master the skill defined in the objective. i.e., what is to be done, how well and under what conditions.<sup>41</sup> The developer of the programme needs to decide on the kind of learning that needs to take place so that the behaviour can be learnt. There also needs to be enough practice-time built into the programme. Another feature of CB is that the learner always knows the objective so s/he will know what is expected. Advocates of this method believe that this empowers the learner.<sup>42</sup>

Opperman and others who advocate this method of training do so as they believe it offers a number of benefits that traditional training methods are unable to provide. They maintain that learners gain confidence as they become 'masters' of the behaviours. Of particular relevance to this research is the belief that 'the

learner is able to analyse his individual experiences which he considers worthwhile and which he can apply to his personal life'<sup>43</sup>

The **CB learning experience** is described as being tightly controlled, but the researcher believes that one is unable to control it to such an extent that all participants have the same learning experience. In some instances this is positive as a learner may acquire more than one behaviour from a learning experience, but it can also be negative as there may be undesired learning outcomes. An unintended consequences could be that, this method attempts to work at only one level or area and does not consider how other parts of the learner's 'makeup' may be affected by the learning experience.<sup>44</sup>

The second major concept in CB is that of **modular**. The behaviour (skill, task etc) to be learnt is broken up into manageable and immediately meaningful chunks, known as modules. In some instances behaviours are taught in a particular sequence to achieve the terminal objective. These are known as dependent, as opposed to independent, objectives. The modular framework results in both the feedback and mastery of behaviours having definite ends and beginnings.

In the CB '**learning event**' of training programmes the student is given instructional modules which claim to contain enough information to enable the student to master the behaviour. It is a self-contained package with a planned series of learning experiences to help the student master the specified objective. The developers of such programmes claim that their guidelines are **unambiguous** and that the programme is individualised and student-centred in content, level and pace. So, according to the developers, students are able to start at a level appropriate to themselves, cover modules which meet their own needs and progress at a rate which is comfortable to themselves. The learners progress is monitored so learner and instructor know what is happening.<sup>45</sup>

Critics of this approach believe that the kind of learning students experience when this framework is used differs from other more traditional methods. According to Popkewitz who bases his analysis on experience with school-based competency programmes there are at least five elements which characterise this kind of learning situation. The elements are not unique to schools and are equally appropriate for training programmes.

A summary of these elements follows:

- 1 It is a curriculum development process which is dominated by the assumptions of **rational** planning, and results in a professional search for **efficiency** which emphasizes intellectual certainty and **standardization**.
- 2 The organisation of classroom discourse, school work, and social interaction sustains and legitimizes **routines** and technical procedures.
- 3 A warm, supportive psychological environment is created that makes it pleasant for pupils to participate in **routines** of school life.
- 4 Ambiguity, creativity, and non-standard learning which are not institutionally sanctioned, even if valued by teachers, are assigned peripheral status.
- 5 Professional and community support is obtained for standardization and efficiency as normal and reasonable values in the conduct of schooling.<sup>46</sup>

These five elements describe a position which argues that when this method is implemented both students and instructors seem to get caught up in a routinised circle of learning and testing. Attempts to get as many ticks as possible marked off charts appear to override overall goals. Popkewitz and others would argue that this fervour results in assessment-led learning. This has an emphasis on learning outcomes rather than on the learning process which they believe to be equally important.

There is also the opposite side of this argument. It can be argued that as long as the learning process and assessments are valid, then in terms of the current understanding of possible goals for education, the focus on learning outcomes is justified. The benefit comes from seeing individual learning events as part of a system which has larger benefits, such as access to the labour market.

At this stage it is appropriate to introduce the work of **Mathews and Lloyd** who are trade unionists based in Australia. They theorise that it is possible to design an educational system using the notion of competencies which is capable of producing "well-rounded, technologically literate citizens who have some insight into the processes of scientific and technological development."<sup>47</sup> In support of this view they introduce a few key concepts. Mathews maintains that the education system must be "flexible, adaptable, integrated and accountable". These terms are expanded to include notions such as: coherent career paths based on flexible and broad skill formation; developing imaginative linkages, cross-accreditation and work-study arrangements; the breaking down of curriculum and other barriers and the development of flexible learning strategies.<sup>48</sup> The concepts as described above have influenced and helped to formulate Cosatu's present position on training and ABE.

The work of Mathews and Lloyd presents a picture of CB learning which appears to be quite different from earlier pictures. As the programmes are still being developed it is still too early to assess to what extent their theoretical positions will be able to deliver in practice. It is quite possible that the concerns of Popkewitz will still be in evidence.

In reviewing the building industry this research will consider whether or not there is any evidence of this 'new', more flexible, version of CB in their new training programme. The concern for **flexibility** both in curriculum development and delivery caters to concerns for meeting individual needs in different contexts while the emphasis on cross-accreditation and career pathing is a response to concerns for finding a way of providing effective large-scale provision.

As already mentioned students are assessed according to known criteria, i.e., criteria known in advance to both the student and the trainer. **Assessment** is by criterion referencing and all students are expected to eventually master all the target behaviours. Assessment includes practical exercises.<sup>49</sup>

What counts is what students can do as the result of instruction. Other behaviours from prior learning which the student may have are not assessed or are not deemed relevant. Prior learning is considered in the pre test situation when it is determined which modules the student needs to learn. Usually the behaviours have to be demonstrated or described in exactly the same way as expressed in the written target behavioural objective. Objectives are specific so progress can easily be described and measured by the teacher and students. There is continuous and ongoing assessment with pre and post testing to determine lack until mastery is achieved. All behavioural objectives are measurable in objectively quantifiable terms.<sup>50</sup>

Before being implemented modules need to be trialed. Once the course has been developed the objectives are used to assess the entry requirements for the training programme or the skills required to do the particular job for which the training programmes has been designed.

This section has given a descriptive account of the competency-based training programme framework. This is to form the background and basis for critical analysis in the next section

### 2.3.3. Critique of CB

One of the most common criticisms of CB is that although it may be able to accurately account for the learning of observable behaviours trying to use this method for educational or knowledge learning results in numerous problems.

Developers of CB curricula focus almost exclusively on answering 'what is the most efficient way of teaching this' as opposed to 'what should we teach' and 'how should we do it.' This orientation also impacts on the kind of learning experience. The following section will review CB and education and these concerns for both these areas as well as the implied impact on assessment.

The three sections are:

- \* *Curriculum*
- \* *The learning event*
- \* *Assessment*

- \* *Curriculum*

The analysis which follows focuses on issues about objectives. This includes how the objectives are developed and then met and the role they play on the learning event.

In searching for ways to improve efficiency of learning, developers of CB programmes influenced the content of the curricula. These changes include the tendency to trivialise the learning, as developers found it is easier to describe small units of observable behaviour or discrete skills, than to describe more subtle learning which is not observable. For example demonstrating mastery of creative writing is more difficult than writing objectives to demonstrate mastery of the apostrophe.

This framework inevitably results in the prioritising of observable behaviour to the detriment of other kinds of learning. Schubert argues that this may be an acceptable method if the behaviour consists only of observable actions where limited understanding is necessary, but this is seldom the case in education. For example to observe a mathematician performing and to imagine that one merely needs to learn the observable behaviours ignores the complex network of knowledge and understanding which form the basis of the demonstrated behaviour.<sup>51</sup>

While this criticism is possibly valid for many CB training programmes a number of basic education programmes have been developed which manage to avoid this trap to a large extent. For example, the ALBSU programme, described in the previous section, includes 'knowledge' and 'understanding' criteria in their description of objectives.

Another attempt to avoid this problem and use a more 'softliner' approach to CB is found in the work of Mathews and Lloyd. They use the concept of 'core skilling' as the driving mechanism in the development of a curriculum. Lloyd explains **core skilling** as having four base competencies which are not definitive, but are rather a thematic approach to core knowledge and skill. This concept contrasts with the more traditional approach to vocational training which prepares trainees to work in a particular craft and tends to have the kind of narrow focus criticised above. The move is similar to that experienced in the school system where the traditional barriers between disciplines have broken down.<sup>52</sup>

Lloyd describes the four base competencies as:

**COMMUNICATION** this includes literacy, lateral and critical thinking skills such as to comprehend and express, identify, evaluate and critique ideas of any text.

**SOCIAL ENVIRONMENT** involves contextualising skills in an economic and political framework.

**PHYSICAL ENVIRONMENT** involves providing core information on finite and fragile nature of the environment and the interdependence of humans and physical systems.

**COMPUTER BASED TECHNOLOGY** - the need to be able to have access to some basic computer training.

Lloyd and advocates of this system maintain that this learning experience will form the basis for lifelong learning. Training in the core skills is the same across industry, enterprise and geographic location.

Notions similar to core skilling can be found in many of the new CB courses<sup>53</sup>. They are indications of an international trend of seeing education and training as integrated into an overall system. The programmes are all still fairly new and long or even short term evaluations assessing their effectiveness have not been possible.

Nevertheless the 'new CB' seems to hold interesting opportunities for both kinds of proposals for a framework for ABE. The concern for flexibility both in curriculum development and delivery caters to concerns for meeting individual needs while

the emphasis on cross-accreditation and career pathing caters to concerns for finding a way of providing effective large-scale provision.

CB is a possible, but not essential ingredient of the proposals of Mathews and Lloyd. As it is the concern of this research to consider the option of CB as a framework for ABE provision, it will only be possible to review the ideas of Mathews and Lloyd from within this framework.

A further criticism of traditional CB is the fixation on meeting objectives also called 'mastery learning'. For example, CB does not allow teachers to attempt 'voyage of discovery' learning.<sup>54</sup> The method similarly gives teachers no skills for dealing with questions or unpredicted classroom events or incidents which fall outside of the parameters of the objectives. Also by focusing on mastery learning Schubert believes that it is not possible to account for learning which may only be visible years later or the learning that people do for learning sake.<sup>55</sup> The emphasis on mastery learning by CB has also been identified by Auerbach as potentially negative for second language learning. Auerbach maintains that language is best learnt by making successive approximations and CB may discourage students from trying or learning by insisting that the task must be "mastered".<sup>56</sup>

More recent CB programmes include words such as 'range' in descriptions of target behaviours.<sup>57</sup> This has helped to allay some of the above criticisms.

While this development is to be welcomed there is a loss of control of the CB process. When conditions are tightly controlled such as in the hardliner versions of CB programmes it is easy to keep standards. When the control starts to slip and words such as 'range' become included in a learning process, then standardized assessment becomes more difficult to maintain. One of the obvious gains is that trainers are freed to go beyond the boundaries of the set tasks and can reduce the tendency to be assessment driven. The downfall is that less skilled teachers may feel that they are receiving mixed messages and may not be able to deal with the flexibility. The concern is particularly relevant in South Africa where there is a dearth of skilled teachers and a history of rote learning.

To gain the most benefit of using CB as an organising framework developers of programmes in the South African context, will need to keep a careful line between being too narrowly focused and being so wide that the impact of using a CB framework becomes lost.

Numerous problems have also been raised by critics of CB regarding the **ambiguity of objectives**. Macdonald-Ross describes a tension between writing too briefly and having objectives which are unclear or ambiguous and writing in too much detail making the programme unmanageable. (specificity versus ambiguity).<sup>58</sup> Also although the objectives are presented as truths Macdonald-Ross believes that they will be experienced differently by student and teacher. For example the student may be unaware of some of the underlying assumptions while the teacher is likely to read more into the objective as s/he formulated the objective or has taught it before and thus has a fuller picture than is given by the written word.

CB is often challenged by educationalists from more traditional schools because of the lack of concern for how the objectives are developed. The concern revolves around CB answers to questions regarding the origin of an objective as well as how the decision is made that a particular behaviour is a necessary component of a terminal objective.<sup>59</sup> This argument can be traced back to the reproduction theorists and their concerns for power relations in society and how these are played out in schools and learning environments. While obviously relevant in South Africa where democracy and equity are goals of many educationalists, these concerns may be sidelined if expediency becomes an overriding concern.

A further criticism involves the sequencing of the objectives. There appears to be an assumption of a universal correct or best order and that students will not learn as efficiently if they learn in another order. Although there has been research which would support this argument, for example the work of Gagne, there is also evidence that this is not always the case, for example the work of Mager.<sup>60</sup>

The focus on sequencing in CB also negates the emphasis often placed on **'process'** in the humanities and focuses instead on content or outcomes. The concept that there is a universal order of learning is particularly problematic for language learning. It would be difficult enough to obtain a consensus position on how language is learnt let alone agreement on the exact order in which this happens.

Attempts by Mathews at dealing with this limitation of CB have resulted in the inclusion of **'flexibility'**. Flexibility as an approach includes flexibility for both curriculum development and delivery.

" It is an approach which recognizes the role of both the teacher and student in deciding what and how to learn and which recognises the potential of technologies to enhance the productivity of teachers and the quality of learning."<sup>61</sup>

The notion of flexible skill formation is geared to meeting the needs of an industrial system which is "varied, diverse, and hence more democratic and multi-skilled" as opposed to the Taylorist assembly line paradigm."<sup>62</sup>

As Popkewitz points out this kind of planning also assumes that learning is a smooth progression simple to complex.<sup>63</sup> CB tends to follow a cyclical approach in which the same information is continually re-presented, but in increasing detail or complexity. The learning assumption being that if data is presented often enough it will eventually be learnt. Critics view this as a costly process. A further criticism is that although the process may result in success it is simplistic to assume that it is the result of this process and not some other external event.

The system also creates an artificial **ceiling** for the bright student, who is 'taught' that when all the objectives have been achieved learning is finished.<sup>64</sup>

\* *The learning event*

The structure of CB forces a particular kind of learning event. The curriculum, including the worksheets are usually developed, by some one other than the teacher. This process **separates the teacher from being part of the overall development** of the programme. Teachers become technicians who carry out instructions according to the pre-prepared worksheets. There is a tendency for both teacher and student to get caught up in following the process to develop the isolated targeted skills, without taking cognizance of the overall purpose of the programme. Student and teachers need to buy into detailed record keeping methods so that they know 'where they are' and what they have to do next. These records which include pre- and post-testing are part of an organising format which reinforces and sustains a continual pattern of routine, management of materials and standardization found when the CB format is used. The process creates its own internal legitimacy and ensures that the system sustains itself. The routine nature of this kind of learning experience provides security for the student, but also prevents other kinds of learning experiences from happening as a high value is placed on looking busy and producing a quantity of output.

**Independent learning** is emphasized and the interaction between students and between student and teacher is reduced to discussion around procedure rather than language of ideas. The teacher is kept busy providing individual instruction resulting in extra strain on the pupil and teacher. This process makes peer learning, a particular concern of language programmes, difficult.<sup>65</sup>

The CB system has also been described as having a '**poverty stricken model of teacher-pupil interaction**'.<sup>66</sup> Developers tend to emphasize trivialities as they are easier to analyse into desired terminal behaviours than the more meaningful kinds of interactions happening between students and teachers. Macdonald-Ross believes that the teacher is seen as a simple regulator and the student as a simple adaptive machine. Communication is restricted to stimuli, which/whether questions, assertions, cues and prompts and a schedule of reinforcing events. This is compared to conversational learning which uses a general learning system, has how/why questions and explanations rather than assertions. Apple describes this as a process in which teachers are deskilled and reskilled to a role in which they are divorced from planning a curriculum to merely presenting 'teacher-proof materials'.<sup>67</sup>

The extent of the importance of the kind and level of communication trainees experience in CB learning depends on the skill being learnt. The above criticisms are more relevant for cognitive than technical skill development. For example a **cognitive skill** such as language learning would likely to be significantly affected by a paucity of communication between trainer and trainee, while learning a technical skill such as assembling a machine will be affected to a lesser extent.

Space is made for creativity and problem solving, but within the confines of constitutionally defined work and knowledge. For example, when students are 'finished' their 'real' work then they are given creative writing to do. This decreases their importance as this kind of learning as it is not integrated into the system and thus becomes an afterthought.

In his review of three technical schools using a particular form of CB (IGE - individually guided education) Popkewitz points out the extent to which the method forms a basis of **social control**; "...the effect of viewing technologies as the ends of schooling was to alter social relations by defining the content and nature of schoolwork in such a way that individual control over ideas or work was

denied." 'Individual' can refer equally well to the teacher or the student both who have to follow the predetermined programme if the system is to be maintained.

In IGE the student's responsibility was operationally defined as accepting dependence upon others for ordering activities and striving to master predetermined objectives. Popkewitz describes the teachers responsibility as to concentrate on **procedures of implementation**. By emphasizing the need for standardization (both of knowledge and of the way it was to be presented), teachers were prevented from deviating from the preplanned activities. Further control was achieved by devising the programme so that all ideas and skills were presented in a discrete and ordered form which made it virtually impossible to deviate and follow an interesting or unplanned idea. The message was conveyed that this 'deviation' would not be real learning or worse still would interfere with the *real* learning. As the teachers were not involved in this process of breaking knowledge into measurable discrete chunks, there was a division between conception and execution and another example of students and teachers losing control of their work.<sup>68</sup>

Popkewitz maintains that these changes in schooling coincide with fundamental **changes in structure and function of work in western industrial society**. He maintains that the children at the technical schools were being prepared for the same role their parents had in society - that of a factory worker- and that the kind of person who emerged from the CB system was suited to this role. Factories require people who will accept the system and its organisation and not be self-motivated or self-organised.

This research by Popkewitz was written in the early eighties before the era of post-fordism. The shift in paradigm and the focus of creating education and training systems linked in new ways to the world of work would result in a change in this analysis.

#### \* *Assessment*

In terms of assessment, Popkewitz pokes some holes in the internal legitimacy of the system. He maintains that the pretest is often invalid, that there is often a long wait between objectives and that the whole system places an artificial ceiling on learning. He believes that in the technical schools under review the belief that they were efficient was an illusion.<sup>69</sup>

Macdonald-Ross maintains that by focusing on testing absolute standards and mastery learning in CB evaluation there is a possibility that issues such as construct and content validity can be bypassed. Advocates of CB would tend to maintain that objectives can determine the validity of test items by themselves. This tendency to see objectives as given truths disguises the fact that objectives can be ambiguous, that more than one test item can be written to test a given objective and that the significance of the test item depends in part on the nature of the learning experience. The tendency to equate test results directly with a learning experience is also fallacious as the behaviour change could be the result of some experience outside of the learning experience.<sup>70</sup>

The model also places students continually in a state of deficiency. Although the jargon of a **deficit model** is not used, students are continually placed in positions of remediation to acquire the target behaviour. This view of Popkewitz's is in contrast with advocates of CB who maintain that the students are empowered by the process.<sup>71</sup>

Amongst Popkewitz's negative views regarding CB in technical schools are some positive ones. He maintains that CB gives schools an internal consistency and identity which makes teachers feel less isolated. Teachers often work together to improve procedures. CB has general public appeal, as it uses a language that appeals to important values, such as efficiency and mastery and is seen by students, teachers and parents as working with the latest technology. Popkewitz does point out however that by focussing on efficiency and management issues, the bandwaggoning manages to cloud the existing priorities, values and patterns of social control which remain unscrutinised.<sup>72</sup>

Popkewitz concludes

"technical schooling does not serve community or teachers. The dissociation and fragmentation of knowledge and work in these schools produce a definition of professionalism that limits the creative and purposeful quality of teaching; students are offered a mode of thought that cannot penetrate complex patterns of communication dominant in contemporary society. Schooling is robbed of its liberating and imaginative potential. The focus on skill legitimates a style of work which is fragmented and isolated and unrelated to purposeful activity. If the style is internalized it imposes occupational limitations." 73

In **summary**, much of the criticism of competency-based education hinges on problems with objectives, how these are defined, identified and assessed and how this focus impacts on the learning experience. CB has been criticised as

tending to trivialise learning by focusing on narrowly defined objectives. The nature and amount of communication has been seen as too limited. Mastery learning is seen as problematic in certain contexts. Objectives tend to be ambiguous or too specific and unmanageable. Assessment is not as standardized as originally described as humans still interpret the standard. Problems have also been found with this assumption that learning happens in a particular order and that this learning pattern is the same for everybody.

The analysis has also recognised that there is more than one version of CB. Popkewitz and others would argue that CB learning is essentially about learning procedures. It does not provide learning opportunities which will provide the learner with the understanding necessary to be able to use the skills in a flexible and adaptive way. The more recent users of CB would argue that this is not necessarily the case if one includes notions such as flexibility, range and core skills.

Some of these criticism and views are of particular importance to the review of the building industry while others are more pertinent for ABE. The framework of CB as used in the building industry training programme and these concerns of the educationalists and literacy researchers will be reviewed in the next chapter. The discussion will go beyond looking at ABE in the building industry context and will look at more general implications for ABE.

## **2.4. RELEVANT CURRENT DEBATES IN SOUTH AFRICAN EDUCATION AND VOCATIONAL TRAINING PROVISION.**

### **2.4.1. Knowledge and skills**

The debates in education regarding distinguishing between knowledge and skills and the related attempts to forge links between vocational and academic or mental and mind education are relevant to this research. In the current education system knowledge and skill are separated with knowledge having privileged status. Educationalists in South Africa are trying to find ways to address the imbalance which has resulted from the current dual, but separate system. One of the ways which has been advocated, particularly by the NEPI Human Resource Research Group, is to link the two systems so that flexibility is entrenched and students can transfer from one to the other at will.<sup>74</sup> CB would be a good

framework for this transfer system as courses can be arranged in modular format making transfers easy.

There are other implications, highlighted by the NEPI research, which are relevant at this stage and need to be discussed.

#### **2.4.2. Academic versus vocational education**

One of the guiding principles of the NEPI research was to look at ways to redress imbalances caused by apartheid. Linked to the discussion regarding knowledge and skills is the need to analyse the implications of maintaining the current separate roles of academic and vocational education. The NEPI research identified a shift away from emphasizing vocational education over academic and a move to believing that it was better to provide a good general education than one in which people were prepared for a specific job. This view stems from a recognition that technology is changing rapidly and subsequently the world of work. There is also a sense in which all education is vocational. As stated by Chisolm, the problem of vocational education arises when the different systems entrench a particular kind of work for particular populations.<sup>75</sup>

MFD Young, from the United Kingdom and an advocate of CB, states that it is his

"contention that if your educational reforms perpetuate the division between education and training, the separation of the academic from the vocational and the separation of the humanities from the technical and the technological, then you will not be able, any more than we(UK) have been able, to achieve a democratic system."<sup>76</sup>

Whereas in the past the State has advocated emphasizing technical or vocational education more recent state documentation, such as the Education Renewal Strategy document has moved instead toward emphasizing a good general education. In the ERS document vocational education is not ignored, but it is suggested that it should be located with on the job-training.<sup>77</sup>

A recent Department of Education and Culture report takes a similar line:

"We are not looking for "line fodder" automations who can move straight on to the nearest assembly line...Rather, the qualities which companies are looking for in their recruits include adaptability, the capacity to use knowledge to solve problems and self-reliances - as well the abilities to read, write and speak fluently and use figures, screen and keyboard skills, which are now common to the majority of jobs, as is the need to work as part of a team"<sup>78</sup>

In a report prepared for NEPI, Chisolm discusses the notion of 'academic' as used in 'Bantu Education'. She points out that while Bantu education is often criticized for 'being too academic' it is far from academic, if academic is taken to mean quality general education underlying different branches and activity, but is rather anti academic and a pseudonym for poor quality. She maintains that the only way in which it could be described as academic is:

" In this Deweyan sense, education is academic in so far as it is not grounded in real-life experience and students do not encounter it actively and experimentally in ways which prepare them to play a role in reconstructing a democratic society." <sup>79</sup>

The NEPI:Curriculum Research Group report cautions against accepting that by promoting a single national system one will be guaranteeing equity.

"Firstly, to give expression to the principle of equality, should everyone follow the same core curriculum, regardless of race, gender, ability, social class, or region? Or does differentiation in the curriculum enable differences between students to be expressed and hence lead to greater equity? Consideration needs to be given to how much differentiation(if any) should be possible, on what grounds, and at what points."<sup>80</sup>

### **2.4.3. Economic and political concerns**

The above leads on to a related concern which was focussed on in the NEPI research, that of: What kind of education and training do we require in South Africa, not only to address the political issue of imbalance, but also to meet economic needs. Many of the change agents are currently advocating a 'growth through redistribution' policy. According to Bird the

"central tenet of this model is the need to direct state and other resources into housing and other infrastructural projects such as electrification, in order to provide jobs and meet need simultaneously. It is believed that through the provision of housing and services the backward and forward linkages into the manufacturing sector will be created. Concomitant with this leg of the strategy is an approach to the development of export orientation because it is accepted that in the longer term South Africa's future development is dependent on the manufacturing sector's ability to hold its own in the global economy."<sup>81</sup>

This policy implies a considerably investment in training to meet the needs created by the change to manufacturing, both in terms of general skill upliftment and in terms of how rapidly technology is changing.

The issues raised here in terms of the implication of how knowledge and skills, vocational and academic relate as well as the role of the economic and political systems will be used in the analysis of CB as a system for ABE.

## 2.5. CONCLUSION

This section has concentrated on raising key issues for a CB driven large-scale ABE programme for South Africa. Such a large scale programme will need to weigh the benefits and costs of running a programme which is integrated into an overall system with one which prioritises individual needs.

The key issue from a CB perspective is to find ways to prevent the learning outcome being limited to a procedural understanding of the target skill. It would be preferable if the trainee was able to use the newly acquired skills in a variety of contexts in a flexible and adaptive way.

Running in parallel to these concerns is the South African context. New educational programmes will probably have to work within a system which is attempting to address historical inequalities and be more democratic. These goals will come up against economic restraints and real life problems such as a dearth of well qualified teachers.

The next chapter will provide a detailed account of the CB training programme 'used in the building industry. This third chapter will provide the context for an analysis of the above concerns which is the fourth chapter of this report.

## CHAPTER 2 - REVIEW OF KEY ISSUES IN ABE AND CB - FOOTNOTES

1. RESA 1988. Paper No1.
2. Weiner T. 1991 and French E. 1990.
3. RESA 1988. Paper No1.
4. French E. 1992. p74.
5. Street BV. 1984.
6. Street BV. 1984. p 8.
7. Wagner DA. 1990.
8. Griffin et al 1990
9. Scribner and Cole. 1985. p16.
10. Swwed 1981.
11. Wider Opportunities for Women(WOW). 1992. p6-8.
12. ALBSU 1992. p3.
13. ALBSU 1992. p3.
14. ALBSU 1992. p3.
15. ALBSU 1992. p4.
16. This term used by Popkewitz will be explained in the next section.
17. Cosatu 1992.and ABE:NEPI 1992. p58.
18. Wagner DA. 1993.
19. Wagner DA. 1990 p9
20. Prinsloo MP. 1990. p268.
21. Miller R. Unpublished working paper.
22. Morphet T. 1992. pp97-99.
23. Alant E. 1990. p250.
24. Street B. 1992.
25. Auerbach ER. 1986. p416.
26. Prinsloo 1990. p269, Reder 1989 p13
27. Scribner and Cole in Prinsloo 1990, p269.
28. Griffin 1990. p60.
29. Withers G.1990.p66.
30. Mickelucky in Griffin et al 1990. p62.
31. Arnove R. 1993.
32. Schubert WH. 1986. p192.
33. Miller in Macdonald-Ross. 1973. p358
34. Miller in Macdonald-Ross. 1973. p358
35. Macdonald-Ross M. 1973. p358
36. Auerbach E. 1986. p413.
37. Macdonald-Ross 1975. p360
38. Stenhouse L. 1975.p65
39. Stenhouse L. 1975. p75.
40. Stenhouse L. 1975. p54.
41. Opperman RJ. 1988. p20.
42. Opperman RJ. 1988. p3.
43. Opperman RJ. 1988. p3.
44. Tyler RW. 1982. p163.
45. Opperman RJ. 1988. p27.
46. Popkewitz T. 1982. p61.
47. Mathews J. Hall G. and Smith H. 1988. p502.
48. Mathews et al 1988. p508.
49. Macdonald-Ross 1973. p360 and Opperman 1988. pp20-27.
50. Stenhouse 1975. p64.
51. Schubert WH. 1986. p193.
52. Lloyd C. 1991.

53. For example New Vocationalism Qualifications in the UK and the US SCAN report.
54. Voyage of discovery learning is described as learning in which the teacher only really sorts out the concepts during course. Macdonald-Ross 1973. p362.
55. Schubert WH. 1986. p193.
56. Auerbach ER. 1986. p421.
57. ALBSU is an example.
58. Macdonald-Ross 1973. p366.
59. Macdonald-Ross 1973. p355.
60. Macdonald-Ross 1973. p363.
61. Mathews et al 1988. p517.
62. Mathews et al 1988. p502.
63. Popkewitz T. 1982. p61.
64. Stenhouse 1975. p65.
65. Based on reading Popkewitz, Schubert, Macdonald-Ross and Auerbach
66. Macdonald-Ross 1973. p375.
67. Apple MW. 1982. pp140-150.
68. Popkewitz T. 1982. pp86-94.
69. Popkewitz T. 1982 p69.
70. Macdonald-Ross 1973. p366.
71. Popkewitz T. 1982. p67.
72. Popkewitz T. 1982. pp78-92.
73. Popkewitz T. 1982. p91.
74. HRD:NEPI 1992. p9.
75. Chisolm L. 1992. p3.
76. Young MFD. 1990. p4.
77. Department of National Education. 1991.
78. Banham J. 1990 report DEC p102.
79. Chisolm L. 1992. p2.
80. Curriculum:Nepi. 1992. p5.
81. Bird A. 1992. p13.

**CHAPTER 3**  
**A CONTEXTUALISED STUDY OF OLD AND NEW TRAINING IN THE**  
**BUILDING INDUSTRY.**

---

**3.1. INTRODUCTION**

**3.2. INSTITUTIONAL MAKEUP OF THE BUILDING INDUSTRY**

**3.3. A BRIEF DESCRIPTION OF THE OLD TRAINING PROGRAMME**

**3.4. ANALYSIS AND REVIEW OF THE REQUIREMENTS BY THE BUILDING  
INDUSTRY TRAINING OF THE NEW TRAINING PROGRAMME**

**3.4.1. Lack of employer commitment to training**

**3.4.2. Training programme not meeting needs of new kinds of  
operators**

**3.4.3. Certification**

**3.4.4. Technological, political and social changes**

**3.4.5. Conclusion**

**3.5. DESCRIPTION AND PRELIMINARY ANALYSIS OF THE NEW  
TRAINING PROGRAMME FOR THE BUILDING INDUSTRY**

**3.5.1. Historical perspective**

**3.5.2. The framework of the new building industry training  
programme**

**3.5.3. A closer look at the new training system**

**3.6. CONCLUSION**

### 3.1. INTRODUCTION

This section reviews the findings of the research. The initial focus is on understanding key characteristics of the building industry. The structure of the old training programme is then briefly examined. Perspectives and insights gleaned from interviews conducted with members of the building industry regarding the problems they encountered with the old training programme are then reviewed. This serves to highlight the requirements of the new programme which is then analysed in terms of these needs. Some preliminary analysis is made.

The structure of this section is as follows:

- 3.2. Institutional makeup of the building industry.
- 3.3. A brief description of the old training programme.
- 3.4. Analysis and review of the requirements by the building industry of the new training programme.
- 3.5. Description and preliminary analysis of the new training programme for the building industry.
- 3.6. Conclusion.

### 3.2. INSTITUTIONAL MAKEUP OF THE BUILDING INDUSTRY <sup>1</sup>

The following section is a brief summary of a more detailed discussion which can be found in Appendix A. The description is based on information obtained by the researcher during interviews with all the institutions discussed.

The building industry comprises employers and employees who are either registered, or unregistered with the industrial council. The "registered" are known as the "formal sector" and the "unregistered" as the "informal sector".

Registered **employers** can also be affiliated to the Master Builders Association(MBA) or the Small Builders Association(SBA). A number of unregistered employers belong to organisations which are not "recognised " by the industrial council, for example the Western Cape Black Builders Association.<sup>2</sup>

**Employees** can belong to one of three unions. These are the old craft trade unions, collectively known as the Co-ordinating Committee, CAWU, a Cosatu affiliate or Bicawu a Nactu affiliate. The industrial Council is made up of

representatives of the MBA, SBA, Co-ordinating Committee and CAWU. A substantial portion of people in the building industry do not belong to any of these organisations, but are bound by the agreements, if registered with the industrial council.

Training is organised and provided by the Building Industry Training Scheme (BITS) and by the Building Industry Training Board (BITB). The latter is responsible for setting national standards for training and certification. The Building Industries Federation of South Africa (BIFSA) is an employer body which represents and lobbies for employer needs.<sup>3</sup> There is a close relationship between BITS, BITB and BIFSA with many of the board members being duplicated. <sup>4</sup>The Federation of Associations of Sub-contractors(FASSA), established in 1989, is an attempt by small builders and sub-contractors to counter the power of BIFSA.

The industry is fraught with mistrust and antagonism across the institutions.<sup>5</sup> The growth of the informal sector and the joining of the SBA and CAWU on the industrial council signal attempts at major change in the roles of the MBA and industrial council in the industry. The MBA and the SBA are currently at loggerheads over tendering procedure, the training structure and job grading. The SBA tends to side with the unions against BIFSA, which is seen as a handmaiden of the MBA.

Many of the people in the industry see BIFSA as the training body and from this brief account it starts to become apparent that the accountability of the old and possibly the new training programmes will be questioned by non-MBA members.

This will be one of the challenges which the new training programme will have to meet.

### **3.3. A BRIEF DESCRIPTION OF THE OLD TRAINING PROGRAMME**

The core of the training provided by Building Industry Training Scheme (BITS) was artisan training. As the following description shows it was a typical artisan training scheme for the period prior to 1991.

The training of apprentices involved being indentured by an employer for a period of three years. During this period 24 weeks were spent at Technical College, 18 weeks at BIFCOL and 12 weeks on leave. This left a total of 102 weeks of indentured employment. At the end of three years the trainee obtained artisan status irrespective of whether or not the trade test was passed.<sup>6</sup> During the last years of this programme the national pass mark was 29%.<sup>7</sup>

The other major training programme provided by BITS was for management. The management training programme was from Supervisor level and had been available at the BITS Training Colleges for 10 years. The course known as Building Industries Federation Manpower Advancement programme (BIFMAP) consists of nine separate phases with each phase taking three days to complete. The course was certificated, but was not recognised outside of the building industry and did not carry the same status as an artisan certificate.

Other short courses of skills training aimed below artisan level were conducted according to need, often at the request of employers. These training programmes were either uncertificated or held certificates similar in status to the management and supervisory programmes.

Recently short courses have also been run by Entrepreneurial Development of South Africa (EDSA) in association with the Small Business Development Corporation. These courses are targeted at the informal sector, but as they are not linked to the new training programme of the building industry they fall outside the parameters of this research.<sup>8</sup>

The training programmes were conducted at four colleges (BIFCOLs). The cost of training up to and including artisan level was paid for through a levy system. All registered employers paid a levy on each of their workers. Training from supervisor level was also borne by the employer, but was per person trained.

The training scheme had been underused. For example, in 1990, 2 138 trainees underwent training at the four BIFSA colleges for a total of 10 986 weeks. This means the average length of training was five weeks. Compared to the number of workers in the industry, given by BIFSA in the 1990 Annual report as 250 000, these figures are very low.<sup>9</sup>

While the general use of BIFCOL has remained low there has also been a decline in the number of apprentices registered. Figures quoted in the BIFSA Annual report of 1990 indicate a decline from 1 624 registered apprentices in 1973 to 252 in 1989.<sup>10</sup> Since 1978 fewer than 1200 artisans annually have completed their training. The figure in 1989 was 1 090 completed and 286 registered. This is with a BIFSA estimated annual need of 3 000.

The SBA members have particularly strong feelings on this, as expressed to the researcher by their general secretary:

"BIFSA is able to tap all employers as we pay a levy every week for every worker. The training costs for the whole of South Africa, both capital and running costs were in the vicinity of about R15 million for last year - ending in about in June 1990. They trained about 1 650 workers out of a workforce of three- quarters of a million. This comes to less than .6% of the workforce. I work out that it cost an average of R9 090 per worker for an average of 4.2 weeks of training."<sup>11</sup>

This scenario sketched by Matthews for the 1990 period is likely to still be an accurate one. This is further supported by the fact that two of the four BIFSA training colleges were sold earlier this year.

In feedback to the researcher to a draft report prepared for the Industrial Council on the feasibility of embarking on a literacy programme, both the MBA and Fraser stated that they regarded these figures of Matthews as a distortion of the facts. They said that there was only a workforce of a quarter of a million and that it was not appropriate to work out training unit costs in this way as the budget covers other costs such as safety and loss control. In direct response to Matthews, Fraser gave the following information to the researcher regarding cost of training. During the 10-year period, 1982-1991, R126 million was spent on training 32 000 trainees. This gives the average cost of training at R2 600.00 per trainee. The figure given by Mr Fraser to the researcher is of dubious worth as simple arithmetic, using this information gives the cost of training at R3937.50 per trainee.

Fraser also pointed out that the sale of the two training colleges meant that training could be more decentralised with BITS making use of existing training facilities owned by other organisations. This was also more cost effective.<sup>12</sup>

There is an obvious tension between the SBA and the MBA and BIFSA over the levy system and the manner in which funds are allocated for training. The lack of support for the training programme could either be a symptom or cause of this tension. In the researcher's opinion it is more likely to reflect the general frustration felt by the SBA over the hegemonic control of the building industry by the MBA. This view will be developed further in the following section.

The BIFSA Annual Report reviewed possible reasons for this situation of lack of support for training, particularly the artisan training programme. The report focused on employer concerns to explain this situation.

Reasons given by BIFSA for this decline include:

- \* employers have to contractually undertake to employ the apprentice for three years when they have no assurance of continued operation due to the cyclical nature of the industry.
- \* employers have to undertake to train the apprentice in all facets of the trade when their operation may not allow this.
- \* employers have to contend with absence of the apprentice from the site for long periods due to attendance at technical college, BIFSA or due to military call up.
- \* automatic promotion of the apprentice to artisan status on the effluxion of the contract period irrespective of competence.<sup>13</sup>

These views and others will be explored in the next section.

### **3.4. ANALYSIS AND REVIEW OF THE REQUIREMENTS BY THE BUILDING INDUSTRY OF THE NEW TRAINING PROGRAMME**

In order to be more cost-effective and be seen as a viable operation catering to the needs of the building industry, the new programme will need to be better supported. A variety of reasons and solutions were given to the researcher. These included: Lack of employer commitment to training; training programme not meeting need of new kinds of operators; certification; technological, political and social changes. These four "reasons" will now be explored:

### 3.4.1. Lack of employer commitment to training

The majority of those employed in the construction industry are employed on a contractual basis. They are employed to work at a particular site and when the job is completed are retrenched unless the employer has a suitable position at another site. The extent of this situation is shown in a manpower statistic giving the labour turnover in 1985 in the building industry as 7,1%, while it was 2,5% in the manufacturing industry for the same period.<sup>14</sup> This phenomenon has earned the industry the reputation of being a "hire and fire" industry.<sup>15</sup>

This situation exists in part because of the pattern of **cyclical fluctuation**. This worldwide pattern refers to a phenomena in which the output of the building industries tend to fluctuate considerably more than that of manufacturing and the economy. The cycle in the building industry is related to the general economy. When there is an increase in the interest rate then the cost of building materials goes up with a parallel decline in interest in building. Both of these factors result in a downturn in the building industry. <sup>16</sup>

While it is true that continuity in production is dependent on the maintenance of continuity in demand, in the building industry houses and buildings cannot be stockpiled in down periods thus the demand for buildings is almost by definition sporadic and discontinuous.<sup>17</sup> The industry in South Africa has been in a down cycle since 1989, and this is expected to continue for some time.<sup>18</sup> When the downturn continues for a long period, such as at present, the nature of the industry changes. Larger companies, which traditionally carry the major responsibility for providing some stable, long term employment and training opportunities in the industry, start to cut back and sub-contract while smaller companies disappear. Sessions, Manager of Stocks and Stocks, confirmed that a feature of the cycle was that during times of economic downturn, training was abandoned by employers. <sup>19</sup>

Bird, speaking on behalf of Cosatu at a recent Manpower conference, outlined her concern that although there had been some positive changes regarding manpower policy, the principle of "**voluntarism**" for training programmes remained. Her concern centred around an understanding that as long as training

was in the hands of the employer and not the state, (or preferably a combination of key stakeholders) that training would continue to focus on meeting short term needs. This meant that training could not be linked to a "coherent growth plan for economic development." <sup>20</sup>

At this stage two possible reasons for the lack of support for training have been highlighted. These are: the high turn over of labour which results in a reluctance by employers to train and secondly the change to sub-contracting procedures by larger employers. Under conditions which result in an increase in sub-contracting and if building is still taking place, then there should be similar numbers of employees spread amongst "small" employers. The question must then be asked why are these "smaller" employers not sending people on training courses?. Two views are offered.

The Master Builders Association in Paarl believe that the "kleinman" will not send people for training.

"My ander opsig is dat as jy mense stuur gaan jy net dieselfde werkgewers wat nou opleiding doen oor en oor stuur - maar jy gaan nie jou kleinman kry - hy stuur nie mense vir opleiding nie. Hy doen niks want as hy daardie mens uithaal dan verloor hy 'n werksdag. Hy gaan liewe met 'n halfde werkspan aan."<sup>21</sup>

David Mathews, Chairman of the Small Builders Association gave the researcher a different explanation, expounding a problem of **access**. The meeting took place before the new programme was introduced.

"I tried to get a man registered for training a few weeks ago. I arranged with the Head of the Training College here to send him out. We set a date and he indicated that BIFSA was very keen to train as I believed it was. When I contacted the Industrial Council they said you can't register the workman as you are not registered with the BITB as an accredited employer. I then contacted the Training Board who said they had scrapped that requirement and would fax the Industrial Council to tell them. The Industrial Council still refused to register the man for training as in terms of their agreements accreditation of the employer is still a requirement."<sup>22</sup>

Mathews continued during the interview to describe what were in his opinion "fairly onerous and bureaucratic requirements" of either the Industrial Council, BIFSA or the BITB with which an employer had to comply if s/he wanted to send people for training.

The Black Builders Association in addition to the above, described other problems linked to access such as location and length of training programmes.<sup>23</sup>

In conclusion the lack of support of training seems to be a complex combination of historical factors and changes in the nature of the building industry. In the past it seems feasible to assume that "smaller" builders were in the minority and were content to poach trained workers from the "big" builders. This situation allowed the MBA over the years to take control of the organisation and nature of training. However with the increase in sub-contracting and the accompanying changes in terms of an increase in the variety of training need, this hegemonic situation became less favourable to the "small" builder and an area of contestation.

The above discussion has covered all but one of the reasons given by BIFSA for the lack of support for training. The remaining concern is that of passing artisans purely on the "**effluxion of time**". This process allowed trainees to become artisans after a period of three years irrespective of whether or not any exams had been passed. The 29% success rate in the final years of the programme speaks for itself.

#### **3.4.2. Training programme not meeting need of new kinds of operators**

This development of **sub-contracting** has many attractive features for the major contractors, but has repercussions in other sectors of the industry. The central complaint being that the "rules of the game" were devised for large and established companies, not for small and emerging ones."<sup>24</sup>

For the main contractor the main features of Sub-contracting are that a lower capital outlay is required while gaining indirect access to cheaper labour. Also it is possible to shift the risks associated with the business cycle and strikes onto the sub-contractor. Krafchik argues that the primary benefit to building contractors of sub-contracting is this reduction in direct and indirect labour costs.<sup>25</sup> The most obvious benefit is that of circumventing the Industrial Council regulations prohibiting the use of uncertified labour for skilled work as this responsibility would now lie with the sub-contractor. Contractors can also maintain a smaller, flexible workforce of their own.

The sub-contracting relationship invariably takes place under conditions of extremely uneven bargaining power. The major production costs in construction are the land, raw materials and labour. The main contractor usually takes responsibility for both land and raw materials so the sub-contract is on a labour only basis. This leaves the sub-contractor very little leeway and invariably unable to pay even Minimum Wages and still show a profit.

Krafchick in researching the informal building sector in the Western Cape found that labour costs facing sub-contractors in the low-cost housing industry on the Cape Peninsula are 40% lower than the costs facing contractors. Contractors and sub-contractors are legally forced to pay the minimum basic wage and the compulsory contribution to the Industrial Council Stamp Fund, out of which pension and leave are paid to workers. A large majority of his sample (68.7%) were not registered employers with the Industrial Council and thus avoided the regulations regarding pay. He also found that employment amongst sub-contractors was skewed towards unskilled workers, an indication of the wide practice of employing unskilled workers to perform skilled work. More than two thirds of his sample who were employed as artisans did not have the relevant trade qualifications.<sup>26</sup>

The development of sub-contracting as a major factor in the industry has serious long and short term implications for training programmes. In the short-term the survival needs of artisans who have suddenly become employers or are self-employed must be met. In the long term training programmes for artisans need to take account of the possibility of further structural or technological changes in the world of work. These concerns should not be limited to artisan level, but should permeate throughout the training levels.

At a meeting of small builders in Khayelitsha the Chairman of the Western Cape Black Builders Association endorsed this view.

"I am worried about our role in the New South Africa as in the past we were only trained to handle a trowel etc. Now we are working as sub-contractors and we don't know how to make a profit as we have never been trained to do this."<sup>27</sup>

### 3.4.3. Certification

The study revealed a number of positions on certification by the various groupings. These will now be briefly explored.

CAWU, an affiliate of Cosatu, expounded the Cosatu policy and expressed concerns for nationally recognised certificates which were linked to career paths.<sup>28</sup> BIFSA and the MBA indicated that a system of certification based on elements other than a measure of skill acquisition, such as "effluxion of time", warranted review as it was out of step with other industries and was a lengthy and somewhat unfair system.

"Ideally a new system would have to be diverse enough to cater for the wide variety of firms involved in the industry from multi-national giants to small one man shows, from large conglomerate suppliers to the ever present sub-contractor. In addition it should be flexible enough to handle supervisors coming from a wide range of backgrounds and with a diversity of career paths ahead of them. Always to be considered is the need to cater for those whose background has caused them to be of low educational attainment and who would probably not be at home in either English or Afrikaans."<sup>29</sup>

The SBA criticised the current system for not recognising training of "semi-skilled" and "unskilled" workers which was acquired informally.

"If you consider that buildings are being built, training is clearly taking place, it is just not taking place at BIFSA, it is taking place on site. That is the most important place, but the laws mitigate against it because it is against the agreement(industrial council) to take a labourer and allow him to use a paint brush. You are immediately contravening the regulations, which are there of course to protect the inflated wages of the craft trade union members."<sup>30</sup>

There is also the potential to exploit such a labourer who has become highly skilled and is legally only entitled to general worker wages.

In summary, concerns regarding certification are:

- \* There should be a national system with clear career path opportunities.
- \* Certification should be linked to skill acquisition and not effluxion of time or something similar.
- \* The system should not privilege one group (e.g., language, race, training level) over another.
- \* Informally acquired skills should be recognised.

#### **3.4.4. Technological, political and social changes**

In chapter two of this document the changing world of work is discussed. Mention is made of changes in the structure of labour as well as changes as the result of technological advances. The extent of change in the building industry identified by this research and the impact of this on training will now be discussed.

Interviews with a wide spectrum of those concerned with the building industry revealed that there had been little change as a result of technological advancement.

This finding is supported by Krafchick who found in his research that the role of technological change has been overemphasized for the construction industry. Innovation in the construction industry had been limited because of the volatile nature of the industry which discouraged the large capital outlays required. He conceded that there had been an increase in off-site work, but maintains that this has had only a minor impact on skill levels.<sup>31</sup>

Although the research found that it was possible there would be some change in labour as a result of the inclusion of CAWU on the Industrial Council, there was little evidence of change at the time of the research. None of the employers interviewed indicated that they were changing or considering changing their current structure to one which took account of post-Fordist principles of organisation such as "quality circles" or "just in time". Prinsloo and Watters argue that this finding is understandable as post-Fordist restructuring is more appropriate and manageable in some sectors and industries and less appropriate in others.

"In significant respects, both Fordist and post-Fordist organisation of production relates to factory-based manufacturing industries whereas the building industry is a site-based industry." <sup>32</sup>

They take this position explaining that in site-based industries there is little chance for the infrastructure required by post-Fordist forms of organisation to develop because employees are continually being deployed or moved to new sites.

Although the current research found that the building industry has remained relatively untouched by technological and structural labour changes, the research did reveal that social and political changes within the industry had had an impact. The breakdown of the apprenticeship system and the removal of racial legislation are examples of this.

The implications of these changes at the work place were explored during the research by Krafchik. He concludes that

"the biggest single problem for the industry is with first line supervisors who are mostly black with no management training as they are given very little responsibility or authority and very little information from senior management."

According to Krafchik this problem is a historical one and stems from the old scenario in which white foremen worked with white artisans. There is now an unwillingness on the part of the foremen to train the black artisans, partly due to racial prejudice and partly from the history of on the job training, in which artisans traditionally learned by asking. Usually black artisans are not as assertive or articulate, have no role models or history of upward progression and thus are generally alienated. More educated blacks do not see themselves as having a future in the construction industry.<sup>33</sup>

This has important implications in the development of a new training programme as these are permanent changes, and people need to be trained to manage the changed political and social structure of their workplace.

In addition to the above the construction industry has a number of characteristics peculiar to it. These characteristics also contribute to making the design of a new training framework a complex one. One of these features is the degree to which it is **unique**. In this research many participants, particularly employers, emphasized this characteristic, citing it as a reason why the industry required special treatment. The implications of this view will now be explored.

One of the ways in which the industry views itself as unique is the extent to which **each new job is unique**. This is a feature related to the site-based nature of work. The skill requirements are different from those in a production line where skill requirements are constant. This feature of building sites ideally calls for workers

with a flexible skill base and a good general basic education. This contrasts sharply with the existing very low level of skills available in the industry. The managing director of BIFSA maintains that the high cost of building is directly related to the lack of skills in the workforce. Most building is not done once, but a number of times, before the client is satisfied. Contractors build this tearing down and re-building into their costing.<sup>34</sup>

Butt maintains that the construction industry requires specialist knowledge not only at skill level, but also at supervisory and management levels.

"Construction is among those industries wherein the managerial process is deeply and inextricably interwoven with the design and operational technology: the one inseparable from the other." <sup>35</sup>

Merrifield believes that this point has been exaggerated by BIFSA among others and that most workers do carry out "Taylorist" type tasks which are very similar at each site as most design innovation is done by specialists off the site.<sup>36</sup> This view would be supported by Lloyd who argues that employers use arguments of uniqueness and flexibility in order to keep labour isolated from public training centres. This strategy of alleging "singularity of operation" prevents labour from developing a common identity and of perceiving themselves as having skills to market to a wide range of operations. Lloyd believes that training could have a generic base with employees acquiring the specialised skills as required. This would provide labour with a stronger power base and identity from which to market themselves.<sup>37</sup>

For example, in South Africa, an artificial barrier has been created between construction and shipping. There is no reason why a person cannot be trained in general carpentry skills using the kind of framework outlined by Lloyd and then receive specialist training to work in either construction or shipping. The current structure of training makes this an unusual rather than an obvious procedure. As discussed in chapter two Lloyd advocates that people are trained in "core skills" to overcome this problem.

In summary, it would appear that developers of a new training programme for the building industry would be advised to provide trainees with flexible core skills so they are able to cope with the amount of uniqueness which exists in the building industry. This strategy would also help in preparing workers for possible changes in the industry such as resulting from technological advancement.

### **3.4.5. Conclusion**

The previous discussion has outlined some of the features and current concerns that exist within the building industry. The main pitfalls of the old programme have also been identified. The challenge for the new training programme will be to effectively address these "features, concerns and pitfalls" which can be summarised as follows:

- \* employees tend not to remain at the same site or even with the same employer for a substantial period of time, but tend to be employed on a contract basis;
- \* although controversial, there is a certain amount of uniqueness in the construction industry;
- \* the building industry is a site-based industry;
- \* sub-contracting and the special training needs that this involves is likely to remain as a characteristic of the industry, its influence varying according to the state of the economy;
- \* that this is a particular "moment in time " in South Africa during which most industries will need to review their structure and modus operandi. In addition extra demands are likely to be made on the building industry in addressing the housing shortage;
- \* Lack of employer commitment to training;
- \* Training programme not meeting need of new kinds of operators;
- \* Certification and its role;
- \* Technological, political and social changes.

In conclusion, a new training programme needs to be able to prepare trainees to work in an industry which has seen a growth in sub-contracting and a situation in which artisans often start their own business. This change in structure in which large employers do not employ, but sub-contract labour, means that if training is to be encouraged, then there is a need for a training programme which is not reliant on resources either of money or time of individual employers. There is also a need for a national training and job grading system which recognises all kinds of skill acquisition, can cater for low educational levels, uniqueness of jobs and have way of access for the unregistered or informal sector.

### **3.5. DESCRIPTION AND PRELIMINARY ANALYSIS OF THE NEW TRAINING PROGRAMME FOR THE BUILDING INDUSTRY.**

#### **3.5.1. Historical perspective**

In 1974, BIFSA carried out a national survey of large, medium and small contractors and sub-contractors and concluded that the training system best suited to the building industry was a combination of on-site and institutional off-site training. BIFSA was instrumental in setting up the Building Industrial Training Board (BITB) in 1987, now concerned with

"monitoring the manpower and training needs of the building industry at all levels; facilitating the satisfaction of identified manpower and training needs; and facilitating the optimal development of the labour force potential of the industry." <sup>38</sup>

The new training programme is the result of an investigation co-ordinated by Building Industry Training Board (BITB) with the co-operation of 10 Industrial Councils. According to the report the investigation sought to find a method of standardizing the job categories at a national level and to ascertain the training requirements for the future. The investigation recommended that:

"A comprehensive list covering every possible task that could be performed in every category from the lowest limited skill category to the designated trades must be drawn up by the BITB." <sup>39</sup>

This was done and the report states that a committee comprising six employers and six employees identified a considerably long list of 719 competencies practised in 20 trades. They graded the competencies into four levels of skill, i.e., advanced, higher, low and lower.

The investigation also recommended that a more practical method should be determined to distinguish between artisan and other job categories and that competence should be accepted as the only criterion which would entitle a person to perform a specific task. A person would be judged competent if he could prove that he had successfully completed the prescribed institutional and on-site training.

This reflects a move away from apprenticeship training which could be completed with the effluxion of time to a competency based system, but retains a craft-based framework for identifying job grades and job types. Thus this meets in part the concerns regarding certification expressed earlier in the chapter, i.e., that certification should be based on skill acquisition and not something such as effluxion of time.

The concerns of the researcher regarding the concept of skill and competency as used in this programme and its applicability for ABE programmes will be explored in the next chapter.

In January 1990 the BITB took over the administration of the new artisan training programme from the Department of Manpower. BIFSA are now responsible for artisan training for the industry. This reflects the state's withdrawal from training responsibilities. BITB began converting their training programmes to CB in 1987 so in 1990 when the law changed they were ready and already conversant with the system. Between 1987 and 1990 a variety of training options were tried out. The proposal launched for discussion during 1990 and 1991 is outlined in the next section.

### 3.5.2. The framework of the new building industry training programme.

In outlining the new programme, Neil Fraser stated:

" Our new training model tries to provide a clearly defined career path and an effective, relevant training method to enable someone with limited education to rise to the highest possible levels of his competence."<sup>40</sup>

This new system has five levels. At the bottom end of the scale is the general worker category which has no educational entry requirements. After two years of site experience or the equivalent of standard 1 and some training or site experience, a general worker will be entitled to do a skills test and become an Assistant to Artisan/Tradesman. The remaining three categories have **education entry** requirements. These are functionally literate and numerate, standard 5 or equivalent and standard 7 or equivalent respectively. To qualify as a designated tradesman, trainees are also required to pass N2 at a technical college during their training. At all three levels training has three components.

These are site experience; passing competency based modules at a Training Performance Criteria(TPC) level which happens at a BIFSA training centre and thirdly passing competency based modules at a Production Performance Criteria Level(PPC) which happens on site with an accredited employer. Refer to Appendix C for a diagram of the training model. The two levels of TPC and PPC were introduced to try and improve transfer of learning, however the quantity of work done in a period of time is the main difference between a TPC and a PPC. Referring to discussion in the previous chapter, particularly the work of Vygotsky and Morphet, this alone cannot ensure that transfer of learning will take place. It is also necessary to take into consideration the previous learning experiences of the trainee.<sup>41</sup>

In the design of this new programme BIFSA have recognised the need for trainees to have a sound general basic education in order to move through their programme. They have also recognised that a large proportion of their potential trainees do not have the appropriate educational competencies. They have made a proviso for two levels of basic education within their training module. At the end

of these programme trainees will be accepted for tradesman training. This implies that trainees will no longer require standard 7 or N1 as an entry requirement. This is still being contested by some of the old Craft unions at Industrial Council level.

This structure removes the responsibility for artisan training from the employer only, to one of **joint responsibility** by the industry and the employer. The advantage of this is that in times of economic downturn when employers are loathe to train, BIFSA will be able to undertake training. Costs are only the responsibility of the employer during the time the trainee is doing his fixed period of improvership (like an internship at the end of training).

This interest in breaking away from the old apprentice system is favoured by employers for reasons described above and by employee bodies such as Cosatu. Cosatu sees the shift as an opportunity to take responsibility for training away from individual employers. There is also the possibility of devolving the 'skill elitism' distinction which developed between skilled and unskilled labour. They also believe that a different system could also address the long term problems of accreditation and portability of skills particularly those acquired informally.<sup>42</sup>

According to BIFSA all registered employers and employees are entitled to attend courses in this new programme. BIFSA have also made provision for unemployed people to attend shortened versions of various courses.<sup>43</sup> This raises the issue of access. According to BIFSA this should no longer be a problem as even unregistered employers could send trainees as long as they paid. However, it can be questioned whether or not the new structure is really able to meet the needs of the smaller builder. They will still have problems in terms of the time and location of the training as these factors have not changed. The perception in the field is that the training programmes will still be under utilised. The change in the policy of access to the training programme does not appear to be widely known as the following indicates. Merrifield argues that the new training programme will not solve the needs of the current scenario in the building industry.

" The main weakness of BIFSA's new training program is that the bulk of the productive work is being done by sub-contractors who tend not to be MBA members and thus do not have easy access to the training programme." <sup>44</sup>

Thus although Fraser maintained that access was no longer a problem, the evidence in the field does not endorse this and the training programme is still perceived to be geared to the needs of the MBA.

### 3.5.3 A closer look at the new training system

This section will review the new training programme in terms of the curriculum, the learning event and assessment procedures. Both the skills and supervisor training programmes will be reviewed. The following headings are used in the analysis of this section:

- \* *Curriculum - a look at one of the modules in more detail*
- \* *Learning event*
- \* *Assessment*
  
- \* *Curriculum*

As described above the curriculum in terms of structure and content was designed by BITB with the co-operation of ten Industrial Councils. The designing took place before the SBA or CAWU were members of the councils and thus does not necessarily reflect their concerns.

The 719 competencies identified by the committee represent the training framework for the **skills training programme** for 20 trades. Some of the competencies do appear to be generic across trades. For example most training programmes at level D include modules such as 'erect and dismantle scaffolding', 'interpret basic drawings'. From the information given to the researcher it is difficult to tell how comparable these modules which appear across trades.

It is possible to conclude that training is individual to specific trades and the concept of general training followed by specialist training has not been applied. A typical structure of a training programme outlines a course map for carpentry as having been designed to meet five duties.

These duties are:

A	Basic Carpentry skill	4 modules
B	Erecting Formwork and Shoring	11 modules
C	Constructing roof structures	4 modules
D	Erecting ceilings & partitions	6 modules
E	Finishing carpentry	4 modules

The flow diagram found in Appendix D indicates that the 4 modules comprising Basic Carpentry are prerequisite for the other four levels which are independent and can be taken in any order. Within a level there are some modules which must precede others as can be seen in the diagram.

The training will probably equip a successful trainee to complete all carpentry tasks associated with the construction industry. The person will be able to carry out the tasks using a drawing and will not need verbal instructions.

As the competency based method prides itself on being able to cover all skills that a person will need, one must assume that the training presumes that there will be some other person who will do such tasks as determining what tasks need to precede others, will solve planning problems and will interface between the trades as these aspects are not covered in the training. The lack of these aspects of the "task" in the training programme indicates a narrow view of skill. This view contrasts with broader definitions of skill as used by Lloyd, Mathews and Morphet.<sup>45</sup> The implications of using this narrow view of skill will be explored in the next chapter.

A person completing this training programme who worked on his/her own or in a small company would require further training to be able to work independently and be successful. This would indicate that the needs of the artisan/sub-contractor, as expressed earlier in this chapter, have not been met.

\* *A look at one of the modules in more detail*

'Build a block wall with door and window frame' is a module from the bricklaying training programme at E2 level. The module has two aims; to learn how to interpret the drawing and to build a block wall with door and window frame

The modules or tasks have three parts. These are: doing the task, doing a self check test and then doing a performance test.

The **doing** of the task need not be actual construction, but could be identifying key points. For example knowing what to look for in a drawing. The first aim in this module has ten and the second 20 such key points. If the trainee is required to do some actual construction it is suggested that the trainee ask the instructor to demonstrate each step. The aim involving building a wall has 20 steps to be demonstrated.

The **self test** can take the form of a multiple choice test or a check list to which the trainee must give a "yes" response to all the items to be successful. There are 21 items to be checked for the building a wall aim in this module.

The **performance test** is evaluated by the instructor. In line with the CB framework the trainee knows what the performance test will be and on what basis s/he will be evaluated before s/he starts the test.

At this level of analysis it becomes apparent that the new training programme is very similar to the early versions of CB which use a narrow definition of skill. It is likely that trainees who finish this programme will be capable of demonstrating mastery of individual skills. It is equally likely that the trainees would be unable to provide a complete description of a building operation or demonstrate that they were able to use their skills in a flexible and adaptive way.

The **supervisory training programme** has been revised as part of the new structure and now has just over 50 modules divided into 9 categories. One of the categories contains seven modules which are all technically related and are prerequisites for the other modules. The other eight categories are: organisational human behaviour, financial control, estimating and tendering, production management, human behaviour, industrial relations, legal requirements, general information. Modules are graded into first line supervisor, Junior and Senior Foreman levels. Butt states that the main thrust of the course is to be "skilful management of resources, notably manpower, money and time." Butt believes

the course is able to equally well meet the needs of a "bakkie builder" (or small builder) and a person employed by a large conglomerate.<sup>46</sup>

\* *Learning event*

In the skills training programme, training is an **individual event**. Trainees select a module from the courses available according to their own needs and work their way through it at their own pace. Instructors are available to demonstrate or answer questions. When a student feels s/he is ready they approach the instructor who tests them. This learning experience does not make use of peer learning. The modules are all pre-written and pre-determined. There is thus very little scope for them to be adapted to meet the needs of individual learners such as second-language users.

While the concern for the individual is laudable, this focus prevents the valuable experience of team learning from happening. Not only is this a loss in terms of learning, but it is also a loss in terms of gaining experience in working as part of a team. This is a problem in terms of the current changes in the workplace where team work is becoming the norm.

Burroughs feels that the BITB instruction manuals are alienating. In her research she found trainees who previously were able to do tasks from practical experience were no longer able to do them after reading the manual. She argued that the texts were not written in a user-friendly mode that was appropriate to the target audience. Trainees found the manuals confusing. This finding also indicates that the training system is not catering for people with different learning experiences.<sup>47</sup> These findings imply, that even though, the developers have stressed the individual, they have not recognised the need to cater for individuals with differing learning histories. The implication of this for ABE will be explored in the next chapter.

Developers of CB programmes profess that the **modularisation** format caters to individual needs. Individual trainees can enter and exit at various points. Also modules can be selected in a multitude of patterns. This is the case with the building industry training programme. The inference drawn from this is that the programme will cater for all. However, despite the modular format the programme

could still be experienced as alienating by some trainees. For example, if a programme was developed using a particular frame of reference without regard for other frames of reference, then, that there is a modular format, is of no consequence. Training programmes need to be developed in such a way that they are sufficiently flexible and able to meet trainee needs who come with a wide variety of learning histories. This is not the case with the building industry training programme which has the same programme for all trainees. An example of this is the distinction made in the PPC and TPCs. While these two methods of assessment mean that there is some concern for transfer of learning, the fact that only time is used to distinguish the two methods of assessment is indicative of a concern particular to certain cultural groups.

As described in chapter two the CB learning experience is believed by some to be a very particular one. The emphasis on the concepts of modular and competency force the learning experience into being a quest for efficiency. What is to be learnt is presented in an uncontested way as the information to be learnt. Critics of CB maintain that students are socialised into a role of receiving rather than generating knowledge. While it was difficult to prove in this research because of the limited access to trainees, it is very likely, because of the way the programme was developed, that these comments are applicable to the building industry training programme.

\* *Assessment*

With the advent of the new training programme the construction industry has an internally **nationally recognised certification** system. This training programme has been accredited by the Department of Manpower and a variety of training institutions and employers have in turn been accredited as training institutions by the Building Industry Training Board. This system of accreditation means that for the first time trainees will receive certificates which within the industry will be recognised nationally. The certificates are not recognized across industry borders at this stage. Courses below artisan level, at artisan level and management courses are certificated in this new system.

All assessment of training is by CB. This is done at three levels. The first is a **self-evaluation** which is provided in the training manuals. Its format varies from

multiple choice questions to a checklist of things which must be done correctly. The second and third levels are the Training Performance Criteria (**TPC**) and the Production Performance Criteria (**PPC**).

Vorster outlines these as:

" For its system of product accreditation, the BITB introduced a Skills Register, which identifies performance standards which are to be met, as well as the conditions under which competence is to be demonstrated on two levels, i.e., TPC and PPC. The TPC time allocation applies to the time in which the project has to be completed during institutional training, and the PPC identifies the performance time after completion of institutional training plus site exposure and development, which standard will also apply for the purpose of the qualifying trade test."<sup>48</sup>

For example for a joiner doing the B2b task which is "machine components for counter balanced sliding sash window" the TPC is 21 hours and the PPC is 15 hours.

The method of assessment allows for people who have acquired skills informally at any of the levels to be assessed. This is a strength of the new framework and must be viewed in a positive light by the SBA. However, although the structure allows informally acquired skills to be recognised, most of the objectives are written in such an esoteric language that it is probably virtually impossible to demonstrate mastery of a task without going through the training programme. This view is based on a reading of the objectives in the training manuals. The researcher recognises that in practice the assessors may use their discretion. However the CB system with its emphasis on 100% mastery mitigates against this being a common occurrence.

While the changes described above are an improvement on the old system and must be commended, there are some areas of concern.

The process of continually assessing trainees as found in CB programmes can result in an unnecessary focus on assessment. The student works continually on a deficit model in that s/he is continually having to acquire a behaviour which s/he lacks. The systems of assessment as used in the building industry are typical of the early 'hardliner' versions of Cb described in chapter two. The objectives focus on immediately observable behaviour which tends to be easily measurable.

The continual emphasis on assessment has another "unintended consequence". This is that an artificial ceiling is created in the learning process as someone who has met all the objectives could believe s/he is finished learning. The long term implication of this is that an opportunity to create life-long learners, currently generally viewed as desirable, is lost.

Writers of CB programmes tend to report that the target skills and the method of assessment is unambiguous and fair. As discussed earlier the developers of the building industry training programme believe they have developed such a system. However critics of CB systems believe that the target behaviours are not as unambiguous as they are made out to be and that many in fact could be assessed in a number of ways.<sup>49</sup> An obvious element of subjectivity comes from the person doing the assessment who has to interpret when a behaviour has been performed successfully. The choices made by developers in terms of the kind of target behaviour identified have also been found to reflect norms pertaining to a particular social class. If these criticisms are real, then it is possible to say that a CB system is as likely as any other system to privilege certain kinds of students. It is equally possible to say that it is unlikely that the building industry has not fallen into this trap.

CB programmes receive criticism for focusing only on **short term retention**. The building industry has tried to deal with this by introducing Terminal Performance Criteria(TPC) and Production Performance Criteria(PPC). As the TPC assessment happens at the training centre and PPC at the work station this should also cater for 'transfer of learning' concerns. However, the assessment is not as valid as it initially appears as the only difference in the criteria between the two levels of assessment is time.

A positive aspect of skill development using the CB system is that it helps students to **focus on the task** to be learnt and this helps with learning. In the ABE method of meeting individual needs, learning often becomes very unfocused with both the learner and teacher often going off in different directions. This makes it difficult to judge learning outcomes and often students get lost and dissatisfied.

### 3.6. CONCLUSION

This preliminary analysis of the new training has revealed that in some respects the programme is a considerable improvement on the old system, but it has also shown that it still falls short of meeting all the needs of the various parties in the industry.

There seems to be some agreement that the move to a competency based system is an improvement on the old system in which a person could obtain artisan status based purely on having completed three years of "time". There is however some concern that the skills and objectives have been too narrowly defined to be able to produce workers with flexible skills. This concern relates specifically to an identified need for builders to be able to work in "unique" situations. There is also the more general concern that to meet goals, such as economic development, workers with multi-skills who are able to work in a team will survive change better. There is also a theoretical concern that trainees trained in narrowly defined skills have difficulty transferring these skills to other contexts.

The move to introduce a system which allows a person "with only his health to rise to the highest possible levels of his competence" has generally been favourably received.<sup>50</sup> As could be expected the old craft unions in protecting their traditional territory have been critical of a system which excludes education as an entrance requirement. The apparent "ease of access" which is so proudly spoken about by BIFSA officials is also viewed with suspicion by non-MBA members. At the time of this research the system still had to be tested.

Finally, in terms of an indication of overall intent, there is possible cause for concern that the needs of the "new" kinds of builders such as sub-contractors seems to have been ignored by the developers of this new programme.

The appropriateness of this system of learning for people within the building industry for a cognitively complex skill such as ABE as opposed to the bounded and performative building skills taught in the new building skills training programme, will be reviewed in the next chapter.

### CHAPTER 3 - A CONTEXTUALISED STUDY OF OLD AND NEW TRAINING IN THE BUILDING INDUSTRY - FOOTNOTES

1. Description of the institutional makeup based on information obtained during interviews with representatives of all the key institutions.
2. The industrial Council has no formal relationship with this body.
3. Stated by Neil Fraser, Executive Director, BIFSA, to the researcher.
4. This is a very brief account, a more comprehensive description appears in Appendix A.
5. An example of this is the dispute recorded by the researcher between the David Mathews, Chairman of the Small Builders Association and Neil Fraser, Executive Director of BIFSA regarding the cost of training.
6. BIFSA Annual report 1990. pp55-57.
7. BIFSA Annual report 1990. p58.
8. More information can be obtained from EDSA or Wolfgang Thomas of SBDC, Western Cape.
9. BIFSA Annual report 1990. p51.
10. BIFSA Annual report 1990. p54.
11. Meeting with committee of Small Builders Association, July 1991.
12. Personal communication, November 1991.
13. BIFSA Annual report 1990. p53.
14. 2,5 vs 7,1% turnover
15. Industrial Council Internal report, January 1991.
16. Personal communication W Krafchik and B Hindle
17. Krafchik W. 1991c. p56.
18. BIFSA 1990.
19. Jeff Sessions, telephonic communication, 18 July 1990.
20. Bird A. 1991. paper 5
21. Meeting with the MBA of Paarl, July 1991.
22. Personal communication with David Mathews, chairman of SBA, 18 July 1990.
23. Khayelitsha and small builders meeting
24. Chairman, Western Cape Black Builders
25. Krafchik W. 1991c. p56.
26. Krafchik W. 1991c. p 71.
27. Mr Khakaza, July 1991.
28. Meeting with Western Cape representatives of CAWU, 3 August 1991.
29. Butt P. 1991. p27.
30. Meeting with representatives of SBA, 18 June 1991.
31. Krafchik W. 1991a. p 26.
32. Prinsloo MP. and Watters KA. 1991. A company having no permanent work place is referred to as "site-based". Smaller building companies usually fall into this category.
33. Krafchik W. 1991b.
34. Personal communication with Neil Fraser
35. Butt P. 1991. p28.
36. Merrifield A. 1991 Personal written communication.
37. Lloyd 1991. p 13.
38. BIFSA Annual report 1990. p49.
39. BIFSA Annual report 1990. p52.
40. CAPE TIMES, 18 April 1991
41. Vygotsky in Miller R. and Morphet T. 1989.
42. Lloyd 1991. p2. and Bird A. 1991.
43. Fraser N. 1991. Personal communication

44. Merrifield 1991. Written communication.
45. Lloyd 1991, Mathews et al 1988 and Morphet 1989.
46. Butt P. 1990. BIFSA Annual Report, p76.
47. Burroughs E. 1992, Personal communication.
48. Vorster JA. 1991. paper No 8.
49. Macdonald-Ross 1973. p366.
50. Fraser N. 1991.

## **CHAPTER FOUR**

### **ANALYSIS OF COMPETENCY-BASED EDUCATION**

---

#### **4.1. INTRODUCTION**

#### **4.2. ANALYSIS OF THE NEW TRAINING PROGRAMME OF THE BUILDING INDUSTRY**

**4.2.1. To what extent has the new programme avoided the pitfalls of the old training programme**

**4.2.2. To what extent is the CB format suited to the building industry**

**4.2.3. Conclusion**

#### **4.3. ASSESSMENT OF A CB DRIVEN ABE FOR THE BUILDING INDUSTRY**

**4.3.1. General issues**

**4.3.2. Language and literacy issues**

#### **4.4. ASSESSMENT OF CB FOR LARGE SCALE ABE**

#### **4.5. CONCLUSION**

#### **4.1. INTRODUCTION**

This chapter contrasts the theoretical positions raised in chapter two with the research findings of chapter three. The analysis covers three areas. The first focus is on the building industry and their new training programme. Secondly an ABE programme based on lines similar to the CB building industry programme is considered. The third focus reviews CB as a system for ABE beyond the boundaries of the building industry.

#### **4.2. ANALYSIS OF THE NEW TRAINING PROGRAMME OF THE BUILDING INDUSTRY.**

In many respects training in the building industry is ahead of other industries in South Africa as BITB was one of the first to implement a national training programme. In comparison to the old training programme the new one is innovative and although not linked to other educational or training systems it is internally consistent and is obviously geared to be implemented on a large scale.

The programme is still relatively new and it is difficult to judge how successful it is likely to be. In the preliminary analysis in chapter three the new programme was reviewed in terms of three specific concerns, i.e., the curriculum, the learning event and the assessment. The analysis in this chapter focuses on two more general concerns. These are:

- 4.2.1. To what extent has the new programme avoided the pitfalls of the old programme;
- 4.2.2. To what extent is the CB format suited to the building industry.

##### **4.2.1. To what extent has the new programme avoided the pitfalls of the old programme.**

In chapter 3.3 the pitfalls of the old training programme were outlined. Briefly, there seemed to be concerns at the levels of input and output and as a result the training programme was poorly attended.

Based on attendance during the trial period of the new programme, there still seems to be a potential problem with poor attendance. It can already be argued that the new programme will continue to have this problem because the developers of the programme did not address a number of key issues. Cosatu

would argue that this issue of poor attendance will remain for as long as training is a voluntary commitment by employers.<sup>1</sup> They would argue further that training programmes will continue to encounter problems such as this as long as they are developed by a small group of people rather than all the stakeholders.

A number of these stakeholders, including Cosatu, would also argue that like the old programme, the new programme does not meet their needs and thus will not be well supported. These stakeholders would argue that in developing the new programme the designers did not take into account the changes in labour which have occurred in recent years, specifically the increase in sub-contracting and the growth of the informal sector. The programme appears to have been designed in content, structure and institutional location to meet the needs of the Master Builders. The specific needs of the new labour market have been largely ignored, both in terms of the kind of training and in terms of where and when the training is offered. In addition only people working for registered builders have access to the programmes.

The issue of voluntarism was also raised by the Co-ordinating craft unions as part of a concern of control. At present the employer controls the training programmes. The co-ordinating unions believe that this power will be misused.

"We are very suspicious about it. The first thing we think of is cheap labour as the employer will stifle the person. They will get him up to standard 3 and then keep him there- doing certain tasks of an artisans work, but not allowing him to become a specialist because then he will have to pay them."<sup>2</sup>

This situation reflects something for which CB programmes are commonly criticised - that of ignoring the context. In this case the prevailing economic, social and political context. This absence of 'the context' in the building industry training programme is not an accident, but indicative of a site of tension. To include the context which continually changes would make the programme too unpredictable. It was much easier to develop the programme as if it were in a vacuum.

For example, there is currently a general call for flexible workers. To take this into account and to include modules to encourage this, means that standardisation and assessment procedures of CB would be compromised. There would also be more demand placed on the skill of the instructor.

The potential pitfalls of the building industry training programme as discussed above have particular relevance for this research. It appears that the structure of a CB programme cannot on its own guarantee large-scale provision. The programme must be developed in such a way that the content, structure and institutional location of the programme meets the needs of the consumer. As this is not the case with the new building industry training programme it is quite likely that the problems encountered by the old programme with input levels will remain.

#### **4.2.2. To what extent is the CB format suited to the building industry.**

The building industry training programme has maintained a craft basis for categorising training programmes. As raised in chapters two and three, it has been predicted that trainees completing similar craft based programmes could find themselves unemployable after a short period because of technological changes resulting in the demise of their particular craft. The problem is compounded when, as was found in the building industry training programme, the objectives are narrowly defined and closely related to work related tasks. This programme would leave trainees unprepared for changes in the structure of the workplace. However, unlike like other trades, such as electronics, the building trades have, to date remained relatively untouched by technological developments. While this is likely to remain true for many of the building trades because of their nature, it is possible that in some trades, a new technique, such as computer-aided-design has not been utilised because of low skill levels.

The concern regarding maintaining the craft-based system with its narrow focus also links to a theoretical view of the Human Resource Development Research Group of NEPI.<sup>3</sup> As discussed in chapter two this group indicated that to teach specific skills in a technical education framework at school level was not as "empowering" as teaching a more academic programme which focused on general skill development. In this respect the building industry training programme appears to be similar to those programmes which have been criticised for not empowering people.

The way the new building industry training programme is constructed allows a person to focus only on their area of work and ignore the whole. In terms of the needs of the industry and ABE it would seem to make sense to move from the "whole" to the "bits" and back again so that trainees keep a perspective on their role in the "whole" and can take into account the needs of other "bits". In the

building industry this would mean that this aspect of building would not be in the hands of the supervisor and would encourage independent planning and work. This could lead to a more equal work environment.

#### **4.2.3. Conclusion**

This analysis has shown that the CB system as used in the building industry training programme can be described as 'hardliner'. The skills are narrowly defined and terminal objectives are measured in observable behaviours. There is a focus on mastery learning of isolated 'bits'. There has been little if any attempt to provide trainees with a general understanding of the industry. The system of describing skills within craft boundaries (as opposed to using a core skill format) has been maintained. While the modularised format allows for multiple entry and exit points this alone can not meet the potential variety of trainees learning needs.

On the positive side, the system has provided the industry with a nationally recognised programme for training. Access while still restricted, has improved and education has not been used as a reason for exclusion. There has been some attempt to improve transfer of learning by using the TPC and PPC system of assessment, but this is unlikely to be adequate.

From the above discussion it is clear that the CB format, as used in the building industry training programme, may be an improvement on the old system in the short term. In comparison to the old training programme which allowed success to be based purely on the effluxion of time, the new training programme with its insistence on mastery has much to offer. However in the long term it is very likely that both trainees and the building industry will encounter output problems.

#### **4.3. ASSESSMENT OF A CB DRIVEN ABE FOR THE BUILDING INDUSTRY.**

This section will focus on implications of using CB for an ABE programme for the building industry. The critique has two sections. The first section covers general issues while the second deals with language related concerns.

The concerns discussed in the previous section are relevant for ABE as well. These will not be repeated. The analysis will focus on the theoretical issues raised in chapter two, which dealt with ABE provision.

### 4.3.1. General issues

In the building industry, as well as in South Africa, the current challenge for ABE is to find a way of large-scale provision, which is able to meet both individual and general needs. These two factors 'large scale' and 'needs' can be used to gauge the relative merits of a variety of potential options. To organise ABE using a CB system is one possible option. These options, including the CB option, fall along a continuum, at the one end of which is what has already been described as 'free-standing' ABE and the other total integration into an overall education system. CB could fall anywhere along this continuum. However, in the South African context, it has a particular location and is usually located at the total integration end of the continuum.

These options can also be viewed as a tension between development and equity concerns in policy formation. In terms of ABE this debate reflects two contrasting positions. As outlined in chapter two, on the one hand there is a call for large scale provision of ABE as part of a complete plan for revitalisation of the country and the introduction of democracy. This plan considers a multi-skilled workforce as a prerequisite for economic growth. On the other hand is a concern to empower individuals by designing programmes to meet individual needs. The focus is on the individual, usually what the developer perceives as the learning needs, the learning context and the kind of literacy required by this individual. Literacy is seen as a sufficient goal, that is, it does not need to be integrated into a complete learning package to be justified. It can be 'free-standing'.

Thus to be part of the building industry training programme will in the opinion of some, be a considerable 'win' for an ABE programme. There is a link to skill development and job opportunity for people with little or no education. As courses and modules are certificated there is also an option to market the newly acquired skills. However in the opinion of the advocates of free-standing literacy programmes, using CB is a potential loss as it impacts, in their opinion, not only on the content, but also on the process and outcome of the learning experience. This latter group also tend to view literacy and second language learning as requiring learning situations different from general skill acquisition. In their opinion to integrate performative and cognitive skills into one system will mean that literacy and language training will not be able to be treated differently. As outlined

above the significance of these concerns depends not only on the desired role of the literacy programme, but also on one's view of literacy.

Current theoretical understandings of the learning process, as outlined in chapter two, indicate that there is a strong possibility that the modular format may prevent ABE learners from gaining an overall picture of the target skill. ABE is essentially about learning a series of complex cognitive skills as opposed to the performance skills required in the building industry. Although the theoretical positions regarding the nature of the cognitive learning experience vary considerably there would be general concern for the potential loss of the 'gestalt' because of this CB focus on the 'bits'.

A second concern with modular is that the training programme in the building industry focuses on observable behaviours. Language and writing skills are inherently difficult to divide into small measurable chunks without meaning being lost and it would be tempting to focus only on observable behaviour. This would mean that the more subtle aspects of language learning such as pragmatics could be lost.

'Softer' versions of CB go beyond measuring only observable behaviours. An example of a softer version is the ALBSU programme, which as described earlier, includes knowledge and understanding objectives.

The modular structure purports to allow flexibility in terms of the order in which skills are learnt. However the process of learning is described so specifically that there is very little flexibility in 'how' the learning could take place. The implication is that there is only one way to learn the target behaviour. The current knowledge available on second language learning indicates that this is not true.

A further overall concern has to do with the CB use of curriculum as fact rather than as a process. In the building industry system there is very little space for deviation to cater for individual learning problems. This problem was referred to in the context of the building industry curriculum and it is equally applicable here. The current structure of the building industry CB training programme does not take into account the needs of trainees with different learning histories or social experiences. This would be a potential long term loss for ABE. As indicated in chapter two this format may also result in problems with the transfer of newly acquired skills to other contexts.

A further consequence of the 'curriculum as fact' structure found in Cb programmes such as the building industry, is that there is an assumption that the curriculum can be prespecified. The building industry format does not allow for innovation by either the trainer or trainee. This seems to be a particularly valid concern for the broad expanse of learning involved in acquiring a second language. This is a problem particular to this version of CB. This problem does not exist in other versions of CB, such as used in the ALBSU programme, where modules are more flexible and wide ranging.

#### **4.3.2. Language and literacy concerns**

The building industry training programme is essentially about technical skill acquisition while language and literacy learning is about a particular kind of 'mind' or cognitive skill acquisition. This distinction is the basis for many of the issues discussed below.

As outlined in previous chapters some theorists working in the literacy field regard the context and manner in which one becomes literate determines to a large extent the kind of literacy that is acquired. Street argues that the CB context will provide one with a particular kind of literacy. Following this line of argument leads one to consider that it could be possible that a CB kind of literacy, such as would be found in the building industry version of CB, might meet the needs of the developer (or the nation), but not the learner.

Extrapolating from the views of Scribner and Cole, it can be hypothesized that of the three dimensions of literacy an ABE programme based on the building industry version of CB, is likely to only provide the learner with literacy skills at the dimensions of technology and function. The CB format would make it difficult for literacy to be acquired at the dimension of social meaning.

The finding of this research that this kind CB programme does not take account of the context within which it is developed and tends to focus narrowly on a limited variety of skills would be a concern for researchers such as Street and Griffin. Their concern would be that a CB format may not be able to address these special requirements.

In addition to concern regarding the kind of literacy which building industry trainees would acquire is a concern for the process of learning. The building industry curriculum can be described as seeing the 'curriculum as fact' as opposed to seeing the 'curriculum as practice'. As outlined earlier this involves trainees acquiring, rather than synthesizing or generating knowledge. The main concern with this point is that trainees are unlikely to be able to challenge existing systems or be empowered as a result of their learning and that the status quo is more likely to be entrenched. This concern is likely to be also true for an ABE programme if it is developed using the same process and structure as was used in the building industry training programme.

A second point regarding the process of learning involves the focus on the individual. It is difficult to dispute a common sense understanding that language, as a tool of communication, should be learnt in a group environment. The conventional CB format, which is used in the building industry, makes this difficult. It has also been argued earlier that by denying peer learning trainees are prevented from learning how to work in a team. This structure could prevent trainees from learning a whole variety of skills such as comparing, developing or refining ideas and critical thinking.

A third point concerning the process of learning is the focus on mastery. Languages are inherently creative and unpredictable and this focus on mastery may hinder real learning of the language as trainees are discouraged from making progressive approximations.

In summary, this section has analysed the specific concerns of literacy and language learning when using a CB system. This analysis has focused on what is lost or gained from the perspective of those concerned primarily with individual needs. While many of these 'losses' would be of secondary concern to those focusing on national needs, there does seem to be a case for being concerned about using the kind of CB found in the building industry training programme, for ABE provision. It can also be concluded that while there may be some concern regarding specific aspects of CB it can be said that it does provide a viable option for constructing a system of large-scale provision. This cannot be said for the advocates of 'free-standing' literacy programmes who have tended to only provide programmes on a small scale. Their criticisms will be valuable for advocates of CB programmes who can build the concerns which relate specifically to ABE issues into CB curricula.

#### **4.4. ASSESSMENT OF CB FOR LARGE SCALE ABE.**

The following section reviews the potential wins and losses for ABE if a CB system is adopted for large scale provision. In the analysis ABE is seen as part of an integrated education system which uses CB as a way of organising the curriculum.

The first assumption to be challenged is the notion of CB. The finding of this research is that, as with literacy, there is not a CB, but many CBs.

From previous discussions, it is possible to conclude at this point that the version of CB used in the building industry training programme has limited appeal for a large scale ABE programme. Concerns pivot on the narrow view of skill which has resulted in a restricted curriculum and a mediocre learning experience. General research on CB programmes indicates that this kind of CB programme results in a loss of the 'gestalt', problems with transfer of learning to other contexts and a lack of long term retention. Trainees tend to be trained to meet immediate needs and in the long term their training cannot guarantee that they will be capable of adapting to technological or even general change.

Recent innovations in CB in both training and ABE fields have introduced some promising options. These programmes have adopted notions such as core-skill; range for acceptable mastery of an objective and the concepts of knowledge and understanding in description of objectives.

However these innovations should not be adopted without review as they have their own set of limitations. The most obvious limitation is that they are 'imports' and local conditions need to be taken into account. The 'moment in time' and history of provision in both Australia and the United Kingdom, where most of these ideas originate, differs significantly from South Africa.

To give a very specific example: Unlike the United Kingdom, in South Africa there is dearth of well-qualified teachers. The situation in ABE is particularly chronic. In the version of CB found in the building industry this would not be such a serious problem. People can be trained to manage this kind of programme in a relatively short time. However this is not the case with the 'softliner' versions. CB programmes which use core skills and broadly defined objectives require skilled

teachers if they are to work. The programme on its own cannot guarantee that the outcomes will be any different from those found in the early versions of CB.

The current moment in time demands that the economic, political and social context be taken seriously in planning new education and training systems. This has been found to be a general weakness with CB programmes. At this stage there are two specific points to be made. The first concerns implementation and the second the appropriateness of CB. The problem with implementation is that a way has to be found to implement a new system at a variety of levels and locations. The current suggestions imply that this process will allow very little space for transformation or slow change and will be much like trying to start with a clean slate. The potential pitfalls and ramifications of this, will not be reviewed as they are beyond the scope of the current research.

#### **4.4.1. The appropriateness of CB.**

As described previously the goals of the Cosatu programme include "equipping people with the knowledge and skills needed for governance."<sup>4</sup> This goal takes seriously the issues of equity and democracy.

It has been proposed that having one system for education, and training which takes into consideration the economic, social and political context is likely to promote equity. The belief is that if there is one system, programmes which used to be privileged over others (eg academic over vocational, university over technical, white over black etc) will lose their status. CB is also seen as a suitable way in which to organise such a system as the modular structure allows people to enter and exit according to individual needs. It is also thought to be less ambiguous and more standardized than other systems, thus helping less advantaged people. These premises will now be considered.

The findings of this research indicate that the belief that a one system structure will on its own promote equity cannot be accepted unconditionally. The "one system" policy as proposed by Numsa has been specifically criticised as likely to privilege employed, male, urban workers. A large scale programme for ABE which tries to promote equity will need to look closely at a variety of options. For example, it could well be that a parallel as opposed to a national system is a better option. Other issues such as voluntarism, responsibility, ownership and the role of certification will also need to be addressed.

There are also specific issues regarding the nature of the curriculum. Research, sited previously, indicated that in the long term equity and empowerment were more likely if cognitive rather than technical skills were taught. The current focus of Cosatu is 'core-skilling' which appears to be an appropriate move. Combining a wide range of core skills that go beyond observable behaviour, with notions such as range, in the concept of mastery hold promising options. At this stage only time will tell whether or not this promise of core skilling will be able to deliver.

#### **4.5. CONCLUSION**

This chapter has analysed the potential win/lose situation involved in using CB as a system of ABE provision. The analysis has gone beyond the specific concerns of the building industry to looking at large scale provision of ABE for South Africa.

The analysis has shown that to use the CB system as it is used in the building industry is unlikely to provide long term solutions for ABE provision. However, the building industry training programme has demonstrated that it is possible to design and implement a national large scale programme. Providing a link for ABE into a national system is another positive feature. However the concerns of democracy and equity as well as the special requirements of literacy and language learning make the building industry version of CB a less viable option.

The main hope for CB as a system lies in whether or not it is possible to adapt the concepts of core-skilling etc to local conditions.<sup>5</sup> The final challenge will be to include the concerns outlined by the advocates of 'free-standing literacy' into a large-scale programme. The curriculum, learning experience and assessment procedures will benefit if the developers of a large scale ABE programme manage to hold these two concerns.

## **CHAPTER 4 - FOOTNOTES - ANALYSIS OF COMPETENCY-BASED EDUCATION**

1. Bird A. 1991.
2. Member 1991. Meeting with Co-ordinating union committee.
3. HRD:NEPI 1991.
4. Refer to footnotes in chapter 2.
5. Core-skilling etc is only looked at within a CB framework in this report. It can be used as a concept in other contexts.

## CHAPTER 5 CONCLUSION

---

This research examined the system of competency-based education. The research focused on competency-based education as used in the building industry. These findings were then analysed in terms of the implications for large scale provision of Adult Basic Education. The research found, that like literacy there is more than one version of CB and that the learning process and outcomes differs in these versions.

The version of CB used in the building industry was described as an example of a 'hardliner' version of CB. In the building industry version the narrow interpretation of skill and focus on 'bits' were felt to be particularly problematic for ABE. The research found that looser or 'softliner' version of CB had tried to deal with these limitations. However, these were new developments and it still had to be proven whether or not they were going to be able to deliver.

The use of CB as a system for large scale provision was found to be a useful option. The potential of being able to link ABE to an articulated and integrated education system was an enormous advantage. The modular format in providing multiple entry and exit points was found to be beneficial as it is able to cater for the individual needs of adults. This kind of structure is also more likely to lead to 'life-long' learning than other formats.

\* *Further concerns*

Although this research reviewed only the building industry version this interpretation of CB can be found in most CB training programmes in South Africa.<sup>1</sup> If CB is to be adopted as a system of provision for education in South Africa then it will be essential that a common understanding of CB is developed. A concern already exists that the right kind of literacy is taught. A similar concern must be developed for CB.

This research has also indicated that it is unfounded to assume that using a CB system, even a good one, will on its own solve many of the inherited education problems in South Africa. A good CB system with a well thought out curriculum which allows flexible learning experiences and effective assessment procedures is as likely to fail as any other. The CB system on its own is not able to ensure equity or promote democracy. To be successful systems need to be maintained by a good infrastructure. For example, to prevent CB being 'assessment led' will require not only a good curriculum, but also good teacher training. It may also be useful to begin, as Auerbach suggests, to view CB as a tool amongst other tools and not the beginning and end of curriculum development.

## **CHAPTER 5 - FOOTNOTES - CONCLUSION**

1. Examples of this version of CB were found in technical training manuals for both the clothing and mining industry.

## BIBLIOGRAPHY

---

- ABE:NEPI. 1992. *National Education Policy Investigation: Adult Basic Education Research Group*, A project of the National Education Crisis Committee, Oxford University Press and NECC, Cape Town.
- Adult Education and Extra-Mural Studies. 1992. *Developmental Strategy in Adult Basic Education: A study conducted for the Independent Development Trust*, Unpublished paper, produced by the Staff of the Department of Adult Education and Extra-Mural Studies, University of Cape Town, Cape Town.
- Alant E. 1991. Precursors to Literacy, Conference on Literacy and Basic Adult Education in Southern Africa, *HSRC Conference Proceedings*, September 1990, P242-250.
- ALBSU 1992. *The Adult Basic Skills Unit Standards for Basic Skills Students and Trainees*, ALBSU Publication, London.
- ANC 1990. *The African National Congress policy document for a democratic South Africa*, Johannesburg.
- Apple MW. 1982. *Education and Power*, Ark Paperbacks, Boston
- Arnove R. 1993. Seminar at Maryland Centre, Hanover Park, 15 February.
- Ariovich G. 1990. Outlook for the building industry, *The SubContractor*, July/August, p55-59.
- Auerbach ER. 1986. Competency-based ESL: One Step Forward or Two Steps Back?, *Tesol quarterly*, Vol.20, No. 3, p411-429.
- Baker J. 1989. An introduction to FASSA, *The SubContractor*, January, p4-7.
- Ball SJ. 1990. *Politics and Policy Making in Education: Explorations in policy sociology*, Routledge, London.
- Bannister BJ. 1987. Trade Unionism in the building Industry, Unpublished treatise for BSc(Quantity Surveying), UCT.
- BIFSA 1990. Building Industries Federation of South Africa Annual Report.
- Bird A. 1991. Negotiation for change: The COSATU view of changes needed in the provision of adult education and training in South Africa, *Proceedings of Manpower Development for the New South Africa: National Symposium*, Vol 1, paper 5.
- Blank WE. 1982. *Handbook for developing Competency-based training programmes*, Prentice-Hall, Inc., Englewood Cliffs, New Jersey.
- Bridgman DHM., Palmer I. and Thomas WH. (ed) 1992. *South Africa's Leading Edge? A guide to the Western Cape economy*, WESGRO, Cape Town.

- Burroughs E. 1992. Personal communication.
- Butt P. 1991. Supervisory training in the building industry, *SA Builder*, May, p25-32.
- Clifford M. & Kerfoot C. 1992. Chapter 4: English: Language of hope, or broken dreams? in Hutton B (ed), *Adult Basic Education in South Africa: Literacy, English as a second language, and numeracy*, Oxford University Press.
- Cosatu 1991, Discussion paper on *Human Resource Development for the Commonwealth Expert Group Meeting*, Cosatu.
- COSATU 1992. COSATU's approach to Adult Basic Education, *Cosatu*, Johannesburg.
- Chisolm L. 1983. Redefining Skills: Black education in South Africa in the 1980s, *Comparative Education*, Vol 19, No 3, p357-371.
- Chisolm L. 1992. South African technical colleges: Policy options, Working paper presented at the NEPI conference on Human Resource Policy for a New South Africa, Durban, p3.
- Coetzee DF. 1991. Illiteracy in South Africa: Some Preventative strategies from a development perspective, Conference on Literacy and Basic Adult Education in Southern Africa, *Proceeding of HSRC Conference*, September 1990, P76-109.
- Curriculum:NEPI 1992. *National Education Policy Investigation: Curriculum Research Group*, A project of the National Education Crisis Committee, Oxford University Press and NECC, Cape Town.
- De Klerk FW President, 1990, Cape Times, 3 February.
- Department of National Education 1991. Education Renewal Strategy: A discussion document, *Government Printer*, Pretoria.
- Fanaroff B. 1991. *Technological advance in South African industry: The interests of the workforce*, Department of Adult Education and Extra-Mural Studies, University of Cape Town.
- Fraser N. 1991. BIFSA press release, *CAPE TIMES*, 18 April.
- French E. 1990. Literacy and the Private Sector, *Institute of Personnel Management Journal*, May, p4-18.
- French E. 1992. Adult Literacy in South Africa; past and present, in Hutton B (ed) 1992. *Adult Basic Education in South Africa: Literacy, English as a second language, and numeracy*, Oxford University Press.
- Gelb S.(ed) 1991. *South Africa's Economic crisis*, David Philip and Zed.
- Gelb S. 1990. Democratising Economic Growth: Alternative Growth Models for the Future, *Transformation* 12, p25-41.

- Griffin P., Jewell R., Forwood A., Francis R., 1990. Developing Competency Rating Scales in Adult literacy: An analytic approach, *Open Letter: Australian Journal for Adult Literacy Research and Practice*, Vol 1 , No.1, p54-65.
- Hooper R (ed) 1971. *The Curriculum: Context, design and Development*.
- HRD:NEPI 1992. *National Education Policy Investigation: Human Resources Development Research Group* , A project of the National Education Crisis Committee, Oxford University Press and NECC, Cape Town.
- HSRC/NTB. 1989. Investigation into skills training in the RSA, *HSRC Education Research Programme*, NO 14.
- Hutton B (ed) 1992. *Adult Basic Education in South Africa: Literacy, English as a second language, and numeracy*, Oxford University Press.
- IPM 1991. Manpower Training act of 1981 as ammended, Fact sheet, *Institute of Personnel Management Journal*, July 1991.
- International Labour Office 1991. The impact of techonological change on work and training, *Tripartite European meeting on the impact of technological change on work and training*, Geneva. ILO publication.
- Kraak A. 1987. Uneven Capitalist Development: A case of deskilling and reskilling in South Africa's Metal Industry, *Social Dynamics*, 13(2), p14-31.
- Kraak A. 1991a. Developing an Alternative institutional framework for education and training, Working Paper, *Human Resources Research Group, National Education Policy Investigation*.
- Kraak A. 1991b. Post-Fordism and a future education and training system for South Africa, Unpublished working document.
- Kraak A. 1991c. *Beyond the market: Comprehensive Institutional Restructuring of South African Labour Markets: Education, Training and Work*, Education Policy Unit, University of Witwatersrand, Johannesburg.
- Krafchik WA. 1991a. Growth possibilities and constraints in the Western Cape, Draft Paper, Cape Town.
- Krafchik WA. 1991b. The construction industry, *Commonwealth Report on training needs in South Africa*.
- Krafchik WA. 1991c. *Small-scale enterprises, Inward Industrialisaton and housing: a case study of sub-contractors in the Cape Peninsula low-cost housing industry*, Working paper no 32, South African Labour and Development Research Unit.
- Lello V. 1989. The Growth resource, *The SubContractor*, South Africa, May/June, p32-33.
- Lloyd C. 1991. Chapter 7, Redefining workplace politics: The role of skill formation, Draft form of book to be published in Australia.

- Macdonald-Ross M. 1973. *Instructional Science 2*, Amsterdam Elsevier Scientific Publishing Co.
- Mathews J., Hall G., Smith H., 1988. Towards flexible skill formation and technological literacy: challenges facing the education system, *Economic and Industrial Democracy*, vol 9, p497-522.
- Merrifield A. 1991. Personal communication, November.
- Miller R. Conceptual issues in theorizing about cognition, unpublished working paper, University of Natal.
- Morphet T. 1989. IR:Developing and Refining Corporate ideology, *HRM Yearbook*, pp 54-59.
- Morphet T. 1992. Introduction to the problems in adult learning, in *Adult Basic Education in South Africa*, Hutton B (ed), Oxford University Press, Cape Town.
- Muller J. 1987. Much Ado: "Manpower Shortages" and Educational Policy Reform in South Africa, *Journal of Educational Policy*, vol.2, no.2, p83-97.
- NUMSA 1990. Work for All, Occasional Publication, No 1, *NUMSA: Education and Research*, Johannesburg.
- Opperman RJ. 1988. Guidelines for the implementation of Competency-based modular training, Facilitation of in-service training and competency-based modular training, *Proceedings of National Symposium, Department of Manpower*, Vol 3, October, UNISA, p1-52.
- Popkewitz T. 1982. Chapter 4 - Making schools efficient: Technical schooling, in *The Myth of Educational Reform*, University of Wisconsin Press.
- Prinsloo MP. 1991. The limits of the modernizing and conscientising agendas in adult literacy work: Steps towards an Integrated approach to adult literacy teaching, Conference on Literacy and Basic Adult Education in Southern Africa, *Proceedings of HSRC Conference*, September 1990,
- Prinsloo MP. and Watters KA. 1991. Brickies up against the Wall: Education and Training in the building industry, Paper presented at Kenton-on-the-Katberg.
- Reeder D. 1981. Chapter 12:A Recurring debate: Education and Industry, in Dale R et al, *Education and the State*, vol 1, Falmer Press, London.
- Reder SM. 1985. *Giving Literacy away: An alternative for increasing Adult Literacy Development, Training Capacity and Program Participation*, National Adult Literacy Project, Far West Laboratory and the Network, Inc.,
- RESA 1988. *Strategies in Education and Training in South Africa 1960-1987: The Role of Corporate Capital*, Research on Education in South Africa, Paper No1.
- SCANS Report 1991. *What Work Requires of Schools: A SCANS Report for America 2000*, US Department of Labour, Washington.

- Schloss R. 1989. Under one banner, *The SubContractor*, South Africa, January, p43-47.
- Schubert WH. 1986. *Curriculum Perspectives, Paradigm and Portability*, Macmillan, New York.
- Schuller T. 1981. Common discourse? The Language of Industrial democracy, in *Economic and Industrial Democracy*, Sage, London and Beverley Hills, vol 2, p261-291.
- Scribner S. and Cole M. 1981. *Psychology of Literacy*, University Press, Massachusetts.
- Spours K and Young M, 1988. *Beyond Vocationalism: A new perspective on the relationship between Work and Education*, Working Paper No4, University of London, London.
- Stenhouse L. 1975. Chapter 5 - Behavioural Objectives and Curriculum Development, in *An Introduction to Curriculum Development*.
- Street BV. 1984. *Literacy in Theory and Practice: Cambridge studies in oral and literate cultures*, Cambridge University Press.
- Street BV. 1992. Literacy seminar, University of Cape Town, Cape Town, 10-12 August.
- Tanner B. 1989. Behind the sub-contract, *The SubContractor*, South Africa, May/June, p18-19.
- Taba H. 1982. Chapter 2.4, The types of Behavioural Objectives, in Lee V and Zeldin D (ed), *Planning in the curriculum*, Open University, Hodder and Stoughton.
- Tyler RW. 1982. Chapter 2.5, The form of Objectives, in Lee V and Zeldin D (ed), *Planning in the curriculum*, Open University, Hodder and Stoughton.
- Van Heerden G. 1991. *Adult Literacy in South Africa: a centre for Adult Education study*, Centre for Adult Education, University of Natal, Pietermaritzburg.
- Vorster JA. 1991. Application of the Principle of Accreditation in Manpower Training - Industry Training Boards in Particular, *Proceedings of National Symposium Manpower development for the new South Africa*, Vol 2, paper No 8.
- Wagner DA. 1990. Literacy and research: Past, Present and future, part of *Literacy lessons series*, International Bureau of Education, UNESCO, Paris.
- Wagner DA. 1993. Literacy Seminar, University of Cape Town, Cape Town, 20 February.
- Watters KA. 1991. A literacy programme for the building industry: A feasibility study, Unpublished research, Department of Adult Education and Extra-Mural Studies, University of Cape Town.

- Weiner T. 1982. Personal communication, Personnel Director, Barlow Rand.
- Webb TL. 1989. Closer Links for increased productivity, *The SubContractor*, South Africa, January, p10-11.
- Wexler P. 1987. *Social Analysis of Education: After the new Sociology*, Routledge & Kegan Paul, London and New York.
- Wider Opportunities for Women (WOW) 1992. Best Practices for any Adult Literacy Program Design, *Literacy in Context (LINC) Toolkit*, p6-8.
- Withers G. 1990. A response to Griffin et al, *Open Letter: Australian Journal for Adult Literacy Research and Practice*, Vol 1 , No.1, p66-67.
- Wolpe H. 1992. The proposed economic structure of a post apartheid South Africa, working paper, National Education Policy Investigation.
- World Bank Publication 1984. *The Construction Industry: Issues and Strategies in Developing Countries*, World Bank Publication.
- Young M. 1990. Education for a Democratic South Africa: Lessons from the English experience, Modified version of paper given at IDASA Conference, 21-23 September, p1-9.
- Unknown 1992. Adult Basic Education Accreditation Framework Project, Volume 2 appendices, Draft Competence Statements for adult reading and writing, Ministry of Employment, Post-Secondary Education & Training, Victoria, January 1992.

## **LIST OF INTERVIEWS**

### **Key stakeholders - organisations**

Representatives of the Master Builders Association of Cape Peninsula, 18 July 1991.

Representatives of the Master Builders Association of Paarl, 22 July 1991.

Representatives of the Small Builders Association, 18 July 1991.

Representatives of the Co-ordinating Union, 17 July 1991.

Representatives of the CAWU, 3 August 1991.

Small Builders Forum, Khayelitsha, 16 July 1991.

Officials of the Building Industrial Council-Western Cape, number of meetings during period May-November 1991.

Employees of Dura Construction. 5 August 1991.

### **Meetings with individuals**

Neil Fraser, Director BIFSA, a number of meetings.

Bert Parker, Principal, BIFSA Training Centre, Belhar, 28 June 1991.

Warren Krafchik, Economics Department, University of Cape Town, a number of meetings.

Bob Hindle, Lecturer, Department of Construction Economics and Building Management, University of Cape Town.

Bruce Boaden, Head of Department of Construction Economics and Building Management, University of Cape Town, 9 July 1991.

Tony Keal, Industrial Relations Manager, Murray and Roberts

Andrew Merrifield, Researcher, University of Natal.

Jeff Sessions, Stocks and Stocks, telephone call, July 1991.

Mr Khakaza, Chairman, Western Cape Black Builders Association, 22 July 1991.

## Appendix A

### INSTITUTIONAL MAKE-UP OF THE CONSTRUCTION INDUSTRY

The analysis which follows reflects information on the location and interests of builders, both employers and employees, who are in the business of housing and non-housing construction. The civil engineering sector is not included and information on informal and unregistered small builders is limited.

The structure and makeup of the industry with only minor variations is the same nationally. Details such as actual figures are given to assist in clarification, but are only for the Western Cape.

The first major institutional distinction is whether a builder is part of the **formal** or **informal** sector. The only defining characteristic of the informal sector is that its activities are not recorded in official returns. By implication, unregistered companies are not subject to agreements reached by the industrial council, with regard to wage minimums, benefits and conditions of service. They are of particular significance in the area of low- cost housing provision.

There are 1 596 companies in the formal sector in the Western Cape. Within this sector a distinction can be made between **party** and **non-party** companies. Party companies are aligned with one or other of the building associations and, through them, are represented on the industrial council for the industry. Non-party companies are subject to the agreements reached on the council but are not represented on the council. There are roughly 800 non-party companies. Ilco Homes is the only large company in the Western Cape in this category, the rest being small and often transient in nature.

#### 1 BUILDERS ASSOCIATIONS

The two major associations representing divergent organisational interests are the **Master Builders and Allied Trades Association (MBA)** and the **Small Builders Association (SBA)**. In addition there is the Master Masons and Quarry Owners Association, but this is very small by comparison, in the Western Cape for example, there are 11 members.

The **MBA** companies (670 in the Western Cape) co-operate to protect their mutual interests through a complex system of tendering which involves not tendering against non-MBA members in certain situations. The MBA represents the interests of the large, established builders and claims to employ 70% of the workforce in the formal sector.

The **SBA** has 120 members in the Western Cape and has been represented on the Industrial Council since May 1991. Member companies, in terms of the SBA constitution have 75 or less employees. The largeness of the SBA's definition of small is being contested by the MBA. The SBA emerged out of dissatisfaction amongst smaller companies at being represented on the Industrial Council by MBA companies who refuse to tender against them. The SBA are strong proponents of deregulation in the industry and are opposed to wage minimums. They are highly critical of the new training proposals for the industry, as well as the old.

## **2 EMPLOYEES**

According to the 1985 Census 6% of those employed are employed in the construction industry. According to Neil Fraser, executive director of BIFSA, the construction industry in 1990 employed 250 000 people nationally. This figure reflects only those people employed in registered companies and does not reflect the informal sector.

In the Western Cape, using the Industrial Council annual returns this extrapolates to 43 216 people employed in the industry in the Western Cape. This number also excludes the considerable number of workers who are not registered with the council.

### **2.1 WORKER ORGANISATIONS**

The Construction and Allied Workers Union (CAWU) is the largest union, representing largely the interests of the unskilled and semi-skilled workers. CAWU, a Cosatu affiliate, was launched result of an amalgamation of 7 unions on the 31 January 1987. In the Western Cape it had a signed up membership in 1991 of 8 000 and a paid-up membership of 1563.

Until 1985 the Co-ordinating Unions were exclusively craft unions with craftsmen as their members. In 1985 they opened their doors and now have a number of general workers as paid up members although they still mostly substantially represent the view of the skilled workers in the building industry.

In the Western Cape this group comprises:

Amalgamated Society of Woodworkers of SA (1 820), Amalgamated Union of Building Trade Workers of SA (1 579), SA Operative Masons' Society (40), SA Woodworkers Union (2752) and the Building Workers Union (7811).

There are approximately 21 174 workers registered with the industrial council who are not union members, but the sympathies of most of them probably lie closest to CAWU.

### **3. BUILDING INDUSTRIAL COUNCIL**

The industrial council system is one in which employers and employees voluntarily form an organisation to negotiate employment conditions and wages for an industry. The results of these negotiations are legislated via the Department of Manpower and are binding on all employers and employees in the jurisdiction of the particular industrial council whether or not they are members of the industrial council.

Employers and employees are equally represented. Until recently the employer interests were represented by the Master Builders Associations and the employees by the Co-ordinating Unions Committee, a group of old craft unions. Two bodies have joined the BIC within the last year, namely the SBA and CAWU. This was as a result of the changed ruling of 1989 which allowed for more equitable worker representation and a Cosatu decision to participate on Industrial Councils in some industries. In addition to providing a forum for negotiations on wages and conditions of employment, the BIC monitors the agreements, through agents working on behalf of the dept of Manpower and administers the pension, medical aid, sick leave pay and the tool fund.

The substantial number of builders not registered with the industrial council are not represented in any industry forum. The Western Cape Black Builders' Association comprises small builders doing labour only sub-contracting and shack upgrading. They now have access to entrepreneurial training through

the Small Business Development Corporation but no access to skill training. Nactu union members are not represented on industry forums either.

#### **4. TRAINING STRUCTURES**

Training is currently organised and provided by the Building Industry Training Scheme (BITS) and by the Building Industry Training Board (BITB). The latter is responsible for setting national standards for training and certification.

The Building Industries Federation of South Africa (BIFSA) are perceived to be the suppliers of training by many people in the building industry, but according to Neil Fraser, Executive Director of BIFSA, BIFSA is an employer body who represent and lobby for employer needs and is not involved in training. The confusion in the industry regarding the role of BIFSA is understandable as even in the BIFSA 1990 Annual Report there is continual reference to BIFSA being involved in training. One of the items listed in the mission statement is "providing education, training and development for the upliftment of employers and employees in the industry." There is also a department falling under the executive director of BIFSA called Education/Training.

There are twelve members on the national board of BITS and fourteen on the national board of BITB. In the 1989/90 committees seven of these members are on both boards. According to the 1990 BIFSA Annual Report there is employee representation on BITB and one non-party representative on BITS. Other than these representatives the 1989/90 committee members are all members of the MBA.

Training policy and practice seems to be made by a very small group of people. Various other interests which could be involved seem to be under represented or missing altogether. These include employees, non-party employers and unregistered builders. This perhaps explains the perception the researcher received that BIFSA represented the interests of the MBA in the industry.

Training up to artisan level is paid to BITB by registered employers through a training levy which is administered by the Industrial Council. Training above artisan level (eg supervisor training) is paid for separately. Unregistered

employers can send trainees on these courses and are charged varying amounts depending on the level of the course.

The BITB was established in 1987 and as a result of changes in the Manpower Act obtained its current legal status in 1990. In January 1990 the BITB took over the administration of the new artisan training programme from the Department of Manpower. The major function of this body is to maintain the training standards in the industry.

BIFSA, or more correctly BITS, is viewed with some suspicion by other bodies in the industry. This is because historically BIFSA is seen as an employer body looking after the interests of the MBA. Employers not belonging to the MBA and employees feel that their interests and concerns have been largely ignored.

With the current lack of support by the MBA for BITS in terms of the number of trainees they are sending one must be concerned at the current status of BITS

## Appendix B

### FORMAL EDUCATION LEVELS IN THE INDUSTRY

A questionnaire requesting information on levels of education was distributed by the researcher to all the participating bodies on the industrial council in the Western Cape. This included individual companies and employer and worker organisations

Of the 43 216 workers registered with this industrial council, information was received on approximately 18 000 workers.

	<b>Number</b>	<b>%</b>
Unable to read and write	7498	41,6
Less than std 2	1520	8,4
Std 2 - 5	1873	10,4
Std 6 - 8	1136	6,3
Std 9 - 10	472	2,6
Post std 10	107	0,6
<b>sub total</b>	<b>2611</b>	<b>69,9</b>
unknown -	5395	30,0
<b>TOTAL</b>	<b>18006</b>	<b>99,9</b>

(Information obtained by the industrial council from interviews of 221 workers at their offices produced a very similar breakdown.)

This data suggests that 60,4 % of the people surveyed are functionally illiterate, i.e., have less than a standard 5 level of education. If one assumes the same distribution amongst the 'unknown' figure, this figure becomes 80%.

It is not surprising, then, that both the industrial council and BIFSA are looking at mounting an Adult Basic Education programme for the industry.

BUILDING INDUSTRY TRAINING MODEL



BITB

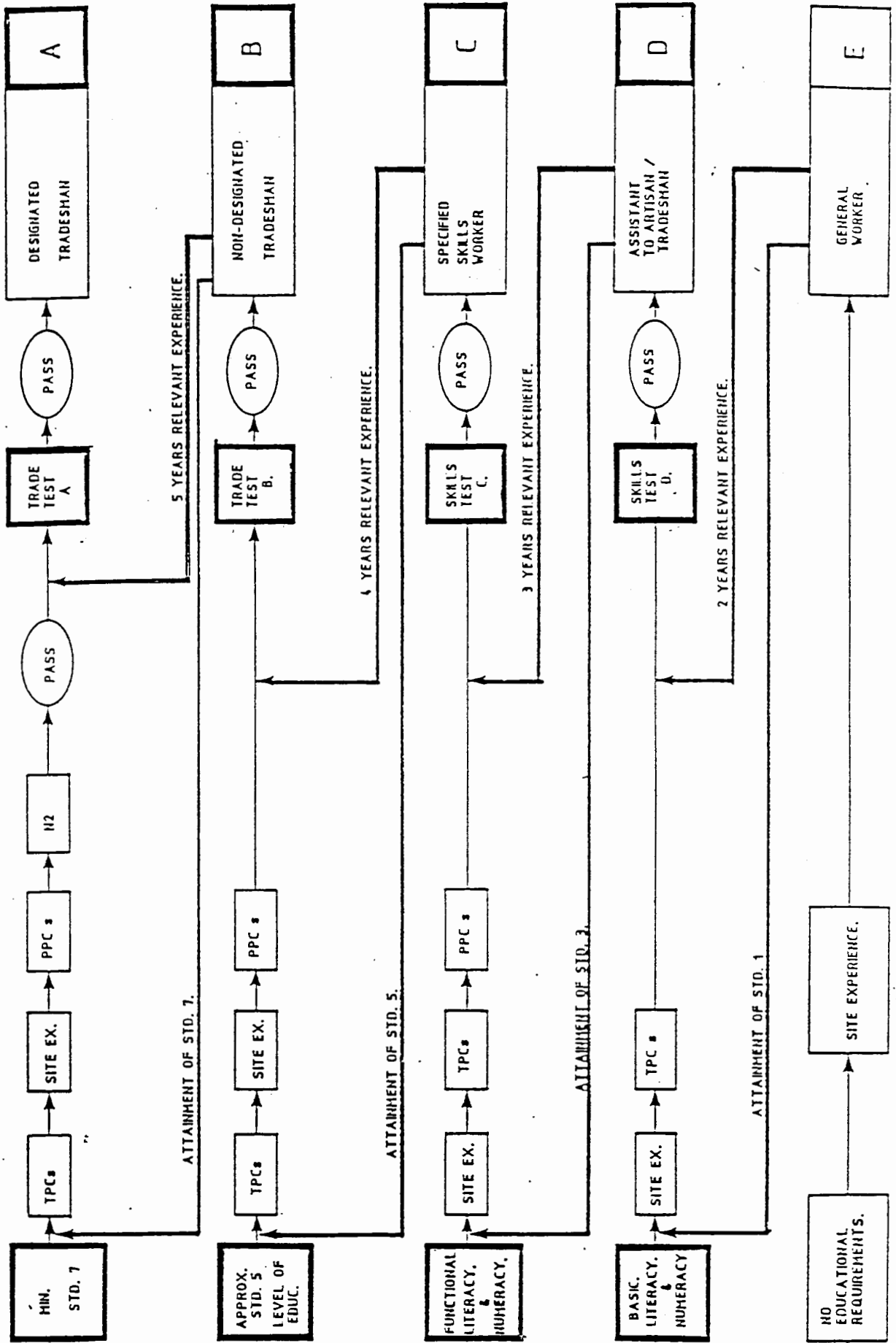

LITERACY & NUMERACY TRAINING TO FACILITATE ADVANCEMENT TO THE APPROPRIATE LEVEL.

COURSE MAP CARPENTER

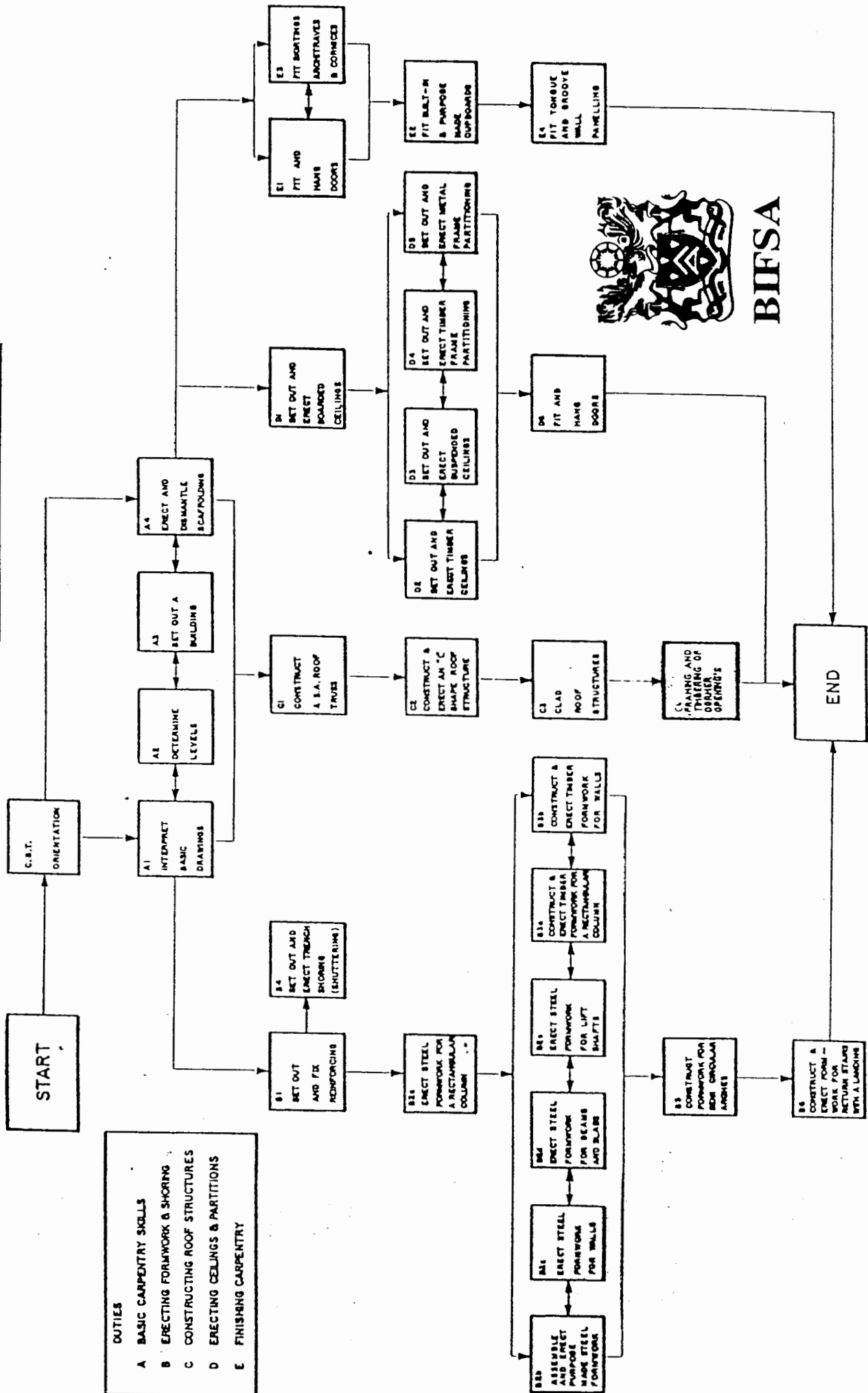

- DUTIES**
- A BASIC CARPENTRY SKILLS
  - B ERECTING FORMWORK & SHORING
  - C CONSTRUCTING ROOF STRUCTURES
  - D ERECTING CEILINGS & PARTITIONS
  - E FINISHING CARPENTRY