

The copyright of this thesis vests in the author. No quotation from it or information derived from it is to be published without full acknowledgement of the source. The thesis is to be used for private study or non-commercial research purposes only.

Published by the University of Cape Town (UCT) in terms of the non-exclusive license granted to UCT by the author.

UNIVERSITY OF CAPE TOWN
DEPARTMENT OF MECHANICAL ENGINEERING

RONDEBOSCH, CAPE TOWN, SOUTH AFRICA



**Research, Design and
Construction of a team of
Small Size League Soccer
Robots for RoboCup Soccer**

Prepared by Justin Pead

Robotics and Agents Research Laboratory

University of Cape Town

Supervised by Stephen Marais

Robotics and Agents Research Laboratory

University of Cape Town

February 2013

Acknowledgements

Firstly, I would like to thank my supervisor Stephen Marais, for being available to assist with support and direction throughout my thesis as well as the additional increased support as the final deadline approached.

I would also like to thank Tracy Booysen, the Chief Scientific Officer in the department of Mechanical Engineering. She was always willing to pass ideas about circuit complications and really assisted when technical glitches reared their ugly head.

I would like to thank Glen Newins and his team in the Mechanical workshop for their willing assistance with any mechanical problems encountered and their assistance in building the parts required for my project.

I would like to mention Nicolas Larsen for his assistance in the construction of the SSL covers. Without his guidance in composites, the task of creating the covers would have been substantially more difficult.

Finally, I would like to thank all the students (Eugene, Peter, Cameron, Richard, Brad, Roger, Thomas and Julian) in the Robotics and Agents Research Lab (RARL) for the atmosphere created by the lab. I would like to specifically mention Michael and David for their additional assistance with the mechanical sections at the beginning of their MSc projects in 2011.

Plagiarism Declaration

1. I know plagiarism is wrong. Plagiarism is to use another's work and present it as one's own.
2. I have used the IEEE convention for citation and referencing. Each significant contribution to, and quotation in, this project from the work, or works, of other people has been attributed, and has been cited and referenced.
3. This project is my own work and is submitted in complete fulfilment of a M.Sc. (Mechanical Engineering) at the University of Cape Town.
4. I have not allowed, and will not allow, anyone to copy my own work with the intention of passing it off as their own work.

Signature ..

Signed by candidate

Justin Pead

Monday, 15th May 2013

Summary

Small Size League (SSL) Soccer at RoboCup uses the complexity of a well known human sport to extend the capabilities of mobile robotics as well as automated computer control. The game creates an environment where technically complicated miniature soccer robots are required to perform the tasks based on computer algorithms to outsmart similar systems. SSL creates a publically accessible window into complicated systems that an outsider is capable of comprehending. Examples of SSL platforms are shown in Figure 1 below.



Figure 1: FU_Fighters RoboCup Winning Team 2004 (Left), Some B-Smart robots with different covers (Middle), Winning robots playing for SKUBA in 2009 (Right) [1][2] [3]

University of Cape Town (UCT) Robotics and Agents Research Laboratory (RARL) began research into developing modules for SSL from 2005. The final design which incorporated all modules required for SSL with similar specifications to the international teams can be seen in Figure 2.

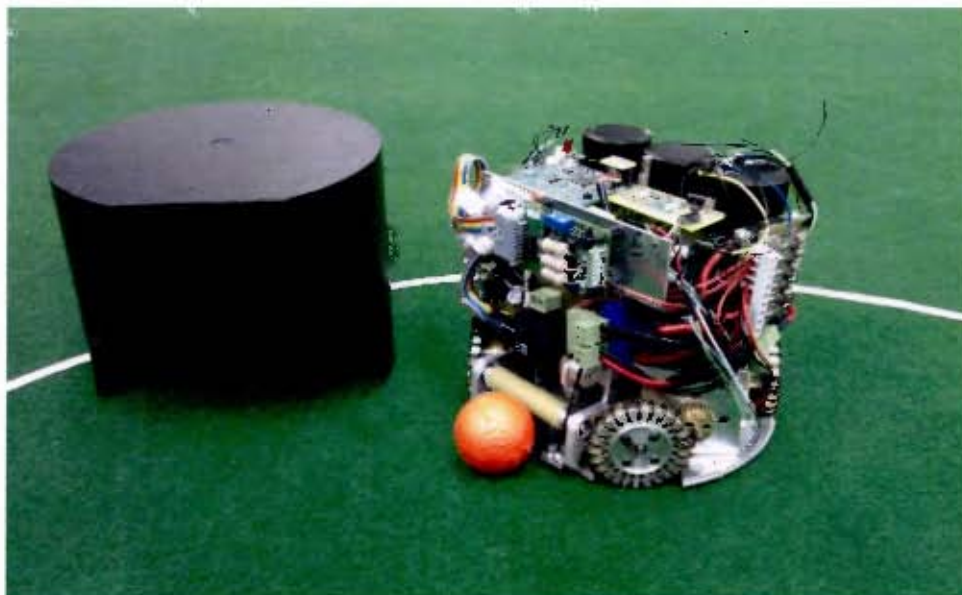

Figure 2: University of Cape Town Final Small Size League Robot Design

This document is a report on the research and design behind the construction of a fully functional SSL team for RoboCup. This document initially reviews the past and current systems used including mechanics for locomotion, kicking and ball control and integrated electronics required for each module.

The following system modules and properties were deemed vital for a SSL robot:

- **Locomotion**
- **Ball Control Systems**
- **Control and Communication**
- **Power Systems**

Technically speaking the modules individually are not complex, however attempting to fit all subsystems into the tight size constraints of 180 mm diameter with 150 mm height changes the complexity of the overall design drastically. Once these modules had been identified, design for manufacture and assembly principles were applied with emphasis on modularity for discrete testing and ease of replacement.

1. Locomotion Module

The key aspect of SSL soccer is the speed at which the game is played, a typical robot has the capability of moving at velocities of greater than 3 m/s. On a field with a length of 6m, this means a robot could potentially be anywhere on the field in under 3 seconds. With such a dynamic environment quick and agile control for the locomotion of the robot was essential.

The locomotion assembly comprised of a Maxon EC45 flat 50 W motor operating each of the 4 omni-wheels on the robot. Each wheel was operated by an independent controller implementing proportional control over and above the integrated controller embedded in the motor. The driving modules had the potential to get the robot to reach a straight speed of 4 m/s however these speeds were not obtained experimentally because of the size of the playing field.

2. Ball Control System

The most significant aspect of a soccer robot was the capability of interacting with a ball. The Ball control systems include systems such as the main kicker, chip kicker and dribbler. These systems are responsible for kicking, lifting and holding the ball for each robot.

The primary component on the ball control system was the main kicker. Maximum permitted ball speeds in SSL was 10 m/s. The fastest kick performed repeatedly by UCT's design was 9 m/s. The system was not as kicking effective as the veteran international teams although a safe and repeatable system was developed.

3. Control and Communication

Because of the inherent dynamic nature of the game, quick response time was essential to compute the latest data with the smallest propagation delay. The control module was responsible for operating all the subsystems on the robot with minimal processing time needed before reacting to new instructions.

As the full system was designed to operate autonomously, an interface was created to manually control robots during testing and using the Logitech[®] Rumblepad controller. The images shown in Figure 3 below are a guide to operating the SSL robots. The controller which is connected to the PC while the interface is running connects and controls the SSL robot.



Figure 3: Logitech Rumblepad Controller (Left), Manual Controlling Interface for the SSL Robot (Middle), Operating SSL robot (Right)

4. Power Systems

The robots in SSL pack a fair punch, and as a result consume significant power. A safe, reliable and lasting power system was needed for low voltage control of both motors and electronics. Additionally the kicking module relied on an electro-mechanical kicker which demanded a significantly higher voltage for operation. The power system for the kicker should therefore also be included in the power system.

Concluding Remarks

Once the system had been manufactured and assembled, various tests were performed to gauge the actual performance against the design specifications that were set at the start of the project. Overall the robot performed very well, meeting all the design requirements that were required, and only missing the optional chipper module ambitions.

The final robot without cover can be seen in Figure 4 and weight of the robot was significantly higher than SKUBA although this could be attributed to the fact that UCT had more power in locomotion and electrical kicking potential.

Suggested improvements that could be made to the system include further weight reductions, increasing the efficiency of the solenoid system, removal of the integrated motor controllers and design of discrete motor controllers, and improving the fine movements of the SSL Robot.

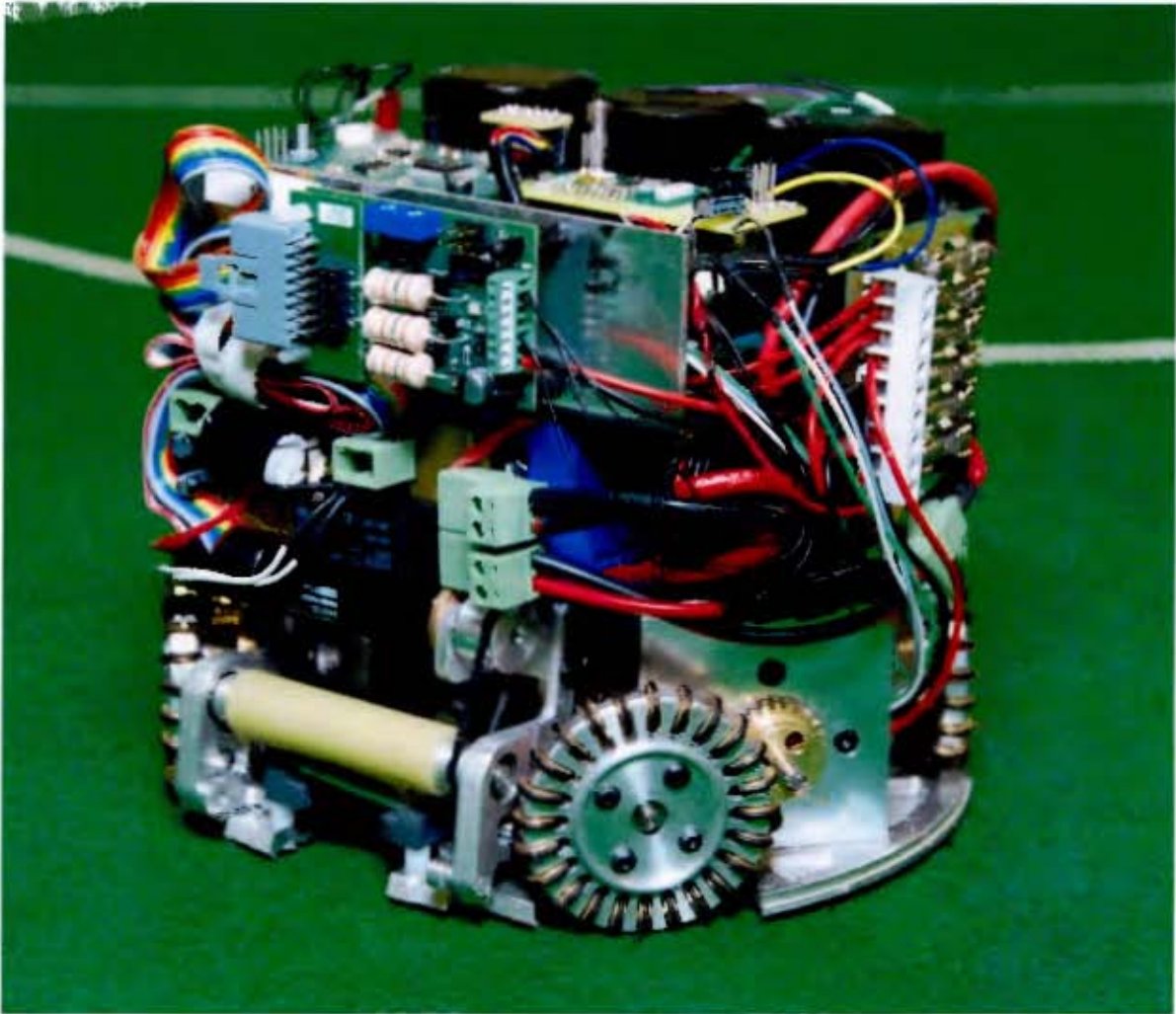

Figure 4: UCT Final SSL Robot

Acknowledgements.....	b
Plagiarism Declaration.....	c
Summary.....	d
List of Figures.....	m
List of Tables.....	q
1. Introduction.....	1
2. Background Research.....	5
2.1 The Rules and Regulations for SSL.....	5
2.1.1 Game Structure.....	5
2.2 Rule requirements and restrictions in SSL.....	6
2.2.1 Field.....	6
2.2.2 Goal Post.....	7
2.2.3 Robot.....	8
2.2.4 Ball.....	8
2.3 Rules Affecting Design and Construction.....	8
2.3.1 Kicking.....	8
2.3.2 Dribbling.....	9
2.3.3 80/70 Rule.....	10
2.3.4 Chipping.....	10
2.3.5 Locomotion.....	10
2.3.6 Shape.....	10
2.4 Team Description Papers.....	11
2.4.1 Electronics for Control.....	13
2.4.2 Motors and Wheels for Locomotion.....	14
2.4.3 Ball Control Module.....	20
2.4.4 Main Kicking Module.....	20
2.4.5 Chipping Module.....	23
2.4.6 Battery Pack.....	24
2.4.7 Software.....	25
2.4.8 Vision Systems.....	25
2.5 UCI Undergraduate Research.....	26
2.5.1 Locomotive platform.....	26

2.5.2	Ball Control Module	77
2.6	Concluding Remarks.....	28
3.	Specifications	29
3.1	4 omni-wheel platform:	30
3.2	Full omni-directional movement:	30
3.3	Competitive acceleration and velocity:	30
3.4	Battery requirements:.....	30
3.5	High level commands sent to the robot:	30
3.6	Ball Control System:	30
3.7	Kicking:.....	30
3.8	Chipping:	30
3.9	Modular Design:.....	31
3.10	High Level Speed Control:.....	31
3.11	Wheels do not affect playing surface	31
3.12	Size Requirements	31
3.13	Maximum Allowable kick speed	31
3.14	Operational Team before December 2011	31
4.	Conceptual Design	32
4.1	Module Placement.....	32
4.2	Gearing.....	34
4.2.1	Bevel Gearing.....	34
4.2.2	Internal Spur Gearing.....	35
4.2.3	External Spur Gearing	36
4.3	Summary	36
5.	Mechanical Design	37
5.1	Base and Solenoids	39
5.1.1	Kicking Solenoid	39
5.1.2	Chipper.....	42
5.2	Dribbler	42
5.3	Locomotion Assembly.....	44
5.3.1	Omni wheel Assembly	45
5.3.2	Front Assembly	49

5.3.3	Rear Assembly.....	50
5.4	Mounting of Controlling Electronics.....	53
5.5	Mounting of Kicking Electronics Module.....	55
5.6	Cover.....	57
5.6.1	Mould Construction.....	57
5.7	Summary.....	60
6.	Electrical Design.....	61
6.1	Motor Control Board.....	63
6.1.1	Design Parameters.....	63
6.1.2	Possible Functionality.....	64
6.1.3	Modules.....	65
6.1.4	Schematic.....	65
6.1.5	Board Layout.....	70
6.2	SSL Kickerboard.....	72
6.2.1	Design Parameters.....	72
6.2.2	Preliminary Testing.....	74
6.2.3	Modules.....	74
6.2.4	Schematic.....	75
6.2.5	Recommended Start-Up and Operating Procedure.....	80
6.2.6	Board layout.....	82
6.2.7	Construction.....	85
6.3	Fuse Board.....	86
6.3.1	Design Parameters.....	86
6.3.2	Possible Functionality.....	86
6.3.3	Schematic.....	86
6.3.4	Board layout.....	87
6.4	LiPo Protection Board.....	88
6.4.1	Design Parameters.....	88
6.4.2	Possible Functionality.....	88
6.4.3	Modules.....	88
6.4.4	Schematic.....	89
6.4.5	Recommended Start-Up Procedure.....	93

6.4.6	Board Layout	94
6.5	Stackable Wireless	95
6.5.1	Design Parameters	95
6.5.2	Possible Functionality	95
6.5.3	Schematic	96
6.5.4	Recommended Start-Up Procedure	96
6.5.5	Board Layout	96
6.6	Summary	97
7.	Software and Algorithms	98
7.1	Computer Software	98
7.2	Robot Software	99
7.2.1	Robot Locomotion Control Algorithms and Code	99
7.3	Communication Protocols	101
7.3.1	UART Communication (PC to Master)	101
7.3.2	I ² C Communication (Master to Slave/Slave to Master)	105
7.4	Summary	106
8.	Testing and Results	107
8.1	Testing Environment	107
8.1.1	Field	107
8.1.2	Scaffold Structure	107
8.2	Locomotion	107
8.2.1	Magnitude	107
8.2.2	Angle	108
8.2.3	Rotation	108
8.3	Ball Control Systems	110
8.3.1	Kicker	110
8.3.2	Dribbler	117
8.3.3	Chipper	117
8.3.1	Cover Testing	118
8.4	Communication	118
8.4.1	Simcom Modules	118
8.4.2	Amber Wireless Modules	119

8.5	Power	120
8.5.1	Battery.....	120
8.5.2	External Capacitors	120
8.5.3	LiPo Protection Board	120
8.6	SSL Robot Weight.....	121
8.7	Summary	121
9.	Conclusions and Recommendations	122
9.1	Conclusions from Testing	122
9.1.1	Locomotion	122
9.1.2	Kicking.....	123
9.1.3	Chipping Module.....	124
9.1.4	Communication Modules.....	124
9.1.5	Battery Module	124
9.2	Recommendations based on Conclusions	126
9.2.1	Improve modular design	126
9.2.2	Reduction in Weight	126
9.2.3	Kicker Compression arrestor.....	126
9.2.4	Redesign of the Chipping module.....	126
9.2.5	Mechanical matching of the golf ball.....	126
9.2.6	Kicker Impact Distancing.....	126
9.2.7	Discrete motor speed controllers	127
9.2.8	More Powerful microcontroller	127
10.	References	128
11.	Sample Technical Drawings	133

List of Figures

Figure 1: FU_Fighters RoboCup Winning Team 2004 (Left), Some B-Smart robots with different covers (Middle), Winning robots playing for SKUBA in 2009 (Right) [1][2] [3].....	d
Figure 2: University of Cape Town Final Small Size League Robot Design.....	d
Figure 3: Logitech Rumblepad Controller (Left), Manual Controlling Interface for the SSL Robot(Middle), Operating SSL robot (Right).....	f
Figure 4: UCT Final SSL Robot	g
Figure 1.1 A Small Size League (SSL) Robot Soccer match[1]	1
Figure 1.2: Pictorial description of SSL configuration [6].....	2
Figure 1.4: 3 wheel omni-directional platform created by Craig Inman Bamber [3]	3
Figure 1.3: Last UCT SSL competition robot which used a differential drive.....	3
Figure 1.5: Final UCT SSL Robot	4
Figure 2.1: The overall layout of the SSL playing field [7].....	6
Figure 2.3: Goal posts (viewed from above) [7].....	7
Figure 2.2: The Defensive Area of each Goal [7].....	7
Figure 2.4: The maximum size of a robot [7].....	8
Figure 2.5: Dribbler location on SSL platforms [7].....	9
Figure 2.6: SKUBA Dribble Bar 2008 (Left), Dribble Bar 2009 (Right)[8][9]	9
Figure 2.7: 80/20 Rule Explained Graphically [7].....	10
Figure 2.8: Shape Requirement for a SSL robot [5]	10
Figure 2.9: Skuba Main Controller Board [51]	13
Figure 2.10: Control Board Data flow for B-Smart [16]	13
Figure 2.11: UCT SSL Prototype Motors [3]	14
Figure 2.12: SKUBA using Maxon EC45 30W Motors.....	15
Figure 2.13: UCT Differential Drive SSL Robot	15
Figure 2.14: SKUBA 2009 90° Omni-wheel [9]	16
Figure 2.15: UCT SSL prototype (exposed) created by Craig Inman Bamber and theoretical velocity profile.[3]	17
Figure 2.16: Plasma-Z (2009) 4 omni-wheel design and velocity profile from their design. [11].....	17
Figure 2.17 : 90° Omni wheel circumference indicating flat sections	18
Figure 2.18: CAD model of a 45° omni-wheel (Mecanum Wheel) used primarily in MSL.[52]	18
Figure 2.19: Austrian Cubes MSL Robot (2010)	19
Figure 2.20: Space lost due to increasing omni wheel diameter as a result of size restrictions.....	19
Figure 2.21: The dribbler bar for the RoboDragons (2010) [10].....	20
Figure 2.22: Conceptual sketch of a solenoid kicker	21
Figure 2.23: Graph of Kicking Speed vs. Stored Electrical Energy.....	22
Figure 2.24: Skuba 2009 Flat plate solenoid kicker	23
Figure 2.25: RoboDragons (2009) Robot chassis clearly showing the location of main and secondary solenoids [37].....	24
Figure 2.26: LiPo battery typically used in SSL [11]	25
Figure 2.27: UCT's first 4 Omni-wheeled Prototype	26

Figure 2.28: First version of the four omni wheel motor assembly	27
Figure 2.29: Ball Control Module created by Mr David Iwabona in 2010[54]	27
Figure 4.1: Concept placement for base and ball control module	32
Figure 4.2: Concept placement for the locomotion assembly.....	32
Figure 4.3: Concept placement for the battery	33
Figure 4.4: Concept placement for the kicker electronics	33
Figure 4.5: Concept placement for the control electronics.....	34
Figure 4.6: Final concept layout for the robot.....	34
Figure 4.7: SKUBA wheel configuration in 2009[51].....	35
Figure 5.1: SSI Robot and Cover.....	37
Figure 5.2: Covered SSL Robot.....	37
Figure 5.3: SSL Final Design (Exploded View).....	38
Figure 5.4: Base and Solenoids (Exploded View)	39
Figure 5.5: Main kicking solenoid without wire (Exploded View).....	40
Figure 5.6: Solenoid bolt breakages.....	40
Figure 5.7: Coiled solenoid used in the kicker	41
Figure 5.8: Kicking Solenoid off the base	41
Figure 5.9: Chipper solenoid (Exploded View).....	42
Figure 5.10: Swinging Dribbler components.....	42
Figure 5.11: Dribbler module (Exploded View).....	43
Figure 5.12: Basic Dribbler Assembly.....	43
Figure 5.13: SSI Robot Front Close up view of Dribbler Assembly.....	44
Figure 5.14 Locomotion Test Assembly	45
Figure 5.15: Omni-wheel (Exploded View)	46
Figure 5.16 Half Wheel Component (CAD)	46
Figure 5.17 Brass mini-wheel without an O-Ring (Left) Drawing showing sizes in mm (Right).....	47
Figure 5.18: Omni-wheel assembly.....	47
Figure 5.19: Assembled omni-wheel.....	47
Figure 5.20: Omni-wheel placement (Cross Section).....	48
Figure 5.21: Front Motor Mount (Exploded View)	49
Figure 5.22: Front Motor Drive Unit (Cross Section)	49
Figure 5.23: Front Motor Assembly (Top View) allowing space for the Ball Control Module	50
Figure 5.24: Rear motor mount from front (Exploded View)	51
Figure 5.25: Rear motor mount from rear (Exploded View).....	51
Figure 5.26: Rear motor bracket	51
Figure 5.27: Solidworks Render of the motor brackets (Rear View)	52
Figure 5.28: Front and rear motor bracket with wheel shaft	52
Figure 5.29: Controlling Electronics Module.....	53
Figure 5.30: Controlling Electronics for a SSL Robot (Exploded View)	54
Figure 5.31: Kicking Module.....	55
Figure 5.32: Capacitors and Kickerboard module (Exploded view)	55
Figure 5.33 Capacitor Discharge Module.....	56
Figure 5.34: Completed SSL Cover	57

Figure 5.35: Mould Assembly (Exploded)	57
Figure 5.36: Mould side panels before machining.....	58
Figure 5.37: Mould side panel in the process of machining.....	58
Figure 5.38: Mould side panel	58
Figure 5.39: Mould top plate being machined.....	59
Figure 5.40: SSI Cover made using the mould.....	59
Figure 5.41: Final SSL cover.....	60
Figure 6.1: Wiring diagram for a SSL robot	61
Figure 6.2: UCT SSI Robot Battery	62
Figure 6.3: Motor Control Board.....	63
Figure 6.4: Simplified Modular Schematic of the Motor Control Board.....	65
Figure 6.5: Motor Control Board used on a SSL robot.....	65
Figure 6.6: Motor Control Board (Full Schematic).....	66
Figure 6.7: Analogue Voltage Protection Circuitry	67
Figure 6.8: MAX3232 and required components for operation	67
Figure 6.9: A Single Buffer of the 74HCT125 IC.....	68
Figure 6.10: Dual 8 Bit DAC with an LM358 for additional modifiable gain	68
Figure 6.11: The Power Regulation for the MCB	69
Figure 6.12: Stackable Connection Bus used on the MCB	69
Figure 6.13: Motor Control Board Layout Diagram	70
Figure 6.14: Final version of the Kickerboard used in SSI	72
Figure 6.15: Kickerboard Prototype constructed as a proof of concept.....	74
Figure 6.16: Simplified Modular Schematic of the Kickerboard	74
Figure 6.17: Kickerboard (Full Schematic)	75
Figure 6.18: Optional External Safety Relay Circuitry	76
Figure 6.19: External Relay Protection with indicator LED	76
Figure 6.20: Switching Oscillator on the Kickerboard.....	77
Figure 6.21: Charging IGBT I with MOSFET driver.....	77
Figure 6.22: IGBT Driver for the Main Power IGBTs	78
Figure 6.23: Jumper Configuration for LVL_SEL and Onboard CLK.....	78
Figure 6.24: Kickerboard Resistor Transistor Logic waveforms.....	79
Figure 6.25: Resistor Transistor Logic for the Kickerboard.....	79
Figure 6.26: Kickerboard Layout Diagram.....	82
Figure 6.27: The location of Jumpers on the Kickerboard	84
Figure 6.28: The location of LEDs on the Kickerboard.....	84
Figure 6.29: The location of the potentiometers on the Kickerboard	85
Figure 6.30: Silkscreen omission of a value on the Kickerboard.....	85
Figure 6.31: Schematic for the Fuse Board.....	86
Figure 6.32: Fuse Board Layout Diagram.....	87
Figure 6.33: Simplified Modular Schematic of the LiPo Protection Board	88
Figure 6.34: LiPo Protection Board (Full Schematic).....	89
Figure 6.35: LiPo Protection Voltage Regulation	91
Figure 6.36: Soft Trigger Op amp and configuration resistors	91

Figure 6.37: Soft Trigger monostable for a timed output.....	92
Figure 6.38: Soft Cut transistor arrangement.....	92
Figure 6.39: Hard Cut with Optional Soft Cut transistor and controlling MOSFET.....	93
Figure 6.40: Warning outputs for the Soft trigger.....	93
Figure 6.41: LiPo Protection Board Layout Diagram.....	94
Figure 6.42: Schematic for the Stackable Wireless board.....	96
Figure 6.43: Stackable Wireless Board Layout Diagram.....	97
Figure 7.1: Command information flow for an SSL Robot.....	98
Figure 7.2: SSL Control Interface for the Computer.....	98
Figure 7.3: Rumblepad Game Controller Controls.....	99
Figure 7.4: SSL Motor Velocity Calculation.....	100
Figure 7.5: Simplified flowchart for wheel Velocity Calculation.....	101
Figure 8.1 UC1 SSL Field in the Robotics and Research Agents Laboratory.....	107
Figure 8.2: Forward translational test starting position.....	108
Figure 8.3: Forward translational test resting position.....	109
Figure 8.4: Left translational movement Testing; Start (Left), Final Position (Right).....	109
Figure 8.5: Rotational Testing: Start (Left) and Final Positioning (Right).....	110
Figure 8.6: Linear speed sensor placed on its front.....	111
Figure 8.7: Ball guide and locator.....	111
Figure 8.8: Ball speed test setup.....	112
Figure 8.9: Linear speed sensor calibration.....	112
Figure 8.10: Direct Oscilloscope Kicking Capture (Dry fire, Rear Position).....	114
Figure 8.11: Direct Oscilloscope Kicking Capture (Front Position).....	114
Figure 8.12: Direct Oscilloscope Kicking Capture at 250V (Dry fire).....	115
Figure 8.13: Graph of kick speed variability based on Kick Lnable timing.....	115
Figure 8.14: Graph of Kick Speed vs. different core materials.....	116
Figure 8.15: Preliminary assembly of the chipper without dribbler assembly.....	117
Figure 8.16: Ping times created from bi-directional communication between two Simcom 20 modules.....	119
Figure 9.1: Direct Oscilloscope Kicking Capture (Dry fire, Rear Position).....	123

List of Tables

Table 2.1: Team Ranking and TDP placement based on year.....	11
Table 2.2: Table Indicating dribbler motor and backspin bar speeds.....	20
Table 2.3: Electrical information relevant to kicking for each team.....	22
Table 3.1: Table of Specifications.....	29
Table 5.1: Different Gearing Comparison	44
Table 6.1: Design Parameters for the MCB.....	64
Table 6.2: Expected Operational Voltages and Current for the MCB.....	64
Table 6.3: Motor Control Board Pin Layout.....	71
Table 6.4: Design Parameters for the Kickerboard.....	73
Table 6.5: Operating specifications for the Kickerboard	73
Table 6.6: Kickerboard Pin layout	83
Table 6.7: Fuse Board pin layout.....	87
Table 6.8: Design Parameters for the LiPo Protection Board.....	88
Table 6.9: Recommended Start-Up for the LiPo Protection Board	93
Table 6.10: LiPo Protection board Pin layout	94
Table 6.11: Design parameters for the Stackable Wireless boards	95
Table 6.12: Stackable Wireless Pin Layout.....	97
Table 7.1: Correct Data Stream from the Host Machine	103
Table 7.2: Skewed Data Stream Possibility 1	104
Table 7.3: Skewed Data Stream Possibility 2	104
Table 7.4: Skewed Data Stream Possibility 3	104
Table 7.5: Skewed Data Stream Possibility 4	104
Table 7.6: Skewed Data Stream Possibility 5	105
Table 7.7: Skewed Data Stream Possibility 6	105
Table 7.8: Table of Slave Motor Control Board I2C addresses	105
Table 8.1: Angle Byte Information Table	108
Table 8.2: Table highlighting battery considerations.....	120

1. Introduction



Figure 1.1 A Small Size League (SSL) Robot Soccer match[3]

Historically robots have been used to perform repetitive tasks requiring little or no ‘conditional logic’*. These simple tasks would fit into the *dirty, dull and dangerous* category which is where the field of robot design thrives [4]. The demand for robots in commercial environments is increasing; however these require the ability to make use of complex algorithms and have large amounts of conditional logic. The lack of robots in business and production could imply these systems do not yet meet the requirements dictated by the commercial applications. This deficit potentially occurs because this field is in its infancy thus further research is needed to create mobile robots robust enough to handle tasks involving complicated conditional logic. RoboCup provides such a platform in which these fields of concern can be competitively tackled.

The RoboCup Federation is a non-profit organisation based in Switzerland and was established to create a competition that inspires people to overcome the challenges faced when producing complicated, mobile, robotic platforms[5][6]. RoboCup hosts an annual competition with four divisions: RoboCup Rescue, RoboCup@Home, RoboCup Junior and RoboCup Soccer where Small Size League (SSL) is a subdivision of RoboCup Soccer shown in Figure 1.1. The annual contest creates a window into the world of robotics; a realm previously inaccessible to the public [6][7].

*Conditional Logic: decisions based on multiple monitored inputs resulting with the potential for numerous possible outcomes

RoboCup Soccer was launched with the intention of not only introducing a popular sport to robotics, but one which provided sufficient challenges to inspire the growth in the industry that is sought. RoboCup Soccer aspires to field an autonomous soccer team that could challenge and defeat the FIFA World Cup Champions in the year 2050 [7]. This would be a remarkable achievement considering robots to date do not have the agility or the tactical abilities of a human. Different leagues were established to focus on different issues arising from each league with the goal of beating FIFA's champions in 2050. These leagues are Simulation, Mid Size League (MSL), Standard Platform League (SPL) Humanoid and SSL [6].

SSL Soccer is played on a 6m x 4m miniature soccer field by two opposing teams with the aim of each team to score as many goals as possible in the opponent's goal area. Each team may not consist of more than 5 robots on the field.

The game time is split into two equal 15 minute halves with a 10 minute break between the halves. As with soccer if a conflict with the SSL game rules occurs, time is stopped and continued once the consequences of the offence have been carried out.

Each team is supplied identical information obtained by 2 cameras placed 4 metres above the field and shared via an SSL vision programme provided by the RoboCup organisers. Each team uses high level control to determine how to play and compete using this data. A wireless link allows the host machine to communicate with each robot. A simplified diagram of this is given below (Figure 1.2).

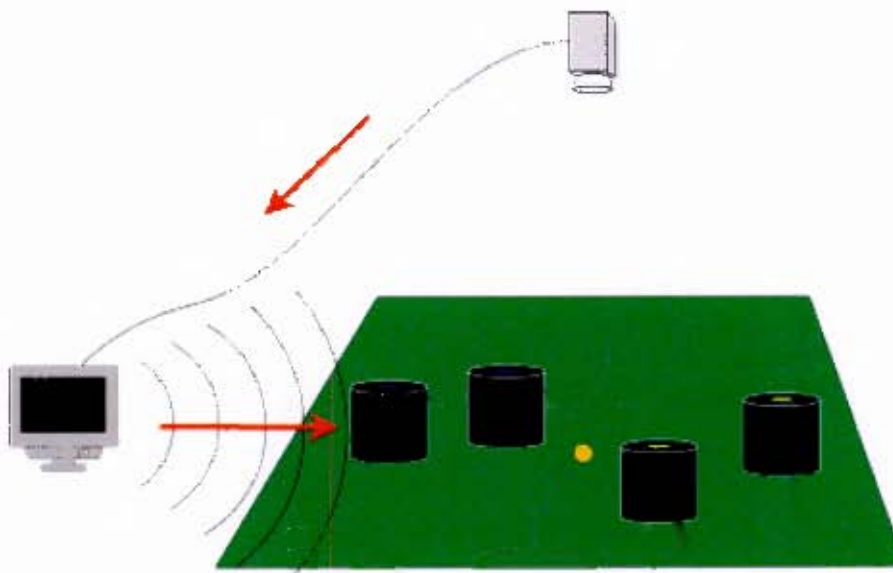

Figure 1.2: Pictorial description of SSL configuration [8]

UCT has not participated in RoboCup Soccer internationally, although there have been national competitions in which UCT was victorious. The robots that competed in the last competition shown in Figure 1.3 were based on a differential drive.

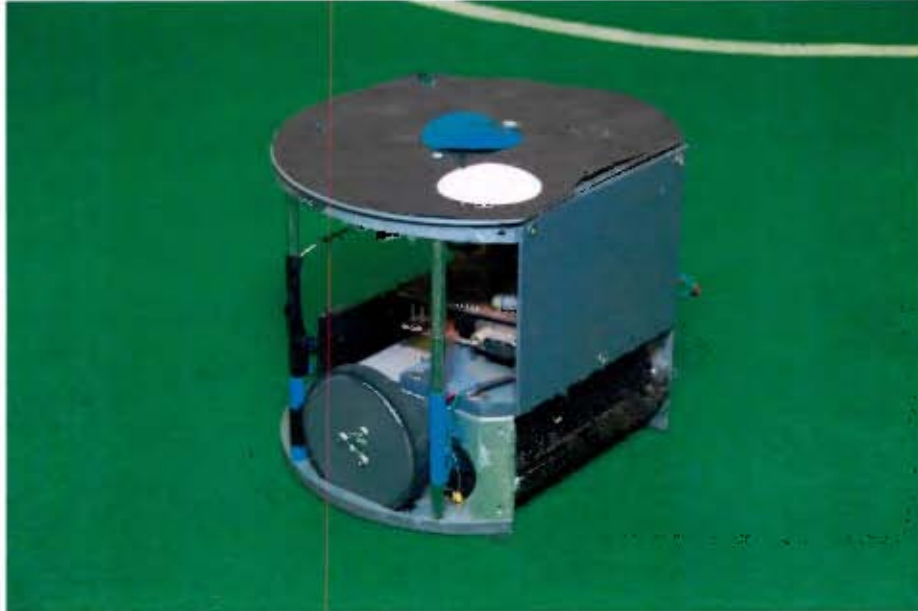

Figure 1.3: Last UCT SSL competition robot which used a differential drive

A differential drive motion is identical to the motion of a tank; the orientation of the robot needs to be in the direction of intended travel. More agile robots using mechanically complicated omni-directional systems have emerged in SSL internationally. In 2005, an undergraduate student from UCT; Craig Inman-Bamber built an omni-directional prototype in a 3 wheel configuration as shown in Figure 1.4.

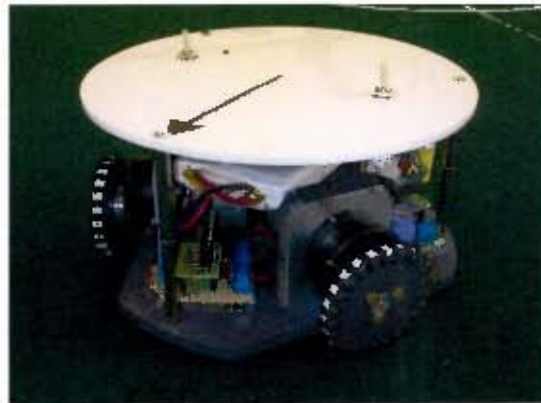

Figure 1.4: 3 wheel omni-directional platform created by Craig Inman Bamber [5]

The omni-directional platform greatly increases mobility as the robot is capable of moving in any direction whilst having the front facing any orientation. In SSL competition in 2011, all robots utilised omni-directional wheels for locomotion. Every year the competition improved significantly and the mechanical challenge faced was to incorporate larger and more powerful components and accessories into the space restrictions.

The scope for the project was the research of SSL and then the design and construction of a team of at least 7 SSL robots capable of performing competitively in an International RoboCup competition. A low level operational software structure needed to be created to allow for future development in high level controlling systems. A single uncovered robot is shown in Figure 1.5.

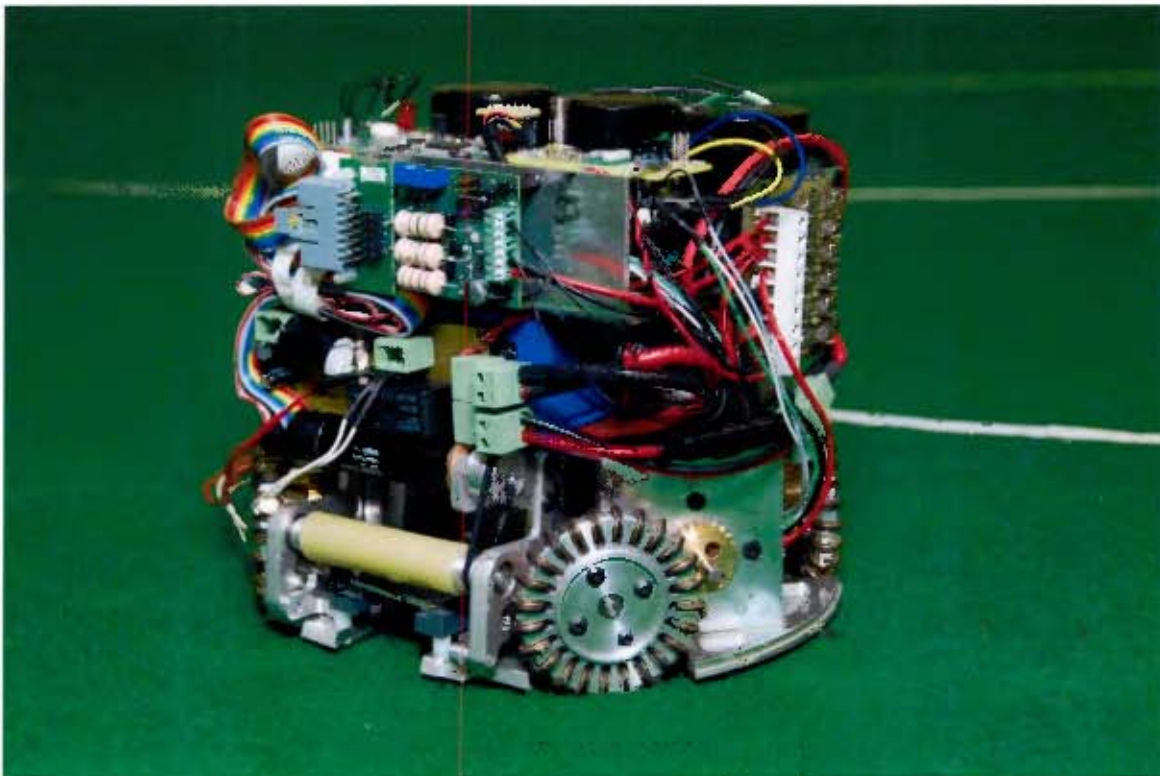

Figure 1.5: Final UCT SSL Robot

The following chapters begin with background research into the past and present comparable robotic platforms used in SSL, followed by a detailed list of specifications for both mechanical and electrical requirements, then detailed analysis of the design of the systems, and finally the testing and conclusions and recommendations drawn from those tests.

2. Background Research

In order to develop a competitive SSL robot platform it is imperative to understand the rules and restrictions for the game which govern the design for each robot and components. Current competitive designs, as well as the path each design underwent in its history would provide a baseline for any design as well as all faults other teams make would reduce the potential pitfalls with the UCT design. Similarly to any athlete, determining factors that could provide any advantage in speed, agility, strength or stamina would be beneficial to gain an edge over the competition.

2.1 The Rules and Regulations for SSL

The rules of SSL have been adapted over the years to converge to the RoboCup goal in 2050 [6]. This section covers the rules from 2010 as these regulations would affect design specifications on a SSL Robot.

2.1.1 Game Structure

The game is played by two opposing teams with the aim of each team to score as many goals as possible in the opponent's goal area. A goal is scored when the ball is legally moved through the opposition's goal posts during a section of game play.

As stated earlier in the introduction, a team may not consist of more than 5 robots on the field. One of these 5 robots needs to be designated the goal keeper and the match may not start unless each team consists of at least 1 robot.

Any robot can be replaced provided the following rules are followed.

- The referee needs to be informed before a substitution takes place
- A replacement may only be done during a stoppage of play
- Replacements are carried out from the halfway line
- No more than 5 robots per side on the field at any point of time
- If the replaced robot was the goalkeeper, a new goal keeper needs to be allocated and the referee needs to be informed [9].

2.2 Rule requirements and restrictions in SSL

2.2.1 Field

The playing field is a level green felt or mat on top of a hard surface. The dimensions for the field can be seen in Figure 2.1.

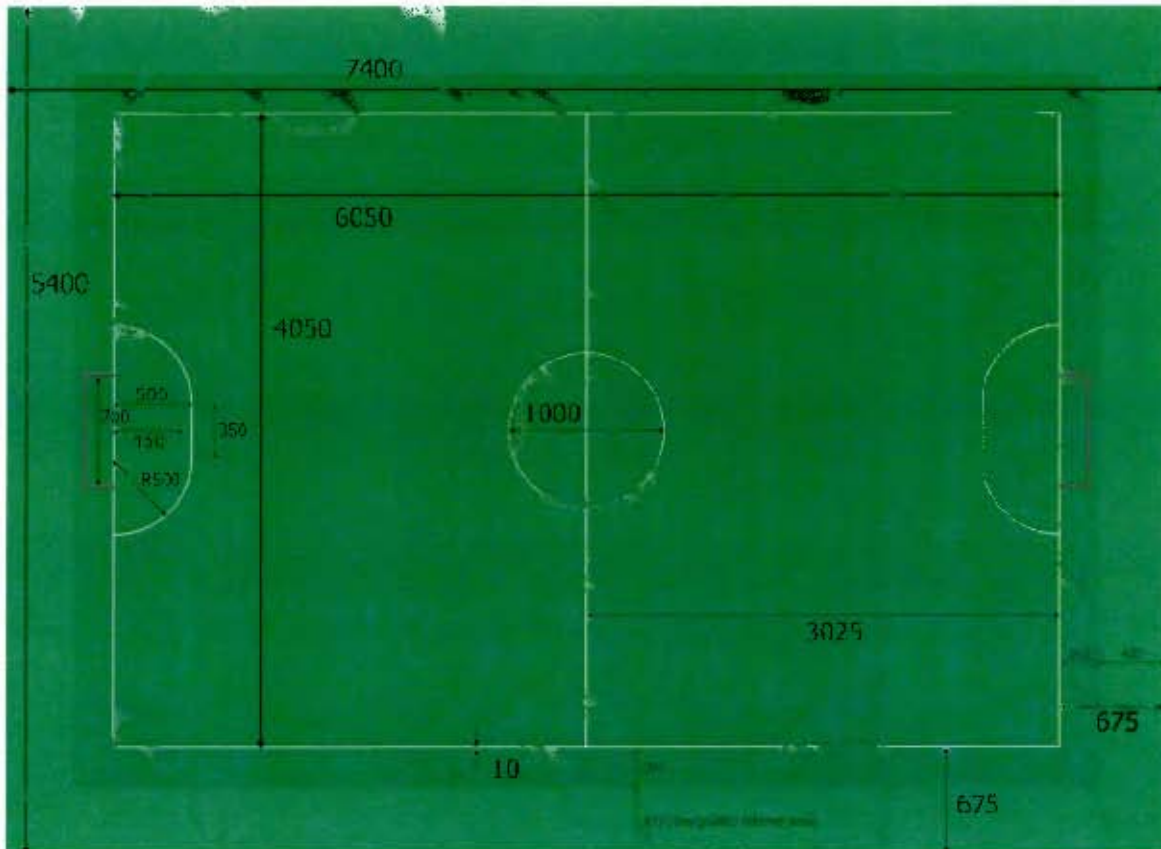

Figure 2.1: The overall layout of the SSL playing field [9]

The field boundary is a large rectangle with length 6050mm and a width of 4050mm. An additional 675mm on each side of the boundary is allocated to ensure there is no conflict with anything on the field. 250mm of the 675mm is dedicated to the robots, while the additional 425mm is where the human assistants are permitted to walk. All lines are 10mm wide and run along the boundary. Each line is included in the area it borders. There is a line across half the length of the field and is denoted the half way line [9].

A circle with a diameter of 1000mm is placed in the centre of the half way line. The goal posts are situated midway along the width of the boundary rectangle.

There is an inner 'D' situated around each goal on the inside the field (Figure 2.2).

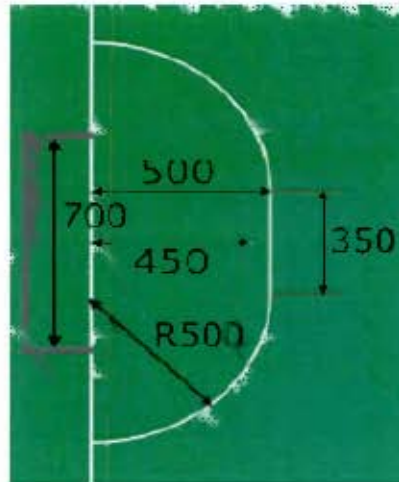

Figure 2.2: The Defensive Area of each Goal [9]

The inner 'D' denotes the defence area for the robots. The consequences for offences committed in this region are more severe.

2.2.2 Goal Post:

The goal is 700mm long and 180mm deep. The walls are required to be 20mm thick and 160mm high from the surface of the playing field as seen in Figure 2.3 [9].

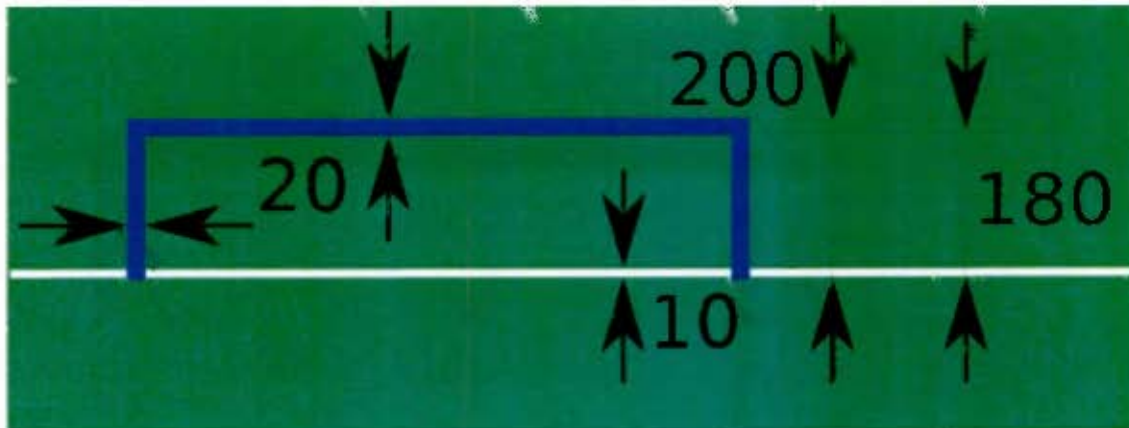

Figure 2.3: Goal posts (viewed from above) [9]

A round steel cross bar no larger than 10mm in diameter must be placed on top of the goalmouth. It should be dark in colour and sit 155mm above the playing surface. A net is secured from this bar to the rear of the goal posts. This ensures a goal can only be scored if it enters the goals within the height of the robots and through the posts [9].

2.2.3 Robot

Each robot must be able to fit into a 180mm ID cylinder and not exceed a height of 150mm (Figure 2.4). The top of the robot must be flat to conform to shape requirements which are discussed later in section 2.3.6.

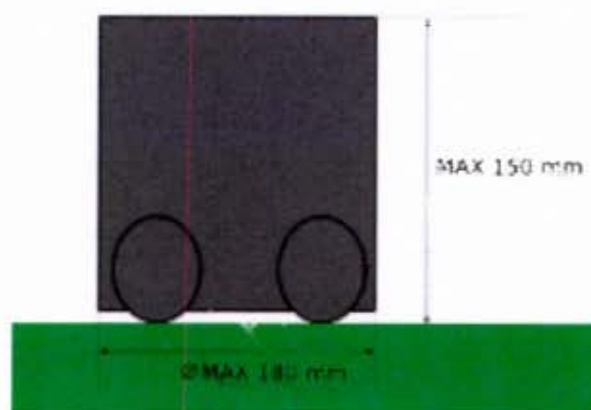

Figure 2.4: The maximum size of a robot [9]

2.2.4 Ball

A standard golf ball weighing 46g with a diameter of 43mm is used in SSL. It is painted orange to assist the vision systems that provide information to the robot systems.

2.3 Rules Affecting Design and Construction

Design and construction focuses on the factors within the rules that restrict or control the manner in which a robot may interact with objects during the game.

2.3.1 Kicking

In order to kick a golf ball at sufficient speeds with repeatability, a high power robust system needs to be used. Safety standards dictate that a robot must not have in its construction anything that is dangerous to itself, another robot or humans [9].

High power systems are by no means safe but the vagueness of the above rule has lent itself to a degree of flexibility throughout the years. Kicking devices have ranged from pneumatic systems to high voltage electrical systems but if protected within the body of the SSL robot, it could be considered safe.

In terms of the power of a kick, the only restriction found states that "An indirect free kick is also awarded to the opposing team if a robot kicks the ball such that it exceeds 10 m/s in speed" [9]. This specified the limit that was placed on the kicker speed which was specified to no greater than 10 m/s.

2.3.2 Dribbling

The ball can be actively held against the surface of the robot provided it is spinning towards it. The dribbling module has a roller that makes contact with the ball which ensures that the ball has backspin; keeping the ball in control at all times. An amendment to the rules in 2009 conditioned that the dribbler bar had to be a uniform cylinder from end to end; absent of any concave shapes cut into it. Furthermore, the bar cannot restrict motion in any direction or remove a degree of freedom of the ball. The roller may not be coated in adhesive material or anything that may leave residue on the ball or field [9]. The spin exerted on the ball must be perpendicular to the playing surface as indicated in Figure 2.5. Any deviation from the above is in direct violation of the rules.

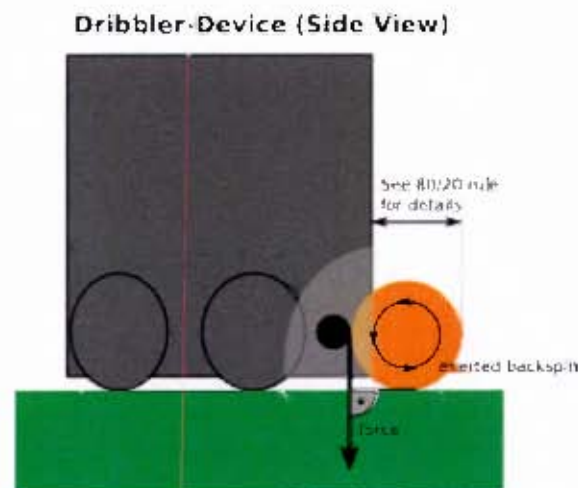

Figure 2.5: Dribbler location on SSL platforms [9]

When reviewing 2008 Team Description Papers (TDP), one can observe the Skuba modifications formulated to comply with the new rules set out in 2009 (Figure 2.6).

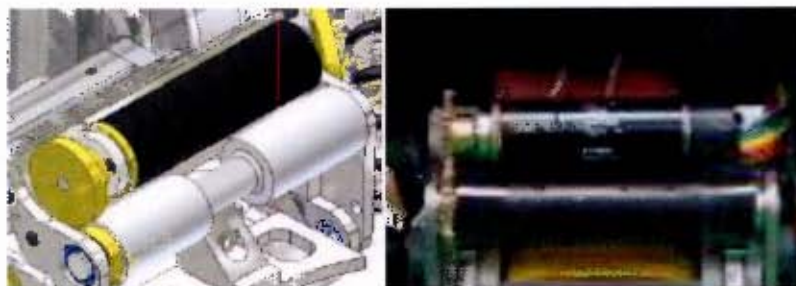

Figure 2.6: SKUBA Dribble Bar 2008 (Left), Dribble Bar 2009 (Right)[10][2]

bearing. These colours and ID's were essential for the SSL vision software to correctly identify all elements and provide a matrix of information.

2.4 Team Description Papers

Submission of Team Description Papers (TDPs) was a requirement for the top 8 teams of the previous year, and encouraged for the other competitors. The TDP contain information relevant to the team's accomplishments that aided them to their success. Each TDP was freely downloadable for each year that the project has been run.

Table 2.1 contains all TDPs considered and their placement over the years which determine their significance in this dissertation. Any particular team cannot change everything in a single year so each TDP tends to focus on the areas of improvement and thus all TDP need to be combined to get an overall understanding of current SSL designs and improvements. The TDP from the following teams have been read and are considered in the following sections:

Table 2.1: Team Ranking and TDP placement based on year

Year	Team	Placement
2009	Skuba[2]	1 st
2009	RoboDragons[11]	2 nd
2009	Plazma-Z[12]	3 rd
2009	Odens[13]	4 th
2009	KIKS[14]	KO Quarters (Skuba)
2009	CMDragons[15]	KO Quarters (Odens)
2009	ZjuNlict[16]	KO Quarters (Plazma-Z)
2009	B Smart[17]	KO Quarters (RoboDragons)
2009	ER Force[18]	KO before quarters (B Smart)
2009	Immortals[19]	KO before quarters (KIKS)
2009	MRL[20]	KO before quarters (ZjuNlict)
2009	RoboPet[21]	KO before quarters (Odens)
2009	BRocks[22]	Eliminated before KO
2009	Eagle Knights-RoboBulls[23]	eliminated before KO
2009	Oweripito-CU[24]	Eliminated before KO
2009	Parsian[25]	Eliminated before KO
2009	RFC-Cambridge[26]	eliminated before KO
2009	RoboPET	Eliminated before KO
2009	ThunderBots[27]	Eliminated before KO
2009	Austrian Cubes[28]	Eliminated before KO
2009	Sharcity[29]	DNF
2009	FURGBOL[30]	DNF
2009	Khainui[31]	DNF
2009	OMID[32]	DNF
2009	Botnia Dragon Knights[33]	DNF
2008	CMDragons[34]	2 nd
2008	Skuba[10]	3 rd
2008	AUA_Ares[35]	KO Quarters (ZjuNlict)
2008	3-Smart[1]	KO Quarters (Plazma-Z)
2008	FANTASIA[36]	KO Quarters (CMDragons)
2008	RoboDragons[37]	KO Quarters (Skuba)
2008	Khainui[38]	KO before quarters (Skuba)

2008	Botnia Dragon Knights[39]	KO before quarters (AUA Ares)
2008	MRL[40]	KO before quarters (B-Smart)
2008	KIKS[41]	Eliminated before KO
2008	Eagle Knights RoboBulls[42]	Eliminated before KO
2008	Parsian[43]	Eliminated before KO
2008	RoboJackets[44]	Eliminated before KO
2008	Strive[45]	Eliminated before KO
2008	ER Force[46]	Eliminated before KO
2007	FURGBOL[47]	Eliminated before KO
2007	RFC Cambridge[48]	Eliminated before KO
2005	Owaribito-CU[49]	Not Known

[50]

In the TD? there are definite sections that each team discussed; subdivisions were created to assist in the understanding of different modules:

- **Electronics for Control**
Robot controllers (single/distributed controller), wireless link between the host system and individual robots
- **Motors and Wheels for Locomotion**
Number of wheels, choice of motors and speed encoders, gear ratio and gear connections.
Omni wheel design and assembly
- **Ball Control Module**
Dribbler motors, new design of back-spinning bars, gear ratios, assembly
- **Main Kicking Module**
High voltage generation, quantity of stored electrical energy, solenoid design and construction, kicking times and speed
- **Chipping Module**
Mechanical design of chipping components, solenoid type and chip distance
- **Battery Pack**
Battery Voltage, capacity and runtime
- **Software**
Game Prediction, game tactics, simulation
- **Vision Systems**
Before 2009 RoboCup did not offer vision software to provide robot information. Each team developed their own information gathering camera/software integration.

These systems were individually investigated to determine the optimal path for design and implementation.

2.4.1 Electronics for Control

Control for an SSL robot varied from team to team depending on their competitiveness and their experience in SSL. The more experienced teams such as *Skuba*, *Austrian Cubes*, *RobaDragons* and *Plazma-Z* used a single high density board [11][12][28] [51]. These incorporated controller boards typically include motor controllers, debugging components (LFDs and buzzers), wireless modules and controlling ICs or FPGAs or both (Figure 2.9).

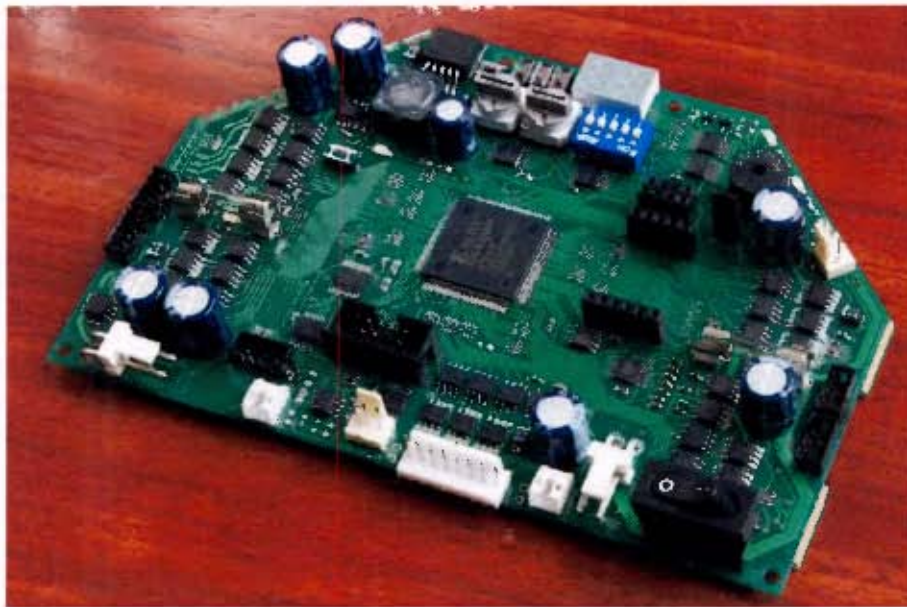

Figure 2.9: Skuba Main Controller Board [51]

Less experienced teams typically used a more modular approach to their circuitry to reduce complexity. As of 2010 *RFC Cambridge* intended changing from their single board design to a modular design to simplify debugging issues. Each circuit could be individually tested to ensure stability and the possibility of easy and cost effective replacement. *B-Smart* used a discrete system with the associated data flow given below in Figure 2.10.

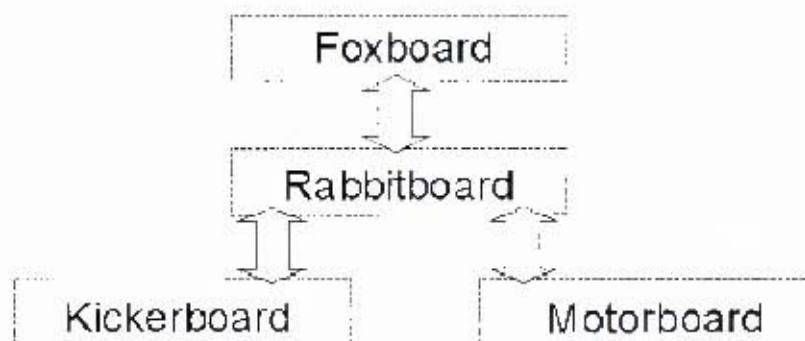

Figure 2.10: Control Board Data flow for *B-Smart* [17]

The *Foxboard* acts as the wireless link to the host system and is used for the communication of high level intelligence. The two main foci for the wireless modules were transfer speeds and physical size as the shortest communication time possible between transmission was desired and size is always a concern [13] [15]. The computation of SSL instructions was centralised to the host machine, however if communication could be sent at a higher level to the robots some computation could be done in a decentralized manner and less data would need to be transferred across the wireless link. The decentralisation of computation could improve overall transfer times. The host machine was capable of computing viable moves faster than the communication modules could transmit those particular moves to a robot. The host machine would be given proportionally more processing time for computation of the next frame if a smaller number of bytes were sent to each robot. A simple example of sending less data could be sending a desired position instead of individual motor velocities. The robot would need to perform in the same manner with the smaller data stream for it to improve the response time of the entire team.

The *RabbitBoard* would receive information from the *Foxboard*, determine what operations needed to be done with the information received and control the information to each of the *Motorboards* and would operate the *Kickerboard* [17].

2.4.2 Motors and Wheels for Locomotion

2.4.2.1 Motors Used in SSL

The previous national competitions were not as competitive compared to current international standards. The omni-directional platform used motors with a power output of less than 4W [5]. Figure 2.11 shows the omni directional prototype made by Irman-Bamber in his final year project [5]; the configuration would not be possible for competition as there is no space for any other systems on the platform.

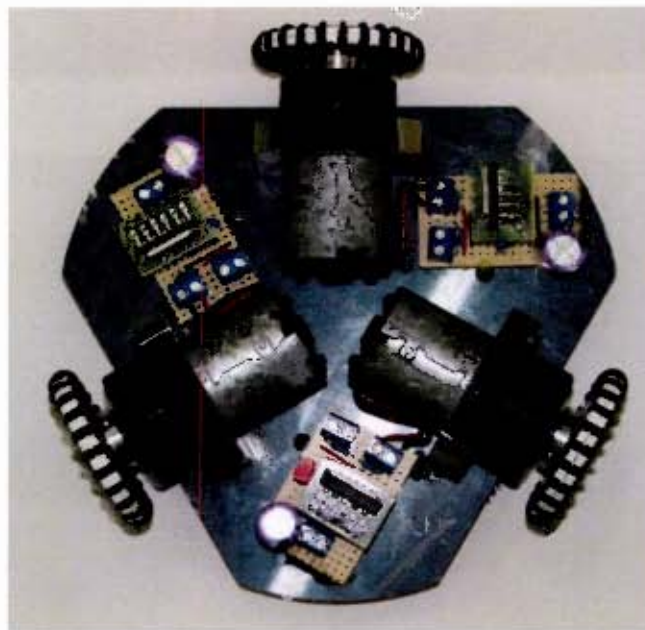

Figure 2.11: UCT SSL Prototype Motors [5]

Skuba, Plazma-Z, RoboDragons, CMDragons and several other teams used Maxon EC45 30W brushless motors [2][11] [12][34]. These motors have a large output power and occupy a compact area (Figure 2.12).

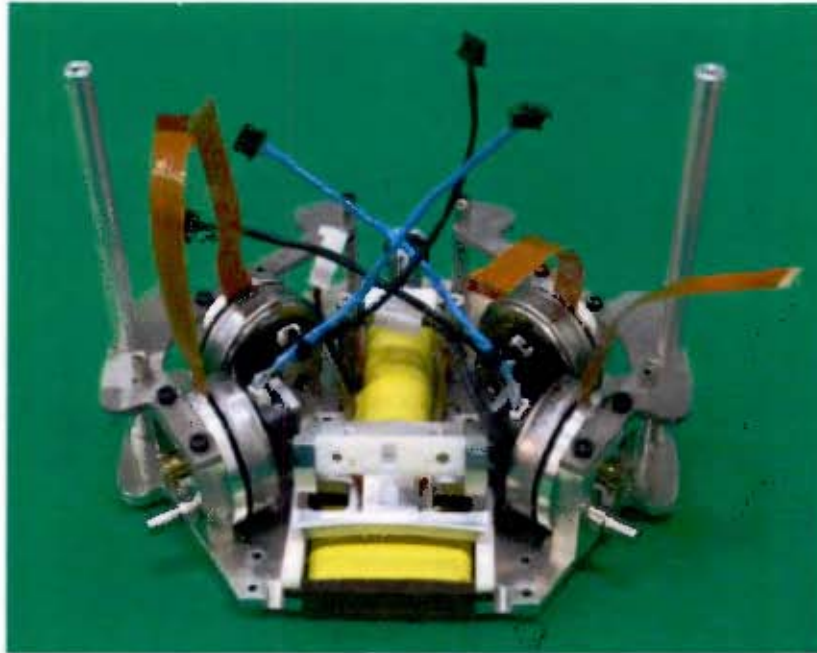

Figure 2.12: SKUBA using Maxon EC45 30W Motors

These motors come with optional extras such as internal speed controllers and shaft encoders. The more experienced teams control the motor windings from their own controller boards with shaft encoders.

2.4.2.2 *Methods of Locomotion*

UCT has never participated internationally in RoboCup SSL. The last national competition was in 2004 which UCT placed 1st. During the last competition, the robots operated with a differential drive system. This older system would not provide sufficient agility in current competition (Figure 2.13).

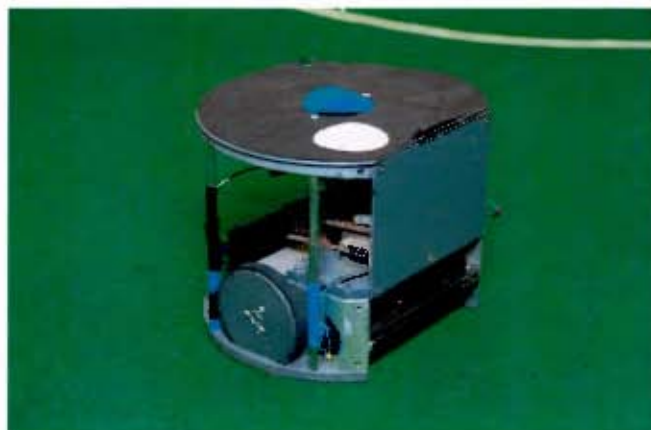

Figure 2.13: UCT Differential Drive SSL Robot

As a differential drive is similar to tank, the robot could only move forwards and backwards with this drive system. The ball control modules were located on the front of the robot and could only control the ball while facing it.

Presently robots in the competition can still only handle the ball while it is in front of the robot, however they are able to move in any direction and able to rotate to any orientation at the same time, allowing for much better mobility and ball control.

An omni wheel is a standard large wheel with smaller wheels located on its circumference with their direction of motion at an angle (typically 45° or 90°) to the larger wheels direction of motion. Figure 2.14 is an example of a 90° omni-wheel used by SKUBA in 2009.



Figure 2.14: SKUBA 2009 90° Omni-wheel [2]

A conventional wheel without slipping only provides motion along the axis of this rotation. Omni-wheels provided controlled motion along their drive axis and the additional smaller wheels provide free motion along each smaller wheel's rotational axis. Using computed control with at least 3 wheels positioned accordingly, a robot could have full planar control. In RoboCup, this means every robot can move in any direction at any point in time and simultaneously rotate to a defined bearing. An omni-directional platform can be used with 3 wheels like UCT's first prototype made by Inman-Bamber [5].

The number and position of the motors on the robots would directly affect the maneuverability. Using 3 wheels located along the vertices of a triangle shown in Figure 2.15 would produce a triangular velocity profile also provided. The 3 wheeled platforms have a significant advantage over the differential drive counterparts because of their ability to move laterally without changing their orientation.

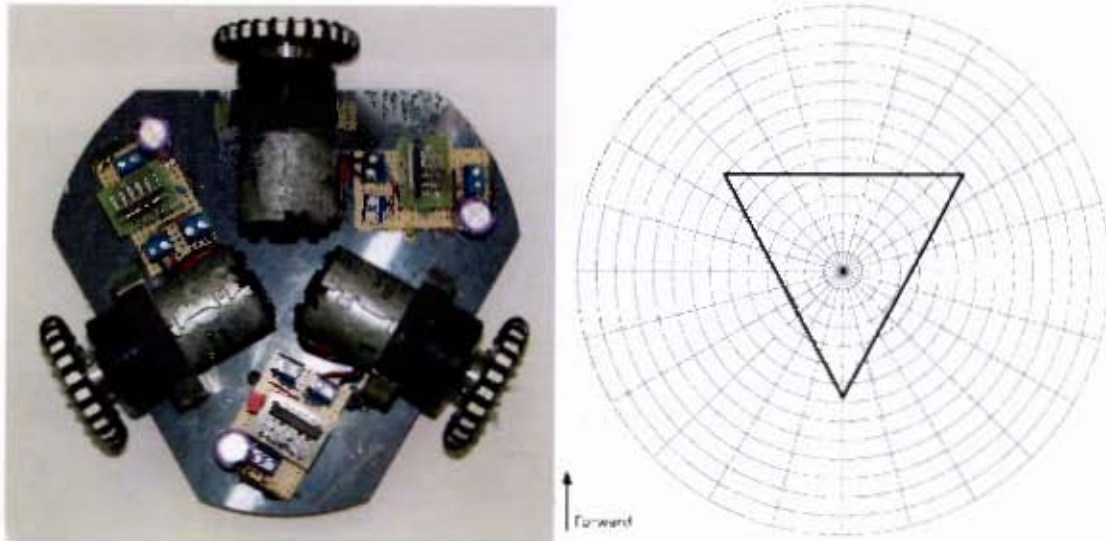

Figure 2.15: UCT SSL prototype (exposed) created by Craig Inman Bamber and theoretical velocity profile.[5]

The 3 wheel design is becoming obsolete due to its sharp nature of the possible velocity profile (Figure 2.15). Most teams in RoboCup SSL now use a 4 omni-wheel design. The 4 wheel systems were superior to the 3 wheel equivalents because their profile is more uniform for a given random direction with additional driving power on the ground (Figure 2.16).

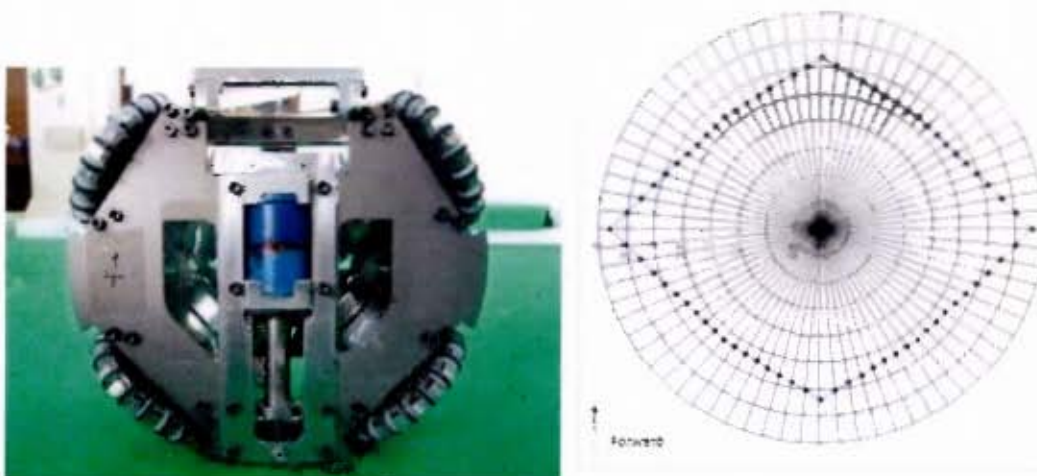

Figure 2.16: Plasma-Z (2005) 4 omni-wheel design and velocity profile from their design. [12]

There are 2 main types of omni-wheels commonly used in RoboCup. There are 45° and 90° omni-wheels. Each wheel type has benefits and drawbacks. Although all teams use the 90° omni-wheels in SSL to reduce calculation complexity and reduce wheel size. The following sections give a brief description on these different types.

90° Omni Wheel

90° omni-wheels are on all the robots competing in SSL. The smaller mini wheels surrounding the larger wheel create points of contact with the ground because the robot will rest on a mini-wheel. The outline created in red on Figure 2.17 is an effective circumference for the omni-wheel created by the irregularity of the mini-wheels. The 90° omni-wheel will roll over this effective outer circumference and the number of mini-wheels is approximately inversely proportional to the ride vibration.



Figure 2.17 : 90° Omni wheel circumference indicating flat sections

Increasing the number of smaller wheels may make the ride less bumpy, but increase the moving parts and complexity for each wheel.

45° Omni Wheel (aka Mecanum Wheel)

A 45° omni-wheel uses rollers instead of mini-wheels. These rollers are offset 45° on the main wheels circumference which can be seen in Figure 2.18.



Figure 2.18: CAD model of a 45° omni-wheel (Mecanum Wheel) used primarily in MSL.[52]

45° omni wheels have a lower ride vibration as the rollers improve the effective circumference of the wheel. A drawback to 45° omni wheel is that it is wider than the 90° omni-wheel. The 45° omni-wheel is too wide for use in SSL as it removes internal space which is needed for ball control systems. In MSL the more common omni-wheel is the 45° version. The *Austrian Cubes* used it in their MSL robots in 2010 (Figure 2.19).



Figure 2.19: Austrian Cubes MSL Robot (2010)

Because of the maximum size restrictions in SSL, a larger wheel diameter forces the motors inwards to follow the circumference requirements and less space is available in the robot for the ball control systems. This is illustrated in Figure 2.20 below.

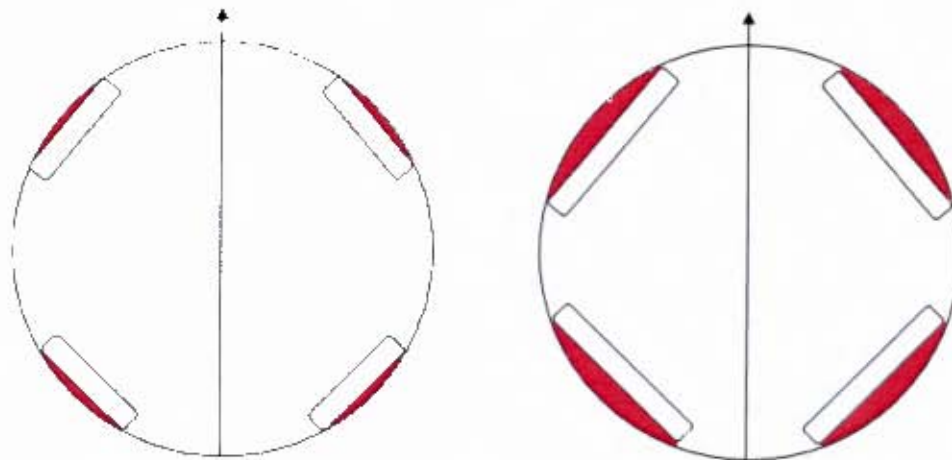

Figure 2.20: Space lost due to increasing omni-wheel diameter as a result of size restrictions

2.4.3 Ball Control Module

A dribbler module is a back spinning bar that makes contact with the ball while close to that particular robot. The bar spins the ball which in turn makes the ball roll against the robot.

The dribbler is essential to control the ball when receiving a pass and moving around the field. Figure 2.21 is the dribbler bar of *RoboDragons* 2010 team. The new rules require the bar to be cylindrical with no change in circumference along the entire back spinning bar.

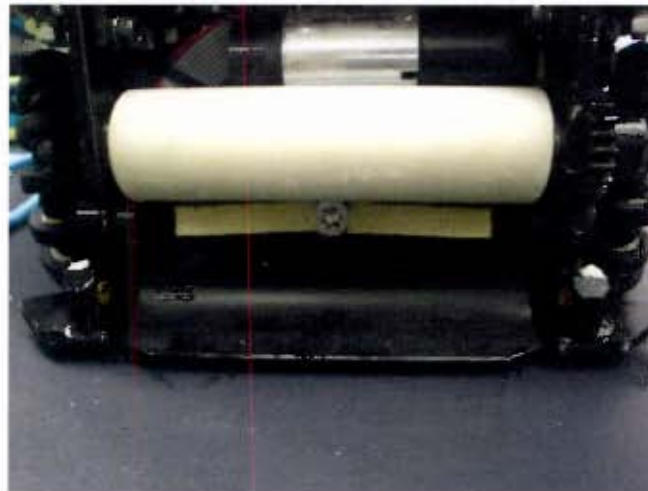

Figure 2.21: The dribbler bar for the *RoboDragons* (2010) [11]

Teams have slightly different arrangements with different motors and rotational speeds which can be seen in Table 2.2.

Table 2.2: Table Indicating dribbler motor and backspin bar speeds

Team	Motor	Power Rating	Maximum RPM
Skuba (2010)	Maxon EC16	15W	13000
RoboDragons(2010)	Maxon EC16	15W	14444
ODENS(2010)	Maxon RE-Max24	11W	Not Disclosed
Skuba (2009)	Maxon EC16	15W	13000
B-Smart (2008)	Faulhaber 2224U006SR	Not Disclosed	Not Disclosed

This shows that the teams who shared their motor information in their ETDPs typically used the EC16 15W Maxon motor with approximately 10000RPM.

2.4.4 Main Kicking Module

2.4.4.1 Pneumatic

Pneumatic kickers are used in the *Austrian Cubes* in their MSL. The high pressure air is forced into a piston and the ball can be kicked at variable speeds by using a throttling valve. Implementation of pneumatics has failed with *LR-Force* in SSL due to unreliability when reducing the size of the system [46]. When *ER-Force* systems were performing optimally, they could not achieve kicking speeds

similar to the other competitors [46]. The size requirements on SSL make it difficult to have discrete systems for each module.

2.4.4.2 *Electro-Mechanical*

The majority of teams that submitted literature in the last 3 years used electro mechanical kickers. The electro-mechanical kickers used in SSL use a linear actuator or solenoid to kick the golf ball. A solenoid is a length of wire wound on a hollow shell. If the wire has a current flowing through it, a magnetic motor force (MMF) is induced within the shell. The MMF pulls the ferromagnetic material to the centre of the field which is in the centre of the coil illustrated in Figure 2.22. This will displace the non-magnetic material and provide linear actuation. The conversion of electrical energy to mechanical kinetic energy using the solenoid typically has a low efficiency. Because the non-magnetic material has a short impact time with the golf ball, a large amount of energy needed to be dissipated in that short period of time.

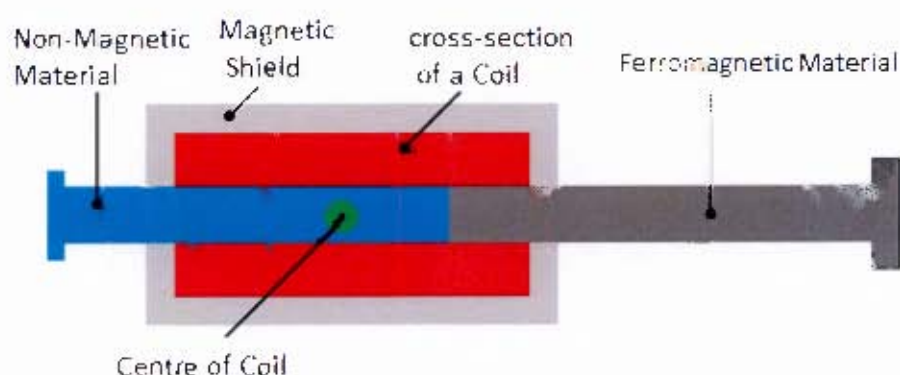

Figure 2.22: Conceptual sketch of a solenoid kicker

An Electro-mechanical kicker would allow every actuator to be electrical. This would minimize the number of components needed and also decrease complexity.

The energy from the battery would need to be converted to a higher potential and then that stored energy would need to be created into kinetic energy through the solenoid. This can be broken down into 2 separate systems: the electrical system which converts the low DC voltage to the high DC voltage and then activates the solenoid; the mechanical solenoid which uses the produced MMF and kicks the golf ball.

The rules stated that the ball may not travel at more than 10m/s and the robot could not be unsafe for other robots or people observing the game.

Each team with an electro mechanical kicker used a charge pump to generate a high voltage. The amount of energy stored was proportional to physical size of external capacitors. Table 2.3 below gives a description of some teams and their electrical configurations.

Table 2.3: Electrical Information relevant to kicking for each team

Team	Charging Voltage (V)	Capacitor Value (μF)	Electrical Energy (J) ($\frac{1}{2}CV^2$)	Achieved Speed (m/s)	Mechanical Energy (J)	Efficiency (%)
Skuba(2010)	250	5400	168.75	17	3.312	1.95
Austrian Cubes (2009)	170	7800	96.16	10	2.3	4.1
Immortals (2009)	500	560	100.8	9	1.863	1.83
RoboDragons (2009)	250	4900	153.125	9	1.863	1.22
B-Smart (2009)	200	2200	44	8	1.472	5.35
FF Force (2009)	200	4900	38	7	1.177	1.15
Botnia Dragon Knights (2009)	200	8800	176	18	7.452	4.23
KIKS (2008)	200	4000	80	12	3.312	4.14
FANTASIA (2008)	150	4400	49.5	10	2.3	4.54
Robolackets (2008)	300	2000	90	9	1.863	2.07

From Table 2.3 above, the following graph can be generated from the data from each team (Figure 2.23).

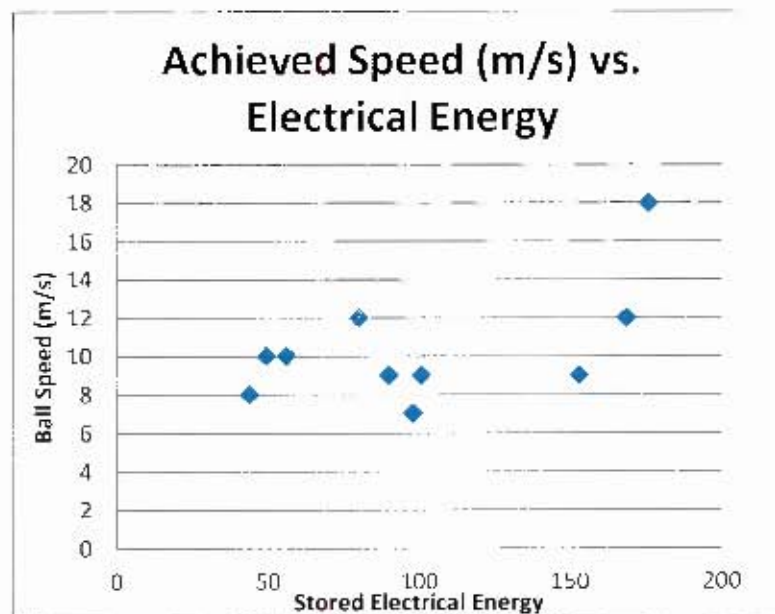

Figure 2.23: Graph of Kicking Speed vs. Stored Electrical Energy

If the kicking solenoids were similar a correlation between the energy stored for a kick and the final speed would be identified. The overall efficiency of the conversion from electrical to mechanical energy is vital for high kicking speeds, and this varies widely between team to team.

Electrical Kicking systems have a low efficiency when converting from electrical to mechanical energy. The marginal differences between teams efficiency create significant ball speed differences on the field.

2.4.5 Chipping Module

All robots that had chip kicker modules used the same bank of high voltage capacitors as the kicker to receive a burst of energy. As physical space was already limited, it was impractical to have more than one high energy source available on the robots. For the chipper module, different teams had vastly different designs. This was possibly an indication that no one team had found a solution which fulfilled all the requirements one might place on a chip module.

The main issue with the chip kicker was that all the forward space is occupied by the dribbler and the main kicker. Three different designs are investigated:

- Flat Solenoid
- Multiple Solenoids
- Rear Solenoid

2.4.5.1 Flat Solenoids

Skuba designed a flat plate type solenoid that could be placed under the main kicker shown in Figure 2.24. It did not generate as much force as the main kicker but could be placed below and in line with the chipping device. When activated, the plunger strikes the ball below the ball's centre of gravity forcing it vertically and forward.

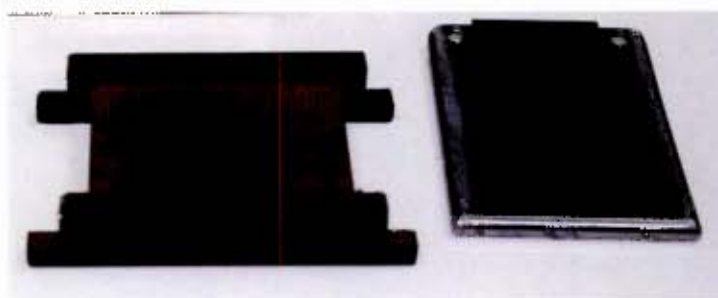

Figure 2.24: Skuba 2009 Flat plate solenoid kicker

This system was compact and according to their results in competition capable of working consistently. Another team that successfully used the flat plate solenoid is *MRL* (2009) [20].

2.4.5.2 Multiple Solenoids

The centre channel of the SSL robot was occupied by the main kicker. Some teams had developed a system that provides force on each side of the main kicker pushing a plunger beneath the main kicker. Figure 2.25 shows both smaller solenoids on each side of the main kicker on *RoboDragons*.

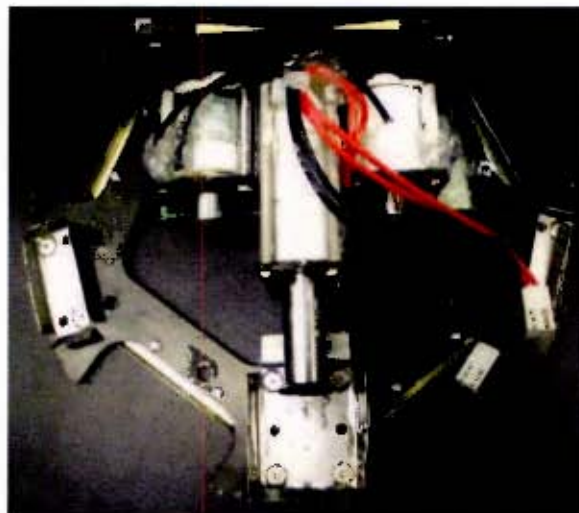

Figure 2.25: RoboDragons (2009) Robot chassis clearly showing the location of main and secondary solenoids[37]

The requirements placed on these side solenoids are that they respond in an identical manner when they are activated. If it does not, it could create large side forces and damage the chipping components. The creators of the *Austrians Cubes* advised against building a multiple solenoid arrangement because of their initial testing and their system's self destructing.

2.4.5.3 Rear Solenoids

Another possibility was to place a secondary solenoid close to the back and used linkages to push the chipper paddle. The additional mechanical linkages reduce the efficiency of an already weak solenoid and were typically ineffective. Some teams with rear solenoids include the *Austrian Cubes* and *Parsian*. Their systems could perform chip kicks, although efficiency is lower than that of *Skuba* for the corresponding year.

2.4.6 Battery Pack

Most teams used a single LiPo 3S battery shown in Figure 2.26. This easily has enough instantaneous power for everything to run and is light and small to fit into the robot.



Figure 2.26: LiPo battery typically used in SSL [12]

Some teams operated with two batteries, the first for controlling circuitry and the second to run power applications. This would remove the electrical noise on the logic power supply because it is operating off a completely different supply. However two batteries would occupy more space in the robot and require both to be replaced during a battery change.

2.4.7 Software

System software can be broken down into 2 sections: low level and high level. Low level contains all the simple algorithms that are required to operate an individual robot; these include motor velocity control, wireless communications and kicking commands.

High level control contains game prediction, path planning, game tactics, play making, and winning strategies which govern what the low level control needs to be doing.

Good high level control is crucial for the SSL team to function and perform competitively; however the project scope would be too large for a single MSc student and is not included in this project.

Low level software would be microcontroller code used to govern the speed of each motor to perform a required action by the supporting higher level code or individual commands of the Host PC.

2.4.8 Vision Systems

Before 2009, vision was individually done by each team. Currently there is an open source program called *SSL vision* which monitors the field makes correction for camera skewing and produces a matrix of information for each team to process. This removes any of the advantages some teams would get before the game of soccer had begun.

2.5 UCT Undergraduate Research

Two undergraduate projects were assigned to the SSL program in 2010. These projects were run concurrently with this MSc project. The two undergraduate projects were; creating a 4 omni wheel locomotive platform with integrated systems and designing and constructing a ball control module.

2.5.1 Locomotive platform

From the TDPs, the majority of teams preferred the Maxon LC45 30W brushless motors. After a preliminary study conducted prior to the project it was determined that the 50W equivalent was insignificantly larger with a negligible price increase. Maxon 50W motors were purchased with internal speed control in order to simplify motor control.

Mr G Sechu built UCT's first 4 omni-wheeled locomotive platform shown in Figure 2.27[53]. He opted for a spur gear arrangement with an idler as a gearing match could not be found without the idler.

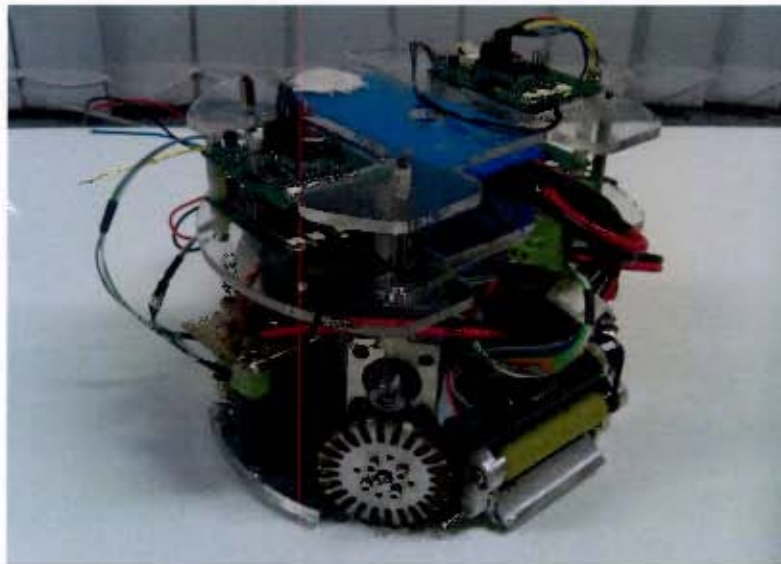

Figure 2.27: UCT's first 4 Omni-wheeled Prototype

The wheel assembly was made up by an omni-wheel, EC45 50W Maxon motor, and three gears located by the holding bracket which can be seen in Figure 2.28. The additional gearing created additional vibration, complexity and noise. After the completion of the prototype, the space under the motors in the wheel assemblies could not be used and was wasted. The height of the motors also increased the centre of gravity (CG). An alternative spur gear arrangement was investigated without an idler gear.



Figure 2.28: First version of the four omni-wheel motor assembly

2.5.2 Ball Control Module

Mr David Lwabona was responsible for designing and implementing the mechanical systems necessary for ball manipulation for SSL. The three core subsections were: a kicker, a dribbler and a chipper [54].

He successfully integrated the 3 modules into the space constraints defined for him shown in Figure 2.29. Each of the core elements was tested and only the chipper module didn't meet the desired expectations.

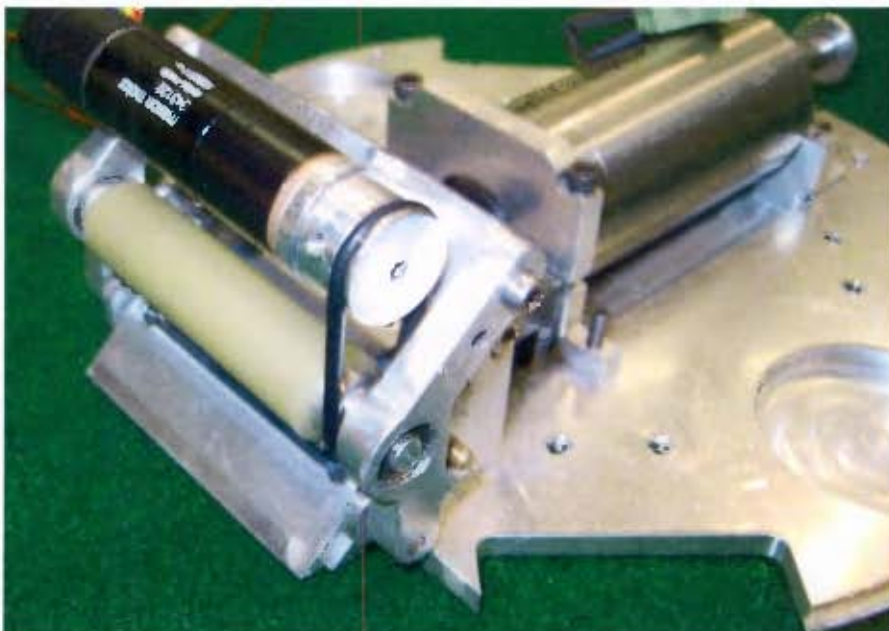

Figure 2.29: Ball Control Module created by Mr David Lwabona in 2010[54]

2.6 Concluding Remarks

In SSL the game is dynamic and high paced, many modules are combined to create a successful robot. Condensing the list of modules to four separate systems; Locomotion, Ball Control Systems, Control and Communications and Power Systems is beneficial for a modular approach.

If these systems were not stable at high speeds, it would be beaten by a more effective team. This placed requirements for high power on the robot so it could respond to commands quickly and high data transfer speed with a low latency. A 3 wheel design would offer more space on the robot, but the 4 wheel designs have greater agility and make the 3 wheel design obsolete.

The 45° omni-wheel offers more stability than the 90° counterpart. Because space is vitally important, the 45° wheel will not fit on the robot and as such, all teams in SSL only use 90° omni-wheels.

The teams that have been competing for several years and maintain a high rank typically use a single integrated circuit board which has gone through many revisions and contains many debugging capabilities. It would be foolish to believe this could be undertaken in a single iteration of these circuit boards. This is the first time UCT has attempted to make a full SSL team and a modular approach would be better for the team as well as a generic board to assist in low level control on supporting projects.

Although most teams used a single lower voltage battery, we will attempt a larger voltage battery in order to reduce the currents in the wires for power purposes and thus keep consistent power throughout. This should also improve kick charging times. A higher voltage motor will have more torque and should have a lower output speed and require less gearing. With these considerations, it seemed that deviating from the norm of the other teams would be beneficial.

3. Specifications

From the Background Research in Chapter 2, it is possible to describe the requirements necessary for a successful and competitive robot as an overview. The information in Table 3.1 provides functional objectives that can be used to determine successful integration.

Table 3.1 : Table of Specifications

No.	Demand (D) / Aim(A)	Requirement	Measurable Outcome	Final Outcome
Manoeuvrability				
1	D	Create a 4 Omni-wheel Platform	Yes/No	Yes
2	D	Full Omni-directional manoeuvrability	Yes/No	Yes
3	D	Higher acceleration and velocity than previous JCT prototypes	Yes/No Accel: $1.8m/s^2$ Vel: $0.64 m/s$	Yes, Accel: $6 m/s^2$ Vel: $3 m/s$
3	A	Acceleration and Velocity similar to high tier teams in competition internationally	Yes/No Accel: $5 m/s^2$ Vel: $3.5 m/s$	Yes, Accel: $6 m/s^2$ Vel: $3 m/s$
Power Specifications				
4	D	Capable of playing without battery replacement. Playing aggressively with frequent kicking	Half a game (15min) Full game (30 min)	Full game
Wireless Communication				
5	A	High level commands sent for omni directional speed control	Yes/No	Yes
Ball Control Systems				
Dribbler				
6	D	Dribbler captures and controls golf ball with movement	Yes/No	Yes
Kicker				
7	A	Kicker capable of kicking greater than $10m/s$	$10m/s$	$9.02m/s$
7	D	Kick multiple times in short succession	Yes/No	Yes, 2 seconds
Chipper				
8	A	Successfully chip with a height greater than $150mm$	$150mm$ Vertically	Approximately $50mm$
Controller Boards				
9	D	Modular Circuit Board Design	Yes/No	Yes
10	D	High Level Speed control communication	Yes/No	Yes
Rules				
11	D	Wheels cause no harm to playing surface	Yes/No	Yes
12	D	Robots fit within space constraints	$180mm$ diameter $150mm$ height	Yes
13	D	During play robots kick slower than $10m/s$	Yes/No	Yes
Time				
14	D	Operational Team before December 2011	Yes/No	Yes

Each specification labelled above is justified in greater detail.

3.1 4 omni-wheel platform:

A 3 wheel design had been implemented already and does not have the desired speed and traction believed to be required for SSL competitively. A 4 wheel design was the requirement to improve traction and movement.

3.2 Full omni-directional movement:

The robot needed to be capable of moving in every direction with similar velocities. If the robot were to behave in an omni directional manner, it would simplify higher level controlling algorithms when the robot is required to move perpendicular to the current direction of travel.

3.3 Competitive acceleration and velocity:

The intention was to compete internationally and to be considered competitive. This implies the opposition do not have significant differences in velocity and acceleration to UCT's design.

3.4 Battery requirements:

The battery was required to power the robot a minimum of half the game to allow for a replacement at half time. It would be ideal if it did not need replacement during the half time.

3.5 High level commands sent to the robot:

A high level command sent to a robot can be achieved faster than low level command. When high level commands are sent, it would reduce load on the host machine. The reduction in load yields a higher overall refresh rate of commands from the host machine and an overall higher response time.

3.6 Ball Control System:

Successful dribbler modules control the ball long enough for it to be kicked or moved with the controlling robot. Without a working ball control module, the ball would bounce off the robot and could not be controlled. This component was essential for a successful team.

3.7 Kicking:

SSI 2010 rules dictate the ball may not be kicked at a velocity greater than 10m/s. Some teams in the competition were capable of kicking at the speed limit. If UCT could achieve similar speeds the project has a better chance at being competitive.

3.8 Chipping:

Some teams had the ability to lift the ball off the playing field and over robots. This allowed the game to be played in a non-planar fashion which made game tactic algorithms more complicated.

and sophisticated. UCT robots having a similar chipping module would be beneficial in maintaining competition.

3.9 Modular Design:

Controller boards are the most expensive electrical components. Multiple generic boards are more cost effective to manufacture in the event of a board failure. Each board could be simply replaced in the event of a single failure. A modular design reduces debugging time, because the problematic component/board can be located faster.

3.10 High Level Speed Control:

If low level control was implemented, more data would need to be transferred from host machine to individual robots resulting in longer communication times. Communication times are the greatest factor in reducing the response time of individual robots. When a shorter message is sent at the same speed, each robot can respond faster.

3.11 Wheels do not affect playing surface

The rules state that a robot may not compete if there is any damage to the playing surface or other robots.

3.12 Size Requirements

The maximum size requirements are absolute, and breaking this rule would result in exclusion for that particular robot.

3.13 Maximum Allowable kick speed

A kick of greater than 10m/s is not allowed in accordance with the rules and UCT cannot play competitively.

3.14 Operational Team before December 2011

A National SSL competition was organised for early December 2011 between four Universities. UCT was required to have an operational team for this competition.

4. Conceptual Design

Typically the conceptual design determines the overall shape and underlying structure of the topic in the design, however with the strict size requirements already placed on the robot by the rules, and the motors selected based with concurrent projects, concepts were based on positioning of modules and different gearing structures. Once the allocated space for each module had been established, different motor gearing and placement configurations were considered to adhere to size restrictions.

4.1 Module Placement

An SSL robot had well defined modules essential for successful operation. These key modules were Locomotion, Ball Control Systems, Control and Communications and Power Systems. The ball control system was used from Mr Lwabona's final year project. Figure 4.1 shows the concept of a base plate and the space required for the ball control module.

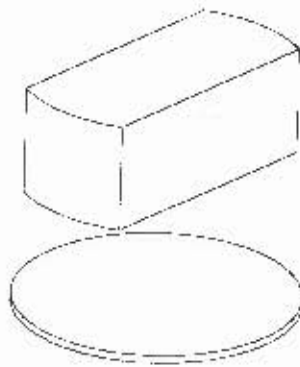

Figure 4.1: Concept placement for base and ball control module

The available space on the sides of the ball control module needed to house the motor assembly. Figure 4.2 shows the proposed location for the locomotion assembly for the robot.

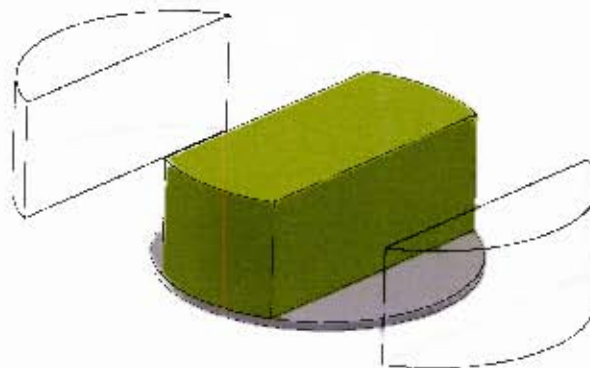

Figure 4.2: Concept placement for the locomotion assembly

The battery was the next concern once the larger and heavier components had been located on the robot. The optimal location for the battery would be as low to the ground as possible because the

battery mass is significant to the overall centre of gravity (CG). Additional factors that were considered were placing the battery in a location for ease of replacement while also keeping the CG at the centre of the robot. The final concept shown in Figure 4.3 had the battery located at the front of the robot above the ball control module.

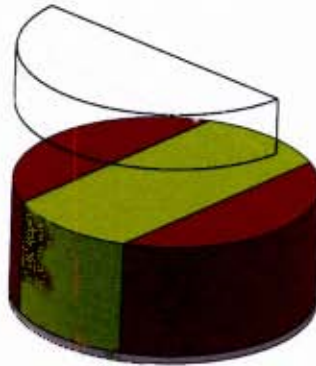

Figure 4.3: Concept placement for the battery

The kicker electronics were the components and electronics that are associated with the high voltage required for kicking excluding the solenoid. This module had the electrical potential energy to be very dangerous. The desire was to place it close to the solenoid to minimize high current wiring and keep the module discrete for removal when not being utilised on the robot. The proposed placement for the kicker module was at the rear as shown in Figure 4.4.

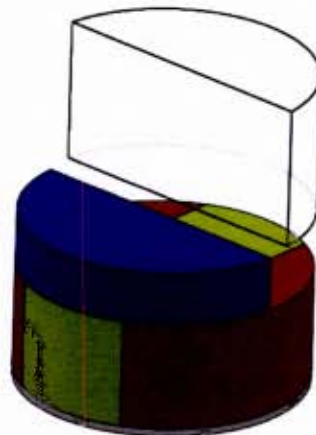

Figure 4.4: Concept placement for the kicker electronics

The final module for the robot was its control and communication module. The remaining space available was above the battery module as seen in Figure 4.5. It was beneficial to place the controlling electronics higher up in the robot because it had a low density and little significance on the CG. Additional benefits were ease of replacement and debugging during testing.

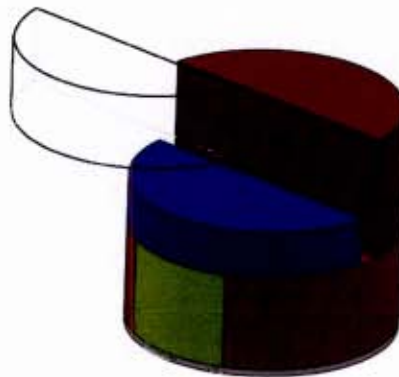

Figure 4.5: Concept placement for the control electronics

After the placement for all components was finalised, the design process began achieving the desired constraints shown in Figure 4.6.

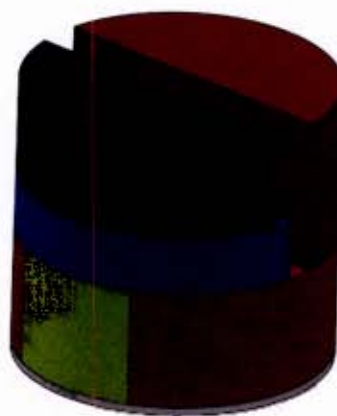

Figure 4.6: Final concept layout for the robot

4.2 Gearing

The locomotive module constraints had been established in terms of the robot alternative gearing solutions became necessary, as the original solution from Mr Sechu would not meet the criteria. Different gearing methods would have to be investigated.

4.2.1 Bevel Gearing

A bevel gear arrangement on the motor modules would allow the motors to be placed orthogonal to the wheel shaft. The initial concepts were to place the motor directly above each wheel and create a symmetrical drive assembly.

4.2.1.1 Vertical Bevel Gears

In a similar manner to having the wheels smaller, if the motors were placed above the wheels, large motor diameter forced longer shafts on the omni-wheel side of the bevel gear arrangements which partially removed the space from the centre of the robot. Additionally with the motors placed vertically, the height of the centre of gravity (CG) of the entire robot would increase as the motors are placed higher which in turn would reduce the maximum acceleration before toppling. Additionally the space created by raising the motors could not be adequately utilised with any of the larger components. The inability to optimise the additional space created by raising the motors, and the reduction in potential acceleration, the vertical bevel gears were discarded.

4.2.1.2 Angled Bevel Gears

As the vertical bevel arrangement forced the motors higher, if the design were to be complicated, and the motors were set at an angle the CG would be lowered and the space that couldn't be used potentially could be filled. The machining process for angled motor brackets would require time on the CNC mill which was a bottleneck within the UCT workshop and the design would have a longer lead time. If the motors were angled to the rear or front, this would offset the CG which would load different wheels with different weights and increase the risk of a single wheel wheel-spinning.

4.2.2 Internal Spur Gearing

An internal gear on the drive assembly would increase the density of the overall drive unit. SKUBA implements an internal gear arrangement on their omni-wheel which can be seen in Figure 4.7.

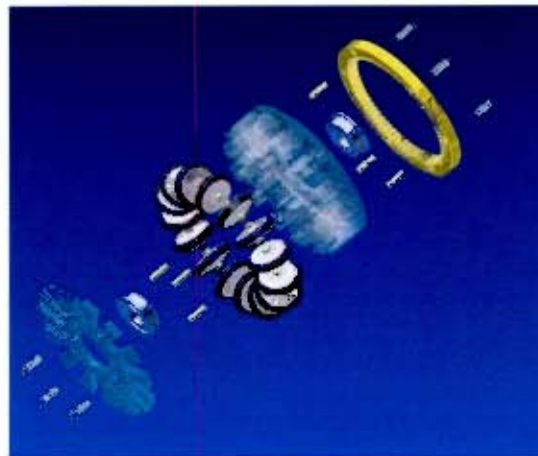

Figure 4.7: SKUBA wheel configuration in 2009[51]

The internal gear arrangement appeared promising; however internal gears with acceptable modules and size could not be affordably sourced which removed it as a possible concept.

4.2.3 External Spur Gearing

As Mr Sechu had already created an external spur gear arrangement with an idler, an alternative spur gear arrangement was investigated without the idler gear.

The original design parameter was to source external gears with a ratio of approximately 2 and a module of 1. No solution for a symmetrical module could be found and thus a hybrid design was investigated, and a workable solution was found for a gear ratio of 2 and a module of 0.8 without an idler. The hybrid external gear configuration provided a greater density in design and became the solution for the design framework.

4.3 Summary

This chapter defined the problem of space constraints within SSL and created a systematic approach to create modules on the robot that would fulfil the specifications. These modules could individually conform to space requirements and make the approach more structured. Once it was determined that each module had the potential to fit within the constraints, a more detailed mechanical approach to each module was necessary. Different gear arrangements were briefly investigated to determine the best approach for design.

Chapter 5 covers the mechanics associated with each module discussed within the conceptual design and brings a solid structure to a SSL robot.

5. Mechanical Design

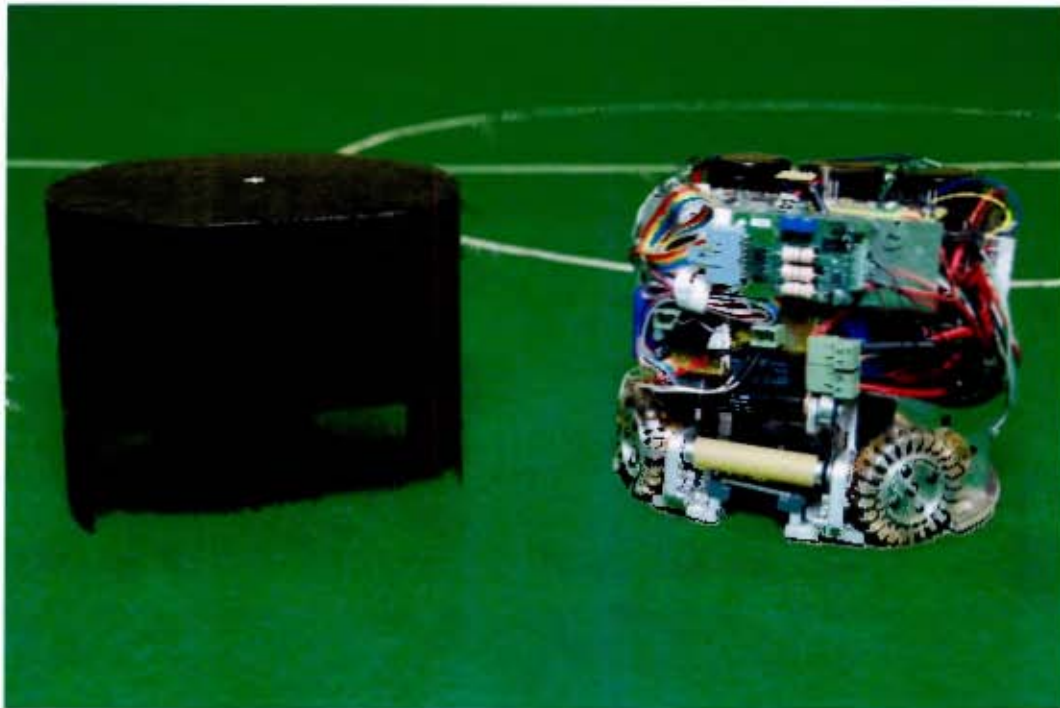

Figure 5.1: SSL Robot and Cover

In SSL, the space requirements to which the robot must conform created difficulty which filtered down to each component and module. Figure 5.1 is a fully assembled SSL robot with the cover placed on the left of it. The clearance between the cover and the maximum permissible size is less than 1mm. Figure 5.2 is a covered SSL robot ready for operation.

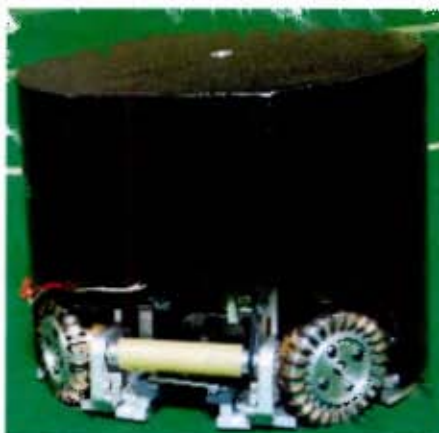

Figure 5.2: Covered SSL Robot

The robot design was focussed on complete modularity such that any piece could be removed and replaced within the interval of 10 minute between halves. Figure 5.3 is an exploded view of the modules created which make up a SSL Robot.

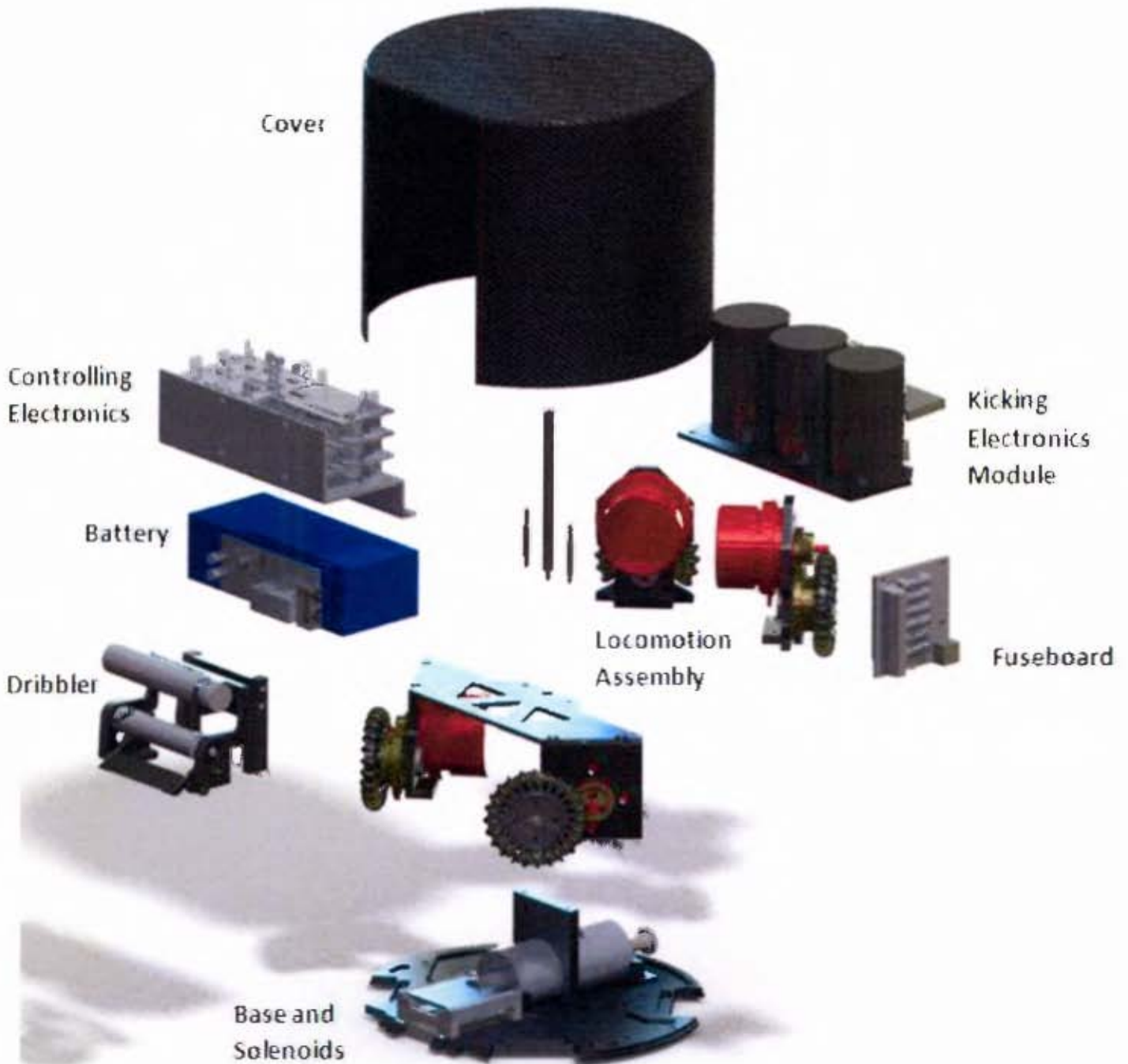

Figure 5.3: SSL Final Design (Exploded View)

Each of these discrete systems is broken down in more designed detail in the following pages.

5.1 Base and Solenoids

The base is the backbone of the robot and was the essential foundation for all the other modules. Size constraints prevented the solenoids from being discrete modules that screwed onto the base. The individual pieces were slotted into cutaway grooves on the base. These components are the most difficult to remove if necessary. Figure 5.4 shows the components that make up the complete structure of this section.



Figure 5.4: Base and Solenoids (Exploded View)

5.1.1 Kicking Solenoid

The solenoid design was used from a previous final year project presented by David Iwabona [54]. Figure 5.5 shows the final kicking solenoid exposed without wire. Modifications to the kicking strength resulted in the solenoid self destructing in “dry” fires due to the increase in force when using the original model created by Mr Iwabona.



Figure 5.5: Main kicking solenoid without wire (Exploded View)

The original design incorporated a thread on the kicker piece screwing into the core. As the thread was created from the softer shaft material, the thread was not capable of supporting the tensile forces during the arresting of the bar. Figure 5.6 shows three tests created to determine which section of the pieces needed to be modified. The first test with the simple bolt prompted that a new design was necessary.

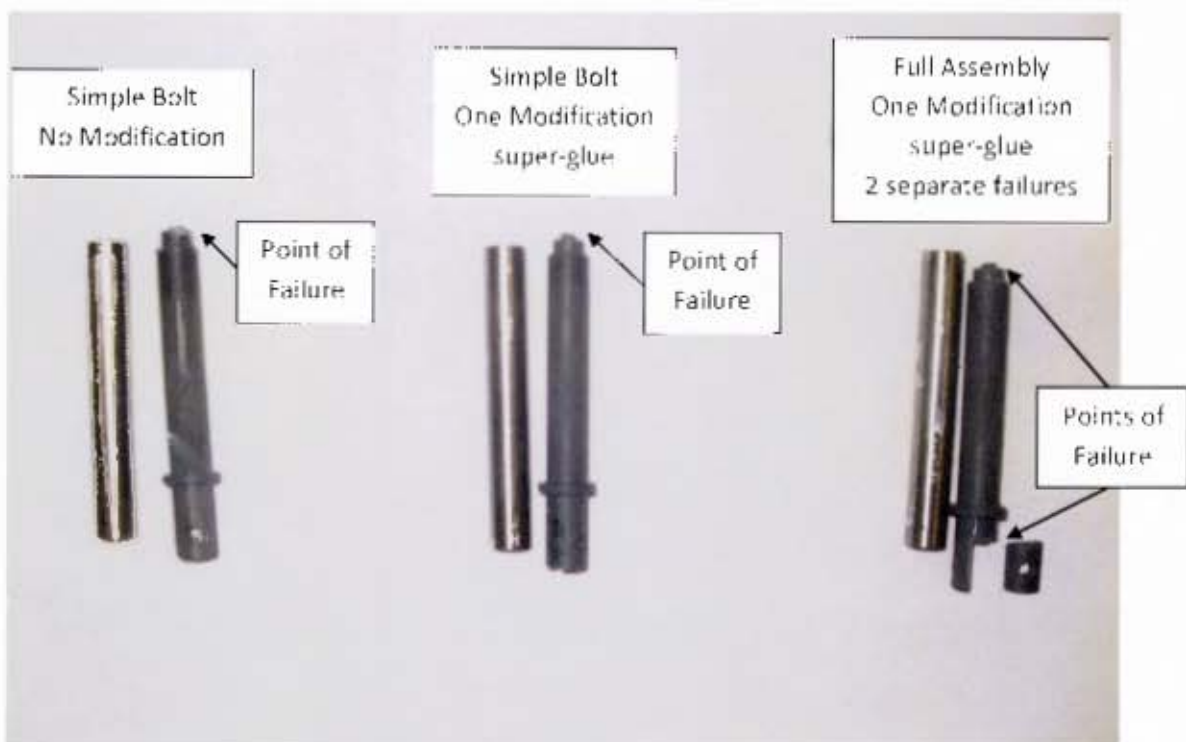

Figure 5.6: Solenoid bolt breakages

The second test was aimed at determining the additional strength required. Superglue was placed in the thread and contact surfaces which had no effect on the durability of the kicking pieces. This may have been because superglue is brittle and cannot sustain shock loads. The third of significance was aimed at determining whether any other portion of the shaft needed modification. It became evident that the shaft diameter cannot be reduced close to the kicking paddle as the momentum of

the aluminium paddle placed additional stress on the shaft pieces which would wear after several kick cycles.

The design was modified to incorporate an M4 threaded bolt between the shaft and core pieces where the pieces were separating. This stud provided a more secure connection between the 2 pieces. Additionally the shaft piece diameter was not reduced when reaching the kicker paddle to increase the cross sectional area, as well as the cut out in the shaft piece was rounded to reduce stress loading which can be seen in Figure 5.5 on the previous page.

Different gauge wire was wrapped around the core to determine an optimal wire gauge. This is discussed in the Testing Section. A fully wired core is shown in Figure 5.7.

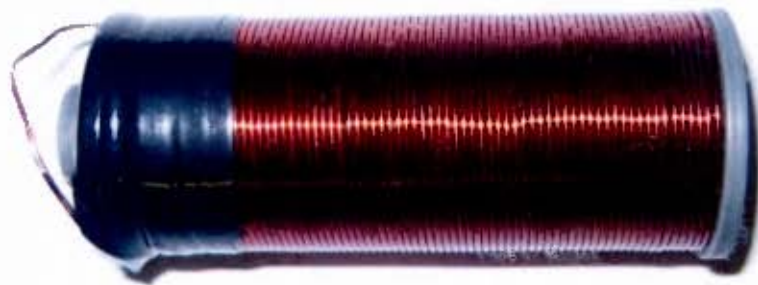

Figure 5.7: Coiled solenoid used in the kicker

The final module before being placed onto the base is shown in Figure 5.8. The solenoid bolt resets from the rear spring. The optimal length of magnetic portion of the solenoid bolt was calculated by Mr Lwabona in his final year project. The ratios between the inner core and shaft lengths were changed to compare theoretical and practical results, with negligible differences in final kicking speed.



Figure 5.8: Kicking Solenoid off the base

5.1.2 Chipper

The chipper solenoid design was used from a previous undergraduate project presented by David Lwabona [54]. A flat solenoid was implemented for chip kicking. Wire was coiled around the chip body items and inserted into the base. Figure 5.9 shows the 4 components that make up the chipper solenoid.

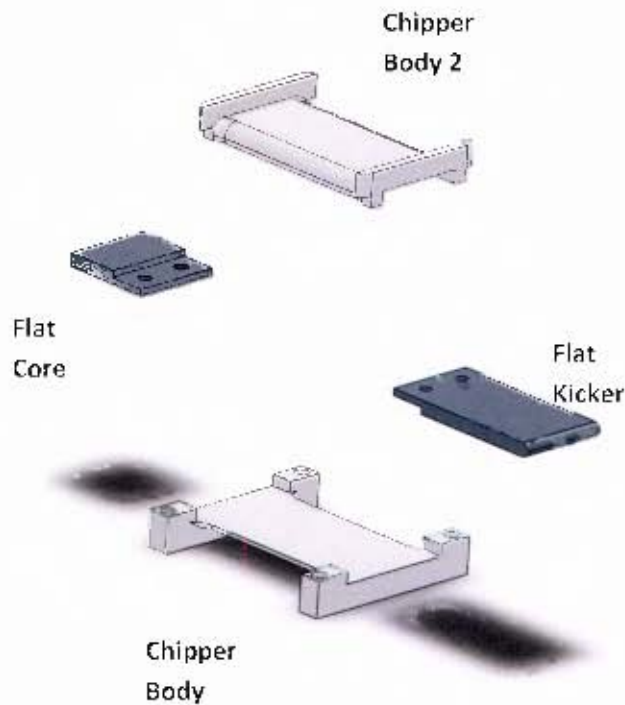

Figure 5.9: Chipper solenoid (Exploded View)

5.2 Dribbler

The dribbler section was designed in 2011 by David Lwabona shortly after handing in his final year project. The assembled components in Figure 5.10 are hinged to the base to absorb impact from any ball. This section would be connected to the holding brackets which are sprung forward to provide resistance to slow incoming balls.



Figure 5.10: Swinging Dribbler components

Figure 5.11 indicates the pieces required for this module to correctly function.

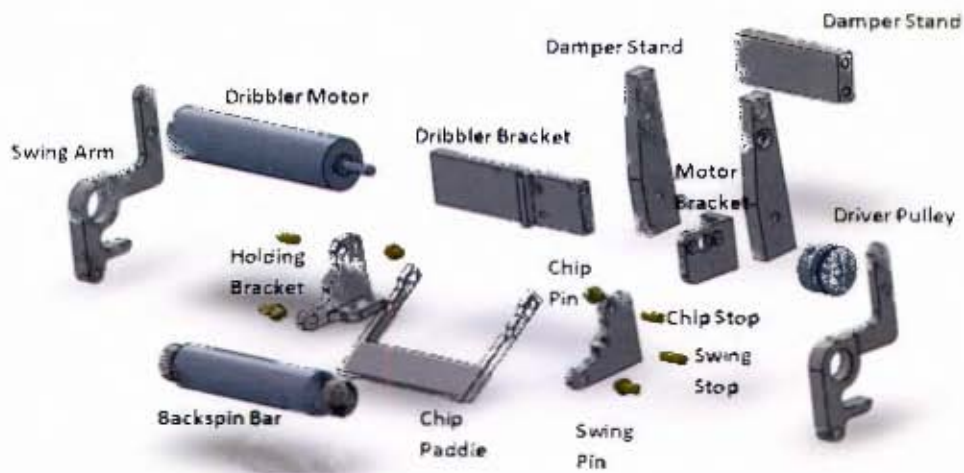

Figure 5.11: Dribbler module (Exploded View)

The initial assembly for an operational dribbler requires: the motor, driver pulley, drive belt, brackets, swing arms, backspin bar and bearings which can be seen in Figure 5.12.



Figure 5.12: Basic Dribbler Assembly

The front view of the robot without chipper can be seen in Figure 5.13 below.

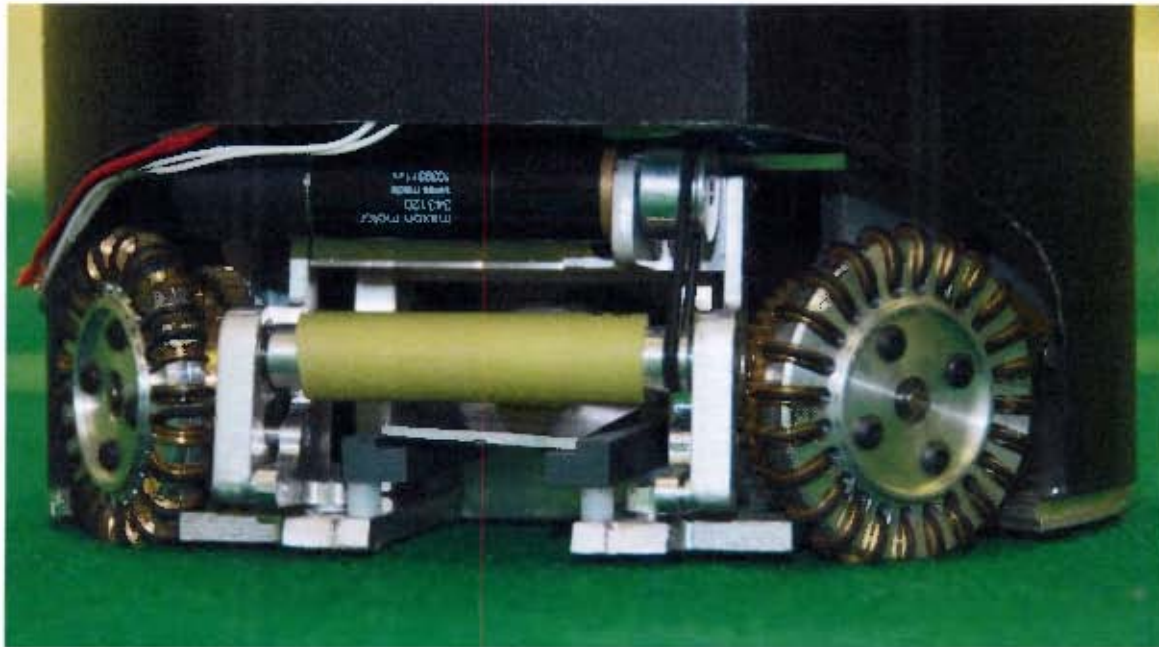

Figure 5.13: SSL Robot Front Close up view of Dribbler Assembly

5.3 Locomotion Assembly

The final design incorporated a spur gear design over the bevel gear design because of the reasons listed in Table 5.1.

Table 5.1: Different Gearing Comparison

Spur Gear	Bevel Gear
Lower Centre of Gravity	Higher Centre of Gravity
Cheaper	More Expensive
More compact	Less compact

The new design was improved by removing the idler gear and modifying the gear ratio. This modification optimised space by creating different motor brackets for the front and back. The final locomotion assembly secured to the base can be seen in Figure 5.14.

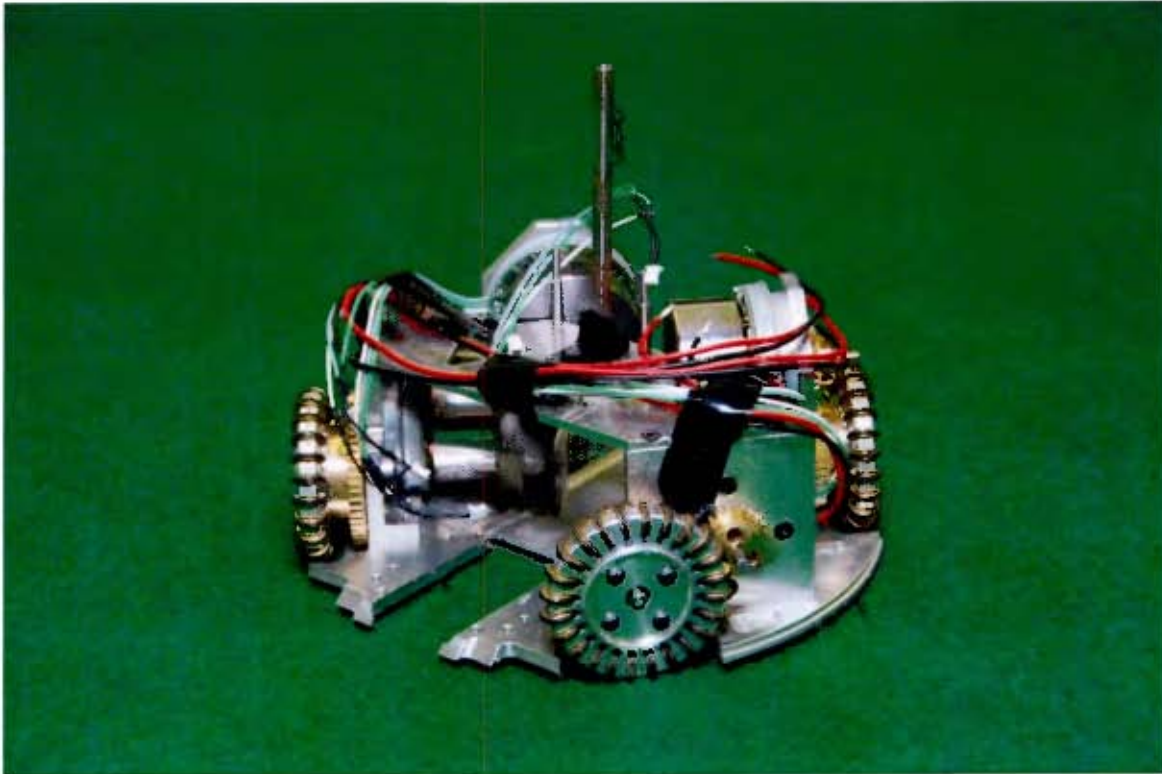

Figure 5.14 Locomotion Test Assembly

5.3.1 Omni-wheel Assembly

The reason for an SSL Robot's agility was due to the use of omni-wheels. An omni-wheel is a wheel that provides grip for locomotion in one direction, while allowing for slip in a different direction to allow for full planar and rotational motion.

The exploded assembly of an omni-wheel can be seen in Figure 5.15. Each piece is clearly visible excluding the four M3 x 12mm CH screws which secure the whole omni-wheel assembly. The components required to make an omni-wheel were 2x 494 ball bearings, 1x 0.8M 50T spur gear, 2x half wheels, 24x mini wheel with O rings.



Figure 5.15: Omni-wheel [Exploded View]

The half wheels were created symmetrically to reduce component variation which reduced machining time, and allowed less spare components to be needed. The CNC mill was essential for milling the mini wheel shaft holes visible in Figure 5.16.



Figure 5.16 Half Wheel Component (CAD)

The mini wheels were machined out of brass because it provided less friction between the aluminium half wheels. An additional benefit of using brass is that it would be easier to machine to tolerance rather than plastic.

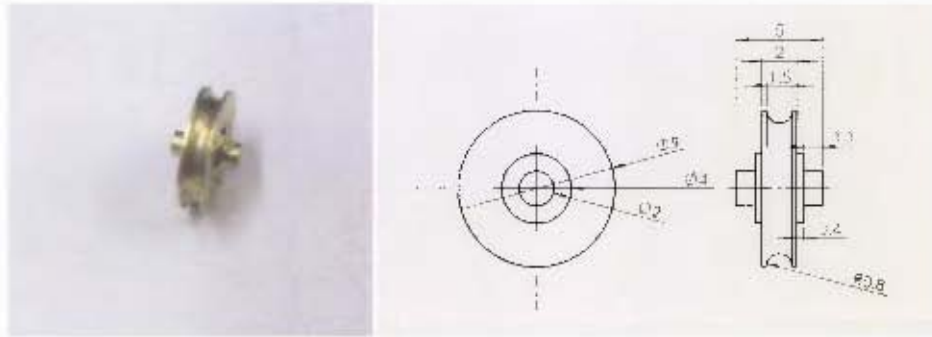

Figure 5.17 Brass mini-wheel without an O-Ring (Left) Drawing showing sizes in mm (Right)

O Rings were added onto each mini-wheel to provide better traction on the playing surface. The omni-wheels required the tightest tolerances throughout the robot because any error in the shaft slots for the half wheels would result in greater play or no play for rotation of the mini-wheels. Figure 5.18 shows the components to create the omni-wheel assembly.



Figure 5.18: Omni-wheel assembly

The gears were specifically selected from a KHK catalogue and modified to reduce the weight, locate a bearing and act as the nut for M3 x 12mm cheese head bolts. The final assembled omni-wheel can be seen in Figure 5.19 below.



Figure 5.19: Assembled omni-wheel

The omni-wheels were secured onto separate steel shafts as a precaution to protect the motors in the event of inevitable impacts the wheels would receive from balls or possible robot impact. Figure 5.20 is a cross section of the wheel fitting onto a fixed shaft on the front assembly. The size of the new external gear required a slot to be cut into the base. The slot for the gear was not cut through in an attempt to minimize the fibres from the field getting caught in the rotating sections of the robot.

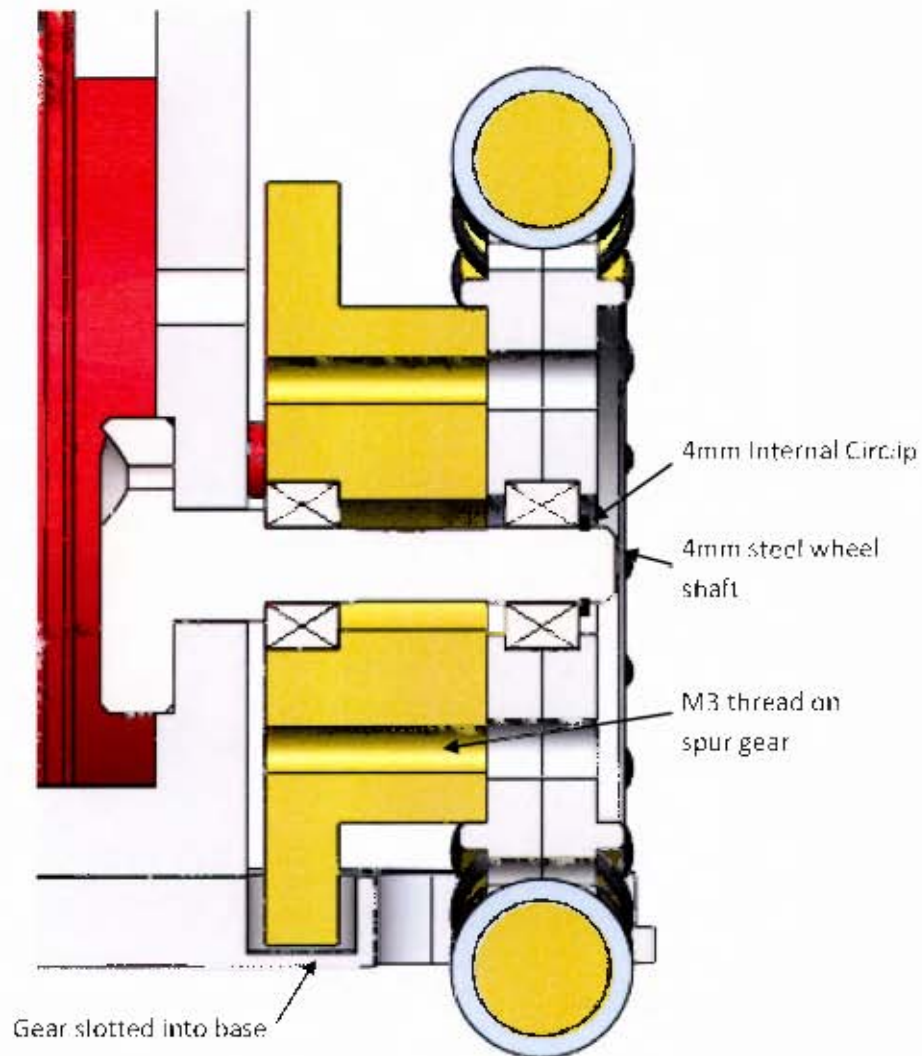

Figure 5.20: Omni-wheel placement (Cross Section)

5.3.2 Front Assembly

The front bracket shown in Figure 5.21 the motor is placed on the gear centre distance adjacent to the wheel. The Front wheel assembly was mirrored on each side with a bracket used to connect the front wheel assemblies and stiffen the chassis. This bracket was the flooring for the battery which is easily slotted. The battery was secured with an elastic band for quick replacement.

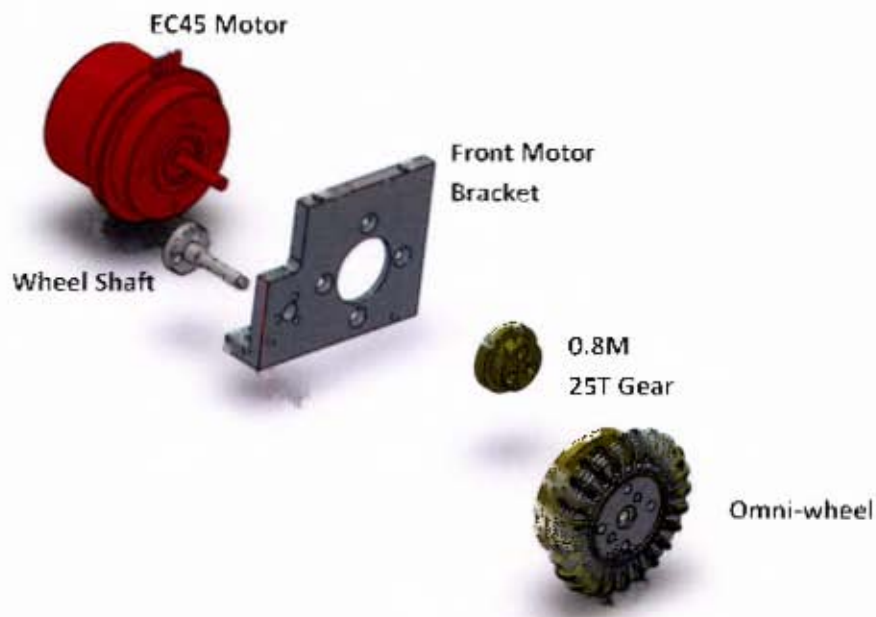

Figure 5.21: Front Motor Mount (Exploded View)

The front drive unit motors were lowered by machining away from the front of the robot as much as possible. Cut outs were made to the base in order to accommodate for the new motor locations. The motor (red) in Figure 5.22 can be seen intersecting with the base structure, and thus a weight saving cut out was placed at the same location.

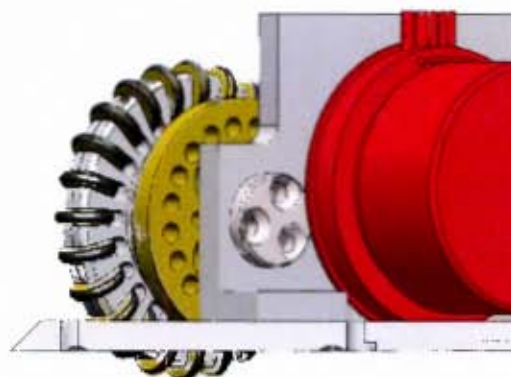

Figure 5.22: Front Motor Drive Unit (Cross Section)

The additional space in the front was needed for the ball control module. Figure 5.23 is an overhead view of the space created by offsetting the front motors. This horizontal angle of gear centre distance could not be done on the rear motors as the space required overlaps with the front motors. The motors for the rear needed to be located in a different manner to the front motors and a hybrid design was created.

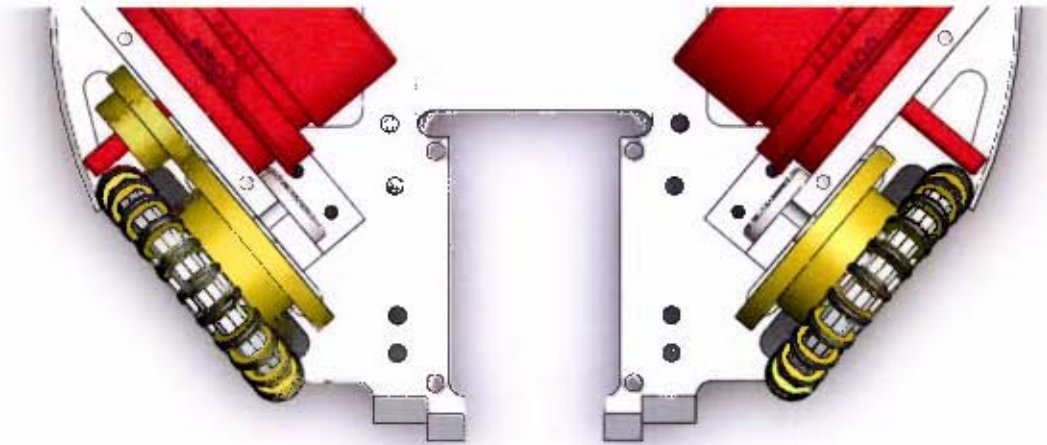

Figure 5.23: Front Motor Assembly (Top View) allowing space for the Ball Control Module

5.3.3 Rear Assembly

As stated earlier, the rear motors could not be placed at the same gear centre distance as the front motor without clashing. The solution was to have the motor sit vertically above the gear pair. The rear motor modules can be seen in Figure 5.24 and Figure 5.25. The raised height of the motors at the back created additional space for the kicking solenoid.

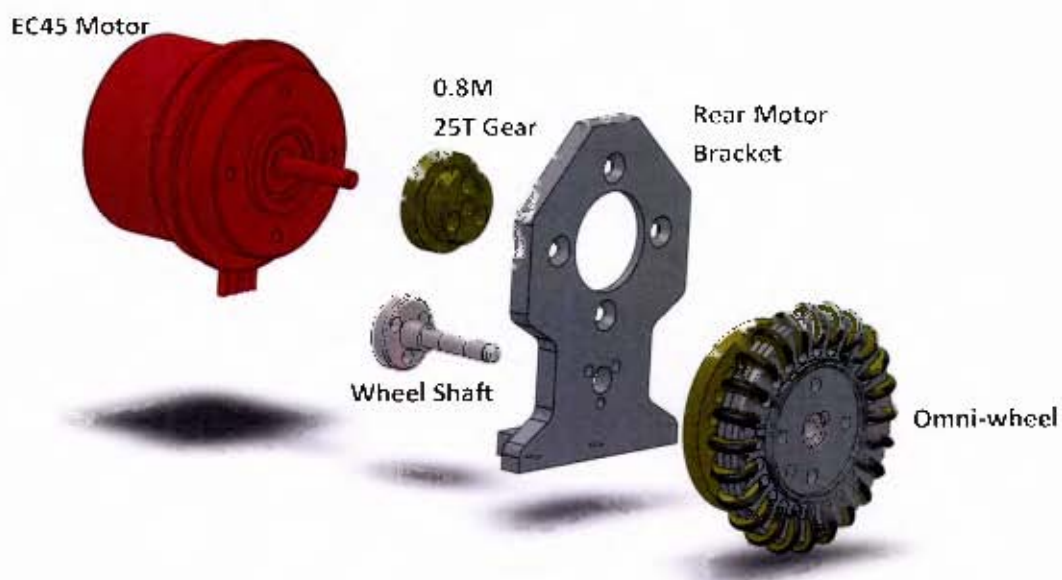

Figure 5.24: Rear motor mount from front (Exploded View)

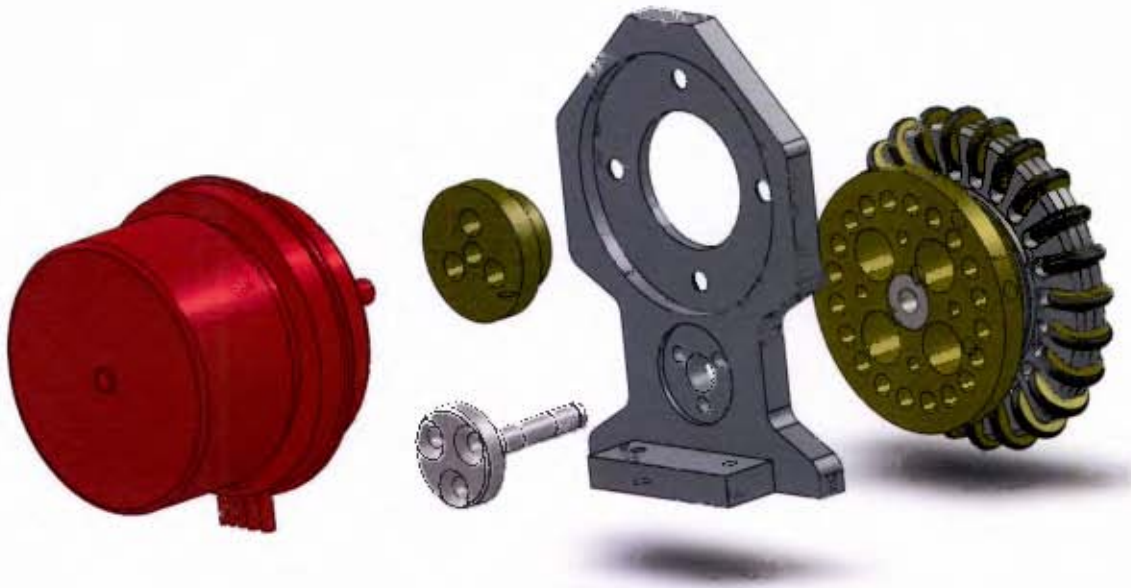

Figure 5.25: Rear motor mount from rear (Exploded View)

The motor brackets allow for front and rear wheel modules to be assembled before mounting to the base. An assembly of the rear motor mount can be seen in Figure 5.26 without an omni-wheel.

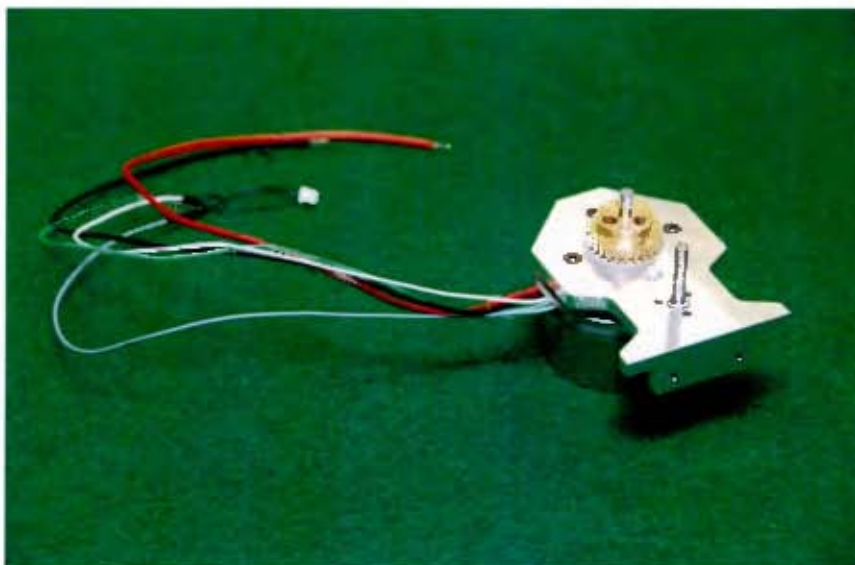

Figure 5.26: Rear motor bracket

The motors and wheel shafts fit into the motor brackets and are secured with M3 x 8mm C/S screws. Figure 5.27 shows the cut outs in each of the brackets for the motors and the wheel shafts. If the brackets did not incorporate the cut outs, the motors would have internal conflicts with the kicking solenoid.

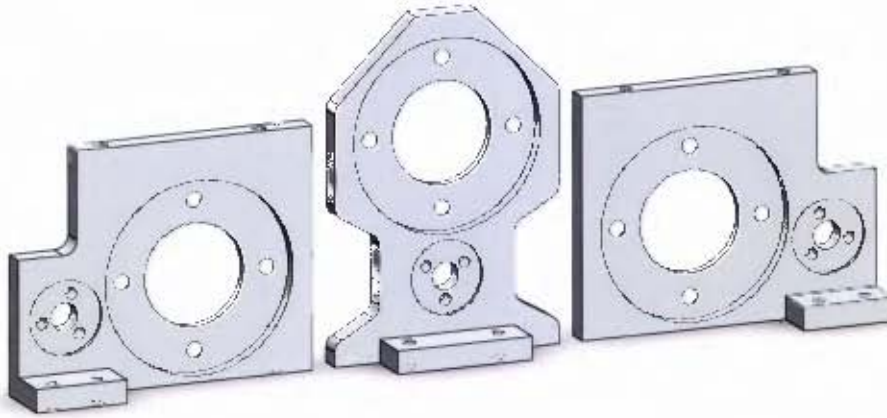

Figure 5.27: Solidworks Render of the motor brackets (Rear View)

A front and rear motor bracket are shown in Figure 5.28 below. The motor and shaft cut outs were used to locate the motor and shaft respectively.



Figure 5.28: Front and rear motor bracket with wheel shaft

5.4 Mounting of Controlling Electronics

The control for the robot was governed by a cluster of five Freescale HCS08GMC95D8GT16A microcontrollers shown in Figure 5.29. Each microcontroller operates on an individual Motor Control Board (MCB) which is discussed in Chapter 6.

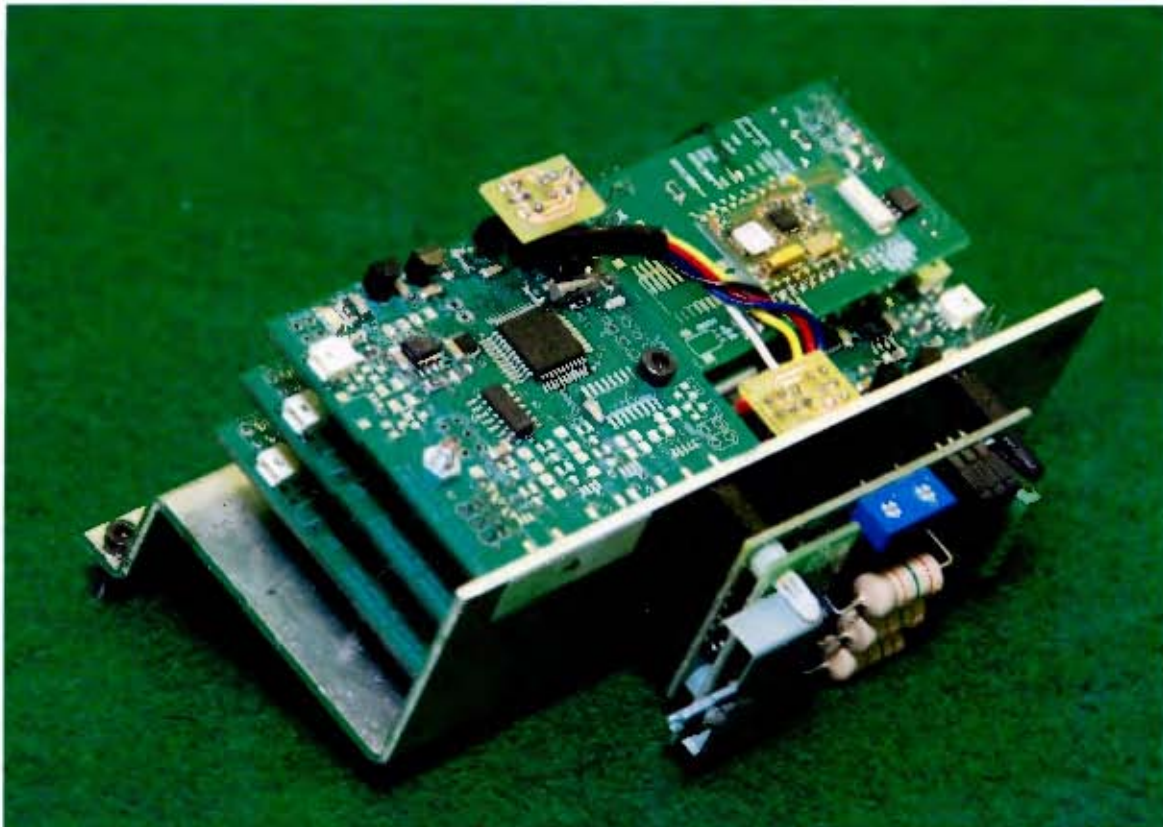

Figure 5.29: Controlling Electronics Module

The controlling electronics fit completely onto the front cover. This created the possibility for any/all of the boards to be easily replaced if necessary. The wiring required to operate the SSI robot was kept to a minimum to allow for easy connection and simple wiring. This was also achieved by a common bus connection on the MCB. Figure 5.30 shows the location of each motor specific board placed on the robot.

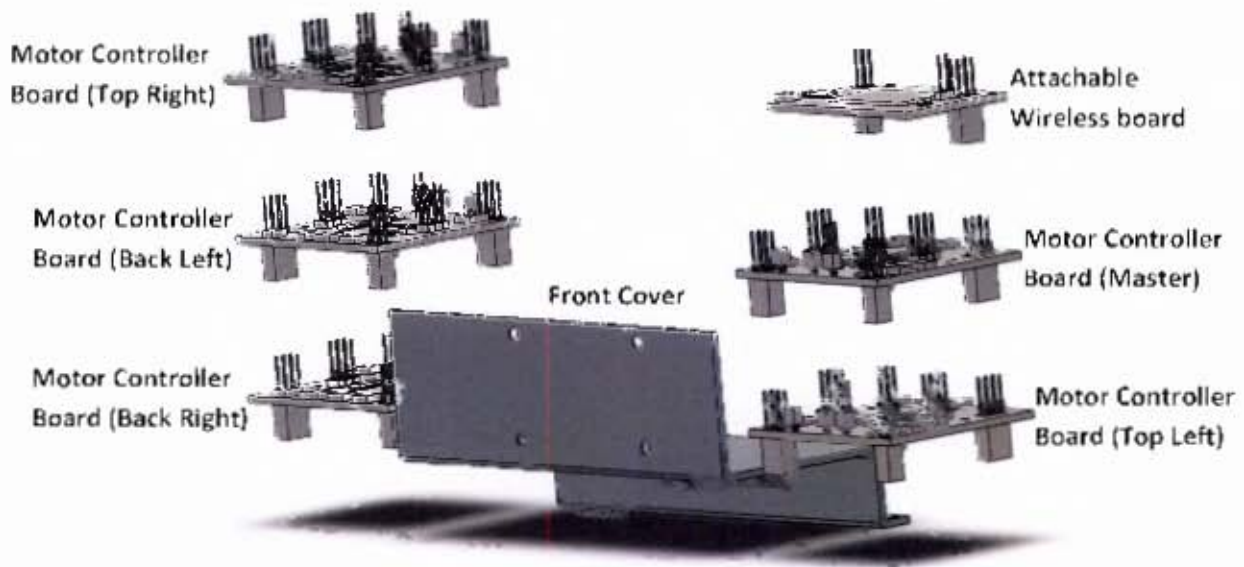

Figure 5.30: Controlling Electronics for a SSL Robot (Exploded View)

The Attachable wireless board is the communication link between the host PC and the Master MCB. Data was transmitted to the Master MCB through an UART protocol from the attachable wireless board which was designed to be placed on the top of the stack.

5.5 Mounting of Kicking Electronics Module

The kicking modules comprise of anything that produces or contains a high voltage other than the solenoids. This system shown in Figure 5.31 was required to be modular to reduce the danger associated with the robot. All efforts were made to ensure this module was kept safe from the rest of the robot.

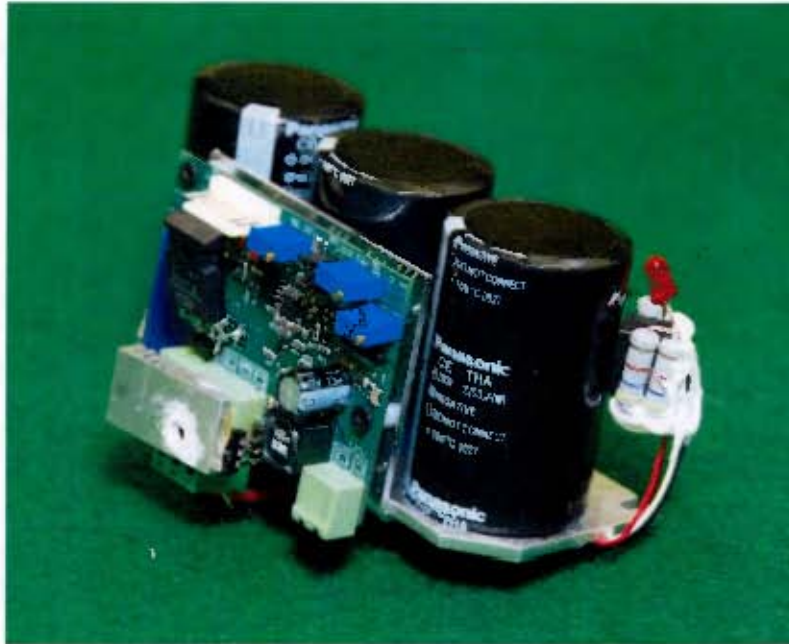

Figure 5.31: Kicking Module

The capacitors are physically too big to fit on the Kickerboard itself and were externally wired in parallel to the Kickerboard. Figure 5.32 shows the exploded layout of components and the mounting brackets. The Kicker Bracket allowed the Kickerboard PCB to be removed from the capacitor module if necessary.

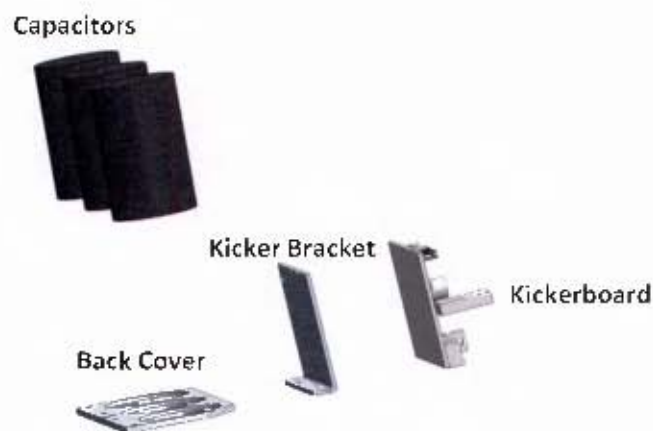

Figure 5.32: Capacitors and Kickerboard module (Exploded view)

The external wiring for the capacitors presented exposed high voltage wires. Silicon sealant was tested at 400V DC to determine whether it could perform as an insulator and shield the exposed wires. The sealant provided good insulation and was used for all high voltage exposed wires.

As high voltage could potentially be present after the board power has been removed, additional fixed components were added to ensure the capacitors would return to a safe known state. This was done with the relay and resistors shown in Figure 5.33 and explained further in Chapter 6.



Figure 5.33 Capacitor Discharge Module

5.6 Cover

The SSL cover was responsible for protection of all components within the robot. The cover was also used to conform to the shape requirements in the SSL rules. The final cover was formed with fibre glass using a female mould to ensure a quality finish on the outward facing side and painted black in accordance to the rules in SSL. Figure 5.34 is a completed cover on a SSL Robot on the field.



Figure 5.34: Completed SSL Cover

5.6.1 Mould Construction

A 4 piece mould was used to create the cover. This was needed to ensure the cover could be easily removed from the mould after construction. The mould was constructed out of Supawood, as it was cost effective and strong enough to hold shape after machining. The four parts of the mould are shown in Figure 5.35.

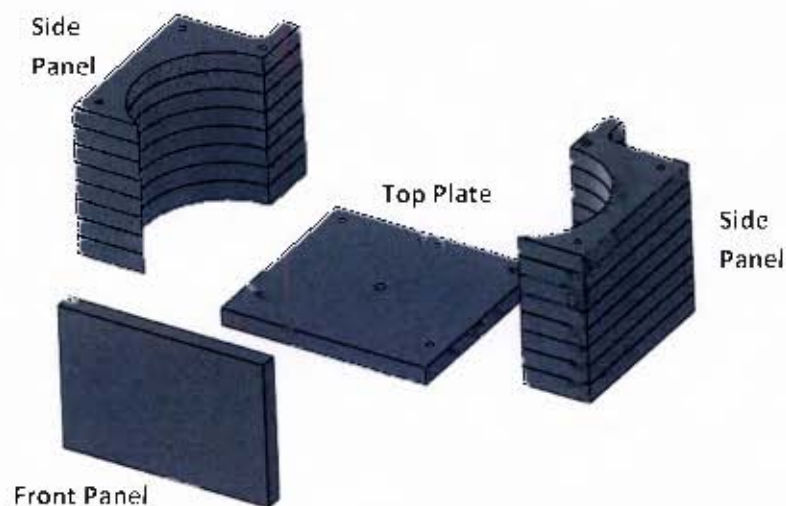

Figure 5.35: Mould Assembly (Exploded)

5.6.1.1 Construction of the side panels of the mould

The height of a completed side panel was 160mm comprising of 8 layers of 20mm Supawood. The Side Panels are constructed using a stack of identical pieces as no machining tool could plunge vertically deep enough to construct the combined piece.

The individual pieces were glued into pairs to reduce the number of parts and machining time. Three 6mm holes were drilled to locate the parts during moulding, construction and machining. The preparation of the Supawood before being cut out can be seen in Figure 5.36.



Figure 5.36: Mould side panels before machining

After the paired blocks were secured, they were milled using the CNC Milling machine (Figure 5.37)

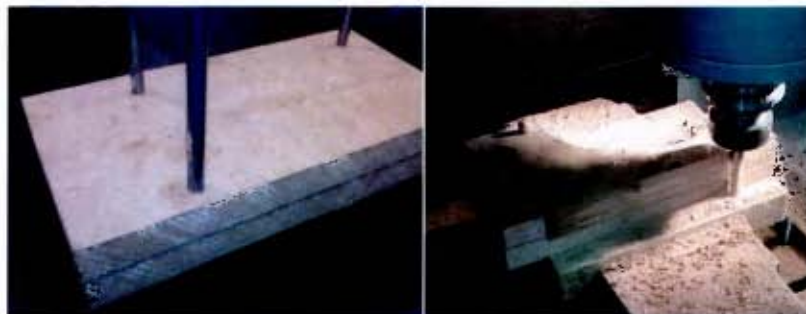

Figure 5.37: Mould side panel in the process of machining

After 4 pairs were machined, they were securely glued and secured using the location holes. A single side panel can be seen in Figure 5.38. Two side panels were created to produce the shape necessary for the cover.



Figure 5.38: Mould side panel

5.6.1.2 Top Plate of the mould

The Top plate is used to locate all other pieces on the mould. It has an additional circular boss to provide spacing for a washer for securing the cover onto the SSL Robot. Figure 5.39 shows the circular boss and the location holes for the side panels during the machining process.

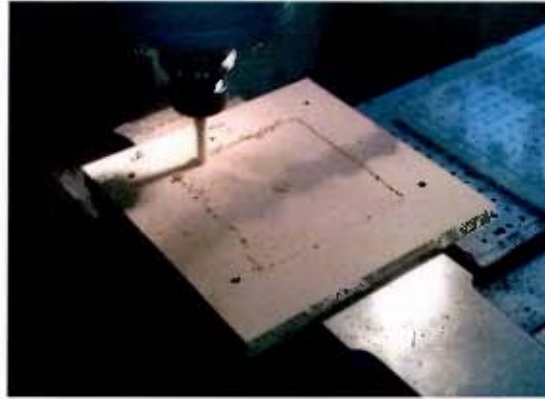

Figure 5.39: Mould top plate being machined

5.6.1.3 Front Panel of the mould

The front panel was a piece of square material high enough to be taller than the final part. During the moulding process, all pieces are screwed together to ensure a tight fit.

After the fibre has been moulded, the cover has not been cut to the correct height. The first cover part is shown in Figure 5.40.



Figure 5.40: SSL Cover made using the mould

The additional fibreglass was measured, and black tape was placed on the cutting seam. The tape was placed to reduce fraying from cutting.

Figure 5.41 shows the final black cover with the top securing indent visible. The final covers have the ability to take a full impact kick from UCT's solenoid kickers with no visible damage and still conform to the size and shape requirements in the rules.



Figure 5.41: Final SSL cover

5.7 Summary

This chapter has dealt with the design behind the mechanical systems that combine to produce a SSL robot. Structure was formed around the four modules discussed in earlier chapters.

The mechanical design can be summarised as follows. The design began from a well known problem and strict space constraints on every module. Once a subsystem was capable of fitting into the allocated space preliminary testing was conducted to determine whether a revision was required. After each system passed basic assessment, focus was placed on integrating all subsystems to create a full SSL robot.

6. Electrical Design

A Small Size League (SSL) robot required many electrical modules for it to function in competition. These individual modules could be designed into an integrated SSL robot board or could be built in a discrete manner for augmentation and individual testing. The more experienced teams develop complete integrated boards for their robots. Teams with minimal experience opt for a modular approach to reduce the cost of a single fault. Because this was the first time UCT built a complete system, the design of these modules were constructed in a discrete manner on Printed Circuit Boards (PCB). Some PCB contain multiple hundred components each and was described in terms of their functional modules rather than their components. Each green block in Figure 6.1 was a PCB on a SSL robot. All of the PCB excluding the *Dribbler Motor Controller* were designed and built for this thesis.

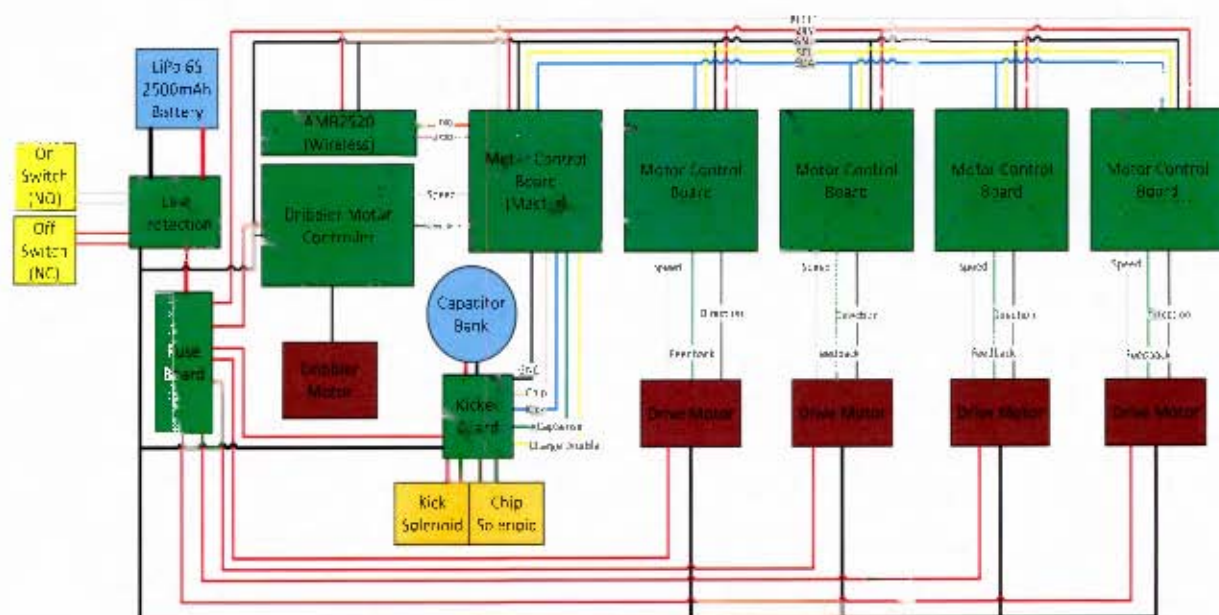

Figure 6.1: Wiring diagram for a SSL robot

The battery chosen to operate the UCT SSL robot was a *Hyperion 6S 25C 2500mAh* shown in Figure 6.2 on the following page. The nominal voltage for this pack is 22.2 V however a battery does not have a fixed voltage. The LiPo battery voltage was in the range of 25.2 V – 18 V and all circuitry needed to be capable of operating across the full range of voltages. A higher voltage battery should also improve kick charging times. Additionally selecting higher voltage motors would provide more torque than lower voltage counterparts and should have a lower output speed and require less gearing.

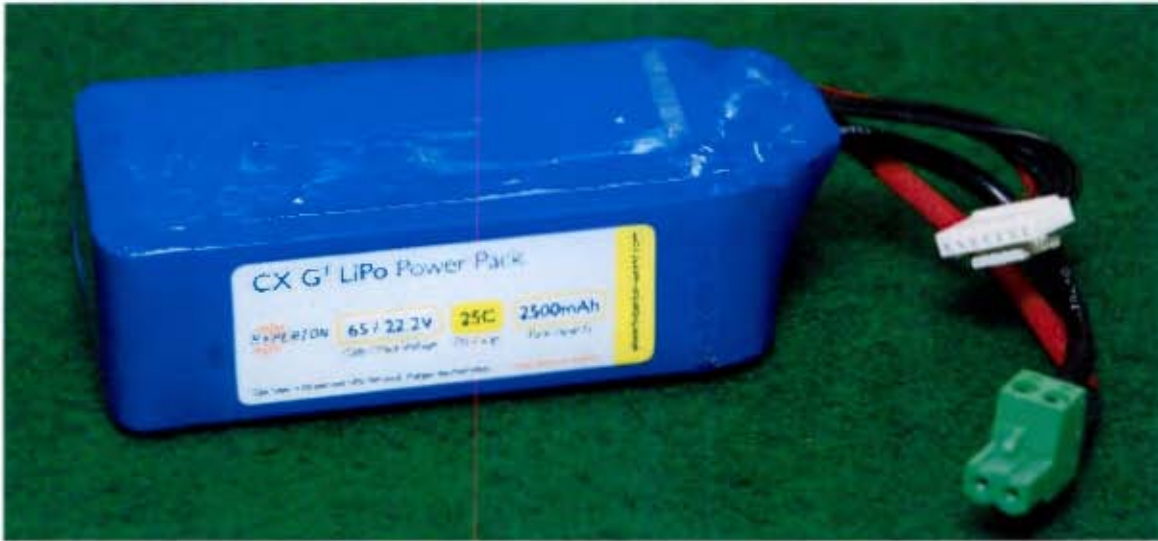

Figure 6.2: UCT SSL Robot Battery

As the battery voltage varies, the nominal voltage will be considered unless the worst case values are needed.

A description of each PCB including design parameters, modules, schematic, construction, revision modifications and final function are described in detail in this chapter. This document provides the information necessary to use the PCB created for SSL purposes.

6.1 Motor Control Board



Figure 6.3: Motor Control Board

6.1.1 Design Parameters

The Motor Control Board (MCB) was designed to provide overall control and speed control for an SSL robot. Additional requirements placed on these boards were to be a generic platform to allow multiple projects within the lab to have a simple integrated board that could function as a high level motor controller.

6.1.1.1 Maxon Motor Control

The fundamental purpose of the MCB was to control a motor, and specifically Maxon motors which the RARL was currently using for projects. The Maxon motors used by UCT RARL had similar controlling wires namely speed, direction, and feedback. Depending on motor the analogue speed voltage varies from 0 – 10.8 V or 0 – 5 V. The motors with integrated controllers operate off the higher 10.8V while the external controllers operate off 5V logic. The *direction* control is a digital input of 5V for both controller types. The feedback wire provides a pulse train of 6 pulses of 5V per revolution on the motor shaft.

6.1.1.2 SSL Operation

On an SSL robot the board worked in conjunction with 4 other controller boards. Each board can operate on an I²C bus, and has both UART lines available for communication with external peripherals. An onboard dual 8 bit DAC connected to a LM358 buffer allows for a possibility of two Maxon motors to be controlled. General digital I/O pins are available for outputs such as motor direction as well as analogue inputs for battery monitoring.

The critical specifications for SSL are briefly identified in Table 6.1.

Table 6.1: Design Parameters for the MCB

Specification	Justification
Operate off a minimum supply of 25.2 V	The robot battery has a nominal voltage of 25.2V
Receive UART communication from another source	The boards are an interface for low level devices to connect to a PC or higher level system.
Possibility to Control multiple other modules (Motor(s), Kicker Board, Dribbler) (More I/O available than necessary)	Each MCB was required to operate multiple other devices.
Small in size	Easily fit into any application
Communicate to similar devices	Multiple boards working together

6.1.2 Possible Functionality

This board is configurable for most motor controller applications. The board cannot drive the motor power directly although it has sufficient control and communication to work as a high level device. The controller is a Freescale HCS08GMC9S08GT16A which could be programmed with a programming Background Debug Module (BDM). Additional modules were placed on the MCB to create a more versatile controlling platform. The most significant addition for SSL was the stackable connectors for *Power*, *Reset* and *I²C lines*. The stackable connectors removed the need for a 5 wire bus being connected to each MCB. The typical voltages and currents during operation are displayed in Table 6.2 along with justifications behind those expected values.

Table 6.2: Expected Operational Voltages and Current for the MCB

Factor	Useful Information		Limiting Factor
	Value		
Supply Voltage	15 V -30 V		LM317 + LM358 Maximum Supply Voltage
Expected Idle current	10-20 mA		LED and supporting electronics

The final function of the MCB varies depending on which function it will operate when on the SSL robot. In the *Master* position, Data will arrive on the UART line. The Data will be of the form *robotID*, *magnitude*, *angle*, *rotation*, *timeout*, *controlByte* and *Checksum*. This is discussed further in Chapter 7 relating to Software. Once the MCB has calculated required actions, the information is sent through the I²C bus to the other MCB to initiate locomotion.

6.1.3 Modules

Figure 6.4 is a layout of the modules that make up the MCB with each block located where the module would be when viewing the board from above.

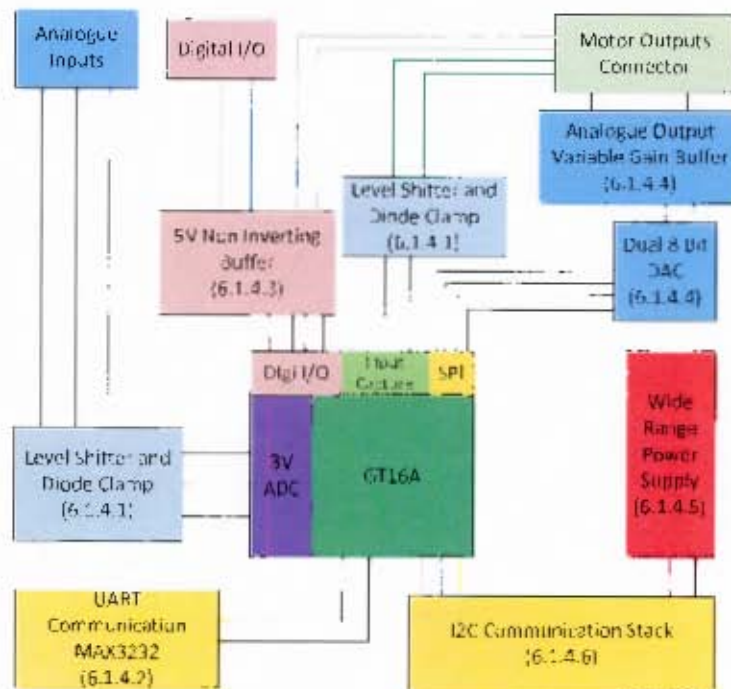

Figure 6.4: Simplified Modular Schematic of the Motor Control Board

Not every module/component was needed for SSL, board components that are not necessary were not populated in order to save on unit pricing. Figure 6.5 shows a MCB that was used in a functional robot.



Figure 6.5: Motor Control Board used on a SSL robot

6.1.4 Schematic

The full schematic of the MCB is shown below in Figure 6.6. Each of the individual blocks in the module section above is explained in full detail.

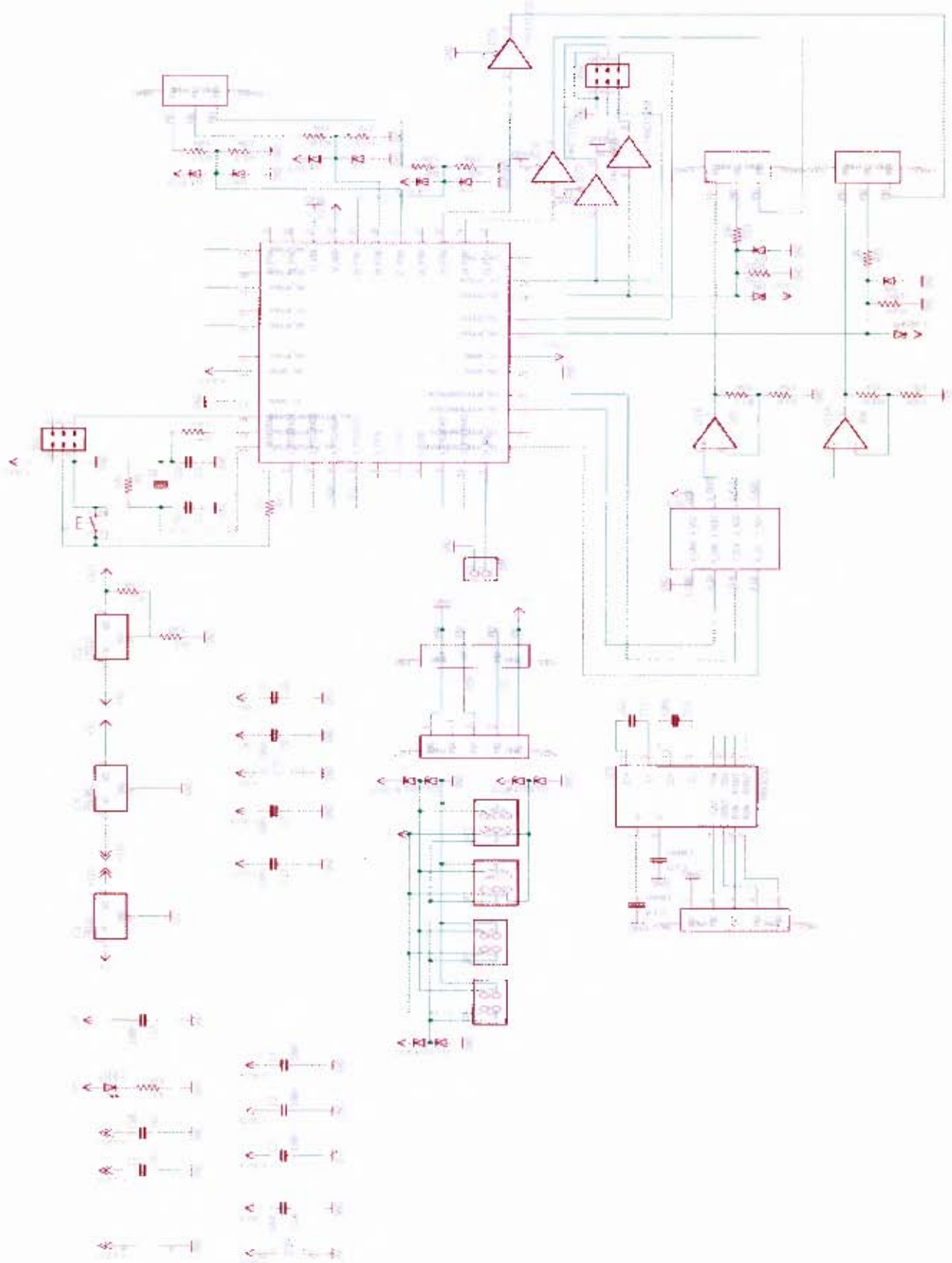

Figure 6.6: Motor Control Board (Full Schematic)

6.1.4.1 Level Shifter and Diode Clamp

The expected analogue input voltage would be greater than 3.3 V and thus could destroy the GT16A on the board. This module uses a voltage divider to reduce the input signal magnitude. If the signal is still greater than 3.3 V or less than 0 V the diodes will conduct to ensure the output of this module does not exceed the safe range for the G116A. The current configuration in Figure 6.7 below a 0V – 5V signal is expected on the input side.

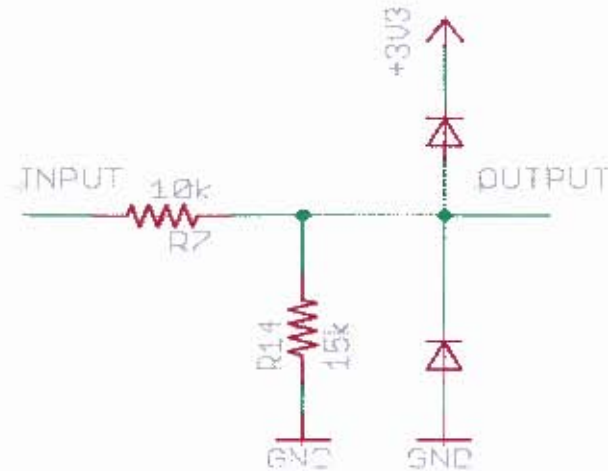

Figure 6.7: Analogue Voltage Protection Circuitry

6.1.4.2 UART Communication

RS-232 is a common communication protocol. An interface IC called the MAX3232 was required to convert TTL logic from the G116A to the logic levels for RS-232. Figure 6.8 is the required setup for this IC. The IC also requires a V_{CC} and V_{SS} which are 3V and 0V respectively.

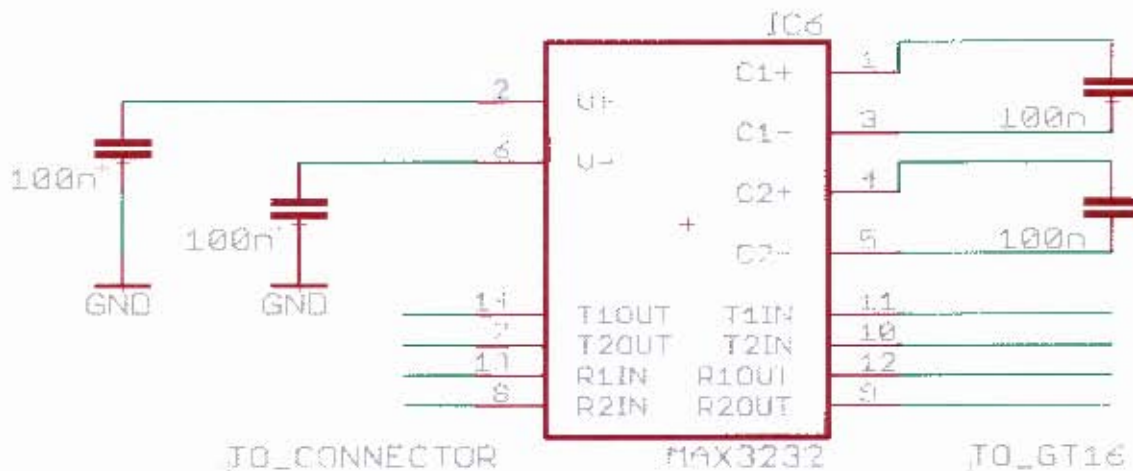

Figure 6.8: MAX3232 and required components for operation

6.1.4.3 5V non-inverting buffer

The non-inverting buffer (74HCT125) is a quad non-inverting TTL compatible 5 V buffer which operates off 5 V. This was essential for converting 3.3 V logic to buffered 5 V logic for the Maxon Motors. Figure 6.9 is a single buffer for the quad package.

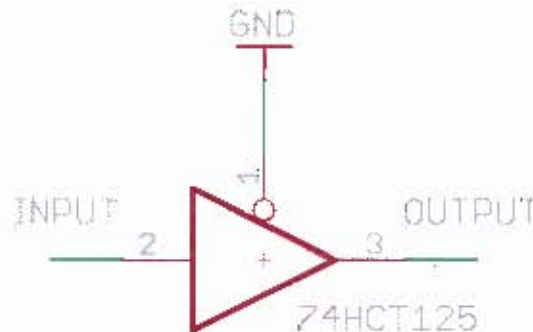

Figure 6.9: A Single Buffer of the 74HCT125 IC

6.1.4.4 Dual 8 bit DAC + Analogue Output Variable Gain Buffer

The DAC chip was a FVM2219 which receives information from the SPI lines on the GT16A. The DAC can operate on both 3.3 V and 5 V. The GT16A operates off 3.3 V and the DAC was forced to operate on the same supply for SPI communication logic levels. The Maxon motors which operate off an analogue voltage require the signal to be in the range of 0 – 10.8 V. The LM358 takes the 0 – 3.3 V signal and amplifies it to 0 – 10.8 V. The resistors providing the non-inverting gain could be replaced allowing the board to provide an analogue speed voltage for different motors in the RARL. Figure 6.10 shown is the schematic for the DAC with analogue gains on the output stage.

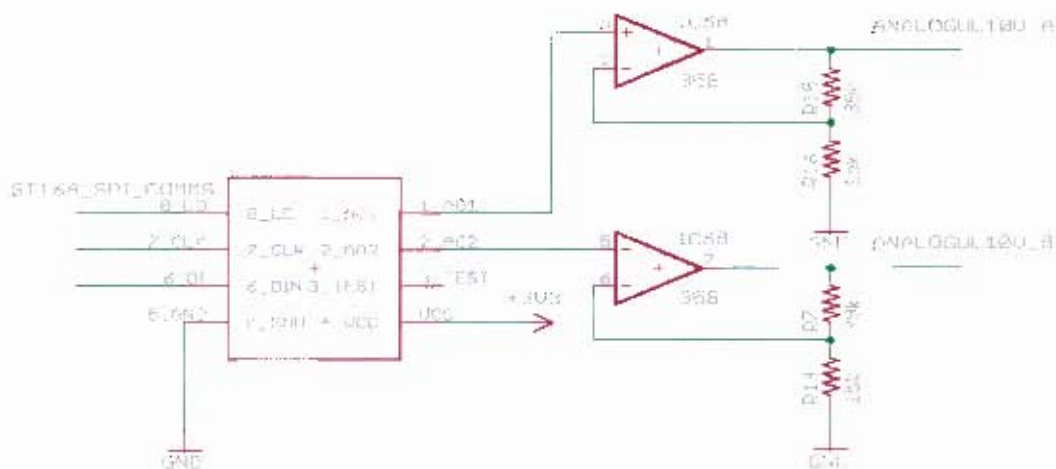

Figure 6.10: Dual 8 Bit DAC with an LM358 for additional modifiable gain

6.1.4.5 Wide Range Power Supply

An SSL Robot operated off a 25.2 V battery and for this board to remain generic it would need to be capable of operating off a wide supply range. Figure 6.11 below show the voltage regulators on each MCB. This allows a board to operate on a voltage from 14 V – 30 V. The capacitors are placed physically close to all ICs on the MCB.

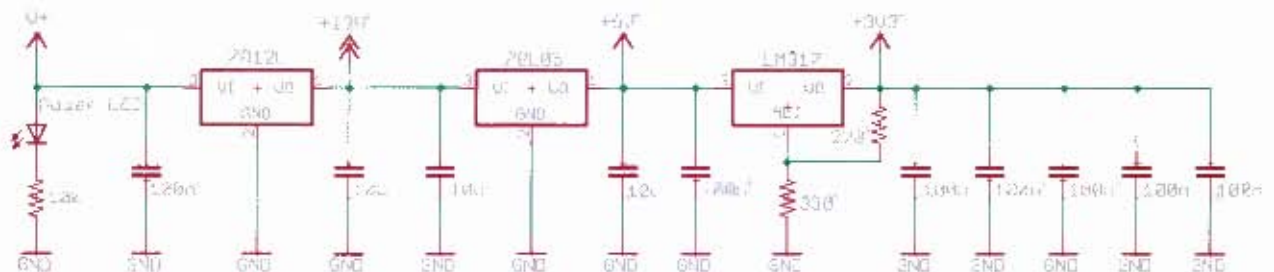

Figure 6.11: The Power Regulation for the MCB

6.1.4.6 PC Communication stack

The communication stack was responsible for minimizing the wiring on the SSL robots. Earlier versions of the MCB used wires as the bus. The stackable connector allows each board to have a common bus of power, I²C and Reset without any wires as the boards can be stacked on top of each other. Figure 6.12 shows the connection on the stackable pins.

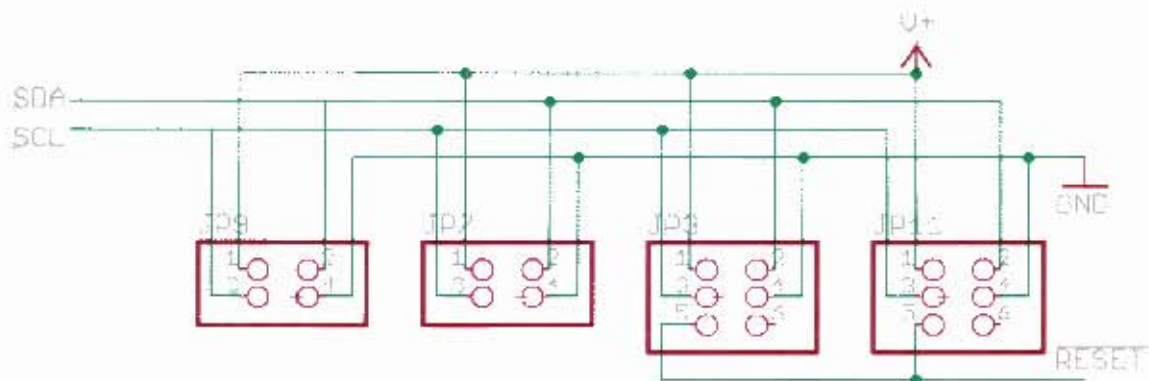

Figure 6.12: Stackable Connection Bus used on the MCB

6.1.5 Board Layout

An accurate diagram is given below in Figure 6.13. All measurements are in millimetres and the connectors and pin numbering are explained in Table 6.3 on the following page.

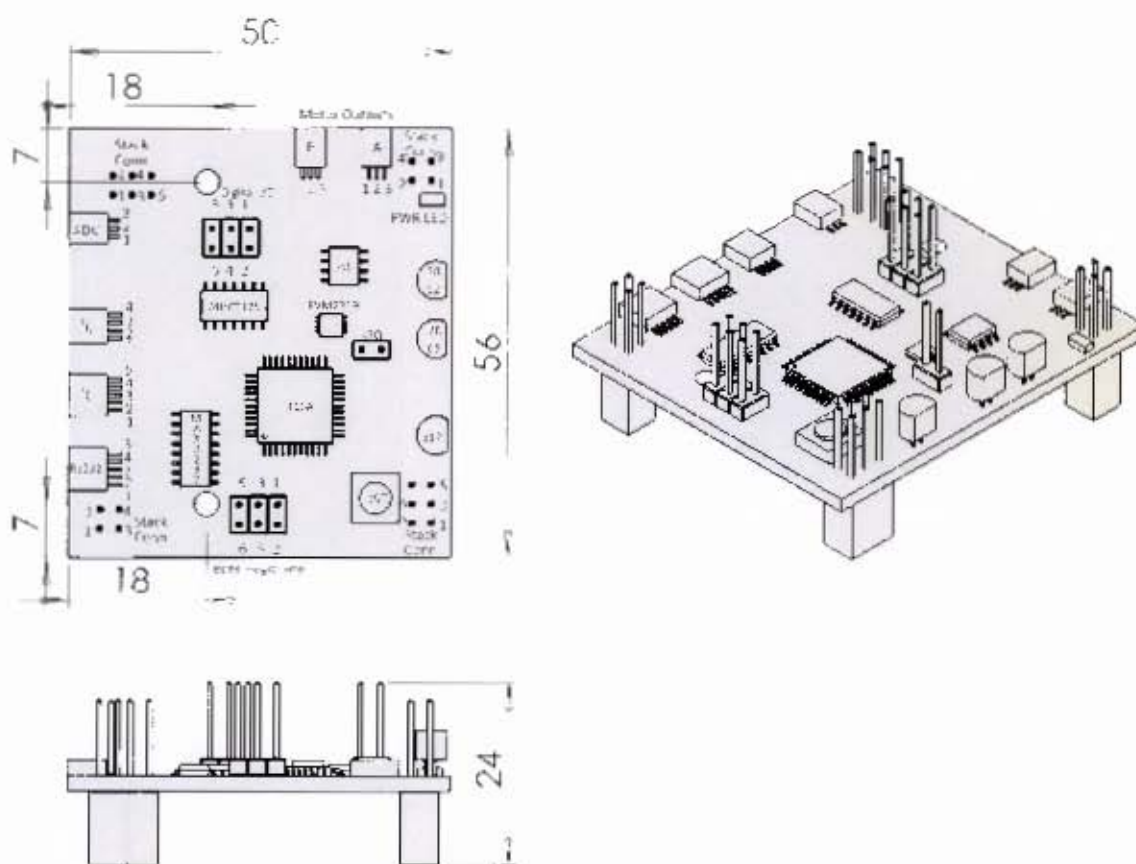

Figure 6.13: Motor Control Board Layout Diagram

Table 6.3: Motor Control Board Pin Layout

Input / Output	Description	Pin no.	Pin Name	Pin Use	Connector
RS232	RS232 is a series of standards for serial communication between devices. An onboard MAX3232 converts the standardised RS232 logic to 3.3 V TTL logic for the GT16A.	1	Rx1	Receive Line 1 on the GT16A (PTC1)	Pico-clasp 5 pin
		2	Tx1	Transfer Line 1 on the GT16A (PTC0)	
		3	Rx2	Receive Line 2 on the GT16A (PTC1)	
		4	Tx2	Transfer Line 2 on the GT16A (PTC0)	
		5	GND	Reference	
ADC	The ADC on the GT16A, converts a voltage range of 0-3V to 0-255 (8 Bit) or 0-1024 (10 Bit). Some Voltages may be higher than 3.3 V, because of this the protection built on to the board when configured correctly (voltage divider) allows for any positive voltage.	1	ADC1IN	Analogue Input 1 (PTB5)	Pico-clasp 3 pin
		2	ADC2IN	Analogue Input 2 (PTB6)	
		3	ADC3IN	Analogue Input 3 (PTB7)	
Motor Output	The MAXON motors can be connected to these dedicated connectors to control speed, change direction and monitor speed.	1	Direction	Motor Spin Direction (5 V Buffered - ConnA: PTB3 ConnB: PTB2)	Pico-clasp 3 pin
		2	Monitor	Hall Effect Sensor feedback (Protected: Voltage Divider - ConnA: P1DC ConnB: PTD3)	
		3	Speed	Analogue Voltage Speed C - 10.8 V (SP to DAC)	
I2C (5 Pin connector)	The connectors allow for a common bus connection which is directly wired to the Stack Conn	1	GND	Reference	Pico-clasp 5 pin
		2	IReset	Common Reset throughout the Stack (RST)	
		3	SDA	I2C Data Line (PTC2)	
		4	SCL	I2C Clock Line (PTC3)	
		5	V+	Unregulated Power	
I2C (4 Pin connector)	The connectors allow for a common bus connection which is directly wired to the Stack Conn	1	GND	Reference	Pico-clasp 4 pin
		2	SDA	I2C Data Line (PTC2)	
		3	SCL	I2C Clock Line (PTC3)	
		4	V+	Unregulated Power	
Stack Conn	Stack Conn is the connectors that allow the boards to be stacked and share a communication without the need for wiring.	1	V+	Unregulated Power	2x3 Pin Header OR 2x2 Pin Header
		2	SDA	I2C Data Line (PTC2)	
		3	SCL	I2C Clock Line (PTC3)	
		4	GND	Reference	
		5	IReset	Common Reset throughout the Stack (RST)	
Digital I/O	Additional I/O pins for configurable Applications	1	PTD3_5V	Caution: Shared with MAXON pins	2x3 Pin Header
		2	PTD1	PTD1	
		3	PTD4	PTD4	
		4	P1D4_5V	Buffered (PTD4)	
		5	GND	Reference	
		6	GND	Reference	

6.2 SSL Kickerboard



Figure 6.14: Final version of the Kickerboard used in SSL.

WARNING

Before using this board, understand that it can generate High DC voltages and can store large amounts of energy. Under certain conditions can shock or electrocute an individual. If this board is being used for high voltages use extreme caution.

6.2.1 Design Parameters

The Kickerboard shown in Figure 6.14 is a charge pump and the backbone to any electrical kicking in SSL. The board was required to operate off an unregulated battery voltage and charge external capacitors to a fixed voltage by means of a charge pump. As the energy stored in the capacitors is similar to the potential of a defibrillator, safety features and indicators were essential to provide warning and protection without hindering the full potential of the device. Earlier revisions of the Kickerboard included total failure, electrically too noisy, over-heating and insufficient safety respectively.

Table 6.4 details the list of specifications for the Kickerboard. The design parameters were forced to be more generic as Stellenbosch University had requested to use this PCB for their SSL team.

Table 6.4: Design Parameters for the Kickerboard

Specification	Justification
Operate off a supply of 11 VDC to 30 VDC	The robot battery has a nominal voltage of 22.2V
Operate as a discrete module.	The Kickerboard can be tested off robot, with no additional circuitry.
Possibility to be controlled by an external source.	The design is intended to be incorporated with a controlling MCB.
Small in size	Easily fit into any application
Communicate to similar devices	Multiple boards working together
Store high voltage potential energy	Lower voltages will not generate the currents required through the solenoid
Capable of discharging that energy in 20 ms	The kick duration will be in the range of 10ms
Recharge to a high energy state quickly	After a kick, the energy stored is reduced and needs to be recovered

The Kickerboard can generate a high potential voltage that can be driven through a device on an interval basis; High power in short bursts. Table 6.5 specifies some useful information when operating the Kickerboard.

Table 6.5: Operating specifications for the Kickerboard

Factor	Useful Information	
	Value	Limiting Factor
Supply Voltage	10 V -30 V	LM358 Maximum Supply Voltage
Expected Idle current	40 mA	
Lowest Recommended Charging Frequency	14 kHz - 24 V supply / kHz – 12 V supply	Charging Current (>1.5 A) – Inductor + Charging IGBT Temperature

*The charging inductor has no series resistance other than its parasitic component. This means if the charging is not stopped, it will short out the supply. (Duty Cycle Dependant During Testing: 50%)

6.2.2 Preliminary Testing

Before attempting a PCB, a circuit was developed and tested. It was initially constructed on Veroboard. The prototype board performed suitably at charge times in the order of about 30 s which was not suitable for SSL. The prototype provided a proof of concept shown in Figure 6.15, and a more robust PCB was constructed

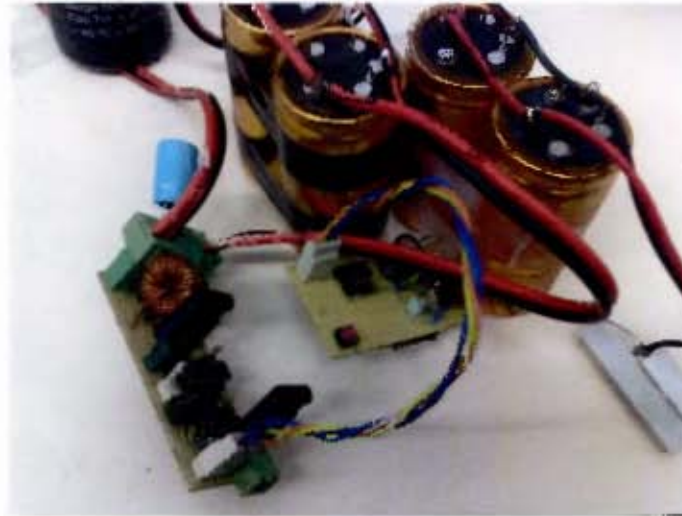

Figure 6.15: Kickerboard Prototype constructed as a proof of concept

6.2.3 Modules

Understanding the final Kickerboard modules is simpler if each module is considered individually and understood as an element before considering the circuit in its entirety. Figure 6.16 is a complete layout of all modules that make up a Kickerboard.

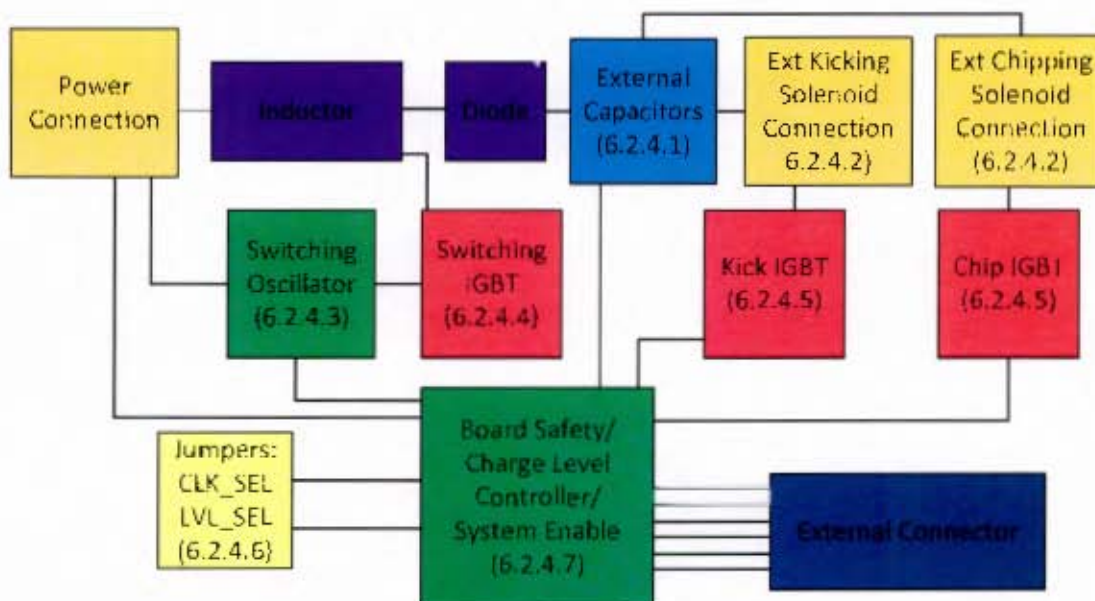

Figure 6.16: Simplified Modular Schematic of the Kickerboard

6.2.4 Schematic

The full schematic of the Kickerboard can be seen in below.

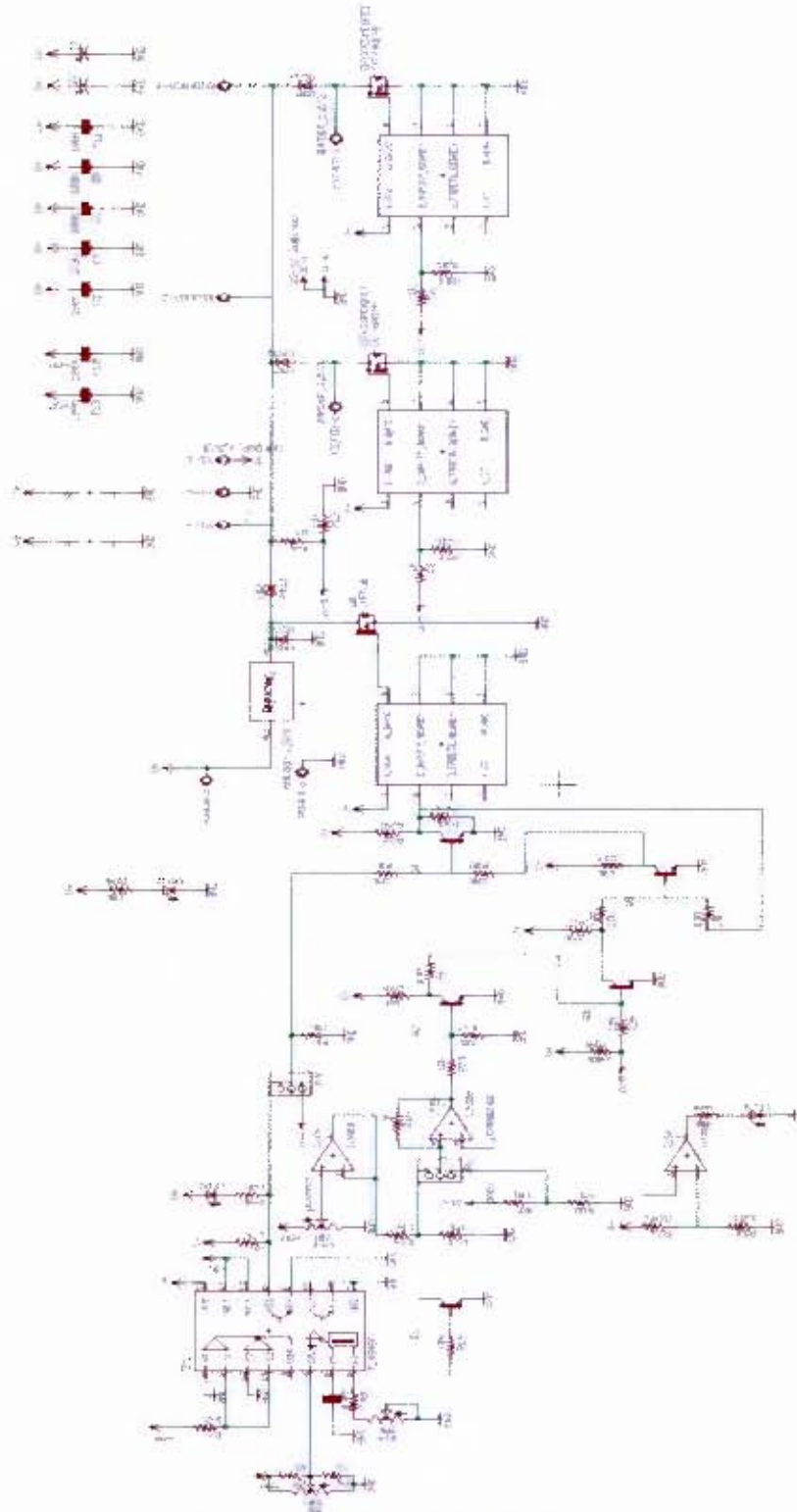

Figure 6.17: Kickerboard (Full Schematic)

6.2.4.1 External Capacitors

The external capacitors connection is a 3pin connection for power, high voltage and ground. The external capacitors are needed to store the high voltage and are mounted off the PCB due to physical size. The additional power connection was added for optional safety which was implemented on the SSL robots from UCT. The design incorporates an external relay connecting a resistor with the normally closed connections to the external capacitor as shown in Figure 6.18.

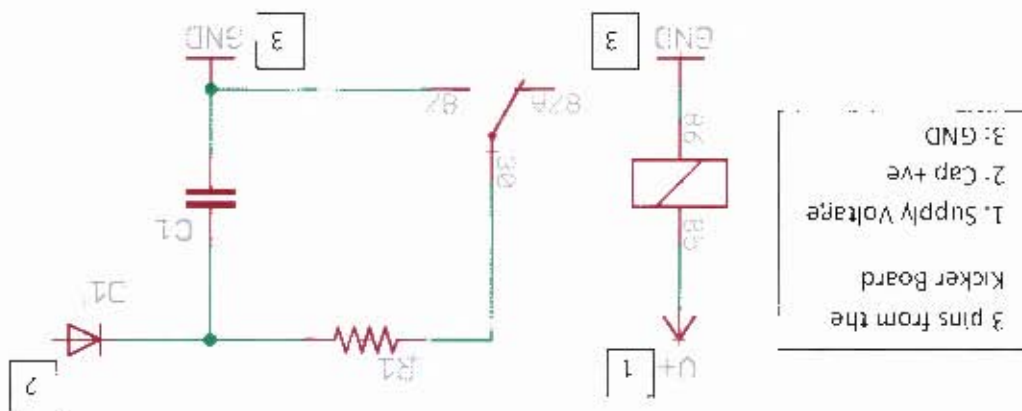

Figure 6.18: Optional External Safety Relay Circuitry

When power is supplied to the Kickerboard, it is also fed to the relay which would disconnect the parallel resistor. Once power is disconnected, the relay contacts change state and the terminals will close and the system will discharge to a safe state based on the time constant equal to $4RC$ ($4 \times 2.4k \times 5.6 \text{ mF} = 60 \text{ seconds}$). An additional LED is also attached to the original external capacitors in the same configuration as the resistors in the figure above, to indicate discharging. The system should be considered dangerous while the LED remains lit which is visible in Figure 6.19.



Figure 6.19: External Relay Protection with indicator LED

6.2.4.2 External Kicking\Chipping Solenoid Connection

The external connections for the Kicker and Chipper are 2 pin phoenix connectors placed as close as possible to the connections of the external capacitors. Each solenoid has an independent IGBT for activation with the main external capacitors.

6.2.4.3 Switching Oscillator

A PWM signal was generated using a TL494. This IC was chosen based on the requirement of a wide supply voltage of 10 V - 30 V. The 3 key features are the two potentiometers for controlling frequency and duty cycle and the transistor which shuts down the PWM. The frequency and duty cycle control are directly related to charging time of capacitors and current through the charging devices. The transistor seems redundant because there are enable pins further on in controlling circuitry, however this is crucial in ensuring a single charging cycle is not clipped short which is discussed on page 79.

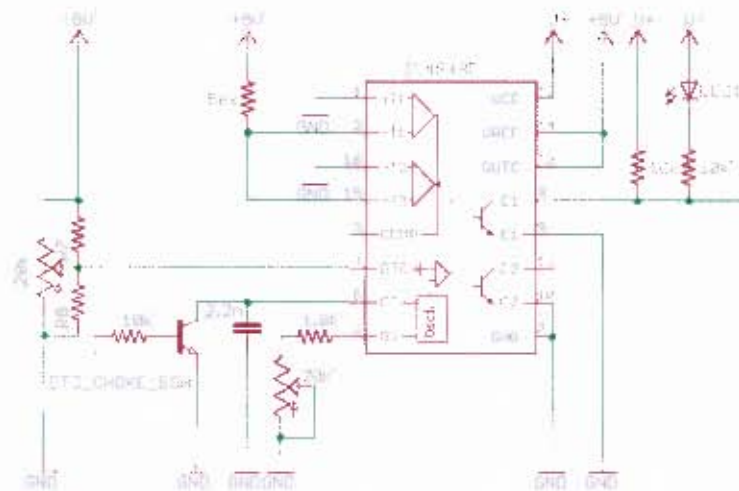

Figure 6.20: Switching Oscillator on the Kickerboard

6.2.4.4 Switching IGBT

The IGBTs on the Kickerboard are all handling large currents for their respective size. If the Kickerboard were operating on a slow oscillating frequency, the switching IGBT could be sinking 3A. The digital switching time for the IGBT needs to be minimized in order to reduce the power losses associated with switching. A MIC5020 which is a MOSFET driver is used to convert the control signal to a signal that has sufficient power to drive the respective IGBTs.

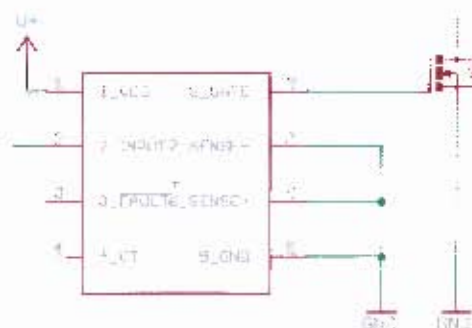

Figure 6.21: Charging IGBT with MOSFET driver

6.2.4.5 Kick/Chip IGBT

The Kick and Chip modules are identical in arrangement. The additional resistors are added to ensure an input of 12 V will not damage the MIC5020 with an additional external resistor which can be seen in Figure 6.22 as a pull down to reduce LMI and prevent false triggering.

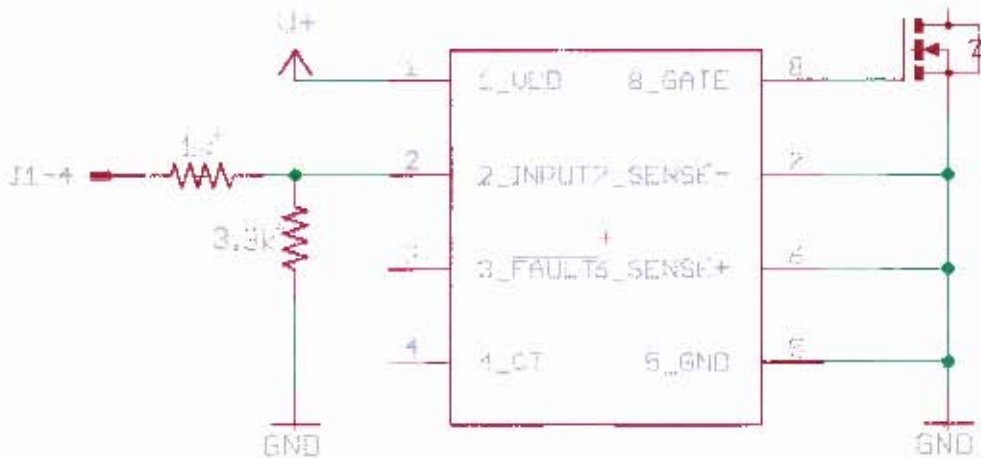

Figure 6.22: IGBT Driver for the Main Power IGBTs

6.2.4.6 Jumpers Settings

The jumpers are added for the possibility of changing the device from external control to internal control or visa-versa. The DACV input was assumed to be 5 V, which is converted to 3 V before the jumper. This potential divider was added for hysteresis, and as a result the potentiometer requires a buffer for consistency. The schematic is shown in Figure 6.23.

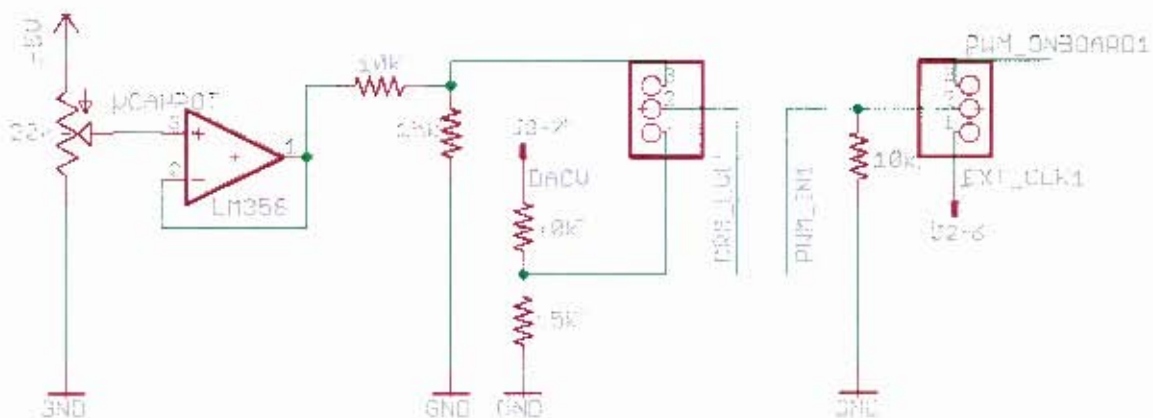

Figure 6.23: Jumper Configuration for LVL_SEL and Onboard CLK

6.2.5 Recommended Start-Up and Operating Procedure

6.2.5.1 Start-Up

Follow the instructions below in order to test the board. This should give one some insight as to how to use this system effectively. Please read through the instructions completely at least once before attempting to use the board.

Procedure	Reasoning/Expectations
Ensure CRG_DIS is floating (left disconnected)	Default value is high, which is disabled.
Ensure Clock Select jumper is connected in the External configuration.	Upon start-up, a clock or logic high is required to prevent the logic from latching on.
Connect the EXT_CLK to input power	This will latch the clock high on start up and ensure no charging.
Ensure the Final Level Voltage is being permanently monitored (VCapSense)	This will ensure one knows when the system becomes dangerous and ensures you can stop anything if it begins charging.
Plug in Power	Large initial currents as external capacitors charge to correct voltage.
Wait for input current to become expected (idle or switch off system)	If the input current is high continuously – the device may be charging or short circuiting somewhere. (wait 2s at most)
Measure and adjust the voltage of the Level Select jumper pin (Lower jumper, Right side)	Initially adjust this voltage to something low to ensure correct board operation. (Recommend 1V on pin – as this is approximately 100V output.)
Connect the Level Select jumper in internal mode.	Ensuring the board will disable charging at 100V
Ground the CRG_DIS pin	This enables the kicker board and its PWM will start. However with the jumper disconnected, the IGBT will not activate. It is running using the EXT_CLK with no PWM signal
Measure the output PWM waveform on the internal clock on jumper pins.	Modify the Internal Oscillator to a suitable high frequency to ensure low* current charging initially. The charging frequency is dependent on supply voltage. *Rule of thumb : frequency = 1000*Supply Voltage
Disconnect the CRG_DIS and ensure it is left floating	Default value is high, which is disabled.
Connect the Clock Select jumper in internal mode	Ensuring the board will charge slowly when enabled.
Ground the CRG_DIS pin	Enables the board to charge to the selected Voltage with the selected clock (Set to a low output voltage and a slow charge frequency)

The board should stop at the desired output voltage and then can be used in the desired way.

6.2.5.2 *Operating Guidelines*

Do not change the *Level Select Voltage* when the system is maintaining a charged voltage:

The final output voltage uses a comparator with hysteresis. If the capacitors are holding a charge, the charge level will be on the lower threshold and not the actual value. If you increase the threshold to greater than the current charge value, the threshold will jump higher which is undesirable. As a rule, ensure you are only changing the charge level when the capacitors have been discharged first.

Understand that the components that are connected to the High Voltage connectors are at charge voltages:

The switching system completes the connection to GND when completing the circuit. This means that the solenoid will be at a high voltage when it is plugged in and must be considered dangerous at all times.

6.2.6 Board Layout

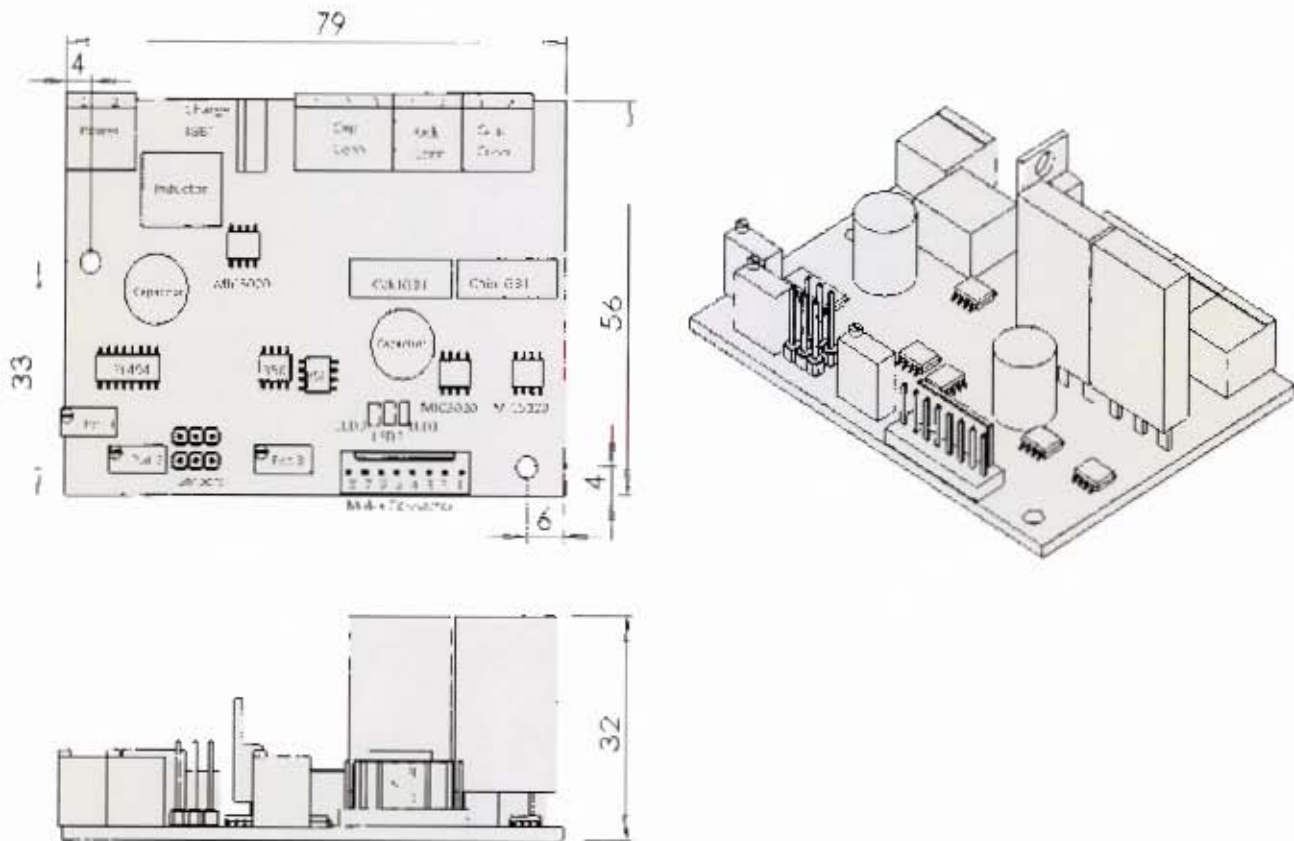

Figure 6.26: Kickerboard Layout Diagram

The Kickerboard has the possibility of hurting an individual because of the high potential voltages generated. Once the Kickerboard has been turned on, avoid both the component and solder side of the board between the 2 onboard capacitors and the capacitor connectors (Cap Conn) indicated on the diagram in Figure 6.26.

Table 6.6: Kickerboard Pin layout

Input / Output	Description	Pin no.	Pin Name	Pin Use	Connector
Power	Power connection for the Kickerboard	1	GND	Ground	Phoenix 2 pin Shrouded
		2	V+	Battery Voltage	
Cap Conn	External Capacitor connection for the kicker board	1	V+	External Relay Power	Phoenix 3 pin Shrouded
		2	GND	Ground	
		3	HV	High Voltage	
Kick Conn	External Kicker Solenoid Connection	1	Kick IGBT	IGBT Collector	Phoenix 2 pin Shrouded
		2	HV	High Voltage	
Chip Conn	External Chipper Solenoid Connection	1	Chip IGBT	IGBT Collector	Phoenix 2 pin Shrouded
		2	HV	High Voltage	
Molex Connector	The Molex Connection is to provide pins for controlling the Kickerboard externally.	1	GND	Reference	Molex 8 pin
		2	VCapSense	Scaled Capacitor Voltage Level	
		3	Chip	Chip Signal	
		4	Kick	Kick Signal	
		5	CRG_DIS	Capacitor Charge Circuit Disable	
		6	EXT_CLK	External Clock Line	
		7	DAC_V	External Final Voltage Level Line	
		8	GND	Ground	

6.2.6.1 Output Pin Labels and Explanations

VCapSense: (Output)

VCapSense provides an analogue voltage which is the voltage on the external charged capacitors scaled down by 100.

Chip and Kick: (Input)

TTL Logic level compatible enable for the kick IGBT. Onboard protection allows a high signal to be 15 V. These inputs require the source to drive at least 4 mA.

Low: Idle State.

High: Kicking State.

Charge Disable: (Input)

Charge Disable (*CRG_DIS*) is TTL Logic disable for the charge pump. Grounding this pin will enable the system provided the *level select* voltage has not been reached. If this pin is left disconnected, its default value is 3V which is disabled.

Low: Charging State.

High: Disabled State.

EXT_CLK: (Input)

The board can operate on either an external or internal clock. To use the external clock, ensure the associated jumper is in the correct position. The external clock source Input is inverted when it finally reaches the charging IGBT.

DAC_V: (Input)

The board can operate on either an external or internal final voltage level. To use an external level, ensure the associated jumper is in the correct position. The external DAC Voltage is expected to be between 0 – 5 V. The 5 V signal is reduced to 3 V on board, and then works on the same ratio as the VCapSense signal. An example of this is given below.

4.1 V is reduced to 2.46 V, which will charge to a final voltage of 246V.

6.2.6.2 Jumpers

There are 2 jumpers on the Kickerboard. The first jumper is responsible for the origin of the charging IGBT clock while the second jumper is whether the final charging voltage is referenced on the board or off the board. The locations of the jumpers are indicated in Figure 6.27 below. The internal states for both jumpers are highlighted in yellow.

1. CLK_SEL (INT/EXT)
2. LVI_SEL (EXT/INT)

NOTE: Internal and External are on opposite sides for each jumper.

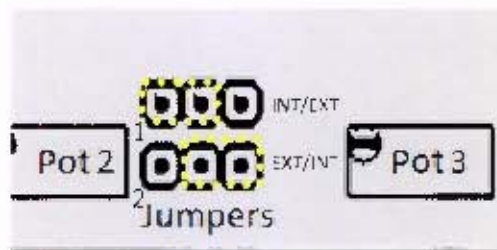

Figure 6.27: The location of Jumpers on the Kickerboard

6.2.6.3 LED Indicators

There are 3 LEDs on the kicker board indicated on Figure 6.28. They were arranged in such a way that the power LED (green) is in the middle and the 2 red LEDs are on either side. The red LED on the left is a *Danger* LED. It will remain lit when the capacitors are at a voltage greater than 30V. The red LED on the right is the *Enabled* LED. It will remain lit when the kicker charging is enabled.

- LED1: Enabled (Red)
- LED2: Power (Green)
- LED3: Danger (Red)

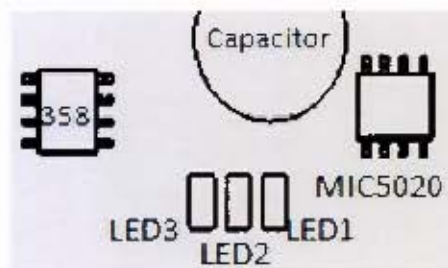

Figure 6.28: The location of LEDs on the Kickerboard

6.3 Fuse Board

The Fuse board is a common power connection area for the battery to supply power to each individual component and in the possible event of a failure potentially save the equipment. The fuses are placed in the open for easy access to any fuse that may blow open.

6.3.1 Design Parameters

Create a common fuse platform for each module to connect. Provide a single connector for the battery to power the entire robot.

6.3.2 Possible Functionality

This board could be used in other robots as it has a common battery input and multiple fused outputs. Figure 6.31 is the schematic of the fuse board.

6.3.3 Schematic

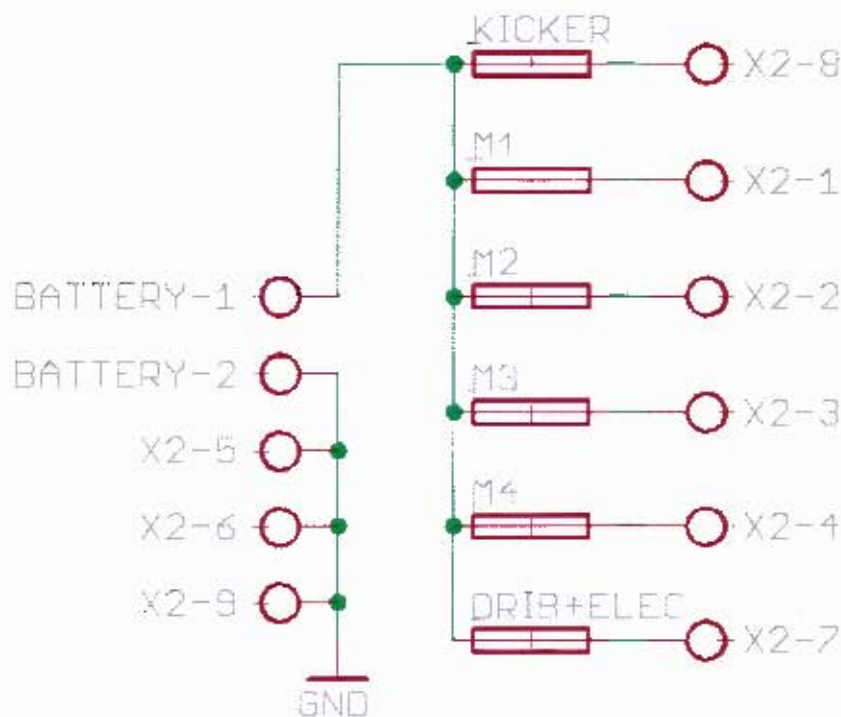

Figure 6.31: Schematic for the Fuse Board

6.3.4 Board Layout

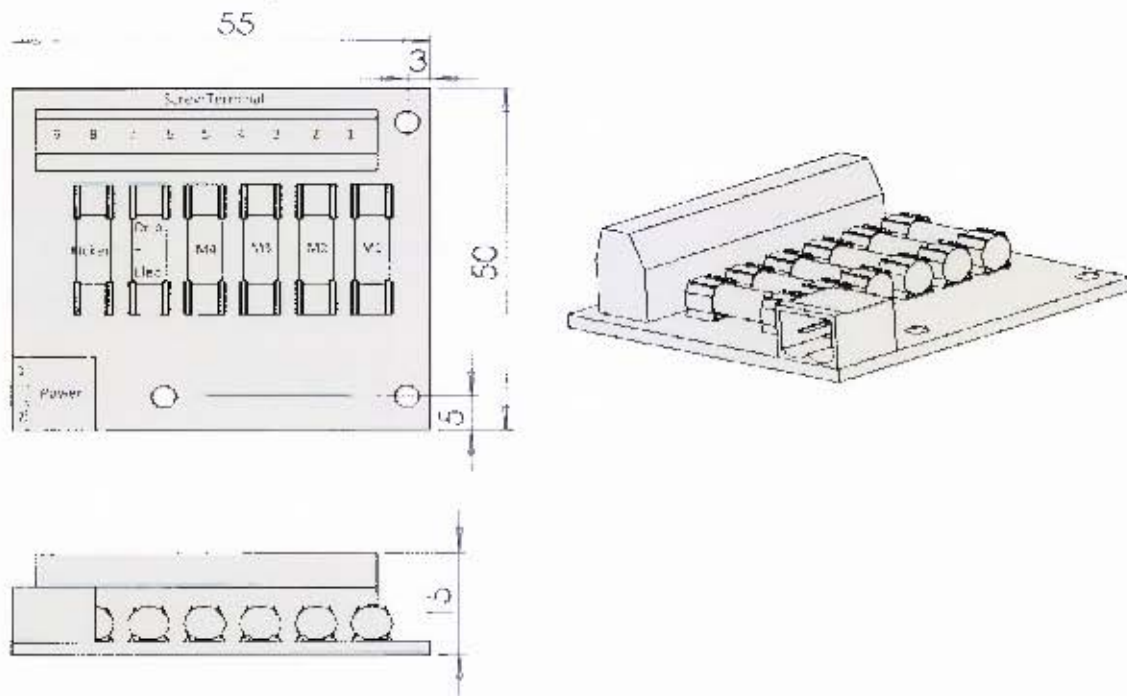

Figure 6.32: Fuse Board Layout Diagram

Table 6.7: Fuse Board pin layout

Input / Output	Description	Pin no.	Pin Name	Pin Use	Connector
Power	Power connection for the Fuse Board	1	V+	Battery Voltage	Phoenix 2 pin Shrouded
		2	GND	Ground	
Screw Terminal	The Screw Terminal provides an easy connection without the need for connectors	1	M1	Motor 1 Power	Screw Terminal 9 pin
		2	M2	Motor 2 Power	
		3	M3	Motor 3 Power	
		4	M4	Motor 4 Power	
		5	GND	Ground for M1–M2	
		6	GND	Ground for M3–M4	
		7	Drib+Elec	Dribbler and Electronics power	
		8	Kicker	Kicker Power	
		9	GND	Ground for Kicker and Dribbler and Electronics	

6.4 LiPo Protection Board

LiPo Protection board ensures a battery cannot be damaged through excessive discharging. A low voltage warning is generated and once the battery voltage has reached a minimum, the board physically disconnects the battery with the use of a relay.

6.4.1 Design Parameters

Lithium Polymer (LiPo) batteries are notorious for being particularly volatile if mistreated. Any mistreatment includes heating, impact and over-discharge. Electrically speaking the only preventative measure is ensuring the battery voltage does not go below a threshold voltage.

Table 6.8: Design Parameters for the LiPo Protection Board

Specification	Justification
Operate off a wide supply range	The aim was to make this board as generic as possible
Operate as a discrete module.	Needs to function completely independently
Small in size	Easily fit into any application
Provide a low voltage detect signal	Information that the battery voltage is low
Physically disconnect the battery before any damage can be done	If the battery voltage dips too low, the battery will be ruined. Presumably this is not the case if your robot turns off.

6.4.2 Possible Functionality

This module can be used with any battery greater than 14V application using a max of 10A.

6.4.3 Modules

Figure 6.33 is a simplified layout of the modules that make up the LiPo Protection board.

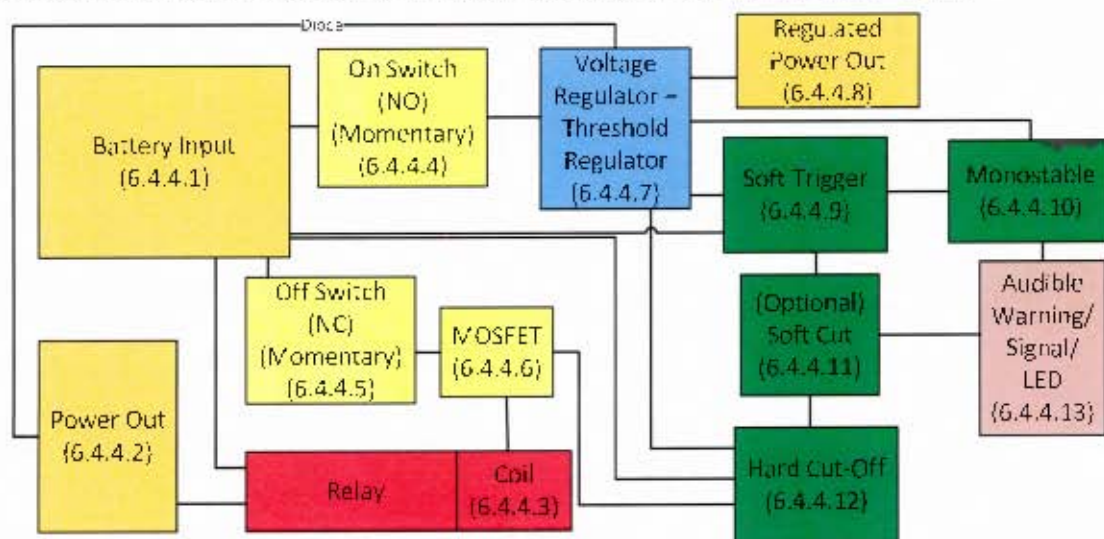

Figure 6.33: Simplified Modular Schematic of the LiPo Protection Board

6.4.4 Schematic

The full schematic for the LiPo protection board can be seen in Figure 6.34.

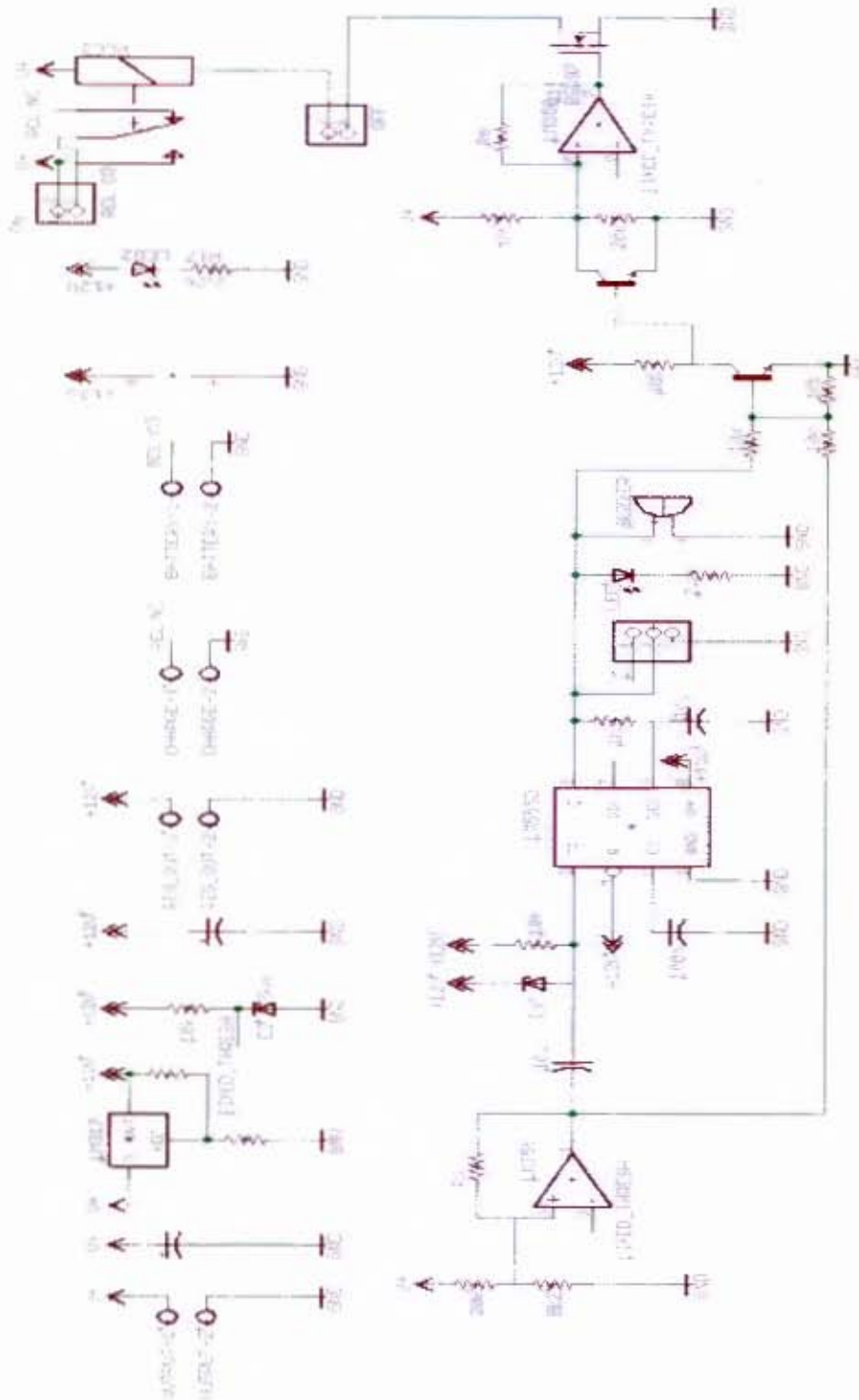

Figure 6.34: LiPo Protection Board (Full Schematic)

6.4.4.1 *Battery Input*

The battery input is any power input that this circuit would isolate when the voltage were determined to be low.

6.4.4.2 *Power Out*

Power out is directly connected to the battery input when the circuit is on and the battery voltage is greater than the determined threshold.

6.4.4.3 *Relay(Coil)*

The coil of the relay is held on while the battery voltage is higher than the determined threshold. As soon as the voltage is too low, the signal controlling the relay is removed and the mechanical contacts open disconnecting the battery input source.

6.4.4.4 *On Switch*

The On switch is a jumper to allow the switch to be located on a different surface. It provides power to the controlling circuitry of the LiPo board when closed. Once the control components are functional, if the *battery input* is greater than the threshold the *relay coil* is energised and *power out* becomes connected to *battery input*.

6.4.4.5 *Off Switch*

The Off switch is a jumper to allow the switch to be located on a different surface. It is normally closed, because it is in series with the *relay coil*. Opening this connection prevents the relay from remaining open and disconnects the *power out* from *battery input*.

6.4.4.6 *MOSFET*

The MOSFET is the electrical control for the circuits controlling cut-off. If the threshold is reached, the MOSFET becomes open and shuts down the board.

6.4.4.7 *Voltage Regulator – Threshold Regulator*

In the design of this board it became apparent that some systems might need a regulated power supply before the relay coil arms. This functionality is incorporated in this board. The regulator should also provide additional stability during current spikes on the battery. The threshold regulator is a Zenor diode running on a constant voltage which can be seen in Figure 6.35.

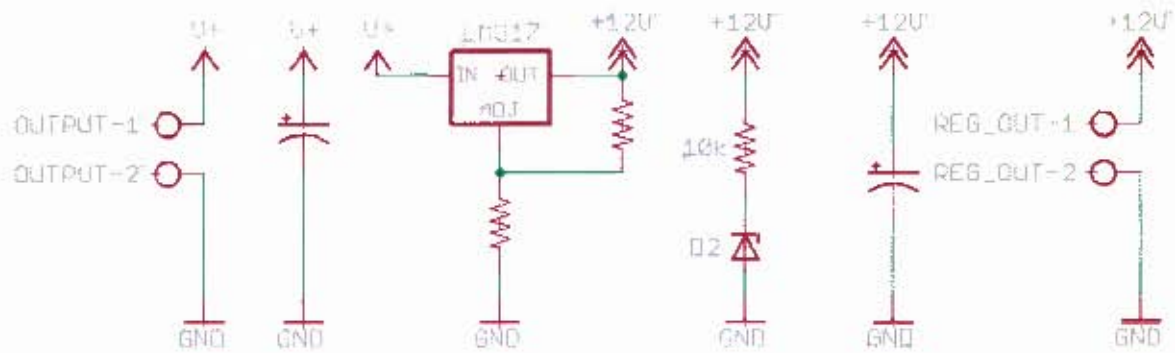

Figure 6.35: LiPo Protection Voltage Regulation

6.4.4.8 Regulated Power Out

The *regulated power out* is an additional feature for any device that needs a constant voltage, if this were to be the only power board on a system.

6.4.4.9 Soft Trigger

The soft trigger is an op-amp used as a comparator with the possibility of hysteresis seen in Figure 6.36. The fixed threshold came from the Zenor diode and the soft cut was determined by the voltage divider. This arrangement is designed to cut on the 6S LiPo batteries used in SSL. A logic low is produced when the threshold is reached. This logic low would trigger the monostable.

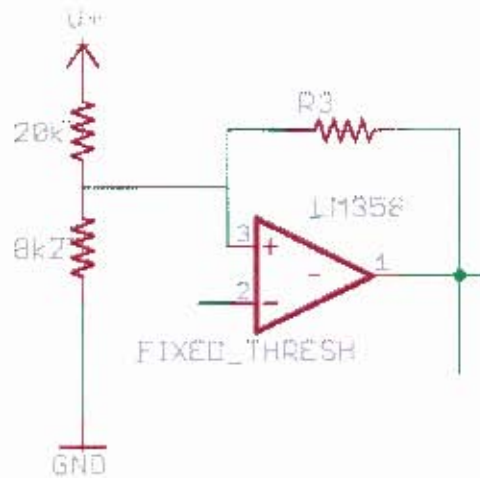

Figure 6.36: Soft Trigger Op-amp and configuration resistors

6.4.4.10 Monostable

The monostable was added to create a pulse of low battery indication or warning before corrective action may happen shown in figure 6.37. This system is a LM555 configured to act as a monostable with a few seconds time constant.

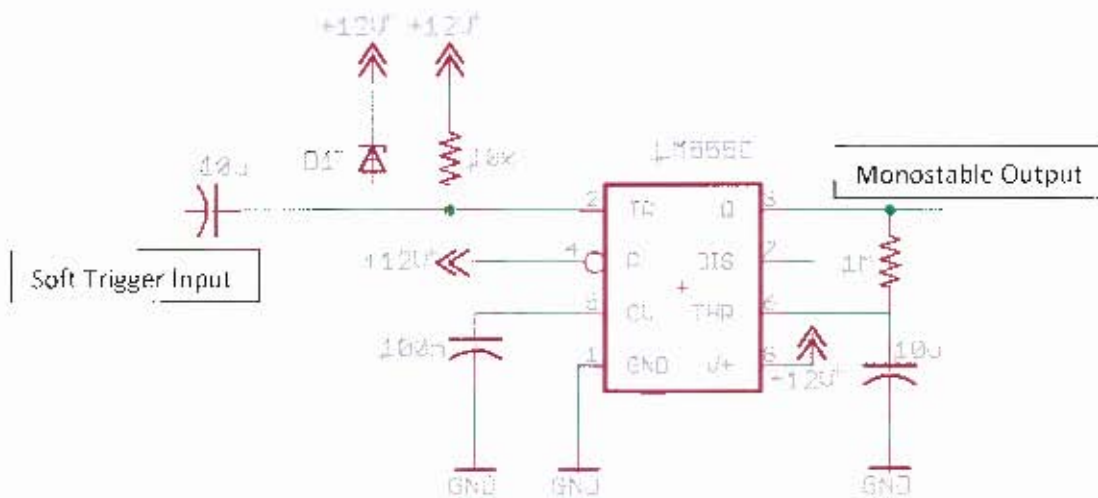

Figure 6.37: Soft Trigger monostable for a timed output

6.4.4.11 Soft Cut

The soft cut will turn off the board after the soft trigger has been activated and the monostable has completed its low voltage indication. The Op-amp soft trigger and the monostable provide the inputs respectively. The soft trigger remains high in normal operation the 20k resistor is not bypassed with the transistor (T₂). Once the soft trigger has triggered, The op amp output becomes low and the output of the monostable transitions to high still ensuring the 20k resistor is not bypassed. If the soft trigger is still low, and the monostable timer has expired the 20k resistor is bypassed which forces the hard cut to take effect. This section is optional, because the soft trigger can provide a warning level and no action. If a LiPo is only partially discharged and then recharged it will last longer, however if ones applications require a longer battery life the soft cut can just be an indication and not a shutdown action. The module can be seen below in Figure 6.38.

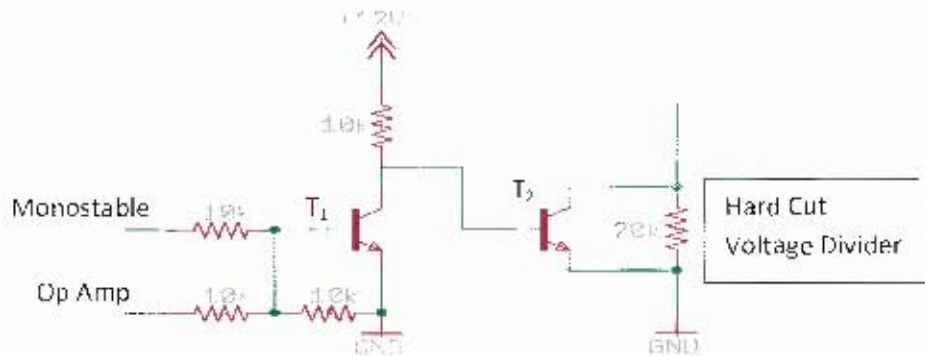

Figure 6.38: Soft Cut transistor arrangement

6.4.4.12 Hard Cut-Off

The hard Cut-Off controls the MOSFET and determines whether the output is connected to the battery input via the relay. The threshold is set with the same Zener diode used in the soft trigger and the resistors are chosen to cut protecting a 6S LiPo pack. If the soft cut transistor is soldered on the board, the transistor will force the +ve input of the op-amp low and the system will turn off.

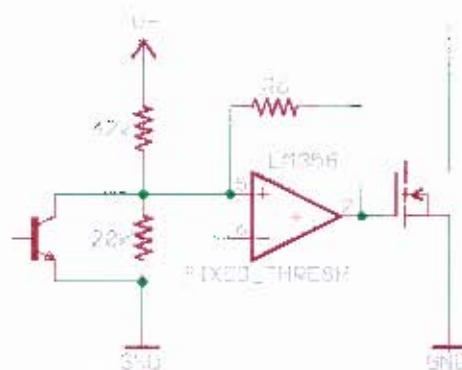

Figure 6.39: Hard Cut with Optional Soft Cut transistor and controlling MOSFET

6.4.4.13 Audible Warning/Signal/LED

The circuit was built to be generic so multiple external signals are placed on the board so that the user can choose which they prefer to use. There is an LED indicator, a buzzer and a 3 pin jumper. The 3 pin jumper has an open collector from the LM555 on pin 1, the LM555 output on pin 2 and reference on pin 3 which can be seen in Figure 6.40.

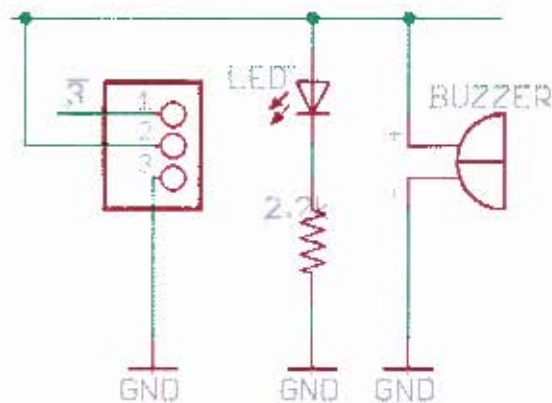

Figure 6.40: Warning outputs for the Soft trigger

6.4.5 Recommended Start-Up Procedure

The recommended start up procedure is very simple if you have already configured the board to function for your specific application. Table 6.9 is a guide for start up of the LiPo board.

Table 6.9: Recommended Start-Up for the LiPo Protection Board

Procedure	Reasoning/Expectations
Ensure the Voltage dividers for the soft trigger and hard cut are correct.	To ensure the LiPo Protection board is configured to protect the battery that is being plugged in.
Ensure the battery is connected in the correct polarity.	The battery polarity on the connector and the Ext Power connector are opposite. This was done for reasoning on SSL to ensure the battery could not connect to anything else.
Close the ON switch	This will turn on the device.

6.4.6 Board Layout

The board was designed to fit onto a side of a LiPo 6S pack which is the limiting 30mm width. The regulated output power connector is not indicated on Figure 6.41 below as it is not used in SSI. The soldering location for it is below the capacitors. Two 3.2mm drill holes are indicated on opposite corners of the PCB. The bottom side of this board contains the SMD devices because it is a single layer board. Refer to the EAGIF files as to which components you need to remove when configuring the devices however the more important components are indicated. If one wishes to remove the soft cut feature simply do not solder the isolation transistor T_2 in Figure 6.38 and Figure 6.41.

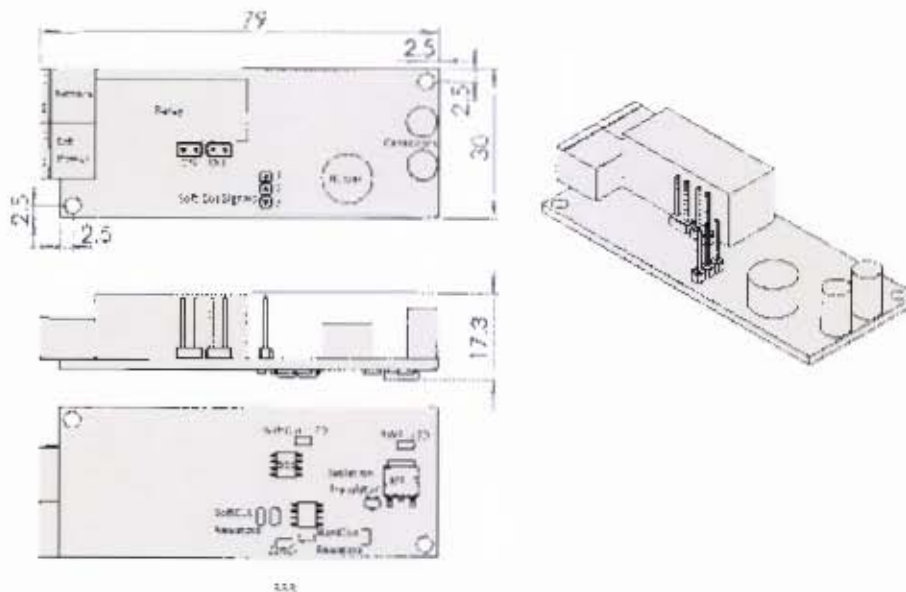

Figure 6.41: LiPo Protection Board Layout Diagram

Table 6.10: LiPo Protection board Pin layout

Input / Output	Description	Pin no.	Pin Name	Pin Use	Connector
Battery	Power connection for the Kickerboard	1	GND	Ground	Phoenix 2 pin Shrouded
		2	V+	Battery Voltage	
Lxt Power	The output voltage if the relay is armed	1	V-	Output Voltage	Phoenix 2 pin Shrouded
		2	GND	Ground	
Soft Cut Signals	The soft cut alert signals	1	I3	Open Collector (LM555)	1x3 Pin header
		2	Cut	LM555 Output	
		3	GND	Ground	

6.5 Stackable Wireless

Because the controller boards were generic, a wireless connection to the host machine needed to be established to any MCB. The Stackable Wireless board achieved this, as well as connecting to the MCB stack to remove the requirement of additional power wiring.

6.5.1 Design Parameters

An easy to use wireless board with low latency and high transfer speeds is difficult to find. Often after finding such a device, getting it to operate seamlessly is also a challenge. The stackable wireless board is aimed at removing these difficulties. The board was designed with the intentions of Table 6.11 below.

Table 6.11: Design parameters for the Stackable Wireless boards

Specification	Justification
The board would need to regulate its own voltage.	The aim was to make this board as generic as possible
Operate as a discrete module.	Needs to function completely independently
Small in size	Easily fit into any application
The board needs to comply with the already created stacking standard.	Reduce the wiring required to get wireless communications connected to the MCB.
Features and external connections needed to be simplified.	Ease of use outside of SSL.

6.5.2 Possible Functionality

The module can operate on any voltage greater than 5V using the built in LM317 or on 3V if the LM317 is bypassed. RS232 communication was placed on board to allow the device to interface with a PC or similar media. This board is designed to operate in what is known as transparent mode, which implies the paired devices act as a wire between the two modules and nothing more.

6.5.3 Schematic

Figure 6.42 is the schematic for the Stackable Wireless board. The relevant modules include; Power LFD, stackable connectors, LM317, decoupling capacitors, MAX3232 and connector, AMB2520 wireless board and finally external pull down resistors.

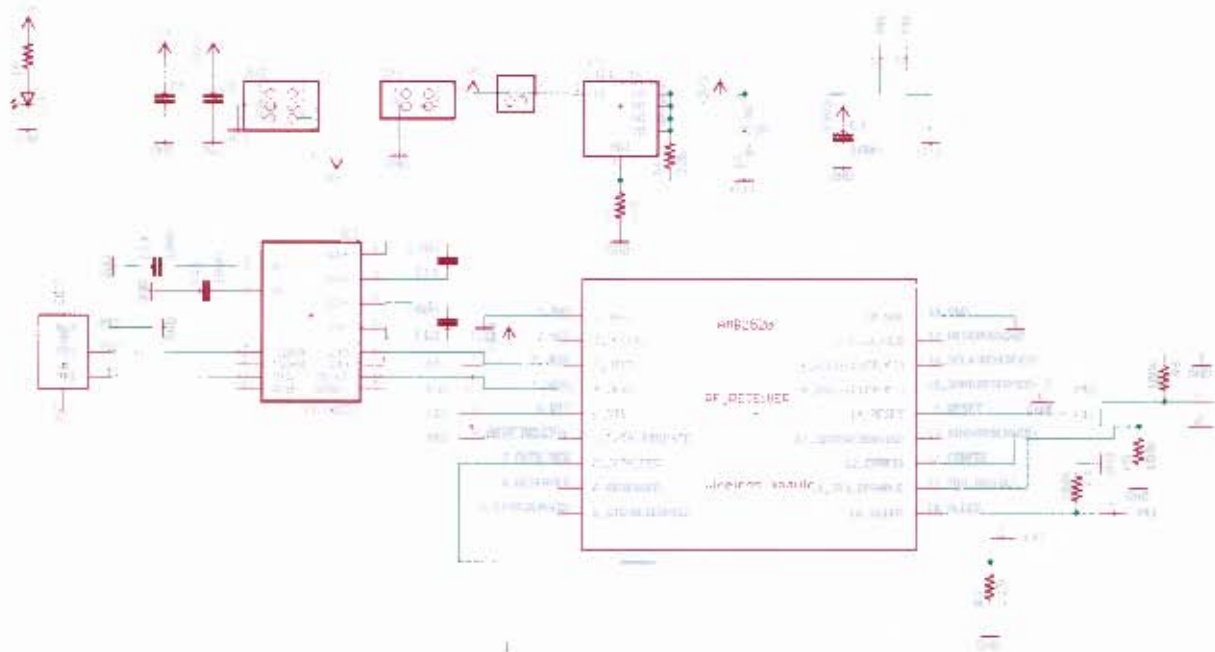

Figure 6.42: Schematic for the Stackable Wireless board

6.5.4 Recommended Start-Up Procedure

Because the AMB2520 is a plug and play device, once power has been connected it will operate as if there is a fixed connection between the 2 modules if you transmit at the default BAUD of 38400.

6.5.5 Board Layout

The stackable wireless board is designed to fit on the stackable connection on the MCB. It has optional drill holes for applications which require mounting. All sizing and location information is given in Figure 6.43 on the following page.

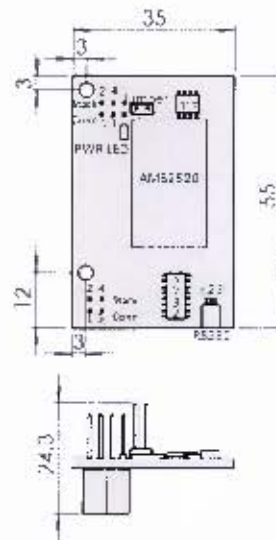

Figure 6.43: Stackable Wireless Board Layout Diagram

Table 6.12: Stackable Wireless Pin Layout

Input / Output	Description	Pin no.	Pin Name	Pin Use	Connector
Stack Conn	Power connection for the Kickerboard	1	V+	Battery Voltage	2x2 pin header OR 2x3 pin header
		2	DNC	Do not connect (I2C for MCB)	
		3	DNC	Do not connect (I2C for MCB)	
		4	GND	Ground	
RS232	RS232 Compatible Connector	1	Rx	Rx line into AMB2520	picoclasp 3 pin
		2	Tx	Tx Line out AMB2520	
		3	GND	Ground	

6.5.5.1 Jumper Possibility

The jumper on the board connects the stackable connectors to the input of the LM317. This can be removed and the 3V line can be powered directly.

6.6 Summary

This chapter began with defining the electrical systems required to augment the mechanical systems to create a robot. Once the problem statement had been defined, specifications were placed on each PCB to create a task list for each design.

After multiple revisions for some PCB, all specifications were met for all the PCB. The chapter continued by describing how each system was designed, how it operates, pin outs and other vital information in the use of the boards.

Once the mechanical systems had been tied in with the electrical systems, integrating software was the only hurdle to produce a robot that could be tested. The following chapter introduces the software systems that govern the architecture of a robot.

7. Software and Algorithms

Small Size League (SSL) is a fully autonomous soccer playing system with the inclusion of the host machine and camera system. The robots receive commands from the host machine after game tactics have been computed. The host machine subsystems of SSL were not within the scope of the thesis and as such the robots were not fully autonomous. Because the SSL robots needed to be ready to function autonomously a test bed needed to be created for thorough testing. The test bed needed to integrate with the operational instructions the PC would send to control the robots. Figure 7.1 shows information flow for the robot and the in the testing environment from the Logitech controller to the individual robot.

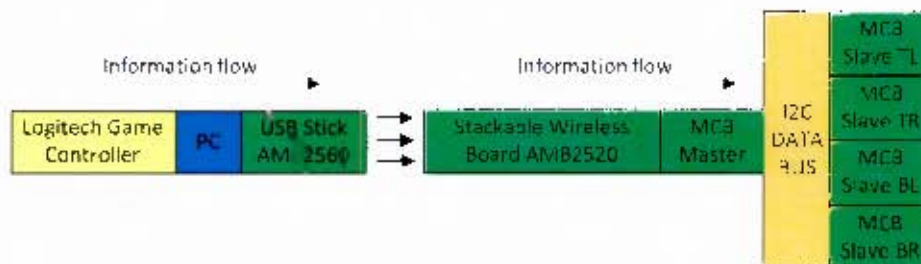

Figure 7.1: Command information flow for an SSL Robot

7.1 Computer Software

Labview was the simplest software to integrate a Logitech Rumblepad controller to the PC as it uses windows drivers. An application was made to control an SSL team using multiple game controllers for testing. Figure 7.2 shows the open application window for the PC operating the robots. The data flow can be seen in Communication Protocols in chapter 7.3.

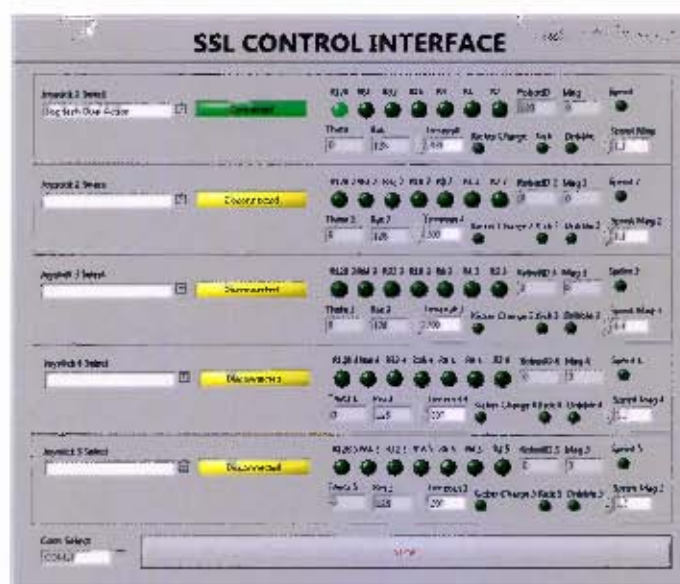

Figure 7.2: SSL Control Interface for the Computer

The system was designed and tested on the Logitech™ Rumblepad controller. Controls were matched to any PlayStation soccer game. Figure 7.3 indicates the necessary controls for the robot.

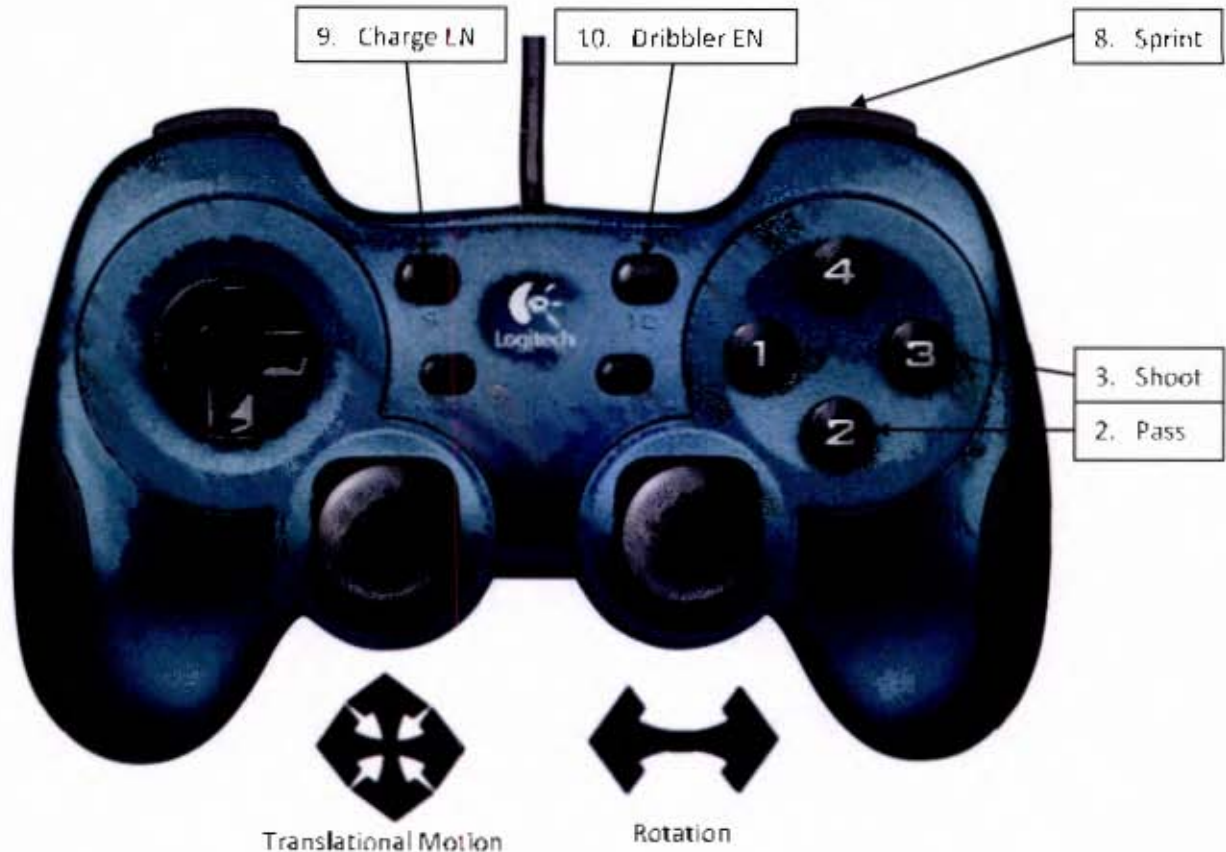

Figure 7.3: Rumblepad Game Controller Controls

7.2 Robot Software

7.2.1 Robot Locomotion Control Algorithms and Code

Movement information for individual robots could be sent in two possible methods, either sending the desired velocity or sending the wheel speeds to the robot. Sending the wheel speeds would use the Host PC computational power which is more than the SSL robot. However with sending the motor speeds the communication link would have more packets of data to send to each robot and reduce the effective refresh rate.

The velocity vector with rotation could be sent using 3 packets of data. Each packet of data was assigned to a single byte and any robot movement could be comprised of 3 bytes. The vector was sent in polar co-ordinates as it simplified the required calculations on the SSL platforms. Figure 7.4 assisted in creating the generic algorithm to calculate motor speeds.

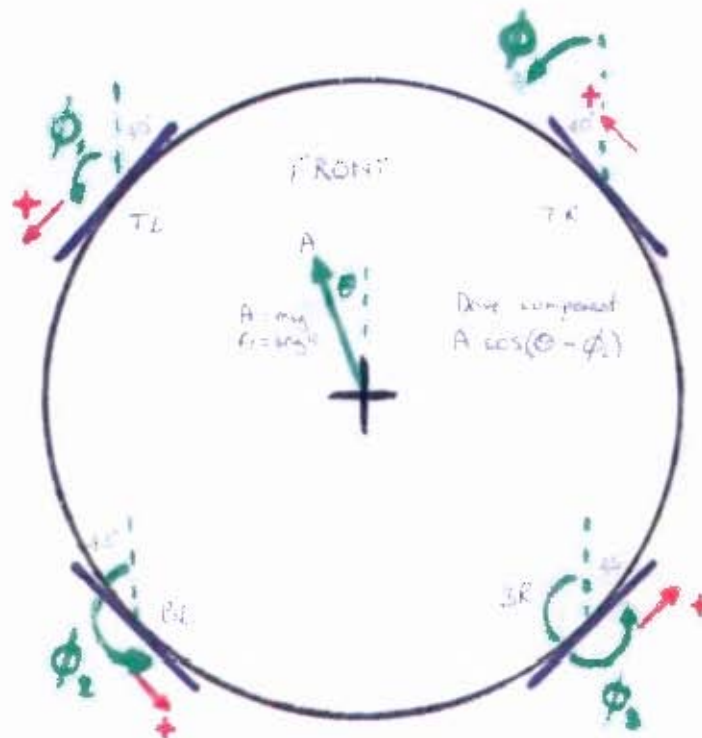

Figure 7.4: SSL Motor Velocity Calculation

Each motor was assigned a positive rotation and an offset angle from forwards to their positive rotation ϕ_i , which was hardcoded based on the final SSL design. Using polar co-ordinates and the same rotational direction for θ , the motor speed became $A \cdot \cos(\theta - \phi_i)$ which included the direction in the sign of the result. This created the wheel velocities for translational motion and a simple positive or negative rotational offset could be added to all the velocities provided it does not exceed the motors maximum speed. These algorithms were simplified and implemented on the 8 bit microprocessor.

Figure 7.5 on the following page is a simplified flowchart for the code implementing the velocity calculation. A lookup table was used for *cosine* as the math library was not used to optimise the speed of calculations.

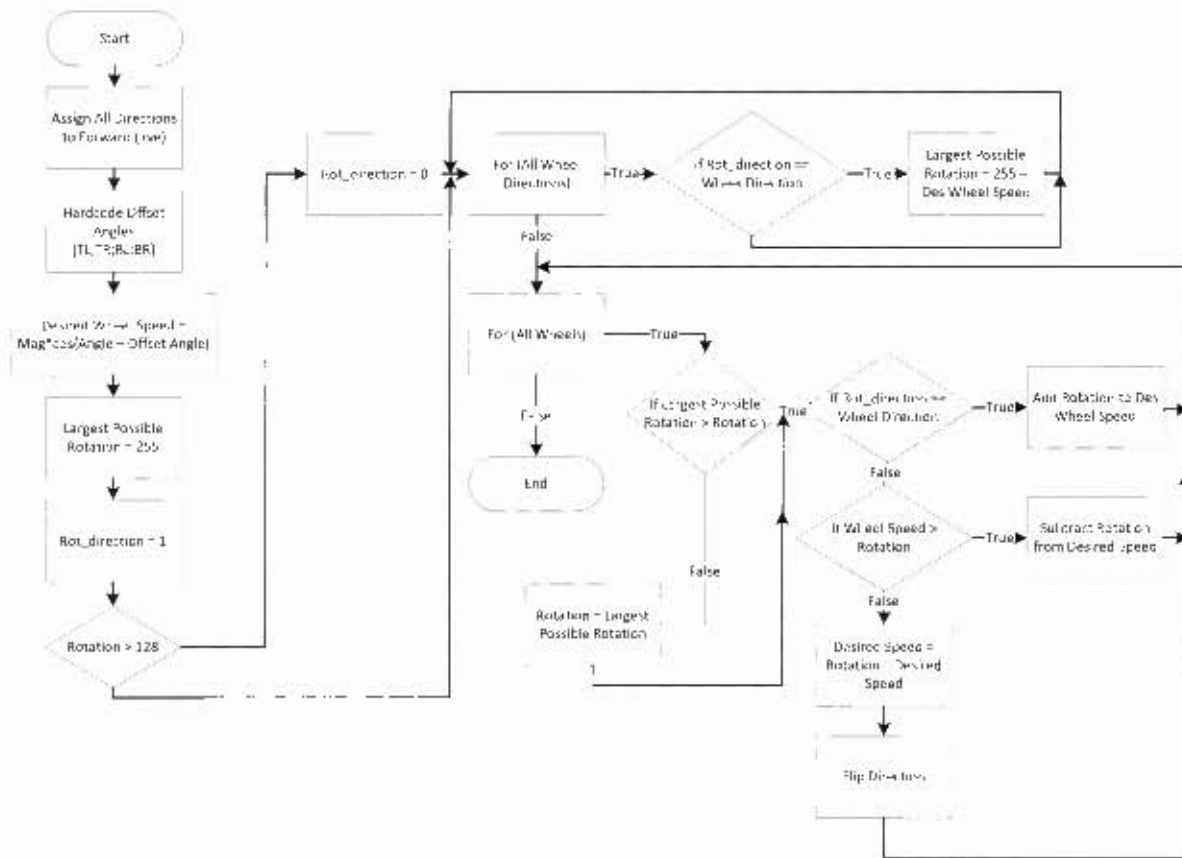

Figure 7.5: Simplified flowchart for wheel Velocity Calculation

All calculations were scaled to use unsigned chars and further increase calculation speed. An additional reduction was conducted with the lookup table as cosine is an even function; only ¼ of the lookup table was needed to correctly reconstruct the full graph.

7.3 Communication Protocols

7.3.1 UART Communication (PC to Master)

For any given data communication there are 7 bytes sent to the MCB. The data is sent at a default BAUD of 38400, and in the order of *RobotID*, *Magnitude*, *Angle*, *Rotation*, *Timeout*, *Control* and *Checksum*.

RobotID

Bit 7	Bit 6	Bit 5	Bit 4	Bit 3	Bit 2	Bit 1	Bit 0
Robot 128	Robot 64	Robot 32	Robot 16	Robot 8	Robot 4	Robot 2	1 (Forced Odd)

Each Robot on the field is assigned a bit in the *RobotID* byte instead of a unique value. By assigning a bit instead of a value, a single command can be sent to any combination of robots. A broadcast on the field can be achieved by assigning the number 255 to *RobotID*. This could be used as an electronic safety and full field shutdown. Bit 0 is masked 1 for error checking reasons discussed later.

Magnitude

8 Bit unsigned character 0 – 255

Magnitude is a scale of the desired velocity for a robot. A detailed description on robot motion can be found in the testing section of the main body.

Angle

8 Bit unsigned character 0 – 255

Angle is a measure of the translational motion off line of the robots forward orientation. A detailed description on robot motion can be found in the testing section of the main body.

Rotation

8 Bit unsigned character 0 – 128 – 254 (Forced Even)

Rotation is a measure of how much offset needs to be added to the motor velocity to allow for rotation as well as translational motion. Bit 0 is masked 0 for error checking reasons discussed later.

Timeout

8 Bit unsigned character 1 – 255 (Forced Odd)

Timeout is an additional measure of safety. If a timer counting in milliseconds becomes greater than the *Timeout* value the robot will stop all motors. Bit 0 is masked 1 for error checking reasons discussed later.

Control

Bit 7	Bit 6	Bit 5	Bit 4	Bit 3	Bit 2	Bit 1	Bit 0
KickerEn (Charge)	Basic Kick Enable	KickNow	Kick Bit 1	Kick Bit 0	Dribbler Enable	Dribble Now	1 (Forced Odd)

The *Control* contains all other operations which do not involve movement. Kick, Dribble and charge for a kick.

Bit 7: This bit enables the charging of the Kickerboard to high Voltages.

Bit 6: Indication of whether a kick is desired or not.

Bit 5: The robot must kick now or wait for the light barrier^{*} to indicate the presence of a ball.

Bit 4: The high bit in the power setting for a kick.

Bit 3: The low bit in the power setting for a kick.

Bit 2: Activates the possibility of the dribbler.

Bit 1: The robot must dribble now or wait for light barrier^{*} to indicate the presence of a ball.

Bit 0: Masked 1 for error checking reasons discussed later

^{*}Light barrier is an optional component which could be added onto the robots to allow for better information to whether the ball is in a kickable position in front of the robot.

Checksum

8 Bit unsigned character 0 – 255

The CheckSum, was a truncated sum of all the bytes sent in an unsigned char for additional error checking.

The number of bytes transmitted over the wireless link was reduced by not sending a start or stop byte between devices. This complication required additional error checking to be placed on the robots as the information between robots is a continuous stream. This continuous stream created the possibility of a single byte being lost in transmission and all following data being incorrect. A structure was put in place to ensure incorrect data would not be accepted as data, and then once false data had been recognised, to skew the data further. After this had been done multiple times, the system would wrap back to the working stream. There are 7 possible cases that need to be considered for 7 byte data stream. The tables below indicate how the data is either ignored or accepted.

Table 7.1: Correct Data Stream from the Host Machine

	Byte0	Byte1	Byte2	Byte3	Byte4	Byte5	Byte 6
Possible Data Stream	RID	Mag	Angle	Rot	Tout	Cbyte	Checksum
Required Parity	ODD	X	X	EVEN	ODD	ODD	X
Probability of Acceptance	1	1	1	1	1	1	1

The bytes that did not need the full resolution were forced either odd or even, because 4 bytes are forced either high or low, there is a pattern in the correct information which needs to exist for the data to be accepted. With the bytes in the correct places, this stream would be accepted.

Table 7.2: Skewed Data Stream Possibility 1

	Byte0	Byte1	Byte2	Byte3	Byte4	Byte5	Byte 6
Possible Data Stream	Checksum	RID	Mag	Angle	Rot	Tout	Cbyte
Required Parity	ODD	X	X	EVEN	ODD	ODD	X
Probability of Acceptance	1	1	1	0.5	0	1	1

With a single byte rotated in the data stream; last communications *Control* mistakenly assumed to be the first byte in this stream, byte 4 does not need the requirement of being odd. The data is ignored.

Table 7.3: Skewed Data Stream Possibility 2

	Byte0	Byte1	Byte2	Byte3	Byte4	Byte5	Byte 6
Possible Data Stream	Cbyte	Checksum	RID	Mag	Angle	Rot	Tout
Required Parity	ODD	X	X	EVEN	ODD	ODD	X
Probability of Acceptance	1	1	1	0.5	0.5	0	1

With two bytes rotated, now byte 5 is expected to be odd. The data is ignored.

Table 7.4: Skewed Data Stream Possibility 3

	Byte0	Byte1	Byte2	Byte3	Byte4	Byte5	Byte 6
Possible Data Stream	Tout	Cbyte	Checksum	RID	Mag	Angle	Rot
Required Parity	ODD	X	X	EVEN	ODD	ODD	X
Probability of Acceptance	1	1	1	0	0.5	0.5	1

With the data shifted 3 bytes, the stream clashed with byte 0 and byte 3 and only a possibility of passing on the other bytes. The data is ignored.

Table 7.5: Skewed Data Stream Possibility 4

	Byte0	Byte1	Byte2	Byte3	Byte4	Byte5	Byte 6
Possible Data Stream	Rot	Tout	Cbyte	Checksum	RID	Mag	Angle
Required Parity	ODD	X	X	EVEN	ODD	ODD	X
Probability of Acceptance	0	1	1	0.5	1	0.5	1

With a 4 byte shift, the byte 1 is expected to be odd and would be even. The data is ignored.

Table 7.6: Skewed Data Stream Possibility 5

	Byte0	Byte1	Byte2	Byte3	Byte4	Byte5	Byte 6
Possible Data Stream	Angle	Rot	Tout	Cbyte	Checksum	RID	Mag
Required Parity	ODD	X	X	EVEN	ODD	ODD	X
Probability of Acceptance	0.5	1	1	0	0.5	1	1

A 5 byte shift, Byte 3 is expected to be even and the data is ignored.

Table 7.7: Skewed Data Stream Possibility 6

	Byte0	Byte1	Byte2	Byte3	Byte4	Byte5	Byte 6
Possible Data Stream	Mag	Angle	Rot	Tout	Cbyte	Checksum	RID
Required Parity	ODD	X	X	EVEN	ODD	ODD	X
Probability of Acceptance	0.5	1	1	0	1	0.5	1

Finally on the 6 possibility, Byte 3 is expected to be even again and the data is ignored.

7.3.2 I²C Communication (Master to Slave/Slave to Master)

In the final design bi-directional communication was dropped, because the additional information for the master had adverse effects on the performance of the robots with the motor speed controllers. This is discussed further in the testing section in Chapter 8.

A packet of information for the slave devices on the I²C bus has 3 bytes; *Address*, *Data*, *Control*.

Address

The address byte is a requirement for I²C and each slave has a unique address which is created during start-up of that particular device. Each controller board is given a 7 bit address and the least significant bit would be 1 as the Master is writing to the slaves. The list of addresses can be found in Table 7.8

Table 7.8: Table of Slave Motor Control Board I²C addresses

Control Board	Address (Hex)	Address (Binary)
Top Left	82	100001X
Top Right	88	1000100X
Bottom Left	8A	1000101X
Bottom Right	8C	1000110X

Bit 7	Bit 6	Bit 5	Bit 4	Bit 3	Bit 2	Bit 1	Bit 0
1	0	0	0	1/0	1/0	1/0	1

Data

The next byte is the data byte which is an unsigned motor speed value.

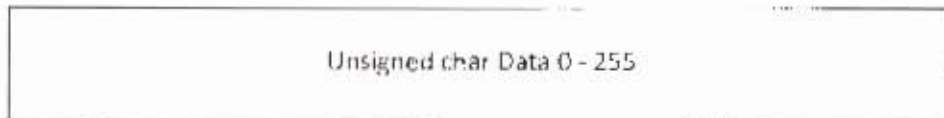
ControlByte

The *controlByte* contains the necessary information to use the data byte. It contains the intended motor direction, which DAC to write this data value and whether to reply with the current motor velocity.

Bit 7	Bit 6	Bit 5	Bit 4	Bit 3	Bit 2	Bit 1	Bit 0
DACA	DACB	Direction	Reply	X	X	X	X

7.4 Summary

This chapter began with defining the need for a software interface to control the robots manually before an autonomous system could be developed. It is then explained how the locomotive algorithms were developed in high level systems followed by creating identical algorithms on an 8 bit system.

Data structures and information flow down to the lowest level throughout the robots was defined and explained with information regarding error free communication

Now that the mechanical, electrical and software systems have been defined, testing could be conducted on the discrete systems followed by system integration and a final robot could emerge after testing.

8. Testing and Results

Individual modules of the SSL robot were tested before integration of the full system. Some systems and structures were constructed to perform testing for the SSL systems.

8.1 Testing Environment

In order to test the modules and complete assemblies, a testing area needed to be constructed for the SSL robots. The first of which requirement was a field or playing surface.

8.1.1 Field

The field in SSL is well defined within the annual rules governing the competition. All rules were adhered to when constructing a field for UCT as shown in Figure 8.1.



Figure 8.1 UCT SSL Field in the Robotics and Research Agents Laboratory

Half a field would have been adequate for testing; however a location for the competition needed to be set and UCT was hoping to host the competition which necessitated a full field being created.

8.1.2 Scaffold Structure

In Accordance with the rules, 2 overhead cameras are required to be placed in the middle of goal line and the halfway line of each side. These cameras needed to be located at a vertical height of 4m above the playing field. Additional lighting was also placed onto the scaffolding to ensure the minimum lighting requirements were followed.

8.2 Locomotion

The robot movement was governed by 3 bytes. These 3 controlling bytes were *Magnitude*, *Angle* and *Rotation*. Polar co-ordinates were used in SSL, because it greatly reduced calculation complexity on the low level electronics.

8.2.1 Magnitude

The magnitude byte is a scalar factor which determines the rate of translational movement. The full byte is available for data. Sending a value of 0 in the magnitude byte would stop translational motion.

8.2.2 Angle

The angle byte determines the direction the robot will move without changing its current orientation. 360 degree intervals are divided into the 256 possibilities for the angle byte which increment in a counter clockwise manner when viewing the robot from above. Sending a value of 0 in the angle byte would indicate travelling forward. Table 8.1 provides a quick guide to 4 possible *Angle Bytes* and the corresponding direction of travel provided the *Magnitude* byte is not zero.

Table 8.1: Angle Byte Information Table

Angle Byte	Movement Direction	Keyboard Game Equivalent
0	Forward	"W"
64	Strafe Left	"A"
128	Reverse	"S"
192	Strafe Right	"D"

8.2.3 Rotation

The rotation byte was responsible for on the spot rotation of the robot. The nominal value for rotation is 128 which is no rotation on the platform. Reducing the rotation byte below 128 will make the robot rotate left with magnitude equal to the offset from 128. Increasing the rotation value will have the same effect except with the robot rotate right.

The locomotion tests were conducted using a laptop with Labview software and a fully charged SSL Robot. Once the connection between testing PC and SSL robot had been established the robot was placed on the field and tests were conducted.

8.2.3.1 Translational Omni directional control

In order to confirm omni-directional translational movement the robot was required to move in set directions at variable speeds without changing its orientation. Tests were conducted on a straight line section on the middle of the field. In forward testing, the robot front was established with a piece of tape on the cover, and the robot was controlled to move forward down a line section. The initial test condition can be seen in Figure 8.2.



Figure 8.2: Forward translational test starting position

The robot was fully capable of moving in an omni-directional manner, however occasionally during motor acceleration and deceleration particular motors would respond faster. This marginal

differential in motor speed would result in a motion or rotation which was not desired. An example of the typical offset error can be seen in Figure 8.3

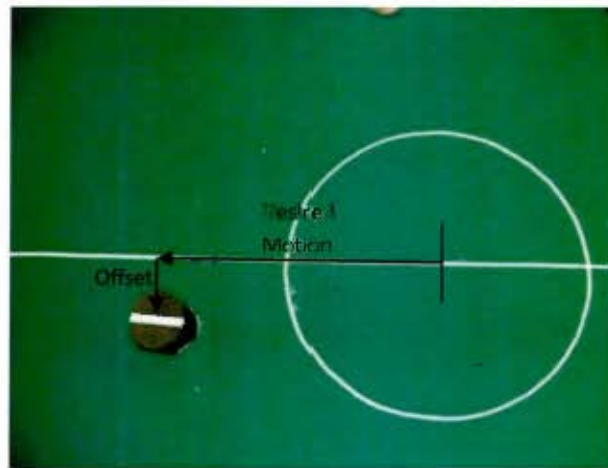

Figure 8.3: Forward translational test resting position

Similar tests were conducted for left, right and reverse translational motion. This can be seen in Figure 8.4

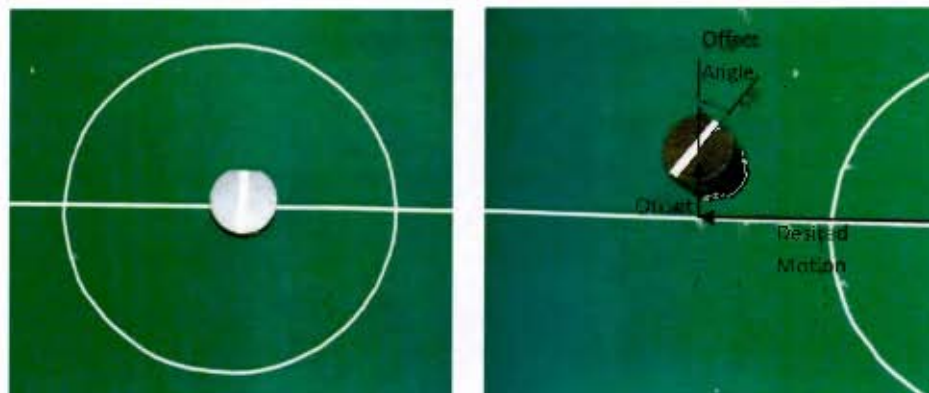

Figure 8.4: Left translational movement Testing; Start (Left), Final Position (Right)

In an attempt to remove the variance in the motor speed controller control rates, a closed loop was created on the MCB. The loop determined the individual wheel speeds required for the desired velocity vector and created 10 incremental steps for each motor to achieve before all motors proceed to the next speed step. The Master MCB would keep track of all motor speeds and communicate updated information when all wheels were moving that its individual desired speed. Ideally, this would ensure the wheel speeds were kept in closer ratios and hence reduce the overall error.

This modification to the system did not improve as the motor's internal controller would ramp the speed based on the desired value and the desired values were 1/10 of the original produced significantly slower response rates. This system did have an effect on the final offset error, however the robots were designed for speed purposes and the system was abandoned. The additional offsets

were minor and the camera system provides an additional control loop which would eliminate the offsets present at lower control levels.

8.2.3.2 Rotational Control

For rotation testing, the robot was placed in the centre of the field and made to rotate. Multiple turns were conducted and the deviation from the centre of field was observed throughout the test.

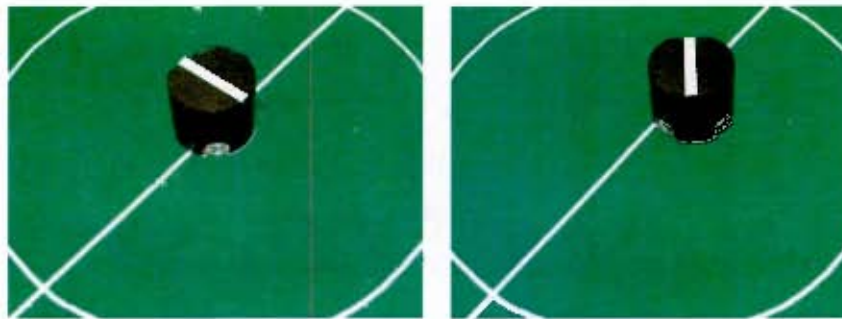

Figure 8.5: Rotational Testing: Start (Left) and Final Positioning (Right)

In a similar manner to the translational tests the rotation would keep the robot on the same spot during constant rotation. If one motor were to change velocity at a different speed to the motors there would be deviations similar to the translational motion. As stated earlier, these deviations would be accounted for in the final camera control loop.

8.2.3.3 Speed Testing

Straight line speed tests were conducted on the platform to determine whether the locomotive speeds were comparable to UCT's older model, and current competitive models. The straight line tests provided the following results.

UCT 2005 Model	Current Design	SKUBA[2]
Accel: 1.8 m/s ²	Accel: 6 m/s ²	Accel: 5 m/s ²
Vel: 0.64 m/s	Vel: 3 m/s	Vel: 3.5 m/s

The SSL robot comfortably outperforms the older model, but fails to prove itself against SKUBA's velocity statistics. Theoretically the SSL robot was capable of greater velocities which could not be tested as the robot would require stopping before colliding with another object off field.

8.3 Ball Control Systems

8.3.1 Kicker

The kicker module was tested as a group as each piece was core to the final success of the module. The final requirement was kicking velocity and repeatability in terms of accuracy and time interval.

8.3.1.1 Kicking speed

In order to keep test variables consistent throughout testing, 3 systems were developed.

A linear speed sensor was designed and built for testing. The sensor was milled from a block of HDPE, with 2 holes drilled horizontally through the piece which can be seen in Figure 8.6. A photodiode and LED combination were placed in the horizontal drilled holes, which created the light barrier



Figure 8.6: Linear speed sensor placed on its front

A slot was cut into a plate shown in Figure 8.7 which would be secured to the test bench. The ball was placed in the slot as far back as possible. The placement of the ball increased repeatability and provided more consistent testing.



Figure 8.7: Ball guide and locator

The combination of the linear speed sensor and ball guide allowed for accurately measurable and repeatable testing for horizontal ball velocity. The combination can be seen in Figure 8.8

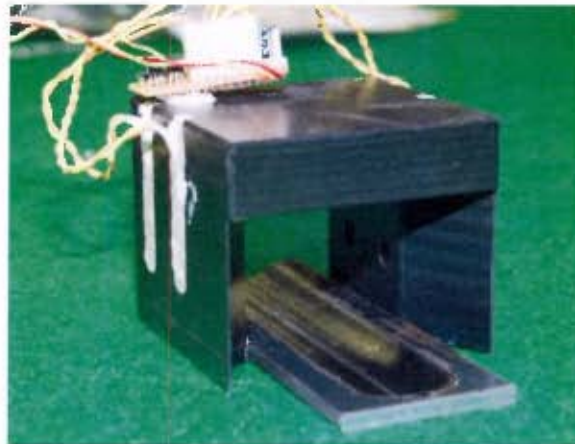

Figure 8.8: Ball speed test setup

The kicker solenoid was secured to the desk on a robot platform for fixed placement testing.

The linear speed sensor was tested to ensure the validity of testing by determining the repeatability of the light barrier. The sensor digitally transitioned from a low to high transition from a ball triggering the light barrier followed by a high to low transition when the ball left the sensor shown in Figure 8.9.



Figure 8.9: Linear speed sensor calibration

During a kick, there are 3 stages that need to be considered;

Stage 1: The Kickerboard IGBT completes the circuit for the solenoid and current begins to flow. The current waveform was a function of the inductance of the solenoid and the resistance of the wire. During this stage, the ferromagnetic core would be gaining kinetic energy to impart onto the ball.

Stage 2: The ball no longer receives kinetic energy from the kicker and travels away from the kicking plate. This may be before the kicker core has reached its front position.

Stage 3: The kicker core has reached the front position, and the circuit must be disconnected to prevent unnecessary drain on the capacitor bank.

When considering stage 1, the magneto motor force (MMF) generated by the solenoid is related to the number of turns (N) and current (I), and thus maximizing the current would produce the greatest kicking speeds. The waveform of the current was needed to determine how the impedance of the solenoid affected the current in the coil before striking the ball due to the short stroke.

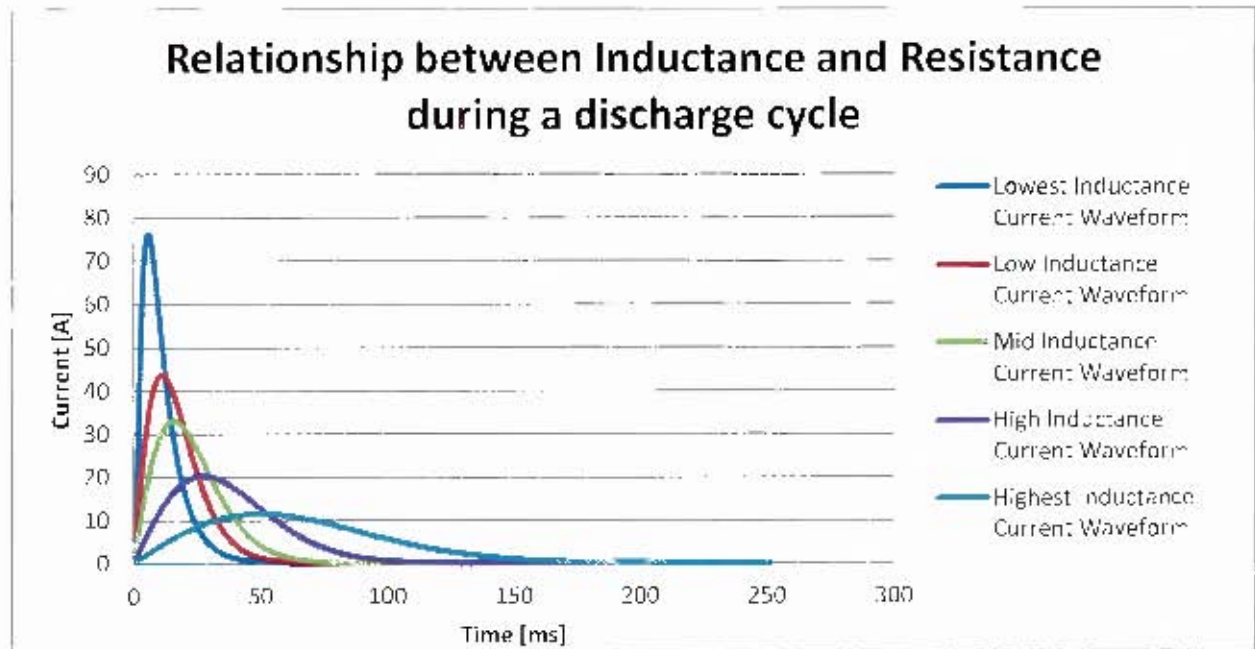

In the graph the area under graph is energy stored in the capacitors. A low inductance reduces the time required to drain the capacitors and effectively reduce the time to convert the electrical energy to magnetic energy.

Performing these tests was essential to determine whether the energy stored in the capacitors was being released into magnetic potential. The resistance determined the maximum current in the solenoid. The inductance affected the rate of change of the current.

Without a slow motion capture of the ball being stuck by the kicking solenoid, it would be impossible to determine the exact time the kicker strikes the ball and the timeframe for this process and the particulars of stage 2.

A simple calculation could determine the expected time for the solenoid core to reach the front position. This was not necessary after noticing features on the current waveform while conducting testing for stage 1.

To determine whether the resistance or inductance was controlling the current in the solenoid, a 50mm length of wire from the solenoid was stripped and oscilloscope probes were placed on the wire.

Figure 8.10 is the direct capture from an oscilloscope during a “dry” kick cycle. The blue signal is the Capacitor Voltage, which initially is 46.8V and settles at 12V after a kick signal held high, the yellow is the Kick signal to the Kickerboard and the green signal is a measure of the current flowing through the solenoid during the kicking cycle.

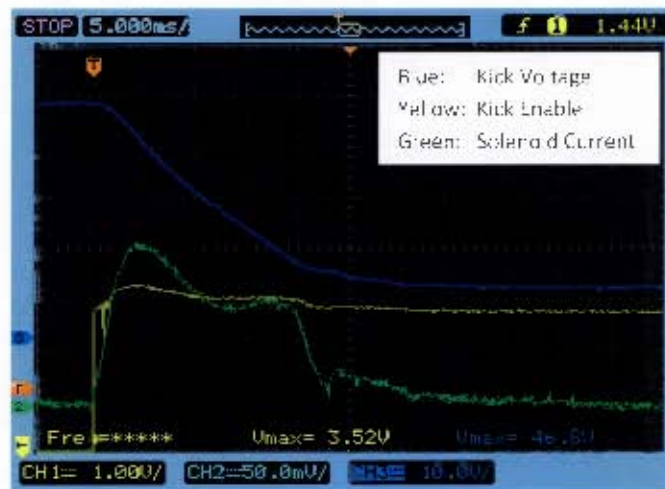

Figure 8.10: Direct Oscilloscope Kicking Capture (Dry fire, Rear Position)

The green signal was of particular interest as it has a sharp current rise time which indicates full current rise time of 4ms. This revealed that the resistance of the solenoid is the determining factor for the maximum current and the inductance has significance, but does not seriously adversely affect kicking power. During these tests, a second crest on the current waveform can be seen in the data. This 2nd crest can be seen across all data samples at varying voltages.

It was theorised, that the 2nd crest was a result of the mechanical parts moving in the electrical coil. The theory was verified, by performing similar testing with the solenoid locked in the front position. Figure 8.11 was a kick with the solenoid placed in the front position and revealed no second crest present during a kick.

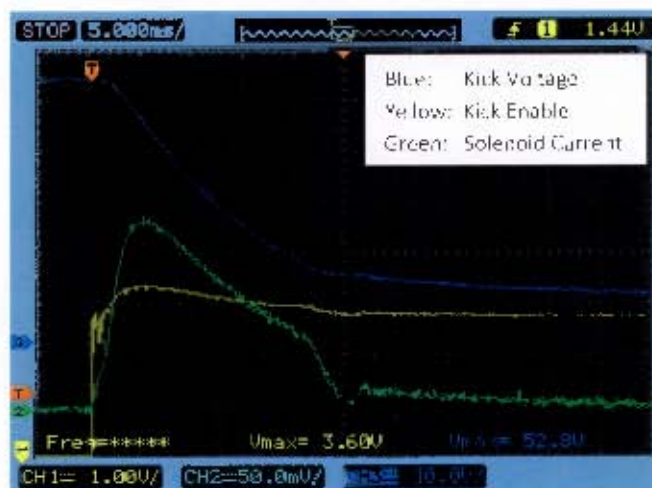

Figure 8.11: Direct Oscilloscope Kicking Capture (Front Position)

The tests were performed at incremental capacitor voltage levels, with no deviation in the appearance of the additional crest. The 2nd crest would be present after shorter time intervals from kicking instances at higher voltages; this could be a result of the solenoid core moving faster to the front position.

Additional verification was performed by determining the 2nd crest time at maximum capacitor voltage of 250V. In the particular case of Figure 8.12, the 2nd crest peak presented at 5.5ms which was visible using the white cursors.

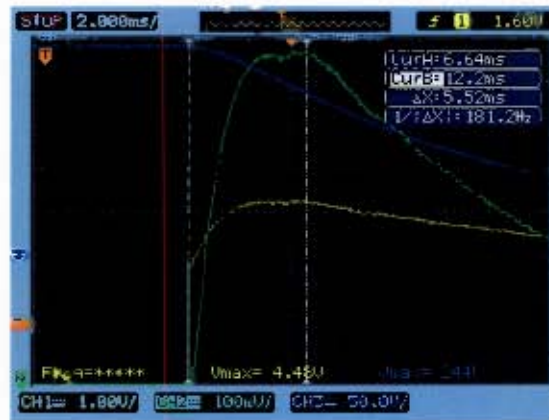

Figure 8.12: Direct Oscilloscope Kicking Capture at 250V (Dry fire)

When kicks were performed while striking the ball, the 2nd crest would present before 8ms of kicking. The kick enable line was then disabled after an 8ms kick, to determine if it had an effect on final kicking speed. The results are included in the Speed Variability section.

8.3.1.2 Speed Variability

A requirement for SSL is that a robot could kick hard in order to score a goal, but an equally important requirement was to move a ball to a friendly robot during passing. The speed variability was a requirement for slower friendly passing between robots. Tests were conducted by varying the kick enable times sent to the Kickerboard. Four different kick enable times [11ms, 8ms, 5ms, 3ms] were tested over a range of sample core materials [Nylon, HDPE, PVC, Teflon].

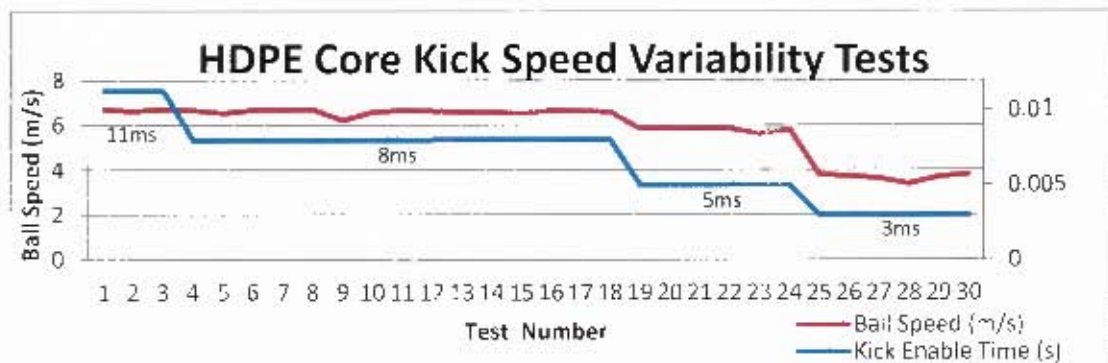

Figure 8.13: Graph of kick speed variability based on Kick Enable timing

The kicking tests provided a direct correlation between kick enable times and final ball speed times. Kick Enable times of greater than 8ms produced no difference in final ball speed across all samples. Varying the kick enable times from 8ms to lower time values would provide sufficient control for both passing and shooting at goal.

8.3.1.3 Material Optimisation

As no high speed kicking tests had been performed at UCT, material optimisation could not be carried out prior to this project. The mobile inner core was comprised of 2 materials, a ferromagnetic core and a non-ferromagnetic material.

Ferromagnetic

Varying the ferromagnetic material would have a significant impact on final ball speed. However after many hours of communication with transformer companies the optimal material purchased by these companies was fabricated into laminated layers which cannot be machined further. Recommendations from the technical groups which were contacted were to use a high silicon and low carbon content in the chosen material. After consulting with the UCT workshop, EN3B steel would be best suited based on those requirements. A specimen of mild steel was also machined as a comparison. The FN3B was indistinguishable from the mild steel provided by the UCT workshop.

Non-magnetic

As already mentioned, 4 different materials were compared to determine an optimal material which would produce a faster kick with no additional increase in energy. The data provided in Figure 8.14 show that Nylon has the greatest average kick velocity.



Figure 8.14: Graph of Kick Speed vs. different core materials

8.3.1.4 Wire Thickness

As mentioned earlier, Magneto Motor Force (MMF) is the product of Number of turns (N) and current (I). The amount of turns could not be accurately determined during the solenoid wiring process, although thinner wire should result in a larger number of turns and a greater resistance. A range of solenoids were wired using 0.4, 0.6, 0.8 and 1mm outside diameter of copper wire. The resistances ranged from 30 to 1.6Ω. The lower resistance and thicker wires, allowed a larger energy to be placed into the solenoid, and thus increased the magnitude of the kicks.

8.3.1.5 Final Power

After all optimisations had been performed, the maximum kicking speed was tested. Using a 21 AWG wire, with a total resistance of 1.6Ω , an EN3B and Nylon core, capacitors charged to 250V and a 8ms kick enable time. The highest recorded kick speed was 9.07m/s. Unfortunately 10m/s was not achieved, but during power testing it was noted that having the ball placed slightly away from the robot produced better kicks and is mentioned in the recommendations.

8.3.1.6 Charge Time/Cold Start

The Kickerboard external capacitors could be fully discharged, partially charged or fully charged. Each particular state has its own reset time. The board has the ability to kick at any point in time but with a kick at a voltage below 250V the expected kicking speed would differ. The three 2200uF capacitors rated voltage was 250V which stores 206J of energy. The charge time is referred to as the time taken to charge back to 250V directly after a kick which typically drains the capacitors to 150V. This charge time with partially discharged capacitors could be less than 3 seconds when allowing the Kickerboard to run at higher currents. The cold start time was defined as initial turn on of the system and the capacitors were fully drained and charged to 250V. The cold start time would be shorter than 7 seconds.

8.3.2 Dribbler

The dribbler was required to control a golf ball while in contact with the robot. In undergrad, Mr Lwabona [54] indicated that with a minimum ball speed of 288rpm the ball could be controlled adequately but with additional speed the control was further improved. From his results, the motor was given a binary speed setting of maximum speed or off. This binary setting removed the complexity from the device to either be on or off. The system was tested and was capable of capturing a golf ball propelled towards it at passing speeds.

8.3.3 Chipper

The chipper module was responsible for lifting the ball off the playing field and over the height of a robot. The chipper module designed is shown in Figure 8.15.

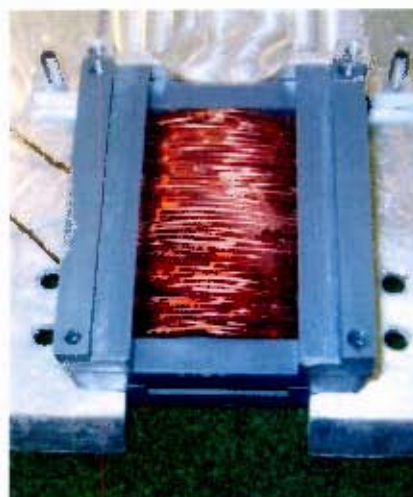

Figure 8.15: Preliminary assembly of the chipper without dribbler assembly

The assembly required the chipper mechanism to be assembled and placed onto the base structure first which created additional difficulty when challenges were encountered. As the chipper was using the same energy from the Kickerboard, the resistance of the chipper needed to be similar to the main kicker such that the Kickerboard would not break the firing IGBT from a short circuit. The chipper resistance was aimed at being around 2Ω. The length of wire for the kicker solenoid was significantly more than the chipper solenoid and as a result a thinner wire was used for the chipper to match the resistance.

In the preliminary tests on the chipper using maximum kicking strength the ball was not able to reach 150mm in vertical height which is the maximum height of an SSL robot. The launch angle of the ball suggested the ball was slipping when making contact with the chipper paddle. No simple design solution could be found without a complete redesign for the chipping system.

An additional observation was the chipping paddle experienced greater friction after multiple chips.

8.3.1 Cover Testing

The cover of the SSL robot has 2 purposes: Protect the sensitive systems and provide a flat surface on the top for identification by the autonomous systems. The cover adhered to the size requirements for the overall robot as well as providing the correct shape for autonomous vision.

During kicker testing, the cover was placed and secured in the firing line of the balls. After repeated impacts, no sign of damage was visible on the cover or objects being protected by the cover.

8.4 Communication

Communication latency between host PC and multiple robots needs to be minimized to create seamless robot control. Two Simcom SIM20 modules were purchased from a local distributor *Otto Marketing* for initial testing. After further information from Austria, two different modules from Amber Wireless were also purchased.

8.4.1 Simcom Modules

The Sim20 modules had a local distributor and were the first systems to be tested. The modules had two possible communication modes; Transparent and Command.

Transparent was believed to be optimal as no additional data needed to be transmitted to the modules. The default BAUD rate was 9600 however the bidirectional ping times were 2.95 seconds on average. The reason for the large ping delay was that in transparent operation, the buffer is required to sit idle for 1.4 seconds before data would be transmitted. Transparent mode was not suitable for any communication in SSL.

Command mode data is sent with additional headers which the Sim20 module interprets and executes. Figure 8.16 shows the improvement in ping time but the communication between the Sim20 modules was not reliable and not sufficient for high speed communication continuously for 30 minutes.

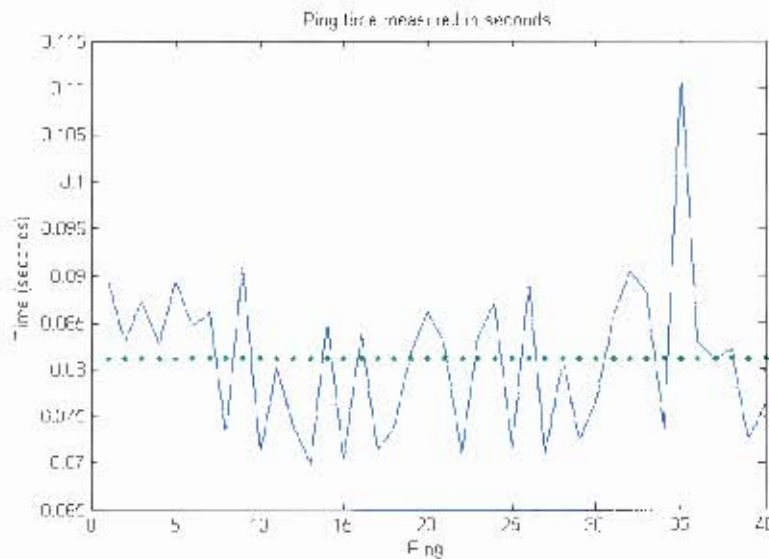

Figure 8.16: Ping times created from bi-directional communication between two Simcom20 modules

Additionally a particular data character (0x32) could not be sent in command mode as it would stop data transmission because it was the command break point for the modules.

The Simcom modules would not be adequate for SSL applications because of the inherent latency and unreliability of the modules.

8.4.2 Amber Wireless Modules

AMB2520 modules were purchased after the devices were used by the *Austrian Cubes* in 2010. The default BAUD rate for the modules was 38400. The first test conducted on the devices was continuous operation between multiple modules for more than 30 minutes. With a single device running a ping test to a separate module and an observer device receiving data, all three devices were 100% operational after the test duration. The mean ping time throughout the 30 minutes of operation was 7.3ms with a lower standard deviation compared to the Simcom modules.

The AMBF8 wireless modules were capable of transmitting data at a default BAUD of 38400 to a maximum speed of 115200. Each Robot required 7 bytes for a successful transmission and if 5 robots were being issued commands the number of bits for a full field update would be 280 before the headers required for communication. Using the default settings it was potentially possible of transmitting at 109Hz which was far greater than the PC could compute data received from the cameras at 50Hz.

8.5 Power

The power requirements for SSL relate to the battery as a low power source and the external capacitors a high voltage source for the Kicking mechanism.

8.5.1 Battery

The battery is responsible for all electrical power. It would be ideal if it were capable of operating for the full duration of a match, with only half a game being the requirement. Considerations for the battery are listed in Table 8.2 below.

Table 8.2: Table highlighting battery considerations

Component	Maximum Current (A)	Expected Current (A)	Time On (%)	Time On x Expected Current x an hour (mAh)
Motor Control Boards (x5) + Wireless Module	0.25	0.15	100%	150mAh
EC 45 Motors (x4)	20	4	90%	3600mAh
Dribbler Motor + Dribbler Controller	3	1	20%	200mAh
Kickerboard	4	2	5%	100mAh
Total	27.25	7.15	N/A	4050mAh

The full length of a SSL game is 30min so the anticipated mAh rating required for 30min is 2025mAh. The batteries purchased were Hyperion LiPo 6S 2500mAh 25C. A 25C LiPo pack would be able to deliver 25x its capacity which implies the maximum continuous output current is 62.5A which is significantly higher than the perceived maximum current. The battery is capable of handling the worst case scenario for current and has the capacity for 30min of play.

The batteries were tested during testing operations and under less strenuous conditions were only replaced after 90minutes of runtime which were disconnected by the LiPo Protection boards discussed in the following section.

8.5.2 External Capacitors

The external capacitors are responsible for the high impulse energy for the solenoids. The important factors for the capacitors are physical size and energy density to maximize the energy stored and the energy transfer for optimal kicking. The final version of the robot had space for three 2200uF 250V Capacitors, whereas the first design could only support 2 capacitors. The final design also placed all high voltage components close together which allowed for greater safety and compartmentalisation. During kick testing the temperature and physical shape of the capacitors were monitored to ensure no damage was done to the components during rapid discharge. After at least one hundred kicks, no visible signs of damage or temperature change were apparent on the capacitors.

8.5.3 LiPo Protection Board

The LiPo Protection boards do not provide power to the robot but were instrumental to the safety of the battery. The battery was simulated using a bench power supply under a small load on the output

terminals of the LiPo Protection board. The board modules were tested by varying the voltage supplied on the power supply.

The board was required to physically disconnect the battery from any system once the battery has reached a minimum threshold defined on the PCB. Two separate systems were tested the soft cut/trigger and the hard cut.

8.5.3.1 *Soft Cut/Trigger*

The Soft Cut/Trigger was responsible for alerting the human operator that a battery was approaching a low voltage. A buzzer and a visible LED were used to alert the operator that the soft trigger was activated. When the voltage dipped below the Soft Trigger voltage the board produced an audible alert for 30 seconds before returning to normal operation provided the voltage had returned to a safe value before the warning had expired or the isolation transistor was removed. If the isolation transistor was connected, after the 30 seconds had elapsed the hard cut was automatically triggered and the robot power was disconnected if the voltage was below the predefined Soft Trigger limit.

The Soft Cut/Trigger performed as expected with and without the isolation transistor during testing.

8.5.3.2 *Hard Cut*

The Hard Cut was responsible for disconnecting the battery when a hardware defined minimum voltage limit had been reached. If the voltage was dropped below the defined minimum at any point during operation the relay would transition and disconnect the supplied power.

The Hard Cut ensured the battery would not be drained below a minimum threshold as expected.

8.6 **SSL Robot Weight**

The overall mass for all mobile applications should be considered. As the SSL robot was expected to perform agile manoeuvres keeping the system light would be beneficial. The weight of the robot was not listed as a specification and the robot weighed 4kg fully assembled. The winning team of 2009, 2010 and 2011; SKUBA weighed 2.3kg [51].

8.7 **Summary**

In this chapter the testing of each section and the robot as a whole was conducted. This included tests relating to locomotive, ball control systems, communication and power.

Conclusions from the testing are developed in Chapter 9 of the document.

9. Conclusions and Recommendations

In conclusion, overall the robot platform was acceptable for competition in SSL nationally and potentially internationally. Although the team does not have software ready for competitive play, essential hurdles have been overcome and from this prototype a capable team could emerge. Several challenges were discovered and the design failed to meet desired results in certain areas. These complications could be overcome with higher level code but would significantly increase the complexity of the code. The recommendations were split into Mechanical and Electrical improvements to the overall structure of the robot.

9.1 Conclusions from Testing

After the tests were conducted conclusions were formed based on the outcomes of the tests.

9.1.1 Locomotion

The overall omni-directional motion of the SSL platform was successful. The specification was to create a platform capable of speeds similar to international teams. Any translational motion was possible provided the acceleration was within the frictional limits of the surface and omni-wheels.

Within the testing of locomotion was the integration of the discrete MCB acting as a single controlling unit. After successful testing of omni-directional translation and rotation, the integration of the MCB was evident.

Theoretically the current design had the potential to drive the wheels at a speed of 4.1m/s in the forward direction. Experimentally the highest speed was 3m/s however if the system could be optimised further it could achieve speeds greater than SKUBA who won RoboCup SSL in 2009, 2010 and 2011.

Minor inaccuracies were evident occasionally during the acceleration and deceleration of the motors. These errors would offset the robot from its original trajectory, but did not affect the robot during constant operation. As the robot would operate under closed loop control in a match situation, the host machine would be able to compensate for the new offset error with updated instructions. These factors were deemed acceptable for the locomotion requirements.

As this fault occurred in both translational and rotational motion, it could be from three possible factors:

As the Master MCB transmitted data serially to each Slave MCB, the slaves higher in the information queue spool up the motors faster and result in the robot offset.

This possibility was ruled out because information was sent in the order of Top Left (TL), Top Right (TR), Bottom Left (BL), and Bottom Right (BR). Therefore the motor with the largest offset would be the BL motor. During testing, no pattern could be established for the offsets.

The (Slave) MCB failed to transmit data to the onboard DAC.

The inner control loop on the Slave devices was operating at 250Hz, which means the longest failed data stream could at worst case only be milliseconds which would not produce a noticeable delay to offset the motor speeds.

The Maxon internal motor controllers are not performing identically

As the controllers are built into the motor, they could not be individually tested and with all other alternatives exhausted, it would appear the controllers were the cause of the inaccuracies.

9.1.2 Kicking

The original specification for kicking was to achieve a kicking speed greater than the maximum allowable speed and then reduce the power of the kick on the robots.

9.1.2.1 Kicking Enable Time

A full power kick takes a finite amount of time for the shaft inside the solenoid to move from the rear position to the front position. If the electronics for the kicker were disabled before the shaft had reached the front position, time that could have been used to provide more force to the bolt would be wasted. However the exact opposite is possible. If the electronics continue to allow current to flow when the solenoid is in the front position the energy would be wasted in the form of heat. The variability in kicking times produced different ball exit velocities. The maximum kicking Enable time needed to be established. During testing the current travelling through the solenoid was recorded and during kicks an additional discrepancy was noticed on the waveform shown in green on Figure 9.1.

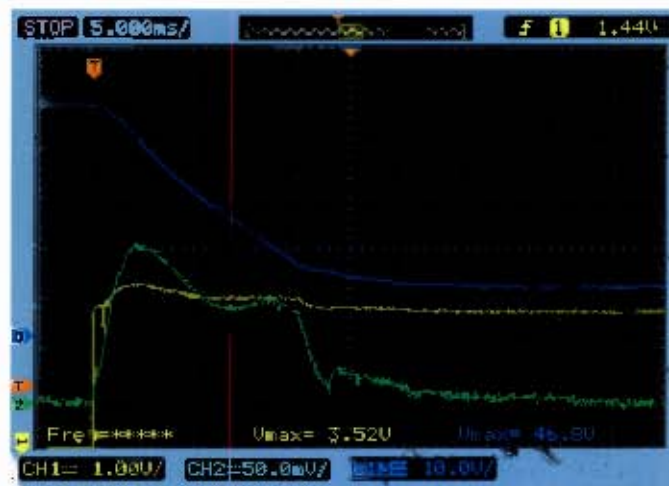

Figure 9.1: Direct Oscilloscope Kicking Capture (Dry fire, Rear Position)

The expected waveform was to rapidly reach a maximum current and reduce in magnitude with discharging capacitors in blue which was not the case as with all kicks. A secondary crest was present in kicks where the solenoid bolt was able to travel inside the solenoid. It was believed that the electro-mechanical aspect produced the 2nd crest as the bolt reached the front position. The theory was tested and followed logical predictions based on it. When kicking a ball the 2nd crest was present before 8ms at maximum power. 8ms became the highest kick enable time with no reduction in

performance which allowed the capacitors to only be partially discharged between kicks and still have the potential to kick immediately.

During kick testing and after observing slow motion golf ball collisions, it became apparent that the ball's impact time with the colliding object is a small fraction of the solenoid shafts motion. This fact implied that timing when the solenoid bolt makes contact with the golf ball is significant and if it were too close, it would only prod the ball out the contact zone.

9.1.2.2 Kicking Power

The maximum kicking speed allowed in SSL was 10m/s. The Electrical system was capable of storing 206.75J of energy in the external capacitors at 250V which was the largest reservoir of energy across all international teams to date. After a kick at full power, typically 75J was remaining in storage.

The total energy required to move a golf ball on a surface at 10m/s is comprised of 5.6J kinetic, and 0.91J in rotational energy. An efficiency of greater than 5% in the electro-mechanical conversion would generate a kick greater than 10m/s.

The highest achieved speed from the kicking module was 9.02m/s. Although the kick did not meet the initial specifications, the electronics met the requirements to compete internationally.

9.1.2.3 Ability to Pass

Varying the time of activation of the kicking solenoid had a proportional relationship to ball velocities. This met the specification of varying the final ball speed to allow passing between robots. The timer module was used to operate the enable time for the kicking IGBT. Because the timers on the Master MCB had multiple purposes, only 4 kicking speeds could be chosen.

9.1.3 Chipping Module

The chipping module was an optional specification which allowed the ball to be lifted off the playing surface and make the passing between robots non linear. The tests on the chipping module indicated the module could not lift the golf ball a height greater than 60mm which was not sufficient to pass over an opponent SSL robot. As no minor modification to the chipping module could produce more favourable results with the specification only being optional it was discontinued.

9.1.4 Communication Modules

The Sim20 modules which were sourced locally did not perform on a level similar to the AMBER wireless modules. The AMBER wireless modules met the requirements placed on the wireless communication with the default configurations as their update rate was higher than the best camera refresh rate. When the game of SSL increases further in speed, the AMBER wireless modules could be increased and would still be able to ensure it is not the bottleneck in the data flow.

9.1.5 Battery Module

The battery module was the only source of power for the robot. It was required to last 15 minutes without replacement and when depleted, ensure replacement could be done within the halftime window.

9.1.5.1 *Supplying Power*

During testing the battery performed better than expected as the motors were operating well below their rated values. The pack size could be reduced to reduce the weight of the robot if it were deemed necessary.

9.1.5.2 *LiPo Safety*

Due to the volatility of LiPo battery packs if mistreated from impact or over-discharge. The cover was tested to handle the impact of a golf ball, and an additional PCB was constructed to permanently monitor the voltage of the battery and physically disconnect it once the voltage had reached a predetermined minimum voltage. Both tests relating to the safety of the LiPo battery were completely successful, which removes the possibility of unnecessarily damaging the LiPo battery.

9.2 Recommendations based on Conclusions

Mechanically there were many different modules and components and most performed ideally, with a few exceptions with the overly complicated sections on the robot.

9.2.1 Improve modular design

The overall modular design of the robot was primarily split into the four key modules; locomotion, communication and control, ball control module and power systems. These sub systems were reliable and worked as expected. The only complications arose were with the assembly and disassembly of the ball control module.

Because the Ball control module was assembled on the base of the robot, it needed to be robust. This placed additional complications on the chipper module when the system began having issues as disassembly of the whole robot would have been required for modifications to the chipper.

The Ball control module should be redesigned and incorporated onto the robot, without the need to remove all other components on the base. Additionally the number of parts for the Ball Control Module should be reduced to simplify construction and maintenance.

9.2.2 Reduction in Weight

The robot was capable of moving itself around the field at a competitive speed. However the design was about 73% heavier than SKUBAs competing design [51]. A reduction in weight would reduce the power required and increase the potential manoeuvrability of the robot further.

9.2.3 Kicker Compression arrestor

The tension arresting of the kicker bolt, placed unnecessary tension through the thread of the bolt. If the arrestor was placed in the front of the kicker, a compression arrestor would place the load onto connecting surfaces rather than through thread and reduce the occurrence of the breakages.

9.2.4 Redesign of the Chipping module

As the chipping modules did not meet the optional requirements scope for this section are still wide open. The electrical system required for kicking and chipping is optimal in terms of power which would assist the project.

9.2.5 Mechanical matching of the golf ball

If the kicker bolts mechanical impedance were matched to a golf ball, the reflected vibrations and residual momentum in the shaft and would reduce the impact on the arrestor. The mechanical matching would produce optimal kicks as the bolt would transfer most of its kinetic energy to the ball similar to a Newton's cradle [55].

9.2.6 Kicker Impact Distancing

During testing, it was discovered that varying the distance of the golf ball from the robot greatly affected the final velocity of the golf ball during kicks. This could be a result of the ball being pushed away from the kicker piece before the kicker itself has received the full energy from the solenoid. The ball travelled faster if it was not flush against the robot. Locating the optimal position and changing the length of the kicker pieces such that this length is against the side of the robot would produce effective and optimal kicking speeds for the robot.

9.2.7 Discrete motor speed controllers

The original motors ordered for the SSL robots were not adequate for aggressive speed control which would be optimal for competition. The Maxon integrated controllers provided unnecessary protection to the brushless motors. The motors for SSL were required to perform aggressive and quick control which the integrated speed controllers prevented. The weight of the robot frame increased the difficulty in controlling the robot because it could generate considerable momentum, a discrete controller for the brushless motors would allow for powerful breaking of the wheels which would improve response as the wheels only free wheel back to standstill. The discrete controllers may provide access to the higher theoretical acceleration and speed of the robot.

9.2.8 More Powerful microcontroller

The HCS08GMC9508GT16A proved capable of operating an SSL robot. Many modifications to the high level code were necessary to make an 8bit microcontroller capable of performing the operations optimally. A more powerful microprocessor which is inexpensive would allow the programming of the full system to be more intuitive which is always beneficial during maintenance and debugging.

10. References

- [1] T. Lauc, A. Burchardt, K. Cierpka, S. Fritsch, N. Gode, K. Huhn, T. Kirilov, B. Lassen, L. Lyatif, M. Miezal, M. Modzelewski, U. Nehmiz, M. Schwarting, A. Seekircher and R. Stein, "B-Smart Team Description for RoboCup 2008," Universitat Bremen, Bremen, 2008.
- [2] K. Sukvichai, P. Wasuntapichaikul, J. Srisabye and Y. Tipsuwan, "SKUBA 2009 Team Description," Faculty of Engineering Kasetsart University, Bangkok, 2009.
- [3] "Robot Soccer Carnegie Mellon University," [Online]. Available: <http://www.cs.cmu.edu/~robosoccer/small/>. [Accessed 13 09 2012].
- [4] "Dull dirty and Dangerous," 30 November 2011. [Online]. Available: <http://www.dulldirtydangerous.com/>. [Accessed 30 November 2011].
- [5] C. Inman-Bamber, Robot Soccer Platform, University Of Cape Town, 2005.
- [6] "Official RoboCup website," 30 November 2011. [Online]. Available: <http://www.robocup.org/>. [Accessed 30 November 2011].
- [7] "RoboCup 2011 Istanbul," 30 November 2011. [Online]. Available: <http://www.robocup2011.org/en/default.asp>. [Accessed 30 November 2011].
- [8] "Wiki website for Small Size League RoboCup," 30 November 2011. [Online]. Available: http://wiki.robocup.org/wiki/Small_Size_League. [Accessed 30 November 2011].
- [9] "Laws of the RoboCup Small Size League 2010," RoboCup, 2010.
- [10] J. Srisabye, P. Hoonsuwan, S. Bowarnkitiwong, C. Onman, P. Wasuntapichaikul, A. Signhakarn, P. Wechsuwanmanee, R. Dumnernkittikul, K. Sukvichai and Y. Tipsuwan, "Skuba 2008 Team Description," Faculty of Engineering Kasetsart University, Bangkok, 2008.
- [11] H. Achiwa, J. Maeno, J. Tamaki, S. Suzuki, T. Moribayasi, K. Murakami and T. Naruse, "RoboDragons 2009 Extended Team Description," Aichi Prefectural University, Aichi, 2009.
- [12] C. Chuengsatiansup, I. Charoensripongsa, K. Wongsuphasawat, K. Rattana, P. Doungsodsri, A. Buathong, K. Wejwittayaklung, M. Wongsaisuwan and W. Wannasuphprasit, "Plasma-2 Extended Team Description Paper," Bangkok, 2009.
- [13] K. Kanaya, T. Kinura and Y. Masutani, "ODENS 2009 Team Description," Osaka Electro-Communication University, Osaka, 2009.

- [14] R. Sato, T. Horii, Y. Yamada, S. Teshima, H. Hattori, M. Watanabe, K. Ito and T. Sugiura, "KIKS 2009 Team Description," Toyota National College of Technology, 2009.
- [15] S. Zickler, J. Bruce, J. Biswas, M. Licitra and M. Veloso, "CMDragons 2009 Extended Team Description," Carnegie Mellon University, Pittsburgh, 2009.
- [16] Y. Wu, X. Qiu, G. Yu, J. Chen, X. Rie, Y. Wu and R. Xiong, "Extended TDP of ZjuNlict 2009," Zhejiang University, Hangzhou, 2009.
- [17] T. Laue, A. Burchardt, S. Fritsch, S. Hinz, K. Huhn, T. Kirilov, A. Martens, M. Miezal, U. Nehmiz, M. Schwarting and A. Seekircher, "B-Smart Extended Team Description for RoboCup 2009," Universitat Bremen, Bremen, 2009.
- [18] P. Blank, M. Bleier, S. Drexler, J. Kallwies, P. Kugler, D. Lahmann, P. Nordhus, P. Kugler, D. Lahmann, P. Nordhus, P. Kugler, D. Lahmann, P. Nordhus, C. Riess, T. Swadzba and J. Tully, "ER-Force Team Description Paper for RoboCup 2009," University of Erlangen, Nuremberg, 2009.
- [19] M. R. Niknejad, S. Ali Salehi Neyshabouri, S. Ali Ghazi MirSaeed, S. Sadegh Mohseni Salehi, S. Faraji, E. Kamali and A. Reza Nourian, "Immortals 2009 Team Description Paper," Iran University of Science and Technology, 2009.
- [20] M. A. Sharbafi, A. Haghshenas, M. Gorji, E. Hashemi and A. Azidehak, "MRL Team Description 2009," University of Qazvin, Qazvin, 2009.
- [21] A. Santos, E. Nascimento, F. Zanatto, G. Francischini, J. Gurzoni, L. R. Lutti, M. Cortez and F. Tomidandel, "RoboFEI TEAM 2009 Team Description Paper," FEI University Centre, Brazil, 2009.
- [22] M. Akar, I. Akin, H. Karaoguz, O. Cigdem, M. Cakan, H. S. Calayir, G. Kaki, D. Sallihoglu and C. Y. A. Yanik, "BRocks - Team Description," Bogazici University, Istanbul, 2009.
- [23] E. Torres, J. Rodríguez, P. Aguilar, C. Alegría, L. Ramos, A. Moses, J. Blackburn, M. Morales and A. Weitzenfeld, "Eagle Knights RoboBulls 2009: Small Size RoboCup League," Florida, 2009.
- [24] Y. NAGASAKA, M. SAEKI, T. SOGO, S. SHIBATA, H. FUJIYOSHI, T. FUJII, Y. TANAKA, S. ISHIHARA, M. JYUO, H. MIZUGUCHI, T. ADACHI, T. ITOH, S. KUSATOMI and S. SUZUMURA, "Owaribito-CU 2009 Team Description," Chubu University, Chubu, 2009.
- [25] V. A. Monajjemi, H. Ghaednia, S. Khoshbakht, M. Rohani, V. Mehrabi, A. Pahlavani, E. Omid, M. Shahbazi, F. Atashzar, A. A. Amir Ghasvand, H. Ghaednia, E. Sheikhi, S. Poorjandaghi, H. Bazargani and A. Gheidari, "Persian Team Description for Robocup 2009," Amirkabir Univ. Of Technology, Tehran, 2009.
- [26] D. Robinson, W. Chan, A. Colin, K. Haller, J. Henion, B. Johnson, S. Kanev, K. Lawton, K. Modzelewski, A. Ramirez, J. Tang and G. Trotter, "RoboCup Team Description Paper: RFC Cambridge," Massachusetts Institute of Technology, Cambridge, 2009.

- [27] A. Jiwa, A. Li, A. B. Moosavi zadeh, H. Hu, G. Stelle, B. Knoll, K. Baillie, J. Pasion, L. Wong and J. Yuen, "UBC Thunderbots 2009 Team Description Paper," University of British Columbia, 2009.
- [28] W. Craffonara, M. Locher, C. Lueglinger, M. Trapp, A. Hofmann and P. Kleinrath, "Austrian Cubes Team Description Paper for RoboCup 2009," University of Applied Sciences Technikum Wien, Vienna, 2009.
- [29] S. M. H. Jamali, M. Saleh, H. Azad, M. Faraji, N. A. Ashrafi and M. Donyapor, "Shariaty Robotic Group 2009 Team Description Paper," Shariaty College, 2009.
- [30] T. Santos, L. Estrada, E. M. Goncalves, V. Oliveira and S. Botelho, "FURGBOL Team Description Paper," 2009.
- [31] T. Surakamhang, A. Srithong, K. Saelee, N. Anongthong, W. Boonprakob and M. Karnjanadecha, "Khainui Team Description for Robocup 2009," Prince of Songkla University, Songkhla, 2009.
- [32] M. Najafi, M. Hosseinzadeh, E. Darestani, S. Davarpanah, A. Kiaei, M. Abdolghafar, S. Alikhani, S. Manuchehri and S. M. Nasiri, "DMID 2009 Team Description Paper," Shahed University of Tehran, Tehran, 2009.
- [33] Y. Liu, T. Glocker, J. Shu and Z. Jiangtao, "Botnia Dragon Knights - Team Description Paper for RoboCup 2009 Small Size League," 2009.
- [34] S. Zickler, D. Vail, G. Levi, P. Wasserman, J. Bruce, M. Licitra and M. Veloso, "CMDragons 2008 Team Description," Carnegie Mellon University, Pittsburgh, 2008.
- [35] W. Cui, L. Liu, B. Guo, J. Tao, X. Gai and W. Cai, "AUA Ares 2008 Team Description Paper," Aviation University of Airforce, China, 2008.
- [36] P. Li, Z. Wang, F. He, Y. Huangfu, J. Jia, L. Zhao, T. He and H. Li, "FANTASIA 2008 Team Description Paper," 2008.
- [37] J. Maeno, H. Achiwa, T. Moribayashi, J. Tamaki, N. Hiramoto, R. Nakanishi, R. Narita, K. Otake, M. Tanaka, S. Ueno, K. Murakami and T. Naruse, "RoboDragons 2008 Team Description," Aichi Prefectural University, Japan, 2008.
- [38] K. Jindarak, N. Anongthong, A. Srithong, K. Saelee, V. Boonprakob, T. Surakamhaeng and M. Karnjanadecha, "Khainui Team Description for Robocup 2008," Prince of Songkla University, Songkhla, 2008.
- [39] Y. Liu, R. Chomentowski, Glocker and Tobias, "Botnia Dragon Knights - Team Description Paper for RoboCup 2008 Small Size League," Finland, 2008.
- [40] D. Bakhshandeh, A. Azidehak, M. Gorji and M. Ahmad Sharbafi, "MRL Small Size 2008 Team Description," Iran, 2008.

- [41] K. YAMAUCHI, T. YOSHIMOTO, S. HORII, T. CHIKU, M. WATANABE, K. ITOH and I. SUGIURA, "The description of team "KIKS"," Japan, 2008.
- [42] E. Torres, J. Rodríguez, P. Aguilar, O. Ponce, A. Moses and A. Weitzerfeld, "Eagle Knights RoboBulls 2008: Small Size," 2008.
- [43] A. Amjad, A. Ghiasvand, M. Mehdi Korjani, M. Rohani, H. Ghaedria, S. Sadatmand and V. Monajjemi, "Persian Team Description for Robocup 2008," Amirkabir University of Technology, Tehran, 2008.
- [44] A. Bardagjy, R. Shtylman, S. Posey, J. Kulpe, P. Marks, B. Johnson, J. McConville, S. Donnan, Y. Nemat and J. Nieman, "RoboJackets 2008 Team Description Paper," Georgia Institute of Technology, Atlanta, 2008.
- [45] "Strive(Small Size) Team Description 2008," Shanghai University, Shanghai, 2008.
- [46] P. Blank, M. Bleier, S. Drexler, J. Kallwies and P. Kugler, "ER Force Team Description Paper for RoboCup 2008," University Of Erlangen-Nuremberg, Erlangen, 2008.
- [47] S. Botelho, E. Estrada, G. Simas, L. Taddei, M. Galeriano, M. Medeiros, P. Drews Jr, R. Deon, R. Almeida, Neves and Renato, "FURGBOL Team Description Paper," Brazil, 2007.
- [48] W. Chan, A. Colin, M. George, K. Haller, A. Harlan, K. Lawton, K. Modzeleski, J. Moe, R. Panas, J. Tang, C. Walker and J. Yang, "RoboCup Team Description Paper: RFC Cambridge," MIT + Harvard University, Cambridge, 2007.
- [49] Y. Tanaka, M. Sasaki, S. Shibata, Y. Nagasaka, H. Fujiyoshi and T. Fujii, "Owaribito CU 2005," Chubu University, Japan, 2005.
- [50] "RoboCup Small Size League," Wikipedia, [Online]. Available: http://wiki.robocup.org/wiki/Small_Size_League. [Accessed 9 12 2011].
- [51] J. Srisabye, P. Wasuntapichaikul, C. Onman, K. Sukvichai, S. Damyot, T. Munintarawong, P. Phuangjaisri and Y. Tipsuwan, "Skuba 2009 Extended Team Description," Kasetsart University, Bangkok, 2009.
- [52] "Thingiverse," [Online]. Available: <http://www.thingiverse.com/thing:2473>. [Accessed 7 July 2012].
- [53] G. Sechu, "Development of a new F180 Robot Platform," University of Cape Town , Cape Town, 2010.
- [54] D. Lwabona, "Ball Handling Mechanism for a Small Size League Robot," University Of Cape Town, Cape Town, 2010.

[55] F. Herrmann and M. Seitz, "How does the ball chain work?," Institut für Didaktik Physik, Karlsruhe, 1982.

[56] A. da Fontoura, B. Jurkowski, B. Albrecht and B. Guedes, "RoboPET Team Description Paper," Universidade Federal do Rio Grande do Sul, Porto Alegre, 2009.

11. Sample Technical Drawings

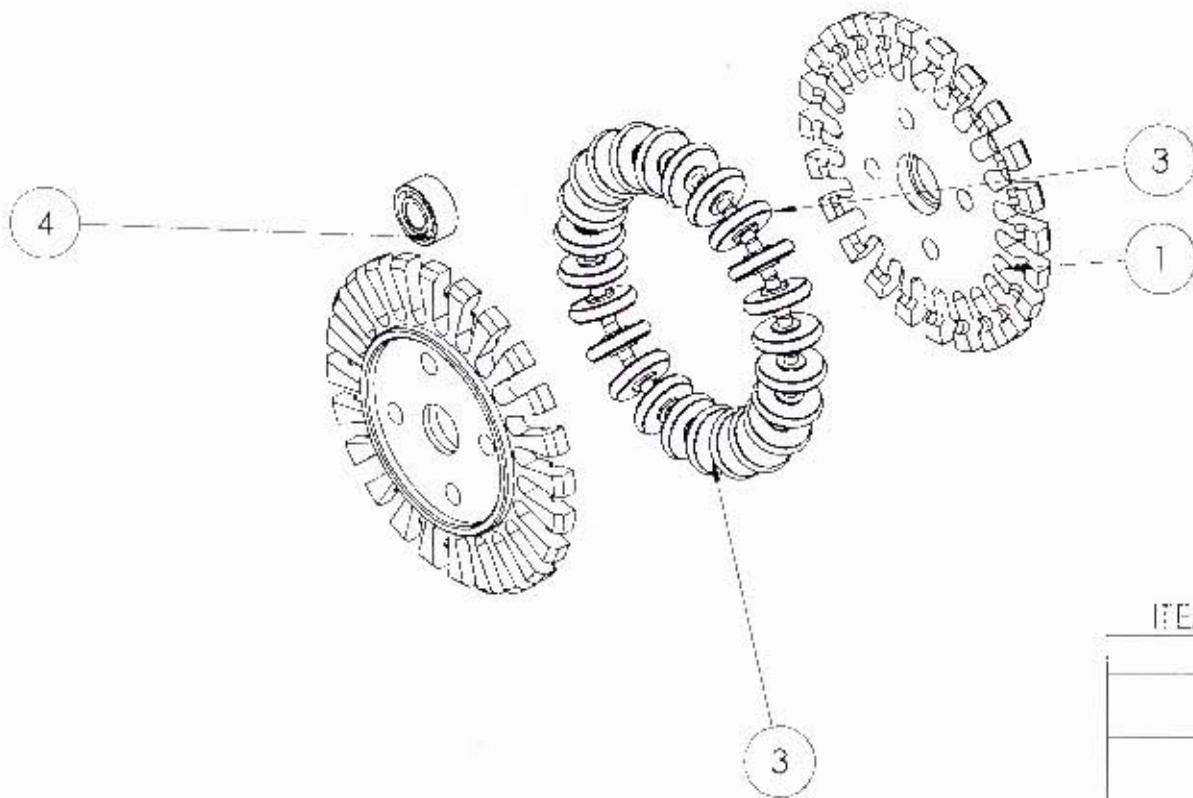

ITEM NO.	PART NUMBER	QTY.
1	HalfWheel	2
3	MiniWheelComplete	24
4	AFBMA 20.1 - 38-4 - 10,SI,NC,10_68	1

A4
Landscape

University of Cape Town
Department of Mechanical Engineering

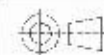

Title

Omn-Wheel

Assembly
Drawing

Scale:

1:1

Date:

2011/03/03

of

Sheet 1

Drawn By: Justin Poac

Drawing Number

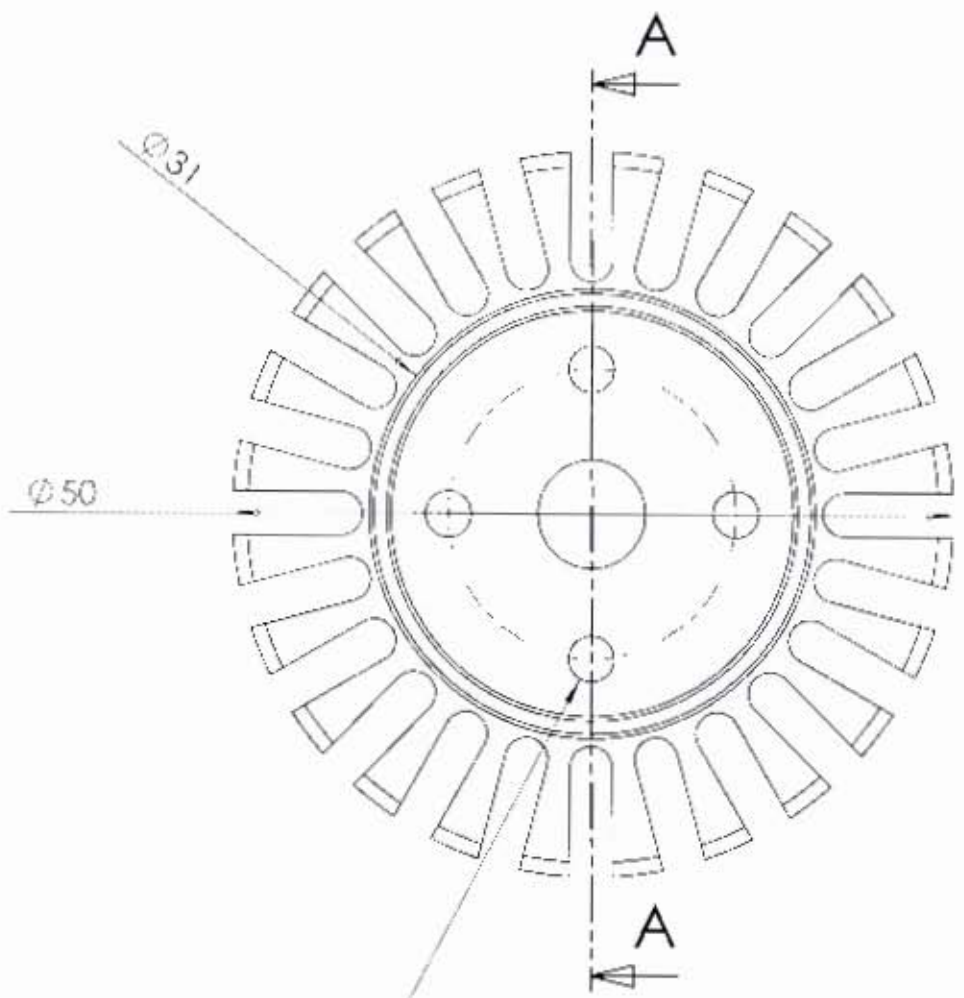

4 x $\phi 3.2$ Eq'l Spaced
On PCD $\phi 20$

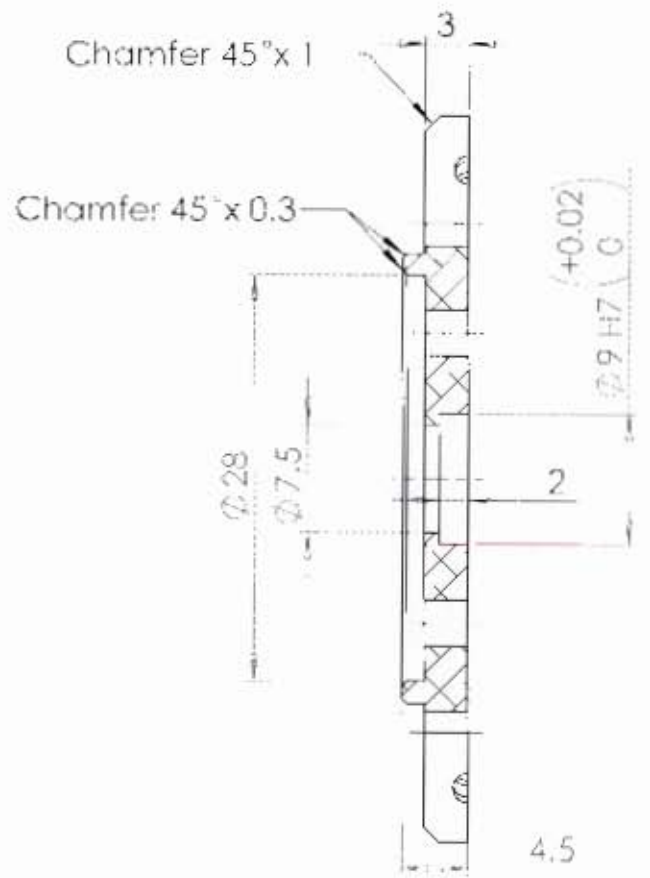

SECTION A-A

A4 Landscape		University of Cape Town Department of Mechanical Engineering		
		Title: Half Wheel		
Quantity: 56	Part Finish: -	Date: 2011/03/02	Scale: 2:1	of: Sheet 1 / 1
Material: 6061 Alloy	Drawn By: Justin Poed		Drawing Number: P-17	

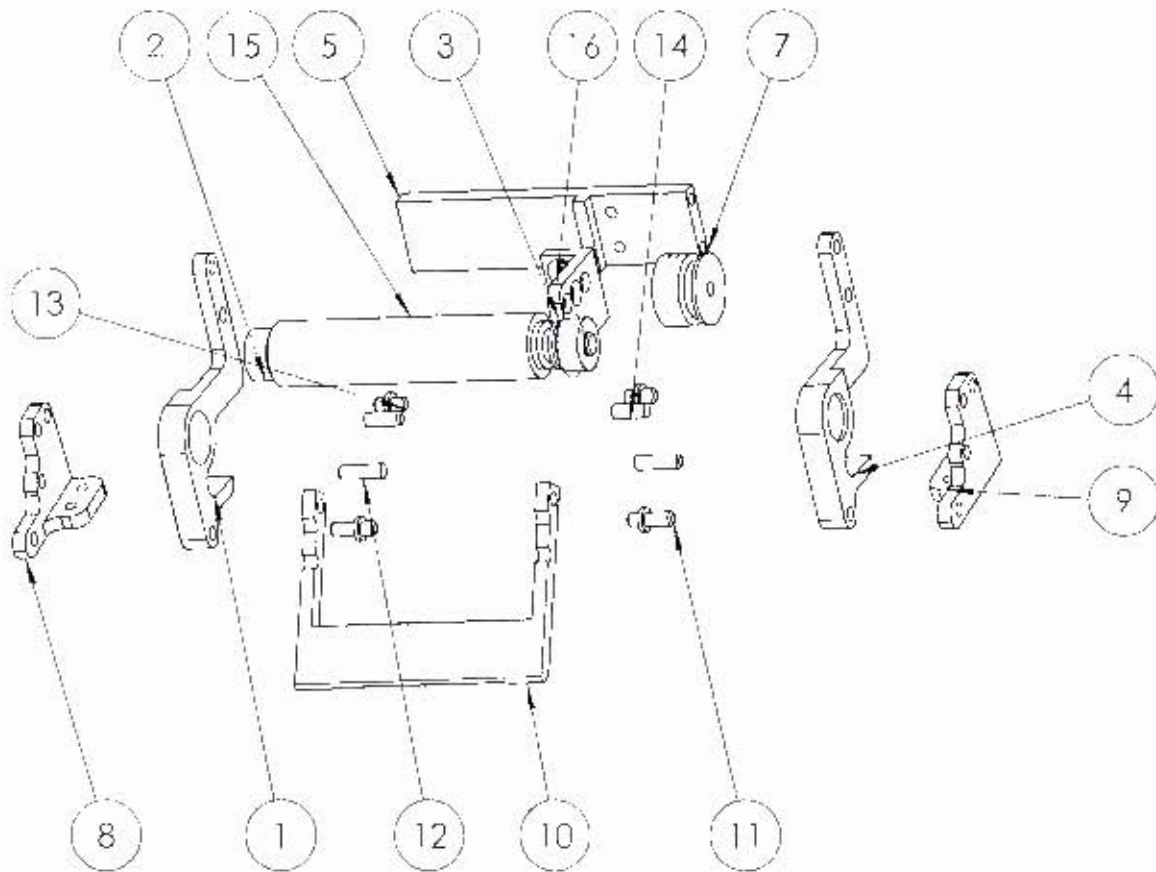

ITEM NO.	PART NUMBER	QTY.
1	Right_Swing_Bracket	1
2	685zz	2
3	Dribbler Shaft	1
4	Left_Swing_Bracket	1
5	Connecting_Arm	1
6	Dribbler Motor	1
7	Driver Pulley 1	1
8	Right Holding Bracket	1
9	Left Holding Bracket 1	1
10	chipper_bar	1
11	Swing_Pin	4
12	Swing_Stop_Pin	2
13	Chip_Pin	2
14	Chip Stop	2
15	surgical_tubing1	1
16	Dribbler_Motor_Bracket_2	1

A4
Landscape

University of Cape Town
Department of Mechanical Engineering



Title:

Dribbler_Assem

Assembly
Drawing

Scale:

1:1.5

Date:

2011/03/03

of

Sheet1

1

Drawn By: Justin Pearce

Drawing Number:

All Chamfers are 45 Degrees x 0.5mm

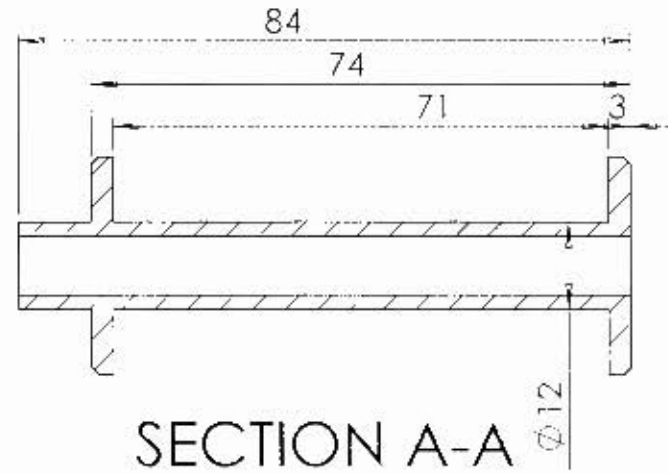
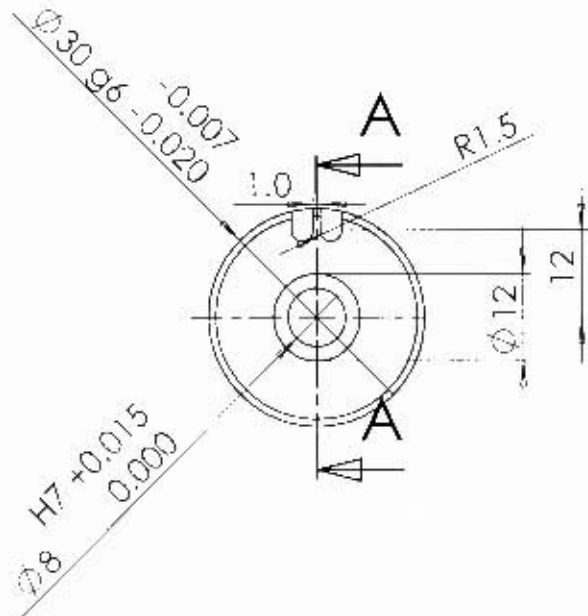

A4 Landscape	University of Cape Town Department of Mechanical Engineering			
	Title: Solenoid shaft			
Quantity: 7	Part Finish	Date: 2011/03/04	Scale: 1:1	of Sheet: 1
Material:	Drawn By: Justin Peard		Drawing Number	

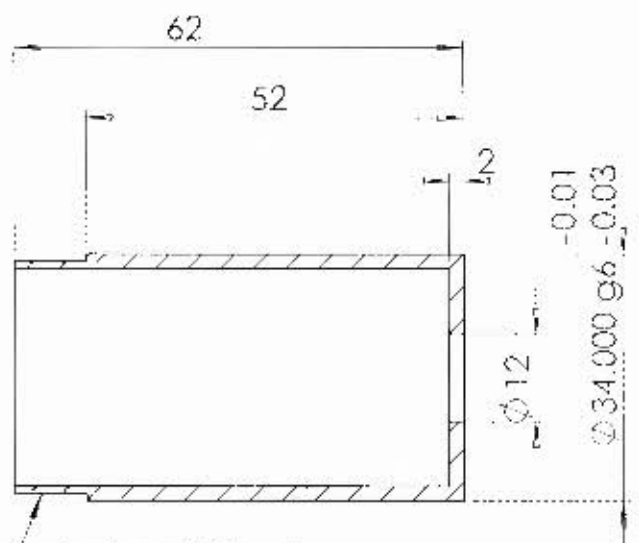
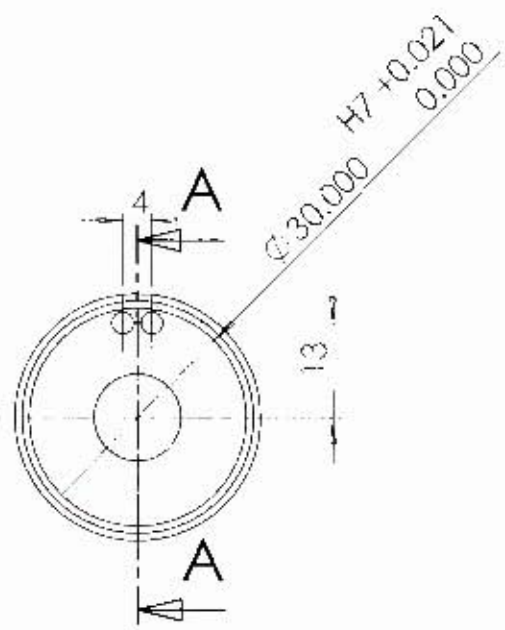

SECTION A-A

M32 x 1.5 Thread

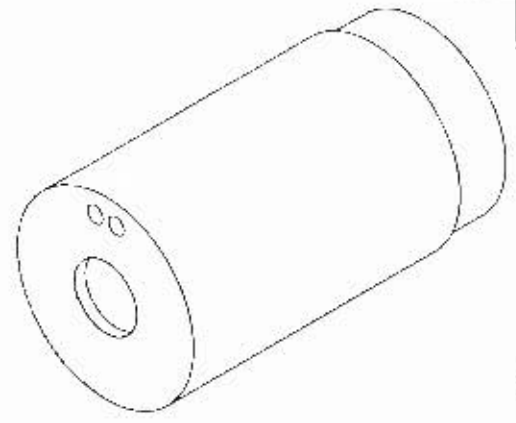

A4 Landscape	University of Cape Town Department of Mechanical Engineering			
	Title: solenoid_shield1			
Quantity:	Part Finish:	Date:	Scale:	of
		2011/03/04	1:1	Sheet1 1
Material:	Drawn By: Justin Peard		Drawing Number	

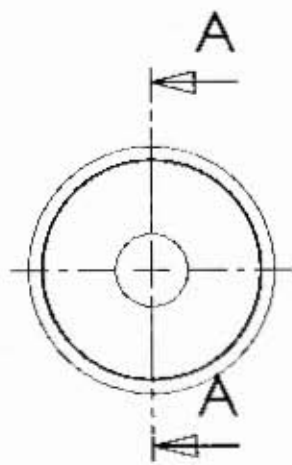

M32 x1.5 Thread

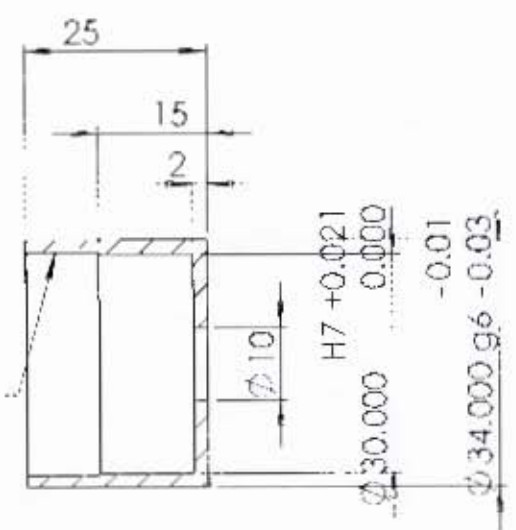

SECTION A-A

A4 Landscape		University of Cape Town Department of Mechanical Engineering		
		Title: Solenoid_shield2		
Quantity	Part Finish	Date	Scale	of
7		2011/03/04	1:1	Sheet 1 1
Material	Drawn By: Justin Pead		Drawing Number	

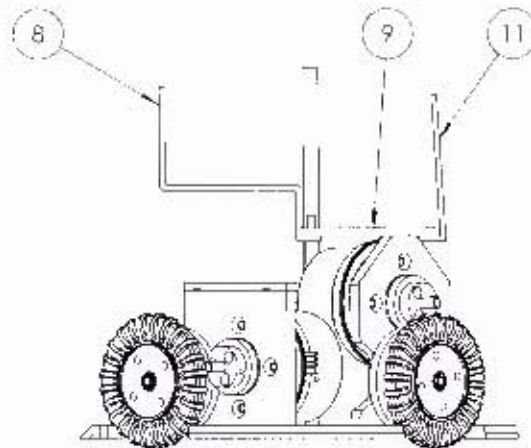
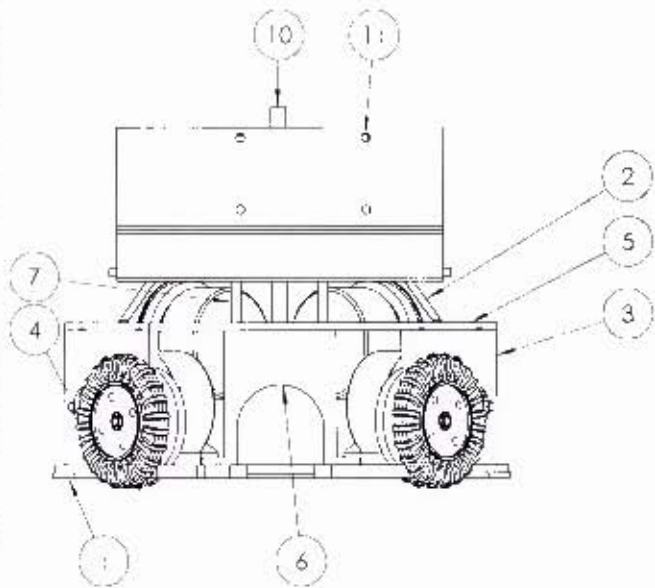
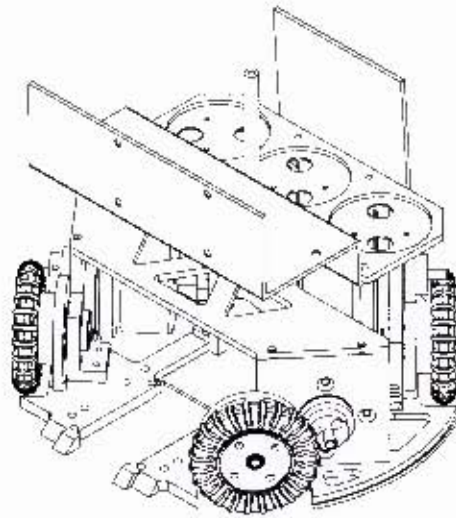
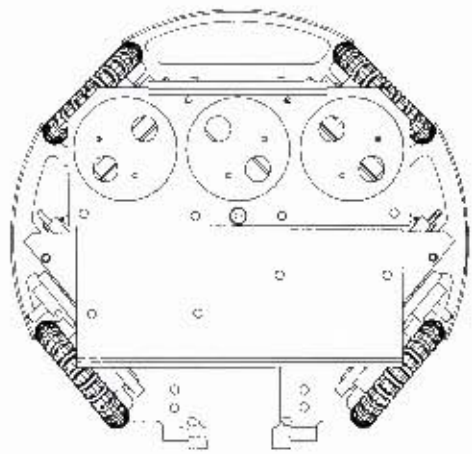

ITEM NO.	PART NUMBER	QTY.
1	base	
2	RearWheelBracketComplete	2
3	Motor_Bracket FL_Complete	1
4	Motor_Bracket FR_Complete	1
5	Cover_Front	2
6	Top_C_Bracket	1
7	Spacer_Front	2
8	Bracket_Front	1
9	Cover_Back	1
10	Spacer_Cover	1
11	Kicker_Bracket	1

as Landscape		University of Cape Town Department of Mechanical Engineering	
 Assembly Drawing		Title SSLRobot	Scale: _____ Date: _____ of _____ 1:1 2011/03/05 Sheet 1 Drawn By: Jason Peac Drawing Number: _____

EBE Faculty: Assessment of Ethics in Research Projects (Rev2)

Any person planning to undertake research in the Faculty of Engineering and the Built Environment, at the University of Cape Town is required to complete this form before collecting or analysing data. When completed it should be submitted to the Supervisor (where applicable) and from there to the Head of Department. If any of the questions below have been answered YES, and the applicant is NOT a fourth year student, the Head should forward this form for approval by the Faculty EIR committee: submit to Ms Zulpha Geyer (Zulpha.Geyer@uct.ac.za; Chem Eng Building, PH 021 650 4791).

NB: A copy of this signed form must be included with the thesis/dissertation/report when it is submitted for examination

This form must only be completed once the most recent revision EBE EIR Handbook has been read.

Name of Principal Researcher/Student: Justin Pead Department: Mechanical Engineering

Preferred email address of the applicant: justinpead@gmail.com

If a Student: Degree: MSc Supervisor: Stephen Marais

If a Research Contract: indicate source of funding/sponsorship:

Research Project Title: Research, Design and Construction of a team of Small Size League Soccer Robots for RoboCup Soccer.

Overview of ethics issues in your research project:

Question 1: Is there a possibility that your research could cause harm to a third party (i.e. a person not involved in your project)?	YES	<input checked="" type="checkbox"/> NO
Question 2: Is your research making use of human subjects as sources of data? If your answer is YES, please complete Addendum 2.	YES	<input checked="" type="checkbox"/> NO
Question 3: Does your research involve the participation of or provision of services to communities? If your answer is YES, please complete Addendum 3.	YES	<input checked="" type="checkbox"/> NO
Question 4: If your research is sponsored, is there any potential for conflicts of interest? If your answer is YES, please complete Addendum 4.	YES	<input checked="" type="checkbox"/> NO

If you have answered YES to any of the above questions, please append a copy of your research proposal, as well as any interview schedules or questionnaires (Addendum 1) and please complete further addenda as appropriate. Ensure that you refer to the EIR Handbook to assist you in completing the documentation requirements for this form.

I hereby undertake to carry out my research in such a way that

- there is no apparent legal objection to the nature or the method of research; and
- the research will not compromise staff or students or the other responsibilities of the University;
- the stated objective will be achieved, and the findings will have a high degree of validity;
- limitations and alternative interpretations will be considered;
- the findings could be subject to peer review and publicly available; and
- I will comply with the conventions of copyright and avoid any practice that would constitute plagiarism.

Signed by:

	Full name and signature	Date
Principal Researcher/Student:	<u>Justin Pead</u>	<u>08/02/13</u>
This application is approved by: Supervisor (if applicable):	<u>T. Marais</u>	<u>08/02/13</u>
HOD (or delegated nominee): <i>Final authority for all assessments with NO to all questions and for all undergraduate research.</i>		<u>11/02/2013</u>
Chair: Faculty EIR Committee For applicants other than undergraduate students who have answered YES to any of the above questions.		