



A MACHINE VISION BASED NON-CONTACT MEASURING TOOL FOR MENSURATION IN INDUSTRY AND MANUFACTURING

Mark Matthews B.Sc.(Eng.) Cape Town

11 October, 1994

Submitted to the Department of Surveying and Geodetic Engineering, University of Cape Town in fulfilment of the requirements of the degree of Master of Science in Engineering

The University of Cape Town has been given the right to reproduce this thesis in whole or in part. Copyright is held by the author.

The copyright of this thesis vests in the author. No quotation from it or information derived from it is to be published without full acknowledgement of the source. The thesis is to be used for private study or non-commercial research purposes only.

Published by the University of Cape Town (UCT) in terms of the non-exclusive license granted to UCT by the author.

ACKNOWLEDGEMENTS

I would like to acknowledge the valuable assistance and advice received from the following people:

Prof. Dr. H. R  ther, my supervisor.

Mr Kari Laatikainen, Senior Technical Officer in charge of the departmental workshop.

Graeme van der Vlugt, Mike Calitz and Nick van der Merwe, PhD students in the department.

Julian Smit, fellow M.Sc. student.

Special thanks are due to my family and friends for their support and encouragement during my work on this thesis.

TERMS OF REFERENCE

This thesis was initiated by Prof. H. Rüter, the head of the Department of Surveying and Geodetic Engineering, in April 1993, with the aim of promoting the use of digital photogrammetry in local industry.

His specific instructions were:

- To design a non-contact measuring tool with the following characteristics:
 - Theoretical basis: Close Range Digital Photogrammetry
 - Operating principles: Maximum automation, suitability for unskilled users and portability.
 - Application area: Industry, manufacturing, quality control and architecture.
 - Accuracy: distance dependant, sub-millimetre - centimetre.
- To acquire and assemble the equipment needed for the measuring device.
- To develop the software to drive the device.
- To test the device.
- To report on the results.

SYNOPSIS

This thesis report discusses the design, implementation and testing of a non-contact measuring tool based on the principle of stereo photogrammetry. The system uses a pair of CCD video cameras and a frame-grabber in a PC to capture the pair of images this requires. The software on the PC then measures the image co-ordinates of points selected by the user and transforms them into space co-ordinates for the points. The transformation requires knowledge of the relative positions and orientations of the cameras. This is found in a calibration stage from images of a calibration frame. The cameras are mounted on a bar, which guarantees that the relative positions and orientations of the cameras remain invariant within certain limits. This makes the system portable.

A literature review found only one description of a similar system. This was a system developed for the North Sea oil industry. It was based on a PC equipped with special image processing hardware and used either video cameras or digital cameras to acquire images. It was reported to have achieved high accuracy's.

The system makes use of the standard photogrammetric techniques of the Direct Linear Transformation and the collinearity condition equations to determine the camera positions and orientations and the collinearity condition to calculate space co-ordinates of object points. The image co-ordinates needed by these techniques are found by using image processing techniques. The locating of target centres during calibration can be done by calculating the centre of gravity of a image region containing the target. Placing the region correctly requires that the extent of the target is found. This is done by locating its edge and then following it around. Finding identical target points in each image for measuring requires that an image matching technique is used. This system uses an area-based least-squares matching technique. A variation on the least-squares technique that allowed for minimising the L1-norm instead of the L2-norm was also used.

The hardware for the system consists of a PC with super VGA display, a frame-grabber, a pair of CCD video cameras and a video monitor. A tripod with a camera mounting bar and a pair of calibration frames are also used.

The software for the system consists of four programs. The first program, called "CALIB", deals with the calibration of the cameras. It displays the image of the calibration frame on the PC monitor for the user to identify the targets on the frame. When all the targets have been identified, the user starts the

calibration procedure. If the calibration is successful, the results are displayed on screen and written to file.

The second program, called "MEASTOOL", carries out the actual measurement. It displays the pair of images on the PC monitor for the user to select points to measure. The measurements are made by the user first selecting the point in the left image and then in the right image. The software then determines the image co-ordinates and calculates the space co-ordinates from them. The distance from the previous point is then found from the space co-ordinates.

The third program, called "TEDIT", provides a simple template editor. It displays an enlarged view of the template and provides tools for finding and changing the grey-value of a pixel, rotating the template and saving the changed template, either under a new name or under its old name.

The fourth program, called "PMT" provides a menu for accessing the rest of the software. It also controls the frame-grabber.

The system was tested by measuring a number of objects. The first object measured was the calibration frame. The results here were good, with most errors being of the order of 1 to 3 millimetres for distances of the order of 100 millimetres. The second object was a polystyrene block. This gave poor results, with errors of the order of 1 to 8 millimetres for distances of the order of 100 millimetres. The third object was a computer tape reel. This gave good result, with error of the order of 1 to 3 millimetres for distances of the order of 100 millimetres being achieved. The last object measured was a vernier calliper. This gave good results with the errors all less than a millimetre for a distance of the order of 30 millimetres.

The report concludes that the system can produce good results under near ideal conditions but has reduced accuracy under more realistic conditions. The accuracy depends on the nature of the object being measured. A further conclusion is that the use of generalised feature templates for feature location does not produce consistent results.

The report recommends that an alternative method of finding edges being developed for use with object that have ill-defined edges.

TABLE OF CONTENTS

ACKNOWLEDGEMENTS.....	i
TERMS OF REFERENCE	ii
SYNOPSIS.....	iii
TABLE OF CONTENTS	v
LIST OF ILLUSTRATIONS	vii
LIST OF TABLES.....	ix
GLOSSARY.....	x
1. INTRODUCTION	1
2. LITERATURE REVIEW	4
3. DISCUSSION OF THEORY.....	5
3.1. PHOTOGRAMMETRY	6
3.1.1. DIRECT LINEAR TRANSFORMATION.....	7
3.1.2. COLLINEARITY EQUATIONS.....	9
3.1.3. LENS DISTORTION	11
3.2. IMAGE PROCESSING TECHNIQUES.....	12
3.2.1. DETERMINING THE CENTRE OF GRAVITY.....	12
3.2.1.a) Edge Detection	12
3.2.1.b) Edge Following.....	13
3.2.2. IMAGE MATCHING	15
4. SYSTEM DESCRIPTION.....	18
4.1. EQUIPMENT	18
4.2. SOFTWARE.....	21
4.2.1. CHOICE OF PROGRAMMING LANGUAGE	21
4.2.2. OVERVIEW OF SOFTWARE STRUCTURE	21
4.2.3. THE PROGRAM “CALIB”	22

4.2.4. THE PROGRAM "MEASTOOL"	28
4.2.5. THE PROGRAM "TEDIT".....	31
4.2.6. THE PROGRAM "PMT"	33
4.2.7. FORMAT AND NAMING OF DATA FILES.....	34
4.2.8. FORMAT AND NAMING OF IMAGE FILES.....	37
5. TEST RESULTS.....	39
5.1. OBJECT 1: THE CALIBRATION FRAME.....	39
5.2. OBJECT 2: POLYSTYRENE PACKING PIECE.....	41
5.3. OBJECT 3: COMPUTER TAPE REEL	44
5.4. OBJECT 4: VERNIER CALLIPER.....	47
5.5. THE OVERALL PERFORMANCE OF THE MEASURING SYSTEM	49
6. CONCLUSIONS.....	50
7. RECOMMENDATIONS.....	51
8. LIST OF REFERENCES	52
9. BIBLIOGRAPHY.....	53
APPENDIX A: TEST RESULTS.....	A1
APPENDIX B: CALIBRATION FRAMES.....	A7

LIST OF ILLUSTRATIONS

Figure 1: The basic equipment of the photogrammetric measuring tool	1
Figure 2: Typical Set ups for photogrammetric measurement	5
Figure 3: Image co-ordinate systems	7
Figure 4: The collinearity condition.....	9
Figure 5: Graph of Thresholding Function	12
Figure 6: Effect of Thresholding on Target Image, showing edge positions	13
Figure 7: Pixel numbering for Freeman chain code	14
Figure 8: Schematic diagram of the system equipment	19
Figure 9: The tripod and camera mounting bar	20
Figure 10: The calibration frame	20
Figure 11: System directory structure	22
Figure 12: The screen display of the program "CALIB"	23
Figure 13: Menu structure in program "CALIB"	23
Figure 14: Thresholding menu.....	24
Figure 15: Screen displays showing the calibration sequence.....	27
Figure 16: The screen display of the program "MEASTOOL"	28
Figure 17: Menu structure in program "MEASTOOL"	29
Figure 18: Screen displays showing the measurement sequence	30
Figure 19: The screen display of the program "TEDIT"	32
Figure 20: Menu structure in program "TEDIT ".....	32
Figure 21: The screen display of the program "PMT"	33
Figure 22: Stereo-pair of the calibration frame.....	39
Figure 23: Histogram of error scales from remeasuring the calibration frame.....	40
Figure 24: Stereo-pair of the polystyrene block	41
Figure 25: Diagram of polystyrene block showing measurements taken.....	41
Figure 26: Histograms of measurements of the polystyrene block	43
Figure 27: Histograms of error scales for the measurement of the polystyrene block	43
Figure 28: Stereo-pair of the computer tape reel	44
Figure 29: Diagram of the computer tape reel, showing measurements taken	45
Figure 30: Histograms of measurements of computer tape reel.....	46
Figure 31: Histograms of error scales for the measurement of the computer tape reel	46
Figure 32: Stereo-pair of the vernier calliper	47
Figure 33: Histogram of measurements of the vernier calliper.....	48

Figure 34: Histogram of error scales for the measurement of the vernier calliper..... 48

LIST OF TABLES

Table 1: Specification of ITC CCD cameras	19
Table 2: Summary of errors from measurement of point positions on calibration frame	40
Table 3: Summary of errors from measurement of distances on calibration frame.....	40
Table 4: Summary of errors from measurement of polystyrene block	42
Table 5: Summary of errors from measurement of computer tape reel	45
Table 6: Summary of errors from measurement of the vernier calliper	47

GLOSSARY

Calibration frame: A framework carrying a number of target points the XYZ-positions of which have been accurately determined.

CCD: Abbreviation for Charge Coupled Device. A solid state sensor used in some video cameras to form the image.

Digital camera: A camera in which the image is captured and stored electronically instead of on film. The film is usually replaced with a CCD sensor and digital memory.

Frame-grabber: An electronic device for digitizing and storing images from a source of video signals(usually a video camera). It normally takes the form of an add-on circuit board in a PC.

Non-metric camera: A camera that was not specifically designed for photogrammetric use, typically mechanically and optically unstable.

PC: An IBM or compatible Personal Computer.

Space co-ordinates: Cartesian point co-ordinates in 3 dimensions, i.e. X, Y and Z values.

1. INTRODUCTION

This thesis report discusses the development of a non-contact measuring tool based on digital photogrammetry. Photogrammetry is traditionally defined as “the science or art of obtaining reliable measurements by means of photographs.”¹ This concept has been extended in recent years to include the use of images obtained from sources other than ordinary film cameras, such as video cameras and digital cameras. As part of this development, the use of computer-based digital image processing has become increasingly important as researchers try to achieve full automation of the photogrammetric process.

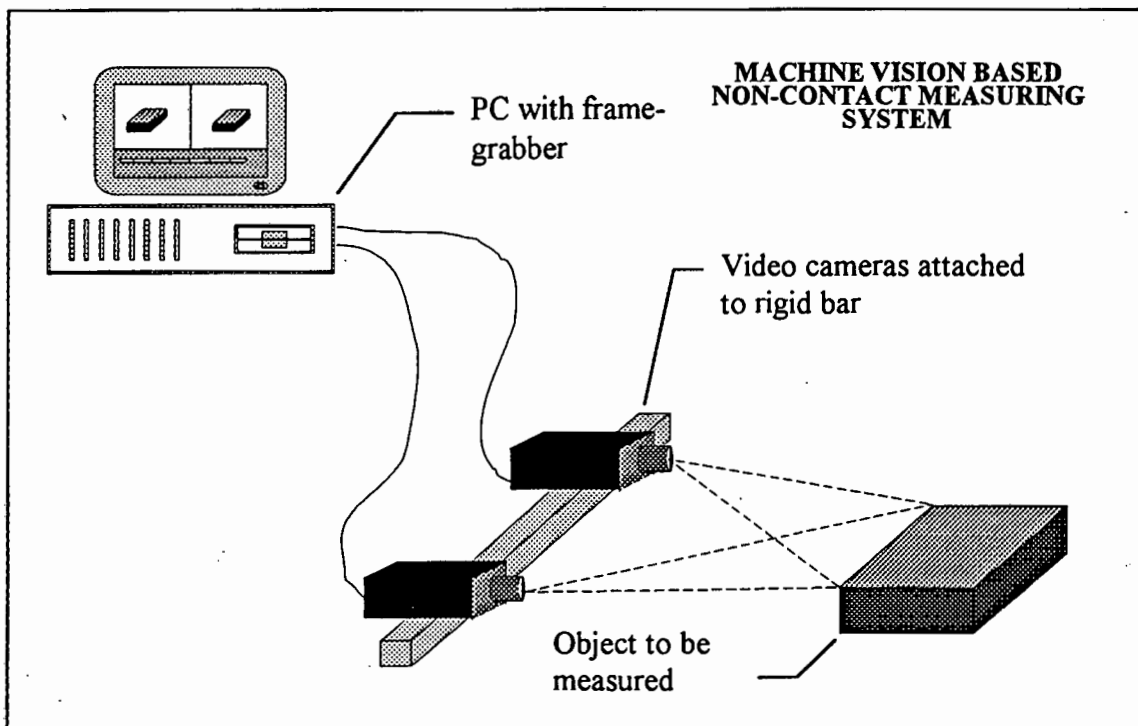

Figure 1: The basic equipment of the photogrammetric measuring tool

The measuring system developed in this project makes use of the principle of stereo-photogrammetry to achieve non-contact measurement. This involves using two images of an object, taken from different angles, to obtain three dimensional position information for points on the object. The position information is found by first measuring the co-ordinates in both images of the

¹ Slama, Chester C. ed. Manual of Photogrammetry, 4th ed., Falls Church: American Society of Photogrammetry, 1980, p1

points on the object, and then transforming these image co-ordinates into the space co-ordinates of the points. In the system developed in this project, the images of the target object are captured using CCD video cameras and a frame-grabber card in a PC. The cameras are mounted on a rigid bar, as shown in Figure 1. The images captured from the cameras are shown side-by-side on the PC's monitor to allow the user to select points on the object to be measured. The PC then processes the images to obtain the space co-ordinates of the points selected by the user. The dimensions and other metric information of the object can be calculated from these co-ordinates. The process requires knowledge of the relative positions and orientations of the cameras (the so-called relative orientation parameters). These parameters are calculated in an initial calibration stage from images of a calibration frame. Mounting the cameras on a bar guarantees that the relative orientation parameters will remain invariant within certain mechanical limits, thus making the system portable. This makes it possible to move the camera system to the object to be measured, rather than having to move the object to be measured to the cameras.

The objectives of the thesis were as follows:

1. To design the equipment for the measuring system.
2. To develop computer software to control the equipment and perform the necessary data manipulation.
3. To implement and test the system.

The objectives of this report are:

1. To discuss the theory underlying the system.
2. To describe the system and its implementation.
3. To set out results obtained in testing.
4. To draw conclusions from these results.
5. To make recommendations based on the conclusions.

The information contained in this report was obtained by personal research and study of published papers and references.

The report starts by explaining the underlying theory, continues with a discussion of the design and implementation of the system and then presents results obtained in testing. Finally, it draws conclusions and makes recommendations.

2. LITERATURE REVIEW

A brief review of literature in the field of photogrammetry found only one description of an existing, similar system. This was a system developed by a company called Camera Alive for measurement in the North Sea oil industry, where measuring tasks range from underwater corrosion and weld defect monitoring to measuring the whole of the side of an oil rig platform above water. It is described by Turner and Yule². The system was developed in response to the company's observation that the oil industry was reluctant to use traditional photogrammetric methods because of the delays in obtaining results caused by the need to develop and analyse photographs ashore. The Turner and Yule system is based on a PC and makes use of either video or digital cameras to capture images. The cameras are mounted on a remotely operated vehicle or on a frame that can be carried by a diver. Specialised image processing hardware is used to obtain acceptable operating speeds. The equipment allows for real-time stereo viewing by using a liquid crystal filter on a video monitor and polaroid glasses. Measurements can be taken directly from the display. It is also possible to build a complete three dimensional drawing and overlay it on the stereo image. The measurements and drawings can be transferred to a CAD system. Accuracy's of the order of 1 in 500 with video cameras and 1 in 2000 with the digital cameras have been reported.

² Turner, D.J. and Yule, D.J., "A Digital Non-Contact Measurement System", Photogrammetric Record, Vol.14 No.82, October 1993 pp583-594

3. DISCUSSION OF THEORY

This section discusses aspects of the theory of digital photogrammetry, on which the system developed in this project is based. Measurement by photogrammetry is fundamentally a two stage process. The first, or calibration, stage involves the determination of the relative position and orientation of each camera used. This stage includes the determination of parameters for the modelling of distortion introduced by imperfections in the camera lenses. Each camera calibration is processed separately. The second, or measuring, stage is the determination of the space co-ordinates of object points. Typical set ups for each stage are shown schematically in Figure 2.

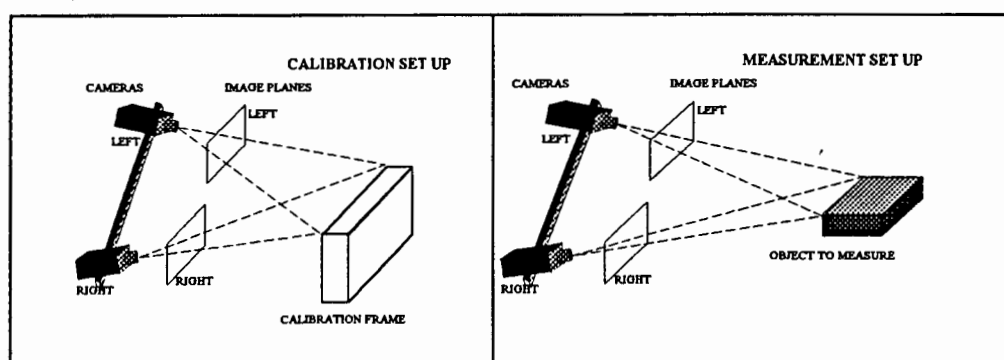

Figure 2: Typical Set ups for photogrammetric measurement

The calibration of a camera system involves three different forms of orientation, namely interior, relative and absolute. Interior orientation is the determination of the co-ordinates of the principal point and the principal distance of the camera. The principal point is the point where a line from the perspective centre of the lens system, perpendicular to the image plane, meets the image plane. The principal distance is the length of this line. Relative orientation is the determination of the position and orientation of one camera relative to the other. Absolute orientation is the determination of the position and orientation of each camera relative to some fixed co-ordinate system. The relative orientation parameters can be obtained from the absolute orientation parameters by shifting the origin of the co-ordinate system to the position of one of the cameras and rotating the co-ordinate system so that its axes are parallel to those of the camera.

To determine space co-ordinates in an arbitrary co-ordinate system, it is sufficient to have relative and interior orientation parameters. In this project, only the relative positions of object points are important, and not the co-ordinate system in which they are determined. Therefore the co-ordinate system can be arbitrary and only relative and interior orientation parameters are needed. They are obtained by performing two separate absolute orientations relative to a calibration frame. Since the co-ordinate system established by the calibration frame is entirely arbitrary and not fixed to any larger co-ordinate system, the absolute orientation parameters obtained are effectively relative orientation parameters.

Performing the orientation involves using the known space co-ordinates of the points on the calibration frame together with their sub-pixel image co-ordinates to obtain the camera orientation parameters. The points on the calibration frame are marked with circular targets, and both the space and image co-ordinates must be those of the target centre.

In the measurement stage, the image co-ordinates of target points are used together with the camera orientation parameters to obtain the space co-ordinates of the target points. A target point is defined as any point in the image that the user wants to find the co-ordinates of. At this stage it is necessary to have co-ordinates in each image for the same object point.

There are three main models available for the determination of camera parameters and space co-ordinates. These are the Direct Linear Transformation(DLT), the 11-parameter transformation (modified DLT) and the collinearity condition equations. This project makes use of the DLT and the collinearity equations, which will now be discussed.

3.1. PHOTOGRAMMETRY

The determination of the position and orientation of the cameras and the calculation of space co-ordinates for target points make use of standard photogrammetric techniques. These techniques were typically designed for an image co-ordinate system with the origin located at the principal point and x increasing to the right and y to the top. The principal point is the point where a line from the perspective centre of the lens system, perpendicular to the image plane, meets the image plane. A digital image, such as is used in this system, has a co-ordinate system with the origin at the top left corner, with x increasing to the right and y to the bottom. These systems are shown in Figure 3. This difference in co-ordinate systems necessitates the transformation of the image co-ordinates, using the equations shown below,

where w is the width of the image, h its height and s_x and s_y the horizontal and vertical scales. These scales are the horizontal and vertical dimensions of a pixel in millimetres. They serve to convert the co-ordinates from units of pixels to units of millimetres, which are the standard unit for photogrammetric measurement. With this transformation, the principal point is approximated by the centre of the image and the correction required from this approximation to its most probable position becomes one of the unknowns in the applicable equations.

$$x_{mm} = s_x \left(x_{pix} - \frac{w}{2} \right)$$

$$y_{mm} = s_y \left(\frac{h}{2} - y_{pix} \right)$$

Here x_{pix} and y_{pix} are the pixel co-ordinates in the digital image system and x_{mm} and y_{mm} are the co-ordinate in the standard image system, in millimetres.

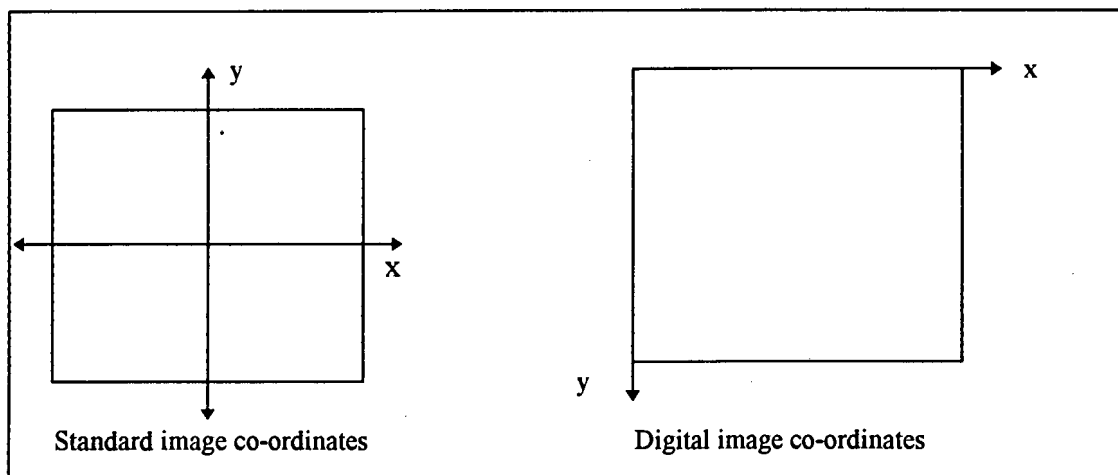

Figure 3: Image co-ordinate systems

3.1.1. DIRECT LINEAR TRANSFORMATION

This transformation was originally developed for use in close range photogrammetry using so-called non-metric cameras and provides a direct mapping between image co-ordinates and space co-ordinates, independent of any camera parameters. The equations are:

$$x = \frac{b_{11}X + b_{12}Y + b_{13}Z + b_{14}}{b_{31}X + b_{32}Y + b_{33}Z + 1}$$

$$y = \frac{b_{21}X + b_{22}Y + b_{23}Z + b_{24}}{b_{31}X + b_{32}Y + b_{33}Z + 1}$$

where x and y are the image co-ordinates of an object point and X, Y and Z are the corresponding space co-ordinates and the b_{xx} terms are the transformation parameters.

For the calibration of a camera, the space co-ordinates of the object point and its corresponding image position are known and the transformation parameters are unknown. Two equations are written for each point, giving $2n$ equations in 11 unknowns for n object points. This indicates that at least 6 points are needed for calibration. A least squares model is used to solve the equations, if there are more equations than unknowns, which should always be the case.

For the measuring stage, the image co-ordinates of the object point and the transformation parameters are known and the space co-ordinates of the object point unknown. Two equations are written for each image, giving $2n$ equations in 3 unknowns for n images. Thus, at least 2 images must be used to find the space co-ordinates. Again, typically, there are more equations than unknowns, so that a least squares model is used to solve the equations.

Since the physical situation that this transformation is modelling has only 9 independent parameters, i.e., the space co-ordinates of the perspective centre of the camera, the three orientation angles and the three interior orientation parameters, and there are 11 transformation parameters, the transformation parameters are not strictly independent. This leads to a less accurate result than could be obtained from more traditional models, such as the collinearity equations. It is also possible to derive approximate values for the parameters of the collinearity equations from the DLT parameters. For these reasons, the DLT is often only used to obtain provisional values for calibration by the collinearity equations. This approach was adopted for this project.

3.1.2. COLLINEARITY EQUATIONS

These equations express the condition that the camera's perspective centre position, an object point and its image position must lie on the same straight line. This is shown in Figure 4. Here the camera is at C and the point A appears in the image at a.

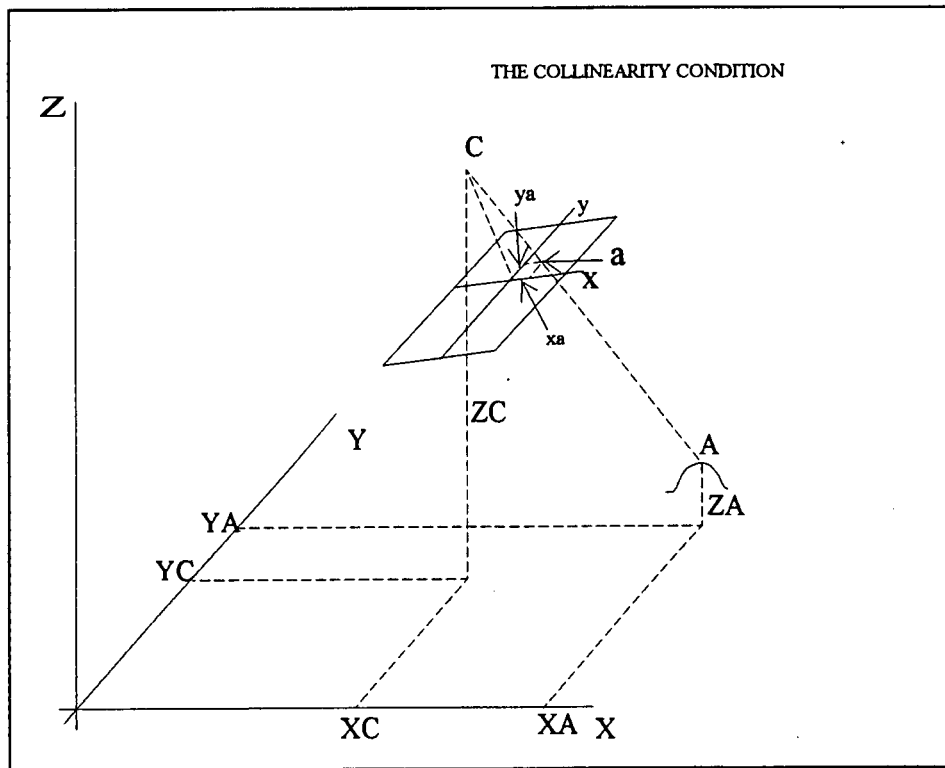

Figure 4: The collinearity condition

The collinearity equations for this point are:

$$x_a - x_p = f \frac{(X_A - X_C) \cdot r_{11} + (Y_A - Y_C) \cdot r_{12} + (Z_A - Z_C) \cdot r_{13}}{(X_A - X_C) \cdot r_{31} + (Y_A - Y_C) \cdot r_{32} + (Z_A - Z_C) \cdot r_{33}}$$

$$y_a - y_p = f \frac{(X_A - X_C) \cdot r_{21} + (Y_A - Y_C) \cdot r_{22} + (Z_A - Z_C) \cdot r_{23}}{(X_A - X_C) \cdot r_{31} + (Y_A - Y_C) \cdot r_{32} + (Z_A - Z_C) \cdot r_{33}}$$

The r_{xx} terms in the equations are the elements of a 3 by 3 rotation matrix, expressing the rotations needed to bring the image co-ordinate system parallel to the space co-

ordinate system. Their relation to the rotation angles depends on the chosen rotation model. For example:

$$r_{11} = \cos \kappa \cos \phi$$

$$r_{12} = -\cos \kappa \sin \phi$$

$$r_{13} = \sin \kappa$$

$$r_{21} = \cos \omega \sin \phi + \sin \omega \sin \kappa \cos \phi$$

$$r_{22} = \cos \omega \cos \phi - \sin \omega \sin \kappa \sin \phi$$

$$r_{23} = -\sin \omega \cos \kappa$$

$$r_{31} = \sin \omega \sin \phi - \cos \omega \sin \kappa \cos \phi$$

$$r_{32} = \sin \omega \cos \phi + \cos \omega \sin \kappa \sin \phi$$

$$r_{33} = \cos \omega \cos \kappa$$

The angles are measured positive anticlockwise when seen from the positive end of the axis of rotation. The angle ω is the rotation about the x-axis, κ that about the y-axis and ϕ that about the z-axis. The equations given above assume a rotation sequence of ϕ, κ, ω . The co-ordinates of the camera X_c, Y_c and Z_c and the orientation angles ϕ, κ and ω are known as the elements of exterior orientation and the co-ordinates of the principal point, x_p, y_p and the principal distance f of the camera are known as the elements of interior orientation.

During the calibration procedure, the space co-ordinates of the object points and their corresponding image co-ordinates are known and the elements of orientation are unknown. One set of equations is written for each object point, giving $2n$ equations in 9 unknowns for n object points. This means that a minimum of 5 non-coplanar points is needed to calibrate a camera. Using more points gives increased accuracy in the calibration parameters. Since there are more equations than unknowns, the equations are solved using a least squares model.

During the measurement procedure, the elements of orientation and the image co-ordinates of the object point are known and the space co-ordinates of the object point are unknown. One set of equations is written for each image, giving $2n$ equations in 3 unknowns for n images. This means that at least 2 images are needed to obtain space

co-ordinates. Once more, there are more equations than unknowns, so that a least squares model is used to solve the equations.

3.1.3. LENS DISTORTION

The lens of the camera inevitably introduces some distortion into the image. This distortion must be modelled in order to obtain accurate results. A number of possible models are available, from which a simplified version of the Brown model was chosen for this project. The equations of the model are:

$$dx = \bar{x}k_1r^2 + P_1(r^2 + 2\bar{x}^2) + 2P_2\bar{x}\bar{y}$$

$$dy = \bar{y}k_1r^2 + 2P_1\bar{x}\bar{y} + P_2(r^2 + 2\bar{y}^2)$$

$$\bar{x} = x - x_p$$

$$\bar{y} = y - y_p$$

$$r = \sqrt{\bar{x}^2 + \bar{y}^2}$$

The dx and dy terms are added to the left hand side of the appropriate equation in whichever model is used to calibrate and measure. In this project, they appear in the collinearity equations, giving

$$x_a - x_p + dx = f \frac{(X_A - X_C) \cdot r_{11} + (Y_A - Y_C) \cdot r_{12} + (Z_A - Z_C) \cdot r_{13}}{(X_A - X_C) \cdot r_{31} + (Y_A - Y_C) \cdot r_{32} + (Z_A - Z_C) \cdot r_{33}}$$

$$y_a - y_p + dy = f \frac{(X_A - X_C) \cdot r_{21} + (Y_A - Y_C) \cdot r_{22} + (Z_A - Z_C) \cdot r_{23}}{(X_A - X_C) \cdot r_{31} + (Y_A - Y_C) \cdot r_{32} + (Z_A - Z_C) \cdot r_{33}}$$

The photogrammetric techniques discussed above require the use of accurate(sub-pixel) image co-ordinates to obtain accurate results. Determining these co-ordinates requires that image processing techniques such as image matching, determining the centre of gravity of an image region, edge detection and edge following be used. The next section is a brief discussion of these techniques.

3.2. IMAGE PROCESSING TECHNIQUES

3.2.1. DETERMINING THE CENTRE OF GRAVITY

One method of finding the sub-pixel image co-ordinates of the target centres, needed during the calibration stage, is to calculate the weighted centre of gravity of a window containing the target. Placing the window correctly, with the minimum number of background pixels and the whole target in the window, requires that the extent of the target is determined by locating and following its edge. The process starts with the user selecting an approximate window around the target. This window is then refined by the methods described below.

3.2.1.a) Edge Detection

As the location of the edge is only needed to single pixel accuracy, it is sufficient to define the edge by thresholding the image. This means that pixels with a grey-value above a threshold are set to 255(white) and those with grey-values below the threshold to 0(black), as illustrated by the graph in Figure 5. The threshold value can be calculated from one of two formulae or it can be chosen interactively by the user. The two formulae are:

$$t = g_{\min} + \frac{(g_{\max} - g_{\min})}{4}$$

$$t = \frac{g_{\min} + g_{\text{mean}}}{2}$$

where t is the threshold value, g_{\min} the minimum grey-value in the window, the g_{\max} maximum and g_{mean} the mean.

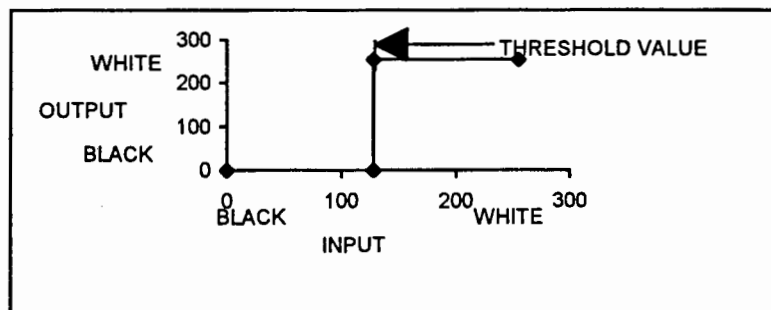

Figure 5: Graph of Thresholding Function

This makes the image of a target appear as a step function in grey-scale. An edge pixel is then defined as a pixel with a grey-value of 0 that has at least one neighbouring pixel with a grey-value of 255, ie., those that lie at the base of the step. This is illustrated in Figure 6.

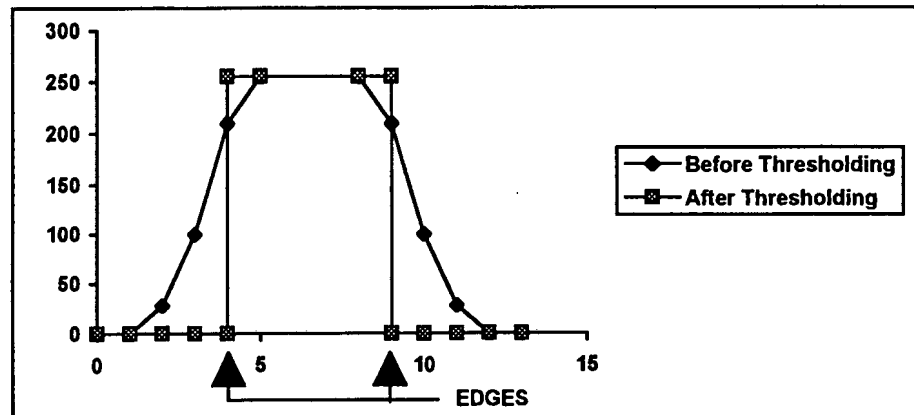

Figure 6: Effect of Thresholding on Target Image, showing edge positions

The search for an edge pixel is started in the centre of the window and proceeds to the right along the row of pixels. If the edge is not found before the right edge of the window is encountered, the search continues at the left edge of the window on the row of pixels below the starting point. The grey-value of each pixel is tested and when a change from 255 to 0 or from 0 to 255 occurs, the edge has been found. The edge pixel is the pixel with a grey-value of 0. A change of grey-value from 255 to 0 will occur if the search has started inside the target and thus the right edge of the target is encountered first while a change from 0 to 255 will occur if the search started outside the target and the left edge of the target is encountered first.

3.2.1.b) Edge Following

Once the first edge pixel has been located in the manner described above, the edge is followed around using a variation of the Freeman chain coding

algorithm. This variation was described by Rubinstein³. This algorithm defines a sequence for examining the neighbouring pixels of an edge pixel to locate the next edge pixel. The pixel numbering used in the sequence is shown in Figure 7, where 'x' is the current pixel, i.e. the edge pixel that has just been found and a successor to which is being sought.

7	0	1
6	x	2
5	4	3

Figure 7: Pixel numbering for Freeman chain code

The edge pixel found by the edge detection method described above becomes the first current pixel. The search for the next edge pixel starts at pixel 0 and follows the numerical sequence illustrated. The grey-value of each pixel is tested and when a change from 0 to 255 occurs, the edge has been found. The edge pixel is the pixel with a grey-value of 0. When an edge pixel is found, it becomes the current pixel and the search for the following edge pixel starts with the direction in which the new current pixel was found, e.g., if the new current pixel was pixel 1 from the previous edge pixel, the search from the new current pixel starts with pixel 1. This process continues until the current pixel gets back to the first edge pixel or at any stage the search returns to the starting direction without an edge pixel being found. If the former condition occurs first the edge has been followed in a clockwise direction, but if the latter condition occurs first the process has failed.

Once all the edge pixels of a target have been found using the methods described, the maximum and minimum x and y co-ordinate values are found and used to define the

³ Rubinstein, M., *Assessing target centring algorithms for use in near-real-time-photogrammetry*, M.Sc. thesis, University of Cape Town, 1990, pp84-85

required window containing the target. Background pixels are eliminated by setting pixels with a grey-value below a chosen threshold to 0. The same threshold value as used to find the edge is used here. The co-ordinates of the centre of gravity of the window are then calculated from:

$$y_0 = \frac{\sum y \cdot g}{\sum g}, \quad x_0 = \frac{\sum x \cdot g}{\sum g}$$

where the sums are taken across all pixels in the window and x is the pixel x-coordinate in terms of the pixel count, y is the pixel y-coordinate and g is the pixel grey-value. These are the standard formulae for the weighted centre of gravity with the grey-values as weight.

3.2.2. IMAGE MATCHING

As discussed above in sec. 3.1, the co-ordinates in each image of an object point must be found before its space co-ordinates can be calculated. This task requires the use of an image matching technique to guarantee that identical object points are identified. The technique chosen for this thesis was area-based least squares matching as proposed by Gruen⁴. This technique minimises the grey-scale differences between an image patch and a corresponding region of a search image by affine transforming the search patch into a best fit with the corresponding image patch. A patch is defined here as being a small sub-section of an image, normally square in shape, with a size of a few tens of pixels per side. The image patch would normally come from the left image and the search would be carried out in the right image, which is therefore called the search image. Alternatively, a template can be used for the image patch.

The patch and search image are defined as two-dimensional functions, $f(x, y)$ and $g(x, y)$ respectively. The objective is to find a location in $g(x, y)$ such that:

$$g(x, y) = f(x, y) - e(x, y)$$

⁴ Gruen, Armin W., "Adaptive Least Squares Correlation-A powerful image matching technique", Presented paper to the ACSM-ASP convention, Washington DC, March 1985

where $e(x, y)$ is an error term introduced to account for image noise. This equation may be considered as a non-linear observation equation modelling observations $f(x, y)$ with function $g(x, y)$. The initial approximation of the matching area in $g(x, y)$ is defined as $g^0(x, y)$. To allow for image deformations, caused by the cameras observing the scene from differing perspectives, image shaping parameters are introduced. The shaping is achieved by resampling $g(x, y)$ over a grid, transformed using an affine transformation defined by:

$$\begin{aligned}x &= a_{11} + a_{12}x_0 + a_{21}y_0 \\y &= b_{11} + b_{12}x_0 + b_{21}y_0\end{aligned}$$

Substituting these into the observation equation and linearizing by forming a Taylor series and taking only the first order terms leads to:

$$f(x, y) - e(x, y) = g^0(x, y) + \frac{\partial g^0(x, y)}{\partial x} dx + \frac{\partial g^0(x, y)}{\partial y} dy$$

where:

$$\begin{aligned}dx &= da_{11} + x_0 da_{12} + y_0 da_{21} \\dy &= db_{11} + x_0 db_{12} + y_0 db_{21}\end{aligned}$$

Simplification leads to:

$$\begin{aligned}f(x, y) - e(x, y) &= g^0(x, y) + g_x da_{11} + g_x x_0 da_{12} + g_x y_0 da_{21} + \\&\quad + g_y db_{11} + g_y x_0 db_{12} + g_y y_0 db_{21}\end{aligned}$$

where:

$$g_x = \frac{\partial g^0(x, y)}{\partial x}, \quad g_y = \frac{\partial g^0(x, y)}{\partial y}$$

These terms represent the grey-scale gradient in x and y at each point in the patch. They can be calculated from:

$$g_x = \frac{g(x+1, y) - g(x-1, y)}{2}$$

$$g_y = \frac{g(x, y+1) - g(x, y-1)}{2}$$

An iterative least squares approach is used to solve the observation equation, with initial values for the parameters set to:

$$a_{11} = b_{11} = a_{21} = b_{12} = 0$$

$$a_{12} = b_{21} = 1$$

This process yields refined estimates for the transformation parameters. The resulting transformation is applied to the initial estimate for the match point to obtain a final match point.

A variation on the least squares estimation technique, using the weighting function

$$p = \frac{1}{|r| + \varepsilon}$$

proposed by Kubik, Merchant and Schenk⁵, where r is the residual from the previous iteration and ε is any small number, is also used in the system developed for this thesis. The ε term is introduced to avoid the possibility of division by 0, and can be of the order 10^{-4} . The initial weights are set to 1. This is a robust model which leads to the minimising of the sum of the absolute values of the residuals(L1-norm) rather than the sum of the squares of the residuals(L2-norm) as with traditional least squares estimation. The user can select which model to use.

⁵ Kubik, K., Merchant, D. and Schenk, T. "Robust Estimation in Photogrammetry", Photogrammetric Engineering and Remote Sensing, Vol. 53 No. 2, February 1987, pp167-169

4. SYSTEM DESCRIPTION

This section describes the system as implemented. The first part gives details of the equipment used for the system and the second describes the software written to drive the system.

4.1. EQUIPMENT

The equipment used for this project is as follows:

- An IBM compatible 386 PC with a numeric coprocessor and a super VGA display driver equipped with 1 MB of display memory. This large display memory is needed to allow the use of a display resolution of 1024 by 768 pixels by 256 colours. This resolution is the lowest available that will allow two full 512 by 512 images to be displayed side by side on the monitor.
- A Silicon Video Mux frame-grabber/image processing card for the PC, manufactured by Epix Inc. The specific model used was a SVM-GRB-1MB-20-14.3 with 1 MB of image memory and a maximum pixel clock frequency of 20 MHz. The grey-scale resolution of the frame-grabber is 8 bits per pixel, giving 256 grey-values. The standard pixel clock frequency of 14.3 MHz was used on the unit incorporated in this system, as this system was to use standard video cameras. This frequency determines how often the frame-grabber samples the video signal, and thus the maximum number of pixels per line of image. For a video signal with a vertical frequency of 15.625kHz, corresponding to 625 lines per frame at 25 frames per second, this gives 768 pixels per line, allowing for synchronisation and blanking periods that are not digitised. The actual number of pixels per line and lines per frame stored by the frame-grabber can be configured by the software, within the maximum of 768 pixels and 580 lines. For this system the image dimensions used are 512 pixels by 512 lines.

The system software was written specifically for this frame-grabber, but in a manner that will allow for a change to a different card. The change can be effected by rewriting a small part of the software.

- A pair of CCD video cameras manufactured by ITC. The specifications are shown in Table 1.

Image device	0.5" interline transfer CCD
Image area	7.95mm × 6.45mm
Picture elements	795 × 596

Table 1: Specification of ITC CCD cameras

- A video monitor for displaying the output from the frame-grabber. This is particularly important when setting up and calibrating the camera system.
- A tripod with a mounting bar for the cameras. This is shown in Figure 9.
- One large calibration frame and one small calibration frame. The large frame is shown in Figure 10. Details of the target layouts and co-ordinates for the frames can be found in Appendix B.

A schematic diagram of the equipment is shown in Figure 8

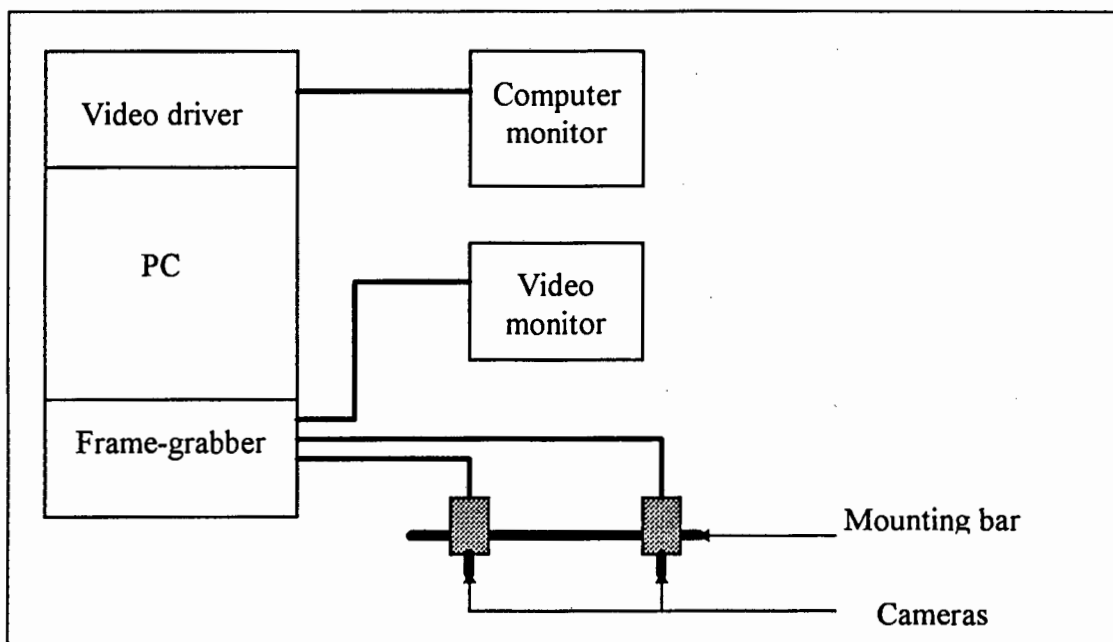

Figure 8: Schematic diagram of the system equipment

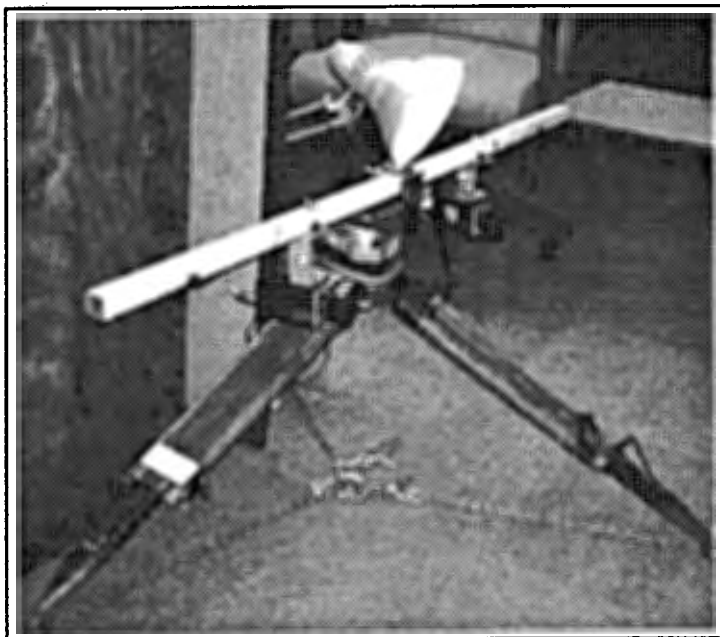

Figure 9: The tripod and camera mounting bar

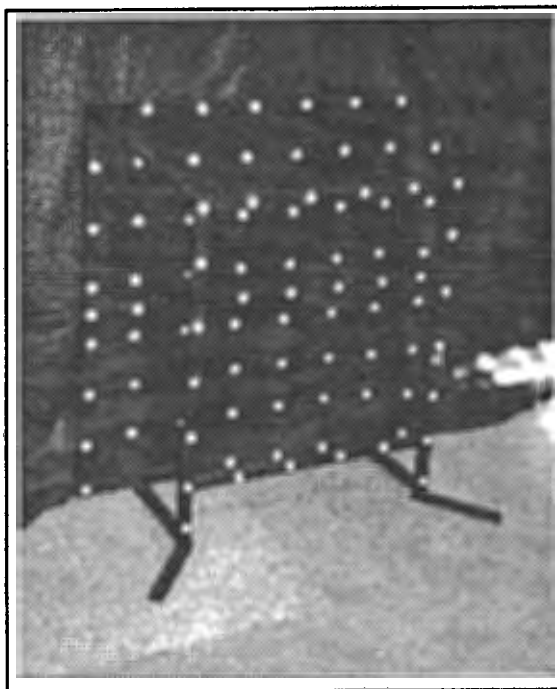

Figure 10: The calibration frame

4.2. SOFTWARE

This section discusses the software that was developed for the system. It starts with a discussion of the programming language used and then gives a brief overview of the structure of the system software. It then discusses each of the system's component programs and ends with a discussion of the naming and formats of the data and image files used by the system.

4.2.1. CHOICE OF PROGRAMMING LANGUAGE

The software for this project was written in a combination of C and C++. The main reason for this choice was the availability of compilers for these languages

The main compiler used was GNU C, a product of the Free Software Foundation. This compiler was used because it incorporates a DOS extender, allowing easy access to the full memory of the PC. This simplifies the handling of the image data as full images can be held in memory, avoiding the need to repeatedly read the data from disk during a program run. Borland C++ was used for those parts of the system that interface to the frame-grabber as the software library supplied with the card was designed for use with this compiler.

4.2.2. OVERVIEW OF SOFTWARE STRUCTURE

The software that drives the system consists of four main programs. These programs reside in their own directory on the PC's hard drive. The first, named PMT, forms the main user interface to the system. It also controls the frame-grabber. The second, named CALIB, deals with the calibration procedures. The third program, named MEASTOOL, is the actual measuring system. The fourth program is a simple template editor called TEDIT. These programs use a number of data files which are stored in two sub-directories in the main directory, named "data" and "images". This directory structure is illustrated in Figure 11. As their names imply, the "data" directory hold data files, and the "images" directory holds image files. The last three programs are normally called up from the menu provided by PMT, but can also be run independently if necessary, making for a more flexible system.

The image and data files that relate to one specific job are connected by name through a project set up. Part of the set up is a project file that stores information about the

camera configuration for that job. The name of this file determines how all other files connected to the project will be named.

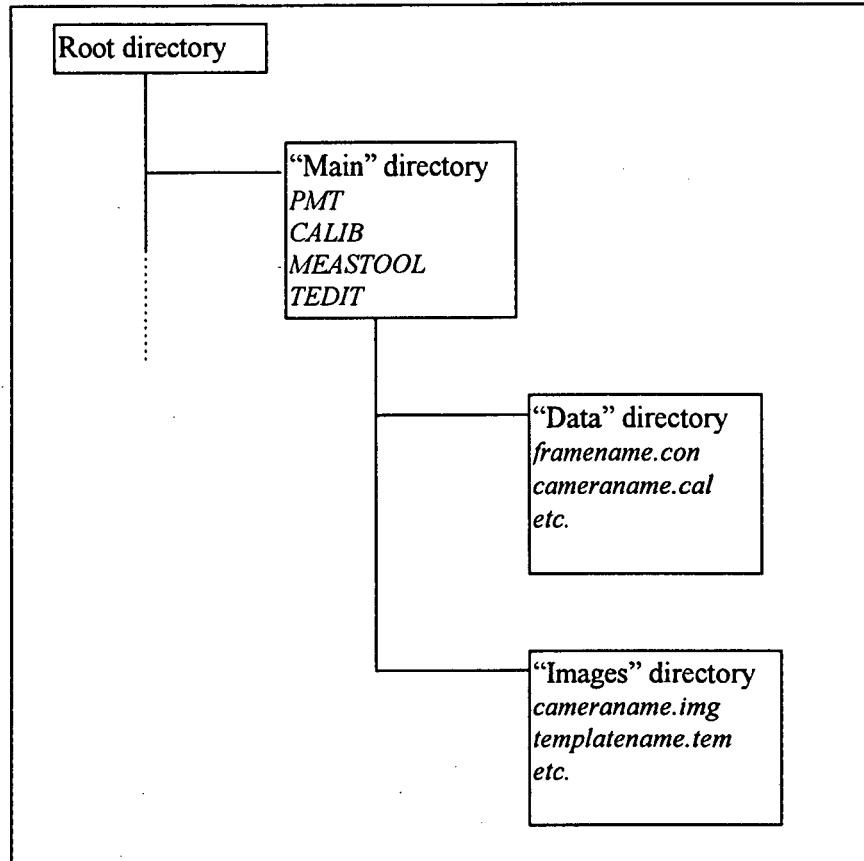

Figure 11: System directory structure

4.2.3. THE PROGRAM "CALIB"

The program called "CALIB" forms the calibration module of the system. It is responsible for calculating the elements of orientation and the lens distortion parameters for a camera. It makes use of a graphic display layout and menu structure that is designed to make operating the program as easy as possible. A photograph of this screen display is shown in Figure 12. The image is displayed at the top left of the screen with a row of buttons below. These buttons give access to all the menu options and operations, such as selecting the target centring method, setting the threshold for centre of gravity calculation and starting the calibration calculations. The full menu structure is illustrated in Figure 13.

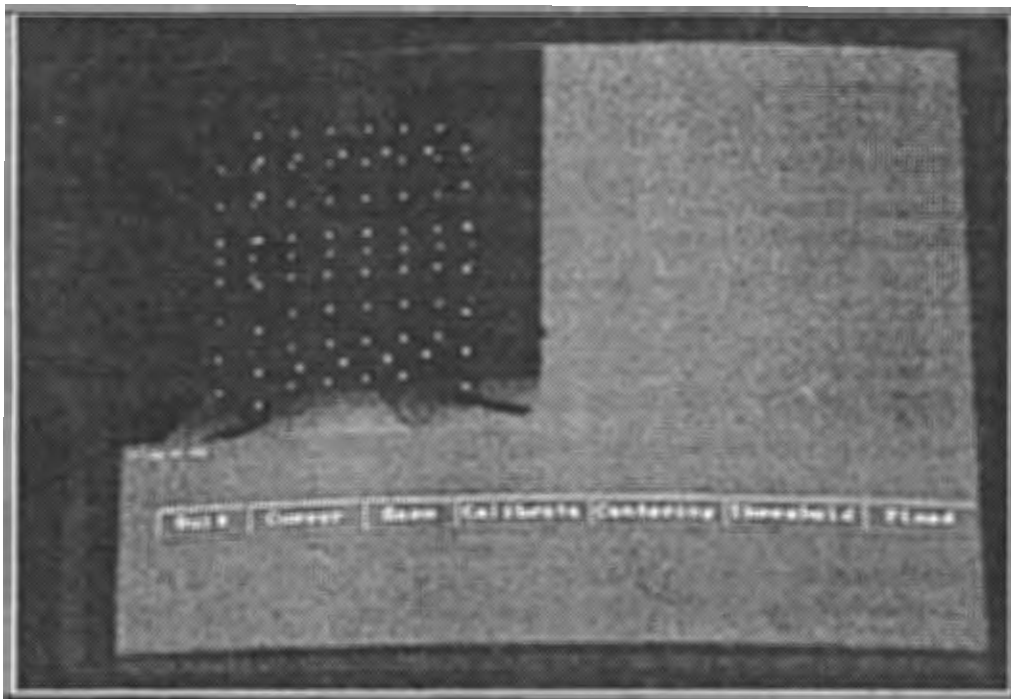

Figure 12: The screen display of the program "CALIB"

LEVEL ONE	LEVEL TWO
QUIT Leave the program	
CURSOR Choose the cursor type	2 Cross-hairs surrounded by a box. The size of the box shows the size of the window that will be used in centring.
	3 Plain cross-hairs.
ZOOM Switch between normal and zoom view	
CALIBRATE Start calibration calculations.	
CENTERING Choose method of finding target centres.	CofG Find centre of gravity.
	Match Match a circle template
THRESHOLD Choose threshold for centre of gravity calculation.	1 Interactive thresholding. Allows user to visually select a threshold value
	Π Use function (min. grey-value + mean grey-value) / 2
	Ω Use function (min. grey-value + (max. grey-value - min. grey-value) / 4)
FIXED Choose which parameters to hold fixed	

Figure 13: Menu structure in program "CALIB"

The CURSOR and ZOOM options are tools that make the identification of targets easier. The CURSOR option offers a choice of two styles of cursor. The first is a cross-hair surrounded by a square box, the second a plain cross-hair style cursor. If

the user has chosen to use the centre of gravity centring technique, the box represents the area that will be used as the provisional window for the centre of gravity calculation. If the user chooses to use the template matching method, the box represents the initial match area for the matching routine. The ZOOM option allows the user to zoom in on an area of the image. When the user selects this option, the cursor becomes a magnifying glass while it is over the image. When the user clicks on a point, the system magnifies the area surrounding the point by a factor of two. Selecting the menu option again restores the full image.

The “THRESHOLD/T” and “FIXED” options bring up separate menus. The “FIXED” menu lists the collinearity and lens distortion parameters, each on its own button. A depressed button here indicates that the parameter will be held fixed during the collinearity model stage of the calibration. The “THRESHOLD/T” menu is illustrated in Figure 14.

DONE
Return to main menu
<< Decrease threshold by 10
< Decrease threshold by 1
> Increase threshold by 1
>> Increase threshold by 10

Figure 14: Thresholding menu

This menu allows the user to interactively set the threshold value that will be used for locating the edge of the target during the centre of gravity calculations if centre of gravity centring is chosen. The space below the buttons displays status information such as the screen co-ordinates of the cursor and the number of iterations performed by the two least squares adjustments involved in calibration. The space to the right of the image is used for user input of the target numbers and to display the calculated calibration parameters.

The calibration is carried out in a three stage process. The first stage involves identifying the targets on the frame that appear in the image. The second stage involves performing a DLT calibration using the image co-ordinates and the corresponding space co-ordinates of the targets to obtain transformation parameters for that camera. The space co-ordinates must be in millimetres. No provision for lens distortion is made at this stage. These parameters are then converted to the elements of orientation, using the equations shown below. These equations were found in a set of unpublished notes written by Graeme van der Vlugt.

$$\lambda^2 = 1/(b_{31}^2 + b_{32}^2 + b_{33}^2)$$

$$x_p = (b_{11} \cdot b_{31} + b_{12} \cdot b_{32} + b_{13} \cdot b_{33}) \cdot \lambda^2$$

$$y_p = (b_{21} \cdot b_{31} + b_{22} \cdot b_{32} + b_{23} \cdot b_{33}) \cdot \lambda^2$$

$$c_x^2 = (b_{11}^2 + b_{12}^2 + b_{13}^2) \cdot \lambda^2 - x_p^2$$

$$c_y^2 = (b_{21}^2 + b_{22}^2 + b_{23}^2) \cdot \lambda^2 - y_p^2$$

$$c = \frac{c_x + c_y}{2}$$

$$\begin{bmatrix} X_c \\ Y_c \\ Z_c \end{bmatrix} = \begin{bmatrix} b_{11} & b_{12} & b_{13} \\ b_{21} & b_{22} & b_{23} \\ b_{31} & b_{32} & b_{33} \end{bmatrix}^{-1} \cdot \begin{bmatrix} -b_{14} \\ -b_{24} \\ -1 \end{bmatrix}$$

$$r_{31} = b_{31} \cdot \pm \lambda$$

$$r_{32} = b_{32} \cdot \pm \lambda$$

$$r_{33} = b_{33} \cdot \pm \lambda$$

$$r_{21} = \pm \lambda \cdot (b_{13} \cdot r_{32} - b_{12} \cdot r_{33}) / c_x$$

$$r_{22} = \pm \lambda \cdot (b_{11} \cdot r_{33} - b_{13} \cdot r_{31}) / c_x$$

$$r_{23} = \pm \lambda \cdot (b_{12} \cdot r_{31} - b_{11} \cdot r_{32}) / c_x$$

$$r_{11} = \pm \lambda \cdot (b_{22} \cdot r_{33} - b_{23} \cdot r_{32}) / c_y$$

$$r_{12} = \pm \lambda \cdot (b_{23} \cdot r_{31} - b_{21} \cdot r_{33}) / c_y$$

$$r_{13} = \pm \lambda \cdot (b_{21} \cdot r_{32} - b_{22} \cdot r_{31}) / c_y$$

$$\kappa = \sin^{-1}(r_{13})$$

$$\bar{\omega} = \tan^{-1}\left(-\frac{r_{23}}{r_{33}}\right)$$

$$\bar{\phi} = \tan^{-1}\left(-\frac{r_{12}}{r_{11}}\right)$$

$$\omega = \bar{\omega} \quad \text{or} \quad \bar{\omega} + 180^\circ$$

$$\phi = \bar{\phi} \quad \text{or} \quad \bar{\phi} + 180^\circ$$

As can be seen, the equations for the rotation angles do not give unique results. The ambiguity in ω and ϕ results in four sets of angles and the ambiguity in λ doubles this to eight. These ambiguities are resolved by using each set of angles to calculate a rotation matrix using the formulae of sec. 3.1.2 and comparing the result to the rotation matrix represented by the r_{xx} terms in the above equations. The set that gives the smallest difference is adopted as the provisional values for the rotation angles.

The provisional values found from the above equations are then passed to the third stage, a collinearity condition equation based calibration which yields refined values for the elements of orientation and values for the lens distortion parameters. In this stage it is possible to hold chosen parameters fixed. This is achieved by setting the appropriate diagonal element in the $A^T A$ matrix of the least squares model to a very large value, of the order of 10^{100} . This effectively means that the correction for that parameter will be 0 for every iteration and its value will not be changed. The DLT is used here purely as a means of finding provisional values for the elements of orientation.

In the first stage the image of the calibration frame is displayed on the PC's monitor for the user to identify the targets by pointing to them one at a time with a mouse. For each target the user points out, the system attempts to locate the centre, either by matching a circular template to the point or by calculating the centre of gravity of a window around the point, depending on which method the user has chosen. If the centre of gravity method has been chosen, the program takes a provisional window surrounding the target, finds and follows the edge of the target using the techniques described in sec. 3.2.1, and then calculates the centre of gravity of a new window that is set at the edge of the target. If the template matching technique has been chosen,

the program uses the image matching method of sec. 3.2.2 to match a circular template to the target. Once the centre of the target has been found, the user is asked to input the number of the target. This must correspond to the number of the target in the file of space co-ordinates. This manual system of target identification was chosen for its simplicity. It also make the quality of the image less critical.

When all the targets in the image have been identified, the user initiates the second and third stages. These stages perform least squares adjustments to carry out the DLT model for provisional values and then the collinearity model calibrations. If the adjustments are successful, the calculated values for the elements of orientation and the lens distortion parameters are displayed on the right side of the screen and saved to file. The DLT parameters are also saved to file. This sequence of operations is illustrated in Figure 15

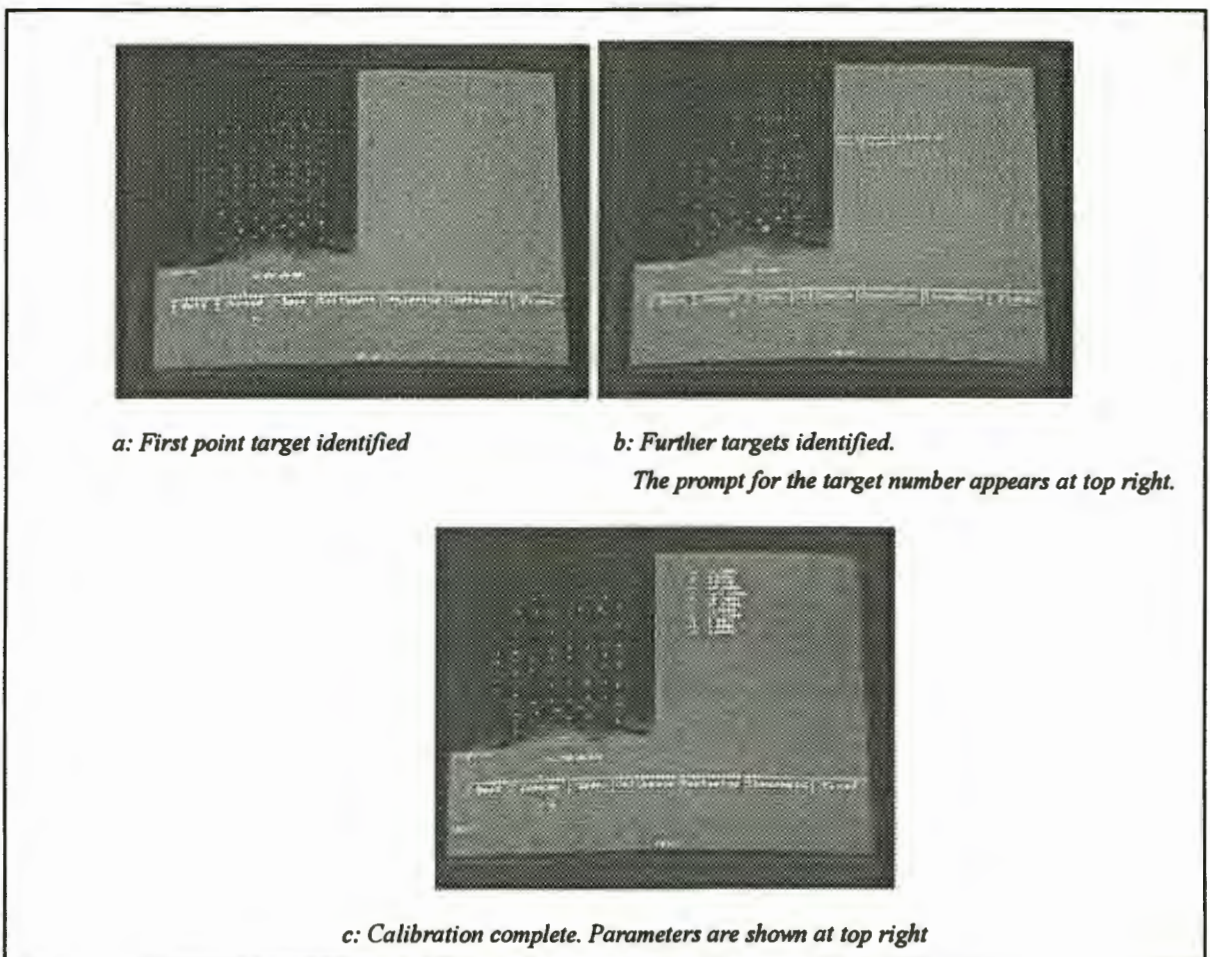

Figure 15: Screen displays showing the calibration sequence

4.2.4. THE PROGRAM "MEASTOOL"

The program called "MEASTOOL" is the heart of the system, being responsible for carrying out the actual measurement functions. It makes use of a display and menu structure similar to "CALIB" to maintain a uniform user interface. The screen display is illustrated in Figure 16. The image pair is displayed at the top of the screen with the menu buttons below. The space between the images and buttons is used to display status information such as image names and the image co-ordinates of selected points. The space co-ordinates of selected points and measurement results are also displayed here. Additional status information such as the number of iterations performed by the matching routine and the screen co-ordinates of the cursor appear below the buttons. The menu structure is illustrated in Figure 17.

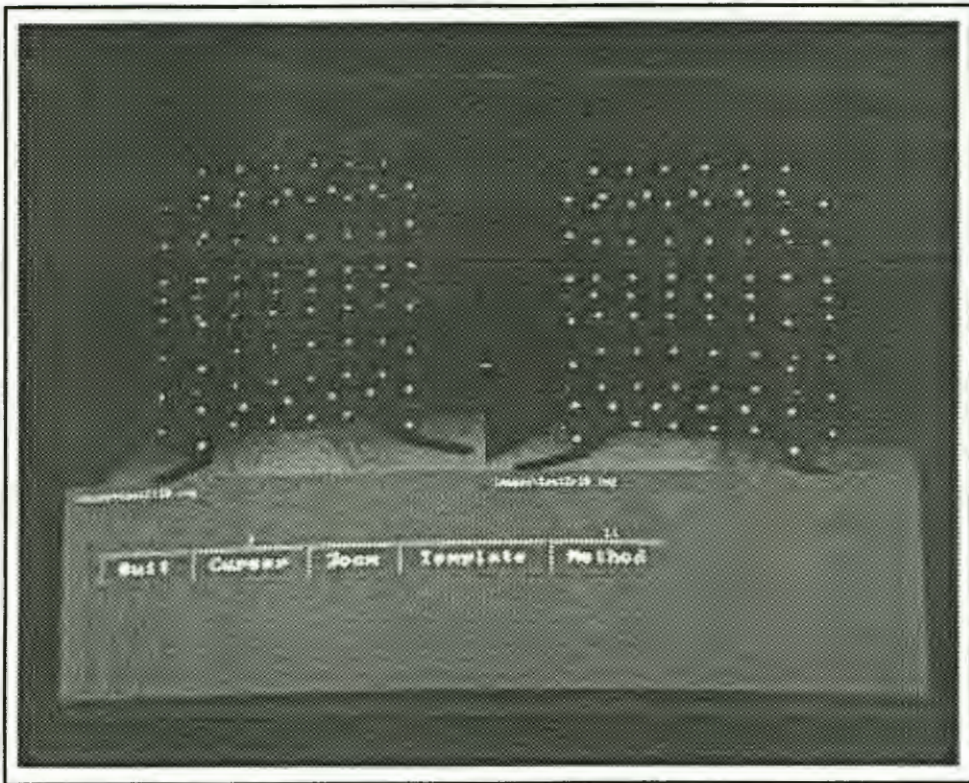

Figure 16: The screen display of the program "MEASTOOL"

LEVEL ONE	LEVEL TWO
QUIT Leave the program.	
CURSOR Choose the cursor type.	2 Cross-hairs surrounded by a box. The box represents the window that will be used in matching
	3 Plain cross-hairs.
ZOOM Toggle between zoom and normal views.	
TEMPLATE Choose the template for locating point in left image.	NONE No template. The point in the left image is the location of the cursor.
	USER A user-defined template. The user is asked to input the name of the template.
	r A top left corner.
	7 A top right corner.
	L A bottom left corner.
	J A bottom left corner.
	O A circle.
METHOD Choose the image matching method.	L1 L-1 norm matching.
	L1f L-1 norm matching with some parameters held fixed.
	L2 Least squares matching.
	L2f Least squares matching with some parameters held fixed.

Figure 17: Menu structure in program "MEASTOOL"

The CURSOR and ZOOM options serve the same purpose as the options of the same name in the program "CALIB", which were described above. The "METHOD/L1f" and "METHOD/L2f" options bring up a menu of affine transformation parameters. A depressed button here indicates that the parameter will be held fixed in matching. The parameters are held fixed using the same technique that is applied to the parameters in the calibration stage, i.e. the appropriate diagonal element of the $A^T A$ is set to a value of the order of 10^{100} . This facility is useful when attempting to match an edge location. If the edge is parallel to one of the image sides, the shift in that direction can be held fixed, preventing the match point from simply sliding along the edge and never converging.

The METHOD option allows the user to select the adjustment method that will be used by the matching routine. If either the L1 or L1f option is chosen, the matching routine uses the robust, or L1-norm, estimation technique discussed in sec. 3.2.2. If

either the L2 or L2f option is chosen, the matching routine uses the standard least square estimation technique.

The TEMPLATE option allows the user to select a template for matching to the selected point in the left image. Five standard templates, namely a circle and four corners, are provided, as well as the USER option, which allows for entering the name of a user-defined template. Selecting the NONE option disables template matching for locating points in the left image.

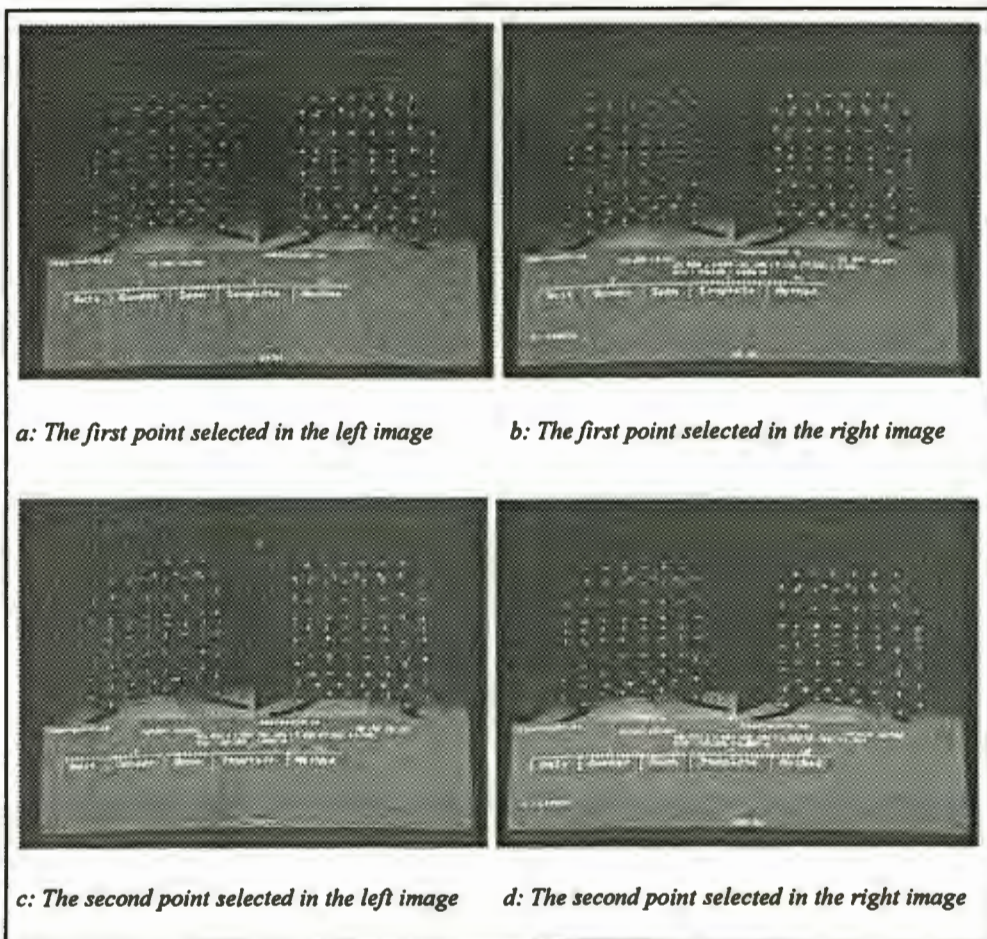

Figure 18: Screen displays showing the measurement sequence

The measurement sequence, illustrated in Figure 18, works as follows. The user first indicates the point to measure in the left image using the mouse cursor. If a template has been selected, it will be matched to the user selected point to obtain sub-pixel coordinates. If no template has been selected, the pixel co-ordinates of the cursor are

adopted as the target point. The user then selects the approximate matching point in the right image. A patch surrounding the point in the left image will then be matched to the user selected point in the right image to obtain sub-pixel co-ordinates for the matching point. The initial design of the system was for the user to indicate the point in the left image only and then to use epipolar geometry to search for the corresponding point in the right image. This idea was dropped as it was felt that it would make the system too slow. The system then calculates the space co-ordinates of the point, using the calibration data for the current project and the image co-ordinates just found in a least squares solution of the collinearity equations. From these space co-ordinates and those of the previous point measured, the distance between the points is calculated from the equation shown below. For the first point measured in a program run, the distance calculated is the distance from the origin. The space co-ordinates and distance are given in millimetres. They are saved to two files, one for co-ordinates, and one for distances.

4.2.5. THE PROGRAM "TEDIT"

The program called "TEDIT" is a simple template editing utility. Its display structure and menu system are similar to "CALIB" and "MEASTOOL". The screen display is shown in Figure 19. The template being edited is displayed at the top left of the screen, enlarged 20 times by representing each pixel in the template as a 20 by 20 square on screen. To the right of this is a square that shows a sample of the current grey-value with a pair of buttons that allow the user to change the grey-value. This feature acts as a selector for choosing the grey-value a pixel will be set to when editing. Below the template are the menu buttons, which give access to the menu options shown in Figure 20. Below the grey-value selector is a normal size view of the template.

The program has two main operating modes, called query and edit modes. In query mode, clicking in a square(pixel) in the enlarged template returns the current grey-value of that pixel. The value is displayed between the buttons and the enlarged template. In edit mode, clicking in a square sets the pixel that it represents to the grey-value selected with the selection box on the right of the template.

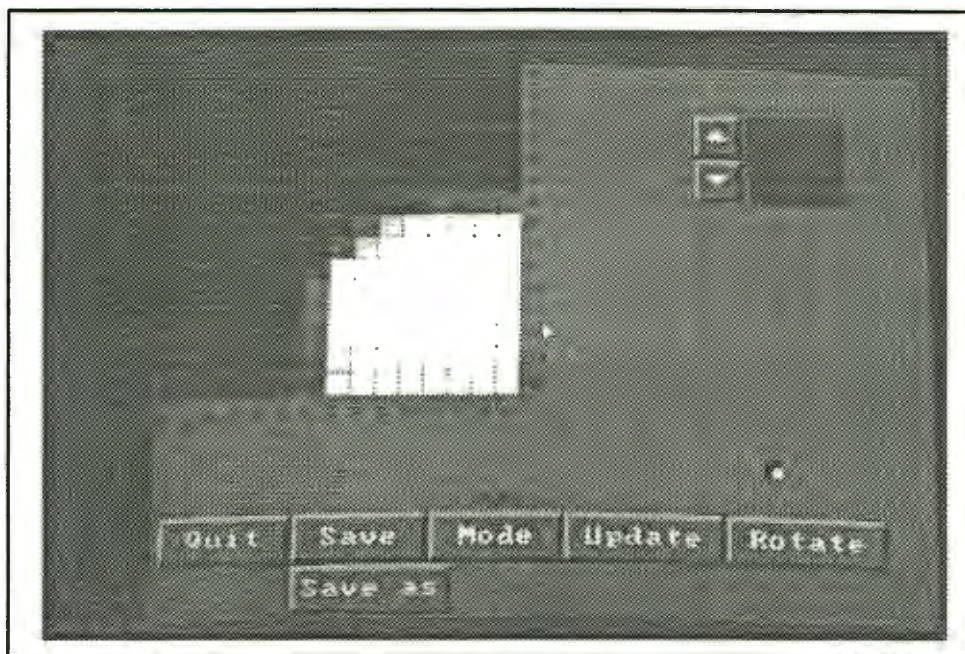

Figure 19: The screen display of the program "TEDIT"

It is also possible to rotate a template clockwise around its centre in 90 degree steps using the ROTATE option. Selecting the UPDATE option causes the normal size view of the template to be updated to reflect any changes made to the template in the enlarged view. The SAVE AS option allows the user to save the template under a new name so that it is possible to create new templates by editing existing ones. The SAVE option saves the template to file, making any changes made to the template permanent. This simple set of facilities was found to be sufficient to allow the user to generate templates for locating features in "MEASTOOL".

LEVEL ONE
QUIT Leave the program. The current template is not saved.
SAVE Save the current template.
SAVE AS Save the current template under a new name.
MODE Toggle between query and edit modes.
UPDATE Update the normal size view of the template to reflect any changes in the enlarged view.
ROTATE Rotate the template 90 degrees clockwise about its centre.

Figure 20: Menu structure in program "TEDIT "

4.2.6. THE PROGRAM "PMT"

The program called "PMT" provides the entry point for the system. It displays a menu that gives access to all other parts of the system. It also fulfils the important function of controlling the frame-grabber. The menu differs from the other programs in that it is not graphic in nature but uses special function keys. The screen display is shown in Figure 21.

The menu options are:

F1: Capture / measure single image pair

This option allows the user to go through a complete image capture and measuring cycle. The images and measurements are not stored. It uses the calibration data from the last project that the user worked on.

F2: Capture / save multiple image pairs

This option allows the user to capture and store up to 99 image pairs, for measuring later. The number of images that can be captured is also limited by the capacity of the hard-drive fitted to the PC They are stored under a project name which the user enters.

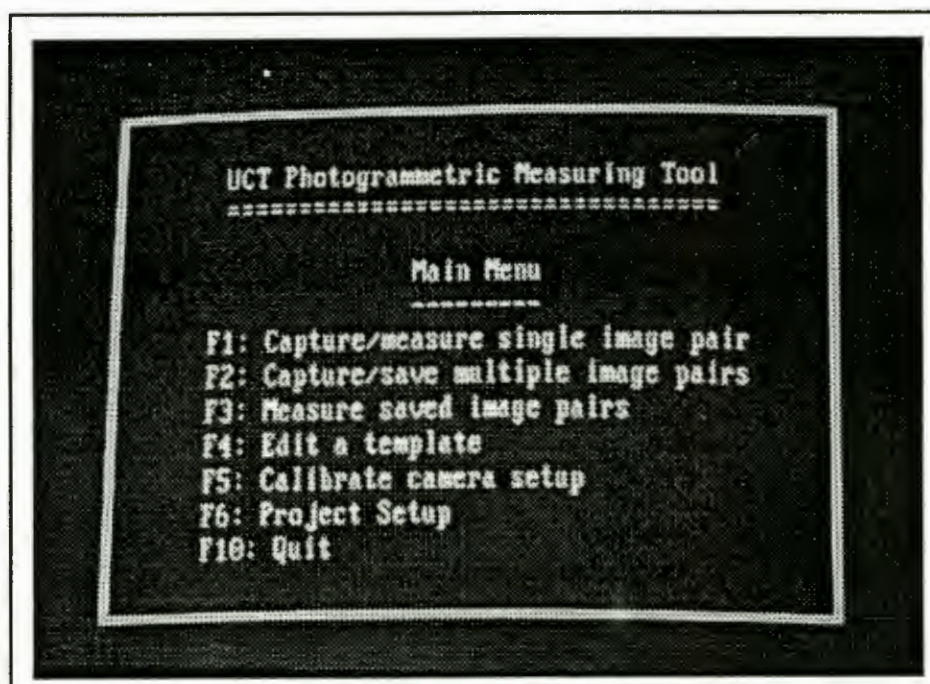

Figure 21: The screen display of the program "PMT"

F3: Measure saved image pairs

This option allows the user to make measurement from image pairs saved using option F2.

F4: Edit a template

This option gives access to the template editing program.

F5: Calibrate camera set up

This option allows the user to calibrate a single camera. It can capture a new image through the camera or work with a stored image. If a new image is used, it can be stored for later re-use.

F6: Project set up

This option allows the user to input the parameters of a particular project set up. The parameters are the name of the calibration frame used to calibrate the camera system, a name and channel number, and the image dimensions and the pixel scale factors for each camera. They are referred to in all other options where camera data is needed.

F10: Quit

This options ends the program and return to DOS.

The decision to use a separate program with a menu system to access the various parts of the system was taken to keep the system as simple as possible for the user. The control of the frame-grabber was integrated with the menu system as this function had to be coded in Borland C and it was easier to write one program to deal with both the menu and controlling the frame-grabber rather than writing a separate program for each function.

4.2.7. FORMAT AND NAMING OF DATA FILES

The data input and output of the system is stored in a number of files on the PC. One of these files must be generated outside of the system. This is a file of space coordinates of targets on a calibration frame. The file is named *framename.con* and must have the following format:

Col. no.	1	2	3	4
	pt no.	X	Y	Z

The file must have one line for each target point. *Framename* is an arbitrary name chosen by the user.

The remaining files are generated by the system and consist of project set-ups, camera calibration data, image co-ordinates and measured space co-ordinates and distances. The project set-up files are named *projectname.prj*, where *projectname* is a name for the project chosen by the user. They are generated by the project set-up procedure and store information about the physical set-up of the system needed for image capturing and in the calibration and measuring sections of the system. They take the following format:

Row no.	
1	Calibration file name
2	Left camera name
3	Left camera channel number
4	Right camera name
5	Right camera channel number

The channel numbers refer to the frame-grabber input channel to which the camera is connected. The camera names are arbitrary names that the user assigns to each camera and are used by the system when naming the calibration and physical parameter files. The project set up procedure also generates a file for each camera, named *cameraname.cam*, which contains the image dimensions and pixel scales. *Cameraname* is the name listed for the camera in the project set up file. The files have the following format:

Line no.	
1	image height
2	image width
3	horizontal scale
4	vertical scale

The image height and width are given in pixels and the scales are in millimetres per pixel. These dimensions and scales are derived from the configuration of the frame-grabber and from the specifications of the camera respectively. This information must be input to the system by the user.

The image co-ordinate files are generated during both the calibration and measuring stages and are named *imagenam.e.obs*, where *imagenam.e* is the name of the image file containing the image from which the observations were taken. They have the following format:

Col no.	1	2	3	4	5
	pt. no.	x	y	σ_x	σ_y

The file will contain one line per image point. The value are in pixels.

Two calibration files are generated per camera by the calibration procedure. The first file, named *cameraname.res*, where *cameraname* is the name listed for the camera in the project set up file, contains the DLT parameters and has the following format:

Col. no.											
	b11	b12	b13	b14	b21	b22	b23	b24	b31	b32	b33

The second file, named *cameraname.cal*, where *cameraname* is the name listed for the camera in the project set up file, contains the elements of orientation and lens distortion parameters and has the following format:

Col. no.	1	2	3	4	5	6	7	8	9	10	11	12
	x _p	y _p	c	X _c	Y _c	Z _c	ω	κ	ϕ	k ₁	P ₁	P ₂

The co-ordinates are in millimetres and the angles in degrees.

The calculated space co-ordinates are stored in a file named *projectnameNN.dat* with the following format:

Col no.	1	2	3	4	5	6	7
	pt no.	X	Y	Z	σX	σY	σZ

The calculated distances are stored in a file named *projectnameNN.dis* with the following format:

Col no.	1	2	3	4
	pt no. from	pt no. to	distance	σ distance

Here *projectname* is the name of the project to which the measurements relate and *NN* is the number of the image pair in the project from which the measurements were taken. The values in these files are in millimetres.

4.2.8. FORMAT AND NAMING OF IMAGE FILES

The images used by the system are stored in "flat" or byte image format. This means that the image file has one byte, representing the grey-value, for every pixel in the image. The pixels are read from left to right across the rows and from the top of the image to the bottom. This format was used because it offers the simplest means of dealing with images, needing no special decoding or encoding when reading from or writing to file.

The system uses two different types of image, small template images and full images. The template images are 15 by 15 pixels and represent ideal images of some typical feature types, such as circles and corners. The full images are those captured by the cameras and are 512 by 512 pixels in size. The template images are named *templatename.tem*, where *templatename* is the name of the template chosen by the user, and the full images *imagenname.img*, where *imagenname* takes one of two forms. For images captured for calibration, it is the name of the camera from which the image was captured, as listed in the project set up file. For images captured for measurement, it is *projectname[l/r]NN*, where *projectname* is the name of the project to which the image pair belongs, *[l/r]* represents either an l or an r for left or right image and *NN* is the number of the image pair that the image is part of.

5. TEST RESULTS

This section sets out the test methods used and the test results obtained. The system was tested by measuring a number of test objects with known dimensions and comparing them to the system output. The objects were chosen to give a variety of shapes and sizes.

5.1. OBJECT 1: THE CALIBRATION FRAME

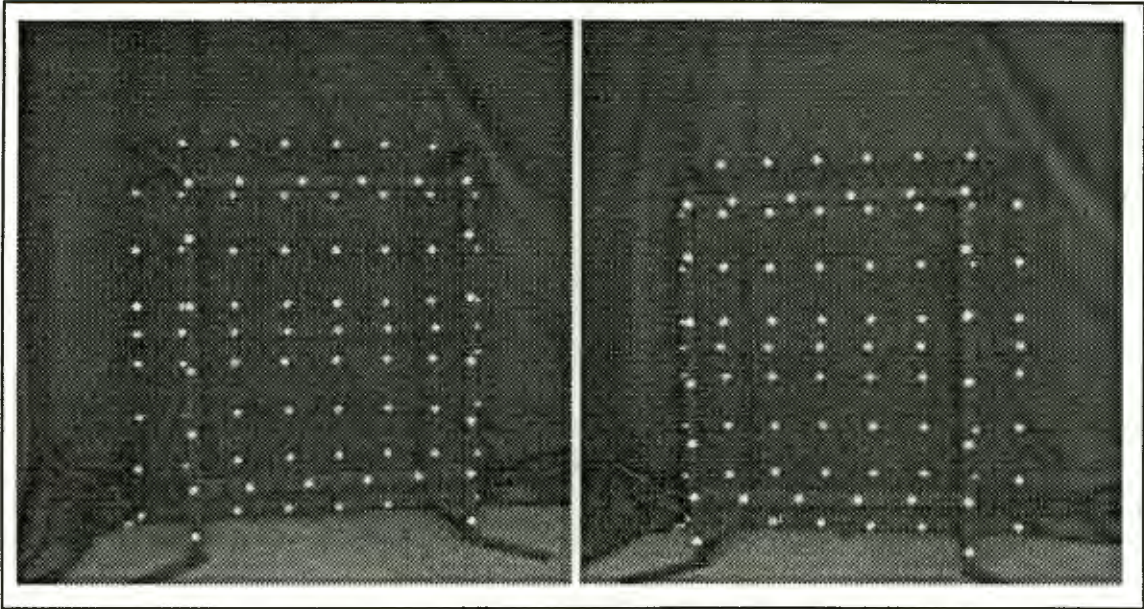

Figure 22: Stereo-pair of the calibration frame

The first object measured was the calibration frame used for performing the calibration of the system. Measurements were made on the same pair of images used for calibration. They are shown in Figure 22. These images were captured with a base/height ratio of approximately 1:3 and the cameras turned inward by approximately 10 degrees. Remeasuring the frame was considered to present near ideal test conditions, as the points to measure were clearly marked and the true co-ordinates accurately known. The test was performed by measuring the position of all points on the frame visible in both images and the distances between successive points. A summary of the errors in the results obtained are set out in Table 2 and Table 3.

	X	Y	Z
Maximum	2.142	2.476	1.663
Average	0.475	0.851	0.544
RMS	0.632	1.024	0.665
Minimum	0.012	0.006	0.011

Table 2: Summary of errors from measurement of point positions on calibration frame

	Distance
Maximum	2.814
Average	0.580
RMS	0.739
Minimum	0.004

Table 3: Summary of errors from measurement of distances on calibration frame

The numbers in the tables are in millimetres. The accuracy in distance ranges between approximately 1 in 40 and 1 in 25000 with an average of 1 in 1100. The histogram in Figure 23 shows that most of the errors are between 1 in 500 and 1 in 1000. Values below 1 in 500 or above 1 in 3000 should be considered outliers and therefore not a true reflection of the system's accuracy. A full table of results can be found in appendix A.

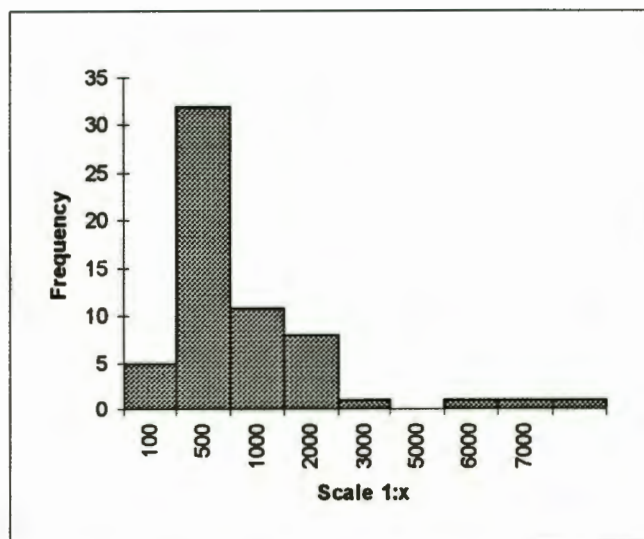

Figure 23: Histogram of error scales from remeasuring the calibration frame

5.2. OBJECT 2: POLYSTYRENE PACKING PIECE

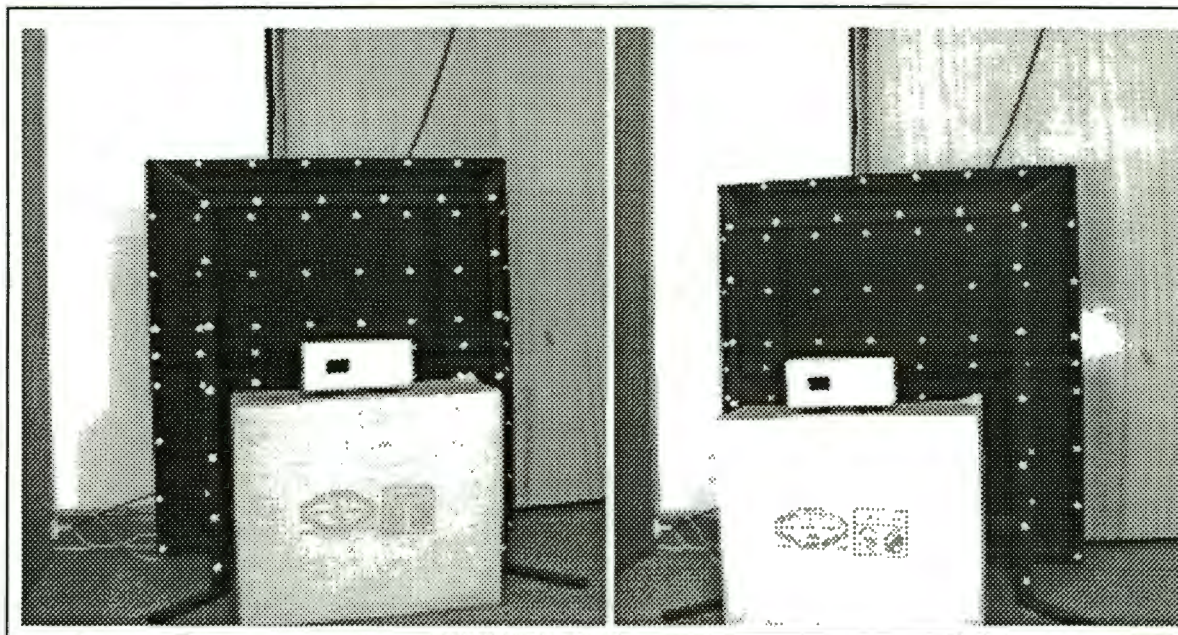

Figure 24: Stereo-pair of the polystyrene block

The second test object was a polystyrene packing piece from one of the cameras. It was essentially a rectangular block with a rectangular cut-out near one end. The edges of the block were rounded and thus poorly defined. The stereo-pair is shown in Figure 24. The base/height ratio for these images was approximately 1:3 and the cameras were turned inward by approximately 10 degrees. The test measurements taken were of the length and width of the block, as shown in Figure 25.

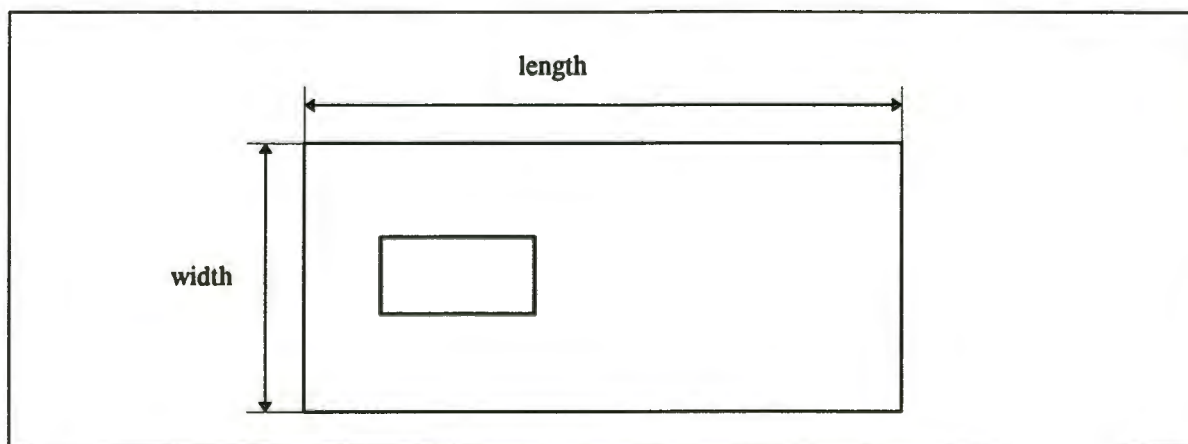

Figure 25: Diagram of polystyrene block showing measurements taken

Each measurement was repeated 10 times. For comparison, the same measurements were made with a vernier calliper. These measurements were 158.75mm for the length and 64.07mm for the width.

This test was used to check the accuracy and repeatability of the measuring system in a more realistic situation. The mean length measured was 160.981mm with a standard deviation of 2.379mm. The mean width measured was 67.843mm with a standard deviation of 1.477mm. A summary of the errors in the results is shown in Table 4. The values are in millimetres.

	Length	Width
Maximum	7.695	6.084
Average	2.231	3.770
RMS	3.163	4.022
Minimum	0.391	0.689

Table 4: Summary of errors from measurement of polystyrene block

As can be seen, these results were somewhat disappointing. While the measurements obtained were consistent, as can be seen from the histograms in Figure 26, they were consistently wrong. The errors appear to be mainly due to the difficulty in identifying the edge of the block. This problem arose from the uniform white colour of the block, which makes the front and back edges difficult to distinguish in the images, and from the rounding of the edges. The histograms in Figure 27 show the spread of the error scales.

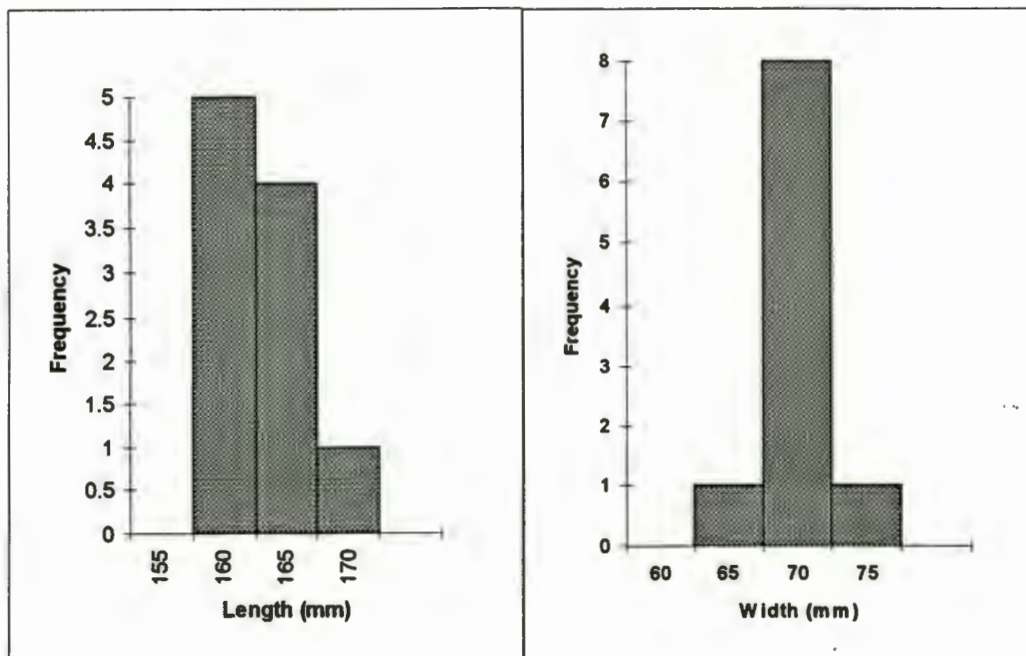

Figure 26: Histograms of measurements of the polystyrene block

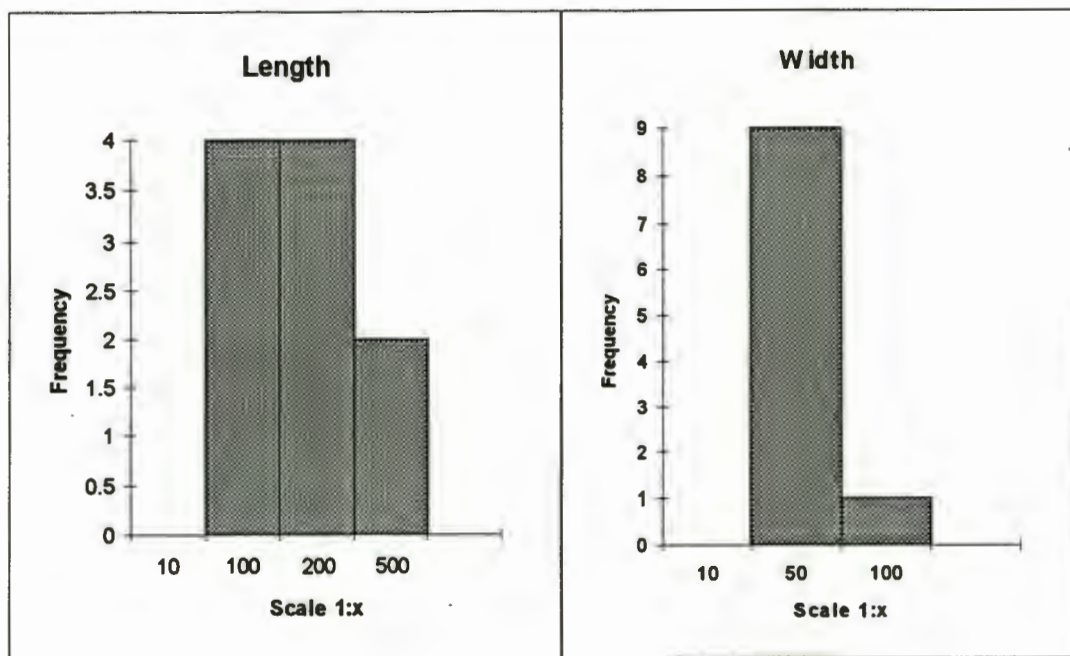

Figure 27: Histograms of error scales for the measurement of the polystyrene block

These error scales confirm the large errors in the measurements and the apparent repeatability of the measurements. A full table of measurements can be found in appendix A.

5.3. OBJECT 3: COMPUTER TAPE REEL

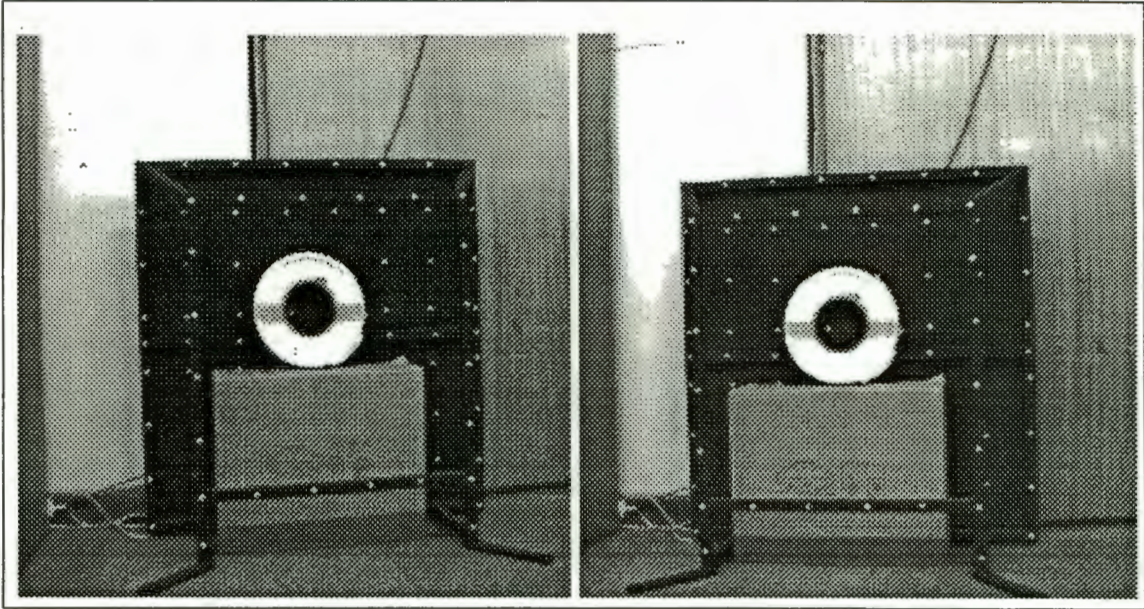

Figure 28: Stereo-pair of the computer tape reel

The third object measured was a computer tape reel. The stereo-pair is shown in Figure 28. These images were captured with a base/height ratio of approximately 1:3 and the cameras turned inward by approximately 10 degrees. The measurements taken were of the width of the reel and the diameter of its inner opening, as shown in Figure 29.

The measurements were repeated ten times. The same measurements were made with a vernier calliper for comparison. This gave values of 62.225mm for the width and 93.3mm for the diameter.

The mean value obtained for the width was 62.380mm with a standard deviation of 1.770mm. The mean value for the diameter was 93.730mm with a standard deviation of 1.167mm. A summary of the errors in the measurements is shown in Table 5. The values are in millimetres.

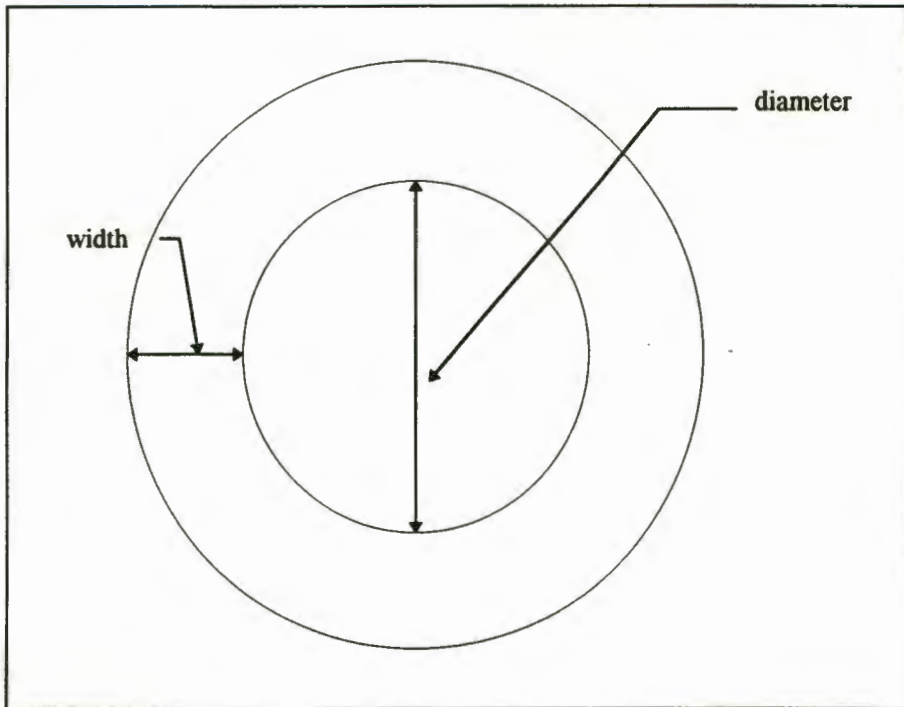

Figure 29: Diagram of the computer tape reel, showing measurements taken

	Width	Diameter
Maximum	3.004	2.223
Average	1.512	1.013
RMS	1.584	1.181
Minimum	0.431	0.015

Table 5: Summary of errors from measurement of computer tape reel

As can be seen, these results were better than those obtained from the polystyrene block. The histograms in Figure 30 show that the measurements obtained were again consistent. This improvement can be attributed to the fact that the reel had better defined edges than the block. Some of the error was due to a dark coloured band at the inner edge of the reel, which made it slightly more difficult to identify this edge. It also proved very difficult to obtain a reliable match with a template in the left image. This meant that the edge positions had to be estimated by eye, possibly introducing further error. Histograms of the error scales are shown in Figure 31. A full table of results can be found in appendix A.

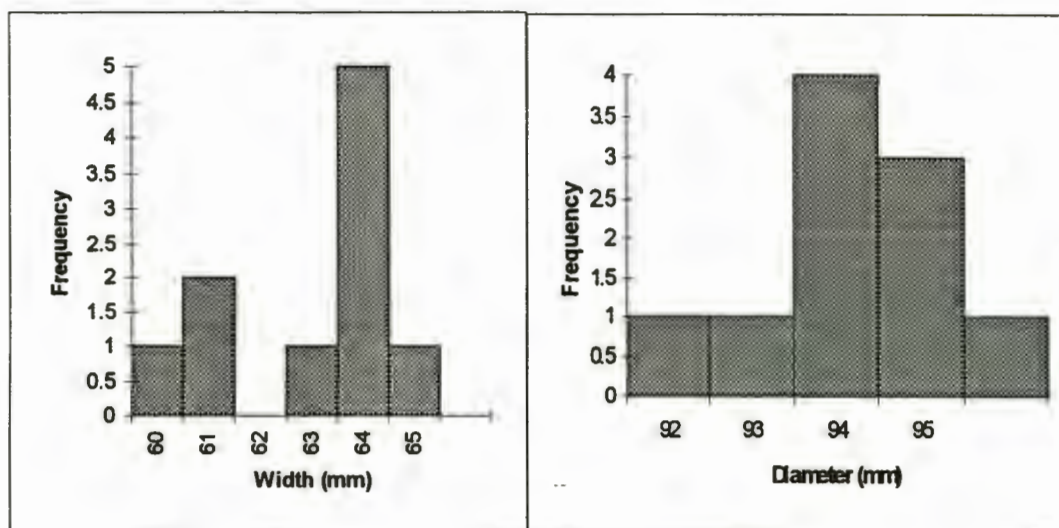

Figure 30: Histograms of measurements of computer tape reel

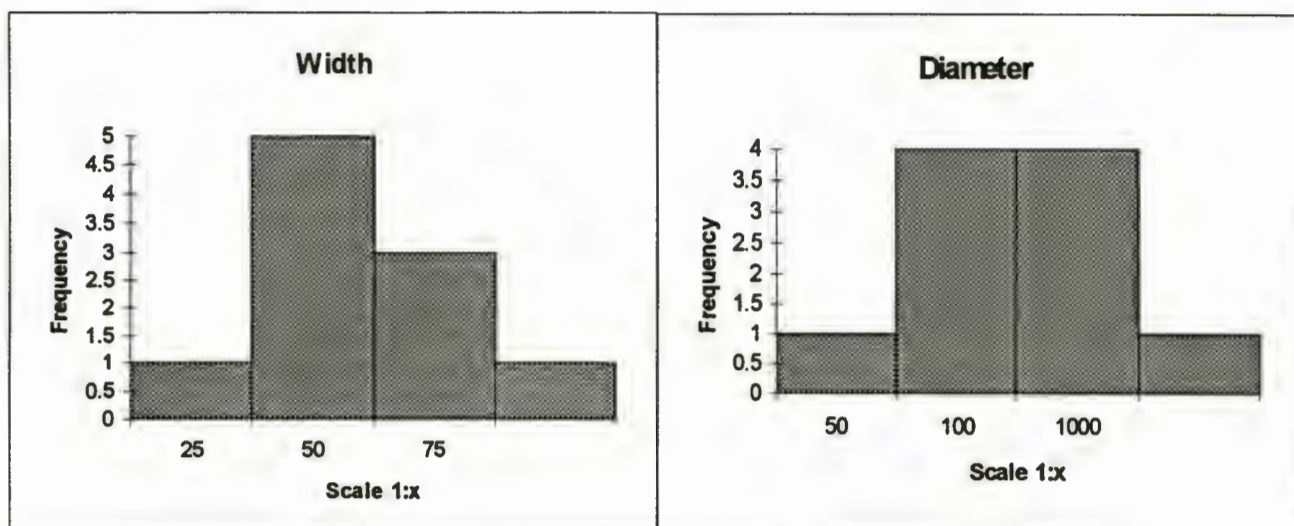

Figure 31: Histograms of error scales for the measurement of the computer tape reel

5.4. OBJECT 4: VERNIER CALLIPER

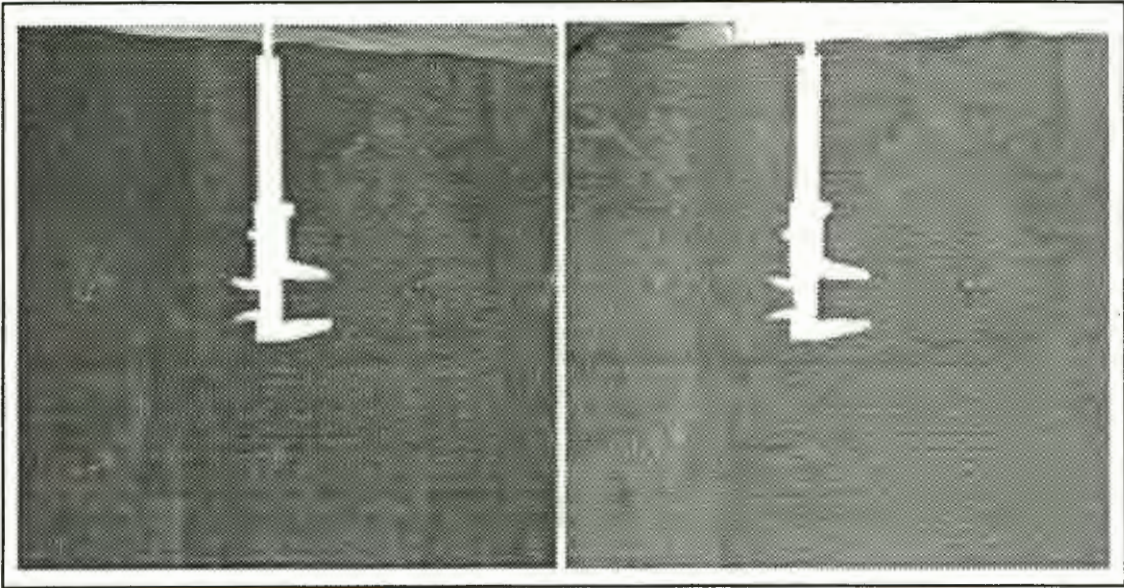

Figure 32: Stereo-pair of the vernier calliper

The fourth object measured was a vernier calliper. The stereo-pair is shown in Figure 32. These images were captured with a base/height ratio of approximately 1:2 and the cameras angled inward by approximately 10 degrees. The calliper was opened to a random distance and ten measurements of the gap between the jaws taken. The results were compared to the actual value read off the vernier scale, which was 29,90mm.

The mean value obtained was 29.830mm with a standard deviation of 0.405mm. These relatively good results can be attributed to the well defined edges of the jaws of the calliper. A summary of the errors in the results are shown in Table 6. These values are in millimetres.

	Gap
Maximum	0.544
Average	0.355
RMS	0.390
Minimum	0.142

Table 6: Summary of errors from measurement of the vernier calliper

It again prove extremely difficult to obtain a reliable match with an edge template in the left image. Thus it was necessary to estimate the edge position by eye, introducing some error to the measurement. Once more, the measurements obtained all fell into a narrow range, as shown in Figure 33, indicating that the system has good repeatability. A histogram of the error scales appears in Figure 34. A full table of results is shown in appendix A.

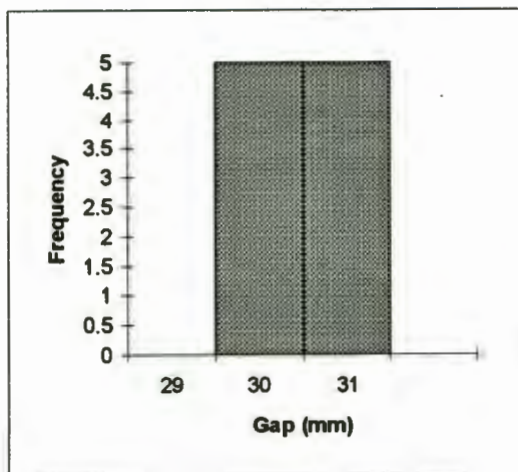

Figure 33: Histogram of measurements of the vernier calliper

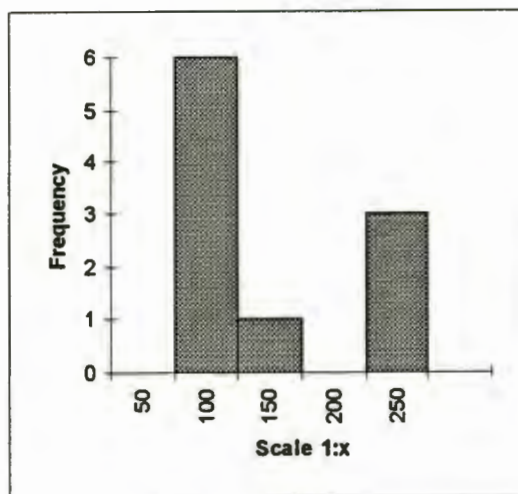

Figure 34: Histogram of error scales for the measurement of the vernier calliper

5.5. THE OVERALL PERFORMANCE OF THE MEASURING SYSTEM

The following observations were made concerning the overall performance of the system:

- The L1-norm estimation technique performed more reliably than the L2-norm technique for the image matching routine.
- The template matching method for locating target points when measuring failed frequently.
- The manual target identification method used in the calibration routine proved time consuming and error-prone as it relies on the user being able to correctly identify the targets on the frame and enter the correct target number.

6. CONCLUSIONS

The following conclusions can be drawn from the test results set out above:

1. Under near ideal conditions, the system is capable of very accurate measurement.
2. Under realistic conditions, the accuracy varies from good to very bad, depending on the nature of the object being measured. Objects with well-defined edges can be measured with good accuracy, while those with poorly defined edges can only be measured with poor accuracy.
3. The use of image matching with generalised feature templates to locate features to sub-pixel accuracy does not consistently produce reliable results. A template that works for a feature in one image might not work for a similar feature in another image.
4. The L1-norm estimation model appears to be better for image matching than the L2-norm model.
5. Manual target identification for calibration is not satisfactory.

7. RECOMMENDATIONS

The following recommendations can be made:

- 1) An alternative method of finding target points when making measurements should be developed for use with objects that have weakly defined edges. Some form of edge detection that can find edge locations to sub pixel accuracy would be suitable.
- 2) A method of defining a template from the image that will be used for measuring should be added to the system to make the template matching method more general.
- 3) An automatic target search routine should be added to the calibration routine to reduce the risk of the user identifying targets incorrectly.

8. LIST OF REFERENCES

- 1) Slama, Chester C. ed. Manual of Photogrammetry, 4th ed., Falls Church: American Society of Photogrammetry, 1980, p1
- 2) Turner, D.J. and Yule, D.J., "A Digital Non-Contact Measurement System", Photogrammetric Record, Vol. 14 No.82, October 1993, pp583-594
- 3) Gruen, Armin W., "Adaptive Least Squares Correlation-A powerful image matching technique", Presented paper to the ACSM-ASP convention, Washington DC, March 1985
- 4) Kubik, K., Merchant, D. and Schenk, T. "Robust Estimation in Photogrammetry", Photogrammetric Engineering and Remote Sensing, Vol. 53 No. 2, February 1987, pp167-169
- 5) Rubinstein, M., Assessing target centring algorithms for use in near-real-time-photogrammetry, M.Sc. thesis, University of Cape Town 1990, pp84-85

8. BIBLIOGRAPHY

- El-Hakim, S. F., "Real-Time Image Metrology with CCD Cameras", Photogrammetric Engineering and Remote Sensing, Vol. 52 No.11, November 1986, pp1757-1766
- Gruen, Armin W., "Adaptive Least Squares Correlation-A powerful image matching technique", Presented paper to the ACSM-ASP convention, Washington DC, March 1985
- Gruen, Armin W., "Towards Real-Time Photogrammetry", Photogrammetria, Vol. 42, pp209-244
- Karara, H. M., ed., Non-topographic Photogrammetry, 2nd ed., Falls Church: American Society of Photogrammetry and Remote Sensing, 1989
- Kubik, K., Merchant, D. and Schenk, T. "Robust Estimation in Photogrammetry", Photogrammetric Engineering and Remote Sensing, Vol. 53 No. 2, February 1987, pp167-169
- Rubinstein, M., Assessing target centring algorithms for use in near-real-time-photogrammetry, M.Sc. thesis, University of Cape Town 1990
- Rüther, H. "Digital Photogrammetry-Introduction to a new tool for the Photogrammetrist", Presented paper to the workshop of ISPRS V/4, Pretoria, July 1991
- Rüther, H. "A Digital Photogrammetry System for the Measurement of surfaces in near real-time", South African Journal of Surveying and Mapping, Vol. 20 part 3, August 1989
- Slama, Chester C. ed., Manual of Photogrammetry, 4th ed., Falls Church: American Society of Photogrammetry, 1980
- Turner, D.J. and Yule, D.J., "A Digital Non-Contact Measurement System", Photogrammetric Record, Vol. 14 No.82, October 1993, pp583-594
- Wolf, Paul R., Elements of Photogrammetry, New York: McGraw-Hill, 1974
- Wong, Kam W. and Ho, Wei-Hsin, "Close-Range Mapping with a Solid State Camera", Photogrammetric Engineering and Remote Sensing, Vol. 52 No.1, January 1986, pp67-74

APPENDICES

APPENDIX A: TEST RESULTS

TEST OBJECT 1: CALIBRATION FRAME

The following table contains detailed results of the measurement of the point positions on the calibration frame. Values are given in millimetres.

Pt	CALIBRATION FRAME			SYSTEM OUTPUT			ERRORS		
	X	Y	Z	X	Y	Z	X	Y	Z
1	577.52	-222.42	577.46	577.056	-221.592	578.063	0.464	0.828	0.603
2	493.97	-221.51	579.66	493.427	-219.993	580.193	0.543	1.517	0.533
3	390.2	-220.79	579.29	389.658	-220.131	579.89	0.542	0.659	0.6
4	288.2	-220.35	580.17	287.386	-218.739	580.786	0.814	1.611	0.616
5	189.5	-220.25	579.76	188.831	-219.732	580.333	0.669	0.518	0.573
6	99.88	-220.41	581.2	99.821	-221.3	581.423	0.059	0.89	0.223
7	577.15	-221.07	492.41	576.505	-219.831	492.692	0.645	1.239	0.282
8	99.77	-219.73	493.44	99.5695	-219.451	493.66	0.2005	0.279	0.22
9	576.39	-219.82	390.64	575.449	-218.045	389.047	0.941	1.775	1.593
10	98.45	-219	393.74	98.1064	-219.767	393.2	0.3436	0.767	0.54
11	576.86	-218.63	292.97	576.802	-218.849	292.272	0.058	0.219	0.698
12	98.58	-218.38	293.01	98.8171	-218.374	292.296	0.2371	0.006	0.714
13	576.67	-217.59	191.85	576.223	-216.467	191.332	0.447	1.123	0.518
14	99.23	-217.98	192.93	99.4962	-218.575	192.65	0.2662	0.595	0.28
15	577.04	-216.78	100.51	576.077	-215.306	99.9102	0.963	1.474	0.5998
16	484.38	-216.78	100.72	482.943	-217	100.07	1.437	0.22	0.65
17	385.94	-216.91	103.24	383.798	-215.229	101.971	2.142	1.681	1.269
18	285.18	-217.04	103.72	284.711	-216.144	102.686	0.469	0.896	1.034
19	194.72	-217.26	104.1	194.646	-217.026	103.614	0.074	0.234	0.486
20	99.45	-217.87	101.29	99.5544	-218.366	101.086	0.1044	0.496	0.204
21	576.22	-215.99	24.07	575.698	-216.766	23.8464	0.522	0.776	0.2236
22	97.11	-217.79	18.96	97.6661	-218.566	18.7827	0.5561	0.776	0.1773
23	584.03	-2.61	679.93	583.158	-3.53935	681.046	0.872	0.92935	1.116
24	484.93	-3.06	678.36	483.71	-3.48526	679.097	1.22	0.42526	0.737
25	386.36	-3.59	678.01	386.417	-4.21917	678.288	0.057	0.62917	0.278
26	285.01	-3.65	677.42	284.715	-4.51122	678.525	0.295	0.86122	1.105
27	186.51	-3.27	677.39	184.704	-3.76569	678.565	1.806	0.49569	1.175
28	85.07	-2.93	675.75	86.0963	-5.40629	676.648	1.0263	2.47629	0.898
31	487.78	16.89	587.44	487.187	17.1333	587.72	0.593	0.2433	0.28
32	386.6	16.52	586.68	386.333	17.7504	587.229	0.267	1.2304	0.549
33	287.03	16.38	586.16	287.69	16.7403	586.382	0.66	0.3603	0.222
34	186.92	16.76	587.23	186.524	16.9049	587.776	0.396	0.1449	0.546
39	488.24	17.56	485.51	487.418	18.7498	485.69	0.822	1.1898	0.18
40	387.64	16.99	485.03	387.535	19.3136	485.42	0.105	2.3236	0.39
41	285.78	16.77	484.4	286.435	14.8724	483.703	0.655	1.8976	0.697
42	185.95	17.19	483.94	185.744	16.6356	484.946	0.206	0.5544	1.006
47	486.01	18.18	388.78	485.679	18.8809	388.733	0.331	0.7009	0.047
48	384.31	17.53	388.91	384.298	19.0948	388.393	0.012	1.5648	0.517

Pt	CALIBRATION FRAME			SYSTEM OUTPUT			ERRORS		
	X	Y	Z	X	Y	Z	X	Y	Z
49	284.86	17.3	387.52	284.328	17.1859	387.371	0.532	0.1141	0.149
50	185.68	17.49	388.01	185.581	17.7756	387.88	0.099	0.2856	0.13
55	489.09	-0.74	340.74	488.516	-0.358063	340.751	0.574	0.381937	0.011
56	385.94	-1.14	340.61	386.052	-0.004141	340.233	0.112	1.135859	0.377
57	288.04	-1.66	340.36	287.588	-1.53427	339.95	0.452	0.12573	0.41
58	187.47	-1.87	339.77	187.521	-0.397023	340.282	0.051	1.472977	0.512
63	488.37	19.21	286.3	488.428	19.8908	285.228	0.058	0.6808	1.072
64	390.12	18.75	284.77	390.043	20.1977	284.283	0.077	1.4477	0.487
65	288.69	18.45	284.09	288.226	18.8557	283.732	0.464	0.4057	0.358
66	185.42	18.36	282.82	185.208	19.8768	282.55	0.212	1.5168	0.27
71	482.63	20.27	191.19	482.228	20.2076	190.641	0.402	0.0624	0.549
72	383.65	19.82	192.46	384.094	19.4154	192.199	0.444	0.4046	0.261
73	284.98	19.45	190.51	284.95	20.6602	189.55	0.03	1.2102	0.96
74	182.94	19.3	188.7	182.538	18.1733	188.386	0.402	1.1267	0.314
79	484.49	21.46	99.14	484.659	20.2593	99.0439	0.169	1.2007	0.0961
80	382.07	21.19	99.94	382.605	20.7098	98.6369	0.535	0.4802	1.3031
81	284.5	20.63	99.68	284.252	20.4014	99.605	0.248	0.2286	0.075
82	184.1	20.41	99.4	183.962	19.5136	97.7371	0.138	0.8964	1.6629
86	489.1	3.38	4.7	488.767	2.52807	5.25141	0.333	0.85193	0.55141
87	389.32	2.75	4.79	388.55	2.60468	4.23632	0.77	0.14532	0.55368
88	289.44	2.3	1.43	289.239	1.35229	1.34811	0.201	0.94771	0.08189
89	188.85	1.85	0.41	189.219	0.537231	0.494862	0.369	1.312769	0.084862
MINIMUM RMS AVERAGE MAXIMUM							0.012	0.006	0.011
							0.631817	1.024143	0.664976
							0.47487	0.850678	0.544144
							2.142	2.47629	1.6629

The following table contains detailed results from the measurement of the distances between successive points on the calibration frame. Values are in millimetres.

Pt FROM	Pt TO	FRAME	SYSTEM	ERROR	SCALE l in
0	1	846.4396	846.318	0.121636	6959
1	2	83.58391	83.6722	0.088286	947
2	3	103.7731	103.769	0.004157	24961
3	4	102.0047	102.286	0.281255	363
4	5	98.70090	98.5609	0.140002	705
5	6	89.63171	89.0301	0.601610	149
6	7	485.4593	484.875	0.584321	831
7	8	477.3829	476.937	0.445991	1070
8	9	487.5802	487.244	0.336221	1450
9	10	477.9507	477.364	0.586756	815
10	11	488.9078	489.221	0.313178	1561
11	12	478.2800	477.986	0.294067	1626

Pt FROM	Pt TO	FRAME	SYSTEM	ERROR	SCALE l in
14	15	486.6675	485.531	1.136537	428
15	16	92.66023	93.1492	0.488962	190
16	17	98.47233	99.1794	0.707064	139
17	18	100.7612	99.0939	1.667327	60
18	19	90.46106	90.0743	0.386765	234
19	20	95.31338	95.1342	0.179183	532
20	21	482.9866	482.371	0.615641	785
21	22	479.1406	478.063	1.077630	445
22	23	848.6900	848.842	0.151915	5587
23	24	99.11345	99.4668	0.353342	281
24	25	98.57204	97.2994	1.272646	77
25	26	101.3517	101.702	0.350264	289
26	27	98.50073	100.014	1.513262	65
27	28	101.4538	98.6402	2.813625	36
28	31	412.7551	411.449	1.306172	316
31	32	101.1835	100.858	0.325530	311
32	33	99.57145	98.6509	0.920556	108
33	34	100.1164	101.176	1.059560	94
34	39	318.0272	317.745	0.282264	1127
39	40	100.6027	99.8846	0.718159	140
40	41	101.8621	101.212	0.650185	157
41	42	99.83194	100.715	0.883056	113
42	47	314.7894	314.997	0.207531	1517
47	48	101.7021	101.382	0.320160	318
48	49	99.45997	99.9934	0.533420	186
49	50	99.18139	98.75	0.431392	230
50	55	307.6108	307.114	0.496815	619
55	56	103.1508	102.465	0.685857	150
56	57	97.90170	98.4765	0.574799	170
57	58	100.5719	100.074	0.497949	202
58	63	306.3400	306.573	0.232964	1315
63	64	98.26298	98.3898	0.126811	775
64	65	101.4327	101.827	0.394276	257
65	66	103.2778	103.03	0.247848	417
66	71	311.0200	310.915	0.105078	2960
71	72	98.98917	98.1494	0.839770	118
72	73	98.68996	99.1872	0.497239	198
73	74	102.0561	102.448	0.391838	260
74	79	314.5760	315.061	0.484996	649
79	80	102.4234	102.057	0.366480	279
80	81	97.57195	98.3577	0.785746	124
81	82	100.4006	100.311	0.089631	1120
82	86	319.8173	318.98	0.837308	382
86	87	99.78202	100.222	0.439970	227
87	88	99.93751	99.3612	0.576312	173
88	89	100.5961	100.026	0.570177	176
MINIMUM RMS AVERAGE MAXIMUM				0.004157	24961
				0.738684	3499
				0.580111	1119
				2.813625	36

TEST OBJECT 2: POLYSTYRENE PACKING PIECE

The following table contains detailed results from the measurement of the length of the polystyrene block. The values are in millimetres. The true length was 158.75mm.

LENGTH	ERROR	SCALE
159.141	0.391	406
164.166	5.416	29
166.445	7.695	21
160.555	1.805	88
160.4218	1.6718	95
159.6638	0.9138	174
160.2219	1.4719	108
159.82	1.07	148
159.8342	1.0842	146
159.5373	0.7873	202
MIN.	0.391	406
RMS	3.163445	164
AVE	2.2306	142
MAX.	7.695	21

The following table contains detailed results from measuring the width of the polystyrene block. The values are in millimetres. The true width was 64.07mm.

WIDTH	ERROR	SCALE
64.7588	0.6888	93
68.8802	4.8102	13
70.1544	6.0844	11
67.7864	3.7164	17
67.7521	3.6821	17
68.1661	4.0961	16
66.602	2.532	25
67.6196	3.5496	18
69.2078	5.1378	12
67.475	3.405	19
MIN.	0.6888	93
RMS	4.022204	34
AVE	3.77024	24
MAX.	6.0844	11

TEST OBJECT 3: COMPUTER TAPE REEL

The following table contains detailed results of the measurement of the width of the computer tape reel. The values are given in millimetres. The true width was 62,225mm.

WIDTH	ERROR	SCALE
60.109	2.116	29
64.115	1.89	33
59.221	3.004	21
63.828	1.603	39
63.529	1.304	48
63.303	1.078	58
62.656	0.431	144
63.2674	1.0424	60
63.369	1.144	54
60.3994	1.8256	34
MIN	0.431	144
RMS	1.583880	61
AVE	1.512488	54
MAX	3.004	21

The following table contains detailed results from measuring the diameter of the computer tape reel. The values are in millimetres. The true diameter was 93.3mm.

DIAMETER	ERROR	SCALE
95.5225	2.2225	42
91.6737	1.6263	57
94.9342	1.6342	57
94.47	1.17	80
93.472	0.172	542
92.562	0.738	126
93.059	0.241	387
94.601	1.301	72
93.315	0.015	6220
93.697	0.397	235
MIN	0.015	6220
RMS	1.181058	1979
AVE	1.013333	843
MAX	2.2225	42

TEST OBJECT 4: VERNIER CALLIPER

The following table contains detailed information from measuring the vernier calliper. Values are given in millimetres. The true gap was 29.9mm.

GAP	ERROR	SCALE
29.3565	0.5435	55
29.4696	0.4304	69
30.0419	0.1419	211
30.4101	0.5101	59
29.6613	0.2387	125
29.5135	0.3865	77
30.0494	0.1494	200
30.0419	0.1419	211
30.3863	0.4863	61
29.3742	0.5258	57
MIN	0.1419	211
AVE	0.35545	113
RMS	0.390223	130
MAX	0.5435	55

APPENDIX B: CALIBRATION FRAMES

FRAME 1

The layout of the targets on the large calibration frame is illustrated in the figure below.

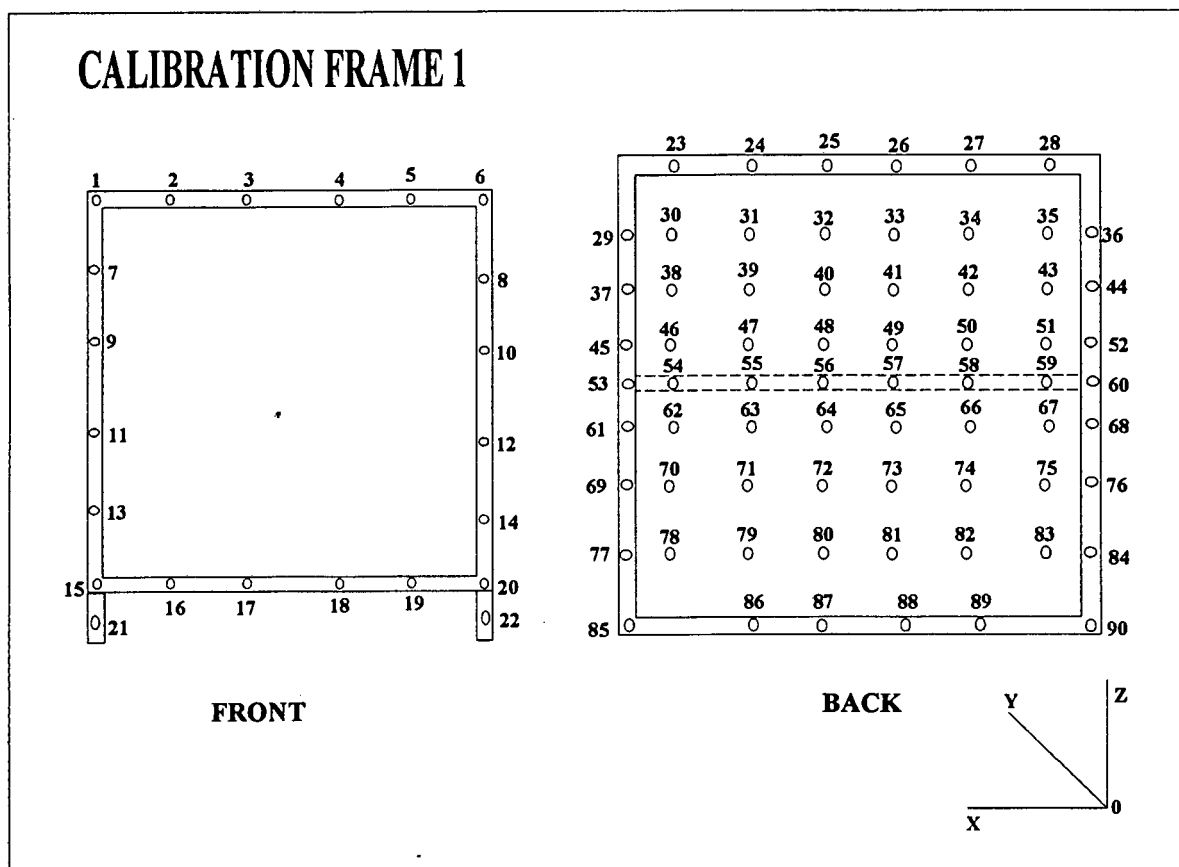

The table below lists the co-ordinates of the targets on the frame. The values are in millimetres.

No.	X	Y	Z
1	577.52	-222.42	577.46
2	493.97	-221.51	579.66
3	390.2	-220.79	579.29
4	288.2	-220.35	580.17
5	189.5	-220.25	579.76
6	99.88	-220.41	581.2
7	577.15	-221.07	492.41
8	99.77	-219.73	493.44

No.	X	Y	Z
9	576.39	-219.82	390.64
10	98.45	-219	393.74
11	576.86	-218.63	292.97
12	98.58	-218.38	293.01
13	576.67	-217.59	191.85
14	99.23	-217.98	192.93
15	577.04	-216.78	100.51

No.	X	Y	Z
16	484.38	-216.78	100.72
17	385.94	-216.91	103.24
18	285.18	-217.04	103.72
19	194.72	-217.26	104.1
20	99.45	-217.87	101.29
21	576.22	-215.99	24.07
22	97.11	-217.79	18.96
23	584.03	-2.61	679.93
24	484.93	-3.06	678.36
25	386.36	-3.59	678.01
26	285.01	-3.65	677.42
27	186.51	-3.27	677.39
28	85.07	-2.93	675.75
29	672.87	-1.48	590.02
30	587.28	17.52	589.63
31	487.78	16.89	587.44
32	386.6	16.52	586.68
33	287.03	16.38	586.16
34	186.92	16.76	587.23
35	87.45	17.11	587.66
36	-2.86	-2.32	585.29
37	672.81	-0.94	488.78
38	585.94	18.07	489.87
39	488.24	17.56	485.51
40	387.64	16.99	485.03
41	285.78	16.77	484.4
42	185.95	17.19	483.94
43	86.68	17.3	482.85
44	-3.63	-2.19	483.94
45	672.56	-0.18	389.6
46	587.98	18.84	388.52
47	486.01	18.18	388.78
48	384.31	17.53	388.91
49	284.86	17.3	387.52
50	185.68	17.49	388.01
51	89.88	17.57	388.48
52	-1.92	-1.9	385.72
53	673.04	0.15	341.94
54	589.02	-0.53	343.08
55	489.09	-0.74	340.74
56	385.94	-1.14	340.61

No.	X	Y	Z
57	288.04	-1.66	340.36
58	187.47	-1.87	339.77
59	88.33	-2.01	338.63
60	-1.86	-1.68	337.85
61	671.51	0.78	289.38
62	586.38	19.81	286.35
63	488.37	19.21	286.3
64	390.12	18.75	284.77
65	288.69	18.45	284.09
66	185.42	18.36	282.82
67	88.94	18.24	281.36
68	-2.62	-1.45	289.36
69	671.78	1.71	191.33
70	582.39	20.64	190.78
71	482.63	20.27	191.19
72	383.65	19.82	192.46
73	284.98	19.45	190.51
74	182.94	19.3	188.7
75	84.08	19.09	182.36
76	-1.15	-0.88	188.78
77	675.45	2.58	91.27
78	584.05	21.68	92.85
79	484.49	21.46	99.14
80	382.07	21.19	99.94
81	284.5	20.63	99.68
82	184.1	20.41	99.4
83	85.12	19.79	93.32
84	-1.06	-0.45	89.64
85	674.17	3.5	2.73
86	489.1	3.38	4.7
87	389.32	2.75	4.79
88	289.44	2.3	1.43
89	188.85	1.85	0.41
90	0	0	0

FRAME 2

The layout of targets on the small calibration frame is shown in the figure below.

CALIBRATION FRAME 2

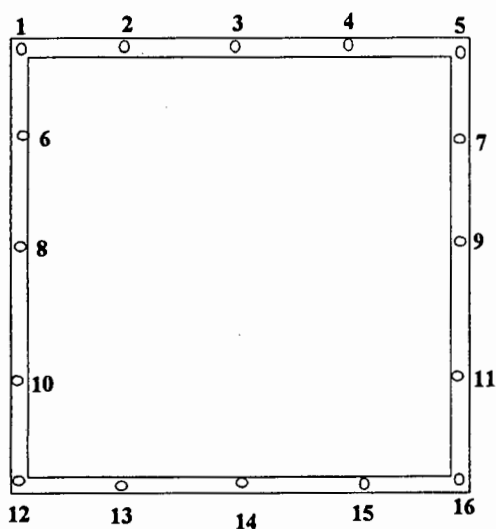

FRONT

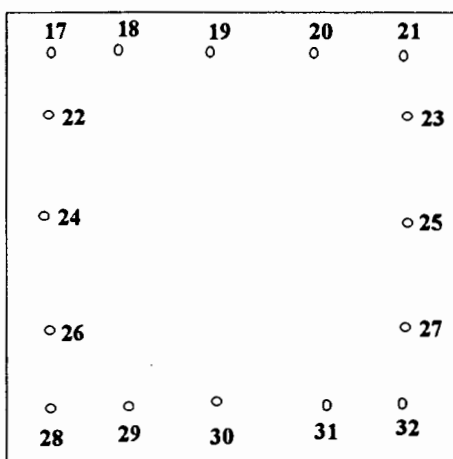

BACK

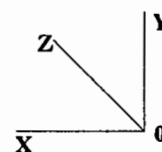

The co-ordinates of the targets are listed in the table below. The values are in millimetres.

No.	X	Y	Z
1	1003.34	1002.14	999.45
2	929.5	1002.96	999.52
3	859.58	1003.54	999.51
4	790.61	1003.23	999.48
5	716.38	1002.48	999.2
6	1005.45	929.09	999.39
7	715.7	928.43	999
8	1005.46	863.2	999.29
9	715.81	860.5	998.61
10	1005.85	790.26	998.9
11	716.97	791.38	998.07
12	1002.92	717.67	998.05
13	930.91	715.84	997.95
14	856.98	715.04	997.73
15	786.88	715.43	997.33
16	717.62	718.52	997.14
17	979.59	981.46	1079.6
18	921.48	983.88	1079.29
19	860.75	984.55	1079.15

No.	X	Y	Z
20	800.56	981.18	1078.98
21	739.71	976.59	1078.6
22	984.21	924.8	1080.05
23	736.4	921.8	1078.73
24	987	860.15	1080.05
25	734.94	859.65	1078.72
26	985.34	796.66	1079.88
27	737.53	795.97	1078.76
28	979.74	738.7	1079.76
29	918.34	737.03	1079.47
30	857.88	734.18	1079.01
31	795.56	735.01	1078.83
32	742.63	736.28	1078.55