

The copyright of this thesis vests in the author. No quotation from it or information derived from it is to be published without full acknowledgement of the source. The thesis is to be used for private study or non-commercial research purposes only.

Published by the University of Cape Town (UCT) in terms of the non-exclusive license granted to UCT by the author.

Commissioning a 400 Hz Rotary Inverter

Wayne Anthony Smith

A dissertation submitted to the Department of Electrical Engineering,
University of Cape Town, in fulfilment of the requirements
for the degree of Master of Science in Engineering.

Cape Town, January 2009

Declaration

I know the meaning of plagiarism and declare that all the work in the document, save for that which is properly acknowledged, is my own.

signature removed

Signature of Author

11 January 2009

University of C
own

Abstract

This dissertation covers the commissioning and testing of an aircraft's constant frequency alternator as the power supply for the Blue Parrot radar. The Blue Parrot is an X-band radar which forms part of the navigation and weapon-aiming system onboard the Buccaneer S-50 SAAF aircraft. The radar set uses a source of three-phase power at 400 Hz, which the constant frequency alternator can supply with the aid of certain auxiliary systems. The auxiliary systems include a prime mover, blower fan and a telemetering system. The prime mover has high starting currents which were reduced significantly by the use of a soft-starter. During testing, the constant frequency alternator started overheating and a blower fan was selected based on its thermal requirements. Significant cooling of the constant frequency alternator's case temperature was achieved by the use of a blower fan and shroud. The generator control unit monitors and regulates all parameters on the unit except for case temperature and blower fan pressure. A telemetering system was designed and built to monitor and display these parameters.

Acknowledgements

Thank you LORD a second time.

I would also like to express my appreciation to those who helped me achieve this milestone.

I firstly want to thank professor Michael Inggs for supervising me while I was on and off campus, thank you for offering me this topic. Thank you to the SANDF who offered me a bursary thereby awarding me the opportunity to complete my masters.

I also would like to thank Chris Wosniak and Leon Heinkelin for their technical support which proved to be invaluable in understanding the principles of the constant frequency alternator. Thank you for sharing your experience with a young man like myself.

Dad, Mom, Julian and Wendy, thank you for motivating me to complete that what I started.

To the staff members and students of RRSg especially Mr and Mrs R Lord and Mr T Bennett. Thank you for your assistance.

Lastly Louis Fernandez who afforded me the much needed time from work to complete my masters. Thank you.

Contents

Declaration	i
Acknowledgements	iii
List of Symbols	xiii
Nomenclature	xiv
Acronyms	xv
1 Introduction	1
1.1 Background to the Constant Frequency Alternator	1
1.2 Background to the Blue Parrot Radar	2
1.3 Introduction to the 400 Hz Power Supply	3
1.4 User Requirements	5
1.5 Project Development	6
2 Theory Review	9
2.1 Constant Frequency Alternator ([1],[5],[6])	9
2.1.1 Alternator	10
2.1.2 Constant speed drive	10
2.2 Thermal Characteristics [1]	12
2.3 The Generator Control Unit (GCU)	13
2.3.1 Voltage control loop (excitation current)	13
2.3.2 Frequency control loop (speed loop)	13
2.4 Frequency Hunting [2]	14
2.4.1 Aim	14
2.4.2 Method	14
2.4.3 Findings	14
2.4.4 Discussion	15

2.5	Gearbox Oil	15
2.6	The Prime Mover	15
2.6.1	The equivalent circuit model of an induction motor [9]	16
3	Commissioning the Siemens 15 kW Induction Motor as the Prime Mover for the Constant Frequency Alternator	18
3.1	Prime Mover Selection	18
3.1.1	Constant frequency alternator's specifications	18
3.1.2	Direct current motors versus induction motors	19
3.1.3	Induction motors	19
3.2	Pre-Commissioning Work	19
3.2.1	Induction motor testing	19
3.2.2	Soft starter	20
3.2.3	Motor connections	21
3.2.4	Mounting	22
3.3	The Load Torque	23
3.4	Starting and Stopping the Prime Mover	24
3.5	Motor Efficiency	24
3.6	Summary	24
4	Commissioning the 400 Hz Generator	25
4.1	Design of the Generator Control Unit's Starting Circuit (GCUSC)	25
4.1.1	Calculating component sizes for the GCUSC	25
4.2	Alternator Load and Power Factor Test Results	26
4.3	Synchronisation	27
4.4	Pre-Commissioning Work	28
4.4.1	Testing the CFA and GCU according to the commissioning instructions provided by the generator manual	28
4.4.2	Wiring harness	29
4.5	Frequency Hunting	30
4.5.1	Bypassing the clutch for the purpose of determining the root cause for frequency failure	31
4.5.2	Changing the induction motor with a dc motor	32
4.6	Discolouration of the Gearbox Oil	32
4.6.1	Incorrect oil viscosity	32
4.6.2	Combustion of oil	33
4.6.3	Incorrect oil level	33

4.6.4	Findings	33
4.6.5	Conclusions	33
4.6.6	Recommendation	34
4.7	Transients	34
4.8	Summary	34
5	Blower Fan Design	35
5.1	Actual CFA Heating	35
5.2	Blower Fan Selection Process	35
5.3	Cooling Ducts and Shroud	37
5.4	Blower Fan Starter	38
5.5	Temperature Sensor Placement	39
5.6	Testing the Blower on the CFA	39
5.6.1	Flowrate test	41
5.6.2	Pressure test	41
5.6.3	Temperature test	41
5.7	Summary	43
6	Telemetry System Design	44
6.1	Temperature Measured from the Rotary Inverters Case	46
6.1.1	LM35DZ and bi-metal sensor placement	46
6.2	Pressure Measured from Inside the Cooling Shroud [14]	47
6.2.1	Pressure transducer placement	47
6.3	Current Measured in the Red Phase	48
6.3.1	Precision rectifier	49
6.4	Voltage Measured Across the Red and Blue Phases	50
6.4.1	Precision rectifier	53
6.5	Results	53
6.6	Summary	55
7	Telemetry Software	56
7.1	Software Design	56
7.2	Analog to Digital Converter Setup	58
7.2.1	Status and control register	59
7.2.2	Data register	59
7.2.3	Clock register	59
7.3	Universal Asynchronous Receiver Transmitter Emulator	59

7.3.1	Put serial	59
7.3.2	Get serial	60
7.3.3	Testing the UART on the sensor and transmitter board	61
7.3.4	Testing the UART on the receiver and display boards	61
7.4	Transducer Scaling	61
7.5	Temperature Decoding	62
7.6	Pressure Decoding [14]	63
7.7	Current Decoding	66
7.8	Voltage Decoding	67
7.9	Summary	69
8	Conclusions	70
9	Recommendations	72
	Appendix	73
A	Induction Motor	73
A.1	No Load Test	73
A.1.1	Methodology	73
A.2	Locked Rotor Test	75
A.2.1	Methodology	75
A.3	The Induction Motor's Equivalent Circuit Impedances Based on the No Load and Locked Rotor Tests	77
A.4	Soft Starter	77
B	Constant Frequency Alternator	79
C	Blower Fan	80
C.1	Flowrate Test	80
C.2	Cooling Shroud Design	80
D	Telemetry System	82
D.1	The Telemetry Power Supply	82
D.2	LAH50-P Calibration (Current LEM)	82
D.2.1	Methodology	82
D.3	LV25P Calibration (Voltage LEM)	83
D.3.1	Methodology	83

E Telemetry Source Code	85
E.1 Sensor and Transmitter Source Code	85
E.2 Receiver and Display Source Code	93
F Dismantling the 400 Hz Motor Generator Set	111
G List of Suppliers and Budget	112
Bibliography	113

University of Cape Town

List of Figures

1.1	The donated constant frequency alternator (left) and the generator control unit (right).	2
1.2	Rotary inverter's system diagram.	4
1.3	Frequency trace during frequency hunting and normal operation.	6
1.4	Constant frequency alternator's temperature response to a 2.2 kW load with forced cooling.	7
1.5	The telemetering system designed for the rotary inverter.	7
2.1	Principle of operation of the alternator [1].	10
2.2	Principle of operation of the constant speed drive [1].	11
2.3	System configuration during testing.	14
3.1	Induction motor's current vs slip showing the soft starting effect.	20
3.2	Soft starter's schematic.	21
3.3	Induction motor's connections for anti-clockwise rotation from the non drive end.	22
3.4	Induction motor secured to a plinth with ant-vibration rubber feet.	22
3.5	Induction motor's torque vs slip showing the soft starting effect.	23
4.1	Schematic for the generator control unit's starting circuit.	26
4.2	Alternator load test setup.	27
4.3	The soft starter with synchronising auxiliary contact.	28
4.4	Constant frequency alternator's wiring harness.	30
4.5	Frequency failure fault finding method.	31
4.6	Tools used to re-fill the gearbox sump	34
5.1	Actual heating of the constant frequency alternator.	36
5.2	The blower fan selection chart by Alstom.	37
5.3	Cooling ducts also showing the apparatus used to measure flowrate.	38
5.4	The cooling shroud.	38
5.5	Re-wiring the blower fan starter via an auxiliary contact on the soft starter.	39

5.6	The 400 Hz rotary inverter.	40
5.7	CFA's temperature response to a 2.2 kW load with forced cooling.	42
5.8	CFA's temperature response to a 4.8 kW load with forced cooling.. . . .	42
6.1	The telemetering system designed for the rotary inverter.	45
6.2	LM35DZ and Bi-metal temperature sensor and switch placement.	46
6.3	Differential summer circuit.	47
6.4	24PCAFA6G pressure sensor placement.	48
6.5	LV25P voltage circuit.	51
6.6	LAH50P current circuit.	51
6.7	Precision rectifier circuit.	51
6.8	LV25P voltage sensor schematic.	52
6.9	LAH50P current sensor schematic.	52
6.10	Precision rectifier schematic	52
6.11	Generator case temperature vs ADC input.	54
6.12	Blower fan pressure vs ADC input.	54
6.13	ADC input vs generator current.	55
6.14	ADC input vs generator voltage.	55
7.1	Software flow diagram.	58
7.2	Bit sent over PTB0 with the sensor and transmitter board.	61
7.3	Temperature display.	68
7.4	Pressure display.	68
7.5	Current display.	68
7.6	Voltage display.	68
A.1	The equivalent no load circuit.	73
A.2	The equivalent locked rotor circuit.	75
A.3	Soft starter schematic.	78
C.1	The dimensions of the measuring airflow window	80
C.2	The designed cooling shroud.	81
D.1	The 15 VA bipolar power supply designed for the telemetering system.	82
D.2	Calibration setup for the LAH50P current transducer.	83
D.3	Calibration setup for the LV25P voltage transducer.	83

List of Tables

2.1	Speeds of rotational components within the constant frequency alternator.	11
2.3	Percentage of input power used to maintain synchronous speed.	12
2.4	The constant frequency alternator's thermal characteristics.	13
2.5	Induction motor's rated specifications [2].	16
3.1	The constant frequency alternator's power rating at different speeds.	18
3.2	Characteristics of the prime mover.	19
4.1	Component values of the GCUSC.	26
4.2	System load test results.	27
4.3	Comparing the measured excitation current against the technical manual's.	28
4.4	Winding resistance values.	29
4.5	Mobil Jet Oil II characteristics.	33
5.1	Comparison between an Alstom and a Veritech blower fan.	36
5.2	CFA hotspot readings on load.	40
5.3	Blower fan flowrate measurement.	41
7.1	I/O functions and allocations.	57
7.2	Sensor scaling.	61
A.1	No load test results using a three phase variac.	74
A.2	The induction motor's current values at incremental voltages.	75
A.3	Equivalent circuit parameters.	77
A.4	Induction motor's impedance at slip intervals.	77
B.1	Continuity test on the wiring harness.	79
D.1	LAH50P calibration before and after readings using the precision rectifier at 50 Hz.	83
D.2	LV25P calibration under variable voltage at 50 Hz with a 200 Ω scaling resistor.	84

G.1 Components purchased during commissioning and company details. . . . 112

University of Cape Town

List of Symbols

I_s	—	Stator current
$D1$	—	Differential gear
C	—	Degrees celcius
Pa	—	Pascal
P_{pairs}	—	Pole pairs
R_{th}	—	Thevenin resistance
f	—	Frequency
R_1	—	Stator resistance
R_2	—	Rotor resistance
X_1	—	Stator reactance
X_2	—	Rotor reactance
X_m	—	Magnetising reactance
V_{th}	—	Thevenin voltage
T_{em}	—	Shaft torque
ω_{syn}	—	Induction motor's synchronous speed
$N_{compensation}$	—	Speed of the eddy current cup shaft speed
N_{in}	—	Input speed to the constant frequency alternator
$N_{alternator}$	—	Alternator's synchronous speed
Δ	—	Delta connected network
Y	—	Star connected network
P_{in}	—	Input power
P_{out}	—	Output power
Q	—	Flowrate
R_4	—	Voltage transducer's scaling resistor
R_6	—	Current transducer's scaling resistor

Nomenclature

Alternator—An alternator is an electromechanical device that converts mechanical energy to alternating current electrical energy.

Blower Fan—Centrifugal radial bladed fan enclosed in a metal housing driven by 2.2 kW induction motor.

Constant Frequency Alternator—An aircraft generator operating a 400 Hz which performs its own speed control with the aid of a constant speed drive.

Generator—The constant frequency alternator including the generator control unit. The generator's rating is 15 kVA.

Generator Control Unit—Is the constant frequency alternator's control unit. This performs voltage and speed regulation as well as protecting the device against electrical damage.

Generator Control Unit Starter Circuit—Is a 28 Vdc circuit used to switch on the generator control unit when the soft starter interlocks the delta contactor. This circuit receives power via a single phase 220 V mains and delta auxiliary contactor.

Prime Mover—Is the 15 kW induction motor and soft starter. This is coupled to the input to the constant frequency alternator.

Rotary Inverter—Is the collective term used in the dissertation for the prime mover, generator and blower fan.

Soft Starter—Is the low voltage switchgear used to reduce the motor's voltage at startup. Also referred to as a star delta starter, all housed in an orange metal enclosure.

Telemetry System—An apparatus for recording the readings of an instrument and transmitting them by radio frequency.

Acronyms

ADC – Analog to Digital Converter

CFA – Constant Frequency Alternator

CSD – Constant Speed Drive

CT – Current Transformer

D1 – Differential Gear One

D2 – Differential Gear Two (also referred to as the speed step up gear)

EMCSD – Electro-Mechanical Constant Speed Drive (same as CSD)

FLR – Frequency Limiting Resistors (also referred to as over speed resistors)

GCU – Generator Control Unit

GCUSC – Generator Control Unit Starter Circuit

PF – Power Factor

PG – Pulse Generator

PMG – Permanent Magnet Generator

RF – Radio Frequency

RRSG – Radar Remote Sensing Group

SAAF – South African Air Force

SANDF – South African National Defence Force

UART – Universal Asynchronous Receiver Transmitter

UCT – University of Cape Town

VT – Voltage Transformer

X Band – Frequency Range from 8 - 12 GHz

Chapter 1

Introduction

1.1 Background to the Constant Frequency Alternator

A constant frequency alternator is an engine-driven generator used as the primary electrical power source onboard military and commercial aircraft. The Mirage F1-C aircraft, where this particular constant frequency alternator was salvaged, use both DC and AC sources of power. The aviation voltage standards are 28 Vdc and three-phase 200 volts line-to-line at 400 Hz. These voltages are distributed to all the electrical equipment onboard the aircraft. Each Mirage F1-C aircraft has two constant frequency alternators [5].

The engine-driven AC generator can be thought of as a rotary converter, which takes mechanical energy and converts it into electrical energy. Variable engine speeds are passed through a constant speed drive, which turn the alternator at a set speed. The speed at which the alternator turns determines the output frequency in these engine-driven machines. Since the engine speed varies, it is necessary for the constant speed drive to turn the alternator at constant speed to keep the frequency stable at 400 Hz [1]. The constant frequency alternator uses a differential gear assembly and an eddy current brake to ensure that synchronous speed is delivered to the alternator. Synchronous speed, 8000 rpm, is the speed needed to produce an output frequency of 400 Hz. Figure 1.1 below shows the constant frequency alternator which is a three-phase 200 volt line-to-line, 400 Hz machine.



Figure 1.1: The donated constant frequency alternator (left) and the generator control unit (right).

Each constant frequency alternator has a voltage and frequency regulator in the form of a generator control unit, which monitors and controls the electrical output. The generator control unit is responsible for regulating the output parameters such as voltage, current and frequency, and at the same time monitoring fault conditions.

One positive consideration of using a 400 Hz constant frequency alternator is that it is smaller in size and weight, because these devices require fewer copper windings to generate the same electrical current. One negative aspect of using these high frequency devices is that they are subjected to reactive voltage drops over the long power cables of the plane. The higher frequency is still preferred, however, as size and weight are limited onboard the aircraft the drop in voltage is a good trade-off [3].

The next section will give a background to one of the loads for which the power supply is being commissioned.

1.2 Background to the Blue Parrot Radar

The Blue Parrot is an X-band radar that forms part of the navigation and weapon-aiming system onboard the Buccancer S-50 SAAF aircraft. Situated in a pressurised pod installed on anti-vibration mounts inside the nose of the plane, the radar set consists of a fibreglass antenna with transceiver unit and drive assembly. The radar set is power intensive in that calculations performed by the weapon-aiming computer are achieved by differential gears and servo motors. The input electrical specifications of the radar set are three-phase 200 volts line-to-line at 400 Hz. The power required to operate the radar set is 2.2 kVA at a lagging power factor of 0.85 [21].

1.3 Introduction to the 400 Hz Power Supply

An engine-driven AC generator, which had been removed from a grounded Mirage F1 fighter plane was donated to the University by the SAAF. Given the capacity of the AC generator, it was decided that it should be used to supply the aircraft radars in the department with a source of 400 Hz three-phase power for laboratory purposes. An alternative approach would have been to use a frequency converter to supply 400 Hz power to the radars. This latter approach would have been cost effective, as it does not incorporate the auxiliary systems used in the AC generator approach as shown in Figure 1.2. The generator approach is to all intents and purposes educational.

The donated systems included the constant frequency alternator and control unit, whereas the auxiliary systems were either designed, selected or built. Onboard the aircraft the constant frequency alternator served as primary source of power to all systems. The engines fulfilled two purposes: (i) that of being the prime mover and (ii) that of being the source of ventilation for cooling. In this project, an induction motor was used as the prime mover, whereas a blower fan provided the necessary cooling.

The system diagram in Figure 1.2 shows an induction motor driving an alternator via a constant speed drive thereby ensuring that the speed to the alternator remains fixed. Ventilation is provided in the form of a blower fan, which stabilises the operating temperature of the constant frequency alternator. The soft starter serves a control and protection function to the rotary inverter in addition to being the motor starter. The generator control unit monitors the alternator and constant speed drive's parameters all except for case temperature and ventilation pressure, which is done by the telemetering system. The telemetering system is a RF-link between the wendy house and the laboratory. The students can thus view the measured parameters so that early action can be taken against any faults that might occur. The radar receives its source of power via a circuit breaker with over-current protection.

Figure 1.2: Rotary inverter's system diagram.

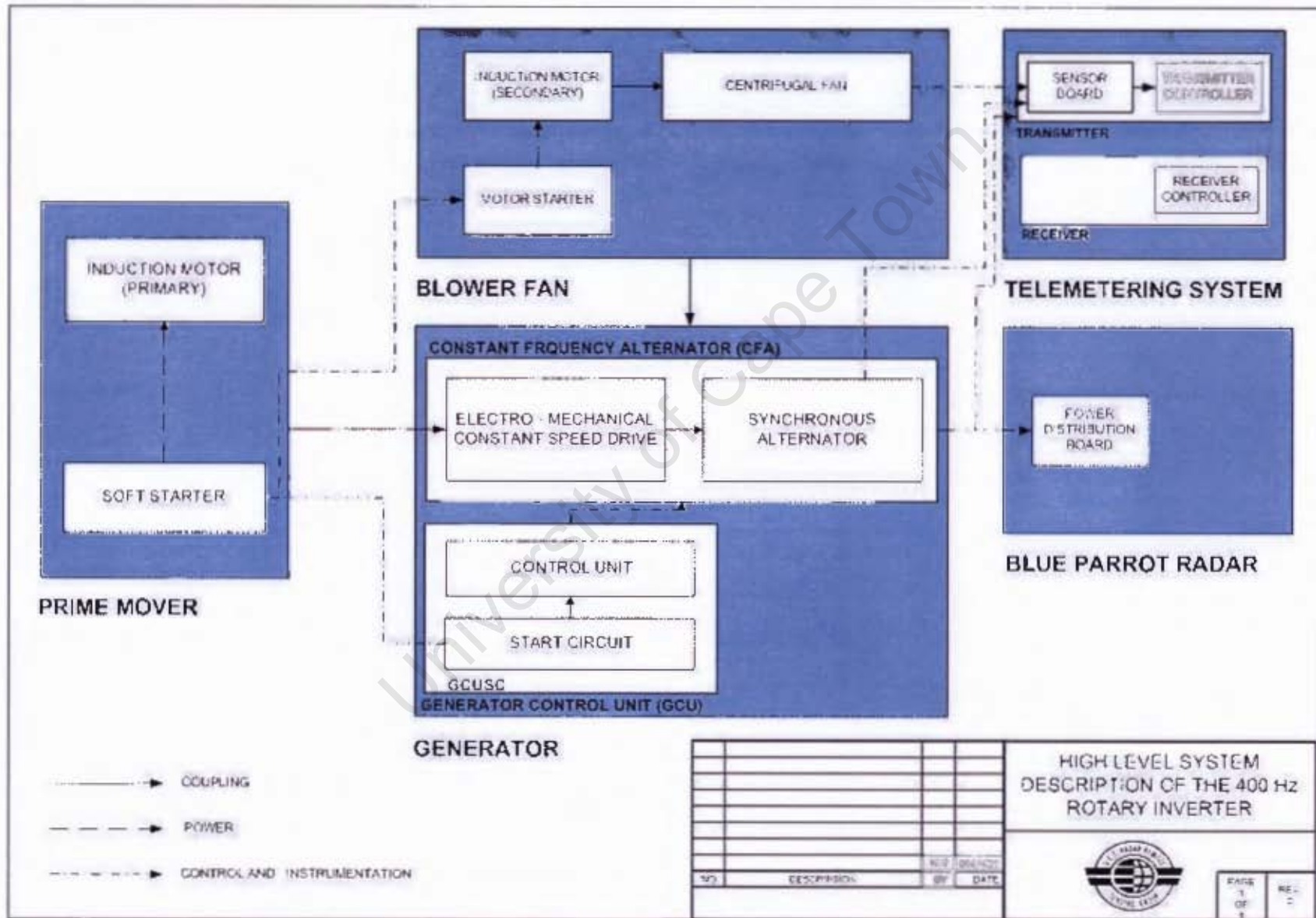

1.4 User Requirements

The goal of the project is to commission a three-phase 200 V, 400 Hz power supply using a constant frequency alternator. The power supply is to be used at the University of Cape Town for laboratory purposes. The power supply shall be located in a wendy house outside the 6th floor of the Menzies building at the University.

The objectives of the project are listed below [2]:

1. To select a suitable prime mover according to its electrical and mechanical requirements of the generator.
2. The system should have a single point where it can be started and stopped .
3. To select a suitable blower fan that stabilises the constant frequency alternator's operating temperature according to its thermal requirements.
4. To design a ventilation shroud for the constant frequency alternator.
5. To design the start circuit for the generator control unit which should be synchronised to the soft starter.
6. To build a wiring harness between the constant frequency alternator and generator control unit.
7. To design a telemetering system which will monitor the following parameters, namely:
 - (a) line-to-line voltage across (between phases a-b),
 - (b) line current (phase a),
 - (c) constant frequency alternator's case temperature, and
 - (d) the blower fan pressure.

1.5 Project Development

Chapter 2. The underlying theory covering all aspects of commissioning the constant frequency alternator as a 400 Hz power supply is explained in this chapter. Section 2.1 reviews the mechanics of the constant frequency alternator as well as the voltage and speed control loop found in the generator control unit. Section 2.2 lists the thermal requirements of the constant frequency alternator. Section 2.6 covers the theory for analysing the performance of induction motors.

Chapter 3. The selection, testing and commissioning of a suitable prime mover is covered in this chapter. Onboard the Mirage F1-C a gas-turbine is coupled to a constant frequency alternator, which produces three-phase power at 400 Hz. Similarly, for this project a suitably sized electrical induction motor replaces the gas-turbine. The soft starter not only serves as a starter for the motor but as a control and protection function for the rotary inverter as well.

Chapter 4. This chapter covers the commissioning and testing of the 400 Hz generator that has been coupled to the induction motor. It was noted during testing that an intermittent frequency hunting fault was picked up repeatedly and an investigation into the root cause is documented. The illustration below is a trace of the supply frequency during hunting and normal operation.

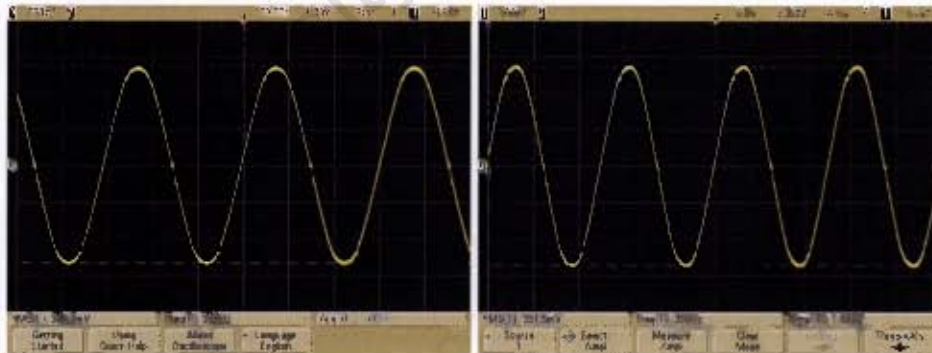

Figure 1.3: Frequency trace during frequency hunting and normal operation.

Chapter 5. This chapter covers the selection, commissioning and testing of the blower fan on the constant frequency alternator under various loads. In Figure 5.7 the constant frequency alternator is supplying a 2.2 kW load, which gave two results. Firstly the blower fan is able to stabilise the generator case temperature to 46.5 C. Secondly the thermal protection trips the rotary inverter if the blower fan fails and in so doing allowing the case temperature to exceed 68 C.

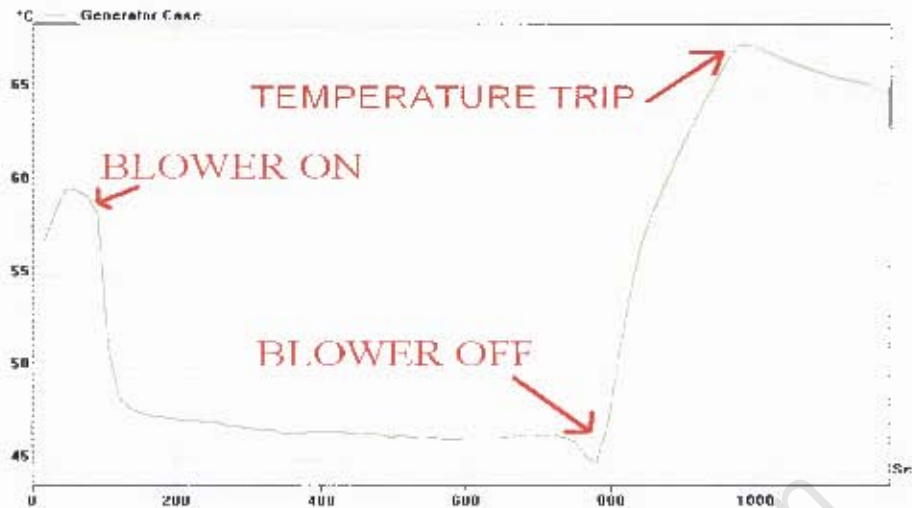

Figure 1.4: Constant frequency alternator's temperature response to a 2.2 kW load with forced cooling.

Chapter 6. The chapter describes the design of the telemetering system. The system consists of sensors, interfacing electronics, power supply and two microcontrollers. The temperature and pressure sensors proved to interface easily, however, noise corrupted the pressure reading which necessitated the need for a differential summer which solved this problem (see Section 6.2). The voltage and current readings required more thought as each reading first required rectifying and level shifting through a precision rectifier circuit. Each sensor has been calibrated to a 0 - 5 V scale (see Table 7.2). The telemetering system works well on vero board, however, it would be more robust for student use if it were printed onto circuit board (see Figure 1.5).

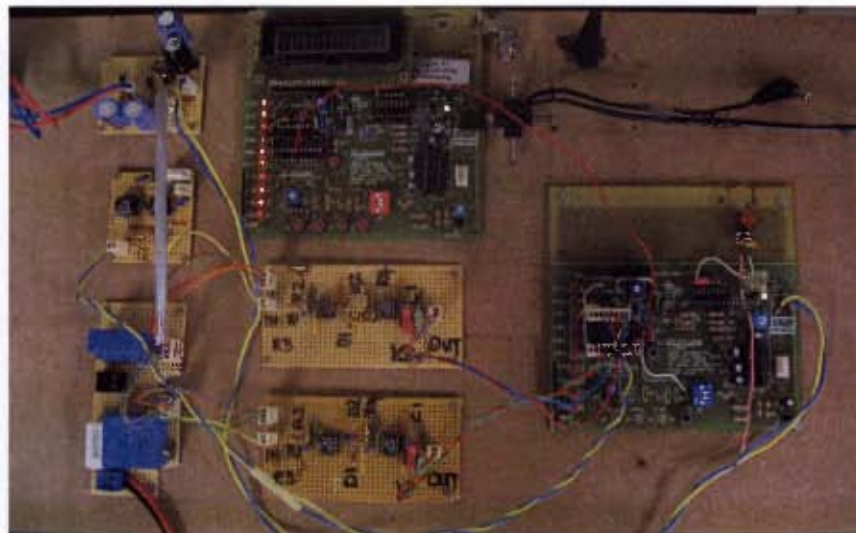

Figure 1.5: The telemetering system designed for the rotary inverter.

Chapter 7. The objective of this chapter was to re-use code already written by a student who programmed a monitoring unit to measure the same four parameters, however, what was supposed to be a straight forward exercise turned out to be a time consuming debugging exercise which could not be solved in the required time, for this project. However, despite not achieving communication between boards the analog to digital conversion as well as the decoding routines were successful.

Chapter 8. Conclusions

Chapter 9. Recommendations

University of Cape Town

Chapter 2

Theory Review

The underlying theory, covering all aspects of commissioning the constant frequency alternator as a 400 Hz power supply, is explained in this chapter. Section 2.1 reviews the operation of the mechanical parts of the constant frequency, as well as the voltage and speed control loop found in the generator control unit. Section 2.2 lists the thermal requirements of the constant frequency alternator. Lastly Section 2.6 covers the theory of analysing the performance of induction motors.

2.1 Constant Frequency Alternator ([1],[5],[6])

The engine-driven constant frequency alternator can be thought of as a rotary converter, in that it takes mechanical energy and converts it into electrical energy. Variable engine speeds are passed through a constant speed drive, which turns the alternator at a set speed. The speed at which the alternator turns determines the output frequency in these engine-driven machines. Since the engine speed varies it is necessary for the constant speed drive, to turn the alternator at a constant speed to keep the frequency stable at 400Hz. The constant speed drive uses a differential gear assembly and an eddy current brake to ensure synchronous speeds are delivered to the alternator. Synchronous speed is 8000 rpm for a 6 pole alternator to produce an output frequency of 400 Hz. Figure 1.1 shows the constant frequency alternator, which are three-phase 200 volt line-to-line, 400 Hz machines. The constant frequency alternator consist of: an alternator, electro-mechanical constant speed drive and an eddy current brake cup. The electro-mechanical constant speed drive and the eddy current brake cup will be referred to as the constant speed drive and brake cup respectively. Together these parts make it possible for the alternator to produce three-phase 200 line-to-line voltages at 400 Hz, when driving speeds and torque fall between 2680 rpm - 8320 rpm and 77.9 N.m - 30.0 N.m [1].

2.1.1 Alternator

The alternator is a six pole pair synchronous machine with an operating frequency of 400 Hz at an armature speed of 8000 rpm. Excitation is supplied through a permanent magnet generator which consists of a fixed magnet, a half-controlled converter, exciter and alternator winding. The magnet is stationary where the exciter winding, alternator windings and converter rotates through the static field. The excited winding produces three phase current which feeds the half-controlled converter. Controlled DC field current is fed to the alternator rotor winding which induces a voltage across the alternator stator winding. The stator voltage is controlled by regulating the DC field current.

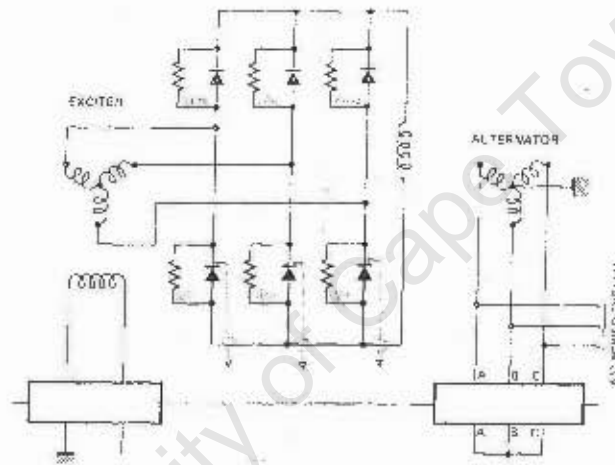

Figure 2.1: Principle of operation of the alternator [1].

2.1.2 Constant speed drive

The purpose of the constant speed drive is to take rotational engine power irrespective of the input speed and to turn the alternator at constant speed. This is necessary to generate 400 Hz three-phase power. This consists of a differential gear assembly and a brake cup or compensation link, as it is sometimes referred to in literature. This gear assembly is similar to a motor vehicle's differential transmission. In a motor vehicle the front wheels are allowed to rotate at different speeds to each other, so that the turning circle is reduced when taking a corner. The differential gear action of the generator keeps the speed of the alternator's end constant, whereas the brake cup side changes in such a way to compensate for the difference in speed. Equation 2.1 governs the difference speed. The equation reads, the difference between the motor input speed and brake cup compensation speed should be the synchronous speed of the alternator. Synchronous speed of the alternator is 8000 rpm. For motor speeds less than 4000 rpm the brake speed compensates by adding

speed through differential action whereas speeds greater than 4000 rpm compensates by braking (see Table 2.1). For example, driving the constant speed drive with a motor speed of 3000 rpm would only produce 6000 rpm for the alternator shaft by the gear ratio $2N_{in}$. Clearly the difference in synchronous speed is 2000 rpm, which is compensated for by the brake cup.

$$N_{\text{alternator}} = 2N_{\text{in}} - N_{\text{compensating}} \quad (2.1)$$

- $N_{\text{alternator}}$ – synchronous speed of 8000 rpm, which stays constant.
- N_{in} – speed of the prime mover, typically 2920 rpm.
- $N_{\text{compensation}}$ = the speed of the brake cup.

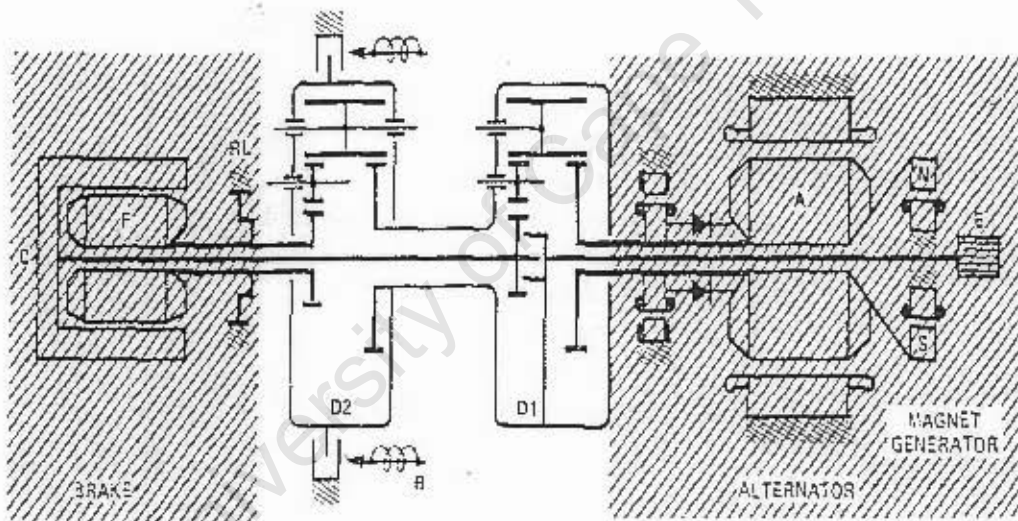

Figure 2.2: Principle of operation of the constant speed drive [1].

Table 2.1: Speeds of rotational components within the constant frequency alternator.

rpm	rpm	rpm	rpm	-
Input [E]	Output [A]	Brake Cup [C]	Brake Inductor [F]	Clutch [B]
8000	8000	8000	0	not excited
6000	8000	4000	0	not excited
4000	8000	0	0	not excited
3000	8000	-2000	-6000	excited
2000	8000	-4000	-4000	excited

Calculating the ideal motor input speed [6]

The compensation power required to maintain constant speed is given by the Equation 2.2, below, which is the work of [6]. Changing the input speed and tabulating the results from Equation 2.1 produces the results presented in Table 2.3.

$$\frac{P_{\text{compensation}}}{P_{\text{out}}} = \frac{T_{\text{compensation}} \omega_{\text{compensation}}}{T_{\text{out}} \omega_{\text{out}}} \quad (2.2)$$

- $P_{\text{compensation}}$ - Compensation drive power
- P_{out} - Output power
- $T_{\text{compensation}}$ - Compensation torque
- T_{out} - Output torque
- $\omega_{\text{compensation}}$ - Compensation speed
- ω_{out} - Output speed

Table 2.3 below shows that at 4000 rpm the least amount of compensation power is required from the induction motor. This infers that 4000 rpm would be the ideal prime mover speed.

Table 2.3: Percentage of input power used to maintain synchronous speed.

$N_{\text{alternator}}$ [rpm]	N_{input} [rpm]	$N_{\text{compensation}}$ [rpm]	Input Power Used [%]
8000	2750	-2500	-31.25
8000	3000	-2000	-25
8000	3250	-1500	-18.25
8000	3500	-1000	-12.5
8000	3750	-500	-6.25
8000	4000	0	0
8000	4250	500	6.25
8000	4500	1000	12.5
8000	4750	1500	18.75
8000	5000	2000	25
8000	5250	2500	31.25

2.2 Thermal Characteristics [1]

The specification used for the design of the ventilation unit [1].

Table 2.4: The constant frequency alternator's thermal characteristics.

Power [kVA]	Flow Rate [$\frac{L}{sec}$]	Pressure [Pa]	Period [min]
12-15	100-130	3000	indefinite
10	self ventilation		20 min

2.3 The Generator Control Unit (GCU)

Seven feedback loops control the CFA output. They are contained in a shielded die-cast rectangular box called the GCU. Stacked printed circuit board contain the control and protection loops and are listed below. Not all the feedback loops are required for operating the CFA in constant speed mode; those that are, are listed below [1]:

- Voltage (196 - 200 V)
- Frequency (396 - 404 Hz)
- Over-current (> 45 A)
- Torque (sudden changes)

The most critical of these are the voltage and the frequency, which are discussed below.

2.3.1 Voltage control loop (excitation current)

Stator voltages are measured by step-down voltage transformers and compared to the reference comparator inside the regulator. Depending on the stator voltage, the firing angle of the rectifier's is either increased or decreased from its set point. This regulates the rectifiers DC voltage. The DC voltage is fed to the alternator's rotor windings where it becomes excitation current. This excitation current sets up the magnetic field, which induces a voltage across the stator terminals. This is the operation of the voltage loop.

2.3.2 Frequency control loop (speed loop)

Frequency of supply is determined by the speed at which the magnetic airgap field cuts the three pole pairs [9]. The speed of the airgap field is determined by the rotor shaft speed. When these poles are cut at 8000 rpm, it produces 400 Hz stator voltages. The frequency loop controls the following [1].

1. Ensuring that the alternator's frequency falls between 396 and 404 Hz.
2. Controlling brake-cup direction and speed.
3. Engaging and disengaging differential gears.

2.4 Frequency Hunting [2]

The student whose research was on selecting a prime mover, preceded the work done for this thesis, encountered a frequency hunting problem when testing the system. In an attempt to solve the problem the student carried out the following tests.

2.4.1 Aim

The aim of this test was to compare the functioning of the working CFA from the Mirage aircraft with the potentially faulty CFA, in order to establish whether the fault lay with the GCU or with the CFA.

2.4.2 Method

In order to test this, both CFAs were coupled separately with the same control unit, as shown in the figure. Thereafter, if the problem persisted the control units were exchanged.

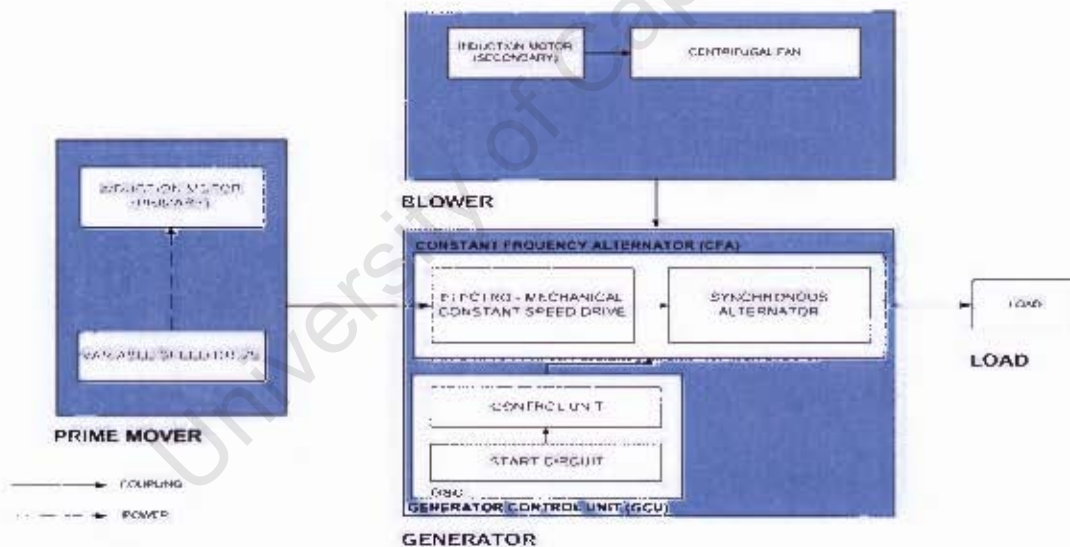

Figure 2.3: System configuration during testing.

2.4.3 Findings

Both generators had a frequency hunting problem as configured in the setup below. Both the other CFA and the control unit were interchanged. Two possible causes were identified.

1. The variable speed drive was trying to regulate the input speed whilst the constant speed drive was performing the same function [22].

2. The frequency limiting resistor circuit were needed for constant frequency operation [22].

2.4.4 Discussion

The manner in which the variable speed drive was used was not documented by the student whose work preceeded this project. Therefore it is assumed that the variable speed drive operated in open loop. This open loop operation would keep the voltage and frequency constant, which means that the induction motor would be running at 3000 rpm at full rated torque and current [23]. If the variable speed drive was varying the input speed, then the CSD would override any regulation in input speed. It is suggested that this might not be the root cause.

The frequency limiting resistors are designed to brake the speed of the alternator during rapid engine speed changes by shunting the coils across the alternator's stator. This has the effect of braking the alternator speed. If these resistors were faulty then the problem could be eliminated by replacing them. When the frequency limiting resistors were removed, however the hunting problem was still present. When the resistors were placed back, the problem was eradicated. This reason leaves a gap in uderstanding the nature of the hunting problem, which is addressed in the Section 4.5.

2.5 Gearbox Oil

The generator's gearbox uses a Mobil Jet Oil 254 for lubrication. The colour of healthy oil is brown, whereas dirty oil is black in colour. At all times the sump should be filled with 630 ml of oil to cover moving parts. The constant frequency alternator should be in the horizontal position while generating and re-filling with oil (see Reference [34] for instructions on filling and re-filling of gearbox oil).

2.6 The Prime Mover

The selection of the prime mover for the constant frequency alternator formed part of an undergraduate thesis project [2]. A 15 kW induction motor was selected; its specifications are shown in Table 2.5 below.

Table 2.5: Induction motor's rated specifications [2].

Parameter	Value	Units
Rated Voltage	380	V-l
Rated Current	26.5	A
Connection	Delta/Star	
Frequency	50	Hz
Rated Output	15	kW
Speed at Rated Power	2940	rpm
Efficiency at full load	90	%
Efficiency at 3/4 load	90.2	%
Power Factor	0.90	p.u
Rated Torque	49	N.m
Weight	77	kg

2.6.1 The equivalent circuit model of an induction motor [9]

The per phase equivalent impedance Equation 2.3 can be used to calculate the performance of induction motors by using the calculated parameters in Table A.3. This equation is dependant on slip s which is 1 at startup and almost zero at rated speed. In Chapter A.3 this equation is used to calculate the input impedance over the full slip range to obtain a current profile of the induction motor.

$$Z_{in} = R_1 + jX_1 + \frac{jX_m(\frac{R_2}{s} + jX_2)}{\frac{R_2}{s} + j(X_m + X_2)} \quad (2.3)$$

- R_1 - stator resistance
- X_1 - stator impedance
- X_m - magnetising impedance
- R_2 - rotor resistance
- X_2 - rotor impedance
- s - slip

The stator current Equation 2.4 below uses the phase-to-neutral voltage V_{ph} at different input impedances Z_{in} to calculate the startup current I_s (see Equation 2.4).

$$I_s = \frac{V_{ph}}{Z_{in}} \quad (2.4)$$

- I_s - stator current.
- V_{ph} - phase to neutral voltage.
- Z_{in} - input impedance.

Equation 2.5 determines the available torque which the induction motor can be loaded with at startup. The equation uses the thevenin equivalent voltage V_{th} and impedance R_{th} and X_{th} as the stator parameters in the calculation, (see Reference [8]). This equation can be used for determining a torque profile for the motor.

$$T_{em} = \frac{1}{\omega_{sync}} \times \frac{(V_{th})^2}{(R_{th} + \frac{R_2}{s}) + (X_{th} + X_2)^2} \quad (2.5)$$

The motor equation $N = \frac{120f}{p}$ shows that a two pole (p) induction machine on a 50 Hz (f) supply has a maximum speed 3000 rpm.

University of Cape Town

Chapter 3

Commissioning the Siemens 15 kW Induction Motor as the Prime Mover for the Constant Frequency Alternator

The selection, testing and commissioning of a substitute prime mover is covered in this chapter. Onboard the Mirage F1-C, a gas-turbine is coupled to a constant frequency alternator, which produces the mechanical power to generate three-phase power at 400 Hz. In the method used in this dissertation, the induction motor replaces the gas-turbine.

3.1 Prime Mover Selection

3.1.1 Constant frequency alternator's specifications

The driving shaft requirements show that the constant frequency alternator can operate in two power modes i.e at high and low rotational speeds. Table 3.1 lists the requirements for driving the constant frequency alternator in both modes.

It is the function of the constant speed drive to deliver constant rotational speed at 8000 rpm to the alternator rotor irrespective of the input speed. For the purpose of maintaining constant rotor speed the constant speed drive includes two differential gears and an electro mechanical brake all controlled by the frequency regulation system of the regulator. Therefore it is not necessary for both the motor and the constant speed drive speeds to be regulated.

Table 3.1: The constant frequency alternator's power rating at different speeds.

Power Rating [kVA]	PF	Rotational Speeds [rpm]	Torque [N.m]
15	0.75	5600 - 8320	77.9
12	0.75	2680 - 5600	30.4

3.1.2 Direct current motors versus induction motors

Since speed control is not required on the motor side an ordinary DC or an AC induction motor can be used. Induction motors are more viable than DC motors, because the latter have brushes that require maintenance [9]. As a result, an induction motor was chosen.

3.1.3 Induction motors

The ideal motor would be a 4000 rpm at 30.4 N.m machine, which is explained in Section 2.1.2. However this cannot be achieved in an induction machine due to the speed limitation on a 50 Hz supply (see Section 2.6). The available motor sizes in this range are 11, 15 and 18 kW. The 11 kW motor has insufficient torque, whereas an 18 kW has a surplus at a higher cost, for this reason a 15 kW induction motor was chosen. Table 3.1 lists the motor's requirements.

Table 3.2: Characteristics of the prime mover.

Parameter	Value	Unit
Rated Voltage	380	VI-I
Rated Current	26.5	A
Rated Output	15	kW
Rated Torque	49	N.m
Speed at rated output	2940	rpm
Frequency	50	Hz
Connection	∇/Y	

3.2 Pre-Commissioning Work

3.2.1 Induction motor testing

A no load and locked rotor test was performed on the motor to calculate the equivalent circuit, which enables the following current profile to be predicted. These test results can be found in Appendix A. The following graph was created using the formula $I_{\text{stator}} = \frac{V_{\text{ph}}}{Z_{\text{in}}}$ where V_{ph} and Z_{in} are phase voltage and input impedance respectively. The phase voltage is 220 V and 380 V in a star and delta connected network respectively. Input impedance is calculated using Equation A.13 over the slip interval, and plotted for the star and delta configurations as shown below. The graph in Figure 3.1 shows the motor's phase-current profile under the star and delta configurations versus slip. The green curve represents the current profile of the star configuration, whereas the yellow curve represents that of a delta configuration. The result is consistent with the literature, which predicts a 5-8 times larger starting current [8]. It was found that the startup current causes nuisance-tripping

on the upstream circuit breaker during laboratory testing, and that it would do the same if it were installed in the wendy house on the sixth floor. Fortunately this problem can be overcome by a commercially available soft starter.

Motor Phase Current vs Slip

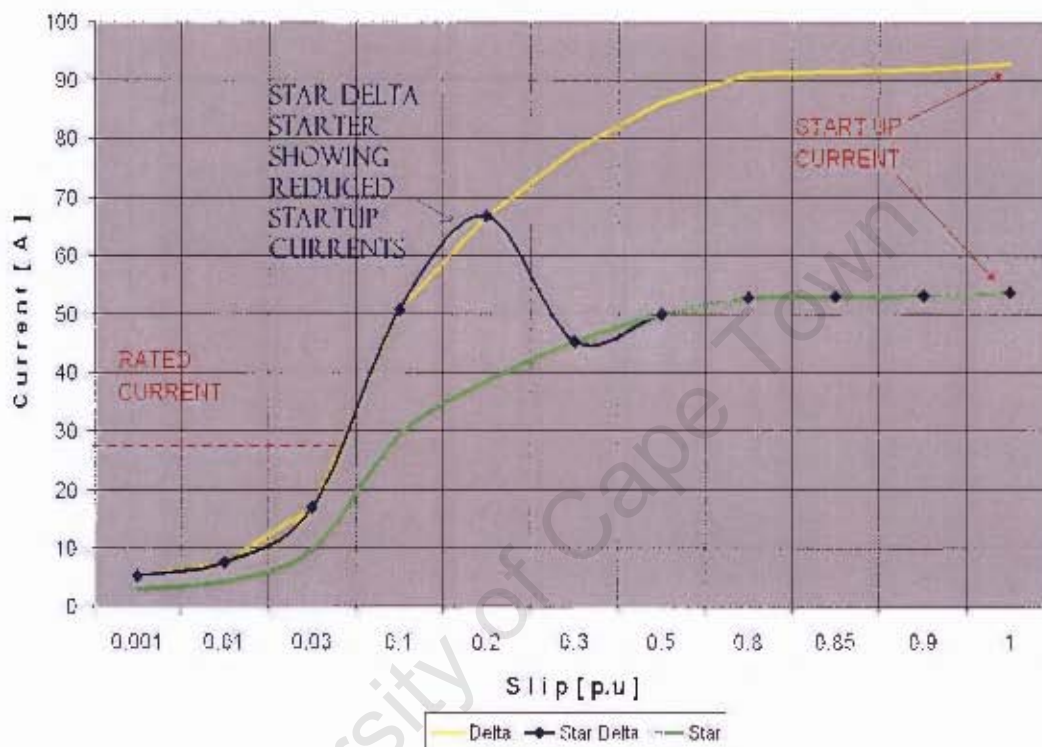

Figure 3.1: Induction motor's current vs slip showing the soft starting effect.

3.2.2 Soft starter

Owing to the upstream circuit breaker tripping during motor start up and belonging to the University, it could not be changed, thus a soft starter was purchased.

The star delta starter can be used on the induction motor as both ends of the three phase winding are available at the junction box (see Section 3.3). At start up, voltage is applied to one end of the winding while the other end is connected in a Y point. During this connection $\frac{1}{\sqrt{3}}$ of the voltage is applied and the current is reduced by the same amount [37]. The test shows this to be true as one phase draws 90 Amps during a direct on line start and 53 Amps with a star connection (see Figure 3.1). The torque is reduced by a factor of $\frac{1}{3}$ (see Section 3.3). This brings the motor shaft speed from standstill to 75 % of its rated speed. To bring the shaft to 2920 rpm the star point is open circuited and the three phase motor winding is connected in Δ , thereby supplying the full rated voltage

and current to the motor and allowing it to reach full speed. The configuration for the starter shows the following switchgear viz. thermal overload relay, timer, delta and star contactors. The time the soft starter takes to make the transition between star and delta is set to 12 seconds. The thermal overload is set to trip once the current drawn exceeds 1.1 times rated current (29.3 A).

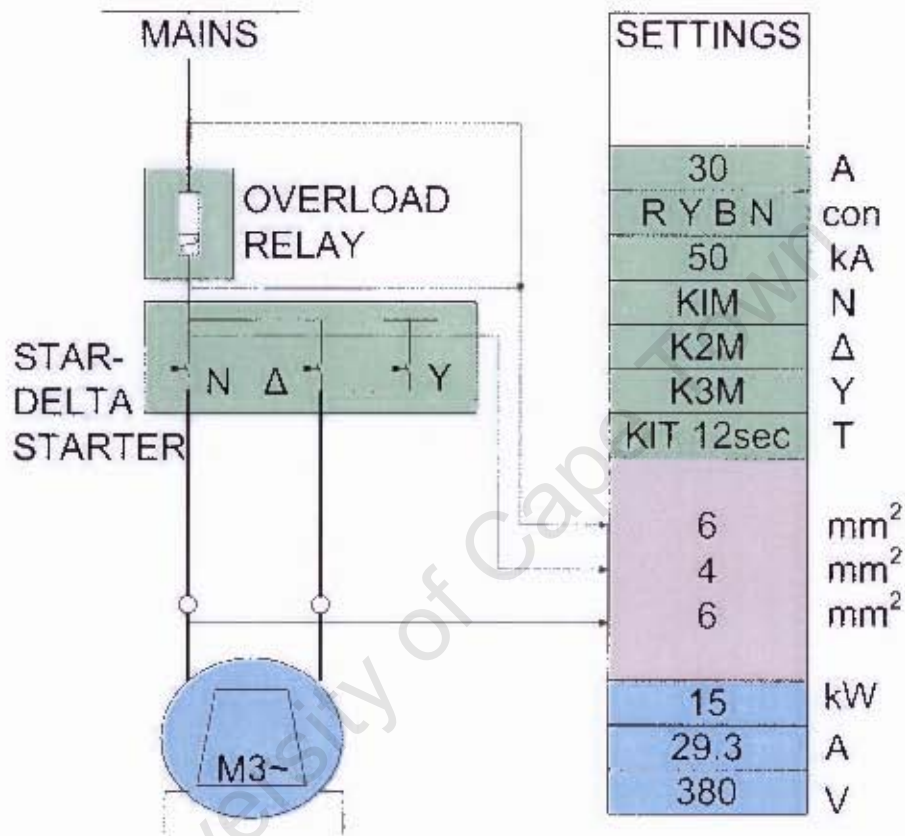

Figure 3.2: Soft starter's schematic.

3.2.3 Motor connections

The terminal connections are colour coded as illustrated in Figure 3.3. The connections W2, U2, V2 are wired from the overload relay whereas U1, V1, W1 are connected to the star and delta contactors. Not shown is the earth connection to the motor case which must be secured to ensure earth fault protection.

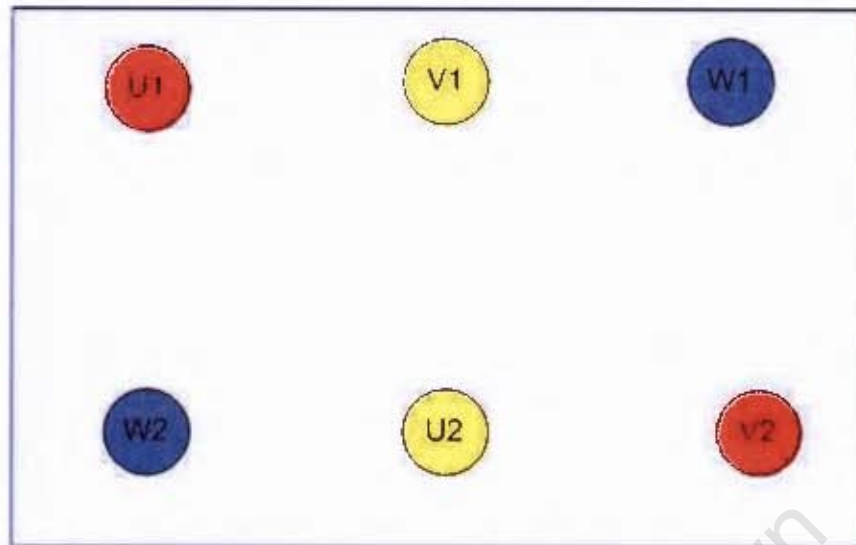

Figure 3.3: Induction motor's connections for anti-clockwise rotation from the non drive end.

3.2.4 Mounting

The induction motor rests on a metal plinth with anti-vibration feet the advantage of which reduces movement between the motor and plinth. The plinth in turn stands on anti-vibration feet which reduces the noise between the plinth and the floor.

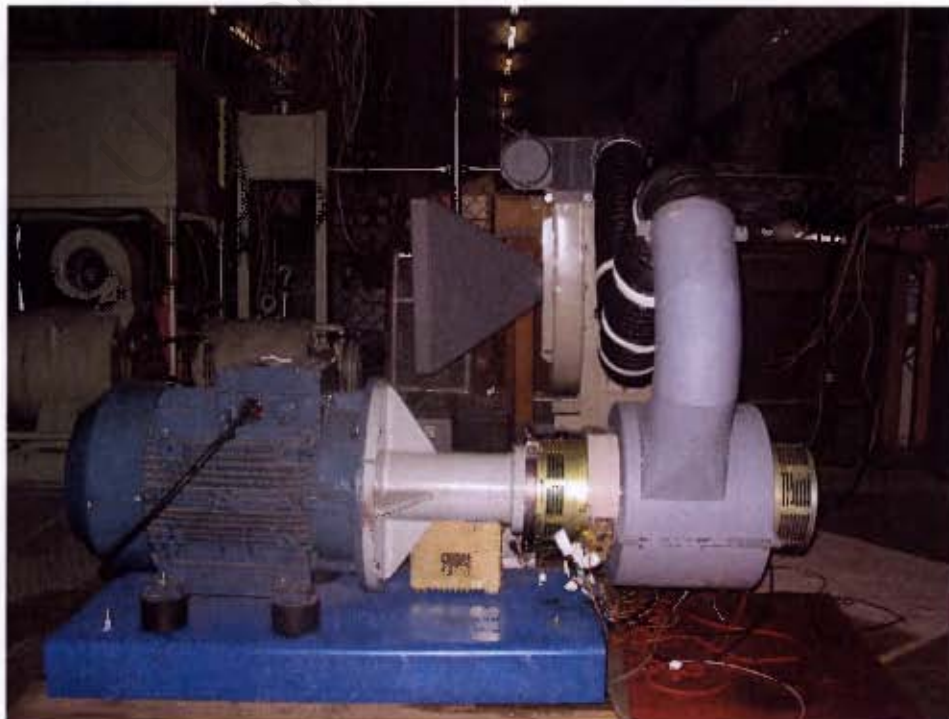

Figure 3.4: Induction motor secured to a plinth with anti-vibration rubber feet.

3.3 The Load Torque

It was assumed that the load would impose a torque of 30.4 N.m on the motor as soon as the load circuit breaker is closed on the generator side. The assumption was based on Table 3.1. During the star connection the motor's torque is less than 30.4 N.m, which would result in a stall if the coupled generator were started with a load attached. A stall occurs when there is a negative difference between the motor's and load's torque. Figure 3.5 was calculated based on Equation 2.5 which clearly shows the motor's torque versus slip. The motor did stall while the generator with load was started during the reduced torque state as shown by the fuchsia curve outside the red vertical lines in Figure 3.5. To solve this, the generator should not start under the star contactor but that it should be synchronised with the delta contactor. This is covered in Subsection 4.3.

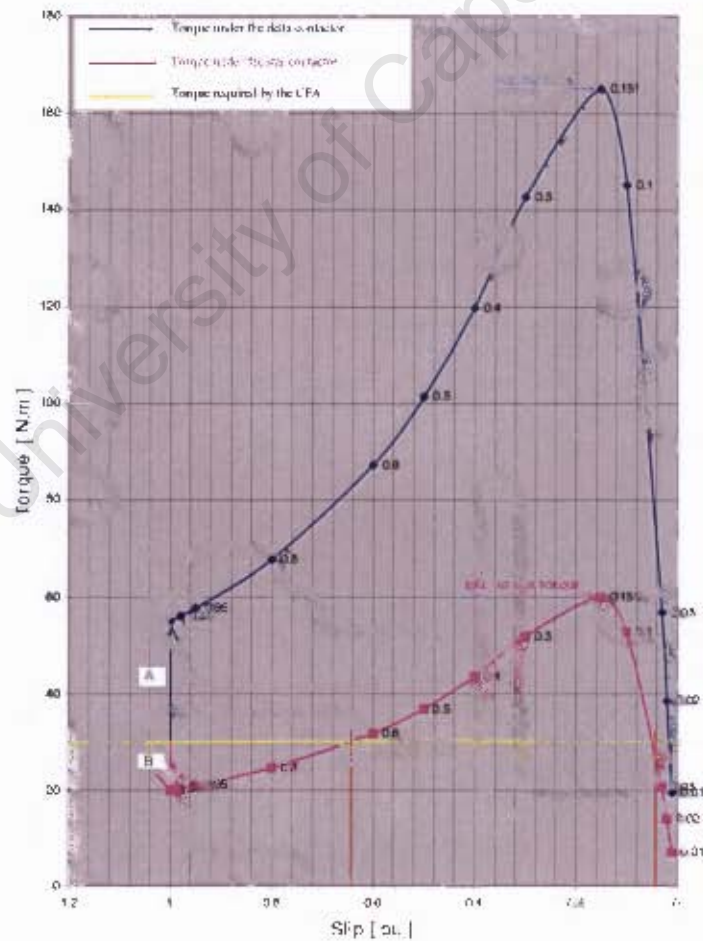

Figure 3.5: Induction motor's torque vs slip showing the soft starting effect.

3.4 Starting and Stopping the Prime Mover

The induction motor is started and stopped via the push button on the front panel of the soft starter, provided that the mains supply is switched on. The generator and blower fan will be re-wired to start from the soft starter (see Sections 4.3 and 5.4 respectively).

3.5 Motor Efficiency

Using the name plate table parameters we can calculate the input power to the motor to be :

$$\begin{aligned}P_{in} &= 3 \times V \times I \times \cos\Theta \\P_{in} &= 3 \times 400 \times 15.40.9 \\P_{in} &= 16632W\end{aligned}$$

Using the rated torque and shaft speed we can calculate that the induction motor is rated to deliver :

$$\begin{aligned}P_{out} &= T_{rated} \times \omega_{rated} \\P_{out} &= 49N.m \times 314 \frac{rad}{sec} \\P_{out} &= 15386W\end{aligned}$$

The rated efficiency of the Siemens induction motor is $\frac{P_{out}}{P_{in}} = 92.5 \%$.

3.6 Summary

In conclusion, the chapter provided the following useful information, viz:

- Nuisance tripping was resolved by the use of the soft starter.
- The soft starter serves as a central point of control for the motor, generator and blower fan.
- The generator cannot be started when the motor is operating in the reduced torque mode, owing to the fact that there is insufficient torque.
- Motor efficiency is calculated to be 92.5%.

Chapter 4

Commissioning the 400 Hz Generator

This chapter covers the design of the generator control unit's starter circuit, commissioning and testing of the 400 Hz generator, the investigation into the intermittent frequency fault, the proposals for determining root cause for frequency failure and the investigation into the discolouration of the gearbox oil. The constant frequency alternator and generator control unit will hereafter be referred to as the CFA and GCU respectively.

4.1 Design of the Generator Control Unit's Starting Circuit (GCUSC)

The GCU is powered from the permanent magnet generator inside the CFA as soon as the input speed reaches 2600 rpm via relay K1. Relay K1 closes the three phase AC windings of the permanent magnet generator onto the power regulator circuit inside the GCU. The circuit needed to close K1 should source 28 Vdc at a minimum of 200 mA. Onboard the aircraft this power would come from the battery banks, which would be used for the essential auxiliaries required to start the aircraft. The GCUSC receives 220 VAC via the red phase and neutral from the motor's soft starter. See Section 4.3 for synchronising the GCUSC to the soft starter.

4.1.1 Calculating component sizes for the GCUSC

Capacitor C2 couples 28 V via a 3 pin molex connector to the GCU. Taking into consideration a 4 V drop across the LM317 regulator and bridge rectifier (B1), the secondary transformer voltage should compensate for the voltage drop which shall be 32 V_{rms}. A 24 V transformer can be used if small currents are being drawn. This is because capacitor C1 charges to the peak of the rectified output across B1, ($\sqrt{2} \times 23V$). This was measured and this is why a 24 V secondary transformer was chosen. For protection a 20 mA fuse is selected according to the transformer equation $\frac{V_2 A_2}{V_1}$ where A_2 is 200 mA.

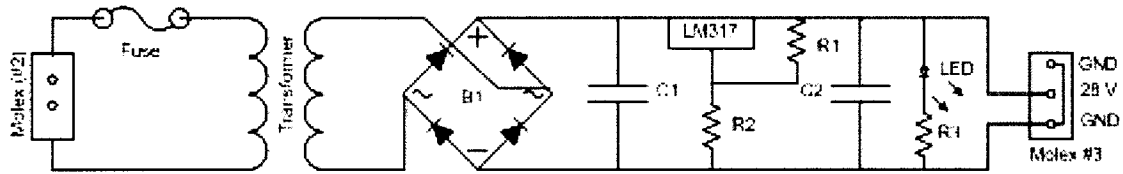

Figure 4.1: Schematic for the generator control unit's starting circuit.

The component values for the GCUSC is listed in Table 4.1.

Table 4.1: Component values of the GCUSC.

Component	Value	Component	Value
V_{out}	28V	LM317	Adjustable
I_{out}	200 ma	C1	1000uF
I_{in}	23 mA	C2	470uF
Transformer	24 VA	Fuse	20 mA

The GCUSC supplies 200 mA at 28 Vdc.

4.2 Alternator Load and Power Factor Test Results

Figure 4.2 shows the test setup for the system. The setup includes an induction motor mechanically coupled to the alternator via a solid coupling, while the blower fan is supplying forced air through a shroud over the alternator. The blower fan is not shown in the figure.

Due to the laboratory equipment limitations only one Chauvin Arnoux power meter and two Fluke multimeters were available to be used for measurements and metering. The Chauvin Arnoux power meter was connected with voltage probes across the motor terminals, while current probes were clamped over the individual phases of the supply power cable to the motor. The load is balanced therefore one phase of the load is measured and the total power is calculated by multiplying by the single phase result by 3. One Fluke meter measured voltage across the red and blue phase, while the other measured current in the red phase.

The alternator was tested with resistor banks. Three banks were used where each bank consisted of 4 resistors. Each resistor had impedance of $Z = 60\angle 0.053^\circ$. The inductances of these resistors are considerably low and the power factor is close to 0.99 even in the worst case where all resistors are connected in series.

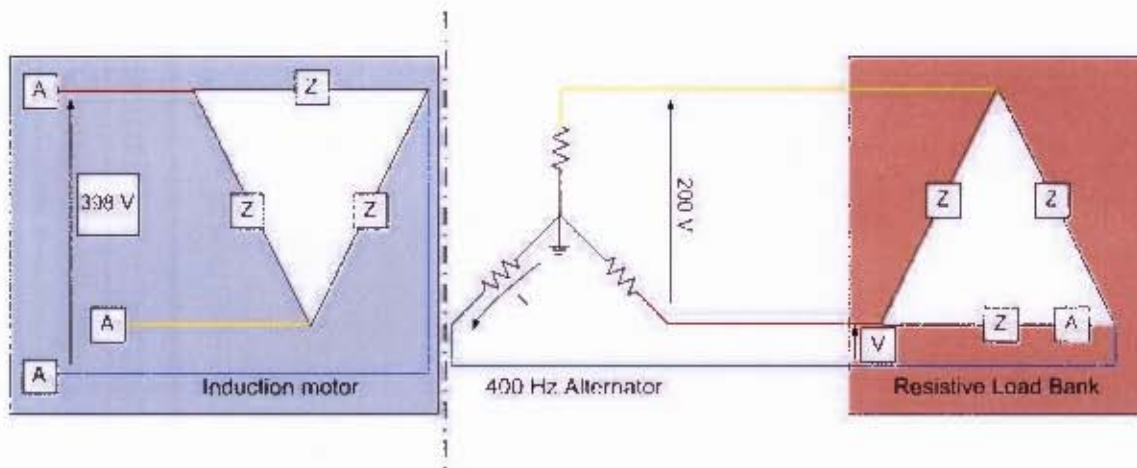

Figure 4.2: Alternator load test setup.

The four tests used the following resistor combinations: 240 Ω , 150 Ω , 80 Ω and 15 Ω . The 240 Ω test has four resistors connected in series, whereas the 15 Ω has four resistors connected in parallel per phase for all three phases. The 150 Ω combination has two resistors in parallel and two in series, whereas the 80 Ω has three resistors in parallel and one resistor in series.

Overall system efficiency was calculated by the consumed power of the load (output of the generator) divided by the input power across the motor. Results are shown in Table 4.2.

Table 4.2: System load test results.

Motor			Alternator			Load		System
[V]	[A]	[kW]	[V]	[A]	[kW]	Impedance	PF	Efficiency
397	1.04	0.65	200	1.80	0.62	240 \angle 0.045 $^\circ$	0.99	95%
395	1.72	1.20	197	3.00	1.02	150 \angle 0.042 $^\circ$	0.99	90%
395	3.81	2.24	196	6.10	2.23	80 \angle 0.033 $^\circ$	0.99	90%
395	12.12	7.75	189	21.00	6.86	15 \angle 0.041 $^\circ$	0.99	86%

4.3 Synchronisation

As mentioned in Subsection 3.3, the acceleration torque of the motor is insufficient to prevent a stall in the reduced torque region, as illustrated by the fuchsia curve outside the red vertical lines in Figure 3.5. The feasible solution would be to synchronise the generator start circuit with the delta contactor, which corresponds to full rated conditions. This can be done by connecting the generator start circuit supply via an auxiliary contact mechanically coupled to the delta contactor. Figure 4.3 shows the auxiliary contact mechanically coupled onto the delta contactor. This solution meets the single button start requirement as well as preventing the motor from stalling.

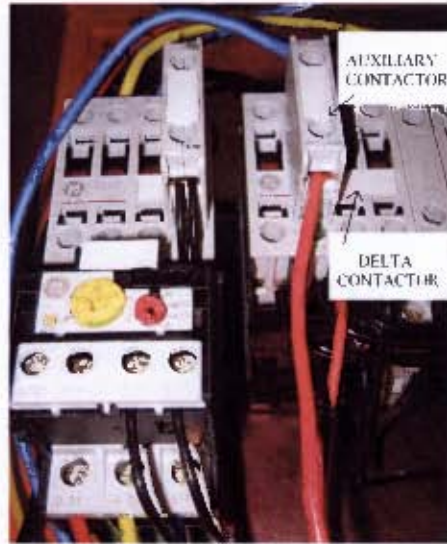

Figure 4.3: The soft starter with synchronising auxiliary contact.

4.4 Pre-Commissioning Work

4.4.1 Testing the CFA and GCU according to the commissioning instructions provided by the generator manual

The first evaluation tests the excitation current loops of the GCU according to the CFA's technical manual. It can be deduced from the results in Table 4.3 that the control circuit is operating properly for low speeds¹.

Table 4.3: Comparing the measured excitation current against the technical manual's.

Clutch (Coil E)						
Terminals	Documented Amps		Measured Amps			
E-N	0.5	-	0.8	0.66	-	0.7
Clutch (Coil F)						
Terminals	Document Amps		Measured Amps			
F-N	0.15	-	0.25	0.16	-	0.22
Brake (Coil B)						
Terminals	Document Amps		Measured Amps			
L-M	0.8	-	1.2	0.07	-	1.2

The second test performed was to verify whether the electrical insulation of the generator is good. A weak spot in the insulation would cause a short on the winding, which can

¹ For speeds less than 4000 rpm the method of speed control is governed by the brake and clutch coils. These work together in order to engage a speed doubling gear.

be picked up by measuring the resistance. The results from Table 4.4 suggest that the insulation strength of the generator is satisfactory. From the test results obtained, it can be concluded that the generator is in a condition to be used.

Table 4.4: Winding resistance values.

alternator's phase windings				
Terminals	Documented Ω			Measured Ω
A-N	0.109	-	0.134	0.122
B-N	0.109	-	0.134	0.119
C-N	0.109	-	0.134	0.121
alternator inductor (excitation control)				
Terminals	Documented Ω			Measured Ω
R-P	23.6	-	28.6	28.4
brake inductor				
Terminals	Documented Ω			Measured Ω
L-M	6	-	7.5	7.1
magnetic clutch coils				
Terminals	Documented Ω			Measured Ω
N-E	147	-	179	172
N-F	27	-	33	31
pulse generator windings				
Terminals	Documented Ω			Measured Ω
S-V	6.3	-	7.7	6.98
V-N	1.53	-	1.87	2.75
S-N	7.83	-	9.57	8.68
permanent magnet generator phase coils				
Terminals	Documented Ω			Measured Ω
T-G	0.75	-	1	DNM
G-H	0.75	-	1	DNM
H-T	0.75	-	1	DNM
frequency limiting resistors				
Terminals	Documented Ω			Measured Ω
U-J	11	-	14.5	12.75
J-K	11	-	14.5	12.75
K-U	11	-	14.5	12.75

4.4.2 Wiring harness

As the existing wiring harness had perished and required repairing, a new harness was made connecting the CFA to the GCU and the GCUSC. The harness uses amphenol connectors. The harness is 3 m in length and was tested for continuity (see Section B).



Figure 4.4: Constant frequency alternator's wiring harness.

4.5 Frequency Hunting

Frequency hunting is the intermittent problem of the alternator trying to keep its output at 400 Hz but instead oscillating between 328 and 336 Hz. The voltage during frequency hunting is 200 volts line-to-line [2].

The first signs of frequency hunting appeared while a previous student was working on the CFA. In an attempt to find the cause of the problem the student checked the motor, motor starter and wiring harness connections first before obtaining a replacement CFA and GCU off the same Mirage from Leon Heinkelin. Leon is an engineer at the University of Stellenbosch who has experience with these aircraft power supplies, and he was asked to investigate.

The first investigation tried to establish whether the CFA or GCU was faulty. Leon's GCU was thus used to control the CFA. However, frequency hunting still occurred. Thereafter the GCU was used to control Leon's CFA where frequency hunting failed to occur. The first investigation thus concluded that the problem lay with the CFA.

The second investigation sought to establish which component in the CFA was faulty. The frequency limiting resistors were disabled, as they were thought to be faulty. These resistors shunt the alternator when the engine speed of the aircraft accelerates or decelerates faster than 1000 rpm per second. Shunting across all three phases weakens the magnetic field so that the rotor slows down and hence the frequency dips. When these resistors were re-enabled, it was documented that the CFA no longer suffered from the spurious frequency hunting problem [2].

During commissioning of the CFA however, the spurious frequency hunting problem re-appeared and when the frequency limiting resistors were disabled and re-enabled the prob-

lem remained. Leon was contacted in October 2006 in which time the wiring harness, coil resistances, excitation currents, frequency limiting resistors, frequency control circuit, fuses and brushes were checked and all were found to be within specification (see Section B).

Section 5.3 of the generator technical manual lists factors which may cause the constant frequency alternator to hunt for the reference frequency. See Figure 4.5 below.

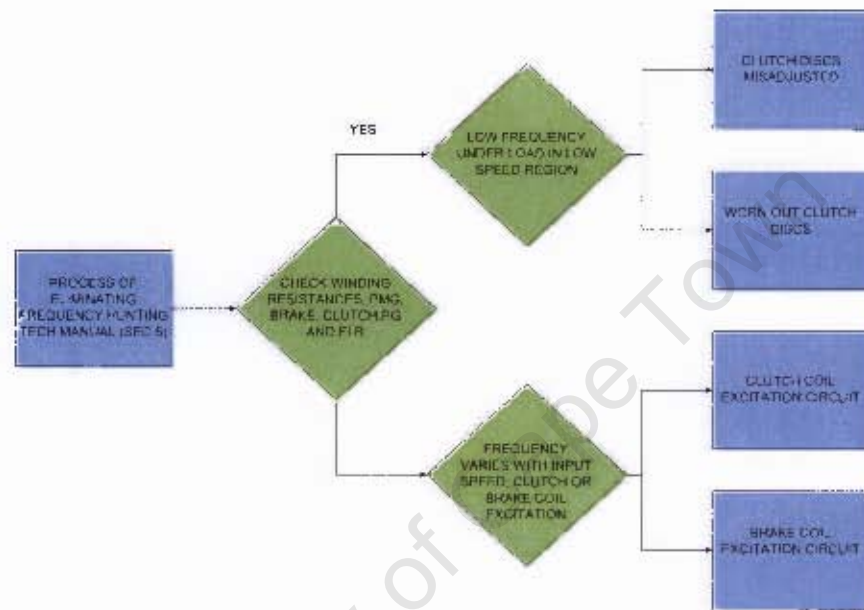

Figure 4.5: Frequency failure fault finding method.

The above figure suggests that during low input speeds the clutch mechanism is the probable cause for failure if the coil resistances are not faulty, which in this case were not. Low input speed refers to rotations less than 5150 rpm. The induction motor falls under this category. Therefore it is likely that the clutch mechanism is faulty.

4.5.1 Bypassing the clutch for the purpose of determining the root cause for frequency failure

The clutch² is used during low input speeds, as Table 2.1 illustrates. Operating the constant frequency alternator above 5150 rpm disables the clutch. Once the clutch has been disabled, then it could be said for certain whether or not the problem lies with the clutch.

²Dassault Aviation was contacted by email from their website to acquire a new clutch (part number module clutch -66567 for a constant frequency alternator P/N 15202-1/2), however, Prof Mike Inggs said that it would not be necessary.

One method of operating the system as is above 5150 rpm would be to over-excite the induction motor by using a variable speed drive. This could be done only for testing the output frequency of the generator with no load attached, due to the drop in torque experienced in this mode it would be unwise to couple a load to the generator [8]. Care must be exercised not to operate the induction motor for too long a time as the bearings are not rated for speeds higher than 3000 rpm [25], [27]. If bypassing the clutch solves the problem then it is suggested that Dassault Avionics should be contacted regarding a replacement clutch.

4.5.2 Changing the induction motor with a dc motor

In conversation with Professor Mike Case from the University of Johannesburg, the student's attention was brought to another theory behind the frequency hunting problem. The theory behind the conversation is that as the CSD regulates the alternator's speed, the induction motor experiences a change in load. The problem with this is that as the induction motor's load changes, so does its speed. The change in motor speed fights against the CSD's action, which is trying to keep the alternator at 8000 rpm. This fighting between the CSD and motor could be a possible cause for the problem of frequency hunting. The solution would be to use a gearbox coupled to either a synchronous reluctance or DC motor which does not share the same load-speed relationship as do induction motors. It would be satisfying to test the merits behind both theories, perhaps as a further research topic.

4.6 Discolouration of the Gearbox Oil

This section lists the possible factors which could result in the gearbox oil discolouring. Associate Professor Andy Yates from the department of mechanical engineering at the University of Cape Town was consulted to identify the possible causes for the discolouration.

4.6.1 Incorrect oil viscosity

Low viscose oil will barely cover metal surfaces inside a gearbox, thus leaving exposed areas, which can result in metal to metal friction. Such friction would cause the accumulation of metal particles suspended in the oil sump.

Oil with a high viscosity would sufficiently cover metal surfaces but will result in heat losses, as the CFA tries overcome the drag imposed on it by the oil. This excessive heat generated by the gearbox would cause premature oil degradation.

Mobil Jet Oil II is the recommended oil to be used in the CFA's gearbox [33].

Table 4.5: Mobil Jet Oil II characteristics.

Properties	Values
Viscosity at 100C	27.6 cST
Flash point	270C
Fire point	285C

4.6.2 Combustion of oil

Oil in a car's engine that makes its way past the piston rings would mix with the combustion mixture, resulting in oil burning and hence discolouration. The end result is black oil in the gearbox sump.

4.6.3 Incorrect oil level

The required volume of oil is 800ml and this can be checked when oil no longer flows passed the refill valve. Too much oil will result in the unit malfunctioning, whereas too little oil would cause metal to metal friction [34].

4.6.4 Findings

During the project the gearbox oil was replaced twice with an amount of 630 ml. A syringe was used to refill the gearbox with oil. The reason for using this amount and not 800 ml is because at this point no more oil could be forced passed the refill valve, which is when the manual suggests that the gearbox is filled. My assumption at the time was that during emptying, not all the oil could be removed. If my assumption was right, then the gearbox had a sufficient amount of oil covering the metal surfaces and that another factor resulted in the oil discolouring. If my assumption was wrong, then the gearbox was running low on oil and chances are that there was metal to metal friction inside the gearbox which more than likely resulted in the premature degradation of the oil.

4.6.5 Conclusions

Table 4.5 shows that the oil grade used is within the suggested viscosity range, which can rule out viscosity as the cause of the discolouration of oil. Combustion, too, can be ruled out due to the fact that it is gearbox oil that is being discoloured and not oil in the engine. I suspect that my original assumption might have been wrong, which resulted in the operation of the CFA with a low amount of gearbox oil to protect the metal parts inside the CFA. This could have been caused by the fact that I did not apply enough force onto the syringe to force oil passed the refill valve.

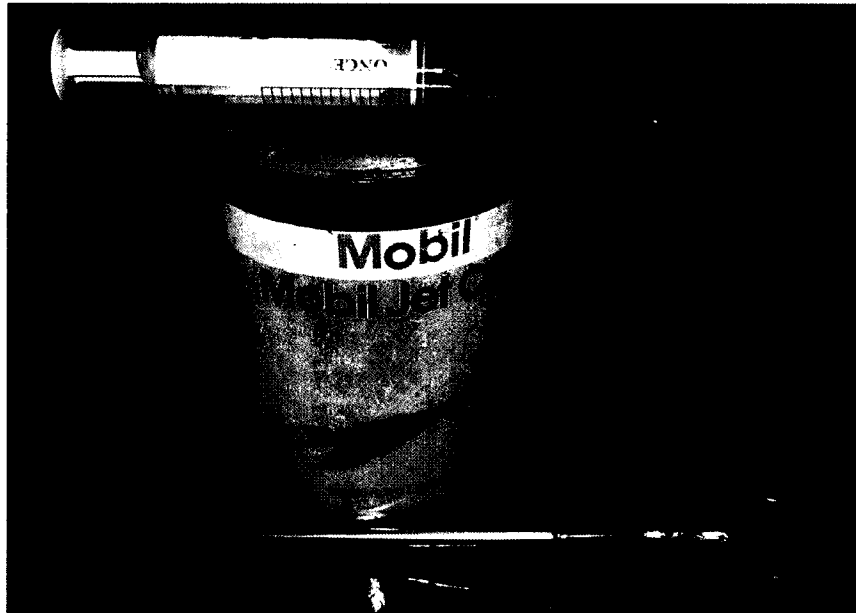

Figure 4.6: Tools used to re-fill the gearbox sump

4.6.6 Recommendation

The syringe and nozzle used were not the proper tools for the job of re-filling a pressurised sump. This requires tools that exert a big enough force to pass oil through a valve and into a sump. I recommend that a pressurised oil feeder be used for the re-filling of oil in future.

4.7 Transients

The effects of transients on the 400 Hz rotary inverter could not be investigated, owing to the frequency hunting problem.

4.8 Summary

In conclusion, the chapter provided the following useful information, viz:

- The GCUSC was designed, built and tested.
- Pre-commissioning work concludes that the CFA, GCU and new wiring harness is functional.
- It is propable that discoloration of the gearbox oil was caused by running the CFA with too little oil in the sump.
- The 400 Hz Generator is not in a state to be commissioned until the frequency hunting problem is solved.

Chapter 5

Blower Fan Design

Onboard the aircraft the CFA is supplied with forced air bled from the compressor of the jet engine turbine for it to operate properly. The operating temperature of the constant frequency generator shall not fall below -50 C and rise above 80 C while the generator control unit shall not exceed -50 C and rise above 85 C [35]. Operating the constant frequency generator continuously requires forced ventilation. Generating at 10 kVA or less the constant frequency generator is allowed to self-ventilate for a period not exceeding 20 minutes [35]. The recommended forced ventilation flow rate should be $130 \frac{\text{g}}{\text{s}} / 11 \frac{\text{m}^3}{\text{s}}$ over the eddy current brake and $100 \frac{\text{g}}{\text{s}}$ over the alternator at a pressure of 3 kPa. These are recommended conditions for the constant frequency generator to operate properly ¹. The rest of the chapter covers the selection and testing of the blower fan unit.

5.1 Actual CFA Heating

Four tests were conducted in the Goodlet laboratory in order to establish the actual heating of the CFA, without forced air cooling. A no load, 2.5 kW, 5 kW and a 7.5 kW test was carried out under the same temperature conditions and using the same thermocouple temperature sensor. Temperature readings were recorded at the same intervals for 4 minutes. The no load test clearly shows that the CFA generates heat by the friction of its rotating parts. The remaining tests shows that forced cooling is necessary as each trend line approaches the maximum temperature at different rates in Figure 5.1.

5.2 Blower Fan Selection Process

Alstom Manufacturer's use the selection chart for choosing a blower fan for a specific application (see Figure 5.2). There are four factors that are used in the selection process.

¹The generator control unit is built on an aluminium heatsink.

Temperature vs Load Response

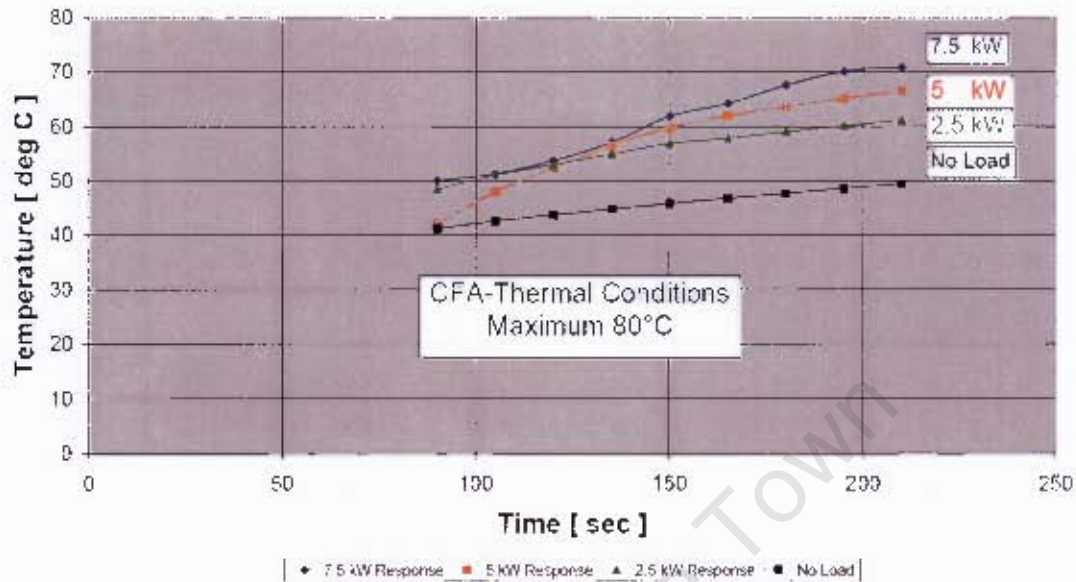

Figure 5.1: Actual heating of the constant frequency alternator.

These four factors are required flowrate, the required pressure, the altitude and the temperature of the environment. The required flowrate and pressure are read off the chart in Figure 5.2, which is made for standard temperature and atmospheric conditions. This implies that derating pressure and flowrate according to the correction factors found in the Alstom centrifugal fan selection guide (see Reference [21]). These correction factors can be neglected due to the fact that the blower fan is situated in Cape Town² and the temperature deviation is small. The blower is selected by matching the flowrate ($11 \frac{m^3}{s}$) at the pressure required (3 kPa) by using the chart. The chart selects the 4P-1 blower fan with the following characteristics (see Table 5.2). The table compares Alstom's model to that of Veritech's. Veritech was the manufacturer selected to design the blower fan.

Table 5.1: Comparison between an Alstom and a Veritech blower fan.

Characteristic	Alstom	Veritech
Blade Type	Radial	Radial
Blade Diameter	1,05m	1,05
Speed	1500 rpm	3000
Motor	4 kW	2.2 kW
Poles	4	2

²Cape Town is at sea level thus derating can be neglected.

Radial bladed Fans

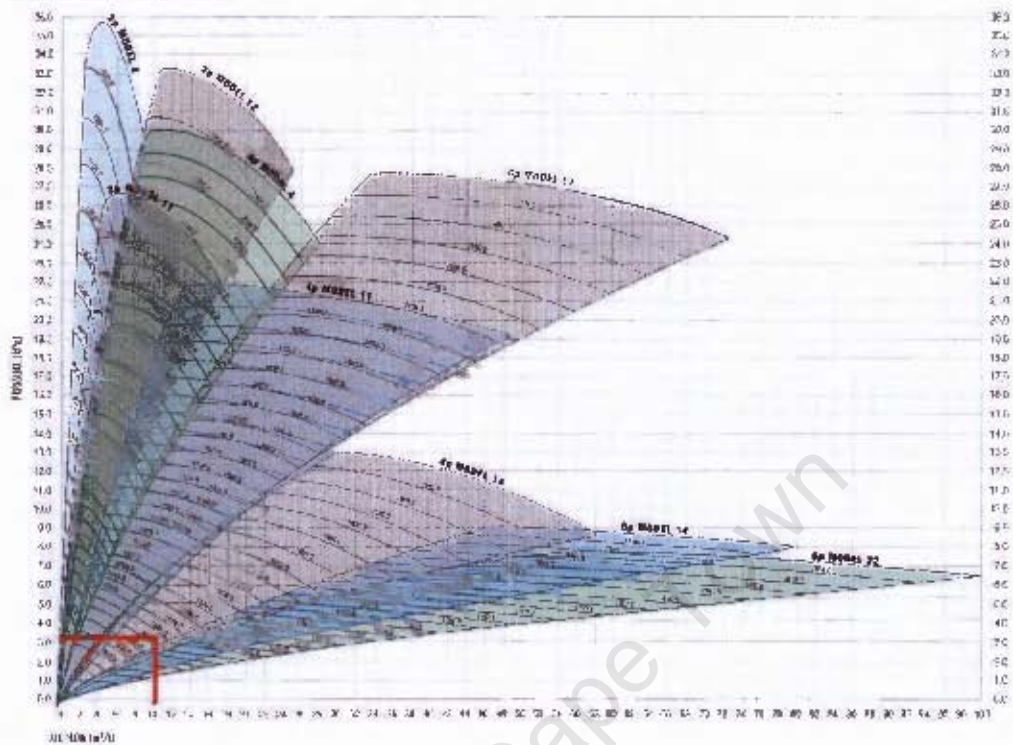

Figure 5.2: The blower fan selection chart by Alstom.

5.3 Cooling Ducts and Shroud

Provision is made for air to pass over the electrical windings of the CFA via two inlet vents and exit via two exhaust vents. Cooling is needed so that the winding insulation does not perish, which would result in a short circuit between windings.

Previous work done by a student incorrectly documented the position of the two inlet and two exhaust vents. Based on the student's work dimensions for inlet ducts were designed and built for the exhaust vents which could not be interchanged. These ducts were then installed over the CFA exhaust vents instead of the inlet vents. Operating the blower fan with air passing into the exhaust vents had a negligible cooling effect on the generator [2]. This is why a shroud was designed and built, which provided sufficient cooling. The rates of cooling and the shroud dimensions are summarised in Sections 5.6.3 and C.2 respectively.

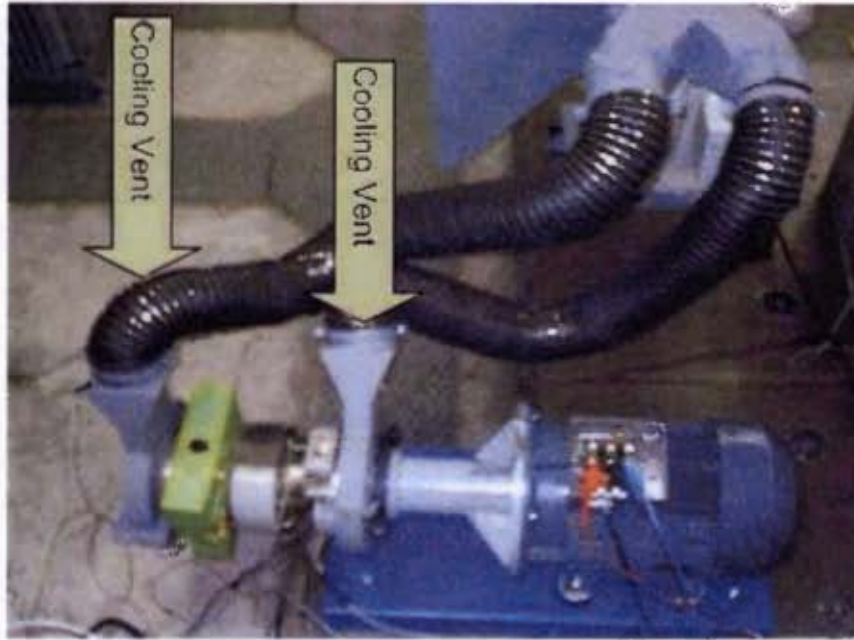

Figure 5.3: Cooling ducts also showing the apparatus used to measure flowrate.

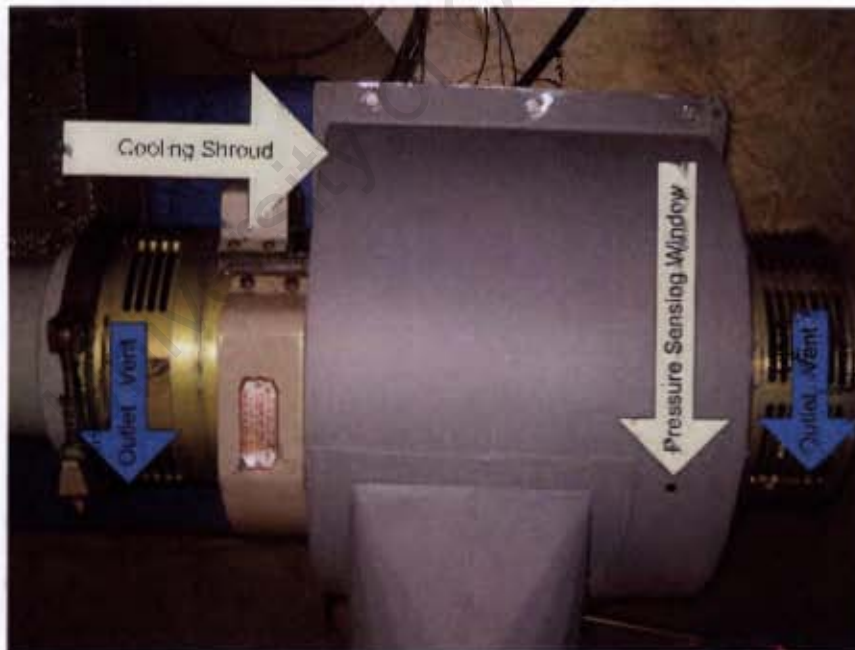

Figure 5.4: The cooling shroud.

5.4 Blower Fan Starter

The blower's motor uses a push button operated contactor for starting, which uses 220 VAC to make and break electrical contact. However, this does not meet the user require-

ment of having a single start button. The same auxiliary contact method for starting the GCU can be used to start the blower fan. This solution requires re-wiring the push button operated contactor and reconnecting it via an auxiliary contact attached to the delta contactor of the soft starter (see Figure 5.5).



Figure 5.5: Re-wiring the blower fan starter via an auxiliary contact on the soft starter.

5.5 Temperature Sensor Placement

Overheating deteriorates the electrical insulation of the CFA windings. The suggested operating temperature for the CFA is below 80 C [1]. Table 5.2 below was obtained by running the generator for short intervals and taking temperature readings off different surfaces with a handheld temperature gauge. It was found the metal surfaces heat up quicker when compared with the alternator's windings except on the brake inductor. From these results³ one can infer that the brake inductor windings have a higher insulation grading than the alternator windings, as a result of the heat to which the former are constantly exposed.

5.6 Testing the Blower on the CFA

Three tests were carried out to verify whether Veritech's blower fan can supply what was asked for.

³During these tests the CFA was operating normally, however a spurious result was recorded during reading 3 over the Brake-cup winding

Table 5.2: CFA hotspot readings on load.

Test Position	Placement Region	Reading 1	Reading 2	Reading 3
1	Heatsink Top	47.0	59.4	69.0
2	Heatsink Oil Plug	44.6	58.0	71.6
3	Heatsink J1a Connector	40.0	49.0	60.2
4	Brake-cup winding	41.0	49.0	54.2
5	Brake inductor windings	55.0	64	*
6	Alternator windings	37.0	43.0	51.0

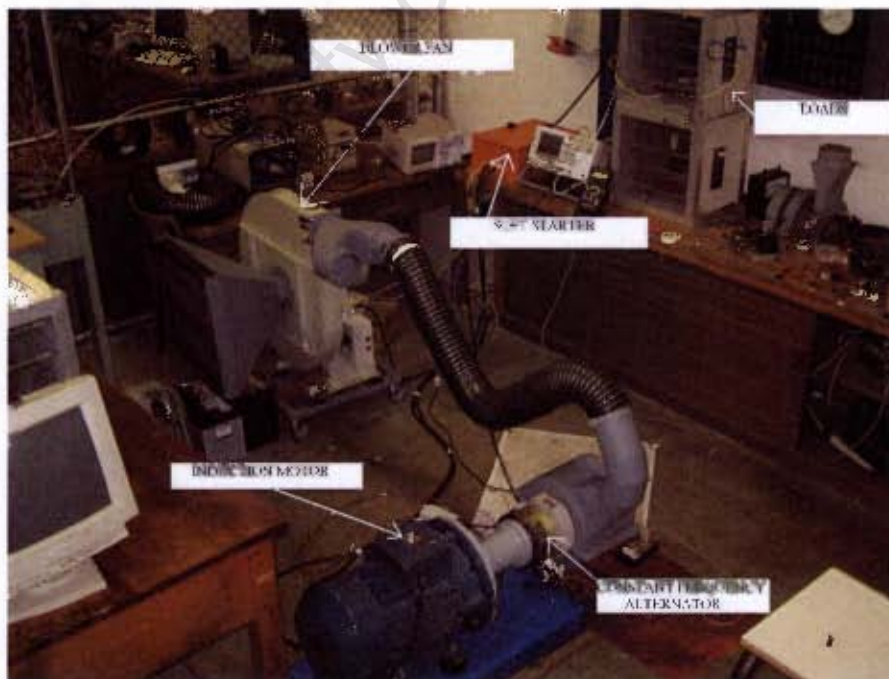

Figure 5.6: The 400 Hz rotary inverter.

5.6.1 Flowrate test

At the time this test was carried out the old cooling ducts were used and were incorrectly placed due to the reason given in Section 5.3. A cardboard cube was made to fit around the “exhaust vent” while the cooling ducts were positioned over inlet vents and forced air was allowed to pass through (see Figure 5.3). The exiting flowrate was measured through a window of 40 mm x 30 mm in size at a distance of 750 mm (see Figure C.1). An anemometer was borrowed from the department of mechanical engineering and used to measure the airspeed. Flowrate is calculated using the Equation $Q = A.v$. The flowrate measured is shown to be $94 \frac{m^3}{s}$ which is 8 times the flowrate required.

Table 5.3: Blower fan flowrate measurement.

Result	Airspeed [v]	Area [A]	Flowrate [Q]
1	$40ms^{-1}$	$2.35m^2$	$94 \frac{m^3}{s}$

5.6.2 Pressure test

A pressure transducer placed inside the cooling shroud perpendicularly to the airflow produces a static reading as opposed to placing it inline to the airflow [36]. The fullscale reading on the pressure transducer is 17 mV at 7 kPa, however, a noisy signal was measured. Due to the fact that the noise on the signal was greater than the fullscale transducer reading, this test proved to be inconclusive. Amplifying the transducer reading solved this problem (see Section 6.2).

5.6.3 Temperature test

The figures below shows the temperature response of the generator to a 2.2 and a 4.8 kW load.

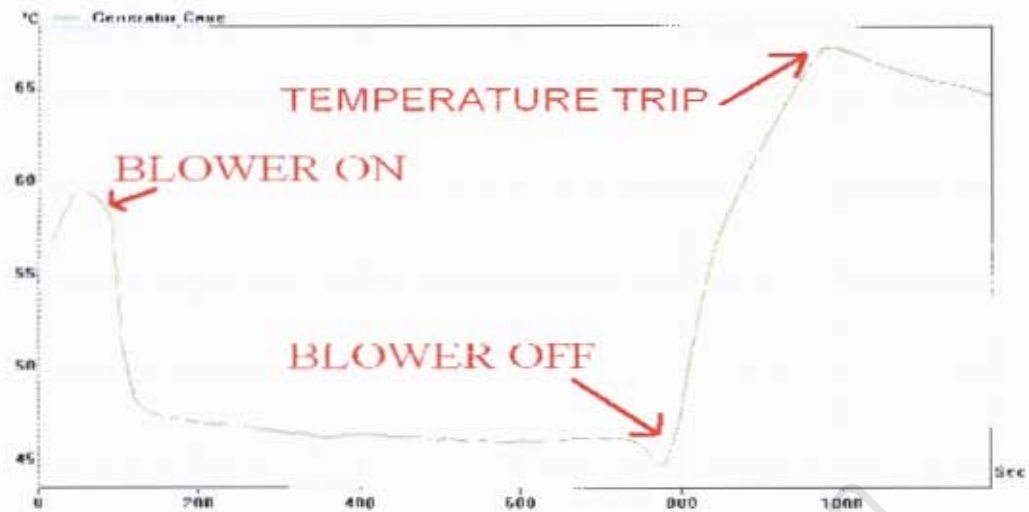

Figure 5.7: CFA's temperature response to a 2.2 kW load with forced cooling.

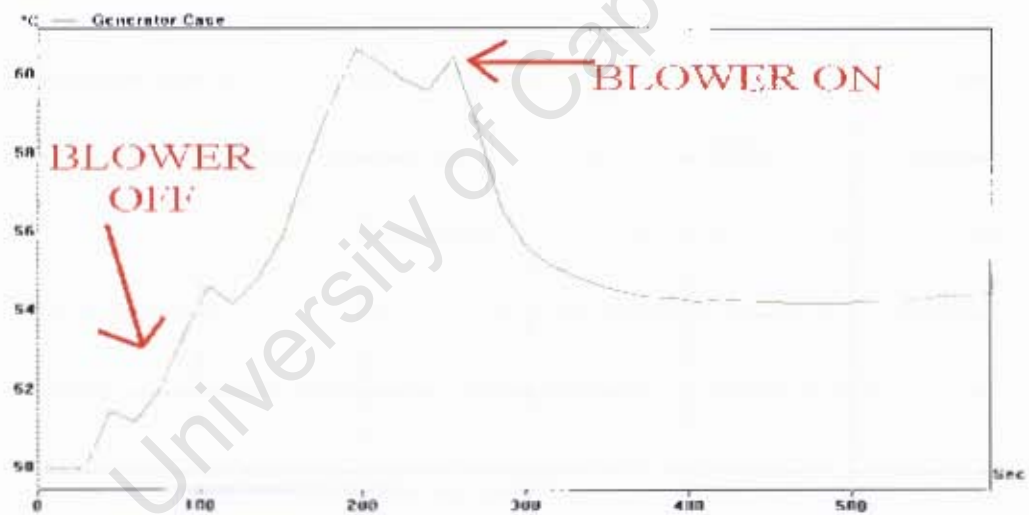

Figure 5.8: CFA's temperature response to a 4.8 kW load with forced cooling..

Testing the blower fan at the required 2.2 kW load

A 2.2 kW load was coupled to the CFA, the power required by the Blue Parrot radar's distribution board, which yielded the following useful results (see Figure 5.7) :

1. The stabilising temperature lies between 45.5 C and 46.5 C when supplying its rated load under forced cooling.
2. Thermal protection operates between 65 C and 68 C.
3. The time it takes to stabilise the CFA's temperature is 11 minutes.

Testing the CFA at 4.8 kW

The test provided the following results (see Figure 5.8) :

1. The stabilising temperature lies between 54 C and 54.5 C.
2. The time it took to stabilise the CFA's temperature is 6.5 minutes.

5.7 Summary

In summary this chapter provided the following information:

- The blower fan delivers more than the required flowrate.
- The previous student recorded the incorrect airflow direction resulting in the design of the wrong ducts, which caused the CFA to overheat. The overheating problem was corrected by the design of the cooling shroud, which not only directs airflow over the electrical windings but over the heatsink as well.
- The stabilising temperature is between 45.5 C and 46.5 C when supplying its rated load under forced cooling.
- The time it takes to stabilise the CFA's temperature is 11 minutes for it's rated load.
- Thermal protection operates between 65 C and 68 C.

Chapter 6

Telemetry System Design

The Oxford dictionary defines a telemetry system as an apparatus for recording the readings of an instrument and transmitting them by radio. For the purposes of this project the 400 Hz rotary inverter is the instrument, the apparatus for recording are two microcontrollers and radio frequency transmission is achieved through a transmitter and receiver.

The parameters measured from the 400 Hz rotary inverter are: (1) single phase line-to-line voltage across red-and-blue phase, (2) current in the red phase, (3) ventilation pressure inside the cooling shroud, and (4) rotary inverter's case temperature.

The two microcontrollers used are based on the HC908Jk1 development board designed by Sam Ginsberg. Each development board uses a 14.7456 MHz clock, 12 ADC channels with 8 bit resolution, 1.5 Mb of flash memory, 4 push buttons and an LCD. Four ADC channels [1:3, 9] would digitise the four parameters mentioned in the above paragraph and send the signal over the serial pin PTB0. The receiver would actively wait for the serial data on PTB0 before displaying it over the LCD. The radio frequency (RF) transmitter connects to PTB0 on the transmitter and sensor board where the RF receiver connects to PTB0 on the receiver and display boards. Both RF modules operate on the amateur band 433 MHz and uses 17 cm whip antennae. Unfortunately the telemetry system communicates by a fixed link, shown in the picture by a red wire, instead of the RF transmitter and receiver.

Now each reading will be explained.

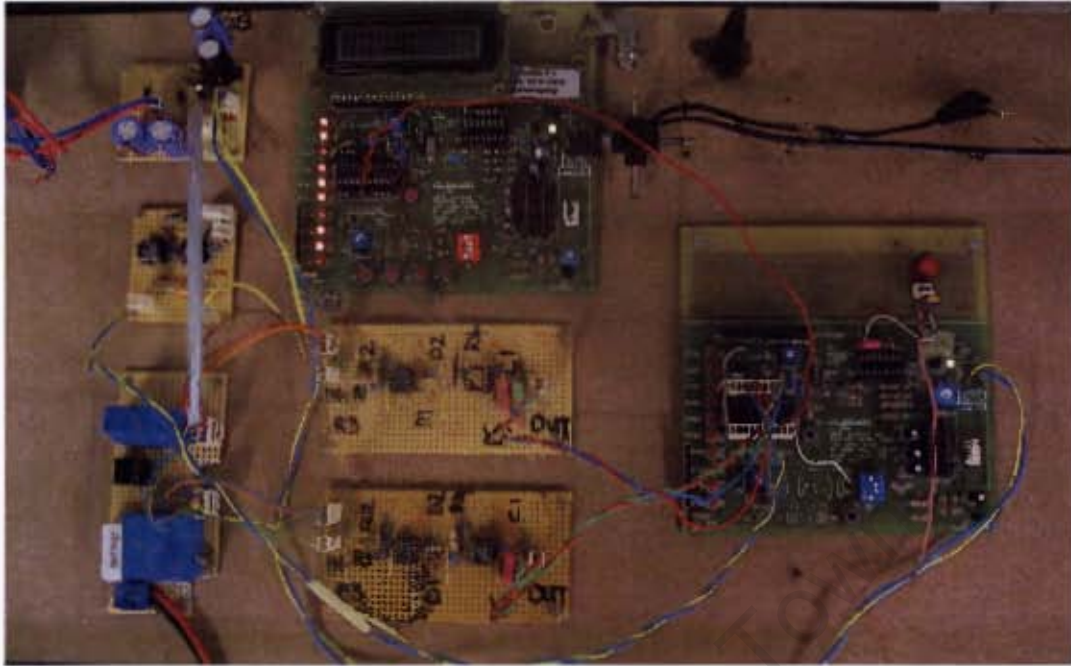

Figure 6.1: The telemetering system designed for the rotary inverter.

University of Cape

6.1 Temperature Measured from the Rotary Inverters Case

The LM35DZ measures the rotary inverters case temperature which should not exceed 80 C. The temperature sensor outputs 10 mV for every degree rise in temperature over a 0 - 150 C range. The LM35DZ temperature sensor is used for measuring the case temperature only.

Thermal protection comes in the form of a bi-metal switch glued with Pratley adhesive to the case. The bi-metal switch is closed under normal operating temperatures and open circuits between 65 - 70 C. The bi-metal sensor is placed in series with the main switchgear panels stop switch (see Figure A.3).

6.1.1 LM35DZ and bi-metal sensor placement

Table 5.2 shows hot spot readings taken from the surface of the rotary inverter, alternator and brake windings. The LM35DZ was placed on the warmest flat surface for measuring. The bi-metal is placed on the same surface as the LM35DZ temperature sensor.



Figure 6.2: LM35DZ and Bi-metal temperature sensor and switch placement.

6.2 Pressure Measured from Inside the Cooling Shroud [14]

The 24PCAFA6G pressure sensor measures the cooling air pressure of the ventilation system from the inside of the shroud. The cooling shroud is designed to accommodate the pressure sensor. The sensor is firmly mounted onto the inside wall of the shroud and safe from possible vibration or leakage damages. The fundamental criteria required of the pressure sensor are:

- Range: 0.5 - 3.7 kPa gauge pressure
- Minimum ± 10 Pa tolerance

The pressure sensor has a silicon diaphragm with a range of 0 - 1 psi (0 - 6.9 kPa). The sensor has an output voltage of 0 - 16.7 mV over its full range, thus 3 kPa will yield 8 mV. This is very small and was corrupted by noise during testing (see Section 5.6.2). This is why the pressure signal is amplified 488 times by the differential summer in Figure 6.3 below. The inverting pin on the first opamp is a virtual earth thus the input current is $\frac{V_1}{R_7} + \frac{V_2}{R_8}$, where R7 and R8 are equal. This will result in the output pin of the first opamp to be $V_{out} = -(V_1 + V_2)$ thus the output of the second opamp will be $V_{out} = V_1 + V_2$.

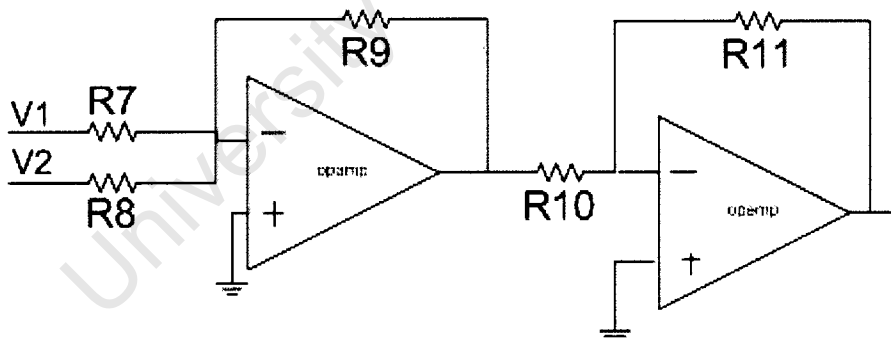

Figure 6.3: Differential summer circuit.

6.2.1 Pressure transducer placement

Placing the 24PCAFA6G pressure sensor perpendicular to the airflow gives rise to better results as opposed to placing it in line to the airflow [36].

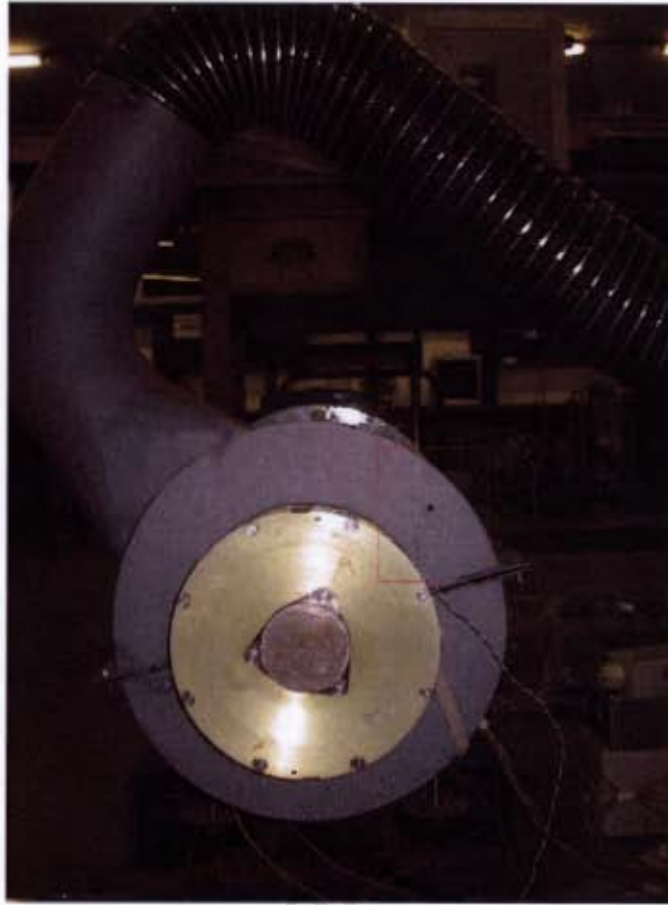

Figure 6.4: 24PCAFA6G pressure sensor placement.

6.3 Current Measured in the Red Phase

The current LEM is located on the same board as the voltage sensor. To measure a typical current reading the assumption is that a 2kW resistive load will draw 10 A. The LAH50P sensor reduces this value to 5 mA reading on the secondary. Passing the output current into a 2.2 k Ω resistor gives rise to 10.62 V rms or 15 V peak-to-peak. The sensor's output voltage is fed into a precision rectifier circuit (see Figure 6.7).

$$P = VI\cos\theta$$

$$\text{power factor of a resistive load} = 1$$

$$I = \frac{2 \text{ kW}}{200 \text{ V}}$$

$$\text{typical load current} = 10 \text{ A}$$

$$\text{scaling used} = 2000 : 1$$

$$I_s = \frac{10 \text{ A}}{2000}$$

$$I_s = 5 \text{ mA}$$

$$V_{\text{rms}} = \frac{15 V_{\text{peak}}}{\sqrt{2}}$$

$$V_{\text{rms}} = 10.62 \text{ V}$$

$$\text{resistor size} = \frac{10.62 \text{ V}}{5 \text{ mA}}$$

$$\text{resistor size R6} = 2.2 \text{ k}\Omega \quad (6.1)$$

6.3.1 Precision rectifier

This precision rectifier circuit is used in digital voltmeters to turn AC into DC for measurements. The rectifier circuit has to consider two paths viz the positive and negative half cycles. The positive half cycle uses two inverting opamps whereas the negative half cycle uses one. The RC averaging circuit dictates what the resistor values should be. The time constant of this circuit should be such that it takes 10 cycles (period = 10ms) before it reaches 63% of the peak rectified voltage. The longer the time constant, the less the ripple voltage will be. With that in mind the time constant is set 100 ms where the input period being 10ms. Amplification is not necessary, owing to correct transducer scaling. The gain for the negative half cycle is set by R5 and R3, and this should be 1. Therefore the remaining resistor values are calculated using Equation 6.2. The resistor values for the precision rectifiers are; R1=2.2 M Ω , R2=2.2 M Ω , R3=2.2 M Ω , R4=1 M Ω , R5=2.2 M Ω . Capacitor C1 has a value of 1 uF (see Figure 6.10).

$$V_{\text{outDC}} = V_{\text{inAC}} \left(\frac{R5}{R4} - \frac{R5}{R3} \right) \quad (6.2)$$

6.4 Voltage Measured Across the Red and Blue Phases

Medium voltage measurements at power stations, for example, are typically measured using a voltage transformer and transducer combination before sending a 4-20 mA reading to the control desk, where the signal is converted into a voltage reading.

A LEM voltage sensor and a precision rectifier circuit are used to measure, scale and rectify the generators line voltage, between red and blue phases, into a 0-5 V signal. This is done so that it can be digitised by the ADC. Once the signal is digitised it can be manipulated for transmitting.

Applying the red-and-blue phases across a 27 k Ω resistor gives rise to an input current to the sensor of 7.5 mA. A fixed scale of 1:2.5 is applied which gives rise to an rms output current of 18.8 mA. Passing the output current into a 566 Ω resistor gives rise to 10.62 V rms or 15 V peak-to-peak. The sensor's output voltage is fed into a precision rectifier circuit.

$$I_p = \frac{200 V_{\text{rms}}}{27 \text{ k}\Omega}$$

$$I_{p_{\text{rms}}} = 7.5 \text{ mA}$$

$$\text{scaling} = 2.5 : 1$$

$$I_s = 2.5 \times 7.5 \text{ mA}$$

$$\text{secondary rms voltage} = \frac{15 V_{\text{rms}}}{\sqrt{2}}$$

$$\text{secondary rms voltage} = 10.62 \text{ V}$$

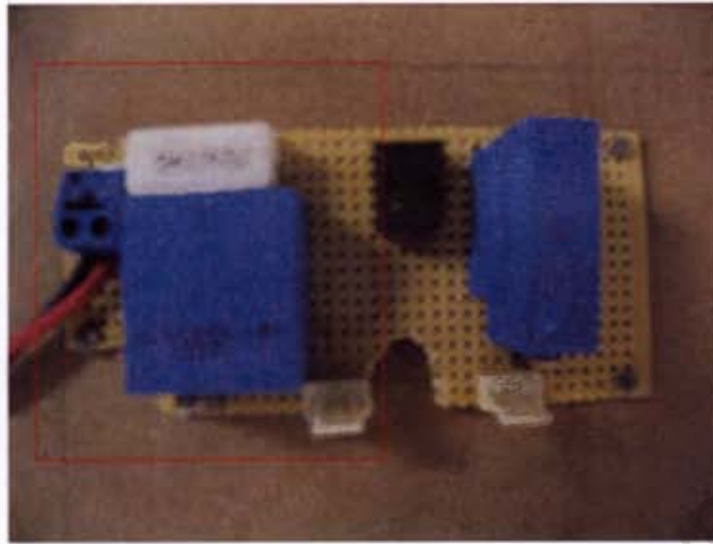

Figure 6.5: LV25P voltage circuit.

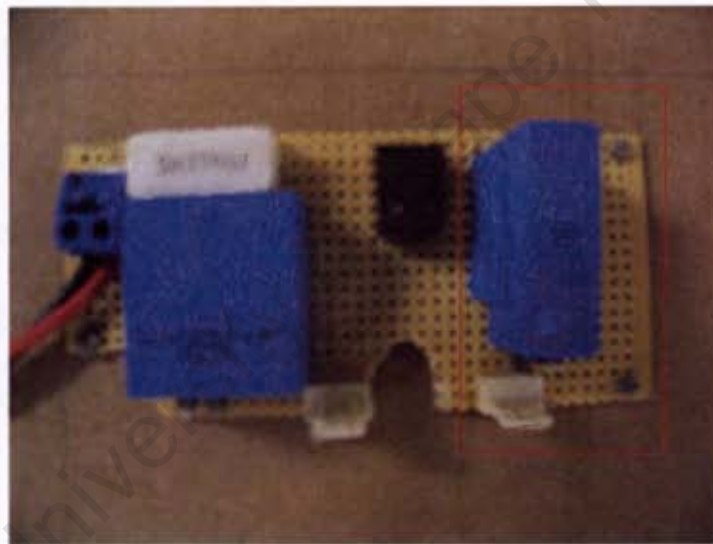

Figure 6.6: LA1150P current circuit.

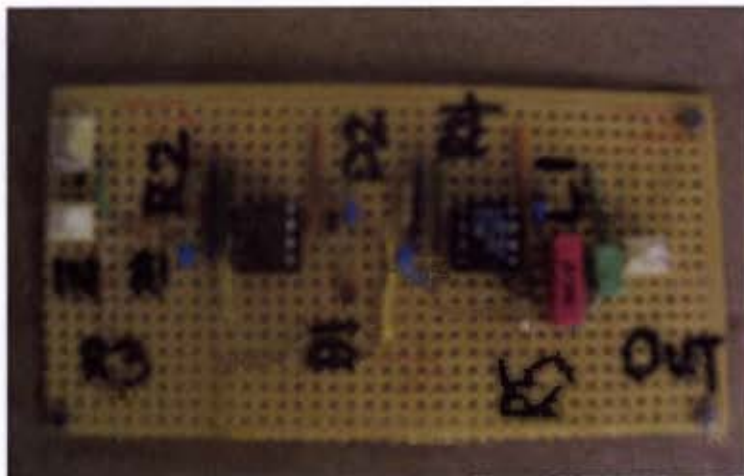

Figure 6.7: Precision rectifier circuit.

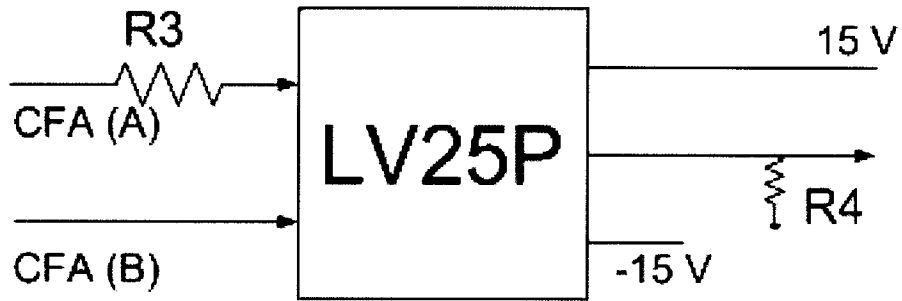

Figure 6.8: LV25P voltage sensor schematic.

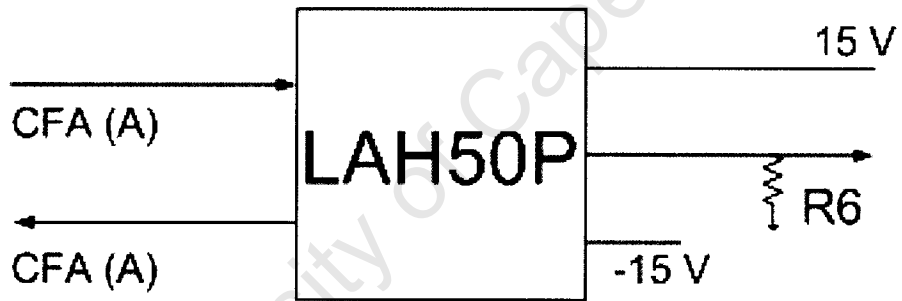

Figure 6.9: LAH50P current sensor schematic.

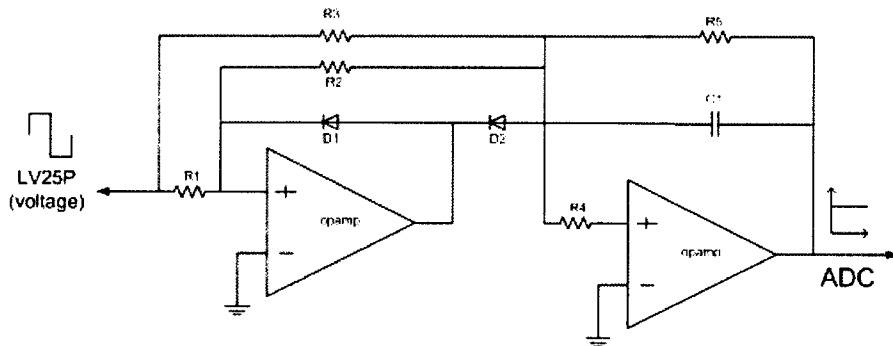

Figure 6.10: Precision rectifier schematic .

$$\text{resistor size} = \frac{V_{\text{rms}}}{I_{\text{rms}}}$$

$$\text{resistor R4} = 566 \Omega \quad (6.3)$$

6.4.1 Precision rectifier

Both current and voltage sensors output a 15 V peak-to-peak swing which makes the selection of the gain setting resistors and the averaging capacitor the same (see Section 6.3.1).

6.5 Results

Figure 6.12 and 6.11 shows the forced air pressure and the case temperature are linear between 0 - 4000 Pa and 0 - 80 C respectively. The x-axis represents the input fed to the ADC on the sensor and transmitter board. Figures 6.14 and 6.13 shows the voltage and current transducer measurements are linear between 0 - 250 V and 0 - 7 A respectively. The y-axis represents the input fed to the ADC on the sensor and transmitter board. Calibration setup and results can be found in Section D.

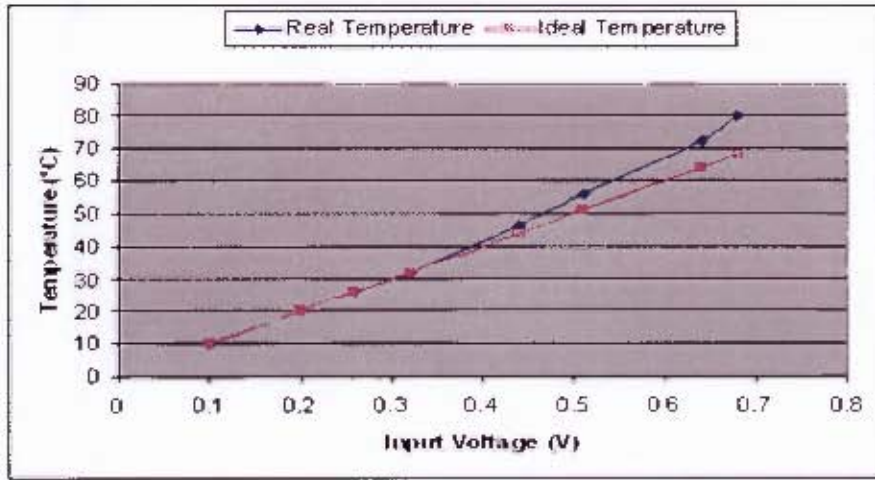

Figure 6.11: Generator case temperature vs ADC input.

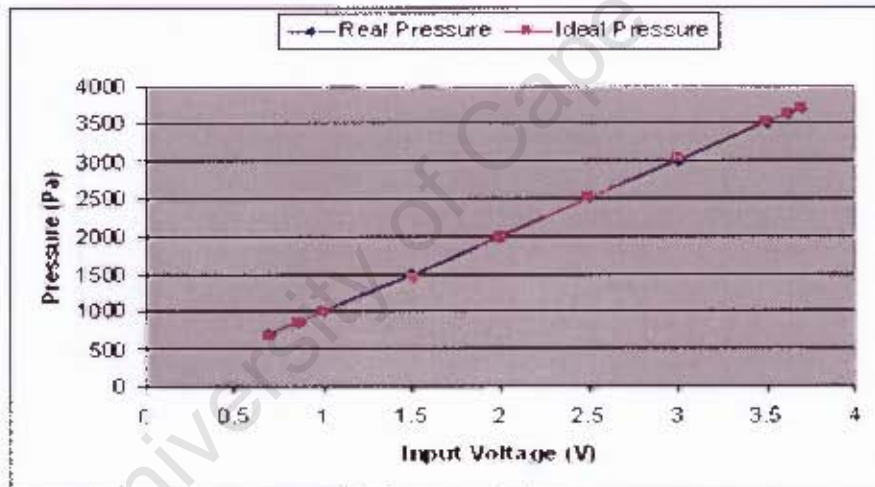

Figure 6.12: Blower fan pressure vs ADC input.

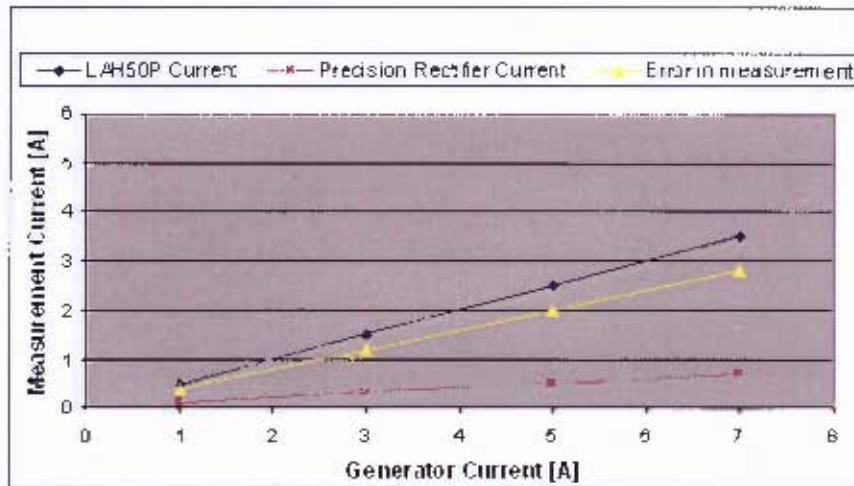

Figure 6.13: ADC input vs generator current.

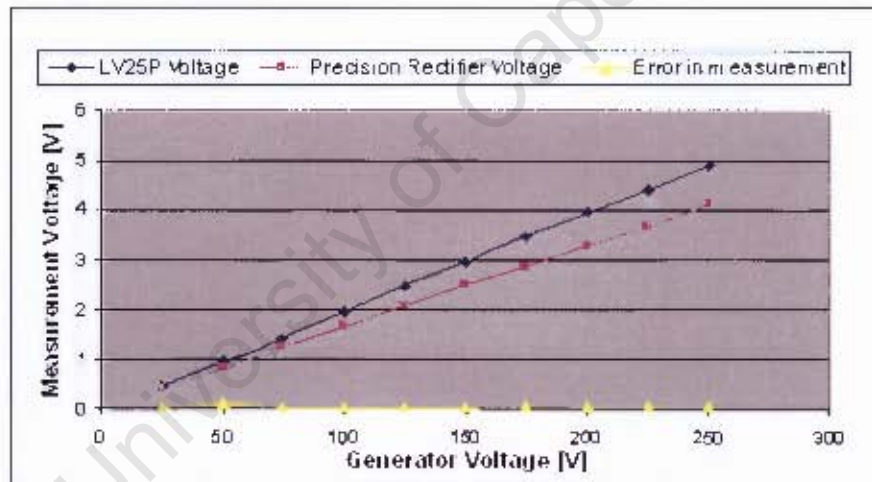

Figure 6.14: ADC input vs generator voltage.

6.6 Summary

The telemetering system successfully measures voltage, current, pressure and temperature via the interfacing electronic circuits designed. The next chapter covers the analogue to digital converter, UART emulator and decoding routines.

Chapter 7

Telemetry Software

The microcontroller software serves an early warning indication for the telemetry system. Data is analysed from four sensors and warns the user when the system is operating out of specification. The monitored parameters are listed in Section 1.4 point 7. Both microcontrollers are programmed in Assembler. This chapter explains the analogue to digital converter, UART emulator and decoding routines.

7.1 Software Design

The sensing and transmitter microcontroller (micro 1) is in the wendy house with the motor, generator and blower fan, whereas the receiver and display microcontroller (micro 2) are located in the Microwave Lab on the 6th floor of the Menzies Building. The flow diagram illustrates the process of sending four parameters remotely (see Figure 7.1).

Headers 01, 02, 03 and 04 are used to separate readings in the sensor and transmitter board's software (see Table 7.1). A header 01 is loaded into the accumulator where it's placed on a stack. The stack is called up by the `put_serial` routine where each bit is pushed out over PTB0. At this point the temperature sub routine is called, which selects the ADC channel and after the conversion stores the result in the ADR register before sending it to the accumulator. Once the temperature reading is in the accumulator the `put_serial` routine sends the byte over PTB0.

The `put_serial` routine is what the micro 1 uses to send a byte over the microcontroller's serial communication pin 15. A transmission sentence consists of 1 start bit followed by 8 data bits and a stop bit. The baud rate is set by the variable "bit delay" which stores the period of a bit. A one second delay between calling the `put_serial` routine is necessary to ensure that the receiver is waiting in the `get_serial` routine.

On the receiver and display board the `get_serial` routine waits until a header is sent from the sensor and transmitter board. Once the header has been received the code compares

Table 7.1: I/O functions and allocations.

Sensor and transmitter micro 1			Receiver and display micro 2		
Function	Port	Pin	Function	Port	Pin
Temperature	B3	12	Serial comm	B0	15
Pressure	D2	17	LCD	D6	10
Current	B1	14	LCD	D7	9
Voltage	B2	13	LCD	B4	11
Serial comm	B0	15	LCD	B5	8
Headers			LCD	B6	7
Temperature		01	LCD	B7	6
Pressure		02			
Current		03			
Voltage		04			

it to the four possible headers viz, 01-04. If none of the four headers are received, the code will interpret this as an error and will go to the wait for data routine. The next byte will most probably be sensor data, which will give an error too. On receiving the correct header the code will exit the wait for data routine and will go to the appropriate decode routine. This will display the result until the next header is received. Both the transmitter and receiver loops continuously see Figure 7.1. See Section E for the source code.

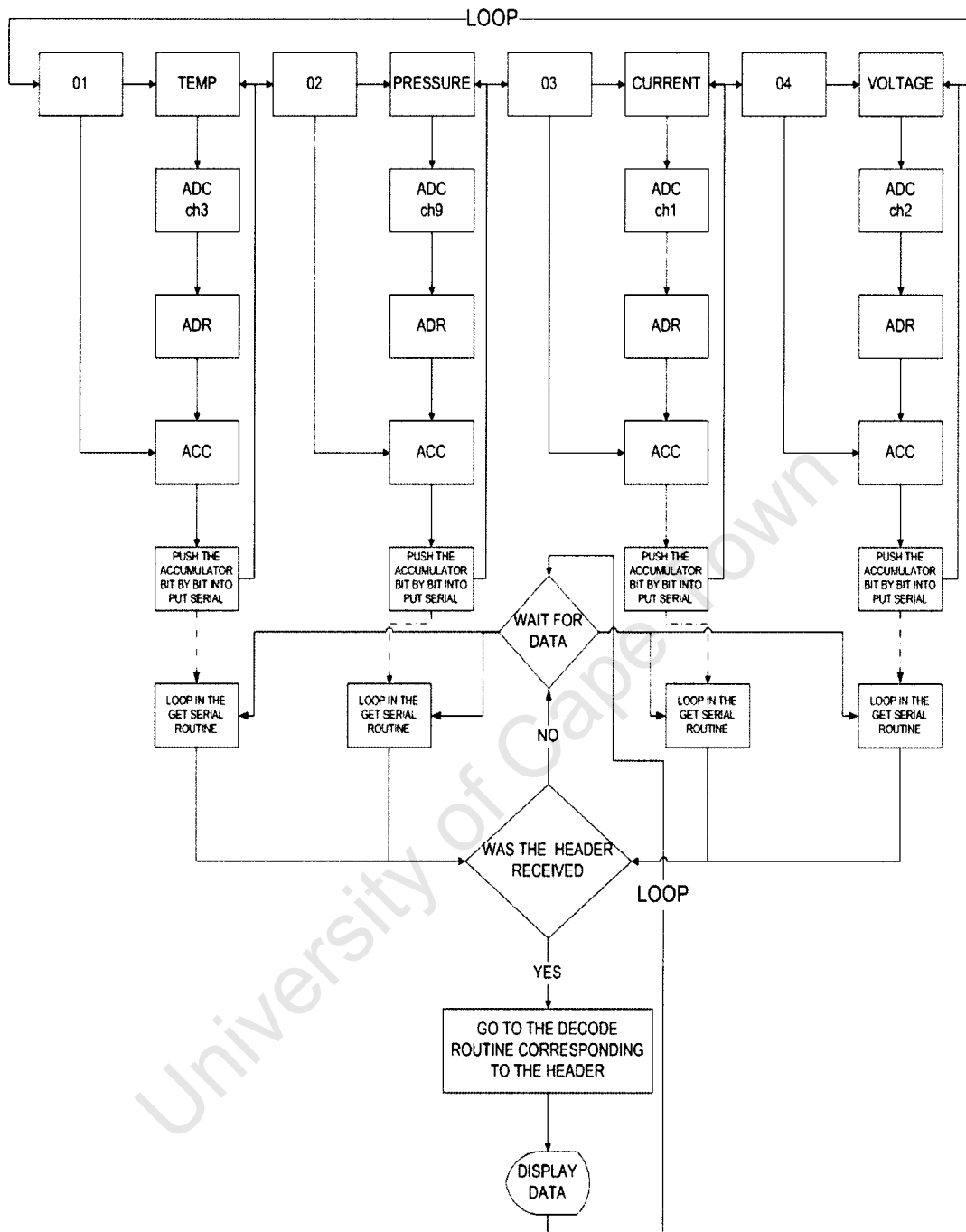

Figure 7.1: Software flow diagram.

7.2 Analog to Digital Converter Setup

The ADC has 12 channels with 8 bit resolution. The embedded ADC uses 3 registers to perform a successful conversion, viz the status and control, data and clock registers.

7.2.1 Status and control register

This register chooses between continuous or single ADC conversions and which input pins are used. After a successful conversion bit 7 is set, and cleared when conversion data is written to the data register.

7.2.2 Data register

Each time a conversion is complete this register is updated with the 8 bit result until the next conversion is complete and the register is overwritten.

The code `lda ADR` moves the result from the data register to the accumulator.

7.2.3 Clock register

Writing to the pre-scale bits in this register selects the clock frequency used to perform a conversion. It is recommended that ADC clock be set to 1 MHz.

7.3 Universal Asynchronous Receiver Transmitter Emulator

7.3.1 Put serial

The byte sent is pushed onto HX register by the PSHX instruction. Toggling PTB0 initialises the receiver telling it that 8 data bits and a stop bit is to follow. This why the value 9 is stored in the bit count variable "X". The carry bit is necessary as each bit is rotated to the right until the cycle is complete. Each bit is then toggled according to each state until the X register decrements to zero. This method of a UART routine is known as bit banging. See `put_serial` routine below.

```
pshx
bclr 0,PTB ;start bit
bset 0,DDRB
sec ;initialize carry flag
ldx #9
```

`send_loop:`

```
jsr bit_delay
rora
bcc bitlo
bset 0,PTB
```

```

    bra next_loop
    bitlo: bclr 0,PTB

next_loop:

    dbnzx send_loop
    bset 0,PTB ;stop bit
    jsr bit_delay ;stop bit and gaurd time
    jsr bit_delay
    bclr 0,DDRB ;pullup resistors hold stop state
    pulx
    rts

```

7.3.2 Get serial

The receiver stays in the wait_for_start routine until a start bit is received. The half_bit_delay samples the PTB0 for the start bit. On receiving the start bit the receive loop is called where bits are checked for their status. The instructions “clc” and “sec” clears and sets the status of the carry bit. The receive loop cycles 8 times until the variable “code” represents the transmitted byte.

```

    pshx
    bclr 0,DDRB ;serial line is input
    clra
    ldx #8

wait_for_start:

    brset 0,PTB,wait_for_start ;wait for the start bit
    jsr half_bit_delay ;sample each bit at half it's period

receive_loop:

    jsr bit_delay
    brset 0,PTB,bithi
    clc
    bra rotate

bithi: sec
rotate: rora

    dbnzx receive_loop
    jsr bit_delay ;wait for stop bit
    pulx
    bset 0,DDRB
    rts

```

7.3.3 Testing the UART on the sensor and transmitter board

To test the UART code was written whereby a pot on PTD2 was varied, the result interpreted by the ADC and sent to the put_serial routine. A scope probe was connected to PTB0 and the result was captured on the oscilloscope in Figure 7.2. The result shows the start bit, 8 data bits and the stop bit.

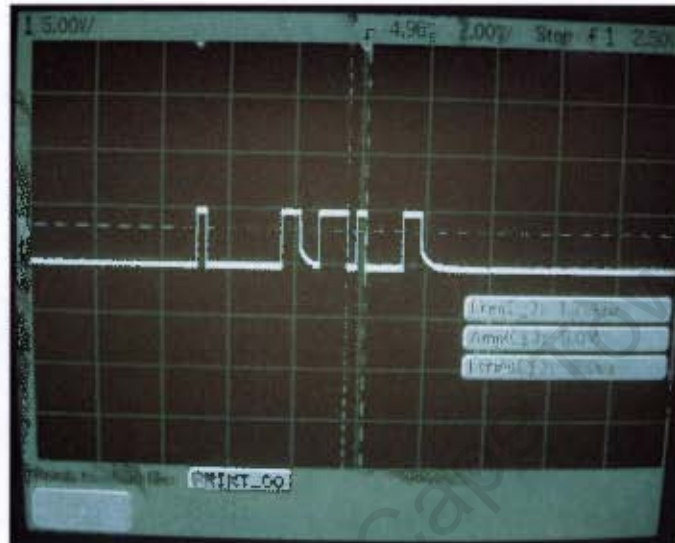

Figure 7.2: Bit sent over PTB0 with the sensor and transmitter board.

7.3.4 Testing the UART on the receiver and display boards

Time did not allow for testing the UART on the receiver and display board.

7.4 Transducer Scaling

The transducer resolutions were amplified as far as possible such that to match the ADC step sizes. This ensures that a small transducer increment translates to a small ADC change as opposed to a small increment translating into a big ADC change, see Table 7.2.

Table 7.2: Sensor scaling.

Sensor	Sensor range	ADC Channel	ADC step size	Scale	Results
Temperature	0-150 C	ADC3	20 mV	$\frac{10\text{ mV}}{1\text{ C}}$	Figure 6.11, 7.3
Pressure	0-4240 Pa	ADC9	20 mV	$\frac{20\text{ mV}}{16\text{ Pa}}$	Figure 6.12, 7.4
Current	0-50 A	ADC1	20 mV	$\frac{20\text{ mV}}{200\text{ mA}}$	Figure 6.13, 7.5
Voltage	0-250 V	ADC2	20 mV	$\frac{20\text{ mV}}{1\text{ V}}$	Figure 6.14, 7.6

7.5 Temperature Decoding

To obtain a decimal number reading from the temperature sensor input the bin method was used. This uses three storage variables for the unit, ten and hundred positions of the decimal number. Each time these separate bins are incremented depending if a “1” is found. See Figure 7.3 for a temperature reading.

```
brclr 0,disp_no,bit1  
inc units
```

bit1: brclr 1,disp_no,bit2

```
lda units  
add #2  
sta units
```

bit2: brclr 2,disp_no,bit3

```
lda units  
add #4  
sta units
```

bit3: brclr 3,disp_no,bit4

```
lda units  
add #8  
sta units
```

bit4: brclr 4,disp_no,bit5

```
inc tens  
lda units  
add #6  
sta units
```

bit5: brclr 5,disp_no,bit6

```
inc tens  
inc tens  
inc tens  
lda units  
add #2  
sta units
```

bit6: brclr 6,disp_no,bit7

```
lda tens
add #6
sta tens
lda units
add #4
sta units
```

bit7: brclr 7,disp_no,rollover

```
inc hundreds
lda tens
add #2
sta tens
lda units
add #8
sta units
```

7.6 Pressure Decoding [14]

The scaling has an amplification of 488. Each ADC increment is set to 16 Pa. The ADC digital number is multiplied by 16. This bin has 4 four bin variables viz. units, tens, hundreds and thousands. Each bit is checked see whether it is set or not. If bit 0 is set (the decimal number equals $20 = 1$) the pressure is 16 Pa. This is due to each digital increment being 16 Pa. Therefore 6 is added to the unit bin and 1 is added to the tens bin (see Figure 7.4).

mult:

```
mov    #$00,units
mov    #$00,tens
mov    #$00,hundreds
mov    #$00,thous
lda    #$1B          ; convert pressure
cmp    mult_no
beq    pressure
```

pressure:

```
lda    #$00
```

```
brclr 0,PTB,inc1
mov   #$06,units
mov   #$01,tens
jsr   overflow
```

inc1: brclr 1,PTB,inc2

```
lda   units
add   #$02
sta   units
lda   tens
add   #$03
sta   tens
jsr   overflow
```

inc2: brclr 2,PTB,inc3

```
lda   units
add   #$04
sta   units
lda   tens
add   #$06
sta   tens
jsr   overflow
```

inc3: brclr 3,PTB,inc4

```
lda   units
add   #$08
sta   units
lda   tens
add   #$02
sta   tens
lda   hundreds
add   #$01
sta   hundreds
jsr   overflow
```

inc4: brclr 4,PTB,inc5

```
lda   tens
add   #$06
```

```
    sta    tens
    lda    tens
    add    #$05
    sta    tens
    lda    hundreds
    add    #$02
    sta    hundreds
    jsr    overflow
```

inc5: brclr 5,PTB,inc6

```
    lda    units
    add    #$02
    sta    units
    lda    tens
    add    #$01
    sta    tens
    lda    hundreds
    add    #$05
    sta    hundreds
    jsr    overflow
```

inc6: brclr 6,PTB,inc7

```
    lda    units
    add    #$04
    sta    units
    lda    tens
    add    #$02
    sta    tens
    lda    thous
    add    #$01
    sta    thous
    jsr    overflow
```

inc7: brclr 7,PTB,out

```
    lda    units
    add    #$08
    sta    units
    lda    tens
    add    #$04
```

```

        sta     tens
        lda     thous
        add     #$02
        sta     thous
        jsr     overflow

```

out: rts

7.7 Current Decoding

After a successful current conversion the ADR register stores the result in the variable `disp_no`. This number is broken down into its hundreds, tens and units quantities. This number in `disp_no` is divided by 100 where the quotient is placed in the accumulator and the remainder is placed in H. The variable stores the quotient by the “sta hundred” instruction. To obtain the tens the quotient of the first division is multiplied by a hundred which is subtracted from the original number in `disp_no`. The answer is divided by 10 and the quotient is placed in the variable `tens`. Lastly the variable `units` are multiplied by 10 and subtracted from the original number in `disp_no` to obtain the units. The number is broken into hundreds, tens and units. See Figure 7.5 for a typical current reading.

```

        clrh ;hundreds=int(disp_no/100)
        lda  disp_no
        ldx  #$64
        div
        sta  hundreds
        mul ;disp_no=disp_no-100*hundreds
        sta  tens
        lda  disp_no
        sub  tens
        sta  disp_no
        ldx  #$0A ;tens=int(disp_no/10)
        clrh
        div
        sta  tens
        mul ;units=disp_no-10*tens
        sta  units
        lda  disp_no
        sub  units
        sta  units
        rts

```

7.8 Voltage Decoding

After a successful voltage conversion the ADR register stores the result in the variable `disp_no`. This number is broken down into its hundreds, tens and units quantities. This number in `disp_no` is divided by 100 where the quotient is placed in the accumulator and the remainder is placed in H. The variable stores the quotient by the “sta hundred” instruction. To obtain the tens the quotient of the first division is multiplied by a hundred which is subtracted from the original number in `disp_no`. The answer is divided by 10 and the quotient is placed in the variable `tens`. Lastly the variable `units` are multiplied by 10 and subtracted from the original number in `disp_no` to obtain the units. The code jumps to the `bcd` routine. See Figure 7.6 for a typical voltage reading.

```
clrh ;hundreds=int(disp_no/100)
lda disp_no
ldx #$64
div
sta hundreds
mul ;disp_no=disp_no-100*hundreds
sta tens
lda disp_no
sub tens
sta disp_no
ldx #$0A ;tens=int(disp_no/10)
clrh
div
sta tens
mul ;units=disp_no-10*tens
sta units
lda disp_no
sub units
sta units
rts
```

The typical displays can be seen in Figures 7.3, 7.4, 7.5 and 7.6.



Figure 7.3: Temperature display.



Figure 7.4: Pressure display.



Figure 7.5: Current display.



Figure 7.6: Voltage display.

7.9 Summary

The objective of this chapter was to re-use code already written by a student who programmed a monitoring unit to measure the same four parameters, however, what was supposed to be a straight forward exercise turned out to be a time consuming debugging exercise which could not be solved in the required time, for this project. The following was achieved:

- The analog to digital converter is setup on four channels ports [B1-3, D2] and decodes the analog data in the 8 bit data register.
- The UART emulator on the sensor and transmitter board successfully sends data.
- The UART emulator on the receiver and display board failed to interpret the transmitted sensor data via a cable.
- The decode routines were written and were tested on the sensor and transmitter board.

Chapter 8

Conclusions

The goal of the project is to commission an airborne generator as a source of three phase power at 400 Hz for ground based radar equipment at the University. The generator is planned to be housed in a shed outside the Menzies building which shall distribute 200 V line-to-line over power cables terminating onto a 45 Amp circuit breaker located in the microwave laboratory. The objectives were met as follows:

The induction motor chosen meets the generator's drive end requirements for 12 kVA operation. A cast iron coupling mechanically links the motor's shaft to the drive end of the generator. Starting the coupled induction motor tripped the upstream breaker. This was due to the large startup currents inherent to induction motors, which are in the order of 2-3 times that of rated current (see Section 3.2.1). Fortunately an off the shelf soft starter can be used to solve this problem. Replacing the upstream circuit breaker would be a feasible solution, however, the breaker is the property of the University and could not be altered.

Soft starters reduce the voltage by a factor of $\frac{1}{\sqrt{3}}$ in order to reduce the starting current by the same factor, however, this reduces the torque by a factor of $\frac{1}{3}$. This created a problem whereby there was insufficient torque from the motor to overcome its standstill inertia and drive the generator, as a result the motor stalled thus tripping the overload relay. This problem was solved by using an auxiliary contact which was used to start the generator when the motor reaches full rated conditions (see Section 4.3).

The generator and its control unit were tested according to the pre commissioning tests provided by the technical manual and no fault was found on both items (see Section 4.4). This was particularly important as the age of the generator was disconcerting. To start the generator an external DC signal supplies a holding current of 200 mA to relay K1, which would have been supplied by batteries onboard the aircraft, now had to be designed. A 28 Vdc power supply was designed and started the generator successfully (see Section 4.1). This unit was used to synchronise the generator to the motor's starter to prevent it from stalling. A resistive load bank was used to test the generator response to various loads. Table 4.2 summarises these results. Out of these tests two other important results were learned. The first was the generator's voltage decreased below its specified range when

it supplied loads greater than 2.2 kW. The second result was that the generator's case temperature reached 63 % of its maximum operating temperature under no load within 3.5 minutes.

The generator was setup according to the 12 kVA operation and while in this region the amount by which the voltage and frequency should vary is between 1% - 2% respectively. However, during tests it was shown that the voltage began to vary outside this range for loads greater than 2.2 kW.

Onload the generator began to reach 88% of its maximum operating temperature in 3.5 minutes. So as is, the generator is of not much use. A blower fan was selected to source forced cooling at a rate $11 \frac{\text{m}^3}{\text{s}}$ at 3 kPa. The cooling shroud supplies cooling air into the inlet vents and over the gearbox housing. Forced cooling was able to reduce and stabilise the generator's operating temperature while supplying a 2.2 kW and 4.8 kW loads to 45 C - 55 C respectively.

The telemetering system was designed to relay system parameters to user in the shed as the temperature of the generator case and the blower fan pressure should not exceed 80 C and 3 kPa respectively. The voltage and current can be measured from the microwave laboratory.

The problem of frequency hunting raised its ugly head latter on in the project whereby the generator's frequency oscillates between 328 and 336 Hz while the voltage remains at 200 V line to line. The root cause of this problem has not been investigated thoroughly; however there are two assumptions which are addressed in Section 4.5. For this reason the rotary inverter system should not be used.

Chapter 9

Recommendations

1. The 400 Hz generator is not in a state to be used as the intermittent frequency problem could not be solved during the time allowed for this project. However, before frequency hunting the load tests suggests that the 400 Hz generator should not supply loads greater than 2.2 kW, as larger loads affect the voltage tolerance negatively (see Section 4.5).
2. Further research should investigate whether the intermittent frequency hunting problem is caused by the induction motor or the generator's constant speed drive (see Section 4.5).
3. A pressurised pump feed should be used to replace the gearbox oil in future as an impractical amount of force is required on the syringe as the sump fills up (see Section 4.6).
4. The shed should be sound proofed since the noise emitted from the blower will become problematic especially around the 6th floor level of the Menzies building.
5. The telemetering system works well on a breadboard, however, it would be more robust for student use if it were printed onto a circuit board.
6. The UART emulator was tested on the sensor and transmitter board and the result was that it sends data, however, time did not allow for the receiver and display board to be tested. A final recommendation is put forward that the receiver and display board be tested on a terminal emulator, this will assist in debugging, once solved this will make the telemetering system fully functional.

Appendix A

Induction Motor

A.1 No Load Test

There are negligible differences in rotational losses between a loaded motor and one that is not. This is why I performed the test with an unloaded shaft. The no load test gives an indication of the rotational losses in an induction motor.

$$P_{Rotational} = P_{input} - 3I_{line}^2 R_1 \quad (A.1)$$

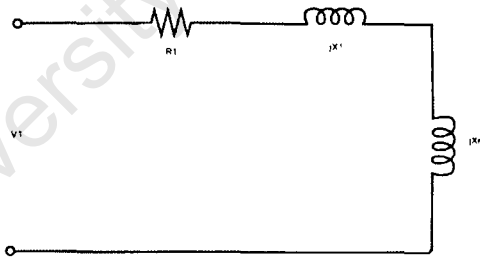

Figure A.1: The equivalent no load circuit.

A.1.1 Methodology

Measuring the line-to-line voltage and phase current of the motor, we can manipulate the circuit to determine parameters R_1, jX_1, jX_m . There being no distinction in the reactive components of the circuit jX_1 and jX_m are lumped together to form the no load reactance in Equation A.5.

Table A.1: No load test results using a three phase variac.

Frequency [Hz]	Voltage [V_line]	Amperes [A_phase]	Power [W_per phase]	PF
50	59.3	2.6	132	0.910
50	107.7	1.9	170	0.850
50	156.3	1.7	165.2	0.643
50	209.0	1.9	186	0.473
50	260.0	2.3	215	0.355
50	313.0	2.9	240	0.271
50	363.0	3.9	286	0.206
50	397.0	5.4	284	0.130

$$\begin{aligned}
 Z_{NL} &= \frac{V_{phase}}{I_{line}} \\
 Z_{NL} &= \frac{397V}{5.4A} \\
 Z_{NL} &= 73.5\Omega
 \end{aligned}
 \tag{A.2}$$

The stator on the motor is delta connected, which implies that the phase and line-to-line voltage are the same.

$$Z_{NL} = R_{NL} + jX_{NL}
 \tag{A.3}$$

We get the following from Equation A.1.

$$\begin{aligned}
 R_{NL} &= \frac{P_{NL}}{I^2} \\
 R_{NL} &= \frac{284W}{5.4^2A} \\
 R_{NL} &= 9.7\Omega
 \end{aligned}
 \tag{A.4}$$

The no load power reading in TableA.1 is taken from the Chauvin Arnoux 8334 Power Meter.

$$\begin{aligned}
 X_{NL} &= \sqrt{Z_{NL}^2 - R_{NL}^2} \\
 X_{NL} &= 72.8\Omega
 \end{aligned}
 \tag{A.5}$$

These are the results from an unloaded motor shaft.

A.2 Locked Rotor Test

Preventing the motor-shaft from rotating implies low slip which results in a low rotor impedance. The low rotor impedance shunts the magnetizing impedance jX_m , reducing the equivalent circuit to the figure below.

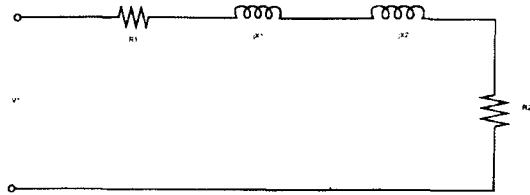

Figure A.2: The equivalent locked rotor circuit.

A.2.1 Methodology

In this test the rotor is held stationary by a G-clamp. The voltage on the three-phase auto-transformer is slowly increased until the ammeter reads 26.6 A. In my first attempt I assumed the auto-transformer could deliver the motor's rated current and ended the experiment by blowing 3, 20 Amp fuses. The fuses were replaced and the problem was soon remedied, with the use of use of a Delta-Wye current step up transformer. This provided the rated 26.6 Amps to the motor.

Table A.2: The induction motor's current values at incremental voltages.

Frequency [Hz]	Voltage [V]	Ampere [A]	Power [W]	PF
50	64.2	24.9	374.6	0.403
50	67.1	26.1	416.0	0.409
50	67.9	26.1	425.0	0.413
50	69	26.6	441.0	0.414

$$\begin{aligned}
 Z_{LR} &= \frac{V_{line}}{I_{phase}} \\
 Z_{LR} &= \frac{69.0V}{15.4A} \\
 Z_{LR} &= 4.5\Omega
 \end{aligned}
 \tag{A.6}$$

$$\begin{aligned}
R_{LR} &= \frac{P_{LR}}{I_1^2} \\
R_{LR} &= \frac{441W}{(15.4)^2 A} \\
R_{LR} &= 1.86\Omega
\end{aligned}
\tag{A.7}$$

The locked rotor impedance of ($Z_{lr}=V/I$) is used to calculate the X locked rotor impedance

$$\begin{aligned}
X_{LR} &= \sqrt{(Z_{LR}^2 - R_{LR}^2)} \\
X_{LR} &= \sqrt{(4.48)^2 - (1.86)^2} \\
X_{LR} &= 4.1\Omega
\end{aligned}
\tag{A.8}$$

The parameters X1 and X2 are approximately equal in value.

$$X_{LR} = X_1 + X_2 \tag{A.9}$$

$$X_1 = X_2 = 2.05\Omega \tag{A.10}$$

The Equation A.11 is obtained from the no load equivalent circuit.

$$\begin{aligned}
X_m &= X_{NL} - X_1 \\
X_m &= 73.4 - 2.05 \\
X_m &= 71.4\Omega
\end{aligned}
\tag{A.11}$$

Calculating R_2

$$\begin{aligned}
R_2 &= \left(\frac{X_2 + X_m}{X_m} \right)^2 \times (R_{LR} - R_1) \\
R_2 &= \left(\frac{2.05 + 71.4}{71.4} \right)^2 \times (1.06) \\
R_2 &= 1.12\Omega
\end{aligned}
\tag{A.12}$$

Below are the circuit parameters for the IEEE equivalent circuit for the 15 kW induction motor using a digital power meter.

Table A.3: Equivalent circuit parameters.

Parameters	Values [Ω]
R1	0.8
X1	1.95
Xm	70.34
R2	0.66
X2	1.95

A.3 The Induction Motor's Equivalent Circuit Impedances Based on the No Load and Locked Rotor Tests

The per phase input impedance can be calculated using the equation:

$$Z_{in} = R_1 + jX_1 + \frac{jX_m(\frac{R}{s} + jX_2)}{\frac{R}{s} + j(X_m + X_2)} \quad (A.13)$$

From startup to full speed the range of slip varies from 1 - 0 respectively. The following table shows impedance at the slip intervals and was used to plot 3.1.

Table A.4: Induction motor's impedance at slip intervals.

SLIP	Z1 Ω
0.001	72 $\angle 84^\circ$
0.01	50 $\angle 54^\circ$
0.1	7.5 $\angle 18^\circ$
0.2	5.7 $\angle 45^\circ$
0.3	4.8 $\angle 53^\circ$
0.5	4.4 $\angle 62^\circ$
0.8	4.2 $\angle 67^\circ$
0.85	4.1 $\angle 68^\circ$
0.9	4.1 $\angle 69^\circ$
1.0	4.0 $\angle 72^\circ$

A.4 Soft Starter

The star delta starter modified with thermal protection for the generator.

Figure A.3: Soft starter schematic.

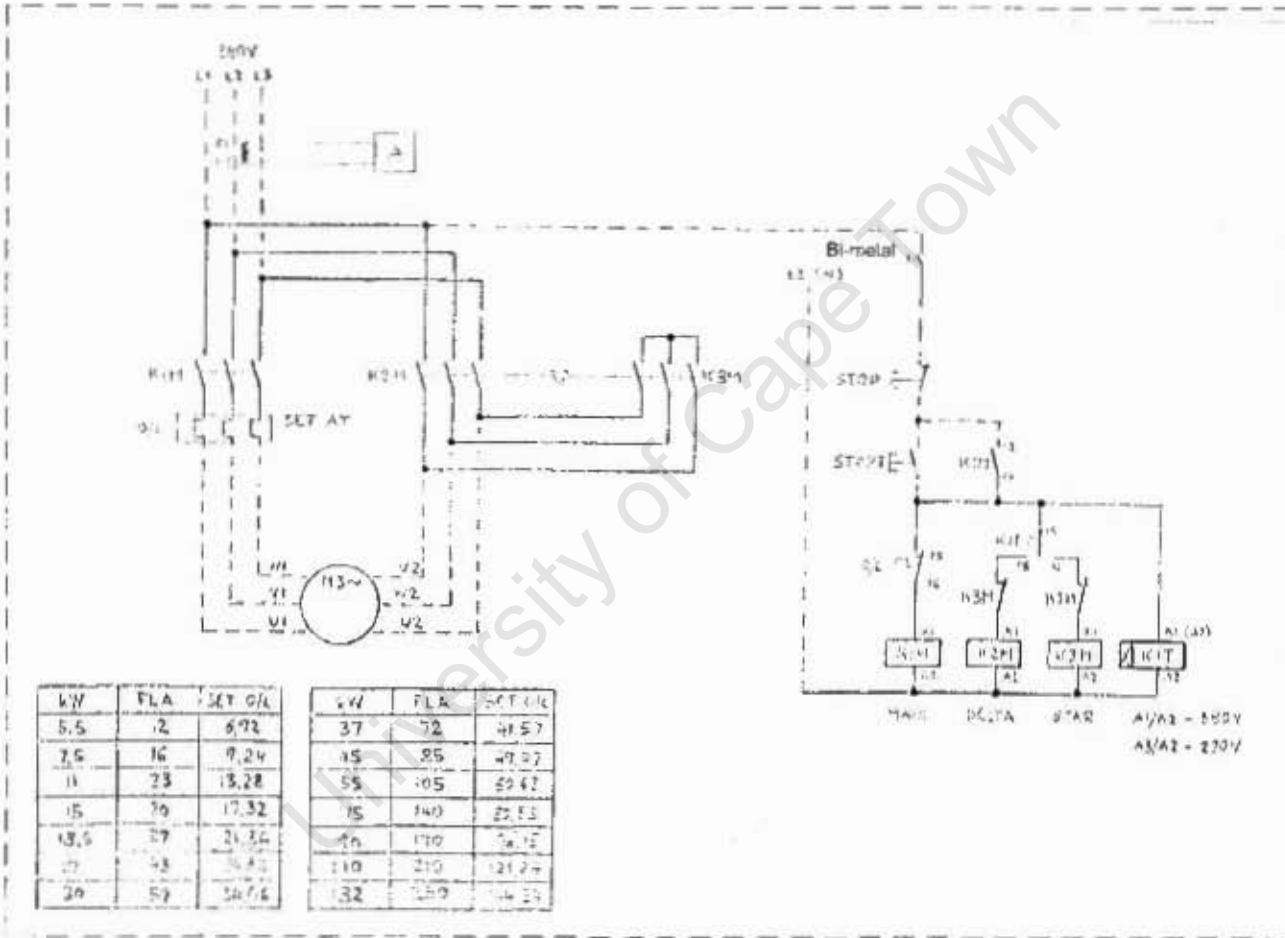

Appendix B

Constant Frequency Alternator

The continuity test results on the new wiring harness showing full continuity.

Table B.1: Continuity test on the wiring harness.

Terminals (from)		Terminal (to)	Continuity
A	-	d	yes
B	-	e	yes
C	-	f	yes
k/J1	-	c	yes
u/J1	-	b	yes
j/J1	-	a	yes
t/J1	-	t	yes
h/J1	-	h	yes
g/J1	-	g	yes
p/J1	-	p	yes
r/J1	-	r	yes
f/J1	-	f	yes
e/J1	-	e	yes
l/J1	-	l	yes
m/J1	-	m	yes
n/J1	-	n	yes
v/J1	-	v	yes
s/J1	-	s	yes
A	-	p	yes
B	-	u	yes
C	-	s	yes
f	-	gnd	yes
g	-	28V	yes
D/J2	-	A/adj	yes
H/J2	-	B/adj	yes
V/J2		C/adj	yes

Appendix C

Blower Fan

C.1 Flowrate Test

This test was carried out to verify whether the fan could deliver $11 \frac{m^3}{s}$ at 3 kPa. The anemometer was kept at a distance A from the opening C. The dimensions of C are 40mm x 30mm.

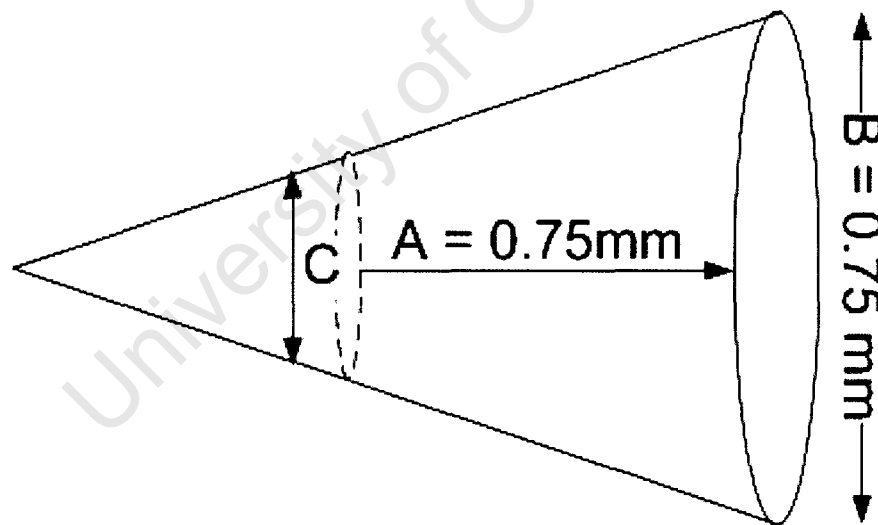
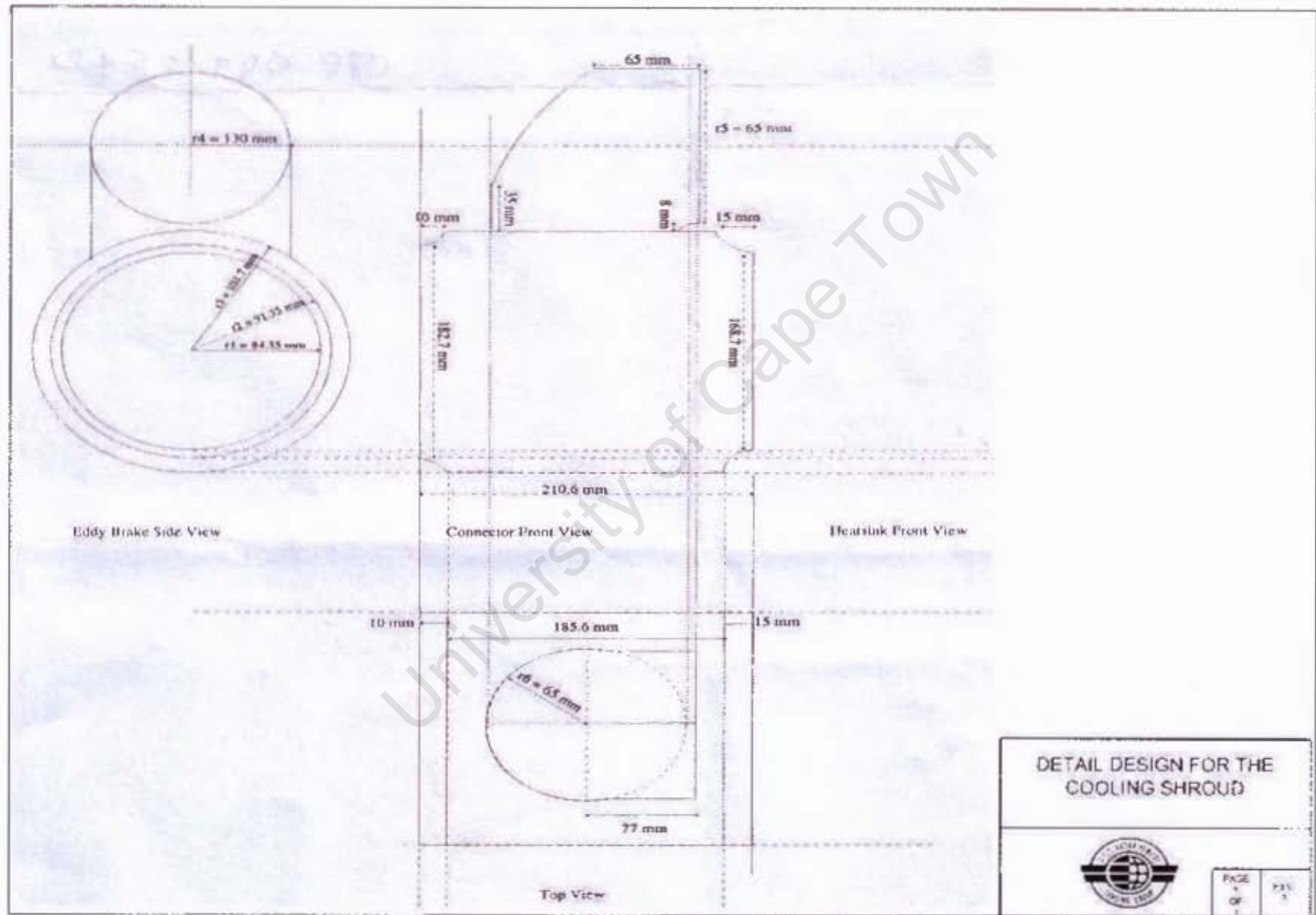

Figure C.1: The dimensions of the measuring airflow window .

C.2 Cooling Shroud Design

The cooling shroud designed in place of the ducts.

Figure C.2: The designed cooling shroud.



Appendix D

Telemetry System

D.1 The Telemetry Power Supply

A 15VA power supply was designed according to the schematic shown below.

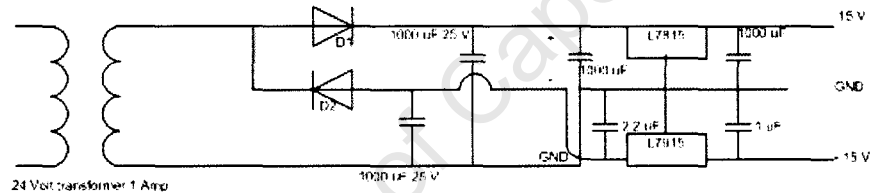

Figure D.1: The 15 VA bipolar power supply designed for the telemetry system.

D.2 LAH50-P Calibration (Current LEM)

Equipment used for calibrating the voltage transducer:

1. Auto transformer
2. LAH50-P current transducer
3. Load Bank (50 - 200 Ω)
4. Power supply
5. Precision rectifier (AC-DC)

D.2.1 Methodology

The resistance of the rheostat is varied which results in a changing load current, results are recorded in Table D.1 below.

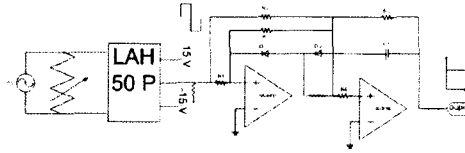

Figure D.2: Calibration setup for the LAH50P current transducer.

Table D.1: LAH50P calibration before and after readings using the precision rectifier at 50 Hz.

Load	Load Current [A]	Secondary Current [mA]	Full Scale Voltage [V]
1k	1	0.5	0.1
500	3	1.5	0.3
200	5	2.5	0.5
10	7	3.5	0.7

D.3 LV25P Calibration (Voltage LEM)

Equipment used in calibrating the voltage transducer:

1. Auto-transformer
2. A 50 Ω load
3. LV25P voltage transducer
4. Power supply
5. Precision rectifier

D.3.1 Methodology

The auto-transformer is varied from 25 to 250 V where the load resistance is kept fixed. An oscilloscope measures the transducers secondary voltage and rectifiers it, and the results are shown in Table D.2 below.

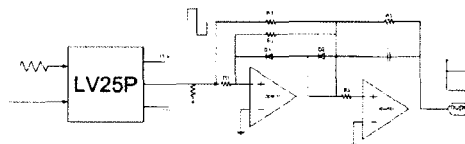

Figure D.3: Calibration setup for the LV25P voltage transducer.

Table D.2: LV25P calibration under variable voltage at 50 Hz with a 200 Ω scaling resistor.

Line to line voltage [V]	V rms	Rectifier [V dc]	ΔV
25	0.48	0.43	0.05
50	0.98	0.83	0.13
75	1.43	1.25	0.02
100	1.97	1.65	0.03
125	2.47	2.06	0.04
150	2.98	2.48	0.05
175	3.47	2.86	0.06
200	3.95	3.26	0.07
225	4.40	3.67	0.07
250	4.90	4.1	0.08

Appendix E

Telemetry Source Code

E.1 Sensor and Transmitter Source Code

; This program reads in 4 sensor values and transmits them via the UART of the uC

; If the sensor values exceed certain limits a shutdown operation executes and waits

; until push button 4 is pressed to begin again

TOPRAM EQU \$0080 ;Top of RAM area, JK1/3=0080, JK8=0060

TOPROM EQU \$F600 ;Top of Flash area JK1=F600, JK3=EC00, JK8=DC00

TOPVECTORS EQU \$FFDE ;Top of Interrupt Vector table

;To calculate bit delay constants:

;Bit_del=(((crystal speed)/16)/baud rate)-5

;Half_bit_del=Bit_del/2

Bit_del EQU \$5b

Half_Bit_del EQU \$2d

\$Include 'j13regs.inc'

;===

org TOPRAM

temp ds 1

templ ds 1 ; temp limit

```

presl ds 1

presh ds 1

immax ds 1

ilmax ds 1

immin ds 1

ilmin ds 1

del1 ds 1

;===

org TOPROM

main:

mov #$03,CONFIG1 ; Disable the watchdog timer

mov #$0F,DDRB

mov #$00,PTB ; set data transfer line to 0

mov #$FF,DDRD

clra

clrx

clrh

bset 5,PTD ; turn on cooling system

bclr 2,PTD ; open load circuit breaker

bclr 3,PTD ; open mains circuit breaker

mov #$40,ADCLK

begin:

jsr tdelay

lda #$01

jsr put_serial

mov #$03,ADSCR ; read in temp (0-5V) on PTB bit 3

```

```

jsr wait_adc ; send temperature

mov ADR,temp

asl temp ; times temp by 2

lda temp

jsr tdelay

lda #$02

jsr put_serial

mov #$09,ADSCR ; read in pres (0-5V) on PTD bit 2

jsr wait_adc ; send pressure

lda ADR

jsr tdelay

lda #$03

jsr put_serial

mov #$01,ADSCR ; read in il (0-5V) on PTB bit 1

jsr wait_adc ; send load current

lda ADR

jsr tdelay

lda #$04

jsr put_serial

mov #$02,ADSCR ; read in Vm (0-5V) on PTB bit 2

jsr wait_adc ; send mains current

lda ADR

jmp begin

;===

shutdown:

jsr tdelay

```

```

lda #$05

jsr put_serial

bclr 5,PTD ; turn off cooling system

jsr tdelay

bset 2,PTD ; turn on load circuit breaker

jsr tdelay

bset 3,PTD ; turn on mains circuit breaker

wait

;===

wait_adc:

brclr 7,ADSCR,wait_adc

jsr tdelay

lda ADR

jsr put_serial ; send data to PTB0

rts

;===

; TIMER DELAY

;===

stdelay: mov #$05,dcl1 ; time delay for 5 sec

tdelay: mov #$01,dcl1

mov #$E1,TMODH ; time delay for 1 sec

mov #$00,TMODL

mov #$16,TSC

loop: brclr 7,TSC,loop

dbnz dcl1,tdelay

rts

```

```

;===
; SERIAL DATA TRANSFER SUB-ROUTINES
;===

;This function gets a byte of data from the serial pin of the microcontroller,
;in this case PTB0. The result is returned in the accumulator.

;Baud rate set by constants, see top of file.

;clobbers: nothing

;calls: bit_delay and half_bit_delay

get_serial:

pshx

bclr 0,DDRB ;serial line is input

clra

ldx #8

wait_for_start:

brset 0,PTB,wait_for_start ;wait for the start bit

jsr half_bit_delay ;sample each bit in the middle of its duration

receive_loop:

jsr bit_delay

brset 0,PTB,bithi

clc

bra rotate

bithi: sec

rotate: rora

dbnzx receive_loop

jsr bit_delay ;wait for stop bit

pulx

```

```

bset 0,DDRB

rts

;===

;This function sends a byte out over the serial pin. The input data
;comes in via the accumulator. Baud rate as set in constants section
;of the code.

;clobbers: nothing

;calls: bit_delay

put_serial:

pshx

bclr 0,PTB ;start bit

bset 0,DDRB

sec ;initialize carry flag to stop bit value to prevent glitches

ldx #9

send_loop:

jsr bit_delay

rora

bcc bitlo

bset 0,PTB

bra next_loop

bitlo: bclr 0,PTB

next_loop:

dbnzx send_loop

bset 0,PTB ;stop bit

jsr bit_delay ;stop bit and guard time

jsr bit_delay

```

```

bclr 0,DDRB ;pullup resistors hold stop state

pulx

rts

;===

;delay for 1 bit period. Used by the serial send and receive routines

;clobbers: nothing

bit_delay:

pshx

ldx #Bit_del

loop1: nop

dbnzx loop1

pulx

rts

;===

;delay for half a bit period. Used by the serial receive routine

;clobbers: nothing

;branches to bit_delay

half_bit_delay:

pshx

ldx #Half_bit_del

bra loop1

;===

No_irq:

;This interrupt handler catches interrupts that happened when no

;interrupt should have occurred. For this reason the processor is halted

;and user intervention is required. This routine is only called under severe

```

```

;fault conditions.

stop ; Stop the processor and wait for a reset.

rti ; return

;===

org TOPVECTORS

dw No_irq ; ADC Conversion Complete interrupt

dw No_irq ; Keyboard interrupt

dw No_irq ; Unused

dw No_irq ; Unused

dw No_irq ; Unused

dw No_irq ; Unused

dw No_irq ; Unused

dw No_irq ; Unused

dw No_irq ; Unused

dw No_irq ; Unused

dw No_irq ; TIM1 Overflow interrupt

dw No_irq ; TIM1 Channel 1 interrupt

dw No_irq ; TIM1 Channel 0 interrupt

dw No_irq ; Unused

dw No_irq ; interrupt line

dw No_irq ; Software interrupt

dw main ; Reset Vector

;===

```

E.2 Receiver and Display Source Code

```
; This program receives code value (1-5) from UART to determine if
; temp/pres/im/ig/shutdown is sent.
TOPRAM EQU $0080 ;Top of RAM area JK1/3=0080, JK8=0060
TOPROM EQU $EC00 ;Top of Flash area JK1=F600, JK3=EC00, JK8=DC00
TOPVECTORS EQU $FFDE ;Top of Interrupt Vector table
;To calculate bit delay constants:
;Bit_del=(((crystal speed)/16)/baud rate)-5
;Half_bit_del=Bit_del/2
Bit_del EQU $5b
Half_Bit_del EQU $2d
$Include 'jl3regs.inc'
;=====
org TOPRAM
comma ds 1
del1 ds 1
del2 ds 1
code ds 1
strlen ds 1 ;string display variable
lcd_temp ds 1 ;string display variable
hundreds ds 1 ;bcd decode/display variable
tens ds 1 ;bcd decode/display variable
units ds 1 ;bcd decode/display variable
thous ds 1 ;bcd decode/display variable
disp_no ds 1 ;bcd decode input argument
bcd_no ds 1
mult_no ds 1
;=====
org TOPROM
main:
mov #$03,CONFIG1 ; Disable the watchdog timer
mov #$FF,DDRB ; port B outputs
mov #$00,PTB
mov #$FF,DDRD
bclr 2,DDRD ; make pot 0 - 5V available
```

```

bclr 3,PTD ; make sure buzzer is off
mov #$00,comma ; place a comma in LCD when set as #$FF
jsr lcd_init ; initialize the LCD module
jsr clear_lcd
ldhx #msg1 ; = LCD on
jsr lcd_string
; mov #$40,ADCLK
; mov #$29,ADSCR
display:
jsr get_serial ; get code, it determines which sensor data is going to be sent next
mov #$01,code
cmp code
beq disp1 ; get temperature
mov #$02,code
cmp code
beq disp2 ; get pressure
mov #$03,code
cmp code
beq disp3 ; get load current
mov #$04,code
cmp code
beq disp4 ; get mains current
mov #$05,code
cmp code
beq disp5 ; shutdown
bra display
; if code gets here then code bits not sent properly
jsr clear_lcd
ldhx #msg2 ; = Error in code
jsr lcd_string
jsr lcd_line2
ldhx #msg3 ; = transfer
jsr lcd_string
jsr tdelay
jmp display
disp4:

```

```

jmp disp_4 ; branch function couldn't reach disp_4, so use jmp
disp3:
jmp disp_3 ; branch function couldn't reach disp_3, so use jmp
disp5: ; shutdown
ldhx #msg11 ; = S-Down
jsr lcd_string
bset 3,PTD
wait
disp1: ; get temperature
jsr get_serial
sta disp_no
asl disp_no ; mult temp by 2 cos ADC divides by 2
jsr decode
jsr clear_lcd
ldhx #msg4 ; = Temperature
jsr lcd_string
jsr lcd_line2
jsr bcd_display
ldhx #msg5 ; = Degrees C
jsr lcd_string
jmp display
disp2: ; get pressure
jsr get_serial
sta PTB
mov #$1B,mult_no ; multiply digital no. by 1B to get BCD no.
jsr mult
jsr clear_lcd
ldhx #msg6 ; = Pressure
jsr lcd_string
jsr lcd_line2
jsr bcd_disp
ldhx #msg7 ; = Pa
jsr lcd_string
jmp display
disp_3: ; get load current
jsr get_serial

```

```

sta PTB
mov #$FF,comma ; insert comma on LCD
mov #$C8,mult_no ; multiply digital no. by C8 to get BCD no.
jsr mult
jsr clear_lcd
ldhx #msg9 ; = Load Current
jsr lcd_string
jsr lcd_line2
jsr bcd_display
ldhx #msg10 ; = Amps
jsr lcd_string
mov #$00,comma
jmp display
disp_4: ; get mains current
jsr get_serial
sta PTB
mov #$FF,comma ; add comma on LCD
mov #$C8,mult_no ; multiply digital no. by C8 to get BCD no.
jsr mult
jsr clear_lcd
ldhx #msg8 ; = Mains Current
jsr lcd_string
jsr lcd_line2
jsr bcd_display
ldhx #msg10 ; = Amps
jsr lcd_string
mov #$00,comma
jmp display
;=====
lcd_init:
;Initialize the LCD module by turning it on, setting it into four bit
;mode, clearing the display, setting up the cursor and activating 2 line display
jsr delay1
bset 4,DDRB
bset 5,DDRB
bset 6,DDRB

```

```

bset 7,DDRB
bset 6,DDRD
bset 7,DDRD
mov #$32,PTB
jsr lcd_command
jsr pulse_e
jsr delay1
jsr pulse_e
jsr delay1
jsr pulse_e
jsr delay1
mov #$22,PTB
jsr lcd_command
jsr pulse_e
mov #$02,PTB ;send out the command to clear display and
;set up the cursor
jsr lcd_command
jsr pulse_e
mov #$C2,PTB
jsr pulse_e
mov #$22,PTB ;2 line etc
jsr pulse_e
mov #$82,PTB
jsr pulse_e
rts
;=====
clear_lcd:
mov #$02,PTB
jsr lcd_command
jsr pulse_e
mov #$22,PTB
jsr pulse_e
mov #$02,PTB
jsr pulse_e
mov #$12,PTB
jsr pulse_e

```

```

rts
;=====
home_lcd:
;Send the LCD cursor to the top left hand corner.
mov #$02,PTB
jsr lcd_command
jsr pulse_e
mov #$22,PTB
jsr pulse_e
rts
;=====
display_char:
;Display the character in the accumulator on the LCD
psha
ora #$02
sta PTB
jsr lcd_data
jsr pulse_e
pula
nsa
ora #$02
sta PTB
jsr pulse_e
rts
;=====
lcd_line2:
;Move the LCD cursor to the bottom left hand corner
mov #$C2,PTB
jsr lcd_command
jsr pulse_e
mov #$02,PTB
jsr pulse_e
rts
;=====
pulse_e:
;pulse the strobe line of the LCD

```

```

jsr delay4
bset 7,PTD
jsr delay4
bclr 7,PTD
jsr delay4
bset 7,PTD
jsr delay4
rts
;=====
lcd_command:
;clear the LCD register select line. This makes the LCD accept commands.
bclr 6,PTD
rts
;=====
lcd_data:
;Set the LCD register select line. This makes the LCD accept data.
bset 6,PTD
rts
;=====
lcd_string:
;Display a text string. The address of the string is in H:X
;The length of the string is the first character in the string
;eg '3the' will display 'the'
mov X+,strlen ;get the string length, increment pointer
lcd_loop: mov X+,lcd_temp
lda lcd_temp
jsr display_char
dbnz strlen,lcd_loop
rts
;=====
bcd_disp:
;Display a BCD number on the LCD. The number comes in in the variables hundreds,
;tens and units. an offset of $30 is added to convert the number to ASCII
lda thous
add #$30
jsr display_char

```

```

bcd_display: lda hundreds
             add #$30
             jsr display_char
             lda tens
             add #$30
             jsr display_char
             lda #$FF
             cmp comma
             beq addcomma
uni: lda units
     add #$30
     jsr display_char
     rts
addcomma: ldhx #msg12 ; = ,
          jsr lcd_string
          jmp uni
;=====
decode:
;Decode an 8 bit binary number to BCD and pack it into the variables hundreds,
;tens and units, ready for display.
clrh ;hundreds=int(displ_no/100)
lda displ_no
ldx #$64
div
sta hundreds
mul ;displ_no=displ_no-100*hundreds
sta tens
lda displ_no
sub tens
sta displ_no
ldx #$0A ;tens=int(displ_no/10)
clrh
div
sta tens
mul ;units=displ_no-10*tens
sta units

```

```

lda disp_no
sub units
sta units
rts
;=====
; convert binary no. into "bins" of units, tens, hundreds and thous
; so they can be display on LCD
mult:
mov #$00,units
mov #$00,tens
mov #$00,hundreds
mov #$00,thous
lda #$1B ; convert pressure
cmp mult_no
beq pressure
lda #$C8 ; convert current
cmp mult_no
beq current_
current_ : ; branch can't reach current so use jmp function
jmp current
pressure: ; pressure decoding process, see chapter 3.3.4 of thesis for explanation
lda #$00
brclr 0,PTB,inc1
mov #$06,units
mov #$01,tens
jsr overflow
inc1: brclr 1,PTB,inc2
lda units
add #$02
sta units
lda tens
add #$03
sta tens
jsr overflow
inc2: brclr 2,PTB,inc3
lda units

```

```
add #$04
sta units
lda tens
add #$06
sta tens
jsr overflow
inc3: brclr 3,PTB,inc4
lda units
add #$08
sta units
lda tens
add #$02
sta tens
lda hundreds
add #$01
sta hundreds
jsr overflow
inc4: brclr 4,PTB,inc5
lda tens
add #$06
sta tens
lda tens
add #$05
sta tens
lda hundreds
add #$02
sta hundreds
jsr overflow
inc5: brclr 5,PTB,inc6
lda units
add #$02
sta units
lda tens
add #$01
sta tens
lda hundreds
```

University of Cape Town

```

add #$05
sta hundreds
jsr overflow
inc6: brclr 6,PTB,inc7
lda units
add #$04
sta units
lda tens
add #$02
sta tens
lda thous
add #$01
sta thous
jsr overflow
inc7: brclr 7,PTB,out
lda units
add #$08
sta units
lda tens
add #$04
sta tens
lda thous
add #$02
sta thous
jsr overflow
out: rts

current: ; current decoding process
lda #$00 ;units == 1st decimal place
brclr 0,PTB,iinc1 ;tens == units
mov #$02,units ;hundreds == tens
jsr overflow
iinc1: brclr 1,PTB,iinc2
lda units
add #$04
sta units
jsr overflow

```

iinc2: brclr 2,PTB,iinc3

lda units

add #\$08

sta units

jsr overflow

iinc3: brclr 3,PTB,iinc4

lda units

add #\$06

sta units

lda tens

add #\$01

sta tens

jsr overflow

iinc4: brclr 4,PTB,iinc5

lda units

add #\$01

sta units

lda tens

add #\$03

sta tens

jsr overflow

iinc5: brclr 5,PTB,iinc6

lda units

add #\$03

sta units

lda tens

add #\$06

sta tens

jsr overflow

iinc6: brclr 6,PTB,iinc7

lda units

add #\$05

sta units

lda tens

add #\$02

sta tens

```

lda hundreds
add #$01
sta hundreds
jsr overflow
iinc7: brclr 7,PTB,out
lda units
add #$01
sta units
lda tens
add #$05
sta tens
lda hundreds
add #$02
sta hundreds
jsr overflow
jmp out
;=====
overflow:
; this checks if bins are >9 then increments higher bin
lda units
cmp #$0A
bcs ts ; if 10 > units then branch
sub #$0A
sta units
inc tens
ts: lda tens
cmp #$0A
bcs th ; if 10 > tens then branch
sub #$0A
sta tens
inc hundreds
th: lda hundreds
cmp #$0A
bcs te ; if 10 > hundreds then branch
sub #$0A
sta hundreds

```

inc thous

te: rts

;

msg1:

db !6

db "LCD on"

msg2: db !13

db "Error in code"

msg3: db !8

db "transfer"

msg4: db !12

db "Temperature:"

msg5: db !10

db " Degrees C"

msg6: db !9

db "Pressure:"

msg7: db !3

db " Pa"

msg8: db !13

db "Mains current"

msg9: db !12

db "Load current"

msg10:db !5

db " Amps"

msg11:db !7

db " S-Down"

msg12:db !1

db ", "

;

;delay4 = short, delay1 = intermediate and delay5 = very long

delay4:

mov #\$01,dell

bra delay2

delay5:

mov #\$FF,dell

bra delay2

```

delay1:
mov #$20,del1
delay2: mov #$FF,del2
delay3: nop
nop
nop
dbnz del2,delay3
dbnz del1,delay2
rts

;=====
; Timer delay
;=====

tdelay:
mov #$E1,TMODH ; time delay for 1 sec
mov #$00,TMODL
mov #$16,TSC
loop: brclr 7,TSC,loop
rts

;=====
; SERIAL DATA TRANSFER SUB-ROUTINES
;=====

;This function gets a byte of data from the serial pin of the microcontroller,
;in this case PTB0. The result is returned in the accumulator.
;Baud rate set by constants, see top of file.
;clobbers: nothing
;calls: bit_delay and half_bit_delay
get_serial:
pshx
bclr 0,DDRB ;serial line is input
clra
ldx #8
wait_for_start:
brset 0,PTB,wait_for_start ;wait for the start bit
jsr half_bit_delay ;sample each bit in the middle of its duration
receive_loop:
jsr bit_delay

```

```

brset 0,PTB,bithi
clc
bra rotate
bithi: sec
rotate: rora
dbnzx receive_loop
jsr bit_delay ;wait for stop bit
pulx
bset 0,DDRB
rts
;=====
;This function sends a byte out over the serial pin. The input data
;comes in via the accumulator. Baud rate as set in constants section
;of the code.
;clobbers: nothing
;calls: bit_delay
put_serial:
pshx
bclr 0,PTB ;start bit
bset 0,DDRB
sec ;initialize carry flag to stop bit value to prevent glitches
ldx #9
send_loop:
jsr bit_delay
rora
bcc bitlo
bset 0,PTB
bra next_loop
bitlo: bclr 0,PTB
next_loop:
dbnzx send_loop
bset 0,PTB ;stop bit
jsr bit_delay ;stop bit and gaurd time
jsr bit_delay
bclr 0,DDRB ;pullup resistors hold stop state
pulx

```

```

rts
;=====
;delay for 1 bit period. Used by the serial send and receive routines
;clobbers: nothing
bit_delay:
pshx
ldx #Bit_del
loop1: nop
dbnzx loop1
pulx
rts
;=====
;delay for half a bit period. Used by the serial receive routine
;clobbers: nothing
;branches to bit_delay
half_bit_delay:
pshx
ldx #Half_bit_del
bra loop1
;=====
No_irq:
;This interrupt handler catches interrupts that happened when no
;interrupt should have occurred. For this reason the processor is halted
;and user intervention is required. This routine is only called under severe
;fault conditions.
stop ; Stop the processor and wait for a reset.
rti ; return
;=====
org TOPVECTORS
dw No_irq ; ADC Conversion Complete interrupt
dw No_irq ; Keyboard interrupt
dw No_irq ; Unused
dw No_irq ; Unused
dw No_irq ; Unused
dw No_irq ; Unused
dw No_irq ; Unused

```

dw No_irq ; Unused
dw No_irq ; Unused
dw No_irq ; Unused
dw No_irq ; TIM1 Overflow interrupt
dw No_irq ; TIM1 Channel 1 interrupt
dw No_irq ; TIM1 Channel 0 interrupt
dw No_irq ; Unused
dw No_irq ; interrupt line
dw No_irq ; Software interrupt
dw main ; Reset Vector

University of Cape Town

Appendix F

Dismantling the 400 Hz Motor Generator Set

1. With all circuit-breakers off disconnect the three-phase load bank from the alternator's terminals noting the which bundles are attached to which phase of the CFA. Note the neutral wire attached to the GCU shielding.
2. Disconnect the three-phase supply from the soft starter, motor and fan terminals. Keeping note of the orientation. Reversing wires changes motor direction.
3. Disconnect the fan coil start signal from the auxiliary contactor attached to the delta relay inside the soft starter.
4. Disconnect the 28 V signal line from the auxiliary contactor attached to the delta relay.
5. Disconnect the pressure and temperature switch connections from the soft starter.
6. Remove the cooling shroud from the alternator carcass by loosening the six 8mm bolts from the shroud lip. Remove ventilation piping and carefully compress and store in a safe place.
7. Remove the wiring harness from the alternator and keep the side attached to the GCU connected.
8. Wrap phase wires around the alternators aluminium frame and detach the clamp.
9. Sliding the alternator out of the motors shaft keeping the CFA in the horizontal plane at all times. Do not knock tilt or rotate the CFA as oil displaces under these circumstances.
10. Remove the coupling unit from the flange of the motor using a spanner.

Appendix G

List of Suppliers and Budget

Table G.1: Components purchased during commissioning and company details.

System	Components	Supplier	Rand amount	Year
Prime Mover	Induction Motor- 15 kW	Alstom	6 042,00	2003
Prime Mover	Soft Starter- Wye/Delta	Retlaw Engineering	a/o	2004
Generator	400 Hz Generator	SAAF	Donation	a/o
Generator	Amphenol Connector	Saftec Sales	1 500,00	2006
Ventilation	Veritech Fan and Ducts	Veritech	17 953,36	2005
Ventilation	Duct- Cooling Shroud	Veritech	4 286,00	2007
Monitoring	Data Logger and Sensors	RS Components	3 686,00	2006
Monitoring	LEM modules LV/LAH	Denver Technology	1 036,00	2006
Monitoring	Thermal Switch- Bi	RS Components	193,06	2006
Monitoring	Pressure Switch- Low	RS Components	243,17	2007
		Total	34 939,59	2007

Bibliography

- [1] Avions Marcel Dassault and Breguet Aviation. (1985). Generator and Regulator Manual Technical Manual.
- [2] Zyambo, J. (2004). Commissioning a 400 Hz Power Supply: Final year project, Department of Electrical Engineering, University of Cape Town.
- [2] Smith, W.A. (2005). Commissioning a 400 Hz Power Supply: Technical Report, Department of Electrical Engineering, University of Cape Town.
- [3] Yoon, J.N. (accessed 2008). 400 Hz Electrical Systems, web page, www.aerospaceweb.org/question/electronics/q0219.shtml
- [4] ABB South Africa. (2000). Commissioning procedures for three phase induction motors, Application Note.
- [5] Wild, T.W. (1996). Transport Category Aircraft Systems, Jeppeson Sanderson Publishers Inc, ISBN 0-884875-232-7, Chapter 4.
- [6] Dishner, B. and Morris, A. (1989). A novel electromechanical approach to constant frequency power generation. Proceedings of the IEEE 1989 National Aerospace Electronics Conference (NAECON 1989). Volume 4, pp 1765 - 1769.
- [7] Taha, M. and Trainer, D.R. (2004). Adaptive reactive power control for aircraft applications. Second International Conference on Power Electronics, Machines and Drives (PEMD 2004). (Conf. Publ. No. 498), Volume 2, pp 469 - 474.
- [8] Sen, P.C. (1997). Principles of Electric Machines and Power Electronics, 2nd Edition. Wiley Publishers. ISBN 978-0-471-02295-4. Chapter 5: Asynchronous Machines, pp 222 - 247.
- [9] Sen, P.C. (1997). Principles of Electric Machines and Power Electronics, 2nd Edition. Wiley Publishers. ISBN 978-0-471-02295-4. Chapter 6: Synchronous Machines, pp 292 - 365.
- [10] Motorola Inc. (1997). Three Terminal Positive Voltage Regulators. Datasheet, MC7800D.
- [11] ST Microelectronics. (2004). Negative Voltage Regulators. Datasheet, L7900.

- [12] ST Microelectronics. (2001). Low Power J-FET Quad Operational Amplifiers. Datasheet, TL064.
- [13] Radiometrix. (2004). UHF FM Data Transmitter and Receiver Modules. Datasheet, TX2-433-160-5V/ RX2-433-160-5V.
- [14] Browne, D. (2005). Generator Status Monitoring Unit. Final year project, Department of Electrical Engineering, University of Cape Town.
- [15] National Semiconductor. (2000). Precision Centigrade Temperature Sensor. Datasheet, LM35DZ.
- [16] LEM. (2003). Current Transducer. Datasheet, LAH 50-P.
- [17] LEM. (2003). Voltage Transducer. Datasheet, LV25-P.
- [18] RS Components. (1999). Pressure Transducer. Datasheet, 288-8533.
- [19] Moeller. (2004). Motor Control Star Delta Starter. Product Catalog.
- [20] Alstom. (2007). Centrifugal Fans Radial Bladed Fans. Product Catalog.
- [21] Ferranti . (1975). Blue Parrot Radar S.A. , Technical Manual for the South African Defense Force.
- [22] Zyambo, J. (2004). Commissioning a 400 Hz Power Supply. Thesis disertation, Department of Electrical Engineering, University of Cape Town. pp 58-59.
- [23] Telemecanique. (2000). Variable Speed Drive Altivar 30 kW. pp 10-13.
- [24] SABS IEC 60034-1. (1985). Rotating electrical machines. Part 1, Rating and performance.
- [25] SABS IEC 60034-2A. (1991). Rotating electrical machines. Part 2A, Methods of determining losses and efficiency.
- [26] SABS IEC 60034-5. (1972). Rotating electrical machines. Part 5, Classification of degrees of protection provided by enclosures of rotating electrical machines.
- [27] SABS IEC 60034-6. (1972). Rotating electrical machines. Part 6, Methods of cooling.
- [28] SABS IEC 60034-7. (1992). Rotating electrical machines. Part 7, Classification of types of construction and mounting arrangements.
- [29] SABS IEC 60034-8. (1972) Rotating electrical machines. Part 8, Terminal markings and direction of rotation of rotating machines.

- [30] SABS IEC 60034-12. (1980). Rotating electrical machines. Part 12, Starting performance of single speed three-phase cage induction motors for voltages up to and including 660 V.
- [31] SABS 1804-2. (1999). Rotating electrical machines. Part 2, Low voltage three-phase standard motors.
- [33] Avions Marcel Dassault - Breguet Aviation. (1985). Generator and Regulator Technical Manual. Section 6.1.3: Products required for periodic maintenance operations, pp 6-2.
- [34] Avions Marcel Dassault - Breguet Aviation. (1985). Generator and Regulator Technical Manual. Section 9.2: Oil draining and filling, pp 9-2 - 9-3.
- [35] Avions Marcel Dassault - Breguet Aviation. (1985). Generator and Regulator Technical Manual. Section 0: Characteristics, pp 00-12 - 00-13.
- [36] Johan. (2005). Veritech Ventilation Systems. In conversation regarding the placement of pressure sensors.
- [37] Imphotronics Company. (accessed 2006). Imphotronics Systems. Motor starters, star delta, web page, http://www.imphotronics.com/m_start.htm#StarDelta