

**IMPROVING OPERATIONS VIABILITY AND REDUCING VARIETY  
USING A.D.I.S  
(Accurate Drawing Information System)  
A MULTIVIEW METHODOLOGY OF DESIGN**

**submitted by : PETER MONTGOMERY**  
**SCHOOL OF ENGINEERING MANAGEMENT**  
**UNIVERSITY OF CAPE TOWN**

**Thesis submitted in partial fulfilment of the requirements for the  
Degree of MA Industrial Administration**

**SEPTEMBER 1997**

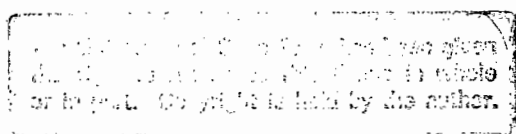

The copyright of this thesis vests in the author. No quotation from it or information derived from it is to be published without full acknowledgement of the source. The thesis is to be used for private study or non-commercial research purposes only.

Published by the University of Cape Town (UCT) in terms of the non-exclusive license granted to UCT by the author.

**DECLARATION**

**I, the undersigned, do hereby declare that the work contained in this thesis is my own original work and has not previously been submitted at an University for the purposes of a degree**

**PETER MONTGOMERY**

**22 SEPTEMBER 1997**

## **ACKNOWLEDGEMENTS**

The author would like to thank the following people who made contributions towards this thesis:

1. Professor Tom Ryan for his input, constructive criticism and support.
2. Management and involved personnel at Gabriel Shockabsorbers for their enthusiasm in ADIS and its implementation
3. My wife, Lucia for the extensive help and unfaltering support.

## SYNOPSIS

Gabriel S.A. is a South African shockabsorber manufacturing company which has undergone a strategic repositioning to become internationally competitive. This entailed a move away from the traditional hierarchical management structure and production line manufacturer, to a flatter structure with cross-functional Business Units. Each Business Unit is made up of self-contained, Manufacturing cells run by self-directed work teams. The objective of this change is to ensure that Gabriel S.A. becomes a world class manufacturer..

The company has gone a long way down this road in implementing World Class Manufacturing techniques through the Gabriel Total Quality Production System (GTQPS). However, problems still arise within the system, especially with regard to new product/component designs and changed designs reaching the shop floor timeously. This is aggravated by the necessity to penetrate new markets and retain existing ones successfully. The number of quotations to be prepared will increase. As will the subsequent number of required assembly and component drawings and modification to existing products. These, in turn, will involve revisions to current drawings. This is compounded by the fact that in the current business operations, there are already concerns regarding the routine drawing information requirements.

This thesis investigates the affect of the drawing information system on the viability of the Manufacturing cells and documents the intervention of a socio-technical drawing information system..

A framework for inquiry into the situation was synthesised using Charles Peirce's Scientific method and three Systems Thinking Methodologies, namely, Stafford Beer's Viable Systems Model, Peter Checkland's Soft Systems Methodology and the Multiview methodology of Information Systems Development.

During the immersion phase, the Viable Systems Diagnosis showed that the Business Units represent viable units as described by the Viable Systems Model. The Viable Systems diagnosis also showed that the engineering change procedure was a good platform to facilitate

drawing changes (well co-ordinated and with effective feedback loops). However, the distribution of these changes to the Manufacturing cells was inefficient.

The analysis of the Human Activity System during the first stage of the Multiview methodology entailed developing a Rich Picture of the problem situation. This involved gathering world views of all the stakeholders of the current engineering change system and the method of drawing utilisation. These world views are tabled below:

	STAKE HOLDER	WORLD VIEW
1	Development Director	Aware of the expense of scrap caused by incorrect drawings on the shop floor
2	Engineering Secretary	System will reduce drawing distribution time
3	Manufacturing cells	Fear of computer technology
4	Business Unit Engineers	a) Will improve Quality, Reaction time, flexibility and cost b) Concerned about instability of current computer network
5	ECO Committee	Rapid introduction of changes
6	Info System Department	a) Cost of new system b) Intrusion into their domain.

From the views obtained during the development of the Rich Picture, five main areas were identified being:

- \* Creating the change package,
- \* Creating and updating the product structure,
- \* Engineering change order (ECO) procedure,
- \* Drawing distribution,
- \* Daily usage system.

Root definitions were developed for each of these areas to give a concise description of their essential natures. An iterative process was undertaken which resulted in the Accurate, Product Drawing Information System which encompasses the five systems mentioned above. The Root Definition being: " A system through which engineering can introduce new product changes channelled via the Engineering Change Order committee to the Manufacturing cells in

an efficient way so that it can be used on continuous basis for building product. This system is owned by the Development Engineering Department and operated by the Manufacturing cells to access information loaded by the Development Engineers via the ECO committee."

In order to complete the analysis of the human activity system, conceptual models were developed. These models illustrated the discrepancies between reality and the theoretical ideal. From the findings in this immersion stage, the hypothesis was made that by introducing an accurate, drawing information system (ADIS) the viability of the Business Unit Manufacturing cells would be improved and the variety in the drawing information transfer process within the organisational structure, would be reduced.

The next four stages of the Multiview process were used to verify the hypothesis. This involved the design, implementation and testing of a new system. The first stage of the verification phase involved Multiview Stages 2 - 4 from which it was decided to pursue three sub-systems generated in the immersion phase. These were the engineering change number system, drawing distribution system and daily usage of drawing system. This resulted in an intervention being made through the actual design of the system. To ensure the acceptability of the intervention a new computer system was designed with the total involvement of the Manufacturing cell's team members.

Different options covering the socio-technical objectives of the proposed system were presented to all of the Original Equipment Shock cell operators. These objectives were intensely debated in the team's Green Area. The best socio-technical option was "On-line drawing viewers in each Manufacturing cell and Engineering office, linked to the network using a Windows operating system". Thereafter the human computer interface was designed using Multiview Stage 4.

This stage encompassed the dialogue and design of the new system. Input from all the stakeholders and users of the new system had to be combined. Some implications were:

- Reducing Product Management's variety by simplifying the drawing release procedure,
- Making the management of drawing paper files obsolete,

- Eliminating the Business Unit Managers' responsibility for drawing distribution,
- Reduction of expensive mistakes due to production errors as a result of incorrect drawing information.

The fifth and final stage of Multiview was the testing of the accurate drawing information system. This involved building a prototype test computer workstation and placing it in the production environment. All aspects of the new system were monitored and compared to the information retrieval and drawing distribution of the old manual system.

In brief, the results were:

Activity	Old System	New System
Raising an ECO number	29 minutes	1,5 minutes
Drawing Distribution	7,4 Days	11 seconds
Finding a Drawing	2 minutes	45 seconds
Replace a Missing Drawing	45 minutes	0

The cost of scrap as a direct result of drawing problems of the old system is conservatively estimated at R767 309.

As a result, the conclusion showed that the hypothesis was verified. The introduction of an Accurate Drawing Information System improved both the viability of the Manufacturing cells and the variety of drawing information dealt by the various stakeholders in the organisation.

Furthermore, based on the conclusions of these findings, a series of recommendations have been made. These are:

1. To implement ADIS into all the Manufacturing cells;
2. To utilise the system in the Engineering offices;
3. To entrench the work station as production equipment such that the computer forms part of the cell's cross-training matrix;

4. To change the current computer network to one that is robust and free from trouble as it is imperative that the cell's stations do not stop working. A computer station that is "down" will bring that cell to a standstill;
5. To change the role of the Information Systems Department from a steering function to a support role;
6. To use the Multiview methodology for future system developments;
7. To develop the Manufacturing cells' computer stations, enabling the cell members to track their daily world class targets, reducing the workload of the cell's facilitator;
8. To develop the software into an intranet web page to further enhance the usability of the system in the future.

In essence, the viability of operations and variety of information has been improved by the holistic development of this system. Users of any system have a right to decide if a system will affect their lives in an adverse way. The Multiview methodology of Information Systems Design was able to facilitate this philosophy ensuring that all stakeholders and users had an active participative role to play in the design and the system's consequent acceptability upon its introduction.

# TABLE OF CONTENTS

<b>ACKNOWLEDGMENTS</b>	<b>i</b>
<b>SYNOPSIS</b>	<b>ii</b>
<b>Chapter 1. INTRODUCTION</b>	<b>1</b>
<b>Chapter 2. THE FRAMEWORK AND PROCESS OF ENQUIRY</b>	<b>5</b>
2.1 The Scientific Method	5
2.1.1 Four Methods in Fixing Belief	6
2.1.2 The Stages of the Scientific Method	8
2.1.3 Argyris' Learning Models	12
2.2 Systems Thinking	14
2.2.1 Emergence and Hierarchy	15
2.2.2 Communication and Control	15
2.2.3 System Classes	17
2.3 Systems Thinking Views	17
2.3.1 Ackoffs View on Systems Thinking	17
2.3.2 Stafford Beer - Handling a System (VSM)	18
<b>Chapter 3. SYSTEMS THINKING METHODOLOGIES</b>	<b>20</b>
3.1 Viable Systems Modelling (VSM)	20
3.1.1 Feedback	20
3.1.2 Holism	21
3.1.3 Three Laws of Cybernetics	21
3.1.4 Viable Systems Model	23
3.2 Soft Systems Methodology (SSM)	28
3.2.1 The Seven Stages of SSM	30
3.3 Multiview Methodology	33
3.3.1 Information Systems	33
3.3.2 Multiview's Five Stages	35
3.4 Conclusion	38
<b>Chapter 4. THE RESEARCH PROCESS</b>	<b>39</b>
4.1 Introduction	39
4.2 Research Methods	40
4.2.1 Classical Experiments	41
4.2.2 Quasi-Experiments	41
4.2.3 Action Research	42
4.2.4 Survey Research Design	43
4.2.5 Ethnography	44
4.3 Conclusion - Choosing the Research Method	45
<b>Chapter 5. SUMMARY OF THE RESEARCH FRAMEWORK</b>	<b>46</b>

<b>Chapter 6.</b>	<b>VIALE SYSTEMS DIAGNOSIS OF GABRIEL S.A. AND THE ENGINEERING CHANGE PROCEDURE</b>	<b>49</b>
6.1	Background to the Change of Company Structure	49
6.1.1	Final Assembly Business Unit (B.U.1)	50
6.1.2	Internal Supply Business Unit (B.U.2)	50
6.1.3	Paint, Pack and Despatch Business Unit (B.U.3)	50
6.2	Viable Systems Diagnosis of the Business Unit Structure	51
6.2.1	System Identification	51
6.2.2	System Diagnosis	53
6.3	Variety	67
6.4	Engineering Change	69
6.4.1	Sources of Change	69
6.4.2	Sequence of Change Procedure	71
6.4.3	Model of the ECO Procedure	74
6.5	Conclusion	77
6.5.1	Business Units and the Company Structure	77
6.5.2	Engineering Changes	79
<b>Chapter 7.</b>	<b>MULTIVIEW STAGE 1 : THE HUMAN ACTIVITY SYSTEM</b>	<b>81</b>
7.1	Developing the Rich Picture	81
7.2	Constructing the Root Definition	86
7.2.1	The Change Package CATWOE	86
7.2.2	Creating the Structure CATWOE	87
7.2.3	The ECO Procedure CATWOE	87
7.2.4	The Drawing Distribution CATWOE	88
7.2.5	The Daily Usage CATWOE	88
7.2.6	The Accurate Efficient Product Information System CATWOE	88
7.3	Building the Conceptual Model	89
7.3.1	Create the Engineering Change Package	90
7.3.2	Create/Modify Product Structure Model	93
7.3.3	The ECO Procedure Model	95
7.3.4	Drawing Distribution Model	98
7.3.5	The Daily Usage Model	101
7.4	Defining the Hypothesis	104
<b>Chapter 8.</b>	<b>MULTIVIEW STAGE 2 : FUNCTIONS AND EVENTS</b>	<b>105</b>
8.1	Creating the Function Model	105
8.2	Establishing Events and Data Flow	109
8.2.1	System 1 Operations Unit Daily Usage Data Flow	109
8.2.2	Drawing Distribution Data Flow	111
8.2.3	ECR Registration Data Flow	112
<b>Chapter 9.</b>	<b>MULTIVIEW STAGE 3 : ANALYSING AND DESIGNING THE SYSTEM'S SOCIAL AND TECHNICAL ASPECTS</b>	<b>113</b>
9.1	The Socio-Technical Design of the Accurate Drawing Information System	113

9.2	The Socio-Technical Objectives and Alternatives to a New System	116
9.2.1	Social Objectives and Alternatives	116
9.2.2	Technical Objectives and Alternatives	118
9.2.3	Ranking the Socio-Technical Alternatives	120
9.3	Conclusion	121
<b>Chapter 10.</b>	<b>MULTIVIEW STAGE 4 : DESIGN OF THE HUMAN COMPUTER INTERFACE</b>	<b>123</b>
10.1	Dialogue Analysis	123
10.2	The Design of the Drawing Viewing System	126
10.2.1	The Viewing Package	126
10.2.2	Computer Hardware	128
10.2.3	The Working Prototype	129
10.2.4	Work Instructions : Defining the User Dialogue	130
10.3	Summary	136
<b>Chapter 11</b>	<b>MULTIVIEW STAGE 5 : IMPLEMENTATION AND TESTING OF THE INSTANT ACCESSIBLE DRAWING INFORMATION SYSTEM</b>	<b>138</b>
11.1	Technical Design	138
11.1.1	Retrieval of Drawings	139
11.1.2	Structure of the Database and Maintenance	140
11.1.3	System Control	140
11.1.4	Recovery from Errors and Breakdowns	141
11.1.5	Monitoring the System	142
11.2	Implementation of the Accessible Drawing System	143
11.2.1	Additional Network Requirements	143
11.2.2	Hardware Security	144
11.2.3	Training and Usage	144
11.2.4	Problems	146
11.3	Testing of the Instant Drawing System	148
11.3.1	Testing the Human-Computer Interface	149
11.3.2	Testing the Daily Usage System	150
11.3.3	Testing the Drawing Distribution System	150
11.3.4	Testing the Raising of an ECO Number	150
<b>Chapter 12.</b>	<b>TEST RESULTS AND FINDINGS</b>	<b>151</b>
12.1	Human Interface Test Findings	151
12.1.1	Results	151
12.1.2	Observations	153
12.2	Daily Usage Test Findings	153
12.2.1	Results	154
12.2.2	Observations	155
12.3	Drawing Distribution Test	156
12.3.1	Results	158
12.3.2	Observations	158
12.4	Raising and ECO Test	159
12.4.1	Results	159

	12.4.2 Observations	161
12.5	Findings on the Quality Cost Impact	162
	12.5.1 Quality Scrap Report	163
	12.5.2 Corrective Action Reports	163
	12.5.3 Opportunity	164
12.6	Discussion on the Tests	164
<b>Chapter 13.</b>	<b>CONCLUSIONS</b>	165
	13.1 The Origin of ADIS	165
	13.2 ADIS in Context	166
	13.3 The Development of ADIS using Multiview	166
	13.4 Conclusions drawn from Tests & Findings	168
	13.5 Cost of Implementation	169
	13.6 Advantages of ADIS	170
	13.7 Concerns	171
<b>Chapter 14.</b>	<b>RECOMMENDATIONS</b>	172
	14.1 Implementation of ADIS	172
	14.2 Multiview	172
	14.3 Future Development of ADIS	173
<b>Chapter 15.</b>	<b>REFLECTION ON MY LEARNING</b>	175
	<b>BIBLIOGRAPHY</b>	177

## **APPENDICES**

- 1.** Table of the Business Unit Structure
- 2.** Measures Summary Sheet
- 3.** Change Model
- 4.** After Market Shockabsorber Drawing
- 5.** O.E. Parts List
- 6.** E.C.R Document
- 7.** I.S.I.R Marked up Drawing
- 8.** Inter-cylinder Drawing
- 9.** Cross Training Matrix
- 10.** Quote for Workstation
- 11.** Officially Stamped and Signed Drawing
- 12.** O.E. Shock Cell Layout
- 13.** Fax to Cyco Agents
- 14.** A Master Drawing
- 15.** New Format Drawing
- 16.** New Format Drawing
- 17.** New Format Drawing
- 18.** New Format Drawing
- 19.** New Format Drawing
- 20.** New Format Drawing
- 21.** New Format Drawing
- 22.** New Format Drawing
- 23.** New Format Drawing
- 25.** Photographs of the ADIS Workstation
- 26.** Photographs of the ADIS Workstation
- 27.** Photographs of the ADIS Workstation
- 28.** Corrective Action Report 1
- 29.** Corrective Action Report 1
- 30.** Corrective Action Report 1

## CHAPTER 1

### INTRODUCTION

Gabriel S.A. is one of two local shockabsorber manufacturers in South Africa. The products that the company manufactures include shockabsorbers, struts, cartridges and gas springs. These products are aimed at three different markets, namely, automotive manufacturers (Original Equipment ie. O.E.), replacement market, (Aftermarket) and export. As result of the reduction in tariff protection and the increasing pressure to become internationally competitive, Gabriel S.A. has undergone a strategic repositioning. This involved a move away from the traditional hierarchical management structure and production line manufacturer, to a flatter structure with cross-functional Business Units. These Business Units are each made up of self-contained, Manufacturing cells run by self-directed work teams. The objective of this rather drastic re-organisation was to ensure that Gabriel S.A. become an efficient, fast, superior quality manufacturer who seeks to attain high levels of customer satisfaction. This quest necessitates that Gabriel S.A. continuously implements the standards of World Class Manufacturing.

The drive to penetrate new markets and retain existing ones successfully, is going to involve an increase in the number of quotations being prepared, an increase in the number drawings required and modification to existing products, which will involve revisions to current drawings.

The company has gone a long way down the road in implementing World Class Manufacturing techniques through the Gabriel Total Quality Production System (GTQPS). This has had a tremendous impact in terms of productivity. However, problems still arise within the system, especially with regard to new designs and changed designs reaching the shop floor timeously. During the process of daily operation of the business, many activities occur to manufacture the product. Of concern is the flow and impact of information as a result of change. There are three main reasons for this concern. Firstly, when a product does not conform to specification, deviations have to be raised to inform all concerned. This is done to ensure that the parts' quality is not compromised, that material adjustments can be made and that production can continue without interruption. Secondly, sometimes permanent changes to drawings and parts' lists that are required as a result of deviations/modification of components or supplier or a change in the customer specifications. Thirdly, when a new product is released into the system

as result of a new model or customer placing new business with us. The problems that occur with these changes are numerous and they seem to take excessive time to reach the concerned areas on the factory floor. The problems include the new drawings, production and inventory.

Another area of concern is that there is over 12 000 drawings situated in files in the various Manufacturing cells. These files should contain only the latest revision of the drawings pertaining to a relevant area. However, as there is no way in controlling and auditing these files effectively drawings can and do, get lost. Similarly, old drawings are sometimes not replaced by the new ones, resulting in incorrect drawing levels being on the shop floor. The consequences of incorrect or missing drawings is that errors are made. These errors, in turn, result in parts or final products being scrapped off. Not only are these errors extremely expensive, but they have an adverse affect on customer satisfaction levels, the placement of future business and the viability of the Business Units and their Manufacturing cells.

The question arises that if the viability of the Manufacturing cells is being compromised through incorrect or missing drawing information, is there a system that can be implemented which can ensure instant access to the correct information by these Manufacturing cells? Is there a methodology to facilitate the implementation of the system in a manner that is socially acceptable by all users and stakeholders?

The answer to these questions is addressed in this thesis. This is done by developing a Research Framework (see Fig 1.1) and investigating the Multiview methodology of Information Systems Design which is used to model the current situation at Gabriel S.A. It is also used to conceptualise a new model of the system, to design and implement a system to provide a solution to the above concerns. The thesis will cover the design and development of the system. Thereafter a prototype is built which is implemented into a Manufacturing cell and tested.

Chapter 2 of the thesis covers the philosophical development of the Research Framework based on the work of Charles Peirce's Scientific Method, describing the four methods of fixing belief and the reasons why his Scientific method is the best way to fix belief. Two of Chris Argyris' learning models are described being, the ladder of influence and his concept of double loop

learning. This is followed by a discussion on Systems Thinking as an extension to the Scientific Method for coping with complex managerial situations.

Chapter 3 consists of discussions on three methodologies of Systems Thinking. These are Viable Systems Modelling which is used for diagnosing organisational behaviour (concepts of the VSM are used throughout the thesis), Soft Systems Methodology and the Multiview Methodology that is a socio-technical approach for Information Systems Design.

In order to immerse into the research environment and gather information, different research techniques must be considered. These techniques are experimental research design, quasi-experiments, action research, surveys and ethnography. They are detailed in Chapter 4 using the work of Gill and Johnson as a resource. The chapter is concluded by a discussion on the type of research is used for this thesis.

Chapter 5 summarises the synthesised research framework and is followed by Chapters 6 and 7 which form the abductive phase of the Research Framework. Chapter 6 details the Viable Systems Diagnosis that investigated the Business Units and the manner in which they are integrated into the whole company structure as well as the Engineering Change System, within the framework of VSM. Chapter 7 uses Multiview Stage 1 to investigate the human activity system, by finding out the different world views various stakeholders have to Gabriel's systems. This stage develops a Rich Picture of the situation from which Root definitions are extracted. Conceptual models are developed from these Root definitions. The chapter is concluded by defining the hypothesis.

Chapters 8 to 11 are dedicated to the next four stages of Multiview and form the verification stage of the Scientific Method, dealing with the development and eventual introduction of the new Accessible Drawing Information System (ADIS). These sections include functions and events, designing the social and technical aspects, designing the human computer interface and finally, the implementation and testing of ADIS.

Chapter 12 details the findings from the tests performed in Chapter 10 on the old and new systems. These findings include the costs of poor quality as a result of the current system. Chapters 13 draws conclusions on the new system using Multiview. This is followed by a

chapter on recommendations. These include the full implementation of ADIS and a move to use Multiview as a tool for future information system's developments. The final chapter of this thesis deals with the author's reflection of his learning experience.

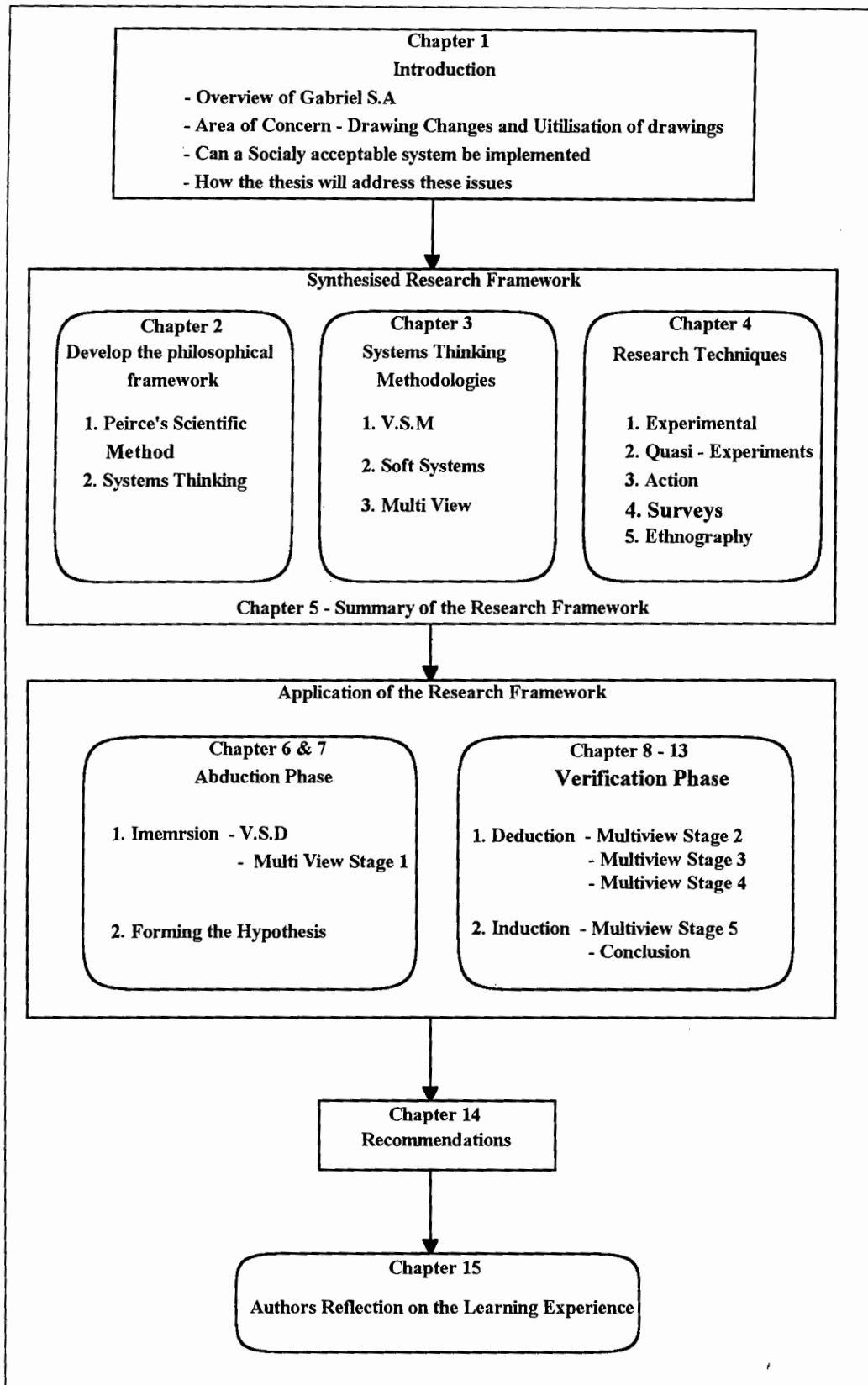

Fig 1.1: The Thesis Framework

## CHAPTER 2

### THE FRAMEWORK AND PROCESS OF INQUIRY

The purpose of most management projects is to carry out an inquiry into situation or problem that is of concern. Managers, being pragmatic, are not concerned in how, but in the results. To search for answers that can be confidently stated as the truth, a framework is needed which transforms the concern or uncertainties into belief, the knowledge into action. This framework must be thorough and rigorous to eradicate any doubt of the results.

This chapter deals with the development of the framework. Firstly, it will firstly describe Peirce's Scientific Method that is the chosen framework for the enquiry, showing why it is the best way of fixing belief. This is followed by a discussion on Argyris' learning models (Ladder of inference and double loop learning). The chapter is concluded with a discussion on Systems Thinking as an extension of the Scientific Method enabling it to cope with complex managerial situations.

#### 2.1 THE SCIENTIFIC METHOD

The Scientific Method is a means to find out what really is happening in a problem, a means to discover the answer or the truth. Those beliefs, according to Peirce, that allow people to act in the most effective, efficient way. Peirce believed that to understand science, one must understand what the scientist is about<sup>1</sup>. The scientist's motive is to search for knowledge for knowledge's sake. The scientist is driven by the truth about the ways of nature for the sake of learning. This theory goes further to highlight that the method of science undertaken to learn about the truth, is clearly related to one's motives. Although the scientist may start out using an inappropriate method, sooner or later he will make use of the correct Scientific Method if he is truly moved by his love for truth and knowledge.

The practical person, unlike the scientist, is driven by results and action. Managers being practical people are concerned with situations, initiating inquiry, making decisions, implementing changes and analysing the results of their actions. In order to do so, he must believe "with all the force of his manhood" that the object of his action is good, and his plan of

action right<sup>2</sup>. In pursuing truth, the questions that have led to the process, are embedded in doubt, which is the start of the cycle of enquiry. The discussion of the Scientific Method will cover methods in fixing belief, the stages of enquiry, verification and fallibilism.

**2.1.1 FOUR METHODS IN FIXING BELIEF**

To proceed with the quest for the truth, the inquirer must find a method that will satisfy his desire to find the truth in the most reasonable way<sup>3</sup>. Belief according to Peirce, is habit in that people respond in a particular way when certain situations occur. As a result of this, beliefs are established so that action can be taken accordingly. Similarly, the person will, depending on their belief, have expectations of something occurring in a certain way whenever the particular situation arises. The cycle or process according to Peirce's method of fixing belief is as follows (see Fig 2.1 below).

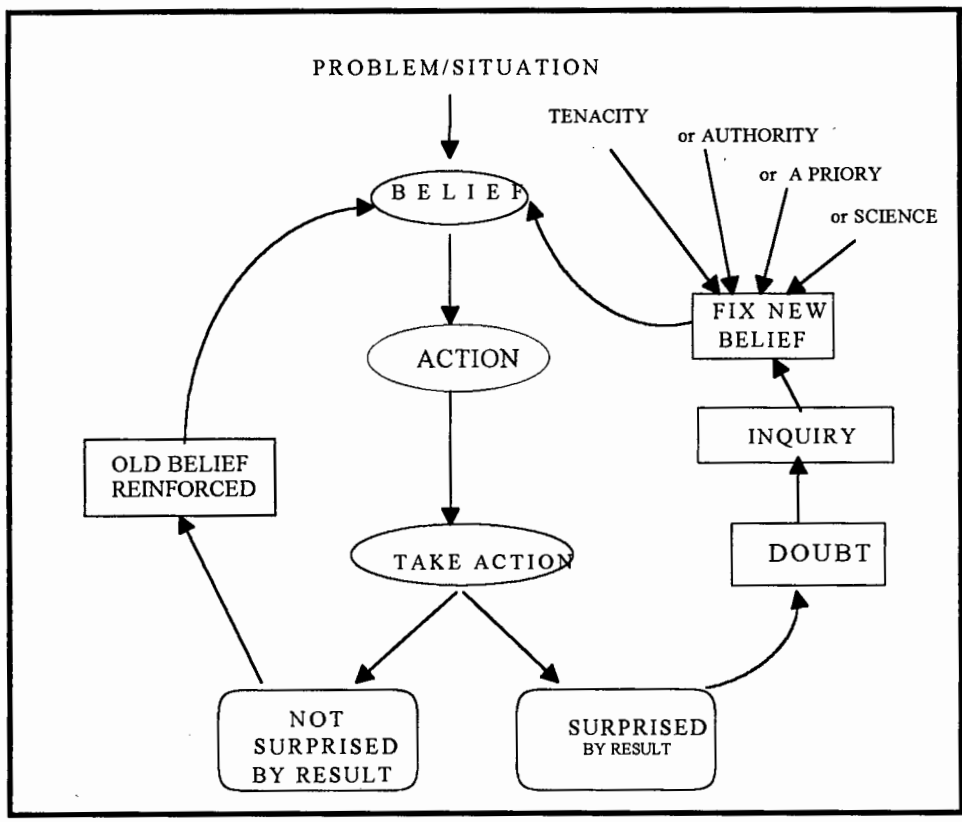

Fig 2.1 - The Process of Fixing Belief

The manager or researcher encounters a problem or situation and acts according to their pre-defined belief. The action taken has two distinct outcomes. Firstly, if the outcome meets

their expectations, there will be no experience of surprise. Secondly, if the result is different to what was expected, surprise will be experienced followed by doubt in how to act when the situation reoccurs and what the expected outcome will be.

The manager or researcher's doubt in their belief gives rise to a feeling of surprise that will initiate an inquiry into why their belief is not true. This inquiry results into a reassessment and changing of belief, the fixing of a new belief. The fixing of belief can be done, according to Peirce, in four different ways, namely, Tenacity, Authority, A priori and the Scientific Method.

#### **2.1.1.1 The Method of Tenacity**

The weakest method has been found to be that of tenacity. In this method the inquirer looks at a situation with the conviction of his pre-conditioned beliefs. This conditioning occurs over time and is biologically easier to remember things thus resulting in people having rigid paradigms. It is very difficult to make a paradigm shift because these paradigms are so deeply rooted. The possibility of entertaining new beliefs are therefore remote as the comfort of the old beliefs will have to be discarded. The result is that by using the method of tenacity, the person will not undertake a route of inquiry that will disturb that belief.

#### **2.1.1.2 The Method of Authority**

This method addresses some of the shortcomings of the method of tenacity by imposing the will of an institution. The institution forces people to believe in those things that it wants them to believe in, and punishes those refusing. This method does not allow for innovative thinking or investigations and ultimately leads to doubt and a weakening of their beliefs that have been forced upon them.

#### **2.1.1.3 The Method of A Priori**

The a priori method is one where man adopts views and assumptions that are agreeable to him without questioning them. The problem that arises with this method of fixing belief is that the assumptions or views held by one person are usually not the same as those held by others.

#### **2.1.1.4 The Scientific Method**

The Scientific Method is the most satisfactory way to fix belief as the doubts that arise in the inquirer's mind are answered by something that is affected by his thinking. The enquirer is able, unlike the three other methods, to exert his free will with rigour, a precise formulation of method that is clear, definite, testable and repeatable. Because rigour is one of the key concepts of this method, no shortcuts are taken. It is a methodology which is coherent and followed rigorously in order to find absolute truth.

### **2.1.2 THE STAGES OF THE SCIENTIFIC METHOD**

The Scientific Method consists of various stages, namely, immersion, the formation of the explanatory hypothesis, abduction, verification of the hypothesis and fallibilism.

#### **2.1.2.1 Immersion**

As there is no human knowledge that is not based on observed facts, it can be said that experience is the beginning of all our knowledge<sup>4</sup>. The inquirer thus starts his work with a background of experience. It is a cognitive phase, involving the awareness of an external object. The observation with which scientific enquiry begins holds something that is unexpected. It is this unexpected discovery that surprises the enquirer, moving him to search for a reason or explanation for this event resulting in the formulation of several general hypotheses to explain this experience.

#### **2.1.2.2 The Formulation of the Explanatory Hypothesis - Abductive Phase**

Inquiry begins with a hypothesis that will try to explain the surprising phenomena that have occurred. This hypothesis is formed through a process of abduction that gives the researcher a theory or theories that can be verified through an inductive phase. Abduction suggests the hypothesis in a form of questions which try to explain the facts that have been observed. Two main characteristics of this explanation offered by abduction are that the explanatory hypothesis renders facts that have been observed as necessary. Secondly, that the facts that

are different to the facts to be explained, are not directly observable. Abduction can however only suggest what may be true. The enquirer will, by suggesting new ideas, attain understanding.

When choosing an explanatory hypothesis, it is extremely important that it can be verified through experimentation. The initial hypotheses that the inquirer comes up with are often experienced based guesses. The hypothesis selected must be such that it is fairly broad. It should include the following three phenomena to economise the verification phase:

1. The hypothesis must be experimentally verifiable;
2. During the abductive stage, time, money and energy must be considered. The unsuitable hypotheses must be discarded right at the start without putting them through a test phase thus avoiding a waste of resources;
3. The best hypothesis, as Peirce says, in the sense of the one most recommending itself to the enquirer, is the one most readily refuted if false<sup>5</sup>.

The learning loop that occurs, when the hypothesis that has been chosen does not meet the facts, is important as the experience and knowledge gained can be used in the next hypothesis.

### **2.1.2.3 The Two Phases of Verification**

There are two basic phases of verifying the hypothesis being deduction and induction. In this process the enquirer tries to establish if his hypothesis is close to the truth. Experimental conclusions are drawn from the hypothesis from which he tries to see if they actually occur. He will then establish a set of rules or conditions under which the results should be observable. To achieve this, the hypothesis should be rephrased as a question before observations are made. The resemblance's should be randomly noted and the failures as well as the success of the predictions should be honestly noted.

Although verification must be carried out according to a set of rules, the inquirer must be detached in order make repeated attempts to prove the hypothesis false. Thus, on proving the hypothesis valid and verified, a progression in science can be made.

### **(a) The Deductive Phase**

The first stage in the verification process is to design tests which evaluate the hypothesis. The enquirer establishes predictions based on his experience from the testable hypothesis and he watches them to come true. Deduction is thus an unfolding of experiential events from the explanatory hypothesis. Its main function is to develop this hypothesis by drawing experience based results from it. The results must be observable and the truth must be reached through experience and not by a reasoning process. The deductive process therefore must produce observable predictions from the hypothesis. Trust in the hypothesis is enhanced if the predictions come out as expected, partially verifying the hypothesis.

The deductive process in the scientific enquiry is terminated by predictions of the "if-would" type - the results of the test must be virtually unknown. Therefore, this deductive phase of verification ends with predictions that have been observed from the explanatory hypothesis.

### **(b) The Inductive Phase**

The inductive stage is where the enquirer tests those predictions that he has observed from the explanatory hypothesis. It is a phase where nature is examined in detail to see if the predicted observable events of the hypothesis occur. The enquirer then evaluates the results of the hypothesis to establish whether his theory "holds water". From this he is urged to change, reject or modify the hypothesis. If the hypothesis is not adopted, the abductive and deductive process is repeated (Argyis's double loop learning)<sup>6</sup> to ensure that the truth is reached. The modified hypothesis which results from the testing and new abduction must be submitted to the same test as the previous hypothesis. Thereafter acceptance, modification or rejection of the hypothesis occurs again. It is this repeated process that narrows the gap, resulting in belief. The failure of a hypothesis can be valuable as the enquirer has gained experience that could highlight useless or useful areas for future hypotheses.

To ensure that the results are not disastrous, the enquirer must predesignate the characteristics of the object. He must decide what he is testing before tests are begun. He must also honestly pledge that the areas being examined are a fair, clear sample of the class of areas under scrutiny. It is impossible to test the whole class, therefore a representative sample of the area of concern must be selected. The inductive process asks how close the hypothesis compares to the truth, thus generating a proportion of events from the hypothesis that can be verified. As a result of this phase the enquirer will be able to pass judgement on his explanatory hypothesis.

The Learning process that is experienced through the testing of predictions can be used as a basis for a revised hypothesis that is formed by a new abduction phase. The experience on which the new abduction is formed is gained in the testing of events of the previous hypothesis. From this experience, the enquirer is able to form a better, more correct hypothesis. The enquirer's increased familiarity will enable him to instinctively select a more suitable hypothesis to explain the events.

#### **2.1.2.4 Pragmatism**

According to Peirce, his method of enquiry is pragmatic. His "pragmatic Maxim" states that a person only knows and understands something when they conceive what the practical implications on the situation are. Therefore, as modern managers, the practical implications of our decisions must be understood. The positive and negative results of past actions must be taken into consideration, developing and changing our mental models of situations.

Peirce's Pragmatic Maxim also implies that any hypotheses that are proposed must be verifiable and testable. However, he claims that although experiments continue from which the scientist will expect certain results, no belief can be permanent or stable. If it was, the scientist or researcher would have reached absolute perfect knowledge, which is not possible as shown in his theory of fallibilism.

### **2.1.2.5 Fallibilism**

Peirce's work states that knowledge gained through scientific enquiry cannot be absolute. The method can eventually converge on the truth. However, it never really reaches the final total truth, therefore there should always be some hesitancy about the real value of the results. The enquirer must never be happy and content with what he has achieved as there is always the possibility that errors have occurred in the process. The knowledge that he is capable of making a mistake is the restraint that he places on his optimism. " The best knowledge which we possess is uncertain and inexact. What is one day acknowledged as doubt free can be proved false the next."<sup>7</sup>

It can be concluded that the Scientific Method is the best way to do meaningful enquiry to find the truth. With the other three methods, the enquirer is unable to exercise his free will rigorously. The method of Tenacity uses a process of conditioning, the method of authority is an autocratic process and the method of apriority uses known axioms as being true without questioning them. The Scientific Method allows the enquirer to develop his understanding of the truth whilst still being able to acknowledge that closure is not final, that genuine doubt may start a new process of inquiry.

### **2.1.3 ARGYRIS' LEARNING MODELS**

As previously discussed, models of reality are based on the beliefs one has of the world. The Scientific Method of fixing belief was described as well as the impact of these beliefs in decision making, the theory of pragmatism. Argyris developed Peirces' ideas by producing his "Ladder of Inference" model that is designed to describe how beliefs are formed and how they influence actions and the way we understand things as shown in Fig. 2.2 below. The Ladder explains how these beliefs or mental models are adopted. Information from an experience is gathered. This Information is interpreted and given meaning from which assumptions and conclusions are drawn. From these conclusions, beliefs are adopted and action is taken.

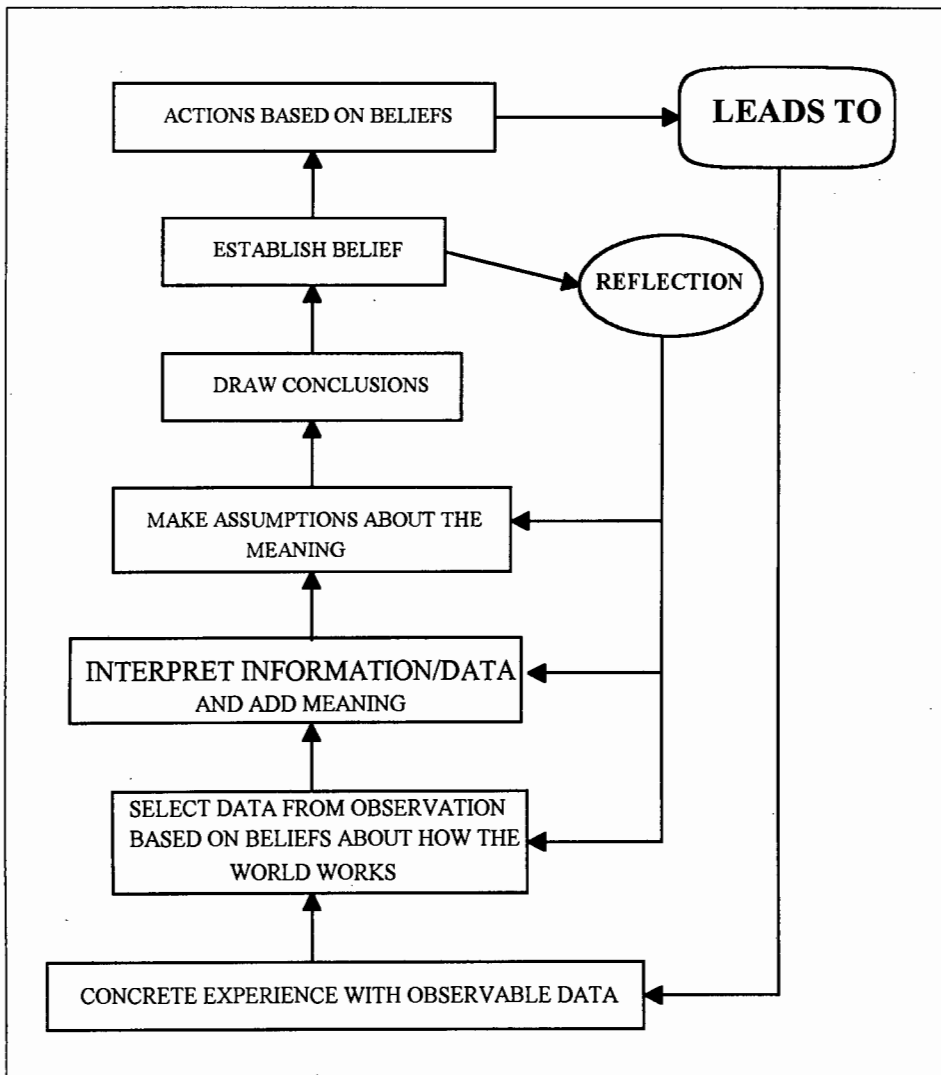

Fig 2.2 - The Ladder of Influence <sup>8</sup>

Argyris calls these beliefs "Theories in use" on which behaviour is based. This theory in use will, in problematic situations, determine what action is to be taken as well as an indication of the desired outcome. However, the desired outcome can and does sometimes differ from what is experienced. When this occurs, the mental model can be either modified or changed. Argyris' work shows that learning is only worthwhile if there is a change in the mental model of a situation, namely, one goes through a process of double loop learning<sup>9</sup>. Unlike single loop learning where beliefs are changed by means of error detection and resulting correction, double loop learning provides a means of converging on the truth through continuous learning and feedback as shown in Fig. 2.3 below.

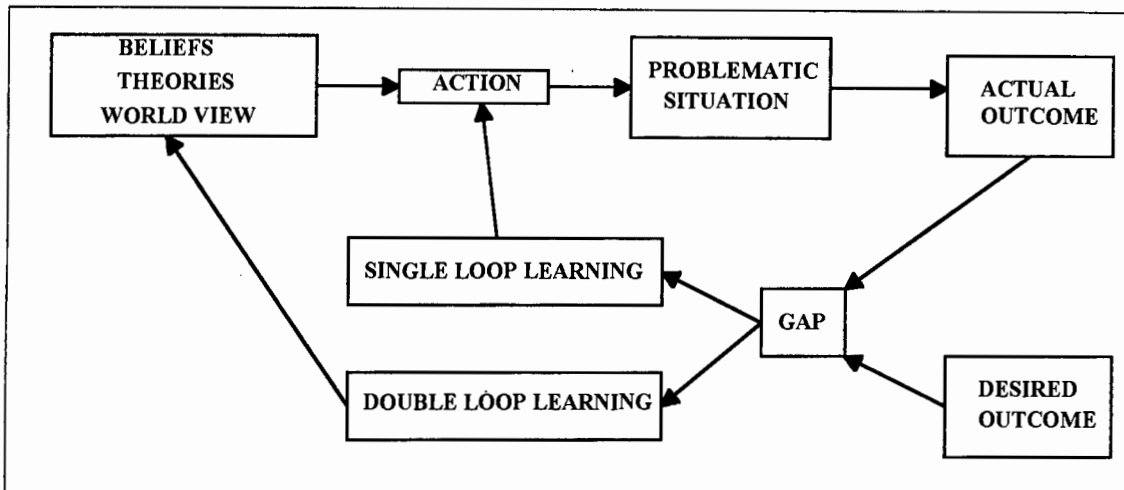

Fig 2.3 Argyris's learning loops (Source: UCT lecture notes - Ryan, T (1995))

## 2.2 SYSTEMS THINKING

We have seen that the Scientific Method is the best way to do meaningful enquiry in order to find the truth. However, the scientific approach based on reductionism, repeatability and refutation can struggle when extremely complex phenomena occur, namely, the type of phenomena with several interacting variables, which exceed those with which the scientist can cope.<sup>10</sup> This is shown in two main areas that are rich in complexity being the social sciences and management problems. Studies in these areas result in trends occurring rather than defined results or laws. Unlike using science, where results are expected, social and managerial systems evolve and change continuously, reacting to predictions made about themselves.

Systems Thinking has come about as a response to dealing with these areas of intense complexity. These areas of social sciences and management are all unrestricted and present considerable problems for the methods of science. Systems Thinking is an attempt to retain much of the tradition of the Scientific Method and supplement it with a way of tackling complex irreducible problems. This is done through a process of thinking that is based on wholes and their properties.

System Thinking is founded on two sets of ideas, namely, emergence and hierarchy, and communication and control. It is a matter of finding out the properties of systems in various classes and the way which they act on each other in order to combine and form a wider system showing emergent properties.

### **2.2.1 EMERGENCE AND HIERARCHY**

Hierarchy theory is concerned with the differences between one level of complexity and another. Its ultimate aim is to be able to account for the relationships between the different levels and to account for how these observed hierarchies are formed. To know what generates the different levels, what separates and what links them.

The theory is said to be built on the fact that the emergent properties, associated with a set of elements at one level in a hierarchy, are associated with what appear as constraints upon the degree of freedom of the elements. The imposition of constraints upon activity at one level, which harnesses the laws at that level to yield activity that is meaningful at a higher level. This is an example of regulatory control. Hierarchies are characterised by these processes of control operating at the interfaces between the levels.

### **2.2.2 COMMUNICATION AND CONTROL**

The theory of communications and control can be defined as cybernetics. Cybernetics deals with all forms of behaviour insofar as they are regular, determinate and reproducible. It demands that attention should be paid to the sources of command and control in the system as seen in the Viable Systems Model of Stafford Beer.

Hierarchical control requires three conditions to be met<sup>11</sup>. They are:

1. The imposition of a constraint must impose new functional relations;
2. The constraint must be optimal;
3. The constraint must act on the dynamics of the lower level.

All control processes require communication upon a flow of information, in the form of instructions or constraints, which may be manual or automatic. Continuing this effective control in an environment that is ever-changing, requires a controller whose variety can equal or exceed the variety of information (Ashbeys law of requisite variety)<sup>12</sup>.

The idea of negative feedback is central in understanding control. This allows scientific explanation to be given of purposeful, active behaviour that requires negative feedback. In this process, information is transmitted about any divergence from a pre-set goal. Corrective action is taken to bring the behaviour back towards the goal. Communication is equally significant. If we wish to control the actions of a machine or humans, we have to communicate through some type of medium. Thus the theory of control can be seen as part of the theory of messages.

The Systems Thinker must be aware of the problems with which the reductionist methods of science are unable to cope. He takes the arguments that nature is hierarchically organised with emergent properties at various levels of complexity, seriously. He will try out the usefulness of thinking with coherently organised entities that cannot be properly reduced merely to be collected into one group of their components. The Systems Thinker will also seek an account of the structure of reality. This includes the processes found within this structure in terms of the whole system. The observer should be able to describe the behaviour of his system in two ways. One way being that he may concentrate on inputs and outputs in which the system may be considered as a "black box" that embodies the transformation process. The other way being that he may describe the state of the systems internals in terms of suitable variables.

The background to the ideas of emergence, hierarchy, communications and control provide the Systems Thinker with a systems approach (which is complementary to the reductionist approach of the methods of science) to tackling problems.

### **2.2.3 SYSTEM CLASSES**

Persuing Systems Thinking becomes a matter of finding out the properties of systems in various classes and the way that they act on each other, combining to form a wider or bigger system showing emergent properties.

Any whole entity that an observer sees as a figure against the background of the rest of reality, may be considered as a system from one of five classes of systems, that apparently make up the universe. These being natural, designed physical, designed abstract, human activity and transcendental systems. Natural systems are evolution made and are irreducible and include man who in turn can create the human activity and designed systems. Designed physical systems exist because they are needed in some types of human activity systems. However, the case of social systems shows that real world entities may not fit into one class, they are usually a mixture of linked activities and relationships that need to be accounted for in practical work in the real world.

## **2.3 SYSTEMS THINKERS' VIEWS**

### **2.3.1 ACKOFF'S VIEW ON SYSTEM THINKING**

Ackoff shows that to understand something using the method of science, the thing that is being studied has to be reduced into its various components, identified and thereafter understood. Systems Thinking, on the other hand, is the putting together of things or synthesis. Machine-age thinking had three steps, namely, separating the elements of that which needs to be explained, explaining the properties or behaviour of the separate elements and synthesis of the elements by collecting the explanations together to give an explanation of the whole.

The important point to note is that unlike the machine-age thinking, in Systems Thinking, synthesis precedes analysis. In analytical thinking, the thing to be explained is treated as a whole to be taken apart. It is thus a reducing process of looking into things. In contrast,

Systems Thinking, treats the thing to be explained as a part of the whole system. It is an expanding process of looking out of things.

In Systems Thinking, increases in understanding are believed to be obtainable by expanding the systems to be understood, not by reducing them to their elements. Understanding proceeds from the whole to its parts, not from the parts to the whole<sup>13</sup>.

By looking at systems in an input, output way (teleologically - goal seeking and purposeful), a system's goals, objectives and ideals can be as objectively established as the number of elements it contains. This is the opposite of looking at a system deterministically (input orientated). Systems Thinkers thus focus on teleological systems, namely, they are concerned with the purpose of the system, its parts and of the larger system of which it is a part.

### **2.3.2 STAFFORD BEER-HANDLING A SYSTEM**

Beer states that there are things that can be said of systems once the conventions about their nature, boundaries and purpose have been established, for example, the 80 - 20 rule. Any system that has an effort applied to make it work which produces a pay-off from the system that is of a non-linear nature. It is fairly easy to get good results from a system at the start, as long as the most appropriate efforts are used, while it is difficult to get the last bit of pay-off at the finish. For example, eighty per cent of production goes to fulfilling twenty per cent of the orders. This gives rise to a management strategy which chops off the uneconomic tail of the curve as too much effort is used in the final eighty percent to raise the pay-off through its final twenty percent. Therefore if one saves eighty per cent of the cost and gets a twenty per cent cut in earnings, profitability is increased.

S. Beer shows that this has several problems from the Systems Thinking point of view. For example, when the relationship between the effort and pay-off on a very convex curve running through an eighty - twenty point does the same again after the so called uneconomic tail has been cut off. By being consistent, all the tails of the new curves will be cut. Management usually fails to contemplate the systemic consequences of policies that are accepted conventions. There is not enough agreement as to the real nature of the system concerned.

Ultimately therefore, a system cannot be handled properly, unless an insight to the system nature, i.e. its purpose and boundaries, is obtained. System Thinking is about gaining a different, wider perspective of a situation under observation. This can be done by several different methods.

This chapter has developed the philosophical aspect of the research framework using Charles Peirce's Scientific method, learning models and Systems Thinking as an extension to the Scientific method for coping with complex social and managerial situations.

The following chapter will discuss three systemic methodologies that will be considered for use in the framework for enquiry of this thesis. The three methodologies being Stafford Beer's VSM (Viable Systems Modelling), SSM (Soft Systems Methodology) and finally, Multiview, a Soft Systems approach to Information Systems Design.

## **CHAPTER 3**

### **SYSTEMS THINKING METHODOLOGIES**

This chapter covers three methodologies of Systems Thinking which are considered in the framework of enquiry of this thesis. In short, Systems thinking is really about gaining different, wider perspectives of a situation under observation. This can be done by several different methods. Firstly, Stafford Beer advocates using cybernetics - VSM (Viable Systems Modelling) and VSD (Viable Systems Diagnosis) for diagnosing the enterprise. Secondly, Soft Systems Methodology (SSM) is used for studying complex management issues and thirdly, in the case of information systems, the SSM based Multi view methodology can be used.

#### **3.1 VIABLE SYSTEMS MODELLING (VSM)**

Stafford Beer advocates using cybernetics, namely, VSM (Viable Systems Modelling). Cybernetics according to Beer is the science of an effective organisation. These systems have characteristics that consist of complexity, dynamics, random behaviour (probabilistic), integral and openness. Cybernetics looks at the patterns, laws, principles and behaviours that characterise complex, dynamic, probabilistic, integral open systems.

Three central concepts of cybernetics are that of circular causality (feedback), holistic behaviour and the cybernetic laws.

##### **3.1.1 FEEDBACK**

Complex systems that show the above characteristics have to be controlled. This can only be done through a process of self-regulation that is ensured by means of a feedback loop or mechanism that has a positive nature. There are generally two types of feedback being negative feedback (balancing) and positive (reinforcing) feedback. A positive or reinforcing feedback loop will show a growing situation that will eventually explode out of control. On the other hand, a negative or balancing loop operates when there is a goal oriented behaviour

resisting any disturbance that tries to displace it from the goal. The negative feedback loop is thus one that promotes stability.

### **3.1.2 HOLISM**

The second concept is that systems can have a holistic behaviour by having characteristics that belong to the system as a whole, but not to the parts. Thus the system has emergent properties that do not give a hint of properties that the whole system possesses.

### **3.1.3 THREE LAWS OF CYBERNETICS**

From a fairly large set of laws, three laws of nature and their immediate deductions, are representative of cybernetics. The reason being that all systems are subject to these three laws<sup>14</sup>.

#### **3.1.3.1 Self Organising Systems**

Law 1:- *Complex systems organise themselves.* The characteristic structural and behavioural patterns in a complex system are primarily a result of interactions among the parts. In other words, it is that way because of the mutual adjustment of parts made through the process of interaction.

Law 1a - *Complex systems have basins of stability.* Some parts of a system show signs of stability while others do not. A marble positioned halfway up a hill is in a state of instability as it can roll to another position. To enable stability, the marble must be pushed over the top of the hill and put in a basin where a new stability is found. Thus, as the law states, in the design of organisations, one must know and understand what basin the system is going to be placed in.

### **3.1.3.2 Feedback Loops**

Law 2:- *The output of a system is dominated by the feedback.* Between systems there are continuous inputs and output or interactions called high gain amplifiers that change a given input. The law thus selects out those systems that have characteristics of circular causality and inputs that are changed by a large amount by one the systems.

Law 2a:- *All outputs that are important to the system will have associated feedback loops.*

This law implies that any system that does not have a feedback loop is defective. The text (referred to in footnote 14) has a good example (hospitals) to show the effect of not having a feedback loop designed into the system.

As stated previously, there are two types of feedback being positive and negative. It is by invoking sets of these interlocking feedback loops that the peculiar nature of self-organising systems can be explained. Some of these peculiarities can seem to be contradicting. The difference between a positive and negative loop is one of degree where a negative feedback loop can be transformed into a positive one by making very small changes in the system. Making a change from negative to positive will change the system from a stable system to one that will explode out of control.

### **3.1.3.3 Requisite Variety**

Law 3:- *Given a system and some regulator of that system, the amount of regulation attainable is absolutely limited to the variety of the regulator.* This law implies that the relative complexity of the regulator and the system that is being regulated is extremely important. Variety is the number of different states a system can be in, therefore the more complex the system, the more states it can find itself in. Regulation of the system is the continuous interaction between the system and the regulator. However, due to different perceptions and world views, the regulator is often incapable of actually perceiving the aspects of the system.

*Law 3b:- Most of the regulation of very complex systems is achieved through interaction of the parts. One part acts to regulate some other part. The mechanism through which complex systems organise themselves is done through a series of interlocking feedback loops. These loops will interact until each of them reaches a level of stability under the conditions provided by each other. The law of requisite variety makes explicit, the amount of control one given part can have on another.*

Following from the three basic laws of cybernetics, the researcher when investigating an organisation, will most probably find one that is messy and problematical . Furthermore management will be in a state of confusion, not knowing which way to turn. To address the situation, a series of interrelated question types could be asked. These questions have to do with the people's paradigms of those situations. If, for instance, the paradigm is mechanistic or of a reductionist nature, the problem can be split up and dealt with in the separate parts. However, if the paradigm is holistic, the researcher can deal with critical aspects without the situations' participants knowing about the specifics. A typical set consists of seven questions covers the system's definition, the system's purpose, the system's constraints, its meta language, its dynamics, the required output and its self -organising ability. The answers to these questions define the organisation's identity and its understanding of what it is.

### **3.1.4 VIABLE SYSTEMS MODEL**

The Viable Systems Model is a fairly general model, applicable to all systems. Amongst other features, it has variety filters, the system and recursion.

#### **3.1.4.1 Variety**

A system is viable if it is capable of responding to environmental changes, even if those changes could not have been have been foreseen when the system was designed. For this system to remain viable it must achieve Requisite variety. This is achieved when the output variety at least matches the input variety, for the system as a whole. In other words, as Ashby's Law of Requisite variety states, "control can only be obtained if the variety of the controller (and all its parts) is at least as great as the situation to be controlled"<sup>15</sup>. The scale of

variety within a firm is of crucial importance. To understand it, one needs to gradually acquire an insight into the way variety proliferates and into the way it is absorbed.

### 3.1.4.2 Systems

The Viable Systems Model is made up essentially of five main elements, namely, implementation, co-ordination, control, development and policy (See Fig 3.1). The functions of these systems must be adequately performed in the organisation. Within the model, high importance is given to information channel design and the links between the different functions, the rest of the total system and the environment in which it operates. Each of these five systems is discussed, below.

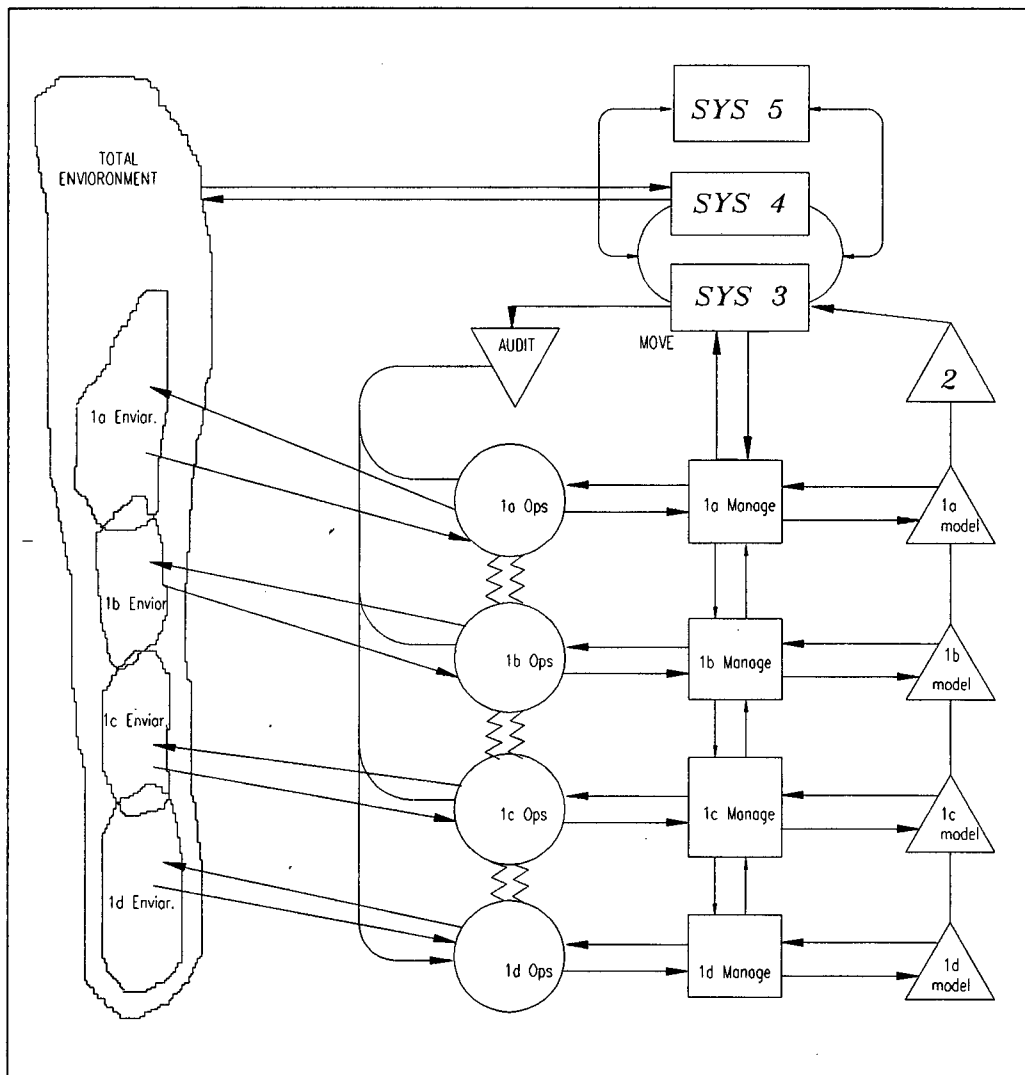

Fig 3.1 - The Viable Systems Model<sup>16</sup>

(i) SYSTEM 1 (IMPLEMENTATION)

System 1 of the organisation consists of the various parts directly concerned with implementation. The carrying out of the tasks that the company is supposed to be doing. The system must be autonomous in its own right so that it can absorb the variety that would otherwise flood upper management. The restrictions of the parts of System 1 are that they still belong to the organisation and have to accept implementation instructions from upper management (see Fig. 3.2). The parts of System 1 must show the features of a Viable System (the structure of the organisation recurs in the system).

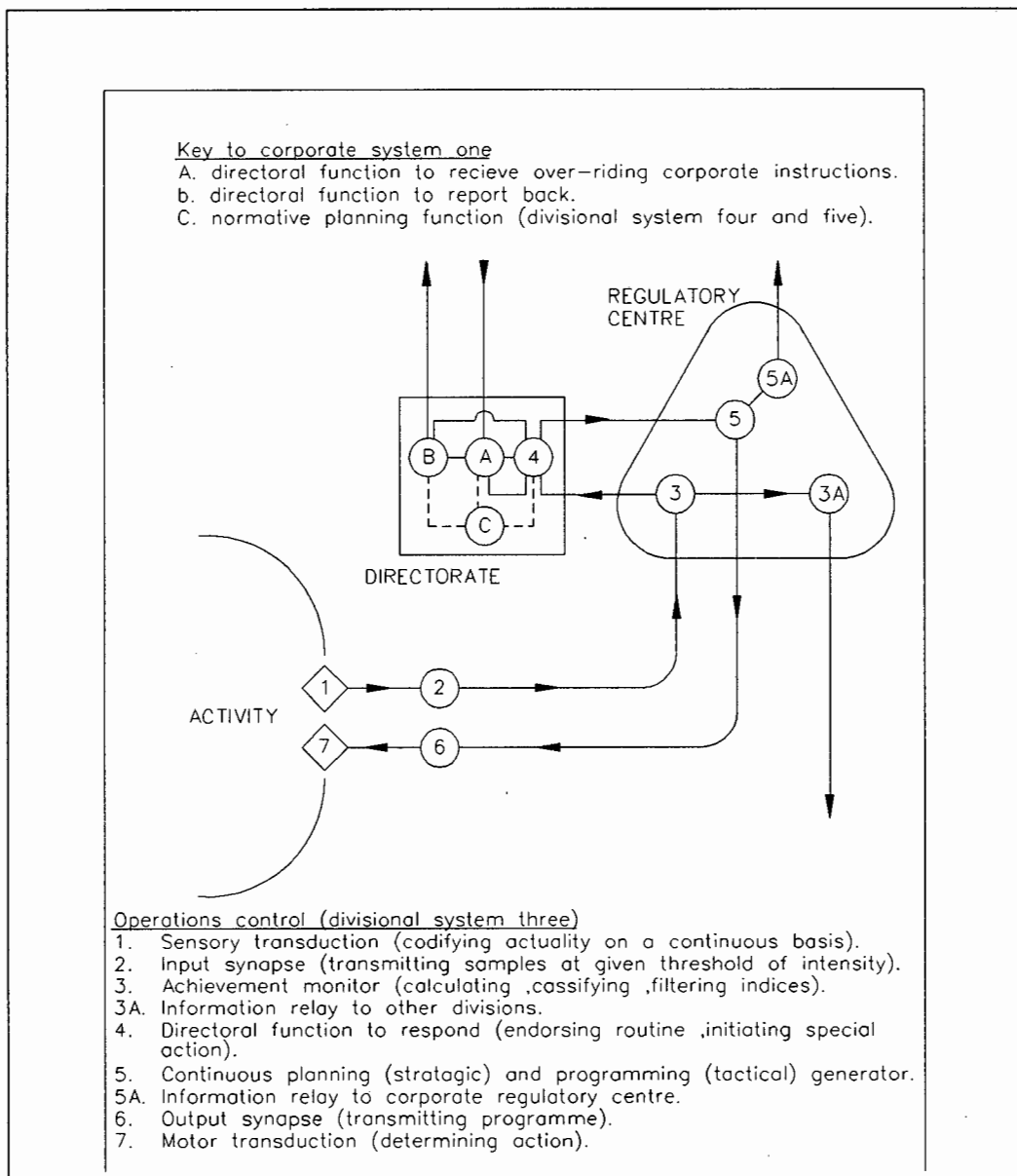

Fig 3.2 System 1, Organisation of Divisional Management <sup>17</sup>

(ii) SYSTEM 2 (CO-ORDINATION)

System 2 is a co-ordinating function that interlinks the divisional regulatory centres to the corporate regulatory centre. It is an elaborate interface between System 1 and System 3 and is the only means whereby uncontrolled oscillations between the divisions can be prevented. System 2 therefore acts as a monitor and co-ordinator of the divisions of System 1 and acts as an input filter into System 3.

(iii) SYSTEM 3 (CONTROL)

This is the highest level of autonomic management and the lowest level of corporate management that governs the stability of the internal environment of the organisation. As System 3 belongs to the vertical command lines, it is therefore a transmitter of policy and special instructions to the divisions and thus steers the company in the direction of the policies generated by System 5. It is also a receiver of the internal environment. The functions of System 3 can be summarised as follows:

- a control function maintaining internal stability;
- interpreting and transmitting a high management policy and directives (steering);
- allocation of resources to System 1;
- ensures effective implementation of higher management policy and directives;
- audits/monitors System 1.

System 1, System 2 and System 3 are thus set up as a three tier, autonomic system intended to maintain a homeostatic internal balance. They must optimise performance within an accepted framework under established conditions that are dependent on a steady stream of appropriate instructions from upper management.

(iv) SYSTEM 4 (INTELLIGENCE/DEVELOPMENT)

System 4 is a major contributor to information requirements for top level decision-making. It is based on information from the external and internal environment. This information is collected by System 4 as direct input from the outside world and switched into System 5, namely, it feeds the highest level of decision-making. Therefore System 4 must contain some model of the corporation and must deal with issues from the environment such as:

- design,
- product plan,
- external training,
- societal constraints,
- market development (research),
- technological development.

The functions of System 4 can be summarised as follows:

- an intelligence/development which gathers all relevant information about the total environment;
- o provide a model of the organisation's environment;
- to distribute the information gathered from the environment up to System 5 or down to System 3 appearing as its degree of importance;
- to bring external and internal information together for decision-making;
- to transmit urgent information from the 3-tier Autonomic system (1, 2 and 3) to System 5.

(v) SYSTEM 5 (POLICY)

System 5 is responsible for the direction of the whole enterprise and is the thinking part of the organisation. The executive management rather than being isolated from each other, must reinforce each other in an interactive assemblage of managers called a multinode. System 5 consists of the following functions:

- to be responsible for policies;
- to respond to filtered signals from Systems 1, 2, 3 and 4;
- to arbitrate between internal and external demands on the organisation as represented by System 3 (control) & System 4 (Development/Intelligence);
- to represent the organisation to the external environment.

#### **3.1.4.5 Recursion**

The Triple Recursion System Theorem of Beer states that the system in focus is in the centre of a higher level of recursion in which it is embedded and it contains a set of viable systems which exist at the next lower level of recursion. This theorem validates the five-tier hierarchical V.S.M. model.

## **3.2 SOFT SYSTEMS METHODOLOGY (SSM)**

As discussed in Chapter 2, Systems Thinking came about as a response to the inadequacy of the Scientific Method's ability to cope with complex social systems or managerial problems. However, although systems engineering is an impressive way to deal with those types of projects, it has failed when applied to changing, ill-defined and messy situations with which managers have to deal with on a day-to-day basis.

Soft Systems Methodology (SSM) is an action research based method of problem solving that has evolved from systems engineering to succeed where the later has failed. It a learning system which studies complex problematical human situations and is aimed at making improvements to that situation by taking sensible action. S.SM articulates a process of enquiry that leads to action that changes the situation. This changed situation leads on to further inquiry as there will new things to find out. This results in a learning cycle consisting of seven stages. Before looking at the seven stages of the SSM process, five general features must be discussed.

(i) Feature 1

SSM is a process for managing. Any-one who is a manager is reacting and trying to cope with a continuous succession of changes of interacting events and ideas. By reacting to these continuous changes, the manager must understand and evaluate them, choose a course of action and then take action. This, in turn, leads to on-going learning, new understandings and further actions.

(ii) Feature 2

From assumption 1, SS.M assumes that different groups of people being autonomous, will have different understandings and perceptions of a situation. They will therefore make different evaluations that will lead to a range of different actions, giving managers more issues to try and cope with.

(iii) Feature 3

By articulating the process of reacting to the changes, systems ideas of holism, consisting of emergent properties will be helpful.

(iv) Feature 4

A set of activities linked to one another in a structure that is logical in order to establish a purposeful whole, can be taken to be a new concept of system called the human activity system. SSM has to engage with the concept of using system's language to give accounts of purposeful activities. In order to do this, it was forced to take account of the need to describe any human activity system in relation to a particular World View. Thus one must accept that in any real world, purposeful action can be mapped by several human activity system, descriptions that are based on different assumptions about World View.

(v) Feature 5

The fifth and last characteristic of SSM is that it is a process of inquiry. SSM learns through a process of comparing the perceptions of real problem situations to pure models of the purposeful activity. Thus it provides an explicit comparison based on systems models that are used in an organised process that, in itself, is a learning system. The purpose of this is to achieve a readiness to take purposeful action in the problem situation.

### **3.2.1 THE SEVEN STAGES OF SSM**

#### **3.2.1.1 Finding out (Stages 1 & 2)**

Finding out about a problem situation can be carried out through three related analyses. The first one takes the intervention in the situation as its subject matter. It identifies the clients who cause the intervention to take place and the problem solvers who do the study. The problem solvers then generate a list of problem owners. The second analysis looks at the problem as a social system, thus establishing the significant social roles for the situation, the role holder's behaviour and the values to which performance in the roles is good or bad. The third analysis examines the situation politically by asking about the disposition of power. These three stages give a Rich Picture from which some systems of purposeful activity can be selected which are relevant to the problem situation.

#### **3.2.1.2 Formulating Root Definitions (Stage 3)**

The formal expression of Systems Thinking in SSM begins by writing down the names of relevant systems (Root definitions) which carry out purposeful activity. The core of the Root definition is the process of transformation that changes some defined input into a defined output.

This stage is the formulation of Root definitions that can be related to a set of questions from which a model can be built called CATWOE:

- C - Customer - Who are the victims/beneficiaries of the purposeful activity?
- A - Actors - Who would do the activities?
- T - Transform - What is the purposeful activity expressed as input transformed to output?
- W - World view - What view of the world makes this definition meaningful?
- O - Owner - Who could stop this activity?
- E - Environment - What constraints in its environment does this system take as constraints given?

Selected relevant systems should always include issue-based Root definitions. If Stage Three is well ordered and yields both primary task and issue-based Root definitions, they will be able to be modelled in the next stage.

#### **3.2.1.3 Building Conceptual Models (Stage 4)**

The model building process of SSM is done by describing the activities named in the Root definition that have to be in the system. They have to be structured according to logical dependencies. The activities that are to be described should not exceed the concepts that one can cope with at once, as shown in the seven plus minus two theory. The model that is finally developed is that of a speculative system that can adapt to a changing environment through a process of communication and control. The system will consist of a sub-system to monitor and control and to enable the system to examine operations, modifying them by taking action as this change occurs. The monitoring system must pay attention to efficiency, efficacy and effectiveness so that measures can be defined to facilitate control action. The concept of hierarchy cannot be ignored as no system can be conceived singularly. It is recursive of a wider system and similarly, has further sub-systems.

Once the model has been completed using activities in the operational sub-system, the activities can in turn be made sources of Root definitions that can be modelled. The model building should be focused only on Root definitions. Thus the elements in the model must relate back to the Root definition.

#### **3.2.1.4 Comparing the Model and Reality (Stage 5)**

The models that have been developed in the previous stage are now used to compare the difference between them. This is a comparison of what is happening in the real world or the perceived real world as seen from different World Views. There are essentially four approaches to assist in this comparison. The first, is to simply record the differences that are obvious between the models and current perceptions and occurrences. The second approach is to use each model to define questions that are concerned with the activities and their relevant links, for which answers are sought in the situation in question. The third way is to operate the system on paper; to write scenarios that can be compared to historic data or experience from those in the situation. The final approach is to endeavour to build a model of part of the reality that is similar to a model that is relevant to it. Once this done, the comparison between the two reveals differences, providing information for discussion on improving the problem situation.

#### **3.2.1.5 Defining Changes (Stage 6)**

In this stage, the differences found in Stage Five discussed or debated to find possible changes that are worth trying in order to improve the problem situation. The changes that are suggested, must satisfy two criteria. They must generate ideas that are systematically desirable and culturally feasible.

#### **3.2.1.6 Taking Action (Stage 7)**

Once the changes have been found worthwhile, they must be implemented. This completes the SSM cycle. The perceptions of the problem situation will have changed through the willingness to make those changes. This presents a more structured problem situation that, by implementing the changes, can be tackled by using S.S.M. in further cycles. Relevant systems

will include systems designed to implement the changes. This becomes an easily followed process that is modelled through the Root definitions and the CATWOE questions.

The Soft Systems Methodology can be therefore be seen as a complex social process in which assumptions of the world are expressed in system's models. These assumptions are debated, challenged and tested, which makes it a participative process. It is a learning system that is continually making comparisons due to the continuous succession of changes. It seeks to articulate a process where a compromise is sought between conflicting views and interests aimed at the implementation of improvements.

### **3.3 MULTI VIEW**

Multiview is an action learning approach that looks at information systems holistically. It is concerned with both the technical and social aspects of a system 's design. It is developed by exploring the areas of application and addressing problems associated with analysis and design activities of the information system. It is also a methodology that structures the tasks for analysts and users during the analysis and design phases and it comprises five main stages. To discuss Multiview, it is necessary to describe what information systems are, the approaches to their development and the stages of Multiview.

#### **3.3.1 INFORMATION SYSTEMS**

By definition *'An information system is any system which assembles, stores, processes and delivers information relevant to an organisation, in such a way that information is accessible and useful to those who wish to use it, including managers, staff, clients and citizens. An information system is a human activity (social system) which may or may not involve computer systems'*<sup>18</sup>

All systems pass through a typical life cycle consisting of the system definition, development of the system and installation & operation of the system (see attached diagram). This cycle is normally started when someone decides that there is a problem or concern with the processing

of information that needs correction or improvement. The study apart from setting the scope should identify the problem area and its main features. It must identify the stakeholders and the need for the project from the company's point of view. It must allocate resources to carry out the project. In terms of Gabriel, the VSM study is being used to address the above. Once the above areas have been identified, a feasibility study will be carried out which includes:

- Description/overview describing what the system will do;
- What the project will involve - time and manpower;
- Cost benefit analysis;
- How difficult the project will be, how satisfactory and usable the results will be.

This is followed by a detailed work study which analyses the information requirements. These include specifying the data that is to be kept by the system and the function that the system is to perform. It is extremely important to assess how the system will be used by the potential users on a daily basis. At Gabriel investigations are beginning to show that this has been neglected. It is therefore imperative that the end-users be involved in defining the systems requirements. The study also defines :

- Activities of the users,
- Reports required,
- Queries to be answered,
- Function and data models,
- User interface requirements.

When the study is complete, a conceptual model of the system is designed which meets the specified requirements.

### **3.3.2 MULTI VIEW AND THE FIVE STAGES**

As discussed, Multiview covers 5 stages of design and analysis:

1. Analysis of human activity;
2. Information analysis;
3. Analysis and design of the socio technical aspects;
4. Design of the human - computer interface;
5. Design of the technical aspects and testing the system.

These stages are necessary to create a system that is complete from a social and technical point of view. The outputs from these stages consist of both issue and task-related matters in order to identify the real problems are to be solved (Stage 1), and to assist in formation of the system that will be defined (Stages 2-5).

**Note :** The stages are described briefly because they will be elaborated on when Multiview is applied in practice.

#### **3.3.2.1 Stage 1 : Analysis of Human Activity**

The focus of the first Stage is to search for a particular world view that forms the basis for describing system's requirements that will be used in the next 4 stages. The world view is taken from the problem situation through discussion on the company's main purpose. At Gabriel, this could arguably be to manufacture shockabsorbers. The first Stage consists of four phases each consisting of several substages and is an action learning process:

- a) Perceiving the problem situation (sub stages 1-3);
- b) Constructing systems models (sub stages 4-7);
- c) Comparing model to reality (sub stage 8);
- d) Decide comparison and implement (sub stages 9-10).

## Process

Firstly, a Rich Picture of concern is drawn with the help of the owner of the problem. It is a process of gathering and interpreting data with the aim of forming a holistic summary of the situation. The Rich Picture is diagrammatic perception of the situation showing:

- the structures of processes and their relationships,
- the clients of the system,
- the participants,
- the tasks performed,
- the environment,
- the system owner.

Secondly, problem themes are extracted from are those things that are found on the Rich Picture that could be contributing to the problem. From the themes, relevant systems are made up to give useful insight to the problem. By using the CATWOE technique<sup>19</sup>, the Root definition has been developed to define the problem. The system can be checked for adherence to six specific characteristics. Once agreement is met on the Root definition, a conceptual (activity) model is constructed which consists of lists of verbs describing the activities of the system. The conceptual (activity) model is then compared to the real world as drawn on the Rich Picture. The differences are then discussed with the problem owner resulting in negotiation of changes and implementation.

### **3.3.2.2 Stage 2 : Analysis of Information (data flow and functions)**

This stage consists of modelling information and is made up of two phases, namely, the development of the functional model and the entity model.

## Functional Model

From the Root definition that was refined through the CATWOE criteria discussed above, the main function of the system is identified. It is then broken down into its sub-functions

(hierarchical model). Data Flow diagrams are then compiled which show the sequence of events.

### **3.3.2.3 Stage 3 : Analysis and Design of the Socio Technical Aspects**

The main area of focus in this stage is that the people that are going to use the system must be involved in the analysis and design of it. This will facilitate the implementation, operation and success of the project. By involving the users, human factors can be integrated into the system. The make of the outline of the socio technical analysis and design is as follows:

*'The central concern at this stage is the identification of alternatives: alternative social arrangements to meet social objectives and alternative technical arrangements to meet technical objectives. All the social and technical alternatives are brought together to produce socio-technical alternatives. These alternatives are ranked in terms of their fulfilment of the above objectives and secondly in terms of cost, resources and constraints in both socio and technical terms. In this way the best solution can be selected and the corresponding computer tasks, role sets and people's tasks can be defined.'*<sup>20</sup>

Thus this stage emphasises the statement of the alternative systems rather than the development, and offers a choices according to social and technical considerations.

### **3.3.2.4 Stage 4 : Design of the Human-Computer Interface**

The entity model derived in Stage Two and the computer tasks, people's tasks and role set from Stage Three are the inputs to this stage. This stage makes decisions on technical system alternatives. The ways that the user interacts with the computer will be important in the acceptability of the system. Decisions are then taken on specific conversations and interactions that the different types of user will have on the system as well as the different types of functions that it will have (input, outputs, minimum keystrokes, error proofing etc.). The technical requirements that become the input to Stage 5 are then designed to fulfil these interfaces.

### **3.3.2.5 Stage 5 : Design, Implementation and Testing**

The inputs for this stage come from the previous four stages above. As the methods of the previous stages have been thoroughly examined, Stage 5 will already have the human considerations integrated into the technical sub-systems that will be designed. Stage 5 covers all the technical details that might have been missed in the previous four stages, testing of the human and technical aspects of the system and finally the actual implementation of the system into its working environment.

## **3.4 CONCLUSION**

This chapter has detailed three methodologies of Systems Thinking, namely, VSM, SSM and the Multiview methodology. The application of these methodologies is essential in order to gain a broader perspective of the situation in question. The next step therefore is to gather the required information. The alternative research techniques to do this are described in the following chapter.

## CHAPTER 4

### THE RESEARCH PROCESS

#### 4.1 INTRODUCTION

As previously discussed, it was found that the Scientific Method is the best way to do meaningful enquiry to find the truth. To cope with complex managerial situations, the Research Frameworks of the Viable Systems Methodology and Multiview were synthesised. However, to facilitate this search for truth, a strategy or method is required to research the problem that is of concern and to provide a method of data collection. This research process must be a rigorous, disciplined and systematic procedure with the aim to solve problems and increase knowledge. This chapter discusses alternative research techniques and concludes with the techniques which are chosen for this thesis.

There are many different approaches to management research as there are different ways of classifying it. Research can be classified according to its purpose, for example, it may be concerned in solving a theoretical issue or in solving a practical problem in a company. It can also be classified in its broad approach to a problem, namely, from laboratory experiments to ethnographic methods of field research. Between the two extremes of laboratory experiments and ethnographic methods of field research, are the survey, quasi-experiments and action research methods. Research roughly follows the seven step sequences of Howard and Sharp<sup>21</sup>. It is a systematic procedure that entails:

- identifying a broad area,
- topic selection,
- deciding the approach,
- formulating a plan ,
- collecting information ,
- analysing data,
- presenting the findings.

These stages are not always clear cut. They are frequently recycled in an iterative process where the topic and the approach are revisited and modified as work is planned and action is

taken. Before work can begin, it is logical that a topic must be chosen. This must be done systematically in one of two ways. The first being a literature analysis, a stating of the problem and the major questions, and thereafter the data collection. The second being the action and ethnographic research methods that put open-ended constraints on the problem formulation.

## 4.2 RESEARCH METHODS

As previously discussed, there are various methods of management research, each with their own various commitments, for example, laboratory experiments, quasi-experiments, surveys, action research and ethnography. In order for the researcher to ensure that the outcome of his research is the product of repeatable, objective and valid answers, four research-structuring steps should be followed. These steps are:

- To identify the theoretically dependant variable, namely, the particular phenomenon or factor whose variation is to be explained;
- To identify the phenomenon or factor whose variation affects the dependent variable. This explanatory variable is known as the theoretical independent variable;
- To monitor the variations in the dependent and independent variable, it is necessary to operationalise them. This allows for measurement and observation of the variations. This also enables change or manipulation of the independent variable;
- To control the effects (extraneous variables) on the dependent variable, as the influence of the extraneous variables could confuse the interpretation of observations and threaten the validity of the findings.

*It is vital in deductive hypothesis testing research, if we are to be able to make warranted statements about the relationship between the independent variables and to develop a research design that neutralises, rules out or controls for their confounding influence upon the dependent variable. Only when we have ruled out any rival hypotheses to those under*

*test, can we claim internal validity for our research findings. Only at that point can we make warranted statements about the association between independent and dependent variables<sup>22</sup>.*

#### **4.2.1 CLASSICAL EXPERIMENTS**

True or classical experiments are not used extensively in management research as the behaviour of the subject under observation is made under laboratory conditions and not in its natural environment. To test predictions through the design of a true experiment, the researcher must be able to manipulate occurrences of the independent variable directly. The subsequent changes of the dependent variable must be measurable, and the extraneous variables must be controllable. A key characteristic of this type of experiment is that of randomly or systematically selected control and experimental groups. The experimental group consists of subjects who are subjected to the effects of the independent variable. The effects on the dependent variable are monitored and measured. The control group consists of subjects that have not been subjected to the testing. This group is then compared to the first group where differences with the independent variable are noted. These two groups are used to reduce or remove the effects of the extraneous variables and thus test predictions that have been posed by the phenomena.

A concern regarding this type of testing is that several types of biases can occur. These biases can be due to changes affecting members of both groups, changes in the measuring process and the subjects' reaction to the process of the test. The concern regarding these biases as well as further weakness in the classical experimental method have given rise to alternative research designs. One such design being the quasi-experiment method.

#### **4.2.2 QUASI - EXPERIMENTS**

Quasi-experiments are experiments that are performed in their natural settings in an attempt to approximate the classical experimental method, by analysing causal relationships between the dependent and independent variables. The main difference of this method is that apart from not being performed in laboratory conditions, the subjects cannot be systematically or randomly allocated to control and experimental groups. This type of experiment does away with the artificiality of the classical experiment and allows experimentation to be conducted in

their true environment i.e., the production line. Another reason for this type of experiment, is to investigate causal relationships where ethics in the manipulation or assigning the subjects to their groups can occur. The quasi-experiment is thus especially useful in researching social policies. The naturalism of the quasi-experiment has ecological validity and allows the researcher to delve into areas that would be ethically problematic for the classical method.

The concern with quasi-experiments is that manipulation of the independent variable is limited and there is usually a lack of similarity between the experimental and control group. This creates doubts about the validity of the research findings. A more meaningful variation of the quasi-experiment is that of action research.

#### **4.2.3 ACTION RESEARCH**

Action research involves a planned intervention by a researcher, or more often a consultant, in some naturally occurring events. The effects of that intervention are then monitored and evaluated with the aim of discerning whether or not that action has produced the expected consequences. In other words, the researcher acts on his or her beliefs.

Rapoports definition<sup>23</sup> :- *Action research aims to contribute both to the practical concerns of people in an immediate problematic situation and to the goals of social science by joint collaboration within a mutually accepted ethical framework.*

Action research requires close collaboration as problems can arise between management and academics. Management normally would be concerned that the aims and results of the research that are used for adding to academic theory whilst the academics would be concerned that the results would be primarily focused on solving the organisation's particular problems. These ambiguities are dealt with by action research in each stage of the research sequence. It would seem that action research is essentially a valid approach as both management and researcher's objectives can be met.

## **4.2.4 SURVEY RESEARCH DESIGN**

Survey research finds itself in a place somewhere between classical experimental research and ethnography depending on the partiality and intentions of the researcher. In other words, deductive methodology being used in the field to assess causal relationships born from the logic of an experiment or, using inductive methodology to investigate a substantive area. It is therefore important to be clear whether the theory is to be tested deductively or inductively, so as to establish whether the survey type will be analytical or descriptive.

### **4.2.4.1 Analytical Surveys**

As analytical surveys test a theory in the field, it is important to specify all the independent, dependant and extraneous variables. At the same time, existing research, theories and literature must be taken into account. This is essential as the researcher has a better chance of controlling extraneous variables and thus improving the validity of findings.

### **4.2.4.2 Descriptive Surveys**

Descriptive surveys look at the particular characteristics of a specific population of subjects. These surveys typically examine areas such as motivation, morale, satisfaction and stress.

To proceed with a survey, it is important to design a questionnaire in such a way that the resulting data can be analysed easily and that the questions are free from bias. These two objectives can be met by:

- the focus of the questionnaire,
- the questionnaires phraseology,
- the form of response,
- the sequence of the questions,
- the questionnaires overall presentation.

#### 4.2.5 ETHNOGRAPHY

The main feature of ethnographic research is based on a natural mode of inquiry by observation in the subjects' environment. It focuses on how people interact in a way that is regularly observable. It is generally a long, intensive investigation by immersing oneself into the area being studied and actively participating in the daily activities of that area. This can be done either in an overt or covert way where the researcher and his purpose are known to the group being studied or that he is secretly hidden like a spy in the group. In studying an area of concern in your current place of work, overt observation is the only possibility as the people to be studied will know who you are. However, this has problems as the reaction and the way the group behaves are more than likely to be unnatural.

The diagram below shows four ethnographic areas which the researcher can adopt, the choice being determined by the degree of participation by the observer in the actual activities and whether the people involved as the subject of research are actually aware of the researcher or not.

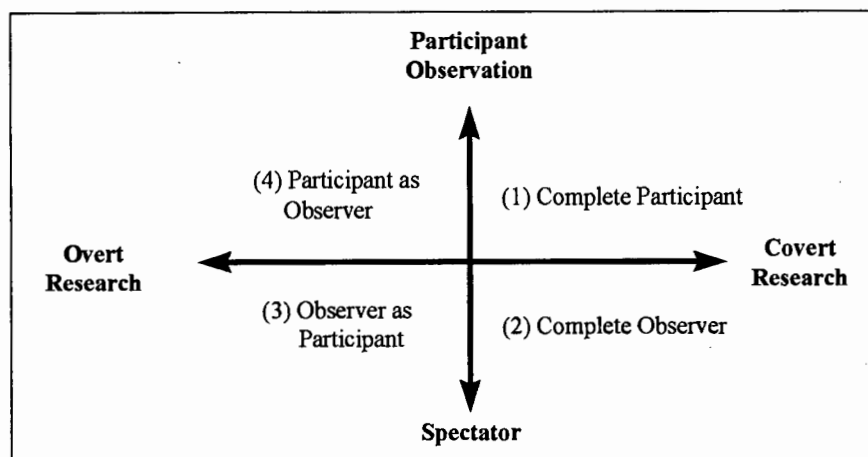

Ethnography that uses inductive methodology, has several advantages over the positivist methods as the ethnographic researcher is able to infiltrate his subjects' environment. It is thus able to pick up factors of importance that would have been missed by the deductive methods of research.

### **4.3 CONCLUSION - CHOOSING THE RESEARCH METHOD**

Traditionally, research in management issues has shown that certain research processes have been deemed better or more appropriate than others. Each of these research processes has different strengths when applied to certain situations. Similarly, they all have inherent weakness that, when applied to the wrong situation, can have unexpected outcomes from which it would be difficult to draw conclusions. The problem that arises is, which method is the right one to use. It would be tempting to use them all to cancel out the various weaknesses. However, as this is very time consuming and expensive, it is important to weigh up the given situation and choose the most relevant method. While studying the subject, it is then possible to change the research method as required. Obviously, therefore, it is important to have an understanding of these methods' strengths and weaknesses in each situation and choose that methodology that is most suitable.

As this thesis deals mainly with social issues, two main types of research will be used. Firstly, Action research will be used as it is complementary with both SSM and Multiview. However, the author will have to paint a picture of all the issues that are contributing to the problem situation. To do this, the views of the relevant stakeholders and observations of the actual situation, will have to be captured. Since all the stakeholders know the author, the second research method which will be employed is overt ethnography.

The following chapter summarises the philosophical level, the methodological level and chosen research techniques into the synthesised research framework.

## CHAPTER 5

### SUMMARY OF THE RESEARCH FRAME WORK

In developing the Research Framework for this thesis, three distinct levels have been considered, namely, the philosophical, methodological levels and the technique level as shown in Fig 5.1 below.

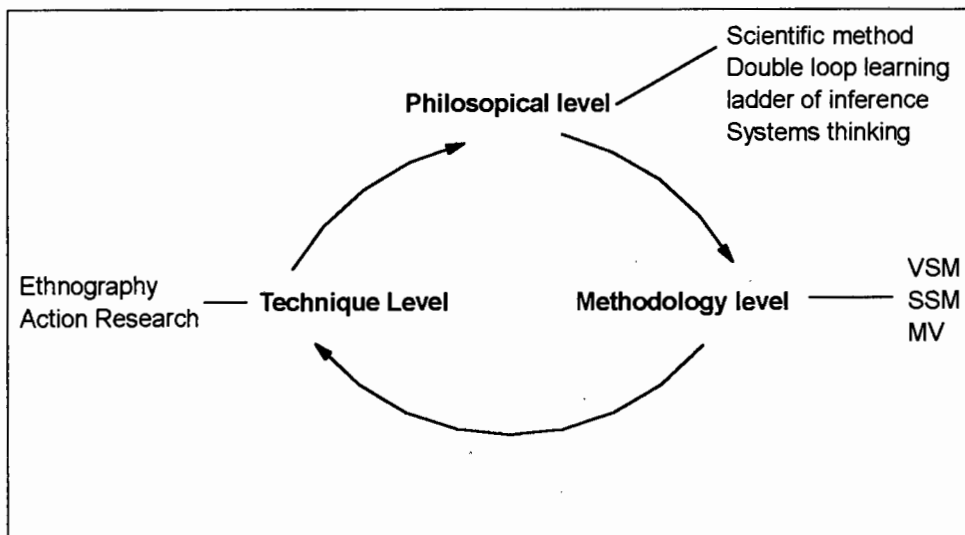

Fig 5.1

The philosophical level was developed from the works of Charles Peirce's Scientific method and Checkland's views on Systems thinking. This level formed the basis of conducting meaningful enquiry into a complex issue which is the purpose of this thesis. Peirce's Scientific method (the cycle of doubt, abduction and verification) was used. It is believed to be the best way to fix belief and offers a means to conduct pragmatic inquiry into situations in a rigorous manner. Peirce's work includes the systemic theories of his pragmatic maxim and fallibilism. The pragmatic maxim is a feature which facilitates result oriented decision-making while the theory of fallibilism shows that we cannot attain the exact universal truth since there is always learning as knowledge is continuously growing.

The Peircian cycle allows for double loop learning. Argyris' work developed these ideas, producing the ladder of inference which Peter Senge argues makes people aware of the beliefs

they are using . How these beliefs influence the decisions people make and future beliefs they develop. The ladder of inference was used as it is a useful model to help determine how our mental models influence our actions. Argyris's double loop learning model takes his ladder of inference theory further and argues that learning is only meaningful if there is a resultant change in behavior. This offers the inquirer through the learning cycle, to change his mental model (belief) or formulate a new one of the situation which is of concern.

The scientific, mechanistic and analytical approaches of reductionism have shortcomings as they are not readily able to cope with complex socio-technical situations. This is because there are systemic interactions and links that occur between man, machines, products, systems and environments. Therefore the philosophical framework was expanded further to incorporate the System Thinking ideas of Checkland.

The research framework's second level considers three Systems Thinking Methodologies being Beer's Viable Systems Modeling (VSM), Soft Systems Thinking (SSM) and Multiview (MV). Initially, VSM was considered as the required methodology as it deals with variety effectively. However, considering the complex social nature of the project, the Soft Systems based Methodology and Multiview for information systems design was included.

The third level being the technique level, is developed for using an appropriate method in actually going about collecting and absorbing information. This thesis uses ethnographic and action research as the selected techniques.

In applying the framework (shown in Fig. 5.2) to this thesis, Chapter 1 considers a situation at Gabriel S.A. which causes concern. This concern initiates doubt which in turn raises questions. The research framework is developed and is followed by the immersion and abduction stage using the Viable Systems Diagnosis of Gabriel's Manufacturing cells and developing a Rich Picture using Multiview Stage 1. The hypothesis is formulated at the end of this stage and is followed by the next four stages of Multiview. These stages form the verification stage of the Scientific Method, dealing with the development and introduction of the new Accessible Drawing Information System (ADIS).

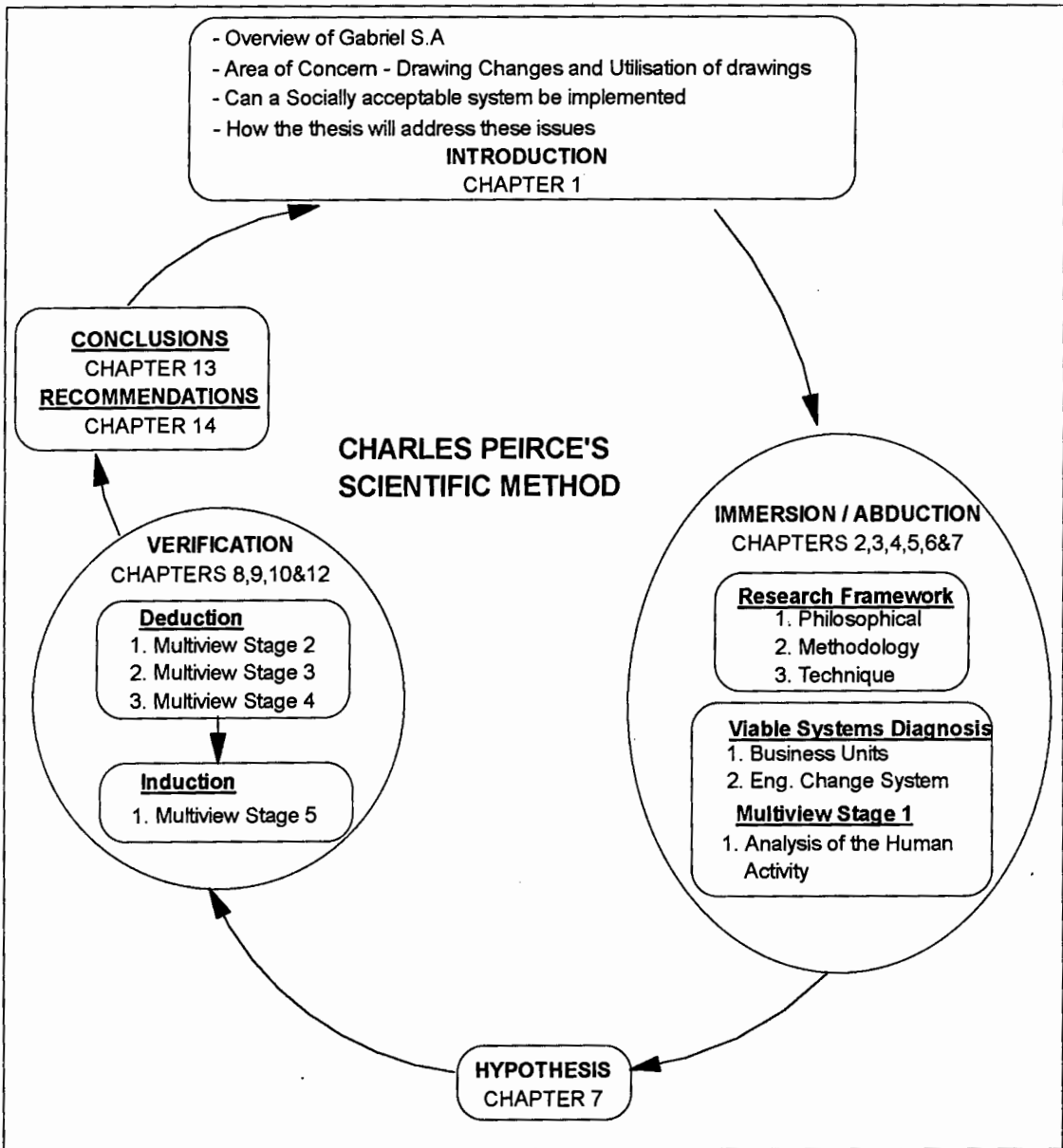

Fig 5.2 - The Research Framework

## **CHAPTER 6**

### **VIABLE SYSTEMS DIAGNOSIS OF GABRIEL S.A. AND THE ENGINEERING CHANGE PROCEDURE**

The aim of this first phase of the research framework's application will be to investigate the Business Units, and the manner in which they are integrated into the whole company structure as well as the Engineering Change System, within the framework of VSM. To do this investigation and to analyse the problems therein, "Viable Systems Diagnosis" (VSD) will be used to compare the company structure to the "Viable System Model" (VSM). This project will firstly look at the background of the change from the old structure to the new one. This will be followed by a discussion on Systems Thinking techniques and the Viable System model from which a Viable System Diagnosis will be performed on the current company structure focusing on our three Business Units. Thereafter, the engineering changes and the Engineering Change procedure (ECO) will be looked at within the framework of the VSM.

#### **6.1 BACKGROUND TO THE CHANGE OF COMPANY STRUCTURE**

As mentioned in the introduction, the company recognised the need for change. The first stage of the transition was to introduce the principle of Business Units (factories within factories). The Production Management was reduced to three Business Units, namely, the Final Assembly Business Unit (B.U.1); Press Parts and Rod Manufacturing Business Unit (B.U.2) and the Gas springs, Cartridges, Paint, Pack and Despatch Business Unit (B.U.3). These Business Units were further divided into production cells. The Business Units are run by Business Unit Managers who report directly to the Managing Director. Each Business Unit Manager has a Process Engineer, two Maintenance personnel, a Production Scheduler and a Foreman who report directly to him. In addition, there is a Development /Manufacturing Engineer and a Quality Engineer who are dedicated to each Business Unit. Each Business Unit is comprised of the following production cells: (See attached table - Appendix 1 for a detailed description of the Business Units' structure).

### **6.1.1 FINAL ASSEMBLY (B.U.1)**

- Original equipment cell (manufactures shocks for motor plants). These units are of a very high specification and are tested 100% in the cell cycle;
- After-market shocks cell;
- Tube manufacturing cell (shockabsorbers);
- Tube manufacturing cell (struts);
- Sub-assembly (valve assemblies for AM shock and strut cells)
- Original equipment and strut cell;
- After-market strut cell;
- Monotube shock cell;
- Strut body and tube manufacture cell (CNC and robots).

### **6.1.2 INTERNAL SUPPLY BUSINESS UNIT (B.U.2)**

- Manufactures parts for the Strut and Shock Business Units;
- Spring Seat and Bracket Press cells;
- Small part press cell (valves);
- Small part press cell (components);
- Rod polishing;
- Small Rods;
- Large Rods;
- Chrome plant;
- Rod assembly cells (projection welding).

The internal supply Business Unit Manager is also responsible for the tool room.

### **6.1.3 PAINT, PACK AND DESPATCH BUSINESS UNIT (B.U.3)**

- Paint line, labelling and packaging cell;
- Warehouse;
- Cartridge cell;
- Dustbin cell (low volume odd shocks - time consuming slow build);
- Gas spring cell.

## **6.2 VIABLE SYSTEM DIAGNOSIS OF THE BUSINESS UNIT'S STRUCTURE**

The procedure for using the VSM for diagnosing the faults of an organisation can be roughly divided into two activities:

- System identification
- System diagnosis

### **6.2.1 SYSTEM IDENTIFICATION**

In order to use the Viable System Model, it is necessary to determine the purpose pursued by the organisation. The purpose is then taken and used to determine the relevant system for achieving that purpose. This system is called the system in focus. The purpose of the company is to manufacture shock absorbers and this is done by the Business Units which therefore makes the Business Units the system in focus. One must assume therefore that the Business Unit is a viable system in order to test the assumption against the model.

As one of the principles of Viable Systems Diagnosis is recursion, then looking at the whole company in which the "system in focus" is embedded in recursion level one, recursion level zero becomes Gabriel S.A. and recursion level two, the breakdown of the Business Unit as seen in Fig 6.3

V.S.M OF GABRIEL S.A.

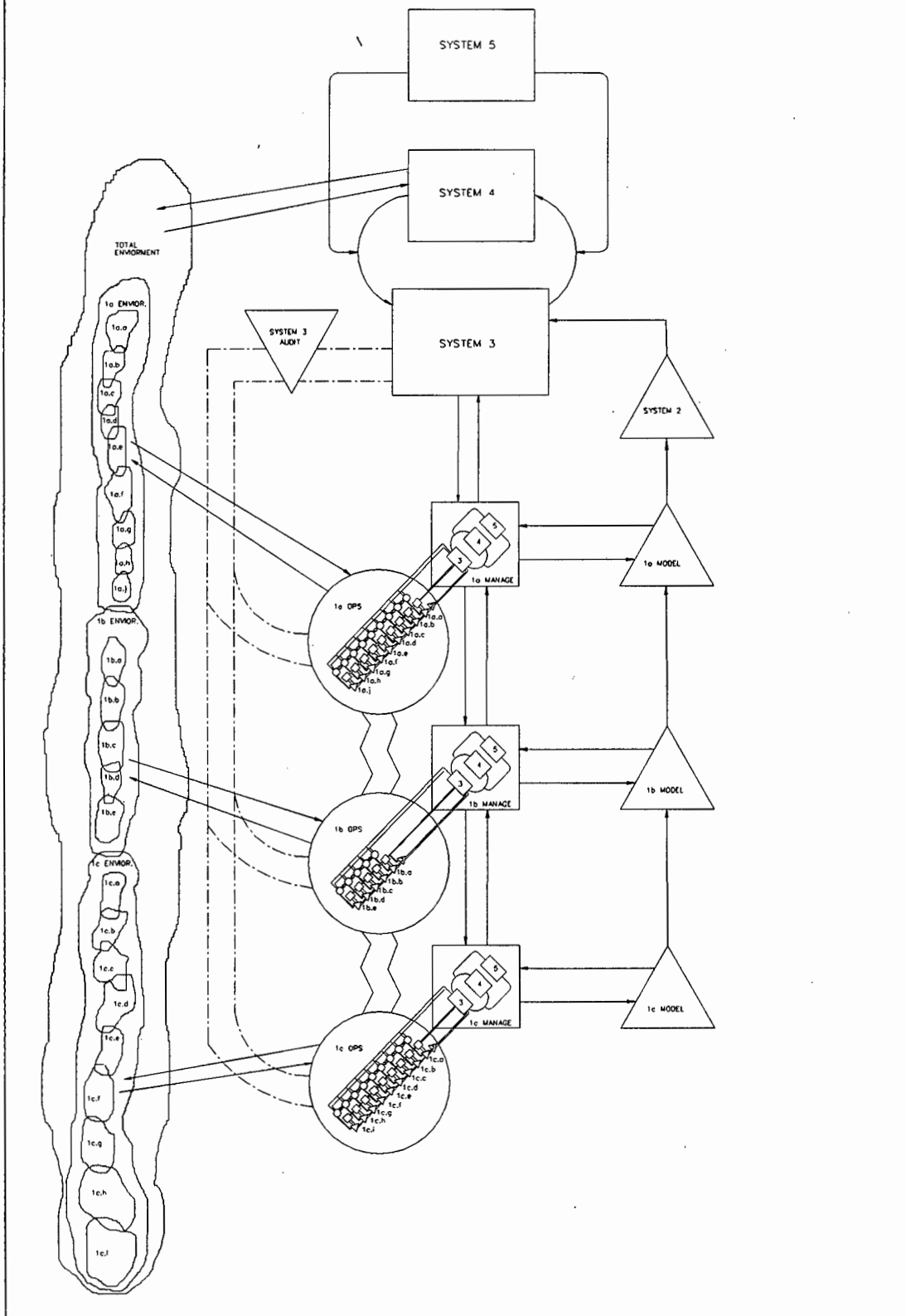

Fig 6.1 - VSM Diagram of Gabriel S.A. showing recursion 2

## 6.2.2 SYSTEM DIAGNOSIS

In order to carry out a system diagnosis it is necessary to look at the company in terms of VSM and to study Systems 1 - 5 of the "system in focus".

The organisation in terms of VSM is made of sets of organisational units (System 1), an internal management team (System 3), an external and future function (System 4), an identity function (System 5) and a co-ordination function (System 2). However, it is important to see how Gabriel fits into this system in order to investigate the areas of concern.

### 6.2.2.1 System One

In order to diagnose System 1, the make up, purpose and members' responsibilities must be described.

#### i) MAKE UP OF THE ORGANISATIONAL UNITS

In Systems 1, the organisational units are made up of a set of operations. Each operation has responsibilities (environment) which in the terms of the methodology are represented by amoeba shapes i.e. :

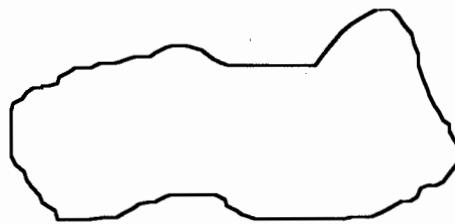

This environment is not alone as it is embedded in the environment within which the whole organisation deals with. The operations environment is made of complicated interactions, the first is the actual operation which is represented by a circle. This operation in turn has a management element which is described as a square and finally, the management team has a model which they believe represents their view on how the whole unit is managed. This diagram<sup>24</sup> looks as follows:

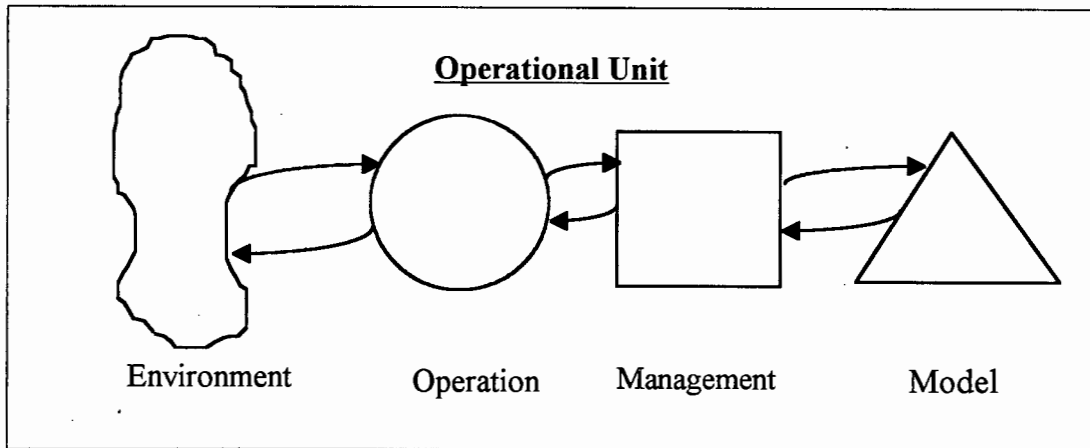

The arrows between the shapes represent a flow of information being for instance, drawings, memos, instructions, material etc. In terms of the model however, it is important to treat these flows as content of information rather than the different mediums of information. The variety of information flow will be discussed in section 7 below.

The System 1 at Gabriel consists of three Business Units comprising of various numbers of Manufacturing cells which manufacture certain ranges of product and a Management team . Therefore, the System One of Gabriel would be made up of a set of three of the above model of the Operational Units as shown in Fig 6.1 and Fig 4.1 in Chapter 4.

## ii) PURPOSE OF SYSTEM 1

The purpose of the System 1 Business Units is as follows:

- Manufacture shock absorbers;
- Ensure world class standards are maintained;
- Durability;
- Performance;
- Testing;
- To ensure maintenance of machines, fixtures and tooling;
- To ensure that the production is not stopped due to machine breakdown;
- Health and safety standards of workers are upheld.

The Business Units are also affected by several environmental factors, namely:

- Market forecast of shock absorber requirements;
- Shortages of components;
- Political factors e.g. strikes, go slows and stay aways;
- Availability of spare parts to support breakdowns, and
- Qualified maintenance technicians.

The composition of System 1 within Gabriel (Fig 6.2) is as follows. The Business Unit is managed by the Business Unit Manager who reports to the Managing Director. He essentially leads the Business Unit Management team and Manufacturing cells.

### iii) MANAGEMENT GROUP AND MANUFACTURING CELLS

The System 1 Business Units consist of:

- a) Development / Manufacturing Engineer
- b) Quality Engineer
- c) Process Engineer
- d) Foreman (Scheduler)
- e) Cell leaders and E.I. team members (Operators) who run the production cells
- f) Maintenance personnel

The Management group of the three System 1 Business Units are responsible for ensuring that the following activities are performed in terms of the cell certification guidelines of the Gabriel Total Quality Production System:

- Measurements and audit systems are put in place;
- Establishing priority lists to ensure timing is maintained;
- Capability studies and relevant action plans;
- Designing Poka-Yoka devices;
- PPM & Scrap studies and relevant action plans;
- Assisting in cell members cross-training;

- Implementing cell teams suggestions;
- Pre-Audit plan and revision;
- Cell Layout.

These people report directly to the Business Unit Manager. However, two team members dedicated to the unit, namely, a Development Engineer and a Quality Engineer also have affiliations to System 3 and System 4 Management. The Development Engineer reports on development matters to the Chief Engineering Executive and the Quantity Engineer reports to the QA Manager.

The structure of the Business Unit members' positions as described below can be seen in more detail in Fig 6.2 and the table in Appendix 1.

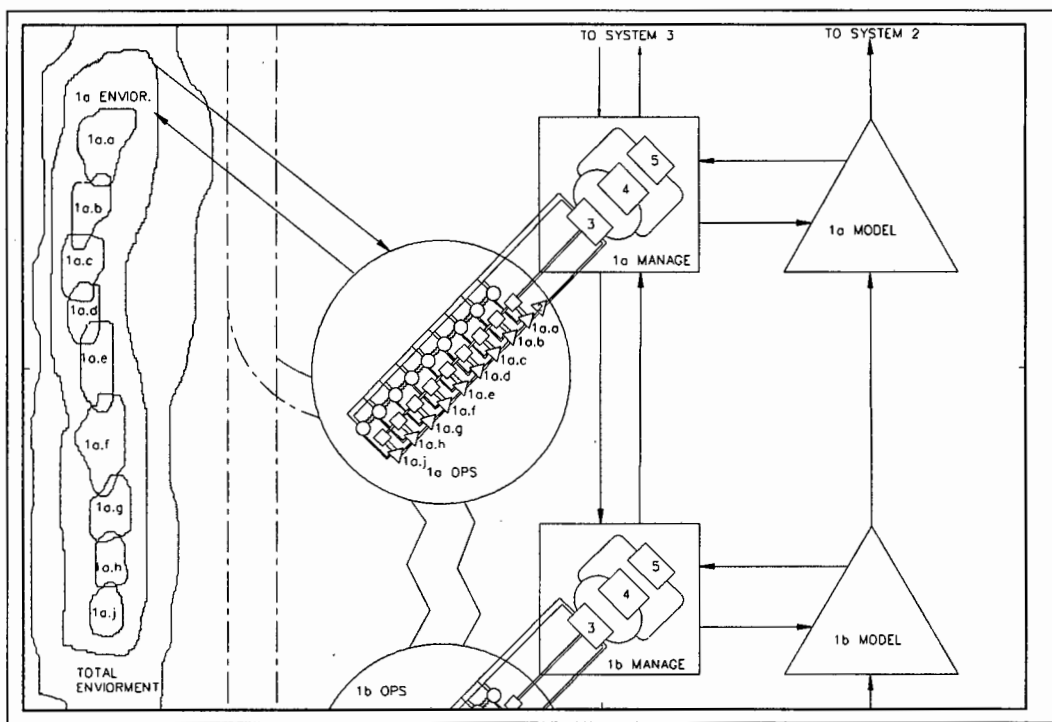

Fig 6.2

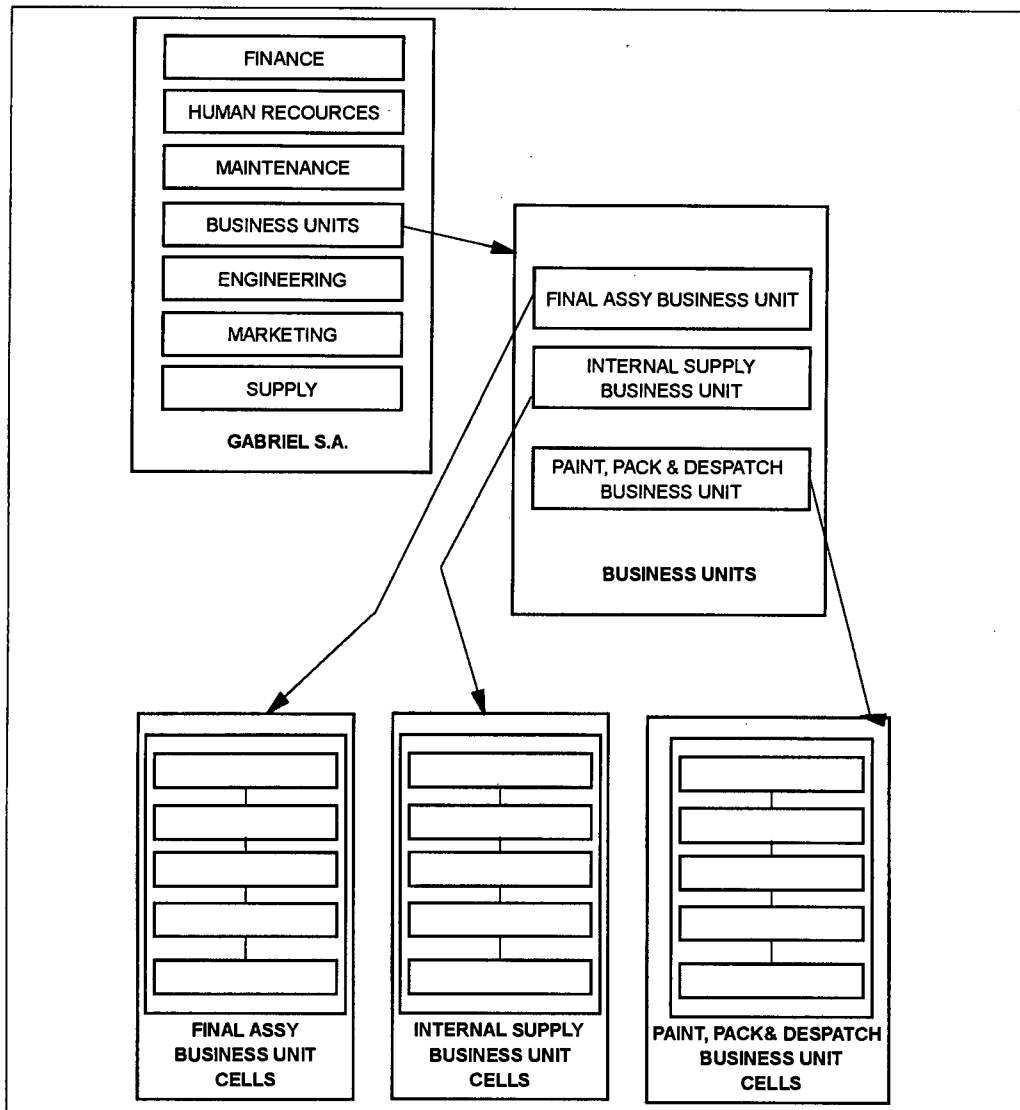

Fig. 6.3 - Triple Recursion

(a) DEVELOPMENT ENGINEER:

He reports indirectly to the Business Unit Manager. His role within the Business Unit is that of support. For example, when problems are encountered in production which the QA Engineer is unable to solve, the Development Engineer would have to investigate and find a quick solution to this problem. Another example, would be a supervisory and training role rendered when a new product or design of shock absorber is being introduced into the cell. The Development Engineer's involvement is vital to ensure that new products developed are done within Business Unit's assembly process capability. The Development Engineer also

reports to the Chief Engineer which enables him to maintain his identification with external environment, as will be discussed in System 4. Further to this, the Development Engineer also fills the role as the Operations Manufacturing Engineer, performing process, quality and design for manufacture. The long term goal of the company is to have only a team of cross functional Engineers responsible for all aspects of engineering that enter the Business Unit.

(b) **QUALITY ASSURANCE ENGINEER:**

The continuous flow of the Quality Engineer's responsibility in the Business Unit is to investigate the same areas during the production process. These can arise from components that are not made to specification or to processes which are not capable, due to assembly tolerances. The QA Engineer will involve the Development and Process Engineer when changes in process or components are required to ensure the smooth build of shock absorbers. He is also responsible for ensuring that the audits required by the Quality Manager are carried out.

This entails random checking of parts, capability studies of processes and machines, and the checking of cell leader's documentation as required by the cell work instructions. He also enforces the cell to do "first offs", namely, first samples off the line are checked to ensure that specifications are being met.

(c) **PROCESS ENGINEER:**

The Process Engineer reports directly to the Business Unit Manager. He is responsible for designing process within all Manufacturing cells' cycle time. The Process Engineer is actively involved in ensuring that production is maintained and that the operator error in setting up a process is reduced with policies of continuous improvement, Poka Yoka and the rules of Kanban. He is also involved in detailed machine, tooling and fixture designs that are required through the introduction of new or modified products and improvements required by the Manufacturing cells' suggestions for continuous improvement.

(d) FOREMAN

Schedulers have the function of receiving the production loading for the day from the Master Scheduler. He in turn establishes constraints in building the required shock absorber. Schedulers will ensure that all relevant internal suppliers receive their Kanban cards and that production is maintained, namely, reduce stoppages due to parts shortages. All the Business Unit cell leaders report problems to the Unit Foreman who in turn will decide whether the problem can be controlled/solved within the cell. If not, he will involve the relevant personnel within the Shock Business Unit Management team.

(e) CELL LEADERS AND E.I. TEAM MEMBERS (OPERATORS)

The cell team's members are responsible (over and above the cells operation) for the rest of the requirements for certification of the cell i.e. :

1. Compiled operating and setup instructions
2. Organised housekeeping rules
3. Implemented work place organisation and visual controls
4. Redesign of tooling for quick changeovers
5. Established current and improved lead times
6. Assisted with cell layout
7. Established a suggestion forum for continuous improvement.

The Manufacturing cell's E.I. teams involvement are extremely important as it ensures that the cells are designed according to their own specifications within the GTQPS framework.

#### **6.2.2.2 System Two (Co-ordination)**

During the management of the four Business Units, interactions or feedback loops occur that can affect each other. To ensure that these systems do not move into a state of instability, a co-ordinating system is required called System 2. This System is subservient to the Business Unit Managers, but as the System is embedded in the Meta System (System 3), it has the

backing and power of the Meta System behind it. The System 2 function at Gabriel consists of:

Production Scheduler  
Maintenance and Toolroom  
Development Engineering  
Bulk Stores.

i) **PRODUCTION SCHEDULER**

One of the main areas of potential conflict for the Business Unit is in parts shortages. The parts' stores have come under severe criticism due to component shortages required to assemble shock absorbers and struts. These shortages occur mainly from our external suppliers who either have breakdowns in their production process, or they supply parts of unusable quality that have been rejected by QA inspection in our goods receiving (all bought-in parts are inspected). This puts immense pressure onto all the systems as our clients (OE Motor Manufacturers) have daily requirements and not meeting them, could mean stoppages of their production lines. Further pressure is incurred due to urgent checking and testing of these parts for usability without effecting the quality of the final product thus ensuring the avoidance of excessive line stoppages. The lack of parts/shortages ultimately requires nifty reshuffling by the Production Scheduler of the daily build, namely, rapid changing of the order of the parts build to suit the availability of parts and thereby maintain the required order of the build.

ii) **DEVELOPMENT ENGINEER**

Co-ordination of new projects entering the Business Unit and engineering changes to current shock absorbers, are done through project and engineering change meetings which are organised by the Development Engineer. All relevant people involved from the Business Unit, through to the Marketing department are involved. Design, quality standards and processes are discussed in detail, with responsibilities being given to the relevant people. This meeting is minuted and all participants are issued with an agreed timing plan. Once the project has been approved, further meetings within the Business Unit are still co-ordinated by the Development Engineer.

### iii) MAINTENANCE

There are basically three types of maintenance performed at Gabriel, namely, Routine maintenance, Preventative maintenance and Break Down maintenance. The routine general maintenance of the machines like oil levels and loose fittings are carried out by the cell operators in System 1. Routine and breakdown maintenance is generally carried out by the Shock Business Unit's two maintenance personnel.

Preventative maintenance is also carried out by these two Shock Business Unit members and additional personnel from the Maintenance department if specialist skills are required. The withdrawal of machinery from production for this type of maintenance is done through negotiation between the Business Unit Manager and the Maintenance Manager to ensure that production is not seriously disrupted. Most major maintenance especially on critical machines and cell layouts is performed during shutdown or weekends.

The Business Unit has various controls at each cell to show visibly what type of maintenance must be performed, when and by who. In the case of routine maintenance, this is filled in daily before production starts in the morning by the cell operators. These reports are then monitored by the Maintenance personnel.

#### **6.2.2.3 System Three (Management Team)**

The Systems 3 Management team at Gabriel must ensure that the company produces the companies required outputs, ensure that the required resources for the function of the System 1 is ensured. They must also manage the System 2 function of co-ordination. This System at Gabriel consists of the Quality, Human Resources, Financial / I.S.D departments and Business Unit Managers.

There are several audit and control features at Gabriel Shock Absorbers which consist of the following:

- Control of Production-Build loading;
- Financial Audits;

- Quality Audits;
- Gabriel Total Quality Production System Audits.

(i) CONTROL OF PRODUCTION BUILD:

Loading of business has to be done in line with the capacity of the production lines which may include the utilisation of overtime, and additional shifts. In other words the targets that are set must be at a level for which they are capable.

As discussed in the introduction and the background, we manufacture in three main areas, being original equipment, export and after-markets. The daily target for these are set up as follows:

- Original equipment is controlled by releases issued by the various motor manufacturers. This business is very steady and continuous.
- Export is controlled by firm orders with required delivery dates. This business is extremely viable but further orders depend on Gabriel's reliability in filling the order quantities required and ensuring the timeous delivery thereof.
- After-market is controlled by historical standards and usage. These requirements are issued by orders from our warehouse network and the Marketing department.

The master scheduler is responsible for loading the daily production requirements. He receives these parts which are then compared to a red list (components that are below a certain trigger safety stock level, namely if the safety stock level for a component within a shock number is 1000 and the Kanban level reaches this number, the part number will show up on a "red list" to which the bill of materials is compared from which those highlighted parts may not be part of the bill of materials). If they are, they are brought up at a daily shortages

meeting where if the shock level at trigger and build requirement is 280, the parts can be drawn.

Once the parts for a build have been verified, the top level Kanban card is issued to the relevant production cell. All the sub-assembly cards are then issued to the different internal supply sections. These cards are retrieved with the parts to the cell. Only when all the cards are returned, does production of that shock commence on a first-in, first-out basis.

(ii) FINANCIAL AUDITS

Budgets are negotiated between System 5 and other various departments. These are either approved or not. If approved, they are submitted to the Gabriel Head Office in the United States for final approval. The System 1 Manager is fairly free to utilise the budget at will, in order to achieve the objectives.

(iii) QUALITY CONTROL/AUDITS:

There are two types of Audits that occur at Gabriel i.e. External Audits and Internal Audits.

a) EXTERNAL AUDITS:

The company's method of operating is dictated ultimately through the company policy manual which covers the whole spectrum from quality through to management as laid down by ISO 9000. From this policy manual is derived a set of operating procedures which ensure that the policies are met. Our original equipment Clients (VW, BMW, Mercedes Benz, Delta etc.) audit these policies and procedures on an annual basis they award a rating. It is imperative that the company "achieves the desired rating (A Rating) as this dictates whether or not we retain the business."

b) INTERNAL AUDITS:

To achieve these ratings the QA Manager sets up procedures that have to be agreed to by the various department managers. The Business Unit QA Engineer is supposed to ensure that all

the policies and procedures required by the Quality Manager are adhered to, namely, are work instructions followed, are the maintenance reports filled in, is the scrap being recorded, are "first offs" being performed, etc.

The Quality Manager together with the Chief Engineer do random audits on all the departments during the year. Problem areas which are not performing are identified and corrective action procedures are implemented. These results are recorded and supplied to the motor manufacturers.

The QA Department also audits all components and raw material that enters the factory from our various suppliers, local and foreign. This is done either by goods receiving inspectors or the QA laboratory, depending on the complexity of the component. Monthly teardown of final assembled shocks is performed (motor manufacturing requirement) to ensure that all Client and Gabriel specifications are adhered to. These teardown audits consist of dimensional checking, salt-spray tests for paint adhesion and rig durability tests to check shock components' long term durability (these tests simulate 100 000 km "on car" conditions).

#### (iv) GABRIEL TOTAL QUALITY PRODUCTION SYSTEM (GTQPS) AUDITS

As discussed in System 1, the Manufacturing cells must adhere to the principles and philosophies of GTQPS. On a daily basis they must record a series of measures which enables management by "walk about" or at a glance. Further to this, a monthly audit is performed on all the Manufacturing cells, summarising the data accrued from the daily reports. This information is then compiled in a format (see the GTQPS monthly measures report on Appendix 2) that is analysed by System 3 and forwarded to our parent company in the USA. Deviations away from the previous months performance must then be fed back to the relevant cell where a corrective action plan is established and submitted to the System 1 Manager and to System 3.

#### **6.2.2.4 System Four - (Future)**

At Gabriel, System 4 is essentially being performed by the Research and Development department, the Marketing/Sales department and the Quality department. These departments have contact with the whole/total environment with which Gabriel deals. They therefore try to identify critical areas that can affect the company; they look at creating the company's desired future.

##### **i) RESEARCH AND DEVELOPMENT**

As previously discussed, the R & D is involved in four main areas of business, namely, original equipment, export, after-market and gas springs. The department consists of the Engineering Executive, O.E. Product Manager and five Engineers who are embedded in the Business Units.

##### **(a) ORIGINAL EQUIPMENT**

Original equipment could be considered a "hassle" area of business as these projects, due to the very high specification and technology requirements, tend to be very lengthy and time consuming. They also require more staff to run these projects, especially when compared to the export and the after-market development.

##### **(b) AFTER-MARKET (REPLACEMENT SHOCKS) AND EXPORT**

After-market and Export development are run by one Engineer and a Draughtsman. These units are "knife and fork" parts using our basic valve design and incorporating fairly wide tolerances for specifications which make them fairly easy to build. The turnover time for the development of these shocks is very quick. In contrast to the original equipment shocks and struts, virtually no experimentation or testing is done and the emphasis is on production volumes and turnover.

### (c) GAS SPRINGS

This is very similar to the after-market and replacement shocks. The Development Engineer is responsible for all changes that occur in design and the control of these changes being through the Engineer change meetings. Project meetings are held by the Development Engineer when new products are being introduced. Rationalisation and continuous improvement programmes are run by the Development department.

The intelligence function of development is to monitor development in the international market through new models being introduced locally by motor manufacturers and new technology being developed overseas.

### ii) MARKETING

The overall role of the Marketing department is to create a desirable positioning for Gabriel shock absorbers amongst the existing and potential target markets. In order to fulfil this responsibility, this department has to:

- develop a suitable advertising strategy and liaise with the Advertising agency to ensure the objectives of this strategy are met;
- initiate and control all below-the-line promotions (primarily with retailers and fitment centres);
- control a customer service line (for immediate reaction to customer queries and complaints);
- commission research projects to monitor Gabriel shock absorbers' position relative to that of the competition by keeping abreast of consumer and distributors' perceptions regarding our product;
- look for new business opportunities, for example, to examine the export potential into other Sub-Saharan African countries, the Far East, Europe, North and South America.

Further areas of monitoring the total environment include political, human resources and government regulations (SAH). These areas fall within the scope of the Human Resources and Finance/ISD departments.

### 6.2.2.5 System Five - (Policy)

System3 manages the whole operation ensuring that the stability is maintained. System Four looks to the outside environment for new trends and future business. The tension that this can create requires a system that can harness this tension to the companies advantage. Therefore System Five's function is to create a company identity consists of the Managing Director, the R&D Director and the Human Resources Director.

## 6.3 VARIETY

In the Business Units of System 1, there are many interactions between the Management functions and the Operations being the Manufacturing cells. These are generally far more complex than that of management with the Business Units pushing through endless streams of information to Management (see fig 6.4 below<sup>25</sup>).

Due to the fact that there will probably be few filters, Management will most certainly be overwhelmed and will possibly ignore the flood of data, or try and cope with this data to the detriment of other necessary functions.

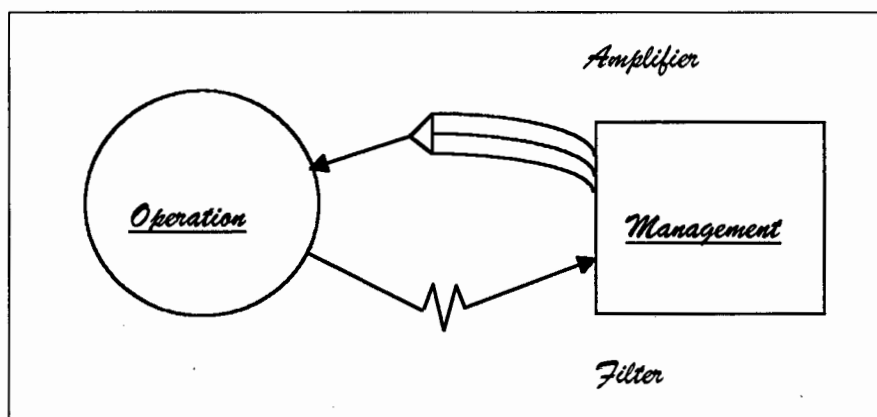

Fig 6.4

If the information system is well designed (which is part of the area which will be investigated), there will be defined filters which will extract information which is meaningful from this bombardment. On the other hand, the Management's ability to send information back to the Business Units due to factors like logistics and responsibilities that involve him outside of the Unit, there are however in all businesses or systems, filters which occurs between the operation and management as it is totally impossible for the latter to absorb the information that is generated. It is therefore critical that the Manager is able to delegate responsibility to other members of his Management team. Likewise there will almost always be an amplification between the Manager and the Business Units. Therefore, the design of the filters are critical to ensure that the system remains in good health, doing the things that it is supposed to do.

The three Business Units at Gabriel shown on Fig 6.1 (and Appendix 1) of the organisation each have numerous Manufacturing cells. Each have self directed work teams operating along the guidelines of our internal GTQPS (Gabriel Total Quality Production System). This System 1 (System 1a.a. ) has various visual controls which are intended among other things to provide the System 1 Business Unit Management teams with relevant information against the day's targets. The aim of these visual controls are to enable management of the cell at a glance.

The information that is required for the cell to perform its purpose is done through the issuing of Kanban cards. The cells progress in terms of its adherence and growth to the GTQPS program is done through the teams facilitator who is normally someone picked from the management team (i.e.: the facilitator for the O.E.Shock cell is the writer). The facilitator assists the cell members in gathering all the relevant info and compiles a standardised report which is sent directly to the GTQPS committee which resides in System3 and generally bypasses the Unit Manager.

Problems occur however with filtering and amplifying the variety within System 1. The Business Unit Managers fail to effectively delegate responsibility to members of the Management team and therefore becomes swamped in a deluge of unnecessary information / problems. Likewise, the Manufacturing cells run into problems when there are insufficient components due to incorrect KANBAN levels or parts shortages, problems of conformance to

specification and machine breakdowns and incorrect drawing information. These in turn result in the filters being bypassed.

## **6.4 ENGINEERING CHANGE**

Engineering changes essentially come from two main sources, namely, external and internal sources. With each request for change, a fairly complex sequence of events (see Appendix 3 for the change model) takes place which will be described.

### **6.4.1 SOURCES OF CHANGE**

As mentioned above, we have two main areas from which change can be derived, namely, internal or external sources.

#### **i) INTERNAL CHANGE**

Internal requests for change come from several different systems, being:

Change requested from an Operation 1 Manufacturing cell as a result of continuous non-conformance to specification. These changes usually are a result of the shockabsorber not meeting the resistance specification due to unavailability of valving parts or dimensionally incorrect parts due to drawing errors. They can also be derived through innovative cost savings as a result of their Employee Involvement suggestion meetings (cheaper parts or deletion of unnecessary parts).

Changes as a result of deviations from drawings which have been running consistently like that for three batches of production and are now to be made permanent. These changes come directly from System 1.

Changes as a result of a supplier (from the external environment) whose component requires a relaxation of tolerance in order to be able to manufacture. These tolerances or dimensional changes are made when they do not have a critical impact on resistance requirements of the shockabsorber.

Changes as a result of a change in supplier (due to continuous bad quality or uncompetitive pricing) which is done by the purchasing department which sits in System 4.

Change due to the rationalisation of components i.e.: changing from the old Gabriel design valving to our World Class New World design. This type of change can be made with no communication to the external environment if it is going to be used in our replacement market. However, when used on our Original Equipment (O.E.) customers, this change becomes quite complex.

## ii) EXTERNAL CHANGE

This is change requested by O.E. customers. This is usually derived as a result of a change of specification by the O.E. customer's mother company, i.e.: a change in overseas design of mounting bushes on the car might dictate that the rod design would require changes as our local customers would be forced to use the mounting bushes if they were not sourced locally. A good example which will be used throughout this report, is a current change to a O.E. customer's front strut. This particular strut was originally designed in Germany with an indent to cater for snow chain clearance. The localisation of this component excluded this indent for obvious reasons - no snow in S.A. However, Germany changed the mounting method of their ABS sensor to mount on the flat part of the indent instead of vehicles body. The local car manufacturer being a user of the imported ABS sensor suddenly received the new design on their production line, which caused a stoppage as they did not fit to the car body and likewise, did not fit to the local strut. This led to a panic and a request for an urgent change to an indented tube which led to a dire situation which will be described further in the conclusion (Chapter 13).

Change as a result of rationalisation in design. As described under internal changes, we are currently in progress with the implementation of our local New World design valving. In order to implement this change with our O.E. customers, a lengthy programme is required. Our System 4 O.E. Product Manager has to submit a re-quote on the current design showing a significant price reduction and improved quality performance to name but a few advantages.

If accepted by the customer, a sequence of events occur which include:

Proposal drawings

Proto type samples

Durability and functional test to client's specifications

On car durability (takes 6 months)

Off tool samples

Approval testing.

#### **6.4.2 SEQUENCE OF THE CHANGE PROCEDURE**

The sequence of events that model the change procedure originate from a need for this change derived from the requirements as mentioned above. These events can be seen on the ECO model (Appendix 3). Once a change has been approved, an Engineering Change Order (ECO) is raised by the relevant Development Engineer who is part of both the Business Unit in System 1 and System 4. This ECO is complied with a list of the new or modified parts as well as a set of drawings and a timing schedule. The ECO is passed on to the Product Manager (System 4) who, through a time consuming and laborious procedure, modifies or compiles a bill of materials called a product structure on the information system called 'Rascal' (he has many of these to do per month). This structure is then returned to the Development Engineer who checks it for accuracy against the new parts list. The System 4 Product Manager then costs the product and in the case of a change in an original equipment shockabsorber, submits relevant information to them for approval. The structure is then returned and is taken to the ECO meeting. At the meeting various members are given responsibilities from which a time plan is decided with respect to an immediate release of a change or a staggered release (Queued release).

##### **i) ECO Meeting**

The ECO meeting comprises of strategic people from different areas of the business who form the ECO committee as follows:

ECO Chairman (Product Manager)	- System 4
Process Engineers	- System 1
Quality representative	- System 3
Purchasing	- System 2 & 4
Stores	- System 2
Business Unit Managers	- System 1 & 3
Development Engineering	- System 4
Production Scheduler	- System 2 & 3

a) **PROCESS ENGINEER (SYSTEM 1)**

The Process Engineer is given the job of ensuring that all the correct fixtures and tools are available to manufacture the new component with the help of the relevant System 1 Operation cell leader. If these are not, he must design, manufacture and supply the System 3 committee with a time plan of when the tools will be ready. This will give the System 2 Production scheduler the information to co-ordinate the loading of the component into production once all the tools are available.

b) **QUALITY REPRESENTATIVE (SYSTEM 3)**

The Quality representative must ensure that all relevant checking fixtures and gauges are available for the new product, in cases where they are not, he must arrange through the System 2 Purchaser, the manufacture or purchase of these with a detailed time plan as in 2.1 above. He must also ensure that relevant test specifications are correct and check to see if any special testing is required (ISIR) which will delay release.

c) **PURCHASING (SYSTEM 2 &4)**

The Purchasing department must ensure sourcing of local and imported parts for the change are occurring within the time frame and must communicate late arrival or changes in timing thus performing a System 4 function. These changes have a wide range of impact. Not only does production get delayed from a lack of parts, the Quality department must perform acceptance testing which could further delay introduction. Apart from component sourcing,

Process Engineering can be affected by the Purchasing department as they also source all the bought in fixtures and tooling and raw materials for the internal manufacture of the latter. The Purchasing department (once supply of the relevant requirements have been met) must co-ordinate with the supplier and the relevant systems to ensure the parts or equipment arrive as defined in the timing plan to the correct specification. He must also maintain a continuous feedback loop to the various systems and the external environment in order to facilitate any deviations away from the plan.

#### d) STORES

The stores (System 2) position in implementing change is fairly complex as they must co-ordinate and ensure the availability of parts for the introduction of the change. In the case of an immediate change, they must ensure that components which are "robbed" from other current jobs are replaced timeously, so that those jobs do not stop due to shortages of parts. In changes that are done after a 'run-out' of stock, the stores must establish how many of those parts are still in stock and establish how many more batches including parts that are still in transit from overseas will occur. Once they have established the relevant data, the stores adjust the KANBAN, triggering the requirement of parts. When new parts are required, a new KANBAN in the relevant production cell must be created. This new KANBAN rack, being empty will in turn trigger a request for parts which will be replenished according to the levels and rules of KANBAN. In order to assess the size and position of new KANBAN racks in the relevant System 1 Operation (Manufacturing cell), the Stores must co-ordinate with that cell's team and the Systems Management team. The positioning and size of the racks are of critical importance because the cell's ergonomics plays an important role in productivity.

#### ii) RELEASE OF CHANGE INTO PRODUCTION

Once the ECO committee have met all the requirements and all are in agreement, the change is released (be it immediate or queued by the Product Managers). By doing this, the drawings are signed off and passed over to the Development clerk who then makes copies for all the System 1 Manufacturing cells that are affected, Quality departments and the master file which resides in the System 4 Development office. A Card is updated or created with the new level

or new part in a cardex system. All the drawings are then stamped and signed by the Product Managers before they are distributed (O.E customer rating requirement).

The distribution occurs by handing over the pile of drawings to the relevant System 1 Business Unit Managers who in turn sign the cardex card thereby acknowledging that they have received them. The Business Unit Managers then, themselves, systematically, go to each Production cell and remove the old level drawings and replace them with the new level drawings. The old level drawings speedy removal is critical as delays result in costly errors, scrap and delays in production which can leave customers dissatisfied with our service, which can affect the placement of future business as seen in the change model (Appendix 3).

### **6.4.3 MODEL OF THE ECO PROCEDURE**

The purpose as discussed, of the ECO procedure is to ensure that engineering changes are introduced into production with minimum disruption. The prescribed procedure for this change is modelled (see Fig 7.6 Chapter 7) through a series of four main steps being:

- Step 1. Appreciate Change
- Step 2. Impact of Change on design and process
- Step 3. Defining Cost Impact
- Step 4. Define Change Dates

#### **i) STEP 1 - APPRECIATE CHANGE**

The purpose of this stage is to establish the nature of the change by enquiring whether:

- a) Is a new part to be added
- b) Is it a purchased part
- c) Is it a purchased consumable
- d) Is it a manufactured part

Apart from enquiring about the type of part, it is also required that the method of change is established, namely, is it either a part run-out or a mandatory change.

ii) STEP 2 - IMPACT OF CHANGE ON DESIGN AND PROCESS

This step defines the impact of the change on the design and the process by asking if:

1. Are drawing changes required (System 1 Manufacturing Engineer)
2. Are there changes to the process required (System 1 Process Engineer)
3. What are the implications of the change on production capacity (System 1 Management Team)
4. What are the outwork implications i.e. : will our subcontracted piston rod manufacture be affected (System 4 Purchasing)

iii) STEP 3 - IS IT A PURCHASED CONSUMABLE

Step 3 ensures investigation by the System 4 Purchasing and System 1 Engineers into the costs and rationalisation aspects of the change and ensures that wherever possible, the change results in a reduction of product cost, part numbers and suppliers by asking:

1. Is an additional part being added?
2. What is the cost of the new part?
3. If a part is being replaced by a new part, what is the cost of that part?
4. What is the cost of a change in / additional process
  - change can affect throughput
  - cycle time
  - setup
  - lead time?
5. Is a new supplier being added?

iv) STEP 4 - DEFINE CHANGE DATES

Step 4 determines the earliest date that a change can be implemented and must take into account whether the change is mandatory or if a run out of parts must take place. As this step encompasses timing, the implications thus include tooling lead times, lead time to reach KANBAN levels on new parts and the run out of old parts and, the response time of suppliers to the required change in the case of purchased parts. The Step 4 questions consist of:

1. When will the current inventory level run out (System 2 Stores)?
2. Do we write off excess old stock if the change is mandatory (System 3 Finance)?
3. What is the amount of this write off (System 3 Finance)?
4. What is the earliest supplier response date (System 4 Purchase )?
5. Have the KANBAN implications been defined (System 2 Stores)?
6. What is the earliest tooling date (System 1 Process Eng.)?
7. What is the drawing change date (System 1 Manufacturing Eng.)?
8. What is the drawing release date (System 4 Product Manager)?

From the above, the System 3 ECO meeting must determine the longest lead-time that will occur in the change. The balancing out of the shorter lead-time items and the feedback of that information to the various internal and external suppliers must also be done through the ECO meeting.

Only once these four steps have been completed, is the decision to implement the change or not, taken by the System 4 Product Development. This is done by justifying the change in terms of the different steps' answers. The relevant System 1 Manufacturing Engineer must then ensure that the new drawings are ready prior to the effective implementation date. This is to ensure that the suppliers receive their drawings with sufficient lead time for them to complete the required KANBAN levels of the new part .

The next step in the ECO process, if no new parts are involved, is to modify the structure. If a new part is required, that part must first be added to the Part Master and the Item file is then completed.

This is followed by modifying existing, or adding new purchase orders, and to update the vendor price list. All update drawings are forwarded to the relevant vendors/suppliers in order to ensure that we receive the correct level parts.

Only once these steps have been completed, is the structure added to the system, in line with the effective change dates in the change register. Only after these have been verified, are the KANBAN cards produced for the new part. The System 1 Business Unit Managers are then given the new drawings prior to the first build.

## **6.5. CONCLUSION**

The aim of this chapter is firstly, to evaluate the Business Units and to establish how they fit into the whole company. Secondly, to investigate engineering changes using the methodology of VSM and VSD which will not be criticised. An assumption that the Business Unit is a viable system was made and from there, the system in focus (being the Business Units) shown in Fig 6.1 was developed. This leads to the necessity of examining the results of the diagnosis, to test whether the assumption on viability is correct.

### **6.5.1 BUSINESS UNITS AND THE COMPANY STRUCTURE**

This chapter shows that System 1 represents production and has representatives from various departments of the organisation. This can be seen on the table in Appendix 1, namely, Development/Manufacturing Engineer, QA, Production and Process Engineering. Production cells communication between these people within the unit, is both horizontal and vertical (recursion of the organisation seen in System 1), absorption of variety is high through GTQPS filters. However, control of drawings and the usage thereof seem to be problematic as the Business Unit Managers are unable to cope with the flood of drawing changes as a result of rationalisation and new drawings for export products. Communication between the Business Units is good, with the emphasis being on ensuring that production is maintained without cause for alarm in higher Management. This results in amicable negotiation of shared resources through System 2 in daily production meetings where the Business Unit Managers and relevant Systems representatives establish the forthcoming day's production priorities.

There is also a high level of intercommunication between the section of the Units i.e. between Strut QA and Shock process. From this, the System 1 Business Units would seem to represent viable units as laid down by the preambles of VSD with the exception of control of drawing information.

System 2 seems to be represented well as shown by the VSD. The main problem of co-ordination that was lacking in the old structure has been addressed with the Business Units' Production Schedulers co-ordinating between themselves and the Master Scheduler to ensure production is not disrupted, highlighting problems between System 3 and the Business Unit Managers.

Likewise System 3 audits and controls are well established as they are essential requirements laid down by the various motor manufacturers. These controls ensure that our products maintain a high standard of quality. The exception to this is however, that it is impossible to audit the approximately twelve thousand drawings in the Manufacturing cell's drawing files.

System 4 at Gabriel functions within the principle of VSD with a high level of communication between the Marketing, Development and Purchasing departments. These departments monitor the external environment transmitting relevant information upwards and downwards. The speed of communication between System 4 and System 1 is improved greatly with the integration of the Development Engineers in System 1 Business Units. The Human Resources department although autocratic in appearance are approachable. However, they implement company policy as dictated by System 5 without much negotiation with the Systems 3, 2, 1 Managers.

System 5 incorporates System 4's Executives who filter variety between System 5's MD. However, the MD and Executives get involved in day-to-day operation of the System 1. This happens as the Business Unit Managers report directly to the MD. However, due to the size and nature of the company, the writer would deem this as acceptable since the Business Unit Managers, in recent months, have become more autonomous. Time will be the telling factor as to whether this will remain. A structural change to the Business Unit Managers reporting to an executive below the MD would surely ensure that variety is reduced.

## 6.5.2 ENGINEERING CHANGES

The introduction of engineering changes into the system involves all of the systems with the exception of System 5. As can be seen on the Engineering Change model (Appendix 3), the process is quite involved with complex levels of communication and responsibilities. The ECO procedure itself seems to be a fairly good platform within the framework to facilitate the changes into the organisation. All the different systems are well co-ordinated with good feedback loops that have been put into place through the ECO checklist. Problems, however, arise as the checklist is not properly utilised, resulting in most of the members neglecting to perform various critical duties which results in production errors, scrap, rework and ultimately a dissatisfied customer.

Further to this, the ECO meetings occur weekly and thus, releases occur weekly, which means that the system is not flexible to cope with urgent change requirements. Tracking of changes show that an urgent change can take up to 10 days. This lengthy lead time can, and does, have dire consequences.

Looking back to the earlier example of the indented tube, our Process department was assured, correctly, that tooling for the change was available as we were currently exporting that unit with the indent for European replacement market. The change, however, went through due to a customer requirement, 3 days before the ECO meeting. Production went ahead and the parts were shipped. This should not have been a problem except that there was a change in the customer and internal part number. As the ECO committee had not yet signed off or released the drawings, the parts were marked with the old number, resulting an elaborated process of requesting deviations from our customer in order to ship the urgently required product. Even though the change and unreasonable timing were due to the customer's error, the situation caused by the deviation procedure compromised the customers satisfaction and had an impact on our supply audit rating.

It is important for the company as a World Class player, to be able to respond to engineering changes in a way that will maintain our competitive edge and ensure customer satisfaction. In order to achieve this, the VSD has highlighted several areas that can be improved. The

amount of drawings that are required and distributed due to changes weekly are enormous. The fact that this has an impact on the variety of drawing information that management can deal with and that the viability of the Manufacturing cells can be compromised if this information is not disseminated to them on time, merits further investigation. This investigation using the Soft Systems Methodology for Information System Design (Multiview) will follow, beginning with Multiview Stage 1, the human activity system. It is important for the company as a World Class player, to be able to respond to engineering changes in a way that will maintain our competitive edge ensuring customer satisfaction. In order to achieve this, the study has highlighted several areas that can be improved. Firstly, by creating instant access of the correct latest level drawings by the System 1 Manufacturing Units; secondly by providing a quicker method of creating new product structures and related activities; and finally by enforcing the existing ECO model and related checklist.

The introduction of computer terminals into each of the Manufacturing cells to give them instant access to information and the creation of product structures directly from the source drawings will be investigated in the next five chapters which follow the Multiview methodology of Information Systems design.

## CHAPTER 7

### MULTVIEW STAGE 1 - THE HUMAN ACTIVITY SYSTEM

The first stage of the Multiview technique is to analyse the human activity system, which is essentially, a means for finding out the different world views which people have towards a system. These views, which are used to define the system's requirements, are taken from the problem situation which has given rise to the concern. The process starts by developing a Rich Picture of the problem situation. Thereafter, a Root definition is extracted from the problems seen in the Rich Picture. Once consensus has been attained on the Root definitions, conceptual models will be constructed followed by the hypothesis formulation.

#### 7.1 DEVELOPING THE RICH PICTURE

The Rich Picture shown in Fig 7.1 represents the daily occurrences of providing information to the shop floor. This information, which is required by the three System 1 Business Unit Manufacturing cells comes in the form of drawings. The accuracy and availability of this information is essential in order for the cells to maintain their primary task of manufacturing shock absorbers.

The development engineering department issues drawing changes and introduces new product drawings to the factory almost on a daily basis. These drawings are in the form of paper copies and have to be distributed to the Manufacturing cells via a committee (Engineering Change Order - ECO committee). This committee is comprised of various people from the company. There is also a process of loading the parts' list information of these drawings into the company's computer information system. The ECO committee has a need to provide a better service to the Business Units because it is essential that changes or new products are introduced smoothly. This is currently not happening. The delays due to the distribution inefficiency are disturbing to this committee as costly errors are being made.

The Development Engineering Director is also aware that the incorrect and/or lack of information is being supplied to the Manufacturing cells and has resulted in expensive mistakes being made. Further to this, he loses his secretary for up to half a day, every day of the year while she attends to the requirements of distributing drawings to the relevant Business

Units. This procedure seems to be fairly cumbersome and complex. Furthermore, the Development Engineering Director feels that valuable time is being wasted by the Product Manager who manually compiles the structure for engineering changes or new products and then loads them into the computer system.

The building in the Rich Picture represents the many different Manufacturing cells that make up the three System One Business Units. These cells are serviced in terms of their information needs, by the different Business Unit Managers. This service is originated by the ECO committee via the clerical function of the Development Engineering Secretary. This secretary feels that a system will surely benefit her in terms of a reduction in her workload and paperwork. The link between the cells and the Engineers of the relevant System One Business Units can be seen in more detail in the VSD. The link represents the lines of communication in terms of normal day-to-day interaction with the cell members and the monitoring and the tracking of GTQPS requirements. The cell Operators seem to fear the introduction of a system in their cell as they are not computer literate. They fear that the system could be difficult to operate, while at the same time, they realise the need for accurate information in order to maintain the manufacture of World Class shockabsorbers.

Different opinions by the Business Unit Engineers of a pending system range from extremely positive to negative. On the positive side, a system could improve quality, reaction time, flexibility and cost. It could also have far-reaching, positive influence in terms of the information flow. The negative reaction stemmed from the current frustrations encountered with the stability of the existing computer network. The information generated by the release documents as a result of the final output of the ECO procedure, is passed on via the Product Manager to the Engineering secretary /clerk. She, as previously mentioned, goes through a very time-consuming exercise of distributing the new drawings to the System 1 Business Unit managers. Once the drawings have been signed for, they are supposed to be systematically replaced in each relevant cell. The procedure, however, tends to break down at this point because the Business Units have to deal with too much variety and forget to complete the cycle. This, in turn, results in problems as can be seen on the change model (see Appendix 3).

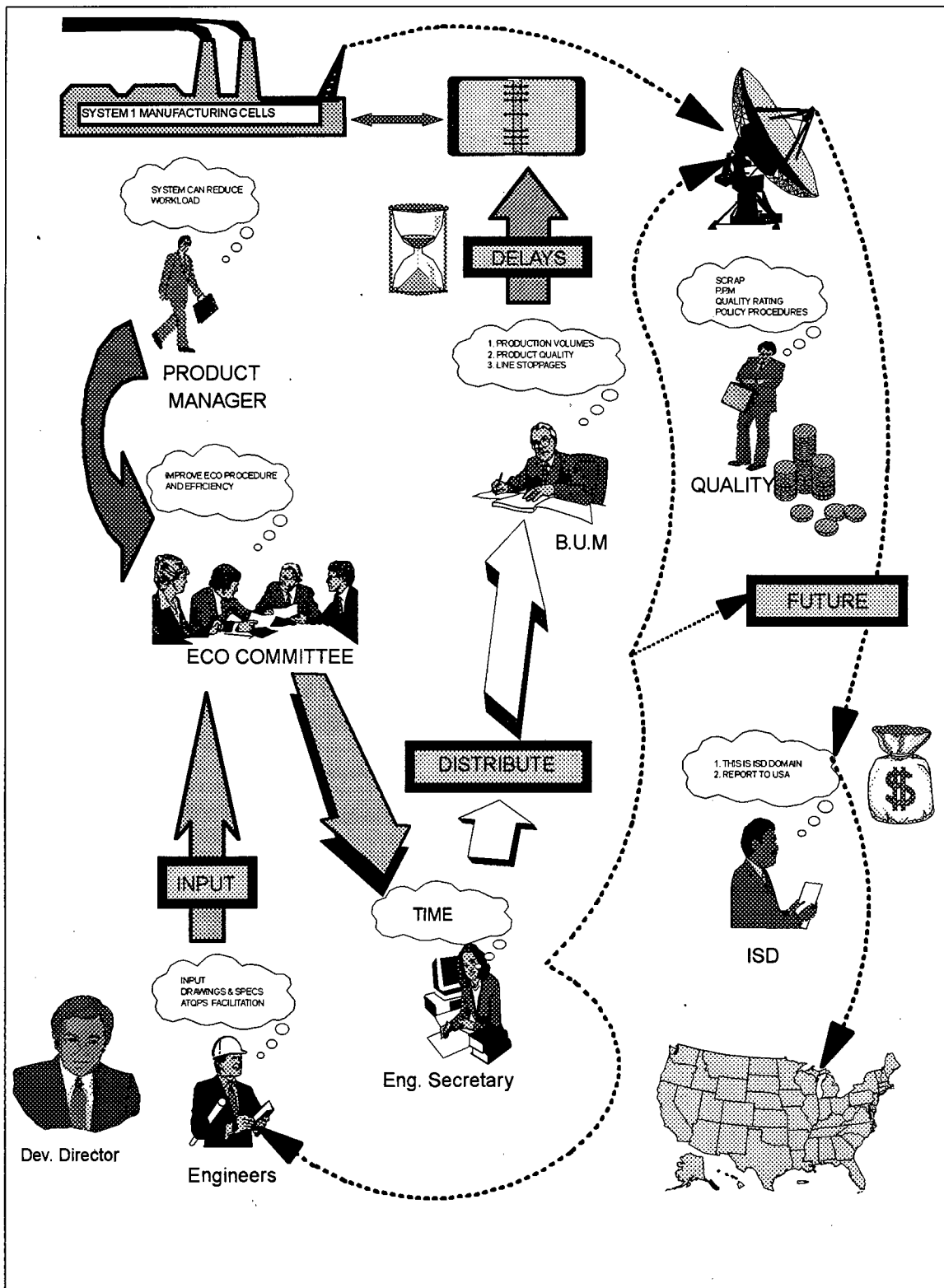

Fig 7.1 - Rich Picture of current situation

The link between the Manufacturing cells and the Information Systems department is shown by a radar which represents a future connection envisaged by the writer. Although this connection has now been recognised by various stakeholders, this department is resistant to the writers in-depth involvement.

It was originally thought that the main area of concern was a need to automate the compilation of structures directly from the source drawings. However, after discussions with various players, the focus has moved to the lack of accurate information that is apparent on the shop floor.

The Rich Picture shows various people linked in one way or another. The Development Engineering department is the owner of the system. They are the only people who can stop production, by withdrawing drawings because of errors or potential hazards, due to design problems. Likewise, they are the only department with the authority to introduce a new product onto the shop floor. The Development Engineering department which falls under System 4, is responsible for running the ECO Committee. This ECO committee ensures the systematic and smooth introduction of new product releases and engineering changes into the system. The Development Engineering Director is also responsible for Quality Engineering and is thus affected directly by the consequences of late or incorrect releases of drawings onto the factory floor.

The system's actors consist of the Business Unit Managers, the ECO committee, Development secretary/clerk, Business Unit Engineers, Manufacturing cells, Product Manager and the Development / Manufacturing Engineers. In terms of the system, the Business Unit Managers have to take responsibility for accepting the pack of new drawings from the Development Engineering clerk by signing for them on a cardex system. Each Business Unit Manager then has to distribute them to the various relevant Manufacturing cells where he removes all the old level drawings and replaces them with the new level drawings. He is also, amongst other things, responsible for the Business Unit's output in terms of production volumes and other performance measures, as laid down by the Gabriel Total Quality Production System (GTQPS). The Business Unit's performance is severely hampered by scrap which can be generated through various stages of the process, including scrap generated through incorrect information.

The purpose of the ECO committee is to ensure that the ECO procedure is adhered to and that the engineering changes and releases, are introduced to System One operations smoothly with minimum disruption. This is achieved by using the four stages which, when adhered to, provide a framework that efficiently facilitates the changes into the organisation. However, as

the committee meets weekly, and the framework is rarely adhered to, changes can get out of control with disastrous results.

The Development clerk has to make a set of copies of all the drawings for the different relevant departments. This entails a lengthy process of writing out new cards in the cardex system, copying all the drawings for each department or cell and physically going to each Business Unit Manager as discussed above. The Product Manager, apart from chairing the ECO committee, is responsible for the loading of the product part numbers onto the information system. He is also the final person who signs off all new product releases and engineering changes before these are copied by the clerk and distributed throughout the company.

The members of the different System 1 Manufacturing cells require, in terms of audit requirements, up-to-date, correctly released drawings for all stages of the manufacturing process. These drawings are paper copies of the original master drawing and are kept in files in the production cell. Invariably, these paper drawings get damaged or go missing which results in either a line stoppage while a replacement drawing is sourced from System 4 or the Operators resort to guessing what the dimensions required by the drawing should be.

The Business Unit Engineers have an impact on the change system as their input in terms of process, development and quality requirements is critical to the successful implementation of the changes. The Development Engineer is responsible for:

- creating new or changed drawings on Auto Cad;
- compiling or modifying parts lists ,where necessary;
- saving drawings in correct directory on the file server;
- compiling the ECO paperwork;
- checking the structure which has been compiled by the Product Manager from the Engineers parts list.

The Information Systems department, who are accountable for all new computer systems and relevant hardware, offer a service to all departments by providing required reports and maintaining the existing and future networks. The Rich Picture shows that the Information

Systems department is concerned about the cost implications of the system. They also seem to resent what they believe is an "intrusion" in their domain.

## 7.2 CONSTRUCTING THE ROOT DEFINITION

Multiview uses the technique of Root definition to address problems that are seen in departments such as I.S.D. The ISD problem arises because they state that the system is perfect, while the users feel that the same system is a waste of time, or that it does not do what it is supposed to do.

As discussed in the description of the Multiview Technique, the Root definition is a verbal, concise description of the system which captures its essential nature. If well formed, it should check for the presence of the six CATWOE characteristics.

The first stage of creating this definition is to put down these six headings and to fill them in. This has been done for five areas from the dynamic change model being :

1. Create the change package
2. Create/update product structure system
3. ECO procedure
4. Information Distribution system
5. Daily usage system.

A sixth CATWOE has then been created for the encompassing system for the above five areas.

### 7.2.1 THE CHANGE PACKAGE CATWOE

Customer	The System 4 Product Manager
Actors	The System 1 Development/Manufacturing Engineers
Transfer	Turning a change request into drawings and subsequent change documents
World View	Must be accurate and quick
Owner	Development Engineering
Environment	External and internal customers

Root Definition:

"A system which is a means to enable the quick compilation of changes requested by customers, suppliers and manufacturing. These changes done such that the product remains buildable within our processes and high specifications."

### 7.2.2 CREATING THE STRUCTURE CATWOE

Customer	The Information Systems Department
Actors	The Product Manager
Transfer	Create a bill of materials from the drawing parts list
World View	Loading structures is not user friendly
Owner	Finance Department
Environment	Computer system

Root Definition:

"A system which is used by Product Engineering to transfer the data on the top level drawing's parts list into the companies information system. This data is then used by all functions of the business including costing, inventory control finance and sales to name but a few."

### 7.2.3 THE ENGINEERING CHANGE ORDER (ECO) PROCEDURE CATWOE

Customer	System 1 Manufacturing cells
Actors	The ECO Committee
Transfer	Control of material, processes and tooling in preparation for the change
World View	Complexity
Owner	The ECO Committee chairman (Development)
Environment	Company wide and external suppliers

Root Definition:

"A system which co-ordinates the introduction of new products and engineering changes in a manner which is economically viable, responsive and problem free into production".

#### **7.2.4 THE DRAWING DISTRIBUTION CATWOE**

<b>Customer</b>	System 1 Manufacturing cells
<b>Actors</b>	The Development secretary and Business Unit Managers
<b>Transfer</b>	Delivery of released drawings from the ECO committee to the end users
<b>World View</b>	Time consuming, difficult to co-ordinate and control
<b>Owner</b>	Development engineering and the ECO Committee
<b>Environment</b>	Manufacturing and Managers offices

Root Definition:

"Could be called a system which enables the ECO committee to get released drawings onto the shop floor".

#### **7.2.5 THE DAILY USAGE CATWOE**

<b>Customer</b>	External customers (i.e.: O.E. factories) and internal customers
<b>Actors</b>	The manufacturing cell's operators
<b>Transfer</b>	Turn drawing information into products
<b>World View</b>	Is this the right level drawing
<b>Owner</b>	Development Engineering
<b>Environ.</b>	Manufacturing cells

Root Definition:

"The daily use of drawings by the Manufacturing cells for maintaining production. Ensures that the operators have the right information so that they can build shockabsorbers and check to see if they meet the required specifications".

#### **7.2.6 THE ACCURATE, EFFICIENT PRODUCT INFO SYSTEM CATWOE**

After several iterations, by looking at the previous CATWOE's , this CATWOE was developed encompassing the five systems above.

<b>Customer</b>	The three Business Units and subsequent Manufacturing cells
<b>Actors</b>	ECO Committee, Product Manager, Business Unit Managers and the Development Clerk
<b>Transfer</b>	To provide accurate, instant information which will improve the quality of production build <b>Owner</b> The Development Engineering Department
<b>Environment</b>	Factory floor

**Root Definition:**

"A system through which engineering can introduce new product changes channelled via the ECO committee to the Manufacturing cells in an efficient way so that it can be used on continuous basis for building product. This system is owned by the Development Engineering Department and operated by the Manufacturing cells to access information loaded by the Development Engineers via the ECO committee."

### **7.3 BUILDING THE CONCEPTUAL MODEL**

In order to complete the analysis of the human activity system, a model of the different activities' relationships has to be built. If this conceptual model is to be helpful, it must show discrepancies between the real world occurrences and what should theoretically be happening. The purpose of a computing system is to improve things, as opposed to just automating the status quo. Therefore, a focus on distribution of information rather than the automation of the component structure, seems to be the correct direction for the system design.

The outcome of the conceptual model must, if successful, give us a scaled down model of the proposed situation which can be shown and explained to the client. A plan to which the System Designer can adhere is also required.

The first level for the conceptual model is called The Accurate, Efficient Product Information System. This system was originally thought to be one, large, complicated model. However, by using Multiview, five sub models have been developed (see Fig 7.2 below) which relate to

those system for which the Root definitions were developed above.

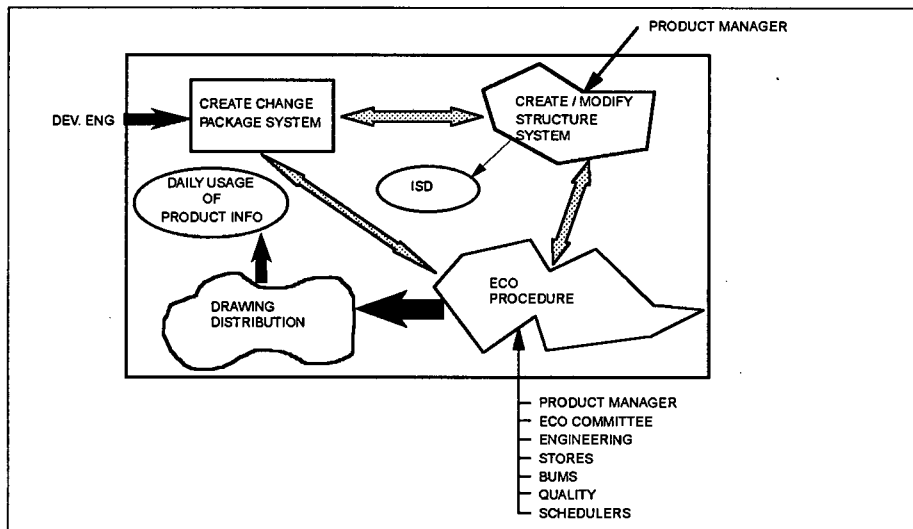

Fig 7.2 : Conceptual model level 1 : Accurate, Efficient Product Info System

### 7.3.1 CREATE THE ENGINEERING CHANGE PACKAGE

The current creation of the Engineering Change package consists of six central entities (see Fig. 7.3). These are, the original request for change, raising the ECO number, creating relevant drawings, modifying parts list, checking them and forwarding it to the Product Manager.

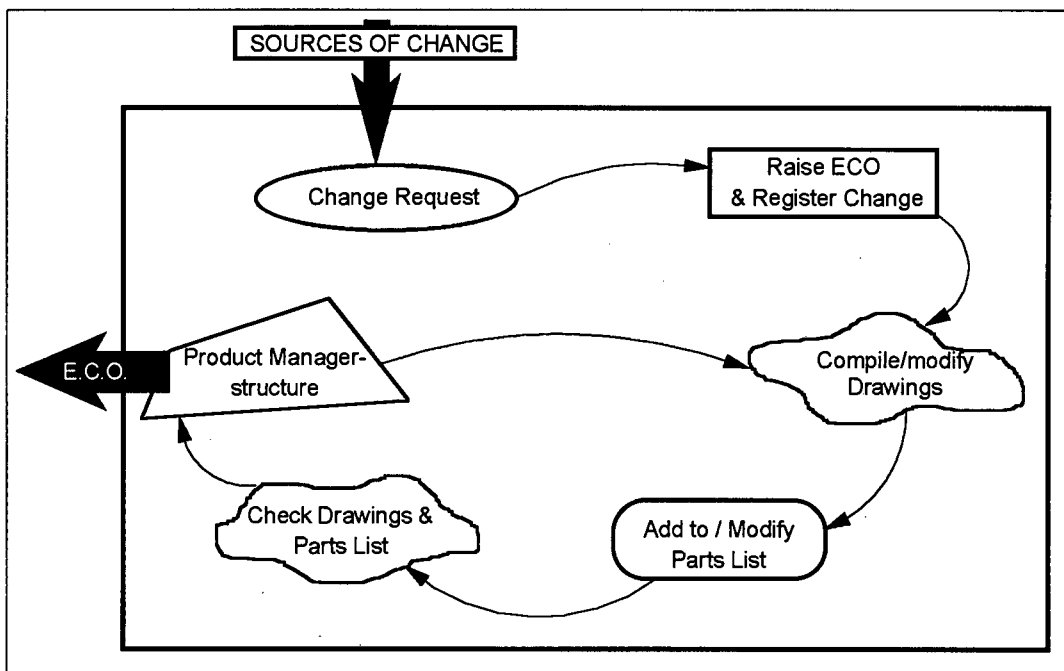

Fig 7.3 - Concept model for Engineering change packages

### 7.3.1.1 Original Request for an Engineering Change

Engineering changes essentially come from external and internal sources. With each request for change, a fairly complex sequence of events (see Appendix 3 for the detailed change model) takes place. This sequence has now been broken down into these five sub models.

#### i) Internal Change

Internal requests for change come from several different systems. Firstly, requests can come from an Operation 1 Manufacturing cell as a result of continuous non-conformance to specification. These changes are usually a result of the shockabsorber not meeting the resistance specification due to unavailability of valving parts, or dimensionally incorrect parts, due to drawing errors. They can also be derived through innovative cost savings as a result of their Employee Involvement suggestion meetings (cheaper parts or deletion of unnecessary parts). Secondly, the requests can come from drawings which have been running under deviation consistently for three production batches and are now to be made permanent. Thirdly, internal changes can be as a result of a supplier (from the external environment) whose component requires a relaxation of tolerance in order to be able to manufacture consistently. Fourthly, they can come as a result of a change in supplier (due to continuous bad quality or uncompetitive pricing) which is done by the purchasing department which sits in System 4. And finally, from changes due to the rationalisation of components.

#### ii) External Change

External changes come mainly as a request by our O.E. customers. This is usually as a result of a change of specification by the O.E. customer's mother company, i.e. : a change in overseas design of mounting bushes on the car might dictate that the rod design would require changes. This would be the case if our local customers are forced to use the imported mounting bushes. Another change could arise as a result of a rationalisation in design. We are currently in progress with the implementation of our local, New World design valving. In order to implement this change with our O.E. customers, a lengthy programme is required. It involves our System 4 O.E. Product Manager submitting a re-quote on the current design, showing a significant price reduction, and an improved quality performance, to name but a few advantages.

### **7.3.1.2 Raising and Registration of ECO's**

Once a change has been approved, an Engineering Change Order (ECO) is raised by the relevant Development Engineer who is part of both the Business Unit in System 1 and System 4. The process of registering an ECO entails contacting the Product Manager, describing to him, a brief reason for the change and then waiting while he logs the change in book called the ECO change register. This procedure becomes frustrating when the Product Manager is not available. When this happens, the Engineer must make a trip from their factory based office all the way to the administration block where the Product Manager's office is situated. The Engineer will then find the ECO register and fill in the change details himself. The actual ECO is a document which shows what the reasons for the change are and details the extent of the change by listing old part numbers or dimensions and the revised or new ones.

### **7.3.1.3 Compiling Drawings , Modifying Parts Lists and creating the Product Structure**

Once an ECO has been raised, a set of new drawings will be made or the existing drawings will be modified. This change usually means modifying the top level part numbers release level as all changes for that product must be recorded. The products parts list which, in the case of original equipment shockabsorbers, is on a separate spreadsheet attached to the drawing is then updated if a component is changed. In terms of Aftermarket Replacement shockabsorbers, this parts list is integrated into the drawing (see Appendix 4). This compiled with a list of the new or modified parts as well as a set of drawings and a timing schedule. The ECO is then passed on to the Product Manager (System 4) who creates a product structure.

The final conceptual model entails modifying the method of raising an engineering change. This will mean changing the system such that the relevant Engineer can access the change register on a computer terminal, and thus will be able to take out a number himself. This will most certainly reduce the variety of information that the Product Manager deals with on a daily basis and speed up the Change Package system.

### 7.3.2 CREATE / MODIFY THE PRODUCT STRUCTURE MODEL

Once the Product Manager has received the change package, he will, through a time consuming and laborious procedure, modify or compile a bill of materials called a product structure on the 'Rascal' information system (he usually has many of these to do per month). This procedure (see Fig 7.4 below) starts by the Product Manager adding the new top level part number to the computer system's part master file as well as its description and the origin of the parts assembly (i.e. is it being internally assembled or bought in?).

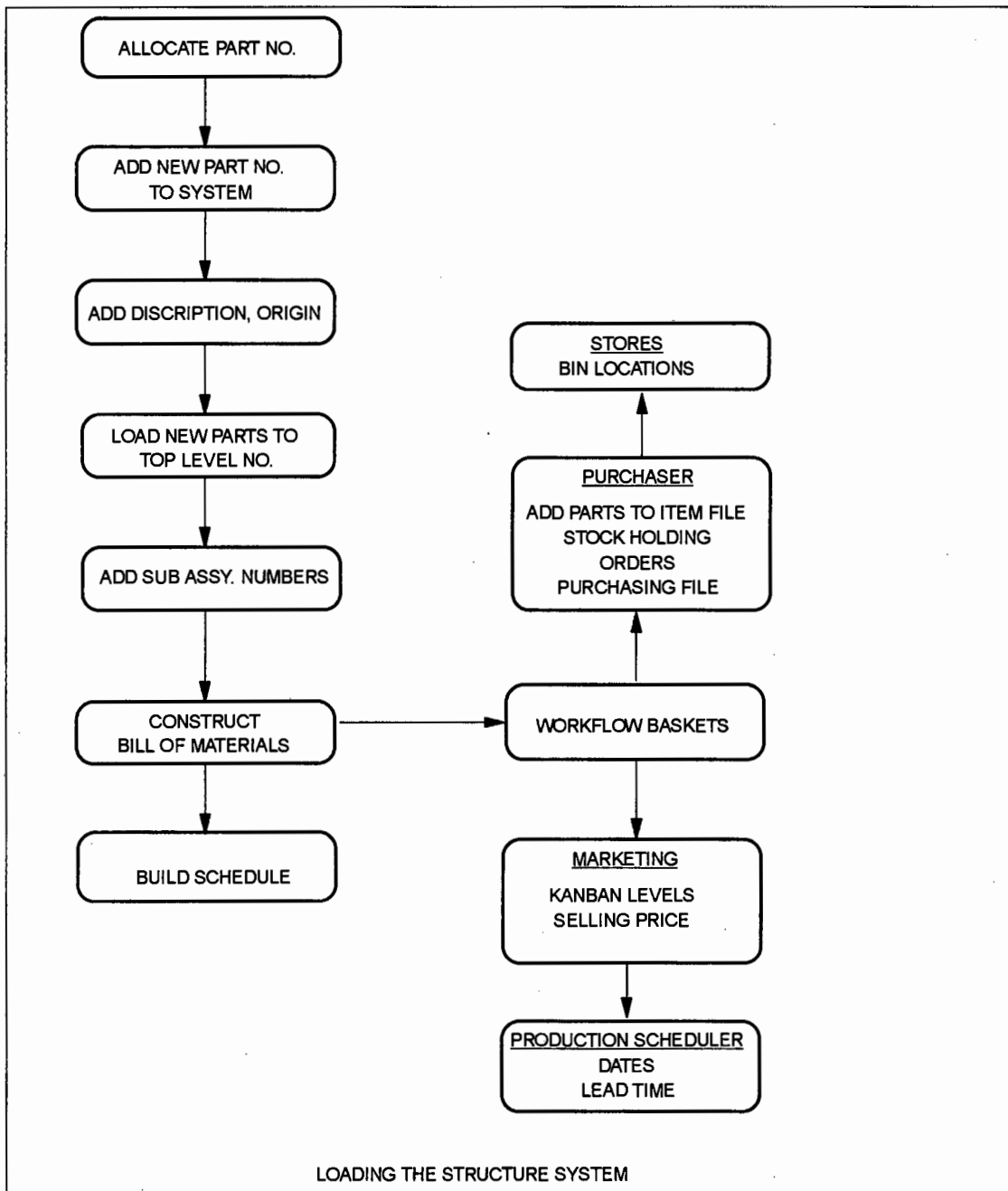

Fig 7.4 - Loading the Structure System

This number is, for instance, the shockabsorber part number which is made up of a number of sub -assemblies. These, in turn, consist of a series of different components (see parts list Appendix 5). The new sub assemblies are added and are, in turn, broken down into their individual components.

The next step is to bring all these entities together by constructing the full bill of materials for the new or modified top level part number. The Product Manager then adds this information to the system's workflow basket which requires actions by various departments. The new parts are added to the System 4 purchasing work flow basket where the purchaser adds these parts to the Item File. The Item File is used to define the components requirements in terms of stock holding, ordering, cost and suppliers. The bill of materials is loaded into the System 4 Marketing Department where the build schedule, selling price and KANBAN levels are established. Finally, the store take the information from their workflow basket to set up bin locations for the components in the KANBAN racks which are located in the Manufacturing cell where the new shockabsorber will be made.

Once the structure has been completed, it is then added to the system, in line with the effective change dates in the change register. This structure is then returned to the Development Engineer who checks it for accuracy against the new parts list. Only once this cycle has been completed, can the KANBAN cards be completed for the new part.

The System 4 Product Manager then costs the product. In the case of a change in an original equipment shockabsorber, he will submit the relevant information to them for approval. The structure is then returned and is taken to the ECO meeting. At the meeting, the various members are given responsibilities and a time plan is agreed with respect to an immediate release of a change, or a staggered release (Queued release). This will depend on whether or not parts are to be run out.

The concept model Fig 7.5 below shows that the Creating a Structure System could be removed and be replaced by an automated structure creation which would be linked to the Auto Cad generated drawings and controlled by the relevant Business Unit Engineer as shown below.

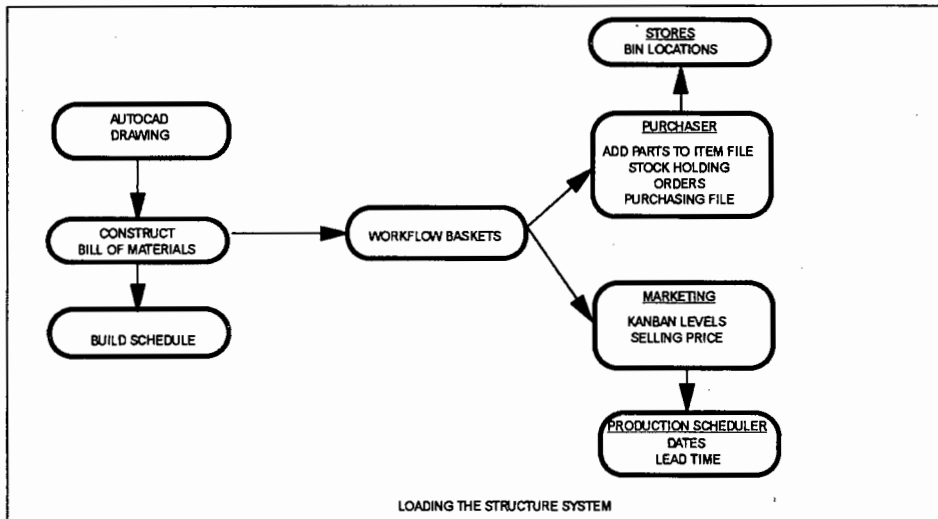

Fig 7.5 - Concept Model of Loading the Structure System

### 7.3.3 THE E.C.O PROCEDURE MODEL

The output from the bill of materials in the structure model showed that certain information is passed on to various people in the business through the work flow baskets . These people, together with the Product Manager and other stake holders in the change cycle, form a group called the ECO Committee who manage the multi-stage ECO procedure.

The Engineering Change Release Order consists of four central stages. The purpose of the ECO is to ensure, through the interaction of the ECO committee, that all changes and newly released products reach the factory floor in a smooth manner. These four stages as seen in the concept model Fig 7.6 consist of appreciating the change, looking at the changes impact on the design and process, defining the cost impact and finally, establishing the change implementation dates.

#### 7.3.3.1 Appreciate Change

The purpose of this stage is to establish the nature of the change. This is done by finding out whether there is to be a new part added to the system, whether the part is made or purchased or if it a consumable like hydraulic oil. This stage also decides on the change method. There can either be a change which is mandatory or one which requires the run out of existing components.

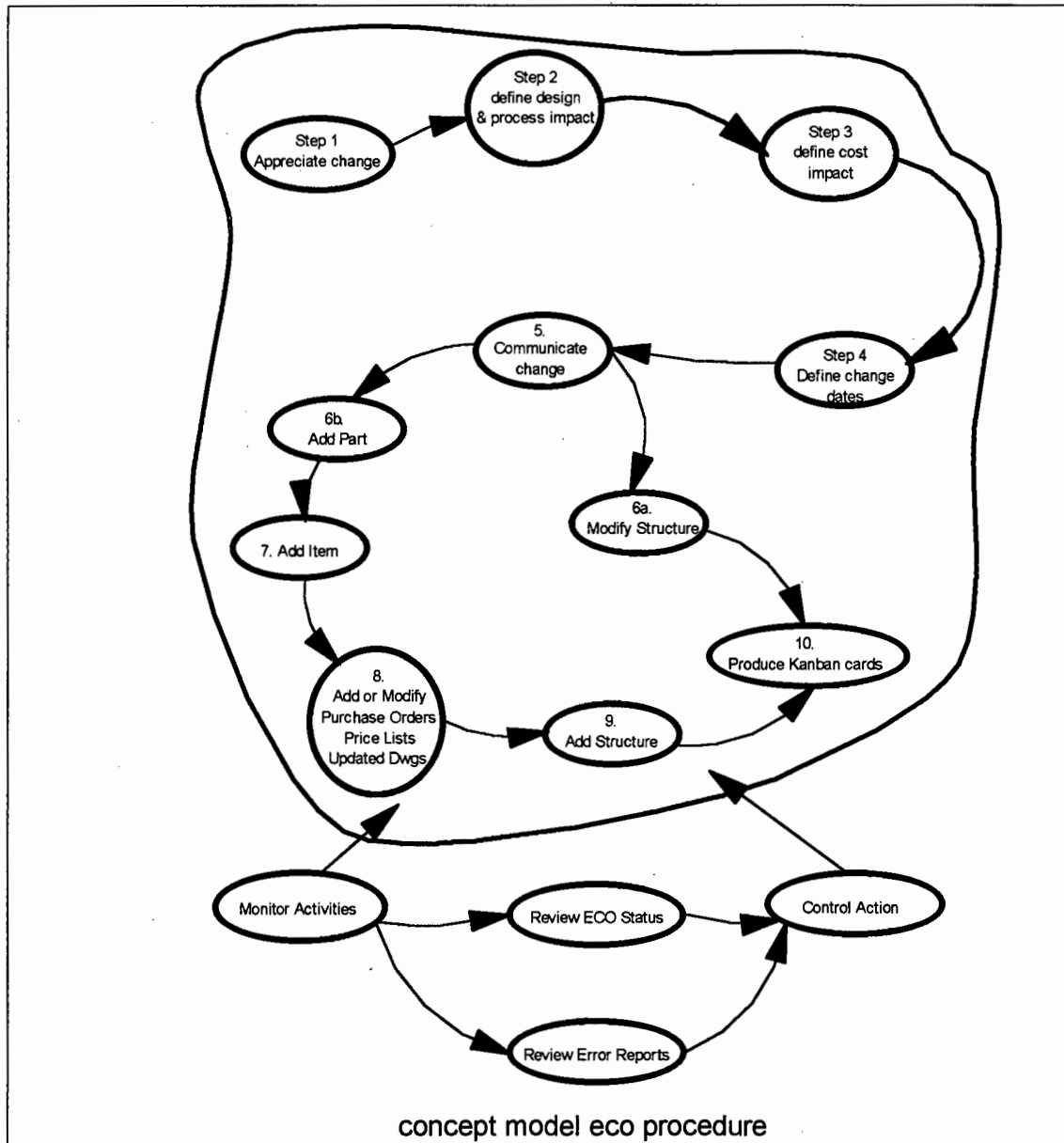

Fig 7.6

### 7.3.3.2 Impact of Change on Design and Process

Stage Two of this concept model involves defining what the impact of the change will be on the design and the process. The design might require changes to the drawings whilst the change may have a significant impact on the manufacturing process required to make that part. A major change could also have an impact on the relevant Manufacturing cell's output capacity which will in turn affect the companies profitability. Finally, parts might have to be contracted out to a supplier due to a lack of capacity which will have further implications.

### **7.3.3.3 Is It a Purchased Consumable**

Stage Three ensures investigation by the System 4 Purchasing, and System 1 Engineers, into the costs and rationalisation aspects of the change. It ensures that wherever possible, the change results in a reduction of product cost, part numbers and suppliers.

### **7.3.3.4 Define Date Changes**

Stage Four determines the earliest date that a change can be implemented and must take into account whether the change is mandatory or if a run out of parts must take place. As this stage encompasses timing, the implications thus include tooling lead times, lead time to reach KANBAN levels on new parts and the run out of old parts and, the response time of suppliers to the required change in the case of purchased parts.

From the above four stages, the System 3 ECO meeting must determine the longest lead-time that will occur in the change. The balancing out of the shorter lead-time items and the feedback of that information to the various internal and external suppliers must also be done through the ECO meeting. Only once these four stages have been completed, is the decision to implement the change or not, is taken by the System 4 Product Development.

The next step in the ECO process (if not done before as in the previous concept model) is to produce the products structure. The items as previously discussed are passed to the workflow basket. All updated drawings are forwarded to the relevant vendors and suppliers in order to ensure that we receive the correct level parts in time. Only once these steps have been completed, is the structure officially added to the system, in line with the effective change dates in the change register. The relevant System 1 Manufacturing Engineer must then ensure that the new drawings are ready prior to the effective implementation date. This is to ensure that the internal suppliers receive their drawings with sufficient lead time, in order for them to complete the required KANBAN levels of the new part. After these have been verified, the KANBAN cards are produced for the new part and the drawings distributed to the various Business Unit Managers.

As discussed in the operation research project, the ECO procedure is a sound model as it comprises a solid feedback system using a checklist which answers all the question that arise from the four stages. The only area envisaged which requires further streamlining, is the compilation of the structure that can occur during the ECO model, or before in the create / modify the product structure model, as discussed.

#### **7.3.4 DRAWING DISTRIBUTION MODEL**

As seen in the Rich Picture, the exercise of distributing the drawings poses various problems that could be rectified in a new concept model. The Rich Picture is outlined in a process which is detailed in the model shown in Fig 7.7 below. The input to the Drawing Distribution system starts as an output from the ECO procedure as discussed. The ECR and its set of original drawings is passed on to the System 4 Development Engineering Clerk. The Clerk establishes which Manufacturing cells require a copy of the drawings by looking at a table of the three System One Business Units. A set of copies is then made for each relevant cell as well as copies for the development master file, reference files, Goods Receiving, Quality departments and relevant suppliers. The ECR document (see Appendix 6) is then copied and attached to each set of drawings. The next step is to update the cardex system by either adding the new drawing level to an existing part card (a drawing change to an existing part or component), or by creating a new card for a new part or component.

Each and every drawing that is to be distributed is rubber stamped (see Appendix 11) with an official release stamp and a level stamp which coincides with the change or release level. These are required by our Original Equipment customers (VWSA, BMW etc.) as part of our Quality policy and procedures as laid out in detail in Gabriel S.A manuals. The reason for these requirements is to ensure change traceability and to maintain production build to the correct release level, ensuring that unofficial ad- hoc marked up drawings are not in the production floor. This could result in costly mistakes being made. The officially stamped drawings are then taken to the Product Manager who then signs all of them.

The Clerk then takes the pile of drawing sets to each relevant System 1 Business Unit Managers , where they sign the cardex cards acknowledging receipt of the change and drawings. The Business Unit Managers then arrange for all the drawings to be laminated in a

plastic sheath. Once this has been done, the drawings are then taken to each relevant Manufacturing cell. At the cell, the old level drawings are removed from the drawing file and replaced with the new ones. The old level drawings are then destroyed and disposed of.

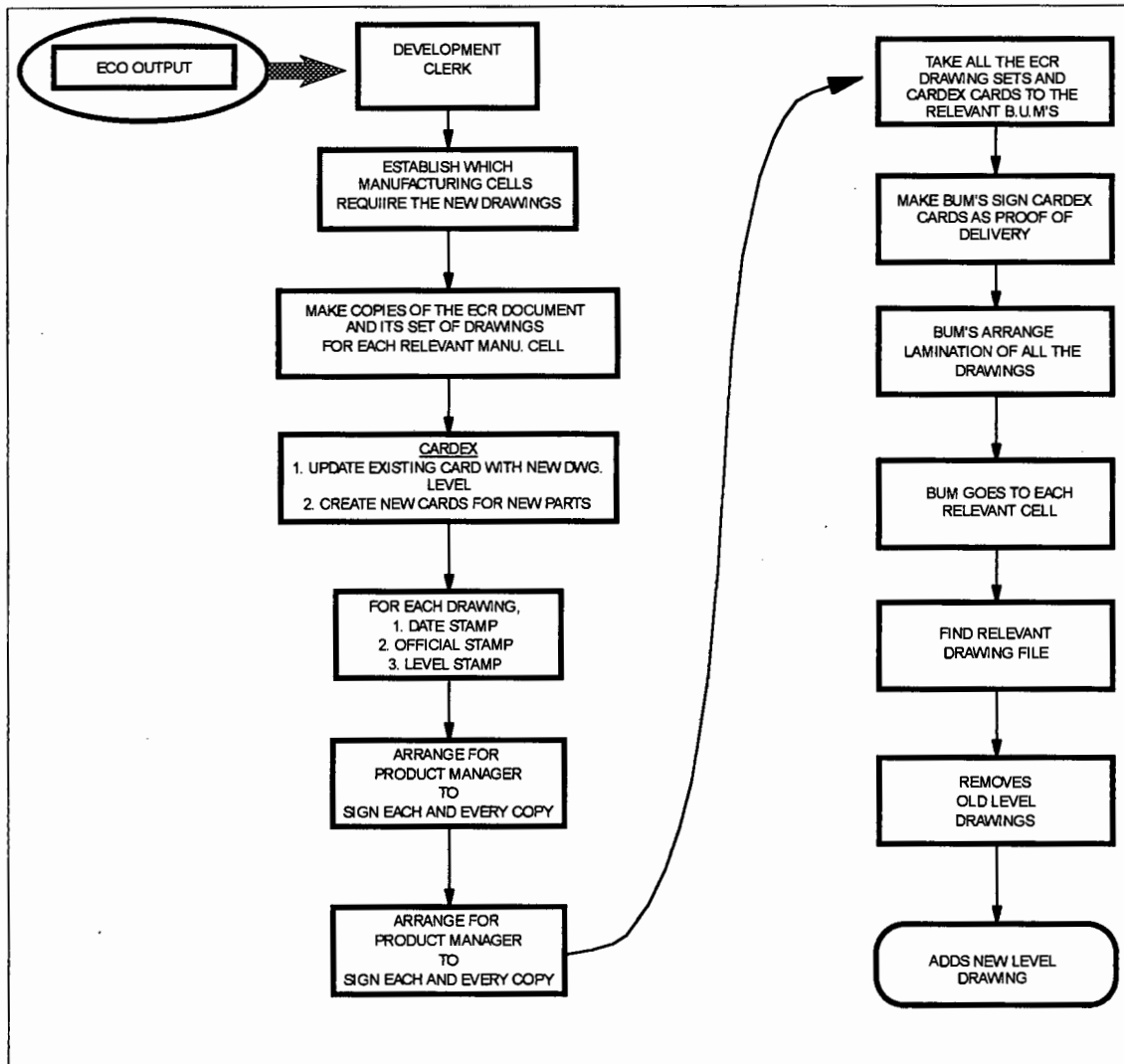

Fig 7.7 - Current model of drawing distribution

To compound the complexity of the distribution of the changed drawings, it is not uncommon to have more than ten change packages being co-ordinated by the Development Clerk at the same time. This means that almost daily, hundreds of drawings will be going through the process of being copied, stamped, signed and distributed to the cells. The Rich Picture shows that this compounds problem areas. Delays are created because the Business Unit Managers cannot cope with the variety of information that they have to deal with over and above their daily responsibilities. These delays can lead to expensive errors being made. As a new product being introduced for manufacture originates in various Business Units, sometimes one Manufacturing cell will receive the drawings on time while another might not. This usually results in the correct component or sub assembly being made in one place while another part

will be made to the old level drawing. The final result is that a defective shockabsorber will be assembled in the final assembly cell as the product will not conform to the drawing specification (see Chapter 12 for Error and Cost Table).

The Level 2 concept model (see Fig 7.8 below) that has been developed for the distribution of drawings, entails the Product Manager moving the CAD drawing from the development file server to a new production file server. This would be done on the agreed ECO introduction date as described in the ECO procedure model. The previous level drawing would, likewise, be moved to a backup directory in case it might be required if there is an error in the change drawings or documentation. The Development Clerk would still have to make one hard copy, namely, a set of official drawings for the master file. These would be used by the System 3 Quality department for doing inspection reports on the new parts or components (see Appendix 7). The advantage of this concept seems to be an enhanced means of managing the efficiency of the distribution of information. It will also create an auditing system which can be effectively controlled by the System's owner.

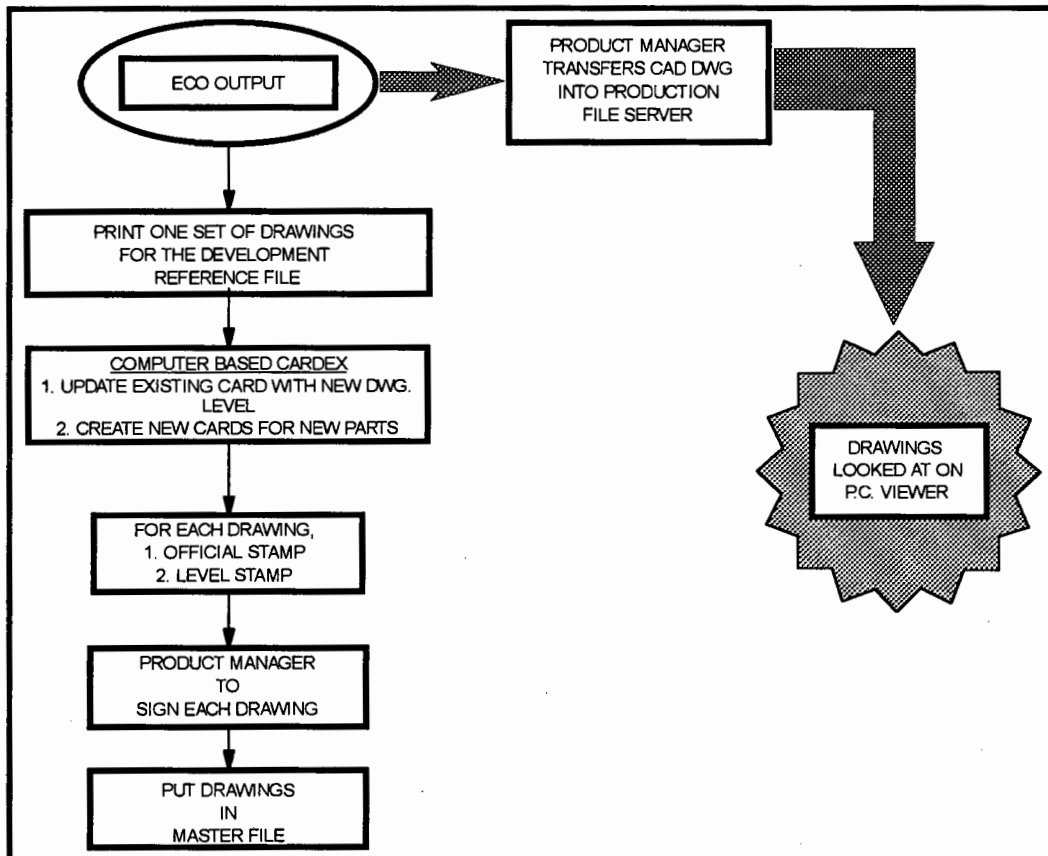

Fig 7.8 - Concept model - drawing distribution

### 7.3.5 DAILY USAGE MODEL

The daily activities of the Manufacturing cells which make up the operations of the three System 1 Business Units evolve around the purpose of their existence, which is making shockabsorbers. The starting point of making a shockabsorber in the final assembly is (see Fig 7.9 below) to pick the correct valving components from the KANBAN racks. Other supplier cells to the final assembly cell would use the drawings to retrieve dimensions for making the required sub-assemblies, for example, shockabsorber inter cylinder assembly (see Appendix 8) and piston rods.

A Manufacturing cell operator would look for the particular drawing in a drawing file which is kept in their Green Area. This entails finding the correct file and then paging through the file in order to find the drawing. This might seem easy, however, these drawings are usually not placed in a sequential order. Two situations occur at this stage, the first is finding the drawing and the second, not finding the drawing. If the drawing is found, the Operators pick the required parts from the KANBAN racks and staging areas which are located in the cell. The shockabsorber (first off) is then assembled and tested against the drawing specifications. If the first-off parts meet the drawing specification, full production commences. If however, the drawing is not found, a further two situations occur. The Operators either organise a new copy of the drawing or try to manufacture the shockabsorber from memory or experiences which inevitably results in dire consequences with huge amounts of shockabsorbers being scrapped off. (see Chapter 12 for error and cost table).

The scenario of organising a replacement drawing entails finding the relevant Engineer, who in turn walks to the Development office and makes a copy of the drawing from the master file. The Engineer has the drawings stamped with the official release and level stamp. The Product Manager then signs off the drawing. The new drawing is then replaced in Manufacturing cell's drawing file. The problem that occurs when this happens is that the cell's production comes to a standstill and thus has an impact on the daily output figures. This is one of the reasons why the Manufacturing cells take risks in making products without having the correct information at hand.

A further problem that has been observed is that management, due to the excessive variety of information that they are unable to control, tend to neglect maintaining the drawing files. As the system is owned by Development Engineering, the Development department should have a drawing file auditing procedure in place. The question arises, why are drawings missing from the Manufacturing cell's drawing file. Drawings are seen, in the eyes of management and management groups as policy documents which must be controlled. However, Production Operators seem have little respect for drawings, removing them from files, damaging them or forgetting to put them back. The reason behind this seems to be that the Operators do not fully understand that drawings are important control documents, but see them rather just pieces of paper with pictures on them. This is highlighted by the fact that they are often referred to as comics.

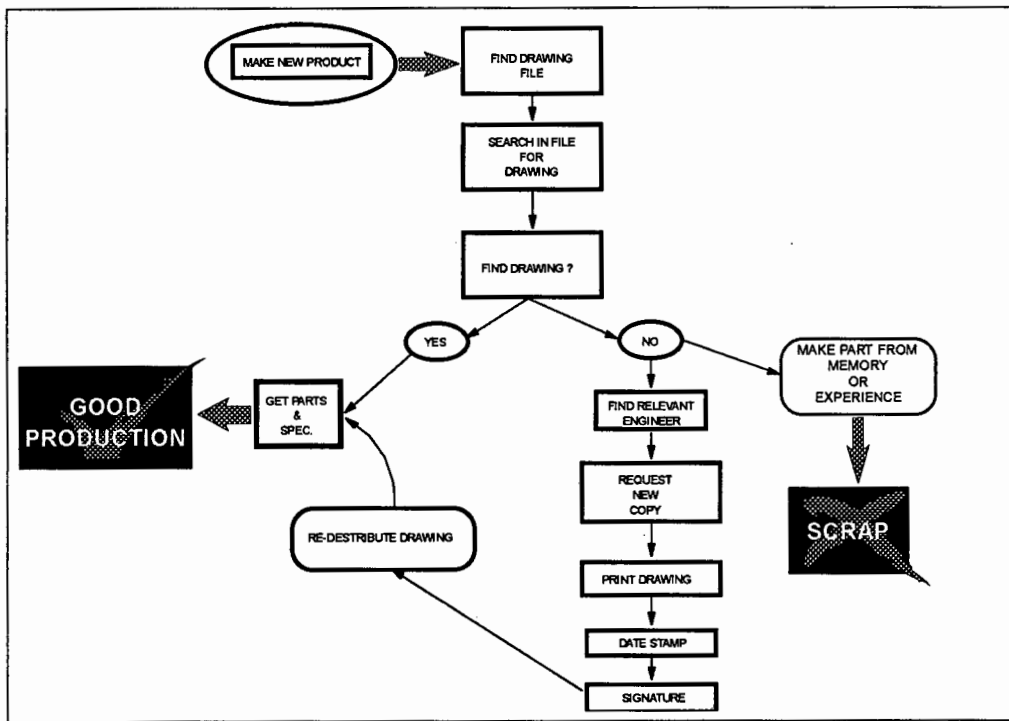

Fig 7.9 - current daily usage of information

The Level 2 Concept model evolved for the daily usage of information simplifies how drawings are used. The Manager's variety is reduced such that the system is self auditing requiring no input from the Business Unit Managers. The concept model (see Fig 7.10 below) entails using the concept model developed for the drawing distribution. The Operator types in the part number, views the drawing and makes the part. The drawing will always be there, which will mean that there will be no reason for the cell to stand still while replacement drawings are being obtained. Likewise, the engineering time wasted replacing missing

drawings will disappear. Finally, scrap produced through a lack of incorrect information will severely reduced. It will not disappear completely, as human error in misreading a drawing could still occur.

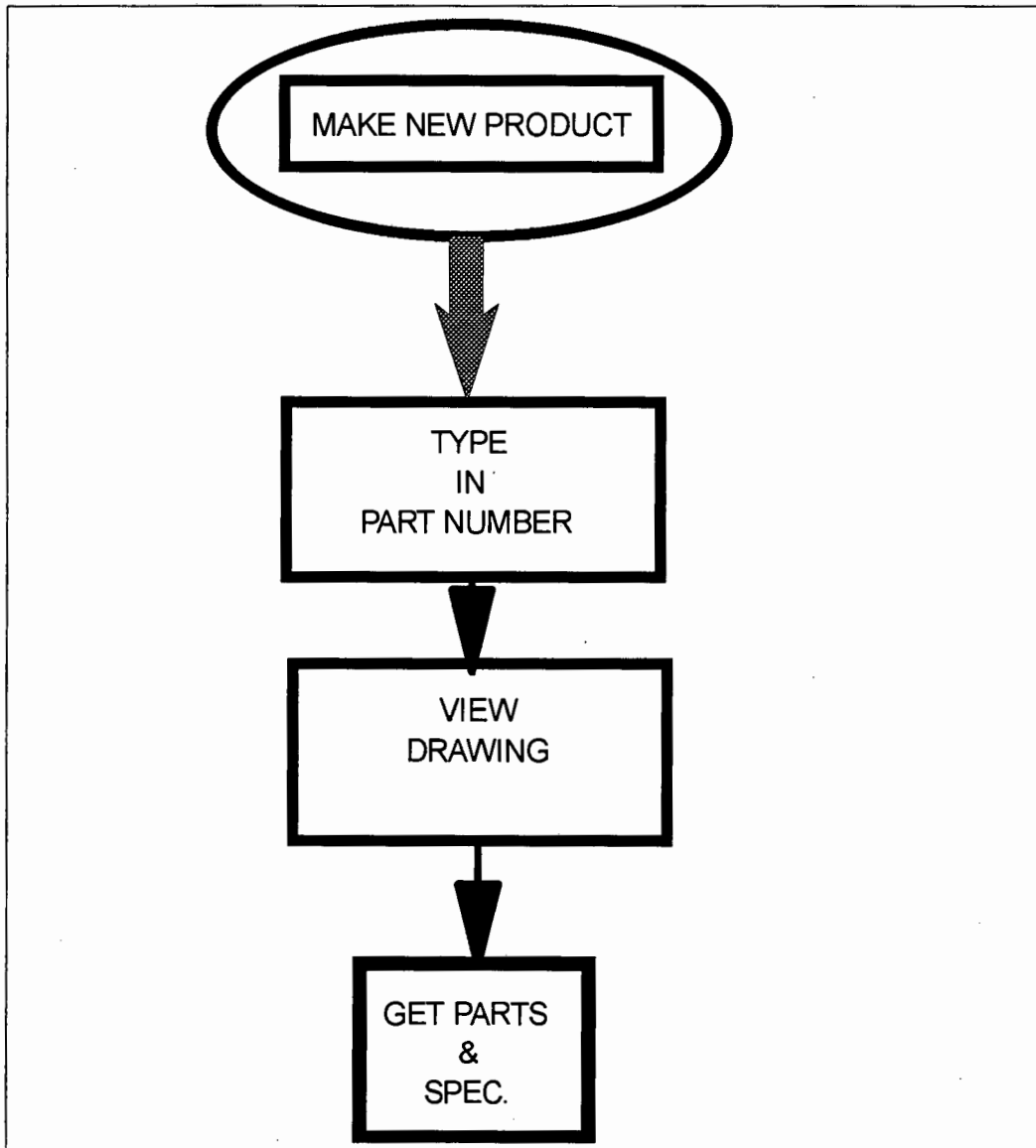

Fig. 7.10 - Concept model for daily accurate information

## 7.4 DEFINING THE HYPOTHESES

During the immersion stage of this thesis, the Viable System Diagnosis showed that the engineering change system was the cause of the Business Units Manufacturing cells' viability being undermined. The application of the first stage of the Multiview methodology confirmed that the flexibility and speed of change introduction was inadequate. It also highlighted that a further problem exists in the Manufacturing cell's actual usage of the current drawings.

**It is therefore hypothesised that by introducing an accurate drawing information system, the viability of the Business Units Manufacturing cells will be improved and the variety of drawing information reduced.**

In order to verify the hypothesis, this appropriateness of this theory must be tested. In order to do this, an intervention must be made by designing and implementing a new system using the next three stages of the Multiview methodology. On completion of this intervention, a series of tests will be run on each of the relevant models. If the hypothesis is true, the complexity of the drawing distribution will be reduced and the operations viability enhanced through the immediate availability of correct level drawings.

## **CHAPTER 8**

### **MULTIVIEW STAGE 2 - FUNCTIONS AND EVENTS**

In Stage 1, an overview of the whole situation was described using the Rich Picture. The Root definitions of the purpose of the Stage 1 human activity system were then found. Thereafter, the overall picture of the information flow was developed by building conceptual models of the various systems. Stage 2 of Multiview analyses the functions and the events that are derived from the Stage 1 Root definition and associated Concept models. The main parts of the second stage of Multiview consist of :

- 1) development of Function models;
- 2) development of Data Flow models.

#### **8.1 CREATING THE FUNCTION MODEL**

The first step of Stage 2 is to create a Function model. This model will detail the functions that have to be performed in the new system in a hierarchical manner. This process was started when the Concept model and its five, level 2 sub-models were developed. In this phase, the concept model is extended by removing all the physical things and concentrating purely on the functions to be performed. The Function model thus breaks down the main functions into smaller tasks or sub-functions. It is important, in order to ensure that the agreed functional breakdown is the most useful, that this phase is done with the assistance of the problem owner. In the case of this project, the problem owner is defined as the Product Development department. The reasoning behind this is that there are always, in human situations, different world views, and likewise, no correct answer.

The function chart represents at any level, all the functions that the system needs in order to operate. In this project, the main function derived from the Root definition, was providing/maintaining accurate information (drawings & specifications) to the System One Operational Units. The Function Chart showing the main function and the relative sub-functions can be seen in Fig 8.1 below.

The five sub-functions are defined as:

- creating the change pack;
- adding the structure;
- the ECO procedure;
- drawing distribution;
- daily usage.

Each of these sub-functions have been further broken down, with the exception of the ECO procedure, and loading the structure. Creating the Change Pack has been broken into getting the Change number and building the Pack. The Building the Pack has been expanded to compiling the drawings, specifications and ECR/ERA document. The Drawing Distribution function has been expanded into updating the master file and loading the changed or new drawing onto a production file server. The Drawing Distribution function has been expanded into updating the master file and loading the changed or new drawing onto a production file server.

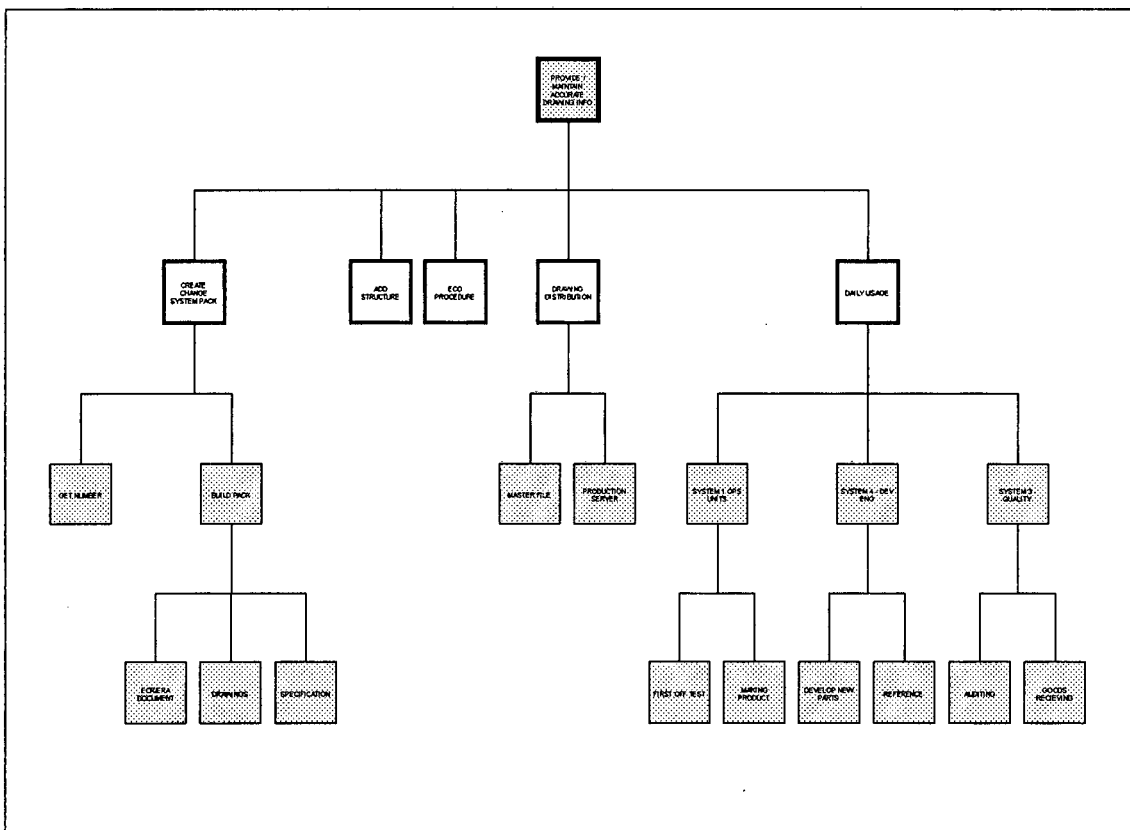

Fig 8.1 - Function Model

The Daily Usage function consists of three sub-functions being the System 1 Operations Management group and Manufacturing cells, System 4 Development Engineers and System 3 Quality department. The System 1 Manufacturing cells will use the system to firstly, retrieve the drawing in order to manufacture the product.

This will be done by either getting parts from the parts list or making the products' sub-assemblies from the drawing's dimensions and specified materials. Secondly, the system will be used to do a 'first-off' test to check whether or not, the product meets the specification on the drawing. This test is performed as soon as the first completed unit comes off the line. The System 4 Development Engineering department will use the system functionally to develop new parts and to use the existing drawings as a reference. The Systems 3 Quality department require the drawings to perform audit checks on products that are complete, and have been taken off the paint and pack line at random. The Quality department's goods receiving inspection use the information for checking the incoming parts and components for conformance to the particular drawing.

The Add Structure and ECO procedure have not been broken down as neither of them, as discussed in Multiview Stage 1, will be developed as part of this project. The three sub-functions that will be developed from this Stage will be, getting the Engineering Change number (Fig. 8.2), Drawing Distribution (Fig 8.3) and the System 1 Operation Units (Fig. 8.4). The System 3 and System 4 functions although, shown on the chart, will not change and thus will not be pursued in this project.

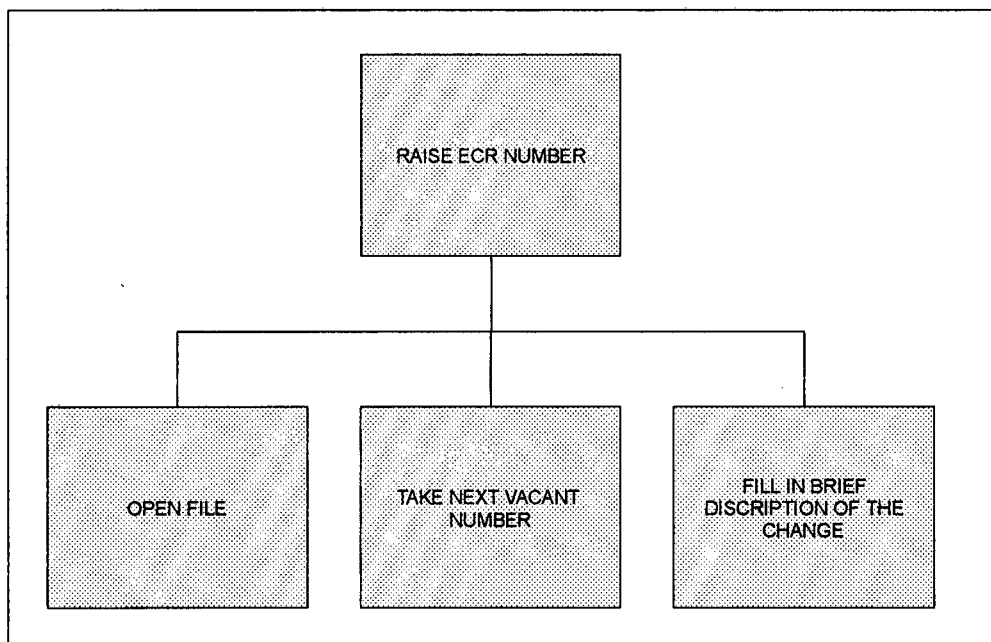

Fig 8.2 - Function Chart sub-function of get ECR number

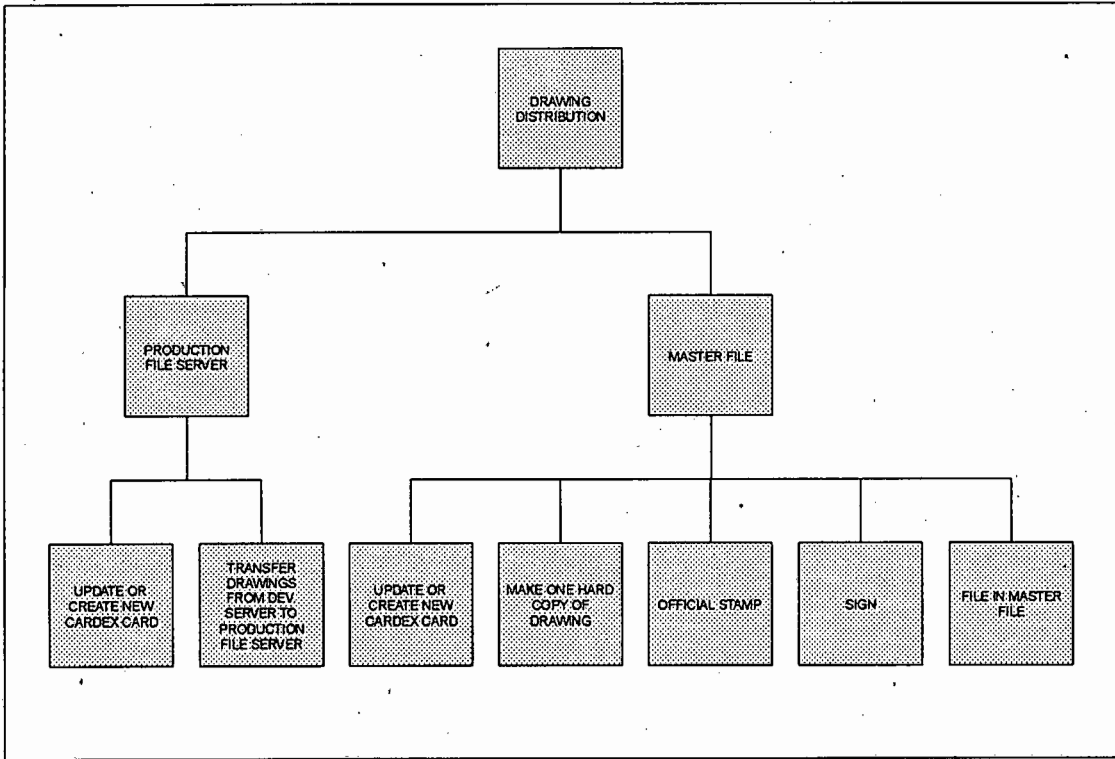

Fig 8.3 - Sub-function chart - Drawing Distribution

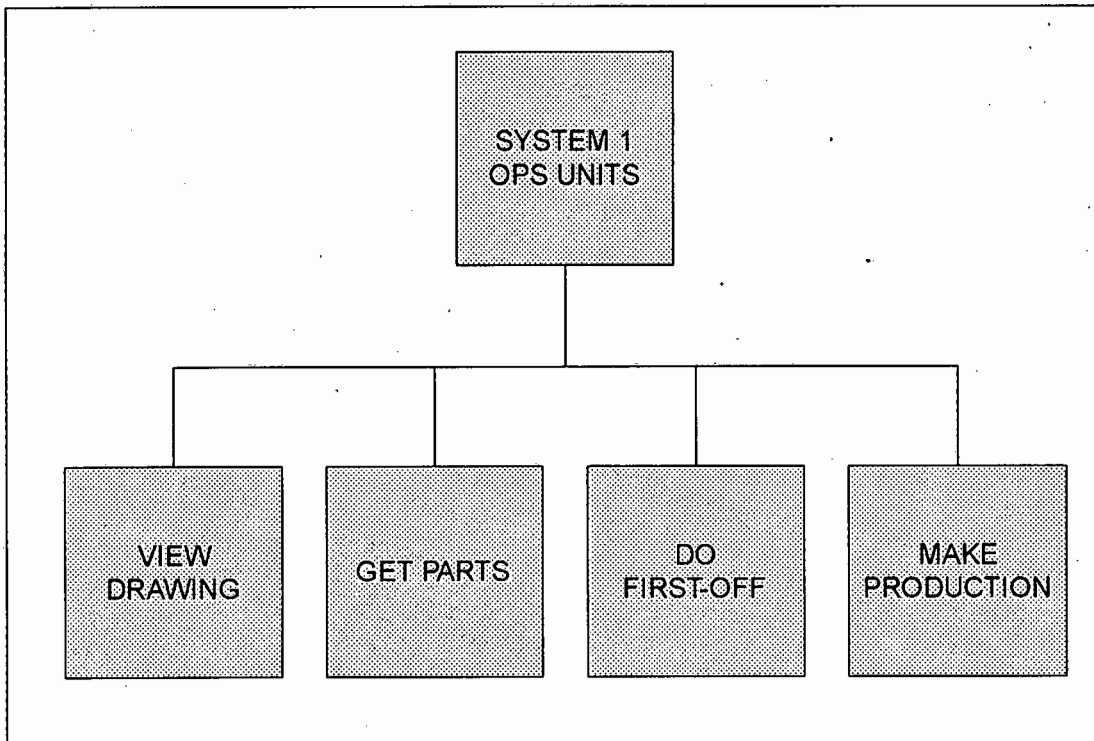

Fig 8.4 - Sub-function chart - Daily usage - System 1 Ops. Units

## **8.2 ESTABLISHING EVENTS AND DATA FLOW**

In this phase of Stage Two, the operations which start each of the functions or actions are considered. In order to do this, the information flows which occur in the functions chart are examined. Data flow diagrams are then developed which give precedence to the processes, functions and data usage. The data flow diagrams for the three functions being pursued, are constructed out of boxes which represent the functions from the chart, and arrows, representing events or operations that connect the different functions. Data or information flows in the direction of the arrows, undergoing changes as it passes through the processing function boxes. Bold and dotted line arrows sometimes point into the function boxes. The bold arrows represent data being captured while the dotted line arrows represent the input of information.

### **8.2.1 SYSTEM 1 OPERATIONS UNIT DAILY USAGE DATA FLOW**

From the System 1 Operations Unit Function model (Fig. 8.4), a series of four sub-functions can be seen, namely, view drawing, get the parts, make the 'first-off' and start production. However, several other functions are required in order to start and finish the main function of the Operational Unit. These additional functions are: getting the KANBAN cards, receiving sub-assemblies and cards, delivering the finished parts and feedback to scheduler.

The sequence of the data flow (see Fig 8.5) begins with the schedule for build being loaded onto the cell. This is done by placing the final products top level KANBAN card on the top row of the KANBAN board. The cell leader takes the associated sub-assembly cards from the KANBAN card rack and distributes them to the relevant internal supplier i.e.: piston rod card would go to our internal piston rod Manufacturing cell. Typically, in the case of original equipment (O.E.) shockabsorbers which are manufactured in the O.E. Shock cell, KANBAN cards for each top level shock number would consist of four cards namely, piston rods, inner cylinder tubes, inter cylinder tubes and dust cover tubes. All the small valving parts, mounting bushes and ancillary components are no longer kept in the bulk store but in specially allocated KANBAN racks in each relevant Manufacturing cell.

Once these cards are delivered, the receiving cell begins the manufacture of the required part or supplies the cell with existing parts from their own KANBAN rack. These parts are then returned with the card to the Cell Leader. The Cell Leader then places each of these cards on receipt under the top level card on the KANBAN board. Production can only begin once all the cards have been returned to the cell (with parts). As various top level shocks numbers are loaded onto the cell each day, the various suppliers are continuously supplying parts to the cell, placing the sub-assemblies into specific staging areas demarcated on the floor.

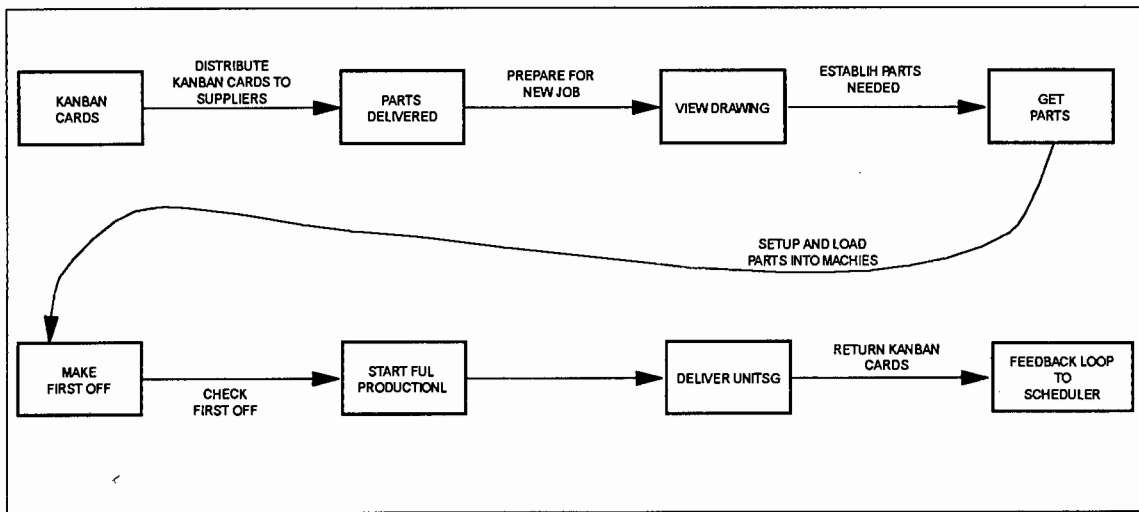

Fig. 8.5 - Data flow diagram 'System 1 Ops. Unit Daily Usage'

The first function when production starts is to view the drawing. From the drawing, the small parts required from the cell's valving parts KANBAN rack are established. As discussed in previous chapters, this probably the most critical stage of production. Incorrect drawings or nonexistent drawings result in errors and scrap products being made. The various operators then fetch their relevant parts from the rack and load them into their different machines. Once all the machines are loaded, set-up and ready to go, production begins by making a 'first off' which is essentially making the first complete unit. This completed unit is then checked against the drawing requirements to see if it meets relevant specifications and these results are recorded. Thereafter, if the results are within the required drawing tolerances, full production begins.

When production of the shockabsorber is completed, the batch of units including the top level card is delivered to the paint and pack spray line. The card is hung on their KANBAN board and thereafter it is returned to the Production Scheduler. This final action is the feedback loop

which informs the Production Scheduler that the units have been processed through to final goods receiving (FGR) for despatch. Although using KANBAN cards is a manual means for inventory control, it is a most effective, immediate, visible record which will not be changed.

### 8.2.2 DRAWING DISTRIBUTION DATA FLOW

The Drawing Distribution function chart has two lower functions, namely, adding the changed drawing to the master file and, transferring the computerised Auto Cad drawing from the development file server to the new production file server. The transfer sub-function is the system which requires analysing in terms of its data flow (see Figure 8.6).

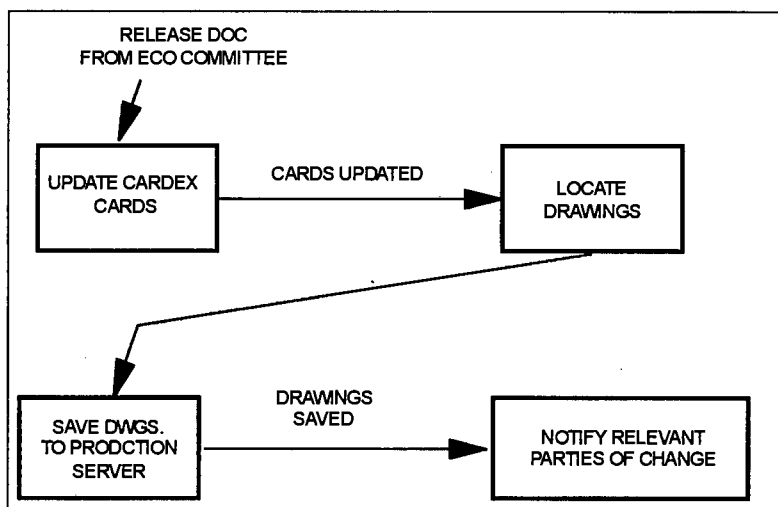

Figure. 8.6 - Data flow diagram 'Drawing Distribution'

The release or initiation of the process is triggered by the release document being signed off by the ECO committee. This notification is then passed on to the Product Manager. He instructs his secretary to update or create a new cardex card. Once the card has been updated, the Product Manager locates the relevant drawings on the development file server. The actual release of the drawing now takes place in the form of just transferring this drawing file from the current development directory to the production directory. Once the drawing has been saved, notification of the official release is done by electronically mailing all the relevant parties.

### 8.2.3 ECR REGISTRATION DATA FLOW

The three sub-functions seen in Figure 8.2 are initiated by a request from various sources as discussed in Multiview Stage 1. The process of data required for raising the change number (see Figure 8.7), commences by the function of receiving the change information. The file containing the ECR registration numbers is found and opened. The first vacant number following the last entry is taken. A brief description of the change as well as the date is filled in next to the new number. The file is then save and closed. The building of the change package then follows, which is later forwarded to the ECO committee.

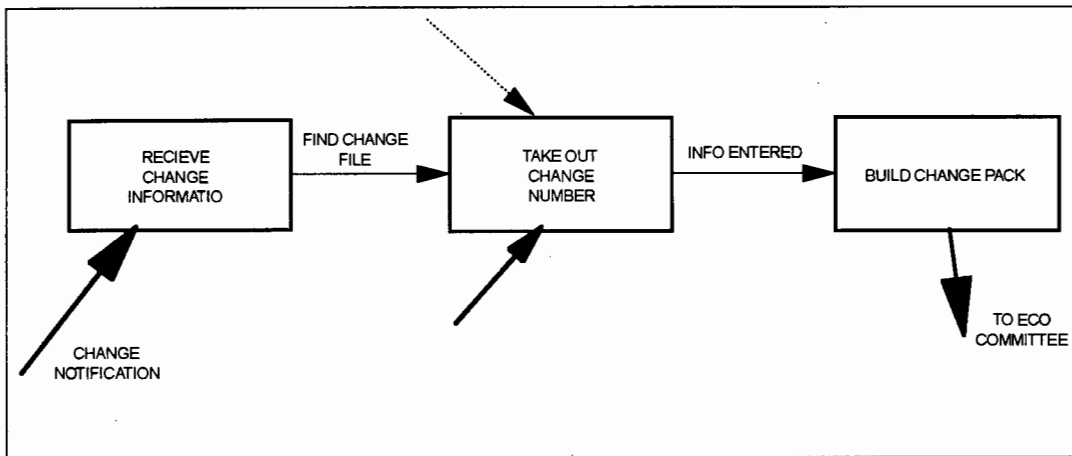

Figure. 8.7 - ECR Registration data flow

## CHAPTER 9

### MULTIVIEW STAGE 3 - ANALYSING AND DESIGNING THE SYSTEMS SOCIAL AND TECHNICAL ASPECTS

The first two Stages of Multiview are used to look at the current problem of accurate information for the factory floor in terms of accessible drawings, and for modelling its information needs. However, although the users of the current system had input in helping to define the situation, it is essential that their involvement in the proposed system is maintained. The reason for this is to ensure acceptability of the computerised system, guaranteeing its success.

In order to analyse the socio-technical aspects of the new system, the socio-technical design and alternatives must be discussed. This is followed by a ranking of the alternatives and a decision on which system should be adopted.

#### 9.1 THE SOCIO-TECHNICAL DESIGN OF THE ACCURATE DRAWING INFORMATION SYSTEM

As discussed in developing the problem situation, the purpose of Gabriel S.A. is to manufacture shockabsorbers, struts and cartridges. Likewise, the System 1 Manufacturing cells' purpose is the same. In order to fulfil this objective, the various System 1 cells require instant, accurate drawings. As seen in Multiview Stage 1, without this information, mistakes are made that result in costly scrap; the Manufacturing cell come to a stand still (unplanned down time) and this results in reduced throughput.

The proposed system envisaged to meet the requirements of accurate drawing information, will consist of personal computers located in each Manufacturing cell. These work stations in turn, will be connected via the current network, to the development file server where the Auto Cad drawings will reside in a production directory. For the system to succeed, it is important that the work station enhances the current situation by improving access to the drawings which were previously kept as paper copies in lever arch files. In other words, it is important

for the system to be very easy to use therefore making it quicker, than the usual hunting through the files for the required drawing.

As the system will be used in all aspects of manufacturing, from making individual parts to manufacturing the final product, it is essential that the work station is placed in a convenient part of the Manufacturing cell. For example, in the O.E. Shockabsorber cell, the system will be used for establishing what parts are needed from the cell KANBAN rack for assembling the shockabsorber. Secondly, it will be used to check the shockabsorber for compliance to the drawing specification. The situation of the station would therefore be as near as possible to the KANBAN racks, and in close proximity to the cell's Green Area where all first-off records and associated information is kept.

The final placing of the work station will, however, depend on the decision of the cell's Green Area members. One of the integral factors of our World Class initiatives, is Employee Involvement (E.I.) through self-directed work teams. The system would most certainly be resisted, if not rejected, if it was thrust upon the workers without prior consultation. Apart from adhering to these E.I. principles, the participation of the cell members is essential as they have a thorough knowledge of their working environment which entails them to a right to have input into the system's design.

The idea of a computer system in the Manufacturing cells was initially regarded by the cell Operators with suspicion. Typical questions related to how difficult would it be to work and how would they cope without the paper files. This uncertainty has been reversed to the extent that the cells are now not only expressing a need for the proposed system but are in agreement with the writer's vision of how it might evolve in the future to capture cell performance data. The relationship that has been developed in terms of this project has leaned towards a consultative nature, where the Operators, who will be the system users, have been asked for ideas on how, for example, the drawing format should be presented. This topic will be expanded in Stage 4.

The proposed system will be used as a viewer of drawings, providing an image of drawings when requested. The only action required from the Operators will be to type in the required part number. The system, at this stage, will not require any input of data from the Operators.

The writer has been able to source a package that can be adapted from its normal purpose and configured for simplified use by non computer literate users. The package comes in Windows and DOS format which poses a dilemma. On the one hand, through a DOS package we can run "dumb" terminals at fairly low cost which are protected from user tampering and are thus secure. On the other hand, the Windows option is more user-friendly, and fulfils the needs exactly. However, the Windows based terminals are more costly. They require more RAM (Random Access Memory) and a hard drive. The resident hard drive and the nature of Windows may allow the user to tamper although it is possible that protective protocols are available. It is possible that Windows can be run directly from the network. However, the increased traffic that occurs due to this will slow the whole network down. This means that a new, specific network server might be required.

The Socio-technical Stage of Multiview also requires questioning on how the system will fit into the everyday routines of the Manufacturing cells. The system will not be used by experts, but rather by all the cell members as and when needed. Therefore training the Operators how to use the system / work station, will be like any other machine in the cell. The cell leader will be trained by the writer on how to use the system. At the same time, he will assist in compiling a detailed operating instruction manual which will be situated at the work station. The work station will then feature as one of the cell's machines on their cross training matrix (see Appendix 9). The cross training system is quite simple in that the cell leader will train one of the Operators who will in turn train the next one. Since one of our GTQPS World Class targets is to have the cells members 100% cross trained in all their particular machines, all the Operators will be required to learn to work the new system. The advantage of this is that the Operators grading and salary packages are linked to a skills matrix. If the system successfully introduced, it might be added to the skills matrix, thus benefiting the Operators financially.

The first part of Stage 3 has been concerned with how the new workstation will fit into the workers' lives and has required active participation by the O.E shock cell's members. This theory of participation is enhanced by offering a choice or choices of alternative systems to the Operators, which will be developed in the following section.

## **9.2 THE SOCIO-TECHNICAL OBJECTIVES AND ALTERNATIVES TO THE NEW SYSTEM**

In order to ensure the participation of the System 1 Manufacturing cells in deciding what system they want, the different options or alternatives were put on the table. In the case of this proposed system, several different systems were put forward, which were debated in the cells Green Area by the green area team (O.E Shockabsorber cell).

These systems were split into two areas being firstly, social objectives and alternatives and secondly, technical objectives and alternatives. These were then expanded and ranked. From these, the best Socio-technical solution was picked, namely, T3 - S2 In-Line Drawing Viewers in each Manufacturing cell and Engineering offices and personal computers linked to the network using a Windows based operating system.

### **9.2.1 SOCIAL OBJECTIVES AND ALTERNATIVES**

In performing the analysis on the Socio-technical objectives of the system, the most important social issues of the new system were decided by the team as being:

- it must be acceptable to the cell's Operators, System 1 Operations (B.U.M) Managers and all the System 3,4 5 departments;
- it must reduce the frustration experienced by the cell's teams when they cannot find the drawings;
- the System 3 Finance department which encompasses the Information Systems department (I.S.D.) want to remain in control.

The first social objective relates to possible resistance of the system by the Manufacturing cells if the system is too complicated. It must be acceptable by the System 1 Business Unit Managers and the System 3 Quality and Finance departments as well as the System 4 Product Engineering department in terms of releasing the changed or new drawings into the system for production and an efficient, secure means of drawing distribution.

The second objective correlates with the different areas shown in developing the problem situation in the Rich Picture. These problems and resulting frustrations have a direct impact on the cell's performance and growth. This is either due to missing drawings which result in either cell down-time while the replacement drawings are found, or scrap products being made, as a result of the wrong level of drawing being on the floor. The latter as a result of bad drawing distribution.

The third objective is a requirement of the System 3 Finance department /Information Systems department that they maintain control. One of the criteria is that they must ensure that all the system's hardware and software meet their requirements. This is especially important as the Manufacturing cells will have access to the computer network in order to view drawings which will be in the production directory on the file server. The I.S department is also concerned in the security of the software in the cells' computer as well as the computer's safety itself. These concerns are valid as the users are essentially computer illiterate, and might erase information from the computers local drive either by accident or by tampering.

In developing the social objectives, the following information was examined. A concern was raised regarding who was going to be using the system. The original concept was planned to include, only the Manufacturing cells and the Product Development department. However, as the software for viewing drawings is networkable, almost anybody who has a connected computer could use the system. This is especially valid for Process Engineers and the System 4 Purchasing department who regularly need to look at drawings. At present they have to go to the main Office Block to fetch a copy of the required drawings. The system will have no impact on the job security of the Manufacturing Units. If anything, it will improve their job content as the cell members will have access to gaining computer skills which would normally not be available to them. The existing system has few, if any, good points. The existing system, coupled with lack of discipline, lends itself to disorganisation, untidiness, and as discussed earlier, has gained no respect. The new system will be placed in a central, visible position which should assist in making the area look professional and organised. Drawings will not be in a paper format and will not be left lying around on the Green Areas' table.

The system will as seen in the Stage 1 Concept models, improve the efficiency, the speed and the accuracy of distributing, retrieving, using and maintaining changed and new drawings.

However, before the system can be accepted, the social alternatives (see model fig 8.1) were put forward, being a better system of managing the current release, distribution and usage paper system. The requirement of this is obviously maintaining the system in terms of management, discipline, requiring extensive auditing of the drawing files in all the of the Manufacturing cells on a regular basis. The other alternative offered was an online, fast drawing viewer which would ultimately be placed in each and every Manufacturing cell with the removal of all paper copies of drawings from the shop floor. This system would allow the users to look at drawings immediately. These drawings which are already CAD drawings in the development directory and would be transferred to the new production directory, with changes and new drawings being added in conjunction with the ECR timing, as defined by the ECO committee.

In order for a decision to be made on the future system , the technical objectives and alternatives must be examined.

### **9.2.2 TECHNICAL OBJECTIVES AND ALTERNATIVES**

The technical areas for this part of the investigation of the objectives and alternatives, pertain mainly to how things are technically possible to achieve in the company. As seen above, these range from quick access, to accurate, instant drawings which apart from being modelled, are taken from the Root definition defined in Multiview Stage 1, being: a system which is a means through which Engineering can introduce new product or product changes via the ECO committee to the Manufacturing cells in an efficient way. The system must able to be used by the users on a daily to access the current and new information (drawings & specifications).

The technical objectives of the system which were developed (see model Fig 9.1), consists of: firstly, ensuring instant accessibility to the latest level of released drawings and specifications at all times and secondly, the system must be able to release changed and new products or parts into production efficiently. Thirdly, it must be able to cope with future expansion.

The first and second objectives above, were shown in the previous stages, as essential in reducing errors, scrap, and delays. The extension of the solution to the problems seen in the current situation is to have continuous accessibility to the information. This means that the

technical alternatives supporting the objective, must be robust. The computer system must not fall over or "crash" as this would mean that there would be no drawings available to the Manufacturing cells at all.

The third objective of expanding the system relates to future use of the computers. A particular vision which has been mentioned earlier, is for the Manufacturing cells to have a package on the computer which they will be able to input the performance measures required of them, directly into the system. This will most certainly cut out the variety of information that the facilitators of the various cells have to deal with on a monthly basis. Currently, this information is compiled from a chart which is updated daily by the various cell leaders.

In order to meet the technical objectives, the following alternatives were offered. The first alternative was to have a dumb terminal linked to the central computer via the network with Windows or Dos operating systems. The cost of the dumb terminals was thought to be less than that of a personal computer. However, when investigated, the cost differentiation was marginal. The constraint of dumb terminals, especially with a Windows operating system, is that a swap file, which is a requirement for Windows would not be set up in the computer itself, but on the network drive. This is because dumb terminals do not have their own local drives as do conventional computers. The drawback of the swap file being on the network drive is that the whole company's network would slow down excessively due to the proliferation of the dumb terminals sending operating information to their individual swap files, i.e.: twenty dumb terminal would require twenty swap files on the networks central computer. The other drawback was that there was no economically viable way of obtaining specially developed Windows chips to replace the normal Windows program which would require a local hard drive.

The second alternative was offered to use personal computers in the cells, each with its own hard drive, loaded with Dos. The proposed system would be linked to the central file server where the software package and the production drawing directory would reside. The actual software package offered to the cell comes in either Dos or Windows format. Therefore this second option was offered with the Dos version of the viewing package.

The Dos version of this package while it does not have heavy memory requirements, is fairly complicated to operate. This was demonstrated to the O.E. Shockabsorber cell and Management. The reason for this was the excessive amount of key strokes required in order to open the required drawing as well as the inability to customise the drawing to suit our requirements. This will be described in the next Multiview stage.

The third alternative demonstrated, was obviously similar to the second stage with the difference being using the Windows version of the viewing package. The advantages of this package was that it was easy to customise. It was also easy to use in that most of the operating of the system is done by using the mouse. The I.S. department were concerned with the users accessibility of reaching and meddling with restricted and operating files on the network and local drives. The system was then setup with Windows loaded from the network, with a swap file located on the local drive. The Windows setup was done with only the package left on the system, allowing no accessibility for the user to tamper with his own system or the networked files which were setup as read only for those relevant to the user. All other files were on the system were protected from accessibility through the network administration software. The main disadvantage of the Windows version of the package is the extra memory requirements . With insufficient memory, this package becomes very slow. Adding more memory results in an increase cost per terminal.

The last alternative was to maintain the status quo, using the current manual system, which needs no further discussion.

### **9.2.3 RANKING THE SOCIO-TECHNICAL ALTERNATIVES**

When the model was shown to the stakeholders, some of the alternatives were discarded, leaving behind those that might be feasible. The two main options that were considered feasible and that satisfied the social and technical objectives were the online personal computers linked to the central computer via the network. Although the two alternatives are similar, the main difference, is whether to use a Windows package versus a Dos package.

The social alternative recommended was therefore option S2 being in-line computer viewers in each Manufacturing cell and Engineering offices. A major factor that had to be considered,

was the future vision of enabling the cells to possibly have a package developed in order to catch the information required for the GTQPS cell performance measures. This would most certainly not have been possible using the existing manual system .

The technical alternative recommended was option T3 being personal computers, linked to the file server via the network. The Operating system and Viewing package will be Windows as it is easy to customise and it is user-friendly. This will be discussed further in the later stages of Multiview. Although it is a bit more expensive (in terms of hardware) than the Dos version, the constraints of the Dos version shown in the model (Fig 9.1) highlight the fact that the Dos package would be a backward step as the company is moving rapidly to a full blown Windows Operating system. The other constraint that the Dos package showed, was that it is not easy to customise as opposed to the Windows' version which can be adjusted to fit the requirements almost exactly.

### **9.3 CONCLUSION**

This third stage looked at the systems social and technical objectives which were presented to various stakeholders. By including these stakeholders and of course, mainly the Manufacturing cell's Operators, the way in which the system would fit into their current daily methods was considered. The alternatives which were presented offered two similar but different Operating systems which were demonstrated on a test site (the writer's office computer). The final solution which was agreed by all involved being option T3-S2 seemed to satisfy the socio-technical objectives defined in the beginning. This solution will be carried through to the next stage of Multiview for the design of the human, computer interface.

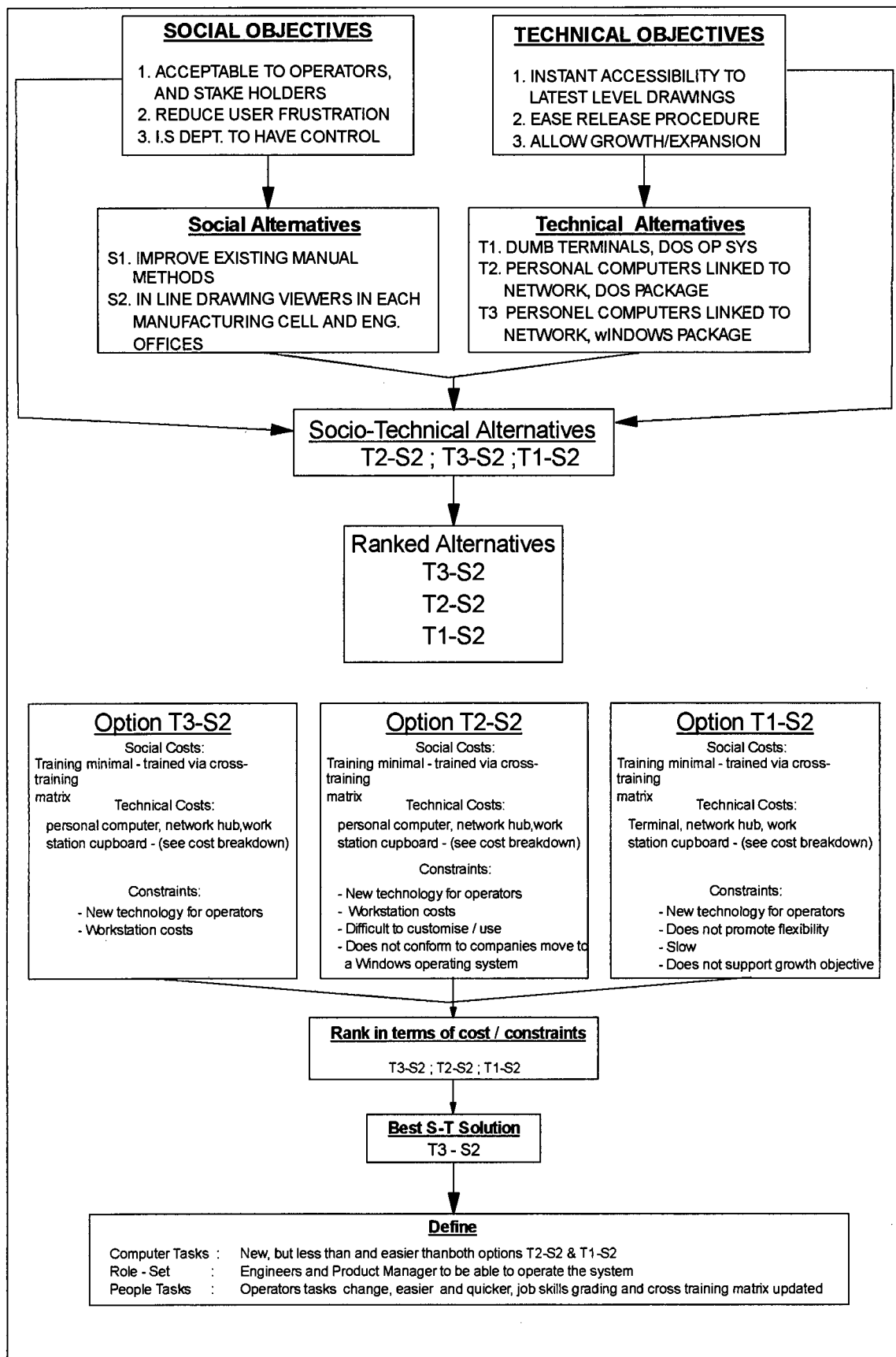

Fig 9.1 - Socio-Technical Aspects Model

**CHAPTER 10**  
**MULTIVIEW STAGE 4**  
**DESIGN OF THE HUMAN COMPUTER INTERFACE**

The fourth stage of the Multiview methodology deals with how the new system's users communicate with the computer. This area of the systems development is called the human interface and in the MultiView methodology, is called dialogue. This dialogue occurs through various forms ranging from inputting data, running programmes or instructions and retrieving information. As this stage involves the dialogue and design of the system, the contents of the next two phases become fairly technical in terms of the actual design and implementation.

Apart from what the user is doing, the dialogue includes other interactions in terms of how the communication happens. This can include using the keyboard to instruct the computer, using a Windows desk top which is made up of icons that can be triggered to carry out a command and also by using a mouse which is essential in Windows programs. The mouse is used in conjunction with the Windows desktop to move a pointer or cursor around the screen. The pointer is moved to an icon where a button on the mouse is pressed to start the command represented by that icon. This is of particular importance due to the fact that this type of interface will be used for the new system.

In order to ensure that the human interface is properly designed, this chapter will first look at the analysis of the new systems dialogue, followed by systems design which will include package selection and proto-type design.

### **10.1 DIALOGUE ANALYSIS**

Although the new system is fairly simple in that very little communication is required in terms of inputting data, two main users have been identified. The first is the Product Manager who will release the new or changed drawings into the system. The second is the System 1 Manufacturing cells and Process Engineers who will use the system to view the drawings. These three types of users can be divided into two main categories being routine users and casual users of the system.

Currently, the Product Manager and Development / Manufacturing Engineers are fairly advanced users of the Gabriel Information System. The Manufacturing cell's operators are currently computer illiterate, having had no, or little exposure to computers at all.

The Product Manager and Development Engineers are routine users who use computers as a daily tool. As the current operating system is Windows based, these users are quite proficient, the new method of releasing drawings for production is quite easy. When the Development Engineer has completed the drawing changes, he saves the drawing in the development directory which resides on the networked file server, and is "backed up" on a daily basis, during the night. The current development draw directory is broken down into several sub-directories which relate to the category of part as shown in Fig. 10.1 below.

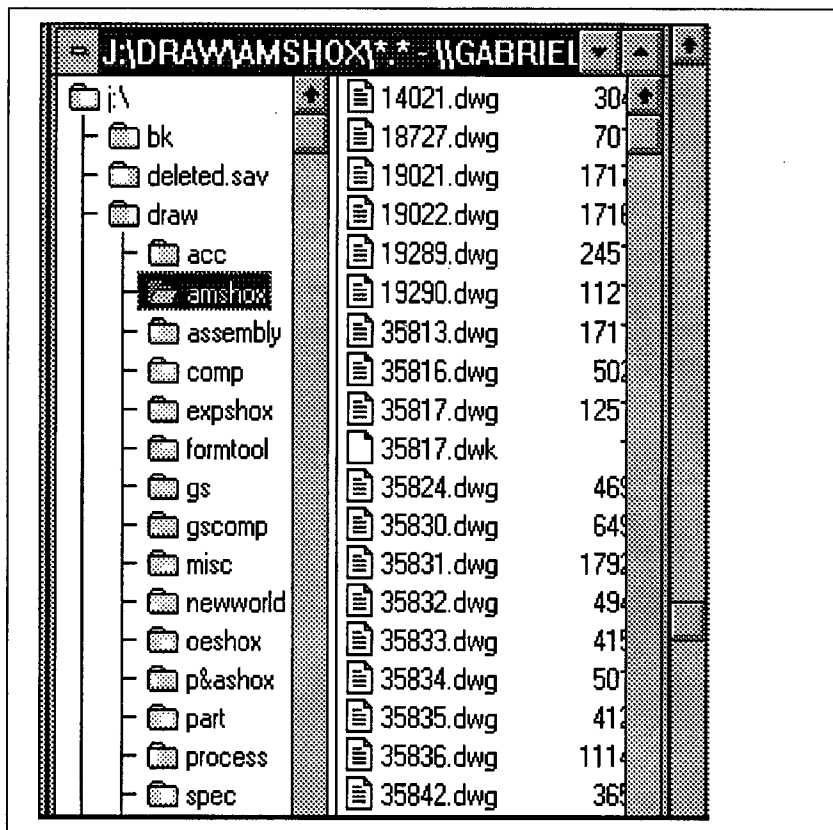

Fig. 10.1 - Current Development Drawing Directory

The Product Manager will simply copy the released drawings on the date which corresponds to that required by the ECO committee, to the production directory. This directory, unlike the development one, is not broken down into the many sub-directories as shown above. The parts therefore fall into place in a sequential order as they are moved. This is irrelevant as order has no consequence in how the drawing will be found by the users. The main factor is to eradicate the complexity of the user having to hunt around the development type of directory to find a particular drawing. This is especially relevant in cases where the user might not know if the product is an O.E shock or an Export shock. The purpose of the production directory is therefore to enable the user to type in a required part number and be able to find it no matter what category the part falls into.

The system that the user will have to view the drawing must automatically (without the input from the user) load itself and fill the screen in a ready to use format. This is, as discussed earlier, quite possible with Windows. All the person will have to do is type in a part number via the keyboard and the manipulation of the pointing device (mouse).

An additional requirement is to ensure that the drawings are instantaneously available to all users. This is needed as any delay (as previously discussed) will have an impact on the cells throughput which affects the companies overall performance. This also means that many users must be able to see the same drawing at the same time. These requirements by the nature of Windows and our network software is not a problem, especially as the package that will be used does not actually open the drawings but merely previews them.

The final outcome of the way that the new system will work under Windows is a very fast, easy, reliable method of ensuring that the users have instant access to all released drawings, all the time. The details of the human interface dialogue and actual system design must still be discussed the development of the Operating Instructions which will occur in the implementation stage of Multiview.

## **10.2 THE DESIGN OF THE DRAWING VIEWING SYSTEM**

The Multiview methodology has explored why we need a system for instant accurate access to the latest correct level of drawings as well as an outline of what this new system will do. The design stage covers details on how the objectives of the system will be met and includes the program or packages that will be used, the type of computers, databases, prototypes, and the way or procedures of how to work the new system.

### **10.2.1 THE VIEWING PACKAGE**

Once the concept of having a system for viewing drawings in the production environment had been established, the problem whether to have the program designed specifically for our application, or finding a ready made package became apparent. In order to decide which route to take, an investigation into who could design the system was undertaken. The following broad specification of our requirements was put together. The system would have to read or be able to see Auto Cad drawings. The system would have to be easy to use. The systems manipulation of the viewed drawing in terms of zooming and panning in order to see details closer, would have to be simple, as well as allowing the user to return to the original full screen display. The request was sent to several prominent local developers who advised us against the local development of a purpose-built system. Their suggestion was to find an off-the-shelf package.

This was not as easy as it seemed as there has been no evidence to date of any local companies who are using an online computerised drawing viewer in a production environment. These requirements were also put onto a bulletin board on the Inter-Net, with no success. After an extensive search, a local Auto Cad dealer suggested looking at an Auto Cad product called Auto Manager, which is used in the USA for managing a drawing office. The demonstration that followed, lead to the sourcing of Auto Manager Classic from the Netherlands.

The Auto Manager Classic package is a basic entry level file management product which allows anyone, to view drawings faster than the original Auto Cad drawing program. It also allows the user to flip through multiple drawings, zoom, pan and examine drawings from any angle. The feature of being easy to browse through directories on network drives made the

system even more attractive, as one of the requirements was to be able to just type in the part number to view the drawing.

However, when choosing any package, a number of considerations must be looked at. One of the most important questions was whether or not the package was readily available. This seems to be no problem as the local agent, who is our current Auto Cad supplier was able to establish a reliable source and negotiate a trial working copy of the package in question. This package was then setup on the writer's machine where the following questions were addressed by actual installation and trials of the loan software:

- The speed of access to retrieve drawings from the network directory was almost three times faster than when using Auto Cad .
- The package is customisable, in that it can be setup to open when the computer is switched on. The package can also be modified, to ensure that it is safe from tampering by the user. The users however, will help in defining the how the package will be setup.
- A consideration that will play an important part in the successful implementation of the system is cost. This package, for what it can do, is extremely inexpensive, coming in at approximately seven hundred rand which is far less than the tens of thousands of rands that would have been required to develop the purpose-built package.

Further advantages of the package are that the system has an extensive on line 'help' facility and tutorial to enable users to get out of potential problems. The systems is also friendly in that, if a mistake is made, an error screen appears with clear instructions to assist rectification enabling the user to continue without the system crashing. The package is also very easy to install, which means that in-house people can set the system up.

## 10.2.2 COMPUTER HARDWARE

The design stage of Multiview also requires an investigation into the hardware specification of the system. The Auto Manager Classic software package has two different requirements. These differences, depend on whether the Dos or Windows version is used. The Dos version of the package has a very low specification as it can be installed on the now obsolete PC/XT computers. The Windows version, however need a higher specification. This version can run on 286, 386 ,486 and pentium computers. A further consideration when using Windows is that it requires at least four megabytes or R.A.M (random access memory) in order to run.

As cost was considered a major constraint by some of the system's stakeholders, they initially instructed the writer to find obsolete 286 processors. These are still available in the second-hand market. The strategy of going the 286 route had many pitfalls, the main ones being, that secondhand machines could have a very limited life span, being prone to break downs. The second concern was that it would be impossible to ensure that all twenty of the required machines would be exactly the same. Thirdly, one of the objectives is to have efficient instant access to drawings and the 286 machines would not fit the bill as they are extremely slow.

The obvious choice was to settle for 386 type of computers. However, our local supplier was able to source the much faster 486 processors for less than the 386 ones. The following machine (see detailed quote Appendix 10) was then purchased in order to build the prototype which if acceptable, would be setup in the O.E. Shock Manufacturing cell for a trial period which will be detailed in Multiview Stage 5.

Prototype Specification:      486 SX 'Cad View' Work Station  
   Mother Board - 486 SX 33 MHz  
   Mono VGA Monitor  
   240 Meg IDE drive  
   Network Card - 3 Com  
   Mouse  
   Keyboard

The decision to use a black and white monitor was important as a colour monitor would push the price up to an unacceptable level. A further reason to use the mono monitor was also the fact that current drawings are black and white, and that the Auto Manager Classic package can be customised to show the drawings in mono.

### **10.2.3 THE WORKING PROTOTYPE**

Once all the parts had been supplied, the system was set up using Windows, loaded from the Network, with the required swap file and certain Windows configuration files being installed on the machines local hard drive. The next step was arranging Windows such that no typical Windows folders and programs were left available on the machine. If these were needed in future for changing the system setup, they could be reinstalled from the Network.

After the Operating system had been installed, and checked for its security in terms of the I.S.D. department's requirement for tamper protection, the Auto Manager package was installed in both Dos and Windows formats, in order to prove the technical alternatives as discussed in Stage 3 (see fig.9.1 Chapter 9).

Once management had come to an agreement that the model presented to them was valid, and the additional cost value added, customisation of the package started. This was done as agreed by the writer and the System 1 Manufacturing Operators. The system had to start up by itself (apart from switching the machine on). The request for a drawing was to be done by simply typing in the required part number. This was enabled by instructing the program through Windows program manager, to default the Auto Manager's working directory to the production files on the network directory.

Although the operation of the Auto Manager package seemed easy for computer literate users like the Engineers, it was obvious that the operators in the O.E. Manufacturing cell were worried how the system would work. This concern resulted in the specific dialogue between the Operators and the new computer being defined for them in a step-by-step work instruction procedure.

#### **10.2.4 WORK INSTRUCTIONS - DEFINING THE USER DIALOGUE**

In order to ensure continuous operation of any machine or piece of equipment at Gabriel, one of the GTQPS principles is to establish a set of operating work instruction which is kept next to each machine. These, together with all our other visual controls in each cell, ensure that the variety of communication and information bombarding the System 1 Managers is filtered. The operating instruction itself plays a significant role in assisting as a variety filter. The reason for this, is that it enables anybody who has to work in the cell, to set-up and operate any machine without needing assistance. Further to this, the Manufacturing cell's machines are tabulated on the cell's cross training matrix, which shows the trained status of each cell member relative to each machine. The advantage of this, is that the manager does not have to be burdened with the worry of the cell standing (machines not running) due to a lack of fully trained operators. This is of particular importance, especially when some of the cell's members are absent, and have been temporarily replaced for the day by workers from another cell. Similarly, the manager does not have to be concerned with the cell members training as this is done by the members themselves and is recorded by the Cell Leader on the cross training matrix when they have met a pre-determined standard.

The new computer, as an operational tool in the Manufacturing cell, must be accessible by all of the cell's Operators as well as those working in the cell on a temporary basis. Therefore, procedure designed for ensuring the correct dialogue between the worker and computer was established.

The first step in this procedure or communication, is concerned with starting the computer at the start of the day. This is spelt out in detail in the first Step of the work instruction (Fig. 10.2 below). At the same time, the user is told in Step 2, where to position the mouse in order to open a drawing file. The following Steps 3 and 4 (Fig 10.3) guide the user, by manipulation of the mouse, to a position where the package is ready to look for a required drawing. The user is then asked to type in the part number in order to retrieve the drawing.

The third set of steps are concerned with errors in drawing retrieval. Fortunately, this package is read only in that it looks at the image of the drawing. The advantage of this, is that the users cannot accidentally modify or erase the drawing. However, the user can type in the incorrect part number. As the procedure shows in Fig 8.4, this is no problem and assures the user not to worry. It directs the Operator through the error message back to a previous step where the part number can be retyped. The final step (Fig 10.5) shows the user how to close the drawing in preparation for the next one, as well as how to shut down the computer at the end of the day. This procedure for running the system was put together and formatted as an initial draft in order to assist with the initial introduction into the O.E. Shock Manufacturing cell.

## OPERATING INSTRUCTIONS CAD VIEWING STATION

### STEP 1.

- OPEN THE TWO CUPBOARD DOORS
- PULL OUT THE KEYBOARD DRAWER
- SWITCH ON THE COMPUTER BY PRESSING THE GREEN BUTTON (1) IN

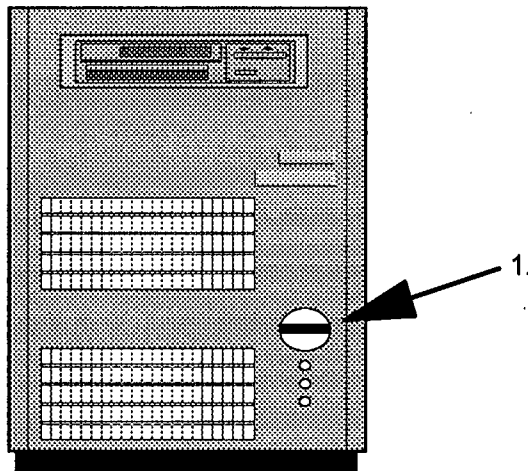

### STEP 2.

- WAIT UNTIL THE SCREEN BELOW APPEARS
- MOVE THE MOUSE (NEXT TO THE KEYBOARD) UNTIL THE ARROW ON THE SCREEN IS ON THE WORD **FILE** (2)
- CLICK THE LEFT BUTTON ON THE MOUSE ONCE

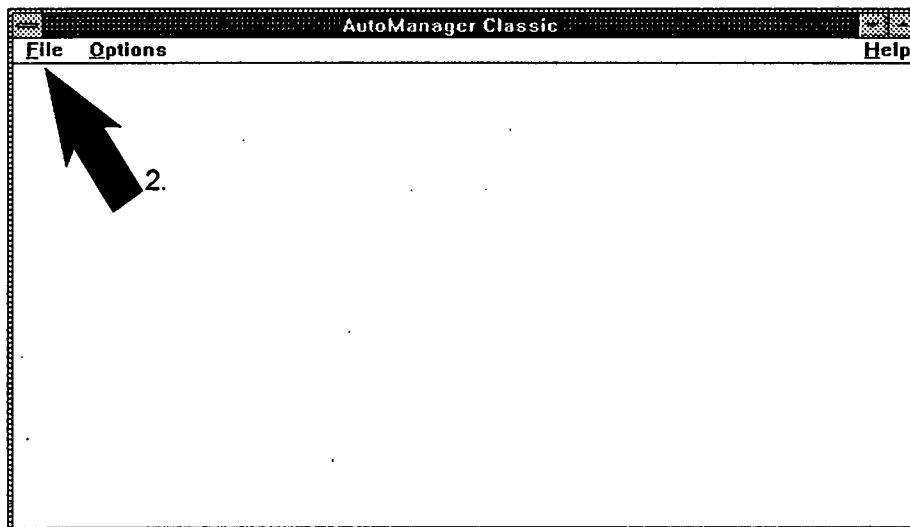
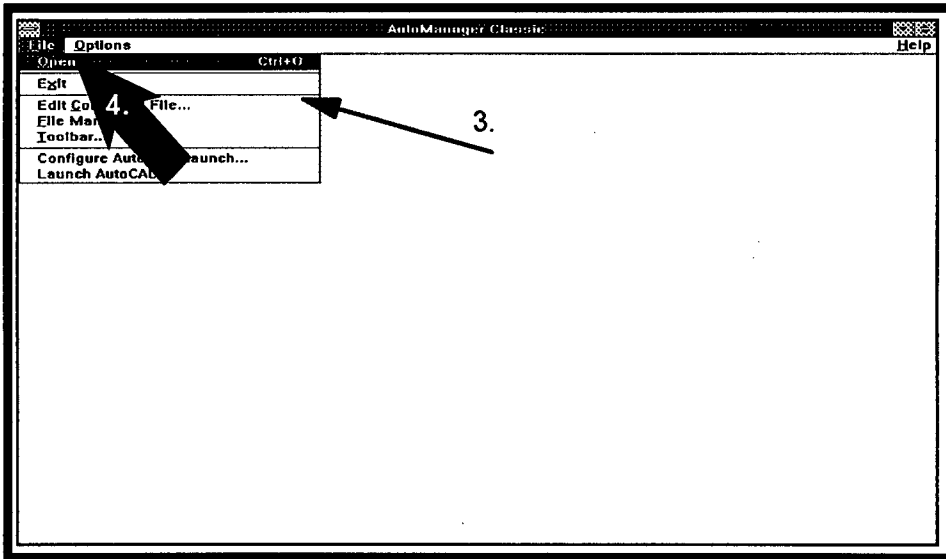

Fig. 10.2 - Stages One and Two of the operators dialogue with the computer

**STEP 3.**

- AFTER CLICKING THE MOUSE BUTTON ONCE, THE BOX (3) OPENS BELOW
- MOVE THE MOUSE UNTIL THE ARROW (4) IS **ON OPEN**
- CLICK THE LEFT BUTTON ON THE MOUSE ONCE



**STEP 4.**

- THE "OPEN FILES" BOX WILL NOW APPEAR
- TYPE (ON THE KEYBOARD) THE REQUIRED PART NUMBER NOW IE: **927007.DWG**  
REMEMBER TO TYPE **.DWG** IMMEDIATELY AFTER THE NUMBER
- MOVE THE MOUSE ON TOP OF THE OK BUTTON (5) AND CLICK THE **LEFT** BUTTON **ONCE**

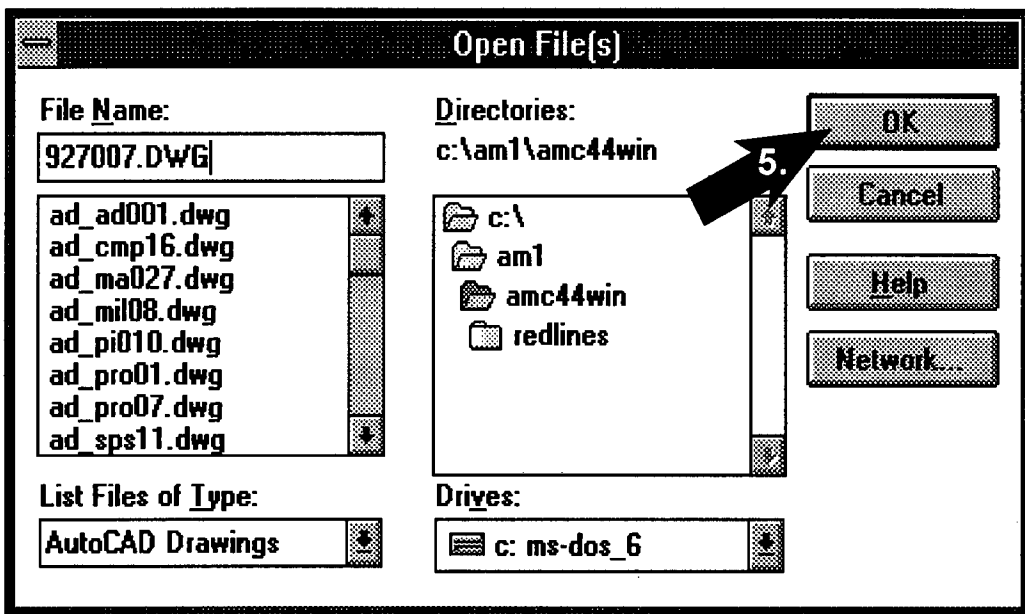
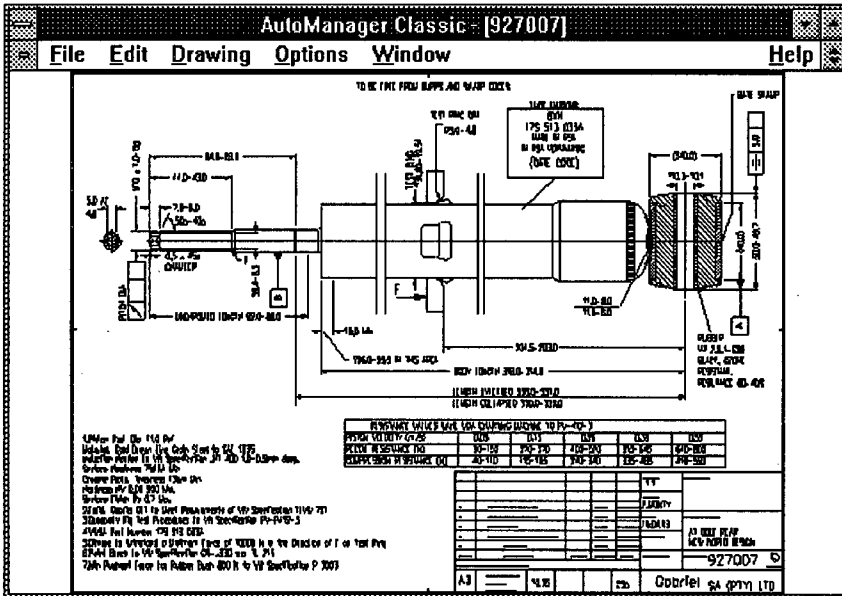

Fig. 10.3 - Stages Three and Four of the Operators Dialogue with the Computer

**STEP 5.**

- THE DRAWING SHOULD NOW APPEAR AS BELOW



**STEP 6.**

- IF YOU HAVE TYPED THE WRONG NUMBER IN OR, IF THE NUMBER IS NOT ON THE SYSTEM, THE BOX BELOW WILL APPEAR
- DO NOT WORRY. MOVE THE MOUSE UNTIL THE ARROW (6) IS ON THE **OK** BUTTON AND CLICK THE LEFT BUTTON ON THE MOUSE
- GO BACK TO **STEP 4** AND REPEAT

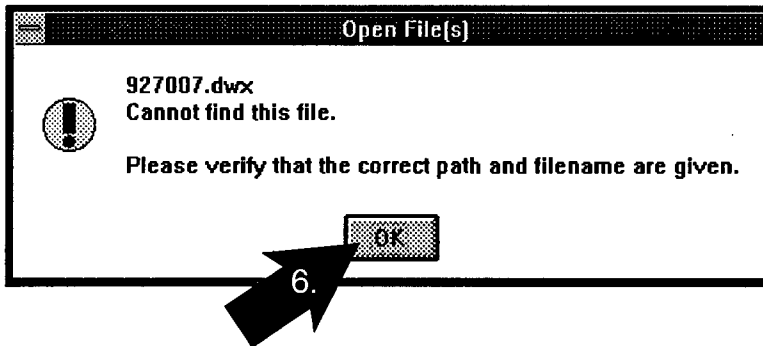
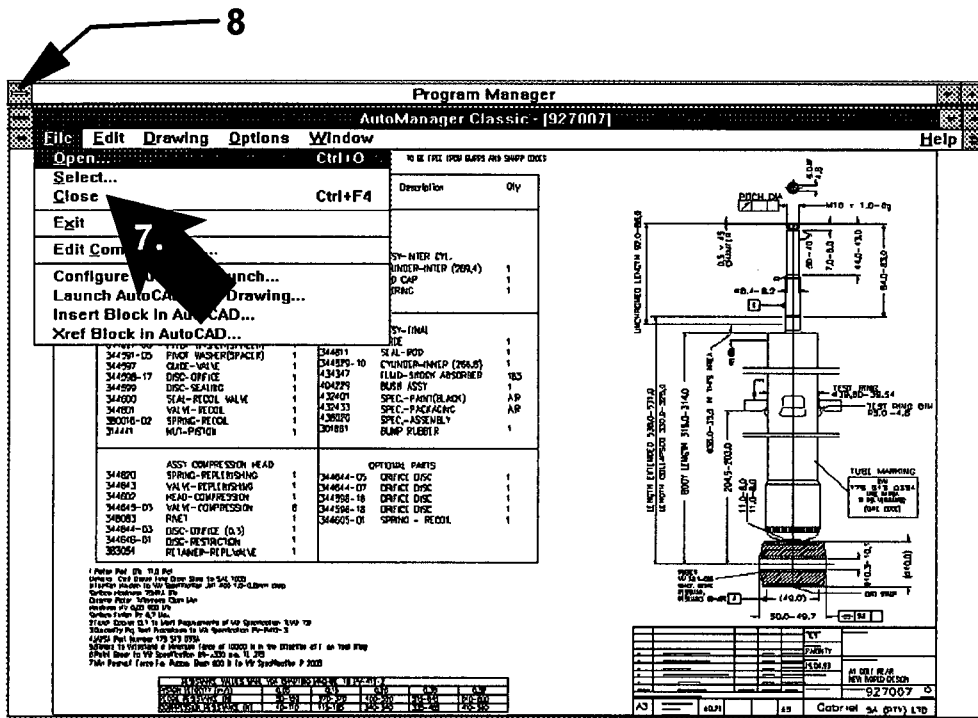

Fig 10.4 - Error Dialogue

**STEP 7. - TO CLOSE A DRAWING**

- MOVE THE MOUSE ARROW (7) TO THE THE FILE HEADING AND PRESS THE LEFT MOUSE BUTTON
- IN THE BOX THAT APPEARS - MOVE THE ARROW TO "CLOSE" AND PRESS THE LEFT MOUSE BUTTON
- THE DRAWING WILL DISAPPEAR



**STEP 8. - TO SWITCH OFF THE COMPUTER**

- MOVE THE MOUSE TO THE BLOCK WITH THE MINUS SIGN IN THE TOP LEFT HAND CORNER (8)
- CLICK THE LEFT MOUSE BUTTON TWICE - QUICKLY
- THE BOX THAT APPEARS WILL ASK IF YOU WANT TO EXIT WINDOWS
- MOVE THE MOUSE ARROW TO THE OK BUTTON AND PRESS THE LEFT MOUSE BUTTON
- ONLY ONCE THE "WINDOWS" SCREEN DISAPPEARS - SWITCH THE COMPUTER OFF BY PRESSING THE BUTTON SHOWN IN STEP 1

Fig. 10.5 - Stages 7 and 8 close drawing and computer shut down dialogue

The completion of the initial work instruction highlighted an new area of concern, which had been touched on before. These operating instructions require the movement and interaction with a mouse in order to instruct the program to do certain things. Although a broad outline was given in the instructions, the package requires further use of the mouse in order to zoom into areas as well as moving the drawing around the screen (discussed at the beginning of this chapter). This prompted the writer to sit down with the twenty members of the O.E. Shock Cell in order to decide how the best way of describing the mouse could be attained. The result of this discussion was the additional operating instruction seen in Fig 10.6 overleaf.

### **10.3 SUMMARY**

This stage has been concerned with the dialogue and design of the new system which must be done as a team combining input from the stakeholders and users of the new system. The dialogue relating to this system has a significant impact on the System 4 Product Manager, System 1 Business Unit Managers and the System 1 Operating Units. The Dialogue of the Product Manager is aimed at reducing his variety in terms of simplifying the release procedure as well as making the management of the paper files almost obsolete.

The Business Unit Managers variety will be significantly reduced as he will no longer have to spend time, (which could be utilised more effectively) to distribute and attempt to manage the current paper drawing system. This could be taken further as disciplinary hearings will reduce as the Operators will no longer be punished for making stupid errors due to information not being available. The impact of this could be a reduction of variety for the Human Resources department and other Managers and Union members who spent time sitting in these hearings.

The next stage of Multiview will look at results of the system after it has been implemented and tested in the Manufacturing cell as well as iterative aspects of revisiting areas in the design of the human interface dialogue and design of the system.

**USING THE MOUSE**  
**FOR**  
**ZOOMING AND PANNING**

**ZOOMING - GETTING A CLOSE UP VIEW OF PART OF A DRAWING (TO LOOK CLOSER AT AN AREA ON THE DRAWING)**

1. MOVE THE MOUSE ARROW TO ONE CORNER OF THE AREA YOU WANT TO LOOK AT
2. PRESS THE **LEFT** MOUSE BUTTON AND KEEP HOLDING IT DOWN
3. MOVE THE ARROW TO THE OPPOSITE CORNER OF YOUR REQUIRED AREA.
4. **RELEASE** THE **LEFT** MOUSE BUTTON.

**PANNING - CHANGE THE POSITION OF THE DRAWING**

1. MOVE THE MOUSE TO A POINT ON THE DRAWING
2. PRESS THE **RIGHT** MOUSE BUTTON AND **HOLD IT DOWN**
3. MOVE THE ARROW TO THE PLACE WHERE YOU WANT THE DRAWING TO MOVE.
4. **RELEASE** THE **RIGHT** BUTTON

**HOW TO RETURN TO THE LAST OR FULL PICTURE OF THE DRAWING - (BY USING THE KEYBOARD) :**

1. TO RETURN TO THE ORIGINAL FULL PICTURE - PRESS THE **END** KEY (BETWEEN THE DELETE AND PAGEDOWN KEYS)
2. TO RETURN TO THE PREVIOUS VIEW - PRESS THE **BACKSPACE** KEY.

**CAUTION**

**DO NOT UNDER ANY CIRCUMSTANCES OPEN THE TOPICS - EDIT, DRAWING, OPTIONS, WINDOW**

Fig 10.6 - Dialogue for using the mouse

**CHAPTER 11**  
**MULTIVIEW STAGE 5 - IMPLEMENTATION AND TESTING**  
**OF THE INSTANT ACCESSIBLE DRAWING INFORMATION**  
**SYSTEM**

The Fifth Stage of Multiview looks at the implementation and testing of the new accessible drawing system. This stage uses all the outputs of the previous stages, namely, the Concept models from Stage Two, the computer tasks that were decided on in Stage Three, and the technical requirements of the Human Computer Interface that were developed in Stage Four.

### **11.1 TECHNICAL DESIGN**

The implementation of the accessible drawing system took the prototype system and placed it into the production environment. However, although the implementation of the system entailed taking an existing package, setting up a machine and putting it into the production environment, a form of technical design was carried out before implementation. This design took the following into account:

1. Retrieval of drawings
2. Structure of the database
3. Data Base maintenance
4. System Control
5. Recovery from errors and breakdowns
6. Monitoring of the system

The objective for doing a technical design of the system was to examine all areas of the computer system and the users which may have been missed previously.

The testing of the system will take the form of monitoring the new system and comparing the information retrieval and the drawing distribution to the old manual system.

### 11.1.1 RETRIEVAL OF DRAWINGS

As discussed in Multiview Stage 4, the drawing retrieval will be done by the users through an existing software package which has been adapted to suit our specific needs. Unlike most information systems, such as the current production, sales and marketing "Rascal" system, the new drawing system does not require any type of reports to be generated. This is done on this system by requesting a query of a set of databases. All that this drawing retrieval system does, is look at an existing drawing that resides in a standard Windows file directory. The files are not actually opened when a drawing is requested. Likewise, the files cannot be modified or printed. This means that the users do not have any input which adds to a database.

This drawing retrieval is relatively simple to operate, and can be done via the basic dialogue which will be used in the form of Operating instructions in the Manufacturing cells (see Fig 11.1).



Fig 11.1 - Work Station with Operating Instructions

### **11.1.2 STRUCTURE OF THE DATABASE AND MAINTENANCE**

The drawing information system does not utilise a database in the pure sense of the word, but is rather a compilation of files that have been moved by the System 4 Product Manager from that systems development directory, into the System 1 production directory. There is therefore no requirement for establishing relationships between the data, as is normally found in database packages. This meant that no structuring of a database was required. However, as seen in Multiview Stage Four, it is important for a new directory to be established as the development directory consists of family grouped sub-directories which are filled with both released, and partially finished concept drawings. Once the system has been fully implemented in all the cells, the new directory will reside in a dedicated computer which will act as a specific network file server for the new production drawing system.

The maintenance of the database is fairly straight forward. The drawings are not put into the production directory as a result of a of information generated from a report, but as a straight forward copy through Windows file manager from one directory to the other. Windows asks whether or not the user (Product Manager) really wants to overwrite the existing info, at which at that point, the user can change his mind. The current development directory which consists of approximately five thousand drawings, is (as discussed in the previous stages) backed up every night which secures the information in the event of a network 'crash' or permanent failure of the local hard drive.

### **11.1.3 SYSTEM CONTROL**

This section of the technical design looks at the controls that need to built into the system, in order to maintain its operation. In any system, it is possible to make mistakes when inputting information or finding errors in the program or package. On top of this, the computer can breakdown or the network might go down, leaving the Manufacturing cells void of drawings.

Fortunately, the end users of the Drawing system do not input data into the system. This means the drawings cannot be corrupted or lost. However, this does not prevent them from typing in the wrong part number which also requires the file extension. i.e.: 927007.dwg

The input of the wrong part number, or requesting an invalid number is not a problem as the package informs the Operator of his error and gives an explanation of what to do. As seen in the development of the dialogues in Stage 4, the user just follows the steps on the computer and those detailed on the Operating instruction, in order to type in the corrected number.

The other type of error which is difficult to control, is when the users change the positioning of the view on the screen by moving or minimising it. This is usually a fairly convenient way of customising a Windows desk top. However, for the Manufacturing cell's Operators, this might become a problem as they could easily get confused on the whereabouts of the program if they tampered with the screen settings. This has been addressed by loading the Windows software directly from the network and by training the System 1 Cell Leaders in how to operate the new Drawing system. If the screen cannot be recovered by the user, by virtue of the Windows program being write protected, resetting the computer will restore the original settings. It is anticipated that the cell Operators will quickly become familiar in how Windows works, and will be able to re-adjust the positioning of the current program themselves. A further example of the simplicity of the workstation is that they will have no Windows programs at all except for the start-up folder which contains only the Auto Manager program.

In the event of a machine malfunction, which could include an Operator accidentally doing something as basic as unplugging the computer, the Operators have been instructed to contact the trustee of the system.

#### **11.1.4 RECOVERY FROM ERRORS AND BREAKDOWNS**

Apart from machine malfunctions, computer systems will break down. This is one of the reasons why the introduction of the new system has been rather late. During the development of the Rich Picture, one of the areas of resistance to the system came from of the Engineers and Managers. The concern was based on their experience of the company's computer network which, at that stage, was very unstable. This resulted in the network continuously crashing, which meant that the users would loose work as most of the Windows office packages are run from the network i.e.: Lotus, AmiPro and Freelance Graphics, to name but a few.

Another factor of concern, was the fact that it was very difficult to actually get onto the system as the company only had a twenty person user licence. This had become a critical issue as at that stage, there were almost fifty potential users over and above the need for the new Drawing system for the shop floor. Needless to say, had the system been introduced to the Manufacturing cells at that stage, acceptance of the system could have been adversely affected. There would have been major frustrations due to instability of the network as well as the inaccessibility of drawings due to the broken link between the cell's computer and the net-work file server.

This problem has been recently overcome with the major upgrade of the company's network to Novell 4 which caters for an unlimited amount of users and has a sophisticated network management tool. This tool enables the I.S. Department to sort out networked computers by doing a diagnosis on them from the I.S. office instead of manually going out into the factory or offices to find and rectify faults.

In the event of the system crashing, or the Manufacturing cell's computer breaking down or losing the network connection, no information will be lost apart from the drawing image dropping off the screen. Unlike our major 'Rascal' system where a crash has serious implications due to the extensive traffic of data, the drawing system just needs reconnecting. If the computer breaks, a replacement is installed which is relatively easy to configure as all the programs (Windows and AutoManager) reside on the dedicated network file server.

#### **11.1.5 MONITORING THE SYSTEM**

A final area which requires attention before installation of the workstation into the O.E. Shock cell is the necessity for monitoring activity which will occur on it. As discussed in the section on recovery, the new network upgrade has a network management tool which includes a monitoring system. Apart from logging the start and end of a session on the network, the system is able to see how the computer is being used. This is important as it will be able to gauge the drawing systems acceptance into the production environment. This will be done by counting how many times it is used to access drawings on a daily basis.

It is also able to control the access rights to other programs and files, which in the case of the drawing system, the Manufacturing cell has no access to any other programs apart from their own Windows and Auto Manager programs as well as the Production drawing directory.

## **11.2 IMPLEMENTATION OF THE ACCESSIBLE DRAWING SYSTEM - (ADIS)**

Once all the requirements from the first four stages and the considerations of the technical designed had been met, the system was prepared for actual installation into the O.E. Shockabsorber Manufacturing cell. This installation was not as simple as first expected. Several new requirements had to be investigated and certain user problems became immediately apparent, even though they had been considered during the investigation into the new system. These areas include additional network requirements, hardware security, training, usage and finally, user problems.

### **11.2.1 ADDITIONAL NETWORK REQUIREMENTS**

The network requirements have been discussed to some extent in previous chapters. However, additional work on the network hardware was necessary before the system was actually installed. This new requirement stemmed from a relocation of the O.E. Shockabsorber cell. It was relocated from one end of the factory to the other in order to link it to a Tube Manufacturing cell. The purpose of this linkage was to ensure that the whole product could be made from beginning to end in a contained area. This would reduce lead-time, work-in-progress and improve customer satisfaction as shown on the Systems Dynamic model (Appendix 2).

The downside to the move was that the already laid cabling for the computer had been laid to the old position just prior to the scheduled installation. The new position meant that a new cable had to be re-laid. This presented a problem as the test site was beyond the specified distance from the current network Hub. This required the necessity of implementing a new

Hub which could cater for the additional cable distance. In reality, the new Hub would have been required anyway when the full system was implemented.

After much deliberation, the additional hardware requirements were addressed and the network connection was set up in the cell's new location. The workstation's actual position was to be located near the cell's green area, between the Final Assembly cell and the Tube cell, allowing for easy access by both these areas (see layout Appendix 12).

### **11.2.2 HARDWARE SECURITY**

Another area of great concern to the I.S. department, was to secure the hardware from tampering and theft. The latter being a problem in our factory. This concern was further exacerbated by the fact that the successful implementation of the full system depended, firstly, of the high visibility the system would receive. Secondly, it depended on the system's robustness to stand up to all types of odd happenings that occur in the factory.

For this reason a special cupboard was designed to hold the computer (see Fig 11.1 and Appendix 25 to 27). The cupboard comprised of two lockable sections where the processor and the keyboard and mouse are stored. The black and white screen is located in the top section which is also where the operating instructions are kept. The cupboard also has a facility to store the cell's existing quality and first-off files. Apart from security, the cupboard gives the work station a very professional look.

### **11.2.3 TRAINING & USAGE**

As soon as the system was installed into the cell, the cell was bombarded by a mass of operators from all over the factory. The problem with this was that everybody wanted to "play" with the computer. This presented a delicate situation as it was important not to destroy the future users' excitement in the system. To overcome this, the cell leader was made a custodian of the system's keys. This was felt to be a bit premature as the system still needed fine tuning, however, it was felt that the system would most certainly get a fair test if it was made fully accessible to the cell members. The main requirement of this step was that the cell

leader had to ensure that he had full control of the system in terms of other Manufacturing cell's attentions, allowing only himself and his team to use the system.

The training that the cell leader and several of his team received was done by the writer. Each one of the members was instructed to start the system up from scratch, opening drawings and finally, closing the drawings. The training was done with the assistance of the operating instructions which were developed in Multiview Stage Four and hung in the top part of the cupboard as shown in Fig. 11.1.

The following observations were made. The operating instructions were inadequate in that they did not fully cater for usage of the mouse. A set of instructions were compiled to address this problem and can be seen in the Stage Four. The Operators also had difficulty in co-ordinating and handling the mouse which was evident in the way that it was delicately moved around the screen. It was then positioned in a certain place, let go, with the pressing of the mouse button occurring without the mouse being held firmly in the hand. The usage of the mouse, although recognised during the dialogue stage as potential problem, was easy to take for granted by experienced users. The operators, however, have quickly learnt to move the mouse with ease, showing a growing confidence in the system.

Another issue which arose as the members of the cell use the system, is that there are several shortcuts to retrieving the drawing, for example, pressing the enter key instead of moving the mouse to the OK button on the screen. This would seem contrary to good system design where access to the information should be done with the minimum of instructions. The decision to use the mouse manipulation initially rather than taking the short cuts is really a means of forcing a learning curve on the new users. This ensures that they become familiar with the co-ordination of the mouse. Once all the members have shown that they can use the system as currently required the operating instructions (with the consent of the cell's team members), will be modified to include all the short cuts as well as manipulation of the various Windows screens.

## 11.2.4 PROBLEMS

The introduction of a new system is seldom free from teething problems. This system was no exception. Two problems were encountered after the system had been in used on the very first day. The first was a bug in the package which would not recognise Auto Cad drawing symbols and the second, a problem highlighted by the users on the drawing format.

### 11.2.4.1 Symbol Recognition

The package that has been used for viewing drawings (Auto Manager) was specifically developed as a drawing office management tool for managing Auto Cad drawings. The Auto Cad drawing package uses a series of key strokes in order to show certain international dimensioning symbols such as diameters, degrees, plus or minus, and finally, underlining as listed below:

- For a diameter, the keystrokes are %%C followed by the dimension which results in O 50;
- For degrees, the keystrokes are the dimension followed by %%D which results in 45;
- For a plus or minus sign, the keystrokes are %%P which results in
- For an underlined dimension, the dimension or text is preceded by %%U

The problem which occurs when a drawing is viewed by Auto Manager which has dimensions made up using the above keystrokes, is that the symbols did not seem to be recognised by the viewing package. The result was that whenever one of these drawings were opened, the correct symbols were replaced by a substitute symbols designated by Auto Manager (See Appendix 13 - fax to local agents).

This seemed to be illogical as the sample drawings that are supplied with Auto Manager show the correct symbols. In order to find a solution to the problem, extensive communication was entered into between the writer and our local agents and the software developers in the Netherlands. The reaction received, was that the system was developed using American fonts and that we would have to live with the problem. These fonts that are used by Auto Cad and

are developed in the USA, change depending on which type of language is used, for example, we use British English as opposed to American English fonts.

This situation was unacceptable as it would most certainly have reduced the chances of successful implementation. The only way that the package could be used was to create a table showing the users what the alternative symbols represent. This would require a major paradigm shift on the part of the users. This would have probably created resistance to the acceptance of the system.

The system's bug seemed to lie in the type of font so the writer endeavoured to break into the packages program (written partially in a program language called AutoLisp) to find out where the font problem resided. The writer was surprised to find a hidden file comprising of several different types of fonts which matched the font names and extensions of those used by Auto Cad exactly. All that was required was to copy those font files into the Auto Cad font directory and overwrite the existing current files. This resolved the problem was completely. The reaction from the local agents and the foreign developers was quite incredible. The Auto Manager users' manual will be revised with documentation of this solution. Apparently this problem has been one experienced internationally and has gone unresolved until now.

#### **11.2.4.2 Drawing Format**

The second problem encountered was the O.E. drawing format. All our final assembly shockabsorber drawings consist of an outline drawing of the shock in question as well as the component breakdown or parts list. Aftermarket drawings have the parts list as in integral part of the drawing (see Appendix 4). Original Equipment drawings however, require a considerable amount of extra details that are requested by the Original Equipment factories. Because of the added details and specifications, the parts list is not part of the drawing. This parts list is a spreadsheet which is the attached to the back of the drawing.

This format, with the separate parts list cannot be seen by the Viewing package, which makes it useless in applying it in the O.E. Shock cell. In order to overcome the problem, the System 1 Operators, were asked to assist in defining an alternative drawing format. The agreed solution was to have two types of final drawings for O.E. shocks. The first would be the

current detailed drawing which shows all the factory requirements. This would be renamed with the same part number with an additional letter M i.e.: 927007 would become 927007M. It would show that this drawing was the master drawing (see Appendix 14). The second would be to change the original drawing. This entailed deleting all the information, leaving a basic outline drawing and the critical dimensions. The parts list was then added to the drawing in a similar manner as those seen on the Aftermarket drawings. The main difference being that the new area that makes up the parts list is used more effectively. This means that the new drawings parts list can be zoomed (enlarged) to fit the computer's screen exactly which cannot be done on current aftermarket drawings.

The main problem that affected the implementation of the system was that more than forty drawings had to change to this format. This took a considerable amount of additional time (each taking approx. three hours to modify) - see Appendices 15-23 for nine examples of the new formatted drawings.

### **11.3 TESTING OF THE INSTANT ACCESSIBLE DRAWING SYSTEM**

Before full implementation of the new system can take place, it must be tested in order to prove to Management and other stakeholders that the system is viable. The tests that will be performed on the system will cover the human interface criteria, the differences between the old and new distribution systems and the daily usage system. A brief description on the system for raising an ECO will also be included, with a small test showing the time saved.

These tests will be in the form of gauging the users' reactions and ability. The distribution and daily usage systems will be in the form of comparing the differences in time taken to achieve the desired results. The test findings will follow in the next chapter.

### 11.3.1. TESTING THE HUMAN - COMPUTER INTERFACE

As seen in the previous chapters, the Auto Manager package is an off-the-shelf, ready-to-use software package designed for use in conjunction with Auto Cad. Being a Windows version, different types of dialogue are required by the users. The questions required to test the human interface, are: does the new accessible drawing system support all the required dialogues for the Manufacturing cells as well as the those required by the System 4 Product Manager for releasing drawings into the system?

After the pilot workstation was installed in the O.E. shockabsorber cell and one week after the four key cell members had been trained, their useability of the system was tested. An additional Operator, who had not used the system yet, was also put through the test routine. The test included, opening a new drawing, zooming and moving around the drawing, closing the drawing, and finally, testing their ability to re-open a drawing in the event of making a mistake. These tests were designed to see how well they could retrieve the correct drawing and to observe their co-ordination and dexterity with the mouse.

Each of the five Operators tested, were given exactly the same drawing to open as well as commands to follow which are listed below:

1. Open drawing 927005
2. Zoom into the parts list
3. Move the parts list from left to right
4. Go back to the full drawing
5. Close the drawing
6. Open a new drawing 927XYZ (incorrect number)
7. Correct and open 927007
8. Close drawing.

These commands were not run "blind" as the Operators were allowed to run through the sequence with the help of the operating instructions which had been mounted in the workstations cabinet as shown in Fig. 11.1 and Appendices 25 to 27 . The emphasis of this

test was to not to establish the time taken to do each command, but to rather to establish acceptance and ease of the procedure.

### **11.3.2 TESTING THE DAILY USAGE SYSTEM**

The test procedure for the daily usage system is really a comparison between the Operators using the existing paper drawing system to the new computerised drawing viewer system. The operators were asked to find a specific drawing . This was timed from the start of the request, to the presentation of the correct level drawing. Then same request was repeated. However, the second request tested the time taken to retrieve a drawing which was missing from the drawing file. In order to prevent a line stoppage, the "missing" drawing was returned to the cell leader while the test subject went through the motions of finding a replacement. The time and sequence of events will be described in the following chapter.

### **11.3.3 TESTING THE DRAWING DISTRIBUTION SYSTEM**

The testing of the Drawing Distribution System comprises of a comparison between the current manual system (as discussed in the Rich Picture) and the computer system developed from the Concept model. The test was performed on several actual changes that had just been released by the ECO committee. These changes each had a number of different drawings and were timed from the end of the ECO committee meeting to the time the drawings reached the various System 1 Manufacturing cells. At the same start time, the writer released the same drawings into the production directory using Windows file manager in the same way the Product Manager would. These times are listed and discussed in the following chapter on the test findings.

### **11.3.4 TESTING THE RAISING AN ECO NUMBER**

This was a straight forward comparison done between requesting a number from the ECO committee chairman and opening the Lotus Spread sheet and taking the number out myself. A time was also taken for walking to the Development offices to raise a number manually, in the event of the ECO Chairman not being available at the time of the request.

## **CHAPTER 12**

### **TEST RESULT AND FINDINGS**

The findings of the four tests will be discussed under the headings of the human interface, daily usage, drawing distribution, and raising an ECO number. These discussions include tabulated test results as well as observations made by the writer. As the new system has only been recently put into place, the best means of accessing improvements was by timing the various activities and comparing them to the old system. The observations also include a section on the costs incurred through errors that occurred as a direct result of the old systems of daily usage and drawing change distribution.

#### **12.1 HUMAN INTERFACE TEST FINDINGS**

The purpose of testing the human computer interface, was to find out the effectiveness of the dialogues required by the system. These were developed in Multiview Stage 4. Although the test required monitoring the ability of the Operator to follow the operating instructions, the purpose of timing them was firstly, to find out if there is an advantage in retrieving drawings by using the new system versus the old. The second reason was to show that a stranger can operate the system with ease.

##### **12.1.1 RESULTS**

The average time for each activity was listed on Table one, which showed the following:

- (i) Opening the drawing

The average time for the Operators who were familiar with the system was 49 seconds. This operation, by following the operating instructions included, moving the mouse to a place on the screen where the mouse button was clicked in order to open the "File" box. This was followed by the Operators typing in the required part number followed by moving the mouse to the OK button on the screen. The fifth user took only a fraction longer (70 seconds) to retrieve the same drawing. The reason was that unlike the other test subjects, this operator

had to read the operating instructions, while using the system for the first time. He also made a mistake in typing in the number without the file extension.

(ii) Zooming

Once the drawings were opened, the Operators were asked to zoom into the parts' list. This entailed, moving the mouse to the to left hand corner and selecting the required area by dragging the mouse across the area to the lower right hand corner. The average time taken by the first four Operators was 4 seconds while the fifth user took 12 seconds. The total average time therefore, to open a drawing and zoom into the parts' list was 53 seconds.

(iii) Panning

The Operators were asked to move the parts list from the right hand side of the screen to the left hand side. This entailed using the mouse to pick a starting place near the right hand edge of the screen followed by dragging the mouse to left hand side. The purpose of the test is to show the user that by moving the parts' list, other parts of the drawing can be viewed easily. The average time taken was 2,8 seconds for the normal Operators and 7,2 seconds for the new Operator.

(iv) Returning to the full screen

This test is designed to test the Operators' ability to return to the full screen view in the event of getting lost on the drawing through multiple zooming and panning. This is achieved by pressing the 'END key' on the keyboard. The average time recorded for this operation was 1.15 seconds, while the new Operator took 3.2 seconds.

(v) Closing the drawing

The Operators were asked to close the drawing that required moving the mouse to the same place as in the first test. The "file box" was clicked and the "close topic" selected, the result being a blank screen. The average time taken to close the drawing was 8,9 second while the fifth Operator took 23 seconds.

#### (vi) Incorrect drawing request

The purpose of this test was to check the Operators' ability to continue using the system if an error occurs. Each Operator was asked to type in a part number that was deliberately wrong. The Operators then had to follow the instructions and open another number that was given to them as the error message (see Fig 10.4, Chapter 10) appeared. The average time taken was 31.65 seconds. This compared favourably to the first test that required only opening the drawings, taking approximately 2,4 seconds longer to negotiate the error message. Similarly the new Operator achieved almost the same time as he had in the first test (69,5 seconds versus 70 seconds). This showed a level of consistency as this Operator made the same mistake in the first test as was required in this one.

### 12.1.2 OBSERVATIONS

After one week of usage, the O.E. Manufacturing cells' Operators seemed to be getting a firm grasp in the system's operation. Of interest, was the Operators use the mouse. This lack of confidence in co-ordinating the mouse and the movement of its cursor on the screen is not unusual, and will improve with practice. The fact that the Operator who was not familiar with the system was able to achieve the systems objectives, proved that the systems dialogues are quite adequate. However, problems still occur as the number required by Auto Manager needs the file extension typed in after the part number (i.e.: 927007.dwg). As seen in the test, it is easy for a new Operator to miss this instruction and to type in just the part number. A solution for this would be to attach a large sign in the work station cupboard in order to remind them to type in the additional ". dwg"

## 12.2 DAILY USAGE TEST FINDINGS

The daily usage of the old system that used paper drawings, was checked in two different situations. The first test monitored the time taken by one of the Operators to go to the cell's Green Area, find the file and finally, locate the drawing. For the second test, the same parameters were used with the main difference being that the required drawing was purposefully removed from the file. The first test was run on three Operators. The second

test one was run once. The reason for this being that the Cell could come to a stand still without production, or could slow down as a result of one of the Cell members arranging a replacement drawing as developed in Multiview Stage 1. These results are then compared to the results recorded from the tests on the Human Interface.

### 12.2.1 RESULTS

The time taken to open the drawing 927008, is listed in Table 2 below. The time taken to arrange a replacement for the missing drawing is seen in Table 3.

	Drawing Retrieval Time
Operator 1	1min 50 sec
Operator 2	2 min 3 sec
Operator 3	2 min 15 sec

Table 2 - Time to retrieve drawing 927008

	Drawing Replacement Time
Operator	15 min
Writer	45 min

Table 3 - Time to arrange replacement drawing

#### (i) Retrieving the drawing

The average time taken to retrieve a drawing from the drawing file was 2 minutes. In comparison to the human interface tests, the time taken to open the drawing was on average, 49 seconds that is only approximately 1 min 10 seconds slower than the paper system.

However, the main difference between the two systems is the way in which the drawing is utilised once open, or retrieved. For the paper system, the drawing is removed from the file

and used by the Operator to find relevant parts for the next job from the KANBAN racks. The problem is that the drawing is required by all the Operators as they each have to find the parts applicable to the machine process that they operate. The computerised system enables the drawing to be conveniently displayed in a centralised position where several Operators can stand around it. This allows them all to see what parts are needed at the same time.

(ii) Arranging a Replacement Drawing

The test was originally going to be done once. However, the test on the Operator showed a startling result. The time required to find a replacement drawing was only 15 minutes. When comparing this to the original model that was developed in the first stage of Multiview, this result seemed impossible as the Operator would have been required to go to the Engineers office. There he / she would request the drawing replacement and then wait while the Engineer went to the Development office to copy the original, have it officially stamped and then signed. This however did not happen. All the Operator did, when asked to get the drawing and having found it missing, was to go to the gauge room to look for the same drawing. This meant that the Operator left his work area and went to another area of the factory. There was no guarantee that the drawing would be the correct level drawing.

For this reason, a second test was run where the writer simulated the steps required. The time taken to follow the modelled steps was approximately 45 minutes. This time was rather conservative as the Operator would most probably not have known who to approach and would have wasted further time.

### **12.2.2 OBSERVATIONS**

The time to retrieve the drawings between the old and new system seems to be marginal as there was approximately only one minute between the two systems. However, the slowest time taken on the computerised system was still less than the old one, the result coming from a totally new Operator! The significance of the new system shows that the drawings can be used more productively by all the members of the Manufacturing cell. The old system requires the removal of the drawing from the file that is carried around the cell by one person. This drawing is then passed from one Operator to the other as each retrieves the parts which they

require. The outcome of this practice gives rise to the test that followed as drawings are often lost as a result of being removed from the file.

The second test highlighted a new problem, namely, that the Operators take shortcuts in order to maintain production. The danger in going to another drawing file, located in a different cell, is that the drawing might not, for various reasons, be the correct level drawing. This would result in the Operators making the parts to an incorrect drawing. This could result in scrap or a major inconvenience while deviations are being raised with our customer in order for the company to supply them with the out of specification parts.

### **12.3 DRAWING DISTRIBUTION TEST**

The purpose of this test was to determine the time taken for drawings to reach the System 1 Manufacturing cells from the moment they are released by the ECO committee. The test was done two ways on four different release packages. The first method was to monitor the old system and the second method was to monitor the time taken to copy the drawings from the development directory to the production directory. The consequences of the old system were also added to the table overleaf.

Part No .	Change No.	Description	No of Diff. dwgs	Time (old Sys)	Time (new Sys)	Consequences of old System
940204		Indented tube	5	10 days	12 sec	Urgent change - dwgs not on the floor in time, tubes incorrectly marked with the old part No. - deviation needed
383286 314330		Modify rod material spec.	5	6 days	11,5 sec	Drawing late, 4 tons of the old material ordered
927008		Modify tube lengths	5	7 days	11sec.	1000 units scrapped due to incorrect tube length - units completely built - leaking due to incorrect closure length
61902		Mono Gas tube and rod change	4	8 days	10,6 sec.	Rod area had the changed dwgs in place, tube cell did not - New rods built into old tubes -scrap
940181	4232	single weld assy		6	11 sec	Parts made drawings not on the shop floor

Table 4

### **12.3.1 RESULTS**

Table 4 shows the results of four drawing changes that were monitored from the moment they were released from the ECO committee. The current manual paper systems time is shown in the column- time (old System). These times vary from 4 to 10 days. The consequences of the late arrival of these drawings are shown in the end column and will be discussed in more detail later. The average time to distribute the drawings to production using the new system is 11,25 seconds.

### **12.3.2 OBSERVATIONS**

In order to monitor the time taken to distribute the drawings to the various Manufacturing cells, the functions and actions that occur between the ECO committee and the drawings being replaced in the production files were considered as a black box. The reason was that it was extremely difficult to be available in the different areas while these activities were being performed. For example, the time taken for the System 4 Development Clerk to copy, stamp and obtain the signatures, was not detailed. These times were, however, part of the overall distribution time.

Of interest, was that some of the distribution times of the old system took two days as opposed to the normal average of six days. The reason for the shorter time is purely a result of fewer changes being released that week. Fewer changes require fewer drawings and related actions. A second observation was that drawings for a change are distributed to different System 1 Business Units. These drawings are then distributed by the Business Unit Managers to the various Manufacturing cells at different times. The result as seen in the table is that one area will make one of the parts to the new change level while another area, could make another part needed for the same change, to the old level. The assembly of these two or more parts will obviously result in a mistake and the product will ultimately be scrapped off.

Most of the changes tabulated were done before the system was implemented. However, in order to test the distribution time using the new system, the drawings effected by those changes were identified in the development drawing directory. The Product Manager then copied them, using Windows file manager, to the production directory. The average

distribution time measured was 11,25 seconds. The time taken to move one drawing was then measured at approximately 3 seconds. If this is then multiplied by the amount of drawings required to move, a figure of more than 15 seconds is attained for more than 5 drawings. This is 4 seconds slower than the tested times. The reason for the faster time is simply as a result of the techniques used in Windows for moving files. It is not necessary to move files individually. All the required files can be selected and copied across as a group by simply holding down the Control key and then dragging the group across to the production directory using the mouse.

## **12.4 RAISING AN ECO TEST**

In order to test the system, the current numbering system was copied from the files, onto a Lotus spreadsheet. As the Author, two other Development Engineers and the Product Manager are the only Operators of this system, the testing of the system was a simple comparison done between the manual system and the accessible computerised Lotus spreadsheet.

### **12.4.1 RESULTS**

The manual test was split into two areas. The first was the normal case of telephoning the Product Manager for an ECO number. The second was the case where the Product Manager is unavailable, which requires the Development Engineers to visit the Manager's office, find the file, and take out the next number for the Engineering Change. The test of the Lotus spreadsheet entailed opening Lotus on the computer, finding the ECO file, opening it and then taking out the next number.

#### **(i) Manual Test 1 - Telephoning for a number**

The time taken to take out a number by telephoning the Product Manager was approximately 5 minutes.

(ii) Manual Test 2 - Unavailable Product Manager

The second test consists of the same process of phoning the Product Manager as in test 1 above. In test 2, however, the Manager is not available that means that the person seeking the request must walk up to the Development office, find the book and take out the number. As the three Development Engineers that use the system are situated in different positions in the factory, the time was recorded for each of these.

Engineer 1	45 minutes
Engineer 2	32 minutes
Engineer 3	10 minutes

These times show that the Engineers are situated at various distances, with Engineer 3 being the closest (works in the same office as the Product Manager).

(iii) Computerised raising of ECO numbers

The test, establishing the time taken to raise an ECO number on the networked Lotus spreadsheet, entailed starting the Lotus program, finding and opening the ECO file, moving down the spreadsheet to the last number and filling in all the details. These details include, the part number of the shockabsorber in question, a brief description of the change and finally, the date. The test was run timing the exercise from the start, to closing the Lotus spreadsheet. Three times were taken, giving the following results:

Trial 1	1 min 24 seconds
Trial 2	1 min 33 seconds
Trial 3	1 min 16 seconds
Trial 4	1 min 26 seconds

#### 12.4.2 OBSERVATIONS

The time taken to raise an ECO between the Product Manager and Engineer 3 is fairly similar. It shows only a 5 minute difference. The other two Engineers, being situated in the factory as part of the System 1 Business Units, took longer than half an hour to raise the ECO number. The time taken to raise the same number on the new system took less than 1,5 minutes for all four trials. The time does not take into account the time wasted through distractions that arise when travelling through the factory. As often happens, people stop each other to chat or to find out information.

Although a significant advantage has been shown for this simple system, resistance has come from the Product Manager. His department feels that there will be a lack of control because the two Engineers situated in the factory do not know what other changes are in progress. In other words, a change that the Engineers might be registering, could possibly be combined with another change already in progress.

Apart from the benefits of the system, Engineers often need to access the ECO files in order to look for historical information of previous changes. This is currently impossible due to the logistical position of these Engineers. The convictions of Product Management are unfounded as these Engineers were able to manually register their own ECO numbers when they were still located in the Development Engineering office. If the Product Manager feels strongly about control, the Engineers could raise the number and notify the Manager through the Networked mailing system.

The fact remains that the system will most certainly reduce the variety of work that is required by the Product Manager. As the system is on-line, he can monitor the registration of changes, responding and managing them through the electronic mail if he does not agree with an Engineering Change. Since the Development Engineers now fill the role as cross-functional Business Unit Engineers, endeavours should be made to reduce excess, non-value added work, such as walking miles through the factory just to raise an ECO number. This is especially so since their function, apart from manufacturing responsibilities, is to facilitate rapid change requirements.

## 12.5 FINDINGS ON THE QUALITY COST IMPACT

As discussed in the development of the Rich Picture, one of the main areas of concern, is the cost of poor quality as a result of incorrect drawings being used, drawings not being available or drawings not being used to manufacture the part. Several errors caused by these problems are tabled below with their associated costs:

Part No	Description	Qty	Error	Cost
940204	A3 Golf	450	Incorrect No	Inconvenience
927008	Uno	2000	leakers - wrong level Dwg	R95540
J55821	Exp. Merc	400	Incorrect Dwg	R18880
61902	Mono Gas	400	Wrong level Drawings	R52912
E69807	Mono Gas	300	Incorrect Dwg	R11379
EG51346	Shock	150	Drawings not used	R3855
G35859	Strut	200	Drawings not used	R5562
927014	Opel	300	Wrong parts	R13770
832005	Kombi	250	Wrong parts, wrong level Dwg	R15375
E35612	Honda	1000	Incorrect Dwg, parts exported	R550066
			<b>TOTAL</b>	<b>R767307.00</b>

These costs shown in the table have been derived from three sources, namely, corrective action reports, scrap reports and being at the right place at the right time.

The table shows that more than R767 307.00 has been lost in errors related to drawings. This drawing could be of the incorrect level, unavailable or the Operators' simply failed to use the drawings.

### **12.5.1 QUALITY SCRAP REPORT**

The problem encountered in investigating the cost of errors, was the lack of real evidence, as many of these errors are disguised in the Quality scrap report. The reason is that the Manufacturing cells do not record the root cause of why the parts have been rejected. The System 3 Quality department however, audit the Manufacturing cells on a weekly basis, comparing the scrap docket with the actual scrap on hand. Once satisfied that everything is in order, the Quality Engineer opens the scrap buggy, into which the scrap is put. These scrap dockets are then fed back and processed by the IS department. The output being the computerised scrap analysis, which breaks down all the scrap in the various departments and costs. These costs in the scrap report do not show the cost of the final product, but a breakdown of some of the parts comprising of the final product. The costs on the table were generated from these breakdowns in as much as the reports were scanned for large quantities in excess of two hundred parts. These were then identified as units that had been stripped down. The actual cost taken for the table is the full cost price of the relevant shockabsorber or strut.

### **12.5.2 CORRECTIVE ACTION REPORTS**

The corrective action reports are issued by the Quality department and passed on to the "culprit" for which a corrective action is filled in and signed. This essentially is a form of feedback for quality problems, where accountability is acknowledged with a timing plan for ensuring the problem does not re-occur. During the investigation, apart from finding actual shockabsorbers that had been scrapped, corrective action reports were found highlighting deviations away from policy procedure. Three corrective action reports (see Appendices 28 to 30) had been filed against the Business Unit Managers for not distributing newly released drawings timeously into production. As can be seen in Appendix 30, one of the corrections is based on the feasibility of this new system.

### **12.5.3 OPPORTUNITY**

It is very difficult to actually pinpoint quality rejects as a direct result of drawings and drawing availability problems. One of the ways discovered while doing research into this area, was being at the right place, at the right time. This opportunity highlighted three products that were scrapped off and caused major inconveniences.

### **12.6 DISCUSSION ON THE TESTS**

Looking back at the test method used, the most pertinent way to establish the effectiveness of the system was to do comparative time tests between the old and the new systems. Contrary to the Scientific method that advocates doing both internal and ecological validity testing, only ecological testing was used as the tests on both the old and new systems mimic reality. The reason for this was that the time differences especially between the old and new distribution methods were significantly different.

It was felt that to design a test to exclude all uncontrollable factors was unnecessary as it would show the same results. The test on the new system could be called an internal validity test as the image of the drawings appear through information travelling through the computer network. This has little persuasive influences acting on it, apart from other data that might slow the whole network down fractionally. For this reason, it has been assumed that the information arrives "clean" on the screen. The internal validity test breaks down, however, when the human interface occurs. This is deemed to be negligible when compared with the old system especially when the new system's recorded times of seconds, is compared to the manual system's results in days.

## **CHAPTER 13**

### **CONCLUSION**

#### **13.1 THE ORIGIN OF ADIS (ACCESSIBLE DRAWING INFORMATION SYSTEM)**

As discussed in the introduction, the Accessible Drawing Information System (hereafter referred to as ADIS) arose from a concern that the current information system undermines the viability of the three Business Unit's Manufacturing cells. This concern was initially investigated using the Viable Systems Diagnosis. VSD suggested that the existing Engineering Change system was the cause for this situation because the variety of drawing information management deals with is excessive. This variety could compromise the Manufacturing cell's viability. As a result, the soft systems methodology for information systems design (Multiview) was applied.

During the formulation of the Rich Picture, using Multiview, the focus of this concern changed such that it now covered the areas of flexibility and speed of the Engineering Change system. Firstly, the concern focussed on the complexity of the drawing distribution part of the change system. Secondly, the concern broadened to cover the daily usage of drawings. This was believed to be totally out of control, resulting in serious errors due to a lack of the correct level drawings or as a result of missing drawings.

ADIS attempts to provide the operators of the various Manufacturing cells with the latest level of drawing instantly when requested. The objective is to cut out the variabilities that occur in the manual paper system. Secondly, ADIS provides a means of ensuring that the release procedure of distributing drawings is swift and accurate. This system cuts out all the idiosyncrasies and errors that occurred with the manual distribution of drawings.

## **13.2 ADIS IN CONTEXT**

The original Level 1 Concept model of the Accurate Efficient Product Information system shown in Fig. 7.2, Chapter 7 showed five sub-models comprising of the Create Change Package System (Raising an ECO number), Creating a Structure System, ECO procedure system, Drawing Distribution System and the Daily Usage System. It was concluded at the end of the First Stage of Multiview that two of these systems would not be developed any further. The Structure creation system currently works quite well in terms of its accuracy and methods. This system however, should be revisited at a future date, as a separate project, to develop an automated structure system using the Multiview methodology. The ECO procedure was discarded as the current system, although part of the holistic Level 1 system, works well and has built in feedback loops acting as an early warning system for the ECO committee.

ADIS is a computerised drawing viewing system that is linked to the network, giving each Manufacturing cell online, direct access to all the Auto Cad drawings. These are only the drawings that have been moved from the Development directory to the Production directory when released by the ECO Committee. The beauty of ADIS is that it a very simple system that utilises an off-the-shelf package called Auto Manager. Auto Manager is easy to customise and is user-friendly, enabling a computer illiterate Operator to access the required drawings by following the simple operating instructions that are displayed in the work station.

## **13.3 THE DEVELOPMENT OF ADIS USING MULTIVIEW**

Multiview was used to explore the area of concern. It focussed on an application area that was developed into ADIS. Multiview uses a fair amount of Soft Systems Methodology as it is looks at both the human and the technical aspects of the current situation and the development of information system. The five stages of Multiview were followed and the following was concluded:

- a) A series of conceptual models were developed of the desired system.  
These were constructed from the impressions of all the stakeholders with the

assistance of the Rich Picture and Root definitions. Three relevant concept models were constructed for further development, namely, the Drawing Distribution System, the Daily Usage System and finally, the ECO number system.

- b) These concept models were used to establish how they fit into the daily aspects of the operation of the Business Units in order for them to perform their purpose of manufacturing shock absorbers. This resulted in the relative function and events being developed.
- c) As the users have a fundamental right to decide whether or not a system will affect their lives in an adverse way, Multiview was able to help the Manufacturing cells' Operators in making a decision to accept ADIS. This was very important as the philosophy of the teams are that they are self-directed, empowered to accept or reject processes that they feel might improve or hinder their objectives.
- d) Multiview proved to be a valuable tool in assisting in the development of the Human Computer interface. This was of extreme importance as the systems end users were going to be Manufacturing cells' Operators, most of which had never used a computer (let alone a Windows based one) before. By using Multiview, the author was able to design a very easy to follow operating instruction with the help of the Original Equipment Shock cell Operators. These Operators then tested these instructions. As a result improvements in the dialogue were made and then re-tested.

The importance of this stage was that intense interest was gained by the Operators, especially as they were made to feel like they were an integral part of the system development. This ensured that news of the system (ADIS) spread throughout the factory resulting in a growing wave of interest, with requests for similar workstations coming from other Manufacturing cell teams.

- e) Multiview assisted in further technical aspects of ADIS and the implementation of the first workstation into the O.E. Shock cell. Technical aspects that had been missed included addressing the I.S. departments need for ensuring the work stations security from theft. Secondly, to ensure that there is no chance of tampering or removing files on the Network. This resulted in a cupboard being designed and made which apart from protecting the system, gives a professional look in the cell.

Further to this, Multiview highlighted two areas that could have had disastrous consequences to the project's success. Firstly, it led to the discovery of Auto Manager's shortfall in its ability to read Auto Cad drawing symbols. This resulted in frantic correspondence with the package developers. The solution to the problem was finally solved by the Author. Secondly, the O.E. drawings required a change in format as they do not show the parts list. This resulted in all the drawings being converted to a format that met the users' requirements.

### **13.4 CONCLUSIONS DRAWN FROM TESTS AND FINDINGS**

After implementation of ADIS into the first cell, Multiview facilitated the design of tests, the results of which were compiled. The conclusions of the tests consist of the tests performed on ADIS which produced findings from timed comparisons between the three new systems and the old, manual systems. The conclusions drawn from these findings are detailed below.

The findings proved the hypothesis that the old system does not promote the viability of the Manufacturing cells was well founded. The reason was that the test results show that it can take up to 10 days for a newly released drawing to reach the floor. The Cost of Quality findings show that as a result of the drawings not reaching the floor, several errors have been made. These errors have been extremely expensive as the units are scrapped off, requiring a re-schedule of the build to maintain supply. The implementation of ADIS showed that the drawing distribution is reduced from an average of six days to several minutes!!

The nature of the system ensures that all the Manufacturing cells will have the latest level drawing at the same time which will result in a significant reduction in the variety that the stakeholders have to deal. Most of them will be excluded from the ADIS system with the exception of the Product Manager who still has to release the drawings to production. The time taken to do this is greatly reduced, freeing him to focus on more value-added functions. The system also allows a degree of control and auditing by the System 4 owners, which was impossible before. This is made possible through the Windows software that allows file manipulation, searches and queries through file manager. The System 1 Business Unit Managers no longer have to co-ordinate the distribution of these drawings into the Manufacturing cells as this is done automatically for them on the system. This also frees them up and allows them to focus on management issues.

The daily usage system shows that there is only a minute difference between the old and new system. However, the significant difference seen in the tests is the way in which the drawings are used. It is now possible for the members to use the drawings by communally sharing them instead of passing them around the cell to be used by each individual. The significant difference between the manual system and ADIS is in the event of a missing paper drawing. Where a replacement drawing takes at least forty-five minutes to find, ADIS does not lose drawings. The consequence of missing drawings is that the cell comes to a standstill, contributing to downtime, lost production, missed schedules and ultimately, a negative impact on customer satisfaction.

### **13.5 COST OF IMPLEMENTATION**

From the Rich Picture it was seen that the Finance department were concerned about the costs of this system. The actual cost of implementing the total system will be R90 000.00 which includes:

- 15 workstations;
- network hub;
- cabling;
- workstation cupboards;
- 15 User Software Licence.

The cost of quality has conservatively be shown as R767 309 for nine examples of scrap units that have been found purely by accident (refer to Chapter 12, sub-heading 12.5).

Approximately 9500 jobs are loaded per annum. Therefore, taking a conservative estimate of 50% of the above figure, the annual value of lost revenue would be approximately R383 655 000, which is the amount used in the following calculation.

Management time has been estimated R36 000 per annum. The secretary's time has been estimated at R16 000 per annum. This gives a total manpower cost of R52 000. Add this to the R383 655 lost revenue and one has a total amount which could be saved, would be R451 655.

$$\text{payback} = \left( \frac{90000}{451655} \right) = 0.2 \text{ months}$$

This calculation excludes costs that are saved from down time, frustration and the gains to be made from this system.

## 13.6 ADVANTAGES OF ADIS

The testing of ADIS proved beyond doubt that this system can effectively:

- Eliminate the delays of the manual distribution system;
- Reduce Manufacturing cell's downtime as drawing are always accessible;
- Reduce scrap as correct level drawings are always available;
- Contribute to an improvement in the Operators' skills level;
- Reduce management's variety, increase control of their operations;
- Increase Customer satisfaction by consistently supplying a better quality product.

## 13.7 CONCERNS

Although the system shows that initial results are good and warrants implementation, pitfalls loom on the horizon and need to be considered with care. The Soft Systems Approach in developing this system involving the Manufacturing cell's operators, has developed trust in the sincerity of Gabriels approach to employee empowerment. It is therefore important to involve the team in any future development of the system. This is especially true with the Informations System department which may still proceed in their normal autocratic manner and possibly undermine the success of the project. This could also mean that they could introduce different viewing software into the cell in the same unsuccessful manner which has been applied in the past. The consequences of this could be such that no pre-introduction training will be done with the team. Furthermore if their involvement is neglected inadequate visual operating instructions will be developed.

## **CHAPTER 14**

### **RECOMMENDATIONS**

#### **14.1 IMPLEMENTATION OF ADIS**

Due to the success of the first test site and from the supporting conclusions found in Chapter 13, it is recommended that ADIS should be fully installed into all the Business Unit Manufacturing cells. As the concept models have shown, in conjunction with the actual test results of the working system, ADIS will reduce the complexity of the distribution of drawings onto the shop floor. Similarly, it will ensure that the Manufacturing cells will always have the latest level drawings instantly at their disposal.

Although ADIS is a simple system, it is important that every operator in the company can use it. The reason for this, is to ensure there is no possibility that Manufacturing cells can come to a standstill as a result of no-one being able to operate the system. For this reason a further recommendation made is to include the system in the Green Area's cross training matrix, which visually shows the status of the cell members' skill levels as well as the overall effectiveness of the cell's cross-training program.

As Engineers and Management also require access to drawings for various reasons to facilitate decision making, it is recommended that the Auto Manager software is installed onto their office computer workstations. Engineering will find the package of valuable use as the Auto Cad package can be started from within Auto Manager. This is important as time can be saved as engineers can run through lots of drawings quickly, opening them in Auto Cad only when required.

#### **14.2 MULTIVIEW**

From the conclusion, it can be seen that Multiview has been an effective holistic methodology using different techniques, approaches and tools for the analysis, design and implementation of new or modified information systems. Based on the success of ADIS, it is recommended that

Multiview could be used to re-think at least two other areas concerning the company's main UNIX based information system, Novell network and Windows software packages.

The current information system that Gabriel uses to control the operations of the company is called Rascal and runs on a UNIX based network. Although the workings of the system are sound, the efficiency of the system is limited due to its age. The main limitation is a result of a non-user friendly interface. Multiview should be used to analyse problems that exist with this interface, with the objective of simplifying it, making it user-friendly for all.

There are going to be many future enhancements, additions and changes to the current networked software packages. Therefore, the second recommendation for the continued use of Multiview relates to the role of the Information Systems Department.

Traditionally, IS departments see themselves as a steering function within the organisation. However, the viable systems model and the Viable Systems Diagnosis shows that the I.S. department's role should be one of a System 2 co-ordination and support. Therefore, instead of forcing changes onto end-users by deciding what is best for them, the role of the IS department should be of a consultative one, especially as there are a high level of end-users using networked packages and the Rascal information system.

Multiview could be used by the IS Department as a methodology to facilitate the selection of future software packages which would be acceptable to the majority of end-users.

### **14.3 FUTURE DEVELOPMENT OF ADIS**

By fully implementing ADIS throughout the factory, each Manufacturing cell will be equipped with its own computer workstation. These workstations could be used for another function other than just viewing drawings.

Currently, the Manufacturing cells' team members have to capture various performance related measures as a requirement of the Gabriel Total Quality Production System (GTQPS) on a daily basis. These measures include production numbers, cell downtime, set-up time, lead time,

scrap, parts per million reject to name but a few. This data is then forwarded to the relevant cell's facilitator who then compiles the monthly GTQPS report sheets. This report sheet compares the figures for the current month to the previous month as well as the world class benchmark. The facilitator then constructs a series of BOS (Better Operating System) charts which track those measures that do not meet the world class requirements as well as a list of relevant corrective actions.

ADIS could be used by the operator to input these daily measures which would then be captured by a specially designed program. This program would compile the monthly reports for each cell and similarly, produce the BOS charts for those items which are not performing. This system would simplify and reduce the extra workload that is required to facilitate the Manufacturing cells, ensuring that the reports are submitted to the GTQPS co-ordinator in time which does not usually happen.

## CHAPTER 15 REFLECTION ON MY LEARNING

The process of developing this thesis has taught me how to conduct a rigorous and structured inquiry into situations which are complex and problematic. Through this process, a framework for conducting inquiry was developed. It consisted of three core levels being philosophical, methodological and technique.

Using Peirce's work, the philosophical approach was built based on the concepts of fixing belief, pragmatic management, fallibilism and double loop learning. The development of this first level of the framework was expanded to deal with complex social situations using Systems Thinking.

The initial immersion in the abductive stage of the Peircian cycle suggested that cybernetics (Beer's Viable System's Modeling) was the most appropriate methodology to deal with variety. This led to the belief that the engineering change system needed to be redesigned. However, an iterative process was applied where another Systems Thinking Methodology was employed to develop an information system using the Soft Systems based Multiview. This identified a different scenario which resulted in the development of the accurate drawing information system (ADIS).

During the development of this thesis various writings and theories have been encountered. Learning styles, action learning in particular, has made a significant impact on the author. These new approaches have empowered the author to tackle problem situations outside the boundaries of his experience. This is particularly evident in the subject which was finally chosen for this thesis. During the development of the Rich Picture, the management of Information Systems department were extremely negative about the investigation into a new system which would focus on the availability of accurate drawings to the shop floor. The author was requested to find an alternative topic for the thesis. However, after the author's persistence and a presentation of the initial results, the topic and the "outsider" (namely, the author) were accepted with reservation. The end result has been the implementation of the new system in almost 30 Manufacturing cells at the time of writing!

Further evidence of the learning acquired after the application of the Research Framework is shown in the solution which the author discovered to the software problem discovered in the Auto Manager package. The patience to investigate and to search for a solution to the problem allowed the author to overcome constraints imposed by Auto Manager. The problem had been experienced by the software developers internationally and yet to date, it had gone unsolved. Although the solution appeared simple, it involved many hours of persistence on the part of the author. In fact, the author's solution has resulted in the revision of the user manual for this package.

Gabriel S.A. is driven by its world class initiative of waste reduction and employee empowerment. The test site chosen to develop the Accurate Drawing information System was the Original Shockabsorber Manufacturing cell, which comprised a team of seasoned empowered employees actively participating in the destiny of their cell. This team proved invaluable and reinforced the author's commitment to the inclusion of all stakeholders in the design of systems that will affect their lives. By applying the systems approach the classical obstacles found in implementing change were avoided.

## BIBLIOGRAPHY

### 1. LIST OF REFERENCES

- 1 Reilly, F. Charles Pierce' s Theory of Scientific Method. Fordham University Press 1970.
- 2 Reilly, F. Charles Pierce' s Theory of Scientific Method. Fordham University Press 1970.
- 3 Reilly, F. Charles Pierce' s Theory of Scientific Method. Fordham University Press 1970.
- 4 Reilly, F. Charles Pierce' s Theory of Scientific Method. Fordham University Press 1970.
- 5 Reilly, F. Charles Pierce' s Theory of Scientific Method. Fordham University Press 1970.
- 6 Argyris, C. Good Communication that blocks learning. Harvard Business Review, July - August 1994.
- 7 Reilly, F. Charles Pierce' s Theory of Scientific Method. Fordham University Press 1970.
- 8 Senge, P. The Fifth Discipline Fieldbook. New York: Doubleday, 1994.
- 9 Argyris, C. Good Communication that blocks learning. Harvard Business Review, July - August 1994.
- 10 Checkland, P. Systems Thinking, Systems Practice. John Wiley and Sons 1981.
- 11 Checkland, P. Systems Thinking, Systems Practice. John Wiley and Sons 1981.
- 12 Clemson, B. Cybernetics: A New Management Tool. Abacus Press, 1984.
- 13 Argyris, C. Good Communication that blocks learning. Harvard Business Review, July - August 1994.

- 14 Clemson, B. Cybernetics: A New Management Tool. Abacus Press, 1984
- 15 Beer, S. Brain of the firm. John Wiley & Sons, 1979
- 16 Clemson, B. Cybernetics: A New Management Tool. Abacus Press, 1984
- 17 Clemson, B. Cybernetics: A New Management Tool. Abacus Press, 1984
- 18 Multiview - An Exploration in Information Systems Development - Blackwell Scientific Publications Series.
- 19 Multiview - An Exploration in Information Systems Development - Blackwell Scientific Publications Series.
- 20 Multiview - An Exploration in Information Systems Development - Blackwell Scientific Publications Series.
- 21 Gill, J. & Johnson, P. Research Methods for Managers. Paul Chapman Publishing Ltd, 1991
- 22 Gill, J. & Johnson, P. Research Methods for Managers. Paul Chapman Publishing Ltd, 1991
- 23 Gill, J. & Johnson, P. Research Methods for Managers. Paul Chapman Publishing Ltd, 1991
- 24 Clemson, B. Cybernetics: A New Management Tool. Abacus Press, 1984
- 25 Clemson, B. Cybernetics: A New Management Tool. Abacus Press, 1984

## 2. LIST OF SOURCES

1. Stafford Beer Diagnosing the System for Organisation.
2. Barry Clemson Cybernetics - a New Management Tool.
3. Stafford Beer Brain of the Firm - (2nd Edition).
4. University of Hull - School of Management MBA (1990 Edition) Organisational Design and Behaviour.
5. Edited by R Espejer and R Harnden (1989 Edition) The Viable Systems Model Interpretations and Applications of Stafford Beer's VSM.
6. David J. Lu Kanban - Just in Time at Toyato.

7. The Open University Press Systems.
8. Robert L Flood and Michael C Jackson (2nd Edition) Creative Problem Solving - Total Systems Intervention.
9. John Gill and Phil Johnson Research Methods for Managers.
10. Francis E. Reilly Charles Peirce's Theory of Scientific Method.
11. Course Handout Systems Thinking : The Systems Movement in the Context of Science.
12. Ross Ashby An Introduction to Cybernetics.
13. Blackwell Scientific Publications Series Multiview - an Exploration in Information Systems Development.
14. Benjamin B. Tregoe and John W. Zimmerman Top Management Strategy
15. Argyris, C. Harvard Business Review, July - August 1994 Good Communication that Blocks Learning.
16. Peter Senge The Fifth Discipline Field Book, New York Double day, 1994.
17. Minto, B. London Minto International Inc. 1982  
The Pyramid Principle: Logic in Writing and Thinking.
18. Ackoff, R. John Wiley & Sons, 1974 Redesigning the Future.
19. Checkland, P. Systems Thinking, Systems Practice. John Wiley and Sons 1981

SYSTEM 1a	SYSTEM 1b	SYSTEM 1c
<b>1a Management</b> Manager D.Burns Sys 5 Dev eng P.Montgomery Sys 4 Process Eng I.Hendricks Sys 3 T.Dory Sys 3 H.Abbot Sys 3 Quality Eng T.Mancini Sys 3 Forman G.Yon Sys 3 I.Smith Sys 3 G.Hendriks Sys 3	<b>1b Management</b> Manager K.Walters Sys 5 Dev eng N.Wells Sys 4 Process Eng J.Fletcher Sys 3 Quality Eng P.Solomans Sys 3 Forman C.Williams Sys 3	<b>1c Management</b> Manager S.Nuttal Sys 5 Dev eng B.Morar Sys 4 Process Eng P.Copson Sys 3 R.Cosman Sys 3 Quality Eng R.Smart Sys 3 Forman B.V.Rensberg Sys 3 M.Jacobs Sys 3 R.Davids Sys 3 Prod. Control J.Williams Sys 2
<b>1a Operations</b> <b>1a.a.- O.E. Shocks</b> Cell Leader Shift1 T. Williams Cell Leader Shift2 N.Festus members 7/SHIFT <b>1a.b.- O.E. Struts</b> Cell Leader Shift1 R. Iosper Cell Leader Shift2 R.Bowers members 5/SHIFT <b>1a.c.- A.M. Shocks</b> Cell Leader Shift1 D.Lawrence Cell Leader Shift2 T.Jonathen members 11/SHIFT <b>1a.d.- A.M. Struts</b> Cell Leader Shift1 S.Samaai Cell Leader Shift2 D.Josephs. members 6/SHIFT <b>1a.e.- Shock Tube</b> Cell Leader Shift1 M.Steer Cell Leader Shift2 G.Buttress members 3/SHIFT <b>1a.f.- Strut Tube</b> Cell Leader Shift1 A.Devilliers Cell Leader Shift2 A.Jafta members 4/SHIFT <b>1a.g.- Robot Weld</b> Cell Leader Shift1 A.Devilliers Cell Leader Shift2 A.Jafta members 5/SHIFT <b>1a.h.- Mono Gas</b> Cell Leader Shift1 K.Simms members 5/SHIFT <b>1a.i.- Sub Assembly</b> Cell Leader Shift1 R.Benjamin members 13/Shift	<b>1b Operations</b> <b>1b.a.- Warehouse</b> Cell Leader Shift1 P.Odonus Cell Leader Shift2 I.Arianse members 6/Shift <b>1b.b.- Paint &amp; Pack</b> Cell Leader Shift1 C.Snel Cell Leader Shift2 E.Liesh members 14/Shift <b>1b.c.- Gas Spring</b> Cell Leader Shift1 M.Van Rooyan Cell Leader Shift2 E.Kriel members 7/Shift <b>1b.d.- Cartridge</b> Cell Leader Shift1 C.Williams members 5/Shift <b>1b.e.- Dust Bin</b> Cell Leader Shift1 C.Williams members 5/Shift	<b>1c Operations</b> <b>1c.a.- Rod Welding</b> Cell Leader Shift1 E.Meyer members 5/Shift <b>1c.b.- Rod Polising</b> Cell Leader Shift1 H.Stevens Cell Leader Shift2 M.Oliver members 3/Shift <b>1c.b.- Chrome Plant</b> Cell Leader Shift1 C.Iekeur Cell Leader Shift2 D.Boonzier members 4/Shift <b>1c.d.- Small Rods</b> Cell Leader Shift1 W.Stoffels Cell Leader Shift2 N.Eaton members 5/Shift <b>1c.e.- Large Rods</b> Cell Leader Shift1 R.Aarendorf Cell Leader Shift2 V.Crouch members 5/Shift <b>1c.f.- Valve Press</b> Cell Leader Shift1 M.Davids members 4/Shift <b>1c.g.- S/Seat Press</b> Cell Leader Shift1 R.Polser Cell Leader Shift2 A.Joot members 3/Shift <b>1c.g.- Comp. Press</b> Cell Leader Shift1 N.Egypt members 4/Shift <b>1c.i.- Bracket Press</b> Cell Leader Shift1 R.Polser Cell Leader Shift2 A.Joot members 3/Shift

TABLE OF OPERATIONS (SYSTEM 1) STRUCTURE DETAILS

## 1995 GTQPS CERTIFIED CELLS MEASURES

CELL: OE SHOCK CELL

DATE: AUGUST 95

MEASURE	INITIAL TARGET	WORLD CLASS TARGET	DATA @ CERT	MAY	JUNE	JULY	AUG	SEPT	OCT	NOV	DEC
Suggestions per Employee	2 per employee per month	24.0	2	2	2	2	2				
% of Suggestions Implemented	75%	85%	75%	78%	76%	82%	81%				
% of Cell Employees on Work Team	100%	100%	100%	100%	100%	100%	100%				
Training Hours per Person	40	40	25	23*	23*	23*	23*				
% of Cell Cross-Trained	100% XT set-up & operate 3	100% XT on all unit positions	3/30%	3/30%	3/30%	3/30%	3/30%				
Labor as a % of COP	12.0%	10.0%	n/m	2.3%	4.12%	4.09%	4.18%				
Scrap as a % of COP	2.0%	0.5%	n/m	1.5%	0.42%	0.36%	2.59%**				
Changeover Time	6 minutes	2 minutes	15min	15min	15min	15min	15min				
shockabsorbers	12 minutes	10 minutes									
struts	5 days	4 days	5	5	5	5	5				
Raw Material (Hours)	4 hours	4 hours	4	4	4	4	4				
WIP (Hours)	5 minutes	2 minutes	1.7Hrs	27 min	27 min	27 min	27 min				
Leadtime (Minutes)											
Process Capability	100%	100%	100%	100%	100%	100%	100%				
% Studied	75%	90% long term capable	60%	60%	60%	60%	60%				
% Cpk > 1.67	100	25	2090	637	0	3774	1773				
PPM Defective	10.0%	5.0%	n/m	25,6%	25,8%	33%	30%				
% Unplanned Downtime	98.0%	100.0%	n/m	95,3%	100%	87%	84%				
Availability											
Units/Manhour				10.9	12.45	12.54	12				

\* Change due to additional new operators

\*\* High scrap due to defective resistance, due mainly to contamination caused by a change in the washing process. The new washing machines filtration and flush frequency is being investigated.



ENGINEERING PARTS LIST & OUTLINE DRAWING

NOTE:-

- 1 VALVE CODE: 32(6-2.20)05-85/RD 3x1.5+VS 0.2+0D 1.2+V 2x0.2
- 2 STROKE: 179.0 DEAD LENGTH: 110.8 REB STOP: 90.2
- 3 SECTION DWG: 422454
- 4 ASSEMBLY SPEC: 438420
- 5 PACKAGING SPEC: 432520
- 6 EXTEND SHOCK BEFORE CLOSURE.

ITEM No	PART No	PART NAME	QTY
50	212305	ASSY - INTER CYL	
51	314569-07	CYLINDER - INTER (362.5)	1
52	314555	CAP - END	1
53	314407	SEAT - SPRING	1
54	212200	ASSY - MTG BRACKET	
55	314596	BRACKET - MTG OUTER	1
56	314597	BRACKET - MTG INNER	1
57	314417	BRACKET - ATTACH RH	1
58	314418	BRACKET - ATTACH LH	1
59			
60	314374	PLATE - STRIKER	1
61			
62			
63			
64			
65	432408	FINISH SPEC - WHITE	AR
66			
67			
68			
69			
70	144122	PACK - ACCESSORY	
71	411519	NUT - LOCKING	1
72	414406	PLATE - BRAKE PIPE	1
73	414411	BOLT	2
74	414412	NUT - NYLOC	2
75	424461	SHEET - INSTRUCTION	1
76			
77			
78			
79			
80			
81			
82			
83			
84			
85			
86			
87			
88			
89			
90			

ITEM No	PART No	PART NAME	QTY
1	212338-21	ASSY - PISTON ROD	
2	314705	ROD - PISTON (396.6)	1
3	313059	SUPPORT - REB STOP	1
4			
5		ASSY - PISTON	
6	380004	SPRING - BY PASS	1
7	380003	VALVE - BY PASS	1
8	314497-04	PISTON	1
9	314423-01	DISC - ORIFICE	1
10	380047-01	DISC - SEALING	1
11	380048	DISC - BACK UP	1
12	380007	VALVE - RECOIL	1
13	380016-03	SPRING - RECOIL	1
14	383104	GUIDE - RECOIL VALVE	1
15	314441	NUT	1
16	314433	SEAL - PISTON	1
17			
18			
19			
20		ASSY - COMP HEAD	
21	383211	RETAINER - SPRING	1
22	344620	SPRING - REPL	1
23	383212	VALVE - REPL	1
24	383213-05	DISC - RESTRICTION	1
25	314553-02	HEAD - COMP	1
26	314658	DISC - BAFFLE	1
27	383214-11	DISC - ORIFICE	1
28	383065-02	SPACER	1
29	383215-03	VALVE - COMP	2
30	383216	RIVET	1
31			
32			
33			
34			
35	212133	ASSY - GUIDE & BUSH	
36	314454	HEAD - INNER CYL	1
37	313141	BUSH - GUIDE	1
38	372324	SEAL - ROD	1
39	314388	RETAINER - SEAL	1
40	314455	PACKING - HEAD	1
41	314254-03	CYLINDER - INNER (321.9)	1
42	313074	STOP - REBOUND	1
43	434347	FLUID - SHOCK ABS ml	230
44	437600	LUBRICANT - ROD SEAL	AR
45			
46			
47			
48			
49			

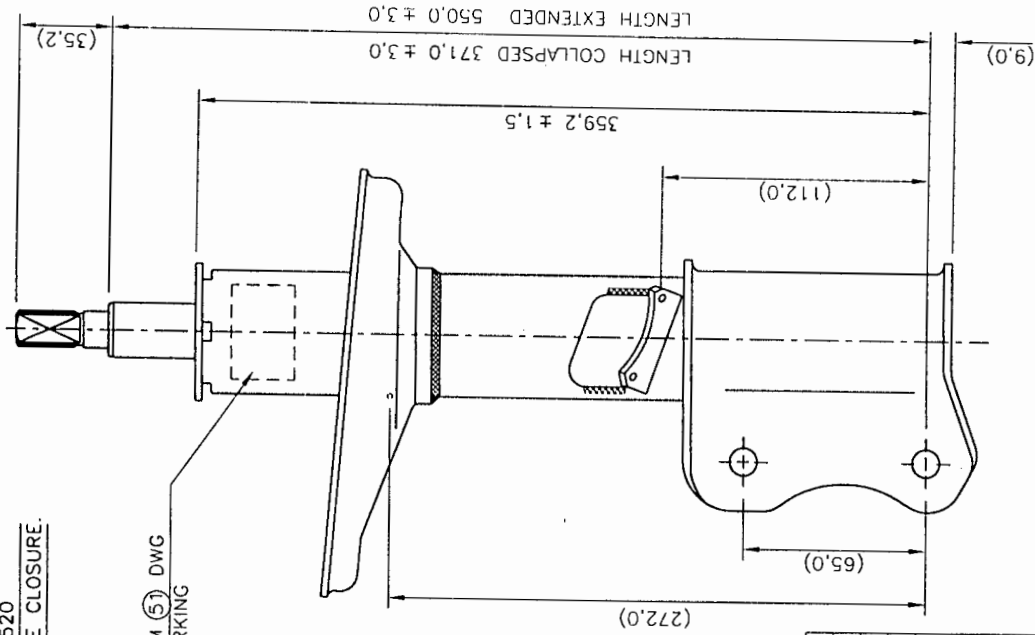

RESISTANCE SPEC	1700
PISTON VELOCITY (m/s)	
0.13	0.26 0.39 0.52
RECOIL (N)	
700	1300
420	850
COMPRESSION (N)	
250	(300) (380)
150	550 400

<p>Gabriel SA (PTY) LTD</p>		<p>CUSTOMER NAME &amp; PART No</p> <p>35846 BORE DIA 30 ROD DIA 20</p>	<p>DATE</p> <p>21.02.88</p>
		<p>APPLICATION</p> <p>CATALOGUE REPLACEMENT</p>	<p>DATE</p> <p>21.02.88</p>
<p>DRAWN</p> <p>F. BESTER</p>		<p>DWG No</p> <p>35846</p>	<p>RELEASED</p> <p>DR</p>
<p>CHECKED</p> <p>N.WELLS</p>		<p>APPROVED</p>	<p>DATE</p> <p>07.02.91</p>
<p>REVISIONS</p>		<p>CHK'D</p> <p>E.C.O.</p>	<p>DATE</p> <p>11.08.95</p>
L	MOD ITEMS 21,23,24,29,30,60	4206	11.08.95
K	MOD ITEMS 1,3,41,51	N.W	13.01.95
J	MOD ITEM 70	N.W	02.08.94
H	MOD ITEM 22,30,70 & ACCESSORY PACK	N.W	11.03.94
G	MOD PACKAGING SPEC.	N.W	28.10.93
F	REVISED & REDRAWN	-	3781
LTR	REVISIONS		

Gabriel SA (Pty) Ltd.  
PARTS LIST

Gabriel Part No.	927014	Issue Level:B
Customer	DELTA	Date:21.06.95
Customer Part No.	90 495 324	E.R.A :4159
Application :	DELTA ESTATE	

Part No.	Description	Qty	Material
344649-01	ASSY-PISTON ROD ROD-PISTON (248,5)	1	437630
344650	EYERING	1	437612-13
348042	CAP-DUST TUBE	1	437629-08
344612	ASSY-PISTON STOP-PISTON	1	437611-15
344613-03	STAR SPRING	1	437609-08
344614-02	DISC-BYPASS	1	437609-30
344608	PISTON	1	
344533	RING-PISTON	1	
344639-06	DISC-RESTRICTION (15,2)	1	437609-04
344597	GUIDE-VALVE	1	
344598-18	DISC-ORIFICE	1	437609-02
344599	DISC-SEALING	1	437609-02
344600	SEAL-RECOIL VALVE	1	
344601	VALVE-RECOIL	1	
380016-08	SPRING-RECOIL	1	
314441	NUT-PISTON	1	
344620	ASSY COMPRESSION HEAD SPRING-REPLENISHING	1	
344643	VALVE-REPLENISHING	1	437609-14
344602	HEAD-COMPRESSION	1	
344645-02	VALVE-COMPRESSION	4	437609-02
348083	RIVET	1	
383054	RETAINER-REPL.VALVE	1	
314041-21	ASSY-INTER CYL. CYLINDER-INTER (249,0)	1	437002-2
344628	END CAP	1	437632-38
344641	STUD	1	
344617	ASSY-FINAL HEAD-INNER CYLINDER	1	
300037	SEAL-ROD	1	
300031	RETAINER-SEAL	1	
300038	SPRING-SEAL	1	
344616	HEAD-INTER CYLINDER	1	
310025	PACKING-HEAD	1	
344529-11	CYLINDER-INNER (235,0)	1	437639-05
434347	FLUID-SHOCK ABSORBER	220	
414521	BUSH ASSY	1	
305785-09	DUST TUBE (202,0)	1	
432401	SPEC,-PAINT	A.R	
432534	SPEC,-PACKAGING	A.R	
	SPEC,-ASSEMBLY		
	SECTION DRAWING		
	OPTIONAL PARTS		
344598-17	RECOIL ORIFICE DISC	1	
344598-19	RECOIL ORIFICE DISC	1	
344645-02	DISC VALVE	2	
344591-02	PIVOT	2	



# ENGINEERING CHANGE

NUMBER : **4232**  
ISSUE DATE : 23.11.95

INITIATING DATA : P.MONTGOMERY  
ACTIONED BY : P.MONTGOMERY DEPT : S.B.U. DATE : 23.11.95  
PART No. : VARIES PART DESC. : A1 GOLF STRUT  
CUSTOMER : VWVA CUSTOMER No : ISSUE :

## PROPOSED CHANGE :

TO CHANGE ALL A1 OE AND P&A STRUTS TO SINGLE WELD DESIGN

## REASON FOR CHANGE :

THROUGHPUT IMPROVEMENT

**COMPONENT No's:** 314330 314521

<b>ASSEMBLY No's:</b>	940181	940182	940183	940184	940185	940186	P940181
P940182	P940183	P940184	P940185	P940186	212331	212332	212046 212032

## DETAILED DESCRIPTION OF CHANGE

PISTON ROD 314330 NOW LEVEL C - REDRAWN ON CAD  
 INTER CYLINDER 314510 C - ADD TAB 7  
 LOWER MOUNTING BRACKET WAS 212046 B NOW LEVEL C : DIA 49,0-48,2 NOW 47,8-47,6  
 INTER CYLINDER ASSY WAS 212331A NOW LEVEL B - MOD DRAWING TO SHOW SINGLE WELD  
 INTER CYLINDER ASSY WAS 212332A NOW LEVEL B - MOD DRAWING TO SHOW SINGLE WELD  
 WELDED ROD ASSY 212032 V - ADD TABS 102 AND 103

940181 NOW LEVEL D PISTON ROD WAS 314268 NOW 314330, ASSY ROD WAS 212032 NOW 212032-103  
 940182 CYLINDER INTER WAS 314510-06 NOW 314510-07  
 940183  
 940184

940185 NOW LEVEL D PISTON ROD WAS 314268 NOW 314330, ASSY ROD WAS 212032 NOW 212032-102  
 940186 CYLINDER INTER WAS 314510-06 NOW 314510-07

P940181 NOW LEVEL B PISTON ROD WAS 314268 NOW 314330, ASSY ROD WAS 212032 NOW 212032-103  
 P940182 NOW LEVEL B CYLINDER INTER WAS 314510-06 NOW 314510-07  
 P940184 NOW LEVEL C  
 P940183 NOW LEVEL D

P940185 NOW LEVEL C PISTON ROD WAS 314268 NOW 314330, ASSY ROD WAS 212032 NOW 212032-102  
 P940186 CYLINDER INTER WAS 314510-06 NOW 314510-07

E: -

1. SLEEVE TO BE SECURELY BONDED TO RUBBER BUSH
2. NO RUBBER FLASH PERMISSIBLE ON ENDS OR BORE OF SLEEVE
3. Z1= SHORE A HARDNESS 55 (NOM.) TO SPEC GME 60 252  
Z2= RESILIENCE 80% MIN (DIN 53512)  
Z3= OZONE RESISTANCE TO FLTM EUBP1-1 RATING No2
4. PARTS A AND C TO BE PHOSPHATE COATED
5. SLEEVE TO WITHSTAND 40KN MIN AXIAL LOAD
6. MUST CONFORM TO REQUIREMENTS ON GM DRAWING 90 473 831

**I.S.I.R.**

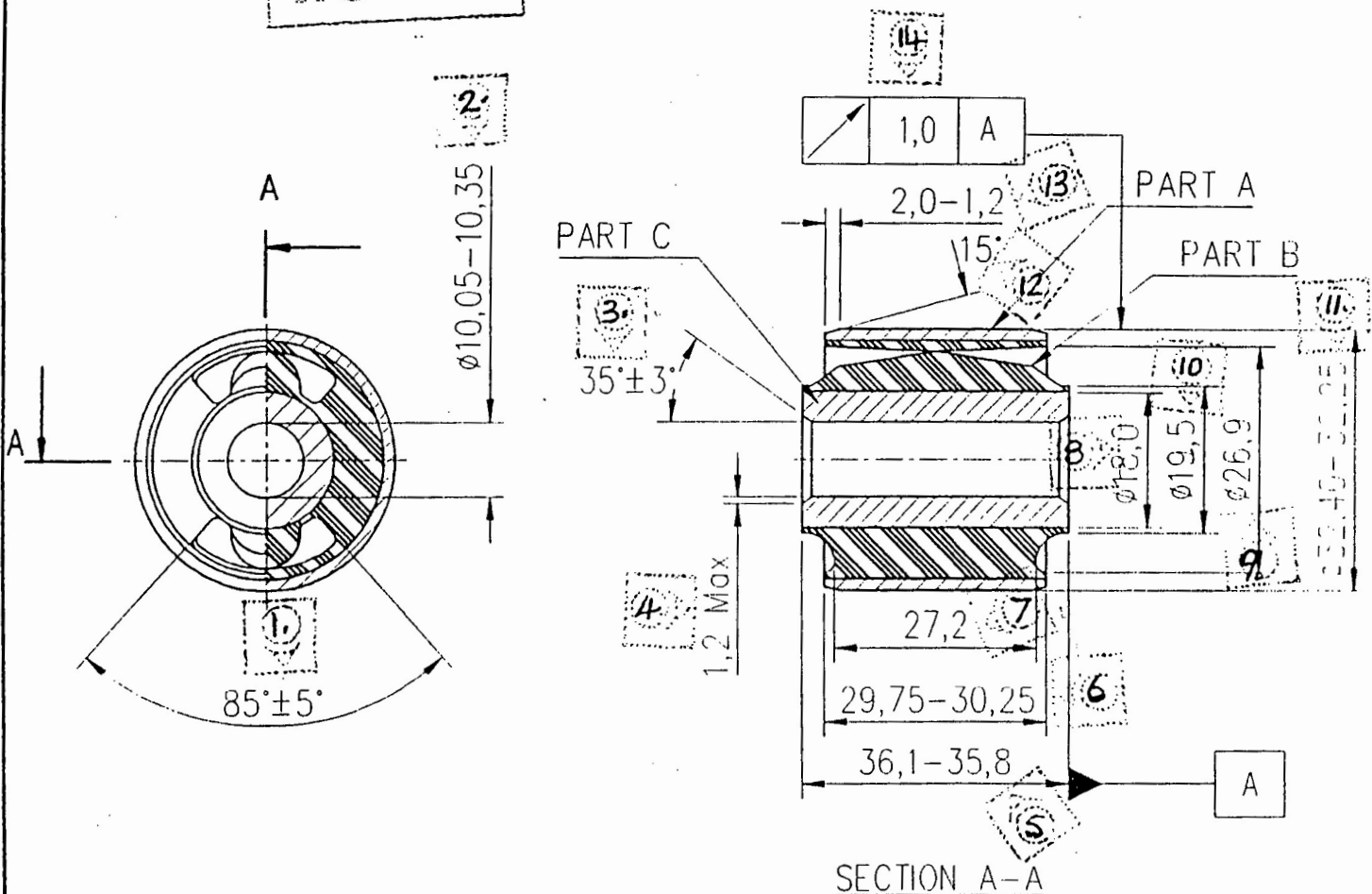

REF. DELTA 90 473 831

					SCALE	MATERIAL
					1:1	RUBBER-SAE J200M4AA
					DRAWN	521 B13,F17,K11,Z1,Z2,Z3
					P.MONTY	STEEL SAE 1010 OR EQUIV
					DATE	DESCRIPTION
					23.06.94	BONDED BUSHING
					CHECKED	ASSEMBLY
A	RELEASE	-	1327	31.08.94	APPROVED	DWG No. 414521
LTR.	REVISIONS	CHK'D	E.C.O.	DATE		
THIRD ANGLE PROJECTIONS						
A4	TOLERANCES UNLESS SPECIFIED	±0,3	±	±	± 2 DEG	Gabriel S.A. (Pty) Ltd

TO BE FREE FROM BURRS AND SHARP EDGES

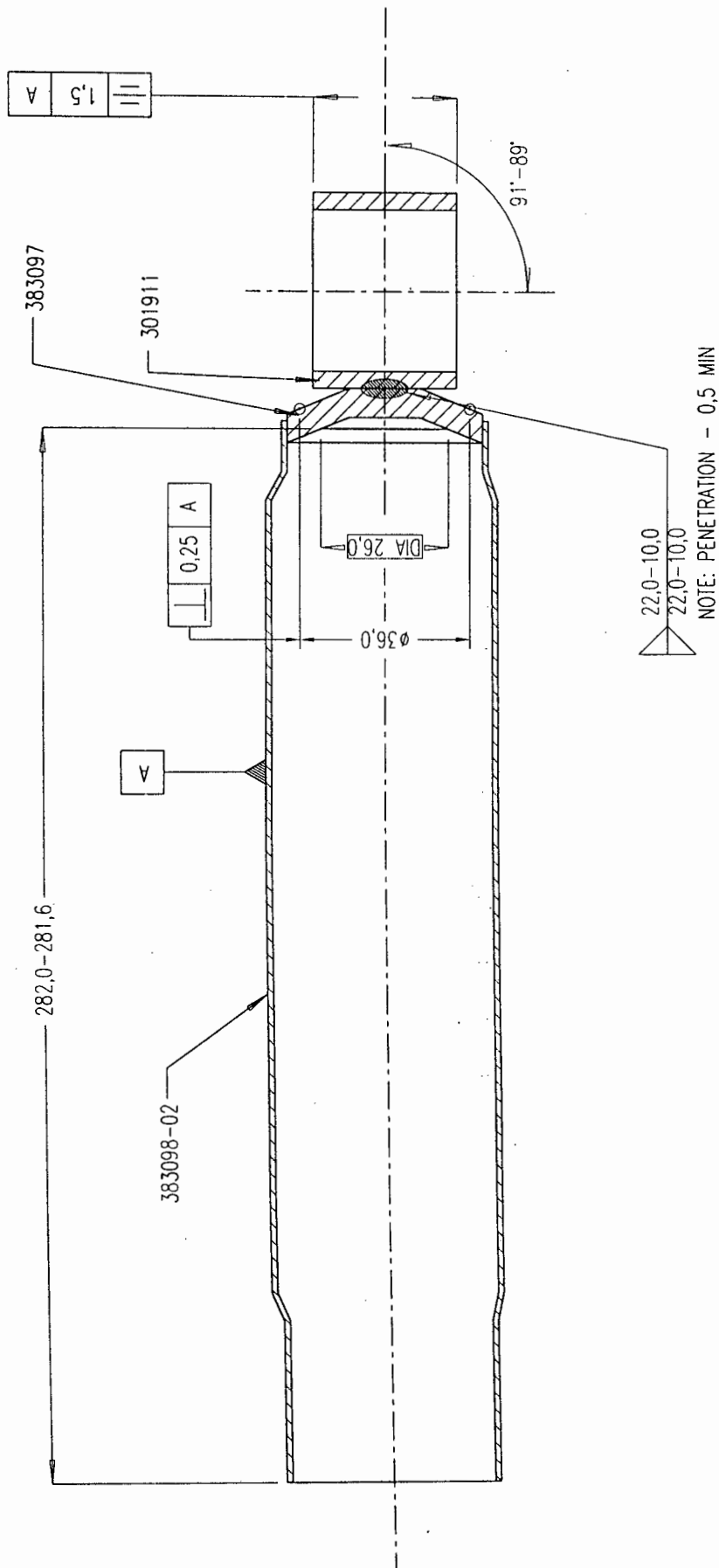

NOTE:  
 1. ASSEMBLY SHALL BE TESTED UNDER 70-100kPa (0.70-1.00Bar) AIR PRESSURE FOR LEAKAGE. NO LEAKAGE PERMITTED.

2. SEAM WELD SHALL WITHSTAND TENSILE TEST - 30kN

SCALE		MATERIAL	
1:1			
DRAWN		P. MONTY	
DATE		9.06.92	
DESCRIPTION		VW KOMBI REAR(H/D) WELDED INTER ASSEMBLY	
B	ADD DIM	1930	21.06.93
A	RELEASE	1260	22.04.92
LTR.	REVISIONS	CHK'O	E.C.O.
THIRD ANGLE PROJECTION			
A3	TOLERANCES UNLESS SPECIFIED	± 0.25	± 1 DEG.
DWG No.		832005-3	
GABRIEL SA (PTY) LTD			

# JOB TRAINING RECORD

## CROSS TRAINING MATRIX

NAME & CLOCK NO.	COMP-HEAD ASSY G797	KNOCK-ON & FLARE PRESS G783	DRL FILLING G787	CARDING MACHINE G785	SPINNING MACHINE G871	BUSHING PRESS G876	BUSHING MACHINE G812	ROD VALVE ASSY G790	TORQUE MACHINE G789	STAKING MACHINE G780	SPINNING MACHINE 2 G	GAS FILL MACHINE G	BUMP CAP PRESS G
E. BIKWE 21184	12/34	12/34	12/34	12/34	12/34	12/34	12/34	12/34	12/34	12/34	12/34	12/34	12/34
N. FESTUS 21285	12/34	12/34	12/34	12/34	12/34	12/34	12/34	12/34	12/34	12/34	12/34	12/34	12/34
P. JACOBS 13606	12/34	12/34	12/34	12/34	12/34	12/34	12/34	12/34	12/34	12/34	12/34	12/34	12/34
L. JENKINS 21045	12/34	12/34	12/34	12/34	12/34	12/34	12/34	12/34	12/34	12/34	12/34	12/34	12/34
E. MATHEWS 20517	12/34	12/34	12/34	12/34	12/34	12/34	12/34	12/34	12/34	12/34	12/34	12/34	12/34
J. MBIZA 21508	12/34	12/34	12/34	12/34	12/34	12/34	12/34	12/34	12/34	12/34	12/34	12/34	12/34
C. REISENBERG 21551	12/34	12/34	12/34	12/34	12/34	12/34	12/34	12/34	12/34	12/34	12/34	12/34	12/34
I. PANDA 21510	12/34	12/34	12/34	12/34	12/34	12/34	12/34	12/34	12/34	12/34	12/34	12/34	12/34
S. VANDERROSS 21416	12/34	12/34	12/34	12/34	12/34	12/34	12/34	12/34	12/34	12/34	12/34	12/34	12/34
T. WILLIAMS 21290	12/34	12/34	12/34	12/34	12/34	12/34	12/34	12/34	12/34	12/34	12/34	12/34	12/34
M. WILSON 21516	12/34	12/34	12/34	12/34	12/34	12/34	12/34	12/34	12/34	12/34	12/34	12/34	12/34
S. WINNAR 21126	12/34	12/34	12/34	12/34	12/34	12/34	12/34	12/34	12/34	12/34	12/34	12/34	12/34
C. ADAMS 21539	12/34	12/34	12/34	12/34	12/34	12/34	12/34	12/34	12/34	12/34	12/34	12/34	12/34
D. CROWSTER 21545	12/34	12/34	12/34	12/34	12/34	12/34	12/34	12/34	12/34	12/34	12/34	12/34	12/34

1. STANDARD WORK OPERATION (IN TRAINING)



2. STANDARD WORK OPERATION + SPC (INSPECT)



3. STANDARD WORK OPERATION + SPC + SET-UP



4. STANDARD WORK OPERATION + SPC + SET-UP + TRAINER



# PROBITY COMPUTER SYSTEMS

(Probyt Systems c.c. T/A, Reg. No. CK87/01/01072/23)

PO Box 15905

Vlaeberg

8018

Office 33, Freeway Park

Camp Road, Maitland

Tel: +27 21 510 2520

Fax: +27 21 510 4791

Mobile: +27 82 554 1319

## Gabriel (SA) Pty Ltd.

Attention: **Freddy Benjamin**

White Road

3 Retreat

7945

Tel: +27 21 72 1007

Fax: +27 21 75 1927

## QUOTATION

6 July 1995

Attention: **Freddy Benjamin**

**486 SX CAD Windows "View only" Workstation: Evaluation machine**

Fujitech Challenger One 486SX 33 MHz	R 596.82
4 MB DRAM (4 * 1 MB SIMM) Full Parity	R 870.42
Fujitech AVGA 20 VGA Card 512 K RAM	R 288.35
Denco Mini Tower and Ad Valorem duty	R 382.24
101 Keyboard KB2000	R 100.59
14" Mono VGA Monitor not delivered	R 0.00
Maxtor 273 MB IDE hard drive	R 663.88
	R 0.00
MS Defender Mouse	R 127.41
IDE Combi Controller 2 Serial 1 Printer	R 87.18
Latex Keyboard Cover	R 0.00
<b><u>Total including VAT</u></b>	<b>R3116.89</b>

The Keyboard Covers are manufactured on demand and may take 14 days to deliver.

Labour will be charged at R135 per hour for non-network support and R165 per hour for Network Support. Component prices may change without notice due to fluctuating exchange rates. All prices quoted above include VAT. Please contact me should you need any further information.

Yours sincerely

**Andrew Mayers**

Probity Computer Systems

ref: \\data\quotes\gabriel\486taken.doc

Member: R.A. Jones



# LAYOUT - ORIGINAL EQUIPMENT SHOCKABSORBER CELL

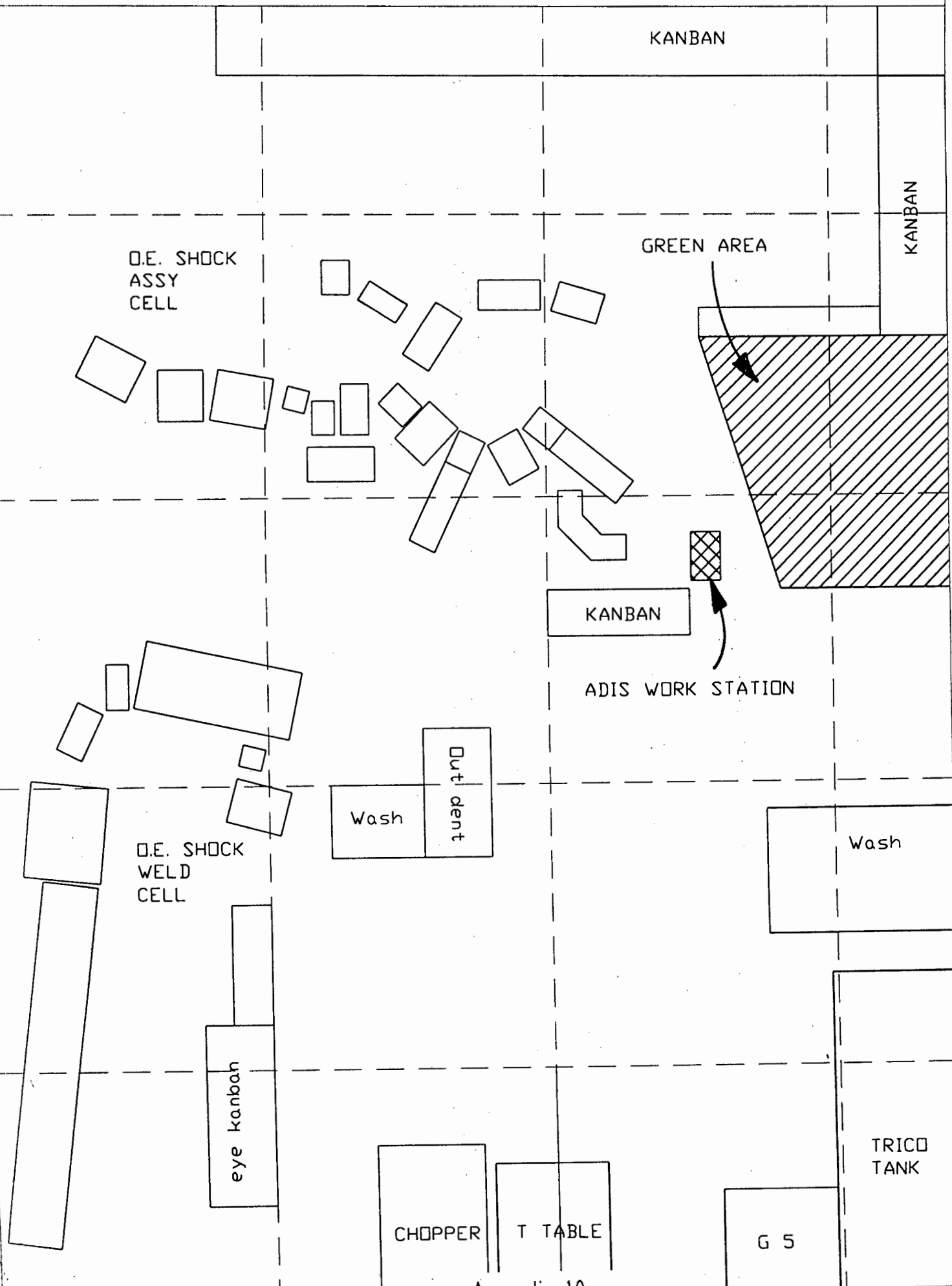



The

quick-thinking shocks - Die flinkdink skokbreker Gabriel SA (Pty) Ltd

To : ACAD CENTRE

Co. Reg. No. 62/02926/07

Fax No : 011-3151050

White Rd, Retreat, Cape, RSA

P.O.Box 30214

Sender : P.MONTGOMERY

Tel (021) 72-1007, 72-1057

Fax No's.

Page : 1 OF 2

Marketing : (021) 757203

Finance : (021) 726380

Attn : ALEX MACDONALD

Personnel : (021) 751927

Supply / Engineering : (021) 753380

Date : 11 October 1995

---

ALEX

AS DISCUSSED WITH YOU YESTERDAY, I AM CURRENTLY INVESTIGATING THE FEASIBILITY OF USING CYCO SOFTWARE'S AUTOMANAGER CLASSIC AS AN AUTOCAD VIEWER ON OUR PRODUCTION LINES. ALTHOUGH THE PACKAGE THAT I AM EVALUATING MEETS MOST OF MY REQUIREMENTS, IT IS HOWEVER, UNABLE TO READ AUTOCAD SYMBOLS IN BOTH TEXT AND DIMENSIONS AS CAN BEEN SEEN ON THE ATTACHED SHEET

PLEASE NOTE THE FOLLOWING:

1. WE ARE USING STANDARD ACAD FONTS
2. WE ARE USING AUTO MANAGER CLASSIC FOR WINDOWS - VER 4.4

AS I ENVISAGE MORE THAN 15 WORKSTATIONS WITH THIS PACKAGE, IT IS ESSENTIAL, THAT THE PRODUCTION LINE OPERATORS ARE ABLE TO READ THE SYMBOLS ON OUR CURRENT ACAD 11 & 12 DRAWINGS THUS ENSURING THE SUCCESSFUL IMPLEMENTATION OF THE PROJECT.

NOTE: WILLIAM AT AFRACAD IS EXPERIENCING THE SAME PROBLEM.

COULD YOU PLEASE URGENTLY INVESTIGATE AND CONTACT ME WITH POSSIBLE SOLUTIONS AS WELL AS FUTURE DEVELOPMENTS IN THE SOFTWARE TO READ ACAD 13 DRAWINGS.

REGARDS

PETER MONTGOMERY

ø50 style = standard, font = txt  
Automanager Classic shows ?50

ø50 style simplex font romans  
Automanager Classic shows ?50

ø50 style simplex, font simplex  
Automanager Classic shows ?50

50°  
Automanager Classic shows 50 ◊

±50  
Automanager Classic shows ?50

50  
Automanager Classic shows 50 (is OK)

TO BE FREE FROM BURRS AND SHARP EDGES

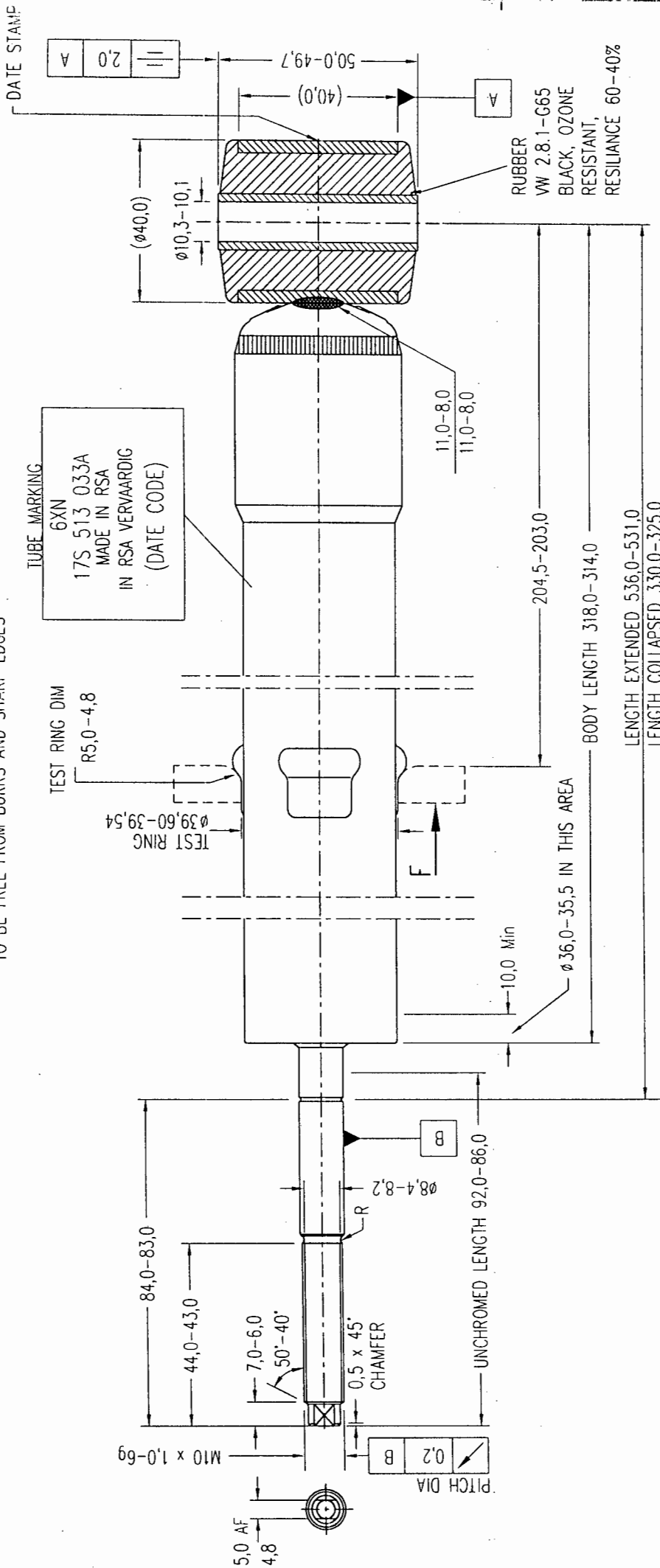

RESISTANCE VALUES WAHL VDA CHARTING MACHINE TO PV-412-2

PISTON VELOCITY (m/s)	0,05	0,13	0,26	0,39	0,52
RECOIL RESISTANCE (N)	50-150	270-370	400-520	515-645	640-800
COMPRESSION RESISTANCE (N)	40-110	115-185	240-340	335-465	410-550

1. Piston Rod: Dia. 11,0 Ref.
2. Material: Cold Drawn Fine Grain Steel to SAE 1035
3. Induction Harden to VW Specification JHT 400 1,0-0,5mm deep.
4. Surface Hardness 75HRA Min.
5. Chrome Plate: Thickness 13um Min.
6. Hardness HV 0,05 900 Min.
7. Surface Finish Rz 0,7 Max.
8. Fluid: Gabriel GLT to Meet Requirements of VW Specification TLVW. 731
9. Durability Rig Test Procedures to VW Specification PV-P412-3
10. VWSA Part Number 17S 513 033A
11. Simple to Withstand a Minimum Force of 10000 N in the Direction of F on Test Ring
12. Paint Black to VW Specification Off-x330 s.o. TL 215
13. Min Pushout Force For Rubber Bush 800 N to VW Specification P 2003

MATERIAL		SCALE	
		1:1	
DRAWN		P.MONTY	
E	MOD PARTS LIST	4192	29.06.95
D	MOD PARTS LIST	4132	07.03.95
C	MOD DWG	4082	29.08.94
B	MOD DWG & PARTS LIST	4056	23.06.94
A	RELEASE	1324	28.03.94
LTR.	REVISIONS	CHK'D	DATE
THIRD ANGLE PROJECTION		APPROVED	
TOLERANCES UNLESS SPECIFIED		±0,25	
±5'		±5'	

DWG No 927007M  
1993

Gabriel SA (PTY) LTD



Part No.	Description	Qty	Port No.	Description	Qty
344609-01	ASSY-PISTON ROD	1	314041-20	ASSY-INTER CYL.	
344619	ROD-PISTON (292.5)	1	344628	CYLINDER-INTER (290.0)	1
348015	STUD	1	310040	END CAP	1
	CAP-DUST TUBE	1		EYERING	1
344612	ASSY-PISTON	1	344617	ASSY-FINAL	1
344613-02	STOP-PISTON	1	300037	HEAD-INNER CYLINDER	1
344614-02	STAR SPRING	1	300031	SEAL-ROD	1
344608	DISC-BYPASS	1	300038	RETAINER-SEAL	1
344533	PISTON	1	344616	SPRING-SEAL	1
344639-05	RING-PISTON	1	310025	HEAD-INTER CYLINDER	1
344597	DISC-RESTRICTION	1	344529-08	PACKING-HEAD	1
344598-22	GUIDE-VALVE	1	434347	CYLINDER-INNER (278.5)	1
344600	DISC-ORIFICE	1	414154	FLUID-SHOCK ABSORBER	250
380016-04	DISC-SEALING	1	305785-13	BUSH ASSY	1
314441	SEAL-RECOIL VALVE	1		DUST TUBE (254.0)	1
344591-03	VALVE-RECOIL	1	432401	SPEC.-PAINT	A.R
	SPRING-RECOIL	1	432534	SPEC.-PACKAGING	A.R
	NUT-PISTON	1			
	SPACER	1			
344620	ASSY COMPRESSION HEAD	1			
344643	SPRING-REPLENISHING	1	344598-21	RECOIL ORIFICE DISC	1
344602	VALVE-REPLENISHING	1	344598-23	RECOIL ORIFICE DISC	1
344645-02	HEAD-COMPRESSION	1	344591-02	SPACER	1
348083	VALVE-COMPRESSION	3	344645-02	DISC VALVE	2
344644-06	RIVET	1	344605-02	RECOIL SPRING	1
344646-03	DISC-ORIFICE	1	344644-05	COMPRESSION ORIFICE DISC	1
383054	DISC-RESTRICTION	1	344644-07	COMPRESSION ORIFICE DISC	1
	RETAINER-REPL-VALVE	1			

NOTE:  
 1. PISTON ROD HARD CHROME PLATED  
 SHOCK ABSORBER MUST MEET SPECIFICATIONS 90 222 900  
 FOR M-N SEE 90 222 900  
 FOR Y SEE OF 04 0001 AND 90 222 900  
 THROUGHOUT FULL RANGE OF TRAVEL

2. DELTA PART No 90 374 181

RESISTANCE VALUES WAHL VDA CHARTING MACHINE-100mm STROKE						
PISTON VELOCITY (m/s)	0.13	0.26	0.39	0.52	0.78	1.04
RECOIL RESISTANCE (N)	290-170	725-545	900-680	1030-790	1240-960	1680-1320
COMP RESISTANCE (N)	170-70	250-150	330-210	385-265	510-350	670-490

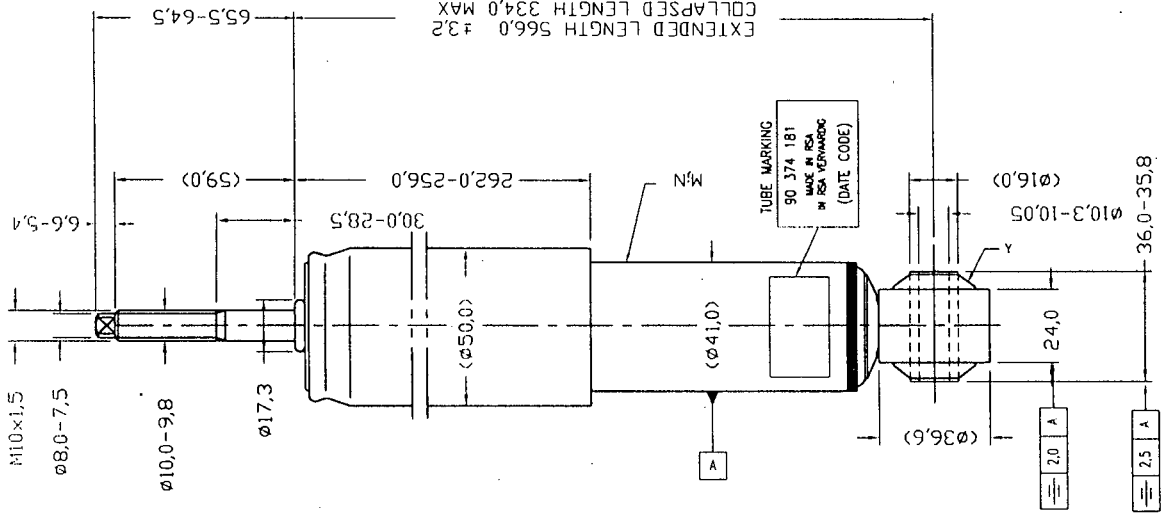

MATERIAL		SCALE	1:1
F	MOD PARIS LIST	4159	07.03.95
E	MOD PARIS LIST	4085	13.09.94
D	MOD PARIS LIST	4018	12.04.94
C	MOD DRAWING	4001	24.01.94
B	MOD DRAWING	3906	01.01.93
A	RELEASE	1227	01.03.91
LTR.	REVISIONS	CHK'D	DATE
THIRD ANGLE PROJECTION			
UNLESS SPECIFIED			
DELTA REAR SHOCK NON GAS			ING No. 927004 © 1993
TOLERANCES			Gabriel SA (PTY) LTD

TO BE FREE FROM BURRS AND SHARP EDGES

Part No.	Description	Qty	Part No.	Description	Qty
344609-01	ASSY-PISTON ROD	1		ASSY-INTER CYL.	
344619	ROD-PISTON (292,5)	1	314041-19	CYLINDER-INTER (299,3)	1
348015	STUD	1	344628	END CAP	1
	CAP-DUST TUBE	1	310040	EYERING	1
344612	ASSY-PISTON	1		ASSY-FINAL	
344613-02	STOP-PISTON	1	344618	GUIDE	1
344614-02	STAR SPRING	1	344611	SEAL-ROD	1
344533	DISC-BYPASS	1	437600	LUBRICANT-ROD SEAL	A.R.
344639-13	RING-PISTON	1	344529-05	CYLINDER-INNER (276,0)	1
344597	DISC-RESTRICTION	1	434347	FLUID-SHOCK ABSORBER	250
344598-21	GUIDE-VALVE	1	431419	GAS NITROGEN	A.R.
344599*	DISC-ORIFICE	1	414154	BUSH ASSY	1
344600	DISC-SEALING	1	305785-13	DUST TUBE (254,0)	1
344601	SEAL-RECOIL VALVE	1	301861	RECOIL BUMP RUBBER	1
380016-6	VALVE-RECOIL	1	432401	SPEC.-PAINT	A.R.
314441	SPRING-RECOIL	1	432534	SPEC.-PACKAGING	A.R.
	NUT-PISTON	1	438420	SPEC.-ASSEMBLY	
344620	ASSY COMPRESSION HEAD	1		OPTIONAL PARTS	
344643	SPRING-REPLENISHING	1		SPACER	1
344602	VALVE-REPLENISHING	1	344591-02	DISC VALVE	2
344645-02	HEAD-COMPRESSION	1			
348083	VALVE-COMPRESSION	6			
344644-06	RIVET	1			
344646-01	DISC-ORIFICE	1			
383054	DISC-RESTRICTION	1			
	RETAINER-REPL. VALVE	1			

NOTE:  
 1. PISTON ROD HARD CHROME PLATED  
 SHOCK ABSORBER MUST MEET SPECIFICATIONS 90 222 900  
 FOR M.N. SEE 90 222 900  
 FOR Y. SEE OF 04 0001 AND 90 222 900  
 THROUGHOUT FULL RANGE OF TRAVEL  
 2. DELTA PART No 90 372 079  
 3. EXTENDING FORCE OF PISTON ROD 100N ±20N AT LENGTH 450 ±2  
 UNDER A TEMPERATURE OF +23°C ±2K

RESISTANCE VALUES WAHL VDA CHARTING MACHINE-100mm STROKE			
PISTON VELOCITY (m/s)	0,13	0,26	0,39
RECOIL RESISTANCE (N)	320-200	830-610	1020-780
COMP RESISTANCE (N)	160-60	270-150	360-240
		470-330	750-550
			1050-790

DRAWING LEVEL  
**E**

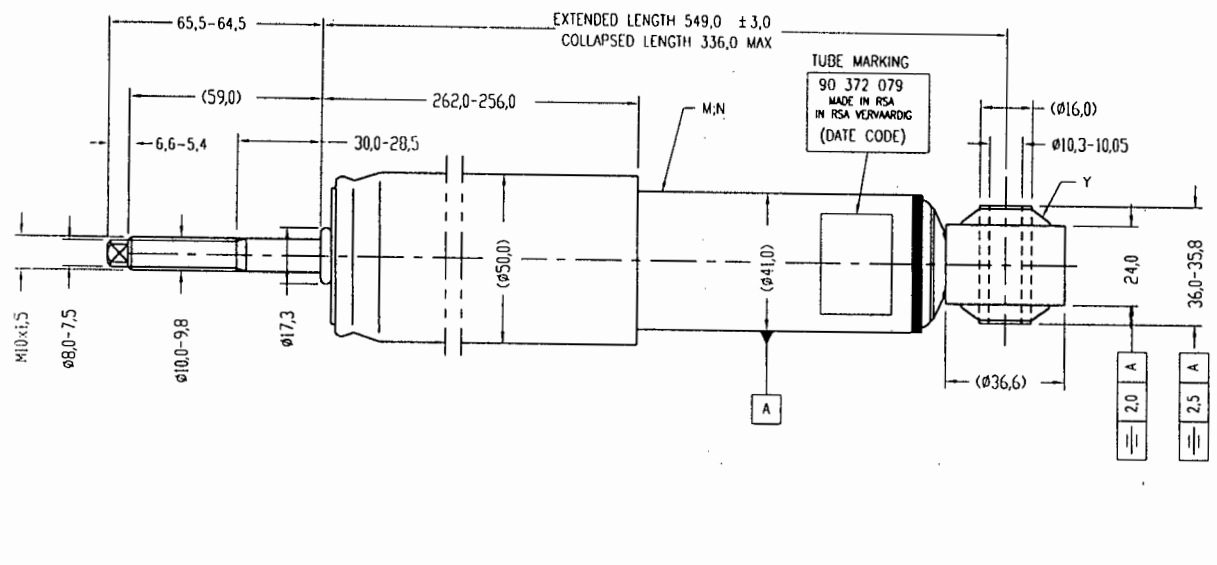

SCALE		MATERIAL	
1:1	DRAWN	C.M.W	
	4159	06.05.95	
E	MOD PARTS LIST	12.04.94	DATE
D	MOD PARTS LIST	20.05.92	DATE
C	Mod Piston Rod	3006	CHECKED
B	MOD DRAWING	01.03.93	PM
A	RELEASE	1228	DATE
LTE	REVISIONS	CHK'D	DATE
	THIRD ANGLE PROJECTION		
A3	TOLERANCES UNLESS SPECIFIED		
			DWG No. 927005
			© 1993
			Gabriel SA (PTY) LTD







TO BE FREE FROM BURRS AND SHARP EDGES

Part No.	Description	Qty	Part No.	Description	Qty
383091	ASSY-PISTON ROD	1	832005-03	ASSY-INTER CYL.	1
301911	ROD-PISTON (275,0)	1	383098-02	CYLINDER-INTER(281,0)	1
360024	RING-EYE	1	383097	END CAP	1
	CAP-DUST	1	301911	RING-EYE(LOWER)	1
383035	ASSY-PISTON	1	383134	ASSY-GUIDE & SEAL	1
383036-01	STOP-PISTON	1	314394	HEAD-INNER CYLINDER	1
383037-01	SPRING-STAR	1	383135	SEAL-ROD	1
383282	VALVE-BYPASS	1	437600	CUP-ANTI FOAM	A.R
383265	NUT-PISTON	1	314403	LUBRICANT-ROD SEAL	1
383040-03	PIVOT WASHER	1		STOP-RECOIL	1
383038	PISTON	1	383187-02	CYLINDER-INNER(255,5)	1
383043-21	SEAL-PISTON	1	434347	FLUID-SHOCK ABSORBER	300
383044	DISC-ORIFICE	1	383251	DUST-TUBE(193,0)	1
383045	DISC-SEALING	1	414474	BUSH-RUBBER	2
383041	DISC-BACKUP	1	414386	SLEEVE	2
383137-03	VALVE-RECOIL	1	432401	SPEC-PAINT(BLACK)	A.R
383083-04	SPRING-RECOIL (58-62)	1	432534	SPEC-PACKAGING	A.R
383057	SPACER 7,0	1	438420	SPEC-ASSEMBLY	
	NUT-ADJUST	1	422459	SECTION DRAWING	
383054	ASSY-COMPRESSION HEAD	1		OPTIONAL PARTS	
383047	RETAINER-SPRING	1	383043-20	DISC-ORIFICE	1
383048	VALVE-REPLENISHING	1	383043-22	DISC-ORIFICE	1
383064-02	SPRING-REPLENISHING	1	383137-04	SPRING-RECOIL 53-57	1
383107-02	DISC-RESTRICTION	1	383137-02	SPRING-RECOIL 63-67	1
383050-19	HEAD-COMPRESSION	1	383083-05	SPACER 7,1	1
383051-02	DISC-ORIFICE	1	383083-06	SPACER 7,2	1
383053	VALVE-COMPRESSION	5	383083-03	SPACER 6,9	1
	RIVET	1	383050-13	DISC-ORIFICE	1
			383050-15	DISC-ORIFICE	1
			383051-02	VALVE-COMPRESSION	1

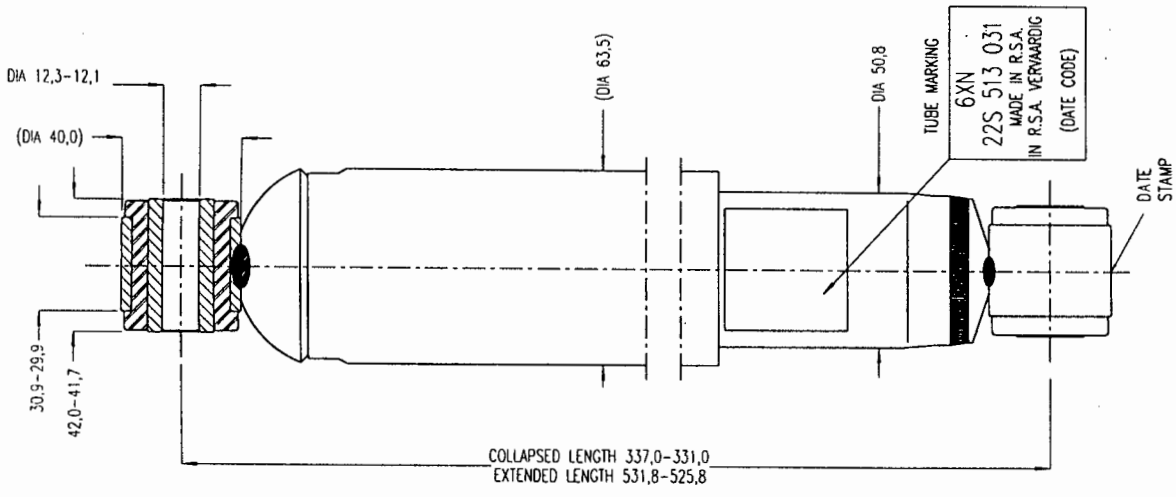

MATERIAL		OUTLINE DRAWING	
SCALE	1:1	DRAWN	P. MONTY
MOD PARTS LIST	4091	20.01.95	DATE
MOD PARTS LIST	4009	01.02.94	9.06.92
MOD PARTS LIST	3909	11.03.93	CHECKED
RELEASE	1260	22.04.92	N.WELLS
REVIEWS	CHK'D	E.C.O.	DATE
THIRD ANGLE PROJECTION			APPROVED
TOLERANCES UNLESS SPECIFIED	± 0,5		
A3			

DESCRIPTION: VW KOMBI REAR 32 BORE SHOCK ABSORBER (DIA 15 PISTON ROD)  
 DWG No. 832005 © 1995  
 Gabriel SA (PTY) LTD

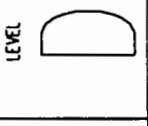

FOR MASTER DRAWING SEE 832005M

RESISTANCE VALUES WAHL VDA CHARTING MACHINE TO PV-412-2			
PISTON VELOCITY (m/s)	0,13	0,26	0,39
RECOIL RESISTANCE (N)	585-855	920-1180	1210-1500
COMPRESSION RESISTANCE (N)	180-300	245-355	305-405
			0,52
			1505-1835
			365-475

PART No.	DESCRIPTION	QTY	PART No.	DESCRIPTION	QTY
283023-02	ASSY-PISTON ROD	1	832006-03	ASSY-INTER CYL.	1
383290	ROD-PISTON (273,3)	1	383098-01	CYLINDER-INTER(221,4)	1
383095	SUPPORT-REBOUND STOP	1	383097	END CAP	1
			383089	RING-EYE(LOWER)	1
383284	ASSY-PISTON	1		ASSY-GUIDE & SEAL	
383045	STOP-PISTON	1	383134	HEAD-INNER CYLINDER	1
383285-04	DISC - BACKUP	1	314394	SEAL-ROD	1
383184	DISC-BYPASS	1	437600	LUBRICANT-ROD SEAL	A.R
383173	PISTON	1	314403	STOP-RECOIL	1
383174-06	RING - PISTON	1	383187-01	CYLINDER-INNER(195,2)	1
383175	DISC - RESTRICTION (17,0)	1	434347	FLUID-SHOCK ABSORBER	255
383176-02	GUIDE - RECOIL VALVE	1	414485	ASSEMBLY-BUSHING(LOWER)	1
383177	DISC - ORIFICE (0,38)	1	283021	ASSY-BUMP STOP SUPPORT	1
383178	DISC - SEALING	1	432401	SPEC-PAINT(BLACK)	A.R
383179	SEAL-RECOIL VALVE	1	432534	SPEC-PACKAGING	A.R
383183-04	VALVE - RECOIL	1	438420	SPEC-ASSEMBLY	
383182	SPRING - RECOIL (270N)	1	422458	SECTION DRAWING	
	NUT - PISTON	1			
832006-02	ASSY-COMP HEAD	1		OPTIONAL PARTS	
383054	RETAINER-SPRING	1	383176-01	DISC-ORIFICE(0,20)	1
383212	VALVE-REPLENISHING	1	383176-03	DISC-ORIFICE(0,45)	1
344620	SPRING-REPLENISHING	1	383050-20	DISC-ORIFICE(0,22)	1
383107-02	HEAD-COMPRESSION	1	383050-13	DISC-ORIFICE(0,37)	1
383050-12	DISC-ORIFICE(0,3)	1			
383051-02	VALVE-COMPRESSION	5			
348083	RIVET	1			
383213-06	DISC-RESTRICTION	1			

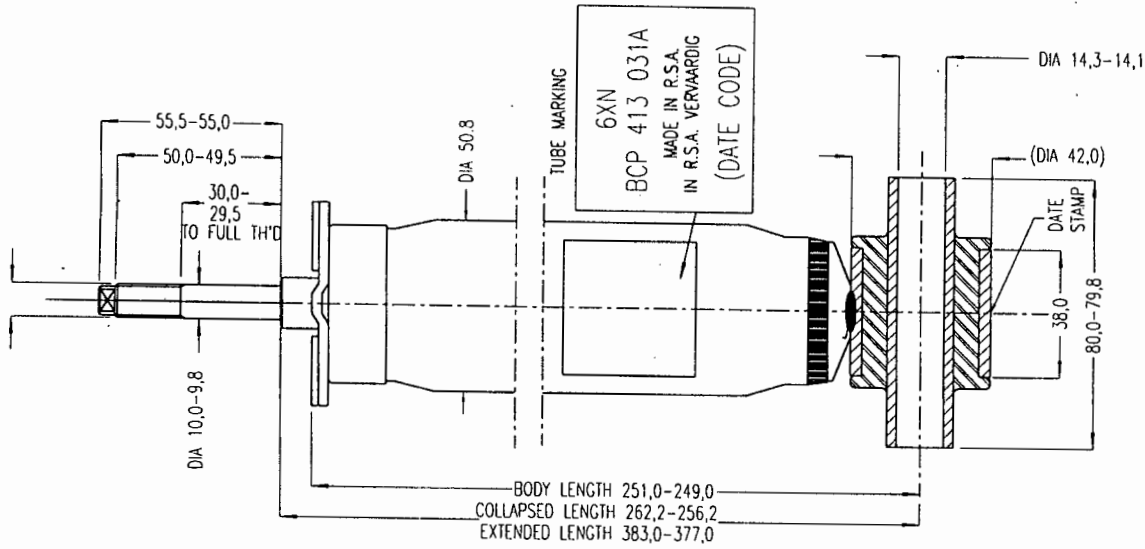

FOR MASTER DRAWING SEE 832006M

RESISTANCE VALUES WAHL VDA CHARTING MACHINE TO PV-412-2			
PISTON VELOCITY (m/s)	0,13	0,26	0,39
RECOIL RESISTANCE (N)	1140-1680	1545-1985	1835-2265
COMPRESSION RESISTANCE (N)	385-645	520-760	635-855
			735-965

LEVEL  
A

SCALE		MATERIAL		OUTLINE DRAWING	
1:1					
DRAWN		P. MONTY		DATE	
				25.10.94	
A		RELEASE		CHECKED	
		1.346		25.10.94	
L.T.R.		REVISIONS		APPROVED	
		CHKD		E.C.O.	
				DATE	
A3		TOLERANCES		DWG No.	
		± 0,5		832006 ©	
		SPECIFIED		1984	
Gabriel SA (PTY) LTD					

Part No.	Description	Qty	Part No.	Description	Qty
980041	CARTRIDGE				
383238	ASSY-PISTON ROD	1	383080-02	ASSY-INTER CYL. CYLINDER-INTER(343.0)	1
383028	ROD-PISTON (377.4) SUPPORT-REB STOP	1	314555	END CAP	1
383169	ASSY-PISTON	1	283020	ASSY-FINAL	1
383170-05	STOP-PISTON	1	383085	ASSY-GUIDE & BUSH	1
383171	WASHER-BYPASS PIVOT	1	311936	HEAD-INNER CYLINDER	1
383172	DISC-BYPASS	1	374233	BUSH-INNER CYL HEAD	1
383177	PISTON	1	437600	SEAL-ROD	1
383116	BAND-PISTON	1	314035	LUBRICANT-ROD SEAL	A.R
383174-08	DISC-RESTRICTION	3	383000-07	STOP-RECOIL	1
383175	GUIDE-RECOIL VALVE	1	434347	CYLINDER-INNER(308.6)	1
383176-20	DISC-ORIFICE	1	414369	FLUID-SHOCK ABSORBER CENTRALISING COLLAR	260
383177	DISC-SEALING	1	438420	SPEC-ASSEMBLY	1
383178	SEAL-RECOIL VALVE	1	T.B.E	SECTION DRAWING	
383179	VALVE-RECOIL	1			
383183-04	SPRING-RECOIL	1			
383170-05	SPACER	2			
383182	NUT-PISTON	1			
383048	ASSY-COMPRESSION HEAD	1		OPTIONAL PARTS	
383047	SPRING-REPLENISHING	1	383176-19	DISC-ORIFICE	1
383107	VALVE-REPLENISHING	1	383176-21	DISC-ORIFICE	1
383051-02	HEAD-COMPRESSION	1	383050-23	DISC-ORIFICE	1
383051-01	VALVE-COMPRESSION	2	383050-26	DISC-ORIFICE	1
383053	RIVET	1			
383065-01	SPACER	1			
383050-22	DISC-ORIFICE	1			
383049-03	DISC-RESTRICTION	1			
383211	RETAINER-REPL. SPRING	1			

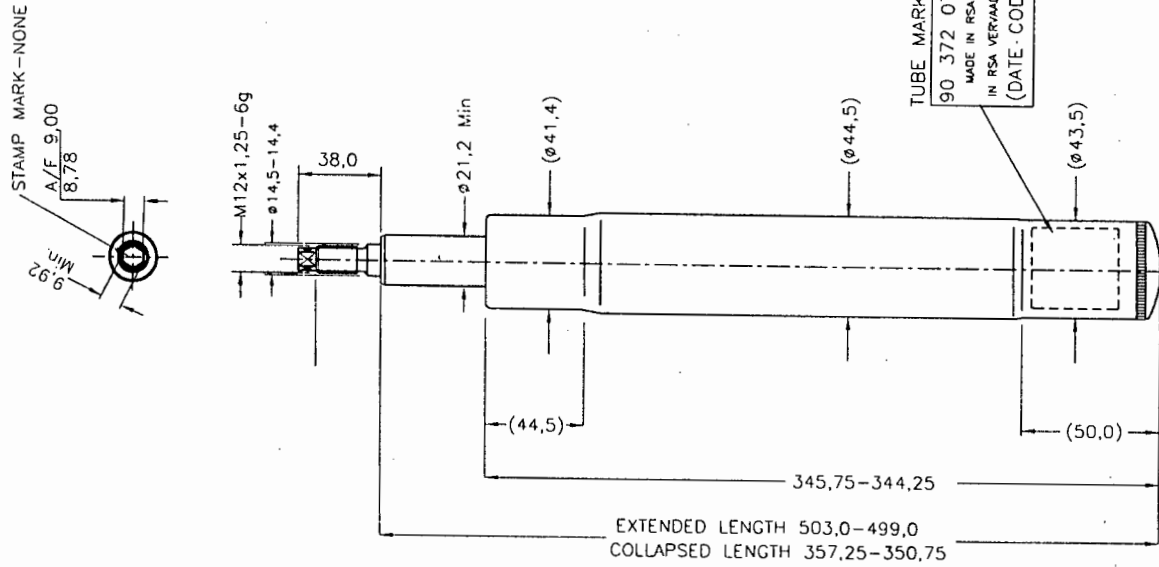

SCALE		MATERIAL	
1:2			
DATE	C.M.W	DATE	DESCRIPTION
15.11.92		12.05.92	DELTA 2700 CARTRIDGE
3978		3906	03.03.92
3906		1248	04.10.92
1248			
CHKD	E.C.O.	DATE	APPROVED
THIRD ANGLE PROJECTION		TOLERANCES UNLESS SPECIFIED	
A3	±0,25	±5	DEG.
DWG No. 980041		© 1993	
Gabriel SA (PTY) LTD			

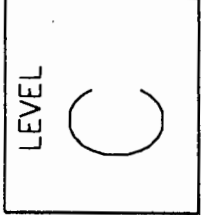

NOTE

- Delta Part Number 90 372 076
- For Master Drawing 980041M

SPEED(RPM)	RESISTANCE VALUES WAHL CHARTING MACHINE TO GWE L-0-11. STROKE 100mm				
	25	50	75	100	150
RECOIL RESISTANCE (N)	280-160	690-510	1110-850	1270-970	1540-1200
COMPRESSION RESISTANCE (N)	160-60	300-180	420-280	540-380	690-510
					950-710

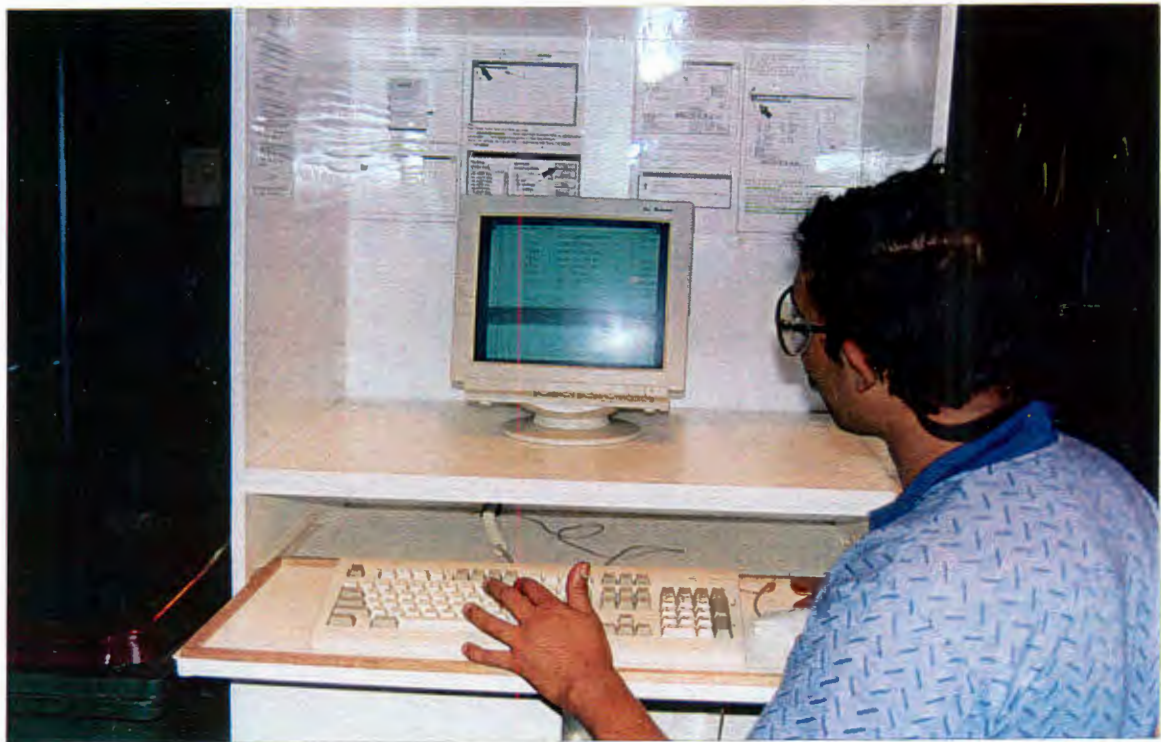

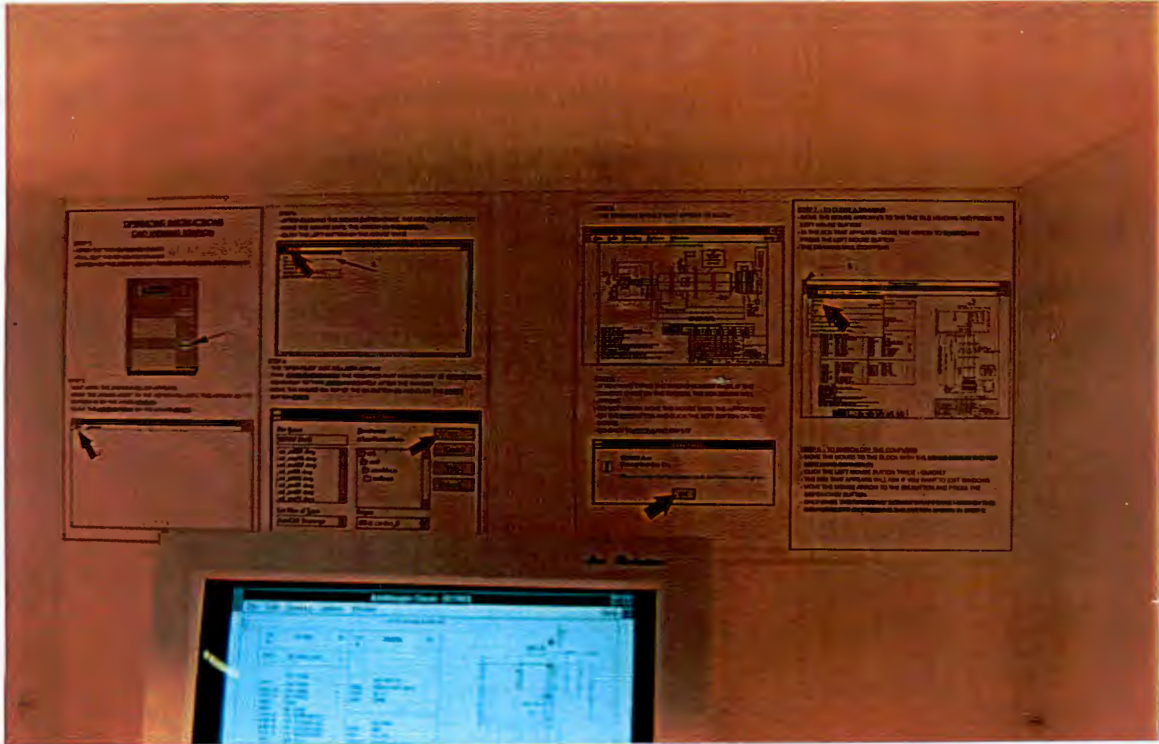



①

Gabriel SA (Pty) Ltd.

CORRECTIVE ACTION REPORT		SYSTEM	<input checked="" type="checkbox"/>	PROCESS		No. 106/95
Department: GAS SPRING			Responsibility: MR. K. WALTERS. MR. B. CHERTKOW			
Part No. 990045		Part Name: NISSAN SENTRA BOOT GAS LIFT				
Non Conformance: IDENTIFICATION PART NO. IS INCORRECT COLOUR. <u>CUSTOMER COMPLAINT</u> REFER ATTACHED NISSAN CAR No: 6355/8/95.						
Apparent Cause: 1/ OPERATOR ERROR. 2/ INCORRECT DRAWING						
Initiated by: D. Burgess		Sig:		Date: 11/10/95.		

Findings / Root Cause: INCORRECT LEVEL DRAWING (432594 'A') IN GAS SPRING CELL. LEVEL 'B' DRAWING WAS ISSUED TO B.U.M. ON THE 7th MONTH. <u>NOTE</u> LEVEL 'A' DRAWING DOES NOT SPECIFY COLOURS FOR I.D.		
Name: D. Burgess	Sig:	Date: 11/10/95

Suggested Corrective Action: 1/ CORRECT LEVEL DRAWING TO BE ISSUED TO GAS SPRING CELL. 2/ DRAWING 990045 TO INDICATE PART NO. COLOUR. <u>NOTE</u> ALL DRAWINGS MUST BE ISSUED TIMEOUSLY AND ALL OLD LEVEL DRAWINGS DESTROYED.		
Name: D. Burgess	Sig:	Date: 11/10/95

Corrective Action Taken:		
Effectuated by:	Sig:	Date:

F.M.E.A. Updated:	Yes	No
-------------------	-----	----

Review Date :	Cleared:
---------------	----------

Gabriel SA (Pty) Ltd.

CORRECTIVE ACTION REPORT		SYSTEM	<input checked="" type="checkbox"/>	PROCESS		No. 27/95.
Department: B.U.M. SHOCK/START ASSEMBLY			Responsibility: MR. D. BURN.			
Part No. N/A		Part Name: N/A				
Non Conformance: NEW DRAWINGS NOT BEING ISSUED TIMEOUSLY. (REFER INTERNAL QUALITY SYSTEM AUDIT REPORT FOR PROCEDURE O.P. 2.1 DRAWING ISSUE AND CONTROL DATED 14/3/95)						
Apparent Cause: SYSTEM LAPSE						
Initiated by: D. BURGESS		Sig:		Date: 11/3/95.		
Findings / Root Cause: DRAWINGS ISSUED TO ASSEMBLY AREA B.U.M. ARE NOT BEING ISSUED TIMEOUSLY BY HIS SUBORDINATES. EG. DRAWINGS ISSUED IN FEBRUARY AND 1ST WEEK OF MARCH WERE STILL ON SUBORDINATES DESKS.						
Name: D. BURGESS		Sig:		Date: 14/3/95		
Suggested Corrective Action: DRAWINGS TO BE ISSUED TIMEOUSLY.						
Name: D. BURGESS		Sig:		Date: 14/3/95.		
Corrective Action Taken: B.U.M. SUBORDINATES REQUESTED TO ENSURE DRAWINGS ARE ISSUED TIMEOUSLY.						
Effected by: D. BURN		Sig:		Date: 18/4/95.		
F.M.E.A. Updated:		Yes		No <input checked="" type="checkbox"/>		Not applicable
Review Date: 18/5/95				Cleared:		

Gabriel SA (Pty) Ltd.

CORRECTIVE ACTION REPORT		SYSTEM <input checked="" type="checkbox"/>	PROCESS	No. 77/95
Department: <i>STEEL MANUFACTURE</i>		Responsibility: <i>MR D. BURN</i>		
Part No. <i>N/A</i>	Part Name: <i>N/A</i>			
Non Conformance: <i>NON-COMPLIANCE TO O.P. 2.1 DRAWING ISSUE AND CONTROL.</i>				
Apparent Cause: <i>SYSTEM FAILURE.</i>				
Initiated by: <i>D BURGESS</i>		Sig:		Date: <i>25/8/95</i>

Findings / Root Cause: <i>DRAWINGS NOT BEING ISSUED TIMELY TO PRODUCTION LINE. (DRAWINGS DATED 31/7/95 STILL IN OFFICE).</i>		
Name: <i>D. BURGESS</i>	Sig:	Date: <i>25/8/95</i>

Suggested Corrective Action: <i>DRAWINGS TO BE ISSUED TIMELY.</i>		
Name: <i>D BURGESS</i>	Sig:	Date: <i>25/8/95</i>

Corrective Action Taken: <i>EVERY EFFORT NOW BEING MADE TO ISSUE DRAWINGS THE SAME DAY.</i>		
<u>NOTE</u> <i>INVESTIGATIONS IN HAND TO ESTABLISH THE FEASIBILITY OF PUTTING A COMPUTER TERMINAL INTO EACH CELL TO ELIMINATE THE NEED FOR DRAWINGS.</i>		
Effectuated by: <i>D BURN</i>	Sig: <i>D Burn</i>	Date: <i>28/8/95</i>

F.M.E.A. Updated:	Yes	No <input checked="" type="checkbox"/>
-------------------	-----	--

Review Date : <i>2/10/95.</i>	Cleared:
-------------------------------	----------