

Represencing Place

*The assembly of a vertical landscape
from in-between space*

Mishkah Collier

The copyright of this thesis vests in the author. No quotation from it or information derived from it is to be published without full acknowledgement of the source. The thesis is to be used for private study or non-commercial research purposes only.

Published by the University of Cape Town (UCT) in terms of the non-exclusive license granted to UCT by the author.

**'Re-presenting Place: The assembly of a vertical landscape
from in-between space'**

By Mishkah Collier

Supervisors:

Melinda Silverman and Fadly Isaacs

This dissertation is presented as part fulfillment of the degree of Master
of Architecture (Professional) in the School of Architecture, Planning and
Geomatics, University of Cape Town

2017

Plagiarism Declaration:

1. I know that plagiarism is wrong. Plagiarism is to use another's work and pretend that it is one's own.
2. I have used the Chicago / Harvard convention for citation and referencing. Each contribution to, and quotation in, this report from the work(s) of other people has been attributed, and has been cited and referenced.
3. This report is my own work.
4. I have not allowed, and will not allow, anyone to copy my work with the intention of passing it off as his or her own work.

Signature

Signed by candidate

Contents

Preface	9
Introduction	11
The Bo-Kaap	13
Siting	17
Re-presencing the wounded site	17
Surrounding site description	19
The duality of tangible and intangible social constructs	
The stoep	29
The courtyard	33
The lane	37
The street	41
Janaazah	
Ramadan	
Eid	
The programmatic catalyst to re-presencing the site	51
Prayer	53
Cleansing and Economy	55
Dwelling	57
Memorialisation of the sacred through the everyday	59

Architectural Investigation	61
The forgotten site – the spatial configuration of the historical site	65
Urban Response	71
A vertical community - layering of the programme	73
Economic diversification	75
Cultural integrative learning	75
Socio-religious and socio-cultural congregation	77
Communal living	79
A vertical landscape of in-between spaces	83
Circulation	83
Social platforms	87
Courtyards	89
Places of pause	91
Concluding thoughts	92
Final Drawings	94
Bibliography	86
List of Figures	87



Preface

This project began with a personal attachment to place. An attachment to the Bo-Kaap as the embedded landscape of my spatial memory and cultural identity. My family holds a deep place attachment to the Bo-Kaap. It's the inscribed space of my forefathers and the only place that they've known as 'home'. Since the abolition of slavery in 1834, my family has come to reside in the Bo-Kaap, an uncovering that was discovered through my research at the beginning of the year. After the abolition of slavery, my grandfather's great grandfather purchased the property on the corner of Castle Street and Maxwell Lane, where his family lived for 3 generations until their home was expropriated under the Slums Area Act in 1934. His great-grandchildren later came to purchase available land towards the top of Longmarket Street, which was not affected by the Slums Area Act. This is where my family continues to live till this day.

Having grown up in the Bo-kaap, I've witnessed its constant state of flux and the urban pressures that continue to disrupt its historical urban fabric and social character. This realisation has prompted my interest in the Bo-Kaap as both a physical and social space of past and present contestation.

2. "View of Chiappini Street", painting by Pieter Hugo Naudé (20th century)

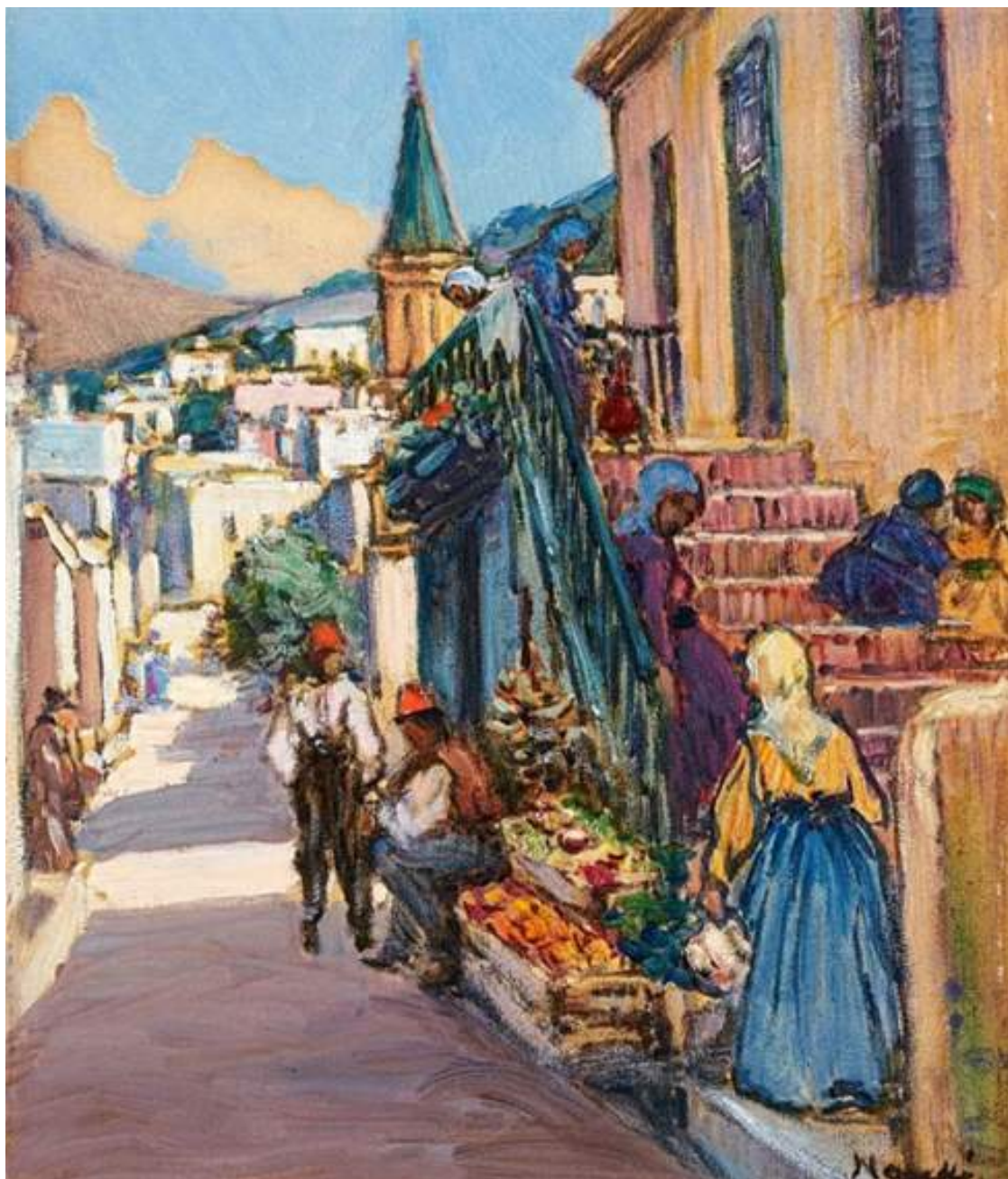

Introduction

Since the early 20th century the Bo-kaap had suffered many oppressive injustices, from the Slums Area Act to the Group Areas Act, both of which were used to forcibly remove many people. More recently, the Bo-kaap has been affected by development pressures that have resulted in gentrification. Due to its location abutting the city, the area has a high locational value, which which has attracted the interest of private developers. The gentrification of the Bo-kaap has since caused a rapid increase in rates and land value, putting pressure on low to medium income families that have resided there for generations. These families are now being forced to sell their properties. This, in turn causes a loss of social history, tradition and culture; all of which are key elements to the community of Bo-Kaap.¹

In the face of densification pressures that accompany gentrification, this dissertation aims to explore ways in which inscribed historical spatialities can be harnessed in the context of gentrification in order to keep the community and their cultural traditions intact. Through the study of the evolution of the urban morphology of the Bo-Kaap, I have identified a number of spatial types that contributes to the communal environment of the Bo-Kaap, both historically and presently. The spatial types that make up this urban network, namely the 'stoep', the 'lane', the 'courtyard' and the 'street' facilitate the social and cultural engagement of everyday and sacred practices of its community life. This dissertation project addresses the social and cultural engagement of everyday and sacred practices whilst also capturing the historical narrative of the Bo-Kaap. In doing so, I hope to harness the essence of the historic spatialities of the stoep, the lane, the courtyard and the street in a multi-storey mixed use building that re-presences the community of the Bo-Kaap within the city.

¹ Lees, Shin and Morales. "The place of gentrification in Cape Town" In *Global Gentrifications: Uneven Development and Displacement*, 419-440. Bristol: Policy Press 2015



3. (above) 'Cape Town 1860',
photograph from the Morrison
Collection edited by author

4. Aerial photograph of the Bo-Kaap,
taken by Sharon Benjamin.



The Bo-Kaap

From the early 19th century onwards, the Bo-kaap flourished as a residential neighbourhood flanking the city. Houses were first constructed along the edge of Buitengracht Street, starting at Dorp Street and spreading across towards Strand Street, creating a ribbon of dense urban Cape Dutch houses between Rose Street and Buitengracht Street.² With the abolition of slavery, came a sudden increase in the free population who came to seek cheap housing. This rise in the need for affordable inner city housing caused further extension of the Bo-Kaap towards Signal Hill.³ By the late 19th century, the city grid followed through into the Bo-Kaap, with dense blocks of urban houses covering the more gradual slopes of Signal Hill.⁴ By the early 20th century, the Bo-kaap was declared a slum area under the Slums Area Act, allowing the state to expropriate houses. With people no longer having ownership of their homes, these houses (that were in perfectly liveable conditions before) fell into disrepair.⁵

The State had ulterior motives in terms of the future of the land on which the “Malay Quarter” sat and the ribbon of houses between Rose Street and Buitengracht Street were the first to go. The expropriated houses within this ribbon were soon demolished and the properties consolidated into larger erven to be sold off to “white business owners”. These respective blocks were later zoned for “commercial and light industrial use” and continued to be sold off to “white business owners” despite the Bo-kaap becoming a designated Malay Group Area.⁶ The prioritisation of cars had a massive impact on the aforementioned blocks too and some of these once dense urban residential blocks became a series of parking lots.

2 Fransen and Cook, *The Old Buildings of the Cape* 1980

3 Davids, *The Mosques Of Bo-kaap. A Social History Of Islam At The Cape* 1980

4 Fransen, *A guide to the old buildings of the Cape* 2004

5 Truluck. *Bo-Kaap: Changing Attitudes and Actions*. Honours Thesis, Cape Town: University of Cape Town 1989, 24

6 *Ibid*, 21

5. Plan of Bo-Kaap and the city, highlighting the change in the height of the built fabric and the change in the 'City Boundary line'

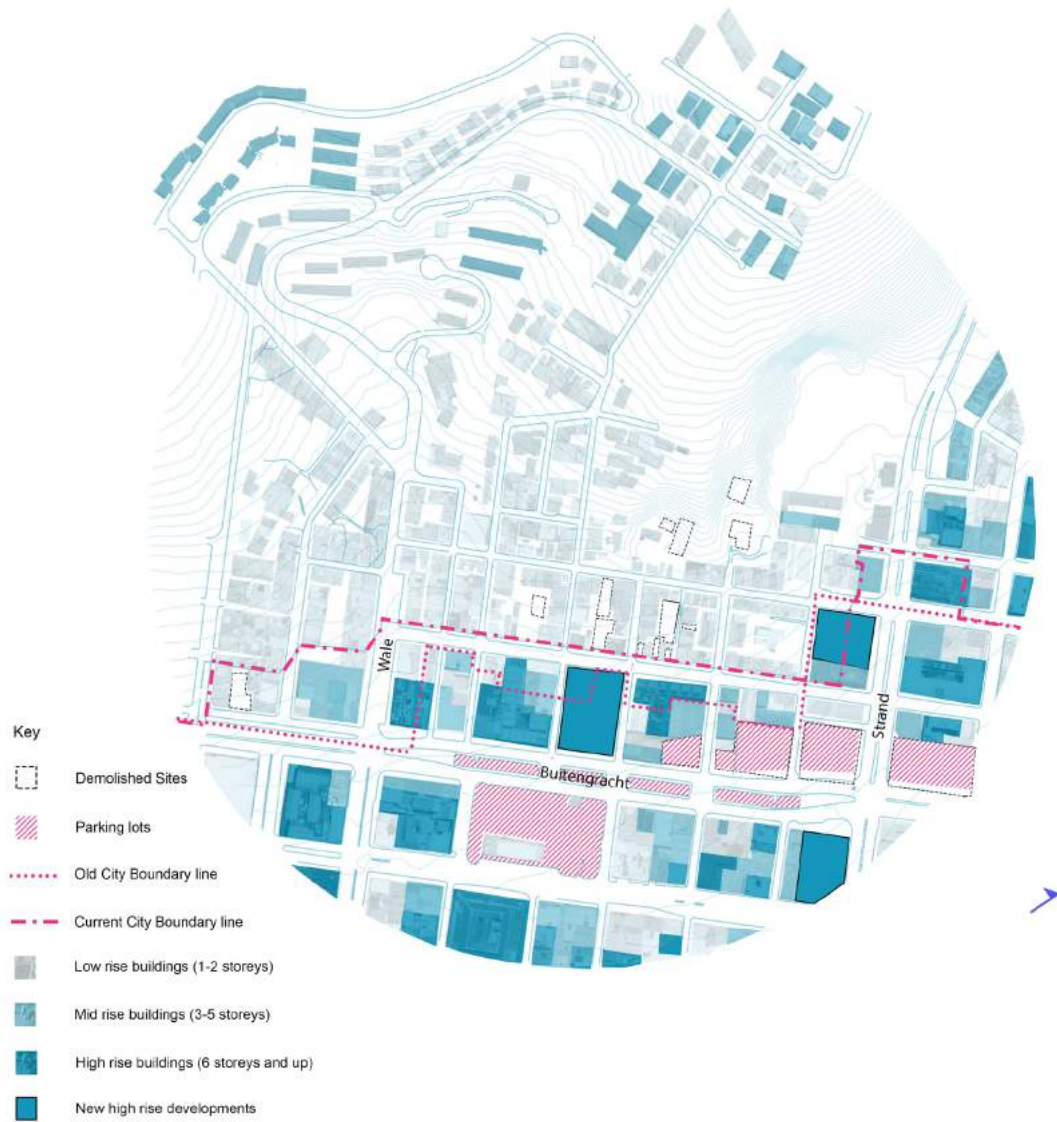

Since then, the commercial activity between Rose Street and Buitengracht Street has continued to encroach on the Bo-kaap. The expansion of the commercial city is illustrated by the 'City Boundary Line' which demarcates the boundary between the Bo-Kaap and the city. This line was first illustrated in the mid 20th century and has recently been updated to include more of the historical Bo-Kaap fabric within the boundary of the city. With this shifting boundary line, comes the increase of large mixed use commercial buildings on properties that were once classified as part of the Bo-Kaap. These changing architectural typologies from once humble low-level residential fabric to obtrusive mixed use commercial developments and high end apartments change the spatial qualities of the Bo-kaap. This change in the spatial quality, in turn, changes the urban morphology of the Bo-Kaap, making it more conducive to gentrification and slowly continuing to erode the social and cultural character of its streetscape.

6. Site provocation relating to the 20th century forced removals

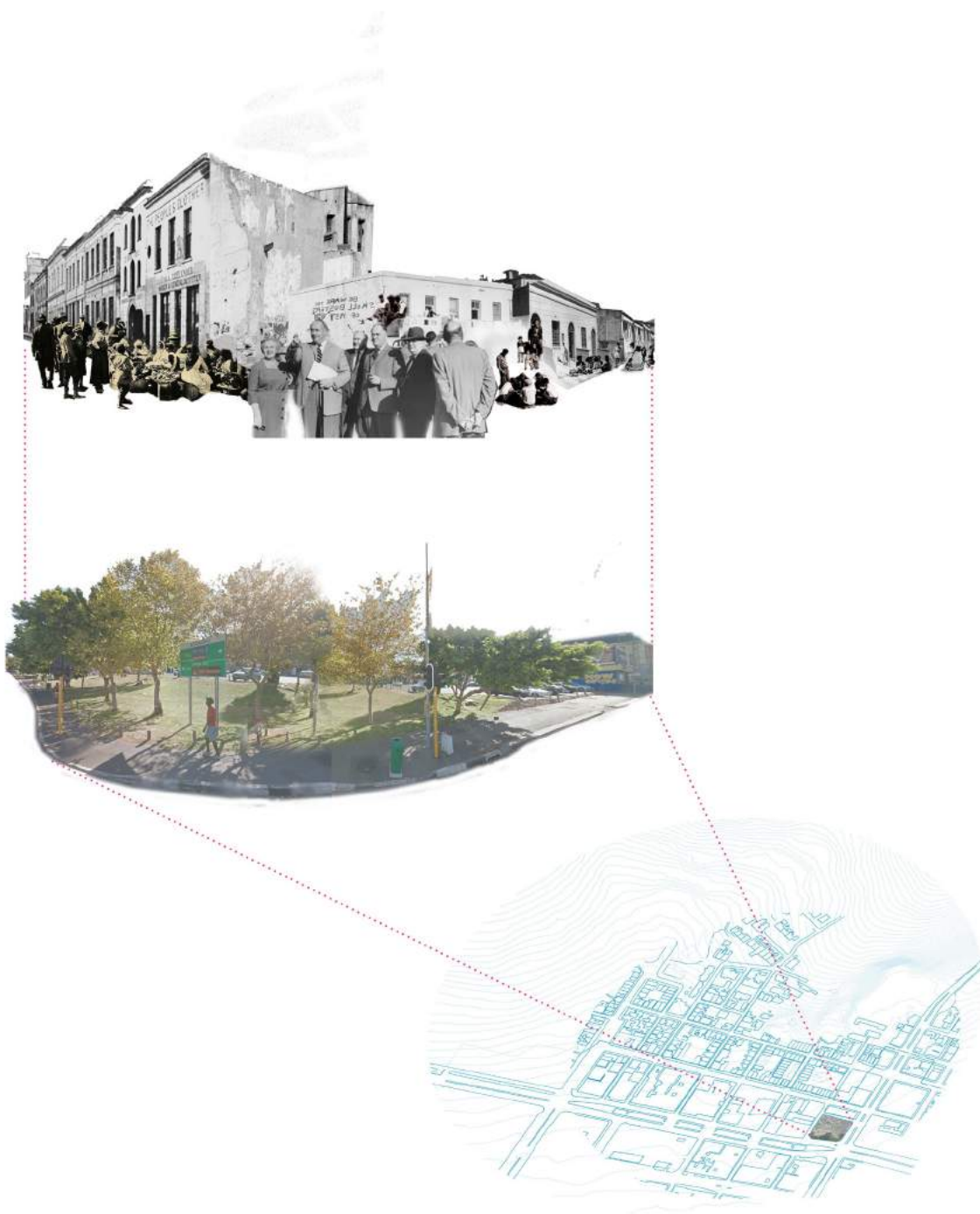

Siting

Re-presencing the wounded site

Despite the continuous rise in large scaled commercial developments, the previously mentioned series of parking lots, which are state owned, continue to serve as reminders of the loss of homes, and the people who were forcibly removed for the expansion of the city. The site that I've identified for my dissertation project is one such site. The empty parking lot is bounded by Castle Street, Buitengracht Street, Strand Street and Rose Lane. This site is of great personal significance to me, as it comprises of the property where my family lived before the forced removals. In addition to my personal attachment to the site, it also offers great opportunities due to its location between the Bo-Kaap and the city. The location of my identified site offers the opportunity to become a reminder of a forgotten narrative that can to be retold and remembered.

This vacant parking lot has been reduced quite substantially from what it once was when there were still houses on the site in order to allow for the widening of Buitengracht Street. The current parking lot is flanked by a substantial patch of grass that is occupied by a range of people throughout the day. Working people from the city can be seen having lunch there during the afternoon and homeless people are often found catching the last rays of the sun on this grass bank in the evening.

7. The change in the urban fabric of the site from the 19th century

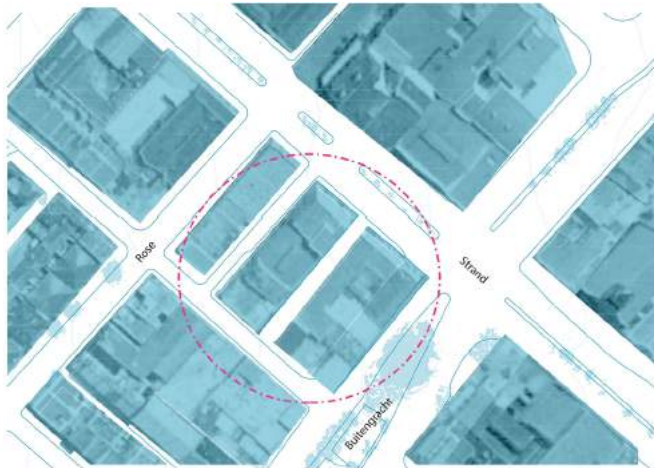

Early Site Urban Fabric

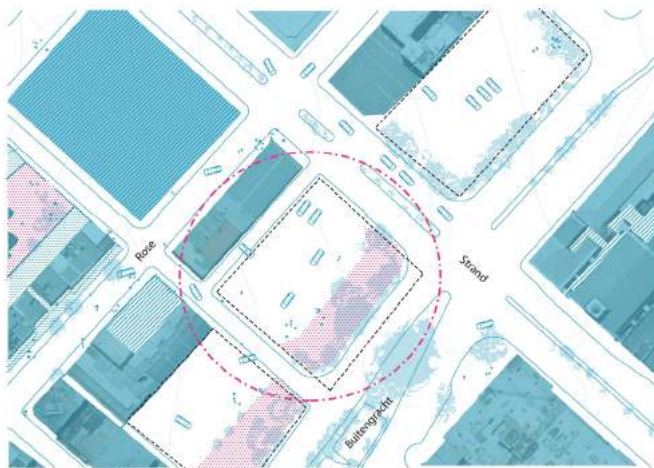

Current Site Urban Fabric

Key

-  Future/Current Developments
-  Existing Buildings
-  Privately Owned Fenced Space
-  Outdoor Semi Private Space (Stoeps and Shared gated street)
-  Grass Public Space
-  Parking Lots on Demolished

Surrounding site description

The Bo-Kaap, situated along the slopes of Signal Hill, has a steep topography that has given rise to a number of interesting retaining elements, like the stoep and the Buitengracht retaining wall, both of which address this mountainous slope. The site of this dissertation project sits at the corner of Buitengracht Street and Strand street and has a 4,5 m rise in the slope from Strand Street to Castle Street. The site is located where the Bo-kaap meets the city, and hence acts as a mediator between the high-rise developments of the city and the fine grained fabric of the Bo-kaap.

The site is bounded by two different spatial qualities, one on the two adjacent sides that face Bo-Kaap and the other two that face the city. Rose Lane and Castle Street are both more in accordance to the parameters of domestic streets. Both Rose Lane and Castle Street are quite narrow, allowing only enough width for one car and therefore permitting very little vehicular activity, making both streets more conducive to pedestrian activity. Comparatively to the aforementioned streets, Buitengracht Street and Strand Street are both indicative of the city with much wider two-way traffic lanes that are separated by wide islands. Both streets do not encourage pedestrian activity and are very much traffic oriented. In accordance to the types of domestic or city paced vehicular activity that occurs in the streets bounding the site, the range of various building and programmatic types that face these streets reflect this. The site is surrounded by both low level historic buildings and newly constructed high-rise developments.

8. Change in built fabric of Strand Street between 2009 and 2017

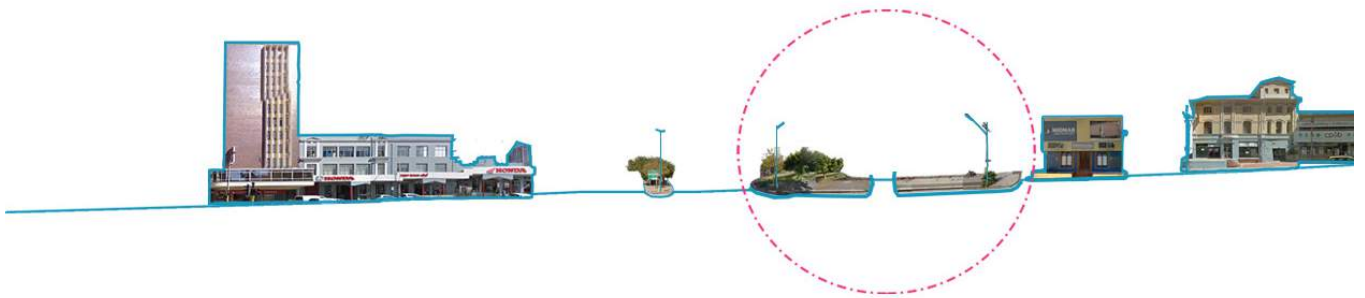

Strand street Elevation starting at Bree street and ending at the Strand street Quarry 2009

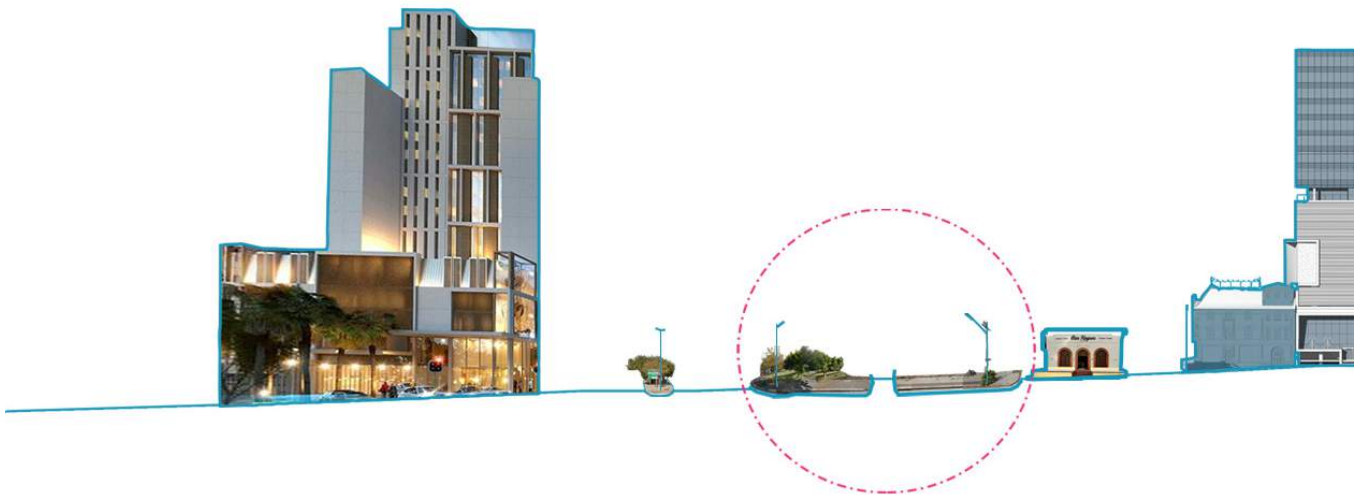

Strand street Elevation starting at Bree street and ending at the Strand street Quarry 2017 and current construction

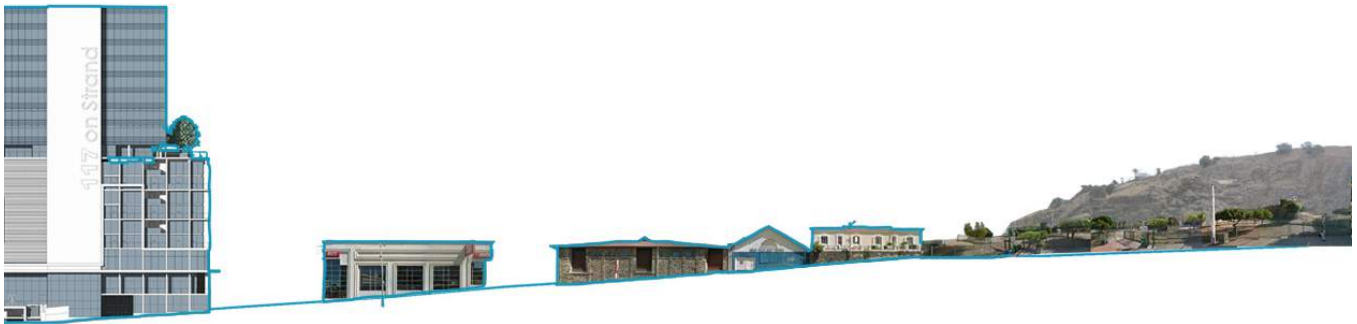

9. Image showing the site in relation to the new high rise developments, the surrounding parking lots and Bo-Kaap along the slope signal hill



The buildings along Rose Lane and Castle Street are historical buildings that have remained since the 19th century. These buildings are more domestically scaled but vary immensely in programme. The series of single storey terrace buildings opposite Rose Lane is consists of Marco's African Place, a traditional African restaurant, a tourist oriented African cuisine restaurant, and 'Bar Keeper Liquor Store'. In addition to the parallel parking lot on Castle Street, there is a pair of three storey high terrace buildings that are occupied by a recently opened 'Dog Hotel and Daycare Centre' and a warehouse.

Much like Castle Street, there is another parking lot parallel to the site on the other end of Strand Street, alongside a three storey high historical building occupied with various showrooms and a much taller apartment block. The expansive width of Buitengracht Street, with a traffic island at its centre, creates a substantial buffer between the site and the new nineteen storey high SunSquare Hotel. The ground floor of this hotel development is set to include high-end retail and restaurants. It's clear from the new developments going up around the site that there is a newfound emphasis being put on street activation with retail stores on the ground floor.

The site is currently zoned for parking but is surrounded by properties that are zoned for Mixed Use 3 development. This zoning allows the development on these erven to reach a maximum height of 35m, and 60m if a departure is granted on the basis of the Tall Building Policy that was adopted in May 2013 by the City of Cape Town.⁷ The current rate of commercial expansion of the sites along the Bo-Kaap allows one to assume that all vacant available erven in this region are susceptible to developments that are inappropriate to the fabric of the Bo-Kaap.

⁷ City of Cape Town 2012

10. illustration of the building f
facing the site

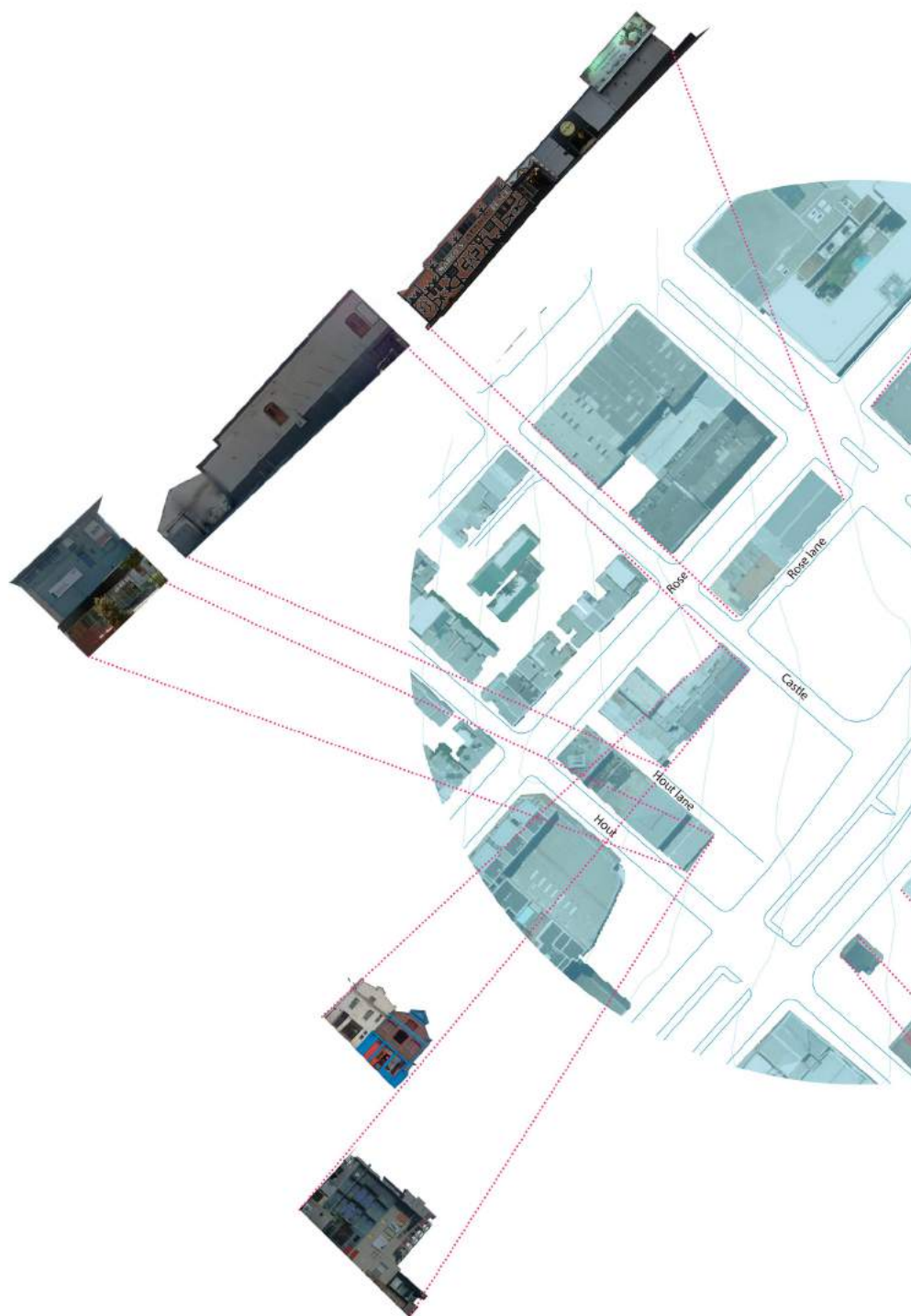

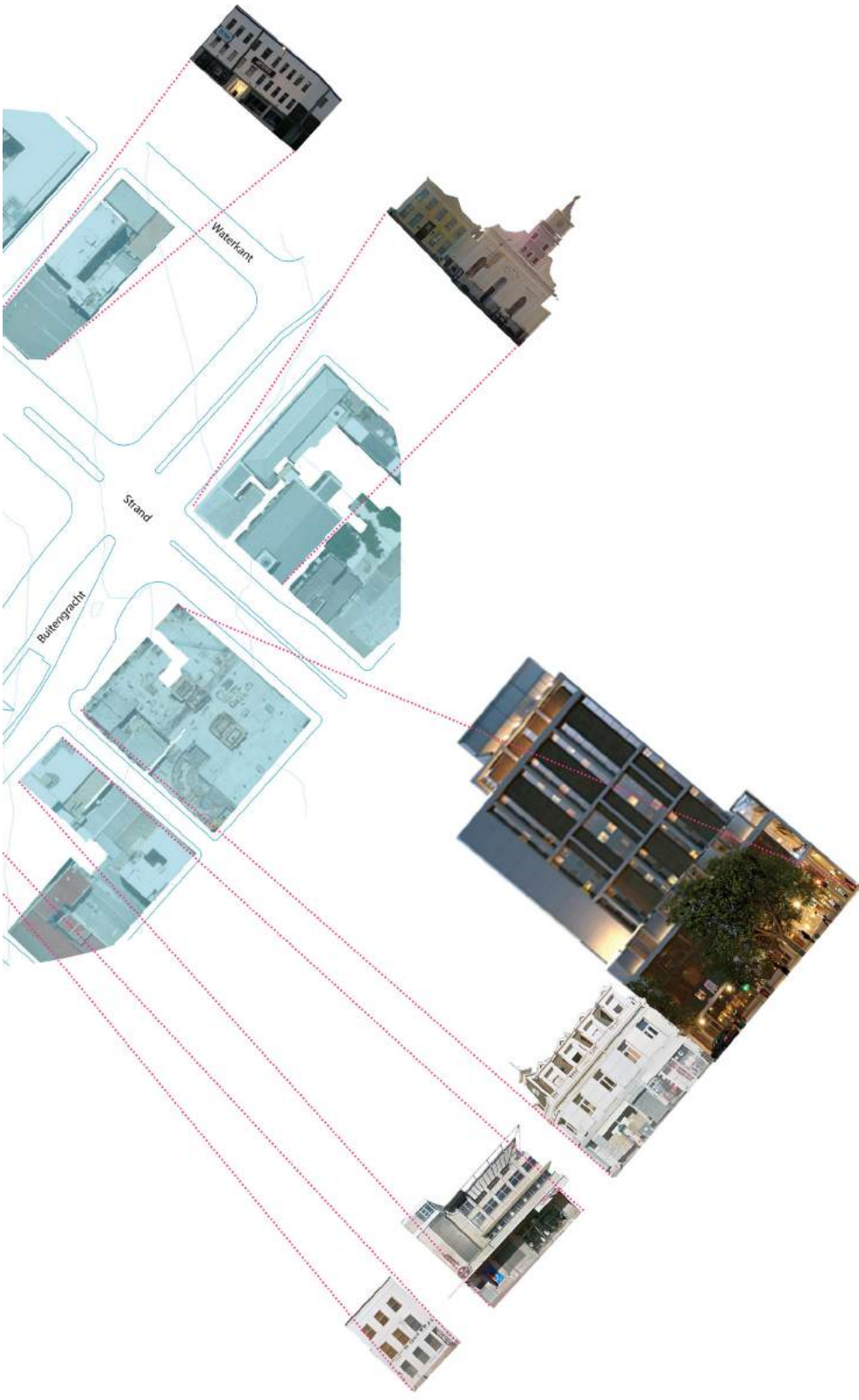

11. Evolution of the urban fabric of the Bo-Kaap between the 18th century and the 20th century, highlighting the street (pink diagonal hatch), stoeps (dark pink diagonal hatch), lanes (blue diagonal hatch) and courtyards (blue dotted hatch)

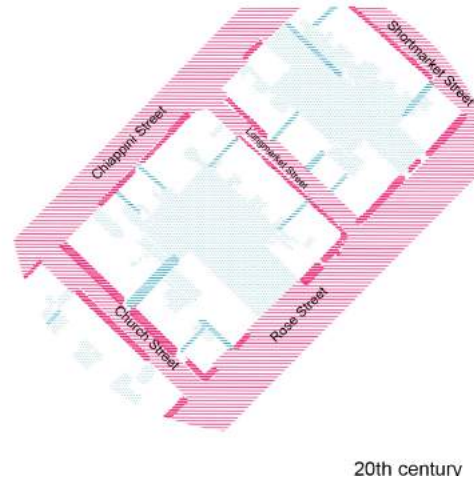
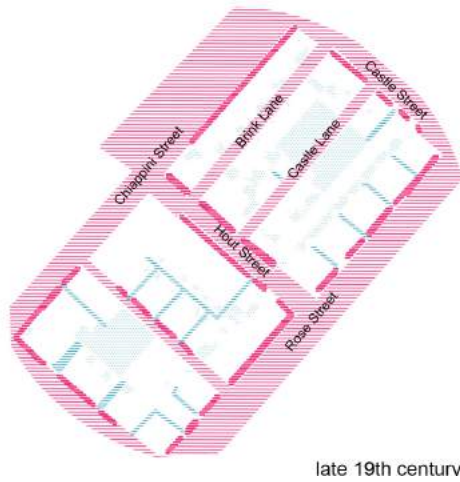
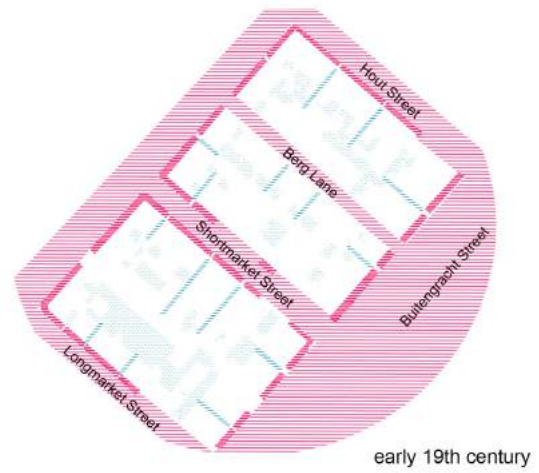
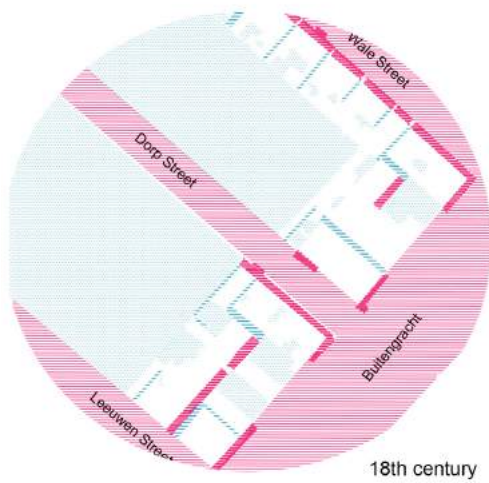

The duality of tangible and intangible social constructs

In order to uncover the spatial elements that constitute the social network of space within the Bo-Kaap, one must simultaneously uncover the everyday and sacred practices that occur within these spaces. Michel de Certeau is of the opinion that spatial practices elude the formalising of space, where everyday and sacred practice constitutes the making of place and not the other way around.⁸ In *The Practice of Everyday Life*, de Certeau highlights the significance of “in-between” space to allow for an ambiguity of practices that occur within them. In the context of the Bo-Kaap, these “in-between” spaces can be identified as the stoep, the courtyard, the lane and the street, all of which make up the social network of the Bo-Kaap. In order to harness the spatial quality of these elements in my dissertation project, I undertook the task of analysing and exploring scenarios where I felt that these space types were successful. These scenarios would then be utilised to configure the social network of this dissertation project, both laterally and vertically, to create an urban community based around these in-between spaces.

⁸ de Certeau, Michel. *The Practice of Everyday Life*. Translated by Steven Rendall. University of California Press, 1984

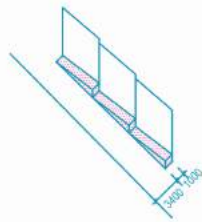

Stepped stoep fronting lane with no bankjes, no frontages on other end of lane.

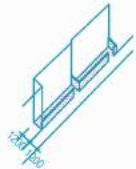

Flat stoeps fronting narrow service lane, no frontages on other end of the lane.

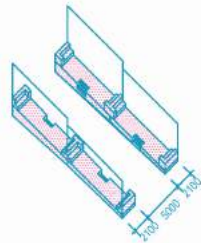

Stoeps with side bankjes fronting street, mirrored on the other end of the street.

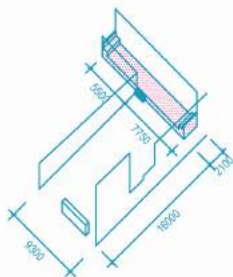

Stoep fronting front shared courtyard.

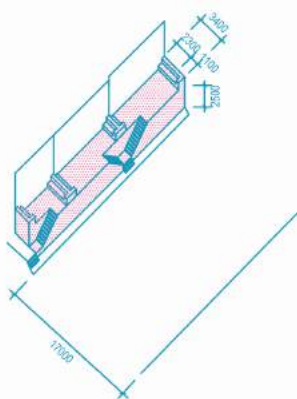

Raised stoep above wide busy street, across from lower stoeps.



12. Diagrams of different stoep types

The stoep

The construction of the stoep is alluded to be part of the rubble and stone foundation base of the house, traditionally raised nearly a metre from the street level at its highest point in response to the steep conditions of the Cape terrain.⁹ The stoep has since become significant to the social sphere of the Bo-Kaap, for mediation between the privacy of the house and public engagement of the street.

The main entrance of a typical Bo-Kaap house leads from the stoep to the passage, with the living room situated closest to the entrance and therefore the stoep. Jan Gehl identifies spaces of this type as 'soft edges', threshold spaces at the entrance to a house that provides an obvious way to support the everyday life between buildings. He furthermore highlights the importance of the smooth transition from the public street, to the threshold space (the stoep), to an entrance that leads to an adjacent living space.¹⁰

9 Lewcock. *Early Nineteenth Century Architecture in South Africa: A Study of the Interaction of Two Cultures, 1795-1837.* the University of Michigan: A.A. Balkema 1963, 378

10 Gehl, Jan. *Life between buildings: Using public space.* London: Island Press, 2011, 187



13-16. Scenes depicting the social activity that occurs in and around the stoep.

Despite the variance in design of the stoep at present, many of the general principles remain consistent to allow for social engagement of the surrounding from the semi-privacy of the stoep. These principles include the following:

- The level change between the street and the stoep, however slight this may be, allows for a slight disjunction between the publicness of the street and the semi-privacy of the stoep;
- The omission of full height walls between the stoeps of adjoined houses allows for lateral engagement of neighbours, and in turn allows for the perceived collective ownership of this semi-private sphere;
- The occurrence of one or more side bankjes for seating, gives way to a number of additional practices, like reading, that can occur whilst sitting. The addition of seating also improves the comfort of the space.

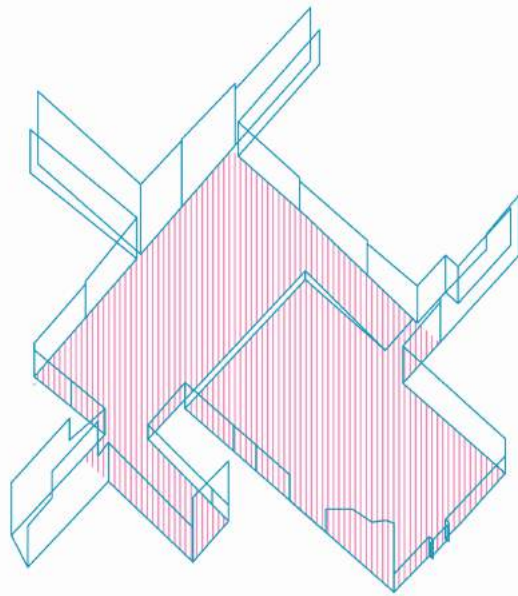

1380m²

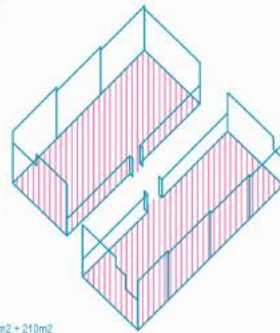

180m² + 210m²

Communal courtyards

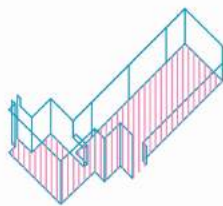

145m²



70m²

Shared courtyards



7m²



9m²



15m²



13m²

Private courtyards



17. Diagrams of different courtyard types

The courtyard

The courtyards that make up the network of space within the Bo-Kaap, both historically and currently, are made up of various sizes and types. They include small private courtyard spaces that are accessed from the kitchen or through a door that leads off from a lane at the side of the house, medium sized courtyards that are shared between two or three houses and again accessed through the kitchen or a door leading from the shared service lane, and larger communal courtyards. The communal courtyards were historically accessed off lanes that led from the main streets and fronted by a row of houses, with the stoeps (and therefore entrances) facing the courtyard. The communal courtyards of the renovated and restored blocks of the Bo-Kaap, however, are much bigger than they were previously and are bounded instead by the backs of houses on all sides.



18-21. Examples of courtyard types in the Bo-Kaap.
(top to bottom): Private courtyards at the back of the house, shared courtyard, communal courtyard

The range in sizes, types and possession of the aforementioned courtyards allow for a range of different practices to occur within them. The courtyard serves as an integral space for both fluid everyday practices, as well as less frequent sacred practices, a few of which are listed below:

- The courtyard often serves as an extension to the kitchen on sacred occasions like Eid, Mouloud or more frequent festivities throughout the year, when massive pots of food are prepared and stored in the courtyard before the food is dished;
- The courtyard becomes a significant space on Eid al-Adha when the extended family gathers in this private outdoor space for the ritual sacrifice of sheep;
- Everyday activities like the hanging and drying of laundry occur in the more privatised courtyards;
- Because of the relationship between the house and the private, shared and communal courtyards, the courtyard becomes a safe place for kids to play with constant supervision;
- A common historical practice that is still found in private courtyards in the contemporary context of the Bo-Kaap, often those that are accessed through a side door that opens up to a public alley, is retail trade. There are a number of older community members in the Bo-Kaap who make use of the opportunity of selling goods, often fruit and vegetable produce, from their homes.

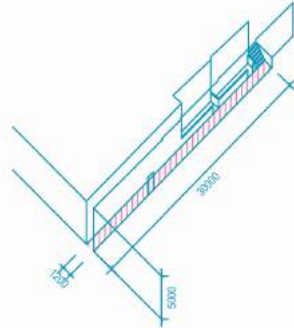

Service lane, with stoeps coming off of it, leading to street on the other end. Used as a shortcut through the block.

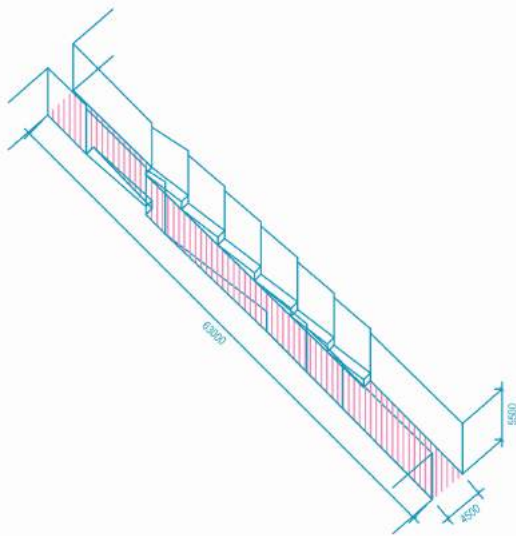

Public lane

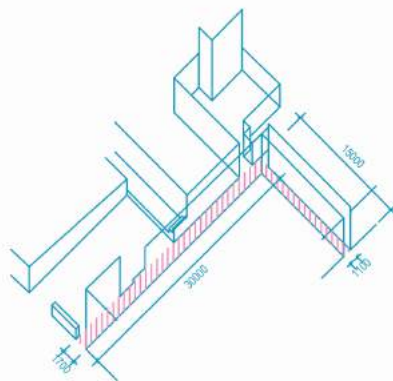

Service lane leading to shared courtyard



22. Diagrams of different lane types

The lane

Like the stoep, the lane was not envisioned as a space of social exchange and came into existence based on analytical planning of the residential block and regulatory measures. Similarly to the courtyards in the Bo-Kaap, the lanes are found in a range of various conditions, the wider lanes were consequent to the configuration of smaller houses on residential blocks that were based on the city grid; the narrower service lanes were planned based on fire regulations during the 18th century but seemed to have become a convenient means of circulation.¹¹

¹¹ Shell. "Arson and Architecture." In *Children of bondage : a social history of the slave society at the Cape of Good Hope, 1652-1838*. Johannesburg: Wwatersrand university press 1994, 272



23-26. Examples of lane types in the Bo-Kaap.
(top to bottom): public lane with one edge of frontage, service lane with one edge of frontage, lanes leading to courtyards

The lanes, whether or not they fall into the category of the wider street-like lane or narrow service lane, are distinctly different based on the specificity of their surroundings. The lane, as opposed to the wider street, creates a more intimate setting for neighbours whose houses face out onto the lane, especially those with stoeps fronting them. The narrower adjoining lanes, which cut between houses, create a sense of forced social engagement that cannot be achieved with more generous use of space. In *Life Between Buildings*, Jan Gehl notes that these narrow spaces, because the user experiences them at close range and with considerable intensity, are perceived as “intimate, warm and personal”, constituting a healthy environment for successful communal life.¹² In the Bo-Kaap, in the case where narrow lanes become apprehensive spaces because they don’t lead to a specific destination or an adjoining street, but instead to a dead end or large open space (which is not a common occurrence), there is often the introduction of a ‘house shop’ that opens up onto the stoep in order to activate this space and make it seem more inviting.

¹² Gehl, Jan. *Life between buildings: Using public space*. London: Island Press, 2011, 69

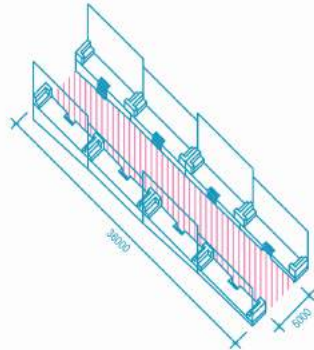

Domestic scaled one way street with no side walks.

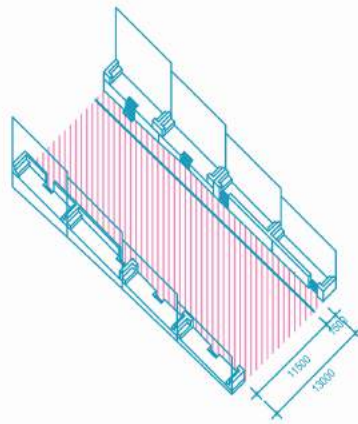

two way street with side walk on one end of the street.

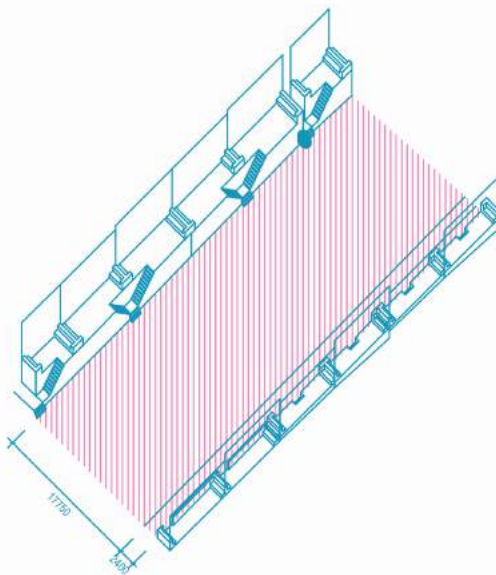

Wide heavy traffic public street.



27. Diagrams of different street types

The street

One of the greatest successes of the Bo-Kaap is the vibrancy of the street throughout the day, which truly becomes a space that one occupies, rather than just a thoroughfare. With regards to the streets in the Bo-Kaap, the relationship between the stoep and the street can be perceived to be interconnected, and the success of the street can be assumed to be directly related to the success of the stoep to activate the space.

The significance of the edge condition to activate a public space is theorised by Christopher Alexander in his book *A Pattern Language*. According to Alexander, the modern city has transformed streets into spaces for “going through” and not “staying in”, which directly contradicts his belief that the role of the street is to cater to people as a public space right outside of their homes.¹³

The complete public nature of the street allows for a larger scope of social interaction to occur, between both strangers and acquaintances, both everyday and on sacred occasions. On an everyday basis, the streets of the Bo-Kaap are filled with playing children, neighbours socialising and the constant buzz of tourists. These activities are furthermore heightened at the start and end of the working day, with a significant amount of the residents walking to and from the city (to work or public transport nodes). At sunset, however, the call to prayer ceases the activity in the social sphere of the street and allows for a moment of pause before people continue with their evening activities.

¹³ Alexander, Christopher. *A Pattern Language*. New York: Oxford University Press, 1977



28-31. Sacred and everyday practices that take place in the street. (top to bottom): playing in the street while onlookers watch from the stoeps, wedding photographs, sale of fish from the back of a bakkie and Cape Minstrels

Since Islam was brought to the Cape by muslim slaves from North West Africa and the East, Signal Hill has been a space of islamic practice and therefore a place of deep significance for the Cape Muslims. This attachment to place was a key factor in the movement of many emancipated Cape Muslim slaves to settle in the Bo-Kaap, which is now has a predominantly Muslim populace. This religious and cultural heritage of the bulk of the residents of the Bo-Kaap has a direct influence on the appropriated use of the social and public spaces within the Bo-Kaap. In *The Practice of Everyday Life*, De Certeau uses the theory of 'lived space' to explain the idea that people articulate spaces through the manifestation of cultural practices, creating place rather than becoming subject to it. Resultant to that, the street becomes the place where many traditional public activities take place, transforming the atmosphere of the street as they occur.¹⁴

The sacred practices that take place in the streets of the Bo-Kaap are cardinal to its communal life. These practices, despite not happening everyday, are so integral to the spatial quality of the street, and the Bo-Kaap at large, that the two have become indistinguishable. In order to design spaces that harness the spatiality to which I refer, I have analysed three examples of these practices, namely the Janaazah, Ramadan and Eid, in order to uncover the qualities that they have on space.

¹⁴ de Certeau, Michel. *The Practice of Everyday Life*. Translated by Steven Rendall. University of California Press, 1984

32. Katel being carried from the house to the mosque, photograph taken by Henk Kruger



33. Mourners spilling out into the street outside of the flat of the deceased



Janaazah

In the Muslim community, at the time of death, people gather in and around the house of the deceased, the bulk of people usually spilling out across the street. Before the body of the deceased is taken to the cemetery to be buried, it is taken to the Mosque for the mourners to offer a prayer on behalf of the deceased. A procession of male mourners carries the katel with the body of the deceased to the mosque through the streets of Bo-Kaap, stopping all activity in the street at that moment in time. At this moment, all activity happening in the street becomes secondary, with the funeral procession filling up the entire street.

*Janaazah - funeral

*Katel - coffin

34. Child taking "cookies" to her neighbours during the Ramadan, photograph taken by Ashraf Hendricks



Ramadan

The month of Ramadan comes about once a year and has a significant effect on the social cohesion of the community of the Bo-Kaap. The activities of the day start significantly earlier, having to wake up before sunrise to eat the first meal before fasting until sunrise. Given that the Ramadan is such a holy month in Islam, Muslims spend more of their time in the mosque. This heightened use of the mosques at the five daily prayer times causes a resultant increase in the activity of the street at those times when people walk to the mosque. This prolongs the social hours of the day, as people usually use the time after mosque in the evening to socialise in the street before returning to their homes. Another social attribute of the Ramadan is the traditional practice of gifting your neighbours with parcels of cakes and savouries in the evening leading up to the breaking of the fast. At this time, children take to the street, walking to and from their homes to their neighbours' whilst their parents stand outside to watch them and simultaneously socialise, bringing the street to life once more.

*Ramadan - the holy month in which Muslims fast in order to commemorate the revelation of the Quran.

35. Families watching over the activity on the street from their stoeps, photograph taken by Brenton Geach



36. Children playing out in the street on Eid, photograph taken by Branko de Lang



Eid

Another festivity that activates the street is the celebration of Eid. On this day, the street is a constant hub of activity, as the social engagement of the community is brought to the forefront. The highlight of Eid is the fluidity of social encounters that extends from the home out onto the street, creating a perceived sharing of space through the blur of semi-private and public. The spatial relationship between the living space of the home, the stoep and the street on this day, creates this fluidity of social space, which furthermore strengthens the social ties of the community with this perceived shared space.

*Eid - Two important religious celebrations. Eid-al-fitr marks the end of the Ramadan and Eid-al-adha is the celebration of sacrifice.

37. Illustration showing the Prayer Quarry in relation to the site

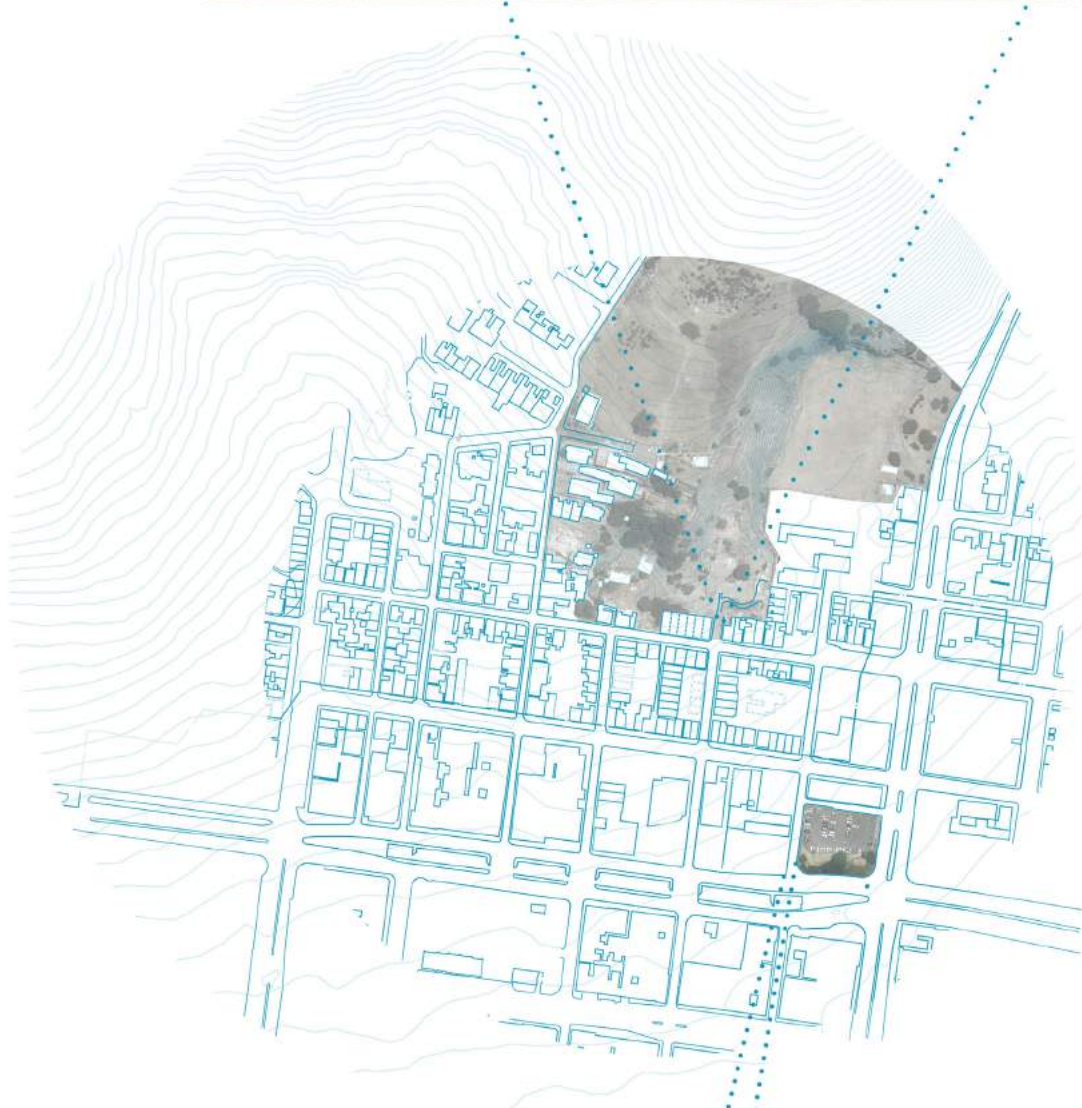

The programmatic catalyst to re-presencing the site

The design development of this dissertation comprised of an active unlayering of the site, both in its specificity as well as in the larger context of the Bo-Kaap. This unlayering of the site was based on the past and present. It has taken into account both quantitative and qualitative research in order to uncover the contemporary response to a site with such rich historical significance.

In my quest to uncover what it is that the site could become in order to re-presence the community of the Bo-Kaap in the city, I analysed the history of the Prayer Quarry, a landscape with deep historical significance. This quarry, at the foot of Signal Hill, is an open landscape that encapsulates the atmosphere of an intricate history. In *Atmospheres*, Peter Zumthor refers to 'atmosphere' as something that is perceived through our emotional sensibility, where our subconscious tells us an enormous amount about a space straight away.¹⁵ For this reason, I used the Prayer Quarry as a catalyst to prompt the programmatic and atmospheric spatialities of the design of this dissertation project.

15 Zumthor. *Atmospheres: Architectural Environments, Surrounding Objects*. Birkhauser 2006

38. Collage depicting prayer in the Prayer Quarry



Prayer

Many of the slaves that were brought to the Cape from the 17th Century onward, came from North West Africa and the East, and were Muslim. The ban on religious freedom, however, prohibited them from practicing their religion in public. This prohibition gave way to a number of everyday and sacred practices being held on the slopes of the mountain, out of sight of the formal city.¹⁶ This is how the Prayer Quarry came to be.

In response to this prohibition, the Muslim Um'mah (community), still predominantly slaves, found refuge in the Prayer Quarry. It became the first place in the Cape where Jumu'ah salaah (congregational Friday prayer) was held but after the eventual establishment of mosques, the quarry was no longer needed for salaah (daily prayer) purposes.¹⁷

16 T. Toffa "Cape Town. Bo-kaap: The architecture of identity." Vernacular architecture society of sa: workshop ii. studies and debates in vernacular architecture. Cape Town, 2004. 16-35

17 Davids, The Mosques Of Bo-kaap. A Social History Of Islam At The Cape 1980

39. Collage depicting the wash house
in the Prayer Quarry



Cleansing and Economy

Many years thereafter, a municipal wash-house was constructed in the Prayer Quarry in the early 20th century but was demolished less than a century later. The washing of clothes by washerwomen was an early practice that also occurred along the slopes of the mountain, using the natural pools, and carried on well into the 19th century. This trade 'evolved' with the introduction of municipal wash-houses, where predominantly coloured women were employed to wash clothes for a living, an act that can be seen as the start of economic empowerment for these women.¹⁸

18 T. Toffa "Cape Town. Bo-kaap: The architecture of identity." Vernacular architecture society of sa: workshop ii. studies and debates in vernacular architecture. Cape Town, 2004. 16-35

40. Collage depicting the informal dwellings in the Prayer Quarry



Dwelling

Displacement was the main ramification of the Slums Area Act, as people were forced from their homes without any alternative living arrangements given to them. Before the Bo-Kaap, Roggebaai was declared a slum and homes were demolished by the State without the provision of alternative housing for the displaced people of Roggebaai, resulting in homelessness for this community.¹⁹ Due to the humiliation of State as this situation, they allowed the people of Bo-Kaap to stay in their previously owned homes and ,furthermore, forced displaced families into the homes of strangers whose houses had not yet fallen into disrepair.²⁰ Some families, with nowhere to go, once again found refuge in the Prayer Quarry, where they put up informal houses until they could afford a better situation. The Prayer Quarry has since been the site of an on and off informal settlement.

19 Truluck. Bo-Kaap: Changing Attitudes and Actions. Honours Thesis, Cape Town: University of Cape Town 1989, 24

20 Ibid, 24

41. Ensemble of the collages and the current state of the Prayer Quarry



Pray



Cleanse



Dwell

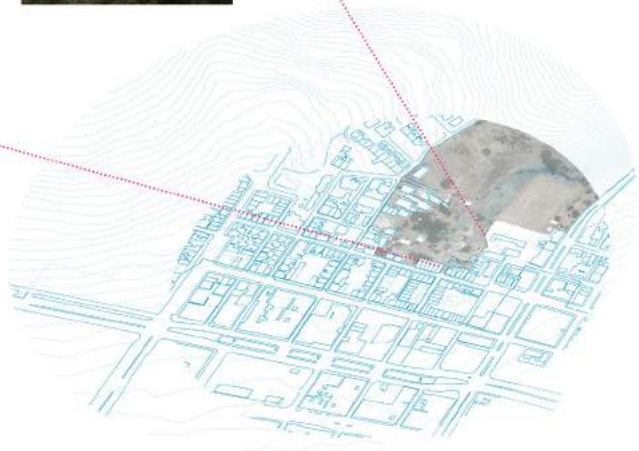

Memorialisation of the sacred through the everyday

The everyday practices of 'prayer', 'cleansing' and 'dwelling' are significant to domesticity both in general and in the Bo-Kaap. These three practices were the starting point towards programming the project and can be explored further under the following three categories: congregational gathering, economic empowerment and housing. All of the aforementioned categories are tied together with a space that allows for engagement through different means of communication to enhance the understanding of the cultural heritage of the Bo-Kaap and its people.

According to Setha M. Low and Denise Lawrence-Zuniga in the introductory chapter titled *Locating Culture in The Anthropology of Space and Place: Locating Culture*, 'inscribed space' is based on the relationship that people have with their occupied environments and the meaning that they attach to these spaces in order to transform a space into a place. 'Inscribed space', however, surpasses just the attachment of meaning to place but involves the manifestation of cultural practice and narratives into concretized places.²¹

²¹ Low, Setha M., and Denise Lawrence-Zuniga. "Locating Culture." In *the anthropology of space and place*, 1-43. Oxford: Blackwell Publishing, 2003

42. The historical urban fabric of the site. The built fabric shown as solid fill, lanes as dark dotted hatch, stoeps as diagonal hatch and courtyards shown as sparse dotted hatch

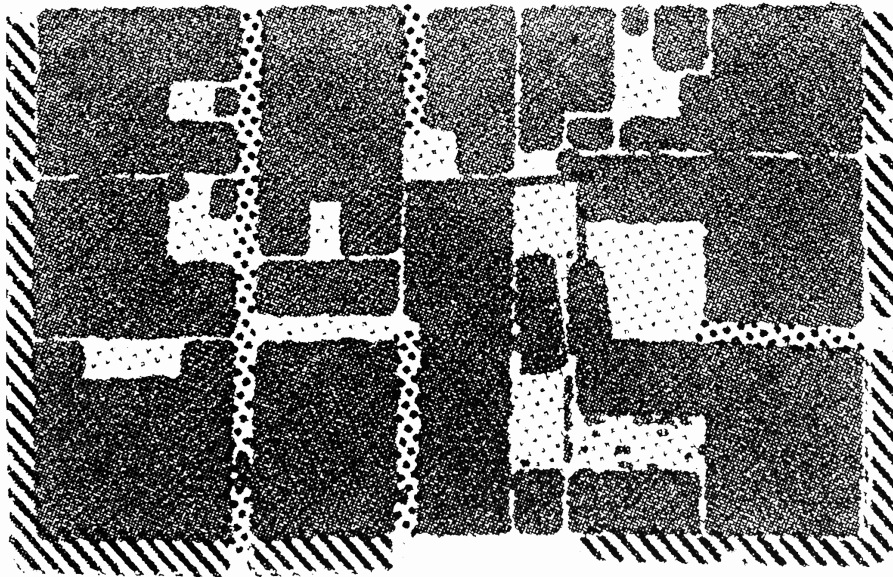
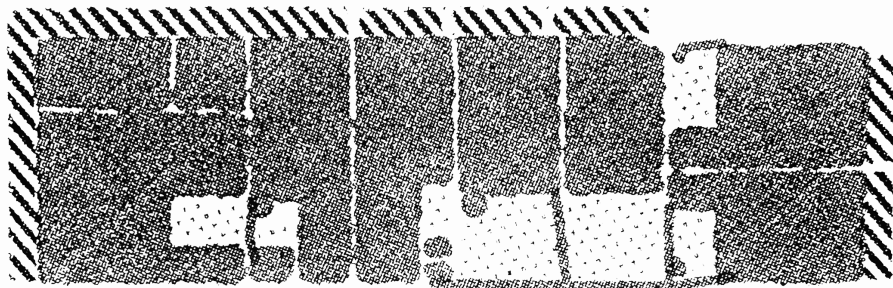
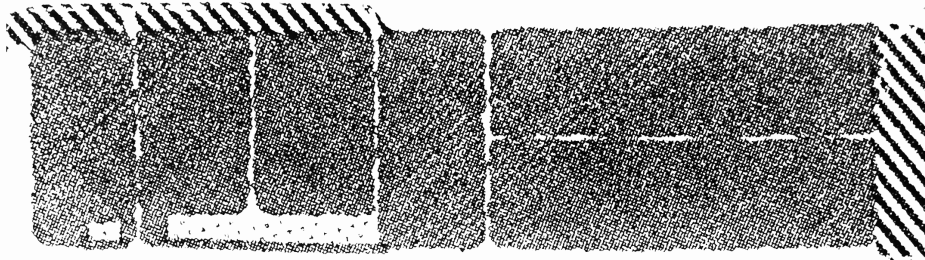

Architectural Investigation

The forgotten site – the spatial configuration of the historical site

Much like the current historical urban fabric of the Bo-Kaap, the site once had a fine urban grain, made up of two separate blocks of small erven that have now been consolidated into one, and the absorbed historical Maxwell Lane that previously divided the two blocks. The two respective blocks were constructed of homes, many of which had an attached business. I know from stories told to me by my grandfather that his grandfather owned a green-grocer at their home in Castle street (at the corner of Maxwell Lane), where he traded from the courtyard. According to the Almanac, from the 19th century, there were many retail and service providers living where my site is situated today, alluding to the fact that the streets and lanes surrounding and cutting through my site were once activated by retail activity.

43. Experimentation of form through model building



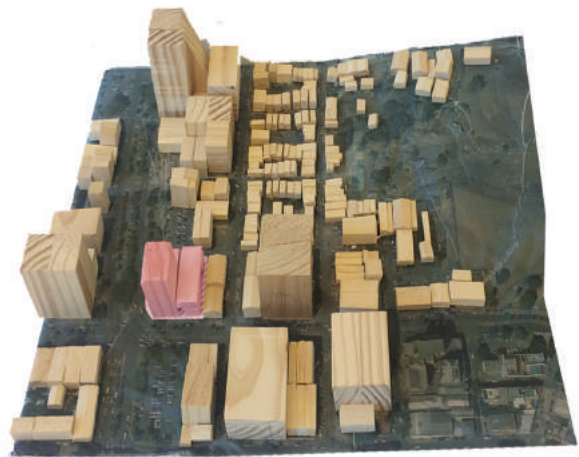

isometric drawing showing project in relation to the context of the Bo-Kaap and the city

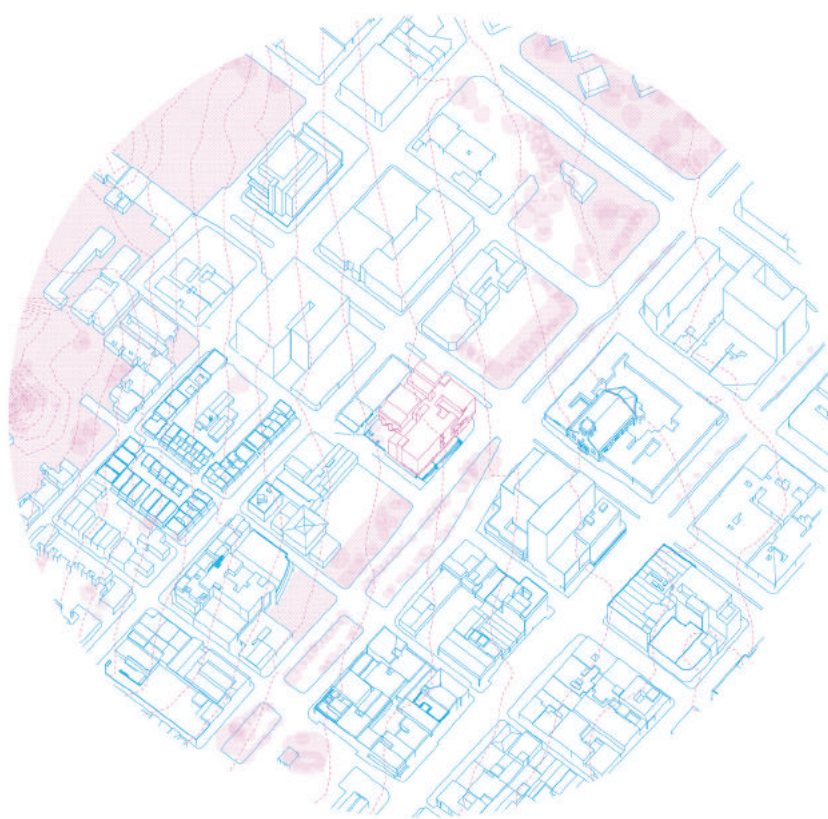

Urban Considerations

The reinstatement of Maxwell Lane was one of the initial urban factors that i considered in the design of the scheme. The reintroduction of Maxwell Lane allows for a smooth transition from the busy vehicular focused Strand Street to the more discreet pedestrian friendly Castle Street. The height difference between Strand Street and Castle Street allows for the introduction of two ground levels, using Maxwell Lane as a vertical connection through the site. This lane is intended to break the massing up into two complementing buildings and is therefore left open to the sky.

In response to the low level buildings on the edges of the site that face the Bo-Kaap , the building between Maxwell Lane and Rose Lane will be no more than 4 floors high, and have a communal courtyard at the corner of Castle Street and Rose Lane, onto which Maxwell Lane terminates. The placement of a low level building and courtyard on the northwestern edge of the site allows northern light to filter down into Maxwell Lane as well as reach the extremities of the building between Maxwell Lane and Buitengracht Street. The placement of the city along the southeastern edge creates an opportunity to block the strong southeasterly wind with the placement of the taller building along that edge, in response to the context of the city.

Street perspective showing integrative courtyard in Castle Street



Street Perspective
Castle street elevation

1:200

On the ground floor edges along the lower levelled fabric of Rose Lane and Maxwell Lane, the project activates the narrower streets with the introduction of retail. In addition to the retail along Buitengracht Street, the ground floor levels along Buitengracht Street opens up to an interpretation centre with an adjoined library and amphitheatre, both of which are accessed from the large communal courtyard space. This concentration of public activity at the lower levels of the project allows for street activation throughout the day. The upper levels of the building houses the vertical housing cooperative, which overlooks Maxwell Lane, allowing for surveillance in the evenings, when the lane is no longer busy with street activity.

The site is further utilised with the implementation of underground parking for the residents of the coop and general users of the building. This varying programme is tied together with the introduction of the large integrative courtyard space that engages with all the programmes on some level. This courtyard is seen as a spatial device that encourages diverse social engagement of all the users of the project.

44. Collages exploring public courtyard spaces

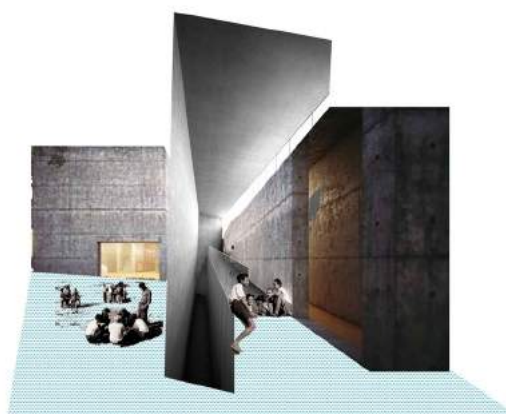
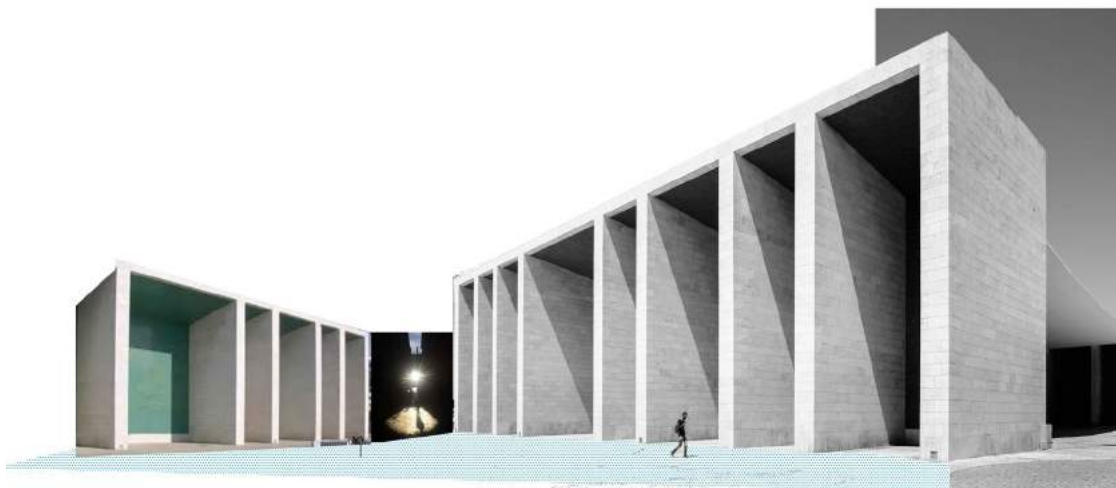

45. Collage exploring site massing

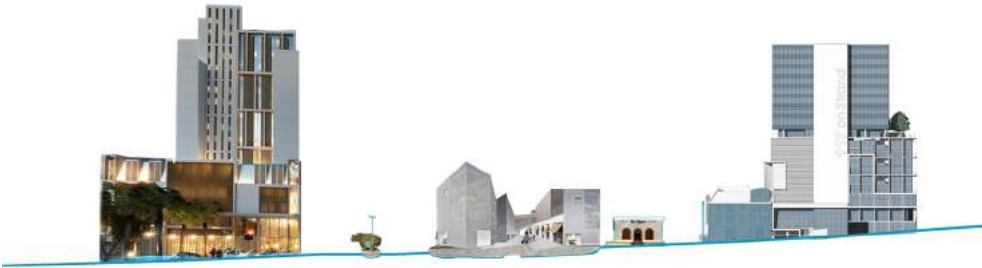

46. Re-presenting the historical practices in the contemporary

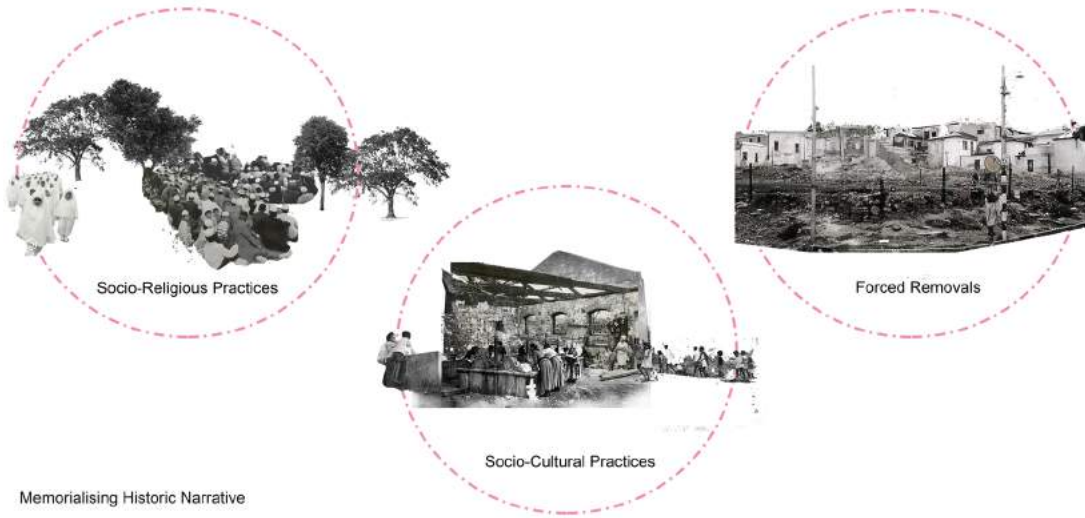

A vertical community - layering of the programme

Learning from the catalytic site explored earlier in this document, the programme of the project aims to memorialise both the historical narrative of the site and the Bo-Kaap at large through the social and cultural engagement of everyday and sacred practices. In doing so, the programme of this project will have to be made up of a range of different programmatic, social and spatial types, which is in keeping with the mixed use zoning of the properties surrounding it. The difference, however, between the mixed use developments currently being constructed around the Bo-Kaap and this design project is the significance of the community of the Bo-Kaap in all aspects of the design, as this project is envisioned as an extension of the Bo-Kaap and its community.

47. Collage provocation of 'retail throughfare' through Maxwell Lane connecting the two ground floors (Strand Street and Castle Street).



48. Collage provocation of 'retail frontage' along Rose Lane and Castle Street



Economic diversification

There is currently a growing populace of young entrepreneurs within the community who are in search of affordable retail spaces close to home. However, the locational value, as previously discussed has caused such a rise in rental prices in the Bo-Kaap, rendering the discovery of an affordable place for trade in the Bo-Kaap impossible.

The retail component of this project is designed to allow for multi-cultural and multi-income based retail spaces. It is intended to be a way to mediate between the cultural economy of the Bo-kaap and the commercial city by catering to the needs of the community and that of the city at large through the creation of spaces for economic opportunities for local entrepreneurs from the Bo-Kaap as well as those from outside of the community. This mixture of tenancy allows for the preservation and sharing of the cultural heritage of the Bo-kaap as well as the diversification of cultural exchange.

The introduction of retail along the urban edges of the site, and along Maxwell Lane, is envisioned as a social activator for Rose Lane and Castle Street. Both of the aforementioned streets are currently quite inanimate spaces, as the vacancy of the site provides no frontages across from the occupied buildings opposite it, suggesting that the introduction of retail at ground level will improve the quality of the streetscape surrounding the site.

49. Model diagram to locate interpretation centre and library on the site



Cultural integrative learning

The location of the project at the start of the Bo-Kaap renders it as the threshold space between the Bo-Kaap and the city, giving rise to project as the possible first destination point upon entrance into the Bo-Kaap. This allows for the opportunity of the design of a space geared towards dialogue and engagement between the community members of the Bo-Kaap and visitors with an interest in the community and its history.

An interpretation centre, unlike a conventional museum, provides visitors with the opportunity of interpretive and interactive engagement of the cultural and historic significance of the site. Linkage between the interpretation centre and a library/archival space that is geared towards the community aims to probe integration between the social groups using the respective spaces. This linkage, furthermore, lessens the likelihood of the space becoming geared towards tourists, the outcome of the current Bo-Kaap museum. There's currently no library in the Bo-Kaap, so the introduction of one could be very beneficial to the community and become a well used space.

The interpretation centre is located on the lower ground level, at the corner of Strand Street and Buitengracht Street, the corner of the building that is most marketable to the city. The design of the interpretation centre is envisioned to be as inviting as possible, with maximised transparency wherever possible in this three storey component of the project.

Due to the communal nature of the library, the entrance is located on the upper ground level, at the corner facing the Bo-Kaap, to allow for a slower paced atmosphere when approaching the library. The library consists of a range of stepped levels due to the nature of the steep site, allowing the design of a mezzanine floor above part of the ground floor that steps down 1,5m (aligning itself with the first floor of the interpretation centre). The interpretation centre is accessible via a bridge above the retail space below.

50. Collage showing site in relation to the Mosques and Tana Baru cemetery



51. The Prophet's Mosque, the first place of islamic communal religio-social gathering

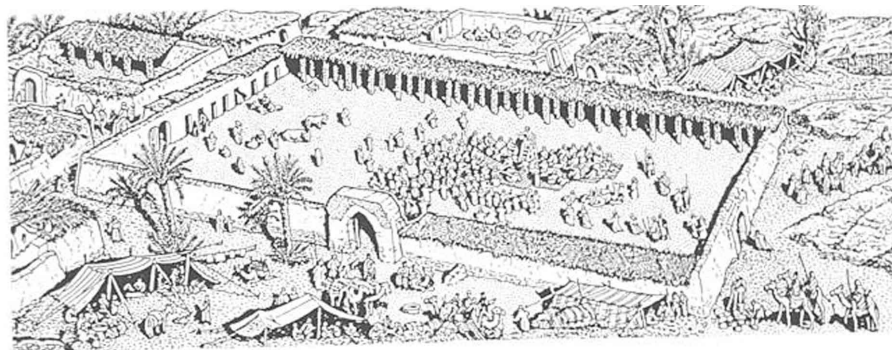

Socio-religious and socio-cultural congregation

The Bo-kaap is home to seven Mosques, all of which are socially removed from one another. This social fragmentation has promoted to the loss of communal sense within the community over the recent years, leaving its members with no clear conviction of the importance of the Ummah (community). This has prompted the design of a space for communal congregation, one that will prompt the re-establishment of the significance of social life as one rooted in religion and culture in order to bring about a greater sense of community cohesion within the Bo-kaap.

This congregational space is therefore envisaged as one of integration, a space for the community to come together in celebration of important socio-religious and socio-cultural events that happen throughout the year. This large undercover space makes use of the communal courtyard that is situated adjacent to it, to allow for spillage when especially large gatherings are taking place there. With the use of folding stacking doors as a means of division, this space of gathering can be divided into smaller spaces, so that a number of smaller gatherings can happen simultaneously if need be.

52. Conceptual sketch of the massing of the housing co-op. The sketch highlights the circulation and open spaces

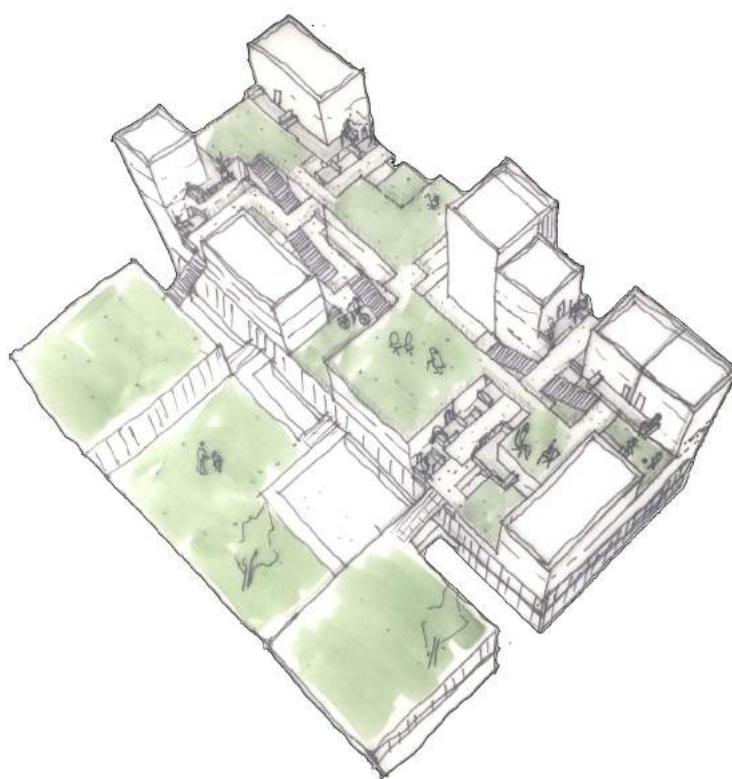

Communal living

According to the Bo-Kaap Civic and Ratepayers Association's (BKCRA), the community is in need of affordable housing. Due to the steep influx of rates and land values, the long time residents can no longer afford to live in houses that their families have resided in for generations. At present, many houses in the Bo-Kaap are made up of extended families and in many cases this is the only way that these families are able to continue to live in the Bo-Kaap. However, as these extended families continue to grow, the space of these homes become insufficient. Due to the nature of many families in the community to live as extended families in one home, the relationship between family members becomes integral to their financial and social wellbeing. The unaffordable rental prices and impossibly high property prices in the Bo-Kaap that is associated with gentrification. This makes it near impossible for these families to stay close to one another in the case of one of the families moving out.

53. Image highlighting the overlapping social spaces in the housing co-op. These spaces allow for the extension of social engagement of residents across floors.



54. Illustration of the Maxwell Lane, showing the public interface on the ground floors and the circulation of the housing co-op above.



Through limited equity cooperative housing, residents will be able to buy 'shares' into the coop if they wish to live there and the low-cost rent will be maintained. If residents decide that they would no longer like to live in the coop, the shares get sold back to the co-op. This system gives residents the same stability and security as an owner-occupied house because there is no possibility of unlawful eviction and residents are able to live in their home as long as they are able to pay the subsidized rent. This dissertation project envisages the Coop to belong to a community based organisation, rather than to an individual, preventing the sale of units to the open market at market related prices.

The housing cooperative, the key programme of this dissertation project, is located above the public programmes of the ground floors. This living component is in keeping with the memorialisation of the historical narrative of the site through the re-presencing of everyday and sacred practices that occur within it.

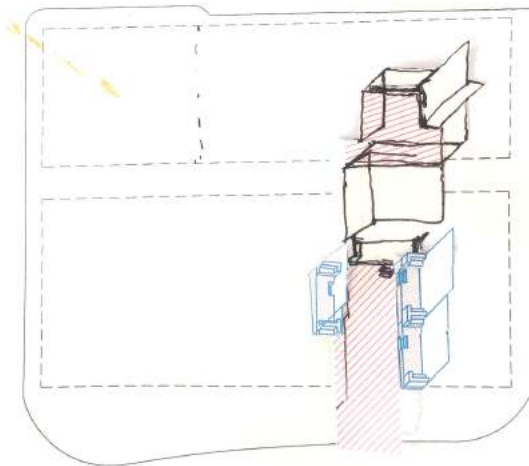
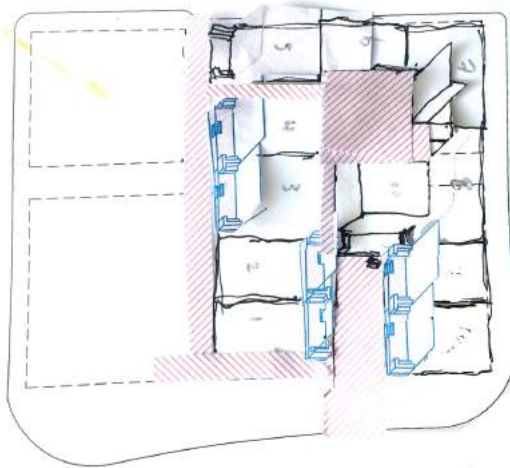
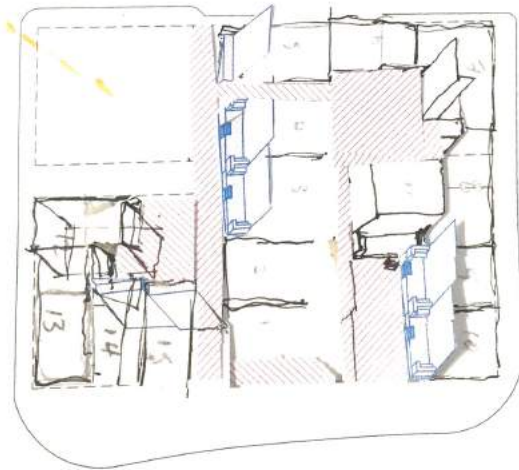

55. Collage layering of stoeps, lanes, courtyards, streets and housing units to design floor plans

A vertical landscape of in-between spaces

The housing cooperative is designed in keeping with the fine grained urban fabric of the Bo-Kaap, despite the urban pressure of vertical densification. In order to harness the social qualities of the Bo-Kaap streetscape in a vertical landscape, the project considers the everyday and sacred practices that will occur within it. These practices are manifested in the spatial design through the use of principles taken from in-between spaces like the stoep, the courtyard, the lane and the street.

Circulation

The entrance lobby of the housing coop, comprised of the main stairway and the first lift core, leads off from the previously mentioned integrative courtyard. The circulation through the in-between spaces mentioned before, are foreground in the design through the introduction of various staircases and two separate elevator cores. The building consists of two main circulation cores, in addition to other singular staircases spread throughout the vertical community. The first elevator circulates from the basement parking levels to the public amenities on the lower and upper ground floors and stops on the first floor of the housing coop. The second elevator functions solely for the housing coop. The first floor, where residents have to circulate from one lift core to another, becomes the main social platform, with the largest open social spaces.

**56. Massing exploration of overlapping
in-between spaces**

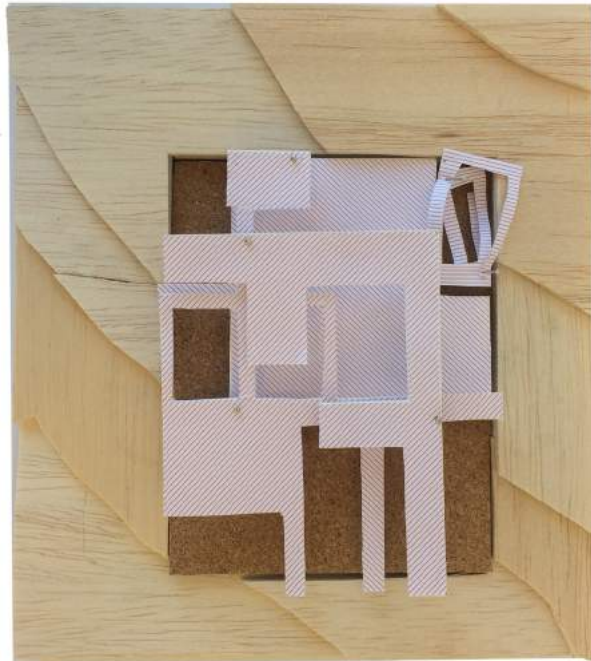

57. Massing exploration carving in-between spaces into plaster of paris



58. Illustration showing the levels of in-between spaces that are connected both laterally and vertically

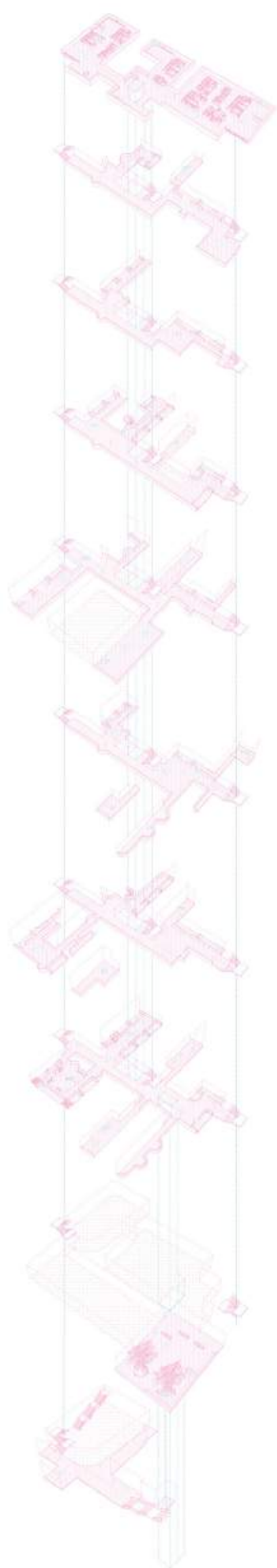

Social platforms

The fourth floor is another important social platform, and therefore the space with the most open social 'street' space. This floor provides residents with an indoor space of gathering that is no more than 200 square meters, for sacred and cultural events like a Janazah. Due to the ambiguity of the practices that will take place in this space, it will be subdivided through the use of movable doors in order to allow for flexibility of spatial configuration, especially in the case where there is the required separation men and women. Similarly to the findings in the exploration of the street earlier in document, there is a vast expanse of 'street' space abutting the space of gathering, allowing for spillage in case of a bigger function.

Another significant finding from the ritual of the Janazah is the minimum width required for a funeral procession to carry the katel to the mosque. A standard of two meter wide lanes between two residential units provides a comfortable width for the funeral procession and the two flanking men carrying the katel to fit through.

The roof terrace on the eighth floor is another social platform onto which an elevator stops. It provides the residents with a small-scale urban agricultural garden, allowing for a source of local food production. This space allocates households with specific square meterage of garden space, allowing for private ownership of spaces within a greater cohort.

59. Communal courtyard with overlapping stoeps and circulation bridges.



60. Private courtyards



Courtyards

There are 80 residential units in total, all of which are spread over 7 floors. These units are configured around the in-between spaces that constitute the social sphere, facing either a vertical street or opening onto a courtyard space. These in-between spaces are configured both laterally and vertically in order to create a network of overlapping and interweaving social spaces that encourage social cohesion of this extended vertical community of the Bo-Kaap.

Because of the verticality of the project, the courtyard offers an opportunity for shared space in a communal setting where outdoor space is limited. The range in courtyard sizes and edge conditions throughout the project creates a hierarchy of spaces that directly influences its atmospheric and spatial qualities. These atmospheric and spatial qualities create a range of either intimate shared courtyards between a smaller cluster of units and more social settings where the courtyard is large enough for more units to live out onto the courtyard. Despite the relevance given to the social courtyards, the importance of everyday domestic practices that occur in private courtyards should not be undermined, and provision is made in the living units for this type of space.

61. Illustration showing the relationship between the shared courtyard, stoeps and shared private lanes.

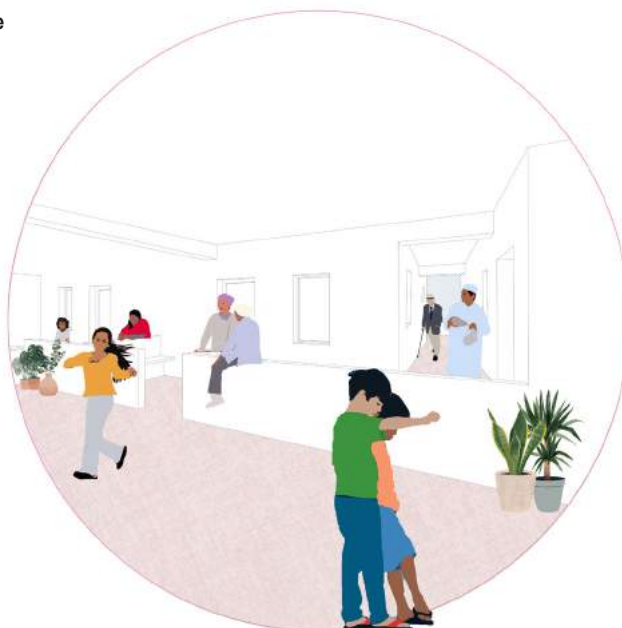

62. Illustration showing the relationship between the overlapping social and circulatory spaces.



Places of pause

The significance of the street, as spaces for people to pause and socialise at key moments of the day and during the celebration of sacred celebrations, becomes important in the design of the circulatory in-between spaces. The idea of the stoep, is complementary to the vibrancy of the street at these times, as it provides the street with pockets of more intimate socialisation; it is both an extension of the home as well as an extension of the street. This spatial relationship between the street and the stoep provides a key design consideration to enhance the spatial quality of the circulation of the project with the use of stoeps at key threshold spaces. This stoep is utilised in a number of different spatial configurations throughout the coop, creating a range of intricacies of different hierarchical and atmospheric space types.

The stoep, as a place of pause, is used to enhance the socialisation of the coop. Some of these spaces follow the traditional stoep and become extensions of the living space within the house, opening up to a vertical 'street'; some are detached from the house with narrow lanes, to ensure that the stoep overhangs an open space below, encouraging social cohesion between floors; longer stoeps that connect to smaller residential units are placed between the two units to encourage a shared space; and some open directly onto courtyards, becoming the threshold between the shared intimate courtyard and the home. This fluidity of social space allows for the opportunity of spillage out onto the stoep, street, lane and courtyard, allowing for all spaces to become shared spaces on special occasions, allowing for social cohesion as well as the possibility of sharing of intimate spaces between neighbours.

Concluding thoughts

The forgotten history of forced removals in the Bo-Kaap was fundamental to this project. It provided a point of entry for memorialising the historical narrative of the Bo-Kaap whilst also capturing the relevance of the contemporary everyday and sacred practices of the community of the Bo-Kaap. In light of the pressure put on the community due to gentrification, the relevance of the community and their cultural practices gave way to the idea of memorialising the historical narrative of the forced removals through the social and cultural engagement of the everyday and sacred practices that once took place on the identified site of this project. This allows for the re-presencing of the Bo-Kaap and its community within the city.

Evident from the constant encroachment of the city since the 20th century until the present day, the densification pressures that accompany gentrification will continue to plague the Bo-Kaap and other historically low-income areas bounding the city. The change in the social and spatial quality of the Bo-Kaap is manifested in the construction of large contemporary mixed-use developments. These developments do not consider the intricate urban texture of the Bo-Kaap and the social and cultural intricacies that propagate within these spaces. This change in the architectural typology, which is spurred on by densification, causes the urban morphology to become less fine grained, which strips the urban fabric of these intricate in-between spaces that complemented the social and cultural character of the Bo-Kaap.

In response to these architectural and social changes, this dissertation explores ways in which contemporary architecture can enhance the social character of the Bo-Kaap. By foregrounding both the community of the Bo-Kaap as well as their inscribed historical spatialities, this dissertation project aims to harness the essence of the stoep, the lane, the courtyard and the street in a multi-storey mixed use building in order to keep the community and their cultural traditions intact, even in the face of gentrification.

Final Drawings

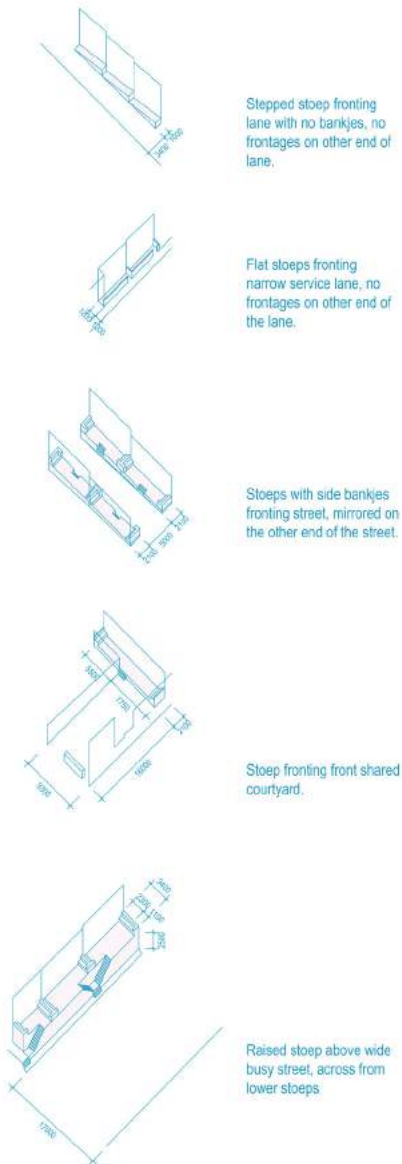

Diagrams showing variance in stoep types

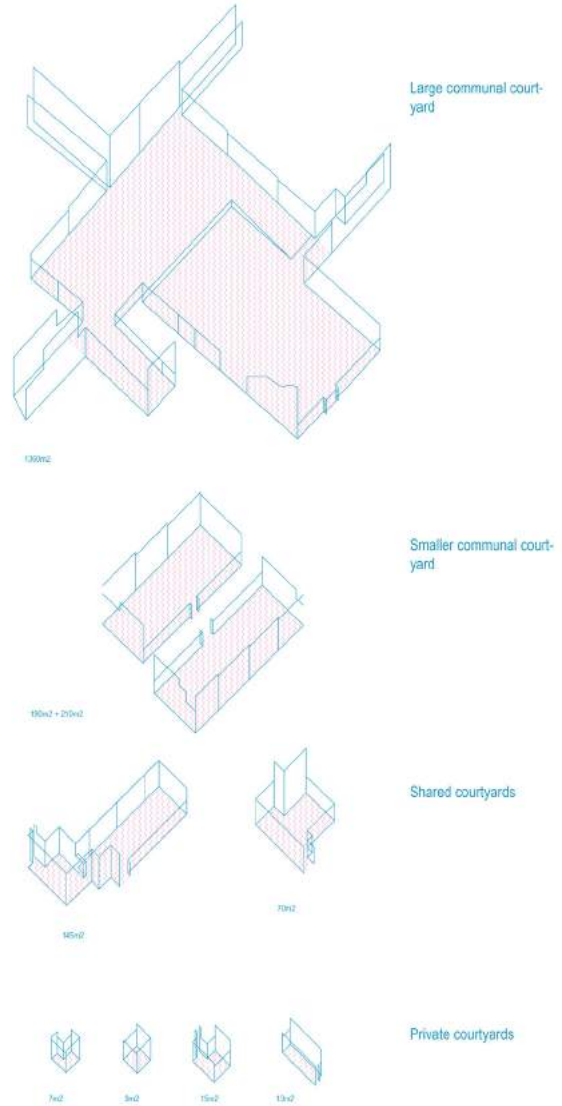

Diagrams showing variance in courtyard types

Spatial kit of parts

1:350

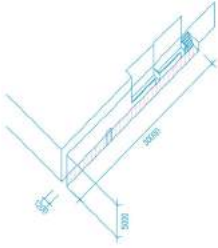

Service lane, with stoeps coming off of it, leading to street on the other end. Used as a shortcut through the block.

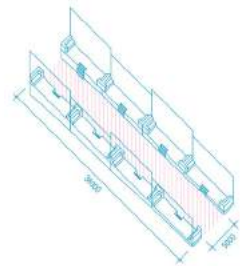

Domestic scaled one way street with no side walks.

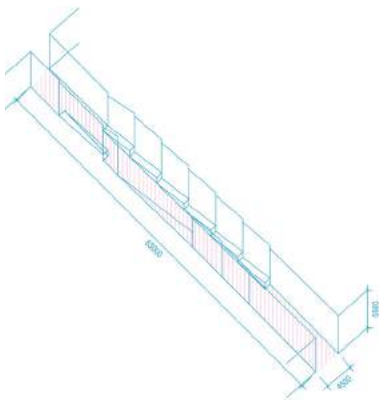

Public lane

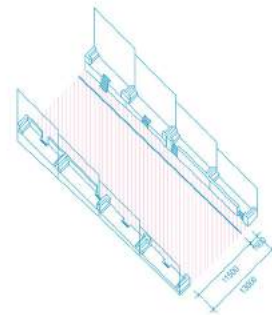

Two way street with side walk on one end of the street.

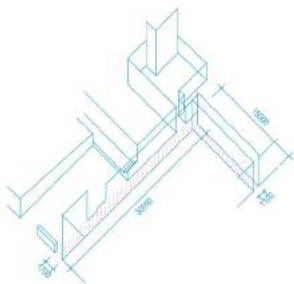

Service lane leading to shared courtyard

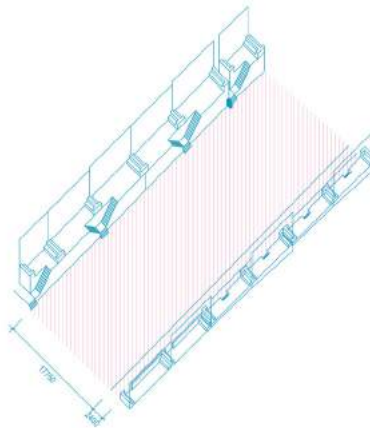

Wide heavy traffic public street.

Diagrams showing variance in lane types

Diagrams showing variance in street types

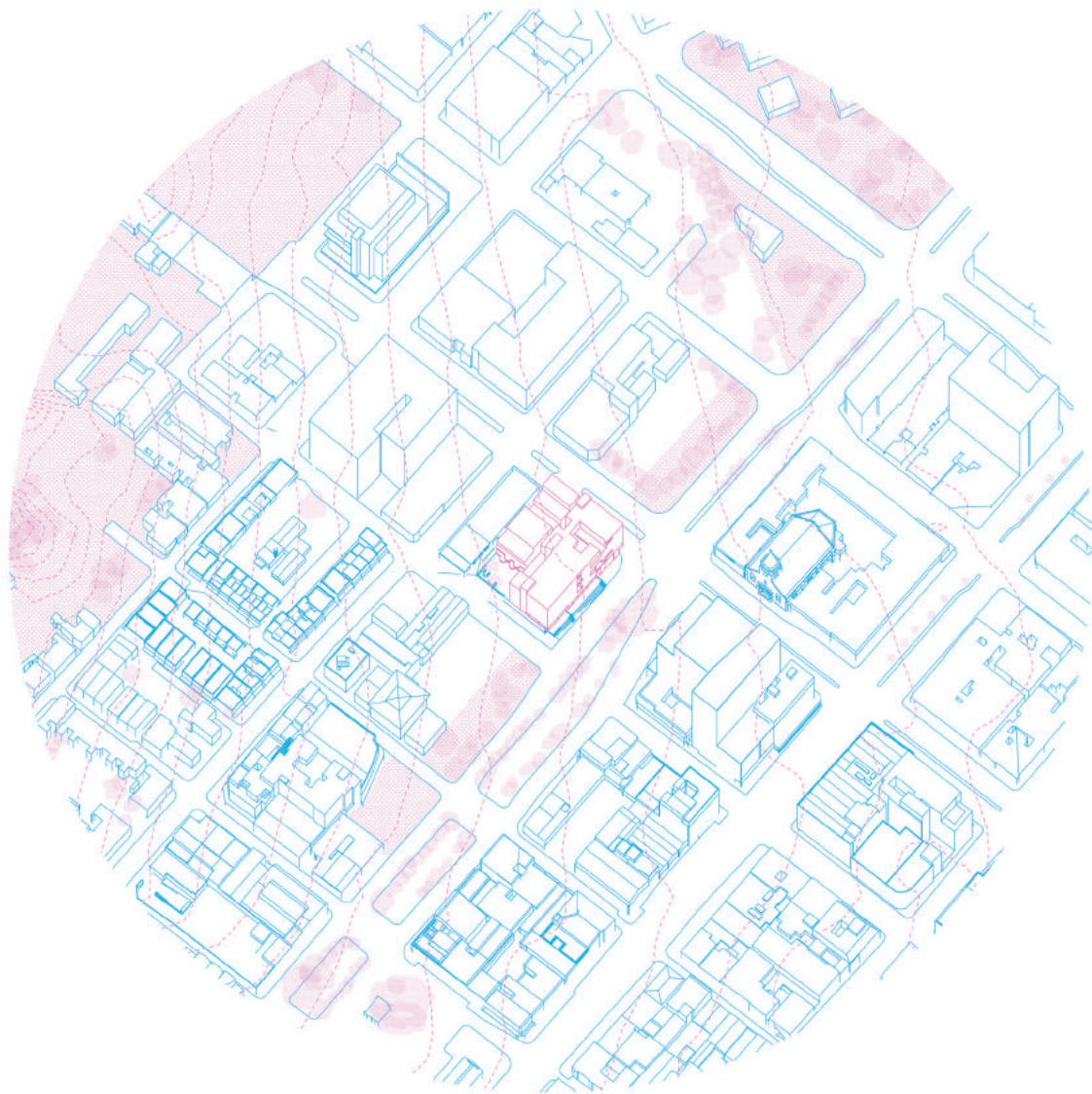

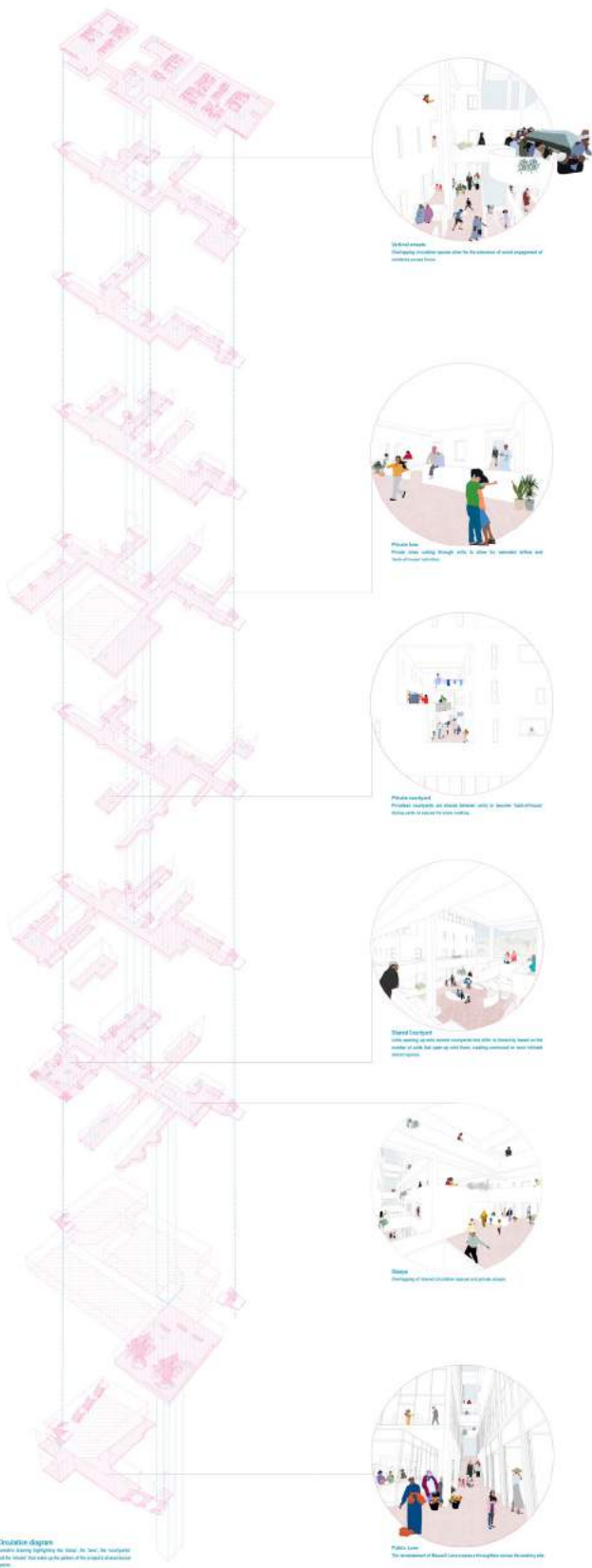



Key

- 1 Interpretive Centre, Lobby + Cafe
- 2 Cafes
- 3 Storage + service space for retail below
- 4 Major retail anchor
- 5 Storage
- 6 Small retail + cafe space
- 7 Small retail spaces
- 8 Security office
- 9 On site parking on three basement levels below

Lower ground floor plan

1:200 

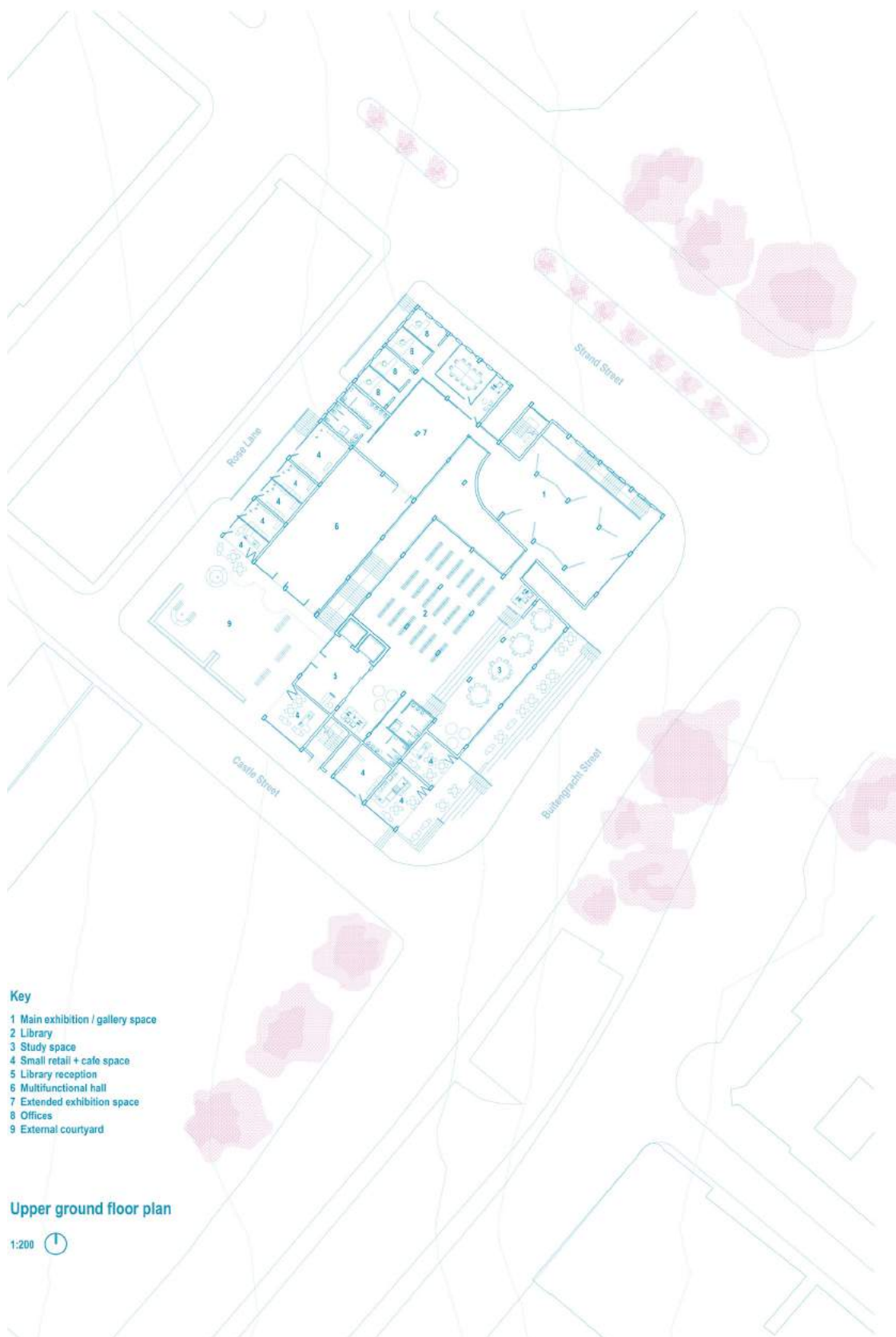



First floor plan

1:200 



Second floor plan

1:200





Fourth floor plan

1:200 



Third floor plan

1:200 

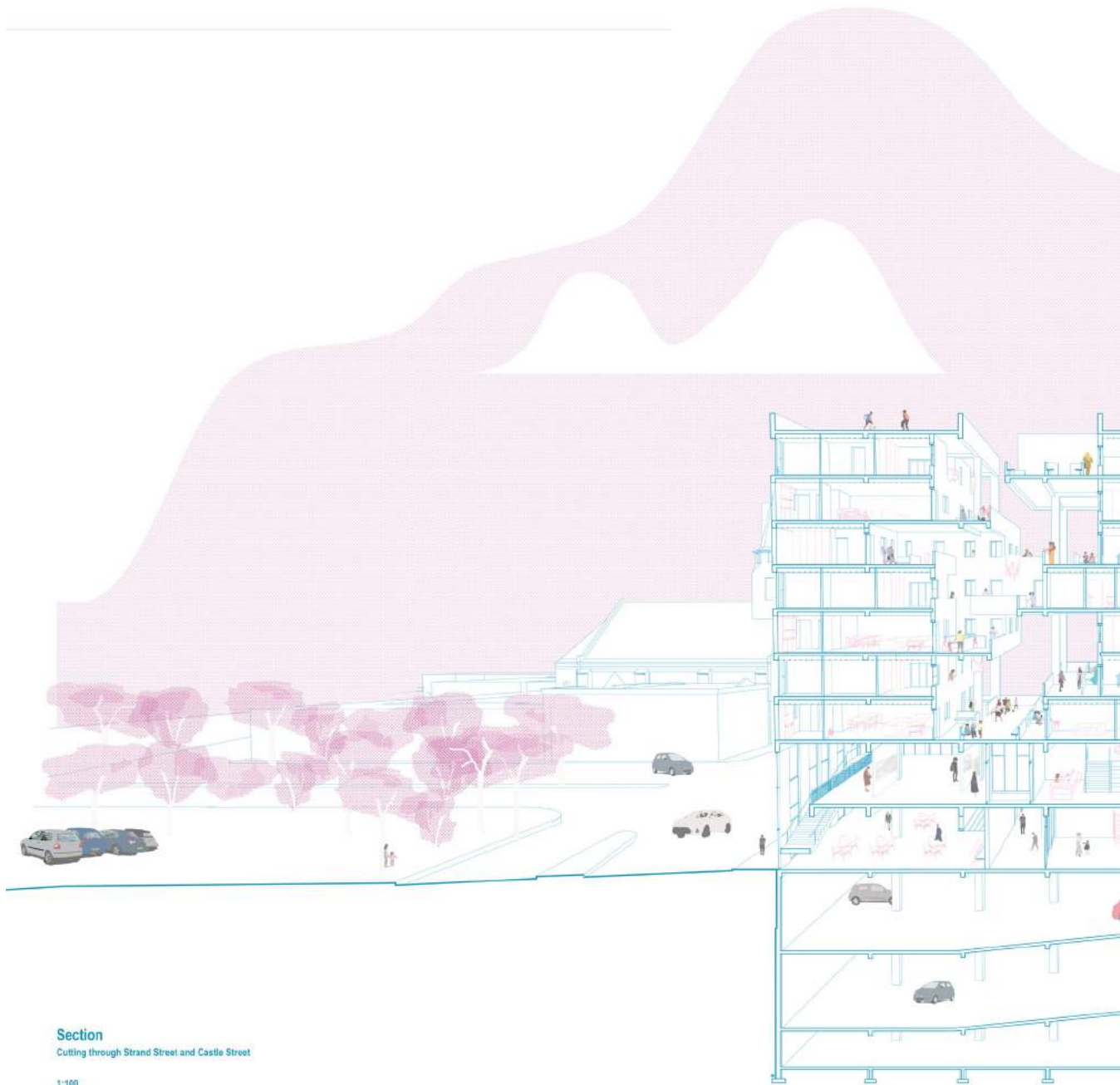

Section
Cutting through Strand Street and Castle Street

1:100





Street Perspective

Castle street elevation

1:200





North eastern elevation

Strand Street

1:200



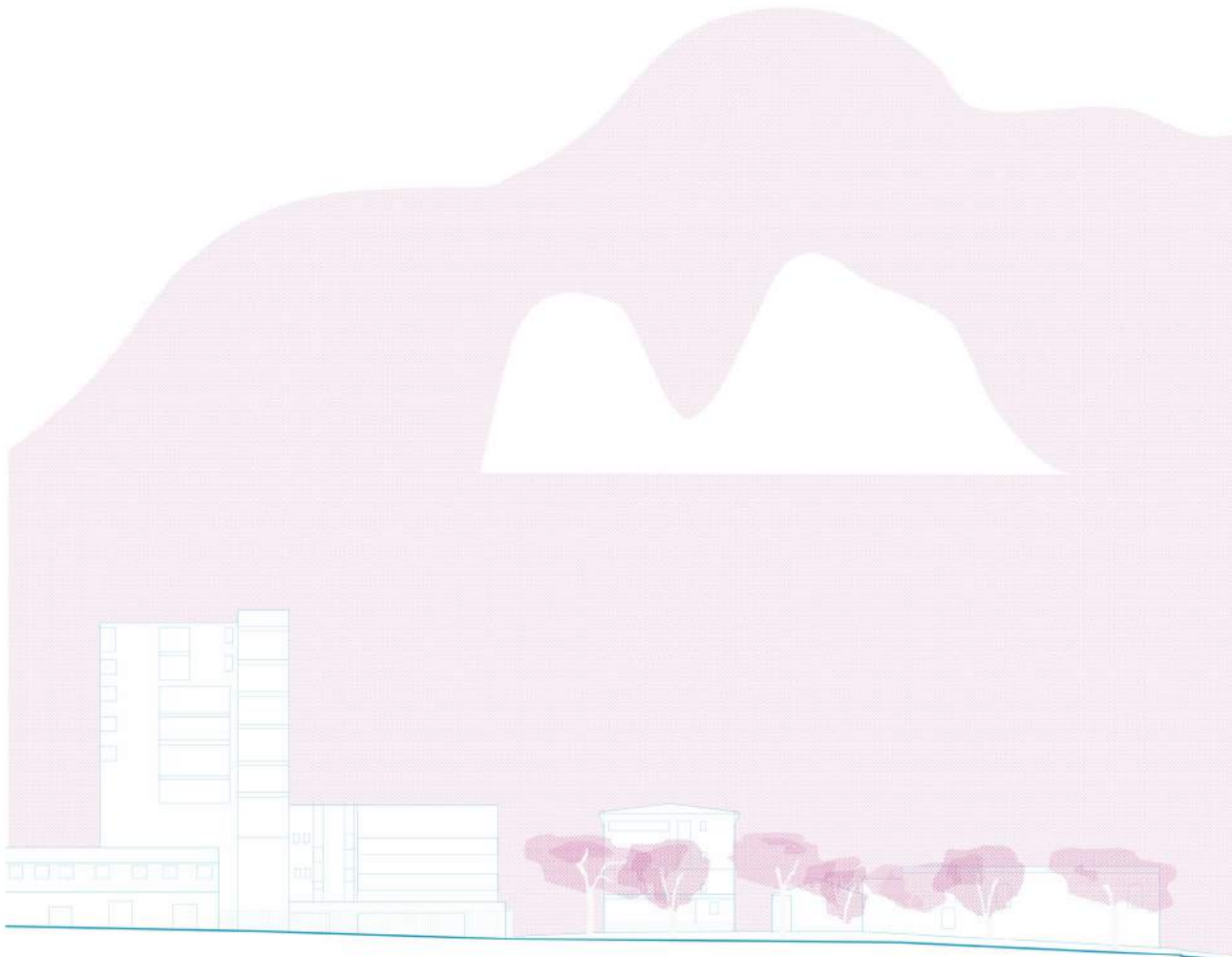

South western elevation

Buitengracht Street

1:200



Bibliography

- Alexander, Christopher. *A Pattern Language*. New York: Oxford University Press, 1977.
- City of Cape Town. "Spatial Development Framework." Statutory Report, Cape Town, 2012.
- Davids, Achmat. *The Mosques Of Bo-kaap. A Social History Of Islam At The Cape*. Cape Town: The South African institute of arabic and islamic research, 1980.
- de Certeau, Michel. *The Practice of Everyday Life*. Translated by Steven Rendall. University of California Press, 1984.
- Environment and Heritage Resources Management Branch. "Bo-Kaap Heritage Protection Overlay (HPO)." Cape Town, 2015.
- Fransen, Hans. *A guide to the old buildings of the Cape*. Johannesburg: Jonathan Ball Publishers, 2004.
- Fransen, Hans, and Mary Alexander Cook. *The Old Buildings of the Cape*. Cape Town: A A Balkema, 1980.
- Gehl, Jan. *Life between buildings: Using public space*. London: Island Press, 2011.
- Lewcock, Ronald B. *Early Nineteenth Century Architecture in South Africa: A Study of the Interaction of Two Cultures, 1795-1837*. the University of Michigan: A.A. Balkema, 1963.
- Low, Setha M., and Denise Lawrence-Zuniga. "Locating Culture." In *the anthropology of space and place*, 1- 43. Oxford: Blackwell Publishing, 2003.
- Shell, Robert. "Arson and Architecture." In *Children of bondage : a social history of the slave society at the Cape of Good Hope, 1652-1838*, 247-276. Johannesburg: Wiywatersrand university press, 1994.
- Todeschini, Fabio, and D Japha. "Cultural identity and architectural image in Bo-Kaap, Cape Town." In *The end of tradition?*, by edited by Nezar AISayyad. 2004.
- Toffa, Tariq. "Cape Town. Bo-kaap: The architecture of identity." *VERNACULAR ARCHITECTURE SOCIETY OF SA: WORKSHOP II. STUDIES AND DEBATES IN VERNACULAR ARCHITECTURE* . Cape Town, 2004. 16-35.
- Truluck, Timothy. *Bo-Kaap: Changing Attitudes and Actions*. Honours Thesis, Cape Town: University of Cape Town, 1989.
- Worden, Nigel , Vivian Bickford-Smith, and Elizabeth van Heyni. *Cape Town : the making of a city : an illustrated social history*. Cape Town: New Africa Books, 1998.
- Zumthor, Peter. *Atmospheres: Architectural Environments, Surrounding Objects*. California: Birkhauser, 2006.

List of Figures

All images in this document produced by the author unless otherwise stated.

2. "View of Chiappini Street", painting by Pieter Hugo Naudé
3. 'Cape Town 1860', image from the Morrison Collection, reproduced from the National Archive and edited by author
4. Image taken by Sharon Benjamin.
13. "Children at Play - Girl Excluded", image taken from <http://costandinos.blogspot.co.za>
14. Image taken from <http://alamy.com>
15. Image from the P. Lyons Collection, reproduced from the National Archive
16. Photographer unknown, image taken from Etienne du Plessis' Flickr page
18. 'Alley between Haut Street and Berg Lane, Bo-Kaap', image taken by Eve Andersson
19. Image taken from <http://dev.iziko.org.za/dedi6.cpt3.host-h.net/museums/iziko-bo-kaap-museum>
20. Image taken from Independent Newspapers Collection from UCT Digital Collections
21. Still shot taken from <https://www.shutterstock.com/video/clip-30526909-stock-footage-bo-kaap-lion-s-head-and-table-mountain-aerial-shot.html?src=rel/11605712:0/gg>
23. Image (Ref: PHA) 'CT. Malay Quarter', reproduced from the South African National Library, Cape Town
25. Image taken from The Early Cape Muslims: A Study of Their Mosques, Genealogy and Origin by Frank Rosslyn Bradlow
28. Image from the P. Lyons Collection, reproduced from the National Archive
29. Image taken at the Bo-Kaap Museum
30. Image taken from <https://www.awoltours.co.za/blog/2013/02/28/bike-tour-the-bo-kaap-cape-town/>
31. 'The streets of Bo-Kaap after carnival, 2006', image taken by Tessa Gordon
32. Image taken by Henk Kruger for IOL
34. Image taken by Ashraf Hendricks
35. Image taken by Brenton Geach for IOL
36. Image taken by Branko de Lang

