



Philip Glass's *Tirol Concerto for Piano and Orchestra* (2000)

A Compositional Analysis of the Second Movement

Wilhelm Delpont

This dissertation is submitted in partial fulfilment of the requirements for the degree of Master of Music at the University of Cape Town.

April 2015

The copyright of this thesis vests in the author. No quotation from it or information derived from it is to be published without full acknowledgement of the source. The thesis is to be used for private study or non-commercial research purposes only.

Published by the University of Cape Town (UCT) in terms of the non-exclusive license granted to UCT by the author.

Declaration

I hereby declare that this dissertation, submitted in partial fulfilment of the requirements for the degree of Master of Music at the University of Cape Town, has not been submitted by me previously for a degree at another university. I declare that it is my own work and that any contributions to or quotations in this dissertation have been cited and referenced.

Signed:

W. H. Delpont

Date:

15/07/2015

Acknowledgements

I hereby acknowledge the financial assistance I received from the National Research Foundation (NRF) for this research project. The opinions I have expressed and the conclusions I have drawn are entirely my own, and not necessarily those of the NRF. I am grateful for the academic support from my supervisor, Dr Martin Watt at the University of Cape Town, and that of Prof. Ernest May and Dr Jeffrey Swinkin at the University of Massachusetts (Amherst). The non-academic support from friends and family is equally important, if not more so.

Abstract

Philip Glass is best known for his role in the establishment of the 1960s minimalist movement, which was characterised by an extensive reduction of musical means. Since the mid-1970s, the composer has adopted a richer, more complex musical language, and distanced himself from the minimalist label. Academic scholarship on the composer's more recent compositions is severely limited, with the result that he is often still viewed as a minimalist. This dissertation's focus is on a more recent work by Glass, the *Tirol Concerto for Piano and Orchestra* (2000), and thus seeks to contribute to our knowledge of the composer's more recent stylistic development and the extent to which it is minimalist. The research approach entails compositional analyses of the concerto's second movement from both literary and theoretical perspectives. The movement's conception, its background and factors that had an influence on its compositional content are explored through literature studies. This is followed by theoretical investigations of its musical characteristics through the application of functional harmonic analysis and neo-Riemannian theory. Findings from the research provide evidence that the composition's title stems from the 'Tyrolean character' that was requested by its commissioners. However, relations between the movement and the film *The Truman show* (1998) challenge the composer's affirmations of a Tyrolean folk-song basis. Musically, the movement consists of a simple, repetitive structural and harmonic framework that undergoes superficial variations through melodic, textural and rhythmic changes. Transformational coherence within a functional structure is an essential component of the movement's harmonic content. This dissertation concludes that the piece contains musical characteristics consistent with all of Glass's stylistic periods, including minimalism, as well as new compositional devices that have not been identified previously. It recommends further study of the composer's more recent output, especially through transformational perspectives, and a reconsideration of the ontology and appropriateness of stylistic labels such as minimalism.

Keywords: Philip Glass, *Tirol Concerto*, minimalism, *The Truman Show*, transformational theory

Table of Contents

Chapter 1: Introduction	1
1.1 Background and Motivation.....	1
1.2 Research Focus and Value	2
1.3 Research Aim and Objectives	3
1.4 Research Methodologies	4
Chapter 2: Glass's Stylistic Development.....	7
2.1 Introduction	7
2.2 Early American Works (1952–1964)	7
2.3 Paris Works (1964–1967)	7
2.4 New York Minimalist Works (1967–1970).....	8
2.5 The End of Minimalism (1970–1974)	9
2.6 The Opera Trilogy (1976–1983).....	10
2.7 Non-symphonic Compositions since the Trilogy (1981 –).....	12
2.8 Symphonic Works and Concertos (1987–)	13
2.9 Conclusion	14
Chapter 3: General Information and Background.....	16
3.1 Introduction	16
3.2 General Information and Compositional Background	16
3.3 Performances, Recordings and Applications.....	17
3.4 Reception and Popularity	20
3.5 Conclusion	21
Chapter 4: Tyrolean Relations	22
4.1 Introduction	22
4.2 <i>Maria! hilf doch mir</i>	22
4.3 Adaptation of <i>Maria! hilf doch mir</i>	27
4.4 Conclusion	34
Chapter 5: Film Relations	35
5.1 Introduction	35
5.2 <i>Raising the Sail</i>	35

5.3 Plot, Soundtrack and Reception.....	36
5.4 Conclusion.....	37
Chapter 6: Basic Compositional Content	39
6.1 Introduction.....	39
6.2 Tonality and Key	39
6.3 Form and Structure	42
6.4 Harmonic Content.....	46
6.4.1 Functional Approach.....	46
6.4.2 Transformational Approach	52
6.5 Structural Deviations.....	59
6.6 Fractal Relations and Organicity.....	60
6.7 Conclusion.....	62
Chapter 7: Variations	64
7.1 Introduction.....	64
7.2 Harmonic Variations.....	64
7.2.1 Melodic Applications.....	64
7.2.2 Accompanimental Changes.....	71
7.2.3 Scales	71
7.3 Textural, Rhythmic, Orchestral and Timbral Variations	73
7.4 Inversional and Dynamic Variations	77
7.5 Conclusion.....	78
Chapter 8: Comparisons.....	79
8.1 Introduction.....	79
8.2 Characteristics of Earlier Periods.....	79
8.3 New Developments	81
8.4 Conclusion.....	82
Chapter 9: Conclusion.....	83
9.1 Introduction.....	83
9.2 Findings on Research Objectives.....	83
9.3 Contribution to Knowledge and Recommendations.....	85

9.4 Limitations	86
9.5 Self-reflection	86
List of References	87
Appendix A: Score of the Second Movement of the <i>Tirol Concerto</i>	96
Appendix B: Analytical Methodologies in Current Musicology	118
Appendix C: Plot and Principal Themes of <i>The Truman Show</i>	120

List of Figures

Figure 1: Performances of the 'Tirol Concerto'	18
Figure 2: Handwritten signature of 'Maria! hilf doch mir'	23
Figure 3: Later copy of 'Maria! hilf doch mir'	24
Figure 4: First verse of 'Maria! hilf doch mir'	25
Figure 5: Original text of 'Maria! hilf doch mir' from Sieber (1839).....	26
Figure 6: Introductory chorale to the 'Tirol Concerto'.....	28
Figure 7: Original melody of 'Maria! hilf doch mir' transposed to B \flat major	29
Figure 8: Glass's adaptation of 'Maria! hilf doch mir' in the first movement	30
Figure 9: Chords foreign to the B \flat major tonality in the introductory chorale	31
Figure 10: Comparison of phrase 40 of the first movement with the introductory chorale	32
Figure 11: Comparison of the second movement's first melody with 'Maria! hilf doch mir'.....	33
Figure 12: Natural and raised sevenths in Handel's 'Passacaille', HWV 432 No.7.....	40
Figure 13: Natural sixth and seventh steps in the second movement	41
Figure 14: Superimposition of raised and flattened sixth and seventh steps	42
Figure 15: Overall structure.....	43
Figure 16: Basic harmonic progression.....	44
Figure 17: Overall harmonic content	45
Figure 18: Overlapping cadences on phrase level.....	47
Figure 19: Second inversion tonic chords at the end of the movement.....	48
Figure 20: Upward resolution of the seventh in a progression from V 7 to i.....	49
Figure 21: Progression from III to i through an inversion of V 7 in Mozart's 'Rondo', K.511	50
Figure 22: Progression from III to i through inversions of V 7 in the second movement	51
Figure 23: NRT transformations in third-related chords of the basic harmonic progression	53
Figure 24: NRT transformations in third-related chords of the basic harmonic progression	54
Figure 25: Constant tones and parsimonious voice-leading in a progression from i to VI.....	54
Figure 26: Terminations and resolutions of F \sharp	55
Figure 27: Movement from VI to III	56
Figure 28: Movement from VI to \flat VII.....	56
Figure 29: Hypothetical NRT transformations in chords that are not third related	57
Figure 30: Hypothetical NRT transformations in chords that are not third related	57
Figure 31: Basic harmonic progression considered on the 'Tonnetz'	58
Figure 32: Mirror structures	61
Figure 33: Melodic content.....	65
Figure 34: Melodies and instrumentation	66
Figure 35: Harmonic variation with melody 1	66
Figure 36: Harmonic variations with melody 2	67
Figure 37: Harmonic variations with melody 3	68

Figure 38: Overall harmonic content with melodic variations	70
Figure 39: Scales on consecutive V chords	72
Figure 40: Textures of sections 1–3	74
Figure 41: Textures of sections 4–6	74
Figure 42: Textures of sections 7–8	75
Figure 43: Textures of sections 9–11	75
Figure 44: Beat divisions in the accompaniment.....	76
Figure 45: Inversional and bassline variations	77

Symbols and References

The *Tirol Concerto for Piano and Orchestra's* score¹ is in the form of a handwritten manuscript, which makes reading it complicated at times. The music examples included in this dissertation have been set to a digital format by the author. Errors that have been found on the handwritten score are pointed out in the discussion where necessary. The original score has no key signature indications, and makes use of accidentals throughout. This further complicates ease of reading, as certain overarching tonalities are assumed at times. The use of bracketed accidentals in many cases does, however, reduce confusion.

The *Tirol Concerto's*² entire score is divided into smaller segments that are only a couple of bars in length. Each of these segments is numbered on the score in a block, and ends with a double bar line. The divisions and numbering were done by the composer. The segments are often repeated, as indicated with repeat and *dal segno* signs on the score. These segments usually contain a single phrase and are too short for the blocked numbers to be considered rehearsal marks. For this reason they are referred to as 'phrases' in the discussion. In this text these phrases are abbreviated as P(n), where 'n' is a phrase's blocked number on the score. P1 thus refers to phrase 1 of a particular movement. Bars are not numbered on the original score. For this reason they are referred to as P(n)B(n), where 'n' is a bar's number in a particular phrase. P2B3 thus refers to bar 3 of blocked phrase number 2 of a particular movement.

Conventional Roman numeral symbols are applied throughout the document. A chord that does need clarification, however, is the major subtonic chord (F \flat , A, C) of G minor. Symbol \flat VII is used for this chord to indicate that the harmonic minor's seventh step is flattened by a semitone from F \sharp to F \flat .

Numbers less than 21 are written out in the text, except where they form part of a sequence. In reference to numbered entities such as bars, phrases, melodies and sections, numerals are used. For example, "bar 2 has been omitted" instead of "bar two has been omitted". The Harvard-UCT reference and citation style is applied.

¹ A copy of the score of the second movement of the *Tirol Concerto* can be found in Appendix A.

² The full title is often shortened to *Tirol Concerto* for ease of reference.

Chapter 1: Introduction

1.1 Background and Motivation

Philip Glass is best known for his role in the establishment of the minimalist music movement of the 1960s, along with fellow American composers La Monte Young, Terry Riley and Steve Reich (Strickland, 2014). Strickland (1993:7) defines minimalism as:

A movement, primarily in postwar America, towards an art – visual, musical, literary, or otherwise – that makes its statement with limited, if not the fewest possible resources, and art that eschews abundance of compositional detail, opulence of texture, and complexity of structure.

Accordingly, these composers pioneered a new compositional language in which harmonic, melodic and rhythmic elements were reduced to a minimum, and in which the use of processes dominated thematic material (Potter, 2014). In the late 1960s Glass developed a unique additive minimalist style, as seen in compositions such as *Two Pages* (1968) and *Music in Fifths* (1969) (Strickland, 2014). Characteristics of these works are their pulsating rhythms, extensive repetitions, repeated quavers and formal structure (Bernard, 1993:99, 122).

In the mid-1970s Glass underwent an epochal shift away from the minimalist style that made him famous. Page (1997b:5) writes that the composer in fact loathes the minimalist label that is so often applied to him. In 1980 Glass stated “I think that word should just be stamped out! To call it ‘minimal’ is just a mistake” (1997a:50). Accordingly, the author of Glass's biography on his official website announces that in the last couple of decades “there has been nothing ‘minimalist’ about his output” (*Philip Glass: Biography*, 2015). Potter (2000), Strickland (1993) and Schwarz (1996) agree that Glass’s purely minimalist writing ended in the 1970s and concluded their discussions on minimalism around this time. Strickland (1993:253) believes that the composer adopted a more cumulative, progressive and harmonically complex style after his minimalist period. Compositions that followed are characterised by melodic emphasis, timbral diversity, richness and harmonic movement (Smith, 2007).

However, even though four decades have passed since the scholarly renunciation of the term, Glass is often still viewed as a minimalist composer. In a BBC review of Glass's opera *Waiting for the Barbarians* (2005) the author writes: “Its music contains all the characteristics of the minimalist style that made him famous” (*Philip Glass Opera...*, 2005). Many recent publications on 20th-century music have limited themselves to a discussion of Glass as minimalist too.³

³ Ross (2007) and Whittall (2003), for example, are two of numerous such publications.

Stylistic labels such as post-minimalist, neo-romantic, neo-tonal, and neo-classical have been given to the composer's more recent compositional language. However, there is still no consensus in scholarly writing on the application, ontology, scope or specific characteristics of these labels. Bernard (2003:130) argues that such terms are limited and insufficient, and believes that an adequate term has yet to be coined. Not surprisingly, contradictory statements on the stylistic nature and minimalist extent of Glass's more recent compositional language are clearly evident.

There are a fair number of publications on Glass's compositions from his minimalist period and especially his opera trilogy.⁴ However, academic scholarship on his more recent compositions and in particular his symphonic works is severely limited.⁵ Even the comprehensive music dictionary *Grove Music Online* (2014)⁶ contains only a brief description of them. Numerous authors have commented on the lack of musicological scholarship on Glass, especially in relation to his more recent compositions. York (1985:81) writes:

Much controversy has surrounded the work of the American composer, Philip Glass. Although his compositions have been performed with critical and popular acclaim in Europe and America, in such auspicious institutions as Carnegie Hall and the Metropolitan Opera, there have been few efforts to understand the structure of this music and there seems to have been little if any serious analysis of the work to justify praise or criticism.

Maycock (2002:15) asks: "what about Philip Glass the writer of symphonic scores? There is next to nothing to read about him". There are gaps in the musicological, and especially the analytical, study of Glass's more recent compositional style. Schwarz (1996:108) writes: "Philip Glass is more than just a composer. By the 1990s, he has attained the enviable status of mass-culture phenomenon. No living composer has sold more recordings and become such a force". If Schwarz's views are true, then musicological scholarship has mistakenly ignored four decades' output of a very important role player in contemporary music.

1.2 Research Focus and Value

The contradictory opinions on Glass's more recent compositional style can possibly be attributed to insufficient scholarly knowledge on the topic. Only through academic research can the gap in musicological practice, as noted by York (1985:81) and Maycock (2002:17), be eliminated. This dissertation attempts such an academic study and seeks to contribute to our knowledge in the

⁴ Glass's opera trilogy comprises *Einstein on the Beach* (1976), *Satyagraha* (1980) and *Akhmatov* (1983).

⁵ Chapter 2 contains a literature review of academic scholarship on Glass's compositions.

⁶ The last update of *Grove Music Online* was done in 2014.

field. Its subject matter is a more recent composition by Glass, the *Tirol Concerto for Piano and Orchestra* (2000). This relatively unknown work falls outside the composer's ground-breaking minimalist period of the 1960s and 1970s, and is one of many symphonic works on which there is very little academic information available.

This dissertation undertakes a compositional analysis of the second movement of the *Tirol Concerto*.⁷ Analysis in this sense constitutes both contextual and theoretical perspectives in the exploration of the piece's compositional content. Grimshaw (2002:476) argues that technical, analytical approaches can offer much insight into Glass's compositional strategies, his development and the stylistic changes he underwent as a symphonist. This dissertation's importance and value lie in supplementing such insights. It contributes to our understanding of Glass's more recent compositional language and its stylistic nature. It challenges the appropriateness of stylistic labels such as minimalism and post-minimalism, and attempts to address the contradictory, incoherent opinions in current musicological scholarship. Even though the subject matter of this study is only a small sample of the composer's oeuvre, it is representative of an almost untouched branch of scholarly work. Finally, the technical, analytical nature of the research approach is an important addition to a musicological field that is saturated with descriptive, informal literature.

1.3 Research Aim and Objectives

The overall aim of this dissertation is to provide a compositional analysis of the second movement of Glass's *Tirol Concerto*. The following objectives have been identified as important in realising the aforementioned aim:

- Review of academic literature on Glass's compositional language from his early minimalist works to his more recent compositions in order to identify the changes that have taken place in his stylistic development;
- Explore the piece's background and conception by scrutinising factors that had an influence on its compositional content, such as the requirements of its commission and its relation to other works;
- Critically evaluate the piece's compositional content through a theoretical analysis of its musical characteristics and the techniques applied by the composer in its composition;
- Relate the piece's musical characteristics to Glass's earlier works in order to better understand the composer's more recent compositional language, its minimalist extent, and the presence of any new compositional devices.

⁷ The second movement of the *Tirol Concerto* is often referred to here as 'the piece' for ease of reference.

1.4 Research Methodologies

A vast amount of literature is available on Philip Glass, the majority of which is in the form of reviews, newspaper clips, magazine articles and online literature. Academic research on the composer is limited, especially on the compositions he wrote after his minimalist period. In past academic literature a range of research approaches was applied to the composer and his compositions. The majority of these are biographical in nature with only descriptive references to compositions, as seen in Mertens (1983) and Schwarz (1996), for example. More contextual approaches are seen in the publications of Strickland (1993) and Fink (2005). Strickland questions the ontology of minimalism in music and the arts, whilst Fink relates minimalism to American consumerism in a socio-musicological perspective.

Analytical research on Glass's early compositions, and minimalism in general, are quite rare. "Minimal music was not accompanied by a flood of polemical rhetoric – and the academics have accordingly given them little analytical attention", writes Warburton (1988:135–136). His approach identifies and describes minimalist techniques such as repetitions, additive rhythms, phasing and overlapping. In Bernard's (1995) study minimalist compositions are transformed to the visual domain and interpreted within a global framework. A quantitative analysis of the repetitions, pulses and rhythmic patterns in *Two Pages* (1968) is done by York (1985). Wu's (2009) application of a 'post-Schenkerian' analysis to *Glassworks* (1981) is also noteworthy.

Warburton (1988:136) states that more conventional analytical approaches should be applied to Glass's compositions after the 1970s as result of the resurgence of tonality, triadic chord sequences and cadential progressions in his work. However, there is still little scholarly material, and it is only Glass's own publication (1987), the seminal work by Potter (2002)⁸ and a thorough study by Richardson (1999) that include some analytical material. Analytical studies on Glass's symphonic works, concertos and compositions of the last two decades are virtually non-existent. Maycock's (2002) approach to these works is descriptive, with only superficial analytical considerations. The application of transformational theory in addition to functional analyses, as applied in this study, has not been found in any literature on the composer.

The information included in this dissertation is a product of two principal research strategies that are directly related to its research aim and objectives. The first two research objectives are realised through the application of literature based studies. Literature on Glass's compositional language is reviewed in order to identify the changes in musical parameters in the composer's oeuvre. Special emphasis is given to the composer's early works in order to circumscribe their

⁸ Chapman (2013:3) writes that Potter's publication "has served as the cornerstone of all minimalist musicology in the twenty-first century".

minimalist qualities. Sources included in the literature review are primarily academic in nature and consist of scholarly books and periodicals. Important works referenced are Glass's autobiographical publication (1987), and those of Schwarz (1996), Potter (2000), Mertens (1983) and Strickland (1993). The comprehensive inclusion of non-academic literature such as magazine articles, internet sources and newspaper entries in this section is not feasible considering the vast amount of information available on the composer's entire oeuvre. The product of this literature review is a chronological summary of the musical characteristics of Glass's compositional output divided into the most important stages.

Explorations of the piece's conception, its background, and factors that had an influence on its composition are also done through literature studies. Information on its initial commission, performances, applications and reception is included. Both academic and non-academic sources on the *Tirol Concerto* are consulted in this section because of the specificity of the subject matter and the lack of available information. Important sources consulted are Maycock (2002), Lepuschitz (2002), archival material on the folk song *Maria! hilf doch mir* (1822),⁹ and the film *The Truman Show* (1998). Most information included is in the form of literary and historical discussions. However, some analytical comparisons of the movement's melodic material to *Maria! hilf doch mir* and *The Truman Show's* soundtrack are included.

Analytical approaches such as those promoted by Grimshaw (2002:476) are implemented to realise the dissertation's third objective: to critically evaluate the piece's compositional makeup. In-depth analyses of the piece's musical content and the compositional techniques applied by the composer are undertaken. The principal characteristics discussed are structure, tonality and harmony, whilst shorter considerations of texture, rhythm, dynamics and orchestration are also included. These analytical approaches are primarily based on readings of the concerto's score.

Two theoretical perspectives are adopted in the analysis of the piece's harmonic content. Firstly, in accordance with Warburton's (1988:136) suggestion, a conventional approach through the application of functional harmonic analysis¹⁰ is done. The piece's tonal, triadic content, and its chordal and cadential progressions, are to some extent explainable through such an approach. However, the approach is limited in cases where the tonal language is not functional. Engebretsen

⁹ The punctuation and use of capitals in the title have been kept constant with Sieber's original text (1839), which is discussed in more detail in Chapter 4.

¹⁰ Functional harmonic analysis constitutes conventional Roman numeral analysis within a tonal syntactical framework.

and Broman (2007:59) propose transformational theory, and in particular neo-Riemannian theory (NRT), as an alternative to functional analysis for neo-tonal¹¹ music. They write (58):

Neo-tonal works, particularly those sometimes referred to as 'neo-Romantic', often include passages that are triadic but tonally indeterminate [...] these passages may include certain functional elements, such as anchoring cadences, but whereas the Romantic-era passages tend to be organized so as to integrate smoothly into otherwise full functional frameworks, neo-tonal passages often appear in nonfunctional contexts or in some way mark their distance from the historical mode.

Following the application of a functional harmonic approach, a neo-Riemannian perspective is adopted in the analysis of the piece's harmonic content. It is, however, through the combination of both functional harmony and NRT that the piece's compositional content is best explored.

A comparative approach is applied to achieve the fourth and final objective: to collate the piece's musical characteristics with those of Glass's earlier works. In this section the musical characteristics of the second movement of the *Tirol Concerto* are compared to those of the composer's main stylistic periods in order to establish their origin and initial applications. In doing so, the piece's minimalist qualities are identified, as well as those that stem from other periods of the composer's stylistic development.

Mouton (2001:138) argues that it is important for scholars to constantly reflect, in a critical manner, on their research decisions and methodologies. Scholarly paradigms, meta-discourses and philosophies within a field of study should be taken into account when deciding on research strategies (140). Accordingly, trends in current musicological scholarship were studied, and it was decided that a combined theoretical and contextual research approach is most suitable to achieve this dissertation's research aim. A discussion on the position of analytical methodologies, such as those applied in this dissertation, within current musicological paradigms, is included as Appendix B.

¹¹ The authors do not specifically clarify their use of the term 'neo-tonal'. However, it can be seen as an umbrella term for compositions in the 20th and 21st centuries in which there is a resurgence of triadic, tonal musical parameters.

Chapter 2: Glass's Stylistic Development

2.1 Introduction

When questioned on changes in his compositional style, Philip Glass remarked, "It is an evolution that seems to be continuing" (Simon, 1983:137). This chapter reviews the academic literature on Glass's compositional language from his early minimalist works to his most recent compositions in order to identify the changes that have taken place in his stylistic development. This is in accordance with the dissertation's first research objective. The product of this literature review is a more or less chronological overview of Glass's compositional output, which is divided into his main stylistic periods. Discussing all the compositions in Glass's oeuvre would be a near impossible task considering the size of the composer's output. "What critic could keep up with the amount of music the man writes", jests Gann (2001:118). Hence, the compositions on which academic literature is available frame the chronological narrative.

2.2 Early American Works (1952–1964)

Numerous compositions by Glass were published during his student years, but were later disowned by the composer (Fisk & Nichols, 1997:466). Not much is known about these compositions except that they were in a "more traditional style" (Mertens, 1983:67). Glass states that "they were just music like everybody else wrote" (Grimes, 1997:19), and that they were the errors of his youth (Kozinn, 1997:104). A twelve-tone string trio was written while the composer was still studying in Chicago. However, Glass rejected atonality soon afterwards and the compositions that followed were in a tonal style reminiscent of Copland (Schwarz, 1996:109, 111). Choral works such as *The Haddock and the Mermaid* (1962–1963) and *Haze Gold* (1962) are mentioned by Potter (2000:253), who considers them to be quite unadventurous.

2.3 Paris Works (1964–1967)

Of Glass's Paris compositions during his studies with Nadia Boulanger, only a score of the *String Quartet No. 1* (1966) has survived. Potter (2000:274) writes that these early works are all quite similar and based on repeated structures. Strickland (1993:207) states that although repetitive emphasis is already found, the compositions are quite different from those that followed in New York. *Play* (1965) is a reductive, static work scored for soprano saxophone, and makes use of only two notes in a repetitive, pulsing rhythm (Glass, 1987:19). *String Quartet No. 1* is a highly dissonant, almost serial composition in contrast to the New York minimalist works (Strickland,

1993:206). Its two main sections are subdivided into an array of smaller parts separated by pauses, unlike the more continuous structures found later in the composer's development (Potter, 2000:275). Strickland (1993:206–207) writes that the first string quartet contains repeated syncopated figures, phrases in symmetrical blocks and a regular metre. Alburger (2003:3) argues that the piece is in a symmetrical ternary rondo form, whilst Potter (2000:276–277) mentions its cyclical structures and palindromic patterns.

2.4 New York Minimalist Works (1967–1970)

The compositions written on Glass's return from Paris in 1967 are considered truly minimalist. Schwarz (1996:119) writes that Glass's New York compositions became radically more simplified, and that his use of dissonance and chromaticism ceased. The works are orchestrated for amplified instruments and characterised by perpetual motion, pulsating rhythms and relentless repetitions with no changes in dynamics or tempo (122–123). Strickland (1993:208, 211) notes their diatonic motorism, synchronised voices, parallel intervals, harmonic stability and fixed metre. They are made up of modular, fragmented material on a small number of pitches and played in continuous quavers. Glass writes (1987:8) that his early works were based on a highly arithmetic system derived from Indian music, which he labelled "additive processes". It soon became a characteristic feature of Glass's style and his most innovative contribution to the minimalist movement. In additive technique, repeated melodic or rhythmic figures are augmented or reduced by the addition or omission of small cells (Mertens, 1983:70). Cyclical applications are found too, in which rhythmic patterns of different lengths are superimposed, causing them to synchronise intermittently (Glass, 1987:59). Phrygian, Myxolydian, Lydian and pentatonic modalities result from the compositions' different note combinations, writes Potter (2000:280). Wasserman (2009:20) refers to the character of Glass's minimalist compositions as "non-narrative", Rockwell (1983:113) as "meditative and trancelike", and Karolyi (1996:112) as "hypnotic".

Potter (2000:252) divides Glass's minimalist works into two categories: those using intuitive, loosely structured additive processes, and those that apply such processes in a more rigorous manner. He believes the latter are seen in compositions following *1+1* (1968). Of the New York dayworks preceding *1+1*, only *Strung Out* (1967) for amplified violin was ever published (278). In addition to the aforementioned minimalist characteristics, the piece's mechanical arpeggios and scalar passages in major and pentatonic modalities can be noted (Alburger, 2003:6). Repetitive patterns in triplet figures, and the omission of bar lines and accidentals on the score

are also seen (Strickland, 1993:212). Other New York compositions preceding *1+1* include: *Head On* (1967), *Gradus* (1968) and *Piece in the Shape of a Square* (1968).

Since *1+1*, a logical sequence of compositions followed that introduced thicker textures, more elaborate contrapuntal applications and strict additive processes (Potter, 2000:287). In these works there are no regular metres and the number of repetitions played often remains unspecified. Instrumentation and registers are flexible, dynamics loud, tempos fast, and rhythms regular and steady (ibid.).

1+1 (1968) is a percussive piece for amplified table top based on two rhythmic units that are systematically combined and alternated (Schwarz, 1996:120). The piece is not fully notated and has an improvisational element, as performers decide on the sequence and number of repetitions of the rhythmic units (Potter, 2000:270). In *Two Pages* (1968), two amplified instruments play patterns of only five pitches in rhythmic and melodic unison. York (1985:95, 98) argues that the piece has a tonal polarity, and identifies its stages of stability and instability. In *Music in Fifths* (1969) Glass doubles the pitch scheme of *Two Pages* at the perfect fifth (Potter, 2000:292). Whilst it has a more regular metre than *Two Pages*, it is structurally and harmonically less sophisticated (293). In *Music in Contrary Motion* (1969) Glass applies two voices in a tonal inversion. Potter states that Glass adds pedal points and that the piece's additive processes are harder to follow than those of previous works (294–295). In *Music in Similar Motion* (1969) the number of contrapuntal voices is increased to four (Schwarz, 1996:123). Potter (2000:299) believes that the piece has a “much richer, more complex modality than may be found in any of Glass's earlier works”, and a “subtlety, richness and depth foreign to its predecessors” (294).

2.5 The End of Minimalism (1970–1974)

It is widely recognised in scholarly writing that Glass's truly minimalist period ended in the 1970s. Mertens (1983:72) states:

An evolution can be seen after 1970, when he [Glass] leans towards a growing vertical differentiation – the use of harmony as structural principle. The musical texture has become richer and more differentiated through the expansion of Glass's ensemble and the concern with rhythmic structure is no longer dominant.

Similarly, Strickland (1993:253) argues that minimalism proper in Glass's compositions ended in 1974, even though the label gained popularity in literature only afterwards. Schwarz (1996:128) refers to the composer's work after 1974 as “maximalist”, and Potter (2000) ends his book on

minimalism with Glass's opera *Einstein on the Beach*¹² (1976). In *Music with Changing Parts* (1970) Glass combines elements from *Music in Fifths*, *Music in Similar Motion* and *Music in Contrary Motion* (Strickland, 1993:229). It contains elements of improvisation as performers are allowed to add sustained notes and drones to certain sections (Potter, 2000:306). Whilst the piece is rhythmically similar to previous works, an increased emphasis on harmony, textural changes, timbral colour and root movement chordal progressions are found (307–309). Coordinated dynamics, expanded registers and contrapuntal lines contribute to the establishment of what Potter refers to as a “shifting sound world” (311). Mertens (1983:77) writes that the piece contains harmonic differentiations through the application of sudden modulations and tonal transitions.

Schwarz (1996:127) as well as Haskins, Glass and Riesman (2002:512) believe that *Music in Twelve Parts* (1971–1974) is Glass's first true ‘non-minimalist’ work. *Music in Twelve Parts* is characterised by directional harmony, modulation, tonal organisation, cadences and chromaticism (Schwarz, 1996:128). Rhythmic ingenuity, counterpoint and metric variations are also found (Potter, 2000:315). Potter argues that in this composition harmony for the first time becomes a structural tool for Glass (313–314). He views the tonal system as coherent yet ambiguous, and details the tonalities and modalities of the twelve parts with corresponding pitch combinations. Other characteristics that have been noted include: shifting tonal colours (Ehrlich, 1997:19); ever changing rhythmic patterns (Lange, 1997:89); dense textures (Howell, 1997:95); overlapping figures (Lemieux, 2000:36); and hints of root movement harmony (Potter, 2000:312).

2.6 The Opera Trilogy (1976–1983)

Following the four-hour-long *Music in Twelve Parts*, Glass embarked on an even bigger project, an opera. His first opera *Einstein on the Beach* (1976) was followed by another two, *Satyagraha* (1980) and *Akhnaten* (1983), to complete what is known as his opera trilogy. In the operas the composer developed a much more expressive language than in any of his earlier work (Glass, 1987:62). They are richer, with more melodic emphasis, narrative developments and timbral diversity (Potter, 2000:16). Greater separations between melody and accompaniment, as well as foreground and background structures are also evident (327, 338).

Much of *Einstein's* compositional material was taken from a work titled *Another Look at Harmony* (1976) (326). In Glass's ‘new look at harmony’, he explored a “new way of combining rhythmic

¹² *Einstein on the Beach* is often shortened to *Einstein* for ease of reference.

and harmonic structure into an overall unified process” (Glass, 1987:62). In the piece, Mertens (1983:79) writes:

Chords are used in a way that takes them outside the tonal functionalism of the classical system – that is, relatively simple chords are placed side by side in parallel on different degrees of the scale, causing the tonal relationship to disappear too.

Einstein forms a link between Glass’s minimalist compositions and the operas that followed, as its material contains elements of both. Additive rhythms, cyclic processes, streams of eighth notes, and drones, which are reminiscent of earlier works, are found. However, an increased emphasis on harmony and simple root–movement progressions are also evident, which are representative of the operas that followed (Glass, 1987:62). Glass (ibid.) writes: “once this [harmonic] movement had entered my music, it marked a sharp break with the very rhythmically charged, but harmonically static, music I had written before”. Different combinations of harmonic progressions and rhythmic structures are applied in each of *Einstein’s* scenes (59). A chaconne bassline is used, which would become an important characteristic in *Satyagraha* and many of the composer’s later compositions (Potter, 2000:327). In accordance with some earlier works, *Einstein* is often tonally ambiguous with a polytonal character (Gann, 1997a:207). Subsections in the opera are well demarcated in contrast to earlier compositions, as barred meters and phrasing indications are present (Potter, 2000:338). Potter believes that *Einstein* is made up of an extended tonal plan in which harmony actually becomes a structural element (327), whilst Raickovich (1994:71–72) identifies thematic unity and core motives in the opera.

Schwarz (1996:144) argues that Glass’s minimalist style was replaced by a neo–romantic, more expressive style in the 1980s. This statement rings true in relation to *Satyagraha*¹³ (1980), which Glass (1987:170) refers to as his “lyrical opera”. Rockwell (1983:118) states that *Satyagraha* is sensuous, flowing, meditative, and reminiscent of Fauré and Bruckner. It has a more standard orchestration than *Einstein*, but adds an electric organ (Glass, 1987:113). Schwarz (1996:143) states that *Satyagraha’s* vocal lines are small in range, but soar above the orchestra. Extensive use of the chaconne form through different rhythmic and vocal combinations over seven harmonic progressions is found (Gann, 1997b:268). Modal applications are common, as seen in the use of repeated Phrygian scales in the opening (Binford–Walsch, 2002:170). Hutcheon and Hutcheon (2011:726) state that the piece’s repetitions give the music a mantric, meditative quality.

¹³ Mahatma Gandhi’s passive resistance against racial prejudice in South Africa is the opera’s principal theme (Roddy, 1997:168).

Glass (1987:170) refers to *Akhnaten* (1983) as his “tragic opera” and states that it depicts everything from the violent to the lyrical (173). Warburton (1984:47) believes that it is intimate and expressive, and hesitantly refers to it as neo-classical, whilst Karolyi (1996:112) in contrast views it as new-romantic. Glass (1987:171) states that he made use of a colourful orchestration and a more soloistic compositional approach in the opera. He also applies leitmotifs, and assigns thematic devices and key centres to certain characters. Richardson (1999:68), in his extensive and detailed book on *Akhnaten*, states that harmonic ambiguity and bitonality are a distinctive feature of the opera. Such characteristics are also pointed out by Jouve-Martín (2010:89), Gann (1997a:205) and Frandsen (1993:243). Various elements contribute to the opera’s harmonic ambiguity, as detailed by Frandsen (1993:256) and Richardson (1999:69–82): obscure cadences; the emission of chordal thirds; avoidance of raised leading tones; unconventional voicing; parallel motion; second inversion triads; added-note chords; pedal notes; contrapuntal polytonality; overlapping melodies; and pseudo-modulations. Additive processes are also seen in *Akhnaten*, but are applied less rigorously than in earlier works. Block additive procedures in which a whole section is extended and not only a single bar are also found (Richardson, 1999:55, 57). Richardson states that complex rhythms, syncopation and polymetres contribute to the opera’s exciting character and sense of instability (59). He also believes that the entire opera can be viewed as a large cadential arc with subsidiary cadences (88). Other characteristic elements include dissonant passing notes (60), chaconne variation form (62), ritornellos (66) and the use of tonal blocks (87–88).

2.7 Non-symphonic Compositions since the Trilogy (1981 –)

Academic scholarship on the compositions that followed *Music in Twelve Parts* and the opera trilogy is incredibly limited. *Koyanisqaatsi* (1981) for chorus and bass solo has a dark, sombre and romantic character (Crowe, 2008:8–9). Reesman (2002:142) highlights its hypnotic arpeggios, whilst Fink (2005:161) believes that it rocks on a two-chord progression. *The CIVIL warS* (1983) and *The Juniper Tree* (1984), similarly to *Akhnaten*, assign thematic devices and key centres to principal characters (Glass, 1987:172). *Songs from Liquid Days* (1985) sees Glass collaborating with the pop artists Paul Simon and David Byrne (201). Swed (1988:578) states that *The Making of the Representative for Planet 8* (1986) has a sophisticated harmonic language with unconventional cadences and long-ranging harmonic progressions.

The Voyage (1992) is a dark, brooding, chromatic and dissonant opera commissioned by the Metropolitan Opera in New York. Repeated scales and soaring lyricism are present, as well as a more complex orchestration and irregular rhythmic cycles (Schwarz, 1996:160–161). The

composer states that he applied augmented triads in an extended diatonicism towards bitonality in *The Voyage* (Jouve–Martín, 2010:89). Other characteristics that have been noted are: polytonal qualities (ibid.), structural ingenuity (Swed, 1993:238) and syncopated rhythmic levels (Gann, 1997b:267). In *La Belle et la Bête* (1994), augmented triads are again found, as well as the use of whole-tone scales (Novak, 2011:148). *In the Penal Colony* (2000) is characterised by continuous shifts in tone and tempo in contrast to Glass's more regular rhythmic applications (Hostetter, 2001:66). The film score for *The Man in the Bath* (2001), according to Gann (2001:118), makes use of unexpected dynamic contrasts, rhythmic shifts and innovative melodies.

Crisp and Hillman (2010:30–31) write that Glass's soundtrack to *The Hours* (2002) is non-progressive, nonlinear, cyclic and makes use of repeated harmonies, triads and scalar passages. Its textures change continuously throughout and soaring melodies with triplet ostinatos in thirds are common. Force (2004:200, 205) believes that Glass's repetitions were in fact "softened" to fit the film's scenery. Wasserman (2009:20) writes that *Waiting for the Barbarians* (2005) ranges from the lyrical to the brutal, with hues of Shostakovich and Debussy. Dunn (2008:45) mentions the 19th-century type choral writing in *Appomattox* (2007), whilst Hajdu (2009:274) asserts that predictable melodies and chordal patterns can be found in the *Book of Longing* (2007).

2.8 Symphonic Works and Concertos (1987–)

"I never cared much for writing symphonic music because you just don't get many performances", Glass announced in 1989 (Thomson et al., 1989:195). However, the composer's attitude changed soon afterwards, as is evident from the large number of symphonies and concertos composed since then. There is very little academic writing on Glass's symphonic works, apart from a publication by Maycock (2002), from which most of the following information has been summarised.¹⁴

In Glass's symphonic works he returns to the style of the conventional concert tradition, writes Grimshaw (2002:474). He adds that his symphonic writing is lush, romantic and lyrical, with orchestral timbres and textures reminiscent of Elgar and Holst. Maycock (2002:82, 109) holds that Glass's symphonic works are elaborate and highly expressive, with long build-ups to climaxes, and dark orchestral colours. They are characterised by repeated scales, burbling arpeggios and predictable syncopations (Schwarz, 1996:166). Further characteristics include: subtle harmonic shifts; the use of themes and variations (Wasserman, 2009:20); repetitive, slowly

¹⁴ The *Tirol Concerto* will be dealt with later.

revolving passages (Reesman, 2002:142); sensuous and rich melodic writing (Binford-Walsch, 2002:169); and chromatically related triads (Gann, 1997a:203).

The *Violin Concerto* (1987) contains an expansive slow movement that can be seen as a predecessor for the lyrical slow movements of concertos that followed (Maycock, 2002:90). It incorporates pulsing chords, arpeggios, scales and chaconne variations within changing textures, which are also regular characteristics of Glass's later symphonic works. The *Violin Concerto's* juxtaposition of tonal blocks and sections can also be noted. Glass's *Low Symphony* (1992) is based on material from a pop album by David Bowie. Schwarz (1996:165) writes that it is genuinely symphonic, with climaxes, thematic statements, arching lyricism, and a post-romantic style reminiscent of Copland and Vaughan-Williams. Maycock (2002:81, 83) also views it as "Coplandesque", whilst Swed (1993:238) mentions its English pastoral symphonic character. In addition to Glass's application of traditional harmonic sequences, the use of bitonality and juxtaposed tonal blocks is noteworthy (Maycock, 2002:84).

Symphony No.2 (1994) contains many of the features of the *Low Symphony*, such as pulsations, blocks of music and textural changes over a static harmony (85-86). *Symphony No.3* (1995), for string orchestra, makes use of unconventional metres, rhythmic cycles, chromatic scales and longer progressions. Oscillations, luscious melodies and layered textures over repeated harmonic patterns are again found (87-89). The *Concerto for Saxophone Quartet* (1995) has a light timbre combined with augmented harmonies, free developments and scherzo characteristics (110-112). Glass's *Heroes Symphony* (1996) was also inspired by David Bowie and specifically written for use in a dance production (90-92). *Symphony No.5* (1999) is a choral symphony in twelve movements with a spiritual text (94-95). Maycock writes that it has a freer format than previous symphonies, grand sonorities, expressive solos and lyrical qualities (97-98).

Fitting its commission, the *Concerto Fantasy for Two Timpanists* (2000) is a percussive, brash, physical work that incorporates irregular metres into an energetic whole (115). Glass's *Cello Concerto* (2001) has a long lyrical slow movement and an energetic finale. Further characteristics include modal tonalities, drones, a sparse orchestration and virtuosic writing (125, 127). *Symphony No.6* (2002) combines developing rhythms, quick-changing chords and bitonality into a powerful and grand orchestral piece (101). Anderson (2014:62) writes that Glass's *Symphony No.10* (2012) has medieval flavours and echoes of Janáček and Bruckner.

2.9 Conclusion

With Glass's tenth symphony the chronological discussion of his oeuvre comes to an end. This chapter's objective was to review available academic literature on the composer's compositional language in order to identify the changes that have taken place in his stylistic development. His

compositional output was divided into a number of periods that more or less correspond to general changes in his compositional style. Characteristics of each of these periods were noted in relation to important compositions. It can be concluded that there is an element of sameness in all the composer's compositions. The presence of repeated patterns, arpeggios, additive processes, scales and cyclical structures for example, are essentially *Glassian*. From the discussion it is also evident that Glass's compositional language has changed considerably from his early repetitive, harsh, mechanical minimalist works to his lyrical, melodic, lush symphonic writing. In the following chapter the focus of the dissertation changes from Glass's entire oeuvre to concentrate on a specific composition, the *Tirol Concerto*.

Chapter 3: General Information and Background

3.1 Introduction

In pursuing the second research objective this chapter explores the background and conception of the *Tirol Concerto*. It opens with some general information on the piece and discussions on its title and the requirements of its commission. Listings of the concerto's performances, recordings, films, and applications in dance productions follow. The chapter concludes with a review of the composition's reception and popularity.

3.2 General Information and Compositional Background

The *Tirol Concerto* was published in 2000 by *Dunvagen Music Publishers* and is the first of two piano concertos by Glass. It has three movements, with a conventional fast–slow–fast tempo division (Glass, 2000:i–ii).¹⁵ However, the first movement has a chorale–like introduction of fifteen bars in a slower tempo. A performance of the *Tirol Concerto* lasts approximately 28 minutes, of which the long dominating second movement takes up around 17 minutes (Guérin, 2011). The concerto is orchestrated for solo piano and string orchestra consisting of violins (first and second), violas, cellos and double basses (Glass, 2000:ii).

The word 'Tirol', as used in the composition's title,¹⁶ is German for the English 'Tyrol'. The Tyrol is Austria's third–largest province and Innsbruck is its capital. The Tyrol lies in the heart of the Alps, hence commonly referred to as "The Land in the Mountains". It is a popular ski destination and is known for its natural beauty, glaciers, mountain ranges and valleys (*Tirol – Place of Power...*, 2015).

The *Tirol Concerto* was commissioned by the *Festival Klangspuren*¹⁷ with support from the *Tyrol Tourist Board (Tirol Werbung)* and the *Stuttgart Chamber Orchestra* (Glass, 2000:i). In conversation with Maycock (2002:118), Glass states that the *Tyrol Tourist Board* "had the idea that if people knew something about Tirolean culture, more of them would go to Tirol". The central requirement of the commission was for Glass to write a piano concerto with a 'Tyrolean character' (Lepuschitz, 2002). Thomas (2012) comments in his review of the concerto on the

¹⁵ Tempo indications are 168, 84 and 175 crotchet beats per minute for the respective movements.

¹⁶ Glass uses the German spelling 'Tirol' in the concerto's title. In this text 'Tirol' is used in reference to the work, or when included in direct quotations. However, the correct English term 'Tyrol' and its adjective 'Tyrolean' are used in all other cases.

¹⁷ *Festival Klangspuren* is an annual contemporary music festival in the Tyrol (Maycock, 2002:117).

“incongruous” nature of approaching Glass for a Tyrolean commission. In conversation with Maycock (2002:118) Glass states:

They said, would I write a ‘Tirol Concerto’ and I said, what would that be, and they said we’ll send you some music volumes with the theme and could it appear in the concerto? That was the commission. I said, send me the music and let me look at it.

In order to fulfil the requirements of the commission Glass visited the Tyrol and studied sound documents and sheet music of Tyrolean folk music (Lepuschitz, 2002). Following the visit the composer used Tyrolean folk music material directly in the *Tirol concerto*, writes Lepuschitz.¹⁸

A further requirement of the commission was for Dennis Russell Davies to be able to conduct the concerto from the piano (Guérin, 2011). Davies, who has played and conducted Glass’s music since the 1980s, was the chief conductor of the *Stuttgart Chamber Orchestra* at the time. He was involved in the conceptual discussions for the commission and played an important role in the compositional process (Davies, 2004).

3.3 Performances, Recordings and Applications

The *Tirol Concerto* had its world premiere at the *Festival Klangspuren* in Jenbach, Austria on 22 September 2000, with Davies conducting the *Stuttgart Chamber Orchestra* (Guérin, 2011). In 2003 Davies and the *Stuttgart Chamber Orchestra* toured extensively with the concerto (ibid.). Davies (2004) writes that they played “countless performances before widely varied audiences both in Europe and North America”. Their American tour of roughly twenty performances included such prestigious venues as *Carnegie Hall* and the *Metropolitan Museum (Grosser Erfolg...*, 2003). Figure 1 contains a list of all the performances of the *Tirol Concerto* on which information is available.

¹⁸ Chapter 4 contains a detailed discussion on the composer’s use of folk music material.

Date			Solist	Orchestra	Conductor	Venue	City	Country
2002	Sep	22	Dennis R. Davies	Stuttgart Chamber Orchestra	Dennis R. Davies	Festival Klangspuren	Jenbach	Austria ¹
2003	Mar	8	Dennis R. Davies	Stuttgart Chamber Orchestra	Dennis R. Davies	Stockton Performing Arts Center	Pomona	USA ¹
2003	Mar	10	Dennis R. Davies	Stuttgart Chamber Orchestra	Dennis R. Davies	Metropolitan Museum Of Art	New York	USA ¹
2003	Mar	11	Dennis R. Davies	Stuttgart Chamber Orchestra	Dennis R. Davies	American Theater	Hampton	USA ¹
2003	Mar	14	Dennis R. Davies	Stuttgart Chamber Orchestra	Dennis R. Davies	Twitchell Auditorium	Spartanburg	USA ¹
2003	Mar	15	Dennis R. Davies	Stuttgart Chamber Orchestra	Dennis R. Davies	Spivey Recital Hall	Morrow	USA ¹
2003	Mar	16	Dennis R. Davies	Stuttgart Chamber Orchestra	Dennis R. Davies	Stephens Center	Birmingham	USA ¹
2003	Mar	20	Dennis R. Davies	Stuttgart Chamber Orchestra	Dennis R. Davies	Flagler College	St. Augustine	USA ¹
2003	Mar	22	Dennis R. Davies	Stuttgart Chamber Orchestra	Dennis R. Davies	Branscomb Auditorium	Lakeland	USA ¹
2003	Mar	24	Dennis R. Davies	Stuttgart Chamber Orchestra	Dennis R. Davies	Riverside Theater	Vero Beach	USA ¹
2004	Mar	13	Dennis R. Davies	Stuttgart Chamber Orchestra	Dennis R. Davies	Stadhalle	Überblick	Germany ¹
2004	Apr	30	Ralf Gothóni	Northwest Chamber Orchestra	-	-	Seattle	USA ²
2005	Jan	13	Ralf Gothóni	Tapiola Sinfonietta	Ralf Gothóni	Sellosali Hall	Espoo	Finland ¹
2005	Jan	14	Ralf Gothóni	Tapiola Sinfonietta	Ralf Gothóni	Tapiolasali Hall	Espoo	Finland ¹
2005	Jul	13	Maki Namekawa	Stuttgart Chamber Orchestra	Dennis R. Davies	Westfälisches Industriemuseum	Hattingen	Germany ¹
2005	Sep	25	-	Northwest Chamber Orchestra	Paul Barnes	-	Seattle	USA ¹
2006	May	31	-	-	-	Universität für Musik und darstellende Kunst	Vienna	Austria ¹
2008	Nov	27	-	NOMOS String Orchestra	-	-	Bytom	Poland ¹
2009	Apr	25	-	Tallinn Chamber Orchestra	-	-	Tallinn	Estonia ¹
2009	May	13	-	Athens State Orchestra	-	-	Athens	Greece ¹
2010	Apr	18	Dennis R. Davies	Basel Symphony Orchestra	Dennis R. Davies	-	Basel	Switzerland ¹
2010	Jun	24	-	Kioi Sinfonietta	-	Kioi Hall	Tokyo	Japan ¹
2010	Jun	28	Ralf Gothóni	Ensemble Kanazawa	Ralf Gothóni	Concert Hall Ishikawa	Ongakudo	Japan ¹
2011	May	15	Ralf Gothóni	Ganam Philharmonic	Ralf Gothóni	Duksu Palace	Seoul	South Korea ¹
2011	Oct	19	-	Jovan Kolundzija Festival Orchestra	Mladen Tarbuk	Kolarac Hall	Belgrade	Serbia ¹
2011	Nov	22	-	Orchestra Kamerata	-	Athens Concert Hall	Athens	Greece ¹
2012	Jun	6	Ralf Gothóni	English Chamber Orchestra	Ralf Gothóni	Naantali Church	Naantali	Finland ¹
2012	Jul	31	Dennis R. Davies	Musikdorf Ernen Festivalorchester	Xenia Jankovic	-	Ernen	Switzerland ¹
2012	Sep	27	Nicolas Horvath	Ensemble instrumental de Nice	Avner Soudry	Théâtre des Variétés	Monaco	Monaco ³
2014	May	7	Helen Lin	Classic Orchestra	Chang Kuos	Chun Shan Concert Hall	Taichung	Taiwan ¹

¹(Philip Glass: Performances, 2014); ²(Bargreen, 2014); ³(Philip Glass Intégrale..., 2014)

Figure 1: Performances of the 'Tirol Concerto'

Four compact discs have been released with recordings of the concerto: *Tirol Concerto for Piano and Orchestra* (Glass, 2002a), a special edition release by the *Tyrol Tourist Board*; *Dennis Russell Davies Performs Philip Glass* (Glass, 2004); *The Concerto Project Vol. IV* (Glass, 2011); and *Glass Cuts: Philip Glass Remixed* (Glass, 2005). The first three CDs listed contain the same recording: Davies as soloist and conductor with the *Stuttgart Chamber Orchestra*. The recording was made on November 2002 in the *Mozartsaal*, Liederhalle, Stuttgart (Glass, 2011). *Glass Cuts* contains a remix of the *Tirol Concerto* by the Argentine composer Sebastián Escofet (Christensen, 2005). The *Tyrol Tourist Board's* release of the second movement of the *Tirol Concerto* is available on *YouTube* (see Glass, 2002b for the URL), and has had more than 310 000 views by March 2015! The *Tirol Concerto* is one of eight concertos by Glass that was released in a series called *The Concerto Project*. Other concertos in the series include the second piano concerto, a double concerto for violin and cello, a concerto grosso, and concertos for cello, timpani, saxophone quartet and harpsichord (*The Concerto Project...*, 2001).

Excerpts from the *Tirol Concerto* have been included in two films: *Looking Glass*, a DVD released in 2005 by *Ideale Audience International* as part of the contemporary music series *Juxtapositions*, and *Tirol – Land im Gebirg'* (2000), a ten-minute short film by the acclaimed Austrian film maker Georg Riha. *Looking Glass* is a documentary film about Glass, and features Davies performing and conducting the second movement of the *Tirol Concerto* at the *Metropolitan Museum* in New York. *Tirol – Land im Gebirg'* (*Tyrol – Land in the Mountains*) combines the second movement of the *Tirol Concerto* with various stills and nature scenes from the Tyrol. The film was commissioned by the *Tyrol Tourist Board* and *Cine Tirol* (Lepuschitz, 2002). It is one of the most successful films of the *Tyrol Tourist Board* and has won numerous international film awards, among others the 2010 *Cine Tirol Award* (*Cine Tirol Award...*, 2009). The film's "moving images and [...] moving music about Tyrol, the country the soul yearns for, soothe the soul", writes Lepuschitz (2002). *Cine Tirol* states how a "magische verbinding" (magical connection) exists between the nature images of the *National Park Hohe Tauern* in East Tyrol and the *Tirol Concerto* (*Cine Tirol Award...*, 2009).¹⁹

Music from the *Tirol Concerto* has been used in a number of professional dance productions: Stephen Mills's *Light/The Holocaust and Humanity Project* (2005) for the *Pittsburgh Ballet Theatre* (Meeder, 2009), and *Hush* (2005) for *Ballet Austin* (Kaufman, 2013); Jorma Elo's *Glow-Stop* (2006) for the *American Ballet Theatre* (Zlokower, 2006); Sol León and Paul Lightfoot's *Shoot the Moon* (2006) for the *Nederlands Dans Theater* (*Nederlands Dans Theater 1*, 2007); Andrew Simmons's *A Song in the Dark* (2010) for the *Royal New Zealand Ballet* (*Royal NZ Ballet...*, 2006); Marie

¹⁹ A copy of the film is available on *YouTube* (see Riha, 2000 for the URL).

Stockhausen and Marco Goetze's *Bitter Sweet* (2013) for the *Tiroler Landestheater* (*Bitter Sweet*, 2013); and Liam Scarlett's *Hummingbird* (2014) for the *San Francisco Ballet* (Ossola, 2006).

Because of its 'Tyrolean character', the concerto is regularly used with official Tyrolean promotional events and films. Lepuschitz (2002) writes that the concerto has become a type of musical ambassador for the Tyrol. The work is believed to have a distinctive Tyrolean sound following its use of Tyrolean folk music material, therefore its 'nationalistic' use (*Grosser Erfolg...*, 2003). Sections from the *Tirol Concerto* were also reused by Glass in his 2005 opera *Waiting for the Barbarians* (Ingram, 2008:206).

3.4 Reception and Popularity

In conversation with Maycock (2002:119) on his *Tirol Concerto*, Glass states: "Like the 'Violin Concerto' I really set out to write a popular piece". In general, reviewers have had positive responses to the *Tirol Concerto*. Maycock writes (2002:119) that "In aspiring to popularity he [Glass] seems to have hit the button", and "the piece is in demand, [...] it is being well received". "One of Glass' [sic] most moving compositions", writes Escoda (2013); "Beautiful and touching" are the words used by Scarlett, choreographer of the *San Francisco Ballet* (Ossola, 2006). Ingram (2004b:110) believes that the concerto is "unpretentious, and authentically joyous", adding that it "should not be undervalued or underestimated". McDonagh (2003) of the *Classical Music Review* mentions its "myriad charms and depths". "One of the most relaxed and reflective sounding pieces produced by Glass in a long time", writes Lewis (2004). Other individuals have been more negative: Felciano (2014) states that the second movement "flows like a stagnant river", whilst Cappelle (2014) simply finds it "too repetitive".

As is common in reviews of new compositions, the *Tirol Concerto* has often been compared to the compositional styles of other composers. Ingram (2004a:181) writes how "Glass meets Poulenc, Beethoven, and Prokofiev" in the concerto. He further parallels the work with Malcolm Arnold's and Francis Poulenc's two-piano concertos in layout and melodic charm, and Mozart in lightness. The author of an advertisement for a performance at the *Théâtre des Variétés* in Monaco writes that influences from Shostakovich are apparent in the concerto (*Philip Glass Intégrale...*, 2012). Finally, Scarlett believes Ravel is reflected in the concerto's "Bolero-style building and layering" (Ossola, 2006).

3.5 Conclusion

This chapter included information on the background and origin of the *Tirol Concerto*. A few points can be highlighted from the discussion. The *Tirol Concerto* is the first of two piano concertos by Philip Glass. It is orchestrated for piano and string orchestra, and has a conventional concerto structure and tempo indications. 'Tirol' in the concerto's title is indicative of the 'Tyrolean character' requested from its commissioners. Performances of the concerto have taken place across the globe and it has been included in numerous recordings, films and dance productions. The *Tirol Concerto* has been largely popular and positively received since its premiere. In the following chapter the background and conception of the *Tirol Concerto* are further explored through a study of its 'Tyrolean' influences and its relation to other works.

Chapter 4: Tyrolean Relations

4.1 Introduction

The previous chapter on general and background information made mention of the ‘Tyrolean character’ that was requested for the *Tirol Concerto* by Glass’s commissioners. Accordingly, the composer based his composition on Tyrolean folk music material after a visit to the Tyrol. This chapter investigates the matter in more detail in pursuit of the second research objective. The influences of the commission on the concerto’s compositional content and its relationship to Tyrolean folk music are explored. Most of this chapter consists of a discussion of the relation between the *Tirol Concerto* and a Tyrolean folk song, *Maria! hilf doch mir*. In the first half of the discussion, the background, historical use, religious text, and musical characteristics of *Maria! hilf doch mir* are investigated. This is followed by an exploration of Glass’s adaptation of the folk song in the concerto.

4.2 *Maria! hilf doch mir*

In the *Tirol Concerto* Glass used folk music material directly in his music and not only for atmospheric purposes; he combined a Tyrolean “ethnological aspect with variations on the classic concerto mode”, writes (Lepuschitz, 2002). Glass himself states (Maycock, 2002:118):

What you hear at the beginning is a Tirolean [sic] folk song which of course sounds like folk songs from all over the world, in the way that folk songs have that quality of always being familiar.

In the programme notes of the *Tyrol Tourist Board’s* recording Lepuschitz (2002) provides some information on the folk music material used in the concerto. He states that the composition is based on a folk song about the Holy Virgin that originates from the town Alpbach in Austria around 1820. He provides the song’s German text and title, *Maria! hilf doch mir*, but little further information on its origin and use in the concerto.

Searches in numerous Austrian archives were conducted by the author in an attempt to obtain the original folk song used by Glass. Records matching *Maria! hilf doch mir’s* text were found in the *Österreichischen Volksliedwerk*, *Vorarlberger Landesarchiv*, *Niederösterreich Volksliedarchiv*, *Kärntner Volksliedarchiv*, *Salzburger Volksliedwerk* and the *Tiroler Volksliedarchiv*. The comprehensive musical database, *Répertoire International des Sources Musicales*, also contained a number of entries consistent with Lepuschitz’s text. However, each of the records obtained had a different melody and harmonisation of the text of *Maria! hilf doch mir* or similar texts. According to Dr Annemarie Bösch-Niederer at the *Vorarlberger Landesarchiv*, the text is quite

well known in Austria (Bösch-Niederer, personal communication 2014, September 2). Its use was particularly popular in songs of the 19th century and many of them became folk songs at a later stage (ibid.).

Only one of the records obtained matched the text of *Maria! hilf doch mir* as specified by Lepuschitz and melodic material from the *Tirol Concerto*. This record was found in the *Josephus Weber Collection* of the *Tiroler Volksliedarchiv*, catalogue number A7249. The manuscript is dated 1822 and originates from *St. Jakob's Parish* in Innsbruck (Josephus Weber Collection). A copy of the first page of the handwritten signature by the collector, Josephus Weber, can be found in Figure 2, and a later copy that is also held in the archive in Figure 3.

1. Andachtsvolle Bitte oder Bittlied
 zu Maria Hilf in der Stadtperre zu
 hl. Jacob in Innsbruck
 (gepredigt in einem Brauerhause auf dem Wege
 nach Alpbach.)
 Die Handschrift stammt aus dem Jahre
 1822.
 Aufgenommen am 9. Juli 1911
 v. J. Weber, Schwarz.

Sammlung des
 Tiroler Volksliedarchivs
 für das
 Deutsche Volkslied
 in Österreich

Maria = vi = a! hilf doch mir
 1. Heft dein Kind zu dir.
 1. bist so ja, in Sal-ten Raum: so

Figure 2: Handwritten signature of 'Maria! hilf doch mir'

Andachtsvolle Bittseufzer
oder Bittlied.

1. Ma- ri- a! Hilf doch mir, es fleht dein Kind
zu dir. Du bist es ja, die hel- fen kann: So
nimm dich, Mut- ter! mei- ner an. Hilf, Ma- ri- a,
hilf o hilf, hilf Ma- ri- a hilf, o hilf!

2. Du bist der Gnadenthron:
Denn Jesus ist dein Sohn,
Der sterbend noch vom Kreuz herab
Dich selbstest mir zur Mutter gab
Hilf Maria ...
3. Beschütze, leite mich,
Zeig stets als Mutter dich,
Ja, weil dein Sohn mein Bruder ist,
So zeig, daß du die Mutter bist.
Hilf Maria ...

Figure 3: Later copy of 'Maria! hilf doch mir'

Josephus Weber (1878–1968) found the original manuscript of *Maria! hilf doch mir* in a farmhouse near Alpbach early in the 20th century (Josephus Weber Collection). Weber was a music professor at the *Lehrerbildungsanstalt (College of Education)* in Innsbruck as well as a committee member of the *Österreichischen Volkslied-Unternehmens (Austrian Folk-song Initiative)*, and an avid collector of Tyrolean folk music (Schmidt, 1968:80). He made a copy of the original manuscript in 1911 and gave it to the archive of the *Tiroler Landesmuseen* as part of a larger collection of records collected between 1911 and 1914 (Josephus Weber Collection). According to Gerti Heintschel at the *Tiroler Volksliedarchiv*, the composer of *Maria! hilf doch mir* and its exact origin have remained unidentified (Heintschel, personal communication 2014, October 13). It is not a well-known folk song in Austria, but somewhat more common in the Innsbruck area (ibid.). Only one recording of the folk song could be obtained, as included on the compact disc *Der Güldene Rosenkranz: Lobgesang in der Wallfahrtskirche Maria Locherboden* (2000). These factors call into question Glass's statement that "if you play this [folk song] in Austria everyone recognizes it" (Maycock, 2002:119).

Maria! hilf doch mir has a religious, Christian text and was originally intended for use in the veneration of the Virgin Mary. The song is referred to as an *Andachtsvolle Bittseufzer oder Bittlied* (*Devotional Lamentation or Song of Plea*) in the original manuscript obtained from the *Tiroler Volksliedarchiv*. Figure 4 contains the first verse of *Maria! hilf doch mir* with an English translation.

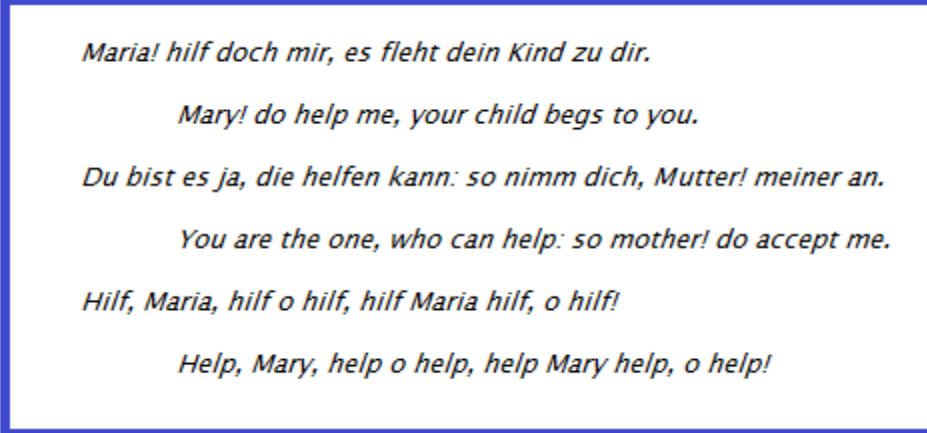

Maria! hilf doch mir, es fleht dein Kind zu dir.
Mary! do help me, your child begs to you.
Du bist es ja, die helfen kann: so nimm dich, Mutter! meiner an.
You are the one, who can help: so mother! do accept me.
Hilf, Maria, hilf o hilf, hilf Maria hilf, o hilf!
Help, Mary, help o help, help Mary help, o help!

Figure 4: First verse of 'Maria! hilf doch mir'

The text of *Maria! hilf doch mir* was first published in the book *Die Rufende Stimme* (1839) by Franz Sieber (Bösch–Niederer, personal communication 2014, September 2). The song has twenty verses in total, each ending with a call for help to the Virgin Mary. *Die Rufende Stimme* contains Catholic prayers and devotional texts for everyday household use. *Maria! hilf doch mir* can be found in a section with prayers and pleas to the Virgin Mary (Sieber, 1839:111). Figure 5 contains an excerpt of the original text of *Maria! hilf doch mir* as taken from Sieber's publication (1839:111).

Hilf, o Maria! hilf und gedenke, o aller-
 feligste Jungfrau Maria! von allen Zeiten her
 sey es nicht erhöret, daß ein einziger, der seine
 Zuflucht zu dir genommen, deine Hilfe angerufen,
 und um deine Fürbitte gebeten hat, von dir ver-
 lassen worden sey. Durch solches Vertrauen
 aufgemuntert, nehme ich meine Zuflucht zu dir,
 o Jungfrau über alle Jungfrauen und Mutter
 meines Erlösers! zu dir trette ich, und stelle
 mich armen Sünder mit Seufzen vor dein Ange-
 sicht: du wollest nicht mein Wort verschmähen,
 o Gebäretin des ewigen Worts! sondern höre
 gnädig und erhöre mich Armseligen, der ich mir
 jetzt erlaube, meine dringendste und flehendlichste
 Bitte an dich zu stellen, dich als meine himm-
 lische Mutter mit kindlicher Liebe und mit wah-
 rem Vertrauen so anzurufen:

1. Maria! hilf doch mir;
 Es steht dein Kind zu dir.
 Du bist es ja, die helfen kann:
 So nimm dich, Mutter! meiner an.
 Hilf, o! Maria hilf.

Figure 5: Original text of 'Maria! hilf doch mir' from Sieber (1839)

From the above discussion it is clear that *Maria! hilf doch mir* was originally intended for use in religious practices. Glass's adaptation of the folk song in the *Tirol Concerto*, however, has no religious references or intentions. None of the sources consulted mention any way in which the religious aspects of *Maria! hilf doch mir* had an influence on Glass's composition. It follows then that the folk song is adopted purely for the fact that it is Tyrolean and not for the veneration of the Virgin Mary. Musically, the distressed calls for help to the Virgin Mary, as found in the text, are not reflected in Glass's adaptation. In the first movement of the *Tirol Concerto*, for example, the melody is found in a cheerful setting with an abundance of major chords and bright tonalities. The compositional transformation of *Maria! hilf doch mir* then does not reflect the original text's meaning nor its religious context. The suitability of using a religious text as the basis for the *Tirol Concerto*, a secular instrumental work, is debatable. It is possible, however, that much of the folk song's initial religious connotations were lost in its adoption into Tyrolean folk-music culture and its consequent displacement from religious contexts.

The manuscript of *Maria! hilf doch mir* obtained from the *Tiroler Volksliedarchiv* (Figure 3) provides only the song's melody and text. There is no indication of other musical parameters such as instrumentation, accompaniment, dynamics and harmonisation. It can be assumed that traditional Tyrolean folk-music practices with regards to instrumentation and harmonisation were applied in its performance. Nothing in particular stands out as unconventional or striking in the song's melodic, rhythmic or structural make-up. *Maria! hilf doch mir* has a lyrical twelve-bar melody in G major that consists of mainly stepwise motion. An unchanging 4/4 metre and a relatively straightforward rhythmic structure are evident. No obvious modulations are present, and a straightforward harmonisation with diatonic chords and conventional cadences is possible.

4.3 Adaptation of *Maria! hilf doch mir*

According to Lepuschitz (2002) and Maycock (2002), all three movements of the *Tirol Concerto* are related to *Maria! hilf doch mir*. Glass, in conversation with Maycock (2002:118), confirms that the concerto's opening is an adaptation of a Tyrolean folk song, and that both the melody of the second movement and one of the themes of the third movement relate back to it.²⁰ He further states (ibid.) that 'if you listen to the whole concerto it does seem like a whole piece'. This statement then reflects Glass's belief that the use of *Maria! hilf doch mir* in all three movements has a unifying effect on the concerto. Maycock (2002:121) writes:

The tune is constantly there, in disguise. The variations Glass does write are on a variation of the tune, in that the slow movement's melody starts out from a fresh look at the melodic outline of its first two phrases.

He adds that if there are any perceptual disappearances of the Tyrolean folk-song influences, they are only temporary (121).

Lepuschitz (2002) argues that the theme from *Maria! hilf doch mir* precedes the opening of the *Tirol Concerto* almost completely, which is indeed the case. The introductory piano solo to the first movement (Figure 6) contains the *Tirol Concerto's* most obvious adaptation of the melody of *Maria! hilf doch mir*. In this introductory chorale Glass uses almost the entire melody in the soprano line, but has transposed it to B \flat major. Lepuschitz (2002) states that Glass omitted the two bars corresponding to 'es fleht dein Kind zu dir' and did his own harmonisation of the melody. This is confirmed by the composer in conversation with Maycock (2002:118): "I

²⁰ Glass's adaptation of the folk song in the third movement of the *Tirol Concerto* is not discussed since it falls outside the scope of this dissertation. However, some folk-song adaptations in the first movement are outlined in this chapter for a comparison with those of the second movement.

reharmonized it, but it's their melody. I actually dropped out one phrase which was redundant, I trimmed it a little bit".

The image displays a piano score for the introductory chorale of the 'Tirol Concerto'. The score is written for piano (Pno.) and consists of five systems of music, each with a treble and bass clef staff. The tempo is marked as quarter note = 108. The key signature is one flat (B-flat major/D minor). The score includes various dynamics: *mp* (mezzo-piano), *mf* (mezzo-forte), *p* (piano), and *pp* (pianissimo). It also features performance instructions such as *Poco rit. ...* and *Rit.*. The piece begins with a series of chords in the right hand and a melodic line in the left hand. The first system (measures 1-3) starts with a *mp* dynamic. The second system (measures 4-6) includes *mf* and *p* dynamics. The third system (measures 7-9) is marked *p* and *pp*, with a *Poco rit. ...* instruction. The fourth system (measures 10-12) includes *mp*, *mf*, and *dim.* (diminuendo) markings. The fifth system (measures 13) begins with a *dim.* marking and ends with a *pp* dynamic and a *Rit.* instruction.

Figure 6: Introductory chorale to the 'Tirol Concerto'

A comparison of the melody of *Maria! hilf doch mir* (Figure 7) and the melody used by Glass in the introductory chorale (Figure 8) reflects their similarities.²¹ Phrase 2, which corresponds to 'es fleht dein Kind zu dir' in the original text, is left out in Glass's version.²² The other five phrases are elongated through the addition of extra beats and bars.²³ Glass extends the original melody of *Maria! hilf doch mir* with the addition of a couple of bars after the final B \flat tonic. This is marked as phrase 7 in Figure 8.

Phrase 1

Phrase 2

Ma - ri - a! Hilf doch mir - , es fleht dein Kind zu dir. Du

Phrase 3

Phrase 4

bist es ja, die hel - fen kann: So nimm dich, Mut - ter! mei - ner an.

Phrase 5

Phrase 6

Hilf, Ma - ri - a, hilf o hilf, hilf Ma - ri - a hilf, o hilf!

Figure 7: Original melody of 'Maria! hilf doch mir' transposed to B \flat major

²¹ A B \flat major key signature has been added to Glass's version (Figure 8) for ease of comparison, as only accidentals are used in the score.

²² Corresponding phrases have been numbered on the figures.

²³ These additions are not the same as Glass's additive processes of the 1960s and 1970s.



Figure 8: Glass's adaptation of 'Maria! hilf doch mir' in the first movement

Maycock (2002:118) argues that Glass harmonised the original melody in a “rather personal way with a leaning towards ambiguous chords using flattened degrees of the scale”. A detailed harmonic analysis of the first movement of the *Tirol Concerto* falls outside the scope of this study, but Glass’s unconventional harmonisation of the introductory chorale is obvious. It is possible to harmonise the melody of *Maria! hilf doch mir* in a relatively straightforward manner through the application of diatonic chords and conventional cadences in the key of B \flat major. However, Glass makes use of a more contemporary idiom. He applies various accidentals in secondary voices, thus hinting at chords and tonalities outside B \flat major. Chords foreign to the B \flat major tonality and that contain accidentals are blocked in Figure 9.

The image displays a piano score for an introductory chorale, marked with a tempo of 108. The score is written in 4/4 time and consists of five systems of music. The first system (measures 1-4) begins with a piano (*mp*) dynamic and features a series of chords in the right hand, with some chords highlighted by blue boxes. The second system (measures 5-8) continues with a mezzo-forte (*mf*) dynamic, followed by a piano (*p*) dynamic in the final measure. The third system (measures 9-12) starts with a piano (*p*) dynamic and includes a *Poco rit.* marking. The fourth system (measures 13-16) begins with a mezzo-forte (*mf*) dynamic and includes a *dim.* marking. The fifth system (measures 17-20) starts with a piano (*pp*) dynamic and includes a *Rit.* marking. The score is labeled 'Pno.' and includes various musical notations such as clefs, time signatures, and dynamic markings.

Figure 9: Chords foreign to the B \flat major tonality in the introductory chorale

Following the introductory chorale, the theme of *Maria! hilf doch mir* “recurs in sequences of Glass’s repetitive pattern technique throughout the first movement”, writes Lepuschitz (2002). A number of the first movement’s phrases can be linked to the melody of *Maria! hilf doch mir* or

Glass's harmonisation of it. To illustrate this point phrase 40 (P40) of the first movement is shown in Figure 10. This phrase corresponds to bar 1 and the start of bar 2 of the introductory chorale in terms of melodic and harmonic makeup, as indicated in the figure. Numerous sections in the first movement can be related to *Maria! hilf doch mir* in this manner.

The figure displays a musical score for the first movement of a concerto, specifically focusing on phrase 40 (P40). The score is arranged in two main sections. The upper section, labeled 'P40', consists of six staves: Piano (Pno.), Violins 1 (Vlns. 1), Violins 2 (Vlns. 2), Viola (Vlas.), Violoncello (Vlcs.), and Double Bass (Dbs.). The Piano part is marked with *mf* and *cresc.*, while the string parts are marked with *mf*, *cresc.*, *f*, and *mf*. The lower section, labeled 'Introductory chorale', is a single staff for Piano, marked with *mp* and *mf*. Blue boxes highlight specific harmonic and melodic elements in both sections, with blue lines connecting them to show their correspondence. The first movement section is marked with dynamics like *mf*, *cresc.*, *f*, and *mf*. The introductory chorale is marked with *mp* and *mf*.

Figure 10: Comparison of phrase 40 of the first movement with the introductory chorale

As discussed earlier, Glass, Maycock and Lepuschitz confirmed that the second movement of the *Tirol Concerto* is also based on *Maria! hilf doch mir*. According to Lepuschitz (2002), “A sequence of three notes from the original melody forms the basis of the slow and lyrical second movement”, but he does not specify which notes. The melodies of both *Maria! hilf doch mir* and the second

movement consist predominantly of stepwise motion. Therefore they share numerous three-note combinations with similar intervallic structures. Lepuschitz's claim that the melody of *Maria! hilf doch mir* forms the basis for the entire slow movement's melodic content is rather vague and dubious. Maycock (2002:121) states that the start of the slow movement's melody²⁴ is an adaptation of the first two phrases of the folk song. Minimal similarities between the opening phrases of *Maria! hilf doch mir* and the second movement's first melody are present. It is only the stepwise melodic line seen in the first few bars of the second movement's first melody that can be paralleled to phrase 3 of *Maria! hilf doch mir*, as indicated in Figure 11.

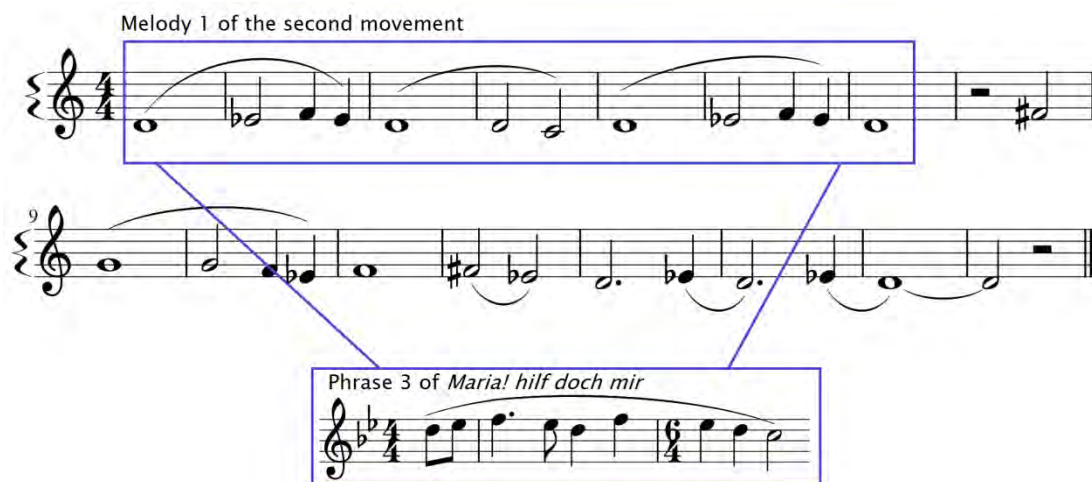

Figure 11: Comparison of the second movement's first melody with 'Maria! hilf doch mir'

This stepwise progression is found on the same pitches (C, D, E \flat , F) in both melodies. However, their rhythmic content, note durations and tonalities are clearly different. The progression forms part of both the G Aeolian and B \flat major scales and would thus be common in any stepwise melodic lines in pieces with these tonalities. Apart from this resemblance, there are few other similarities between *Maria! hilf doch mir* and the second movement. Three melodies are in fact used in the movement, which makes possible influences from the folk-song melody even less direct. It seems possible then that these stepwise melodic similarities are purely coincidental and not as directly related to *Maria! hilf doch mir* as affirmed by Maycock, Lepuschitz and Glass himself. Discussions in the following chapter of the relation between the second movement and *The Truman Show* (1998) raise further doubts about the Tyrolean basis of the movement.

²⁴ A total of three melodies are in fact found in the second movement. These melodies are discussed in detail in Chapters 6 and 7.

4.4 Conclusion

In this chapter the conception and origin of the *Tirol Concerto* were explored through a discussion of Tyrolean influences on its compositional content. It was concluded that in order to meet the requirements of his commission, Glass used a Tyrolean folk song directly in the concerto. The religious folk song that dates from 1822 and originates from the *St. Jakob's Parish* in Innsbruck was identified as *Maria! hilf doch mir*. Glass's adaptation of the folk song, however, is without any religious significance and used purely for the fact that it originates from the Tyrol. It has been suggested by Maycock, Lepuschitz and Glass that all three movements of the *Tirol Concerto* are related to *Maria! hilf doch mir*. The first movement contains the most obvious adaptation of the folk-song melody in its introductory chorale as well as a number of subsequent phrases. There are, however, minimal similarities between the melodies of *Maria! hilf doch mir* and the second movement. These similarities are much less direct than those of the first movement, which then raises questions about the second movement's proclaimed Tyrolean basis. In the following chapter the relations between the second movement and the film *The Truman Show* are discussed, which further challenges its apparent Tyrolean qualities.

Chapter 5: Film Relations

5.1 Introduction

The apparent Tyrolean influences on the compositional content of the *Tirol Concerto* and the requirements of its commission were discussed in the previous chapter. It was concluded that Glass based the concerto on a Tyrolean folk song, but that its relation to the second movement is unclear. In the following section the connections between the second movement and *The Truman Show* (1998), for which Glass helped to compose a soundtrack, are discussed. This concludes the exploration of the conception, origin and background of the movement, and of the factors that had an influence on its compositional content, as stipulated in the second research objective. The chapter opens with a discussion on the relation with and shared musical characteristics of the second movement and a track, *Raising the Sail*, from *The Truman Show*. The chapter concludes with a paragraph on the film's musical reception, and final words on the second movement's origin.

5.2 *Raising the Sail*

In an advertisement for a concert of Glass's Piano Concertos at the *Théâtre des Variétés* in Monaco, the author writes that a melody from the *Tirol Concerto* was also used in *The Truman Show* (*Philip Glass Intégrale...*, 2012). On further investigation of *The Truman Show's* soundtrack, it was established that there is indeed a connection between the concerto and the film score. *Raising the Sail*, track seventeen from the soundtrack of *The Truman show*, and the start of the second movement of the *Tirol Concerto* are almost identical in melodic, harmonic and rhythmic content.²⁵ What is conspicuous, however, is that *The Truman Show* was released by *Paramount Pictures* in 1998, two years before the publication of the *Tirol Concerto*. This then challenges the validity of affirmations by Glass, Maycock and Lepuschitz that like the first movement of the *Tirol Concerto*, the second movement is based on *Maria! hilf doch mir*. The link between the *Tirol Concerto* and *Raising the Sail* is never mentioned in any of Glass's literature on either works. It was never published as a score²⁶ and it is not included in Glass's official list of compositions.

²⁵ A copy of *Raising the Sail* is available on *YouTube* (see Glass, 1998 for the URL).

²⁶ Information on the musical characteristics of *Raising the Sail* had to be obtained from the film's soundtrack since no score is available.

Raising the Sail makes up only two minutes of *The Truman Show's* soundtrack and is thus quite insignificant in comparison to the dominance of the seventeen-minute second movement of the *Tirol Concerto*. It is possible that Glass started work on the *Tirol Concerto* before the release of *The Truman Show* and consequently used some of its preliminary compositional material for the film score.²⁷ However, considering the size and tempo of the composer's output, it seems more feasible that the short excerpt from the film was extended and reworked to the second movement of the *Tirol Concerto*. The structural makeup of the second movement, as discussed in more detail in Chapter 6, is further evidence for this notion. The movement consists of eleven variations over a repeated harmonic progression. The part that undergoes variation is an almost exact replica of *Raising the Sail*. A comparison of the two reveals that they have the same key, tonality, melody, orchestration, harmonic progression, textures and dynamics. Only small changes in metre and consequently rhythmic makeup are seen.²⁸ It seems realistic to assume then that the film's track was extended through variation and repetition to the second movement of the *Tirol Concerto*. It is improbable that the entire track (with the correct length for its application in the film) was extracted from a Tyrolean based concerto that happened to have a modular structure, and that was published only two years later.

5.3 Plot, Soundtrack and Reception

The Truman Show was written by Andrew Niccol and directed by Peter Weir (Niccol, 1998:109). It stars Jim Carrey in the leading role as Truman Burbank, the unwitting star of a famous reality show. At the age of 30 Truman starts to question his 'fake world' and tries to escape in a sailboat, nearly drowning. The film ends with Truman leaving the massive set of *The Truman Show*, supported by his fans worldwide.²⁹ Even though *Raising the Sail* is relatively short, it is played at one of the most climactic and emotional scenes of the movie. It starts when it seems as if Truman has drowned following his attempted escape. *Raising the Sail's* fittingly mournful and elegiac character strengthens the film's *mise-en-scène* at this point.

A number of composers contributed to the film's soundtrack, which was released on Milan Records in 1998 (Bolan et al., 1998). In the credits Burkhard Dallwitz is listed as the film's composer, with Glass only listed as composer of "additional music" (Niccol, 1998:109–110). Jeff

²⁷ The exact date on which Glass was commissioned to write the *Tirol Concerto* is unfortunately not stated in any literature.

²⁸ The minimal differences between *Raising the Sail* and the second movement of the *Tirol Concerto* are detailed in Chapter 6.

²⁹ A more detailed discussion of the film's plot and themes is included as Appendix C.

Bond (1998b:28) writes that Glass was initially commissioned to score the entire film, but “the filmmakers ultimately decided against utilising him for the full score, wanting to distinguish between the movie-within-the-movie and the movie itself”. Similarly, Adams (1998a:47) argues that the film’s music can be divided into three parts: that of the actual film, that of the reality show, and that which obscures the line between the two. Glass’s compositions for the film are believed to comprise the last category of the three (ibid.). Ultimately, Glass was not involved with the film’s soundtrack from early on and his tracks were added only later (1998b:24). Both original compositions and some that were reused from previous film scores by Glass were included in the soundtrack (Brown, 1998:422). According to Bolan et al. (1998), Glass composed three original tracks for the film: *Dreaming of Fiji*, *Truman Sleeps* and *Raising the Sail*. If *Raising the Sail* was indeed composed especially for the film, as stated in the film’s documentation, then it follows that it was recycled and developed to become the second movement of the *Tirol Concerto*.

In the majority of cases music from *The Truman Show* has been met with great acclaim. In 1999 Dallwitz and Glass’s soundtrack won them a *Golden Globe Award* for best original film score (1999 *Golden Globe...*, 1999). In the same year an *ASCAP*³⁰ *Film and Television Music Award* was given to the composers (Newman, 1999:75). Brown (1998:423) refers to the soundtrack as “one of cinema’s most creative, original, and probing interactions of music and film”. Adams (1998a:47) states that in *The Truman Show* one is both embraced and dissected by the score, and that it leaves you feeling totally engaged and satisfied. Many authors have also commented on the suitability of Glass’s compositional language for the film. Brown (1998:422) believes that Glass’s compositions are “totally right for *The Truman Show*”. Kendall (1998:30) writes that the “movie’s notions of artificiality vs. reality, repetitions vs. change play right into Glass’s hands”. Finally, Bond (1998a:30) states that Glass’s minimalistic effects are fitting for *The Truman Show* in the way that “every day is exactly the same, rigidly controlled and streamlined just like Glass’s whirligig electronic and orchestral effects”. Other reviewers were less positive: Bettencourt (2004:28) writes: “*The Truman Show* mixed the dull-ish Philip Glass and the really boring Burkhard Dallwitz”.

5.4 Conclusion

This chapter discussed the relations between the second movement of the *Tirol Concerto* and *The Truman Show*. It was found that *Raising the Sail* from *The Truman show* and the second movement of the *Tirol Concerto* are almost identical in compositional makeup. However, *The Truman Show* was released two years before the *Tirol Concerto*, which questions the validity of

³⁰ *American Society of Composers, Authors and Publishers*

claim by Glass, Maycock and Lepuschitz that the second movement has a Tyrolean basis. If *Raising the Sail* was indeed composed especially for *The Truman Show*, as stated in its soundtrack (Bolan et al., 1998), then it follows that it was recycled, reworked and extended to the second movement of the *Tirol Concerto*. The movement's structure, which consists of repeated variations of *Raising the Sail*, supports this notion. The propriety of Glass's application of the same compositional material in both an American blockbuster and a 'Tyrolean' concerto' is debatable. It is noteworthy that the film connection is never mentioned in any literature or statements and that a Tyrolean basis is confirmed by the composer instead.³¹ Consequently, this has resulted in the repeated 'misapplication' of the piece for its 'Tyrolean character' as, for example by *Cine Tirol* and Georg Riha in the promotional film *Tirol – Land im Gebirg*'. This then concludes the dissertation's literature studies, and the exploration of the piece's conception, origin, background and factors influential in its compositional content, as stipulated in the second research objective. The following chapter presents an analytical perspective to investigate the piece's compositional makeup and its musical characteristics.

³¹ As cited earlier in the chapter in his discussion with Maycock (2002:118).

Chapter 6: Basic Compositional Content

6.1 Introduction

Following the literature studies in the preceding chapters, the second movement of the *Tirol Concerto* is now approached from a theoretical perspective. This chapter presents an analysis of the second movement to identify its musical characteristics and the composer's compositional techniques. This is the first of two chapters in support of the dissertation's third research objective. The focus of this chapter is on the movement's basic compositional content through an investigation of its structural and harmonic makeup. The chapter opens with an overview of the piece's tonality, which is followed by a discussion on its structure and the relation of this structure to harmonic content. Following this are detailed analyses of the piece's harmonic content through the application of two theoretical perspectives: functional analysis and transformational theory. The chapter concludes with some comments on structural deviations, fractal relations and organicity.

6.2 Tonality and Key

The movement is written in the key of G natural minor, or the Aeolian mode on G. However, elements of both the harmonic and melodic minor are also present, as apparent from the interplay between the natural and raised sixth (E^b and E^{\sharp}) and seventh (F^{\flat} and F^{\sharp}) steps. Aeolian applications of the natural seventh or the subtonic (F^{\flat}), instead of a raised seventh or leading tone (F^{\sharp}), are found in both the melody and accompaniment. In the accompaniment a raised seventh is never used for chords built on scale degree three or seven. The composer clearly avoids the use of an augmented mediant triad (B^b , D, F^{\sharp}), and applies a major triad (B^b , D, F^{\flat}) instead. Similarly, he replaces the diminished leading tone chord (F^{\sharp} , A, C) with a major subtonic chord (F^{\flat} , A, C). Chords III and b VII are thus found instead of III^+ and vii° , as notated in the analyses below. The composer's preference for simple consonant triads (major and minor) in place of augmented and diminished sonorities is obvious.

Harmonic minor elements are found in both the accompaniment and melody of the piece. In the accompaniment, a raised seventh is found in all instances of the dominant (V) chord (D, F^{\sharp} , A). The minor v chord (D, F^{\flat} , A), which is actually the fifth step of the Aeolian mode, is avoided. A possible reason for this is the weak dominant quality of v in a dominant to tonic progression. The movement from a natural seventh (F^{\flat}) to tonic (G) is much weaker than that of a raised seventh (F^{\sharp}) to tonic. This is not necessarily problematic in the application of non-dominant chords, such as III and b VII. The application of a raised seventh strengthens dominant to tonic

movement, emphasises the tonic as key centre, and results in goal-oriented, forward motion. The composer thus opts for a stronger, functional dominant and tonal movement in his application of the raised seventh. This practice is not unconventional, as reflected in George Handel's *Passacaille* from his *Suite in G minor*, HWV 432 No.7 (Figure 12). Handel applies the natural seventh (also F \flat in this case) in all chords other than the dominant, as seen with the \flat VII and III harmonies in bar 2 of the extract. However, in bar 4 when the dominant chord is played, the raised seventh (F \sharp) is found.

The image shows a musical score for Handel's 'Passacaille' in G minor, HWV 432 No. 7. It consists of two systems of four bars each. The first system shows chords i, iv, \flat VII, and III. The second system shows chords VI, ii, and V. Blue boxes highlight the seventh notes of the \flat VII and V chords in the upper voice, showing the natural seventh (F \flat) in the first system and the raised seventh (F \sharp) in the second system.

Figure 12: Natural and raised sevenths in Handel's 'Passacaille', HWV 432 No.7

The raised seventh is also used melodically in the second movement of the *Tirol Concerto*, but only with V chords. It is never used with any other harmonies in either the melody or accompaniment. The entire piece thus corresponds to the Aeolian mode except for V chords in which raised sevenths are found. However, although the natural seventh is never used in the accompaniment of a V chord, it is sometimes applied melodically above a V chord. In such instances the raised and natural sevenths are thus superimposed, which results in the formation of double-graded, mixed-third or split-third chords.³² Thus, chord v (D, F \flat , A) is never found in the piece, but vV (D, F \flat , F \sharp , A) is.³³

³² Dominant split-third chords are labelled as vV to indicate their combined minor and major quality.

³³ The manner in which the composer arrives at this interesting superimposition is discussed in more detail in Chapter 7.

Melodic minor applications, in which the augmented second between the natural sixth and raised seventh steps of the harmonic minor are avoided, are also seen in the movement.³⁴ Sections in the Aeolian mode combine the natural sixth (E_b) and natural seventh (F_b) steps in both ascending and descending order.³⁵ This can be seen in the piece's opening, for example, when an ascending $D-E_b-F_b$ progression is played by the first violins (Figure 13).

The musical score for Figure 13 shows the beginning of the second movement in G minor, 4/4 time. The first violin part (Vlns. 1) starts with a half note D4, followed by an ascending eighth-note triplet of E-flat4, F-flat4, and G4. A blue box highlights this triplet. The second violin part (Vlns. 2) plays a half note B-flat3. The viola part (Vla.) plays a half note D4. The violoncello part (Vcls.) plays a half note D4. The double bass part (Dbs.) plays a half note D4. The dynamics are piano (p) for the first violin and mezzo-piano (mp) for the other instruments. Roman numerals 'i' and 'VI' are indicated below the bass line.

Figure 13: Natural sixth and seventh steps in the second movement

The natural sixth and seventh combinations (E_b and F_b) are primarily found with non-dominant harmonies, but sometimes in the melodies of V chords. Raised sixth and seventh combinations (E_b and F_b) are also found in both ascending and descending order, but only with V harmonies.³⁶ Superimpositions of both these combinations are then sometimes found with V harmonies, as seen in P8 (Figure 14), for example. These superimpositions add a special dissonance to V chords, which contribute to their dominant quality and increase their push for resolution.³⁷

³⁴ This is also seen in the Handel excerpt (Figure 12), as indicated in blocks.

³⁵ A single exception is the natural sixth to raised seventh found in P3B4.

³⁶ An exception is the use of E_b in the F major scales over $bVII$ harmonies in P27B3 and P32B3.

³⁷ The special dissonant qualities of dominant chords are further discussed in Chapter 7.

Figure 14 shows a musical score for a piece in G minor, 4/4 time. The score includes parts for Piano (Pno.), Violins 1 (Vlns. 1), Violins 2 (Vlns. 2), Viola (Vla.), Violoncello (Vcls.), and Double Bass (Dbs.). The Pno. part features a blue box around a chord in the right hand, and the Dbs. part features a blue box around a chord in the left hand. The score is marked with dynamics *p* and *pp*. The key signature is G minor, and the chord progression is vV^7 and V^9 .

Figure 14: Superimposition of raised and flattened sixth and seventh steps

6.3 Form and Structure

The overall structure of the movement is graphically illustrated in Figure 15.³⁸ The piece is 212 bars in length, divided into 53 phrases of 4 bars each. No deviation from the four-bar phrase length or 4/4 metre occurs.³⁹ The piece can be divided into eleven sections of between four and six phrases each.⁴⁰ Sections 1 and 11 are shorter than the others, and can be viewed as an introduction and conclusion respectively. Sections 2 to 10 are variations of section 1. The first seven variations, sections 2 to 8, are exactly the same length and have the same phrase repetitions. The last two variations, sections 9 and 10, are longer and contain additional phrases and repetitions. These elongations and repetitions are directly related to the piece's harmonic content and elaborated on later in the chapter. Various phrase repetitions, of both single and

³⁸ The figure's layout will make more sense after the discussion on harmony, since the piece's structure is directly related to its harmonic content.

³⁹ In *Raising the Sail* a 6/4 metre is applied, which somewhat changes the melody to a dotted rhythm.

⁴⁰ *Raising the Sail* is made up of section 1 and 2 of the movement only. Sections 3 to 11 are thus an extension of the film's track, as mentioned in the previous chapter.

consecutive phrases are found within each of the sections. Such repetitions are indicated with repeat signs and highlighted in grey in Figure 15.

Section 1	Introduction		P1	P2	• P3 •	P4 •	
Section 2	Variation 1	• P5 •	P6	P7	• P8 •	P9 •	
Section 3	Variation 2	• P10 •	P11	P12	• P13 •	P14 •	
Section 4	Variation 3	• P15 •	P16	P16	• P17 •	P18 •	
Section 5	Variation 4	• P19 •	P20	P21	• P22 •	P23 •	
Section 6	Variation 5	• P24 •	P25	P26	• P27 •	P28 •	
Section 7	Variation 6	• P29 •	P30	P31	• P32 •	P33 •	
Section 8	Variation 7	• P34 •	P35	P36	• P37 •	P38 •	
Section 9	Variation 8	• P39 •	P40	P41	• P42 •	• P43 •	P44
Section 10	Variation 9		P45	P46	• P47 •	P48	P49 •
Section 11	Conclusion		P50	P51	P52	P53	

Added phrases and repetitions

Figure 15: Overall structure

The piece's structural layout and sectional divisions are directly related to its harmonic content. All eleven sections are based on a single, basic harmonic progression,⁴¹ as illustrated in Figure 16. The basic harmonic progression can be subdivided into three parts that undergo repetitions, as indicated in the figure. In most cases repetitions of the first part of the progression are written out on the score as two separate phrases.⁴² Occasionally the repetitions are not written out, but indicated with repeat signs, as seen in P16, for example. A dominant seventh (V^7) is found in all initial statements of part 1 of the basic harmonic progression, but only in some repetitions. Symbol $V^{(7)}$, where the seventh is bracketed, indicates this variation, as seen in part 1 of Figure 16. Symbol V^7 is used when a seventh is found in all statements of the V chord, as seen in part 2 of Figure 16, for example.

⁴¹ This progression is referred to as 'the basic harmonic progression' hereafter.

⁴² Both P1 and P2 of the piece correspond to the progression I-VI-III- $V^{(7)}$, for example.

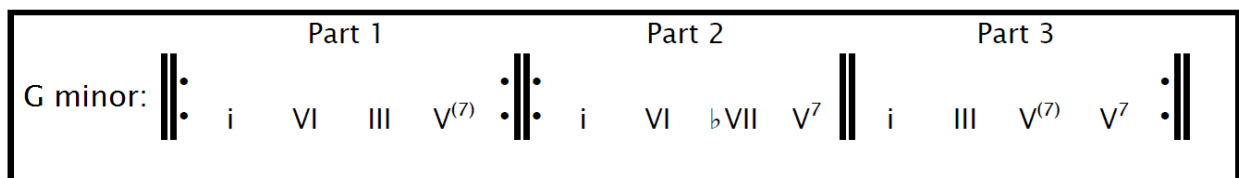

Figure 16: Basic harmonic progression

From the relation between structure and harmony in the piece it is clearly evident that it is a chaconne. It consists of a set of variations over a repeated harmonic progression. Changes in textures, chord inversions, orchestration and non-chord notes are used by the composer to create variation between different sections, as detailed in Chapter 7. Figure 17 superimposes the piece's basic harmonic progression (Figure 16) and its structural layout (Figure 15). The harmonic content of all 53 phrases of the piece is thus indicated in Figure 17. Each phrase is divided into four harmonies, which are consistent with its four bars. From the vertical columns it is obvious how the same harmonies are applied at the same position in each section.

A few minor deviations from the general structural layout can be pointed out, as indicated in Figure 17. In sections 2 to 9, part 1 of the basic harmonic progression is preceded by a four-bar tonic phrase.⁴³ Sections 9 and 10 have an extra statement and additional repeat of part 3 of the basic harmonic progression. In section 11 parts 2 and 3 of the basic harmonic progression are replaced with a cadential progression, i-V-i-V-i. Following the discussion of the movement's harmonic content in the next section, the effect and reasons for these structural deviations are explained.

⁴³ A four-bar tonic phrase is not found between sections 1 and 2 of *Raising the Sail*.

Section 1	G minor:	P1	P2	P3	P4	
		i VI III V ⁷	i VI III V	i VI bVII V ⁷	i III V V ⁷	
Section 2	P5	P6	P7	P8	P9	
	i - - -	i VI III V ⁷	i VI III V	i VI bVII V ⁷	i III V V ⁷	
Section 3	P10	P11	P12	P13	P14	
	i - - -	i VI III V ⁷	i VI III V	i VI bVII V ⁷	i III V V ⁷	
Section 4	P15	P16	P16	P17	P18	
	i - - -	i VI III V ⁷	i VI III V	i VI bVII V ⁷	i III V V ⁷	
Section 5	P19	P20	P21	P22	P23	
	i - - -	i VI III V ⁷	i VI III V	i VI bVII V ⁷	i III V V ⁷	
Section 6	P24	P25	P26	P27	P28	
	i - - -	i VI III V ⁷	i VI III V	i VI bVII V ⁷	i III V V ⁷	
Section 7	P29	P30	P31	P32	P33	
	i - - -	i VI III V ⁷	i VI III V	i VI bVII V ⁷	i III V V ⁷	
Section 8	P34	P35	P36	P37	P38	
	i - - -	i VI III V ⁷	i VI III V	i VI bVII V ⁷	i III V V ⁷	
Section 9	P39	P40	P41	P42	P43	P44
	i - - -	i VI III V ⁷	i VI III V	i VI bVII V ⁷	i III V V ⁷	i III V V ⁷
Section 10	[Blue bracket]	P45	P46	P47	P48	P49
		i VI III V ⁷	i VI III V	i VI bVII V ⁷	i III V V ⁷	i III V V ⁷
Section 11		P50	P51	P52	P53	[Blue bracket]
		i VI III V ⁷	i VI III V	i V i V	i - - -	

Tonic phrase extension

Cadential phrase replaces part 2 and 3 of the basic harmonic progression

Additional statement of part 3 of the basic harmonic progression

Figure 17: Overall harmonic content

6.4 Harmonic Content

The basic harmonic progression (Figure 16) consists of only five consonant chords: i, III, V, VI and \flat VII. Harmonic movement among these chords is to some extent conventional and explainable through a functional analytical approach. However, such an approach is also clearly limited as the tonal language is unconventional and non-functional at times. Engebretsen and Broman (2007:59) write:

Although neo-tonal composers generally do avoid thoroughgoing use of functional tonal syntax, the disruption of functional tonality is not, given their historical position, their most pressing compositional concern. Instead, they grapple with the creation of their own alternative tonal languages and discovery of their own solutions to the challenges of projecting pitch centers and larger-scale tonal structures in the absence of a normative tonal practice.

In the piece, chords in non-functional progressions are often related by thirds, have common tones and undergo parsimonious voice-leading transformations. This calls into question the viability of an analytical approach rooted in transformational theory. In the following sections the piece's harmonic content is approached from both these perspectives. First a functional, harmonic analysis⁴⁴ of the basic harmonic progressions is done, which is followed by a transformational, neo-Riemannian approach.

6.4.1 Functional Approach

The second movement is essentially tonal and has a functional, harmonic backbone. The clear statement, emphasis and dependence on tonic and dominant entities, and harmonic movement between them, are evidence of this. Progressions from tonic to dominant, and consequent resolutions to the tonic, are found throughout the movement. All three parts of the basic harmonic progression (Figure 16) start on the tonic and end on the dominant chord. In fact, all 53 phrases of the piece start on the tonic chord, and every dominant sonority is followed by a tonic chord. Such i-V-i progressions are essential to functional harmony, and results in tonal centrality and a sense of forward motion. However, the perpetual, repeated application of i-V-i progressions in the piece creates continuous, cyclical motion and, paradoxically, a sense of stasis that hides this functionality. This cyclical character is further emphasised by the piece's phrase and sectional repetitions, as discussed earlier. Constant harmonic repetition of this nature is

⁴⁴ Chord inversions are not indicated in subsequent Roman numeral analyses, as they are not applied in a functional role. This is discussed in more detail in Chapter 7.

relatively uncommon in conventional harmonic practice, but consistent with the minimalist school.

Almost every phrase comprises a tonic to dominant movement and thus concludes with a half cadence. The only exceptions are the tonic introductory phrases,⁴⁵ as mentioned earlier, and the final concluding tonic phrase.⁴⁶ It is unfitting to label each phrase-end as half cadences, as there is no sense of rest or finality following the continuous cyclical harmonic motion. Dominant chords at the end of phrases are not felt as arrival points, as they resolve to the tonic chords of subsequent phrases. These tonic chords constitute the start of new progressions again, and cannot be seen as true cadential points either. The continuous, repeated and overlapping i–V–i movements are clearly evident throughout the piece, as illustrated in Figure 18, for example.

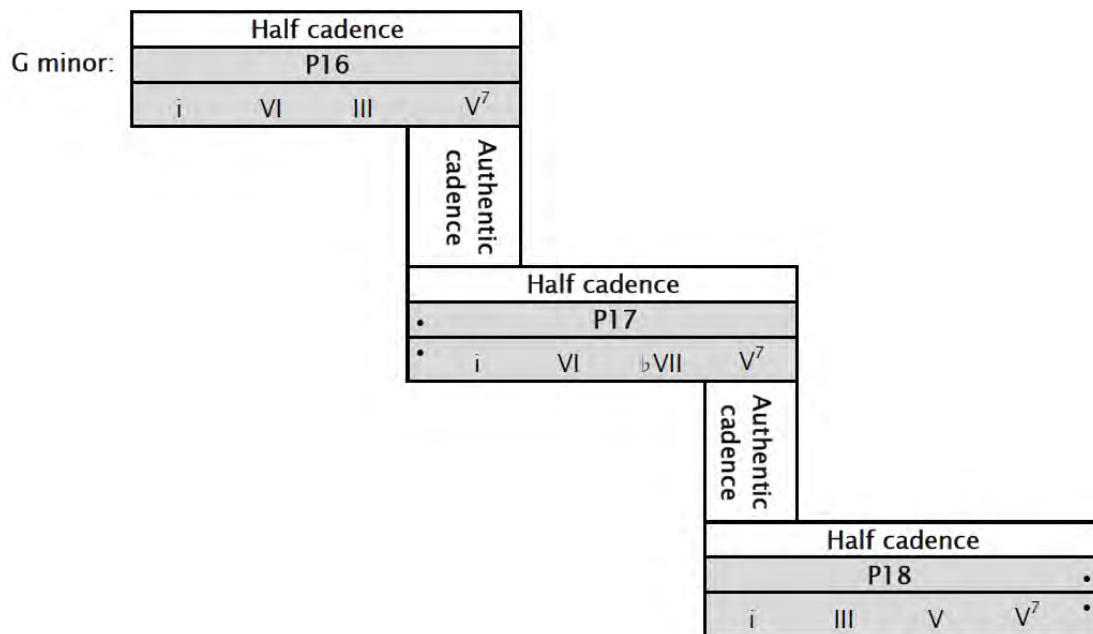

Figure 18: Overlapping cadences on phrase level

The cadential properties of phrases are mirrored on a sectional level. Most sections start on a tonic and end on a dominant.⁴⁷ Again one can argue that an arrival point is reached when an entire section *cadences* on the introductory tonic phrase of a subsequent section. However, these tonic phrases are part of subsequent sections, as is evident from the introduction of their

⁴⁵ This can be seen at P5, P10, P15, P19, P24, P29, P34 and P39 on the score.

⁴⁶ This can be seen at P53.

⁴⁷ It is only the final section that ends with a tonic resolution (P53).

textures. Overlapping i–V–i cadential movements are thus again seen, which supports notions on cyclical repetition discussed earlier. Only at the very end of the piece, after seventeen minutes of continuous cyclical motion and overlapping pseudo–cadences, is a true authentic cadence found. The similarities, and mirror relations between the movement’s larger and smaller structures, as is evident in these cadential movements, are referred to again later in the chapter.

Unorthodox, unconventional and non–functional chord inversions are found throughout the piece. For example, second inversion triad chords are common, and the piece ends on second inversion tonic chords, as illustrated in Figure 19. The basic harmonic progression is repeated with different chord inversions in each section. It is argued in Chapter 7 that inversions are in fact used as a variation technique. Chord resolutions are also unconventional and non–functional in many cases. This can be seen in the upward resolution of the leading tone in the movement from V⁷ to i in P1B4, for example (Figure 20).

The musical score for Figure 19 consists of six staves. The top staff is for the Piano (Pno.), with two parts: the right hand (RH) and the left hand (LH). The RH part features two main chordal sections: P52B4 (a triad in second inversion) and P53B1 (a triad in second inversion). The LH part features a continuous eighth-note accompaniment. The dynamics are marked *pp*. The middle three staves are for Violins 1 and 2 (Vlns. 1, 2) and Viola (Vla.), all of which are silent (indicated by a horizontal line with a dash). The bottom two staves are for Violoncello (Vcls.) and Double Bass (Dbs.). The Vcls. part features a melodic line with a *pp* dynamic. The Dbs. part features a melodic line with a *pp* dynamic. The key signature is G minor, and the time signature is 8/8. The chord symbols at the bottom are V⁷ and i⁶/₄.

Figure 19: Second inversion tonic chords at the end of the movement

The musical score for Figure 20 is set in G minor and consists of five staves: Vlns. 1, Vlns. 2, Vla., Vcs., and Dbs. The key signature has two flats (Bb and Eb). The time signature is 8/8. The score is divided into two measures by a double bar line. The first measure is labeled 'PIB4' and contains a whole note chord in the first violin part, a whole note chord in the second violin part, a whole note chord in the viola part, and a whole note chord in the double bass part. The second measure is labeled 'p i' and contains a whole note chord in the first violin part, a whole note chord in the second violin part, a whole note chord in the viola part, and a whole note chord in the double bass part. A blue arrow points from the seventh degree of the first measure to the first degree of the second measure, indicating the upward resolution of the seventh. Dynamic markings 'p' are present in the first violin, second violin, and double bass parts in the second measure.

Figure 20: Upward resolution of the seventh in a progression from V^7 to i

Each part of the basic harmonic progression has a different, relatively unorthodox progression from i to V . Chords VI , $bVII$ and III are used between i and V , and pre-dominant chords such as ii° and iv are clearly avoided. In the following section the basic harmonic progression is dissected into two-chord modules to make more sense of its functionality.

The movement from i to VI is found twice in the basic harmonic progression and is rather conventional. VI is often used as a substitute or extension of i in functional harmony, since the chords share two common tones. Accordingly, when VI follows i , it does not necessarily create the sense of a new harmony, or of tonal movement. This is especially so when VI is used in first inversion and shares a bass note with i . In functional harmony the progression from i to VI is often followed by a pre-dominant chord such as iv or ii° . This is, however, not the case in the basic harmonic progression. In the piece VI is then best considered an extension of i rather than a preparation or link to a pre-dominant or dominant sonority.

In the first two parts of the basic harmonic progression VI is followed by III . Whilst a movement from III to VI is relatively common in functional harmony, especially as part of a chain of descending fifths ($III-VI-ii^{\circ}-V-i$), the reverse progression from VI to III is not. The progression from VI to $bVII$, as found in part 2 of the basic harmonic progression is also rather uncommon and unconventional.

In functional harmony chord III is often found between i and V in the background, or larger harmonic structures of minor keys. In such cases, chords iv and \flat VII are usually found between i and III, as they form ii and V of III respectively. Chord III then resembles a tonic or primary chord when preceded by intervening iv and \flat VII chords. In part 3 of the basic harmonic progression chords i and III, however, are found in direct succession without the application of any intervening chords. Again, a movement from i to III does not necessarily create the sense of a new harmony, or of tonal movement, as the chords share two common tones. Chord III can then also be seen as an expansion or extension of i rather than a true progression.

In conventional practice III typically progresses to V through a pre-dominant chord such as iv or $\text{ii}^{\circ 6}$. Less common are instances in which III moves directly to an inversion of V^7 , which then resolves to i. An example of this can be seen in Mozart's *Rondo in A minor*, K.511 (Figure 21).

A minor: III

$V^7_{3/4}$

i

Figure 21: Progression from III to i through an inversion of V^7 in Mozart's 'Rondo', K.511

Pre-dominant chords are never found between III and V^7 in the second movement of the *Tirol Concerto*. However, progressions from III to i through inversions of V^7 are, as seen in P12B3, for example (Figure 22). In such progressions there is a sense of tonal movement, as a result of the chromatic semitone between the natural ($F\flat$) and raised seventh ($F\sharp$).

The musical score for Figure 22 is a multi-staff arrangement. At the top left, it is labeled 'PI2B3'. The instruments are: Pno. (Piano), Vlns. 1 (Violin 1), Vlns. 2 (Violin 2), Vla. (Viola), Vcls. (Violoncello), and Dbs. (Double Bass). The Pno. part features a complex texture with sixteenth-note patterns and sixteenth-note chords, marked with 'mf' and 'mp'. The string parts (Vlns. 1, Vlns. 2, Vla., Vcls., Dbs.) are more melodic and harmonic, with dynamic markings of 'mf' and 'mp'. The bottom of the score shows the chord progression: G minor: III, V², 6/5, mp, i. The '6/5' and 'i' are marked with 'mp'.

Figure 22: Progression from III to i through inversions of V⁷ in the second movement

It is worth noting that III and v (the minor dominant chord) have more similar contents and share two common tones (D, F \flat) as result of the application of the natural seventh. As discussed earlier in the section on tonality, the natural seventh (F \flat) is often added to chord V in the piece, which then results in the formation of split-third chords. In such cases it is possible to consider III as a replacement or anticipation of vV, especially when it is in first inversion and shares a bass note (D) with vV. The scales used with chord III in sections 6, 7 and 9 all start on D, the bass note of vV, which supports this notion.⁴⁸

The last progression to consider is from \flat VII to V⁷, as seen in part 2 of the basic harmonic progression. \flat VII in the natural minor is conventionally applied as a preparation for III, but not used in this way in the piece. A direct progression from \flat VII to V⁷ is seen, which is not entirely unconventional in functional harmony, and sometimes seen in Baroque music. Chords \flat VII (F \flat , A, C) and V⁷ (D, F \sharp , A, C) share two common tones, have one that differs by a semitone, and one that differs by a tone. In the piece \flat VII is always followed by V with the seventh included (V⁷), which generates an extra common tone (C). Important to note again is the commonality between

⁴⁸ This is discussed in more detail in Chapter 7.

these successive chords, as also pointed out in the progressions from i to VI, i to III and III to vV. Similar to the application of III to vV, progressions from \flat VII (F \flat , A, C) to vV⁷ (D, F \flat , F \sharp , A, C) are often found in the piece. In such cases the commonality between successive chords is even greater, as they share three common tones (F \flat , A, C).

Shared notes between successive chords is a significant feature of the harmonic content, as seen in the progressions from i to VI, i to III, III to vV, and \flat VII to vV⁷. It seems evident then that commonality has a more important place in the choice of successive chords than function. Accordingly, extensions rather than progressions from i to V are seen through the application of III, \flat VII and VI chords in the piece.

6.4.2 Transformational Approach

Neo-Riemannian theory (NRT) provides a way of studying triadic, diatonic progressions that are functionally incoherent and unresponsive to traditional, functional and tonally-organised analyses. Cook (2005:111) writes: “neo-Riemannian theorists seek to capture intuitions of coherence in music that is generally agreed not to find accommodation under the roof of a tonal hierarchy as historically constructed”. Engebretsen and Broman (2007:65) add that a “neo-Riemannian perspective can offer insight into the organization of some triadic passages in neo-tonal works”. NRT is a form of transformational theory and studies coherence between triads on the basis of voice-leading and common tone preservation instead of harmonic function and root progression. In order for two successive chords to be related by NRT transformations, they should be consonant triads separated by a third, share two common tones, and undergo parsimonious voice-leading⁴⁹ changes. It was concluded earlier that the piece consists of consonant triads, that subsequent chords often share common tones, and that progressions are often non-functional. In addition, the majority of chords in the piece are separated by thirds: chord i moves to either VI or III, and V is approached from either \flat VII or III in the basic harmonic progression. It is then only the movements from VI to \flat VII and VI to III that are not third related. These factors support the notion of NRT as a viable analytical approach for the movement, as implemented in the following section.

The following transformations are found when NRT is applied to the third-related chords of the basic harmonic progression, as illustrated in graphical and notated formats in Figures 23 and 24. The movement from i to III undergoes an R-transformation as G descends a tone to F, whilst B \flat and D remain common tones. Chord i changes to VI through an L-transformation as D ascends

⁴⁹ Voice-leading is considered parsimonious if either semitone or tone movement between subsequent tones occurs.

a semitone to E_b , whilst G and B_b are common tones. The movements from III to vV and $bVII$ to vV are more complex and undergo two successive transformations. Chord III moves to v through an L-transformation as B_b descends a semitone to A, whilst D and F remain common tones. Chord v then moves to V through a P-transformation when F ascends a semitone to $F\sharp$, and notes D and A remain unchanged. The movement from $bVII$ to v undergoes an R-transformation as C ascends a tone to D, whilst F and A are common tones. Similar to the previous example, chord v then moves to V through a P-transformation as F ascends a semitone to $F\sharp$, whilst D and A remain unchanged. Chord $bVII$ is, however, always followed by a dominant seventh (V^7), which means that F_b , A and C are in fact common tones. The movements between i and V in consecutive phrases or parts of the basic harmonic progression corresponds to an N-transformation. However, as discussed earlier, movements from V to i are quintessentially tonal and better considered part of the piece's functional backbone.

G minor:	i	R transformation	III
	G	↓ Tone	F
	B_b	Constant	B_b
	D	Constant	D

i	L transformation	VI
G	Constant	G
B_b	Constant	B_b
D	↑ Semitone	E_b

III	L transformation	v	P transformation	V
B_b	↓ Semitone	A	Constant	A
D	Constant	D	Constant	D
F	Constant	F	↑ Semitone	$F\sharp$

$bVII$	R transformation	v	P transformation	V
F	Constant	F	↑ Semitone	$F\sharp$
A	Constant	A	Constant	A
C	↑ Tone	D	Constant	D

$bVII$	R transformation	v^7	P transformation	V^7
F	Constant	F	↑ Semitone	$F\sharp$
A	Constant	A	Constant	A
C	Constant	C	Constant	C
C	↑ Tone	D	Constant	D

Figure 23: NRT transformations in third-related chords of the basic harmonic progression

Figure 24: NRT transformations in third-related chords of the basic harmonic progression

These transformations do not only pertain to the basic harmonic progression in a theoretical sense, but are directly evident in the score. Figure 25, for example, shows how two notes remain constant in a progression from *i* to *VI* in P2, whilst a third undergoes parsimonious voice-leading by a semitone. In some cases variations and more complex statements of the transformations are also found. Subsequent chords might, for example, contain inversional changes or additional sevenths and added notes that colour the basic, theoretical transformations. Such variations and colourations are further discussed in Chapter 7.

Figure 25: Constant tones and parsimonious voice-leading in a progression from *i* to *VI*

Important to note is the change that is required from $F\flat$ to $F\sharp$ to complete the movement from *III* to vV and $bVII$ to vV . This interplay between the natural and raised seventh steps was discussed in the section on tonality. Had the natural seventh ($F\flat$) not been present, a direct transformation

between chords III and V, and chords \flat VII and V would not have been possible. Both chords III and \flat VII need to move through the minor dominant chord (v) for direct transformations to occur. This relation is not only theoretical or hypothetical, but present in the piece through the application of split-third chords. Even though $F\flat$ and $F\sharp$ are superimposed in the dominant harmony, a sense of progression from $F\flat$ to $F\sharp$ still exists. The natural seventh is always found at the start of V harmony and usually terminates or resolves before its end, whilst the raised seventh is always sustained throughout. In P8B4, for example (Figure 26), $F\flat$ resolves to the chordal ninth ($E\flat$) before the end of the bar, whilst in P11B4 the $F\flat$ terminates before the end of the bar.

The figure displays a musical score for two piano parts, P8B4 and P20B4, and their resolutions. The P8B4 part features a piano (Pno.) with a split-third chord in the right hand, highlighted by a blue box, and strings (Vlns. 1, Vlns. 2, Vlas., Vcls., Dbs.) playing a sixteenth-note pattern. The P20B4 part shows a similar piano part but with a different resolution. The bottom of the score indicates the chord progression: G minor: vV⁷, V⁹, vV, V⁷.

Figure 26: Terminations and resolutions of $F\flat$

The only two chord relations of the basic harmonic progression that have not been considered from a transformational perspective are VI to III and VI to \flat VII. These chords are not separated by thirds and thus cannot undergo direct neo-Riemannian transformation. Considering their commonality and voice-leading changes, the following can be noted: when VI moves to III, G descends by a tone to F and $E\flat$ by a semitone to D, whilst $B\flat$ stays constant, as seen in P6 for example (Figure 27). In a movement from VI to \flat VII all three notes ascend by a tone, as seen in

P12, for example (Figure 28).⁵⁰ Although the transformational properties in these progressions are not as direct as the neo-Riemannian transformations discussed earlier, commonality and direct voice-leading are still apparent. Considering that they are not applied in a functional manner, their transformational coherence is still important.

Figure 27 is a musical score for a movement from VI to III in G minor. The score is written for five staves: Vlns. 1, Vlns. 2, Vlas., Vlbs., and Dbs. The key signature is one flat (Bb). The score is labeled with a transformation P6B2. The first measure is marked with a '6' above the staff. The second measure is marked with a '6' above the staff. The third measure is marked with a '6' above the staff. The score is divided into two measures by a double bar line. The first measure is labeled 'G minor: VI' and the second measure is labeled 'III'. Blue annotations highlight the voice leading between the two measures, showing the movement of individual notes from the VI chord to the III chord.

Figure 27: Movement from VI to III

Figure 28 is a musical score for a movement from VI to bVII in G minor. The score is written for five staves: Vlns. 1, Vlns. 2, Vlas., Vlbs., and Dbs. The key signature is one flat (Bb). The score is labeled with a transformation P27B2. The first measure is marked with a '6' above the staff. The second measure is marked with a '6' above the staff. The third measure is marked with a '6' above the staff. The score is divided into two measures by a double bar line. The first measure is labeled 'G minor: VI' and the second measure is labeled 'bVII'. Blue annotations highlight the voice leading between the two measures, showing the movement of individual notes from the VI chord to the bVII chord.

Figure 28: Movement from VI to $bVII$

⁵⁰ However, the composer sometimes makes use of a descending minor third between E \flat and C, and stepwise movement between G and F \sharp , and B \flat and A respectively.

Even though direct transformations are not present in the progressions from VI to III and VI to \flat VII, a theoretical neo-Riemannian perspective can still be adopted. Such a view is then hypothetical and in the form of middle-ground analysis of the score rather than a direct foreground analysis. The simplest, shortest movement between VI and III is through an LR transformation cycle. An LRLR cycle needs to be applied in the shortest movement from VI to \flat VII. Figures 29 and 30 show these transformation cycles in graphical and notated formats.

G minor:

VI	L transformation	(i)	R transformation	III
E \flat	↓ Semitone	D	Constant	D
G	Constant	G	↓ Tone	F
B \flat	Constant	B \flat	Constant	B \flat

VI	L transformation	(i)	R transformation	(III)	L transformation	(v)	R transformation	\flat VII
E \flat	↓ Semitone	D	Constant	D	Constant	D	↓ Tone	C
G	Constant	G	↓ Tone	F	Constant	F	Constant	F
B \flat	Constant	B \flat	Constant	B \flat	↓ Semitone	A	Constant	A

Figure 29: Hypothetical NRT transformations in chords that are not third related

Figure 30: Hypothetical NRT transformations in chords that are not third related

From the figures it is evident that chord i completes the LR cycle between VI and III, whilst chords i, III and V must be inserted between VI and \flat VII to complete the LRLR cycle. Interestingly, these theoretical chords are already part of the basic harmonic progression! No foreign chords need to be applied to complete the movement. A close proximity and relation between the five chords of the basic harmonic progression are thus clearly evident. The five chords were not merely chosen

at random, but are part of an organic transformational framework. Only specific chord combinations would allow such coherent transformations in harmonic progressions.

Considering the previously discussed chordal transformations on the *Tonnetz* further emphasises the coherence and proximity of the piece's harmonic content.⁵¹ Four of the five chords of the basic harmonic progression move horizontally across the LR alley of the *Tonnetz*, as seen in Figure 31. This movement is mainly without conventional harmonic functional movement and based on a transformational coherence among closely related chords. This subdivision of the horizontal alley corresponds exactly to a specific collection of chords from the Aeolian mode. Only the vertical movement from v to V deviates from the LR alley and undergoes a P-transformation. This P-transformation raises F \flat to F \sharp , in accordance with earlier discussions on the interplay between the natural and raised seventh. It is quintessentially this movement that results in the formation of the leading tone, harmonic pull of the dominant, and the piece's functional, tonal backbone. In correspondence with functional harmony, the dominant chord then resolves to the tonic. However, the resolution is not final, as the tonic chord forms part of a new LR alley again, and the cycle starts afresh.

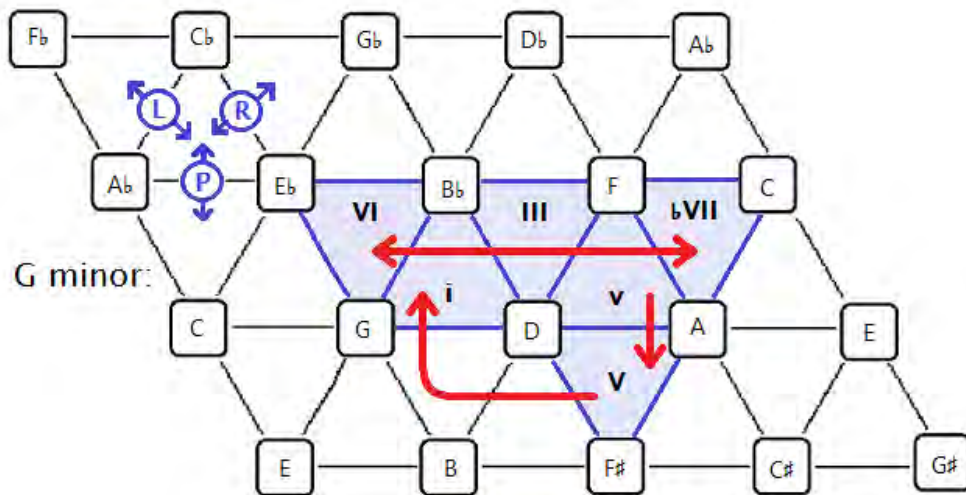

Figure 31: Basic harmonic progression considered on the 'Tonnetz'

Figure 31 clearly illustrates the cyclical transformational quality of the basic harmonic content, which is repeated extensively for almost the entire composition. The cyclical nature of the composition is then not only evident in its structure and repetitions, but also in the composer's choice of harmonic content. Neo-Riemannian theory provides a clear, meaningful way in which

⁵¹ Also called the *Table of Tonal Relations*, the *Tonnetz* is a geometric model that maps different NRT transformations.

to show transformational relations between chords of the basic harmonic progression. Coherence in terms of commonality, transformational proximity and parsimonious voice-leading would have been lost in a functional perspective. These transformational, non-functional relations between chords are essential in the piece's circular, repetitive nature and the composer's harmonic language in this case.

6.5 Structural Deviations

Following the preceding discussion on harmony, the deviations in the piece's structural layout that were mentioned earlier (Figure 15) can now be reassessed. Four-bar tonic phrases are found before the start of the basic harmonic progression in sections 2 to 9.⁵² These phrases extend the opening harmony and introduce the texture, orchestration and variations of each new section.⁵³ The tonic phrases create points of rest between the continuous, cyclical repetitions of the different sections. However, as argued earlier, cadential overlap is apparent, since the tonic phrases make out both the end of a previous and the start of a new cycle. A tonic phrase is not found before section 1 and the piece begins straightaway with part 1 of the basic harmonic progression. One can argue that preceding the piece with a four-bar tonic phrase would have resulted in an undesirable static opening.

In sections 9 and 10 additional statements and repeats of part 3 of the basic harmonic progression (i-III-V⁽⁷⁾-V⁷) are found. These additional cyclical repetitions can be viewed as a delay of the return of the final tonic phrase in P53. In contrast to previous sections, four-bar tonic phrases are not inserted before sections 10 and 11, which further emphasises this notion. In previous sections exactly 24 bars of cyclical repetitions⁵⁴ are played between subsequent tonic phrases. However, 80 bars of cyclical repetitions are found between P39 and the return of the delayed tonic in P53. An extension of the cyclical content before the final resolution from V to i is thus apparent. It is possible to parallel this compositional property to dominant extensions in functional harmony.

In section 11 parts 2 and 3 of the basic harmonic progression (i-VI-^bVII-V⁷ and i-III-V⁽⁷⁾-V⁷) are replaced with a straightforward cadential progression (i-V-i-V-i). The circular repetitions and continuous movements that were characteristic of previous sections are thus replaced with a conventional authentic cadence. This brings the movement to a conclusive stop with a strong movement from V to i that is rooted in functional harmony. Had the cadential progression not

⁵² This can be seen at P5, P10, P15, P19, P24, P29, P34 and P39.

⁵³ These properties are discussed in more detail in Chapter 7.

⁵⁴ The total number of bars played between P5 and P10, for example.

been added, the direct termination of the cyclical harmonic movements would have brought the piece to an abrupt and unconvincing end. The combination of a functional backbone and circular repetitions, as discussed earlier, is thus apparent on a structural level too.

6.6 Fractal Relations and Organicity

An earlier discussion on cadences briefly outlined similarities between the piece's larger and smaller structures. The format of the piece's overall structure mirrors that of sections and phrases, as illustrated in Figure 32, for example. All three structural levels consist of an extension from tonic to dominant through the application of cyclical repetitions or extensions, and a resolution to the tonic. A fractal dimension to the piece's structural makeup is thus evident.⁵⁵

At phrase level tonic chords connect to dominant chords through non-functional transformations based on chords VI, III and \flat VII. Cyclical repetitions are seen in the extension and replacement of the tonic and dominant harmonies by these chords. Each phrase ends with a dominant that resolves to the tonic of a subsequent phrase. However, cadential aspects are overshadowed by cyclical repetitions and the tonic's function in a subsequent phrase.

Tonic to dominant extension through the application of cyclical repetitions can also be seen on a sectional level. The four-bar tonic phrases that precede sections 2 to 9 are followed by cyclical repetitions of non-functional i-V phrases. Each section concludes with part 3 of the basic harmonic progression (i-III-V⁽⁷⁾-V⁷). This is the most 'dominant' subdivision of the basic harmonic progression, as V⁽⁷⁾ is sustained for two bars and emphasised through increased dissonance.⁵⁶ Each section's dominant phrase resolves to a tonic phrase of a subsequent section. However, cadential aspects are again hidden through cyclical repetitions and the tonic phrase's role in a subsequent section.

The movement as a whole conforms to the aforementioned structural formats as well. Cyclical repetitions are found on a sectional level through the repeated application of the entire basic harmonic progression. Sections 10 and 11, the 'dominant prolongation', represents the dominant entity in this case. These sections contain additional statements and repetitions of part 3 of the basic harmonic progression and omits tonic phrases altogether, as previously discussed. The piece as a whole resolves to the tonic in P53. For the first time the tonic does not form part of a new structure and a true authentic cadence is finally played.

⁵⁵ The mirroring of larger and smaller structures is also evident in the piece's dynamic indications, as discussed in Chapter 7.

⁵⁶ Increased dissonance results from the application of split-third chords and added notes, as discussed in Chapter 7.

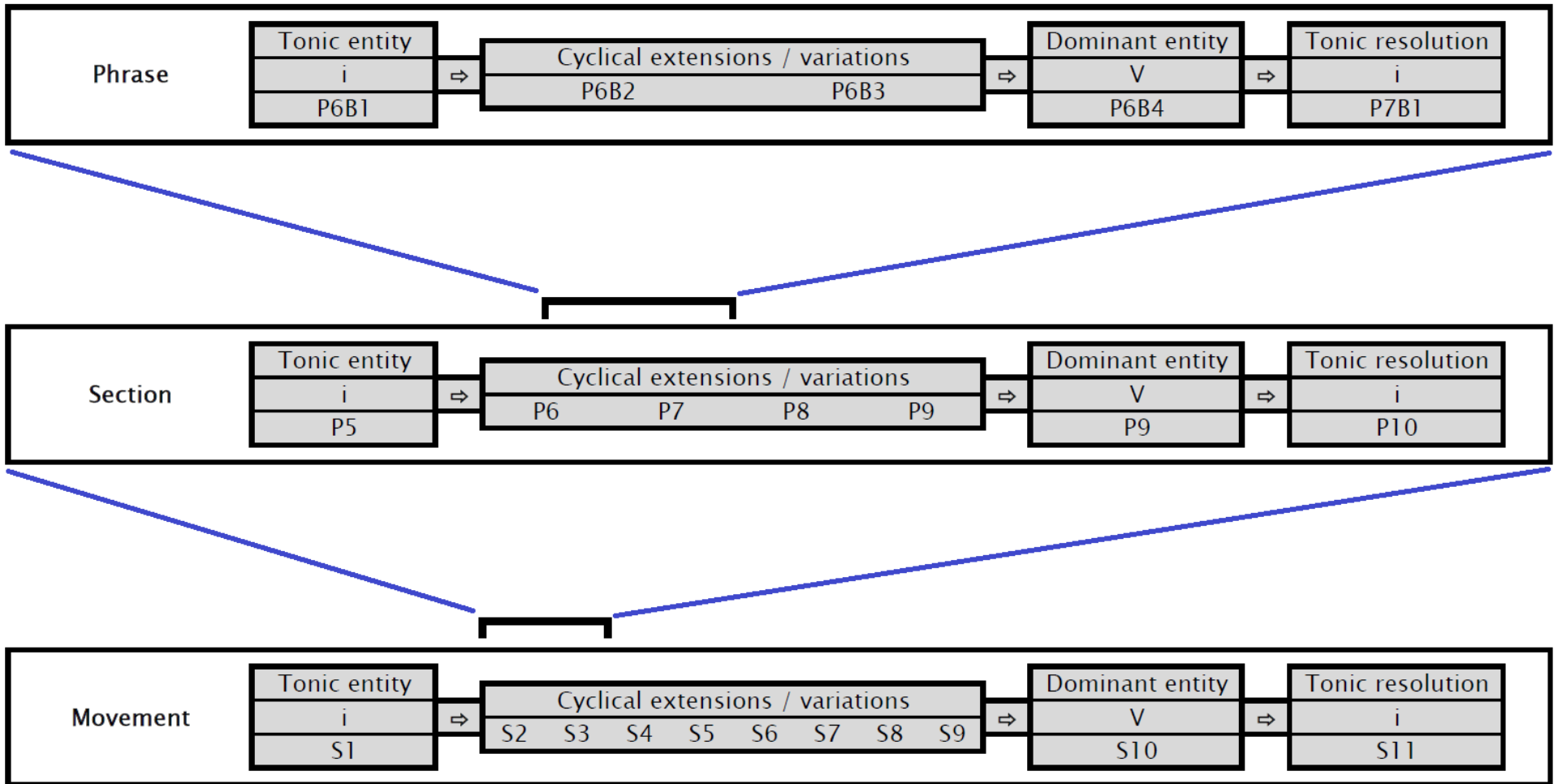

Figure 32: Mirror structures

It can then be argued that an overall i–V–i progression, or authentic cadence, encompasses the structure of the entire piece. Subdivisions at sectional and phrase level also constitute i–V–i progressions. However, the functionality of such progressions are hidden by the cyclical repetitions and overlapping of cadences, as previously discussed.

Considering the piece's harmonic content and structural makeup, a systematic, organic quality is evident. The entire composition of seventeen minutes is made up of eleven sections based on single progression of only five consonant chords. No changes in phrase lengths or metre are seen, and similarities between smaller and bigger structures are evident. The piece as a unified, coherent, fractal whole is built up of small repeated, cyclical figures, through a precisely considered process.

6.7 Conclusion

In this long and detailed chapter theoretical analyses of some of the second movement's compositional content were presented to investigate its musical characteristics. The chapter focused on the movement's basic compositional content through analyses of its structural and harmonic makeup. The following main points, as detailed in the main discussion, can be emphasised: the piece is written in G natural minor, but with an interesting interplay of the natural and raised seventh steps that results in the formation of split-third chords. The piece is in the form of a chaconne and dividable into eleven sections with extensive repetitions and variations of a repeated basic harmonic progression.

The piece has a functional, tonal framework and its harmonic content is to some extent conventional and explainable through functional analysis. However, such functionality is hidden by cyclical repetitions, overlapping of cadences and unconventional progressions, the result of which is a lack of direction and stasis. Subsequent chords that are related by thirds, have common tones, and undergo parsimonious voice-leading transformations are common in the piece, which calls into question the viability of a transformational approach. Through neo-Riemannian theory a number of transformational relations can be identified in the basic harmonic progression on both foreground and middle-ground level. There is a close proximity and coherence between all chords of the basic harmonic progression and together they form an organic, transformational framework. Viewing such transformations on the *Tonnetz* clearly reflects the cyclical nature of the composition's harmonic content in addition to its cyclical structural makeup. NRT unearths transformational coherence in the piece's harmonic content that would not have been obvious in a functional approach. Transformational coherence is an

essential component of the circular, repetitive nature of the piece, and the composer's compositional language in this case.

There are similarities between the piece's larger and smaller structures, which gives it a fractal dimension. The piece has an organic quality in which the basic compositional content is a product of a simple, coherent, structural and harmonic process. This raises the question: if the entire seventeen-minute piece is made up of such simple, basic compositional material, how then does the composer keep the listener's attention? The following chapter discusses the ways in which Glass colours the basic compositional content. A number of techniques are applied by the composer to create variation and interest.

Chapter 7: Variations

7.1 Introduction

The preceding chapter discussed the simple, organic framework central to the movement's basic compositional content. It was concluded that the seventeen-minute piece is made up of eleven sections that are based on a repeated progression of only five consonant chords. This chapter investigates the processes through which the composer creates variation between the different sections' basic compositional content. These processes colour and diversify the sections in order to keep the compositional material interesting, and to hide the simple, repetitive structural backbone. In support of the third research objective, this discussion concludes the critical evaluation of the piece's compositional content, its musical characteristics, and the elements applied by the composer in its composition. First the ways in which harmonic variation is created through the application of melodic material, accompanimental changes and scales are explained. This is followed by discussions on textural, rhythmic, timbral and orchestral variations. The chapter concludes with a short section on inversional and dynamic changes.

7.2 Harmonic Variations

7.2.1 Melodic Applications

Harmonic variation, or rather colouration, results from the superimposition of melodic material on the basic harmonic progression. Whilst the basic harmonic progression remains unchanged throughout the entire piece, the application of varied melodic material creates added-note and extended-third chords. No variation on the basic harmonic progression is found in sections without melodic material, which supports this notion. Often a contradiction or clash between the melodic and accompanimental material is seen. Especially noteworthy is the addition of the natural seventh (F \natural) to the V harmony and the subsequent formation of split-third chords, as discussed earlier.

Expansive melodic lyricism dominates the second movement of the *Tirol Concerto*. In Chapter 4 the apparent influences of *Maria! hilf doch mir* on the piece's first melody were discussed. Three different melodies are in fact used in the piece, of which the third is somewhat related to the second (Figure 33).⁵⁷ The melodies are usually played in the top voices of the piano or violins,

⁵⁷ In *Raising the Sail* the embellishments of D through the application of an upper neighbouring note, E \flat , in bars 13 and 14 of melody 1 do not occur. The rest of the melodic material is the same.

except in section 8, where the melody is played in the lower strings.⁵⁸ Melodies start on the first chord of the basic harmonic progression and are not found in the tonic introductory phrases. They are characterised by long note values, stepwise motion and the application of non-chord notes. A list of the piece's sections, the melodies applied and the instruments that play them is provided in Figure 34.

The image displays three musical melodies in 4/4 time, each on a single treble clef staff. Melody 1 consists of two lines of music. The first line starts with a whole note G4, followed by quarter notes A4, B4, and C5, then a whole note D5. The second line starts with a whole note E5, followed by quarter notes F5, G5, and A5, then a whole note B5. Melody 2 consists of two lines of music. The first line starts with a whole rest, followed by quarter notes B4, C5, D5, and E5, then a whole note F5. The second line starts with a whole note G5, followed by quarter notes A5, B5, and C6, then a whole note D6. Melody 3 consists of three lines of music. The first line starts with a whole note B4, followed by quarter notes C5, D5, and E5, then a whole note F5. The second line starts with a whole note G5, followed by quarter notes A5, B5, and C6, then a whole note D6. The third line starts with a whole note E6, followed by quarter notes F6, G6, and A6, then a whole note B6. All melodies feature long note values and stepwise motion.

Figure 33: Melodic content

⁵⁸ In section 8 the melody is played by the violas, cellos and double basses.

Section	Melody	Instrument
Section 1	Melody 1	Violins I
Section 2	Melody 1	Piano
Section 3	Melody 2	Violins
Section 4	No Melody	-
Section 5	Melody 2	Piano
Section 6	Melody 1	Violins I
Section 7	No Melody	-
Section 8	Melody 1 and 2	Piano and lower strings
Section 9	Melody 3	Violins
Section 10	Melody 1	Piano
Section 11	Melody 1 and 2	Piano and violins

Figure 34: Melodies and instrumentation

In the following section the piece's melodic content and the resultant harmonic variations from each melody are discussed. Harmonic variations are indicated in blocked Roman numerals beneath the basic harmonic progression of the respective melodies in Figures 35–37. In bar 12 of melody 1 (Figure 35) F# resolves to E \flat over a V⁷ harmony, which then creates a dominant ninth (V⁹) chord. This harmonic variation is thus seen in all the sections with melody 1.⁵⁹ It can be argued that the E \flat is a passing note from the F# to the D in the bar that follows. However, the special emphasis it receives in certain instances suggests that it forms part of the V chord.

The figure displays two staves of musical notation in G minor. The first staff shows a sequence of chords: i, VI, III, V⁽⁷⁾, i, VI, III, V⁽⁷⁾. The second staff shows: i, VI, bVII, V⁽⁷⁾, i, III, V⁽⁷⁾, V⁽⁷⁾. A boxed 'V⁹' is placed under the second V⁽⁷⁾ in the second staff, with a '12' above it indicating the bar number.

Figure 35: Harmonic variation with melody 1

In melody 2 (Figure 36) the F \sharp played above III in bar 3 is extended to V⁽⁷⁾ in bar 4. This variation is seen in all the sections with melody 2.⁶⁰ A split-third chord (vV⁽⁷⁾) that combines the natural

⁵⁹ This can be seen at P3B4, P8B4, P27B4, P37B4 and P47B4.

⁶⁰ This can be seen at P11B4, P20B4 and P35B4.

(F \flat) and raised seventh (F \sharp) is thus found here. The superimposition of the major and minor chordal thirds adds an interesting dissonance to the dominant harmony, as mentioned earlier. Because F \flat terminates before the end of the bar in this instance, it can be argued that it is a type of suspension from the previous bar rather than a chord note. However, bars 15 and 16 of the extract contain a clearer example of the split-third chord. An F \flat is again found above a V chord, but only this time it does not terminate or resolve, and it is extended for the entire harmony.⁶¹

Figure 36: Harmonic variations with melody 2

In bar 10 of melody 2 a C \flat is played as an added sixth above the VI harmony.⁶² Although this note can be viewed as an anticipation of the C \flat that follows in bar 11, it receives special emphasis as a chord note. The composer could quite easily have moved through a C passing note to a B \flat chord note on the VI harmony to avoid the added sixth. Theoretically, a minor subdominant seventh chord, iv 7 (C, E \flat , G, B \flat), is formed when C \flat is added to the VI harmony. However, it is obvious in the accompanimental repetitions of the basic harmonic progression that it is an altered VI chord, VI $^{+6}$. The added C \flat is only found melodically and serves as a colouration or variation of the VI harmony.

Worth mentioning is the G that is played as an added sixth above III in bar 14 of melody 2.⁶³ This is not theoretically an added note, as the G resolves to an F \flat at the end of the bar. However, its high tessitura and long duration strengthens its influence on the III sonority. The F \flat to which it resolves can be seen as an anticipation of the F \flat in bar 15, which strengthens its function as a chord note. Theoretically, a minor seventh tonic chord, i 7 (G, B \flat , D, F \flat), is formed when G is

⁶¹ This can be seen at P14B3–4 and P23B3–4.

⁶² This can be seen at P13B2, P22B2 and P37B2.

⁶³ This can be seen at P14B2, P23B2 and P38B2.

added to the III harmony. However, it is obvious from the repeated basic harmonic progression in the accompaniment that it is best considered an altered III chord, III⁽⁺⁶⁾.⁶⁴ In section 8 the melody is played in the lower strings, and the aforementioned added notes (F \flat , C \flat , G \flat) form the bass notes of the harmonic progression.⁶⁵ In this case the notes receive extra emphasis and an increased harmonic importance in their bassline position. A clear variation of the basic harmonic progression is thus evident.

Melody 3 has a fragmented quality and is made up of a number of repeated modules. It is used in the section with additional phrases and repetitions, section 9, which makes its modular content fitting. It is somewhat related to melody 2, and also contains a C \flat as an added sixth to VI, as seen in bar 10 of the extract.⁶⁶ B \flat and its embellishments through upper neighbouring notes and stepwise triplet figures make up the majority of the melodic material. B \flat is a chord note of i, VI and III, but its suspension as an added sixth above V, as seen in bars 4, 8, 15, 16, 19 and 20 of Figure 37, is rather unconventional.⁶⁷ It is possible to view the added B \flat as a thirteenth instead of a sixth, if C and E \flat (the chordal seventh and ninth) in the triplet figures are also viewed as chord notes. However, their use as non-chord embellishing notes of B \flat seems more obvious.

The image shows a musical score for G minor, measures 4 through 20. The melody is written in a treble clef with a 4/4 time signature. The score includes various chordal annotations and melodic figures. The chords are labeled as follows: Measure 4: i, VI, III, V7, i, VI, III; Measure 8: V7, i, VI, bVII, V, i, III; Measure 10: V, V7, i, III, V, V7, i; Measure 15: V, V7, i, III, V, V7, i; Measure 16: V, V7, i, III, V, V7, i; Measure 19: V, V7, i, III, V, V7, i; Measure 20: V, V7, i, III, V, V7, i. The annotations V7+6, VI+6, and V+6 are highlighted in blue boxes.

Figure 37: Harmonic variations with melody 3

⁶⁴ The added sixth (+6) is kept in brackets in this case since its resolution to F \flat in the bar can be argued.

⁶⁵ This can be seen at P35B4 and P37B2.

⁶⁶ This can be seen at P42B2.

⁶⁷ This can be seen at P40B4, P41B4, P43B3–4 and P44B3–4.

In sections 4 and 7 no melodic material is found, and no deviations or variations from the basic harmonic progression occur. In section 8 a polyphonic combination of melodies 1 and 2 is seen, which means that the resultant harmonic variations are a combination of those discussed for both melodies. Section 11 contains only fragments of melodies 1 and 2, and very few deviations from the basic harmonic progression. In P50 and P51 a variation of the first three bars of melody 1 are played by the piano, whilst the first four bars of melody 2 are played by the violins. Little melodic material is found in P52 and P53.

Minor differences between the repeated statements of melodies in the various sections are found. Most of these changes occur through the addition of chordal notes or resolving non-chord notes, and thus do not result in any harmonic changes.⁶⁸ However, a number of melodic changes that do influence the piece's harmonic content somewhat can be noted. In P8B4, for example, F \flat does not progress to F \sharp as in the original statement (P3B4). A split-third chord is thus found here, which is an unconventional harmonic variation for melody 1.⁶⁹ At the end of section 8 the melody in the lower strings is replaced with accompanimental material. Instead of ending melody 2 on an extended F \flat in P38B3–4, as is originally the case in P14B3–4, chord notes A, E \flat and F \sharp are played. Accordingly, a split-third chord is not found at the end of P38 but a V⁹ sonority. In P50B3–4 the melody does not progress to F \flat as with the original statement in P14B3–4, but moves to chord note D. A split-chord is thus not found here, which makes sense since the section contains the final tonic resolution, as discussed earlier. Changes in rhythm and note durations are also found between the melodies of different sections, which obviously do not influence harmonic content. Taking all the aforementioned melodic changes into account, the piece's harmonic table can be revised. Figure 38 illustrates the compositional makeup of the entire movement.⁷⁰ Changes to the basic harmonic progression as result of melodic applications are indicated in bold.

⁶⁸ For example, the addition of chord notes D and C in P26B4 in comparison with the original statement in P2B4; the added changing figures in P36B4 and P35B4 in comparison with the original statements in P1B4 and P2B4 respectively; the use of chordal notes a third higher in P45B4 and P46B3–4 in comparison with the original statements in P1B4 and P2B3–4 respectively; the omission of F \flat as a neighbouring note in P50B2 in comparison with the original statement in P1B2; and the addition of B \flat as a passing note in P22B4 and P37B4 in comparison with the original statement in P13B4.

⁶⁹ It is possible that this is an error in the score, as it does not conform to the general framework.

⁷⁰ Label S(n) refers to a section number and M(n) to the melody applied in each section.

S1	M1	G minor:	P1	P2	P3	P4	
			i VI III V ⁷	i VI III V	i VI bVII V ^{7,9}	i III V V ⁷	
S2	M1	P5	P6	P7	P8	P9	
		i - - - -	i VI III V ⁷	i VI III V	i VI bVII vV ^{7,9}	i III V V ⁷	
S3	M2	P10	P11	P12	P13	P14	
		i - - - -	i VI III vV ⁷	i VI III V ⁷	i VI ⁺⁶ bVII V ⁷	i III ⁽⁺⁶⁾ V vV ⁷	
S4	-	P15	P16	P16	P17	P18	
		i - - - -	i VI III V ⁷	i VI III V ⁷	i VI bVII V ⁷	i III V V ⁷	
S5	M2	P19	P20	P21	P22	P23	
		i - - - -	i VI III vV ⁷	i VI III V ⁷	i VI ⁺⁶ bVII V ⁷	i III ⁽⁺⁶⁾ V vV ⁷	
S6	M1	P24	P25	P26	P27	P28	
		i - - - -	i VI III V ⁷	i VI III V ⁷	i VI bVII V ^{7,9}	i III V ⁷ V ⁷	
S7	-	P29	P30	P31	P32	P33	
		i - - - -	i VI III V ⁷	i VI III V ⁷	i VI bVII V ⁷	i III V V ⁷	
S8	M1&2	P34	P35	P36	P37	P38	
		i - - - -	i VI III vV ⁷	i VI III V ⁷	i VI ⁺⁶ bVII V ^{7,9}	i III ⁽⁺⁶⁾ V ⁷ V ^{7,9}	
S9	M3	P39	P40	P41	P42	P43	P44
		i - - - -	i VI III V ^{7,+6}	i VI III V ^{7,+6}	i VI ⁺⁶ bVII V ⁷	i III V ⁺⁶ V ^{7,+6}	i III V ⁺⁶ V ^{7,+6}
S10	M1		P45	P46	P47	P48	P49
			i VI III V ⁷	i VI III V ⁷	i VI bVII V ^{7,9}	i III V ⁷ V ⁷	i III V V ⁷
S11	M1&2		P50	P51	P52	P53	
			i VI III V ⁷	i VI III V ⁷	i V i V	i - - - -	

Figure 38: Overall harmonic content with melodic variations

7.2.2 Accompanimental Changes

The basic harmonic progression and the variations created through melodic applications form the compositional backbone of the piece. However, a number of peculiar harmonic changes in the accompaniment of V chords may be noted. This then supports earlier notions of increased dissonance on V sonorities. Such changes are minimal, however, considering the piece's generally coherent nature. In P26B4 a raised sixth ($B\sharp$) is added to the V^7 harmony ($V^7, +\sharp 6$). The chord can also be spelled as a seventh chord on III, but a V sonority is more correct in terms of the basic harmonic progression. In the same bar a G is added to the violin part, but it resolves to the chordal seventh at the end of the bar. In P40B4, $B\flat$ is stated as an added sixth to V^7 in the piano part ($V^7, +6$). This is possibly an error in the score, as all previous occurrences of this figure resolved at the end of the bar.⁷¹ In P42B4 a ninth ($E\flat$) is added to V^7 in the left hand of the piano part. $E\flat$ and G are regularly added to V^7 in the accompaniment, but resolve to chord notes towards the end of a bar. It is notable that such added notes are often used in combination and that the presence of extended-third sonorities can be argued. This is especially true in section 9, where there is a strong dependence on notes $E\flat$ and $B\flat$ (the chordal ninth and thirteenth) in the melody too.⁷² The presence of extended-third sonorities on V^7 can still be seen as a form of harmonic variation, even though resolutions occur in most cases.

7.2.3 Scales

In sections 6, 7 and 9, repeated scales are played in the violin and piano parts. These scales are used for textural variation, but also create some harmonic colouration. In most occurrences the G Aeolian scale is found, which supports earlier discussions on tonality. The scales start on different bass notes that correspond to the harmonies to which they are applied. For tonic harmonies the G Aeolian scales starts on G, the bass note of the tonic harmony. However, on the second of two consecutive statements of the tonic harmony, the scales start on the chordal fifth (D). This then creates some variation between subsequent tonic chords, as seen in P24 and P39, for example.

In VI harmonies the Aeolian scales start on $E\flat$, the bass note of VI. In III harmonies the scales start on D, the chordal third, but more importantly the bass note of V. This then supports previously posited notions that III serves as a type of extension or anticipation of V in the basic harmonic progression. F major scales starting on the bass note F are used with $\flat VII$ harmonies in P27B3 and P32B3. These F major scales correspond to the F major sonority of $\flat VII$ harmonies,

⁷¹ These resolutions can be seen at P27B4, P32B4, P41B4 and P42B4.

⁷² Examples of this can be seen at P27B4, P32B4, P41B4 and P42B4.

and contain the only occurrence of E \flat outside a V chord. In P42B3 a G Aeolian scale starting on F is applied to the \flat VII harmony. This phrase is found in section 9, which has numerous statements of B \flat and the E \flat in the melody. It is possible that the composer applied G Aeolian in this case to avoid a clash between E \flat and E \natural on the \flat VII harmony.⁷³

The scales used with V harmonies are more varied and contain more interesting added notes. A more dissonant quality to dominant chords and an increased harmonic pull can again be argued. G Aeolian scales starting on A, the chordal fifth, are seen in the first of any two consecutive V harmonies. The first of two consecutive V harmonies usually does not contain the dominant seventh either. It can be argued that a less dominant sonority is used in the middle of progressions towards a final dominant chord. A more varied, dissonant, 'intervallic scale' is used on the second of two consecutive V harmonies and all single occurrences of V. Figure 39 shows the application of G Aeolian and the intervallic scale on two consecutive V harmonies.

The musical score for Figure 39 is written in 4/4 time and G minor. It features six staves: Piano (Pno.), Violins 1 (Vlns. 1), Violins 2 (Vlns. 2), Viola (Vla.), Violoncello (Vcl.), and Double Bass (Dbs.). The piano part is divided into two measures, each with a blue box highlighting a specific scale. The first measure, labeled P28B3, shows a G Aeolian scale starting on A. The second measure, labeled P28B4, shows an intervallic scale. The violin parts play a similar intervallic scale. The viola, cello, and double bass parts play a G Aeolian scale. The chord progression is V7-V7.

Figure 39: Scales on consecutive V chords

⁷³ Clashes between natural and raised sixth and seventh steps are only applied to V sonorities, as discussed earlier.

In the intervallic scale one note remains constant whilst the other one moves stepwise. The note that is kept constant is usually D, the bass note of V, but varied at times. For example, in the V⁷ chords of part 2 of the basic harmonic progression, a G that resolves to an F[♯] at the end of the bar is found. A number of different combinations of stepwise notes are used in the intervallic scales. These notes form the G harmonic minor scale in most cases, which supports earlier discussions on the tonality of V harmonies. However, the additions of F[♭] and C[♯]⁷⁴ to the intervallic scales in some cases are also noteworthy. The use of F[♭] is found with V harmonies that are stated before the return of tonic introductory phrases.⁷⁵ An increased dominance through the use of a split-third chord can thus again be argued in these dominant sonorities.

7.3 Textural, Rhythmic, Orchestral and Timbral Variations

In addition to harmonic changes, textural, rhythmic and orchestral changes are also used as a variation technique. A homophonic texture with a clear division between melody and accompaniment is apparent throughout the piece. However, different textures, timbres and rhythms are applied in each of the eleven sections, and the melodies are alternated between different instrumental groups. An instrument that had long note values in one section might have repeated figures or scales in the next, even though the harmonic content remains unchanged. Noteworthy are the shorter note values in section 4 and 7, which are the only two sections without melodic material. *Pizzicato*, *arco*, *staccato* and *sostenuto* indications add timbral diversity to the different sections. Figures 40–43 illustrate the textures and variations of accompanimental patterns in each of the eleven sections. The figures are of a single bar excerpt of a VI chord from each section.

⁷⁴ C[♯] is most often found as a chromatic passing note between C[♭] and D in the intervallic scale.

⁷⁵ This can be seen at P28B4 and P33B4.

Section 1: P1B2 Section 2: P8B2 Section 3: P11B2

Pno.

Vlns. 1 Melody 1

Vlns. 2

Vla.

Vcls.

Dbs.

G minor: VI

Detailed description: This figure shows the musical textures for three sections: Section 1 (P1B2), Section 2 (P8B2), and Section 3 (P11B2). The score is in G minor, VI, and 4/4 time. The instruments are Piano (Pno.), Violins 1 and 2 (Vlns. 1 & 2), Viola (Vla.), Violoncello (Vcls.), and Double Bass (Dbs.). Section 1 features a piano accompaniment and Violin 1 playing Melody 1. Section 2 introduces a sixteenth-note pattern in the piano and Violin 1, with Violin 2 and Viola also playing sixteenth-note patterns. Section 3 features a sixteenth-note pattern in the piano and Violin 1, with Violin 2 playing Melody 2 and the Viola playing a sixteenth-note pattern. The Double Bass part is a simple bass line in all sections.

Figure 40: Textures of sections 1-3

Section 4: P16B2 Section 5: P20B2 Section 6: P25B2

Pno.

Vlns. 1 Melody 2

Vlns. 2

Vla.

Vcls.

Dbs.

Detailed description: This figure shows the musical textures for three sections: Section 4 (P16B2), Section 5 (P20B2), and Section 6 (P25B2). The score is in G minor, VI, and 4/4 time. The instruments are Piano (Pno.), Violins 1 and 2 (Vlns. 1 & 2), Viola (Vla.), Violoncello (Vcls.), and Double Bass (Dbs.). Section 4 features a sixteenth-note pattern in the piano and Violin 1, with Violin 2 playing a sixteenth-note pattern. Section 5 introduces a sixteenth-note pattern in the piano and Violin 1, with Violin 2 playing a sixteenth-note pattern. Section 6 features a sixteenth-note pattern in the piano and Violin 1, with Violin 2 playing Melody 1 and the Viola playing a sixteenth-note pattern. The Double Bass part is a simple bass line in all sections.

Figure 41: Textures of sections 4-6

Section 7: P30B2

Section 8: P35B2

8

Figure 42: Textures of sections 7-8

Section 9: P40B2

Section 10: P47B2

Section 11: P50B2

8

Figure 43: Textures of sections 9-11

From the figures it is apparent that whilst melodic lines are usually made up of sustained note values, the accompaniments comprise continuously repeated rhythmic figures. Each instrument has a different rhythmic makeup that is only changed when a new section is introduced. The rhythmic patterns have a regular, continuous character and are made up of repeated modules in an unchanging $4/4$ metre. Such rhythmic modules are usually a single beat in length and consist of equal divisions of the beat into crotchets, quavers, triplets and semiquavers. Different modules or beat divisions are found in the different instruments and superimposed to a whole. Figure 44 shows an example of beat divisions into four, three, two and one in the accompanimental instruments of P18.

P18B1

Pno.

Vlns. 1

Vlns. 2

Vlas.

Vcls.

Dbs.

G minor: i

Figure 44: Beat divisions in the accompaniment

Rhythmic modules usually ascend and are made up of either repeated notes or broken chords. The use of scales, arpeggios and hemiola is also apparent, as is regularly found in Glass's compositional language. The melodies' rhythms are slightly more varied than those of the accompaniment, and the use of dotted notes and changing note durations is present. Melodies' rhythms are varied between different sections too, as can be seen in section 6, for example, in which long note values are replaced with repeated quavers. In sections 8 and 10 repeated triplet figures replace the long notes of initial melodic statements.

7.4 Inversional and Dynamic Variations

Another way of creating variation is through the application of different chord inversions and basslines. It has already been mentioned that chord inversions are regularly applied in an unconventional and non-functional manner in the piece. Inversions are not used to support tonal movement or to establish a functional, tonal bassline, but as a means of variation. Even though the basic harmonic progression stays the same, the chord inversions and basslines are changed in each section. In section 8, for example, the melody is played in the lower strings, which means that the bassline and chordal inversions are purely dependent on the melodic material. Figure 45 illustrates the differences in the basslines and inversions of sections 3 and 5, as an example.⁷⁶ Both these sections are based on the same harmonic progression, make use of the same melodic material, and have the same added-note dissonances. Textural, dynamic, inversional and bassline changes are then the only variation between the sections. Non-functional inversional applications and unconventional resolutions further support notions of transformation rather than functional coherence in the piece's harmonic content, as discussed in Chapter 6.

Section 3

G minor: (i) i_4^6 (i) i i_4^6 VI^6 III V^2 $\frac{6}{5}$ i_4^6 VI^6

III V^2 $\frac{6}{5}$ i_4^6 VI^6 $bVII^6$ V^7 i III V^6 V^2

Section 5

G minor: i_4^6 i_4^6 i i i VI III V^7 2 i VI

III V^7 i^6 VI^6 $bVII^6$ $V^{\frac{6}{5}}$ 7 2 i_4^6 III V^6 V^7

Figure 45: Inversional and bassline variations

⁷⁶ In order to show the inversional changes Figure 45 contains Roman numerals with inversion symbols.

Dynamic indications in the movement correspond largely with melodic contours. The start of sections is usually quite soft with a gradual build up in loudness to the second last phrase and a return to softer dynamics at the end of a section. Each section has a different dynamic indication, which then contributes to variation together with changes in texture and timbre. Sections 4 and 7, in which shorter note durations and a lack of melodic material are found, also have louder dynamics. Considering the piece as a whole, a gradual increase in loudness is seen from sections 1 to 9 before softer dynamics return in sections 10 and 11. In correspondence with earlier discussions on the piece's fractal nature, dynamic indications on a global level mirror those on a sectional level.

7.5 Conclusion

This then concludes the critical evaluation of the piece's compositional content, its musical characteristics and the techniques applied by the composer in its composition. The purpose of this chapter was to evaluate the different ways in which Glass colours, varies and diversifies the piece's basic compositional content. A number of ways were identified in which superficial variations hide the simple, organic and repetitive structural backbone of the piece. The following important points were raised in the main discussion: harmonic variation results from the superimposition of three melodies on the basic harmonic progression, accompanimental deviations, and the application of scales. Increased chromaticism is obvious in dominant sonorities through the application of intervallic scales, non-chord notes and split-third chords. Different textures, timbres, chordal inversions and dynamics are applied in each section, thus creating further variation. Different rhythmic applications are also seen, which are characterised by repeated modules, an unchanging metre and equal divisions of the beat.

Chapter 8: Comparisons

8.1 Introduction

The second movement's musical characteristics were detailed in the previous two chapters. In this short chapter such characteristics are related to the composer's earlier works and stylistic periods, as discussed in Chapter 2, in order to better understand his more recent compositional language. Through this comparison the piece's minimalist qualities, those that stem from other periods, and any new compositional devices can be noted. This discussion is in support of the fourth research objective, as stipulated in the introductory chapter. The chapter opens with a comparison of the movement's musical characteristics with Glass's main stylistic periods to establish their origin and initial applications. This is followed by a list of new compositional elements, or musical characteristics, in the piece that were not seen in Glass's earlier works.

8.2 Characteristics of Earlier Periods

Chapter 6 discussed the cyclical nature of the second movement as result of overlapping cadences, and the extensive repetition of unconventional harmonic progressions, phrases, sections and chords. It was concluded that a sense of stasis is apparent as result of these factors in combination with a regular, unchanged metre, and straightforward rhythmic applications. These applications are not only attributes of Glass's New York minimalist compositions, but already seen in the earlier works completed in Paris (1964–1967), such as the *String Quartet No. 1*.

Many other characteristics of Glass's New York minimalist compositions (1967–1970) are also apparent in the second movement of the *Tirol Concerto*. These include the continuous quaver patterns, rhythmic drive and the repeated application of identical rhythmic modules in the piece's accompaniment. Extensive repetitions of scales, arpeggios, hemiola and triplets, as seen in the movement's textural content can also be attributed to this period. Further minimalist characteristics are the movement's formal structure, organic nature and the dependence on processes in its composition. The piece's modal quality and its regular, equal divisions of the beat are also worth mentioning. Elements of Glass's New York minimalist style that are not seen in the second movement are the fast tempos, loud dynamics and pulsating motorism of compositions such as *Two Pages*. Strict, rigorous additive processes, the use of amplified instruments and improvisational or indeterminate elements are also not found.

Since the 1970s, the end of Glass's purely minimalist period, an increased importance of harmony as structural principle became evident, as mentioned with regards to *Music with Changing Parts*

and *Music in Twelve Parts*. Chapter 6 detailed the role of harmony as a structural principle in the second movement's chaconne form. The basic harmonic progression determined the piece's sectional divisions, textural changes and melodic applications. The application of harmony in a more functional manner was identified as occurring in *Music in Twelve Parts* in the early 1970s. The movement's harmonic backbone and its dependence on tonic and dominant sonorities can thus be linked to compositional changes during this period. Further musical characteristics from the early 1970s that are found in the piece include the use of cadences, contrapuntal melodic lines, changes in dynamics and expanded registers.

Many characteristics of the second movement can be linked to changes in Glass's compositional language in the opera trilogy, such as melodic emphasis, richness and expressivity. The piece's homophonic texture and the separation between melody and accompaniment also stem from this time. Mertens (1983:79) states that simple chords are placed in parallel outside a tonal functionality in *Einstein* and *Another Look at Harmony*. These elements are clear in the movement, as discussed in its application of five simple, consonant triads in non-functional progressions, and the avoidance of augmented and diminished sonorities. The chaconne structure of the second movement was first applied in *Einstein* and later used in *Satyagraha* and the *Violin Concerto*. The application of barred metres, regular phrasing, and an extended tonal plan also stem from this time.

In *Satyagraha* Glass for the first time adopted a more standard orchestration and lyrical qualities, as can also be seen in the string orchestration and melodic writing of the second movement. Many of the musical characteristics of *Akhnaten*, as detailed by Richardson (1999), can be paralleled to the movement too. A presence of tonal ambiguity can be argued in the piece, although it is less obvious than that of *Akhnaten*. The piece's interplay between harmonic and melodic minor elements, and the superimposition of raised and natural sixth and seventh steps, contribute to this ambiguity. Also worth mentioning are its parallel, second inversion, added-note and extended-third chords, overlapping melodies, unconventional voicing, and the avoidance of the raised leading tone, as also seen in *Akhnaten*. It has already been pointed out that the rigid additive processes characteristic of Glass's minimalist period are not found in the piece. However, the less rigid sectional additions that were also identified in *Akhnaten* by Richardson (1999:55, 57) are seen in the piece's extensions of sections 9 and 10. Richardson mentions how *Akhnaten* can be seen as a large cadential arc with subsidiary cadences (88), an aspect that was also pointed out in the piece in Chapter 6.

The majority of musical characteristics of the second movement can be linked to Glass's compositions up to the opera trilogy. Not many stylistic changes in the piece can be paralleled

to the compositions that followed.⁷⁷ The biggest change in Glass's compositional language following the trilogy is his adoption of the symphonic genre. The composer completed approximately twenty symphonic works since the *Violin Concerto* in 1987. In addition to his adoption of a symphonic style, the following later musical characteristics can be noted: the long, expansive, lyrical, dominating slow movement of the *Tirol Concerto* can be paralleled to that of the *Violin Concerto* and *Cello Concerto*. The applications of repeated harmonic progressions with changes in texture are also found in his second and third symphonies. Crisp and Hillman (2010:30–31) write of Glass's application of non–progressive, nonlinear, triadic and cyclical harmonic progressions in *The Hours*, which relates directly to discussions on the movement's transformational and non–functional chord relations. Wasserman's (2009:20) identification of subtle harmonic shifts, and theme and variations structures in *Waiting for the Barbarians* are also worth noting.

8.3 New Developments

In addition to the musical characteristics that were related to Glass's earlier compositions and stylistic periods, a large number of new compositional elements or musical applications can also be listed. These elements were used in the second movement of the *Tirol Concerto* for the first time, or were used in other compositions, but not included in any previous academic literature. Only a brief list of the new musical applications in the second movement follows, since detailed discussions were included in the previous two chapters.

- Interplay between natural and raised seventh steps to apply dominant sonorities, but to avoid augmented and diminished chords.
- Superimposition of raised and natural seventh steps into split–third V chords.
- Avoidance of the augmented second interval, but the consequent superimposition of natural and raised sixth and seventh steps on V chords.
- Use of a functional, tonal backbone dependent on movements from V to i, but in which functionality is hidden through cyclical repetitions, overlapping of cadences and unconventional progressions.
- Avoidance of tonal movement and directionality through harmonic content that is static, transformational and non–functional.
- Use of unorthodox progressions in which pre–dominant chords are avoided and subsequent chords are chosen on their commonality.

⁷⁷ It is, however, important to keep in mind the lack of academic scholarship on Glass's compositions in the last few decades.

- Applications of subsequent chords that are related by thirds, have common tones, and undergo parsimonious voice-leading transformations.
- Use of chords that have a close proximity and coherence, and that are part of an organic, transformational framework that is viewable on the *Tonnetz*.
- Repeated overlap of cadential cycles on both phrase and sectional level with the application of a true cadential progression reserved for the end.
- Application of tonic phrases to introduce the texture and orchestration of subsequent sections, and act as resting points between cyclical applications.
- Extension of cyclical procedures to delay the final return of the tonic.
- Mirroring of larger and smaller structures at phrase, sectional and global level.
- Application of a simple, organic, coherent, fractal whole that is dependent on a particular harmonic and structural process.
- Superficial variation of a simple, coherent background structure.
- Harmonic variation through the application of melodic material on an unchanged harmonic progression, and the subsequent formation of added-note, extended-third and split-third chords.
- Application of textural, orchestral, inversional and bassline changes to create variations of the basic harmonic and structural content.
- Increased dissonance of dominant chords and a consequent harmonic pull through the application of split thirds, added notes, and chromaticism.

8.4 Conclusion

When questioned on changes in his compositional style, Philip Glass remarked (Smith & Smith, 1995:136):

I was thinking about rhythmic structure in the early 1970s, about harmonic structure in the mid to late 1970s, about polytonality in the early 1980s – and in the late 1980s I was starting to think about tonal relationships in a much more general way. Yet I don't really leave any of those things behind. The rhythmic structures I used twenty years ago are still there.

This statement rings true when the second movement of the *Tirol Concerto* is compared to the composer's earlier compositions. Glass's compositional language has changed remarkably since his early minimalist works, but elements from previous stylistic periods are still present. However, there are also characteristics that the composer has left behind and new compositional devices that have been used for the first time, or never included in the academic literature on his oeuvre before.

Chapter 9: Conclusion

9.1 Introduction

The overall aim of this dissertation was to provide a compositional analysis of the second movement of Philip Glass's *Tirol Concerto*. Through the application of both theoretical and more contextual analyses, the piece's compositional content and factors that had an influence on it were explored. The rationale for undertaking this research was a combination of two factors: the lack of musicological scholarship on Glass's more recent compositional style, and ongoing discourses on the appropriateness of stylistic terms such as minimalism to his work. Four research objectives were identified in order to realise the dissertation's aim. This chapter is a summary of the main conclusions and findings for each research objective. Recommendations for further study, the dissertation's main contributions to knowledge, its limitations and a short passage of self-reflection follow.

9.2 Findings on Research Objectives

The first research objective was to review the available academic literature on Glass's compositional language from his early minimalist works to his more recent compositions in order to identify the changes that have taken place in his stylistic development. Through a chronological summary of academic sources it was concluded that a certain degree of sameness is apparent in Glass's compositional language from his earliest to his most recent work. Repeated patterns, arpeggios, additive processes, scales and cyclical structures, for example, are essentially *Glassian*. However, considerable changes in Glass's compositional language have also taken place, as discussed in detail in Chapter 2. The mechanical, rigid processes that dominated the composer's early compositions, for example, have been replaced with melodic, expressive tonal writing in his later symphonic works. **Key point:** Whilst some features of Glass's compositional language have remained constant throughout his stylistic development, others can be listed that have undergone remarkable change.

Extensive literature studies were undertaken to realise the dissertation's second research objective: to explore the background and conception of the second movement of the *Tirol Concerto* by scrutinising factors that had an influence on its compositional content, such as its commission and its relations to other works. It was found that Glass's *Tirol Concerto* is a popular work that has been well received and that has had numerous performances around the world. The work's title is intended to reflect the 'Tyrolean character' its commissioners requested from the composer. Accordingly, Maycock, Lepuschitz and Glass stated that the entire composition is

based on a Tyrolean folk song. The folk song was identified as *Maria! hilf doch mir*, a religious folk song that originated in Austria around 1822. Whilst the relationship between the first movement of the *Tirol Concerto* and *Maria! hilf doch mir* are clear, connections to its second movement are debatable. This matter is further complicated by the fact that the compositional content of the second movement is almost identical to *Raising the Sail*, which had been completed two years earlier. *Raising the Sail* was composed to support a climactic scene in *The Truman Show*, to which its elegiac, mournful character is fitting. It then follows that *Raising the Sail* was most probably recycled, reworked and extended to the second movement of the *Tirol Concerto*, and that it was not based on *Maria! hilf doch mir*. This matter is further supported by the piece's structural and compositional make-up. Glass's affirmation that the second movement has a Tyrolean basis, and the consequent application of the work for promotional purposes by its Tyrolean commissioners, are therefore questionable. **Key point:** Evidence on the relation between the second movement of the *Tirol Concerto* and *The Truman show* challenges notions of the Tyrolean folk-music basis of the movement as affirmed by the composer.

The dissertation's third research objective was to critically evaluate the piece's compositional content through theoretical analyses of its musical characteristics, and the techniques applied by the composer in its composition. It was concluded that the piece's basic compositional content is an organic product of simple, coherent structural and harmonic processes. A G natural minor tonality is present, but with interesting interplays between harmonic and melodic applications. Structurally, the piece is a chaconne, with eleven sectional variations of a basic harmonic progression. A conventional tonal framework that is analysable through functional harmony is apparent, but this functionality is hidden by extensive repetitions, continuous movement and cyclical applications. Subsequent chords are often third-related, share common tones and undergo parsimonious voice-leading. Accordingly, the progressions are fruitfully analysable through a neo-Riemannian perspective on both foreground and middle-ground level. In a transformational approach the composition's cyclical, tonal content and its coherent, organic makeup are clarified in a way not possible in functional analysis. Transformational coherence is an essential component of the piece's compositional content, and possibly an aspect of the composer's more recent compositional language. Continuous, overlapping pseudo-cadential movements are apparent throughout the piece with a true authentic cadence found only at the very end. There are similarities between the piece's larger and smaller structures that result in a fractal dimension. Superficial variations hide the simple, organic and repetitive structural backbone of the piece. The application of melodic material creates harmonic variation through the formation of added-note, split-third and extended-third chords. Increased chromaticism is found in dominant sonorities through the application of intervallic scales, non-chord notes and split-third chords. Scalar, textural, timbral, inversional and dynamic changes further vary the

piece's basic compositional content. Different rhythmic applications are found that are characterised by repeated modules, an unchanging metre and equal divisions of the beat. **Key point:** The movement consists of a simple, repeated, organic structural and harmonic framework that undergoes superficial variations through a range of compositional applications.

In the fourth and final research objective the piece's musical characteristics were compared to those of Glass's earlier works in order to better understand the composer's more recent compositional language, its minimalist extent, and the presence of new musical applications. It was concluded that similarities between the movement's compositional content and all the other periods of Glass's stylistic development are present. Minimalist characteristics such as repetition, cyclical applications and unchanging metres, for example, are still found in the piece. However, other minimalist elements such as loud dynamics, and rigid additive processes are not. Characteristics from all the other stylistic periods are also seen in the movement, and so is the application of new, innovative compositional devices. **Key point:** The movement contains musical characteristics of all Glass's stylistic periods, including minimalism, as well as novel compositional devices.

9.3 Contribution to Knowledge and Recommendations

This dissertation has revealed new knowledge on the second movement of the *Tirol Concerto*: firstly, in relation to the work's conception and factors influential in its compositional content; and secondly, on its musical characteristics and the relation of these to Glass's previous stylistic periods. An important contribution is the new and effective application of a transformational approach to Glass's compositions. This approach is recommended for future analytical studies of Glass and other composers' 'neo-tonal' compositions. Another recommendation is the academic study of Glass's more recent compositions, as there are still very few academic undertakings in the field. A more critical examination from reviewers and writers who erroneously situate Glass's entire oeuvre under a diverse umbrella of 'minimalism' is much needed. The acknowledgement of changes in the composer's compositional language over the last 30 years should be included in textbooks, dictionaries and other academic publications. Finally, comprehensive research on the ontology and scope of labels such as post-minimalism should be able to consider information obtained from studies such as this one in a stylistic perspective.

9.4 Limitations

Unfortunately, length restrictions limited the scope of this dissertation to a single movement of the *Tirol Concerto*. More comprehensive, unified conclusions could have been drawn if a study of all three movements, or even both the piano concertos, had been possible. It would have been greatly beneficial if the composer had been available for commentary on the concerto and its conception. This is especially so for clarification on the work's apparent relation to *The Truman Show* instead of *Maria! hilf doch mir*. Further explorations of these matters in future studies are suggested.

9.5 Self-reflection

Two years ago I did my first literature search on the topic of this dissertation. Loathes and loves have come and gone. There has been frustration with the vast amount of information available on the composer. There has been feverish excitement on hearing his music played in *Carnegie Hall*, New York. Today, 16 March 2015, I did my last literature search on the topic, and I see that Glass is releasing an autobiography only a couple of days after this dissertation is due.⁷⁸ It has been 28 years since the composer's last literary publication. Guérin (2015) writes:

A memoir at this point, that covers the body of work from the beginning (including his first composition, a string trio in Chicago in the early 1950s) to the recent past is overdue. Can't wait to read it.

I must agree with Guérin – such a publication is long overdue and I can't wait to read it too!

A publication long overdue

Can't wait to read it too

Long overdue

Read it too

Overdue

Too

⁷⁸ The publication's title is *Words without Music: a Memoir*, and it is set for release on 6 April 2015.

List of References

- 1999 Golden Globe Award Winners*. 1999. Available:
http://www.goldenglobes.com/golden_globe_winners/1999 [2014 November, 11].
- Adams, D. 1998a. The three legs of Truman. *Film Score Monthly*. 3(6): 29–30, 47.
- Adams, D. 1998b. Zen and the art of motion picture scoring. *Film Score Monthly*. 3(2): 24–30.
- Alburger, M. 2003. Philip Glass: String quartet to Strung out. *21st Century Music*. 10(7): 3–7.
- Anderson, M. 2014. BBC proms 2013: Helmut Lachenmann, John McCabe, Colin Matthews, Philip Glass, Naresh Sohal and Anthony Payne. *Tempo*. 68(267): 61–63.
- Bernard, J.W. 1993. The minimalist aesthetic in the plastic arts and in music. *Perspectives of New Music*. 31(1): 86–132.
- Bernard, J. W. 1995. Theory, analysis, and the “problem” of minimal music. In *Concert music, rock, and jazz since 1945: essays and analytical studies*. E. West Marvin & R. Hermann, Eds. New York: Rochester Press. 259–283.
- Bernard, J.W. 2003. Minimalism, postminimalism, and the resurgence of tonality in recent American music. *American Music*. 21(1): 112–133.
- Bettencourt, S. 2004. Making the best of the worst, 2003 edition: a scribbler's list. *Film Score Monthly*. 9(1): 27–28.
- Binford-Walsh, H. 2002. Philip Glass (1937–). In *Music of the twentieth-century avant-garde: a biocritical sourcebook*. L. Sitsky, Ed. Westport: Greenwood Press. 168–172.
- Bitter Sweet*. 2013. Available: <http://www.landestheater.at/info/stueck/bitter-sweet-767> [2014, November 19].
- Bolan, M., Chopin, F., Dallwitz, B., Glass, P. & Kilar, W. 1998. *The Truman show* [Sound recording]. Los Angeles: Milan Records.
- Bond, J. 1998a. Transcendental muzak. *Film Score Monthly*. 3(6): 30.
- Bond, J. 1998b. Tru tracks: an interview with composer Burkhard Dallwitz. *Film Score Monthly*. 3(6): 28–29.
- Brown, R.S. 1998. Film musings. *Fanfare*. 22(2): 421–429.
- Bujic B. 2014. Disciplines of musicology – sociomusicology. Available:
<http://www.oxfordmusiconline.com> [2014, May 23].

- Cappelle, L. 2014. *San Francisco ballet, Théâtre du châtelet, Paris – review*. Available: <http://www.ft.com/cms/s/2/9bb74a12-10c3-11e4-b116-00144feabdc0.html#axzz3IKUs1Vo> [2014, November 11].
- Chapman, D.A. 2013. Collaboration, presence, and community: The Philip Glass ensemble in downtown New York, 1966–1976. PhD Thesis. Washington University.
- Christensen, D. 2005. *Glass cuts: Philip Glass remixed*. Available: http://www.philipglass.com/music/recordings/glass_cuts.php [2014, October 28].
- Cine Tirol Award an Georg Riha*. 2009. Available: <http://www.cinetirol.com/de/released-archive/cine-tirol-award-an-georg-riha-1562153.html> [2014, November 11].
- Cook, R.C. 2005. Parsimony and extravagance. *Journal of Music Theory*. 49(1): 109–140.
- Crisp, D. & Hillman, R. 2010. Chiming the hours: a Philip Glass soundtrack. *Music and the Moving Image*. 3(2): 30–38.
- Crowe, T.R. 2008. *Rare birds: conversations with legends of jazz and classical music*. Jackson: University Press of Mississippi.
- Dahlhaus, C. 1983. *Foundations of music history*, translated by J.B. Robinson. Cambridge: Cambridge University Press.
- Davies, D.R. 2004. *Dennis Russell Davies performs Philip Glass*. Available: http://www.philipglass.com/music/recordings/dennis_russell_davies_performs_philip_glass.php [2014, October 28].
- Der Guldene Rosenkranz: Lobgesang in der Wallfahrtskirche Maria Locherboden*. 2000. [Sound recording]. Landeck: Aktiv Sound Records.
- Dunn, J. 2008. San Francisco, War memorial opera house: Philip Glass's 'Appomattox'. *Tempo*. 62(244): 44–45.
- Duckles, V & J. Pasler. 2014. The nature of musicology. Available: <http://www.oxfordmusiconline.com> [2014, May 23].
- Escoda, C. 2013. *The classical, the post-modern and all that jazz at Smuin ballet*. Available: http://www.huffingtonpost.com/carla-escoda/post_4810_b_3281445.html [2014, November 19].
- Ehrlich, D. 1997. *Inside the music: conversations with contemporary musicians about spirituality, creativity and consciousness*. Boston: Shambhala Publications Inc.

- Engebretsen, N. & Broman, P.F. 2007. Transformational theory in the undergraduate curriculum: a case for teaching the neo-Riemannian approach. *Journal of Music Theory Pedagogy*. 21: 36–65.
- Fallows, D. 2014. New musicology. Available: <http://www.oxfordmusiconline.com> [2014, May 23].
- Felciano, R. 2014. *The dancers have it*. Available: <http://www.danceviewtimes.com/2014/05/the-dancers-have-it.html> [2014, November 11].
- Fink, R. 2005. *Repeating ourselves: American minimal music as cultural practice*. Berkeley: University of California Press.
- Fisk, J. & Nichols, J. Eds. 1997. *Composers on music: eight centuries of writings*. 2nd ed. Boston: Northeastern University Press.
- Force, K.A. 2004. La Monte Young, Terry Riley, Steve Reich, and Philip Glass: the evolution of minimalism and audience response. MA Dissertation. University of Ottawa.
- Frandsen, P.J. 1993. Philip Glass's "Akhnaten". *The Music*. 77(2): 241–267.
- Gann, K. 1997a. *American music in the twentieth century*. New York: Schirmer Books.
- Gann, K. 1997b. Midtown avant-gardist (1992). In *Writings on Glass*. R. Kostelanetz & R. Flemming, Eds. New York: Schirmer Books. 265–270.
- Gann, K. 2001. Departing from recipe: Philip Glass writes the best of music and the worst of music. *The Village Voice*. 46(32):118.
- Glass, P. 1987. *Music by Philip Glass*. New York: Harper & Row.
- Glass, P. 1998. *Truman show 17 – Raising the sail* [Video File]. Available: <https://www.youtube.com/watch?v=vS3WrXEA-m-g&index=13&list=PL8ABB24E844EB3C1B> [2014, December 15].
- Glass, P. 2000. *Tirol concerto for piano and orchestra*. New York: Dunvagen Music Publishers.
- Glass, P. 2002a. *Tirol concerto for piano and orchestra* [Sound recording]. Innsbruck: Tyrol Tourist Board Special Edition.
- Glass, P. 2002b. *Tirol concerto for piano and orchestra – movement II* [Video File]. Available: https://www.youtube.com/watch?v=oJM16Q_edQw [2014, December 15].

- Glass, P. 2004. *Dennis Russell Davies performs Philip Glass* [Sound recording]. New York: Orange Mountain Music.
- Glass, P. 2005. *Glass cuts: Philip Glass remixed* [Sound recording]. New York: Orange Mountain Music.
- Glass, P. 2011. *The concerto project vol. IV* [Sound recording]. New York: Orange Mountain Music.
- Grimes, E. 1997. Interview: education (1989). In *Writings on Glass*. R. Kostelanetz & R. Flemming, Eds. New York: Schirmer Books. 12–38.
- Grimshaw, J. 2002. High, "low," and plastic arts: Philip Glass and the symphony in the age of postproduction. *The Musical Quarterly*. 86(3): 472–507.
- Grosser Erfolg für Tirol concerto in New York*. 2003. Available: <http://www.presseportal.de/pm/16017/434284/grosser-erfolg-fuer-tirol-concerto-in-new-york> [2014, November 20].
- Guérin, R. 2011. *The concerto project vol. IV*. Available: <http://www.philipglass.com/music/recordings/conProVollIV.php> [2014, October 28].
- Guérin, R. 2015. *Philip Glass news: Words without music*. Available: <http://www.philipglass.com/news.php> [2015, March 16].
- Hajdu, D. 2009. *Heroes and villains: essays on music, movies, comics, and culture*. Cambridge: Da Capo Press.
- Haskins, R., Glass, P. & Riesman, M. 2002. Philip Glass and Michael Riesman: two interviews. *The Musical Quarterly*. 86(3): 508–529.
- Hooper, G. 2006. *The discourse of musicology*. Aldershot: Ashgate.
- Hostetter, M. 2001. Kafka's torturing genius: Philip Glass and JoAnne Akalaitis adapt 'In the penal colony'. *The Village Voice*. 46(23):66.
- Howell, J. 1997. Listening to Glass (1974). In *Writings on Glass*. R. Kostelanetz & R. Flemming, Eds. New York: Schirmer Books. 94–97.
- Hutcheon, L. & Hutcheon, M. 2011. Philip Glass's Satyagraha: para-colonial para-opera. *University of Toronto Quarterly*. 80(3): 718–730.
- Ingram, P. 2004a. Classical recordings. *Fanfare*. 28(2): 181.

- Ingram, P. 2004b. The want lists 2004. *Fanfare*. 28(2): 99–129.
- Ingram, P. 2008. Glass: Waiting for the barbarians. *Fanfare*. 32(2): 206–207.
- Josephus Weber Collection. A7249. Tiroler volksliedarchiv, Tiroler landesmuseen, Innsbruck. (Unpublished).
- Jouve–Martín, J.R. 2010. Music, history, and science fiction: Philip Glass's "The voyage" and the operatic lives of Christopher Columbus. *Clio*. 40(1): 87–108.
- Karolyi, O. 1996. *Modern American music: from Charles Ives to minimalists*. London: Cygnus Arts.
- Kaufman, S. 2013. *At Kennedy center, three new takes on ballet offer two revelations*. Available: http://www.washingtonpost.com/entertainment/theater_dance/at-kennedy-center-three-new-takes-on-ballet-offer-two-revelations/2013/06/08/a51763cc-d059-11e2-8845-d970ccb04497_story.html [2014, November 11].
- Kendall, L. 1998. Don't miss 'The Truman show'. *Film Score Monthly*. 3(2): 30.
- Kerman, J. 1985. *Musicology*. London: Fontana Press.
- Kozinn, A. 1997. The touring composer as keyboardist (1980). In *Writings on Glass*. R. Kostelanetz & R. Flemming, Eds. New York: Schirmer Books. 102–108.
- Lemieux, G.C. 2000. Construction, reconstruction and deconstruction: Music in twelve parts by Philip Glass. PhD Thesis. University of Iowa.
- Lange, A. 1997. Chronicle, 1977–1980. In *Writings on Glass*. R. Kostelanetz & R. Flemming, Eds. New York: Schirmer Books. 87–93.
- Lepuschitz, R. 2002. *Tirol concerto for piano and orchestra*. Available: http://www.philipglass.com/music/recordings/tirol_concerto_for_piano_and_orchestra.php [2014, October 28].
- Looking Glass* [DVD]. 2005. Produced by P. Bardet; directed by E. Darmon; written by E. Darmon & F. Mallet. Paris: Ideale Audience International.
- Lewis, D.N. 2004. *Dennis Russell Davies performs the music of Phillip Glass*. Available: <http://www.allmusic.com/album/dennis-russell-davies-performs-the-music-of-phillip-glass-mw0000138873> [2014, November 11].
- Maycock, R. 2002. *Glass: a portrait*. London: Sanctuary Publishing Limited.

- Mertens, W. 1983. *American minimal music: La Monte Young, Terry Riley, Steve Reich, Philip Glass*. London: Kahn & Averill.
- McDonagh, M. 2003. *Classical music review: new releases*. Available: <http://www.classical-music-review.org/reviews/GlassPiano.html> [2014, November 17].
- Meeder, C. 2009. *Light/the holocaust and humanity project*. Available: <http://www.pbt.org/lightthe-holocaust-and-humanity-project> [2014, November 11].
- Mouton, J. 2001. *How to succeed in your master's and doctoral studies: A South African guide and resource book*. Pretoria: Van Schaik.
- Mugglestone, E. 1981. Guido Adler's "The scope, method, and aim of musicology" (1885): an English translation with a historico-analytical commentary. *Yearbook for Traditional Music*. 13:1-21.
- Nederlands Dans Theater 1*. 2007. Available: <http://www.musiccenter.org/mobile/music-center-presents/?depth=1&srcid=4838> [2014, November 11].
- Newman, M. 1999. Four win three from ASCAP. *Billboard – the International Newsweekly of Music, Video and Home Entertainment*. 111(19): 75.
- Niccol, A. 1998. *The Truman show: the shooting script*. New York: Newmarket Press.
- Novak, J. 2011. Throwing the voice, catching the body. *Music, Sound & the Moving Image*. 5(2): 137-156.
- Ossola, C.A. 2006. *Hummingbird*. Available: https://www.sfballet.org/tickets/production/program_notes?prodid=2334 [2014, November 11].
- Page, T. 1997a. Dialogue with Philip Glass and Steve Reich: two from the steady school (1974). In *Writings on Glass*. R. Kostelanetz & R. Flemming, Eds. New York: Schirmer Books. 46-50.
- Page, T. 1997b. Philip Glass (1989). In *Writings on Glass*. R. Kostelanetz & R. Flemming, Eds. New York: Schirmer Books. 3-11.
- Philip Glass: Biography*. 2015. Available: <http://www.philipglass.com/bio.php> [2015, January 20].
- Philip Glass Intégrale des Concerti pr Piano*. 2012. Available: <https://www.weezevent.com/philipglass-lentrepot> [2014, November 11].

Philip Glass: Performances. 2014. Available:

<http://www.musicsalesclassical.com/composer/work/540/12320> [2014, November 25].

Philip Glass Opera gets Ovation. 2005. Available:

<http://news.bbc.co.uk/2/hi/entertainment/4236740.stm> [2013, October 18].

Potter, K. 2000. *Four musical minimalists*. Cambridge: Cambridge University Press.

Potter, K. 2014. *Minimalism*. Available: <http://www.oxfordmusiconline.com> [2014, January 20].

Raickovich, M. 1994. 'Einstein on the beach' by Philip Glass: a musical analysis. PhD Thesis. City University of New York.

Reesman, B. 2002. Philip Glass. *Mix*. 26(5): 142.

Richardson, J. 1999. *Singing archaeology: Philip Glass's Akhnaten*. Hanover: University Press of New England.

Riha, G. 2000. *Tirol – land im gebirg'* [Video File]. Available:

<https://www.youtube.com/watch?v=SPxHWfFRF5k> [2014, October 12].

Rockwell, J. 1983. *All American music: composition in the late twentieth century*. New York: Knopf.

Roddy, J. 1997. Listening to Glass (1981). In *Writings on Glass*. R. Kostelanetz & R. Flemming, Eds. New York: Schirmer Books. 167–177.

Ross, A. 2007. *The rest is noise*. New York: Farrar, Straus and Giroux.

Royal NZ Ballet – The tower season of from here to there. 2006. Available:

<http://www.eventfinder.co.nz/2010/feb/dunedin/royal-nz-ballet-the-tower-season-of-from-here-to-there> [2014, November 19].

Schmidt, L. 1968. Josephus Weber. In *Jahrbuch des Österreichischen volksliedwerkes XVII*. Vienna: Bundesministeriums für Unterricht. 80.

Schwarz, R. 1996. *Minimalists*. London: Phaidon Press Limited.

Sieber, F.X. 1839. *Die rufende stimme, oder anweisung zu einem gottseligen lebenswandel, und zu einem glückseligen tode, ein christkatholisches gebet-, haus- und erbauungsbuch für familien und jeden Katholischen Christen, insbesondere auch für alle erwachsene kinder, arme waisen, dienstboten, und überhaupt für alle armen, niedrigen und bedrängten : enthaltend: allgemeine und festtägliche, sehr kräftige, nützliche und trostreiche*

andachtsübungen und gebete, als auch lehren und betrachtungen über religiöse gegenstände und die standes-pflichten. Augsburg: Anton Herzog.

Simon, L. 1983. Music and film: an interview with Philip Glass. *Millennium Film Journal*. 133–139.

Smith, S. 2007. If Grant had been singing at Appomattox. Available: <http://nytimes.com/2007/09/23/arts/music/23smit.html> [2012, October 15].

Smith, G. & Smith, N.W. 1995. *New voices: American composers talk about their music*. Portland: Amadeus Press.

Stanley, G. 2014. Disciplines of musicology – historical method. Available: <http://www.oxfordmusiconline.com> [2014, May 23].

Strickland, E. 1993. *Minimalism: origins*. Bloomington: Indiana University Press.

Strickland, E. 2014. Philip Glass. Available: <http://www.oxfordmusiconline.com> [2014, January 20].

Swed, M. 1988. Philip Glass's operas. *The Musical Times*. 129(1749): 577–579.

Swed, M. 1993. Editor's note to Philip Glass's Akhnaten. *The Musical Quarterly*. 77(2): 236–240.

The Concerto Project Vol. I. 2004. Available: http://www.philipglass.com/music/recordings/concerto_project_1.php [2014, November 17].

The Truman Show [DVD]. 1998. Produced by S. Rudin, A. Niccol, E.S. Feldman & A. Schroeder; Directed by P. Weir; Written by A. Niccol. California, USA: Paramount Pictures.

Thomson, V., Glass, P., Sandow, G. & Bunker Clark, J. 1989. The composer and performer and other matters: a panel discussion with Virgil Thomson and Philip Glass, moderated by Gregory Sandow. *American Music*. 7(2): 181–204.

Tirol – Land im Gebirg' [Video Recording]. 2000. Directed by G. Riha. Innsbruck: Cine Tirol.

Tirol – Place of Power at the Heart of the Alps. 2015. Available: <http://www.tyrol.com/tirol-at-a-glance> [2015, January 29].

Thomas, R. 2012. *Glass: Tirol Concerto; Passages (excerpts)*. Available: <http://www.classical-music.com/review/glass-15> [2014, November 11].

Warburton, D. 1984. Philip Glass's "Echnaton". *Tempo*. 149:46–47.

- Warburton, D. 1988. A working terminology for minimal music. *Intégral*. 2:135–159.
- Wasserman, A. 2009. The "Opera news" awards: Philip Glass. *Opera News*. 74(5): 20.
- Whittall, A. 2003. *Exploring twentieth-century music: tradition and innovation*. Cambridge: Cambridge University Press.
- Williams, A. 2001. *Constructing musicology*. Aldershot: Ashgate.
- Wu, C. 2009. The aesthetics of minimalist music and a Schenkerian-oriented analysis of the first movement "Opening" of Philip Glass' Glassworks. MMus Dissertation. University of North Texas.
- York, W. 1985. Form and process. In *Contiguous lines: issues and ideas in the music of the '60's and '70's*. T. DeLio, Ed. Lanham: University Press of America. 81–107.
- Zlokower, R.E. 2006. *American ballet theatre – Glow-stop, Sinatra suite, Grand pas classique, Rodeo – Onstage with the dancers*. Available: <http://www.robertaonthearts.com/dance/American%20Ballet%20Theatre%20-%20Glow-Stop,%20Sinatra%20Suite,%20Grand%20Pas%20Classique,%20Rodeo.html> [2014, November 11].

Appendix A: Score of the Second Movement of the *Tirol Concerto*

TIROL CONCERTO

FOR PIANO AND ORCHESTRA

By Philip Glass

Commissioned by the Festival Klangspuren
with support of TIROL - WERBUNG
and the Stuttgart Chamber Orchestra
World Premiere Performance: September 22, 2000

Copyright © 2000

DUNVAGEN

Music Publishers Inc.

All Rights Reserved

Movement II

1

$J=84$

Musical score for measures 1-4. The score is for Violin I and II, Viola, Cello, and Bass. The key signature has one flat (B-flat) and the time signature is 4/4. The tempo is marked $J=84$. Dynamics include *p*, *mp*, and *p*. The first measure features a long melodic line in the Violin I and II parts, with the Viola and Bass providing harmonic support. The Cello has a rhythmic pattern of eighth notes.

2

Musical score for measures 5-8. The score is for Violin I and II, Viola, Cello, and Bass. Dynamics include *p*, *mp*, and *p*. The melodic lines in the Violin and Viola parts continue, with the Bass part showing a more active rhythmic pattern in the later measures.

3

Musical score for measures 9-12. The score is for Violin I and II, Viola, Cello, and Bass. Dynamics include *mp*, *mf*, and *p*. The texture becomes more complex with more active lines in the Violin and Viola parts.

4

Musical score for measures 13-16. The score is for Violin I and II, Viola, Cello, and Bass. Dynamics include *mf*, *dim.*, *p*, and *mp*. The first three measures feature a *dim.* (diminuendo) marking across all parts. The section concludes with a *D.S.* (Da Capo) instruction.

5

Musical score for measures 5-8. The score includes parts for Violin I and II, Viola, Cello, and Bass. The key signature has one flat (B-flat). The time signature is 3/4. The music features sixteenth-note patterns in the strings, with dynamic markings of *mp* and *P*. A fermata is present over the first measure of each part.

6

Musical score for measures 9-12. The score includes parts for Violin I and II, Viola, Cello, and Bass. The key signature changes to two flats (B-flat and E-flat). The time signature is 3/4. The music features sixteenth-note patterns in the strings, with dynamic markings of *P*, *mp*, and *pp*. A fermata is present over the first measure of each part.

7

Musical score for measures 13-16. The score includes parts for Violin I and II, Viola, Cello, and Bass. The key signature has two flats (B-flat and E-flat). The time signature is 3/4. The music features sixteenth-note patterns in the strings, with dynamic markings of *P* and *pp*. A fermata is present over the first measure of each part.

8

Musical score for measures 8-11. The piano part begins with a dynamic of *mp* and ends with *P*. The violin I and II parts play sixteenth-note patterns, starting with *P* and ending with *pp*. The viola part starts with *P* and ends with *pp*. The cello part starts with *P* and ends with *pp*. The bass part starts with *P* and ends with *pp*.

9

Musical score for measures 12-15. The piano part includes dynamics *mp*, *dim.*, *P*, and *PP*, with first and second endings. The violin I and II parts include *P*, *dim.*, and *pp*. The viola part includes *P*, *dim.*, and *pp*. The cello part includes *P*, *dim.*, and *pp*. The bass part includes *P*, *dim.*, and *pp*. The section concludes with *DS.*

10

Musical score for measures 16-19. The piano part starts with *mp* and ends with *P*. The violin I and II parts are mostly silent. The viola part starts with *mp* and ends with *P*. The cello part starts with *mp* and ends with *P*. The bass part starts with *mp* and ends with *P*.

11

Musical score for measures 11-14. The score includes parts for Piano, Violin I and II, Viola, Cello, and Bass. The piano part features sixteenth-note patterns with slurs and accents. The strings play sustained notes with slurs. Dynamics include *mp* and *f*. The key signature has one flat, and the time signature is 4/4.

12

Musical score for measures 15-18. The score includes parts for Piano, Violin I and II, Viola, Cello, and Bass. The piano part continues with sixteenth-note patterns. The strings play sustained notes with slurs. Dynamics include *mf* and *mp*. The key signature has one flat, and the time signature is 4/4.

13 *S.*

Musical score for measures 13-14. The score includes staves for Piano (P), Violin I and II, Viola, Cello, and Bass. The piano part features sixteenth-note patterns with slurs and accents. The strings play sustained notes with slurs. Dynamics are marked *mp* for all instruments.

14

Musical score for measures 14-15. The score includes staves for Piano (P), Violin I and II, Viola, Cello, and Bass. The piano part continues with sixteenth-note patterns, including a *mf* dynamic and a *dim.* marking. The strings play sustained notes with slurs. Dynamics for strings are marked *(mp)*, *mf*, *dim.*, and *P*. The section ends with *D.S.*

15

Musical score for measures 15-16. The score includes staves for Piano (P), Violin I and II, Viola, Cello, and Bass. The piano part features sixteenth-note patterns with slurs and accents, marked *mf* and *mp*. The strings play sustained notes with slurs, marked *mf* and *mp*. The section is marked *7 loco* and ends with a double bar line.

16

Musical score for measures 16-19. The score includes a grand staff (piano) and five string staves (Violin I, Violin II, Viola, Cello, Bass). The piano part features eighth-note chords with a melodic line in the right hand. The strings play a rhythmic accompaniment of eighth notes. Dynamics are marked *mf* for the piano and *mf* for the strings. Measure numbers 8 and 7 are indicated above the piano staff.

17

Musical score for measures 20-23. The score includes a grand staff (piano) and five string staves (Violin I, Violin II, Viola, Cello, Bass). The piano part continues with eighth-note chords. The strings play eighth-note accompaniment. Dynamics include *f* for the piano and *f* for the strings. Measure numbers 8 and 7 are indicated above the piano staff.

18

Musical score for measures 24-27. The score includes a grand staff (piano) and five string staves (Violin I, Violin II, Viola, Cello, Bass). The piano part features eighth-note chords. The strings play eighth-note accompaniment. Dynamics are marked *mf* for the piano and *mf* for the strings. Measure numbers 8 and 7 are indicated above the piano staff.

D.S.

19

Musical score for measures 19-20. The piano part features a melodic line with a fermata and a 'loco' marking. The strings play a rhythmic pattern. Dynamics include *mf* and *mp*. A fermata is present over the piano part in measure 19.

20

Musical score for measures 21-22. The piano part continues with a melodic line. The strings play a rhythmic pattern. Dynamics include *mf* and *mp*. A fermata is present over the piano part in measure 21.

21

Musical score for measures 23-24. The piano part features a melodic line with a fermata and a 'loco' marking. The strings play a rhythmic pattern. Dynamics include *mf*, *f*, and *mp*. A fermata is present over the piano part in measure 23.

22

Musical score for measures 22-23. The piano part features a melodic line with a fermata over the final measure. The strings play a rhythmic accompaniment. Dynamics include *mf* and *mp*. A section marker 'S' is present at the end of measure 23.

23

Musical score for measures 23-24. The piano part continues with a melodic line. The strings play a rhythmic accompaniment. Dynamics include *f*, *mp*, and *f*. A section marker 'S' is present at the end of measure 24. The text "mp D.S." is written at the end of the score.

24

Musical score for measures 24-25. The piano part features a melodic line with a fermata over the final measure. The strings play a rhythmic accompaniment. Dynamics include *mf*, *mp*, and *p*.

Musical score for measures 25-27. The score includes parts for Piano, Violin I, Violin II, Viola, Cello, and Bass. The Piano part features a complex melodic line with many beamed notes. The strings play sustained notes with dynamic markings of *mf*, *f*, and *mf*. The Violin I and II parts have a *sost.* (sostenuto) marking. The Viola, Cello, and Bass parts also have dynamic markings of *mf*, *f*, and *mf*.

Musical score for measures 28-30. The score includes parts for Piano, Violin I, Violin II, Viola, Cello, and Bass. The Piano part has a *dim.* (diminuendo) marking in measure 28. The strings play sustained notes with dynamic markings of *mp* and *mf*. The Violin I and II parts have dynamic markings of *mp* and *mf*. The Viola, Cello, and Bass parts also have dynamic markings of *mp* and *mf*.

Musical score for measures 31-33. The score includes parts for Piano, Violin I, Violin II, Viola, Cello, and Bass. The Piano part has a *mp* marking in measure 31. The strings play sustained notes with dynamic markings of *f*, *mf*, *dim.*, *mp*, and *mf*. The Violin I and II parts have dynamic markings of *f*, *mf*, *dim.*, *mp*, and *mf*. The Viola, Cello, and Bass parts also have dynamic markings of *f*, *mf*, *dim.*, *mp*, and *mf*.

27 *S*

8 *mf* *f* *mf* *f* *loco* *ch* *f*

Violin I *mf* *f* *mf*

Violin II *mf* *f* *mf*

Viola *mf* *f* *mf*

Cello *mf* *f* *mf*

Bass *mf* *f* *mf*

28

8 *dim.* *mp* *mp* *mf* *mp* *mf* *mp* *mf* *mp* *mf*

Violin I *f* *mp* *mf* *mp* *mf*

Violin II *f* *mp* *mf* *mp* *mf*

Viola *f* *mp* *mf* *mp* *mf*

Cello *f* *mp* *mf* *mp* *mf*

Bass *f* *mp* *mf* *mp* *mf*

8 *mf* *dim.* *mp* *mf* *S*

Violin I *mp* *mf* *S*

Violin II *mp* *mf*

Viola *mp* *mf*

Cello *mp* *mf*

Bass *mp* *mf* *D.S.*

29

loco

Piano
f, mf

Violin I
pizz. f, arco mf

Violin II
pizz. f, arco mf

Viola
pizz. f, arco mf

Cello
pizz. f, (pizz.) mf

Bass
pizz. f, (pizz.) mf

30

Piano
f, sim.

Violin I
f, pizz. non div.

Violin II
f

Viola
f, pizz. non div., f (pizz.)

Cello
f (pizz.)

Bass
f, f (pizz.), f

31

Musical score for measures 30 and 31. The score includes parts for Piano, Violin I and II, Viola, Cello, and Bass. Measure 30 features a piano accompaniment with eighth-note patterns in both hands. The Violin I part has a melodic line with slurs and accents. The Violin II part has a rhythmic accompaniment. The Viola, Cello, and Bass parts provide harmonic support with sustained notes. Measure 31 begins with a piano fortissimo (f) dynamic marking and features a piano accompaniment with a circled melodic phrase in the right hand. The Violin I part continues with a melodic line, and the other instruments provide harmonic support.

Musical score for measures 32, 33, and 34. The score includes parts for Piano, Violin I and II, Viola, Cello, and Bass. Measure 32 features a piano accompaniment with eighth-note patterns in both hands. The Violin I part has a melodic line with slurs and accents. The Violin II part has a rhythmic accompaniment. The Viola, Cello, and Bass parts provide harmonic support with sustained notes. Measure 33 continues the piano accompaniment and violin parts. Measure 34 concludes the section with a piano accompaniment and violin parts.

Musical score for measures 32-34. The score includes parts for Piano, Violin I and II, Viola, Cello, and Bass. The key signature has one flat (B-flat). Measure 32 features a piano accompaniment with eighth-note patterns in both hands. Violin I has a melodic line with a slur and a fermata, marked *non div.* and *f*. Violin II plays a sustained chord. Viola, Cello, and Bass provide harmonic support with sustained notes.

Musical score for measures 35-37. Measure 35 is marked with a box containing the number 33. The piano accompaniment continues with eighth-note patterns. Violin I has a melodic line with a slur and a fermata, marked *gva-* and *loco*. Violin II has a melodic line with a slur and a fermata, marked *dim.* and *mf*. Viola, Cello, and Bass provide harmonic support with sustained notes.

Musical score for measures 38-40. Measure 38 is marked with a box containing the number 33. The piano accompaniment continues with eighth-note patterns. Violin I has a melodic line with a slur and a fermata, marked *gva-* and *loco*. Violin II has a melodic line with a slur and a fermata, marked *dim.* and *mf*. Viola, Cello, and Bass provide harmonic support with sustained notes. The score concludes with a *D.S.* marking.

34

Musical score for measures 34-35. The score includes parts for Piano, Violin I and II, Viola, Cello, and Bass. The piano part features a sixteenth-note arpeggiated pattern in the left hand and chords in the right hand. The strings play a rhythmic pattern of eighth notes. Dynamics include *mf*, *mp*, and *arco*.

35

Musical score for measures 35-36. The piano part continues with the arpeggiated pattern. The strings play a rhythmic pattern of eighth notes. Dynamics include *mf*.

36

Musical score for measures 36-37. The piano part continues with the arpeggiated pattern. The strings play a rhythmic pattern of eighth notes. Dynamics include *mf*, *cresc.*, and *f*.

37



37

Piano: *mf*

Violin I: *mf*, *f*, *mf*

Violin II: *mf*, *f*, *mf*

Viola: *mf*, *f*, *mf*

Cello: *mf*, *f*, *mf*

Bass: *mf*, *f*, *mf*

38

38

Piano: *(mf)*, *f*, *mf*, *f*, *mf*

Violin I: *mf*, *f*, *mf*, *f*, *mf*

Violin II: *mf*, *f*, *mf*, *f*, *mf*

Viola: *mf*, *f*, *dim.*, *mf*

Cello: *mf*, *f*, *dim.*, *mf*

Bass: *mf*, *f*, *dim.*, *mf* *D.S.*

39

39

Piano: *f*, *mf*

Violin I: *f*, *mf*

Violin II: *f*, *mf*

Viola: *f*, *mf*

Cello: *f*, *mf*

Bass: *f*, *mf*

Musical score for measures 40-42. The score includes a grand staff (piano) and five string staves (Violin I, Violin II, Viola, Cello, Bass). The piano part features a complex, rhythmic accompaniment with many sixteenth notes. The strings play sustained notes with some rhythmic patterns. Dynamics include *mf*, *f*, and *p*. The key signature has two flats.

Musical score for measures 41-43. The score includes a grand staff (piano) and five string staves (Violin I, Violin II, Viola, Cello, Bass). The piano part continues with its complex accompaniment. The strings have more active parts, including some triplets. Dynamics include *mf*, *f*, and *p*. The key signature has two flats.

Musical score for measures 42-44. The score includes a grand staff (piano) and five string staves (Violin I, Violin II, Viola, Cello, Bass). The piano part continues with its complex accompaniment. The strings have more active parts, including some triplets. Dynamics include *mf*, *f*, and *p*. The key signature has two flats.

42 8

Musical score for measures 42-43. The score includes parts for Piano, Violin I and II, Viola, Cello, and Bass. The piano part features a complex rhythmic pattern with many sixteenth notes. The strings play sustained notes with some movement. Dynamics include *f*, *mf*, and *f*. A fermata is present over the final notes of the strings in measure 43.

43

Musical score for measures 44-45. The score includes parts for Piano, Violin I and II, Viola, Cello, and Bass. The piano part continues with a similar rhythmic pattern. The strings play sustained notes. Dynamics include *f*, *mf*, and *f*. A fermata is present over the final notes of the strings in measure 45. The text "D.S." is written at the end of the score.

D.S.
(Repeat good after D.S.)

44

Musical score for measures 46-47. The score includes parts for Piano, Violin I and II, Viola, Cello, and Bass. The piano part continues with a similar rhythmic pattern. The strings play sustained notes. Dynamics include *f*, *mf*, and *f*. A fermata is present over the final notes of the strings in measure 47.

45

Musical score for measures 45-48. The score includes a grand staff (piano) and five individual staves for Violin I, Violin II, Viola, Cello, and Bass. The piano part features sixteenth-note patterns with slurs and accents, and includes markings for *mp* and *loco*. The string parts are mostly rests, with some initial notes in the Violin I and II parts.

46

Musical score for measures 49-52. The score includes a grand staff (piano) and five individual staves for Violin I, Violin II, Viola, Cello, and Bass. The piano part continues with sixteenth-note patterns, including a *cresc.* marking. The Violin II part has a melodic line with slurs. The Viola part has a melodic line with slurs. The Cello and Bass parts are mostly rests.

47

47

Piano part: *mf*, *loco*, *dim.*, *mp*

Violin I: *mf*, *mp*

Violin II: *mf*, *mp*

Viola: *mf*, *mp*

Cello: *mf*, *mp*

Bass: *mf*, *mp*

48

48

Piano part: *mp*, *mf*, *mp*, *mf*, *mp*, *p*

Violin I: *mp*, *p*

Violin II: *mp*, *p*

Viola: *mp*, *p*

Cello: *mp*, *p*

Bass: *mp*, *p*

49

49

Piano part: *mp*, *p*

Violin I: *mp*, *p*

Violin II: *mp*, *p*

Viola: *mp*, *p*

Cello: *mp*, *p*

Bass: *mp*, *p*

D.S.

50

Musical score for measures 50-51. The score includes parts for Violin I, Violin II, Viola, Cello, and Bass. The key signature is B-flat major (two flats). The time signature is 8/8. The music features a piano introduction with a dynamic of *p*, followed by a section marked *mp* (mezzo-piano) and a final section marked *p*. The Violin I part includes a *gva* (glissando) marking and a *7* fingering. The Viola, Cello, and Bass parts are mostly silent, indicated by horizontal lines.

51

Musical score for measures 52-53. The score includes parts for Violin I, Violin II, Viola, Cello, and Bass. The key signature is B-flat major (two flats). The time signature is 8/8. The music features a piano introduction with a dynamic of *p*, followed by a section marked *pp* (pianissimo). The Violin I part includes a *loco* marking and a *pp* dynamic. The Violin II part includes a *p* dynamic. The Viola, Cello, and Bass parts are mostly silent, indicated by horizontal lines.

52

Musical score for measures 52-55. The score includes parts for Piano, Violin I and II, Viola, Cello, and Bass. The piano part features a complex texture with chords and moving lines, marked with dynamics *P* and *pp*. The strings (Violin, Viola, Cello, Bass) are mostly silent, with some entries in measures 53-55 marked with *P* and *pp*.

53

Musical score for measures 56-59. The score includes parts for Piano, Violin I and II, Viola, Cello, and Bass. The piano part continues with chords and moving lines, marked with *pp* and *(pp)*. The strings (Violin, Viola, Cello, Bass) are mostly silent, with some entries in measures 57-59 marked with *pp* and *(pp)*.

End Movement II

Appendix B: Analytical Methodologies in Current Musicology

Music score analysis was a cornerstone of historical musicology and dominated research methodologies up to the last few decades of the 20th century (Duckles & Pasler, 2014). Such methodologies were largely qualitative, empirical and positivist in nature, and reflected romanticist ideologies of the genius composer, the master-work canon and the autonomous work uninfluenced by socio-historical contexts (Bujic, 2014). Considering Guido Adler's seminal 19th-century paper on musicology, as translated by Mugglestone (1981), the aims of historical musicology and the choice of such methodologies are better understood. Mugglestone (2) writes that "Adler was very conscious of the fledgling status of the discipline [musicology] in academia, especially vis-à-vis the fine arts", and that in "establishing musicology as an academic discipline, Adler was attempting to make the study of the history of music scientific". Accordingly, positivist, factual-based, analytical methodologies analogous to those in the natural sciences were promoted (3).

In the new musicology movement that originated in the 1980s, the positivist, formalist and analytical methodologies of historical musicology were replaced with more qualitative, descriptive and contextual approaches. Drawing from postmodernism, these approaches incorporated the psychological, philosophical, social and perceptual factors believed to have been ignored in historical musicology (Fallows, 2014). Analytical studies of music scores were largely rejected and the emphasis was placed on the study of music as a human, social and cultural phenomenon influenced by individual perceptions and perspectives (Stanley, 2014).

Kerman's publication *Musicology* (1985) is considered a major catalyst in the change from the historical to the new musicology. It is often interpreted as discouraging of positivist, analytical research methodologies altogether, although this was not truly the author's intention. Kerman (1985:12, 42) argues that restricted musicological approaches are those that concentrate only on the factual, verifiable, uncontroversial and positivistic, without being insightful or showing critical interpretation of the aesthetic music experience. He states that "research has for some time been poised on the brink of the classic positivistic dilemma: more and more facts, and less and less confidence in interpreting them" (54). He then promotes broader, more comprehensive analyses that take into account historical and social contexts, listener perception, expressiveness and affect (73, 109). However, Kerman's motivation for an interpretive, critical analysis has snowballed to a full-scale rejection of positivism, formalism and analytical methodologies in the new musicology (Hooper, 2006:6). Williams (2001:6) believes that the criticism Kerman envisaged was more a "patchwork of analysis, criticism, history and, possibly, aesthetics that would link music to underlying human values".

In recent years musicology has undergone critical introspection, and many of the new musicology's postmodernist trends have been challenged. Hooper (2006:13) questions the immediate, uncritical acceptance of postmodernist theories and the consequent rejection of highly developed, sophisticated, true musicological methodologies. He states: "it remains my firm conviction that several aspects of an ostensibly postmodern mode of thought are simply inherently irreconcilable with a number of the presuppositions that must necessarily form the basis of any institutionalized research discipline – musicology included" (3). Methodologies with a positivist or formalist basis, such as analysis, are then still appropriate and even crucial in certain areas of musicological scholarship. Hooper adds that "music itself and the correlative interpretive and analytical practices that are dependent on it are not 'ideological' fictions but instead represent entirely necessary moments within any discourse which seeks to grasp and represent particular musical works or utterances" (137). In accord with Kerman, he encourages a mediation between "systematic" analytical theory and music's "life-world" contexts, believing this to be a "more productive basis from which to pursue a mode of interpretation that is rigorously work-centred and yet socially aware" (138).

Similar to Hooper's arguments, Williams (2001:x) argues that modernist rational argumentation is at times more valuable than unsustainable postmodern relativism and decentred subjectivism. Of urgent interest to him (19) is the connection of methodologies in which the specifics of music as well as its wider social processes are recognised, as previously proposed by Dahlhaus (1983) and Kerman (1985). Williams (2001:28) critiques analytical approaches that ignore socio-historical contexts and that study music as a pure entity, reflective of an inner logic. He supports Kerman's ideals of a more contextual, critical analysis that combines musicology with humanistic ideologies (121). Williams concludes that "analysis, when rid of formalist fundamentals, describes and generates musical structures that are indeed socially mediated" (124).

It is with the Kerman, Hooper and Williams arguments in mind that this dissertation's research methodologies were decided on. Analytical methodologies, which in relation with current musicological trends, are broad, critical and take into account context. This dissertation's research focus incorporates both an analytical approach of the musical score and a more contextual, historical approach to its conception, reception and background. Having critically examined the different methodologies available, as suggested by Mouton (2001:138), those applied were chosen as most suitable for the dissertation's research objectives.

Appendix C: Plot and Principal Themes of *The Truman Show*

In *The Truman Show* (1998) Jim Carrey stars as Truman Burbank, the unwitting star of a famous reality show viewed by millions worldwide. Unknown to Truman, he has been filmed by concealed cameras, 24 hours a day, since his birth. The town he lives in is in fact an enormous set and his family and friends are all actors. Christof, the show's producer, controls and engineers Truman's entire life and everything that happens to him. He has instilled in Truman a fear of water and travelling that prevents him from attempting to leave his hometown. At the age of 30 Truman starts questioning his reality. He starts recognising actors in different roles and comes across a studio light that has fallen from the 'sky'. Eager to find out the truth he attempts to leave Seahaven in a sailboat, bravely overcoming his fears. Meanwhile, the show's viewership hopes for Truman's escape as they sit nailed in front of their television sets. In an attempt to stop his star from leaving, Christof creates a massive storm that engulfs Truman's boat. A courageous Truman does not give up and shows great determination in realising his goal. As his boat capsizes in the massive storm, Truman disappears under water, apparently drowning. The audience looks on wordless and a glassy-eyed Christof orders the storm's end with the words "That's enough" and bows his head. As the storm settles down, sunlight reappears and a distressed, choking Truman awakes on the boat deck having survived Christof's onslaught. A few moments later we see a relieved Truman raise the boat's sail and stare up at the blue sky, when suddenly the boat cracks through the studio's wall. Truman discovers a stairwell against the wall and leaves with his catchphrase "Good afternoon, good evening and good night". The film ends with Truman's fan base celebrating his escape and Christof ending the show.

Brown (1998:421) parallels themes of Truman's escape from Seahaven to society's escape from the promises of capitalism. He writes (*ibid.*):

The drama of *The Truman Show* lies in the main character's gradual discovery that he is trapped in a mammoth staging of the capitalist mythology, which, via product logos and the mini-dramas of advertising, promises an earthly paradise via the glories of consumption. The chief medium via which this carrot-on-stick pseudo-religion and its iconography are promulgated is, of course, television, and in that sense *The Truman Show* stands as a brutally cynical laying bare of the absurdities of capitalism's promise of an earthly paradise.

He believes (*ibid.*) that Truman Burbank shows "great faith", and recognises "that there is something deeper than the life he is living, that there is something beyond these appearances". There is also Truman's "great determination" as he "meets his fears (of water, of death) and becomes free (from the TV show: maybe) by leaving the polluted Eden of capitalist promises and walking out of it all".

