

**FACULTY OF ENGINEERING AND THE  
BUILT ENVIRONMENT**

**DEPARTMENT OF CONSTRUCTION ECONOMICS  
AND MANAGEMENT**

**CONSTRUCTION TECHNOLOGY I  
COURSE READER  
PART A**

**Compiled By:** Abimbola Olukemi Windapo *PhD, PrCM, FNIOB*

**Illustrated By:** Bayonle Windapo

# CONTENTS

1. Structure of the Construction Industry
2. The Building as a System
3. Development Planning
4. The Use of Regulations in the Construction Industry
5. The Building Site

# THE STRUCTURE OF THE CONSTRUCTION INDUSTRY

The structure of the construction industry will be considered in the following sections:

## THE CONSTRUCTION INDUSTRY, ITS SIZE, ROLE IN THE ECONOMY AND ITS CHALLENGES

The image of the construction industry differs between individuals. According to cidb (2004), the industry has a low-tech image and deteriorating profitability. According to these documents, these two factors have been discouraging bright young people from entering the built environment professions.

A survey of 2010 First Year students in the Department of Construction Economics and Management, at the University of Cape Town presents a differing view. They view the construction industry as:

1. Broad based involving different skills, a baseline of all industry with many different jobs involved for people of all levels, involves a lot of management, an environment for people and machinery, engineers, architects and workmen working together to design and construct buildings – relationships and collaboration.
2. Lucrative, very competitive (cut-throat competition), there is a lot of money, cash, fruitful, it is an important part of a growing country such as South Africa's economy, an important factor in the economic cycle.
3. A manufacturing process, very hands on/practical, involves a lot of processes, refines raw materials into a finished product, well planned and organized industry, cruel, very rough with many people working on a building site together, fierce, busy, dirty, requires both brains and muscle, time consuming, variety of products.
4. Always growing with room for improvement, fast developing industry with many opportunities, has great investment opportunities and a platform for growth and expansion, presents boundless opportunities and promise, a fast growing industry at the centre of the commercial world, dynamic, immense potential for business and investment.
5. Large made up of many sectors, and comprising of two sides – building and sales.

According to Ofori (1990) the construction industry may be defined as that sector of the economy which plans, designs, constructs, alters, maintains, repairs and eventually demolishes buildings of all kinds, civil engineering works, mechanical and electrical engineering structures and other similar works. Thus the industry includes:

- a. Persons, enterprises and agencies, both public and private, involved in physical construction; both those whose main activity is construction and the relevant part of entities engaged in other field of activity who retain some construction activity (such as maintenance unit of a bank or manufacturing enterprise).
- b. Those providing all kinds of planning design, supervisory and managerial services related to construction.

The outputs of the construction industry are predominantly capital investment goods, i.e. buildings, facilities and infrastructure that others use in the creation of goods and services. The construction industry's delivery chain consists of many complex composite parts, often operating and / or resulting in difficult and aggravating circumstances (complicated) involving multiple participants operating from inside and out of the industry, resulting in a system or

systems that may be assembled with completely new and never ending combinations and variations.

The construction industry is therefore usually portrayed in the following ways:

**1. In terms of its different sectors:**

- a) Professional services sector
- b) Contracting sector
  - i. Building contractors
  - ii. Civil engineering contractors
  - iii. Specialist sub-contractors
  - iv. Labour subcontractors
- c) Public sector
- d) Finance and Investment Sector
- e) Material manufacturers and supply sector
- f) Equipment manufacturers, supply and hire sector

**2. In terms of its activities:**

- Planning/Conception
- Design
- Construction
- Repair, maintenance and alteration
- Demolition

**3. In terms of its products**

- ◆ Buildings
- ◆ Airports, harbours
- ◆ Electrical, telecommunications and gas works
- ◆ Roads, bridges, railways, tunnels and via ducts
- ◆ Reclamation, sewers, dams, canals and pipelines

**References**

cidb (2004) South African Construction Industry Status Report: *Synthesis Review on the South African Construction Industry and its Development*, Construction Industry Development Board (cidb), ISBN: 0-621-35072-9, Brooklyn Square.

Ofori, G. (1990) *The Construction Industry: Effects of its Economics and Management*, Singapore University Press, National University of Singapore.

# AN OVERVIEW OF THE CONSTRUCTION INDUSTRY'S STRUCTURE; ITS PARTICIPANTS, THEIR ROLES AND RESPONSIBILITIES; THE BUILT ENVIRONMENT PROFESSIONS, THE ROLE OF REGISTRATION COUNCILS AND OTHER INDUSTRY STAKE HOLDERS

## CONSTRUCTION INDUSTRY'S STRUCTURE; ITS PARTICIPANTS, THEIR ROLES AND RESPONSIBILITIES

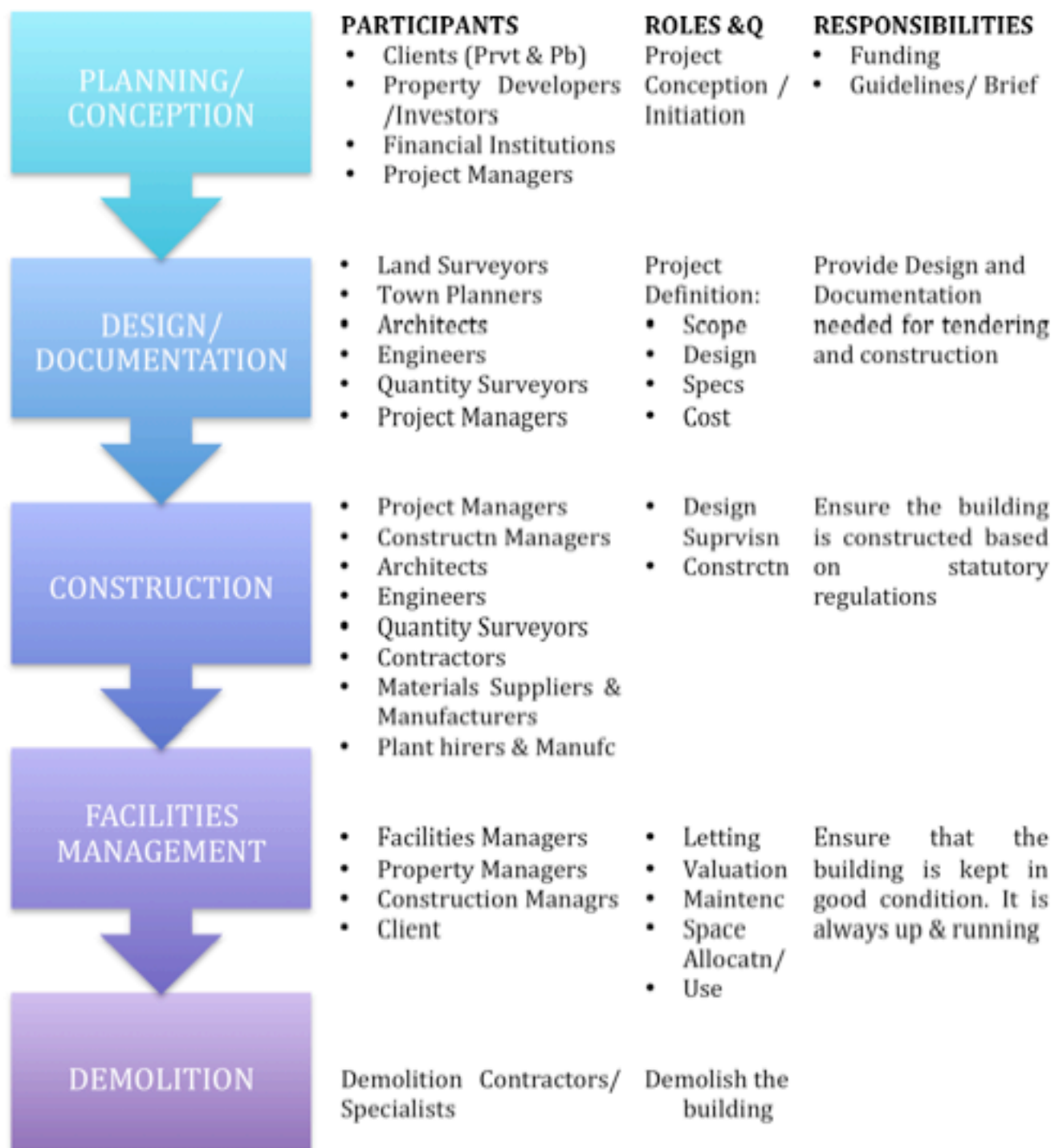

The structure of the construction industry in South Africa reflects that of most developed construction economies (cidb, 2004). It includes the design professions, principal contractors and specialist subcontractors and a well developed materials manufacturing and supply sector.

The contractor sector includes a small number of highly sophisticated large firms operating nationally, regionally and internationally, several medium-sized localized contractors operating in two or more provinces and a large number of small firms operating locally that typically employ fewer than ten permanent staff.

Leading South African construction companies compete with the world's best. Eight listed companies, account for about 23% of South Africa's total output. Approximately 50% of their work is undertaken cross-border, reflecting their **global competitiveness**. Offshore work on major projects enables these companies to consolidate **specialist expertise** that is then readily available to the South African market.

## THE BUILT ENVIRONMENT PROFESSIONS

The Built environment professions as defined by the Council for the Built Environment (CBE) - namely architects, engineers, landscape architects, project and construction managers, valuers and quantity surveyors - play an indispensable role in the production of the built environment - they are crucial to the industry's ability to deliver infrastructure, they are required to provide imaginative thinking, be at the cutting edge of technology, exercise strategic managerial skills, and be skilled craftsmen in order to conceptualize and manage the delivery of the physical infrastructure that is fundamental to the development of the community they serve.

Professionals are acknowledged for their ability to add real value through the devising of physical solutions in response to their briefs, maximizing the potential of the site, and overcoming planning and other constraints.

Construction industry participants exercise a significant influence on the lives of their customers, which include current users, those who pass by their buildings, and those users yet to be born. They therefore must ensure that they deliver physical infrastructure that is responsive to their customers' needs. For example, a role that **architects** have played since time immemorial is that of trusted advisor to their clients when undertaking the procurement and delivery of public facilities and infrastructure.

The Construction Education and Training Authority (CETA) Report identifies the following strategic functions that built environment professionals have to perform in the delivery process:

- Identification of the needs of users of infrastructure;
- Interpretation and conversion of the needs into practical, workable and affordable infrastructure components appropriate to the South African population, geographic and climatic environment, and the capabilities of available human and technological resources;
- Preparation of designs and costing of construction projects;
- Evaluation of alternative tenders for execution;
- Administration of construction activities as well as overall project management; and
- Preparation of workable operation and maintenance programmes.

A healthy, viable and dynamic professional corps is therefore vital to the ability of the construction industry to improve its performance and to create a climate in which our industry

can adapt to the rapidly developing changes impelled by local transformation and international globalization.

## **THE ROLE OF REGISTRATION COUNCILS AND OTHER INDUSTRY STAKEHOLDERS**

Following a process of broad stakeholders engagement, specific legislation established include:

- ◆ **The Council for the Built Environment Act of 2000 (Act No. 43 of 2000)**  
This council was established to promote greater co-ordination, development of the professions and their enhanced contribution to national development. It provides for the establishment of an overarching Council for the Built Environment under which six independent statutory professional councils function. The six professional councils are:
  - ◆ South African Council for the Architectural Profession (SACAP);
  - ◆ Engineering Council of South Africa (ECSA);
  - ◆ South African Council for the Quantity Surveying Profession;
  - ◆ South African Council for Project and Construction Management (SACPCM);
  - ◆ South African Council for the Property Valuers Profession; and
  - ◆ South African Council for the Landscape Architectural Profession.

Each of the above professional councils is regulated by a separate act.

Objects include the provision of strategic leadership to advance national, social and economic goals and to ensure the inclusion by the professions of previously disadvantaged individuals and groups in the short, medium and long term.

- ◆ **Planning Professions Act 2002 (No. 36, 2002)**

The Act provides for the establishment of the South African Council for Planners as a juristic person;

- a. To provide for different categories of planners and the registration of planners;
- b. To authorize the identification of areas of work for planners;
- c. To recognize certain voluntary associations;
- d. To protect the public from unethical planning practices; to maintain a high standard of professional conduct and integrity;
- e. To establish disciplinary mechanisms and an Appeal Board; and to provide for incidental matters.

## **ASSOCIATIONS AND INSTITUTIONS**

There are also various associations and institutions existing in the construction industry. These include:

- The Association of Professional Design Draftsmen
- Concrete Masonry Association
- Council for Scientific and Industrial Research (CSIR)
- Master Masons' and Quarry Owners' Association (South Africa)
- Master Builders Association
- National Association of Home Builders
- Portland Cement Institute
- South African Property Owners Association (SAPOA)
- The South African Bureau of Standards (SABS)

## **THE NATURE OF THE BUILT 'PRODUCT' AND HOW ITS CHARACTERISTICS AFFECT THE ORGANIZATION OF THE INDUSTRY**

The outputs of the construction industry are predominantly capital investment goods, i.e. buildings, facilities and infrastructure that others use in the creation of goods and services. When the demand for goods and services decreases, the demand for supporting facilities also decreases, with the obvious exception being the government sector. The level and characteristics of the demand for building and civil engineering works may be changed, at least over short periods, by deliberate acts of policy. This is partly because the public sector in construction is very important in most countries. Construction seldom creates its own market, although it has proved to be very adaptable to rapid changes in demand.

Buildings and structure form and alter the nature, function and appearance of the natural and built environment: in that they impact on rural areas, villages, towns and cities. Buildings are known to have long life (they outlive the owner): many of the buildings still in use around the world are many hundreds of years old.

The construction, use, repair, maintenance and demolition of buildings consume energy (energy used for space heating and cooling, water heating and lighting accounts for 64% of the energy used) and resources and generate waste in excess of any other industrial sector. Construction activity is a consumer of materials and scarce resources (water and energy), it is a significant contributor to global warming emissions (including CO<sub>2</sub> from the burning of fossil fuels), contribute to air pollution (smoke and dust pollution), generates vast quantities of waste, contaminates the soil and destroys existing vegetation.

Buildings are a crucial part of government's strategy to improve the quality of life; they constitute the infrastructure through which health care, education and housing are provided. It therefore can be said to provide – economic, social and environmental benefits. Shelter influences the health of their users. Health and safety are primary reasons that some countries regulate the built environment professions and legislate certain minimum standards.

### **THE OUTPUT OF CONSTRUCTION**

There are several ways in which the product of the construction industry may be broken down for the purpose of analysis. Those most usually accepted are:

- New work and maintenance and repairs;
- Residential building, non-residential building and other construction works;
- Public sector and private sector;
- Modern and traditional categories.

Different categories of construction consume different inputs, follow different patterns of financing, grow at different rates, utilize different technologies, and are handled by different professions or contractors. A separate analysis is therefore required to see how these categories affect the organization of the industry.

### **NEW WORK AND MAINTENANCE AND REPAIRS**

The first method of breaking down construction products distinguishes between new work and maintenance and repairs. The distinction is not as obvious as it may appear. Although it is possible to identify clearly items at the opposite extremes of the range covered by construction activity (for example, a completely new school or hospital building, as compared

with the periodic replacement of paint or electric bulbs), there is a large area in the middle, variously described as conversions, alterations, additions, major repairs etc., which according to the methods of reporting, may be attributed either to new work or to maintenance and repairs.

Building maintenance is a labour-intensive operation requiring a large number of skilled operatives in the finishing trades (painters, plasterers, roofers etc.). It is mostly handled by small firms; or by self-employed artisans whose numbers are often limited. In civil engineering work, some of the maintenance operations may be mechanized. Handling the large unskilled labour force in the direct employment of public authorities presents a special problem of organization, management and supervision in which the critical factor is the availability of trained foremen and supervisors.

## **RESIDENTIAL BUILDING, NON-RESIDENTIAL BUILDING AND OTHER CONSTRUCTION WORKS**

Different countries interpret these terms in different ways; sometimes it is even impossible, within a single project, to separate unequivocally the two categories. Many firms carry out both building and civil engineering work, although separate departments often organize it. In some countries, however, these two activities are carried out by separate firms, frequently belonging to different trade or professional associations and in some cases negotiating contracts or wages on a separate basis. The nature of civil engineering works tend to favour the larger firms, since it consists mostly of large “one-off” contracts, often requiring the use of expensive and highly specialized plant.

Changes of emphasis between categories of building output are facilitated by the fact that residential and non-residential building utilize the same mix of factors of production and may be tackled by the same labour force and, up to a point, by the same contracting organizations. But there is no real interchangeability between building and civil engineering work for various reasons, including the differences in the size of firms and in contractual arrangements. On the other hand, although few building firms can successfully enter the civil engineering field, the converse is fairly easy because civil engineering contractors have a higher level of managerial skills, financial resources and familiarity with the deployment and efficient use of an expensive array of plant and equipment.

## **PUBLIC SECTOR AND PRIVATE SECTOR**

Construction output may also be classified according to whether the client is a public authority or a private body, individual or collective. The public sector dominates in civil engineering works, where it may account for more than 90 % of the total annual output, housing, building for education, for health and other social services whilst the private sector is more important in luxury housing, buildings for industry and commerce. Private clients also account for a sizable portion of the total demand and the production side of the industry is almost entirely in the hands of private building concerns, including a large number of self-employed artisans.

It is customary for public departments to employ their own labour to carry out a substantial part of maintenance and repair work on publicly owned buildings. This is because maintenance work is made up of a large number of small operations that are not easy to describe in unequivocal and binding terms in a legal agreement, which would be a prerequisite for farming out to a contractor.

## MODERN AND TRADITIONAL CATEGORIES

The three preceding sections have analyzed the output of construction by **type of work** and by **sector of use**. An even more important distinction is based on the different levels of technology used by the construction industry. Four separate categories may be identified; they are:

1. The international-modern;
2. The national-modern;
3. The national-conventional; and
4. The traditional;

**The international-modern** category includes major civil engineering works, public buildings in a prestige class, and high-quality private buildings in large urban centers. It is international in that it employs technologies borrowed from the most advanced countries and that it is largely-sometimes exclusively in the hands of expatriate firms. It depends heavily on imports of expensive materials and components, of sophisticated plant and machinery, and of professional, managerial and supervisory skills. It conforms to international quality standards; it is based on internationally accepted contractual documents and practices, and so on.

**The national-modern** category may be regarded as a scaled down version of the international sector. It caters to both public and private demand in major urban centers. It constructs a large proportion of minor public buildings, (schools, health centers, police stations etc.), private commercial and industrial buildings, secondary roads and other minor civil engineering works.

Although it is based on technologies imported from industrialized countries, the quality standards have been scaled down to local conditions. It requires a large number of skilled operatives in various building trades. It employs the simpler mechanical aids and plant (concrete mixers, block-making machines, hoists, scaffolding etc.). It is handled by mainly by national firms whose organizational pattern and technical competence is often a pale copy of the middle-range construction firms in industrialized countries. It uses almost exclusively locally produced building materials and components, although a small proportion of imported fittings and equipment may be employed.

**The national-conventional** category is transitional and the term “intermediate technology” is often used to describe it. It is characterized by a mixture of traditional materials and techniques and a few selected modern inputs, such as cement for floors and blockwalls, corrugated iron or asbestos cement roofing sheets, hardwood for joinery, glass paint and other finishes. Such materials are used in varying amounts according to the sophistication of the client.

This building covers a large proportion of privately built dwellings in urban and semi-urban centers, as well as a good deal of rural infrastructure and community development. For a number of technical and administrative reasons, the public authorities do not generally finance buildings in this category. Most of the work is carried out by local artisans and by small emerging indigenous contractors who lack working capital, simple plant and tools and basic management skills. The national-conventional category of building provides an ideal training ground for local artisans to acquire the necessary experience to undertake modern construction.

**The traditional** category of building predominates in rural areas and in some cases in the areas between rural and urban settlements. It lies almost entirely outside the monetary sector, and the labour is mostly unskilled men carrying out “do- it- yourself” jobs.

## **THE BUILDING AS A SYSTEM**

A system can be defined as a complex whole with different parts working together, for example, a mechanical device or an integrated network. Common characteristics of a system are:

- There is inter-relation and interdependence of its different parts
- Holism – the parts are viewed as part of a greater whole
- Goal seeking – systems have goals
- Part of a hierarchy
- Its parts can be differentiated
- It is complex

The parts of a system can also be classified as sub-systems or components.

A building can be said to be a static structure having an external envelope that encloses space. A building is a system because it is made up of different parts or components/sub-systems, which are inter-related, and interdependent, the different parts, which can be easily differentiated, are viewed as part of the whole structure.

The building components help to define, organize and reinforce the perceptual and conceptual elements of a building. It should be noted also that the building components are made up of different elements. These major components/parts of a building which include – floors, walls, foundation, roofs, doors, windows, staircases and drainage, water supply, electrical services can come together in a number of ways depending on the following:

- the materials used
- technical ability
- subsoil conditions
- use of building (function)
- environment
- the method of resolving and transferring forces on and within the building and
- the desired physical form of the building

# EVOLUTIONARY NATURE OF BUILDING TECHNOLOGY AND PRACTICE AND HOW IT CONSTRAINS THE BUILT FORM

## References:

- Osbourn, D., and Greeno, R. (2007) **Mitchell's Introduction to Building**, 4<sup>th</sup> Ed, Pearson Education Ltd, Essex.
- Basalla, G. (1999) **The Evolution of Technology**; Cambridge University Press, 1999.

When a building is constructed, two main physical resources are involved. These are:

- Materials** necessary to form the various parts, and
- Technical ability** to assemble the parts into an enclosure. See figure below.

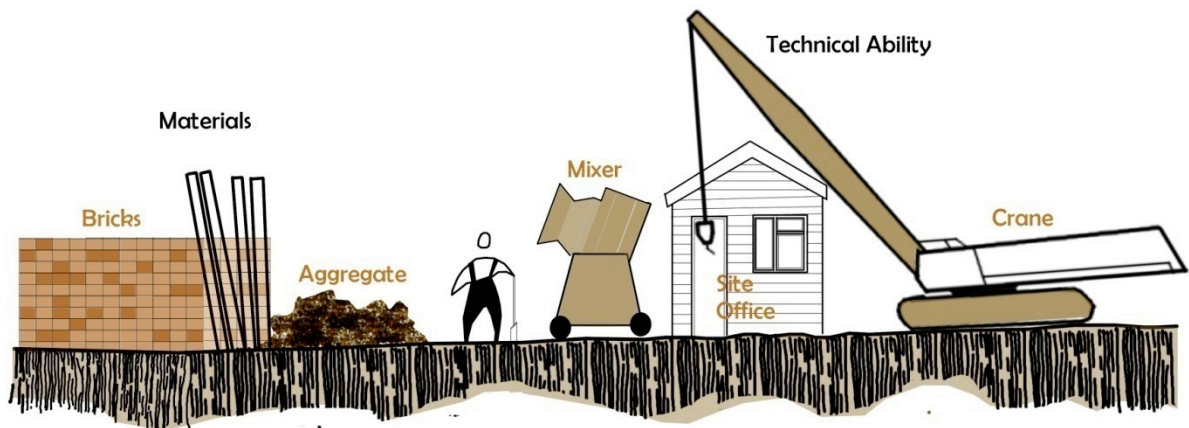

Initially the **materials** employed were those, which could most easily be sourced from the accessible areas of the surface of the earth, such as stone, limestone, mud, clay, wood etc. The **technical ability** was mostly simple, having evolved from the convenient methods of economically working the rudimentary characteristics of these available materials.

Early humans used readily available materials and inherent manipulative skills/**technology** to build shelters such as caves, tents and simple mud houses. At one time, need prompted the building of pyramids, temples and so forth and at another time it inspired movement about the earth's surface. We cultivate **technology** to meet our perceived needs.

Traditional wisdom about the nature of technology has customarily stressed the importance of necessity and utility. Technologists through the ages provided humans with the utilitarian objects and structures necessary for survival. **Technology** is a discipline that focuses on the invention, production and uses of material artifacts. Humans developed **technology**/their inherent manipulative skills by:

1. **Inventing tools** which led to indigenous construction methods and
2. Developing ways of **changing the natural state of materials** so that they could be used to greater advantage.

Each innovation devised usually resulted in buildings, which although initially providing a good standard of comfort and convenience, eventually became sub-standard accommodation as requirements become more elaborate.

Therefore, the current uses of particular construction methods no longer need to rely on locally available materials or traditional technical ability (the world is now a global village). Continued investigation has resulted in the enormous range of materials now becoming available which may be used singly, in combination with one another or even to form new materials. Technological developments are interrelated with this range and use of materials, and enable virtually anything to be constructed.

Below is a list of materials and tools invented by man over the ages for use in building construction:

### **1. The Wheel**

Popularly perceived as one of the oldest and most important invention in the history of the human race. It is known as the greatest technical achievement of the **Stone Age**. Before the coming of the wheel, large heavy objects were moved on sledges – wooden platforms with or without runners, Cylindrical rollers (smoothed logs) placed beneath the vehicle were used to facilitate the movement of the sledges, and it is thought these rollers inspired the invention of the wheel.

The first wheels were either solid wooden disk cut from a single plank or tripartite models consisting of three wooden slabs trimmed to shape and fastened together with cleats. The wheel made the construction of massive structures like the **pyramids** in Egypt possible.

### **2. Stone Tools**

The oldest surviving made things are stone tools. They stand at the beginning of the interconnected, branching, continuous series of artifacts shaped by deliberate human effort. For at least two million years, men and women in all parts of the earth made stone tools, hundreds of billions of them. For most of the time tools were made by chipping and flaking techniques that when carried out by skilled workers yielded a serviceable instrument within a relatively short time – axes, hammers, knives and scrapers of all sorts were produced by these means. As a material for making tools, stone has weaknesses. Although it is easily obtained and worked, stone is less durable than metal and less readily shaped.

### **3. Metal Tools**

The form of a stone tool is more closely determined by the nature of its material than is the form of a metal tool. The latter can be cast into almost any shape called for by the task at hand. The metal tool is less brittle, therefore, less likely to break. If it does break or show wear, it can be melted down and recast. The earliest metal tools such as knives, axes and hammers had as their closest antecedents stone prototypes.

In 1867, Karl Marx was surprised to learn that five hundred different kinds of hammers were produced in Birmingham, England, each one adapted to a specific function in industry or the crafts. These included – stone mason hammers, carpenter's hammer, blacksmith hammer, curved hammerhead and so forth.

**What forces led to the proliferation of so many variations of this ancient and common tool?**

#### **4. Mechanical Plants and Equipment**

Machines are a vital resource to the accomplishment of a construction project. One of the most obvious problems in constructing a project is how to transport heavy building materials. Machines provide the solution to the problem.

From the time man decided to build some type of simple structure for protection from the elements through the construction of the Great Pyramids, the temples at Angkor Wat in Cambodia, and continuing until the middle of the nineteenth century, work was accomplished by the muscle of man and beast.

When Ferdinand de Lesseps began excavating the Suez Canal in April 1859, **corvee** labourers, provided by the Egyptian viceroy, did the work of digging that trench in the desert. Human labour assisted only by a few machines continued the work for the next 4 years. But in 1864, Lesseps and his engineers began turning to machines, and ultimately 300 steam-powered mechanical dredges were put to work. Those machines, in the final three years of the project, excavated the majority of the main canal's 74 million cubic meters.

**Mechanization-machines-transformed the project and continue to transform how projects are built.**

#### **5. Cement**

Throughout history, cementing materials have played a vital role. They were used widely in the ancient world. The Egyptians used calcined gypsum as cement. The Greeks and Romans used lime made by heating limestone and added sand to make mortar, with coarser stone for concrete.

The Romans found that cement could be made which set under water and this was used for the construction of harbours. The cement was made by adding crushed volcanic ash to lime and was later called 'pozzolanic' cement, named after the village of Pozzuoli near Vesuvius. In places such as Britain, where volcanic ash was scarce, crushed brick or tile was used instead. The Romans were therefore the first to manipulate the properties of cementitious materials for specific applications and situations.

Smeaton, building the third Eddystone lighthouse (1759) off the coast of Cornwall in Southwestern England, found that a mix of lime, clay and crushed slag from iron making produced a mortar, which hardened under water. Joseph Aspdin took out a patent in 1824 for "Portland Cement", a material he produced by firing finely ground clay and limestone until the limestone was calcined. He called it Portland cement because the concrete made from it looked like Portland stone a widely used building stone in England.

#### **6. Concrete**

Concrete, unlike any other structural building material, allows the architects and engineers to choose not only its mode of production, but its material properties as well. Its inherent value is in its plasticity. Concrete is a composite material made from a mixture of cement, aggregates (sand and granite) and water to form slurry. Once this slurry is poured into formwork, and it sets, it takes the shape of the form.

Traveling through time, one learns that the Roman builders and the Pharaohs of Egypt knew the art of proportioning of concrete in a primitive way. Structures from as early as the 1200 BC have been found with polished, lime-concrete floors and surfaces of hard coloured plaster. Even earlier during the Neolithic period, builders knew "burning limestone, slaking the lime, mixing the mortar, spreading the concrete and finishing the surface.

In the early centuries as we have now, time, money and human ability were important factors in choosing building materials. Skill was required for building formwork – skill that may have been difficult to identify within large groups of slave labourers. Projects involving elaborate arches and utilitarian structures were supplemented in their strength by bricks and left in place forms as they attempted to economize and conserve skilled labour. With the decline of the Roman Empire, society lost the ability to mold the ingredients into cementitious materials. Only ruins exist as a testament to Roman ingenuity and the history of concrete. The use of concrete was lost for centuries until discovered again in the nineteenth century and put to work as a material used in the construction of large warehouses, apartment buildings and factories.

Discovery in a modern sense of concrete actually occurred during the eighteenth and nineteenth centuries. Reinforced concrete was introduced by casting square, twisted, steel bars into the concrete mortar to increase the strength of concrete. When reinforced concrete was first introduced as a building material, there were limitations on the heights that those buildings could reach. As materials testing continued to improve, built forms of reinforced concrete were witnessed gradually. Super tall buildings are a relatively recent addition to the history of cities around the world. Technology of the nineteenth century made their development possible. Over the history of tall building structures, the changes in technology have been tremendous and part of this comes from the daily strategies of human living.

Little more than a century ago, reinforced concrete was invented. In that short period of time, reinforced concrete has gone from being a very limited material to one of the most versatile building materials available today. The first reinforced concrete buildings were heavy and massive. Valuable floor spaces were taken up by the massive concrete structural systems. Today, due to our increased knowledge and improved technology, reinforced concrete buildings can be tall, graceful and elegant. Due in part to the use of shear-walls, innovative structural systems and ultimate strength design, very little usable floor space is occupied by the structure.

## **7. Steel**

Iron is reduced from its natural ore state with carbon to produce steel. Steel, along with concrete and masonry materials have existed for a long time in the history of civilization but not in such a configuration. Steel is a material that has high strength and it can carry a greater imposed load than any known material. The nineteenth century saw steel rolling mills establishing standard shapes, which were later to become the foundation of the skeleton steel design for skyscrapers.

The skeleton framed steel construction made the skyscraper possible. Because steel is much stronger than all forms of masonry and concrete, it is capable of sustaining far greater load in a given space and therefore obstructing less of the floor area in performing its function.

The use of straight round steel bars with heavy metal stirrups in concrete increased the strength of concrete. This made skyscrapers in concrete possible. For skyscrapers to be possible, the insitu concrete used has to be reinforced with steel reinforcement.

# THE FUNCTION OF A BUILDING AND HOW IT RELATES TO ITS ENVIRONMENT

(Reference: Building Construction Handbook by Roy Chudley & Roger Greeno pgs 2 – 4)

The function of a building includes:

## 1. Shelter

Shelter provides –

- a. Security for people, their possessions and activities
- b. Good standard of comfort and convenience.

## 2. Identity – Social status, religion, educational, residential etc

A building must indicate culture, status and mood, whilst creating the humanized space in which to learn, experience and carry out daily functions in comfort.

**A good building must satisfy three conditions:**

- a. **Commodity:** comfortable environment conditions
- b. **Firmness:** stability and safety
- c. **Delight:** Aesthetic and psychological appeal.

**Environment** is defined as:

Surroundings which can be natural, man-made or a combination of these e.g. trees, rock outcrops, shrubs and bushes, waterways and lakes, grasses and wild flowers.

**Built environment** is defined as:

A creation by man with or without the aid of the natural environment e.g. buildings, roads, bridges, pools, paved areas, trees and shrubs etc. A building must be built in such a way that it **complements /blends** with the natural environment. For example:

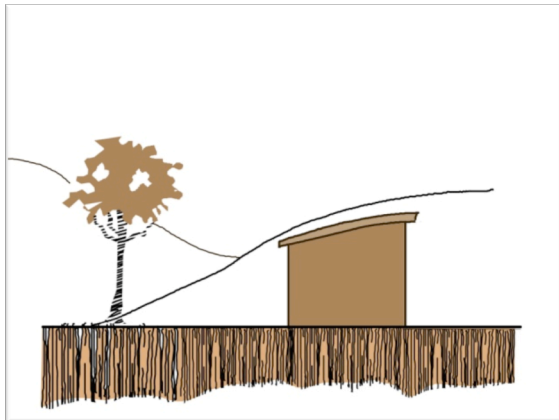

- **Split-level construction** to form economic shape and complement the natural contours of the land.

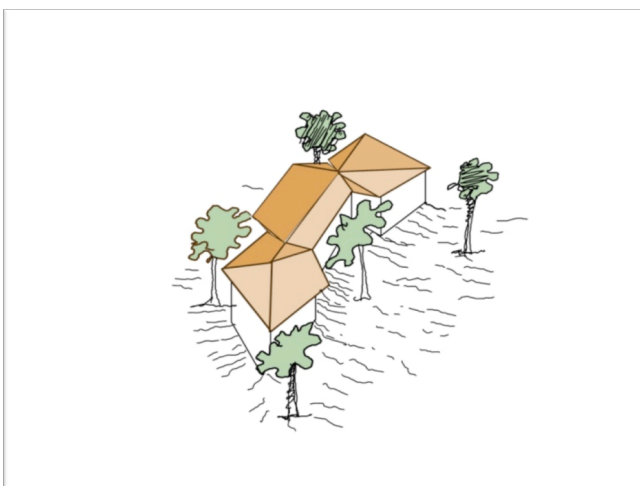

- **Shape can be determined by existing trees** to conserve the natural vegetation and trees.

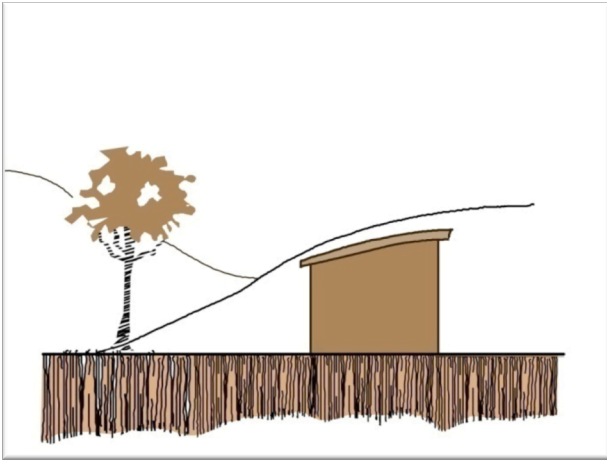

- **Stepped Elevation** or similar treatment to blend with the natural contours of the land.

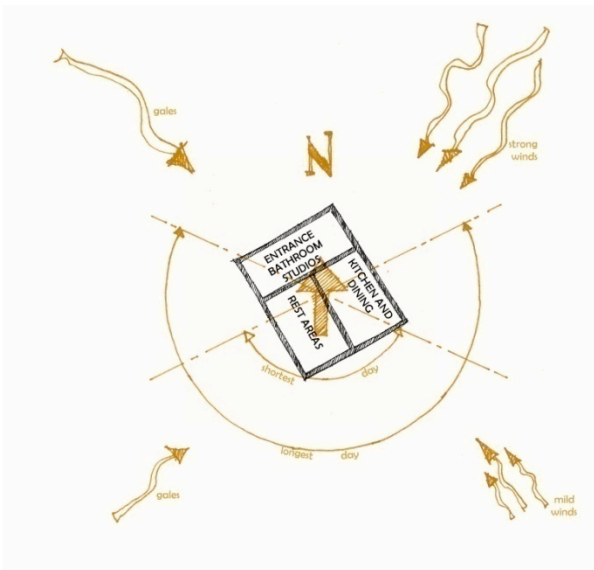

- **Building orientation** made to blend into daylight and view aspects

# THE IMPACT OF THE ENVIRONMENT ON THE SELECTION OF BUILDING TECHNOLOGY

The following environmental factors and statutory requirements have to be considered in the selection of building technology:

- Planning requirements – zoning, heights, developable area etc;
- Building regulations – performance standards to be maintained;
- Land restriction by vendor or lessor (stating what type of house/buildings should be constructed);
- Availability of services – water, electricity, gas etc;
- Local amenities including transport – roads, paving's, street lights, police station etc;
- Sub-soil conditions – good load bearing capacity/poor, swampy/water logged soil/ dry land;
- Levels and topography of land – sloppy, high ground, low ground, valleys, mountains;
- Adjoining building or land – high-rise, low-rise, abandoned, fully built, vacant;
- Use of building – residential, educational, industrial, health, institutional;
- Day light and view aspects – glazing and other materials used;
  
- Other environmental factors such as:
  - Extreme weather conditions
  - Hurricanes/high velocity winds
  - Earthquakes – Haiti & Chile (earthquake proof buildings)
  - Flooding – New Orleans
  - Bush fires
  - Unwanted Intruders; also affects the building technique selected.

## Physical considerations on site include:

1. Natural contours of the land;
2. Natural vegetation and trees;
3. Size of land and/or proposed building;
4. Shape of land and/or proposed building;
5. Approach and access roads and foot paths;
6. Services available;
7. Natural waterways, lakes and ponds;
8. Restrictions such as rights of way, tree preservation and ancient buildings;
9. Climatic conditions created by surrounding properties, land features or activities
10. Proposed future developments.

# IMPACT OF BOTH THE ENVIRONMENT AND FUNCTION ON THE SELECTION OF BUILDING TECHNOLOGY AND PRACTICE

Compare different types of shelter

- Basic and for status
- Residential and Religious/Institutional
- Green Buildings (recycling) and Conventional Buildings

Compare different areas

1. UCT (on the slopes of Table mountain) and Pinelands
2. South Africa and Chile/Haiti (Rock and Sand)

# THE RELATIONSHIP BETWEEN BUILDING SPACE & BUILDING / STRUCTURAL FORMS

**Reference:** Foster, J. S. and Greeno, R. (2006) Mitchell's Structure and Fabric 1; Pearson Education Ltd, Essex.

**Buildings** are concerned with providing in physical form the 'envelopes' to spaces within buildings and it has been a primary activity of man throughout history. Organizationally, the building process is concerned with the rational and economic use of the resources for building activity – men, materials, machines, money and management in order to produce buildings in the quickest and most economic manner.

Typically, **the building process** involves two broad and related activities – design and construction. The design process is concerned with the size, shape and disposition of the spaces within the building and defined by its fabric, and with the nature and form of the building fabric and its services. In the past, a limited number of available materials resulted in a limited number of structural forms and methods of construction. The introduction of new materials, which is now a continuing and expanding process, with properties differing from those of the traditional materials, requires the rapid development of new building techniques and new forms of structure appropriate to the nature of these materials.

The **environmental requirements** of the internal spaces set the performance standards of the building fabric and the attainment of these standards sets the practical problem of designing the structural concept. The task of solving this problem is usually that of selecting the structures, which would meet these performance standards in the most economical ways. The designer must know the limit within which his choices must be made in terms of structural principles.

The **architect**, however, in trying to meet performance standards also seeks architectural significance for his buildings. This he must do through the fabric, for it is this, which defines and gives character and form to the spaces within it. The building form develops from the functional requirements of the building as a shelter, the materials of which it is built, the type of construction used for the fabric and the methods used in its production.

**The choice of materials** for the building fabric and the manner in which they are used depends to a large extent upon their properties relative to the environmental requirements of the building and upon their strength properties. The strength which the fabric of the building must possess in order to function as an 'environmental envelope' is derived from materials of appropriate strength used in accordance with known structural principles. Thus, an appreciation of building construction and the ability to devise new forms of construction is developed from knowledge of materials and an understanding of structural principles and the overall behaviour of structures under load.

## Structural Concepts

The building fabric, having been broadly conceived in terms of an environmental envelope by the architect, must be of such a nature that it can withstand safely all the forces to which the building will be subjected in use. That is, the building must be developed as a **structure**, a product, which for practical purposes does not move in any appreciable manner under its loads. Buildings are known to vary widely in form and appearance however throughout history buildings have all developed from three basic concepts of structure. These are – **skeletal**, **solid** and **surface** structures.

# 1. Skeletal Structures

As the term implies this consists essentially of a skeleton or framework, which supports all the loads of a building and resists all the forces acting on the building and through which all the loads in the building are transferred to the soil on which the building rests.

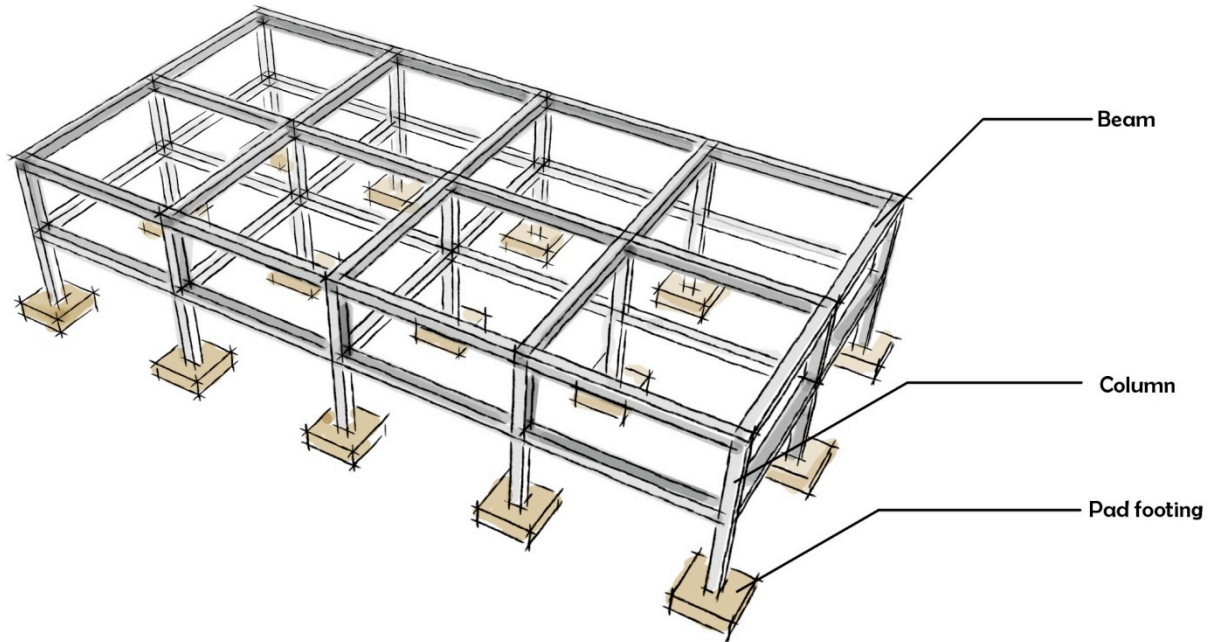

Simple examples are the North American Indian and the mid European Wigwams in which a framework of poles or branches supports a skin stretched across it or tree bark-enclosing membrane.



Wigwam

This elementary form has evolved throughout history into **frameworks**, which consists essentially of pairs of uprights (columns) supporting some form of spanning members (beams).

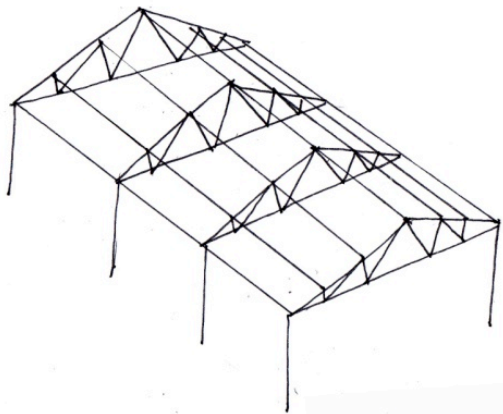

SHED FRAME

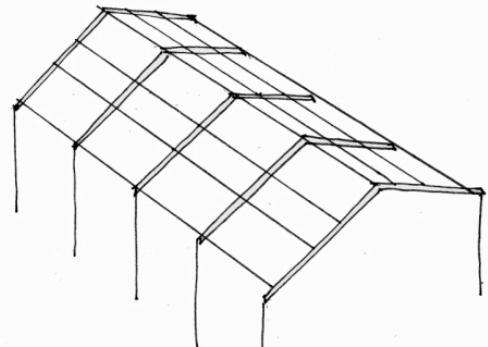

RIGID FRAME

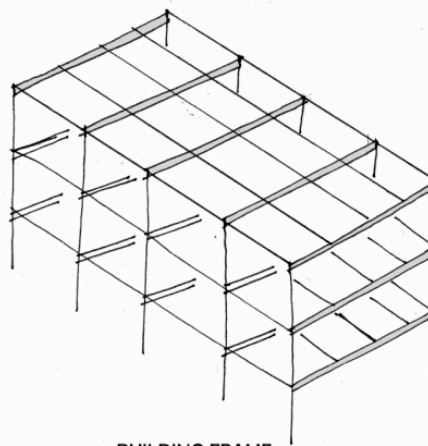

BUILDING FRAME

These are spaced apart and tied together by longitudinal members to form the volume of the building. In these buildings, the vertical supports are in compression.

### **Suspended or suspension structures:**

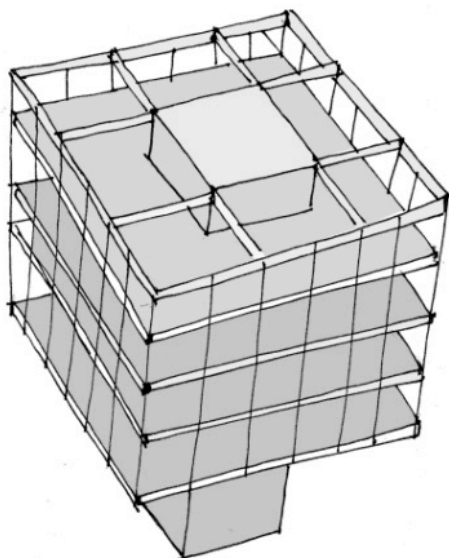

SUSPENSION STRUCTURE

These are skeletal structures in which the floors are suspended from the top of the building by vertical supports in tension.

Other forms of the skeletal structure are the frameworks or lattices of interconnected members known as **grid structures**.

**Space Enclosure:** By its nature the skeleton frame cannot enclose the space within it as an environmental envelope and other enclosing elements must be associated with it. The significance of this clear distinction between the supporting element and the enclosing element is that the latter can be made relatively light and thin and is not fixed in its position relative to the skeleton frame – it may be placed outside or inside the frame or may fit into the panels of the frame as may be seen in examples of contemporary steel or concrete frame structures. Skeletal structures are suitable for high and low-rise buildings and for long and short-span buildings.

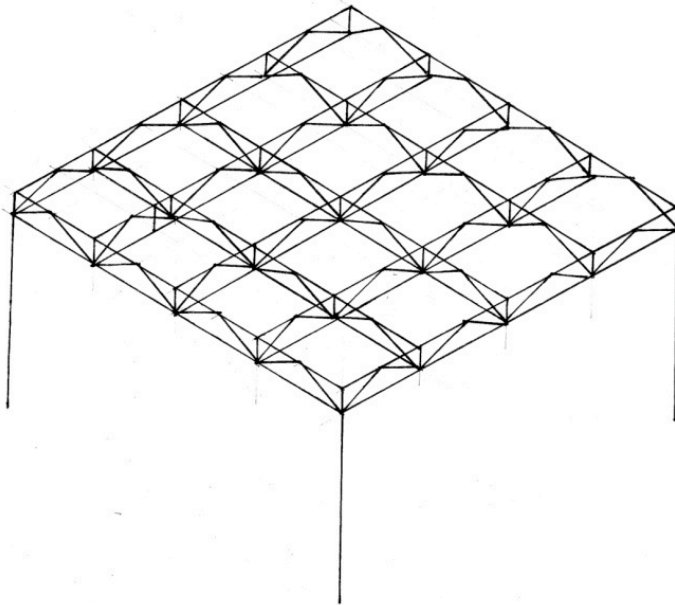

GRID STRUCTURE

## 2. Solid Structure

In this form of structure the wall acts as both the enclosing and supporting element. It falls therefore within the category of load-bearing wall structures, a term implying a structure in which all loads are transferred to the soil through the walls. The characteristic of this particular form is a wall of substantial thickness due to the nature of the walling materials and the manner in which they are used such as in masonry and mass concrete work.

The **Eskimo igloo** is an example of this type of construction. Although for technical and economic reasons circular plan forms have been less used than rectangular forms for buildings constructed in this way.

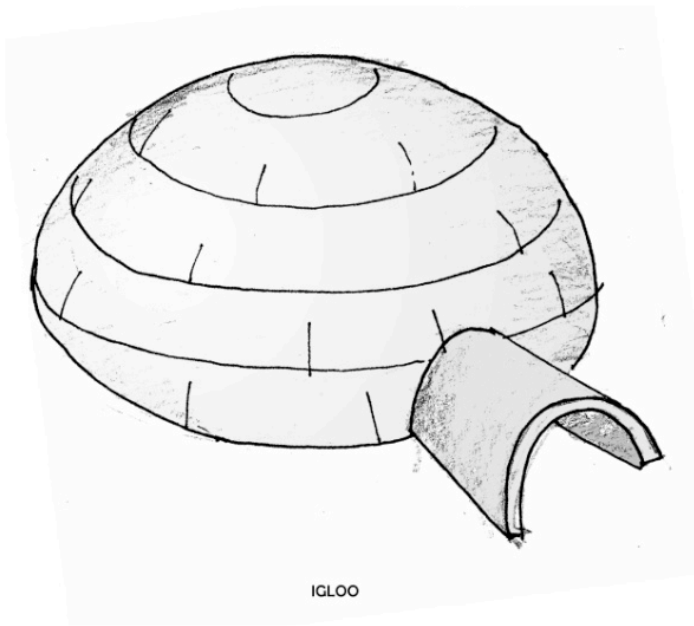

IGLOO

Solid construction in the form of **brick and stone wall buildings** has been used for ages and in certain circumstances, in its various modern forms it is still a valid and economic type of construction for both high and low-rise buildings if these are of limited span permitting types of floor structure which impose an even distribution of loading on the wall.

**Roof structures** are not vaulted over in solid construction, even over limited

spans such as that of the Eskimo igloo, because of the problems of construction and the existence of cheaper, lighter and more quickly erected alternatives.

**Space enclosure** of the solid structure is limited due to the short spans required for stability and transfer of loads to the ground.

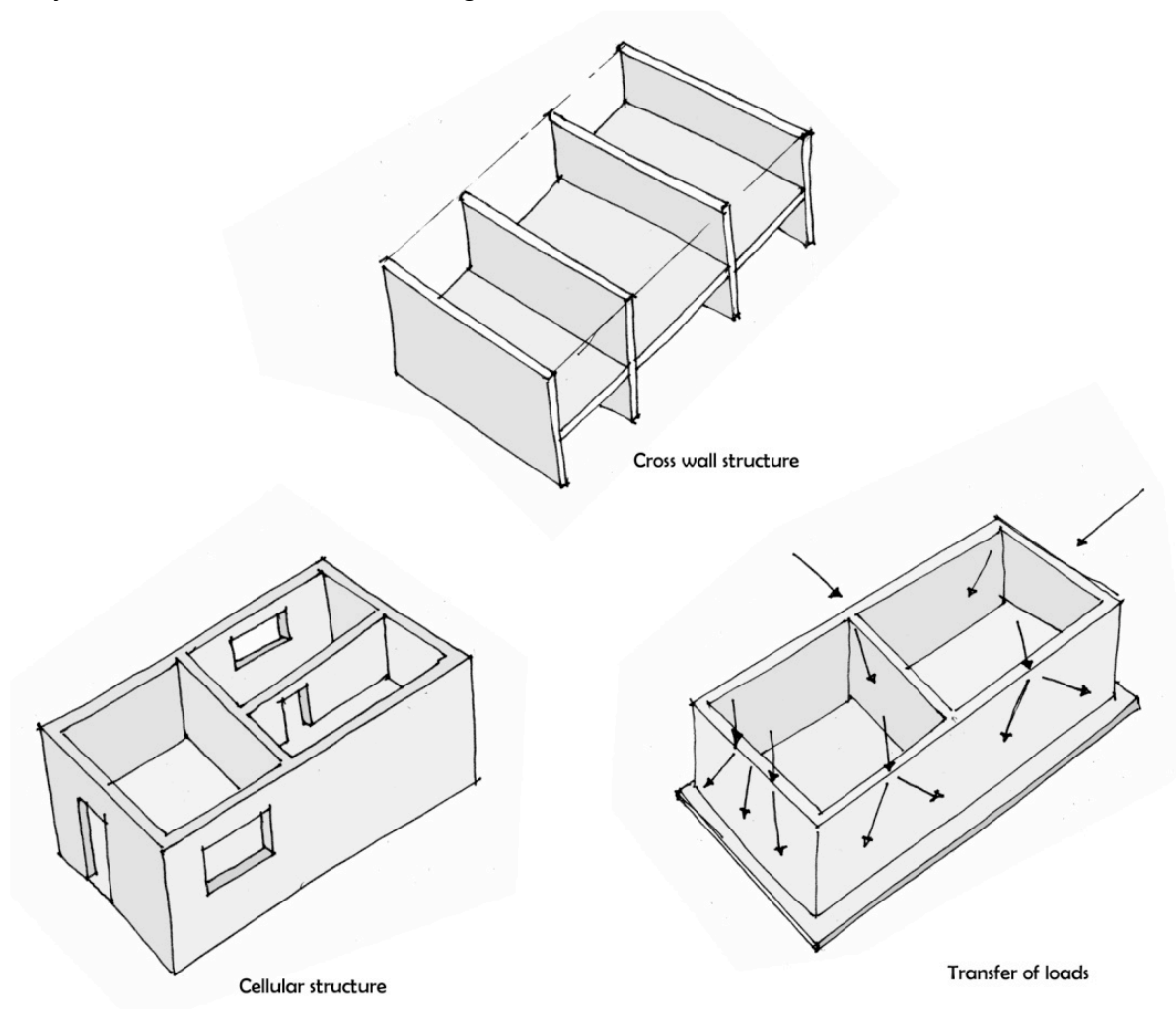

### 3. Surface Structure

Surface structures fall into two broad categories:

- Those in which the elements are made of thin plates of solid material which are given necessary stiffness by being bent or curved, and
- Those in which the elements consist of very thin flexible sheet membranes suspended or stretched in tension over supporting members.

**A Zulu woven branch and mud hut and modern reinforced concrete shell and folded slab structures** are typical of the first. In this form also the wall and the roof may act as both the enclosing and supporting structure. The manner in which particular materials are used results in quite thin wall and roof elements.

Those in the second group are used for roofs and are known as **tension structures**. One form is typified by the traditional **Bedouin tent** of which modern applications has been made such as roofing temporary exhibition buildings. Utilizing suitably developed membranes, this form can now be used for roofing permanent structures.



**Bedouin tent**

Another form in this group using **compressed air as the supporting medium** for similar types of membrane dispenses with compression members over which, in the tent form, the membrane is stretched. In this form, the membrane is fixed and sealed at ground level and is tensioned into shape and supported by air pumped into the interior and maintained under slight pressure. Alternatively, inflated tubes may be incorporated which form supporting ribs to the membrane stretched between them. These are called **air-stabilized** or **pneumatic structures**.



**Air supported structures**

In a third form in this group, the membrane consists of **steel cables suspended from supports** and carrying a thin applied cladding and weatherproof covering. These are forms of **hyperbolic parabolic structures**.

**Space enclosure** – surface roof structures are particularly economic over wide spans because of thin membranes. These structures enclose more space than either the skeletal structure or the solid structure.

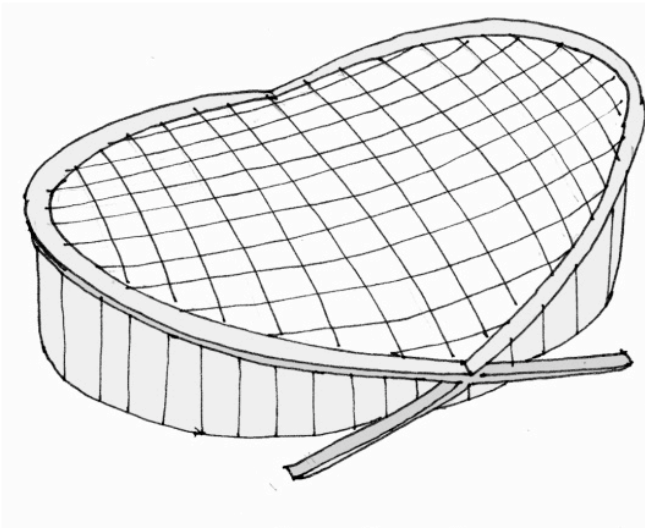

# DEVELOPMENT PLANNING

## Project Life Cycle

Projects can be managed by using a life cycle approach. The construction manager is required in the following phases as prescribed by the South African Council for the Project and Construction Management Professions (SACPCMP – see pgs. 102 - 113), which has been combined into four main phases/stages shown in the Figure and Table below.

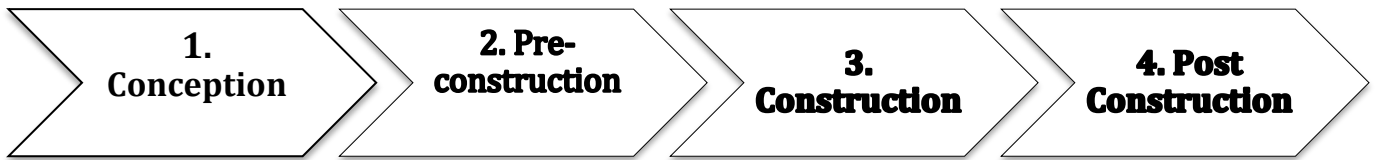
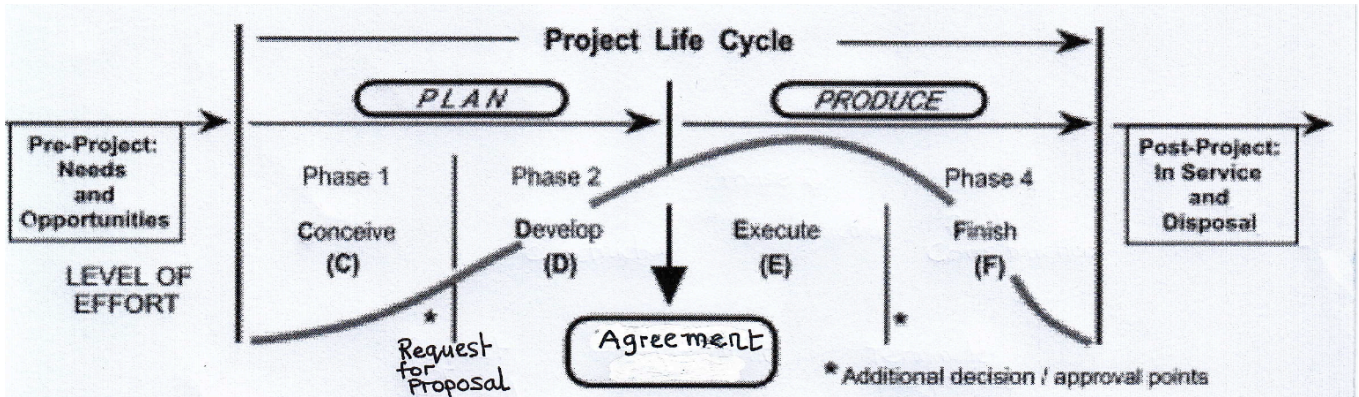

<b>SACPCMP CLASSIFICATION</b>	- Project Initiation & Briefing;  - Concept & Feasibility	- Design Development;  - Tender Documentation & Procurement	- Construction Documentation & Management	- Project Close Out.
<b>Activities / Services Performed</b>	- Identify a need - Scope (Draft); - Terms of Reference. - Budget Estimate	- Develop a proposed solution; - Design Appraisal; - Plan Deliverables - Schedule Plan; - Budget; - Risk Identification; - Quality Plan	- Perform the Project; - Production of Key Deliverables; - Quality Management; - Time Management; - Budgeting & Cost Control; - Risk Management; - Issue Resolution; - Health & Safety; - Reporting;	- Contract Closeout; - Team Feedback; - Recommendations for further action; - Post Implementation Review.

## CONSTRUCTION ACTIVITIES – THE DOCUMENTS

The documents used during the building construction process are as follows:

1. **Architects Drawings** – small scale plans and elevations showing the general arrangement of the building and its layout. Working drawings, which are to larger scales – giving specific details and data – usually used to show the components/elements of the building.

2. **Engineers Drawings** – including civil, mechanical and electrical engineers – small-scale plans and drawings to specific details on larger scales also.
3. **Schedules** – Used for collating and recording of similar standard items or repetitive design information about a range of similar components e.g. reinforcement, doors, windows, ironmongery, sanitary and electrical fittings, referenced to in the drawings. Used also in collating colour and décor schemes.
4. **Specification** – A document that supplements the working drawings. It sets out precisely the specific requirements for materials and workmanship.
5. **Bill of Quantities (BOQ)** – Written document prepared by a quantity surveyor in accordance with the standard method of measurement (SMM). It gives a description and measure of items/components/elements required to carry out a building project based on the drawings, specifications and schedules.
6. **Contract document** – usually a pro forma document but could be specifically prepared. It includes the various documents that together form the legal contract and sets out the precise conditions and terms of contract.

## COMMUNICATING INFORMATION

### 1. Drawings used in the Construction Process

#### i. Block and Site Plans

- a. These are used to locate site, buildings, define site levels, indicate municipal services to buildings, identify parts of site such as roads, footpaths and boundaries and used in giving setting out dimensions for the site and buildings. Suitable scale for the block and site plans is should not usually be less than 1: 2500.

#### ii. Floor Plans, Elevations and Sections

- a. Floor plans are used to identify and set out parts of the building such as rooms, corridors, columns, doors, windows etc. Elevations are used to show the external appearance of all faces of the building and to identify the special building features, the roof design, doors and windows. Suitable scale for the floor plans and elevation should not be less than 1: 100.
- b. Sections are used to provide vertical views through the building to show method of construction and the location of internal components such as staircases and voids. Suitable scale is not less than 1: 50.

#### iii. Component Drawings

- a. These are drawings usually used to identify and provide information for components to be supplied by a manufacturer or to show components not completely covered by the major construction drawings. Suitable scales for component drawings range from 1: 20 to 1: 5.

For ease of interpretation, it is expected that all drawings are fully annotated and dimensioned.

## 2. Drawing Types

Drawings can be prepared in the following format: ~

### i. Sketches

- a. This is a draft or rough outline of an idea. It can be produced free-hand or with the help of drawing instruments

### ii. Orthographic projections

- a. This is a means of drawing independent views of a solid object on a plane surface.

### iii. Isometric projections

- a. This is a pictorial projection of a solid object on a plane surface, drawn so that all vertical lines remain vertical and of true scale length while all horizontal lines are drawn at an angle of  $30^{\circ}$  and are also of true scale length.

### iv. Axonometric projection

- a. This follows the same principles for the isometric projection; the only difference is that the drawing is produced at an angle of  $45^{\circ}$ .

### v. Perspective projection

- a. This is a means of representing a three dimensional view of a solid object on a plane surface.

## 3. Method Statement

This can be said to be a definite expression in writing of the procedure that will be adopted for accomplishing each activity identified in a construction project. It is a document prepared by the contractor and submitted along with other tender documents while tendering for a project. If the contractor wins the contract, it becomes part of the contract documents that serves as a basis for agreement between the client and the contractor.

It precedes the preparation of the construction programme and contains the detail necessary for construction of each element of a building. It is prepared from information available in the contract documents. It provides information on productivity levels required of site staff and operatives, it indicates the resource requirements and also determines the time required to produce each construction element. It complements construction programming by providing detailed construction analysis of each activity.

Traditionally, method statements were presented in tabular form with seven columns as follows:

S/No	Description of work	Qty	Methodology	Labour/Plant Requirement	Duration	Remark

However, nowadays it is customary to see method statements with more columns detailing items such as Health and Safety requirements, Risks identified and Quality requirements depending on the purpose and use of the method statement.

#### **4. Construction Programme**

This is defined by SACPCMP (2009 pg 82) as the programme for the works indicating the logic sequence and duration of all activities to be completed by the contractors, subcontractors and suppliers, in appropriate detail, for the monitoring of the progress of work.

Chappell, Cowlin and Dunn (2009) defined a programme as a schedule or chart showing stages in a scheme of work. The main or master programme is usually produced by the contractor, which may produce many subsidiary programmes during the course of a contract to assist in the effective planning of sub-contract work.

It provides a timetable for coordinating the issue of drawings and information, the placing of orders and delivery of materials and the operations of plant and sub-contractors, showing the sequence of operations and the total output rates required of labour and plant. The precise form in which the programme is set down on paper may depend to some extent on the type of work being undertaken and the people for whom it is intended. The popular forms of construction programmes are: -

- a. The network analysis - Programme Evaluation & Review Technique (PERT) and Critical path Analysis
- b. Gantt Chart or Bar Chart

# **STATUTORY LAWS/REGULATIONS GUIDING THE DESIGN AND CONSTRUCTION OF BUILDINGS**

There are a number of legislative measures that impact directly and indirectly on the operating environment of the construction industry. There are in addition, certain South African Bureau of Standards (SABS) Codes of Practice and Standard Specifications that are regulated as compulsory specifications, compliance with which is therefore a statutory requirement in the design and construction of buildings.

The following is a list of applicable legislation, together with a short summary of each item's intent:

## **1. 2003 Regulations in terms of the Occupational Health and Safety Act, 1993**

The construction industry has a poor track record generally regarding the awareness of workers' health and safety. The regulations require that both the client and the contractor take responsibility for the implementation of safety requirements such as – Personal Protection Equipment (PPE), safety plans, first aid, site supervisors, health and safety representatives etc. The regulations set out responsibilities for the client to ensure that the principal contractor meets all the construction requirements. The client must ensure that the contractor has the necessary competence and resources to execute the work safely.

The regulations require the contractor to submit to the client a suitable and sufficiently documented health and safety plan that is to be applied from the commencement date for the duration of the project.

## **2. Housing Consumers Protection Measure Act (Act 95 of 1998)**

The Act regulates the home building industry to ensure the construction of structurally sound houses. The Act gives statutory body status to the National Home Builders Registration Council (NHBRC).

All home construction including houses constructed using Department of Housing subsidies, falls under the ambit of the Act and must be registered with the NHBRC and comply with the requirements of the NHBRC Home Building Manual. This manual sets out acceptable house construction practices. Prescriptive solutions are specified for each aspect of design and construction, but provision is also made for the acceptance of non-conventional methods and materials, subject to proof of acceptable performance being rendered. The prescriptive design and construction rules are intended to validate the warranty requirements of the NHBRC.

## **3. Housing Act (Act 107 of 1977)**

The Act establishes general principles applicable to housing development in all spheres of government. It requires the Minister of Housing to establish a Housing Code to deal with financial and administrative issues, and norms and standards for house construction. An appendix sets out certain design and construction requirements for houses built with subsidy funding. Whilst these are intended to be compatible with the National Building Regulations, in many instances, they are constructed to lower standards than stipulated (cidb, 2004).

#### 4. Physical Planning Act 1991 (Act No 125 of 1991)

The act sets out to promote orderly physical development and makes provision for the preparation of national and regional development plans and regional and urban structure plans by authorities responsible for physical planning.

#### 5. The National Building Regulations and Building Standards Act (Act No. 103 Of 1977)

This Act is the overarching legislation on building control in South Africa. The Act governs all buildings erected within the area of jurisdiction of a local authority. National Building Regulations are promulgated in terms of the Act and impose certain obligations on the State (including provincial and local authorities), building owners (and prospective owners), architects, engineers and other competent persons, and those involved in the construction and demolition of buildings.

National Building Regulations, mandatory throughout South Africa, replaced the building regulations and byelaws of individual local authorities made their first appearance in 1985. In 1988, the 1985 Regulations were withdrawn and replaced by an entirely new set of National Building Regulations. The 1985 Regulations made extensive use of 'functional' regulations supplemented by so-called 'deemed-to-satisfy requirements', which were set out in Schedules to the Regulations.

The 1988 Regulations took this approach much further. Except for regulations of an administrative nature, the 1988 Regulations are now almost entirely 'functional' and the 'deemed-to satisfy requirements' have been removed from the Regulations. These requirements are now embodied in a separate document, South African Bureau of Standards - SABS 0400 Code of Practice for the application of the National Building Regulations. (The **SABS 0400 Code of Practice** is a non-statutory document, which contains technical information needed for the practical applications of the Regulations).

The National Building Regulations are **functional** in nature in that they do not **prescribe** how a building should be constructed but rather stipulate conditions that the building design or construction of the building must satisfy. The statutory regulations are supported by a set of **deemed-to-satisfy rules** that are **prescriptive**, i.e. the **rules** describe design and construction methods, materials and solutions that if applied, will ensure that the building will satisfy the requirements. The regulations and the associated deemed-to-satisfy rules are contained within SABS 0400 Code of Practice for the Application of the National Building Regulations.

The regulations are intended to be **flexible** in that they permit the application of **conventional** design and construction solutions in accordance with the deemed-to-satisfy rules as well as **innovative**, non-conventional methods and materials provided that these can be proved to perform acceptably. The rules accept an Agrément certificate as being deemed to satisfy.

#### Background to Building Regulations in South Africa

Building regulations and building standards evolved through series of activities and man's action that have taken place through the ages. Standards in buildings are probably as old as man and in the early years, it is possible that standards were passed on to successive

generations orally in the absence of a written language. The evolutions of standards and building regulations can be divided into three distinct historical phases. These are the ancients and early industrial phase, the modern industry phase and organizational phase.

The Building Regulation is a statutory instrument, which sets out the minimum performance standards for the design and construction of buildings. It represents laws that relates specifically to the control of the design and construction of buildings. Building regulations can come in the form of by-laws and it is worth to note that Building Regulations is not static and must respond to change and advancement in building technology.

The aim of Building Regulations is to ensure that buildings perform in such a way as to provide essentially equivalent and socially acceptable levels of health, safety, welfare and amenity for building occupants and for the community in which the building is located. The desirability of uniform building regulations in South Africa, to replace the large number of varying sets of local building regulations and by-laws in force in the cities and towns of South Africa, has long been recognized. The idea was first mooted in 1947 by the South African bureau of Standards (SABS), which proposed the formation of a set of building regulations to be mandatory throughout South Africa.

An important change in policy came about with the promulgation in 1977 of the National Building Regulations and Standards Act (Act 103 Of 1977). This provided legislative authority for the compulsory introduction of National Building Regulations, which when promulgated would override and supersede all existing municipal building regulations and building byelaws.

## **Summary**

The National building Regulations were promulgated by the Minister in terms of Section 17 (1) of the National Building Regulations and Building Standards Act (Act 103 of 1977, as amended). The Act is much more than a piece of enabling legislation – it contains a great deal of administrative machinery of a nature which in the past used to form part of sets of building regulations or building bye laws. Thus, the Act and the Regulations form, so to speak a seamless whole, to be read together as though they formed a single document. Indeed, neither can exist without the other. However, the legislation is now intimately associated with a third element which is SABS 0400, Code of practice for the Application of the National Building Regulations.

The 1988 Regulations therefore comprised of a comparatively short document. The bulk of technical information needed for practical application of the Regulations is now to be found in the Code of Practice SAB 0400. Consequently three distinct divisions would be studied:

- The Act;
- The Regulations; and
- The Code.

## The Act

### **NATIONAL BUILDING REGULATIONS AND BUILDINGS STANDARDS ACT 103 OF 1977**

as amended by Standards Act 30 of 1982

National Building Regulations and Building Standards Amendment Act 36 of 1984

National Building Regulations and Buildings Standards Amendment Act 62 of 1989.

National Building Regulations and Buildings Standards Amendment Act 49 of 1995.

**Aim:** To provide for the promotion of uniformity in the law relating to the erection of buildings in the areas of jurisdiction of local authorities; for the prescribing of building standards; and for matters connected therewith.

The Act consists of 34 Sections including:

◆ **Definitions:**

Define the following terms as defined the ACT – Building, Owner and Structural System.

◆ **Provision for the exemption of part or all of the area of jurisdiction of a local authority from the application of any or all of the National Building Regulations**

These exemptions therefore allow for the erection of buildings (e.g. shacks, incremental housing, spaza shops etc) in informal settlements.

◆ **Duties of draftsmen of plans, architects, engineers and land surveyors**

Which is to put their names, addresses and professional registration numbers on all documents prepared by them.

◆ **Prohibition of the erection of buildings without the prior approval of the local authorities**

It sets out certain procedural requirements and criminal sanctions for contravention of the Section. For example, any person erecting any building in contravention of these provisions shall be guilty of an offence and liable on conviction to a fine not exceeding R100 for each day on which he was engaged in erecting such building.

◆ **Appointment of a Building Control officer by the Local Authority**

The function of a Building Control Officer is to administer various provisions of the Act and Regulations. Who is he? What are his qualifications? (Refer to the National building Regulations – Section A17)

**Note:** It is suggested by (Freeman, 1990) that the City or Town Engineer or the Chief Building Surveyor or other professional officer with similar qualifications and status should normally be designated as Building Control Officer.

◆ **Functions of Building Control Officers**

What are his functions? (See Section 6)

◆ **Approval by local Authorities**

◆ **Provisions enabling a Local Authority to take action when a building is dilapidated or dangerous**

◆ **Section 14 – Certificates of Occupancy (C of O) in respect of buildings**

This provides for the issue of the C of O a document stating that the local authority is of the opinion that a building conforms with the Act and regulations and to approved plans. Occupation of such a building in the absence of such a certificate (with certain exceptions) is prohibited.

◆ **Section 23 – Exemption from liability**

This section indemnifies local authorities against certain forms of loss or damage resulting from the granting by them of approvals, certificates etc under the Act or the Regulations and also prescribes that such a grant does not exempt owners from their legal responsibilities.

# THE NATIONAL BUILDING REGULATIONS

(Published under Government Notice No R1081 dated 10 June 1988 and amended by Government Notice No R1725 dated 26 August 1988)  
The Regulations came into operation on 1 October 1988.

Areas dealt with by the regulations include:

## Part AZ: Coming into operation, Definitions and Standards

Definitions of words such as:

- i. Artificial ventilation system
- ii. Building line
- iii. Competent person
- iv. Drainage Installation
- v. Foundation
- vi. French Drain
- vii. Habitable Room
- viii. Incremental House
- ix. Load
- x. Manhole
- xi. Minor building work
- xii. Natural ventilation
- xiii. Rational design (reasoning)
- xiv. Septic tank
- xv. Sprinkler system
- xvi. Structural wall

## Part A: Administration

### A1 Application

Part of which states that:

“The designing, planning and supervision of the erection of any building or structure or the performance of any function in connection therewith in terms of these regulations is subject to the provisions of any law in terms of which the person undertaking such work or performing such function is required to be registered as an Architect in terms of the Architects’ Act; or to have a specified qualification, certificate, status or other attribute or to have had experience or training of a specified nature or for a specified period”.

### A2 Plans and particulars to be furnished

- ◆ A site plan
- ◆ Layout drawing
- ◆ Drainage installation drawing
- ◆ Other plans required by the local authority may include;
  - i. General structural arrangement
  - ii. General arrangements of artificial ventilation
  - iii. A fire protection plan
  - iv. Occupational health and safety plan

### A3 Preliminary Plans and Enquiries

Provision for obtaining the local authority’s comments on preliminary sketch plans and on proposed materials or systems of construction so as to save time and abortive cost in the preparation of detailed final plans.

## **A4 Local Authority May Require Additional Documents and Information**

Such as: -

- Structural drawings
- Structural concrete documentation
- Structural steelwork documentation
- Structural timber documentation
- Structural masonry wall documentation
- Documentation for foundations

## **A5 Application Forms and Materials, Scales and Sizes of Plans**

Plans, drawings and diagrams shall be drawn to a suitable scale selected from one of the following scales:

- i. Site plans: 1:1000, 1:500, 1:300, 1:200 or 1:100
- ii. Drainage installation drawings: 1:200, 1:100, 1:50
- iii. Fire protection plans: 1:200, 1:100, 1:50 or 1:20

## **A6 Site Plans**

### **A7 Layout Drawing**

The layout drawing shall consist of as many plans, sections and elevations as may be necessary to indicate, where relevant, the position, form, dimensions and materials of the proposed building to be erected.

## **A8 Drainage Installation Drawings and Particulars**

### **A9 Fire Protection Plan**

This states the requirements for fire protection

## **A10 Symbols on Fire Protection Plan**

## **A11 Pointing out of Boundary beacons**

### **A12 Street Levels**

Where any building is to be erected on a site abutting a constructed street, the owner of such building shall subject to the requirements of sub regulation erect such building in accordance with the levels of such street.

Where any portion of any street abutting the site on which any building is to be erected has not been constructed, the owner of such building shall request in writing, from the local authority the levels at which such portion of the street is intended to be constructed (risk!).

### **A13 Building Materials and Tests**

Materials used in the erection of a building shall be of a quality adequate for the purpose for which it is to be used.

**Note:** It can be argued that compliance with deemed-to-satisfy requirements of the Code is sufficient to establish compliance with the requirements of the Regulations; but non-compliance with the requirement of the code does not necessarily mean non-compliance with the Regulations.

## **A14 Construction**

- 1) Where construction of any building or element of a building is carried out in compliance with the requirements of any relevant code of practice, such construction shall be deemed to comply with the requirements of these regulations in respect of construction methods and workmanship.
- 2) All workmanship in the erection of any building shall be in accordance with sound building practice.
- 3) Any building including any structural element or component thereof shall be constructed so as to comply with the requirements of part B of these regulations.
- 4) Where any Code of Practice or document has been used as a basis for the design of any building, any construction procedure described in such code or document shall be observed in the erection of such building.

## **A15 Installations Maintenance and Operation of Mechanical Equipment**

### **A16 Qualifications of a Building Control Officer**

The minimum qualification of any building control officer appointed in terms of Section 5 of the Act shall be of a standard equivalent to a senior certificate plus 3 years tertiary education, in one of the following building disciplines:

- a. Civil engineering;
- b. Structural engineering;
- c. Architecture;
- d. Building management;
- e. Building science;
- f. Building surveying; or
- g. Quantity surveying.

### **A17 Certificate of Appointment of a Building Control Officer**

### **A18 Control of Plumbers and Plumbing Work**

No person shall perform the trade of plumbing as contemplated in Government Notice R.1875 of 31 August 1979 unless he is a trained plumber or works under the adequate control of a trained plumber or approved competent person.

The intent of this regulation is to replace the previously existing system, whereby plumbers were registered or licensed by individual local authorities, by a national system of training and testing under the Manpower Training Act (Act 56 of 1981).

- The previous system used by some local authorities of registering plumbing or drainage contractors falls away.

### **A19 Appointment of Persons Responsible for Design**

Where a 'rational design' of:

- Stability of any excavation
- Structural work

- Artificial ventilation
- Drainage installation
- Storm water disposal system
- Fire protection system etc. is the basis of an application, not only must the design be carried out by a properly qualified person – professional engineer or other approved competent person -, but also construction must be supervised by such a person.

## **A20 Classification and Designation of Occupancies**

Any occupancy in any building shall be classified and designated according to appropriate occupancy class given in column 1 of Table 1 for the type of occupancy contemplated in column 2 of such Table, and such classification shall be shown on the fire plan contemplated (see pg. 63 of Freeman, 1990).

## **A21 Population**

The population of any room or storey or portion thereof shall be taken as the actual population of such a room, storey or portion thereof. Where such population is not known, the population shall be calculated from the criteria given in Table 2 (see pg 67 of Freeman, 1990).

## **A22 Notice of Intention to Commence Erection or Demolition of a Building and notices of Inspection**

Any owner who fails to comply with the requirements of this regulation shall be guilty of an offence.

## **A23 Temporary Buildings**

## **A24 Standardization of Interpretation**

1. Where so requested, in writing, by any local authority, the owner of any building, the council may examine the plans, specifications or other documents which accompanied or which are intended to accompany any application to the local authority in question, perform any tests that it considers necessary and inspect the site on which such building is to be erected, and issue a report in connection therewith.
2. Where the council finds that the proposed building complies with all the relevant requirements of these regulations it shall report accordingly, and any application for approval to erect such building, where accompanied by such report, shall be deemed to satisfy the requirements of the Act: Provided that such report shall clearly identify any plans, specifications or other documents which have been examined by the council.

## **A25 General Enforcement**

This regulation is of the greatest importance, as it provides the legal machinery for enforcing all the National Building Regulations. It covers several different situations:

- A. Changes of use of a building – sub regulations (1) and (2).

- B. Work carried out and completed in contravention of pre-existing building regulations or by-laws – sub regulation (3).
- C. Work carried out in contravention of pre-existing regulations or by-laws and still being carried on after the National Building Regulations came into force – sub-regulation (4), (6) and (7).
- D. Deviating from approved plans – sub-regulations (5), (6) and (7).
- E. Unauthorized work – sub-regulations (6) and (10).
- F. Orders to rectify contraventions of any of the National building Regulations apart from those relating to unauthorized work – sub – regulation (9)

Any person who fails to comply with any notice contemplated in this regulation shall be guilty of an offence.

## **PART B: STRUCTURAL DESIGN**

### **B1 Design Requirement**

States that buildings and any structural element shall be designed in accordance with Part B of section 3 of SABS 0400, to provide strength, stability, serviceability and durability in accordance with accepted principle of structural design, so that it will not impair the integrity of any other building or property.

## **PART C: DIMENSIONS**

### **C1 Room and Buildings**

States that any room or space should have dimensions that comply with Part C of section 3 of SABS 0400.

## **PART D: PUBLIC SAFETY**

This part contains the following sections:

### **D1 Change in Levels**

### **D2 Pedestrian Entrances to Parking Areas in Buildings**

### **D3 Ramps**

### **D4 Swimming Pools and Swimming Baths**

### **D5 Deemed-to-Satisfy Requirements**

The requirements of regulations D1, D3 and D4 shall be deemed to be satisfied where change in levels, the design of ramps and driveways, or access to swimming pools as the case may be complies with Part D of section 3 of SAB 0400.

## **PART E: DEMOLITION WORK**

This part contains the following sections:

### **E1 Demolition of any Building**

### **E2 Safeguarding of Basements**

### **E3 Prohibition of any Methods**

### **E4 General Penalty**

## **PART F: SITE OPERATIONS**

These include:

### **F1 Protection of the Public**

### **F2 Damage to Local Authority's Property**

### **F3 Unstable Soil Conditions**

### **F4 Preparation of Site**

Before any foundation is laid, the area to be covered by any building shall be properly cleared of vegetable matter, tree stumps, timber and other cellulose material, debris or refuse and any other material contaminated with faecal matter.

### **F5 Soil Poisoning**

This regulation is aimed at the control and destruction of termites, which in certain parts of South Africa can cause structural damage to buildings.

### **F6 Control of Dust and Noise**

- i. The owner of any land on which excavation work is in progress or on which any building is being erected or demolished shall take precautions in the working area and on surrounding roads and footways to limit to a reasonable level the amount of dust arising from the work or surroundings thereof.
- ii. During specified periods such as Sunday, Good Friday, before 06h00 or after 17h00 on any Saturday etc. carry on any activity or use or permit to be used in the course of any building, demolition or excavation work, any machine, machinery, engine, apparatus, tool or contrivance, however powered, which in the opinion of the local authority may unreasonably disturb or interfere with the amenity of the neighbourhood.

### **F7 Cutting into, Laying open and Demolishing Certain Work**

### **F8 Waste Material on Site**

### **F9 Cleaning of Sites**

### **F10 Builder's Shed**

### **F11 Sanitary Facilities**

## **PART G: EXCAVATIONS**

### **G1 General Stability Requirements**

Where any excavation is to be carried out on any site and it may impair the stability of any property or service, such measures shall be taken by the owner of such site as may be sufficient to ensure that such stability is maintained.

The requirements of this regulation G1 shall be deemed satisfied if the excavation complies with Part G of section 3 of SABS 0400.

## **PART H: FOUNDATIONS**

1. The foundations of any building shall be designed to safely transmit all the loads from such building to the ground.

2. The requirements of sub regulation (1) shall be deemed to be satisfied where the design and construction of such foundation complies with Part H of section 3 of SABS 0400.

## **PART J: FLOORS**

### **J1 General Requirements**

Any floor of any building shall be:

- a. Strong enough to support its own weight and any loads imposed upon such floor; and
- b. Have a fire resistance appropriate for its use and where required be non-combustible.

The requirements for floors shall be deemed to be satisfied where the design and construction of any floor, and any under-floor membrane, comply with Part J of section 3 of SABS 0400.

## **PART K: WALLS**

These include:

### **K1 Structural Strength and Stability**

### **K2 Water Penetration**

### **K3 Roof Fixing**

### **K4 Behaviour in Fire**

### **K5 Deemed-to-Satisfy Requirements**

The requirements of regulations K1, K2, K3 and K4 shall be deemed to be satisfied where the structural strength and stability of any wall, the prevention of water penetration into or through such wall, the fixing of any roof to such wall and the behaviour in a fire of such wall, as the case may be, comply with Part K of section 3 of SABS 0400.

## **PART L: ROOFS**

These include:

### **L1 General requirements**

The roof of any building shall be so constructed that it would:

- a. Resist any forces to which it is likely to be subjected;
- b. Be durable and waterproof;
- c. Not allow the accumulation of any rain water upon its surface; and
- d. As part of a roof and ceiling assembly provide adequate height in any room immediately below such assembly.

### **L2 Fire Resistance and Combustibility**

Where necessary such roof or roof and ceiling assembly shall be non-combustible.

### **L3 Deemed-to-Satisfy Requirements**

The requirements of regulations L1 and L2 shall be deemed to be satisfied where any roof or roof and ceiling assembly as the case may be, complies with Part L of section 3 of SABS 0400.

## **PART M: STAIRWAYS**

### **M1 General requirements**

1. Any stairway, including any wall, screen, railing or balustrade to such stairway, shall be capable of safely sustaining any loads to which it is likely to be subjected and shall permit safe movement of persons from floor to floor.
2. Any such stairway shall have dimensions appropriate to its use.

### **M2 Fire Requirements**

### **M3 Deemed-to-Satisfy Requirements**

The requirements of regulations M1 and M2 shall be deemed to be satisfied where the design of any stairway complies with Part M of section 3 of SABS 0400.

## **PART N: GLAZING**

### **N1 Type and Fixing of Glazing**

1. Any material used in the glazing of any building shall be of a secure and durable type and shall be fixed in a manner and position that will ensure that it will –
  - a. Safely sustain any wind loads to which it is likely to be subjected;
  - b. Not allow penetration of water to the interior of the building; and
  - c. Be apparent in the case of clear glazing to any person approaching such glazing.
2. Glass, plastics and organic coated glass shall be selected in order to provide, in the case of human impact an appropriate degree of safety.
3. The requirements of sub-regulations 1 and 2 shall be deemed to be satisfied where the glazing material is selected, fixed and marked in accordance with Part N of section 3 of SABS 0400.

## **PART O: LIGHTING AND VENTILATION**

### **O1 Lighting and Ventilation Requirement**

### **O2 Special Provision of Natural lighting**

### **O3 Approval Of Artificial Ventilation Systems**

No person without the prior written approval of the local authority install any artificial ventilation system in any building: provided that this prohibition shall not apply in the case of room air conditions or other individual appliances installed for comfort.

### **O4 Design of Artificial ventilation systems**

Any rational design of an artificial ventilation system shall be carried out by or under the supervision of a professional engineer or other approved competent person and such engineer or person shall certify that the system has been designed to comply with Regulation O1.

## **O5 Artificial Ventilation plant**

## **O6 Testing of Artificial Ventilation Systems**

## **O7 Fire Requirements**

In addition to the requirements of this Part, lighting and ventilation shall be provided to comply with Part T of these regulations.

## **PART P: DRAINAGE**

### **P1 Compulsory Drainage of Buildings**

### **P2 Design of Drainage Installation**

### **P3 Control of Objectionable Discharge**

### **P4 Industrial Effluent**

### **P5 Disconnections**

### **P6 Unauthorized Drainage Work**

### **P7 Inspection and testing of Drainage Installation**

Any drain, discharge pipe or ventilating pipe shall be so installed as to be capable of withstanding the test pressures contemplated in rule PP26 or PP27 as the case may be, contained in section 3 of SABS 0400 and such tests shall be carried out in the presence of the building control officer of, or other officer duly authorized by, the local authority.

## **PART Q: NON-WATER BORNE MEANS OF SANITARY DISPOSAL**

### **Q1 Means of Disposal**

Where water-borne sewage disposal is not available, other means of sewage disposal shall be permitted by the local authority: Provided that in the case of chemical or pail closets a satisfactory means is available for the removal and disposal of sewage from such closets.

### **Q2 Permission**

No person shall construct any pit latrine without the permission of the local authority.

### **Q3 Construction, Siting and Access**

## **PART R: STORMWATER DISPOSAL**

### **R1 Storm water Disposal Requirements**

The owner of any site shall provide an approved means for the control and disposal of accumulated storm water, which may run off from any earthworks, building or paving. The means of storm water disposal is the subject of rational design prepared by or under the supervision of a professional engineer or other approved competent person; or such means of storm water disposal is in accordance with Part R of section 3 of SABS 0400.

### **R2 Saving**

## **PART S: FACILITIES FOR DISABLED PERSONS**

### **S1 Application**

### **S2 Facilities to be provided**

### **S3 Deemed-to-Satisfy Requirements**

Regulation S1 defines the categories of buildings in which special provision must be made for disabled persons, whilst Regulation S2 sets out in broad functional terms the facilities to be provided; Regulation S3 offers a choice between compliance with deemed-to-satisfy requirements or the provision of an approved alternative design.

The expression 'disabled person' is not defined; the context of the Regulations indicates however, that the intention is to cater for the needs of persons using wheelchairs or who are able to walk but cannot negotiate steps, as well as persons with impaired vision.

## **PART T: FIRE PROTECTION**

### **T1 General Requirements**

1. Any building shall be designed, constructed and equipped that in the case of fire-
  - a. The protection of occupants or users therein is ensured and that provision is made for the safe evacuation of such occupants or users;
  - b. The outbreak, spread and intensity of such fire within such building and the spread of fire to any other building will be minimized;
  - c. Sufficient stability will be retained to ensure that such building will not endanger any other building: Provided in the case of any multi-storey building no major failure of the structural system shall occur;
  - d. The generation and spread of smoke will be minimized or controlled to the greatest extent reasonably practicable; and
  - e. Adequate equipment and means of access and detecting, fighting, controlling and extinguishing such fire is provided.
2. The requirements of sub regulation 1 shall be deemed to be satisfied where the design, construction and equipment of any building-
  - a. is the subject of rational design proposals prepared by a professional engineer or other approved competent person; or
  - b. Complies with Part T of section 3 of SABS 0400:

### **T2 Offences**

1. Any owner of any building who fails to provide sufficient fire extinguishers to satisfy the requirements of sub regulation T1e, or who installs fire extinguishers that do not comply with the relevant SABS specification, or who fails to ensure that such fire extinguishers are installed, maintained and serviced in accordance with SABS 0105, shall be guilty of an offence.
2. Any person who causes or permits any escape route to be rendered less effective or to be obstructed in any way, which may hinder or prevent the escape of any person from a building in the case of fire or any other emergency, shall be guilty of an offence.

## **PART U: REFUSE DISPOSAL**

- U1 Provisions of Areas**
- U2 Access to Areas**
- U3 Refuse Chutes**

## **PART V: SPACE HEATING**

1. Any system of space heating shall be so designed, constructed and installed as to operate safely and any flue, flue pipe or chimney used in such system shall be so designed as to safely remove any smoke or noxious gasses produced by such system.
2. The requirements of sub regulation (1) shall be deemed to be satisfied where the design and construction of any flue pipe, chimney, hearth or fireplace complies with Part V of section 3 of SABS 0400.

# **SOUTH AFRICAN BUREAU OF STANDARDS CODE OF PRACTICE SABS 0400-1987 FOR THE APPLICATION OF THE NATIONAL BUILDING REGULATIONS**

- 1. Scope**
- 2. Definitions**
- 3. Compliance With Regulations**

This section of the Code contains rules that in each case represent a way of satisfying the relevant national building regulation where such regulation is a functional regulation, i.e. compliance with the rule will be deemed to satisfy the regulation.

The section has therefore been divided into the same parts as the National Building Regulations and for ease of reference all the regulations in each part have been reproduced whether or not they have a 'deemed-to-satisfy' rule associated with them.

# THE SITE

(Ref: Chudley R., & Greeno R. (2006) Building Construction Handbook, 6<sup>th</sup> Edition Butterworth-Heinemann, Oxford)

## PRELIMINARY ITEMS/BILL No 1

There are many items in the preliminary stage of building construction which impacts on the final building and tender cost. The items that constitute this Bill have to be determined during the tender stage and are usually incorporated in the site works.

These items include:

### 1. Site Analysis/Site Survey

- Site Investigation
- Soil Investigation

### 2. Site Layout Considerations

- Site security – hoardings, lighting
- Site office accommodation
- Safety and Health Considerations
- Site storage
  - Materials storage
  - Materials testing

### 3. The Building Team (Ref: Osbourn D., and Greeno, R. (2007) **Mitchell's Introduction to Building**, Pearsons Education Limited, Essex)

### 4. Setting out of a building

- Setting out trenches
- Setting out a framed building
- Setting out reduced levels, leveling, angles  
(These would be better understood when you start APG 2026F – Elementary surveying next session. You need however to know the basics and what to look out for – so, use these pages as a guide)

### 5. Site Operations

- Site Clearance/Excavation
- Methods of Excavation – Use of Mechanical plant vs Manual labour
  - Tools used in manual excavation
  - Principal machines used for clearing and excavation (pgs 147 – 155)
- Temporary/Earthwork support to excavations up to 2.5m deep
- Leveling of Trenches

# SITE INVESTIGATION

(Reference: Building Construction Handbook by Chudley R., & Greeno R. pgs. 63 -65)

## Refer to Part F – Site Operations and Part G – Excavation of the National Building Regulation

The basic objective of **this form** of site investigation is to collect systematically and record all the necessary data, which will help in the design and construction processes of the designed work. Anything on adjacent sites, which may affect the proposed works or conversely anything appertaining to the proposed works, which may affect an adjacent site, should also be recorded.

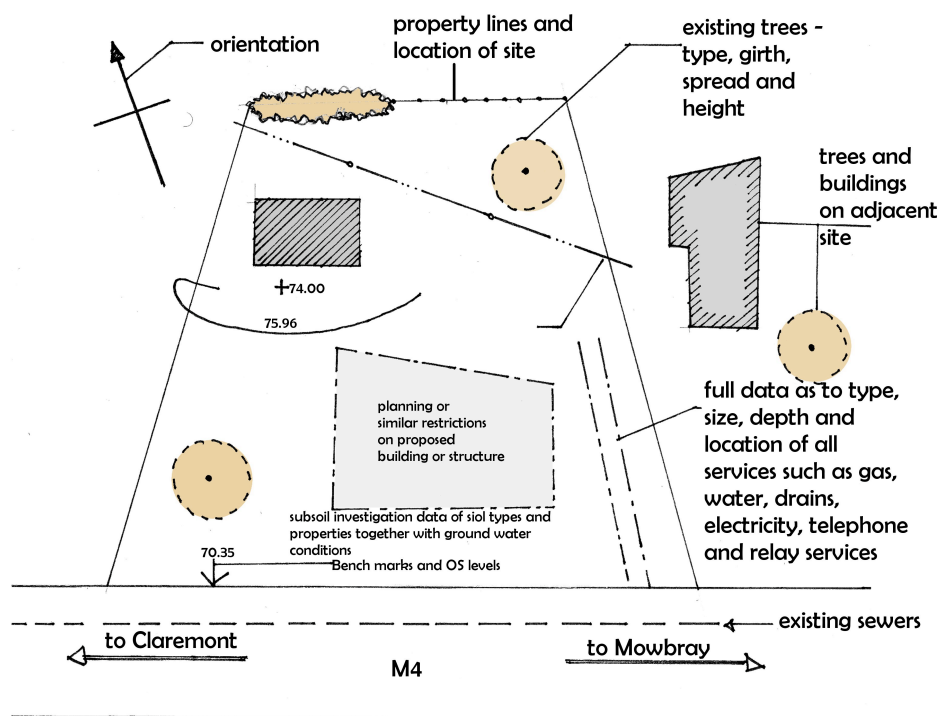

Typical data required include:

- Site Orientation
- Access roads
- Distance to building materials/plant suppliers market
- Boundary hedges and or fencing
- Property boundary lines and location of site
- Existing buildings/structures
- Existing trees – type, girth, spread and height
- Trees and buildings on adjacent site
- Details of above ground obstructions such as transmission lines
- Contours and site levels – sloppy, undulating or flat
- Bench Marks and Oversight Levels
- Planning or similar restrictions on proposed building or structure
- Full data as to type, size, depth and location of all services such as gas, water, drains, sewers, electricity, telephone and relay services
- **Subsoil investigation** to obtain data of soil types and properties together with ground water conditions. These data is usually collected by means of **Trial Pits** and **Hand Auger Holes**.

## TRIAL PITS AND HAND AUGER HOLES

Its primary aim is to:

1. Obtain subsoil samples for identification, classification and ascertaining the subsoil's characteristics and properties and may also be used to
2. Establish the presence of any geological faults and the upper or lower limits of the water table.

### TRIAL PITS:

Minimum plan size = 1.2x1.2m

Maximum economic depth = 4.0m

Formed by hand or mechanical means of excavation

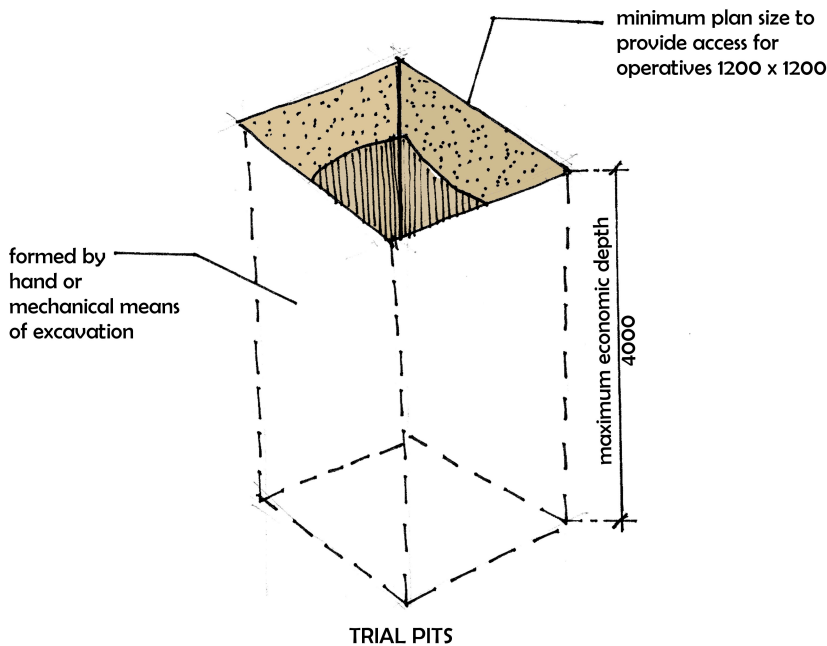

### General Use:

- Dry ground which requires little or no temporary support to sides of excavation

### Subsidiary Use:

- To expose and/or locate underground services.

### Advantages:

Subsoil can be visually examined insitu – both disturbed and undisturbed samples can be obtained.

**Disturbed soil samples:** The natural structure of the subsoil is disturbed.

**Undisturbed soil samples:** These are soil samples obtained using

coring tools, which preserve the natural structure and properties of the subsoil.

### HAND AUGER HOLES

Diameter range = 50 to 150mm

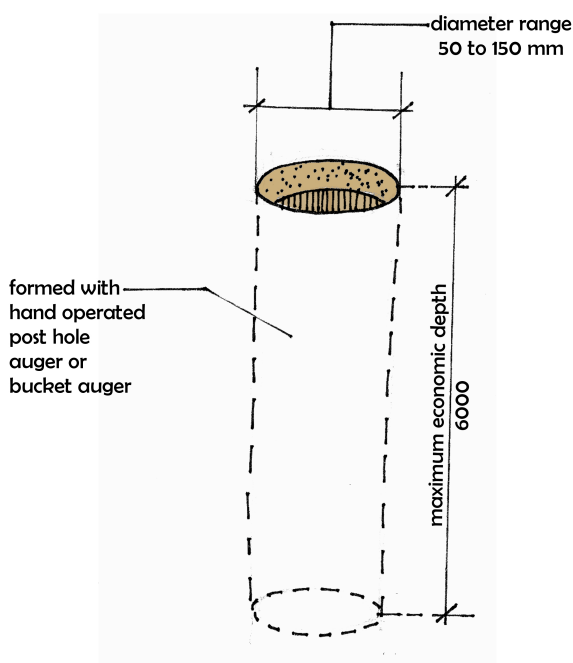

Maximum economic depth = 6.0m

Formed with hand operated post-hole auger or bucket auger.

### General Use:

- Dry ground but liner tubes could be used if required to extract subsoil samples at a depth beyond the economic limit of trial holes.

### Advantages:

Generally a cheaper and simpler method of obtaining subsoil samples than the trial pit method.

# SOIL INVESTIGATION

Reference: Building Construction Handbook by Chudley R., & Greeno R. (2006) pgs. 66 -79

## REFER TO PART F: SITE OPERATIONS OF THE BUILDING REGULATIONS

### CLAUSE F3 Unstable Soil Conditions, which states that:

1. Where any local authority has reason to believe that there may be **unstable subsoil** or **unstable slopes** in the area in which a site upon which a building is to be erected, is situated, it shall so inform the applicant.
2. Whether or not such local authority has informed such applicant in terms of sub-regulation 1, the applicant shall, if any unstable soil or unstable slope is evident within the boundaries of such site, submit to the local authority particulars specifying the **measures** he considers necessary to make provision for any differential movements or other effects which could be detrimental to such building and the local authority may require such particulars to be prepared by a professional engineer or other approved competent person.

While **site investigation** is an all-embracing term covering every aspect of the site under investigation, **soil investigation** is specifically related to the subsoil beneath the site under investigation and could be part of or separate from the site investigation.

### Purpose of Soil Investigation:

1. Determine the suitability of the site for the proposed project.
2. Determine an adequate and economic foundation design.
3. Determine the difficulties, which may arise during the construction process and period.
4. Determine the occurrence and/or cause of all changes in subsoil conditions.

### Depth of Soil Investigation:

This is usually based on the following factors:

1. Proposed foundation type.
2. Pressure bulb of proposed foundation.
3. Relationship of proposed foundation to other foundations.

### Typical Examples~

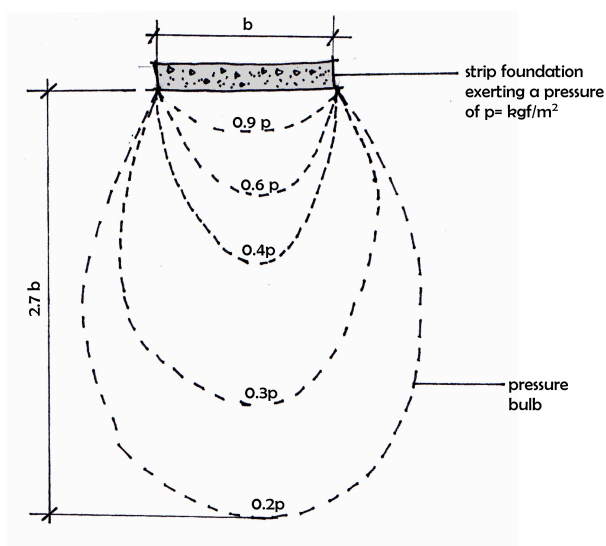

### 1. Strip Foundation

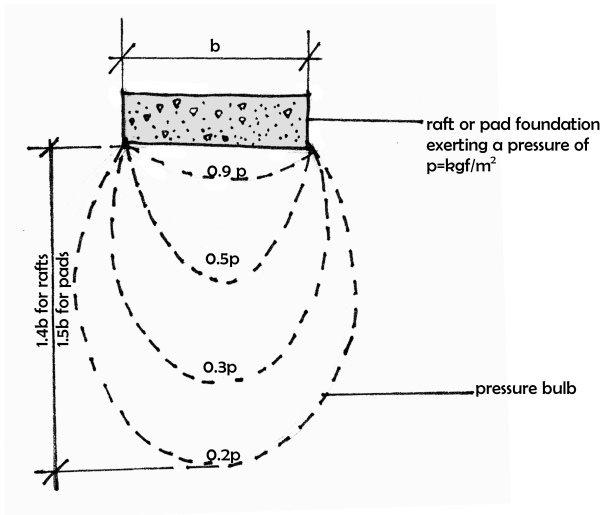

## 2. Raft/Pad Foundation

### 3. Pad Foundations close to one another

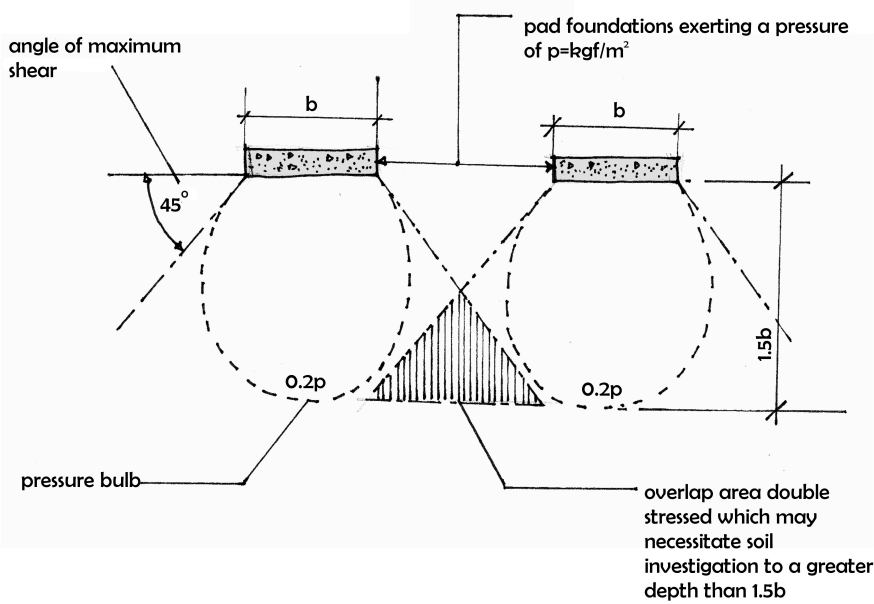

The shear strength can be defined as the resistance offered by a soil to the sliding of one particle over another.

### 4. Different Foundation Types on the same site ~ Pad & Raft Foundation.

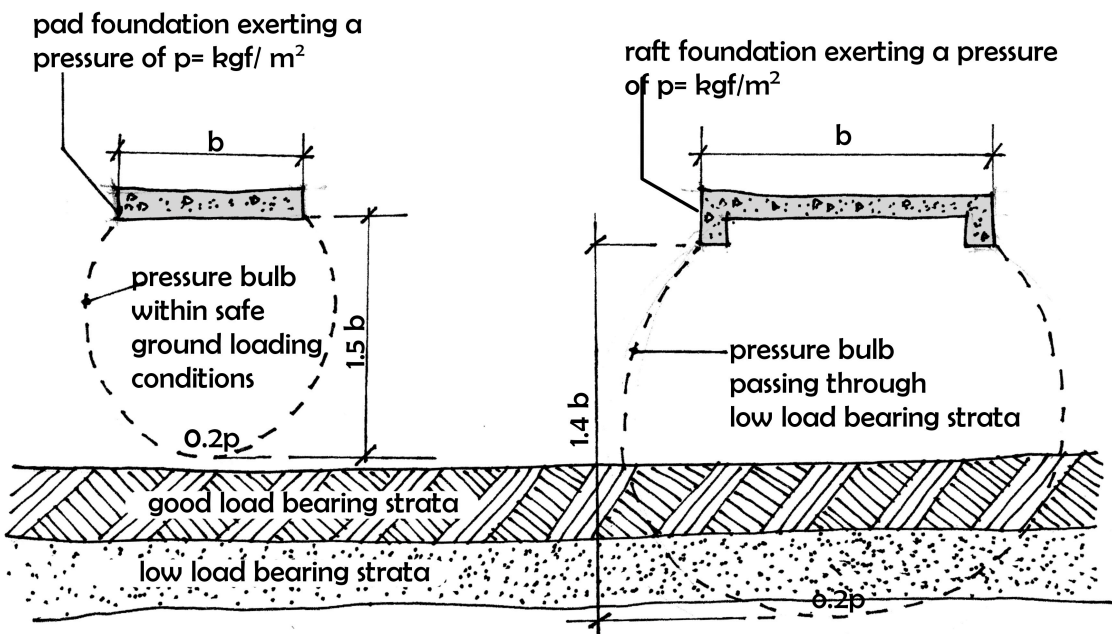

## Soil Investigation Methods ~

The method chosen will depend on several factors:

1. Size of contract.
2. Type of proposed foundation.
3. Type of sample required.
4. Type of subsoil's which may be encountered.

As a general guide, the most suitable methods in terms of investigation depth are:

1. Foundations up to 3.00m deep – trial pits.
2. Foundations up to 30.00m deep – borings.
3. Foundations over 30.00m deep – deep borings and insitu examinations from tunnels and/or deep pits.

## Typical Results showing compression strengths of clays: - (pg. 77)

Very soft clay	– less than 25 kN/m <sup>2</sup>
Soft clay	- 25 to 50 kN/m <sup>2</sup>
Medium clay	- 50 to 100 kN/m <sup>2</sup>
Stiff clay	- 100 to 200 kN/m <sup>2</sup>
Very stiff clay	- 200 to 400 kN/m <sup>2</sup>
Hard clay	- more than 400 kN/m <sup>2</sup>

**NB.** The shear strength of clay soils is only half of the compression strength values given above.

# SITE LAYOUT CONSIDERATIONS

Reference: Building Construction Handbook by Chudley R. & Greeno R. (2006) pgs. 80-104

## General Considerations ~

General appreciation of the site should be obtained by conducting a thorough site investigation at the pre-tender stage and examining in detail the drawings, specifications and Bill of Quantities to formulate proposals of how the contract would be carried out if the tender is successful. This will involve a preliminary assessment of plant, materials and manpower requirements plotted against the proposed time scale in the form of a bar chart.

Other Considerations regarding site layout include:

1. Access considerations
2. Storage considerations
3. Accommodation considerations
4. Temporary services considerations
5. Plant considerations
6. Fencing and Hoarding considerations
7. Safety and Health considerations

## Typical Site Layout Example ~

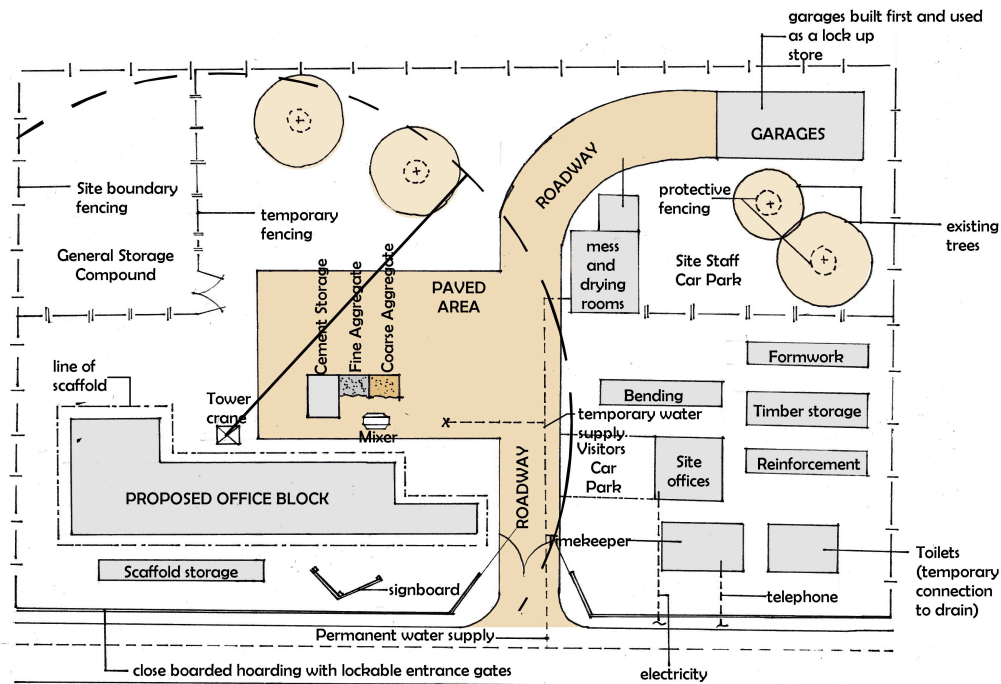

## Access Considerations ~

Considered for both on and off site access. Routes to and from the site must be checked for the suitability of transporting all the requirements for the proposed works. Access on site for deliveries and general circulation must also be carefully considered.

## Typical Site Access Considerations

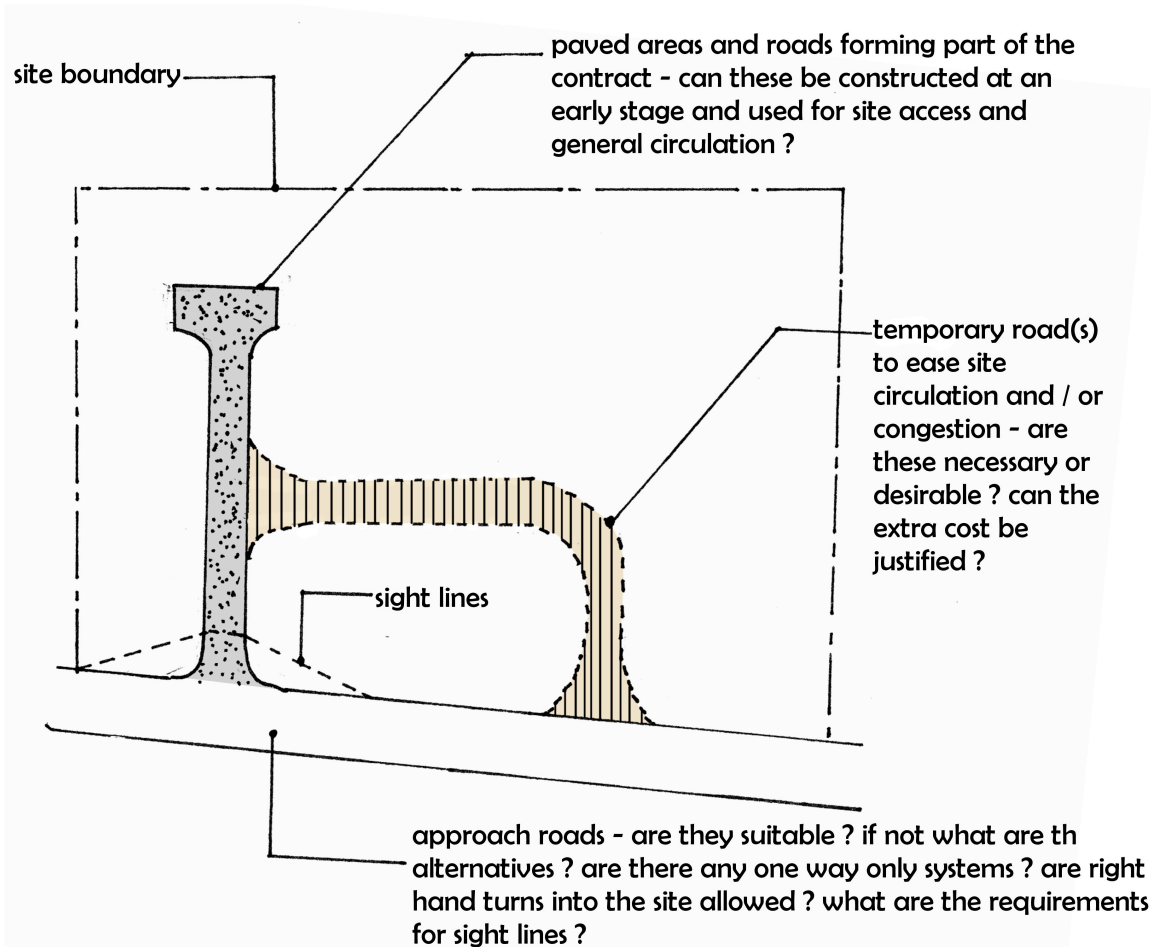

### Storage Considerations ~

- Amount and types of materials to be stored;
- Security and weather protection requirements;
- Allocation of adequate areas for storing materials and working space around materials;
- Location of storage areas to reduce double handling, without impeding general site circulation and work in progress.

### Accommodation Considerations ~

- Number and type of site staff anticipated;
- Size and units of accommodation;
- Location of offices to give easy access for visitors and at the same time a clear view of the site;
- Location of mess room and toilet to reduce walking time to a minimum;

### Temporary services considerations ~

- What, when and where are they required?
- Possibility of having permanent services installed at an early stage should be explored;
- Coordination with the various service undertakings is essential.

### **Plant Considerations ~**

- What plant, when and where is it required?
- Static or mobile plant?
- If mobile, check circulation routes and if static select the most appropriate position;

### **Fencing and Hoarding Considerations ~**

- What is mandatory and what is desirable?
- Local vandalism records;
- Type or types of fence and hoarding required?
- Explore the possibility of using fencing, which is part of the contract by erecting this at an early stage.

### **Safety and Health Considerations ~**

Check for compliance of all the above conclusions from the considerations with the minimum requirements set out in the **Occupational Health and Safety Act, 1993**.

## SITE SECURITY

### REFER TO PART F: SITE OPERATIONS OF THE BUILDING REGULATIONS

#### CLAUSE F1 Protection of the Public States that:

1. In cases where danger or serious inconvenience to the public may ensue from the demolition or erection of a building on any site, the local authority may require that the owner of such site, before any work is commenced, shall **erect a fence, hoarding or barricade** to prevent the public from entering such site and to protect them from the activities on such site.
4. Any person undertaking any work of erection or demolition on any site shall **confine all operations** in connection with such work within the boundaries of such site and shall not encroach upon or over any street or public place abutting such site, except with the prior written approval of the local authority and subject to the conditions contained in such approval, with regard to the safety and convenience of persons using such street or public place.

The **primary objectives** of site security are –

1. Security against theft.
2. Security from vandals and
3. Protection of innocent trespassers.

The need for and type of security will vary from site to site according to the neighbourhood, local vandalism record and the value of goods stored on site. Perimeter fencing, internal site protection and night security may all be necessary.

## Typical Site Security Provisions ~

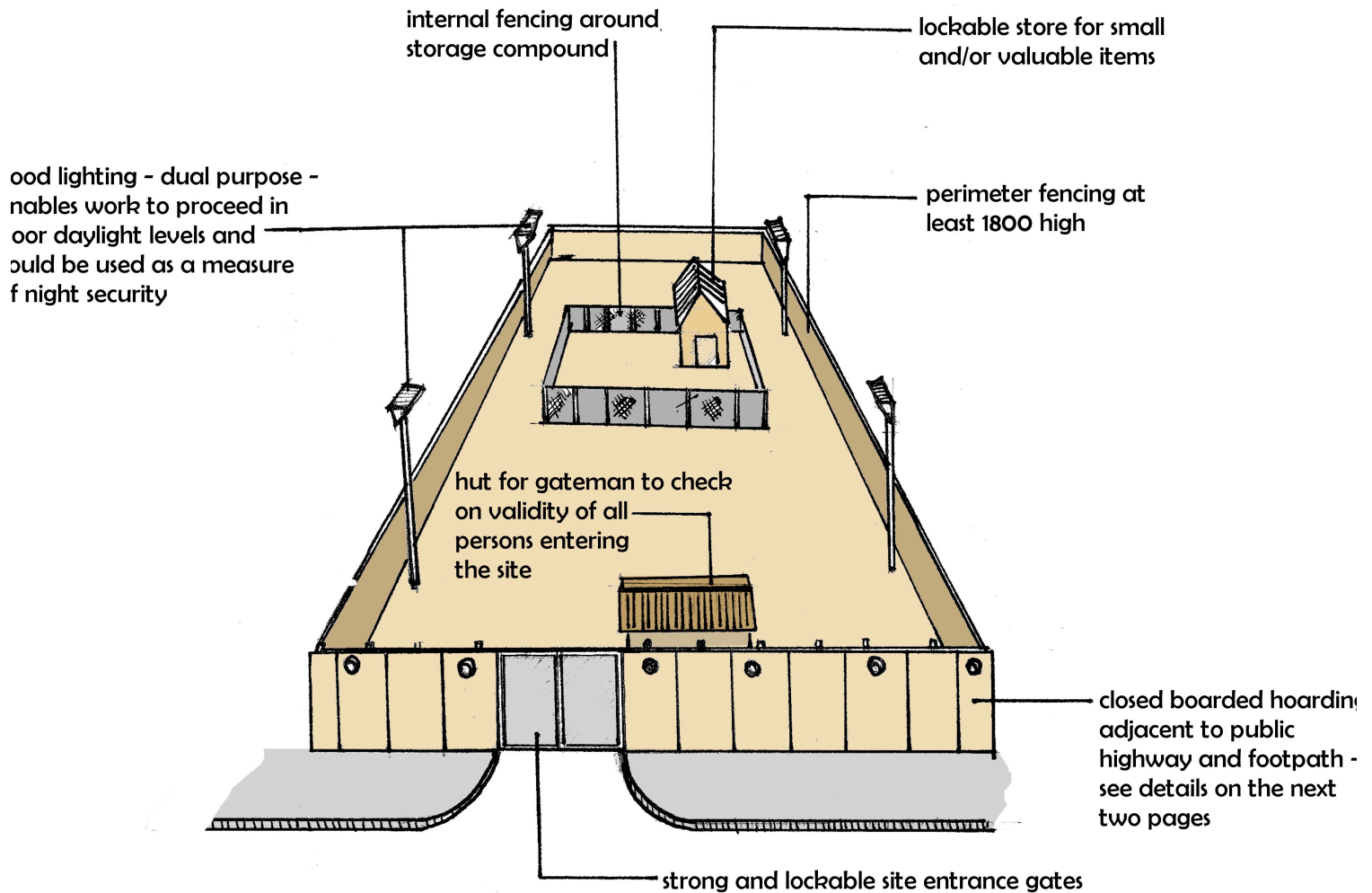

### **Hoardings~**

Close-boarded fence hoarding must be erected prior to the commencement of building operations if such operations are adjacent to a public footpath or highway. The hoarding needs to be:

- Adequately constructed to provide protection for the public
- Resist impact damage.
- Resist anticipated wind pressures.
- Adequately lit at night.

Before a hoarding can be erected a license or permit must be obtained from the local authority. The license will set out the minimum local authority requirements for hoardings and define the period of the license.



## Site Office Accommodation:

The arrangements for office accommodation to be provided on site are a matter of choice for each individual contractor. Generally separate offices would be provided for site agent, clerk of works, administrative staff, site surveyors, health and safety officers, sales staff etc.

### Typical Example ~

**Portable Cabin** with four adjustable steel legs with attachments for stacking. Paneling of galvanised steel sheet and rigid insulation core. Plasterboard inner lining to walls and ceiling, Pyro-shield windows with steel shutters and a high security steel door.

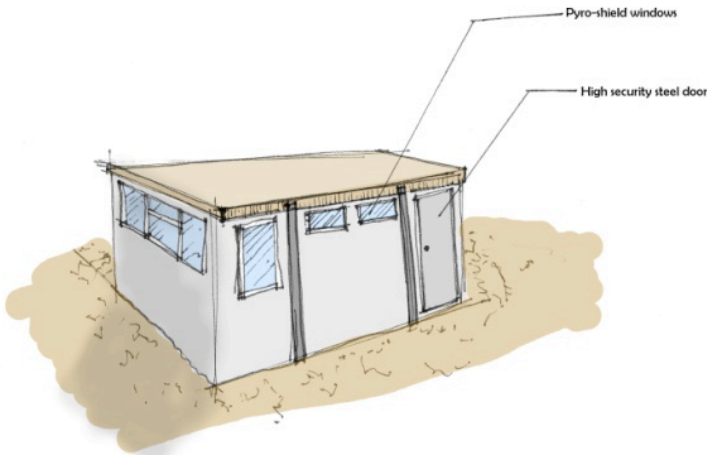

## SITE SAFETY AND HEALTH ACCOMMODATION

The following minimum accommodation is required for the health and wellbeing of persons on construction sites:

TYPE OF ACCOMMODATION	REQUIREMENT	No of persons employed on site
<b>FIRST AID ROOM</b>	Used only for rest & treatment & in charge of trained person	If more than 250 persons are employed on site, each employer of more than 40 persons should provide a first aid room
<b>SHELTER &amp; ACCOMMODATION FOR CLOTHING</b>	All persons on site to have shelter & a place for changing, drying & depositing clothes. Separate facilities should be provided for male & female staff	Up to 5 where possible a means of warming themselves and drying wet clothes 5 <sup>+</sup> adequate means of warming themselves and drying wet clothes
<b>REST ROOM/CANTEEN</b>	Drinking water, means of boiling water, preparing & eating meals for all persons on site. Arrangements to protect non-smokers from tobacco smoke.	10 <sup>+</sup> facilities for heating food if hot meals are not available on site
<b>WASHING FACILITIES</b>	Washing facilities to be provided for all persons on site for more than 4 hours. Ventilated & lit. Separate facilities for male & female staff	20 – 100 if work is to last for more than 6 weeks – hot & cold or warm water, soap & towel. 100 <sup>+</sup> work lasting more than 12 months – 4 wash places <sup>+</sup> 1 for every 35 persons over 100
<b>SANITARY FACILITIES</b>	To be maintained lit ventilated & kept clean. Separate facilities for male & female staff	Up to 100 – 1 convenience for every 25 persons 100 <sup>+</sup> 1 convenience for every 35 persons

## SITE STORAGE

Materials stored on site prior to being used or fixed may require protection:

- For security reasons&
- Against the adverse effects of exposure to the weather – sun, rain etc

**Small and Valuable Items** ~ these should be kept in a secure & lockable store, similar items should be stored together in a rack or bin system and issued against an authorized requisition.

**Large or Bulk Storage Items** ~ these items can be stored within a lockable fence compound. The form of fencing chosen may give visual security such as the chain link fencing with precast concrete posts or those that lack visual security such as the close boarded fences constructed with the same methods used for hoardings.

### Typical Storage Compound Fencing ~

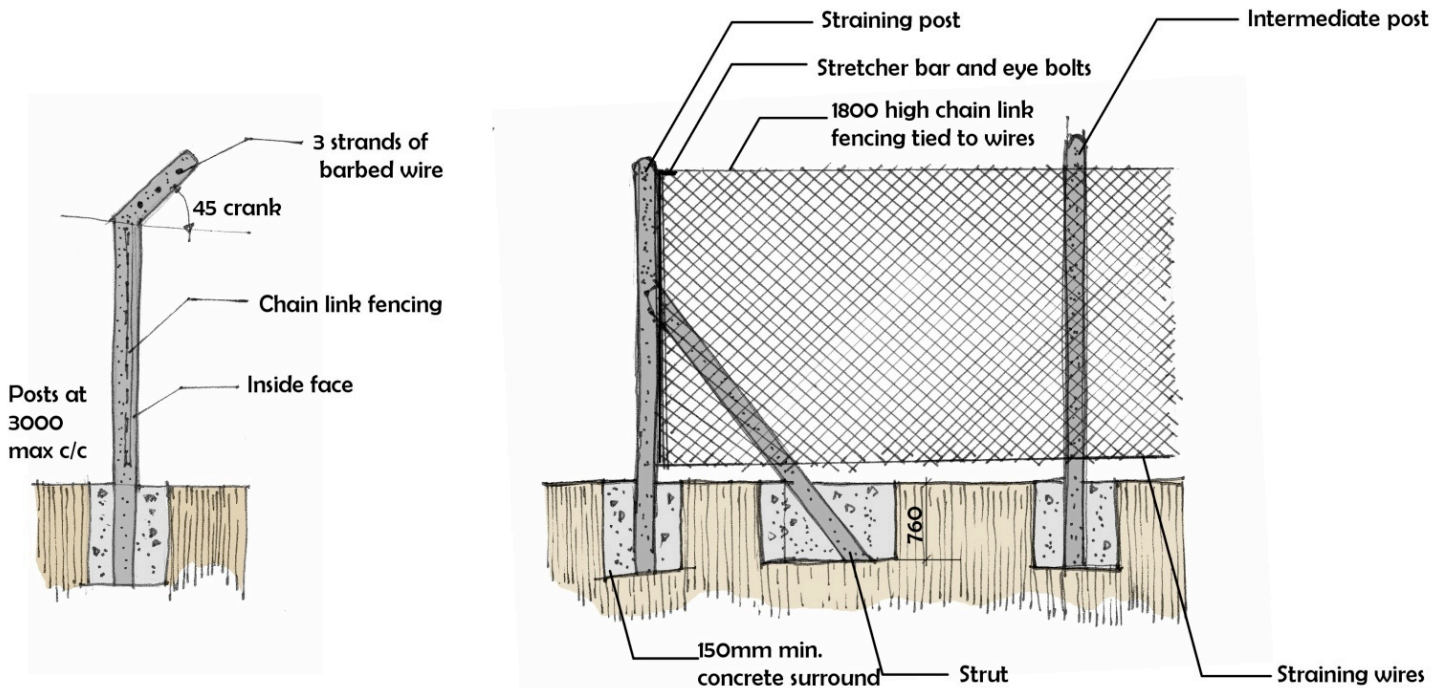

## CHAIN LINK FENCING WITH PRECAST CONCRETE POSTS

**STORAGE OF MATERIALS** ~ This can be defined as the provision of adequate space, protection & control for building materials and components held on site during the construction process.

Consider the following materials and think of the actual requirements for their proper storage:

1. Cement
2. Bricks
3. Cement blocks
4. Granite aggregate

5. Sand aggregate
6. Sawn Timber
7. Plywood/Shutterply
8. Ceiling Board
9. Barge board
10. Precast Concrete Lintel
11. Mesh Reinforcement,
12. Reinforcement bars,
13. Galvanised Iron Rolls
14. Rock wool – Isotherm
15. DPC Dampcourse
16. Builders Plastic
17. Aluminium windows
18. Wooden door frames
19. Panel Doors
20. Mortice Lockset
21. Brass Butt Hinges
22. Emulsion paint
23. Copper tubing
24. PVC waste pipe
25. Geyser
26. Sink pillar & mixer taps
27. Toilet seat
28. Water Closet
29. Wash Hand Basin
30. Bath
31. Electrical switch & socket
32. Conduit pipes
33. Electric cables
34. Circuit Breakers
35. Electrical fittings – lamp holders, fluorescent etc
36. Ceramic tiles
37. Porcelain fix, tile fix, mosaic fix & mosaic tile grout
38. Carpets
39. Laminate flooring

## **Need for storage and control of materials held on site ~**

1. **Physical properties** – size, shape weight & mode of delivery will assist in determining the safe handling and stacking method(s) to be employed on site, which in turn will enable handling and storage costs to be estimated.
2. **Organisation** – this is the planning process of ensuring that all the materials required are delivered to site at the correct time, in sufficient quantity, of the right quality, the means of unloading is available and that adequate space for storage or stacking has been allocated.
3. **Protection** – building materials and components can be classified as durable or non-durable, the latter would usually require some form of weather protection to prevent deterioration whilst in store.

4. **Security** – many building materials have a high resale and/or usage value to persons other than those for whom they were ordered.
5. **Costs** – to achieve an economic balance of how much expenditure can be allocated to site storage facilities, the following should be taken into account: -
  - a. Storage areas, fencing, racks, bins etc.,
  - b. Protection requirements.
  - c. Handling, transporting and stacking requirements.
  - d. Salaries and wages of staff involved in storage of materials and components.
  - e. Heating and/or lighting if required.
  - f. Allowance for losses due to wastage, deterioration, vandalism and theft.
  - g. Facilities to be provided for sub-contractors.
6. **Control** – checking quality and quantity of materials at delivery and during storage period, recording delivery and issue of materials and monitoring stock holdings.

## Brick Storage

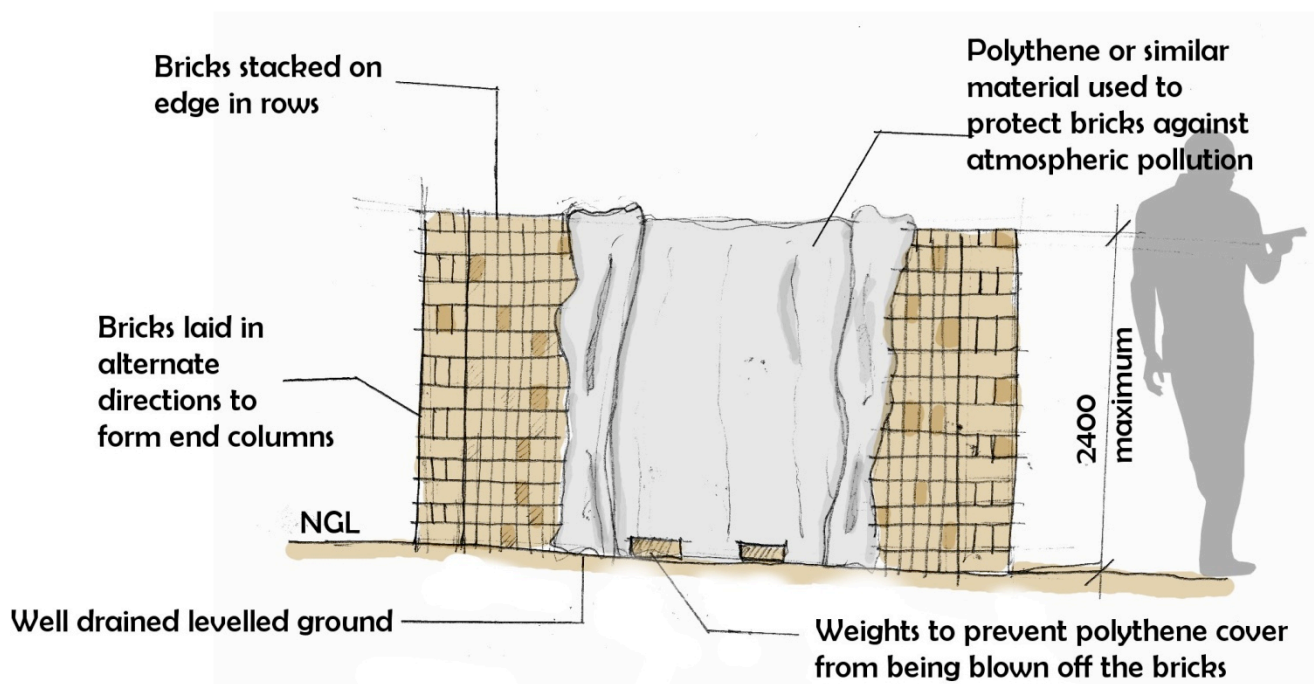

**Bricks**~ may be supplied loose or strapped in unit loads and stored on timber pallets.

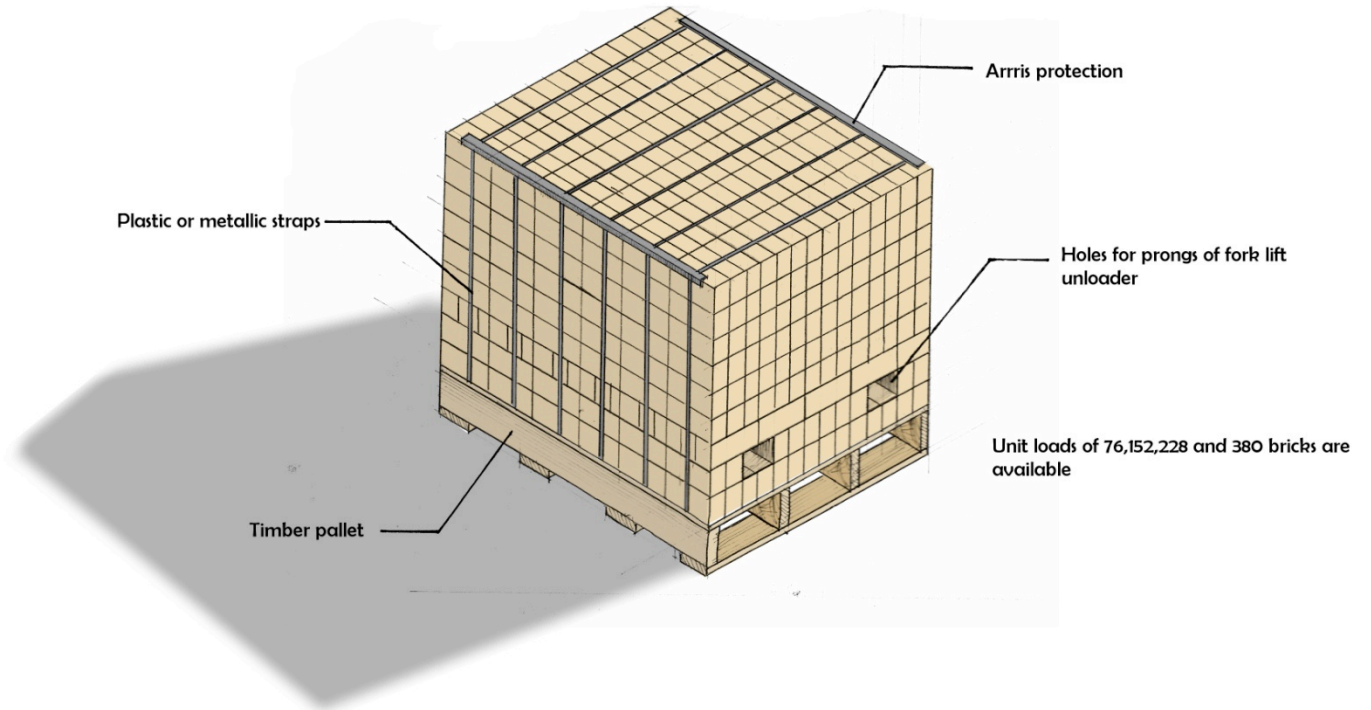

## Cement Blocks Storage

**Blocks** ~ may be supplied loose or in unit loads on timber pallets.

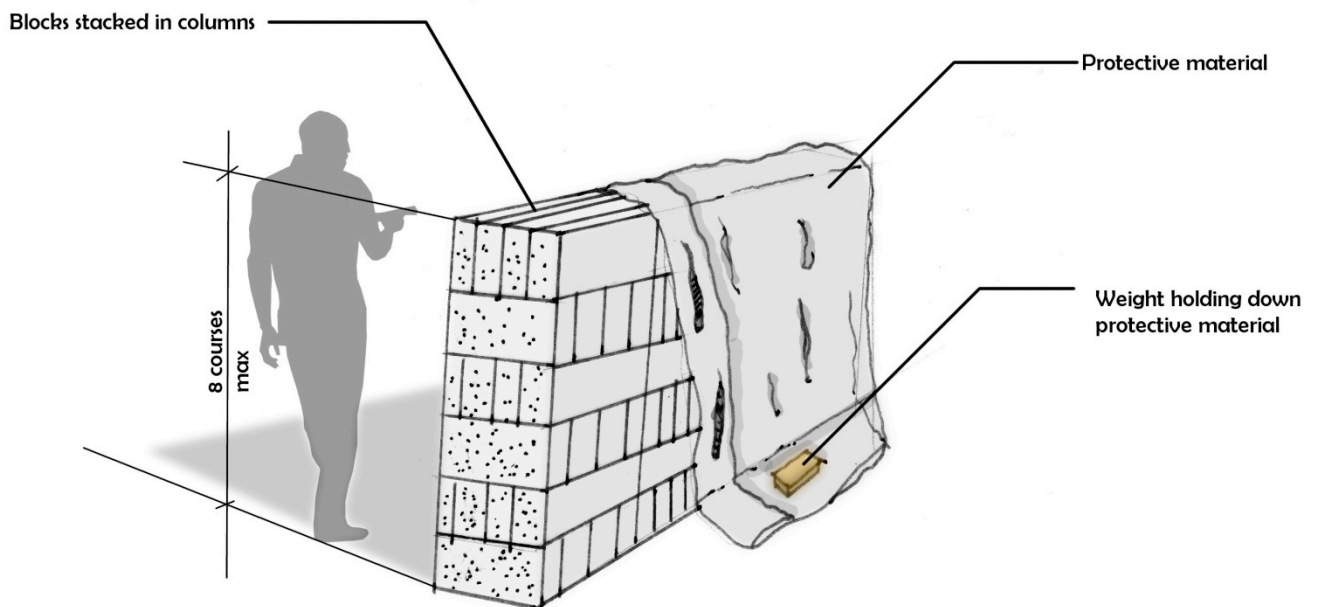

## Roofing Tiles Storage ~

**Roofing Tiles** ~ may be supplied loose, in plastic wrapped packs or in unit loads on timber pallets.

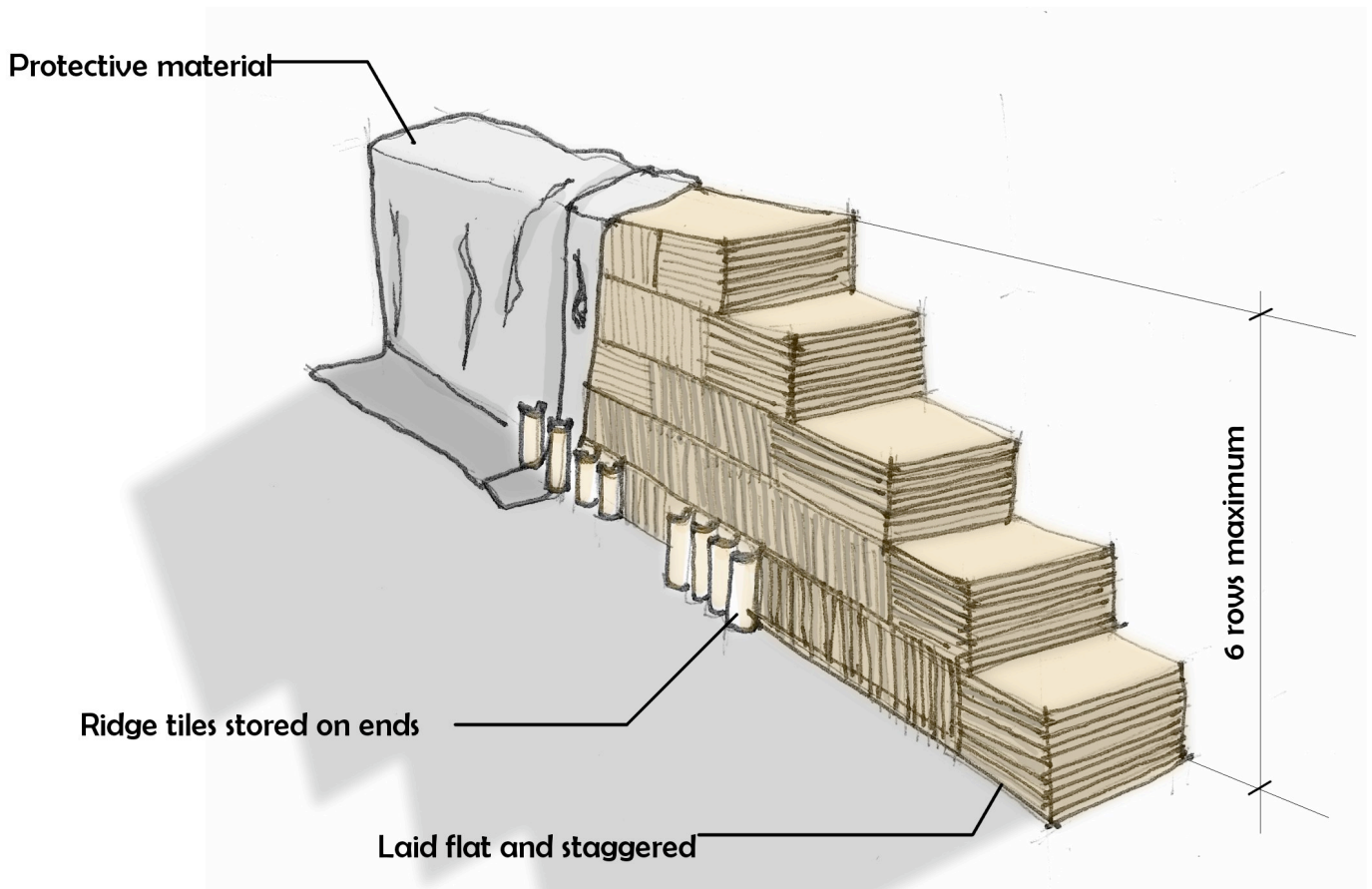

**Drainage Pipes Storage** ~ Supplied loose or stacked together on timber pallets.

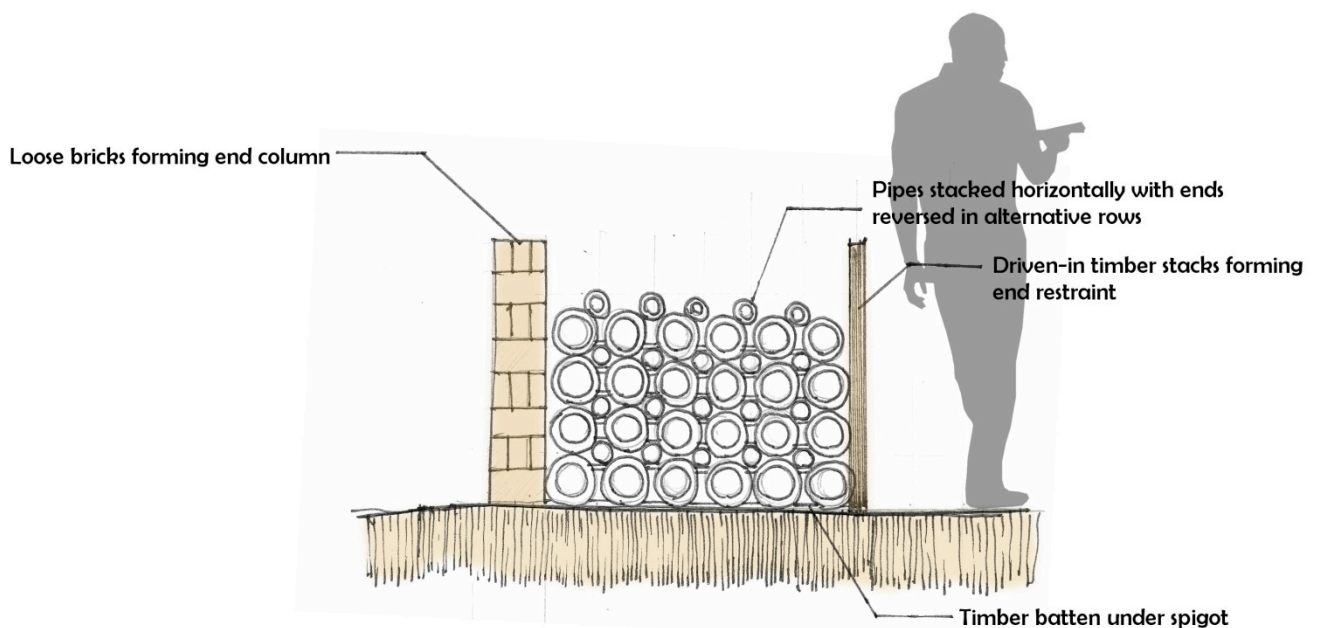

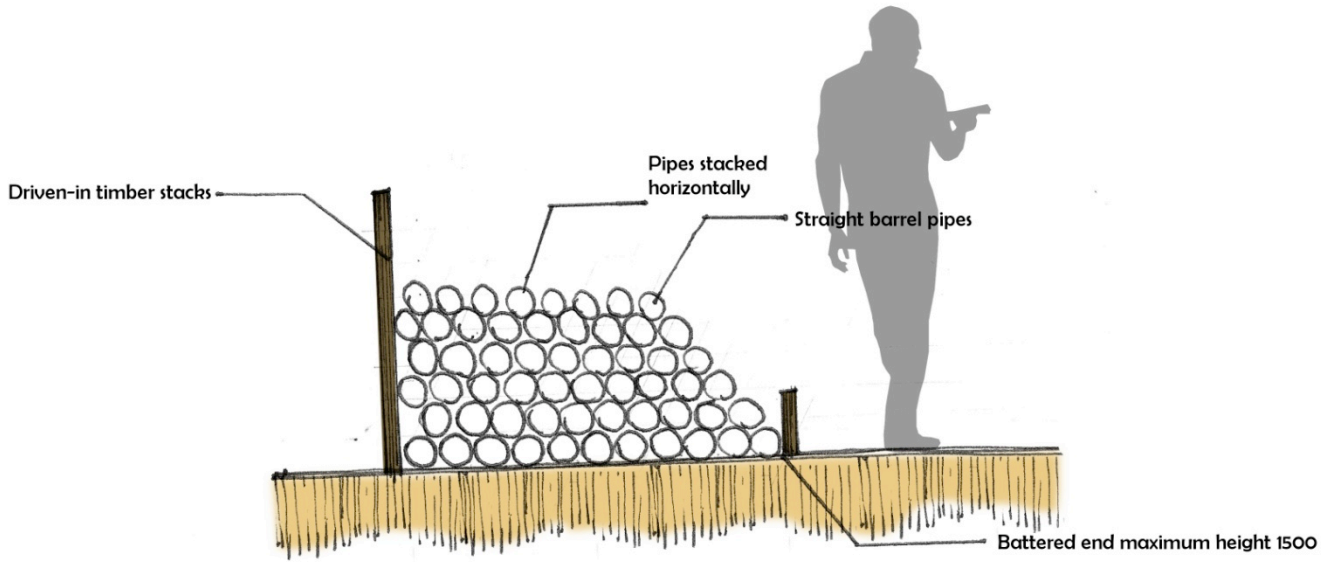

### Baths Storage ~

Baths ~ stacked or nested vertically or horizontally on timber battens

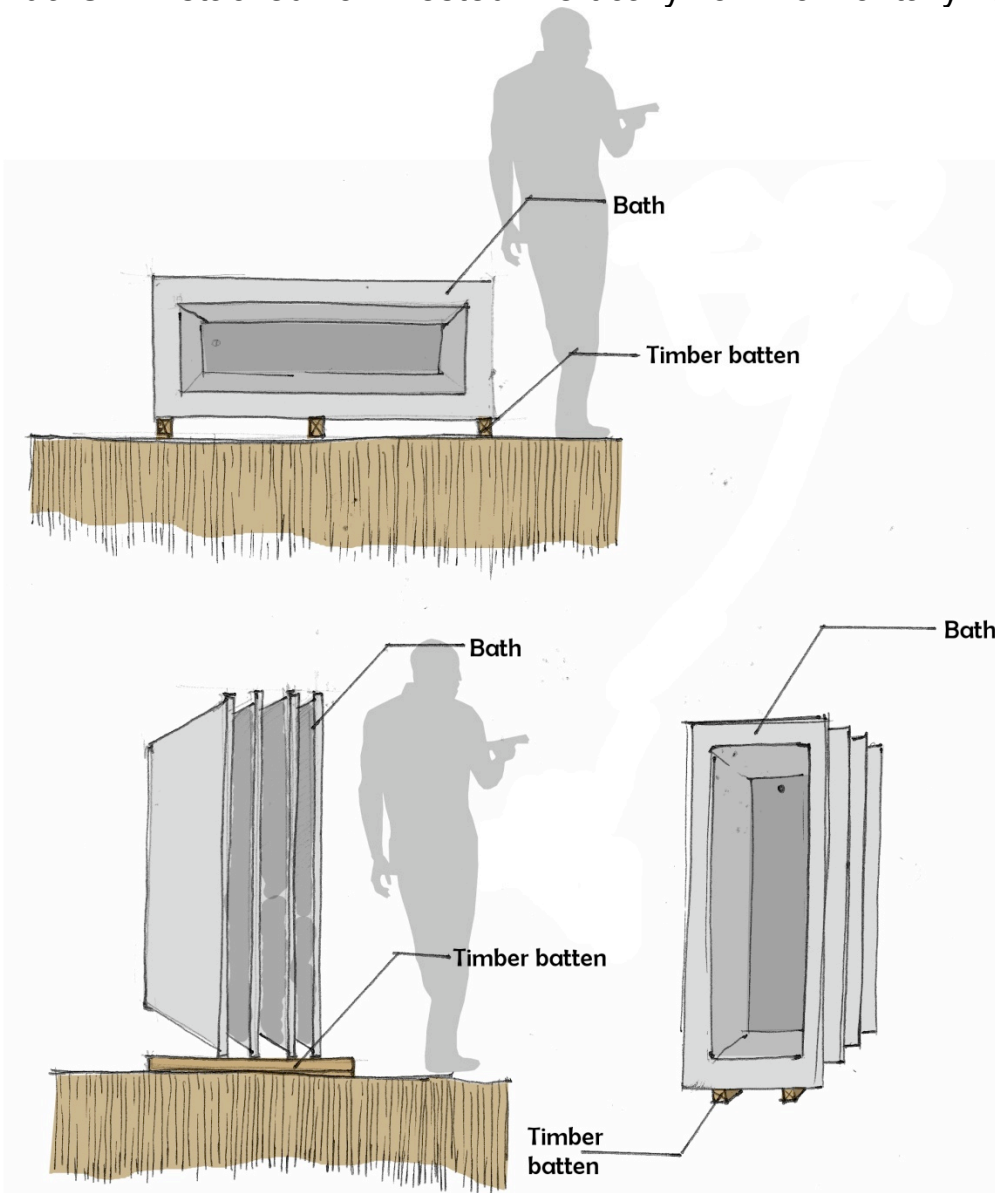

**Basins** ~ stored similar to baths but not more than four high if nested one on top of another.

**Corrugated and Similar Sheet Materials** ~ stored flat on a level surface and covered with a protective polythene or similar sheet material.

### **Cement Storage ~**

Whichever type of cement is being used it must be properly stored on site to keep it in good condition. The cement must be kept dry since contact with any moisture whether direct or airborne could cause it to set.

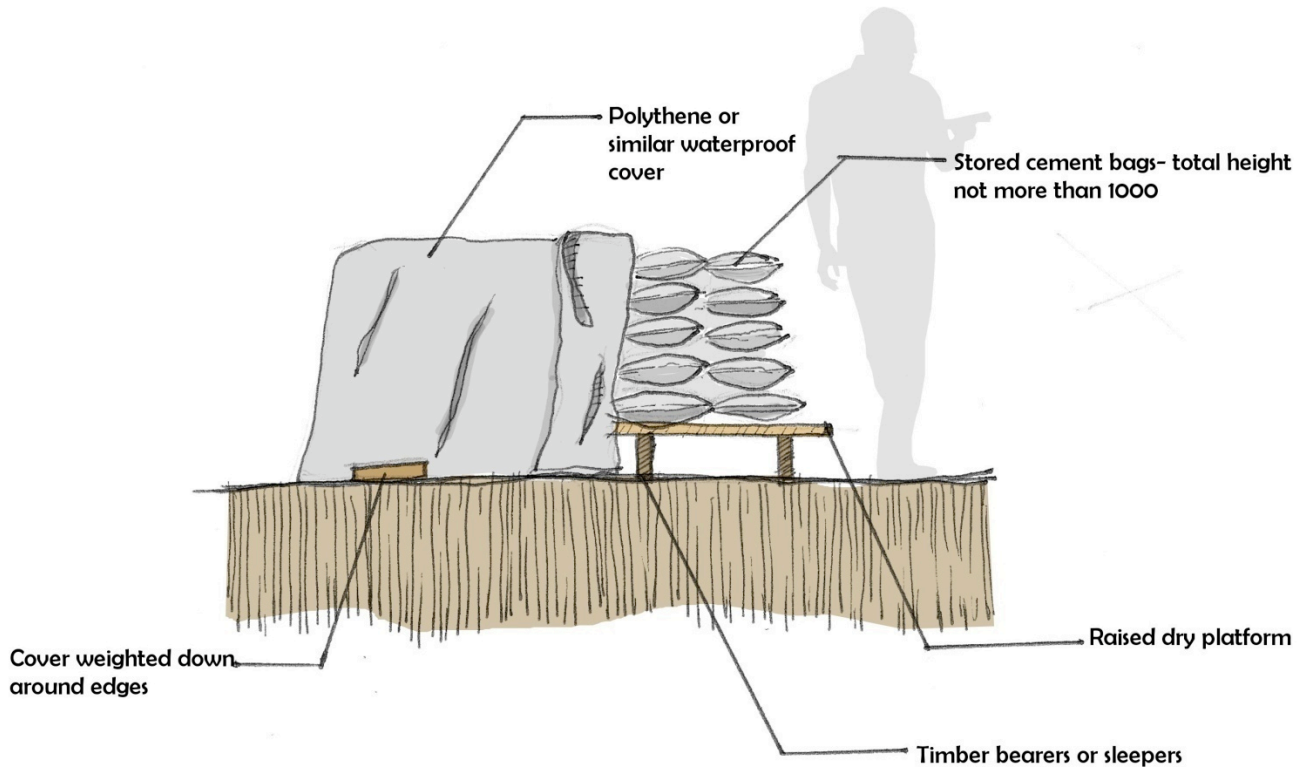

**LARGE CONTRACTS** – bagged cement use watertight sheds whilst for bulk delivery/loose cement, a **cement storage silo**.

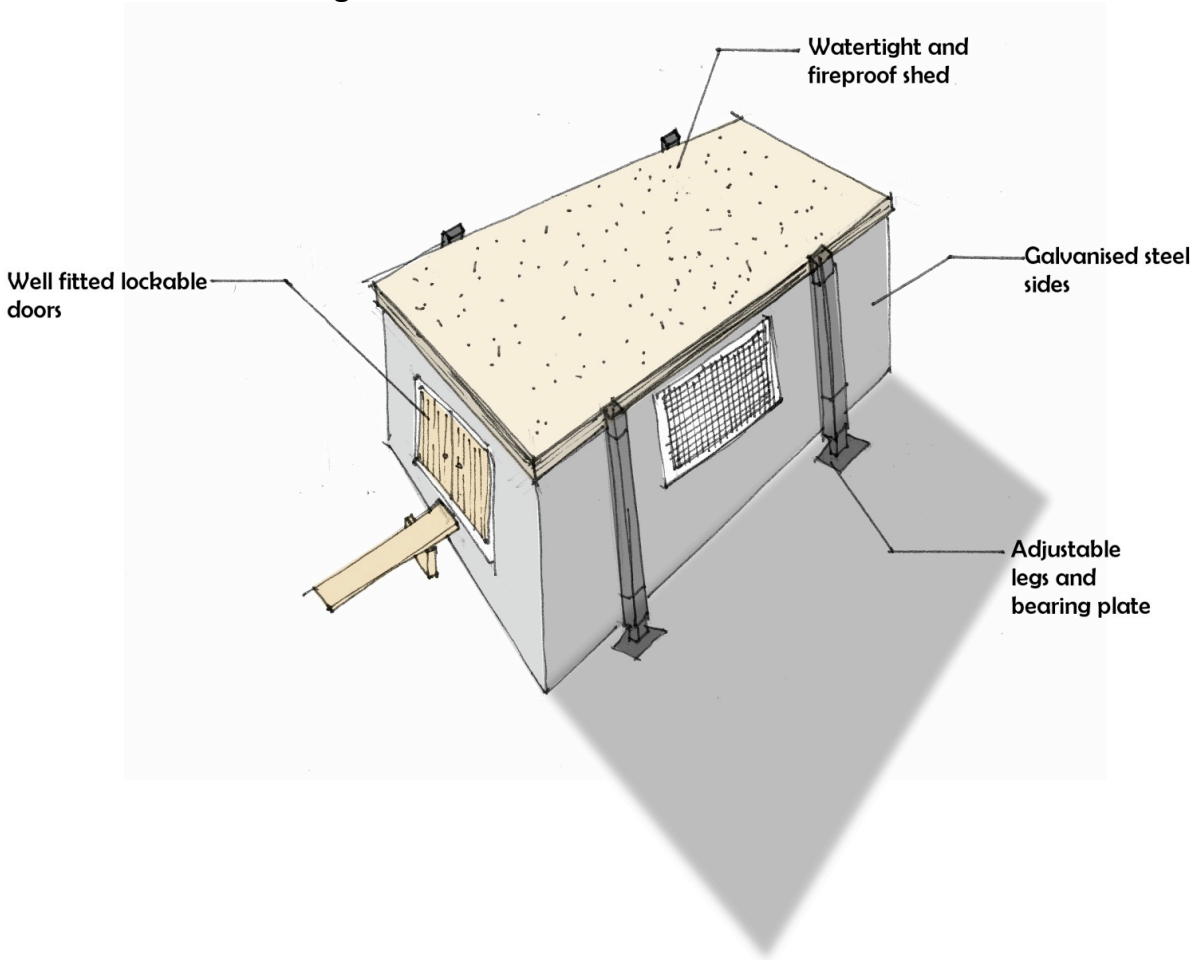

## Aggregates ~

Essentials of storage are to keep different aggregate types and/or sizes separate, store on a clean, hard, free draining surface and to keep the stored aggregates clean and free of leaves and rubbish.

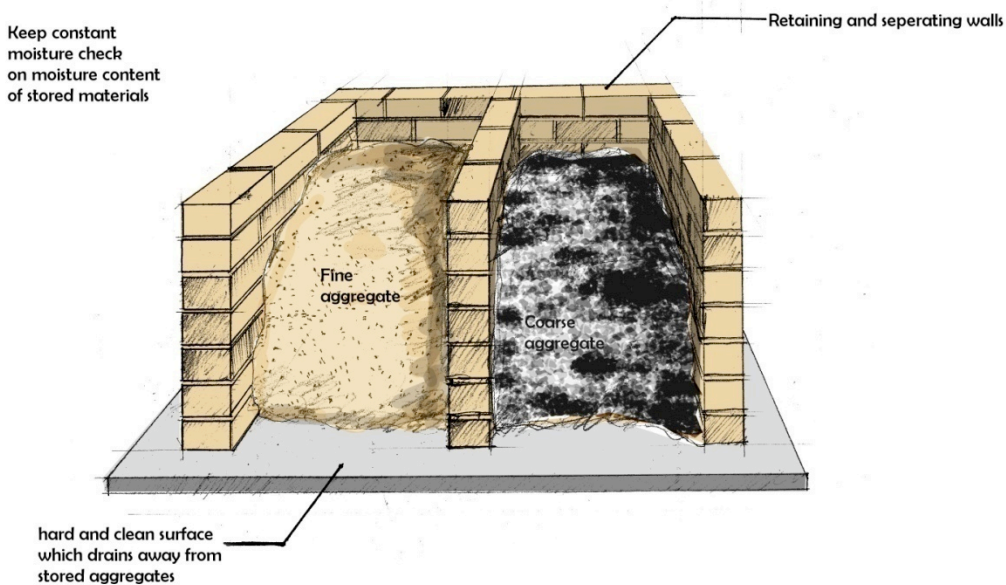

## MATERIAL TESTING

**Site Tests** ~ The majority of materials and components arriving on site will conform to the minimum recommendations of the South African Bureau of Standards (SABS) and therefore the only tests that need to be applied are those of:

1. Checking quantity received against amount stated on the delivery note,
2. Ensure quality is as ordered and a visual inspection to reject damaged or broken goods.

Other tests, which may be carried out include:

1. Moisture content of timber test, which can be read direct from a **moisture meter**.
2. Test for **compliance with dimensional tolerance**, which covers clay bricks.
3. Testing sand for bulking – percentage increase in the volume of sand due to addition of water.
4. Silt test for sand – to ascertain the cleanliness of sand.
5. Slump test – to test concrete mixture for consistency.
6. Crushing test – use of test cubes to ensure that concrete has achieved the required design strength.
7. Non-destructive tests of concrete – Rebound/Schmidt hammer test, Windsor probe test, pull out test, vibration tests etc.

# THE BUILDING TEAM

**Reference:** Osbourn D., and Greeno, R. (2007) **Mitchell's Introduction to Building**, Pearsons Education Limited, Essex

Building is a group activity and its success depends on a good understanding between large numbers of people. The participants involved can be conveniently arranged into groups or teams according to their particular interest and/or involvement as follows and shown in the figure below:

- Client Team
- User Team
- Design Team
- Research team
- Legislative team
- Manufacturing Team
- Construction Team
- Maintenance Team

## THE CLIENT TEAM

The client, or the prospective building owner, has the responsibility for:

1. Defining the building to suit needs i.e. producing a clear and accurate brief (or list of requirements);
2. Establishing and providing the necessary finances;
3. Agreeing to design and construction phases; and
4. Managing and running the completed project.

The client usually nominates a project manager and the principal contractor as soon as possible to help him carry out his duties.

The type of client varies from a house owner requiring nominal changes e.g. a loft conversion, to a multi-national organization redeveloping industrial premises or constructing new prestigious offices.

## THE USER TEAM

A building User Team forms a vital link between design concepts and built reality. Formulating user requirements may be simplified when clients and occupants are the same. However, this is not always the case, and it is the initial responsibility of a non-user Client Team to establish user requirements when formulating a brief with its professional advisers.

Typical user teams, which can supply information, are tenants' associations, medical associations, consumer associations, tourist boards, unions, etc.

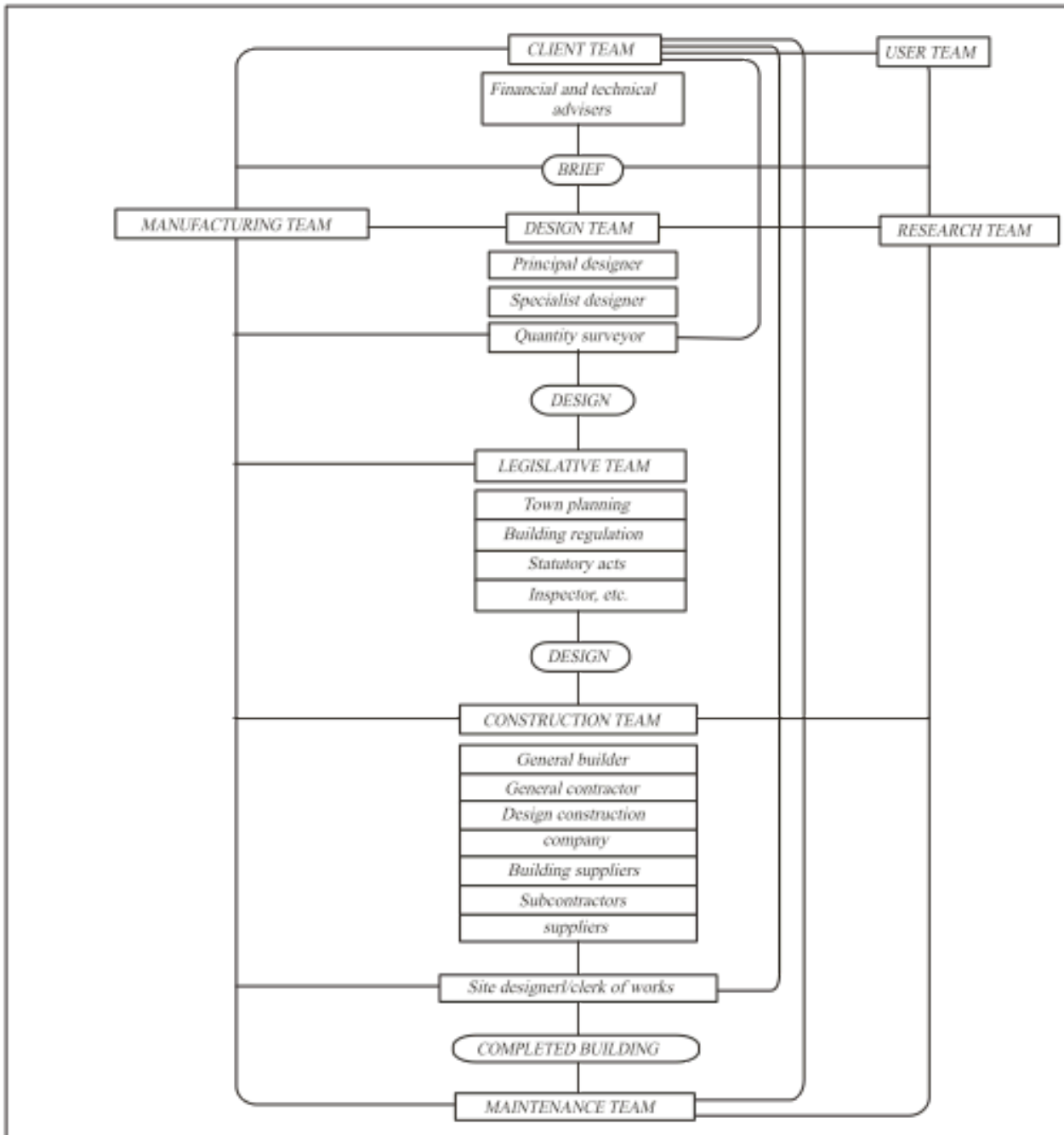

## DESIGN TEAM

Within this team, there are two types of building designers:

- a. **Principal designers** with the overall responsibility of the design of the project; and
- b. **Specialist designers** who provide expertise concerning certain aspects of a building and whose requirements are often coordinated by the principal designer.

Cost control and financial advice to client, principal and specialist designers, is generally provided by a **Quantity surveyor**.

### Principal designers

These include **architects**, **interior designers** and **building surveyors**. Whilst architects design and provide the production information on most building projects, the interior designer

prepares design and production information for the interior of a building and building surveyors are sometimes responsible for the design and supervision of repairs to the components of a building.

### **Specialist designers**

These include **civil** and **structural engineers, services engineers** and those concerned with specific aspects of architecture such as landscape, interiors, office planning etc. Civil and structural engineers are employed to assist principal designers on building projects, which contain appreciable quantities of structural works such as reinforced concrete, complex steel or timberwork or foundations, which are either complex or abnormal.

Services engineers which include electrical and mechanical engineers work with other designers and are concerned with environmental control: lighting, heating, air-conditioning and sound modulation; electrical installations, plumbing and waste-disposal systems; and mechanical services such as lift installation.

### **Quantity surveyor**

The quantity surveyor's primary role is to prepare a bill of quantities from the drawings and specifications supplied by the Design Team. The quantity surveyor may also be expected to give cost advice during the various stages of the design of a building, and during construction period the QS must measure and value the work carried out.

## **RESEARCH TEAM**

These are **researchers** who make understanding and development of current construction methods (materials and technical ability) possible. The process of building has moved from a craft-based art towards a science-based technology over a period of about 100 years. This is particularly true in the environmental science area of energy usage, thermal comfort, sound control and lighting, where quantifiable criteria have found application in the design of the external envelope of a building.

## **LEGISLATIVE TEAM**

The National Building Regulations and Building Standards Act (Act No. 103 of 1977) require formal application for permission to build. Therefore, after the client's brief for a building has been established, it will be necessary for the Design Team to start negotiation with the municipality in which the building is to be situated in order to clarify certain legal requirements. These are supported by many other legal requirements concerning health and safety, fire precautions, planning laws, mining etc.

The Design Team also has legal responsibilities under the Occupational Health and Safety Act of 1993 because its projects must not create hazards for building operatives during construction.

## **MANUFACTURING TEAM**

The Manufacturing Team supplies the materials, components and equipment, which are used during the construction processes of a building, and therefore incorporates many organisations and interests.

## CONSTRUCTION TEAM

There are over 50 separate trades such as bricklayer, carpenter, electrician, tiler, joiner, metalworker, painter, plasterer, plumber, steel fixer and so forth, associated with construction. Therefore, the erection of a building depends on an industry where total reliance is placed on the diverse attitudes, abilities and adaptability of its workers. Not too long ago, the main contractor employed most workers. Today however, most specialist trades are employed as **nominated subcontractors** by the client while relatively few key trades are employed directly by the main contractor as **ordinary subcontractors**.

Although this system of site organization remains normal with most small and many medium sized building companies, there is an increasing tendency for the larger main contractors to become **building managers**, responsible for the coordination of the erection of a building using only nominated subcontractors or suppliers. Perhaps the main reason for this is the fact that the continuous employment of the trade operatives cannot be guaranteed during periods of economic recession. Enforced redundancies are sometimes contractually difficult and likely to prove expensive.

Main contractors can be divided into three basic groups:

- a. **General builders** – who take on a wide range of work, concentrating on particular types and sizes of projects, which are seldom in excess of R10 million.
- b. **General contractors** – these include multi-national organisations having international, national and regional headquarters.
- c. **Design and build companies** – these companies provide a service, which is more elaborate than the previous two as they will undertake the responsibility for both design and construction of a building project.

All these companies could employ trade operatives as part of their regular staff and use subcontractors to deal with the specialist construction areas necessary for a particular project.

The size of a contractor's site construction team is determined by the following factors:

1. The size and nature of the project (this determines the number of workers employed);
2. The effectiveness/productivity of the personnel involved (this either reduces or increases the number of personnel employed);
3. The needs of the client (if he wants the project delivered in 12 weeks or 52 weeks);
4. The workload of the contractor in question.

# SETTING OUT A BUILDING

(Reference: Chudley R., & Greeno R. (2006) Building Construction Handbook, 6<sup>th</sup> Edition Butterworth-Heinemann, Oxford pgs. 107 - 113)

## Setting Out the Building Outline

This task is usually undertaken once the site has been cleared of any debris or obstructions, any reduced level excavation work is finished and before building operations are started on site. It is usually the contractor's responsibility to set out the building using information provided by the designer or architect. Accurate setting out is of paramount importance and should therefore only be carried out by competent persons and all their work thoroughly checked, preferably by different personnel and by a different method.

The **first task** in setting out the building is to establish a **base line** to which all the setting out can be related. The base line very often is the **building line**, which demarcates the front wall of the building. The building line in relation to a site means a line prescribed in any town planning scheme or any other law designating the boundaries of the area of the site, or a position on site given by the local authority in front of which no development is permitted. Usually a set back of 6m is the minimum distance allowed from the beacons at the front of a site to the building line. The front of the building is then positioned by checking this distance.

## Typical Setting Out Example ~

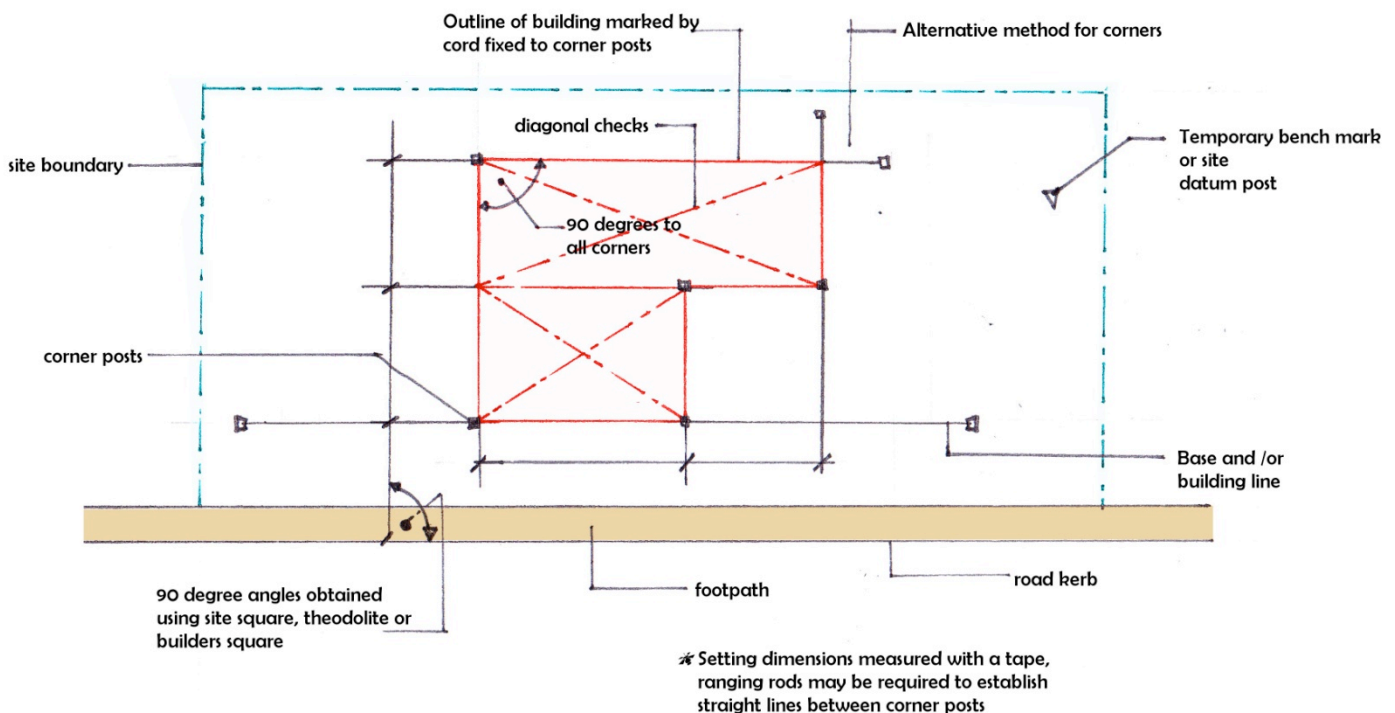

The **second task** is to establish the walls, which are at right angles to the building line. To do this, 50 x 50mm corner posts are driven firmly into the ground at the corner of a building. A nail is then driven into the middle of the corner post to secure the cord/twine marking the building outline.

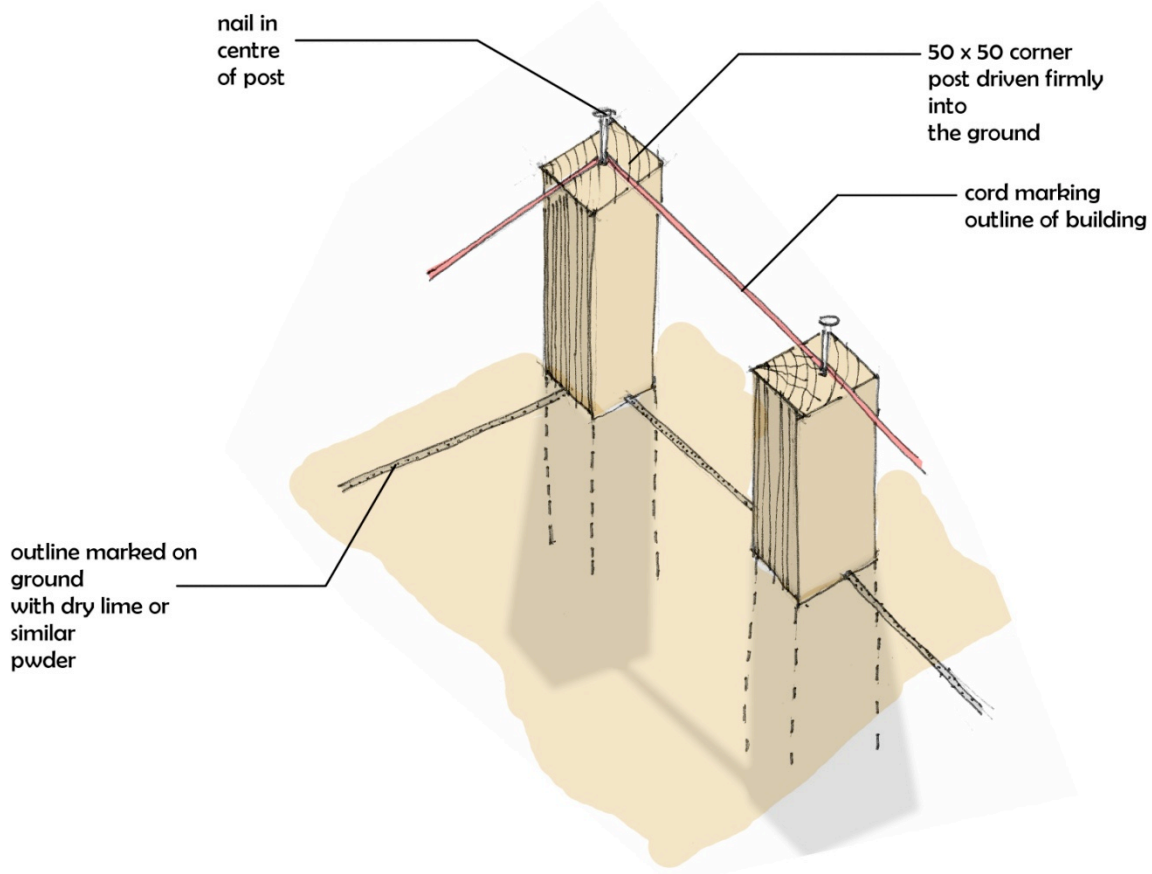

The **third task** is to ensure that the walls are at right angles to each other and this can be done using **three methods** including:

- a. **The 3:4:5 Method:** The method uses the algebraic calculation of right-angled triangles to set out the angles of the building. This method is very good for rectangular and square buildings.

To do this, a distance of 3m is measured back along the building line from the first corner post. At that point, another post/peg is driven into the ground and the measuring tape is properly secured to it with a nail. A distance of 4m is also measured from the building line along the outline of the wall to be built at right angles to the building line. At that point, another post/peg is driven into the ground and the measuring tape is properly secured to it at the 7m mark. The tape is then stretched out to give the position of the 2<sup>nd</sup> post/peg at the 12m mark. The twine extended on the 4m line is at right-angles to the building line following from the example given below:

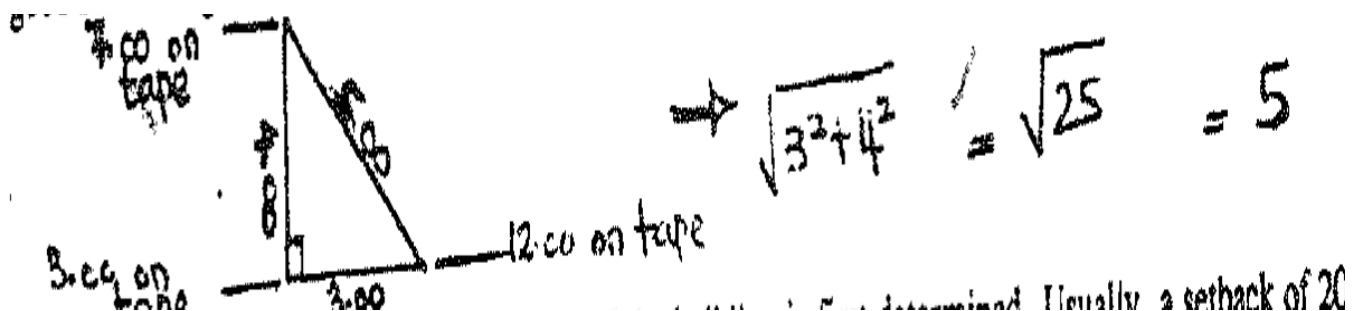

- b. **The Builder's Square Method:** This method is similar to the 3:4:5 method the only difference being in the instrument used. In this method, the walls perpendicular to the building line is determined by using a builder's square which is a right-angled triangular timber frame with sides varying in length from 1.5m to 3.0m. The square is placed on the building line and two pegs are driven in on the return side as shown below:

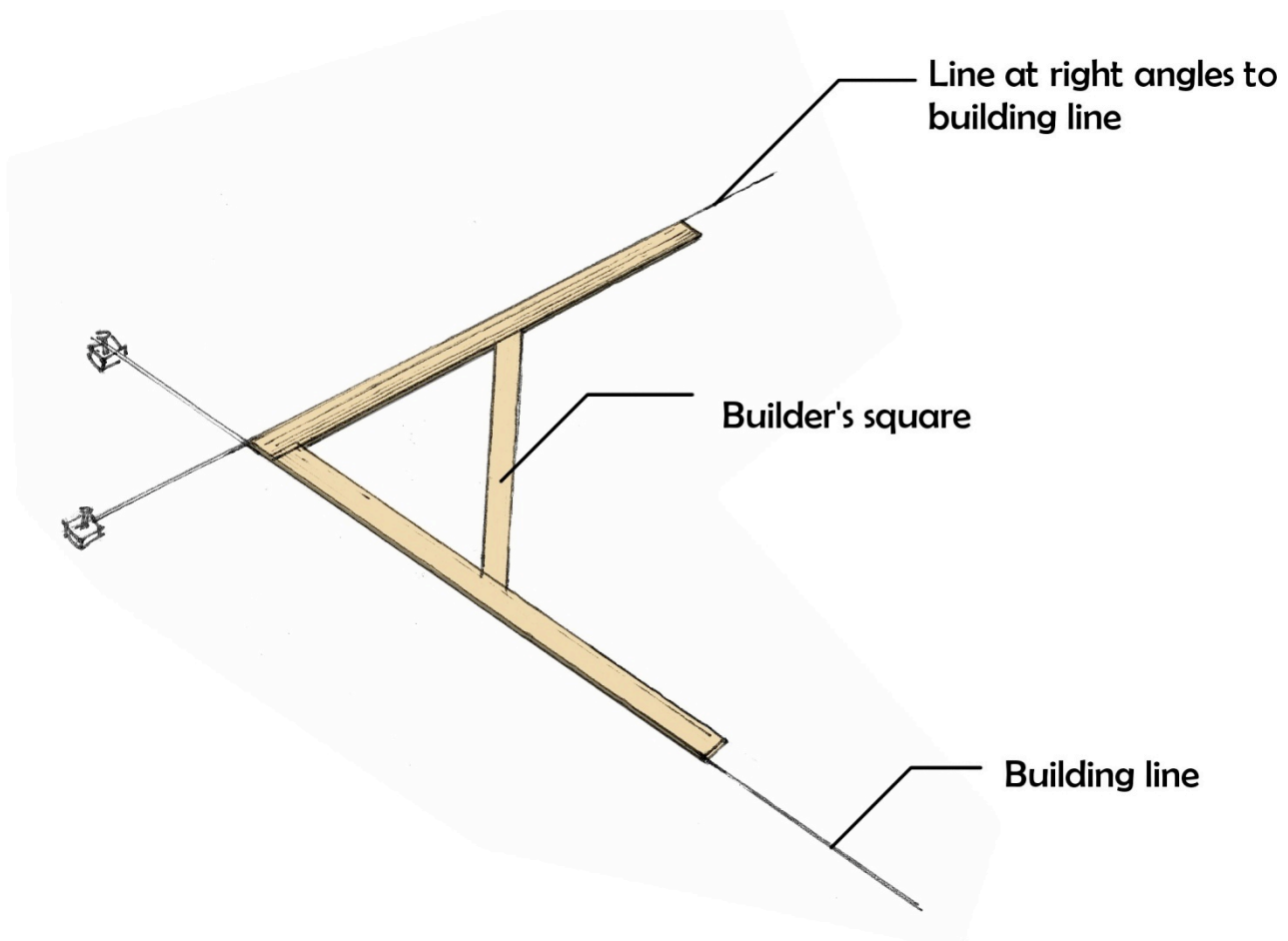

- c. **The Theodolite Method:** The method makes use of a topographic machine called the Theodolite. This method is very fast and accurate especially for complex buildings with different angles and inclinations. These machines can be used for taking angles, levels and distances.

To use it, transfer the distance of one of your reference points to one of the building's angles. Then set the machine on the point O. To start, it is better to put the angle of the machine at 0 (zero). When rotating the machine for another line with the angle already measured, the rotation should be anti-clockwise. The Theodolite should be read until the desired angle is obtained. At any given point, the staff should be viewed well and it should be ensured that the chain boy holds the staff vertically straight. See diagram below:

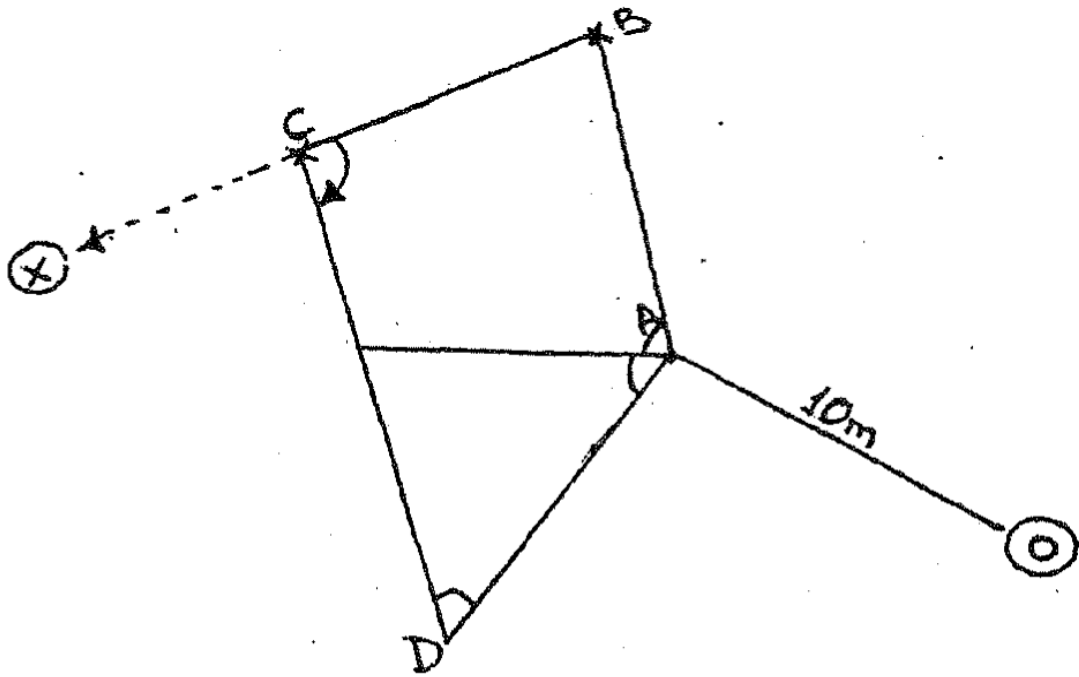

Using these methods, all other walls can also be established.

**Temporary Bench Mark:**

This is a fixed point on site to which all levels are related and should be established at an early stage in the contract. Where possible, it should relate to an ordnance benchmark. On site it can be any permanent feature such as a drain cover or a firmly driven post.

## Setting Out Trenches

The objective of this task is twofold:

1. It must establish the excavation size, shape and direction and;
2. It must establish the width and position of the walls.

The outline of the building would have been set out and using this outline, profile boards can be set up to control the position, width and possibly the depth of the trenches. A typical layout is shown below:

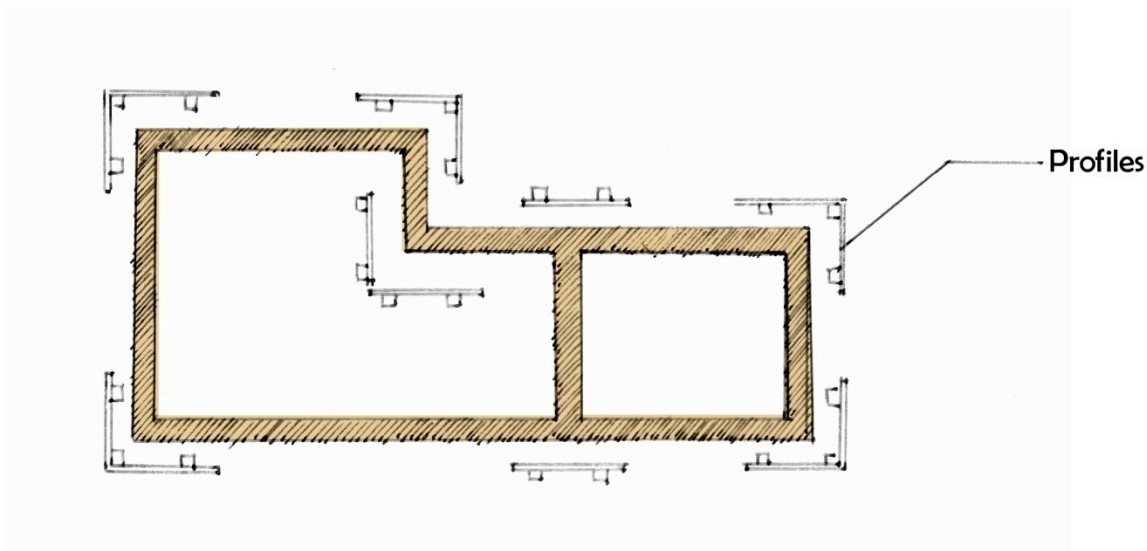

**Profile boards** should be set up at least 2.0m clear of trench positions so they do not obstruct the excavation work. The level of the profile cross-board should be related to the site datum and fixed at a convenient height above ground level.

The **trench depth** is controlled using a level and a staff whilst the **trench width** can be marked on the profiles with nails or saw-cuts and with a painted band if required for identification.

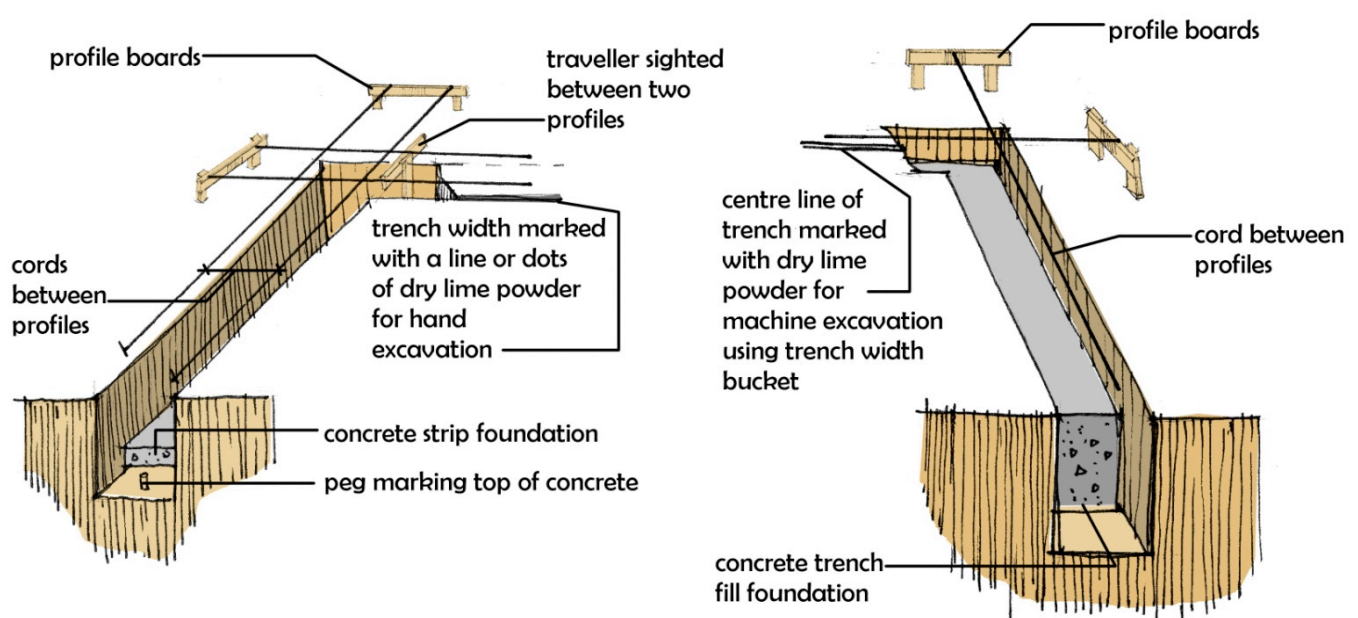
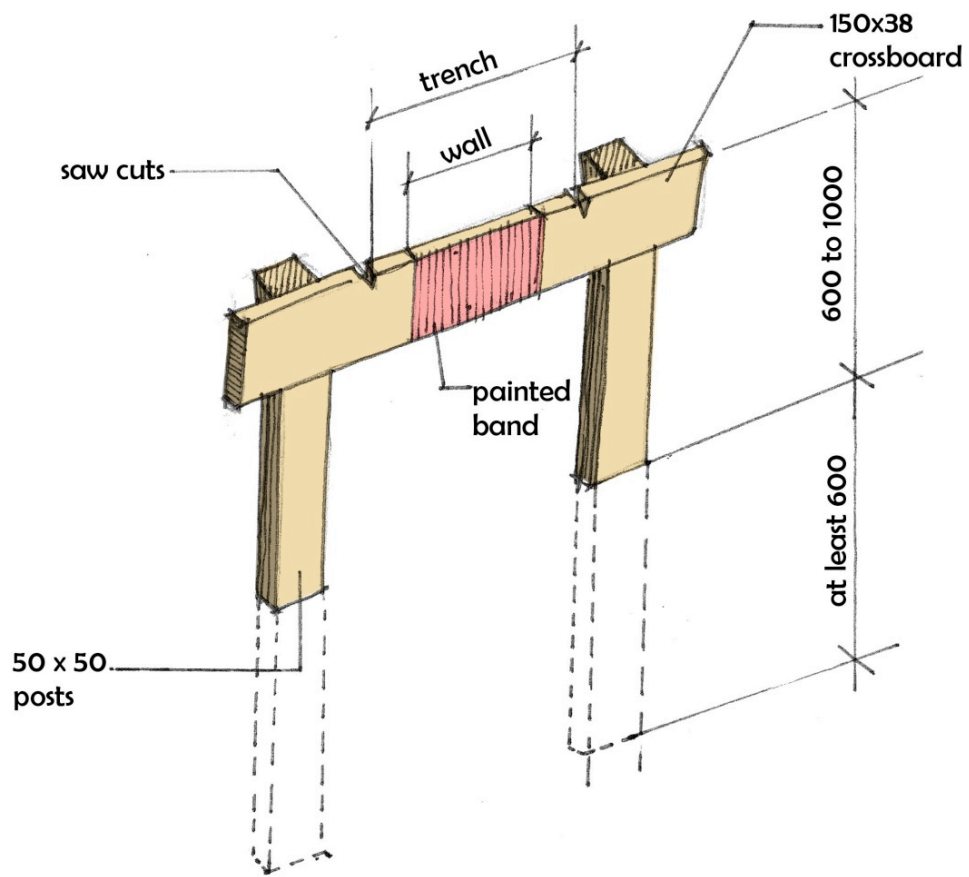

The corners of the walls are transferred from the intersecting cord lines to mortar spot on concrete using a spirit level.

# Setting Out A Framed Building

Framed buildings are usually related to a grid, the intersections of the grid lines being the centre of an isolated or pad foundation. The grid is usually set out from a base/building line, which does not form part of the grid.

Setting out dimensions for locating the grid can either be given on a drawing or will have to be accurately scaled off a general layout plan. The grid is established using a Theodolite and marking the grid line intersections with **stout pegs**. Once the grid has been set out,

- Offset pegs or profiles can be fixed clear of any subsequent excavation work.

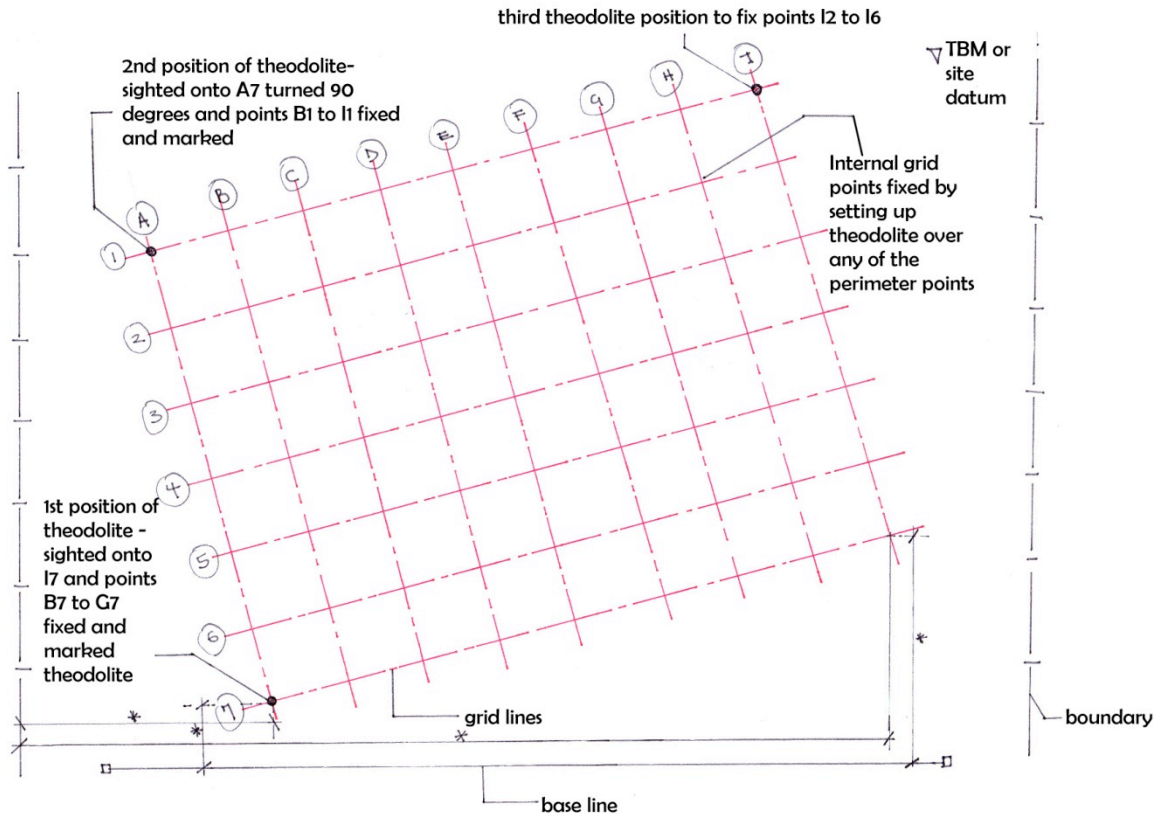

- Pad templates are positioned with cords between profiles and the pad outline is marked with dry lime or similar powder.

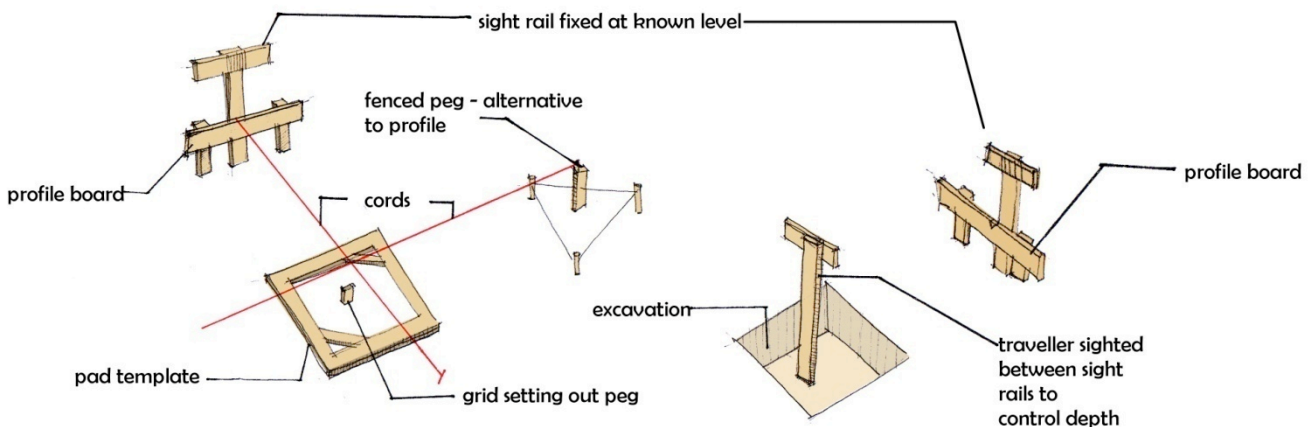

The control of excavation depth can be by means of a traveler sighted between sight rails or by level and staff related to the site datum.

## Setting Out Reduced Levels Excavations

The overall outline of the reduced level area can be set using a Theodolite, ranging rods, tapes and pegs working from a base line as shown below:

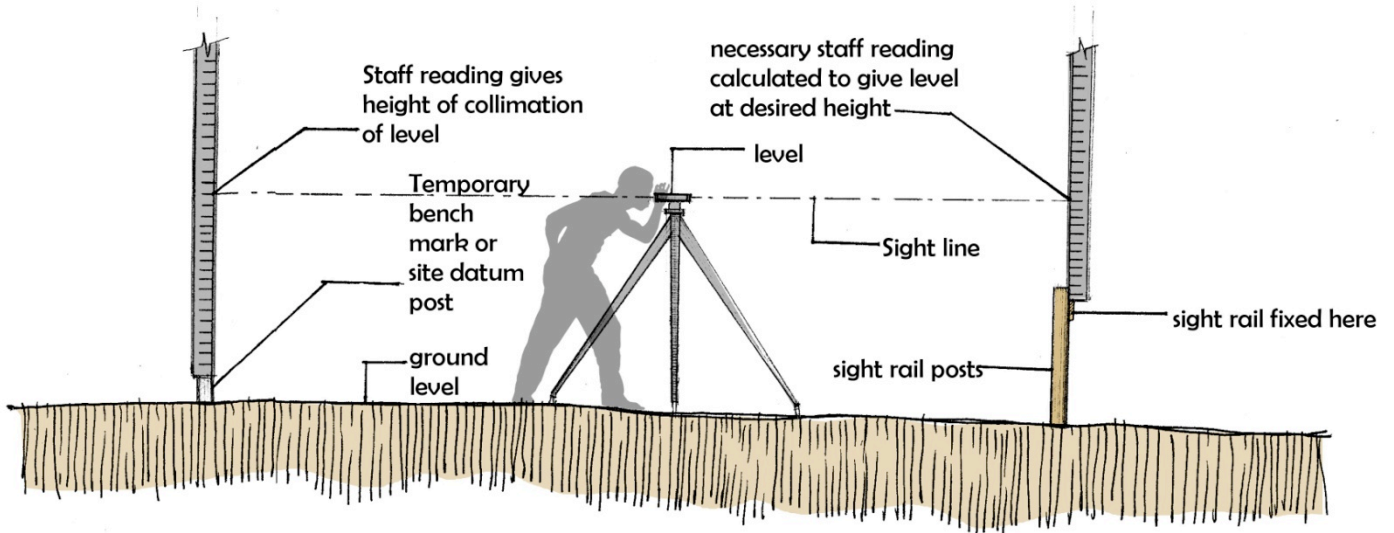

To control the depth of excavation, sight rails are set up at a convenient height and at positions, which will enable a traveller to be used as shown below:

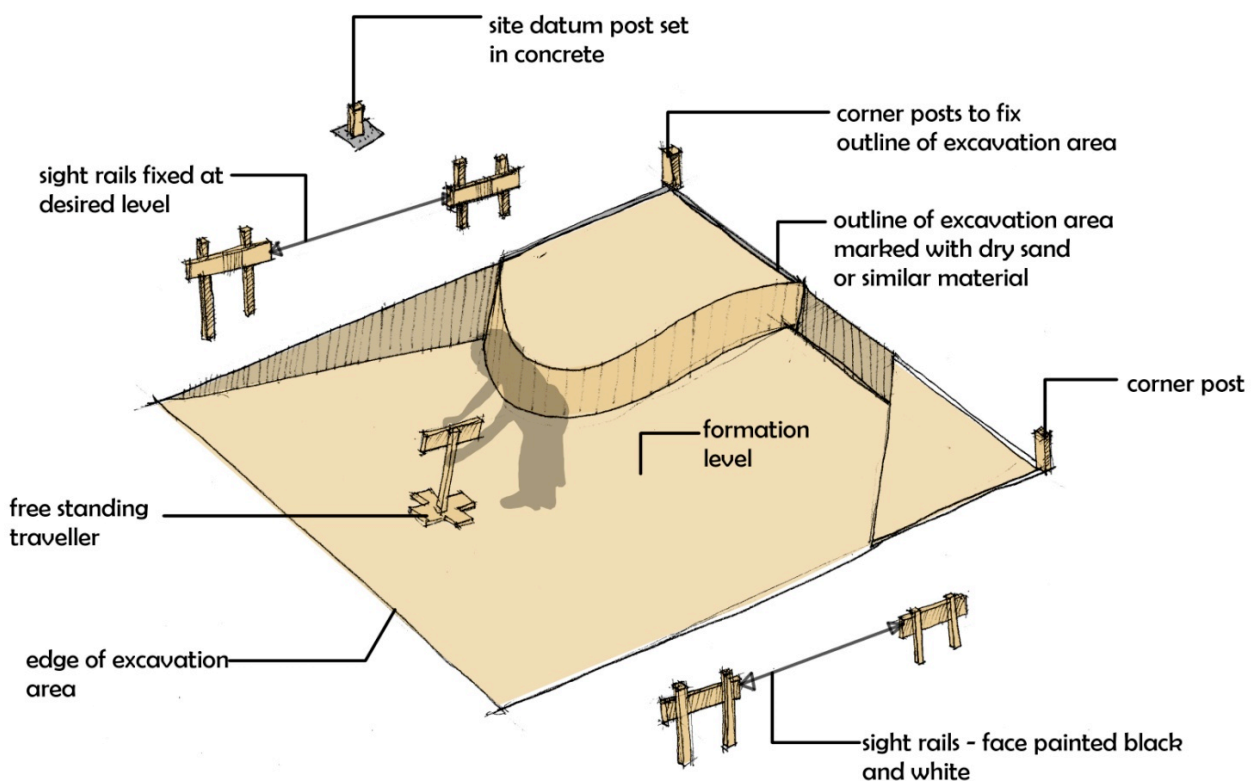

$$\text{height of traveller} = \text{desired level of sight rail} - \text{formation level}$$

## Setting Out Levels/Leveling

Leveling is the process of establishing height dimensions relative to a fixed point or datum. Datum is the mean sea level, which differs from country to country. Relative benchmarks are located throughout the country. Reference to Ordnance Survey maps of an area will indicate benchmark positions and their height above sea level, hence the name Ordnance Datum (OD). On site, it is usual to measure levels from a temporary benchmark (TBM) i.e. a manhole cover or other permanent fixture, as an OD may be some distance away.

Instruments consist of a level (**tilting** or **automatic**) and a staff. Trade name in some places is **Dumpy Level**. A **tilting level** is basically a telescope mounted on a tripod for stability. An **automatic level** is easier to use than a tilting level. There is no need for manual adjustment. It is approximately leveled by centre bulb bubble.

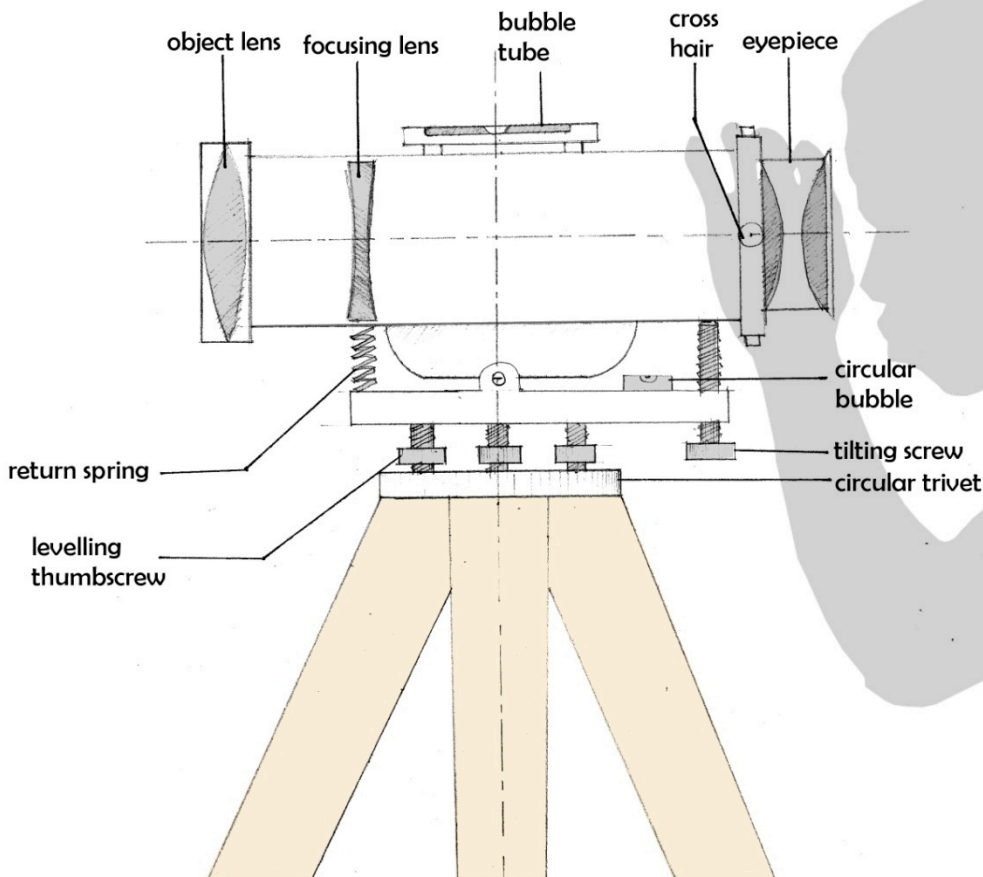

**Application** ~ used to determine differences in ground levels for calculation of site excavation, volumes and costs.

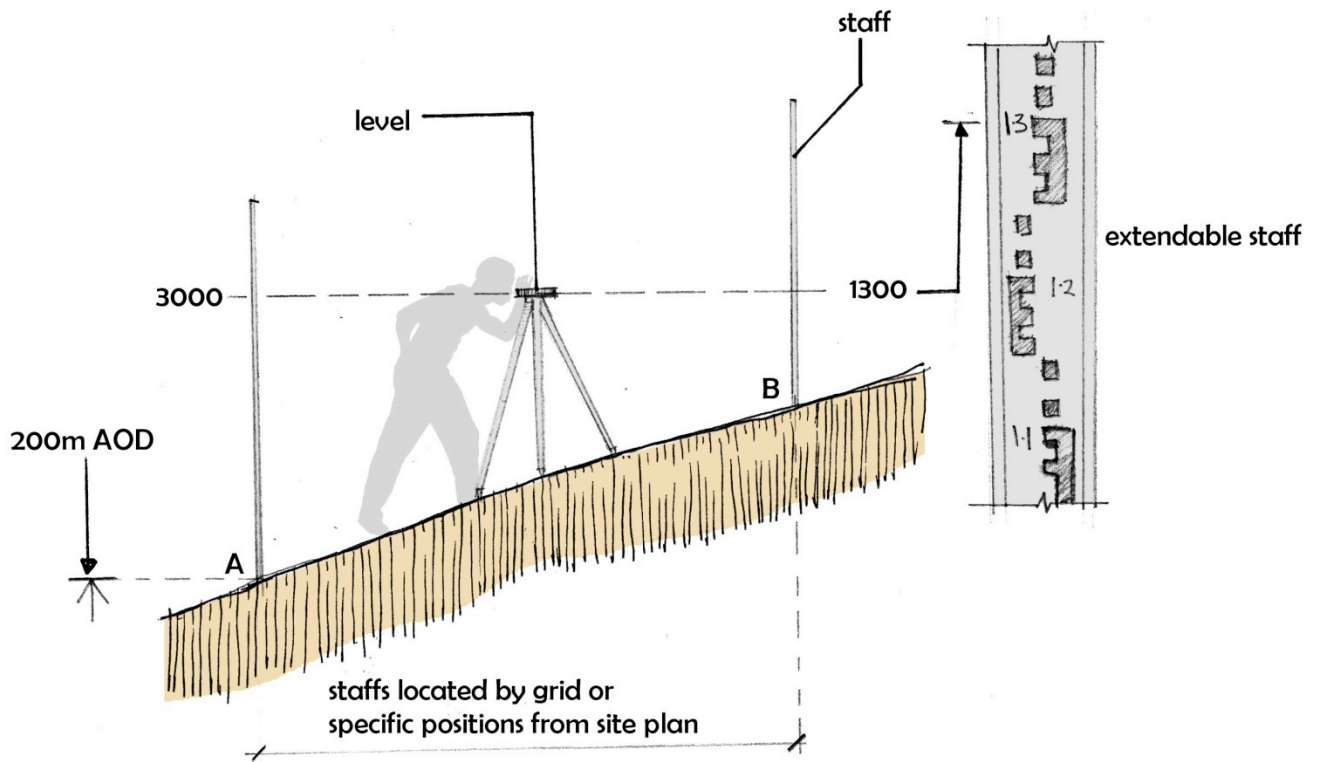

## Setting Out Angles

The instrument used is a Theodolite. A Theodolite is a tripod-mounted instrument designed to measure angles in the horizontal or vertical plane.

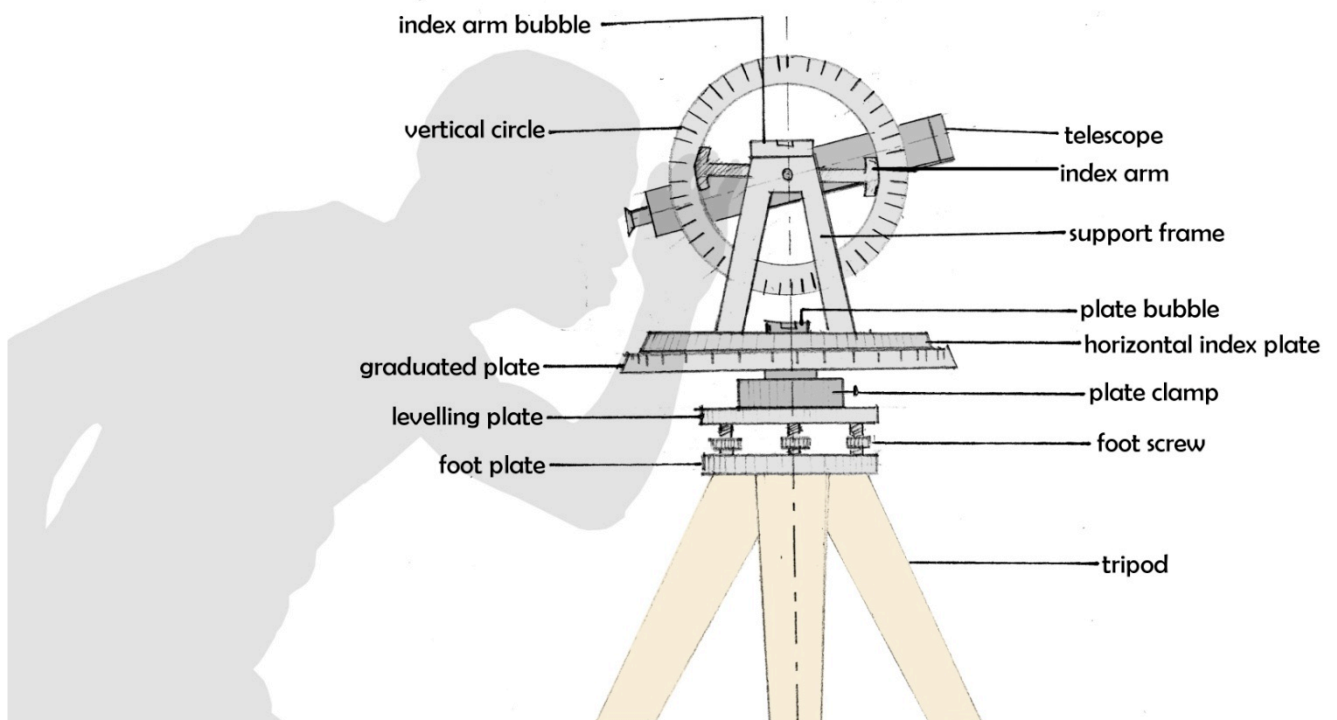

# SITE OPERATIONS

**Reference:** Chudley R., & Greeno R. (2006) Building Construction Handbook, 6<sup>th</sup> Edition Butterworth-Heinemann, Oxford pgs. 147 – 155 and 251 - 256

Refer to Building Regulations Clause A12 – Street Levels and F4 – Preparation of sites.

## EXCAVATIONS

(Refer to Part G: Excavations of the National Building Regulation, Clause G1 – General Stability Requirements which states that: “Where any excavation is to be carried out on any site and it may impair the property or service, such measures shall be taken by the owner of such site as may be sufficient to ensure that such stability is maintained.”)

### Types of Excavation:

1. **Oversite Excavation:** that is the removal of compressible topsoil or termite infested soil (Building Regulations Requirement).

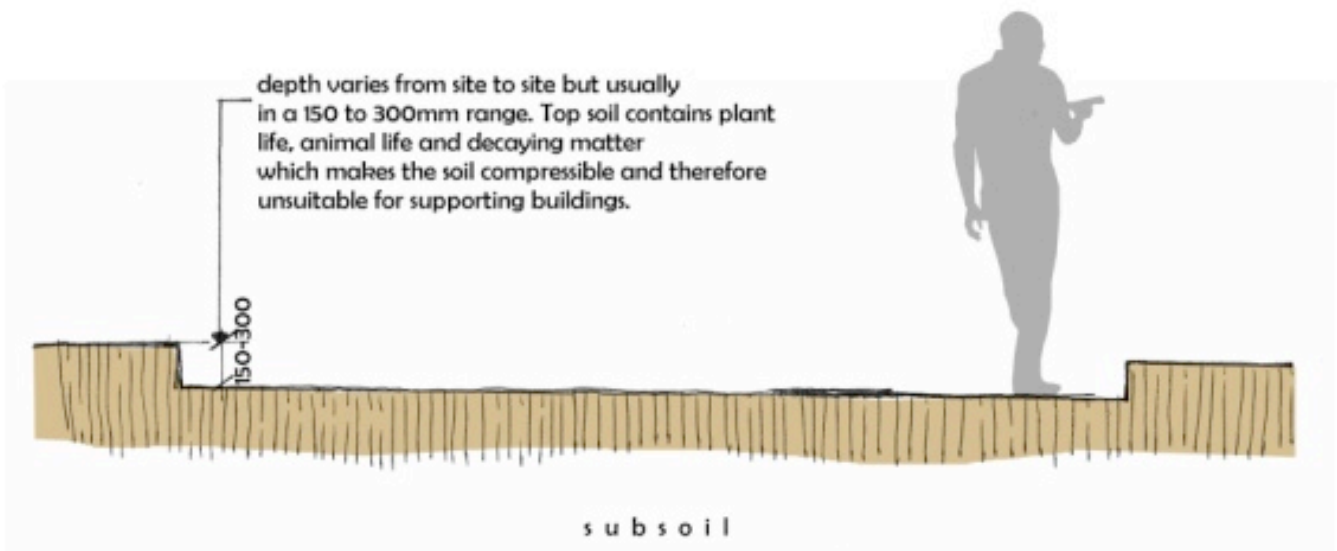

2. **Excavation to Reduced Levels:** this is carried out below the **oversite level** to form a level surface on which to build. Sometimes, it consists of cutting and filling operations. The level to which the ground is reduced is called the **formation level**.

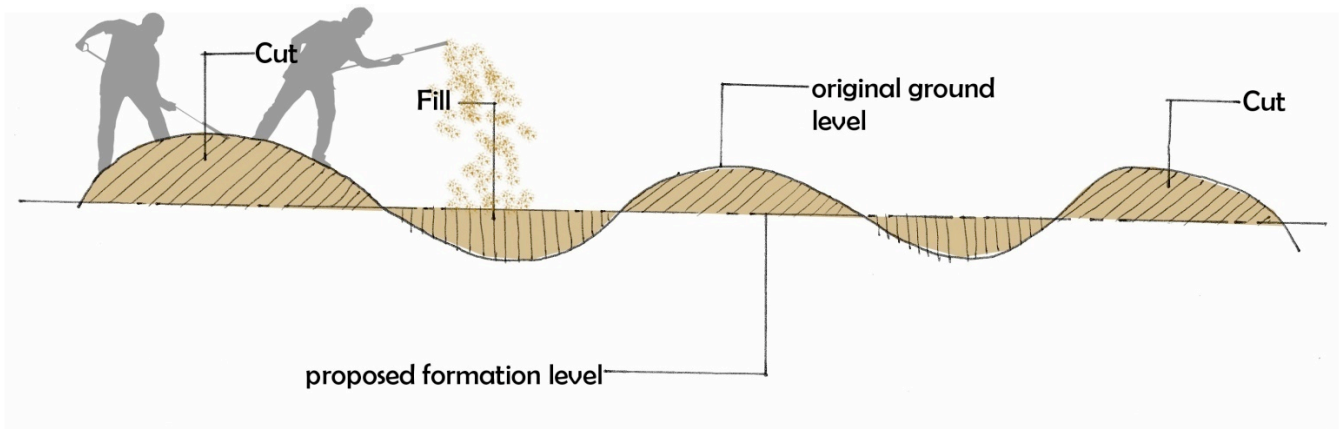

3. **Trench Excavations:** These are narrow and linear excavations primarily for strip foundations and buried services such as water pipes, electrical cabling, telephone services etc.

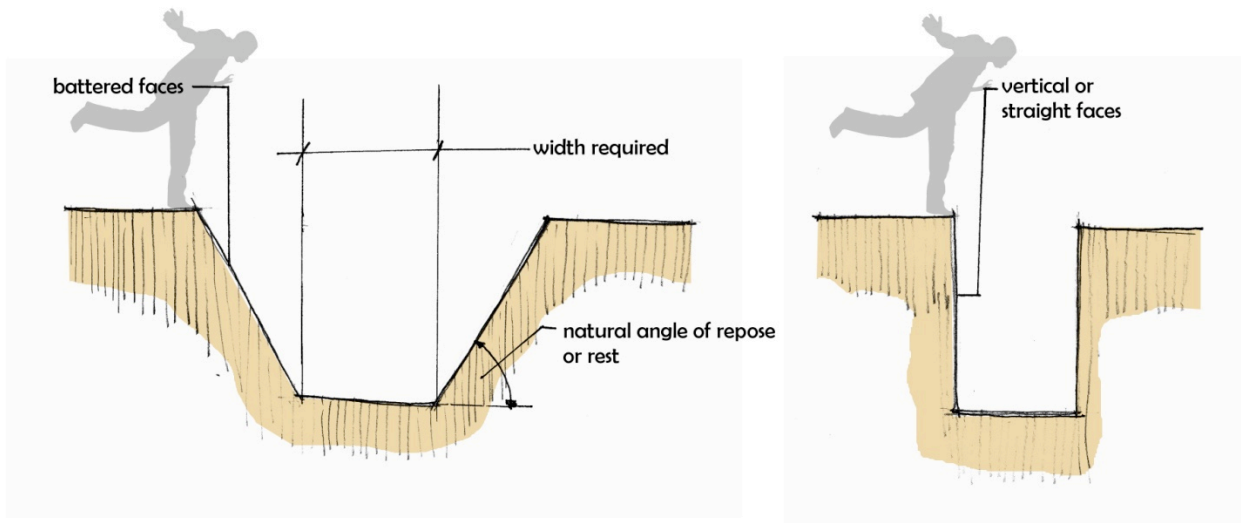

Examples of trench excavations are the **battered faces** and the **vertical/straight faces**. The advantage of the former is that no **temporary support** is required for the sides of the excavation because the soil is at a natural angle of repose/rest whilst its disadvantage, which is the advantage of the latter, is that it involves **extra cost** for excavation and **backfilling**.

4. **Pit Excavation:** these are isolated pits used for the construction of pad foundations for columns and piers or for the construction of soak away pits/manholes. The sides of the pit excavation can be either battered or straight as described above with the attendant advantages and disadvantages.

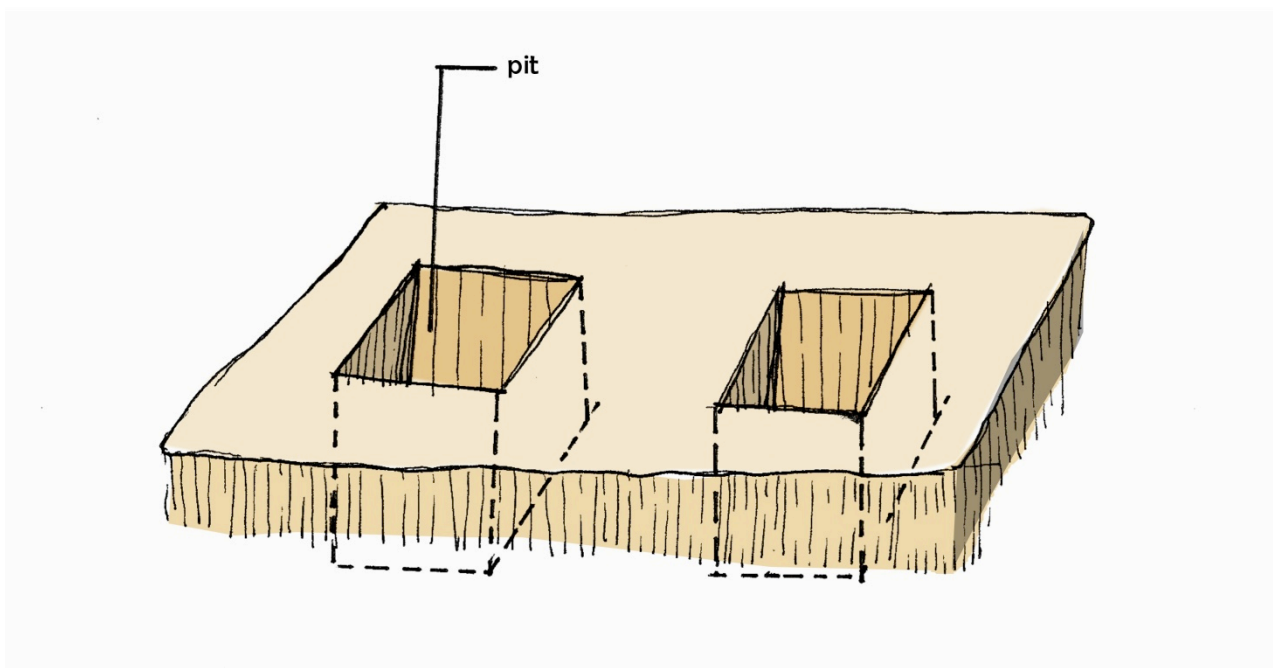

# METHODS OF EXCAVATION

There are two methods of excavation ~

1. The Manual Method and
2. The Mechanical Method.

Whilst the **manual method** of excavation uses mainly hand labour for forming excavations, the **mechanical method** of excavation makes use of machinery whose motive power is provided by either an internal combustion engine or by an external electric motor.

Furthermore, whilst the manual method of excavation is used on relatively small jobs or very restricted sites, the mechanical method of excavation is used on large public works projects and building sites.

## Use of Mechanical Plant vs. Manual labour

Mechanical plant can be considered for use on site for one or more of the following reasons:

### a. General Considerations

- i. Increased production.
- ii. Reduction in overall construction costs.
- iii. Carry out activities, which cannot be carried out by the traditional manual methods in the context of economics.
- iv. Eliminate heavy manual work thus reducing fatigue and as a consequence increasing productivity.
- v. Replacing labour where there is a shortage of personnel with the necessary skills.
- vi. Maintain the high standards required particularly in the context of structural engineering works.

### b. Economic Considerations

- i. The introduction of plant does not always result in economic savings since extra temporary siteworks such as road works, hardstandings, foundations and anchorages may have to be provided at a cost, which is in excess of the savings made by using the plant.
- ii. The site layout and circulation may have to be planned around plant positions and movements.
- iii. Plant must be fully utilized and not left standing idle in order for it to be economic, because whether hired or owned, plant will have to be paid for even if it is non-productive. Full utilization of plant is usually in the region of 85% of on site time.
- iv. Many pieces of plant work in conjunction with other items of plant such as excavators and their attendant haulage vehicles therefore a correct balance of such plant items must be obtained to achieve an economic result.

### c. Maintenance Considerations

Need for plant repair workshops and a skilled mechanic on site.

## Tools Used in Manual Excavation

These include: Shovels, Diggers, Pick Axes and Spades.

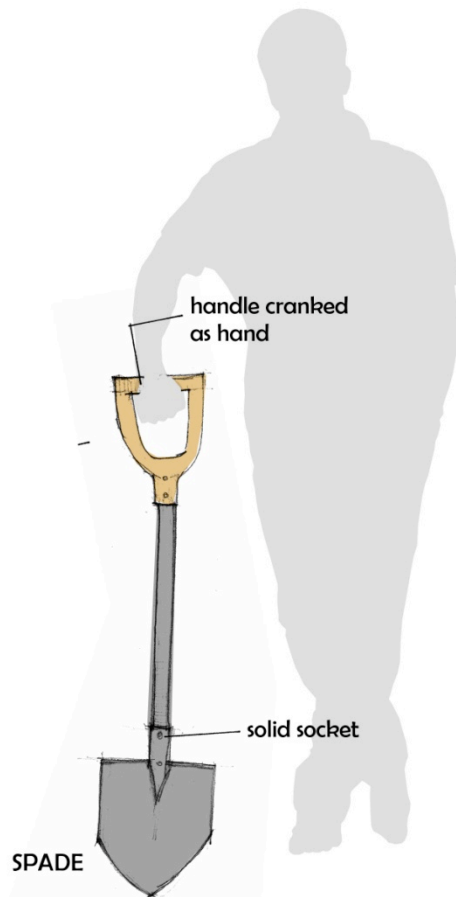
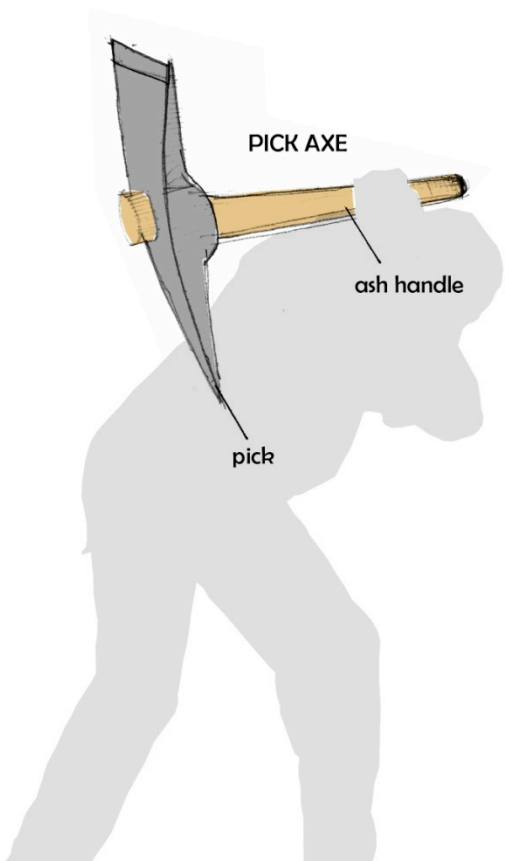
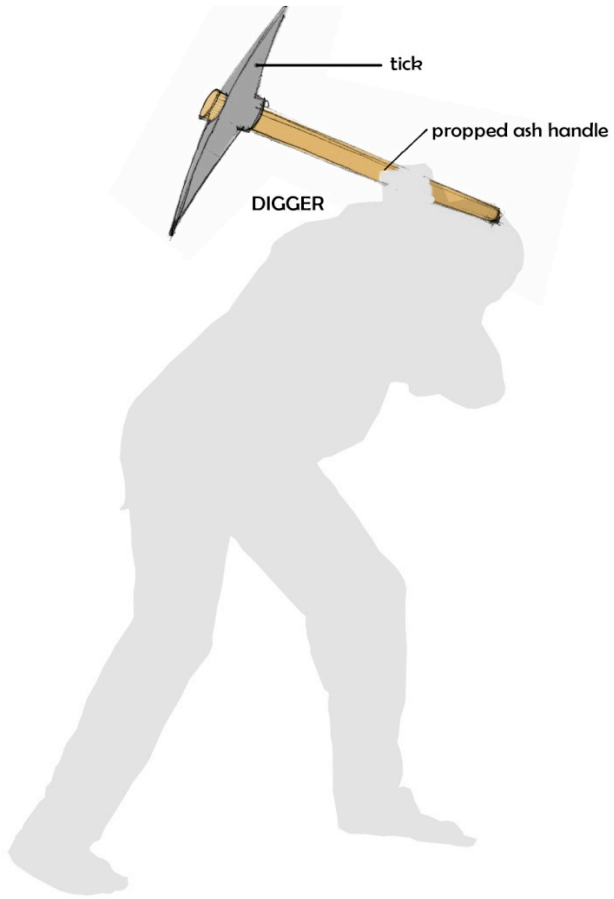
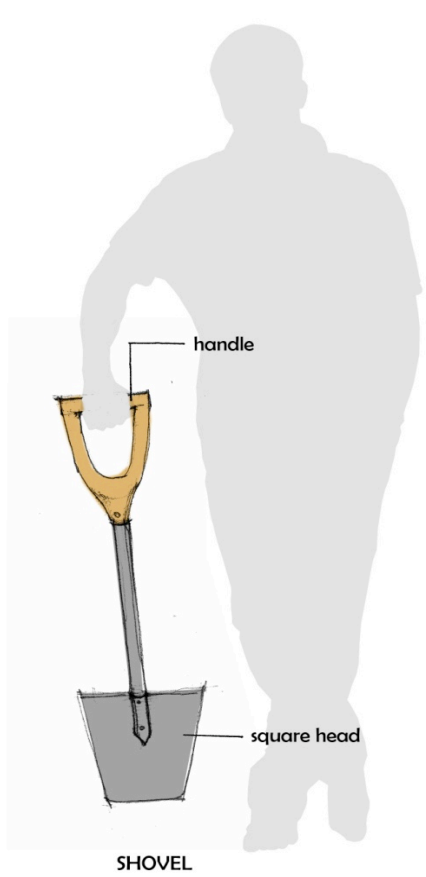

# PRINCIPAL MACHINES USED FOR CLEARING & EXCAVATION

## A. Site Clearance and removal of Top Soil ~

On relatively small sites, this could be carried out by manual means using hand held tools such as picks, shovels and wheelbarrows.

On all sites except in restricted areas, mechanical methods could be used. The actual plant employed being dependent on factors such as ~

- i. The volume of soil involved,
- ii. Nature of site and;
- iii. The time required for excavation.

For clearing of top soil where the upper level of earth cleared is usually not exceeding 300mm deep, the mechanical plants used are ~

- i. The mechanical shovel for cut only operations and
- ii. The bulldozers for cut and fill operations.

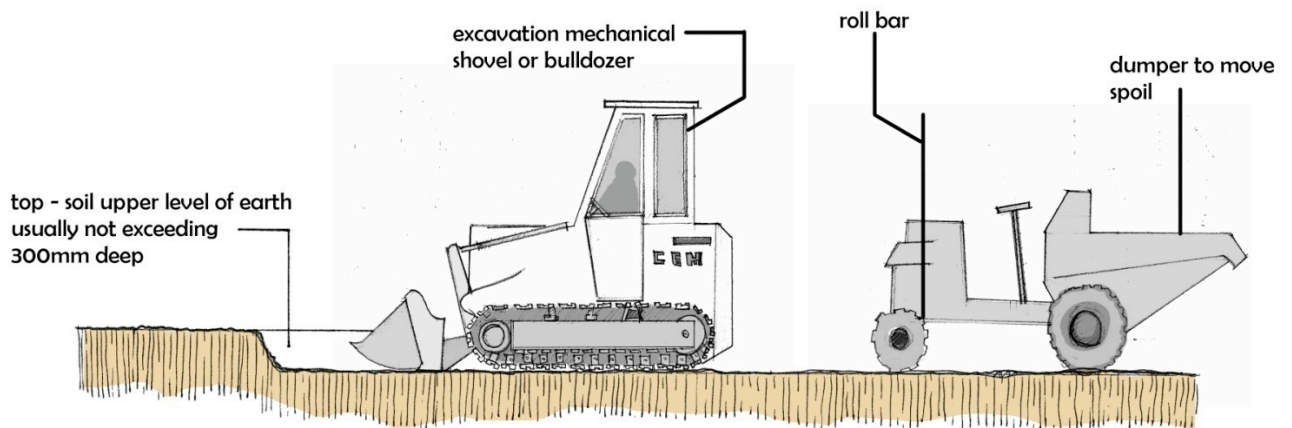

## B. Reduced Level Excavations ~

On small sites, hand processes can be used as stated above.

On all sites, mechanical methods could be used dependent on factors given above.

For reduced level excavation, the mechanical plants used are also ~

- i. The mechanical shovel for cut only operations and
- ii. The bulldozers for cut and fill operations.

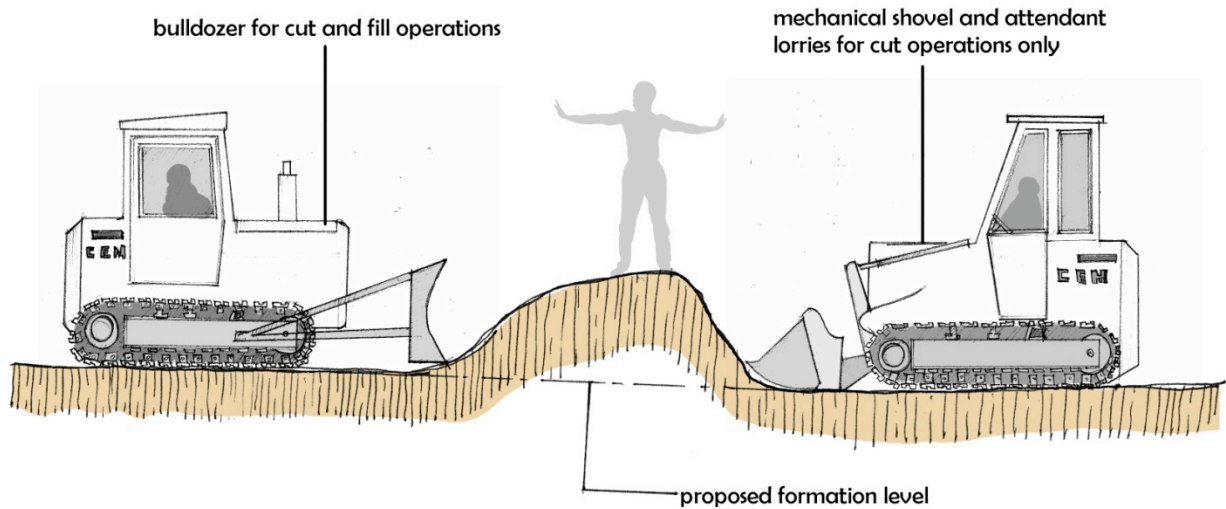

### C. Trench and Pit Excavations ~

On small sites – hand processes as given above are used on site but if depth of excavation exceeds 1.20m, some other method of removing spoil from the excavation will have to be employed.

On all sites, mechanical methods dependent on the factors given above could be used for trench and pit excavation. The mechanical plants used are ~

- i. The Backactor and
- ii. The Face Shovel

#### The Backactor / Drag Shovel

This machine digs below its own level and because it can be firmly held while excavating, it

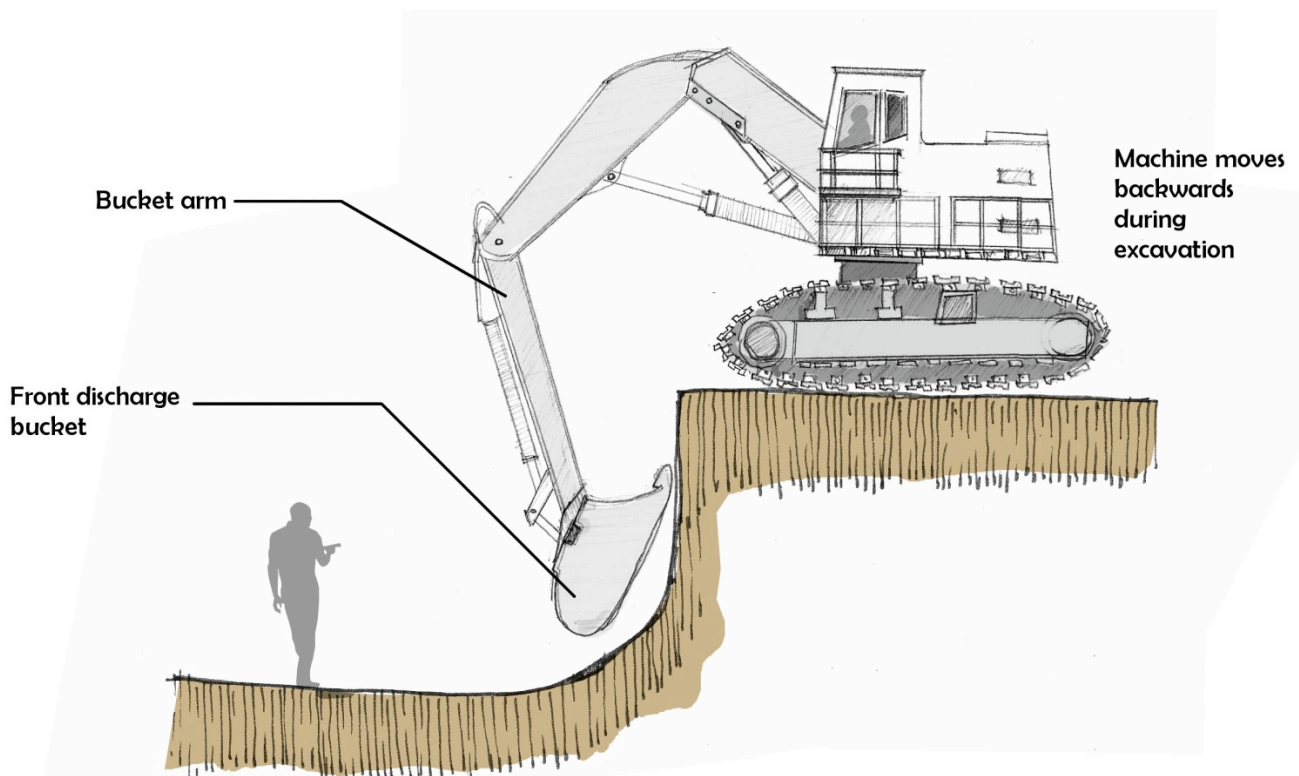

can dig heavy soils like clay and loose rocks, gravel etc. It is chiefly employed for digging

trenches for foundations and drains, sewers, water pipes etc. It is used also for excavating basements, especially on confined sites, which preclude the use of the shovel at the required level.

### The Face Shovel

The revolving frame with its superstructure is Caterpillar mounted. The machine can thus operate over rough ground and climb steep gradients. It can be rotated full circle. The shovel is the most powerful of the excavators, as the “cutting power” is concentrated on the firmly held bucket. It is therefore very suitable for excavating heavy material such as clay and loose rocks. Although essentially used for upward and forward cutting, the shovel can excavate to a limited extent below ground level.

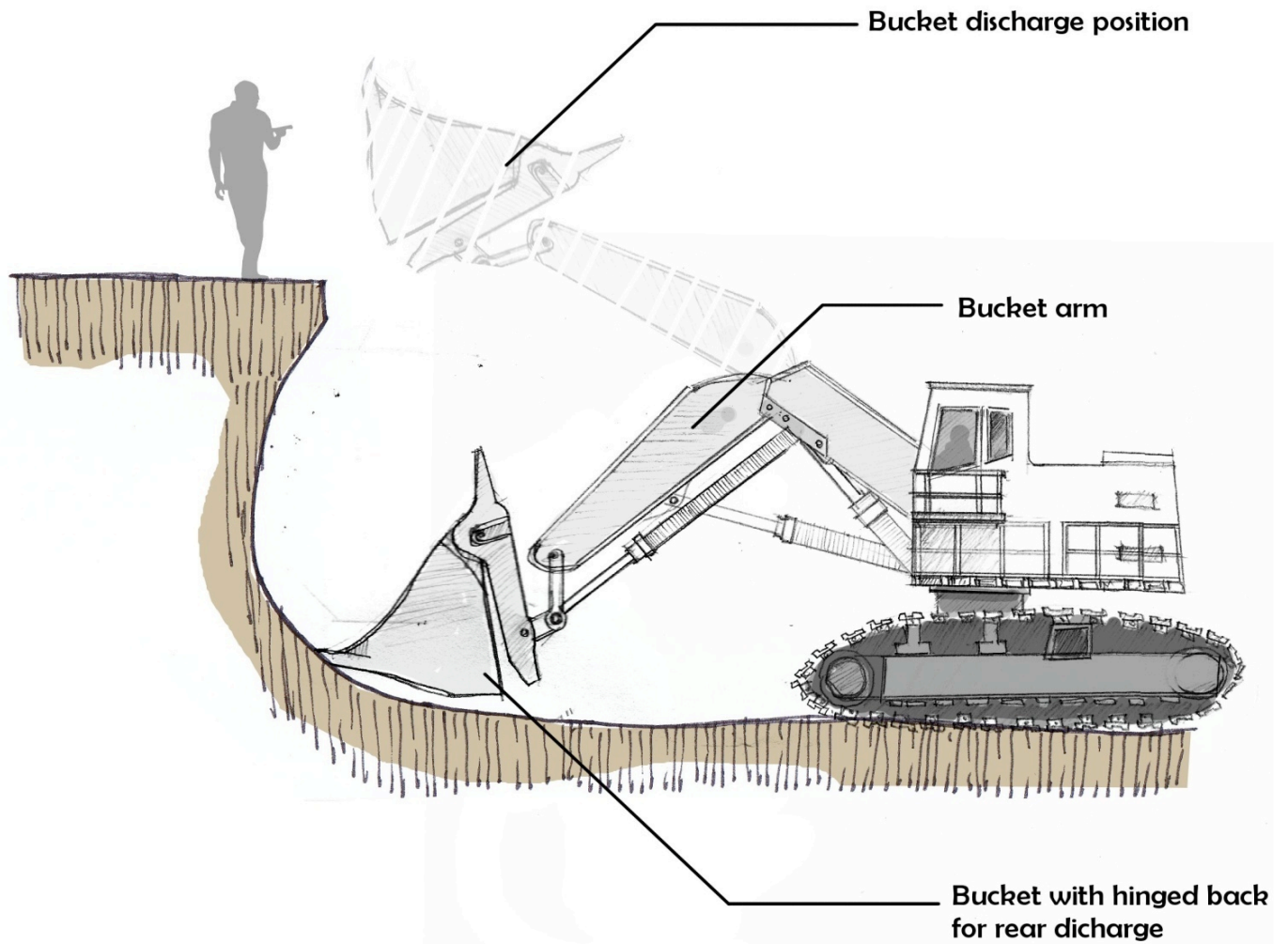

# TEMPORARY/EARTHWORK SUPPORT TO EXCAVATIONS UP TO 2.5M DEEP

Excavation for foundation trenches, pits and drains are one of the most dangerous areas where site operatives are employed because all subsoil's have different abilities in remaining stable during excavation works. Most will assume a natural **angle of repose** or rest unless given temporary support.

Therefore, adequate supply of timber supports and props to withstand earth pressure on open trenches are necessary. Trench support has acquired the term **timbering or planking and strutting**, implying timber components. Whilst timber is often the most convenient

material for shallow trenches as seen in the adjacent drawing ~

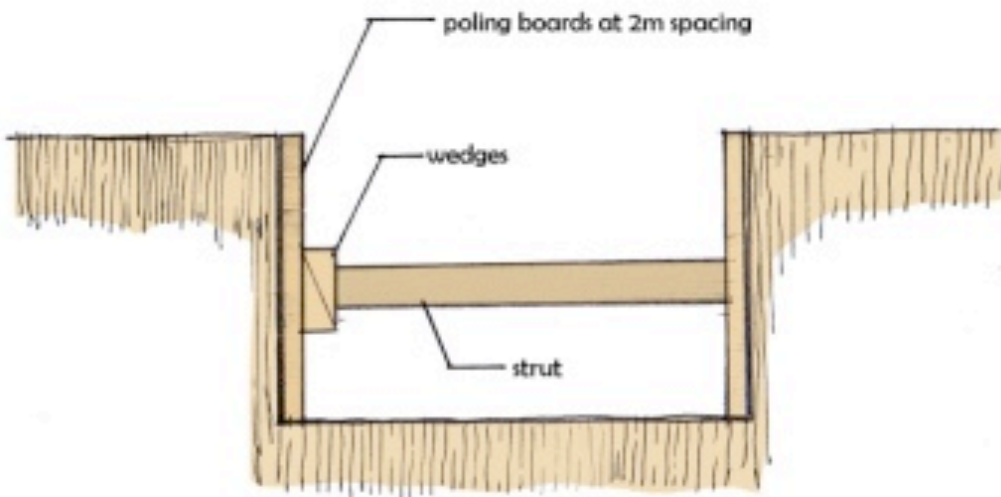

**Steel interlocking poling boards** are often used for deep waterlogged subsoil.

**Adjustable steel struts** are also more convenient and have considerable re-use value for all depths of excavation.

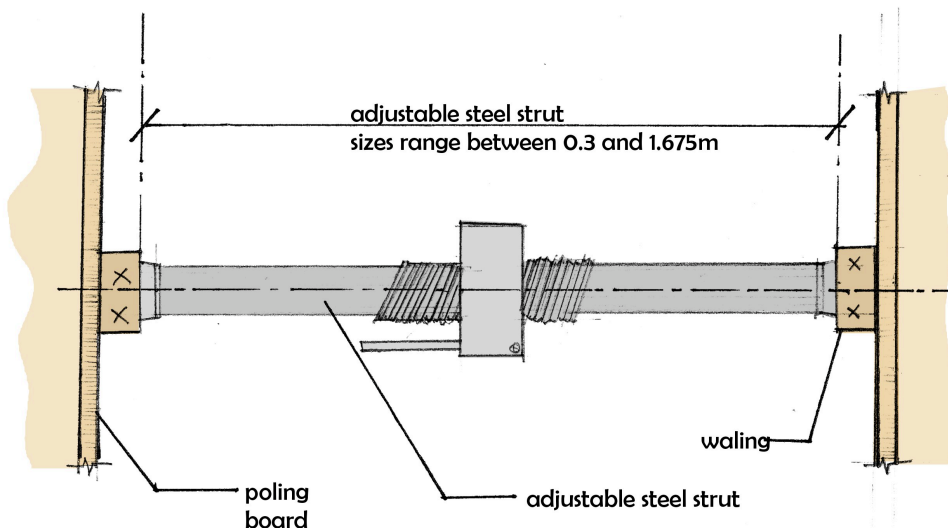

In reasonably/moderately firm subsoil such as stiff clay and hard clay, **poling boards** face the subsoil with direct support from **struts** or longitudinal support from **horizontal waling** as shown below ~

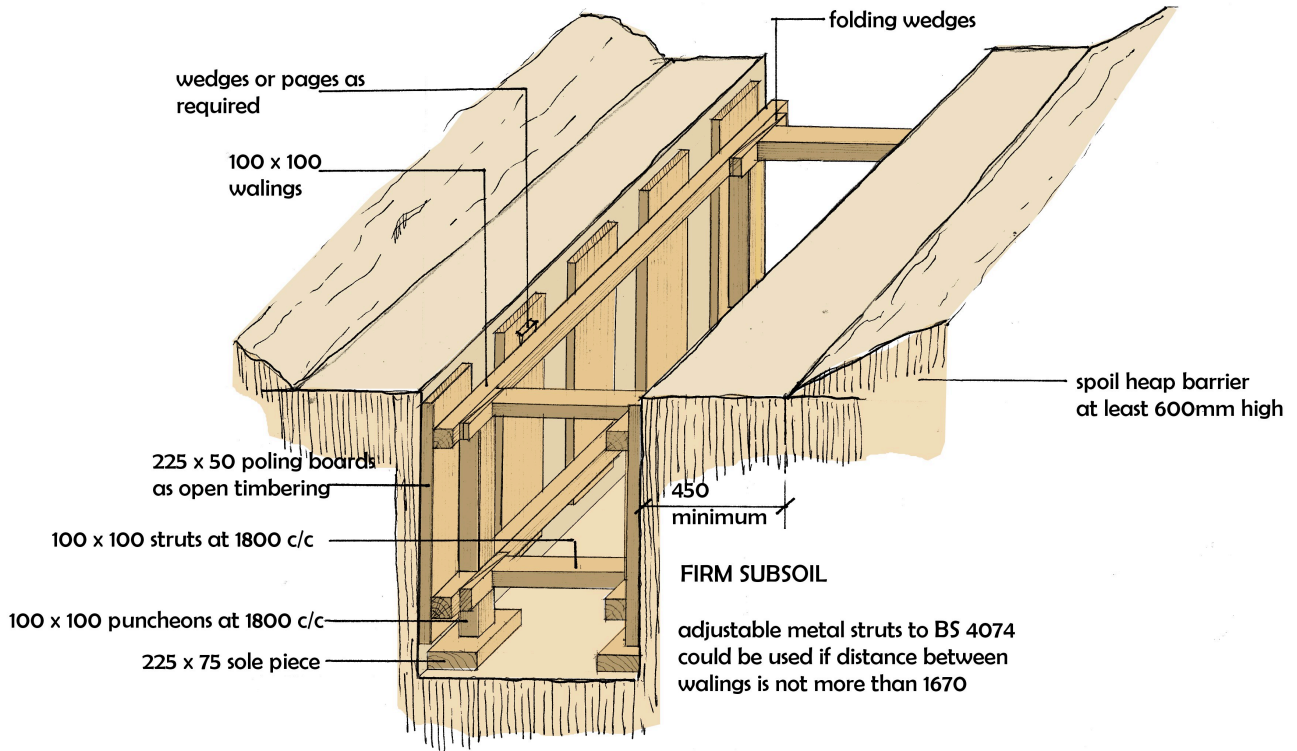

Used in this way, the horizontal waling ranges in size from 75 x 100mm to 225 x 50mm.

**In loose or saturated subsoils** such as wet clay, gravel, loose rocks, dry sand and wet sand, 225 x 50mm runners/poling as close timbering may be used to totally sheet or board the trench by directly facing the subsoil as shown below ~

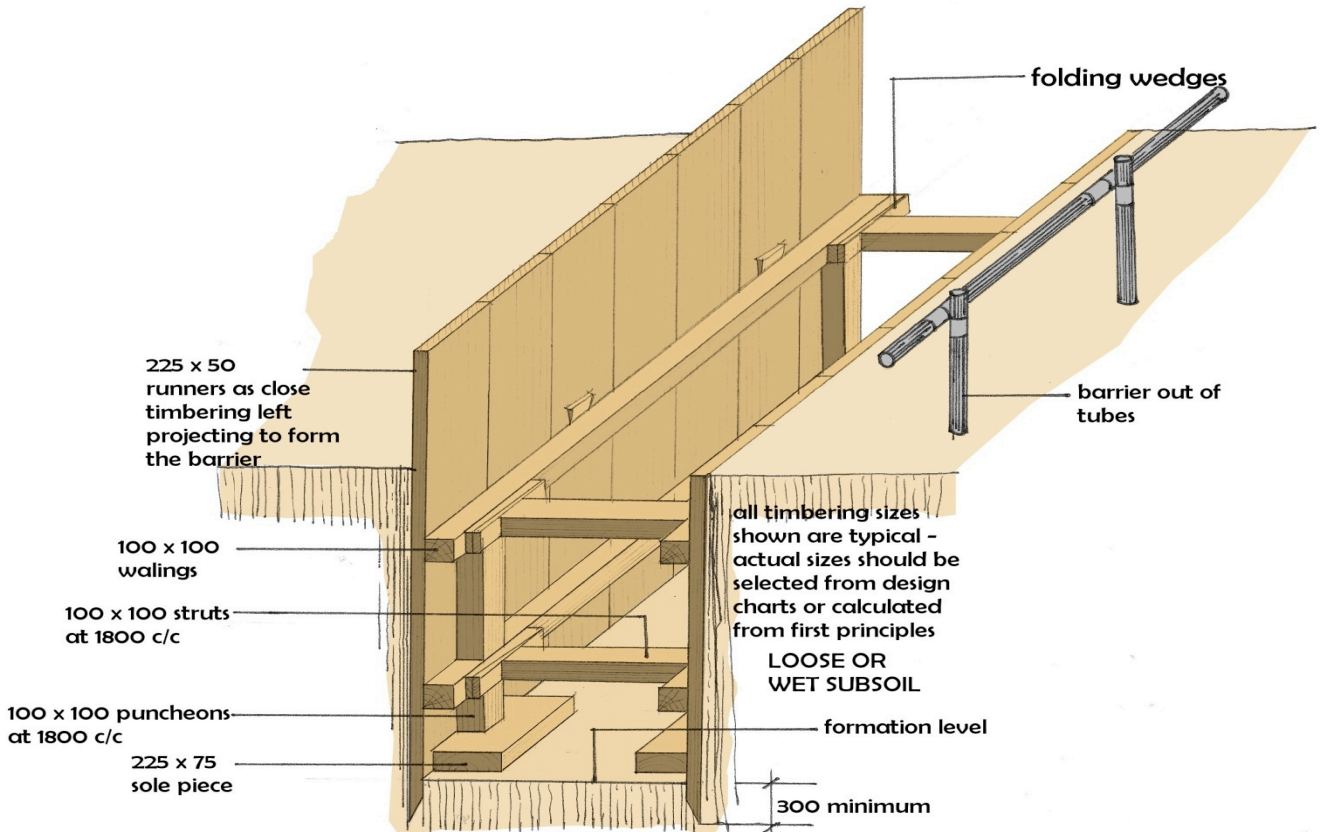

**Struts** should be designed to resist opposing subsoil thrust and earth pressure. Struts may be overcut in length and driven in place by a sledgehammer. Otherwise they are cut slightly under length and wedged between waling and poling. Square timber sections of 75 x 75mm or 100 x 100mm section are usually the most suitable.

## Leveling and Bottoming of Trenches ~ Use of Leveling Rods and Boning Pegs

**Leveling rods** or **leveling** staffs are straight rods or bars designed for use in measuring a vertical distance between a point on the ground and the line of collimation of a leveling instrument which has been adjusted to a horizontal position; it is usually made of wood with a flat face which is graduated in terms of some linear units and fractions thereof, the zero of the graduations being at one end of the rod. The leveling rod is used to indicate whether any part of a horizontal surface is higher than another.

**Boning pegs** are small hard wood cubes located and driven into the ground so that their tops are in a line marking a desired gradient.

**Leveling and bottoming of trenches** is the process whereby heights of certain points in the trenches are measured with the use of leveling rods in order to establish if the depth of the trench is uniform across the excavation and if not, boning pegs are used to mark the desired gradient and then leveling off the bottom of the trenches as shown below.

