

The copyright of this thesis vests in the author. No quotation from it or information derived from it is to be published without full acknowledgement of the source. The thesis is to be used for private study or non-commercial research purposes only.

Published by the University of Cape Town (UCT) in terms of the non-exclusive license granted to UCT by the author.



**UNIVERSITY OF CAPE TOWN**  
IYUNIVESITHI YASEKAPA • UNIVERSITEIT VAN KAAPSTAD

---

**AN INVESTIGATION INTO USING RAMMED STONE  
COLUMNS FOR THE IMPROVEMENT OF A SOUTH  
AFRICAN SILTY CLAY**

**Laxmee Sobhee-Beetul**

**Bachelor of Science (Eng.) in Civil Engineering**

**University of Cape Town, 2010**

**A thesis submitted to the University of Cape Town in partial fulfilment of  
the requirement for the degree of Master of Science in Engineering**

Department of Civil Engineering | University of Cape Town | November 2012

## DECLARATION

1. Plagiarism is to use another's work and to pretend that it is one's own. I know that plagiarism is wrong.
2. I have used the Harvard convention for citation and referencing. Each significant contribution to and quotation in this report from the work or works of the other people has been attributed and has been cited and referenced.
3. This report is my own work.
4. I have not allowed and will not allow anyone to copy my work with the intention of passing it off as his or her own work.

.....  
Laxmee Sobhee-Beetul  
SBHLAX001

University of Cape Town

## ACKNOWLEDGEMENTS

First and foremost, I praise God, the merciful and passionate, for the support and blessings throughout this journey.

I offer my love and gratitude to my parents, Mr Ramraj K.Sobhee and Mrs Savitri Sobhee, who gave all they could to help me achieve my dreams.

There are no words to describe the love for my husband, Ashvind Beetul, who supported me through this thesis, especially when the work had come to a standstill. Thank you sweetheart for always being there for me.

The opportunity to study for this degree was given by Dr Denis Kalumba who very willingly agreed to supervise me. Words are lacking to describe my appreciation for him. He has been an excellent supervisor whose guidance I have always appreciated. Thank you very much for motivating me and guiding me all the way through.

A special thank you for the financial support received from the Geotechnical Engineering Research Group at the University of Cape Town.

I acknowledge the assistance received from UCT Civil Engineering staff. A particular word of appreciation for the Geotechnical laboratory manager, Mr Noor Hassen, and the chief technical officer, Mr Charles Nicholas, in the workshop who were always ready to help me in difficult times during my experiments.

Special recognition for Esorfranki, Cape Town, for allowing access to their site in District Six to collect the Cape Town clay which was the primary base material in this research.

A big thank you to the postgraduate Civil Engineering students who were always willing to help in lifting the box – Matteo, Rakesh, Marco, Tom, Philemon, Ramonate, Mbongeni, Michael, Masuzyo, Keketso, Nicholas, Emmanuel, Patrick, Kabani and Charles.

Over the years, many people and institutions have provided their help, support and cooperation in countless ways. I extend my gratitude to all of them. Thank you everyone and God bless you all.

Laxmee Sobhee-Beetul

SBHLAX001

## **DEDICATION**

To my supervisor, Dr Denis Kalumba

University of Cape Town

## ABSTRACT

Ground improvement is the term used to describe the act of modifying the soil properties in geotechnical engineering. It is often required when the existing ground conditions do not meet the requirements for a construction project. The techniques of improving the ground are many and they usually aim at reducing settlement, increasing bearing capacity, mitigating liquefaction, improving drainage, retaining unstable soils or remediating contaminated soils. Among these techniques, stone column technology which was pioneered in the 1950s' aimed at improving both cohesive soils and silty sands. Although the technique has been used successfully in many advanced countries, its application in South Africa is minimal. This limited use is associated with a lack of research, instrumented case studies and design specifications pertaining to local ground conditions.

In this investigation, the behaviour of rammed stone columns installed in a South African clay (sourced from District Six in Cape Town) was studied through extensive laboratory tests conducted in a specifically designed rectangular wooden tank. A testing programme was established whereby the majority of the tests were conducted on the local clay, with a few performed on Kaolin for comparison purposes. The effect of moisture content (OMC, LL and 1.2LL) of the base soil specimen, the column diameter (50 mm, 70 mm and 100 mm) and the column material (Klipheuwel sand, Cape Flats sand and crushed aggregate) on the normal compressive stress applied up to a settlement of 50 mm were studied. The vertical stresses and settlements were recorded electronically and analysed.

Results indicated an increase in vertical applied stress with a simultaneous reduction in settlement when improving Cape Town clay with rammed stone columns. The in-depth analysis showed that the vertical bearing stresses were generally higher with larger columns, irrespective of the column material and the moisture content of the base soil. Furthermore, 100 mm diameter crushed aggregate columns repeatedly exhibited higher improvement compared to identical columns made out of sand. Nevertheless, for smaller columns the coarser sand (Klipheuwel) performed better than all three column materials. In general, columns failed in bulging with the maximum bulge occurring within the top third of the column. This study deepened the understanding of the performance of rammed stone columns in fine grained soils. The results obtained recommended full scale investigations with a view of applying the technology in slope stability, strip footing foundations and supporting lightweight structures.

## TABLE OF CONTENTS

<b>DECLARATION</b> .....	<b>ii</b>
<b>ACKNOWLEDGEMENTS</b> .....	<b>iii</b>
<b>DEDICATION</b> .....	<b>iv</b>
<b>ABSTRACT</b> .....	<b>v</b>
<b>TABLE OF CONTENTS</b> .....	<b>vi</b>
<b>LIST OF FIGURES</b> .....	<b>x</b>
<b>LIST OF TABLES</b> .....	<b>xv</b>
<b>NOTATIONS</b> .....	<b>xvi</b>
Introduction .....	1
<b>1.1 Introduction</b> .....	<b>2</b>
<b>1.2 History</b> .....	<b>3</b>
<b>1.3 Justification of study</b> .....	<b>3</b>
<b>1.4 Research objectives</b> .....	<b>4</b>
<b>1.5 Scope and limitations of this study</b> .....	<b>5</b>
<b>1.6 Overview</b> .....	<b>5</b>
Ground Improvement Techniques .....	7
<b>2.1 Introduction</b> .....	<b>8</b>
<b>2.2 Ground improvement techniques</b> .....	<b>8</b>
2.2.1 Hydraulic Method .....	8
2.2.1.1 <i>Preloading</i> .....	8
2.2.1.2 <i>Vertical Drains</i> .....	12
2.2.1.3 <i>Ground Freezing</i> .....	14
2.2.2 Chemical Method.....	16
2.2.2.1 <i>Grouting</i> .....	16
2.2.3 Inclusions .....	20
2.2.3.1 <i>Geosynthetics</i> .....	20

2.2.4 Mechanical Method .....	22
2.2.4.1 <i>Dynamic Compaction</i> .....	22
2.2.4.2 <i>Stone columns</i> .....	25
<b>2.3 Summary of the characteristics of the discussed techniques .....</b>	<b>28</b>
A Review of Rammed Stone Columns.....	30
<b>3.1 Introduction.....</b>	<b>31</b>
<b>3.2 Installation process .....</b>	<b>31</b>
<b>3.3 Theory behind stone columns .....</b>	<b>33</b>
3.3.1 Characteristics of the most typical base soils .....	33
3.3.2 Design principles .....	34
3.3.2.1 <i>Stone columns dimensions</i> .....	34
3.3.2.2 <i>The unit cell concept</i> .....	36
3.3.2.3 <i>Ultimate vertical stress for individual stone columns</i> .....	37
3.3.2.5 <i>Settlement of stone column foundations</i> .....	39
3.3.3 Effect of column inclusion on the base soil .....	41
3.3.4 Failure mechanism of stone columns.....	42
<b>3.4 Previous research on rammed stone columns .....</b>	<b>45</b>
3.4.1 Previous laboratory effort into rammed stone column investigation.....	45
3.4.2 Field studies .....	54
<b>3.5 Summary of literature .....</b>	<b>63</b>
Research Materials and Methodology .....	65
<b>4.1 Introduction.....</b>	<b>66</b>
<b>4.2 Materials .....</b>	<b>66</b>
4.2.1 Soil characterisation tests.....	66
4.2.2 Base soils .....	67
4.2.3 Column materials .....	69
<b>4.3 Methodology .....</b>	<b>71</b>

4.3.1 Testing programme .....	71
4.3.2 Apparatus and equipment used in the laboratory tests.....	73
4.3.2.1 Testing machine.....	73
4.3.2.2 Equipment used in the preparation of the test specimens .....	73
4.3.3 Preparation of materials .....	77
4.3.4 Experimental procedures .....	78
4.3.4.1 Improved clay tests.....	78
4.3.4.2 Control tests .....	80
4.3.4.3 Repeatability tests.....	81
4.3.5 Testing.....	81
4.3.6 Quality Assurance .....	83
4.3.7 Data processing.....	83
4.3.7.1 Vertical applied stress .....	83
4.3.7.2 Stress concentration ratio .....	84
4.3.7.2 Settlement reduction ratio .....	84
<b>4.4 Summary.....</b>	<b>84</b>
Results, Analysis and Discussions .....	86
<b>5.1 Introduction.....</b>	<b>87</b>
<b>5.2 Results .....</b>	<b>87</b>
5.2.1 Repeatability of results .....	87
5.2.2 Stress-settlement behaviour of stone columns .....	88
5.2.2.1 Effect of diameter .....	89
5.2.2.2 Effect of column material .....	94
5.2.2.3 Effect of moisture content.....	98
<b>5.3 Analysis and Discussions .....</b>	<b>102</b>
5.3.1 Stress-concentration ratio.....	103
5.3.1.1 Effect of diameter .....	103

5.3.1.2 <i>Effect of column material</i> .....	105
5.3.1.3 <i>Effect of moisture content</i> .....	107
5.3.2 Settlement reduction ratio .....	109
5.3.3 Comparison of the behaviour of stone columns in kaolin with those in Cape Town clay under similar conditions.....	114
5.3.4 Failure mechanism of selected columns .....	115
<b>5.4 Applications</b> .....	<b>120</b>
Conclusions .....	123
<b>6.1 Introduction</b> .....	<b>124</b>
<b>6.2 Conclusion</b> .....	<b>124</b>
6.2.1 Stress-settlement behaviour .....	124
6.2.2 Stress concentration ratio, n.....	125
6.2.3 Settlement reduction ratio, SRR .....	125
6.2.4 Comparison of Kaolin with Cape Town clay .....	125
6.2.5 Failure mechanism of coarser columns at LL and 1.2LL .....	125
<b>6.3 Recommendations</b> .....	<b>126</b>
References .....	127
Appendices .....	134

## LIST OF FIGURES

Figure 2.1: Preloading through an embankment prior to construction of the final structure (Stapelfeldt, 2012) .....	9
Figure 2.2: Installation pattern (square and triangular) of vertical drains (Stapelfeldt, 2012).....	13
Figure 2.3: Application of ground freezing in a tunnel excavation (Bilfinger Berger, 2012).....	14
Figure 2.4: Common grouting techniques (Hayward Baker, 2012) .....	19
Figure 2.5: Different types of geosynthetics (a) Geogrids, (b) Geotextiles, (c) Geomembranes and (d) Geocells (GGPL, 2012) .....	20
Figure 2.6: Application of a geogrid in the sub-base during the construction of a highway across a marsh area (Tensar, 2008).....	21
Figure 2.7: Weight being dropped on the ground to densify soil through the vibratory waves (Hayward Baker, 2012) .....	23
Figure 2.8: Installation process of vibro-displacement stone columns (Vibro Menard, 2012).....	26
Figure 2.9: Installation process of vibro-replacement stone columns (Hayward Baker, 2012).....	26
Figure 3.1: Stone column installation by the ramming method (pre-bored with temporary casing for support) .....	32
Figure 3.2: Rammed stone column installation by repeated pounding (Kruger <i>et al</i> , 1980).....	33
Figure 3.3: Tributary pattern for (a) triangular and (b) square installation (Zahmatkesh and Choobbasti, 2010).....	35
Figure 3.4: A typical unit cell indicating the effective diameter, $D_e$ (Goughnour, 1983). .....	37
Figure 3.5: Stresses when loading (a) a friction pile and (b) a stone column (Hughes and Withers, 1974) .....	38
Figure 3.6: Settlement of an embankment on a stone column foundation .....	41

Figure 3.7(a): Failure modes of rammed stone columns in non-homogeneous cohesive soils (After Ghanti and Kashliwal, 2008).....	43
Figure 3.7(b): Failure modes of rammed stone columns in a homogeneous soft layer (After Ghanti and Kashliwal, 2008) .....	43
Figure 3.8: Failure modes of group of rammed stone columns (After Ghanti and Kashliwal, 2008).....	44
Figure 3.9: Stress-settlement behaviour for singular column (After Isaac and Madhavan, 2009).....	46
Figure 3.10: Stress-settlement behaviour for group of seven columns at a spacing of 3 times diameter-3D (After Isaac and Madhavan, 2009) .....	47
Figure 3.11: Stress-settlement behaviour for group of seven columns at a spacing of 2.5 times diameter-2.5D (After Isaac and Madhavan, 2009) .....	47
Figure 3.12: Single column test set-up for loading applied on (a) column area only, (b) entire area (Ambily and Gandhi, 2007) .....	48
Figure 3.13: Stress-settlement behaviour under entire area loading for (a) spacing to diameter ratio of 2, (b) spacing to diameter ratio 3 (Ambily and Gandhi, 2007).....	49
Figure 3.14: Stress-settlement relationship of unimproved and improved clay with different number of stone columns (After Karim <i>et al</i> , 2009) .....	51
Figure 3.15: Relationship between clay layer thickness and (a) load-settlement behaviour (b) settlement reduction ratio (Shivashankar <i>et al</i> , (2011) .....	52
Figure 3.16: The three zones of major concern on the site (Van der Westhuizen and Parrock, 2010) .....	55
Figure 3.17: RIC machine operating (Van der Westhuizen and Parrock, 2010).....	57
Figure 3.18: Settlement readings against time (Van der Westhuizen and Parrock, 2010) .....	58
Figure 3.19: Piezometer readings against time (Van der Westhuizen and Parrock, 2010) .....	58
Figure 3.20: Load test set-up on a singular column (Sundaram and Gupta, 2010).....	61
Figure 3.21: Load-settlement curve from load test of a singular column (Sundaram and Gupta, 2010).....	62

Figure 4.1: Base materials (a) Kaolin, (b) Cape Town clay .....	68
Figure 4.2: Column materials (a) Cape Flats sand, (b) Klipheuwel sand and (c) crushed aggregates .....	70
Figure 4.3: Experimental set-up (box on the Zwick Universal Testing machine connected to a computer).....	73
Figure 4.4: (a) Field scenario of row of columns with one column in the testing box, (b) Plan view of the row of columns .....	74
Figure 4.5: (a) Rectangular wooden box used for containing test specimen, (b) wooden board and (c) hand compactor for clay compaction at OMC .....	75
Figure 4.6: (a1) to (a3) Steel cylinders with corresponding diameters of 100 mm, 70 mm and 50 mm, (b1) to (b3) 2 kg hand compactors for the respective diameters, (c1) to (c3) loading plates of length 200 mm, 140 mm and 100 mm, (d1) and (d2) adaptors used with the collar for adjusting the column diameters to 70 mm and 50 mm respectively, (e1) to (e3) helical augers for each column, (f) collar attached to frame which is fitted on top of the box, (g) hand tamper and (h) cylinder for transferring the applied load to the loading plates. ....	76
Figure 4.7: Mechanical mixer used for mixing clay with water.....	77
Figure 4.8: Prepared wet clay in plastic storage container .....	78
Figure 4.9: Testing sample ready for the cutting process.....	79
Figure 4.10: Installed crushed aggregate column of diameter 100 mm .....	80
Figure 4.11: Prepared test specimen for the control test with loading plate of length 100 mm.....	81
Figure 4.12: (a) Schematic view of loaded system, (b) Prepared specimen in box on machine prior to testing .....	82
Figure 5.1: Repeatability of results for three selected tests at LL .....	88
Figure 5.2: Effect of column diameter on stress-settlement behaviour at OMC of base soil for columns from (a) Klipheuwel sand, (b) Cape Flats and (c) Crushed aggregates .....	91
Figure 5.3: Effect of column diameter on stress-settlement behaviour at LL of base soil for columns from (a) Klipheuwel sand, (b) Cape Flats and (c) Crushed aggregates .....	92

Figure 5.4: Effect of column diameter on stress-settlement behaviour at 1.2LL of base soil for columns from (a) Klipheuwel sand, (b) Cape Flats and (c) Crushed aggregates .....	93
Figure 5.5: Effect of column material on stress-settlement behaviour at OMC of the base soil for column diameters of (a) 50 mm, (b) 70 mm and (c) 100 mm.....	95
Figure 5.6: Effect of column material on stress-settlement behaviour at LL of the base soil for column diameters of (a) 50 mm, (b) 70 mm and (c) 100 mm.....	96
Figure 5.7: Effect of column material on stress-settlement behaviour at 1.2LL of the base soil for column diameters of (a) 50 mm, (b) 70 mm and (c) 100 mm.....	97
Figure 5.8: Effect of moisture content of base clay on stress-settlement behaviour for Klipheuwel sand columns of diameters (a) 50 mm, (b) 70 mm and (c) 100 mm.....	99
Figure 5.9: Effect of moisture content of base clay on stress-settlement behaviour for Cape Flats sand columns of diameters (a) 50 mm, (b) 70 mm and (c) 100 mm .....	100
Figure 5.10: Effect of moisture content of the base clay on stress-settlement behaviour for crushed aggregate columns of diameters (a) 50 mm, (b) 70 mm and (c) 100 mm .	101
Figure 5.11: Effect of column diameter on stress concentration ratio at (a) OMC, (b) LL and (c) 1.2LL.....	104
Figure 5.12: Effect of column material on stress concentration ratio at (a) OMC, (b) LL and (c) 1.2LL.....	106
Figure 5.13: Effect of moisture content of the base clay on stress concentration ratio for columns of (a) Klipheuwel sand (b) Cape Flats sand and (c) Crushed Aggregate.....	108
Figure 5.14: Effect of column diameter on settlement reduction ratio at (a) OMC, (b) LL and (c) 1.2LL.....	111
Figure 5.15: Effect of column material on settlement reduction ratio at (a) OMC, (b) LL and (c) 1.2LL.....	112
Figure 5.16: Effect of moisture content of the base clay on settlement reduction ratio for columns of (a) Klipheuwel sand (b) Cape Flats sand and (c) Crushed Aggregate.....	113
Figure 5.17: Comparison of stress-settlement behaviour of Cape Town clay with Kaolin .....	115
Figure 5.18: Plan of a deformed Cape Flats sand column in the box after testing.....	116

Figure 5.19: Top view of the test box indicating sections of a typically deformed column (not to scale) .....	116
Figure 5.20: Comparison of failure mechanism of Cape Flats sand columns at LL and 1.2LL .....	118
Figure 5.21: Comparison of the failure mechanism of Cape Flats sand and crushed aggregate columns at 1.2LL .....	119
Figure 5.22: (a) Cross-section of a strip footing supported on 3 rows of stone columns, (b) Cross-section of a two storey house supported on 6 rows of stone columns, (c) Cross-section of an oil storage tank supported on 6 rows of stone columns, (d) Stone columns used for supporting the embankment while at the same time providing stability to the natural slope.....	122

University of Cape Town

## LIST OF TABLES

Table 2.1: Description of some methods of preloading .....	10
Table 2.2: Benefits of the different techniques considered in this chapter .....	29
Table 3.1: Comparison of all plate load tests, different construction and different seasons (Van der Westhuizen and Parrock, 2010) .....	57
Table 4.1: Experiments conducted for soil classification.....	67
Table 4.2: Mechanical properties of base soils .....	68
Table 4.3: Mechanical properties of column materials .....	70
Table 4.4: Description of symbols in testing schedule.....	71
Table 4.5: Box testing schedule for Kaolin .....	71
Table 4.6: Box testing schedule for Cape Town Clay .....	72

University of Cape Town

## NOTATIONS

1.2LL	1.2 times the liquid limit
$A$	plan area of unit cell attributed to a column
$A_c$	cross-sectional area of stone column
$A_p$	cross-sectional area of the loading plate
CA	crushed aggregate
CFS	Cape Flats sand
$C_h$	horizontal coefficient of consolidation
$c_p$	soil cohesion at base or point of stone column
$c_s$	side cohesion of stone column in clay
CT	Cape Town clay
$c_u$	undrained cohesion
$C_v$	vertical coefficient of consolidation
$d$	average diameter of the stone column
$D$	diameter of stone column
D1	stone column diameter of 50 mm
D2	stone column diameter of 70 mm
D3	stone column diameter of 100 mm
$D_c$	resultant depth of compaction
$D_e$	Effective diameter of stone column in unit cell
$F_m$	vertical load applied through the machine
$h$	drop height of weight for dynamic compaction
K	Kaolin

$k$	a factor of $\frac{4}{\pi}$ and $\frac{2}{\pi\sqrt{3}}$ for square and triangular stone column layout respectively
$k_d$	an influence factor for dynamic compaction
KS	Klipheuwel sand
$L_c$	length of column
LL	liquid limit
$M$	depth to column diameter ratio
M1	moisture content of base soil at OMC
M2	moisture content of base soil at LL
M3	moisture content of base soil at 1.2LL
$n$	stress concentration ratio
OMC	optimum moisture content
P1	loading plate of 100 mm x 150 mm
P2	loading plate of 140 mm x 150 mm
P3	loading plate of 200 mm x 150 mm
$R$	effective radius of vertical drain
$R_e$	effective radius of stone column in unit cell
$S$	stone columns or vertical drains spacing
$s_{c1}$	settlement of untreated soil within depth of treatment
$s_{c2}$	settlement of untreated soil below stone columns
$s_{imp}$	settlement in any improved clay corresponding to the stress at the settlement of $s_{unimp}$
SRR	settlement reduction ratio

$s_{unimp}$	settlement of 50 mm in any unimproved clay (control tests)
$u$	pore pressure
$W$	weight of the dropping mass for dynamic compaction
$\delta$	settlement of foundation
$\rho_{col}$	effective density of the column material
$\sigma$	vertical applied stress to the loading plate
$\sigma'_{vc}$	ultimate vertical effective stress
$\sigma_{imp(50)}$	stress exerted on an improved clay at a settlement of 50 mm
$\sigma_l$	reduced limit pressure
$\sigma_o$	horizontal earth pressure at rest in total stress
$\sigma_{ro}$	total in situ lateral stress
$\sigma_{unimp(50)}$	stress exerted on an unimproved clay at a settlement of 50 mm
$\sigma_v$	vertical applied stress on top of column
$\sigma_{vM}$	vertical stress at a depth given by M
$\phi'_c$	effective angle of internal friction for column material

University of Cape Town

C  
H  
A  
P  
T  
E  
R  
**1**

***Introduction***

---

## 1.1 Introduction

Ground improvement is a geotechnical engineering term ascribed to the act of altering and improving poor ground conditions in order to meet the desired ground properties for construction projects. Often, ground improvement methods prove their effectiveness in cases where soil replacement is not feasible because of environmental, financial or technical reasons. An improvement in the ground engineering properties can be achieved by reducing the pore water pressure, decreasing the volume of voids in the soil or adding a stronger material to the soil. Each technique is formulated to address a particular problem such as: reduction in settlement, increase in bearing resistance, improvement in overall stability of structures and slopes, mitigation of liquefaction, retaining of unstable soils, improvement of workability and usability of fill materials and remediation of contaminated soils. However, most techniques are not limited to a single benefit.

The number of methods which can be employed for improving ground conditions are numerous among which vibration, dewatering, grouting, chemical additions or material inclusions are the most popular worldwide (Moseley and Kirsch, 2004). Stone column installation is a technique which is used to increase the bearing capacity, reduce settlement, mitigate liquefaction and improve drainage in marginal soils. These columns are installed by creating an opening in the ground which is then filled with a coarse granular fill such as stones, crushed aggregates or even sand. Stone columns have often been a preferred choice since they are considered to be one of the most versatile and cost effective method for ground improvement (Isaac and Madhavan, 2009). Additionally, they are easy to install and hardly have any negative impact on the surrounding environment.

Stone columns can be installed using either the vibratory or the ramming technique (Som and Das, 2006). Vibrated stone columns mainly employ a vibratory probe for executing the installation by either replacing or displacing the in-situ soil, hence referred to as vibro-replacement and vibro-displacement respectively. On the other hand, rammed stone columns use a rammer which is dropped in a pre-bored hole to compact the replacement material until a cylindrical dense mass of high stiffness is achieved up to ground level. Comparatively, rammed stone columns require less sophisticated instrumentation and skills than vibrated stone columns. Therefore, the ramming method is usually cheaper.

## 1.2 History

The concept of ground improvement by means of stone columns has been used for many years although the equipment and approach lacked today's degree of advancement. According to Ghanti and Kashliwal (2008), the technique has its origin in India where the columns were indigenously installed by the ramming method. The first documented successful application of stone columns was in the construction of the Taj Mahal in India, one of the seven wonders of the world. This massive structure was completed in A.D 1653 and has been supported until today by the hand-dug pits which were backfilled with stones (VGNL, 2011).

In 1830, French military engineers used stone columns as a support system for the heavy foundations of the ironworks at the artillery arsenal in Bayonne which was resting in soft estuarine deposits (Hughes and Withers, 1974). The columns used, with load carrying capacity of 10 kN each, were installed at depths of 2 m and diameter of 0.2 m by driving stakes into the ground which were afterwards removed and the holes were backfilled with crushed stone columns. Hughes and Withers (1974) claim that stone columns were long forgotten until they were rediscovered in the 1930s as a by-product of vibroflotation in the compaction of granular soils. However, it was not until the early 1960s that the technique gained its popularity, with cohesive soils, in the form of vibro-replacement or vibro-displacement (Hughes and Withers, 1974; Arman *et al*, 2009; Ambily and Gandhi, 2007). Stone columns can extend very deep and at large diameters. Ranjan and Rao have reported stone columns of depths up to 15 m while Datye and Nagaraju noted diameters ranging between 400 mm and 750 mm (Purushothama Raj, 2005).

## 1.3 Justification of study

South Africa is known for its diverse rock formations, among which some are the world's most preserved ones (Schlüter, 2008). Over the years, the action of weathering has resulted in the formation of some soft or weak soils (fine silt and clay) which are considered as marginal soils in the construction industry. In the past, these soils were considered to be both economically and technically not feasible and engineers would thus opt for the replacement of the in situ soil with an engineered fill or rather change the location of the project (Raju and Valluri, 2008). With time, engineers have come to terms with some of the ground improvement techniques, among which is the stone column technology that have been

successfully used in many countries, to enhance the geotechnical properties of poor soils. According to AGIS (2011), the percentage of these soils of poor properties can be approximated as 40% of the South African soil coverage (Appendix A). Due to the increasing demand for construction, as a result of population growth and rapid development, the need for larger areas of land has arisen for the expansion of services which has necessitated the improvement of some of these weak soils through various techniques to accommodate for construction. However, for some reason or the other the inclination towards certain technologies has been privileged. In fact, it is noted that techniques such as dynamic compaction, dynamic replacement with dump rock and piling are the most predominantly used techniques in the improvement of bearing capacity and settlement of local soils (Visser, 2012). Vibro-compacted stone columns have been occasionally used in the country, with in-situ soil mixing and various grouting methods being some potential solutions.

The application of stone columns in South Africa has been barely discernible and it is believed that the main reason for their limited use can be correlated to a lack of research, instrumental case studies and design specifications with respect to local ground conditions. Therefore, this study was undertaken with a view to understand the behaviour of stone columns in a South African silty clay whereby the results were anticipated to promote the technique. A focus on the ramming technique of stone column installation was preferred since the method is considered to be environmentally friendly and relatively cheap compared to other techniques. Above all, the installation does not require skilled labour.

#### **1.4 Research objectives**

The lack of adequate information about the design and application of stone columns in South Africa has rendered the review of the technique locally almost impossible. However, the knowledge acquired from the literature in Chapter 3 enabled the identification of some of the most important factors governing the behaviour of stone columns. Thus, this investigation aimed at observing the strength and settlement characteristics of the improved clay under some of these conditions. In order to achieve the aim, the following objectives were to be met using bench-scale experiments:

- a) Determine the effect of column diameter, column material and moisture content of the base soil on the stress-settlement behaviour of the improved clay.
- b) Establish the effect of column diameter, column material and moisture content of the base soil on stress concentration ratio.
- c) Establish the effect of column diameter, column material and moisture content of the base soil on settlement reduction ratio.
- d) Compare the stress-settlement relationship of improved Kaolin with that of Cape Town clay under similar conditions.
- e) Estimate the failure mechanism of coarser columns (Cape Flats sand and Crushed aggregate) at high moisture contents, liquid limit and 1.2 times liquid limit, through brief observations and measurements after testing.

### **1.5 Scope and limitations of this study**

This investigation considered the vertical load carrying capacity of rammed stone columns at settlements of up to 50 mm only since Eurocode 7 suggests this maximum allowable settlement for normal structures. The objectives were achieved by varying only the column material, column diameter and moisture content of the base soil. The investigation did not consider the following as they would have required more time and specialised instrumentation:

- Pilot-scale investigations
- Improvement by means of a group of stone columns
- Effect of column length and spacing on vertical load carrying capacity
- Detailed observation and an in-depth analysis of the failure mechanism of each column under different testing conditions
- Mitigation of liquefaction and drainage of water from base soil into stone columns
- Cost effectiveness of the technique

### **1.6 Overview**

Chapter 1 initially introduces the study and gives a brief overview of the background of stone columns, the justification for this investigation and the ultimate objectives to be achieved. In Chapter 2, some common ground improvement techniques, including stone columns, are discussed in order to identify the advantages and disadvantages of each technique and to

predict their most appropriate relevancy. Chapter 3 focuses exclusively on rammed stone columns whereby the installation process, design principles and behaviour of the columns are discussed. A literature review, comprising both laboratory and field studies, is also presented in Chapter 3 to establish a profound basis for accomplishing the aims of this study. Chapter 4 describes the materials used and the methodology adopted in executing the laboratory investigations. The results obtained from the study are presented and discussed in Chapter 5 which ends with some possible applications of stone columns. Finally, in Chapter 6 conclusions from this study are stated and recommendations for further research are made.

University of Cape Town

University of Cape Town

***Ground Improvement  
Techniques***

---

## **2.1 Introduction**

The application of ground improvement techniques requires adequate experience regarding any particular problem since each method is mostly adapted to a certain problem. Over the years, engineers have developed a good understanding of each technique and have thus combined a few of them to generate more effective solutions to some ground problems during construction. Nevertheless, there is still some reluctance towards new technologies although they are often more efficient.

Since ground improvement encompasses many approaches, it is often classified under the following categories: mechanical, hydraulic, chemical, inclusions and reclamation. This chapter aims at briefly describing some common techniques in order to provide an understanding of the importance of the different available techniques and their suitability. At the end of the chapter, the different methods are compared.

## **2.2 Ground improvement techniques**

### **2.2.1 Hydraulic Method**

#### **2.2.1.1 Preloading**

Preloading of a soil involves the application of an external load, for a long duration, to a desired site in order to alter the geotechnical conditions of the ground. The technique is considered to be mostly effective on normal to lightly overconsolidated silts, clays and organic deposits although it can also be applied to loose sands (Bowles, 1997). Conventionally, preloading is performed prior to construction. Nevertheless, the techniques can be applied to completed projects.

For many years, preloading has been used for construction projects such as road embankments, bridge abutments, warehouses and storage tanks. The method essentially results in two changes: faster settlement and increase in effective stress. During preloading, the load applied is high enough to produce a stress similar to that of the proposed structure. The ratio of the weight of the preload to that of the final structure is often referred to as the coefficient of surcharge (Purushothama Raj, 2005). The higher the coefficient, the shorter the time required to attain consolidation. A higher coefficient also results in a higher post-preloading factor of safety against a base failure. However, high coefficients imply longer

time for construction of the preload and a concern for the stability of the temporary structure. Additionally, enough time must be allocated for the process in the construction program since the technique works over several months. Generally, the time required to achieve full consolidation is dependent on the thickness of the soil and its permeability. Therefore, it is crucial to establish a balance between the two governing factors of time and coefficient of surcharge. Conventional theories of consolidation can contribute to determine this balance. Figure 2.1 shows a preloading scenario where a surcharge is also applied.

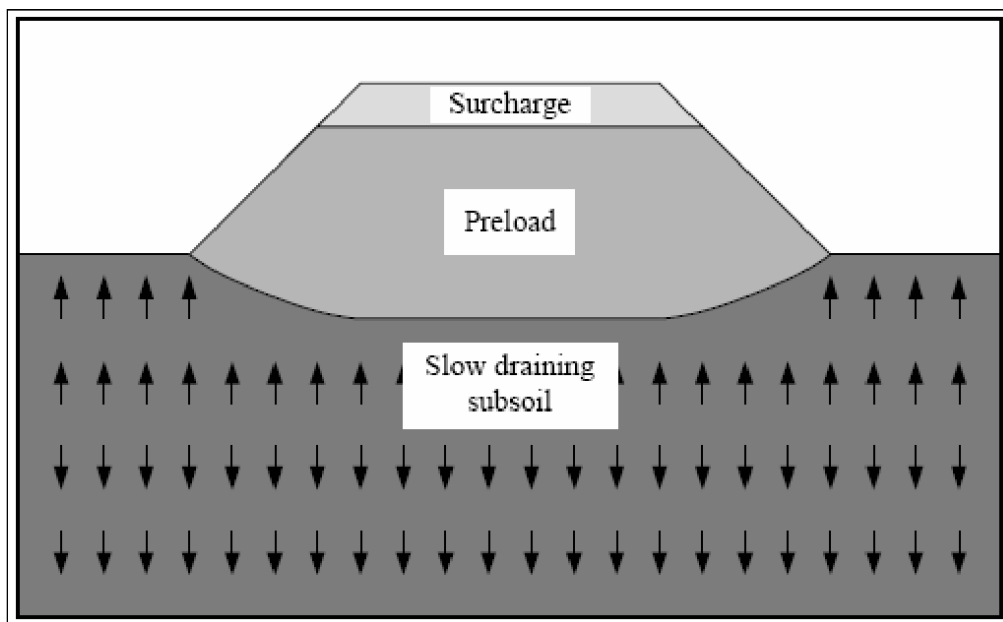

Figure 2.1: Preloading through an embankment prior to construction of the final structure (Stapelfeldt, 2012)

During preloading, the pore pressure increases and as the process continues, pore water pressure gets dissipated thereby increasing the effective stress. In so doing, the amount of settlement increases. However, the presence of excess pore water pressure, after removal of the preload, must be catered for since settlement will take place under the final structure to be constructed under such circumstances.

The most common method of preloading is the heaping of fill materials in which case these materials are reused for the same project at a later stage. However, heaping can be disadvantageous since it is prone to base failure. Other methods of preloading are thus

employed depending upon their suitability for each project. Some of these methods are briefly described in Table 2.1 below.

Table 2.1: Description of some methods of preloading

<b>Method</b>	<b>Brief Description</b>
Embankment loading	This is the most commonly used method of preloading. Three to eight months is usually allocated for the process (placement of load to its removal) and the typical height of preload soil varies between 3 m and 8 m although a maximum height of 18 m is allowed. The resulting settlement is often between 0.3 m to 1 m.
Preloading through final structure	Application of this method is mostly in the construction of liquid storage tanks. The tank is constructed and gradually filled with water to allow for consolidation. Once the rate of settlement is also zero, the tank is emptied and jacking is used to level its base. This method is effective since these tanks are usually constructed from flexible steel plates.
Lowering of water table	This process is very effective in soils of high permeability. According to Purushothama Raj (2005), lowering the water table using a suitable dewatering system results in a loss of effect in buoyancy thereby causing the soil above the water table to gain a unit weight of about $10 \text{ kN/m}^3$ . In the process, for every meter of water table lowered, a loading of about 0.5 m depth of fill is produced. When this method is combined with placement of a heaping fill, the rate of settlement is accelerated.

Inundation or preponding	When the water table is low, this method is often preferred. Inundation or preponding results in an opposite action. During the process, loose bonds between particles are broken and the surface tension forces and weight of water are increased. Consequently, adequate densification of soil is produced. However, the result is highly dependent in the type of soil.
Vacuum preloading	A layer of sand which is covered by an impervious membrane is placed on the surface of a soft clay. A vacuum is induced in the sand which produces the same effect as an overload. To enhance the performance, vertical drains can be coupled with this method.
Jacking	Mostly applied to individual footings in the construction of new buildings, this method is a standard approach to preloading of footings and piles in underpinning.

Advantages of preloading:

- Relatively low cost compared to other techniques,
- Possibility of reusing the fill material for other purposes on the same project,
- Uses simple construction equipment for earth moving job,
- Installation of monitoring equipment is cheap and quick, and
- Production of uniformly improved properties of the treated ground.

Disadvantages of preloading:

- Involves the transportation of a large amount of fill material, and
- The length of time required to achieve results (several months) may lead to delays in construction.

### ***2.2.1.2 Vertical Drains***

The application of a load on a granular sandy soil causes an almost immediate settlement. However, for fine grained cohesive soils, which tend to be saturated and have a low permeability, the rate of consolidation is very low. Settlements in these types of soils occur over a long period of time since excess pore water pressure dissipation is slow. Under these circumstances, the use of vertical drains enable a rapid dissipation of pore water pressure thereby increasing the rate of settlement. This technique is often use in conjunction with preloading which subsequently reduces the time of preloading and the time for construction.

The main reason for rapid drainage from vertical drains is the shorter drainage paths which are created in the clay. Consequently, consolidation is then predominantly due to horizontal drainage instead of vertical drainage. Traditionally, vertical drains are installed by driving boreholes through the clay layer and the opening is filled in with an appropriately graded sand. Craig (2004) claims that the typical diameters for these boreholes are between 200 mm and 400 mm while their depths have extended to more than 30 m. The sand types used are carefully chosen in order to allow for proper flow of water without washing in the fine particles. During backfilling, it is important to make sure that no discontinuities arise since necking can occur, thus rendering the drain ineffective. As the clay consolidates, it is laterally displaced. This effect can also cause necking. Because of these possible side effects, it is more common to use the prefabricated vertical drains (PVD) presently. Furthermore, PVDs may be more economic than conventional drains for certain areas of treatment.

Sandwicks drains used today consist of a filter stocking which is completely filled with sand. With typical diameters of about 65 mm (Craig, 2004), these drains tend to be flexible and resist the effect of lateral soil displacement. As such, necking is not a concern. Sandwicks are usually installed by either pushing into pre-bored holes or by placing them in a mandrel which is driven into the ground. Band drains are also installed by the mandrel driving

method although they require and anchor at their lower end so as to retain their position during withdrawal of the mandrel and also to prevent soil from entering the mandrel. However, they consist of a flat plastic core which is indented with drainage channels and surrounded by a sufficiently strong layer of filter fabric having a small mesh. The mesh size of the fabric prevents the passage of soil particles which can cause clogging while its strength ensures that it is not squeezed into the channels. Typical dimensions of these prefabricated drains are 100 mm x 4 mm and for design purposes, the diameter is taken to be the ratio of the perimeter to  $\pi$  (Craig, 2004).

In general, drains are installed in either a square or a triangular pattern. The spacing of the drains is considered to be the most important design factor since the main objective of vertical drains is to reduce the length of the drainage path. Most evidently, the spacing must be smaller than the clay thickness. For an efficient design, the horizontal ( $C_h$ ) and vertical ( $C_v$ ) coefficients of consolidation must be accurately known although  $C_h$  is the most important factor. The higher the ratio of  $C_h/C_v$  (normally between 1 and 2), the more effective the installation will be. Figure 2.2 shows typical installation patterns for vertical drains.

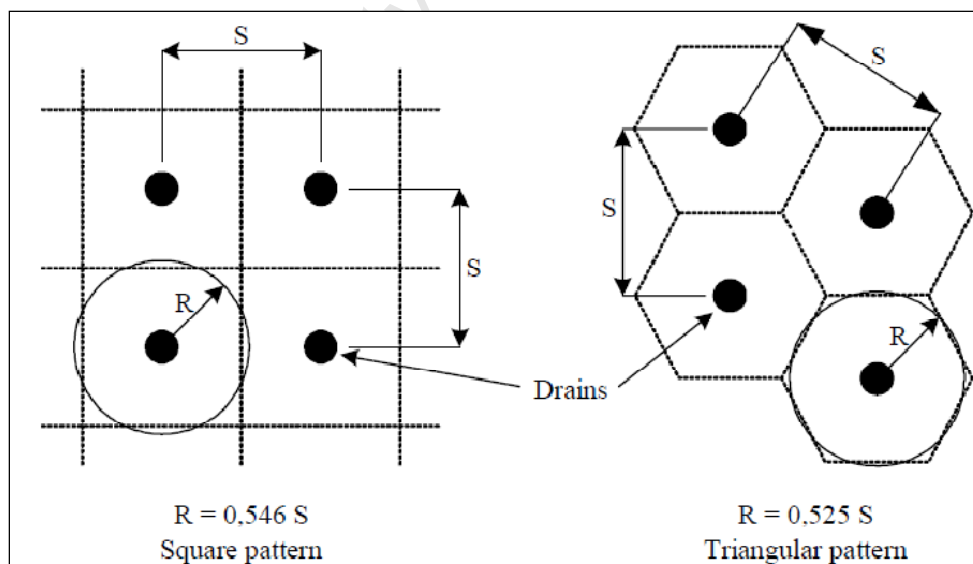

Figure 2.2: Installation pattern (square and triangular) of vertical drains (Stapelfeldt, 2012)

Advantages of vertical drains:

- Prefabricated drains can be fairly economic, and
- Enables soils to be brought into service more quickly.

Disadvantages of vertical drains:

- Installation can sometimes be costly,
- Improper installation can cause necking, and
- Possible ineffectiveness in overconsolidated clays in case the vertical stress after consolidation remains less than the preconsolidation pressure.

### 2.2.1.3 Ground Freezing

Ground freezing refers to the process of converting in situ liquid water in soils into a solid state, from which the compressive and shear strength are increased while the permeability is decreased to almost zero. This technique is applicable to any type of soil or rock despite the varying structure, permeability and grain size of each material. Nevertheless, it is mostly suited for soils with finer particles such as silts and clays. Ground freezing is mainly used for tunnel excavation, earth support, groundwater cut-off, soil stabilisation and temporary underpinning of bordering structures during permanent underpinning (Jessberger *et al*, 2003). Figure 2.3 shows the application of ground freezing during the excavation process for a tunnel.

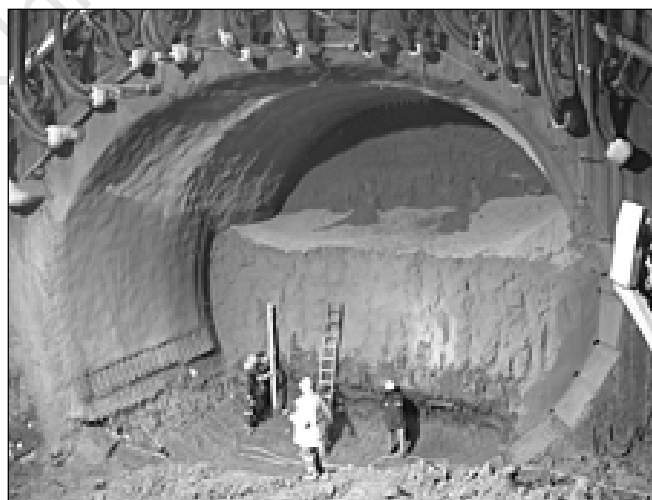

Figure 2.3: Application of ground freezing in a tunnel excavation (Bilfinger Berger, 2012)

The effectiveness of this method is highly dependent on the amount of water present in the soil since water will freeze under the provided lower temperatures thereby cementing the soil particles and increasing the strength of the ground. In saturated soils, the water freezes to produce an impermeable stratum. Water is added in cases where it is not sufficient to fill the pores completely. The resulting strength achieved is highly dependent on the temperature at which freezing occurs, the amount of moisture present and the nature of the soil. Therefore, an in-depth site investigation is highly recommended prior to the treatment. From the outcome of the site investigation, the most efficient design can be chosen which comprises the appropriate freezing pipes and adequate power. The treatment plant also includes monitoring during the freezing process to ensure formation of the barrier wall as well as completion of freezing. Monitoring is mainly achieved through temperature-monitoring pipes which are installed during the drilling process.

Ground freezing can be achieved in two ways: indirect method or direct method. For the indirect method, heat is removed through the circulation of a secondary coolant, calcium chloride (brine), in the ground driven pipes. A primary refrigeration plant is used for the removal of the heat whereby the primary refrigerant is often ammonia. The time required for the process heavily depends on the spacing between the ground driven pipes, the size of the pipes and the capacity of the plant. On the other hand, the direct method uses the primary refrigerant, liquid nitrogen, to remove the heat directly through the series of tubes driven in the ground. As such, the method is more efficient than the indirect method. The freezing speed is much quicker with this method and thus makes it more appropriate for emergency use. The direct method of ground freezing is usually recommended for short periods of freezing. Thereafter, the conventional freezing method can be used to maintain the state during work executions. A further advantage of this method over the indirect one is that elaborate plants and equipment are not required. However, the choice of the method is always dependent on the availability of plants and the cost estimates for the procedure.

Advantages of ground freezing:

- No extraneous materials required,
- Ground normally reverses to its original state,
- Applicable to a wide range of soil and rock types,
- Appropriate for a temporary support during excavation in a high water content area, and

- Use of same cooling plant on different projects.

Disadvantages of ground freezing:

- Indirect method is slow although cheaper than the direct method,
- Possible occurrence of frost heave,
- Increase in permeability after thawing due to ice lenses build ups causing enlargement of fine fissures, and
- May not work in regions of high water flow at high temperatures.

## **2.2.2 Chemical Method**

### **2.2.2.1 Grouting**

Grouting is a process which has been used for many years although recent technologies have helped to improve the technique to be better adapted to more circumstances. The technique, which is applicable to rocks and all soil types, involves the injection of a fluid substance into a soil or into rock fissures with the intention of improving stability or reducing permeability. Used in both temporary and permanent works, grouting is highly applicable in the following areas: settlement reduction, prevention of liquefaction, void filling, repairs around tunnels or beneath dams, underpinning and control of ground movement during tunnelling. Although the approaches to grouting are many, only a few of the most common ones are elaborated in this section. Figure 2.4 shows a few grouting methods which are discussed below.

#### *Compensation Grouting*

During compensation grouting, the ground is intentionally fractured by injecting a cement based grout through sleeve port pipes at high pressure. In so doing, interlinked veins of grout are formed which act as a soil reinforcement while simultaneously causing some degree of consolidation. The process which is performed in several phases involves repeated grout injections at each port to guarantee the formation of multiple fractures. As the number of fractures increases, heaving occurs on the overlying soils and structures. Therefore, this technique is mostly used for controlling or reversing settlement of existing structures and is often carried out from outside the building.

### *Compaction Grouting*

With compaction grouting, the grout is still injected in the soil at high pressures. However, the grout is relatively stiff which therefore results in the formation of a bulbous cement mass instead of permeating the soil matrix. The inclusion of these bulbs displaces and densifies the surrounding soil. The effect is an increase in bearing capacity, a reduction in foundation settlements and a mitigation towards liquefaction potential. Additionally, this technique can also pre-treat sinkholes and stabilise karstic formations.

### *Permeation Grouting*

Permeation grouting injects fluid grouts into the ground with the main purpose of filling in the voids in the soil matrix to form a hardened mass. By filling in the voids, the water flow is controlled and thus permeability is reduced. At the same time, the formation of the solidified mass produce an increase in strength and stiffness. This method is applicable in sands, gravels, fissured or fractured rock. The effectiveness of this technique is largely dependent on the spacing between two ports of injection and the rate and pressure at which the grout is injected.

### *Jet Grouting*

Jet grouting involves the ejection of a cementitious grout slurry from a rotating grout tube, at high pressure, into the in situ soil. During the process, the jet follows a radial path thereby mixing the coarse in situ materials with cement while simultaneously replacing the fines. As a result, a large diameter grout column is formed in the ground. Jet grouting can be used with a wide range of soil types although a clean, loose, medium to coarse sand is the ideal type of soil. This technique is applicable in the following circumstances: formation of cut-off walls for groundwater control, formation of grout column to support structures, underpinning, creation of rigid soil inclusions and increase in impermeability of in situ soils.

Advantages of grouting:

- Filling in of voids, fissures or fractures,
- Suitability to different soil types due to the numerous available techniques, and

- Selected techniques applicable to existing structures.

Disadvantages of grouting:

- Can be an expensive process in some circumstances,
- Often requires a large working space, and
- Inaccurate determination of the strength of the grout and the pressure at which it is injected results in an undesired soil-grout matrix.

University of Cape Town

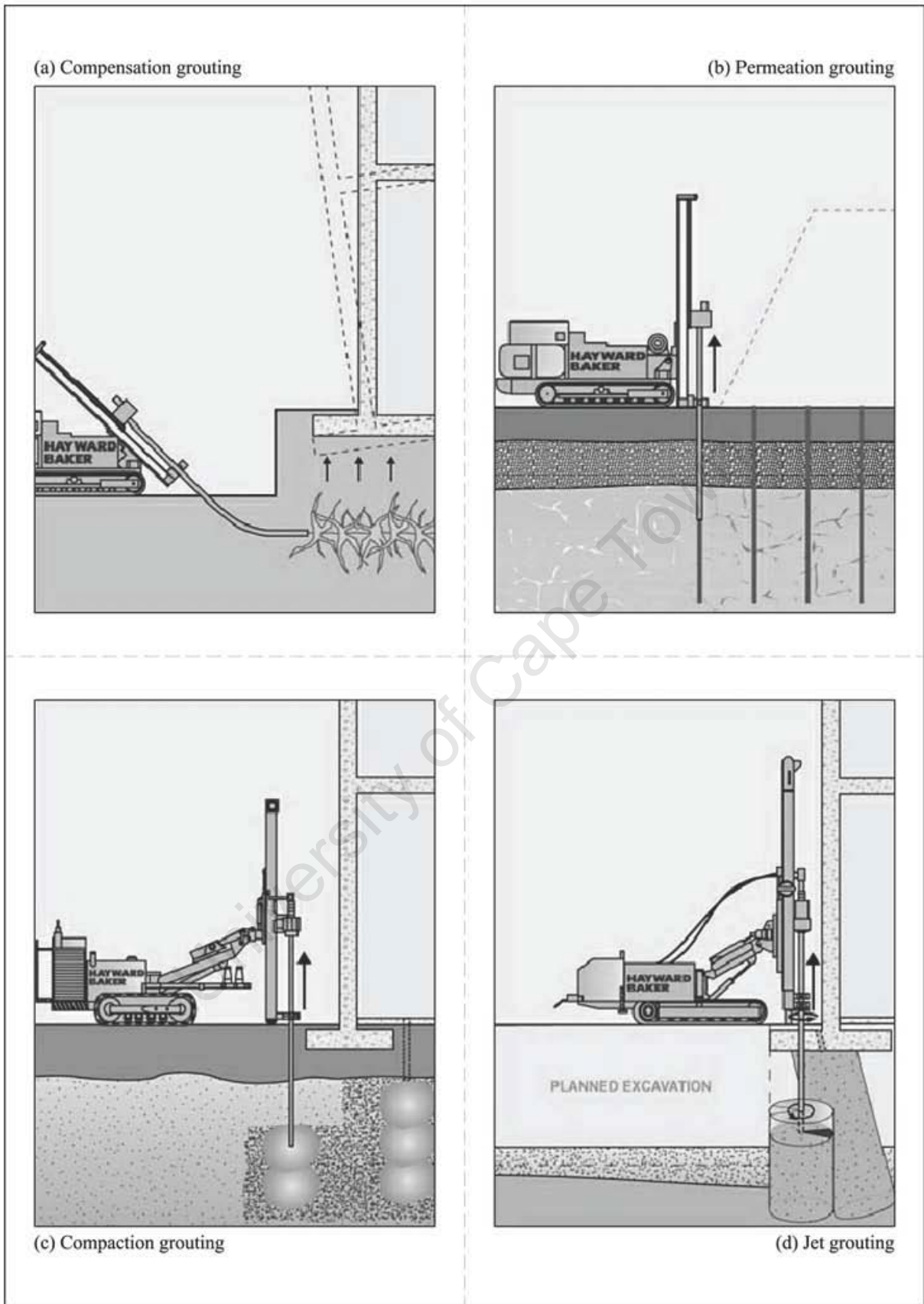

Figure 2.4: Common grouting techniques (Hayward Baker, 2012)

## 2.2.3 Inclusions

### 2.2.3.1 Geosynthetics

“The ASTM has defined a geosynthetic as a planar product manufactured from a polymeric material used with soil, rock, earth or other geotechnical-related material as an integral part of a civil engineering project, structure, or system” (Holtz, 2001). These reinforcing polymers have been successfully used in geotechnical works for decades and are mostly popular in the following applications: filtration, drainage, separation, fluid barrier, protection and reinforcement. Made from synthetic polymers such as polypropylene, polyester and polyethylene, geosynthetics are highly resistant to biological and chemical degradation as well as animal attacks. However, due to their polymeric nature the working temperature, environmental pH and UV exposure must be properly verified for compatibility. Additionally, care against tearing or rupture must be taken during transporting and installing since the strength of the geosynthetic may be affected.

Today the types of geosynthetics on the market are many. Out of the selection, the most popular ones include geogrids, geocells, geotextiles and geomembranes (Figure 2.5). Each of these is briefly described in this section.

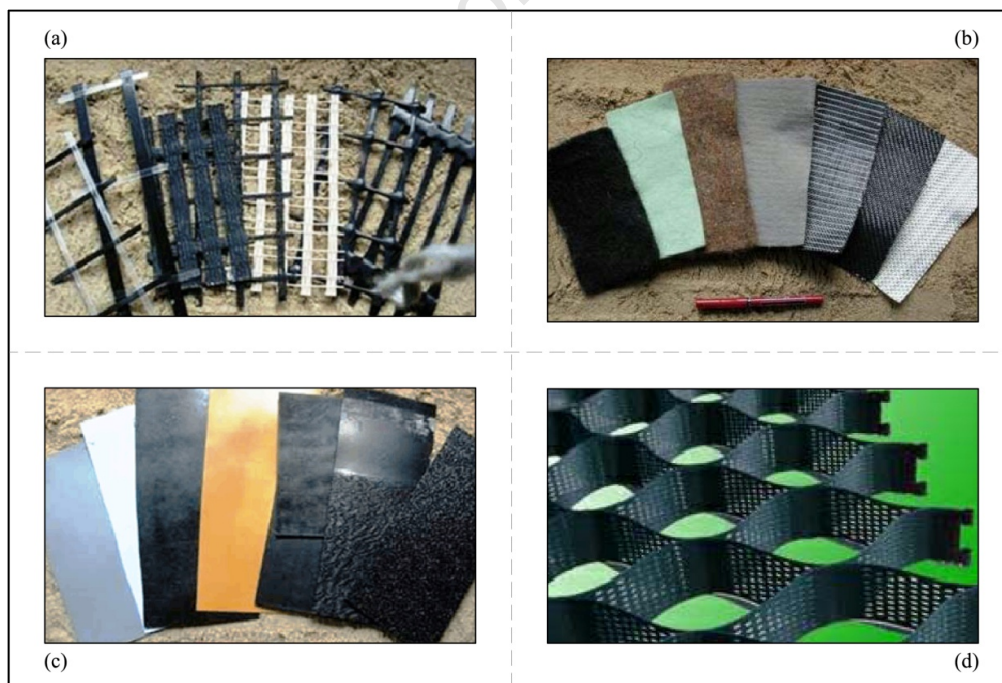

Figure 2.5: Different types of geosynthetics (a) Geogrids, (b) Geotextiles, (c) Geomembranes and (d) Geocells (GGPL, 2012)

Geogrids are grid-like polymeric materials which are formed by joining ribs to form a high strength structure of large apertures between ribs in the transverse and longitudinal directions. They are mostly manufactured from polypropylene, high density polyethylene and polyester. Because geogrids undergo very small strains and have high tensile properties, they are able to transfer forces from a soil under tension thereby allowing the soil to bear higher stresses. This type of geosynthetic is mostly common in base reinforcement, embankment reinforcement, pile cap platforms and earth retaining wall construction. Figure 2.6 demonstrates the application of a geogrid as a mode of reinforcement.



Figure 2.6: Application of a geogrid in the sub-base during the construction of a highway across a marsh area (Tensar, 2008)

Geocells are stiff 3-D honeycombed cellular structures normally made from polyethylene strips which are welded together. Their cell-like shape intends for infilling with gravel or compacted soil while their porous surface allows for water drainage. Geocells are mainly applicable in slope protection and earth retaining works.

Geotextiles are permeable synthetic textile materials which are used in geotechnical application for separation, drainage, filtration, reinforcement and soil protection. They are typically manufactured from one of the four families namely polyester, polyamide, polypropylene or polyethylene and they are classified as woven, non-woven or knitted. Common applications of geotextiles include road and drainage construction in addition to

erosion control along coastlines and mountainsides. On contrast with geotextiles, geomembranes are impermeable and are often made from polyvinyl chloride, polypropylene and high-density polyethylene. The choice of material influences the characteristics of the geomembrane and therefore the most suitable material must be chosen to best suit the intended purpose. Additionally, the chosen material also impact on the installation process, performance and lifespan of the product. Due to their non-porous nature, geomembranes are mostly applicable in solid waste or water containments and mining.

Advantages:

- High quality control during the manufacturing process,
- Possess light weight and thinness properties which applies smaller loads on subgrades and which requires less working space,
- Relatively easy installation process,
- Availability of published standards from organisations such as ISO, ASTM and GSI, and
- Easy accessibility to the design methods.

Disadvantages:

- Reduction in performance and lifespan due to improper handling, storage and installation,
- Improper choice of material in pH sensitive or high UV exposure environments which compromise the long-term performance, and
- Clogging of some geosynthetics due to failure in designing for soil particles sizes.

## **2.2.4 Mechanical Method**

### ***2.2.4.1 Dynamic Compaction***

Dynamic compaction is a method used to increase the density of a soil by expelling air voids between soil particles thereby reducing the volume of the soil. The process involves dropping a heavy weight from a certain height repeatedly on the ground (Figure 2.7) and at regular spaced intervals until a grid pattern is formed.

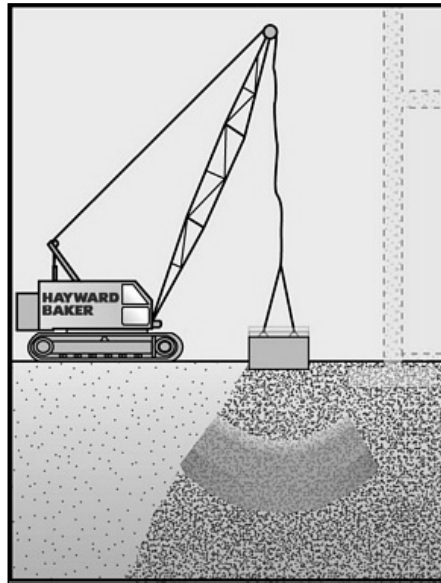

Figure 2.7: Weight being dropped on the ground to densify soil through the vibratory waves  
(Hayward Baker, 2012)

The resulting amount of compaction from this process and the depth of treatment depends mainly on the weight, the height from which it is dropped, the distance between treatment points, the soil thickness and the soil type. Given that vibration is the main controller of this method, it is worth noting that a thick soil layer will result in minor compaction. To achieve different degrees of compaction, the weight as well as the dropping height can also be varied. Lighter weights will result in less compacted soils due to the smaller applied force. Such will be the case for a shorter dropping height due to the lower amount of potential energy being transformed to vibration. The following equation shows the relationship between the depth of compaction and its controlling parameters.

$$D = k_d \sqrt{Wh}$$

where :  $D$  = resultant depth of compaction (m),

$k_d$  = an influence factor between 0.375 and 0.7 which increases with material coarseness (Moseley and Kirsch, 2004),

$W$  = weight of the dropping mass (tonnes), and

$h$  = drop height (m).

According to Moseley and Kirsch (2004), the depth of treatment can be 6 m and 8 m, for weights of 8 tonnes and 15 tonnes, at impact speeds of 35 mph and 50 mph respectively. They also added that the shape of improvement in the ground can be approximated as being similar to that of the Boussinesq distribution of stresses for a circular foundation.

Dynamic compaction is applicable to all soil types except in soft silts, peat and clays where compaction results in bouncing back of the material due to the minimal presence of voids between the particles. Furthermore, this type of compaction is possible for materials located both above and below the water table, although the reaction differs (Franki, 2008). However, when granular and cohesive soils are subjected to the high energy impact during dynamic compaction, the reaction differs. Granular soils are usually more easily compacted especially if they are above the water table. This is because the amount of air voids present is high in contrast to that of cohesive soils. As such rearrangement of the soil particles, to form a denser state, is achieved through the release of trapped air. For cohesive soils, compaction above the water table is straightforward and quick. However, below the water table dynamic compaction squeezes the water out through the creation of zones of positive water pressure gradient (Moseley and Kirsch, 2004). While drainage is fast, the process is further accelerated when additional drainage paths are formed due to shear and hydraulic fracture.

Advantages of dynamic compaction:

- Fast and economical for sites of areas between 5000 m<sup>2</sup> to 10 000 m<sup>2</sup> and where the depth of soil to be treated is too deep to be excavated or replaced (Bowles, 1997),
- Applicable to most soil profiles,
- Compaction possible above and below water table, and
- Possible use in fills with presence of rubble, boulders and rocks.

Disadvantages of dynamic compaction:

- Possible damage to surrounding structures due to the vibrations caused,
- Often impractical in saturated clays where dissipation of water is long, and
- Noise pollution and flying of debris during pounding.

#### 2.2.4.2 Stone columns

Stone columns installations are one of the various ways of improving marginal soils, such as fine silts and clays, to allow for construction. These columns are known to increase the bearing capacity, reduce settlement, mitigate liquefaction and improve drainage. Above all these advantages, stone columns are relatively easy to install. During their installation, an opening is created in the ground which is eventually filled with a coarse granular material such as stones, crushed aggregates or even sand. Although numerous types of ground improvement techniques are available and efficient, stone columns have often been a preferred choice in the United States, Europe and Asia for improving soft soils since they are considered to be one of the most versatile and cost effective method for ground improvement (McKelvey *et al*, 2004; Isaac and Madhavan, 2009) in addition to their environmentally friendly characteristic. They represent the most natural and ecologically neutral foundation system in existence, using natural stones which are widely available in the majority of areas. Their ecological balance can be improved further through the use of recycled concrete material. Moreover, the technique discourages the complete removal of the in-situ soil within the depth of strata requiring improvement. As such, transporting and dumping of in-situ soil is minimised, thereby reducing the carbon footprint from fuel emissions and the cost associated with the removal process. This minimal removal of in-situ soil, coupled with the easy and fast installation of stone column, often makes the process economically preferable in sites where time is critical by reducing the waiting period for the project start-up.

Stone columns can be classified as a mechanical method since it is installed by either of the two mechanical methods: vibration or ramming (Som and Das, 2006). The vibratory method involves introducing a vibratory probe in the ground which penetrates and creates an opening. During the process, there is penetration, compaction and backfilling. Two popular methods which use the vibratory probe are vibro-displacement and vibro-replacement (Figures 2.8 and 2.9 respectively). The difference between the two methods is that in the replacement method the in situ soil is removed and the opening is filled with new material while in the displacement method the soil is compacted by the penetration and vibration processes in order to achieve densification of the surrounding soil. On the other hand, the ramming method (Chapter 3) employs compaction of the column material by dropping a weight through a certain height. An opening is created and a coarse granular fill is placed in the opening and compacted through several blows, in different layers, until ground level is reached.

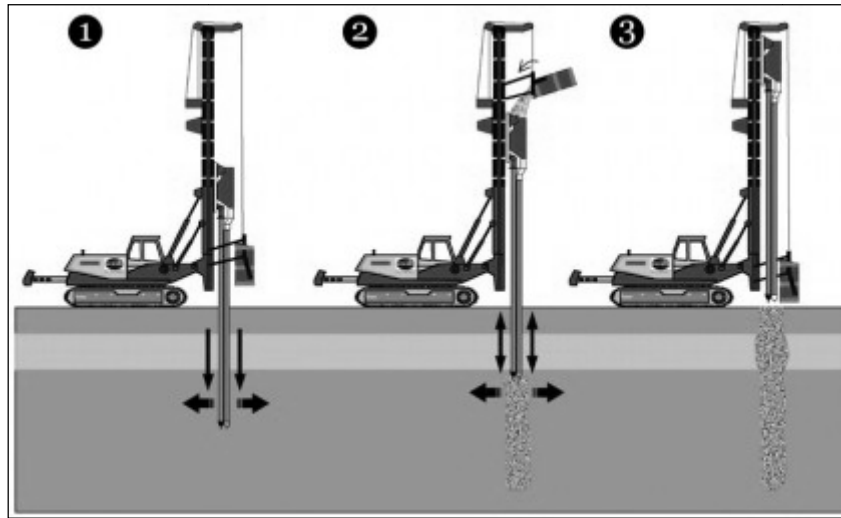

Figure 2.8: Installation process of vibro-displacement stone columns (Vibro Menard, 2012)

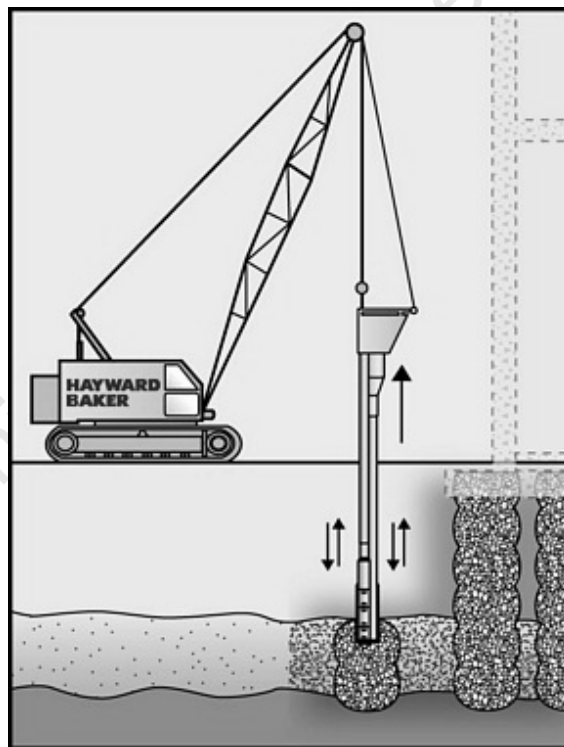

Figure 2.9: Installation process of vibro-replacement stone columns (Hayward Baker, 2012)

The degree of improvement in soft soils, by the inclusion of stone columns, can be explained by two factors: the higher stiffness of the column material and the densification of the surrounding soil (Isaac and Madhavan, 2009). McCabe et al (2007) explained the behaviour

of stone columns by describing the way the columns work with the existing ground. According to them, stone columns transmit some load to the surrounding soil through shearing stresses along the column-soil interface and the end bearing at the base of the column. However, the predominant mechanism of the transfer of load is explained by the lateral bulging into the surrounding soil. The performance of the column when loaded is understood to be due to the passive resistance of the surrounding soil. In general, maximum bulging is expected to occur at the top of the column since the overburden pressures are lowest at that point.

When designing with stone columns, three aspects need to be assessed namely: the diameter of the columns, the length of the columns and the column spacing. Som and Das (2006) stated that the softer the soil, the bigger will be the resulting diameter of the column after installation. This is due to the aggregates being pushed into the surrounding soil during compaction. Installation of these columns are usually done throughout the depth of the soft compressible strata since the latter contributes significantly to settlement of the foundation. Once the diameter and the length of the column have been established, the spacing between columns is then determined to meet the required criteria. Spacing depends largely on the required load bearing capacity of the foundation and the time which is allowed for consolidation by radial drainage through the columns. Arrangement of the columns can either be square or triangular. For triangular arrangements, the spacing of stone columns must be fairly close and they must be installed to full depth to produce a significant reduction in settlement.

Advantages of stone columns:

- Ramming method can be quite cheap,
- Ramming does not require any special skills,
- Rapid installation,
- Vibratory techniques appropriate for soils of high water content, and
- Combines several functions at the same time – reinforcement, drainage and liquefaction mitigation.

Disadvantages of stone columns:

- Replacement methods produce a large amount of dumping material,

- Smearing during installation can contaminate the column material thereby reducing their drainage efficiency, and
- Only applicable for low capacity structures – buildings of up to two storeys, oil tanks, embankments.

### **2.3 Summary of the characteristics of the discussed techniques**

This chapter attempted to gain familiarity with some common ground improvement techniques and to relate the benefits of using stone columns to other methods. Attention was drawn to techniques with the ability of demonstrating similar functions as stone columns in fine soils such as silts and clays. The majority of the discussed methods, such as ground freezing, grouting and inclusion of geosynthetics, aimed at improving bearing capacity and settlement. However, they often did not support environmental or economical sustainability, in addition to improved drainage and mitigation of liquefaction. In contrast, when dealing with relatively low applied loads such as 2 storey buildings, oil tanks and embankments, stone column installations offers significant benefits such as increase in bearing capacity, densification of the surrounding soil, enhanced drainage, mitigation of liquefaction and reduction in settlement.

Two types of stone columns have been identified (vibro and rammed) for improving silts and clays whereby rammed stone columns were considered more appropriate in this era because of its economic installation and its friendliness to the environment. Besides, the process of installing does not require special skills which makes it more appropriate within the South African context. Hence, the study aimed at demonstrating the suitability and behaviour of rammed stone columns in a local clay. Table 2.2 summarizes the benefits of each technique discussed in this chapter, where the tick signs indicate the suitability of the particular technique for any given improvement factor.

Table 2.2: Benefits of the different techniques considered in this chapter

Technique	Soil type			Improvement factors								
	Sand	Silt	Clay	Bearing Capacity	Densification	Drainage	Liquefaction	Settlement control	Environmental	Economical	Fast process	Reduced permeability
Dynamic compaction	✓				✓					✓	✓	
Stone columns:												
Vibro		✓	✓	✓	✓	✓	✓	✓			✓	
Rammed		✓	✓	✓	✓	✓	✓	✓	✓	✓	✓	
Preloading		✓	✓		✓	✓		✓		✓		
Vertical drains		✓	✓			✓		✓	✓			
Ground freezing:												
Indirect method	✓	✓	✓	✓						✓		✓
Direct method	✓	✓	✓	✓							✓	✓
Grouting	✓	✓	✓	✓				✓				✓
Geosynthetics	✓	✓	✓	✓		✓		✓	✓		✓	✓

University of Cape Town

***A Review of Rammed Stone  
Columns***

---

### **3.1 Introduction**

In an attempt to meet the objectives of this research, a comprehensive literature review was undertaken in order to understand the theory, performance and benefits of rammed stone columns. The chapter further elaborates on experimental works carried by various researchers. The technique, which originated in India, has found its way predominantly in Asia (Ghanti and Kashliwal, 2008). As such, the majority of research work on these columns has been performed by natives of the region. Two case studies, a local and a foreign one, are also presented towards the end of the chapter to illustrate the application of the method in real life problems. Finally, a summary of the major findings is presented.

### **3.2 Installation process**

Stone column installation by the ramming method can be executed in different ways such as: pre-boring of a cohesive soil and filling in with a compacted granular material, augering of holes with a temporary casing in place which is ultimately filled with granular compacted material (Som and Das, 2006) or repeated pounding on a granular bed above a soft clay until the formation of a compacted column (Kruger *et al*, 1980). Som and Das (2006) pointed to a ramming technique which was proposed by Datye and Nagaraju in 1977 and which was further developed by Nayak in 1983. In this technique, a pre-bored hole with temporary casing support is filled with granular material in several compacted layers. Windows with hinged flap valves fixed to the casing at about 2 m intervals facilitate filling of the columnar material while simultaneously preventing entrance of soil in the replacement material during driving and withdrawal of the casing. For very deep stone columns, several casings are used to achieve the desired depth. Casings are preferred mostly in non-cohesive soils due to risks of instability. Figure 3.1 illustrates the ramming method described.

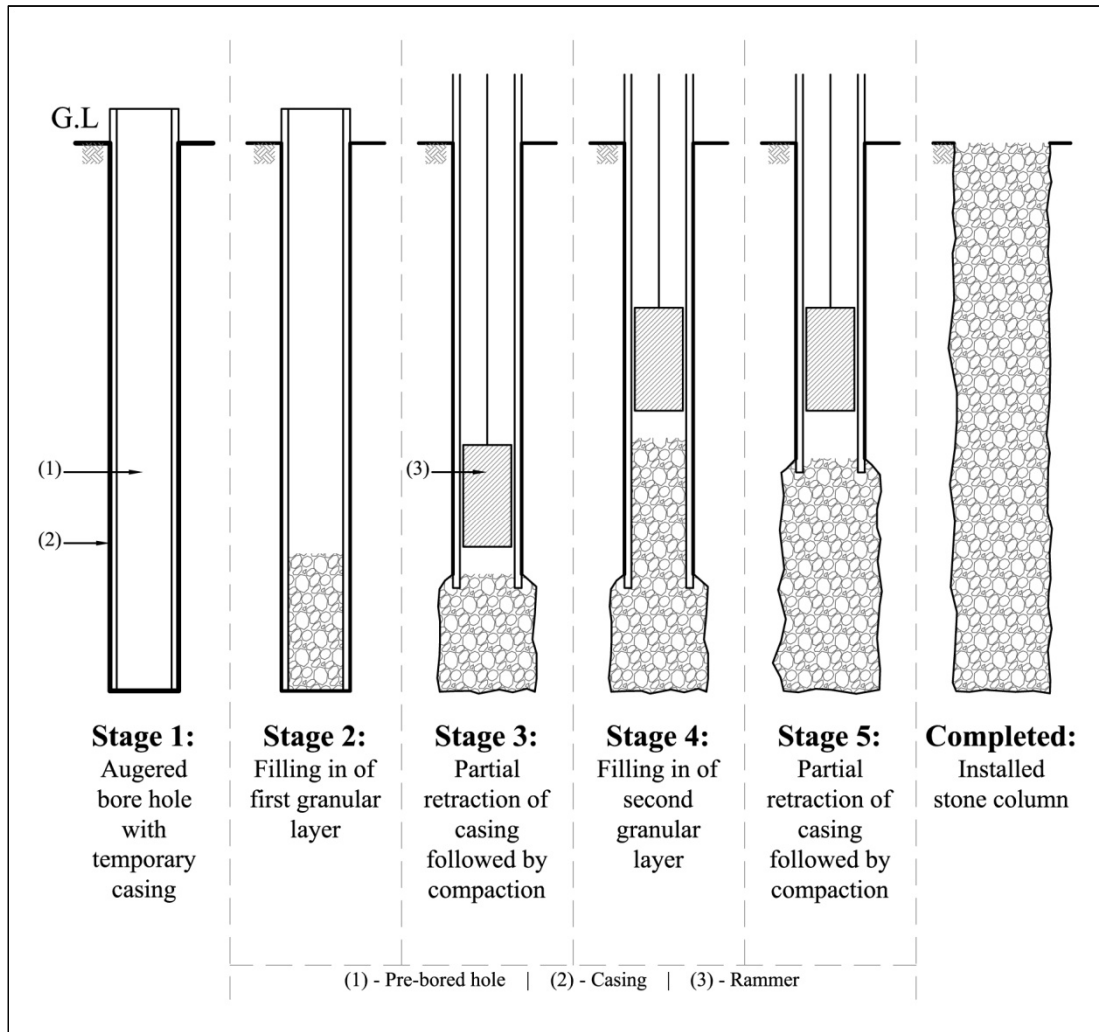

Figure 3.1: Stone column installation by the ramming method (pre-bored with temporary casing for support)

The rammer shown in Figure 3.1 is used for compaction so as to rearrange the stone particles to create good interlock between them and to obtain a high angle of internal friction. The degree of compaction is usually predetermined in terms of the drop height, weight of the hammer and number of drops. According to Purushothama Raj (2005), Datye and Nagaraju (1975, 1985) suggested a hammer weight of 15 kN to 20 kN and a drop height of 1 m to 1.5 m. The generated compaction energy must be adequate enough but not excessive so as to avoid crushing of the column material.

Kruger *et al* (1980) used the pounding approach, which they termed as the dynamic substitution method, on a swampy area which was heavily contaminated by mine slimes. This method dropped a free falling weight of 100 kN to 400 kN from heights of 15 m and

30 m on a rockfill mattress positioned at 1.5 m above water level. Pounding produced an opening which was filled with an imported material. The process, which was performed sequentially until the formation of a large diameter column, is depicted in Figure 3.2.

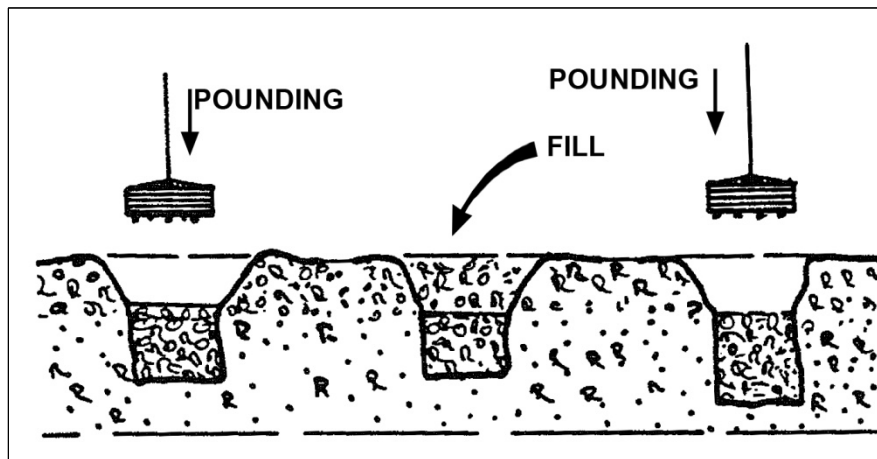

Figure 3.2: Rammed stone column installation by repeated pounding (Kruger *et al*, 1980)

### 3.3 Theory behind stone columns

#### 3.3.1 Characteristics of the most typical base soils

Since stone columns are popular for increasing bearing capacity, mitigating liquefaction and reducing settlement, they are mostly effective in soft soils such as silts and clays and loose soils (Mitchell and Katti, 1981; Murali Krishna and Madhav, 2009; McCabe *et al*, 2009; McKelvey *et al*, 2004). This section focuses on the nature of clay as the soil type for which this technique is mostly suited.

Clay minerals are formed by chemical weathering, often by the action of water (Craig, 2004). According to Bergaya *et al* (2006), the minerals in clay are traditionally classified under 'silicates'. However, since their chemical composition consists of more oxygen than silicon, aluminium or magnesium, the minerals may perhaps be considered as the hydroxides of these elements. Generally, in geotechnical engineering the term clay is assigned to any soil which is made up of particles smaller than 0.002 mm in size although not all clay-size particles are clay minerals (Craig, 2004). Particle size, in addition to mineralogy and moisture content, is the influencing factor for clay behaviour.

Clay particles in soils have a high surface area to mass ratio and they mostly consist of a graded mixture of very small particles. They possess two main properties, cohesion and plasticity, where cohesion refers to the adhering of particles to each other while plasticity is the ability of the material to undergo deformation without any effect of volume change, rebound, cracking or crumbling (Wesley, 2010). Between the particles are capillary attraction forces which accounts for the high retention of water in clay. Because of these forces and low void ratio between particles, clay has a very low permeability which makes drainage very slow. Over a long period, consolidation takes place by expelling excess pore water pressure between the clay particles thereby compressing the material. In so doing, the materials gain strength although differential settlement and cracking are potential problems. Upon regaining water, some clays undergo swelling and lose their strength once more. For these reasons, construction on clays is discouraged and either replacement of the material or ground improvement is recommended.

### 3.3.2 Design principles

#### 3.3.2.1 Stone columns dimensions

Design of stone column predicts the dimensions of the columns, that is length and diameter, and the spacing at which the installation must be executed to achieve desired results. This section covers the relevance of these dimensions in the effectiveness of the technique.

Diameters are designed large enough to accommodate the expected loads. However, the resulting diameter is highly dependent on the equipment used, the weight of the hammer and the uniformity in the procedure. The diameter of a column after installation may often be larger than the expected size depending on the density of the base soil. For low density soils, the diameter tends to be larger since a larger fraction of the column material penetrates the soil during compaction. Priebe (1995) proposed that column diameter and spacing must be determined alongside and must obey the following relation:

$$\frac{A_c}{A} = k \left( \frac{S}{D} \right)^2$$

where:  $\frac{A_c}{A}$  = area replacement ratio,

$A$  = plan area of unit cell attributed to a column,

$A_c$  = cross-sectional area of the column,

$k$  = a factor of  $\frac{4}{\pi}$  and  $\frac{2}{\pi\sqrt{3}}$  for square and triangular column layout respectively,

$S$  = spacing of column, and

$D$  = diameter of column.

Figure 3.3 shows typical square and triangular layout of stone columns (the meaning of  $R_e$  is explained in the section which follows). The spacing of the columns is dependent on the load bearing capacity and the time which is allowed for consolidation by radial drainage through the columns (Som and Das, 2006). According to Greenwood (1970), the spacing of the column influences the settlement improvement ratio. For reduction in settlement, the proposed column spacing (spacing divided by diameter) of 2.5 to 4 to be used for most practical problems involving triangular grids. Although a spacing to diameter ratio of 4 is preferred, the ratio must not be less or equal to 2 for feasibility purposes.

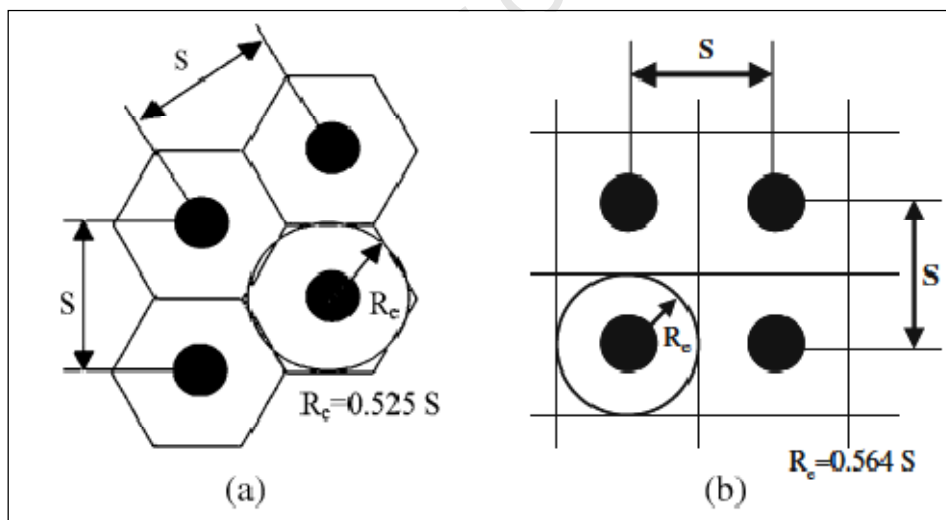

Figure 3.3: Tributary pattern for (a) triangular and (b) square installation (Zahmatkesh and Choobbasti, 2010)

In terms of column length, Som and Das (2006) suggests that the nature of the stratification is more or less the determining factor. Normally, stone columns extend to major compressible strata which contributes significantly to the settlement of the foundation. This extension of

the column accelerates the rate of consolidation through the rapid dissipation of excess pore water pressure from the low permeability base soil.

Bowles (1996) suggested a minimum value for the length of the column since the resistance derived by stone columns is only due to the perimeter shear as opposed to end-bearing. The minimum length is therefore given by:

$$L_c \geq \frac{P - A_c(9c_p)}{\pi d c_s}$$

where:  $P$  = total load on stone column,

$A_c$  = cross-sectional area of stone column,

$d$  = average diameter of the stone column,

$c_s$  = side cohesion of stone column in clay, and

$c_p$  = soil cohesion at base or point of stone column.

### 3.3.2.2 *The unit cell concept*

The unit cell concept is an idealized method for estimating the ultimate strength of a stone column within a base soil. The idealization has been used by many researchers (Priebe, 1995; Ambily and Gandhi, 2007; Goughnour, 1983; Ghanti and Khashliwal, 2008; Abhijit and Das, 2000; Alamgir *et al*, 1996). In 1995, Priebe proposed this concept as a way of estimating the settlement of a stone column foundation. Basically, the concept uses the tributary pattern of the stone columns installation to derive the extent of the effectiveness of the column in the base soil. Goughnour (1983) assumed the loaded area to be large enough compared to the depth of the base soil so as to produce a uniform stress increase and a deformation of the column which is equal to that of the in situ soil from the top. On the other hand, Priebe (1995) states that since all columns are loaded simultaneously, the lateral deformation in the soil at the boundary is assumed to be zero. Balaam *et al* (1978) suggested that the behaviour of any column, in a group of columns, is similar except near the edges of the loaded area. Therefore, only one column can be analyzed to study the behaviour of a stone column. Figure 3.4 shows a typical unit cell where the column spacing is  $S$  and the

effective diameter,  $D_e$  ( $2R_e$ ), is  $1.05S$  and  $1.13S$  for a triangular and square tributary pattern respectively (Goughnour, 1983).

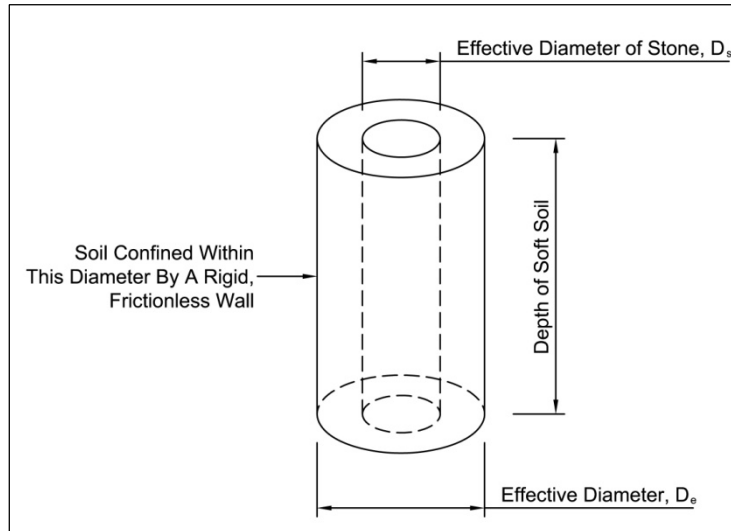

Figure 3.4: A typical unit cell indicating the effective diameter,  $D_e$  (Goughnour, 1983).

### 3.3.2.3 Ultimate vertical stress for individual stone columns

The load carrying capacity of a stone column is dependent on the frictional and cohesion properties of the stones and the surrounding soil, the flexibility and rigidity of the foundation system, and the magnitude of the developed lateral pressure which is exerted on the sides of the column (Malarvizhi and Ilamparuthi, 2011). In 1974, Hughes and Withers studied the effect of reinforcing soft cohesive soils with stone columns. They compared the behaviour of a rigid pile to that of a stone column in a cohesive soil and claimed that both develop end bearing pressures and cohesive resisting stresses. However, for the stone columns bulging was an additional observation which required support from the lateral stresses exerted by the soil. The loading reaction of each method is depicted in Figure 3.5.

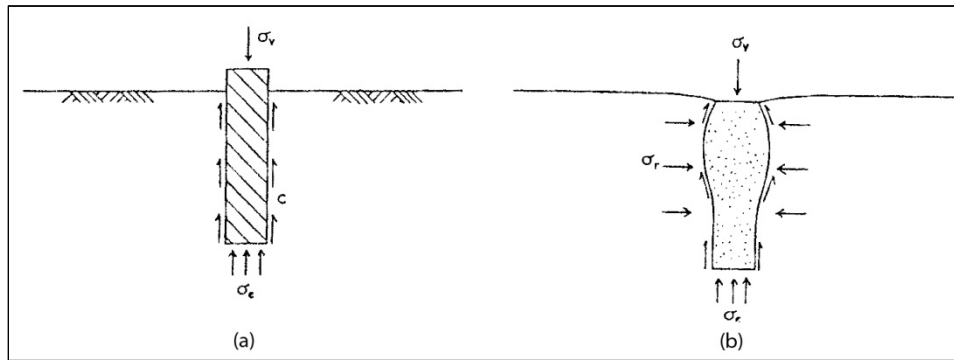

Figure 3.5: Stresses when loading (a) a friction pile and (b) a stone column (Hughes and Withers, 1974)

*“Stone column design has always been semi-empirical. The French found experimentally that arching transferred the vertical loads to the side of the column and then suggested that the ultimate lateral stress the soil could withstand was equal to the bearing capacity of a surface footing. Unfortunately they did not record any experiments which would confirm their suggestion. They seemed more concerned with reducing settlements under their masonry structures” (Hughes and Withers, 1974).*

However, Hughes and Withers (1974) acknowledged that the columns must be treated as being confined by a radial stress similar to a triaxial test and thus claim that the columns are treated as bearing piles which must preferably be founded on a firm layer. Model experiments were conducted on materials of well established properties followed by the presentation of a design procedure.

Hughes *et al* (1975), as cited by Som and Das (2006), identified some factors which govern the soil-column behaviour. These are:

- undrained shear strength of the soil,
- in situ lateral stress of the soil,
- radial stress-strain characteristics of the soil,
- column dimensions prior to loading, and
- stress-strain characteristics and friction angle of the column material.

Hughes and Withers (1974) idealizes the expansion during bulging as identical to a cylinder being expanded against the side of a borehole in a pressuremeter test. According to them, many pressuremeter test results show the radial resistance of the soil reaching a limiting value at indefinite expansion. By applying equations from Gibson and Anderson (1961) and records from a few field tests by Wroth and Hughes (1973), Hughes and Withers (1974) declared that the limiting pressure can be accurately predicted. Furthermore, the ultimate vertical stress, which can be carried by the column as it bulges laterally, can be calculated by the following equation:

$$\sigma'_{vc} = \frac{1 + \sin\phi'_c}{1 - \sin\phi'_c} (\sigma_{ro} + 4c_u - u)$$

where:  $\sigma'_{vc}$  = ultimate vertical effective stress,

$\phi'_c$  = angle of internal friction of column material,

$\sigma_{ro}$  = total in situ lateral stress,

$c_u$  = undrained cohesion, and

u = pore pressure.

Kruger *et al* (1980) also treat the bulging behaviour similarly to a pressuremeter test. They further state that the column stability can be checked by applying limit equilibrium of the column as follows:

$$\sigma'_{vc} = \frac{1 + \sin\phi'_c}{1 - \sin\phi'_c} (\sigma_l - \sigma_o)$$

where:  $\sigma'_{vc}$  = ultimate vertical stress,

$\sigma_o$  = horizontal earth pressure at rest in total rest, and

$\sigma_l$  = reduced limit pressure.

### 3.3.2.5 Settlement of stone column foundations

Settlement in stone column foundations is a combination of the settlement from the soil treated by stone column as well as that below the columns. In the treated soil, settlement arises as a result of lateral drainage into the columns while a load is applied. On the other

hand, settlement from the underlying strata occurs over a period of time. Since the performance of the columns in the ground is dependent on many factors, an exact theoretical analysis is complicated. Therefore, an empirical method is usually adapted in design (Som and Das, 2006; Hughes and Withers, 1974).

When an area large enough compared to the depth of the compressible strata is loaded, the immediate settlement is small. Mitchell and Katti (1981), as mentioned by Som and Das (2006), suggested using a settlement reduction ratio to calculate the settlement of the composite ground. As such, the following equation can be used to estimate the settlement of a foundation as shown in Figure 3.6.

$$\delta = SRRs_{c1} + s_{c2}$$

where:  $SRR = \frac{1}{1+(n-1)A_c}$  = settlement reduction ratio for stone column treatment,

$\delta$  = settlement of foundation,

$s_{c1}$  = settlement of untreated soil within depth of treatment (layer 1),

$s_{c2}$  = settlement of untreated soil below stone columns (layer 2),

$A_c$  = area ratio of stone column installation, and

$n$  = stress concentration ratio (ratio of stress in column to that in base soil).

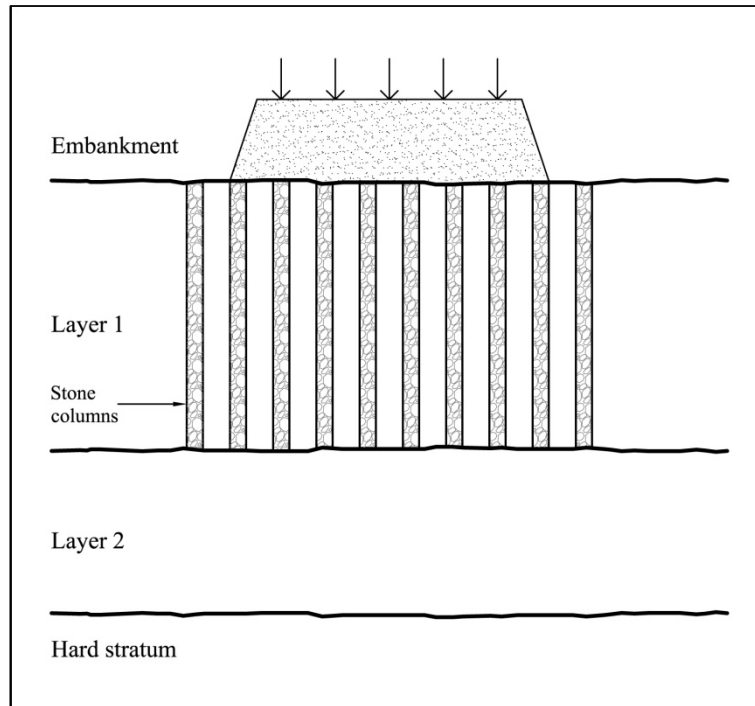

Figure 3.6: Settlement of an embankment on a stone column foundation

### 3.3.3 Effect of column inclusion on the base soil

Stone column has been a widely adopted technique in densifying the base soil, reducing both total and differential settlement, increasing bearing capacity, draining water from the in situ soil and mitigating liquefaction. A less popular application of this technique is in the stabilization of slopes to reduce landslides (Goughnour *et al*, 1991). This section describes how each of the main effects is achieved through the technique.

Installation of stone columns by the ramming action of the falling weight densifies the surrounding soil by firstly replacing parts of the in situ soil with a cohesionless granular material, and secondly by compacting the columnar material such that it penetrates the base soil to form a stiff column. In the process, vibratory waves are generated which contribute to densification. However, since the energy dissipates with increasing distance from the column, maximum densification occurs closest to it. Placement of the columns also reinforces the ground thereby modifying the geotechnical properties of the in situ soil. The load bearing capacity is thus increased while the high stiffness of the column cause a reduction in settlement.

Stone columns can be very effective in soils of high moisture contents due to their high permeability arising from the particle size and thus large void contents in the columns. Therefore, the technique is often a preferred choice where both reinforcement and drainage are required. The installation of stone columns encourage rapid dissipation of pore water pressure from the in situ soil which is generated from repeated loading. According to Madhav and Murali Krishna (2008), drainage can be further accelerated by reducing the spacing of columns which favours horizontal permeability over vertical permeability. Moreover, reduction in column spacing creates shorter drainage paths which in turn increases drainage. The drainage characteristic of stone columns is beneficial in highly liquefiable soils which have the tendency of developing excessive pore water pressures during an earthquake.

Stone columns have occasionally been used in slope stabilisation to reduce landslides. Goughnour *et al* (1991) explains the improvement in terms of the soil along a potential slip surface of a slope. According to him, placement of a series of large-diameter columns of compacted stone, to form a row of columns, improves the slope stability. Cheung (1998) confirms this statement through the construction of a reinforced embankment over a soft ground, improved by 4 rows of stone columns. Monitoring and load testing of the stone columns indicated settlements of less than 15 mm under a test load of 250 kN.

### **3.3.4 Failure mechanism of stone columns**

Stone columns are usually constructed as either end bearing or free floating columns. End bearing columns rest on a firm stratum in the soil while free floating columns have their end implanting in the soft clay, hence floating. When loaded, stone columns are known to fail in four modes namely shear failure (general or local), bulging failure, punching failure and sliding failure (Ghanti and Kashliwal, 2008; Van Impe *et al*, 1997; Hughes and Withers, 1974) although bending can also be an issue with eccentric loading. Figures 3.7 (a) and 3.7 (b) show the types of singular stone column failure in both homogeneous and non-homogeneous soils while Figure 3.8 shows the failure mode of group of stone columns.

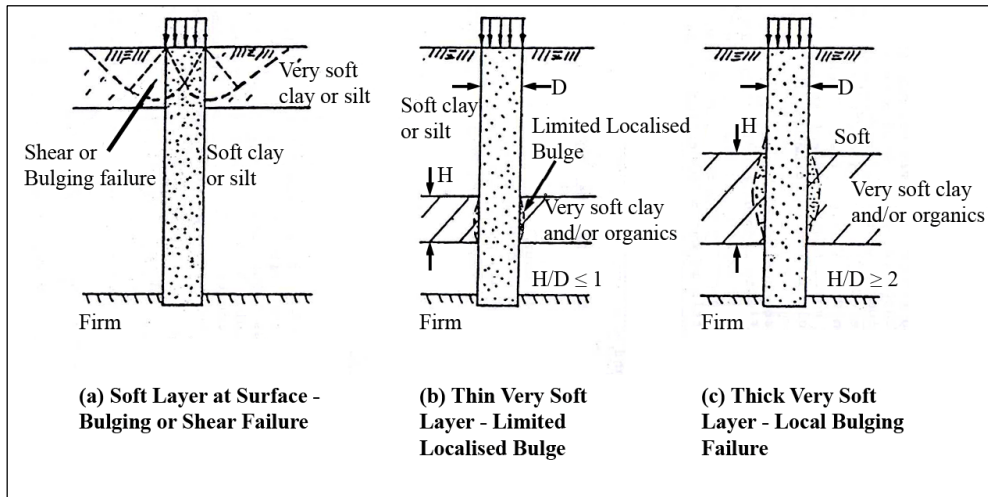

Figure 3.7(a): Failure modes of rammed stone columns in non-homogeneous cohesive soils  
(After Ghanti and Kashliwal, 2008)

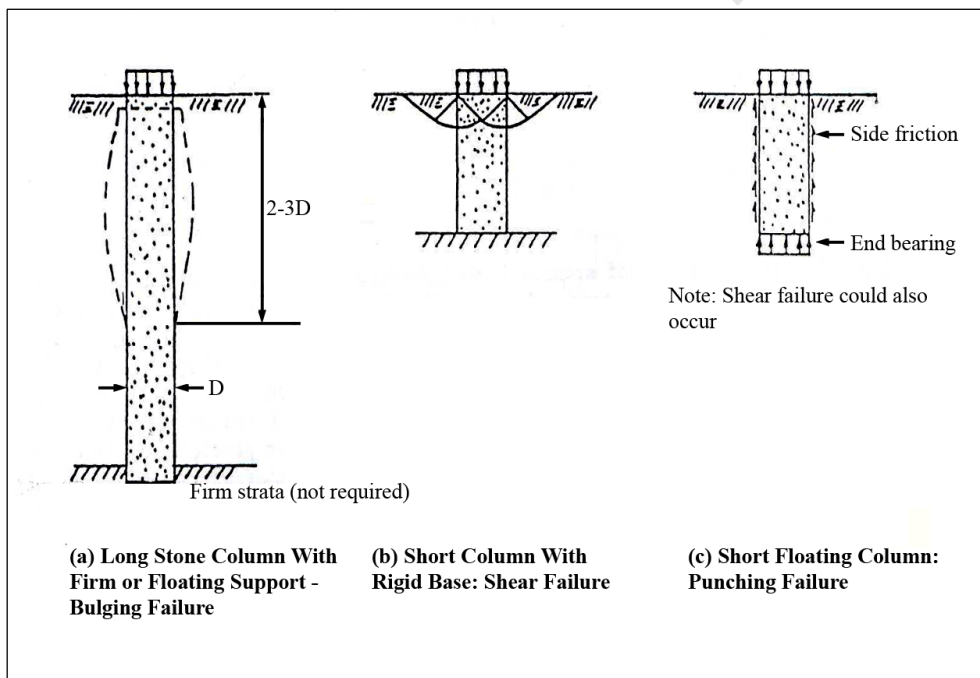

Figure 3.7(b): Failure modes of rammed stone columns in a homogeneous soft layer (After Ghanti and Kashliwal, 2008)

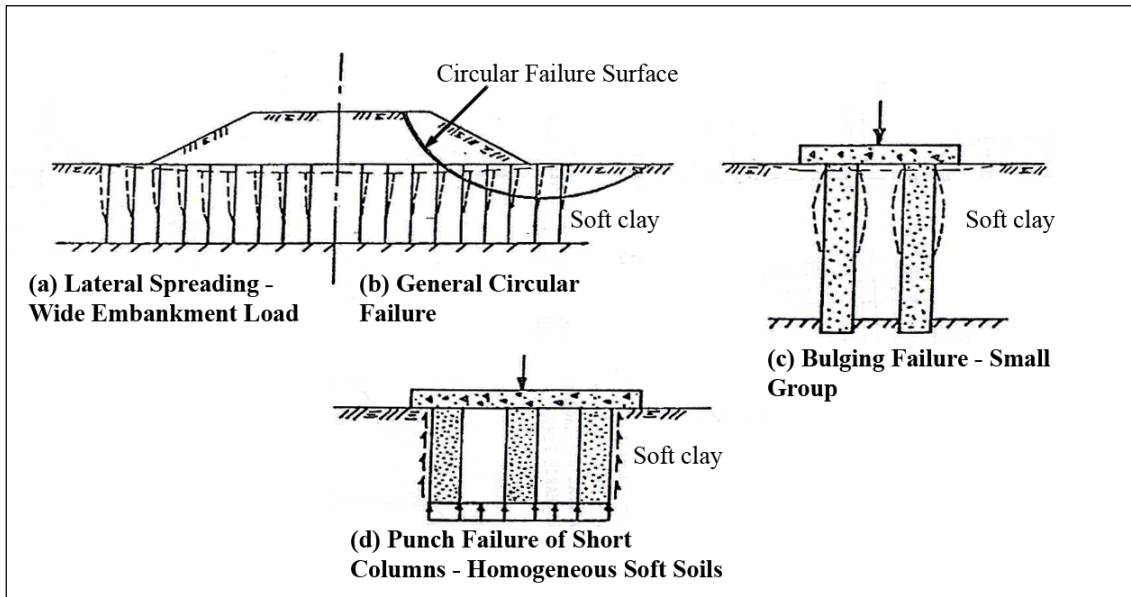

Figure 3.8: Failure modes of group of rammed stone columns (After Ghanti and Kashliwal, 2008)

The mode of failure of the columns are normally dependent on the type of stone column (end bearing or free floating), the type of loads applied to the columns and the passive resistance of the clay within the tributary area. Through a study conducted by Hughes and Withers (1974), it was revealed that the ultimate strength of a singular column, which is loaded on top only, is mainly reliant on the maximum lateral reaction produced in the soil around the bulging zone, with limited degree of movement in the vertical direction within the column (not exceeding 4 times the diameter). For this specific study, a length to diameter ratio of less than 4 indicated end bearing failure before bulging. End bearing mode of failure is related to the equilibrium of the vertical loads on the column only. Therefore, in case the vertical load surpass the shear resisting forces along the column sides and the ultimate base bearing pressure, the column pushes through the soil. Hughes and Withers (1974) proposed the following equation to achieve a vertical stress distribution with respect to depth whereby the stresses changes from maximum of the ultimate value (in bulging zone at the top of the column) to zero at a certain depth. Beyond this depth, any column length will have no significant contribution to the column strength. Consequently, this reduction in length promotes the partial functioning of the base as an end bearing pile, by allowing the base to support some of the applied vertical stress. Drastic shortening of the column can produce a base stress higher than the bearing capacity of the soil thereby causing failure in the end

bearing mode prior to bulging. A critical length of  $4.1D$  was thus established in their study, using the following equation, to achieve both end bearing and bulging failure simultaneously.

$$\sigma_{vM} = \sigma_v + M(\rho_{col}D - 4c)$$

where:  $\sigma_{vM}$  = vertical stress at a depth given by  $M$

$\sigma_v$  = vertical applied stress on top of column

$M$  = depth to column diameter ratio

$\rho_{col}$  = effective density of the column material

$D$  = column diameter

$c_u$  = assumed as constant throughout the column

Van Impe *et al* (1997) claimed that stone column failure is a combination of pile and bulging behaviour rather than independently since the column undergoes lateral confining stresses in addition to shear stresses acting on its cylindrical surface. Thus, the occurrence of the combined failure is more likely, employing which the actual capacities of the column can be more accurately estimated.

### **3.4 Previous research on rammed stone columns**

#### **3.4.1 Previous laboratory effort into rammed stone column investigation**

Presently, there have been several laboratory and theoretical studies conducted on rammed stone columns in countries other than South. These studies have often attempted to establish the most suitable column material, the optimum dimensions of the column or the failure mechanism of the column, among many other objectives.

Isaac and Madhavan (2009) studied the effect of column material in stone column performance. Five materials (quarry dust, sea sand, river sand, gravel and stones), designated as m1, m2, m3, m4 and m5 respectively, were used for singular columns and groups of three and seven columns in a clayey base soil in order to determine the most effective material. Their objective was achieved by observing the load versus settlement response of the columns and by performing a finite element analysis using 15-noded triangular elements with

PLAXIS, to compare with the experimental results. Experiments on single columns of 50 mm diameter were performed assuming the unit cell concept which was represented by a cylindrical tank of height 270 mm and diameter 210 mm. Columns were installed by means of a greased PVC pipe of 50 mm diameter which was put in place before the construction of the clay bed. Finally, column materials were charged in layers subjected to adequate compaction. During the study, the column spacing was also varied (2.5 times diameter and 3 times diameter). The investigation indicated that the load deformation characteristics of the clay was considerably improved by the inclusion of the columns, and stones were the most effective material to produce the columns. Furthermore, gravel produced higher strengths than sand in general although river sand and gravel behaved similarly in certain cases. It was also clearly shown that as the spacing of the columns decreased, their effectiveness were higher. Comparison of the experimental results with that of the finite element method showed high compatibility. Figures 3.9 to 3.11 presents the stress-settlement relation obtained, both experimentally and through finite element method, for singular column and group of columns (Isaac and Madhavan, 2009).

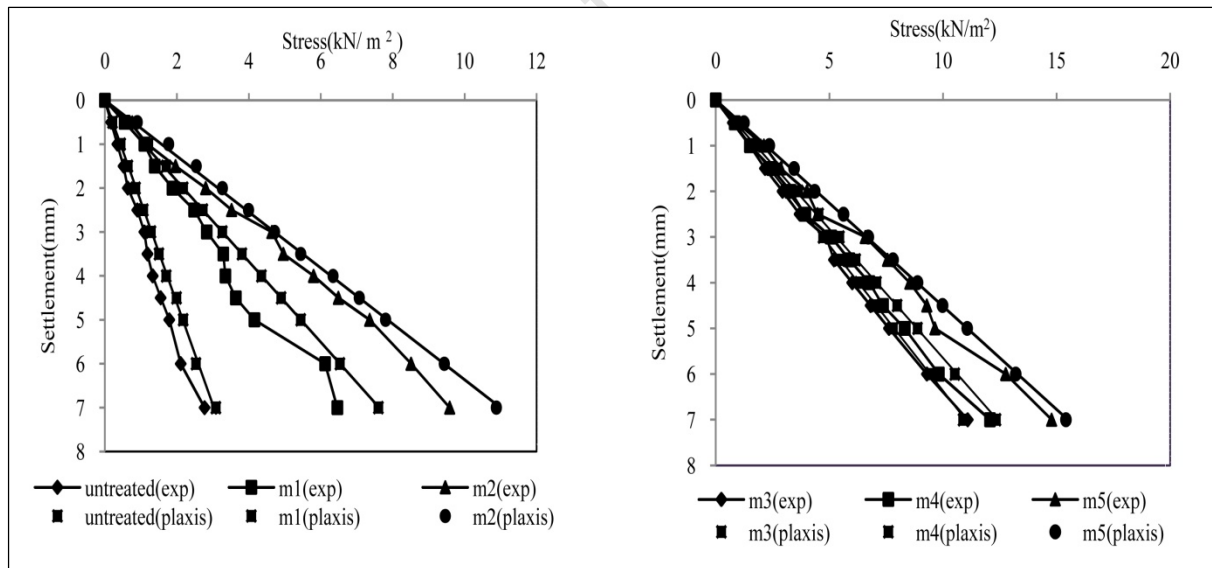

Figure 3.9: Stress-settlement behaviour for singular column (After Isaac and Madhavan, 2009)

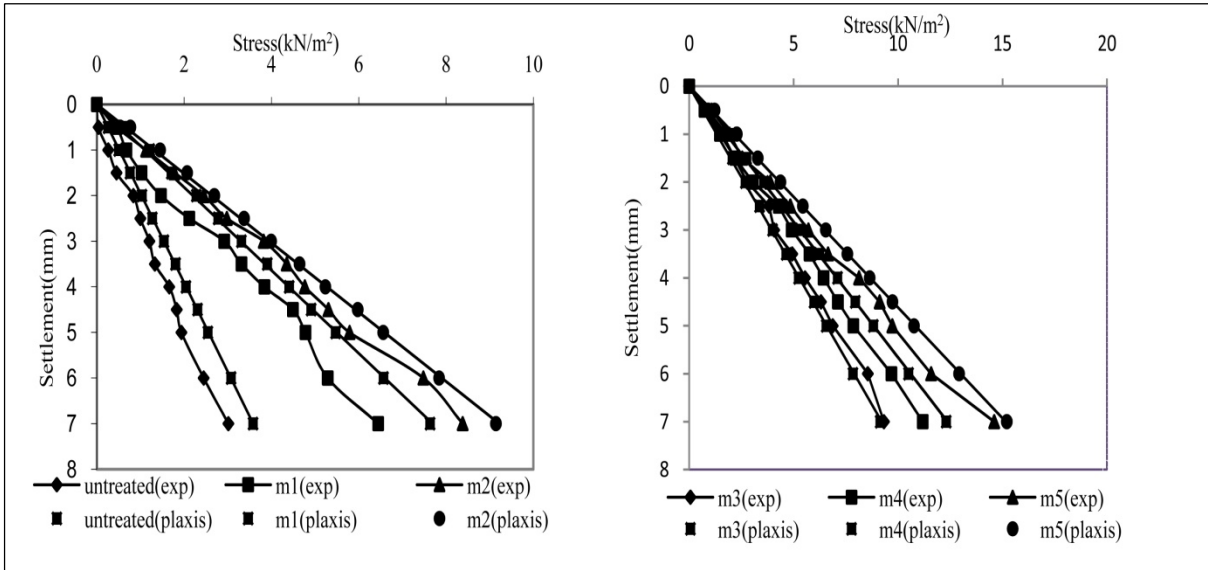

Figure 3.10: Stress-settlement behaviour for group of seven columns at a spacing of 3 times diameter-3D (After Isaac and Madhavan, 2009)

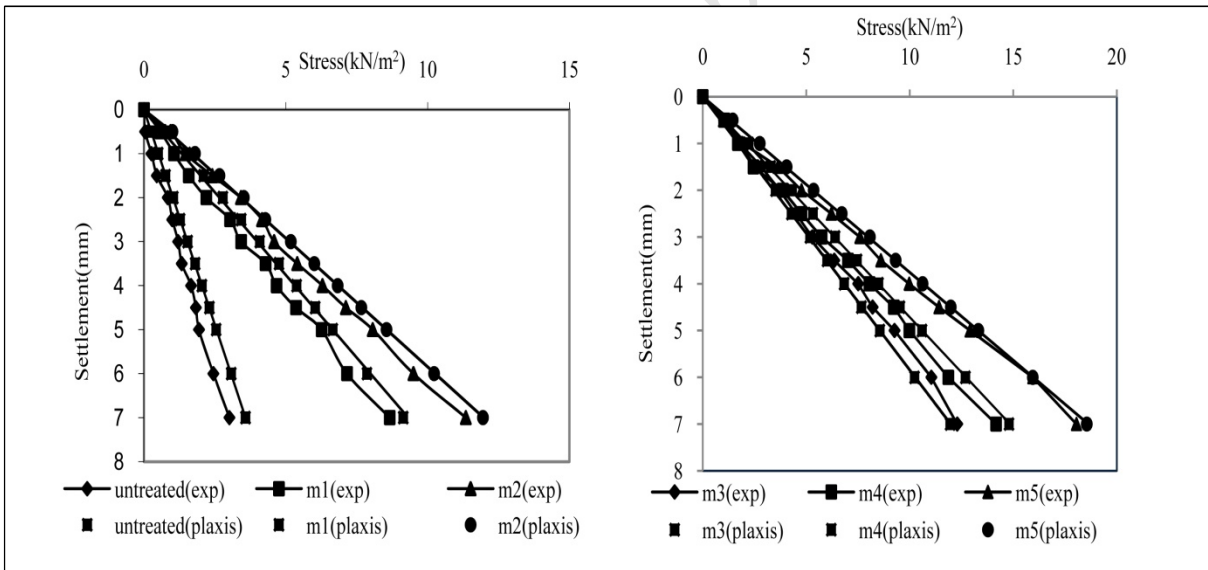

Figure 3.11: Stress-settlement behaviour for group of seven columns at a spacing of 2.5 times diameter-2.5D (After Isaac and Madhavan, 2009)

Ambily and Gandhi (2007) embarked on a similar study although they used singular and groups of seven columns of 100 mm diameter and length 450 mm each, which were installed after the preparation of the clay bed in cylindrical tanks of 500 mm high and diameter ranging from 210 mm to 835 mm. Throughout the study, a locally available clay was used as the base

material while crushed aggregates of sizes between 10 mm and 2 mm were used in the columns of 9 layers, where each was lightly compacted with a 2 kg steel tamper by applying 10 blows through a drop height of 100 mm. Tests were conducted at shear strengths of 7 kPa, 14 kPa and 30 kPa (corresponding to moisture contents of 35%, 30% and 25% respectively) with an applied load at a rate of 0.0625 mm/min. Unlike Isaac and Madhavan (2009), Ambily and Gandhi (2007) provided a 30 mm thick layer above the improved clay to act as a blanket for the group of columns being tested. A typical test arrangement for single column is shown in Figure 3.12.

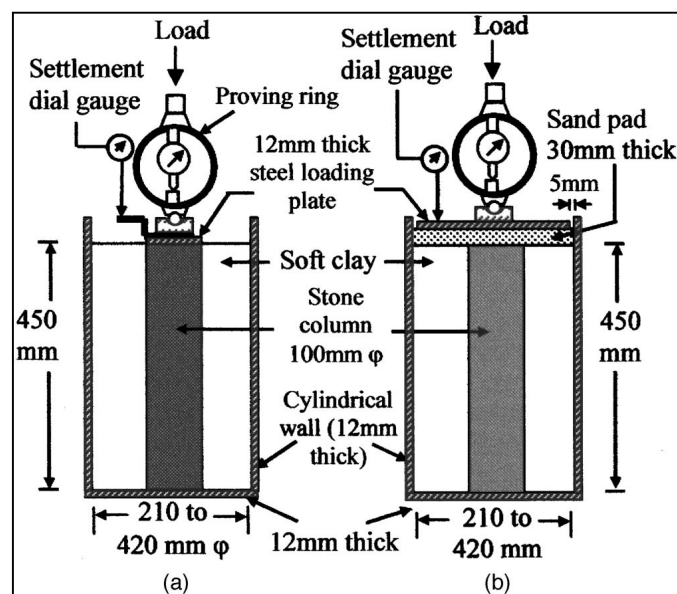

Figure 3.12: Single column test set-up for loading applied on (a) column area only, (b) entire area (Ambily and Gandhi, 2007)

Results from the study revealed that single column tests, where the entire unit cell area was loaded, had good comparison with the group test results. As such, the use of a single column with the unit cell concept, to simulate the field behaviour of an inside column when many columns are loaded at the same time, was justified. In terms of stiffness improvement factor, it was found to be dependent on the column spacing and the internal friction of the stones rather than on the shear strength of the base soil. Some agreement between the results of this study and the observations of Isaac and Madhavan (2009) regarding column spacing and comparison of experimental with finite element results, were noted. Figures 3.13(a) and

3.13(b) show the stress settlement behaviour under entire area loading and the comparison of group column test and single column test respectively.

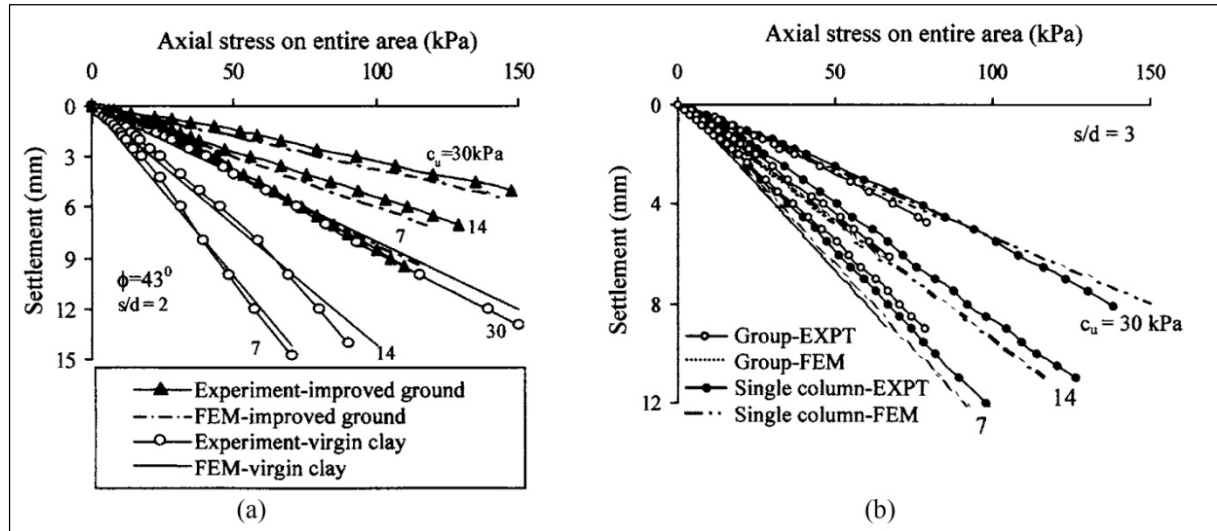

Figure 3.13: Stress-settlement behaviour under entire area loading for (a) spacing to diameter ratio of 2, (b) spacing to diameter ratio 3 (Ambily and Gandhi, 2007)

Ground improvement by stone columns or stone columns with a top layer of granular material was also studied by Aarathi and Bhaskar (2011). More specifically, the study looked at the bearing capacity behaviour of an axi-symmetric load under static compression on the granular surface overlying a stone column reinforced clay bed. The density and thickness of granular material, as well as the number of stone columns, were varied and the results obtained from plate load tests were analysed. In general, more than 2-fold improvement in bearing capacity was obtained by using stone columns. Provision of a top sand layer appeared to improve the bearing capacity and an increase in sand layer thickness produced an improvement of about 8-folds. Moreover, an increase in density of the sand layer from 59% to 70% resulted in more than 10% increase in bearing capacity. Although stone columns and the sand layer independently generated an improvement in bearing capacity, a combination of both showed an enhancement of about 10% more than the sand layer alone.

Rammed stone columns can be installed by two techniques namely augered bore holes (Ambily and Gandhi, 2007; Isaac and Madhavan, 2009) and dynamic compaction. Kruger *et al* (1980) employed the dynamic compaction method, which they termed as the dynamic

substitution method, in describing the design and control methods used for the construction of the Johannesburg western by-pass motorway which was placed on a fill over a swampy area. The ground was highly contaminated by mine slimes coming from slime dams of old gold mines in the vicinity. Employment of the technique was assumed to decrease the time and amount of settlement while increasing the safety factor against circular slip failure of the constructed embankment. However, for feasibility and economical purposes a test zone was carried out where the equipment to be used was decided, the amount of disposed material was estimated, the unimproved soil conditions were observed, column diameters and spacing were randomly chosen and tested, column stability and load transfer mechanism were approximated and settlements were calculated. A testing programme was developed following which the optimum column diameter and spacing were achieved. To control the column characteristics, Menard pressuremeter tests were performed. In this trial study, Kruger *et al* (1980) confirmed that settlements were reduced at once with the inclusion of the columns. They further reported that the bearing capacity was increased since a large part of the overall load was transferred to the columns. Drainage as well as consolidation to avoid liquefaction was also considered. In addition to all the mentioned field observations, the factor of safety against slope failure was also increased. Overall, the technique was found to be both time and cost effective compared to the conventional techniques.

Karim *et al* (2009) conducted a study to compare the amount of improvement in a clay which is subjected to dynamic compaction or stone columns. The investigation was restricted to laboratory tests on a natural base soil classified as a clay of low plasticity, at moisture content of 27% and undrained shear strength of 9 kPa. For installing the singular or group of stone columns, a similar procedure to Ambily and Gandhi (2007) was employed although the diameter and length in this study was much smaller (30 mm and 180 mm respectively) and stones were used in the form of limestone of sizes between 2 mm and 8 mm. On the other hand, dynamic compaction was done on an unimproved wet clay (under same conditions as that for stone columns) by means of drop weights of 2 kg, 3 kg and 5 kg where each weight was dropped through heights of 500 mm, 750 mm and 1000 mm. In general, lower improvement was attained with dynamic compaction compared to stone columns. Installation of 3 columns resulted in a maximum cumulative improvement ratio in settlement of about 178% while that for 1 column was minimum at 16%. Under similar conditions, dynamically compacted clay produced minimum improvement ratio of 8% with a 2 kg drop weight which is released through 1000 mm while a maximum of 69% was recorded with a

5 kg drop weight of equivalent drop height. These results indicate that improvement in settlement is almost twice with stone columns, thereby confirming the higher effectiveness of the technique in clay. Figure 3.14 shows the stress-settlement behaviour of the clay when improved with stone columns.

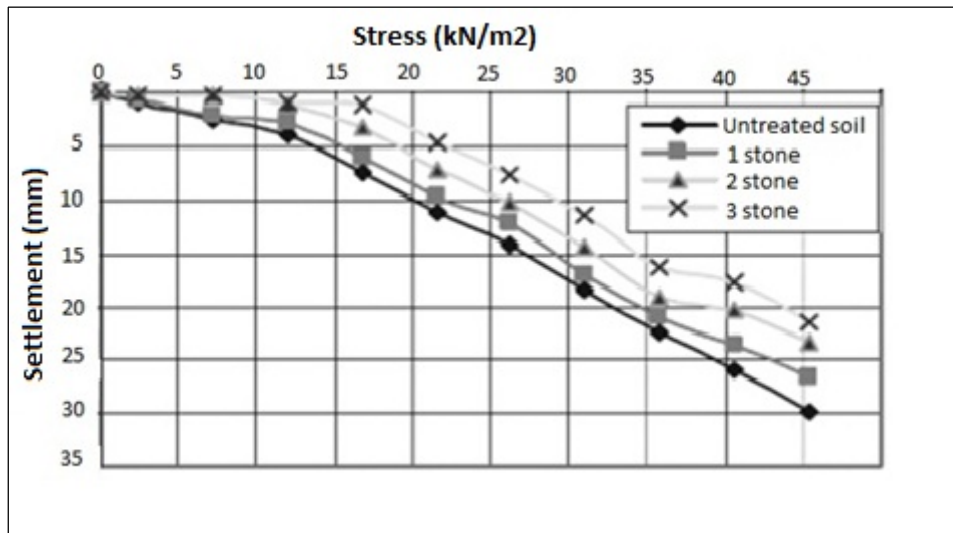

Figure 3.14: Stress-settlement relationship of unimproved and improved clay with different number of stone columns (After Karim *et al*, 2009)

From the review of literature, it is found that the amount of experimental work reported about the study of the behaviour of stone columns in layered soil is very limited. Therefore, a study was carried out to investigate the behaviour of stone columns in layered soils. Singular columns of 90 mm diameter were installed in a cylindrical tank of 780 mm high and diameter 237 mm, filled with a relatively strong silt soil underlying weak soft clay layers. The thickness of the clay layer was varied with respect to the column diameter (D) such that four top layers were investigated (1D, 2D, 3D and 4D) at an area replacement ratio of 15%, column spacing of 2.4D and total soil thickness of 8D. Columns were installed similarly to Ambily and Gandhi (2007) with the silty base soil and clay layer having moisture contents of 40% and 45% respectively. Tests were conducted under two circumstances, at speed of 0.0625 mm/min, such that the vertical stress was applied either over the stone column only or over the entire top surface

The study revealed that the stiffness, load bearing capacity and bulging behaviour of stone columns were significantly affected by the thickness of the overlying soft clay layer. However, the effect was low when the entire area was loaded. Furthermore, an increase in clay layer thickness beyond 2D showed the insignificance of the stiff bottom layer. Reduction in settlement was also found to be marginal (only 20% - 30%) due to the poor lateral confinement of the clay causing excessive bulging of the columns in the upper layers (entire bulging occurred in top weak layer). On the other hand, column area loading pointed out the large effect of the top weak layer on the limiting axial stress of the stone columns. For thickness of 1D, a decrease of 50% in limiting axial stress was observed compared to that in silty soil. Nevertheless, the limiting axial stress at a thickness of 4D was equivalent to that in soft clayey ground. Figures 3.15(a) and 3.15(b) show the effect of top layer thicknesses on load-settlement behaviour and settlement reduction ratio respectively.

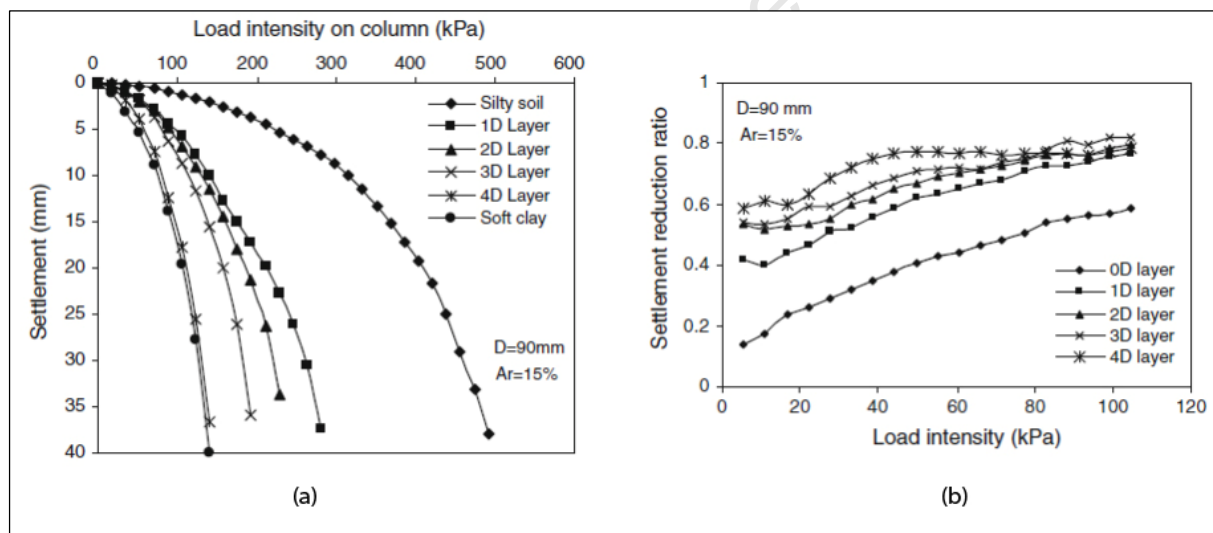

Figure 3.15: Relationship between clay layer thickness and (a) load-settlement behaviour (b) settlement reduction ratio (Shivashankar *et al*, (2011))

While stone columns have a good performance in soft clays, peat and cohesive deposits, their installation may sometimes be complex due to the lateral spread of stones as a result of low confinement from the surrounding poor quality soil. Furthermore, contamination of the stones with the base soil can cause a reduction in their frictional strength as well as obstruct their drainage capacity due to clogging. For these reasons, a combined use of geosynthetics, such as geogrids or geocomposites, with stone column has been proposed by some

researchers (Malarvizhi and Ilamparuthi, 2011; Murugesan and Rajagopal, 2008; Tallapragada *et al*, 2011).

Murugesan and Rajagopal (2008) embarked on the investigation of the behaviour of geosynthetically encased stone columns which was later compared to unreinforced stone columns. Laboratory tests were performed in a clay bed formed in a unit cell tank. The outcome revealed the significant increase of about 3 to 5 times, depending on the stiffness of the geosynthetic, in load capacity of stone columns when encased with a geosynthetic. Also, a smaller column diameter was found to produce higher improvement. Malarvizhi and Ilamparuthi (2011) conducted a similar study although they additionally investigated the effect of slenderness ratios and type of encasing material on the load-settlement response. It was deduced that geogrid encased stone columns had a higher load carrying capacity, with ultimate bearing capacity of 3 times that of untreated bed for reinforced columns as opposed to 2 times that for unreinforced columns, which was negligibly influenced by the slenderness ratio. Reduction in settlement was in line with Murugesan and Rajagopal (2008). Tallapragada *et al* (2011) extended the study by adding a small percentage of fine materials (lime and stone dust) to the granular column material (sand), which was encased in a geosynthetic material, and observing the effect of bearing capacity on the improved ground while varying column diameter, column length and geosynthetic casing type. Columns of diameters 25 mm, 20 mm and 15 mm and lengths 300 mm, 225 mm and 200 mm were tested respectively in base soils (inorganic clay with high compressibility) having 25% by weight of water. The study disclosed a decrease in settlement with increase in column diameter as well as length, irrespective of the geosynthetic casing. These settlement reductions were recorded as 11.88% to 41.47% when increasing from smaller diameter and length to larger ones respectively, with a simultaneous increase in load carrying capacity from 21.62% to 45.00%.

### **3.4.2 Field studies**

*Case study 1: Construction of a Midfield Terminal at O.R Tambo International Airport, Johannesburg, South Africa (Van der Westhuizen and Parrock, 2010)*

#### ***Introduction***

The R30bn construction project of a Midfield Terminal at the O.R Tambo International Airport in Johannesburg (South Africa), in the Gauteng province which is considered to be the business hub of Africa, is the outcome of heavy usage which necessitated regular upgrading and development (BusinessDay, 2010). To meet the high demand, the Airports Company South Africa (client) opted for further development which aimed at maximising the use of the existing available space within the boundaries of the airport to accommodate more passengers yearly.

#### ***The geology of the site***

A geotechnical investigation conducted revealed three different zones of major concern on the site, which are shown in Figure 3.16. The ferricrete area is underlain by hardpan ferricrete at a depth of about 500 mm with clayey gravel overlying it while the swampy area, which is characterised as very soft organic clays, comprises the area within the reeds along the Blaawpan Spruit. These organic clays overlie the alluvial clays to a depth of between 5 m and 8 m. The seepage area is a region of ferricrete which has not been well developed and is underlain by soft clays.

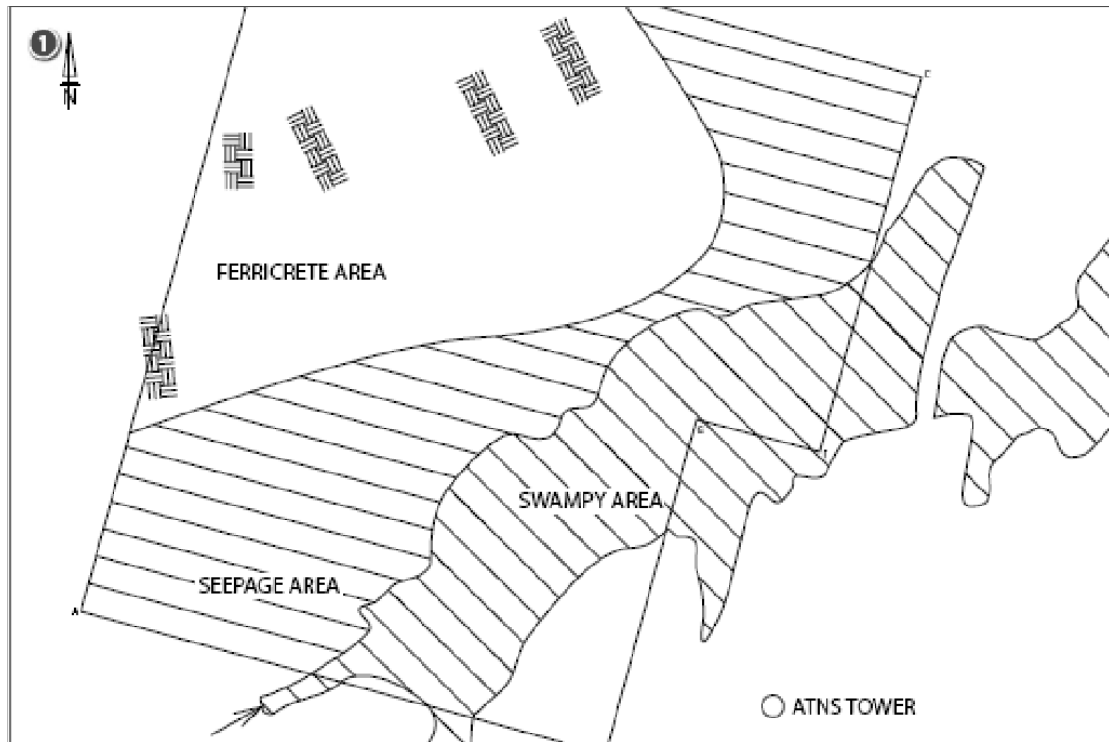

Figure 3.16: The three zones of major concern on the site (Van der Westhuizen and Parrock, 2010)

### ***The problems***

Apron Phase 1 of the Midfield Terminal, required the construction of a 6 m to 8 m high embankment which was estimated to have a density of  $20 \text{ kN/m}^3$  with resulting maximum load of  $160 \text{ kN/m}^2$ . From Piezocone penetration tests (CPTU) performed, The E modulus of each material was obtained (not exceeding 6 MPa) and it was ascertained that the seepage and swampy areas would most probably undergo a settlement of 130 mm to 400 mm in about 5 years.

### ***The treatment objectives***

Stone columns were chosen, installed by means of the dynamic compaction process, to be overlaid by a high strength geosynthetic followed by a blinding platform of 1.5 m thick G6 (natural gravel of size not exceeding 63 mm in South Africa) quality material. The columns were envisaged to combat the range of settlements predicted and also the extended time period. Furthermore, they were expected to provide vertical resistance as well as strengthen the in situ materials during horizontal compaction. As a result, the soil can carry the imposed

load while reducing the settlement. Additionally, stone columns are known to enhance drainage which results in pore pressure being dissipated at a faster rate. Settlement time was, therefore, predicted to be considerably reduced.

An analysis was done prior to any construction work to estimate the settlements, presuming the system to operate as a piled raft foundation whereby stone columns were acting as piles with the reinforced upper layer representing the raft. The stone columns were estimated to have a stiffness of 40 MPa which resulted in a reduced estimated settlement 100 mm to 200 mm for the seepage and swampy areas respectively. In addition, the settlements were envisaged to evenly spread on the site and they were estimated to have occurred around 8 months after the load was applied. Since the actual construction was expected to take more than a year, it was considered that most of the predicted settlement would have occurred by completion of the embankment.

### ***The treatment***

Stone columns of minimum E-values of 50 MPa were installed to depth of about 5 m at 3.5 m centres. The number of blows for the dynamic compaction, which was predetermined, was later revised since excessive bulking on the soil surface occurred indicating an irrelevancy in the amount of compaction. Ten blows were eventually deemed adequate, through hand calculations and plate load tests, to obtain 50 MPa.

During the installation of the stone columns, the in situ clay in the seepage area was observed to be much stiffer than that in the swampy area. It was proposed that a 12 t Rapid Impact Compaction (RIC) rig be used with 8 passes instead of dynamic compaction. Trial columns were installed for quality determination and the result obtained encouraged further use of the machine in the installation process. Figure 3.17 shows the RIC machine at operation.



Figure 3.17: RIC machine operating (Van der Westhuizen and Parrock, 2010)

### **Monitoring**

For monitoring purposes, plate load tests were performed. Excavations of columns as well as trial areas were also part of the monitoring program to ensure that the depth of the columns and their integrity with the base soil were appropriate and in compliance with the specifications. The engineers involved referred to the elasticity theory for the settlement of a rigid circular plate, which was presented by Poulos and Davis in 1974, to calculate the E-value from the data collected during the plate test. Table 2.2 summarises the results obtained for all the plate load tests which were done during construction.

Table 3.1: Comparison of all plate load tests, different construction and different seasons (Van der Westhuizen and Parrock, 2010)

DATE OF TEST	WET OR DRY SEASON	STONE COLUMN LOCATION		METHOD USED	NUMBER OF PASSES OR BLOWS	POULOS & DAVIS E-VALUE (MPa)
		BLOCK	COLUMN			
2008/11/26	Wet	K5	38	DC	15 blows	57
2008/11/26	Wet	K5	99	DC	10 blows	48
2008/12/04	Wet	K5	44	DC	15 blows	65
2008/12/04	Wet	K5	84	DC	10 blows	52
2009/05/14	Wet	E1	86	RIC 12	8 passes	57
2009/05/14	Wet	E2	57	RIC 12	8 passes	51
2009/07/28	Dry	M3	34	RIC 12	8 passes	93
2009/07/30	Dry	D2	98	RIC 12	8 passes	156
2009/07/30	Dry	D2	Between columns	Between columns	Between columns	14

Settlement monitoring was done through the construction of a trial area with a fill of approximately 8m high. Piezometers and measuring plates were also installed to monitor the amount of excess pore water pressures dissipated and the settlement produced by the constructed fill thereby indicating the resulting amount of consolidation. Figures 3.18 and 3.19 show the settlement readings against time and piezometer readings against time respectively.

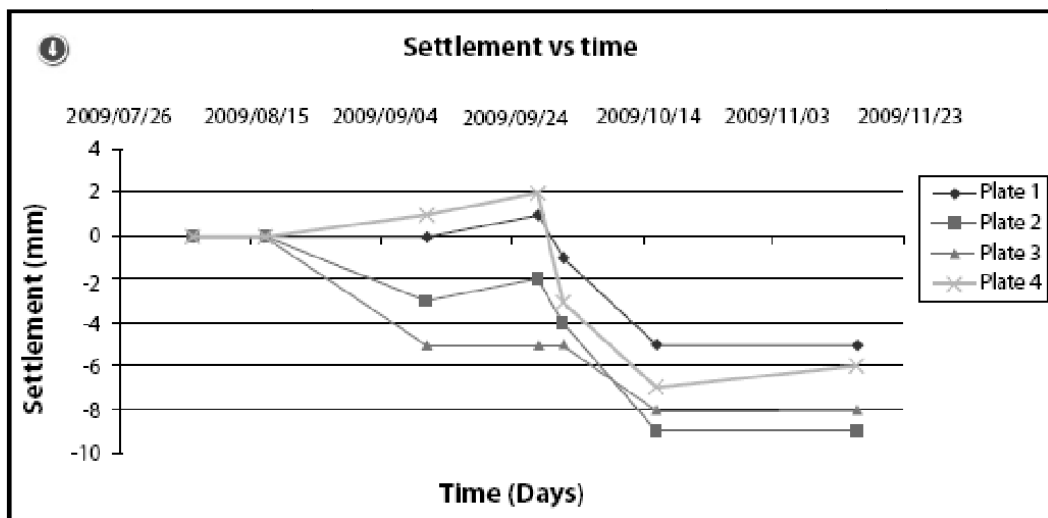

Figure 3.18: Settlement readings against time (Van der Westhuizen and Parrock, 2010)

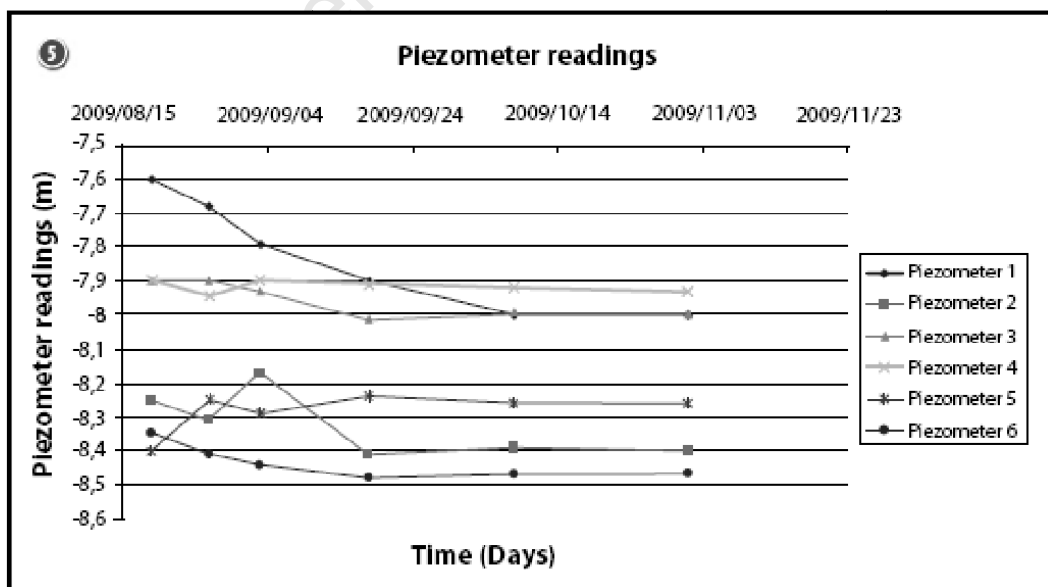

Figure 3.19: Piezometer readings against time (Van der Westhuizen and Parrock, 2010)

### ***Outcome***

The results obtained from monitoring were analysed and affirmative results were obtained. An increase of at least 8 MPa in the stiffness of soils which were between the columns was noted and was taken to be a result of horizontal densification of the soil during column installation.

Piezometer readings indicated that consolidation had already started during the construction and was due to the load being applied by the increasing height of the fill. The first readings were taken 3 months after construction was initiated and it was reported that most settlement had apparently occurred during construction. Piezometer readings taken after the completion of the fill area showed a decrease over the first month and a half followed by constant values.

### ***Conclusions***

Since excess pore pressures were dissipated 5 months after the start of the construction of the fill, it was concluded that the consolidation process of the clay layer had finished. The readings obtained from the piezometers and measuring plates showed that the stone columns, constructed in the trial area, performed as expected. Furthermore, since the trial area was set up in the swampy area, which was considered to be the most critical area, it was assumed that the stone columns in the other areas would also perform similarly.

*Case study 2: Expansion of an aluminium plant in Eastern Uttar Pradesh, India  
(Sundaram and Gupta, 2010)*

***Introduction***

This project involved the construction of a Drum Filter Plant on a Red Mud Slurry Pond for an aluminium industry in eastern Uttar Pradesh, India. Red mud is a waste product obtained while extracting aluminium from its ore. The washing product is pumped into a disposal pond, in a slurry form, where a soft deposit with very low Standard Penetration Test (SPT) values is obtained following the drying of the slurry. This soft deposit behaves similarly to very soft clay which therefore renders construction problematic.

***The geology and location of the site***

The project site, which is located in a valley between two hills, overlies phyllitic shale rock of low-grade metamorphism. The site was essentially formed by filling Red Mud in the valley although some fly ash, bauxite fragments and rock fragments can be spotted. Thickness and uniformity of the filling varies throughout the site with the northern side encountering rock at a depth of between 15 m to 18 m.

Red mud is classified as a clayey silt of medium plasticity, high specific gravity and high pH. The material has a low permeability and tends to retain water which makes dissipation of pore water pressure very slow. In fact, in its natural state the water content was found to be between 32% and 38%. Furthermore, consolidation test results described the soil as under-consolidated to a depth of 5 m to 8 m.

***The treatment objectives***

Pile foundations and stone columns (referred as granular piles by the authors) were the possible approach over open or raft foundations due to the soft consistency and under-consolidation characteristics of the soil. However, stone columns were chosen since they were envisaged to improve the base soil shear strength, accelerate consolidation (expected to achieve over 90% completion within few months of construction), act as drainage systems and at the same time minimise construction costs. To overcome the effect of the under-consolidated soils at 5 m to 8 m depth, it was proposed that columns be installed to depths of 12 m to 14 m.

### *The treatment*

Stone columns of 600 mm diameter and length 12 m below the cut-off level were installed at a spacing of 2 m in a triangular grid pattern which was subsequently covered by a compacted gravel blanket of thickness 200 mm to ensure uniform load distribution over the columns. Raft foundation, of a design net bearing pressure of 12 T/m<sup>2</sup>, was then constructed over the blanket.

For constructing the columns, a hole was bored to the required depth and charged with gravel of 75 mm down (graded) in layers of about 1 m high. Each layer was rammed by a 1 ton-weight down the hole until adequate compaction was achieved. The aggregates used were tested for alkali-aggregate reactivity due to the high alkalinity of the soil.

### *Monitoring and outcome*

Verification of the performance of the granular piles was achieved through a load test which was performed on a single pile, surrounded by 6 others to ensure sufficient peripheral restraint. The test set-up is illustrated in Figure 3.20.

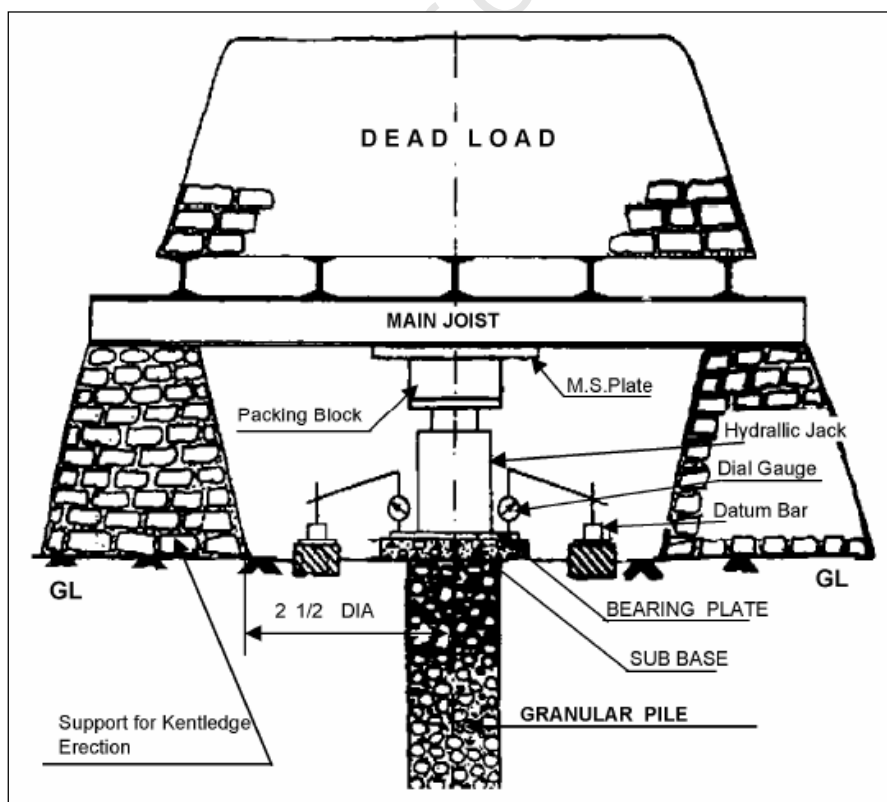

Figure 3.20: Load test set-up on a singular column (Sundaram and Gupta, 2010)

Results obtained from the test showed that a single column had a capacity of about 42 T. Settlement analysis was also performed and the total settlement of the raft foundation, under a pressure of  $12 \text{ T/m}^2$ , was 50 mm. Figure 3.21 shows the load settlement-curve obtained from the load test.

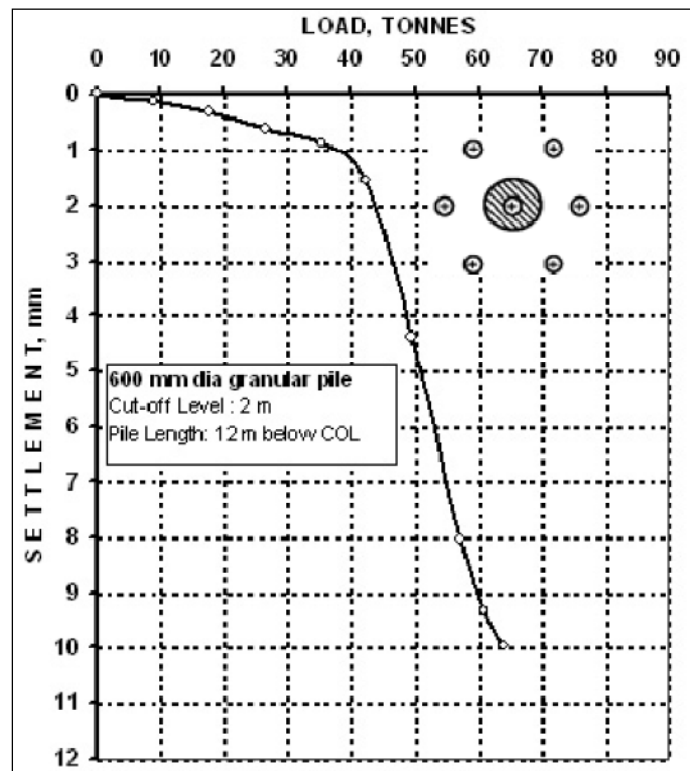

Figure 3.21: Load-settlement curve from load test of a singular column (Sundaram and Gupta, 2010)

### Conclusions

From the testing of the single pile, it was deduced that this technique for improvement of the ground was an economical option to the particular project, with a cost saving of more than 50 percent. In addition, the improved ground was capable of sustaining the structural loads imposed by the raft foundation. However, the authors recommend proper geotechnical investigation and load tests to achieve successful performance of the foundations.

### 3.5 Summary of literature

This chapter has explained the theory behind the operation of rammed stone columns as well as their benefits. The compilation of results from studies undertaken by different researchers has added on to existing information, confirming the importance of column parameters such as length, diameter, spacing and friction angle of the column material. The quality and moisture content of the base soil has also been reported as an influencing factor in the behaviour of the columns. Although a great deal of research has been carried out with the different studies sharing a compatibility in the results obtained, there exists no specific standard in conducting experiments of rammed stone columns. The approaches are many, often resulting in conflicting theories. While some researchers have preferred using circular tanks to represent their unit cell, others have chosen square containers. Additionally, different diameters, lengths and spacing of the columns have been investigated, with spacing and diameter being closely related. Column material has also been noted to vary from study to study.

In conjunction with the previously mentioned statement, the literature review has not revealed any documented research or guidelines about the application of rammed stone columns in South Africa, with the exception of a local case study which was elaborated towards the end of the chapter. Therefore, this research was deemed valuable to contribute to the possibility of using the technique locally, bearing in mind that it can be sustainable both environmentally and economically while serving its purpose in the construction industry. The suitability of the technique on a local problematic soil was tested through this study with a view that the onset of this investigation will encourage deeper related studies to be undertaken in the future to devise some guidelines for the use of rammed stone columns in South African soils.

The rammed stone columns were proposed to be installed through the augering of holes with a temporary casing inserted in the clay bed, after which the columns were to be formed by a replacement method. Clay was chosen as the base material since its percentage in the South African soil is quite high. Also, tests were to be conducted on Kaolin, a testing material which has often been used by researchers studying stone columns. The purpose of using Kaolin as well as a local South African clay would be for the comparison of behaviour of some of the columns installed in both clays, under similar conditions. Improvement would be measured in terms of the vertical applied stress and settlement reduction. To achieve the

purpose of this study, the diameter of columns, column material and base moisture content were to be varied. Although, previous researchers had focussed on circular or square testing boxes, this study would employ a narrow rectangular box to replicate a field scenario of a row of column, a common application of stone column in supporting strip foundations. Chapter 4 elaborates on the experimental approach.

University of Cape Town

University of Cape Town

*Research Materials and  
Methodology*

---

## **4.1 Introduction**

This chapter is divided into two main sections in which the first component provides a detailed description of the materials utilized in this investigation namely: Kaolin and Cape Town clay as base soils (Figure 4.1), and Klipheuwel sand, Cape Flats sand and crushed aggregates as columnar materials (Figure 4.2). The wide range of particle sizes for the columns specifically aimed at studying their respective effect on the degree of improvement. All the materials used in this study were sourced locally and were specifically chosen since they were clean and easy to work with, thus enabling repeatability of results. In order to achieve a better understanding of the nature of each material, mechanical and chemical tests were performed according to the corresponding British Standards in the University Laboratory. Their results are summarised and presented in the subsequent section. Further details about the test results are provided in Appendix B.

In the second section of this chapter, the experimental procedure adopted in executing this bench scale research is thoroughly described. A 1000 mm x 150 mm x 450 mm rectangular wooden box containing the testing specimen was subjected to a vertical compressive load via the Zwick Universal Testing machine. The box size was chosen to replicate a field scenario of a row of columns which was envisaged to be used for strip footings. A field clay was tested at different moisture contents and with different types of columns (varied diameter and column material). Selected tests were performed on kaolin for comparison purposes. The aim of the laboratory study was to examine the performance of clay reinforced with sand or stone columns as compared to unreinforced clay. From the results obtained, the stress concentration ratio and the settlement reduction ratio were both deduced. The results are ultimately presented and analysed in Chapter 5.

## **4.2 Materials**

### **4.2.1 Soil characterisation tests**

Characterisation of the materials was deemed important to be able to understand their behaviour as well as to determine the necessary moisture content of the clays for conducting tests. Table 4.1 lists the different tests undertaken and the corresponding standards which were followed. Detailed results for the tests are presented in Appendix B.

Table 4.1: Experiments conducted for soil classification

Soil Property	Test Method	British Standard Code
Specific Gravity	Small Pycnometer method	BS 1377: Part 2: 1990
Natural Moisture Content	Oven drying method	BS 1377: Part 2: 1990
Optimum Moisture Content	Standard Proctor Test	BS 1377: Part 4: 1990
Maximum Dry Density	Standard Proctor Test	BS 1377: Part 4: 1990
Particle Grading of Sands	Dry Sieve Analysis	BS 1377: Part 2: 1990
Shear Strength	Direct Shear method	BS 1377: Part 7: 1990
Liquid and Plastic Limits	Atterberg Limits	BS 1377: Part 4: 1990

#### 4.2.2 Base soils

- **Cape Town Clay**

The yellowish-brown field clay, referred to as Cape Town clay in this investigation, was excavated from a construction site in the Green Point area of Cape Town, South Africa. The residual Cape Town clay was used for producing a clayey base soil requiring improvement by stone column inclusions. Atterberg limit tests performed on the clay reported a plastic limit of 21.8% and liquid limit of 34.7%, hence classifying the material as a low plasticity clay. Other properties of the clay are given in Table 4.2.

- **Kaolin**

Kaolin was used to conduct one set of experiments at its optimum moisture content of 23.5% in order to compare the results obtained under similar conditions with Cape Town clay. This material was chosen since it was pure, soft, extremely fine and easy to work with. In addition, it was consistent and easily controllable which enabled repeatability of results. On several occasions, Kaolin has been identified as a preferred material for many other researchers who have conducted studies on stone columns.

The white kaolin powder, also referred to as China Clay, was locally sourced from Serina Trading, PO Box 1549, 7985 Sun Valley, Cape Town, South Africa. Characterisation tests performed on the material yielded the properties in Table 4.2.

Table 4.2: Mechanical properties of base soils

Property	Unit	Cape Town clay	Kaolin
Specific Gravity, $G_s$	$Mg/m^3$	2.74	2.60
Natural Moisture content	%	12.7	1.7
Liquid Limit	%	34.7	39.7
Plastic Limit	%	21.8	28.2
Plasticity Index	%	12.9	11.5
Optimum moisture content	%	17.0	23.5
Maximum Dry density	$Mg/m^3$	1.80	1.55
Angle of friction (Peak)	°	39 <sup>*1</sup>	19 <sup>*1</sup>
		0 <sup>*2</sup>	-
		0 <sup>*3</sup>	-
Cohesion (Peak)	$kN/m^2$	37 <sup>*1</sup>	28 <sup>*1</sup>
		3 <sup>*2</sup>	-
		3 <sup>*3</sup>	-

\*1 - OMC

\*2 - LL

\*3 - 1.2LL



Figure 4.1: Base materials (a) Kaolin, (b) Cape Town clay

### 4.2.3 Column materials

- **Cape Flats sand**

Originated from the Cape Flats region of Cape Town, South Africa, Cape Flats sand is a medium dense soil material with minimum presence of fines, light grey and clean which is obtained from the Cape Lime quarry. Observed under a microscope, their particles can be described as being round in shape (Kalumba, 1998). This sand was expected to produce a column mass of high void content (although much lower than that for crushed aggregates). Sieve analysis on the material indicated that the sand was uniformly graded with particle sizes ranging between 0.075 mm and 1.18 mm. Table 4.3 summarizes the mechanical properties of the soil which were obtained from the characterisation tests.

- **Klipheuwel sand**

Klipheuwel sand is reddish-brown in colour and was also sourced from Cape Town in South Africa (Vlakfontein quarry). This material is a well graded, fine to coarse gravelly sand with a slight percentage of silt which is presumed to cause higher cohesion than Cape Flats sand. Direct shear tests conducted on the two sands revealed no significant difference in friction angle. In contrast to Cape Flats sand, the particles in Klipheuwel sand were angular in shape (Kalumba, 1998). This angularity, together with the percentage of fines, was expected to produce better interlocking of particles in the column thereby increasing its stiffness. Table 4.3 provides the mechanical properties tested for this sand.

- **Crushed aggregates**

Greywacke hornfels aggregate which were used during the installation of the stone columns was sourced from the Peninsula quarry and supplied by Afrisam, a company in Cape Town, South Africa. The size of these grey angular particles varied between 2.36 mm and 9.50 mm, with a mean grain size of 8.57 mm (Afrisam, 2008). Due to the absence of fines and the size and shape of the particles in this poorly graded gravel, columns from this material comprised of a large void ratio (void ratios of 0.804 and 0.602 in the loosest and densest states respectively). Table 4.3 mentions some of the relevant mechanical properties for this study.

Table 4.3: Mechanical properties of column materials

Property	Unit	Cape Flats sand	Klipheuwel sand	Crushed aggregate
Specific Gravity, $G_s$	$Mg/m^3$	2.68	2.68	2.61
Natural Moisture content	%	1.5	1.8	-
Average densest dry density	$kg/m^3$	1735	1762	1629
Average loosest dry density	$kg/m^3$	1684	1578	1447
Optimum moisture content	%	14.2	9.8	-
Maximum Dry density	$Mg/m^3$	1.74	1.84	-
Particle Range	mm	0.075-1.18	0.075 - 2.36	2.36-9.50
Mean Grain Size, $D_{50}$	mm	0.65	0.90	8.57
Coefficient of uniformity, $C_u$	-	3.0	6.5	1.25
Coefficient of curvature, $C_c$	-	1.1	1.0	0.97
Angle of friction, $\phi$ (Peak)	$^\circ$	38	37	-
Cohesion, $c$ (Peak)	$kN/m^2$	5	8	-

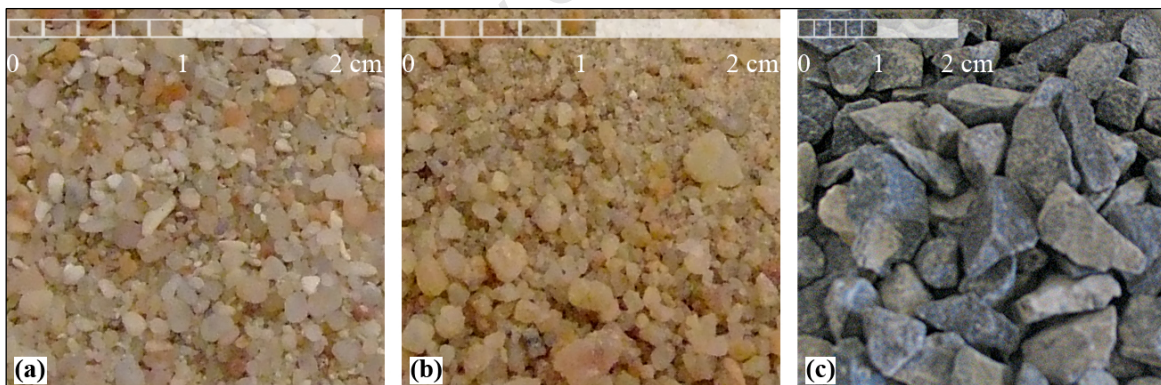

Figure 4.2: Column materials (a) Cape Flats sand, (b) Klipheuwel sand and (c) crushed aggregates

## 4.3 Methodology

### 4.3.1 Testing programme

A total of 44 box tests were carried out. Out of these, 38 tests were performed on Cape Town clay (CT), 2 being repeatability tests, while the other 6 tests were performed on kaolin (K). Testing was carried out on base clay of different moisture contents (M). Column diameters (D) and column materials (KS, CFS or CA) were also varied. Since the loading plate dimension (P) was dependent on the column diameter, different plate sizes were used for the tests. It must be noted that some tests were performed on unreinforced clay (CT or K) which acted as the control experiments. Table 4.4 describes the symbols used in the schedules in Tables 4.5 and 4.6.

Table 4.4: Description of symbols in testing schedule

Symbols	Description
CT	Cape Town clay
K	Kaolin
M1, M2 and M3	Optimum moisture content (OMC), Liquid limit (LL) and 1.2 times liquid limit (1.2LL) respectively
D1, D2 and D3	Column diameters of 50mm, 70mm and 100mm respectively
KS	Klipheuwel sand
CFS	Cape Flats sand
CA	Crushed Aggregates
P1, P2 and P3	Loading plate lengths of 100mm, 140mm and 200mm respectively

Table 4.5: Box testing schedule for Kaolin

Moisture Content	Kaolin Composite	Column Material	Test number
OMC	Clay - Clay	NA	K / M1 / P1
			K / M1 / P2
			K / M1 / P3
	Clay-Stone	Crushed Aggregates	K / M1 / CA / D1 / P1
			K / M1 / CA / D2 / P2
			K / M1 / CA / D3 / P3

Table 4.6: Box testing schedule for Cape Town Clay

Moisture Content	Field clay Composite	Column Material	Test number
<b>OMC</b>	Clay - Clay	NA	CT / M1 / P1
			CT / M1 / P2
			CT / M1 / P3
	Clay - Sand	Klipheuwel	CT / M1 / KS / D1 / P1
			CT / M1 / KS / D2 / P2
			CT / M1 / KS / D3 / P3
	Clay - Sand	Cape Flats	CT / M1 / CFS / D1 / P1
			CT / M1 / CFS / D2 / P2
			CT / M1 / CFS / D3 / P3
	Clay-Stone	Crushed Aggregates	CT / M1 / CA / D1 / P1
			CT / M1 / CA / D2 / P2
			CT / M1 / CA / D3 / P3
<b>LL</b>	Clay - Clay	NA	CT / M2 / P1
			CT / M2 / P2
			CT / M2 / P3
	Clay - Sand	Klipheuwel	CT / M2 / KS / D1 / P1
			CT / M2 / KS / D2 / P2
			CT / M2 / KS / D3 / P3
	Clay - Sand	Cape Flats	CT / M2 / CFS / D1 / P1
			CT / M2 / CFS / D2 / P2
			CT / M2 / CFS / D3 / P3
	Clay-Stone	Crushed Aggregates	CT / M2 / CA / D1 / P1
			CT / M2 / CA / D2 / P2
			CT / M2 / CA / D3 / P3
<b>1.2LL</b>	Clay - Clay	NA	CT / M3 / P1
			CT / M3 / P2
			CT / M3 / P3
	Clay - Sand	Klipheuwel	CT / M3 / KS / D1 / P1
			CT / M3 / KS / D2 / P2
			CT / M3 / KS / D3 / P3
	Clay - Sand	Cape Flats	CT / M3 / CFS / D1 / P1
			CT / M3 / CFS / D2 / P2
			CT / M3 / CFS / D3 / P3
	Clay-Stone	Crushed Aggregates	CT / M3 / CA / D1 / P1
			CT / M3 / CA / D2 / P2
			CT / M3 / CA / D3 / P3

## 4.3.2 Apparatus and equipment used in the laboratory tests

### 4.3.2.1 Testing machine

This investigation utilized the Zwick Universal Testing machine to perform compression tests on stone column reinforced clay beds in a rectangular wooden box of length 1000 mm, depth 450 mm and width 150 mm. The testing specimen was first prepared in the box on ground level after which it was placed onto the machine. Figure 4.3 is an illustration of the experimental set-up. A computer is connected to the apparatus for real time recording of the results during testing.



Figure 4.3: Experimental set-up (box on the Zwick Universal Testing machine connected to a computer)

### 4.3.2.2 Equipment used in the preparation of the test specimens

The bench scale size rectangular wooden box was fabricated to carry the test specimen which was subjected to an increasing compressive force through the Zwick Universal Testing machine. The dimensions of the box was chosen so as to replicate a field scenario of a row of stone columns (Figure 4.4), which can be used to support a strip footing, without compromising the improvement effect produced. As such, the box was constructed with

relatively narrow dimensions thereby restricting horizontal movement in the shortest side, which is often the case with row of columns. On the contrary, the extension of the length of the box on both sides of a column was sufficient to allow free horizontal movement.

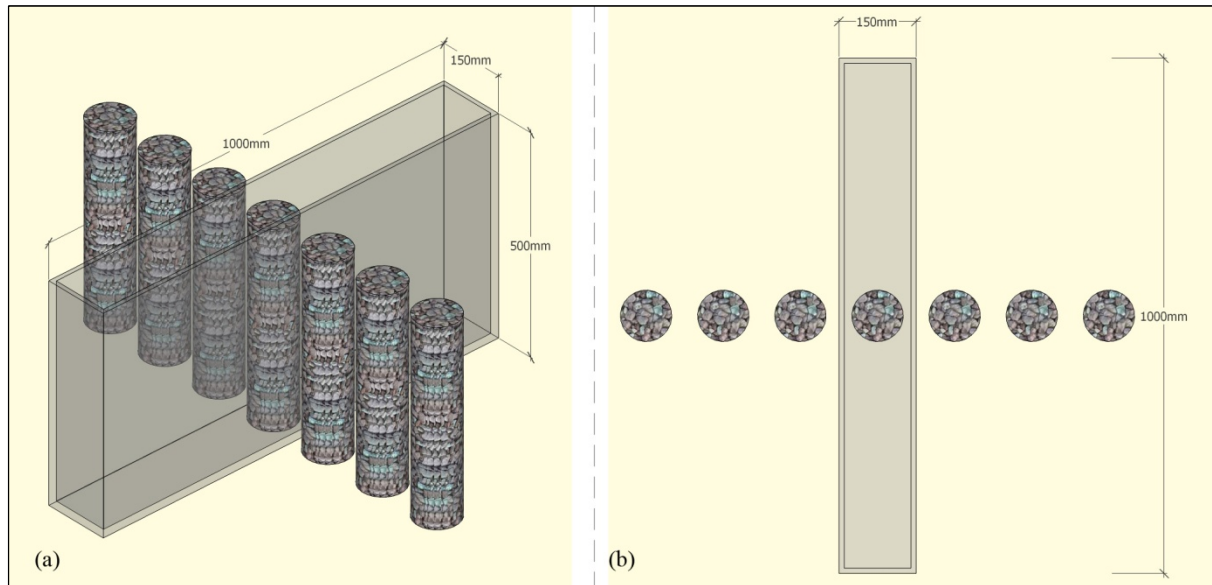

Figure 4.4: (a) Field scenario of row of columns with one column in the testing box, (b) Plan view of the row of columns

The wooden box of size 1000 mm x 150 mm x 450 mm, as shown in Figure 4.5, was constructed from 20 mm thick marine plywood boards (to prevent absorption of water from the clay), the front wall of which was made of 16 mm thick perspex to allow visual assessment of the soil deformation under load testing. The transparent perspex face also allowed for easier test specimen preparation especially during compaction of the different layers of the base soil in the box. Due to the high pressures exerted on the side walls of the box during preparation and testing, a steel frame, constructed from steel angle sections of 40 mm x 40 mm x 5 mm, was fitted along the edges of the box. For lateral support during loading, the box was further reinforced using steel braces fitted along the longest sides of the box. During preliminary testing, LVDTs were placed on the sides of the box to confirm that there were no lateral movements.

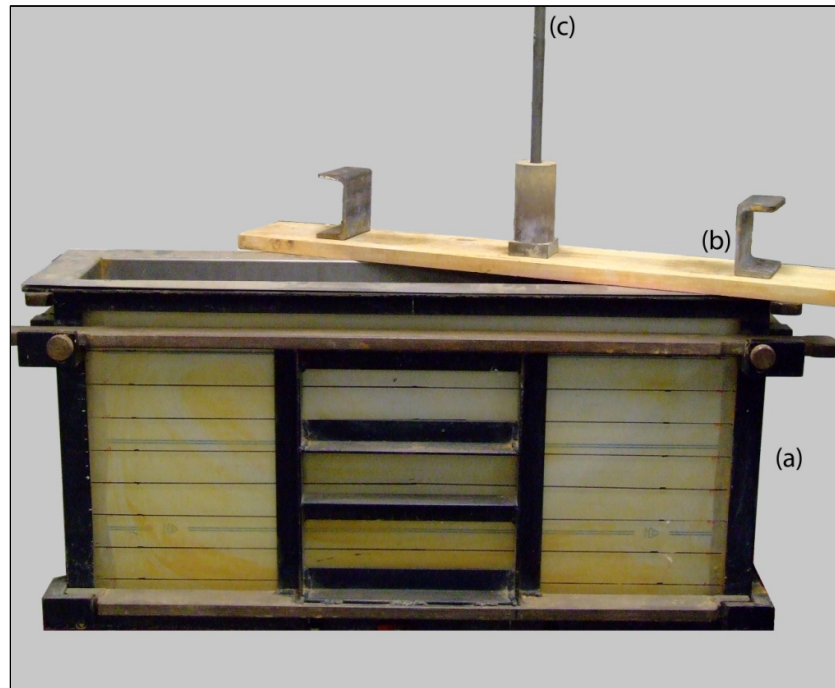

Figure 4.5: (a) Rectangular wooden box used for containing test specimen, (b) wooden board and (c) hand compactor for clay compaction at OMC

Preparation of the test specimen involved other equipment, shown in Figure 4.6. The purpose of each equipment is described as follows:

- **Mechanical mixer:** Used to obtain a homogeneous mixture of clay with a desired moisture content.
- **Wooden board:** Rectangular wooden board fabricated to just fit in the box horizontally for the compaction of each layer of clay.
- **Wide metal scraper:** Levelling of the surface of each layer of clay in the box.
- **Collar:** A short hollow steel cylinder of appropriate thickness centrally attached to a rectangular metal frame fitted on top of the box prior to construction of the column so as to ensure its verticality.
- **Steel cylinders:** Three rigid steel cylinders of external diameters 50 mm, 70 mm and 100 mm and lengths 300 mm that were individually used depending on the desired column diameter.
- **Helical auger:** Three steel helical augers of dimensions 49.5 mm, 69.5 mm and 99.5 mm, which just fitted in the respective cylinders for cutting out clay within.

- **Hand compactors:** Four 2 kg circular steel hand compactors, each of different diameter. One of the compactors is used for the compaction of the clay bed by dropping it on the wooden board while the others, of diameters 48 mm, 68 mm and 98 mm, are used for the column compaction in the respective cylinders.
- **Loading plates:** Three loading plates of dimensions 100 mm x 150 mm, 140 mm x 150 mm and 200 mm x 150 mm for columns of diameters 50 mm, 70 mm and 100 mm respectively. These plates are each centrally placed on top of their corresponding column and the load from the machine is ultimately applied to it.
- **Spirit Level:** For checking the level of the clay surface and the loading plate just before testing.
- **Hand tamper:** Used to apply gentle taps during levelling.

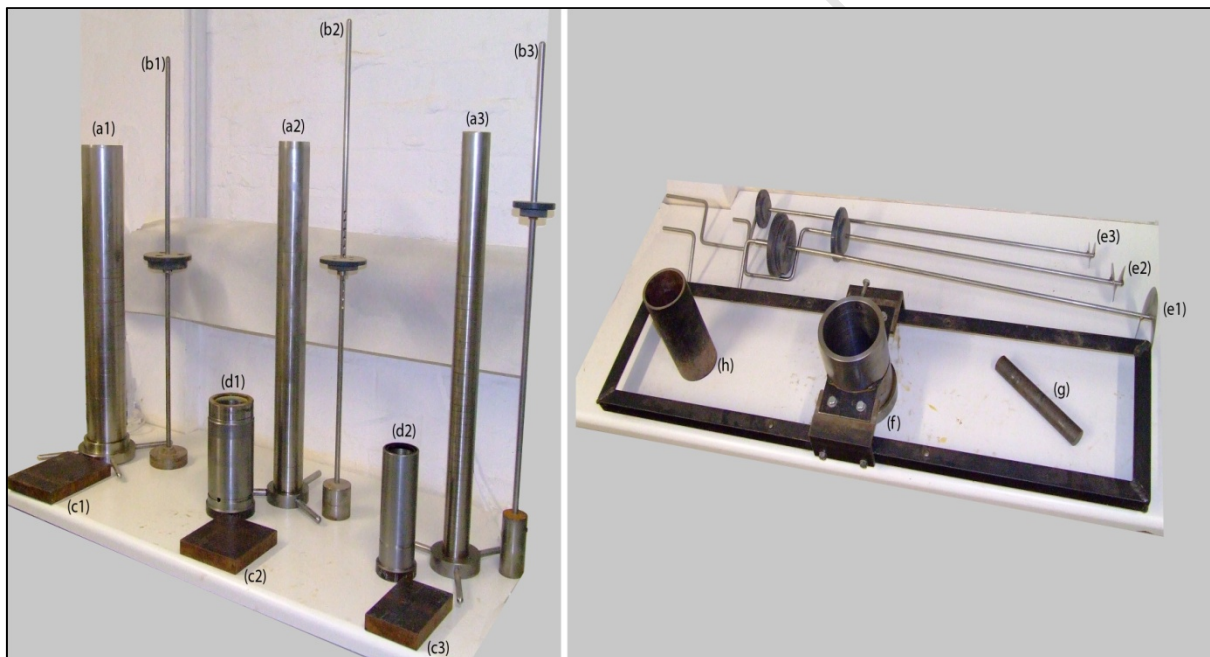

Figure 4.6: (a1) to (a3) Steel cylinders with corresponding diameters of 100 mm, 70 mm and 50 mm, (b1) to (b3) 2 kg hand compactors for the respective diameters, (c1) to (c3) loading plates of length 200 mm, 140 mm and 100 mm, (d1) and (d2) adaptors used with the collar for adjusting the column diameters to 70 mm and 50 mm respectively, (e1) to (e3) helical augers for each column, (f) collar attached to frame which is fitted on top of the box, (g) hand tamper and (h) cylinder for transferring the applied load to the loading plates.

### 4.3.3 Preparation of materials

Prior to preparation of the materials, all Cape Town clay to be used for the investigation was dried overnight in an oven at 105°C. Drying was carried out to eliminate variations in natural moisture content of the field clay which was collected from site on different days. In contrast, Kaolin was not subjected to the drying process since its natural moisture content was minimal. Thus, its moisture content was determined a day prior to mixing and was later accounted for when prepared to the desired moisture content.

For each experiment, 10 kg of clay was measured and poured into the bowl of a mechanical mixer (Figure 4.7) of capacity 12 kg. The mass of water required to achieve the targeted moisture content was measured and poured in to the clay and the mixer was switched on. The mixer was operated at a speed of 139 revolutions per minute for an average time of 10 minutes, a time which was pre-determined to ensure adequate incorporation of the water to the clay. Longer mixing was not necessary since a homogeneous mixture was achieved relatively fast. Also, longer mixing would result in evaporation of water during the process.



Figure 4.7: Mechanical mixer used for mixing clay with water

After obtaining a homogeneous mix, the machine was switched off and the blended material was quickly transferred to a sealable plastic container which was kept closed tightly to maintain the moisture content. The process was repeated 13 to 15 times until the container was filled to a mass of about 130 kg, taking into account that the testing box had a capacity of up to about 110 kg (depending on the moisture content of the base soil). Six samples (2 at the top, 2 at the centre and 2 at the bottom) were then taken for moisture content determination after which a plastic sheet was wrapped around the open surface of the container. The box, which was eventually tightly closed with its lid to prevent any evaporation of water, was left standing for 24 hours before being used for testing to ensure even distribution of water in the mix. After the test was conducted, the material was discarded and a new mix was prepared (following the same method described above) for the subsequent experiment on the testing programme. This procedure was repeated for all 44 tests conducted. Figure 4.8 shows the prepared material which was covered for 24 hours.



Figure 4.8: Prepared wet clay in plastic storage container

### 4.3.4 Experimental procedures

#### 4.3.4.1 Improved clay tests

For each experiment, a thin coat of grease was smeared on the inner surface of the wooden box before being filled with the wet clay. The grease was intended to reduce friction between

the walls of the box and the clay, in addition to protecting the inner box surfaces. The clay specimen at the desired moisture content was placed in the box and compacted in 8 equal layers up to a height of 400 mm. The mass of clay required to fill the tank was recorded for density determination. For each layer, the wooden board was lightly dropped on the soil surface and 36 blows (12 right, 12 left and 12 at the centre) through a height of 180 mm were applied to the board, by a hand compactor of 2 kg, for uniformly compacting the clay via an imparted energy of 127 J. The number of blows and the falling height were predetermined so as to achieve maximum compaction.

After compaction, the top surface was levelled using the wide metal scraper to achieve completion of the clay bed preparation. A single stone column was then centrally constructed in the clay bed by employing a replacement method. The collar was fitted to the box by means of screws and the cylinder of desired diameter was lightly greased and manually pushed through and into the clay until the base of the box was reached. The behaviour of this strong base was assumed to be similar to that of a firm strata in the field. Furthermore, the columns extended to base level since the investigation of floating columns were not within the scope of this study. The thin coating of grease applied to the surfaces of the cylinder served to ease both penetration and withdrawal so as to reduce the amount of disturbance caused to the surrounding compacted clay. The clay within the cylinder was then physically cut out using the respective helical auger. To ensure minimum suction effect during the cutting process, a maximum height of 50 mm of clay was cut at a time until the cylinder of length 400 mm was emptied. During the cutting process, it was important for the cutter to remain erect at all time because of the small difference in diameter compared to the cylinder. Otherwise, bending of the cutter would encourage jamming. Figure 4.9 shows a prepared sample with the 50 mm cylinder pushed in and the auger at the opening of the cylinder.

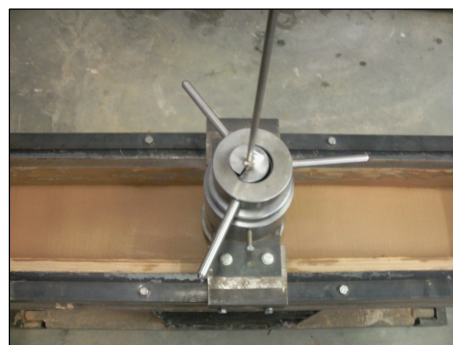

Figure 4.9: Testing sample ready for the cutting process

Upon completion of the cutting process, a damp cloth, attached to a nylon brush, was used to thoroughly clean the inner sides of the cylinder to prevent the column material from sticking to the surface. Once cleaned, a measured mass of column material was fed to the cylinder after which the latter was lifted by 45 mm. The column material was then manually compacted by dropping the respective 2 kg hand compactor 12 times through a height of 180 mm to achieve a column layer of depth 50 mm. The degree of compaction was predetermined so as to achieve maximum compaction while simultaneously avoiding crushing of the column material as well as excessive lateral bulging of the column prior to testing. The process was repeated 8 times to form the column of length 400 mm, thereby levelling it with the top clay surface. The collar and the cylinder were eventually completely removed and some material was added, if the column was slightly lower than expected, to level the column with the clay surface (Figure 4.10). The specimen was then ready to be transferred to the Zwick machine for testing. This procedure was followed for preparation of the test samples for all 44 experiments.



Figure 4.10: Installed crushed aggregate column of diameter 100 mm

#### **4.3.4.2 Control tests**

In these tests, the same experimental procedure as in section 4.3.4.1 was followed, with the exception that no column was constructed in the clay. Once the box was filled to a height of 400 mm, the surface was levelled and the box was transferred to the machine for testing. The aim of these experiments was to aid in comparing the vertical applied stress of the unimproved clay with the stone column reinforced clay at a settlement of 50 mm. The

duration of the control tests were expected to be shorter than the reinforced clay tests since clay has a very low bearing capacity, especially at high moisture contents.



Figure 4.11: Prepared test specimen for the control test with loading plate of length 100 mm

#### **4.3.4.3 Repeatability tests**

To verify the repeatability of results from the experimental procedure, 3 selected tests were conducted twice following the same procedure as described in section 4.3.4.1. The tests included: two 70 mm Klipheuwel sand column tests, two 70 mm crushed aggregate column tests and two control tests with the smallest loading plate. All repeatability tests were conducted in base soils at LL. The results obtained are presented in chapter 5.

#### **4.3.5 Testing**

The tests were carried out in a closed chamber due to the sensitivity of the machine. Small disturbances in the environment could have impacted on the results produced. Before testing, the respective loading plate was centrally placed in the loading box (that is above the column for improved clays) and levelled by means of the spirit level and the hand tamper. Once levelled, a spacing cylinder was centrally placed on the plate and the machine was switched on. The loading platen was lowered until close to but not touching the cylinder. Prior to testing, the following checks were made:

- Box centrally located on machine to avoid eccentric loading
- Loading component just above but not touching cylinder such that the initial force is zero

- Computer program saved as a new file
- All dimensions and testing details saved in the file for the respective test
- Compression rate set to 1.2 mm/min since it is fast enough to produce undrained loading and thus imitating the field condition immediately after construction. Similar loading speed has been used by Murugesan and Rajagopal (2008) when testing stone column in a laboratory.
- The machine pre-set for a maximum allowable settlement of 50 mm
- Initial force on test specimen set to zero

Once the above list was checked and approved, the test was started. The vertical stress produced at settlement intervals of 1 mm was electronically recorded which was ultimately used for studying the effect of varying the clay bed moisture content, column diameter and column material. Figure 4.12 shows a schematic diagram of the loaded system and the loaded box ready for testing.

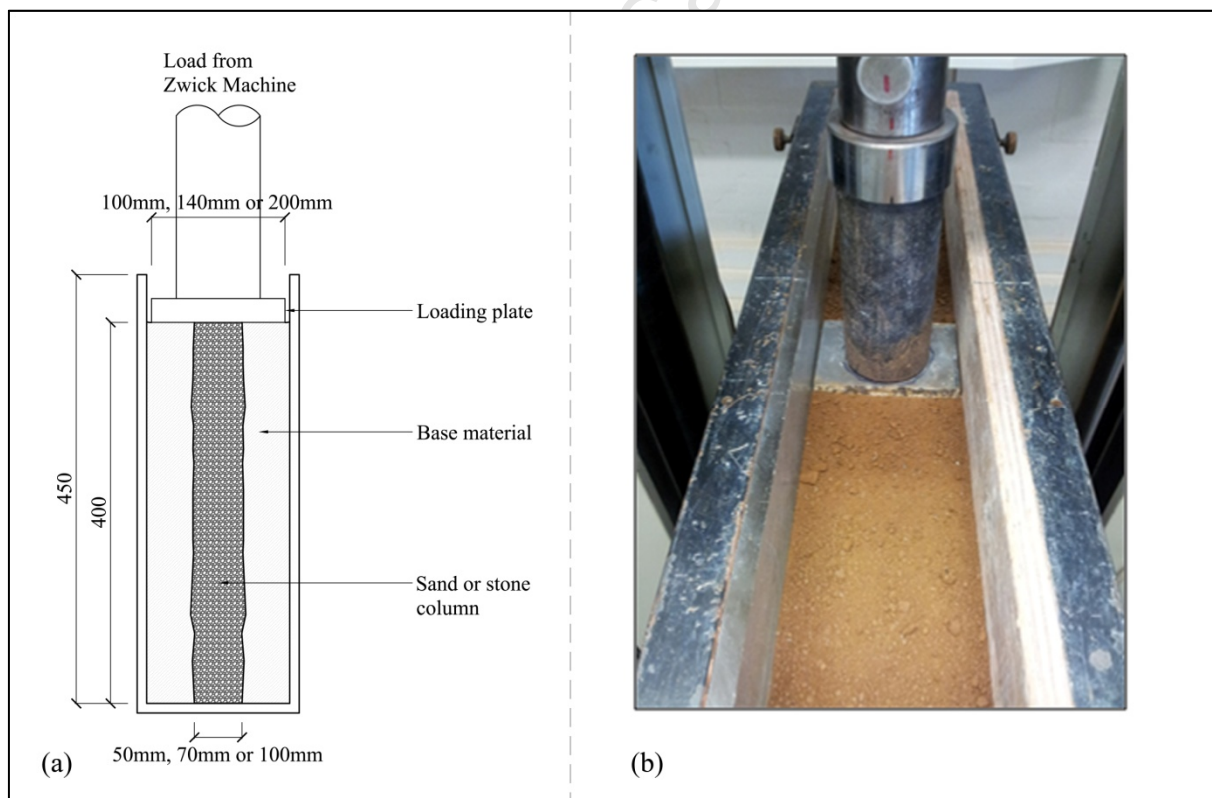

Figure 4.12: (a) Schematic view of loaded system, (b) Prepared specimen in box on machine prior to testing

### 4.3.6 Quality Assurance

To ensure quality in the results produced, numerous factors were strictly adhered to. These are elaborated as follows:

- Mixing of clay with water was long enough to ensure a thorough blend. However, the allocated time did not encourage high evaporation of water, an observation made from the determination of moisture content. Initially, the two products were manually mixed to ensure no splashing of water (resulting in a lowered moisture content) when switching on the motor.
- The clay-water composite was not left standing to the open air for long, after mixing. Transferring of the mixture to the storage container was relatively quick to avoid loss of water. Also, the container was kept closed as far as possible.
- Three samples of soils were taken for moisture content determination before and after each experiment to confirm that the experiment was conducted at the correct degree of saturation. The samples were picked at the top, centre and bottom of the box to ensure a thorough representation of the water distribution in the soil.
- The repeatability of the experimental procedure and results was verified by conducting 3 randomly chosen experiments twice and confirming that their results were repeatable.
- In addition to the above measures, column materials were not re-used at any instance; all materials were sourced at a single time to avoid variability; all equipment was properly calibrated and all tests were conducted under similar physical and climatic (during daytime in summer) conditions.

### 4.3.7 Data processing

#### 4.3.7.1 Vertical applied stress

The vertical applied stress to the loading plate was computed using the following equation:

$$\sigma = \frac{F_m}{A_p}$$

where:

$F_m$  = vertical load applied through the machine

$A_p$  = cross-sectional area of the loading plate

#### 4.3.7.2 Stress concentration ratio

The stress concentration ratio,  $n$ , is defined as the ratio of the stress taken by the improved ground to that of the unimproved ground. Normally, higher  $n$ -values indicate better improvement. In this study, the stresses at settlements of 50 mm were used to calculate  $n$  such that:

$$n = \frac{\sigma_{imp(50)}}{\sigma_{unimp(50)}}$$

where:

$\sigma_{imp(50)}$  = stress exerted on an improved clay at a settlement of 50 mm

$\sigma_{unimp(50)}$  = stress exerted on an unimproved clay at a settlement of 50 mm

#### 4.3.7.2 Settlement reduction ratio

Settlement reduction ratio, SRR, is the ratio of settlement in improved ground to that in unimproved ground. Therefore, the lower the SRR, the higher the improvement achieved. Since maximum allowable stress was not attained in this study, the SRR was calculated as follows:

$$SRR = \frac{S_{imp}}{S_{unimp}}$$

where:

$S_{unimp}$  = settlement of 50 mm in any unimproved clay (control tests)

$S_{imp}$  = settlement in any improved clay corresponding to the stress at the settlement of  $S_{unimp}$

## 4.4 Summary

This chapter has introduced the experimental approach, describing all the materials used and the testing equipment used. Two types of clay bed, namely Cape Town clay and Kaolin,

were used while three types of column materials were tested. Singular columns of diameter 50 mm, 70 mm or 100 mm were installed in clay beds at optimum moisture content, liquid limit or 1.2 times the liquid limit. Installation of the columns was executed by a ramming technique where part of the clay bed was replaced by a coarser material. The columns were loaded at a speed of 1.2 mm/min up to a settlement of 50 mm. Results obtained were proposed to be analysed in terms of stress concentration ratio and settlement reduction ratio.

University of Cape Town

University of Cape Town

***Results, Analysis and  
Discussions***

---

## 5.1 Introduction

This chapter is divided into two main sections. The first section presents the results obtained, from all the tests, in chronological order to aid in establishing vertical applied stress-settlement behaviour with respect to variations in column diameter and material as well as moisture content of the base soil. These results are then analysed and discussed in the second section where aspects such as stress concentration ratio, settlement reduction ratio and failure mechanism of selected columns are covered. A comparison of results is also drawn between several tests that were conducted on both Cape Town clay and Kaolin. In this chapter, all notations used on the graphs were defined in Table 4.4.

## 5.2 Results

### 5.2.1 Repeatability of results

From figure 5.1, it is confirmed that the methodology adopted produced repeatable results. The ultimate vertical bearing stresses for each pair of tests were nearly identical although slight variations were noted along the curves for the improved base soil. Different tests were purposely chosen to ensure compatibility of the methodology with the different testing conditions. Moreover, tests at LL were preferred since this moisture content represented an intermediate value between the two extremes (that is OMC and 1.2LL). Generally, it was noted that the variation in the vertical applied stresses at a settlement of 50 mm, for any two repeatability tests, was relatively low (between 0.9 % and 1.7 % for improved and unimproved clays respectively). This level of accuracy was deemed acceptable since a maximum deviation of 5 % from the mean vertical stresses was considered acceptable in this study.

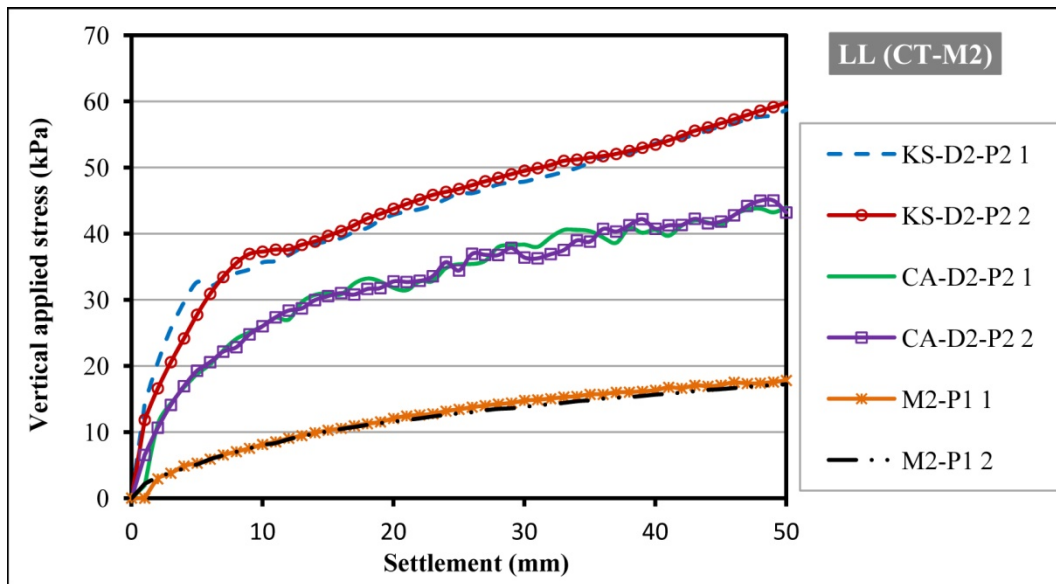

Figure 5.1: Repeatability of results for three selected tests at LL

### 5.2.2 Stress-settlement behaviour of stone columns

Stress – settlement results are presented in sets of 3 graphs such that the effect of the variations on the column behaviour can be perceived. To establish the effect of diameter on the stress-settlement relationship, the moisture content was kept constant for any one set of graph while the column diameter was varied for a particular type of column material. Thus, Figures 5.2 to 5.4 were obtained for OMC, LL and 1.2LL of the base soil respectively. Following a similar scheme, the effect of column material on stress-settlement characteristic was acquired by compiling results for identical diameter columns (D1, D2 or D3) of differing materials on the same graph. Since moisture content was again kept constant for any set of results, Figure 5.5 to Figure 5.7 were obtained. However, in the development of stress-settlement relationships relating to moisture content variations, column material was the main constant parameter for any one set of graphs. Results for the 3 moisture contents at a particular diameter was thus compiled for the three types of column materials, thereby generating Figure 5.8 to Figure 5.10. Generally, the main constant parameter (indicated on the top right hand corner of the graphs) for variation in diameter and column material was moisture content while that for moisture content was column material. The legend additionally serves to distinguish between the constant and the varying parameters.

### 5.2.2.1 Effect of diameter

Figures 5.2 to 5.4 describe the behaviour of the different column diameters under specific conditions. The curves obtained were typically smooth with the exception of the crushed aggregate ones, often producing ‘saw-toothed behaviour’. The latter phenomenon can be explained by the repeated process of build up and subsequent collapse of resistance forces occurring between the angular and coarse aggregates. The collapse of the resistance forces and the large void ratio between the aggregates result in the kinks on the graphs. It is generally observed that any column inclusion produce an improvement in the applied vertical bearing stresses at a settlement of 50 mm. Since moisture content is kept constant for any one set of the results, the graphs of the controls with the different plate sizes were necessary to compare the degree of improvement. All the control graphs indicated similar results, with the vertical applied stresses at a settlement of 50 mm for the three plates differing negligibly.

At OMC (Figure 5.2), the vertical applied stresses of both improved and unimproved base soil were relatively high (between 175 kPa and 350 kPa) at the ultimate settlement of 50 mm. The variation in diameter reported negligible effect on the maximum vertical stresses for Klipheuwel sand columns since all three columns generated similar outcomes. However, the observation with Cape Flats sand and crushed aggregate columns differed as a result of the largest diameter producing much higher stresses, although diameters of 50 mm and 70 mm showed minimal difference in ultimate stresses. At diameter of 100 mm, Klipheuwel and Cape Flats sand columns produced similar stresses of about 325 kPa while that for crushed aggregate column was slightly higher by approximately 25 kPa.

The stress-settlement behaviour of columns investigated in base soils at LL or 1.2LL varied significantly when compared to those tested at OMC. A key observation was the general drastic lowering of the maximum vertical applied stresses for all the tests conducted at these moisture contents, with the lowest stresses recorded at 1.2LL. At LL, Klipheuwel sand column behaviour was again not distinctly affected by the variation in column diameters although the end-stresses for diameters of 70 mm and 100 mm differed negligibly, when compared to the 50 mm diameter columns. On the other hand, Cape Flats sand and crushed aggregate columns demonstrated better performance with the largest columns. In fact, crushed aggregate columns showed an increase in vertical applied stresses as the diameter of the columns was made larger. Nevertheless, it is worth noting that Klipheuwel sand columns generated higher stress capacities than the two other column materials, at the smallest diameter.

For the tests conducted at 1.2LL, the vertical stresses were found to increase with enlargement of the Klipheuwel sand columns, contrary to the observation at OMC and LL for similar column materials. On the other hand, Cape Flats sand columns showed no effect with increase in column diameters although their maximum end-stresses were lower than those for Klipheuwel sand columns. Among the three materials, the highest vertical stresses occurred with the crushed aggregate columns of 100 mm, thereby confirming an improvement in vertical stresses of 6 times that of the unimproved clay at 50 mm settlement.

University of Cape Town

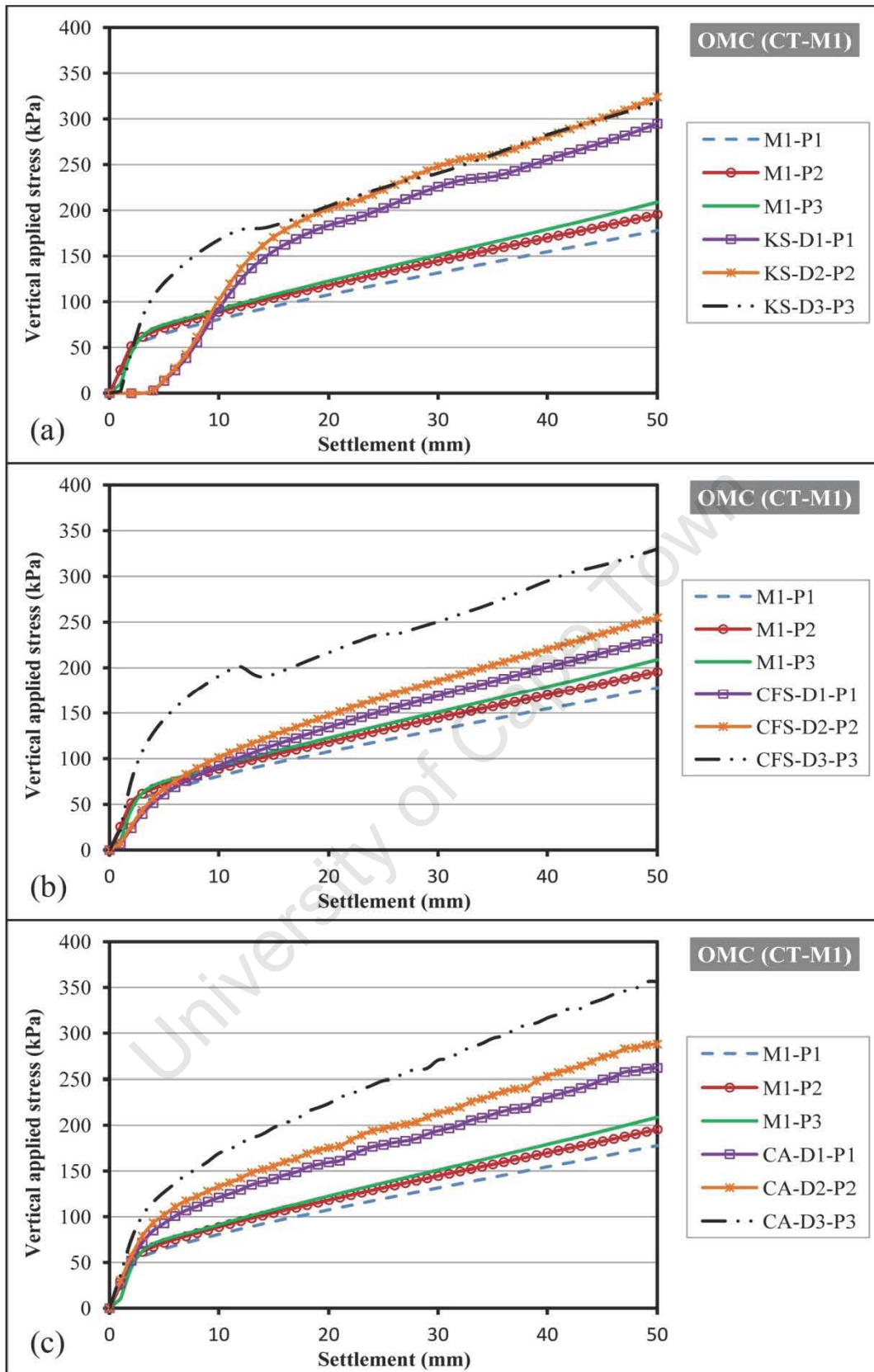

Figure 5.2: Effect of column diameter on stress-settlement behaviour at OMC of base soil for columns from (a) Klipheuwel sand, (b) Cape Flats and (c) Crushed aggregates

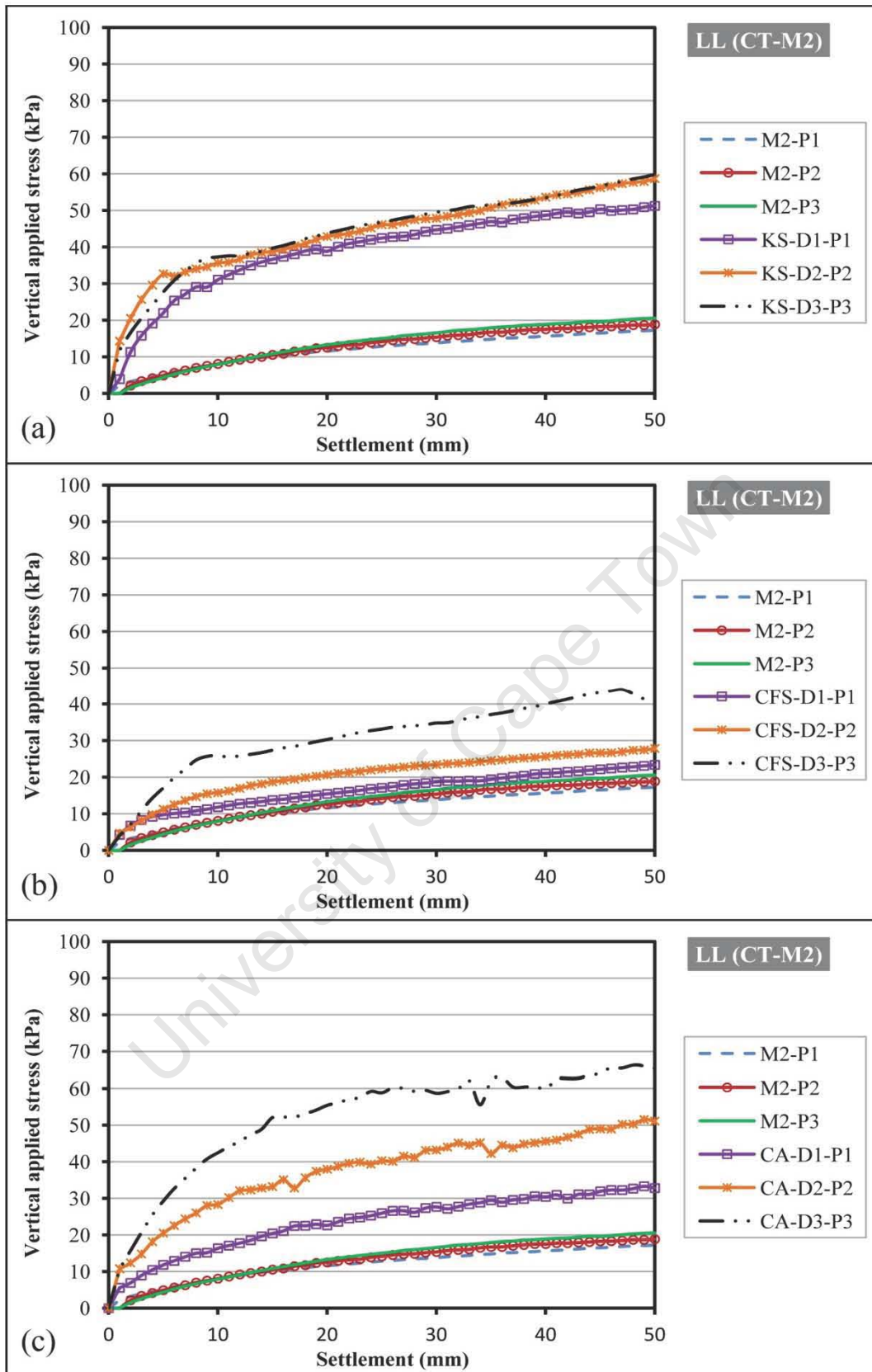

Figure 5.3: Effect of column diameter on stress-settlement behaviour at LL of base soil for columns from (a) Klipheuwel sand, (b) Cape Flats and (c) Crushed aggregates

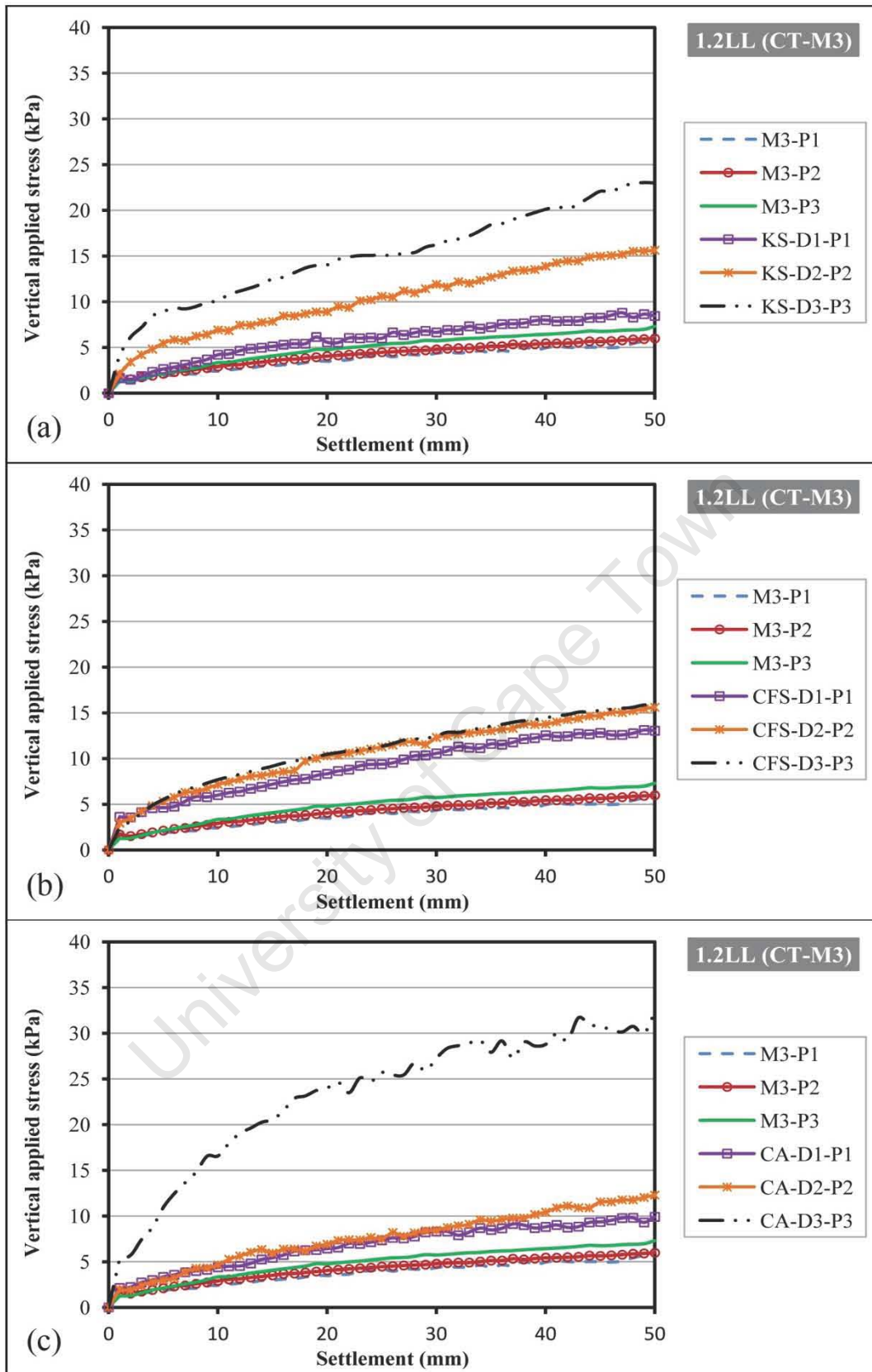

Figure 5.4: Effect of column diameter on stress-settlement behaviour at 1.2LL of base soil for columns from (a) Klipheuwel sand, (b) Cape Flats and (c) Crushed aggregates

### **5.2.2.2 Effect of column material**

Results obtained from Figures 5.2 to 5.4 were used to plot the relationships between column material and vertical applied stresses. These relationships are presented in Figures 6.5 to 6.7. Each of the graphs in these figures consist of a distinct control test. This is because a constant moisture content along with a constant diameter necessitates a single control test result.

At any particular moisture content, crushed aggregate columns of diameter 100 mm exhibited highest vertical stresses at settlements of 50 mm. However, for 50 mm and 70 mm columns, Klipheuwel sand produced highest ultimate stresses. An exception is spotted for these particular columns at 1.2LL where Cape Flats sand produced highest stresses for diameter of 50 mm (Figure 5.7a) while both sands produced the same stresses with 70 mm columns. (Figure 5.7b). This similarity in behaviour of both sands is also observed for 100 mm columns at OMC. In fact, the difference in stress at OMC among the materials was insignificant compared to the stress of the unreinforced base soil.

Generally, Klipheuwel sand was found to be a higher stress bearing material for smaller diameter columns compared to Cape Flats sand and crushed aggregates. On the other hand, Cape Flats sand exhibited lowest vertical applied stresses at all times. This difference in behaviour of the two types of sand demonstrates the effect of grain size, texture and shape on the strength of the columns.

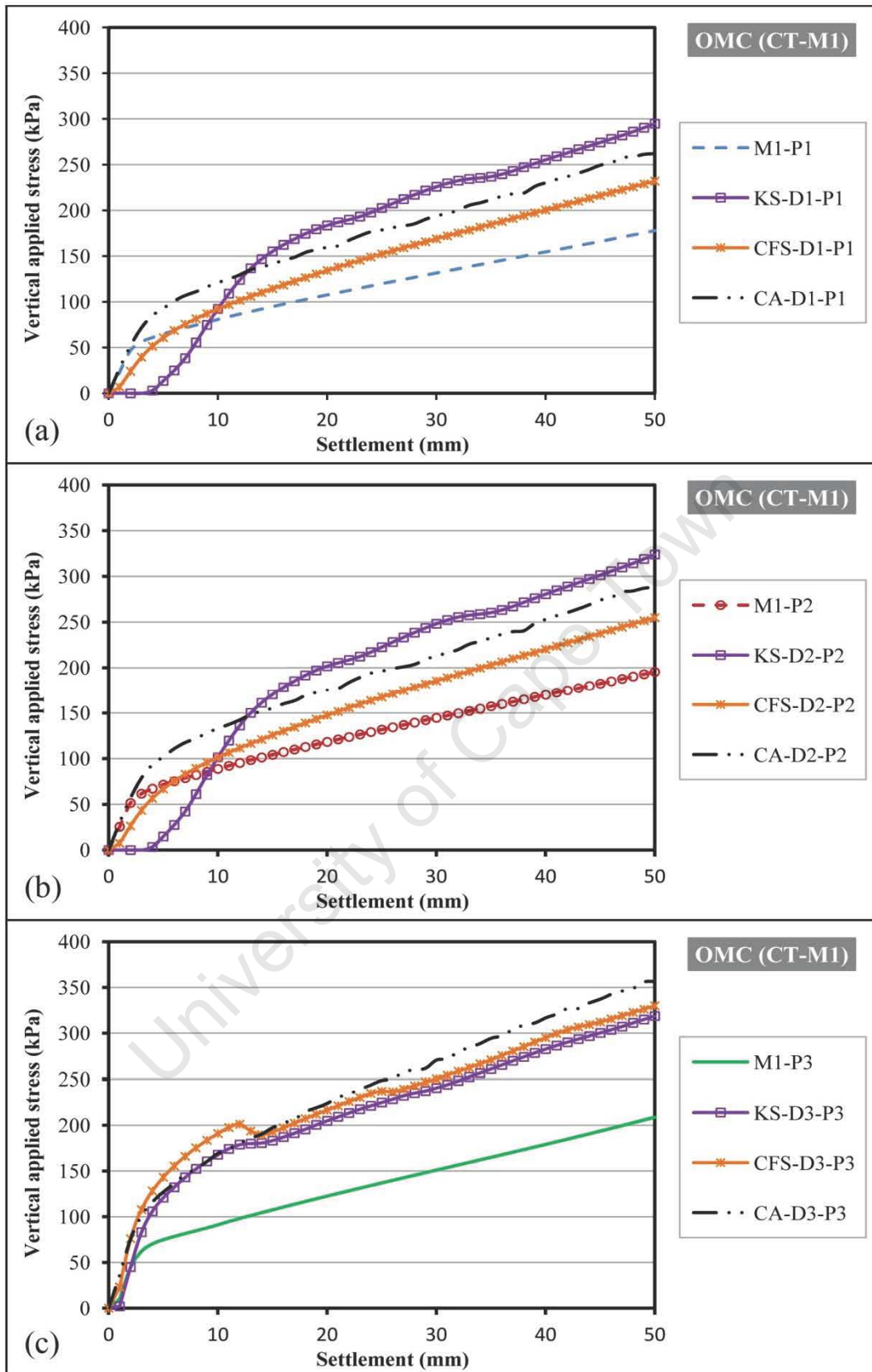

Figure 5.5: Effect of column material on stress-settlement behaviour at OMC of the base soil for column diameters of (a) 50 mm, (b) 70 mm and (c) 100 mm

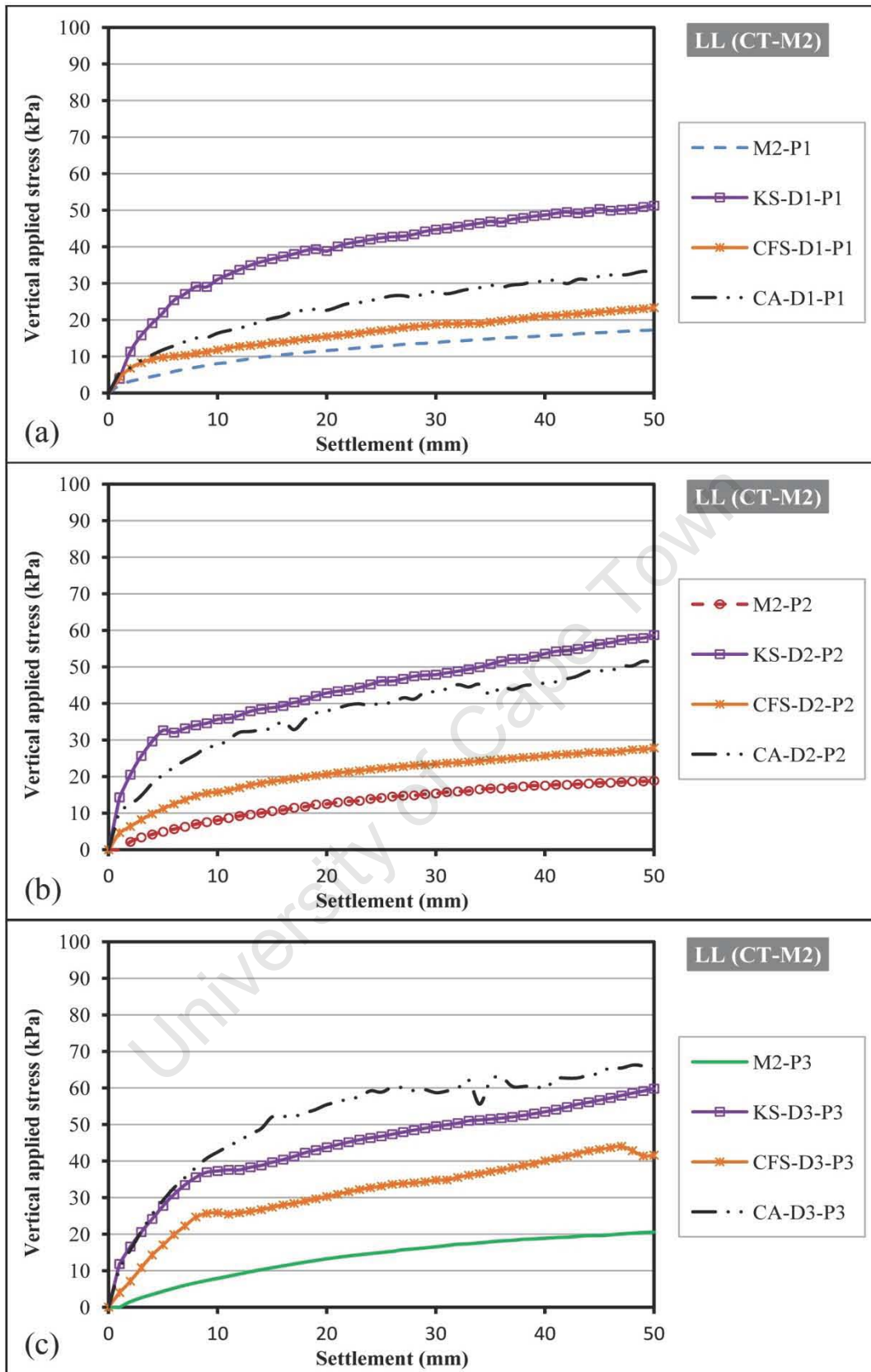

Figure 5.6: Effect of column material on stress-settlement behaviour at LL of the base soil for column diameters of (a) 50 mm, (b) 70 mm and (c) 100 mm

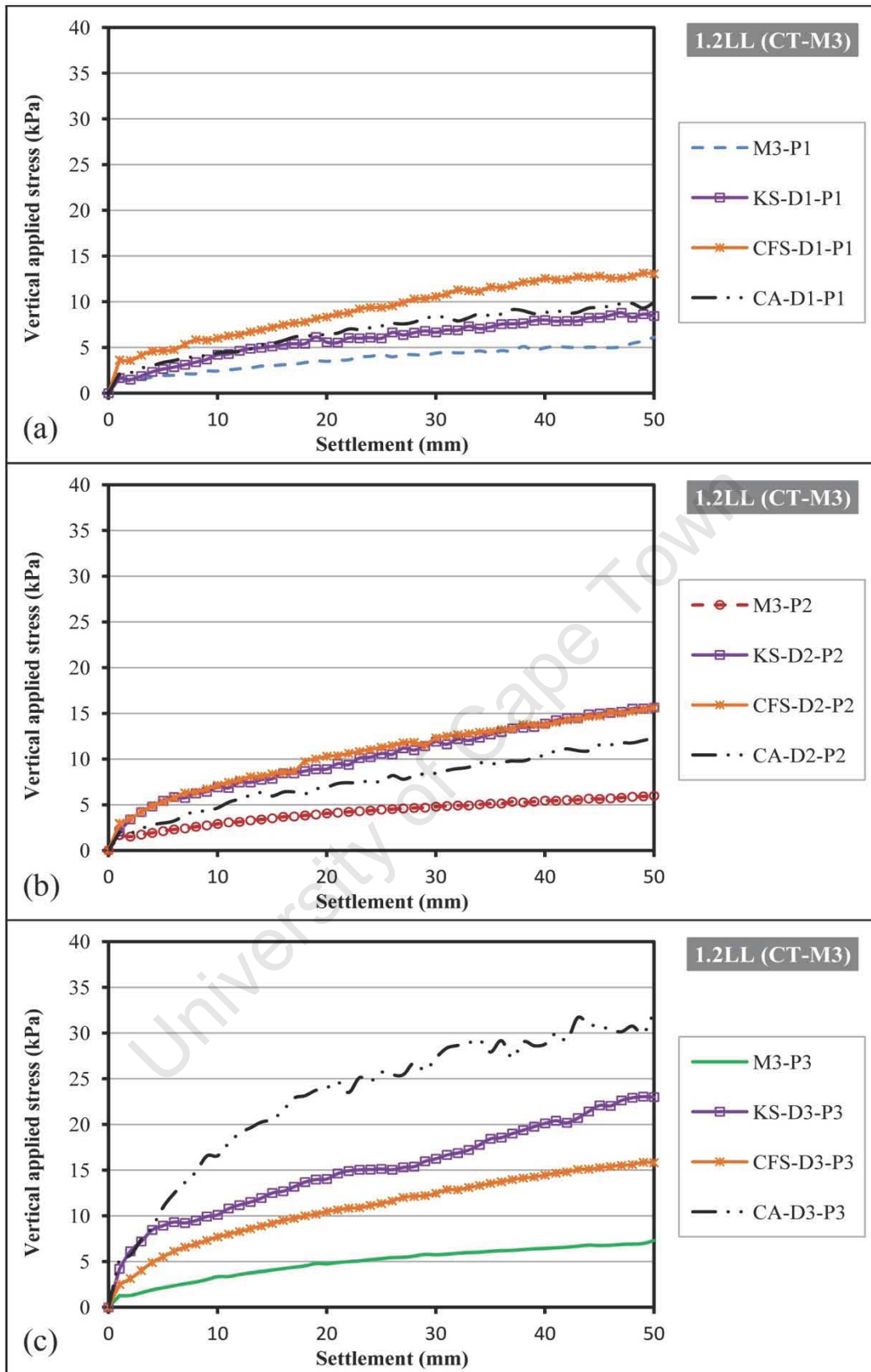

Figure 5.7: Effect of column material on stress-settlement behaviour at 1.2LL of the base soil for column diameters of (a) 50 mm, (b) 70 mm and (c) 100 mm

### ***5.2.2.3 Effect of moisture content***

An increase in water content beyond OMC is normally expected to decrease the strength of a soil. Since sand and stone columns have high stiffness compared to the wet base soil, a gain in vertical applied stress is expected. From Figure 5.8 to Figure 5.10, it is apparent that an increase in moisture content of the base soil results in a decrease of vertical applied stress at a settlement of 50 mm for any column type. At OMC, Klipheuwel sand columns of diameter 50 mm showed lower strengths than the 70 mm and 100 mm columns which produced similar results. The same observation was made for Cape Flats sand and crushed aggregate columns. However, at LL and 1.2LL the vertical applied stresses decreased sharply with 1.2LL producing the lowest vertical stresses. For diameter of 50 mm and 70 mm, all column materials have demonstrated insignificant difference in the ultimate vertical stress at LL and 1.2LL. Nevertheless, a distinct increase in stress was observed for large diameter column at LL and 1.2LL for crushed aggregate.

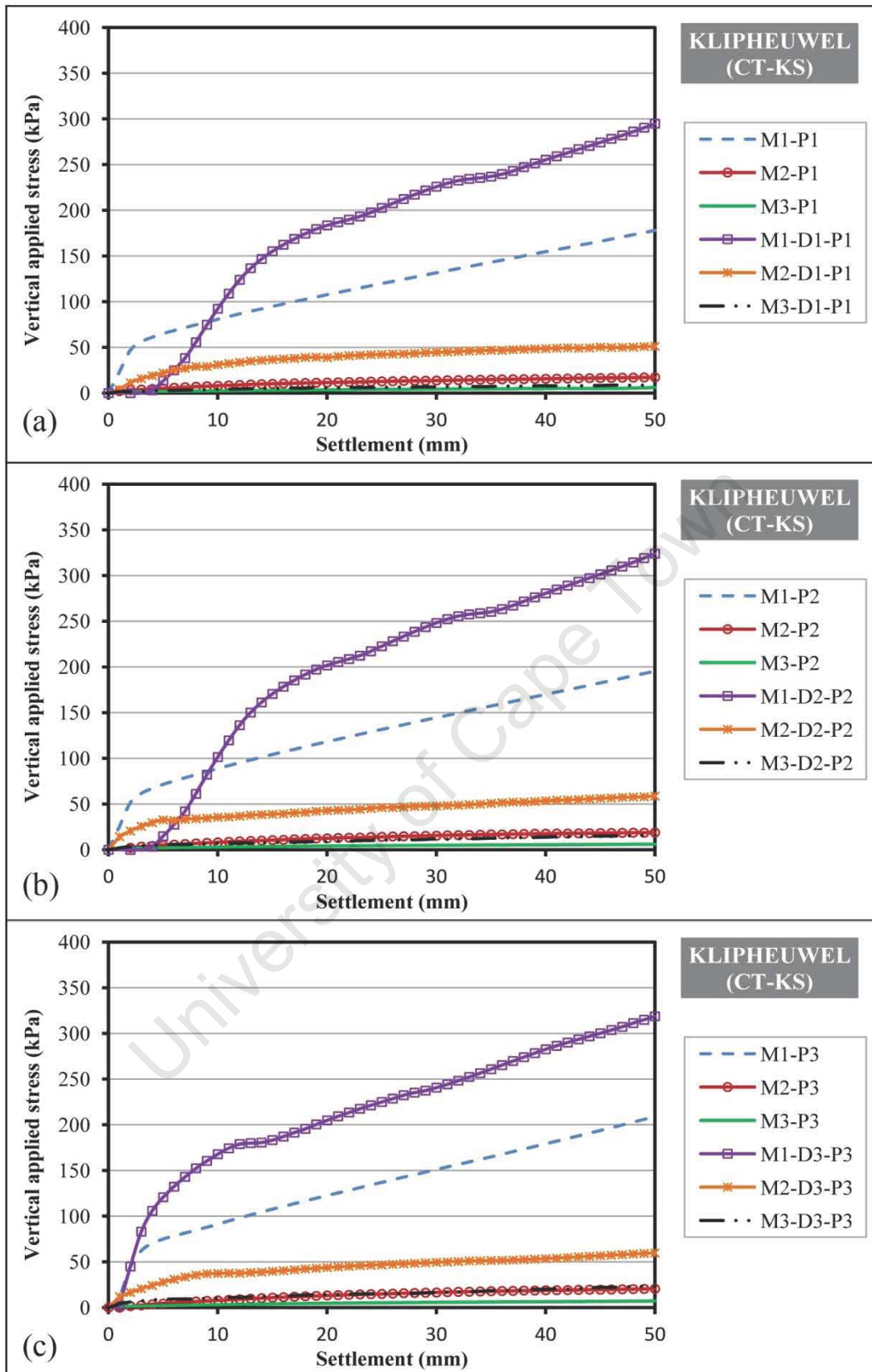

Figure 5.8: Effect of moisture content of base clay on stress-settlement behaviour for Klipheuwel sand columns of diameters (a) 50 mm, (b) 70 mm and (c) 100 mm

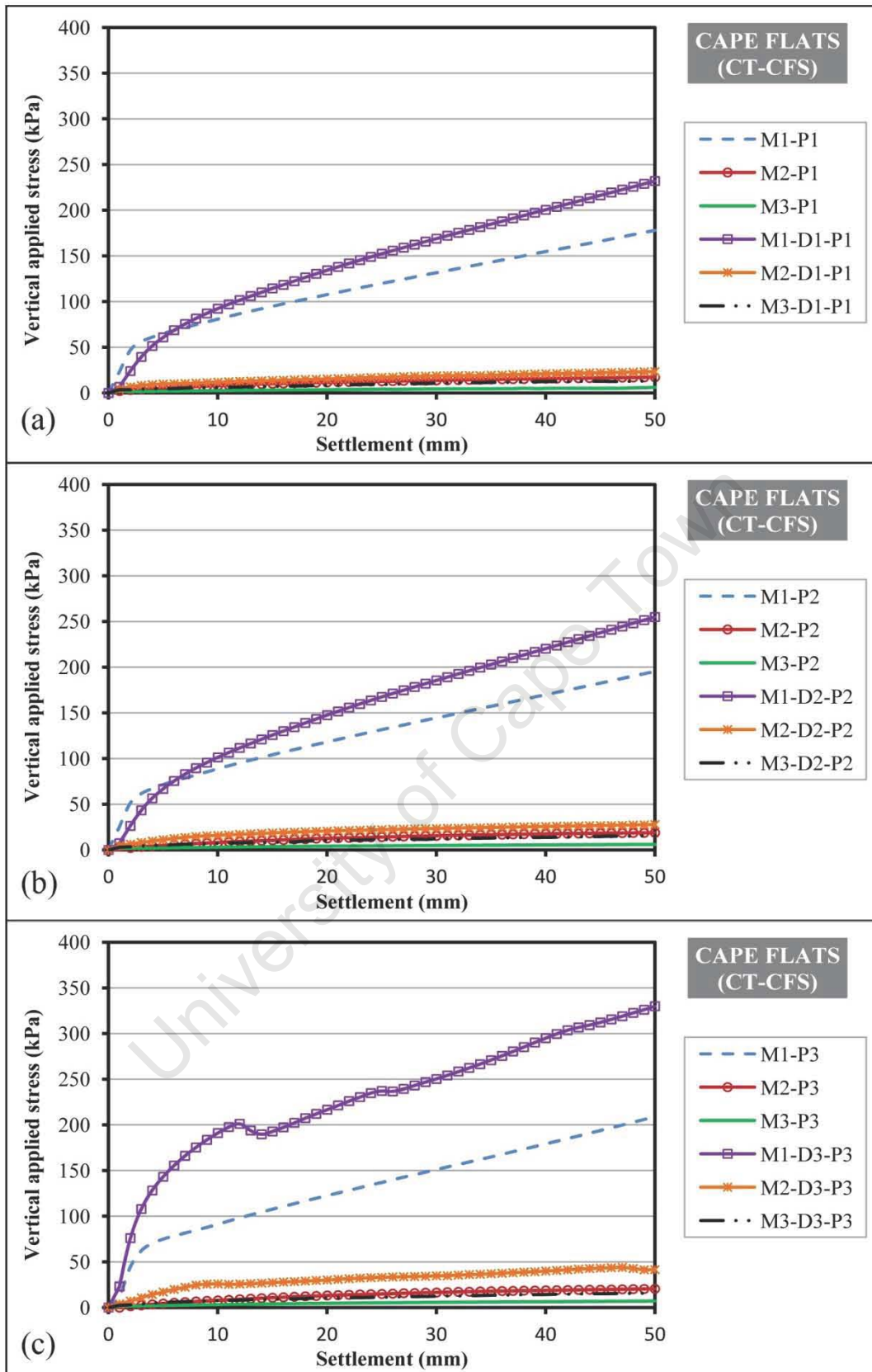

Figure 5.9: Effect of moisture content of base clay on stress-settlement behaviour for Cape Flats sand columns of diameters (a) 50 mm, (b) 70 mm and (c) 100 mm

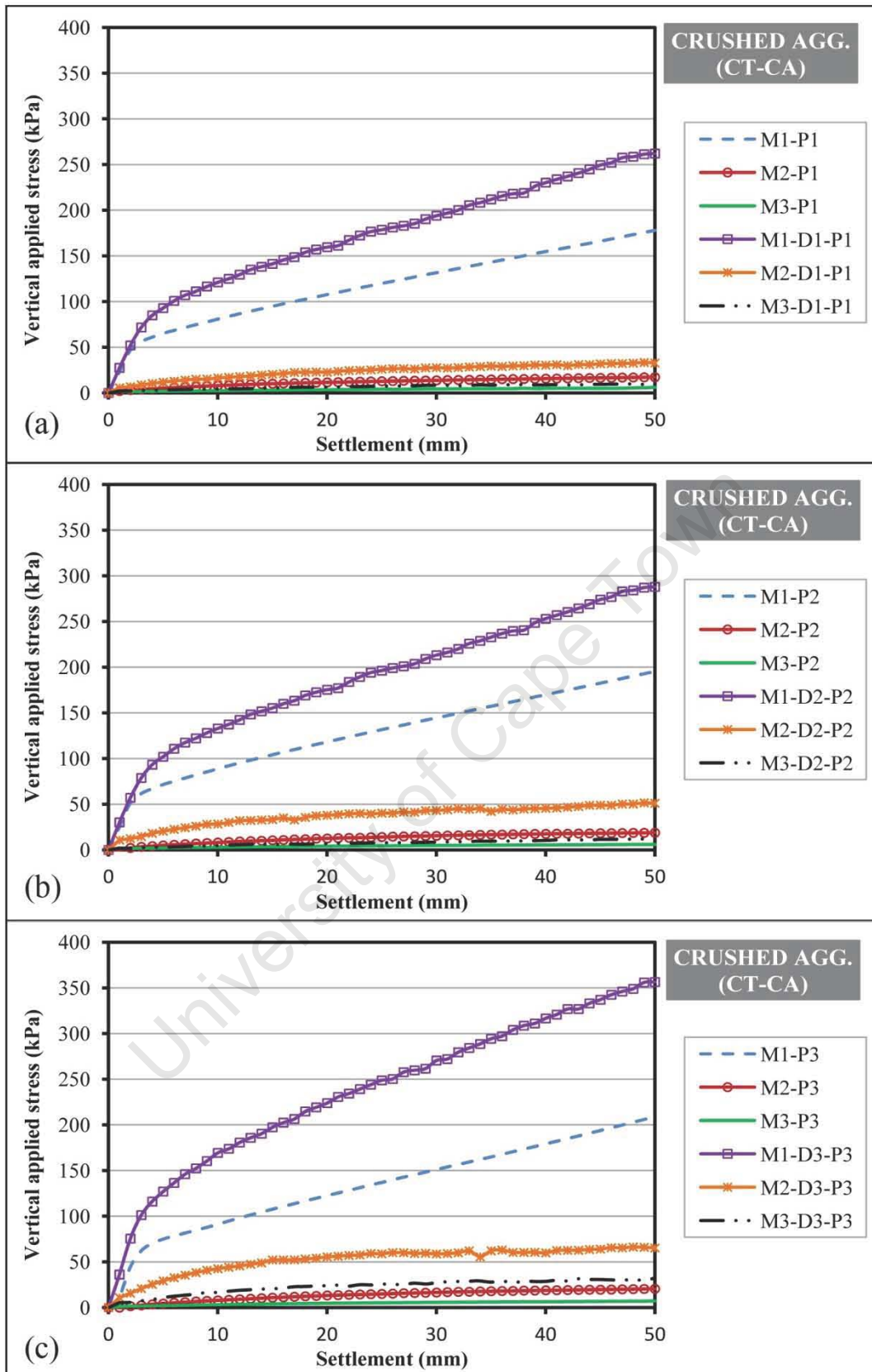

Figure 5.10: Effect of moisture content of the base clay on stress-settlement behaviour for crushed aggregate columns of diameters (a) 50 mm, (b) 70 mm and (c) 100 mm

### 5.3 Analysis and Discussions

Results presented in this section were analysed in terms of two non-dimensional improvement factors namely:

- stress concentration ratio  $n$  - ratio of the applied stress on the improved clay soil to that on the unimproved clay, and
- the settlement reduction ratio SRR - ratio of the settlement of column reinforced clay to that of unreinforced clay at the maximum settlement of 50 mm.

Since settlement is dependent on both ratios (Mitchell and Katti, 1981), a correlation was drawn between these improvement factors and their variables in the study, and presented in Figures 5.11 to Figure 5.16. Each figure comprises 3 graphs forming a set of results. For each graph one parameter was fixed, for instance in Figure 5.11(a) where moisture content was the constant. The behaviour of each material at different column diameters was then established, hence producing 3 curves on Figure 5.11(a). A similar approach was followed to produce the remaining graphs for stress concentration ratio and settlement reduction ratio.

In addition to the improvement ratios, a comparison was drawn between selected tests conducted on Kaolin and Cape Town clay, under similar conditions. The purpose of the comparison served to understand the performance of a singular column in Cape Town clay in relation to one installed in Kaolin, a material which has been widely used as a base clay for several studies (McKelvey *et al*, 2004; Andreou *et al*, 2008).

To study the failure mechanism of some of the columns, the deformation of selected columns was approximated based on their measured dimensions after the test. Columns tested in higher moisture contents (LL and 1.2LL) were of prime concerns since the surrounding confinement was significantly lower as opposed to columns in OMC. Additionally, coarser materials were expected to produce higher deformations due to their penetrating ability in the soft clay at high moisture contents. Therefore, tests conducted on crushed aggregate and Cape Flats sand at LL and 1.2LL were specifically selected to demonstrate the failure mechanism of some columns. Sketches of the approximated deformed columns are provided to enhance the understanding of the behaviour of coarser columns.

### 5.3.1 Stress-concentration ratio

Stress concentration ratio,  $n$ , is an indication of the degree of improvement achieved in relation to vertical bearing stresses. Since it is given by the ratio of composite ground stress to unimproved ground stress, a higher value of  $n$  indicates better improvement as opposed to low stress concentration ratios. Figure 5.11 to Figure 5.13 presents the relationship obtained between stress concentration ratio and the 3 variables of the study.

#### 5.3.1.1 Effect of diameter

All column materials tested in clay at OMC showed no significant difference in  $n$  for small diameters of 50 mm and 70 mm. However, for columns of 100 mm an increase in  $n$  of about 15% and 22% is achieved for crushed aggregate and Cape Flats sand respectively. Unexpectedly, 100 mm Klipheuwel columns in OMC clay showed a decrease which is considered to be an anomaly since smaller Klipheuwel columns followed the same trend as the other materials for this moisture content. This behaviour is possibly due to variations in the installation procedures, resulting in a less dense column than required. Hence, upon application of the load the material gets compacted initially thereby causing a large settlement at a low stress. Since the machine was preset for a maximum allowable settlement of 50 mm, the stress recorded would underestimate the actual capacity of the column. A similar observation is made for an identical column tested in clay at LL. Nevertheless, Cape Flats sand and crushed aggregate columns showed significant increase in  $n$  (from 50 mm to 100 mm columns) from 1.35 to 2.00 and 1.94 to 3.10 respectively, which corresponds to an improvement of 48% and 60%.

At high moisture contents (LL and 1.2LL), it is further observed that an increase in diameter results in an enhanced stress concentration ratio although sand columns produce smaller difference in improvement compared to crushed aggregate columns for diameters of 50 mm and 70 mm. For softer soils (that is at LL and 1.2LL in this study), the vertical stress bearing capacity is very low. By including a 100 mm diameter column (twice as large as the 50 mm column), the replacement material occupies a large proportion of the test specimen, thereby improving its stiffness. As such, 100 mm columns produce much higher  $n$  values than 50 mm columns. Combined with this mechanism crushed aggregate particles possess the advantage of being much coarser, larger and stronger than the sand particles. Consequently,

crushed aggregate columns produced higher percentage increase in the  $n$  values at LL and 1.2LL.

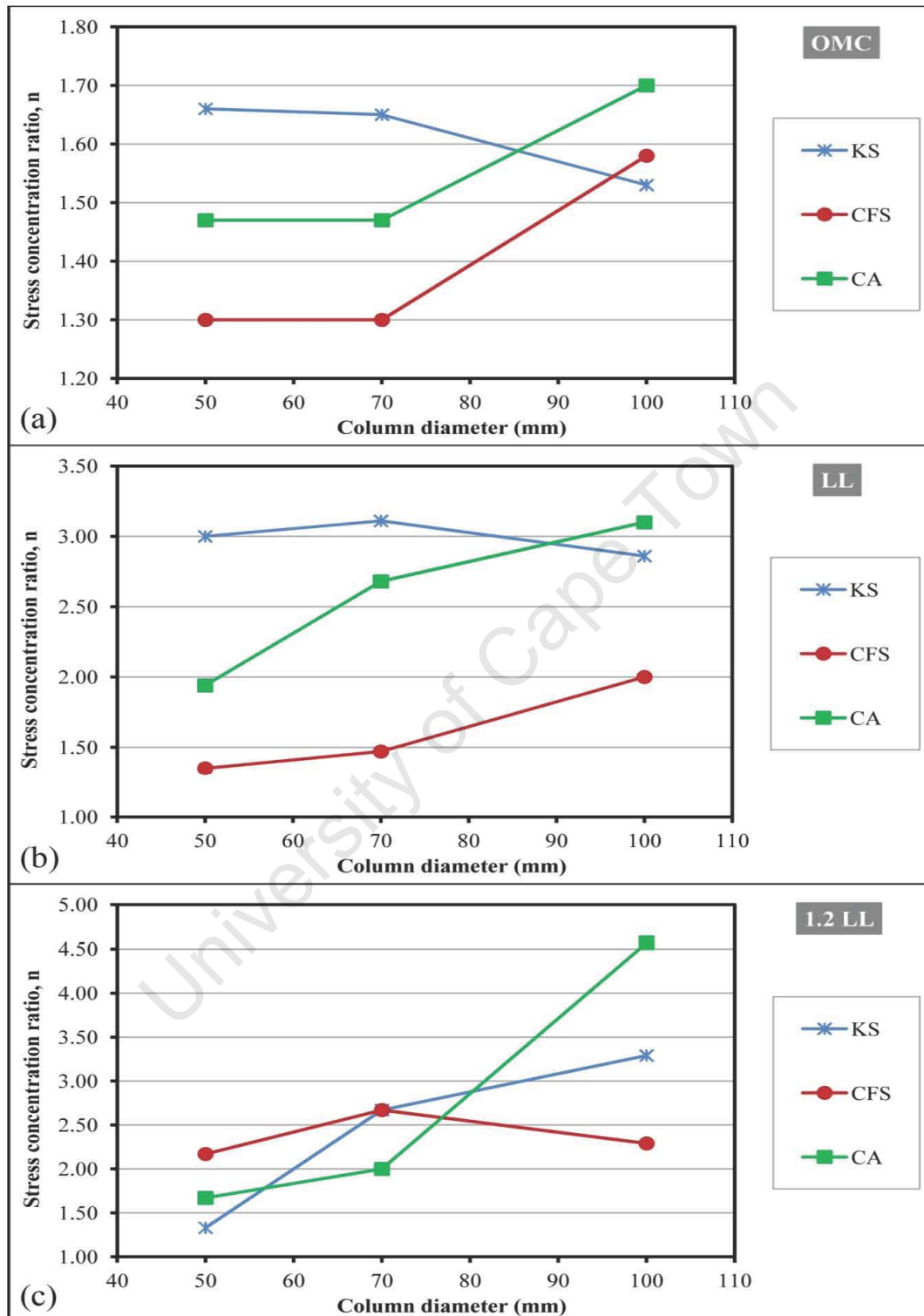

Figure 5.11: Effect of column diameter on stress concentration ratio at (a) OMC, (b) LL and (c) 1.2LL

### ***5.3.1.2 Effect of column material***

From Figure 5.12, it is evident that Cape Flats sand columns produce the least improvement in terms of stress concentration ratio which ranges between 1.3 and 2.65, irrespective of the diameter of the column or the moisture content of the base soil. However, at 1.2LL it appears that both sands produce approximately similar stress concentration ratios at smaller diameters, taking into account the 50 mm Klipheuwel sand column which can possibly be described as an anomaly. It is worth noting that Klipheuwel sand columns have repeatedly shown higher or almost similar  $n$  values when compared to crushed aggregate columns. This characteristic can be described in terms of the grading of Klipheuwel sand, Being a well graded sand with a small percentage of fines, Klipheuwel sand produce columns of high stiffness with low void ratio which in turn results in higher vertical bearing stress capacities. Nevertheless, 100 mm crushed aggregate columns at 1.2LL exceeds the stress concentration ratio of Klipheuwel sand column of similar diameter by 40%.

Although the improvement from larger crushed aggregate columns was relatively high ( $n$  being 4.5), smaller columns of similar materials have revealed poor performance at 1.2LL with  $n$ -values of 1.7 and 2 for column diameters of 50 mm and 70 mm respectively. This behaviour can be explained by the size, strength and angular shape of the particles which easily pushes into the soft soil and as such diminishes the stiffness and possibly diameter of the column. For smaller diameters, the remaining compacted replacement column material is so small compared to larger columns that the gain in strength of the clay-aggregate composite is minimal. In contrast to crushed aggregates, particles of sand are very small which render them incapable of propelling in the clay by breaking their inter-particle forces, hence retaining the size and stiffness of the column. Consequently, the stress concentration ratio is higher for the small sand columns at 1.2LL.

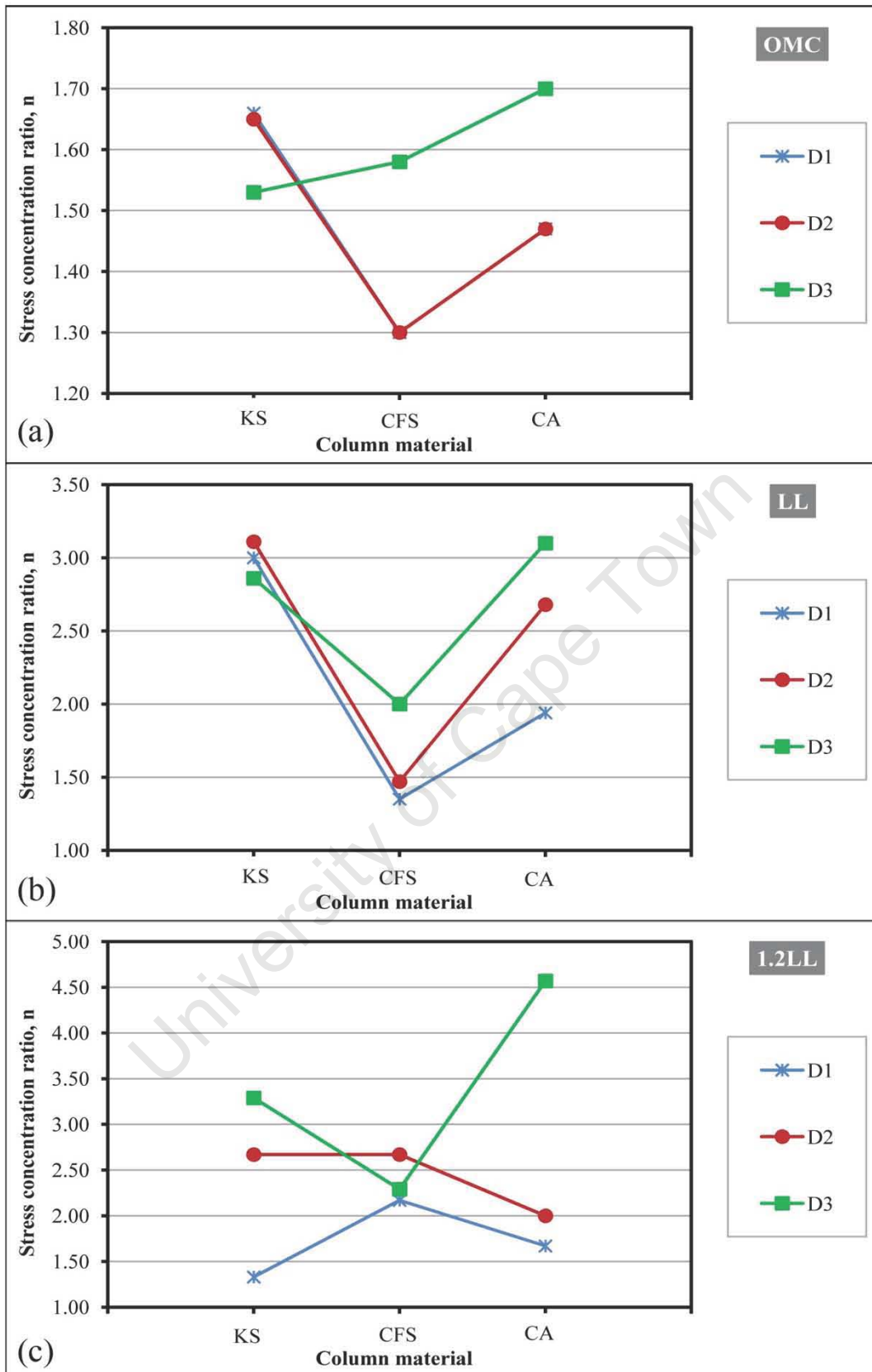

Figure 5.12: Effect of column material on stress concentration ratio at (a) OMC, (b) LL and (c) 1.2LL

### 5.3.1.3 Effect of moisture content

Figure 5.13 describes the trend followed by stress concentration ratio when moisture content is increased. Each graph in the figure presents this relationship for the different diameters of the column materials investigated. In general, all columns (irrespective of material and size) have shown an augmentation in n-value with an increase in moisture content. However, for Klipheuwel sand and crushed aggregate columns of 50 mm and 70 mm, the enhancement in n at 1.2LL was slightly lower compared to that at LL. While for Klipheuwel sand columns the data point is treated as an anomaly based on earlier discussions, the low n-value of smaller crushed aggregate columns is explained in terms of the low confining stress field generated by highly wet clays. The decrease in confinement encourages the contamination of column materials by the intrusion of soft clay on the edge of the column which subsequently reduces the frictional strength of the aggregates. A reduction in frictional strength eventually affects the stress capacity of the column (McKenna *et al*, 1975).

The stress concentration ratio of any large column was revealed to increase with gain in moisture content. The recorded n-value of Klipheuwel, Cape Flats and crushed aggregate 100 mm columns at 1.2LL were 3.29, 2.29 and 4.57 respectively, which shows that improvement in stress capacity with crushed aggregate columns is about twice that with Cape Flats sand. Out of the 2 sands, Klipheuwel sustained higher vertical applied stresses as a product of the well graded particles forming a stiffer column. The range of n values obtained shows good agreement with Barksdale and Bachus (1983) who highlighted typical values of n to be within the range of 2.5 to 5.

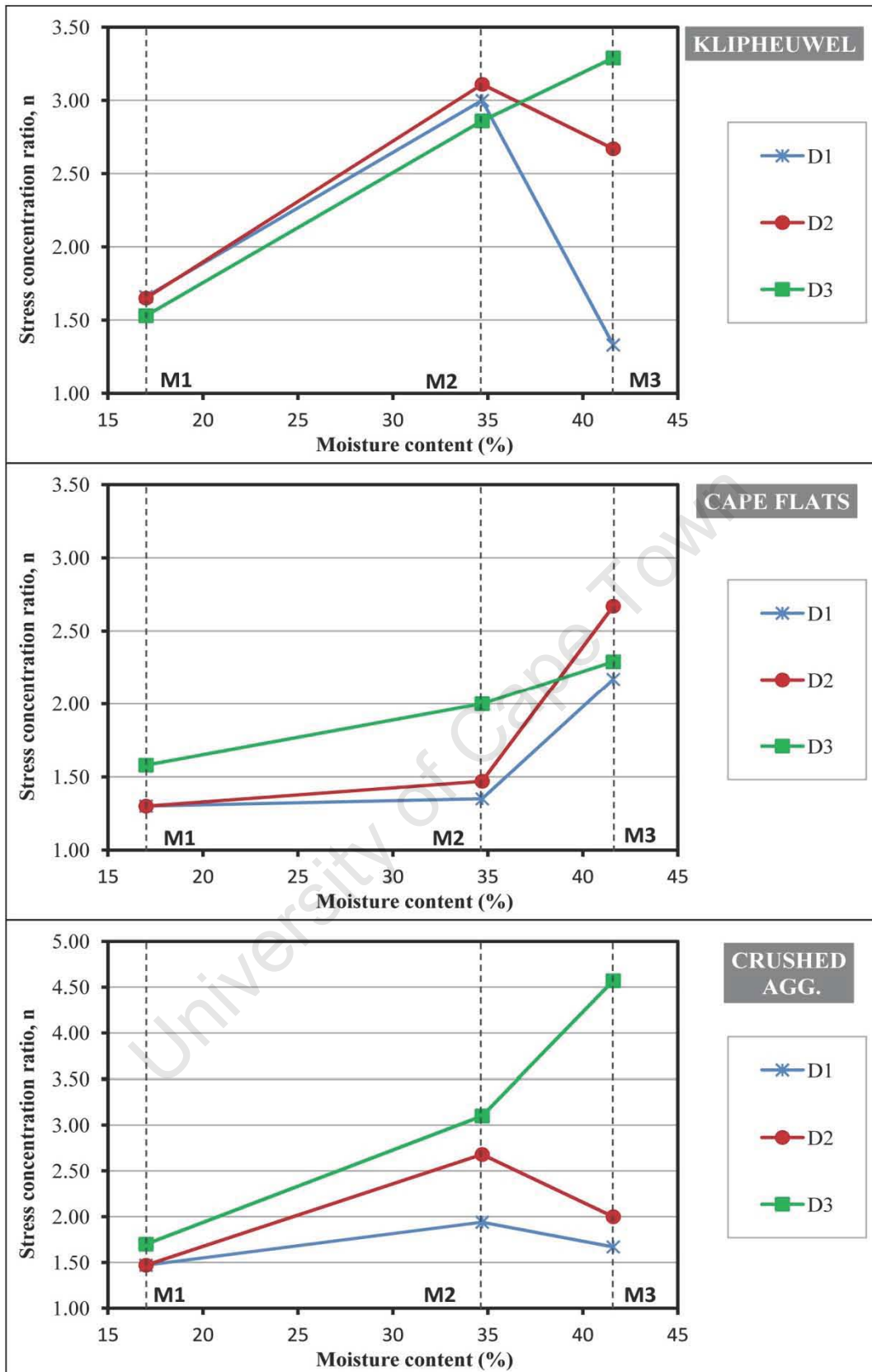

Figure 5.13: Effect of moisture content of the base clay on stress concentration ratio for columns of (a) Klipheuwel sand (b) Cape Flats sand and (c) Crushed Aggregate

### 5.3.2 Settlement reduction ratio

Compared to stress concentration ratio where the larger the  $n$ -value the better the improvement, settlement reduction ratio (SRR) indicated higher improvement with smaller SRR values. This is because it is calculated as the ratio of settlement in improved ground (low settlement) to that in unimproved ground (high settlement) for a particular vertical applied stress. Data were obtained from Figure 5.2 to Figure 5.10 and the SRR values were calculated and plotted as shown in Figures 5.14 to 5.16. These figures constitute 3 sets of graphs where each set looked at the effect of one variable (diameter, column material and moisture content) on the SRR.

Figure 5.14 presents the SRR-diameter relationships at the 3 moisture contents. At OMC, SRR is similar for 50 mm and 70 mm columns of any material type. However, for larger diameters a steep decrease is obtained, especially for Cape Flats sand which recorded a percentage reduction of about 44%. Such behaviour is related to the high proportion of strong replacement material. The anomaly with the large Klipheuwel column is again raised in Figure 5.14(a). For tests conducted at LL and 1.2LL, a general decrease in SRR is achieved as the columns are enlarged. The low strengths of wet clays is largely surpassed by the inclusion of larger stiff columns, as a result of which settlement is reduced.

The effect of column material on SRR (Figure 5.15) reveals Cape Flats sand as the material producing the least amount of improvement in terms of settlement reduction except for 50 mm and 70 mm columns at 1.2LL. This poor enhancement in settlement reduction can be attributed to considering the effect of the size and shape of the particles of column materials. Since crushed aggregates have a higher tendency of losing their particles in clays of high moisture content, small columns made from them provide poor resistance against settlement improvement, thereby allowing Cape Flats sand to produce better improvement in settlement.

An increase in moisture content has demonstrated a reduction in SRR up to LL. Beyond LL, the SRR either remains constant or increases depending on the column material. An exception to this observation is in Cape Flats sand columns where SRR reduces as the moisture content increases. In fact, the settlement reduction ratio produced by the 3 diameters at 1.2LL differed negligibly. It can thus be said that Cape Flats sand column diameters have insignificant effect on settlement reduction at high moisture contents. Klipheuwel and crushed aggregate columns have shown similar trends in SRR with moisture content variations. In base clays wetter than LL, the SRR for larger columns have normalised

to a constant value of about 0.06. This observation implies that at very high moisture contents, large diameter columns of crushed aggregate and Klipheuwel sand performed similarly. In the present study, settlement reduction ratio has been found to vary between 0.05 and 0.65. Similar results were obtained by Zahmatkesh and Choobbasti (2010)\* who executed a numerical analysis through a proposed method for evaluating the settlement and bearing capacity of stone column reinforced soft clay.

University of Cape Town

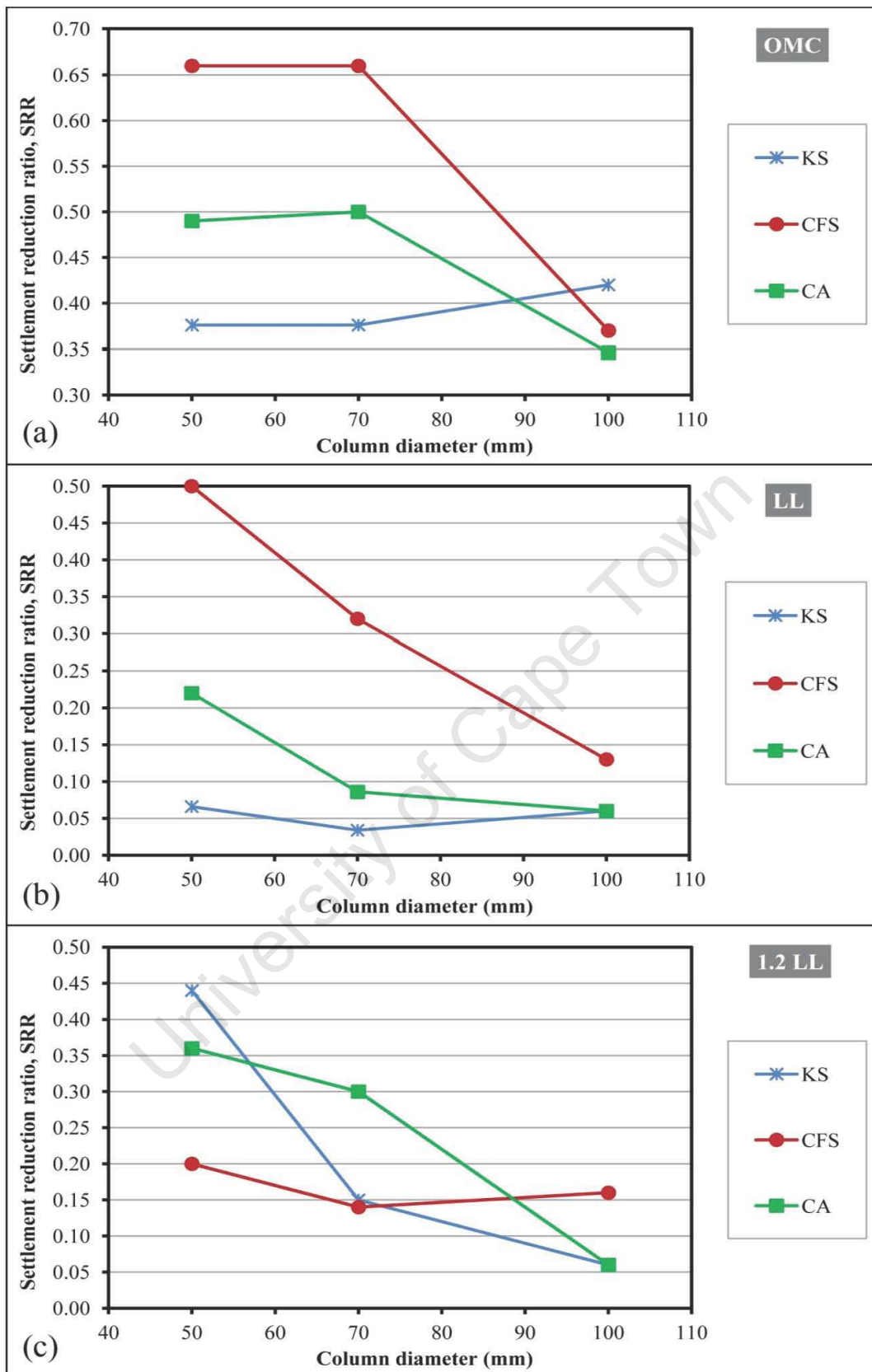

Figure 5.14: Effect of column diameter on settlement reduction ratio at (a) OMC, (b) LL and (c) 1.2LL

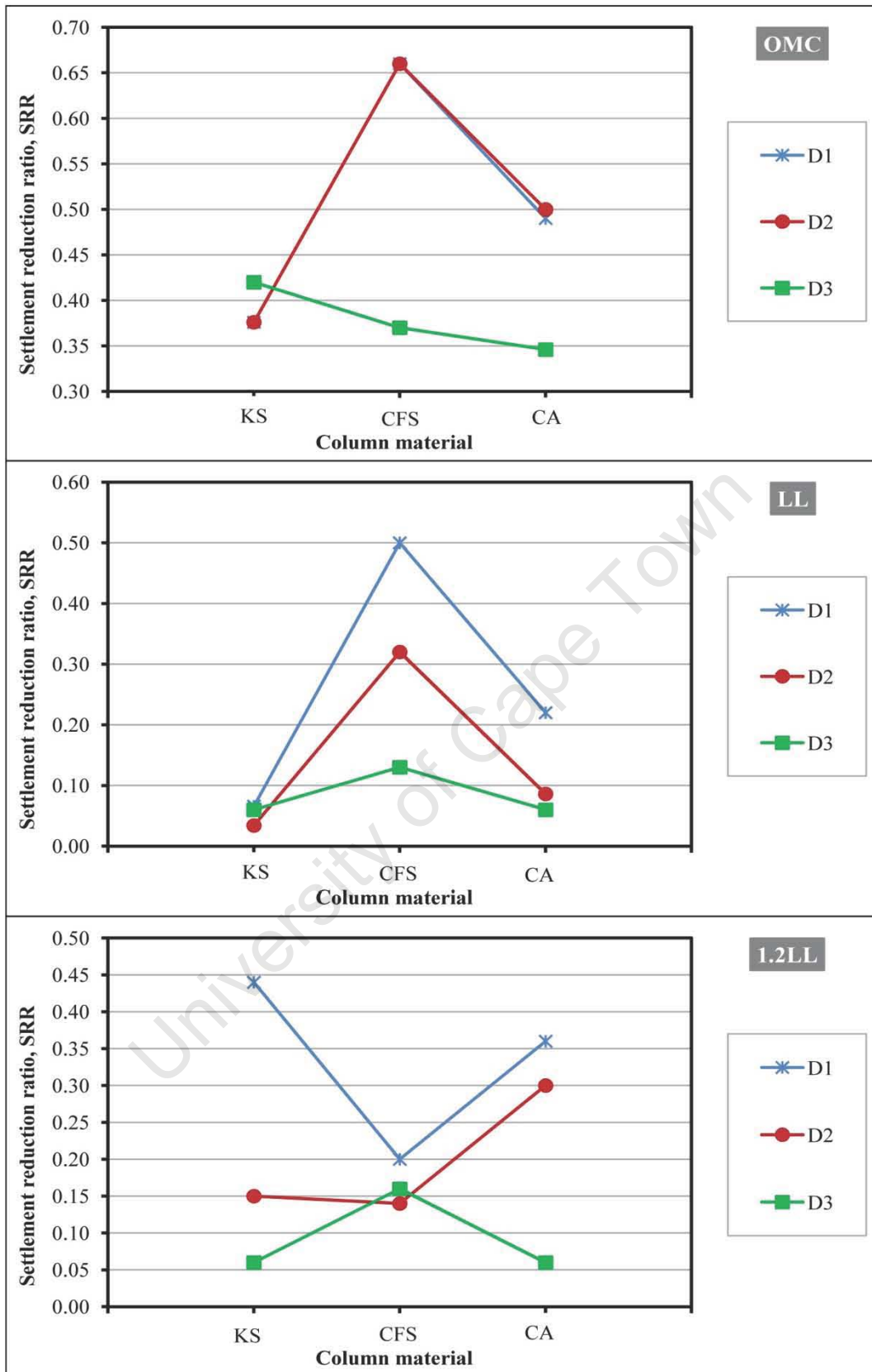

Figure 5.15: Effect of column material on settlement reduction ratio at (a) OMC, (b) LL and (c) 1.2LL

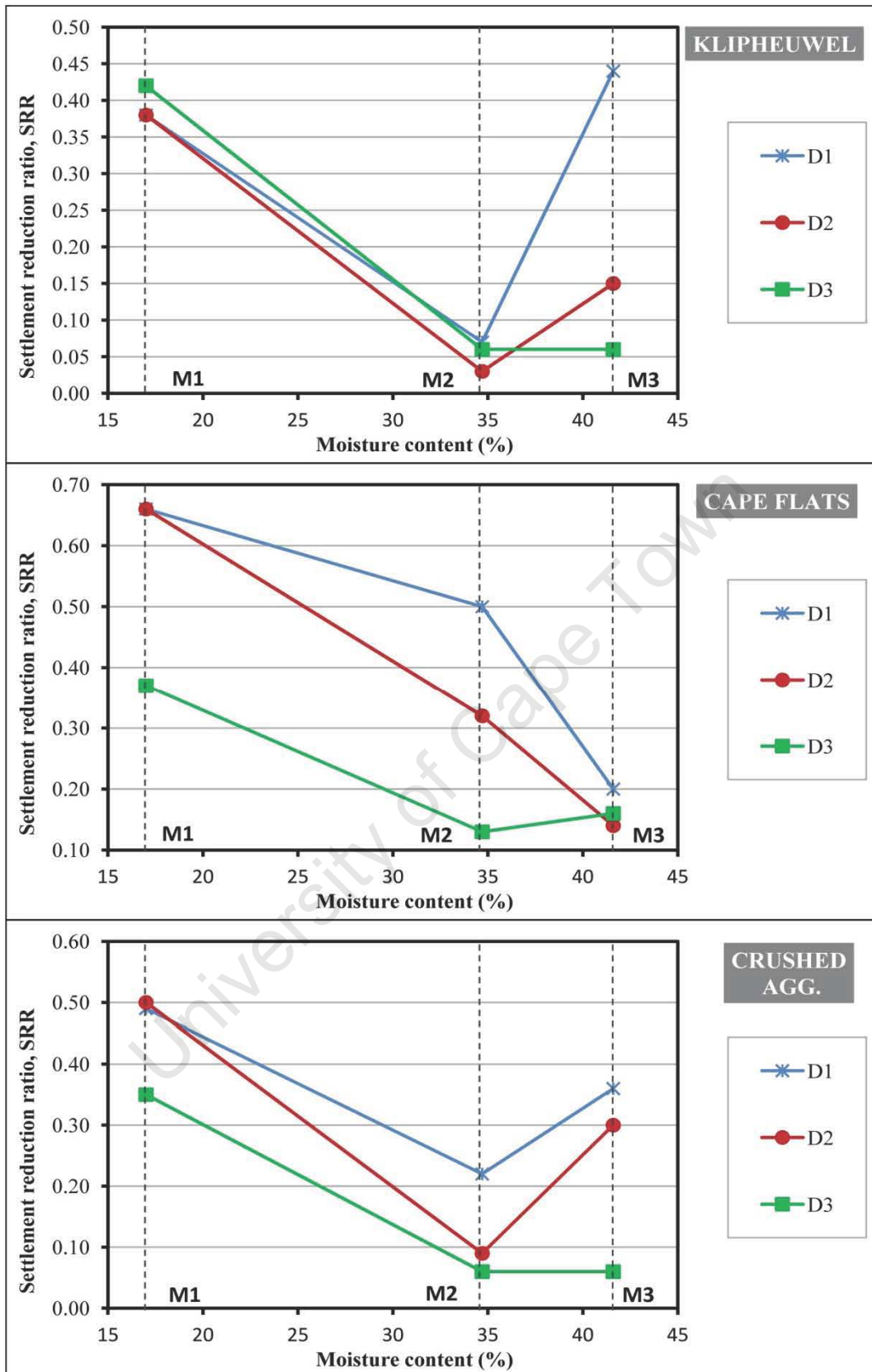

Figure 5.16: Effect of moisture content of the base clay on settlement reduction ratio for columns of (a) Klipheuwel sand (b) Cape Flats sand and (c) Crushed Aggregate

### 5.3.3 Comparison of the behaviour of stone columns in kaolin with those in Cape Town clay under similar conditions

Tests on the 3 diameters of crushed aggregate columns were conducted at the OMC of both Cape Town clay and Kaolin, the load-settlement relationships of which are shown in Figure 5.17. Kaolin was the preferred material since it has been widely used in research conducted on stone columns (Aarathi and Bhaskar, 2011; McKelvey *et al*, 2004; Andreou *et al*, 2008). The comparison was drawn in an attempt to understand the difference in behaviour of the columns in different base soils. Hence, all conditions were kept constant except for the base material. It must be recalled that the OMC of Cape Town clay (17%) and Kaolin (23.5%) differed since the degree of the fineness of their particles were dissimilar.

From Figure 5.17, the smooth graphs follow a similar trend although the ultimate stresses varied. Generally, Kaolin was found to be a strong base material, even without any improvement. Thus, the inclusions of the columns repeatedly showed higher vertical applied stresses than in Cape Town clay at a settlement of 50 mm. In fact, enhancement of Kaolin by the largest diameter column resulted in strength of approximately 700 kPa, twice that of the improved Cape Town clay. This ultimate stress of 700 kPa agrees well with reported data by Loseby (2011) who conducted a similar study on 100 mm stone column reinforced Kaolin.

Variations of column diameter in both base materials have shown an increase in vertical stresses with an enlargement of the diameter of the column. However, for the smallest column (50 mm) in Kaolin the improvement is negligible compared to diameters of 70 mm and 100 mm.

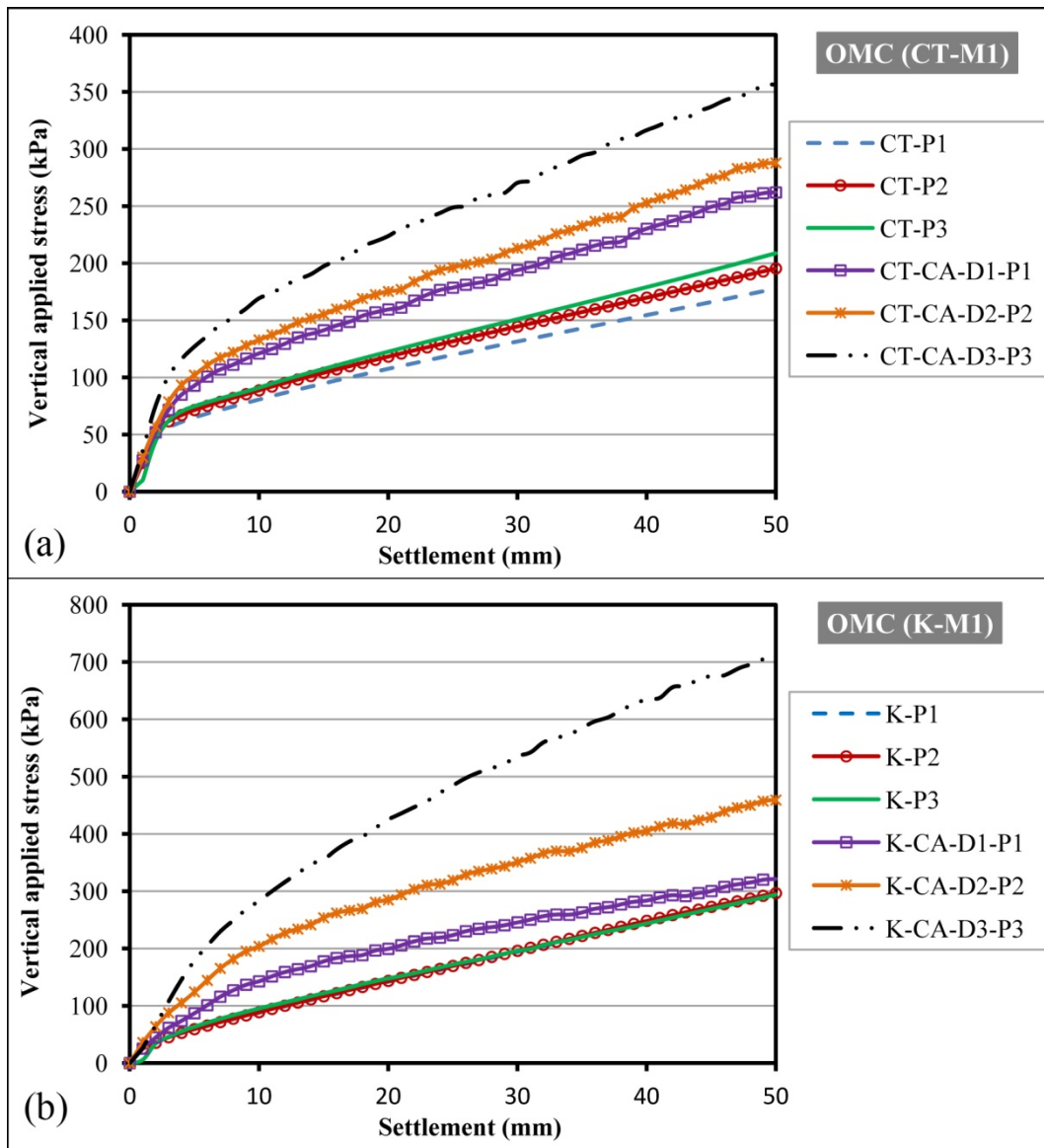

Figure 5.17: Comparison of stress-settlement behaviour of Cape Town clay with Kaolin

### 5.3.4 Failure mechanism of selected columns

Van Impe *et al* (1997) and Hughes and Withers (1974) have described the typical failure modes of stone columns as shearing, bulging, sliding and punching although bending can also occur. To observe the failure mechanism of stone columns which were anticipated to produce largest deformations, the dimensions of selected columns were measured on completion of a test. The tested material in the box was removed in thin layers while simultaneously measuring the diameter of the deformed columns at different depths. Figure 5.18 shows a deformed Cape Flats sand column.

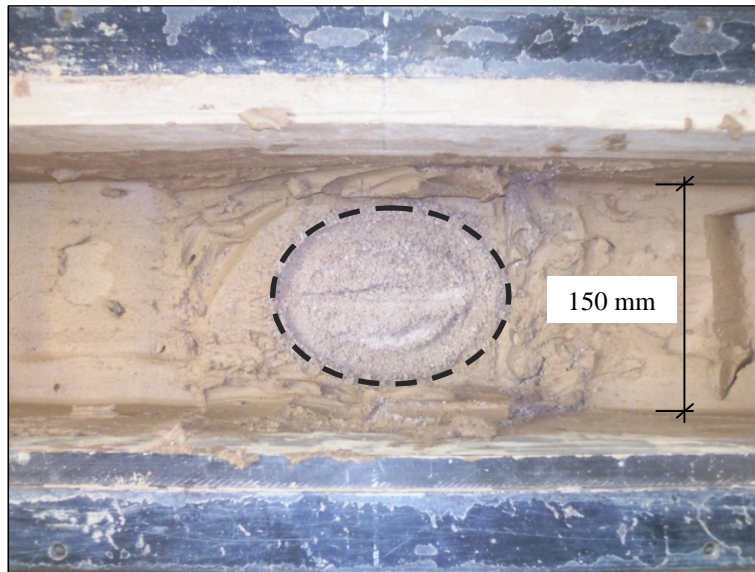

Figure 5.18: Plan of a deformed Cape Flats sand column in the box after testing

Figures 5.20 and 5.21 provide approximated deformations for the selected columns based on column dimensions captured at the end of the experiments. Two sections are provided for each column (Figure 5.19) since their deformation was restricted in the shortest direction of the test box, hence producing an oval deformed shape as shown in Figure 5.18.

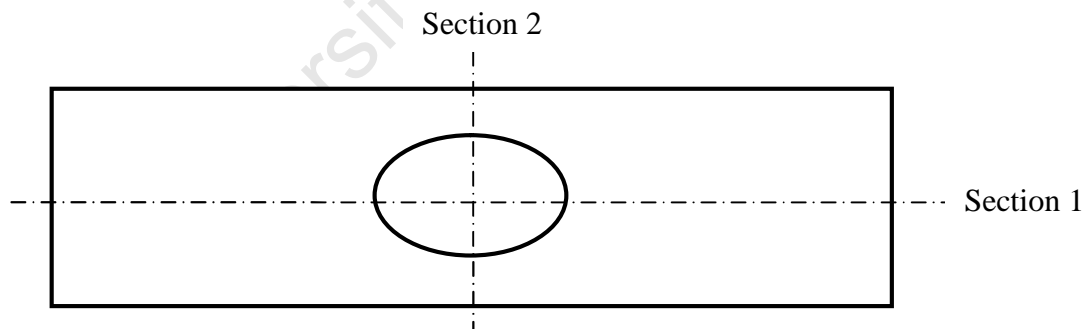

Figure 5.19: Top view of the test box indicating sections of a typically deformed column (not to scale)

Coarser columns, Cape Flats sand and crushed aggregate, installed in clays of higher moisture contents (LL and 1.2LL) were selected for failure mechanism analysis since penetration of granular particles in soft base clays are more prominent than the finer particles present in Klipheuwel sand. In all cases, an outward deformation was observed with the

maximum bulging occurring within the top third of the column length and in the longest direction. In effect, deformations in both the shortest and longest directions were largely concentrated in the upper regions of the column, an observation in line with McKelvey *et al* (2004). The observed distorted shape of the columns demonstrated the main failure mode as bulging.

Figure 5.20 compares the degree of bulging of Cape Flats sand columns in base soils at LL and 1.2LL while Figure 5.21 perform a similar comparison between Cape Flats sand and crushed aggregate columns in the base material of 1.2LL. From the estimated deformations, small diameter Cape Flats sand columns expanded more in 1.2LL base clay compared to bulging at LL, with a recorded increase in diameter of 133% at maximum bulging for 70 mm columns. This occurrence is explained in terms of the lower confining stresses exerted by the surrounding clay on the column at 1.2LL. However, 100 mm Cape Flats sand column exhibited similar low bulging at both moisture contents.

At 1.2LL, the deformations were found to be similar for both crushed aggregate and Cape Flats sand columns. Nonetheless, bulging in the 70 mm Cape Flats sand column was much higher than that in the more coarser column. Taking into account the distortion of the presented columns in Figures 5.20 and 5.21, this test can be classified as an anomaly. The source of error is likely to be in the compaction of each layer of the column material, whereby a higher compaction energy forces the material to push into the clay and thus forming a bulge prior to testing.

The interpretation of the observed deformed columns indicate an increase in bulging as the base soil becomes wetter, a consequence of the lowered confining stress from the surrounding soil. Furthermore, at the highest moisture content (1.2LL), no significant difference was observed in the deformations of crushed aggregate and Cape Flats sand columns.

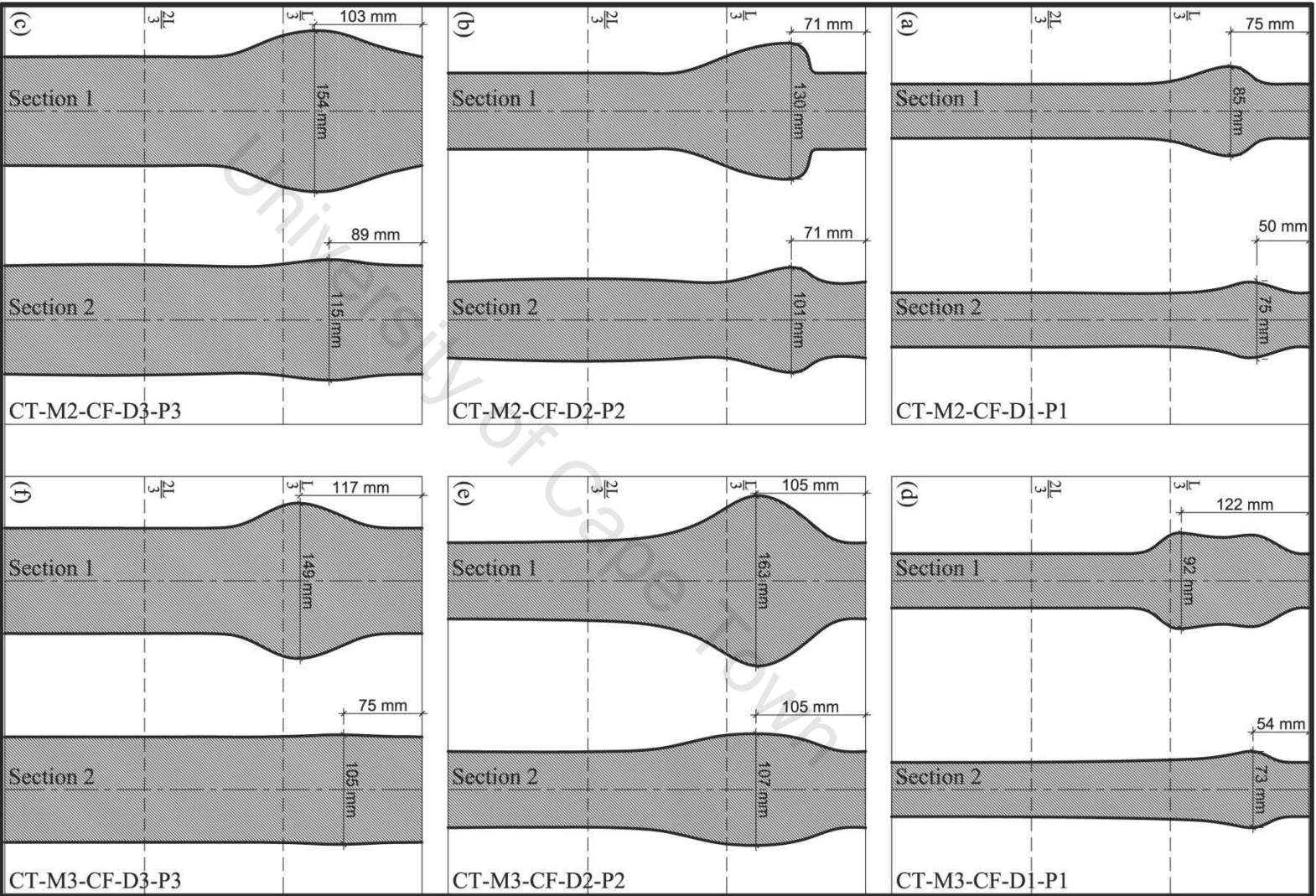

Figure 5.20: Comparison of failure mechanism of Cape Flats sand columns at LL and 1.2LL

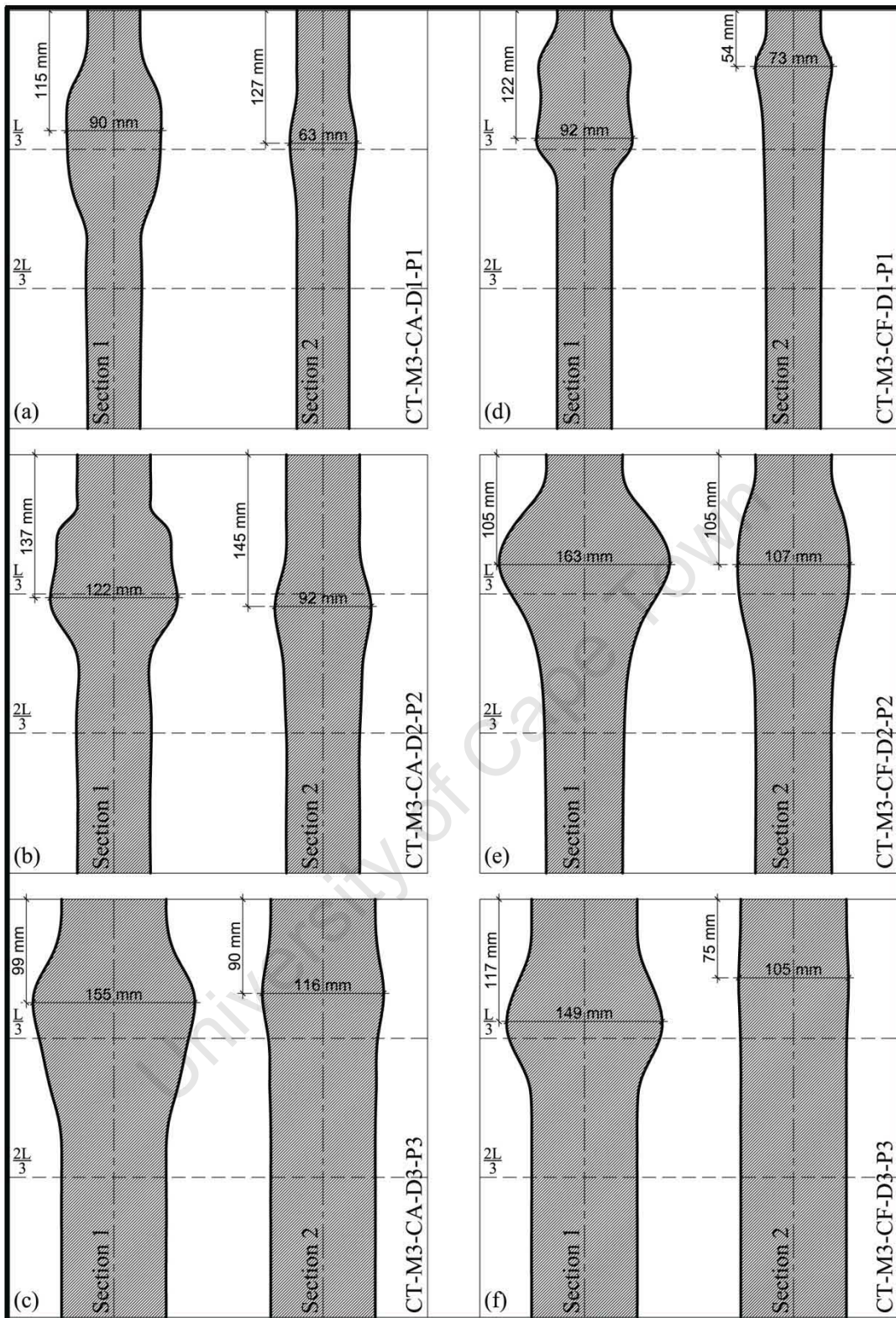

Figure 5.21: Comparison of the failure mechanism of Cape Flats sand and crushed aggregate columns at 1.2LL

## 5.4 Applications

In this study, columns were installed on a hard surface which is representative of the hard stratum in the general ground. By extending the columns to this firm plane, punching failure is avoided. As such, differential settlement is not aroused from punched columns. Columns were not found to fail in the lower part of the length, which is an indication of the adequate carrying capacity of the columns. This observation was made in base clays of all the moisture contents tested. Therefore, installation of the columns in the unimproved ground should preferably be extended to the hard stratum while simultaneously keeping the diameter of the column relatively large. Smaller columns will rather encourage particles migrating in the base soil, especially at high moisture contents. Coarser particles on the edge of the column tend to get contaminated easily, especially in wet soils. This contamination must be avoided since the load carrying capacity of the column is diminished as a result of reduction in stiffness. An approach to reducing this effect is to make the columns larger. Based on the common local applications requiring improvement in bearing capacity and settlement, it is proposed that rammed stone columns be used in the following to support loads of relatively low intensity:

- strip footings,
- storage tanks such as oil tanks,
- embankment support,
- houses (maximum of 2 storeys), and
- slope stability.

When installing stone or sand columns in the field, it is advisable to use a casing for supporting the pre-bored hole since collapsing of the base material into the opening cause a reduction in load carrying capacity. To install these columns, openings can be made by coring in to the ground while simultaneously pushing a casing through up to the desired depth of the column (until hard stratum is attained). The inside surface of the casing must be free of adhering materials to ensure free flow of the replacement material which is afterwards charged in. Placement of the column material is performed in layers whereby each layer is subjected to adequate compaction without crushing of the granular material. The column is constructed in compressed layers while each time retracting the casing by a distance smaller than the layer. It must be ensured that the casing is not completely removed from the compacted parts since smearing effect will encourage contamination with the base material

and therefore reduce the strength of the column. Once the columns are installed up to ground level, footings can be placed above them to support the desired applied loads. This technology is suited for many applications in South Africa, some of which are illustrated in Figure 5.22.

University of Cape Town

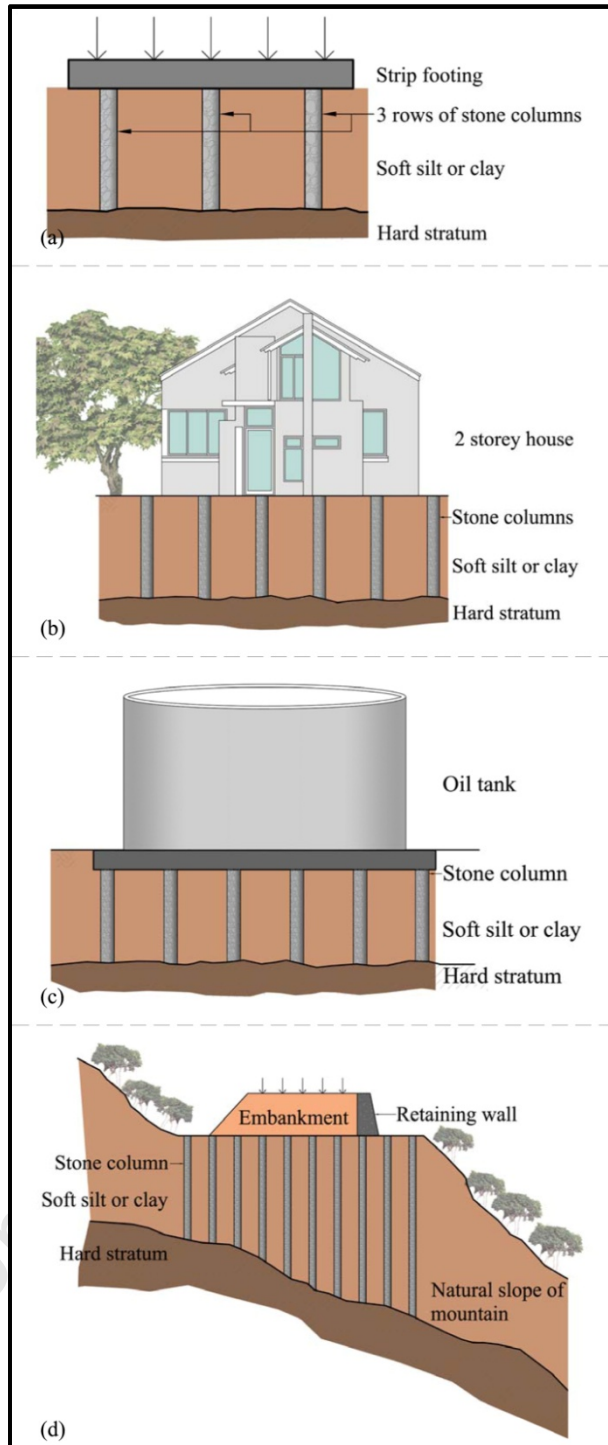

Figure 5.22: (a) Cross-section of a strip footing supported on 3 rows of stone columns, (b) Cross-section of a two storey house supported on 6 rows of stone columns, (c) Cross-section of an oil storage tank supported on 6 rows of stone columns, (d) Stone columns used for supporting the embankment while at the same time providing stability to the natural slope

University of Cape Town

## *Conclusions*

---

## 6.1 Introduction

In this work, the improvement in vertical applied stress and settlement for a South African silty clay was tested when reinforced with rammed stone and sand columns. This soil was chosen since a significant proportion of the weak or soft soils in the country is 40%, which makes them unsuitable as founding layers when no improvement is adopted (AGIS, 2011). To study the behaviour of columns of different diameters (50 mm, 70 mm and 100 mm) and materials (Klipheuwel sand, Cape Town clay and crushed aggregate) in base clays at OMC, LL and 1.2LL, 44 tests were performed, including 2 repeatability and 9 control experiments. Six of the tests were carried out on Kaolin as the base material to aid in comparing their results with those conducted on Cape Town clay. This chapter summarizes the main findings which emerged from this investigation. A few recommendations are also presented for further research work.

## 6.2 Conclusion

### 6.2.1 Stress-settlement behaviour

- The stress-settlement relationships obtained for the different tested conditions showed considerable improvement in both vertical applied stress and settlement, with the inclusion of singular stone columns.
- The vertically applied stress generally increased with enlarged columns, irrespective of the column material and the moisture content of the base soil.
- Crushed aggregate columns of diameter 100 mm continuously produced higher stresses for all moisture contents investigated. In a base soil at 1.2LL, an improvement in vertical stress of roughly 6 times that of the unimproved clay, at a settlement of 50mm, was recorded.
- For smaller columns, the coarser sand column generated higher vertical stresses than the other columns of similar sizes.
- Out of the two sands, Klipheuwel sand was a higher stress bearing material which was attributed to the grading of its particles.

### 6.2.2 Stress concentration ratio, $n$

- At high moisture contents, an enhancement in stress concentration ratio was observed with an increase in column diameter.
- Overall, the stress concentration ratio of any large column increased with gain in moisture content of the base soil. The  $n$ -value of 100 mm diameter columns from Klipheuwel sand, Cape Flats sand and crushed aggregate at 1.2LL corresponded to 3.29, 2.29 and 4.57. These results implied that improvement in stress capacity with crushed aggregate columns is about twice that with Cape Flats sand.

### 6.2.3 Settlement reduction ratio, SRR

- For all column materials, an increase in moisture content of the base soil demonstrated a reduction in SRR up to LL.
- Klipheuwel sand and crushed aggregate columns showed similar trends in terms of SRR when moisture content was varied, with the large diameter columns from both of these materials performing similarly in base soils of high moisture contents.
- The SRR for this study varied between 0.05 and 0.65.

### 6.2.4 Comparison of Kaolin with Cape Town clay

- Kaolin was generally found to be a stronger material than Cape Town clay.
- Improvement of Kaolin with 100 mm crushed aggregate columns produced vertical applied stresses of about twice that of the improved Cape Town clay under identical conditions.
- For both base materials, an increase in vertical applied stresses was obtained with an enlargement of the crushed aggregate columns.

### 6.2.5 Failure mechanism of coarser columns at LL and 1.2LL

- Both sand and crushed aggregate columns failed in bulging irrespective of the moisture content of the base material. The highest observed enlargement of 133% for a 70 mm column was more prominent with Cape Flats sand than with crushed aggregates.

- Maximum bulging of columns occurred within the top third of the column length.

### 6.3 Recommendations

- This study was limited to laboratory experiments. However, since it is now evident that Cape Town clay responded positively to rammed stone column treatment, it will be worthwhile to conduct field tests for enhancing the understanding in their behaviour and for promoting the use of rammed stone columns in South Africa. Field tests are also recommended to account for scale effects arising from variations of the column material and geometry and the base moisture content during laboratory experiments.
- This study omitted an in-depth analysis of the failure mechanism of stone column. Since the failure of these columns are critical in their performance, it is proposed that further studies consider this area of investigation.
- The effect of column length on the performance of the columns was not investigated. Since a minimum length is required for stone columns to derive resistance as a result of the parameter shear rather than the end-bearing, an investigation into columns of different lengths will be necessary.
- Column spacing is a determining factor in calculating the settlement of stone columns improved soils. Therefore, the effect of columns spacing must be investigated. This can be achieved by testing columns installed in different unit cell sizes thereby resulting in different area replacement ratios.
- Although the benefits of stone column are many, this research concentrated solely on the improvement in load carrying capacity and settlement. Other advantages of the technique, such as drainage, economical and environmental effectiveness, must be studied since stone column have often demonstrated high effectiveness in these applications. The effectiveness of the technique can also be compared to other ground improvement techniques under different conditions. Further research on these mentioned aspects can possibly generate a guideline on stone column improvement for South Africa.

University of Cape Town

## ***References***

---

1. AARATHI, P.S., BHASKAR, A.B.,(2011) *Settlement Response of Granular Fill-Soft Soil System with Stone Column*, Department of Civil Engineering, College of Engineering Trivandrum, India, Unpublished.
2. ABHIJIT, S., DAS, S.C., (2000), *Interaction analysis of stone column groups in foundations*, Proc. Indian Geotech. Conf., Bombay, India, pp. 279-284.
3. AFRISAM, (2008), *Concrete Aggregate: Aggregate-product brochure*, Afrisam South Africa.
4. AGIS, (2011), *Natural resources atlas: Soil classes*, Unpublished (www.agis.agri.za: Accessed on the 5<sup>th</sup> of July 2011).
5. ALAMGIR, M., MIURA, N., POOROOSHASB, H.B., MADHAV, M.R., (1996), *Deformation analysis of soft ground reinforced by columnar inclusions*, Comput. Geotech., Vol. 18, No 4, pp.267-290.
6. AMBILY, A.P., GANDHI, S.R, (2007), *Behaviour of Stone Columns Based on Experimental and FEM Analysis*, Journal of Geotechnical and Geoenvironmental Engineering, ASCE, Vol. 133, No 4, pp. 405-415.
7. ANDREOU, P., FRIKHA, W., FRANK, R., CANOU, J., PAPADOPOULOS, V., DUPLA, J-C., (2008), *Experimental study on sand and gravel columns in clay*, Proc. of the Institution of Civil Engineers, Ground Improvement 161, Issue GI4, pp. 189-198.
8. ARMAN, H., FIRAT, S., VURAL, I. GUNDUZ, Z., (2009), *Soil and foundation stability improvement by stone column: A case study in Adapazari city, Turkey*, Scientific Research and Essay – Academic Journals, Vol. 4, No 10, pp. 972 – 983.
9. BARKSDALE, R.D., BACHUS, R.C., (1983), *Design and Construction of Stone Columns*, Federal Highway Administration, Washington DC, Final Report SCEGIT-83-104.
10. BERGAYA, F., THENG, B.K.G., LAGALY, G., (2006), *Handbook of clay science*, p.12, First Edition, Elsevier, The Netherlands.
11. BILFINGER BERGER, (2012), *Ground Freezing*, Foundation Engineering, Unpublished (http://www.civil.bilfinger.com/en/Foundation-Engineering/Services/Ground-Freezing: Accessed on the 9<sup>th</sup> of July 2012).
12. BusinessDay (2010), *Aerial Combat: Airport tariff war exposes regulatory weaknesses*, Published on 23rd April 2010.
13. BOWLES, J.E., (1997), *Foundation Analysis and Design*, Fifth Edition, McGraw-Hill, Singapore.

14. CHEUNG, K.C., (1998), *Geogrid reinforced light weight embankment on stone columns*, Connell Wagner Ltd, Auckland, New Zealand.
15. CRAIG, R.F., (2004), *Craig's Soil Mechanics: Chapter 4*, Seventh Edition, Spon Press, London.
16. EUROCODE 7, *Geotechnical Design-Part 1: General rules*, Annex H, British Standard, BS EN 1997-1:2004.
17. FRANKI, (2008), *A guide to practical geotechnical engineering in Southern Africa*, 4<sup>th</sup> Edition, Franki Africa (Pty) Ltd.
18. GHANTI, R., KASHLIWAL, A., (2008), *Ground Improvement Techniques – with a focussed study on stone columns*, Dura Build Care Pvt Ltd., VIT University, India, Unpublished  
(<http://www.durabuildcare.com/pdf/Ultimate%20Bearing%20Capacity%20of%20a%20SINGLE%20STONE%20COLUMN.pdf>: Accessed on the 6<sup>th</sup> of April 2011).
19. GIBSON, R.E., ANDERSON, W.F., (1961), *In situ measurements of soil properties with the pressuremeter*, Civil Eng. And Pub. Works Rev., Vol. 56, No 658.
20. GGPL, (2012), *Geosynthetic Products*, Gorantla Geosynthetics Pvt. Ltd., Chennai, India, Unpublished  
(<http://www.gorantlageosynthetics.com>: Accessed on the 19<sup>th</sup> of August 2012).
21. GOUGHNOUR, R.R., (1983), *Settlement of vertically loaded stone columns in soft ground*, Proc. 8<sup>th</sup> European CSMFE, Helsinki, pp.235-240  
RATHMEYER, H.G., SAARI, K.H.O., Eds., AA Balkema.
22. GOUGHNOUR, R.R., SUNG, J.T., RAMSEY, J.S., (1991), *Slide Correction by Stone Columns*, Deep Foundation Improvements: Design, Construction and Testing, ASTM STP 1089  
ESRIG, M.I., BACHUS, R.C., Eds., American Society for Testing and Materials, Philadelphia.
23. HAYWARD BAKER, (2012), *Hayward Baker Geotechnical Construction*, Unpublished  
([www.haywardbaker.com](http://www.haywardbaker.com): Accessed on the 12<sup>th</sup> of March 2012).
24. HOLTZ, R.D., (2001), *Geosynthetics for soil reinforcement*, 9<sup>th</sup> Spencer J. Buchanan Lecture  
(<https://ceprofs.civil.tamu.edu/briaud/buchanan%20web/lectures/ninth%20buchanan%20lecture.pdf> : Accessed on the 9<sup>th</sup> of June 2010).
25. HUGHES, J.M.O., WITHERS, N.J., (1974), *Reinforcing of soft cohesive soils with stone columns*, Ground Engineering, Vol 7, No 3, pp. 42-49.

26. ISAAC, D.S., MADHAVAN, S.G., (2009), *Suitability of Different Materials for Stone Columns Construction*, EJGE, Vol. 14, Bund. M.
27. JESSBERGER, H.L., JAGOW-KLAFF, R., BRAUN, B., (2003), *Ground Freezing* SMOLTCZYK, U., Ed., *Geotechnical Engineering Handbook*, Vol. 2: Procedures, pp.117-167, Ernst & Sohn, Berlin.
28. KALUMBA, D., (1998), *Effect of Grading and grain size on the friction characteristics of a sand/geotextile interface*, MSc Thesis, Department of Civil Engineering, University of Cape Town, South Africa.
29. KARIM, H.H., MAHMOOD, M.M., RENKA, R.G., (2009), *Soft clay soil improvement using stone columns and dynamic compaction techniques*, Eng. & Tech. Journal, Vol. 27, No 14, pp. 2546-2565.
30. KRUGER, J.J., GUYOT, C., MORIZOT, J.C., (1980), *The dynamic substitution method*, Int. Conf. on Compaction, Paris  
Editions Anciens ENPC, Laboratoire Central des Ponts et Chaussées, Ecole Nationale des Ponts et Chaussées.
31. LOSEBY, M., (2011), Investigation into the behaviour of rammed stone columns in soft cohesive clays, BSc Thesis, Department of Civil Engineering, University of Cape Town, South Africa.
32. MADHAV, M.R., MURALI KRISHNA, A., (2008), *Liquefaction Mitigation of Sand Deposits by Granular Piles – An Overview*  
LIU, H., DENG, A., CHIU, J., Eds., *Geotechnical Engineering for Disaster Mitigation and Rehabilitation*, Science Press Beijing and Springer-Verlag GmbH Berlin Heidelberg.
33. MALARVIZHI, S.N., ILAMPARUTHI, K., (2011), *Load versus Settlement of Claybed Stabilized with Stone & Reinforced Stone Columns*, Division of Soil Mechanics and Foundation Engineering, Anna University, Chennai-25, India, Unpublished.
34. McCABE, B.A., McNEILL, J.A., BLACK, J.A., (2007), *Ground Improvement using the vibro-stone column technique*, Joint meeting of Engineers Ireland West Region and the Geotechnical Society of Ireland, NUI Galway, The Institution of Engineers of Ireland.
35. McCABE, B.A., NIMMONS, G.J., EGAN, D., (2009), *A review of field performance of stone columns on soft soils*, Proc. of the Institution of Civil Engineers, Geotechnical Engineering 162, Issue GE6, pp. 323-324.

36. McKELVEY, D., SIVAKUMAR, V., BELL, A., GRAHAM, J., (2004), *Modelling vibrated stone columns in soft clay*, Proc. of the Institution of Civil Engineers, Geotechnical Engineering 157, Issue GE3, pp. 137-149.
37. McKENNA, J.M., EYRE, W.A., WOLSTENHOLME, D.R., (1975), *Performance of an embankment supported by stone columns in soft ground*, Geotechnique, Vol. 25, No.1, pp.51-59.
38. MITCHELL, J.K., KATTI, R.K., (1981), *Soil Improvement - State-of-the Art Report*, Proc. of the 10th International Conference on Soil Mechanics and Foundation Engineering, Stockholm, Vol.4, pp. 509-565.
39. MOSELEY, M.P., KIRSCH, K., (2004), *Ground Improvement*, pp. 99, Second Edition, Spon Press, London and New York.
40. MURALI KRISHNA, A., MADHAV, M.R., (2009), *Treatment of loose to medium dense sands by granular piles: Improved SPT 'N' values*, Geotech Geol Eng, Vol. 27, pp. 455-459.
41. MURUGESAN, S., RAJAGOPAL, K., (2008), *Performance of encased stone columns and design guidelines for construction on soft clay soils*, Proc. of the 4<sup>th</sup> Asian Regional Conference on geosynthetics, Shanghai, China.
42. PRIEBE, H.J., (1995), *The design of vibro replacement*, Ground Engineering, Vol. 28, No 10, pp. 31-37.
43. PURUSHOTHAMA RAJ, P., (2005), *Ground Improvement Techniques*, pp.142, First Edition, Laxmi Publications (P) Ltd, New Delhi, India.
44. RAJU, V.R., VALLURI, S., (2008), *Practical applications of ground improvement*, Symposium on Engineering of Ground & Environmental Geotechniques, (S EG<sup>2</sup>), Hyderabad, India.
45. SCHLÜTER, T., (2008), *Geological Atlas of Africa*, p.230, Second Edition, Springer, Berlin, Heidelberg.
46. SHIVASHANKAR, R., DHEERENDRA BABU, M.R., NAYAK, S., RAJATHKUMAR, V., (2011), *Experimental studies on behaviour of stone columns in layered soils*, Geotech Geol Eng, Vol. 29, pp. 749-757.
47. SOM, N.N., DAS, S.C., (2006), *Theory and Practice of Foundation Design*, pp. 315, PHI Learning Pvt. Ltd.
48. STAPELFELDT, T., (2012), *Preloading and vertical drains*, Helsinki University of Technology, Unpublished

- ([http://civil.aalto.fi/en/research/soil/theses/preloading\\_and\\_vertical\\_drains.pdf](http://civil.aalto.fi/en/research/soil/theses/preloading_and_vertical_drains.pdf): Accessed on the 5<sup>th</sup> of July 2012).
49. TALLAPRAGADA, K.R., GOLAIT, Y.S., ZADE, A.S., (2011), *Improvement of bearing capacity of soft soil using stone column with and without encasement of geosynthetics*, International Journal of Science and Advanced Technology, Vol. 1, No 7, pp. 50-59.
50. TENSAR INTERNATIONAL, (2008), *Case study: Glasshoughton coal fields link road UK*, Ref 221, Unpublished  
([http://www.tensarcorp.com/TriAx/Documents/Ref\\_221\\_Glasshoughton.pdf](http://www.tensarcorp.com/TriAx/Documents/Ref_221_Glasshoughton.pdf): Accessed on the 9<sup>th</sup> of July 2012).
51. VAN DER WESTHUIZEN, V., PARROCK, A., (2010), *Stone column construction at O.R. Tambo International Airport's Midfield Terminal Development*, SAICE, Vol 18 No 6, pp. 45-49.
52. VAN IMPE, W.F., MADHAV, M.R., VANDERCRUYSSSEN, J.P., (1997), *Considerations in stone column design*, Ground Improvement Geosystems, Thomas Telford, London  
DAVIES, M.C.R., SCHLOSSER, Eds., *Ground Improvement Geosystems: Densification and Reinforcement*, Thomas Telford Publishing on behalf of the British Geotechnical Society London.
53. VGNL, (2011), *Vibroflotation method of ground improvement*, Vibroflotation & Geotechnical (Nig.) Ltd, Unpublished  
(<http://vibroflotation-ng.com/VGNL%20Profile.pdf>: Accessed on the 13<sup>th</sup> of April 2011).
54. VIBRO MENARD, (2012), *Vibro stone columns*, Unpublished  
(<http://www.vibromenard.co.uk/wp-content/uploads/2011/08/StoneColumns.pdf>: Accessed on the 4<sup>th</sup> of July 2012).
55. VISSER, F., (2012), *Personal communication: email*, Engineering Director at Dura Soletanche Bachy, Johannesburg, South Africa.
56. WESLEY, L.D., (2010), *Fundamentals of soil mechanics for sedimentary and residual soils*, pp. 28, John Wiley and Sons, New Jersey.
57. WROTH, C.P., HUGHES, J.M.O., (1973), *A instrument for the in situ testing of soft soils*, Proc. 8<sup>th</sup> International Conf. On soil Mech. And Found. Eng., Moscow, Vol. 1, pp. 487-494.

58. ZAHMATKESH, A., CHOBBASTI, A.J., (2010)\*, *Investigation of bearing capacity and settlement of strip footing on clay reinforced with stone columns*, Australian Journal of Basic and Applied Sciences, Vol. 4, No. 8, pp. 3658-3668.
59. ZAHMATKESH, A., CHOBBASTI, A.J., (2010), *Settlement evaluation of soft clay reinforced with stone columns using the equivalent secant modulus*, Arab J Geosci, Saudi Society for Geosciences, Springer.

University of Cape Town

University of Cape Town

## *Appendices*

---

## **APPENDIX A. Soil coverage in South Africa**

A.1 Soil coverage in South Africa

A.2 Classification of the South African soils based on A.1

A.3 Constituency of the different soil types

## **APPENDIX B. Classification tests**

Records and outcomes of all the characterisation tests performed are summarised and presented in Appendix B:

### **B.1 Determination of particle size distribution**

*B.1.1 Sieve analysis – Klipheuwel sand*

*B.1.2 Sieve analysis – Cape Flats sand*

*B.1.3 Sieve analysis – Crushed aggregate*

### **B.2 Determination of OMC and maximum dry density (Proctor method)**

*B.2.1 Compaction test – Klipheuwel sand*

*B.2.2 Compaction test – Cape Flats sand*

*B.2.3 Compaction test – Kaolin*

*B.2.4 Compaction test – Cape Town clay*

### **B.3 Determination of the liquid limit and plastic limit (Casagrande apparatus for Liquid limit)**

*B.3.1 Atterberg limits – Kaolin*

*B.3.2 Atterberg limits – Cape Town clay*

#### **B.4 Determination of the specific gravity (small pycnometer method)**

*B.4.1 Specific gravity – Klipheuwel sand*

*B.4.2 Specific gravity – Cape Flats sand*

*B.4.3 Specific gravity – Kaolin*

*B.4.4 Specific gravity – Cape Town clay*

#### **B.5 Determination of the limiting densities of dry sand**

*B.5.1 Minimum and maximum densities of Klipheuwel sand*

*B.5.2 Minimum and maximum densities of Cape Flats sand*

#### **B.6 Determination of the shear strength parameters (Direct shear method)**

*B.6.1 Direct shear results for dry Klipheuwel sand*

*B.6.2 Direct shear results for dry Cape Flats sand*

*B.6.3 Direct shear results for Kaolin at OMC*

*B.6.4 Direct shear results for Cape Town clay at OMC, LL and 1.2LL*

## **APPENDIX A. Soil coverage in South Africa**

University of Cape Town

### A.1 Soil coverage in South Africa (AGIS, 2011)

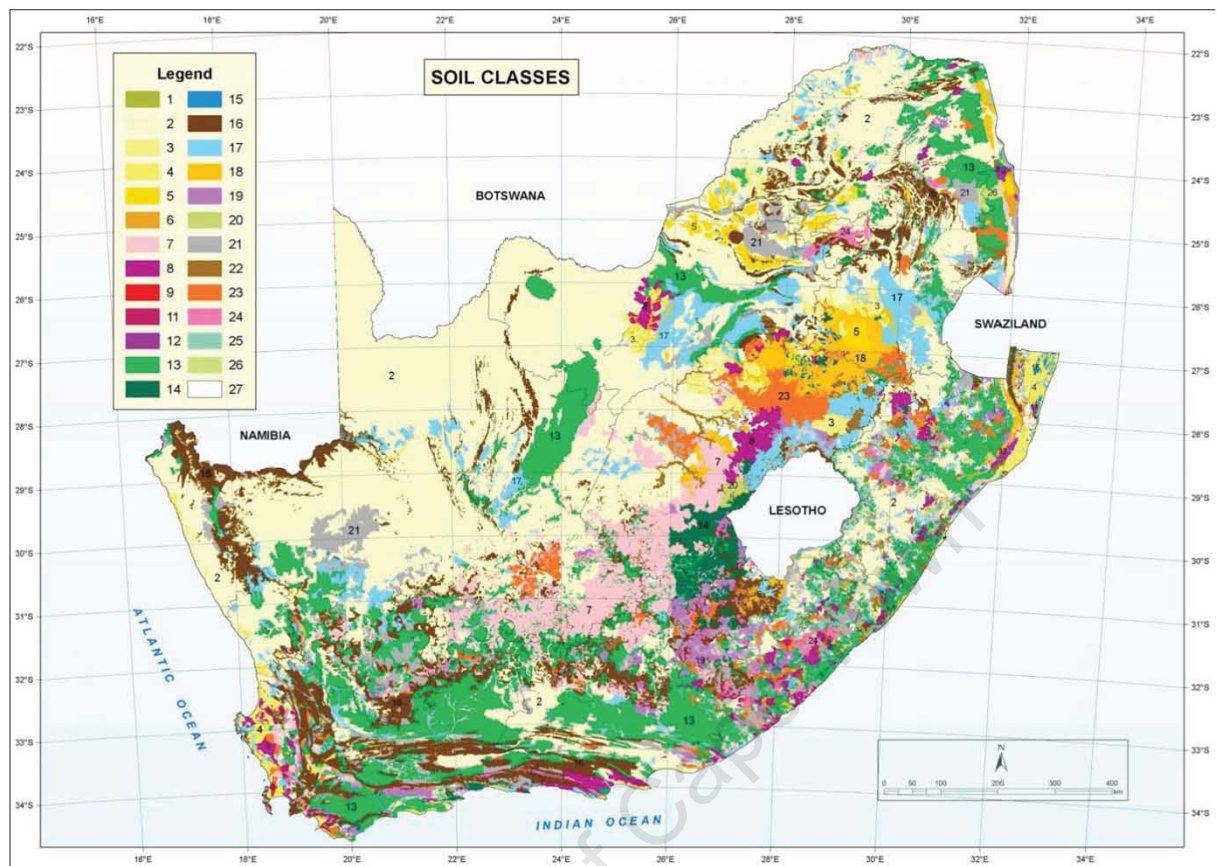

## A.2 Classification of the South African soils based on A.1 (AGIS, 2011)

	Soil class	Favourable properties	Limitations
1	Soils with humic topsoil horizons	Low erodibility; favourable physical properties; high organic matter	Low base status
2	Freely drained, structureless soils	Favourable physical properties	May have restricted soil depth, excessive drainage, high erodibility, low natural fertility
3	Red or yellow structureless soils with a plinthic horizon	Favourable water-holding properties	Imperfect drainage unfavourable in high rainfall areas
4	Imperfectly drained sandy soils	Favourable water-holding properties	May be highly erodible
5	Swelling clay soils	High natural fertility	High swell-shrink potential; very plastic and sticky
6	Dark clay soils which are not strongly swelling	High natural fertility	Somewhat plastic and sticky
7	Soils with a pedocutanic horizon	Somewhat high natural fertility	Restricted effective depth; may have slow water infiltration
8	Imperfectly drained soils, often shallow and often with a plinthic horizon	Relative wetness favourable in dry areas	May be seasonally wet
9	Podzols	May have favourable water-holding properties	May have restricted effective depth; low natural fertility
10	Poorly drained dark clay soils which are not strongly swelling	High natural fertility	Seasonal wetness; plastic and sticky
11	Poorly drained swelling clay soils	High natural fertility	Wetness; very plastic and sticky
12	Dark clay soils, often shallow, on hard or weathering rock	High natural fertility	Restricted soil depth
13	Lithosols (shallow soils on hard or weathering rock)	May receive water runoff from associated rock	Restricted soil depth; associated with rockiness
14	Texture contrast soils often poorly drained	Relative wetness favourable in dry areas	Seasonal wetness; highly erodible
15	Wetland soils	Sustain wetland vegetation	Excessive wetness
16	Non soil land classes	May be water-intake areas	Restricted land use options
17	Association of Classes 1 to 4: Undifferentiated structureless soils	Favourable physical properties	One or more of: low base status, restricted soil depth, excessive or imperfect drainage, high erodibility
18	Association of Classes 5, 6, 10, 11, 12: Undifferentiated clays	High natural fertility	One or more of: high swell-shrink potential, plastic and sticky, restricted effective depth, wetness
19	Association of Classes 7 and 14: Undifferentiated texture contrast soils	Somewhat high natural fertility or relative wetness favourable in dry areas	One or more of: restricted effective depth; slow water infiltration; seasonal wetness; high erodibility
20	Association of Classes 8 and 15: Undifferentiated poorly drained soils	Wetness favourable in dry areas; may sustain wetland vegetation	Seasonal or excessive wetness
21	Association of Classes 13 and 16: Undifferentiated shallow soils and land classes	Soil may receive water runoff from associated rock; water-intake areas	Restricted land use options
22	Association of Classes 17 and 18: Structureless soils and clays	May have favourable physical properties or high natural fertility	Restricted depth, imperfect drainage, wetness, high swell-shrink potential, plastic, sticky.
23	Association of Classes 17 and 19: Structureless and textural contrast soils	May have favourable physical properties, somewhat high natural fertility; relative wetness favourable in dry areas	Restricted depth, imperfect drainage, high erodibility; slow water infiltration; seasonal wetness
24	Association of Classes 17 and 20: Structureless and poorly drained soils	May have favourable physical properties; relative wetness favourable in dry areas; may sustain wetland vegetation	Low base status, restricted depth, imperfect to poor drainage, excessive wetness, high erodibility
25	Association of Classes 17 and 9: Structureless soils and podzols	May have favourable physical properties	Low base status, restricted depth, imperfect drainage, high erodibility
26	Association of Classes 17 and 21: Structureless soils, shallow soils and land classes	May have favourable physical properties; soil components may receive water runoff from associated rock; water-intake areas	Low base status, restricted soil depth, excessive or imperfect drainage, high erodibility, restricted land use options
27	No dominance		

## A.3 Constituency of the different soil types (AGIS, 2011)

	Percentage of province occupied by various soil classes																
	1	2	3	4	5	6	7	8	9	10 <sup>#</sup>	11	12	13	14	15	16	17-26
EC	0.3	17.8		0.5		0.3	6.0	4.7				0.2	26.0	2.5	0.1	0.0	40.9
FS		21.0	6.4		0.8	0.0	16.3	4.7			0.1		1.8	8.0			38.6
G		41.9	4.6		1.2			0.5			0.7		5.4	0.5			45.2
KZN	0.8	29.4	0.5	5.8		0.1	1.9	3.6			0.1	1.0	23.3	0.2	1.0	0.2	30.7
L		55.5	0.8		3.2		1.1	0.8				0.2	14.0				24.4
M		31.7	5.4		4.4	1.0	1.4	0.0			0.2	0.4	9.0	0.3			45.8
NW		62.0	2.1		3.4		0.4	2.1					11.8				18.1
NC		59.4		0.5	0.0		7.7	0.0					10.8		0.0	0.0	21.5
WC		17.6	0.0	4.9			2.4	2.1	0.2				30.8	1.0		0.1	40.5
RSA	0.1	37.4	2.2	1.3	1.5	0.2	4.1	2.1	0.0	0.0	0.1	0.2	14.8	1.4	0.1	0.0	34.0

<sup>#</sup> Class 10 is nowhere dominant but occurs in association with others

## **APPENDIX B. Classification tests**

University of Cape Town

## B.1 Determination of particle size distribution

### B.1.1 Sieve analysis – Klipheuwel sand

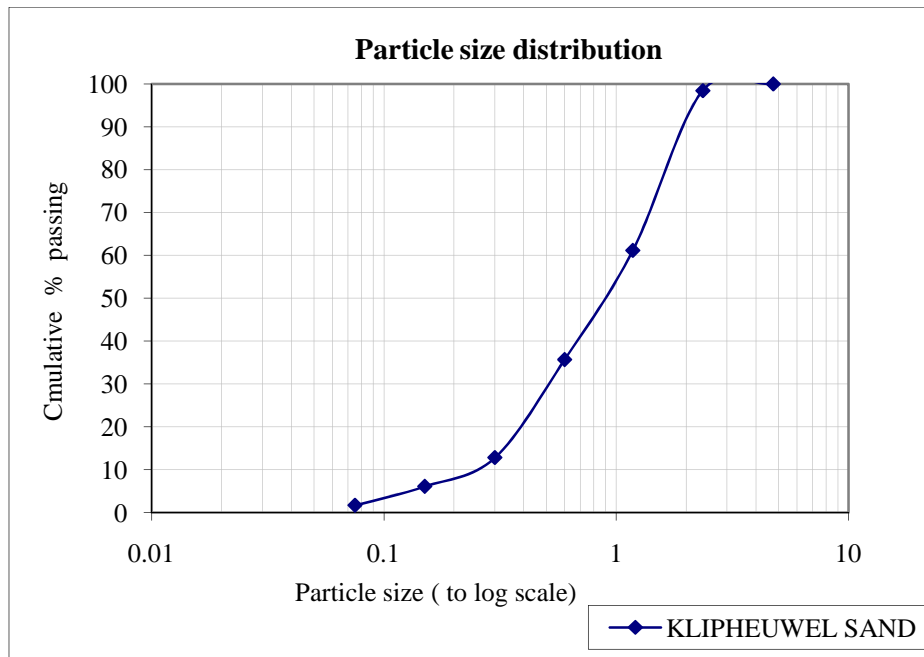

### B.1.2 Sieve analysis – Cape Flats sand

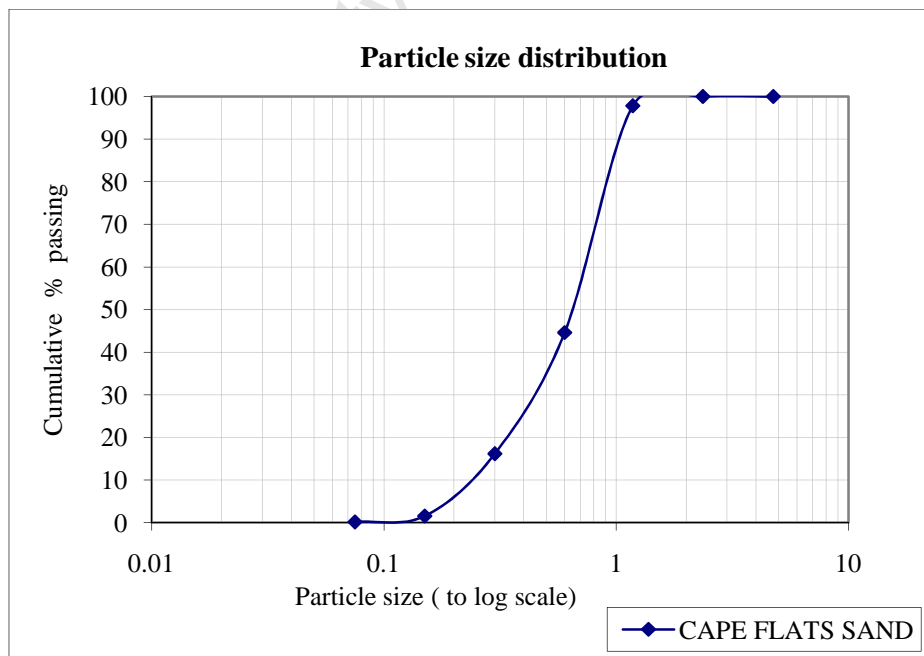

## B.2 Determination of OMC and maximum dry density (Proctor method)

### B.2.1 Compaction test – Klipheuwel sand

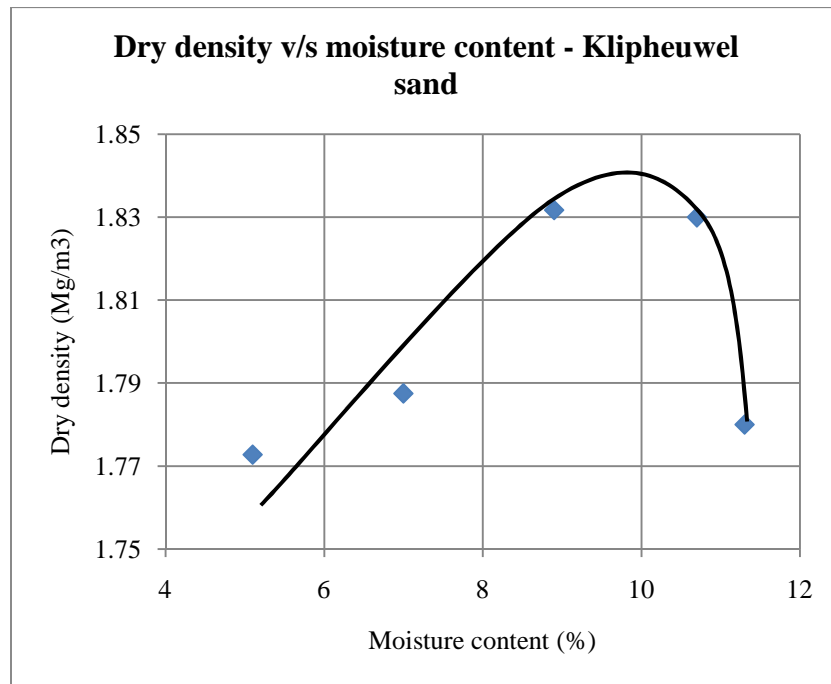

### B.2.2 Compaction test – Cape Flats sand

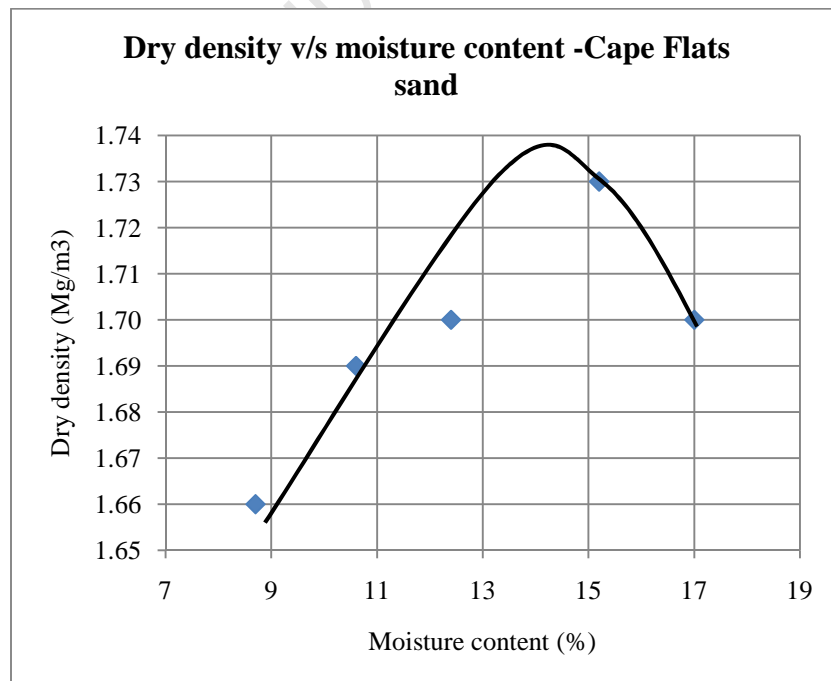

*B.2.3 Compaction test – Kaolin*

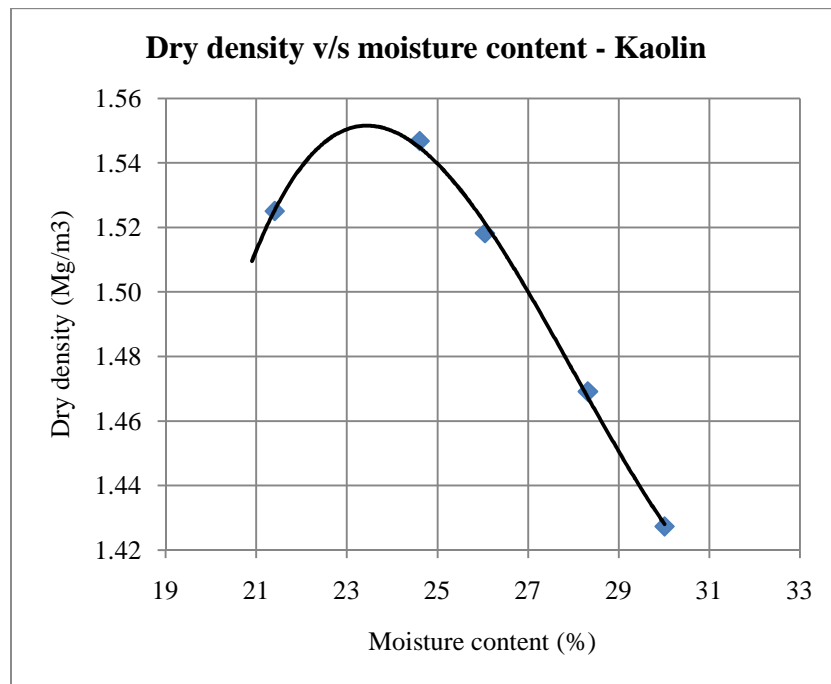

*B.2.4 Compaction test – Cape Town clay*

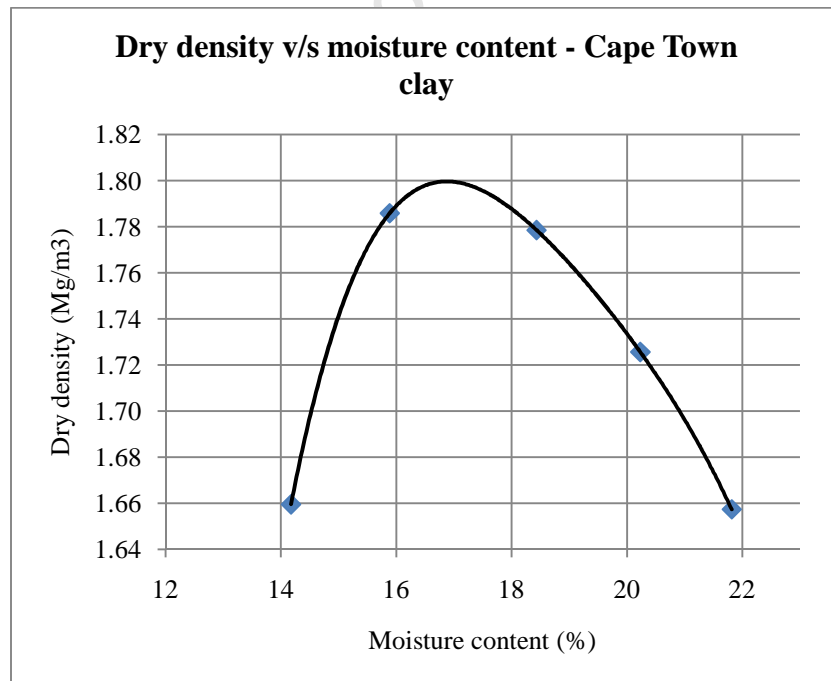

**B.3 Determination of the liquid limit and plastic limit (Casagrande apparatus for Liquid limit)**

*B.3.1 Atterberg limits – Kaolin*

<b>Plastic Limit of Kaolin (28.2%)</b>			
<b>Sample No</b>	<b>1</b>	<b>2</b>	<b>3</b>
<b>Mass of tin (g)</b>	8.092	9.632	8.096
<b>Mass of tin + wet soil (g)</b>	10.277	11.206	9.794
<b>Mass of tin + dry soil (g)</b>	9.816	10.847	9.42
<b>Mass of water (g)</b>	0.461	0.359	0.374
<b>Mass of dry soil (g)</b>	1.724	1.215	1.324
<b>Moisture content (%)</b>	26.7	29.5	28.2
<b>Average moisture content (%)</b>		28.2	

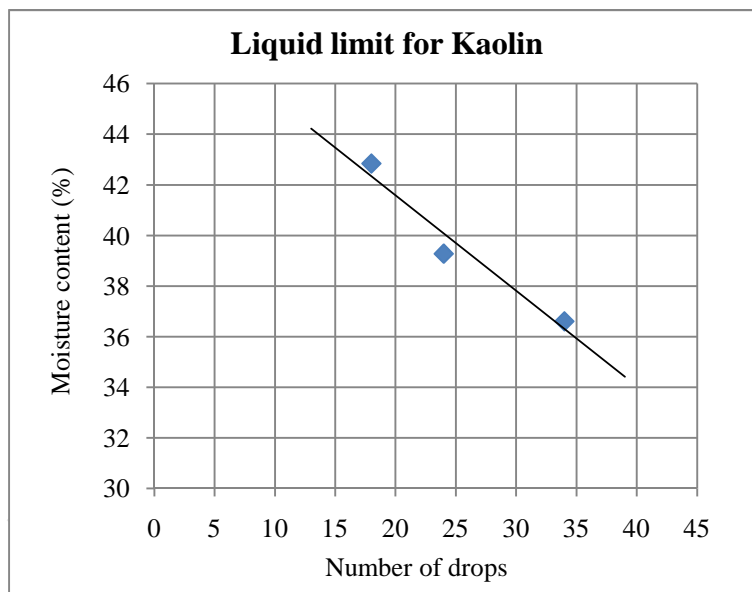

B.3.2 Atterberg limits – Cape Town clay

<b>Plastic Limit of Cape Town clay (21.8%)</b>			
<b>Sample No</b>	<b>1</b>	<b>2</b>	<b>3</b>
<b>Mass of tin (g)</b>	9.705	8.074	9.674
<b>Mass of tin + wet soil (g)</b>	12.296	11.003	11.972
<b>Mass of tin + dry soil (g)</b>	11.836	10.466	11.566
<b>Mass of water (g)</b>	0.46	0.537	0.406
<b>Mass of dry soil (g)</b>	2.131	2.392	1.892
<b>Moisture content (%)</b>	21.6	22.4	21.5
<b>Average moisture content (%)</b>		21.8	

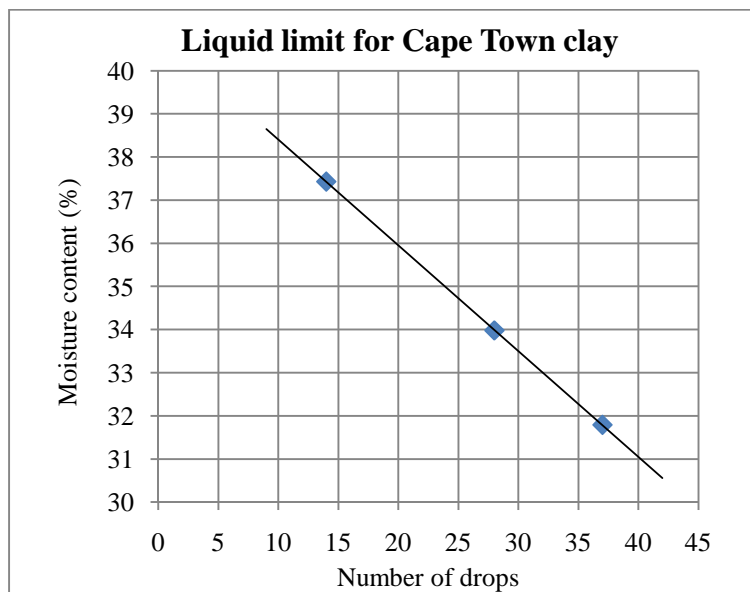

## B.4 Determination of the specific gravity (small pycnometer method)

### B.4.1 Specific gravity – Klipheuwel sand

Klipheuwel sand				
Pyknometer no		1	2	3
Mass of bottle + soil + water (g)	m3	86.795	90.048	91.882
Mass of bottle + soil (g)	m2	39.382	43.336	42.776
Mass of bottle full of water (g)	m4	83.332	84.872	88.215
Mass of bottle (g)	m1	33.868	35.046	36.926
Mass of soil (g)	m2 - m1	5.514	8.29	5.85
Mass of water in full bottle (g)	m4 - m1	49.464	49.826	51.289
Mass of water used (g)	m3 - m2	47.413	46.712	49.106
Volume of soil particles	(m4 - m1) - (m3 - m2)	2.051	3.114	2.183
Particle density (Mg/m <sup>3</sup> )	$(m2-m1)/\{(m4 -m1) - (m3 -m2)\}$	2.69	2.66	2.68
Average Value (Mg/m <sup>3</sup> )		2.68		

### B.4.2 Specific gravity – Cape Flats sand

Cape Flats sand				
Pyknometer no		1	2	3
Mass of bottle + soil + water (g)	m3	88.169	94.54	93.403
Mass of bottle + soil (g)	m2	40.536	46.016	44.914
Mass of bottle full of water (g)	m4	84.376	88.627	88.344
Mass of bottle (g)	m1	34.491	36.61	36.838
Mass of soil (g)	m2 - m1	6.045	9.406	8.076
Mass of water in full bottle (g)	m4 - m1	49.885	52.017	51.506
Mass of water used (g)	m3 - m2	47.633	48.524	48.489
Volume of soil particles	(m4 - m1) - (m3 - m2)	2.252	3.493	3.017
Particle density (Mg/m <sup>3</sup> )	$(m2-m1)/\{(m4 -m1) - (m3 -m2)\}$	2.68	2.69	2.68
Average Value (Mg/m <sup>3</sup> )		2.68		

B.4.3 Specific gravity – Kaolin

Kaolin				
Pyknometer no		1	2	3
Mass of bottle + soil + water (g)	m3	86.858	91.05	87.698
Mass of bottle + soil (g)	m2	40.32	40.884	39.623
Mass of bottle full of water (g)	m4	83.82	87.406	84.676
Mass of bottle (g)	m1	35.355	34.994	34.717
Mass of soil (g)	m2 - m1	4.965	5.89	4.906
Mass of water in full bottle (g)	m4 - m1	48.465	52.412	49.959
Mass of water used (g)	m3 - m2	46.538	50.166	48.075
Volume of soil particles	(m4 - m1) - (m3 - m2)	1.927	2.246	1.884
Particle density (Mg/m <sup>3</sup> )	$(m2 - m1) / \{ (m4 - m1) - (m3 - m2) \}$	2.58	2.62	2.60
Average Value (Mg/m <sup>3</sup> )		2.60		

B.4.4 Specific gravity – Cape Town clay

Cape Town clay				
Pyknometer no		1	2	3
Mass of bottle + soil + water (g)	m3	90.704	93.522	89.619
Mass of bottle + soil (g)	m2	44.934	45.31	42.003
Mass of bottle full of water (g)	m4	84.064	87.244	84.36
Mass of bottle (g)	m1	34.416	35.355	33.804
Mass of soil (g)	m2 - m1	10.518	9.955	8.199
Mass of water in full bottle (g)	m4 - m1	49.648	51.889	50.556
Mass of water used (g)	m3 - m2	45.77	48.212	47.616
Volume of soil particles	(m4 - m1) - (m3 - m2)	3.878	3.677	2.94
Particle density (Mg/m <sup>3</sup> )	$(m2 - m1) / \{ (m4 - m1) - (m3 - m2) \}$	2.71	2.71	2.79
Average Value (Mg/m <sup>3</sup> )		2.74		

## B.5 Determination of the limiting densities of dry sand

### B.5.1 Minimum and maximum densities of Klipheuvel sand

Loosest density - Klipheuvel sand			
Sample No	1	2	3
Volume of empty mould (mm <sup>3</sup> )	949000	949000	949000
Mass of empty mould (g)	4421	4421	4421
Mass of mould and sand (g)	6016	6021	6020
Mass of sand (g)	1595	1600	1599
Density (kg/m <sup>3</sup> )	1681	1686	1685
Average loosest density (kg/m <sup>3</sup> )		1684	
Densest density - Klipheuvel sand			
Sample No	1	2	3
Volume of empty mould (mm <sup>3</sup> )	949000	949000	949000
Mass of empty mould (g)	4421	4421	4421
Mass of mould and sand (g)	6064	6069	6070
Mass of sand (g)	1643	1648	1649
Density (kg/m <sup>3</sup> )	1731	1737	1738
Average densest density (kg/m <sup>3</sup> )		1735	

### B.5.2 Minimum and maximum densities of Cape Flats sand

Loosest density - Cape Flats sand			
Sample No	1	2	3
Volume of empty mould (mm <sup>3</sup> )	949000	949000	949000
Mass of empty mould (g)	4421	4421	4421
Mass of mould and sand (g)	5918	5916	5922
Mass of sand (g)	1497	1495	1501
Density (kg/m <sup>3</sup> )	1577	1575	1582
Average loosest density (kg/m <sup>3</sup> )		1578	
Densest density - Cape Flats sand			
Sample No	1	2	3
Volume of empty mould (mm <sup>3</sup> )	949000	949000	949000
Mass of empty mould (g)	4421	4421	4421
Mass of mould and sand (g)	6105	6084	6092
Mass of sand (g)	1684	1663	1671
Density (kg/m <sup>3</sup> )	1774	1752	1761
Average densest density (kg/m <sup>3</sup> )		1762	

## B.6 Determination of the shear strength parameters (Direct shear method)

### B.6.1 Direct shear results for dry Klipheuwel sand

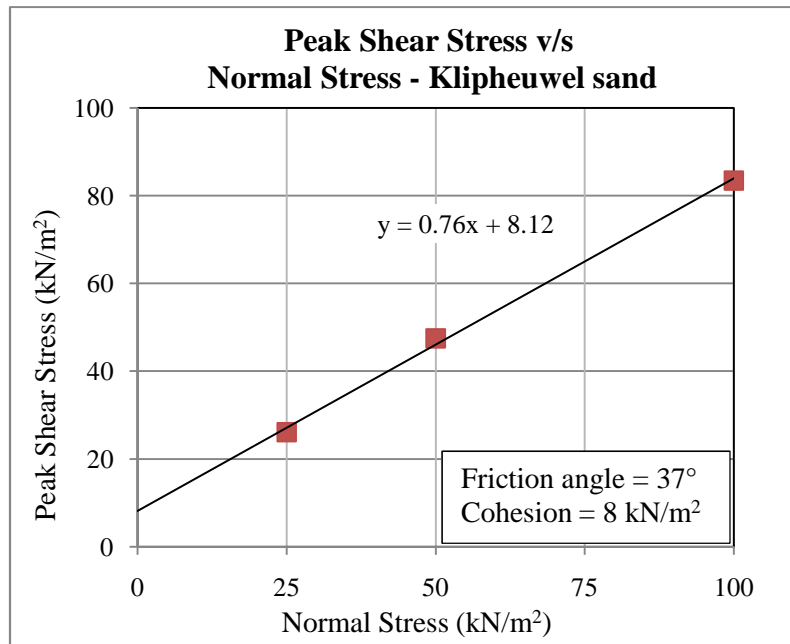

### B.6.2 Direct shear results for dry Cape Flats sand

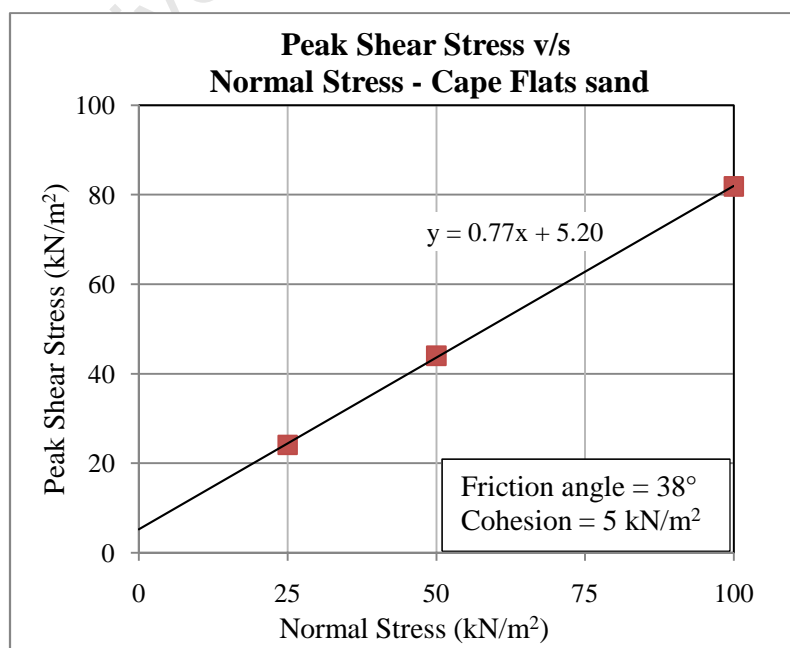

B.6.3 Direct shear results for Kaolin at OMC

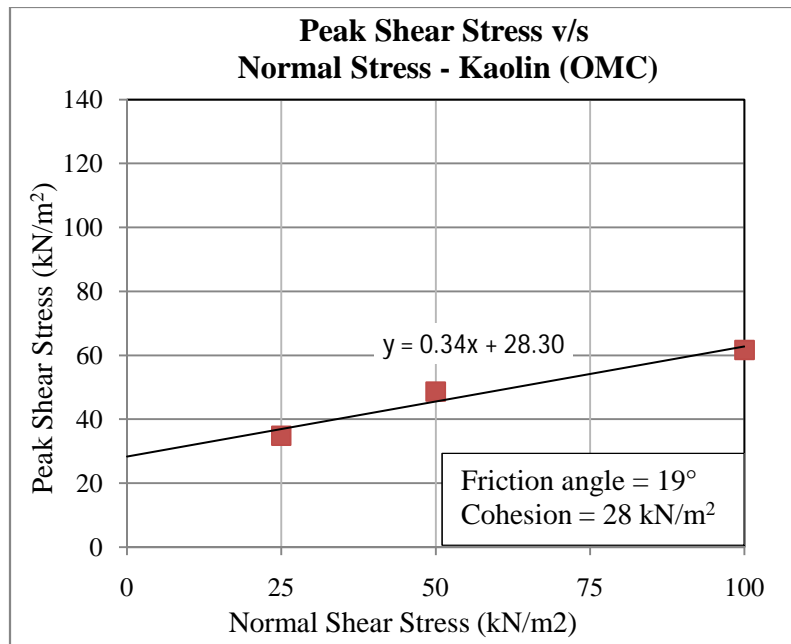

B.6.4 Direct shear results for Cape Town clay at OMC, LL and 1.2LL

- Cape Town clay at OMC

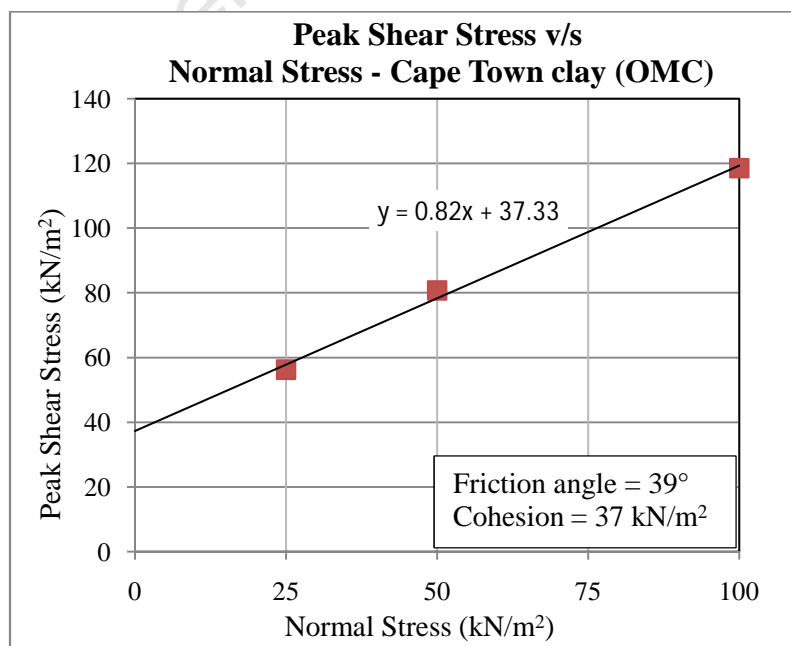

- Cape Town clay at LL

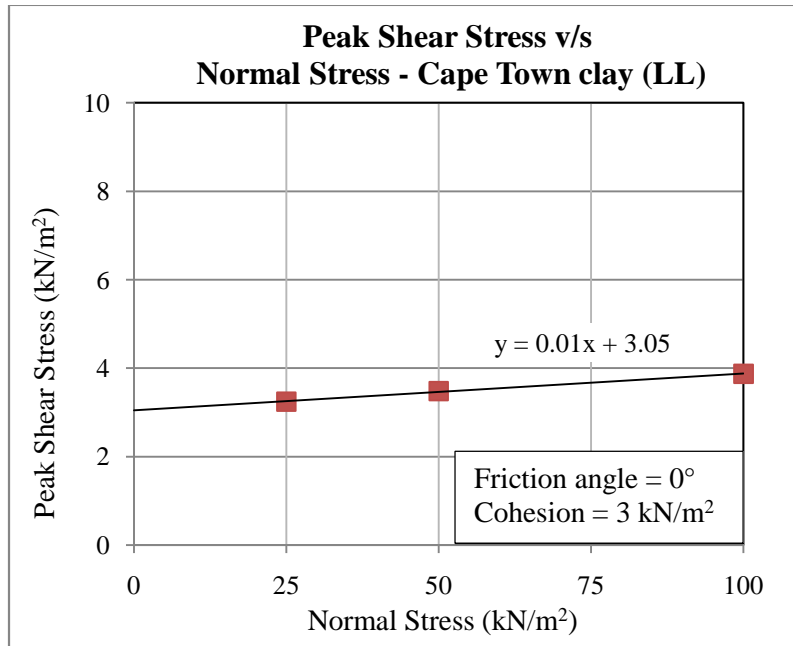

- Cape Town clay (1.2LL)
- 

