

The Place Beyond the Bent Pines

Designing through Exploration, Making and Discovery: an alternative design methodology through an exploration in Timber for an imagining of its use.

by Charlotte de Klerk



The copyright of this thesis vests in the author. No quotation from it or information derived from it is to be published without full acknowledgement of the source. The thesis is to be used for private study or non-commercial research purposes only.

Published by the University of Cape Town (UCT) in terms of the non-exclusive license granted to UCT by the author.

University of Cape Town

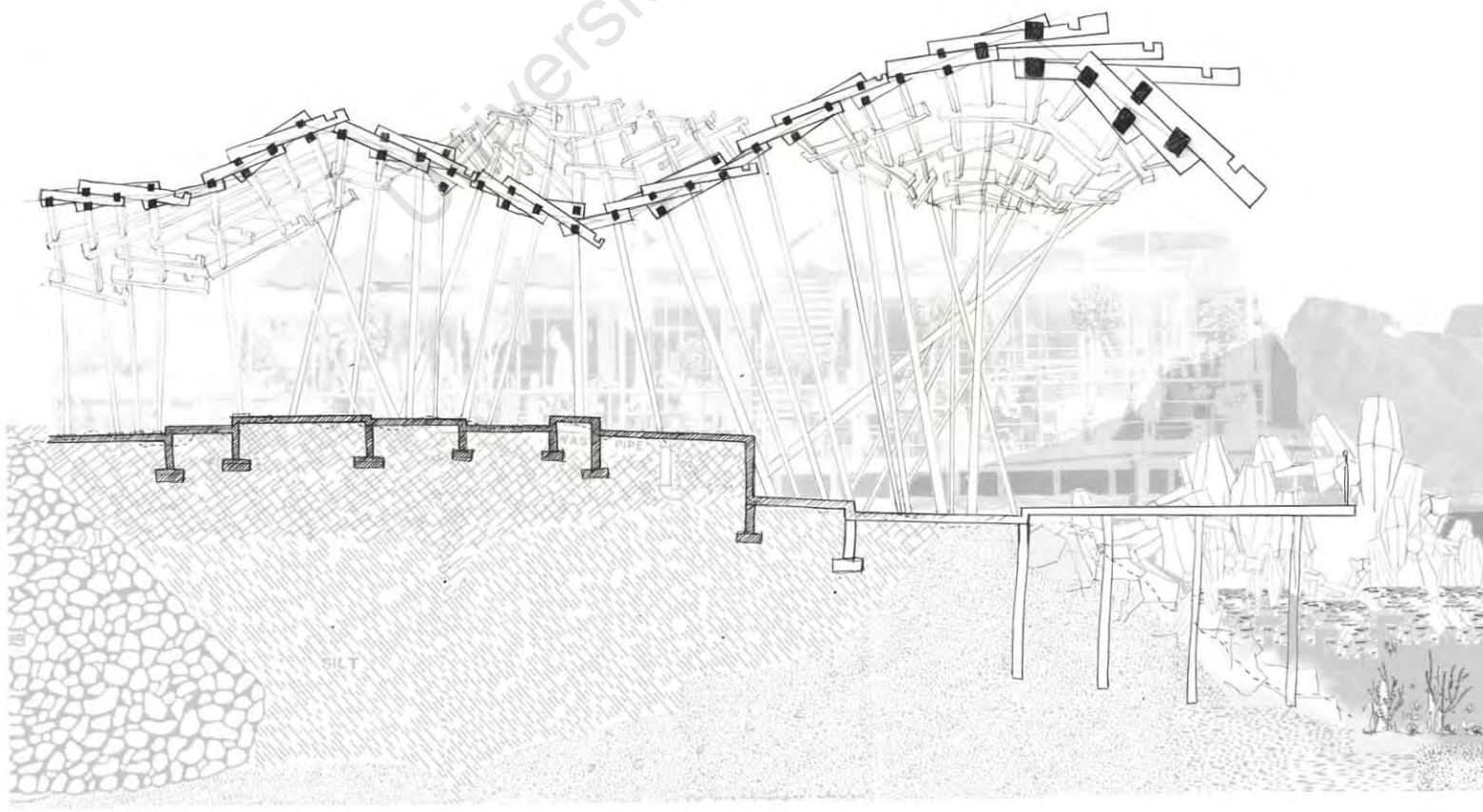

The Place Beyond the Bent Pines

Designing through Exploration, Making and Discovery: an alternative design methodology through an exploration in Timber for an imagining of its use.

Dissertation Design Report
2013

Supervisor's:
Professor Jo Noero (First Semester)
Associate Professor Nic Coetzer
Rob de Jager
Francis Carter (Second Semester)

by Charlotte de Klerk

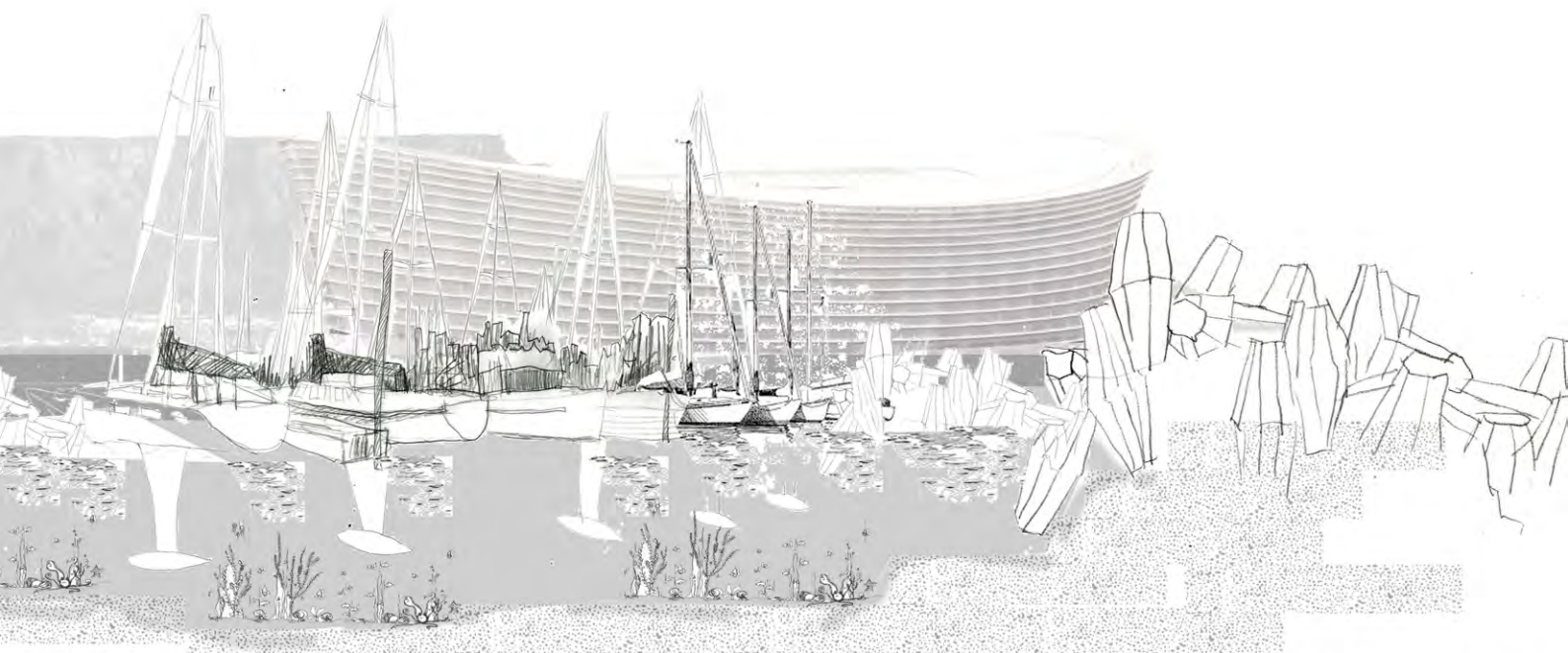

The Place Beyond the Bent Pines

by Charlotte de Klerk

SUPERVISOR'S:

Professor Jo Noero (First Semester)
Associate Professor Nic Coetzer
Rob de Jager
Francis Carter (Second Semester)

This dissertation is presented as part fulfillment of the degree of Master of Architecture (Professional) in the School of Architecture, Planning and Geomatics, University of Cape Town

October 2013

"I hereby: Charlotte de Klerk

a. grant the University free license to reproduce the above dissertation in whole or in part, for the purpose of research.

b. Declare that:

(i) The above dissertation is my own unaided work, both in conception and execution, and that apart from the normal guidance of my supervisors, I have received no assistance apart from that stated below.

(ii) Except as stated below, neither the substance or any part of the dissertation has been submitted for a degree in the University or any other university.

(iii) I am now presenting the dissertation for examination for the degree of Master of Architecture (Professional)"

PLAGIARISM DECLARATION:

1. I know that plagiarism is wrong. Plagiarism is to use another's work and pretend that it is one's own.

2. I have used the Harvard convention for citation and referencing. Each contribution to, and quotation in, this report from the work(s) of other people has been attributed, and has been cited and referenced.

3. This report is my own work.

4. I have not allowed, and will not allow, anyone to copy my work with the intention of passing it off as his or her own work.

Signature _____

University of Cape Town

Abstract

This dissertation demonstrates an experiment in an alternative design methodology, beginning with structural and material exploration rather than conventional design processes where detailing plays less of a role in the design process. The dissertation project is driven by informants discovered through technical research in timber construction through tactile experimentation and the 'act of making'.

Timber remains the material of choice for the length of the dissertation. Timber's particular inherent properties, capabilities and hindrances therefore form the parameters for creative design potential. The dissertation thus aims to demonstrate the importance of understanding materials and tests whether an alternative design process can lead to a more tectonically expressive form.

The dissertation focuses on the use of standardised building components to demonstrate the way in which a timber compilation of standard components can be used to create an extremely varied building form. Additionally, it emphasises the use of localised technologies in order to show that craft still has a place within the context of contemporary South Africa where high unemployment rates and unskilled labour is experienced.

The dissertation further demonstrates the way in which a designed structural timber system, designed purely through informants learnt through the 'act of making', can be applied in a contextualised setting with an appropriate site and programme in accordance with the structure's spatial potential.

The final design aims to form perceptual structure through its tectonic expression in perceiving it as meaningful. Ultimately, the project strives towards depicting an architectural tectonic story where the building is contextualised, Hout Bay, South Africa, and seeks to express a narrative in which one can construe one's own tale as to the mystery of its making.

University of Cape Town

University of Cape Town

Contents

PREFACE: The Catalyst to the Wood Story Sequel: AfrikaBurn Art Installation 2013

INTRODUCTION

PART ONE

Developing an Architectural Proposition

- Early Thinking
- Theoretical Research
- Design Dissertation Proposal
- Hypothesis
- Process/Methodology

PART TWO

Designing through Exploration, Making and Discovery

- Technical Research: Living Wood and Forms in Timber
- Outlining Material Limitations
- Exploration of Structural Concepts
- Structure Explorations & Design Studies

PART THREE

Sketch Design Development

- Adopting a Programme
- Choosing a Site
- Analysis of Site and Surrounds
- Design Development Relating to Site, Programme & Context

CONCLUSION

REFERENCES

BIBLIOGRAPHY

IMAGE REFERENCES (all images by author unless listed in image references)

APPENDIX 1: Study of Tree Species & Timber properties

APPENDIX 2: Study of Timber Products

APPENDIX 3: Evolution of the timber joint

APPENDIX 4: Technical Analysis of Contemporary Timber Structures



Preface: The Catalyst to the Wood Story Sequel:

AfrikaBurn Art Installation 2013

Die oorlog het toe langer as twee weke geduur. Heelwat langer. Sarie“was moedeloos. Haar man was in die veld iewers besig om teen die rooinekke te baklei en sy het weke laas tyding van hom gekry; en boonop, was haar enigste oorlewende kind se sewende verjaarsdag om die draai. Toe maak sy 'n plan: sy sal vir haar kind 'n speelding maak. Nie net enige ou ding nie, maar een van daai “rocking horses” wat sy in die Engelse“... koerant gesien het. Ja...

Installation Description by Group

AfrikaBurn is an art event. Each year it is an opportunity for one's imagination to go where they will, where the stretch of open Karoo gravel becomes a blank canvas for the wildest imaginations. A burst of beauty, colour, fantasy, dreams, fire, noise and joy. Anything is possible on the flat dusty plains of Tankwa Town...

It was the year of 2013 where a group of 11 Capetonians from a range of career backgrounds got together to build an art installation for the event, titled “Archetypes”. The theme called for symbolic stories, myths and legends that illustrate one's relationship to a larger reality, a collective consciousness and the patterns of order that guide us all while giving greater meaning to our personal experiences.

The group banded together in early January to formulate a concept for the event. It was decided that a traditional wooden rocking horse would be the form of play for the “Archetypal” theme. A rocking horse is a child's play toy, traditionally shaped like a horse and mounted on rockers, rumoured to have been around since medieval times. In each generation, however, the rocking horse toy was re-imagined in more contemporary ways. It was thus decided that for this year's AfrikaBurn the rocking horse toy would, once again, be re-imagined into a form appropriate for today.

The horse was built in a garage using standard 50 mm x 50 mm pine timber battens and 21 mm shutter board plywood. The entire horse was designed to use timber dowels and glue at the joints instead of nails or screws. This meant that nothing would be left behind once it was burnt. Enormous amounts of thought and effort went into making sure that the horse was structurally realistic. Serious consideration had to be applied to the appropriate member sizing, timber thicknesses, approximate loading, dowel sizes, how the horse would be assembled on the day, how to prevent the plywood from delaminating over 3 days of rocking, how to ensure the safety of the rockers on the day, what curvature of the rockers would be appropriate to prevent the horse from tipping and most importantly, how to make sure the horse would BURN!!!

The Rocking Horse succeeded way beyond our expectations. It rocked and rocked from the completion of its assembly, right through many nights until the start of the Burning Ceremony. The horse burnt to dust!!

This was my first experiment and exploration using timber in a real-life built scenario. A great deal of understanding of wood as a material was gained through the process and a passion for the 'act of making' was realised. Knowledge, ideas and wisdom taken from this experience became the starting sequel to the dissertation...

Members: Riaan Steenkamp, Fred Kleynhans, Johan Swannepoel, Ann-Mari da Silva, Philipe Selhorst, Chris Davies, Andrew Bowden, Dan Payne, Paul Cosgrove, Sophie Van Den Bergh, and myself.

University of Cape Town

Introduction

The design dissertation report aims to document the design process taken over the course year in a chronological framework of events. The design process is divided into three central parts:

Part 1: Deriving an Architectural Proposition

Part 2: Designing through Exploration, Making and Discovery, and

Part 3: Sketch Design Development.

Part One expresses the initial thinking, develops a design proposal, and summarises the theoretical foundation for the design project.

Part Two documents an in-depth study into Timber as a material and explores a selection of structural concepts through an experimental 'act of making'.

Part Three merges the findings of the first two parts into the design of a contextual sketch proposal.

The report concludes with a summery and consolidation statement, a reflection of the outcome of the project and, within the project's field of enquiry - a speculation of the future.

University of Cape Town

University of Cape Town

PART ONE

Developing an Architectural Proposition

University of Cape Town

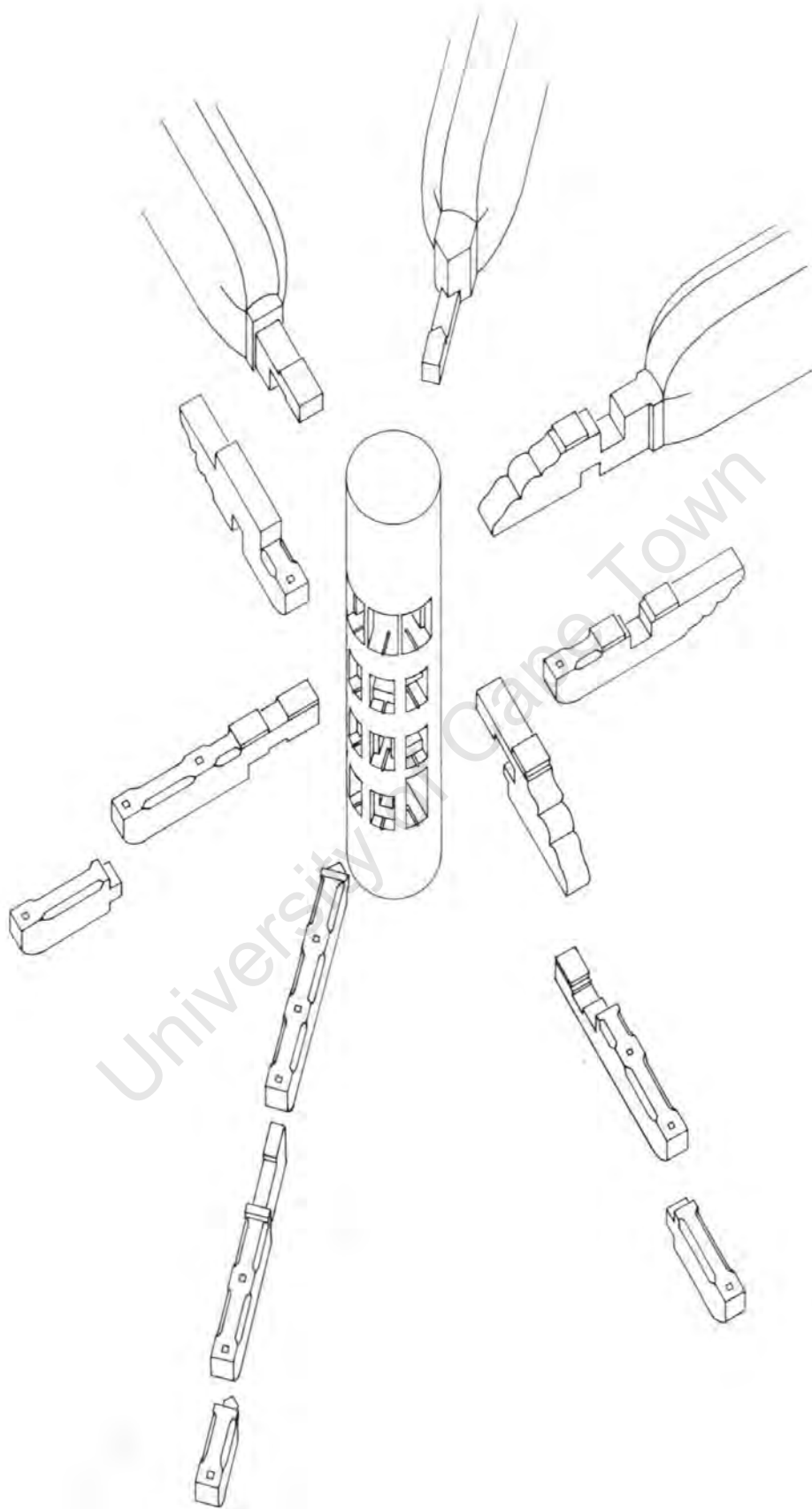

Figure 1: Assembly of Joints (Zwenger, 1997)

Early Thinking

Textures and frameworks, calmness and tension become apparent in details. Surfaces are flat or curved, toroidal or faceted, small- or large-format. The sculptured artistic forms, the body of the rider and the richly differentiated marquetry works, which take their form from their artists' imaginations and can be accepted as artefacts in their own right, juxtaposed with the objects determined to a great extent by function alone, show great exactitude and individuality. (Herzog, 2008)

Throughout my architectural journey at the University of Cape Town, a discovered passion lay in the 'act of making'. It was through this act that I found that my inventive, creative and innovative capabilities were uncovered. Due to the short term duration very little time was available for material exploration of the designed projects, the part for me, that was the most exciting. This being the case, it was decided that I would use this year to follow this interest as an opportunity to explore my creative capacity to its fullest.

A secondary entry point into the dissertation year came with an interest in the expressive and poetical nature of construction and the art of joining. Often pausing at interesting places, analysing the details of buildings and their meanings, one deciphers the details as a narrative to a larger tale:

Imagine yourself sitting on a timber deck at sunrise, looking out onto a quiet alley in the heart of Istanbul's historical city, panning one's eyes along the expressively detailed facades of a middle class neighbourhood. Buckling columns raised and tied onto stone platforms, horizontal repetitions of patterned tongue and groove boards, carved pegs and mortise-and-tenon jointed beams dotted along the surface - these are the details which begin to inform a tectonic architectural story. A materials inherent quality, types of weather exposure, forces of gravity, the history to which it has experienced, the informants as to why they were made in a particular way, the intrigue of the people that live in them and the mystery of how they were assembled - these are the gestures whereby one construes one's own meaning to a story.

On a broader scale, what was prevalent, was the way in which the architect and learner today are removed from their materials and disengaged from the building process and the exploratory 'act of making'. As the production of built form has evolved from crafted processes to the assembly and mass-use of universal standard building components in a naive and assumed manner, this has resulted in built landscapes floundering in their telling of tales of craft, history, culture and meaning.

Consequent to the above mentioned idea, the year aimed to be a process of exploration and experimentation through the 'act of making', a pursuit to learn and explore as much as there is to learn about a materials inherent qualities through tactile engagement with them and how this understanding is fundamental to the innovative making of both structurally realistic and expressive architectural space-making and storytelling built forms.

Theoretical Research:

This research intended to assist in the formation of a theoretical foundation for the initial frame-working idea's and to propel dissertation thinking and decision making. The research was structured around four central and interrelated theories: i.) the role of the maker in the shaping of tales, ii.) the role of the joint as the minimal unit of significance, iii.) the thinking and innovative hand in the 'act of making', and lastly, iv.) the consequences of industrialisation. The writings of theorists Juhani Pallasmaa, Annette LeCuyer, Marco Frascari, William Carpenter and Kenneth Frampton were large contributors to development of these ideas.

The Role of the Maker in the Shaping of Tales

Built landscapes are the practice and art of architectural languages whereby a story can be perceived and construed through its detailing and through its ability to express social and historical commentary of its time. These details can either be 'material joints' as in the connection between a column and a beam, or they can be 'formal joints' as in the case of a courtyard, which is the connection between inside and outside space (Frascari, 1996). In the rapidly growing urban landscape that we live in today, it is architecture which gains a new fundamentality as the primary context of human experience. Every place and space shapes the experience of human perception and it is therefore up to the maker to communicate something meaningful.

In the past, the process of production and making through craft in built forms was a vital and symbolic means of portraying meaning and expression. The architects who contributed to this era envisaged the making of architecture as a vital ritual in which their creations portrayed individual and cultural identities for existential experience and gained meaning for particular people in particular places. Through this, architects tried to create meaningful surroundings in which a relationship between man and man's environment was constructed. The reality of today's practice involves a far greater interest in conventional building typologies, however, their makings are both physically and metaphorically further away from the making process (LeCuyer, 2001). This is what architecture of today is lacking; the distancing of craft from modern making, therefore eliminating the essences of the hand and its ability to shape experiential tales.

The Role of the Joint as the Minimal Unit of Significance

In Marco Frascari's essay, "The Tell-the-Tale Detail", he states that the detail "expresses the process of significance; that is, the attaching of meaning to man-produced objects". He describes details as being the 'locii' where knowledge is of an order in which the mind finds its own working, that is, 'logos'.

Frascari locates the sources of architectural meaning not only in the relationship between spaces, but also the relationship between materials. In an analogy of architecture as a narrative, the details are seen as the words which compose a story. Particular words used in particular ways convey a style to the story, and similarly, details convey a particular identity to a building. With this notion, architecture becomes the art of appropriate selection of words/details in the composition of an enriched tale that deepens an empirical experience of it and adds to the mysterious story of its making. It is therefore the detail which forms perceptual structure for perceiving architecture as meaningful, as well as becoming the place where innovation, creativity and invention emerges.

The Thinking and Innovative Hand in the Act of Making

The process of 'making' by hand allows for the exploration of an idea in different ways and at various scales. Hand modelled representation is a vehicle through which a design idea is tested, developed and translated into physical form. In addition to this, the exploratory 'act of making' is a valuable tool for the generation of ideas and thus plays another fundamental role in the design process of the architect. This act of physical making can have useful impact on current practice as well as learners where the making of experimental models test ideas and explore the materiality and expressive potential of built forms.

The making process can also have a positive effect on the decision making process. Renzo Piano relates the importance of this process of making which benefits architects as well as learners:

An architect must be a craftsman. Of course, any tools will do; these days, the tools might include a computer, an experimental model, and mathematics. However, it is still craftsmanship – the work of someone who does not separate the work of the mind from the work of the hand. It involves a circular process that takes you from the idea to a drawing, from a drawing to a construction, and from a construction back to idea. (Frampton, 1995)

Having substantial knowledge of the processes involved in the production process and working in the way Piano suggests, the architect discovers the values and potentials that materials can perform that goes beyond only its surface appearance. The particular properties, capabilities and hindrances of a particular material form the parameters for individual experimentation, exploration and creativity. This process of discovery can thus have a positive effect on decision making concerning the relationship that materials have with one another and ultimately end in more tectonically expressive and meaningful form.

The Consequences of Industrialisation

It was not until the start of the industrial revolution that the idea of making changed. This age was associated with mass production and standardisation of building components for mass consumption. By the nineteenth century, mechanical making reached a point that allowed manufactured artefacts to be produced at a rapid rate, consequently causing major change to artistic consciousness in the way one perceives and experiences buildings which makes use of these building components.

In Walter Benjamin's essay, "The Work of Art in the Age of Mechanical Reproduction" (1936), Benjamin discusses a shift in perception in the way in which we perceive a work of art due to mechanical mass production, particularly with regards to photography and how it has changed the nature of art. The 'erosion of aura' and the depreciation of presence in even the most faultless mechanically reproduced artefacts are of particular interest within his essay. The fundamental element which is lost through a mechanically reproduced artefact is its 'presence in space and time', or in other words, its unique existence at the place in which it comes into being. An artefact's presence is shaped by the history of its experience from the beginning of its conception, the shape the maker moulded with his hands, changes that may have caused the object's physical condition to deteriorate, and natural environmental forces which may have changed the nature of its composition. Benjamin expresses the idea of this principle as the eliminated element, the 'aura', and goes on to say that "what withers away in the age of mechanical reproduction is the aura of the art work" (1936). The 'aura' as such, can be described as that which decays through the manufacturing process and hence, the quality of its presence and its embodied value to its users.

The theoretical research deepened the understanding of early conceptual thinking and provided body to the dissertation which focuses on an exploratory 'act of making' as a vehicle for design. With the new knowledge learnt, the dissertation was propelled into an alternative design methodology whereby an empirical 'act of making' becomes the starting point to a sequel of discovery, and the findings driving the creation of the final built form.

Design Dissertation Proposal

Every material is distinguished by characteristics peculiar to itself. Knowledge of these is a necessary prerequisite for processing the material appropriately. (Zwerger, 1997)

The enquiry began with the choice of timber as the material for investigation. Owing to timber's complex, aesthetic and warm inherent quality, the means in which it is processed, treated and joined appropriately results in its details being of a very expressive and striking nature.

Timber, once part of a tree, is very telling in the way that by just looking at it, a tale can be told of its existence: what external forces it had to face, how it overcame these forces, how it regained its balance. Gaining knowledge of these informants and appropriating it accordingly aims to illustrate the extent of the opportunities underlying a small and seemingly simple piece of wood.

Informing the explorations was an alternative architectural design methodology constituted by structural and material experimentation rather than beginning in a conventional way with a site and program. This dissertation therefore follows an empirical process of 'making' whereby imagination and material discovery of a material's inherent nature is slowly unfolded through a tactile engagement in the 'act of making'. The opportunities, potentials and limitations of a material which emerges and is learnt through this process, in turn will uncover a particular spatial quality and form of a building. At a later stage, once the resulting structure is read through spatial and programmatic potential, an appropriate site and programme will be decided on and the structure will adapt as a contextual response to spatial requirements and the surrounding landscape.

Driven by the above mentioned ideas, the proposal for the course of the year emphasises a design investigation that focuses on the 'act of making' through an exploration with small scale prototypes, 1:1 test constructions, sketches and computer aided design studies. The design process was thus concluded as an experimentation and development of an alternative architectural design thinking which reciprocates between on-site/prototype making and studio based representations (one that is explicitly counter to the conventional process of design being complete, before the construction/detailing begins). The 'act of making' therefore acts as a vehicle for research and testing of architectural ideas that will be developed further in the final built project.

Hypothesis

The design dissertation focuses on gaining a comprehensive understanding of a material's inherent nature in order to test the notion that these informants serve as the site for innovation and invention. It looks at an alternative design methodology beginning in structural experimentation and how this can override the presumptions that meaning is attached to conventional design processes. The project looks at whether craft still plays a role in the context of South Africa where we face high unemployment rates and unskilled labour. The final stage tests whether the designed structure manifested from learnt characteristics particular to a material, can start to define an appropriate programme placed on a site where it serves as 'meaningful' within its surroundings. Finally the project looks at how standardised materials for universal use can be particularised/imagined for innovative form making.

Process/Methodology

Driven by the above school of thought, a three tiered design process that emphasises investigation across scales was followed. It started with a choice of material and its learnt inherent qualities becoming the informants for the design process, secondly, the exploration and imagining of its use, and finally, the resolution of a design informed and adapted by contextual responses.

The first tier aimed to define material limitations/type of timber and to investigate its properties and applications of its use. Timber was studied according to its properties and behaviours, cultivation, treatment and manufacturing processes and also through an in depth exploration into precedents which use timber as its main structural material.

The second tier began with a study of a selection of structural concepts and timber construction techniques. How they are assembled, grid spacing, appropriate connections, member sizes, loading capacity, appropriate cladding, waterproofing, etc was of focus. Knowledge of these concepts led to the design of an innovative structural system based on one of the structural concepts studied which was then reinterpreted in an imaginative and innovative way.

The final stage in the process began with the selection of a programme appropriate to the spatial potential manifested by the structural system developed. A site was then adopted where the programme selected was suitable for the context. The structural system designed in the second tier was then contextualised/adapted according to site and context concepts to which layers of complexity were then added.

University of Cape Town

EVOLUTION OF THE TIMBER JOINT

PRIMITIVE HUT



MEMBER TO MEMBER
lashing, tying



JOINERY
interlocking carved joints



PREFABRICATED CONNECTORS
Metal fasteners, bolts, nails, screws,
adhesives



PREFABRICATED MEMBERS
slotting, CNC milled



PART TWO

Designing through Exploration, Making and Discovery

University of Cape Town

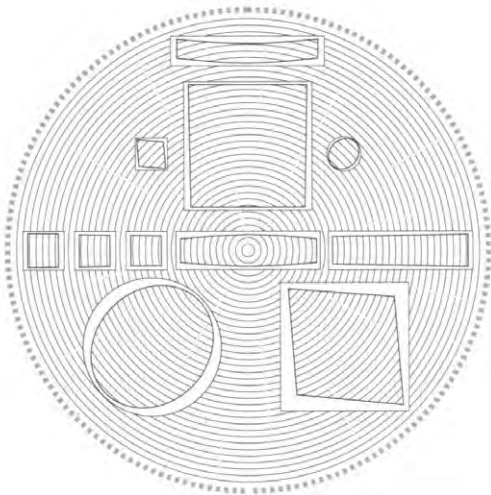
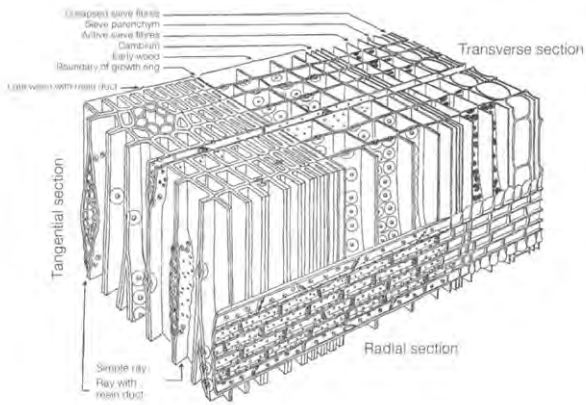
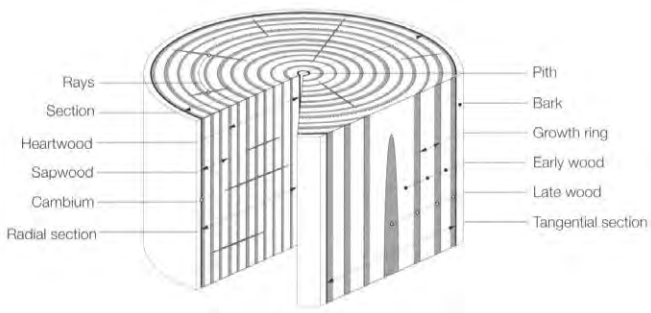

Figure 2
 TOP: Section through tree trunk
 MIDDLE: Wood and inner bark of a coniferous tree
 BOTTOM: Deformations of solid timber sections
 (Herzog, 2004)

Understanding the Tree and the Properties of its Wood

The living organism we call the tree forms the load supporting structure known as wood and has a multitude of advantageous engineering properties. Trees are characterised by the great variety of species with their different characteristics, all growing to considerably different heights and living to considerably different ages.

A cross section through the trunk consists of pith, heartwood, sapwood, cambium, inner bark and outer bark. Growth rings are a result of pronounced seasons when early wood is laid down in the first part of the annual growth period and the subsequent late wood.

The cells of a tree have elongated forms, also known as fibers. The fibers lie in the longitudinal direction within the trunk's cross-section. The older - in evolutionary terms - coniferous wood has a simple structure (such as Pine and Eucalyptus). It consists of mainly one type of cell which transports water and nutrients while providing support. In the younger - in terms of evolution - deciduous wood cells are more specialised and contain vessels. The position and direction of the cells and vessels with respect to each other, together with the growth rings, are responsible for giving the wood its grain structure which gives each species of wood its own distinctive appearance.

The structure of wood cell walls is instrumental in determining the strength and elasticity of the wood. The walls have four layers consisting of lignin for withstanding compressive forces, microfibrils for withstanding tensile forces, and cellulose molecules for tensile forces.

According to the species of wood and the growing conditions of the individual tree, wood will have characteristics in different concentrations. These features include knots, sloping grain, pith, width of growth rings, fissures, bark pockets, crookedness, discolouration, compression wood and insect damage. These features form the wide variety of grades of solid timber and play a fundamental role in deciding where and how an individual piece of timber can be used in a structure.

Timber has very good thermal insulation properties.

The living tree is made up of around 70% water. Wood is hygroscopic meaning that it absorbs and releases moisture depending on humidity. Wood's ability to absorb and release moisture can have a favourable influence on the interior climate of a building, however this also leads to swelling and shrinkage resulting in dimensional changes and splitting. Load carrying capacity of wood decreases as its moisture content increases, and visa-versa. High moisture content also lends itself to fungal and insect damage. In order to regulate the moisture content, wood is kiln dried to achieve the correct moisture content.

Technical Research: Living Wood and Forms in Timber

This part of the design process formed the technical foundation for the design project and made a study of i.) the properties and genetic make-up of wood in its natural living state, ii.) standard timber products available on the market and their behavioural properties as a building material, iii.) the way in which the joint has evolved over time and the reasons for these changes, and, iv.) a technical analysis of a selection of contemporary precedents using timber as their main structural material. A visit to a local sawmill was also insightful, allowing a full understanding of how and why timber is cultivated, milled and treated as necessary.

Before diving into structural design studies, it was important to understand the mechanical properties of the chosen material so that the material could be used appropriately and understood fully. These informants, as inherent properties of timber, hoped to inform the details on the design: joint sizing, span, member sizing, grid layout and spacing, loading capacity, cladding etc.

Understanding the Tree and Properties of its Wood

See page 24 for the information gathered on the properties and genetic make-up of wood in its natural living state. Refer to APPENDIX 1 for a glimpse into my comprehensive study of different types of tree species and the properties of their providing timber.

Timber Products

Through an in-depth study into available timber products (refer to APPENDIX 2 for the information gathered by myself), substantial knowledge was gained on the behaviour of timber as a building material, discovering at what potentials timber can perform that goes beyond only its surface appearance. This study began with timber used in its natural log form, to timber mechanically cut and dimensioned sawn products, and lastly, modern day engineered timber products. The particular properties, capabilities and hindrances of timber form the creative parameters for an individual to experiment with and explore, therefore this process of discovery had a positive effect on the decision making process concerning timber materials and their relationship to one another.

The Evolution of the Joint

The timeline of the timber joint is a lengthy one but proved an important knowledge basis for understanding the behaviour of traditional timber construction systems such as stacking and post-and-beam construction. See APPENDIX 3 for my brief study into the evolution of the joint.

Technical Analysis of Contemporary Timber Structures

APPENDIX 4 demonstrates a comprehensive study and technical analysis of a number of contemporary timber structures, put together by myself. The timber used in the structures varies from dimensioned sawn timber, engineered timber products (laminated timber, plywood), bamboo and recycled paper tubes. It was evident after the analysis that material choice was the first determining factor of the design process. A structural concept was then adopted which was most appropriate to the type of material chosen. This structural concept was then explored and reimagined/reinterpreted in an innovative and creative way.

This study brought different types of structural concepts to the forefront and gave insight into appropriate detailing options for complex timber structures; member sizing, span ratios, assembly, grid spacing, connector types, wall to ground detailing, treatment of timber, secondary reinforcing, bracing, etc. What was also interesting about these projects was that the structures almost always had a secondary layer of reinforcing structure not first recognised by the eye; almost a hidden layer for secondary support.

Outlining Material Limitations

Timber was chosen as the material for study for the length of the dissertation for the following reasons: i.) it is a renewable resource, ii.) its use contributes to the development of a sustainable future (economy, ecology and society), and iii.) with the Forest Stewardship Council certification (FSC) and social pressure to manage forests in a responsible way to maintain growth, progression towards an increase of its use in contemporary architecture today is a potential prospect.

In order to strengthen the idea of sustainability, the idea of particularising the standard, and the idea of finding innovative ways for using standardised products, it was decided to focus on standard dimensioned timber sections found in timber distributor stores as the main structural limitation for the dissertation. In this way, the project would be supporting local business and local labour in the pursuit for job creation and the strengthening of the local economy.

Standard timber products are very accessible and as an example to designers and architects of today, the designs of innovative buildings lie not only in the use of custom made parts, contrary to the new notion of 'mass customisation'.

This idea mentioned above was influenced by Jorn Utzon's work and his use of modular/standard industrially produced building components as an inspiration rather than a limitation. The architect is not only known for his craft precision and ingenuity but also for his exclusive use and variation of a single standard and modular material to create poetical and expressive forms. The Sydney Opera House's thin shell roof, for example, is made up of arched segments of varying curvature from the same range of precast modular units. Utzon's idea for the shell roof was, in turn, influenced by the twelfth-century Chinese building manual Yingzao fashi. Utzon found this document exemplary, largely because it demonstrated how a timber syntax compiled out of interlocking standard components could be used to create an extremely varied range of building forms.

Pine (*Pinus Radiata* and *Pinus Pinaster*) and gum (*Eucalyptus Grandis* and *Eucalyptas Saligna*) form the majority of commercially milled timber sources in the Western Cape. These tree species were imported for commercial plantations to be cultivated on the eastern slopes of Table Mountain because of the over exploitation of indigenous forests when settlers first arrived in Cape Town. These trees also had the advantage of being fast growing, tall, uniform and straight with a felling age of 28-30 years (very short compared to most other timber species).

Standard dimensioned pine lumber is the cheapest form of timber available on the market compared to hardwoods, engineered timber products, and laminated pine beams. It was therefore decided to only use standard dimensioned pine and exclude the latter for the design study, thus adding an exciting challenge for resolving an innovative and structurally sound form using comparably weaker timber. Engineered wood products such as pine plywood and marine ply are also very costly (marine ply being imported) and using glue which contains volatile organic compounds (VOC), making them environmentally unfriendly.

Fundamental Characteristics of Pine:

- Timber is low in density making it soft .
- Straight grain. Knots are common.
- Coniferous evergreen tree growing between 15 and 30m.
- Softwood.
- Moisture varies causing twisting and warping.
- Good bending timber. 25mm material bends well to a radius of 100mm.
- Loss of strength due to mechanical debarking.

Considerations when Building with Dimensioned Pine:

- Moisture treatment is vital to prevent rotting and fungus attack, especially in the Western Cape where moisture content in the air fluctuates substantially throughout the year.
- 50% of the log goes to waste.
- Maximum width is 228mm; length 6.6m.
- Has to be kiln dried.
- Fast burning, fire hazard.
- Can be used in externally exposed environments if treated correctly.
- Easy to work with standard tools.
- Easy sawing and boring.
- Not known to be suitable for steam bending because of regular knots.
- Graded therefore strength is even.
- Knots weaken strength capacity.
- High maintenance retreated every few years.
- Warping & twisting.
- Splitting when nailed/screwed.
- Rots easily – must be CCA treated.
- VOC free
- Medium to high strength capacity – strong along grain, weak along cross section.
- R3000 per cubic meter
- High tolerances needed.
- Expansion and contraction with moisture.

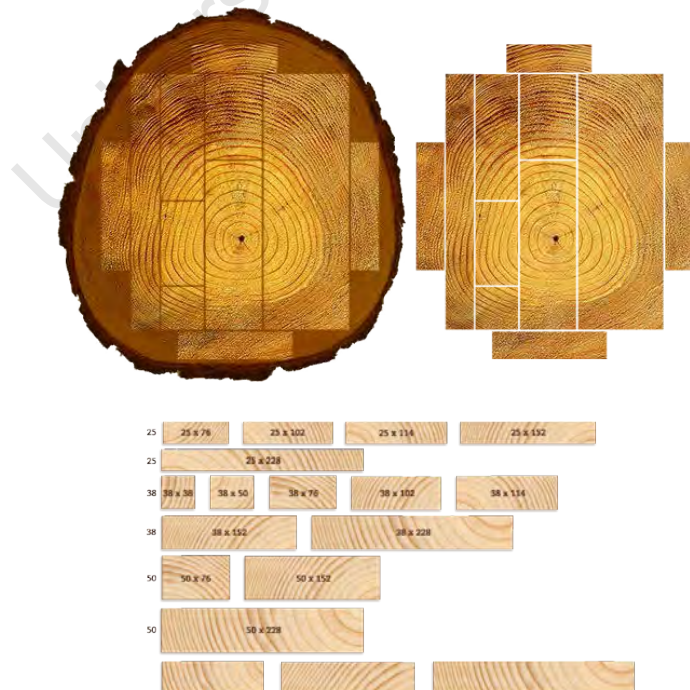
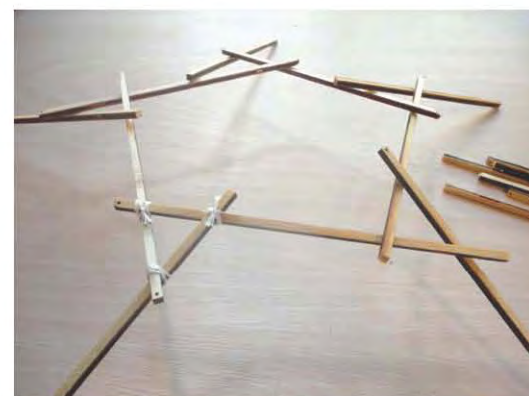

Figure 3
Standard pine dimensions
(Cape Pine 2013)



MODEL STUDY:
Reciprocal frame structure illustrating how the assembly is ordered, beams mutually supporting one another.



Exploration of Structural Concepts

The following pages explore three types of structural concepts in terms of using dimensioned pine sections as the material of choice. These include: Reciprocal and Gridshell structures and a brief look at Geodesic Domes.

The Reciprocal

The reciprocal frame structure has been used since the 12th century mainly in Chinese and Japanese architecture. It is named 'reciprocal' because of the way the beams mutually support one another.

The reciprocal frame consists of a self-supported three-dimensional grillage structure made up of three or more sloping beams, forming a closed circuit. The structural system is predominantly used in roofs and is assembled by first installing a temporary central support that holds the first beam at the correct height. Further beams are then added, each resting on the adjacent one. On the outer end, the beams are supported by a wall, ring beam, or column.

Reciprocal frame structures result in a restricted circular, elliptical and polygonal support grid but can also cover any type of plan forms. Timber members are usually identical, which provides the advantage of being able to use a modular grid system. The structure can span long or short, depending on the type of material used. The structure provides a relatively free open space as no internal supports are needed.

Many variations can be made from the same structural system by varying the geometrical parameters of the reciprocal structure. These could involve varying the length and number of beams, or varying the radii of the inner and outer polygons and member angles. One could also develop a range of reciprocal frame units and merge them together for different spatial qualities and expressions.

The following few pages explore the reciprocal frame using standard pine timber sections through the medium of models, 2D CAD drawings, sketches and form imagining. Due to standard pine sections being uniform in strength (due to prior grading), this would help enforce a uniformly supported reciprocal frame and reduce the possibility of failure in weaker beams, and thus the structural whole.

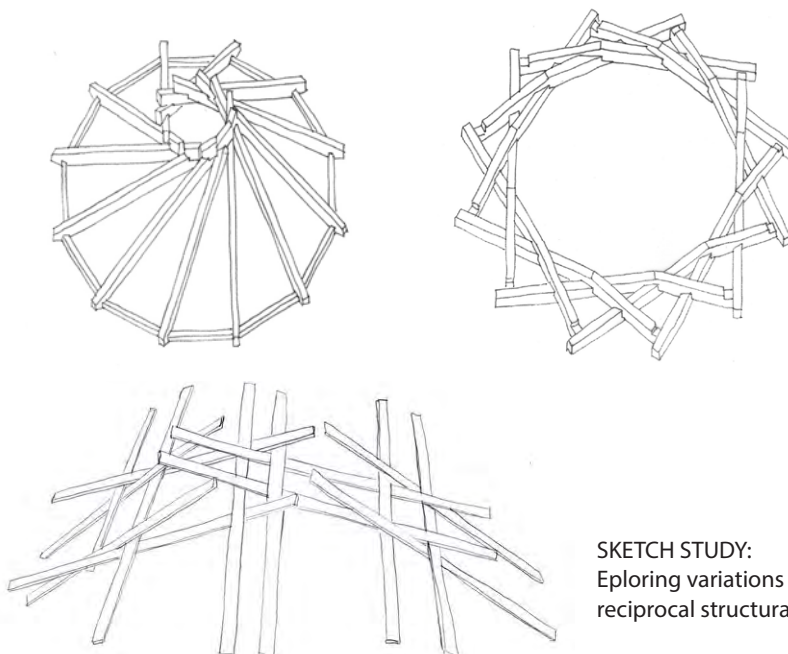

SKETCH STUDY:
Exploring variations using the same reciprocal structural system.

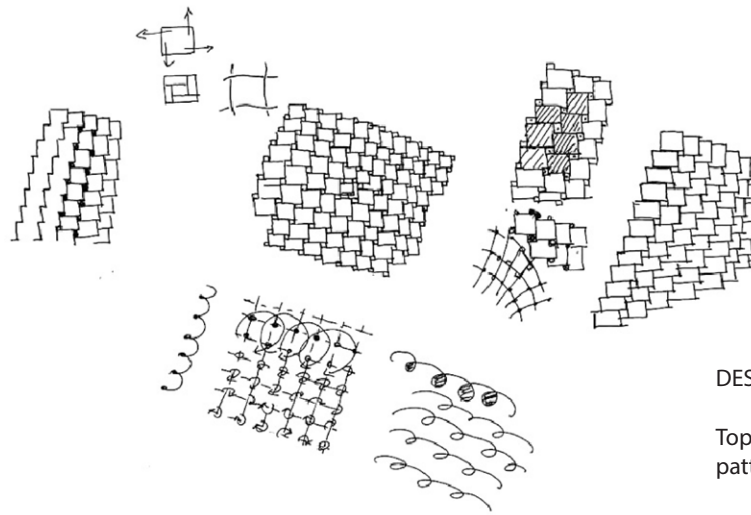

DESIGN STUDY:

Top: Sketch exploration of gridshell pattern in different variations.

Bottom: Digital model, pushing and pulling grid, creating playful design opportunities.

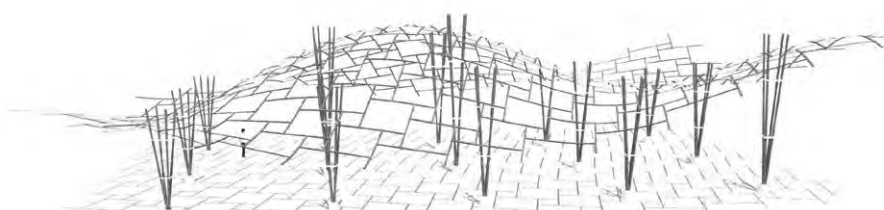
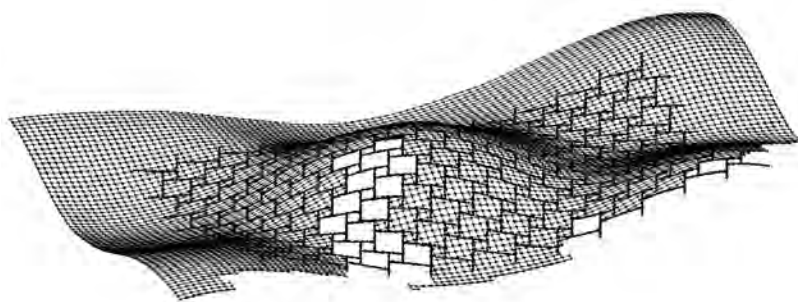
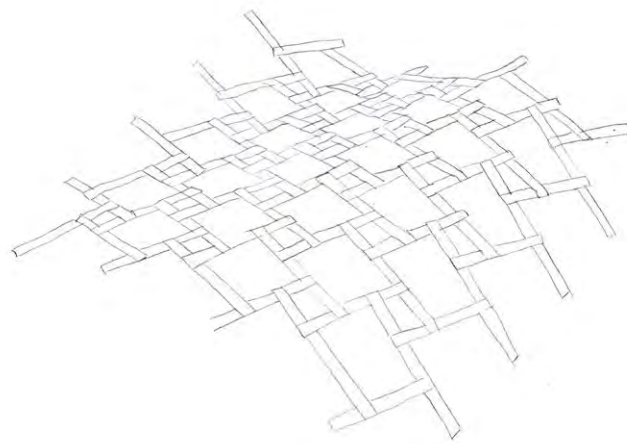



MODEL EXPLORATION STUDY:

Reciprocal frame balsa model illustrating an imagining of different applications of use: wall, roof, whole enclosure, and the different spatial qualities provided by each.

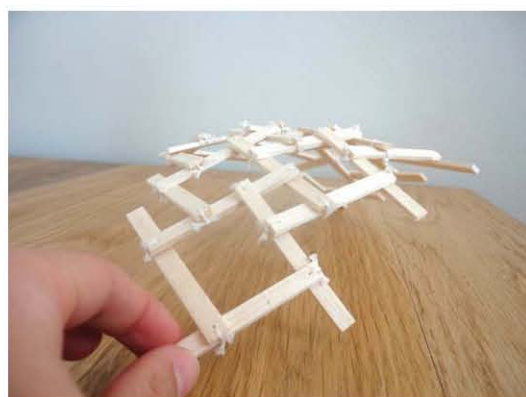
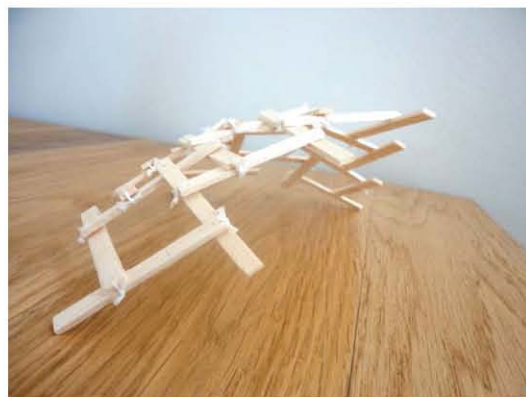
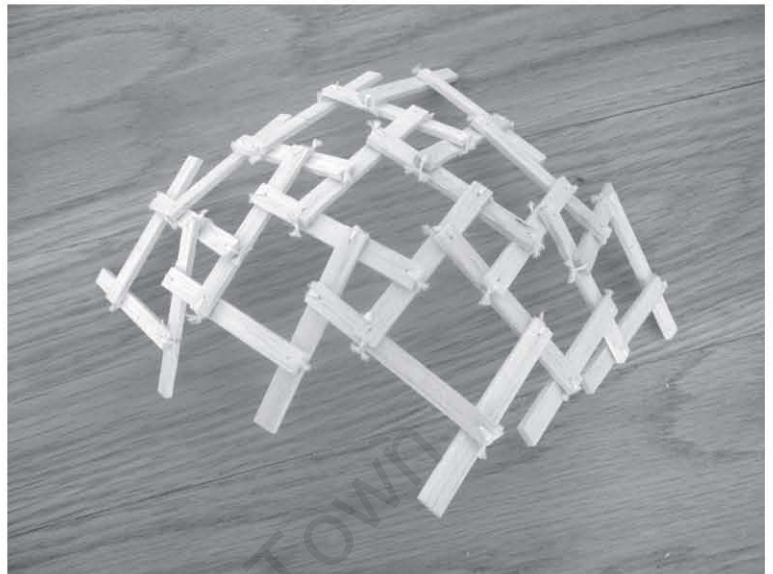
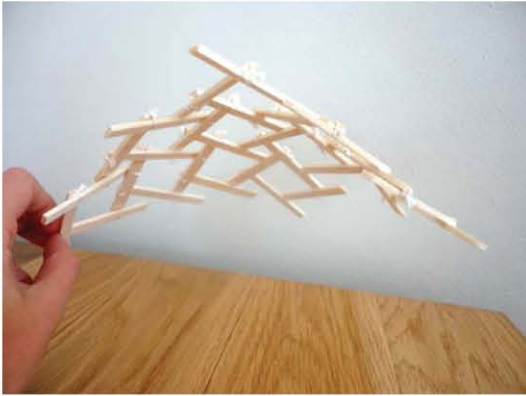

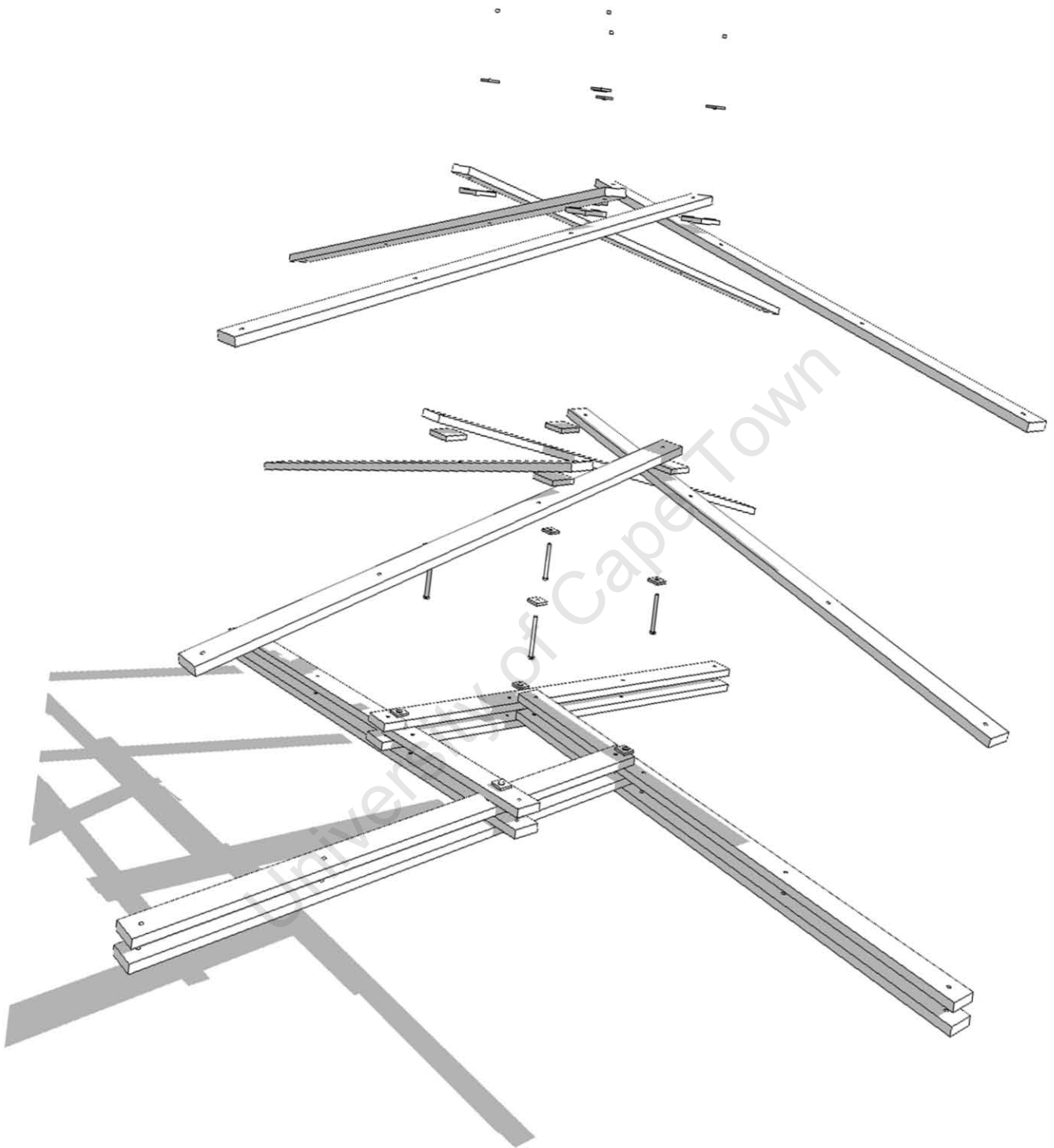

DIGITAL MODEL STUDY:

Digital model of reciprocal connection demonstrating the order of making and assembly for a reciprocal frame module. Timber members bored with holes, bolt, spacer and washer proposed for connection type. Small timber padding layers between timber and bolts for spread of load over a wider area and to prevent indentation of soft pine wood.



MODEL STUDY:

1:10 balsa prototype model of reciprocal modular unit using standard timber section sizes. Exercise posed value for configuring an assembly plan for the final 1:1 model. Shifting of unit creates interesting pattern shapes and potential for variational grid and creating potential for different spatial qualities.

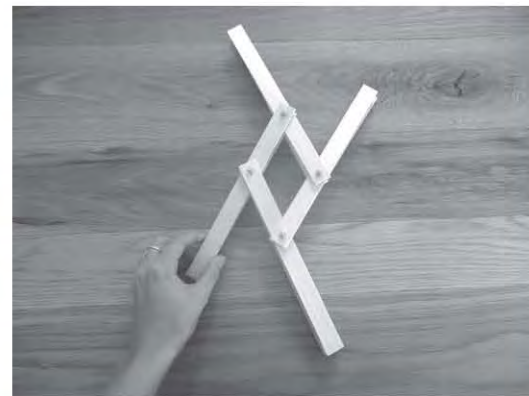
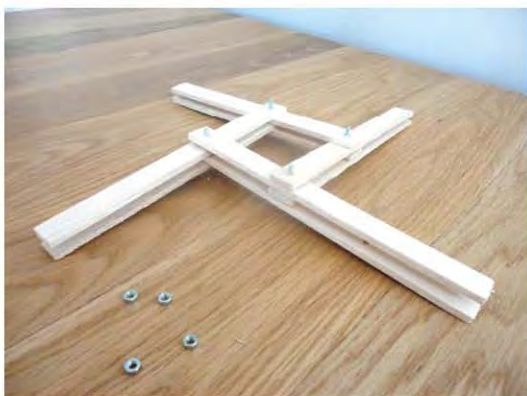
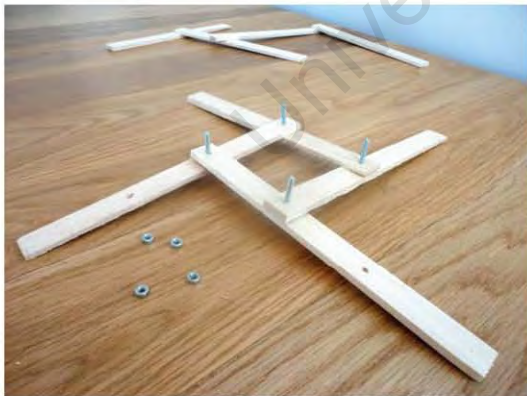
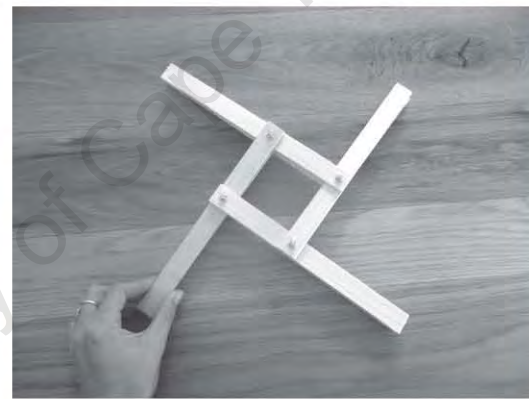
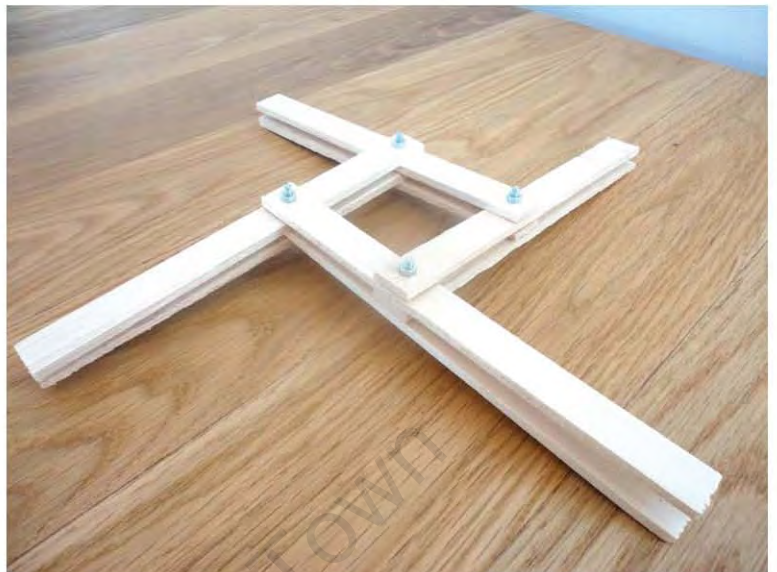
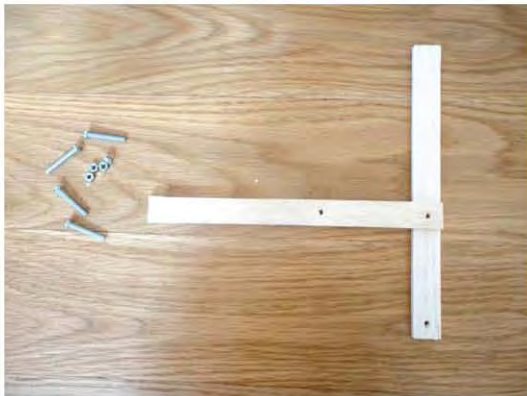

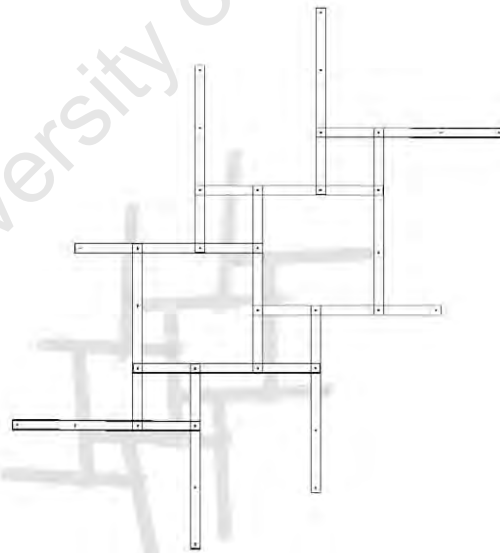
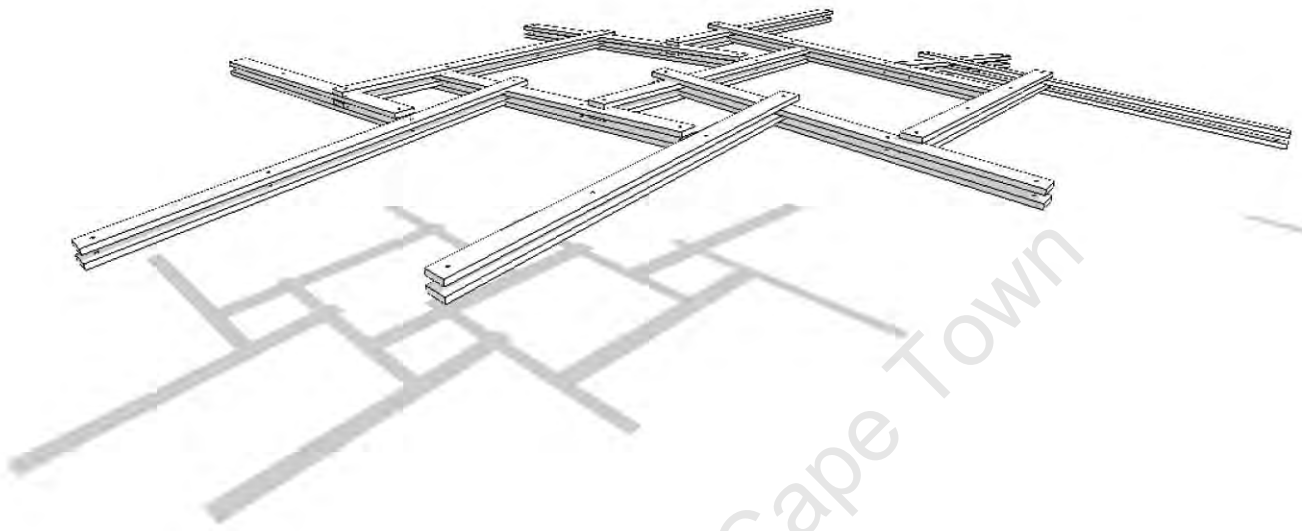

TECHNICAL DESIGN STUDY:
Digital modeling of double layered structure using standard pine sections for a long span. Every modular unit consisting of 4 layers.



ASSEMBLY TEST:
1:1 prototype model of double layered reciprocal modular unit. Built in workshop using standard pine sections. Process demonstrates appropriate assembly method, member by member.



FORM STUDY:

Balsa Gridshell model with fixed joints and continual laths. Testing of a 'timber-type' material and how the structure behaves under particular forces (over bending, snapping). Playfull design opportunities arising from deformation of grid.

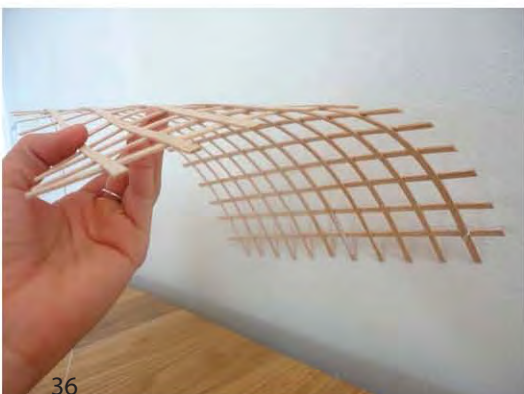
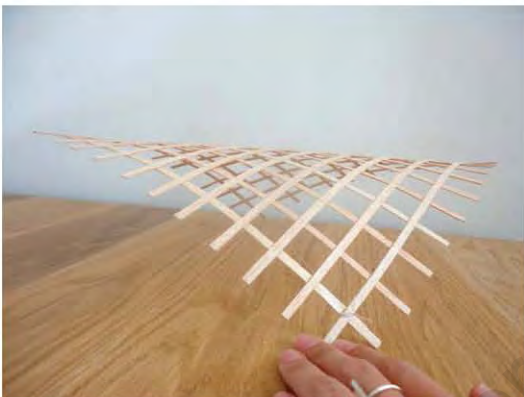

The Gridshell Structure

The timber gridshell structural concept provides the possibility of an irregular, complex and doubly curved shape that is made from a set of standard components. The gridshell is a grid or lattice grid structure and derives its strength from its double curvature.

The gridshell is a three dimensional structure that resists applied loads through its inherent shape. The structure carries applied loads by membrane forces. The loads are carried through tension, compression and shear forces in the plane of the shell resulting in structurally efficient forms with the possibility of very thin sections. Double layer gridshells are necessary when large spans are required and laths are too deep to permit bending in shapes which have tight radii of curvature.

Large span timber gridshells are assembled by initially laying out main lath members flat in a regular square or rectangular lattice. The lattice is then pushed up from the ground into the desired doubly curved form. This technique was used to construct the Mannheim Multihalle Frei Otto, Carlfried Mutschler and Winfried Langner.

Another assembly technique includes laying the laths on top of a temporary scaffolding structure which is then gradually removed to allow the laths to settle into the desired shape. The Japan Pavilion by Shigeru Ban uses this assembly technique.

To form the gridshell, rotation at the nodes and bending and twisting of the constituent laths must be possible. Once formed, shell action is accomplished by diagonal bracing, providing in-plane shear strength and stiffness.

The following pages explore the gridshell concept using standard pine sections as the laths. This presented a challenge as standard timber sections are only available in relatively short lengths (max 6.6m), where traditional gridshells require one long continual lath meeting ground to ground. This was taken as an inspiration rather than a limitation and fuelled an exciting imagining of short standard timber members in a complex gridshell form, providing a new possibility and adaptation of the gridshell structural concept.

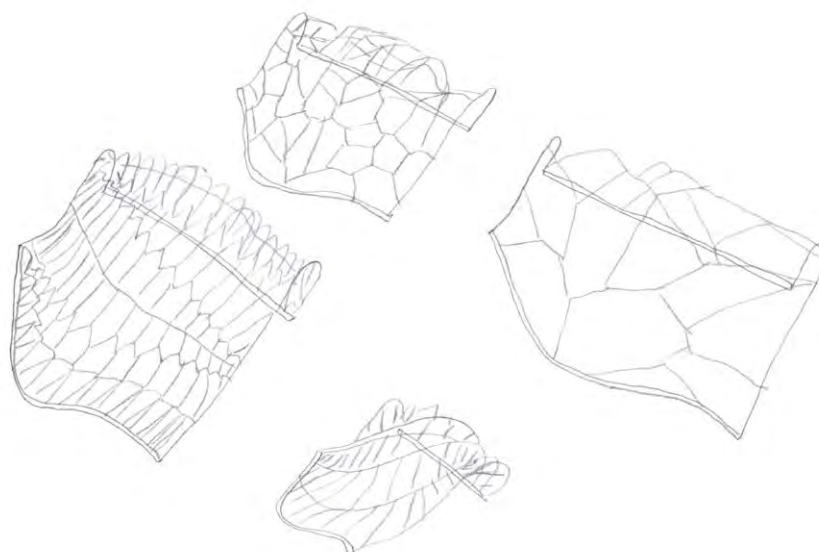

SKETCH STUDY:

Types of gridshell pattern making, posing interesting shapes for particular spatial formations.

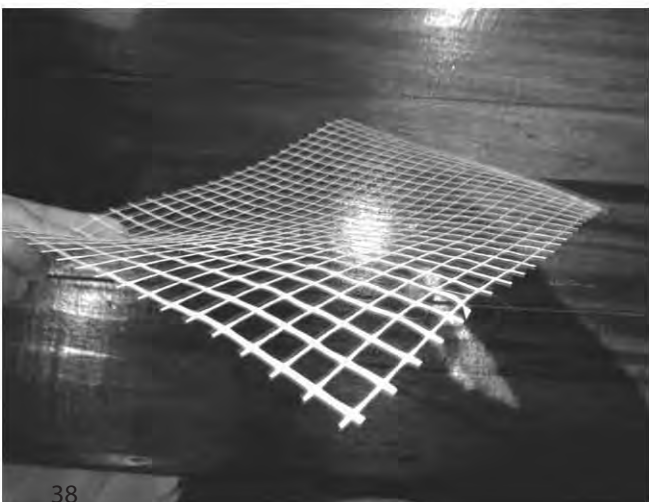
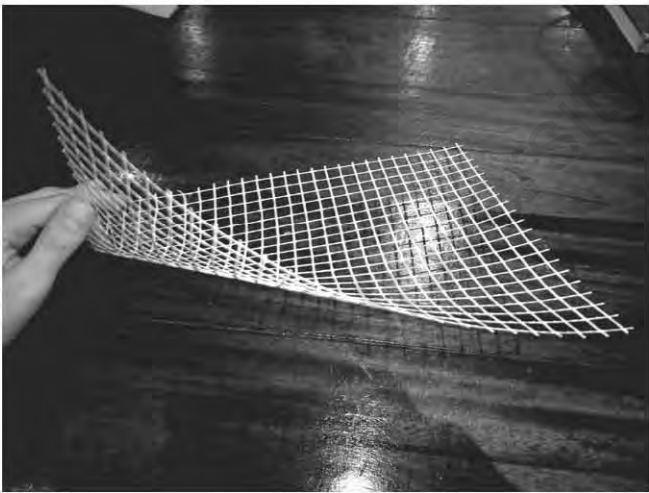
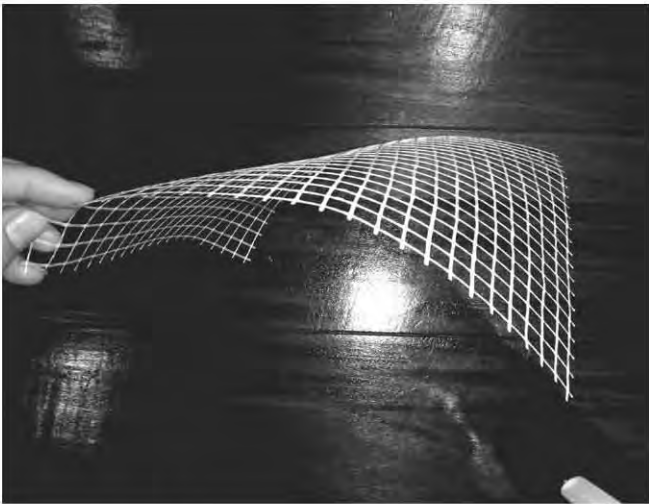
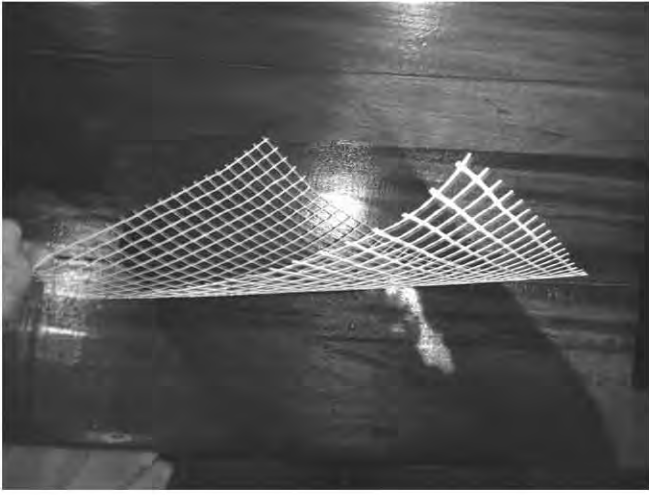

of Cape Town

FORM STUDY:
Left: Explorational gridshell model made out of formwork netting demonstrating variations in gridshell form.

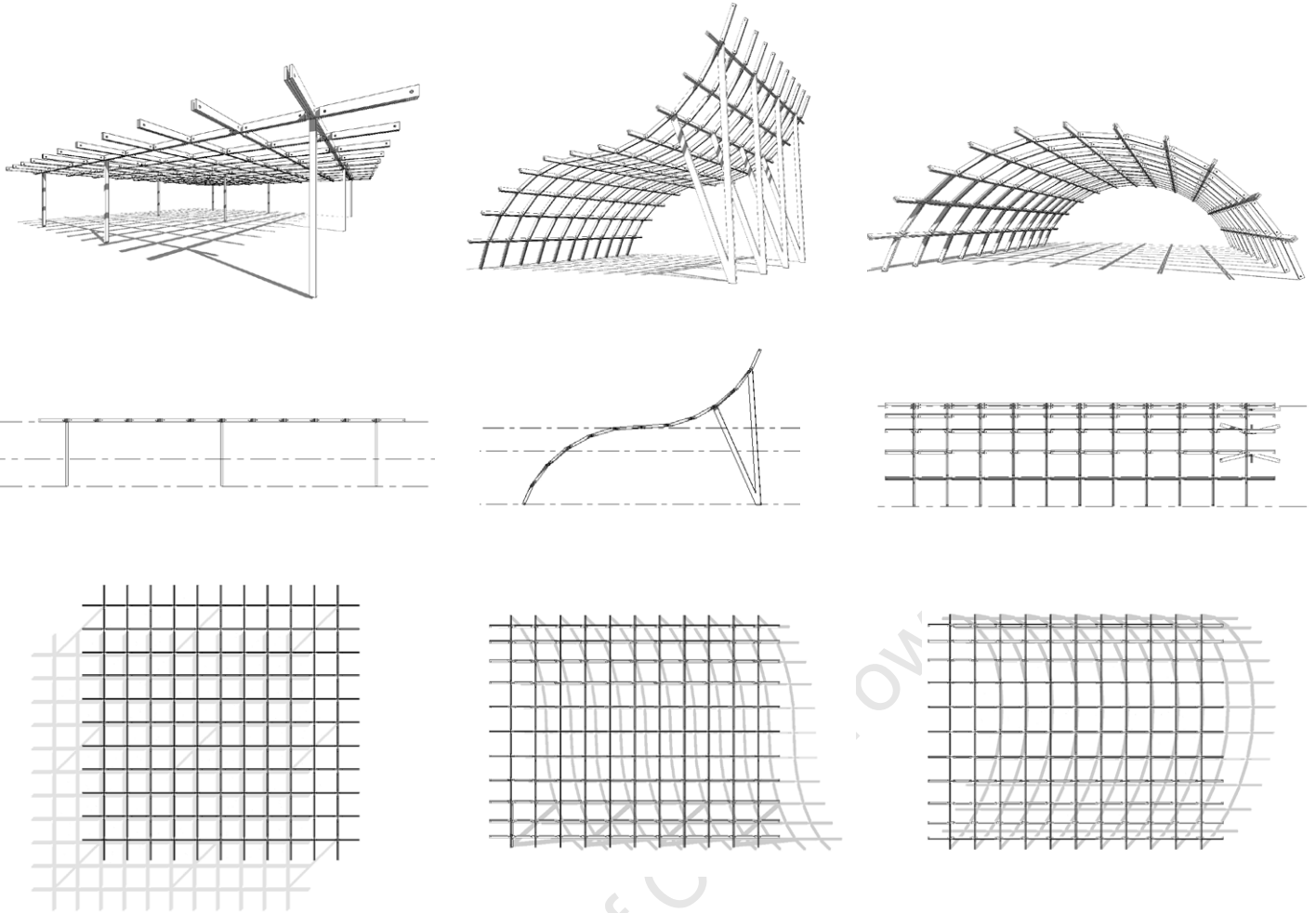

DESIGN STUDY:

Digital revit model explorations using standard dimensioned pine and illustrating different shadow and space-making potentials.

Left: Double layer grid-like roof structure. Joints becoming interesting design potential for the connection of 8 members at one point.

Above: Standard pine members in a distorted gridshell wall and roof structure, playing with the same modular grid and flexible joint connections.

Left: Standard pine members in a double layered barrel vault form. Possible steel members or slotted plywood joints as connections.

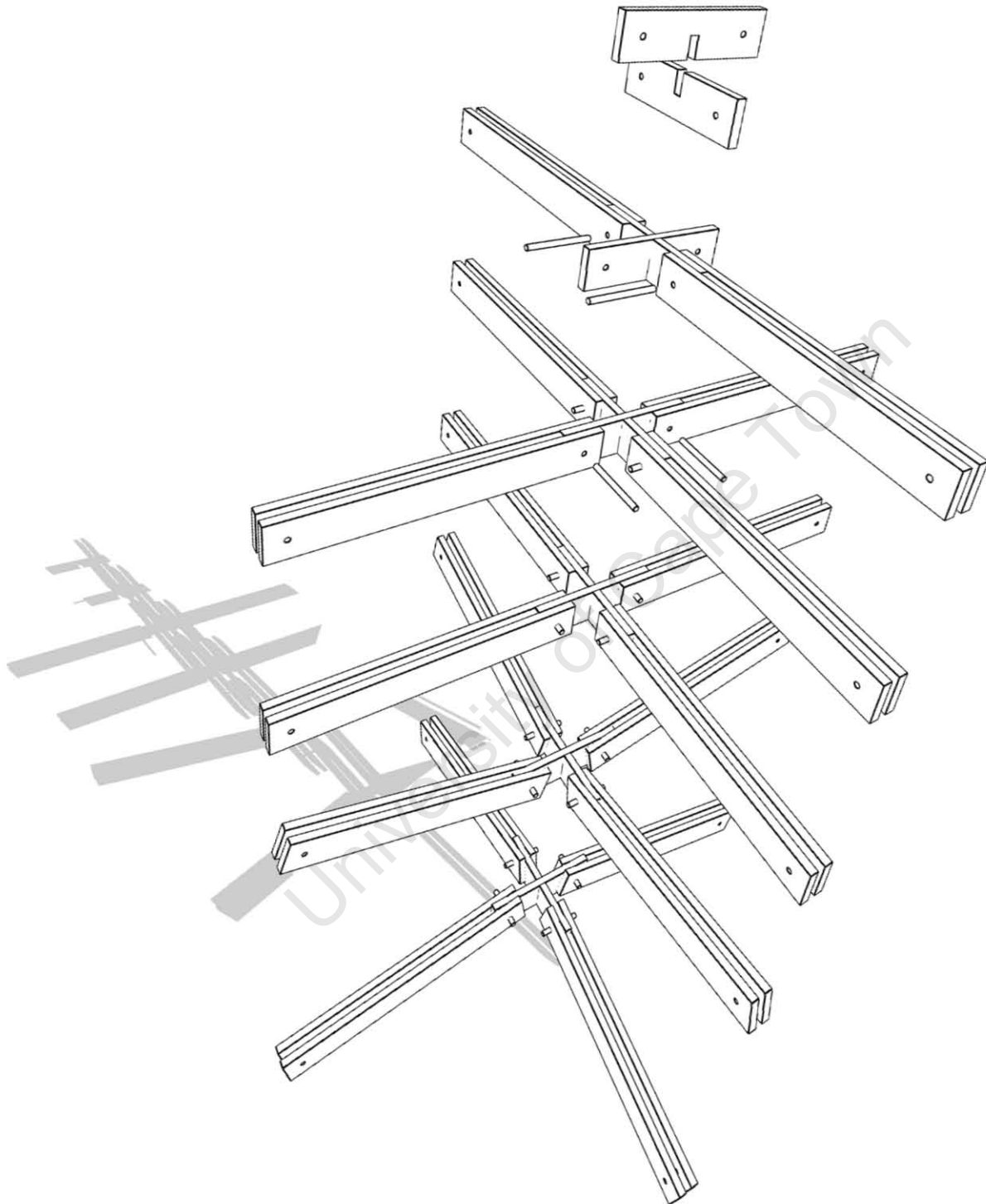

TECHNICAL AXONOMETRIC STUDY:

Exploring possible joining techniques for a flexible double layer grid shell structure. Slotted plywood joints to form connector, double layer timber members fastened to connector with dowel for a moveable connection. Digital axonometric model demonstrating assembly method.

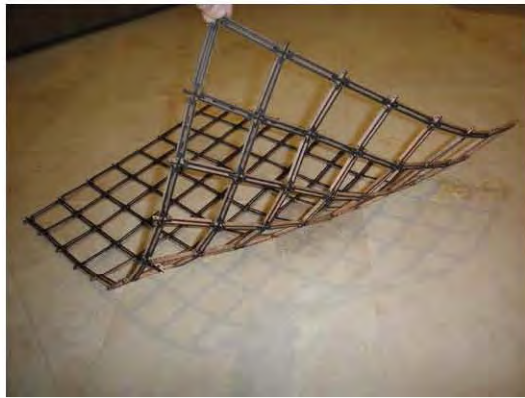

DESIGN MODEL STUDY:

Use of a laser cut model as a tool for form making. Double layer gridshell grid with flexible joint allowed immediate adjustment of form and gives an idea of how grid responds to change.

Above: Double layer gridshell grid with flexible joint suspended on fixed column. Moving columns up and down posed valuable insight into form making opportunities.



Gridshell joints

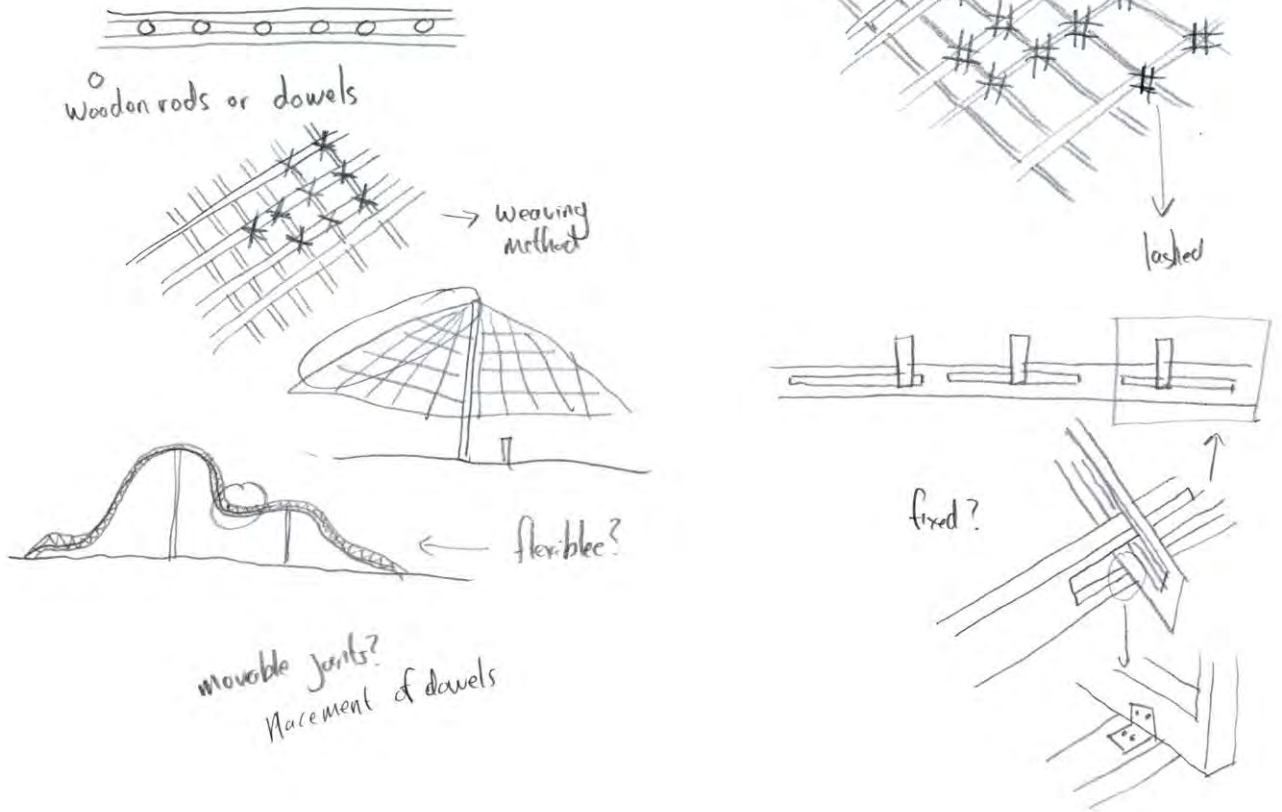

Left:
 DESIGN STUDY
 Imagining gridshell in a real building set up. Demonstrating lines of grid and distortion where relating to plan and columns.

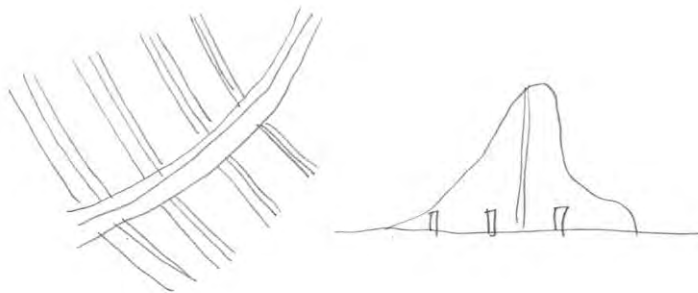

Right:
 TECHNICAL SKETCH STUDY
 Sketching ideas of gridshell structures and possible joining methods.



double layer laths with spacer?



fixed to ground

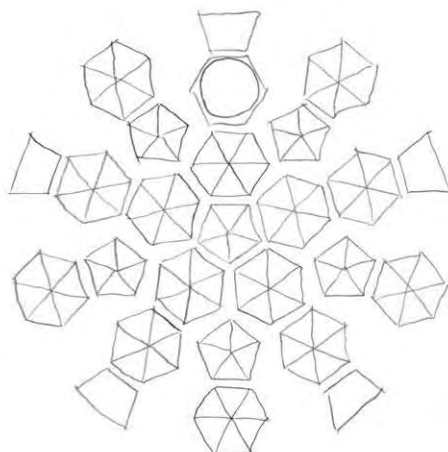
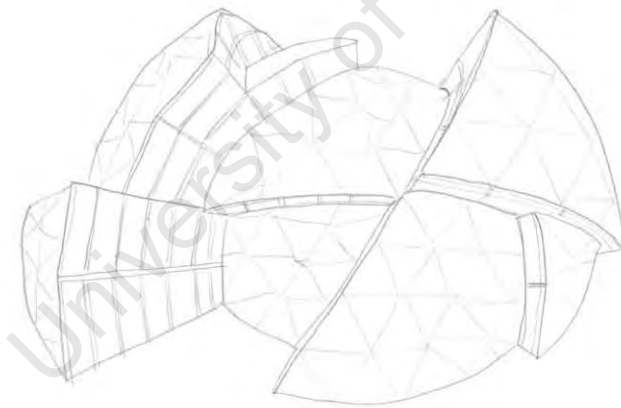
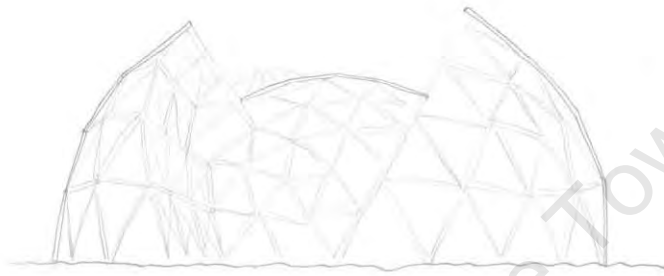
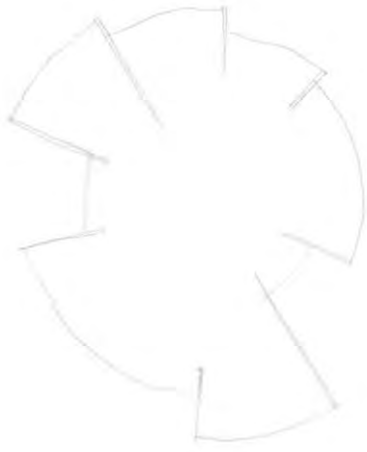

DESIGN STUDY:
Exploration of geodesic dome
using standard pine sections - Its
inherent geometry deconstructed.

The Geodesic Dome

A geodesic dome, developed by Richard Buckminster Fuller, is a spherical or partial-spherical shell or lattice shell structure based on a network of great circles (geodesics) on the surface of a sphere. The geodesics intersect to form triangular elements that have local triangular rigidity and also distribute the stress across the structure.

The geodesic dome encloses the largest volume of interior space with the least amount of surface area. The spherical structure of a dome is one of the most efficient interior atmospheres because air and heat are allowed to circulate without obstruction and therefore allows heating and cooling to occur naturally.

The Geodesic Dome is energy efficient for the following reasons:

- Its decreased surface area requires less building materials.
- The concave interior creates a natural airflow that allows the hot or cool air to flow evenly throughout the dome with the help of air ducts.
- It acts like a down-pointing headlight reflector that reflects interior heat. This helps prevent radiant heat loss.

The Geodesic dome has advantages of being rationally and mathematically calculated, but it lacks in many of the qualities associated with space-making. There is very little opportunity for a structure based on this concept to have a contextual response to its surrounding. The plan is also limited, mainly being restricted to circular.

Other disadvantages and problems:

- Sound, smells and reflected light tend to spread through the entire structure.
- Privacy is difficult because dome is hard to partition.
- As with curved shape, the dome produces wall areas that can be difficult to use.
- Very little variation in structure, therefore little room for exploration of spatial qualities and expressions.

Inspired by the People's Meeting Dome by Kristoffwer Tejlgaard & Benny Jepson, the following pages explore the geodesic dome using standard pine timber sections. Its inherent geometry is attempted to be deconstructed into an unlocked shape that is split up and scaled so that the dome can be shaped by its site. It can form niches, crevices and corners, defining, opening and hiding. Proposals of a system of nodes in steel connect the wood members and build the complex lattice structure.

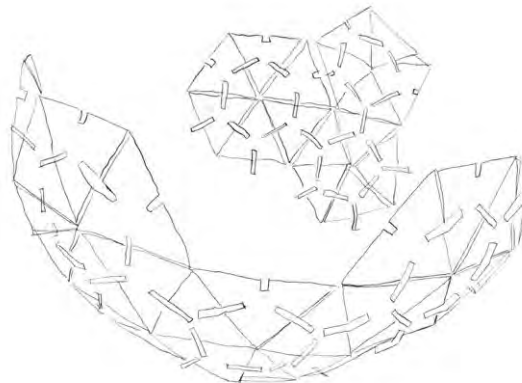



TECHNICAL DESIGN MODEL STUDY:

Laser cut hardwood model of gridshell structure using bent standard timber members. Conceptual exploration and prototyping demonstrating the imaging of the grid. Questions raised such as connector types, possible nut and bolts and spacers?

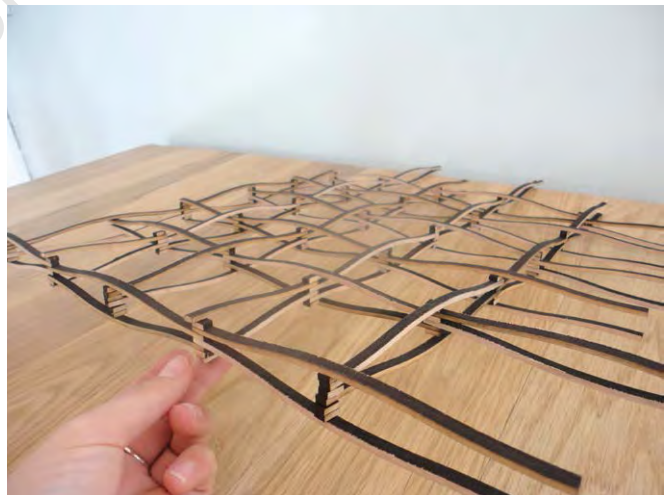
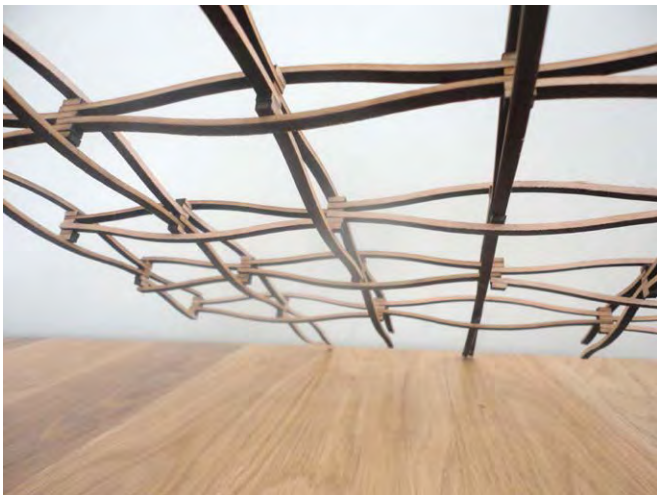
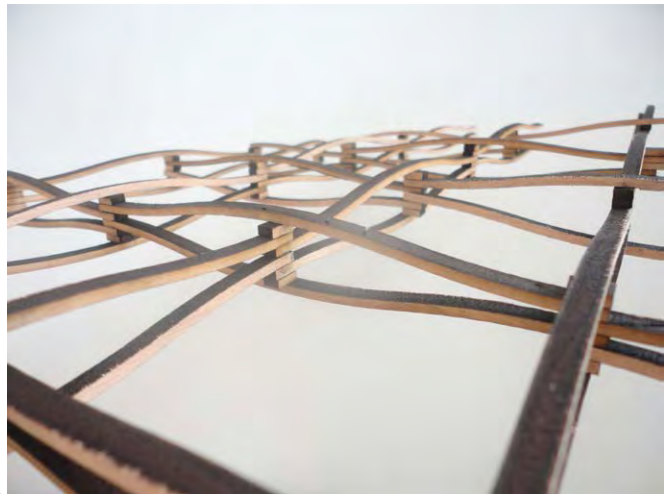
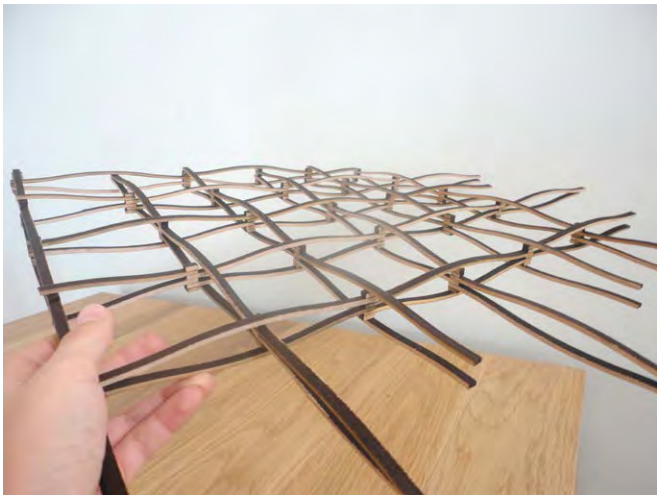

Structure Explorations & Design Studies

The structure selected for further exploration was the gridshell structure. Consequential to standard timbers relatively short length availability, this presented to the project interesting design possibilities and room for an imaginative mind. Adding to this, the use of short timber member lengths posed exciting options for connection types and the possibility of a free-form structure. The gridshell provides beautiful light filtering spatial qualities and is very flexible in covering many types of plan forms. The following pages demonstrate my exploration with short standard timber members in a gridshell structure and possible joining techniques.

The final designed structure (seen to the left) is made up of short standard timber laths, pre-bent into a permanent curvature. The over-lapping and bending of the laths allowed for a continual connection from lath to lath, creating a structure which then behaves like a gridshell. The laths are then connected with a bolt, nut and spacer connection. Two possible techniques were contemplated for bending: steam-bending of laths, or lamination of smaller laths into one larger lath. Steam-bending is an environmentally friendly option, contrasting to glue-laminated timber which uses VOC glue. Both techniques were tested in UCT's workshop using standard pine sections.

Pages 47-49 demonstrate the experiments and documented outcomes of three bending techniques: dry-bending, lamination and steam-bending. The dry-bending test used 25 x 76mm standard pine and the lamination and steam-bending tests used 38 x 38mm standard pine timber as the material for a 1:5 scale prototype model. A decision for a 1:5 scale model was based on the fact that the UCT workshop doesn't have big enough equipment for a 1:1 scale test model. Despite this hindrance, the exercise provided valuable understanding into processes involved in the bending of timber and thus gave a clearer idea of what the final deciding bending technique would be.

What was learnt from the testing of the three bending techniques was how deceptively easy they actually are to perform for a one-man operation working in a relatively small workshop. Steam boxes are quite simple structures and can easily be built. Laminating is also a simple process and can easily be performed by a small group of people in small workshop. This dissolved pre-conceptions that bent timber can only be made-to-order in large factories and with large machinery.

Driven by the above mentioned findings, the proposal for the dissertation project was directed into the possibility of forming part of the government Expanded Public Works Programme, aimed at providing poverty and income relief for the unemployed through temporary work on socially useful projects. Unemployed people from local communities can be recruited and trained to steam bend or laminate the timber for the projects. The trainees can then be groomed into independent constructors to be re-employed for similar projects, or develop their own career path where they can build and sell products such as furniture, fittings or timber construction products and services.

Dry-Bending

A process in which timber is bent in its natural state. The timber is bent into a desirable curved shape with the use of a mould, thereafter clamped and left for a couple of days. This process has the potential for fracturing, especially at knots, and possible degradation of strength capacity due to splitting of the fibers.

Laminating

Glue-laminated timber, known as Glulam, is manufactured from sawn wood and is an attractive architectural and structural wood timber product manufactured by gluing together individual pieces of dimensioned lumber. Wood pieces are then end jointed together. The laminating process allows for the manufacture of one large, strong structural member in numerous shapes and sizes. Glulam is ideal for large columns, beams and curved members under high bending and compression stresses.

Steam Bending

Steam bending is a wood working technique where strips of wood are steam heated in a steam box. The applied heat makes the wood pliable enough to easily bend around a mould to create a curved shape. Wood in its natural state cannot usually be bent to a small radius of curvature without fracturing. However when steam bent, it softens the timber to the point where little or no degrade results when bent. This technique has been used for hundreds of years in many types of products. These include wooden boat building where it is used in the shaping of a boat's hull, in musical instruments such as the violin and guitar, and in furniture making. Steam bending is also a low energy, ecological and economical method of manipulating wood. It doesn't need the expense or drying time of glues to join together several wood pieces to make the desired shape. Steam bending also has less wastage since a smaller piece can be bent into shape instead of cutting the desired shape away from solid pieces.

Universiti



EXPERIMENT ONE: Dry-Bending

25 x 76mm standard pine cuts were bent into shape using walls as support. Getting the timber into shape was difficult once the pliable curvature was exceeded. Splitting at the centre curvature points and fracturing at knots was noticed. Extra strapping was then placed at these weak points to prevent the timber from snapping. Once taken out of the held shape the deflection was at least half of the original bent curvature, almost entirely going back into its straight shape.

Pine has good bending properties but due to the frequency of knots, this method is unsuitable. The results were predictable but served a valuable exercise in learning about the behaviours of timber under certain forces.



EXPERIMENT TWO: Steam Bending

Pinus Radiata is not known for having good steam bending properties because of its frequency of knots. For this experiment, timber for the laths was carefully selected to avoid failures when bending. This would also apply to the final 1:1 scale structure. If in the instance where small knots exist in some of the laths, the knots should be placed on the outside or convex part of the bend and efficient strapping must be used.

Standard 38 x 38mm pine sections were then sawn into 1:5 laths: 38 x 6 x 560mm. Large pieces of wood were used to make a mould, using a jigsaw to cut a positive and negative curved shape.



Water was heated in the steam-box using a blow torch. Once boiling, the laths were inserted and the steam box was plugged with a wet rug to retain the heat and allow steam to escape. Laths were then taken out every 10min to test its pliability. After about 30min the laths were ready and taken out of the steam box and quickly placed into the mould and clamped. Laths were clamped for approximately one day or until dry.

Once removed from the mould, the laths deflected about 1cm into its original shape. This resulted in a testing of 3 more mould shapes with a steeper curve in order to create the right curvature of the lath once steamed.

For a 1:1 scale model a much larger steam box would be needed. Often timber off-cuts are used to make a fire to heat the steam box.

This experiment dissolved preconception that pine would not be suitable for steam bending. I think that with careful selection of timber, this could be a potentially viable option for the project.

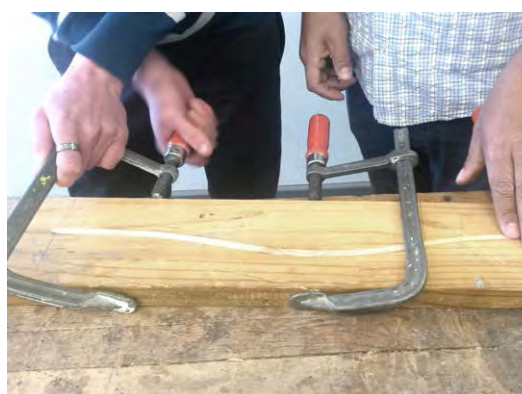



EXPERIMENT THREE: Laminating

For this experiment, moulds were once again made out of large pieces of wood, using a jig-saw to cut the negative and positive curves. Three thin 2mm x 38mm x 560mm laths were then sawn from a larger 38mm x 38mm standard pine section. These three laths were then coated with wood glue, placed into the moulds and clamped overnight. Laminating resulted with only a 5mm deflection.

Laths were then belt sanded to remove excess glue and rough edges were scuffed down.

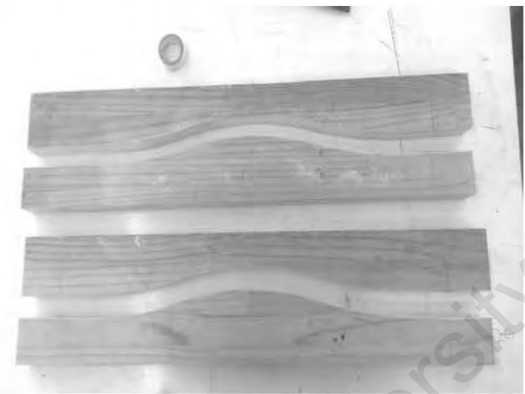

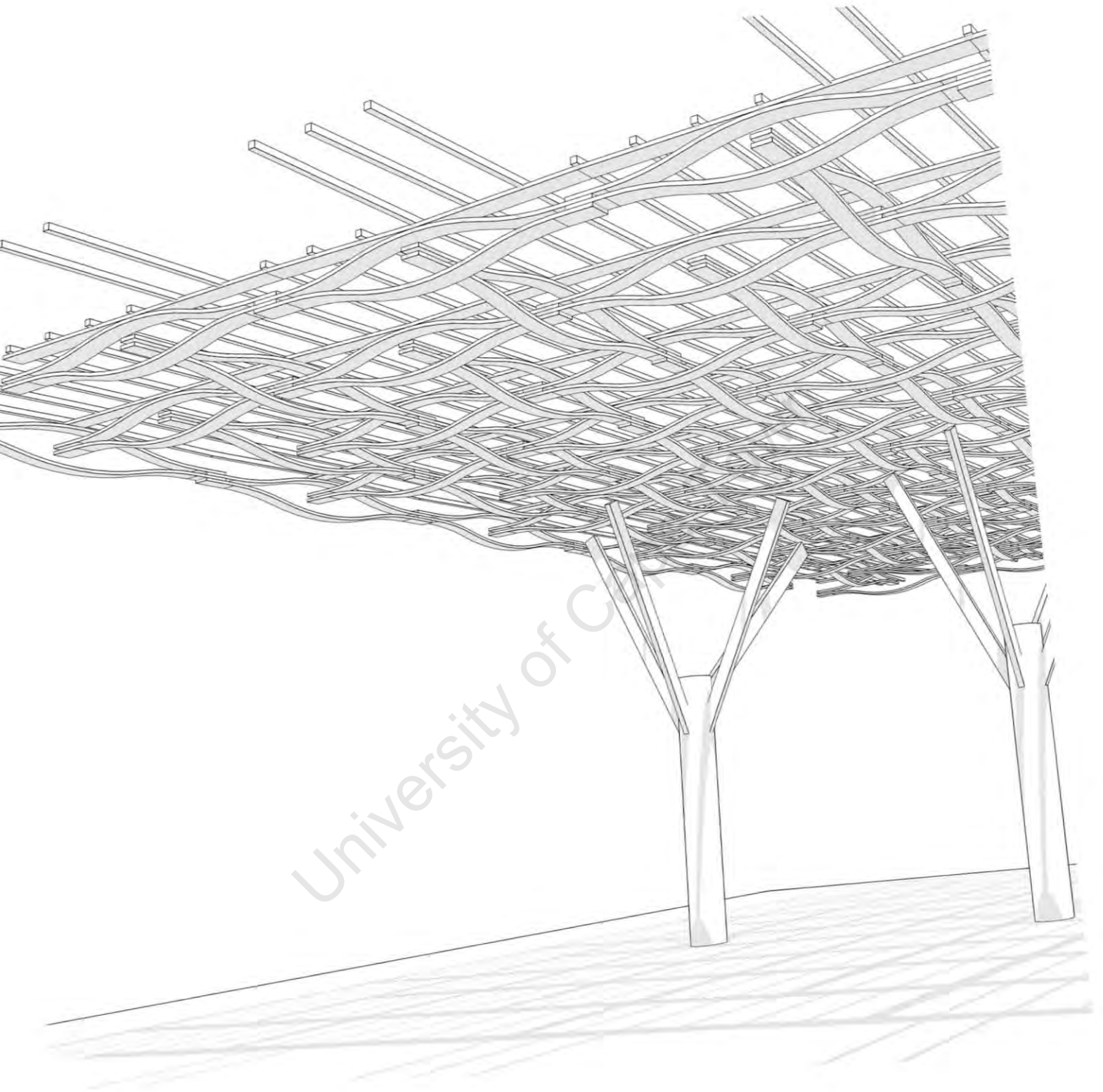

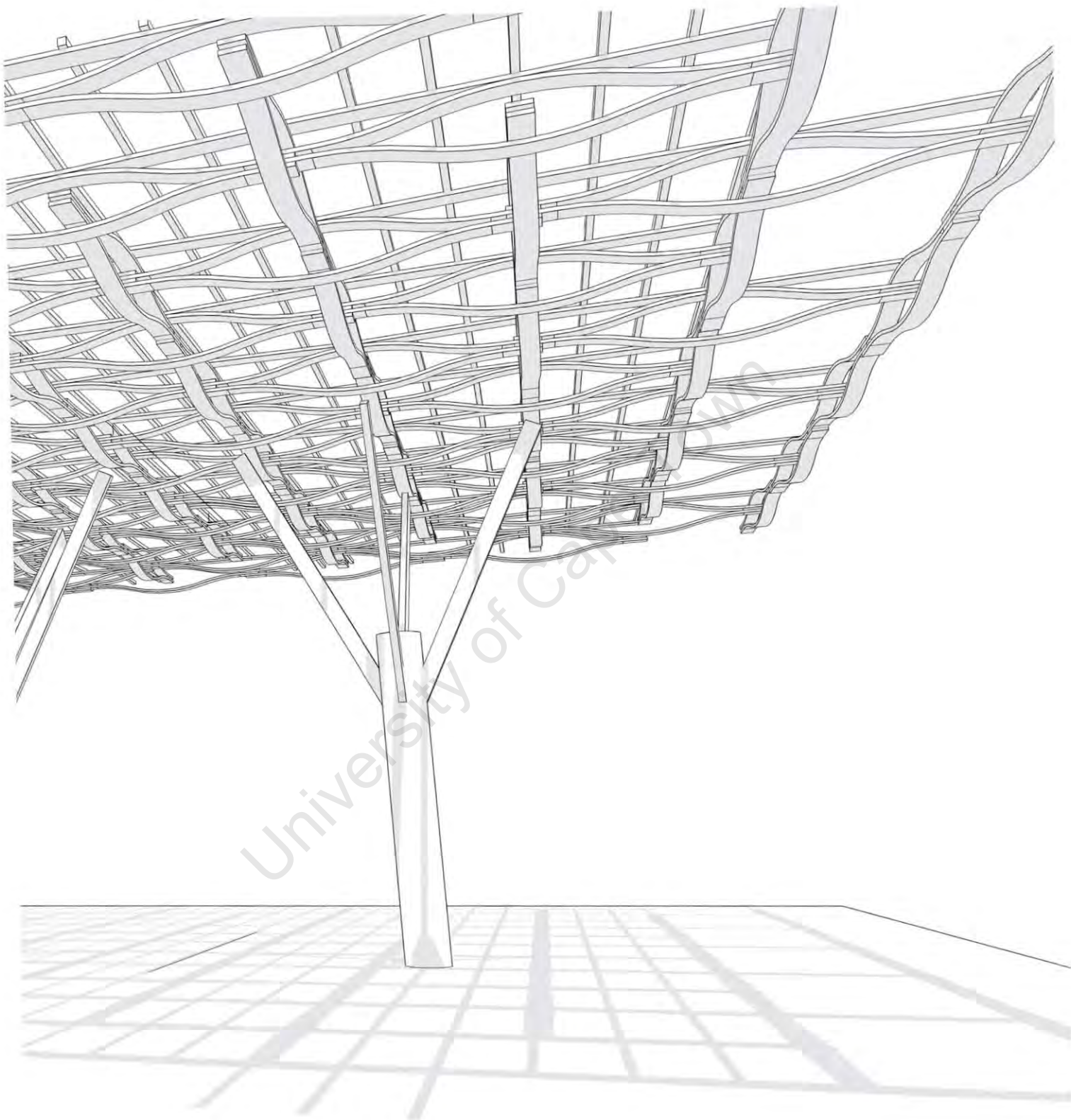

DESIGN STUDY:

Digital model showing steam bent gridshell structure and shadow patterns. Possible 'tree-like' column structures to hold the roof in place and supported at gridshell bolt and nut connections with prefabricated steel connections.

University of Cape Town

PART 3
Sketch Design Development

University of Cape Town

Wood Innovation Design Centre: Schedule of Accommodation:

Entrance lobby	40m ²
Reception	12m ²
Main office x 2	10m ²
Public toilets	30m ²
Exhibition space	80m ²
Public lecture venue	50m ²
Cafeteria & kitchen	50m ²
Design & training studios	45m ²
Small library	30m ²
Computer laboratory	48m ²
Laser cutting facility	24m ²
Main workshop facility to include:	
CNC router area	24m ²
General Wood Working Area	200m ²
Workshop Offices x2	10m ²
Hand tool store	20m ²
Equipment Store	30m ²
External timber storage space (for fire hazards)	72m ²
Kiln	8m ²
Welding and Braising	20m ²
External Sawmill	
Service entry/log offloading	
"Architectural Playground"	
Visitors Entry	
+ 20 parking bays	

WORKSHOP
Hooke Park Precedent



EXHIBITION



FOREST



+

=

Wood Innovation
Design Centre

+

Figure 4: Hooke Park Workshop (FABRICATION STUDIO for CNC LASER CUTTING, 2012)

Figure 5: Timber Exhibition (Tdwa.com, 2012)

Figure 6: Cecelia Forest Pine Plantation (Mangaia-cookislands.blogspot.com, 2010)

Adopting a Programme

Only much later in the year was a programme was chosen for the design dissertation project. The idea being that efforts would be focused on the 'act of making' through experiments in timber throughout most of the year in order to completely explore timber and its qualities to the fullest. Once the predominant system type was established and fully resolved; the steam bent gridshell, an appropriate programme was chosen to fit the spatial qualities and space making potentials provided by the structure. This gave ground to the project and led it into a new stage in the design process where models, sketches and experiments became contextualised in a practical environment.

With the development of a very expressive steam-bent gridshell structure, the project called for a public facility where a large movement of people can experience the building. Going back to one of the initial design ideas and the fact that designers/learners have become distanced from their materials and the making process, it was decided that the programme would be a Wood Innovation Design Centre. In this way, the building would serve as an example of the thinking behind the design dissertation.

The Wood Innovation Design Centre would attempt to celebrate the beauty of wood, promoting the potential and extent of its use and to be the stepping-stone for further innovation and scale that will continue to grow the wood story and industry in South Africa. In addition to this, the centre would bring professionals, learners, and designers in the community together allowing them to participate in the 'act of making' and pooling skills and resources whether for architecture, furniture or crafts.

The Wood Innovation Design Centre would include a timber workshop for production and exploration and an exhibition space to showcase designs and projects. The programme would also encompass the surrounding area to be used as an 'architectural playground' for the making of full scale prototype models. Keeping the facility operational throughout the day and in the evening with a cafeteria, public lecture venue and timber training facility incorporated in the program, hopes would be to attract people from all walks of life and to have a venue to explore their capabilities, artistic talents and creativity.

With the steam-bent gridshell structure applied to the programme's spatial requirements, the idea is that the centre would also serve as an inspiration to other architects and designers, spurring them towards creating innovative designs through the 'act of making'. It is therefore also important for the centre to have a sculptural and poetical quality.

Choosing a Site

The bond between the woodworker and the wood itself had already begun back in the forest. The location and appearance of a tree was decisive criteria for its later use. The master builder himself selected it. The farmer, in the capacity of master builder, observed the forest, whether it was his or not, and so knew about just a few more details which could be significant for its use. (Zwergwer, 1997)

Today it is rare for the location of a tree to be taken into account by the architect when deciding its future usability. Having knowledge of this would bring about a more purposeful application and add depth to its structural meaning. For example, single exposed trees which have to constantly face strong winds and harsh weather conditions results in their heartwood being displaced on one side (Zwergwer, 1997). This leads to uneven displacement of densities on either side of the tree. When the timber goes through a drying process, the softer side shrinks more than the harder side. Acknowledgement of this property and knowledge of the wood allows the architect/designer to exploit this inherent quality.

Through reading substantial amounts about timber and learning their properties and their behaviours, it became clear that it was important for the Wood Innovation Design Centre to be placed within a forested surrounding. In this way, learners and professionals can engage

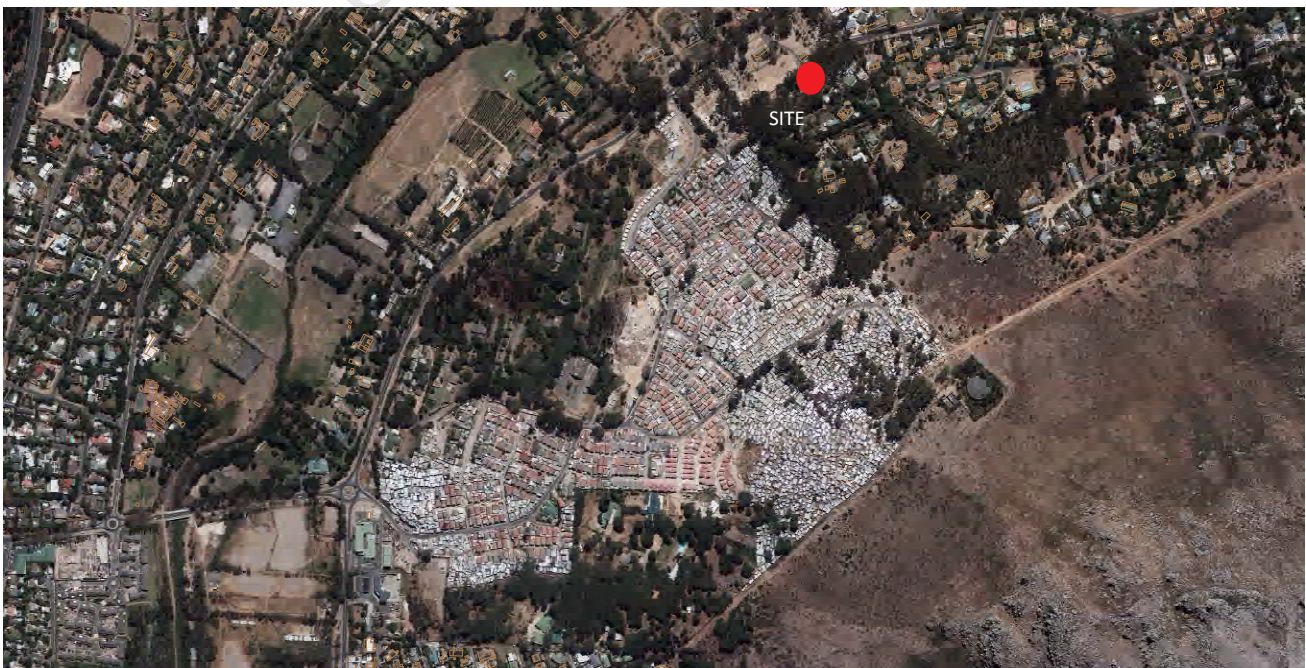

Figure 7: Google earth images of site location

better with the tree growing process and learn more about the appropriate application of particular types of trees exposed to different types of conditions.

It was also important for the workshop to be accessible by transport to all types of people: professionals, students, disadvantaged, disabled, etc and therefore the idea was not to stray too far away from a central hub where the majority of these people work, study and live. Thus, it was decided that Hout Bay would be a good area. Chosen, not only because it is accessible due to the new IRT bus lines and bus stops, but also because Hout Bay forms one of the major links to the history of forestry in South Africa.

Hout Bay is a coastal timber rich suburb located in a valley on the Atlantic Seaboard of the Cape Peninsula, twenty kilometres from Cape Town CBD, Western Cape. It is surrounded by mountains to the North, East and West with the Atlantic Ocean to the south. The suburb is connected to the surrounding areas by Victoria Road along the coastline and Hout Bay Main Road from Constantia Neck.

Hout Bay (translated "Wood Bay") was originally established in 1652 by the Dutch for timber plantations and has established itself as a thriving fishing location. It has grown dramatically over the years as a desirable place of residence, comprising neighbourhoods ranging from very rich to very poor. Due to Hout Bay's forestry history and because of the thick forests still growing in the area, Hout Bay seemed to be perfect place for the dissertation project.

The site chosen is wedged between the Imizamo Yethu informal settlement and the affluent Penzance estate. The site is an open and uninhabited piece of land, lined with rows of over 100 Eucalyptus blue gum trees, evidence of it once being part of a timber plantation. The site sits one row back from Hout Bay Main Road and is bordered by a primary school, a graveyard, Imizamo Yethu informal housing, an old forestry site, and a highly secured high-end residential area. The site is also close to a taxi rank and an IRT bus stop, meaning that workers coming from town can easily commute to and from the site.

The site presently belongs to the city and is zoned as public open space, but future plans intend on giving the land to the neighbouring graveyard for its extension.

See site & context plan on page 60-61.

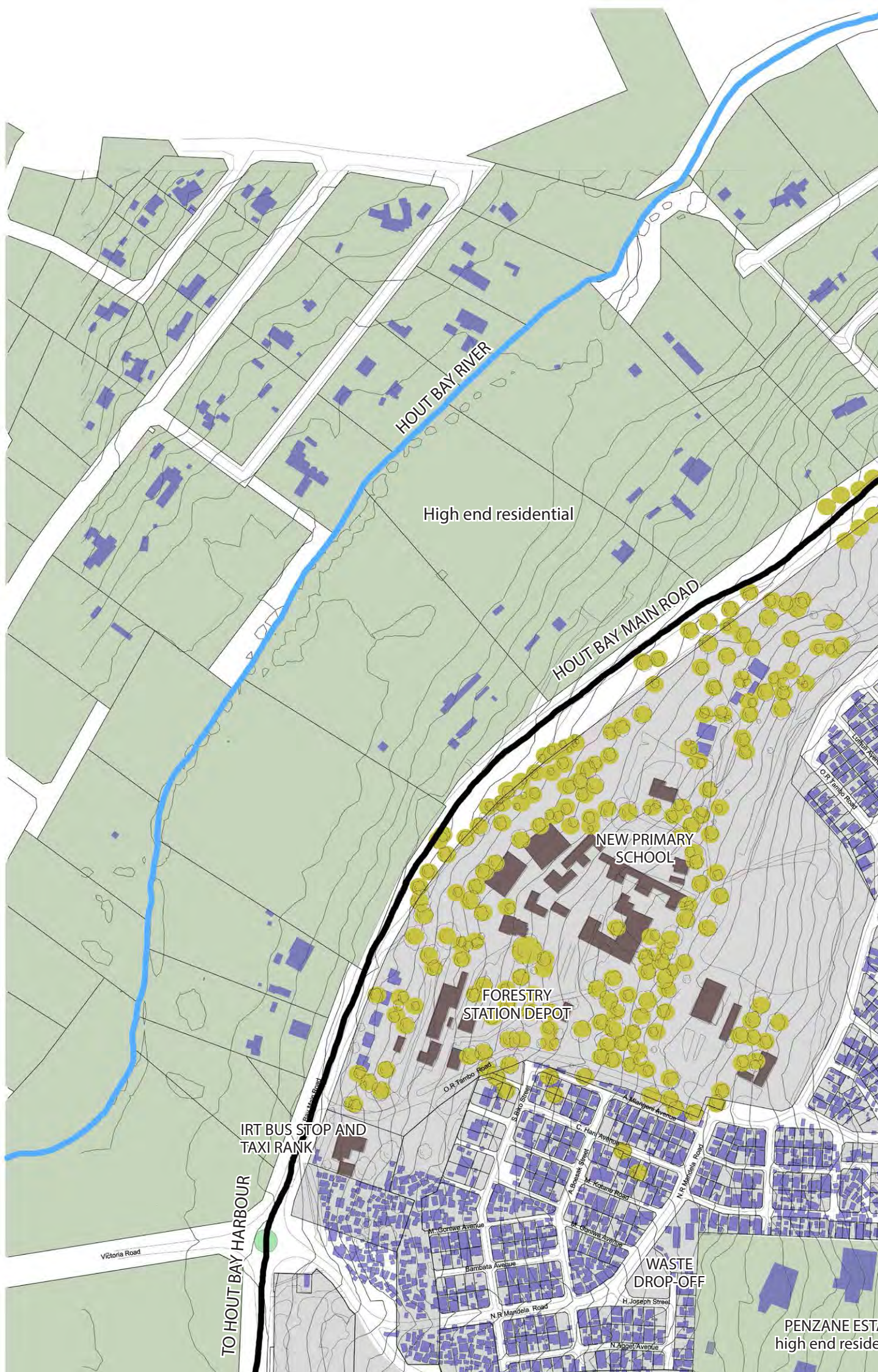

HOUB BAY RIVER

High end residential

HOUB BAY MAIN ROAD

NEW PRIMARY SCHOOL

FORESTRY STATION DEPOT

IRT BUS STOP AND TAXI RANK

WASTE DROP-OFF

TO HOUB BAY HARBOUR

PENZANCE EST high end residence

Victoria Road

Enthol Street

O.R. Tambo Road

O.R. Tambo Road

S. Liso Street

M. Makhani Avenue

C. Flan Avenue

A. Boush Street

M. Kalambe Road

N.R. Mandela Road

M. Gontwe Avenue

M. Gontwe Avenue

Bambata Avenue

N.R. Mandela Road

H. Joseph Street

N. Agget Avenue



TO CONSTANTIA NECK

BUS STOP

PRIMARY SCHOOL

GRAVEYARD

SITE

TIERBOSKLOOF
High end residential

GREEN OPEN SPACE

RDP Housing

IMIZAMO YETHU TOWNSHIP

Informal Shacks

OLD WATER STORE

TABLE MOUNTAIN NATIONAL PARK





SITE STUDY:
Images by author.
Over 100 blue gum trees lining the site
in rows.





Analysis of Site and Surrounds

Slope & Climate

The site is situated on a very steep slope, the slope being North West facing meaning the site is hot in summer but warm on winter afternoons. Because the site is located in a valley, it is fairly protected but does receive a fair amount of summer wind as well as wind deflected from the mountains. The prevailing winds are strong north westerly winds in the winter and moderate to strong south easterly winds in the summer. The seasonal rainfall will mean that the site is dry in summer and wet in winter. This will affect the vegetation and the maintenance of the site as well as factors such as storm water management.

In response to these factors, the design will attempt to use the natural contours of the site for landscaping and accessibility and to create opportunities within the slope by creating seating and recreational spaces within its confines. The design will make efforts to make the most of the northern light for internal warming as the dappled shade of the gum trees will make the building relatively cold in the winter. Planting as a form of a wind break system will be considered for sheltered external spaces.

Vegetation

The vegetation on the site would have originally consisted of Peninsula Granite Fynbos, but this has been completely removed and now only exists in the Table Mountain National Park. Due to the fact that there is no natural vegetation left, the site has already been negatively impacted and thus is not sensitive. The large trees are, however, important from a cultural landscape point of view. New planting should consist mainly of indigenous trees such as Yellow Wood, hardy low-maintenance shrubbery and slow burning plants for fire protection.

Historical and Cultural

Hout Bay is a significant location for tourism as it is connected to scenic drives and routes and also contains a very scenic bay and harbour area. The forestry industry is historically significant and the fishing industry is still a major attraction. Imizamo Yethu has fed off the tourist industry by promoting the area through township tours and providing labour to the area. The site is located a row back from the scenic drive from Constantia Nek to the centre of Hout Bay. The area to the west of the site was originally part of the Kronendal Plantation Farm and the historical Kronendal furrow remains as a memory of this farm. Hout Bay as a tourist destination is important as it presents much needed economic opportunities. Development on the site aims to connect to existing tourist nodes as well as providing access for the broader public to the site.

Geology and Soils

The site exists on the rocks of the Cape Granite Suite and is covered by clay-rich gravelly sandy loam soil from the weathering of the granite. The site also contains some sandstone derived material washed down from the slopes, adding to the colluvial soil. The presence of granite implies that the soils are nutrient rich for vegetation. The presence of clay, however, can cause problems for water retention and heaving of foundations. The clay-rich soil found here has a high nutrient content, beneficial for vegetation. However, the high

clay content may lead to water logged soils or alternatively, areas with a steep gradient may lead to erosion.

Drainage and Storm Water

The presence of the mountain means that a large amount of water moves through the site and down to the Hout Bay Main Road. This water is then drained into the Dias River below the road and washed into the sea. Drainage on the site is in a south westerly direction. Possible use of a detention pond within the landscape plan can provide water flow as a positive influence and for the storage of water in case of fire or drought.

Visual Impact

Consideration of visual impact is extremely important along the scenic drive of Hout Bay Main Road. The design will attempt to maintain existing planting and aim to improve new planting which reinforces the site as a green space. A phased removal of the blue gum trees and a replanting of slow burning indigenous Yellow Wood trees will help to lower a fire spreading risk to the site. Evergreen trees will be used to create visual relief as well as reducing noise and air pollution. In so doing, the new facility may add to the overall aesthetics of the area.

Fire Risk & Fire Management Plan

Due to fast burning gum trees on site and the close proximity to the mountain veld, the trees on the site pose a threat to the workshop itself as well as the spread of a fire to the surrounding areas. In order to prevent fires or the further spread thereof, the design will attempt to follow the Veldfire Related Planning Guidelines as far as possible, as well as being cautious when enforcing fire regulations such as fire extinguishers, safety and evacuation procedures and sprinkler systems. Clip-on wire gauze screens on windows will also contribute to reducing fire damage.

Gradual replacing of the gum trees with indigenous trees will allow for Fynbos to naturally return. Phased removal of trees will start with a 9m clear zone surrounding the building. The felled gum trees would then be used as materials for the workshop.

The landscape plan will use a 15 meter fire break surrounding the site boundary to reduce a fire hazard to neighbouring sites. A lower service entry or "fire road" will provide fire fighters with easy access to the site. Storage of flammable materials such as log piles and storage of sawed timber will be placed away from the main building in a timber shed.

Other Veldfire Related Planning Guidelines:

- 15m firebreak bordering other properties
- Surround building with wide roads of gravel, concrete, pavers etc.
- On-site water storage
- Plant Fire resistant plants
- Plant hedges against boundaries (not cypress)
- Plant vegetable gardens
- Sprinkler installation
- Surround access to all parts of the building for fire trucks
- Place timber storage away from building
- Build with non-combustible materials: tar, paving, soil, concrete, stone, and landscaped grass.
- Tree wind break to prevent spread of fire
- Safe Exit strategy

Social

Development of the site aims to create public space which will provide recreational and community activities for the surrounding community. Use of the building as a community meeting venue will increase the building's use and allow for community gathering. The project also aims to draw residents from the broader community of Hout Bay and link with existing tourist routes.

Timber Resources in Hout Bay

Hout Bay has an abundance of natural and recyclable timber resources which can be used in parts of the construction of the building as well as material for experimentation in the workshop. Timber resources come from the remaining timber plantations, the Hout Bay Waste Drop Off and recycled timber from the Harbour.

Hout Bay still has remains of timber plantations growing many large trees which are both indigenous and exotic. Indigenous species include Wild Fig and Vlier trees and are native to Hout Bay. Many very large trees along the road edges and on the old forestry site contribute significantly to the landscape. Besides many types of pine and gum trees, these include Malaysian Banyan as well as exotic hedge of New Zealand Christmas Tree and Brazilian Pepper Trees. Throughout the area there is also a vigorous growth of Kikuyu grass.

The Hout Bay Waste Drop of, not more than 1km away from the site, sorts their recycling waste into material recovery containers. Large containers filled with useable recycled timber and timber pallets are recovered and available to the community to sort and re-use.

At the Harbour, the shipyard stores useable pieces of wood which comes off the boats after maintenance. The beneficial aspect of ship timber is that it is already treated. The surrounding fisheries in the area also hold hundreds of timber pallets which can be recycled and re-used as workshop material.



TIMBER PALLETS FROM
SURROUNDING FISHERIES



SHIP YARD TIMBER
RECYCLING



HOUT BAY
WASTE DROP-OFF



HOUT BAY FOREST
PLANTATIONS

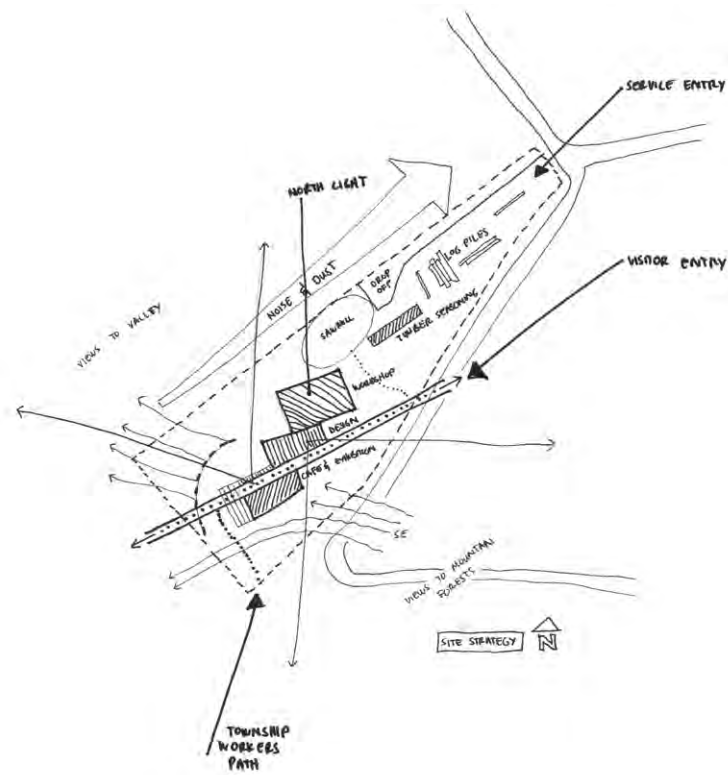
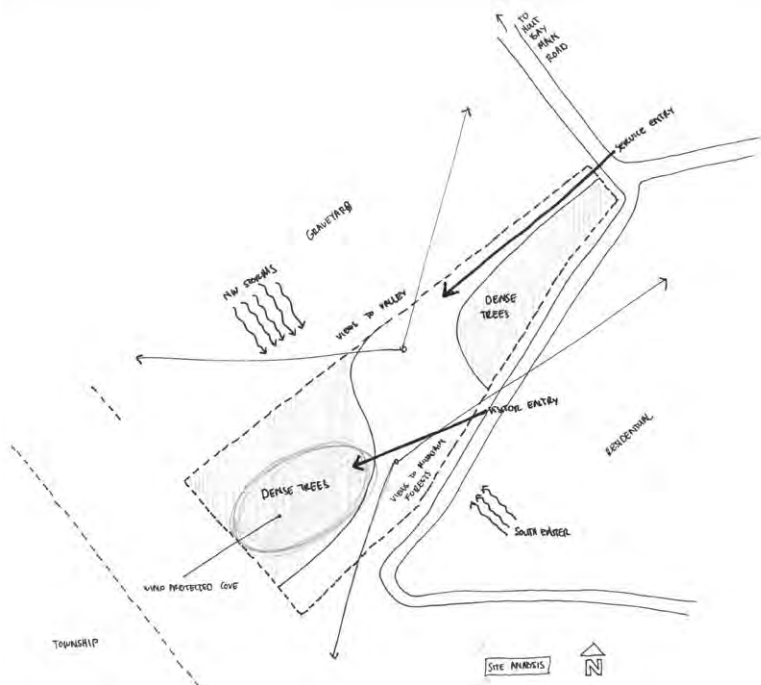

SITE AND DESIGN STUDY:
Site analysis and conceptual site strategy sketches

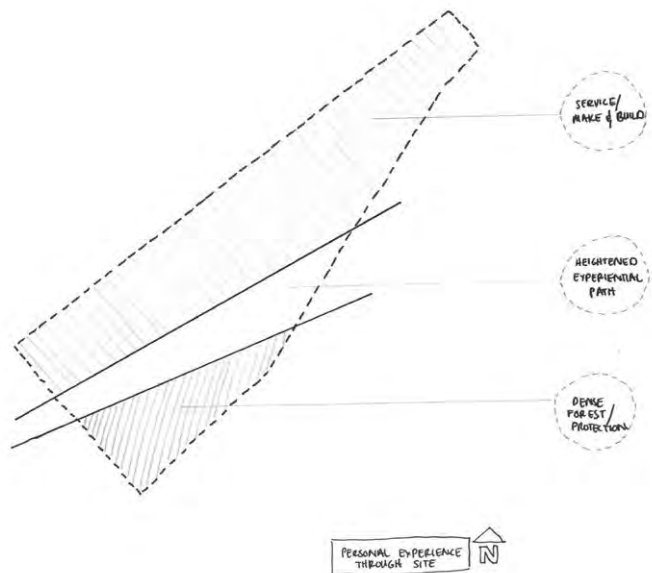
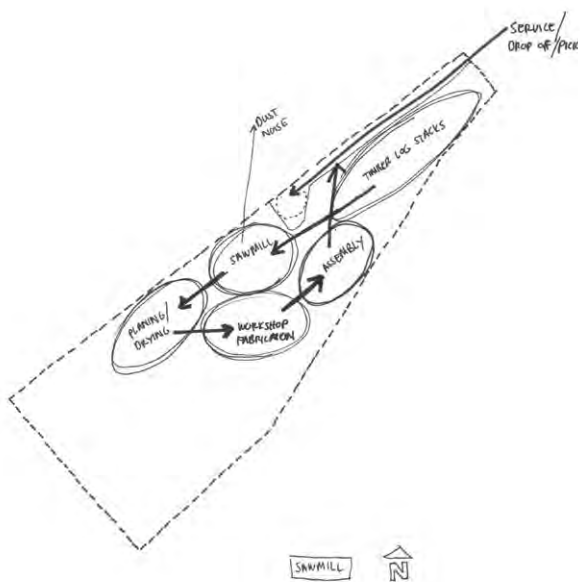

Design Development Relating to Site, Programme & Context

Site Proposal

Consequent to the site being so close to the main scenic drive, the need to retain the site as a green space was taken into account in order to retain the visual character of the scenic route. After mapping the location of the blue gum trees on the site, it became clear where the facility should be positioned in order to minimise tree removal. This would also retain the dappling light effects and tranquil spatial quality that the gum trees provide.

The centre would also need to blend into the landscape and morph into the slope to maintain a forested visual character. It was thus decided to cut/cut-and-fill the building into the steep contours rather than protruding the building on stilts above the ground.

The cut/cut-and-fill structural approach also helps to dampen noise from the machinery in the workshop. Consequent to the site being adjacent to a residential area, this design consideration was fundamental for the building to be successful within its context.

Excellent light quality within the working spaces of the centre is vital for a successful working and learning environment. It was thus decided to rotate the building to a north facing orientation and take advantage of good quality light that the north facing facade provides. The orientation to the north also accommodates the building more comfortably onto the 'triangular-like' shaped site and follows the lines of the contours.

Next, the building was cut into three tiers; workshop, design and exhibition and stretches along the length of the site. This increases the façade area and allows more spaces within the building to benefit from the northern light. The idea of this footprint also permits a good connection between the inhabitant and the forest reinforcing the bond between the woodworker and the woods.

To deal with slope and access, each tier is situated at 1.5m interval levels and is connected by an in-between circulation zone. This space contains a ramp and a staircase and links all the tiers together. The façade materiality of the circulation zone will be treated differently to allow them to light up at night and to emphasise these spaces as circulation space.

There are two access points allowing for a service entry and a visitors entry. The service entry would need to be wide enough to allow for large vehicles to off-load timber logs, as well as an appropriate size space for turning and exiting the site again.

The chosen desire line pathway through the site was a personal one. This pathway has a high spatial quality on the site as it meanders through the trees with a dappled view of the valley. For an encompassing effect the design therefore seeks to place the building around the desire line for heightened experience of the forest by the users.

The design proposal also suggests making complimentary offset areas from this pathway with seating spaces for contemplation as well as tree cultivation gardens and tree labelling for educational meandering. Thus, the design proposal strives to utilise the desire line as an educational tool emphasising the pathway and amplifying the experience of the visitors when approaching the building as well as while moving within the building.

Although the presence of a fence around the site restricts public free flow, it does ensure that the site does not become a settlement area or an area for mischievous behaviour. A boundary fence also aids in the creation of an identity for the centre with a sense of place and safety as one moves across the gateway threshold. The spaces which connect to the security gate are enhanced through paving and planting. Fencing with "clearvu" is chosen to maintain visual connectivity and safety.

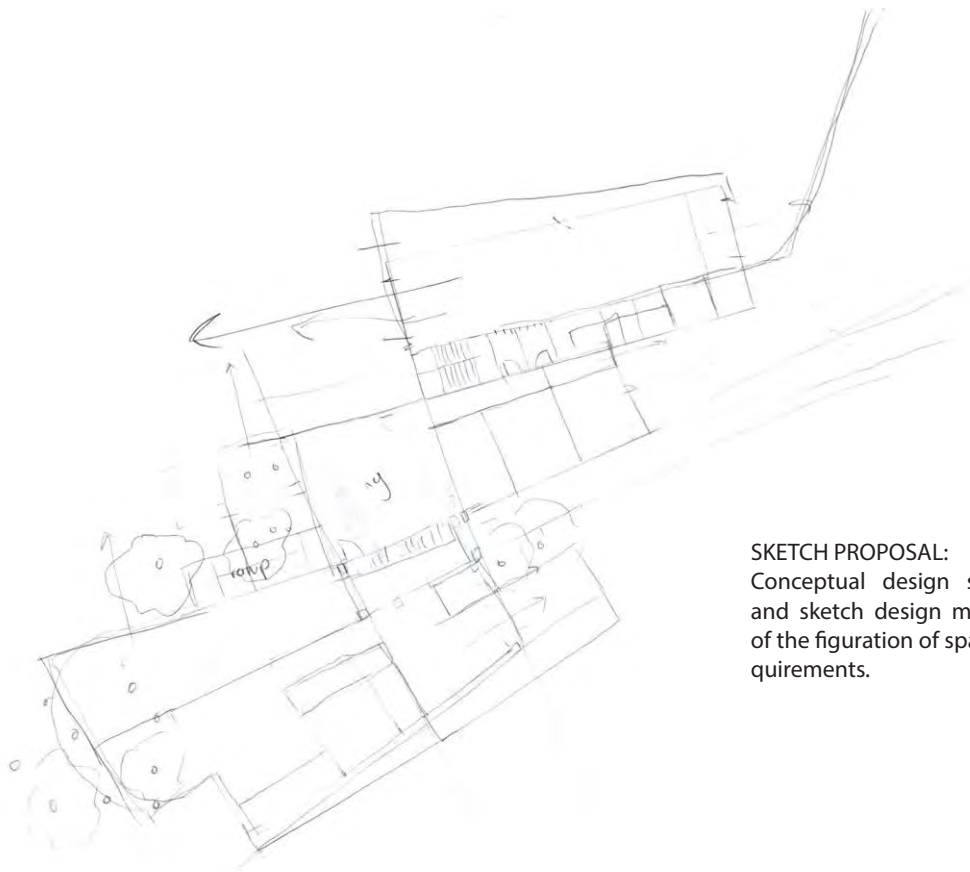

SKETCH PROPOSAL:
Conceptual design strategy sketches
and sketch design model explorations
of the figuration of spaces and space re-
quirements.

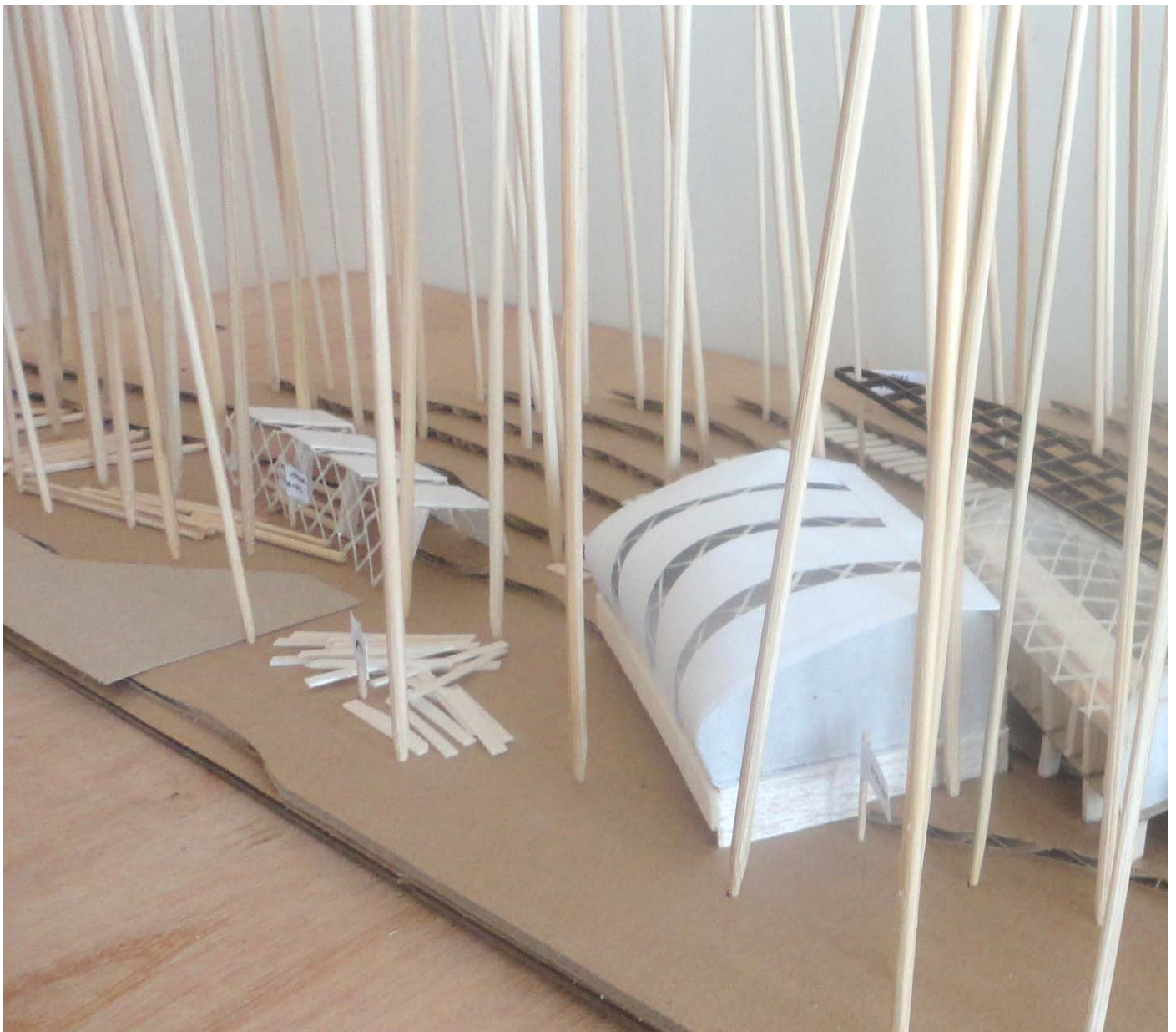

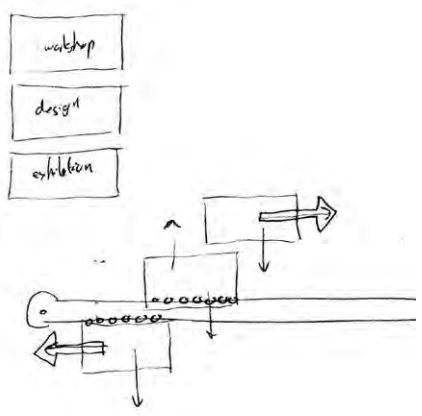
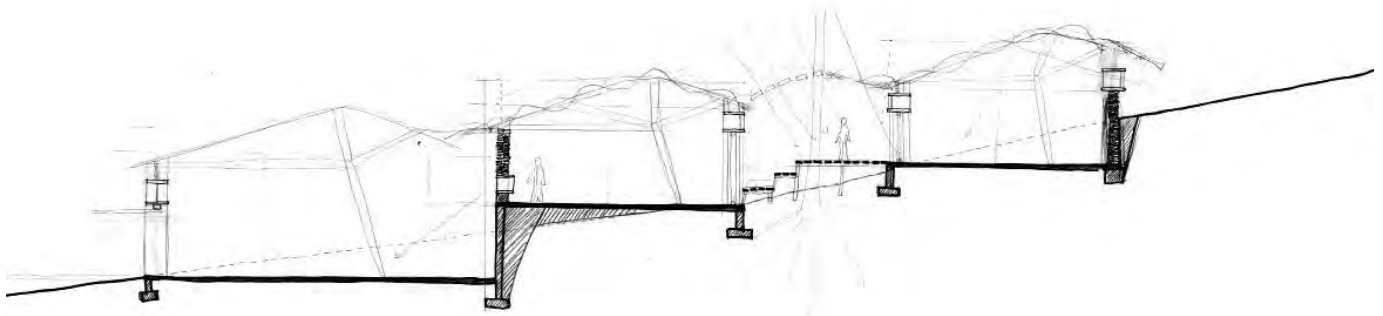

Above:
SITE STUDY
Cut-and-fill / cutting through site, distinguishing possible opportunities regarding light, noise and slope.

Below:
SITE STUDY
Sketch design model exploring the positioning of the three tiers into the slope.



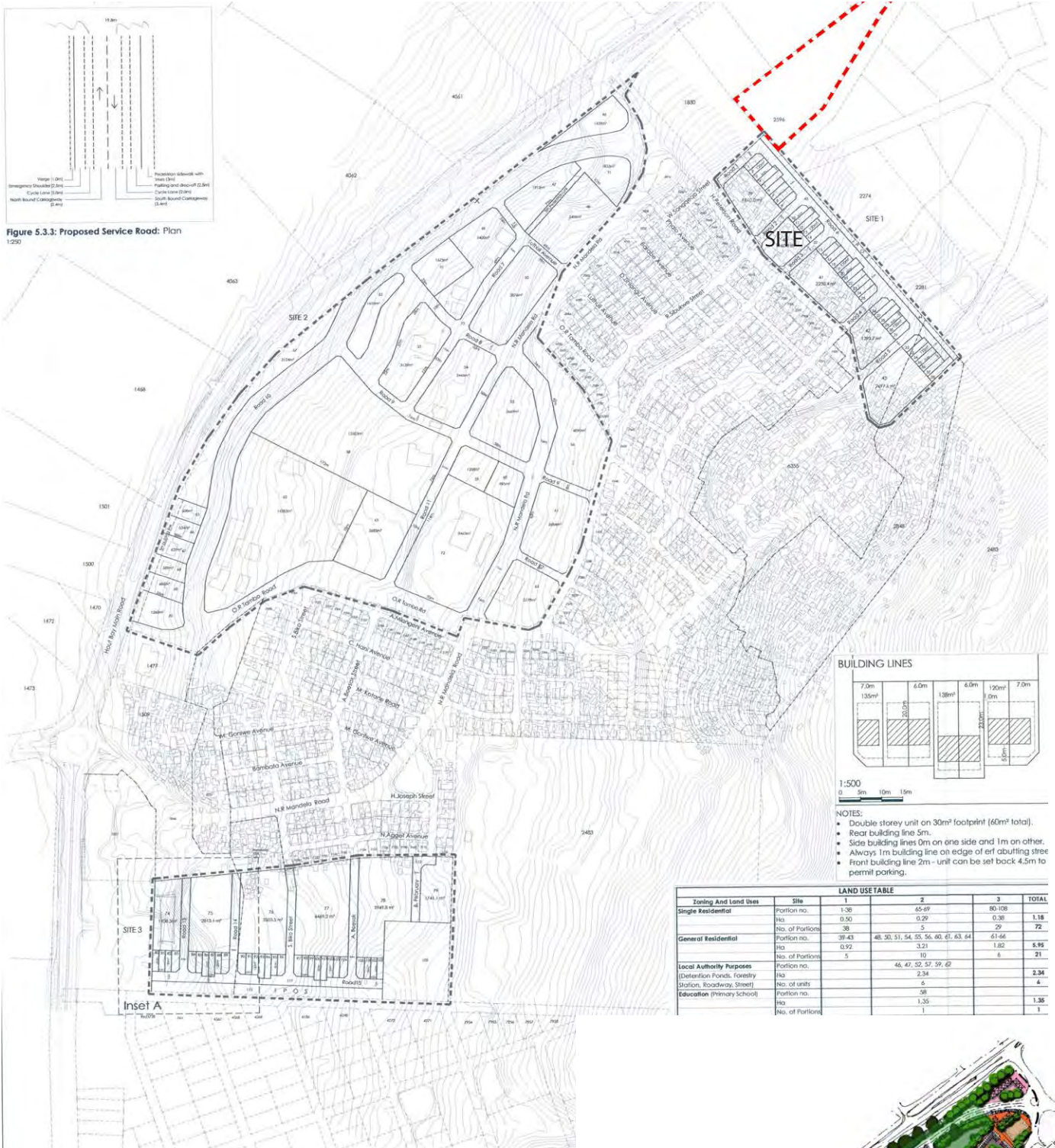

Figure 8: Above
UPGRADE DEVELOPMENT PLAN FOR IMIZAMO YETHU TOWNSHIP IN PROGRESS
(Source cannot be disclosed)

Figure 9: Left
Image showing approved layout plan for residential, community and local authority zoning.
(Source cannot be disclosed)



Urban Relationship to Imizamo Yethu and the Greater Surrounding

An upgrade development plan for Imizamo Yethu informal settlement is currently in progress and attempts to take into account the concerns of the neighbouring residents, to improve social-economic status of the Imizamo Yethu residents and to create a greater sense of community due to the tension between the very low- and very high-ended residential areas. The development plan involves the upgrading of the existing township into formalised mixed-use and residential development over three sites. The proposal also involves the construction of a school (already completed), community facilities, public open space and the various access roads and services needed in the area.

The proposal for the Wood Innovation Design Centre attempts to take into consideration, incorporate the upgrade development plan for the township and to create a sense of ownership amongst the community. Issues such as safety, access, parking, the use of local labour, shared community open space, parking etc. are dealt with in the following ways:

- Open up the road to allow vehicle and pedestrian access from the township.
- Give part of the site back to the community for a public open space for recreation and community activities (Imizamo Yethu currently has no accessible green space and only one play area). The Design Centre responds to the need for positive public space in Imizamo Yethu and the need for shared space with the surrounding neighbourhoods.
- Provide a communal entrance between the two neighbourhoods so as not to favour the one over the other and giving a sense of ownership to all.
- Provide a security box / surveillance tower / controlled entry access gate for a feeling of safety.
- Involve the local community with the construction of centre.
- Provide poverty and income relief for the Hout Bay unemployed population by recruiting workers from the local community to be trained on site during the construction of the centre. Projects such as these have been proven by VPUU (Violence Prevention through Urban Upgrading Organisation) to help create a sense of ownership and pride and substantially reduce the extent of vandalism. The trainees will then be trained to become independent contractors or to be re-employed in similar projects. They can also further their own career paths where they can make products in the workshop and start their own businesses.
- Provide +20 secure on-site parking bays.

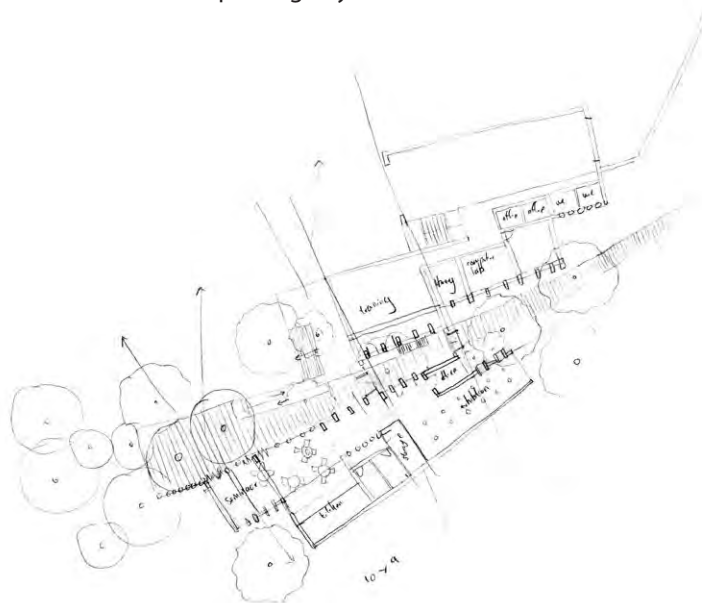

DESIGN CONCEPT SKETCH

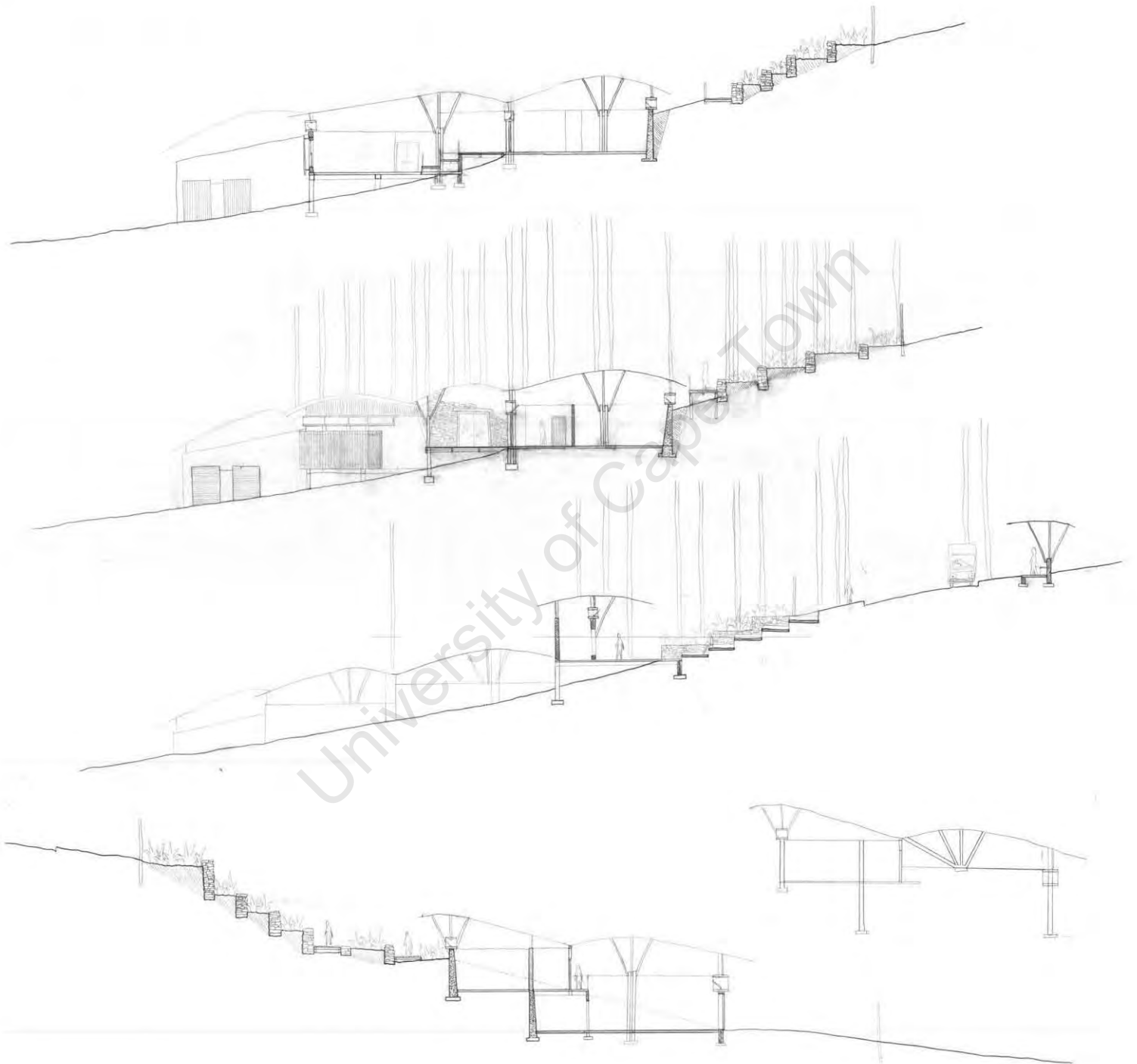



SKETCH DESIGN STUDY: Contextual Gesture

Sketch design studies showing contextual response: cutting away at the site and giving it back to the community with a community park for shared use between high-end residential and informal settlement inhabitants for creating a better sense of community between the two tensioned neighbourhoods.



Figure 10:
Image showing the construction of a hyper thin concrete roof
(Osbbc.ca, 2013)

Steam-Bent-Gridshell Structure Roof Design: Relation to Site & Programme

The structural concept for the project was to reflect a sense of forest within the building, so that the inhabitants inside will always be reminded of the value of being familiar with wood. This was done by using cut down gum trees from the site as column structures for the gridshell roof, therefore continuing the feeling of the forested site within the building.

With the building being sliced into 3 tiers and pulled apart along its length into three slithered spaces (workshop, design and exhibition), the idea was that a large continuous gridshell roof structure would link the three spaces together. The roof would therefore act as a weave, connecting the parts together into one spatial whole.

The next step was to develop the wall and roofing condition relating to structure, context, site and programme. The following typical conditions were identified:

- Wall (timber), cross-ventilation window and gridshell roof.
- Sliding door, cross-ventilation window and gridshell roof.
- Circulation zone façade.
- Workshop gridshell with laminated beams and floor end connections.
- Hypar cement roof covering.

The roof covering is made up of a "hypar" roof covering, a roofing technique pioneered by George Nez. This roofing technique involves an acrylic cement composite applied to a curved surface to create a hypar thin shell concrete roof. Rather than using lumber formwork to create a structural skeleton, a hypar roof uses very little material to create a frame that relies instead on a stretching of fabric or mesh over the frame to form the shape of the curve.

The process is low-tech and low cost and involves stretching a nylon plaster mesh or fabric over a timber frame and stapling it in place. The roof is then coated with a slurry of cement and latex/acrylic admix. Several coating layers are required to form a minimum thickness of 1cm, which is strong enough for multiple people to walk on (Tscglobal.org, 2013). The roof requires 2 or 3 days to cure.

As the project is based on experimental timber construction, the buildings uses timber as its main material palette. Walls use post-and-beam construction, clad with tongue and groove 22mm timber on the outside, and lime plastered on boards on the inside. Floors consist of raised tongue and groove timber floors which are supported by foundations to engineers specifications. This however, doesn't apply to the workshop where a concrete floor will be laid to prevent damage from woodworking.

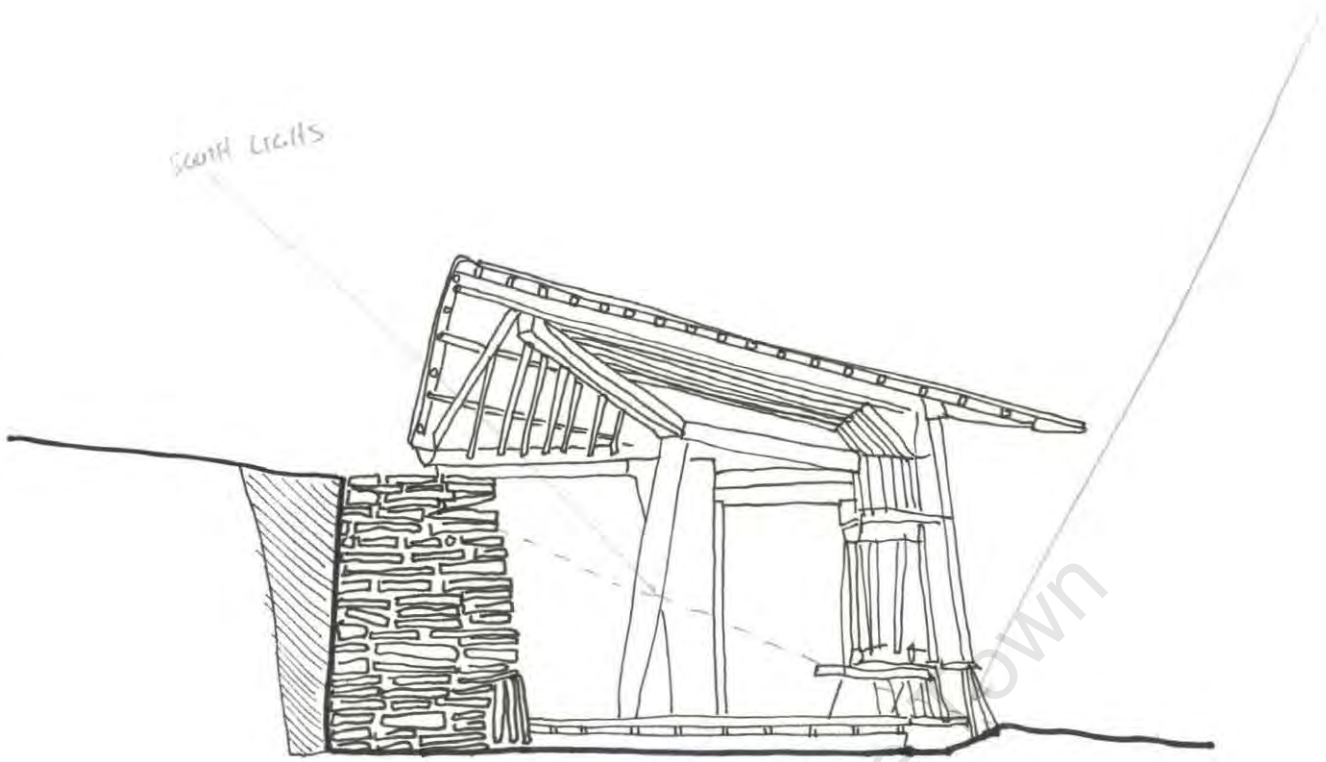

SOUTH LIGHT

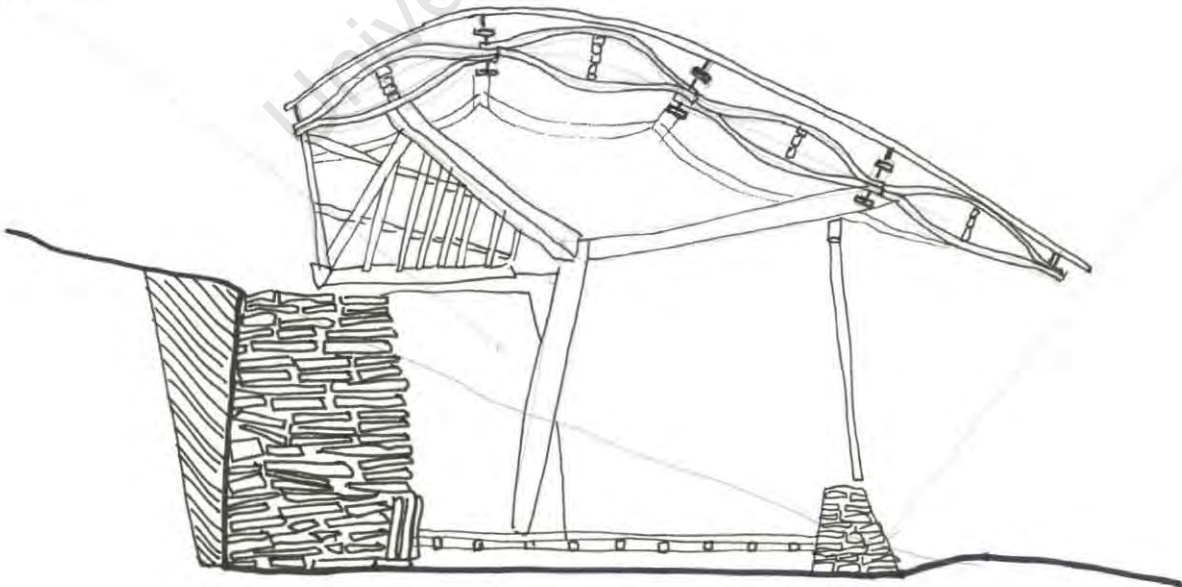

TECHNICAL STUDY:
Explorational sections and imagining of the tectonics of the building using standard pine products for the roof structure and locally sourced stone from local quarries.

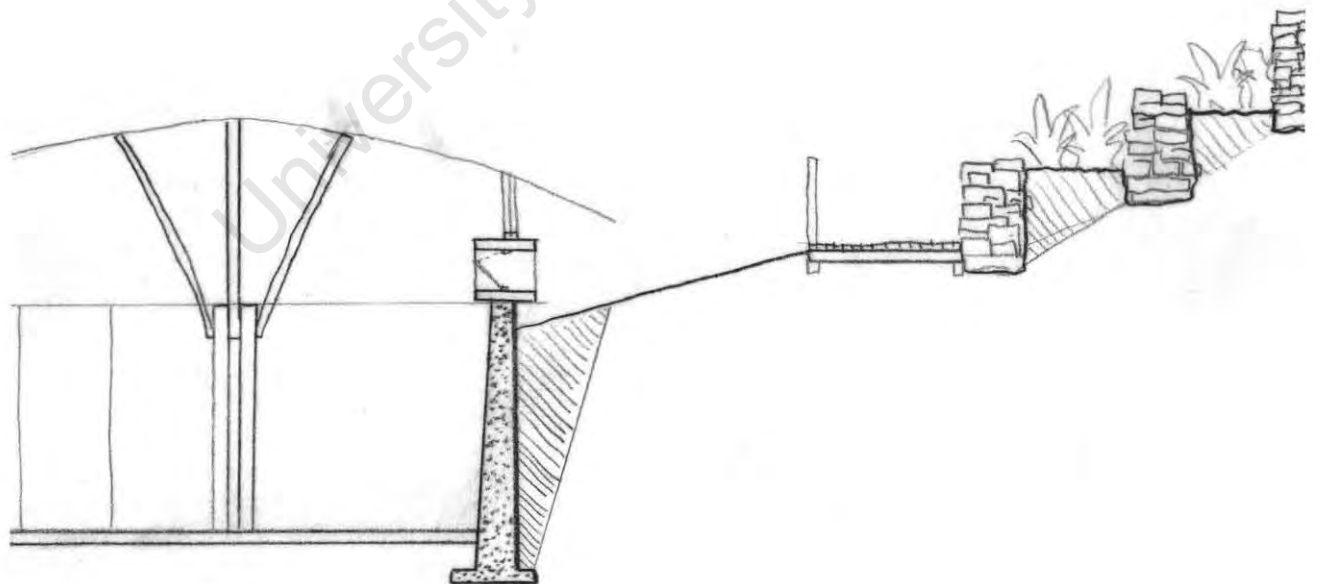
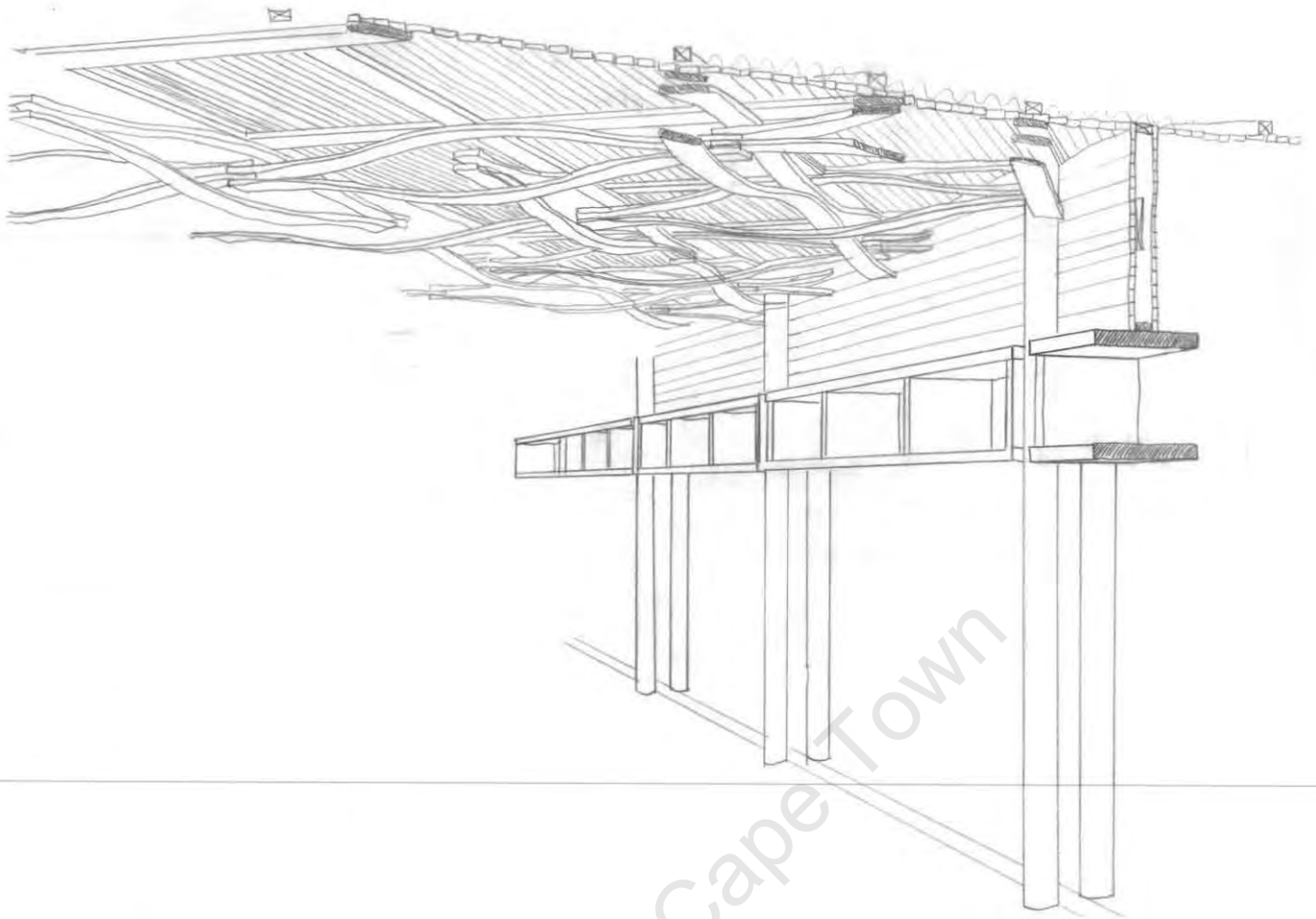

Top Left:
MATERIALITY STUDY
 Sectional studies showing typical detail through glass sliding doors, cross-ventilation window and gridshell roof.

Bottom Left:
SECTIONAL STUDY:
 Section through building showing relationship between pedestrian path and terraces, pedestrian path and building, and building & retaining wall with window details.

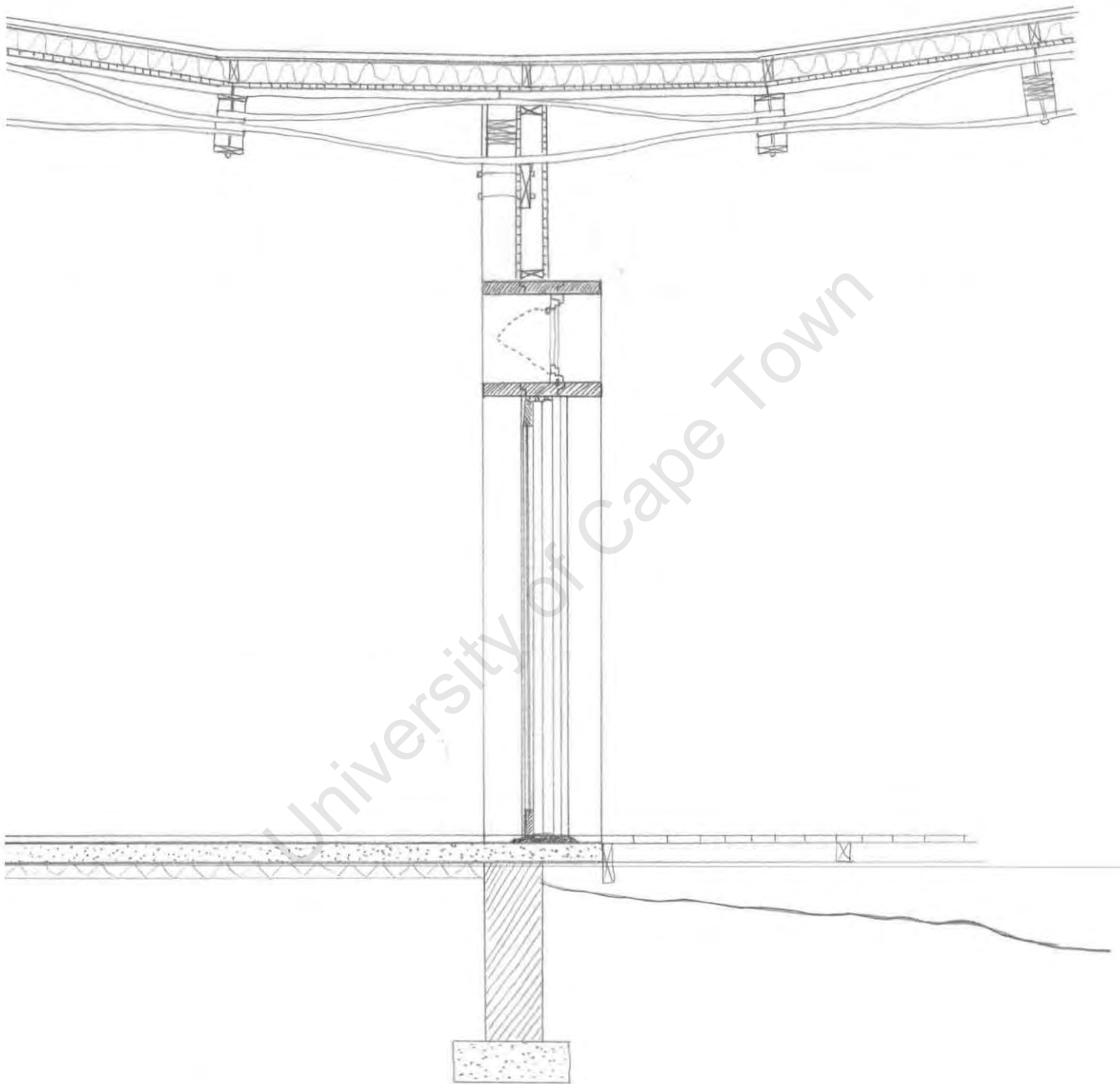

MATERIALITY STUDY:

Sectional detailing: exploring ways to resolve the complicated steam-bent-gridshell roof and wall. The inconsistent gridshell roof leaves factors influencing the type of enclosure and waterproofing.

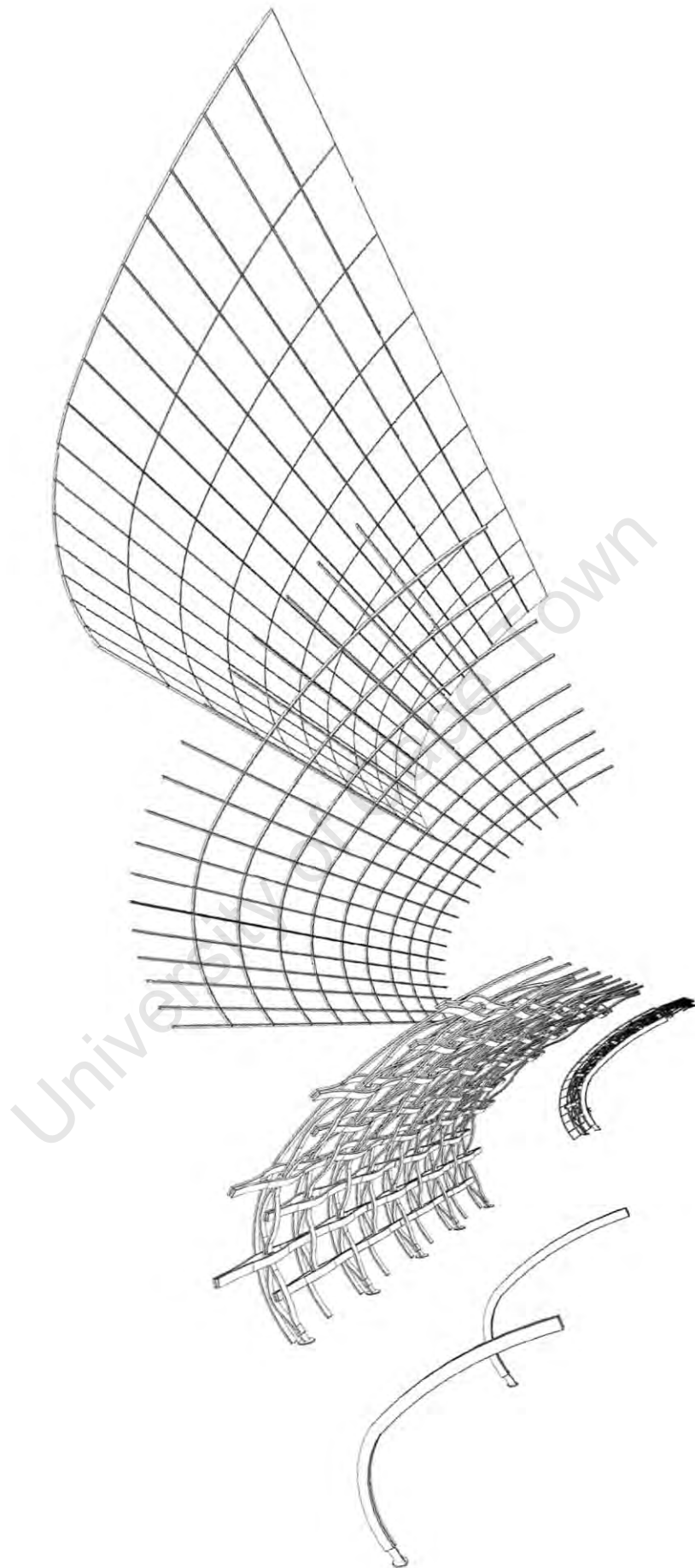

DESIGN STUDY

Exploration with a large open space in the workshop using laminated beams prefabricated on site and steel tensile rods as bracing elements.

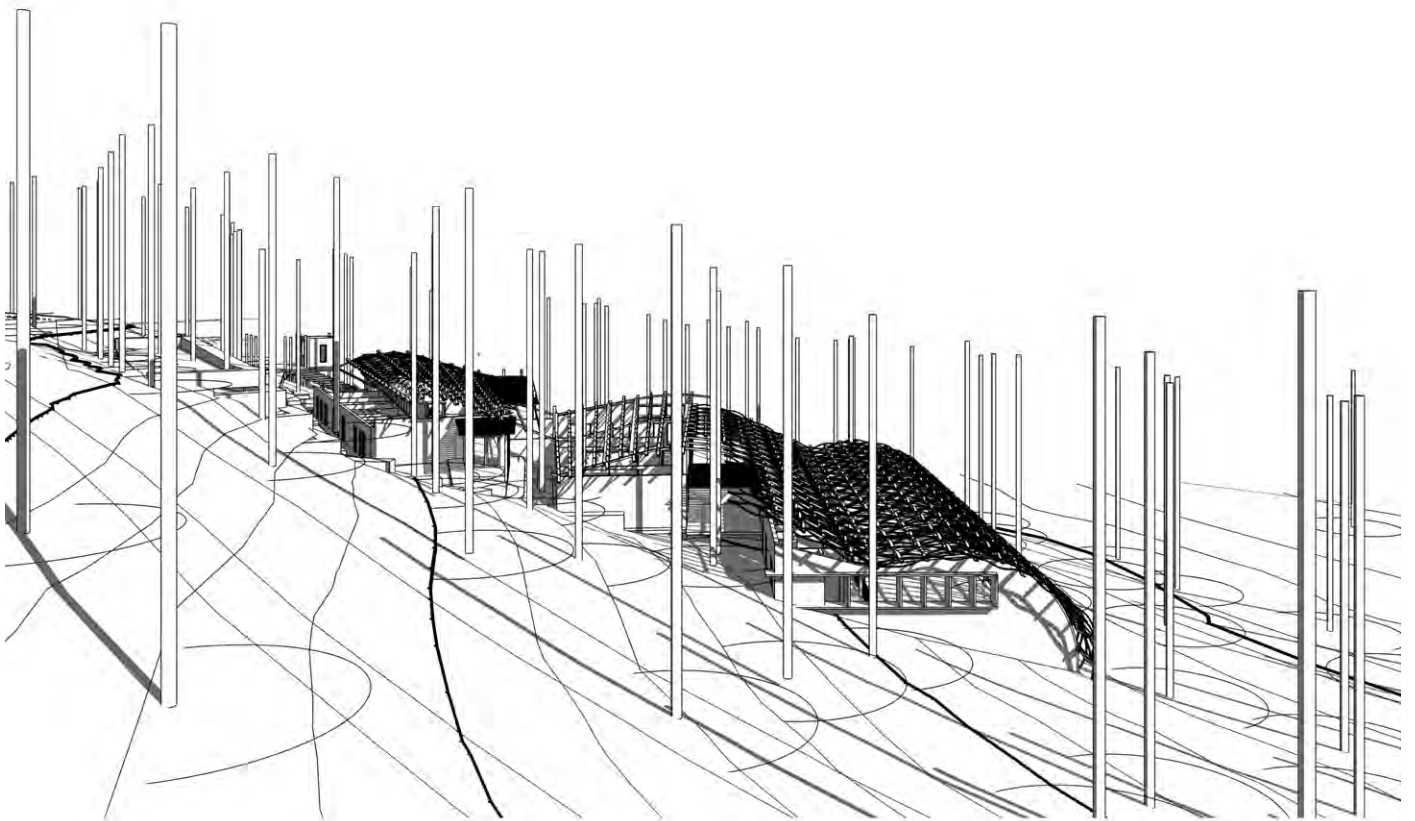
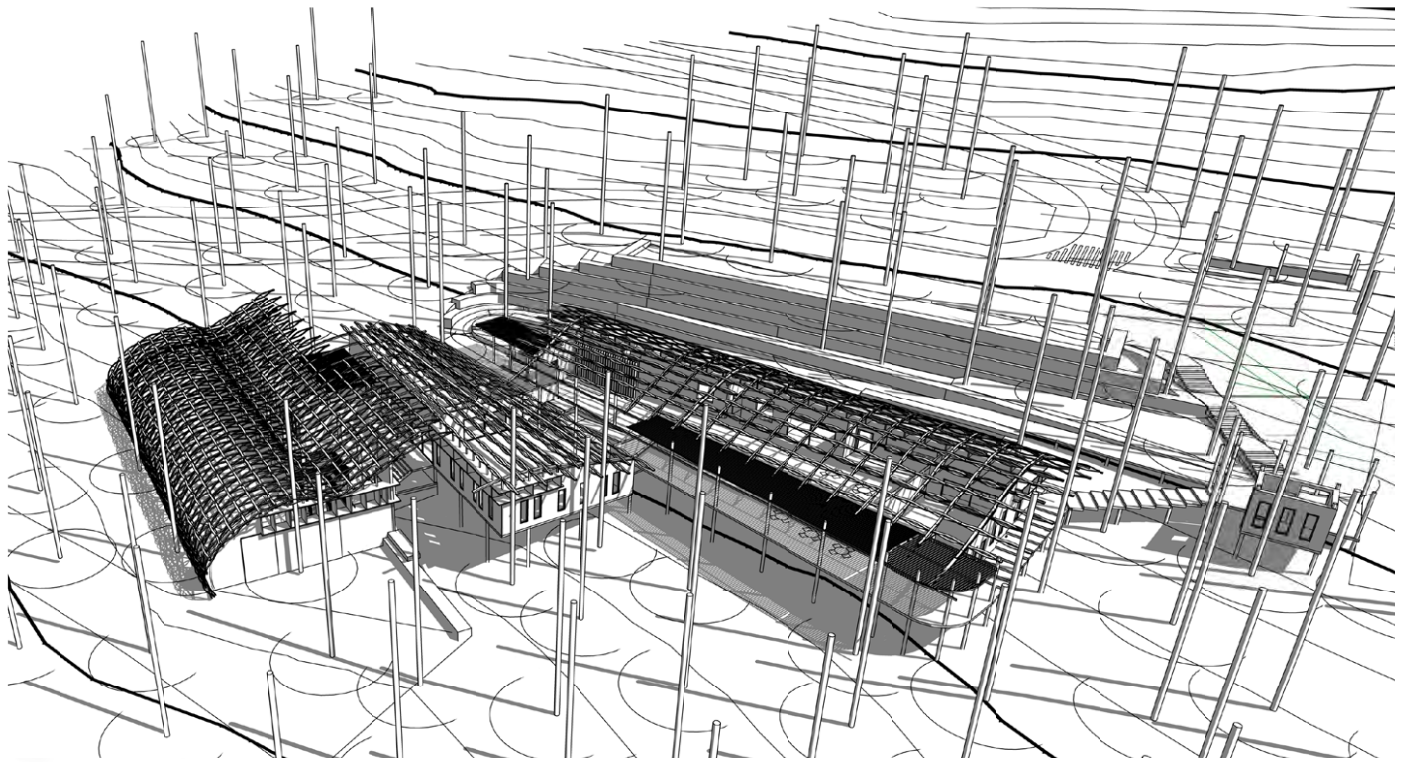

Above:
3D STUDY
Modelling of roof and building on site

Below:
3D STUDY
Modelling of roof and building on site. View from street as
you approach the building.

Conclusion

Commencing the year with a discovered passion for the 'act of making' and an interest in the expressive and poetical nature of construction, the year played out as a process of exploration and discovery into experimental timber construction. This alternative design process fulfilled the pursuit to learn and discover as much as possible about materials and their potentials and how this understanding is fundamental to the innovative making of structurally realistic forms as well as expressive architectural space-making and storytelling building qualities.

Up until this point, the design dissertation has followed the alternative design process stated in the first part of the design report. After substantial studies into timber as a material and analysis of contemporary timber structures, an innovative imagining of a structural type using standard pine was developed; the steam-bent gridshell. Throughout the year, a jumping between mediums of 2D sketching, conceptual modelling, small scale prototyping, 1:1 scale modelling and 3D digital modelling fuelled the ideas and understanding of timber's inherent properties, complex structural forms in timber, and its imagining in a structural and innovative form.

The steam-bent gridshell was then applied to an appropriate programme so that the particular spatial quality provided by the structure would suite the particular spatial requirements of the building. The final built project called for a Timber Innovation Design Centre in Hout Bay. Taking the steam-bent gridshell into a contextual setting, a final built form was explored, growing out of not only structural experimentation but also the adaptation to suite site and contextual considerations.

Local materials and local labour was then included into the project details in order to gain a sense of ownership, place-making and familiarity amongst its inhabitants for a meaningful building within their neighbourhood. With tension between the very rich and very poor living alongside one another in Hout Bay, a considerable amount of thought went into providing a public shared space with the prospect of bringing the two together in order to create harmony and a better sense of belonging within the community.

Thus, the design of the final built form manifested itself out of an empirical experimentation and exploration process for an expressive and meaningful form, as well as a responsive reading of site and surrounding. Throughout this process, it was learnt that a fundamental aspect to meaningful spaces is also in providing a sense of familiarity amongst its inhabitants.

To conclude, the final design attempts to convey the rich story of Hout Bay's history and its inhabitants through its structural tectonic expression. Small inaccuracies and mistakes in the resultant building hope to deepen the tale of its crafted nature, built by the hands of the locals themselves. The building's relationship between its materials hope to form the perceptual structure for perceiving it as meaningful, and to express an enriched narrative to which one can construe their own story to the mystery of its making.

REFERENCES

- Benjamin, W. 2003. Extracts from "The Work of Art in the Age of Mechanical Reproduction". *The Photography Reader*. London: Routledge.
- Carpenter, W, 1997. *Learning by Building: Design and Construction in Architectural Education*. Van Nostrand Reinhold: London.
- Frampton, K. 1990. Rappel a l'ordre: the case for the tectonic. *Architectural design*, 60 (3-4), pp. 19--25.
- Frascari, M; 1981. "The Tell-the-tale Detail," *Theorizing a New Agenda for Architecture: An Anthology of Architectural Theory*, edited by Kate Nesbitt. Princeton Architectural Press: NY, 498-513.
- Harris, R., Dickson, M. and Kelly, O. 2004. *The use of timber gridshells for long span structures*. pp. 1001--1006.
- Herzog, 2008. *Timber Construction Manual: Cultural Dimension*. Birkhause: Boston, PP 8.
- Larsen, OP, 2008. *Reciprocal Frame Architecture*. Elsevier: London.
- Pallasmaa, J, 2005. *The Eyes of the Skin: Architecture and the senses*. Academy Press: London.
- Tscglobal.org. 2013. HyPar Thin Shell Concrete Roofs - TSC GlobalTSC Global. [online] Available at: <http://tscglobal.org/product/> [Accessed: 12 Oct 2013].
- Zwerger, K, 1997. *Wood and Wood Joints: The Material*. Birkhauser: Boston, PP. 10-39.

BIBLIOGRAPHY

- Bell, D. 2004. A lost aesthetic: traditional architectural form in wood and its neglect. *Architectural Heritage*, 15 (1), pp. 1--19.
- Benjamin, W. 2003. Extracts from "The Work of Art in the Age of Mechanical Reproduction". *The Photography Reader*. London: Routledge.
- Besson, R, 2012. 'Manufacturing Difference,' *Dossier*, Sept/Oct 2012, pp. 86-87.
- Calder, D & Charleson. 'Developments in Japanese Timber Architecture,' *NZ Timber Design Journal*, 4: 6, pp. 11-20.
- Canadian Wood Council, 1991. *Wood Reference Handbook*. Canada.
- Carpenter, W, 1997. *Learning by Building: Design and Construction in Architectural Education*. Van Nostrand Reinhold: London.
- Miralles, E., Tagliabue, B., Márquez Cecilia, F. and Levene, R. 2000. *Enric Miralles, Benedetta Tagliabue, 1996-2000*. Madrid: El Croquis Editorial.
- Erman, E. 2002. Timber joint design: the geometric breakdown method. *Building Research & Information*, 30 (6), pp. 446--469.
- Findley, G, 1999. *Rope Works + T: square, diagonal and sheer lashing*. Pdf
- Frampton, K. and Cava, J. 1995. *Studies in tectonic culture*. Cambridge, Mass.: MIT Press. "Introduction: Reflections on the Scope of the Tectonic" pg 1-27.

- "Jorn Utzon: Transcultural Form and the Tectonic Metaphor" pg 247-298.
 "Carlo Scarpa and the Adoration of the Joint" pg 299-334.
 "Postscriptum: The Tectonic Trajectory, 1903-1994" pg 335-376.
 "The Owl of Minerva: An Epilogue" pg 377-388.
- Frampton, K, 1998. *The Details of Modern Architecture*, Volume 2. MIT Press: England.
- Frampton, K. 1990. Rappel a l'ordre: the case for the tectonic. *Architectural design*, 60 (3-4), pp. 19--25.
- Frasconi, M; 1981. "The Tell-the-tale Detail," *Theorizing a New Agenda for Architecture: An Anthology of Architectural Theory*, edited by Kate Nesbitt. Princeton Architectural Press: NY, 498-513.
- Gregotti, V. "The Exercise of Detailing," *Theorizing a New Agenda for Architecture: An Anthology of Architectural Theory*, edited by Kate Nesbitt. Princeton Architectural Press: NY 494-497.
- Gutdeutsch, G, 1996. *Building in Wood: construction and details*. Birkhauser: Boston.
- Hansen, H. and Berg, A. 1971. *Architecture in wood*. New York: Viking Press.
- Harris, R., Dickson, M. and Kelly, O. 2004. *The use of timber gridshells for long span structures*. pp. 1001--1006.
- Herzog, 2008. *Timber Construction Manual: Cultural Dimension*. Birkhauser: Boston.
- Kolarevic, B. 2003. *Architecture in the digital age*. New York, NY: Spon Press.
- Kolarevic, B. and Klinger, K. 2008. *Manufacturing material effects*. New York: Routledge.
- Larsen, Olga Popovic, 2008. *Reciprocal Frame Architecture*. Elsevier: London.
- Lecuyer, A. 2001. *Radical tectonics*. New York, N.Y.: Thames & Hudson.
- McCleary, P, 2003. 'Innovations in Architectural Technology,' *Phi Kappa Phi Forum*, 83: 3, pp. 40-43.
- McCullough, M, 1998. *Abstracting craft: The Practiced Digital Hand*. MIT Press: USA.
- McQuaid, M, 2003. *Shigeru Ban*. Haidon Press Limited: London.
- Mori, T; 2002. *Immaterial | Ultramaterial: Architecture, design and materials*. George Braziller: New York.
- Neumann, O & Schmidt, D, 2006. 'CNC Timber Framing - Innovative Applications of Digital Wood Fabrication Technology', pp. 4-7.
- Aalto, A., Pallasmaa, J., Sato, T. and Ban, S. 2007. *Alvar Aalto*. London: Black Dog Publishing.
- PG Bison, 2009/2010, *PG Bison: Allied products*.
- Unknown. 2013. *Round timber in construction: An introduction* [online] Available at: [http://www.forestry.gov.uk/pdf/crwoodproducts27.pdf/\\$file/crwoodproducts27.pdf](http://www.forestry.gov.uk/pdf/crwoodproducts27.pdf/$file/crwoodproducts27.pdf) [Accessed: 8 Sep 2013].
- Saarinen, E, 1950. *Search for Form: a fundamental approach to art*. Reinhold Publishing Corporation: New York.
- Schon, D, 1985. *The Design Studio: An Exploration of its Traditions and Potentials*. MIT &

RIBA: England.

Sobon, J & Schroeder, R, 1994. *Timber Frame Construction: all about post-and-beam buildings*. Courier Fourteenth Printing: USA.

Tscglobal.org. 2013. HyPar Thin Shell Concrete Roofs - TSC GlobalTSC Global. [online] Available at: <http://tscglobal.org/product/> [Accessed: 12 Oct 2013].

Van Wyk, L, 2000. "Kirstenbosch Resaurant", *Digest of South African Architecture*. pp. 12-16.

York.co.za. 1930. *York - York Timber Holdings Limited: Properties of SA Pine*. [online] Available at: http://www.york.co.za/ops/properties_sapine.asp [Accessed: 8 Sep 2013].

Zwenger, K, 1997. *Wood and Wood Joints: The Material*. Birkhauser, Boston.

FIGURE REFERENCES

(ALL IMAGES BY AUTHOR UNLESS LISTED AND SITED BELOW)

Figure 1

Zwenger, K. 1997. *Wood and wood joints*. Basel: Birkhauser.

Figure 2

Herzog, T. and Zeitler, F. 2004. *Timber construction manual*. Basel [u.a.]: Birkhäuser [u.a.].

Figure 3

#1 Cape Pine | Forests | Sawmilling. 2013. Products - #1 Cape Pine | Forests | Sawmilling. [online] Available at: <http://www.capepine.co.za/product/> [Accessed: 8 Sep 2013].

Figure 4

FABRICATION STUDIO for CNC LASER CUTTING. 2012. The Architecture Association's woodland campus, Hooke Park. [online] Available at: <http://uemfab.blog.com/2012/05/08/the-architecture-association%E2%80%99s-woodland-campus-hooke-park/> [Accessed: 8 Sep 2013].

Figure 5

Tdwa.com. 2012. Event Report (1): TOKYO DESIGNERS WEEK 2011 | TOKYO DESIGNERS WEEK 2013. [online] Available at: http://www.tdwa.com/en/tdw/news/2011reports/tokyo_designers_week2011.html [Accessed: 8 Sep 2013].

Figure 6

Mangaia-cookislands.blogspot.com. 2010. Mangaia - Cook Islands: July 2010. [online] Available at: http://mangaia-cookislands.blogspot.com/2010_07_01_archive.html [Accessed: 8 Sep 2013].

Figure 7:

Google Earth

Figure 8:

Source cannot be disclosed

Figure 9:

Source cannot be disclosed

Figure 10:

Osbbc.ca. 2013. *Ontario Straw Bale Building Coalition - Hypar Lightweight Roofing Workshop*. [online] Available at: <http://www.osbbc.ca/events?eventId=705475&EventViewMode=EventDetails> [Accessed: 12 Oct 2013].

University of Cape Town

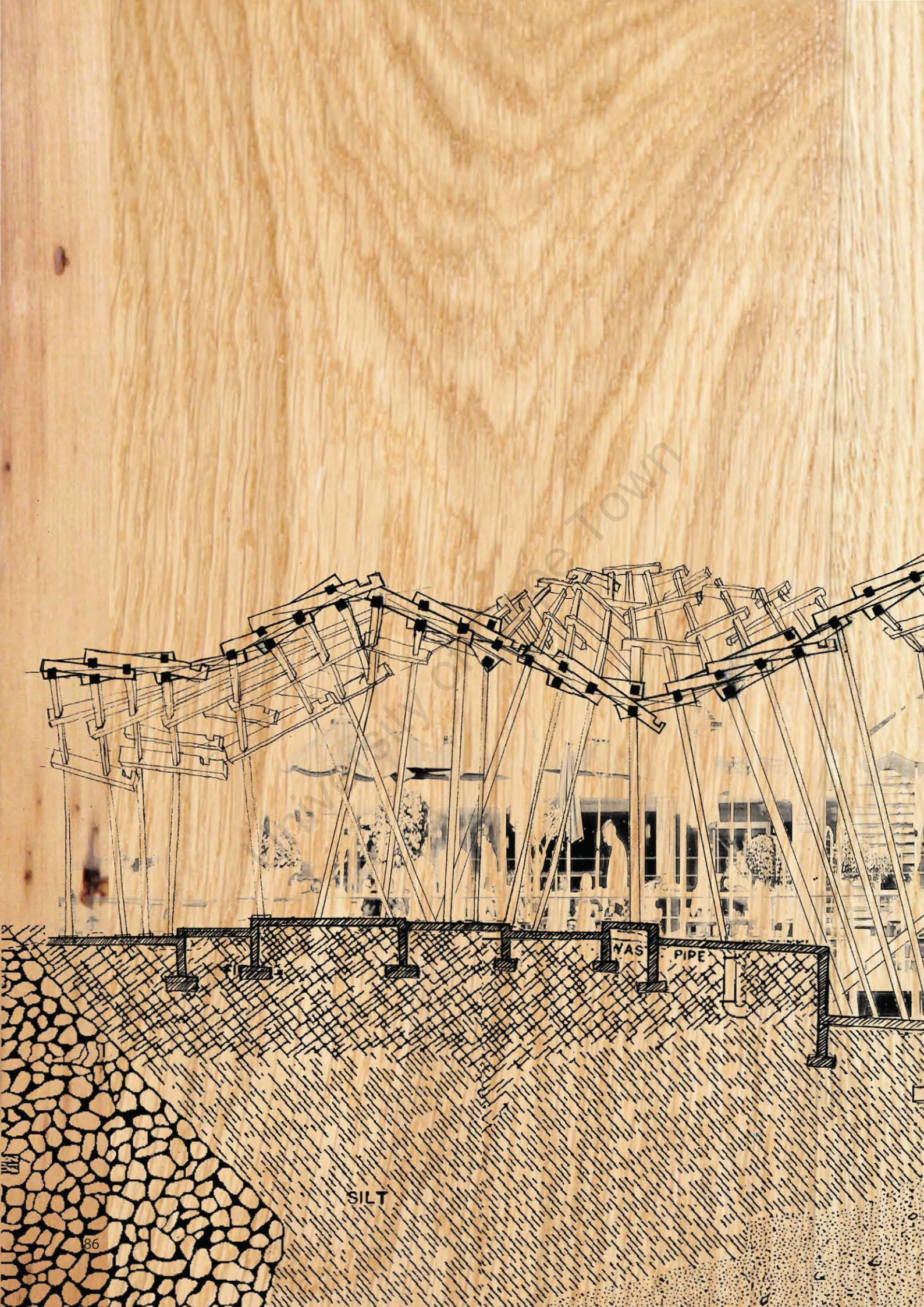

SILT

GAS PIPE