

**RE-PRESENCING WOODSTOCK GASWORKS:**  
Remediation and re-imagination of an industrial landscape

Tasneem Mohamed

University of Cape Town

The copyright of this thesis vests in the author. No quotation from it or information derived from it is to be published without full acknowledgement of the source. The thesis is to be used for private study or non-commercial research purposes only.

Published by the University of Cape Town (UCT) in terms of the non-exclusive license granted to UCT by the author.







Re-Presencing Woodstock gasworks:  
Remediation and re-imagination of an industrial landscape

by Tasneem Mohamed

SUPERVISORS:

Associate Professor Nicholas Coetzer

Melinda Silverman

ASSISTED BY:

Gemma Wentworth

This dissertation is presented as part fulfillment of the degree  
of Master of Architecture (Professional) in the School of  
Architecture, Planning and Geomatics,  
University of Cape Town  
October 2014



I hereby:

- a. grant the University free license to reproduce the above dissertation in whole or in part, for the purpose of research.
- b. Declare that:
  - (i) The above dissertation is my own unaided work, both in conception and execution, and that apart from the normal guidance of my supervisors
  - (ii) Except as stated below, neither the substance or any part of the dissertation has been submitted for a degree in the University or any other university.
  - (iii) I am now presenting the dissertation for examination for the degree of Master of Architecture (Professional)”

Plagiarism Declaration:

1. I know that plagiarism is wrong. Plagiarism is to use another’s work and pretend that it is one’s own.
2. I have used the Chicago convention for citation and referencing. Each contribution to, and quotation in, this report from the work(s) of other people has been attributed, and has been cited and referenced.
3. This report is my own work.
4. I have not allowed, and will not allow, anyone to copy my work with the intention of passing it off as his or her own work.

Signature 

Signed by candidate
---------------------



The financial assistance of the National Research Foundation (NRF) towards this research is hereby acknowledged. Opinions and conclusions arrived at are those of the author and are not necessarily to be attributed to the NRF.

I would like to thank Dr. David Worth, for whose kind sharing of his research is greatly appreciated. The historical information for the site would be otherwise near impossible to come by.

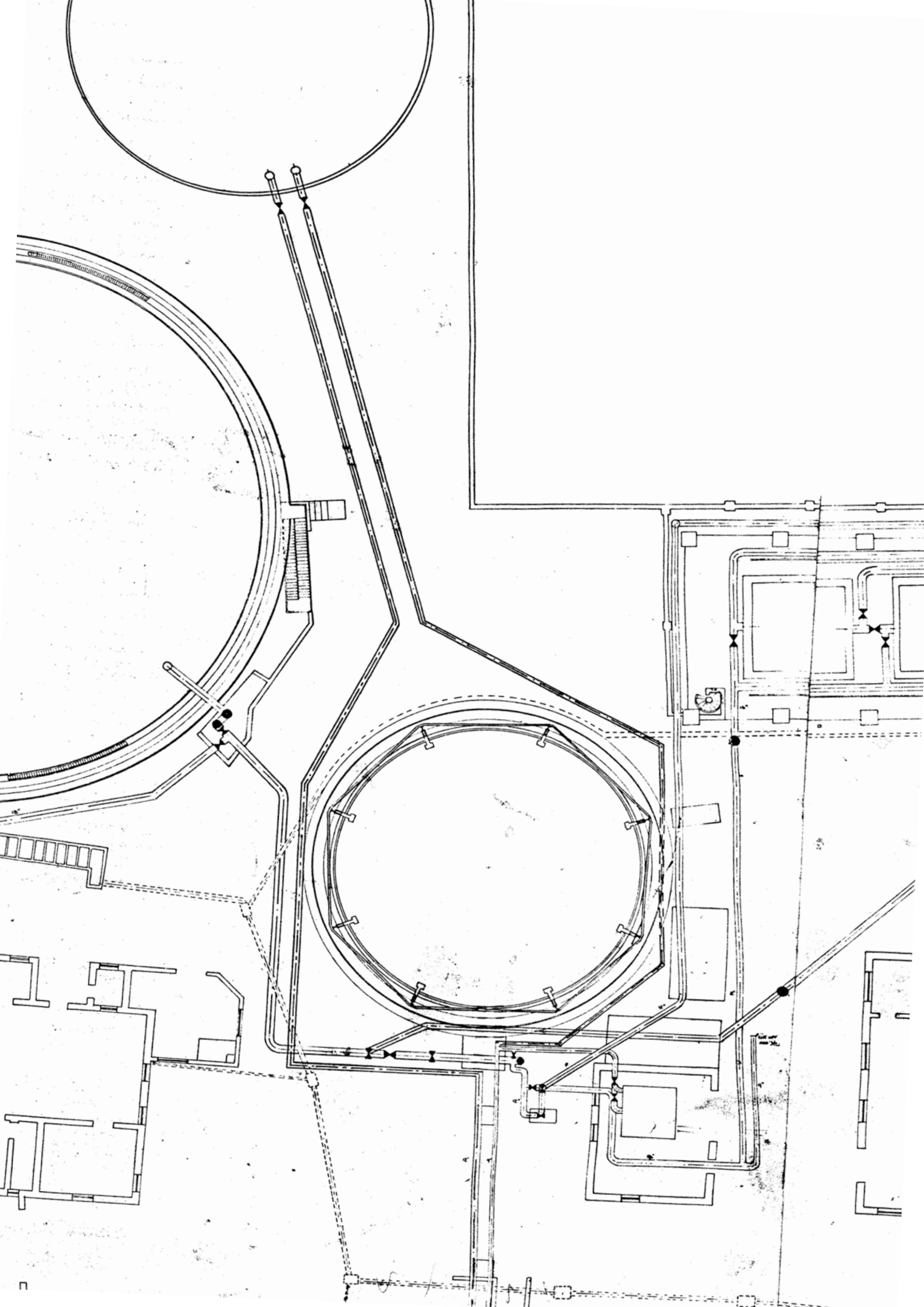

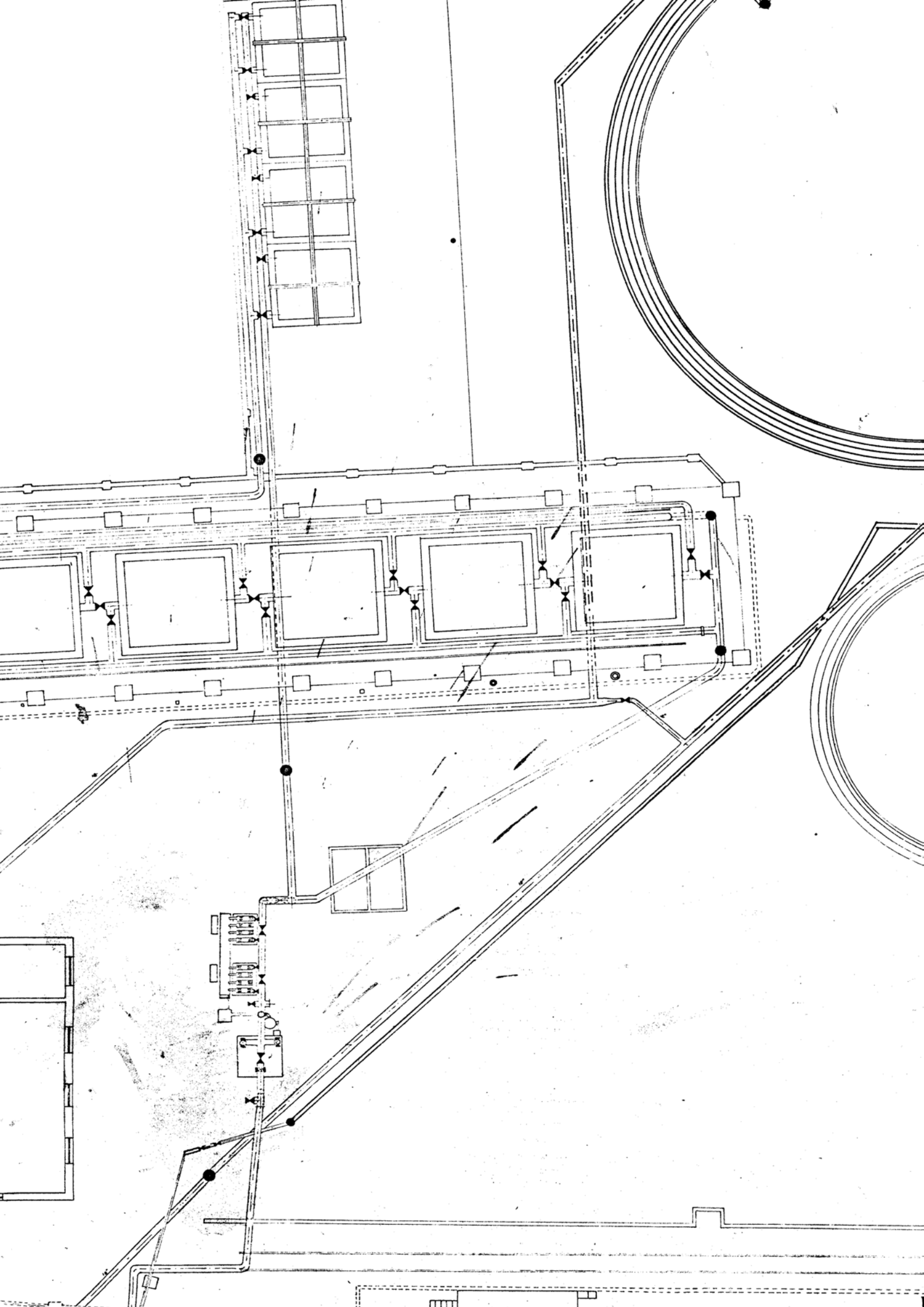



# ABSTRACT

Name: Tasneem Mohamed

Address:  
64 2nd Avenue  
Fairways, Cape Town

Dissertation Title: Re-presencing Woodstock gasworks: Remediation and re-  
imagination of an industrial landscape

This design dissertation follows a narrative process of research and design speculation. The report defines the subject of the project and is the first part of the dissertation. The subject started with an historical narrative that was to be extended in the contemporary landscape, it was about a wasted piece of post-industrial land that was intended to be programmatically re-imagined to redefine our relationship with infrastructure.

The second part and final outcome is a building proposal. Its function has been formed through my initial agenda of redefining the public relationship with infrastructure and industry. The resultant programme is an organic waste to energy plant that shares the site in Woodstock, Cape Town with a research centre, exhibition space, office space and recreational facilities. The story of the site before its current empty life was a catalyst for the investigation. I chose this site for it concealed a hidden narrative in the city that had the potential to disappear with the demolition of the old gasworks in 1996. No above ground structures were built on the site since then because of the polluted soils of the coal gas production on the site for over 100 years. Creating a re-imagined industrial plant that celebrated the industrial history of the site and Woodstock the area became the object of my project. The management of the polluted soils, public pedestrian accessibility to the site and the undesirable ground plane of the context became the first spatial informants for the design project.

My method of site research was through archival research using maps and texts from Cape historical records in the libraries, as well as meeting with an archaeologist, formed my historical analysis. My architectural project aims at replacing emptiness of a post-industrial landscape into a site that is part of the productive urban environment, reflecting ideals of participation and hybridity.



# TABLE OF CONTENTS

<b>Introduction</b>	1
<b>The performance of aesthetics and the technological sublime</b>	3
<b>Revealing and concealing infrastructure</b>	9
<b>A Site</b>	13
<b>Historically:</b>	15
The politics of power	17
The visual presence	21
<b>Currently:</b>	
The buried piping network	31
Polluted grounds	33
Rail divide	35
The open wound	37
<b>Programme</b>	39
Waste to energy	43
Bio-methanisation	51
Miscanthus and algae ponds	53
<b>Design</b>	
Visual connectors	59
The ground plane	63
<b>Remediation and re-imagination</b>	70
<b>Referencing</b>	79
<b>Ethics clearance</b>	81
<b>Architectural drawings</b>	85





# INTRODUCTION

An interest in the life of sites and their change or regeneration over time is what opened the discussion for this investigation. This interest could be described as one in the historical and narrative depth of sites. I was particularly interested in industrial or infrastructural sites. These sites are best described by Dennis Cosgrove in *Social Formations and Symbolic Landscapes* as signifiers of mans' actions on the landscape, as well as our developmental history as a species. My initial interest was an intuitive connection to them, one that understood that there is a strained relationship between industrial infrastructure and the public. I have recognised that there is the opportunity to re-imagine and re-presence these sites. Coupled with a fascination and desire to manufacture a relationship was a social agenda for a typology that aims to bring man to a better relationship with the landscape that he inhabits. To me this 'better relationship' can be achieved through more conscious actions on the landscape through transparency of our process of production and the consequences thereof on the landscape.

The process of investigation and inspiration was largely generated by a historical site investigation of a piece of 'wasted' land. The site was primary chosen because of its' narrative history. The site is in Woodstock on a now undeveloped piece of land that was once the site of Cape Gas, who produced gas on the site from 1888 to 1996. This dissertation report charts the journey of how an interest, social agenda and site narrative have influenced the development of municipal organic waste-to-energy plant that also houses an exhibition space research facility as well as public recreational space. The dissertation, which has a pragmatic, educational and leisure components, appropriates the unused post-industrial site and transforms it into one of regeneration and value in the urban landscape. The mix of programme re-imagines a contemporary industrial waste plant by involving the public in the process to engage consumers from the processes of production.



Figure 1. The now demolished cooling towers, Cape Town  
This is a missed landmark that many have grown a fondness for  
<http://blog.africabespoke.com/cape-town-international-airport-upgrade/>



Figure 2. Hillbrow telecommunications tower, Johannesburg  
When I lived in Johannesburg as a child I would always stare at this tower  
in the car until it was no longer in sight  
[http://commons.wikimedia.org/wiki/File:South\\_Africa-Johannesburg-Hillbrow001.jpg](http://commons.wikimedia.org/wiki/File:South_Africa-Johannesburg-Hillbrow001.jpg)

## THE PERFORMANCE OF AESTHETICS AND THE TECHNOLOGICAL SUBLIME

I have always been intrigued by the, now demolished, cooling towers and the old power station behind it as well other infrastructural sites. Besides their aesthetic, I am also intrigued by what they represent. I would like to start the discussion for this project through explaining the 'performance' of aesthetics and to include the idea of the 'technological sublime' to demystify the power of these sites.

Arthur Danto and Alexander Nahemas are art historians who have written about aesthetics; they suggest that the experience of the visual isn't immediate. They describe the 'performance' of aesthetics as seeing something in your brain that goes back and forward through your subconscious, between awareness and things in the past, what you expect to see or what you have seen before, until what you are seeing registers again. Through this process, the experience is prolonged, even if by a micro-second. The aesthetic experience, then, has to do with the exchange between what you know, from your own personal experiences, and what you are actually seeing. The appearance of what something looks like, its shape, its proportions, the way it reminds us of similar or dissimilar places or forms or spaces is what evokes an emotional, psychological reaction, which is the performance.

In the moment of recognition that there is the possibility of curiosity, and that curiosity leads to a sense of engagement. There is also the possibility of wonder, and that wonder might lead to a sense of connection. (Waugh, 2011, p. 171) An example of this visual experiential relationship would be witnessing the smoke rising from the large concrete shape; one can imagine the processes of evaporation and condensation that are taking place which creates in an illusionary experience of the dynamism involved in such an industrial function.

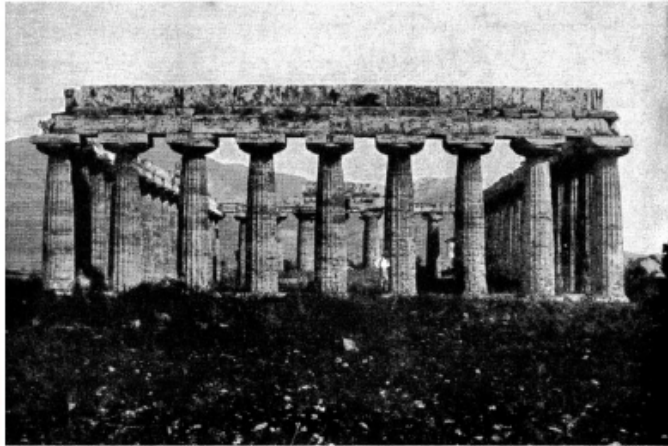

PAESTUM, 600-550 B.C.



THE PARTHENON, 447-434 B.C.

When once a standard is established, competition comes at once and violently into play. It is a fight; in order to win you must do better than your rival *in every minute point*, in the run of the whole thing and in all the details. Thus we get the study of minute points pushed to its limits. Progress. A standard is necessary for order in human effort.

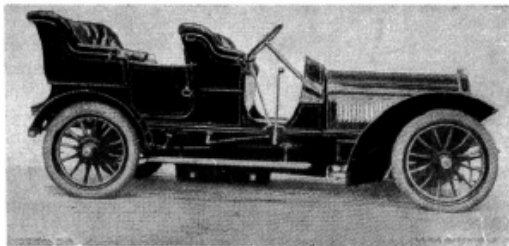

HUMBER, 1907

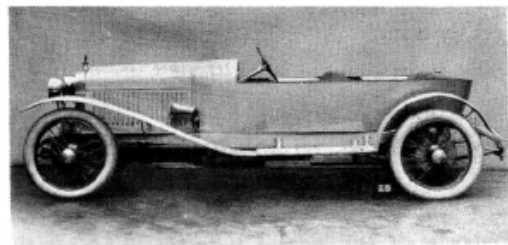

DELAGE, "GRAND-SPORT," 1921

Figure 4. Page from manifesto *Vers une architecture* (1923)

In this manifesto, Le Corbusier talks about the machine aesthetic as one that should replace the historical in order to represent a new age of progress. Le Corbusier *Towards a New Architecture* (2000, Architectural Press, Oxford. Translated by Frederick Etchells)

This leads me to the idea of the 'technological sublime', which will be discussed to explain intrigue of the technological through a psychological and social representation. According to historians Leo Marx and David Nye in *American Technological Sublime*, which is a study of the politics of perception in industrial society, the fascination with technology and major public works has a connection to the 'sublime', an eighteenth century aesthetic notion. Marx equates new technologies with national destiny 'just as natural sublime once held the rhetoric of manifest destiny' (Nye, 1994: 282). According to Nye, the romanticised quest for a pristine nature in the nineteenth century gave way to a civic and national pride over transformed man-made nature.(Ghosn, 2009, p. 107)

The idea is reflected in modernism's quest to tame, control, and discipline nature has been described as 'modernity's Promethean Project'. The engineer became the modern Prometheus, the hero who promised to deliver human emancipation from nature by mobilizing a mixture of imagination, creativity, ingenuity, romantic attitude to recruit nature in the service of humankind. (Ghosn, 2009, p. 105) Technology has the power to dominate nature, shifting a function from nature to technology. The idea of man dominating nature is what possibly leads to a sense of human pride over seeing this, what the human is capable of producing.

The bold engineering art after the 1930's and a new aesthetic of techno-natures replaced classical ornament and historical forms. Large scale industrial infrastructures assumed a status of modern sublime; they can be described as glorious icons, carefully designed and ornamented, celebrating the emergence of what is described as technological sublime. As the objects of mass consumption, from cameras to cars, became admired as the individualised technological sublime, large scale infrastructures were admired as the embodiment of a collective technological sublime; describing the aesthetics of progress.(Ghosn, 2009, p. 107)



Figure 5. Clanwilliam Dam, Western Cape  
<http://www.clanwilliam.org.za/>



Figure 6. Wind Farm 300km outside of Cape Town  
<http://africagreenmedia.co.za/large-cape-wind-farm-approved/>

Maria Kaika and Erik Swyngedouw in *Fetishising the Modern City: The Phantasmagoria of Urban Technological Networks* describes this phenomenon when they attribute infrastructure as becoming fetishised as the material expressions of the promise of a phantasmagoric new world of technological advancement and progress. Marx also describes this fetish as a 'bewildering thing full of metaphysical subtleties and theological capers.' Our essential connection to this aesthetic could then be described as a romantic one.

The glorification of progress through technology reached a point of ambiguity after WWII after the atomic bomb demonstrated the destructive side of technology for human beings. The destruction of nature in terms of pollution and depletion of the earth's resources was also later added to the destruction of our technological progress. Aside from this destructive side, there was an increase in tension over capitalistic modernisation, and after WWII it was slowly revealed that technological innovation and progress were profiting only those who had control over the means of production. (Ghosn, 2009, p. 108) This capitalistic control has not changed despite the industrialisation of western economies since the 1970's. At this point, and increasingly so, technology and progress are inscribed in peoples' lives as a necessity rather than a desire. The fetish character of technological artefacts had largely transformed into being material representations of what Maria Kaika in *Landscapes of Energy* called 'a failed emancipation project'. (Ghosn, 2009, p. 109) She describes dilapidated waste and gasworks as once proud displays of a technological dream that have turned into signifiers of a now regrettable conquest of nature.

There is no backtracking on our energy and technology dependency, but the level of destruction of the cost of our progress can be changed. By doing so, the representation of the technological aesthetic can change to transform meaning, as has happened before.



## REVEALING AND CONCEALING: INFRASTRUCTURE

The intrigue of these infrastructural sites is in their aesthetic, but also by curiosity of being alienated from something I am physically connected to by use.

Considering landscape as the environment in which we act on, the infrastructure forms a part of this system. To get a better connection to our landscape there needs to first be a understanding of the complexity and functionality of it.

The idea of connecting to the landscape that we inhabit is discussed with a solution by Robert Thayer in *Gray Word Green Heart*, who writes about the relationship between the surface and the core of the landscape. He describes the surface as the layer that we can see and engage with. The core is the functional technological and ecological properties of the landscape; this layer is described as the one in which the landscape operationally connects with the larger context. This 'larger context' includes humans. Thayer motivates for a landscape that is transparent; one in which the core properties are visible or accessible. This promotion for transparent landscapes is stimulated by his opinion that the evolution of the relationship between nature and technology can be measured in the widening dislocation between surface and the core values of the landscape in which we live. (Thayer, 1994, p. 140)

Thayer concludes that transparency is the key to sustainability: 'the movement towards sustainable world must include the peeling away of intervening images between landscape function and landscape experience' (Thayer 222). He suggests that transparency and truth will give communities the power to make responsible decisions.

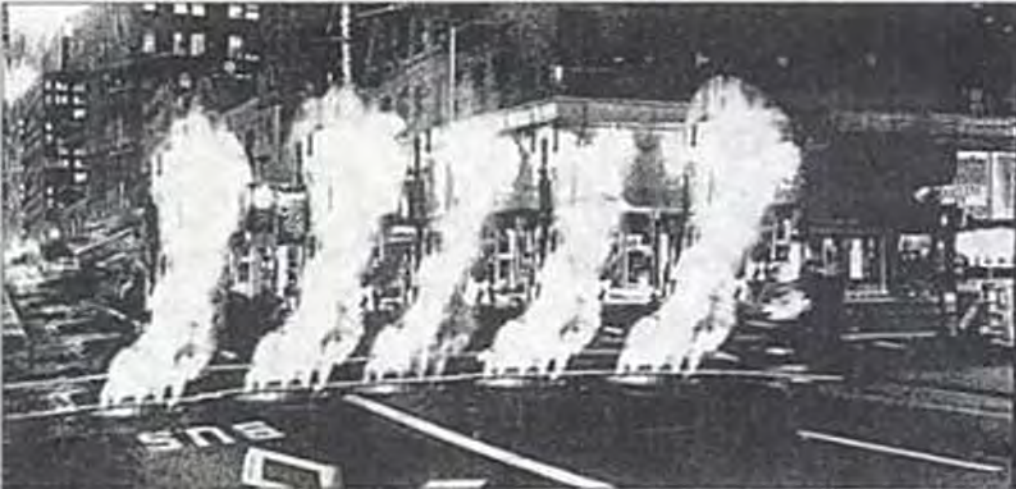

Figure 7. Steam temple for the Lower East side in Manhattan, Gary Strang and Michael Roche  
Gary Strang is a landscape architect that has actively advocated for infrastructure systems to be revealed. The intent of the Steam Temple proposal is to express the wonder of New York's vast infrastructure and its relationship to nature. A landscape is proposed which uses infrastructure as one of the basic raw materials of the urban garden. The garden varies with the seasons; in winter, warm steam rises from the earth while in summer, irrigation equipment doubles as a cooling device.  
Landscape Narratives pg. 148

'To change the situation we require new symbols of possibility.' Leo Marx

When discussing symbolism, Thayer describes landscape as having the potential to represent a testing ground for the validity of the emerging social and political call for sustainability. To align with my intention to invert the tension between machine and society with the possibility of the restructuring of technology to serve ecological and human values would transform their symbolic image.

Exposing the underlying structure of building, infrastructure, natural systems or making transparent what was once concealed is connected with the idea of integrating nature and culture and making people more aware of their actions and their use of resources. This emphasis of process and integration contributes to the objective of the idea that what is in sight will become what is in mind.

Revealing the problem is just the first step toward collectively solving it. This revealing of infrastructure is a confrontational device that encourages society to acknowledge the consequences of consumption through a visual representation. The idea of a confrontational device of an infrastructural device means that it needs to be part of the urban landscape, to which it serves, instead of being outside of the city in the landscape, or concealed below the surface.



## A SITE

The so called strained relationship between the public and infrastructural or industrial sites, as described by myself, is on display through the many derelict sites in post-industrial cities. The idea for a re-imagined relationship and presence for these places becomes a relevant investigation.

Considering my vision to transform the relationship between manufacture, consumption and usage of infrastructural or industrial utility buildings, I had come across the field of Industrial Archaeology, a theme of study I engaged with when deciding on a site. It is a theme that places and highlights the importance of historically important industrial sites. Industrial Archaeology is a multi-disciplinary study of a site to understand the full range of its social and technological history, which to me, is a more faceted than just an architectural investigation of a site, which quickly moves to an urban analysis and response.



Figure 8. Gasworks at the docks, 1800's  
Image from David Worth

## THE SITE: HISTORICALLY

In search of a site, I came across the narrative of the Woodstock gasworks site by Industrial Archaeologist David Worth in 'Gas and Grain: The Network of Industrial landscapes'. He had explained the industry's 100 year presence in the landscape and I had romanticised the idea of re-generating the narrative of the site in a way that reflected contemporary values and needs.

The site is in Woodstock and it had a rich industrial history in Cape Town, as does Woodstock the area. The site is across from the railway line on the length of its southern boundary line. A site close to the railway line, now the Southern Line, was a prerequisite for the gasworks site because the coal delivery to the gasworks stockpile yard was by rail. The gas company produced gas on this site from 1888 to 1996. The production and distribution of gas was for public, domestic and industrial use. Soon after the company stopped production in 1996, the above ground structures were demolished. The site not only housed the production of coalgas, but it is the origin of its' piping network that creates physical underground connections to the city and suburbs, although being invisible to the public gaze.



Figure 9. First street lighting in Cape Town, Greenmarket Square  
Image from David Worth

## THE POLITICS OF POWER

As previously discussed, infrastructural projects, and in this case a industrial utility site, were seen as symbols of prestige in the early days of capitalism particularly. These icons were often recognised by politicians to be icons of national prestige. (Ghosn, 2009, p. 107) This was true for the gasworks site, which in its early days, was seen as a symbol of modernity for the city. (Worth, 2004) The gasworks served the first street lighting in Cape Town in the city centre, and later supplied the households in the emerging southern suburbs with gas for heating and cooking.

Aside from representing modernity as a sense of civic pride, Industrial Archaeologist David Worth has mentioned that this industry should be recognised for its 'cultural significance' in its' representation as an icon of social heritage. The heritage status of historic industrial buildings is dissimilar to what is widely classified as a heritage building in South Africa which is often based on a romanticised heritage of Cape Dutch and Victorian buildings, both of which have foundations in colonial history. South Africa is a colonised country so it is understandable that so much of what we appreciate in our history has colonial references.

This Euro-centric heritage does not however, reflect our current aspirations or visions for our country (Worth, 2004). It is a political heritage that elevates master over slave, colonial over indigenous and individual over collective. This is a heritage that excludes the disempowered and does not reflect an identity that could be morally accepted as one that represents all South Africans.

To attribute the gasworks a heritage site, Worth contrasts ideas of 'Eurocentric' heritage by explaining that the industry once represented all racial, economic, religious, political and social groups in the workplace. Woodstock was an area that remained as the only mixed race area during Apartheid. Industrial history, especially of this site, is then described as being 'indivisibly linked to people.' (Worth, 2004, p. 78) The gasworks also represented the worker and the industry involved in the modernisation of the city centre and later the Southern Suburbs.



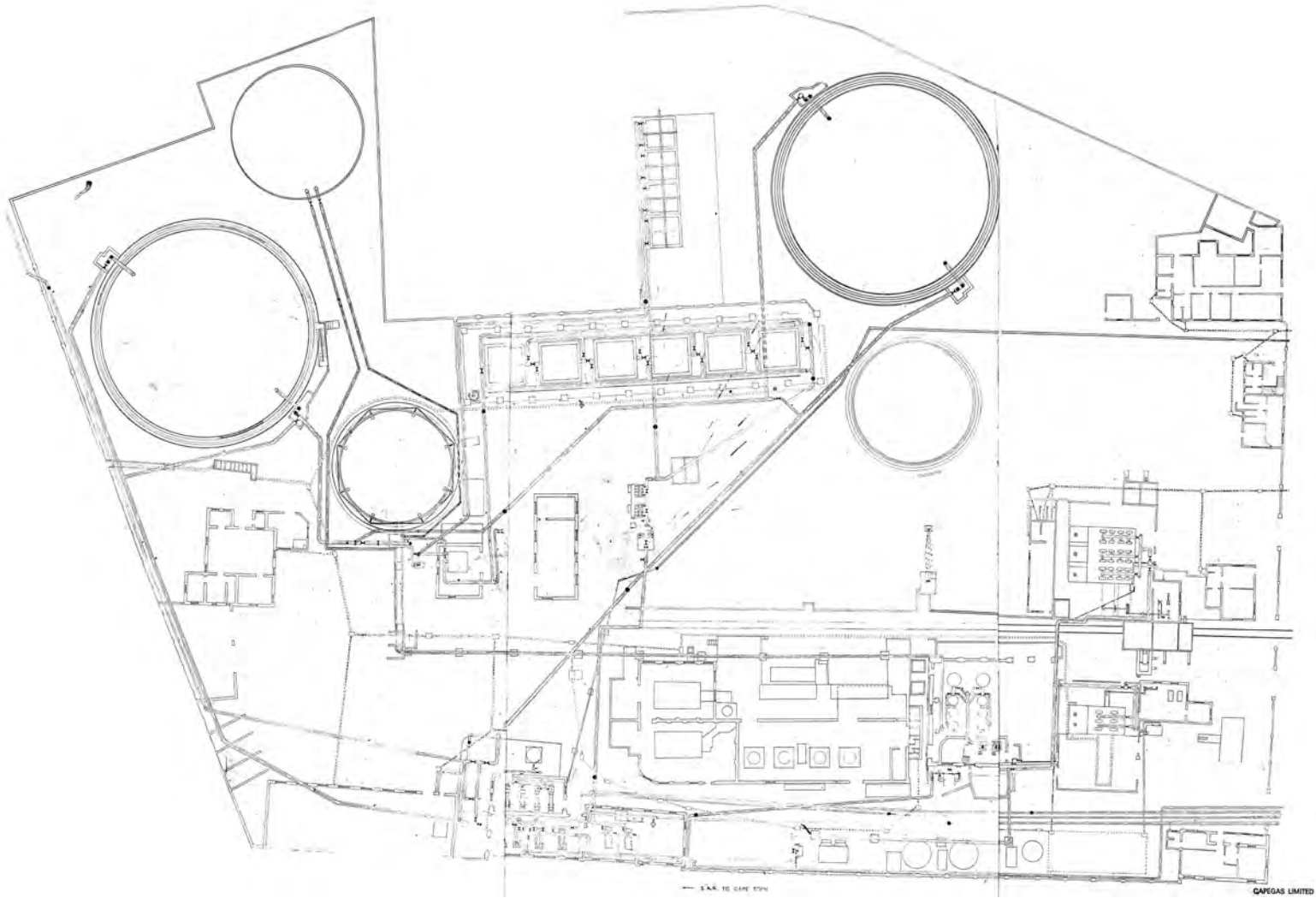

Figure 10. Old Woodstocks gasworks plan  
This plan shows how the site operated like a big machine made up of smaller parts that were components to a whole  
Image from David Worth



Figure 11. View of Woodstock and Devils Peak from the a gasworks structure  
Image from David Worth

## THE VISUAL PRESENCE

Industrial Archaeologists believe that there exists a realm of Industrial structures that is waiting to be analysed, interpreted and taken apart and revealed in layers of complexity and inspiration. Considering this, I have studied the history of the site through the social and technical representations of the gasworks.

Through the investigation of the history of the site I have been inspired by interesting design opportunities through a better understanding of the aesthetic performance of the structures on site, as well as highlighting the limitations of the site on an urban level.

The previous daily on-site spatial experience was an exclusive one. The neighbours of the site and the passing public still, however, had a connection to the processes on site. This connection was a visual one, to the iconic structures of the works in the skyline. These 'iconic' structures were the retort houses and the gasholders.

Individual industrial forms such as grain silos or large water towers often take on the same 'aesthetic' modern value as a 'cathedral-on-a-hill' in the creation of a 'sense of place' (Norberg-Schulz, 1980), and can fulfill a similar role in visual terms as a monument or a landmark. (Holgate, 1992:125). In this description, the classification of the iconic structures is due to their scale and ability to represent the industry outside of its site, which I have concluded was the reason for their 'presence' in the Woodstock landscape. The structures created the opportunity to visually engage with the site by displaying their connections to the processes on site. They could then be described as having a communicative presence in their surrounds.

A greater visual appeal is often achieved through a sense of scale and monumentality of industrial form. This is due to a combination of size and form, where the 'emphatic simplicity and consistency in the composition of the exterior' can render these forms to often be 'monolithic' structures (Machado and el Khoury, 1995:12) and give them an alienating aspect, one of 'object-ness'. The size of an industrial form – of the building section of it or of the elements such as towers – has a direct influence on the aesthetic experience of the observer and can invoke experiences of admiration or enthrallment. (Holgate, 1992, 48)

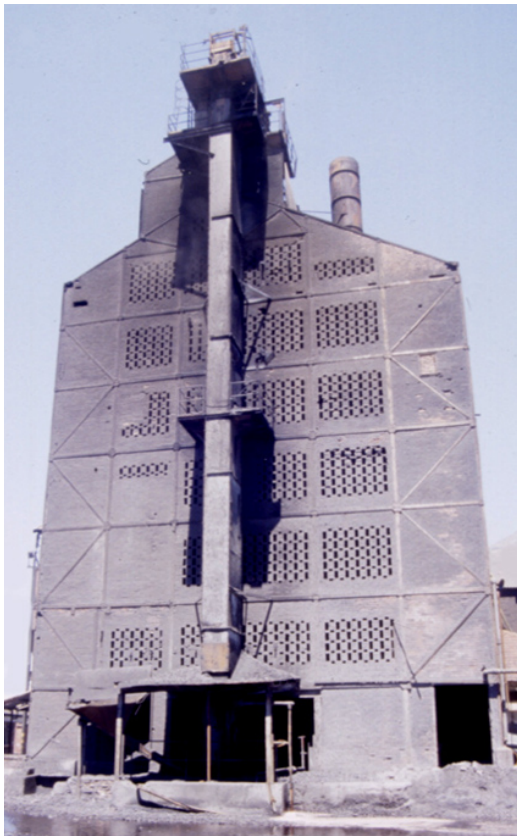

Figures 12 and 13. Retort houses of the old gasworks  
Retort house are essentially shell structures that house retorts, which is where the combustion of coal takes place  
Image from David Worth

## THE STATIC ICON

### The two retort houses

The design of the retort house was not unique; it was most likely a replica of a previously built retort house. The structure encloses the retort machinery and the deck levels that the labourers use when accessing the machinery and feeding the production process. The structure of the building is steel framed with brick infill. The height and shape of the structure is directly related to the retorts that it houses.

The steel structure of the retort houses each created five longitudinal bays. The bays housed the seven 'beds' of retorts. The houses were portal frame structures that had diagonal bracing on the ends of each retort house. The width and height between the sections were 3.5 metres. The height of typical vertical retorts is 7,7metres long.

This length, with that of the space needed below the coke chamber to collect the coke, and the height needed above the retorts by the coal conveyor determined the height of the structure. The steel was bolted with splice plates to join the members.

The steel was most likely galvanised to protect the steel from corrosion, but the durability of the steel differs in terms of corrosion rate depending on the environment of the steel. For this site, the rate of corrosion was high because of the extended and continued exposure to excess from the retorts. The corroded steel gave the structure a rusted machine like aesthetic.

The tectonic in industrial buildings becomes the art of making the joints, of placing the members, of combining the materials. This 'expressive potential' of constructional techniques and materiality (Frampton (1995:2) impacts on the aesthetic of the industrial form. Beauty is derived from the poetic nature of the non-ornamental result of construction; from the 'internalising' the issue of visibility into that of tectonics, which is exemplified by the retort houses.

Retort



Figures 14 and 15. View of the Spiral guided telescoping holder at a low and high capacity, 1996  
Image from David Worth

## THE MOVING ICON

### The gasholders

The gasworks site housed two gasholders in use before demolition (Worth, 2004). The storage of gas was to facilitate the continuity of the manufacturing process when gas was not being distributed and used at the same pace as it was being produced, as well as being storage for peak usage.

There are two basic types of gasholders: rigid waterless and telescoping (Wikipedia, 2009). There are two types of telescoping holders, one that has a fixed external frame with a fixed height at all times, and one that has no fixed frame but is guided by the 'lift' of the frame below (Thomas, 2010). This latter telescoping holder is called a Spiral guided gasholder; the type holder that was in use at the gasworks site.

This gasholder was a self-supporting holder that would expand and contract according to the volume of gas it contained. The steel shells of the holders were a specific thickness for the weight that would be favourable for the gas pressure. The type of gasholder made this form a moving object in the skyline, fluctuating as a visual marker reflecting manufacture and usage.

Gasholders, especially in Victorian times with the telescoping holder type, were cylindrical in form. The circumference of a circle requires less material than any other form of the same volume. The upward and downward movement of the levels of the holders, as well as for economy of materials, suited a cylindrical form.

There is a link between structure and sculptural beauty of industrial forms. The possibility exists that functional structures of geometric form appeal to one's mathematical mind, as they form the main character of the building and are created through calculations by engineers, which, as Le Corbusier saw, results in good art. In other words, geometric forms exude a particular power (Machado and el Khoury, 1995:12) and are "seen often as beautiful because they can be clearly appreciated". (Le Corbusier, 1965: 8,26) This geometry can be seen in the cylindrical form of the gasholders.

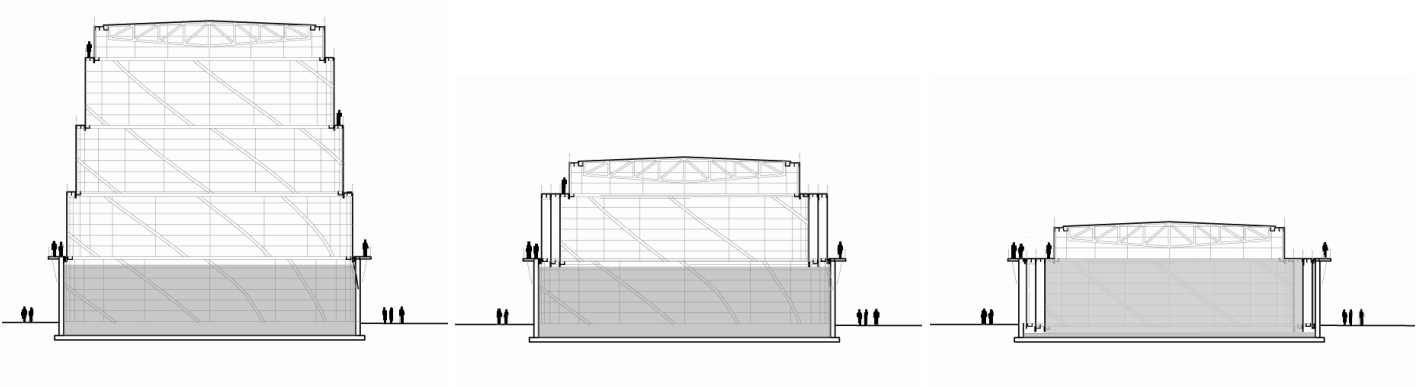

Figure 16. (above) Spiral guided holders of Cape Gas Showing the size of the holder and the expansion and contraction, relative to the human scale. by author



Figure 17. (far left) Close up of spiral guided holder Image Gasholders and their tanks

Figure 18. (left) Detail of the multiple roller carriage which guides the upwards and downwards movement of the gasholder. Image Gasholders and their tanks

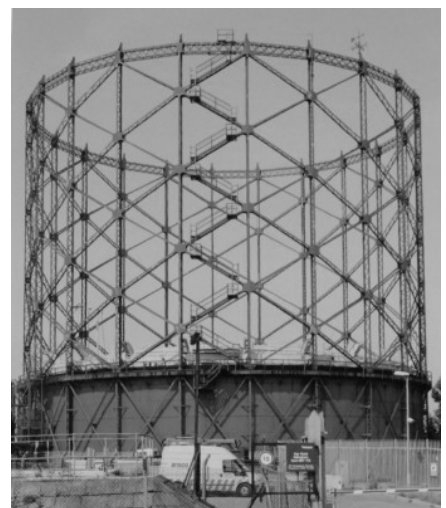
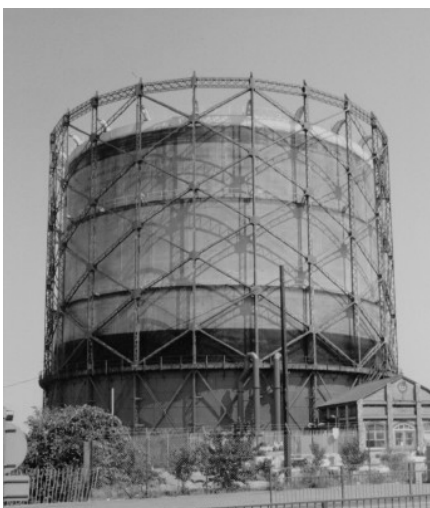
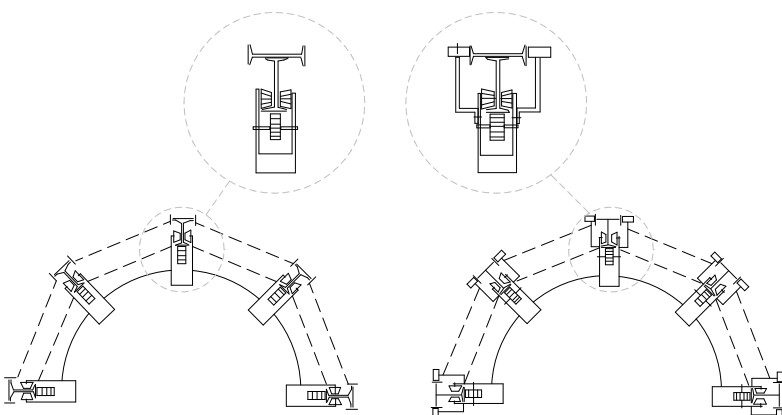

Figure 19. (above) A column gas holder was supported by tall steel columns as it rose and fell Image <http://www.barrygray.pwp.blueyonder.co.uk/Tutoring/NatGas.html>

Figure 20. (left) Plan and section details showing the frame system of a fixed frame holder by author



## THE LIFTING MECHANISM

The spiral guided holder, as with the other telescoping holder, used water to provide a seal for the gas. The tank floats on a circular water reservoir and is held up by the pressure of the gas volume. The pressure is determined by the weight of the structure and the water that is the seal (Thomas, 2010). The holder is then not only for storage, but for establishing the pressure of the gas before it goes to the distribution mains.

The two spiral holders were triple lift holders that had self-guiding rails fixed spirally to each 'lift', or telescoping wall, by helical runners. These rails dictated the walls rotation as the holder went up, guided by the one below (Thomas, 2010). As the walls rotate upwards, the downward lip of the inner tank wall clips to the outer lift to grip the lower lift. This either starts the rotation of the inner tank wall upon injection of more gas, or the lips clip into one another and stop the possibility of expansion once the holder is at capacity.

This differed to the fixed external frame holder, which were installed in Victorian times, as earlier gasholder types. The fixed frame holder was a constant landmark in the landscape, even when the holders were empty. The earlier holders on the site were of this kind; they were landmarks in the townscape in the nineteenth century (Worth, 2004). They were not used since the spiral guided holders were constructed on site.

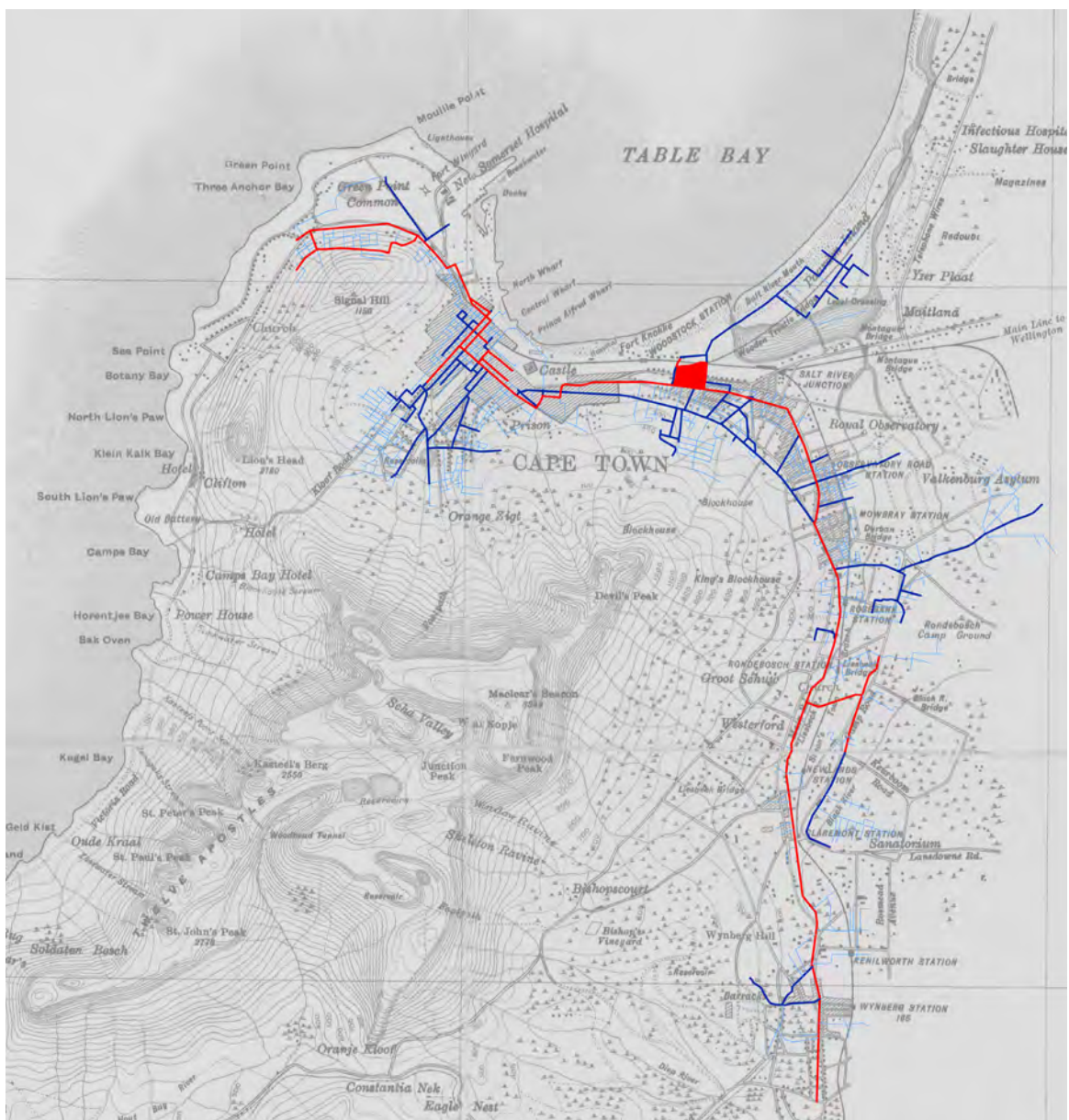

Figure 22. Historical map showing the extents of the buried piping network laid by the gasworks  
 The red line is the gas mains that distribute gas to the high (dark blue) and low (light blue) pressure lines. The red box is the site, the origin of the piping network.  
 by author  
 Source map: Cape Town historical maps

## THE SITE:

### CURRENTLY

#### REMNANTS OF THE INDUSTRY

##### The buried piping network

The buried piping network remains as the remnant of the industry. A majority of the lines are now used by Telkom for data cables.

In terms of historic mapping, the system has similarities with supply systems for water and hydraulic power laid out in the 19th and 20th centuries on terms of its cast iron materiality. The pipes were laid in the same trenches of the Victorian water supply pipes and sewers. The extents of the network also trace the development of the city at the emerging suburbs at the time when gas was widely used industrially and domestically.

Discussing the buried piping network as a structural remnant places symbolic value on the site, as the origin of this network.

I had previously wanted to reveal part of the piping network in some way above ground as an artifact that would be revealed to have a place in the present and future of the landscape. I had also wanted to regenerate the use of the piping network in a way that services contemporary energy needs. I had struggled to imagine a better use for the piping network than for telecommunication cables, so I focused on dealing with the regeneration of the site.

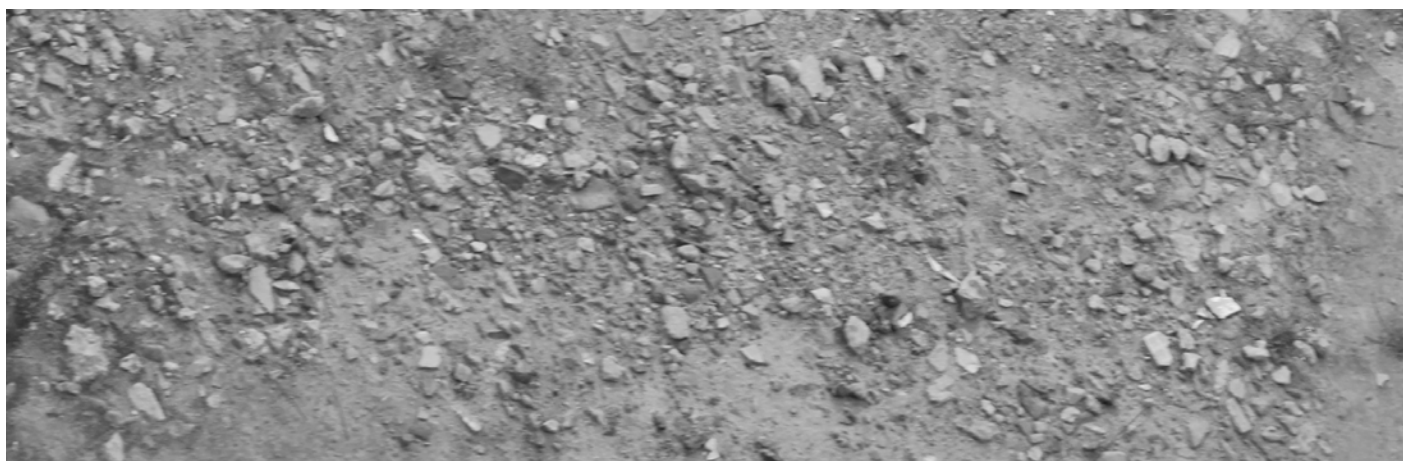
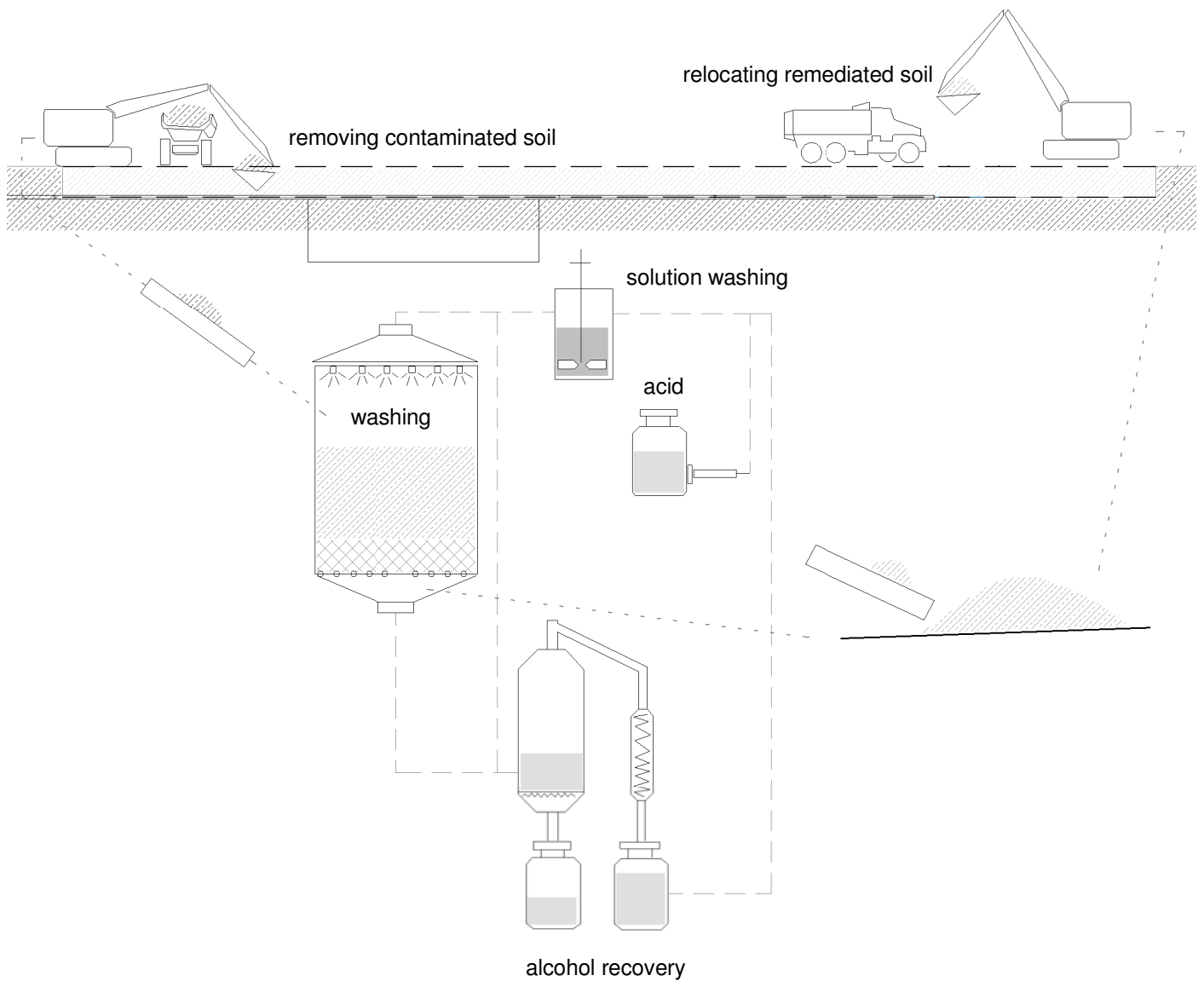

Figure 23. (top) Diagram of soil washing as remediation method  
 This method would be the one most likely employed, as bioremediation is a very long and costly process.  
 by author with reference source  
 Figure 24. (above) Close up image of the ground surface of the site  
 by author

## POLLUTED GROUNDS

Another remnant of the gasworks industry is the coal polluted soil of the site, which is not uncommon for coal gas industrial sites.

The coal gas producing plant required bituminous coal to be heated in the absence of air inside the retorts. Contamination was inevitable not only from the coal gas production itself, but also from the substances imported for the purification process and their decomposition or reaction products. Examples of these pollutants are hydrocarbons, inorganic compounds, metals and asbestos. The polluted soil is not only hazardous to the wider environment via the water table; it is hazardous for construction workers, users and occupiers of the site. If not remediated, the polluted soils can cause chemical attack on building materials.

A contaminated site in an unused or derelict state is not considered a threat as there are no one site receptors to be considered which may be exposed to the harm of the pollutants. If a contaminated site were to be used, receptors would need to be considered and the site remediated. An expert site investigation will have to be undertaken to determine the type and extent of the contamination to address the remediation of the soil.

There are a few remediation methods that are done on former gasworks sites. The cheapest option of excavation and removal moves the soil to a landfill site, which is essentially moving the problem from one site to the next. There are two other favourable methods called Soil washing (using chemicals) and Bioremediation (using micro-biological activity) which moves the soil to controlled environments to remove the pollutants from the soil. The soil can then be returned to the site, or moved to another site.



Figure 25. Aerial photograph highlighting the railway lines surrounding the site area by author with source image from GIS

## THE RAIL DIVIDE

The north and south bound railway lines split and diverge just before Woodstock station to form a seemingly landlocked area, in terms of vehicular accessibility, between the railway line. I have dubbed this landlocked area the 'industrial island'. The 'island' one main vehicular entry and access point. The severing of this area from the 'rest' of Woodstock has de-valued the land. Woodstock has a rich industrial heritage, with many of the first manufacturing factories having started in Woodstock. This 'island' is still largely dominated by industrial functions.

Within the industrial island, the plots are large and the pavements scarce. The industrial buildings take up almost the entire plot with a single or double story mass. The older buildings with the island have smaller footprints that float within the large plot that it is placed in, many of them not being used. The island is not only severed from the urban environment beyond the railway line, but is it formed as a collection of mini islands that has no interest in forming a micro-urban environment. It is in disrepair and under-use, as if waiting to be discovered by the expansion of the CBD and the escalating valuation of Woodstock the area.



Figure 26. The undignified existence

This image shows how the site is currently being used. Since 1996, it was once a shipping container storage yard, now an industrial storage yard that is rented out by neighbours

Image by author

## THE OPEN WOUND

The end of gas production in 1996 was soon followed by the demolition of the above ground structures of the gasworks. The steel frame of the retort houses were corroding and the building, together with the asbestos sheeting, was considered a safety hazard. The buildings were also demolished because the site was thought to be more valuable for a resale if it were clear. No permanent structure has since taken ownership over the site, aside from the neighbouring building annexing a small portion of the site.

Most likely due to the cost involved in the remediation of the polluted soil, the site has remained undeveloped since 1996. It stands as an open wound after serving as the home to the gasworks, an industry that serves other industrial processes and domestic uses, for over 100 years. The site now has the undignified existence of being an underused Industrial storage yard for trucks and parts. It has also since been a container storage yard.

The undeveloped contaminated land of this site persuaded me even more to choose this site. The idea to reconnect what is essentially a 'wasteland' site into the productive urban environment seemed like a valuable investigation.

When I had found out where the site of this industry was, I was initially disappointed because the lack of accessibility and public edges of the site. After finding out why nobody has built on the land since the gasworks, and that the issue of accessibility has created a dystopian-like landscape of large industrial complexes on large plots of land of which many are in disuse, I romanticised the negative characters. The challenge of responding to these constraints seemed excited.



## PROGRAMME

Woodstock, originally known as Papendorp, was an area that started out as a farming space and quickly grew into a community of people that lived and worked in Cape Towns' growing port economy. The area is one of the best example of a South African mixed-use suburb. It has a dense residential population that creeps up the slope of Devils Peak, retail and commercial spaces near Main and Lower Main Roads as well as industrial areas, the site being within the main one.

The reintroduction of an industrial process in the contemporary urban environment on this site acts as a symbol of resilience to the marginalisation of programmatic diversity such as industry; which is what makes Woodstock such a vibrant mixed-use area. It is an intervention of programmatic inclusion.

The aim to invert the apparent tension between the Industrial Island and vibrant Woodstock beyond the railway line, the project needed to be a re-imagined industrial energy producing facility that contributed to a productive public environment that included a level of public engagement of the processes, to encourage a connection with the public beyond the railway line. As an intensified layer of public engagement with the site I wanted the site to fit the profile of a hybrid programmed park space that would include public recreational facilities.

The idea to include recreational facilities was to place a public anchor on site to encourage engagement beyond the railway line, an idea that was supported by the scale of the site. A major influence for the inclusion of public recreational facilities as part of the site was to promote passive engagement with the structures and processes on site.

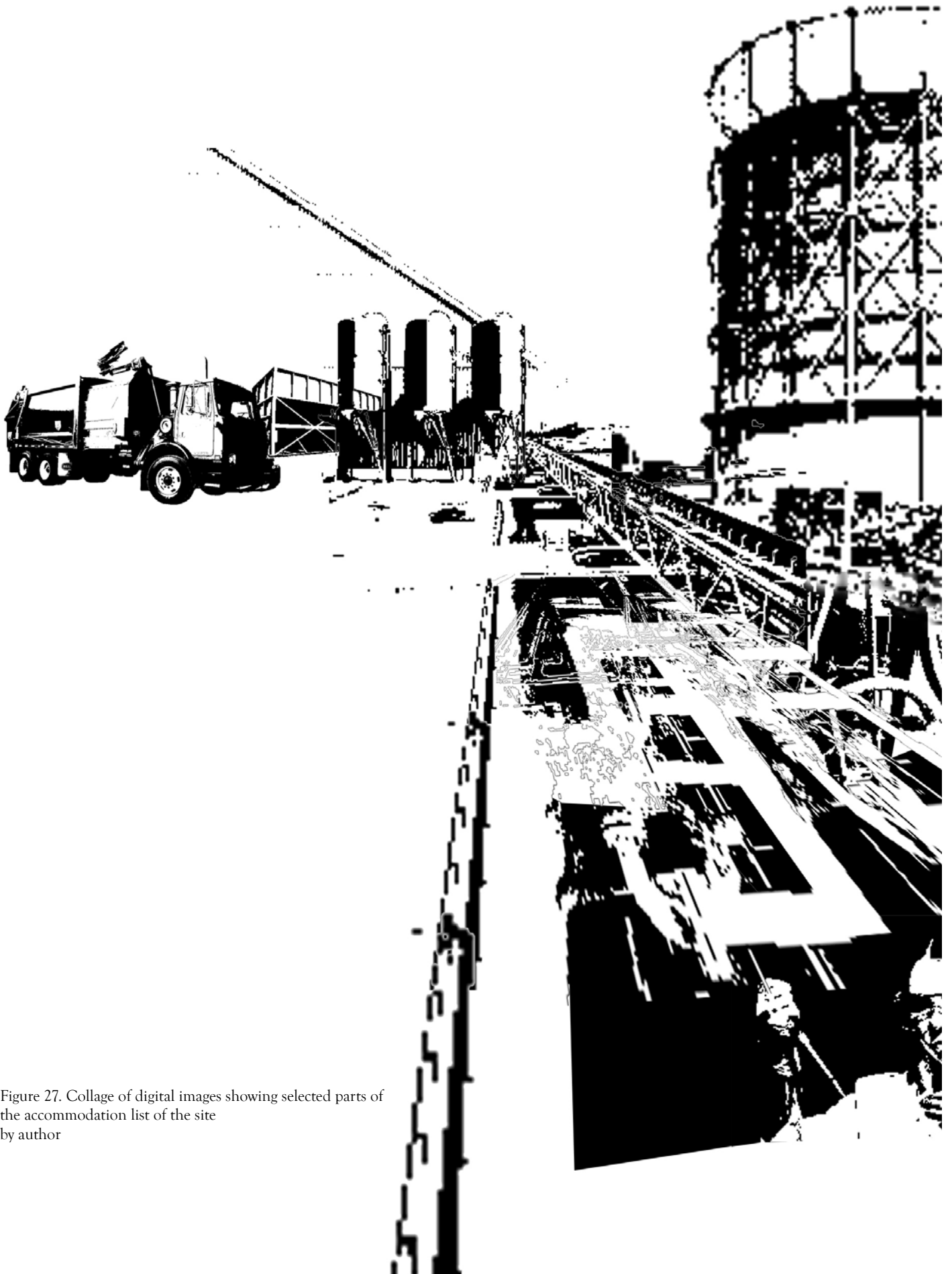

Figure 27. Collage of digital images showing selected parts of the accommodation list of the site by author

The facility shares the site with a biochemical process engineering and energy research centre that is a satellite office and research centre for CSIR. To serve as one of the only convention spaces for science and research in the country, the site also houses a large an exhibition space and auditoria that can be rented out to the public for various events. The functioning waste-to-energy plant shares the open plan lower ground floor with the exhibition space is considered to be an open display of a process that is on permanent exhibition.

The cross programming of the site enhance the spectacular atmosphere of the site, which creates a sense of controlled chaos between the labourers working at the plant and the public engaging in recreational activities with the occasional even or temporary exhibition taking place. The controlled chaos, or designed tension, is amplified by the processing of the machinery. By merging the industrial, institutional and public on site, the programme of waste management and energy production in the city is pragmatic and educational.





## WASTE TO ENERGY

In the context of a society with mounting waste and a dependency of energy, a waste-to-energy plant was decided as a valuable urban industrial programme. The island already has one of 25 of the peninsula's drop-off sites at the opposite end of the road that the site sits on. The drop-off site is for green waste and rubble, and the waste-to-energy plant will use organic waste as feedstock for the energy producing process.

The programme of an organic waste-to-energy plant addresses issues of unsustainable municipal waste management by reconciling waste management as an opportunity for energy production in a system that challenges non-linear resource use. Within the current system, all collected municipal waste gets dumped at one of the three landfill sites in the peninsula through our solid waste collection system. The project is envisioned as being a catalyst for localised waste management schemes that not only relieve the need for more landfill sites; it also reduces the amount of methane gas that is released into the atmosphere by the waste from these landfill sites.



Figure 28. (above) Aerial image showing the route from Albert Road and the highway to get to the site and the drop off site  
Figure 29. (right) Map of the peninsula showing the 25 drop off site and the three landfill sites  
by author with source imagery from GIS



Figure 30. Collage expressing the amount of waste at landfill sites. Reference source from the City of Cape Town annual waste management report by author





Cape Town Municipality  
produces 2 million tons  
of general waste per year

Figure 31. (below) Mapping of food processing companies and restaurants in Woodstock.

Woodstock has a number of food processing industries, restaurants, supermarkets and fast food chains that is targeted for the majority of the supply of the organic waste needed for the production of the waste-to-energy plant.  
by author

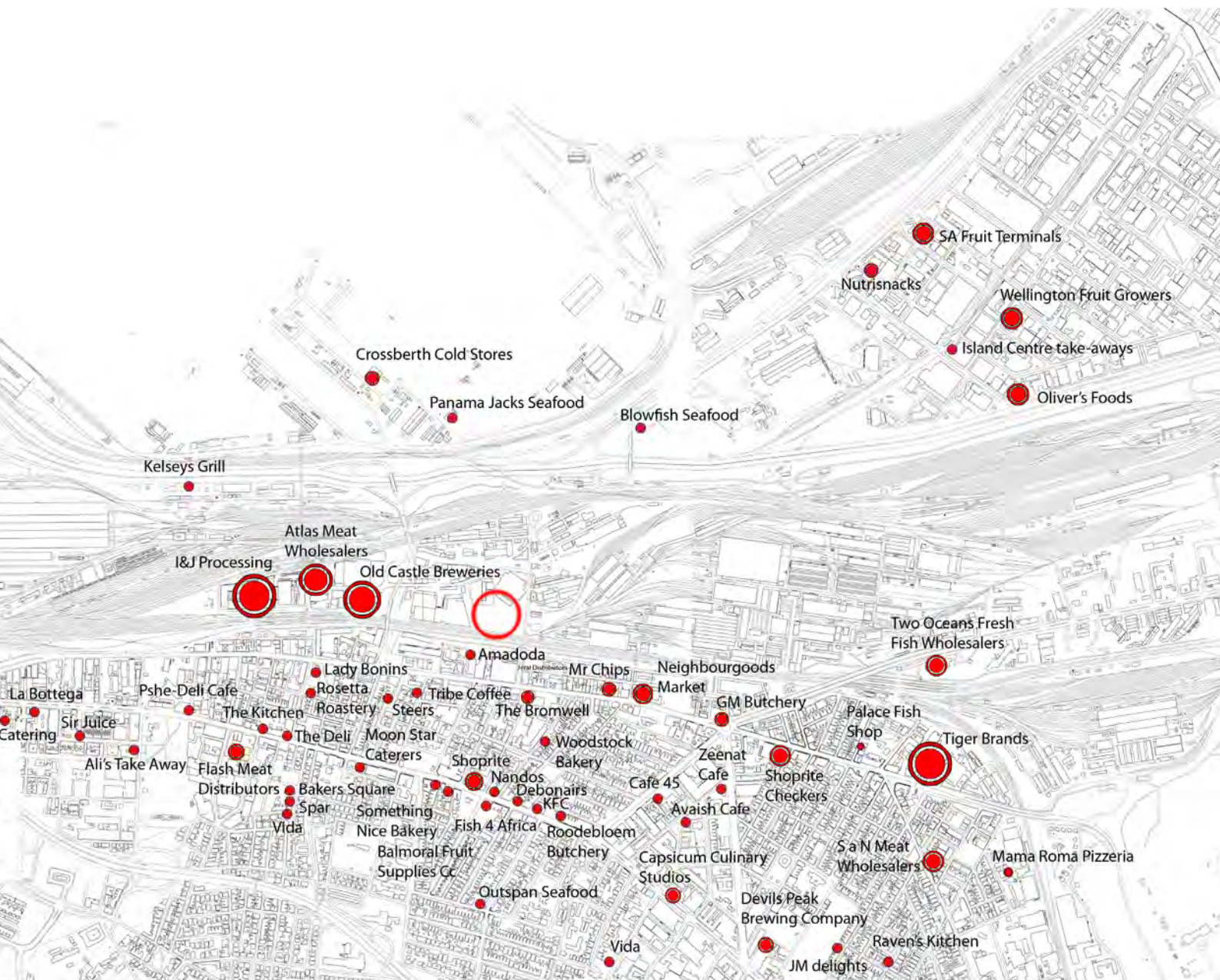

Bio methane gas can be used as a replacement to LPG gas, which is used for heating and cooking.

The programme includes a public drop-off of organic waste and collection point for bio methane gas cylinders which creates the opportunity for the public to take ownership over domestic waste and consumption. The plant is not on a commercial scale, but it focuses on a localised pilot project scheme that is also used by a research centre for the CSIR.

The scheme is about the equalising of energy for the public. The site is activated as the centre for production and distribution instead of using the piping network; which would deny the public the experience and participation in the process. The public participation of the process redefines the nature of an industrial process, and penetrates the island with a public anchor. The encouragement of the local community to participate in their waste management and production of energy aims to catalyse a culture of consciousness and sustainability.

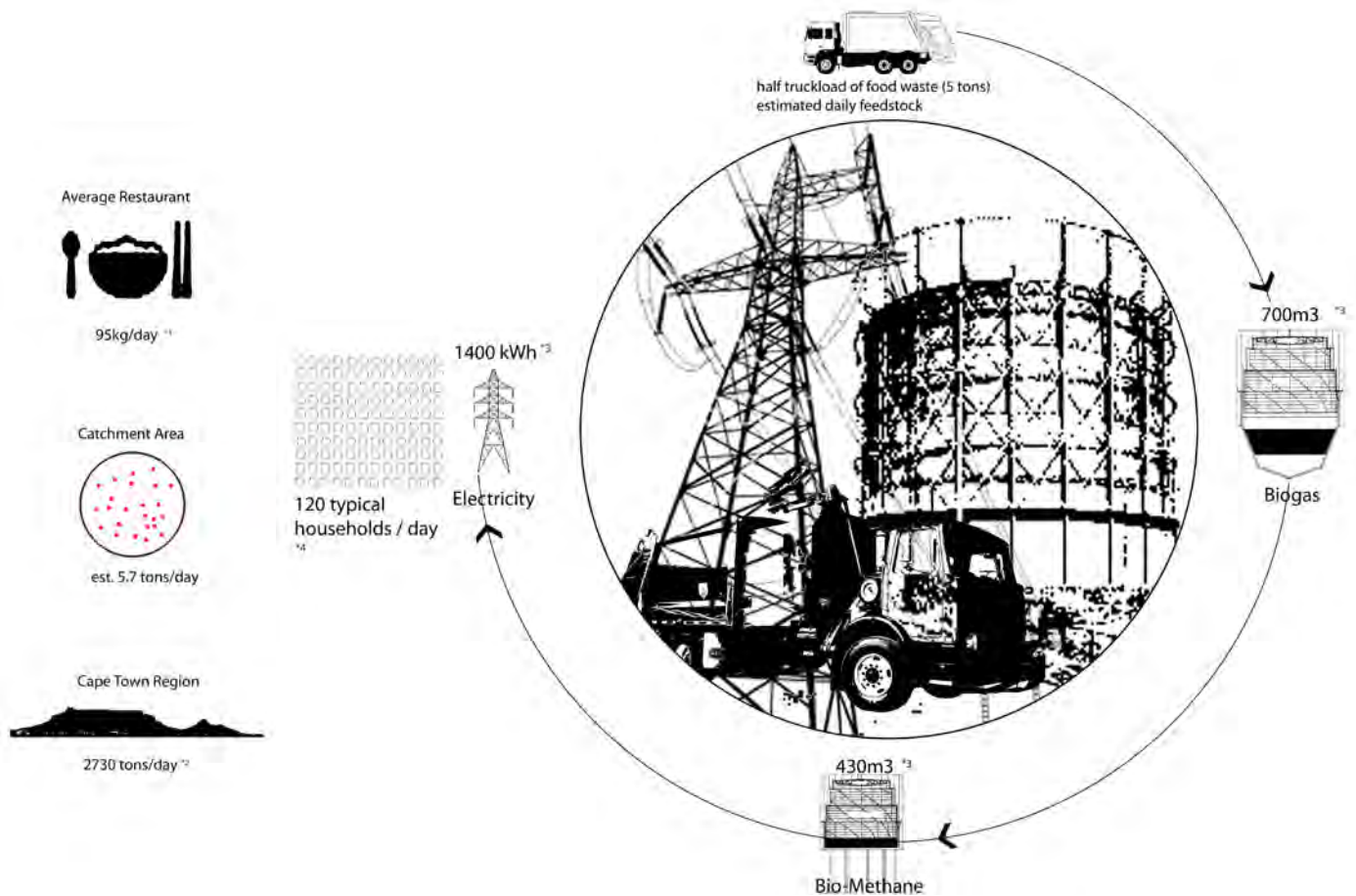
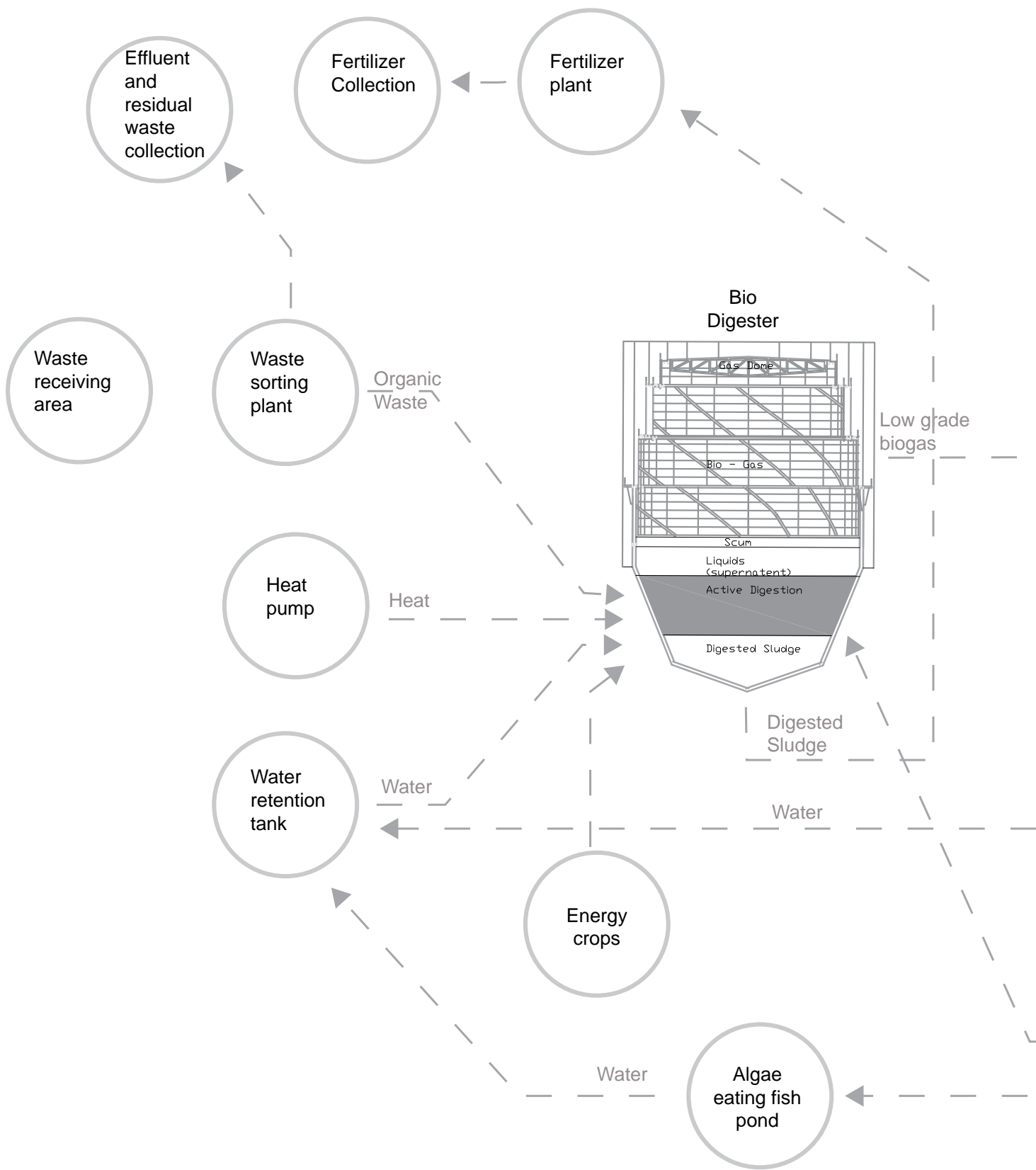

Figure 32. (above left) Daily waste statistics for the Cape Town Region.

Source information,

Figure 33. (above right) Approximate expected daily load to the energy facility and the calculated energy yield from this.

Calculation source information, Technical Document on Municipal Solid Waste Organics Processing, Government of Canada 2013 by author



## BIO-METHANISATION

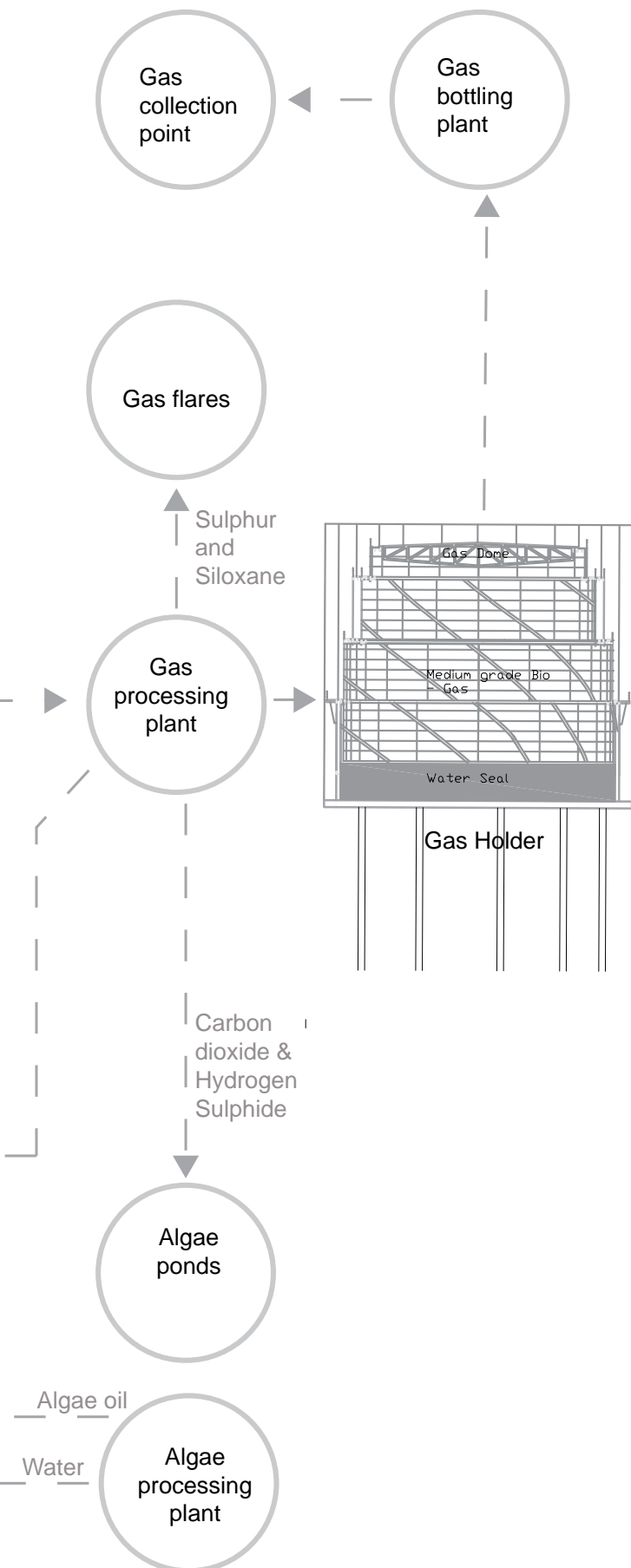

The biogas produced is a mixture of gases formed from the breakdown of organic matter in the absence of oxygen. This process happens in an anaerobic digester. The organic waste is mixed with water to form what is called the slurry at the base of the holder that also stores the gas formed.

The composition of biogas varies depending on the specifics of the anaerobic digestion process in terms of temperature and feedstock. Constant process temperature inside the digester is important for stable operation and a high biogas yield. Digesters are insulated and heated by external heat sources. The most efficient way to deal with the heat supply is to get the heat from a heat pump that is fed by an electricity generator that converts biomethane into electricity.

In an advanced waste treatment facility, like this one, organic waste is separated from other landfill waste before the slurry is formed in order to yield a high methane percentage. In this facility the biogas will be used to convert to electricity, as well as to be used on a domestic scale as an alternative to LPG gas.

After the gas is formed it needs to be purified. To convert to electricity the biogas needs a minor purification to remove the Carbon dioxide and hydrogen sulphide. The gas then gets fed through a generator to be converted to electricity.

To be used as an alternative to LPG with similar energy standards, the biogas needs to be upgraded by a purification process to remove hydrogen sulphide, excess carbon dioxide and to compress the methane percentage of the gas. This gas will then be stored in a separate holder to maintain the compression standards of the gas that will be used for heating and cooking.

The residual waste from the process forms the slurry, which will be collected from the site and sold as a source for fertilizer. The residual gases from the purification system can also be sold.

Figure 34. Diagram explaining the processes of and connected system of waste to energy on site for the plant. Based on a variety of sources when studying the stages and logistics of an organic waste to energy plant. by author



Figure 35. Miscanthus versus switchgrass.

In field trials in Illinois, researchers grew *Miscanthus x giganteus* and switchgrass in adjoining plots. Miscanthus proved to be at least twice as productive as switchgrass. (University of Illinois)  
[http://www.redorbit.com/news/science/1506803/miscanthus\\_a\\_better\\_biofuel/#w66riwe3EAYt5b1V.99](http://www.redorbit.com/news/science/1506803/miscanthus_a_better_biofuel/#w66riwe3EAYt5b1V.99)



Figure 36. Algae ponds, making biodiesel

The circular shape is mostly aquaculture and for production of Spirulina has a health food supplement. It has an arm pinned to the centre of the pond that mixes the algae to make sure sun reached as much algae as possible.  
<http://making-biodiesel-books.com/about-algae/algae-cultivation-in-open-ponds/>



Figure 37. Three Crowns Rural School in Lady Frere District, Eastern Cape

This school uses energy from the on site biogas digester, whose waste water is then treated through the algae pond purification system. The system is what inspired my algae cultivation and pond system. The school was a pilot project built in 2010. It has been successful and many more, larger, schemes will be built using a similar scheme.  
<http://www.ipsnews.net/2012/03/south-africa-rural-school-running-on-methane-bio-gas/>

## MISCANTHUS AND ALGAE PONDS

Miscanthus is a perennial grass that has been researched and investigated in the criteria for the ideal energy crop for combustion to generate heat electricity and ethanol. The crop produces biomass three times more efficiently than conventional agricultural crops such as wheat or maize. It is a non-invasive grass that can be harvested for its leaves and stems twice a year, and only has to be replanted every 25 years. The grass will be planted on site, in the remediated soil to supplement the feedstock for the biodigesters.

It is characterised by relatively high yields, low moisture content at harvest that is satisfied by Cape Town's annual rainfall average, making it a low maintenance and profitable landscaping element.

In South Africa, the grass is recorded to grow up to 2.2 meters a year, making it ideal as an on site wind protector.

The gaseous waste products from the bioprocessing, such as carbon dioxide and hydrogen sulphide, can be added to water to stimulate the growth of micro algae. Waste heat from the digester will be used to support the growth of specific algal species.

The algae goes through a harvesting and processing system, of which the algae biomass as a waste product is also used to supplement the feedstock of the digester. A valuable part of the algae processing is the algae oil. This algae oil will be used and sold by the research centre. Algae oil is valued as future biofuel.

The water waste from the separating process of the algae oil and biomass cultivation is put into a secondary pond that is purified by fish like tilapia feed off the remaining algae content before the water is added to the storm water retention pond.

Source referencing for much of the facts on miscanthus:  
<http://saaea.blogspot.com/2010/11/miscanthus-x-giganteus-sterile-hybrid.html>



Figure 38. Bioenergy village Juehnde, Germany  
This biogas plant is owned by a local cooperative of citizens.

<http://www.ytlcommunity.com/common/printerfriendly.asp?section=1&fileid=29717>



Figure 39. Newtown Creek Wastewater Treatment Plant,  
Brooklyn, New York

In this facility, methane gas will be captured from digesters, heating fuel will be extracted from waste, and butanol – a gasoline alternative – will be extracted from algae that grows in wastewater.

<http://www.renewable-energy-news.info/nyc-plans-to-generate-renewable-energy-from-sewage-treatment-plants/>



Figure 40. Johannesburg Water Northern Wastewater Treatment Works in Diepsloot.

The biogas plant is the first large scale municipal waste water treatment plant in the country. It comprises of three engines and water refurbished digesters.

<http://www.infrastructurene.ws/2013/10/15/biogas-to-power-pilot-project/>



Figure 41. Biodigester at South African Breweries, Cape Town.

The waste water from the brewery manufacture is put into a biodigester, among other waste products of the brewery processing.

Methane gas is lighter than air so if in an open space, or if the room can be opened, the gas will rise. Some gases are heavier than air which makes them sink to the lowest parts of buildings and increases the risk for a spark flame or explosion. Methane gas is then less dangerous than gases heavier than air in case of a leak. The gas is also not poisonous or carcinogenic.

If there is a biogas leak, before the gas is purified, in an enclosed room, it is easily detected by a rotten egg smell.



The intervention supports re-using wasted land to transform it into becoming a site of regeneration and life in a productive urban environment.

A large part of the programme was inspired by the historical narrative of the site and how to sustainably continue our relationship with the landscape. Like the remediation of the polluted soil, the distancing from a landfill waste dependency is a physical mending of a relationship with the earth. The nature of the energy producing plant, and the cross programming of the site challenges the definition of industry as well as redefines our understanding of the opportunity of waste and energy. This new understanding releases a tension between manufacture and consumption in a scheme that feeds a National economic agenda and the sustainability goals of the country.



# DESIGN

## VISUAL CONNECTORS

The site is a 'destination' site as it is not along any major public route or corridor for pedestrian or vehicles. It can be described as hidden behind the buildings of Albert Road.

The decision to re-present gasholders on the site was something that was not a non-negotiable part design intervention from the beginning, but I have favoured the idea since researching the history of the site. The holders are pragmatically suited to the new energy producing scheme on site which concretised the decision to re-present gasholders on the site.

The natural amphitheatre of the residential houses of Woodstock has set up an audience for the holders. View of importance that influenced the placement of the holders is passersby in the train, from the connector road to the highway, and from the connecting Rail road to Albert Road. The scale of the holders is the superseding presence of the site beyond its' boundaries, as was with the old gasworks. The placement of the holders and the forms of the rest of the sites programme is designed to highlight the holders.

The gasholders are landmarks in the skyline, locating the site functions in the landscape. Their expansion and contraction, as with the previous gasholders, is a reflection of manufacture and change that is a communicative device to the community and passers-by.

Figure 42. Section through the site and Woodstock toward Devils Peak.

The setion shows the site on the flat lower part of Woodstock, with a natural amphitheatre set up in the landscape across from the site.  
by author





Figure 43. Methane storage a membrane holder.  
This kind of holder is common in contemporary large scale biogas facilities.  
<http://www.utileengineering.co.uk/gas-holders/>

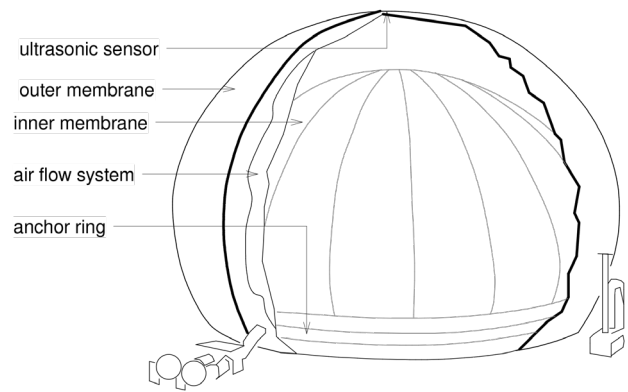

Figure 44. Methane storage a membrane holder showing layers  
This diagram shows the structural layers of this kind of membrane holder.  
by author with source information: <http://www.utileengineering.co.uk/gas-holders/>

## GAS HOLDER AESTHETIC

The contemporary gas storage type is the membrane system that is made of a high strength and elastic pvc coated polyester material. The form of the outer membrane remains the same, despite the fluctuations of the inner membrane that stores the methane gas.

I have chosen to model the gasholders on a similar system as the fixed frame telescoping holder, mainly because I would like to maintain the communicative character of the holders in the skyline, displaying the capacity of the holder in relation to the on site manufacture and usage.

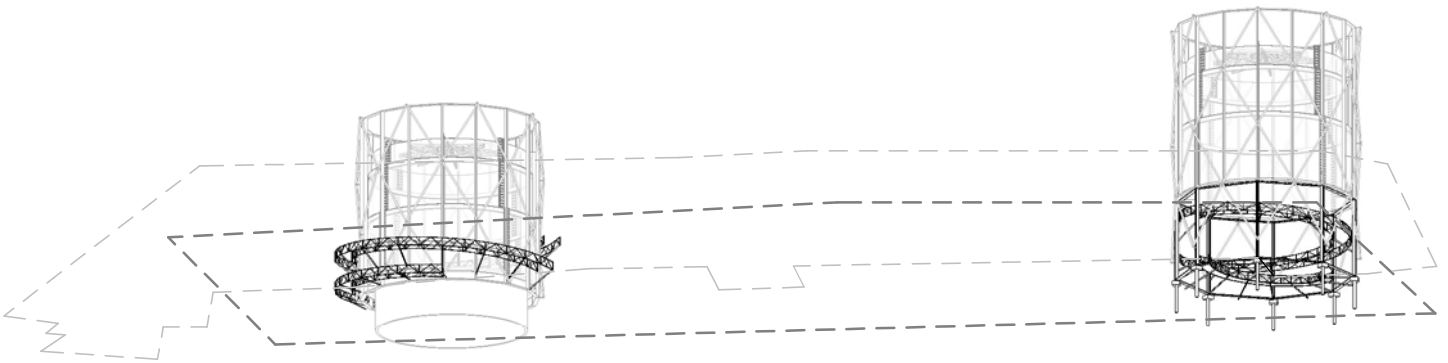

Figure 45. Worms eye view of the holders in my scheme

The drawing shows how the frame structure of the holders being used to clip on the structure of the ramps from the basement parking level to the upper ground floor. The holders form the circulation cores of the site in an effort to create some physical engagement with them through an alternative use, as well as having the holders forming part of the spatial functionality of the scheme. The upper ground floor slab is offset from the edges of the holder to bring a halo of light down to the lower ground floor.

by author



Figure 47. Working models exploring the idea of re-inventing the ground plane of the site.

The idea to re-invent the ground plane was generated by the idea of breaking up the volumes of the site to create a more carved out space that contested the flatness of the site. The idea also aimed to capitalise on the remediation process of the soil, which would have to be carved up as a matter of necessity. This seemed like a good opportunity to re-landscape the site.

by author

## THE GROUND PLANE

The site is a large open plane that has one edge facing an adjacent plot, which is largely an open site with an abandoned building on it. The pedestrian accessibility to the site from the greater Woodstock area or Woodstock Station is over the train tracks on an existing footbridge adjacent to lower main road.

The polluted soil of the site needs remediation. A layer of soil will be carved up and taken away for purification. The building process will continue during this process, with the carved up layer of soil being where the facilities' basement parking will be built.

As previously mentioned the buildings in this 'island' have not attempted to make any connection to the street edge, but choose to either put up walls along their site boundary or put a gated parking lot along the road from of their site, I have concluded that the ground plane is unpleasant for pedestrians, and actively pedestrian unfriendly due to the scarcity of pavements within the island. The conditions described are not surprising considering the industrial nature of 'the island'. In view of this contextual character description, I did not see the point in bringing pedestrians down from the footbridge to the existing ground plane to enter the site. I have decided have invented a new ground plane to the site which I expect to be the main entrance level to the facilities on site. This new ground plane is the upper ground plane that is to start on the same level as the footbridge path above the railway lines.

The new ground plane forms a landscaped park space that connects programme across the site which would also be the roof of the lower ground level that is sandwiched between the curved up basement parking level and the upper ground floor slab. Some of the remediated soil from the site will be returned as used for the soil boxes in the landscaping of the built upper ground level.



The accommodation list for the site enough to occupy the size of the site, but the scale of the site was still challenging to manage. I imagined the largeness of the site to have an alienating effect on the users of the space, an unfavourable spatial condition, especially part of the aim of the programme is to de-alienate a process and perceived relationship with infrastructural forms in the landscape. The vastness and flatness and scale of the site is be attempted to be broken up by splitting and folding the surface of this new ground plane to break the space up to distract the human from feeling intimidated by the scale of the site . The design intervention focuses on the spatial relationships between form and body.

The landscaping of this upper ground slab will be topographically invented to imported interest onto the site and to contest its' flatness. The plane is one that responds to the natural amphitheatre of Woodstock, with the various gardens and levels that will act like different planes of a stage set.

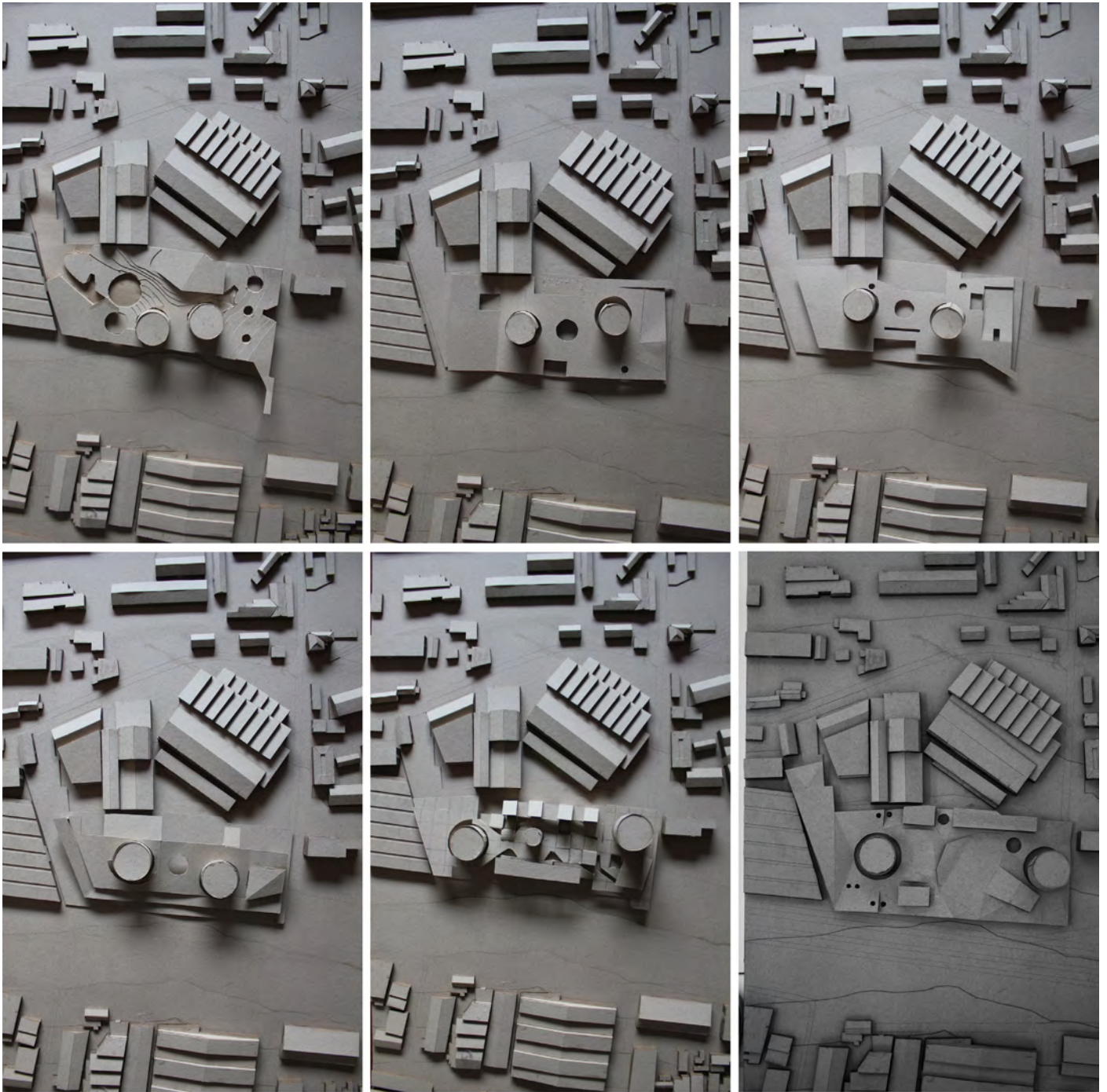

Figure 48. Working models showing the sculpting process of the new ground plane and the treatment of the forms within the site. This series of models displays the process of re-arrangement of the forms that pierced through the upper ground floor, which influenced the void space that was the ruptured landscape that flooded to the site boundary inbetween the forms that pierced through. The challenge was trying to create a pleasant central space on the upper ground floor while also considering the planning of the lower ground floor.  
by author

Arranging the programme on site was done in strata layers that were used to rationalise the solid and void forms of the roofscape of the upper ground level. The solid was the forms that pierced through the upper ground floor from the lower ground floor. When placing the objects of the strata layers, I considered the desired movement on the upper ground slab from the footbridge and between programmes sharing the surface.

The primary strata layer was the gasholders that were the 'pins' or anchors of the space. They were placed for optimum views from beyond the site. The holders also formed the circulation cores of the site, as well as brought in light to the space below. They were then placed at the two ends of the site.

The remaining solids were the second strata layer. The placement of these forms was based on the idea of mending the edge of the site boundary, leaving most of the central space for programmed void space. The programmed void space is the recreational and leisure space.

The third strata layer is the landscaping of the surface that redefines the edges of the void space between the solid forms that pierce through.





Figure 49. Early treatment of the re-imagined landscape  
 This scheme involved the lifting of the surface of the site in areas around a central pathway. There were buildings below the raised landscape in certain areas. There was not much guidance for a logic in this scheme, unlike the later scheme, which partly governed by circulation and structure from basement to top of roof surface.

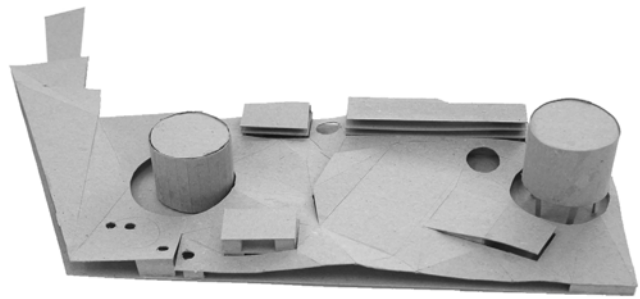
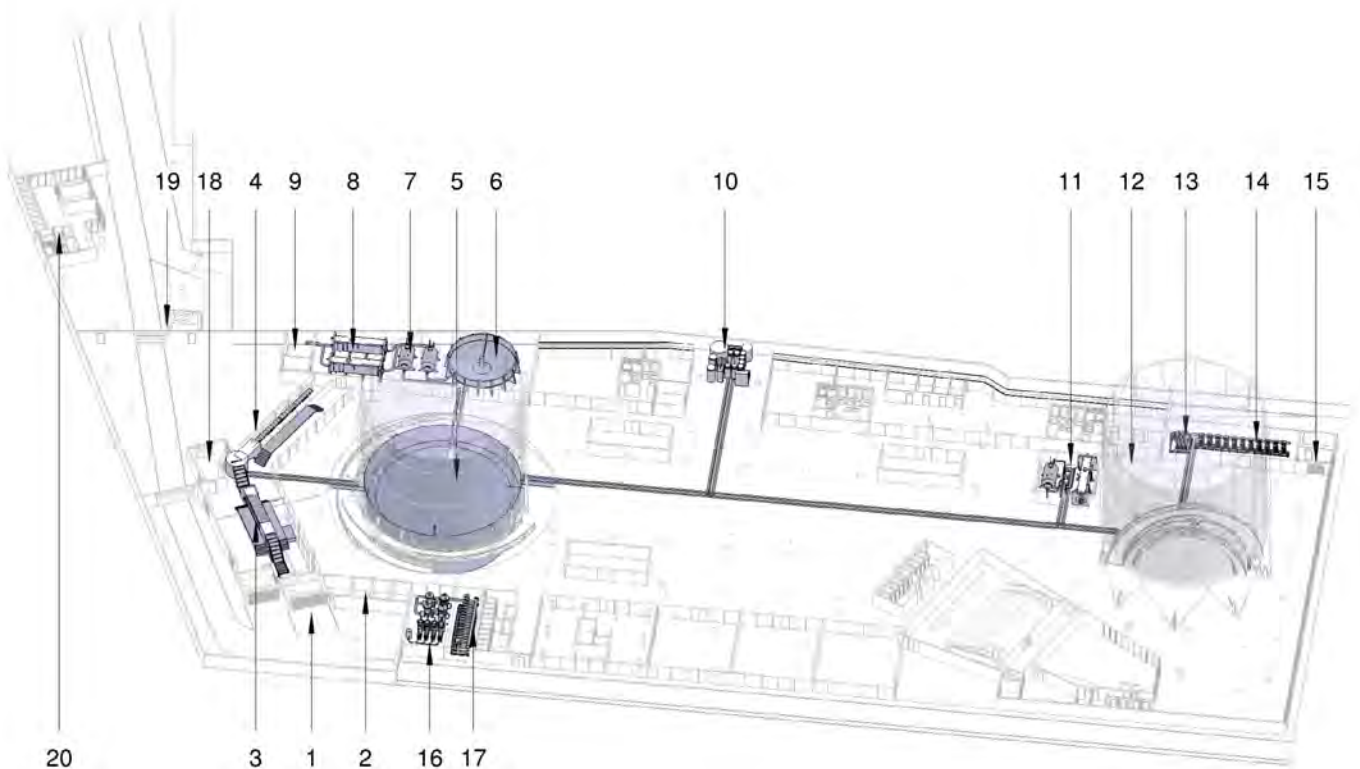
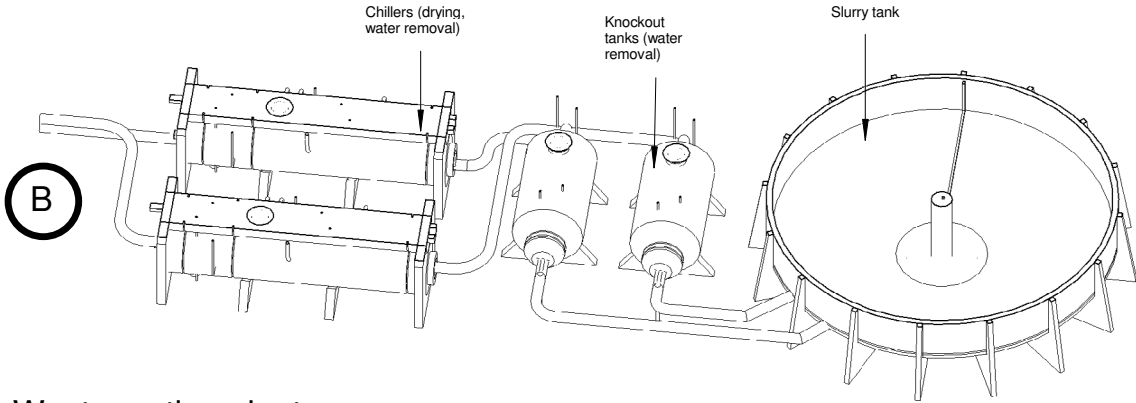

Figure 50. Later treatment of the re-imagined landscape  
 The developed scheme is more sophisticated and rational than the initial scheme. Lifting the ground plane to create two full ground planes meant that two levels would both experience the ruptured landscape, one the inverse of the other, which created a dialogue between the two ground planes. The later scheme did not have defined path, but attempted to create a democratic fluid space on both ground planes.

- 1: Waste drop off-area
- 2: Temporary waste storage bunkers
- 3: Waste sorting plant
- 4: Disposal waste collection bunkers
- 5: Bio-digester
- 6: Used slurry tank
- 7: Knockout tank (water removal)
- 8: Chiller tank (moisture removal)
- 9: Fertilizer packaging and collection
- 10: Biogas processing plant (stage 1)
- 11: Gas processing plant (stage 2)
- 12: Gas holder
- 13: Gas pump
- 14: Gas bottling and filling plant
- 15: Gas collection booth
- 16: Algae processing plant
- 17: Water pumps
- 18: Control booth
- 19: Security booth
- 20: Staff common area

Figure 51. Diagram of machinery and arrangement on site.  
 This image shows my translation of process into a spatial organisation that celebrates character, and programme, of exhibition.  
 The machinery was modelled from information from a variety of technical and retail sources related to bioprocess engineering. The spreading of the machinery across the ground floor give the space the sense of being inside a machine.  
 by author





- A: Waste sorting plant
- B: Fertilizer plant
- C: Gas bottling plant
- D: Biogas processing plant (stage 1)
- E: Biogas processing plant (stage 2)
- F: Algae processing plant

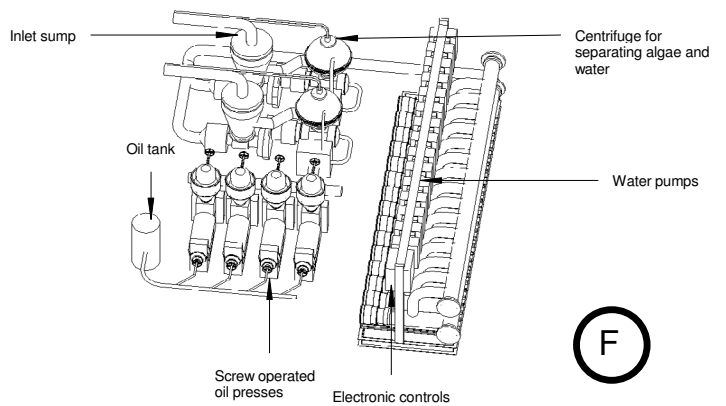
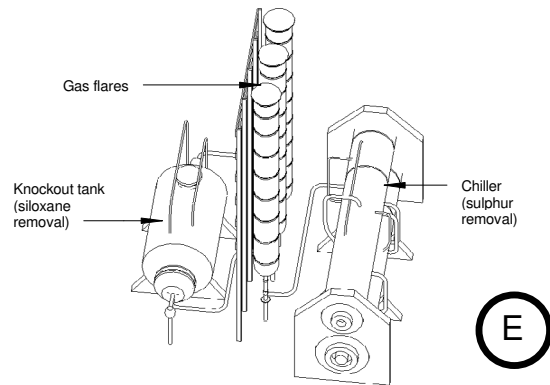
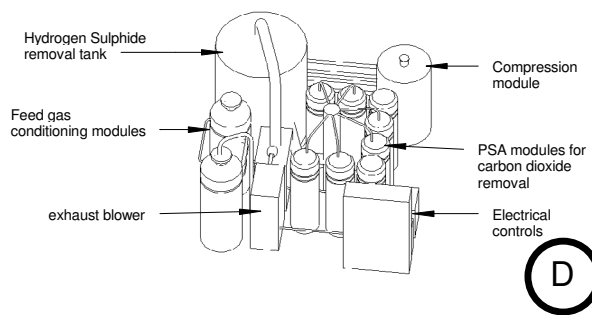
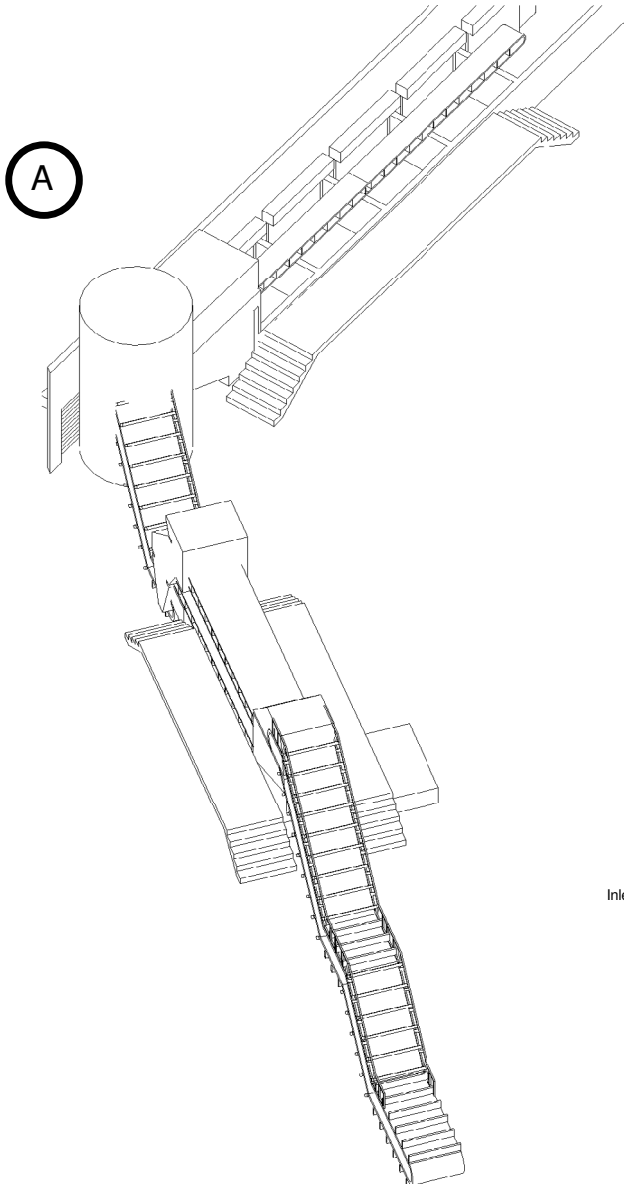
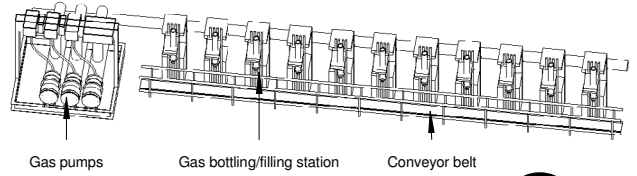
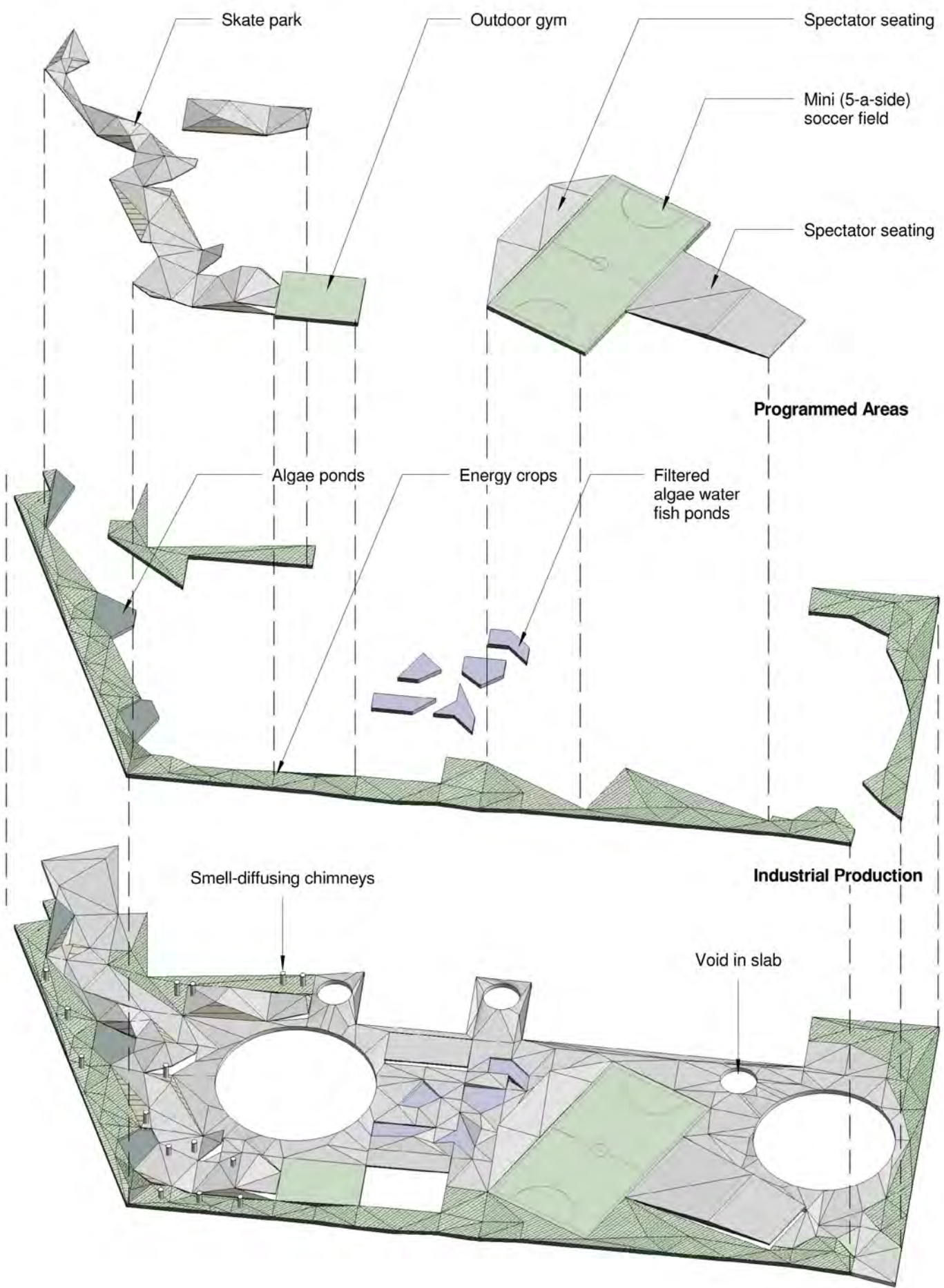

Figure 52. Diagrams showing the roof slab areas and layers.  
This image explains the attitude towards the edges of the upper ground floor and the landscaping of the energy crops and algae pools to the spaces for recreation.  
by author



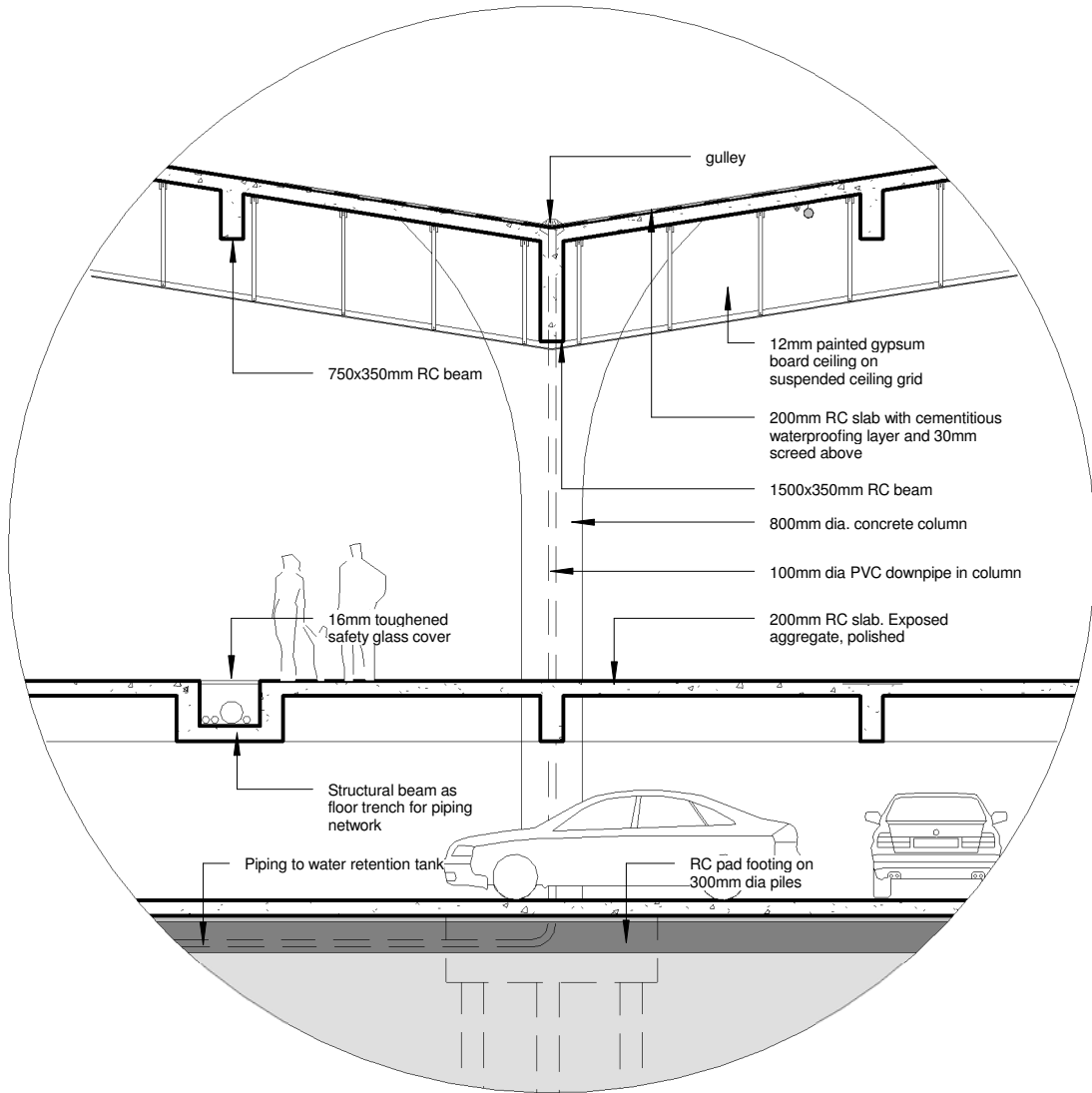

Figure 53. Typical detail of the column and drainage system by author

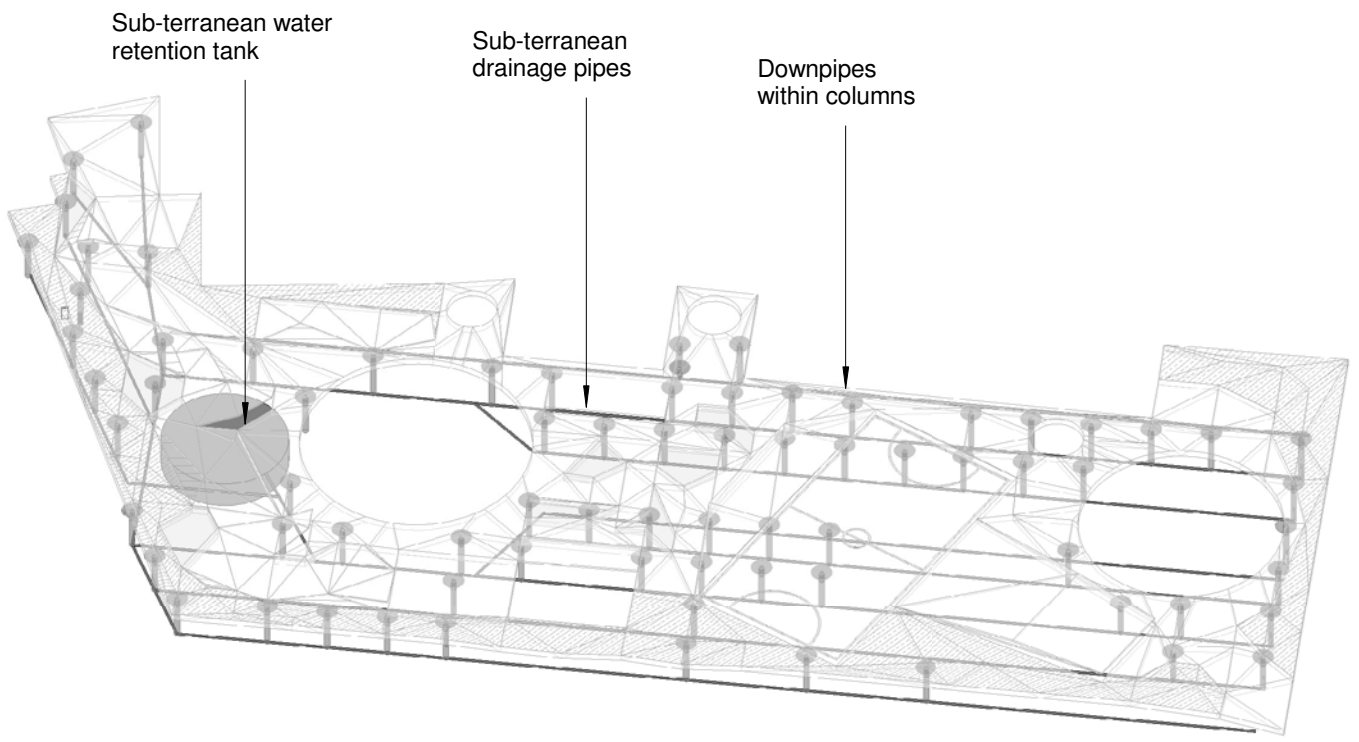

Figure 54. Roof structure and storm water retention scheme  
The collection of the stormwater on the upper ground floor surface was one of the points of guidance when designing the spot height system that sculpted the landscape of the new ground plane.  
by author



- RC structural column. 800mm diameter
- █ RC structural wall
- RC main beams.  
Simply supported beams spanning between structural columns/walls.  
Max span 17m (2 bays). Beam size 1500x350mm
- RC cross beams.  
Beams spanning between main beams at max 4.25m c/c. Max span 8.5m (1 bay). Beam size 750x350mm
- Cantilever beams.  
Max span 7m. Beam size 1500x350mm

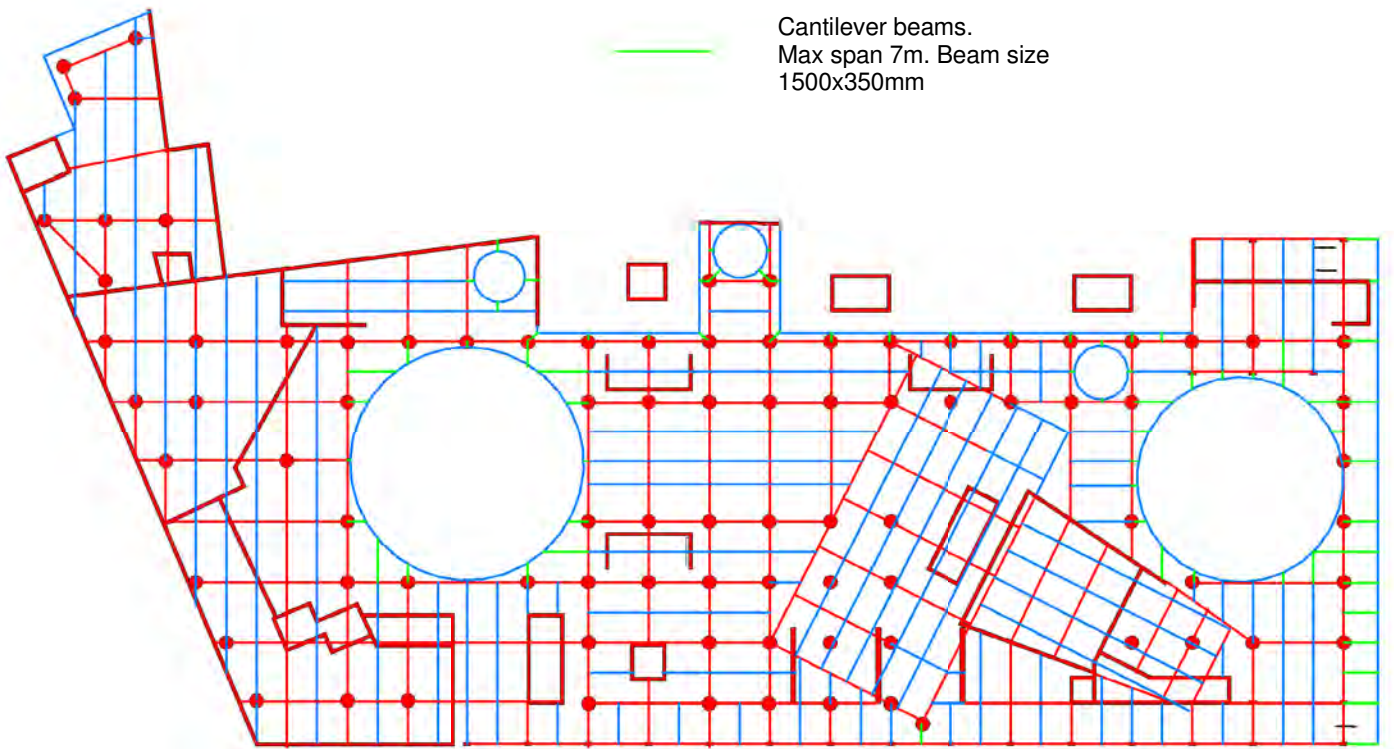

Figure 55. Diagram showing the structural column and beam system of the roof by author



## REMEDICATION AND RE-IMAGINATION

The interest in infrastructural forms in the landscape led me to a site narrative that I romanticised. I began with a thorough investigation of the physical structures of the previous 'life' of the site that was the gasworks, as well as tried to understand what the industry and the forms represented. Clues from this investigation and a programmatic agenda to de-alienate infrastructural sites to becoming inclusive instead of exclusive inspired a programme for a re-imagined energy plant.

The urban condition and the polluted soil of the site were the main generators of a design response. The idea to create an upper ground plane was a major focus and it influenced the design in every aspect. The scale of the site, the lack of public movement or desire in the area and managing the relationships between programmes were the most challenging parts of the design.

The evolution of the scheme became a response that suited the re-presencing of the gasholders. The site operates as a machine, with the processes of the plant becoming integral to the design of the overall scheme. The waste to energy plant and the remediation of the soil on a previously wasted piece of land in the new life of the site is now inclusive instead of exclusive. The historical narrative of the site that I had initially romanticised has been extended in a poetic way that mirrors my interests and programmatic agenda for infrastructural landscapes.



## REFERENCING: BIBLIOGRAPHY

Cogrove, D. (1998). *Social Formations and Symbolic Landscape: With a new introduction*. Wisconsin: The University of Wisconsin Press.

Cook, E. (1976). *Man, Energy, Society*. San Francisco, USA. W.H Freeman

Colin, Eleanor. (2005). *Industrial Archaeology: Future Directions*. New York. Springer

Frampton, K. (1995). *Studies in Tectonic culture: the poetics of construction in nineteenth and twentieth century architecture*. Cambridge, Mass: MIT Press

Ghosn, R. (2009). *Landscapes of energy*. Hong Kong: Harvard University Press.

Holgate, A. (1992). *Aesthetics of Built Form*. New York: Oxford University Press

Jackson, A. (1998). *The development of steel framed buildings in Britain 1880-1905*. Construction History, Volume 14 , 21-40.

Kirkwood, N. (2001). *Manufactured Sites: Rethinking the Post-Industrial Landscape*. London: Taylor & Francis.

Potteiger, P. (1998). *Landscape Narratives*. New York: John Wiley & Sons, Inc.

Thayer, R. (1994). *Gray World Green Heart*. Toronto: John Wiley & Sons, Inc.

Waugh, E. (2011). *Recycling Spaces, Curating Urban Evolution: The landscape design of Martha Swartz Partners*. London: Thames and Hudson.

Worth, David (2004) *Gas and Grain: The Conservation of Networked Industrial Landscapes*. University of Cape Town Cape Town. Unpublished



## EBE Faculty: Assessment of Ethics in Research Projects

Any person planning to undertake research in the Faculty of Engineering and the Built Environment at the University of Cape Town is required to complete this form before collecting or analysing data. When completed it should be submitted to the supervisor (where applicable) and from there to the Head of Department. If any of the questions below have been answered YES, and the applicant is NOT a fourth year student, the Head should forward this form for approval by the Faculty EIR committee: submit to Ms Zulpha Geyer ([Zulpha.Geyer@uct.ac.za](mailto:Zulpha.Geyer@uct.ac.za); Chem Eng Building, Ph 021 650 4791). **NB: A copy of this signed form must be included with the thesis/dissertation/report when it is submitted for examination**

***This form must only be completed once the most recent revision EBE EIR Handbook has been read.***

Name of Principal Researcher/Student: Tasneem Mohamed      Department: APG      (School of Architecture, Planning and Geomatics)

Preferred email address of the applicant: [tasneemmohamed@hotmail.com](mailto:tasneemmohamed@hotmail.com)

If a Student:                      Degree: MArch (Prof)                      Supervisor: Melinda Silverman

If a Research Contract indicate source of funding/sponsorship: N/A

Research Project Title:  
Waste to energy: Re-presenting the Woodstock gasworks

**Overview of ethics issues in your research project:**

Question 1: Is there a possibility that your research could cause harm to a third party (i.e. a person not involved in your project)?	NO
Question 2: Is your research making use of human subjects as sources of data? If your answer is YES, please complete Addendum 2.	NO
Question 3: Does your research involve the participation of or provision of services to communities? If your answer is YES, please complete Addendum 3.	NO
Question 4: If your research is sponsored, is there any potential for conflicts of interest? If your answer is YES, please complete Addendum 4.	NO

If you have answered YES to any of the above questions, please append a copy of your research proposal, as well as any interview schedules or questionnaires (Addendum 1) and please complete further addenda as appropriate. Ensure that you refer to the EIR Handbook to assist you in completing the documentation requirements for this form.

**I hereby undertake to carry out my research in such a way that**

- there is no apparent legal objection to the nature or the method of research; and
- the research will not compromise staff or students or the other responsibilities of the University;
- the stated objective will be achieved, and the findings will have a high degree of validity;
- limitations and alternative interpretations will be considered;
- the findings could be subject to peer review and publicly available; and
- I will comply with the conventions of copyright and avoid any practice that would constitute plagiarism.

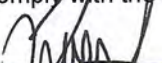
Signed by:  Tasneem Mohamed

	Full name and signature	Date
Principal Researcher/Student:	Tasneem Mohamed	15 October 2014

**This application is approved by:**

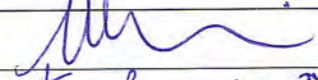
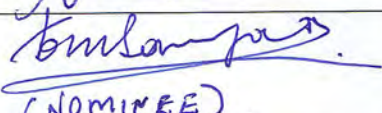
Supervisor (if applicable):		
HOD (or delegated nominee): <i>Final authority for all assessments with NO to all questions and for all undergraduate research.</i>	 (NOMINEE)	17/10/2014
Chair : Faculty EIR Committee For applicants other than undergraduate students who have answered YES to any of the above questions.		



## **ADDENDUM 1:**

### **Design Dissertation Summary**

The investigation started with an interest the symbolic relationship between power infrastructures as well as their aesthetic. This interest influenced a choice in a site. The site I have chosen on the old Woodstock gasworks site of Cape Gas. The above ground structures of the previous facility were demolished in 1996 with the closure of the company.

Programmatically the design dissertation deals with re-imagining the nature of a waste-to-energy plant in a dense mixed use area, exploring how programme could be transformed to include public facilities in a way that releases the exclusive nature of a power plant. The nature of the type is an estranged relation to the public one that I hope to collapse through public engagement. I will be exploring the programmed public facilities park with a functioning sustainable energy plant. Architectural strategies to be sensitive to the narrative of the site and programme will be explored, as well as used to resolve urban issues of the site.

The site is in an industrial island that is landlocked by the north and south railway lines. Beyond the railway lines are lower main road and a dense residential area. No permanent structure has been built on the site since then. The site is close to the CBD, and in an area that's value and demand is rising. I would like to design an intervention with a public element that celebrates not only the industrial history of the site, but of Woodstock the area which is the best example of rich mixed use area in Cape Town. Based on a programmatic agenda and an urban response, I would like to promote a stitching of the two different parts of the area together, by creating a new identity for a factory and making it a public destination and reconcile two (apparently) opposing forces.



# ARCHITECTURAL DRAWINGS

by author



UPPER GROUND FLOOR PLAN  
1:200

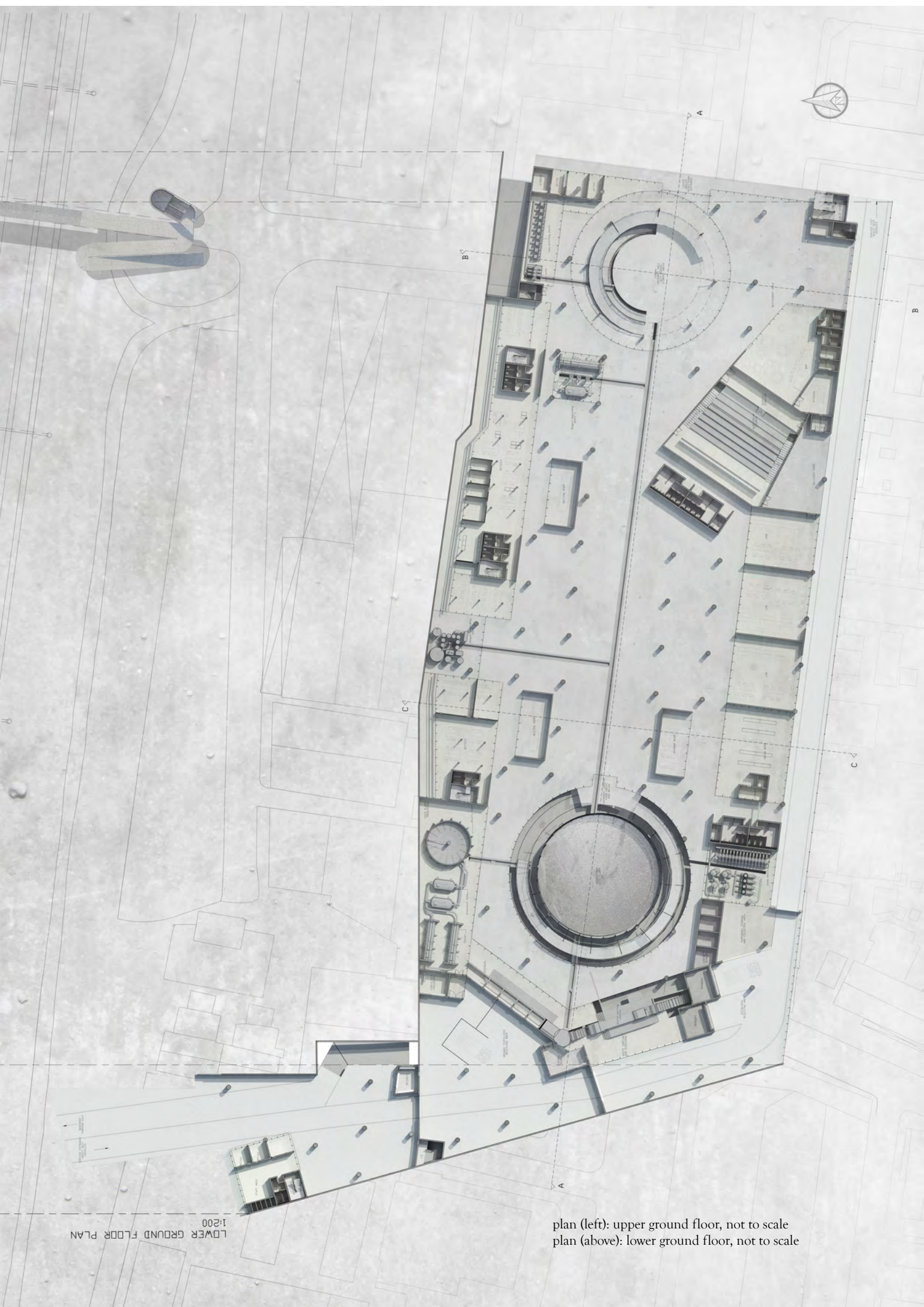

LOWER GROUND FLOOR PLAN  
1:200

plan (left): upper ground floor, not to scale  
plan (above): lower ground floor, not to scale

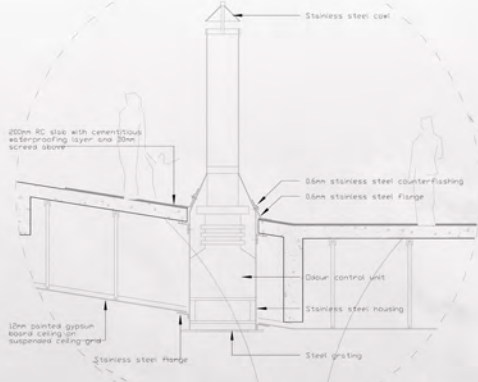
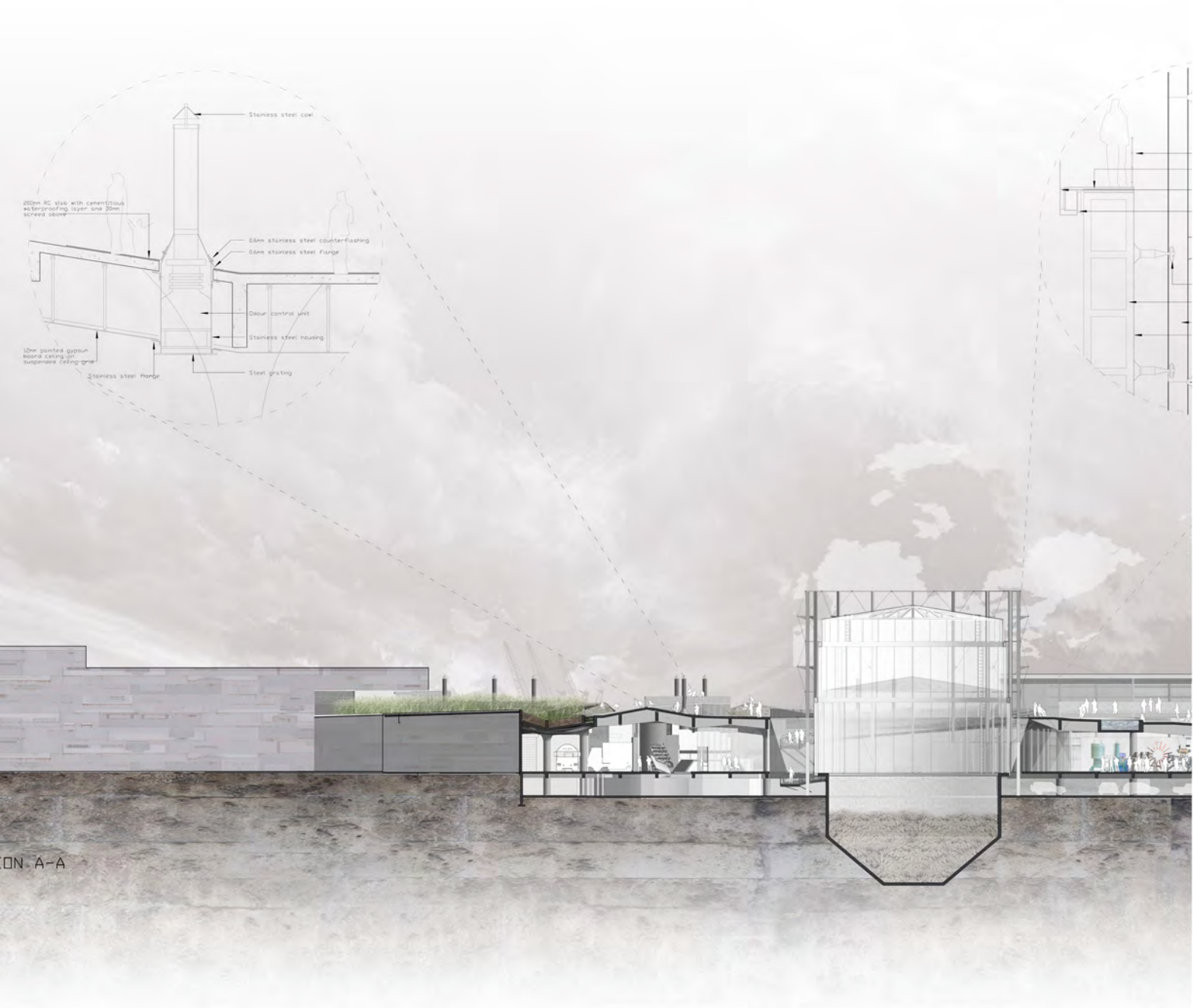

ON A-A

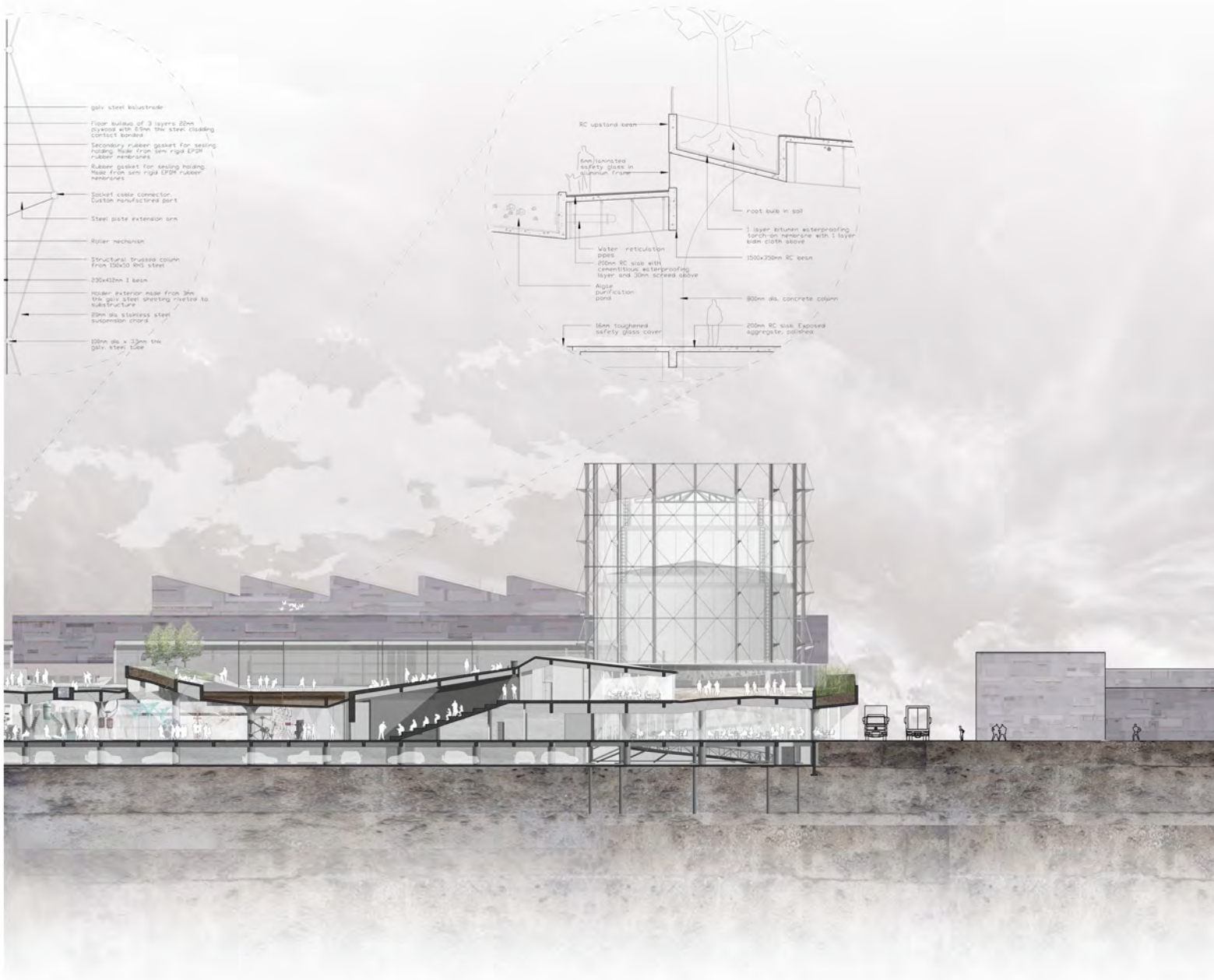

longitudinal section AA with details, not to scale

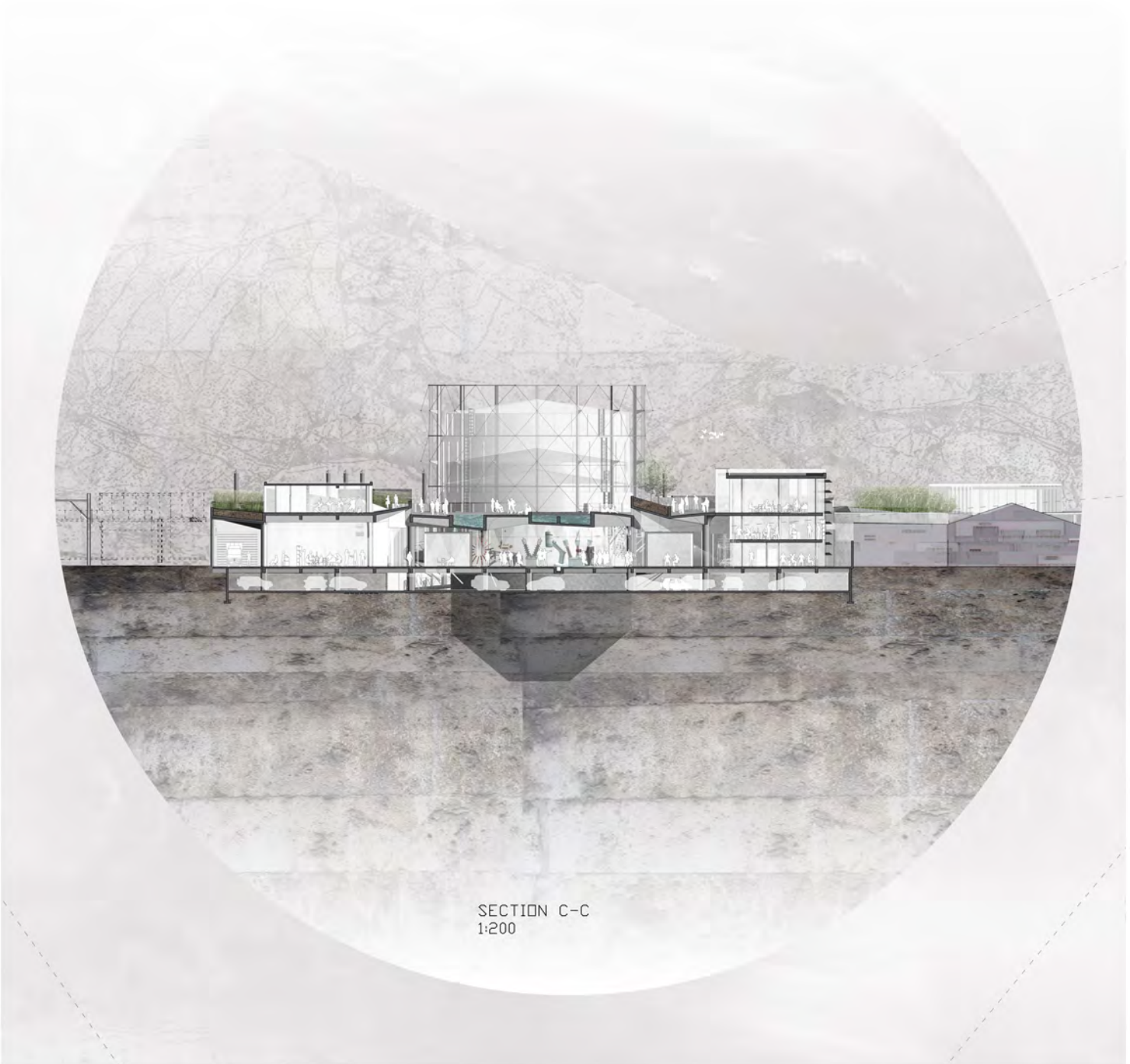

SECTION C-C  
1:200

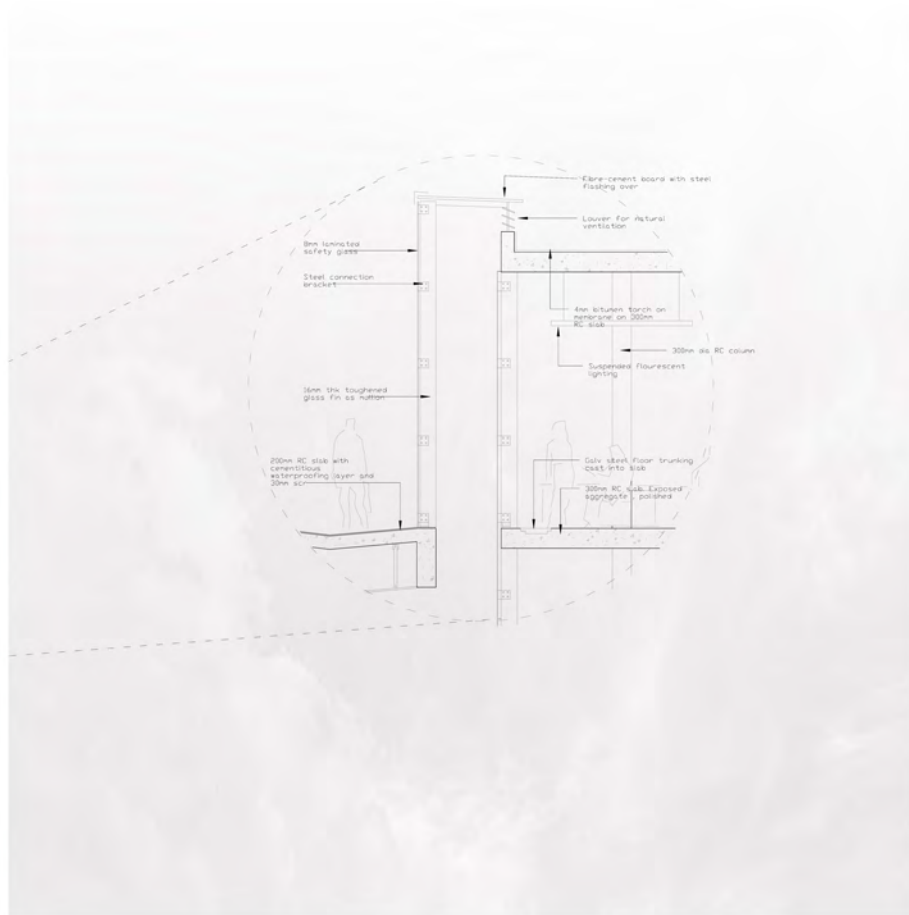

cross section CC with detail, not to scale

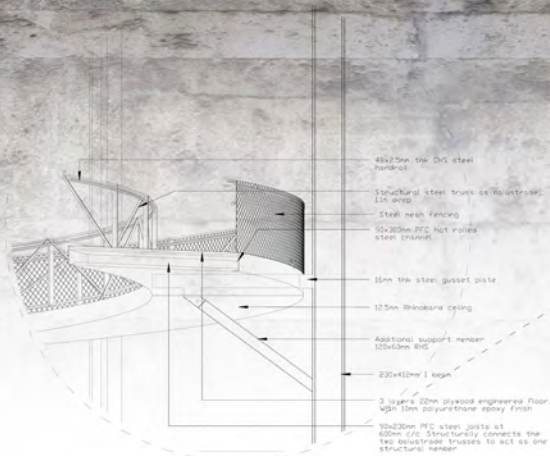
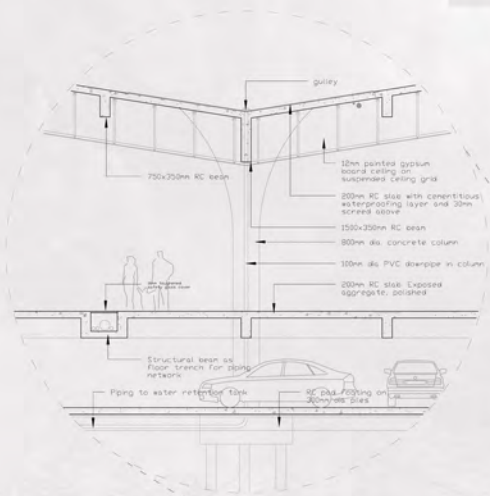

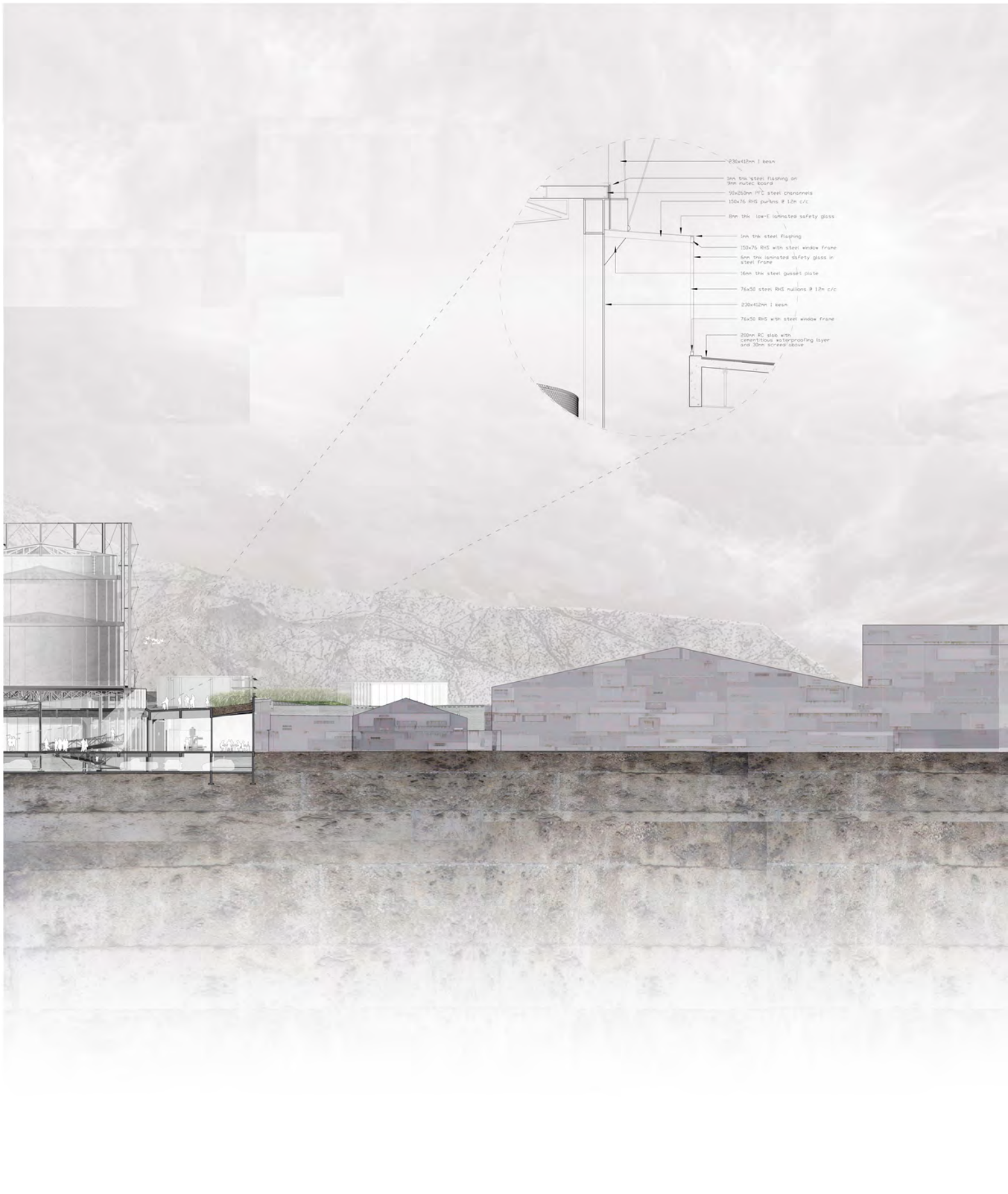

cross section BB with details, not to scale

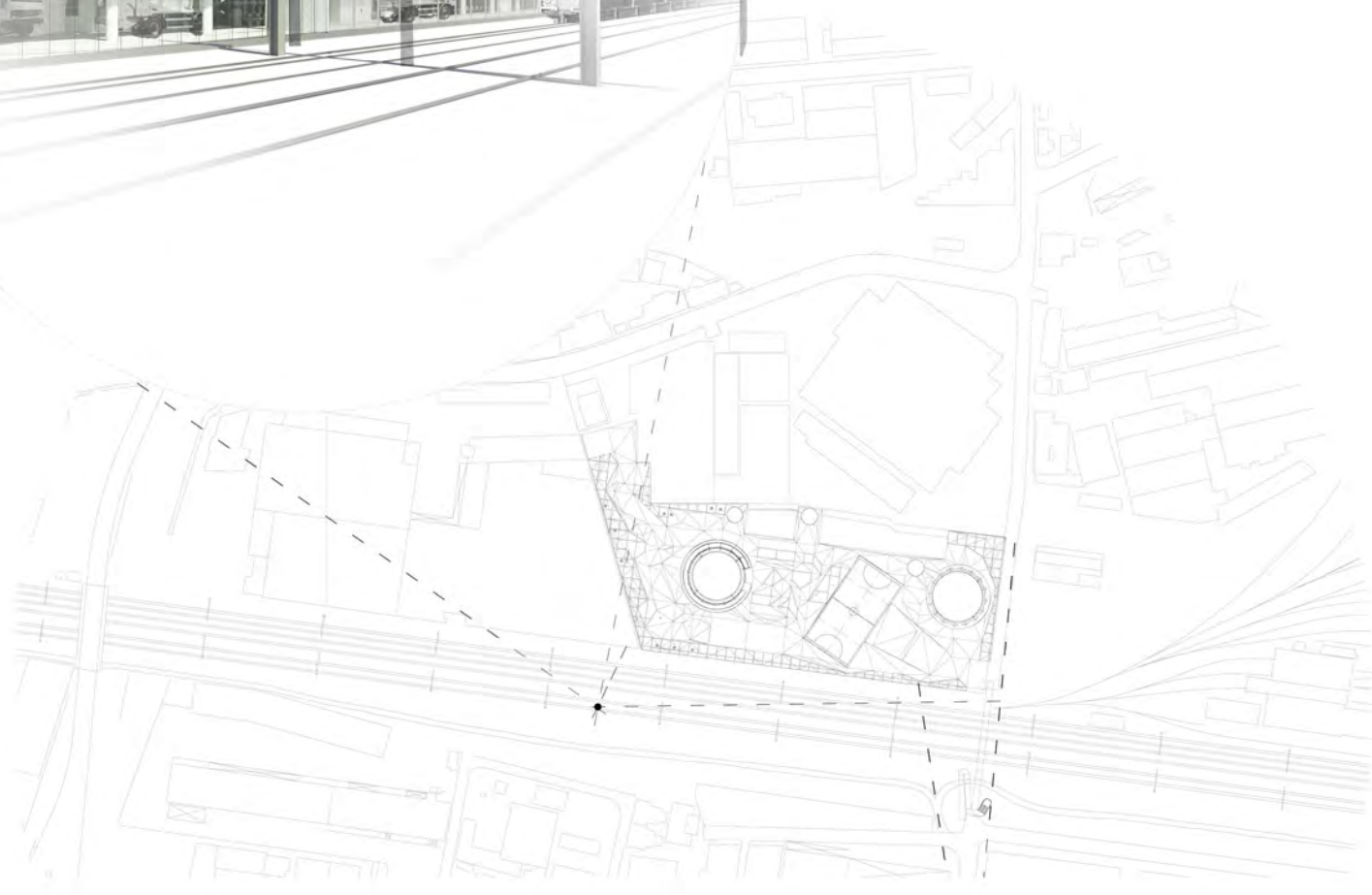

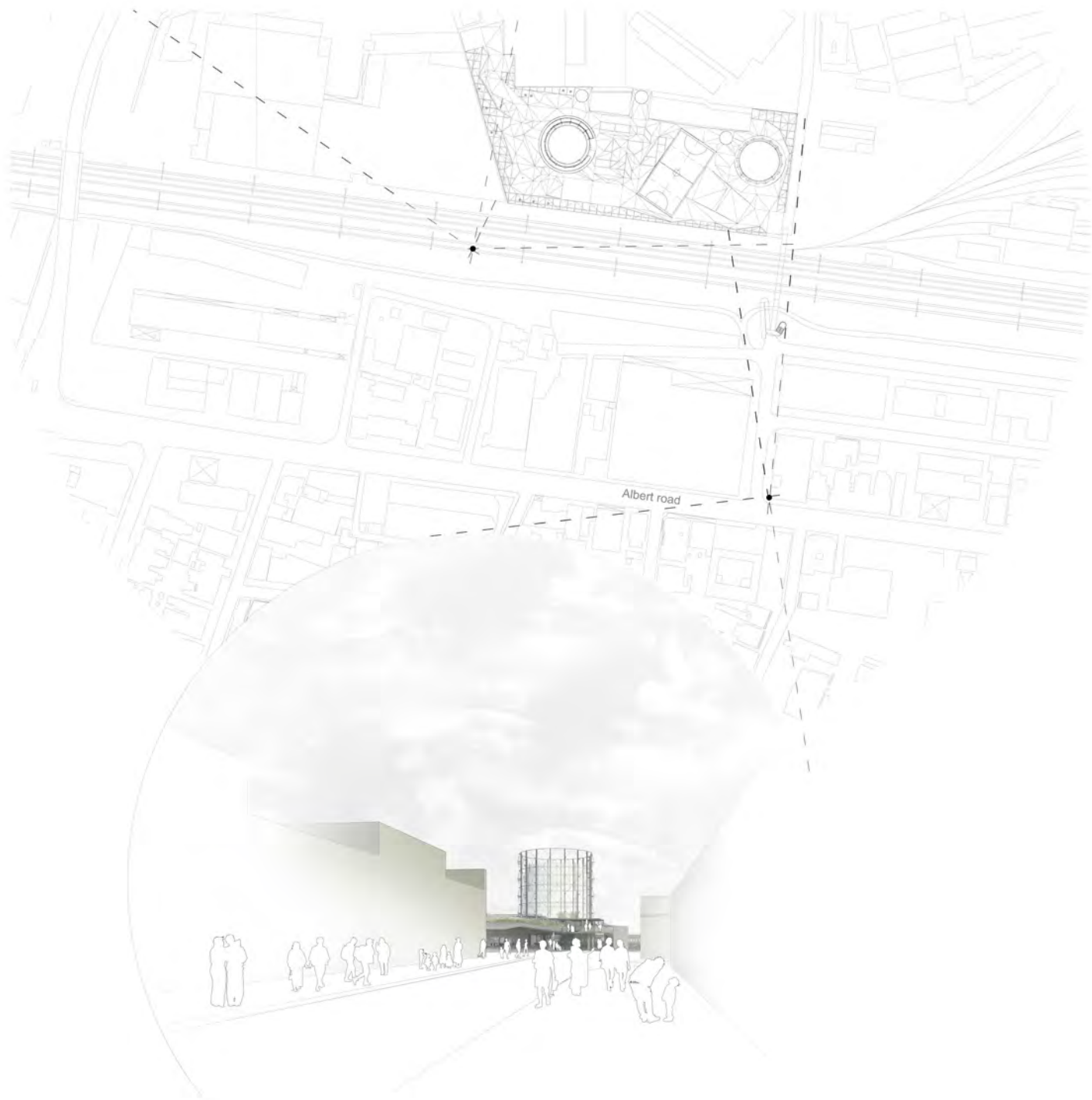





(left): perspectives with reference points, not to scale  
(above): axonometric of the roof plan structural system