

**The Development of an Energy
Education Package
for
Secondary Schools**

Peter Eric Clinton Oxenham

Cape Town

February 1994

Submitted to the University of Cape Town in partial fulfilment of the requirements for the degree of Master of Science in Applied Science.



The copyright of this thesis vests in the author. No quotation from it or information derived from it is to be published without full acknowledgement of the source. The thesis is to be used for private study or non-commercial research purposes only.

Published by the University of Cape Town (UCT) in terms of the non-exclusive license granted to UCT by the author.

DECLARATION

I declare that this dissertation is my own original work. It is being submitted in partial fulfilment for the degree of Master of Science in Applied Science at the University of Cape Town. It has not been submitted for any degree or examination at any university.

Signed by candidate

P E C Oxenham

20th day of February 1994

ACKNOWLEDGEMENTS

It gives me pleasure to thank the following the people and organisations for their contributions and support given towards this project:

Bill Cowan for his supervision and assistance towards the final stages of this project.

The Energy for Development Research Centre(EDRC) and Community Education Resources(CER) for their financial support.

The students, staff members of CER and EDRC for their encouragement and resourceful guidance.

English for Academic Purposes of the University of Cape Town and Programme for Technological Careers for providing the opportunity to trial workshops.

Student teachers and teachers who evaluated the Energy Workshops.

Cathy for her support and patience.

SYNOPSIS

The central objective of this project was to develop a package of energy education workshops for secondary schools. The package contains nine energy workshops. Each workshop comprises a teacher's guide and a student worksheet. The package production process included choosing an education methodology, reviewing energy themes for selection as workshop topics and evaluating the energy workshop package. This dissertation provides insight into the processes of producing this package.

My participation in the Community Education Resource's Masters programme introduced the goal of producing university resources in formats which are accessible to a broader audience.

Energy themes for the workshops were drawn from a review of existing resources, particularly those of the Energy for Development Research Centre, and were selected for their relevance to energy as an agent of development, energy production and environmental concerns, energy policy formulation and vocational interest.

My view of science education encompasses an approach which emphasises scientific knowledge deemed useful in modern technological society. Applications of energy technologies and the role they have in social development are central to each workshop theme. The chosen education methodology proposes a constructivist approach to learning which emphasises that students learn by activities which facilitate classroom dialogue. Here Paulo Freire's codification method is presented as a means of initiating dialogue in the classroom.

The workshop package development process involved the participation of user groups. In this regard English for Academic Purposes of the University of Cape Town and Programme for Technological Careers provided the initial user groups which assisted in the testing of the introductory workshops. This was followed by teachers and student teachers providing comments on individual workshops and the package as a whole.

Feedback provided by teachers was extremely positive. Teachers supported the teaching methodology and viewed the chosen energy themes as relevant to the aim of promoting science and technology awareness among secondary school students.

TABLE OF CONTENTS

Acknowledgements	i
Synopsis	ii
Table of Contents	iii
List of Figures	v
List of Tables	v
CHAPTER 1: BACKGROUND RATIONALE	1
1.1 Contextualising this Project	1
1.1.1 Nomzamo Senior Secondary School, Port Alfred	1
1.1.2 Energy for Development Research Centre	3
1.1.3 Community Education Resources	3
1.2 Scientific and Technological Awareness among Secondary School Students	4
1.3 The Selection of Energy as a Theme	6
1.3.1 Energy as an Agent of Development	6
1.3.2 Energy and the Environment	7
1.3.3 Energy Issues and Policy Formulation	8
1.3.4 Energy Provision and Vocational Guidance	8
1.4 Project Aims	8
1.5 Project Outline	9
CHAPTER 2: EDUCATION METHODOLOGY	10
2.1 A Constructivist Approach to Learning	11
2.1.1 Cognitive Skills and Language	11
2.1.2 The Role of the Teacher	12
2.2 Learning Together – The Codification Method of Paulo Freire	14
2.3 Problem/Issue based Science Education	17
2.4 Critical Competence in Technological Society	20
CHAPTER 3: THE PROCESSES OF ENERGY EDUCATION WORKSHOP PRODUCTION	23
3.1 Academic Discourse and Popular Education Resource Production	23
3.2 User Group Involvement	24
3.2.1 Khanya College	25
3.2.2 English for Academic Purposes Programme, UCT	25
3.2.3 Programme for Technological Careers(Protec)	26
3.2.4 Teacher Involvement	28

CHAPTER 4: REVIEWING ASPECTS OF ENERGY RESOURCES, PRODUCTION AND USAGE IN SOUTH AFRICA AND INTEGRATING SUITABLE THEMES INTO ENERGY WORKSHOPS	31
4.1 Introducing Energy Usage in Society	31
4.2 South Africa's Fuelwood Crisis	33
4.3 Electricity is a Right, not a Privilege	38
4.4 Acid Rain – An Atmosphere of Uncertainty	52
4.5 Renewable Energy Options	59
4.5.1 Solar Building Design	60
4.5.2 Electricity from the Sun	65
4.5.3 Energy from the Wind	68
4.5.4 Biogas – Energy from Waste	71
4.6 Closure	80
CHAPTER 5: TEACHER COMMENTS ON DRAFT ENERGY WORKSHOP PACKAGE	81
5.1 Comments on package aims	81
5.2 Comments on the methodological approach	83
5.3 Comments on the selection of energy as a theme	85
5.4 The issue of non-syllabus based workshops	87
5.5 Implementing workshops in the classroom	89
5.6 Comments on the complexity of concepts	90
5.7 Comments on the use of illustrations	91
CHAPTER 6: CONCLUSIONS	92
6.1 Package Evaluation	92
6.2 Education Methodology	93
6.3 Package Distribution	93
6.4 Closure	94
List of References	95
Appendix 1 – Energy Workshop Package	1-1
Appendix 2 – Energy Workshop Evaluation Sheets	1-2

LIST OF FIGURES

- 2.1 Women carrying wood
- 4.1 National Electricity Grid
- 4.2 Estimated costs of Electrification
- 4.3 Ready Board and Pre-payment Meter
- 4.4 Estimated Primary Energy Usage in South Africa
- 4.5 Trombe-Michel Wall Design student handout
- 4.6 Marseilles Wall Design student handout
- 4.7 Solar Electricity Experiment
- 4.8 Mean wind speeds (ms^{-1}) normalised to 10 m above the ground
- 4.9 Indian Type Gasholder Digester
- 4.10 Floating Gas Holder plant being loaded
- 4.11 Biogas yield vs retention time

LIST OF TABLES

- 4.1 Pilchard tin and manufacturing processes
- 4.2 Power station emissions as a percentage of total emissions
- 4.3 C:N ratios for different organic waste types

CHAPTER 1

BACKGROUND RATIONALE

The main objective of this project was to develop a package of energy education workshops for use in Secondary Schools. Each workshop focuses on an energy issue or theme deemed relevant to South African society. The workshops take the form of teacher's guides and student worksheets and are not targeted at any specific school standard.

This chapter provides some background information relating to the origins of this project and the selection of energy as a central theme.

1.1 Contextualising this Project

1.1.1 Nomzamo Senior Secondary School, Port Alfred

The foundations of this project lie in my experiences as a Physical Science teacher at a rural state controlled secondary school.

The call for 'People's Education for People's Power' took root during 1985 in response to the ongoing education crisis. Two conferences, the Soweto Parents Crisis Committee conference (December 1985), and the Second National Consultative Conference of the National Educational Crisis Committee (NECC) conference (March 1986) were instrumental in formulating a core set of concepts defining the content and practice of People's Education.

Subject commissions for English, History and Mathematics were established at the NECC conference. The task of these subjects commissions was to involve academics, teachers, students and the broader community in discussions about syllabi content and teaching methods with aim of producing People's Education materials for use in schools.

The content of the existing History syllabi made the task of presenting an alternative syllabus a seemingly easy one. The NECC History Commission published a collection of history worksheets for students titled **What is History**¹?

¹What is History? NECC, Skotaville, Johannesburg, 1987.

History teachers at Nomzamo presented some of the worksheets as history lessons. These were accepted, albeit uncritically, as being a fine example of People's History and People's Education.

Science students began to ask, 'Is there a People's Science?' and if there is, 'What kind science will it teach us?'

Science students requested handouts listing and explaining People's Science. No NECC Science Commission had been established and NECC conference papers made scant reference to 'People's Science'.

My answer to these questions referred to my understanding of People's Education as an ongoing process involving the participation of teachers, students and the broader community. I explained that People's Education and therefore People's Science needs to be developed and that Science teachers and students should be part of this process.

As a teacher employed by the Department of Education and Training, (DET), I was expected to rigidly follow prescribed syllabi. DET inspectors visited the school to ensure that the prescribed syllabi were being taught.

In an attempt to develop the concept of People's Science, a group of Standard 9 Physical Science students organised a weekly 'Science in Society' Programme. Each Friday topics were presented for discussion and debate.

A typical example of the type of problem dealt with in the Science and Society Programme is as follows. A student with battery powered lighting in her home wishes to know whether it would be advantageous to replace the batteries with a petrol generator.

Students found the problem interesting and responded enthusiastically. When asked why they were keen to solve this problem, the majority of students stated that they lived in non-electrified homes and therefore found this problem relevant to their own interests. The problem had linked scientific understanding to students' own everyday experiences and needs. Motivation to learn was derived from the perceived usefulness of finding a solution to a relevant problem.

Towards the end of 1988 DET officials visited the school and warned teachers of the 'subversive and revolutionary' nature of Peoples' Education. Municipal Police removed posters and diagrams relating to the Science and Society Programme.

1.1.2 Energy for Development Research Centre

After leaving Nomzamo Senior Secondary School I enrolled for the masters programme offered by Energy for Development Research Centre at the University of Cape Town. This programme comprises course work and a dissertation. The course work focused on new and renewable energy sources and technologies and the applicability of these technologies in developing areas.

While participating in the EDRC course work programme, I realised that many of the issues and problems dealt with in the programme such as energy consumption patterns, the existing woodfuel crisis, the need for domestic electrification and South Africa's renewable energy resource potential could form part of a science programme at a secondary school level. To be suitable, the issues and problems would have to be presented in a format which is accessible to teachers and students. This approach would contrast with existing Science curricula which tend to present an abstract scientific view of energy.

I submitted a dissertation proposal to research and develop a package of energy education materials for secondary schools. This proposal was accepted by the Engineering Faculty.

My interest in presenting energy issues in format accessible to secondary school students led to my involvement in the Master's Programme offered by Community Education Resources (CER), a project of the Centre for African Studies at the University of Cape Town.

1.1.3 Community Education Resources

CER provides a two year training programme for a small group of Masters students from different departments. The training programme focuses on practical and theoretical aspects of popular resource production. Issues covered include popular educational methodologies, theories of learning, educational resource formats and evaluation methodologies.

The emergence of the CER project needs to be seen as an intervention regarding the traditional social function of the university.

According to Kell (1989;6) CER has the following aims and objectives:

- To facilitate the use of resources, research and skills of the University by progressive organisations and the oppressed community,
- To bring ideas and experiences gained in the process of servicing progressive organisations (in particular, the building of links with the democratic mass movement) back into the University environment in order to contribute towards the progressive transformation of the theory and practice of teaching and research,
- To pursue research and produce resource material in an accessible form, which can be utilised by the oppressed community.

The acceptance by University Faculties of the processes of resource production as an accredited part of the student's academic research work is central to CER's goal of transforming the theory and practice of academic research. This project is of particular interest in this respect, as the academic research work incorporates the production of a popular education resource, namely the production of an energy education package for secondary schools.

1.2 Scientific and Technological Awareness among Secondary School Students

A primary aim of physical science curricula currently offered in secondary schools is to prepare students for science and technology programmes offered by tertiary training institutions. This aim is reflected in the content of physical science syllabi which emphasize knowledge and skills deemed necessary for entrance into tertiary science and technology programmes. Thus physical science syllabi emphasize problem solving skills relating to topics such as Newton's Laws of Motion, Vectors, Ohm's Law, Chemical Equilibrium and Chemical Bonding. Although examples might be drawn from an everyday context the usefulness of what is learnt rarely extends beyond the problem itself.

Given that science and technology impact on every realm of human life I believe school science should focus on skills and knowledge that would enable and thus empower school leavers to more meaningfully understand and participate in modern technological society.

South Africa is a developing country in which existing scientific and technological expertise is linked to the needs of the developed sector. The lack of contact with the underdeveloped sector means that the broader community remains unaware of the role of science and technology in social transformation and wealth

generation. Linked to this is the need to promote greater understanding of technological innovations and the impact of these on the quality of life. In this regard, the role that science and technology have played in human development needs to be addressed.

An understanding of the role of science and technology in maintaining the developed/underdeveloped dichotomy within a country such as South Africa, needs to be extended to the international arena, where such an understanding will contribute to a better understanding of the relationship between a country's scientific and technological capability and its position in the world economy.

The concept of Scientific and Technological awareness has attracted various definitions by various authors depending on their perceptions of what is needed for effective participation in a technological society.

In this project Scientific and Technological Awareness is defined as having the ability to understand and critically reflect on the processes of science and the role of science and technology in sustaining and transforming society. Such awareness could facilitate increased democratisation of society by encouraging participation in the processes of science and technology policy formulation at local and national levels. There is a need for students to view science and technology as socially constructed enterprises which are open to public scrutiny.

At a practical level Scientific and Technological awareness would include possessing practical skills related to technological systems which are part of everyday life.

By linking classroom science to learners' everyday interests and to the world outside the classroom interest in science and technology can be stimulated. Motivation to learn is thus derived from the usefulness of what is studied and not only from the quest for certification.

Science Education in secondary schools has an important role in facilitating such an awareness. This project aims to promote Scientific and Technological awareness through the development and distribution of energy education materials. Reasons for selecting energy as a theme are provided in the following section.

1.3 The Selection of Energy as a Theme

1.3.1 Energy as an Agent of Development

The development of technological society is based on the development and utilisation of abundant and sustainable supplies of energy. Energy is the motor of industrial production and is a basis of economic activity. On a domestic level energy is needed for cooking, heating and lighting.

Concomitantly, the absence of affordable and reliable domestic energy supplies for cooking, heating and lighting is a sufficient condition for community underdevelopment. This is the case in many developing countries, where marginalised communities relying mainly on fuelwood to meet their everyday energy needs face an energy crisis as fuelwood supplies diminish due to over-utilisation and agricultural expansion.

The inequalities regarding access to and affordability of domestic energy supplies are exemplified in energy consumption patterns. South Africa provides a rather stark example in this regard.

Containing 4% of Africa's population, South Africa generates more than 50% of Africa's electricity and yet, less than a third of South Africans have access to electricity in their homes. The close relationship between the availability of electricity and the distribution of political and economic power within the society is obvious.

Information concerning the role of energy as an agent of social development is a key aspect of a Scientific and Technological awareness approach to Science Education. Classroom debate on energy production, availability and usage needs to be encouraged. Students need to critically examine their lifestyles and lifestyles they might aspire towards in relation to energy usage.

1.3.2 Energy and the Environment

Linked to energy provision and usage are issues of serious environmental concern. Many of the environmental issues of the 1990's and the future are energy linked.

At present South Africa relies on coal for about 80 % of its energy needs. More than 70% of South Africa's installed electrical capacity is generated within 30000 km² of the Eastern Transvaal Highveld (ETH). Exacerbated by an unfavourable dispersion climate, areas of the ETH are known to have acid rain levels comparable to the worst in the world.

Currently more than half of South Africa's population lives in underdeveloped areas where wood is the principal fuel for cooking and heating. In many areas shortages of fuelwood already exist and wood can no longer be considered a renewable resource. In addition over-utilisation of the wood resource results in the loss of protective ground cover essential for the prevention of erosion.

A greater public awareness of the prevailing fuelwood crisis together with related environmental, social and health problems is required. Possible strategies for solving this crisis need to be shared and debated.

In today's society, increased science and technological awareness is linked to improved consumer awareness. Generally, students are unaware of possible short and long term effects on health and environment of existing energy technologies. A greater awareness of the environmental effects of existing energy technologies, the benefits of alternative supply options and new and renewable energy supply options is needed among school students. Consumer awareness would be of direct relevance to students and could serve to present learning science as useful.

With more than 20 million South Africans not having access to domestic electricity and relying on fuels such as paraffin, gas, wood, coal and candles to meet their energy needs, incidents of shack fires, paraffin poisoning, asphyxiation are all too frequent. The consequences of using such fuels need to be brought to the attention of students.

The concept of electricity as a commodity which is produced, sold and used needs to be promoted. Awareness of issues such as electricity tariff structuring, the costs of using different electrical appliances and electrical appliance efficiencies should be promoted and could result in financial savings for consumers.

1.3.3 Energy Issues and Policy Formulation

Scientific and technological issues which are of current public concern need to be debated and discussed in the science classroom. Such debate could facilitate increased democratisation of society by encouraging public debate on and participation in the processes of energy policy formulation.

An understanding of current energy usage patterns and trends provides a basis for reflecting on possible future energy supply options. In this regard, energy conservation and renewable energy options need to be highlighted.

1.3.4 Energy Provision and Vocational Guidance

South Africa has a shortage of scientifically and technologically trained people. Currently physical science is presented as a subject taken by students wishing to follow careers in science and technology. However, vocational guidance on technological careers is not incorporated into the current curriculum. Energy provision, distribution and usage incorporates a wide range of careers options.

This project aims to stimulate student interest in scientific and technological careers by considering how scientific and technological knowledge is applied in the production, distribution and usage of energy.

1.4 Project Aims

As part of an initiative to promote an awareness of energy issues among secondary school students, the workshop package for secondary schools aims to:

- present science as a human activity that shapes our lives, our environment and our material being,
- present energy as an agent of social development,
- allow students to critically explore the links between energy, technology and society,
- facilitate discussion on issues and problems which are relevant to students' needs as citizens,
- promote an interest in and critical awareness of energy issues,

- mediate practical skills pertaining to energy technologies in everyday use,
- link science to the world of work, hence stimulating interest in science and technological careers.

1.5 Report Outline

Chapter 2 provides an outline of the selected teaching methodology that informs the style of the Energy Workshop Package presentation.

Chapter 3 describes the processes of the Energy Workshop Package development and evaluation of the package.

Chapter 4 presents an overview of energy issues from which workshop content is drawn and the approach taken in each workshop.

Chapter 5 reviews the evaluation of the Energy Workshop Package.

Chapter 6 outlines the conclusions from this study and makes recommendations.

The Energy Workshop Package is included as Appendix 1.

CHAPTER 2

EDUCATION METHODOLOGY

My intention is not to present a teacher or student proof methodology. Teachers and students will interpret any prescribed method according to their own abilities, prejudices and visions. This need not be interpreted as debilitating; engaging with and reflecting on the unintentional and unexpected opens new possibilities.

My choice of teaching methodology derives in part from my own classroom experiences and perceptions regarding the role of science education in preparing students for a participatory role in technological society.

I also accept that the theories and strategies from which I draw exhibit contradictions and anomalies. I have no problems with this as I see these as enriching rather than impoverishing characteristics.

Within the framework of a chosen education methodology this chapter focuses on four issues.

Firstly, I motivate that classroom dialogue is more than giving students a voice in the processes of classroom interaction. As a fundamental component of postmodernist and constructivist approaches to learning, dialogue is closely aligned with cognitive skills development.

Secondly, I present Freire's codification technique as a method for engaging learners in dialogue.

Thirdly, I explain the problem/issue approach to science education in relation to classroom dialogue and constructivist learning theories.

Fourthly, I link the concept of classroom dialogue to the notion of criticality with regard to issues of science and technology.

2.1 A constructivist approach to learning

Constructivism embodies a range of theories which present learning as the reconstruction of meaning rather than the accretion of new concepts.

Constructivists see knowledge as originating within the learner who is always involved in reconstructing meaning. Knowledge does not represent ontological reality and hence 'the truth'. Instead knowledge we have offers a viable explanation of reality which has been constructed in terms of our experiences and thoughts. This approach negates the traditional view that knowledge can be taught by direct transmission and hence deposited into a passive learner by the teacher.

As Wheatley (1991:10) explains:

' a constructivist believes that knowledge is not disembodied but is intimately related to the action and experience of a learner – it is always contextual and never separated from the knower.'

The key issue here is the need for 'action and experience' on behalf of the learner. The learner does not assume a passive role but instead must actively participate in the learning process.

2.1.1 Cognitive skills and language

Constructivist Lev Vygotsky proposes a clear connection between the development of an individual's cognitive skills and the specific historical and cultural situation in which the individual is situated.

According to Vygotsky cognitive skills and knowledge are socially constructed and contextualised within a given historical and cultural situation.

Vygotsky argues for a close social identity between thought and language with language having an important role in constructing meaning. Vygotsky quoted in Moll (1989:717) states the creation and use of linguistic signs show that:

' connections created among external stimuli (social relations) then form connections inside the brain (thought patterns).'

Hence, a key aspect of Vygotsky's understanding of the social construction of knowledge is the dependence of cognitive development on the internalisation of

speech. Verbal formulations employed by the teacher become the internalised speech of the learner. Language is thus the motor of intellectual functioning. Wheatley (1991:11) suggests, 'knowledge is constituted by the language used to express it.'

2.1.2 The Role of the Teacher

Whether a constructivist model of learning implies a particular constructivist model of instruction is an issue of debate among constructivists.

Millar (1989:589) argues against any such link. Millar supports his claim by stating that, 'the process of eliciting, clarification and construction of new ideas takes place internally, within the learner's own head. This occurs whenever successful learning takes place and is independent of the form of instruction.'

Millar goes on to propose that any method of instruction most likely to engage the active involvement of learners may be used.

For Vygotsky effective learning occurs when dialogue takes place within the Zone of Proximal Development (ZPD). The ZPD specifies the parameters of the developing mind for all people and is defined by Vygotsky (1978:86) as:

'the distance between the actual development level as defined by independent problem solving and the level of potential development as determined through problem solving under guidance or in collaboration with more capable peers.'

Firstly, teachers need to actively engage in dialogue with learners in order to identify the ZPD. When operating within the ZPD, teachers avoid teaching concepts or skills students already know and introducing tasks which are beyond students' level of comprehension.

Moll (1989:715) states that for Vygotsky a good teacher:

'uses conversational methods in the classroom to provide learners with new conceptual language which is then internalised and becomes the basis of higher forms of cognitive activity.'

He continues by proposing that a teacher's task is to:

'identify the level and complexity of the discourse of a learner or group of learners, and then to mediate new knowledge to them as a conscious social agent.'

Wheatley (1991:18) argues for a problem solving approach which allows students to, 'operate at their cognitive level using their preferred learning style.'

Watts and Pope(1989:329) suggest that teachers 'need to provide more opportunities for pupils to talk about what they are doing, to become aware of their own ideas and those of their peers and modify their ideas where necessary.'

Scientific knowledge presented in school classrooms is a body of knowledge that has already been consensually agreed upon by scientists. Mediation by teachers should enable students to reach the consensually agreed upon, scientifically valid, interpretation of the topic under discussion.

In constructing their own understandings students often develop their own 'alternative conceptions' which might not match that of the scientifically valid conception.

This requires that as Aronowitz and Giroux (1991:131)state:

'The stories that students bring to class need to be interrogated for their absences as well as for their contradictions.'

Driver quoted in Watts and Pope (1989:328) lists six features of a constructivist perspective as it impacts on schooling:

- Learners are not viewed as passive but are seen as purposive and ultimately responsible for their own learning. They bring their prior conceptions to the learning situation.
- Learning is considered to involve an active process on the part of the learner. It involves the construction of meaning and often takes place through interpersonal negotiation.
- Knowledge is not out there but is personally and socially constructed; its status is problematic. It may be evaluated by the individual in terms of the extent to which it fits with their experience and is coherent with other aspects of their knowledge.
- Teachers also bring their prior conceptions to learning situations not only in terms of their subject knowledge but also their views of teaching and learning. These can influence their ways of interaction in the classroom.

- Teaching is not the transmission of knowledge but involves the organisation of the situations in the classroom and the design of tasks in a way which promotes scientific learning.
- The curriculum is not that which is to be learned, but a programme of learning tasks, materials and resources from which students construct their knowledge.

In summary, constructivists agree that students learn by discussing, experimenting, questioning, reflecting and discovering rather than by the delivery of factual knowledge. During the learning process students also need to develop the ability to critically examine any solutions offered. Knowledge is coconstructed through interactions with other learners. The social setting in which learning occurs underpins the learning process. Hence, the classroom environment should provide opportunities for students to engage in dialogue, explore and where necessary construct new meaning.

2.2 Learning Together – The Codification Method of Paulo Freire

Paulo Freire is known for his education work among illiterate communities in South America.

Freire's codification technique requires that teachers and learners engage in dialogue and therefore collectively and actively participate in the learning process.

Dialogue in the learning process is a key element of constructivist learning theories which have been discussed in Section 2.1

This project presents ways of using Freire's problem-posing technique as a means of mediating energy concepts and issues in the classroom. A critique of the broader successes and failures of Freire's pedagogy extends beyond the scope of this project.

The lesson begins with the teacher presenting learners with a problem posing code. A code needs to be deciphered by the students and may be a picture, a poster, a poem, a song, a newspaper article or a case study. The purpose of the code is to simulate dialogue in the classroom. Codes enable learners to reflect on their own lived experiences by introducing problems which are of relevance to themselves.

When presenting a code, the teacher asks critical questions to help learners discover some of the root causes of the problem under discussion. The teacher's role is that of mediator.

Learners begin by describing and then analysing the situation the code describes. By getting learners to draw from their own experiences and to share their knowledge with other learners the value of the knowledge students bring to the classroom can be emphasised.

As learners analyse the code, themes about which learners have strong feelings emerge. Freire referred to these as 'generative themes'. Generative themes lead to learners wanting to express their thoughts and feelings and hence engage in dialogue.

Supporting this approach Postmodernists Aronowitz and Giroux (1991:15) propose that, 'Central to this pedagogical process is the important double task of affirming the voices that students bring to school, and challenging the separation of school knowledge from the experience of everyday life. The curriculum can best inspire learning only when school knowledge builds upon tacit knowledge derived from cultural knowledge students already possess.'

As a practical example the following image, Figure 2.1, could be used as a code to open discussion on the issue of electrification. The inequitable distribution of electrical power that exists in South Africa is an issue many people feel strongly about and hence could serve as a generative theme.

The teacher could ask the following questions to initiate discussion.

- What are the people in the picture doing ?
- What do they use the wood for ?
- What other energy source do you see in the picture ?
- What are the costs, economic and other of using wood ?
- Are other alternative fuels available ?
- What are some of the problems of changing to other fuels ?

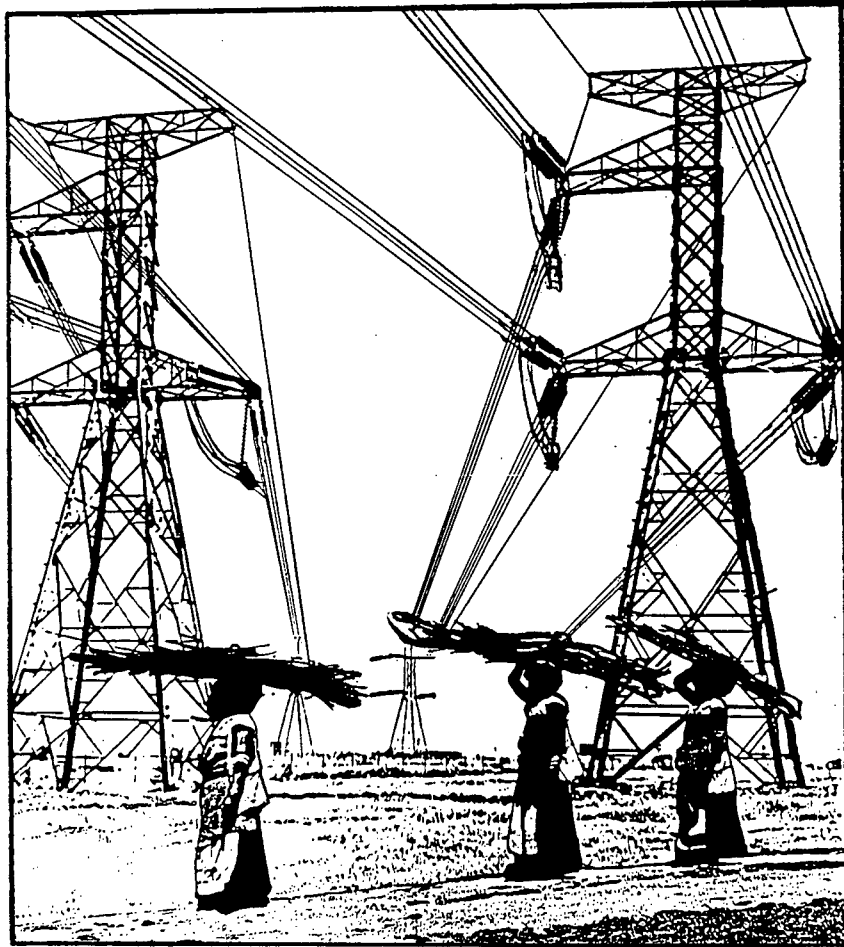

Figure 2.1 Women carrying wood

The choice of code is crucial for the success Freire's method. Teachers need to develop a sensitivity regarding themes and issues which students regard as relevant and feel strongly about.

The emergence of generative themes is a necessary stage in the process of *conscientisation*, a key Freirian concept. Conscientisation is the process whereby learners develop a critical understanding of society and their capacity to change it. Freire (1976:225) defines conscientisation as:

'a permanent critical approach to reality in order to discover it and discover the myths that deceive us and help to maintain the oppressing dehumanising structures.'

For Freire it is the capacity for dialogue that enables humans to move from a state of passive 'naive consciousness' to a state of transformative 'critical consciousness'.

Freire stresses the importance of linguistic issues as he regards linguistic and mental processes to be identical. Freire (1972:28) connects language with people's social reality stating that:

'Insofar as language is impossible without thought, and language and thought are impossible without the world to which they refer, the human word is more than mere vocabulary - it is word-and-action.'

The link that Freire makes between language and thought supports the constructivist notion that cognitive skills and language are interdependent.

2.3 Problem/Issue based Science Education

Freire's codification technique and the constructivist approach to learning suit a thematic Problem/Issue based approach to science education.

The approach taken in this project aims to expand current perceptions of syllabus knowledge to include what is regarded as 'soft' science or issue based science. By locating scientific knowledge within a context relevant to the learner the importance and value of science can be extended beyond the traditional role of science education. The validity of scientific knowledge is extended by including knowledge which is useful in an everyday context.

Examples of programmes following the Problem/Issue approach include the Science in Society (1981) and Science in a Social Context (1983) projects sponsored by the Association for Science Education in the United Kingdom.

According to Hunt (1988:409), these projects arose from the concern that, 'school science has been too academic and remote, failing to draw on the everyday experiences of girls and boys and failing to prepare them for their adult and working lives.'

By contextualising scientific knowledge and skills, science can be presented as a means of gaining control of one's immediate and future environments.

In explaining why learners are motivated by this approach Driver and Millar (1986:21) argue that:

'The incentives offered to pupils to learn are clearly in terms of the relevance of the material to their experiences, concerns and perceived needs as future citizens.'

Motivation for learning is thus derived from the perceived usefulness of solving problems or understanding issues, particularly in the context of everyday life. Learners need to recognise problems under discussion as 'their own'. According to Aronowitz and Giroux (1991:16), recent focus on environmental issues demonstrates: 'the importance of theoretical knowledge for solving one of the most pressing social and political questions of our day: the degree to which the domination of nature by industrial and consumer society distorts our interaction with the environment and may threaten human survival.'

Aronowitz and Giroux also suggest that the criterion of relevance should not be construed as a weakening on 'rigorous' education but as a challenge to the 'formulaic law-like' instrumentalist characteristics of science and mathematics pedagogies.

Skovsmose (1985:340) recommends the following criteria regarding selection of the problem/issue:

- It should be possible for the students to realize that the problem is of importance. That is, the problem must contain subjective relevance for the students. It must have to do with situations connected to the experience of the students.
- The problem must have to do with important processes in society.
- Somehow and to some extent the engagement of the students in the problem-situation and in the process of problem-solving should prepare a basis for (later) political and social engagement.

Selection of suitable problems/issues is an important process and needs to occur with an empathetic understanding of learner's lived experiences. This is none other than a need to identify issues/problems which give rise to Freire's generative themes.

Often learners will not see the relevance of an issue. Here the teacher needs to explore ways of linking the issue under discussion to the learner's lived experiences.

For example, acid rain is an issue which could serve to contextualise SO_2 and H_2SO_4 reactions. If students have little or no experience of acid rain, the topic could be introduced by linking it to issues such as the learner's own energy consumption patterns and burning of fossil fuels.

Broader issues of pollution, social responsibility and the need for citizen awareness could also be used to motivate a study of acid rain. Reactions involving SO_2 and H_2SO_4 would thus assume meaning beyond the reactions themselves as they would be contextualised within a theme which is relevant to the learners.

Another useful method which facilitates classroom dialogue is role-play. Role-play can be used both as an exercise in scientific decision making and as an evaluation tool. Solomon (1991:102) advocates that drama and role-play can be used for helping develop a 'feel' for social settings.

An example of role-play dealing with scientific and technological decision making, which is included in the workshop package, involves the appropriateness of biogas technologies.

Three students were chosen by the class to be engineers working for a government development agency promoting the use of biogas in rural areas.

Three other students were chosen to be representatives of a Village Management Board. These students were asked to take a conservation position, resisting social change.

The development engineers presented an argument supporting biogas as a suitable energy supply option. The rest of the students were asked to participate as villagers.

Attention was given to explaining:

- what biogas is,
- how biogas is made,
- how it can be used,
- costs of building a biogas digester,
- cost of buying cast iron cookers.

I presented this role-play to a group of Std 9 Protec Students.

Some issues raised by students playing the role of villagers included:

- suitability of climatic conditions,
- people's resistance to change,
- people's resistance to outsiders, interference,
- people's energy needs,
- technical skills training – Who will provide these ?
- collection of waste materials,
- availability of water for mixing.

The resulting discussion enabled me to understand the extent to which the students had understood the science of biogas production and student perceptions of the social issues involved in biogas technology dissemination.

2.4 Critical competence in technological society

A key aim of the teaching methodology proposed in this project is to develop a critical awareness among science students. Such an awareness would mean more effective decision making and participation in modern technological society.

The concept of criticality as it is used in this project needs to be located in a historical context. The concept of critical competence can be linked to the emergence of the Critical Theory of the Frankfurt School which was developed in response to an upsurge of positivism, especially the logical positivism of the Vienna Circle of Carnap, Neurath, Schlick et al.

In a broad outline, the Frankfurt School focused their criticism on positivism as both a universal truth and the proper method to attain it.

Their criticism had three aspects:

Firstly, it provided a critique of positivism as an inadequate and misleading conception of social life;

secondly, positivism focused on what exists and hence sanctions the existing order;

thirdly, positivism is a major factor in sustaining and producing a new form of domination, namely 'technocratic domination'.

Critical theorists reject what Nietzsche quoted in Gerhardt (1987:374) called, 'the victory of the scientific method over science' and what Gerhardt (1987:374) refers to as the:

'identification of scientific and technological rationality with reason in general...To the extent that an unreflexive science serves any social order, managing its problems and crises and thus helping to stabilise that order, it is a mere 'handmaiden' of the powers that be'.

Further, since the problems positivist science addresses are translated into technical problems, the substance of the problem, the social context, is often left untouched.

Concomitantly science education presents science and technology as bastions of human development and progress. The apparent successes of science and technology in conquering the hostile world about us have led to an upsurge of faith in the methods of science particularly positivism.

Positivism and technocism continue to dominate scientific thinking. From both the political left and right the struggle has been how to achieve modernity through industrialisation, scientific and technological progress. Little emphasis has been placed on whether these ends were necessarily worthwhile and the possible consequences.

The notion of criticality is an integral component of Postmodernist thought as it has developed over the last two decades.

Proposing that science needs to be removed from its absolutist pedestal and made available and accessible to all students, Postmodernists argue that a critical presentation of science would focus equally on the failures and successes of scientific endeavours within the social context in which they occur.

Postmodernists challenge the notion of modernity within the current paradigm, particularly with regard to the role of science and technology. Giroux and Aronowitz (1991:22) propose that:

'We not only must show the effects of scientific knowledge cum technology on the social world and 'nature' but also must make problematic the assumptions on which the truth claims of science are grounded.'

Giroux and Aronowitz (1991:18) argue that at its best critical pedagogy enables teachers and others to view education as a political, social and cultural enterprise and equates learning with the creation of critical citizens.

The Postmodernist teacher is obliged to interrogate the values underlying the topic under discussion. In addition to promoting a critical understanding of social issues, Freire's codification technique offers a means of socially contextualising hence reconstructing current perceptions of scientific knowledge.

The energy workshops developed as part of this project aim to provide accessible platforms for critical reflection on selected energy issues.

Energy issues facilitate a critical understanding of the links between the scientific endeavour, the associated technological development and the intended social setting. Of particular importance are the issues of energy policy formulation and the social and environmental consequences of energy provision and usage. A critical understanding of energy issues will enable the public to make more informed decisions on issues of energy policy formulation both at local and national levels.

CHAPTER 3

THE PROCESSES OF ENERGY EDUCATION WORKSHOP PRODUCTION

This chapter comprises two sections describing the production of the Energy Education Package. The first section describes the processes as I envisaged they should occur and the second section reflects on the processes as they occurred with deviations from the initial plan.

3.1 Academic Discourse and Popular Education Resource Production

Academic discourse can be defined in terms of subject content, methodology and products. Conventionally, the products of academic work, namely dissertations, research reports and journal papers are written for a primarily academic audience. This approach limits the accessibility of university resources to a broader mass based audience. Many academics would have no qualms with this, arguing that the complexities of academic discourse limit its accessibility to an academic audience and that, in addition, the academic training function of the universities necessitates that, as academics in training, students write for an academic audience.

Universities do not function in isolation from the broader community. Often community groups are the target of research work and contribute to the research process by engaging with researchers and disseminating information. However, the academic format of the results of research work ensures that these results remain inaccessible to communities which might have benefited from gaining accessible results of the research work.

The transformative role of universities could be extended if knowledge generated within the university and the resulting resources were produced in a more accessible format and made available to a broader audience.

The production of accessible resource materials which would benefit a broader audience or user group incorporates the production of a popular educational resource. Popular resources could include, booklets, educational workshops, video tapes or a play.

The Masters Degree training programme offered by CER aimed to equip Masters students with theoretical and practical skills pertaining to the production of popular educational resources. Thus, in addition to their academic dissertation CER proposed that students produce a popular resource on the subject of their research work.

Although this thesis project was accepted by the Engineering Faculty it is an educational project that aims to make existing university resources concerning energy issues more accessible through the development of an energy education package for secondary schools.

The content of the energy workshop package draws from existing resources, specifically those located within the Energy for Development Research Centre.

The acceptance of this project by EDRC is linked to a perception within EDRC that energy concepts and issues need to be made more accessible. In this regard, EDRC has produced a series of pamphlets and media products on issues pertaining to new and renewable energy technologies.

3.2 User Group Involvement

The involvement of a user group in the processes of educational resource production is central to CER's conceptualisation of progressive academic research. CER's conceptualisation of the role of the user group in the production of a popular education resource shaped my understanding of how I should proceed with the production of the energy education package.

My application to participate in the two year CER Masters students' programme required that I specify a user group with whom I would work and develop a popular resource. During the first year of the CER training programme students were expected to establish a working relationship with selected user groups. As my research proposal specifically dealt with the development of energy education materials for secondary schools my targeted user group would be secondary school students.

In addition since the majority of secondary school students in South Africa are second language English speakers my chosen user group would include second language English speakers.

3.2.1 Khanya College

Given my commitment to work with second language English speakers I decided to explore the possibility of working with Khanya College students. Khanya College is a project of the Sached Trust that offers post-matric courses to students from disadvantaged educational backgrounds. Although Khanya students had already matriculated they would have had little exposure to energy issues at school.

After consulting with Khanya College staff space within the Physics programme for the implementation of energy workshops was made available.

Unfortunately Khanya College suspended their teaching programme during 1990 and they terminated the Physics course.

By this stage I had developed an energy workshop which required implementation as part of the CER Training Programme. As an interim measure I approached the English for Academic Purposes (EAP) programme at UCT.

3.2.2 English for Academic Purposes Programme, UCT.

EAP staff supported my proposal and allocated five one hour sessions for an energy workshop series.

An Energy lecture series comprising two workshops and a slide show was developed. The central aim of the first workshop **Energy in our Lives** was to introduce energy in a broader context by getting students to consider energy consumption in their own lives . The second workshop aimed to contrast the energy used in students lives with the energy crisis facing a community living in Lopeng, a remote area of Boputhatswana.

Students were presented with various energy supply options including photovoltaic systems, a woodlot scheme, charcoal manufacture and grid-electrification. Students were required to select one of these supply options and motivate why they considered it to be most suitable for Lopeng.

From the EAP training perspective, students were required to write a structured argument motivating their choice of energy supply. This workshop provided an exercise in report writing with emphasis on synthesis and analysis.

These workshops exposed EAP students to energy as a concept beyond the conventional school textbook definition of energy as 'the ability to do work'.

As a test case for energy as a school theme my assumption was that the sentiments expressed by EAP students would be similar to those of secondary school students.

The EAP lecture series provided me with the opportunity to carry out two tasks: firstly, to test the use of discussion codes as a means of mediating classroom discussion; secondly to gain insight into students' attitudes and feelings concerning energy as a academic theme and as a social issue.

When asked for their comments on the workshops, EAP students stated that they found the content of the workshops, and the energy crisis in rural areas in particular, 'interesting and shocking'.

With regard to the use of discussion codes, students felt these codes 'generated a lot of response'.

My interpretation of these responses was that in terms of the use of discussion codes and the selection of energy as a theme, the proposed approach would be acceptable to secondary schools students.

3.2.3 Programme for Technological Careers (Protec)

In order to further test the selection of energy as a theme I approached Programme for Technological Careers (Protec) students as a potential user group. Protec provides a curriculum based educational support programme for students on Saturdays and an enrichment programme during school holidays. During the 1990 September Vacation School I presented a workshop titled **Energy Sources in South Africa** to Protec Standard 8 students.

Student responses to the worksheet questions provided insight regarding student interest in dealing with energy issues within the South African context.

The topic was introduced by showing students a display of different energy sources and technologies. Students were required to identify energy as a factor linking the items on display.

After being introduced to the concepts of renewable and non-renewable energy sources, students provided their explanations of a non-renewable energy source. Answers given included:

'When something cannot be made again like oil. When it is used and when it is finished and there is no oil left then we cannot make oil because it comes from nature.'

'When something is used so often and cannot be made again. e.g. oil and coal.'

A student evaluation sheet with the following questions was attached to the student worksheet.

1) Write down a few sentences explaining what you have learnt from this workshop.

2) Is what you have learnt in the workshop useful to you? In what ways is it useful?

3) Do you think the kinds of things we have dealt with in this workshop should be part of your science syllabus? Give a reason for your answer.

Student responses to Question 1 question included:

'An electricity are coming from the coal. Coal produces oil and oil produces petrol.'

'Oil is non-renewable and also without coal or oil after some years, there will be no electricity in our land/world.'

'Coal is important in SA because it is used for electricity.'

'I learn about fuels and sources of energy.'

Student responses to the Question 2 included:

'This knowledge is very useful, because when I become an engineer I have knowledge of coal.'

'I must try and learn so that I can help the scientists in finding the better way of living without coal.'

'It (energy) is the source of life and life is dependent on those elements.'

'Yes, it is useful because now we can go out and tell those who know nothing about what I know.'

'I had been learn about electricity and where it did come from.'

Student responses to Question 3 included :

'Yes, because they are very useful and they can help us with our future and knowledge.'

'Yes, it must be added to our syllabus so that we can have knowledge about technology.'

'Yes, it can because all those things are part of science itself.'

'Yes. So that we can be aware of things which are happening around us and we can try and help here and there.'

My interpretation of the student responses was that Protec students considered energy a useful and interesting topic.

3.2.4 Teacher involvement

After the Protec workshops I realised that if the proposed Energy Education Package was to reach secondary school students, teachers would have to be involved in the development of the package. The decision to involve teachers raised a number of issues:

Where on the list of teacher's priorities do methodological and curriculum development issues lie?

Did teachers see a need for Energy Education Workshops?

If not, was the idea of an Energy Education Package marketable?

My initial efforts to involve teachers relied on an Science Teachers Workshop held at University of Western Cape (UWC) on 13th October 1990.

The aims of this workshop included:

- discussing how science teaching can be made relevant to SA schools,
- drawing on the experiences of teachers,
- sharing concrete examples of relevant science teaching,
- establishing groups to take the initiative forward.

About 60 teachers from various education departments attended and a number of interest groups were established. One of these was a Science, Technology and

Society (STS) Interest group. The purpose of this group was to implement innovations relating science, technology and society related issues such as energy. I intended drawing teachers from this group to participate in the development of the Energy Education Package.

The first meeting of the STS Interest group was held in January 1991. The turn out was poor, the meeting was attended by myself and two teachers from the Department of Education and Training (DET). At this meeting our discussion focused on existing problems teachers face regarding their possible involvement in curriculum development initiatives. Problems identified included heavy teaching loads with teachers having to teach up to 47 periods out of a possible 50 periods per week, completing the syllabus, the DET requirement that teachers do not deviate from the existing syllabus and a lack of subject knowledge beyond the syllabus.

Given these constraints and the fact that this project was based on my perceptions of energy within the science curriculum and not on any direct need expressed by teachers, I decided to proceed with the development of further workshops which would be shown to teachers for comment.

Thus the role of teachers in the development of the energy package shifted from direct involvement in the development of the energy workshop package to providing comment on workshops that I had developed.

In addition to receiving comment from practising teachers I decided to obtain comments from UCT Physical Science method student teachers who had completed practical teaching sessions.

In total nine workshops were developed. Comment sheets for individual workshops and the package as a whole were distributed to teachers I had contacted through Protec and the UWC science teachers initiative. The recommended procedure was for each teacher to team up with another teacher from his/her school and work through the package and where possible implement the workshops in the classroom.

Teachers were informed that the package was in draft format and their input would be seen as part of the package development process.

Chapter 4 provides an overview of energy issues from which the content of the energy workshops has been selected and explains how these issues are dealt with in the workshops.

Chapter 5 reports the comments of teachers and student teachers who took part in conducting and evaluating the workshops.

CHAPTER 4

REVIEWING ASPECTS OF ENERGY RESOURCES, PRODUCTION AND USAGE IN SOUTH AFRICA AND INTEGRATING SUITABLE THEMES INTO ENERGY WORKSHOPS

Reviewing energy issues from which the energy workshop package content has been drawn is a central component of the resource development process as the content of each workshop is based on the information obtained in the review.

This chapter aims to provide users of the package and educational resource developers insight into the process of developing the package. For this reason I have attempted to explain scientific and technical concepts in a format acceptable to the non-specialist reader.

4.1 Introducing Energy Usage in Society

The development of modern technological societies has been paralleled with the development of technologies capable of producing abundant and reliable supplies of energy.

While the availability of such energy supplies for industrial production and transportation is a fundamental prerequisite for technological development, access to affordable sources of energy for cooking, lighting and space heating underpins community development at a domestic level.

The abstract scientific view of energy currently emphasised in school Physical Science syllabi leads students to the idea that energy is removed from our lives. While informed students buying a can of food might scan the list of ingredients looking for unacceptable colourants and preservatives, few are aware of the energy inputs required to manufacture and transport the products they use.

Students need to be presented with a wider view of energy. They need to know more about energy in their lives and societies. As citizens and possibly future

scientists, students need to explore and understand links between science, technology and society.

The first workshop of the package **Energy in Our Lives** has the following aims :

- To link energy usage to students' daily activities.
- To introduce the concepts of direct and indirect energy usage.
- To promote an awareness of the importance of energy in sustaining lifestyles in technological society.

This workshop is introduced with a basic needs exercise. The purpose of this is to demonstrate that as energy is needed to provide food, shelter, water and transport it should be considered to be a basic need.

Students form small groups (4 to 6 students per group). Each group draws up a list of what they consider to be their basic needs. After displaying their lists to other groups a class discussion is held on the issue of basic needs.

If energy has not been included as a basic need, the teacher motivates why energy should be considered a basic need by linking energy to the provision of other basic needs such as the provision of food, water and shelter.

While most students are aware that energy is required for cooking or warming a house (direct use) few students are aware that energy is required to produce and transport the products they use (indirect use).

To introduce the concept of direct use of energy, each student draws up a list of what they consider to be a student's daily activities requiring energy to perform. These activities would include: washing, cooking, commuting etc. Next to each activity the source of energy or fuel is listed. This exercise aims to show students that they use energy when carrying out routine daily tasks.

In order to promote an understanding of the indirect use of energy students are given the following 'Pilchard tin' exercise.

Students are required to consider a tin of Pilchards (or any other item of processed food) and draw up a list of the tin's ingredients including the tin, paper wrapping and ink. Next to each item, students are required to list the energy-consuming activity needed to produce the item. Table 4.1 is an example of what is expected.

ITEM/INGREDIENT	ENERGY CONSUMING ACTIVITY
sardines	getting the fishing boat to the fishing grounds, cooking the sardines
tin can	mining iron ore, processing the iron, making the tin
paper wrapping	cutting the trees, transporting logs, making the paper in the mill
oil	transporting and processing the vegetables to obtain oil

Table 4.1 Pilchard tin and manufacturing processes

The purpose of this exercise is to encourage students to consider energy-consuming processes required to produce commodities used in their daily lives.

In the final section of the workshop, students consider the link between energy usage and activities such as mining, manufacture and agriculture. Students are required to consider the annual electrical energy consumption of three countries: the USA, South Africa and India. After discussing reasons for the differences in electrical energy consumption, students calculate the per capita electrical energy consumption for each country.

The concept of per capita electrical consumption is used to link energy consumption and lifestyle. Students are asked whether the calculated per capita electrical consumption means that all South Africans use the same amount of electrical energy per year. This question is used to introduce the inequitable distribution of domestic electrical power in South Africa.

4.2 South Africa's Fuelwood Crisis

South Africa was one of the first countries to use electricity on a commercial basis. Electric street lights were installed in Kimberley in 1882 and by 1906 reticulation systems had been commissioned in Pretoria, Cape Town, Durban, East London, Bloemfontein and Port Elizabeth. Today, South Africa produces more than half of Africa's electricity and yet only about 36% of households have access to grid

electricity. In rural areas where 40% of the population live only 8% of households have access to electricity.(EPRET Database)¹

As a building material and fuel, wood is an important resource in many peri-urban and rural households. Borchers and Eberhard(1991) estimated that fuelwood contributes to about 63% of the total energy used by the urban and rural poor in South Africa and is used by over half of the population for cooking and heating.

The clearing of bush and trees to expand agricultural production and increased demand for fuelwood continue to place pressure on the available wood resource in certain areas.

With fuelwood scarcities on the increase, people have moved from collecting dry wood to cutting growing branches off growing trees. Gandar(1993:3) notes that in a study conducted in an area of valley lowveld 8% of all firewood was cut live. A study by Eberhard(1986:40) observed greenwood in fuelwood headloads. Gandar(1993:1) estimates the total national domestic consumption of fuelwood to be in the order of 10 million tons per annum.

Aron et al(1989:26) provide an overview of national wood consumption and supply. This study predicts a 54% increase in homeland fuelwood consumption between 1980 and 2000. Using a model for demand and supply of fuelwood, the same study predicts a fuelwood deficiency of four million tonnes in the year 2000.

Although this model incorporates a number of simplifying assumptions concerning expected population growth, urbanisation patterns and constraints of supply, it strongly suggests that current levels of fuelwood consumption cannot be sustained. In fact, it is clear that a deficiency of fuelwood accompanied by severe woodland denudation already exists in some regions. Gandar(1984:11) reports that during the past fifty years 200 of the 250 forests in Kwazulu proclaimed in the 1936 Land Act have disappeared.

Associated with the continued reliance on fuelwood as an energy source are considerable social, economic and health costs.

Exposure to smoke and particulates pose serious health risks. Ventilation and time spent close to fires and stoves are factors which determine the extent of the health risk. Studies(WHO 1992:Terblanche et al.:1992) have indicated higher rates

¹ Energy Policy Research and Training Project, EDRC, UCT, 1993.

of bronchial infections, eye infections, pneumonia, cancer and heart diseases in communities using fuels such as fuelwood.

Collecting fuelwood can be a time consuming activity. In many areas women and children spend most of their working day collecting fuelwood. In Kwazulu, for example, Gandar(1984:3) has found that in high grassland areas the average distance walked in collecting one headload was 8.3 kms, a journey which takes an average of 4.5 hours. Gandar(1984:5) suggests that, 'If wood gathering is counted as part of food preparation, more effort is put into the preparation of food than in growing it.'

Clearly, alternative energy demand/supply options are required in areas where wood is becoming increasingly unavailable.

Demand for fuelwood can be reduced through more efficient usage or by substituting other fuels and electricity. However, the socio-economic level of many people relying on fuelwood often prevents an easy transition to more beneficial, but expensive fuels such as paraffin and gas.

Grid electricity is widely regarded as the most convenient and suitable supply option for domestic energy needs. However, the cost of providing an electricity supply can be high if households are spread out or located far from the existing electricity grid. Generally, rural communities facing acute fuelwood shortages are situated far from the existing electricity grid. This reduces the economic attractiveness and affordability of grid electricity as an energy supply option. State subsidisation would be necessary for any large scale rural grid electrification scheme.

In addition many households relying on 'free' wood would find the cost of electricity beyond their budget. Households using fuels such as gas, paraffin and candles could afford electricity as expenditure on these fuels is relatively high.

In the interim, electricity supplies for identified sites such as schools and clinics could be provided by other electricity supply options such as diesel/petrol generators and solar photovoltaic/battery systems. Domestic supply options for rural areas include afforestation programmes, woodlot management schemes, charcoal production, possibly biogas and improved distribution of fuels such as paraffin and bottled gas.

Affordability and availability are key issues in the transition process. Solutions to the fuelwood crisis need to focus on ameliorating poverty in affected areas. The fuelwood crisis is a symptom of broader privation and thus requires an integrated rural development strategy.

Secondary school students are generally aware that wood is a principal fuel in rural areas. However, little information concerning the fuelwood supply crisis and associated economic, social and health costs has been disseminated.

The fuelwood issue is introduced in two workshops namely: **Energy Sources in South Africa** and **Biogas – Energy from Waste**.

The first, **Energy Sources in South Africa**, has the following aims:

- To consider energy sources currently used in South Africa.
- To introduce the following:
 - non-renewable energy sources,
 - renewable energy sources,
 - fossil fuels,
 - timescales,
 - primary and secondary energy sources.
- To discuss the implications of South Africa's continued reliance on non-renewable energy sources.
- To promote the need for:
 - energy conservation,
 - utilisation of non-renewable energy sources.

This workshop is introduced with a display of different energy sources and fuels or images of these.

Students are arranged in small groups(4-6). Each group is required to describe the energy sources/fuels they see (wood, wind, petrol, paraffin, oil, charcoal, gas, flowing water, coal, solar energy and electricity) and think of a common theme or factor linking them. The intention of this exercise is to enable students to understand that energy can be provided in many different ways.

The teacher then explains the concepts of renewable and non-renewable energy sources. The following definitions are given:

Renewable energy sources are finite but are so large that they will not run out in the foreseeable future. The sun is the source of renewable energy sources, these include wind, wave, hydro and solar energy.

Non-renewable energy sources are sources of energy contained beneath the earth's surface and which are limited and irreplaceable. These include fossil fuels such as oil, coal and gas.

Student groups then classify each of the energy sources/fuels as either renewable or non-renewable energy sources.

A discussion on whether wood is a renewable or non-renewable resource is used to introduce the notion of over-exploitation of the wood resource and the need for an alternative energy supply strategy in areas where demand exceeds supply.

The second workshop dealing with the fuelwood crisis is **Biogas – Energy from Waste**. This workshop is introduced in the following way.

Students are shown an image of women walking through a rural village carry woodloads. The teacher presents the following questions to open discussion.

What are the people in the picture doing ?

Why do they use wood ?

What do they use the wood for ?

What are the problems connected with the use of wood as an energy source ?

Are other alternative fuels available to people using wood ?

What are some of the problems people face when changing to other fuels ?

The following information is provided for teacher input:

'In South Africa many people living in underdeveloped areas rely on wood to meet energy needs. Wood used for cooking and heating is called fuelwood.

Years ago, people collected only dry branches from forests and bushes near their homes. Today the land has to support more people. Living forests and trees are cut down for fuelwood and to clear land for agricultural use.

In many areas, wood can no longer be considered a renewable energy resource as trees are not growing fast enough to replace the trees being cut down.

As natural forests are destroyed fuelwood gatherers, mostly woman and children, spend many hours collecting and carrying fuelwood.

This struggle for wood for cooking and heating can be called an energy crisis. Changing to other fuels such as paraffin and gas might not be possible because they are either not available or too expensive.'

The workshop then proceeds to consider Biogas producing technologies and biogas as an energy option. These issues are discussed in Section 4.5.3 **Biogas – Energy from Waste**

4.3 Electricity is a right, not a privilege

While much research attention on energy scarcities initially focused on rural areas, the energy crisis has begun to shift to peri-urban areas as South Africa experiences increasing rates of urbanisation. Peri-urban areas are wedged between the metropolitan centres and rural areas. In these areas there is little access to 'free' fuelwood and most households are not electrified.

According to Theron(1991:75) only about 10% of black South Africans in urban areas outside the 'homelands' have access to electricity in their homes.

Non-electrified peri-urban households rely on a variety of different fuels for their energy requirements, including paraffin, coal, candles, gas, wood and batteries. Studies have shown that apart from piped gas and coal in the Transvaal, these fuels are often more costly to use than electricity (Rivett Carnac, 1979;Eberhard,1984). A recent study, Macroplan cited in Williams(1993:24), conducted in Khayelitsha concluded that households with access to grid electricity spent on average R68 per month in meeting their energy needs, while non-electrified households spent R127.

In addition, these fuels are also potentially hazardous and detrimental to health. Dingley(1988:7) categorises health related problems into four areas:

- a) Respiratory ailments caused by the combustion of fuels in confined spaces.
- b) Burns caused by accidents arising from the domestic use of combustible fuels such as paraffin.
- c) Eye strain caused by reading or studying by candle-light.
- d) The effects of smog over wide areas, often exacerbated by weather conditions.

In addition poisoning due to the ingestion of paraffin or battery chemicals by children is a serious hazard. A study conducted by the Medical Research Council, quoted in Williams(1993:43),found that a total of 436 children, mostly between 12 and 36 months, were treated for paraffin poisoning during 1990.

In underdeveloped urban and peri-urban areas close to the existing electricity grid, all indicators point to electrification as the most suitable supply option.

There are many reasons why electrification is the preferred energy supply option for domestic needs. These include:

- i) Electricity enhances the quality of life. It is a versatile and convenient energy source that allows for the performance of a wide range of tasks.
- ii) Once connection costs have been paid and appliances bought, electricity is more affordable than most other fuels such as paraffin and gas.
- iii) Electricity is a substitute for coal and wood usage in urban areas. This may substantially reduce the air pollution in metropolitan areas.
- iv) Electrification will ameliorate the fire and poisoning hazard of fuels such as paraffin that cause the deaths of hundreds of people every year.

In addition, electrification could provide impetus to the development of the informal manufacturing and business sector.

Eskom Perspective(1993:17) reports that business turnover in a newly electrified rural area increased by more than fifty percent. Shops were able to stock a wider range of goods, electrical appliance stores opened to service the new market and welding firms improved productivity by switching to arc welding.

Supporting the need for electrification, Dingley(1988:14) suggests that,

‘ Electrification is clearly justifiable in urban and high density areas on economic grounds alone. In less densely populated and more remote rural areas, justification would depend on economic, social and perhaps environmental factors.’

Eskom, the national generating authority, supplies more than 95% of South Africa’s commercial electricity. Eskom’s Annual Report(1993:17) reports that Eskom currently has a maximum generating capacity of 36846 MW. In addition the mothballing of power stations has resulted in a reserve capacity of 6051 MW. Eskom’s mothballing programme has been implemented in response to expected electricity demand not materialising. This reserve capacity means that Eskom

could supply non-electrified households without incurring capital expenditure on providing new generating capacity.

Despite having spare generating capacity Eskom's expenditure on electrification remains small in comparison with overall capital expenditure. In 1992, actual expenditure on electrification was about R450 million out of a total capital expenditure of R3.6 billion.

While Eskom has publicly promoted the idea of 'Electricity for All' between 1989 and 1990 only 14 000 new consumers were connected(Theron, 1991:8). Since then the number of new connections has increased dramatically, with a total of 160 000 new households receiving electricity from Eskom and 90 000 from local authorities in 1992. Eskom has committed itself to electrifying 700 000 households by 1996.

The introduction of the Electrification Participation Note(EPN), should provide Eskom with loan capital specifically for financing electrification and other social investments. If successful the EPN could provide capital for the 'Electricity for All' campaign.

Costs of providing electricity to low income consumers should be kept as low as possible in order to maximise the number of households connected. Locally developed technologies such as the Ready Board and Pre-payment meter system provide examples of how technological innovations can make a positive contribution to community development.

The Ready Board is a device comprising two or three plug sockets, light bulb and an earth leakage system. Ready boards can provide up to 12 kilowatts, sufficient to power most household appliances. Pre-payment meters allow electricity users to budget electricity expenditure and eliminate the problem of inadequate postal deliveries in underdeveloped areas.

The use of new technologies such as Pre-payment meters, Ready Boards and aerial bundle conductors has reduced the costs of urban reticulation by up to 50% compared with the underground cable systems.

An understanding of the energy problems faced by non-electrified households and the urgent need for a large scale electrification programme would enhance students' awareness of South African energy issues.

an awareness of the role that technology has in facilitating community development could promote the selection of technological careers among science students.

Two workshops relating to electrification issues have been prepared.

The first, **Living without Electricity**, deals with problems facing people living in non-electrified areas and considers grid electrification as a suitable supply option.

The aims of this workshop are:

- To consider energy usage patterns in non-electrified areas of South Africa.
- To discuss issues and problems relating to energy usage in non-electrified households.
- To introduce electricity as a suitable energy option.
- To consider the costs involved in an electrification programme.

In terms of broader project aims this workshop aims to explore links between science, technology and society by considering the advantages of having a domestic electricity supply.

The workshop is introduced with the teacher displaying an image of women carrying headloads of wood walking beneath electrical powerlines (see Figure 2.1). This image was chosen as it clearly displays the inequitable domestic electricity distribution existing within South Africa. Despite living near a supply of electricity these women do not have electricity in their homes.

A student discussion of this image is followed by a discussion of the following Information Sheet.

INFORMATION SHEET

- **SOUTH AFRICA PRODUCES MORE THAN 50% OF AFRICA'S ELECTRICITY.**
- **MORE THAN 60% OF SOUTH AFRICA'S POPULATION DOES NOT HAVE ACCESS TO GRID ELECTRICITY.**
- **ELECTRICITY IS CHEAPER THAN FUELS SUCH AS GAS, PARAFFIN AND CANDLES.**

Each student group is required to list problems associated with the use of paraffin, candles, wood, car batteries, petrol, coal and gas.

An example of what is expected is provided for the teacher.

paraffin: - fire hazard
 - smells
 - messy
 - poisonous

car batteries: - expensive to charge
 - difficult to transport
 - limited range of appliances
 - contains hazardous chemicals

The intention of this exercise is to get students to reflect on, and share their own feelings and experiences of life without electricity. Students should also consider what activities are impossible without electricity.

The following activity requires students to consider and list any advantages and disadvantages of electricity as an energy supply. Factors that could be considered are: costs, hazards, transportation, maintenance and pollution.

As an example the teacher is provided with the following advantages and disadvantages.

Advantages of electricity as an energy source:

- Versatile energy source which can power many different appliances, can provide good heating and lighting.
- Cheap to use in comparison to other fuels.
(Except for using coal in the Transvaal, and wood which is collected by users.)
- Less hazardous than liquid fuels or gas.
- Does not have to be transported by user.
- Pollutes only at source, suppliers problem.

Disadvantages of electricity as an energy source:

- Distribution and installation costs are relatively expensive, especially distribution in rural areas.
- Appliances are expensive.
- Professional repair and maintenance required.

Students are then shown a sketch of the National Electricity Grid. See Figure 4.1.

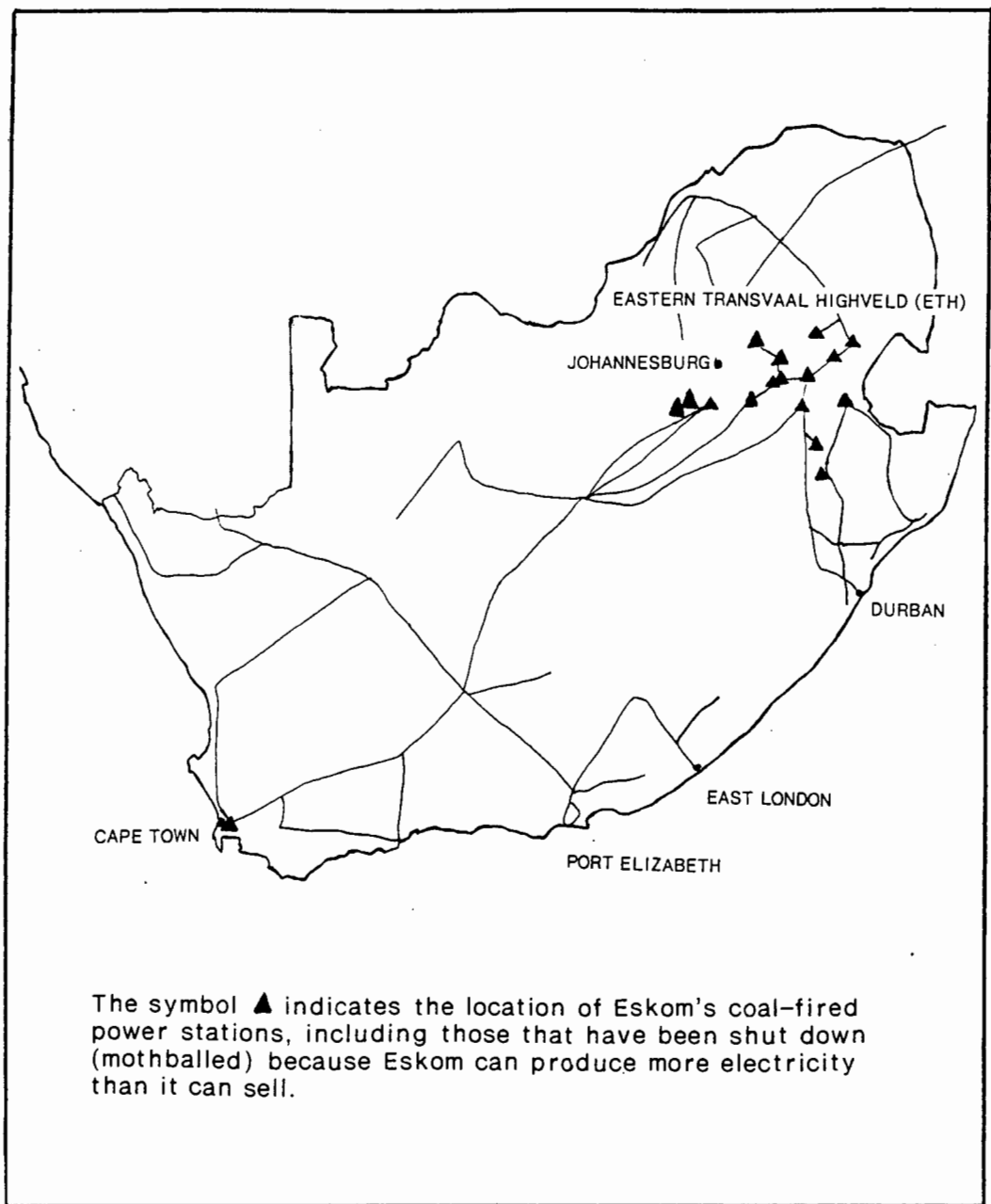

Figure 4.1 National Electricity Grid

The teacher describes the operation of the grid network and the advantages of having a grid system as opposed to having electricity supplied from independent power stations.

The following is provided for teacher input:

'Most power stations are connected to the national electricity grid network. Electricity generated in one part of the country is transmitted to other areas. The main reason for this is that it is cheaper to transmit electricity than transport coal long distances.

The grid is owned and maintained by Eskom and extends beyond South Africa's borders.

It is impossible to say which power station your electricity comes from. If one power station breaks down or needs to be overhauled the grid will still be able to provide electricity.

The national grid comprises of high voltage powerlines which distribute electrical power to various regions of the country. Not all sections of the grid operate at the same voltage. The main transmission system operates at 765 kV, 400 kV, 275 kV and 220 kV.

Power lines and cables operating at lower voltages carry the electricity to cities and towns, where the voltage is reduced in stages for different users. Eskom operates over 122 000 transformers. Heavy industry is supplied at 33 kV and light industry at 11 kV. In urban townships substations contain transformers which transform the voltage from 11 kV to 220 V. There is a substation for every 200 houses.'

The advantage of transmitting electricity at high voltages is also included for teacher input.

'Very high voltages are used for transmitting electricity over long distances, because this reduces the energy losses caused by the resistance of the cables. The energy losses due to the heating effect of current are proportional to the square of the current multiplied by the resistance.

$$\text{Energy loss} \propto I^2 \times R$$

The higher the voltage the lower the current for the same power. Thus energy losses due to heating are less when the transmission voltage is high.'

The location of the coal-burning power stations on the Electricity Grid diagram allows for the following question.

In which area is most of South Africa's electricity generated ? Why ?

The suggested response is:

'Most of South Africa's electrical power is generated in the Eastern Transvaal Highveld as most of the coal reserves are situated in this region.'

The costs of grid electrification are then explained in terms of capital and operational costs. The teacher provides the following input.

'Electrification is a most suitable energy supply option. However, the provision of electricity is expensive. Let's consider some of the costs involved in the processes of electrification.

There are two types of costs involved in electricity provision, **CAPITAL** costs and **OPERATIONAL** costs.

CAPITAL costs are the initial costs of setting up an electrification system. These includes the costs of building power stations, extending the national grid, building transformer stations and wiring houses.

OPERATIONAL costs are the costs of operating and maintaining the network. Operational costs include the purchase of fuel (mainly coal), salaries, maintenance and repair of power stations, the grid system and equipment.'

Figure 4.2, 'Estimated costs of electrification', provides insight into some of the costs of providing electricity. These include the costs of building new power stations, extending the grid and wiring a house.

Mention is made of Eskom's current surplus of electrical generating capacity which could provide homes with electricity without Eskom having to build any new power stations.

The other major cost of providing electricity is the cost of extending the National Grid. Estimated costs of extending the 400 kV grid to areas where no national grid exists are about R 340 000 per pylon and R 120 000 per kilometer for cable.

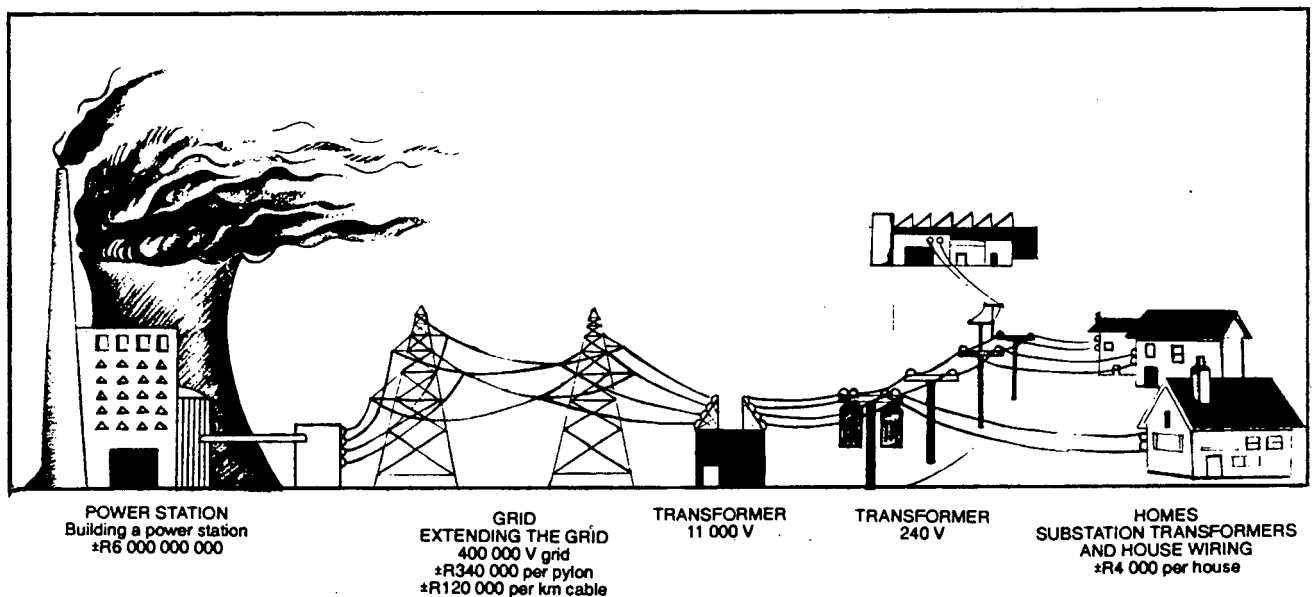

Figure 4.2 Estimated costs of electrification

The cost of wiring a house including substation transformers is estimated to be in the region of R3000 to R4000 per house in urban areas. The cost depends on the number of circuits, plug points and lights. South Africa has very strict regulations governing the electrification of houses. The installation has to be

carried out by qualified electricians and has to be approved by a municipal or council electricity inspector. All these factors push up the costs of electrifying a dwelling.

The vast majority of South Africans who do not have access to electricity are poor and live in dwellings not suited to these strict regulations.

Using the illustration of the Ready Board and Pre-payment system (see Figure 4.3) the teacher explains the operation of this system. After this students are required to discuss what they consider to be the advantages / disadvantages of the Ready board and Pre-payment system.

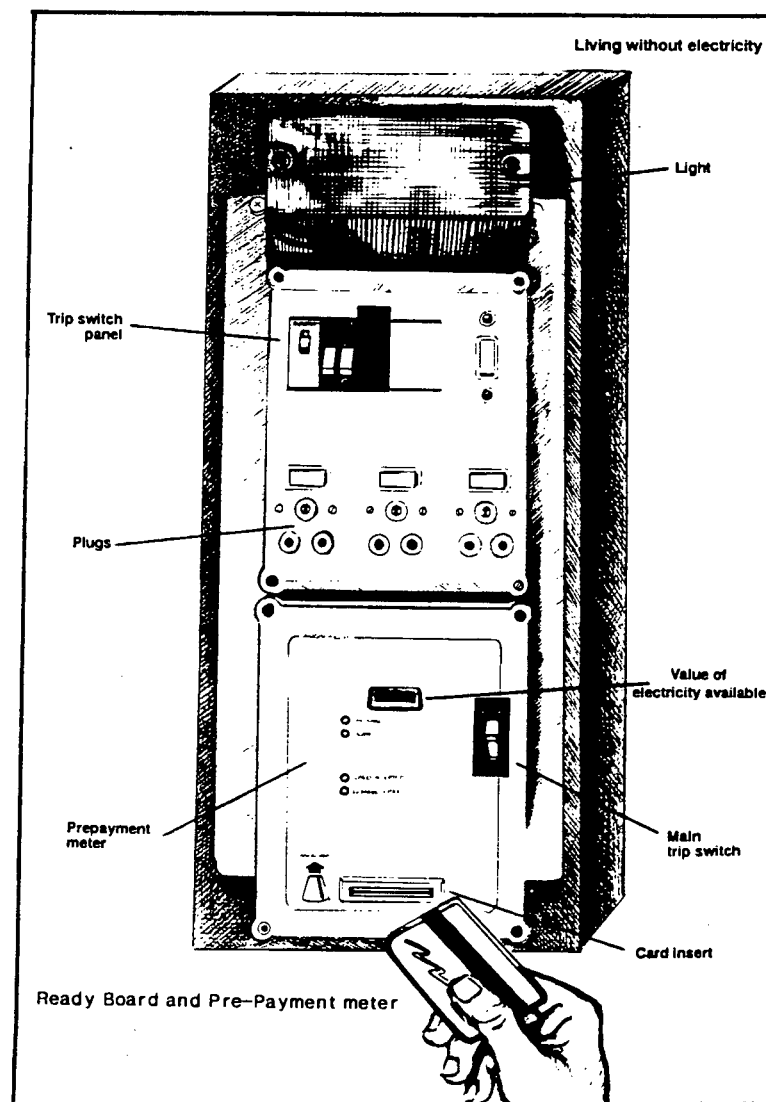

Figure 4.3 Ready Board and Pre-payment meter

This workshop ends with student groups discussing their responses to the following questions.

Where should domestic electrification fit in the list of national priorities such as education, health and food supply?

Which is most important ? Why ?

Who should pay for a domestic electrification programme ?

Is it reasonable to say that all homes must be electrified ?

What about appliances ? Can people afford these ?

As a student project a visit to a local power station is recommended. The following questions are suggested. These questions were based on the opportunity to visit Athlone power station which is owned and operated by the City of Cape Town.

Who owns and operates the power station ?

Does it operate throughout the year ? If not, why ?

What type of fuel does the power station use ?

How much fuel do they use ?

Where does the fuel come from ?

Does it have pollution control measures ?

How much water does the power station require for cooling ?

Is it connected to the grid system ?

How is power provided if the power station breaks down ?

Who receives power in an emergency ?

What job opportunities are available at the power station ? What training and skills are needed ?

Where is this training provided ?

The workshop, **Electricity Costs in the Home**, deals with issues of domestic electricity tariffs, the cost of using electrical appliances and the conservation of electrical energy.

The aims of this workshop are:

- To develop an understanding of power ratings of domestic appliances.
- To enable students to calculate the costs of using electrical appliances.
- To determine the efficiency of a kettle.

To discuss ways of conserving electrical energy in the home.

Students are provided with the worksheet **Electricity Costs in the Home**. Section One of this workshop introduces the concepts of electrical power and energy. This section is of direct relevance to Std 10 students as calculations involving electrical power and energy are part of the current Std 10 Physical Science syllabus.

This workshop introduces the concepts of power and energy by considering the power ratings of common domestic appliances. Firstly, students are required to calculate the current drawn and resistance of a 2kW kettle operating at 220v. Students are required to compare two kettles with different power ratings in terms of the time required to boil a quantity of water and the energy consumed in the process. The purpose of this exercise is to demonstrate that consumers pay for the amount of electrical energy used and that energy used is the product of the appliance power rating and the time for which the appliance is used.

The student worksheet contains the following list of appliances and typical power ratings at 220V ac.

APPLIANCE	POWER RATING (kW)
stove (total)	14
hot water cylinder	4
washing machine	2.75
iron	1
hairdryer	1
1 bar heater	1
vacuum cleaner	0.8
toaster	0.9
microwave oven	0.65
refrigerator	0.11
light bulb	0.06
radio cassette player	0.012
calculator	0.00054

Section Two requires students to consider a monthly electricity account and calculate the tariff charged per kilowatt-hour. Students are then required to calculate the costs of bringing a kettle of water to the boil. This exercise quantifies the cost of using electrical energy.

As an exercise students are required to discuss whether they think electricity is a cheap or expensive form of energy.

Section Three includes an experiment which requires students to determine the efficiency of an electric kettle. An understanding of the concept of efficiency as applied to technological processes and appliances is an important aspect of technological awareness which this project aims to promote.

The teacher provides the following explanation of efficiency.

'Energy efficiency is the ratio of how much energy goes in to an appliance to the amount of useful energy got out. A kettle is not a perfect insulator, some of the electrical energy supplied to the kettle goes into heating the kettle and the surrounding air. Also heat is 'lost' through water that vaporises before the kettle boils. The more energy 'lost', the lower the efficiency.

Efficiency of a kettle is given by the ratio of the electrical energy supplied to the kettle to the energy actually needed to boil the water. Efficiency is usually expressed as a percentage. The greater the percentage the greater the efficiency.

As a percentage the efficiency of the kettle is given by,

$$\frac{\text{ENERGY REQUIRED}}{\text{ENERGY DELIVERED}} \times \frac{100}{1}$$

Students are required to calculate the theoretical amount of energy required to heat a given quantity of water to boiling point and then compare this with the actual amount of electrical energy used. The actual energy used is obtained by measuring the time taken to heat the water and multiplying this by the kettle's power rating.

The following sample calculation is provided for the teacher.

'In order to determine the efficiency of the electric kettle we have to calculate the energy required to boil the water and the actual electrical delivered to the kettle.

Firstly, we calculate the **energy required** to boil the water in the kettle.

The energy required to raise the temperature of a mass of water, m , by an amount $T_2 - T_1$ is given by:

$$Q = mC(T_2 - T_1), \text{ where:}$$

$m = \text{mass of water (kg)}$

$$C = \text{specific Heat Capacity of water} \\ = 4200 \text{ Jkg}^{-1}\text{C}^{-1}$$

$$T_2 = \text{final water temperature} (^{\circ}\text{C})$$

$$T_1 = \text{initial water temperature} (^{\circ}\text{C})$$

The mass of water used in this experiment is 0.5 kg. Measure the initial temperature of the water. The final temperature assumed to be 100°C.

Sample calculation:

$$m = 0.5 \text{ kg}$$

$$C = \text{specific Heat Capacity of water} \\ = 4200 \text{ Jkg}^{-1}\text{C}^{-1}$$

$$T_2 = 100^{\circ}\text{C}$$

$$T_1 = 20^{\circ}\text{C}$$

$$Q = mC(T_2 - T_1) \\ = 0.5 \text{ kg} \times 4200 \text{ Jkg}^{-1}\text{C}^{-1} \times 80^{\circ}\text{C} \\ = 168\,000 \text{ J}$$

Energy required in kilojoules = 168 kJ

Now calculate the actual electrical energy delivered to the kettle.

$$\text{Power} = \text{Energy/Time}$$

Therefore,

$$\text{Energy delivered} = \text{power rating} \times \text{time required}$$

Firstly, note the power rating of the kettle. Power ratings are usually given for a supply voltage of 240 V ac. However the supply voltage in South Africa is about 220 V ac, therefore the power rating has to be reduced proportionally.

Let's assume the kettle has a power rating of 2200 W at 240 V ac. For a 220 V supply this reduces to:

$$\frac{220 \text{ V}}{240 \text{ V}} \times 2200 \text{ W} \text{ or } 2016 \text{ W}$$

Secondly, measure the time it takes to bring the 0.5 kg of water to the boil. Note that this is the same mass used in calculating the 'energy required'.

To demonstrate this calculation we assume it takes 90 s to bring the kettle to the boil.

We can now calculate the energy delivered to the kettle.

$$\begin{aligned}\text{energy delivered} &= 2016 \text{ W} \times 90 \text{ s} \\ &= 181\,440 \text{ J}\end{aligned}$$

The efficiency of the kettle is given by the ratio of the energy required to boil the water to the actual energy delivered to the kettle.

As a percentage the efficiency of the kettle is given by,

$$\begin{aligned}&\frac{\text{ENERGY REQUIRED}}{\text{ENERGY DELIVERED}} \times \frac{100}{1} \\ &= \frac{168\,000}{181\,440} \times \frac{100}{1} \\ &= 92,5 \%\end{aligned}$$

$$\text{Efficiency of the kettle} = 92,5 \%$$

Kettles are very efficient! The main reason for this is that all the heat energy goes into the water as the heating element is emersed in the water.'

Section Four deals with the electricity consumption of domestic appliances such as hot water cylinders, stoves and heaters. Students are required to consider ways in which electrical energy could be conserved, for example, by using smooth-bottomed pots and matching pot sizes with stove plate sizes.

This exercise aims to promote student interest in consumer issues and mediate practical skills pertaining to technologies in everyday use.

As a take-home exercise students are asked to determine which appliances contribute most to the electricity account.

4.4 Acid Rain – An Atmosphere of Uncertainty

The abundance of coal in South Africa has led to the development of a predominantly coal-based electricity supply industry. Approximately 90% of South Africa's electricity is supplied by coal fired power stations. A major concern relating to South Africa's reliance on coal is the contribution of coal combustion to pollution.

Major pollutants are released as a result of fossil fuel combustion. These include: sulphur dioxide, nitrous oxides, carbon dioxide, particulates, hydrocarbons and carbon monoxide.

With the exceptions of carbon monoxide and hydrocarbons, coal is the major contributor to pollutant emissions.

Eskom's centralised electricity supply strategy has resulted in the decommissioning of many small power stations and the construction of some of the largest coal fired power stations in the world. For example, the Lethabo and Tutuka power stations each have an installed rating of over 3600 MW.

Of a total installed electrical capacity of 36 846 MW, about 25000 MW is generated within a 30 000 square kilometer area of the Eastern Transvaal Highveld (ETH).

To exacerbate matters the ETH region contains two major petrochemical plants, various smaller industries, discard coal dumps and townships in which coal is burned for cooking and space heating.

Power stations are the most significant source of air pollution in the ETH. Power station contributions as a percentage of total contributions from all sources are given in Table 4.2

Pollution is best controlled at the source. A wide range of technologies which reduce pollutant emissions from power stations exist.

All power stations in the ETH are equipped with electrostatic precipitators which remove up to 99.8% of particulates. Examples of particulates are silicon (as SiO_2), aluminum (as Al_2O_3) and iron (as Fe_2O_3). Considering that power stations in the ETH release over 350 000 000 tons of particulates per annum electrostatic precipitators serve an important function in controlling pollution.

Emission	Quantity (thousands of tons)	% of total emissions
particulates	356	83
sulphur dioxide	1 111	91
nitrous oxide	372	91
carbon monoxide	44	12
carbon dioxide	135 400	95

Table 4.2 Estimates of Power station emissions as a percentage of total emissions (Els 1990:9)

Sulphur dioxide and Nitrous oxides are released when fossil fuels such as coal are burnt. Despite South African coal having a low sulphur content (about 1%), over 1110 000 tons of sulphur and 372 000 tons of nitrous oxides are emitted by coal burning power stations annually. These gases are basic ingredients in the formation of acid rain.

Although most developed countries require new power stations to be equipped with desulphurisation technologies none of Eskom's power stations currently have NO₂ and SO₂ removal equipment. Eskom estimates that desulphurisation technologies would push up the cost of electricity by 30%. Installing desulphurisation technology for a 3600 MW station would cost in the region of R2 billion before running costs. Eskom suggests that if capital was available it would be better spent on electrifying houses (Eskom Perspective 1993:32).

Another way of reducing the effects of pollution is to disperse emissions over as large an area as possible. Power stations are equipped with tall smoke stacks which release emissions at a height of 200 m.

Climatic conditions have an important role in pollution effects. Tall smoke stacks are particularly important in the ETH because of the frequent occurrence of inversion layers particularly in winter. An inversion layer is a layer of cold air which traps pollutants close to the ground.

In addition to the presence of inversion layers winter pollution levels increase due to three factors:

- i) greater demand for the supply of electricity,
- ii) increased domestic use of coal for space heating, particularly in non-electrified townships,
- iii) veld fires.

The removal of pollutants from the air occurs by two processes, dry phase and wet phase reactions. Dry phase reactions begin with the formation of free radicals, unstable highly reactive molecules, by sunlight.

High energy Ultraviolet light photons split up ozone molecules, (O_3), releasing highly reactive oxygen atoms which then combine with water molecules to form hydroxy radicals, (OH).

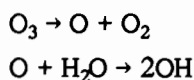

The dry phase reactions of OH with SO_2 and NO_2 are the main gas-phase sources of sulphuric and nitric acids.

The formation of nitric acid occurs as follows:

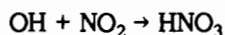

The reactions leading to the formation of sulphuric acid are:

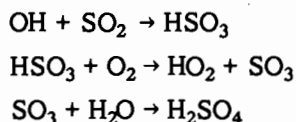

Liquid phase reactions occur in water droplets in clouds.

Nitric acid is produced by the following wet phase reactions:

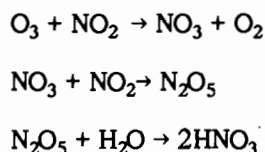

Sulphuric acid is formed when there is enough water present in the atmosphere. The following reactions occur:

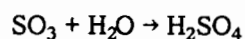
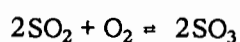
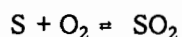

Acidic deposition due to dry phase reactions is called dry deposition and acidic deposition due to wet phase reactions is called wet deposition or acid rain.

Unfortunately no accurate procedures for measuring dry deposition exist. Researchers postulate that dry deposition could equal wet deposition levels depending on prevailing climatic conditions.

Eskom and other organisations such as the CSIR have monitored acid rain in the ETH. A study by Bosman found high levels of acid rain in the ETH. Bosman (1990:1) states that results of a four year study yielded mean monthly bulk and wet-only precipitation pH values below 3.5. In 1990/1991 Turner cited in Van Horen (1993:73) found ETH rainfall to have pH levels of about 4.25.

Precipitation in the ETH can therefore be classified as acidic. Although the acidity of unpolluted rain has a measured pH of around 5.6 (Bosman:1990:1), it must be remembered that the pH scale is logarithmic and that a decrease of two on the pH scale equates with a hundred fold increase in hydronium ion concentration, the yardstick of acidity. Bosman (1990:1) also found acidity is neutralised in the soil and no evidence of acidification in rivers, which thus remain alkaline.

This raises the issue of the relationship between pollution causes and effects. The relationship between power station emissions, acid rain formations and environmental damage remains unclear.

The issue of whether acid rain levels in the ETH are acceptable has not been settled. Measuring pollutant emission levels is straight forward. However, assessing the apparent effects of acid rain pollution and linking these effects to power station emissions has proved to be a formidable task.

The reasons for this include climatic influences. A key factor is knowing how well the ETH climate is able to spread emissions over a larger area. Also South Africa's rivers are largely alkaline and therefore relatively insensitive to acid rain damage.

South Africa does not have spectacular symptoms of acid rain such as dying forests or lifeless lakes which have been reported in Europe where the effects of acid rain have been well publicised. In Europe excessive acidification of soils has resulted in forest decline. There is also considerable evidence that high acidity levels have resulted in the decline of fish, amphibian and bird populations. In some cases, lakes which had substantial trout populations are now fishless.

Although uncertainty exists with regard to acid rain damage in the ETH, acid rain pollution in this area should not be ignored.

Both internationally and locally, acid rain is currently a topical issue that receives considerable media coverage. By exposing secondary school science students to the issues relating to acid rain in the South African context, classroom discussions on topics such as pollution measurements, the economics of pollution control and pollution policy are made possible.

Two workshops, one aimed at promoting an awareness of South Africa's coal-based energy supply and the other focusing on the issue of acid rain, have been developed.

The first, **Energy Sources in South Africa**, the aims of which have been introduced in Section 4.2, requires students to discuss South Africa's reliance on coal. Students are provided with the **Worksheet: Energy Sources in South Africa**.

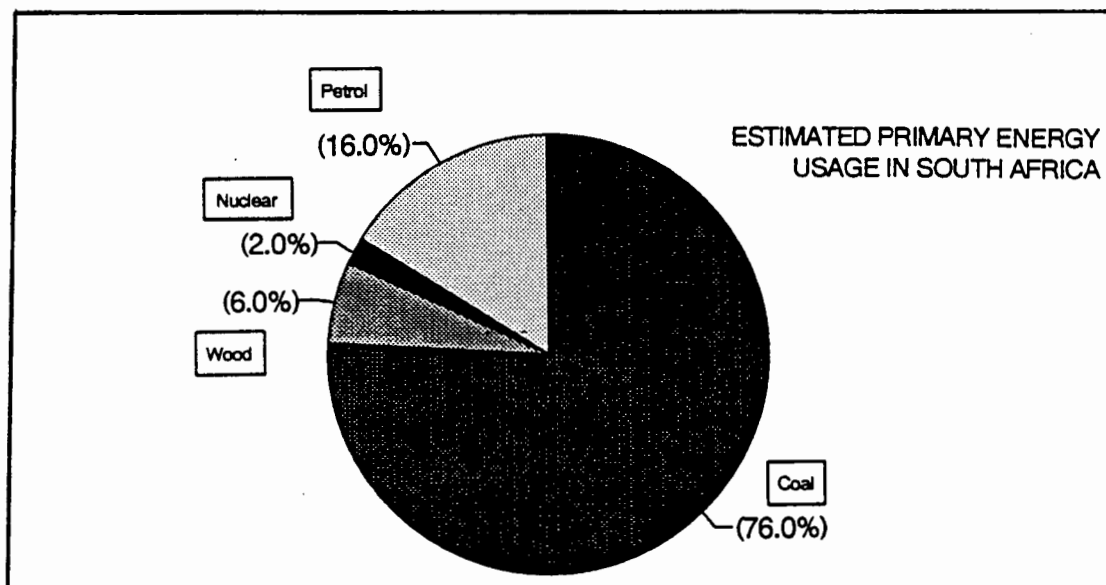

Figure 4.4 Estimated primary energy usage in South Africa.

This worksheet requires students consider the pie diagram showing South Africa's primary energy usage (Figure 4.4) and answer the following questions:

- 1) Which energy source contributes most to South Africa's energy usage ?
- 2) Classify the energy sources as renewable or non-renewable.
- 3) What does this energy usage pattern mean for present and future South African society ?
- 4) Can you think of any solutions to this problem ? Write these down.

The teacher then presents two possible energy strategies.

Firstly, conserving existing fossil fuel resources, and secondly, utilising available renewable energy resources.

Given that approximately 70% of coal used locally is used to produce electricity, conserving electricity would reduce coal consumption. In order to understand the issue of electricity conservation students need to be aware of the sectoral breakdown of electrical consumption. Students are informed that an electrical energy conservation programme would need the support of industry, business and mining.

The teacher then introduces the following renewable energy resources: hydro, solar (photovoltaics, solar passive), wind and wood. This section of the workshop is discussed in Section 4.5

The second workshop, **An Atmosphere of Uncertainty – Acid Rain**, deals with issues of pollution from coal-fired power stations specifically acid rain.

This workshop has the following aims:

- To promote an understanding of the pollution threat from coal-burning power stations, a major contributor to air pollution in South Africa.
- To introduce the issue of acid rain and examine various aspects of acid rain such as its formation, transportation and deposition.
- To promote the need for improved environmental control and policy in South Africa.

The teacher introduces the workshop with the following discussion statement.

'South Africa cannot afford pollution control, we need to spend money on creating jobs, building schools and hospitals. Only when we have these can we afford to control pollution.'

After students have discussed this statement the teacher introduces feedback effects of air pollution on health, productivity and the resulting economic costs.

The issue of social responsibility regarding pollution control is then introduced. Students are required to answer the following questions:

Who are the main polluters ?

Where does pollution occur ?

Who suffers the effects of pollution ?

Who should be responsible for controlling pollution ?

Section Two of this workshop begins with the teacher displaying an image of a coal fired power station. Students are required to distinguish between cooling towers and smokestacks and explain the functions of each. An image of the national electricity grid is used to show the concentration of coal-fired power stations in the Eastern Transvaal Highveld.

The emissions of coal-fired power stations are explained in Section Three. Emissions discussed include carbon dioxide, sulphur, nitrous oxides and particulates. Dry and liquid phase reactions are presented as an optional topic for teachers.

Teachers would find this section of the workshop relevant to the sulphur and nitrogen sections of the Standard 9 Physical Science syllabus.

The movement of pollutants and the formation and effects of acid rain are presented in Section Four. Acid rain pollution offers students insight into the need for interdisciplinary research. Acid rain is presented as a problem that chemists, biologists, meteorologists and other scientists have to work on together.

When discussing the threat of acid rain in the Eastern Transvaal Highveld region a number of uncertainties are raised. These uncertainties include, the relationship between emissions and damage, dispersion mechanisms and deposition area. Such uncertainties demonstrate that scientific research is a process that does not always present immediate solutions.

The final section of the workshop considers existing technologies capable of reducing and controlling acid rain.

As a role-play exercise, three students are chosen to be scientists representing Green Leaf, an environmental pressure group. These students are given the task of informing residents (the class) who live near a coal-fired power station about the formation and dangers of acid rain. Another student is chosen as the power station manager who is invited to explain the value of electricity and the cost of pollution control technologies.

4.5 Renewable Energy Options

South Africa has considerable renewable energy potential which is underutilised. Currently, renewable energy sources contribute insignificant amounts to South Africa's primary energy consumption. The largest renewable contribution is in the form of biomass, mainly derived from fuelwood, the dominant energy source used in underdeveloped areas. This is followed by hydro-electricity mainly in the form of electricity from pumpstations.

If South Africa's renewable energy potential is to be effectively exploited, energy policy needs to provide for the research development and implementation of renewable energy technologies. Students, as citizens, need to be informed of available renewable energy options. This section reviews aspects of South Africa's renewable energy potential and provides an overview of the workshops which have been developed on renewable energy themes.

The following renewable energy options are introduced in the workshop, **Energy sources in South Africa:** Hydro, and solar (water heating, comfort levels in buildings, electricity production), wood and wind.

Ultimately, all our energy resources, except nuclear, originate from the sun. Fossil fuels such as coal, natural gas, and oil have originated from organic matter which has been buried under layers of sand and mud. As the formation of these fuels takes hundreds of millions of years, negligible new supplies are being formed compared with current consumption rates. For this reason fossil fuels are regarded as non-renewable.

Solar radiation may be used to produce thermal energy for:

- the heating and cooling of buildings,
- water heating,
- agricultural and industrial drying,
- distillation, and
- powering of heat engines.

In addition, solar radiation may be converted directly into electrical energy using photovoltaic cells. Two applications of solar energy use have been selected for workshop themes and have been developed in the workshops, **Solar Building Design** and **Electricity from the Sun**.

4.5.1. Solar Building Design

Solar energy may be used for heating and cooling of buildings. Solar design principles apply equally well to low cost housing or high rise office blocks. If solar design principles were applied to low cost housing, space heating costs could be reduced. Likewise, considerable energy and financial saving could be made if buildings relying on air conditioning for cooling were designed to utilise sunshine more efficiently.

As an energy theme, solar design facilitates the contextualisation of scientific concepts such as thermal conduction, convection, radiation and insulation.

The workshop, **Solar Building Design**, has the following aims:

- To consider the importance of solar design, particularly with regard to improving comfort levels of dwellings and reducing space heating costs.
- To introduce scientific principles associated with solar design such as conduction, convection, radiation, reflectivity and thermal capacity.

This workshop begins with students discussing the importance of achieving thermal comfort levels in buildings such as their home or school. The problems associated with using fuels such as wood and coal and naked flame appliances for space heating are considered. Emphasis is placed on discussing the advantages of applying solar design principles to low cost homes.

Solar design is presented as a means of achieving desired comfort levels while reducing the usage of relatively expensive appliances such as paraffin and electric heaters.

Section Two of the workshop considers the movement of heat. The following principles are introduced; conductive heat flow, convective heat flow, radiation, reflectivity, thermal inertia, and window orientation.

A practical demonstration is given for each principle.

Conductive heat flow, conductors and insulators are dealt with in the same section. Students are required to carry out the following activity. Hot tea is poured into a metal cup and a polystyrene cup. By comparing which cup becomes hotter faster the concept of conductive heat flow and the heat conducting ability of different substances are introduced. The teacher offers the following explanation of what happens.

'Heat has been transferred from one body (the tea) to another body (the cup). The outside of the cup becomes hot as heat is transferred through the cup. This type of heat flow is known as **conductive heat flow**.

Conductive heat flow is the transfer of heat from one part of a body to another part of the same body, or between bodies in contact with each other.

Metal is a good conductor of heat whereas polystyrene is a poor conductor of heat.

Metals are good conductors because they have a chemical structure which allows an easy transfer of kinetic energy between atoms. Polystyrene consists mostly of air, as air is poor conductor so is polystyrene.

A substance which is a poor conductor of heat is called an **insulator**.'

Students are required to describe other examples of conductive heat flow and name three good insulators and three good conductors.

Convective heat flow and radiation are important methods of heat transfer. Students are asked to explain how a fire made in one part of a room often warms the entire room. After a discussion the teacher offers the following explanation.

'Heat from a fire warms a room through **convection** and **radiation**. **Convection** is the transfer of heat from one point to another by the mixing of one portion of the air with another. Convection also occurs in liquids. **Radiation** is the transfer of heat from a hot body by means of wave motion through space. Sunshine is a form of radiation. When you feel the 'glow' of a fire, you are feeling the radiation from the fire.'

Students are then required to name other examples of convection and radiation.

Reflectivity is an important factor in solar building design. To introduce reflectivity students are required to paint or colour the outside surfaces of two containers one white and one black. Fill the containers with water, place them in the sun. The water temperature in each container is measured over a period of time.

This activity demonstrates how the colour of outside walls and roof could influence the amount of heat absorbed by a building.

Students are then required to discuss how painting the outside of a dwelling like an iron shack could affect comfort levels.

The final topic discussed is thermal inertia. Thermal inertia is the ability of a body to retain heat. Although different substances have different thermal inertias, the mass of the substance also influences the time for which a body retains heat.

Students are required to consider the following question.

A stone floor or a wooden floor which have been exposed to the sun during the day. After sunset which will retain its heat for longer?

The stone floor, it has a higher thermal inertia.

The final section of the workshop is concerned with practical applications of solar design. Images of a traditional hut and wood and iron shack are used to open discussion on the influence of using different building materials on thermal comfort levels.

The following wall designs, Trombe-Michel (Figure 4.5) and Marseilles (Figure 4.6) are presented as examples of how design techniques can be used for heating and cooling of buildings. Students are shown different design configurations and are required to explain which design configurations are suited to different climatic conditions.

The workshop ends with a home based solar design investigation. Students are required to draw a plan of their homes and determine which rooms are coldest during the night and hottest during the day. Students are also required to present practical ways of improving thermal comfort levels in their own homes.

The Trombe-Michel wall design

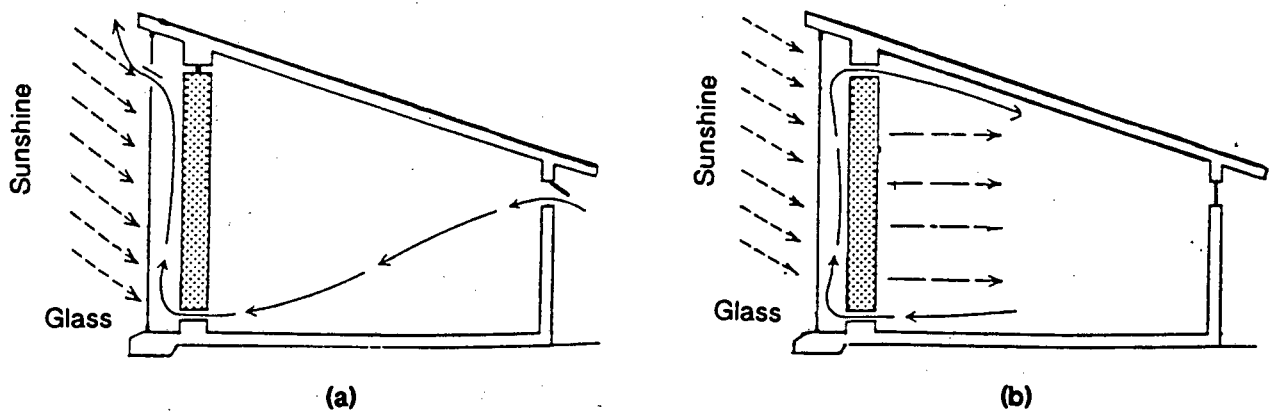

The above two diagrams show two ways in which the Trombe-Michel wall design can be used to circulate air.

- 1) Label the air flows as hot or cool.
- 2) Explain why the air circulates as it does in each diagram.
- 3) Which diagram is best suited to winter/summer conditions?

Figure 4.5 Trombe-Michel Wall Design student handout

The Marseilles wall design

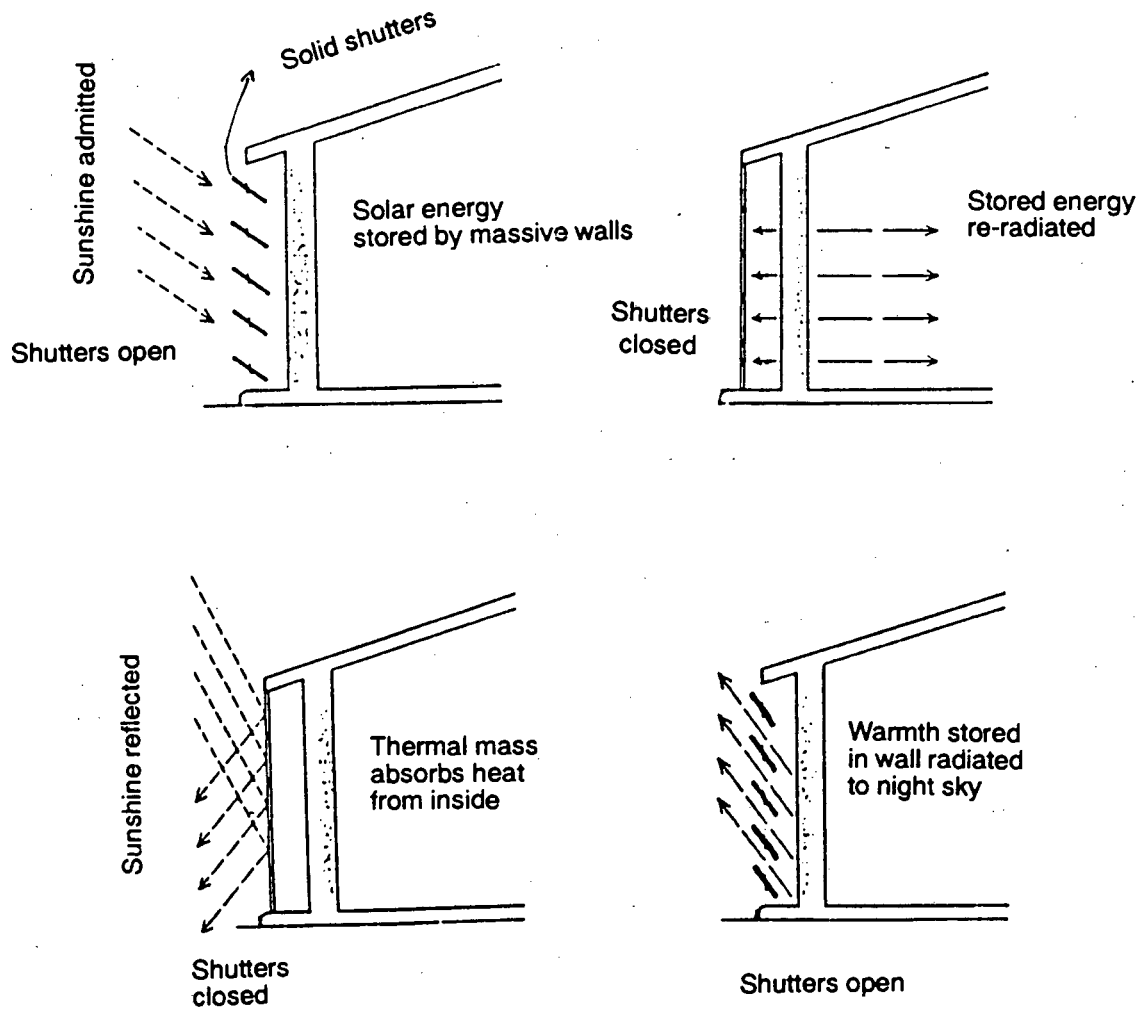

The four different diagrams show how the Marseilles wall can be used on a winter day, winter night, summer day and summer night.

Label the diagrams accordingly and explain how the different design configurations work.

Figure 4.6 Marseilles Wall Design student handout

4.5.2 Electricity from the Sun

On average over a year South Africa receives approximately 5.28 kWh of solar energy per square meter per day. This means South Africa enjoys one of the best solar energy distributions in the world.

There are many practical applications which utilise solar energy. For example solar water heaters are a simple technology which can save electricity. Photovoltaics, a more advanced technology, can actually generate electricity.

However, solar energy technologies currently make a negligible contribution to South Africa's primary energy consumption.

Photovoltaic panels convert solar energy directly into electrical energy, they contain no working parts and require little maintenance. Originally designed to power satellite systems, relatively high costs have limited the dissemination of photovoltaic electricity. However, continuing developments in photovoltaic design and manufacture have resulted in improved conversion efficiencies and reduced costs. This has increased the economic competitiveness of photovoltaic electricity.

Photovoltaic systems are suited to providing low-power electricity supply for lighting and electrical appliances such as radios and television sets but can also be connected to electricity grid systems.

As South Africa utilises its own coal reserves to generate electricity the cost of electricity from the established national grid remains relatively cheap. Photovoltaic systems therefore have to compete against the low cost of grid electricity. Thus photovoltaic systems are economically competitive only in areas which are distant from the electricity grid. The remoteness of many of South Africa's non-electrified communities from the national electricity grid increases the economic competitiveness of photovoltaic systems. In these areas the costs of photovoltaic systems have to be compared with the costs of other off-grid supply options such as petrol and diesel generating sets. Low maintenance requirements however enhance their suitability as an option for providing electricity in remote areas.

Photovoltaic system costs will have to drop much further before they can compete economically with conventional grid electricity.

At present, the main use of photovoltaic systems in South Africa is to provide power for off-grid applications, such as telecommunications, water pumping on farms, refrigeration in rural clinics, TV systems in rural schools and electric lighting in isolated homes.

In some countries, however, photovoltaic systems are used to supply electrical power to the electricity grid.

Accessible information regarding South Africa's solar resource potential, availability, suitability and costs of photovoltaic technologies could assist in promoting a broader awareness of existing renewable energy technologies and their applications. The use of photovoltaic systems for schools, clinics, water-pumping systems and communication systems provides examples of how technology can impact on community life.

The workshop, **Electricity from the Sun**, has been developed with the following aims:

- To introduce South Africa's solar energy resource potential.
- To discuss the earth's energy balance, and consider what happens to the solar energy the earth receives.
- To consider the suitability of photovoltaic electricity as an energy supply option.

Students are introduced to aspects of photovoltaic manufacture and design. These include the manufacture of the semi-conductor materials and panel efficiencies. After a brief explanation of photovoltaic cell operation the teacher poses the following question which is presented as an exercise.

Can South Africa meet its current electrical energy needs using solar energy ?

This exercise is intended to quantify the extent of the available solar resource. Based on an approximate surface area of 1 221 000 km² receiving an average of 5.28 kWh per m² per day and on 1.368 x 10¹¹ kWh Eskom sent out during 1992 South Africa receives approximately 17 000 times more energy from the sun than electrical energy currently used.

The suitability of photovoltaics as a domestic supply option is then considered. This is done by asking students to determine how long it would take, under sunny conditions (1000W/m²), for a single panel (0.5m² area; 10% efficiency) to boil a given quantity of water. The calculated time of 2 hrs demonstrates that a single 12v dc

photovoltaic panel cannot serve the same electricity supply function as 220v ac grid electricity. This exercise is followed by teacher input on dc/ac conversion, using arrays of panels to increase the power output, costing PV systems and the provision of electricity during rainy days and at night.

In order to challenge the notion that photovoltaic electricity is 'free' electricity students are required to consider an advertisement (Figure 4.7), and then answer the following questions.

Why is the word free used so many times ?

Is solar electricity really 'free' ?

This exercise is followed by a discussion of the costs of photovoltaic systems in relation to other electricity generating systems. The teacher introduces the concepts of capital and operating costs and compares PV systems and diesel generators. The teacher's input concludes with a discussion of photovoltaic off-grid applications, such as telecommunications, water pumping and refrigeration in clinics.

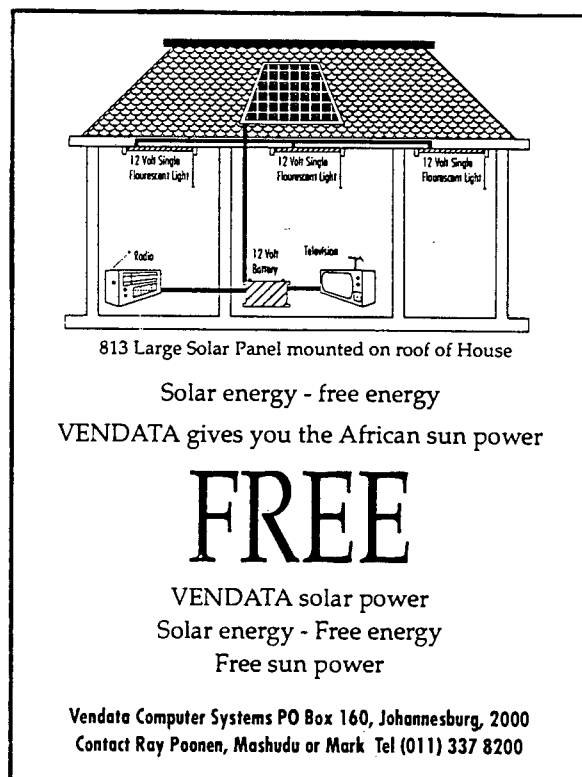

Figure 4.7 Solar Electricity Advertisement

As a concluding exercise, students are required to discuss and list the advantages and disadvantages of photovoltaic systems as an energy supply option.

4.5.3 Energy from the Wind

Wind energy has been exploited for more than a thousand years. Until the last century, wind was the major source of power for milling, grinding and pumping water as well as for sailing ships.

The first electricity generating wind machine was developed in Denmark in 1890. Most early wind generators were used to supply electricity to farms without access to grid electricity. From the 1920's cheap fossil fuels and rural electrification led to the demise of wind generated electricity. It took the oil price crisis of the 1970's to revitalise interest in wind generated electricity. Since then a wide range of wind generators from 50 W to 4 MW output have been developed.

Wind generating systems are operational in many countries. For example, in Denmark over 1400 medium sized wind generators have been installed by about 10 companies. In California, tax incentives have resulted in the establishment of commercial windfarms, with over 12 000 wind generators in operation (Kristoferson & Bokalders, 1987:272).

Wind energy is still widely used for water pumping. Stassen (1986) estimated that approximately 280 000 windmills are in use in South Africa's rural areas.

South Africa is considered to have a moderate wind energy potential. However, it is only in coastal areas that the winds are strong and regular enough for economical electricity generation. Even in the most favourable areas, Dutkiewicz (1986) calculated the lowest possible cost of electricity using wind would be about 50% more than Eskom's average domestic cost of electricity.

Since a cubic power relationship exists between wind velocity and available wind power the competitiveness of wind power depends strongly on wind speeds. In most inland areas of South Africa, wind speeds may be high enough for water pumping, but not for economical electricity generation. Like solar energy, wind can be exploited in areas which are remote from the electricity grid. There are parts of South Africa, near the coast, where wind energy may be an attractive option for off-grid electricity supply.

For example, Eskom has installed a wind generator at a remote school on the shores of Lake Sibaya in northern Natal. The generator charges a battery system which supplies ac electricity via an inverter. The power generated could be used for lighting, water pumping, water purification, refrigeration, school teaching aids

and for using small power tools. This installation is intended to serve as a demonstration site for future systems.

Secondary school science students have little exposure to wind energy.

The aims of the workshop, **Energy from the Wind**, are :

- To consider wind energy as a renewable energy option.
- To consider South Africa's wind energy potential.
- To introduce wind generators and to consider their suitability for providing electricity in the South African context.

This workshop begins with students considering images of wind-generators and a water-pumping windmill.

Students are required to explain the function and operation of each technology.

This discussion is followed by the teacher providing the following historical introduction:

'Historical evidence indicates that windmills for waterpumping and milling grain were being used in Persia and China over four thousand years ago. The first windmills capable of producing small amounts of electrical power electricity were built in Denmark in 1890. The extensive use of coal and oil to generate electricity reduced interest in wind power as a source of generating electricity.

During the early 1970's when oil prices rose sharply and people began to question the world's reliance on non-renewable fossil fuels, interest in wind power was again aroused. Wind energy programmes were established in most European nations and in the United States. Both private companies and governments have carried out research on wind-generators. Larger wind-generators, some capable of producing megawatts of electric power, have been installed in a number of countries. In South Africa most wind energy is used for water pumping.'

The workshop then continues with a discussion on how air pressure differences cause winds. Students are asked to consider the mechanisms of breathing where pressure differences result in the movement of air in and out of the lungs.

This activity is followed by a discussion on how topographical features and land-sea temperature contrasts give rise to localised winds.

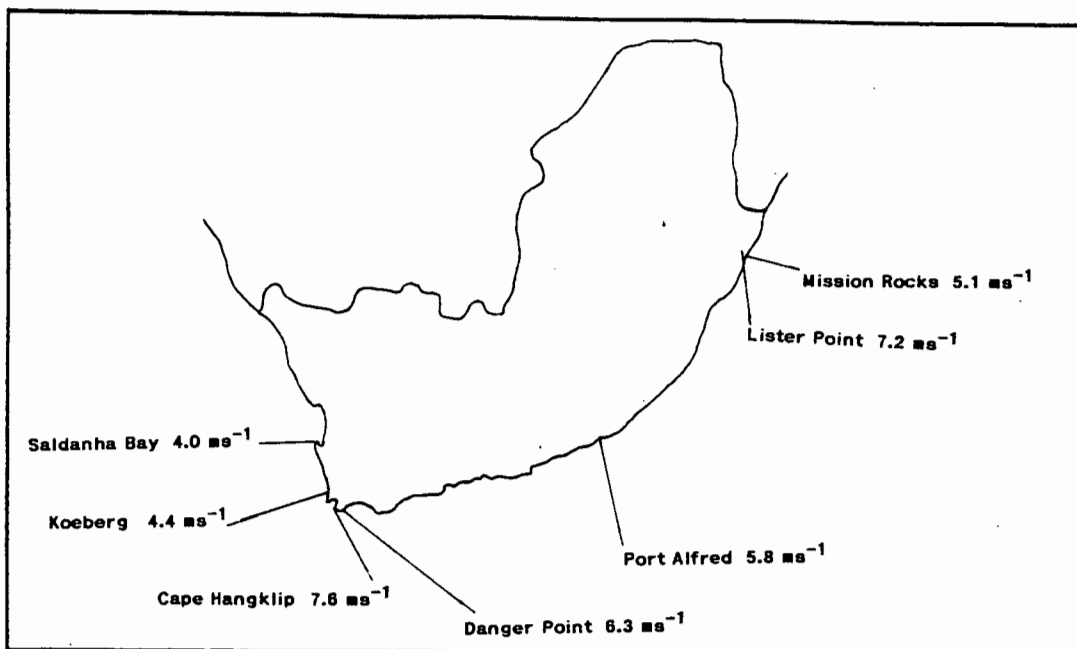

Figure 4.8 Mean annual wind speeds (ms⁻¹) normalised to 10 m above the ground. (Source: Diab,1990)

The teacher then introduces South Africa's wind resource potential. Students are required to consider the map shown in Figure 4.8 and carry out the following:

Study the map and chose three locations for siting wind turbines.

The intention of this activity is to show students that South Africa's best wind energy potential is located along the coastline.

The next section of the workshop deals with extracting energy from the wind. A discussion on this topic enables students to consider the principle of conservation of momentum and to understand why only a limited amount of available wind energy can be extracted. An explanation of why wind power is proportional to the cube of the wind speed is presented as an optional topic.

The teacher then provides an input on wind generators. The generating capacity of existing wind-generators is compared with that of Eskom's coal fired power stations and the option of wind-farms for grid connection is considered.

The provision of electricity when wind speeds are minimal is dealt with as a discussion question. Rechargeable battery systems and diesel generators are proposed as back-up electricity supply options.

As a final activity, students discuss the advantages and disadvantages of wind power.

4.5.4 Biogas – Energy from Waste

Apart from fuelwood, biomass resources include agricultural residues from crops and livestock wastes, forestry residues and urban liquid and solid wastes. Useful energy can be obtained from these resources in a variety of ways: direct combustion, pyrolysis, gasification, carbonisation, fermentation or anaerobic digestion.

Farming occurs in many of South Africa's underdeveloped rural areas where people face fuelwood shortages described in Section 4.2. The availability of a sustainable energy supply option is a prerequisite for the survival and development of communities living in such areas.

When green plants absorb sunshine the process of **photosynthesis** produces sugars such as glucose. In this process energy from the sun is used to break down carbon dioxide and water and produce complex organic molecules such as sugar. The chemical energy stored in sugar is released through respiration when the sugar molecules react with oxygen.

Some of this energy is used to convert the remaining sugar molecules to even more complex molecules as cellulose. **Cellulose** is a chain of complex molecules which are high in chemical energy. Grass contains cellulose.

Cellulose molecules have the general formula: $(C_6H_{10}O_5)_n$, where n is the number of units in the chain.

When a cow digests grass, the breaking down of the complex cellulose molecules releases energy. This energy is used to maintain a warm body temperature and to provide movement of body fluids and limbs.

However, not all the cellulose molecules are broken down by the cows' digestive system. As a result cow dung contains energy rich cellulose.

Cellulose is one of the chemicals found in vegetable, animal and human wastes that can feed the biogas production process.

Biogas is a gas that consists of a mixture of methane and carbon dioxide. These two gases are given off when bacteria convert organic waste material without air being present. This process is called anaerobic digestion.

Although the production of biogas has several complex stages, it can be represented by the following unbalanced reaction.

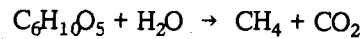

In order to make biogas, animal, human and food wastes and crop leftovers are mixed with water in a specially designed container called a digester. A typical Indian floating holder digester is shown below.

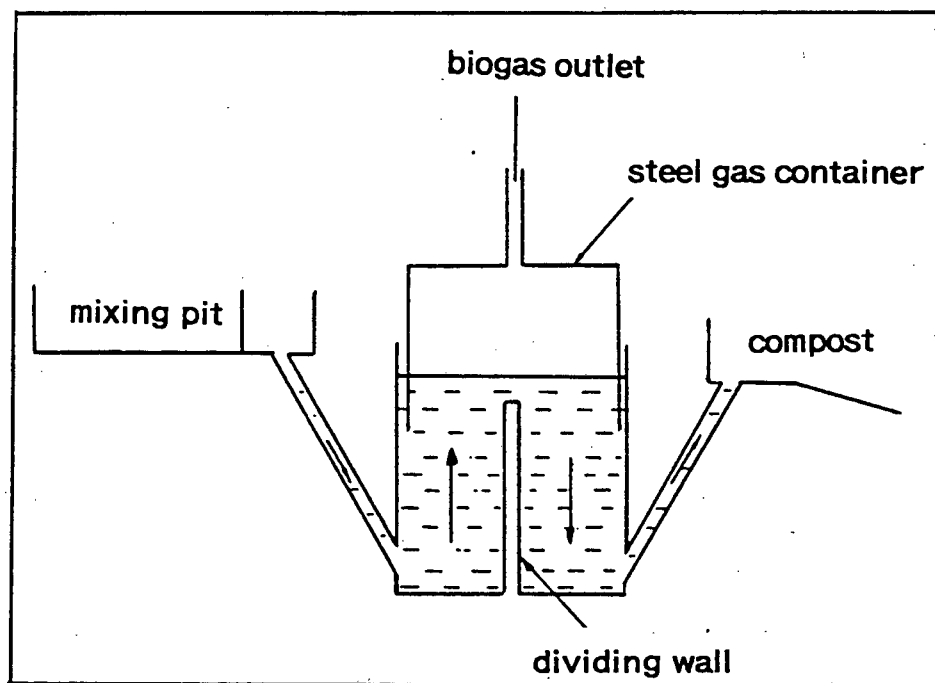

Figure 4.9 Indian Type Floating Gasholder Digester

Waste material and water are placed in the mixing pit. Gas produced is trapped by the steel gas container which floats on the waste mix. As the container is free to move up or down the gas pressure inside the container remains constant. Gas is piped from the gas outlet to where it will be needed.

The container is painted with an anti-corrosion paint to reduce rusting. Once anaerobic digestion has occurred the spent slurry is removed from the slurry channel. Spent slurry is rich in nitrogen and makes an excellent fertiliser.

Biogas production is an energy supply option that requires consideration in areas where suitable conditions exist. Such conditions include the availability of sufficient organic waste materials, water, temperatures between 20°C and 30°C and a willing community.

Gas produced in biogas digester plants can be used directly for cooking, heating and lighting in the home, or for powering combustion engines and generating electricity. Three countries have installed a large number of biogas digesters. Kristoferson and Bokalders(1987:100) provide the following digester numbers: China (7-8) million; India (100 000) and South Korea (29 000).

Biogas production processes are dependent on a number of factors. These include digester size, ambient temperature, water mixing, carbon to nitrogen ratio and fermentation times. Although the technology itself is simple the optimisation of the gas yield requires careful planning.

Law(1990:175) states that apart from individual attempts by a few farmers, biogas activity in South Africa is almost non-existent. Within South Africa's neighbouring countries a number of biogas programmes are in operation. These programmes have been reviewed in Rivett Carnac(1982); Williams and Eberhard(1986) and Law(1990). Law's review of the UNESCO/FAO funded Lesotho biogas dissemination programme provides some indication of the suitability of Biogas as a domestic supply option in South Africa's underdeveloped areas. Of the 28 digesters surveyed in 1988, 16 were inoperative supposedly due to improper handling, lack of maintenance, lack of time for running the digesters and a lack of basic information regarding the operating principles of biogas.

Citing the following problems Lesotho's Department of Energy has advised against the active promotion of biogas(Law 1990:178).

- Biogas shows no clear economic benefit for users since construction costs are fairly high and alternative fuel sources are generally cheaper.
- Many of Lesotho's rural population do not own enough livestock to adequately run a digester. Cattle are also not always kraaled making dung collection difficult.
- Many rural villages have inadequate water supplies.

- Low winter temperatures, particularly in the highlands, mean low gas production rates or sophisticated heating systems.

Problems such as these need to be overcome before biogas can be regarded as a suitable energy supply option in rural areas. In areas where suitable conditions prevail appropriate biogas dissemination strategies would need to be adopted.

As an energy theme Biogas provides a platform for integrating topics from biology (anaerobic respiration), chemistry (chemical reactions of biogas digestion) and technology (digesters). When considering the advantages/disadvantages of biogas as an energy supply option students need to consider the social environment into which the biogas technology is implemented. This approach promotes an understanding of the links between technology, community development and community decision making.

The workshop, **Biogas Energy from Waste**, focuses on the production and use of biogas as an energy supply option.

Biogas – Energy from Waste has the following aims:

- To introduce aspects of the fuelwood crisis that exists in South Africa's underdeveloped rural areas.
- To discuss problems related to a diminishing fuelwood supply.
- To discuss the need for an alternative energy supply option.
- To present biogas as an option for rural domestic energy supply.
- To introduce aspects of the chemistry and technology of biogas formation.

This workshop begins with the overview of the prevailing fuelwood crisis in rural areas which has been dealt with in Section 4.2. This is followed by teacher input on the chemistry of biogas production.

'When green plants absorb sunshine the process of **photosynthesis** produces sugars such as glucose. In this process, energy from the sun is used to break down carbon dioxide and water and produce complex organic molecules such as sugar. The chemical energy stored in sugar is released through respiration when the sugar molecules react with oxygen.

Some of this energy is used to convert the remaining sugar molecules to even more complex molecules as cellulose. **Cellulose** is a chain of complex molecules which are high in chemical energy. Grass contains cellulose.

Cellulose molecules have the general formula: $(C_6H_{10}O_5)_n$, where n is the number of units in the chain.

When a cow digests grass, the breaking down of the complex cellulose molecules releases energy. This energy is used to maintain a warm body temperature and to provide movement of body fluids and limbs.

However, not all the cellulose molecules are broken down by the cow's digestive system. As a result cow dung contains energy rich **cellulose**.

Cellulose is one of the chemicals found in vegetable, animal and human wastes that can feed the biogas production process.

Biogas is a gas that consists of a mixture of **methane** and **carbon dioxide**. These two gases are given off when bacteria converts organic waste material without air being present. This process is called **anaerobic digestion**.

Although the production of biogas has several complex stages, it can be represented by the following unbalanced reaction.



In order to make biogas, animal, human and food wastes and crop leftovers are mixed with water in a specially designed container called a **digester**.

Students are shown an illustration (Figure 4.9) of a Floating Gas Holder plant being loaded. Using this illustration the teacher introduces the different components of a digester plant.

After this a more detailed analysis of factors affecting biogas production rates is presented by the teacher. Biogas plant designers must be aware of these factors which include: temperature, retention times, water mixing and carbon:nitrogen ratio.

Bacterial activity is sensitive to temperature. Production of biogas is greatest when temperatures are high and uniform, (eg 33°C). Simple biogas digesters are best suited to operate in warm tropical regions. At latitudes of greater than 20°, winter gas production generally falls to less than half summer production.

Information regarding temperature sensitivity of bacterial activity transferable to other processes which involve bacterial activity such as production of cheese, wine and organic fertilizers.

FLOATING GAS HOLDER INDIAN BIOGAS PLANT

The Indian biogas programme has been vigorously promoted. There are around 120 000 digestors in operation and the programme is continuing.

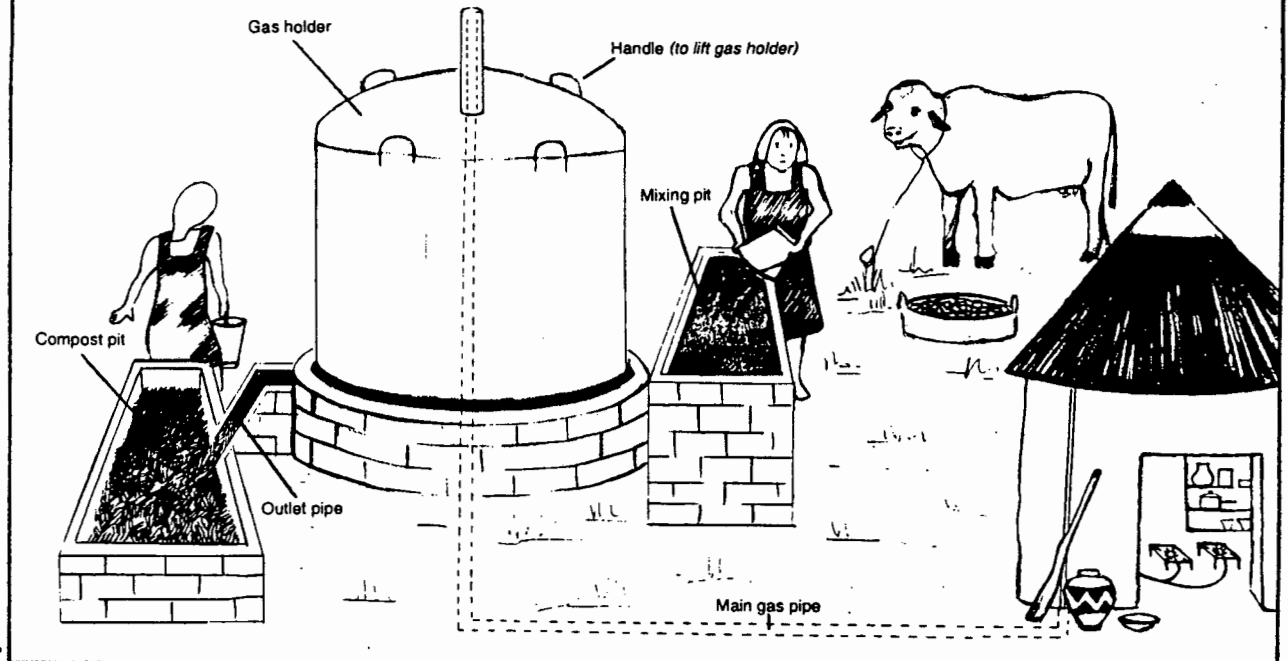

Figure 4.10 Floating Gas Holder plant being loaded

Students are required to discuss whether South Africa's winter temperatures are warm enough to support biogas production and consider ways of overcoming the problem of low temperatures.

The length of time for which waste is left to digest is called retention time. The longer the retention time, the greater the volume of gas that is produced.

As an exercise students are given the graph (Figure 4.11) showing biogas yield vs retention time.

Students are required to compare the biogas yield for 1kg of cow dung at a digester temperature of 20° C and a retention time of 30 days with the biogas yield at a digester temperature of 33° C and a retention time of 100 days. This exercise demonstrates how three variables can be graphically represented and requires that students acquire practical experience in interpreting a graph.

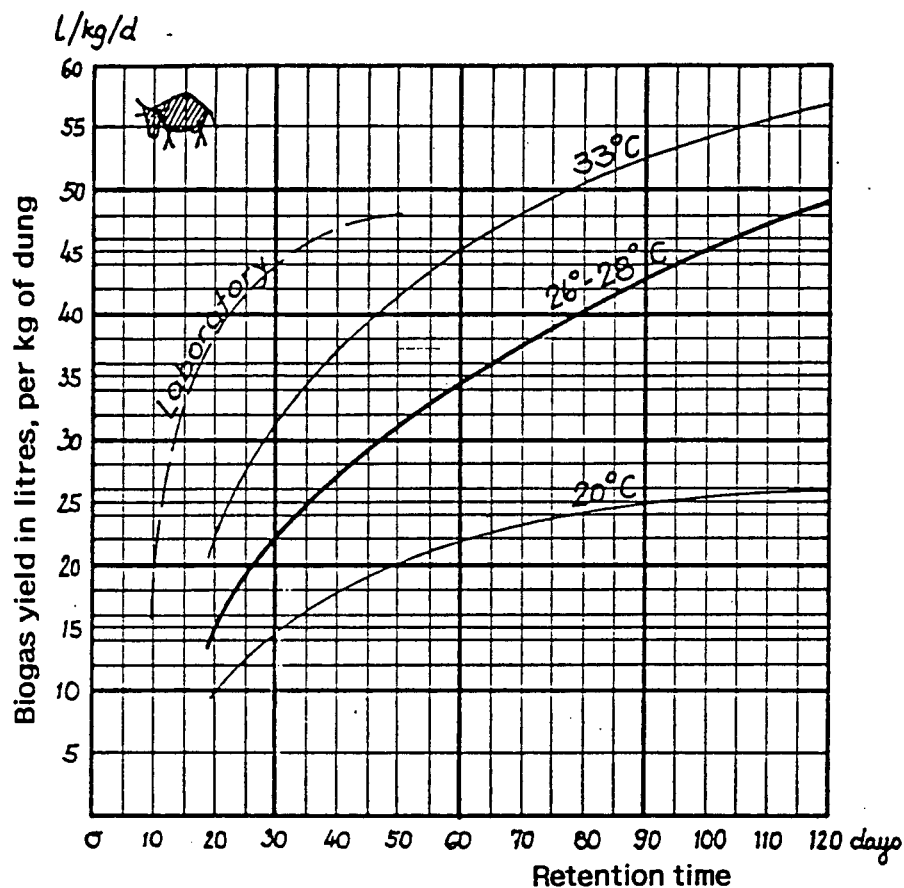

Figure 4.11 Biogas yield vs retention time (Source: Sasse,1984:20)

By adding water to organic waste, the waste mixture is turned into a slurry. This makes it easier for bacteria to come into contact with the feed material which increases digestion and hence biogas production. Cow dung is mixed in a 1:1 ratio with water. If the cow dung is fresh less water is needed as fresh dung contains 86 % water. The total amount of water depends on the quantity of dry waste that is added. Thus the water per quantity of gas produced will depend on other factors which affect biogas production rates such as temperatures, retention times, amount and nature of the fermentation slurry. Under good operating conditions 45 kg of wet cow dung or 5 kg of dry dung plus 5 liter of water would be needed to produce a daily volume of 2-3 m³ of gas. This amount would provide for the domestic needs of a family of five people.

As a discussion question students are required to consider problems the water requirements of biogas production would pose for people living in rural areas.

This exercise could be extended to include an analysis of rainfall patterns and water storage systems.

All living organisms need nitrogen with which to form proteins. Carbon and nitrogen need to be present in the diet in the correct proportions. If there is too little nitrogen, the bacteria will be unable to use all the carbon and the process of breaking down the waste matter will be inefficient. If there is too much nitrogen, it accumulates as ammonia (NH_3) which can kill methane producing bacteria. The optimum C:N ratio is between 20–30 to 1.

The C:N ratios for some organic waste material are given in Table 4.3.

Type of waste	C:N ratio
cattle dung	25
pig manure	13
sheep manure	30
horse manure	25
poultry manure	5
human excrement	8
straw	70
grass	35

Table 4.3 C:N ratios for different organic waste types

Students are required to list mixtures that would have suitable C:N ratios. For example, pig manure and grass.

This exercise exposes students to the concept of ratio and proportion. Students who have encountered ratios in the mathematics classroom will realise that abstract mathematical principles have useful applications.

A discussion on the suitability of biogas as a domestic energy supply option in South Africa offers students and teachers the opportunity to consider the impacts of new technologies on communities.

To facilitate such discussion the following role-play is used.

Three students are chosen to be engineers working for a government development agency promoting the use of biogas in rural areas.

Three other students are chosen to be representatives of a Village Management Board. These students are asked to take a conservative position, resisting social change.

The development engineers must present an argument supporting biogas as a suitable energy supply option while the Management Board members raise problems.

Development engineers must explain:

- what biogas is,
- how biogas is made,
- how it can be used,
- costs of building a biogas digester (approximately R3000 for a domestic plant),
- cost of buying cast iron cookers (about R40 each) - people must buy their own cookers and any other appliances they might need.

The Village Management Board should consider and question the engineers on problems and disadvantages of using biogas.

Some points to be considered include:

- producing and collecting enough waste to generate enough gas
- climatic conditions,
- people's resistance to change,
- people's resistance to outsiders, interference,
- people's energy needs,
- technical skills training -who will provide these ?
- availability of waste materials,
- availability of water for mixing.

The purpose of this role-play is to get students to consider dangers of implementing a technological 'quick-fix' solution to development problems and to show that Community needs and concerns need to be integrated into any development strategy.

The workshop ends with a recommended essay topic and a practical exercise requiring students to construct their own model digester.

In conclusion, this workshop gives students the opportunity to consider the complex interaction of many variables in the biogas production process. This counteracts prevailing reductionist tendencies in science education which isolate variables, focus on abstract laws and hence lose sight of the broader more complex situation.

4.6 Closure

The workshops have been designed as individual units that can be presented separately. Each workshop comprises a teacher's guide and a student worksheet. The student worksheets summarise the workshop content and contain questions for the student to answer. It is left up to the teacher to decide when to distribute the student worksheets.

These workshops have not been designed for presentation in any particular standard. The teacher best knows the abilities of the classes he/she teaches and can therefore decide the workshop target audience. Recommendations are made where topics are syllabus linked.

Energy topics from which the nine energy workshops were derived have been reviewed in this chapter. Each workshop theme has been selected from three broader topics, namely energy in society, electrification issues and renewable energy options. Each of the selected themes promotes an awareness of energy issues and technologies relevant to the South African situation.

The contents of the workshop package is included as Appendix 1. To facilitate easy photocopying the materials were packaged in a ring-file. The teachers' guides and student worksheets were printed on different coloured paper for easy identification.

The comments provided by the teachers and student teachers served as indicators for further refining of the workshops, and are presented in Chapter 5.

Chapter 5

TEACHER COMMENTS ON DRAFT ENERGY WORKSHOP PACKAGE

As an evaluation exercise a draft version of the Energy Education Package was presented to a group of interested teachers and to Physical Science method UCT student teachers for comment.

Teachers and student teachers were asked to complete two Package Evaluation Sheets, one on the whole package and one on an individual workshop.

The aim of this evaluation exercise was to obtain opinions on a number of issues relating to the Energy Education Package. These included: support for project aims, selection of energy as a theme, developing non-syllabus based materials, teaching methodology, design of workshops and implementation of the workshops in the classroom.

Eight teachers from different schools and twenty student teachers from Department of Education, University of Cape Town, participated in this stage of the evaluation process.

The Package Evaluation Sheets are included as Appendix 2.

5.1 Comments on Package Aims

Teachers and student teachers were required to read through the aims of the package and explain whether they supported these aims.

All the teachers and student teachers involved in this evaluation exercise supported the project aims as explained in the introduction.

In particular respondents supported the aim of linking science to students' everyday lives and hence presenting science in a context that is relevant to students. Also energy was considered a useful topic to achieve this aim as energy issues affect every one.

Question:

Read through the aims of this project relating to the promotion of scientific and technological awareness. Do you support these aims ? Explain your answer.

A selection of responses include:

Yes, the aims of this project are to be supported in every respect especially by a science teacher. Science is often regarded as boring to the majority of pupils, not only do the aims of this project create an image of interest in the subject, but they also prove beyond doubt that science is essential and of course very interesting to debate about.

Yes, Pupils learn about energy in isolation as if it were 'out there' . Most pupils see technology as part of 'another world' and do not realise what they have in their homes. The way this approach brings the science of technology to the pupil would bring the pupil closer to science and technology.

Yes, these are realistic aims. A difficult topic – These clear concise aims are reflected throughout the modules. I particularly like the focus on issues relevant to students' needs as citizens and the promotion of interest in consumer issues.

Students are more likely to apply themselves to a subject that they see as relevant to their lives – particularly in schools in township areas where students do not see much relevance in syllabi taught.

Yes, the problems associated with energy concern every one of us and students need to be made aware of and to participate in the problem of solving the crisis our energy supply and environment is in.

Yes! In this technological age we tend to take everything for granted and forget where our basic sources of energy come from. We use sources of energy everyday and thus it needs to be linked up with science in the classroom.

Yes, in the past science at secondary level was not really related to the world in which pupils lived. It was something difficult to grasp/internalise since it had nothing to do with them or the community. This way they can take science home with them.

Yes I do –in fact I think all of science should be taught with these aims in mind. Science is not an abstract academic activity, but a highly relevant aspect which permeates our everyday lives.

Yes, it seems that these workshops bring science into everyday life as opposed to holding it aloof. It also has the so called 'holistic approach' with respect to geography and biology.

Yes, I think it is important to have education about energy saving in particular. It also serves to link science with a purpose for society as a whole.

Yes, in an increasingly 3rd world context it is extremely important to contextualise science education properly.

5.2 Comments on the methodological approach

The methodological approach proposed in this project encourages classroom dialogue and student participation in the learning process. Given that teachers have their own teaching styles and are often reluctant to apply new methods I considered teacher comments on the proposed methodology important. Most respondents supported the proposed approach claiming that it would enhance the learning process.

Concerns relating to the ability of students to participate in activities such as group discussions and role-plays raise an important issue. Students exposed to talk and chalk methodologies which have rendered them passive learners might find it difficult to participate in discussion activities. Clearly, a teaching methodology which proposes active student involvement relies on both teachers and students possessing the confidence and skills required for active participation. Teachers have to be prepared to practise and experiment in developing these skills. These workshops provide teachers with opportunities to implement interactive teaching methods.

Teachers were asked to comment on the following:

Question:

These workshops have been designed to be presented in a way which contextualises science, draws on the everyday experiences of students, and encourages dialogue and student participation in the classroom. Comment on this teaching methodology.

The way in which the workshops are designed is to be commended. It is really nice to see discussion questions where students participate actively in the lessons.

This is what science is all about, it is an experience, therefore I fully agree with the way the workshops have been designed.

Good approach but needs to be more student centred in the area of jargon and concept.

The approach is good. Pupils who are not scientifically inclined can learn things that may have an effect on their own lives. In other words, "it is not just physics for physicists" but "physics for the people."

This approach is excellent for facilitating learning and should be used in all teaching as far as possible.

I feel that in order to learn science one has to 'live' science and only way to do so is to take part in such discussions and workshops.

Very good. The more you draw on what the students knows, the more effective the teaching will be. There could be more discovery involved, not merely supplying the terms for a scientific result.

Ideal obviously the best way of teaching science.

This method should have been implemented a long time ago, workshops encourage student participation and forces an awareness by students on subject matter.

One other thing that makes science difficult and often boring to some students is that they (students) tend to regard it as foreign to their experiences. They usually see very little link between the subject matter and their every day experiences and this even more so to underprivileged ones. So to draw topics that they are certainly familiar with(at their homes) would be to their best interest.

Pupils can identify with the material presented to them. It evokes some sense of ownership which tends to stimulate interest and research. This approach easily lends itself to project work which in its essence spells out pupil participation. Pupils could be given various projects to mastermind their own projects which could improve the self image. When pupils feel important, in control of their own situation, they tend to perform better.

An excellent approach. Students learn more easily if the material is contextualised and based on everyday experiences. Student participation has proved a more effective learning/teaching method than 'show and tell'. The method used in the workshops makes 'energy' a very 'real'.

Respondents were then asked to explain problems they might have with this style of presentation.

Question:

Do you foresee difficulties with this style of presentation ? Explain.

Comments provided include:

No, not at all. In fact encouraging dialogue as a science teaching method in my opinion is still not used by many people and yet it could prove very useful and would produce excellent outcomes. Students have proved to gain a lot more among themselves than from the teacher.

For me - no. Most of my teaching currently is centred around the everyday phenomena.

None, More project work should be considered- pupil finds own information/devises own alternative forms of energy.

Only problems I can see could be at schools where discipline isn't good enough for this sort of informal discussion lesson- but maybe once pupils get interested it would work. Other problem would be if the teacher is not confident enough to present this type of lesson.

No. But perhaps it will be difficult for me who knows nothing about geography to teach eg Energy from the Wind. This approach encourages pupils to participate and will take pressure off the teacher.

I foresee no difficulties at all. To go through the whole package throughout the course of the year, time will have to be well managed.

Student apathy - "it's not for exams".

The time factor. Many schools have periods of 35 minutes each. The approach is essentially good.'

Pupils who are not used to such involvement are often reticent to provide answers and struggle to think creatively. All the more reason for using this approach.

One would have to know the situation in the school before starting.

Pupil attitude - "The pupils sometimes feel that worksheets are a cop-out on your (the teacher's) part, because you don't do any work."

Only the time factor, it would be nice to do as many as possible but this will be difficult.

Personally, I find this approach very effective depending on its implementation.

5.3 Comments on the selection of energy as a theme

Since the package is not syllabus-based, implementation of workshops is at the discretion of individual teachers. It was therefore important that teachers provided their view on the selection of energy as a central theme. All respondents considered energy to be a useful and relevant theme.

Question:

Comment on the selection of energy as a central theme.

A selection of responses include:

Energy is a theme that can be relevant to many school subjects and with food and water is one of the necessities of life.

Alternative sources of energy are particularly useful to the geography syllabus. None are irrelevant.

It is a very important theme, and relates to so many aspects of our lives - it is a good choice.

I think this is a great idea as it will keep the pupils constantly aware of energy throughout the year. In doing so they will be able to relate it to their science ; biology; geography.

Vital, good and a launch pad for important scientific debate.

Energy affects everyone and the environment in a tangible way.

A good choice as it has many aspects, many links with the syllabus and is also a very topical issue.

Energy is part of our everyday lives.

Very good, because of its relevance, and its variety and scope into everyday life.

Energy is relevant. Students can identify with the theme. Prior knowledge of theme could be strengthened and misconceptions rectified.

The next question was also linked to teachers' perception of energy as a theme.

Question:

Comment on the selection of energy topics on which the workshops have been developed. Are there any which you feel particularly useful or irrelevant? Explain your answer.

One that I felt was of utmost importance is the one about electricity cost in homes and analysing electrical bills although I felt that suited a small percentage of pupils if you take it to the South African context.

None are irrelevant. Good selection of topics. Looking at it from the point of view of the teacher needing to convince other teachers of the relevance of lessons like this:

- Electricity costs in Homes fits in with the Std 7 General science.
- Atmosphere of uncertainty could also be brought into Std 8 Biology for better students- shows that the study of ecology needs inputs from other subjects. Also a good topic to remind students of physical science to be aware of the consequences of their actions.

Alternative sources of energy are particularly useful to the geography syllabus. None are irrelevant.

Something like Biogas is great for rural students with minimal electricity- if the option is available.

Which the exception of solar building design, all the others are relevant. Solar building design is a very specialised area and does not (my opinion) have relevance to a more general awareness.

They all look relevant and useful.

I think that they are all extremely useful.

They are all useful.

I think each and everyone of them are useful.

Comments on the usefulness/relevance of individual workshop themes provided further information regarding teachers' view on the relevance of energy as a theme.

Electricity Costs in our Homes:

I think the workshop is very relevant to the world in which we live. It will be particularly useful to those students who come from a less fortunate/underprivileged background. They could even educate their parents on how to reduce financial burdens.

Quite interesting - quite fun to do

Living Without Electricity:

Very relevant - Large percentage of population without electricity.

How many pupils could identify with it however ?

Very relevant in DET/rural situations ?

Energy from the wind:

Very much a relevant topic in energy. Very useful, too in many aspects of subjects (biology, geography, etc)

Energy sources in South Africa:

Very relevant. Useful in making students consider the seriousness of the subject.

5.4 The issue of non-syllabus based workshops

The next issue on which teachers and student teachers were asked to comment was the issue of the Energy Education Package being non-syllabus based. Would teachers be prepared to present workshops not directly syllabus based? Responses to this question also provided insight into teachers' perceptions of existing syllabi in relation to the content of the energy workshops.

The main concern raised by respondents was that of time. Given that teachers struggle to complete the prescribed syllabus teachers felt that not enough time would be available to teach additional materials.

However, a number of respondents felt the value of the Energy Education Package warranted presentation in the classroom despite not being directly syllabus based. Some respondents considered the workshops to be relevant to the syllabus and therefore worthy of implementation.

Question:

These workshops are not directly syllabus based. Do you see this as problematic ? Explain.

A selection of comments include:

An answer would be a big 'NO' as we have seen in our past experiences that science is often regarded as a difficult and often boring concept by a lot of pupils. This is largely because of textbook copying teaching which tend to concentrate on syllabus and hence tends to be abstract to the pupil.

Who are we trying to serve? A board which provided us with a 'syllabus' or a child who has to become a productive, responsible member of his/her community ? I've been 'out of bounds' for a very long time – covering what is required in a different – more relevant way. No problem !

Yes, especially near the end of the year or in schools where they lose lesson time because of stay-aways etc. However, if workshops are planned to fit into years work from the beginning of the years it shouldn't be a problem in most schools.

Yes, time is limited and the syllabus leaves very little time for 'additional' material. This material is relevant to the syllabus–some reshuffling of time is needed to fit it in.

Not problematic – because they are, as you know, indirectly linked to the syllabus.

No, The topics can be included in many areas of the syllabus (Energy, power etc in Std 7 for example) They will interest the pupils and be profitable in terms of linking subject matter.

Definitely not! "Energy is what we encounter in our daily life. Surely we must know as much about it as possible. I think it should be incorporated in the syllabus. If it is not possible, it should still be taught."

In a way , Yes–Time. Teachers are hard pressed to cover the syllabus and will be reticent to give up class time to a topic which is not syllabus based. However I believe that this situation is not actually correct and the teacher should be able to take pupils outside the syllabus. Another problem is that pupils often do not take work seriously that is not for marks!

Yes! The students get examined on what is in the syllabus! Despite this good approach, teachers do not have the time to complete all the work in the syllabus.

Yes – which teacher will set aside time in matric for non syllabus work, teachers generally reluctant because of enormous science syllabus to engage non-syllabus work.

No, as they are relevant to many sections of the syllabus.

Why stick to the syllabus ? Half of it is irrelevant anyway. The more use it has, the more interest you will get from the student.

No, it is important to include topics of direct social interest which are related to what is done.

Yes. Within schools, the allocated time for syllabus work is little. Teachers would rather use extra time to further their work as opposed to additional non-syllabus related issues.

5.5 Implementing workshops in the classroom

The next issue concerned the teachers' willingness to implement the workshops in their classrooms. All respondents indicated a willingness to present the workshops in their classrooms. The issue of time constraints was raised by a number of teachers who felt they did not have enough time to teach non-syllabus based materials. Both the relevance of energy issues and commitment to the proposed teaching methodology were cited as reasons for wanting to present the workshops.

Question:

Would you use these workshops in your classroom? Explain your answer.

Responses included:

Yes, I definitely would given the time. One thing I believe in is that students should be involved in self discovery and this could also be achieved through such workshops.

I would, maybe modify them slightly- but they are definitely useful in bringing certain 'abstract phenomena' closer to the understanding of the pupil.

Yes- makes subjects more interesting, relevant etc, Also I like to teach pupils to think critically.

Yes, if the time was there, certainly it would be difficult to do all of them.

Yes, but in a different form. They are far too daunting because of their wordiness.

Some of them yes. My teaching or aim towards science teaching is a contextual approach. These workshop issues pertain to realistic issues of today.

Yes I would. These workshops as well as the projects would stimulate interest which I feel is needed.

Yes, I like the presentation (discussions, etc) and teaching methodology. Group work is important and it is difficult for just one teacher to design such good worksheets, so they would help tremendously.

Yes, Energy is what we encounter in our daily life. Surely we must know as much about it as possible.

I would use some of them. Others that are too long I would probably leave out.

5.6 Comments on the complexity of concepts

Teachers were asked to comment on the complexity of concepts and issues presented in individual workshops.

Respondents' comments reflected on their own knowledge of the topic and how the topic was dealt with in individual workshops.

The agreement by some respondents that lessons need to draw on existing knowledge and that this makes for effective teaching supports the proposed teaching methodology. A number of respondents cautioned over the use of jargon. Also, some respondents recommended that definitions of scientific terms must be clear and related to everyday experiences.

All the workshops were considered suitable at secondary level. Respondents argued that the workshops could be adapted for a particular standard. For example, the basic principles and applications of **Solar Building Design** could be dealt with in Std 7 with the more sophisticated designs such as the Trombe-Michel Wall design covered from Stds 8-10.

One teacher commented that issues and concepts dealt with in the workshops were:

'quite straight forward and simple to read/follow. All terms/concepts are explained quite clearly which would be of great help to students who have not come across it before.'

Similarly, one respondent felt that **Energy from the Wind** is suitable for Stds 9 and 10, however if the technical questions were adjusted the issues could be presented in Stds 7 and 8.

A most useful comment referred to the need to be more student centred in the area of jargon and concept. However, the teacher best knows the level of language skills of his or her students and will have to analyse the text and concepts in terms of their suitability to the audience.

5.7 Comments on the use of illustrations

Most respondents supported the use of images in the workshops. A number of additional presentation aids were recommended, including the use of videos, slides and overhead projector transparencies.

Positive comments on the layout of individual workshops included, 'very clear, good, neat, nicely highlighted and fine.' However, a strong appeal was made for the greater use of more illustrations and drawings particularly in sections which respondents found 'quite heavy going'. One respondent comments, 'For the lower standards, I think there are too many words, they may lose interest. Words may "turn them off".'

Chapter 6

CONCLUSIONS

6.1 Package Evaluation

The feedback provided in the comment sheets was extremely positive and useful. Respondents showed encouraging support for the package as a whole and the selection of individual workshop themes. Strong support for the teaching methodology was also obtained. Suggestions were considered and appropriate changes made to individual workshops.

The success of any education materials development initiative depends on the commitment and willingness of the teacher to implement the materials in the classroom. Teachers who participated in the evaluation of the materials were motivated and had the confidence and subject knowledge to implement new materials.

The majority of science teachers currently teaching in South Africa have received their training at training colleges where subject course content does not extend beyond the school syllabus. I doubt whether these teachers would have the subject knowledge to deal with extra-syllabus topics such as those dealt with in the workshop package. However, the aim of the structured teacher's guides is to inform and motivate teachers who feel under-prepared and lack the confidence to present the workshops.

Measuring the success of an educational innovation such as the Energy Workshop Package is complex and difficult. Indicators such as the comments given by teachers in Chapter 5 can only be used as an initial guide to the success of a project such as this. However, the approach taken in this project sees educational materials development as an ongoing process where evaluation occurs as an integral part of the development process rather than as a sequel to it. The package will accordingly require additional updating and revision as further feedback from users is obtained. These further revisions of the package, however, extend beyond the academic component of this project.

6.2 Education Methodology

The constructivist learning approach presented in Chapter 2 emphasises that new understandings and skills are constructed on existing knowledge. Before new concepts can be introduced teachers need to secure insight into students' existing knowledge. Such insight will influence the level and way in which the teacher makes his/her presentation.

This project proposes that Freire's codification method is suitable for stimulating classroom dialogue and hence gaining insight into student's existing knowledge. These workshops have been designed to include 'codes' which can be used to initiate classroom dialogue. Sections of the workshops designated as 'Teacher Input' might be viewed as promoting the 'banking' or transmission approach which sees the teacher role as depositing new knowledge. However, I believe that the constructivist approach can include 'Teacher Input' as long as such delivery builds on existing knowledge or, in Vygotskian terms, occurs within the ZPD.

A side aim of this project is to encourage teachers to reflect critically on their own teaching methods. When teachers present the workshops there is no guarantee that they will follow the prescribed format. Teachers have a right to be selective and use the workshops in a manner which suits their teaching style. I hope however that teachers find classroom dialogue useful and see its educational advantages over the dominant monological talk-and-chalk approach. Teachers who feel confident about their own teaching style will be reluctant to change teaching styles.

6.3 Package Distribution

Since this project was independently initiated rather than a response to an expressed teacher need, getting teachers to implement the package is a difficult task. Ideally a strategy aimed at marketing the package, including the interactive teaching approach and energy as a relevant school topic is needed. This is however beyond the budget and brief of this project.

Given that the CER budget allows for only fifty packages to be printed, the challenge of reaching the maximum number of teachers arises. I decided to distribute the package to teacher resource centres and training institutions where the package would be exposed to the greatest number of teachers. The package introduction and teachers' guides should be seen as 'bait' serving to

motivate the need for education on energy issues and hence entice teachers into reading the package and ultimately presenting it in their classrooms.

Teachers have a role in marketing this package to their students. Student perceptions need to be considered; even more than teachers, students are focused on the syllabus and year-end examinations. This is particularly true in schools where teachers do not manage to complete the prescribed syllabus.

Another factor influencing teachers' willingness to implement the package involves the issue of non-syllabus content. Teachers who are examination-focused might perceive the package as a waste of time. The concept of optional topics selected by the teacher and examined internally within the school would allow the workshop package to become part of the official syllabus.

6.4 Closure

The success of this project also needs to be seen in terms of the crisis currently facing South African education as a whole and science education in particular. The crisis reaches beyond the generally accepted problems of inadequate teacher training, large class sizes, limited laboratory resources and heavy teaching loads. The ethos of teaching and learning eroded during decades of apartheid rule has to be rebuilt within the framework of a publicly acceptable and accountable science education policy.

Teachers in particular need to be part of the process of reconstruction. As a teacher this project is my contribution to this process. Perhaps this project will serve as a challenge to other teachers to be pro-active and make their contribution to the arduous task of formulating and implementing a new science education policy.

LIST OF REFERENCES

- Aronowitz, S and Giroux, H (1991). *Postmodern Education – Politics, Culture and Social Criticism*. University of Minnesota Press, Minneapolis.
- Aron, J, Eberhard, A and Gandar, M (1989). Demand and Supply of firewood in the Homelands of South Africa. Second Carnegie Inquiry into Poverty and Development In Southern Africa, Conference Series No.21.
- Borchers, M and Eberhard, A (1991). Household energy supply and price trends. Report prepared for National Energy Council by Energy for Research and Development Centre, University of Cape Town.
- Bosman, HH (1990). The impact of atmospheric sulphate deposition on surface water quality within the Eastern Transvaal Highveld. 1st IUAPPA Regional Conference, Pretoria, October 1990.
- Diab, R (1990). Wind Energy in South Africa. *South African Association of Atmosphere Sciences*, Newsletter No 11, March 1990.
- Dingley, CE (1988). The Need for Electrification. Interim Report No 1, Dept. of Electrical and Electronic Engineering, University of Cape Town.
- Dingley, CE (1990). Electricity for all in South Africa: The Need and the Means. Dept. of Electrical and Electronic Engineering, University of Cape Town.
- Driver, R and Millar, R (1986). Teaching Energy in Schools: Towards an analysis of curriculum approaches. In *Energy Matters*, Driver, R and Millar, R, (Eds), University of Leeds.
- Dutkiewicz, R (1986). Wind energy potential in South Africa. In *Renewable Energy Potential in Southern Africa*, Williams A and Eberhard A (Eds), Energy Research Institute, University of Cape Town.
- Eberhard, A (1984). Energy and poverty in urban areas and peri-urban areas around Cape Town. Second Carnegie Inquiry into Poverty and Development in Southern Africa, Conference Paper No.155, SALDRU, University of Cape Town.
- Eberhard, A (1986). South African Energy Crisis: Some Suggested Strategies. Second Carnegie Inquiry into Poverty and Development in Southern Africa, Post-Conference Series No.13, SALDRU, University of Cape Town.
- Els, C J (1990): Eastern Transvaal Highveld: Air Pollution scenarios and control Strategies. Conference of the National Association of Clean Air: Charting a course for the 90's, Cape Town.
- Eskom Perspective* (1993). Eskom, Sandton.
- Eskom Annual Report* (1993). Eskom, Sandton.
- Freire, P (1972). *Pedagogy of the Oppressed*. Penguin, Harmondsworth.
- Freire, P (1976). A few notions about the word conscientisation. In *Schooling and Capitalism*, (Eds) Dale, R, Esland, G and Macdonald, M, Roulledge and Kegan Paul, London.

- Freire, P (1978). *Pedagogy in Progress*. Writers and Readers Publishing Co-operative, London.
- Freire, P (1985). *The Politics of Education*. Macmillan, London.
- Gandar, MV (1984). *The Poor Man's Energy Crisis: Domestic energy in Kwazulu. Second Carnegie Inquiry into Poverty and Development in Southern Africa, Conference Paper No.156, SALDRU, University of Cape Town.*
- Gandar, MV (1993). *Woodlot management and afforestation. Paper 9, A review of the South African Energy Policy Research and Training Project, Energy for Development Research Centre, University of Cape Town.*
- Gebhardt, E (1987). *A Critique of Methodology. In The Essential Frankfurt School Reader, (Eds) Aroto, A and Gebhardt, E, Basil Blackwell, London.*
- Horkheimer, M (1972). *The Latest Attacks on Metaphysics in Critical Theory: Selected Essays*. Herder & Herder, New York.
- Hunt, A (1988). *SATIS approaches to Science Education. International Journal of Science Education, Vol 10, No 4.*
- Kell, C (1989). *Developing the Unity of Research, Teaching and Extension Service Work in a Resources Project at the University of Cape Town. Paper delivered at Conference on 'Economic Change, Social Conflict and Education in Apartheid South Africa.' held at Grantham, Essex, UK, 29-31 March 1989, hosted by Research on Education in South Africa (RESA).*
- Kristoferson, LA & Bokalders, V (1987). *Renewable Energy Technologies - Their Applications in Developing Countries*. Pergamon Press, Oxford, UK.
- Law, S (1990). *A review of appropriate energy technologies for household use in undeveloped areas in Southern Africa. MSc thesis, Energy Research Institute, University of Cape Town.*
- Millar, R (1989). *Constructive criticisms. International Journal of Science Education, Vol 11, Special Issue.*
- Moll, IC (1989). *Roots and disputes of cognitive development conceptions of teaching. South African Journal of Education, Vol 9, No 4.*
- Prinsloo, M (1987). *Conscientisation and Praxis: Paulo runs into trouble. Paper delivered at Kenton Conference, Salt Rock, November 1987.*
- Rivett-Carnac, JL (1979). *A strategy for electrification of the black townships in and around Durban and its impact on the energy situation in South Africa. Urban Foundation, Durban.*
- Rivett-Carnac, JL (1982). *Biogas - A literature Review*. Institute of Natural Resources, University of Natal, Pietermaritzburg.
- Theron, P (1991). *Public and private sector involvement in the provision of electricity in urban areas of South Africa. MSc Thesis, Energy for Development Research Centre, University of Cape Town.*
- Sasse, L (1984). *Biogas Plants: Design and Details of Simple Biogas Plants*. Friedr. Vieweg & Sohn Verlagsgesellschaft mbH, Braunschweig, Germany.
- Science in a Social Context (1983). *Series of books plus Teacher's Guide*. Association of Science Education, UK.

- Science in Society (1981). Series of readers and Teacher's Guide. Heinemann Educational Books/Association of Science Education, UK.
- Skovsmose, O (1985). Mathematical Education versus Critical Education. In *Is Mathematics Teaching Neutral?* The Murray Trust Mathematics Fellowship, Faculty of Education, University of Cape Town.
- Solomon, J (1991). Teaching about the Nature of the Science in the British National Curriculum. *Science Education*, Vol 75, No 1.
- Stassen, G (1986). Die Regering se rol in die ontwikkeling en implementering van alternatiewe hernubare energiebronne in Suid Afrika. M Phil Thesis, Rand Afrikaans University, Johannesburg.
- Terblanche, APS, Opperman, L, Nel, CME, Reinach, SG, Tosen, G and Cadman, A(1992). Preliminary results of exposure measurements and health effects of the Vaal Triangle Air Pollution Health Study. *South African Medical Journal*, 81, 550-556.
- Tyson, PD, Kruger, FJ and Louw, CW (1988). Atmospheric pollution and its implications in the Eastern Transvaal Highveld. Report prepared under auspices of the National Programme for Weather, Climate and Atmospheric Research. South African National Scientific Programmes Report No. 150.
- Watts, M and Pope, M (1989). Thinking about thinking, learning about learning: constructivism in physics education. *Physics Education*, Vol 24, No 6.
- Wheatley, GH (1991). Constructivist perspectives on science and mathematics learning. *Science Education*, Vol 75, No 1.
- Van Horen, C (1993). Household energy and environment. Paper 16, A review of the South African Energy Policy Research and Training Project, Energy for Development Research Centre, University of Cape Town.
- Vygotsky, LS (1978). *Mind in Society*. Harvard University Press, Cambridge.
- Williams, AT (1993). Energy supply options for low-income urban households. Paper 11, A review of the South African Energy Policy Research and Training Project, Energy for Development Research Centre, University of Cape Town.
- Williams, AT and Eberhard, A (1986). An overview of biogas applications in rural Southern Africa. *Proceedings of Anaerobic Conference*, University of the Orange Free State, Bloemfontein.
- WHO (1992). Epidemiological, social and technical aspects of indoor air pollution from biomass fuels. Report of a WHO Consultation. June 1991. WHO /PEP/92.3A. Geneva.

APPENDIX 1

Energy Workshop Package

ENERGY IN CONTEXT

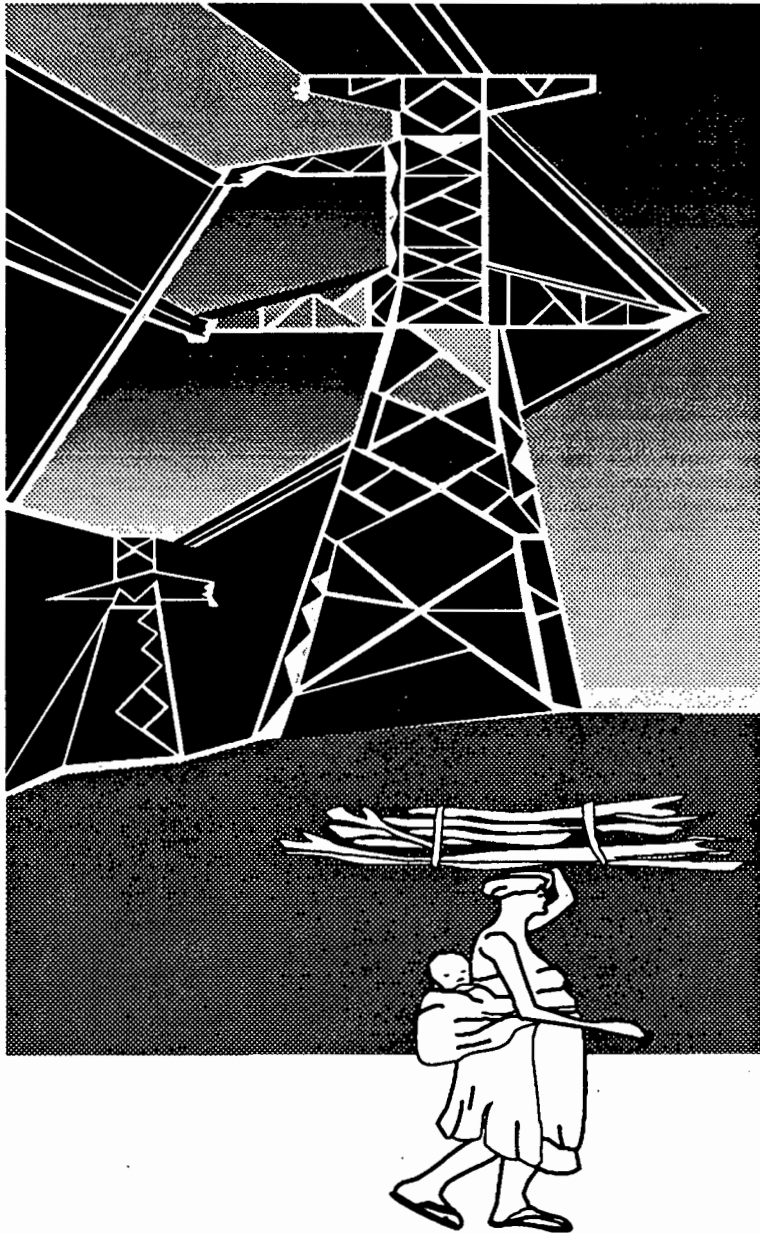

A workshop package
for secondary schools



ENERGY IN CONTEXT

A workshop package
for secondary schools

- **ENERGY IN OUR LIVES**
- **ENERGY SOURCES IN SOUTH AFRICA**
- **LIVING WITHOUT ELECTRICITY**
- **ELECTRICITY COSTS IN OUR HOMES**
- **AN ATMOSPHERE OF UNCERTAINTY – ACID RAIN**
- **ELECTRICITY FROM THE SUN**
- **ENERGY FROM THE WIND**
- **SOLAR BUILDING DESIGN**
- **BIOGAS – ENERGY FROM WASTE**

AN
ENERGY EDUCATION
WORKSHOP PACKAGE
FOR
SECONDARY SCHOOLS

PETER OXENHAM

Community Education Resources

University of Cape Town

1993

ACKNOWLEDGEMENTS

The encouragement and support of Community Education Resources students and staff is gratefully appreciated. Tim James generated titles of the illustrations and designed the cover. Acknowledgements are given to Maryanne Klein for the illustrations she drew.

A special thank you goes to Bill Cowan of Energy for Development Research Centre for his valuable comments, detailed proof-reading and support in putting this package together.

The final printing was done by Goldfields Resource Centre, University of the Western Cape.

The production of this package was supported by a grant from Community Education Resources, University of Cape Town.

All rights reserved. No part of this publication may be reproduced, stored in a retrieval system, or transmitted in any form or by any means, electronic, mechanical, photocopying, recording, or otherwise without prior written permission of the Publishers or author.

ISBN 0-7992-1538-4

THE AIMS OF THIS PACKAGE

As part of an initiative to promote scientific and technological awareness among secondary school students, this package aims to:

- present science as a human activity that shapes our lives, our environment and our material being,
- present energy production as an agent of social development,
- critically explore South Africa's renewable energy potential,
- focus on energy related issues and problems which are relevant to students' needs as citizens,
- mediate practical skills pertaining to domestic energy technologies in everyday use,
- link science to the world of work, hence, stimulating interest in science and technological careers.

PROPOSED TEACHING METHODOLOGY

The proposed teaching methodology aims to:

- encourage student participation in the learning process through discussion and role-play,
- build on knowledge and skills that students bring to the learning situation,
- broaden the science learning base beyond the textbook and laboratory situation.

Energy and the Environment

Major environmental issues of the 90's and the future are energy-linked. At present South Africa relies on coal for about 80% of its energy needs. More than 70% of South Africa's installed electrical capacity is generated within 30 000 km² of the Eastern Transvaal Highveld (ETH). Exacerbated by an unfavourable dispersion climate, areas of the ETH are believed to have acid rain levels comparable with the worst in the world.

More than half of South Africa's population lives in underdeveloped areas where wood is the principal fuel for cooking and heating. Shortages of fuelwood already exist in many areas. Over utilisation of the wood resource has resulted in deforestation and the consequential loss of protective groundcover essential for the prevention of soil erosion.

A greater public awareness of the prevailing fuelwood crisis together with related environmental, social and health problems is required. Possible strategies for solving this crisis need to be shared and debated.

Energy and Consumer Awareness

Non-electrified households rely on fuels and appliances such as candles, paraffin stoves and gas cookers. Not only are these fuels hazardous, they are generally more expensive than electricity to use.

Greater public awareness of disadvantages connected with the use of energy sources such as paraffin, wood, gas and coal could yield direct benefits for consumers. For example, incidents of shack fires, paraffin poisoning, asphyxiation could be reduced.

The concept of electricity as a commodity which is produced, sold and used needs to be promoted. An improved awareness of how to use electrical appliances more efficiently could result in financial savings for consumers. Also the impact of new technologies such the Ready Board and Pre-Payment meter on consumers needs to be debated.



Energy
in our lives

ENERGY IN OUR LIVES

BACKGROUND INFORMATION

At school students learn about different forms of energy. Pick up any Standard 7 Science textbook and you will read,

*Energy is the ability to do work.
Potential energy is energy a body has by virtue of its position.
Kinetic energy is energy a body has by virtue of its motion.*

This narrow scientific view of energy leads students to the idea that energy is removed from our lives. Students need to be presented with a wider view of energy. They need to know more about energy in their lives and societies. As citizens and possibly future scientists, students need to explore and understand links between science, technology and society.

THIS WORKSHOP HAS THE FOLLOWING AIMS:

To link energy usage to students' daily activities.

To introduce the concepts of direct and indirect energy usage.

To promote an awareness of the importance of energy in sustaining lifestyles in technological society.

ESTIMATED TIME: 2 Hours

THIS WORKSHOP COMPRISES FOUR SECTIONS:

- 1) ENERGY AS A BASIC NEED
- 2) DIRECT USE OF ENERGY
- 3) INDIRECT USE OF ENERGY
- 4) ENERGY AND INDUSTRIAL DEVELOPMENT

RESOURCES REQUIRED:

- News print and pens
- A tin of pilchards

STUDENT ACTIVITY:

Each group writes a up list of what they consider be a student's typical daily activities. Next to each activity the students should list the source of energy or fuel used. An example of what is expected is shown below. This example should be copied onto newsprint and shown to the groups before they begin.

DAILY ACTIVITY	SOURCE OF ENERGY/FUEL
hot water to wash	electricity
cooking breakfast	electricity
catching bus to school	diesel

SECTION 3 INDIRECT USE OF ENERGY

Energy and Commodities

Many of the goods we use on a daily basis require energy to make and transport. Commodities such as bread, milk, plastic bags, clothes and tinned food all require energy to produce, pack and transport.

Pilchard Tin Exercise

Student groups consider a tin of pilchards. Each group writes up 'Table of Contents'. This list should include the ingredients and items including the tin, paper wrapping and ink.

Next to each item/ingredient, students list the energy consuming activity needed to produce the item/ingredient. Also include energy needed for transportation.

SECTION 4

ENERGY AND INDUSTRIAL DEVELOPMENT

TEACHER INPUT:

The more commodities a society produces and consumes the more energy the country uses. This means that there is a strong link between energy usage and activities such as mining, manufacture and agriculture. Electrical usage is a useful measure of industrial development.

Copy the following information on newsprint/board.

Electrical energy usage for USA, SOUTH AFRICA and INDIA.

	ELECTRICAL ENERGY USED	POPULATION
USA	2.6×10^{12} kWh	250 000 000
S. AFRICA	1.3×10^{11} kWh	35 000 000
INDIA	2.0×10^{11} kWh	850 000 000

The units of electrical energy used in the above tables are kilowatt-hours, (kWh).

One kWh is enough electrical energy to run a one-bar heater for one hour or a 100W filament light bulb for 10 hours.

(The kWh is explained further in the workshop: **Energy Costs in our Homes**)

Despite having a larger population, India uses much less electrical energy than the USA. Why is this so ?

The USA is more industrially developed than India. This means that the USA has many industries and services which use electrical energy. Most people living in the USA have electricity in their homes and consume goods which have taken energy to produce.

ENERGY IN OUR LIVES

BACKGROUND INFORMATION

At school we learn about different forms of energy. Pick up any Standard 7 Science textbook and you will read,

*Energy is the ability to do work.
Potential energy is energy a body
has by virtue of its position.
Kinetic energy is energy a body has
by virtue of its motion.*

This is a narrow scientific view of energy leads us to the idea that energy is removed from our lives. This worksheet provides a wider view of energy by looking at energy in our lives and societies. As citizens and possibly future scientists, we should be exploring links between energy, technology and society.

ENERGY AS A BASIC NEED

Basic needs are items without which we could not survive. Energy is an important basic need. Other basic needs include food, water and shelter.

Energy has a very important role in our lives. In modern societies energy is needed to provide food, shelter, water, transport, etc. All our daily activities require energy in some form. Without energy we would have no way of running cars, trains or buses. We would have no electricity for cooking, lighting, telephones or radios. Many people are unaware of the importance of energy in sustaining our lifestyles and take energy for granted.

Let's take a tin of Pilchards as an example.

What types of processes go into producing a tin of pilchards ?

To answer this question we have to consider both the ingredients and the tin itself.

Also included is energy needed for transportation.

The following table lists some of the energy consuming activities needed to produce a tin of pilchards.

ITEM/INGREDIENT	ENERGY CONSUMING ACTIVITY
sardines	getting the fishing boat to the fishing grounds cooking the sardines
tin can	mining iron ore, processing the iron, making the tin
paper wrapping	cutting the trees, transporting logs, making the paper in the mill
oil	transporting and processing the vegetables to obtain oil

So we see that energy is needed to make something as simple as a tin of pilchards. Therefore, when we consider how much energy we use in our daily lives, we must not only consider the energy we use for cooking, travelling, heating the house, etc, we must also consider the energy that goes into producing commodities we consume and technologies we use.

ACTIVITY:

List ten commodities you use on a daily basis.

Which of these have required energy to manufacture, process or transport ?

ACTIVITY:

Calculate is the electrical energy usage per capita (amount of energy used per person per year) for each nation ?

NATION	PER CAPITA ENERGY USED (kWh)
USA	
SOUTH AFRICA	
INDIA	

Does this mean that South Africans use the same amount of electrical energy per year ?

No, energy usage is linked to lifestyle. South Africans lead very different lifestyles. Not all people can afford to buy the same amount of goods and services. In addition more than 20 million South Africans do not have access to electricity in their homes.



Energy sources in South Africa

Energy sources in South Africa

DAWN OF THE WORLD
4 500 000 000 YEARS AGO

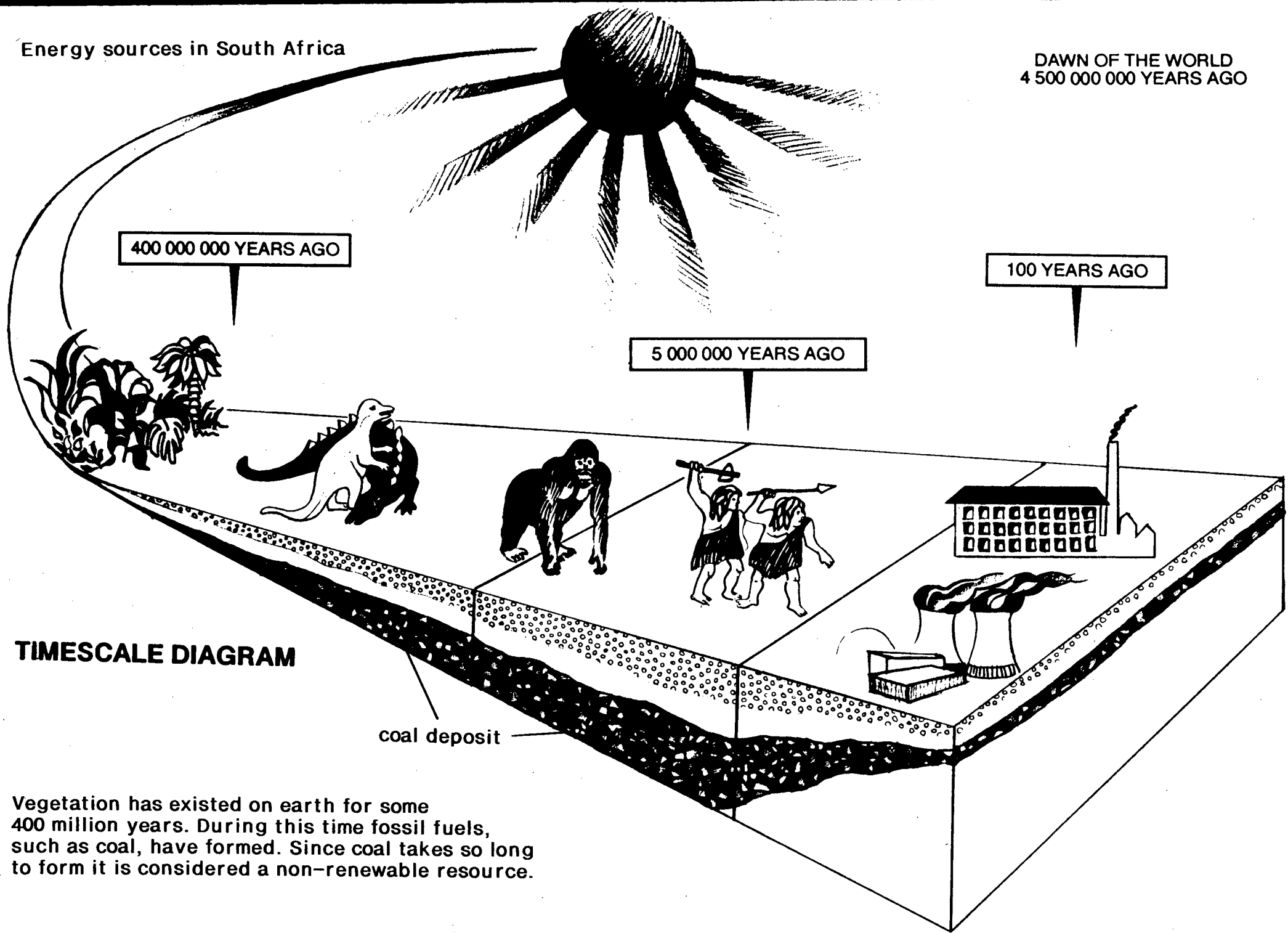

400 000 000 YEARS AGO

5 000 000 YEARS AGO

100 YEARS AGO

TIMESCALE DIAGRAM

coal deposit

Vegetation has existed on earth for some 400 million years. During this time fossil fuels, such as coal, have formed. Since coal takes so long to form it is considered a non-renewable resource.

ENERGY SOURCES IN SOUTH AFRICA

AIMS:

To consider energy sources currently used in South Africa.

To introduce the following:

- non-renewable energy sources,
- renewable energy sources,
- fossil fuels,
- timescales,
- primary and secondary energy sources.

To discuss the implications of South Africa's continued reliance on non-renewable energy sources.

To promote the need for:

- energy conservation,
- utilisation of non-renewable energy sources.

ESTIMATED TIME: 2 Hours

THIS WORKSHOP COMPRISES FOUR SECTIONS:

- 1) INTRODUCING RENEWABLE AND NON-RENEWABLE ENERGY SOURCES
- 2) PRIMARY AND SECONDARY ENERGY SOURCES
- 3) CONSERVING ENERGY
- 4) EXAMPLES OF SOUTHERN AFRICA'S RENEWABLE ENERGY POTENTIAL

RESOURCES PROVIDED:

Student Worksheet: 'PRIMARY ENERGY USAGE IN SOUTH AFRICA'.

Timescale diagram showing coal formation.

Renewable energy sources are finite but are so large that they will not run out in the foreseeable future. The sun is the source of renewable energy sources. These include wind, wave, hydro and solar energy.

Non-renewable energy sources are sources of energy contained beneath the earth's surface and which are limited and irreplaceable. These include fossil fuels such as oil, coal and gas.

Note: Explanations of why the sun is considered a finite energy source and fossil fuel formation might be necessary. Issues of the sun's life expectancy and the formation of fossil fuels can be used to introduce the concept of timescales. The concept of 'non-renewable' needs to be understood in terms of the time taken for fossil fuel formation.

A timescale diagram showing coal formation is provided with the workshop.

DISCUSSION QUESTION:

Which energy sources or fuels on display, could be grouped as renewable and non-renewable ?

Each group to write up their findings on newsprint and give a reason for their choices.

DISCUSSION QUESTION:

Is wood a renewable or a non-renewable energy source ?

Wood can be considered to be both a renewable and non-renewable energy source.

In areas where the wood resource is overexploited, either as a fuel or to make way for agricultural expansion, the wood resource can be considered to be a non-renewable resource.

PRIMARY ENERGY USAGE IN SOUTH AFRICA

STUDENT WORKSHEET WITH ANSWERS

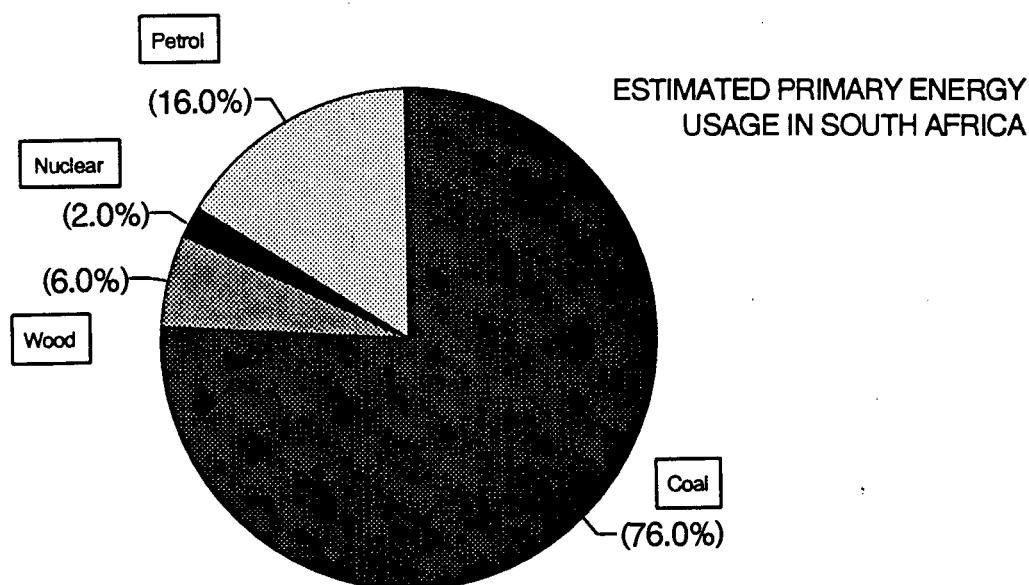

- 1) Which primary energy source contributes most to South Africa's energy usage ?

Coal

- 2) Classify the energy sources as renewable or non-renewable.

Non-Renewable : coal, oil, nuclear.

Renewable : wood, as long as the resource is not being over-exploited.

- 3) What does this energy usage pattern mean for present and future South African society ?

If South Africa continues to rely on non-renewable energy resources future generations will be without an energy supply.

- 4) Are there any solutions to this problem ? Write these down.

We can conserve energy and develop available renewable energy technologies.

other in the Western Cape also provide electricity. In a pump-storage scheme potential energy of the water stored in the dam is converted to kinetic energy as the water flows from the dam. The flowing water is used to drive turbines which generate electricity. Water is pumped to a dam using spare electricity when the demand for electricity is low, when the demand for electricity is high, water is then released through turbines and electricity is generated.

South Africa is a relatively dry country and lacks large rivers which are suitable for large scale hydro-electricity generation. Most of the large rivers of the Southern African region are north of South Africa's borders. If South Africa is to benefit from the large hydro-electric potential of rivers such as the Zaire, Rufiji, Shire and Cunene regional cooperation will be necessary. However, the long term environmental damage of existing large hydro-electric schemes on rivers, needs to be investigated before such a programme is implemented.

DISCUSSION QUESTIONS:

Get students to locate and name the rivers in Southern Africa which they feel would have the greatest hydro-electric potential. Which countries do these rivers flow through ?

Before South Africa could get electricity from these countries we would have to have regional co-operation. Do students think this is possible ?

SOLAR

Solar energy can be used for many different purposes, these include:

areas. At present there are very few wind generators operating. This is mainly due to the availability of cheap electricity generated by coal-fired power stations.

WOOD

Millions of South Africans rely on wood for cooking their food and heating their homes. In many areas the supply of wood is not keeping up with demand. As a result, wood collectors have to walk longer distances to meet their daily wood needs. An alternative energy supply needs to be provided and tree-growing schemes need to be promoted in rural areas where wood is in short supply.

TEACHER INPUT:

Summarise key concepts:

- non-renewable energy sources,
- renewable energy sources,
- fossil fuels,
- primary and secondary sources of energy,
- the need to develop sustainable non-renewable energy sources.

STUDENT WORKSHEET

PRIMARY ENERGY USAGE IN SOUTH AFRICA

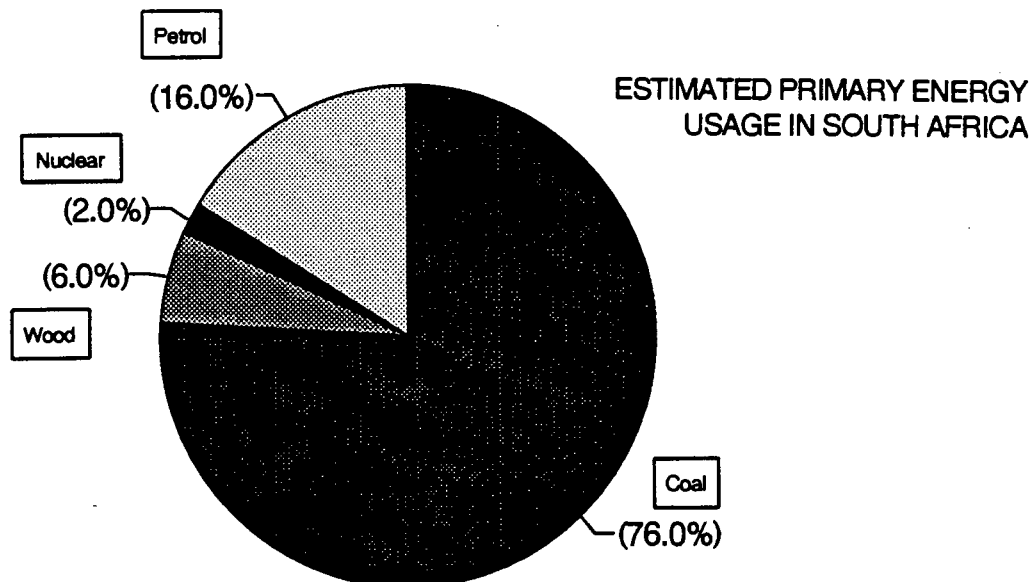

1) Which primary energy source contributes most to South Africa's energy usage ?

2) Classify the energy sources as renewable or non-renewable.

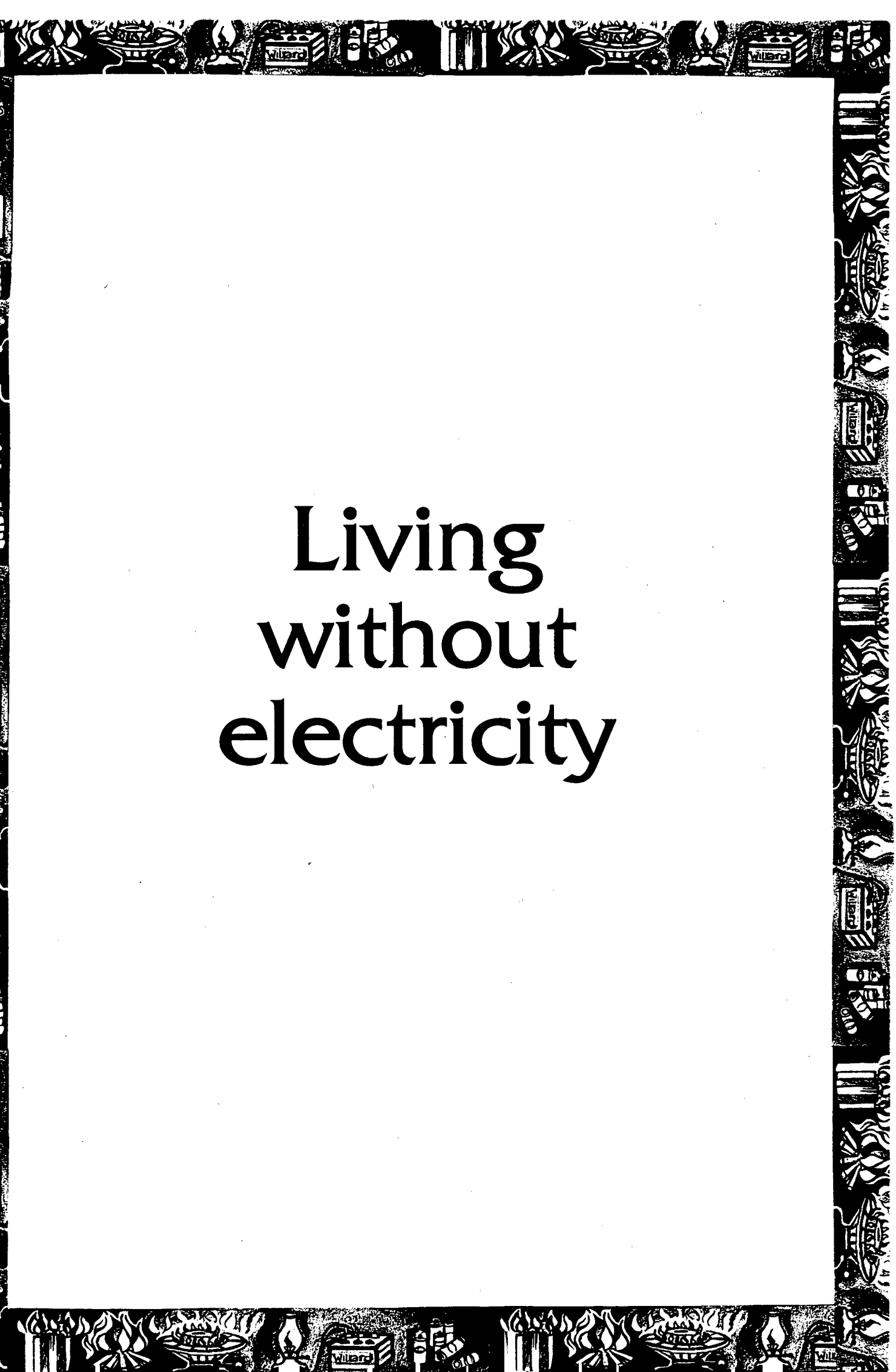

Living without electricity

THE NATIONAL ELECTRICITY GRID

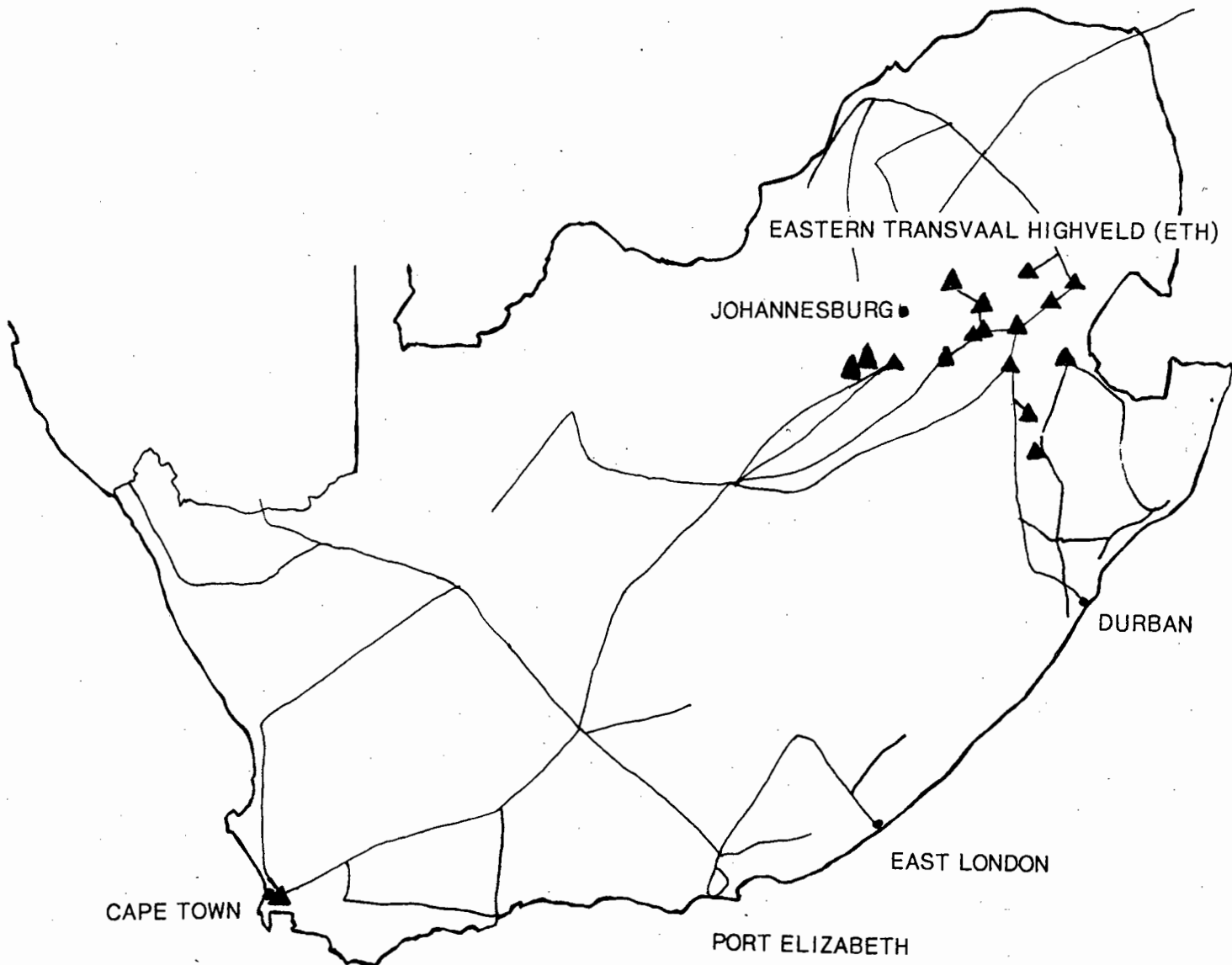

The symbol ▲ indicates the location of Eskom's coal-fired power stations, including those that have been shut down (mothballed) because Eskom can produce more electricity than it can sell.

Living without electricity

Estimated costs of electrification

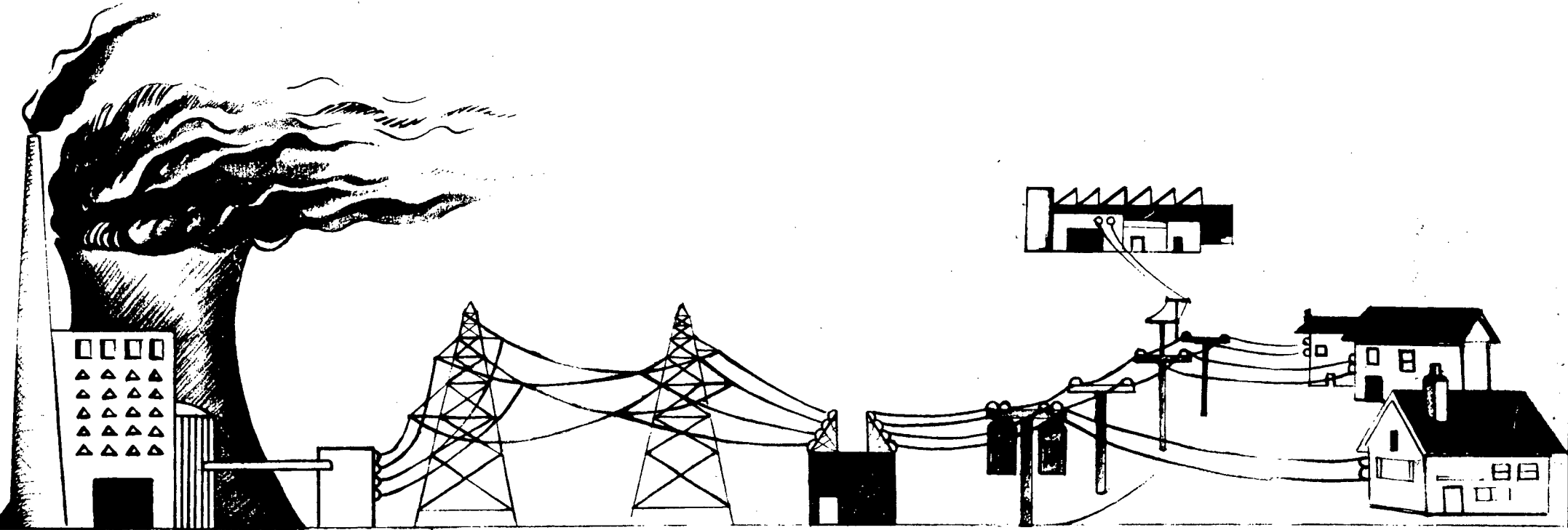

POWER STATION
Building a power station
±R6 000 000 000

GRID
EXTENDING THE GRID
400 000 V grid
±R340 000 per pylon
±R120 000 per km cable

TRANSFORMER
11 000 V

TRANSFORMER
240 V

HOMES
SUBSTATION TRANSFORMERS
AND HOUSE WIRING
±R4 000 per house

Living without electricity

LIVING WITHOUT ELECTRICITY

AIMS:

To consider energy usage patterns in non-electrified areas of South Africa.

To discuss some issues and problems related to energy usage in non-electrified households.

To introduce electricity as a suitable energy option.

To consider the costs involved in an electrification programme.

ESTIMATED TIME: 2 Hours

THIS WORKSHOP COMPRISES FOUR SECTIONS

- 1) INTRODUCING THE ENERGY CRISIS
- 2) THE COSTS OF LIVING WITHOUT ELECTRICITY
- 3) ELECTRIFICATION AS A SOLUTION
- 4) THE COSTS OF ELECTRIFICATION

RESOURCES PROVIDED:

- Image showing women carrying wood near electrical power lines.
- Map showing National Electricity Grid.
- Diagram showing estimated costs of grid electrification.
- Image of Ready Board and Pre-Payment meter.

SECTION 2

THE COSTS OF LIVING WITHOUT ELECTRICITY

TUTOR ACTIVITY:

Write up the following information on the board.

INFORMATION SHEET

- SOUTH AFRICA PRODUCES MORE THAN 50% OF AFRICA'S ELECTRICITY.
- MORE THAN 60% OF SOUTH AFRICA'S POPULATION DOES NOT HAVE ACCESS TO GRID ELECTRICITY.
- ELECTRICITY IS CHEAPER THAN FUELS SUCH AS GAS, PARAFFIN AND CANDLES.

STUDENT ACTIVITY:

Students to form small groups (3-6).

Get students to comment on and discuss each of the points on the Information Sheet.

Each group to make a list of the fuels used by people who do not have access to electricity.

These fuels include:

- paraffin
- gas
- coal
- candles
- wood
- car batteries
- dry cells
- petrol
- diesel

Groups should compare their lists and a single combined list could be written up on the board or on newsprint.

DISADVANTAGES INCLUDE:

- Distribution and installation costs are relatively expensive, especially distribution in rural areas.
- Appliances are expensive.
- Professional repair and maintenance required.

TEACHER INPUT:

The National Electricity Grid

Students to consider map of national electricity grid. This map shows South Africa's national electricity grid. Most power stations are connected to the national electricity grid network. Electricity generated in one part of the country is transmitted to other areas. The main reason for this is that it is cheaper to transmit electricity than transport coal long distances.

The grid is owned and maintained by Eskom and extends beyond South Africa's borders.

It is impossible to say which power station your electricity comes from. If one power station breaks down or needs to be overhauled, the grid will still be able to provide electricity.

The national grid is comprised of high voltage powerlines which distribute electrical power to various regions of the country. Not all sections of the grid operate at the same voltage. The main transmission system operates at 765 kV, 400 kV, 275 kV and 220 kV.

What is the advantage of transmitting electricity at high voltages, i.e. from 220 kV to 765 kV ?

Very high voltages are used for transmitting electricity over long distances, because this reduces the energy losses

CAPITAL costs are the initial costs of setting up an electrification system. These include the costs of building power stations, extending the national grid, building transformer stations and wiring houses.

OPERATIONAL costs are the costs of operating and maintaining the network. Operational costs include the purchase of fuel (mainly coal), salaries, maintenance and repair of power stations, the grid system and equipment.

We will consider some of the capital costs of electrification.

TEACHER INPUT:

Get students to consider the diagram labelled 'Estimated costs of electrification.'

Power Stations

At present, coal burning power stations provide about 90% of South Africa's electricity. As South Africa has vast coal reserves, coal will remain the dominant energy source for many years ahead.

Costs of building coal power stations similar to those in operation, are in the region of 5-8 billion rands.

At present, Eskom has a surplus of electrical generating capacity and could provide all homes with electricity without building any new power stations. This surplus has occurred because new power stations were built to meet an electricity demand that did not materialise.

Extending the National Grid

Extending the 400 kV grid to areas where no national grid exists currently costs about R350 000 per pylon and R125 000 per kilometer for cable.

OPTIONAL DISCUSSION QUESTIONS:

Some topics which are suitable for discussion:

- Discuss any advantages/disadvantages of the Ready Board and Pre-payment meter system.
- Where should electrification fit in to the list of national priorities such as education, health and food supply ? Which is most important?
- Who should pay for the electrification programme ?
- Is it reasonable to say that all homes must be electrified ? What about appliances ? Can people afford these ?

STUDENT SITE VISIT:

INVESTIGATING LOCAL POWER STATIONS

Organise a visit to a local power station.

Possible questions

Who owns and operates the power station ?

Does it operate throughout the year ? If not, why ?

What types of fuel does the power station use ?

How much fuel do they use ?

Where does the fuel come from ?

How much electricity does it produce ?

Does it have pollution control measures ?

How much water does the power station require for cooling ?

Is it connected to the grid system ?

How is power provided if the power station breaks down ?

Who receives power in an emergency ?

What job opportunities are available at the power station ? What training and skills are needed ?

Where is this training provided ?

LIVING WITHOUT ELECTRICITY

INFORMATION SHEET

- SOUTH AFRICA PRODUCES MORE THAN 50% OF AFRICA'S ELECTRICITY.
- MORE THAN 60% OF SOUTH AFRICA'S POPULATION DOES NOT HAVE ACCESS TO GRID ELECTRICITY.
- ELECTRICITY IS CHEAPER THAN FUELS SUCH AS GAS, PARAFFIN AND CANDLES.

THE COSTS OF LIVING WITHOUT ELECTRICITY

Millions of South Africans do not have access to electricity and have to rely on other fuels to meet their energy needs.

Fuels used include: paraffin, gas, coal, candles, wood, car batteries, dry cells, petrol and diesel.

ACTIVITY:

There are many problems linked to the use of these fuels.

Can you think of any problems connected with the use of these fuels that people face ?

Next to each fuel list any problems you can think of.

For example,

- paraffin: - fire hazard
- smells
- messy
- poisonous

GETTING POWER TO THE PEOPLE

The National Electricity Grid

South Africa has an extensive electricity grid.

This map shows South Africa's national electricity grid.

The symbol ▲ indicates the location of Eskom's coal-fired power stations, including those that have been shut down (mothballed) because Eskom can produce more electricity than it can sell.

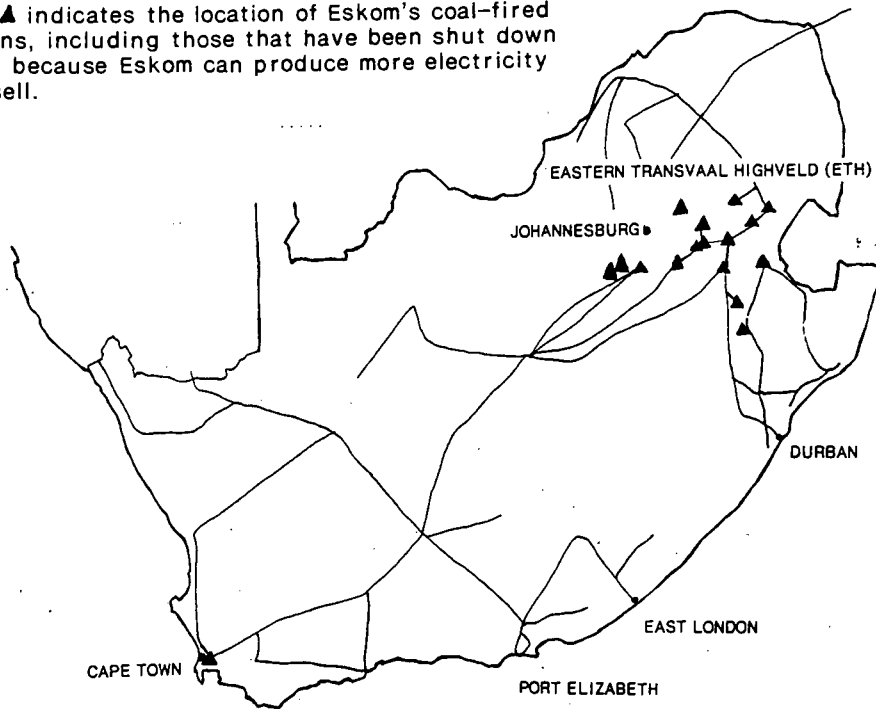

NATIONAL ELECTRICITY GRID

Most power stations are connected to the national electricity grid network. Electricity generated in one part of the country is transmitted to other areas. The main reason for this is that it is cheaper to transmit electricity than transport coal long distances.

The grid is owned and maintained by Eskom and extends beyond South Africa's borders.

Most of South Africa's electrical power is generated in the Eastern Transvaal Highveld as most of the coal reserves are situated in this region.

It is impossible to know which power station your electricity

THE COSTS OF ELECTRIFICATION

Electrification is a most suitable energy supply option. Many of South Africa's rural communities are far from the existing electricity grid. To supply these communities with electricity would mean extending the electricity grid.

Let's consider some of the costs involved in the processes of electrification.

There are two types of costs involved in electricity provision, **CAPITAL** costs and **OPERATIONAL** costs.

CAPITAL costs are the initial costs of setting up an electrification system. These includes the costs of building power stations, extending the national grid, building transformer stations and wiring houses.

OPERATIONAL costs are the costs of operating and maintaining the network. Operational costs include the purchase of fuel (mainly coal), salaries, maintenance and repair of power stations, the grid system and equipment.

Let's consider some of the capital costs of electrification.

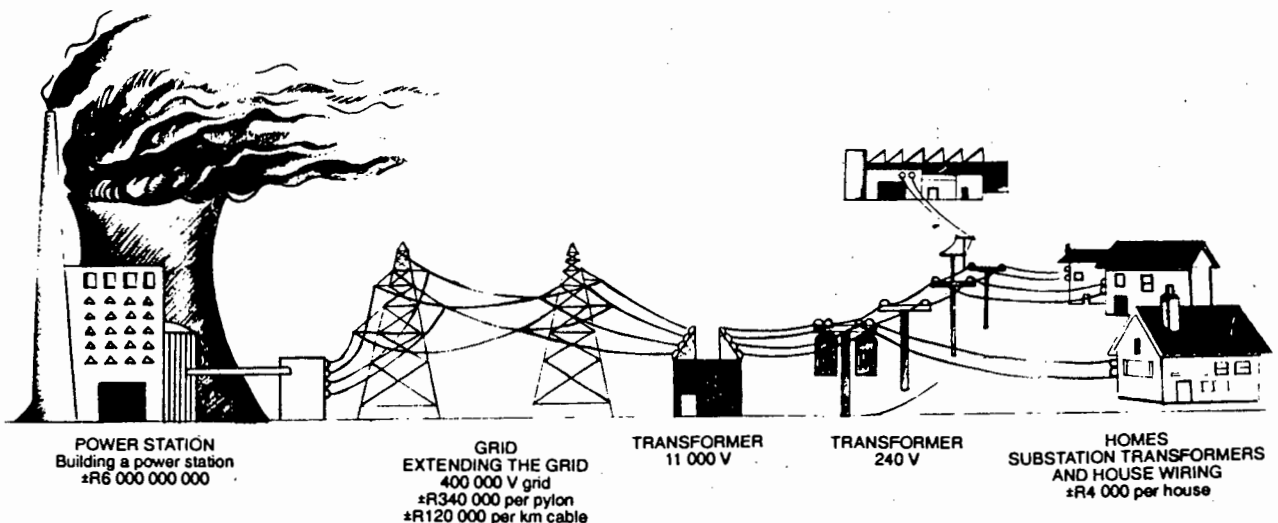

THE COSTS OF ELECTRIFICATION

New technologies : Ready Boards and Pre-Payment Meters

A cheaper domestic electricity supply system, designed for low cost dwellings has been developed.

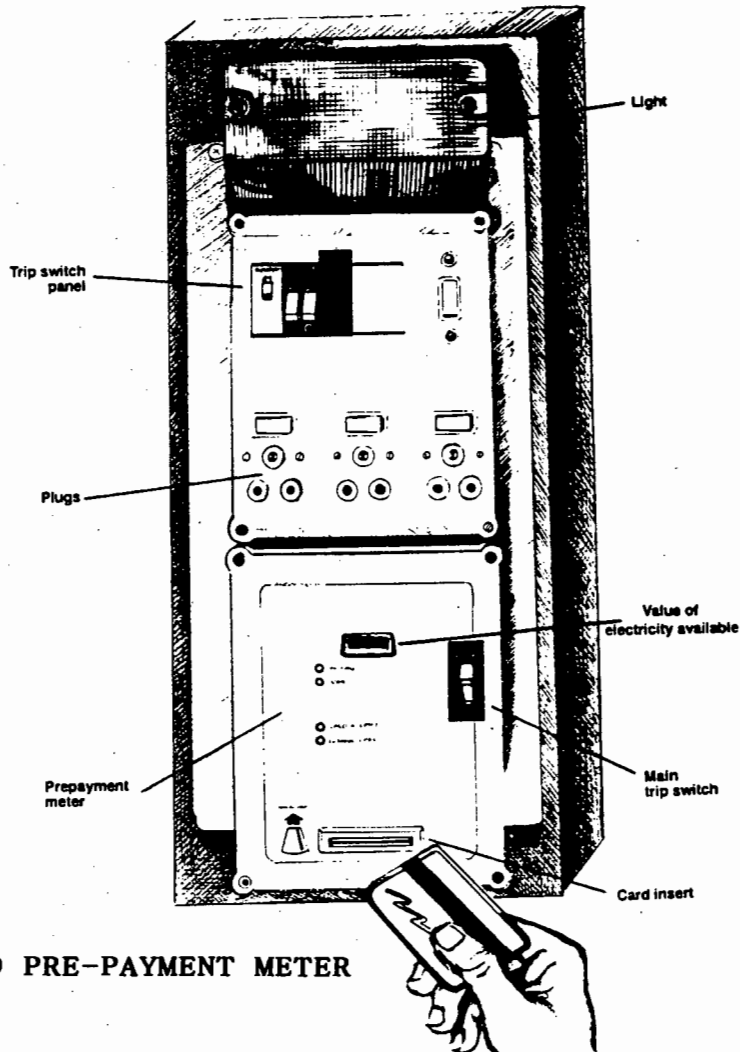

READY BOARD AND PRE-PAYMENT METER

The basic Ready Board design consists of three plug points, a light and a circuit breaker. No electrical wires have to be inserted into the walls. The consumer plugs appliances directly into the Ready Board.

The pre-payment meter system requires consumers to pay for the electricity before they use it. The consumer buys a card, inserts it into the Pre-payment meter and is allowed to use the amount of electricity which has been purchased. A display shows how much electricity is available and a warning light switches on when consumers need to buy a new card.



Electricity costs in our homes

TAX INVOICE



SENDER: CITY OF CAPE TOWN, 12 HERTZOG BOULEVARD
FORESHORE, CAPE TOWN REGISTRATION NUMBER: 4180101877

RECIPIENT: MR G P MITCHELL
27 HANSEN ROAD
MUIZENBERG
7945

INVOICE DATE: 01-09-1993

ELECTRICITY SUPPLIED AT 27 HANSEN ROAD		MBG
ROUND NO	D060-009-4	
BALANCE BROUGHT FORWARD		65,32
PAYMENT 17/08/93		65,32CR
DOMESTIC CONSUMPTION - FROM 13/07/93 TO 11/08/93		56,24
(READING 3098 - 370 kw.h)		
14% VAT		7,87
INVOICE NUMBER	DUE DATE	
168.313.802/010993	15-09-93	R 64,11

Monthly electricity bill

ELECTRICITY COSTS IN OUR HOMES

AIMS:

To develop an understanding of power ratings of domestic appliances.

To enable students to calculate the costs of using electrical appliances.

To determine the efficiency of a kettle.

To discuss ways of conserving electrical energy in the home.

ESTIMATED TIME: 2 Hours

THIS WORKSHOP COMPRISES FIVE SECTIONS

- 1) INTRODUCTION
- 2) POWER RATINGS - WHAT DO THEY MEAN ?
- 3) HOW MUCH DOES ELECTRICITY COST ?
- 4) CALCULATING THE EFFICIENCY OF A KETTLE
- 5) REDUCING ELECTRICITY COSTS IN OUR HOMES

RESOURCES PROVIDED:

- Student Worksheet: 'ELECTRICITY COSTS IN OUR HOMES'
- Monthly electricity bill

RESOURCES REQUIRED:

- Mains power supply
- Electric kettle with label showing power rating
- 500 ml measuring cylinder
- Thermometer

power ratings. Power ratings are given in watts or kilowatts and indicate the rate at which an appliance uses electrical energy. In other words, the amount of electrical energy used per second. As,

$$\text{POWER} = \text{ENERGY/TIME}$$

the unit of power, the watt (W), is equal to a joule per second.

A power rating of 1 W means that the appliance uses 1 joule of electrical energy per second.

$$1 \text{ W} = 1 \text{ J/s}$$

Therefore, power rating of 1000 W means that the appliance uses 1000 joule of electrical energy per second.

STUDENT ACTIVITY:

Allow each group to study the kettle and record the power rating of the kettle in watts (W).

The table below provides typical appliance power ratings.

Appliance	Power Rating (kW)
stove(total)	14
hot water cylinder	4
washing machine	2.75
iron	1
hairdryer	1
1 bar heater	1
vacuum cleaner	0.8
toaster	0.9
refrigerator	0.12
light bulb	0.06
radio cassette player	0.012
calculator	0.00054

We can use the formula:

$$\text{power} = \text{voltage} \times \text{current} \quad (P=VI)$$

to calculate the current drawn by the appliance if we know the voltage at which the appliance operates. Most domestic appliances in South Africa operate at 220 to 240 V ac.

Consider the 1000 W kettle.

This kettle takes 4 minutes to boil. The electrical energy used will be:

$$\begin{aligned}\text{ENERGY} &= 1000 \text{ W} \times 240 \text{ s} \\ &= 240000 \text{ J} \\ &= 220 \text{ kJ}\end{aligned}$$

Consider the 2000 W kettle.

This kettle takes 2 minutes to boil. The electrical energy used will be:

$$\begin{aligned}\text{ENERGY} &= 2000 \text{ W} \times 120 \text{ s} \\ &= 240000 \text{ J} \\ &= 240 \text{ kJ}\end{aligned}$$

Therefore the kettles use the same amount of electrical energy.

Why is this so ?

The same amount of energy is required to raise the temperature of equal quantities of water by the same amount.

Which kettle will cost more to boil ?

We pay for the electrical energy used. Therefore, as both kettles use the same amount of electrical energy the kettles cost the same to use.

Kilowatt-hours: a unit of electrical energy

As you can see from our calculation above, to boil a kettle requires many thousands of joules. For electricity suppliers such as ESKOM to work with such large numbers would be inconvenient, instead electrical energy is measured in kilowatt-hours (kWh).

How many kWh are used to boil the 2000 W kettle ?

SECTION FOUR

CALCULATING THE EFFICIENCY OF A KETTLE

This experiment is performed as a teacher demonstration. Space has been provided on the student worksheet for calculations and answers.

TEACHER INPUT:

What is meant by the 'efficiency' of an electrical appliance ?

Energy efficiency is the ratio of how much energy goes in to an appliance to the amount of useful energy got out. A kettle is not a perfect insulator, some of the electrical energy supplied to the kettle goes into heating the kettle and the surrounding air. Also heat is 'lost' through water that vaporises before the kettle boils. The more energy 'lost', the lower the efficiency.

Efficiency of a kettle is given by the ratio of the electrical energy supplied to the kettle to the energy actually needed to boil the water. Efficiency is usually expressed as a percentage. The greater the percentage the greater the efficiency.

As a percentage the efficiency of the kettle is given by,

$$\frac{\text{ENERGY REQUIRED}}{\text{ENERGY DELIVERED}} \times \frac{100}{1}$$

In order to determine the efficiency of the electric kettle we have to calculate the energy required to boil the water and the actual electrical delivered to the kettle.

Firstly, we calculate the **energy required** to boil the water in the kettle.

Firstly, note the power rating of the kettle. Power ratings are usually given for a supply voltage of 240 V ac. However the supply voltage in South Africa is about 220 V ac, therefore the power rating has to be reduced proportionally.

Let's assume the kettle has a power rating of 2200 W at 240 V ac. For a 220 V supply this reduces to:

$$\begin{array}{r} 220 \text{ V} \\ \text{-----} \\ \text{240 V} \end{array} \times 2200 \text{ W} \text{ or } 2016 \text{ W}$$

Secondly, measure the time it takes to bring the 0.5 kg of water to the boil. Note that this is the same mass used in calculating the 'energy required'.

To demonstrate this calculation we assume it takes 90 s to bring the kettle to the boil.

We can now calculate the energy delivered to the kettle.

$$\begin{aligned} \text{energy delivered} &= 2016 \text{ W} \times 90 \text{ s} \\ &= 181\,440 \text{ J} \end{aligned}$$

The efficiency of the kettle is given by the ratio of the energy required to boil the water to the actual energy delivered to the kettle.

As a percentage the efficiency of the kettle is given by,

$$\frac{\text{ENERGY REQUIRED}}{\text{ENERGY DELIVERED}} \times \frac{100}{1}$$

Hot Water Cylinders

Most hot water cylinders keep a large volume of water heated at a selected temperature for 24 hours a day. Because of the convenience of having the water permanently heated, hot water cylinders use the most electrical energy in the home.

The device that sets the temperature is called a thermostat. The heating element in a hot water cylinder is similar to that of a kettle. When the water temperature drops below the selected temperature the hot water cylinder automatically switches on. The better insulated the cylinder is, the longer it takes for the water to cool down, and element will be switched on less often.

Can you think of ways to reduce the amount of electrical energy your hot water cylinder uses?

Firstly, you can check the thermostat setting. It might be possible to reduce the setting and still have hot water at a comfortable temperature. In summer it might be possible to reduce the setting further. Other hot water saving measures include showering instead of bathing (as showers use less hot water) and making sure you don't use the hot tap for cold water.

Electric Stoves

Electric stoves are heavy users of electricity.

Some things you could do to reduce your monthly electricity bill:

- 1) Make sure the pots and pans you use have flat bottoms. This will improve the conductivity between the hot plate and the pot or pan.
- 2) Match the size of the pots and pans with the stove size.
- 3) Keep the lids on, to avoid wasting heat.
- 4) Don't use more heat than you need to cook the food.
- 5) Use a kettle for boiling water - it is more efficient.

ELECTRICITY COSTS IN OUR HOMES

SECTION ONE

POWER RATINGS – WHAT DO THEY MEAN ?

Most appliances we use in our homes have labels giving their power ratings. Power ratings are given in watts or kilowatts and indicate the rate at which an appliance uses electrical energy. In other words, the amount of electrical energy the appliance uses per second.

The unit of power, the watt (W), is equal to a joule per second.

$$\text{POWER} = \text{ENERGY/TIME}$$

$$1 \text{ W} = 1 \text{ J/s}$$

A power rating of 1 W means that the appliance uses 1 joule of electrical energy per second.

Therefore, a power rating of 1000 W means that the appliance uses 1000 joules of electrical energy per second.

The table below provides typical appliance power ratings at 220 V ac.

APPLIANCE	POWER RATING (kW)
stove (total)	14
hot water cylinder	4
washing machine	2.75
iron	1
hairdryer	1
1 bar heater	1
vacuum cleaner	0.8
toaster	0.9
microwave oven	0.65
refrigerator	0.11
light bulb	0.06
radio cassette player	0.012
calculator	0.00054

Comparing two kettles with different power rating

Consider two kettles operating at 240 V ac. One with a power rating of 1000 W and one with a power rating of 2000 W.

Which kettle will boil *equal* quantities of water faster ?
Why ?

In order to calculate how much electrical energy a kettle uses we need to multiply the kettle's power rating by the time taken to reach boiling.

$$\text{ENERGY} = \text{POWER} \times \text{TIME}$$

Consider the 1000 W kettle.

It takes 4 minutes to boil. The electrical energy used will be:

$$\begin{aligned}\text{ENERGY} &= 1000 \text{ W} \times 240 \text{ s} \\ &= 240000 \text{ J} \\ &= 240 \text{ kJ}\end{aligned}$$

Consider the 2000 W kettle

This kettle takes 2 minutes to boil. The electrical energy used will be:

$$\begin{aligned}\text{ENERGY} &= 2000 \text{ W} \times 120 \text{ s} \\ &= 240000 \text{ J} \\ &= 240 \text{ kJ}\end{aligned}$$

Thirdly, calculate the time taken for water to boil in hours.

energy used in kWh = kilowatts x hours

= kWh

SECTION TWO

HOW MUCH DOES ELECTRICITY COST ?

Study the electricity account your group has been given.

How many kWh did the household use during the month ?

.....kWh

How much did this amount of electrical energy cost ?

.....cents

Calculate the amount in cents per kWh that this household pays for electrical energy.

Firstly, we calculate the energy required to boil the water in the kettle.

The energy required to raise the temperature of a mass of water, m , by an amount $T_2 - T_1$ is given by:

$$Q = mC(T_2 - T_1),$$

where:

m = mass of water (kg)

C = specific Heat Capacity of water
= $4200 \text{ Jkg}^{-1}\text{C}^{-1}$

T_2 = final water temperature ($^{\circ}\text{C}$)

T_1 = initial water temperature ($^{\circ}\text{C}$)

mass of water to be heated (m) = kg

initial temperature of water (T_1) = $^{\circ}\text{C}$

final temperature of water (T_2) = $^{\circ}\text{C}$

Energy required in Joules (Q) = J

Now calculate the actual electrical energy delivered to the kettle.

Firstly, we need the power rating of the kettle.

Power ratings are usually given for a supply voltage of 240 V ac. However the supply voltage in South Africa is about 220 V ac, therefore the power rating has to be reduced proportionally.

Let's assume the kettle has a power rating of 2200 W at 240 V ac. For a 220 V supply this reduces to:

Why is the efficiency of a kettle high ?

The more efficient the kettle the less energy is wasted in the heating process. Highly efficient appliances could help us save electrical energy.

SECTION FOUR

REDUCING ELECTRICITY COSTS IN OUR HOMES

ESKOM supply local authorities, municipalities and councils with electricity and they in turn supply users living within their areas.

Local authorities can charge their own rates for the electricity they supply.

A LOOK AT SOME DOMESTIC APPLIANCES

In order to be able to conserve electricity we need to know which appliances use the most electrical energy. This means considering both appliance power ratings and the time for which they are used.

The two most important applications of domestic electricity are heating and lighting. Heating usually requires much more electrical energy than lighting.

Each of the important appliances will now be discussed.

Electric Heaters

The power ratings of electric heaters depend on the type of heater. Most heaters have a power rating of 1 kW or greater.

Some things you could do to reduce your monthly electricity bill:

- 1) Only use heaters when it is really necessary.
- 2) Close the windows or doors of the room you are heating.
- 3) Turn the heater when the temperature is comfortable.

Note: If we compare the cost of operating a 1 kW heater and a 60 W bulb for one hour we find that the heater costs nearly seventeen times more. Can you prove this ?

Refrigerators

Like hot water cylinders, refrigerators are thermostatically controlled. This means the refrigerator switches on when the air in the refrigerator goes above the set temperature.

Some things you could do to reduce your monthly electricity bill:

- 1) Don't place hot foods in the refrigerator. Let them reach room temperature first.
- 2) Make sure that the refrigerator door seals closed properly.
- 3) Don't open the refrigerator door unnecessarily, and don't leave it open.

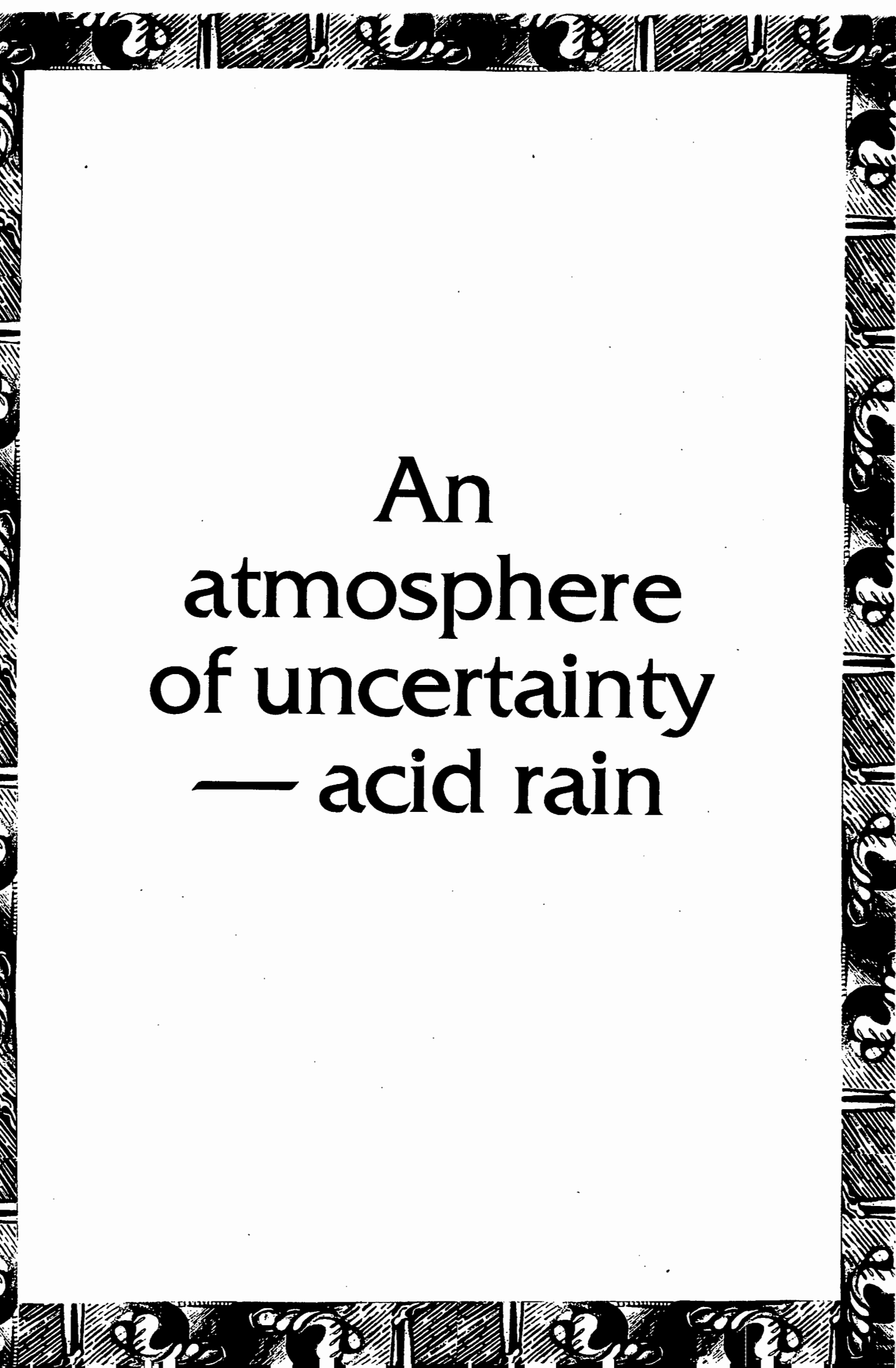

An
atmosphere
of uncertainty
— acid rain

An atmosphere of uncertainty - acid rain

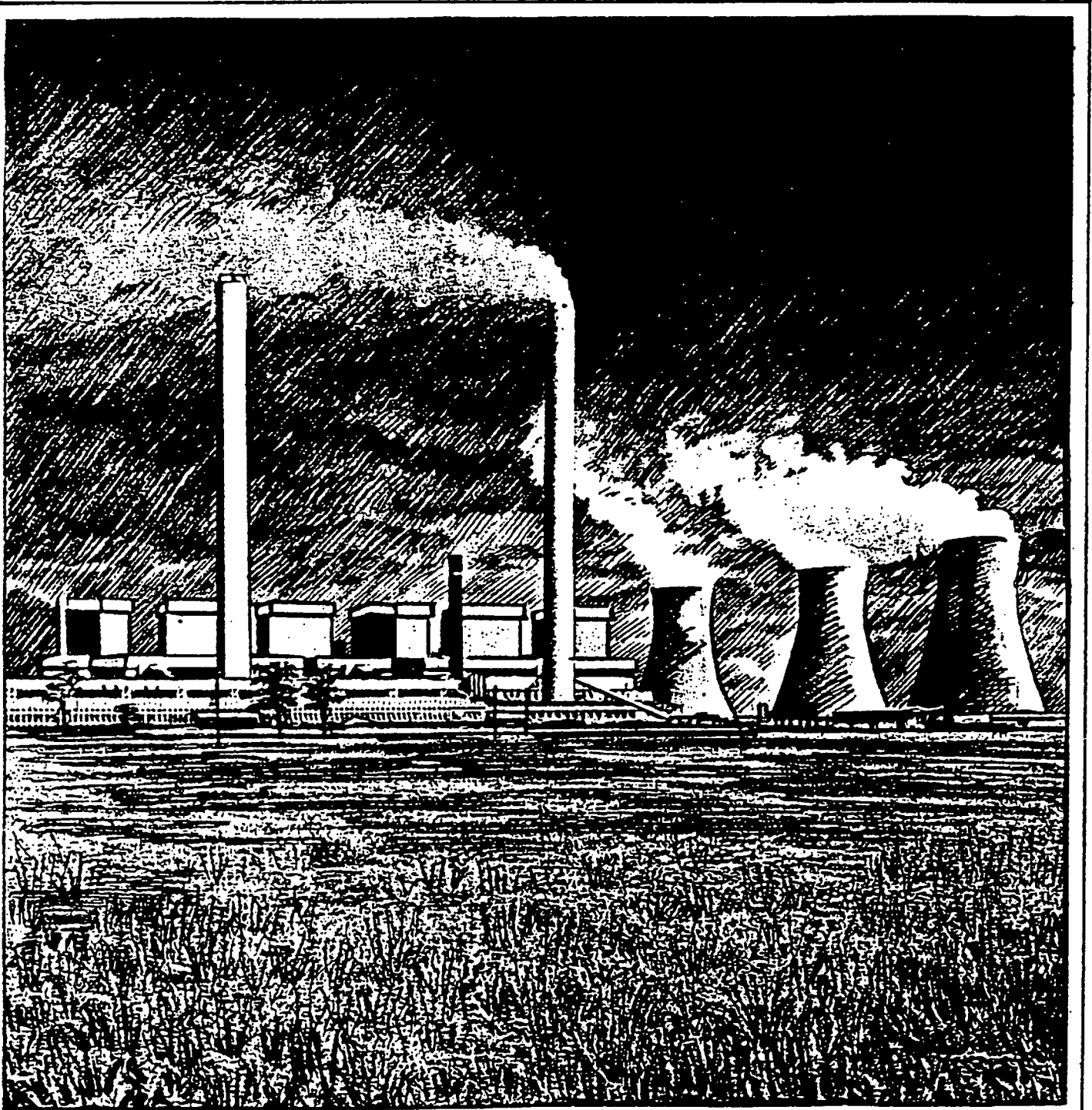

Coal fired power station

AN ATMOSPHERE OF UNCERTAINTY -ACID RAIN

AIMS:

To promote an understanding of the pollution threat from coal fired power stations, a major contributor to air pollution in South Africa.

To introduce the issue of acid rain and examine various aspects of acid rain such as its formation, transportation and deposition.

To promote the need for greater environmental control and policy in South Africa.

CONTEXTUALISING THE SYLLABUS

Issues of acid rain could serve to contextualise sections of the Physical Science syllabus: Std 9 (sulphur compounds) and Std 10 (acids and bases).

ESTIMATED TIME: 2 Hours

THIS WORKSHOP COMPRISES SIX SECTIONS:

- 1) INTRODUCTION
- 2) COAL POWER STATION EMISSIONS
- 3) THE MOVEMENT OF POLLUTANTS
- 4) POLLUTION FROM COAL FIRED POWER STATIONS
- 5) ACID RAIN IN EASTERN TRANSVAAL HIGHVELD
- 6) REDUCING AND CONTROLLING POWER STATION POLLUTION

RESOURCES PROVIDED:

- Student Worksheet: 'An Atmosphere of Uncertainty-Acid Rain'
- Image of coal fired power station emitting smoke.
- Map showing National Electricity Grid.

RESOURCES REQUIRED:

- Dilute sulphuric or nitric acid.

SECTION 2

POLLUTION FROM COAL FIRED POWER STATIONS

TEACHER INPUT:

Display image of a coal-fired power station.

Students who live near a coal-burning power station, might have noticed that power stations have a number of towers.

DISCUSSION QUESTIONS:

Why do most power stations have two types of towers ?

The short fat towers which are thinner in the middle, are cooling towers that release steam into the atmosphere. The long thin towers are smokestacks and release smoke from the burning coal.

Why are the smokestacks tall ?

Winds which disperse smoke are generally stronger higher up. The higher into the atmosphere the smoke is released the better the dispersion.

POWER STATION LOCATION

Display the image of National Electricity Grid.

TEACHER INPUT:

South Africa generates more than 50% of Africa's electricity. About 90% of this electricity is generated by coal burning power stations. Electricity is distributed to the rest of the country through a network of power lines called the national electricity grid.

SECTION 3

COAL POWER STATION EMISSIONS

CARBON DIOXIDE

For every tonne of coal that is burnt approximately two tonnes of carbon dioxide are released. Carbon dioxide can be considered a pollutant as it contributes to the Green House Effect, an effect that possibly changes climates due to the warming of the earth's atmosphere.

Note: Further explanation on the Green House Effect might be necessary.

SULPHUR

All fossil fuels such as coal contain sulphur. The sulphur content of coal depends on the grade of the coal and can vary from between 0.48 % to 5 %. Most coals used in South Africa have a high sulphur content. During burning, sulphur reacts with oxygen and is released as sulphur dioxide.

NITROUS OXIDES

Nitrous oxides, which are formed when nitrogen and oxygen in the air are heated, are also released.

OTHER POLLUTANTS

As the burning process is seldom complete, other pollutants are also released. These include carbon particles (soot), carbon monoxide and hydrocarbons.

The formation of nitric acid occurs as follows:

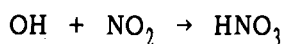

The reactions leading to the formation of sulphuric acid are:

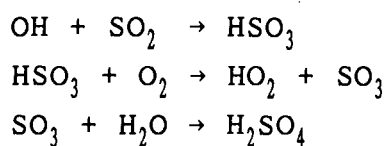

Liquid phase reactions

These reactions occur in water droplets in clouds.

Nitric acid is produced by the following wet phase reactions:

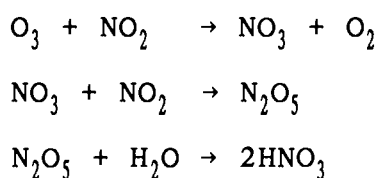

SECTION 4

THE MOVEMENT OF POLLUTANTS

TEACHER INPUT:

Understanding the transportation of pollutants enables us to determine how pollutants are dispersed or spread in the atmosphere. This helps us to know how far the effects of the pollution will spread from the source of the pollution.

4) *Reducing the service life of metals in fences and corrugated iron roofs.*

The results of European and American studies are not directly transferable to other countries. The factors which influence acid rain dispersion differ from country to country.

DISCUSSION QUESTION:

Most of the research work done on the effects of acid rain has been done in industrially developed countries such as USA, Canada and Germany.

Why do you think this is so ?

Most of the effects of acid rain such as the corrosion of buildings are long term. These effects were first observed in developed countries. Also, a high degree of public concern has fuelled the growth of research into environmental issues such as acid rain in these countries.

SECTION 5

ACID RAIN IN EASTERN TRANSVAAL HIGHVELD

TEACHER INPUT:

How much power station acid rain pollution occurs in the ETH ?

There is no easy answer to this question. Firstly, acid rain effects are cumulative and hence damage occurs over a long period. This means measurements need to be conducted over a long period of time before any damage can be properly assessed. Scientists have only recently began to study acid rain and its effects in South Africa.

charged plates (precipitator). From time to time the precipitator needs to be cleaned.

Controlling acid rain pollution

A number of technologies which remove NO_x and SO_2 emissions are currently available.

Technologies for reducing the sulphur content before burning (pre-combustion), during burning and after burning (post-combustion) exist, and are used in many power stations world wide. These technologies are costly, for example, Eskom says, scrubbing equipment would cost approximately R2000 million per power station to install plus additional running costs. Currently, none of these technologies are in use in South Africa.

EXTRA ACTIVITIES

ROLE PLAY:

Three students are chosen to represent scientists from The Green Leaf, an environmental pressure group. These students are given the task of informing residents who live near a coal fired power station (the other students) about the dangers of pollution from power stations. This role play could serve as an evaluation of the workshop.

AN ATMOSPHERE OF UNCERTAINTY -ACID RAIN

POLLUTION FROM COAL FIRED POWER STATIONS

The distribution of electricity through the national grid means that many consumers live long distances from where the electricity is generated. Electricity consumers are often not directly affected by the pollution and are possibly unaware that burning coal causes pollution.

At present more than 50 million tonnes of coal are burnt annually in power stations situated within the Eastern Transvaal Highveld. This high concentration of coal burning power stations introduces a number of pollution problems.

When coal is burnt, a number of gases and small particles are released into the atmosphere. These are called emissions.

COAL POWER STATION EMISSIONS

Carbon Dioxide

For every tonne of coal that is burnt approximately two tonnes of carbon dioxide are released. Carbon dioxide can be considered a pollutant as it contributes to the Green House Effect, an effect that possibly changes climates due to the warming of the earth's atmosphere.

Sulphur

All fossil fuels such as coal contain sulphur. The sulphur content of coal depends on the grade of the coal and can vary from between 0.48% to 5%. Most coals used in South

The next stage of the pollution is **deposition**, the settling of pollutants on surfaces.

ACID RAIN

Acids dissolve readily in water droplets. These acidified droplets are referred to as **acid rain**.

The Effects of Acid Rain

Acid rain pollution is still a new field of research and chemists, meteorologists, physicists, geophysicists, biologists, ecologists and other scientists are having to work together on a problem that occurs in many countries.

Most of the research work done on the effects of acid rain has been done in industrially developed countries such as USA, Canada and Germany.

Why do you think this is so ?

Most of the effects of acid rain such as the corrosion of buildings are long term. These effects were first observed in developed countries. Also, a high degree of public concern in these countries has fuelled the growth of research into environmental issues, such as acid rain.

Some effects of acid rain found in North America and Europe include:

- 1) Increasing the acidity of lakes and rivers and thus causing the death of aquatic life. In Canada, 140 lakes have lost all their fish life due mainly to acidification.
- 2) Reducing crop yields and killing forests. In Europe millions of hectares of forests have been classified as affected by chemical pollution.
- 3) Causing harmful metals such as cadmium and mercury to be carried into soil water, groundwater and streams.

Scientists disagree with regard to the levels of acid rain pollution in South Africa. The scientists who disagree often represent different interest groups, such as Eskom or environmental pressure groups.

South Africa does have an acid rain problem. We cannot afford to wait until the long term effects begin to take root. The acid rain problem needs to be dealt with now.

REDUCING AND CONTROLLING POWER STATION POLLUTION

REDUCING DUST EMISSIONS

Eskom have taken steps to reduce dust emissions from power stations. Standards have been improved from 1000 milligrams per m³ to 100 milligrams per m³. Dust particles are removed using electrostatic precipitators. As dust particles move through the air they become electrostatically charged. These particles are attracted towards oppositely charged plates (precipitators). From time to time the precipitators need to be cleaned.

Controlling Acid Rain Pollution

A number of technologies which remove NO_x and SO₂ emissions are currently available.

Technologies for reducing the sulphur content before burning (pre-combustion), during burning and after burning (post-combustion) exist, and are used in many power stations world wide. These technologies are costly, for example, Eskom says that scrubbing equipment would cost approximately R2000 million per power station to install plus additional running costs.

Currently, none of these technologies are in use in South Africa.



Electricity from the sun

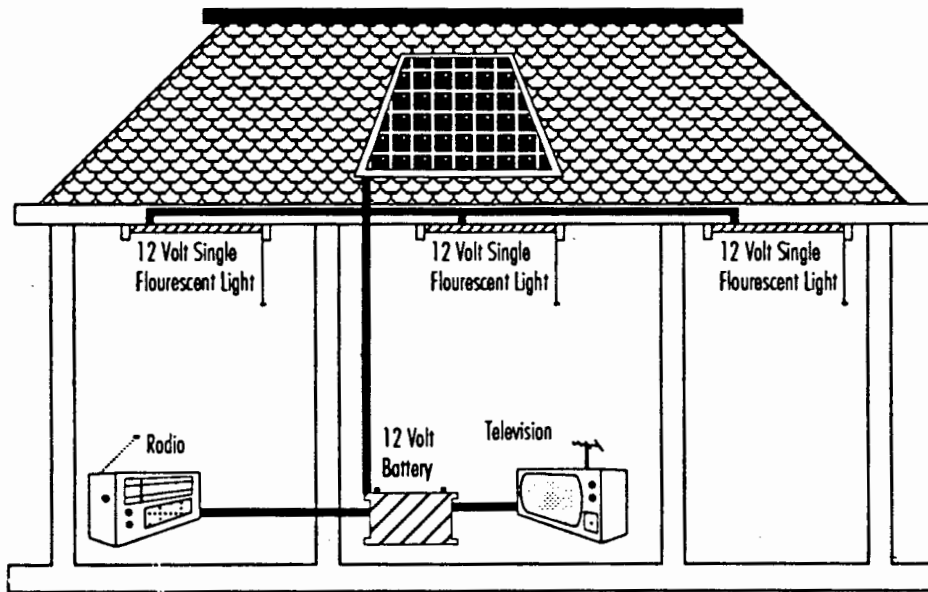

813 Large Solar Panel mounted on roof of House

Solar energy - free energy

VENDATA gives you the African sun power

FREE

VENDATA solar power
Solar energy - Free energy
Free sun power

Vendata Computer Systems PO Box 160, Johannesburg, 2000
Contact Ray Poonen, Mashudu or Mark Tel (011) 337 8200

Solar energy advertisement

ELECTRICITY FROM THE SUN

AIMS :

To consider South Africa's solar energy resource potential.

To discuss the earth's energy balance, a look at what happens to the solar energy the earth receives.

To consider the suitability of photovoltaic electricity as an energy supply option.

ESTIMATED TIME: 2 Hours

THIS WORKSHOP COMPRISES FOUR SECTIONS

- 1) PHOTOVOLTAICS AS AN ELECTRICAL SUPPLY OPTION
- 2) THE EARTH'S ENERGY BALANCE
- 3) POWERING DOMESTIC APPLIANCES
- 4) COMPARING PV SYSTEM COSTS WITH OTHER ELECTRICITY GENERATING SYSTEMS

RESOURCES PROVIDED:

- Student Worksheet: 'ELECTRICITY FROM THE SUN'
- PV Advertisement.

CAN SOUTH AFRICA MEET ITS CURRENT ELECTRICAL NEEDS USING SOLAR ENERGY ?

Teachers can either work through this calculation with students or present it as an exercise.

TEACHER INPUT:

Firstly, we need to know how much electricity South Africa uses per year. This information is obtained from the ESKOM ANNUAL REPORT 1992.

According to ESKOM the total amount of electricity sold in 1992 was 1.381×10^{11} kWh.

Secondly, we need to know how much solar energy South Africa receives each year.

The average amount of solar energy received in South Africa per m^2 per day = 5.28 kWh.

In order to calculate the energy received by South Africa during one day we need to know South Africa's surface area.

South Africa's surface area = $1\,221\,000 \text{ km}^2$

Energy received by South Africa in one day

$$\begin{aligned} &= 5.28 \text{ kW/m}^2 \times 1.221 \times 10^{12} \text{ m}^2 \\ &= 6.45 \times 10^{12} \text{ kWh/day} \end{aligned}$$

Therefore energy received per year:

$$\begin{aligned} &= 6.45 \times 10^{12} \text{ kWh/day} \times 365 \text{ days} \\ &= 2.3 \times 10^{15} \text{ kWh} \end{aligned}$$

Summarise the main energy flows in the earth's energy balance diagram.

About 30% of the incoming solar radiation is reflected by the atmosphere.

Approximately 17% is absorbed by the atmosphere as it passes through.

About 23% is used in evaporation and precipitation.

Winds, waves and ocean currents are a much smaller energy system using only 0.2% of the total radiation reaching the earth.

Photosynthesis accounts for only 0.05% the total solar radiation that reaches the earth's surface.

Therefore most of the solar radiation reaching the earth's surface is either reflected or radiated back into the atmosphere. For this reason the earth's surface does not get hotter and hotter.

SECTION 3

POWERING DOMESTIC APPLIANCES

Let's begin in the kitchen.

Could a single PV module be used to power an electric kettle ?

We need to know how much electrical energy is needed to boil a kettle of water. Assume we have an electric kettle with a power rating of 2 kW that takes 3 minutes to boil.

How long would it take for single PV module to produce the amount of electrical energy needed to boil the kettle ?

$$\begin{aligned} \text{TIME} &= \text{ENERGY} / \text{POWER} \\ \text{TIME} &= 0.1 \text{ kWh} / 0.050 \text{ kW} \\ &= 2 \text{ hours} \end{aligned}$$

Would it be practical to use PV electricity to boil a kettle of water using a single PV module ? Explain.

No, it would impractical at it would take too long.

Remember these are ideal conditions. In practice the kettle would take even longer to boil.

DELIVERING GREATER POWER

Instead of using a single PV module, a number of PV modules can be connected in an array. The total electrical power of an array is equal to the sum of power from each module.

The disadvantage of using PV modules to power high power rated appliances is cost. The cost of buying additional modules makes the use of PV modules unattractive for powering high power domestic appliances such as stoves and electric geysers.

This means that PV modules are best suited to providing small amounts of electricity for low-energy appliances such as lights, TVs, etc.

Are PV modules limited to supplying dc appliances ?

Most domestic appliances, such as washing machines, vacuum cleaners, television sets and refrigerators are designed to operate at the voltage at which grid electricity is supplied. In South Africa grid electricity is supplied to homes at 240 V ac. PV modules are usually designed to produce 12 V dc.

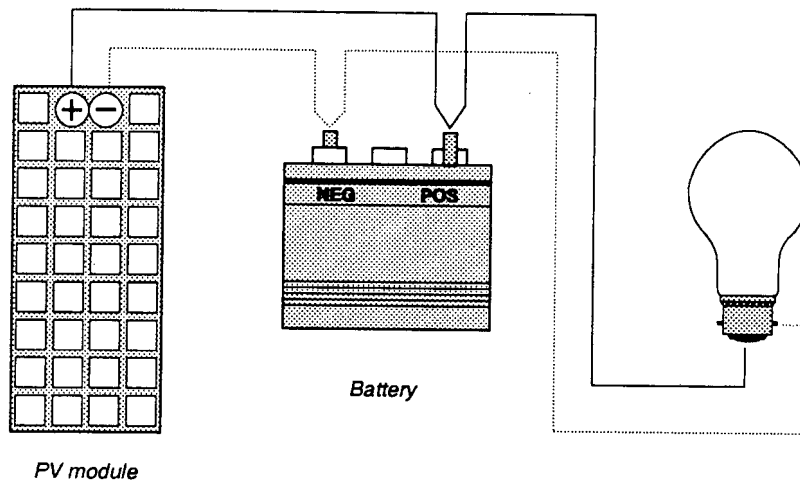

PV MODULE CONNECTED TO BATTERY AND LIGHT BULB

SECTION 4

COMPARING PV SYSTEM COSTS WITH OTHER ELECTRICITY GENERATING SYSTEMS

DISCUSSION QUESTIONS:

Student groups to consider the PV advertisement.

Why is the word free used so many times ?

Is solar electricity really free ?

TEACHER INPUT:

Solar energy is 'free' only once the PV system has been paid for and installed. Most of the costs of PV electricity are capital costs, that is the cost of buying and installing the system. Once the system has been installed, the operating or running costs are low, mainly because sunshine is free, and little maintenance is required.

ELECTRICITY FROM THE SUN

PHOTOVOLTAICS AS AN ELECTRICITY SUPPLY OPTION

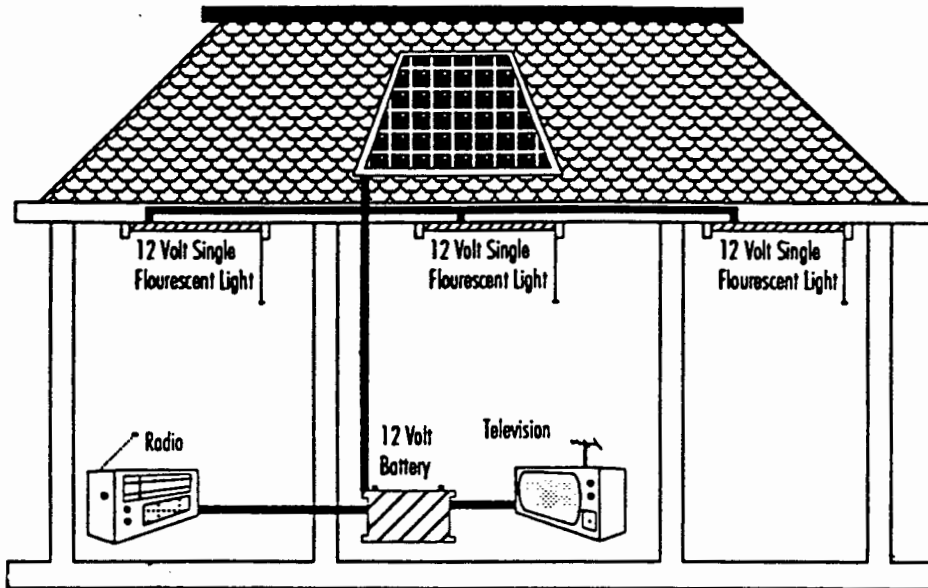

A PHOTOVOLTAIC MODULE MOUNTED ON A ROOF

Photovoltaic cells convert sunlight directly into electricity. Photovoltaic cells are made from silicon which is a common substance found in sand. Although silicon is cheap, before it can be used in making photovoltaic cells, it needs to be processed into a pure form. Usually, silicon crystals are grown, sliced into thin layers and then impregnated with chemicals to create oppositely charged layers. When sunlight strikes the impregnated layers electrons are freed and an electric current is generated. The impregnated substance is called a semi-conductor. The semi-conductor slices are connected together and covered with a sheet of strong glass for protection. This is called a photovoltaic (PV) panel or module .

If South Africa receives so much solar energy during a year why doesn't it get very hot ? What happens to this energy ?

In order to answer this question we have to consider the earth's energy balance.

THE EARTH'S ENERGY BALANCE

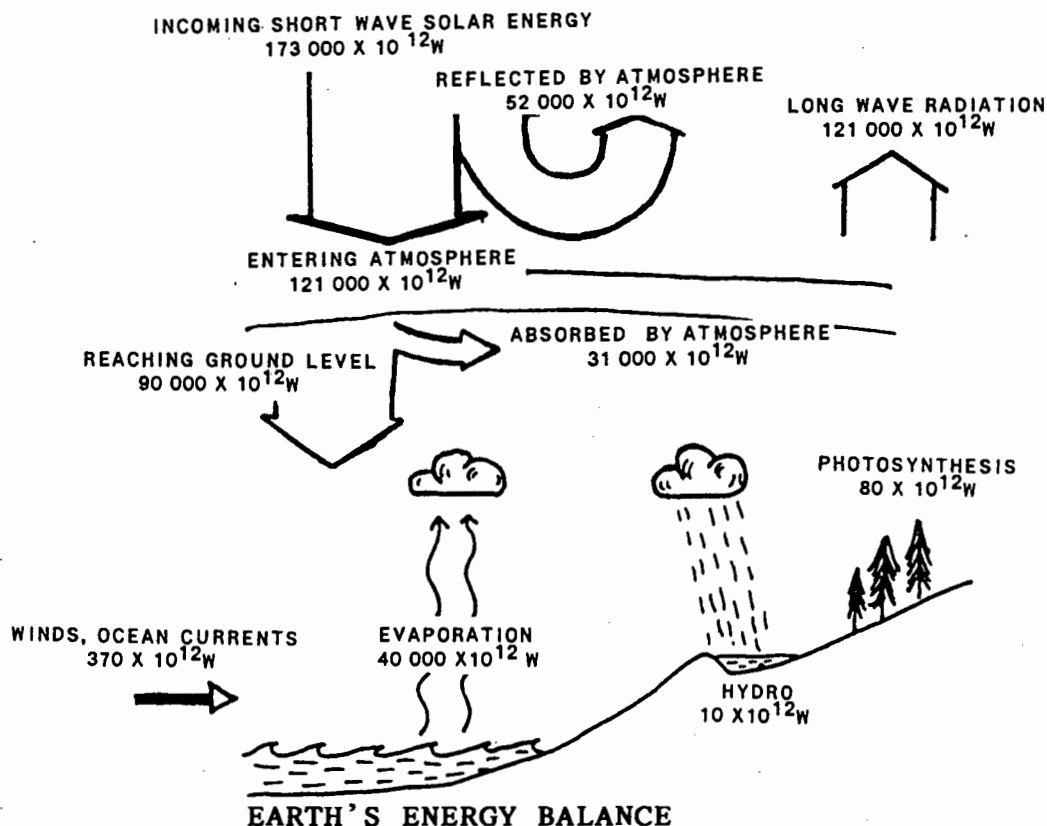

Study the diagram and summarise the main energy flows shown in the earth's energy balance diagram.

How long would it take for a single PV module to produce the amount of electrical energy needed to boil a kettle of water?

We need to know how much electrical energy is needed to boil a kettle of water. Assume we have an electric kettle with a power rating of 2 kW that takes 3 minutes to boil.

Calculate the electrical energy required to boil the water. Would you say it is practical to use PV electricity to boil a kettle of water using a single PV module ? Explain your answer.

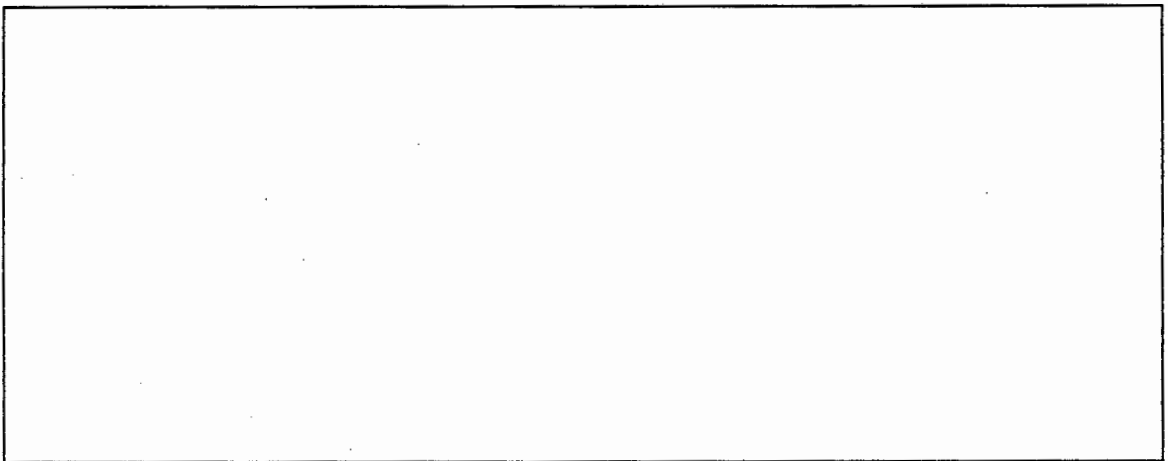

Remember these are ideal conditions. In practice the water would take even longer to boil as the kettle is not 100% efficient.

Delivering greater power

Instead of using a single PV module, a number of PV modules can be connected in an array. The total electrical power of an array is equal to the sum of power from each module.

Are PV modules are limited to supplying dc appliances ?

Most domestic appliances, such as washing machines, vacuum cleaners, television sets and refrigerators are designed to operate at the voltage at which grid electricity is

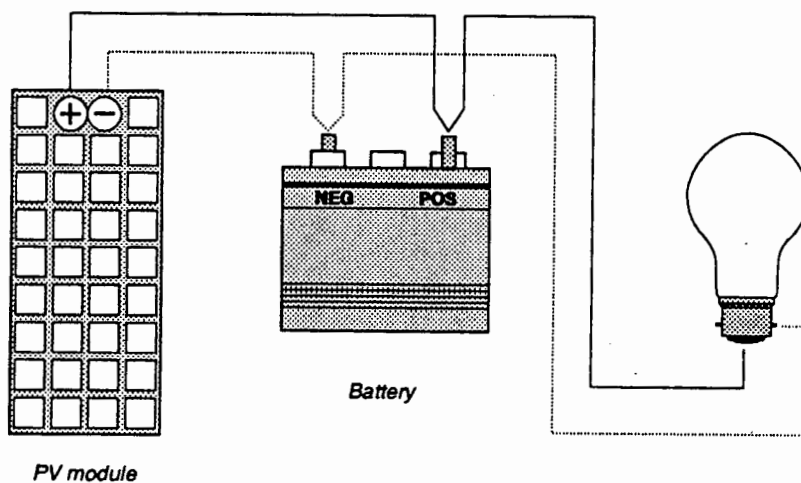

PV MODULE CONNECTED TO BATTERY AND LIGHT BULB

COMPARING PV SYSTEM COSTS WITH OTHER ELECTRICITY GENERATING SYSTEMS

Consider the advertisement for photovoltaics.

Why is the word free used so many times ?

Is solar electricity really free ?

Solar energy is 'free' only once the PV system has been paid for and installed. Most of the costs of PV electricity are capital costs, the costs of buying and installing the

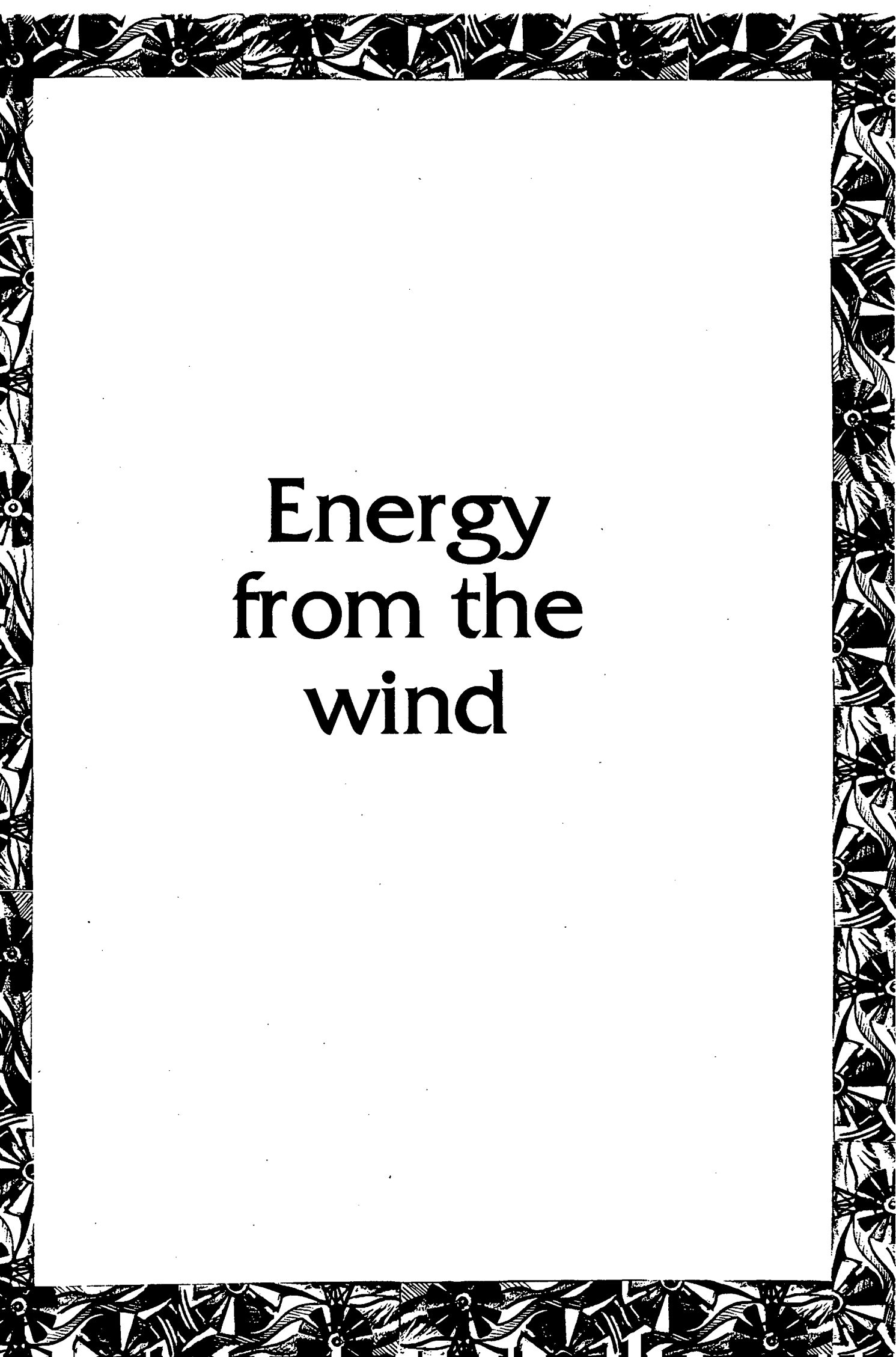

**Energy
from the
wind**



Wind generators

ENERGY FROM THE WIND

AIMS:

To discuss the origin of winds.

To consider wind energy as a renewable energy option.

To consider South Africa's wind energy potential.

To introduce wind generators and to consider their suitability for providing electricity in the South African context.

INTEGRATING SYLLABI

This workshop could serve to integrate geography (wind flows), mathematics (exponential relationships) and physical science (energy conservation).

ESTIMATED TIME: 2 Hours

THIS WORKSHOP COMPRISES FOUR SECTIONS

- 1) INTRODUCING WIND POWER
- 2) SOUTH AFRICA'S WIND RESOURCE
- 3) POWER IN THE WIND
- 4) WIND GENERATORS

RESOURCES PROVIDED:

- Student Worksheet: 'Energy from the Wind'
- Image of a water pumping windmill.
- Image of wind-generators.
- Map of South Africa showing average wind speeds.

There are some areas in South Africa where the wind resource compares fairly well with regions of the world where wind energy is being successfully exploited.

Unfortunately, many inland areas do not receive strong regular winds.

South Africa also has an abundance of cheap coal and hence relatively cheap grid electricity. This reduces the economic attractiveness of wind-generators as an option for electricity grid connection.

However, on a small scale wind is an attractive source of power, particularly in rural areas which are distant from the electricity grid.

THE ORIGINS OF WIND

Note : This section is suitable for Standard 9 students who are familiar with Boyle's Law.

DISCUSSION QUESTION:

What causes air to move in and out of our lungs?

Breathing in

The diaphragm moves downward causing the lungs to expand. This causes the air pressure in the lungs to drop below the air pressure outside. Air from the outside moves into the lungs to equalise the pressure difference.

Breathing out

The diaphragm rises, contracting the lungs and hence increasing the air pressure inside the lungs. As the air pressure in the lungs is greater than the air pressure outside, air moves out of the lungs.

At the sea shore there is generally an air flow from the land to the sea at night and from the sea to the land during the day. This diurnal air flow can be strong and dominate the general wind pattern of the region. Reasons for these breezes are shown in the diagrams below.

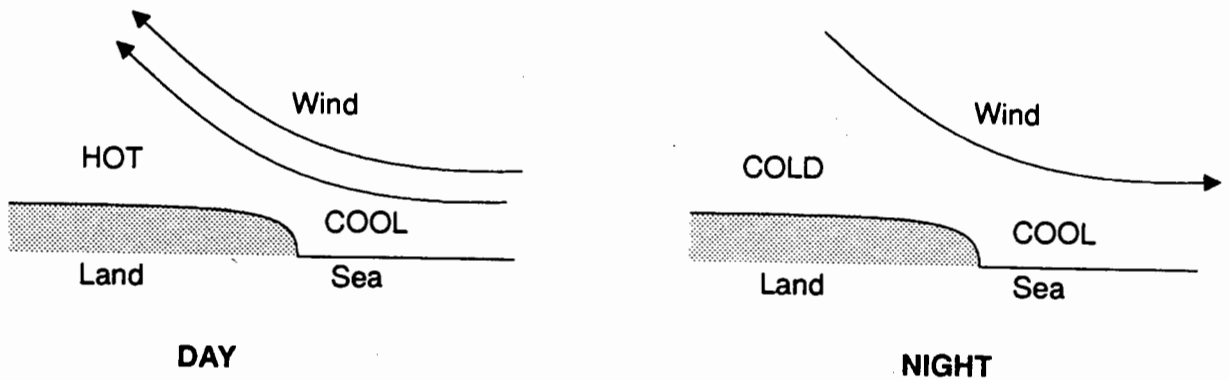

DIURNAL AIR FLOW

SECTION 2 SOUTH AFRICA'S WIND RESOURCE

DISCUSSION QUESTIONS:

What sort of winds provide the best energy source ?

Strong steady winds provide a good reliable source of energy.

Do such winds exist ?

Unfortunately not, although quite strong winds are experienced in coastal areas.

In order to determine whether the wind resource is a suitable energy source scientists consider average wind speeds.

SECTION 3

POWER IN THE WIND

TEACHER INPUT:

Everyone realises that there is more power in a strong wind than in a light breeze. The available power in the wind is derived from the kinetic energy of air molecules and particles.

Note: The following explanation of why the power is proportional to the cube of the wind speed may be omitted. Teachers can present this power/velocity relationship without explanation.

The energy in wind is due to the kinetic energy of moving air.

This is given by;

$Ke = 0.5 mv^2$, where m is mass and v is velocity.

The mass of air flowing through an area A per second is given by :

ρAv , where ρ is the air density.

Therefore the power in a cross-sectional area normal to the wind is given by:

$$P = 0,5\rho v^3$$

Hence the power in the wind is proportional to the cube of the wind speed.

DISCUSSION QUESTIONS:

How does a windmill extract energy from the wind ?

By slowing the wind down. The kinetic energy in the wind is transferred to kinetic energy of the windmill.

What could be done to supply electricity when the wind drops or even stops ?

The wind-generator could be connected to a rechargeable battery storage system. When the wind blows the batteries are charged. When the wind stops the batteries provide electricity.

A wind-generator could also be combined with a diesel generator. Using this combination, diesel fuel can be saved. If large wind-generators are connected to the national electricity grid, energy storage isn't necessary. The wind-generators contribute power whenever sufficient wind is available.

TEACHER INPUT:

Large wind-generators are intended for connection to the electricity grid. Wind-generators arranged together are called a wind farm or park. There are approximately 400 wind farms around the world, most of them in North America and Europe.

To date, the United States is in the forefront of wind energy utilisation. Approximately 14000 wind-generators have been installed in California where generous government tax incentives increased the economic attractiveness of wind generated electricity.

ENERGY FROM THE WIND

INTRODUCING WIND POWER

A brief history of wind power

Historical evidence indicates that windmills were being used in Persia and China for water pumping and milling grain over four thousand years ago. In South Africa most wind energy is used for pumping water.

The first windmill to produce electricity was built in Denmark in 1890. The first electricity producing windmills were capable of producing only small amounts of electrical power. The extensive use of coal and oil to generate electricity, reduced interest in wind power as a source of generating electricity.

During the early 1970's when oil prices rose sharply and people began to question the world's reliance on non-renewable fossil fuels, interest in wind power was again aroused. Wind energy programmes were established in most European nations and in the United States. Both private companies and governments have carried out research on wind-generators. Larger wind-generators, some capable of producing megawatts of electric power have been installed in a number of countries.

There are some locations in South Africa where the wind resource compares fairly well with regions of the world where wind energy is being successfully exploited. Unfortunately, many inland areas do not receive strong regular winds.

Why have the wind speeds been recorded 10 m above to ground ?

Study the map and choose three locations for siting wind turbines.

POWER IN THE WIND

Everyone realises that there is more power in a strong wind than in light breeze. The available power in the wind is derived from the kinetic energy of air molecules and particles. The energy in wind is due to the kinetic energy of moving air.

This is given by;

$$K_e = 0.5 m v^2, \text{ where } m \text{ is mass and } v \text{ is velocity.}$$

It can be shown that the power in the wind is proportional to the cube of the wind speed.

$$P \propto v^3$$

This means that small increases in wind speed produce large increases in available wind power.

By slowing the wind down. The kinetic energy in the wind is transferred to kinetic energy of the windmill.

Do you think all the energy could be extracted from the wind ?

How does the generating capacity of a large 3 MW wind-generator compare with the generating capacity of Eskom's coal fired power stations ?

Eskom's coal-fired power stations generate up to 3000 MW of electrical power.

In order to produce the same amount of power, one hundred 3 MW wind-generators would have to be built.

What could be done to supply electricity when the wind drops or even stops?

The wind-generator could be connected to rechargeable battery storage system. When the wind blows the batteries are charged. When the wind stops the batteries provide electricity. A wind-generator could also be combined with a diesel generator. Using this combination, diesel fuel can be saved.

If large wind-generators are connected to the national electricity grid, energy storage isn't necessary. The wind-generators contribute power whenever sufficient wind is available.

Large wind-generators are intended for connection to the electricity grid. Wind-generators arranged together are called a wind farm or park. There are approximately 400 wind farms around the world, most of them in North America and Europe.

To date, the United States is in the forefront of wind energy utilisation. Approximately 14000 wind-generators have been installed in California where generous government tax incentives increased the economic attractiveness of wind generated electricity.

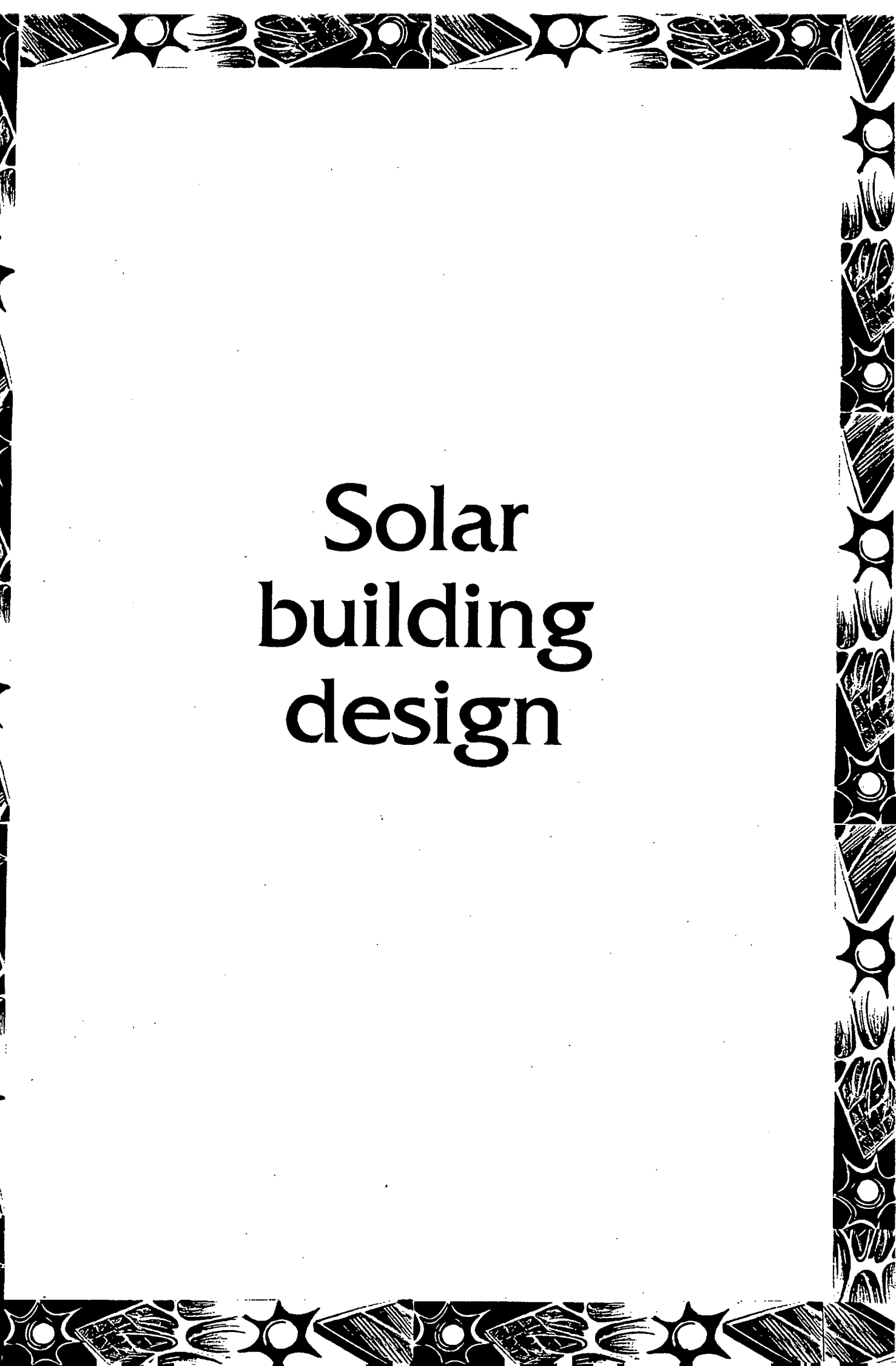

Solar building design

Traditional thatch dwelling

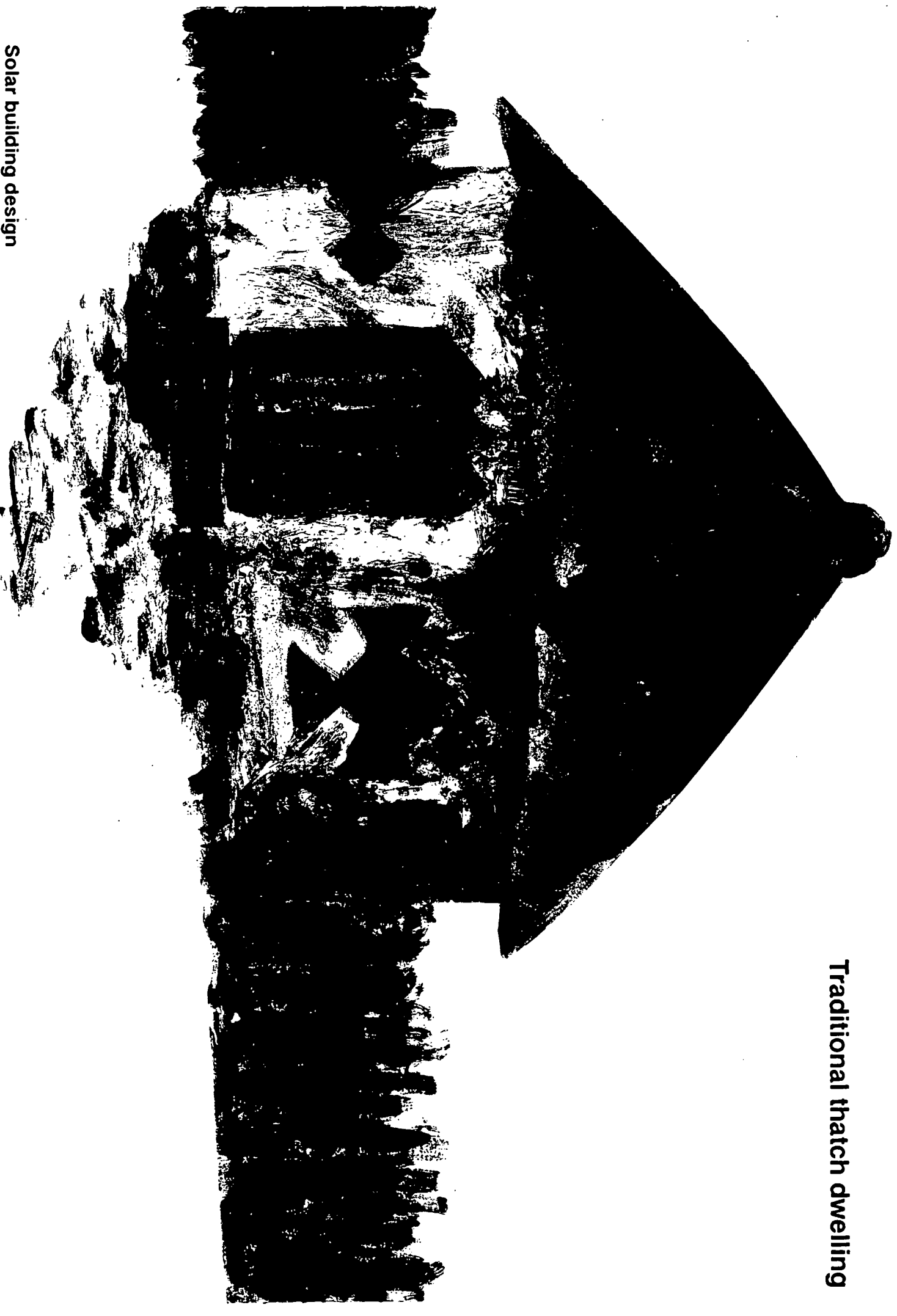

The Trombe-Michel wall design

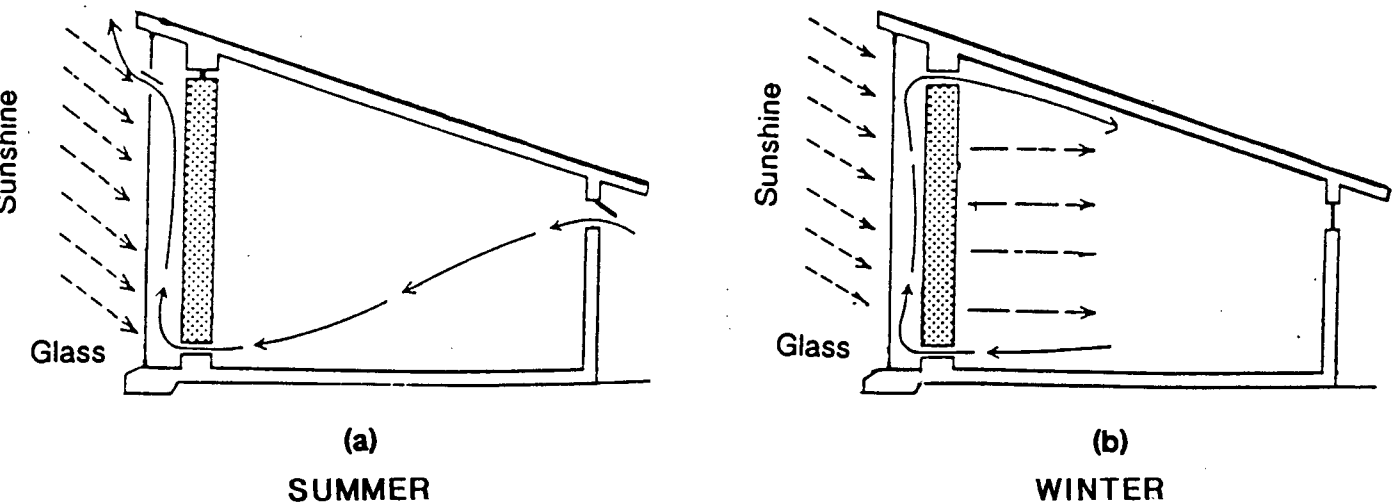

Summer conditions: Both air-vents are open.

Warm air moves upwards between the wall and the glass and moves out of the vent. This air is replaced by cool outside air which enters through the air vent opposite the wall. This system is suited to hot summer conditions.

Winter conditions: Both air-vents are closed.

Air warmed by the sun cannot escape and enters the room through the wall vent. As this air circulates it is continually warmed by the sunshine.

The Marseilles wall design

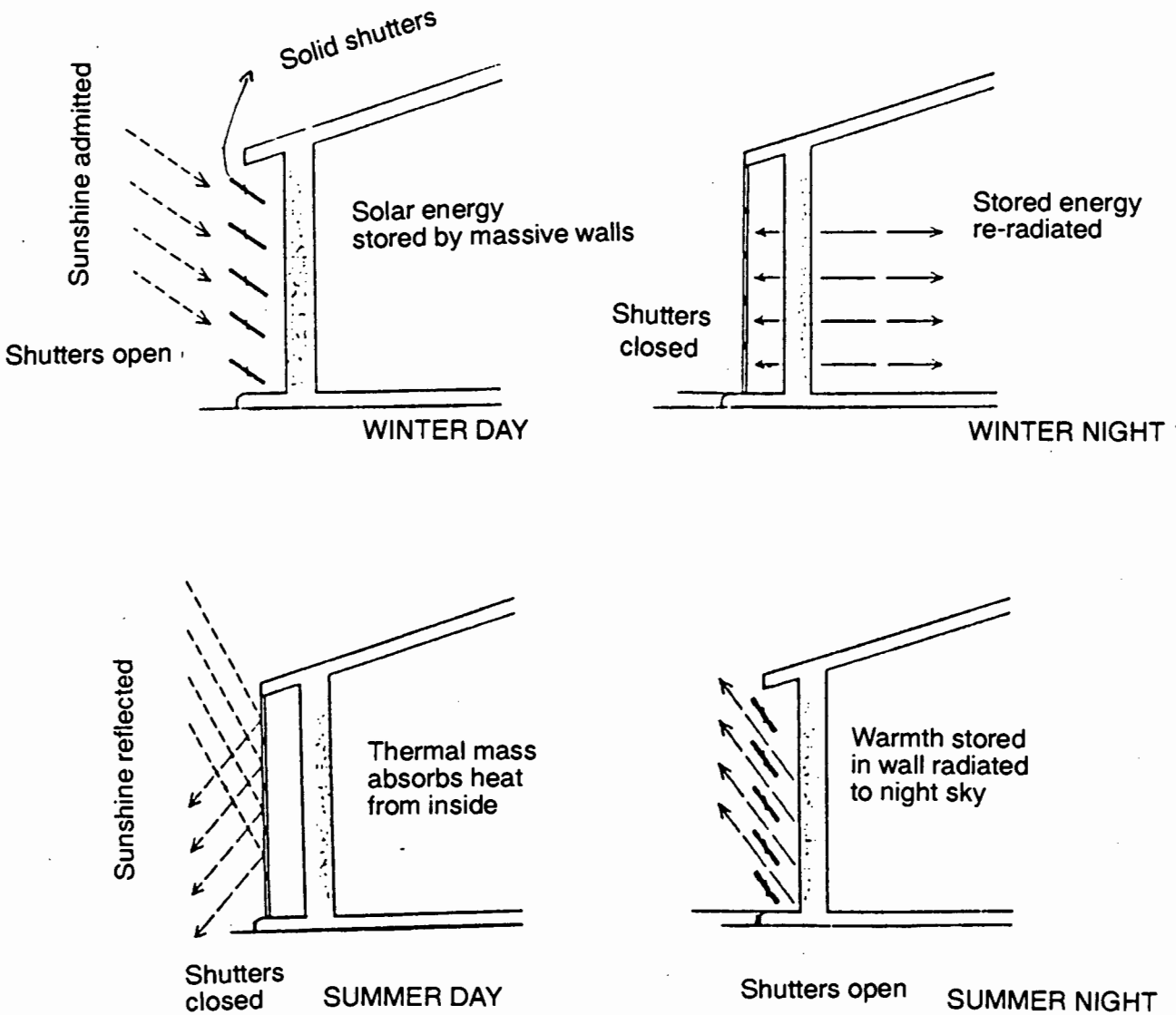

The four different diagrams show how the Marseilles wall can be used on a winter day, winter night, summer day and summer night.

Label the diagrams accordingly and explain how the different design configurations work.

SOLAR BUILDING DESIGN

AIMS:

To consider the importance of solar design, particularly with regard to improving comfort levels of dwellings and reducing space heating costs.

To introduce scientific principles associated with solar design. These include:

- conduction, convection, radiation, reflectivity and thermal capacity.

ESTIMATED TIME: 2 Hours

THIS WORKSHOP COMPRISES FOUR SECTIONS

- 1) INTRODUCING SOLAR DESIGN
- 2) THE MOVEMENT OF HEAT
- 3) USING SOLAR DESIGN
- 4) DESIGN FEATURES FOR HEATING AND COOLING BUILDINGS

RESOURCES PROVIDED:

Images of:

- a wood and iron shack,
- a traditional thatch dwelling.

STUDENT HANDOUTS:

- Trombe-Michel wall designs.
- Marseilles wall designs.

RESOURCES REQUIRED:

- paint or other substance to darken outside of a water container,
- water container,
- thermometer.

Since most of South Africa's electricity is generated by coal-fired power stations the use of electrical appliances is not pollution free.

Appliances which have naked flames are hazardous. Every year many people are burnt by candles, gas stoves and paraffin appliances. Also, many young children are treated for paraffin poisoning every year.

Costs of keeping a house warm depend on the type of heating appliance used and duration for which it is used. Whether a fuel is viewed as cheap or expensive will depend on how wealthy the users are. Poor people are known to spend a good deal of their incomes on heating appliances and fuels. Wood is collected for free in many areas, where it has to be bought it can also be expensive.

TEACHER INPUT:

Another way of improving comfort levels in buildings is to design and construct buildings in a way which makes use of sunshine. Sunshine is a free and abundant energy source. Solar Design is concerned with using sunshine to make buildings comfortable to live and work in. Well designed buildings could reduce the need for expensive, energy consuming appliances.

Solar design would be of direct benefit to the poor. One reason for this is that poor people often live in badly designed and badly sited houses. Many poor people in South Africa live in shanties, houses built by the people themselves with whatever materials are available. Others live in poorly designed low cost housing provided by the state. For example, the houses built when townships such as Soweto and Khayelitsha were established.

CONDUCTORS AND INSULATORS

Tea is poured into a metal cup and a polystyrene cup. Which cup will become hotter ? Why ?

Note: Teachers could demonstrate this.

The metal cup. Metal is a good conductor of heat whereas polystyrene is a poor conductor of heat.

Metals are good conductors because they have a chemical structure which allows an easy transfer of kinetic energy between atoms.

Polystyrene consists mostly of air, as air is poor conductor so is polystyrene.

A substance which is a poor conductor of heat is called an insulator.

STUDENT ACTIVITY:

Students to name 3 good insulators and 3 good conductors.

INSULATORS

air
wood
asbestos
polystyrene
newspaper

CONDUCTORS

water
metal
glass

RADIATION AND CONVECTIVE HEAT FLOW

A fire made in one part of a room often warms the entire room. How does this happen ?

Heat from a fire warms a room through convection and radiation.

Convection is the transfer of heat from one point to another by the mixing of one portion of the air with another. Convection also occurs in liquids.

Radiation is the transfer of heat from a hot body by means of wave motion through space. Sunshine is a form of radiation. When you feel the 'glow' of a fire, you are feeling the radiation from the fire.

THERMAL INERTIA

TEACHER INPUT:

The ability of a body to retain heat is known as its thermal inertia. Different substances have different thermal inertias.

DISCUSSION QUESTION:

A stone floor and a wooden floor are exposed to the sun during the day. After sunset which will retain its heat longer?

The stone floor - it has a higher thermal inertia. Concrete and tar also have a high thermal inertia. For this reason city centres remain warm after sunset.

ORIENTATION

In the Southern Hemisphere, south of the Tropics the sun remains in the northern part of the sky. The side of the building facing north thus receives the most sunshine.

TEACHER INPUT:

By facing walls with windows towards the north the Green House Effect can be used to warm the dwelling in winter. In summer, if the house gets too hot the windows could be shaded from the sun.

SECTION 4

DESIGN FEATURES FOR HEATING AND COOLING BUILDINGS

THE TROMBE - MICHEL AND MARSEILLES WALL DESIGNS

TEACHER INPUT:

You might have noticed that a stone placed in a fire will remain heated for long time after the fire has died down.

This design uses the thermal inertia of a wall to keep temperatures cool in summer and warm in winter.

STUDENT ACTIVITY:

Handout 1 shows a Trombe - Michel Wall design.

Students to explain how the Trombe - Michel Wall works.

Students to discuss which design configuration is best suited to winter/summer conditions.

Hints:

What happens to air if it is heated ?

What purpose do the vents serve ?

Handout 2 shows the Marseilles Wall design.

The four different diagrams show how the Marseilles Wall can be used on a winter day, winter night, summer day and summer night.

Students to label the diagrams accordingly and explain how the different design configurations work.

SOLAR BUILDING DESIGN

PHYSICAL COMFORT IN BUILDINGS

We all would like to live and work in comfortable conditions. Buildings that people live and work in aim to protect the occupants from the extremes of the outside environment. A house, office, classroom or factory is supposed to provide a comfortable environment. Not all buildings do this, some buildings are cold when it's cold outside and hot when it's hot outside.

People living in homes which have electricity have the option of using electrical appliances such as heaters, fans and air-conditioners.

People without electricity, many of them poor, use coal, wood, gas, oil, and paraffin appliances to warm their homes. They also make open coal or wood fires.

Burning fuels such as wood and coal results in smoke and soot. In winter, when most coal is burnt in townships, calm climatic conditions, especially in the Transvaal prevent smoke and soot from blowing away.

Since most of South Africa's electricity is generated by coal-fired power stations the use of electrical appliances is not pollution free.

Appliances which have naked flames are hazardous. Every year many people are burnt by candles, gas stoves and paraffin appliances. Also, many young children are treated for paraffin poisoning every year.

THE MOVEMENT OF HEAT

Conductive heat flow

After hot tea has been poured into a cup the cup becomes warm. Why?

Heat has been transferred from one body (the tea) to another body (the cup). The outside of the cup becomes hot as heat is transferred through the cup. This type of heat flow is known as **conductive heat flow**.

Conductive heat flow is the transfer of heat from one part of a body to another part of the same body, or between bodies in contact with each other.

ACTIVITY:

List some other examples of conductive heat flow.

Conductors and insulators

Hot tea is poured into a metal cup and a polystyrene cup . Which cup will become hotter? Why?

The metal cup. Metal is a good conductor of heat whereas polystyrene is a poor conductor of heat.

Metals are good conductors because they have a chemical structure which allows an easy transfer of kinetic energy between atoms. Polystyrene consists mostly of air, as air is poor conductor so is polystyrene.

A substance which is a poor conductor of heat is called an **insulator**.

Hence, the seats, steering wheel etc warm up.

All hot bodies radiate heat. The radiation from the interior of the car consists of long wave infra-red rays. As these cannot pass through glass most of this radiation remains trapped inside the car. Thus the air inside the car becomes hotter than the air outside. This is known as the Green House Effect.

Thermal inertia

The ability of a body to retain heat is known as its thermal inertia. Different substances have different thermal inertias.

QUESTION:

If stone floor and wooden floor are exposed to the sun during the day, after sunset which will retain its heat for longer? Explain why?

Orientation

In the Southern Hemisphere, south of the Tropics, the sun remains in the northern part of the sky. The side of the building facing north thus receives the most sunshine.

By facing walls with windows towards the north the Green House Effect can be used to warm the dwelling in winter. In summer, if the house gets too hot the windows could be shaded from the sun.



**Biogas —
energy from
waste**

FLOATING GAS HOLDER INDIAN BIOGAS PLANT

The Indian biogas programme has been vigorously promoted. There are around 120 000 digestors in operation and the programme is continuing.

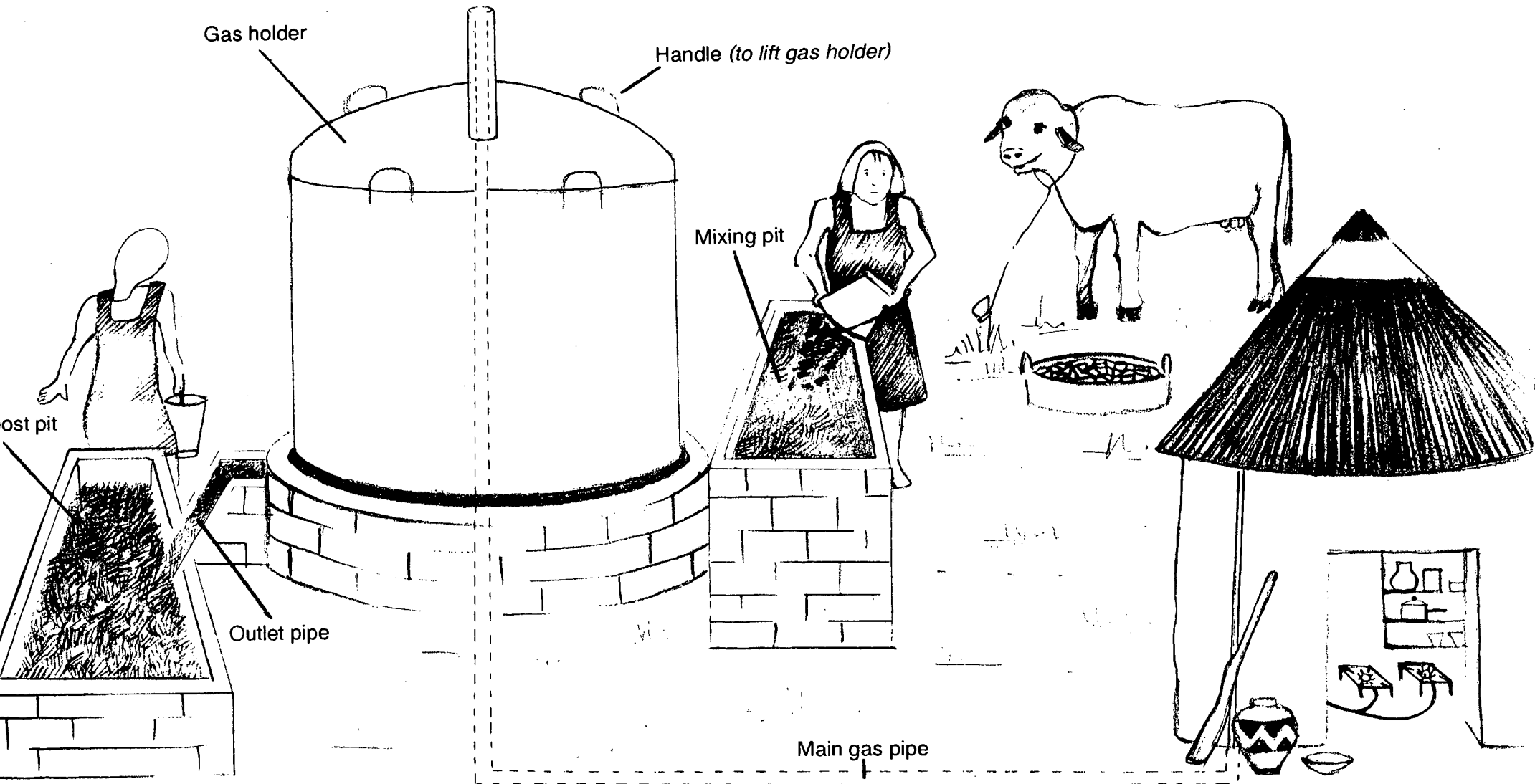

BIOGAS – ENERGY FROM WASTE

AIMS:

To introduce aspects of the fuelwood crisis that exists in South Africa's underdeveloped rural areas.

To discuss problems related to a diminishing fuelwood supply.

To discuss the need for an alternative energy supply option.

To present biogas as an option for rural domestic energy supply.

To introduce aspects of the chemistry and technology of biogas formation.

ESTIMATED TIME : 2 Hours

THIS WORKSHOP COMPRISES FOUR SECTIONS

- 1) INTRODUCING BIOGAS
- 2) THE CHEMISTRY OF BIOGAS PRODUCTION
- 3) FACTORS INFLUENCING BIOGAS PRODUCTION
- 4) ROLE PLAY – PROMOTING BIOGAS IN RURAL AREAS

INTEGRATING SYLLABI

This workshop could serve to integrate aspects of the Biology (Anaerobic digestion) and Physical Science (Organic chemistry) syllabi.

RESOURCES PROVIDED:

- Student Worksheet: 'Biogas - Energy from Waste'
- Image showing women carrying wood.
- Image of Biogas plant being loaded.

RESOURCES REQUIRED:

- See Biogas Experiment: Page 12

and gas might not be possible because they are either not available or too expensive.

Electricity is certainly the most convenient option. However, many rural areas are far from the electricity grid and the cost of extending the grid is very high.

Note: See 'LIVING WITHOUT ELECTRICITY' for more information on the costs of electrification.

Without large scale government subsidisation the electrification of rural areas cannot occur. Other energy supply options need to be considered. Biogas is one such option.

SECTION 2

THE CHEMISTRY OF BIOGAS PRODUCTION

TEACHER INPUT:

When green plants absorb sunshine the process of **photosynthesis** produces sugars such as glucose. In this process, energy from the sun is used to break down carbon dioxide and water and produce complex organic molecules such as sugar. The chemical energy stored in sugar is released through respiration when the sugar molecules react with oxygen.

Some of this energy is used to convert the remaining sugar molecules to even more complex molecules as cellulose. Cellulose is a chain of complex molecules which are high in chemical energy. Grass contains cellulose.

Cellulose molecules have the general formula: $(C_6H_{10}O_5)_n$, where n is the number of units in the chain.

TEACHER INPUT:

How Biogas Digesters work

This workshop considers the floating gas holder Indian type digester shown below.

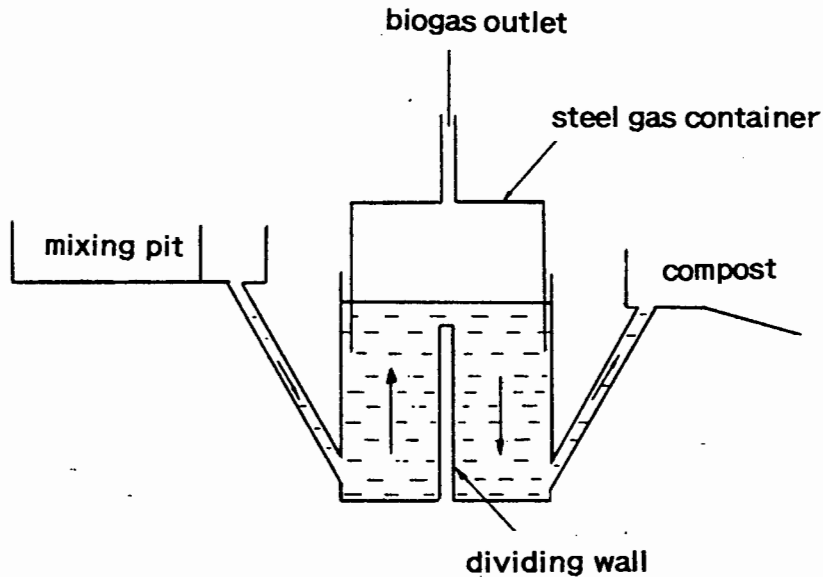

INDIAN TYPE DIGESTER

Waste material and water are placed in the mixing pit. Gas produced is trapped by the steel gas container which floats on the waste mix. As the container is free to move up or down the gas pressure inside the container remains constant. Gas is piped from the gas outlet to where it will be needed.

The container is painted with an anti-corrosion paint to reduce rusting. Once anaerobic digestion has occurred, the spent slurry is removed from the slurry channel. Spent slurry is rich in nitrogen and makes an excellent fertiliser.

Students to consider the image of the digester being loaded.

DISCUSSION QUESTION:

What are the different people in the picture doing?

One person is adding waste to the digester while the other is removing compost.

SECTION 3

FACTORS INFLUENCING BIOGAS PRODUCTION

DISCUSSION QUESTION:

Why is it important for a Biogas digester designer to know how much biogas is produced ?

Biogas plants are designed to meet a certain energy need. For example, to provide enough gas to cook 3 meals a day for ten people and lighting the house at night. The designer then sizes the plant so that enough biogas is produced.

The amount of biogas produced in a digester depends on many factors. Biogas plant designers must be aware of these factors which include :

- Temperature

Bacterial activity is sensitive to temperature. Production of biogas is greatest when temperatures are high and uniform, (eg 33⁰C). Simple biogas digesters are best suited to operate in warm regions such as tropical or temperate regions. At latitudes as high as 20⁰ - 30⁰, winter gas production generally falls to less than half summer production.

DISCUSSION QUESTIONS:

Are South Africa's winter temperatures warm enough to produce Biogas ?

Some inland areas of South Africa experience below zero night time temperatures. Other areas such as Northern Natal experience warm enough temperatures throughout the year.

Students to consider graph of Biogas yield versus Retention time and temperature (Page 4 Student Worksheet).

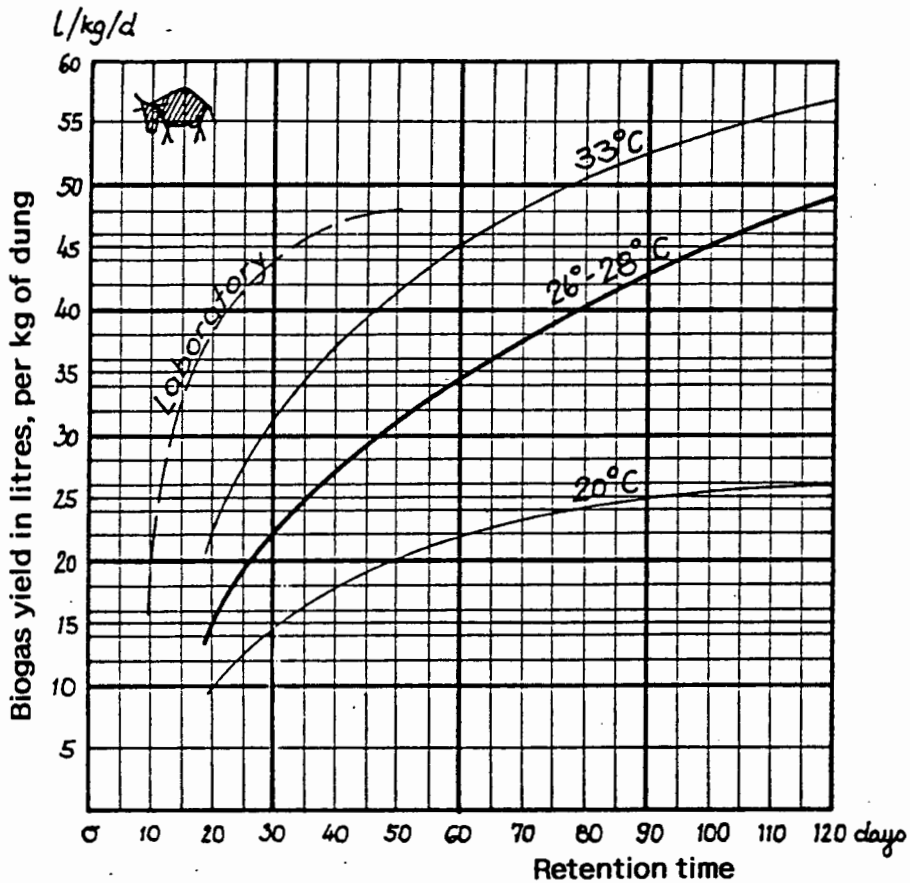

Biogas yield versus Retention time and temperature

Compare the biogas yield for 1kg of cow dung at a digester temperature of 20°C and a retention time of 30 days with the biogas yield at a digester temperature of 33°C and a retention time of 100 days.

At 20°C and a retention time of 30 days,
biogas yield = 14 kg biogas.

At 30°C and a retention time of 100 days,
biogas yield = 55 kg biogas.

Improved hygiene

The following organisms are killed in biogas plants:

- typhoid, cholera, dysentery in two weeks,
- hookworm and bilharzia in three weeks,
- tapeworm and roundworm die completely when the slurry is dried in the sun.

SECTION 4

ROLE PLAY – PROMOTING BIOGAS IN RURAL AREAS

Aims:

To enable students to engage in critical debate concerning issues of biogas use in rural areas,

To provide a forum for evaluating the workshop.

Student Activity:

Three students are chosen to be engineers who work for a government development agency promoting the use of biogas in rural areas.

Three other students are chosen to be representatives of a Village Management Board. Ask these students to take a conservative position, resisting social change.

The development engineers must present an argument supporting biogas as a suitable energy supply option while the Management Board members raise problems.

Development engineers must explain ;

- what biogas is,
- how biogas is made,
- how it can be used,
- costs of building a biogas digester, approximately R3000 for a domestic plant. Government is prepared to pay the initial capital costs.
- cost of buying cast iron cookers R40 each. People must buy their own cookers and any other appliances they might need.

Things to remember :

- Bacterial activity is sensitive to temperature, best results occur if the temperature is kept between 30⁰C-35⁰C. Find ways of keeping the temperature steady. Try to arrange a solar heating device. Keeping the brew near a sunny window might help. How could the temperature be maintained during the night ?

- Bacteria need water. The compost should be mixed 1:1 with water.

- Make sure none of the tubes become blocked.

- Methane molecules are small and can escape easily. Your apparatus should be gas-tight.

- If there is air in the compost container, carbon dioxide will be produced and not methane. You will have to wait for a week or so before biogas is produced.

BIOGAS – ENERGY FROM WASTE

The Struggle for Energy in Rural Areas

In South Africa many people living in underdeveloped areas rely on wood to meet energy needs. Wood used for cooking and heating is called fuelwood.

Years ago, people collected only dry branches from forests and bushes near their homes. Today the land has to support more people. Living forests and trees are cut down for fuelwood and to clear land for agricultural use.

In many areas, wood can no longer be considered a renewable energy resource as trees are not growing fast enough to replace the trees being cut down.

As natural forests are destroyed fuelwood gatherers, mostly woman and children, spend many hours collecting and carrying fuelwood.

This struggle for wood for cooking and heating can be called an energy crisis. Changing to other fuels such as paraffin and gas might not be possible because they are either not available or too expensive.

Electricity is certainly the most convenient option. However, many rural areas are far from the electricity grid and the cost of extending the grid is very high.

Without large scale government subsidisation the electrification of rural areas cannot occur. Other energy supply options need to be considered. Biogas is one such option.

In order to make biogas, animal, human and food wastes and crop leftovers are mixed with water in a specially designed container called a digester.

The digester below is an Indian type digester which has a floating gas holder. Waste material and water are placed in the mixing pit. Gas produced is trapped by the steel gas container which floats on the waste mix. As the container is free to move up or down the gas pressure inside the container remains constant. Biogas is piped from the gas outlet to where it will be needed.

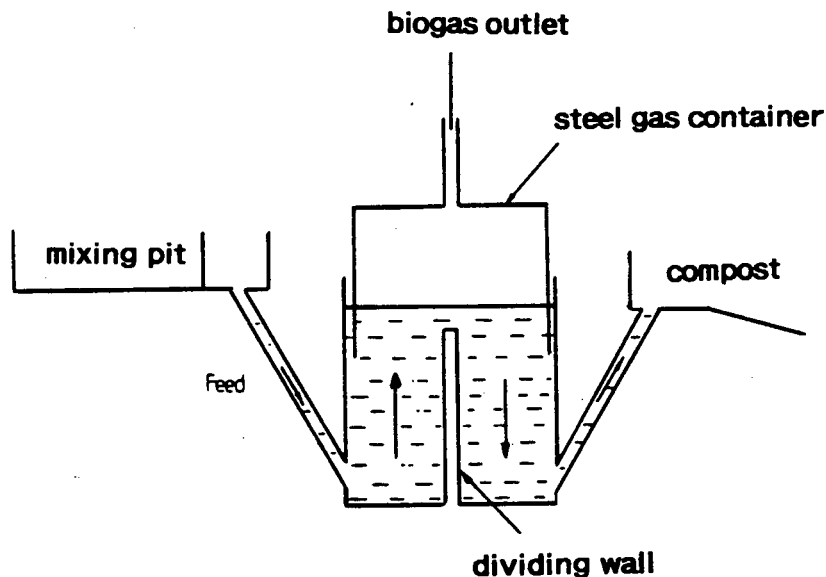

INDIAN TYPE DIGESTER

A CLOSER LOOK AT BIOGAS

Methane is the inflammable component of biogas. Under good conditions, 60% of the gas produced is methane. Biogas is easy to make on farms, as a wide range of organic waste materials in the form of vegetable and animal wastes are available.

Biogas is a good fuel which can be used for cooking, heating and lighting in the home. Biogas can even be used instead of petrol in vehicles. In India and China biogas is used as a fuel by over 70 million people.

Consider graph of biogas yield versus retention time and temperature shown below.

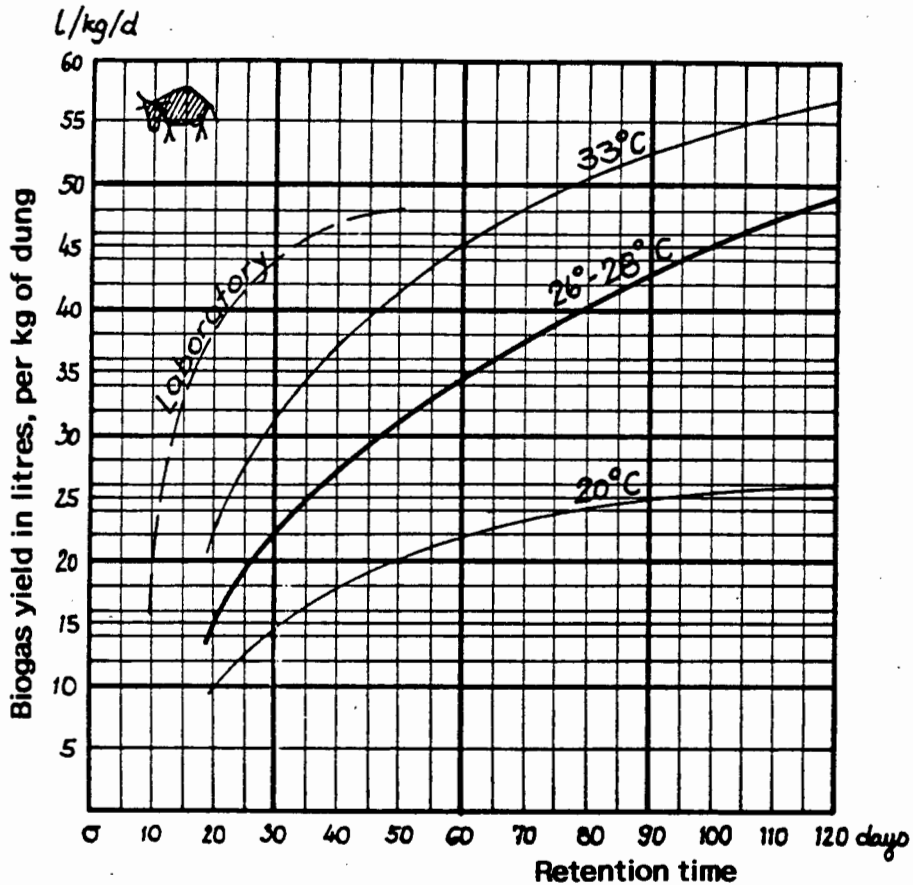

Compare the biogas yield for 1kg of cow dung at a digester temperature of 20°C and a retention time of 30 days with the biogas yield at a digester temperature of 33°C and a retention time of 100 days.

At 20°C and a retention time of 30 days, biogas yield =

At 30°C and a retention time of 100 days, biogas yield =

- Carbon : Nitrogen Ratio

All living organisms need nitrogen with which to form proteins. Carbon and nitrogen need to be present in the diet in the correct proportions. If there is too little nitrogen, the bacteria will be unable to use all the carbon and the process of breaking down the waste matter will be inefficient. If there is too much nitrogen, it accumulates as ammonia (NH₃) which can kill methane producing bacteria. The optimum C:N ratio is between 20 and 30 to 1.

APPENDIX 2

Energy Workshop Evaluation Sheets

ENERGY EDUCATION PACKAGE

Comment Sheet

Name: _____

Read through the aims of the package relating to the promotion of scientific and technological awareness.

Do you support these aims ? Explain your answer.

These workshops have been designed to be presented in way which contextualises science, draws on the everyday experiences of students, and encourages dialogue and student participation in the classroom. Comment on this teaching methodology.

Do you foresee difficulties with this style of presentation ? Explain.

Comment on the selection of energy as a central theme.

Comment on the selection of energy topics on which the workshops have been developed. Are there any which you feel are particularly useful/irrelevant? Explain why.

Do you consider the issues dealt with in the workshops to be relevant to student needs? Explain.

Are there any topics with which you are not familiar? List these.

Would a lack of knowledge/understanding of this issues influence your motivation to teach these topics? Explain.

Would you use these workshops in your classroom ? Explain your answer.

Would you, as a teacher, like to be involved in curriculum development initiatives such as this one ? Explain.

Are there any other comments you wish to make regarding this innovation?

COMMENTS ON AN INDIVIDUAL WORKSHOP

Name: _____

Now that you have worked through the workshop, critically comment on the following:

-usefulness/relevanceof the workshop theme,

-workshop aims,

- complexity of concepts and issues,

Which Standard would the workshop be suitable for ?

Suggest ways in which this workshop could be improved.

You have worked through two workshops. What do you think the general aims of this innovation are ?

Are there any other general comments you wish to make ?

Images:

- Are they useful ?
- Will they work ?
- Are they clear enough ?
- Are more images needed ?

Layout: any comments ?

Readability: any comments ?

Time of presentation: any comments ?

Comment on the student worksheet in terms of:

usefulness,
complexity of questions,
readability,
layout.

You have worked through two workshops. What do you think the general aims of this innovation are ?

Suggest ways in which this workshop could be improved.

Are there any other general comments you which to make ?