

17

ABRASIVE WEAR TESTING OF STEELS IN SOIL

by

S.J. Quirke

A thesis submitted to the Faculty of Engineering,
University of Cape Town in fulfilment of the degree
of Master of Science in Applied Science.

Department of Materials Engineering
University of Cape Town

Apr 11 1987

The University of Cape Town has been given
the right to reproduce this thesis in whole
or in part. Copyright is held by the author.

The copyright of this thesis vests in the author. No quotation from it or information derived from it is to be published without full acknowledgement of the source. The thesis is to be used for private study or non-commercial research purposes only.

Published by the University of Cape Town (UCT) in terms of the non-exclusive license granted to UCT by the author.

ACKNOWLEDGEMENTS

This project has been made possible by a large group of people and I would like to thank those in industry, the Department of Materials Engineering at the University of Cape Town and friends who have helped to complete this work. I particularly wish to thank:

Mr Dave Parker for so readily allowing me to use his farm and equipment for testing. I would also like to thank his staff for being so helpful in carrying out requests, some of which must have seemed rather strange.

Messrs A Andrag and Sons who provided most of the specimens for testing and also undertook to build the test rig used in this project. In this regard, I would especially like to thank Mr Peter Elliot and Mr Willie Roux for all their assistance.

All my associates in the Department of Materials Engineering, most of whom found themselves involved in this work at one time or another. Mrs Helgard Böhm, Mrs Anne Ball, Mr Andrew Rapley, Mr Nick Dreze and Mr Bernie Greeves all require mention. My friend and associate Mr Keith Barker gave me much advice which I greatly appreciate. I would especially like to thank Professor Colin Allen for his guidance and encouragement.

Dr Terry Eyre of Brunel University and Dr Martin Moore of the Fulmer Research Institute who both took a personal interest in this work and gave me valuable advice during their visits to the University of Cape Town.

And finally Suzie Betz for the patience she exercised in typing the script. Now I understand why so many authors thank their typists.

ABSTRACT

A survey has been made of the quality and type of materials used for tillage tools in South Africa. Conclusions have been drawn regarding the inadequacy of the manufacturing processes used and the resultant quality of the tool material.

A rig has been designed for the abrasion testing of materials in soil. The reproducibility of the method has been shown to be high and an evaluation has been made of the relative wear resistance of a series of heat treated steels. A medium carbon boron steel has been shown to have great promise as a tillage tool material because of its high wear resistance and toughness.

The deformed surface layers and the mechanisms of wear of steels subjected to field and laboratory abrasive testing has been examined. The removal of material through predominantly ploughing or cutting mechanisms has been shown to be dependent on the heat treatment and composition of the steels together with the nature of the abrasive.

White surface layers have been observed to form on medium and high carbon steels subjected to soil abrasion. Suggestions have been advanced for their formation.

Attempts have been made to assess the transferability of data between field and laboratory testing.

CONTENTS

ACKNOWLEDGEMENTS	(i)
ABSTRACT	(ii)
CONTENTS	(iii)
CHAPTER 1 : PREFACE	1
CHAPTER 2 : OUTLINING OF THE PROBLEM	2
CHAPTER 3 : AIMS AND OBJECTIVES	10
CHAPTER 4 : LITERATURE SURVEY	11
4.1 : Introduction	11
4.2 : Abrasion	13
4.2.1 : Classification of Abrasion	14
4.3 : Effects of Material Variables on Abrasive Wear	15
4.3.1 : Material Hardness and Composition	15
4.3.2 : Material Surface Hardness	17
4.3.3 : Flow and Fracture Properties	19
4.3.4 : Abrasive Hardness Characteristics	23
4.3.5 : Critical Attack Angle	25
4.4 : Mechanisms	30
4.4.1 : Abrasive Wear in Homogeneous Materials	30
4.4.2 : Abrasive Wear in Heterogeneous Materials	31
4.5 : Mathematical Model of Abrasion	34
4.6 : Effect of Speed on Wear	37
4.7 : White Layer Formation during Wear	38
4.8 : Abrasive Wear by Soil	41
4.9 : Testing Techniques	46
4.9.1 : Field Testing	48
4.9.2 : Single Tyne Test	51
4.9.3 : Laboratory Testing Techniques	53
4.9.4 : Laboratory Abrasion Tests	53
4.9.5 : Low Stress Abrasive Tests	54
4.9.6 : Impact Abrasion Tests	55
4.9.7 : Other Test Methods	55
4.9.8 : Post-wear Specimen Testing	55

	PAGE
CHAPTER 5 : EXPERIMENTAL TECHNIQUES	58
5.1 : Introduction	58
5.2 : Development of a Field Test	58
5.2.1 : Evaluation of Tillage Methods	58
5.2.2 : Field Tests using a Ripper Plough	63
5.2.3 : Conception of a Controlled Field Test	69
5.2.4 : Design and Development	70
5.3 : Field Tests	74
5.3.1 : Temperature Measurements	74
5.4 : Laboratory Methods	76
5.4.1 : Laboratory Wear Tests	77
5.4.2 : Heat Treatment	79
5.4.3 : Mechanical Testing	79
5.4.4 : Microstructural Investigation	80
CHAPTER 6 : RESULTS	82
6.1 : Introduction	82
6.2 : Field Test Results	82
6.2.1 : Profile Development on Specimens during Wear	87
6.2.2 : Surface Examination	89
6.2.3 : Sub-surface Investigation	95
6.2.4 : White Layers	99
6.2.5 : Maximal Hardness of Deformed Surfaces	105
6.2.6 : Thermocouple Test	106
6.3 : Laboratory Tests	108
6.3.1 : Surface Characteristics	109
6.3.2 : Rubbing Test	115
6.4 : Transferability	118
6.5 : Material Properties	120

	PAGE
CHAPTER 7 : DISCUSSION	121
7.1 : Introduction	121
7.2 : Field Test Results	121
7.3 : Comparison of Ranking Orders from Field and Laboratory Tests	124
7.4 : Profilometer Traces	126
7.5 : Thermocouple Test	128
7.6 : Microstructural Investigation	128
CHAPTER 8 : CONCLUSIONS	131
CHAPTER 9 : FUTURE WORK	132
REFERENCES	133

CHAPTER 1

PREFACE

Excavations in ancient cultures have revealed that man has always relied to a lesser or greater extent on working the land in order to produce food. Evidence of tilling may be found in ancient paintings and in the remains of equipment such as ox-drawn ploughs. It is believed that the early ploughs did not turn the soil but merely scratched the surface. This made it easy for two oxen to draw a plough in the light soils in the semi-arid areas of the Mediterranean and the Near East. However, this method of tilling was not appropriate for the damp climate and stiffer soils of northern Europe.

In the latter part of the seventeenth century, peasants in these northern areas began using an entirely new kind of plough. This plough was equipped with a vertical knife to cut the line of a furrow, a horizontal share to slice under the sod and a mouldboard to turn it over. The increase in friction meant that eight oxen had to be used instead of two and consequently people had to pool their oxen to form such large teams.

It appears that these peasants received a portion of the field in proportion to their contribution. This brought about a profound change in agriculture as a new alternative to subsistence farming was introduced. Later, as towns and cities grew, the individual farmer had to produce greater amounts of crops to support those people not actively engaged in agriculture. With the continuous emphasis on more intensive production, there had been a steady rate of improvement through the development of more efficient tilling methods. Unfortunately the materials being used for ground engaging tools today are not meeting the needs laid down by the level of technology and the demands for productivity (White 1967).

CHAPTER 2

OUTLINING OF THE PROBLEM

In 1981 a meeting of interested parties was convened at the Council for Scientific and Industrial Research (C.S.I.R.) in Pretoria to address the problem of wear in the South African agricultural sector. It was quickly established that very little quantitative information was available concerning the wear of tillage tools despite the fact that annually some R30 million is spent on ground engaging tools in South Africa. Concern was expressed about the unacceptable high turnover of tillage tools particularly those operating in the most abrasive soils such as those found in the Western Cape region. The two main problems to emerge were:

1. The rapid wear out of the tools
2. The apparent inconsistent performance of the materials used in these tools

It was later established that ripper points used in the Swartland of the Western Cape lose approximately 1 g of steel to the soil for every five metres of ploughing (Quirke 1983). Failures due to bending and fracture were also recorded regularly by farm managers as shown in figure 2.1.



FIGURE 2.1 : A normal ripper point compared with points bent or fractured during use.

The brittleness or ductility responsible for such behaviour indicated that similar tooling material was receiving variable heat treatment. Two worn ripper points selected at random from one farm highlighted this problem of inconsistent quality. Both of these points had been produced by the same manufacturer, using the same 0.42 per cent plain carbon steel bar. The composition of this steel is given in Table 2.1. One point, shown in figure 2.2, had a microstructure consisting of ferrite and pearlite and a hardness of 270HV30. The second point, shown in figure 2.3, had a microstructure consisting predominantly of bainite and martensite with a hardness of 550HV30.

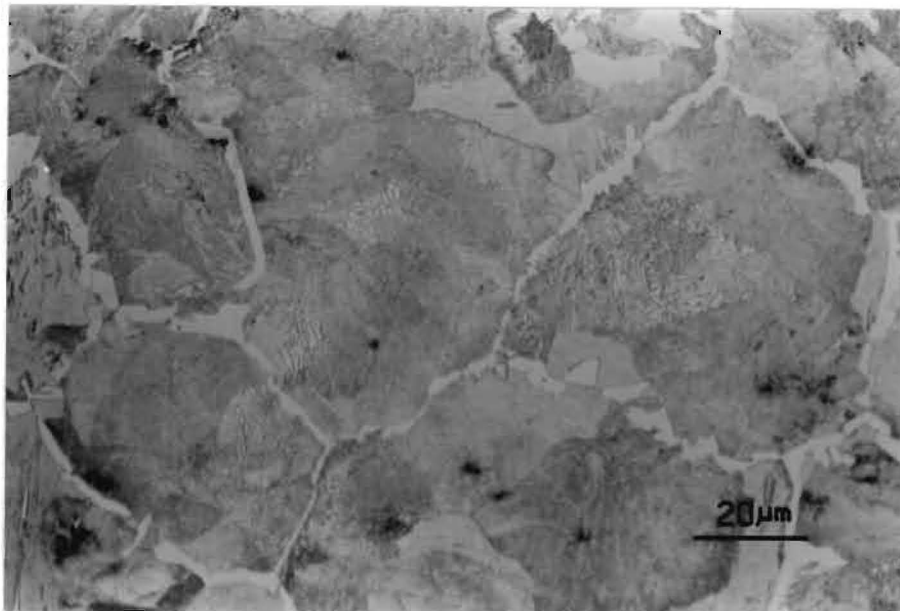

FIGURE 2.2 : Microstructure of an SS10/200 point with a hardness of 270HV30, etched in Nital.

The curiosity generated by these two results led to an extensive metallurgical examination of other tools available to users in South Africa, Quirke (1983). It was found for example that a large variety of steels were being used for the manufacture of ripper points. Generally they were found to be medium to high carbon steels although cast steels containing chromium and silicon were also being utilised. The compositions of these steels are shown in Table 2.1.

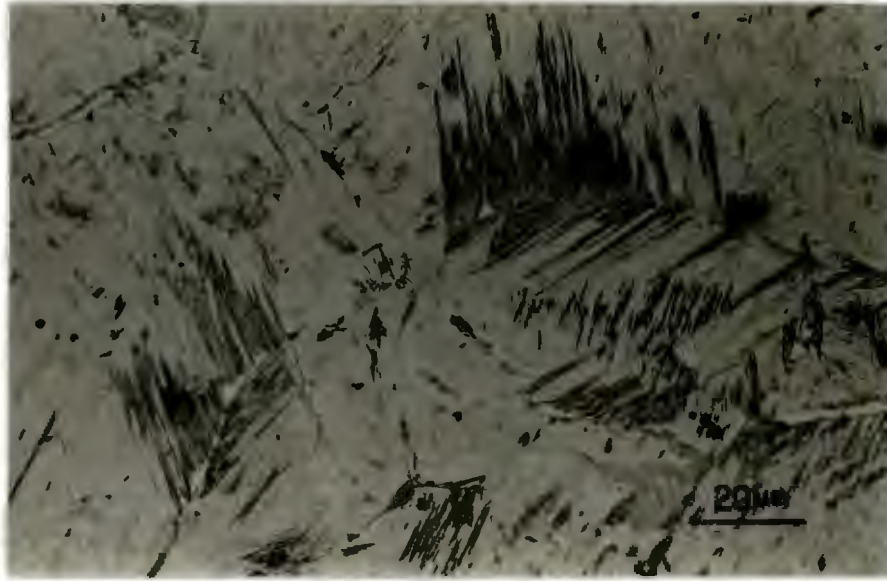

FIGURE 2.3 : Microstructure of an SS10/200 point with a hardness of 550HV30, etched in Nital.

STEEL	C	Mn	P	S	Si	Ni	Cu	Cr	Mo	V	Al
SS10/84	.82	.50	.021	.026	.19	.08	.17	.14	.03	-	.0009
SS10/83	.62	.40	.016	.027	.30	.11	.16	.10	.03	-	.0170
10/44	.62	.74	.016	.020	.35	.08	.23	.85	.02	-	.0080
Cast Steel	.36	.76	.021	.024	1.59	.16	.06	1.12	.25	.016	.0480
SAE 2955	.50	.80	.017	.018	1.52	.11	.15	.15	.02	.010	.0008
SAE 1080	.73	.63	.014	.022	.22	.05	.06	.08	.01	-	.0006
Cast Steel	.20	.80	.029	.028	1.32	.15	.09	1.38	.41	-	.0280
Imported:											
SAE 1070	.68	.81	.026	.190	.11	.02	.01	.02	-	-	.0006
SS10/200	.49	.81	.046	.044	.30	.08	.11	.07	.02	.010	.0050
SAE 2955 (high C)	.79	.77	.021	.030	.15	.04	.14	.02	-	.026	.0005

TABLE 2.1 : Composition of steels used for ripper points.

In addition to the large number of steel compositions used, a range of microstructures was observed for each steel type. This confirmed the earlier suspicions concerning the variability in heat treatments given to tillage tools. The results of a microstructural investigation on three points made from SAE 2955, which was very popular with the manufacturers, illustrates clearly this variability in microstructure.

The first tool had a fine grained, bainitic microstructure with a hardness of 427HV30 (fig. 2.4). The point was recorded to have performed

adequately in service. It was assumed that an austempering process had been carried out on this ripper point to produce such a microstructure. The second point also had a microstructure consisting of bainite, but with a much larger grain size. This indicated that the tool had been held at a high temperature for an excessive period (fig. 2.5).



FIGURE 2.4 : Microstructure of an austempered point. Hardness 427HV30, etched in Nital.

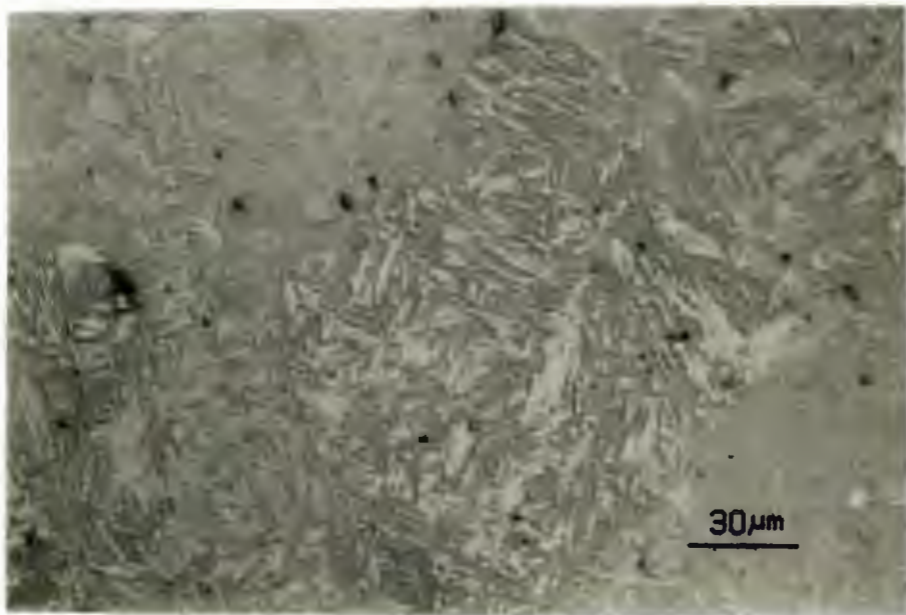

FIGURE 2.5 : Microstructure of a ripper point made from SAE 2955. Note the influence of large austenite grain size. Hardness 422HV30, etched in Nital.

Both of these points had compositions within SAE 2955 specifications. The third point was found to have a carbon content of 0.79 per cent and a silicon content of 0.15 per cent rather than 0.5 per cent carbon and 1.52 per cent silicon, as specified for SAE 2955. The microstructure consisted of unresolved pearlite and ferrite and had a hardness of 390HV30 (fig 2.6). The point had probably been air cooled.

The reason for this variability could generally be ascribed to the lack of metallurgical expertise of manufacturers producing these ripper points. For example, parts were often heated in an uncontrolled fashion to high temperatures in excess of 1000°C. This overheating led to decarburization and grain growth. Often quenching was carried out from too low a temperature after forging. Tempering was seldom applied and quality control carried out on the finished articles was rare.

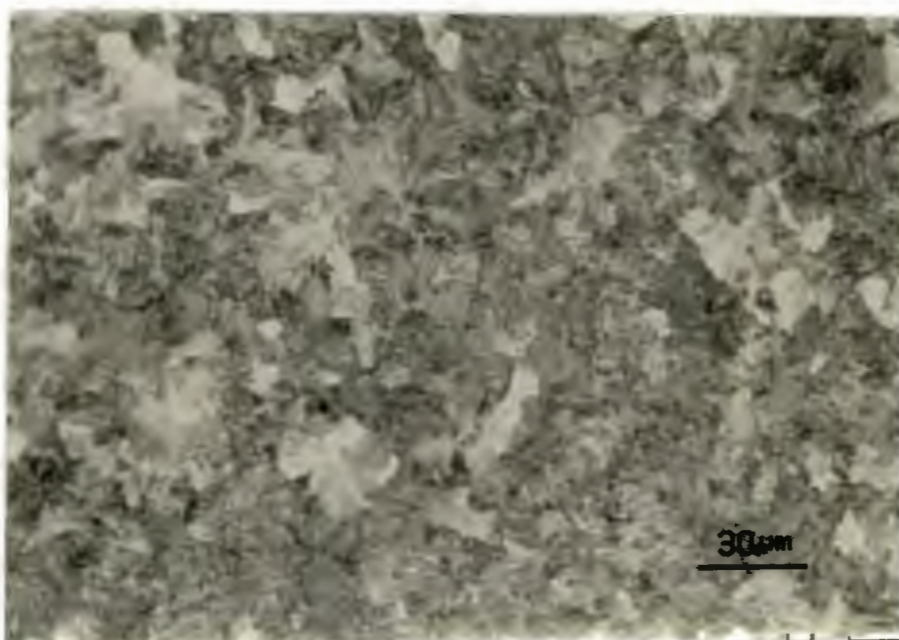

FIGURE 2.6 : Microstructure of a point allegedly made from SAE 2955 - note the unresolved pearlite. Hardness 390HV30, etched in Nital.

Some manufacturers were using these methods on "spring steels" with increased silicon contents. These steels are very sensitive to overheating and decarburization. The coarse grain and decarburized surface are detrimental to the high elastic limit and fatigue resistance properties for which this steel is designed. Because of this, some spring tynes for tools either cracked or bent. The microstructure of a spring tyne that failed during use is shown in figure 2.7.

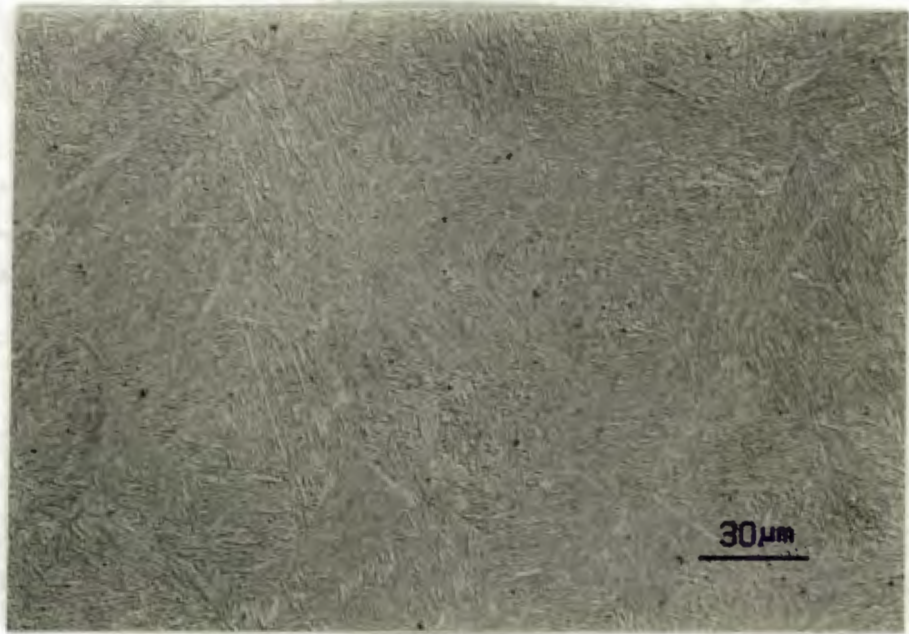

FIGURE 2.7 : Microstructure of a spring tyne manufactured from SAE 2955. Hardness 385HV30, etched in Nital.

A description of the manufacturing process used by one producer will illustrate these general observations concerning heat treatment and procedures.

A large diesel fired furnace was heated to a temperature between 900 and 1100°C. This was not monitored but when it seemed to be hot enough, sections of flat bar, used in the manufacture of ripper points, were loaded into the furnace to form a pile on the hearth. The batch size was usually about eighty ripper points. It must be noted here that the first bars to go in were last to come out and were in the furnace for approximately 100 minutes. The last bars to go in remained in the furnace for only half this time. The door through which the loading was done was approximately 2000 x 40 mm and was not closed throughout the heating and forming operation. Through this door it was possible to see that some bars at the top of the pile were beginning to bend under their own weight which was a good indication of the excessive temperatures reached in some parts of this furnace.

The temperature for forming was estimated by observing the colour of the bars. When a straw yellow was reached, the bars were removed two at a time. First they were carried to a shear press where the corners were removed in order to form a point at each end. When this operation had been completed the two bars were carried to another press where they were

bent to shape. The formed points from the press were placed on a rack. When there were four points in the rack they were carried to an oil bath which stood outside the building for quenching. The time which elapsed between the removal from the furnace and the quenching varied between one and four and a half minutes. This process had obviously been "designed" without attention being paid to the metallurgical considerations. It is therefore not surprising that a wide range in quality was being produced. While this is a summary of procedure in one factory, further reports given by Dr. J.K. Cooper (1983) indicate that such practice is widespread.

The larger manufacturers were found to possess the necessary facilities for heat treatment but no quality control appeared to be performed on incoming materials or heat-treating procedures. Differences in composition of steels received were not established which led to significant differences in the quality of the implements produced. Clearly, on the basis of this evidence, the users of ground engaging tools may expect a range of properties and behaviour for each type of implement purchased.

Farmers in South Africa are aware of the necessity for a more wear resistant material for tilling implements. Dr. Cooper (1983) records various cases of farmers forging their own points and welding truck springs to ripper points in order to improve wear life. One farmer in the Western Cape only uses discs imported from Australia. When these are worn-out he sections them along radii to produce triangular sections which are then welded to the bottom of scarifier points. This, he maintains, dramatically extends the wear life of these tools.

Imported tools made from wrought steel were generally found to be of a higher standard than those locally produced. Indeed, some farmers only use tools manufactured in Sweden or Australia regardless of the higher cost involved because of the improved performance.

As indicated in Table 2.1 it was additionally found that there are also a range of cast steel tillage tools on the market. These tools, however, do not seem to be of a standard higher than the wrought and forged implements. Generally, the cast tools are manufactured from medium or low carbon steels, and it appears that they are quenched from very high temperatures following casting in order to maintain a high hardness.

These tools suffer from subsequent problems related to decarburization, large grain size, shrinkage-cavities and low toughness (fig. 2.9).



FIGURE 2.8 : A section of a disc welded to the bottom of a scarifier point. This eventually failed at the point of attachment.

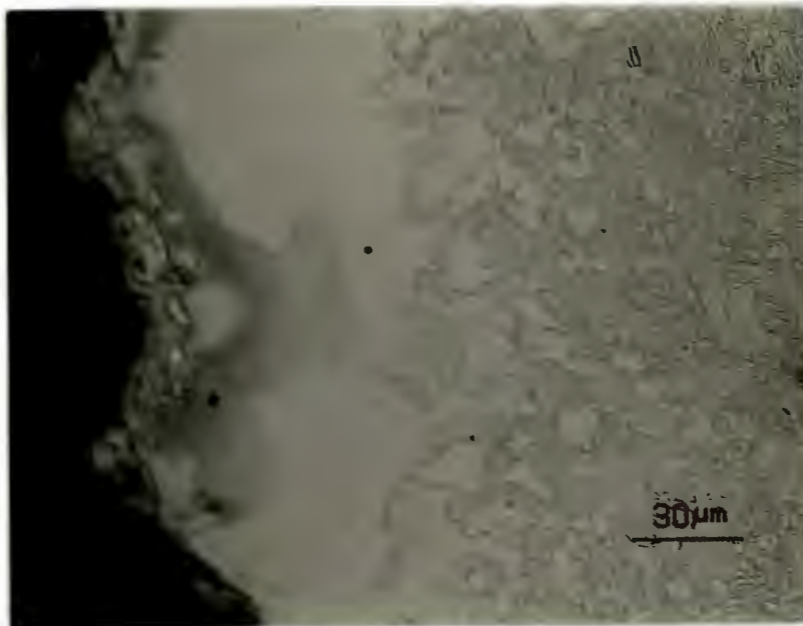

FIGURE 2.9 : Excessive decarburization in cast medium carbon steel ripper point. Bulk hardness 561HV30, etched in Nital.

CHAPTER 3

AIMS AND OBJECTIVES

The overall aim of this programme of work is to understand the mechanisms of wear responsible for the deterioration of ground engaging tools. With such an understanding it will ultimately be possible to advise the agricultural industry on the correct material and heat treatment for a particular soil and location in South Africa. At the present time the selection and heat-treatment of materials appears to be carried out in a non-scientific manner. Opportunity therefore exists for saving national resources by introducing measures to minimise wear in this way. It is considered mandatory that any solutions should be cost effective and involve the use of locally produced materials.

The scientific objectives of this particular study were as follows:

1. To evaluate materials and heat-treatments presently being used for agricultural soil engaging tools.
2. To develop an acceptable method of field testing, which would be simple, efficient and reproducible within acceptable limits.
3. To simulate the wear process using a laboratory test.
4. To analyse the surface deformation and wear characteristics of worn samples.
5. To evaluate the transferability of data between field and laboratory testing.
6. To carry out trials on controlled materials and processing.
7. To evaluate the performance of materials in different operating conditions.
8. To produce a ranking order for materials for use in different conditions.

CHAPTER 4

LITERATURE SURVEY

4.1 Introduction

There are many agricultural techniques that are performed in the process leading to the successful harvesting of crops. Most of these techniques involve the use of ground engaging tools. The practice of drawing a tool through the soil to produce a required condition, is referred to as 'tilling' in this work. Ploughing will refer to a certain material reaction to an abrading particle.

K.G. Gill and Van der Berg (1967) list seven reasons for the use of ground engaging tools:

1. Soil conditioning, in which the soil is loosened or granulated.
2. Plant and plant material control, such as weed control or mulching.
3. Land forming, in which efficient configurations for planting irrigation or drainage are produced.
4. Insertion by inversion of the soil. This is a process by which fertilizers, plant residues and amendments may be incorporated in the soil.
5. Segregation, in which soil and other materials are moved from one level to another. Rocks may be removed or root crops harvested in this manner.
6. Mixing, in which materials are incorporated into the soil.
7. Compaction or firming. This may be used for seed bed preparation or for decreasing permeability in ditches and dams.

The contact between the ground engaging tool and the soil leads to the loss of material from the tool mainly through the process of abrasion. Mohsenin, Womochel, Harvey and Carleton (1956) reported that 1000 tons of iron and steel are lost from ground engaging tools in German soils annually. A survey by the South African Department of Agriculture and Fisheries for the 1980/81 season, cited in the Background Document for Wear in South Africa (1982), showed that the expenditure on maintenance in the agricultural industry was R371 million or 16 per cent of the total capital assets in machinery and implements in that year. A large

proportion of this sum could be directly attributed to the wear of ground engaging tools. The economic importance of wear during tilling is further accentuated by the increase in fuel consumption caused by the increase in draught, which is the resistance of an implement to motion through the soil. This increase amounted to a third of the original consumption in twelve hours in a case recorded by Gill and Van de Berg (1967).

Wear processes are complicated by the design of the tool and it is necessary to use a simple model in order to define the effects of abrasion. Soil engaging tools may be approximated as a wedge section (Miller 1980), as shown in figure 4.1.

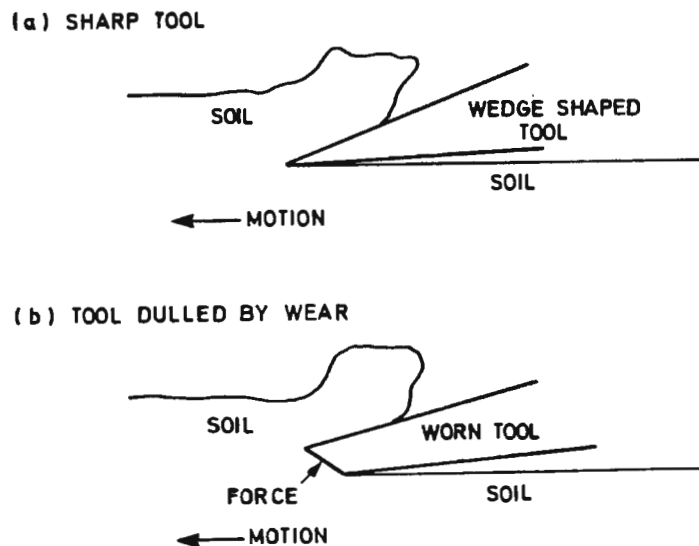

FIGURE 4.1 : Blunting at the edge of a tool leads to compaction, an upward force at the tip of the tool as well as an increase in abrasion rate.

Abrasion causes a change in the shape of the wedge. The local geometry of the edge changes rapidly, causing blunting which in turn leads to compaction of the soil in front of the wedge. As a result abrasive grains are held more firmly in the soil, which in turn leads to intensified abrasion. Furthermore, the blunted implement has a tendency to rise instead of being drawn down into the soil, causing a decrease in the efficiency of the operation.

The majority of work in the wear of ground engaging tools has been directed towards understanding wear mechanisms at the leading edge of the tool. Researchers have utilized the knowledge already gained in the

field of abrasive wear in general in an attempt to understand this specific problem. The same approach will be followed here.

4.2 Abrasion

The definition of abrasion given by the Oxford Dictionary is "scraping off, wearing away; damaged area resulting from this". Notwithstanding the versatility of the dictionary definition, the lack of precision has lead to a consideration of the more rigorous definitions used by other workers.

The Society of Automotive Engineers (1966), cited by McQueer, give the definition of abrasion as, "the removal of material from a surface by the mechanical action of abrasive particles in contact with the surface."

Moore (1974) defines abrasive wear as "The removal of solid material from a surface by the unidirectional sliding action of discrete particles of another material."

Eyre (1983) defines abrasion as "the removal of material from a surface by the mechanical action of an abrasive which has an acicular profile and is harder than the material being worn". He also states that an abraded surface can be characterized by the parallel grooves running in the rubbing direction.

Kruschov and Babichev (1958) stress the importance of the cutting of microchips in characterizing abrasive wear.

McQueer (1985) criticized these definitions as being too specific. The removal of material is not always a characteristic of abrasion and abrasion need not necessarily be caused by particles of another material. In some cases material removed from the worn surface is ground between the wearing surfaces, contributing to abrasion. In addition, abraded surfaces may not exhibit scouring or grooving. Mill balls and some ground engaging components may have a smooth, almost buffed appearance.

It is also apparent that surface damage or changes in the surface as a result of exposure to an abrasive environment should also be considered.

Such changes include plastic deformation, phase changes and recrystallisation, which, while not directly causing the loss of surface material, interact with the mechanisms which produce such loss. Clearly, resistance to abrasive wear is not an intrinsic material property but is dependant upon all the variables in the system. The response to abrasive wear depends on the interaction of material properties, the properties of the abrasive and the environmental conditions in which wear is taking place.

The definition by Richardson (1968), while retaining some universality, seems to be specific enough to be applied to this study : "Abrasion is a dynamic process which is defined as wear by displacement or removal of material caused by particles or protruberances." This is similar to the definition used by Moore in his lecture series in 1985: "Wear by displacement of material caused by hard particles or protuberances".

This, he shows, includes five essential points:

1. The intentional removal of material, as in grinding.
2. Unwanted loss of material from surfaces in relative motion.
3. Deformation damage to surfaces in relative motion.
4. Wear by hard mineral substances.
5. Wear in metal/metal contact, in which a harder surface penetrates and wears a softer one.

4.2.1 Classification of Abrasion

Abrasive wear has been classified by the use of descriptive terms such as grooving, scratching and scouring. However, the definitions applied to these terms are largely subjective in nature and this constitutes dangerous scientific practice. In order to classify abrasion, Noël (1981) used terms such as "two body" and "three body" wear in conjunction with the following definitions used by Avery (1974) :

1. Gouging : A process similar to machining; in which the removal of macroscopic particles from the wearing surface causes grooving of the worn face.
2. High stress abrasion : Abrasive wear generally occuring under "three body" conditions in which microscopic particles are removed from the wearing

surface. The crushing strength of the abrasive is exceeded, causing degradation of the abrasive.

3. Low stress abrasion : A type of abrasion which generally occurs under "two body" conditions, with the abrasive particles sliding over the wearing surface. The stresses are insufficient to cause degradation of the abrasive.

McQueer (1985) discusses the discrepancies caused by the various definitions of two body and three body wear. For instance the system classified by Eyre (1983) as two body wear is classified by Misra and Finnie (1979 and 1981) as three body wear. McQueer (1985) also highlights two problems in the definition of high and low stress abrasion. Firstly, the distinction between high stress and low stress abrasion depends on the properties of the abrasive. Secondly, the same laboratory test used by two different workers has been classified as high stress in one case and low stress in the other.

These problems in the classification of abrasive wear indicate that great care must be taken in comparing field and laboratory test results. Comparison should not be made on the basis of a classification system but rather on the basis of the observable effects of wear in each system using optical and Scanning Electron Microscopy techniques as well as relative volume losses.

4.3 Effects of Material Variables on Abrasive Wear

4.3.1 Influence of Material Hardness and Composition

The work by Kruschov and Babichev (1958), using a pin on disc apparatus for laboratory wear testing, showed that there is a linear relationship between hardness and wear resistance for commercially pure, annealed metals. When this was extended to steels, two effects were observed:

1. The slope of wear resistance against hardness was lower for a given steel heat treated to different hardness values than for pure annealed metals.

- The line of wear resistance against hardness was displaced to higher wear resistance values as the carbon content of the steels was increased.

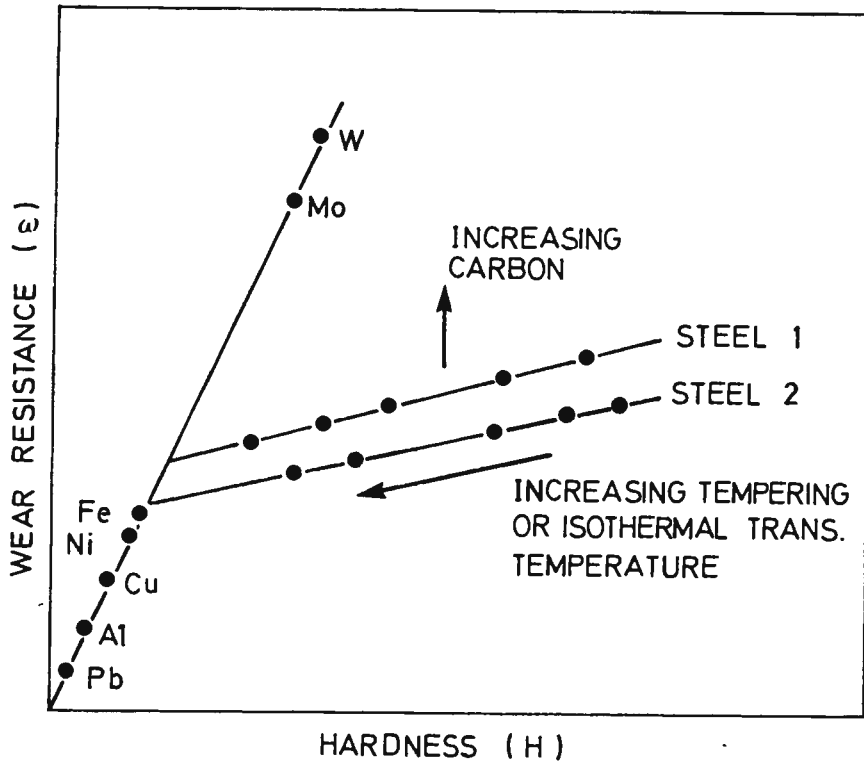

FIGURE 4.2 : Wear resistance as a function of bulk hardness for pure metals and heat treated steels (Kruschov, 1957).

Richardson (1967), Mutton and Watson (1978) and Murray, Mutton and Watson (1979) have extended the investigation of abrasive wear properties to commercially pure annealed metals and carbon steels. While there is general agreement that the wear resistance of commercially pure metals increases linearly with hardness, the relationship between hardness and wear resistance for steels has been re-evaluated by these workers. They found on testing steels with similar hardness levels that the abrasion wear resistance was dependent on carbon content (figure 4.3).

As illustrated, these curves are displaced to higher wear resistance as carbon content is increased. In view of these results it became evident that bulk hardness was an insufficient means of predicting wear resistance. It was suggested that this behaviour could be explained by the surface hardening characteristics of materials.

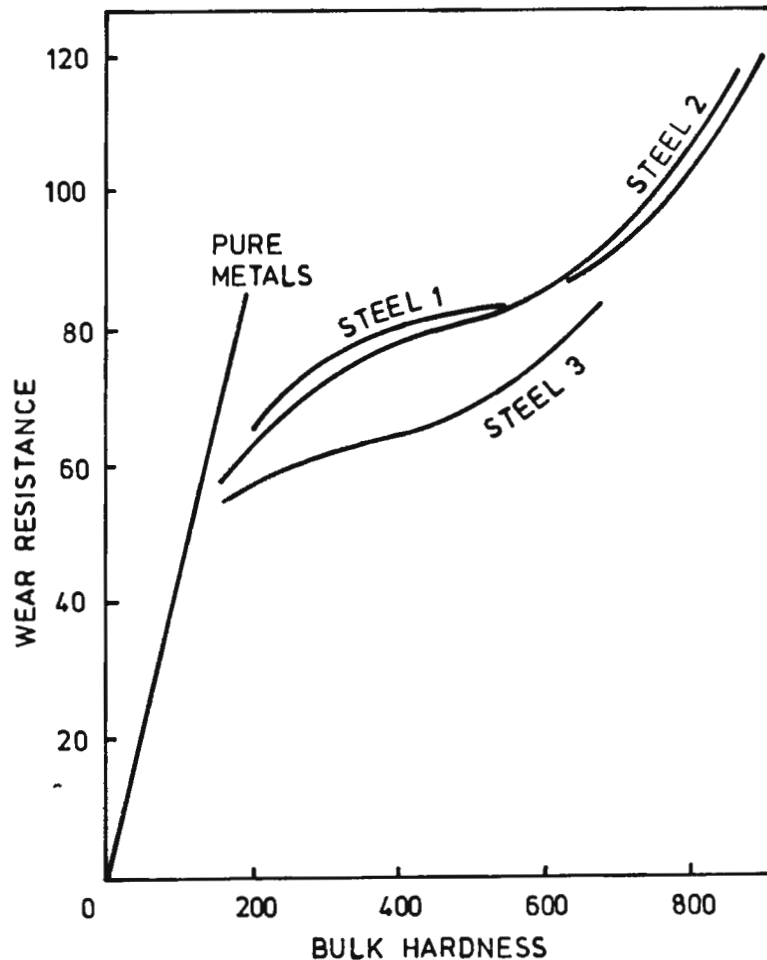

FIGURE 4.3 : The wear resistance of three steels quenched and tempered to different hardness levels. The sigmoidal shape of the plots is characteristic for carbon steels (Murray, Mutton and Watson, 1979).

4.3.2 Material Surface Hardness

Zum Gahr and Mewes (1983) have stated that material removal depends on the shape of abrasive particles and on the mechanical properties of the worn material, such as hardness and shear strength at the strain limit. Kruschov (1974) showed that materials were hardened to a higher degree during abrasive wear than was possible by any pre-test hardening. Work hardening prior to abrasion did not increase the wear resistance of the material. He suggested that the surface of the material being abraded was cold worked sufficiently to reach the limiting hardness of the material. Richardson (1967) also studied the wear of strained surfaces prior to testing. Surface layers were hardened by shot peening, by abrasion in stony soils and working with a blunt hardened trepanning

tool. The highest and most uniform hardness results were obtained by trepanning. These results were plotted against the wear resistance of materials as shown in figure 4.4. It is evident from these results that no satisfactory relationship exists between wear and strained surface hardness.

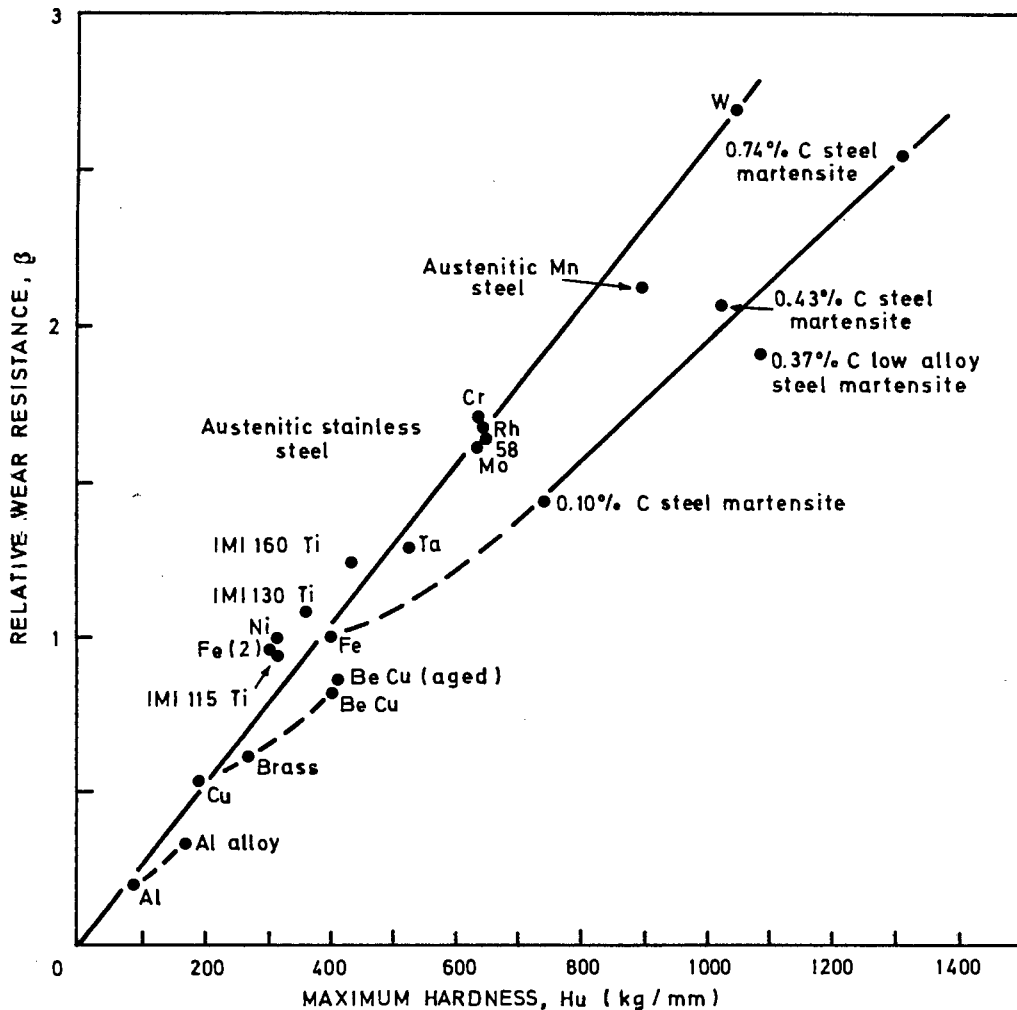

FIGURE 4.4 : Plot of relative wear resistance on 180 grit corundum cloth against maximum hardness of strained surfaces - Richardson (1967).

Moore (1985) showed also that the hardening of surface layers during wear seemed to depend on the original microstructure as well as the composition and carbon content of a steel. This was graphically illustrated when three steels were compared in different heat-treated states but all showing the same hardness. This is shown in figure 4.5. He found that the surface of the 1080 steel quenched and tempered to 450HV30 was softened during wear, whereas the same steel austempered to 450HV30 was hardened during wear.

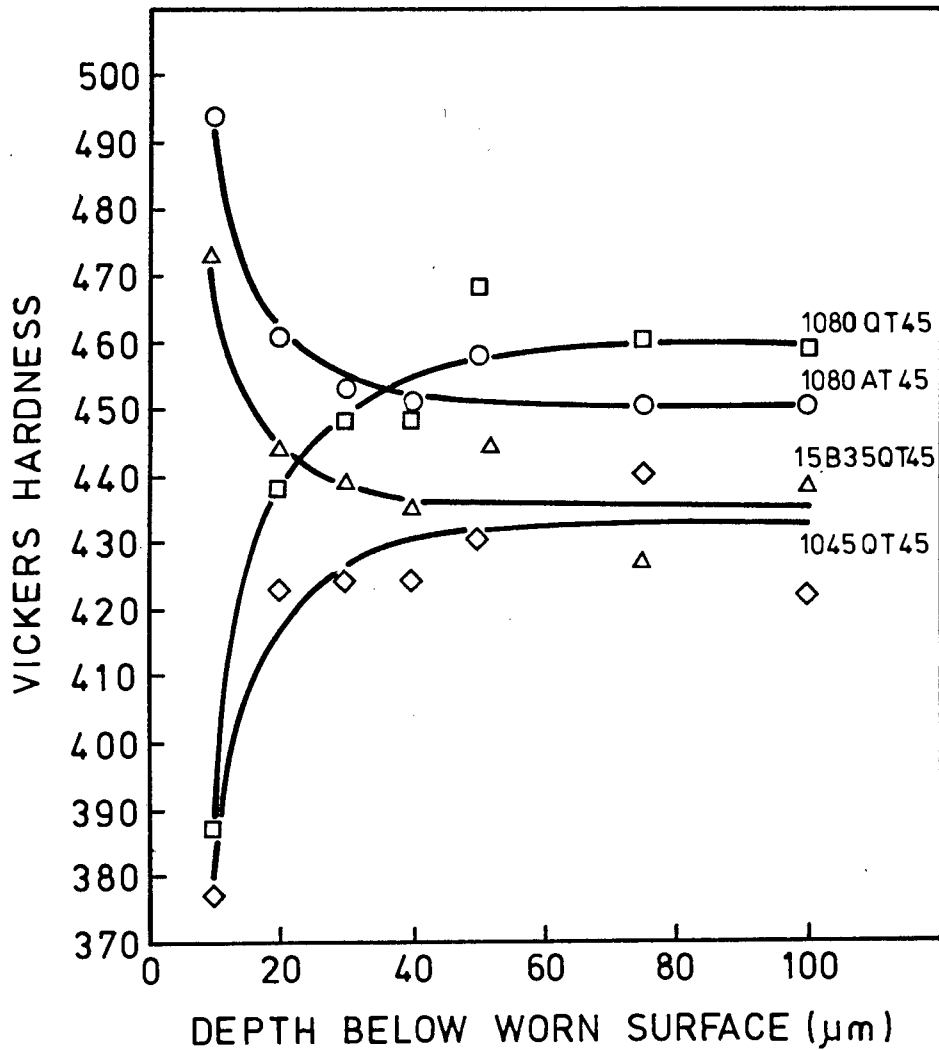

FIGURE 4.5 : Comparison of hardness versus depth for 1080 quenched and tempered to 450HV30 as well as austempered to 450HV30. Also for steels 15B35 and 1045, both quenched and tempered to 450HV30 (Moore, 1985).

4.3.3 Flow and Fracture Properties

An extensive region below a groove produced during abrasion is deformed plastically. It has been suggested that a large part of the energy expended in abrasion is absorbed in this way. Moore and Douthwaite (1976) measured strain and microhardness at points below the surface of copper-silver solder laminate. Microhardness plots showed that the magnitude and extent of strain hardening depends on the initial hardness and strain hardening capacity of the material. The results suggested that strain below the surface is proportional to the abrasive grit size and the square root of the applied load. Their results are shown in figure 4.6.

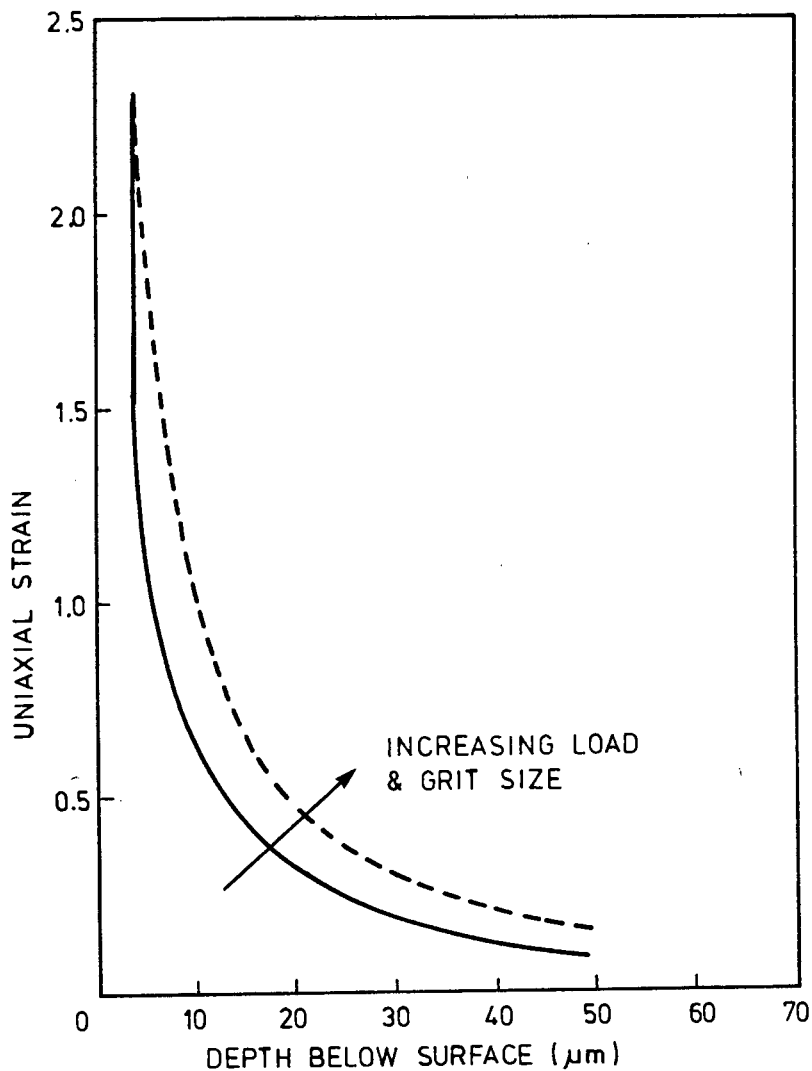

FIGURE 4.6 : The effect of load and grit size on subsurface strain during wear.

The very high strains measured at the surface decreased sharply within the first 10 microns. Moore (1985) demonstrated a similar effect in steels.

Although strain at the extreme surface is independent of grit size and load, high strains occur because an hydrostatic stress system is set up ahead of, and below, the abrading particles. This stress opposes the formation and growth of voids and increases the ductile stress and strain. In this dynamic system, material is lost at the surface as it reaches a critical strain. At the same time, material below the surface is at the point of yielding in a plastic fashion. This situation is depicted by Ball (1983) in figure 4.8. Moore, Richardson and Attwood (1972) suggested that the process limiting strain is fracture. The material is detached from the surface when some fracture criterion is

satisfied. Examination of bulk hardnesses show that not all ductile materials are strain hardened to the same degree during wear (Moore, Richardson and Attwood, 1972). The rate of increase of surface hardness with increase in unstrained hardness varies widely for different groups of materials.

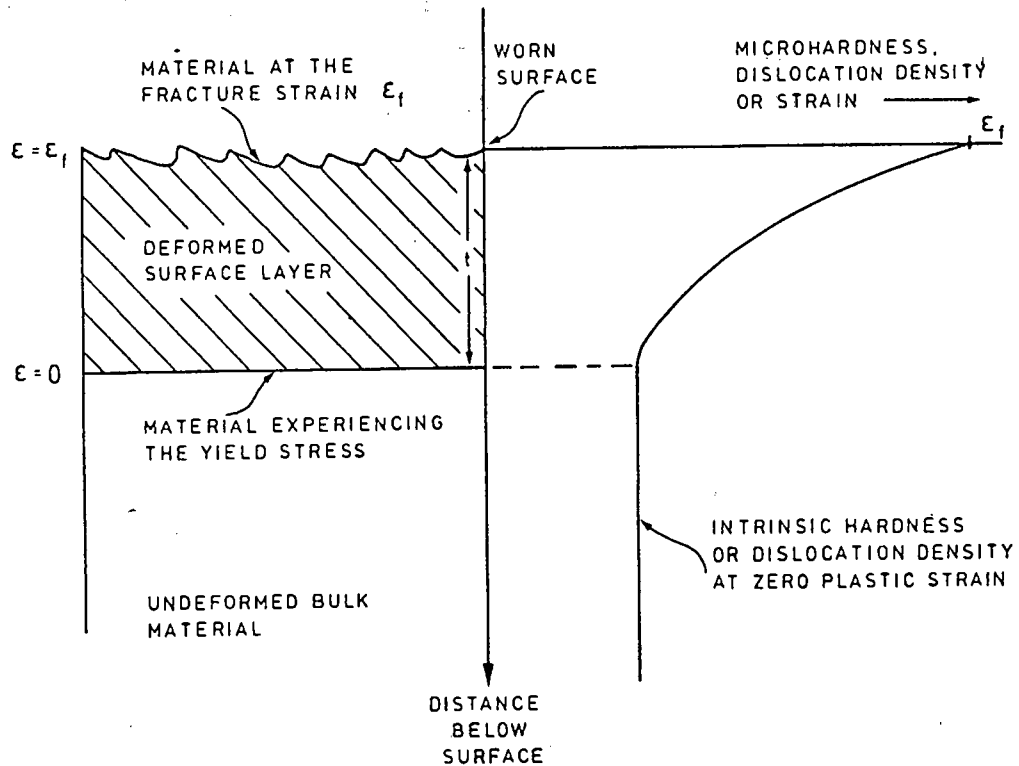

FIGURE 4.7 : Schematic illustration of the deformed surface layer of an abraded material. The curve on the right indicates change in microhardness, dislocation density or strain, with depth.

Strengthening is due to dislocation multiplication and interaction. Pure metals with low initial dislocation densities show a large degree of strengthening. On the other hand, martensitic steels have high initial dislocation densities and may have pre-existing cracks so that any hardening prior to fracture is low.

Ball (1983) uses a series of stress-strain curves for hypothetical materials to demonstrate why no simple or direct relationship exists between wear resistance and mechanical properties. He first shows that materials with a high yield stress and no elongation to fracture are not suitable for wear resistance. They are susceptible to brittle spalling and chipping. Similarly, materials with a low yield point and large

strains to fracture are not usable as each abrasive particle will cause shear of the surface beyond the critical strain to fracture. These two hypothetical materials are shown in figure 4.8 with what he suggests is the optimum characteristic stress strain curve for a wear resisting material.

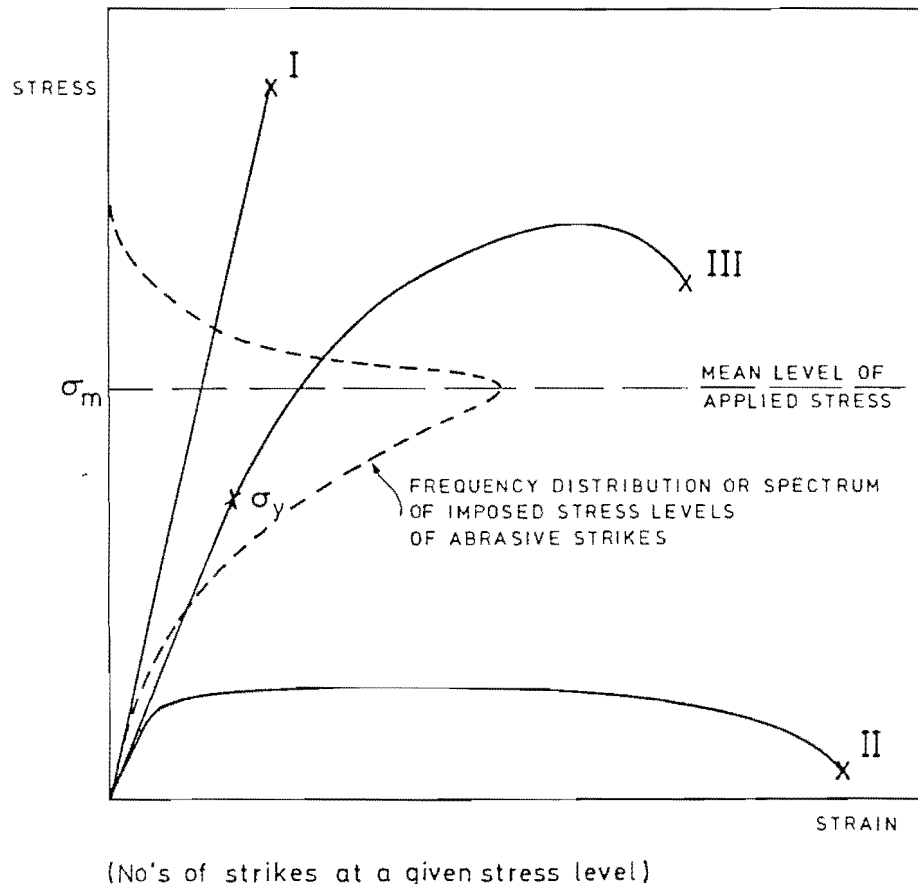

FIGURE 4.8 : The hypothetical stress-strain curves for the wear of three classes of materials. These are superimposed on the frequency distribution of abrasive or erosive strikes of a given stress magnitude.

This shows that the optimal material is one with a moderate yield strength but a high work hardening capacity. He goes on to compare various hypothetical materials to outline the importance of factors in stress strain behaviour. These are as follows :

1. High strain hardening is important; materials with a lower strain hardening rate will reach a critical strain at a lower stress.
2. Yield strength is not important if the ultimate tensile strength and elongation is the same.
3. Higher ductility will not improve wear life.

Ball concludes his study by pointing out that the wear resistance of metastable austenitic stainless steels such as AISI 304, transformation induced plasticity steels and Hadfields manganese steels, being excellent, tend to confirm this analysis. Sin, Saka and Suh (1979) also studied the microstructures of cross sections of worn surfaces to determine the factors affecting wear. These exhibited a gross shearing structure not unlike that in the copper-silver solder laminate. This gross shearing is also illustrated in micrographs by Newcomb and Stobbs (1984) and Griffiths (1983) and is described by Stead (1912).

4.3.4 Abrasive Hardness Characteristics

Moore (1980) illustrates a relationship between wear volume and the ratio of the hardness of the worn surface and the hardness of the abrasive. This is shown in figure 4.9.

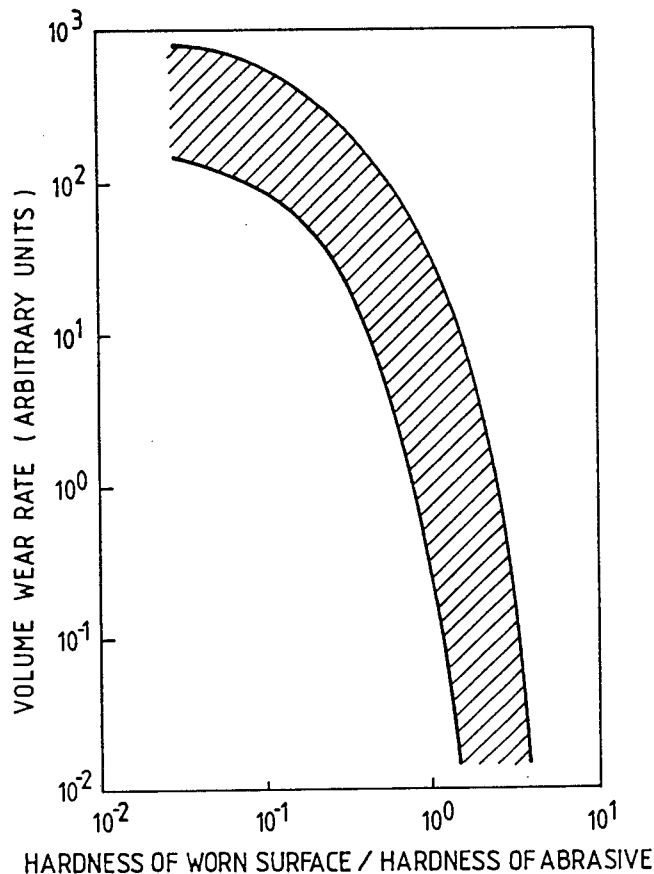

FIGURE 4.9 : Effect of abrasive hardness on the wear of metallic materials and ceramics (Moore, 1980). Note the drastic drop in wear rate at the point where the material hardness is about 0.8 times the abrasive hardness.

This was first demonstrated in 1967 and 1968 by Richardson who showed that the type, strength and size of abrasive particles are important in determining wear rate of tools. This was investigated in laboratory tests because of the difficulty in determining the effect of abrasive properties on volume wear during field tests. Tests were conducted on bonded silicon carbide, corundum, garnet, flint and glass abrasives. One of the most significant findings to come out of this work was that the volume wear of material decreases rapidly when the ratio of material hardness (H_m) to abrasive hardness (H_a) exceeds approximately 0.85. Scratching of the material by the abrasive continues even when $H_m/H_a = 1$ and only ceases when the flow stress of the material equals that of abrasive. Moore (1975) showed that the relationship between volume wear and grit size was roughly linear when H_m/H_a was less than 0.85. When H_m/H_a was greater than 0.85, the relationship was often found to be non-linear. From this he concluded that relative wear resistance is nearly independent of grit size when H_m/H_a is less than 0.85 and is sensitive to grit size when H_m/H_a is greater than 0.85. The effects, he said, were due to plastic flow, blunting and fracture of abrasive grains.

Moore (1975) showed that the ideal wearing material, with a flow stress equal to that of the abrasive, will have a hardness between two and three times greater than the abrasive. In addition, he showed that the size of abrasive particles also has a significant effect on wear. When the grit size was increased in laboratory tests on bonded abrasives under constant load, the wear was found to increase. This, he said, was due to the greater loads carried by fewer abrasive grit particles.

Moore (1980) went on to show that the fracture of abrasive grit particles does not reduce volume wear as much as deterioration of the grit by plastic flow. The final conclusions reached on abrasives were :

- 1) Soft abrasive particles and stones occurring in a firm soil will tend to shatter during wear, producing sharp edges inducing a cutting mechanism. The use of harder materials will lead to only slightly higher wear resistance.
- 2) Hard stones and abrasive particles occurring in weak or loose soils will tend to blunt by plastic flow. The use of a hard material will substantially improve the wear life of an implement.

This is amply illustrated in figure 4.10, the results shown by Moore (1980) on the difference in wear of a 0.3% carbon-low alloy steel between a lapilli tuff and a sandstone when tested under increasing loads.

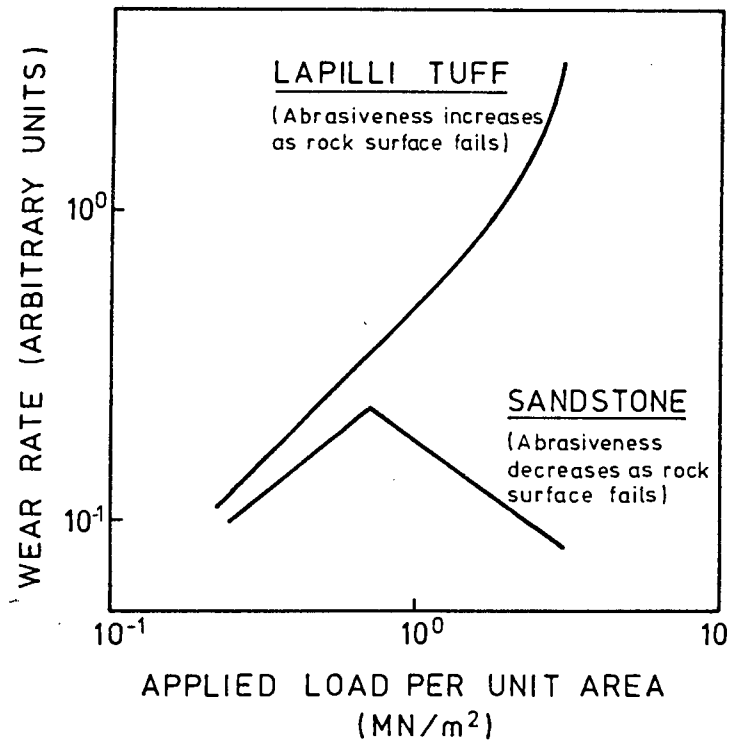

FIGURE 4.10 : The effect of surface failure for hard and soft abrasives. The abrasiveness of the lapilli tuff increases as the rock surface fails whereas the abrasiveness of the sandstone does not (Moore, 1980).

4.3.5 Critical Attack Angle

The attack angle (α) is defined as the angle between the flat leading face of an abrading particle and the surface of the material being tested. This is shown in figure 4.11.

Zum Gahr and Mewes (1983) showed that the rate of wear of a steel is a function of the attack angle of the abrading particle. They did a series of tests with diamond and steel riders on electrolytically polished steel surfaces to determine the effect of attack angle on a factor f_{ab} , which is defined as the ratio of volume of wear debris to the volume of wear groove produced. It was found that the amount of wear debris increased with an increase in attack angle. Mashloosh and Eyre (1986) enlarged on this work by developing a reciprocating single point abrasion tester.

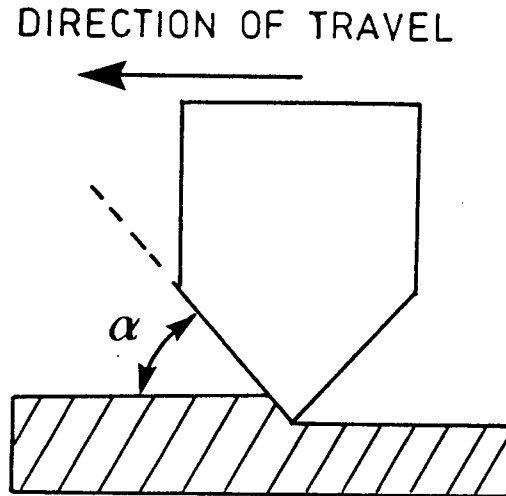
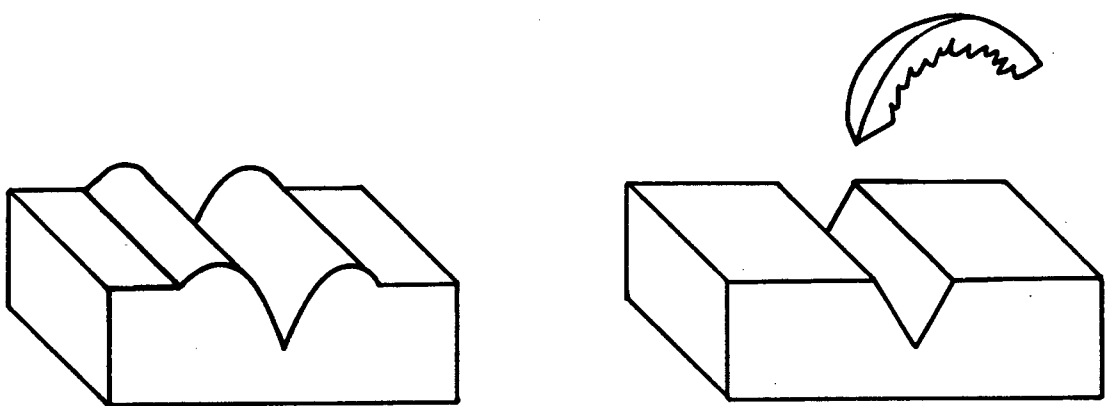

FIGURE 4.11 : Shows how the critical attack angle (α) is defined.

They found that wear rate increases with attack angle to an optimum value and then decreases. Mutton, Murray and Watson (1979) also used a single point diamond indenter on polished surfaces in order to determine the proportion of the groove volume detached as debris. They identified two extreme mechanisms of groove formation in metals, namely ploughing and cutting, as shown in figure 4.12. This observation was confirmed by Mashloosh and Eyre (1986) who state that the attack angle controls the mechanism of surface wear as it changes from ploughing to cutting.



Ploughing : Material is moved to the side of the groove.

Cutting : Material is removed from the surface in the form of a chip.

FIGURE 4.12 : Mechanisms of groove formation.

Mutton, Murray and Watson (1979) also found that cutting took place over a wider range of attack angles in harder steels than in softer. This effect was mentioned by Garrison and Garriga (1983), who found that the degree of ploughing decreases as the hardness of a medium carbon steel increases. The results of Buttery and Archard (1970) and Moore (1985) confirmed this finding. They found that a greater fraction of the scratch groove is removed as the hardness of the steel is increased (figure 4.13).

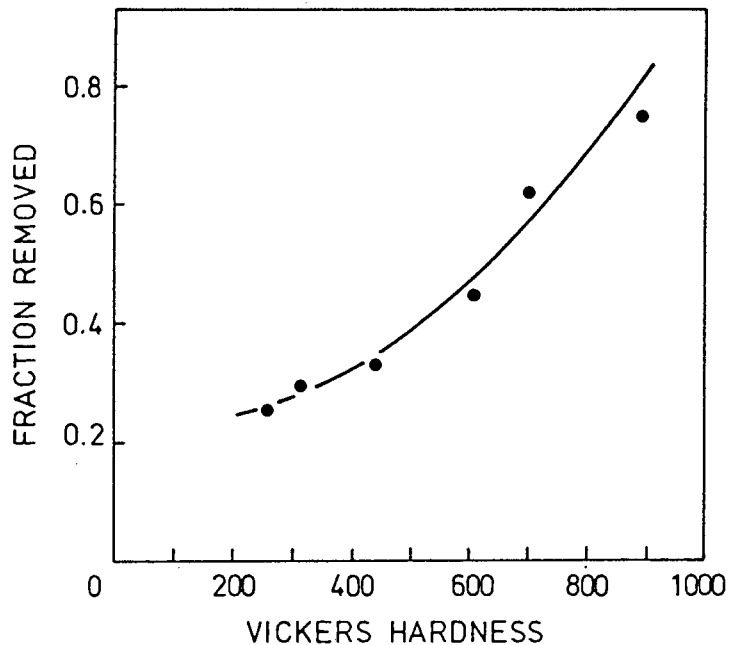

FIGURE 4.13 : The volume of scratch groove removed by cutting from materials of different hardness (Buttery and Archard, 1970)(Moore, 1985).

Zum Gahr and Mewes (1983) showed that, in a range of materials with a similar hardness, a low f_{ab} value (predominantly ploughing wear) produced the highest wear resistance.

As the attack angle is decreased from a maximum to a minimum, the compressive component of the force on the prow region of the moving indenter inhibits chip formation. There is a transformation in the debris produced, from long free continuous chips through segmented discontinuous chips to pure ploughing. This observation was confirmed by Moore and Douthwaite (1976).

The transition from ploughing to cutting has also been represented in the following way by Mutton, Murray and Watson (1979).

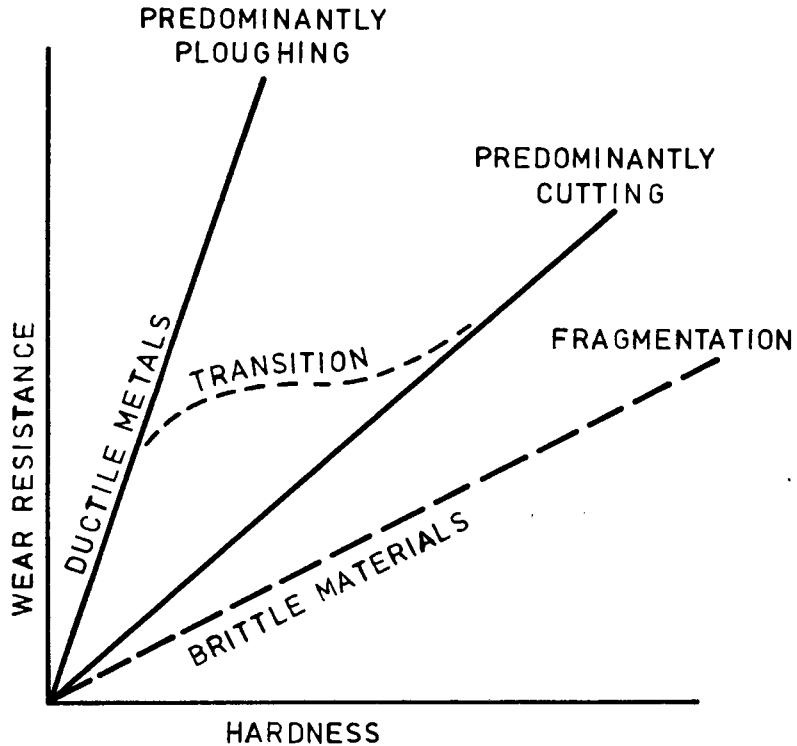

FIGURE 4.14 : The sigmoidal shape of hardness vs wear resistance curves is shown to be related to the change in the mode of material removal from predominantly ploughing to predominantly cutting as the hardness of a steel is increased.

Experiments by Mutton, Murray and Watson (1979) and Mashloosh and Eyre (1986) showed that cracking and fragmentation are induced by the stresses around the indenter for extremely brittle metals resulting in the higher wear volumes indicated on the diagram.

Mutton, Murray and Watson also defined a critical attack angle at which there is a transition from a cutting to a ploughing mechanism of abrasion. The angle varies considerably for different materials, as shown in Table 4.1. These findings are in accordance with work done by Sedrick and Mulhearn (1964) and Mulhearn and Samuels (1962).

The frequency distribution of the attack angle of the contacting points of abrasive particles in commercially available abrasive papers has been determined by two methods. Friedman, Wu and Suratkar (1974) used a specially designed profilometer while Mulhearn and Samuels examined sections of abrasive paper under the microscope. For commercial abrasive particles which approximate to 120° cones, the median attack angle was found to be about 70° , as shown in figure 4.15.

Material	Vickers Hardness	Critical Attack Angle
Lead	5	50° - 60°
Brass	180	50° - 60°
Aluminium	35	80° - 90°
Al - alloy	145	appr. 35°
Copper	120	40° - 50°
Nickel	350	60° - 70°
1082 steel Q&T	860	appr. 30°
Tool steel	760	appr. 30°

TABLE 4.1 : The critical attack angles of various materials.

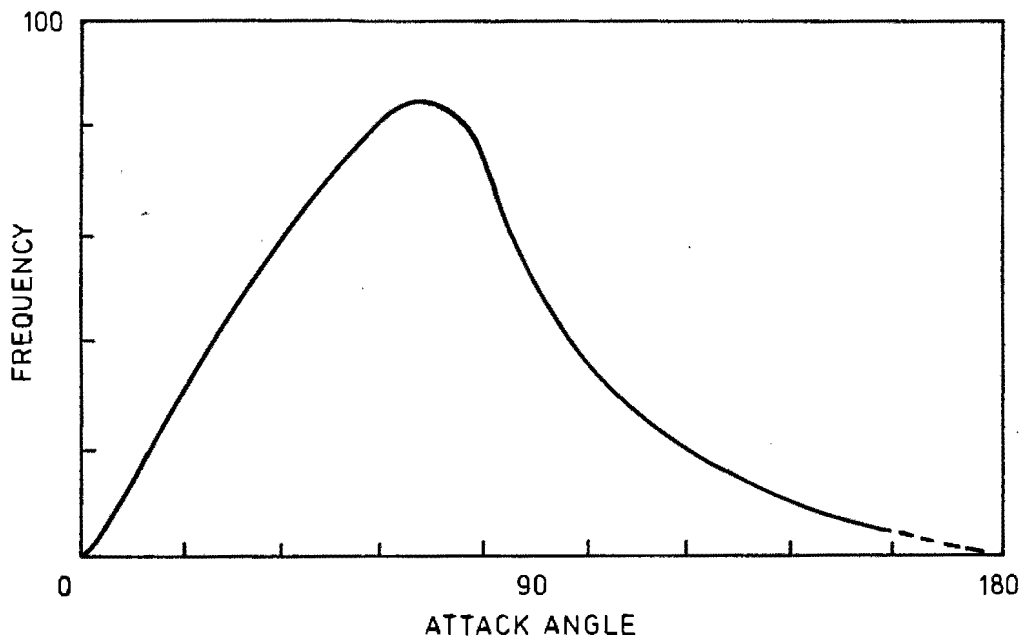

FIGURE 4.15 : The distribution of angles of attack in commercial abrasive paper.

For a metal such as aluminium, with a critical attack angle as high as 90°, only 15 per cent of possible particle contacts will form microchips and the mechanism of groove formation will be predominantly ploughing (figure 4.16 a). However for a tool steel which has a critical attack angle of approximately 30°, about 80 per cent of possible contacts will form micro chips and the mechanism of groove formation will then be predominantly cutting (figure 4.16 b).

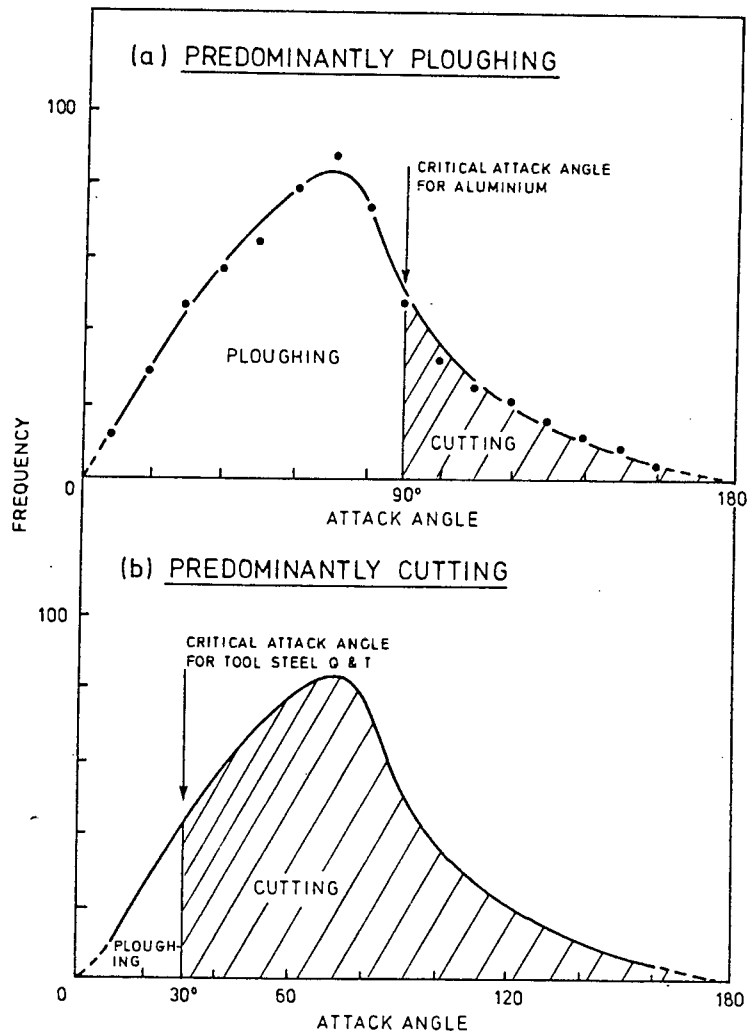

FIGURE 4.16 : The influence of the critical attack angle on the mechanisms of groove formation.

Mutton, Murray and Watson (1978) have shown that ploughing is predominant in the wear of pure metals whereas cutting is predominant in steel of the same hardness. This would account for the lower wear resistance of steels, compared with pure metals of equivalent hardness.

4.4 Mechanisms

4.4.1 Mechanism of Abrasive Wear in Homogeneous Materials

The characterization of material removal and damage at a worn surface is possibly the most reliable method of categorizing abrasive wear situations.

Fracture is the fundamental mode of material removal postulated by Vingsbo (1979) and four mechanisms are suggested :

- i) shearing of junctions
- ii) micro-cutting
- iii) impact
- iv) fatigue

Those four mechanisms may occur alone or in combination and may be further complicated by interaction with phenomena such as heating, plastic deformation, corrosion, phase changes and recrystallisation which are themselves not directly responsible for material removal by abrasion. When this type of analysis is applied to the abrasive wear of metals, the fracture mechanism is most predominantly micro-cutting (Kruschov and Babichev, 1958) while the dominant interactive mechanism is plastic deformation (Sin, Saka and Suh, 1978). The net effect of the interaction between micro-cutting and plastic flow was what Mutton, Murray and Watson (1979) defined as ploughing.

4.4.2 Mechanism of Abrasive Wear in Heterogeneous Materials

The mechanisms of abrasion described in the previous section are complicated by further considerations when these are applied to heterogeneous materials. These are :

- i) Size effects and distribution of microconstituents.
- ii) Failure mechanisms in the matrix.
- iii) Failure mechanisms in the precipitates (i.e. carbides).
- iv) Interface failure.
- v) Interaction of these mechanisms with each other and with the failure mechanisms in the abrasive.

In the introduction to their paper, Kruschov and Babichev (1958) stated that abrasion resistance is dependent upon the size of the structural elements in heterogeneous materials, although they report no experimental data on this topic. Richardson (1967) predicted that the wear resistance of a white cast iron would decrease as the scale of deformation (i.e. groove depth) increases with respect to the size of the carbides. In his following paper on wear by relatively soft abrasives, Richardson (1968) concluded that carbide particles became effective only when "they are in

the same size range, or larger, than the chips which would have been cut in their absence". This theory does not involve any consideration of matrix failure involving plastic deformation.

Experimental work by Zum Gahr (1979) showed that, when all other factors were constant, the abrasion resistance of tool steels bore an inverse relationship to the square root of the mean free path through the matrix. His plot of results is given by figure 4.17.

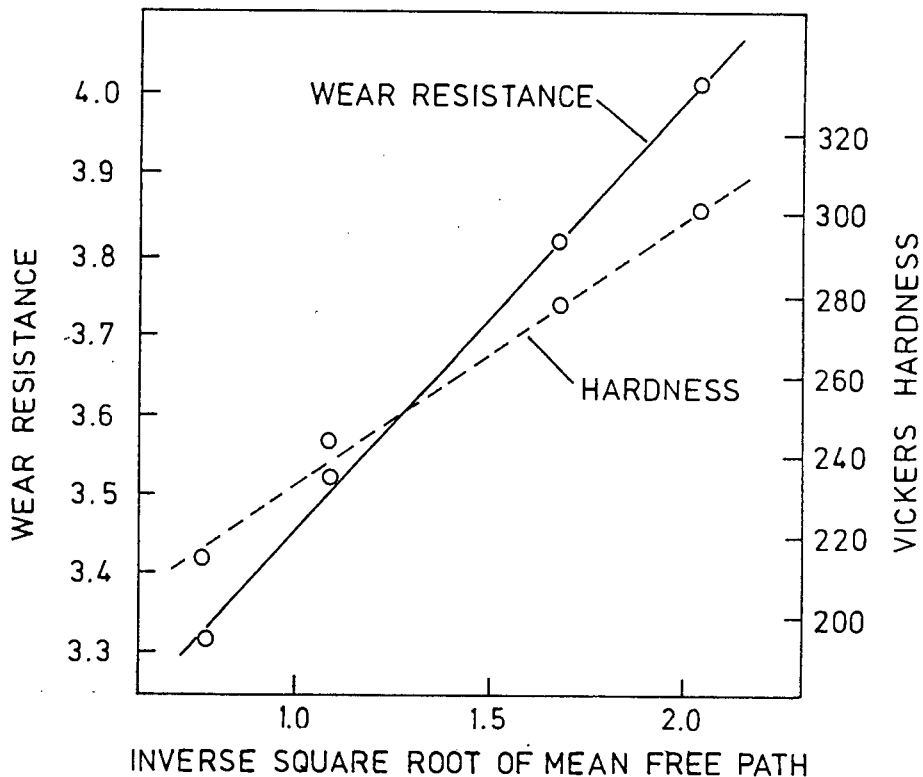

FIGURE 4.17 : Relationship between abrasion resistance and mean free path through the matrix (Zum Gahr, 1979).

An apparent contradiction in the work of Bates (1975), cited in McQueer (1985) and the classical model by Richardson (1968) may only be reconciled by a mechanistic approach. The results published by Bates (1975) indicate that finer spacing between eutectic carbides reduces the abrasive wear rate of white cast irons, an effect only significant at high loads. From the classical model, (Equation 4.13 in the next section), the depth of the groove is shown to be proportional to the load, so by Richardson's interpretation (1968) finer carbides should be less effective at higher loads. Clearly, plastic flow will be of greater

importance at higher loads. In this respect, classification of wear systems by the degree of microcutting/ploughing would possibly have greater value than the conventional high-stress/low-stress categories. Failure of carbides is likely to be due to impact or spalling owing to their hard, brittle nature but the mechanisms of failure in the matrix will be of a similar nature to those described in the section on homogeneous materials.

Interface failure will depend upon both the interface energy (e.g. degree of crystallographic match), and upon the shape and size of the carbides, although it can be argued that the former determines the latter to a great extent. Poor cohesion between carbides and matrix can result in carbides being pulled from the surface, while large acicular carbides can produce planes of weakness in the bulk material leading to macro-fracture and spalling (McQueer, 1985).

Sare (1979) concluded that the rate of abrasive wear of composites is controlled by the slower of two processes, carbide removal and matrix removal. The preferential wear of the matrix will be slight under low stress conditions. The carbides will therefore retain sufficient mechanical support to resist pull-out and fracture and the overall wear process will be controlled by the rate of carbide loss by gradual attrition. The preferential wear of the matrix will become more significant under high stress conditions. Carbides would then become inadequately supported and would be easily pulled out or fractured. The overall wear process would then be controlled by wear of the matrix. Watson, Mutton and Sare (1980) reported that where the abrasives are harder than the metal carbides, a greater degree of strain-hardening or strain induced transformations occur in the matrix. Such observations must influence the interpretation of the role of the carbides and again lead to the conclusion that the failure mechanism throughout the system must be taken into consideration.

4.5 Mathematical Model of Abrasion

Mathematical models of abrasion are used to calculate the effect of certain variables on wear. A simple model was used by Moore (1980) to define the volume of material loss per unit area during wear. Consider the effect of abrasive particles making contact with the surface of a ductile material as shown in figure 4.18.

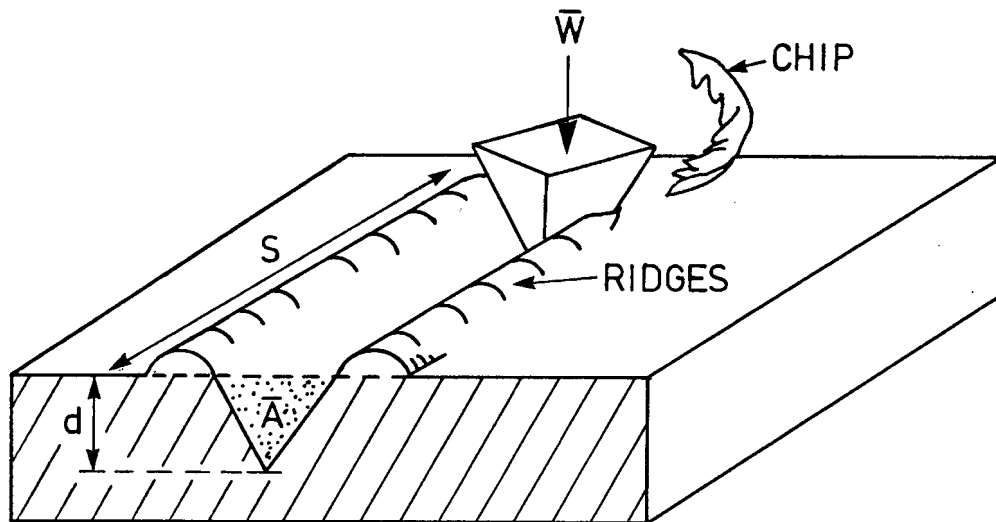

Figure 4.18 : Model of abrasive wear

$$\begin{aligned} v_1 &= \text{The volume removed by one abrading particle} \\ &= C_1 A S \dots\dots\dots(4-1) \end{aligned}$$

where C_1 - proportion of groove volume forming chips
as opposed to ridges
 A - cross-sectional area of groove (figure 4.18)
 S - sliding distance (figure 4.18)

Two major processes take place :

- (i) The formation of a groove with material being continually displaced sideways to form ridges. This does not involve direct material removal.
- (ii) The separation of particles in the form of primary wear debris of microchips.

He suggested that the volume removed by a number of particles can be represented by the following equation:

$$V = K_1 K_2 K_3 \frac{\sigma}{H} S \dots\dots\dots(4-2)$$

Thus the volume removed during abrasion depends on the variables in equation (4-2) which can be classified into three main groups :

Material properties : K_1 - The proportion of total groove volume forming chips as opposed to ridges.
 H - The hardness of the material.

Abrasive properties : K_2 - The size and shape of particles.

External variables : σ - The specimen size and load.
 S - Abrasion path length.
 K_3 - The proportion of particles making contact.

This model is used by Noel (1981) to justify the use of pin on disc abrasion testing methods. When standard material is used for comparing tests, materials and abrasive variables will remain constant thus allowing system variables to be studied.

A model similar to the one developed by Kruschov and Babichev (1958) and used by Moore (1980) was also used by Rabinowicz, Dunn and Russell (1961) to describe the wear rate.

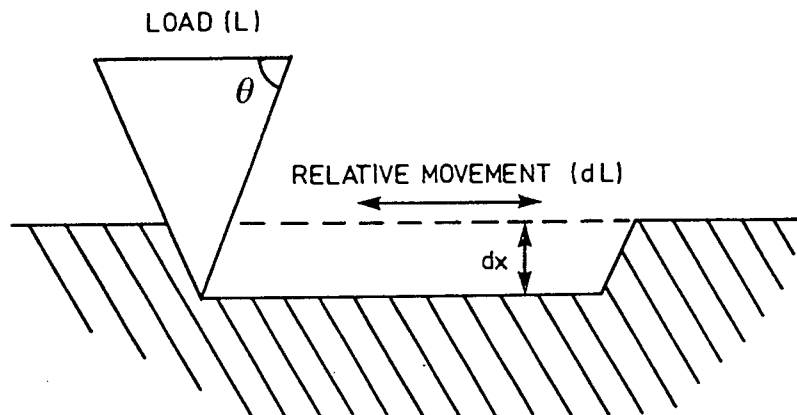

FIGURE 4.19 : Model for calculating volume of material removed by a hard particle moving across a metal surface (Rabinowicz, 1961).

The rate of material removal is given by the equation :

$$\frac{dV}{dl} = \frac{S \tan \theta}{\pi H} \dots\dots\dots(4-3)$$

where : H - hardness of the material
 V - volume of conical indentation

Re-writing this equation in terms of abrasion resistance (ϵ), it becomes

$$\epsilon = kH \dots\dots\dots(4-4)$$

$$\text{where : } k \text{ (const.)} = \frac{\pi}{\tan \theta S}$$

The work by Kruschov and Babichev (1958) showed that there is a linear relationship between hardness and wear resistance for commercially pure, annealed metals. This situation is adequately described in this model. However, the behaviour of steels at different hardnesses is not adequately described by this model. Kruschov and Babichev (1958) suggested that the wear of heterogenous materials could be calculated from the sum of the products of the wear resistance of the individual components and their volume fraction :

$$\epsilon = \alpha \epsilon_A + \beta \epsilon_B \dots\dots\dots(4-5)$$

where : α and β are the volume fraction of phases A and B having bulk wear resistance A and B respectively

However, Mutton and Watson (1978), working with eutectoid steel transformed at different temperatures, demonstrated that this relationship did not adequately explain the behaviour of steels. They found that the volume fraction and abrasive resistance of microconstituents did not vary significantly, whereas the bulk wear resistance changed considerably.

An attempt was made by Larsen Badse (1969) and Sin, Saka and Suh (1979) to take into account plastic deformation and work hardening effects by modifying the equation to the form :

$$\epsilon \propto \frac{H e^n}{S} \dots\dots\dots(4-6)$$

where : n = normal strain hardening component from the true stress/strain curve.

Mutton and Watson (1978) showed that for pure face centered cubic metals such as Copper and Nickel the normal strain hardening component, n , approaches 0.5 whereas the value for value for body centered cubic or hexagonal close packed metals of similar hardness lies between 0.1 and 0.2. The results for pure metals should therefore lie in an area bound by two limiting lines not on a single line. These mathematical models attempt to treat wear resistance as an intrinsic material property. However, any attempt to idealize abrasive and system variables leads directly to over-simplifications (McQueer 1985).

4.6 Effect of Speed on Wear

The effect of speed on wear of steels and copper on bonded abrasives and in soils was investigated by Moore and McLees (1980). Their experiments conducted a maximum increase of about 180 per cent in wear rate over the speed range 0.25 - 0.7 m/s. Moore and McLees compared their results with those of other workers and it appears that, generally, wear rate may increase by up to 50 per cent as the speed increases from 0.25 to 2 m/s, and by about 5 per cent as speed increases from 2-3 m/s.

Worker	Test and Specimen	Speed change (m/s)	Maximum change wear rate (%)
Dovlatyan	Field, cultivator points	0.9 - 2.3	- 30
Richardson	Field, flat plate tines	0.25 - 2.1	+ 57
Singh	Field, flat plate tines	0.28 - 1.1	+ 22
		1.1 - 3.4	+ 2
Singh	Field, plough shares	0.28 - 1.7	+ 47
		1.7 - 3.0	+ 4
Arbesman	Field, plough shares	1.3 - 2.8	+ 4.7
Krushchov & Babichev	Laboratory, bonded abrasives	0 - 2.5	+ 13
Nathan & Jones	Laboratory, bonded abrasives	0 - 2.5	+ 33
Singh	Laboratory, bonded abrasives	0.21 - 2.2	+ 140
Davies	Laboratory, loose sand	3 - 5	+ 800
Singh	Laboratory, loose sand	0.26 - 4.7	+1000

TABLE 4.2 : Previous measurements of the effect of speed on abrasive wear rates, compiled by Moore and McLees (1980).

4.7 White Layer Formation during Wear

These surface layers have been referred to as "hard", "white" or "non-etching" layers and have been reported to form in most ferrous metals under a wide range of conditions involving wear. The first mention of white layers seems to have been by Stead in 1912. He identified the white layers at the surface of steel wire ropes which had been in service. He suggested that their presence was due to the formation of martensite caused by frictional heating in service, followed by the quenching effect of the colder sublayers. Trent (1941) showed that these white layers could be reproduced in the surface layers of wire by striking the wire with a sharp blow or by rubbing it under load. He attributed the featureless appearance of the layers to an extremely fine grain size produced by rapid heating and cooling. Griffiths (1983) defined three categories for the occurrence of these white layers :

1. White layers formed at the surface of engineering components; for instance, leafsprings, turbine shafts, railheads, rollerbearings, piston rings and liners and gun barrels.
2. White layers formed as a result of manufacturing processes such as grinding, blanking, reaming, drilling and milling.
3. White layers resulting from laboratory experiments, typically pin on disc type wear experiments.

These white layers all have two common aspects :

1. They all have an extremely high hardness. Various investigators report hardnesses between 700 and 1200HV30 for steels and cast irons which is far in excess of that produced by conventional hardening processes, Eyre and Baxter (1972).
2. The layers appear to have an amorphous nature. The structure is very resistant to etching and appears white and featureless under optical examination.

In the case of steels it is often possible to recognize a zone below the white layer which is softer than the white layer and the bulk material. Eyre and Baxter (1972) do not discuss this feature but describe it as a heat affected zone. The majority of publications on this subject have been concerned with trying to classify white layers and to understand the mechanics of their formation. Grozin and Iankevich (1962) (cited by Eyre and Baxter, 1972) talk about seven different types of white layer and

show that their characteristics are sensitive to composition and operating conditions. The absence of the acicular morphology normally associated with martensite and the high hardness appear to rule out the possibility of their formation due to normal quenching from austenite. Brainin and Seleznoz (1961) (also cited by Eyre and Baxter, 1972) suggested a mechanism in which diffusion of carbon to the surface is induced by friction, causing the formation of high carbon martensite. However Eyre and Baxter (1972) showed that this is unlikely. Electron micrographs and tempering experiments show that the surface is not high carbon martensite. There is general agreement that the properties of non-etching layers are due to a fine dispersion of second phase particles forming an extremely fine crystallite structure (Eyre and Baxter, 1972).

Theories proposed for the formation of white layers have been divided into three main categories. Eyre and Baxter (1972), Scott, Smith, Tait and Tremain (1975) and Rowntree (1982) (cited in Griffiths, 1983).

1. Surface reaction with the environment causing nitriding, carburizing or oxidation.
2. Rapid heating and quenching, resulting in transformation products.
3. Cyclic deformation resulting in a homogeneous structure with dispersed carbides.

Eyre and Baxter showed that mixing of oxide layers was possible in some cases. They showed how decarburization had occurred below white layers during tempering of a 3% chromium, 0.3% carbon steel in an argon environment. They also cite Welsh (1957) who postulated the formation of nitrogen rich martensites in white layers. Although this was possible Eyre and Baxter do not consider it to be a significant effect. They also suggest that a thermo-mechanical process, involving surface temperature flashes and extensive cyclic deformation, is the most likely method of production of white layers.

In his work on the dry wear of steel, Welsh (1965) had shown that above a certain load, white layers formed and the wear rate decreased. In a similar experiment Eyre and Baxter (1972) used a 3% Cr, 0.3% C steel of a hardness of 200HV. The sliding speed was 100 cm/s and coefficient of friction 0.8. The transition load at which white layers formed was found to be 2.5 kg. Following the work of Archard (1958/9) and citing Jaeger,

they showed that temperatures sufficient to cause austenitization may be produced. Eyre and Baxter (1972) suggest that the combined effects of temperature flashes and plastic deformation during asperity contact would produce a refined structure of martensite. The resultant dislocation substructure would be more stable, having been formed at higher temperatures and possessing smaller elastic stress fields. In addition to this it would be pinned by the fine carbide precipitation. This pinning would account for the observed resistance to tempering. Transmission electron microscope studies of these regions cited by Eyre and Baxter (1972) have revealed a cellular structure with no carbides or very fine carbide stringers, suggesting that further carbon may remain in solution or segregate at dislocations.

Newcomb and Stobbs (1984) investigated a situation in which the attainment of austenizing temperatures was highly unlikely. They studied the formation of white layers in a 0.5% carbon rail steel. Their transmission electron microscope studies revealed a fully martensitic microstructure. They observed the persistence of pro-eutectoid ferrite in the white layers but could not confirm whether this too was observed in transmission electron microscopy. They therefore could not say whether the martensite microstructure existed in the ferrite. Using the work of Archard (1958/9) they calculated a temperature rise of 60°C for a wheel load of 10 tf with one per cent slip at a trail speed of 50 m/s. Citing the work of Tanvir (1971) they found the maximum possible temperature rise to be only 151°C. The percentage slip necessary to produce austenizing temperature was between 5 and 10 per cent depending on the train speed. These, they argue, are artificially high. The transmission electron microscope study also failed to reveal an intermediate zone of martensite with incompletely dissolved carbides, or retained austenite. For this reason Newcomb and Stobbs (1984) looked for a mechanism of formation which was not dependent on temperature.

The effects of high pressure were investigated but they cite work by Hilliard (1963) to show that the austenite temperature would only be lowered by about 20°C at the predicted pressures. Martensite, which would be expected to form at high pressures, was not observed. Newcomb and Stobbs (1983) suggest that the white layer is ferrite containing dislocations supersaturated by carbon transfer from carbides during high frequency pulsed shear fatigue of the rail surface. The dissolution of carbides in pearlite, they reasoned, would produce ferrite

supersaturated with carbon, giving rise to deformation twinning. They cite the calculations of Kallish and Cohen (1970) to show that a dislocation density of $2 \times 10^{13} \text{ cm}^{-2}$ would be sufficient to dissolve the carbides in the ferrite containing 0.6% C. This density is much higher than normally found in deformed ferrite. However, they suggest that the pulsed, subsonic shear stress cycle induced by the wheel contact would cause the mobile carbon free dislocations to contact the carbides. This would lead to a progressive increase in the depth to which carbides would form. They suggest that the measurement of the lattice parameters is necessary to confirm this hypothesis. The white layer phase for a 0.6% carbon steel would be tetragonal if formed from austenite, and cubic if formed by the supersaturation of ferrite.

The work done so far is by no means conclusive. A reasonable explanation continues to elude those dealing with the enigma of white layers. They appear to be a material response to a number of different conditions. If the mechanism of formation can be described and repeated it may be of use in the abrasion resistance industry. Eyre (1984) has expressed his belief that the high hardness, if it could be uniformly produced, would provide excellent wear resistance.

4.8 Abrasive Wear by Soil

A study of abrasive wear by soil involves the consideration of many poorly defined variables. These variables are inter-related in a rather complex fashion. It is therefore necessary to use bonded abrasive papers for studying the effects of the abrasive. Moore (1975) notes the difference between laboratory and field situations. Abrasion on bonded papers must cut and groove the material, whereas abrasive particles in the field may roll along the wearing surface. The abrasive ability of soils may also be reduced when abrasive particles are clogged by very fine particles. Moore (1985) qualified the effect of various forces experienced by a tool working in the soil (Table 4.3). As can be seen from these figures, the draught force itself does not contribute greatly to the force of abrading particles on the tool face. However, a role is played by the soil strength as shown by the resistance to penetration. For instance, stones are held more firmly in soils with a high penetrometer strength.

Type of force	Duration (seconds)	Typical range (MN/m ²)
Draught	-	0.01 - 0.1
Resistance to penetration	0.5 - 5	0.5 - 2.00
Impact	0.001	2.00 - 250

TABLE 4.3 : Forces acting on a ground engaging tool (Moore, 1985).

The most important factor in this regard is the impact force. Although each impact is of a very short duration, the possible abrasive or deforming force is very high. The relative content of stones in the soil will clearly have a marked effect on the wear rate. Moore (1985) followed these results with the analysis of the effects of a flat plate moving through soil. The behaviour of particles in contact with the plate was compared with the orientation of the plate with respect to the direction of movement. The results are shown in figure 4.20.

The wear rate and load on the plate were compared for angles between 0° and 80°. The results of these tests, figure 4.22, show the highest wear at low angles, at which rolling is most likely to occur.

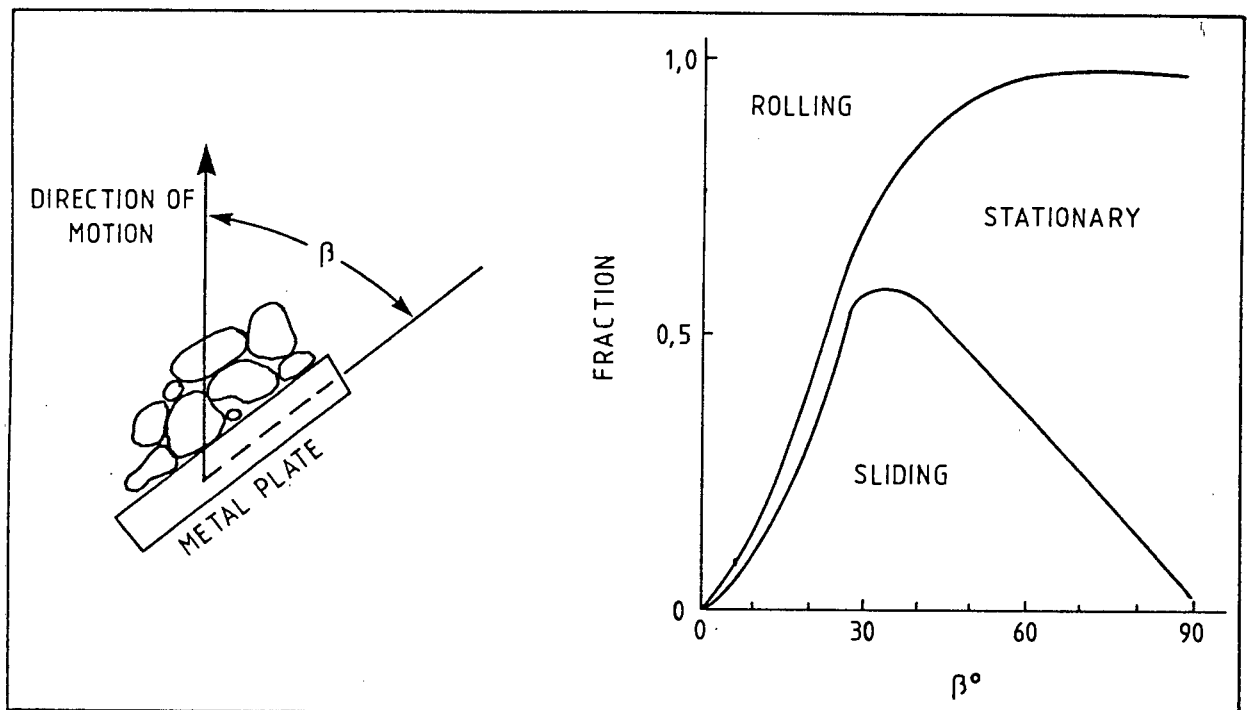

FIGURE 4.20 : The relationship between the orientation of a flat plate moving through the soil and the reaction of soil particles.

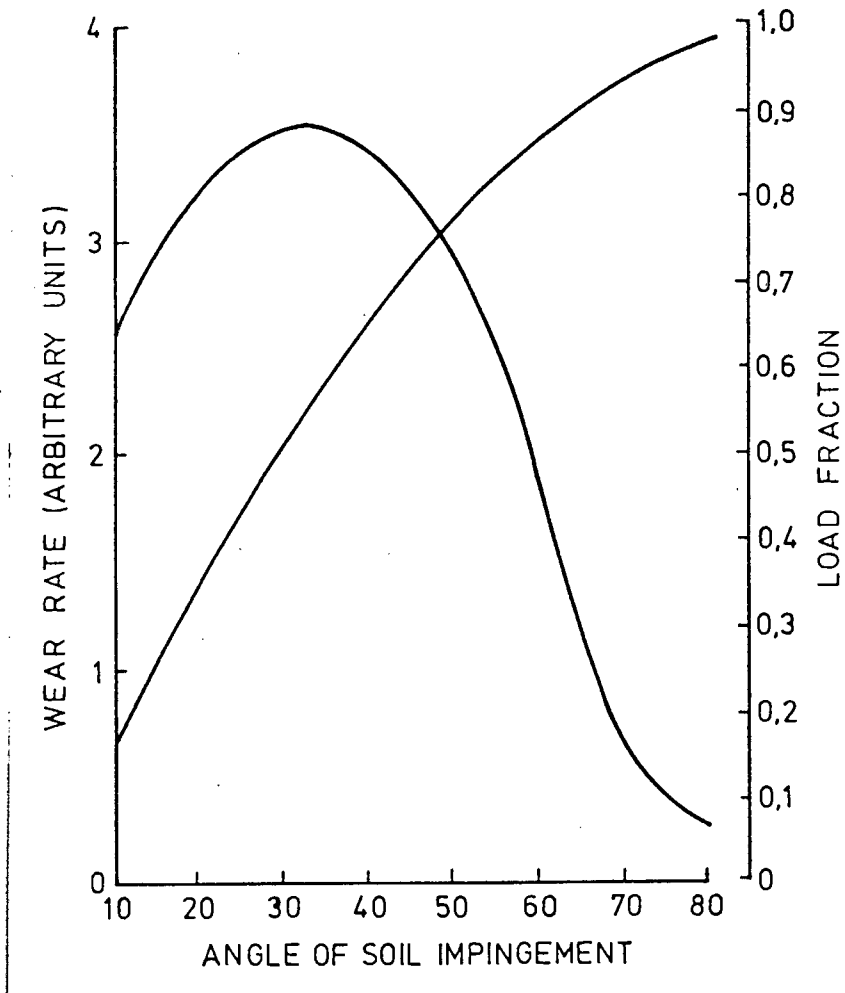

FIGURE 4.22 : Comparison of the change in wear rate and load on a plate with change in angle of soil implement (Moore, 1985).

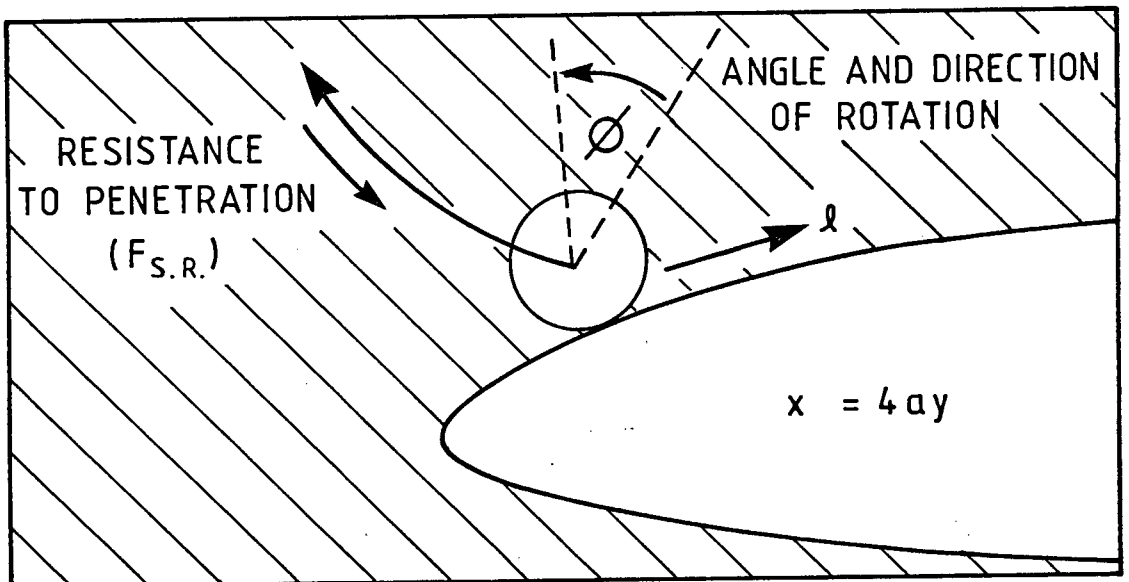

FIGURE 4.23 : Wear of a parabolic profile in stony soil. Rotation of a stone across the surface.

Figure 4.22 clearly shows that the wear is greatest when the normal load is not particularly high. Draught force is therefore not necessarily an important factor in wear by soil. The high wear rate when stones roll over a wearing surface may be explained through the work done by Richardson (1969, cited by Richardson (1975)). The stones in the soil were shown to rotate around the surface of a parabolic indenter in a direction contrary to the movement of the indenter. This is shown in figure 4.23. Richardson suggested that the volume wear per unit sliding distance is proportional to the soil cohesive strength and the sum of the products of stone diameter and volume fraction of each stone size in the soil. This is shown in figure 4.24.

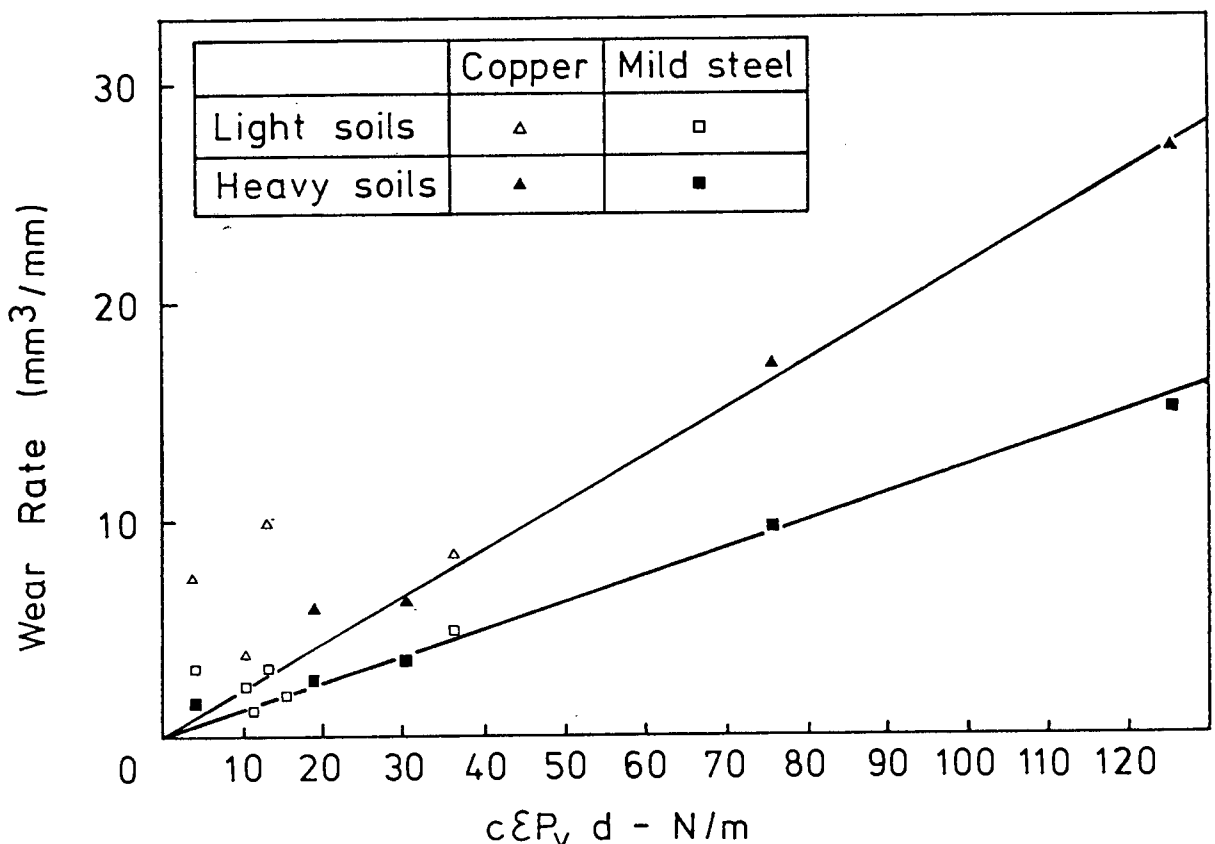

FIGURE 4.24 : Correlation between wear rate and the soil cohesive strength and the sum of the products of stone diameter and volume fraction in soil $C \sum P_v d$ (Moore, 1975).

Richardson (1969) also considered the effect of the resistance to penetration in soils using steel spheres. The results showed that the stress resisting penetration and the number of stones of each size group were the characteristics of the soil affecting the wear rate. He was able to show from his analysis that the contribution of the smaller

stones to wear was minimal. He also demonstrated that the wear increases with the increase in stress resisting penetration, and the increase in the number of stones of a particular size per unit volume especially for the large stone size groups.

From the consideration in figure 4.23 Richardson (1969) cited in Moore (1975) showed that the volume wear caused by stones in soil

$$V = k \sum g(\sigma, a, N, r)$$

where k is a constant

σ = resistance to penetration/ πr^2

a = the focal length of the parabola

N = number of stones of radius r per unit volume

r = radius of the stone

Soil Fraction	Geometric mean Radius (mm)	Proportion by Volume of Soil	Number of Stones per Volume	Percentage of total Wear for	
				a=0.15mm	a=0.36mm
Stones					
38.0	25.40	0.002	38	11.0	10.5
19.0-38.0	13.50	0.019	2 380	56.6	56.2
9.5-19.0	6.75	0.021	16 600	26.4	26.1
4.8- 9.5	3.37	0.007	45 400	4.7	5.2
2.4- 4.8	1.69	0.003	163 000	1.3	2.0
Fine Fraction					
Sand 0.06-2mm		0.226			
Silt 0.002-0.06		0.125			
Clay 0.002mm		0.024			
Chalk		0.184			
Moisture		0.254			
Void		0.135			

TABLE 4.4 : Note that wear is performed predominantly by the stone phase in the soil.

Richardson calculated the proportion of total wear caused by various stone size groups in a typical chalky-sandy loam and that the contribution to wear by smaller stones is very small. He concluded from this study of wear of materials by soil that the ideal wearing material would have to be harder than the abrasive - in the case of steels by a factor of two or three. The hardness of quartz should be considered at 1060 kg/mm². Hard facing materials could be considered although the high contact stresses during wear require a strong matrix material. Improvement normally depends on developing the materials and treatments to meet the conditions of wear and impact. A true assessment of these conditions needs to be made. Contrary to the conclusions of Ball (1983) Richardson placed very little reliance on work hardening in service in soils, especially in wear by softer abrasives. Any departure from unidirectional sliding in this situation would therefore cause a reduction in wear resistance.

4.9 Testing Techniques

The success of any materials testing programme is dependent on the methods used to generate data. Field testing is usually the first approach considered. This, however, involves considerable time and expense. In the agricultural context, large specimens and heavy equipment is also necessary. A carefully designed laboratory test is obviously preferable for the economy of such a project. However, as Uetz, Sommer and Khosrawi (1981) state, "The ultimate assessment of the wear resistance of materials can only be obtained in service".

Feld and Walters (1975) have stated that the three basic requirements for a meaningful wear test are :

1. Reproducibility of results
2. Differentiability of the test
3. Transferability of a simulated test to the real situations

Although reproducibility is important in testing, Avery (1977) pointed out that design engineers regard the results of laboratory wear tests with scepticism due to their dubious validity for predicting performance in service and not because of the variability in results. In narrowing variables down to produce a reproducible test it is possible to reduce applicability or transferability.

Uetz, Sommer and Khosrawi (1981) discussed the testing of components on six levels.

1. Field testing : Using the actual system under study.
2. Stand testing : Mounting the system on a test stand to standardize parameters.
3. Component testing : Tests on sets of specific components in an assembly under test stand conditions.
4. Small scale model testing.
5. Simplified or simulated component testing.
6. Model tests with a simple specimen (eg. pin on disc).

The field test is used to determine the actual working life of a component. The sixth category is used to simulate the processes acting as the real component, particularly in the contact area. The complex variables operating in the original system are isolated and duplicated in the laboratory on simple standard specimens.

The fact that wear performance is systems related is important when considering the transferability of data between wear tests. Moore (1986) and Uetz, Sommer and Koshrawi (1981) give a list of important criteria to be considered when comparing test methods. These may broadly be classified into operating variables and test results.

The field consideration under operating variables is the abrasive. The type, size and shape including the grit size effect and critical attack angles of different abrasives are all relevant. Also important is whether the abrasive is loose or fixed, the contact-time history of abrading particles and the effects of load on abrasive deterioration. In addition to this, the environment (moisture content, corrodent), velocity-time history (ploughing speed) and the ratio of sweeping to swept area should be considered. The swept area is the area of the wearing material or component and the sweeping area is the area of the abrasive medium. The importance of this is related to abrasive breakdown. Moore (1986) provides an example to illustrate various cases. In the case of tillage, the plough point (swept area) is very small compared with the area of the soil tilled (sweeping area). In the case of a chute carrying rocks, however, the swept area (chute) is large compared with the sweeping area (the surface area of a rock passing down the chute). In this case the abrasion path length is long and the efficiency of the abrasive may decrease with sliding distance.

The second and most important consideration is the results of the wear tests and the final resultant state of the worn surfaces. These will show how well the operating variables in the laboratory test have been chosen. Results include the correlation of wear rates from the different methods as well as the physical and mechanical characteristics of worn surfaces. The worn surfaces will give a good idea of the mechanisms of material removal.

Moore (1986) places great importance on the similarity of $K_1.K_2.K_3$ values in different methods. A significant result recorded by Moore (1986) was the similarity between the $K_1.K_2.K_3$ values of his single tyne test and the pin-on-disc test. $K_1.K_2.K_3$ values for the pin-on-disc test were calculated for a range of abrasive types and grit sizes. For the field test a range of soils and applied loads were used. The $K_1.K_2.K_3$ values were between 0.1475 and 0.022 for the pin-on-disc test and 0.13 and 0.017 for the field test.

The RAR values from different tests should be plotted one against the other. Moore (1987) shows that this will give a good indication of whether the laboratory test under or overestimates wear in the field.

4.9.1 Field Testing

Previous attempts at comparing wear rates on soil working tool materials have been limited by the use of practical components as the wearing parts (Richardson, 1967). Many studies have been carried out using tillage tools as test pieces and the results have shown the validity of this statement by Richardson.

Moore stipulates an acceptable error of approximately 10 per cent for field tests. However Mohsenin, Womochel, Harvey and Careleton (1984) found variations in weight losses exceeding 200 per cent when they used a 12 point cultivator under controlled testing conditions. Bowditch (1969) also found that the results of wear tests using a 21 point scarifier were far from uniform. In both of these cases statistical methods were used to reduce the errors.

Moore (1985) has suggested a number of factors to be considered when a test method is being designed for measuring wear rate in the field. The first five concerning design are as follows :

1. Is the method intended to test materials or component design ?
2. Is the attainment of an equilibrium shape important ?
3. Does the testing require a monolithic or a composite component?
4. Will the testing procedure involve frequent removal and weighing of the specimens ?
5. To what extent will the cost and manufacture of equipment and specimens limit the test programme ?

Moore also listed six considerations pertinent to the choice of a method of wear measurement.

1. Is the total volume loss or the change in shape more significant ?
2. Is it necessary or advantageous to carry out measurement on site ?
3. Will information about surface damage be required ?
4. What is the optimum test interval between measurements and how close to this rate will it be possible to carry out sampling ?
5. Is measuring equipment available ?
6. What are the required tolerances ?

Bowditch (1969) listed the factors influencing mass loss that need to be controlled when using this type of equipment. These he said were:

1. 'Stump Jump Force'.

Most ground engaging tools today incorporate a spring loaded mechanism which allows the tool to move over an obstacle in its path. The results of the tests by Bowditch (1969) indicated that the spring force had to be set very carefully. The shanks were caused to retract by normal working loads as well as obstacles. In this way the stump-jump mechanism acted as a crude form of draught control.

2. Location of shears in the longitudinal direction.

The set working depth of a shear can be influenced by its longitudinal position on the frame. If the scarifier frame is

tilted up or down, its front row of shears will be set deeper or shallower than the rear row of shears.

3. Change in longitudinal inclination.

The tilt on the scarifier frame must be set to diminish the effect described above.

4. Lateral position of the frame.

Lateral tilling results in a bias in wear rate of shears relative to its lateral position on the frame. This could be due either to uneven tyre inflation pressure with one wheel running in worked ground or in the inaccurate setting of the frame. The bias could also be the result of round working, where the points on the outside of the curve travel a greater distance than those on the inside.

5. Vertical deviation.

It is extremely difficult to arrange for shears to lie in a common plane.

6. Soil disturbance factor.

Many of the shears on scarifiers work in soil which has been partly disturbed by shears - in preceding rows. In such case, the draught forces and wear rates would be lower.

Moore (1985) outlined some pitfalls possible in wear studies. First in the design of the experiment. He advised the use of simple procedures and a reduction in the number of variables involved. He also suggested the use of statistically designed experiments. Next he suggested a quantitative characterization of service environment and test materials. And finally in testing itself he said the control of implement depth was important. The effects of different materials, soil types and soil compaction caused by tractor wheels can be accounted for in this way.

4.9.2 Single Tyne Test

It may be assumed from the foregoing examples that without fairly sophisticated statistical techniques, the method of using multi-tyne instruments for wear testing is unsatisfactory. Another approach, introduced by Richardson (1967) was the testing of a single tyne. This was mounted on a fully floating rear mounted tractor tool bar. The specimen formed a parabolic profile during running in and this profile altered very slightly during testing. Specimens were either run in on a test site, or in the developed technique, specimens were prepared with chamfered edges. A randomised, split block layout was found to be satisfactory for testing. Four blocks were sufficient to limit the standard error to about 5 percent of mean wear, having extracted variants due to block and material differences. The land was marked out with siting poles to form one or more parallelograms which were divided into four areas of land.

The specimens were taken in random sequence, run a chosen number of passes in 2 or 4 areas and then reweighed. The tractor was driven in a wheel track from the previous run so that each area was worked over starting from one side. A new random sequence was used for each of the blocks comprising the experiment. The total wear of all the specimens was kept constant within about 3 g by giving the more resistant materials more passes per area.

More recently Moore (1975) used a similar procedure to test surface coatings. Instead of a flat plate, he used a single paraboloidal specimen with focal length of 1.55 mm. The paraboloidal shape promoted uniform wear during testing but was chosen primarily to resist extreme impact loads (Swanson 1985).

The specimens were run for 200 m at 1.79 m/s and at a nominal depth of 200 mm. A single run consisted of 4 x 50 m segments, the specimen being rotated through 90° at the end of each segment. Full details of the experimental methods are reported in an unpublished paper referenced by Moore (1975). This idea was also incorporated in a wear probe developed by Studman at the National Institute of Agricultural Engineering in Britain cited by Swanson (1985). The paraboloidal wear specimen, which had a focal length of 7.5 mm, was attached to the leading end of a cantilevered beam type loader. This was strain-gauged to measure the

total draught force, the normal force and the side force exerted in the specimen. Swanson used this procedure to compare field tests with a standard ASTM G-65 rubber wheel abrasion test. The method was shown to be trustworthy when carefully controlled.

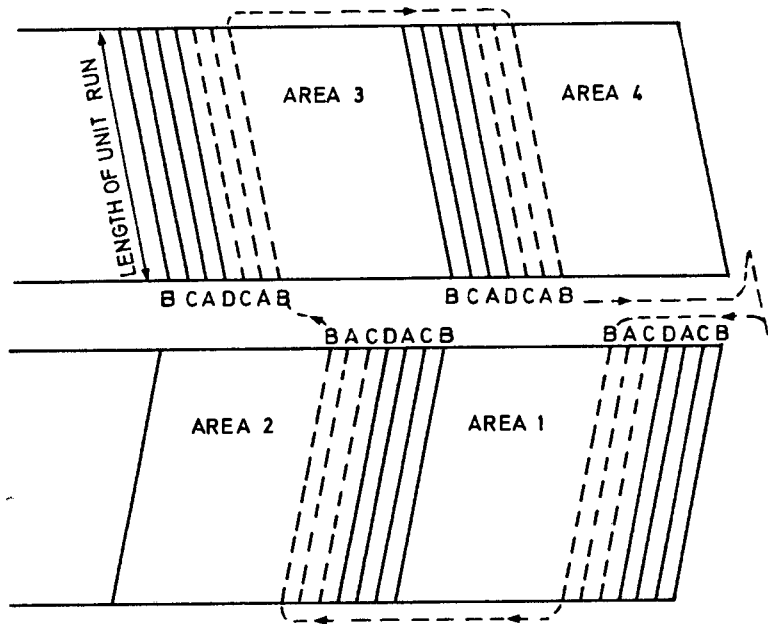

FIGURE 4.25 : Field layout used for testing by Richardson (1967).

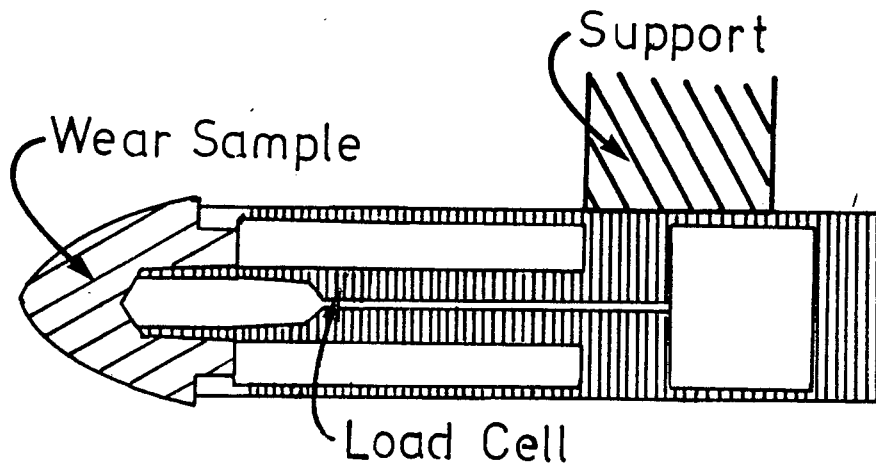

FIGURE 4.26 : Paraboloidal soil wear probe used by Swanson (1985).

4.9.3 Laboratory Testing Techniques

In discussing laboratory testing Avery (1977) divided the variables included into two groups:

- i) Opportunity variables : running time, travel distance, contact area, abrasive feed rate and specimen configuration
- ii) Severity variables : size, angularity and hardness of abrasive, velocity, impingement angle, load and freedom of motion of abrasive

Opportunity variables may, within certain limits, be adjusted to produce a measurable loss of material in a reasonable time. Care should, however, be taken when adjusting severity variables in order to accelerate material loss or enhance the differentiability of the tests. Severity variables also influence the mechanisms of material removal which may alter the whole wear system and reduce the transferability of data.

4.9.4 Laboratory Abrasion Tests

The most common method is the pin on disc arrangement described and used by Kruschov (1974), Richardson (1968) and Torrance (1980). A pin sample is loaded vertically on a rotating disc of abrasive paper and the specimen is traversed during the test, describing a spiral on the paper so that it abrades on unworn particles at all times. There is good transferability of data between the test and agricultural tests run in the field. The main disadvantage of the method is the speed differential between the inner and outer edges of the sample. This necessitates the use of thin specimens which gives rise to edge effect problems outlined by Larsen-Badse and Mathew (1972). The change in speed as the sample moves towards the centre of the disc must be countered with the use of a variable speed drive.

A similar method using a belt-sander has been developed and used by Mutton, Murray and Watson (1977). This form of testing was developed in the Materials Engineering Department at the University of Cape Town by Allen, Ball and Protheroe (1981).

A third method described by Muscara and Sinott (1972) is based on a

vertical milling machine. Abrasive paper is bonded onto the platform and the specimen under load describes a series of passes on this paper - each pass being displaced by one specimen width. A useful feature of these methods is that wear debris may be collected and studied. One of the disadvantages is that the type of abrasive used is limited to commercially available bonded abrasives.

4.9.5 Low Stress Abrasive Tests

Another common method is the sand/rubber wheel abrasion tester described in ASTM Standard G65-80 (ASTM 1980). The tester is illustrated in figure 4.30.

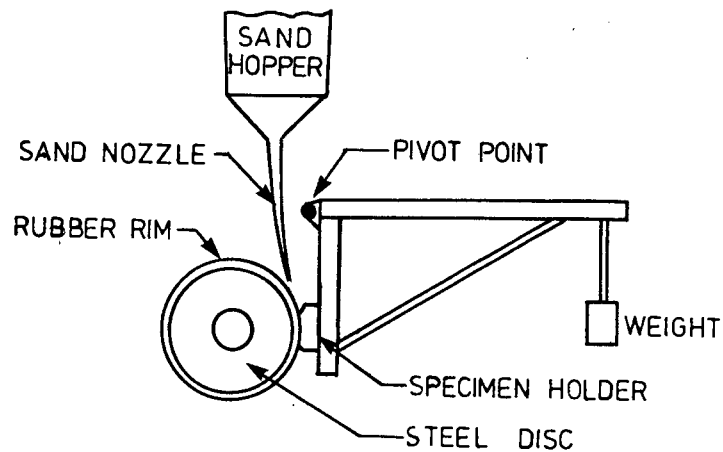

FIGURE 4.27 : Sand-rubber wheel abrasion tester.

The specimen is loaded against a rotating rubber lined wheel. The abrasive is fed between the wheel and the specimen at a controlled rate. This method has the advantage of giving reproducible results. When the standard specifications are followed, data from workers in different laboratories may be compared directly. It has been used extensively by Climax Molybdenum Company (Borik, 1970/72). Rigney and Glaeser (1978) showed that this may be used for testing materials for a ground engaging application. However, McQueer (1985) points out that this attempt to standardise abrasion testing is tending to treat abrasion resistance as a material property instead of a systems property. The refining of the reproducibility of the test has lead to a reduction in applicability. Rabinowicz, Dunn and Russell (1961) and Misra and Finnie (1979,81) used a very similar system with a horizontal rotating plate, against which a wear specimen was loaded.

4.9.6 Impact Abrasion Tests

The effect of impact with stones during tilling is a factor omitted by all the tests described so far. Kruschov (1974) describes two tests that were used to simulate the effects of impact during abrasion.

The first is called a YAM tester. It consists of 2 mm diameter specimen that falls from a fixed height onto an abrasive cloth stretched on a drum. While the specimen rises for a new drop, the drum turns slightly so that the specimen moves across the drum in a continuous direction as well as rotating. This system does not duplicate the wear processes taking place during tilling. While impact is important, abrasion is the major method of material removal.

A second test rig described by Kruschov was designed to simulate the wear in rock drilling and impact crushing of ore. A horizontal shaft with a cam was rotated by a motor. The cam lifted a loaded frame holding a test specimen and allowed it to drop onto a freely laying abrasive layer about 1 mm thick. The abrasive was automatically removed and replaced with a new layer after each impact.

4.9.7 Other Test Methods

Tests have been carried out in order to ascertain the effect of the attack angle of particles on the mode of materials removed from grooves. These single point scratch tests have been mentioned in the section on the effects of attack angle.

4.9.8 Post-Wear Specimen Testing

Once the field and laboratory testing is complete, much may be learned through a carefully planned post-wear specimen testing procedure. Some guidelines were given by Moore (1985), in figure 4.28.

1. Worn surface.

The morphology of the worn surfaces reveals many clues concerning mechanisms of material removal. This is shown by Eyre and Baxter (1972) and Swanson (1985).

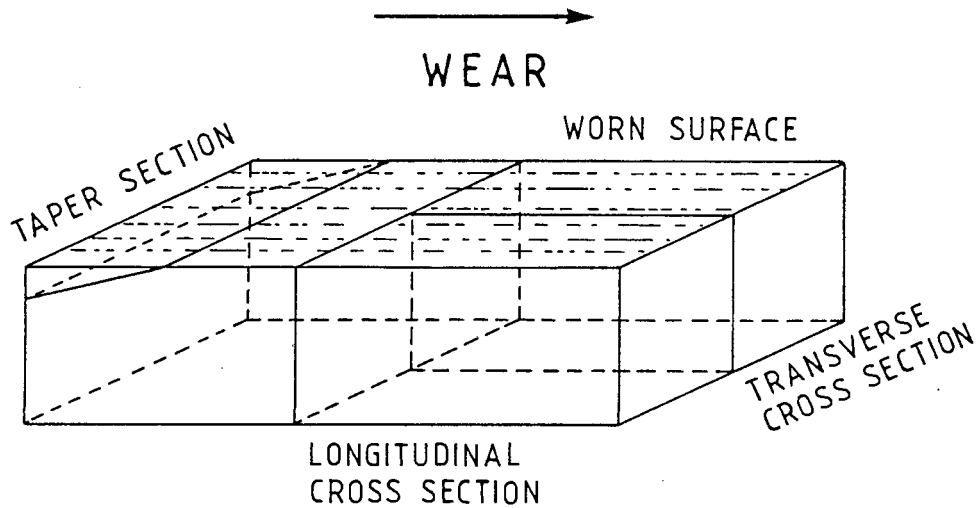

FIGURE 4.28 : How a specimen may be sectioned for post wear examination.

The comparison of worn abraded surfaces is useful for comparing the severity of wear in different situations and is essential for assessing the transferability of data.

2. Wear debris.

The shape characterization of wear debris should be used to complement data from the examination of worn surfaces. This method was used by Eyre (1984) who studied white layer formation on shovel bucket teeth. A standard pin on disc was used but the specimen was not traversed during testing. He describes the change in morphology of wear debris from long continuous machining chips to small compressed platelets. Mashloosh and Eyre (1986) show that the type of debris produced in abrasion clearly indicates the mechanism of deformation and fracture occurring in the wear process.

3. Longitudinal cross section.

Sectioning in this orientation will reveal the effect of a single grain abrading the material.

4. Transverse section.

This may be used to examine the surface damage simultaneously with the resultant sub-surface deformation.

5. Taper section.

This is a more effective way of examining the surface and corresponding sub-surface deformation. The technique is also described by Mutton and Watson (1977), Watson, Mutton and Sare (1980) and Eyre (1984). The specimen is set in araldite and then polished at an angle to the surface to observe subsurface deformation in detail as well as the responsible surface damage.

Optical microscopy has been used to great effect in all the above methods. The most useful tool used for the study of wear debris and surface damage however is undoubtedly the scanning electron microscope. This has been used by all the above researchers. A micro hardness tester has also been shown to be a most useful tool for measuring the subsurface effects of surface damage, Eyre (1984) and Moore (1985).

CHAPTER 5

EXPERIMENTAL TECHNIQUES

5.1 Introduction

The initial experimental work was concerned with the evaluation of the wear resistance of selected materials in tilling tests. A number of tilling methods were evaluated and the most applicable method was used to carry out initial field tests before it was decided to design and construct the special equipment necessary for precise wear monitoring. This consisted of a simple rig bolted to a tractor tool bar. The suitability of a pin on belt facility for ranking materials in order of wear resistance was also investigated. The transferability of data for field and laboratory tests was evaluated on the basis of ranking order of materials, morphologies of worn surfaces and subsurface deformation. This comparison involved the use of optical and scanning electron microscopy. Standard mechanical testing was also carried out to characterize all materials. The method of classification of tests used by Uetz, Sommer and Khosrawi (1981) was adopted for this project.

5.2 Development of a Field Test

Any evaluation of the wear of tillage tools will of necessity involve field testing. This is the best method of collecting meaningful data by which materials may be ranked for wear resistance. This would involve type I testing in the classification given by Uetz, Sommer and Koshrawi (1981). The availability of data from a reliable field test is also fundamental in the development of laboratory testing techniques.

5.2.1 Evaluation of Tillage Methods

Naturally, it would have been most convenient if existing tilling equipment could be used to provide reliable data on wear behaviour. For this reason, the suitability of the various tilling methods as a vehicle for wear testing was investigated prior to any field tests being carried out. A tilling method was required in which many different materials could be tested in the minimum time and which also gave reproducible results. Most of the guidelines summarised by Moore in his lecture series (1985) were considered at this stage.

Firstly it was agreed that the method would be used for testing materials, not designs. A monolithic component was to be tested by a process involving sequential wear, removal and weighing to determine wear rate. It was assumed that the attainment of an equilibrium shape was desirable although the full implications of this assumption were not realised until after the type I tests. The manufacture of specimens was to be handled by a local manufacturer.

Four designs of tillage tools which are currently in widespread use were considered.

a) The Mouldboard Plough

This is an implement used to lift and invert the soil. The four elements comprising this tool each play a role in the production of straight, evenly spaced furrows, namely:

1. A share : A share undercuts the soil and lifts it onto the mouldboard.
2. A shin : The shin is a vertically set blade that neatly cuts the width of each slice of soil.
3. A mouldboard: This is a curved plate designed to turn the slice of soil over in the most efficient manner possible.
4. A landside : A landside is a straight plate which runs along the edge of the cut produced by the shin. This keeps the implement aligned, making it possible to plough along straight furrows.



FIGURE 5.1 : The mouldboard plough.

The theory of operation may be easy to state but in practice design and setting is fundamental to performance. There exists a complex relationship between the four elements comprising the plough. Each one plays a role in the production of straight evenly shaped furrows.

b) The Disc Plough

This is an implement used to invert the soil. It is used where soils are very hard and resist penetration by a mouldboard. A series of concave discs are set on a frame. For greater efficiency the plane in which their circumference lies may be set at a predetermined angle to the direction of movement of the tractor.



FIGURE 5.2 : A disc plough.

c) The Scarifier

This is a light shallow working tool with flanged points. It may be used in conjunction with heavier tools for final seed bed preparation as well as weed control in vineyards and orchards. The point works at a depth of approximately 10 cms to cover seed or uproots weeds which then die in the sun (fig. 5.3).

d) The Ripper Plough

This is probably the most primitive concept in tilling. A set of curved points mounted on tynes are dragged through the soil to break the compacted or hardened surface layer.



FIGURE 5.3 : A scarifier.

Although ripper points themselves are relatively simple in shape, there has been a considerable amount of development in the design of the curvature and the angle of attack of the point for maximum efficiency. The efficiency of an unused point begins to decrease from the moment that it enters the soil because of the high rate of wear at the tip of the tool. The standard ripper plough works at a depth of about 18 cms but the concept has been adapted for 'subsoiling'. This is a technique involving the use of a single robust tyne on a powerful tractor. Hard layers occurring at depths of up to 1 m are broken by this means, usually to control drainage.

Following careful consideration of these tilling methods, it was decided that the disc plough and mouldboard were too large for precision wear testing, since both required a large amount of material for fabrication. The complex nature of the wear process expected in these tools would also make a careful study difficult. Furthermore, it was anticipated that difficulties would be encountered in heat-treating large tools. The problems involved in the production of scarifier points from different materials for testing far outweighed any merits in using this design. In addition there appeared to be no local manufacturer producing scarifier points. It was also believed that the rate of material removal from these three tools would not be consistent with time due to their somewhat complicated and variable profiles.

The shape of ripper points is the least complex of all the ground engaging tools. The relatively simple design and ease with which these points could be produced appeared to suit them admirably to the purpose of wear testing. This simplicity was considered to be the most important factor which would contribute to a constant rate of weight loss with time and facilitate the investigation of wear mechanisms. Furthermore the points were manufactured locally and different materials could also be obtained in suitable dimensions. Finally the choice of the test site was made easier by the fact that the ripper plough is widely used in the Western Cape. The test site chosen for this study was a farm near Hermon. The region is typical of the Swartland and lies at the foot of the Elandsberg mountains. The high clay and pebble content of these soils provides some of the most highly abrasive conditions for tilling in Southern Africa. The first tests were made during the tilling and planting season in May. The beginning of the rainy season is a critical time for the farmer, since the fields may only be tilled once the first rains have fallen. The ground is far too hard when it is dry.

However, once the rain begins to fall in the Cape it may continue without a break until the field becomes sodden to the point where tractors working the field become bogged down. Due to this fact a testing procedure had to be quick and cause the least hindrance to the farmers' tilling programme. The points on an eleven point ripper plough could be



FIGURE 5.4 : Ripper plough used in tests.

changed in a short time with the help of a few assistants. It was decided not to use the middle point on the plough since it did not have a reciprocal point as did the outer five points on each side of the frame. The standard ripper plough used for these initial tests is shown in figure 5.4.

A tachometer wheel was attached to the plough and used for measuring the length of each run. Commercially produced and heat treated medium carbon steel, SS 10/200, ripper points were utilized for the initial testing. Two similar groups of specimens, both numbered from one to ten, were tested. The order in which the samples were mounted on the plough is shown in figure 5.5.

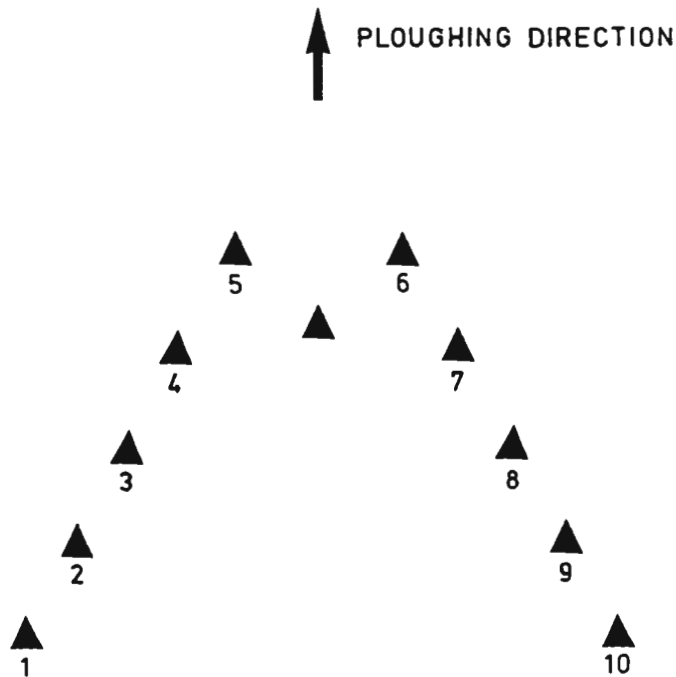

FIGURE 5.5 : The numbering system used on samples in the first tilling test.

5.2.2 Field Tests using the Ripper Plough

Tests were carried out in the following manner:

1. Each sample was weighed to an accuracy of 1 g on a portable battery-operated balance.
2. Each point was then bolted in position and tested for a distance measured by the tachometer wheel. A speed of 7km/h was chosen for testing. This is a standard speed for tilling operations.

3. At the end of a run the points were removed and the second preweighed set of samples was bolted in position. The test was then repeated. A hard bristle brush was used to remove soil from the specimens after each run. Three runs were carried out for both groups. After each run the points were weighed and the weight loss calculated for each. This was then converted to volume loss.

The results of the initial testing are shown in figure 5.6. These indicate that there was a variation in volume loss, for the majority of specimens, of some 10 per cent. Such a result was considered excellent, particularly in view of the almost complete lack of control over the operating variables such as working depth, lateral and longitudinal inclination as well as soil conditions. Unfortunately, volume losses of material from points numbered 3, 5 and 9 were well outside this 10 per cent error range for both sets of specimens. Such results indicate that the reproducibility of field testing using standard equipment might be difficult to attain.

A second series of tests was conducted using a larger range of materials. This testing was thought desirable to give some indication of the likely spread of relative volume losses during any subsequent testing of different materials. This would provide important information in the design of experimental procedures. These points were manufactured

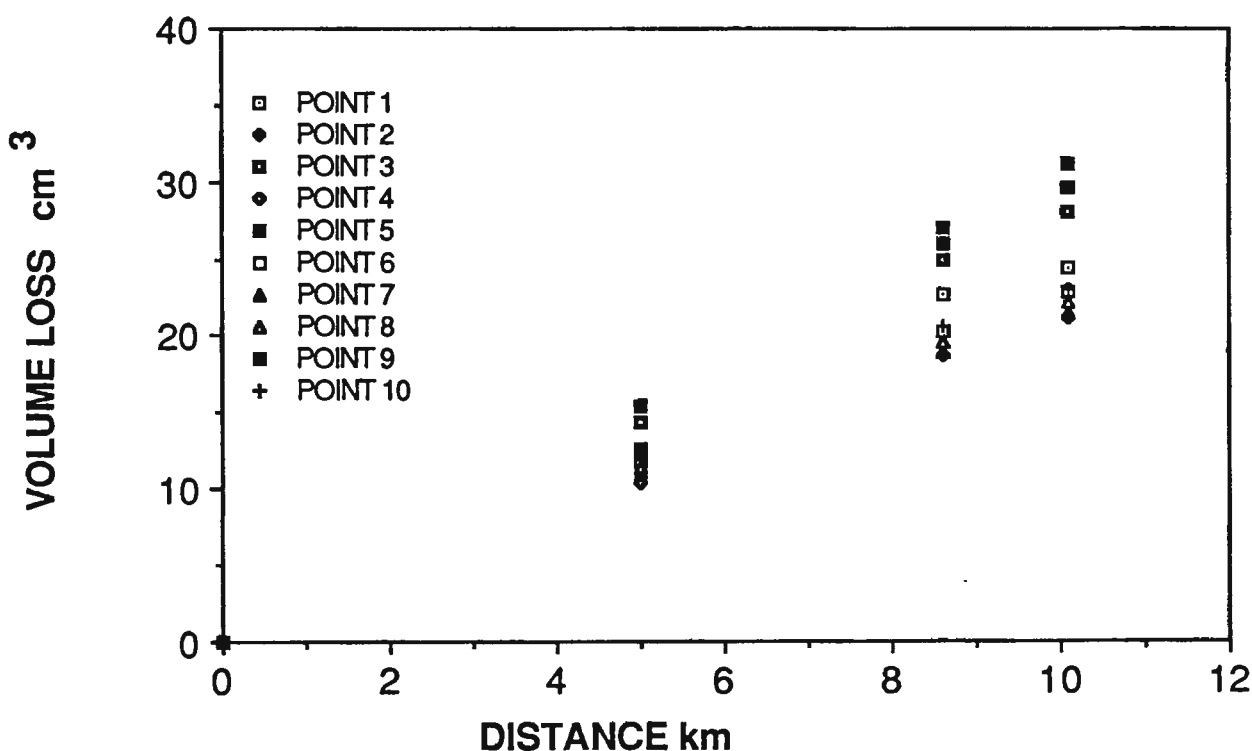

FIGURE 5.6 : Results of field test.

at a local factory and commercially heat treated. The details of the heat treatments are shown in Table 5.1. The position in which the points were mounted on the plough are shown in figure 5.7.

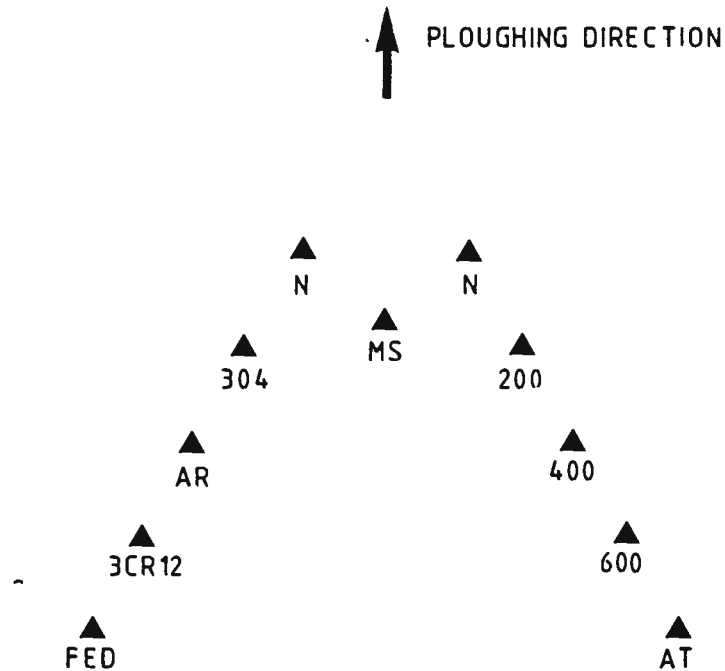

FIGURE 5.7 : The order in which materials are tested on the ripper plough.

Material	Code	Treatment
SS 10/200	N	Normalised from 900°C
	200	Quenched from 840°C Tempered at 200°C
	400	Quenched from 840°C Tempered at 400°C
	600	Quenched from 840°C Tempered at 600°C
	FED	Soaked, 840°C for 20 minutes Quenched fo 250°C for 2 minutes - air cooled Tempered at 400°C for 4 minutes
	AT	Soaked, 840°C for 20 minutes Quenched to 250°C for 40 minutes Air cooled
	AR	As received from manufacturer
3CR12	3CR12	Air cooled from 750°C
AISI 304	304	Quenched from 1050°C in oil
Mild Steel	M.S.	Normalised from 900°C

TABLE 5.1 : Heat treatment and nomenclature used for materials tested on the ripper plough.

The results of these tests are shown in figure 5.8.

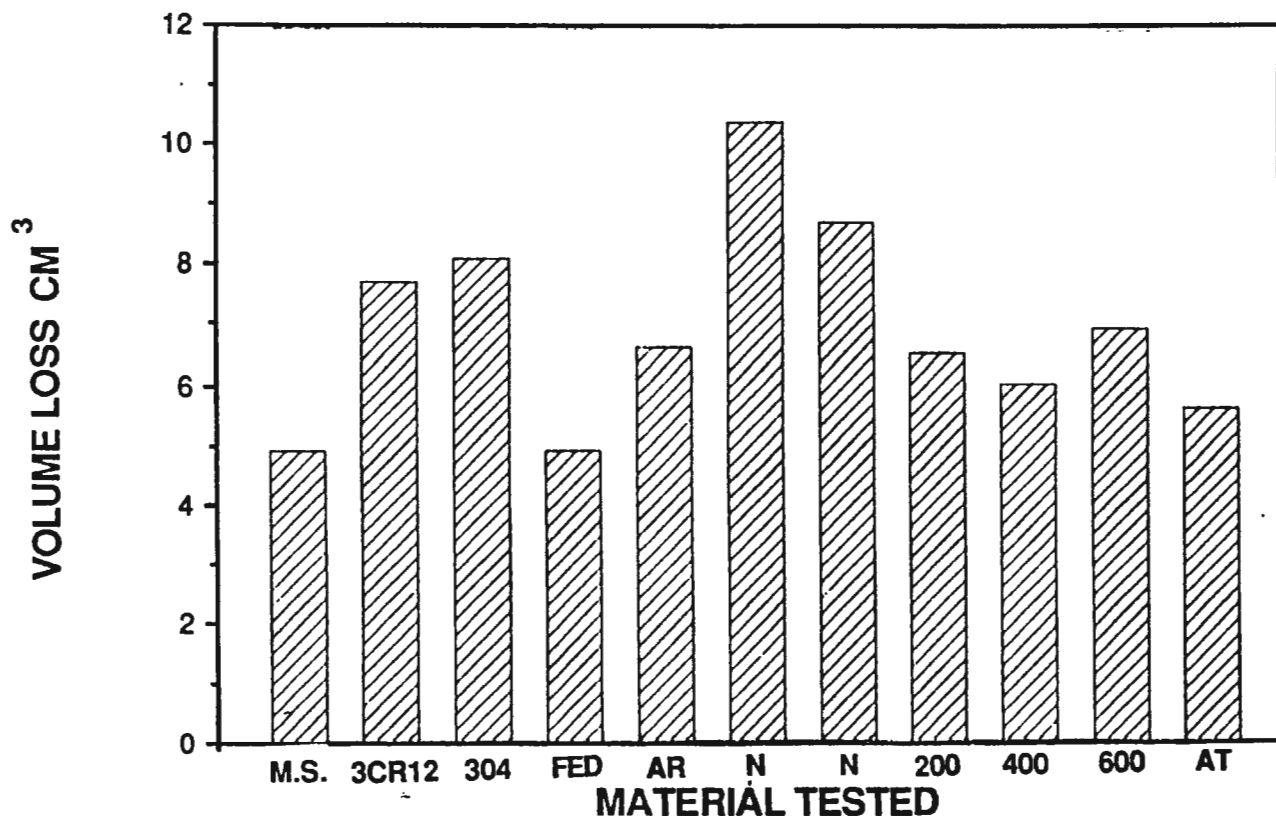

FIGURE 5.8 : Results of tests on various materials on ripper plough.

The ranking order of wear resistance that emerged from this second set of tests did not appear to be consistent with previous results from the laboratory abrasion testing of similar materials. For example, mild steel with a hardness of 110HV30 was found to have a wear resistance greater than a medium carbon steel SS 10/200 quenched and tempered to hardnesses between 239 and 500HV30. SS10/200 samples quenched and tempered at 400°C had a higher wear resistance than the ones treated at 200°C. It was subsequently discovered that the 400°C tempered specimens were harder than those tempered at 200°C.

It appeared that the standard ripper plough was shown by these results to be inappropriate for precise wear testing. The variability in volume loss and the inconsistency in ranking order that emerged indicated that there were factors affecting weight loss on each point that had not been controlled to the necessary degree.

There appeared at least four reasons why the ripper plough proved inadequate:

1. The shape and size of the points varied slightly for each material used. This resulted in different surface areas being exposed to the soil. Furthermore, the sharp point became progressively more blunt with wear and the surface did not remain constant. The poor wear resistant materials experienced greater weight losses resulting in greater shape changes and differences in abraded area than those materials with a high wear resistance.
2. The plough frame on which points were mounted had undergone the normal wear and tear associated with agricultural equipment and some tynes were out of alignment. This led to differences in exposure of each point to the soil and different draft forces on each point. In addition, there is a tendency for tynes of this particular design to bend in the plane normal to the ploughing direction.
3. No account had been taken for the increased wear caused by compaction of the soil for the point ploughing in the tractor wheel track.
4. Since the use of laboratory furnaces was impractical due to the size and shape of the specimens, the points were taken to a commercial firm for heat treatment. The resulting material properties seem to indicate that the necessary care had not been taken in order to ensure the required properties. The specimen tempered at 200°C showed an apparent normalised grain structure. The hardness of the specimen tempered at 600°C was 249HV30, the one of 400°C was 290HV30 and the one at 200°C was 245HV30. This could only be the result of poor heat treating or inefficient documentation of samples. Extreme decarburization was also apparent on some specimens which was most probably due to the high forming temperatures used during fabrication.

Richardson (1967) had said that the use of practical components limits the usefulness of wear tests and this was perhaps a case in point. These tests did however show some of the important characteristics of wear on tools and of test methods which needed to be considered in further testing.

Firstly the eleven point ripper plough gave rise to problems similar to those in the test methods of other researchers. For instance Mohsenin, Womochel, Harvey and Carleton (1956), using a twelve point cultivator, found variations in weight loss measurements in excess of 200 percent. Bowditch (1969) did tests using a multityned scarifier. The design and configuration of the equipment he used was also a major source of experimental error. Bowditch used statistical methods to accommodate these errors. It was believed that these problems could be circumvented by a more controlled, elegant and precise experiment. A second observation was that a great change in the shape of the wearing surface had taken place in the ripper point. Thirdly, it was observed that the greatest amount of wear took place on the bottom of the specimen, tending to shorten it, as shown in figure 5.9. The significance of this becomes clear when one remembers how important the angle of attack is to the efficiency of the plough.

It was concluded from these first tests that a method was required in which these factors could be controlled. It was decided to design a rig in which the relevant observations were incorporated and in which parameters could be standardised.

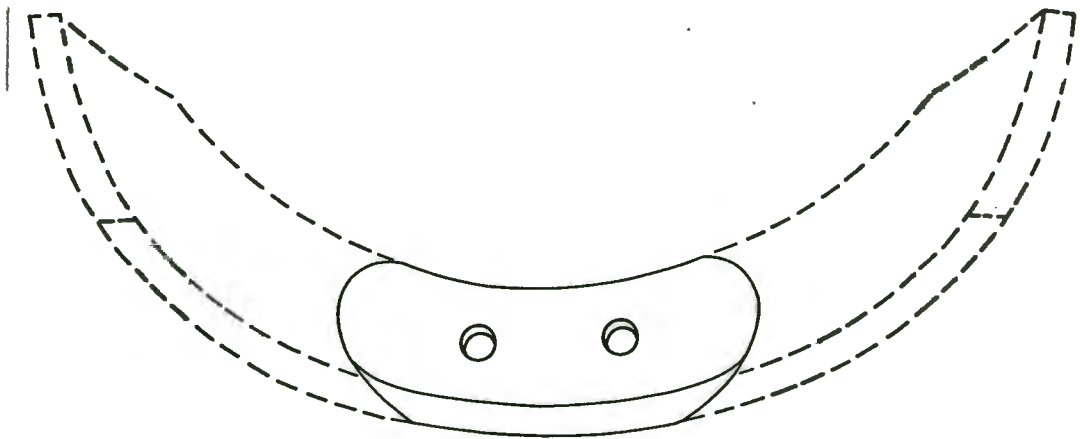

FIGURE 5.9 : Most of the volume lost was from the bottom of the point upwards. Relatively very little volume was lost from the front face and sides of a chisel point.

5.2.3 Conception of a Controlled Field Test

For this reason a wear testing rig was considered, utilizing simple vertical tools in which wear would be concentrated on the bottom surface. The work done by Richardson (1967) and Moore (1975) had already shown that a parabolic profile is formed on the leading edges of wear plates used in field tests. The use of vertical specimens was a suitable interpretation of this concept. This profile was important because once formed it remained the same shape throughout the test, as illustrated in figure 5.10. This would be true for all specimens.

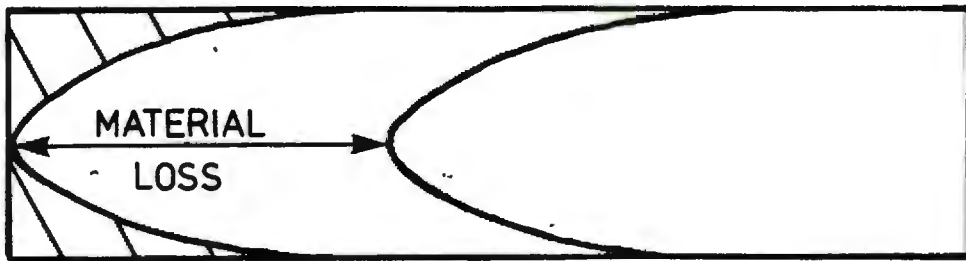

FIGURE 5.10 : The profile developed will present a constant area for material removal.

Furthermore, if the thickness of the specimen were minimized, the stable profiles would quickly be developed leading to a more consistent rate of volume loss with time than was possible with the standard ripper points. It was also decided that the ideal test would be one in which a standard and several specimens could be simultaneously tested. Wear results could then be averaged and normalized in a statistical way. No orientation adjustment facility was included in the design. This was because vertical, horizontal as well as tilt adjustments are possible on tractor tool bars. Setting of the orientation of the rig would need to be done only once for the test. It was not intended to monitor the wear of points or the performance at different orientations. The rig was designed purely to measure the wear performance of different materials.

It was decided that the final test rig design should allow for the testing of a number of short sections of flat bar in a vertical

orientation. Specimens were to be mounted in such a way as to facilitate their easy placement and removal. There were definite advantages in the use of flat bar. These were :

1. A significant weight loss could be realised over shorter distances, using smaller specimens.
2. Small specimens could be heat treated in a more controlled way.
3. The use of flat bar cut down on forming and machining time of specimen. In addition, most specimens could be cut from standard gauge flat bar.
4. Some of the more expensive materials could be obtained more easily if only small samples were required.

5.2.4 Design and Development

The design chosen for the field test rig consisted of six welded sleeves into which sections of flat bar, 16 x 50 mm, could be fitted. These specimens were held in position by means of a 20 mm diameter bolt. The sleeves then were bolted firmly onto a 2 m long section of 100 x 100 mm square tubing. The tubing was mounted onto a tractor tool bar with three point linkage, perpendicular to the ploughing direction. The rig is shown in figure 5.11.



FIGURE 5.11 : The field abrasion test rig.

Abrading six specimen of manageable size simultaneously is a simple, quick and controlled method of testing with a high rate of data production.

One of the disadvantages of a vertically positioned test piece became apparent during initial testing. The sharp attack angle of a ripper plough causes the tool to be drawn into the soil, as illustrated in figure 5.12. The points on the test rig however tended to "float" or bounce along the top of the soil.

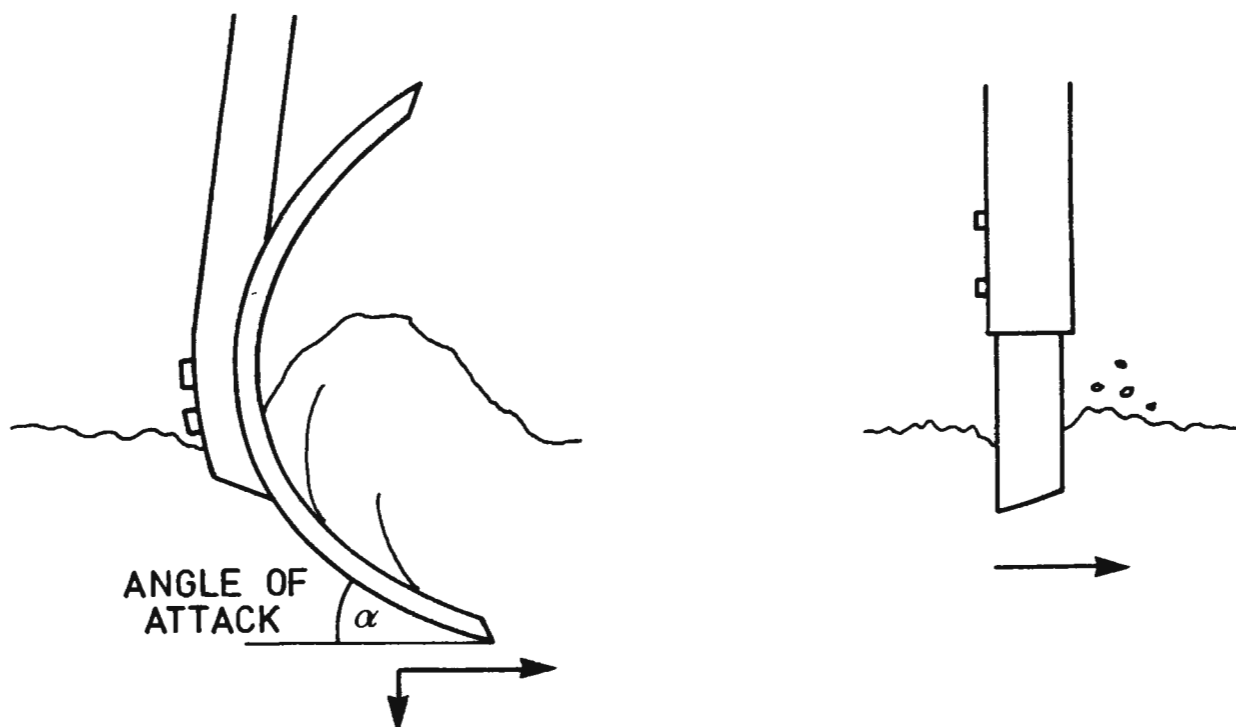

FIGURE 5.12 : A ripper point is drawn down into the soil. The points on the test rig however tended to be forced out of the soil.

This penetration problem was remedied by building a bracket onto the rig. This consisted of two u-shaped arms into which a 44 gallon drum was placed. The drum then filled with rocks through a hole in the side had an extra weight of approximately 180 kg. This ensured a working depth of 5-6 cm which was reasonable for testing purposes.

It was decided to measure wear by the volume lost from each specimen. This was calculated from the weight loss and the density of the steel used. Other methods of monitoring wear such as change in shape or length could also have been used but were considered to be less accurate.

A battery operated balance was used to weigh the ripper points in the initial field test. This balance had a maximal range of 4 kg and was accurate to 1 g. The mass loss on the specimens was expected to be about 10 g/km and each run was designed to be between one and two kilometers long. Each specimen weighed approximately 1.5 kg at the start of testing. The accuracy of measuring for each test would be at least 20 g per run, or greater than 10 per cent, which, according to Moore (1985), is acceptable. The use of a battery operated balance also made it possible for measurements to be made on site. Although this was of great use to the testing programme care had to be taken to shield the balance in windy weather to avoid erroneous measurements. The pre-weighed specimens were bolted in with 14 cm projecting below the bottom of the sleeve. This was the estimated working depth for ripper points.

Once the rig had been assembled on the tractor for the first test, great care was taken to level it. This was done using the coarse adjusting screws on the three point linkage. The rig was set as near to parallel to the tractor axle as possible.

The first tests run with annealed SS 10/200 showed consistently higher weight losses for the middle two points. This was probably due to the pivoting motion of the rig in rocky or hard ground. If points 1 or 6 struck an obstacle the rig tilted sufficiently for the point to move over it. Points 2 and 5 would be subject to the same effect. However points 3 and 4 were between the linkage points on the rig and directly below the weight and did not have the advantage of any leverage when contending with hard obstacles. These points subsequently registered the greater weight loss. For this reason the middle two points were chosen to house the standards for the tests. Annealed SS 10/200 was chosen as a standard because it was readily available.

At this stage further work on the project was impeded by a gripping problem. The bolt in the side of the sleeve had to be fastened very tightly to hold the specimen. This caused the sleeve to deform. For this reason it was decided to replace it with a 9 mm Allen screw fastened through a threaded hole in the back of the sleeve. This gave a firmer grip. However, vibration on the rig was particularly severe in rocky soils and caused the Allen screws to become loose. The specimen would then either slide up the sleeve or fall out. In either case the

results from the run were adversely affected. Consequently, another hole was drilled and tapped in the back of the sleeve to accommodate another Allen screw. In addition to this second screw, locking nuts were used to prevent the screws from becoming loose. This arrangement successfully solved the problem. Finally, a number of sleeves fractured during field testing. A new set of sleeves of more robust design were made which incorporated all the modifications made to the first set.

The results of the first tests run on annealed SS 10/200 are shown in figure 5.13. The experimental error was measured by dividing the magnitude of the spread of results by the mean of the results. The error for the standard samples and test samples were 3.72 and 4.45 respectively. This was well within the limit of 10 per cent set by Moore (1986) for an acceptable test result. It was felt that this was within acceptable limits when the nature of the field test was considered. This point is developed further in the chapter presenting results.

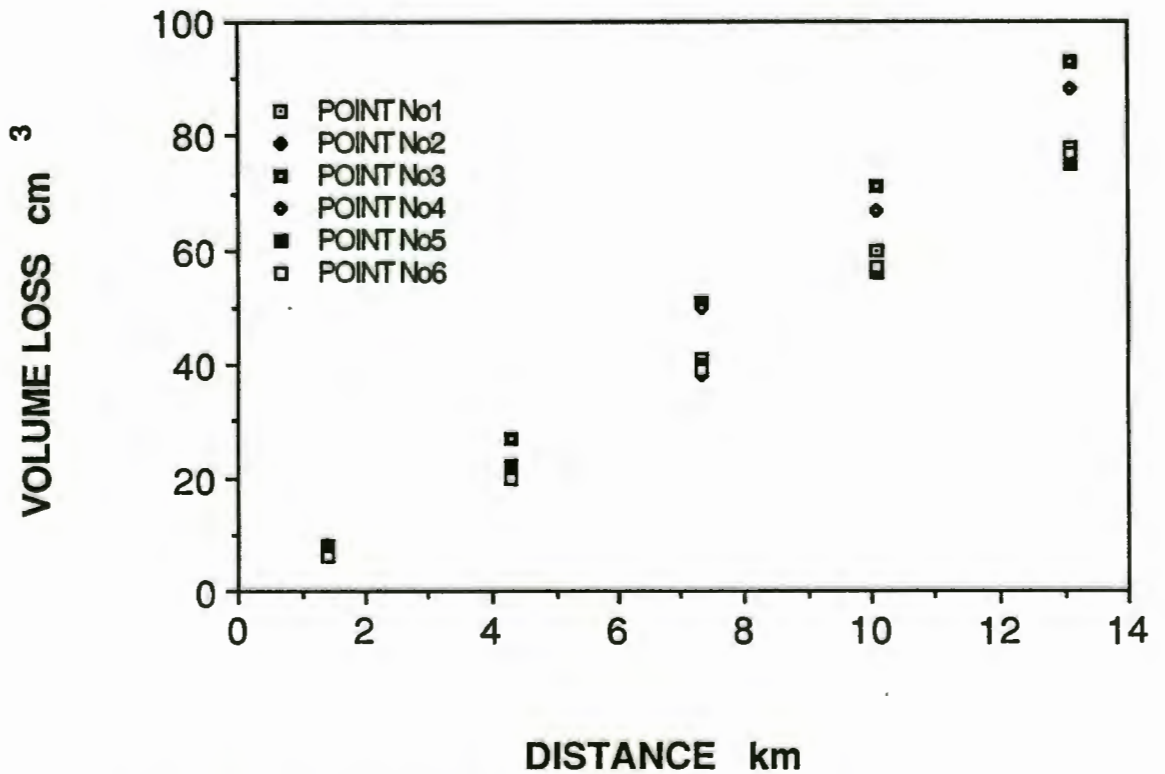

FIGURE 5.13 : The volume loss on the specimens in the new test rig.

5.3 FIELD TESTS

In all subsequent field testing of materials the following procedure was closely adhered to :

1. The specimens were preweighed to within 1 gram and bolted into the sleeve with 14 cm protruding from the bottom.
2. The length of each run ranged from 1 to 4 km. Specimens were removed, cleaned and weighed after each run.
3. Annealed SS 10/200 was mounted in the middle two points, numbered 3 and 4. These were used as standards.
4. Samples of different materials and with differing heat treatments were tested in positions 1, 2, 5 and 6. Four samples of each material were tested in cycles. Run number 1 was carried out for all the groups, then run number 2 etc. In this way any changes taking place in the soil as the day progressed were registered on all the sets tested. The materials tested are shown in table 5.2.

With the first results the wear test rig was re-evaluated. At this point it was felt that Moore's mine field (1985) had successfully been negotiated. The rig, by its inherent design took care of the statistical considerations necessary for the use of more complicated designs. The number of variables involved were reduced by the design and consideration of testing techniques. The rig design allowed for very simple testing procedures. The depth was controlled by the weight placed on the rig. The characterisation of the service environment was a problem. Two sets of field tests were carried out in two different fields during two different seasons. The wear rates did vary in each test but with the careful use of standards the results could be normalised.

5.3.1 Temperature Measurements

It was noticeable that during field testing the specimens became very hot. This indicated that friction and wear resulted in large temperature rises at the surface of the tool. An attempt was made to measure the surface temperature. A 2 mm diameter hole was drilled from the back of the specimen to within 1 mm of the wearing surface. An iron-constantan thermocouple in a tight fitting steel sleeve was inserted in this hole. A TOA electronic x,t battery operated chart recorder was connected to the thermocouple and the temperature during tilling recorded. A diagram of the specimen with a thermocouple in place is shown in figure 5.14.

MATERIAL	C	Si	Mn	S	P	Cr	Ni	Cu	Mo	Al	B
SS 10/200	0.48	0.24	0.94	0.025	0.012	0.16	0.15	0.17	0.024	0.024	-
SS 10/24	0.96	0.25	0.80	0.012	0.026	0.28	0.21	0.24	0.028	0.018	-
Boron C8	0.34	0.32	1.20	0.006	0.021	0.14	0.02	0.01	0.004	0.03	0.003
AISI 304	0.029	0.63	1.45	0.015	0.023	18.9	8.8	0.32	0.14	0.007	-
Mild Steel	0.14	0.20	0.70	0.008	0.014	0.001	0.02	0.005	0.001	0.003	-
3CR12 (in ripper plough)	0.038	0.38	1.11	0.013	0.025	12.2	1.7	0.13	0.13	0.019	-

TABLE 5.2 : Chemical composition of materials tested.

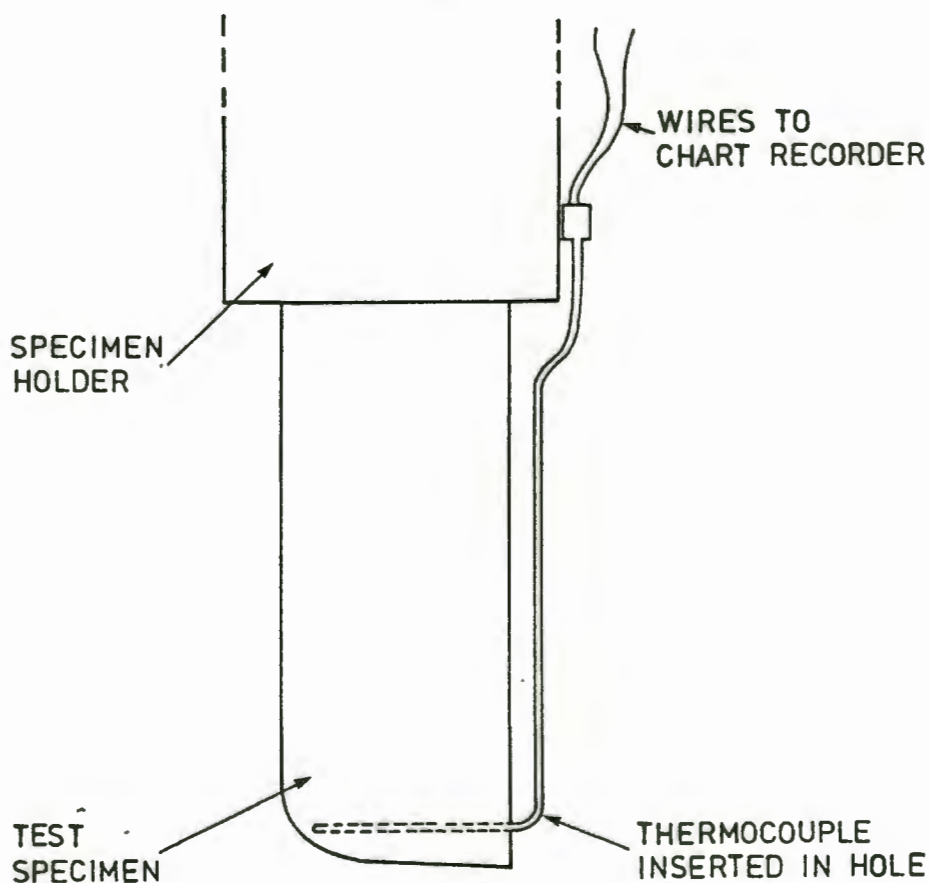

FIGURE 5.14 : Specimen with thermocouple in place.

This technique was also used in the laboratory, on the abrasive wear rig. In order to prevent the measurement of the bulk temperature of the specimen, an iron-constantan thermocouple bead was set in resin in the centre of a 4 mm hole in a steel specimen tested in the laboratory. In this way it was hoped to get some indication of the temperature increase caused by particle strikes on the thermocouple bead.

5.4 LABORATORY METHODS

Various tests were carried out in the laboratory in order to characterize the materials used and to elucidate the wear mechanisms occurring in the field. The tests included laboratory wear tests as well as mechanical tests for impact and tensile strength and hardness. A post-wear specimen programme was also carried out using the optical and scanning microscopes.

5.4.1 Laboratory Wear Tests

In addition to the type I and type II tests it was necessary to investigate wear processes more carefully. In addition to the academic considerations it is much cheaper and less time-consuming to use a small scale laboratory test. Following the classification of Uetz, Sommer and Koshrawi (1981) the methods III, IV and V were considered. These include soil bins, abrasion-impact rigs and other Heath Robinson contraptions. They were expensive and involved time-consuming background study. The little information reaped from these methods did not warrant the energy required to set them up.

Eventually a type VI method was chosen. The pin-on-belt apparatus developed by Allen, Ball and Protheroe (1981) was used to test all the materials. This rig was similar to the apparatus used by Mutton, Murray and Watson (1971). The elegance of this method was more attractive than the empiricism inherent in the construction of some of the other laboratory wear test rigs.

The equipment consisted of a Rockwell Belt Sander, shown in figure 5.15, which had been extensively redesigned and modified in order to function as an abrasion testing machine. A 10 x 10 mm specimen was abraded against a bonded abrasive belt under constant load. A variable drive system allowed tests to be run at different speeds if necessary.



FIGURE 5.15 : The laboratory abrasion test equipment.

The belt was run at a constant velocity of 0.325 m/s for these tests. This method was considered to be superior to the pin on disc method as the problem of differential speed and change in relative motion of specimen and abrasive were circumvented. The specimen was held in a holder that moved in a slide and could be loaded with any desired weight. The holder ran on two rods and was driven across the belt by a screw thread during testing so that the specimen constantly engaged on unworn abrasive. The chain drive for the screw thread could be disengaged. This was necessary if specimen translation during testing was not required.

Three test methods were evaluated :

1. The standard relative abrasion resistance test described by Noel (1981) and Fogel (1980) was carried out. Cutting and ploughing mechanisms of wear were involved in this method. The test was carried out on an 80 grit aloxite belt under a nominal pressure of 789.8 kPa. The specimen was traversed across the belt during the test, continuously being exposed to unworn abrasive particles. Each test consisted of four runs each with a track length of 366 cm, the specimen being cleaned ultrasonically in alcohol, dried and weighed between each run.
2. The second method was intended to duplicate the higher stresses experienced on a tool during ploughing. The format for this test was the same as for the first except that a 40 grit aloxite belt and a nominal pressure of 1421 kPa were used.
3. Although most of the previous work in this subject showed that the main wear mechanisms were cutting and ploughing, a preliminary microstructural study of the worn surfaces and subsurface deformation indicated that rubbing could also be an important mechanism. The third method was intended to reproduce rubbing wear. The test conditions were similar to those in the second method but the specimen was not traversed during testing. The specimen moved in the same track for the whole test. After each run the specimen was removed, weighed and a volume loss was recorded. The length of each run was twice that of the previous run. Two materials were compared in this test. The first was SS 10/200 quenched and tempered at 200°C, and the second was annealed SS 10/200.

5.4.2 Heat Treatment

Heat treatments were carried out using two Naber 33 kW furnaces. Specimens were preheated to approximately 600°C before being transferred to the second furnace where they were soaked at austenitizing temperatures. Field specimens were soaked for one hour and laboratory test specimens for half an hour. The temperatures at which heat-treated materials were austenitized are shown in table 5.3.

Material	Austernizing Temperature	Quenching Media
SS 10/200	860°C	Water
SS 10/24	740°C	Oil
Boron CP	920°C	Water

TABLE 5.3 : Austenising temperatures and quenching media for heat-treated steels:

Decarburization and oxidation were found to be a problem in commercially produced implements and every effort was made to reduce this effect in the test pieces by bleeding dry nitrogen into the furnace at the higher temperatures at a rate of 5cc/min. The SS10/24 was quenched in oil and the SS 10/200 and C8 in water. The SS/24 was quenched in a water-cooled oil bath and the temperature of the oil was measured with a thermometer to ensure that it was not above 25 °C at the time of quenching. The SS 10/200 and C8 specimens were quenched in a 150 litre drum of water. The water was changed between each quenching operation to keep a constant quenching temperature of 25°C. Specimens were tempered to produce the properties listed in Table 5.2. Air furnaces were used to temper the specimens at 400°C and 600°C and a drying cabinet used for the tempering at 200°C.

5.4.3 Mechanical Testing

The materials tested were characterized according to tensile strength, hardness and impact strength by using standard mechanical test methods. The hardness of the specimen was measured using the Vickers diamond pyramid indentation method at 30 kg load on an Esseyway hardness tester. This method is most effective when carried out on a polished surface. In most cases the hardness was measured on specimens which had been polished to 3 micron diamond paste.

Hounsfield tensile test specimens with a gauge diameter of 5 mm were taken parallel to the longitudinal direction (rolling direction) of field test specimens. These were tested on an Instron tensile testing machine and the 2 per cent proof stress and percentage elongation for each was calculated. Hounsfield specimens with a smaller gauge diameter (2,5 mm) were made for the materials with a higher tensile strength. Charpy V-notch specimens for impact testing were also machined parallel to the rolling direction. It was of importance to know how an implement would stand up to impact loading so the notch was positioned in order to measure the impact strength of the material normal to the rolling direction.

5.4.4 Microstructural Investigation

Worn surface morphologies and subsurface deformation from various specimens tested in the field and laboratory were compared. A Nikon and a Reichert MeF2 microscope were used for the optical microscopy. Specimens for investigation were sectioned on the Microtom cut-off wheel and set in hot setting resin. A water wheel was used to polish the specimens in steps from 80 grit to 800 grit carborundum. They were then polished on diamond lapping wheels using 3 micron, 1 micron and finally 0.25 micron paste. Carbon steel specimens were etched in a 5 per cent Nital solution and the 304 stainless steels were electrolytically etched in a 10 per cent oxalic acid solution.

The study of the subsurfaces presented a particular problem because the edges of all specimen were rounded during the polishing process. This obscured the deformed areas that were of interest. It was thought that a hard metal electroplated onto the surface would be the most effective method of preventing this rounding effect. The initial attempt involved electrochrome plating from a solution of chromium trioxide and sulphuric acid using a current density of 0.5 A/cm^2 , and a lead anode. The technique was highly successful and a thick layer of chrome plating was easily formed. This layer, however, had a hardness of approximately 1200HV30, which was far in excess of any of the specimens coated and also resulted in rounding of the deformed edges. Electro-nickel plating, with a hardness of about 300HV30 proved to be more successful. Specimens were plated in a nickel sulphate, nickel chloride, boric acid solution with a nickel anode and a current density of $20 - 30 \text{ mA/cm}^2$. In both methods, great care had to be taken to render the surfaces as clean as possible prior to plating.

The cleaning process was as follows :

1. The specimen to be plated was boiled in alcohol for 10 minutes.
2. This was followed by a dip into a boiling 50% solution of sodium hydroxide and a rinse in water.
3. The specimen was then dipped into a 50% solution of hydrochloric acid and rinsed in water.
4. The final washing was in a 5-10% solution of sulphuric acid.
5. The specimen was then removed from the sulphuric acid and placed in the solution and plated at a low current density.

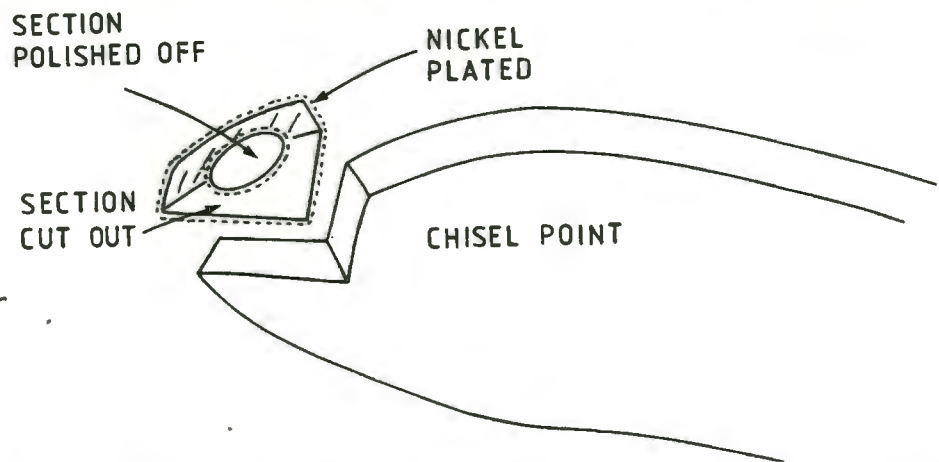

FIGURE 5.16 : Shows how a tool was sectioned, nickel plated and polished for taper section. Specimens from the field wear rig were sectioned and polished normal to the worn surface after nickel plating.

The subsurface deformation of points taken from the test rig was studied in sections cut perpendicular to the worn surface. The specimens from the laboratory tests were ground at an angle of 2° to the worn surface. In the initial investigation of ripper points however a section of the specimen giving an expanded view of the subsurface deformation was desired. A section of the tool was cut off and nickel plated to a thickness of 0.5 to 1.0 mm. The specimen was then ground down to the steel at an angle of about $10^\circ - 45^\circ$ to the worn surface as shown in figure 5.16.

Previous wear studies have clearly shown that the comparison of worn surface morphologies is the most effective method of examining the suitability of the various test methods (McQueer, 1985). Worn surfaces from the laboratory test and sections from the field test specimens were cleaned in ammonia and Arklone, mounted and coated with gold-palladium and examined in the Cambridge S200 scanning electron microscope.

CHAPTER 6

RESULTS

6.1 Introduction

This project is primarily concerned with the development of a field test capable of producing consistent and reproducible data. The results of wear tests using the rig are evaluated in this section and compared with the results from the laboratory wear tests.

In addition the information from the microstructural investigation is reviewed. Micrographs and microhardness showing the extent of deformation are presented and their relevance to the wear data illustrated.

6.2 Field Test Results

The central theme of the experimental work for this project was the development of a field test to accurately model wear processes during tilling. Following the process of development described in the previous chapter, a set of annealed SS 10/200 specimen was tested. The volume loss of metal with distance for each of the six specimens is shown in figure 6.1. These results are similar to those shown in figure 5.14. The average volume loss from the centre two samples is shown together with the average volume loss on the outer four samples. This shows quite distinctly the higher slope on the middle two points. The correlation coefficient was a good measure of the spread of results. Zero would indicate random data and one would indicate a perfect straight line fit. In this first test the correlation coefficient for the standards was 0.989 and for the other positions was 0.999. This was considered to be highly satisfactory. Furthermore, it was a simple matter to calculate the relative wear resistance by dividing the wear rate of the standard by the wear rate of the specimen. This provided a basis for normalizing and comparing results.

The horizontal orientation of the test rig was initially thought to be an important factor influencing wear rates. Consequently, a number of tests

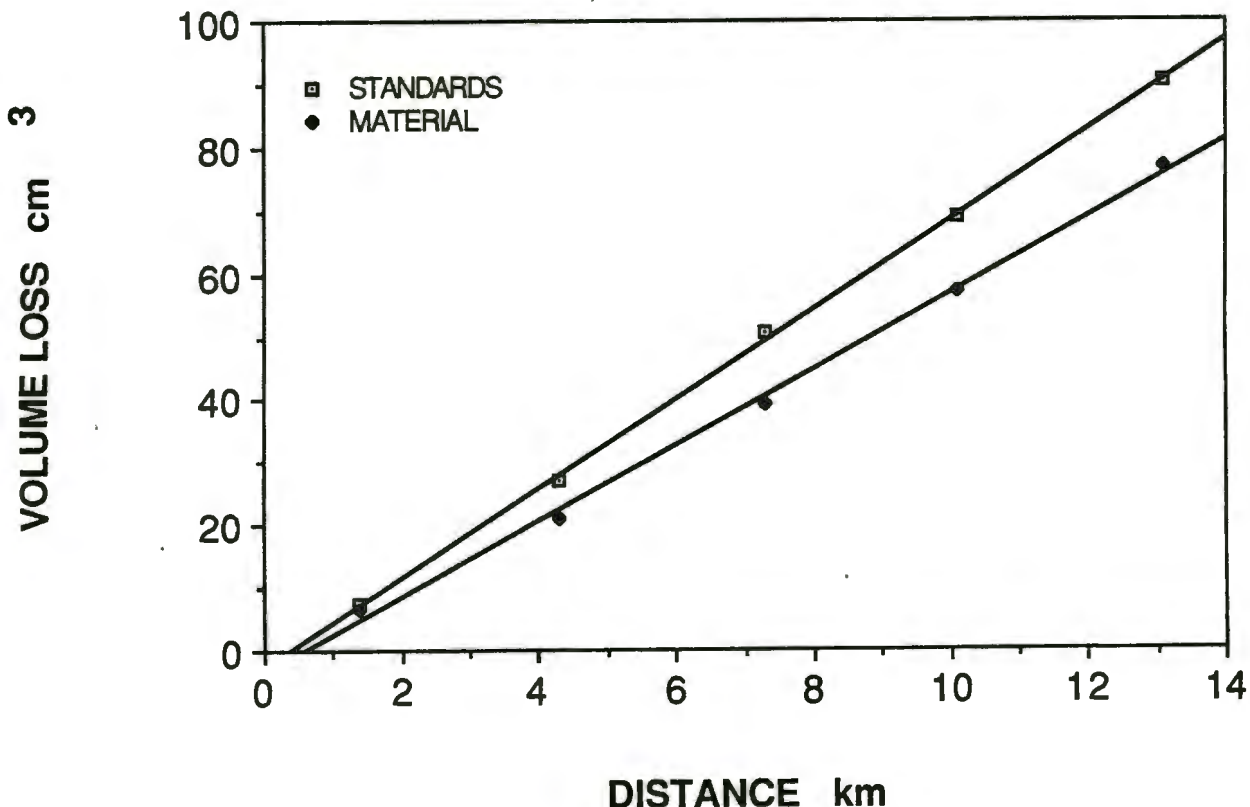

FIGURE 6.1 : Results of a field test on normalized SS 10/200. This clearly shows the higher wear rates registered on points 3 and 4.

were run to establish the effect of tilt on the relative wear rate of a set of samples. However, alterations to the horizontal tilt showed the rig to be self correcting within the limits of the lateral settings available on the tractors used. In any case, some of the tractors used during subsequent testing incorporated only a coarse adjustment for lateral tilting and the fine adjustment necessary for precise horizontal setting was not always possible. Fortunately this did not present a problem. Lateral tilting caused a higher wear rate on the lower end of the rig and a lower wear rate on the upper side. The mean of the results however was consistent. No apparent error was introduced from testing on different tractors. Care, however, was taken to prevent specimens from running in wheel tracks when different sized tractors were used. The following three figures illustrate the consistency and reproducibility of the test method.

The majority of the tests showed a slight increase in wear rate with distance ploughed. This was a minor effect and results remained within the 10 per cent margin. It was, however, apparent in most of the specimens tested.

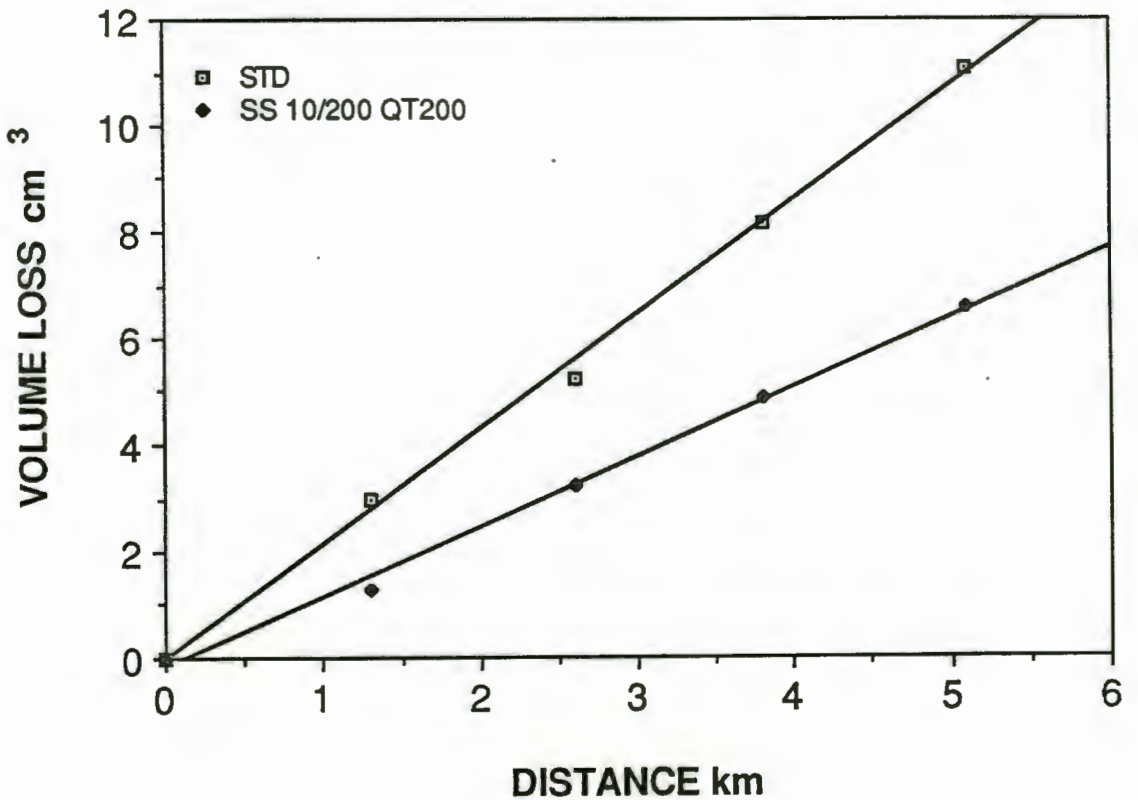

FIGURE 6.2 : The test on SS 10/200 quenched and tempered at 200°C. The correlation coefficient for both the material and the standard was 0,994.

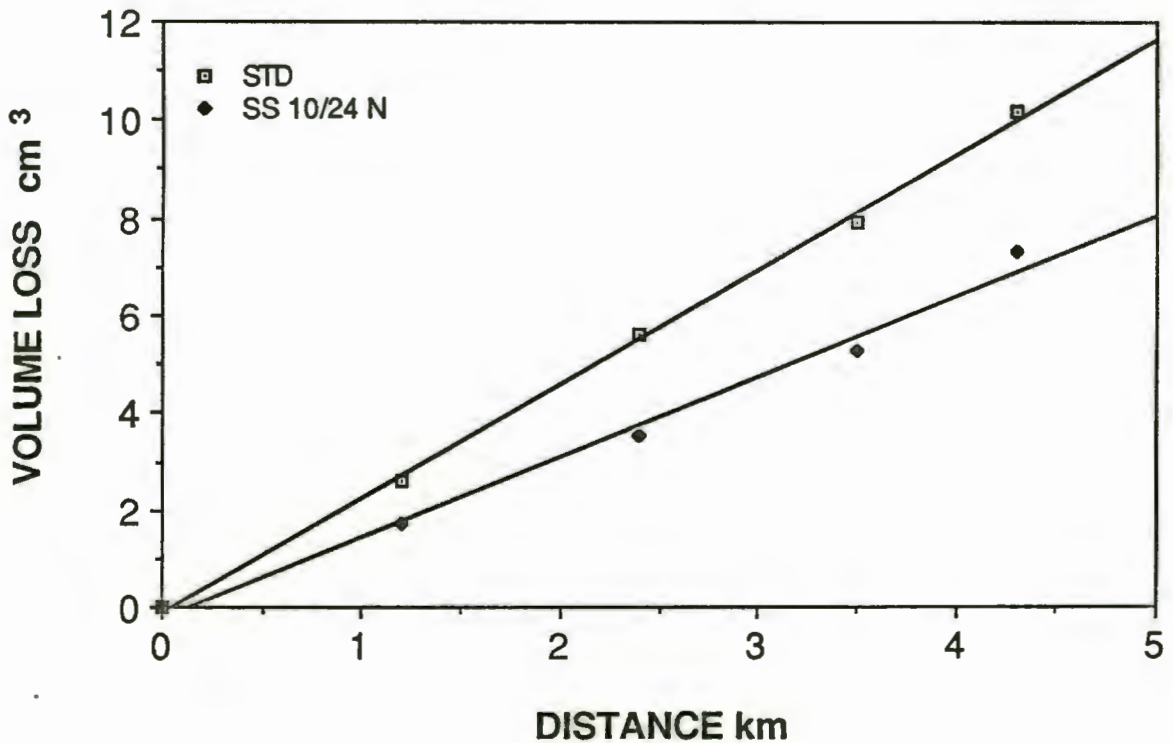

FIGURE 6.3 : The test on normalized SS 10/24 showed a correlation coefficient of 0,999 for the material and the standard.

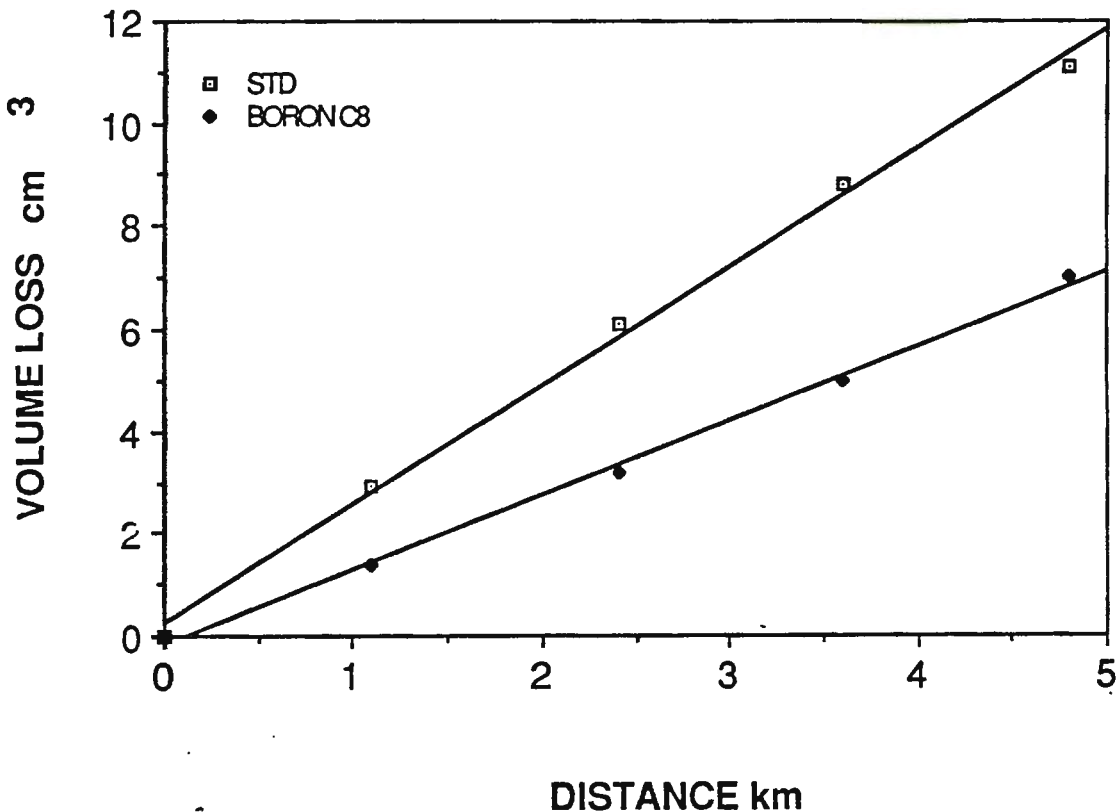

FIGURE 6.4 : The test on Boron C8.

When all the tests had been conducted the results were plotted in a similar manner. Table 6.1 shows the relative abrasion resistance values for all the materials tested both in the field and in the laboratory.

The RAR appeared generally to be related to material hardness. The SS 10/24 quenched and tempered at 200°C was the best performer in all the field tests and showed the highest hardness, in excess of 700HV30. This was followed by Boron C8 with a lower hardness of around 600HV30. There were however notable exceptions. SS 10/200, quenched and tempered at 400°C, had a hardness of approximately 500HV30 with a relative abrasion resistance of 1.29 compared to annealed SS 10/24 with a hardness of 250HV30 and a relative abrasion resistance of 1.36. Furthermore AISI 304 and annealed SS 10/200 were found to be harder than mild steel but gave a lower relative wear resistance.

When hardness was plotted against the RAR, both SS 10/24 and SS 10/200 produced a sigmoidal curve reminiscent of those shown by Mutton, Murray and Watson (1979) as well as Moore (1985). This is shown in figure 6.5.

FIELD TEST			80 GRIT TEST			40 GRIT TEST		
Material	Hardness	RAR	Material	Hardness	RAR	Material	Hardness	RAR
SS 10/24 QT200	710	1.66	SS 10/24 QT200	757	2.65	SS 10/24 QT200	757	2.45
Boron C8	564	1.58	Boron C8	614	1.88	Boron C8	614	2.02
SS 10/200 QT200	610	1.44	SS 10/200 QT200	594	1.73	SS 10/24 QT400	467	1.51
SS 10/24 QT400	536	1.44	SS 10/24 QT400	467	1.58	SS 10/200 QT200	594	1.48
SS 10/24 QT600	299	1.29	SS 10/24 QT600	326	1.51	SS 10/24 QT600	326	1.45
SS 10/24 AN	257	1.24	SS 10/24 AN	255	1.44	SS 10/200 QT400	400	1.37
SS 10/200 QT400	479	1.17	SS 10/200 QT400	400	1.33	SS 10/200 QT600	278	1.31
SS 10/200 QT600	294	1.02	SS 10/200 QT600	278	1.22	SS 10/24 AN	255	1.30
Mild Steel	108	1.00	SS 10/200 AN	195	1.18	SS 10/200 AN	195	1.28
SS 10/200 AN	230	0.91	AISI 304	185	1.16	AISI 304	185	1.10
AISI 304	152	0.69	Mild Steel	118	1.00	Mild Steel	118	1.00

TABLE 6.1 : Results from field and laboratory tests.

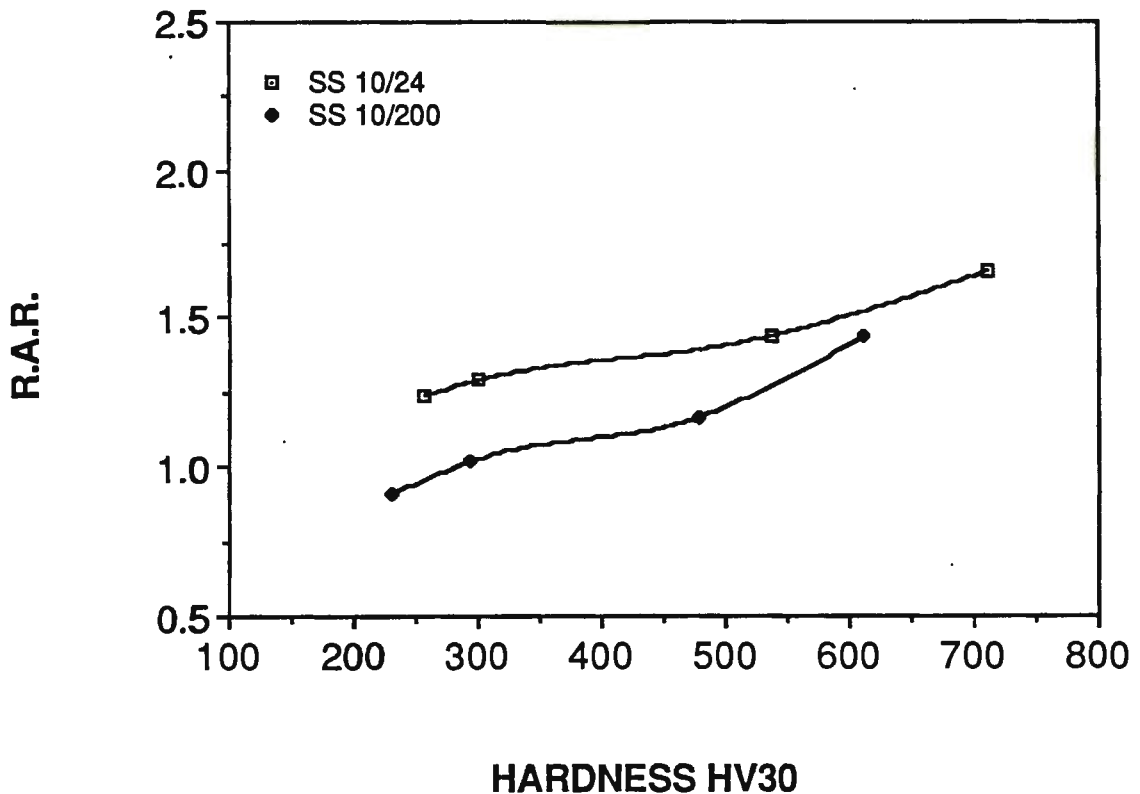

FIGURE 6.5 : Plot of hardness against RAR for SS 10/200 and 10/24.

It should be noted that the shape of each curve is similar but no single curve can be used to relate all the points on the graph. It may be said therefore that wear rate is not in this case determined by hardness.

6.2.1 Profile Development on Specimens during Wear

During testing a parabolic profile formed on each specimen, as depicted in figure 6.6 and illustrated in figures 6.7 and 6.8. However, the high rate of material loss at the bottom of each bar during ploughing retarded the process. Each specimen was shorted by approximately 2 mm with each run, depending on wear resistance. The difference between the shape of each sample for each test run was minimal after the first run. A parabolic profile then gradually took form from the front face of the specimen. Initially, the only effect noticeable was a rounding of the bottom edges of the bar. The slow change in shape was ideal for comparing wear rates. Generally, after many tests the specimen profile became quite sharp. The leading edge became quite narrow. An example of this is shown in figure 6.8.

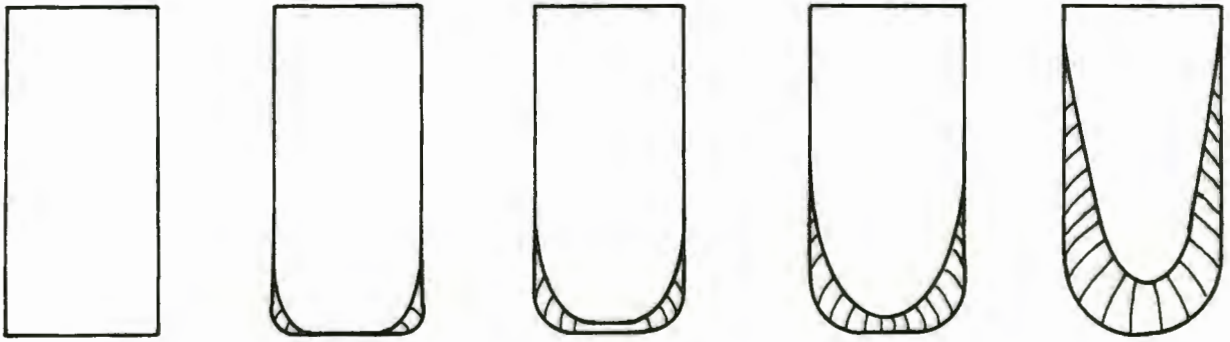

FIGURE 6.6 : Front view of the progressive development of a parabolic profile.

In addition to the formation of a profile, a burr formed on the back of the specimens. The size of this burr appeared to depend on the hardness of the material. For hard material it was merely a lip, which was 1 mm in size. For the softer materials this burr developed into a long tail.



FIGURE 6.7 : Specimens after one run in the field, compared with an unworn sample.



FIGURE 6.8 : The profile became well developed after many tests.

6.2.2 Surface Examination

Examination of the surface characteristics was carried out using a profilometer, optical and scanning electron microscopy. Profilometer traces of surface abrasion suffered by some samples are shown in figures 6.9 and 6.10. The vertical magnification in each case was 500x, and the horizontal 100x. A hard steel, SS 10/24, quenched and tempered at 200°C and a soft steel, mild steel, are presented for comparison. It should be noted that the difference between these specimens is slight.

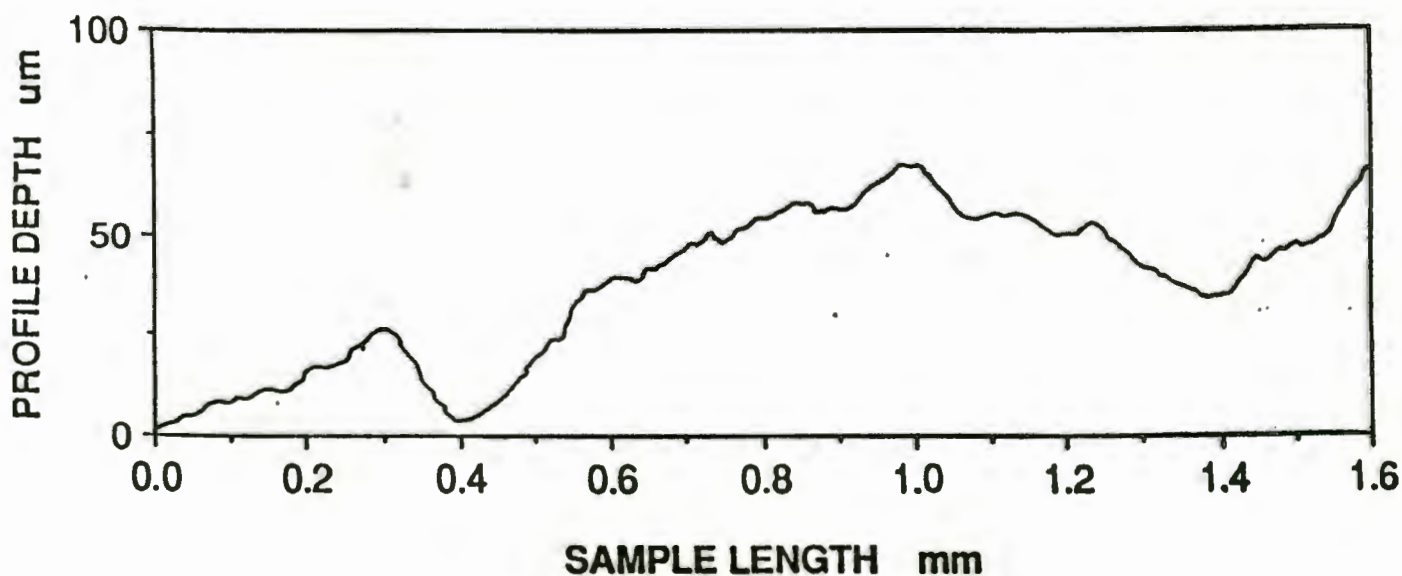

FIGURE 6.9 : The surface of the mild steel specimen.

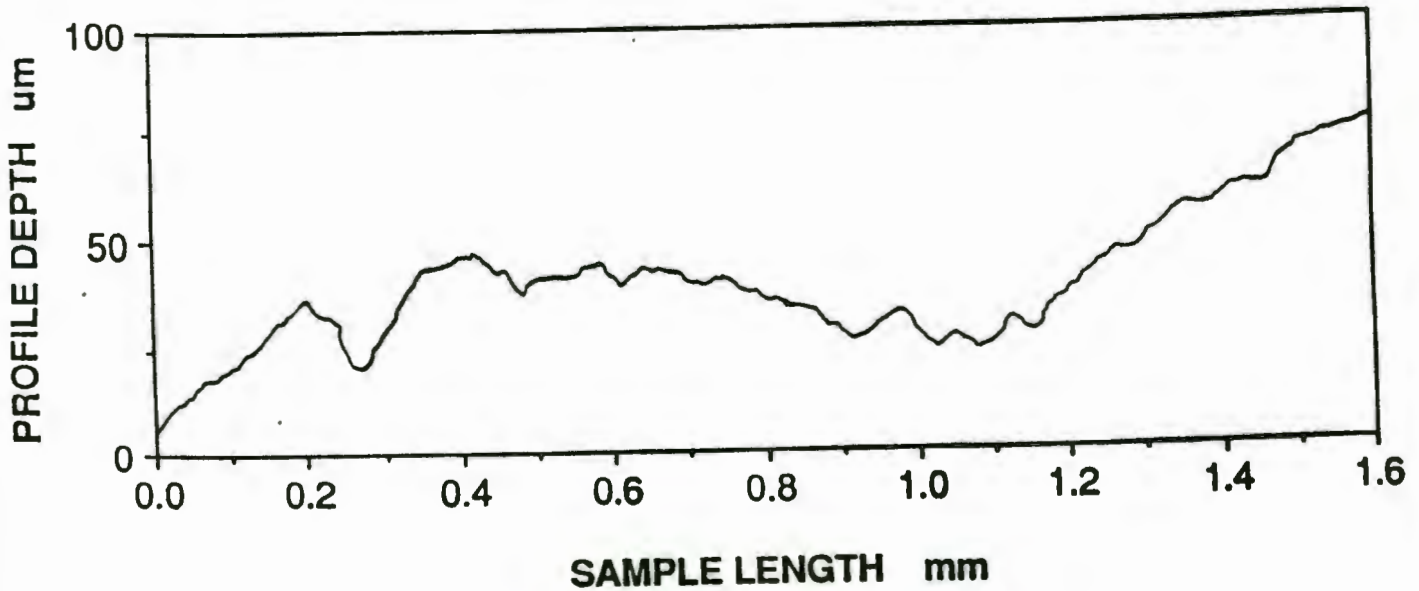

FIGURE 6.10 : The surface of the SS 10/24 quenched and tempered at 200°C.

The height and spacing of peaks in the traces show the topography of the worn surface. This gives an indication of the surface abrasion suffered by the sample. Traces from different materials may be compared. Figures 6.9 and 6.10 show similar topography. This was true for all the materials tested in the field test where none of the specimens showed markedly different roughness on abraded surfaces.

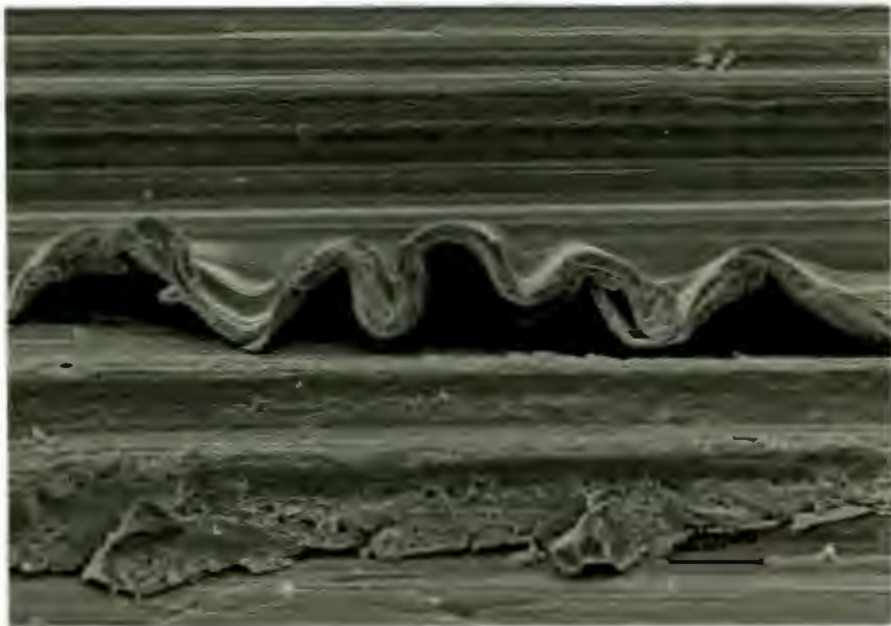

FIGURE 6.11 : Ploughing structures on an SS 10/200 specimen quenched and tempered at 200°C. Hardness 610HV30.

Examination by scanning electron microscopy showed extensive ploughing, cutting, gouging and smearing on the worn surfaces. In addition, soil particles were often found embedded in the surface layers and all samples were found to have a burr attached to the back of the working face. The shape of the burr ranged from a small lip on the back of hard specimens to a large curl on the back of the soft specimens. All these characteristics are illustrated in the accompanying figures.

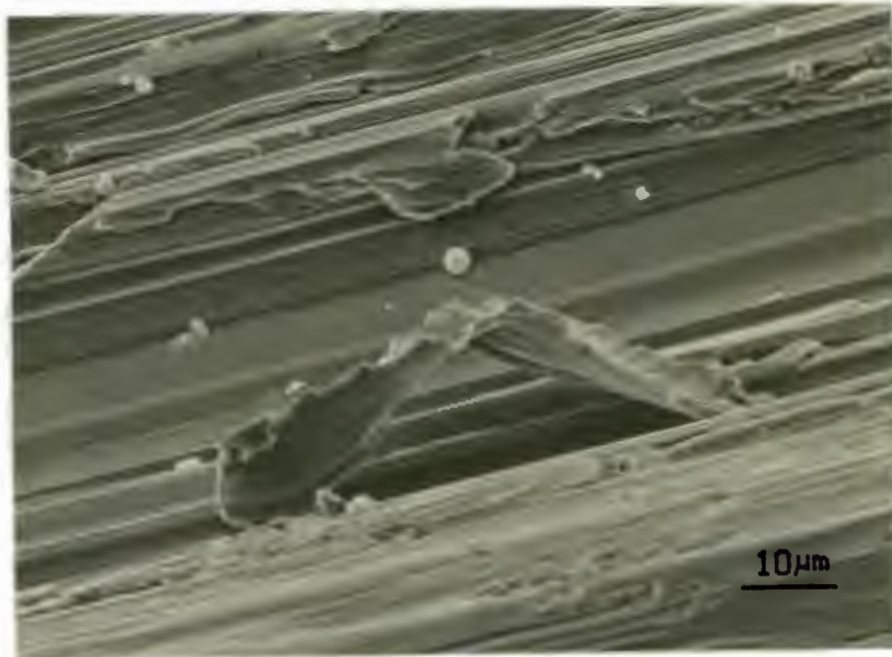

FIGURE 6.12 : A microchip formed by cutting on an SS 10/200 field specimen quenched and tempered at 200°C. Hardness 610HV30.



FIGURE 6.13 : A gouging structure on a normalized SS 10/24 field test specimen.

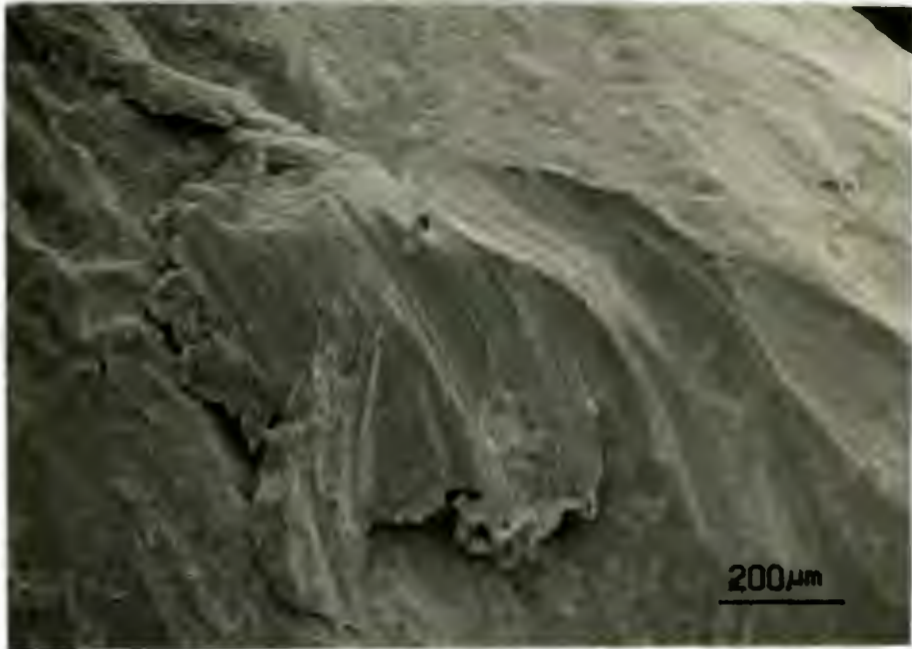

FIGURE 6.14 : A typical smearing structure on the tip of an annealed SS 10/200 plough point. Hardness 230HV30.

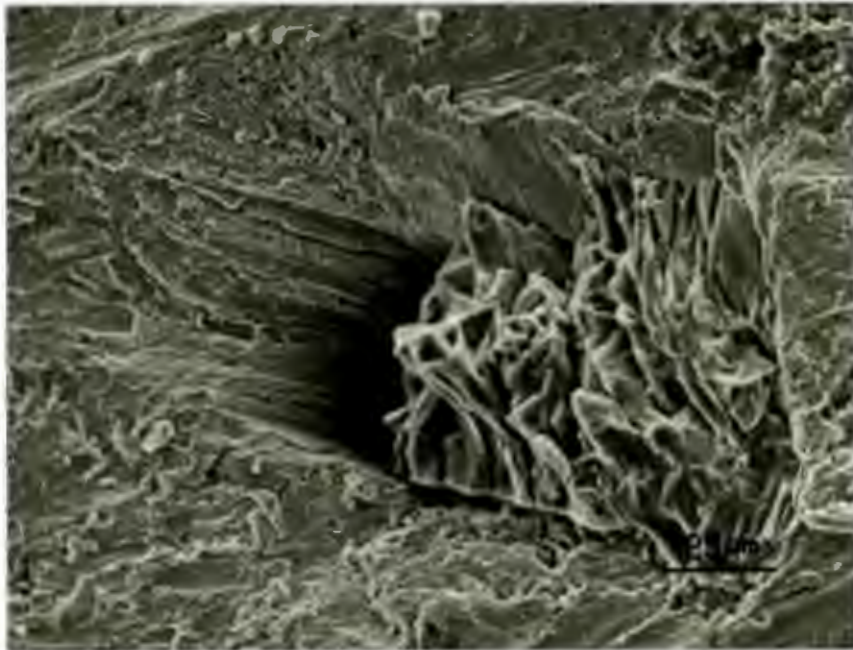

FIGURE 6.15 : A micrograph of a rock chip embedded in a mild steel field specimen. Hardness 118HV30.

Rock chips in the surface of the tool should not be confused with shattered manganese sulphides. The mild steel used for testing was full of these impurities. An example of how these could be confused with rock chips is shown in figure 6.16.

The extensive deformation and smearing on the bottom face of the field test sample is illustrated quite dramatically in figure 6.17.

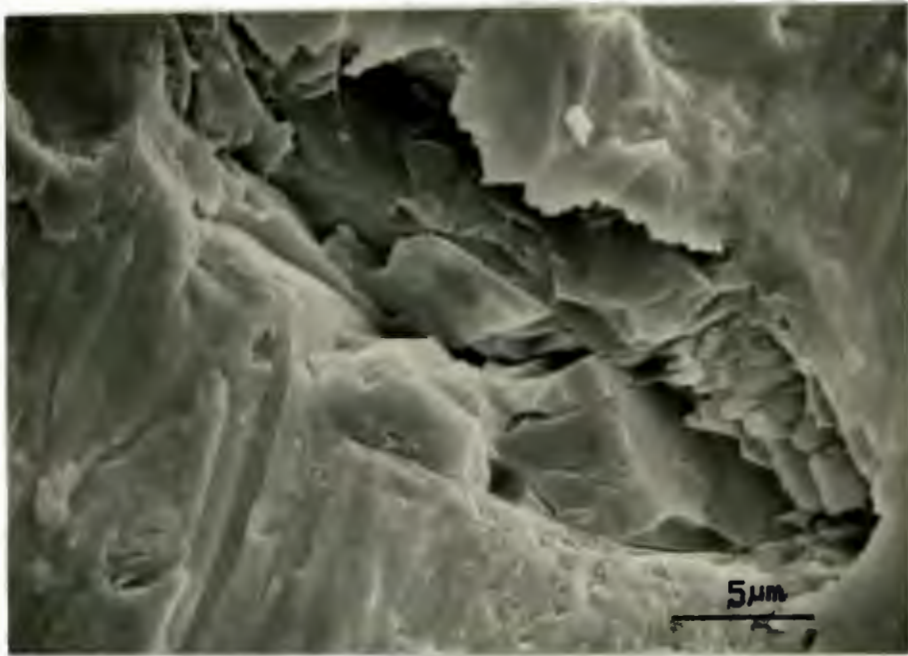

FIGURE 6.16 : A manganese sulphide particle in a mild steel field test specimen. This shows how it shatters at the surface producing chips that may be confused with rock chips. This also illustrates how the wear resistance of a steel may be impaired by brittle fracture of impurities. Hardness 108HV30.

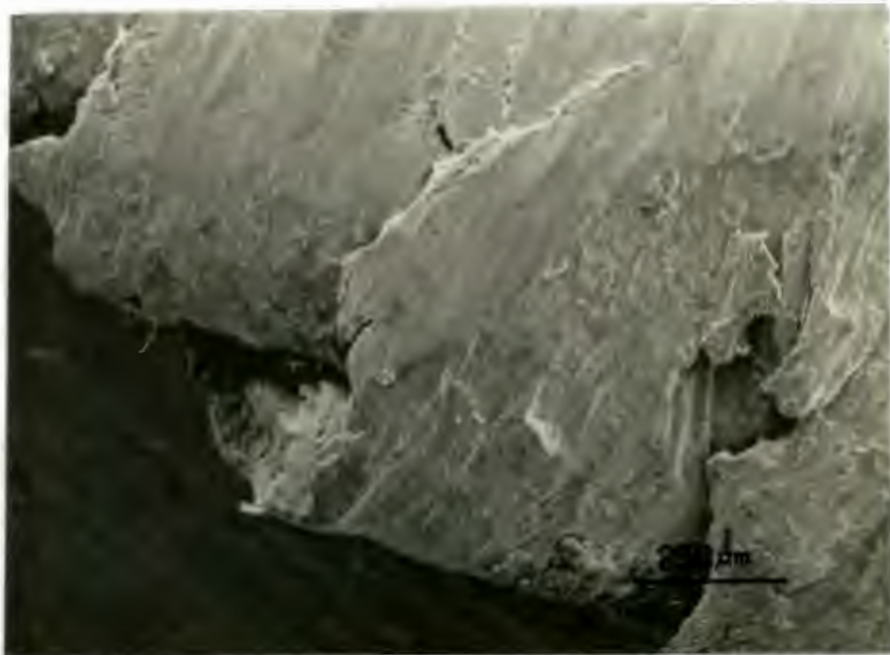

FIGURE 6.17 : Scanning electron micrograph of the burr on a field test specimen. The material is SS 10/24, hardness 257HV30.

The relative displacement of material across the surface formed a heavy burr at the back of the wear specimen, which often showed extensive cracking.

Wear debris found on a small rock in the field was also examined. This showed how the steel had been removed from the specimen by a cutting mechanism, and smeared onto the rock.



FIGURE 6.18 : Wear debris on a rock found in the field. The morphology of the debris is similar to that produced by a cutting mechanism during wear in the laboratory.

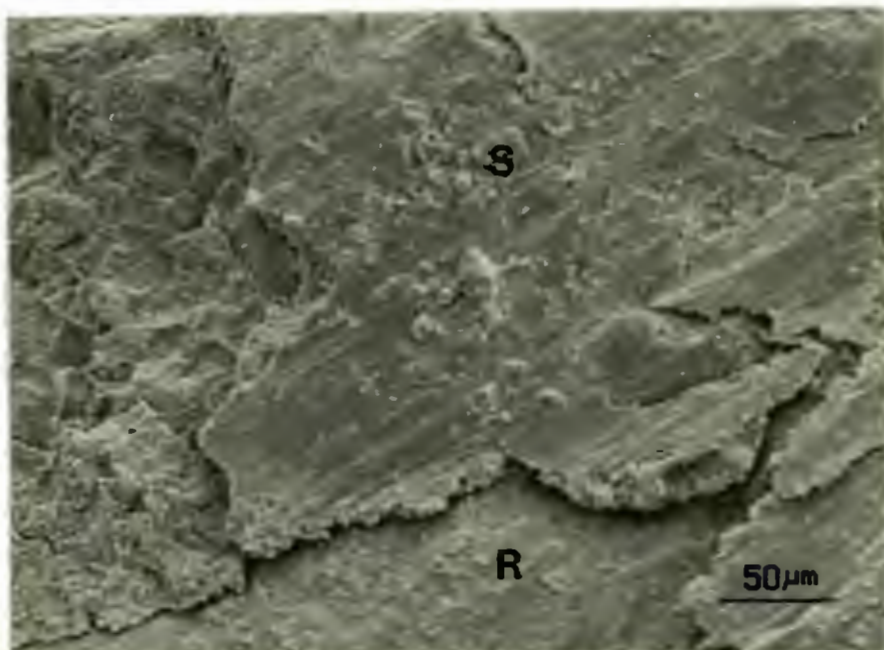

FIGURE 6.19 : Steel (S) smeared onto the rock (R).

6.2.3 Subsurface Investigation

All of the specimens tested in the field showed extensive subsurface deformation. Generally, three regions in the subsurface layers could be distinguished quite clearly. These were:

1. The undeformed region.
2. A strained region.
3. A surface region in which smearing and mixing with abrasive took place. This region was of particular interest because of the occurrence of non-etchant or white layers.

The microstructure of the undeformed regions was dependent only on the chemical composition of the steel and the heat treatment. The transition from undeformed to deformed microstructure occurred up to 500 microns below the surface, but was generally lower than this. This was particularly obvious in specimens such as mild steel as shown in figure 6.20.

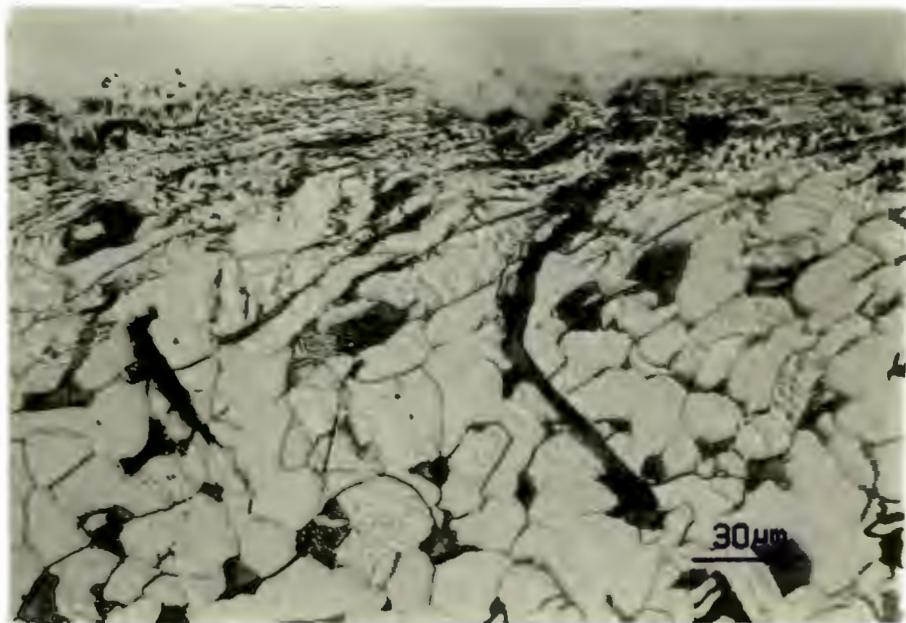

FIGURE 6.20 : A cross section normal to the worn surface of a mild steel specimen in the direction of wear. The depth at which flow begins is clearly illustrated by the deformation in a manganese sulphide stringer. Hardness 108HV30, etched in Nital.

The microstructures of features were also observed in this surface region. The extent of deformation in smearing structures and the inclusion of soil particles into the surface can clearly be seen in the micrographs 6.21 and 6.22. The microstructure of the burr on the back of the specimen is shown in figure 6.23, from a Boron C8 specimen, showing the same deformation characteristics as the surface of the specimen.

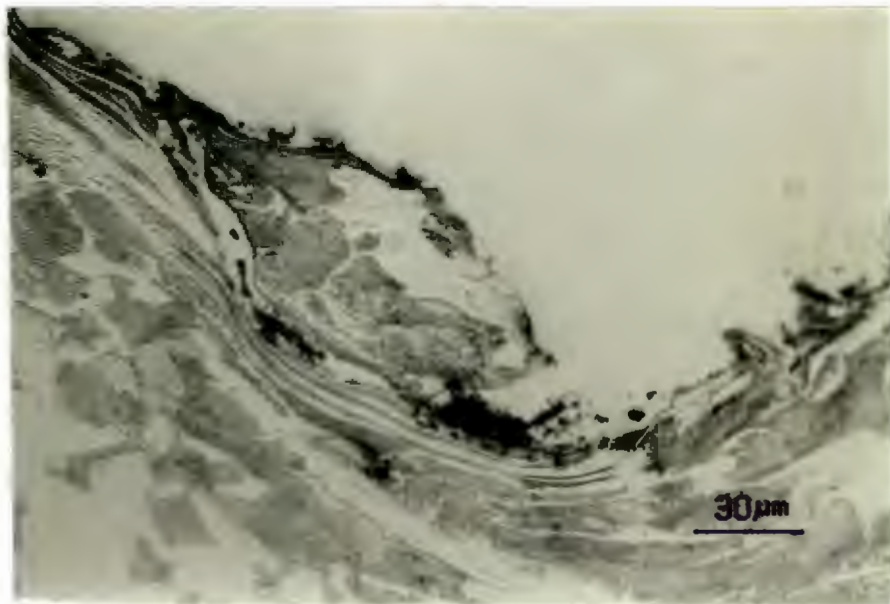

FIGURE 6.21 : The microstructure of a smearing structure similar to the one shown in figure 6.14. The material is normalized SS 10/200. Hardness 230HV30, etched in Nital.



FIGURE 6.22 : Inclusion of abrasive in an SS 10/200 specimen quenched and tempered at 400°C. Hardness 479HV30, etched in Nital.

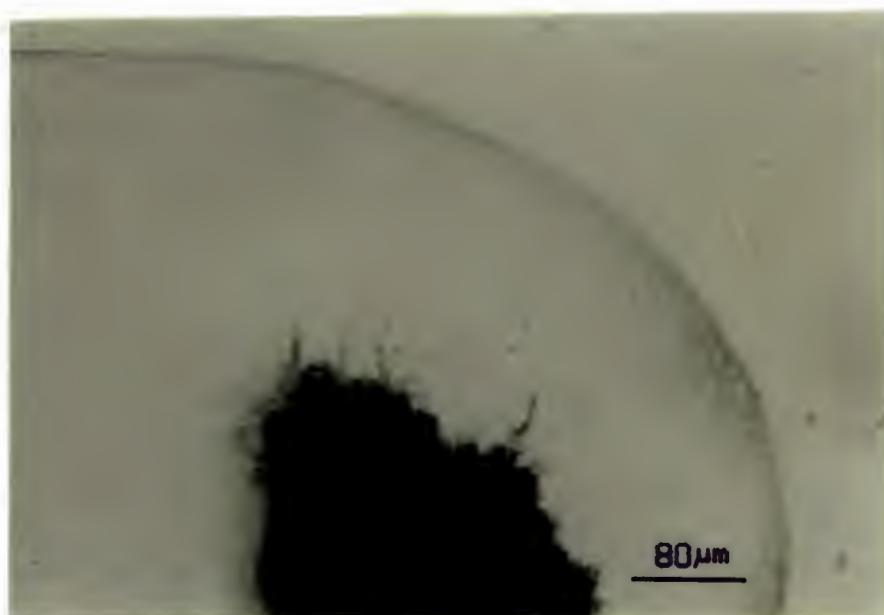

FIGURE 6.23 : Burr on the back of the Boron C8 field test specimen. Hardness 564HV30, etched in Nital.

The large amount of deformation and strain in the abraded surface layers of austenitic stainless steel, AISI 304, was manifest in the form of strain bands in the grain structure. This is shown in figure 6.24.



FIGURE 6.24 : The stain bands formed in AISI 304 during a field test. Region A is the nickel plate used for edge retention. B is a region of high strain similar to white layers found in plain carbon steels. Hardness 152HV30, electrolytically etched in oxalic acid.



The depth to which strain hardening had occurred could be measured simply by using the optical microscope. Microhardness testing on taper sections was also utilized to establish the extent of surface deformation in worn surface layers, as illustrated in figure 6.25.

Microhardness Traverse

Apparent depth of deformation
= 500 microns.

True depth = 321 microns.

Specimen polished at 40° to the worn surface.



FIGURE 6.25 :

Oblique section through a AISI 304 point used in the field test. Note the layer and the slip lines typical of face centered cubic materials. The amount of strain hardening is indicated by the microhardness values. Hardness 152HV30, electrolytically etched in oxalic acid.

6.2.4 White Layers

When the wear test specimens were initially sectioned for microstructural investigation, unetched patches were discovered in the immediate surface layers. These non-etching layers were found to have hardness values between 700 to 1100HV30. Such layers have never been previously observed in tillage tools. The thickness of these layers was usually less than 50 microns. However, in some cases non-etching layers up to 200 microns thickness were measured. Although white layers were often found associated with high strain areas, high strain did not always result in the formation of white layers. Nor did deformation appear to be a prerequisite for their formation. On the contrary, white layers were often observed on surfaces which had apparently suffered only minimal strain. Figures 6.26 to 6.28 illustrate these points.

White layers also appeared to be quite homogenous in the majority of instances as in figure 6.29. However, there were cases where ferrite from the partially deformed region was found in white layers (fig. 6.30). The transition from the partially deformed structure to the white layer occurred over a few microns in distance. Carbides and other microconstituents appeared to be broken down and absorbed into the matrix prior to the formation of these non-etching layers.

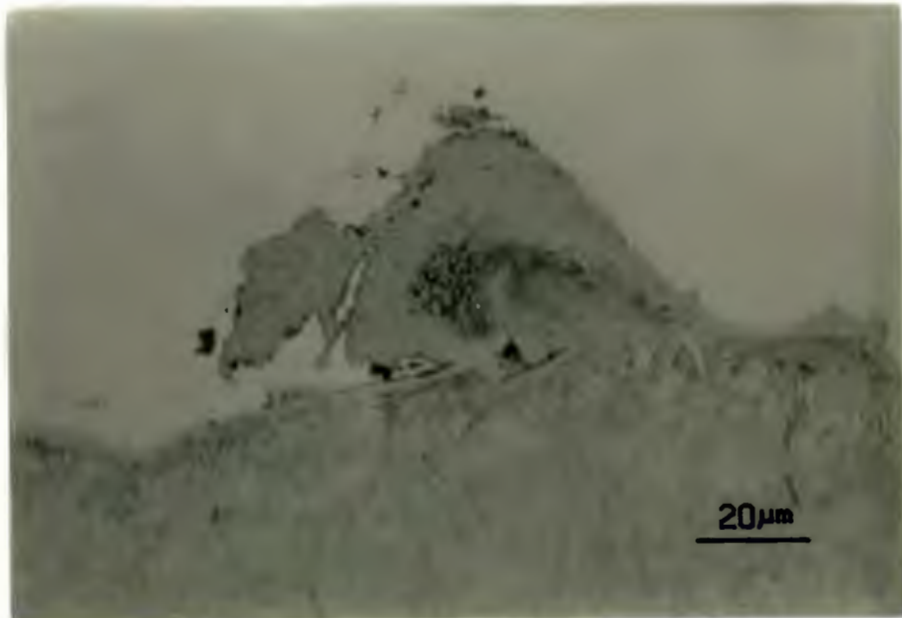

FIGURE 6.26 : The formation of white layer on a smearing structure on a Boron C8 field test specimen. Hardness 564HV30, etched in Nital.

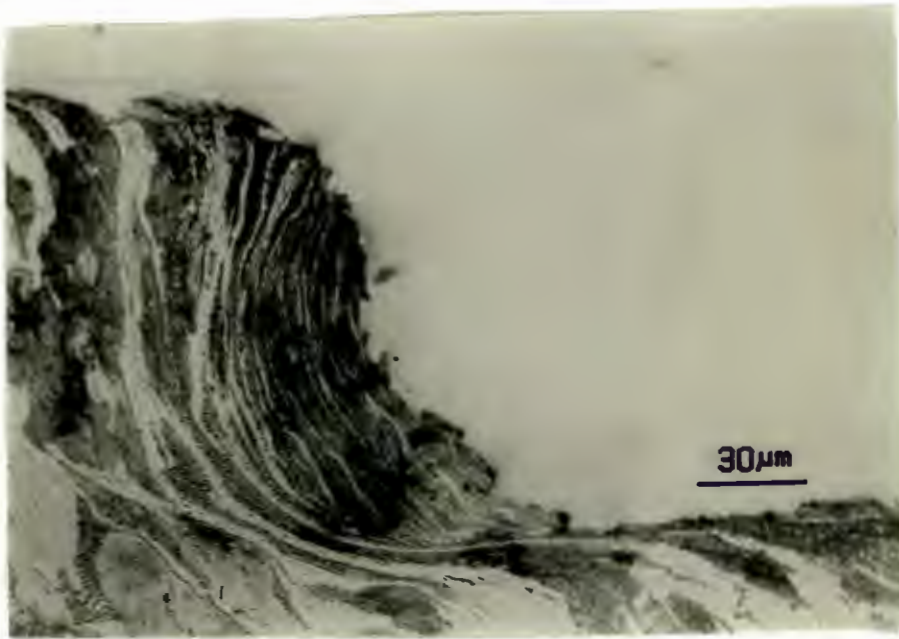

FIGURE 6.27 : A highly deformed region in the surface of an annealed SS 10/200 specimen. There is little evidence of white layer formation. Hardness 230HV30, etched in Nital.



FIGURE 6.28 : The formation of a double thickness of white layer in a situation where there is no surface indication of high strain. The specimen is SS 10/200, quenched and tempered at 200°C. Hardness 610HV30, etched in Nital.

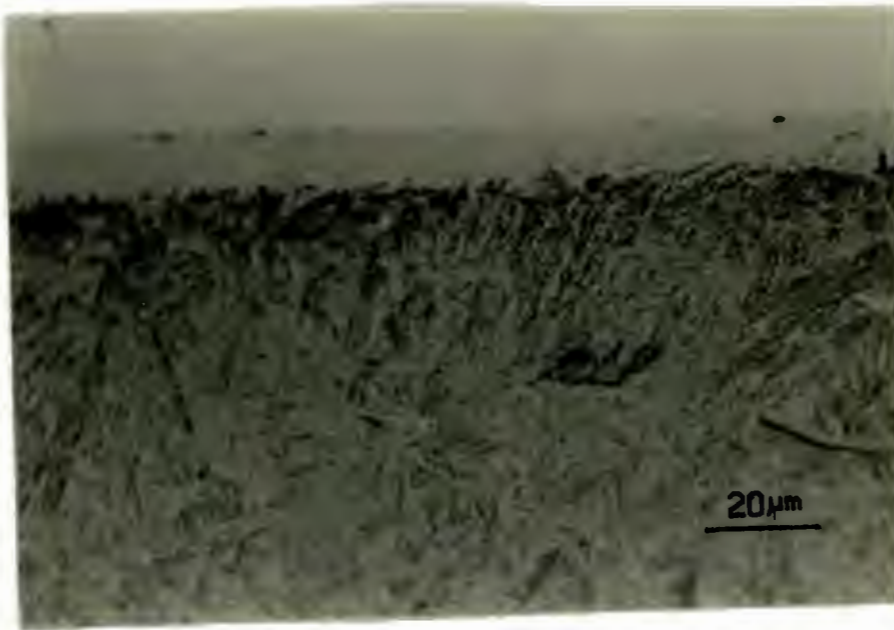

FIGURE 6.29 : A specimen of SS 10/200 quenched and tempered at 200°C showing how all the phases in the microstructure are absorbed in the white layer. Hardness 610HV30, etched in Nital.

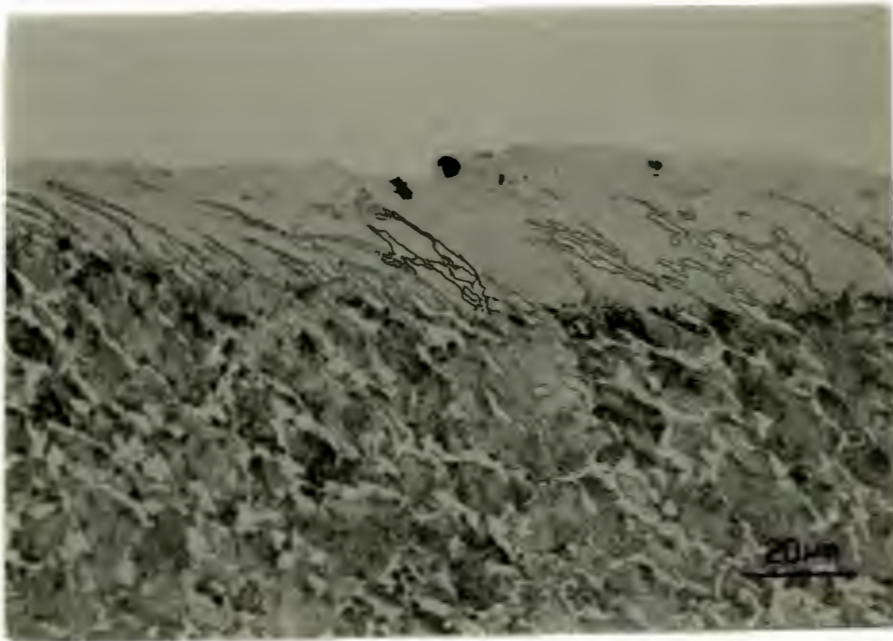

FIGURE 6.30 : A well developed non-etching layer in an annealed SS 10/200 specimen. The ferrite in the matrix is not absorbed into the white layer. Hardness 230HV30, etched in Nital.

A darker etching layer often appeared directly below the white layer. This is shown in figure 6.31. This effect was less noticeable in the softer steel specimens. In the example shown in figure 6.32, a SS 10/24 specimen quenched and tempered at 600°C, there is no dark etching layer.

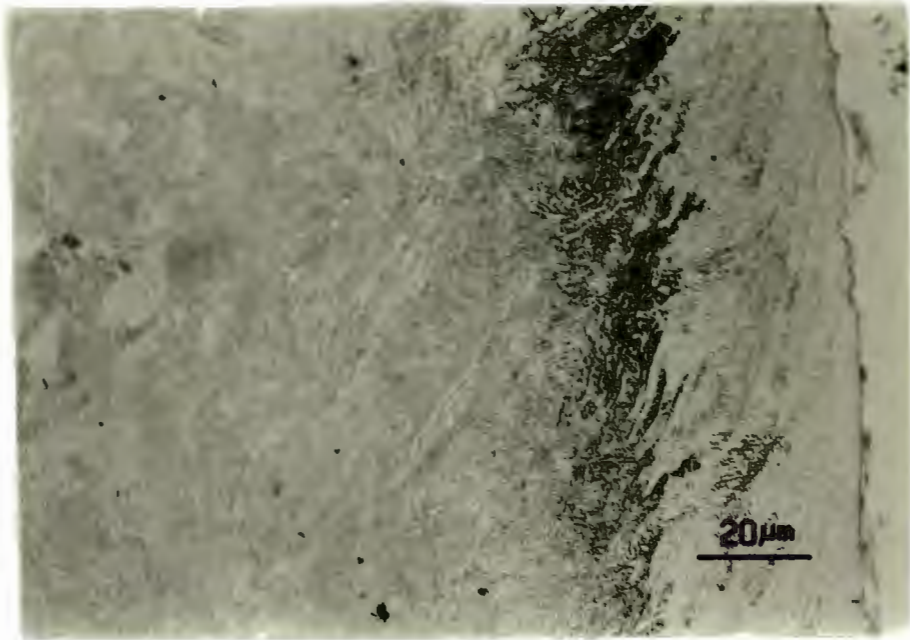

FIGURE 6.31 : A dark etching layer beneath the white layer from an SS 10/200 plough point, quenched and tempered at 400°C. Hardness 290HV30, etched in Nital.

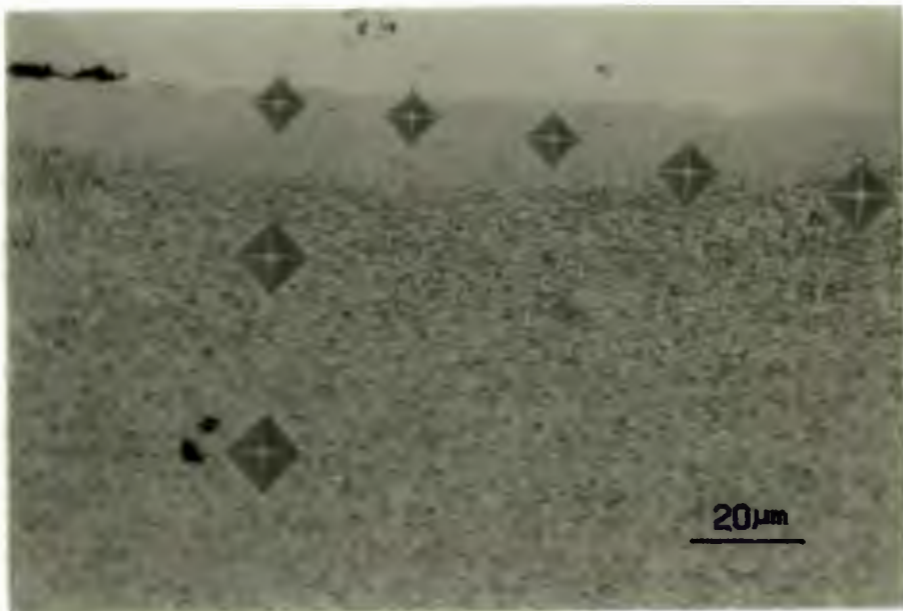

FIGURE 6.32 : White layer in a specimen of SS 10/24 quenched and tempered at 600°C and tested in the field. Hardness 299HV30, etched in Nital.

Microhardness traverses across these regions revealed large changes in properties. In the case of the softer materials such as SS 10/200 quenched and tempered at 600°C, the hardness value decreased across the strained region to the bulk level. This is shown in the following figure 6.33.

In the case of harder materials there is a substantial drop in hardness in the dark etching area below the white layer. This fall in hardness to a value lower than the bulk hardness suggests some form of tempering had occurred. The hardness then increases to a level higher than the bulk microstructure before falling to the bulk level. A typical example of this behaviour is shown in figure 6.34.

A similar case is shown in figure 6.35. In this example softening has occurred at the surface as well as beneath the white layer. Figure 6.36 is a microhardness trace across a specimen in which a double white layer was observed, one below the other. This was not a common observation.

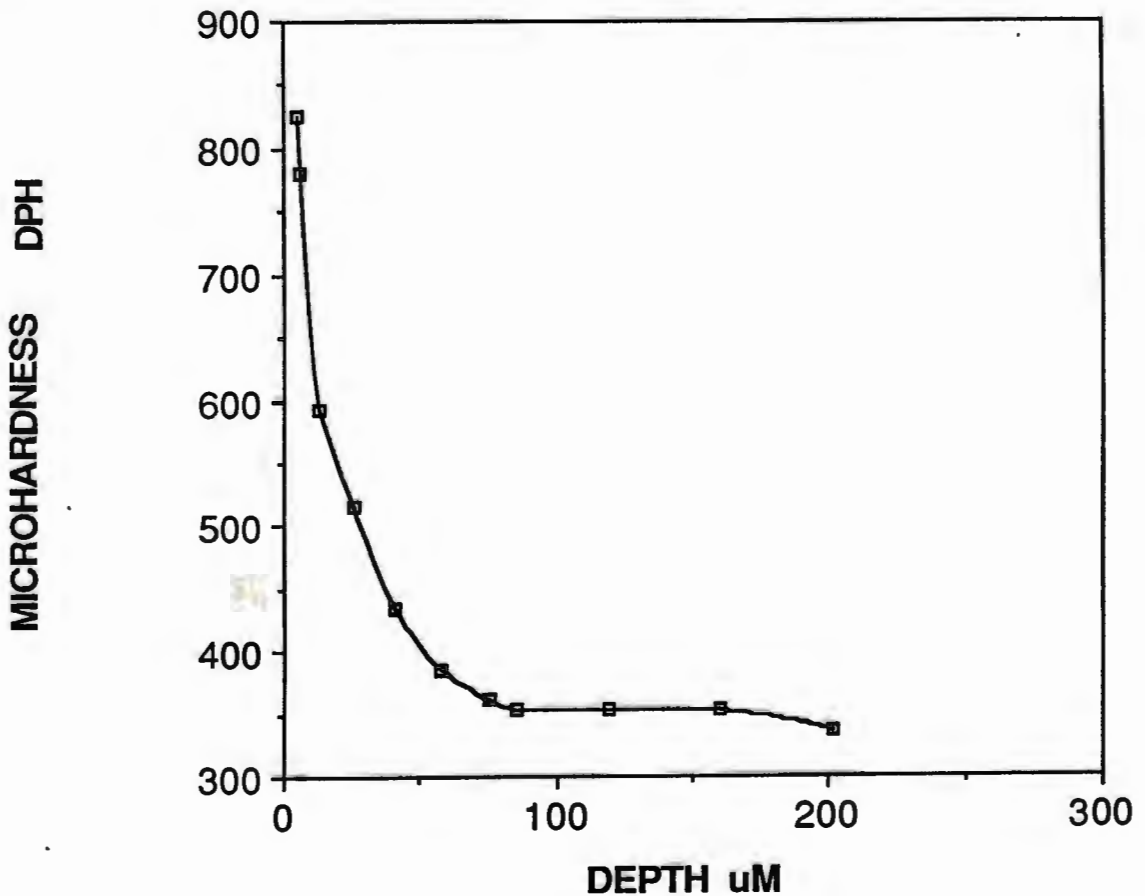

FIGURE 6.33 : The change in hardness with depth through white layers occurring in an SS 10/200 specimen quenched and tempered at 600°C.

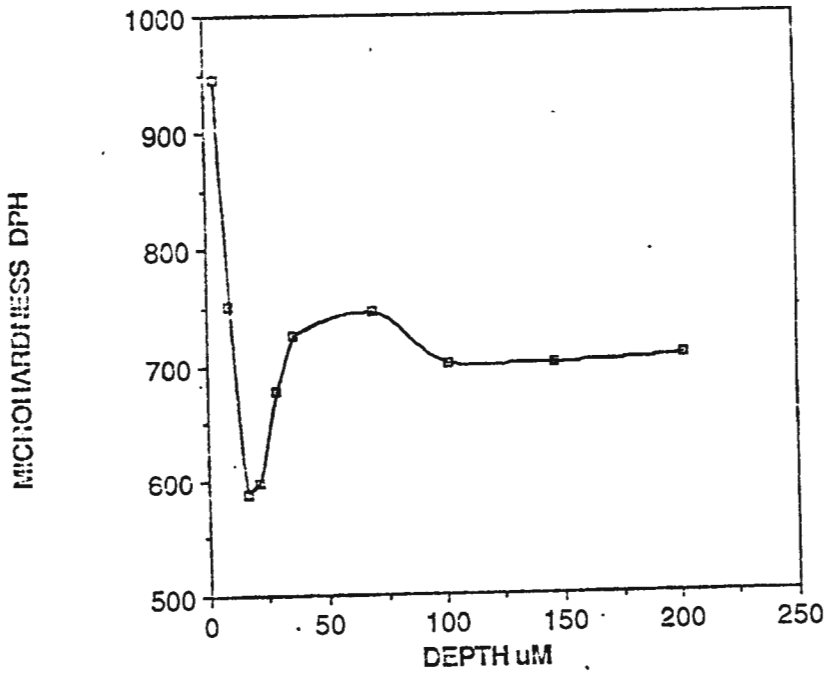

FIGURE 6.34 : The extent to which the hardness decreases in the transition zone between the white layer and the bulk microstructure. The specimen is SS 10/200 quenched and tempered at 200°C, tested in the field.

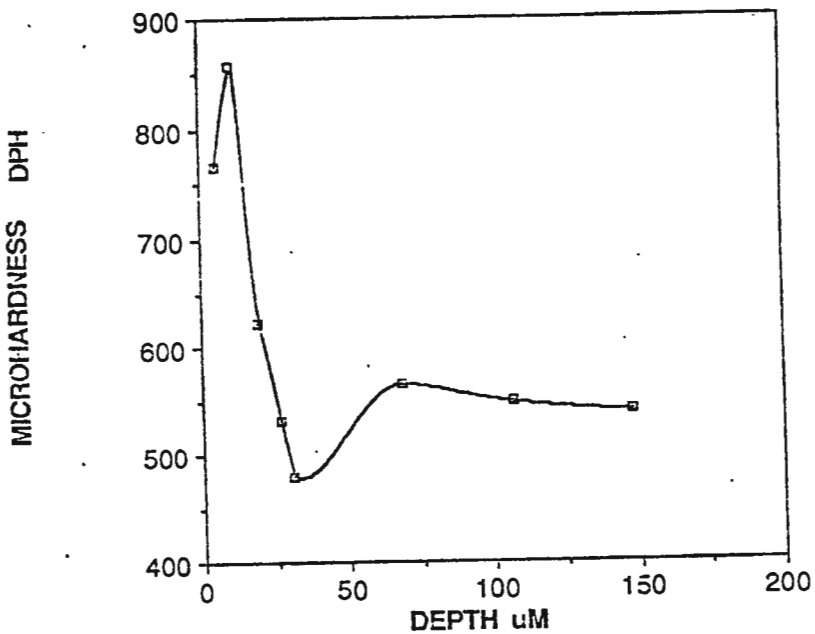

FIGURE 6.35 : Microhardness traces fit in between the two extremes described. The measurements were carried out on an SS 10/200 specimen quenched and tempered at 400°C and tested in the field.

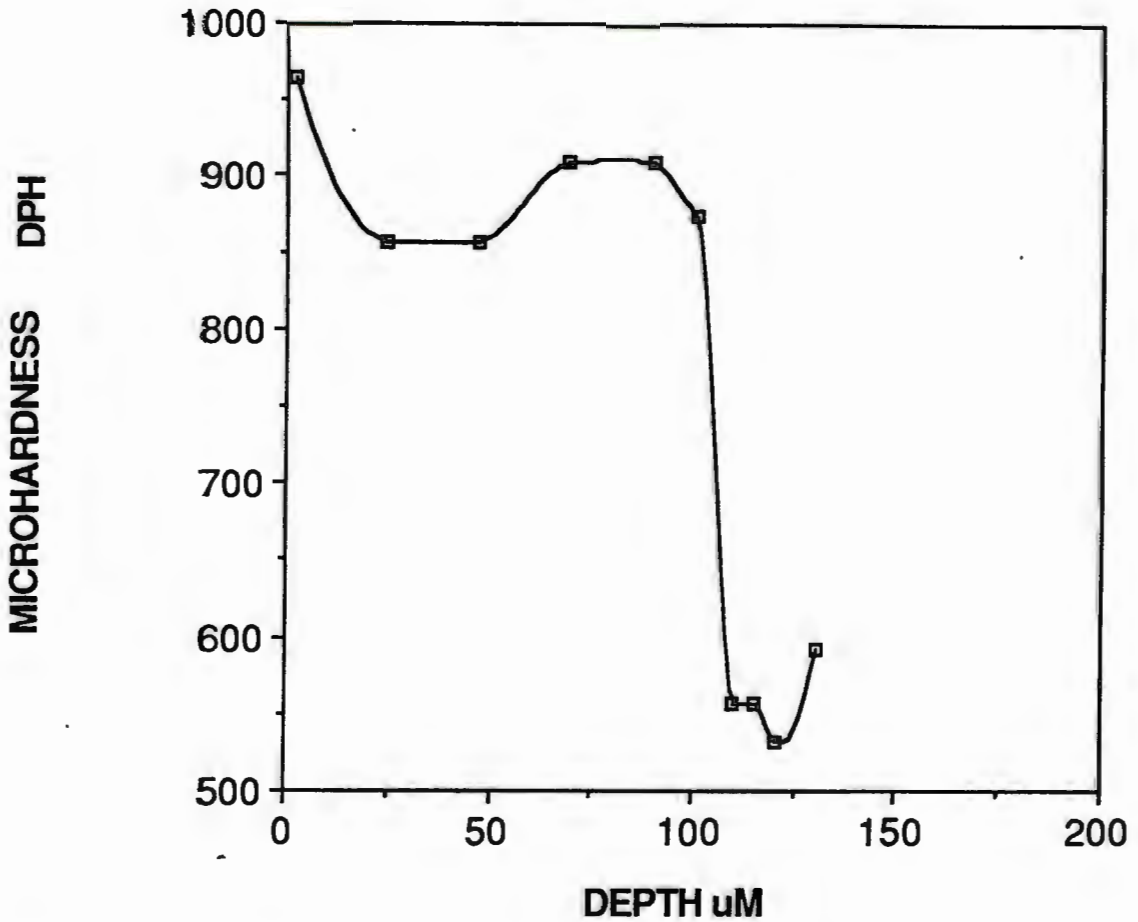

FIGURE 6.36 : A hardness trace through a double white layer in an SS 10/24 specimen quenched and tempered at 400°C and tested in the field.

6.2.5 Maximal Hardness of Deformed Surfaces

The results of hardness testing indicate that the white layer formed on samples is harder in specific regions than others. In order to present the results, the longitudinal section of the test specimen has been divided into four major areas and the maximal hardness for white layers in each of these areas has been tabulated, as shown in figure 6.37 and Table 6.2.

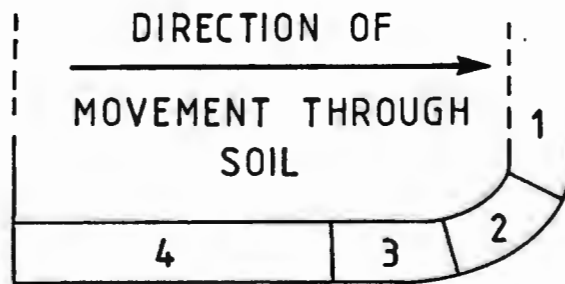

FIGURE 6.37 : The four areas of the specimen.

Region 1 is the leading edge of the specimen. Regions 2 and 3 represent the upper and lower halves of the section on the edge on which impact and abrasion would be greatest. Region 4 is the bottom edge on which the weight of the rig rests. Table 6.2 indicates the highest microhardness measurements recorded for white layers in various steels.

MATERIAL	POSITION			
	1	2	3	4
SS 10/200 QT 200	689	946	783	710
SS 10/200 QT 400	909	841	739(946)	525
SS 10/200 QT 600	-	909	825	774
SS 10/24 QT 200	-	857	-	766
SS 10/24 QT 400	-	1049	870	810
SS 10/24 QT 600	739*	874	795	396
SS 10/24 normalized	-	-	930	750
Boron C8	874	701	874	-

TABLE 6.2 : The maximal hardness of white layers found in various samples.

Although these results are not extensive, they do indicate that the white layer formed at the leading edge of the specimen is harder than the other areas. The highest hardness recorded is in region 2 where the highest pressure may be expected during ploughing.

6.2.6 Thermocouple Test

A typical example of a temperature trace using a thermocouple inserted in a plough point is shown in figure 6.38. The temperature measured was higher in a soil with a high stone content and lower in sandy areas. Nevertheless the highest temperature recorded by this method was only 60°C. Conversely, temper colours found on steel debris collected from the surface of stones during field trials indicated that temperatures in excess of 300°C were reached during wear.

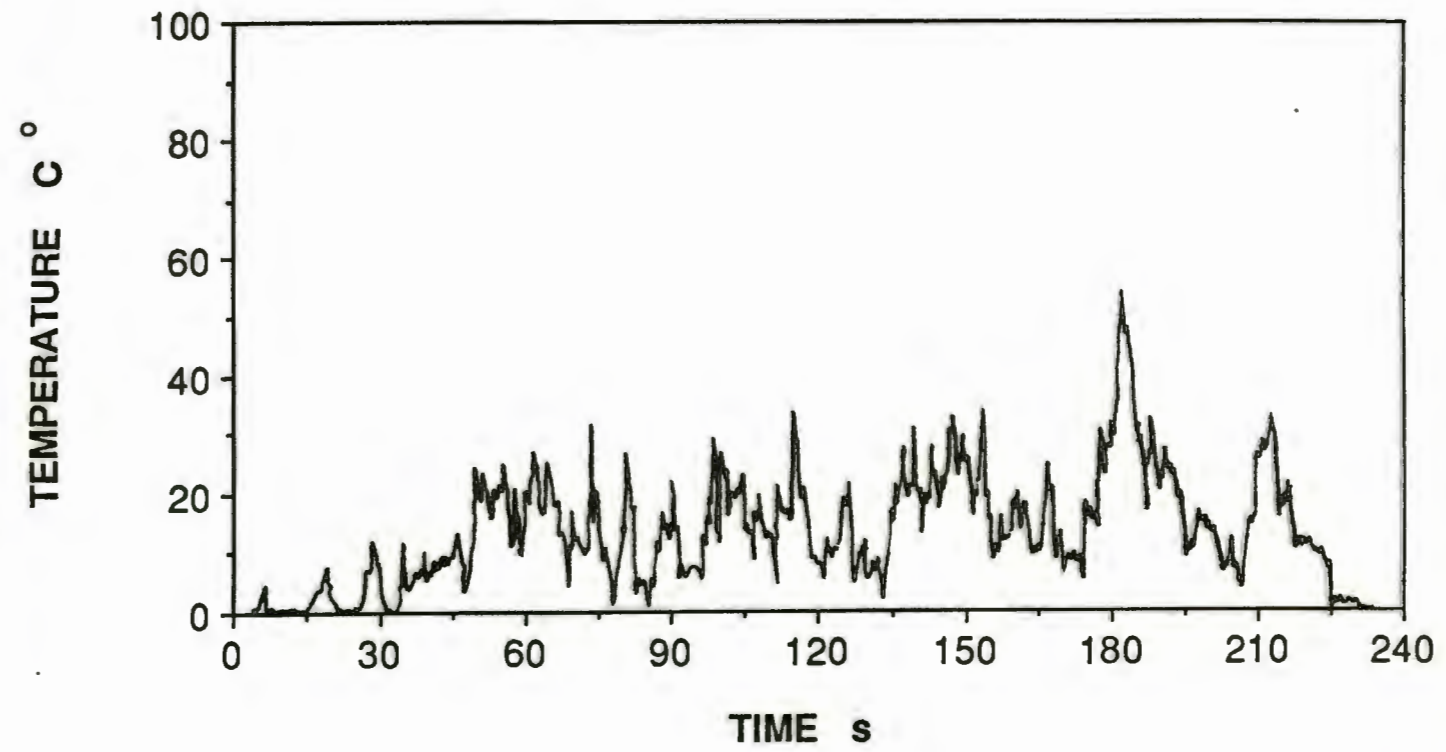

FIGURE 6.38 : A typical temperature trace from the field test.

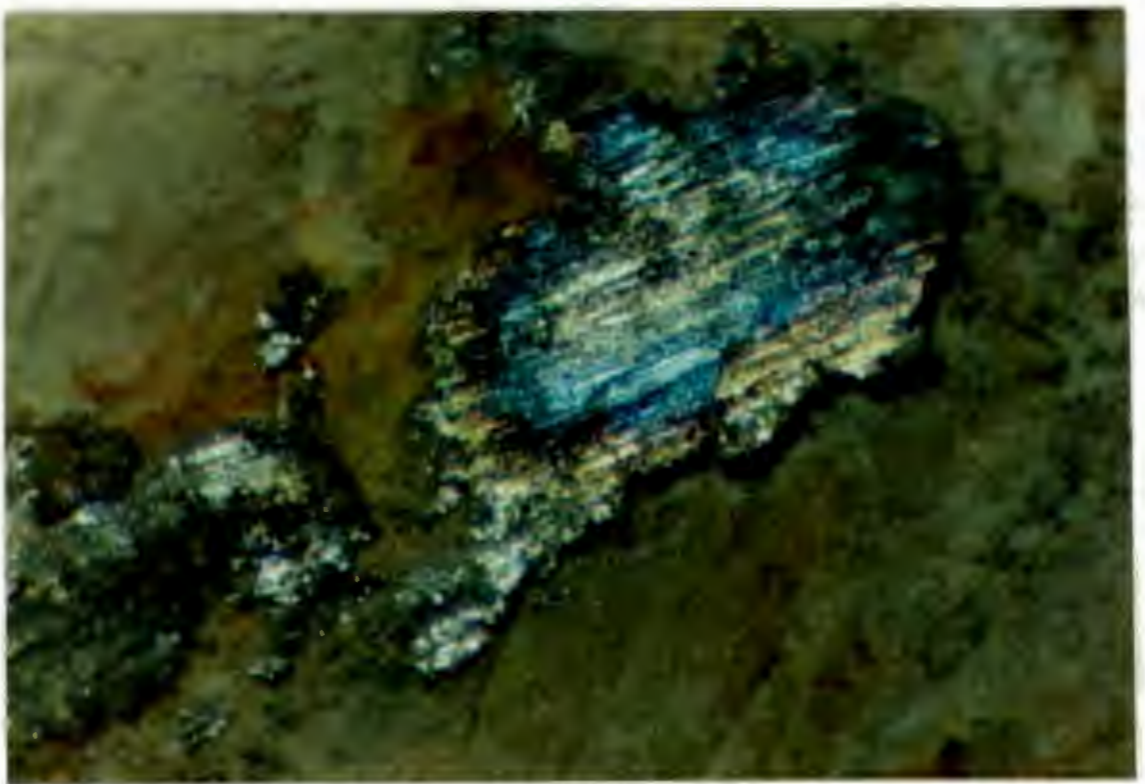

FIGURE 6.39 : Steel debris adhering to a pebble.

6.3 Laboratory Tests

The reproducibility of the pin on belt method of testing has been shown to be excellent by Allen, Ball and Protheroe (1981). Similar materials to those tested in the field were also abraded in the laboratory. The volume loss of the standard for each of the tests was divided by the volume loss of the material to calculate the relative abrasion resistance.

The results for the 80 grit test and the 40 grit test were also ranked in order of decreasing relative abrasion resistance. These are presented alongside those from the field tests in Table 6.1. The ranking order obtained from the materials were generally similar to those from the field test results. The values of the relative abrasion resistance in the 80 grit test were found to be slightly higher than those measured in the 40 grit test. The ranking followed a trend which was generally governed by hardness of the material; those materials with higher hardnesses having the better wear resistance or higher RAR values. However, this was not always true. For example, the SS 10/200 quenched and tempered at 400°C proved to be a notable exception, having a much lower RAR than that predicted from the general trend.

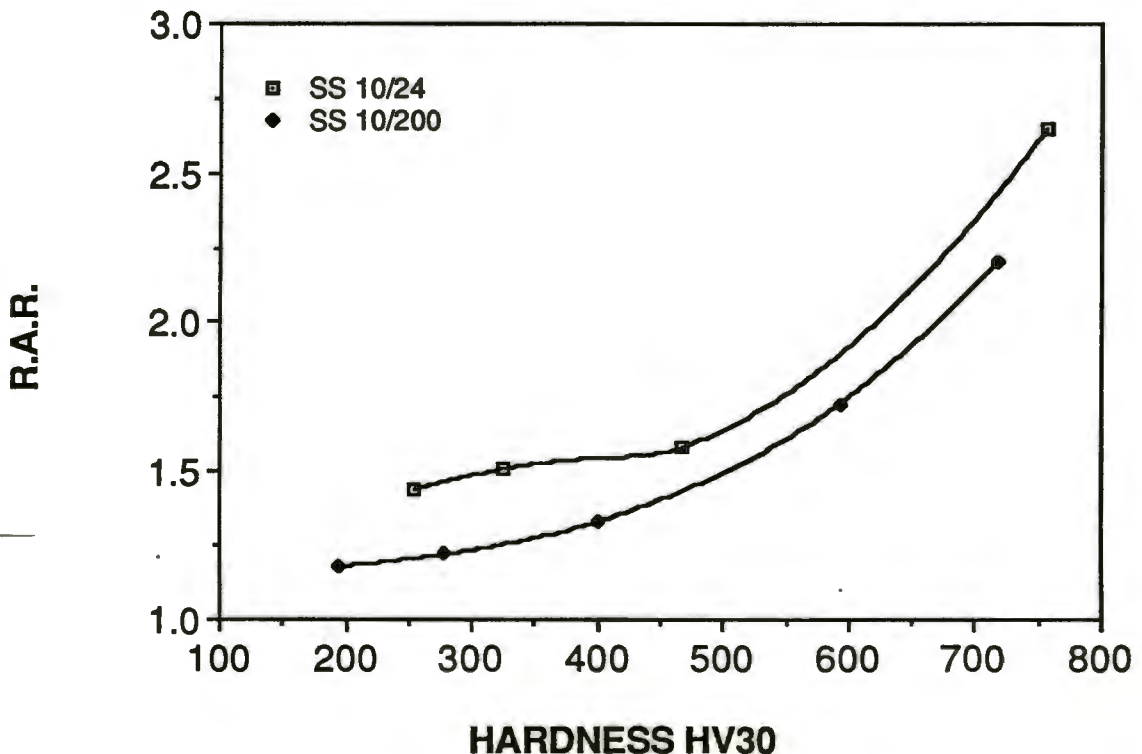

FIGURE 6.40 : RAR plotted against hardness for the 80 grit laboratory test.

A plot of the RAR against hardness for the materials SS 10/24 and SS 10/200 is shown in figures 6.40 and 6.41. These two figures show that there is a difference between materials and wear resistance for the same value of hardness for both. The SS 10/24 shows a consistently higher wear resistance than the SS 10/200 steel, which has a lower carbon content. In addition to hardness and carbon content effect, the SS 10/24 plot suggests a sigmoidal trend, with higher slopes at lower and higher hardness.

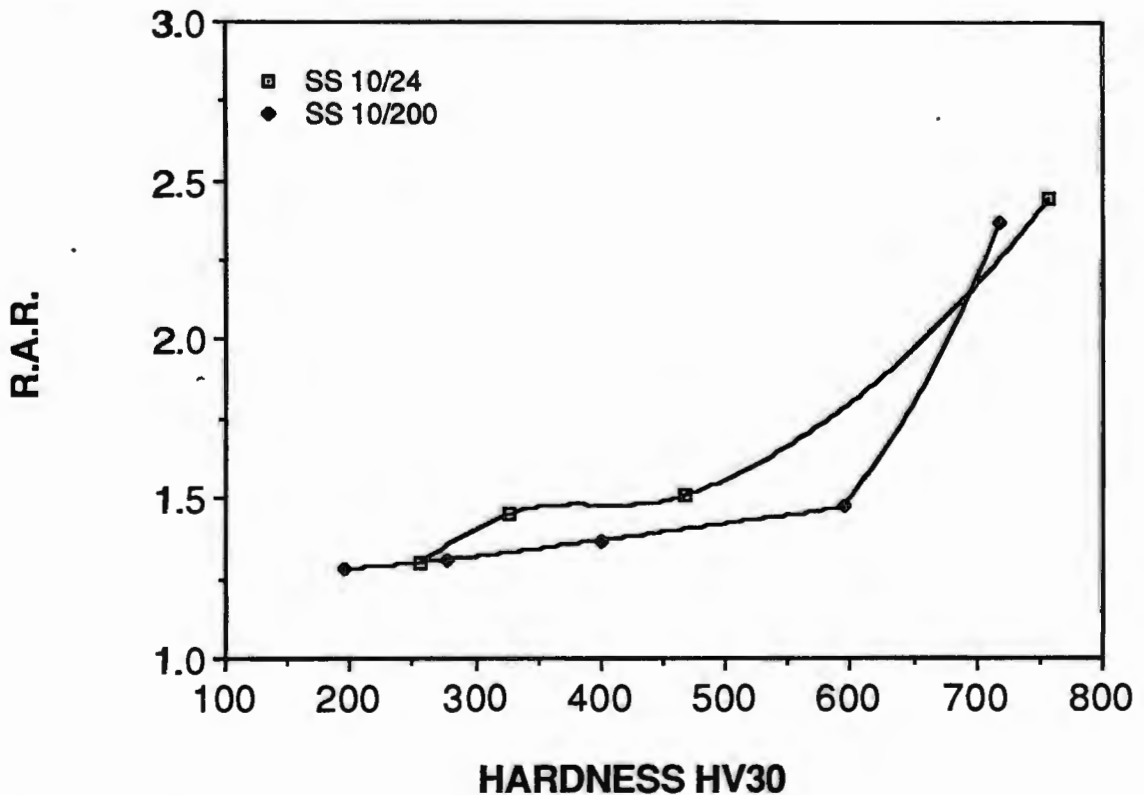

FIGURE 6.41 : RAR plotted against hardness for the 40 grit laboratory test.

6.3.1 Surface Characteristics

Talysurf profiles across the surfaces of both hard and soft specimens show the range of surface morphologies achieved during abrasion testing on bounded belts. The magnification is 500x in the horizontal direction and 100x in the vertical. Laboratory and field test results can be compared directly.

The traces taken from the surface of mild steel are shown in figures 6.42 and 6.43, for 80 grit abrasive and 40 grit abrasive respectively. The difference in topography is readily discernible. The grooves are much deeper and wider for specimens abraded on the 40 grit belt.

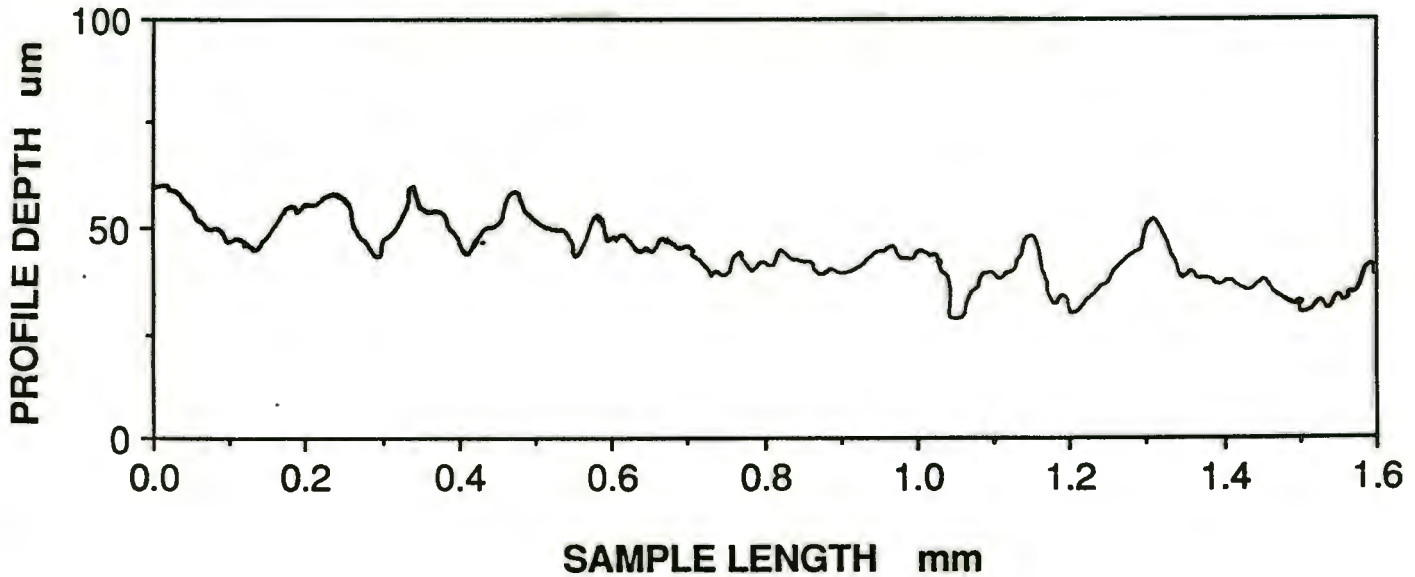

FIGURE 6.42 : Worn surface profile of a mild steel specimen tested in the 80 grit laboratory test (grain size 177-210 microns).

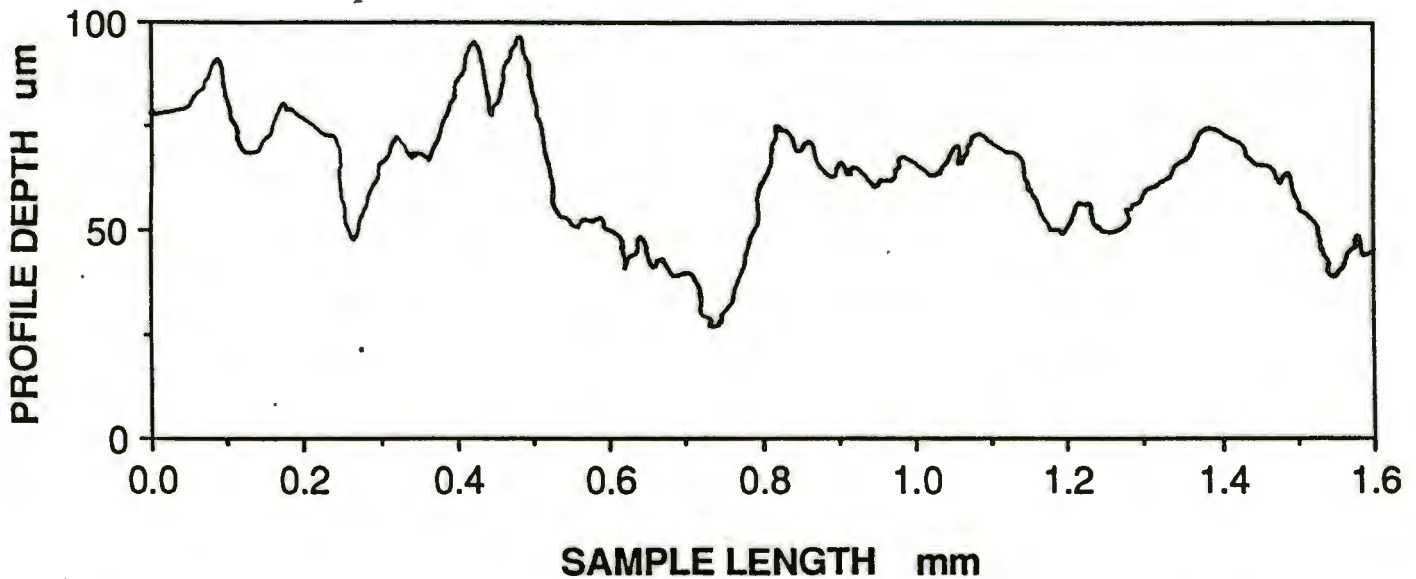

FIGURE 6.43 : Profilometer trace on a mild steel specimen from the 40 grit laboratory test (grain size 420-500 microns).

It is clear from these two profiles that the abrasion has been far more severe in the 40 grit test than in the 80 grit test. Figure 6.43 indicates that the 40 grit abrasive has not been broken down by the mild steel. This becomes more obvious when it is compared with the SS 10/24 steel, quenched and tempered at 200°C. This had a hardness in excess of 700HV30 and there is great similarity between the surface profiles from the two test grits. This similarity was assumed to be due to abrasive breakdown.

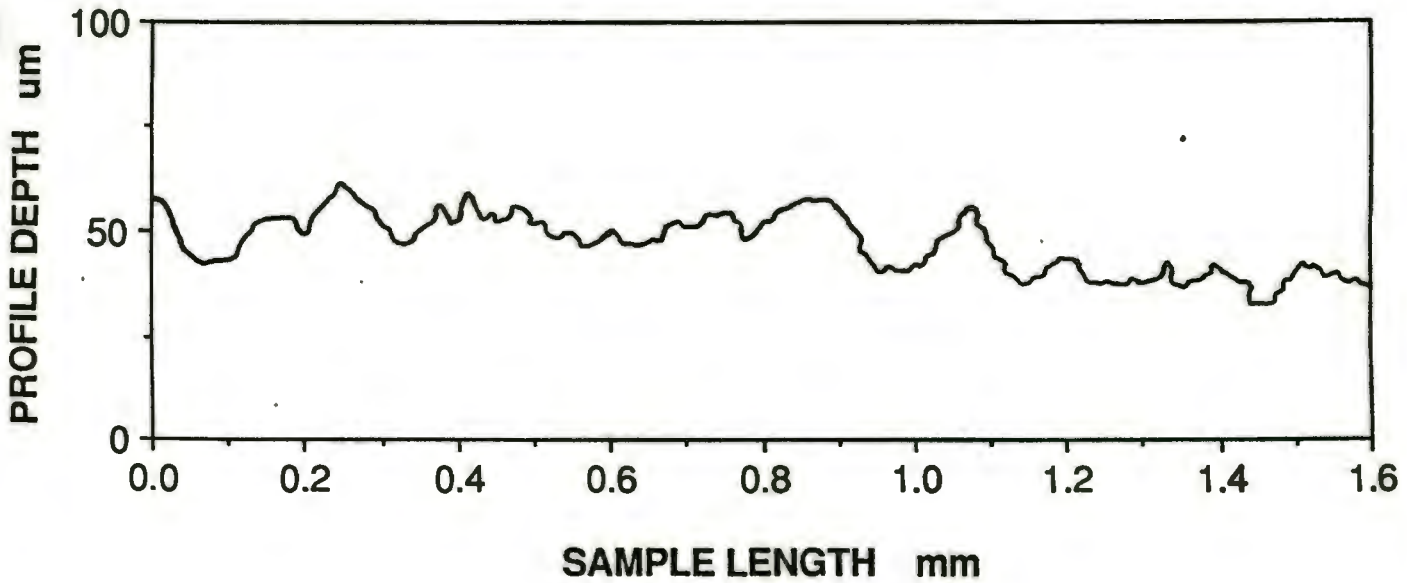

FIGURE 6.44 : Profilometer trace on an SS 20/24 specimen quenched and tempered at 200°C and subjected to the 40 grit laboratory test.

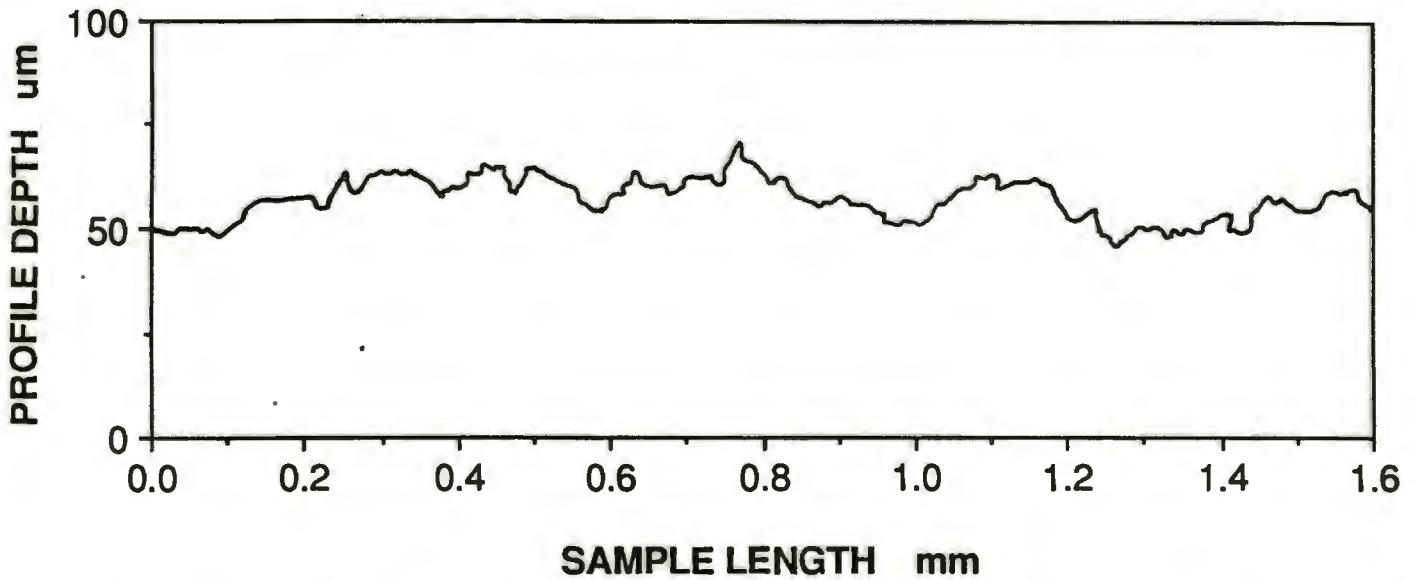

FIGURE 6.45 : Worn surface profile of an SS 10/24 specimen quenched and tempered at 200°C from the 80 grit laboratory test.

Both these profiles are similar in peak height and spacing to the profile of mild steel from the 80 grit test. Figure 6.45 seems to indicate that breakdown of abrasive has occurred.

Scanning electron microscope studies showed regularly grooved patterns on the worn surfaces. When the hard materials are compared with the soft materials, a change in surface topography is discernible. Figure 6.46 shows a normalized SS 10/24 specimen tested in the 40 grit laboratory test. The surface is highly deformed and strewn with 'smeared' wear

debris. This is a classic example of a ploughing mechanism in which large amounts of material are deformed plastically to the sides of the wear groove.

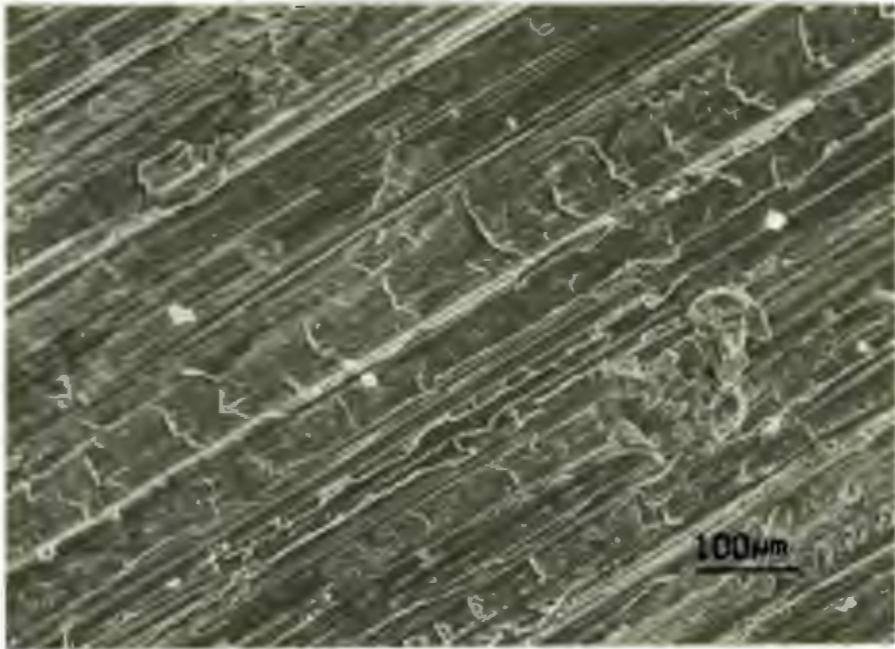

FIGURE 6.46 : Micrograph showing a ploughing mechanism on normalized SS 10/24 worn on 40 grit abrasive. Hardness 255HV30.

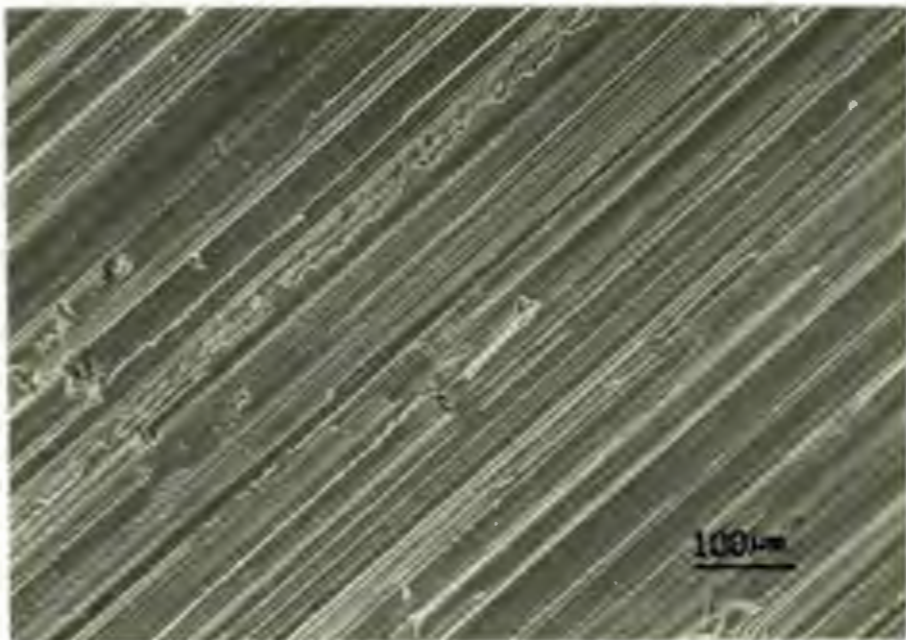

FIGURE 6.47 : The worn surface of an SS 10/24 specimen quenched and tempered at 200°C and tested in the 40 grit laboratory test. Hardness 467HV30.

The surface from an SS 10/24 specimen quenched and tempered at 200°C shown in figure 6.47 is clearly different. In this sample the wear grooves are shallow with much less surface deformation. A wear mechanism has taken place in which a discrete chip has been removed from the surface.

A similar difference was also observed in samples from the 80 grit test. These effects were found in all of the laboratory test specimens for SS 10/24. The difference, however, was not as clear on the SS 10/200 specimens.

The surface morphology was clearly different for these laboratory tests when compared to the field tests in which much larger scale deformation and metal removal occurred.

Specimens from the laboratory test were subsequently cut at an oblique angle to the surface, polished and etched. These samples were used to deduce the depth of deformation in the surface layers. For the AISI 304 specimen shown in figure 6.48, the apparent depth of deformation was measured at 697 microns. This corresponds to a real depth of 24 microns, which is much less than that found in field testing. Results from other taper sections for different worn materials also confirmed that laboratory testing resulted in much thinner deformed surface layers. It is interesting to note that no white layers were observed on specimens abraded in the laboratory.



Apparent depth of
deformation: 697 microns
True depth: 24 microns

Specimen polished at 2°
to the worn surface.

FIGURE 6.48 :

Shows the depth of
deformation below the
surface of an AISI 304
specimen worn on the
laboratory test rig.
Note that this is not as
severe as that caused by
wear in the field.
Hardness 152HV30,
electrolytically etched
in oxalic acid.

6.3.2 Rubbing Test

The volume loss of material during the rubbing test decreased with distance. These results are shown in figure 6.49.

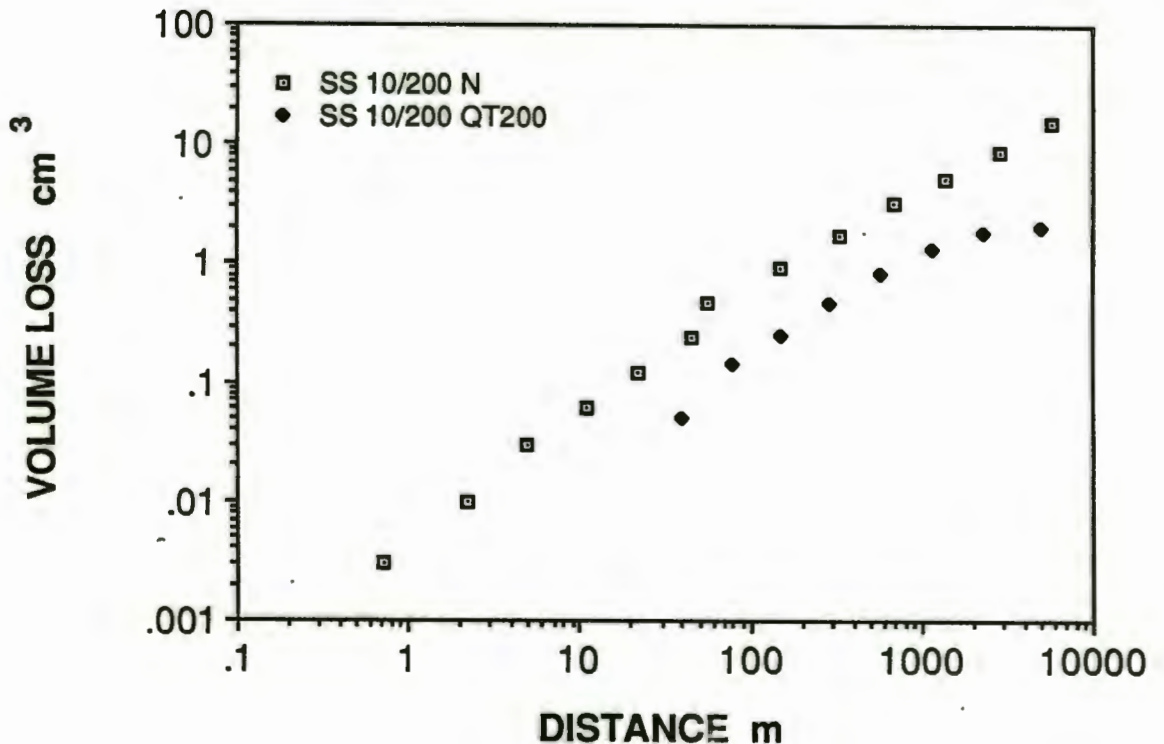

FIGURE 6.49 : A log/log plot from the rubbing test on normalised SS 10/200 and SS 10/200, quenched and tempered at 200°C.

These results indicate that the decrease in volume loss was caused through the gradual degradation of the abrasive during testing. This degradation of the abrasive occurred much faster when testing was conducted on harder material. The volume loss for each run became minimal in this case. For the softer material, however, a significant volume loss occurred for each run and it appeared that only slight deterioration of the abrasive was taking place. This was confirmed by surface profiles recorded on the Talysurf profilometer, as shown in figure 6.50 and 6.51.

The low topography was also shown in the polished appearance of the worn surface. As can be seen in figure 6.49 the volume loss on this specimen had decreased dramatically as the test progressed. This breakdown of abrasive stands in stark contrast to the annealed specimen shown in figure 6.51, in which weight loss did not decrease dramatically after the

first 1000 m tested. The abrasive seems to have reached a stable size and shape, shattering had ceased and further degradation was probably due to blunting.

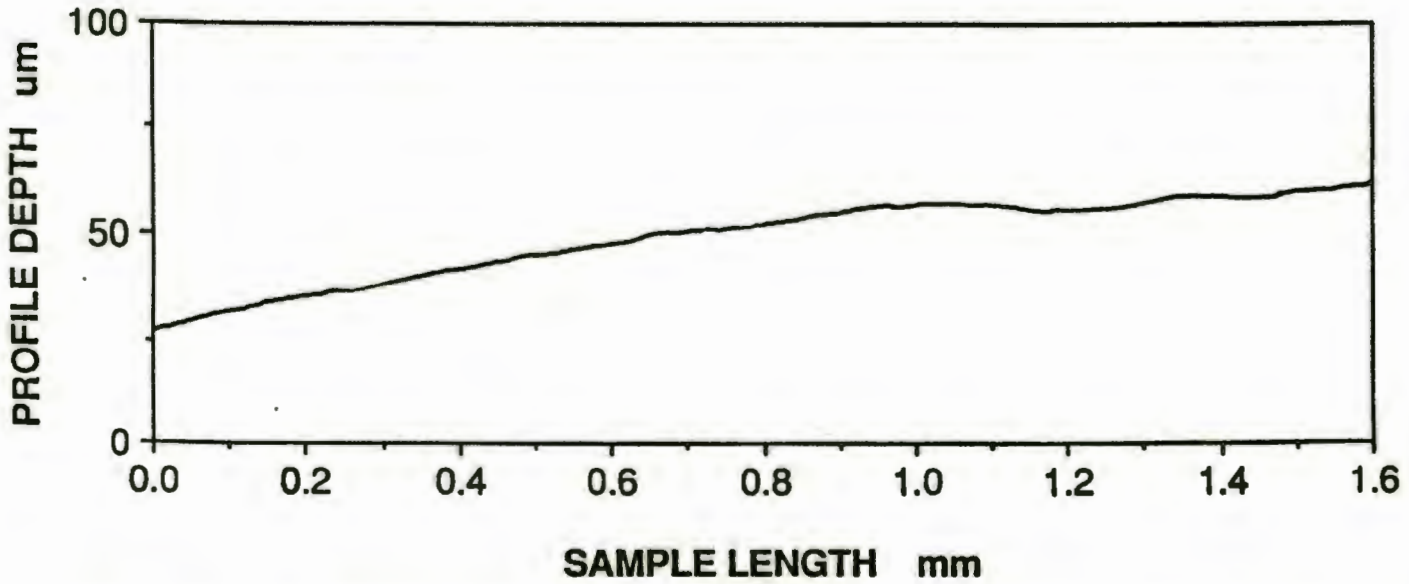

FIGURE 6.50 : The smooth surface on the SS 10/200 specimen quenched and tempered at 200°C and tested for almost 5500 m.

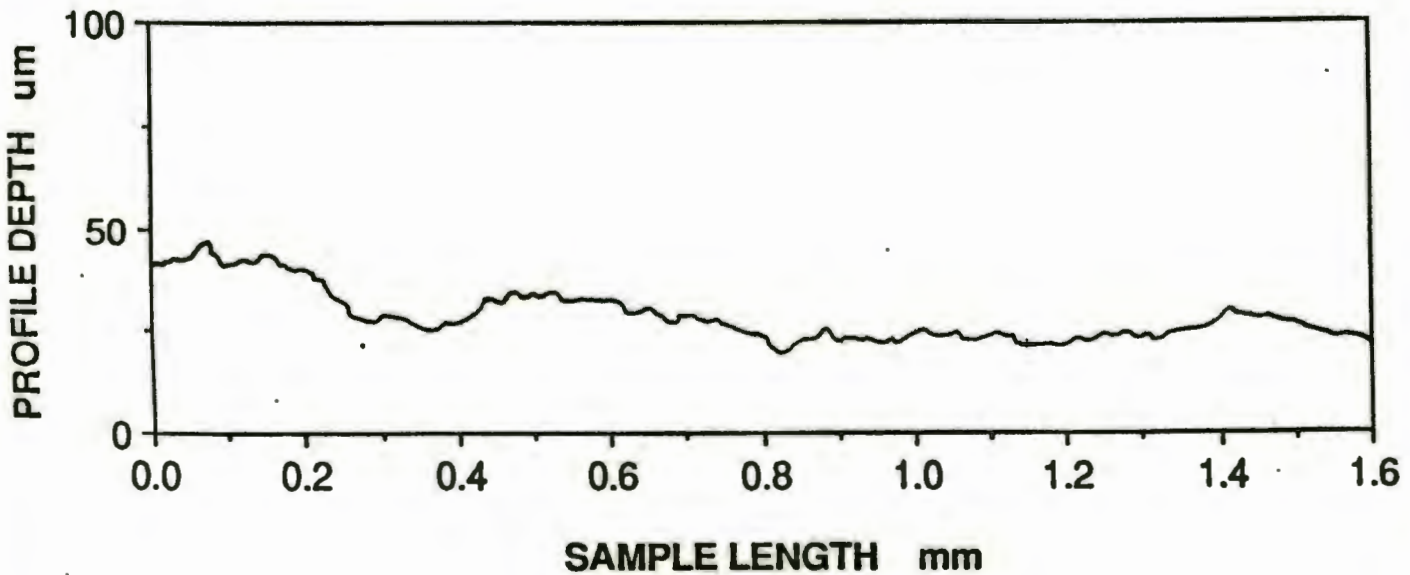

FIGURE 6.51 : A profilometer trace across an annealed SS 10/200 specimen tested in the rubbing test for 4925 m.

The surface of the soft specimen shows how the topography has changed when compared with the surface of the soft 40 grit test specimens. Valley-peak heights are typical of the order of 5-10 microns in this specimen, whereas in the 40 grit test this was 40-60 microns.

The degradation of abrasive during the rubbing test caused a noticeable change in morphology of wear debris. At the beginning of a test, long and thin intricately curled machine chips were produced. A typical example of this is shown in figure 6.52. As the test progressed these became shorter and thicker. The overstated curls became more suggestions of a curve. This intermediate form is shown in figure 6.53.



FIGURE 6.52 : Wear debris from fresh abrasive on the wear rig.

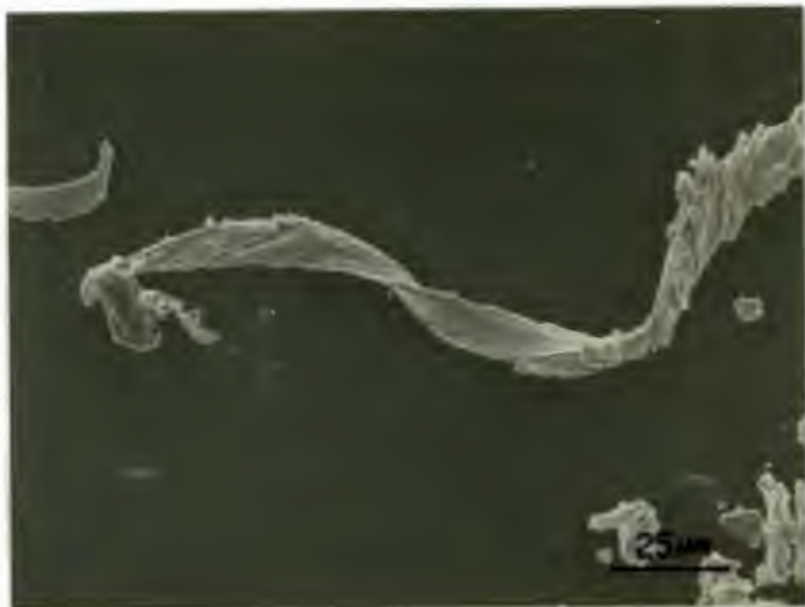

FIGURE 6.53 : As the abrasive begins to break down the morphology of the wear debris changes.

When the weight loss in the test decreased to the point at which it became insignificant, the wear debris changed accordingly. Short and stumpy segmented chunks were produced. These are shown in figure 6.54.



FIGURE 6.54 : Wear debris from the well-advanced rubbing test.

6.4 Transferability

Table 6.1 shows the ranking of materials, in order of wear resistance, to be remarkably similar for all three tests. The similarity between laboratory and field test results indicated plots of RAR's obtained from field testing against each of the laboratory tests, for all the materials. These are shown in the following two figures.

Clearly this plot would be linear if there was a direct transferability of laboratory test results with field test results. Thus the ideal correlation coefficient should be 1. The correlation coefficient in figure 6.56 is 0.72, which is higher than for the 40 grit test and much nearer to the ideal value of 1.

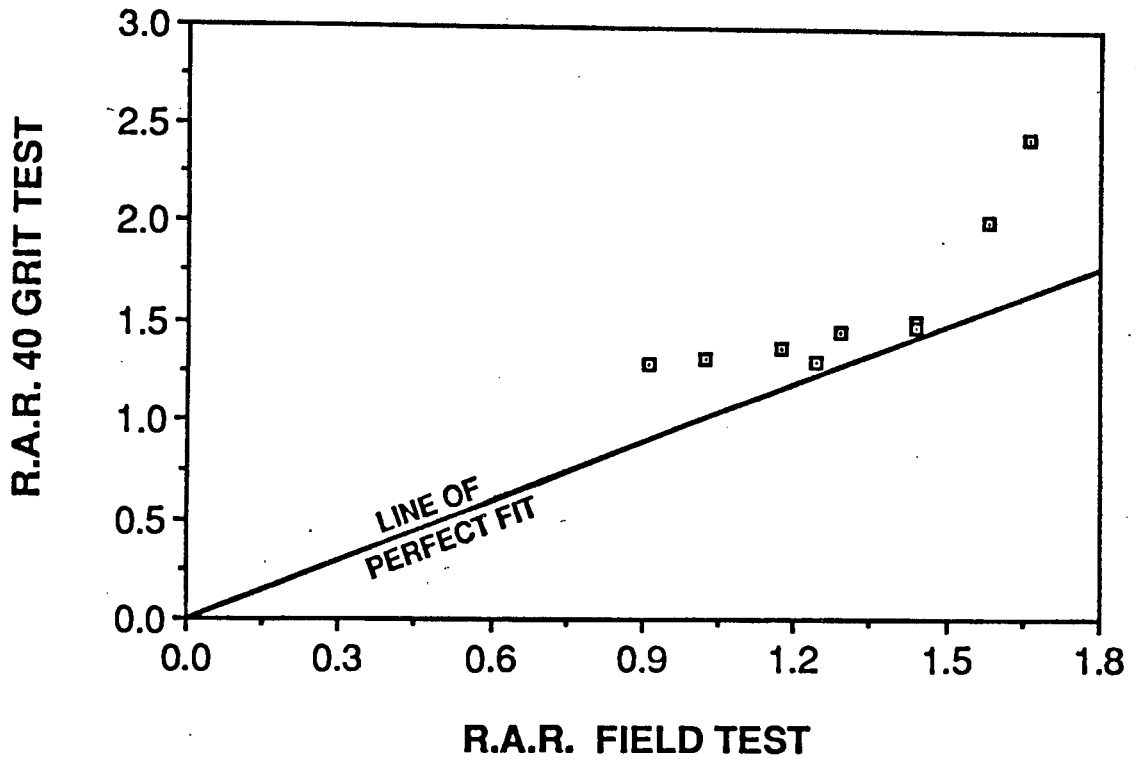

FIGURE 6.55 : Plot of the RAR for the 40 grit test for each material plotted against the RAR for the same material from the field test. The coefficient of correlation is 0.62.

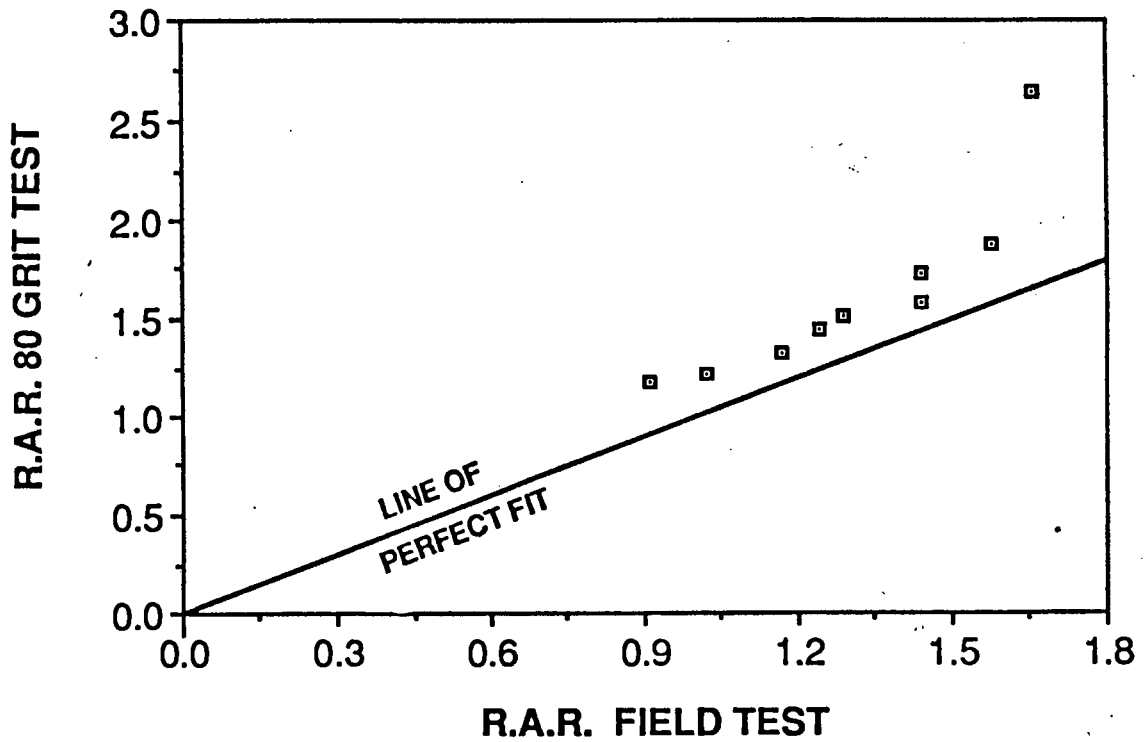

FIGURE 6.56 : The RAR of the field test plotted against the 80 grit laboratory test.

6.5 Material Properties

Following the work of Ball (1983), a comparison was made between the RAR for each material with its mechanical properties of yield strength, ultimate tensile strength and percentage elongation. These material properties are shown in Table 6.3.

MATERIAL	YIELD STRESS Nmm ⁻²	0.2% P.STRESS Nmm ⁻²	UTS Nmm ⁻²	ELONGATION %	CHARPY VN J
SS10/200 Q *	972.6	-	972.6	4.29	2.0
QT200*	1280	-	1280	6.27	2.0
QT400	1143.4	1148	1157.3	10.83	19.3
QT600	734	738	835	21.3	75.5
annealed	559	649	826.7	20.7	11.76
SS10/24 QT200*	864	-	864	4.48	2.0
QT400	1701	1713	1728	11.55	16.7
QT600	882	913.2	1002.3	16.8	31.6
annealed	701.6	924.3	1180.5	7.8	8.3
Boron C8	2022.4	2022.4	2026.6	7.5	50.1
Mild Steel	263	263	410	41	215.6
AISI 304		336	629	70	213.6

TABLE 6.3 : Material properties of test materials. Those marked with an asterisk failed at the grips during tensile tests.

An attempt was made to find the relationship between RAR and each of the material properties in Table 6.3. No useful trends were exhibited however.

CHAPTER 7

DISCUSSION

7.1 Introduction

The primary objective of this work was to develop a test which would be suitable for ranking the abrasive wear resistance of materials when subjected to soil abrasion. It was believed that a comparison of the wear behaviour of similar materials in the laboratory and field testing would provide useful information concerning data transferability and wear mechanisms. The discussion that follows is centered around these objectives and the information gained through the field and laboratory testing of a range of steels.

7.2 Field Test Results

This work has established that the results obtained from the rig developed for the abrasive testing of steels in soil are reproducible. The linearity of the plots of volume loss against distance shown in figures 6.1 to 6.4 confirm the reproducibility of the test method. The spread of the results for each test was below 5 per cent, which is within the margin of error considered reasonable by Moore (1985). The results of the tests on various materials can therefore be regarded as accurate.

The reproducibility of the method is believed to be due largely to the establishment and maintenance of a constant specimen profile during the course of testing. Such stable profiles ensure that the average surface forces acting on the specimens are also constant during field testing. Thus the volume loss should be proportional to the distance travelled, assuming uniformity in the soil constitution.

Unfortunately, the constitution of the soil varied enormously in the test site chosen and due cognizance had to be taken of this fact in the overall design of field testing. The individual testing of points was spread out over regular intervals during the day and large distances were employed in the testing procedure. This soil averaging effect and the large volume losses recorded were clearly sufficient to ensure that the spread of results was within acceptable error limits.

The profile that gradually developed on the leading edges of each vertically orientated specimen was parabolic in nature but because of the orientation of the specimen and the direction of travel it was different from the parabolic shape of the specimens used by Richardson (1967). Narrowing of the leading edge began from the time the unworn specimen entered the soil. The bottom edge of each specimen also became rounded, leading to a constant curvature normal to the direction of movement throughout the test. These two processes lead to the formation of a parabolic shape on the leading corner of the bar.

The change in the profile of the leading corner of the specimen manifested itself in some of the plots as a slight increase in the slope of the line of volume loss against distance ploughed. This effect was most noticeable in the early stages of testing and may be ascribed to an insufficient run-in period before the parabolic profile was developed. The correlation coefficient for all the tests, however, was between 0.8 and 1.0, which is very high. For this reason the effect was considered to be negligible and, in any case, the results did not fall outside the experimental error considered reasonable for this type of testing.

The reason for the increase in volume loss with the formation of the parabolic profile may be explained using Richardson's model of wear (1969). He described how cylindrical stones rolled across the surface of a tool during soil tillage. The direction of rotation of the stones was contrary to the direction of motion of the tool due to adhesion of the soil. Because of this, each stone became effective in machining off more material than may have originally been expected. This meant that the wear on a parabolic shape was higher than on a rectangular profile because the stones rolled less efficiently across the rectangular shape. This gradual increase in wear rate as the profile developed, was offset initially by the high volume loss as the rounding of edges and corners took place.

A range of possible heat treated steels for ground engaging tools were tested. SS 10/200 was used to investigate the wear behaviour of a popular medium carbon steel used in soil tillage. SS 10/24 was used, as suggested by Dr. Cooper (1983), to investigate the possibility of using a high carbon steel for tillage tools. The Boron C8 steel was included

when the simplicity of manufacturing points from this material was realized. Other steels were investigated purely from an academic point of interest. AISI 304 stainless steel was used to study the effects of deformation and wear on microstructure and mild steel to compare the results of all the tests with other wear research in the laboratory.

The results obtained for the RAR of these steels were interesting. The high carbon steel, SS 10/24 in its hardest state, 710HV30, was predictably the best performer with a RAR of 1.66. Less predictable was the RAR of the Boron C8 medium carbon steel, namely 1.58. This boron steel was found to be the second most wear resistant steel and high RAR's were measured both in the field and laboratory tests. Boron C8 is simply quenched in water for optimum material properties. This fact and the high wear resistance make Boron C8 a material worth investigating in more detail. Its high tensile strength and high Charpy V-notch energy are also significant to this study, since wear resistance coupled to good toughness are an essential prerequisite for tillage tools used in the harsh conditions of the Western Cape region. This material must obviously be seriously considered as an alternative to steels presently in use.

For instance a popular steel used for ripper points is the medium carbon steel, SS 10/200, which is hardened and tempered. Even in its hardest state following tempering at 200°C, SS 10/200 had a poorer RAR than the Boron C8 steel with a lower hardness. This result also suggests that microstructure rather than carbon content or hardness has a significant role to play in determining wear resistance. The interstitial hardening effect of Boron may also be important. In the case of the boron steel the microstructure is essentially untempered martensite and bainite compared to the tempered martensite structure in the SS 10/200 steel.

The AISI 304 performed very poorly in the field. The RAR was significantly lower than the mild steel, as shown in Table 6.1. The AISI 304 tested in the laboratory, however, had a wear resistance significantly higher than mild steel. The reason for this difference in behaviour is probably due to the difference in the severity of the experimental conditions between the field and laboratory tests.

In the laboratory test, stress levels were relatively low. In this situation the strain induced martensite which has been shown to occur (Allen, Ball and Protheroe, 1981) would be expected to have a significant effect on the relative abrasion resistance. An increase in martensite together with an increase in work hardening rate would be expected to improve the wear resistance of the steel. In the field, however, the level of stress during abrasion was much higher and impact and gouging play an important role in the removal of material. In this situation, the effect of strain induced surface martensite lowering wear rates is overshadowed by the massive removal of surface layers through direct impact and gouging. Therefore the RAR would be expected to be lower than in the more controlled laboratory tests.

The ranking order of the SS 10/200 and SS 10/24 steels in different hardened states is discussed in conjunction with the ranking order obtained from the laboratory tests.

7.3 Comparison of Ranking Orders from Field and Laboratory Tests

A similar ranking order for the RAR of different steels was produced by both the field and laboratory tests. This order appeared to be determined by the hardness and carbon content of the steels. In general, higher carbon content and higher hardness gave better RAR values. This conclusion indicates a concurrence with the standard work by Krushov and Babichev (1958). However, it appears from Table 6.1 that there are a number of discrepancies. The most obvious example was for the SS 10/200 quenched and tempered at 400°C with a hardness in the 400HV30 range. In all three abrasion tests a high hardness did not produce an equivalent high RAR value. In the field and the 80 grit laboratory test the annealed SS 10/24, which had a hardness of only 257HV30 and an RAR of 1.24, performed better than the SS 10/200 quenched and tempered at 400°C with a hardness of 479HV30 and a RAR of 1.17. Furthermore, in the 40 grit test the SS 10/200 quenched and tempered at 400°C had a lower RAR than the SS 10/24 quenched and tempered at 600°C, which had a hardness of only 326HV30. The difference in hardness between the similar materials used in the field and laboratory tests was a result of the slight difference in heat treatment procedures and in the size of the specimens.

An explanation for these apparent discrepancies can be found when the results of the RAR calculations are plotted against the hardnesses of the steels which were tested. The plots of RAR against hardness showed a trend for each individual material only and not the test itself. These graphs show quite clearly that the SS 10/24 with a higher carbon content has a higher RAR than the SS 10/200 for any similar hardness level. Unlike the Kruschov and Babichev (1958) plots of hardness against carbon content, these plots did not follow a straight line. The lines which best fit the experimental data for the two steels SS 10/24 and SS 10/200 are shown in figures 6.40, 6.41 and 6.5. These are for the 80 grit, 40 grit and soil tests. In every case, two points of inflection on the curve could either be demonstrated or inferred. These best line fits were similar to the sigmoidal curves described by Mutton, Murray and Watson (1979) as well as Moore (1985).

According to Mutton, Murray and Watson (1979) the shape of the plots could be explained by a change from a ploughing wear mechanism at a low material hardness to a cutting wear mechanism at high material hardnesses. This may be reconciled with the soft and hard abrasive wear regimes described by Richardson (1967) and Moore (1975). Below the first point of inflection an increase in hardness resulted in an increase in the wear rate. This change in wear rate with increase in hardness was relatively high and a ploughing mechanism of material removal predominated. Above this first point of inflection, however, an increase in hardness had little effect on the wear rate. The predominant mechanism of material removal changed from ploughing to cutting. A second point of inflection occurred when the ratio of material hardness to abrasive reached a critical figure; 0.85 according to Richardson (1967). Above this second inflection point the RAR increased once more. The point of inflection in the present test occurred in the region of 500-600HV30. The hardness of the aluminium-oxide used in the laboratory test was of the order of 1800HV30. The ratio would therefore be 0.3-0.4 for this test, which is much lower than the figure 0.85 found by Richardson (1967). The reason for this low figure remains unclear. These two points of inflection were clearly demonstrated for the field test results obtained from both SS 10/200 and SS 10/24 steels. In the laboratory tests however the lower point of inflection did not appear to occur in the lower carbon steel SS 10/200. Furthermore the trend was more pronounced for the 40 grit test than for the 80 grit test carried

out on the SS 10/24 steel. The load employed during abrasion testing using the 40 grit alumina was approximately twice that for the 80 grit test. This may indicate that load plays a role in determining wear mechanisms. However, the work of Mashloosh and Eyre (1986) clearly indicates a linear relationship between load and wear volume. It would appear therefore, that these differences are due to steel constitution and the character of the abrasive. The hardness of the abrasive in field testing was much lower than that used in the laboratory tests.

Scanning electron microscope investigation revealed the mechanisms of wear corresponding to the regimes suggested by the RAR plots. In the case of the field tests, the scanning electron micrographs gave only a mere suggestion of the predominant mechanism, probably as a result of the wide range of forces that are brought to bear on a field test specimen, giving rise to a wide range of wear mechanisms occurring simultaneously. In the laboratory tests however the operative variables had been reduced and it was therefore possible to gather qualitative information from the various abraded steels. The examples shown in figures 6.46 and 6.47 show clearly the effects of abrasion when SS 10/24 heat treated to different hardnesses were tested on 40 grit abrasive. The normalised specimen shows the plastically deformed surface and debris usually associated with a ploughing mechanism. The specimen quenched and tempered at 200°C however, shows the clean lines and debris free surface associated with cutting wear. The samples from the 80 grit test viewed in the scanning electron microscope showed the same characteristics. These scanning electron micrographs confirmed the observation that a change of mechanism was taking place with an increase in hardness. This showed how important the plots of RAR against hardness are for understanding the real behaviour of a steel quenched and tempered to different hardness values.

7.4 Profilometer Traces

Very little difference in the topography of the worn surface on specimens taken from the field tests could be discerned from the profilometer traces. The two traces shown in the results are from the hardest and the softest steels used. It is possible that the wide range in the size of the abrasive particles as well as the high stress induced by contacting asperities makes it difficult to make comparisons of this nature.

Trepanning experiments with a blunt tool by Richardson (1967) showed that materials assumed a maximum hardness during wear which was more dependent on composition than heat treatment. Measurements on the maximum hardness of worn layers from the present field tests tended to show similar hardness levels for the steel. This also implies that differences in the wear characteristics between different steels may not be distinguished easily by measurements in surface profile. The microstructural and scanning electron microscope survey on the points worn in the field seem to show the severity of subsurface deformation to be similar for all the materials tested. Extreme smearing and gouging of the surface layers were generally observed to be more frequent on the softer materials. Such observations were the only evidence from the field test of the predominance of ploughing mechanisms in softer steels.

There were, however, significant differences between the surface profilometer traces from the different materials tested in the laboratory. These differences indicated the effect of abrasive on the surface of the steel and also provided information on the effect of the steel on the abrasive. A trace from a mild steel specimen tested on 40 grit paper was compared with one tested on 80 grit paper. There was a great difference between the two traces and the abrasive grain size was mirrored by the topography produced. The depth of wear tracks was much greater for specimens abraded on the 40 grit than the 80 grit alumina. A comparison of the profiles from the 40 grit test and the 80 grit test on SS 10/24 quenched and tempered at 200°C were on the other hand similar. This is due to the harder material causing breakdown of abrasive particles, thus negating the effect of particle size. This breakdown of abrasive was well documented in the rubbing test where the volume loss on the normalised specimen continued to increase while the volume loss on the specimen quenched and tempered at 200°C tapered off. The profile from the softer steel shows how the abrasive has deteriorated to a stable size. The slow change in the slope in the plot of volume loss against distance shows that the only deterioration in abrasive that may be expected is by a blunting mechanism and not by shattering. On the other hand the profile from the hard material shows that the abrasive has been broken down completely by shattering.

When the profilometer traces from the field test were compared with the traces from the laboratory test it became clear that the stresses in each test were different orders of magnitude. This is shown by depth of

surface wear tracks being much greater on the field test specimens. This is not a surprising result when the power of the tractors and the size of the rocks and the weight of the field test rig are considered. Due to the rigidity of the rig it was likely that each point frequently bore the whole mass as it encountered a large rock during testing.

7.5 Thermocouple Test

The thermocouple and chart recorder were not able to measure the temperature produced by each strike on the metal surface. Only a general increase in the temperature of the specimen could be measured. However, steel slivers were found on pebbles in the field which exhibited temper colours of at least 300°C. It can therefore be assumed that individual strikes resulted in surface temperatures much higher than 300°C and possibly much closer to austenitising temperatures.

7.6 Microstructural Investigation

The close examination of the immediate subsurface layers was initially carried out on AISI 304, an austenitic stainless steel. Strain bands were formed in the individual grains as a result of the deformation. The depth of formation of strain bands below the worn surface was used as a measure of the severity of wear in different test methods. This study showed that the deformed zone was about fourteen times deeper in the field test than in the laboratory.

In addition to the surface deformation the field test specimens displayed a phenomenon known as 'non-etching' layers or 'white' layers. The features common to all these layers was that they were extremely hard and etchant resistant. The hardness of the layers was found to be highest in the regions where the surface stresses are likely to be greatest, near the leading edge of the field test specimen. They were only observed in the medium carbon to high carbon steels. Non-etching layers were not observed in mild steel although they were well developed in the Boron C8 specimens.

Various theories about the formation of white layers were rejected immediately, such as surface nitriding or oxide inclusion. There was some mixing of abrasive material in the steels but this was highly localised. White layers were also formed when it was clear that no

mixing had taken place in the surface layers. Such a mechanism of hardening would require extensive mixing of fine oxide inclusions throughout the surface layers. The generally accepted theory for the formation of white layers is the pinning of an extremely fine 'martensitic type' of structure by dissolution of second phase particles such as carbides. The way in which this structure forms remains a problem.

The present work indicates that for the medium and high carbon tools the effect of extensive subsurface strain, perhaps coupled with an increase in temperature, leads to a break up and dissolution of carbide. Clearly, an increase in temperature would increase the rate of such carbide dissolution. Thus the formation of high dislocation densities in the deformed surface layers coupled with extensive carbon in solution could lead to the pinning effect noted above. Such a mechanism of formation is in broad agreement with those proposed by Newcomb and Stobbs (1984) and the thermo-mechanical treatment of Eyre and Baxter (1972). A thermo-mechanical treatment would additionally explain the softened or 'dark-etching' region sometimes found below the white layer. High temperatures in the outer layers would result in sub-critical annealing below these layers where the material did not reach the critical temperature. It would be expected that the amount of softening would reflect the temperature gradient below the white layer. This was exactly what was shown in the microhardness traverses. The hardness was high in the white layer and dropped sharply to a minimum which depended on the material concerned. Hardness then increased gradually with depth to the original heat treated hardness.

However, the theory of white layer formation is incomplete. Some of the observations made in this work can not be explained by either of these two modes. For instance, no white layers were observed to form in mild steel. This suggests that carbon plays an important role in the formation of those layers. The appearance of these white layers would appear to be dependent on the level of carbon in the steel. A Boron steel, for instance, containing 0.3 per cent carbon, showed extensive white layer formation. The formation of white layers in highly deformed areas is understandable. But the formation of white layers in seemingly undeformed areas is more difficult to explain. The formation of double white layers also presents a major problem to the theory. It may be

possible that two single events, the first more severe than the other, caused the double layers. However, the high resistance of white layers to tempering is documented by Eyre and Baxter (1972) and the softened area between the white layers, which shows clearly as annealed microstructure in micrographs, may need to be explained more substantially.

A comprehensive explanation for the mechanism of formation of white layers still remains unclear from this present work. The high hardness of these layers may well be an advantage to wear resisting materials. However this may not be the case for layers with a softened or annealed layer below them. It is likely that high impact stresses, for example, would simply remove these surface layers. This problem would need to be addressed were an attempt made to utilize this phenomenon for wear resistance.

CHAPTER 8

CONCLUSIONS

The main conclusions reached from this study are as follows:

1. A wide range of steels are presently used in tillage tools in South Africa. The quality of these steels was found to be variable, mainly due to the inadequate manufacturing techniques employed.
2. A rig has been developed for the evaluation of materials subjected to soil abrasion. The reproducibility of the test has been shown to be excellent when heat treated steels were subjected to abrasion in the soils of the Western Cape region.
3. An evaluation of the relative abrasion resistance of various heat treated steels has shown a medium carbon steel containing boron to be the most suitable material for tillage tools. This conclusion is based on the high wear resistance and toughness, coupled to the ease of heat treatment.
4. The wear resistance of steels was found to be a function of carbon content, toughness and type of abrasive. The change in mechanism of material removal from predominantly ploughing to predominantly cutting was also found to be a function of carbon content, hardness and the type of abrasive.
5. The transferability of data between laboratory and field testing of similar materials has been shown to be satisfactory.
6. Extremely hard, non-etching surface layers were found on medium and high carbon steels subjected to soil abrasion. Their occurrence has not fully been accounted for in this work.

CHAPTER 9

FUTURE WORK

One of the objectives of this particular project was to produce a table of the ideal materials to be used in different tilling environments. In order to achieve this objective, a comprehensive range of steels should be tested in various sites in South Africa, chosen for their unique or characteristic conditions. This should also include a study of the wear behaviour of different microstructures.

A second feature of this work that requires a more adequate explanation is the low ratio of steel hardness to abrasive hardness at which the wear resistance of a steel was observed to improve. It is suggested that selected steels be tested on abrasive belts using a number of different abrasives such as silicon-carbide and quartz at different grit sizes. The transferability of data between field and laboratory tests should also be investigated to find a suitable set of conditions for use in laboratory testing.

Finally, the characterization of white layers by transmission electron microscopy needs to be carried out. The measurement of lattice parameters is necessary to investigate the different theories of formation.

REFERENCES

- ALLEN, C., BALL, A. and PROTHEROE, B.E. (1981). " Selection of abrasion corrosion materials for gold mining industry equipment." S.A.Inst. of Mining and Metallurgy, **81** , 289-297.
- ALLEN, C., BALL, A. and PROTHEROE, B.E. (1981/82). "The abrasive-corrosive wear of stainless steels." Wear, **74** , 187-305.
- ANON (1982). "Background document for wear in the agricultural sector." CSIR.
- AVERY, H.S. (1974). "Work hardening in relation to abrasion resistance." Materials for the Mining Industry Symposium, Climax Molybdenum Company.
- ARCHARD, J.F. (1958). "The temperature of rubbing surfaces." Wear, **2** , 438.
- BALL, A. (1983). "On the importance of work hardening in the design of wear-resistant materials." Wear, **92** , 201-207.
- BORIC, F. (1970). "Rubber wheel abrasion test." Climax Molybdenum Publication.
- BOWDITCH, H.G. (1969). "Analysis of wear of scarifier shears." J.Agric.Eng.Res., **14** (1), 32-39.
- BUTTERY, T.C. and ARCHARD, J.F. (1970/71). "Grinding and abrasive wear." Proc.Inst.Mech.Eng., **185** , 537-51.
- COOPER, J.K. (1983). "Wear of ground engaging parts. Report on a pilot investigation." Division of Agricultural Engineering (unpublished).
- COOPER, J.K. (1983). Personal communication.
- EYRE, T. (1984). "White etching layers." Lecture series at University of Cape Town (unpublished).
- EYRE, T. and BAXTER, A.M. (1972). "The formation of white layers at rubbing surfaces." Tribology, 256-261.
- FELD, H. and WALTERS, P. (1975). "Contribution to the understanding of mineral/hard metal abrasive wear." Powder Metall.Int., **7** (4), 188-190.
- FOGEL, G. (1980). "The Influence of Microstructure on Abrasive Wear". M.Sc. thesis, University of Cape Town.
- FRIEDMAN, M.Y., WU, S.M. and SURATKAR P.T. (1974). "Determination of geometric properties of coated abrasive cutting edges." J.Eng. for Industry, **96** , 1239-44.
- GARRISON W.M. and GARRIGA, R.A. (1983). "Ductility and the abrasive wear of an ultra-high strength steel." Wear, **85** , 347-360.
- GILL, K.G. and VAN DER BERG, G.E. (1967). "Soil dynamics in tillage and traction." Agricultural Handbook, **316** , Agricultural Research Service, U.S. Department of Agriculture.

- GRIFFITHS, B.J. (1983). "White layer formation at machined surfaces and their relationship to white layer formations at worn surfaces." Brunel University, U.K.
- KRUSCHOV, M.M. and BABICHEV, M.A. (1958). "Resistance to abrasive wear of structurally heterogeneous materials." *Friction and Wear in Machinery*, 12, 12-26.
- KRUSCHOV, M.M. (1957). "Resistance of metals to wear by abrasion as related to hardness." *Proc.Conf. Lubrication and Wear. Inst.Mech.Eng.*, 635-659.
- KRUSCHOV, M.M. (1974). "Principles of abrasive wear." *Wear*, 28, 69-88.
- LARSEN BADSE, J. (1968). "Influence of grit size on groove formation during sliding abrasion." *Wear*, 11, 213-22.
- LARSEN BADSE, J. and MATTHEW, K.G. (1972). "Some effects of specimen size on abrasive wear." *Wear*, 19, 27-35.
- MASHLOOSH, K.M. and EYRE, T. (1987). "Effect of attack angle in abrasive wear". *Metals and Materials*, 2, 426-430.
- MISRA, A. and FINNIE, I. (1979). "A classification of three body abrasive wear and design of a new tester." *Wear of Materials*, ASME, 313-18.
- MISRA, A. and FINNIE, I. (1981). "An experimental study of three body abrasive wear." *Wear of Materials*, ASME, 426-31.
- MILLER, A.E. (1980). "Wear in tillage tools." *Wear Control Handbook*, ASME, 987-998.
- MOHSEIN, N., WOMOCHEL, H.L., HARVEY, D.J. and CARLETON, (1956). "Wear tests of ploughshare materials." *Agricultural Engineering*, 816-820.
- MOORE, M.A. (1974). "The relationship between the abrasive wear resistance, hardness and microstructure of ferritic materials." *Wear*, 28, 59-68.
- MOORE, M.A. (1974). "A review of two body abrasive wear." *Wear*, 27, 1-27.
- MOORE, M.A. (1975). "Abrasive wear by soil." *Trib.Int.*, 105-110.
- MOORE, M.A. (1980). "Fundamentals of friction and wear of materials." *Am.Soc.Metals, Materials Science Seminar*.
- MOORE, M.A. (1985). "Wear." Lecture at University of Cape Town (unpublished).
- MOORE, M.A. (1987). "Laboratory simulation testing for service abrasive wear." *Environment, Houston, USA*.
- MOORE, M.A, RICHARDSON, R.C.D. and ATTWOOD, D.G. (1972). "The limiting strength of worn metal surfaces". *Metall.Trans.*, 3, 2485-91.
- MOORE, M.A. and DOUTHWAITE, R.M. (1976). "Plastic deformation below worn surfaces." *Metall.Trans.*, 7A, 257-265.
- MOORE, M.A. and McLEES, V.A. (1980). "Effect of speed on the wear of steels and a copper by bonded abrasive and soils." *J.Agric.Eng.Res.*, 25, 37-45.

- MULHEARN, T.O. and SAMUELS, L.E. (1962). "The abrasion of metal - a model of the processes." *Wear*, 5, 478-498.
- MUSCARA, J. and SINOTT, M.J. (1972). "Construction and evaluation of a versatile abrasive wear testing apparatus." *Met.Eng.Q.*, 12 (2), 21-23.
- MUTTON, P.J., MURRAY, M.J. and WATSON, J.D. (1979). "Abrasive wear mechanics in steels." *Proc.Conf. on Wear of Materials*, Dearby, Mich., USA.
- MUTTON, P.J. and WATSON, J.D. (1978). "Some effects of microstructure on the abrasion resistance of metals." *Wear*, 48, 385.
- NEWCOMB, S.B. and STOBBS, W.M. (1984). "A transmission electron microscopy study of the white etching layer on a rail head." *Mat.Sci. and Eng.*, 66, 195-204.
- NOEL, R.E.J. (1981). "The abrasive corrosive wear behaviour of metals." M.Sc. Thesis, University of Cape Town.
- QUIRKE, S.J. (1983). "Wear in the Western Cape." Lecture, University of Cape Town (unpublished).
- QUIRKE, S.J. (1983). "A report on agricultural materials." Department of Materials Engineering, University of Cape Town (unpublished).
- RABINOWICZ, E., DUNN, L.A. and RUSSELL, P.G. (1961). "A study of wear under three-body conditions." *Wear*, 4, 245-255.
- RICHARDSON, R.C.D. (1967). "The wear of metals by hard abrasives." *Wear*, 10, 291-309.
- RICHARDSON, R.C.D. (1967). "The maximum hardness of strained surfaces and the abrasive wear of metals and alloys." *Wear*, 10, 353-382.
- RICHARDSON, R.C.D. (1967). "The wear of metallic materials by soil, practical phenomena." *J.Agric.Eng.Res.*, 12 (1), 22-39.
- RICHARDSON, R.C.D. (1968). "Wear of materials by relatively soft abrasives." *Wear*, 11, 245-274.
- RIGNEY, D.A. and GLAESER, W.A. (1978). "Wear resistance." Metals Handbook 1, ASM, 9th edition.
- SARE, I.R. (197.). "Abrasion resistance and fracture toughness of white cast irons." *Met.Tech.1*, 16 (11), 412-418.
- SCOTT, D., SMITH, A.I., TAIT, J. and TREMAIN, G.R. (1975). "Materials and metallurgical aspects of piston ring scuffing; a literature review." *Wear*, 3, 193-315.
- SEDRICK, A.J. and MULHEARN, T.O. (1964). "The effect of work hardening on the mechanics in simulated abrasive processes." *Wear*, 7, 451-459.
- SIN, H., SAKA, N. and SUH, N.P. (1979). "Abrasive wear mechanisms and the grit size effect." *Wear*, 55 (1), 163-190.
- STEAD, J.W. (1911). "Micro-metallurgy and its practical application." *J.West Scot. Iron and Steel Ind.*, 19, 169.

- SWANSON, P.A. (1985). "Comparison of laboratory and field abrasion tests." Deere and Company Technical Center, Moline, Illinois, U.S.A.
- TORRANCE, A.A. (1980). "The correlation of abrasive wear tests." *Wear*, 63 (2), 359-370.
- VINGSBO, O. (1979). "Wear and wear mechanisms." *Wear of Materials*, ASME 620-635.
- WATSON, J.D., MUTTON, P.J. and SARE, I.R. (1980). "Abrasive wear of white cast irons." *Met.Forum*, 3 (1), 74-88.
- WELSH, N.C. (1965). "The Dry Wear of Steels". *Phil.Trans.R.Soc.(A)*, 257, 31-70.
- WHITE, L. (Jr.). "The historical roots of our ecological crisis." Pollution and the death of man - the Christian view of ecology. Ed. Schaefer, Hodder and Stoughton.
- ZUM GAHR, K.H. (1979). "Relation between abrasive wear rate and the microstructure of metals." Wear of Materials, ASME, 266-276.
- ZUM GAHR, R.H. and MEWES, D. (1983). "Severity of material removal in abrasive wear of ductile materials." Wear of Materials, ASME, 130-139.