



Faculty of Health Sciences  
Department of Human Biology  
Division of Biomedical Engineering

Minor Dissertation

# **A Portable Robotic Rehabilitation System towards Improving Impaired Function of the Hand due to Stroke**

*Author:*  
**Albert Opiyo**

*Supervisor:*  
**Dr. Sudesh Sivarasu**

The financial assistance of the National Research Foundation (NRF) towards this research is hereby acknowledged. Opinions expressed and conclusions arrived at, are those of the author and are not necessarily to be attributed to the NRF.

10th March, 2017

*Submitted in partial fulfilment of the requirements for the degree of  
M.Sc. in Biomedical Engineering by Coursework and Dissertation*

The copyright of this thesis vests in the author. No quotation from it or information derived from it is to be published without full acknowledgement of the source. The thesis is to be used for private study or non-commercial research purposes only.

Published by the University of Cape Town (UCT) in terms of the non-exclusive license granted to UCT by the author.

# Declaration

I, Albert Opiyo, hereby declare that the work on which this dissertation/thesis is based is my original work (except where acknowledgements indicate otherwise) and that neither the whole work nor any part of it has been, is being, or is to be submitted for another degree in this or any other university.

I empower the university to reproduce for the purpose of research either the whole or any portion of the contents in any manner whatsoever.

Signed by candidate

Signature .....  
Signature Removed

Date .....  
10/03/2017

# Abstract

Background: Stroke is the leading cause of adult disability with 70 to 85% of initial strokes resulting in hemiparesis. Physical imparity as a result of stroke tends to be severe and majority of impairments are upper limb-related. Impairment is usually accompanied by long term functional loss which requires dedicated post-stroke rehabilitation to regain motor function. The incidence of stroke is increasing rapidly while there remains a shortage of therapists to provide sufficient rehabilitation. There is therefore a high demand for therapists to attend to the rising number of stroke survivors. Robot-aided therapy has emerged as a beneficial tool for providing continuous rehabilitation of the upper limb and is widely being implemented. With this technology, there is great potential to reduce the ill-effects brought about by the low therapist-patient ratio which has hindered sufficient rehabilitation and consequently the effective recovery of motor function among stroke survivors. Hypothesis: The use of a portable robotic rehabilitation system, as a complementary tool, in hand therapy, would promote continuous rehabilitation by encouraging repetition of task oriented exercises which would enhance motor function of an impaired hand. Task-oriented writing practice would potentially improve hand coordination and result in better accuracy while repetitive training would potentially increase hand motor strength. Objectives: 1.To design and manufacture a portable robotic rehabilitation system. 2. To test the performance and usability of the system. Methods: The system was manufactured and its performance tested in a pilot pre-clinical trial involving three participants. The system's ease of use was assessed using a standardised usability scale. Writing accuracy and hand motor strength were also assessed and the results analysed at the end of the study. Results: The average overall score of usability for the rehabilitation system was a few points higher than the average score. The users of the system also experienced increased motivation whilst performing the repetitive and task oriented exercises. There was an improvement in the completion time of the writing accuracy test and the tasks of the trace sample test. The variation in grip strength of the non-dominant hand during the rehabilitation period was small for each of the participants. Conclusion: The rehabilitation system motivated its users to repetitively perform rehabilitative training which may have improved writing accuracy.

# Acknowledgments

Acknowledgment of an indescribable magnitude goes to the Almighty God for giving me the mental, physical and spiritual ability to travel the entire journey of this research study up to the end. My heartfelt gratitude goes out to the following person(s) for contributing directly to the successful completion of this research study:

My supervisor : (Dr. Sudesh Sivarasu) – For supervision and guidance provided from the developmental stages to the final outcome of the research study.

The ReScribe Team : (Mr. Yasheen Brijlal, Mr. Gavin Jones, Dr. Lester John, Dr. Sudesh Sivarasu, Michael Awood) – For their invaluable input and contribution to the research.

Natasha Naidoo - For her dedication, readiness and availability whenever needed to contribute to this research in her field of expertise.

My colleagues : (Gokul Nair, Giancarlo Beukes, Megan Findlay, Cara Mills, Roopam Dey, Lee Kruse, Ameen Bardien, Jonathan Glenday ) – For the untiring effort and continuous moral support provided by each one and technical assistance accorded in their respective fields of expertise.

National Research Foundation – For sponsoring this research study.

My family : (Daddy, Mummy, Nico, Paul) - For the moral support and encouragement throughout the period of this research.

I cordially thank all the other individuals and groups who took part and indirectly contributed to this research study in one way or another. May God bless you abundantly.

# Table of Contents

|  |      |
|--|------|
| Declaration.....                       | II   |
| Abstract.....                          | III  |
| Acknowledgments.....                   | IV   |
| List of Tables.....                    | IX   |
| List of Figures.....                   | X    |
| List of Abbreviations.....             | XIII |
| Chapter 1 – Introduction.....          | 1    |
| 1.1 General Introduction.....          | 1    |
| 1.2 Background of the study.....       | 2    |
| 1.3 Problem Statement.....             | 4    |
| 1.4 Hypothesis.....                    | 4    |
| 1.5 Aim & Objectives of the study..... | 5    |
| 1.6 Significance of the study.....     | 5    |
| 1.7 Limitations of the study.....      | 6    |
| Chapter 2 – Literature Review .....    | 7    |
| 2.1 Stroke and the Upper Limb .....    | 7    |
| 2.1.1 Anatomy of the brain.....        | 8    |
| 2.1.2 The Upper Limb.....              | 11   |
| 2.1.3 Stroke Progression.....          | 13   |
| 2.2 Stroke Rehabilitation.....         | 14   |
| 2.2.1 Rehabilitation Approaches.....   | 16   |
| 2.2.2 Rehabilitation Methods.....      | 17   |
| 2.2.3 Similar technologies.....        | 22   |
| 2.2.4 Previous Work .....              | 23   |
| Chapter 3 – Design Methodology.....    | 25   |
| 3.1 Methodology Flowchart.....         | 25   |
| 3.2 Design Considerations.....         | 25   |
| Section I – Mechanical Design.....     | 25   |
| 3.2.1 Rehabilitation Unit (RU).....    | 25   |

|  |    |
|--|----|
| 3.2.2 Wrist Element (WE) .....   | 27 |
| 3.2.3 Hand Exoskeleton (HE).....                                       | 29 |
| Section II – Electrical & Electronic Design.....                       | 29 |
| 3.2.4 Power Supply.....  | 29 |
| 3.2.5 Actuation.....   | 30 |
| 3.2.6 Control.....   | 31 |
| 3.2.7 Visual User Interface.....                                       | 31 |
| 3.2.8 Safety.....  | 31 |
| Section III – Software Development.....                                | 32 |
| Chapter 4 – Experimental Methodology.....                              | 33 |
| 4.1 Purpose of the experimental study.....                             | 33 |
| 4.2 Study Design.....  | 33 |
| 4.3 Characteristics of the study population.....                       | 36 |
| 4.3.1 Inclusion Criteria.....  | 36 |
| 4.3.2 Exclusion Criteria.....  | 36 |
| 4.4 Testing Procedures and Data Collection.....                        | 36 |
| 4.4.1 Grip Strength Tests.....   | 37 |
| 4.4.2 Writing Accuracy Tests.....                                      | 40 |
| 4.4.3 Rehabilitative training.....                                     | 40 |
| 4.5 Data Analysis.....   | 42 |
| 4.5.1 Accuracy.....  | 42 |
| 4.5.2 System Usability.....  | 43 |
| 4.5.3 Grip Strength.....   | 43 |
| 4.6 Outcome Measures.....  | 45 |
| 4.6.1 Accuracy.....  | 45 |
| 4.6.2 System Usability.....  | 45 |
| 4.6.3 Grip Strength.....   | 46 |
| 4.7 Ethical Considerations.....  | 46 |
| 4.7.1 Ethical Approval.....  | 46 |
| 4.7.2 Consent.....   | 47 |
| 4.7.3 Possible Risks and Safety Concerns.....                          | 47 |
| 4.7.4 Emergency care and insurance for research-related injuries ..... | 47 |
| Chapter 5 - Design Outcome.....  | 49 |

|   |     |
|---|-----|
| 5.1 Mechanical Design.....                        | 49  |
| 5.1.1 Rehabilitation Unit (RU).....               | 49  |
| 5.1.2 Wrist Element (WE).....                     | 53  |
| 5.1.3 Hand Exoskeleton (HE).....                  | 57  |
| 5.2 Electrical & Electronic Design.....           | 60  |
| 5.2.1 Power Supply.....                           | 62  |
| 5.2.2 Actuators.....                              | 63  |
| 5.2.3 Microcontroller ( $\mu$ C).....             | 64  |
| 5.2.4 Display.....                                | 66  |
| 5.2.5 Sensors.....                                | 67  |
| 5.2.6 Safety Devices.....                         | 68  |
| 5.3 Software Development.....                     | 72  |
| 5.4 The Rehabilitation System.....                | 76  |
| 6 Experimental Results & Discussion.....          | 80  |
| 6.1 Rehabilitative training.....                  | 80  |
| 6.2 Accuracy.....                                 | 81  |
| 6.2.1 Trace Sample Test.....                      | 81  |
| 6.2.2 Writing Accuracy Test.....                  | 83  |
| 6.3 System usability.....                         | 87  |
| 6.4 Grip Strength.....                            | 88  |
| Chapter 7 – Conclusion & Recommendations.....     | 92  |
| 7.1 Overview.....                                 | 92  |
| 7.2 Conclusion.....                               | 93  |
| 7.3 Recommendations.....                          | 94  |
| 7.3.1 Design Recommendations.....                 | 94  |
| 7.3.2 Clinical Recommendations.....               | 95  |
| References.....                                   | 96  |
| Appendices.....                                   | 103 |
| Appendix A – Writing Accuracy Test.....           | 103 |
| Appendix B – System Usability Scale.....          | 109 |
| Appendix C – Trace Sample Test.....               | 110 |
| Appendix D – Anthropometric Parameters.....       | 111 |
| Appendix E – Hypothetical Subject Parameters..... | 112 |

|   |     |
|---|-----|
| Appendix F – Formal Ethics Approval.....      | 113 |
| Appendix G – Research Access to Students..... | 115 |
| Appendix H - Code.....                        | 116 |

# List of Tables

|   |           |
|---|-----------|
| <i>Table 1: Indices for the schematic representation of rehabilitation unit</i> | <i>50</i> |
| <i>Table 2: Planar displacement analysis of the wrist support</i>               | <i>55</i> |
| <i>Table 3: Summary of rehabilitation system power requirements</i>             | <i>62</i> |
| <i>Table 4: Arduino Due board specifications</i>                                | <i>65</i> |
| <i>Table 5: Touch screen module specifications</i>                              | <i>67</i> |
| <i>Table 6: Trace sample test results</i>                                       | <i>81</i> |
| <i>Table 7: Writing accuracy test completion time</i>                           | <i>83</i> |
| <i>Table 8: Quantitative analysis of writing accuracy test</i>                  | <i>86</i> |
| <i>Table 9: Score contribution and overall system usability scores</i>          | <i>87</i> |
| <i>Table 10: Mean power grip force</i>  | <i>89</i> |
| <i>Table 11: Mean lateral pinch grip force</i>                                  | <i>89</i> |

# List of Figures

|  |           |
|--|-----------|
| <i>Figure 1: Interruption of oxygenated blood supply to brain cells due to (a) Blockage of blood vessel (b) Rupture of blood vessel.....</i> | <i>7</i>  |
| <i>Figure 2: The motor neuron.....</i>   | <i>8</i>  |
| <i>Figure 3: The blood supply system of the brain.....</i>   | <i>9</i>  |
| <i>Figure 4: The Motor Cortex in the frontal lobe.....</i>   | <i>10</i> |
| <i>Figure 5: The Motor Homunculus.....</i>   | <i>10</i> |
| <i>Figure 6: Bones of the hand (palmar view).....</i>  | <i>12</i> |
| <i>Figure 7: Interaction of patient and therapist during hand therapy.....</i>   | <i>18</i> |
| <i>Figure 8 : A rubber band as a hand rehabilitation tool.....</i>   | <i>19</i> |
| <i>Figure 9: ReScribe rehabilitation device showing a) Writing platform b) HE designed for rehabilitating stroke patients \.....</i>         | <i>23</i> |
| <i>Figure 10: Research study flowchart.....</i>  | <i>26</i> |
| <i>Figure 11: Free body diagram of hypothetical forearm.....</i>   | <i>28</i> |
| <i>Figure 12: Free body diagram of hypothetical hand.....</i>  | <i>28</i> |
| <i>Figure 13: Experimental study design flowchart.....</i>   | <i>34</i> |
| <i>Figure 14: The Jamar Adjustable Hand Dynamometer.....</i>   | <i>37</i> |
| <i>Figure 15: An illustration of the body during the power grip test.....</i>  | <i>38</i> |
| <i>Figure 16: The Jamar Hydraulic Pinch Gauge.....</i>   | <i>39</i> |
| <i>Figure 17: The pinch grip test.....</i>   | <i>39</i> |
| <i>Figure 18: The forearm during rehabilitative training.....</i>  | <i>41</i> |
| <i>Figure 19: The predefined patterns used for rehabilitative training.....</i>  | <i>42</i> |
| <i>Figure 20: The Rehabilitation Unit.....</i>   | <i>49</i> |
| <i>Figure 21: Schematic representation of the rehabilitation unit.....</i>   | <i>50</i> |
| <i>Figure 22: Drawing layout (444x207mm) for 2D-laser cutting.....</i>   | <i>52</i> |
| <i>Figure 23: Drawing layout (643x450mm) for 2D-laser cutting.....</i>   | <i>53</i> |
| <i>Figure 24: Drawing layout (695x312mm) for 2D-laser cutting.....</i>   | <i>53</i> |
| <i>Figure 25: Parts of the WE a) Base Unit b) Vertical lever c) Wrist support d) Servo motor e) Servo arm f) Pivot.....</i>                  | <i>54</i> |

|  |    |
|--|----|
| <i>Figure 26: Illustration of translation movements of wrist support during flexion and extension</i>                              | 55 |
| <i>Figure 27: The wrist support showing position of mechanical stopper</i>   | 56 |
| <i>Figure 28: Mechanism of operation of the wrist element</i>  | 57 |
| <i>Figure 29: Robotic attachment for the left index finger</i>   | 58 |
| <i>Figure 30: (a) Previous design (b) Current design of actuator housing component (top view)</i>                                  | 59 |
| <i>Figure 31: Angular position of sensor hole in the robotic attachment lever showing a) Initial position b) Adjusted position</i> | 59 |
| <i>Figure 32: A schematic diagram of the electronic circuit of the rehabilitation system</i>                                       | 60 |
| <i>Figure 33: Rechargeable Sealed Lead Acid battery</i>  | 63 |
| <i>Figure 34: TGY-90S Digital Metal Gear Servo</i>   | 64 |
| <i>Figure 35: PowerHD 1501MG Analog Metal Gear Servo</i>   | 64 |
| <i>Figure 36: The Arduino Due <math>\mu</math>C</i>  | 65 |
| <i>Figure 37: The 3.2" UTFT Touch Shield</i>   | 66 |
| <i>Figure 38: Rotary linear potentiometer used as hand exoskeleton sensors</i>   | 67 |
| <i>Figure 39: Differential amplifier circuit for sensory signal amplification</i>  | 68 |
| <i>Figure 40: The LM317T adjustable voltage regulation circuit</i>   | 70 |
| <i>Figure 41: Latching push button used as emergency stop switch</i>   | 71 |
| <i>Figure 42: 10A Electrical Fuse</i>  | 72 |
| <i>Figure 43: Pseudo algorithm flowchart for home screen</i>   | 73 |
| <i>Figure 44: Pseudo algorithm flowchart for single select mode</i>  | 74 |
| <i>Figure 45: Pseudo algorithm flowchart for auto play mode</i>  | 75 |
| <i>Figure 46: The rehabilitation system</i>  | 76 |
| <i>Figure 47: Home screen of rehabilitation system (planar view)</i>   | 77 |
| <i>Figure 48: The trace select mode of operation</i>   | 78 |
| <i>Figure 49: Percentage change of completion time in relation to the baseline time</i>  | 82 |
| <i>Figure 50: Graphical representation of writing accuracy test results</i>  | 84 |
| <i>Figure 51: Sample of writing accuracy test results of Participants 1 &amp; 2</i>  | 85 |
| <i>Figure 52: Sample of writing accuracy test results of Participant 3</i>   | 85 |
| <i>Figure 53: Sample of writing accuracy test that was quantitatively analysed</i>   | 86 |

*Figure 54: Analysis of change in grip strength of the NDH in relation to baseline.....90*  
*Figure 55: Analysis of power grip strength of NDH in relation to DH.....91*

# List of Abbreviations

3D – Three dimensional

ABS – Acrylonitrile Butadiene Styrene

ADLs – Activities of Daily Living

AH – Ampere hour

CMC – Carpo metacarpal

DIP – Distal Interphalangeal

DH – Dominant Hand

DOFs – Degrees-of-Freedom

IDE - Integrated Development Environment

KGF – Kilograms of Force

NDH – Non-Dominant Hand

PIP – Proximal Interphalangeal

ROM – Range of Motion

UCT – University of Cape Town

WE – Wrist Element

# Chapter 1 – Introduction

## 1.1 General Introduction

Stroke is the medical condition whereby the flow of blood to the brain is interrupted either by the blockage or rupture of a blood vessel. The interruption of blood flow leads to shortage in supply of oxygen to the brain which results in the damage or death of the brain cells (Stroke Health Center, 2015). The damage in the brain manifests in various forms of malfunction, most commonly in the form of physical disability (Dimyan & Cohen, 2011). Most people who suffer stroke survive the initial attack and the major problem lies in the long term consequences that follow, as the effects are more often severe and disabling. Stroke is reported to be a major cause of death and the leading cause of long-term adult disability in the world (Langhorne, Bernhardt, & Kwakkel, 2011). Approximately 10% of all deaths in the world are attributed to stroke. Of the 15 million people that suffer stroke in the world each year, one-third succumb to the attack and another one-third are left with permanent disability (Hoffman, 2013). There is limited availability of documented information on stroke in South Africa, however, the prevalence can be approximated. Within the South African context, 40,150 of 131,400 stroke victims succumb to a heart attack annually and approximately 32,850 are left with life-changing disability (MyStroke, 2016). Africa is challenged with weak health systems and poor initiatives by the government which has impacted negatively on the prevention of many non-communicable diseases, stroke being one of them (Adeloye, 2014). Majority of the disabilities in the world that come as a result of stroke have been observed to affect the upper-limb (Mullick, Subramanian, & Levin, 2015).

Each year, the incidence of stroke in the world rises rapidly and consequently the number of stroke patients (Mohd Nordin et al., 2014). The rising number of stroke patients has caused a huge imbalance between the number of patients and the number of therapists available. The shortage of therapists, coupled with the rising number of patients, has resulted in a low therapist-patient ratio (Mohd Nordin et al., 2014). Both inadequate and total lack of

rehabilitation among stroke patients worldwide has been attributed to the shortage of therapists. Approximately 10-20% of the South African population is reported to have access to acute stroke units (Fritz, 2006). Inadequate rehabilitation leads to little or no recovery and may give rise to permanent disability. Survivors who do not receive rehabilitation end up having a poor quality of life as they have difficulty in carrying out day to day activities (Go et al., 2014). Activities that require use of the upper limb such as eating, grooming and writing are largely affected because upper limb disability is more prevalent. The condition is worsened by impairment of hand function, which is a necessity for living an independent life (Heo, Gu, Lee, Rhee, & Kim, 2012). Nations that have a large number of stroke survivors suffer from heavy financial healthcare burden (Go et al., 2014). Consequently, there has been a high demand for novel and/or improved rehabilitation interventions and this demand is projected to rapidly increase in the future, particularly when the aging population around the world is taken into consideration (Heo et al., 2012).

## **1.2 Background of the study**

The long-term effects of stroke are devastating and besides death, it plagues the survivor with sensory, motor, cognitive and visual impairment (Laver, George, Thomas, Deutsch, & Crotty, 2015). After a stroke attack, a victim may suffer more than one form of impairment but the most commonly observed impairment is motor impairment which includes hemiparesis, spasticity and disruption of coordination (Dimyan & Cohen, 2011; Schaechter, 2004). Hemiparesis is the weakness of one side of the body in relation to the other. Majority of the survivors that suffer motor impairment have hemiparesis (Krakauer, 2005). This condition impairs motor function of the upper limb and is more prevalent in the upper limb when compared to the lower limb (Brewer, Horgan, Hickey, & Williams, 2013). Up to 40% of those suffering motor function impairment in the upper limb have a completely dysfunctional arm (Edmans, 2011). Since the upper limb plays a major role in the execution of fine motor movements, its dysfunction affects the ability to perform fine motor skills. Recovery from upper limb dysfunction is reported to be much more difficult when compared to the lower limb. Only half of the stroke survivor population has improved upper limb function after six months of

rehabilitation. The difficulty in recovery of upper limb dysfunction can be attributed to the high-level complexity of movements executed by the upper limb (Timmermans, Seelen, Willmann, & Kingma, 2009). This fact has given rise to the need for a more robust and far reaching rehabilitative effort towards improving recovery of upper limb function. It can therefore be concluded that the shortage of therapists has deprived stroke survivors of the attention that is critical to better recovery of function. The timing of rehabilitation is crucial in the recovery of any impairment caused by stroke. It is therefore recommended that rehabilitative treatment be administered immediately at the onset of stroke (Hankey, 2014). The beginning of the recovery phase has the highest potential for recovery. The potential rises exponentially to its peak and plateaus after a period of time. Most improvement of motor function in the upper limb is observed in the first 4 weeks of rehabilitation (Krakauer, 2005). A shortage of therapists suggests that there are many stroke survivors who do not undergo rehabilitation at the onset of stroke. Since majority of impairments are upper limb-related, it may be concluded that there is a high risk of permanent disability among stroke survivors with upper limb dysfunction.

Patients who are fortunate enough to undergo rehabilitation do not recover fully and is attributed to the fact that the potential for recovery that is available is not fully exploited during rehabilitation (Timmermans et al., 2009). A prerequisite for effective recovery of motor function is the continual repetition of task oriented exercises with increasing intensity over a period of time (Poli, Morone, Rosati, & Masiero, 2013; Schaechter, 2004). The most commonly used methods, otherwise known as conventional rehabilitation methods, have been effective in improving motor function of the upper limb. A major shortcoming of the conventional methods is that they require patients and therapists to be physically constrained to each other during rehabilitation (Poli et al., 2013). They also require a great deal of time, effort and resources which gives rise to fatigue on both the patient and therapist. As a result, there is hardly any motivation for practice which is essential, especially the performance of task-oriented exercises (Chang & Kim, 2013; Heo et al., 2012). The lack of motivation to continuously engage in rehabilitative exercises may have compromised the outcome of rehabilitation and it is foreseen that if this condition persists, there is a possibility of many more people living with long term disabilities.

## 1.3 Problem Statement

The low therapist-patient ratio has led to inadequate rehabilitation among the population of stroke survivors and in some cases no rehabilitation at all. Both inadequate and total lack of rehabilitation has been manifested in poor recovery of motor function (Timmermans et al., 2009) or no recovery at all (Edmans, 2011). Subsequently, the number of people living with permanent motor disabilities has risen. Since most motor disabilities are manifested in the upper limb (Mullicket al., 2015) and the timing of rehabilitation is critical for recovery (Hankey, 2014), majority of stroke survivors are at a high risk of suffering permanent upper limb disability. Given the rapidly increasing incidence of stroke, the number of people living with long term disability of the upper limb is expected to rise.

Patients who are admitted to stroke units in the acute phase of stroke are generally discontinued from formal treatment earlier than the recommended period which for most centres is one (Mohd Nordin et al., 2014; Veerbeek, Kwakkel, van Wegen, Ket, & Heymans, 2011) This is done in an effort to improve efficiency in stroke management (Veerbeek et al., 2011) and reduce the high costs that are incurred while providing stroke-related care (Page et al., 2001). As a result, many of the patients who require further intervention are left without a care plan. This has greatly undermined the potential that is available for the patients to recover from their disabilities (Mohd Nordin et al., 2014).

## 1.4 Hypothesis

The use of a portable robotic rehabilitation system, as a complementary tool, in hand therapy, would promote continuous rehabilitation by encouraging repetition of task oriented exercises which would enhance motor function of an impaired hand. Task-oriented writing practice would potentially improve hand coordination and result in better accuracy while repetitive training would potentially increase hand motor strength.

## 1.5 Aim & Objectives of the study

The aim of this research study was to design and develop a portable rehabilitation system towards improving motor function of the hand through repetitive writing practice and test its performance.

The definitive objectives of the study were:

1. To design and manufacture a portable distal arm rehabilitation unit.
2. To design and incorporate a motorised wrist element for the rehabilitation unit.
3. To develop an integrated rehabilitation system comprising of the rehabilitation unit and a hand exoskeleton.
4. To test the performance and usability of the integrated rehabilitation system.

## 1.6 Significance of the study

The high demand for therapists and the growing number of stroke survivors has rendered rehabilitation to be a very costly undertaking. Dependence on highly skilled therapists to administer individualised therapy programs on stroke survivors is labour and resource intensive. A low cost rehabilitation system that enables continuation of treatment in a residential setting after discharge from a clinical setting would therefore be a useful addition to the conventional rehabilitation methods. Implementing the use of the proposed rehabilitation system would promote an increase in the amount of time dedicated for practice, increase motivation and would additionally lower the demand for highly skilled therapists.

The outcome of preliminary trials on the system would provide useful information that would inform the design and experimental methodology before the next study that would be conducted to verify the efficacy of the system. This research study is foreseen, in the long-term, to contribute to lessening the negative impact of stroke by enhancing quality of life and improving the working condition for therapists. It was therefore the goal of this research to build a system geared towards improving motor function of the hand. Furthermore, design

and development was influenced by the need of a system that would eventually be used as a complementary tool in hand rehabilitation to maximise on therapeutic outcome while reducing the depletion of human and economic resources.

## **1.7 Limitations of the study**

The scope of work presented in this research study is limited to the resources that were available during the period of design and development of the rehabilitation system and also to the period of experimental study. The scope was also limited by the time allotted for completion of the research. Due to the aforementioned constraints, the pilot pre-clinical trial was conducted on a very small sample size and the length of experimental study was limited to four weeks. The additional potential research and development areas which were excluded from this study and would otherwise have been included are part of the recommendations for future work outlined in the final chapter.

## Chapter 2 – Literature Review

This chapter gives an overview of stroke, its progression and effects on the upper limb. An analysis of the different interventions that have been used in the past and that are currently used for rehabilitation of stroke survivors is also presented to the reader. The chapter is finally concluded with a summary of the work that has already been completed and is related to the study.

### 2.1 Stroke and the Upper Limb

Stroke as defined by the World Health Organisation(WHO) is “rapidly developing clinical signs of focal (or global) disturbance of cerebral function, lasting more than 24 hours or leading to death, with no apparent cause other than that of vascular origin” (Sacco et al., 2013). Disturbance of cerebral function is caused by the interruption of blood flow to the brain. (Goldstein, 2014). The interruption leads to damage or death of brain cells, known as neurons, and the symptoms are manifested in the malfunctioning of body parts which are controlled by these neurons. Interruption of blood flow is caused by either blockage of a blood vessel causing an ischemic stroke or rupture of a vessel causing haemorrhagic stroke as illustrated in Figure 1a and 1b respectively.

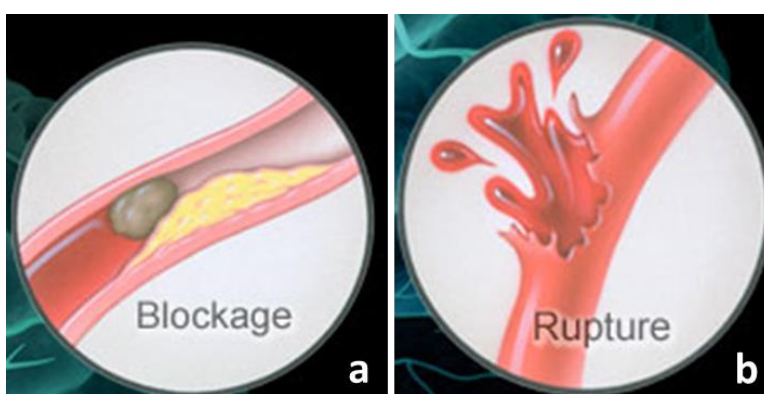

Figure 1: Interruption of oxygenated blood supply to brain cells due to (a) Blockage of blood vessel (b) Rupture of blood vessel (Beckerman, 2016)

Approximately 87% of strokes are ischemic and 13% haemorrhagic (Goldstein, 2014). Haemorrhagic stroke is less common however its effects are devastating often resulting in death. When the stroke lasts for less than 24 hours, it is referred to as a transient ischemic attack (TIA) (Drake, Vogl, & Mitchell, 2015).

### 2.1.1 Anatomy of the brain

The brain governs and coordinates all the activities of the human body and is the organ initially affected by stroke. Information is transmitted from one neuron to another through a synapse, which is the “specialized site where a neuron sends and receives information from other cells”. Neurons may be divided into three classes: sensory neurons, motor neurons and interneurons. Motor neurons are responsible for the transmission of voluntary activity signals from the brain to the muscles (Stroke 2015). The motor neurons have dendrites as indicated in Figure 2 which receive chemical signals from the axon termini of neighbouring neurons by the trigger of an action potential. The action potential travels by jumping the Ranvier nodes and causes the neurotransmitter at the synapse to communicate with the receptors of the neighbouring cells. This causes a change in permeability of the cell membrane and as a result, electric potential travels along the axon to the next synapse (Darnell et al., 1999). Through this repetitive process, information on voluntary activity is carried across multiple neurons from the brain to the skeletal muscles thereby inducing motor changes.

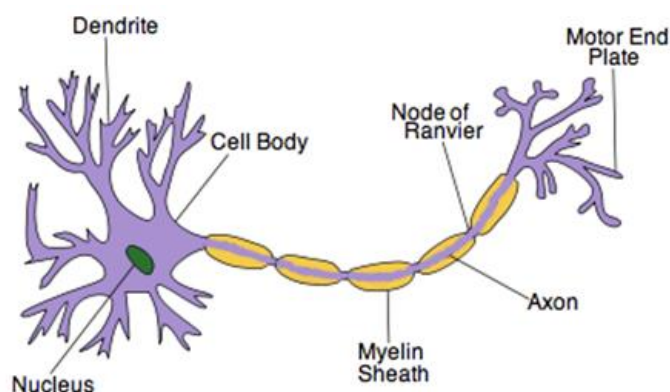

Figure 2: The motor neuron (IB Guides, 2015)

For optimal function, neurons need an adequate supply of oxygenated blood. The two main pairs of vessels that supply the brain with oxygenated blood are the vertebral arteries and the internal carotid arteries as shown in Figure 3. The supply of oxygenated blood is maintained through anterior and posterior circulations. From Figure 3, it can be observed that the anterior circulation begins from the termination of the internal carotid arteries while the posterior circulation originates from the vertebral arteries. The anterior circulation supplies 80% and the posterior 20% of blood to the brain (Goldstein, 2014).

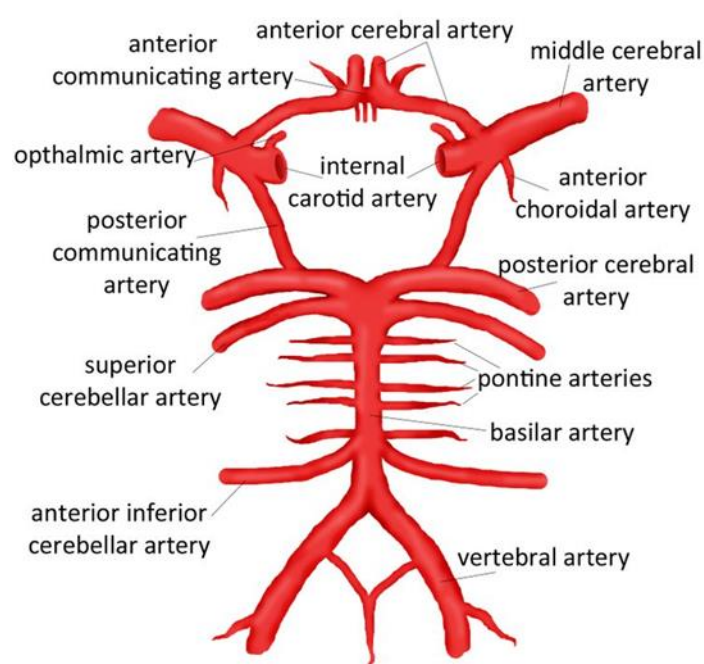

Figure 3: The blood supply system of the brain (Drake et al., 2015)

The brain may be divided into 3 main parts; the forebrain, midbrain (brain stem) and the hindbrain (cerebellum) (TISC, 1999). The forebrain contains the cerebrum which is the largest portion of the brain. The cerebrum is divided into left and right hemispheres, each having four lobes; frontal, temporal, parietal and occipital lobe. Conscious and subconscious regulation of skeletal muscle contractions occurs in the frontal lobe (TISC, 1999).

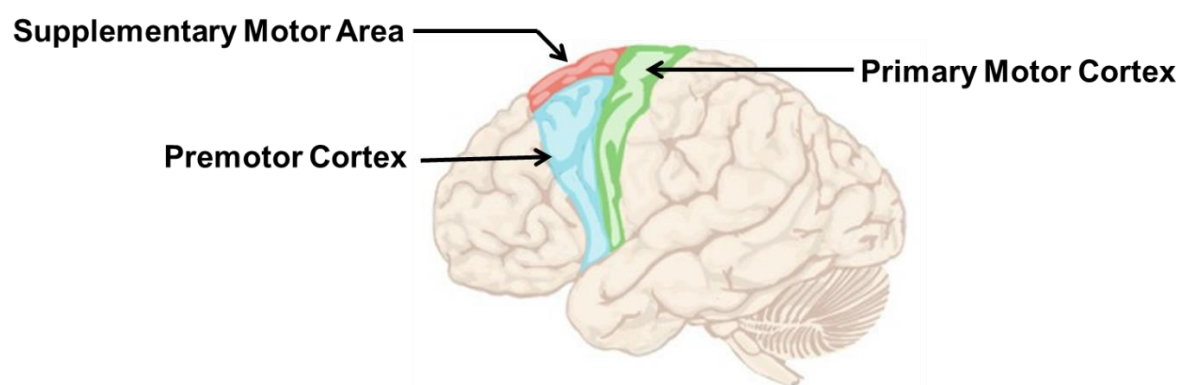

Figure 4: The Motor Cortex in the frontal lobe (Knierim, 1997)

The motor cortex region shown in Figure 4 is located in the frontal lobe of each of the hemispheres of the brain. It has 3 sub regions namely: a primary motor cortex and two secondary cortices; the supplementary motor area and the premotor cortex. The primary motor cortex is the exclusive region of the brain that is primarily responsible for the generation of impulses from the brain to induce motor changes in the body through electrical stimulation. The supplementary motor cortices are involved in motor planning. The premotor cortex is involved in sensory guidance and movement while the supplementary motor area plans and coordinates complex movements such as two-handed movements (BrainHQ, 2013). The primary motor cortex is the signal generation centre for motor control (Schwerin, 2013). A representation of the body in the primary motor cortex is illustrated in Figure 5 in what is known as the motor homunculus.

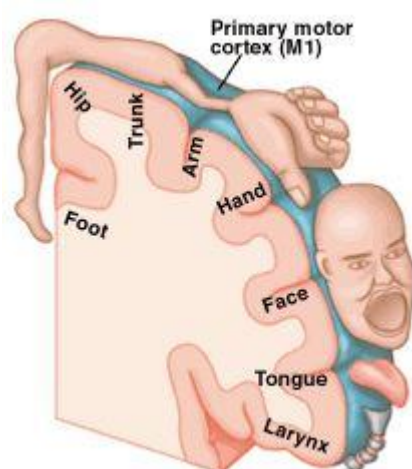

Figure 5: The Motor Homunculus (BrainHQ, 2013)

Different portions of brain matter within the primary motor cortex are responsible for different motor movements of the body. The amount of brain matter dedicated to a particular movement is proportional to the complexity of the movement. Upper limb motor movements are more complicated than lower limb movements, which suggests that the region of brain controlling movements of the upper limb has more matter and occupies a larger portion within the brain (BrainHQ, 2013).

## **2.1.2 The Upper Limb**

The upper limb is made up of the shoulder, upper arm, forearm and the hand. The shoulder joint attaches the upper limb to the rest of the body through the trunk. The upper limb has a wide ROM about the shoulder which enables a highly dynamic movement of the arm in space. Flexion, extension, abduction, lateral and medial rotational movements can all be performed about the shoulder joint. Between the upper arm and forearm is the elbow joint which plays a major role in flexion and extension of the forearm. It also enables pronation and supination of the forearm. The wrist is a complex joint positioned between the forearm and the hand. The various movements about the wrist are enabled by the activation of muscles in the forearm and in the hand. The carpal bones move relative to each other and to the bones that are situated proximally or distally. This allows the hand to be flexed, extended, abducted, adducted and circumducted about the joint (Abyarjoo, Barreto, Abyarjoo, Ortega, & Cofino, 2013).

At the very distal end of the upper limb is the hand, which is critical in executing tasks that are performed by the upper limb. The hand has both a motor and a sensory component. The motor component enables manipulation of objects using the fingers of the hand including grasping, gripping and translation of objects within the hand (Drake et al., 2015). The sensory component is responsible for detecting touch, temperature and pressure. The mobility exhibited in the hand is useful in performing various functions including complex tasks such as writing (Drake et al., 2015).

The human hand, including the wrist, has 21 DoFs and is actuated by 29 skeletal muscles (Balasubramanian, Klein, & Burdet, 2010) while the arm from the wrist to the shoulder has only

7 DoFs (Lum, Godfrey, Brokaw, Holley, & Nichols, 2012). The hand is made up of 27 bones grouped into carpal, metacarpal and phalanx bones as shown in Figure 6. The intersection of these bones form the different joints within the hand. The intrinsic muscles of the hand are attached to these bones to facilitate joint movements. The intercarpal joints contribute to hand positioning in abduction, adduction, flexion and particularly extension (Drake et al., 2015).

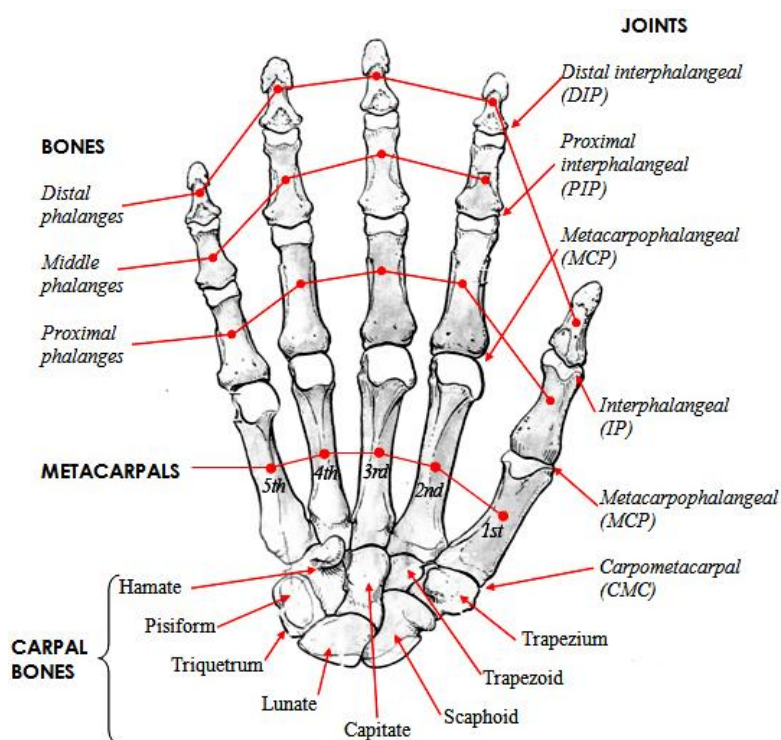

Figure 6: Bones of the hand (palmar view) (SHSC, 2008)

The sensory and motor components of the median, ulnar and radial nerves of the upper limb innervate the hand. The median nerve gives off the branch responsible for innervating muscles which facilitates the fine precision movements of the fingers. The ulnar nerve innervates the muscles used in hand grasping functions. The radial nerve innervates the wrist extensors which are responsible for hand position and stabilization of the fixed carpal bones of the wrist. Collateral ligaments restrict lateral motion in the metacarpophalangeal (MCP) joints and radio-ulnar motion in the interphalangeal (IP) joints. The ligaments tighten when the MCP joints are flexed and they loosen when extended. For the IP joints, they remain tight throughout the ROM (Wilhelmi & Gest, 2015).

### **2.1.3 Stroke Progression**

The primary motor cortex in the brain is connected to the spine through a direct pathway known as the corticospinal tract. Neurons from the motor cortex region give rise to fibres which run to the corticospinal tract. Thereafter, these fibres cross over to opposite sides at the brain stem and terminate at different levels of the spine. At the spine, the fibres synapse with motor neurons which then form synaptic contact with muscle fibres. This facilitates the transmission of neural impulses from the brain, across the body midline to the skeletal muscles situated opposite to the centre of signal generation. The link between the motor cortex in the brain and the muscle fibres within the upper limb sustains the normal function of the upper limb (BrainHQ, 2013).

#### **Effect on the brain**

Stroke is said to have occurred when the flow of oxygen-rich blood to any region of the brain is interrupted for a period long enough to cause the death of neurons in that region (Drake et al., 2015). In the event of a stroke, there is decreased blood flow to the brain which causes a deficiency in energy. With inadequate energy, the electric potential that is necessary for transportation of a signal from one neuron to another cannot be maintained. The neurons are also deprived of oxygen and the end result is death of neurons.

#### **Effect on upper limb**

When the disruption of neuron functionality occurs in the motor cortex region, motor control is affected, voluntary movement is distorted and is manifested in poor hand coordination and dexterity (Pollock et al., 2014a). When neurons are completely damaged, the direct link between the brain and skeletal muscle fibres of the upper limb is partially or totally lost, which is manifested in motor impairment (Krakauer, 2005). Hand motor impairment is manifested in weakness of the fingers, spasticity and abnormal co-activation of muscles (Pollock et al.,

2014b). Nonetheless, the extent to which spasticity affects motor dysfunction is less than that of weakness and abnormal co-activation of muscles do (Krakauer, 2005).

## **2.2 Stroke Rehabilitation**

Rehabilitation is a therapeutic program that is designed to maximise on regaining lost function whilst minimising impairment. Rehabilitation usually involves a team, however the primary contributors to fine motor rehabilitation are physical therapists and occupational therapists. Physical therapists engage their patients in physical activity that is geared towards restoration of movement while occupational therapists include practical applications while engaging in these activities. Secondary stakeholders may be professionals such as nurses or non-professionals such as caregivers and family members (Pollock et al., 2014b). The amount of time spent in therapy is proportional to the intensity of therapy. Increased time input translates to higher intensity. 30-60 minutes of therapy each day is the standard widely used by therapists in motor rehabilitation. This time decreases with progression of the rehabilitation treatment. The total time spent on rehabilitation varies from patient-to-patient and is primarily dependent on the degree of impairment. Nevertheless, rehabilitation usually does not continue for more than 6 months (Schaechter, 2004).

Stroke rehabilitation is usually conducted in dedicated stroke units. The stroke units may have either inpatient or outpatient rehabilitation programs. Inpatient programs are designed to facilitate the admission of patients for the entire duration of treatment while outpatient programs only allow for the treatment of patients on a daily basis without retaining them. Additionally, home based programs exist whereby rehabilitation is performed in a residential setting (Bryer et al., 2010). The extension of therapeutic practice to the home after discharge from formal treatment has popularized home based rehabilitation and may be attributed to the increased intensity of therapeutic exercises which is beneficial for improved outcome. In the South African context, inpatient therapy is preferred to outpatient therapy because of the superior intensive rehabilitation programs offered by the former. Most stroke patients are however treated in public rehabilitation units, which, unlike their private counterparts, do not

have the capacity to provide adequate inpatient rehabilitation services (Bryer et al., 2010; Lynn, 2012).

## **Importance of Rehabilitation**

Rehabilitation is performed in order to gain back some or all of the lost motor function, to improve reduced motor function and also to prevent further complications. Rehabilitative intervention is more effective when employed within the first 6 months of stroke onset. In addition, robot assisted therapy is reported to have brought about an improvement of independence in performing ADLs among patients who were subjected to rehabilitation at an early stage (Masiero, Armani, & Rosati, 2011). Although the conventional methods mostly focus on improving muscle strength, motor control has been identified as an equally important factor that affects upper limb motor function. It is therefore important for the focus of rehabilitation to be placed on these two complementary factors (Cho et al., 2014).

Since upper limb motor deficits are more prevalent than lower limb deficits the former would account for majority of the deficits in any population. If effective rehabilitation measures are not put in place, the ever increasing number of stroke survivors will result in a large population of stroke survivors living with permanent disability (Edmans, 2011; Maciejasz, Eschweiler, Gerlach-Hahn, Jansen-Troy, & Leonhardt, 2014).

## **Factors Affecting Rehabilitation**

There are three main factors outlined in (Brauer, Hayward, Carson, Cresswell, & Barker, 2013) that have a direct impact on the success of rehabilitation: The degree of neural damage, timing of rehabilitation and expertise in rehabilitation. The timing of rehabilitation treatment is critical to recovery from the effects of stroke (Hankey, 2014). Consequently, stroke duration from onset has led to the classification of patients into three phases namely: acute, subacute and chronic phases of stroke (Timmermans et al., 2009). The acute phase is the initial phase of stroke, a period when the patient has just come out of the emergency stage of stroke whereby

emphasis is placed on preventing the recurrence of a stroke and any other complications (Duncan et al., 2005). The subacute phase follows the acute phase and is associated with true recovery. In this phase, motor recovery is stimulated and manifested in the use of the muscles that were initially affected by stroke. The chronic phase is the last phase of stroke and lasts for as long as the effects of stroke are in existence. Minimal recovery is anticipated in this phase and most rehabilitation interventions resort to compensatory methods in dealing with the effects of stroke rather than battling with regaining function (Timmermans et al., 2009).

Rehabilitation in the sub-acute stage of stroke has been determined to be most effective as the potential for recovery of body function is highest in this stage. This potential reduces exponentially from the sub-acute to the chronic stage. Intensive, task oriented therapy has been observed to improve motor deficits in both the acute and chronic phases of stroke (Fasoli, Krebs, Stein, Frontera, & Hogan, 2003). It is however crucial to rehabilitate any form of upper limb motor deficit at the earliest opportunity due to the lower potential for recovery in the upper limb when compared with the lower limb (Timmermans et al., 2009). The implication deduced is that more time should be spent on upper limb therapy to reduce the chance of suffering permanent disability.

### **2.2.1 Rehabilitation Approaches**

The approach to rehabilitation of motor deficits is based on the general condition of the patient and more specifically on the nature of impairment, which is primarily influenced by the degree of damage caused by stroke to the brain (Edmans, 2011; Kalra, 2010). The experience of a therapist may influence the method that is employed in rehabilitation (Kalra, 2010; Schaechter, 2004). However, due to the wide range of preferences, there has been no consensus amongst professionals on the relative benefit of the existing interventions. Rehabilitation approaches may be classified into three main groups:

- a) Restitution
- b) Substitution
- c) Compensation

Restitution and substitution are restorative approaches. The restitution approach works towards restoring function of the damaged tissue and is normally used when damage to the brain tissue is mild, causing minor impairment. Substitution focuses on inducing the unaffected neurons on the opposite hemisphere of the brain to perform the function that has been impaired by stroke. This involves the reorganization of neural pathways to activate and utilize the unaffected neurons. Through repetitive practice, the already established pathway is developed further and the lost function can be performed once again. The compensation approach is normally used when the damage to the brain is severe and has caused physical disability as opposed to impairment. In this approach, the brain is induced to form new pathways as a compensation for the damaged pathways. This allows the victim to achieve the end goals of the lost function without necessarily regaining the ability to perform the particular function that has since been lost (Brewer et al., 2013). Efforts to restore function of an impaired limb have gradually been replaced by compensatory techniques (Fasoli et al., 2003). The aim in shifting of technique is to reduce the hospitalization period of stroke victims and consequently the costs incurred during the rehabilitation period. This has, however, compromised the rehabilitation procedure and resulted in reduced recovery of impairments. Many stroke rehabilitation units have resorted to discontinuing patients from formal treatment at an early stage without providing a treatment plan for the remaining period of recovery (Mohd Nordin et al., 2014). The extent to which this change of treatment plan has contributed to the disabilities is not documented but it is certain that the potential for recovery among stroke survivors has been negatively affected on a global scale.

## **2.2.2 Rehabilitation Methods**

Neuroplasticity is the brain's ability to change its physical structure when demands are placed on it (Arya, Pandian, Verma, & Garg, 2011). The change in structure involves formation of new pathways in the brain, which are then utilised in relearning and performing skills that have diminished after suffering a neurologic condition. Neuroplasticity-based rehabilitation is a technique that has been extensively used in rehabilitation. This technique is widely employed in enhancing neurologic function and has become the basic underlying mechanism of

improving motor function post stroke (Chang & Kim, 2013; Stein, 2012). Through repetitive practice and high intensity training, there has been improvement in motor function and regaining loss of function. As a result of this evidence, neuroplasticity has influenced the application of the methods that are currently used to help patients regain their lost functional skills. A knowledge of neuroplasticity is therefore deemed to be important for the therapists in selecting the type, intensity and repetitiveness of exercises (Edmans, 2011).

## Conventional Methods

Physical and occupational therapists employ several exercises in conventional hand rehabilitation to improve fine motor skills. Therapists frequently offer their patients assistance in executing the movements that are necessary to perform the fine motor rehabilitation tasks (Lum et al., 2012). An example is shown in Figure 7.



*Figure 7: Interaction of patient and therapist during hand therapy (DailyCaring, 2016)*

Patients are also engaged in the manipulation of putty, play dough and rubber bands among other utilities as a means of exercising and thereby rehabilitating fine motor skill. These methods have been effective in improving motor function by increasing muscle strength, ROM and functionality. They however do not exploit all the potential that is available for recovery. For a therapist to offer rehabilitative assistance to a patient, one-on-one physical interaction is inevitable. Studies indicate that effective therapy is only achieved when the exercises are

highly repetitive and intensive (Poli et al., 2013). This requires a lot of time to be dedicated to practice which is time consuming and labour intensive for therapists (Edmans, 2011). The rigorous exercises performed cause fatigue on both the patients and therapists which reduces their motivation. The effort exerted in carrying out these procedures has made intensive rehabilitation quite expensive (Page et al., 2001; Poli et al., 2013). These factors are collectively seen to have a negative impact on recovery as they compromise the outcome of rehabilitation and contribute to long-term disability.

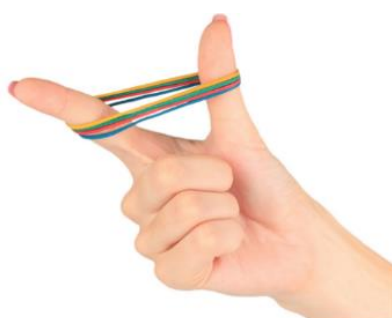

*Figure 8 : A rubber band as a hand rehabilitation tool (FRD, 2015)*

## **Emerging Methods**

Task-oriented training, constraint induced movement therapy (CIMT) and bilateral training are among the methods that have been determined to have a significant impact on functional outcome after stroke rehabilitation (Timmermans et al., 2009). Task-oriented training focuses on the ability to perform a useful skill (Timmermans et al., 2009) by incorporating cognitive, perceptive and musculoskeletal aspects of the human body in therapy (Schaechter, 2004). In using CIMT, the unaffected arm is completely restrained to induce more usage of the affected arm and has been shown to improve dexterity and function (Schaechter, 2004). Bilateral training engages both the affected and unaffected limbs during practice. The simultaneous action of both limbs during practice causes uniform activation of the brain in both hemispheres (Morris et al., 2008) and consequently induces rewiring of the respective neural connections (Wu et al., 2012a). Bilateral arm training has been observed to improve functional use of a limb when the impairment is severe but little or no improvement for mild impairment (Schaechter,

2004). After conducting numerous research studies, there has been no consensus on the best method of rehabilitating upper limb motor deficits (Winstein et al., 2016). Robot-aided therapy is however, increasingly being accepted and adopted by clinicians in the rehabilitation setting as studies prove the potential advantage that robotic rehabilitation may have over the conventional methods of rehabilitation (Heo et al., 2012).

## **Robot-Aided Therapy**

Robot-aided rehabilitation emerged in the 1990s and has since then been rapidly growing (Hesse, Schmidt, Werner, Bardeleben, & Berlin, 2003). The use of assistive technology in rehabilitation is best suited for upper limb motor deficits (Kalra, 2010). The improvements that have been observed while using robotic systems to rehabilitate the upper limb have mostly been observed in the proximal upper extremity (Balasubramanian et al., 2010). This may be attributed to the fact that more attention has been given to rehabilitating the proximal section of the upper limb as is evident in most studies (Basteris et al., 2014; Stein, 2012). Robot-aided neurorehabilitation has been underway for over 20 years and yet active development of devices that rehabilitate the distal upper extremity is reported to have only began in the year 2003. Since then, the development of such devices has been rising steadily. Nearly 75% of the rehabilitation devices that have been developed, have not been clinically tested (Balasubramanian et al., 2010). A comprehensive review of thirty different robotic devices developed for rehabilitating the hand revealed that only 25% of the devices had been tested (Lum et al., 2012). This is attributed to the major complexity of the devices which has rendered them unusable by the patients for whom they have been designed (Balasubramanian et al., 2010).

The use of robotic technology in rehabilitation has promising prospects of overcoming the hurdles that have been experienced while employing the conventional methods of rehabilitation (Heo et al., 2012). Several studies have emphasised on the great potential that robot-aided therapy has in effectively exploiting neuroplasticity. Robot-aided therapy has enabled high level precision in actuation and easy manipulation of parameters such as intensity and repetition of therapeutic exercises (Arya et al., 2011; Lum, Burgar, Shor,

Majmundar, & Van der Loos, 2002). It also enables the quantification of rehabilitation procedures and measurement of outcomes such as changes in kinematics, time, coordination and strength (Poli et al., 2013). These are factors, which would otherwise require the physical presence of a therapist which is a great advantage of robotic intervention over the conventional methods.

Robotic systems may be widely classified into two groups; compensation and remediation systems. A compensation robot assists the user in developing a skill that is an alternative to the lost skill. A remediation robot, also known as a therapeutic robot is used to retrain the limb to perform the skill that has been impaired or completely lost (Chang & Kim, 2013; Fasoli et al., 2003). The therapeutic robots made for the upper limb have further been classified as either end-effector-type devices or exoskeletal devices. End-effector-type devices are designed to apply mechanical forces to the distal segment of the upper limb whilst exoskeletal devices are designed to closely match the anatomical axial alignment of the finger joints and apply forces directly to these joints. This makes the exoskeleton devices relatively more effective in producing the desired movement patterns. The cost of building exoskeletal devices is however higher (Chang & Kim, 2013).

Some rehabilitation devices may have more than one mode of operation, distinguished by the status of the user during rehabilitative training. The rehabilitation device would be used in either active, passive, active-assisted or resistive mode (Basteris et al., 2014). In active mode, the device is fully dependent on input from the user during training whereas in passive mode, full assistance is provided to the user, disregarding any input from the affected limb of the user. In resistive mode, the robot would offer resistance against the motor movements repetitively exerted by the user, causing the limb to grow stronger while maintaining ROM and flexibility. In active-assisted mode, the system is dependent on input from the user and only comes into play when a predetermined condition has been met (Basteris et al., 2014). The ability to perform a wide range of therapeutic exercises in environments other than the clinical setting has made robotic therapy to be among the technologies considered to be positively revolutionising upper limb rehabilitation (Edmans, 2011).

### 2.2.3 Similar technologies

This section gives a brief overview of some of the robotic technologies that have been identified to be relatively similar to that implemented by the rehabilitation system discussed in this research study. There are several devices and systems that have been developed to facilitate hand rehabilitation. The devices employ different actuation mechanisms such as mechanical, electrical or pneumatic actuation, and different sensing methods to achieve hand rehabilitation. The two classes of robotic devices that were reviewed are end-effector type and exoskeletal devices.

The Massachusetts Institute of Technology robot, widely known as MIT-Manus, emerged to be the most widely known end-effector type device that appeared in several literature sources. It has been in development since the 1990s and is used for goal directed exercise training. Several clinical trials have demonstrated the benefit of using this system in improving motor recovery after stroke (Fasoli et al., 2003).

HEXORR, AFX, intelliArm and WaveFlex are some examples of the exoskeletal devices that have been developed for hand rehabilitation. The common denominator is that they all employ electrical actuation mechanisms, which is the case with the hand rehabilitation system discussed in this research study. HEXORR, AFX and intelliArm all have finger joint sensors and can operate in more than one of the operation modes discussed in section 2.2.2. The WaveFlex device is comparatively more limited in function in that the thumb cannot be exercised simultaneously with the other fingers. It however has an advantage of being highly portable (Heo et al., 2012). There are some exoskeletal devices that have been clinically tested namely ARM-Guide, Reha Rob, Armor and T-Wrex. When compared to conventional therapeutic methods, robotic intervention has shown equivalent or better results when compared to the conventional methods of hand rehabilitation. The evidence of efficacy in improving upper limb function has however, not been sufficient to draw definitive conclusions on the benefit of using these devices to rehabilitate patients who are in either the subacute or chronic stages of stroke (Chang & Kim, 2013).

Though some devices like Hand Mentor and WaveFlex have already been commercialised, the high-level complexity of the upper limb has hindered the commercialisation of majority of the devices. More research and development is necessary in order to meet the standard that is required for the practical use of these devices in the clinical setting (Heo et al., 2012).

## 2.2.4 Previous Work

ReScribe is a UCT patented HE that was developed with the intent of rehabilitating fine motor skill. The device is made up of an HE and writing platform as shown in Figure 9. This device falls under the category of devices that operate in passive mode (as discussed in section 2.2.2) by providing intensive, reproducible and repetitive movements that are independent of the user's input. Its HE, shown in Figure 9b, allows 5 DoFs. It has three robotic attachments, designed to be worn on the dorsal side of the hand around the thumb, index and middle fingers. The attachment on the thumb has two segments with a motorised component actuating the interphalangeal joint of the thumb. The other two attachments each have 3 segments with two motorised components for actuating the PIP, DIP and CMC joints. The writing platform houses a touch screen and the electronic circuitry which runs the device.

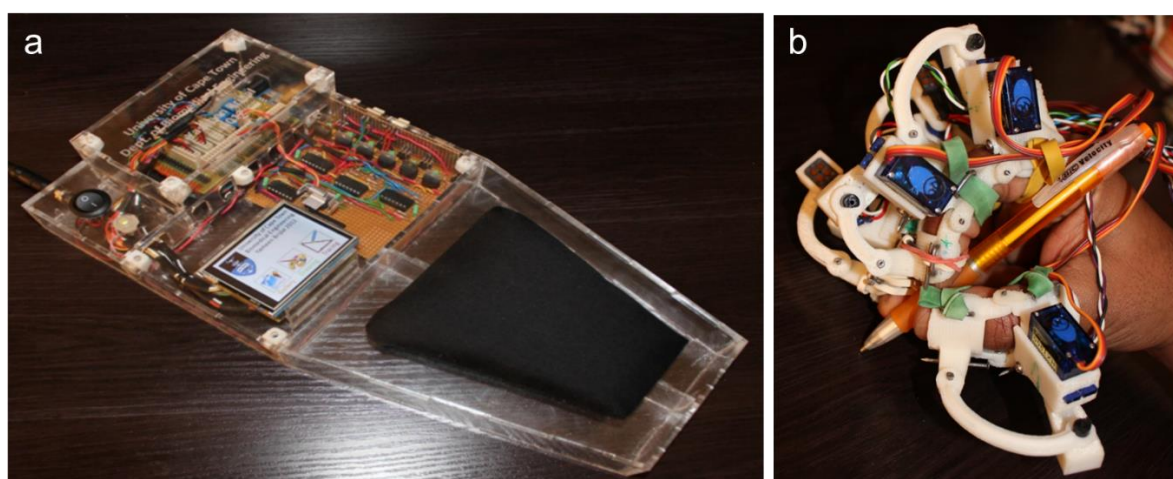

Figure 9: ReScribe rehabilitation device showing a) Writing platform b) HE designed for rehabilitating stroke patients (Brijlal, 2012)

The device operates by repetitively displaying predefined sequences of patterns on a touch screen. The patterns are stored on a memory card connected to the touch screen and enclosed within the platform. With the aid of motorised components on the HE, the patterns are traced using a stylus. The end goal for developing this device was to rehabilitate the paretic limbs of individuals, who have lost fine motor skill especially stroke patients, in order to regain function. This research therefore seeks to further develop this device into a better integrated rehabilitation system that will, potentially, be better suited for use by therapists as a complementary tool in rehabilitating fine motor skill.

## **Chapter 3 – Design Methodology**

This chapter presents a flowchart of the entire research study and provides an overview of the main design parameters that were taken into account before commencement of design and development. The very minute details are not discussed however, the information given here is sufficient to elaborate on the critical steps that were taken prior to building of the rehabilitation system.

### **3.1 Methodology Flowchart**

The flowchart of Figure 10 is a summary of the entire research study highlighting the different stages of design, development and performance testing of the rehabilitation system.

### **3.2 Design Considerations**

The aim of this research study at this stage was to come up with a design for a robust and portable system that would be potentially used by therapists as a complementary tool in rehabilitating upper limb function. The considerations that were taken into account before design are subdivided into the three sections namely: Mechanical Design, Electrical & Electronic Design and Software Design.

#### **Section I – Mechanical Design**

##### **3.2.1 Rehabilitation Unit (RU)**

An RU was designed to house all the components of the system except the Hand Exoskeleton (HE), which was externally connected to the unit while performing rehabilitation routines. The considerations made before designing the unit are listed as follows:

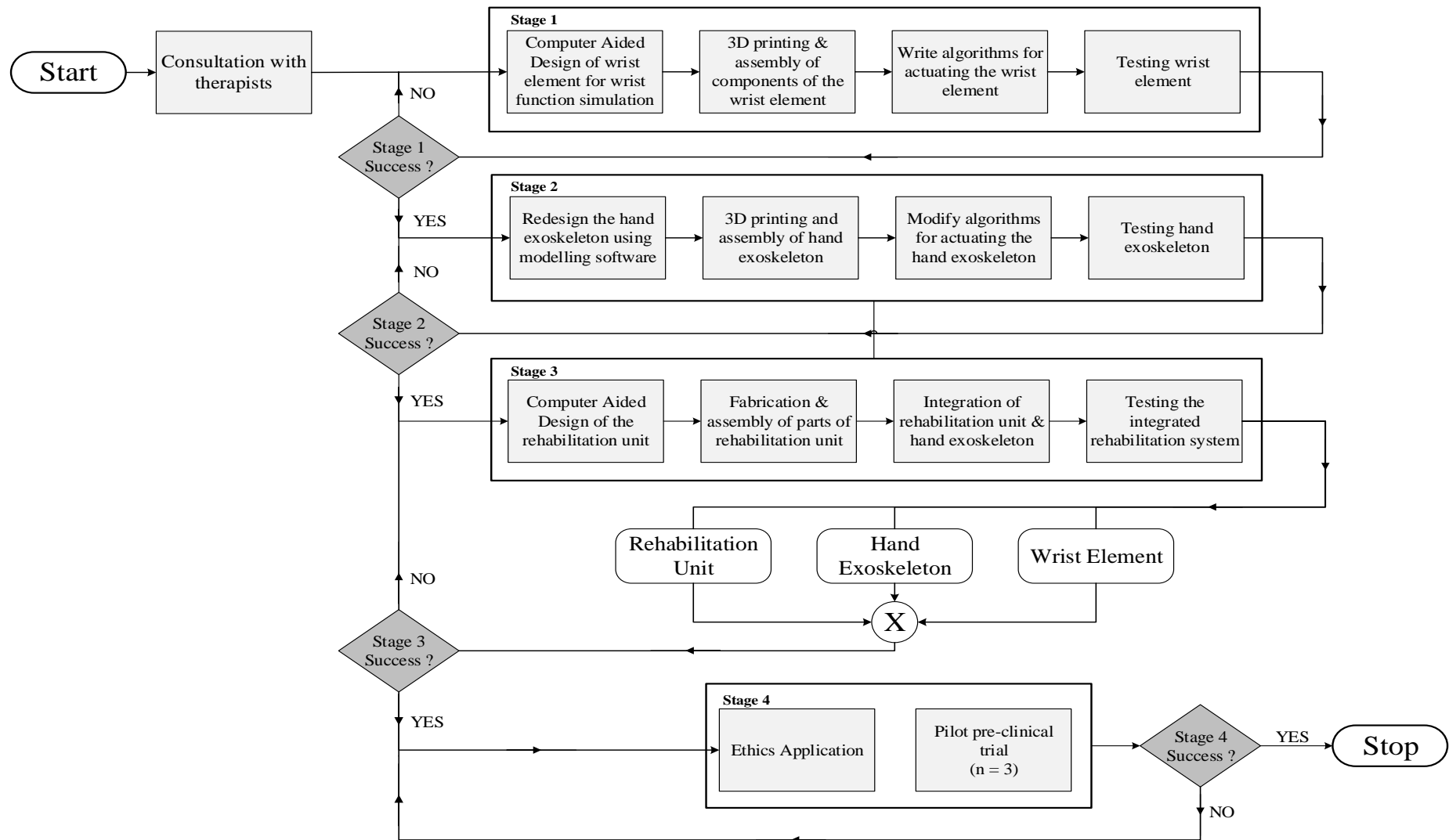

Figure 10: Research study flowchart

- Dimensions of the RU - Portability was a key factor taken into consideration whilst determining the dimensions of the unit. The RU was intended to be portable i.e. easily transportable from one geographical location to another and to have provision for placing the forearm ergonomically on its surface while performing rehabilitation routines.
- Strength of material - The material chosen for building the RU needed to be strong enough to bear the weight of the forearm of the user and weight of the electronic components, housed in the RU.
- Weight of material – The material chosen for building the RU was to have a delicate balance between weight and structural integrity. The material needed to be strong enough to bear the weight of the forearm and light enough to allow for portability.
- Forearm Position – It was necessary to restrict the free movement of the forearm during performance of rehabilitation routines for effective writing practice. This restriction would prevent the user of the system from using the forearm and upper arm to compensate for motor deficits while executing fine motor rehabilitation tasks.

### **3.2.2 Wrist Element (WE)**

The wrist joint plays a key role in writing by enabling flexion, extension, abduction, adduction and circumduction of the hand about the joint. The simulation of wrist functionality was included as one of the features to be incorporated in the rehabilitation system. Due to the complexity of wrist function, only the vertical movements i.e. flexion-extension movements of the human wrist were considered for simulation. This would require a WE capable of bearing the weight of the hand during operation and momentarily lifting the hand along the vertical axis by flexing and extending the wrist joint. Two aspects were identified as a necessary consideration before the design and development of a WE:

- A platform for resting the hand.
- An actuation mechanism for raising the platform.

A motorised actuation mechanism was identified as the most suitable for this application. This is because the wrist would need to be flexed and extended several times within a restricted ROM and with defined intervals of time. The actuation mechanism would therefore need to incorporate an actuator that would withstand the weight of an average human hand and momentarily lift the hand within a defined ROM during operation. The anthropometric parameters shown in Appendix D were used to determine the torque that would be required to lift the hand of a hypothetical subject with the arbitrary parameters highlighted in Appendix E. The free body diagrams shown in Figure 11 & 12 were used to determine the torques needed to lift the forearm and the hand.

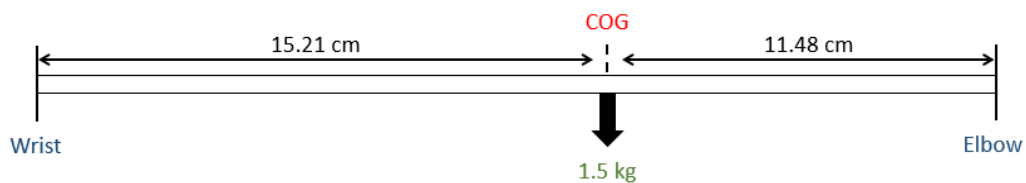

Figure 11: Free body diagram of hypothetical forearm

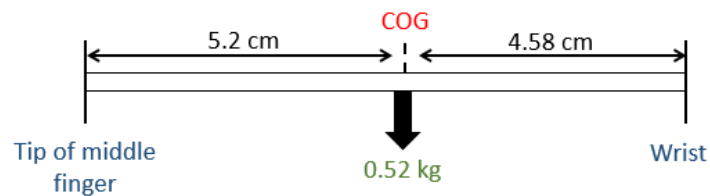

Figure 12: Free body diagram of hypothetical hand

It was determined that when the forearm is pivoted at the elbow, the torque required to lift it is:

$$T = \text{Force } (F) \times \text{radius } (r) \times \text{Safety factor } (sf) = 1.5 \times 11.48 \times 2.5 \approx 43 \text{ kg.cm}$$

When the hand is pivoted at the wrist, the torque required to lift it is:

$$T = F \times r \times sf = 0.52 \times 4.58 \times 2.5 = 5.954 \approx 5.95 \text{ kg.cm}$$

With a safety factor of 2.5 the torque required to lift the forearm and hand would be 43 kg.cm and 5.95 kg.cm respectively. From these calculations, it was concluded that it was more practical to design a mechanism that would lift the wrist as opposed to lifting the whole forearm. Lifting the entire forearm would require the actuator to be unnecessarily large in size which would negatively affect the weight, structure and portability factors of the system.

### **3.2.3 Hand Exoskeleton (HE)**

The general design of the models used for the device discussed in section 2.2.4 was maintained for the HE, however, some minor changes were made. In redesigning the HE, the following requirements were identified:

- Improving the design of the motor housing component by making provision for easy assembly and disassembly of the HE parts.
- Adjusting the motor housing dimensions to accommodate different servo motors.
- A mechanism to prevent actuation of finger joints beyond the desired ROM.

## **Section II – Electrical & Electronic Design**

A robotic rehabilitation system requires a well-designed electrical and electronic system in order to function optimally. The elements of the system had various requirements, which could only be met by an optimally functioning system that responded with high precision outputs necessary for effective rehabilitation. This section, therefore discusses the various electrical and electronic design considerations that were made prior to development of this system.

### **3.2.4 Power Supply**

The following requirements were identified for the power source that would be implemented in running the rehabilitation system:

- A power source that could supply all the voltage and current needs of the different elements of the system namely: WE, HE,  $\mu$ C and operation circuit.
- An alternative power source other than mains power that would allow the rehabilitation system to be used in different geographical locations including remote areas with no access to mains power.

### 3.2.5 Actuation

Motorised actuators were required for the following elements of the system: the HE and the WE. The actuators on the HE would assist in performing flexion and extension movements of the fingers during rehabilitative training while the actuator on the WE would be used for simulating flexion and extension movements of the wrist. The key factors considered whilst selecting the actuators are listed below:

- Strength/ Torque
- Precision
- Physical size

The HE actuators had a minimum requirement of having torque enough to bear the weight of the respective fingers with no resistive force exerted by the user of the system. Small scale actuators would complement a light and portable HE which would improve the feasibility of the system as a portable rehabilitation tool. From the calculations in section 3.2.2, the actuator to be used for the WE needed to have a torque of 7 kg.cm or more. Movement of the wrist along a vertical plane during writing occurs momentarily and is not a continuous process. The actuator therefore needed to have high precision and ability in making small rotary adjustments of position just like those made by the human wrist.

### **3.2.6 Control**

A microcontroller ( $\mu\text{C}$ ) was required for interpreting input from the sensors on the HE and providing control signals for actuating the HE segments and the WE. The  $\mu\text{C}$  would also facilitate the operation of the visual user interface by acting as a power source and also in providing a bi-directional communication channel for the exchange of data. The controller would, therefore require enough digital ports to handle the inputs and outputs for the various components of the system. Furthermore, the controller would also facilitate the transfer and control of data inflow from memory which would be used to determine the actuation signal that is sent to the motorised components.

### **3.2.7 Visual User Interface**

The following are the requirements that were identified for the visual user interface:

- An electronic display with  $\mu\text{C}$  compatibility that would allow for bi-directional communication between the display and the controller.
- An electronic display that would detect and interpret haptic (touch) input from the user and transmit the input to the  $\mu\text{C}$ .
- An electronic display with provision for an external SD card, which would be used as an external memory bank for storing all data and information of the rehabilitation system.

### **3.2.8 Safety**

One of the most important design considerations of this system was safety. All the effort in developing the system would be a failure if safety was not considered during design. The following are the safety considerations that were made:

- Regulation of the input power from the power source to ensure optimal function of the rehabilitation system and also to prevent surges which would disrupt normal system operation or damage of the various electronic components within the system.
- Regulating the voltage and current flowing through the HE to prevent damage of the actuators and unpredictable actuation behaviour on the hand.
- Regulating the voltage and current going to the WE to prevent damage of the actuator and hyperextension of the wrist.
- Algorithms to restrict the ROM by using sensors to detect the angular position of the actuators.

## Section III – Software Development

It was necessary to develop algorithms that would control and coordinate the function of the elements of the rehabilitation system. All the elements that would require digital control were to be operated using a  $\mu\text{C}$ . The use of a  $\mu\text{C}$  required the development of algorithms to control the different operations that would be performed by the  $\mu\text{C}$ . The following are the operations that would be governed by the  $\mu\text{C}$ :

- Interpreting data from external memory and implementing algorithms for displaying rehabilitation routines on the visual user interface of the rehabilitation system.
- Interpretation and processing haptic input from the visual interface.
- Controlled actuation of the HE's robotic attachments.
- Controlled actuation of the movable component of the WE.

## **Chapter 4 – Experimental Methodology**

This chapter provides an overview of the study design and describes, in detail, all the testing methods and procedures that were followed during the period of experimental study of the rehabilitation system. The ethical considerations that were made prior to the experimental study are also highlighted in this chapter.

The protocol used in this pre-clinical study was designed on the basis of the common observation in limb rehabilitation; that the amount of time spent in rehabilitative training is directly correlated to the functional ability of the limb that is undergoing rehabilitation (Beery, Buktenica, & Beery, 1997). Several studies indicate that more time spent in training results in an improvement of function of the affected limb. With robot-aided therapy, progressive research has revealed that it is critical to focus on task-oriented training, which is not only useful in regaining the muscle strength and ROM that has been lost but also the restoration of skill and ability of the affected limb (Balasubramanian et al., 2010). Motor strength and dexterity of the NDH were therefore the factors that were chosen for analysis during this study.

### **4.1 Purpose of the experimental study**

The aim of the experimental study was to investigate the effects of repetitive writing exercises on the NDH and the impact of the rehabilitation system on motor function of the hand, specifically grip strength and writing accuracy.

### **4.2 Study Design**

The study was conducted in three phases consisting of assessment tests and rehabilitative training as depicted in the flowchart in Figure 13. Standardized assessment tests were administered to each participant in each of the three phases, however, rehabilitative training

was only conducted in the second and third phases. The three phases are described in the following subsections.

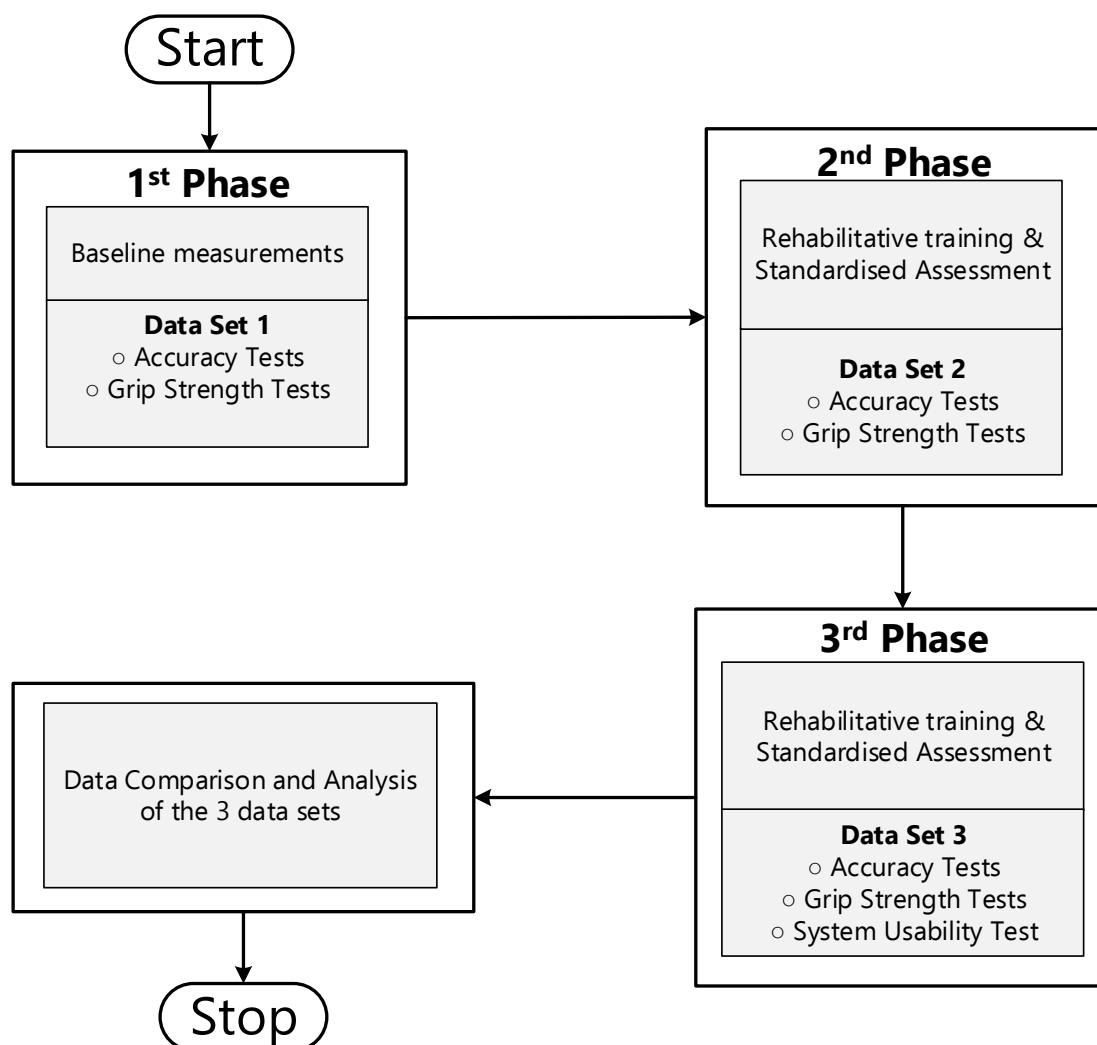

Figure 13: Experimental study design flowchart

### 1<sup>st</sup> Phase

This phase involved the recording of baseline measurements using standardised assessments prior to commencement of rehabilitative training. The participant was required to participate in the assessment tests and the results used as the baseline or reference through the entire period of study. The baseline measurements were used to assess progress during rehabilitation and also in analysing the final outcome of the study. The same tests used for obtaining baseline

measurements were also used for assessment at two-week intervals after rehabilitative training. Writing accuracy and grip strength are the factors that were evaluated using the standardised tests which are further discussed in section 4.4.

### **2<sup>nd</sup> Phase**

The main activity of the second phase was rehabilitative training which was conducted over a two-week period. The activity which the participant was engaged in during rehabilitative training was writing practice using the rehabilitation system. This involved the tracing of patterns displayed on the screen using the NDH with the aid of the HE. Training was administered for 30 minutes each day, 5 times a week for a period of 2 weeks. This translated to a total training time of 150 minutes per week. After 2 weeks of training, the participant was subjected to the standardized assessment tests and the results recorded and stored for analysis. The procedure of rehabilitative training is discussed in detail in section 4.4.

### **3<sup>rd</sup> Phase**

In this final phase, the same rehabilitation routine was administered for an additional 2 weeks after which the final set of data from the standardised assessment tests was collected. At the end of the study, each of the participants had trained for a total of 20 sessions.

Data obtained from the three phases was compiled for evaluation and analysis based on the outcome measures discussed in section 4.6. An additional assessment method that was administered in this phase of the study is System Usability Assessment. Through this method, user feedback was sought from each participant using the standardised scale depicted in Appendix B. From the standardised scale, an overall score was determined for each participant based on their responses. This method of assessment is further discussed in section 4.6..

## **4.3 Characteristics of the study population**

The study population consisted of 3 adult male participants aged 25, 32 and 37 years respectively. Participants from the university postgraduate population were identified and recruited for the study. They were fluent in English and had full capacity of decision making. They had no form of adaptation in the skilful use of both the left and right hand I.e. ambidexterity.

### **4.3.1 Inclusion Criteria**

Only subjects with a dominant right hand were included for the study. Any subject with a form or adaptation in the skilful use of both the left and right hand was not included in the study. Only subjects with finger sizes in a suitable range compatible with the HE were recruited for the study. This was determined by the ability to flex and extend the fingers and to firmly grasp the stylus of the rehabilitation system using all three fingers (thumb, index and middle) with the HE fitted to the dorsal side of the hand.

### **4.3.2 Exclusion Criteria**

Subjects with psychiatric conditions, neurological conditions, neuropathies, osteoarthritis, rheumatoid arthritis, upper limb injuries, impairments or fractures sustained within the last year were not recruited for the study. Subjects that required any form of assistance in performing the basic ADLs and instrumental ADLs were also not included in the study.

## **4.4 Testing Procedures and Data Collection**

The research procedure included baseline measurements, rehabilitative training and standardised assessment at the end of each block of rehabilitative training. Baseline

measurements were used as a reference in assessing the progress during the study and in analysis of the final outcome. Baseline measurements included quantitative assessment of grip strength and qualitative assessment of accuracy in writing. The same tests that were used for obtaining baseline measurements were also used for assessment at the two-week intervals.

### **4.4.1 Grip Strength Tests**

Two tests were employed to quantitatively measure the grip strength of the participants namely power grip and lateral grip tests. These tests were conducted at two week intervals over a four week period by an occupational therapist at the Occupational Therapy Department at Groote Schuur Hospital.

The power grip test measures the combined gripping force of all the fingers of the hand. The power grip strength of each participant was measured using the calibrated Jamar hand dynamometer shown in Figure 14. The dynamometer requires about 1.4 to 2.3 kilograms of force to induce a force that can be read on the dynamometer's scale (Roberts et al., 2011).



*Figure 14: The Jamar Adjustable Hand Dynamometer*

For baseline measurements in the first phase of the study, the grip strength of both the DH and NDH was determined. However for the subsequent measurements of the second and third phase, only the NDH was subjected to this test.

A standardised set of instructions were followed whilst conducting the test with specific instruction on how to grip and release the hand dynamometer. The participant was required to sit on a chair with the back straight, resting against the backrest and feet flat on the floor with knees at 90°. The participant's shoulder was to be adducted and neutrally rotated, elbow flexed at 90° with the forearm and the wrist in neutral position. With the handle fixed in the appropriate position, the participant was asked to squeeze the handle of the dynamometer and the occupational therapist took three readings. The average of the three readings was determined and used as the result. The DH and NDH were alternated for each reading that was taken. Figure 15 is an illustration of how the power grip of the participant was tested. The dynamometer had five different handle positions for altering the span of grasp. However, in this study, the neutral position, which is position 3, was used.



*Figure 15: An illustration of the body during the power grip test*

The lateral pinch grip test was used to measure the combined gripping force generated by the intrinsic muscles of the thumb and index finger of the hand being assessed. The Hydraulic pinch gauge shown in Figure 16 was used to conduct this test.



*Figure 16: The Jamar Hydraulic Pinch Gauge*

The testing procedure was identical to that of the power grip test except for the fact that only the thumb and index fingers were used in generating the grip force that was measured by the dynamometer. Figure 17 is an illustration of one of the participants undergoing the pincer grasp test. Unlike the previous test, there was no variation of gripping positions as the dynamometer used did not have such a provision. The gripping force of both the DH and NDH was measured and recorded.



*Figure 17: The pinch grip test*

## 4.4.2 Writing Accuracy Tests

For this study, two sets of tests were adopted and used to assess accuracy in writing namely the trace sample test and the writing accuracy test. The trace sample test is a component of the widely known Smith Hand Function Test. It requires the participant to perform various writing tasks namely tracing round a rectangle, tracing a curved line and signing using the NDH. The trace sample test is available in Appendix C. While performing these tasks, the participant was timed and the results recorded. This test was performed on both the DH and NDH. The results were assessed both quantitatively and qualitatively. The DH was used as the reference for comparing and analysing changes during rehabilitative training and at the end of the rehabilitation period. For quantitative analysis, time was used as the unit of measurement whilst visual comparison was used to analyse the results qualitatively.

The writing accuracy test was the second set of tests used to assess accuracy in writing. The participant was required to reproduce a set of 18 different pattern sequences in the fastest time possible, using the NDH, whilst striving to be as accurate as possible. The basic shapes, used during rehabilitative training, were also included in the test. The complete writing accuracy test comprising all the pattern sequences is available in Appendix A. All the pattern sequences used in the test, except the basic shapes, were adopted from the writing retraining programme of the occupational therapy department at Tygerberg Hospital.

## 4.4.3 Rehabilitative training

The rehabilitation system was the tool which was used for rehabilitative training in the second and third phases of the study. The main activity carried out during rehabilitative training was repetitive writing practice using the rehabilitation system under supervision of the researcher.

The HE, which is a primary component of the system, was fitted to the dorsal side of the thumb, index and middle fingers of the NDH of the participant as shown in Figure 18. With the forearm of the participant fastened to the rehabilitation unit, the rehabilitation system was switched on by the researcher and the participant guided in initiating the rehabilitation routine. The

rehabilitation system provides three modes of operation as shown in Figure 48. The functioning of these modes is illustrated in section 5.3.

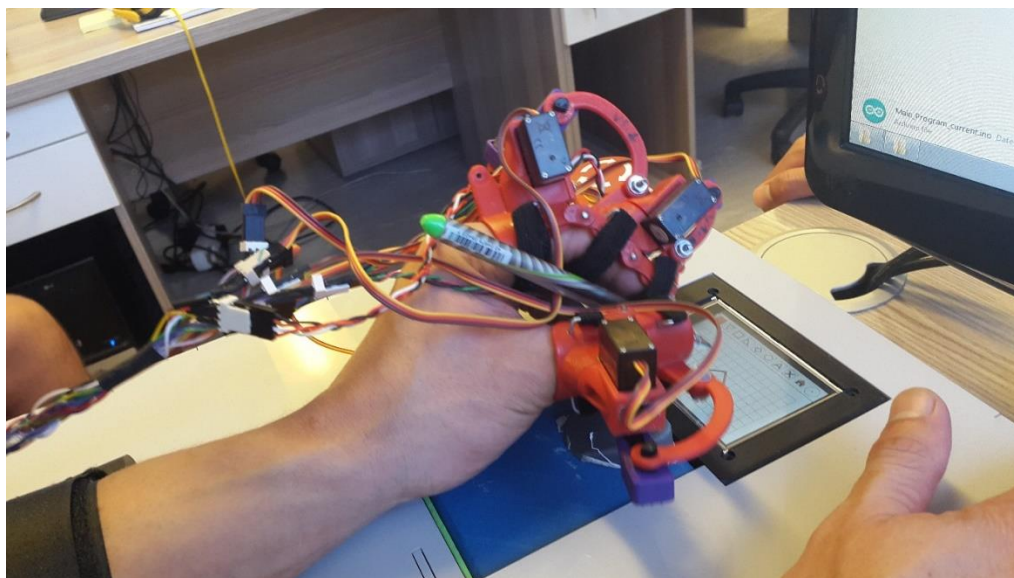

*Figure 18: The forearm during rehabilitative training*

The single select and dual modes required active participation of the researcher while the participant performed the rehabilitation routines whereas in auto play mode, the researcher did not have to be actively involved. As a result, the single select and dual modes of operation were used as trial runs to familiarise the user (participant) with the system before each training session. After the trial run, the auto play mode was used for the remainder of the training session. Different patterns in the form of basic shapes, stored in the memory chip of the rehabilitation unit were displayed on the touch screen. The participant had 3 seconds to set the stylus in position on the red dot as shown in Figure 19 and after the 3 seconds lapsed, the HE actuated the participant's fingers in a coordinated manner to trace the shape that was displayed on the screen in a particular direction. A total of six shapes were used or practice during training. Figure 19 illustrates the basic shapes that each of the participants was subjected to repetitively trace throughout the period of rehabilitative training.

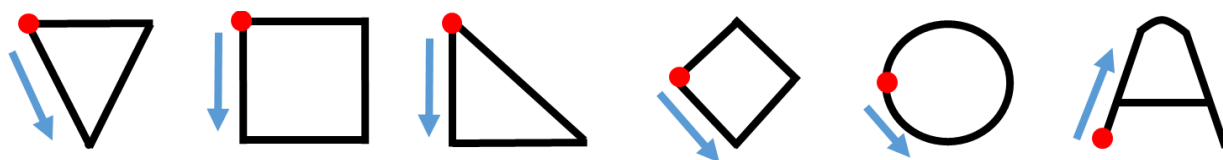

Figure 19: The predefined patterns used for rehabilitative training

During rehabilitative training, the blue arrows shown in Figure 19 were not displayed on the screen. Only the red dots were visible to the user. The red dots guided the user on where to place the tip of the stylus prior to rehabilitative action by the system.

## 4.5 Data Analysis

### 4.5.1 Accuracy

Accuracy was assessed using the trace sample and writing accuracy tests. Similar to the grip strength tests, the baseline test results were also used as a reference for analysing the subsequent tests results both quantitatively and qualitatively. For quantitative analysis, the time taken to complete the writing tasks at the beginning and end of the study was compared. The improvement in completion time was calculated and expressed as a percentage using the formula below:

$$\% \text{ Improvement} = 100 - \left( \frac{3^{\text{rd}} \text{ phase result}_{(NDH)}}{\text{baseline result}_{(NDH)}} \times 100 \right)$$

The same formula used to calculate the percentage improvement in the trace sample test was used for the writing accuracy test. The writing accuracy test completion time was assessed in conjunction with qualitative assessment of writing accuracy. For qualitative analysis, the results of the writing tasks of the 3<sup>rd</sup> phase were compared with those of the baseline and 2<sup>nd</sup> phase to assess improvement in accuracy.

## 4.5.2 System Usability

The system usability scale (SUS) shown in Appendix B is a standardised scale that was used to obtain feedback from the user based on the experience whilst using the rehabilitation system in order to gauge the system's ease of use. The scale has got 10 evaluation items and depending on the response of the user, a score was determined for each item. An item attracted a minimum score of 1 if the user strongly disagreed with the item clause or a maximum score of 5 if the user strongly agreed.

The score contributions for each of the items were then used to determine an overall score. The score contribution for items 1,3,5,7 and 9 were determined by subtracting 1 from the score that was initially determined. For the rest of the items, the score contribution was determined by subtracting the initial score from 5. The score contribution for each item was summed up to obtain a total value and the value multiplied by 2.5 to obtain the overall score for each user. The overall scores for the users were summed up and the average determined. This average was used as a measure for estimating the usability of the system.

## 4.5.3 Grip Strength

The following definitions were formulated to simplify the description of how the experimental results were analysed:

- **Baseline difference:** This is the difference in value between the baseline strength of the DH and that of the NDH for each participant.

$$\text{Baseline difference} = \text{baseline}_{(DH)} - \text{baseline}_{(NDH)}$$

- **Grip strength difference:** This is the difference between the value of grip strength tested before rehabilitation and the value tested after 4 weeks of rehabilitation for each participant.

$$\text{Grip Strength Difference} = 3^{\text{rd}} \text{ phase}_{(NDH)} - \text{baseline}_{(NDH)}$$

The baseline results of both the DH and NDH were used as a reference for assessing power and lateral grip strength of each participant. The results of the subsequent tests were then

compared with the baseline measurements to determine whether there was an improvement or regression in grip strength during the period of study. The results of grip strength, both power grip & lateral grip, were analysed under two main domains:

- Change in grip strength of the NDH over the 4 week period.
- Change in grip strength of the NDH in relation to the DH.

These domains were analysed for each participant and also collectively across all the participants involved in the study. The first step taken in assessment of grip strength was to determine the difference in strength between the DH and the NDH of each of the participants. The formula used to determine the percentage difference is:

$$\% \Delta \text{Grip Strength} = \frac{\text{baseline difference}}{\text{baseline result}_{(NDH)}} \times 100$$

The mean and standard deviation of the test results was calculated for each of the participants and tabulated. To analyse the change in grip strength of the NDH over the 4 week period, the baseline result of the NDH was used as a reference to which the subsequent results were related. For analysis of the change in grip strength of the NDH in relation to the DH, the results measured and recorded at the 2 week intervals were expressed as a percentage of the baseline result of the DH, which was used as the point of reference. The following formula was used:

$$\% \text{ difference in grip strength} = \frac{\text{phase result}_{(NDH)}}{\text{baseline result}_{(DH)}} \times 100$$

The percentage change from the baseline value was calculated by subtracting the % value of the difference in grip strength from 100. The results of all the participants were averaged at the two week intervals and used to formulate graphs for analysing the change in grip strength of the NDH.

The average change in grip strength across the participants after the 4 weeks of rehabilitation was determined by calculating the mean of grip strength difference. The absolute values of grip strength difference for each participant were averaged to obtain this value.

## 4.6 Outcome Measures

There were three outcome measures that were used in assessing the performance of rehabilitation system and its effect on the participants involved in the study. These measures are discussed in the following sections.

### 4.6.1 Accuracy

A larger percentage improvement meant a faster speed of completion. A progressive decrease in the time taken to complete tasks with increasing accuracy was an indication that coordination may have improved as a result of rehabilitative training. If the completion time decreased and accuracy deteriorated as analysed visually, then this was an indication that the rehabilitation system did not improve hand coordination. Increasing accuracy and increased completion time indicated that the system motivated the user to focus and concentrate while completing the writing tasks. Qualitative analysis was conducted by visually assessing how well patterns were reproduced by the participant. An increasing improvement in accuracy over the four week period was an indication that hand coordination had improved.

### 4.6.2 System Usability

The usability of a system when evaluated using the system usability scale is estimated using a single score (Bangor, Kortum, & Miller, 2008). The overall score ranges from 0 -100 and it is important to note that the overall score of this scale is not a percentage, a mistake that is commonly made by many researchers (Brooke, 2013).

The extensive collection of normative data by Bangor et al. (2008), was used as a basis for meaningful interpretation of the overall score (Bangor et al., 2008). Any value below 50 rendered the system to be generally unacceptable whilst a value between 50 and 70 was

considered to be marginal. An overall score above 70 categorised the system as above average and generally acceptable (Brooke, 2013).

### **4.6.3 Grip Strength**

When analysing change in grip strength of the NDH over the 4 week period for each participant, a percentage value greater than 100 indicated that the result had exceeded the initial measurement recorded at the baseline, and thereby indicating an improvement in the grip strength of the NDH. The higher the percentage value, the greater the improvement in strength. Any result with a value below 100 was an indication that the grip strength recorded was lower than the baseline measurement, which meant a decrease in grip strength.

The percentage value obtained when analysing change in grip strength of the NDH in relation to the DH gave an indication of the degree to which grip strength of the NDH had changed in relation to the baseline result of the DH. A small percentage difference value suggested that the grip strength of the NDH may have been improving in relation to that of the DH. A progressively increasing percentage change value over the 4 week period was an indication that the grip strength in the NDH was improving in relation to the DH. A percentage value greater than 100 was an indication that the grip strength of the NDH had exceeded that of the DH.

## **4.7 Ethical Considerations**

### **4.7.1 Ethical Approval**

It is a requirement that before commencement of any study, ethical approval must be sought by application from the relevant bodies. The protocol of this experimental study was therefore documented and submitted for review to UCT's Human Research Ethics Committee for the Faculty of Health Sciences. Formal ethical approval for the study was granted (HREC REF:

711/2016) and is available in Appendix F. Following approval by the ethics committee, an application was made to request for access to UCT students for research purposes. The request was granted and the proof of approval is available in Appendix G.

### **4.7.2 Consent**

Prior to the study, each potential participant was verbally interviewed by the researcher to determine eligibility for recruitment. Hereafter, each participant was provided with an Informed Consent Form which gave a brief overview of the experimental procedure. Ample time was allocated for the participant to familiarise with the procedures after which, the researcher gave a detailed verbal explanation of the procedures to each of the participants. All the participants signed the written informed consent form prior to inclusion in the study.

### **4.7.3 Possible Risks and Safety Concerns**

Rehabilitative training using the rehabilitation system was a harmless and non-invasive exercise. During rehabilitation, the healthy participants were not subjected to perform any movements that predisposed their hands and fingers to unnatural positions. The participants may have experienced minimal discomfort whilst using the standard size HE which is a result of variation in the physical size of fingers amongst the participants. There was, however, no significant harm that resulted through the entire period of study.

### **4.7.4 Emergency care and insurance for research-related injuries**

The study was covered by the UCT no fault insurance policy. The UCT no fault insurance policy states that participants will be provided with emergency care in the event that they experience deterioration in health or well-being, or from any unexpected sensitivity or toxicity, which is

caused by participation in the study. Participants of this study were informed of their right to the UCT no fault insurance policy in the consent form and their obligation to report any side effect and/or injuries sustained during the study to the researchers immediately.

## Chapter 5 - Design Outcome

This chapter broadly discusses the implementation of the outlined design considerations and the evolution of the preliminary design of the rehabilitation system to the final working product. The three major sub-systems are discussed under the following sections; Mechanical Design, Electrical and Electronic Design and Software Development.

### 5.1 Mechanical Design

#### 5.1.1 Rehabilitation Unit (RU)

The RU in Figure 20 was designed using SolidWorks, a 3D Mechanical modelling software. With portability as one of the factors of consideration, this unit was designed to be as compact as possible.

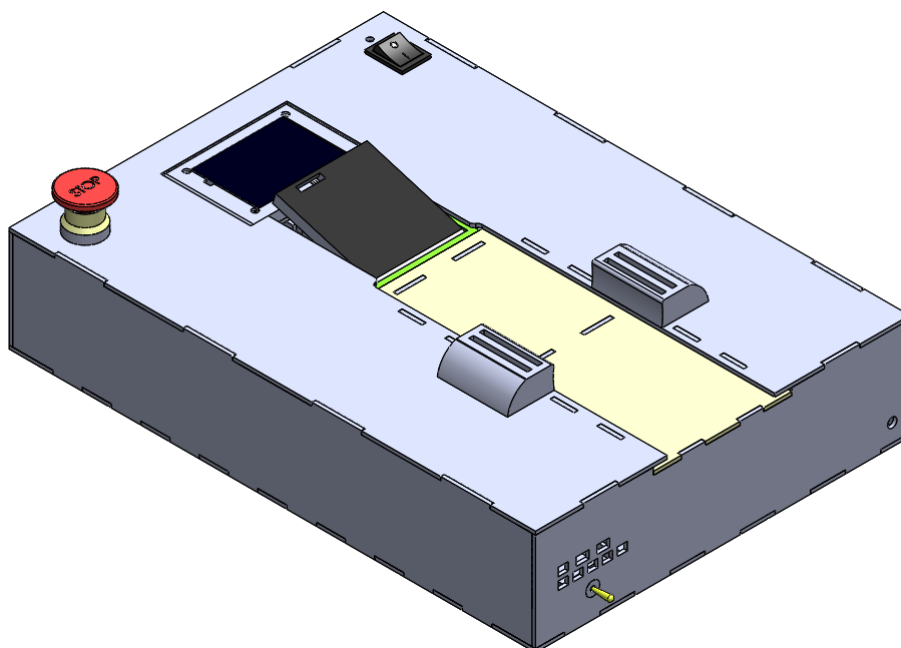

Figure 20: The Rehabilitation Unit

The dimensions of the rehabilitation unit were therefore designed and determined to be 350 x 320 x 92 mm. Figure 21 is a schematic representation of the various parts that make up the rehabilitation unit and Table1 gives the indices for the labels.

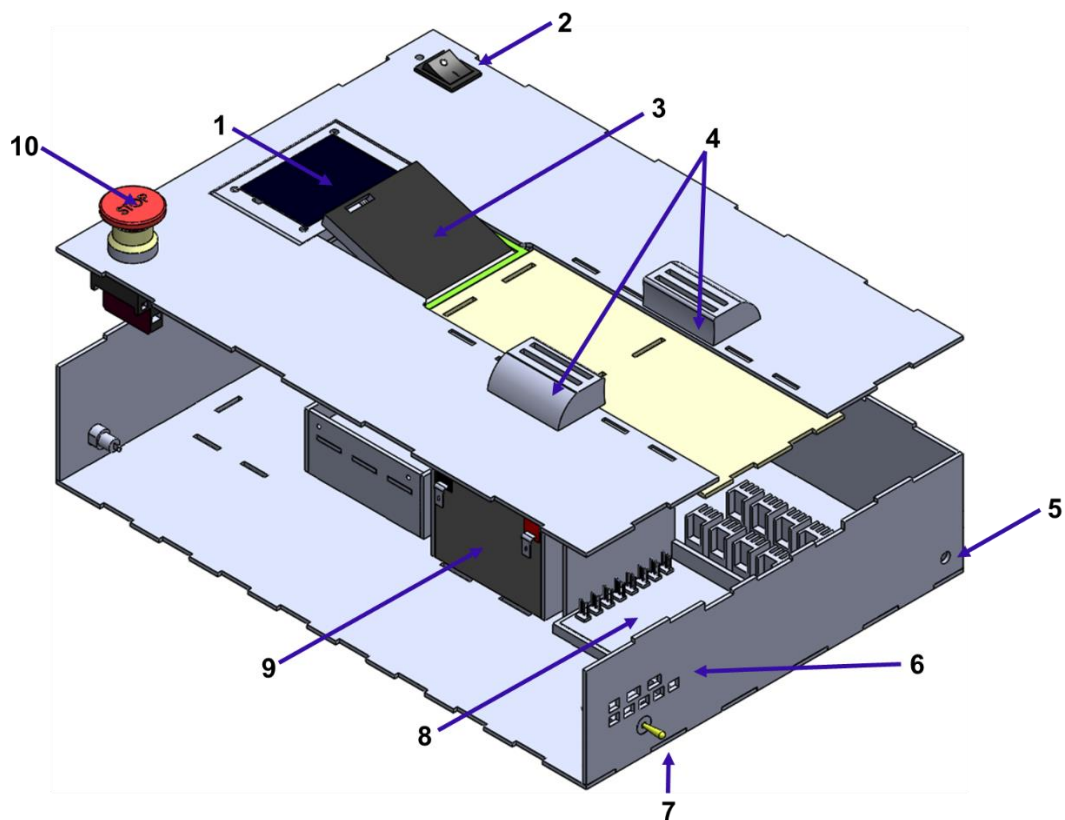

Figure 21: Schematic representation of the rehabilitation unit

Table1: Indices for the schematic representation of rehabilitation unit

| Label | Name             | Label | Name                  |
|-------|------------------|-------|-----------------------|
| 1     | Visual Interface | 6     | Exoskeleton Socket    |
| 2     | Power Switch     | 7     | Toggle Switch         |
| 3     | Wrist Element    | 8     | Main Circuit Board    |
| 4     | Arm Fixators     | 9     | Battery               |
| 5     | DC Adapter Port  | 10    | Emergency Stop Button |

The average length of the human forearm excluding the hand as calculated in section 3.2.2 is approximately 270mm. With a length of 320mm, the RU accommodated for the forearm. It was a design requirement to restrict the lateral movement of the forearm whilst performing writing tasks. This was achieved using the arm fixators shown in Figure 21, which were incorporated into the preliminary design of the unit. The fixators were designed to have a hook and loop fabric fastener running around them, which was used to secure the arm. A space of 80 mm between the fixators was provided for resting and securing the forearm. Ergonomic design for the forearm was not taken into consideration during design, however, the forearm fitted well enough for the user to comfortably perform the rehabilitation routines.

The height of the unit was mainly determined by that of the battery, which had the largest dimension of the components of the system. The battery also had the highest weight value of the components. With the battery laid flat in the horizontal position as shown in Figure 21, its height was reduced from 99mm to 71mm, which allowed the design to be more compact.

### **Choice of Material**

After completion of the design, a material was identified for fabricating the designed parts. Factors like strength and weight influenced the choice of the material mainly due to the portability requirements. With the battery weighing 1.4kg and the arm weighing approximately the same as the battery, the RU needed to bare approximately 3kg during operation. Acrylic sheet, commonly known as Plexiglas was chosen as the fabrication material. Acrylic sheet is a light weight thermoplastic, which allows ease of system relocation. Rigidity of the material was beneficial in bearing the weight of the components within the RU and the weight of the forearm. In the event of an accident in handling the RU, this material would still stand a chance of surviving damage due to its shatter resistant properties. The structural integrity is further discussed in section 5.4.

ABS was initially chosen as the fabrication material for the rehabilitation unit. Its toughness and rigidity, resistance to impact and light weight properties made it the unrivalled choice for fabrication. It was, however, not suitable for laser cutting as the parts would melt and reunite

during the cutting process. This made it very difficult for the laser cutting machine to produce a complete segmentation from one end of the sheet to another. Besides that, it released cyanide gas during the cutting process, which is a very toxic gas and poses a major health risk to the surrounding environment. For this reason, acrylic sheet was used as the alternative. Acrylic sheet is slightly weaker and comparatively more brittle than ABS. It is, however, tough, fairly rigid and can easily be fabricated or machined. Furthermore, the material has the added advantage of lighter weight and cheaper cost.

### Fabrication

2D laser cutting was determined to be the most convenient method to use for fabricating the designed parts given the time constraint and the resources available at the time of design and development. 3mm thick Acrylic sheets were purchased and used for manufacturing the rehabilitation unit. All the parts shown in Figure 21 were specifically modelled for laser cutting except the WE, the housing of the visual user interface and the fixators. The parts, which were not manufactured by laser cutting, were 3D-printed together with the small components for securing the electronic circuitry and  $\mu\text{C}$  within the unit. 3D printing was a better manufacturing option due to the complex structures, which would not be successfully manufactured using the laser cutting machine. Figure 23, 23 & 24 are the drawings that were generated from the SolidWorks designs and used for the laser cutting procedure. Only the main blocks (top & bottom, front & back, left & right) of the RU are labelled on the drawings for simplicity.

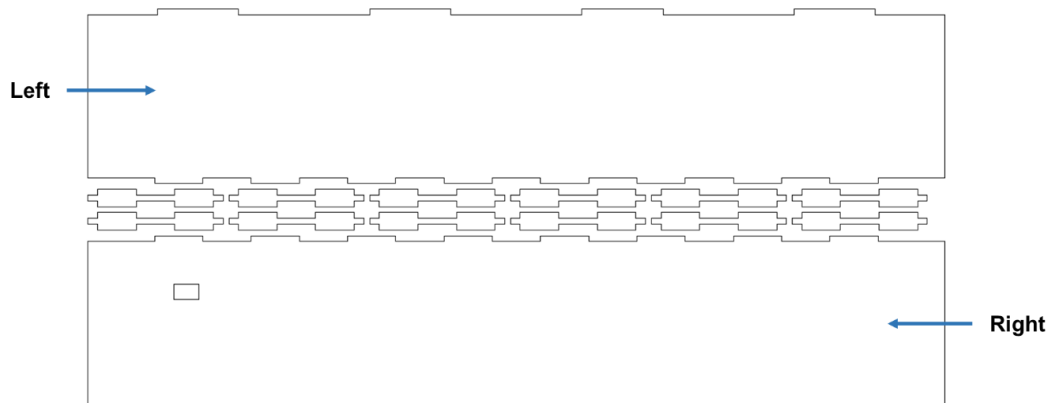

Figure 22: Drawing layout (444x207mm) for 2D-laser cutting

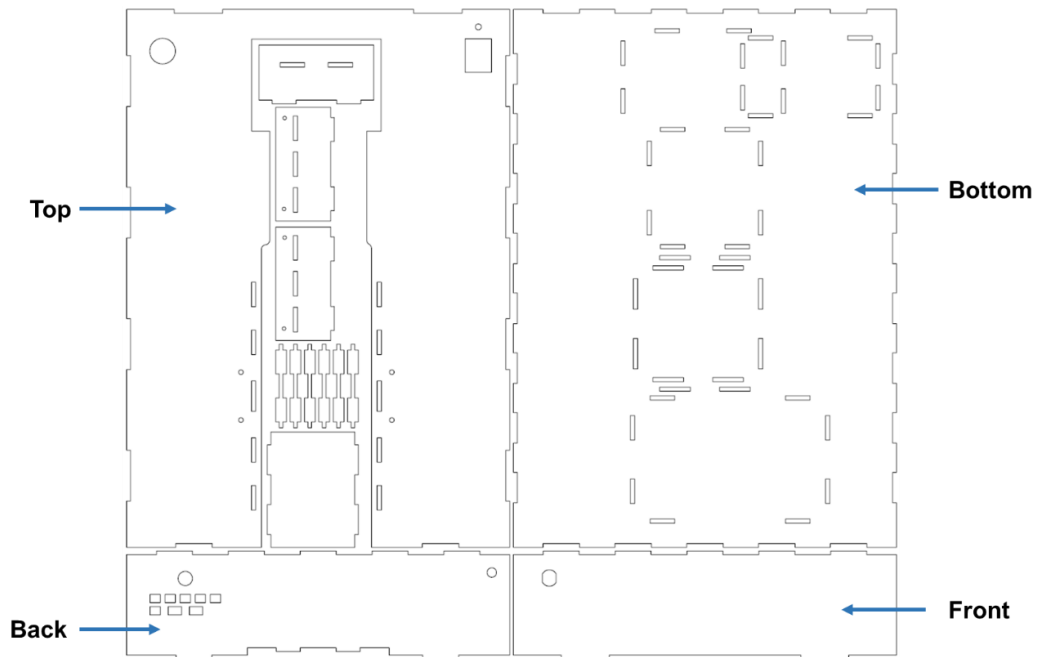

Figure 23: Drawing layout (643x450mm) for 2D-laser cutting

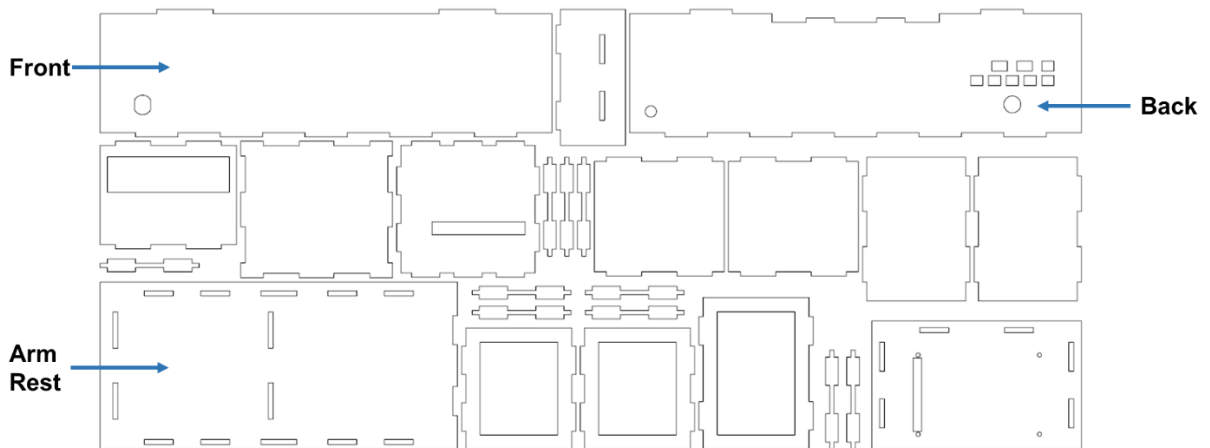

Figure 24: Drawing layout (695x312mm) for 2D-laser cutting

## 5.1.2 Wrist Element (WE)

To simulate wrist functionality, a WE was designed in SolidWorks. The WE is made up of a base unit, vertical lever, wrist support, servo motor and servo arm as shown in Figure 25.

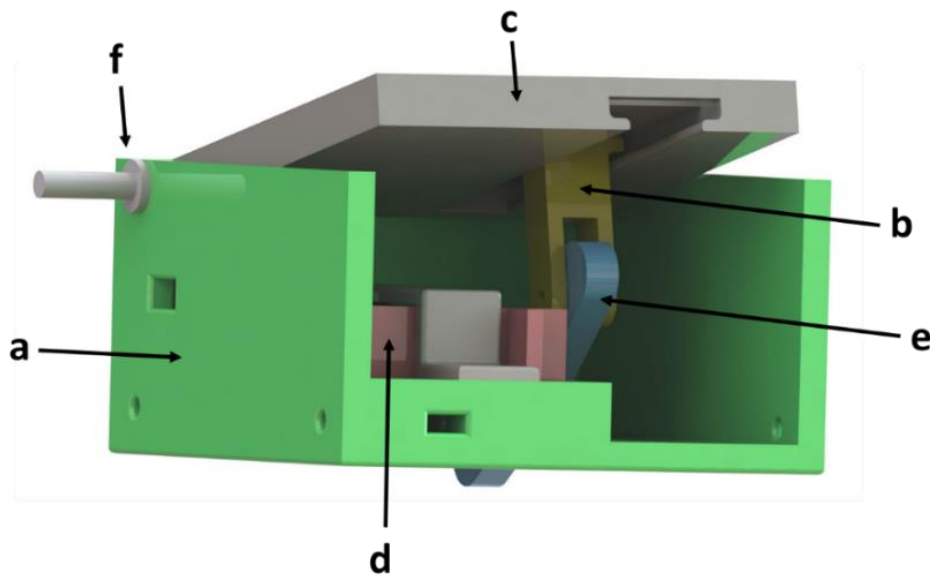

Figure 25: Parts of the WE a) Base Unit b) Vertical lever c) Wrist support d) Servo motor e) Servo arm f) Pivot

All the parts that make up the WE were 3D printed from extruded ABS material with the exception of the actuator. 3D printing made the parts less costly to fabricate but relatively weak when compared to the force that is output by the actuator. In the unlikely event of extension or flexion beyond the limits, the actuator would translate the vertical lever beyond the mechanical limits and possibly cause breakage of the 3D printed parts which would then have to be replaced.

The servo arm of the WE was designed to be directly connected to the rotary shaft of the servo motor. During actuation, the servo arm would rotate and translate the vertical lever in a circular motion. The motion of the vertical lever caused the wrist support to be lifted and thereby momentarily lifting the wrist of the user. During the design process, it became apparent that a physical working model of the WE was required to fine tune the design. The WE model was 3D printed and used in calculations to finalize the design.

It was noted that the wrist support of the WE would move both vertically and horizontally during operation. Figure 26 illustrates the horizontal and vertical movements that the wrist support would make. The horizontal displacement of the point P on the wrist support is

denoted by ' $x$ ' while the vertical displacement is denoted by ' $y$ '. The angle (in degrees) rotated is given by  $\theta$  as shown in Figure 26.

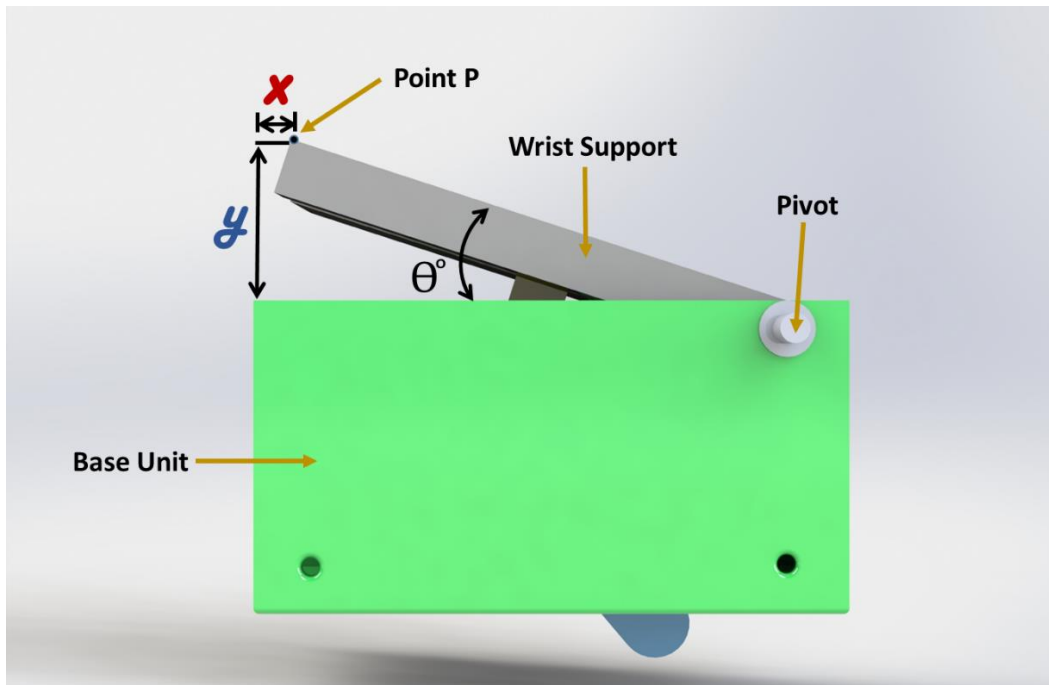

Figure 26: Illustration of translation movements of wrist support during flexion and extension

The horizontal displacement ( $x$ ) was determined to be negligible when compared to the vertical displacement ( $y$ ). Table 2 gives the results of the brief analysis of vertical movement in relation to horizontal movement, including the angle of rotation of the wrist support.

Table 2: Planar displacement analysis of the wrist support

|                  | <b>Horizontal displacement , x (mm)</b> | <b>Vertical displacement, y (mm)</b> | <b>Angular Translation ( °)</b> |
|------------------|---|--------------------------------------|---------------------------------|
| <b>Flexion</b>   | 1                                       | 10                                   | 17                              |
| <b>Extension</b> | 4.5                                     | 21                                   | 47                              |

The user's wrist would not be significantly displaced horizontally during vertical displacement of the wrist support, which is a desirable outcome. The wrist support was also designed to mechanically restrict the simulated flexion-extension movements of the WE. The mechanical stopper shown in Figure 27 would prevent the actuator from over-flexing the wrist of the user. As the vertical lever slides along the groove, it reaches a dead end, which acts as a mechanical stopper and prevents over-extension of the wrist.

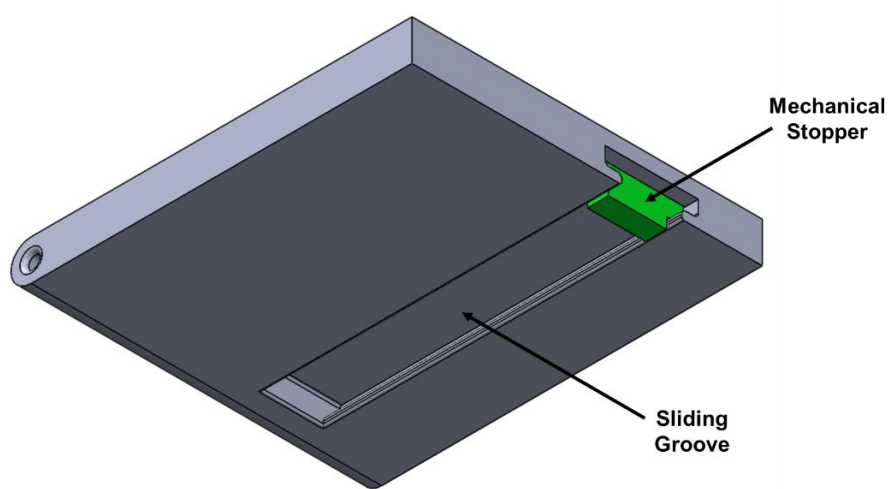

Figure 27: The wrist support showing position of mechanical stopper

To determine the torque required to lift the hand, the mechanism of operation of the WE was analysed. Figure 28 is an illustration of the lifting mechanism of the WE. The torque required to lift the hand using this mechanism was calculated as follows:

$$\cos 6 = \frac{x}{2} \therefore x = 2 \cos 6 \therefore x = 1.989 \text{ cm}$$

$$m = 0.52 \text{ kg} , \quad sf = 2.5$$

$$\text{Torque}(T) = \text{Force} \times \text{Perpendicular distance} \times \text{Safety Factor}(sf) = m \times x \times sf$$

$$\therefore T = 1.52 \times 1.989 \times 2.5 = 7.558 \approx 7.6 \text{ kg.cm}$$

In practice, the wrist support bears the weight of both the hand and the forearm. The average mass of the hand as determined in section 3.2.2 was 0.52 kg.

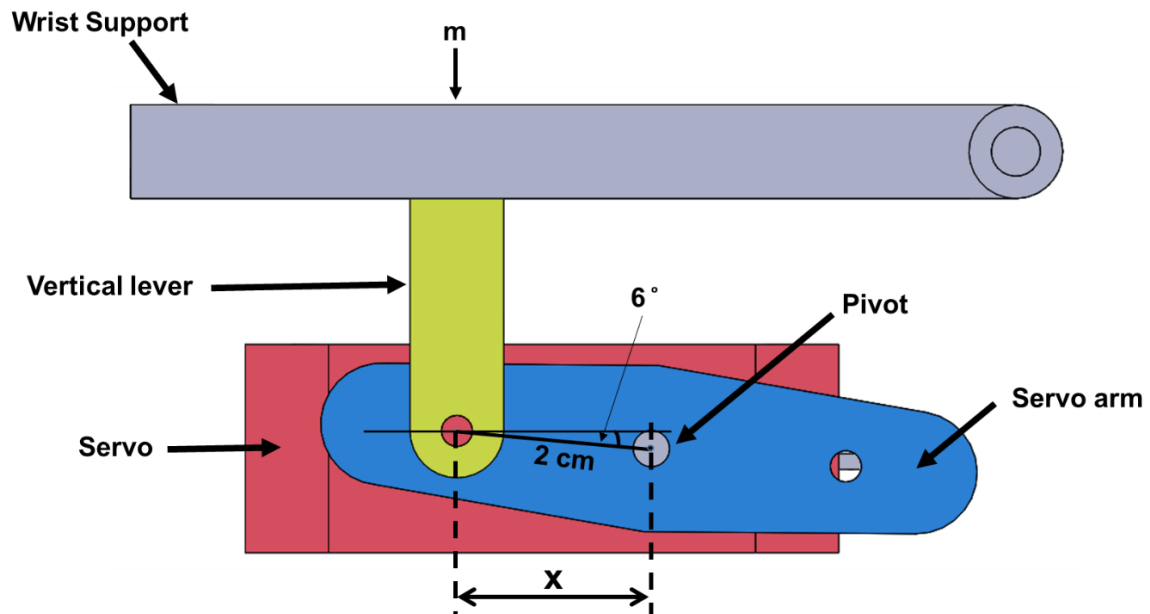

Figure 28: Mechanism of operation of the wrist element

An extra kilogram was therefore included in the calculation to account for the extra weight exerted by the forearm and also the vertical lever. The illustration depicted in Figure 28 requires maximum amount of torque. I.e. when the perpendicular distance ( $x$ ) between the pivot and the vertical lever is longest. In practice, while using the RU, the wrist of the user would not be positioned directly above the pivot point of the WE. An additional safety factor of 2 was consequently added to the calculation of torque for the wrist actuator to ensure that operation was not interrupted in the unlikely event that the torque requirement increased. It was therefore established that the actuator to be used for simulating wrist functionality was to have a minimum torque of 12 kg-cm as shown in the following calculation.

$$T = T \times sf = 7.6 \times 2 \approx \mathbf{15.2 \text{ kg.cm}}$$

The actuator used in the WE is discussed in section 5.2.2.

### 5.1.3 Hand Exoskeleton (HE)

In this research study, the left hand was chosen as the NDH and therefore the robotic attachments were specifically designed to be fitted to the dorsal side of the left hand. The HE comprises of 3 robotic attachments for the thumb, index and middle fingers allowing 5 DoFs.

The robotic attachment designed for the left index finger of the HE is shown in Figure 29. The attachment is made up of 3 segments; a proximal, a middle and a distal segment. The proximal and middle segments would each have a motorised component with an actuator and lever attached to it for actuating the distal segments. The levers have sensor holes for holding rotary sensors that detect the angular position of the segments. The design of the robotic attachment of the middle finger was similar to the index finger unit except for its longer dimension. The attachment for the thumb has 2 segments; a proximal and distal segment with a single motorised component and an actuation lever attached to the component. The actuators are discussed in section 5.2.2.

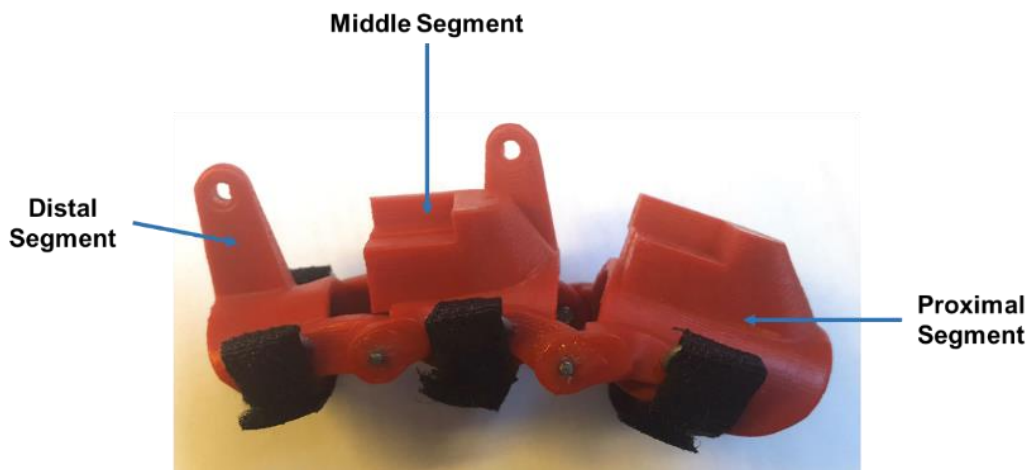

*Figure 29: Robotic attachment for the left index finger*

In the previous design of the HE discussed in section 2.2.4, it was identified that the assembly and disassembly of the parts of the HE was cumbersome. It was necessary to disassemble the parts for replacement as a result of wear and tear and additionally when there was need to change the control system parameters, which, were dependent on physical parameters. In order to access the actuators after assembly, disassembly would often lead to damaging of the actuator housing. A different design for the actuator housing, was therefore developed and replaced in all the robotic attachments of the HE. The advantage of the design is that it allowed the actuators to easily slip into position. Figure 30 provides a visual representation, comparing the current design of the housing with the previous design. The dimensions of the

actuator housing were adjusted to accommodate new motors, which were used with the new design.

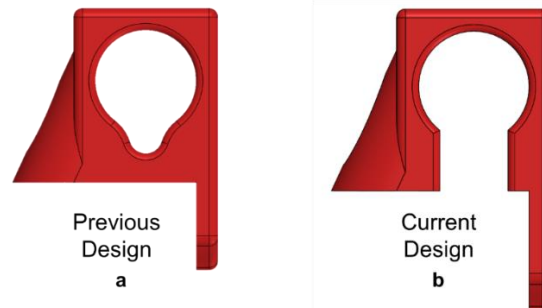

Figure 30: (a) Previous design (b) Current design of actuator housing component (top view)

The actuation levers of the robotic attachments were modified to improve the sensitivity and accuracy of the HE in actuating the segments of the robotic attachments. The rotary sensors on the HE have *dead bands* at the extreme rotation positions. *Dead bands* are regions on the sensor (potentiometer) where rotational changes cannot be measured because there is no change in the sensory signal upon rotation within these regions. In the design, it was necessary to ensure that actuation of the segments did not cause the sensors to rotate in the dead bands. The sensor holes were therefore rotated to adjust the starting angle of rotation on the lever of each component of the HE. Figure 31 provides a visual representation of the lever before and after adjustment. It can be noted from Figure 31 that the sensor hole has been shifted from the zero position by an angle of  $\alpha$ .

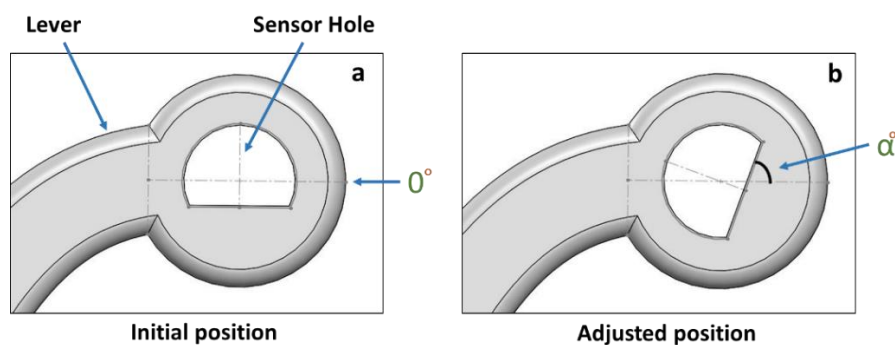

Figure 31: Angular position of sensor hole in the robotic attachment lever showing a) Initial position b) Adjusted position

This adjustment ensured that at maximum extension position, rotation of the potentiometer was safely out of the dead band region and hence every rotary change could be detected.

## 5.2 Electrical & Electronic Design

The system operation, safety mechanisms and the different components chosen for implementing the electrical and electronic system are discussed in this section. A schematic of the electrical circuit that was designed to operate the rehabilitation system is shown in Figure 32. When power from the main source is supplied to the circuit board, it initially passes through the voltage regulators which limit the voltage and current before being transmitted to the actuators on the HE, the WE and the  $\mu\text{C}$ .

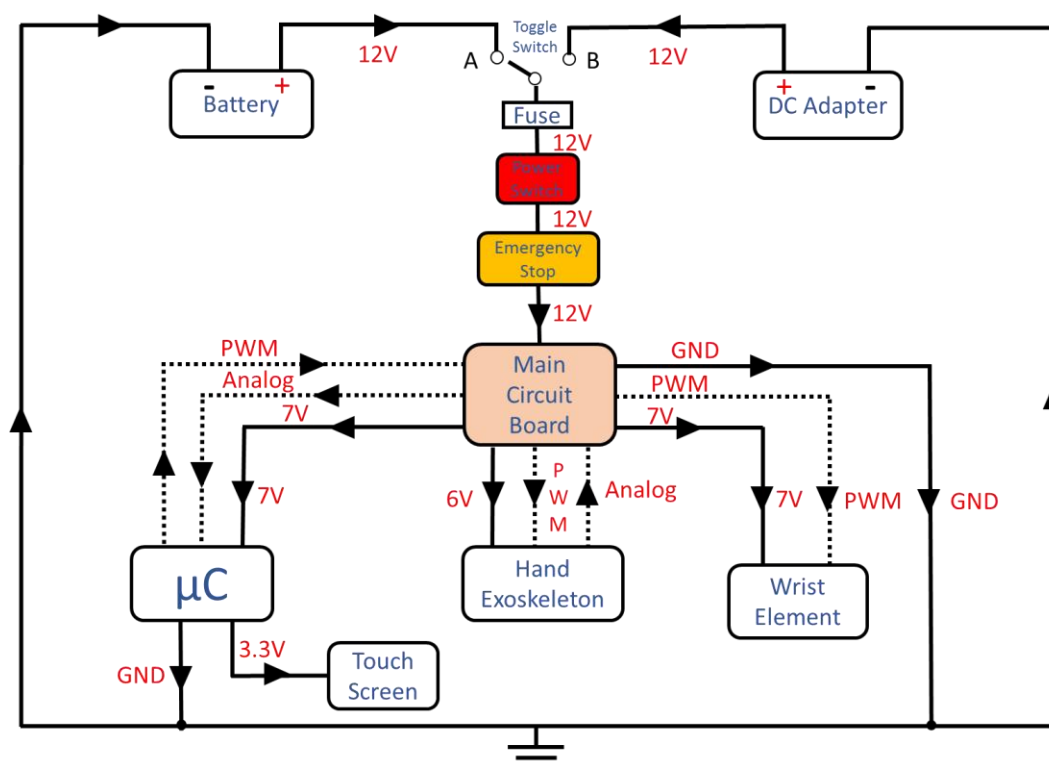

Figure 32: A schematic diagram of the electronic circuit of the rehabilitation system

The  $\mu\text{C}$  is the central processing unit of the system as it handles input and output data simultaneously to ensure that the rehabilitation system runs efficiently. The HE has sensors,

which transmit sensory data as input to the  $\mu\text{C}$  through the main circuit board. The  $\mu\text{C}$  digitizes the input signal and transmits the signal to the HE through the circuit board as illustrated in Figure 32. The  $\mu\text{C}$  provides power to the touch screen display connected to it and facilitates the display of information during rehabilitation routines. The different components that make up this system are discussed in the following sub-sections.

### Main Circuit Board

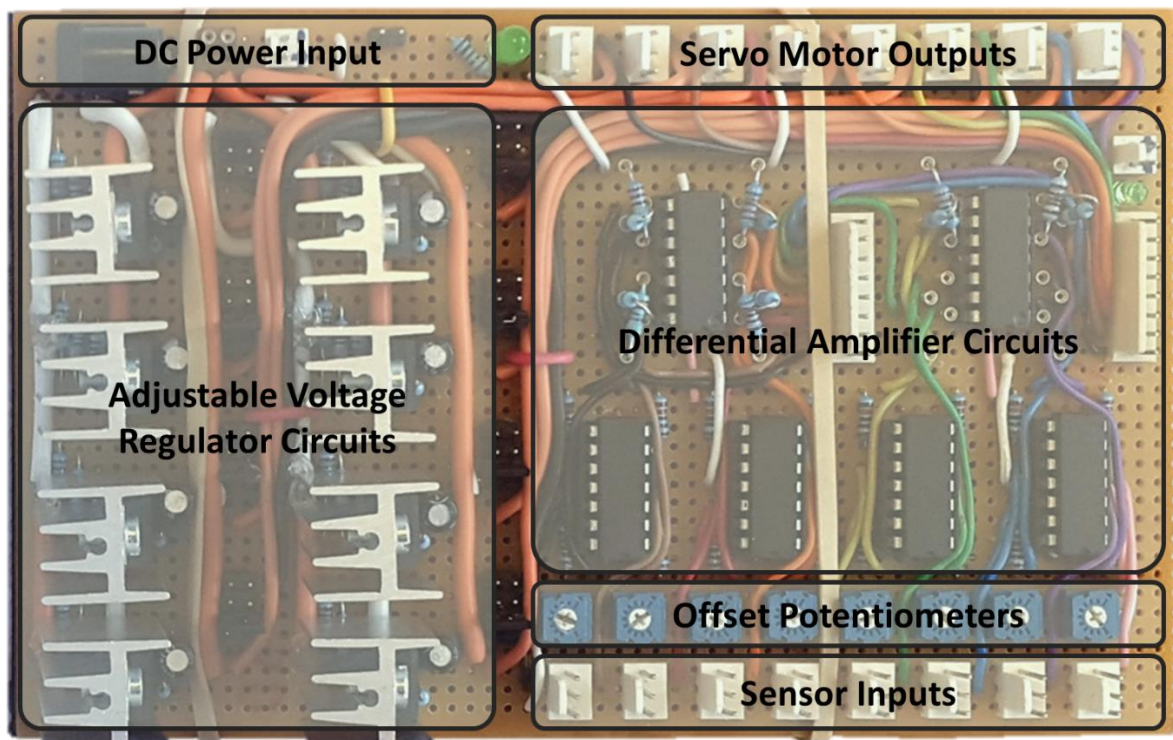

Figure 33: The Main Circuit Board of the rehabilitation system

The main circuit board consists of two major circuits; Adjustable voltage regulator circuits and differential amplifier circuits as shown in Figure 33. The voltage regulator circuits were implemented using voltage regulators which are further discussed in section 5.2.6. The differential amplifier circuits are implemented using integrated circuit chips discussed and illustrated in section 5.2.5. The board also consists of a DC power input, offset potentiometers, sensor inputs and servo motor outputs. When DC power is supplied to the DC power input, the input voltage of 12V is regulated by the voltage regulator circuits and channelled to provide power to the wrist element and hand exoskeleton actuators respectively. During

operation, digital PWM signals are sent from the  $\mu\text{C}$  to the main circuit board and used to control the position of the hand exoskeleton actuators and the wrist element.

Power for the differential amplifier circuit is provided by a regulated 3.3V from the  $\mu\text{C}$ . Each differential amplifier circuit takes input from the hand exoskeleton sensors connected to the sensor inputs and the offset potentiometers. The offset potentiometers are used to increase the usable range of the hand exoskeleton sensors as discussed further in [section 5.2.5](#). The differential output is amplified and sent as input to the  $\mu\text{C}$  for processing.

## 5.2.1 Power Supply

A power supply was necessary for the working of the  $\mu\text{C}$ , WE, touch screen display and the HE. Table 3 shows the power requirements of each of these components. The total maximum power that would be drawn by the system was calculated to be 61.6W. However, in practice, the system did not operate under full load and will therefore draw significantly less power than indicated. When using the external power supply, it was determined that the current drawn by the system did not exceed 0.8 A during rehabilitative training. The system was designed to operate from either of two power sources: an external and an in-built power supply.

*Table 3: Summary of rehabilitation system power requirements*

| <b>COMPONENT</b> | <b>MAX. VOLTAGE(V)</b> | <b>MAX. CURRENT(A)</b> | <b>MAX. POWER(W)</b> |
|------------------|------------------------|------------------------|----------------------|
| $\mu\text{C}$    | 7.0                    | 0.8                    | 5.6                  |
| WE               | 6.0                    | 1.5                    | 9                    |
| Touch Screen     | 5.0                    | 0.4                    | 2                    |
| HE               | 6.0                    | 7.5                    | 45                   |

The incorporation of an in-built power supply enabled the device to be portable. The 12V 4.5AH rechargeable Sealed Lead Acid (SLA) battery shown in Figure 34 was used as the internal power source of the rehabilitation system. The 4.5 Ah capacity of the battery implies that it can supply a constant current of 4.5 amperes for a period of an hour. In reality, this would only

be true if the current was about a tenth of the indicated rating, i.e.  $4.5 \times 0.1 = 0.45A$ . This size of battery was sufficient to supply the power requirement.



Figure 34: Rechargeable Sealed Lead Acid battery

For an alternative power source, 12V 10A DC external adapter plugged to the mains supply was sufficient to run the system. The source of power to be used during rehabilitative training was chosen using the toggle switch as highlighted in Figure 21.

## 5.2.2 Actuators

DC servo motors were chosen as the actuators for all the actuation requirements of the system. The electronic system was designed to control 6 servo DC motors; 5 for actuating the robotic attachments of the HE and 1 for the WE.

### Turnigy TGY-90S Digital Metal Gear Servo

The 2.2 kg-cm digital metal gear servo shown in Figure 35 was used for actuation of all motorised components of the HE's robotic attachments. It replaced the less robust 1.6 kg-cm analog plastic gear servos, which were used in the previous design.



Figure 35: TGY-90S Digital Metal Gear Servo

### **PowerHD 1501MG Analog Metal Gear Servo Motor**

The servo in Figure 36 was used as the actuator of the WE discussed in section 5.1.2. With a torque of 15.5 kg-cm at 4.8V, this servo provided more than enough torque to perform rehabilitation routines safely and efficiently.



Figure 36: PowerHD 1501MG Analog Metal Gear Servo (Barbcatali, 2017)

### **5.2.3 Microcontroller ( $\mu$ C)**

The Arduino Due Board shown in Figure 37 was determined to be the most suitable controller for operating this system. It is a 3.3V board based on the AT91SAM3X8E Atmel  $\mu$ C, which governs all the operations of the rehabilitation system. The features of the Arduino Due board

that made it suitable for use in the development of the rehabilitation system are listed in Table 4. The total DC output current that could be drawn from all the input/output lines of this  $\mu\text{C}$  was 130mA. It also allowed for a maximum of 800mA DC current to be drawn from its 3.3V or 5V power pins alternately.

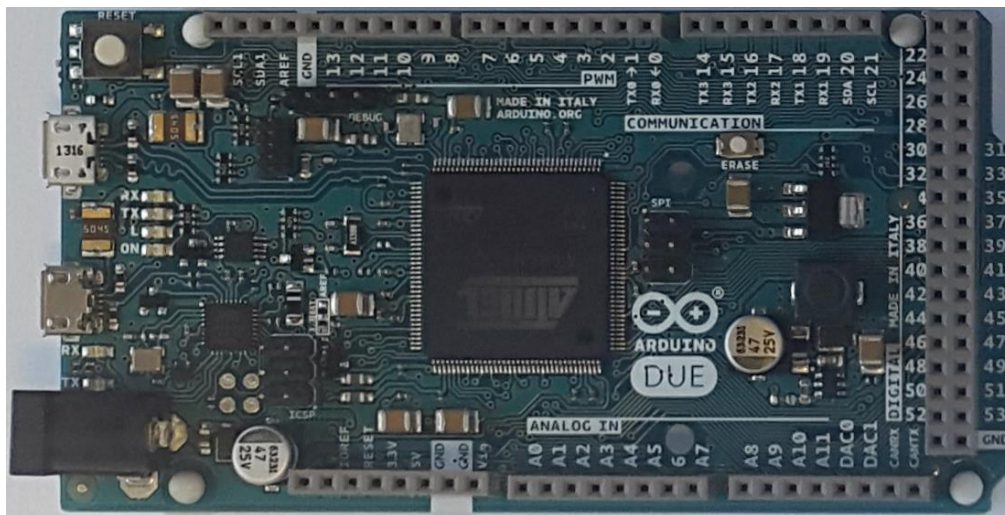

Figure 37: The Arduino Due  $\mu\text{C}$

A regulated 7V supply was used to power the  $\mu\text{C}$  which is within the recommended input voltage range of 7-12V.

Table 4: Arduino Due board specifications

| Feature             | Specification |
|---------------------|---------------|
| Clock Speed         | 84 MHz        |
| Flash memory        | 512Kb         |
| Digital I/O Pins    | 54            |
| Digital PWM Outputs | 12            |
| Analog Inputs       | 12            |
| SD Card Support     | Yes           |

The  $\mu\text{C}$  performed all the control operations that were required for the effective function of the rehabilitation system. It received analog input from the sensors on the HE, converted the analog signals to digital signals and used the data for control. It processed and executed the algorithms that actuated the servos on the HE and prevent hyperextension as well as hyperflexion on the HE and the WE. The 3.3V power pin of the Arduino board was used to power the visual interface of this system. Algorithms were written and stored in the flash memory of the  $\mu\text{C}$  and used to display the patterns on the visual interface.

## 5.2.4 Display

The UTFT Touch Shield (ITDB32S), made for Arduino boards by ITEAD Studio was determined to be a suitable visual interface for displaying the predefined rehabilitation patterns used during the rehabilitation routines. The shield is depicted in Figure 38 and has its features listed in Table 5.

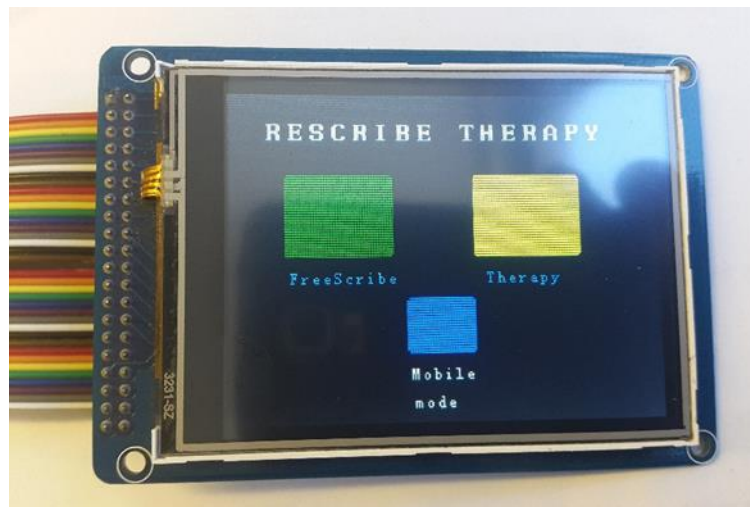

Figure 38: The 3.2" UTFT Touch Shield

There was the option of using a capacitive touch display screen however the resistive screen was chosen because of better precision when receiving haptic input from a stylus. The on-board graphics RAM was sufficient to display images on the screen however an external memory chip was required to store the patterns and load them when necessary.

Table 5: Touch screen module specifications

| TOUCH SCREEN SPECIFICATIONS       |  |
|-----------------------------------|--|
| <b>Operating Voltage</b>          | 3.3V or 5V                                 |
| <b>Screen</b>                     | 3.2" TFT LCD Screen module with 65k colour |
| <b>Display Resolution</b>         | 320 x 240 QVGA                             |
| <b>On-board fast graphics RAM</b> | 172 KB                                     |
| <b>Sampling Rate</b>              | 125 kHz                                    |
| <b>SD-Card Support</b>            | Yes  |

## 5.2.5 Sensors

The electronic system was designed to receive input from 5 rotary linear potentiometers similar to the one shown in Figure 39 which were used as angular position sensors. The sensors would be used to detect the ROM between the segments on the HE. Angular position of the HE segments would then be measured by receiving analog voltage readings from the potentiometers on the  $\mu$ C. A rotation of the HE segment would consequently result in rotation of the potentiometer, which causes a variation in the analog voltage reading sent to the  $\mu$ C.



Figure 39: Rotary linear potentiometer used as hand exoskeleton sensors

To fully utilise the whole range of rotation of the potentiometers, a differential amplification circuit was designed. This would increase the range of analog voltage readings that could be detected by the analog to digital converter (ADC) in the  $\mu\text{C}$ . The differential amplifier circuit that was designed is shown in Figure 40.

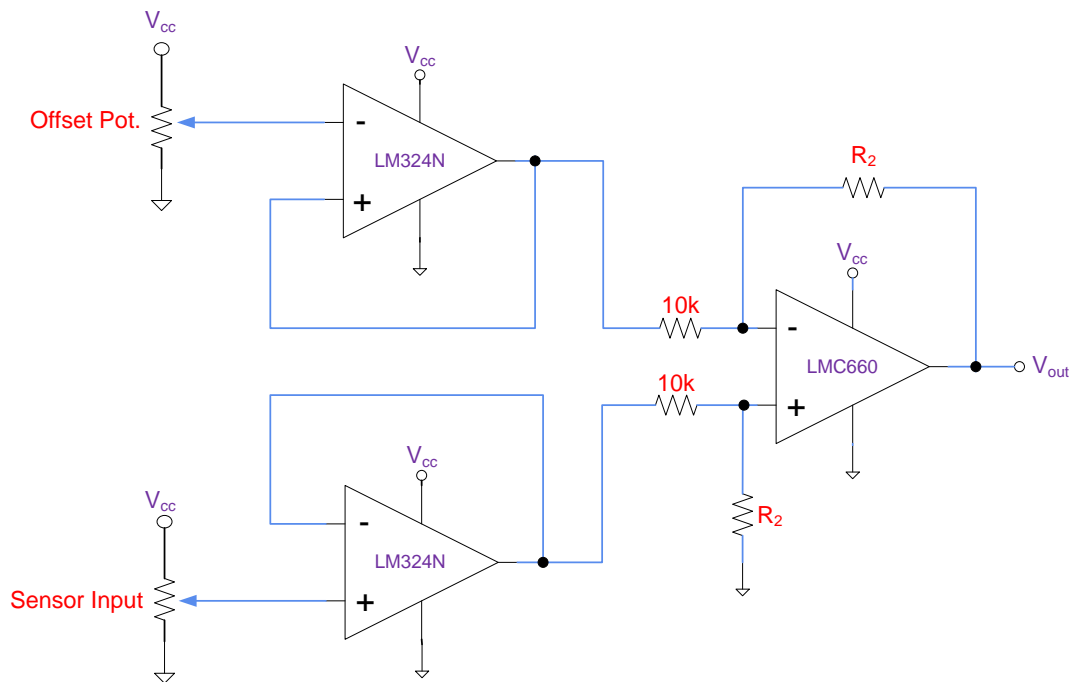

Figure 40: Differential amplifier circuit for sensory signal amplification

The circuit calculates the difference between the voltage reading from the sensor on the HE segment and that from the offset potentiometer and amplifies the difference. The output of the differential amplifier was calculated using the formula below:

$$V_{out} = \left(\frac{R_2}{10k}\right) \times (V_{in} - V_{off})$$

The offset potentiometer gives a negative offset, which expands the range of signal and when amplified, the voltage reading range is wider thereby increasing the precision during control of the fine motor movements of the HE.

## 5.2.6 Safety Devices

To prevent disruption of the normal operation of the system, the electrical and electronic design incorporated mechanisms to prevent undesired actuation by cutting off excessive voltage and current. The ROM of the actuators was restricted to that of a normal healthy hand, which prevented hyperextension of the wrist and fingers. This was achieved by using custom made algorithms in conjunction with the electronic devices discussed below.

## Voltage Regulators

The LM317 3-Terminal Variable Voltage Regulator was used for voltage regulation in the system and a total of seven units were used. Five units were used to regulate the voltage supply to each of the components of the HE. One unit was used for regulating voltage supply to the WE (7V) and another unit for regulating voltage supply to the  $\mu\text{C}$  (9V).

The circuitry that was used to regulate voltage is shown in Figure 41. The circuitry was designed to regulate three levels of voltage; 7V, 6V and 5V using the formula below:

$$V_{out} = 1.25 \times \left( 1 + \frac{R_2}{R_1} \right)$$

Dropout voltage is the minimum difference between input and output voltage that is required for a voltage regulator to remain within the stipulated operating range. It was necessary to use a 12V power supply for the system because the LM317T regulator would require a minimum dropout voltage of 3V.

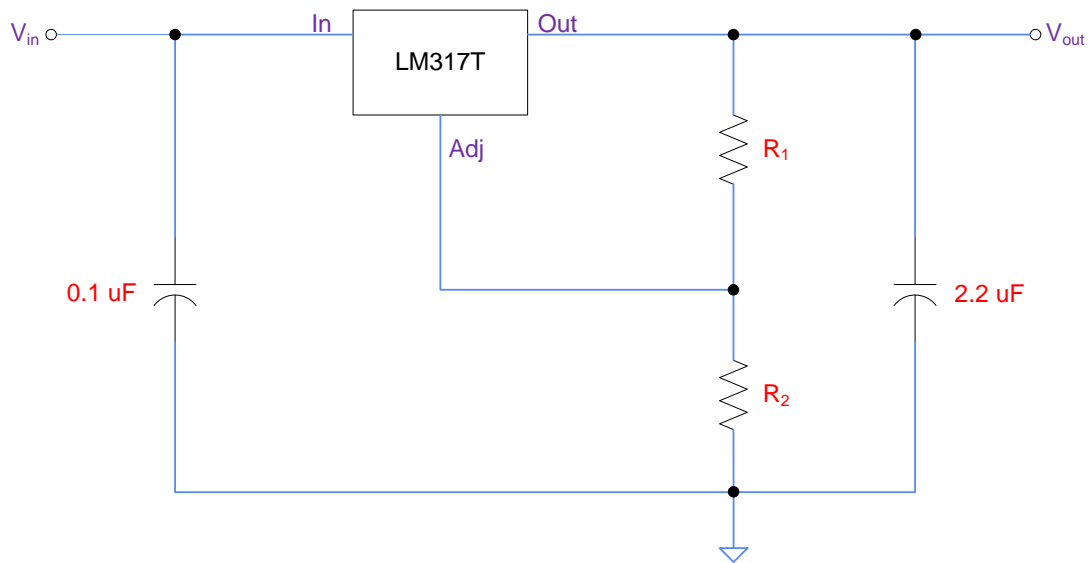

Figure 41: The LM317T adjustable voltage regulation circuit

Therefore, to get an output voltage of 7V, a minimum of 10V voltage supply was required. The sensors fitted on the HE would give angular position based on the voltage divider principle of the rotary potentiometers. From an analog reading of voltage, the position of the respective HE segment would be determined.

With the designated voltage supplied to the servos on both the HE and WE, change in angular position would be predicted and controlled. In the event of under or overvoltage, there was high possibility of unpredictable shifts in position which would result in undesired actuation which would pose a safety risk. Voltage regulators were therefore, necessary to prevent these undesired spikes in either current or voltage.

## Emergency Button

The system was further equipped with an emergency stop button that would be used to immediately cut off power supply to the system in the highly unlikely event of an emergency.



*Figure 42: Latching push button used as emergency stop switch*

A 30mm non-illuminated latching push button shown in Figure 42 was chosen to be configured as the emergency switch for the rehabilitation system. This switch can withstand a current of up to 10A which is higher than the maximum current that all the components of the rehabilitation system can draw as determined from the calculations in section 5.2.1. A relay switch was initially considered for implementing as the emergency button due to its low current requirement. The latching push button was, however, chosen due to its large size and conspicuousness which ideally matched the function it was intended for. Due to the high current it can withstand, it also requires more voltage to activate and therefore thicker wires had to be used to ensure safe handling of current.

## **Fuse**

The 10A electrical fuse shown in Figure 43 was chosen as an extra safety device in case of any unexpected power surges in the electrical circuit of the system. It was connected between the power source of the system and the emergency switch as illustrated in Figure 32 to create an open circuit between the two devices when the current exceeds 10A.



*Figure 43: 10A Electrical Fuse*

## **5.3 Software Development**

The Arduino IDE was used to develop all the algorithms that were used to run the rehabilitation system. Many functions within the algorithms were adapted from those used to run the previous device discussed in section 2.2.4.

### **Algorithm Flow**

The flowchart of Figure 44 is a pseudo algorithmic illustration of the operation of the rehabilitation system from the home screen of the user interface. This was implemented using algorithms that were developed to enable the smooth operation of the three modes of rehabilitative training of the rehabilitation system mentioned in Testing Procedures and Data Collection. The algorithms are available in Appendix H.

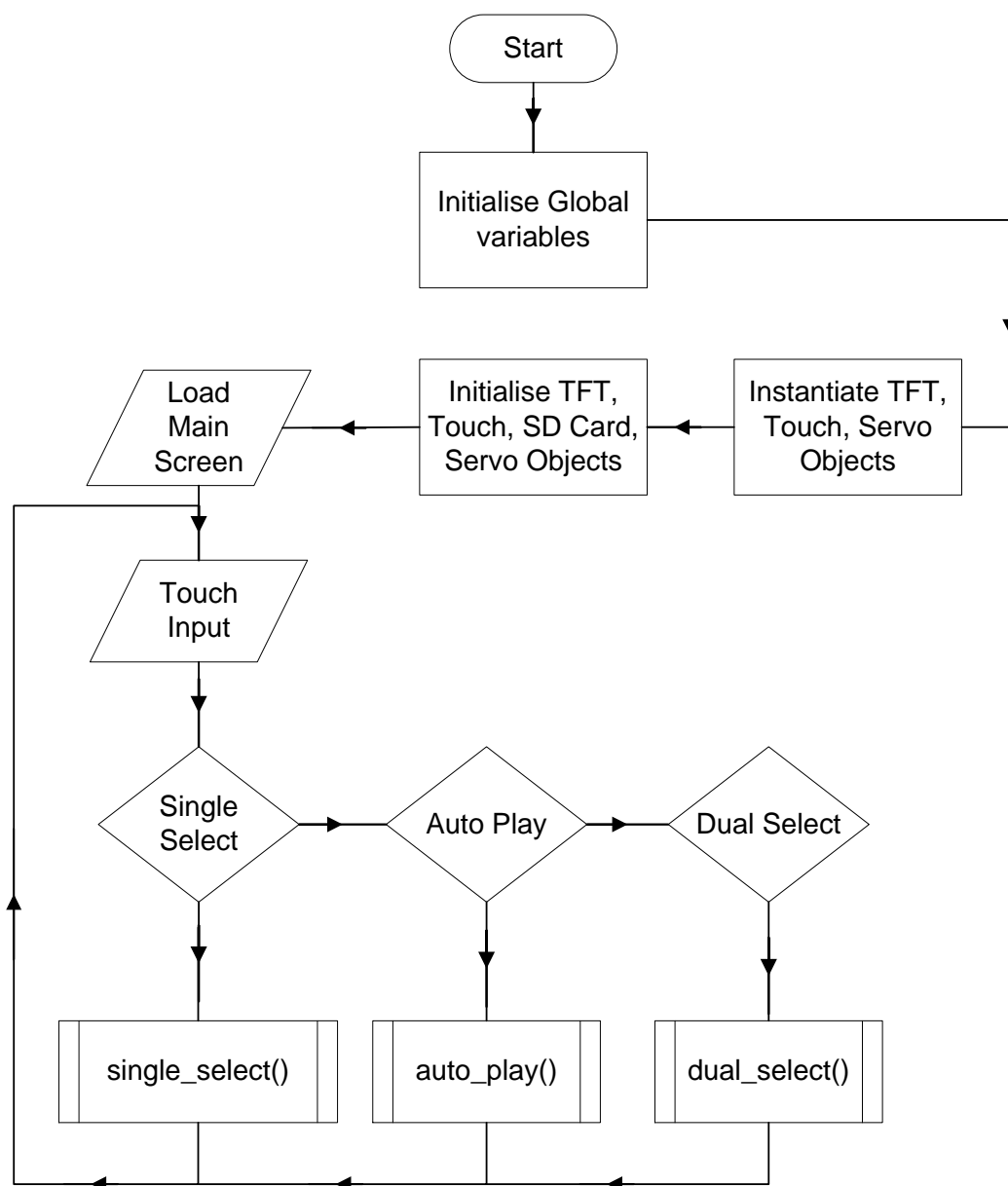

Figure 44: Pseudo algorithm flowchart for home screen

The three modes are: 1) Single select mode where the pattern sequences stored in the memory of the system are selected one by one during rehabilitative training 2) Auto play mode, where the patterns are automatically displayed, one after the other during the training session 3) Dual select mode where a set of two patterns are simultaneously displayed on the screen and the user is required to trace both patterns before selection of the next set of patterns.

The flowchart in Figure 45 illustrates the operation of the system when the single select mode is selected by the user of the system.

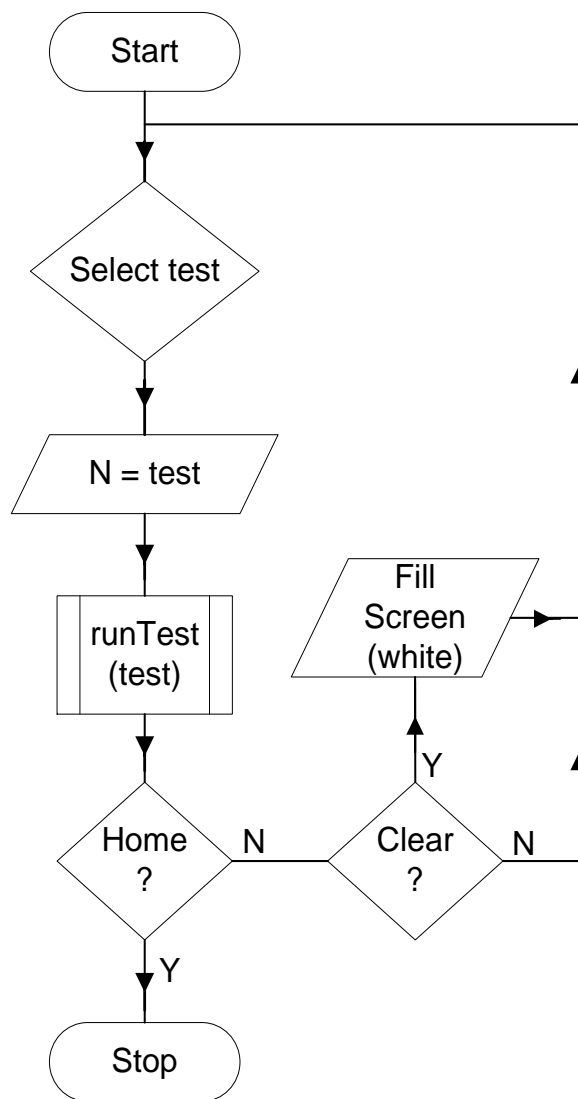

Figure 45: Pseudo algorithm flowchart for single select mode

The flowchart in Figure 46 illustrates the operation of the system when auto play mode is selected.

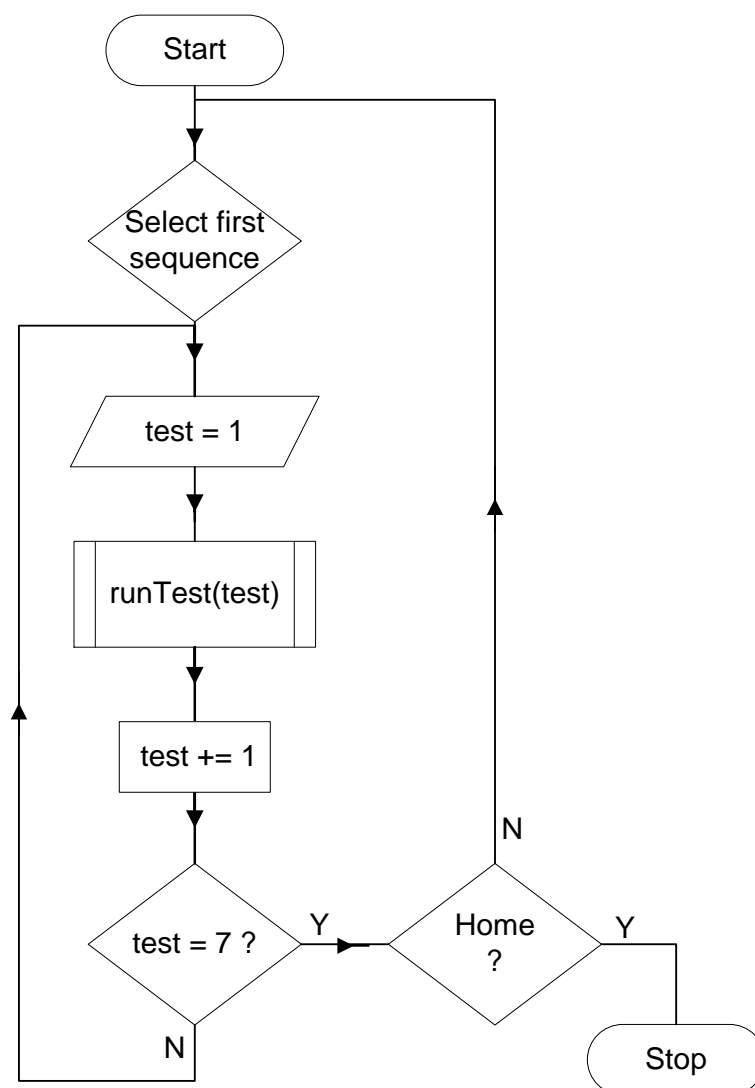

Figure 46: Pseudo algorithm flowchart for auto play mode

A Proportional Integral (PI) digital controller, similar to the one used for actuating the servos of the HE discussed in section 2.2.4 was used to implement digital control for the rehabilitation system. The controller was developed using the blackbox modelling approach. Step tests were conducted on the digital servos used on the HE to determine their input-output behaviour and a suitable PI Controller was designed.

## Software

The default Arduino libraries used to run this system are: *Servo.cpp* and *UTFT.cpp*. The Arduino sketch that was used to run the system is available in Appendix H. For compatibility with the

Arduino board and the UTFT Touch Shield of the system, additional libraries were downloaded and integrated into the Arduino IDE. The following are the integrated libraries:

- URTouch.cpp
- SPI.cpp
- UTFT\_SDraw.cpp
- SdFat.cpp

The URtouch.cpp was necessary for accessing touch functions for the touch screen. The SPI.cpp, UTFT\_SDraw.cpp and SdFat.cpp libraries were used to facilitate the programming of communication between the touch screen display and the  $\mu$ C as well as enabling two-way communication between the SD-card slot of the display and the  $\mu$ C.

## 5.4 The Rehabilitation System

The final product was a compact, portable system with a simple and easy-to-use graphical user interface. Figure 47 shows the complete rehabilitation system with the HE attached to the RU at the testing station where rehabilitative training was conducted. The home screen's user interface is shown in Figure 48 with the three modes of operation mentioned in the previous section and discussed under rehabilitative training in section 4.4.

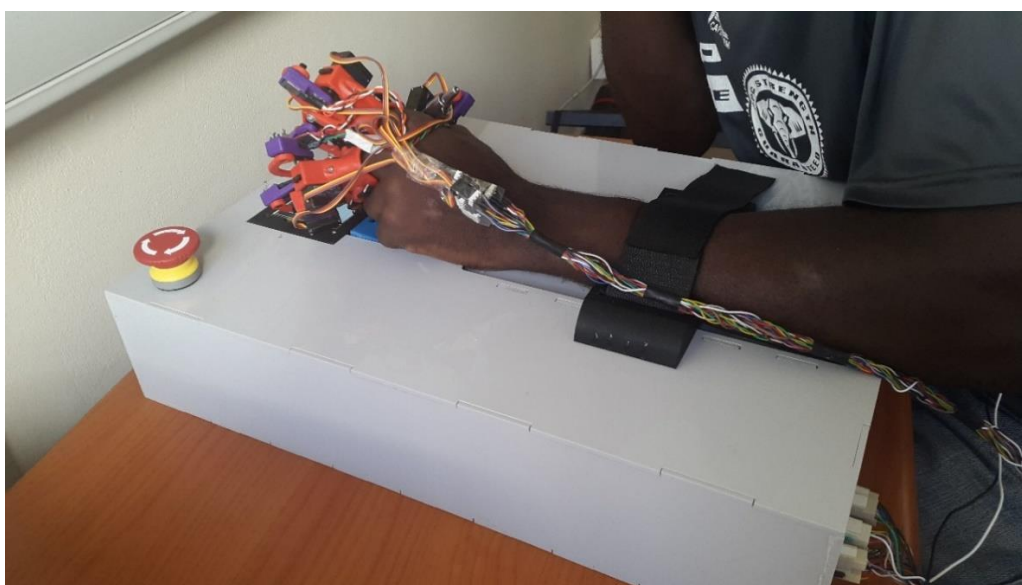

Figure 47: The rehabilitation system

Figure 49 is an image of the touch screen of the system while in the trace select mode of operation with the third pattern of the sequence selected. The number in blue font displayed on the top right side of the screen is the countdown time before motorised actuation commences. This gives time for the user to position the tip of the stylus on the red dot which indicates the starting position of the tracing path as shown in Figure 49.

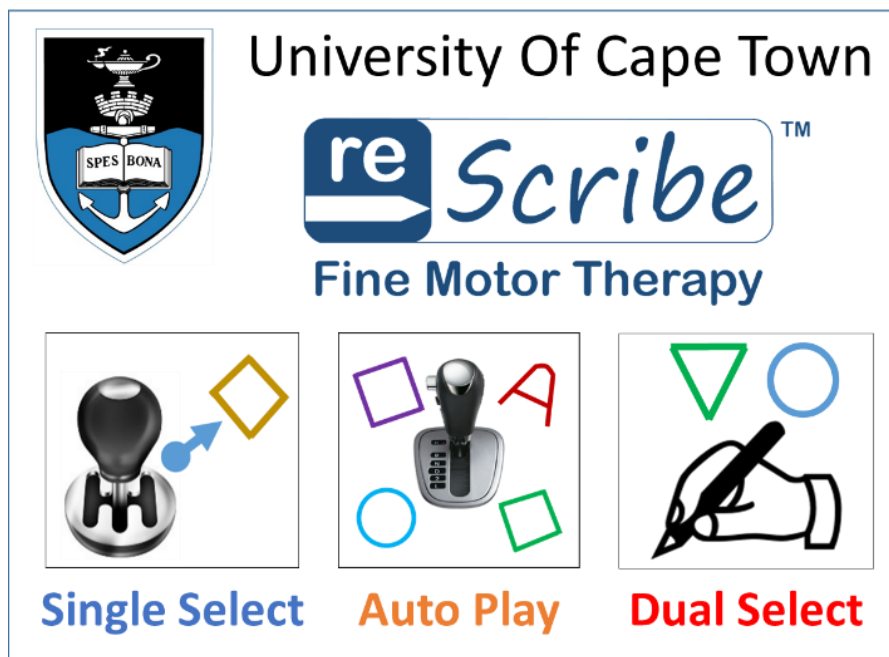

Figure 48: Home screen of rehabilitation system (planar view)

Once the rehabilitation cycle is finished, the user has the option of returning to the home screen by selecting the second last button on the top segment of the screen as shown in Figure 49 or repeating the cycle by touching the icon of the first pattern in the sequence.

## Portability

The shortage of therapists has had a negative impact on stroke survivors and the demand for rehabilitation in the residential setting has been rising rapidly. Such a system is well placed to meet the rising demand especially because of the worsening global economic position. The fact that this system is portable makes it a very useful rehabilitation tool for use in various

locations. The energy supplied by the rechargeable battery is, however, limited and continuous rehabilitation would therefore require access to mains power for recharging purposes. However, with the rapid advances in technology, this limitation may soon be a matter of the past.

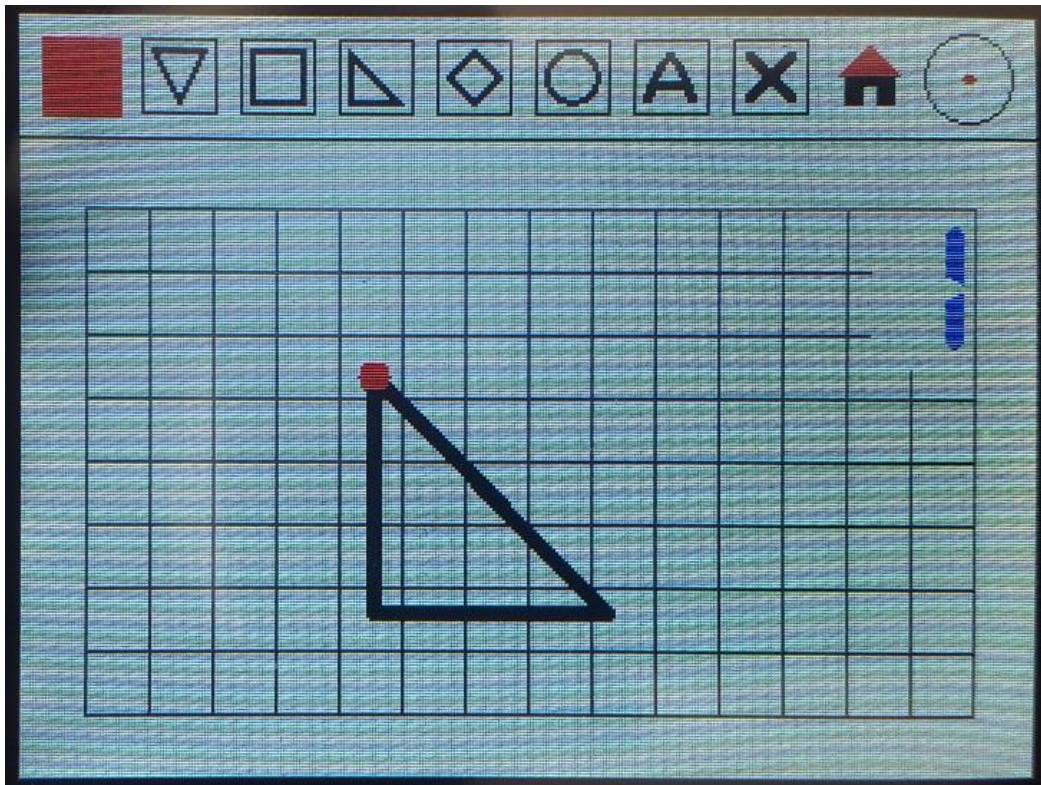

Figure 49: The trace select mode of operation

## Ergonomics

Consultation with occupational and hand therapists prior to design and development of this system revealed that the ergonomics of a rehabilitation device has been observed to have an influence on the attitude of the user towards the device, which may directly or indirectly affect the outcome of rehabilitation. Exposed mechanical parts and more specifically visible electronic components tend to create a negative image on the therapists and have a negative impact on patients. Such a device would be deemed by the average therapist as dangerous and they would not want to entrust rehabilitative care of their patients to such a device. Owing

to the fact that the rehabilitation system was designed with patients and therapists in mind, most of the components of this rehabilitation system were therefore, enclosed leaving only the touch screen display interface and a portion of the WE exposed to the user.

The RU provided a smooth surface for placing the forearm and accommodating the various forearm sizes. It did not cause discomfort during performance of the rehabilitation routines. The elastic straps used for fastening the fingers to the HE provided ample flexibility for the joints of the fingers. This flexibility was, however, limited by the large size of the robotic attachments placed on each finger. For future work, this limitation can be improved by miniaturising the finger components as mentioned in the recommendations section of the final chapter. Since the finger components used for the HE were of standard size, it could only be effectively used by participants within a specific finger size range. The use of adjustable finger components is therefore, also recommended for future work.

## **6 Experimental Results & Discussion**

### **6.1 Rehabilitative training**

The only effort required from the user whilst tracing, was to position and hold the stylus at the starting position of each pattern indicated by a red dot. The assumption made by the rehabilitation system was therefore, that the user had correctly positioned the stylus. The control system then relied fully on the sequential data set points that were stored in memory for actuation. The control system could not detect the position of the stylus during a rehabilitation routine. If the user of the system deviated from the established path for tracing the pattern, the fingers were guided to trace the pattern correctly but in the wrong location of the touch display. This limitation may be alleviated by synchronizing the control system with the touch interface so that the position of the stylus may be tracked and rectified as the need arises. However, synchronization of the touch interface and the control system may introduce a new limitation of the user adapting to the corrective action of the control system rather than focusing on hand motor control.

It was determined that during repetitive practice, the rehabilitation system offered more accurate assistance when tracing patterns that did not have horizontal lines. The user therefore, had to exert more effort coordination-wise while tracing the horizontal lines within the patterns. All the shapes with the exception of the diamond and circle had horizontal lines. The circle was the most accurately replicated shape whilst the rectangle proved to be the least accurate. The difficulty in tracing horizontal lines may be attributed to the fact that while drawing a horizontal line with a fixed forearm largely depends on the lateral movement of the wrist. The joints of the thumb, middle and index fingers are stabilised during this action. The control system is therefore, to a large extent, redundant because it can only control actuation of the finger joints and vertical movement of the wrist. This explains the reason why the circle was most accurately replicated whilst the rectangle was least accurate. To improve accuracy, lateral actuation of the wrist should be added as a feature of the system and is included in the recommendation section of the final chapter.

Rigorous rehabilitation, even during the acute phase of stroke has been reported to minimally increase the chance of regaining functional use of the hand (Lum et al., 2012). The robotic rehabilitation system used in this research study successfully employed repetitive task-oriented rehabilitative training, which improves upper limb function by increasing the probability of restoring functionality to the impaired hand which is critical in performing ADLs (Lum et al., 2012; Masiero, Celia, Rosati, & Armani, 2007).

## 6.2 Accuracy

### 6.2.1 Trace Sample Test

Table 6 provides information on the total time taken by each participant to complete the writing tasks of the trace sample test and the percentage improvement after four weeks of rehabilitation. A shorter completion time indicated a faster completion speed.

*Table 6: Completion time of the tasks performed in the trace sample test and percentage improvement over a four week period*

|   | TASK        |          |                   |                   | % Improvement (After 2 weeks) | % Improvement (After 4 weeks) |
|---|-------------|----------|-------------------|-------------------|-------------------------------|-------------------------------|
|   |             | Baseline | After 2 weeks NDH | After 4 weeks NDH |                               |                               |
| 1 | Rectangle   | 34.3     | 23                | 27                | 32.9                          | 21.3                          |
|   | Curved Line | 33       | 25                | 22.3              | 24.2                          | 32.4                          |
|   | Signature   | 7        | 6                 | 4.5               | 14.3                          | 35.7                          |
| 2 | Rectangle   | 53.9     | 48                | 36                | 10.9                          | 33.2                          |
|   | Curved Line | 45.9     | 32                | 35.8              | 30.3                          | 22.0                          |
|   | Signature   | 19.8     | 18                | 15                | 9.1                           | 24.2                          |
| 3 | Rectangle   | 9.8      | 16                | 12                | -63.3                         | -22.4                         |
|   | Curved Line | 9.7      | 12                | 10.5              | -23.7                         | -8.2                          |
|   | Signature   | 9.8      | 6                 | 4.5               | 38.8                          | 54.1                          |

Figure 50 shows a graph of the average change in completion time in relation to the completion time recorded before the commencement of rehabilitation. The overall average improvement in completing the tasks of the trace sample test was 21.4%. It may be observed from Figure 50 that there was an overall improvement in completion speed of the three different tasks. The average improvement in performing the rectangle, curved line and signature tasks across the participants after four weeks was 10.7%, 15.4% and 38% respectively.

It is worth noting that Participants 1 and 2 recorded a positive improvement over the four week period while Participant 3 recorded a negative improvement. Participant 3 took a longer time to complete the rectangle and curved line tasks as the weeks progressed. This could be attributed to the increased motivation of the user to trace the shapes more accurately and hence a reduction in the completion speed. The other participants improved the completion time while maintaining accuracy.

The greatest improvement in speed was observed in completing the signature task. The participants reported that during the trace sample test, it was much easier to complete the curved line task than to complete the rectangle task, which is evident in the percentage improvement as illustrated in Figure 52.



Figure 50: Percentage change of completion time in relation to the baseline time

In the course of experimental study, it was established that tracing a horizontal line during rehabilitative training was challenging for the participants. Tracing a horizontal line primarily required lateral movement of the wrist, a feature that was absent in the rehabilitation system. The user of the system therefore, had to manually trace the line without aid from the system. The participants in this study reported that, tracing a rectangular shape, during rehabilitative training, was more difficult than the tracing other patterns. It is, therefore, highly likely that this is because the rectangular shape had two horizontal lines whilst the remainder of the shapes, used during rehabilitation, had a maximum of one horizontal line. This difficulty could have been subconsciously transferred while performing the writing tasks of the trace sample test. This may explain the longer time taken to trace the rectangle when compared to the curved line during the tests.

It was difficult to qualitatively analyse the results of the trace sample test. The very minute differences in results at the two-week intervals could hardly be distinguished by visual observation. Quantitative analysis was, therefore, more reliable due to the clear variation in completion time at the two-week testing intervals. The results of qualitative analysis are therefore not presented.

## 6.2.2 Writing Accuracy Test

Table 7 provides the results of the writing accuracy test. The results show that all the participants had a shorter completion time at the end of the four weeks of rehabilitation.

*Table 7: Completion time and percentage improvement of the writing accuracy test for each participant over the four week period*

|          | Completion Time (min) |               |               |                               |                               |
|----------|-----------------------|---------------|---------------|-------------------------------|-------------------------------|
|          | Baseline              | After 2 weeks | After 4 weeks | % Improvement (After 2 weeks) | % Improvement (After 4 weeks) |
| <b>1</b> | 19.5                  | 18.41         | 18.4          | 5.6                           | 5.6                           |
| <b>2</b> | 25.1                  | 18.54         | 18.54         | 26.1                          | 26.1                          |

|          |       |       |      |       |      |
|----------|-------|-------|------|-------|------|
| <b>3</b> | 11.13 | 13.27 | 7.54 | -19.2 | 32.3 |
|----------|-------|-------|------|-------|------|

The mean percentage improvement in completion time for the writing accuracy test at the end of the four week period was 21.3%. Participants 1 and 2 had completion time improvements of 5.6% and 26.1% respectively. The results indicate that the writing tasks were completed in shorter times after the first two weeks of rehabilitative training. However, after the final two weeks, the results showed that their completion times did not change significantly as can be observed in the graph of Figure 51.

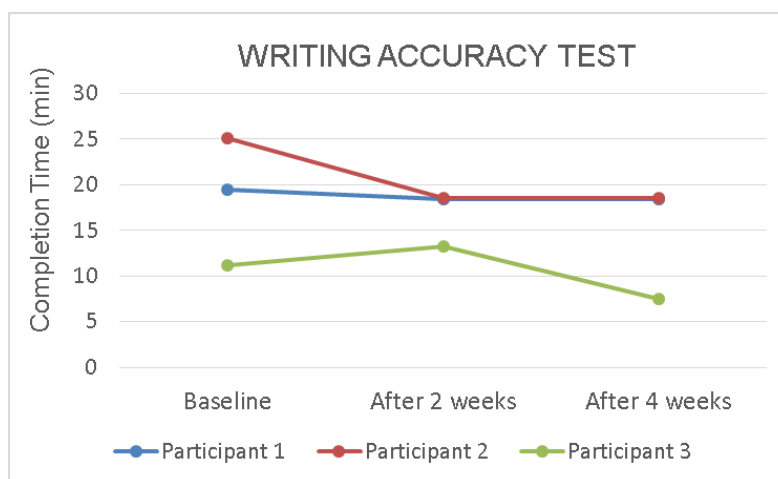

Figure 51: Graphical representation of writing accuracy test results

Despite the minimal change in completion time after the first two weeks of rehabilitation, the accuracy of these two participants had gradually improved over the four week period. Figure 52 and 52 show a sample of the results obtained at the two week intervals. Through visual comparison, it can be concluded that there was a general improvement in accuracy over the four week period for Participants 1 & 2. Participant 3 had a completion time improvement of 32% which was the highest improvement recorded amongst the participants. The results of Participant 3 as illustrated in Figure 53, however, suggest that accuracy did not improve. Although the results in Figure 52 and 52 enabled visual comparison, it was difficult to quantify the degree of accuracy.

|               | Participant 1 | Participant 2 |
|---------------|---------------|---------------|
| Baseline      |               |               |
| After 2 weeks |               |               |
| After 4 weeks |               |               |

Figure 52: Sample of writing accuracy test results of Participants 1 & 2

|               | Participant 3 |
|---------------|---------------|
| Baseline      |               |
| After 2 weeks |               |
| After 4 weeks |               |

Figure 53: Sample of writing accuracy test results of Participant 3

A component of the writing accuracy test was, therefore, identified and a sample selected for quantitative analysis, as shown in Figure 54. The component that was selected required the user to join dots so as to complete the patterns that were repetitively traced during rehabilitative training. The accuracy in joining the dots was quantified by counting the total number of dots that were perfectly joined by the participant. A dot was not counted if the pencil mark missed the dot or just slightly touched the dot. The total number of successfully joined dots, for each testing phase (baseline, 2 weeks, 4 weeks), were summed and expressed as a percentage of the total number of dots. The results are provided in Table 8. It is evident from these results that the accuracy of Participant 3 did not improve over the four week period. Participant 3 scored the lowest percentage in joining dots despite the remarkable improvement in completion time.

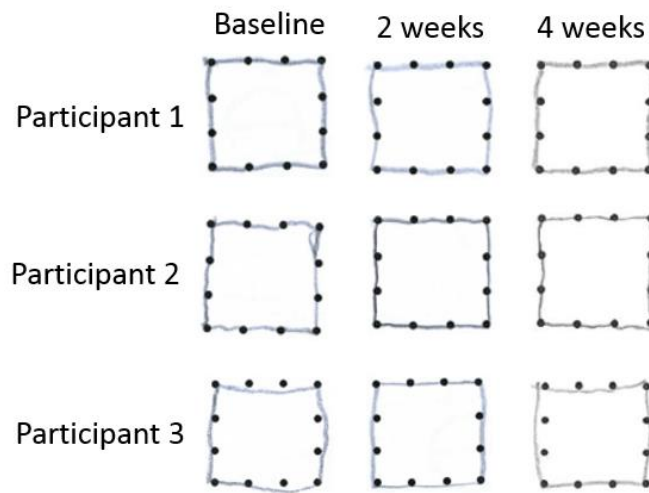

Figure 54: Sample of writing accuracy test that was quantitatively analysed

The value of percentage improvement provides an estimation of the degree to which the rehabilitation system may have improved hand motor control. This estimation, however, does not take into consideration, the results of qualitative assessment. The results show that both quantitative and qualitative analysis methods were critical in drawing an unbiased conclusion.

Table 8: Sample of quantitative results of dots successfully joined while completing the writing accuracy tasks as shown in Figure 54

|          | <b>Baseline</b> | <b>After 2 Weeks</b> | <b>After 4 weeks</b> | <b>TOTAL</b>    | <b>% Completion (After 2 weeks)</b> | <b>% Completion (After 4 weeks)</b> |
|----------|-----------------|----------------------|----------------------|-----------------|-------------------------------------|-------------------------------------|
| <b>1</b> | $\frac{9}{12}$  | $\frac{10}{12}$      | $\frac{10}{12}$      | $\frac{29}{36}$ | 79                                  | 81                                  |
| <b>2</b> | $\frac{9}{12}$  | $\frac{8}{12}$       | $\frac{10}{12}$      | $\frac{27}{36}$ | 71                                  | 75                                  |
| <b>3</b> | $\frac{5}{12}$  | $\frac{8}{12}$       | $\frac{7}{12}$       | $\frac{18}{36}$ | 54                                  | 50                                  |

The results of Participant 3 suggest that training with the system may have boosted confidence in completing the writing tasks, but may not have necessarily improved hand motor control. A qualitative analysis of the patterns traced suggests that there was an improvement in accuracy for Participants 1 and 2 whilst tracing the shapes, which suggests that hand coordination may have improved. Robotic rehabilitation does not only aim to increase the time spent in rehabilitative training but also to increase the user’s attention span whilst performing the rehabilitative tasks (Maciejasz et al., 2014). Having a variety of patterns may have contributed to reducing monotony, which affects attention span, to a great extent. This potentially promoted repetitive practice.

### 6.3 System usability

The system usability scale is reported to be a simple reliable tool that gives reliable results even with small sample sizes which made it an appropriate tool for analysis in this research study. The scale measures both learnability and usability which is an added advantage (Brooke, 2013). Table 9 shows the responses in the form of score contribution of each of the participants involved in this study. The score contribution for each item in the assessment form of Appendix B is a reflection of the thought of the user in relation to the system as a rehabilitation tool.

Table 9: Score contribution and overall system usability scores

| Item | SCORE CONTRIBUTION |               |               |         |
|------|--------------------|---------------|---------------|---------|
|      | Participant 1      | Participant 2 | Participant 3 | Average |
| 1    | 2                  | 3             | 0             | 2       |
| 2    | 3                  | 4             | 4             | 4       |
| 3    | 4                  | 4             | 4             | 4       |
| 4    | 2                  | 4             | 4             | 3       |
| 5    | 2                  | 4             | 3             | 3       |
| 6    | 3                  | 4             | 3             | 3       |
| 7    | 3                  | 3             | 4             | 3       |

|                      |           |           |             |           |
|----------------------|-----------|-----------|-------------|-----------|
| 8                    | 4         | 4         | 3           | 4         |
| 9                    | 3         | 4         | 4           | 4         |
| 10                   | 4         | 4         | 4           | 4         |
| <b>Overall Score</b> | <b>75</b> | <b>95</b> | <b>82.5</b> | <b>84</b> |

The overall score for each participant was determined from the score contributions and the average of the overall scores determined to be 84. A system with a mean overall score of 70 is considered to be above average and generally acceptable (Brooke, 2013). This shows that the users found the rehabilitation system fairly easy to use and therefore the system has good learnability and usability. This conclusion is corroborated by the fact that all the participants found this system easy to use as is evident in the high score contribution of Item 3 for each participant. The implication is that hand rehabilitation patients may easily adapt to using this rehabilitation system, which is beneficial in encouraging repetitive practice and prolonged continuous rehabilitation.

The average overall score of 84 additionally suggests that the tasks that the participants were subjected to, were relatively easy. Research indicates that when the tasks performed during rehabilitative training are extremely easy, the individual undergoing rehabilitation becomes disengaged with the process (Lum et al., 2012). There is a high possibility that the participants may have occasionally lost focus during practice, which may have compromised the quality of repetitive training. It is, however, difficult to measure the degree to which such disengagement affected training and consequently the results.

## 6.4 Grip Strength

The quantitative results presented in this section have been analysed using descriptive statistics as opposed to inferential statistics due to the limitation of a small sample size. A proof of concept analysis was therefore carried out to give a description of the effect that the rehabilitation system had on its users. A pre-clinical trial with a statistically significant sample

size following this trial will be useful in providing conclusive data which can be analysed using inferential statistics. Table 10 provides the test results that were recorded for power grip strength.

Table 10: Mean power grip force

| PARTICIPANT | POWER GRIP FORCE (kgf) |      |         |         | Mean | SD  |
|-------------|------------------------|------|---------|---------|------|-----|
|             | Baseline               |      | 2 weeks | 4 weeks |      |     |
|             | DH                     | NDH  | NDH     | NDH     |      |     |
| <b>1</b>    | 35.3                   | 32.0 | 36.0    | 37.3    | 35.1 | 2.8 |
| <b>2</b>    | 47.6                   | 43.3 | 43.3    | 42.0    | 42.9 | 0.8 |
| <b>3</b>    | 38.0                   | 40.0 | 36.0    | 39.3    | 38.4 | 2.1 |

On analysing the results, Participants 1 and 2 were determined to have stronger grip strength in the DH than in the NDH by 10.3% and 9.9% with baseline differences of 3.3 kgf and 4.3 kgf respectively. Participant 3 had stronger power grip strength in the NDH by 5.3% with a baseline difference value of 2 kgf. The small baseline difference of participant 3 suggests that the DH and NDH may have equal power grip strength. The mean standard deviation of power grip strength of the NDH was found to be 1.9. The mean grip strength of the NDH after the four weeks of rehabilitation was determined to be 2.4 kgf. Table 11 provides the test results for lateral pinch grip strength.

Table 11: Mean lateral pinch grip force

| PARTICIPANT | LATERAL GRIP FORCE (kgf) |     |         |         | Mean | SD  |
|-------------|--------------------------|-----|---------|---------|------|-----|
|             | Baseline                 |     | 2 weeks | 4 weeks |      |     |
|             | DH                       | NDH | NDH     | NDH     |      |     |
| <b>1</b>    | 8.2                      | 7.8 | 7.0     | 7.0     | 7.3  | 0.5 |
| <b>2</b>    | 9.3                      | 8.0 | 7.5     | 8.0     | 7.8  | 0.3 |
| <b>3</b>    | 8.0                      | 8.6 | 7.6     | 7.6     | 7.9  | 0.6 |

Participants 1 and 2 were determined to have stronger lateral grip in the DH than in the NDH by 5.1% and 16.3% with baseline difference values of 0.4 kgf and 1.3 kgf respectively. Participant 3 had stronger power grip strength in the NDH by 7.5% with a baseline difference value of 0.6 kgf. The mean standard deviation of lateral grip strength of the NDH was found to be 0.5. The mean of grip strength difference of the NDH after the four week period of rehabilitation was determined to be 0.6 kgf.

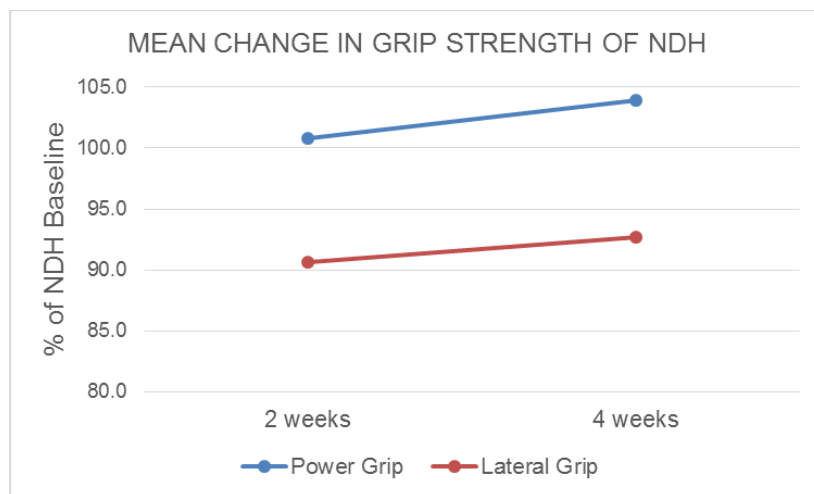

Figure 55: Analysis of change in grip strength of the NDH in relation to baseline

The mean change in grip strength was analysed over the four week period and is presented as a percentage of the baseline as shown in the graph of Figure 55. The mean percentage difference in power grip was determined to be 0.8% after the first two weeks and 3.9 % at the end of four weeks. The positive values indicate that the gripping force was higher than the baseline measurement. For lateral grip, the mean percentage difference in strength was -9.4% after the first two weeks and -7.3% after four weeks. The negative values indicate that the average lateral gripping force was lower than the baseline gripping force. This is depicted in the graphs in Figure 56 where the power grip graph is above the 100% line while that of lateral grip is below the 100% line.

The graph in Figure 56 shows the mean change in power grip strength of the NDH in relation to the DH. The mean percentage difference of power grip strength between the DH and NDH

was -4.1% after the first two weeks and -0.9% after four weeks. For lateral grip, the mean percentage difference between the DH and NDH was -13% after the first two weeks and -11.2% after four weeks. The graph of Figure 56 suggests that power grip strength gradually increased throughout the rehabilitation period while for lateral grip strength, the NDH initially decreased and then slightly increased at the end of rehabilitation.

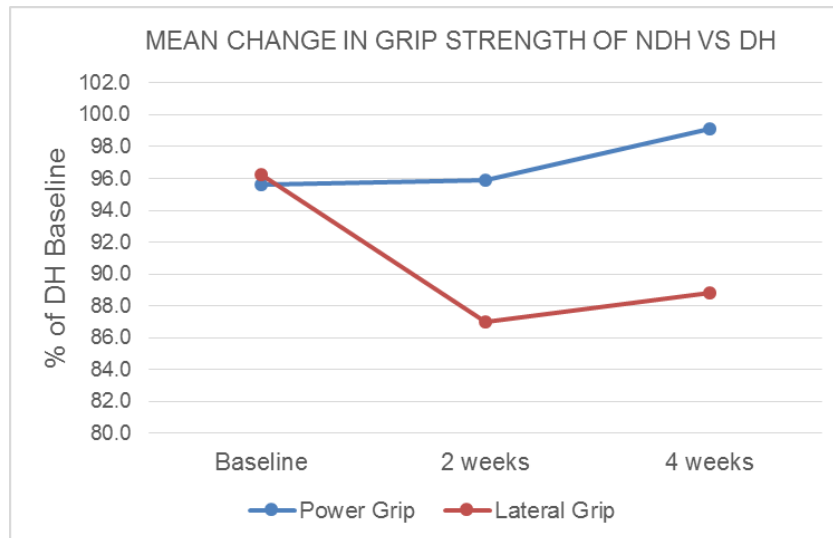

Figure 56: Analysis of power grip strength of NDH in relation to DH

The graphs of both power and lateral grip are below the 100% line which indicates that the average grip strength of the NDH did not improve to the level of that of the DH. With the small sample size, it was not possible to make a conclusion on the overall effect that the system has on the grip strength of its users. The Jamar dynamometer does not accurately measure the force exerted by the finger tips because the cumulative effort that is exerted by the hand is not all captured by the unidirectional grip force of the dynamometer (Mühldorfer-Fodor et al., 2014). This may also have compromised the results. There is a degree of discomfort when exerting force on the dynamometer, even for a healthy population (Mühldorfer-Fodor et al., 2014). Healthy participants are more likely to withstand discomfort than patients with weak fingers. The discomfort is, therefore, likely to affect the measurement results of patients and not healthy participants.

# **Chapter 7 – Conclusion & Recommendations**

## **7.1 Overview**

The aim of this research was to build a system that would, in the long term, serve as a helping hand to both patients and therapists. To the patients, it would be a convenient tool that would enhance the process of regaining fine motor skills and to the therapists, it would help in reducing and possibly alleviating the workload as a result of the rapidly rising number of stroke patients with fine motor deficits.

The primary objective was to design a rehabilitation system that was geared towards improving hand motor control and motor strength through repetitive and task-oriented writing practice. This objective was successfully met. Prior to the design and development of the system, a number of occupational and hand therapists were consulted with the long term product in mind as a measure of ensuring viability and feasibility of the final outcome. Mechanical modelling software was used to conceptualise a suitable design, which was successfully built into a portable rehabilitation system. Algorithms were written and used to develop a simple user interface that facilitated the smooth operation of the hand rehabilitation system with minimal effort from the user.

The secondary objective was to test the performance and usability of the system by conducting a pilot pre-clinical trial. To meet this objective, participants from the university student population were recruited to participate in pilot pre-clinical study. The non-dominant (left) hand of the participants was investigated through a series of tests both quantitatively and qualitatively to verify whether the system had any effect on the function of the NDH. The DH was used as the standard of measure for comparison with the NDH of each participant. The following tests were conducted namely: power grip, lateral pinch grip and writing accuracy. As a way of verifying the potential feasibility of using the system in a clinical rehabilitation setting, system usability was sought using a standardised system usability scale. The findings of the

experimental study led to conclusions and recommendations which have been summarised in the next sections.

## **7.2 Conclusion**

The following statements summarise the conclusions drawn from this study:

- Repetitive practice in performing specific writing tasks improves hand coordination, thereby enhancing writing accuracy. The rehabilitation system discussed in this research study motivated its users to repetitively perform the predefined writing tasks. Through this repetitive training, writing accuracy may have improved.
- The system was simple and easy to use, allowing quick familiarisation and adaptation to its operation. This key advantage would potentially encourage paretic stroke patients to repetitively perform writing exercises using the system, thereby increasing the efficacy of their respective rehabilitation programmes.
- The system may have had an effect on grip strength but the sample size and study period did not allow for a comprehensive analysis. Trial of the system for a longer period of time, on a larger study population suffering from hand motor impairment, would yield a better data set for statistical analysis of grip strength.
- The findings from this study, though not statistically significant, may be useful to hand rehabilitation specialists in objective evaluation and further development of fine motor therapy to improve hand rehabilitation.

It is anticipated that this rehabilitation system will eventually be developed into a product available for use as an adjunct rehabilitative tool for use in both a clinical and residential setting. A pre-clinical followed by a clinical trial of the system is therefore, recommended to determine its effect on hand motor function and verify its efficacy in rehabilitating the fine motor skill of participants with impaired hand function as opposed to healthy participants. A positive outcome of the clinical trial may further lead to the investigation of use of the system in addressing other forms of disability in the continuum of rehabilitation of the upper limb other than stroke-related problems.

Effective rehabilitation of the upper limb has been established to be a complex and difficult task due to the complex nature of the human arm, particularly the hand (Balasubramanian et al., 2010). As a result, extensive research has been carried out, on a worldwide scale, to identify ways and alternative methods of improving upper limb rehabilitation. The rehabilitation system discussed in this study is deemed to be a useful contribution to the ongoing research activity on upper limb rehabilitation. This is largely due to the fact that hand rehabilitation has not been a primary focus in this field of knowledge (Balasubramanian et al., 2010). This research presents information, which will add to the wealth of knowledge in hand rehabilitation and potentially contribute to further development of advanced and well integrated upper limb rehabilitation systems. This is especially true considering the limited presence of robotic intervention as reported by Maciejasz et al. (2014) both in the clinical and residential setting.

## **7.3 Recommendations**

### **7.3.1 Design Recommendations**

The challenges experienced during design and development led to the identification of factors, which can potentially be improved and consequently recommendations to make the system better suited for hand rehabilitation. The recommendations are discussed in the following paragraphs.

The bulkiness of the HE may be reduced with design modifications and use of miniaturised components. The actuators that were used occupied a large amount of space around the dorsal side of the hand, which compromised vision of the display screen and increased the overall weight on the distal end of the hand. Smaller actuators can be used instead and relocated to a more proximal position on the arm so as to lighten the weight on the fingers that are active during rehabilitative training. This will also improve the visual scope of the user whilst tracing the patterns that are displayed on the screen. With these modifications, components for the ring and little fingers can be included on the HE, consequently increasing the degrees-of-freedom of the HE. An additional modification that could be included in future

design is the use of adjustable finger components to accommodate a wider range of finger sizes.

Introducing a second degree-of-freedom to the WE for lateral translation of the wrist would enhance the effective tracing of horizontal lines, which proved to be a challenge during rehabilitative training. Additional subsystems may be added to the rehabilitation system so as to include the entire upper limb in rehabilitation. This would transform the system to be both a fine and gross motor rehabilitation tool.

Replacing the touch screen display unit with a smart device such as a smart phone or tablet would greatly reduce the size of the RU and provide a platform for expanding the functional capabilities of the system. This would open the way for extending development of the system to be better suited for tele-rehabilitation. A more compact RU combined with a miniaturised HE will collectively improve the ergonomics of the rehabilitation system, making it more comfortable and acceptable to the potential users. Incorporation of an internal charging circuit, dedicated to the RU, will make it more user friendly and increase the value of the already existing portability.

### **7.3.2 Clinical Recommendations**

Tripod pinch grip and tip pinch grip tests were not included in the study largely due to the minimal time that was available for conducting this experimental study. In future, these tests should be included in the pre-clinical and clinical trials for comparison with the other grip tests. This will corroborate the outcome of the study. Furthermore, the recruitment of a large study population, inclusive of male and female participants, will give statistical significance to the study and widen the scope of analysis thereby strengthening the validity of the findings.

## References

- Abyarjoo, F., Barreto, A., Abyarjoo, S., Ortega, F. R., & Cofino, J. (2013). Monitoring human wrist rotation in three degrees of freedom, 1–5. <http://doi.org/10.1109/secon.2013.6567517>
- Adeloye, D. (2014). An estimate of the incidence and prevalence of stroke in Africa: a systematic review and meta-analysis. *PloS One*, *9*(6), e100724. <http://doi.org/10.1371/journal.pone.0100724>
- Arya, K. N., Pandian, S., Verma, R., & Garg, R. K. (2011). Movement therapy induced neural reorganization and motor recovery in stroke: A review. *Journal of Bodywork and Movement Therapies*, *15*(4), 528–537. <http://doi.org/10.1016/j.jbmt.2011.01.023>
- Balasubramanian, S., Klein, J., & Burdet, E. (2010). Robot-assisted rehabilitation of hand function. *Current Opinion in Neurology*, *23*(6), 661–70. <http://doi.org/10.1097/WCO.0b013e32833e99a4>
- Bangor, A., Kortum, P. T., & Miller, J. T. (2008). An Empirical Evaluation of the System Usability Scale. *International Journal of Human-Computer Interaction*, *24*(March 2015), 574–594. <http://doi.org/10.1080/10447310802205776>
- Barbcatali. (2017). Servo Collection. Retrieved from <http://www.ebay.co.uk/cln/aiolosc/servo/119265899014>
- Basteris, A., Nijenhuis, S. M., Stienen, A. H. A., Buurke, J. H., Prange, G. B., & Amirabdollahian, F. (2014). Training modalities in robot-mediated upper limb rehabilitation in stroke: a framework for classification based on a systematic review. *Journal of Neuroengineering and Rehabilitation*, *11*, 111. <http://doi.org/10.1186/1743-0003-11-111>
- Beckerman, J. (2016). A Visual Guide to Understanding Stroke. Retrieved March 2, 2017, from <http://www.webmd.com/stroke/ss/slideshow-stroke-overview>
- Beery, K. E., Buktenica, N. A., & Beery, N. A. (1997). *The Beery-Buktenica developmental test of visual-motor integration: VMI, with supplemental developmental tests of visual perception and motor coordination: administration, scoring and teaching manual*. Modern Curriculum Press.
- BrainHQ. (2013). The Anatomy of Movement - Brain Connection. Retrieved November 8, 2015, from <http://brainconnection.brainhq.com/2013/03/05/the-anatomy-of-movement/>

- Brauer, S. G., Hayward, K. S., Carson, R. G., Cresswell, A. G., & Barker, R. N. (2013). The efficacy of SMART Arm training early after stroke for stroke survivors with severe upper limb disability: a protocol for a randomised controlled trial. *BMC Neurol*, *13*, 71. <http://doi.org/10.1186/1471-2377-13-71>
- Brewer, L., Horgan, F., Hickey, a, & Williams, D. (2013). Stroke rehabilitation: recent advances and future therapies. *QJM: Monthly Journal of the Association of Physicians*, *106*(1), 11–25. <http://doi.org/10.1093/qjmed/hcs174>
- Brijlal, Y. (2012). *Development of a Hand-exoskeleton for Handwriting Rehabilitation*. University of Cape Town.
- Brooke, J. (2013). System Usability Scale: A Retrospective. *Journal of Usability Studies*, *8*(2), 29–40. Retrieved from [http://uxpajournal.org/wp-content/uploads/pdf/JUS\\_Brooke\\_February\\_2013.pdf](http://uxpajournal.org/wp-content/uploads/pdf/JUS_Brooke_February_2013.pdf)
- Bryer, A., Connor, M., Haug, P., Cheyip, B., Staub, H., Tipping, B., ... Pinkney-Atkinson, V. (2010). South African guideline for management of ischaemic stroke and transient ischaemic attack 2010: a guideline from the South African Stroke Society (SASS) and the SASS Writing Committee. *South African Medical Journal = Suid-Afrikaanse Tydskrif Vir Geneeskunde*, *100*(11 Pt 2), 747–778.
- Chang, W. H., & Kim, Y.-H. (2013). Robot-Assisted Therapy in Stroke Rehabilitation. *Journal of Stroke*, *15*(3), 174–81. <http://doi.org/10.5853/jos.2013.15.3.174>
- Cho, S., Ku, J., Cho, Y. K., Kim, I. Y., Kang, Y. J., Jang, D. P., & Kim, S. I. (2014). Development of virtual reality proprioceptive rehabilitation system for stroke patients. *Computer Methods and Programs in Biomedicine*, *113*(1), 258–265. <http://doi.org/10.1016/j.cmpb.2013.09.006>
- DailyCaring. (2016). Stroke Therapy Exercises For Upper And Lower Body. Retrieved July 26, 2016, from <http://dailycaring.com/video-stroke-therapy-exercises-for-upper-and-lower-body/>
- Darnell, J., Lodish, H., Berk, A., Zipursky, L., Matsudaira, P., & Baltimore, D. (1999). Overview of Neuron Structure and Function. (W. H. Freeman, Ed.) *Molecular Cell Biology*. New York. Retrieved from <http://www.ncbi.nlm.nih.gov/books/NBK21535/>
- Dimyan, M. A., & Cohen, L. G. (2011). Neuroplasticity in the context of motor rehabilitation after stroke. *Nature Reviews. Neurology*, *7*(2), 76–85.

- <http://doi.org/10.1038/nrneurol.2010.200>
- Drake, R. L., Vogl, A. W., & Mitchell, A. W. M. (2015). Head and Neck. In A. W. V. and A. W. M. M. Richard L. Drake (Ed.), *Gray's Anatomy for Students* (3rd Editio, pp. 835–1135). Elsevier Inc. Retrieved from <https://www.clinicalkey.com/#!/content/book/3-s2.0-B9780702051319000080?scrollTo=%2523hl0005009>
- Duncan, P. W., Zorowitz, R., Bates, B., Choi, J. Y., Glasberg, J. J., Graham, G. D., ... Reker, D. (2005). *Management of Adult Stroke Rehabilitation Care: a clinical practice guideline. Stroke; a journal of cerebral circulation* (Vol. 36). <http://doi.org/10.1161/01.STR.0000180861.54180.FF>
- Edmans, J. (2011). *Occupational therapy and stroke*. John Wiley & Sons.
- Fasoli, S. E., Krebs, H. I., Stein, J., Frontera, W. R., & Hogan, N. (2003). Effects of robotic therapy on motor impairment and recovery in chronic stroke. *Archives of Physical Medicine and Rehabilitation, 84*(4), 477–482. <http://doi.org/10.1053/apmr.2003.50110>
- FRD. (2015). How to Improve Fine Motor Skills in Hands. Retrieved July 21, 2016, from <https://www.flintrehab.com/2015/how-to-improve-fine-motor-skills-in-hands/>
- Fritz, V. (2006). Stroke in South Africa. *Int J Stroke, 1*(1), 47–48. <http://doi.org/10.1111/j.1747-4949.2005.00006.x>
- Go, A. S., Mozaffarian, D., Roger, V. L., Benjamin, E. J., Berry, J. D., Blaha, M. J., ... Turner, M. B. (2014). *Heart disease and stroke statistics--2014 update: a report from the American Heart Association. Circulation* (Vol. 129). <http://doi.org/10.1161/01.cir.0000441139.02102.80>
- Goldstein, T. J. C. and J. N. (2014). Stroke. In R. S. H. and R. M. W. John A. Marx (Ed.), *Rosen's Emergency Medicine: Concepts and Clinical Practice* (8th Editio, p. 1363–1374.e2). Elsevier Inc. Retrieved from <https://www.clinicalkey.com/#!/content/book/3-s2.0-B9781455706051001019>
- Hankey, G. J. (2014). Secondary stroke prevention. *Lancet Neurology, 13*(2), 178–94. [http://doi.org/10.1016/S1474-4422\(13\)70255-2](http://doi.org/10.1016/S1474-4422(13)70255-2)
- Heo, P., Gu, G. M., Lee, S. jin, Rhee, K., & Kim, J. (2012). Current hand exoskeleton technologies for rehabilitation and assistive engineering. *International Journal of Precision Engineering and Manufacturing*. <http://doi.org/10.1007/s12541-012-0107-2>
- Hesse, S., Schmidt, H., Werner, C., Bardeleben, A., & Berlin, K. (2003). Upper and lower extremity

- robotic devices for rehabilitation and for studying motor control. *Curr Opin Neurol Current Opinion in Neurology*, 16, 705–710. <http://doi.org/10.1097/01.wco.0000102630.16692.38>
- Hoffman, R. (2013). *Hematology: Basic Principles and Practice* (6th Editio). Elsevier Inc.
- IB Guides. (2015). Nerves,hormones and homeostasis. Retrieved October 25, 2015, from <http://ibguides.com/biology/notes/nerves-and-hormones>
- Kalra, L. (2010). Stroke rehabilitation 2009: Old chestnuts and new insights. *Stroke*. <http://doi.org/10.1161/STROKEAHA.109.572297>
- Knierim, J. (1997). Motor Cortex. In J. H. B. Byrne (Ed.), *Neuroscience Online*. The University of Texas Medical School. Retrieved from <http://neuroscience.uth.tmc.edu/s3/chapter03.html>
- Krakauer, J. W. (2005). Arm function after stroke: From physiology to recovery. *Seminars in Neurology*. <http://doi.org/10.1055/s-2005-923533>
- Langhorne, P., Bernhardt, J., & Kwakkel, G. (2011). Stroke rehabilitation. *Lancet*, 377(9778), 1693–702. [http://doi.org/10.1016/S0140-6736\(11\)60325-5](http://doi.org/10.1016/S0140-6736(11)60325-5)
- Laver, K., George, S., Thomas, S., Deutsch, J. E., & Crotty, M. (2015). Virtual reality for stroke rehabilitation: an abridged version of a Cochrane review. *European Journal of Physical and Rehabilitation Medicine*, 51(4), 497–506. Retrieved from <http://ovidsp.ovid.com/ovidweb.cgi?T=JS&PAGE=reference&D=prem&NEWS=N&AN=26158918>
- Lum, P. S., Burgar, C. G., Shor, P. C., Majmundar, M., & Van der Loos, M. (2002). Robot-assisted movement training compared with conventional therapy techniques for the rehabilitation of upper limb motor function following stroke. *Archives of Physical Medicine and Rehabilitation*, 83(7), 952–959. Retrieved from <http://www2.archives-pmr.org/scripts/om.dll/serve?action=searchDB&searchDBfor=art&artType=abs&id=aapmr0830952&nav=abs>
- Lum, P. S., Godfrey, S. B., Brokaw, E. B., Holley, R. J., & Nichols, D. (2012). Robotic Approaches for Rehabilitation of Hand Function After Stroke. *American Journal of Physical Medicine & Rehabilitation*, 91(11), S242–S254. <http://doi.org/10.1097/PHM.0b013e31826bcdcb>
- Lynn, T. (2012). Neuroplasticity. Retrieved from <http://www.archhealth.com.au/post/1293314-neuroplasticity>

- Maciejasz, P., Eschweiler, J., Gerlach-Hahn, K., Jansen-Troy, A., & Leonhardt, S. (2014). A survey on robotic devices for upper limb rehabilitation. *Journal of Neuroengineering and Rehabilitation*. <http://doi.org/10.1186/1743-0003-11-3>
- Masiero, S., Armani, M., & Rosati, G. (2011). Upper-limb robot-assisted therapy in rehabilitation of acute stroke patients: focused review and results of new randomized controlled trial. *Journal of Rehabilitation Research and Development*, 48(4), 355–366. <http://doi.org/10.1682/JRRD.2010.04.0063>
- Masiero, S., Celia, A., Rosati, G., & Armani, M. (2007). Robotic-Assisted Rehabilitation of the Upper Limb After Acute Stroke. *Archives of Physical Medicine and Rehabilitation*, 88(2), 142–149. <http://doi.org/10.1016/j.apmr.2006.10.032>
- Mohd Nordin, N. A., Aziz, N. A. A., Abdul Aziz, A. F., Ajit Singh, D. K., Omar Othman, N. A., Sulong, S., & Aljunid, S. M. (2014). Exploring views on long term rehabilitation for people with stroke in a developing country: findings from focus group discussions. *BMC Health Services Research*, 14(1), 118. <http://doi.org/10.1186/1472-6963-14-118>
- Morris, J. H., van Wijck, F., Joice, S., Ogston, S. A., Cole, I., & MacWalter, R. S. (2008). A Comparison of Bilateral and Unilateral Upper-Limb Task Training in Early Poststroke Rehabilitation: A Randomized Controlled Trial. *Archives of Physical Medicine and Rehabilitation*, 89(7), 1237–1245. <http://doi.org/10.1016/j.apmr.2007.11.039>
- Mühdorfer-Fodor, M., Ziegler, S., Harms, C., Neumann, J., Cristalli, A., Kalpen, A., ... Prommersberger, K. J. (2014). Grip force monitoring on the hand: Manugraphy system versus Jamar dynamometer. *Archives of Orthopaedic and Trauma Surgery*, 134(8), 1179–1188. <http://doi.org/10.1007/s00402-014-2027-3>
- Mullick, A. A., Subramanian, S. K., & Levin, M. F. (2015). Emerging evidence of the association between cognitive deficits and arm motor recovery after stroke: A meta-analysis. *Restor Neurol Neurosci*, 33(3), 389–403. <http://doi.org/10.3233/RNN-150510>
- MyStroke. (2016). Overview Of Stroke. Retrieved July 18, 2016, from <http://www.mystroke.co.za/About>
- Page, S. J., Levine, P., Sisto, S. a, Johnston, M. V, SJ., P., & Levine, P. (2001). Mental practice combined with physical practice for upper-limb motor deficit in subacute stroke. *Physical Therapy*, 81(8), 1455–1462.
- Poli, P., Morone, G., Rosati, G., & Masiero, S. (2013). Robotic technologies and rehabilitation:

- New tools for stroke patients' therapy. *BioMed Research International*.  
<http://doi.org/10.1155/2013/153872>
- Pollock, A., Farmer, S. E., Brady, M. C., Langhorne, P., Mead, G. E., Mehrholz, J., & van Wijck, F. (2014a). Interventions for improving upper limb function after stroke. *The Cochrane Database of Systematic Reviews*, 11. <http://doi.org/10.1002/14651858.CD010820.pub2>
- Pollock, A., Farmer, S. E., Brady, M. C., Langhorne, P., Mead, G. E., Mehrholz, J., & van Wijck, F. (2014b). Interventions for improving upper limb function after stroke. *Cochrane Database of Systematic Reviews*, 11, CD010820. <http://doi.org/10.1002/14651858.CD010820.pub2>
- Roberts, H. C., Denison, H. J., Martin, H. J., Patel, H. P., Syddall, H., Cooper, C., & Sayer, A. A. (2011). A review of the measurement of grip strength in clinical and epidemiological studies: Towards a standardised approach. *Age and Ageing*.  
<http://doi.org/10.1093/ageing/afr051>
- Sacco, R. L., Kasner, S. E., Broderick, J. P., Caplan, L. R., Connors, J. J., Culebras, A., ... Metabolism. (2013). An updated definition of stroke for the 21st century: a statement for healthcare professionals from the American Heart Association/American Stroke Association. *Stroke*, 44(7), 2064–2089. <http://doi.org/10.1161/STR.0b013e318296aeca>
- Schaechter, J. D. (2004). Motor rehabilitation and brain plasticity after hemiparetic stroke. *Progress in Neurobiology*, 73(1), 61–72. <http://doi.org/10.1016/j.pneurobio.2004.04.001>
- Schwerin, S. (2013). The Anatomy of Movement. *Brain Connection*. Retrieved from <http://brainconnection.brainhq.com/2013/03/05/the-anatomy-of-movement/>
- SHSC. (2008). Bones and Joints. Retrieved March 2, 2017, from <http://www.sydneyhandsurgeryclinic.com.au/anatomy.asp>
- Stein, J. (2012). Robotics in rehabilitation: technology as destiny. *American Journal of Physical Medicine & Rehabilitation / Association of Academic Physiatrists*, 91(11 Suppl 3), S199-203. <http://doi.org/10.1097/PHM.0b013e31826bcbbd>
- Stroke Health Center. (2015). What Happens. Retrieved October 26, 2015, from <http://www.webmd.com/stroke/guide/stroke-what-happens>
- Timmermans, A. a, Seelen, H. a M., Willmann, R. D., & Kingma, H. (2009). Technology-assisted training of arm-hand skills in stroke: concepts on reacquisition of motor control and therapist guidelines for rehabilitation technology design. *Journal of Neuroengineering and Rehabilitation*, 6(figure 1), 1. <http://doi.org/10.1186/1743-0003-6-1>

## References

---

- TISC. (1999). Anatomy of the Brain. Retrieved October 26, 2015, from <http://www.strokecenter.org/professionals/brain-anatomy/anatomy-of-the-brain/>
- Veerbeek, J. M., Kwakkel, G., van Wegen, E. E. H., Ket, J. C. F., & Heymans, M. W. (2011). Early prediction of outcome of activities of daily living after stroke: a systematic review. *Stroke: a Journal of Cerebral Circulation*, *42*(5), 1482–8. <http://doi.org/10.1161/STROKEAHA.110.604090>
- Wilhelmi, B. J., & Gest, T. R. (2015). Hand Anatomy. Retrieved March 4, 2017, from <http://emedicine.medscape.com/article/1285060-overview#a1>
- Winstein, C. J., Wolf, S. L., Dromerick, A. W., Lane, C. J., Nelsen, M. A., Lewthwaite, R., ... Azen, S. P. (2016). Effect of a Task-Oriented Rehabilitation Program on Upper Extremity Recovery Following Motor Stroke: The ICARE Randomized Clinical Trial. *Jama*, *315*(6), 571–81. <http://doi.org/10.1001/jama.2016.0276>

# Appendices

## Appendix A – Writing Accuracy Test

Participant No. \_\_\_\_\_ Phase \_\_\_\_\_ Date \_\_\_\_\_

Set 1

|   |
|---|
|  |
|   |

Set 2

|   |
|---|
|  |
|   |

Set 3

|   |
|---|
|  |
|   |

Set 4

|  |
|--|
|  |
|  |

Set 5

|  |
|--|
|  |
|  |

Set 6



Set 7



Set 8

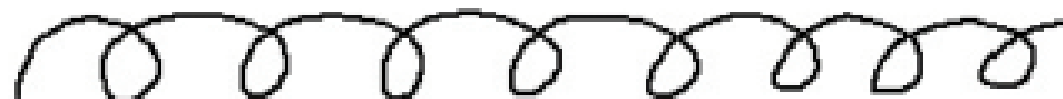

Set 9



Set 10

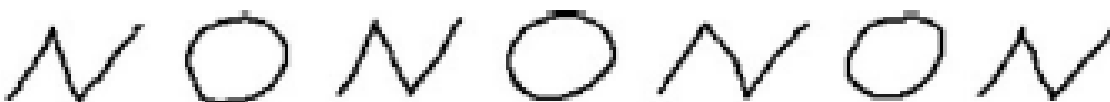

Set 11

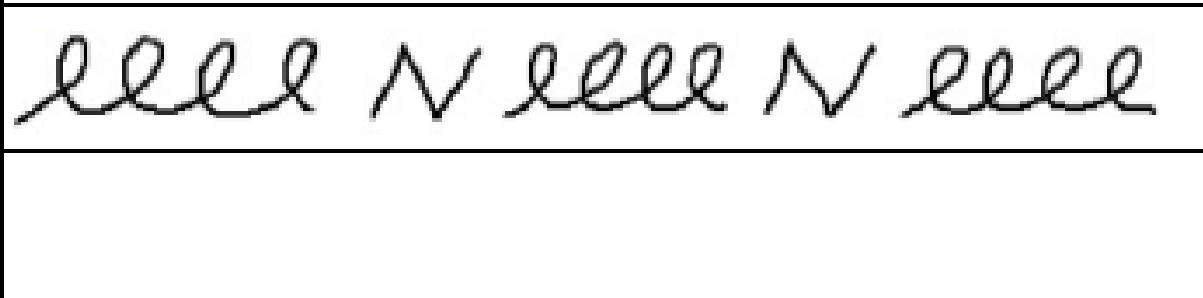

Set 12

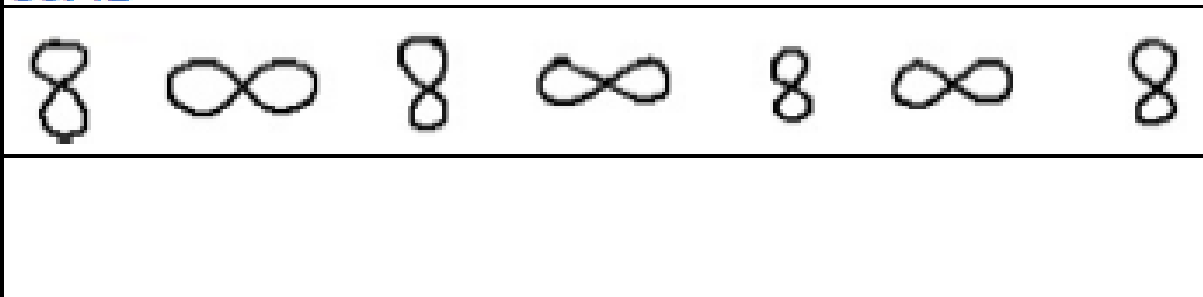

Set 13

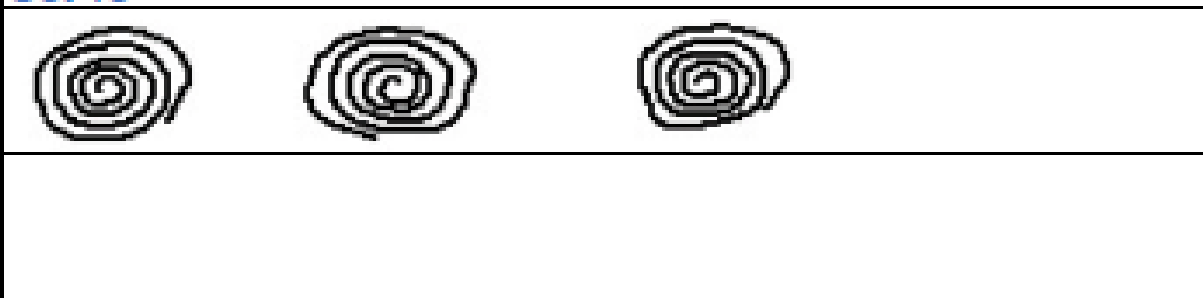



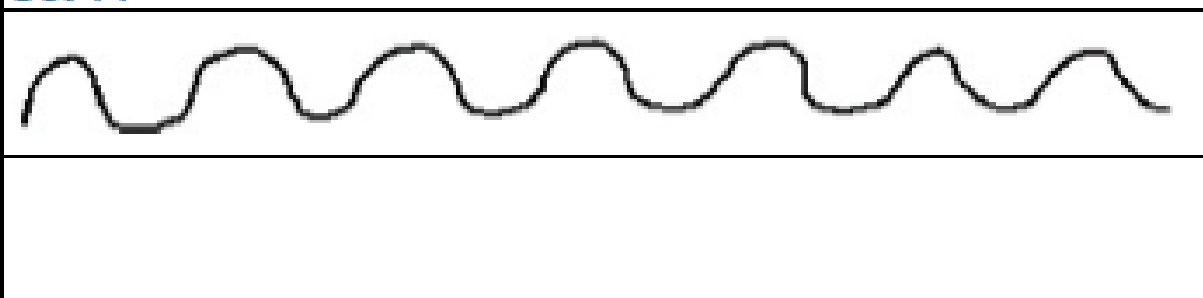



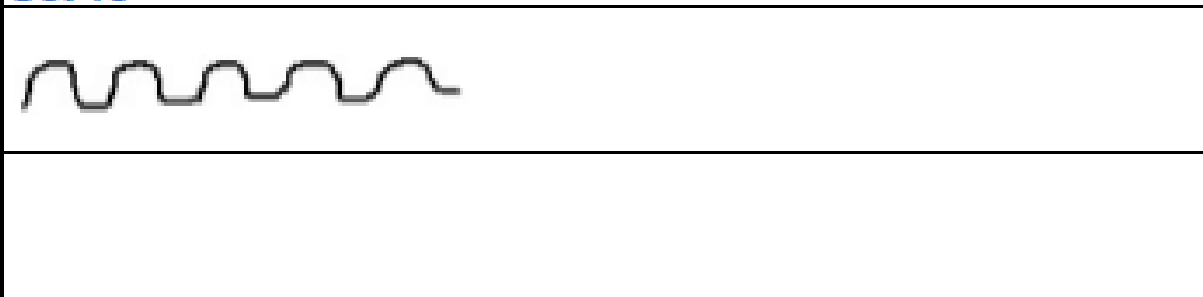



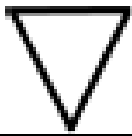
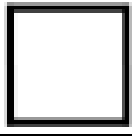
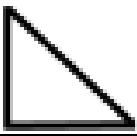





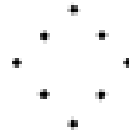
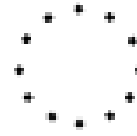
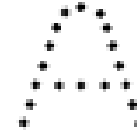
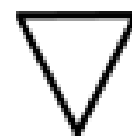
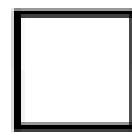
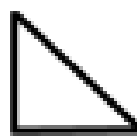



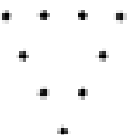

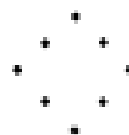
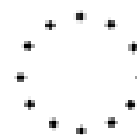

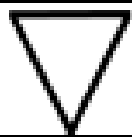
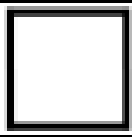
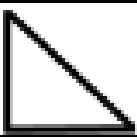

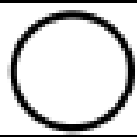

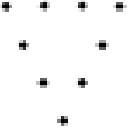

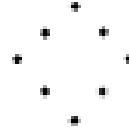
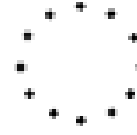

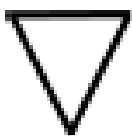
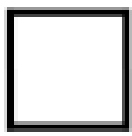
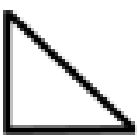
Set 14



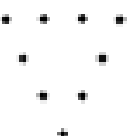

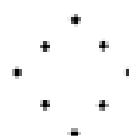
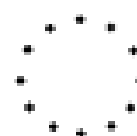
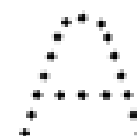
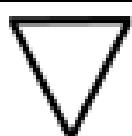
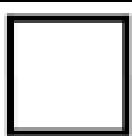
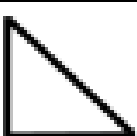

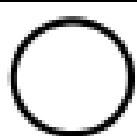
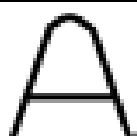
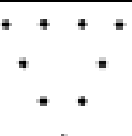

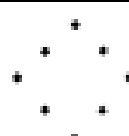
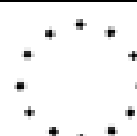
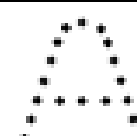
Set 15







Set 16

|   |   |   |   |   |   |
|---|---|---|---|---|---|
|    |    |    |    |    |    |
|    |    |    |    |    |    |
| <b>Rep 1</b>  |   |   |   |   |   |
|    |    |    |    |    |    |
|    |    |    |    |    |    |
| <b>Rep 2</b>  |   |   |   |   |   |
|   |   |   |   |   |   |
|  |  |  |  |  |  |
| <b>Rep 3</b>  |   |   |   |   |   |
|  |  |  |  |  |  |
|  |  |  |  |  |  |
| <b>Rep 4</b>  |   |   |   |   |   |
|  |  |  |  |  |  |
|  |  |  |  |  |  |

Set 17

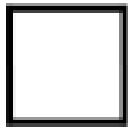
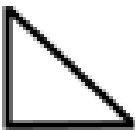
|  |
|--|
|    |
| Rep 1  |
|    |
| Rep 2  |
|    |
| Rep 3  |
|  |
| Rep 4  |
|  |
| Rep 6  |
|  |

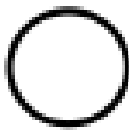
Set 18

|   |
|---|
|       |
| Rep 1   |
|   |
| Rep 2   |
|   |
| Rep 3   |
|   |
| Rep 4   |
|   |
| Rep 5   |
|   |
| Rep 6   |
|   |

## Appendix B – System Usability Scale

### System Usability Scale

© Digital Equipment Corporation, 1986.

|  | Strongly disagree        |                          |                          |                          | Strongly agree           |
|--|--------------------------|--------------------------|--------------------------|--------------------------|--------------------------|
| 1. I think that I would like to use this system frequently                                   | <input type="checkbox"/> | <input type="checkbox"/> | <input type="checkbox"/> | <input type="checkbox"/> | <input type="checkbox"/> |
|  | 1                        | 2                        | 3                        | 4                        | 5                        |
| 2. I found the system unnecessarily complex  | <input type="checkbox"/> | <input type="checkbox"/> | <input type="checkbox"/> | <input type="checkbox"/> | <input type="checkbox"/> |
|  | 1                        | 2                        | 3                        | 4                        | 5                        |
| 3. I thought the system was easy to use  | <input type="checkbox"/> | <input type="checkbox"/> | <input type="checkbox"/> | <input type="checkbox"/> | <input type="checkbox"/> |
|  | 1                        | 2                        | 3                        | 4                        | 5                        |
| 4. I think that I would need the support of a technical person to be able to use this system | <input type="checkbox"/> | <input type="checkbox"/> | <input type="checkbox"/> | <input type="checkbox"/> | <input type="checkbox"/> |
|  | 1                        | 2                        | 3                        | 4                        | 5                        |
| 5. I found the various functions in this system were well integrated                         | <input type="checkbox"/> | <input type="checkbox"/> | <input type="checkbox"/> | <input type="checkbox"/> | <input type="checkbox"/> |
|  | 1                        | 2                        | 3                        | 4                        | 5                        |
| 6. I thought there was too much inconsistency in this system                                 | <input type="checkbox"/> | <input type="checkbox"/> | <input type="checkbox"/> | <input type="checkbox"/> | <input type="checkbox"/> |
|  | 1                        | 2                        | 3                        | 4                        | 5                        |
| 7. I would imagine that most people would learn to use this system very quickly              | <input type="checkbox"/> | <input type="checkbox"/> | <input type="checkbox"/> | <input type="checkbox"/> | <input type="checkbox"/> |
|  | 1                        | 2                        | 3                        | 4                        | 5                        |
| 8. I found the system very cumbersome to use   | <input type="checkbox"/> | <input type="checkbox"/> | <input type="checkbox"/> | <input type="checkbox"/> | <input type="checkbox"/> |
|  | 1                        | 2                        | 3                        | 4                        | 5                        |
| 9. I felt very confident using the system  | <input type="checkbox"/> | <input type="checkbox"/> | <input type="checkbox"/> | <input type="checkbox"/> | <input type="checkbox"/> |
|  | 1                        | 2                        | 3                        | 4                        | 5                        |
| 10. I needed to learn a lot of things before I could get going with this system              | <input type="checkbox"/> | <input type="checkbox"/> | <input type="checkbox"/> | <input type="checkbox"/> | <input type="checkbox"/> |
|  | 1                        | 2                        | 3                        | 4                        | 5                        |

## Appendix C – Trace Sample Test

### C. TRACING SAMPLE

| TRACING     | MALE | FEMALE | DATES |  |  | REMARKS |
|-------------|------|--------|-------|--|--|---------|
|             |      |        |       |  |  |         |
| RECTANGLE   | 5.5  | 6.6    |       |  |  |         |
| CURVED LINE | 6.2  | 8.1    |       |  |  |         |
| SIGNATURE   | 5.5  | 5.9    |       |  |  |         |

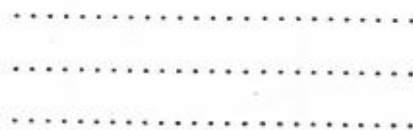
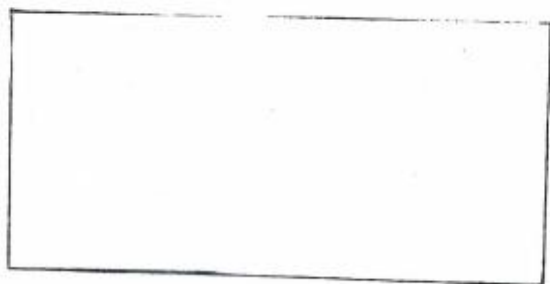

## Appendix D – Anthropometric Parameters

### ANTHROPOMETRIC PARAMETERS FOR THE HUMAN BODY\*

| Segment Lengths |       |         |
|-----------------|-------|---------|
| Segment         | Males | Females |
| Head and neck   | 10.75 | 10.75   |
| Trunk           | 30.00 | 29.00   |
| Upper arm       | 17.20 | 17.30   |
| Forearm         | 15.70 | 16.00   |
| Hand            | 5.75  | 5.75    |
| Thigh           | 23.20 | 24.90   |
| Lower leg       | 24.70 | 25.70   |
| Foot            | 4.25  | 4.25    |

Segment lengths expressed in percentages of total body height.

| Segment Weights |       |         |
|-----------------|-------|---------|
| Segment         | Males | Females |
| Head            | 8.26  | 8.20    |
| Trunk           | 46.84 | 45.00   |
| Upper arm       | 3.25  | 2.90    |
| Forearm         | 1.87  | 1.57    |
| Hand            | 0.65  | 0.50    |
| Thigh           | 10.50 | 11.75   |
| Lower leg       | 4.75  | 5.35    |
| Foot            | 1.43  | 1.33    |

Segment weights expressed in percentages of total body weight

From Plagenhoef S, Evans FG, and Abdelnour T: Anatomical data for analyzing human motion, Res Q Exerc Sport 54:169, 1983.

| Segmental Center of Gravity Locations |       |         |
|---------------------------------------|-------|---------|
| Segment                               | Males | Females |
| Head and neck                         | 55.0  | 55.0    |
| Trunk                                 | 63.0  | 56.9    |
| Upper arm                             | 43.6  | 45.8    |
| Forearm                               | 43.0  | 43.4    |
| Hand                                  | 46.8  | 46.8    |
| Thigh                                 | 43.3  | 42.8    |
| Lower leg                             | 43.4  | 41.9    |
| Foot                                  | 50.0  | 50.0    |

## Appendix E – Hypothetical Subject Parameters

### Subject Characteristics

| PROPERTY | SPECIFICATION |
|----------|---------------|
| Gender   | Male          |
| Mass     | 80 kg         |
| Height   | 170 cm        |

### Segmental Parameters

#### Segmental Length:

$$\text{Forearm} = \frac{15.7}{100} \times 170 = \mathbf{26.69\text{ cm}}$$

$$\text{Hand} = \frac{5.75}{100} \times 170 = \mathbf{9.78\text{ cm}}$$

#### Segmental Weights:

$$\text{Forearm} = \frac{1.87}{100} \times 80 = \mathbf{1.496\text{ kg}}$$



$$\text{Hand} = \frac{0.65}{100} \times 80 = \mathbf{0.52\text{ kg}}$$

#### Segmental Centre of Gravity:

$$\text{Forearm} = \frac{43}{100} \times 26.69 = \mathbf{11.48\text{ cm}}$$

$$\text{Hand} = \frac{46.8}{100} \times 9.78 = \mathbf{4.58\text{ cm}}$$

## Appendix F – Formal Ethics Approval

|   |   |   |
|---|---|---|
|  | <b>UNIVERSITY OF CAPE TOWN</b><br><b>Faculty of Health Sciences</b><br><b>Human Research Ethics Committee</b> |    |
|   |   | <b>Room E53-46 Old Main Building</b><br><b>Groote Schuur Hospital</b><br><b>Observatory 7925</b><br><b>Telephone [021] 406 6492</b><br><b>Email: <a href="mailto:sumayah.ariel@uct.ac.za">sumayah.ariel@uct.ac.za</a></b><br><b>Website: <a href="http://www.health.uct.ac.za/fhs/research/humanethics/forms">www.health.uct.ac.za/fhs/research/humanethics/forms</a></b> |

---

25 November 2016

**HREC REF: 711/2016**

**Dr S Sivasu**  
Division of Biomedical Engineering  
Anatomy Building  
FHS

Dear Dr Sivasu

**PROJECT TITLE: A REHABILITATION SYSTEM FOR IMPROVING UPPER LIMB MOTOR FUNCTION (MMED CANDIDATE - MR A OPIYO)**

Thank you for your response letter dated 11 November 2016, addressing the issues raised by the Human Research Ethics Committee (HREC).

It is a pleasure to inform you that the HREC has **formally approved** the above-mentioned study.

**Approval is granted for one year until the 30 November 2017.**

Please submit a progress form, using the standardised Annual Report Form if the study continues beyond the approval period. Please submit a Standard Closure form if the study is completed within the approval period.  
(Forms can be found on our website: [www.health.uct.ac.za/fhs/research/humanethics/forms](http://www.health.uct.ac.za/fhs/research/humanethics/forms))

**Please quote the HREC REF in all your correspondence.**

***We acknowledge that the student, A Opiyo will also be involved in this study.***

Please note that the ongoing ethical conduct of the study remains the responsibility of the principal investigator.  
Please note that for all studies approved by the HREC, the principal investigator **must** obtain appropriate Institutional approval before the research may occur.

Yours sincerely

  
**PROFESSOR M. BLOCKMAN**  
**CHAIRPERSON, FHS HUMAN RESEARCH ETHICS COMMITTEE**

Federal Wide Assurance Number: FWA00001637.  
Institutional Review Board (IRB) number: IRB00001938  
This serves to confirm that the University of Cape Town Human Research Ethics Committee complies to the Ethics Standards for Clinical Research with a new drug in patients, based on the Medical  
HREC 711/2016

Research Council (MRC-SA), Food and Drug Administration (FDA-USA), International Convention on Harmonisation Good Clinical Practice (ICH GCP), South African Good Clinical Practice Guidelines (DoH 2006), based on the Association of the British Pharmaceutical Industry Guidelines (ABPI), and Declaration of Helsinki (2013) guidelines.

The Human Research Ethics Committee granting this approval is in compliance with the ICH Harmonised Tripartite Guidelines E6: Note for Guidance on Good Clinical Practice (CPMP/ICH/135/95) and FDA Code Federal Regulation Part 50, 56 and 312.

HREC 711/2016

## **Appendix G – Research Access to Students**

*Signed*

## Appendix H - Code

```
//----- Header Files -----//

#include <UTFT.h>           // TFT Graphics library
#include <URTouch.h>       // Touch panel library
#include <SdFat.h>         // SD library
#include <UTFT_SdRaw.h>
#include <SPI.h>

#include <Servo.h>         // Servo library

//----- Variable Declarations -----//
#define SD_CHIP_SELECT 50 // SD chip select pin

SdFat sd;

// Display and touch global variables
// Font object
extern uint8_t SmallFont[];
extern uint8_t SevenSegNumFont[];

// TFT Display object
UTFT screen(ITDB32S,53,52,40,38); //TFT display

// Touch Panel object
URTouch touch(45,44,43,42,41); //Touch input

// SD Card
UTFT_SdRaw myFiles(&screen);

// Colours
// [black, red, pink, orange, green, blue, purple]
byte R[7] = {0, 255, 255, 255, 0, 0, 128};
```

```
byte G[7] = {0, 0, 20, 128, 255, 0, 0};
byte B[7] = {0, 0, 147, 0, 0, 255, 128};

// drawPalette defaults
int box_x1[10];
int box_x2[10];
byte box_y1;
byte box_y2;

byte line_color_box = 0;
byte line_width = 2;

byte line_color_R = R[line_color_box];
byte line_color_G = G[line_color_box];
byte line_color_B = B[line_color_box];

// Touch screen co-ordinates
int X,Y;

//Flags
boolean count_flag;

//-----//
// Sensing and actuation global variables
// Servo objects
Servo servo0;
Servo servo1;
Servo servo2;
Servo servo3;
Servo servo4;
Servo servo5;

// Control system variables
int u_var[5] = {0,0,0,0,0}; // Discrete control action
```

```
int y_var[5] = {0,0,0,0,0}; // Output
float e_var[5] = {0,0,0,0,0}; // Error signal
float v_var[5] = {0,0,0,0,0}; // Continuous control action
float x_var[5] = {0,0,0,0,0}; // Current state variable X(n)
float x1_var[5] = {0,0,0,0,0}; // Previous state variable X(n-1)

// Timer variables
unsigned long my_time; // Time
byte delta = 5; // Sample period
byte control_len = 5; // No. of controlled cycles

//----- Main -----//

void loop()
{
  if (touch.dataAvailable())
  {
    touch.read();
    X = touch.getX();
    Y = touch.getY();

    if ((Y >= 135) && (Y <= 206))
    {
      // Free Drawing
      if ((X >= 24) && (X <= 98))
      {
        screen.setColor(0,255,0);
        screen.drawRect(10,115,105,206);
        screen.drawRect(11,116,105,205);
        delay(500);
        quickDraw();
      }
    }

    // Trace Select: Provides option for selecting a new shape at the end of every trace
```

```
    else if ((X >= 122) && (X <= 196))
    {
        screen.setColor(0,255,0);
        screen.drawRect(112,115,208,206);
        screen.drawRect(113,116,207,205);
        delay(500);
        tracing();
    }

    // Multi-Mode: Cycles through all the shapes
    else if ((X >= 220) && (X <= 294))
    {
        screen.setColor(0,255,0);
        screen.drawRect(214,115,310,206);
        screen.drawRect(215,116,309,205);
        delay(500);
        button_Auto(1);
    }
}
}
}

//----- button -----//

void button(byte n)
{
    count_flag = false; //flag which initiates trace sequence countdown

    switch (n)
    {
        // Test 1
        case 1:
        {
            // Load test 1
```

```
screen.setColor(255,255,255);
screen.fillRect(0,box_y2+9,319,239);
myFiles.load(0, 40, 320, 200, "Test1.RAW", 1, 0);

screen.setColor(255,0,0);
screen.fillCircle(125,96,5);
pre_countDown();

runTest(1);
break;

}

// Test 2
case 2:
{
    // Load test 2
    screen.setColor(255,255,255);
    screen.fillRect(0,box_y2+9,319,239);
    myFiles.load(0, 40, 320, 200, "Test2.RAW", 1, 0);

    screen.setColor(255,0,0);
    screen.fillCircle(127,107,5);
    pre_countDown();

    runTest(2);
    break;
}

// Test 3
case 3:
{
    // Load test 3
    screen.setColor(255,255,255);
```

```
screen.fillRect(0,box_y2+9,319,239);
myFiles.load(0, 40, 320, 200, "Test3.RAW", 1, 0);

screen.setColor(255,0,0);
screen.fillCircle(111,113,5);
pre_countDown();

runTest(3);
break;
}

// Test 4
case 4:
{
    // Load test 4
    screen.setColor(255,255,255);
    screen.fillRect(0,box_y2+9,319,239);
    myFiles.load(0, 40, 320, 200, "Test4.RAW", 1, 0);

    screen.setColor(255,0,0);
    screen.fillCircle(133,140,5);
    pre_countDown();

    runTest(4);
    break;
}

// Test 5
case 5:
{
    // Load test 5
    screen.setColor(255,255,255);
    screen.fillRect(0,box_y2+9,319,239);
    myFiles.load(0, 40, 320, 200, "Test5.RAW", 1, 0);
```

```
screen.setColor(255,0,0);
screen.fillCircle(131,140,5);
pre_countDown();

runTest(5);
break;
}

// Test 6
case 6:
{
    // Load test 6
    screen.setColor(255,255,255);
    screen.fillRect(0,box_y2+9,319,239);
    myFiles.load(0, 40, 320, 200, "Test6.RAW", 1, 0);

    screen.setColor(255,0,0);
    screen.fillCircle(130,172,5);
    pre_countDown();

    runTest(6);
    break;
}

// Clear Button
case 7:
{
    // Clear screen
    screen.setColor(255,255,255);
    screen.fillRect(0,box_y2+9,319,239);
    break;
}

// Home button
```

```
case 8:
{
  // Home screen
  myFiles.load(0, 0, 320, 240, "home.RAW", 1, 0);

  break;
}
}

//----- draw -----//

void draw(boolean draw_mode)
{
  int x,y,x0,y0;
  byte radius = 10; // Debouncing radius
  byte a = 0;

  screen.setColor(line_color_R,line_color_G,line_color_B);

  if (touch.dataAvailable())
  {
    touch.read();
    x0 = touch.getX();
    y0 = touch.getY();
  }

  if (draw_mode)
  {
    while (touch.dataAvailable())
    {
      touch.read();
      x = touch.getX();
      y = touch.getY();
    }
  }
}
```

```
if ((x >= 0) && (x <=319) && (y >= box_y2+9) && (y <=239))
{
    if ((x >= x0+radius) || (x <= x0-radius))
        x = x0;
    else
        x0 = x;

    if ((y >= y0+radius) || (y <= y0-radius))
        y = y0;
    else
        y0 = y;

    screen.fillCircle(x,y,line_width);

}
}
}
else
{
    if (touch.dataAvailable())
    {
        touch.read();
        x = touch.getX();
        y = touch.getY();

        if ((x >= 0) && (x <=319) && (y >= box_y2+9) && (y <=239))
        {
            if ((x >= x0+radius) || (x <= x0-radius))
                x = x0;
            else
                x0 = x;

            if ((y >= y0+radius) || (y <= y0-radius))
                y = y0;
```

```
    else
        y0 = y;

    screen.fillCircle(x,y,line_width);

}
}
}

//----- setLineColor -----//

void setLineColor(boolean draw_mode, byte oldlineColorBox, byte newlineColorBox)
{
    // quickDraw mode
    if (draw_mode)
    {
        // Recolour old box
        screen.setColor(R[oldlineColorBox],G[oldlineColorBox],B[oldlineColorBox]);
        screen.fillRect(box_x1[oldlineColorBox]+7,14,box_x2[oldlineColorBox]-7,24);

        // Colour new box
        screen.setColor(255,255,255);
        screen.fillRect(box_x1[newlineColorBox]+7,14,box_x2[newlineColorBox]-7,24);

        // Set new line color
        line_color_R = R[newlineColorBox];
        line_color_G = G[newlineColorBox];
        line_color_B = B[newlineColorBox];

        // Draw current pen
        screen.setColor(line_color_R,line_color_G,line_color_B);
        screen.fillCircle(box_x2[8]+19,box_y1+12,line_width);
    }
}
```

```
    line_color_box = newlineColorBox;
}

// tracing mode
else
{
    line_color_box += 1;
    if (line_color_box == 6) line_color_box = 1;

    line_color_R = R[line_color_box];
    line_color_G = G[line_color_box];
    line_color_B = B[line_color_box];

    screen.setColor(line_color_R,line_color_G,line_color_B);
    screen.fillRect(7,7,31,31);

    // Draw current pen
    screen.setColor(line_color_R,line_color_G,line_color_B);
    screen.fillCircle(box_x2[8]+19,box_y1+12,line_width);
}

}

//----- drawLineWidthSlider -----//

void drawLineWidthSlider()
{
    // Clear slider area
    screen.setColor(255,255,255);
    screen.fillRect(box_x1[7]-4,0,318,34);
    screen.setColor(0,0,0);
    screen.drawCircle(box_x2[8]+19,box_y1+12,14);

    // Set line width slider
```

```
byte b = 31;
int slider_pos = line_width*4+box_x1[7];
screen.setColor(220,220,220);
for (int a = box_x1[7]+3; a <= box_x1[7]+51; a = a+2)
{
    screen.drawLine(a,31,a,b);
    screen.drawLine(a+1,31,a+1,b);
    b--;
}

// Draw slider position
screen.setColor(180,180,180);
screen.fillRect(slider_pos-2,32,slider_pos+2,8);
screen.fillCircle(slider_pos,19,5);

// Update linewidth indicator
screen.setColor(line_color_R,line_color_G,line_color_B);
screen.fillCircle(box_x2[8]+19,box_y1+12,line_width);
}

//----- setLineWidth -----//

void setLineWidth()
{
    int x,y;
    boolean done = false;

    drawLineWidthSlider();

    while (!done)
        if (touch.dataAvailable())
            {
                touch.read();
                x = touch.getX();
```

```

y = touch.getY();

// Finished select new line width
if ((x >= box_x1[9]) && (x <= box_x2[9]) && (y >= 6) && (y <= 34))
{
    done = true;
    delay(250); // Debounce
    break;
}

// Line width change
else if ((x >= box_x1[7]+3) && (x <= box_x1[7]+51) && (y >= 7) && (y <= 31))
{
    line_width = ceil((x-box_x1[7]+2)/4);
    drawLineWidthSlider();
}
}

// Clear slider area
screen.setColor(255,255,255);
screen.fillRect(box_x1[7]-4,6,box_x2[8]+4,34);

// Replace clear and home buttons
myFiles.load(box_x1[7],box_y1,24,24,"Cross.RAW", 1, 0);
myFiles.load(box_x1[8],box_y1,24,24,"House.RAW", 1, 0);
//screen.loadBitmap(box_x1[7],box_y1,24,24,"Cross.RAW");
//screen.loadBitmap(box_x1[8],box_y1,24,24,"House.RAW");

}

//----- drawPalette -----//

void drawPalette(boolean draw_mode)
{

```

```
byte space = 7;
byte box = 24;
int x1,x2,y1,y2;

// Set colour blocks
x1 = space;
x2 = space+box;
y1 = space;
y2 = space+box;

if (draw_mode)
{
    // quickDraw mode
    for (byte a = 0; a <= 6; a++)
    {
        screen.setColor(R[a],G[a],B[a]);
        screen.fillRect(x1,y1,x2,y2);
        box_x1[a] = x1;
        box_x2[a] = x2;
        x1 = x2+space;
        x2 = x1+box;
    }
}
else
{
    // Tracing mode
    screen.setColor(R[line_color_box],G[line_color_box],B[line_color_box]);
    screen.fillRect(x1,y1,x2,y2);
    box_x1[0] = x1;
    box_x2[0] = x2;
    x1 = x2+space;
    x2 = x1+box;

    for(byte a = 1; a <= 6; a += 1)
```

```
{
  // Draw test buttons
  switch (a)
  {
    case 1:
      {myFiles.load(x1,y1,24,24,"Icon1.RAW", 1, 0); break;}
      //{screen.loadBitmap(x1,y1,24,24,"Icon1.RAW"); break;}
    case 2:
      {myFiles.load(x1,y1,24,24,"Icon2.RAW", 1, 0); break;}
      //{screen.loadBitmap(x1,y1,24,24,"Icon2.RAW"); break;}
    case 3:
      {myFiles.load(x1,y1,24,24,"Icon3.RAW", 1, 0); break;}
      //{screen.loadBitmap(x1,y1,24,24,"Icon3.RAW"); break;}
    case 4:
      {myFiles.load(x1,y1,24,24,"Icon4.RAW", 1, 0); break;}
      //{screen.loadBitmap(x1,y1,24,24,"Icon4.RAW"); break;}
    case 5:
      {myFiles.load(x1,y1,24,24,"Icon5.RAW", 1, 0); break;}
      //{screen.loadBitmap(x1,y1,24,24,"Icon5.RAW"); break;}
    case 6:
      {myFiles.load(x1,y1,24,24,"Icon6.RAW", 1, 0); break;}
      //{screen.loadBitmap(x1,y1,24,24,"Icon6.RAW"); break;}
  }

  box_x1[a] = x1;
  box_x2[a] = x2;
  x1 = x2+space;
  x2 = x1+box;
}
}
myFiles.load(x1,y1,24,24,"Cross.RAW", 1, 0);
//screen.loadBitmap(x1,y1,24,24,"Cross.RAW");
box_x1[7] = x1;
box_x2[7] = x2;
```

```
x1 = x2+space;
x2 = x1+box;
myFiles.load(x1,y1,24,24,"House.RAW", 1, 0);
//screen.loadBitmap(x1,y1,24,24,"House.RAW");
box_x1[8] = x1;
box_x2[8] = x2;

box_y1 = y1;
box_y2 = y2-1;

// Draw borderline
screen.setColor(0,0,0);
screen.drawLine(0,y2+space,319,y2+space);

// Draw linewidth indicator
screen.drawCircle(x2+19,y1+box/2,14);
screen.setColor(R[line_color_box],G[line_color_box],B[line_color_box]);
screen.fillCircle(x2+19,y1+box/2,line_width);

box_x1[9] = x2+5;
box_x2[9] = x2+33;
}

//----- tracing -----//

void tracing()
{
// Draw default palette
screen.fillScr(255,255,255);

line_color_box = 1; // Set default color to red
line_color_R = R[line_color_box];
line_color_G = G[line_color_box];
line_color_B = B[line_color_box];
```

```
drawPalette(false);

int x,y;
boolean exit = false;

do {
  if (touch.dataAvailable())
  {
    touch.read();
    x = touch.getX();
    y = touch.getY();

    // Line width change
    if ((x >= box_x1[9]) && (x <= box_x2[9]) && (y >= 6) && (y <= 34))
      setLineWidth();

    // Line color change / button pressed
    else if ((x >= box_x1[0]) && (x <= box_x2[8]) && (y >= box_y1) && (y <= box_y2))
    {
      // Change Color
      if ((x >= box_x1[0]) && (x <= box_x2[0]))
      {
        setLineColor(false, 0, 0);
        delay(250); // Debounce
      }

      // Test 1
      else if ((x >= box_x1[1]) && (x <= box_x2[1]))
        button(1);

      // Test 2
      else if ((x >= box_x1[2]) && (x <= box_x2[2]))
        button(2);
    }
  }
}
```

```
// Test 3
else if ((x >= box_x1[3]) && (x <= box_x2[3]))
    button(3);

// Test 4
else if ((x >= box_x1[4]) && (x <= box_x2[4]))
    button(4);

// Test 5
else if ((x >= box_x1[5]) && (x <= box_x2[5]))
    button(5);

// Test 6
else if ((x >= box_x1[6]) && (x <= box_x2[6]))
    button(6);

// Clear button
else if ((x >= box_x1[7]) && (x <= box_x2[7]))
    button(7);

// Home button
else if ((x >= box_x1[8]) && (x <= box_x2[8]))
{
    button(8);
    exit = true;
}
}

// Draw on canvas
else if ((x >= 0) && (x <= 319) && (y >= box_y2+9) && (y <=239))
    draw(false);
}
} while (!exit);
return;
```

```
}  
//----- setTest -----//
```

```
void setTest(byte test, int pos, int *r)
```

```
{  
  switch (test)  
  {  
    case 1:  
    {  
      r[0] = test1_set0[pos];  
      r[1] = test1_set1[pos];  
      r[2] = test1_set2[pos];  
      r[3] = test1_set3[pos];  
      r[4] = test1_set4[pos];  
      break;  
    }  
  
    case 2:  
    {  
      r[0] = test2_set0[pos];  
      r[1] = test2_set1[pos];  
      r[2] = test2_set2[pos];  
      r[3] = test2_set3[pos];  
      r[4] = test2_set4[pos];  
      break;  
    }  
  
    case 3:  
    {  
      r[0] = test3_set0[pos];  
      r[1] = test3_set1[pos];  
      r[2] = test3_set2[pos];  
      r[3] = test3_set3[pos];  
      r[4] = test3_set4[pos];  
    }  
  }  
}
```

```
    break;
}

case 4:
{
    r[0] = test4_set0[pos];
    r[1] = test4_set1[pos];
    r[2] = test4_set2[pos];
    r[3] = test4_set3[pos];
    r[4] = test4_set4[pos];
    break;
}

case 5:
{
    r[0] = test5_set0[pos];
    r[1] = test5_set1[pos];
    r[2] = test5_set2[pos];
    r[3] = test5_set3[pos];
    r[4] = test5_set4[pos];
    break;
}

case 6:
{
    r[0] = test6_set0[pos];
    r[1] = test6_set1[pos];
    r[2] = test6_set2[pos];
    r[3] = test6_set3[pos];
    r[4] = test6_set4[pos];
    break;
}
};
```

```
}
```

```
//----- runTest -----//
```

```
void runTest(byte n)
```

```
{
```

```
int r[5] = {0,0,0,0,0}; // Setpoint
```

```
int len = 1000;
```

```
switch (n)
```

```
{
```

```
case 1:
```

```
len = len1;
```

```
break;
```

```
case 2:
```

```
len = len2;
```

```
break;
```

```
case 3:
```

```
len = len3;
```

```
break;
```

```
case 4:
```

```
len = len4;
```

```
break;
```

```
case 5:
```

```
len = len5;
```

```
break;
```

```
case 6:
```

```
len = len6;
```

```
break;
```

```
};
```

```
for(int a = 0; a < len; a += 1) //<len> is the length of the setpoint vector
```

```
{
```

```
    setTest(n,a,r); // get current setpoint for test [n]
    track(r);      // Closed loop actuation
    //delay(1);    // Speed multiplier
}
Serial.println(" ");
Serial.println(" ");
}

//----- track -----//

void track(int current_setpoints[5])
{
    // Draw once every setpoint cycle (CPU intensive process)
    draw(false);

    // Repeat control action [control_len] times
    for(byte a = 0; a <= control_len; a += 1)
    {
        // Wait for next sample period
        do {
            my_time = millis();
        } while (my_time % delta);

        // Calculate control action for each servo
        for(byte b = 0; b < 5; b += 1)
        {
            // Read output
            y_var[b] = analogRead(b);

            // Calculate error
            e_var[b] = current_setpoints[b]-y_var[b];

            // Calculate state
```

```
x_var[b] = e_var[b]+x_var[b];

// Calculate continuous control action
if((b == 1) || (b == 2)) //for index finger servos which move in opposite direction
    v_var[b] = (float)(24*x_var[b]-23*x1_var[b])/1000;
else
    v_var[b] = (float)(-24*x_var[b]+23*x1_var[b])/1000;

// Discretize control action
u_var[b] = round(v_var[b]);

// Apply soft limits
switch (b)
{
    case 0:
        if (u_var[b] > 179)
            u_var[b] = 160;
        else if (u_var[b] < 0)
            u_var[b] = 30;
        break;

    case 1:
        if (u_var[b] > 179)
            u_var[b] = 160;
        else if (u_var[b] < 0)
            u_var[b] = 23;
        break;

    case 2:
        if (u_var[b] > 179)
            u_var[b] = 130;
        else if (u_var[b] < 0)
            u_var[b] = 5;
        break;
```

```
    case 3:
        if (u_var[b] > 179)
            u_var[b] = 165;
        else if (u_var[b] < 0)
            u_var[b] = 60;
        break;

    case 4:
        if (u_var[b] > 179)
            u_var[b] = 150;
        else if (u_var[b] < 0)
            u_var[b] = 30;
        break;

}

// Update previous state
x1_var[b] = x_var[b];

} // End for(b)

// Apply discrete control action
servo0.write(u_var[0]);
servo1.write(u_var[1]);
servo2.write(u_var[2]);
servo3.write(u_var[3]);
servo4.write(u_var[4]);

} // End for(a)

} // End track()
```

```
//----- pre_countdown -----//
//This function displays the countdown time before trace simulation begins
void pre_countDown()
{
    unsigned long start_time = millis();
    unsigned long duration = 3000;
    byte a = 3; //The number of seconds to countdown

    while((millis() - start_time) <= duration)
    {
        screen.setBackgroundColor(255,255,255);
        screen.setColor(0,0,255);
        screen.setFont(SevenSegNumFont);
        screen.printNumI(a,268,61);
        a--;
        delay(1000);
    }

    //Print the number 0 in white colour to clear the portion of the screen
    screen.setBackgroundColor(255,255,255);
    screen.setColor(255,255,255);
    screen.setFont(SevenSegNumFont);
    screen.printNumI(0,268,61);
    //Load image that fills position of the number
    //myFiles.load(0, 40, 320, 200, "square_fill.RAW", 1, 0);

    count_flag = true;

} // end pre_countDown()

//----- button_Auto -----//
//Run through all the tests without selecting
void button_Auto(byte n)
{
```

```
int x,y;
boolean exit = false;

// Draw default palette
screen.fillScr(255,255,255);

line_color_box = 1; // Set default color to red
line_color_R = R[line_color_box];
line_color_G = G[line_color_box];
line_color_B = B[line_color_box];

drawPalette(false);

count_flag = false; //flag which initiates trace sequence countdown

switch (n)
{
  // Test 1
  case 1:
  {
    // Load test 1
    screen.setColor(255,255,255);
    screen.fillRect(0,box_y2+9,319,239);
    myFiles.load(0, 40, 320, 200, "Test1.RAW", 1, 0);

    screen.setColor(255,0,0);
    screen.fillCircle(125,96,5);
    pre_countDown();

    runTest(1);
  }

  // Test 2
```

```
case 2:
{
  // Load test 2
  screen.setColor(255,255,255);
  screen.fillRect(0,box_y2+9,319,239);
  myFiles.load(0, 40, 320, 200, "Test2.RAW", 1, 0);

  screen.setColor(255,0,0);
  screen.fillCircle(127,107,5);
  pre_countDown();

  runTest(2);
}

// Test 3
case 3:
{
  // Load test 3
  screen.setColor(255,255,255);
  screen.fillRect(0,box_y2+9,319,239);
  myFiles.load(0, 40, 320, 200, "Test3.RAW", 1, 0);

  screen.setColor(255,0,0);
  screen.fillCircle(111,113,5);
  pre_countDown();
  runTest(3);
}

// Test 4
case 4:
{
  // Load test 4
  screen.setColor(255,255,255);
  screen.fillRect(0,box_y2+9,319,239);
```

```
myFiles.load(0, 40, 320, 200, "Test4.RAW", 1, 0);

screen.setColor(255,0,0);
screen.fillCircle(133,140,5);
pre_countDown();
runTest(4);
}

// Test 5
case 5:
{
    // Load test 5
    screen.setColor(255,255,255);
    screen.fillRect(0,box_y2+9,319,239);
    myFiles.load(0, 40, 320, 200, "Test5.RAW", 1, 0);

    screen.setColor(255,0,0);
    screen.fillCircle(131,140,5);
    pre_countDown();
    runTest(5);
}

// Test 6
case 6:
{
    // Load test 6
    screen.setColor(255,255,255);
    screen.fillRect(0,box_y2+9,319,239);
    myFiles.load(0, 40, 320, 200, "Test6.RAW", 1, 0);

    screen.setColor(255,0,0);
    screen.fillCircle(130,172,5);
    pre_countDown();
```

```
    runTest(6);
}

// Clear Button
case 7:
{
    // Clear screen
    screen.setColor(255,255,255);
    screen.fillRect(0,box_y2+9,319,239);
    break;
}

// Home button
case 8:
{
    // Home screen
    myFiles.load(0, 0, 320, 240, "home.RAW", 1, 0);

    break;
}
}

do {
if (touch.dataAvailable())
{
    touch.read();
    x = touch.getX();
    y = touch.getY();

    // Line width change
if ((x >= box_x1[9]) && (x <= box_x2[9]) && (y >= 6) && (y <= 34))
    setLineWidth();

    // Line color change / button pressed
```

```
else if ((x >= box_x1[0]) && (x <= box_x2[8]) && (y >= box_y1) && (y <= box_y2))
{
    // Change Color
    if ((x >= box_x1[0]) && (x <= box_x2[0]))
    {
        setLineColor(false, 0, 0);
        delay(250); // Debounce
    }

    // Test 1
    if ((x >= box_x1[1]) && (x <= box_x2[1]))
        button_Auto(1);

    // Home button
    else if ((x >= box_x1[8]) && (x <= box_x2[8]))
    {
        button(8);
        exit = true;
    }
}
} while (!exit);

return;
} //end button_Auto
//----- button_Auto -----//
// EOF
```