

---

Growing a Building

Particularity as a Strategy for Upliftment of Agriculture Towns in South Africa

By: Catharina Malan

Convenors:

Associate Prof. Nic Coetzer (Semester 1)

Prof Ian Low (Semester 2)

Supervisor: Kevin Fellingham

This dissertation is presented as part fulfillment of the degree of Master of Architecture (Professional) in the School of Architecture, Planning and Geomatics, University of Cape Town  
October 2015

"I hereby:

- a. grant the University free license to reproduce the above dissertation in whole or in part, for the purpose of research.  
b. declare that:

- (i) The above dissertation is my own unaided work, both in conception and execution, and that apart from the normal guidance of my supervisors, I have received no assistance apart from that stated below.  
(ii) Except as stated below, neither the substance or any part of the dissertation has been submitted for a degree in the University or any other university.  
(iii) I am now presenting the dissertation for examination for the degree of Masters of Architecture (Professional)"  
Assistance Received: Cutting and sanding context buildings for my presentation model

The copyright of this thesis vests in the author. No quotation from it or information derived from it is to be published without full acknowledgement of the source. The thesis is to be used for private study or non-commercial research purposes only.

Published by the University of Cape Town (UCT) in terms of the non-exclusive license granted to UCT by the author.

## Plagerism Declaration

1. I know that plagiarism is wrong. Plagiarism is to use an other's work and pretend that it is one's own.
2. I have used the Chicago / Harvard convention for citation and referencing. Each contribution to, and quotation in, this report from the work(s) of other people has been attributed, and has been cited and referenced.
3. This report is my own work.
4. I have not allowed, and will not allow, anyone to copy my work with the intention of passing it off as his or her own work.

Signature \_\_\_\_\_

## Ethics Approval

The research for this dissertation has been approved by the University of Cape Town Ethics Board.

Thesis dedicated to late grandparents “Ouma Mien and Oupa Maans” for creating many special memories in Porterville and introducing me to the “platteland culture” where people talk and tell stories in colour.

### Acknowledgements

Supervisor Kevin Fellingham for maintaining enthusiasm till the end  
Parents Avril and Ina Malan for unconditional support and prayer throughout my studies  
Sister Fransie Malan for late night humour & model building  
Kelsey Kay for sharing encouragement over a glass of wine throughout the year  
Supervisor Kevin Fellingham for maintaining enthusiasm till the end  
Jack Radmore for proof reading and sound boarding ideas  
Mr H. Fourie, farmer and owner of Bio-Wheat stone ground flour mill, for his time and invaluable knowledge and experience  
(as well as changing my tyre).  
ACVV member Aletta Visagie for general insight on current and historic town matters  
Farmers Hein and Willem Visagie for sharing their insight and experience on the farming industry in Porterville



# Abstract

## Motivation

Small agriculture towns in South Africa are suffering economically since the number of jobs available in the agriculture sector has been decreasing rapidly. This is attributed to a deepening in capital in the agriculture sector (Hall & Cousins, 2015). Consequently unemployment is the reality of many farming towns and often results in large numbers of young people seeking a better life elsewhere, causing a slow but steady dilapidation of the town. The job seekers move to the city and become yet another burden on the city's already overloaded infrastructure since they have little chance of employment in a city environment with an agriculture skill set.

## Proposition

This dissertation proposes to contribute towards urban upliftment through healing the supporting parts to the urban whole. Based on the complex adaptive systems theory the whole can only function through the parts and thus as well as its parts. This frames the understanding that since agriculture is a major part of the Western Cape's economy, the city (the whole) can only be totally healed through healing the supporting agriculture towns (the parts). The intention is to provide a strategy, through research, mapping and design exploration that will uplift the image and economy of small agriculture towns in the Western Cape. Thus providing the town's people with pride and hope, the unemployed with jobs and the youth with a future.

## Approach

Looking at the two extremes of a centralized and localized approach to architecture, economics and general development, a sustainable mid-way of a locally focused, yet globally relevant, angle is strived towards. This approach suggests moving away from an abstract planning towards using the conditions on the ground and the town plan to provide the future plan through small shifts. A pragmatic approach of developing a theory and methodology through practice has been followed. The sample local town has been mapped and investigated in order to create a grocery list of the existing or available resources, conditions and needs. The content is carefully analyzed to determine the smallest move, with the available resources, that will have the greatest positive effect. The scheme relies on a particularity approach which identifies a local kit of parts. The kit of parts is used to create a spatial connectivity across the town and formulate an urban upliftment scheme. The proposed building serves as supporting infrastructure to the spatial network and culminate the urban, spatial, social and economic schemes. The building is also conceived from the kit of parts and serves as a built analogue for the values of the scheme. This proposed methodology/particularity strategy for upliftment of agriculture towns will be applied to and tested on Porterville (a small farming town about 200km North West of Cape Town) in the form of a speculative project.

## Index

|   |     |
|---|-----|
| Practical framing of Architectural Interest   | 009 |
| Origin of Research Proposal: A Personal Interest  | 011 |
| The Global and the Local  | 013 |
| Theoretical Framing of the Architectural Strategy: Proposing Particularity                      | 015 |
| Understanding Porterville's particularity   | 021 |
| Social, Political, Cultural and Economic Particularity  | 023 |
| Physical, Environmental and Spatial Particularity   | 029 |
| Urban Scheme:   | 037 |
| Zoomed out Urban Scheme   | 037 |
| Zoomed in Urban Scheme  | 041 |
| Practical Workings of the Urban Scheme  | 045 |
| Analysis of the Urban Scheme Using the 5 Elements of Kevin Lynch                                | 047 |
| The Main Architectural Intervention   | 049 |
| Program   | 049 |
| Site Analysis   | 057 |
| Program on Site   | 059 |
| Sectional Concept   | 061 |
| Conceptual 3D Exploration and form finding  | 063 |
| Theoretical Framing of the Architectural Strategy Continued: Setting up a pragmatic methodology | 065 |
| Precedent for Methodology   | 065 |
| Defining the "Local" within a global context  | 065 |
| Evolution of Lifestyle and Habitation   | 067 |
| Development of Knowledge, Materials and the Spread there of                                     | 069 |
| Change in Environment   | 071 |
| Compiling the Grocery list: Selecting a local kit of Parts                                      | 073 |
| Step 1: Compiling a material pallet based on locality limits                                    | 073 |
| Step 2: Investigating the local vernacular structures in and around Porterville                 | 075 |
| Step 3: Investigating the vernacular use and techniques of chosen materials                     | 081 |
| Step 4: Knowing the limitations of chosen materials   | 085 |
| Step 5: Beyond the conventional: International model diffusion                                  | 087 |
| Final Visitor experience: A Walk Through  | 089 |
| Working Drawings  | 091 |
| Scheme Summery  | 093 |
| Bibliography  | 095 |
| Appendix A  | 097 |
| Appendix B  | 099 |
| Appendix C  | 105 |
| Appendix D  | 107 |

# Table of Figures

Figure 1: Porterville's place in the provincial system  
Figure 2: Porterville's place in the National System  
Figure 3: Porterville's place in the International System  
Figure 4: Air Photo of Porterville  
Figure 5: The principles of Permaculture  
Figure 6: Combining gothic vault building methods  
Figure 7: Circular shape in plan drawing from rondawels  
Figure 8: Local labour  
Figure 9: Local materials and techniques to build a modern design  
Figure 10: The use of local materials and a local tradition of weaving  
Figure 11: The use and training of local  
Figure 12: Using light and domes to create a spatial experience  
Figure 13: Disappears into the landscape  
Figure 14: The experiential light qualities  
Figure 15: The physical built environment that the centre needs to fit into  
Figure 16: The use of simple yet labour intensive construction techniques  
Figure 17: The experiential light qualities created by the woven screens  
Figure 18: 2008 Air Photo received from Mobray Planning Office  
Figure 19: Town Layout development  
Figure 20: Dependency ratio  
Figure 21: Representative of the pressure that is put on the city by migration from a failing "local"  
Figure 22: Mechanization and capital deepening of wheat farming in the Swartland  
Figure 23: Showing the change over time of farm sizes  
Figure 24: Climate Information  
Figure 25: Agriculture Change over time  
Figure 26: Porterville on the boundary  
Figure 27: Relating to the river

Figure 28: Network of open space  
Figure 29: Space Utilization  
Figure 30: Layers Overlaid  
Figure 31: Municipality Town Plan  
Figure 32: Summery & Proposition  
Figure 33: Open space bands considered for development  
Figure 34: Precedent: English Gardens  
Figure 35: English Garden Layers  
Figure 36: Parc de la Villette Layers  
Figure 37: Porterville (suggested) Layers  
Figure 38: Contesting follies as "purposeless" structures  
Figure 39: Parc de la Villette Follies  
Figure 40: English Garden Folly  
Figure 41: Figure ground of focused area of Porterville  
Figure 42: Highlights the open squares within the street blocks  
Figure 43: Block Condition  
Figure 44: Through the Curtain: Trees and built fabric forms  
Figure 45: Through the Curtain: A point of height  
Figure 46: 3D drawing of scheme boundary management  
Figure 47: Current property lines  
Figure 48: Show new rented areas & servitudes  
Figure 49: Path, Edge, District, Node, Landmark  
Figure 50: Milling process  
Figure 51: Packing process  
Figure 52: Baking Process  
Figure 53: Sun angles + wind  
Figure 54: Slope/fall towards river  
Figure 55: Area, setbacks (municipal and other), bulk (municipal and context)  
Figure 56: Context in elevations + views  
Figure 57: Lines of circulation)  
Figure 58: Circulation and buffer holds  
Figure 59: Buffer zone and service vs public  
Figure 60: Sun and shade  
Figure 61: Layout on site

Figure 62: Between the operational section 1  
Figure 63: Between the operational section 2  
Figure 64: Between the operational section 3  
Figure 65: Event on the skyline  
Figure 66: Precedent strip  
Figure 67: Form Finding Models photographed  
Figure 68: Digital form finding  
Figure 69: Home development and lifestyle changes  
Figure 70: Materials / Modern Science / Knowledge  
Figure 71: Bridging opportunity  
Figure 72: Radius Material study  
Figure 73: 8 Vernacular structures photographed  
Figure 74: Structural analysis of vernacular structures  
Figure 75: Structural Concept Drawing  
Figure 76: Structure exploded  
Figure 78: Structural development drawings  
Figure 79: Housing typology  
Figure 80: Cape Dutch Home analysis  
Figure 81: Figure: Flexible stick Framework of "Matjieshuis"  
Figure 82: "Matjieshuis" The reed mats rolled out onto the framework  
Figure 83: Cob Rondawel with thatch roof  
Figure 84: Making cob bricks with timber shutters  
Figure 85: Timber framework that is eventually hidden in the cob walls.  
Figure 86: Design development of Material decisions  
Figure 87: Material limits Design Application  
Figure 89: Francis Kere's Library Roof being prepared for setting  
Figure 90: Local potters bringing their work to site to help set the roof  
Figure 91: Internal view - End result of Francis Kere's library  
Figure 92: Final Visitor Experience: A Walk Through  
Figure 93: Working drawings  
Figure 94: Scheme summery drawing in progress



Figure 1: Artifact representing the idea of using spatial structures to initiate connectivity

## Practical Framing of Architectural Interest

**The first week of this academic year was dedicated to a variety of practical exercises to explore and develop an architectural interest. The following exercise helped to shape the architectural thinking for this dissertation. For the complete set of exercises, please see Appendix A.**

Figure 1 spatializes the idea of using spatial structures (architecture) to influence the space/field around it in order to create connections. The lids and rings represent architecture as an object in space used to shape or choreograph the spatial field (elastics) around it in a way that will create certain points of connection and interaction. These points of spatial connection can be strategically determined in order to direct people's spatial perceptions and thus behaviours in ways that will allow desired connections amongst people. Figure 1 also shows how dissimilar object arrangements (one in the blue and the other in the white spatial field) can create different connections that have a particular "social space" around them. Through the process of making, the intersecting spatial field became the uncertain space between the blue and the white fields. This frames the understanding that architecture is often not only a social connector but also a spatial/geographic/environmental connector (explored between the blue and the white spaces in the figure). The connector that mediates and bonds the "blue and the white spatial fields together.

In terms of materiality choice, the artefact in figure 1 consist of two orders: the solid (the lids) and the linear (the elastics). The rings versus the lids became the point of interest because it combines the function of the solid by affecting space while still remaining a linear object. The rings also create a new type of space by holding space within it while still manipulating space around it.

Yet the space within is still connected with the external space. This sparked an interest about building materials serving their functional purpose of enclosure, privacy and structural support but still contributing to enhancing the connection between inside and outside space. This connection could be a physical, visual, social, spatial, environmental or cultural connection.

In summery the artefact advocates creating strong contextual and community connections through spatial flow and manipulation.



Poretville 1994

## Origin of Research Proposal: A Personal Interest

Many of my childhood holidays were spent in a variety of small farming towns visiting my grandparents. I always found the “platteland”<sup>1</sup> culture with its colourful idioms and the laid back life style intriguing. These memories turned into a certain fondness for small towns. On every return visit however, I could see how the towns were slowly slipping into dilapidation and being abandoned by more and more people. The most of the young working force were seeking a better life and more opportunities elsewhere and the town’s average age kept rising. Although the older generations still had a sense of pride in their home town, they were slowly becoming too old to be involved in taking care of and investing time into their town. The understanding of the situation really dawned on me when I heard that some of the many-generation farming families did not know if they wanted to continue farming. Their farms were doing well but they had no faith in their town’s future. They were starting to worry about their children missing out on better education and other career building opportunities. Many people started to send their children to boarding schools far away. Others sold their farms, took their years of knowledge and experience with them and left. It became evident to me that farming towns are failing. They have mostly become dysfunctional pieces of infrastructure that are no longer assisting and encouraging the agriculture economy. The starting point for my dissertation was conceived through considering the harmful effect the failing agriculture towns would have on the Western Cape economy, the food provision for South Africa and a growing population that still depends heavily on the agriculture sector.

---

<sup>1</sup> “Platteland”: The Afrikaans term for small farming towns on the outskirts. Usually associated with isolation, primitivity and a strong sense of community.

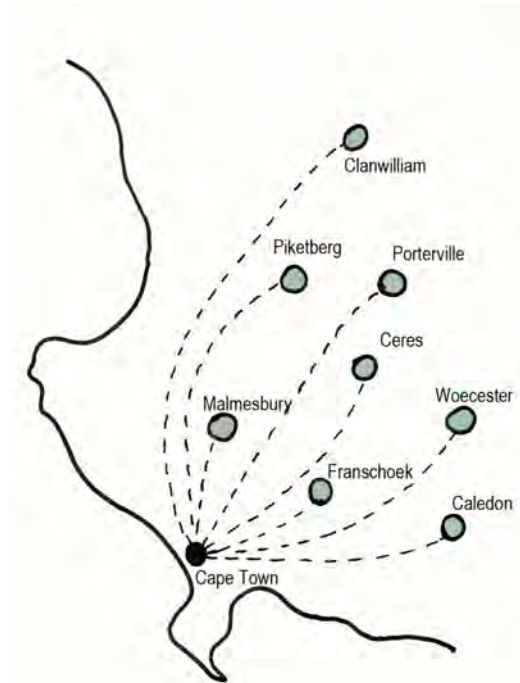

Porterville's place in the Provincial System:  
 Part of the agriculture region feeding the city

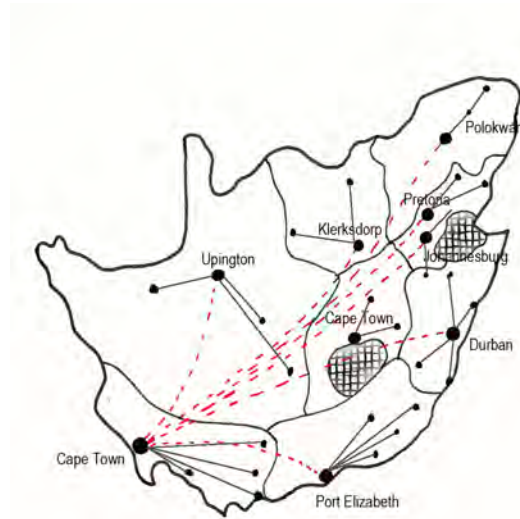

Porterville's place in the National System:  
 Agricultural products get transported to Cape Town  
 and then distributed to the rest of the country.



Porterville's place in the International System:  
 Agricultural products get transported to Cape Town and then  
 exported internationally  
 (majority of exports go to Africa, Asia and the Netherlands)  
 Agricultural exports still exceed agricultural imports

## The Global and the Local

### Uplifting the Urban through the Healing of the Rural

**This section outlines the relevance of focusing this research on local small town when we find ourselves in a global world with “urbanization” as the key theme of most architectural discussions. For the purposes of this dissertation the “local” is seen as people being the local primitive and “global” represents technological development. The aim of the research is to test using architecture as interface between the local and global to achieve a particular sustainable and innovative outcome that will uplift both the local town and thus the broader system.**

Urbanization is a growing trait of the global era which challenges the idea of spending resources on the local rural towns. Yet the cities are full of migrants that left their locality to form part of a more global system (Babb & Held & McGrew, 2003). Most migrants come from an unsuccessful “local” that cannot provide for their needs and often end up in informal settlements in the cities that cannot provide infrastructure at the same rate as the population growth (Babb & Held & McGrew, 2003). The “local” malfunctioning is burdening the city, and thus the whole system (nationally and globally) too (Cilliers, 1998). In contrast investing into the local economy means keeping the various “locals” self-sufficient and preventing the “locals” from overloading the cities (Cilliers, 1998). A healthy local also ensures optimal productivity from small towns as economic participators.

Furthermore, focusing the research on rural agriculture towns is prompted by the fact that food and shelter (architecture) have been two of the basic needs of mankind that have always run in parallel (Cilliers, 1989).

Urbanization and population growth was made possible through the cultivation of land and the domestication of animals, hence optimizing the kilojoules output per hectare (Diamond, 1998). This meant that larger numbers of people could be supported by a restricted piece of land than before (Diamond, 1998). Farming has always been and still is an important part of the economy and no matter how successful the rest of the economy is, food production remains an integral part; so neglecting farming towns will influence the entire system. In addition, South Africa also exports agricultural products which means failing agriculture towns will affect not only South African cities (the national system) but also cities abroad (the global system). The complex system theory confirms this by its explanation of every part needing to be whole and governed in itself in order to make the full system healthy (Cilliers, 1989). The “local” has an identity of its own, yet simultaneously a global identity in the system and needs to live up to both (Brunschiwig.ed.no.72 (7)).

### Porterville as the local

Porterville, a small farming community situated on the border of the Swartland and Berggrivier districts in the Western Cape Province, is selected as a site to conduct the research on. The main economic activity in this region is wheat farming (Visagie 2015). Porterville is also a practical size (3km x 1km radius) for the case study so that the history, culture, physical parameters and resources can be explored thoroughly within the time frame (Visagie, 2015). In so doing a full understanding of the local can be gained. Through a pragmatic process an upliftment methodology framework will be developed and tested on Porterville as the sample town.



Air Photo 1:50 000



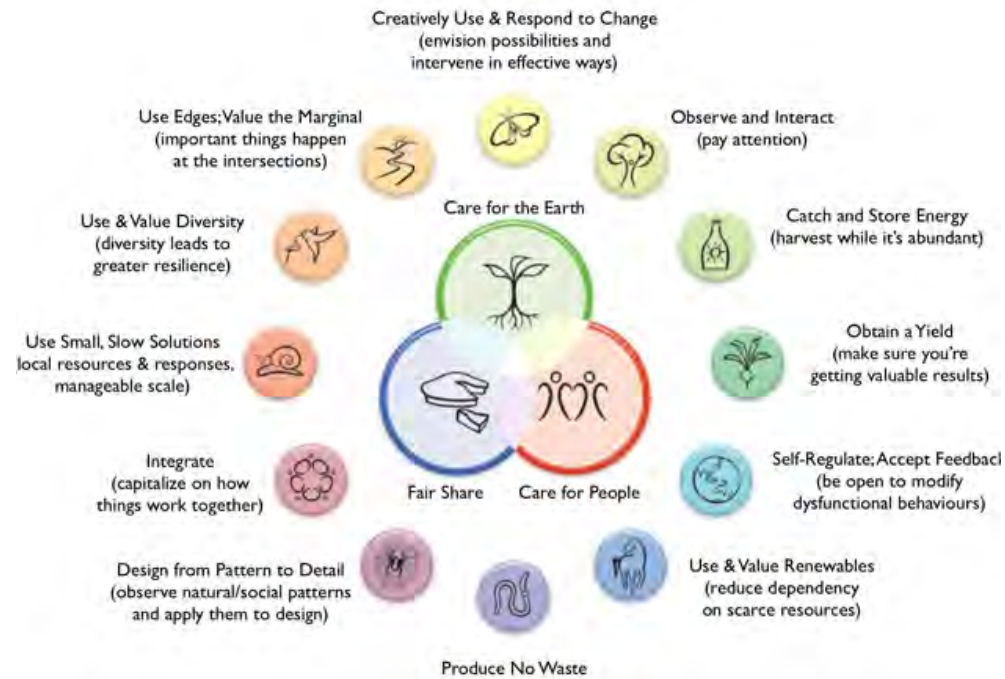

The principles of Permaculture

[Available at: [34https://nurturegreen.files.wordpress.com/2013/09/permaculture-principles.jpg](https://nurturegreen.files.wordpress.com/2013/09/permaculture-principles.jpg)]

# Theoretical Framing of the Architectural Strategy

Particularity as a pragmatic strategy towards a sustainable architecture that is locally rooted but globally relevant

## Introduction

Prior to globalization, "place" had a distinct quality, culture, group of people, building styles, materials and ways of living (Frampton, 1992). This particularity of place ensured a great sense of identity and belonging, and community was established and attached to a specific place associated with specific experiences (Orozco, 2007). Today, however, everything and everywhere has the potential to look like everything and everywhere else. We live in a global world where many borders have been dulled by the mobility of information, physical travel, services, resources and technological advances (Babb, Held and McGrew, 2003). Geography has become a negligible factor in an on-line era. Although a certain amount of globalization and thus mobility of goods, information and people ensure convenience and increased quality of life, mobility without limits has contributed greatly to our global warming crises (Shumen, 1998). Together with the undervalued and overexploited natural resources (Desner, 2008:36) globalization has also resulted in the loss of architectural particularity which in turn resulted in disconnected communities and a loss of cultural rootedness (Frampton 1992). Today people have a global and local citizenship but are often disregarding their role as a local citizen within their local communities. This dual-citizenship, along with increased connectivity, has created a more complex society (Morin, 1992). Yet the architectural response to a complex world has been a one-size-fits-all approach which ignores the genius loci of its context (Frampton, 1992). This theoretical investigation contextualizes the relevance of a local approach for architects working in a global world and comes to understand the discourse that already exists around locality as a strategy to achieve sustainable architecture. Through the analysis of precedent studies alongside a discussion

of locality theories, "Particularity" as an architectural approach is offered. This approach, has a sustainable architecture outcome which is rooted in history and locality, while remaining globally relevant. Simultaneously it results in an innovative and beautiful particular design solution that caters for a complex society. A solution where design celebrates difference in the form of particularity. A solution where architecture is the interface between the people (local primitive) and technological development (the global) while remaining true to both and particular to its local. A solution that celebrates difference and new form within the local.

## Centralized Top Down Versus Localized Bottom Up

Centralized top down planning has resulted in a loss of identity, civic pride and personal association to a locality due to its "one size fits all" approach. On a large scale city centres and shopping malls around the world often look the same, regardless of the context in which it is placed in or the people it serves. On a smaller scale, the effect on a community or humanity is better demonstrated in the Pruitt lego housing scheme. The lack of context response, specific need fulfilment and identity resulted in a total social dysfunction of what was meant to be a community. The dysfunction became so evident that the city decided to demolish the building to take the "problem" away. Since the funding of architecture often results in architecture, economics and politics rubbing shoulders, it is worth noting that top down structures mostly pour money (from the top) into the wrong social project or one that is irrelevant to the community. These choices are often driven by political gain rather than the community's needs. The result: providing a person with a hat when what they really need is shoes. A bottom up approach

is thus suggested (backed by Max Neef's bottom up theories).

Another concern with centralized planning and a global approach is that it has taken its toll on the environment. A consumer driven world revolving only around the economy has put environmental concerns far in the background for a long time. Within the architecture field, planning schemes across the world that have the same aesthetics were achieved by transporting materials across the globe, resulting in loads of pollution. Manufacturing of new fashionable materials and ignoring the old, causes more CO2 pollution and the depletion of resources. Other than the destruction of nature, humans are being separated from nature, our origin, and identity. With nature protesting to being mistreated, it is forcing society to take note. Green schemes are discussed and regulations are put into place to minimize global warming. The idea of sustainable development has become most important to prevent total depletion of all our non-renewable resources. What is interesting is that all the sustainable theories, past, present and interdisciplinary, are centred around a varying degree of locality. The Permaculture and Green Economics strategies are more economically focused but can speak to the building procurement process. Critical Regionalism is more directly an architectural locality theory. Although a local approach to architecture seems best for the environment, having full knowledge of a global intellect and technology but refusing to use it, is primitive and limiting.

## Locality Theories within an Architectural Context

Permaculture, Green Economics and Critical Regionalism are the three main locality theories that will be

### Mapungubwe by Peter Rich



Combining gothic vault building methods with a new form made possible through computer modeling but using clay bricks manufactured on site with research on their strength from Oxford University. [Available at: <http://www.architectureindevelopment.org>]

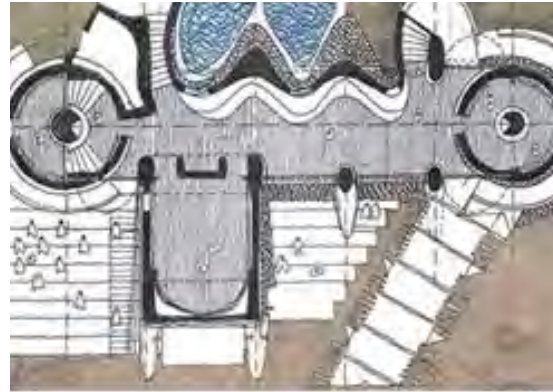

Drawing from the typical vernacular architecture of the rondavel and using the circular shape in plan almost as a string of rondavels. Yet the final form is new and not a replica of the rondavel forms [Available at: <http://assets.inhabitat.com/wp-content/blogs.dir/1/files/2010/08/Mapungubwe-Interpretation-Centre-9.jpg>]



The use and training of local labour to help with unemployment and teach skills that can be used for future job seeking. [Available at: <http://www.directoryofdesign.co.za/pics/news/world-build-1.jpg>]

### DESI Training Centre by Anna Heringer



Using local materials and techniques to build a modern design. Clay walls are not structural enough to build higher than the ground floor, thus a light weight bamboo structure is used for the 1st floor. [Available at: [http://www.google.co.za/Heringer/DESI Trainingcenter/](http://www.google.co.za/Heringer/DESI%20Trainingcenter/)]



The use of local materials and a local tradition of weaving but making it relevant today by introducing new, more sophisticated weaving techniques. [Available at: [http://www.google.co.za/Heringer/DESI Trainingcenter/](http://www.google.co.za/Heringer/DESI%20Trainingcenter/)]



The use and training of local labour to help with unemployment and teach skills that can be used for future job seeking. [Available at: <http://archrecord.construction.com/features/humanitarianDesign/images/0810heringer2.jpg>]

summarized and discussed with regards to the built environment. The aim is to draw merit from these theories where possible, discard the unrealistic and be left with a plausible set of principles that can be used in the built environment to move towards a locally particular architecture without completely disregarding technological development (the global).

## Permaculture

**Theory:** Of the two economically focused strategies, Permaculture is the most extreme theory of locality and advocates a completely closed loop local system with absolutely no exterior alternatives(Desner,2008). The global economy is shifted to many small local economies where communities operate within a closed-loop system. Resultantly the community experiences direct appreciation of the consequences of their own actions and decisions preventing market monopolisers to buy their needs(Cato,2008,48).

**Application to the built environment:** From an architectural perspective, using Permaculture's twelve principles (Figure 2.1) as a framework for decision making throughout the design process can be useful. These principles (see appendix B) work together to achieve a balance between providing for people's basic needs and promoting self-reliance, earth care and the fair-share concept of living within your means and distributing surplus resources(Cato 2008, 24). In terms of construction, a closed loop system that applies to the entire process from sourcing the materials, to resource management, to preparing and building on site and the management of waste, will create a sustainable community(Moore,2008). From a design perspective, clustering residential and commercial zones in order to form smaller, independent

communities will also help strengthen the community. The shortfall of permaculture is however that it ignores **the global technological advances, its benefits as well as** taking into account the current life styles and connections people are accustomed to. Following it entirely will thus be impossible, yet using principles to guide most design decisions will result in a more sustainable, if not totally sustainable, way of building.

## Green Economics

**Theory:** Green economics addresses the economic leg of sustainability more strongly with the assumption that the economy drives society today(Cato,2008). It is the **first theory to offer an alternative to both Capitalism and Communism** by proposing that the economic perspective is stretched to include the economically marginalized and that sustainable values, instead of monetary values, govern economic decisions(Cato,2008, 205). An example of how this would work would be to measure the amount of CO2 produced during the manufacturing of a product and the scarcity value of a natural resource in monetary terms. Green Economics' approach to people is also different. In contrast to the current capitalist economy that has "reduced people to their economic function", Green Economics is people centered and thus held within the community, which is in turn rooted in the environment(Cato,2008,42 & 207). In the perfect world this is realized by substituting monetary interaction with people interaction; and technology and consumption with communities and relationships. According to Green Economics, self-reliance for all necessities is vital and trade is only allowed for luxury items(Cato,2008,207). Furthermore Green Economics aims to create a stable, instead of growing economy, since it is evident that permanent growth, using non-renewable resources, is

impossible(Cato,2008,13).

**Application to built environment:** In order to analyze the advantages, pitfalls and plausibility of Green Economic principles within the built environment, it is discussed with regards to the building procurement process. Currently the building procurement process leaves little room for a local particularity supporting a local economy as required by Green Economics. This is due to three main contributing factors. Firstly product comparisons happen in terms of monetary value and not sustainability or environmental value(Rwelamila, Talukhaba & Ngowi, 2000). Secondly the lack of knowledge of building **procurement officers(and clients) in the sustainability context** and with regards to alternative products and building materials means that they are not comparing **apples with apples and tend to find it easier to just steer clear of the uncertainties**(Rwelamila, Talukhaba & Ngowi, 2000). **Lastly, the financial incentive to build sustainably does not yet exceed the risk and extra effort of exploring the unknown in most people's views**(JCT, 2011). Resources like water and electricity are still too available and affordable resulting in little demand for alternative systems and products. Without financial incentives from government, forceful regulatory shifts or an increase in scarcity in order to increase the demand for sustainable methods, the procurement process at large will carry on favouring physical price comparisons and resource mismanagement(Benyon & Dunkerleu,2000). In other words, shifting both economic and architectural decision-making to becoming centred around people and nature is unrealistic without creating a majority demand for sustainable decisions and purchases. The demand needs to increase enough to effect the supply, so that low prices and sustainability will eventually become synonymous(Rwelamila & Talukhaba, 2000).

Mapungubwe by Peter Rich



Using light and domes to create a spatial experience. [Available at: <https://www.google.co.za/search?q=mapungubwe>]



The physical environment that the centre needs to fit into. It forms part of and almost disappears into the landscape. [Available at: [https://www.google.co.za/search?q=mapungubwe&rlz=1T4GGIE\\_enZA475ZA475&source](https://www.google.co.za/search?q=mapungubwe&rlz=1T4GGIE_enZA475ZA475&source)]



The experiential light qualities created by continuous vault spaces combined by the coloured light quality. [Available at: <https://www.google.co.za/search?q=mapungubwe>]

DESI Training Centre by Anna Heringer



The physical built environment that the centre needs to fit into. [Available at: <https://www.google.co.za/search?q=bangladesh+village>]



The use of simple yet labour intensive construction techniques. [Available at: <http://www.google.co.za/Heringer/DESI+Trainingcenter>]



The experiential light qualities created by the woven screens and fabric roof covering. [Available at: <http://www.google.co.za/Heringer/DESI+Trainingcenter>]

## Critical Regionalism

Theory: Finding a particular architecture through its locality and the genius loci, while keeping sustainability in the foreground, cannot be done without discussing Critical Regionalism. There are three main views, (Critical Regionalism as viewed by A. Tzonis and L. Lefaivre, Critical Regionalism as viewed by Frampton and Authentic Regionalism by William Curtis) with slight variations, on Critical Regionalism. The theories all advocate a counter action by architects against placelessness and a lack of identity as a result of the international style (Orozco, 2007). Critical Regionalism proposes an architecture that integrates the cultural and geographic context but is still tied to modern globalism while providing a unique sense of place or identity (Frampton, 1992). The "critical" refers to the rejection of a duplication of vernacular architecture but rather intends for a critical analysis of past and present cultures, the geographical context, modern and historic techniques and technologies while ensuring a modern local and global relevance (Frampton, 1980, 1985, 1992). This was summed up by J. Orozco as "sustainable, regional place making."

Critical Regionalism as used by A. Tzonis and L. Lefaivre focused on the loss of sense of place and that Critical Regionalism did not directly represent the immediate context but take elements from it and use it in new ways (Tzonis & Lefaivre, 1955). Following on their work, Kenneth Frampton's theory about Critical Regionalism was closer to the romantic view on regionalism as demonstrated in his Points for a Critical Regionalism. Frampton, similar to Palasma in *The Eyes of the Skin*, has a particular focus on using all the senses, not just vision, to experience architecture and create a deeper connection (Orozco, 2007).

The emphasis was not only on form and materiality but also on new experiences. This is especially relevant in this age where the media has replaced experience with information (Louw, 2014, 161). Tapping into a full body experience can create a unique experience of a place and will promote a new powerful sense of place (Orozco, 2007). Frampton, critiquing placelessness established by the uniformity of modernity, recognized the technical and cultural development contribution modernism made to society (Frampton, 1992). He promotes to "reinterpret indigenous solution and reflect technological capacities of modernism." Frampton aimed for an internationally respected level of architecture that reflects the cultural context in a relevant contemporary manner (Orozco, 2007).

The third theory is Authentic Regionalism by William Curtis whose theory advocates a similar aim to Frampton, but is seen as a less direct approach to vernacular and cultural precedent. He focuses on understanding the principles or values behind vernacular ways and decisions and implement these principles into contemporary architecture (Orozco, 2007). This way he avoids stick on ornamentation and ensures contemporary relevance (Curtis, 1982).

## Precedent Studies

Both Mapungubwe by Peter Rich and the DESI centre by Anna Heringer have been recognized internationally as good architecture yet has many site particular origins and materials. These projects served as precedent studies to discuss the extent to which locality theories were applied, the relevance thereof and how the hurdle of staying globally relevant was overcome. The aim was to find a mid-way that harvest as much benefit as possible from a

local approach, remaining particular to place yet globally relevant.

From a Critical Regionalism approach, both Mapungubwe and the DESI centre effectively considered the historical roots, physical context, social context and sense and experience of place. This was achieved by spending time within the communities and doing over and above the bare essential groundwork mapping, analysis and historic research. The combined application of this content specific research, where reasonable, with economic theories around the building procurement process offers a powerful particularity in architecture. Trans-disciplinary research becomes a necessity in order to bring the locality theories and global technological developments together. The figures give a summary of the important points that emerged from the precedent study. For the complete precedent study please see appendix B.

The more locally restricted, the more the architect will have to think "critically" about both the local and global in order to ensure a sustainable (socially, environmentally and economically), globally relevance and an identifiable particularity. The projects did not just copy a vernacular form like the "rondawel" or the Cape Dutch house that has been exploited in so many South African projects, claiming to be of the "local". The precedent taken from local projects go beyond form and includes materiality, technique and ways of thinking. Both projects indicate a bottom up pragmatic approach to ensure a thorough recording and understanding of the local. Overlaid with global thinking and the voice of the community, a sustainable particular architecture is achieved. This approach will be the starting point to form a framework for creating a particular architecture.

Upliftment Strategy for struggling Agriculture Towns in South Africa  
Understanding Porterville's Particularity

020



2008 Air Photo recieved from  
Mobray Planning Office  
1:30 000



# Understanding Porterville's Particularity

Local Problems + Local Solutions + Local Resources + Local Cultures

Drawing from the theoretical framing, the approach to particularity in architecture evidently requires thorough groundwork in order to gain a full understanding of the particular conditions, resources, problems and cultures within a specific context. This section summarizes the findings from a rigorous mapping and research process of Porterville. Porterville was chosen as the sample town for agriculture towns in the Western Cape based on personal familiarity as well as its untouched nature by developers. The town has not been refurbished as a tourist attraction and is still true to its original layout, spatial qualities and typical agriculture town conditions. In conclusion the intervention opportunities as well as the available resources that surfaced through the research process is highlighted. This forms a steady foundation for a particular architectural intervention.



1862: 1st erf layouts by Sir William Porter



British Authorities take over the town square as a central surveillance area. Resultantly the town square shifts.

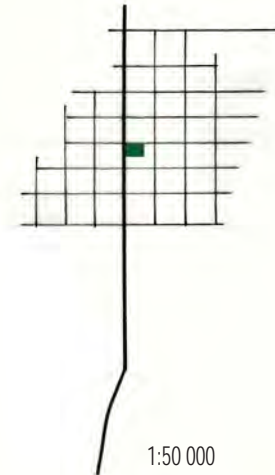

After the South African War and the Great Depression, development of infrastructure and general town growth occurred.

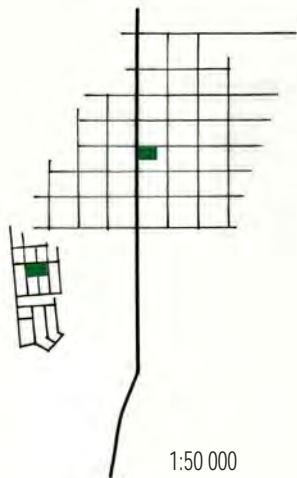

Apartheid policy requires the town to split formally. The non-white area was called Pella. Today known as Monteberta.

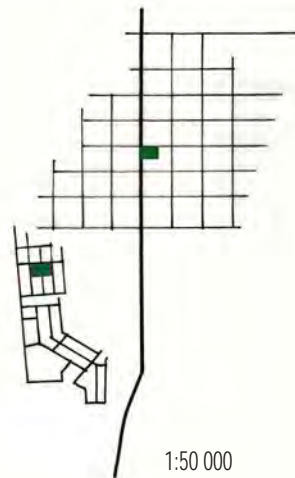

After 1994 Pella was re-named as Monteberta. Although no policy splits the town, it is still spatially segregated. The population growth in Monteberta is evident.

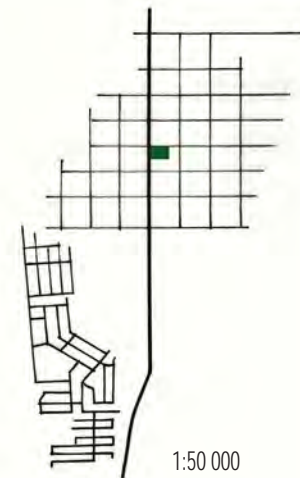

The latest air photograph was taken in 2008 and clearly shown further expansion of Monteberta but stagnation of development within Porterville.



## Social, Political, Cultural and Economic Particularity

### Early History and Shifting Powers

Many rock paintings and artefacts have been discovered by historians in and around Porterville which indicates that the Khoi-San lived and travelled through the area as hunter-gatherers (du Bois, 2006). The town was however founded by Eerwaarde BA Groenewoud who arrived by ship from the Netherlands in 1860 as a missionary. Dutch settlers occupied the town and western ways of living, including farming, was introduced to the area. For a while the Dutch settlers and Khoi-san lived their separate lives but after a smallpox epidemic diminished the numbers of the Khoi-San tribes drastically, many took up employment on Dutch farms as farm workers (du Bois, 2006). The British rule started to take over from as early as 1795, imposing their ways of living and especially gardening. After the Anglo Boer War, the ACVV (Afrikaner Christelike Vroue Vereniging) was established as a union of women who helped those left with nothing after the war (du Bois, 2006). This organization still exists today and is known to help specifically the poor and the elderly in Porterville. They play a vital role in social work in Porterville and really look after the community as a whole (Visagie, 2015). Traditionally the town upgrading of facilities or infrastructure was mainly organized and funded by the farmers. Examples are the first school, hospital and sub power station. Funds would also be raised through large fundraisers organized by the farmers' wives. The municipal funding and planning only happened much later. Today farmers have withdrawn from the town and left it in the hands of the municipality. Funds are often spent on areas undesired by the citizens and urban schemes are drawn up without input from the community. This has caused a negative barrier between the authorities and the citizens (du Bois, 2006). If a new sense of town pride and identity can be established in

the community and developed through a partnership between the municipality and the farming community, the strength and effect of developments and schemes will be so much more effective. Therefore it is not about whose leadership Porterville is under, but rather the willingness of the town's people to take part in shaping the town.

### Town Layout

The town layout over time maps the shift in rule or authority spatially. The spatial layout reflects the thinking of those in power at the time. Figure ... shows the initial town layout by the Dutch Settlers. They used a formal grid layout imposing order and civilization onto a "wild and barbaric" African landscape. This was the way town layouts in the West was done. The West represented a western way of civilized living for the Dutch Settlers. The figures show the minor shifts made by the English authorities. The shifts they made were all centred around optimal surveillance and thus control. They started by taking over the market plane as a type of base. The town centre resultantly shifted. After South Africa gained back their independence, resources and time could be put back into the surrounding farms (neglected during war times) and the prosperity of the towns. Expansion, development and new infrastructure happened during this time. Next the apartheid government was born which came with the separation of communities and residential areas. Consequently Monteberta township was formed just outside, but obviously separate from Porterville. Separating people spatially through prejudice also resulted in splitting the community socially and economically. After the 1994 democratic elections, the spatial gap between Porterville and Monteberta became physically smaller through development and business

expansion, but the economic and social separation is harder to overcome. Businesses, attractions and visitors from Porterville into Monteberta are still rare. The latest aerial photographs show that since 1994 Monteberta has grown in terms of housing and public facilities. Porterville's development has however been stagnant.

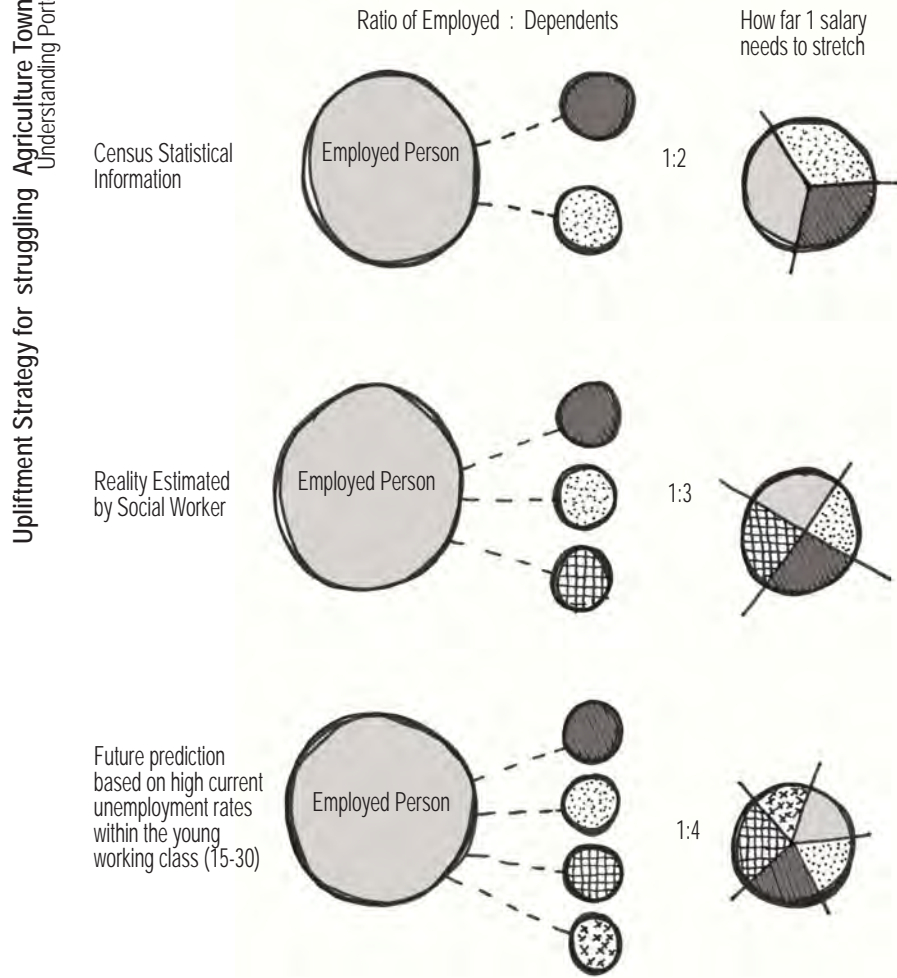

Dependency ratio showing the number of people dependent on average per one working person

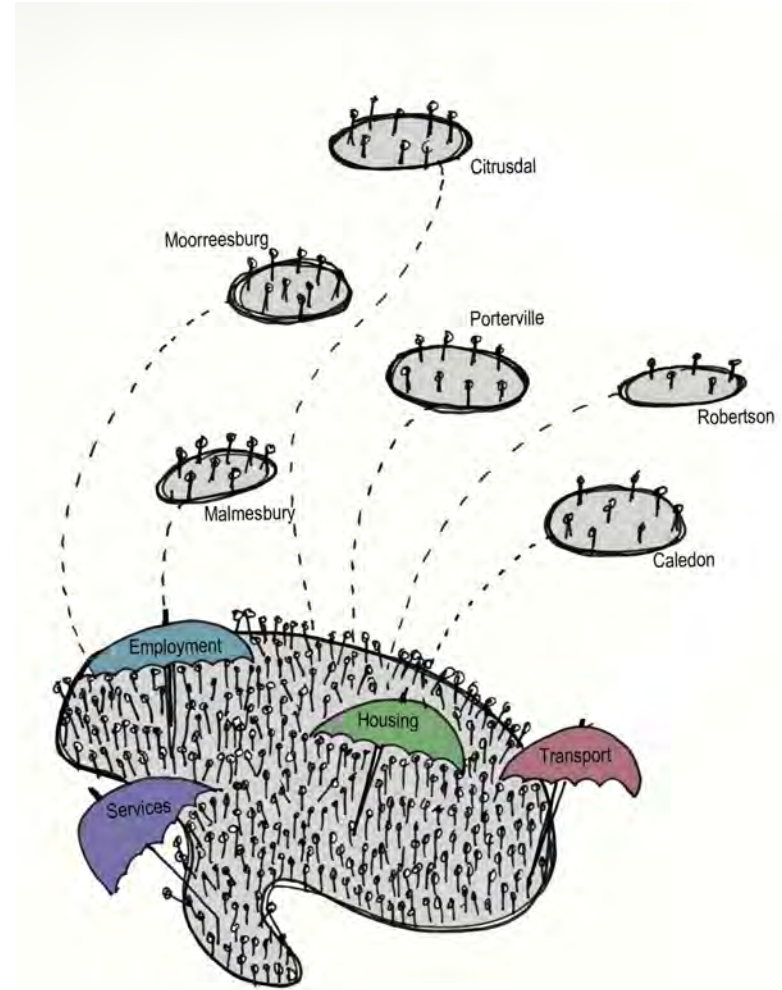

Representative of the pressure that is put on the city by migration from a failing "local" and the false expectations of services the city can provide and for how many people.

## Population, Employment and Migration

Population growth in the Bergrivier district is estimated at 2,85% p.a. according to 2001 - 2011 statistical recordings. Unemployment has decreased from 7,6% to 6,8% over the same time period. Of the economically active youth (ages 15-34) 17,9% are unemployed. Together with available statistic from the last census in 2011 a dependency ratio of 2 dependents to 1 working person is estimated by the Porterville ACVV social worker. **This figure only sees children younger than 15 and adults over 65 as dependents.** In reality the unemployed and discouraged work seekers should be added to the dependents to get an accurate idea of how far one salary needs to stretch. Unemployment within the youth is a great concern since they are the future's older generations, community leaders and the ones who will have to educate and guide the next young generation. If the unemployment problems are not addressed it will only escalate in the future. Unemployment percentages rising is also directly related to poverty, crime and drug percentages rising according to the Bergrivier police department. They also believe that both a low education standard and lacking employment opportunities are the largest contributing factors to unemployment in the larger Bergrivier district (Swartland region economic profile, 2005).

Two types of migration is evident in both Porterville and the larger Bergrivier and Swartland district and occurs both within independent and dependent socio economic groups. The largest one is migration out of the Swartland and Bergrivier region into the cities. The motivation for migration is the hope for more employment opportunities. This results in the young working force diminishing rapidly, making it impossible for the local economy to grow. It also creates a lonely place for young people to

be, thus not inviting any new blood into town. Eventually a decrease in young people result in a gradual economic and physical desertion of a town. Furthermore many of the migrants have an agriculture skill set only, which is often not useful in the city. They end up living in the city unemployed and add to the city's problems of overcrowded informal settlements, lack of services for the growing population and overall unemployment problem increased by rapid urbanization (Swartland region economic profile, 2005). The second type of migration that is present, but less frequent, is the migration of black people between the age of 20 - 35 into the Bergrivier and Swartland area. They are in search of low-skilled employment and believe that they have a better chance in and around the Bergrivier and Swartland districts. Most of these migrants come from the Eastern Cape (Swartland region economic profile, 2005).

There has been a large growth in local employment by the Government sector within the Bergrivier district, which makes the unemployment figures appear better than they are (responsible for the slight decrease in unemployment from 2001-2011). The local labour appears to be absorbed by the local economy but the government sector is not a sustainable source of a growing employment opportunities on its own. The only way the local employment can be expanded is if the local productive sectors and local government sector can jointly absorb the local labour (Swartland region economic profile, 2005).

## Economy

In order to discuss the economy of Porterville, a full understanding can only be gained by discussing it as part of both the Bergrivier and Swartland economies and in

relation to the Western Cape economy. Since Porterville is on the edge between the two districts and wheat is the largest portion of both Porterville's agriculture and the Swartland district's agriculture as a whole, it is hard to separate the two economies (Swartland region economic profile, 2005).

Swartland agriculture is responsible for 1,5% of the Western Cape Economy (Swartland region economic profile, 2005). This figure is considered an underperformance in terms of labour productivity since the Swartland houses 1,8% of the Western Cape's population. This is problematic since agriculture is still the main employment opportunity and provides more than 30% of formal employment in the local communities (Swartland region economic profile, 2005). This makes these communities very reliant on agricultural performance and thus vulnerable. Many external factors like weather conditions, fires, droughts, demand and supply of a product as well as competitive farming can have a great effect on employment and the economy of these communities.

## Current Agricultural Economic Trends

The agriculture sector has shown growth in the Western Cape over the past ten years, yet employment within this sector has decreased. This decrease is contributed to "capital deepening." Agricultural economy has to be discussed within product categories since the economy can be good for one product and really bad for another at the same time. Looking at wheat farming specifically, capital deepening means that the top farmers have managed to invest in advanced farming implements that are highly mechanized and can replace the work of many



Mechanization and capital deepening of wheat farming in the Swartland

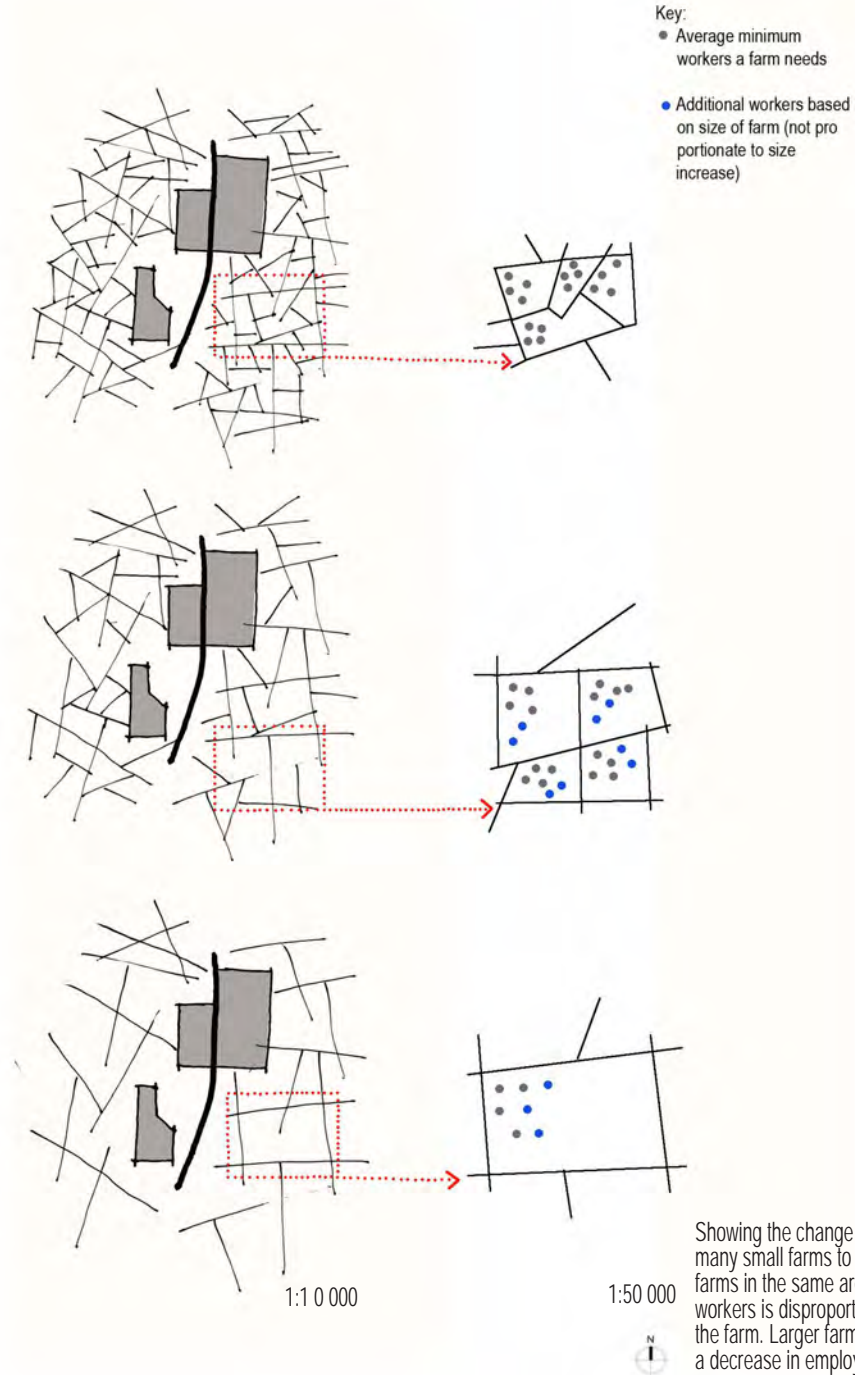

Showing the change over time from many small farms to few and large farms in the same area. Increase of workers is disproportional to the size of the farm. Larger farms therefore mean a decrease in employment.

labourers. Mechanization also provides more productive farming through better ground preparation, more accurate planting and harvesting and the general speeding up of all processes. For this reason, macro farmers can produce the same product (wheat in this example) at a much lower cost than the small scale farmers who are still relying on manual labour and whose profit margins cannot afford expensive implements. Thus the macro farms soon put the smaller farmers out of business and buy their land when they are willing to sell.

Another problem with having fewer large farms versus many smaller farms is that it in itself decreases the employment opportunities. Every farm needs a basic number of start-up labourers. The number of labourers needed does not increase proportionally with the size of the farm land. Thus the same number of hectares of farm land will require more labourers when split into two farms than when farmed by a single farmer (Visagie, 2015). Although capital deepening has a negative effect on employment opportunities, it is vital in order to produce more food with the same land for a constantly growing population. Thus it must be encouraged and employment opportunities must be created in new creative ways. The agriculture sector growth will have to match that of a growing population (Swartland region economic profile, 2005).

## Evolution of Farming

Historically all farms in the area were grazing farms and very large in size. The first farm was a cattle farm that started in 1729 and in 1860 the first crops in the area were planted (du Bois, 2006). Over the years smaller farms originated through subdivisions and later years

due to sales of farms and inheritance of farms split between sons or other family members. Crop farming also needs less land and a smaller farm can therefore still be lucrative. After 2006 however, the wheel started to turn towards reconciling farms for larger scale and more economically feasible farming because large scale farming allows for sharing of resources, implements, buying supplies in bulk (du Bois, 2006).

## The Wheat story: Evolution

The most noticeable part of the wheat story is that wheat used to get processed locally into flour and then distributed. Today wheat is distributed all over the country to a variety of mills and then back again in the form of flour. Sometimes there is even another leg of transport in the form of bread. By locally processing wheat, a lot of transport and thus pollution and petrol usage as well as transport and middle man costs can be excluded.

Climate Information

Temperatures

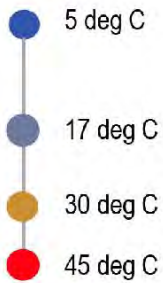

Wind

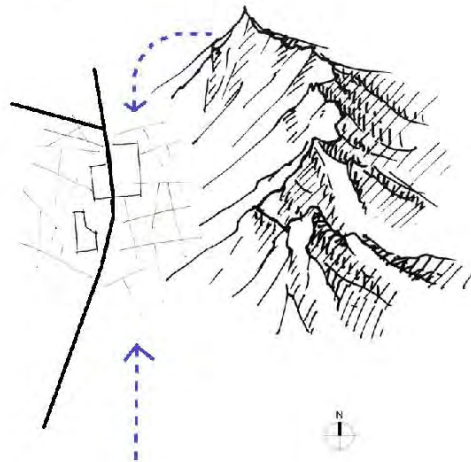

Rain

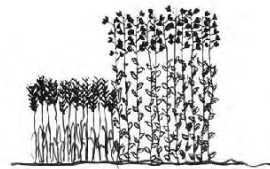

Winter rain 445mm per year:  
enough for growing wheat and  
canola without additional watering



Porterville on the boundary

Agriculture Change over time

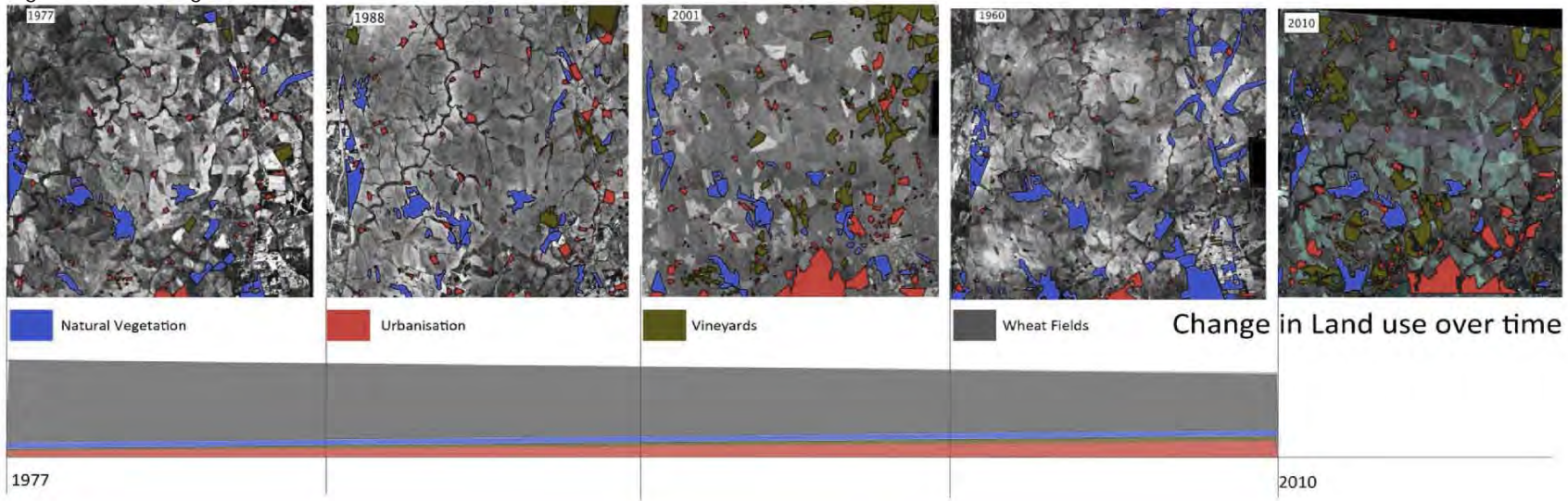

Change in Land use over time

## Porterville's Physical, Environmental and Spatial Particularity

As seen in the precedent study of Mapungubwe and Disa centre, the particularity approach started with rigorous groundwork to determine what is already there and underutilized so that the smallest shift with the biggest effect can be identified. Thus a physical mapping exercise in Porterville was the start of the groundwork and unveiled the following information:

### Environment

Porterville is situated in the Western Cape Province and is officially part of the Bergrivier Municipality but sits on the edge that separates Bergrivier and Swartland Municipalities. Thus the climate and farming conditions is more similar to the rest of the Swartland district than the West Coast. For this reason Porterville is often included in Swartland economic discussions since their largest economic contributor is also agriculture. Porterville will thus be discussed as part of a Swartland small town rejuvenation scheme(Swartland region economic profile, 2005).

### Climate

The average rainfall in Porterville is 445mm per year which falls mainly in winter(SA explorer: South-African Climate,2014). This provides enough water to farm with wheat and canola without extra irrigation(<http://www.flyporterville.info/porterville-weather-climate.html>). Summers are hot and dry with maximum temperatures of 45 degrees Celsius. In July minimum temperatures fall to 5 degrees Celsius. Midday temperatures on average however ranges between 17 and 30 degrees Celsius(SA explorer: South-African Climate,2014). The wind streams

are influenced by the sea breezed from the North and South. This interestingly makes flying on late summer afternoons impossible. November to March are good flying months and the mountain air streams are known worldwide for excellent paragliding(Fly Porterville, 2014).

### Nature

Porterville is known for exceptional hiking routes in the Groot Winterhoek Conservation Area. The conservation area protects mountain fynbos, wildlife and a clean water source to the Cape Metropole and the West Coast. The landscape has altitudes of 1000 to 2077m above sea-level and is known for unique rock formations formed by the weathering process of the sandstone(Cape Nature, 2013).

### Water

The water that runs off the mountain is a clean water source and is captured in the Porterville dam to provide the town with water.

### Vegetation

The natural vegetation is predominantly the mountain fynbos. Many endangered types of fynbos can be seen in this area like the Sorocephalus scabridus - a member of the Protea family, a variety of the red Disas flower as well as the Erica species flowers(Cape Nature, 2013).

### Animals

The animals that are commonly seen are the grysbok, rhebok and klipspringertjies. The Porterville mountains also house predators including leopards, genet, mongoose, wild cat and others but they are rarely spotted. Furthermore there is an estimate of 100 bird species. Looking at the reptiles some rare lizards like the southern rock lizard can be seen. There are however no tortoises and rarely any snakes in the mountains due to the high altitudes. The boomslang and sand snake are the most frequently spotted in the lower lying areas(Cape Nature, 2013).



## Porterville's Particularity through Mapping

### Network of open space

This figure shows all the open spaces in Porterville and how it creates a network that spatially flows through the town, from the outskirts inwards and connecting Porterville and Monteberta. This is typical of small agriculture towns in South Africa. They have the unique luxury of space due to the lack of expansion and high rates of urbanization.

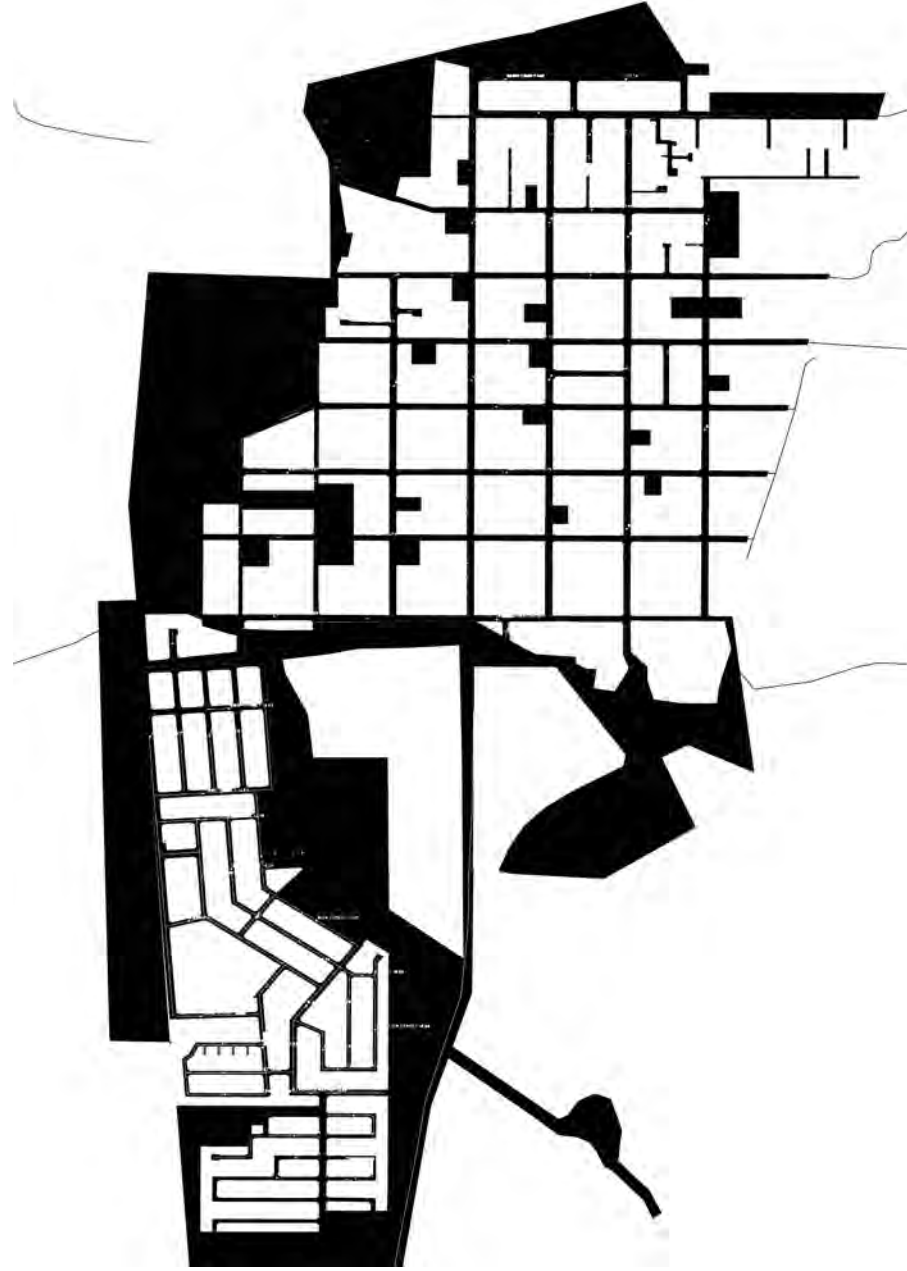

1:20 000  
N

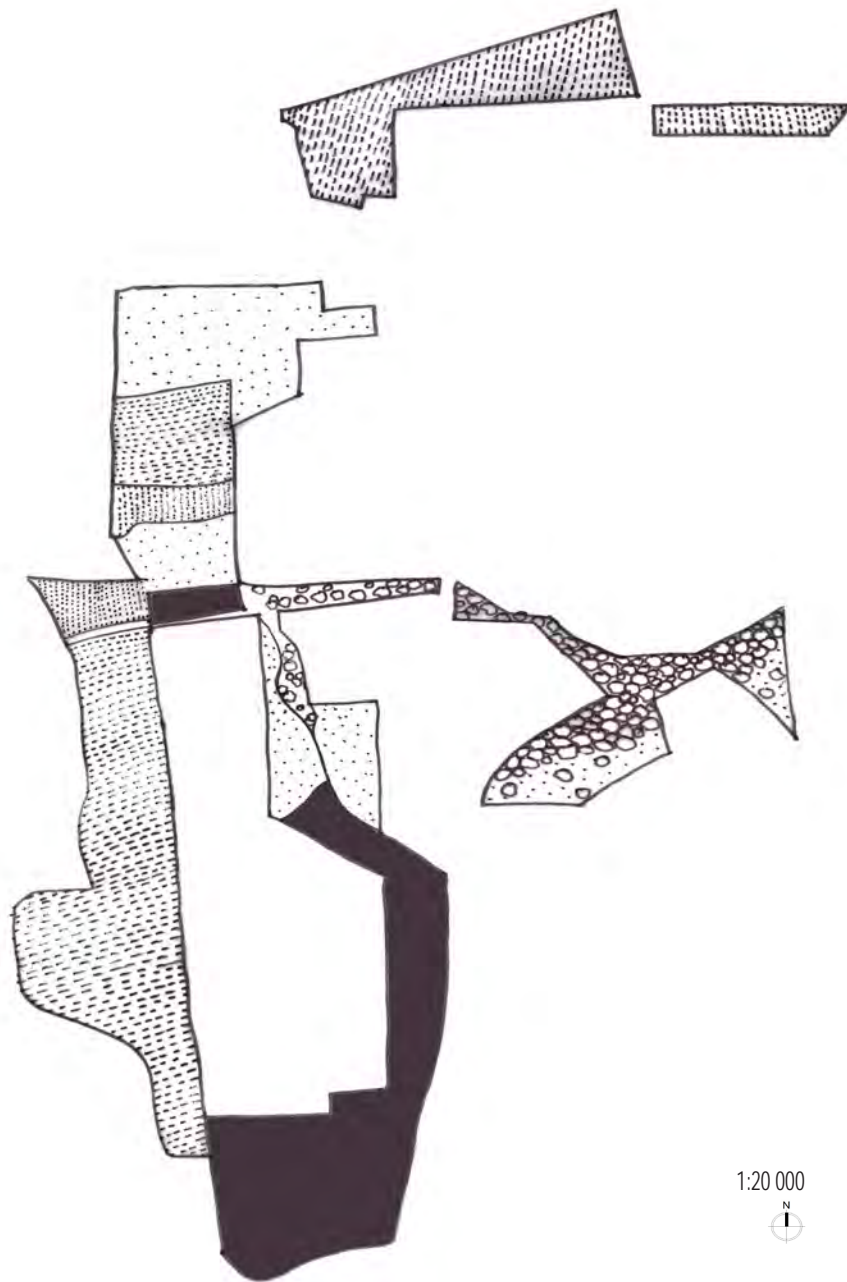

### Space Utilization

Showing that most of the open space is underutilized or not utilized at all. This provides an opportunity to re-appropriate the function of these open spaces so that they can constructively contribute to Porterville at its full potential.

## Layers Overlaid

Overlaying the open space system, road and river system as well as public facilities in Porterville starts to highlight areas where the three interact and can make for an interesting development opportunity. Having these three layers overlap on the chosen site will intensify the sight conditions and opportunities.

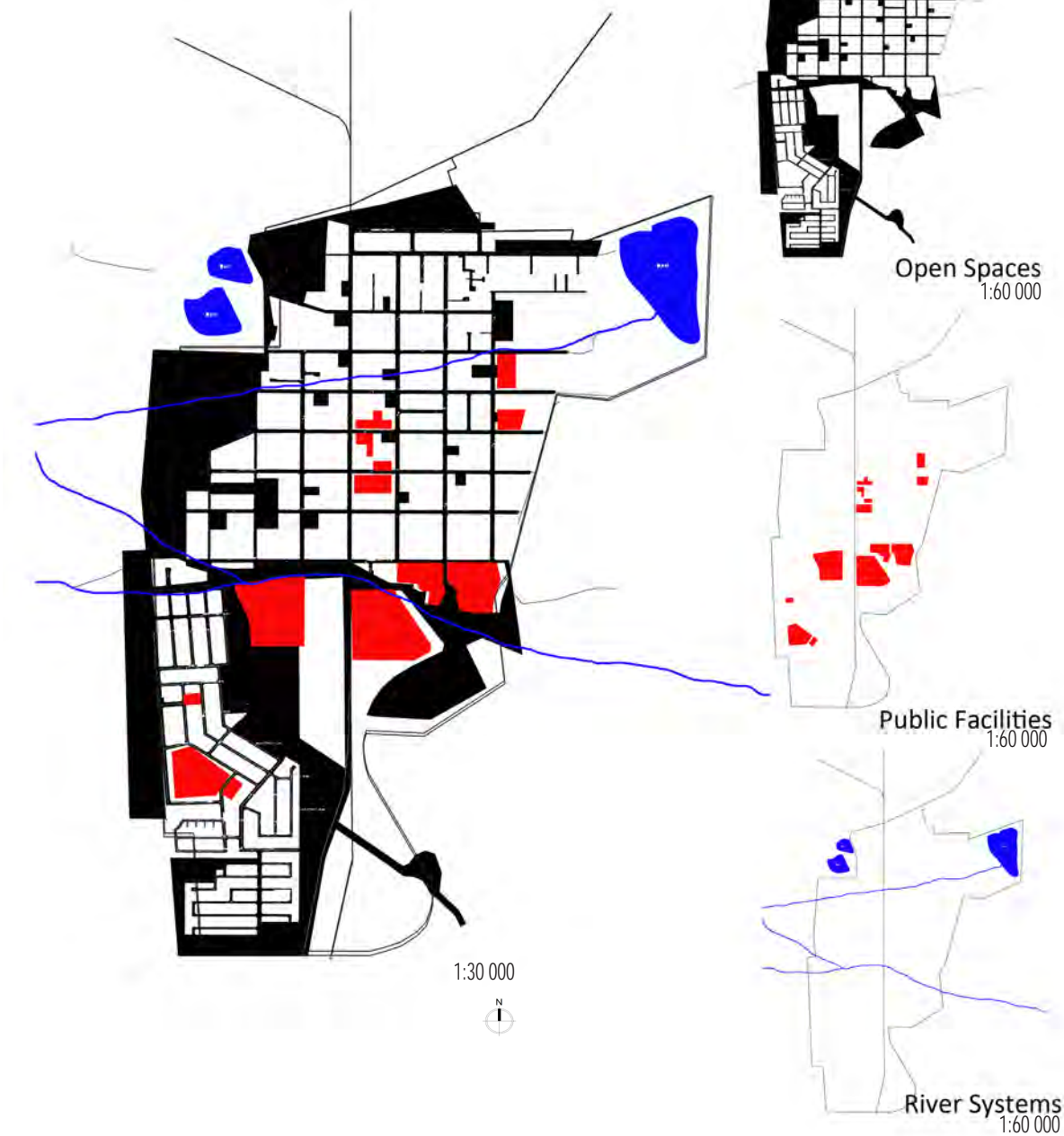



## Summery & Proposition

From all the research gathered in this section of understanding Porterville's particularity, opportunities for intervention have been identified. From the particular social and economic conditions it is evident that the following areas are where intervention and investment is most needed and will make the biggest difference:

1. Encouraging entrepreneurship with on-going support of micro businesses.
2. An economic proposal that encourages local procurement by the government and community of both labour and locally produced goods and services. For this to be effective, quality control is essential.
3. A scheme that regards community public relations and external liaison. This will include aspects like tourism promotion, marketing the place and searching for investments (Swartland Region Economic Profile, 2014).

From a physical and environmental perspective a large network of underutilized open space, mainly government property, has been identified. The proposition is to turn the underutilized spatial system into a green network of organic vegetable gardens. The land is too small to compete with large scale farmers from an economic perspective. A minority demand product where people are willing to pay for its exclusivity will be feasible to produce on a smaller scale and at a higher cost. The organic vegetable market is therefore a good option since the healthy eating has been raised more and more into the lime light and many connections between chemicals in and on food and cancer has been made. Consequentially a minority demand has been created which is currently growing steadily. The green spatial network will become a desirable green belt for pedestrians to walk through and will thus attract and bring together people from all parts of town. Furthermore it will allow pedestrians, whether local or tourists, to engage with and experience the farming process from sowing through to harvesting. This experience will strengthen and renew the town's identity which will install civic pride amongst the citizens and attract many tourists who will exchange money for the experience. The farming of the lands, managing and distributing of the products will also start to address the social and economic needs. These will be refined in the choosing of the specific program.

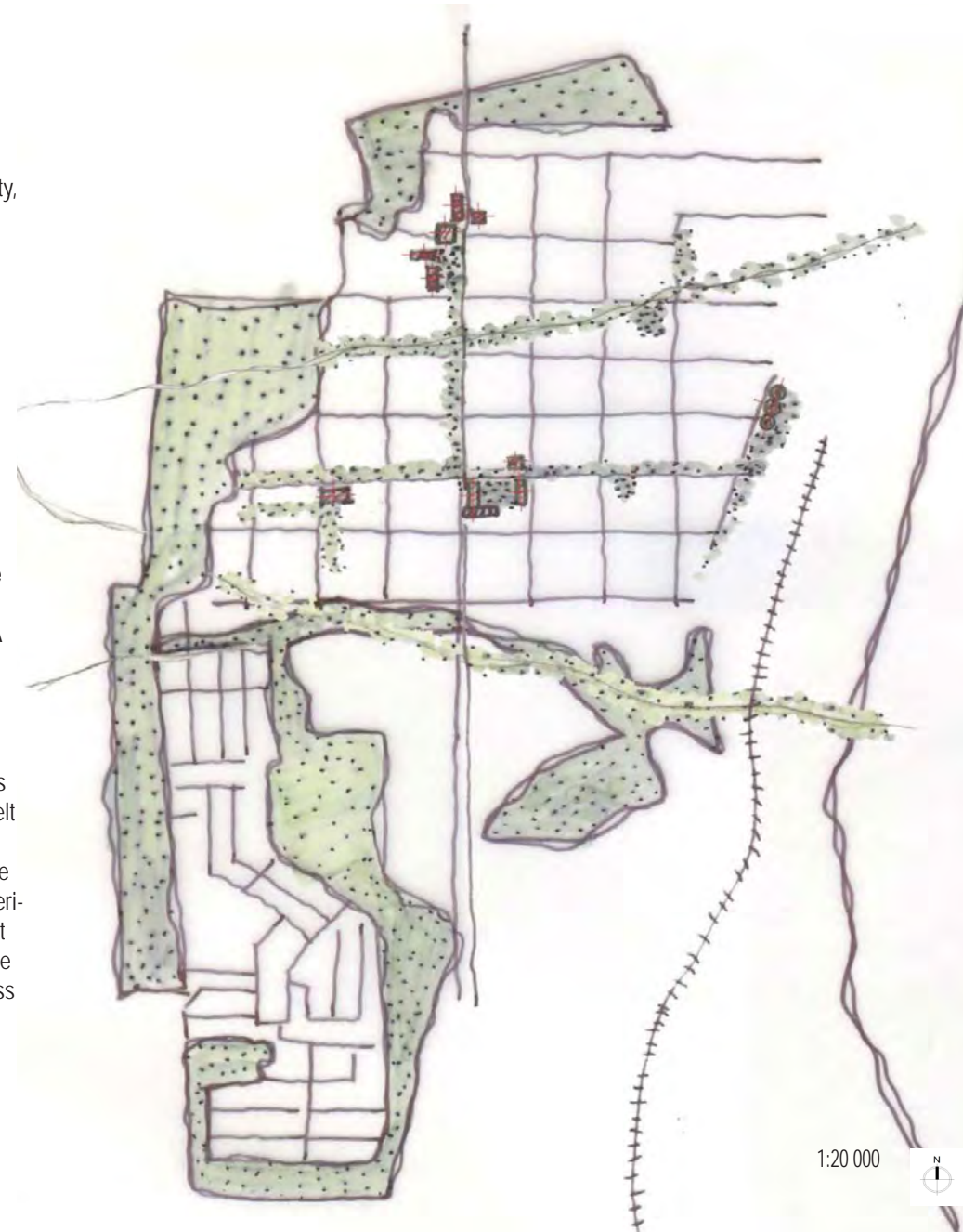

1:20 000



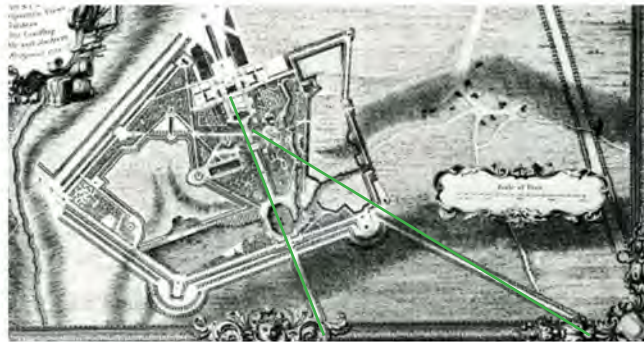
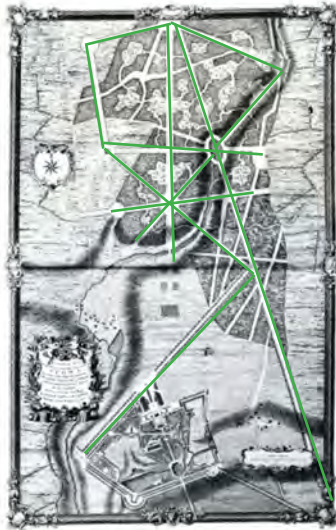

Stowe estate, below, by Charles Bridgeman executed in 1739

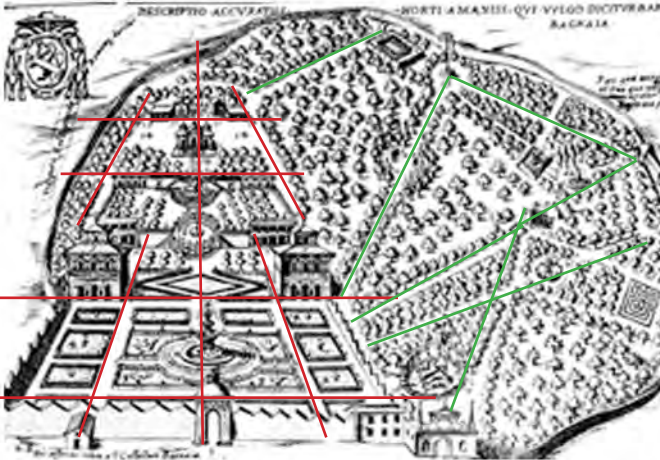
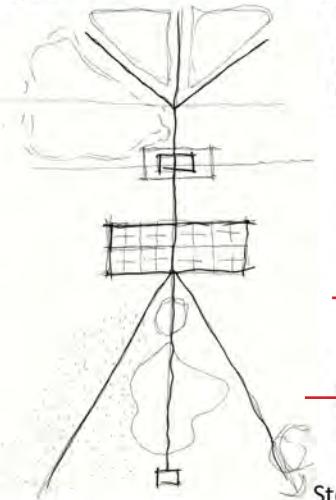

Stowe estate, below, by Charles Bridgeman, executed in 1739

Key:  
— Structured grid garden layout between house and the rest of the more naturalistic garden  
— Strong visual lines of axis but no longer a grid

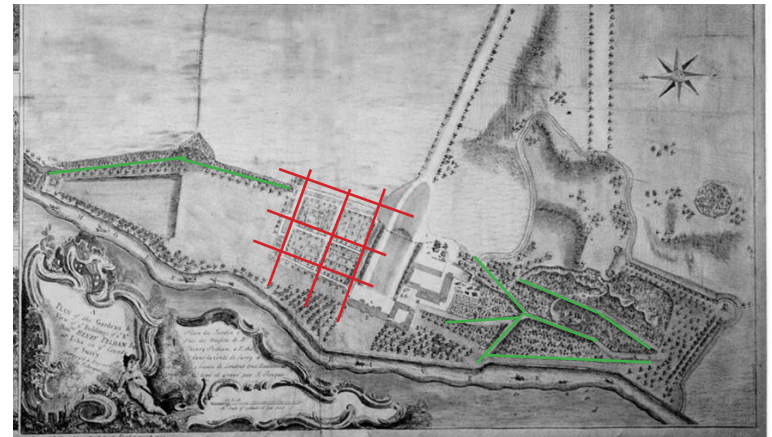
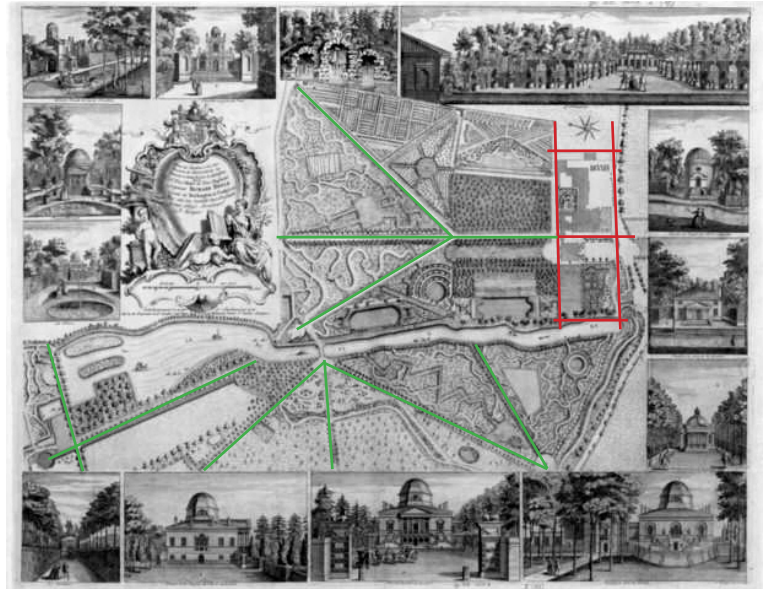

## Urban Scheme

**In this section I will first look at organizing the urban space at a zoomed out scale using various precedent studies as guidance and the required supporting infrastructure as a space organizing tool or element. Secondly a closer look at the town will determine the spatial organization of the space pockets between the existing built fabric. In order for the suggested urban scheme of a green vegetable network to function both physically and economically, it will require a structural layout and planning of the gardens as well as the necessary supporting infrastructure like water access, tool sheds and compost storage.**

### Zoomed out Urban Scheme

Precedent: English Gardens

The English Gardens of the early 18th century strived towards creating an "idealized view of nature"(Cornell University, 2011). The landscape designers made abundant use of colour, strong lines, ornaments and a variety of borders like trimmed hedges and planters to more naturalistic rows of trees to organize the garden space. Other identifiable characteristics are usually the rolling lawns set against a forest-like arrangement of trees, ponds and pools for their reflective quality, gothic ruins, bridges, folly structures and classical architecture(Cornell University, 2011). A tight structured flower garden is usually the mediator between the house and the nature and the further away from the house you move, the looser and more naturalistic the garden becomes. Although a strong axis remains, it usually lets go of the tight grid structure, organized only by pathways, water features and follies.

English Garden Layers

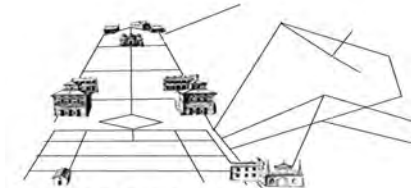

Built Elements holding space

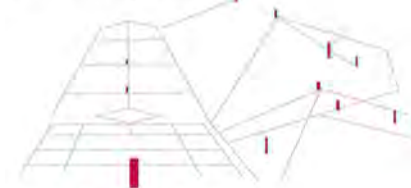

Follies placed on strategic grid points



Water elements



Green topography: structured and organic



Example of an English Garden layout

Parc de la Villette by B. Tschumi

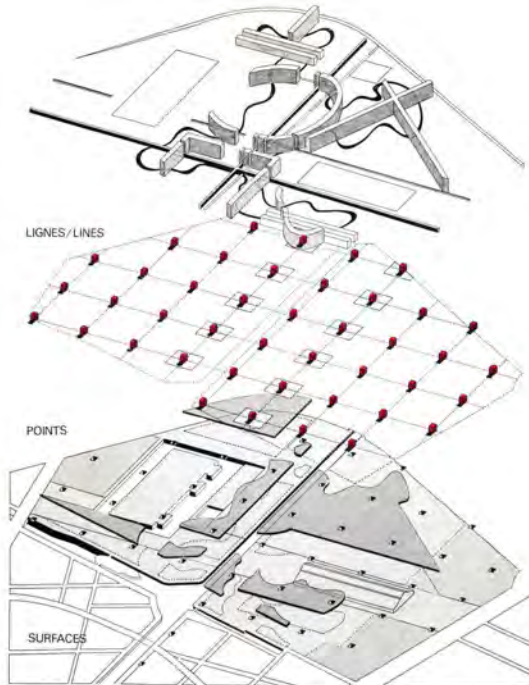

LIGNES/LINES

POINTS

SURFACES

THE SUPERPOSITION OF THE THREE SYSTEMS (POINTS, LINES, SURFACES) CREATES THE PARK, AS IT DEFINES A SERIES OF CALCULATED TRACES WHICH REAFFIRM THE DYNAMISM OF THE PLACE. EACH OF THE THREE SYSTEMS DISPLAYS ITS OWN LOGIC AND INDEPENDENCE.

[available at: [http://2.bp.blogspot.com/-wyPxOIC60cc/UR\\_POyrsh\\_I/AAAAAAAAABkk/N6ZjZd-w7wA/s1600/points\\_lines\\_surface\\_2.jpg](http://2.bp.blogspot.com/-wyPxOIC60cc/UR_POyrsh_I/AAAAAAAAABkk/N6ZjZd-w7wA/s1600/points_lines_surface_2.jpg)]

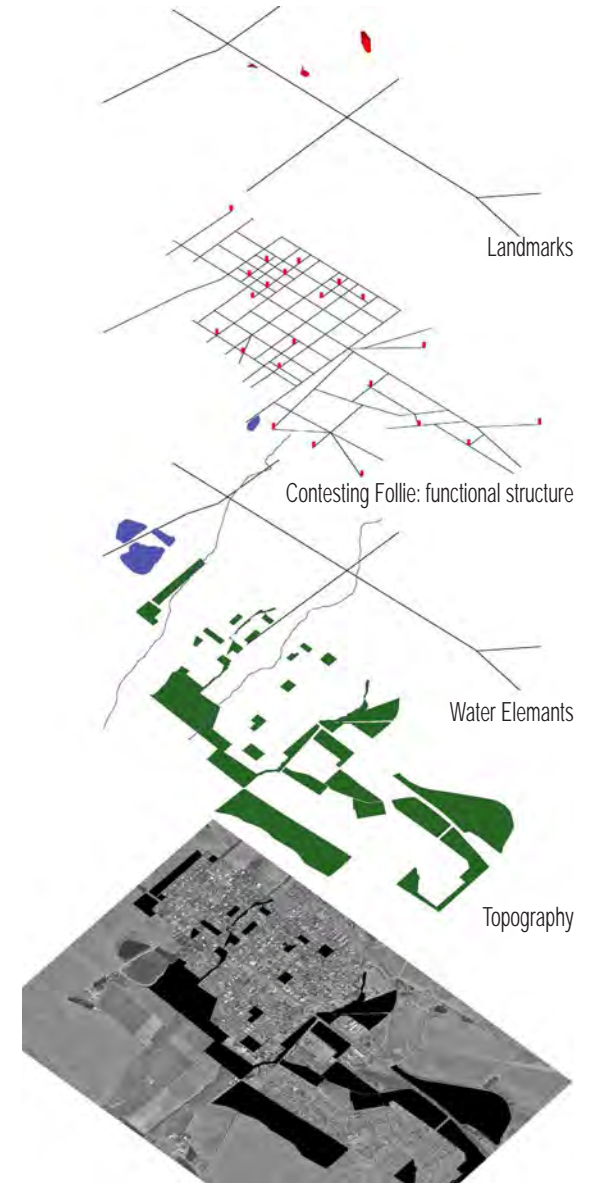

Landmarks

Contesting Follie: functional structure

Water Elements

Topography

Space as resource

## Follies



English Garden Folly

[Available at: <https://www.google.co.za/search?q=english+garden+follies&riz=1T4GGIE>]

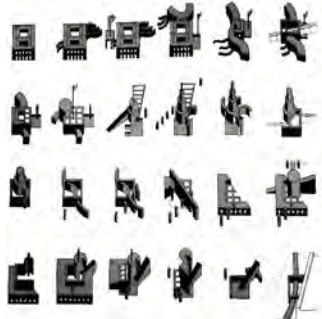

Parc de la Villette Follies

[Available at: <https://www.google.co.za/search?q=parc+de+la+villette+follies&riz=1T4GGIE>]



Contesting follies as "purposeless" structures  
 Functional Suggestions for Porterville

[Available at: <https://www.google.co.za/search?q=english+garden+follies&riz=1T4GGIE>]

## Precedent: Bernard Tschumi

In Parc de la Villette Bernard Tschumi organized the space of the large park by imposing a grid system on top of pedestrian paths. He also took the city axis into account when placing the grid system over the landscape. Follies are used on strategic places of grid crossings to hold and organize the space and create a point of focus in the landscape (Tschumi, 1994). These follies are easily spotted from a far and all have a similar style and the same red colour so that it can be identified as part of the same network of spaces. He also transformed a large landscape through small building shifts so that the buildings' edges hold the entrance spaces or pathways (Tschumi, 1994).

## Follies and forward thinking

With regards to spatial organization, both English garden design and later Bernard Tschumi in Parc de la Villette used follies to organize large amounts of space effectively. I think there's absolute value in using points in the landscape to arrange space but I have to contest the idea of a folly as a structure without a specific functional purpose. Accordingly I will use structures in the landscape to organize the vast space that also serves as the supporting infrastructure for the organic farming scheme. This will range from tool storage, to water towers, to compost containers and wash up facilities. These are places along or at the end of foot paths that also form visually strong lines (a technique used in both English Garden design and Tschumi's work). I have decided to use the main movement/road axis of Porterville as well as the river and leivoor<sup>2</sup> lines to inform a loose grid. The layout of the greenery will be done in the English

Garden style of having a tightly structured garden close to the house, or in this case a more formalistic grid will be imposed on the inner pockets of space, while a more naturalistic layout will apply to the outskirts.

2. Leivoor: channels dug running from the dam and around every street block so that every property gets a chance to open the channel towards their garden for a certain amount of time. This way you have access to a specific amount of water every week to water your garden.



1:4 000

On the left: Figure ground of focused area of Porterville showing large open spaces in the middle of the street blocks

On the right: highlights the open squares within the street blocks



1:10 000

## Zoomed In Urban Scheme

In order for the urban scheme to have maximum positive effect on Porterville and rejuvenate its identity, the scheme needs to be pulled right into the heart of town in order to connect the heart to the outskirts. In order to do this efficiently, the open and unused spaces within the existing built fabric of Porterville has been mapped in closer detail so that boundaries and connections can be established. The spaces are then organized using the previously discussed spatial organization president.

## Block Condition

There is an interesting inverse spatial block condition in Porterville. The street blocks are square and surrounded by a street face on all sides. Houses are built towards the street edge, leaving an oversized back garden. All the back gardens form an open square of land in the middle of the street block. On closer inspection, these back yards were often neglected and unused. The owners cannot afford to garden these large plots and see the rates and taxes as a burden (Visagie, 2015). Some families even keep a sheep or a couple of chickens in these open spaces.

After identifying the pockets of space that will become part of the green spatial network, a grid is overlaid and the spaces are organized by placing infrastructure on key overlaps in the grid and connecting the spaces through the built fabric with pedestrian paths. The pedestrian paths connect perpendicular to the town's main access and follows the same orientation as the town grid. The infrastructure points are however placed on a rotated grid that connects up the grid overlaid on the zoomed out urban scheme.

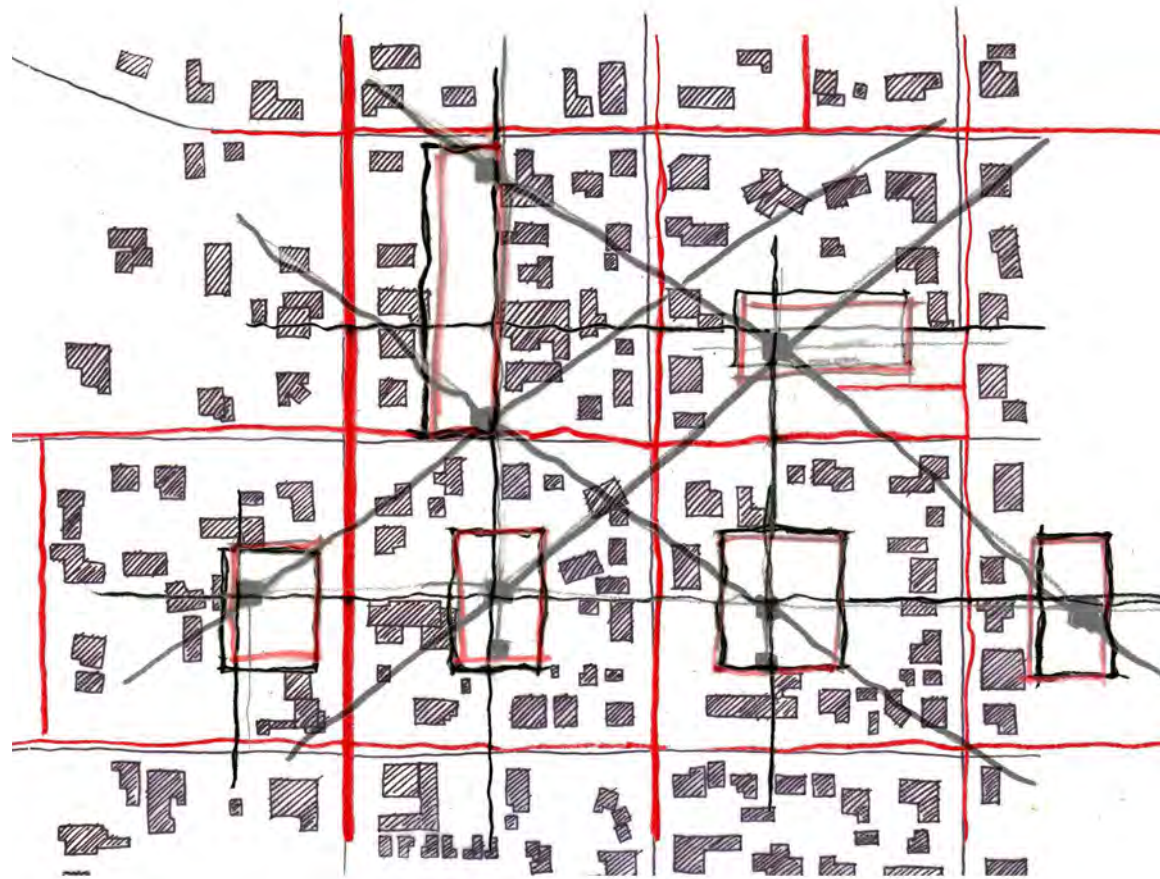

1:4 000





Through the Curtain: Trees and built fabric forms a curtain in front of the open spaces behind  
1:5 000



Through the Curtain: A point of height to make you aware of an event behind the curtain  
1:500

## Point of Height Through the Curtain

From the street however, these open spaces are often a secret veiled by a curtain of trees and a layer of house facades. Infiltrating these spaces will thus require some form of pull or point of height to draw people in behind the curtain. Once through the curtain, the visitor will be faced by a beautiful garden scheme. The vastness and greenery that meets the visitor is unanticipated thus enhancing the delight of the event.

The supporting infrastructure that helps to organize the space can also serve as the element peeking out behind the curtain to capture your curiosity. This starts to suggest the form that these structures need to take is something with height that can act as a visible beacon. Nodes in the city as a focal point is one of Kevin Lynch's elements in *The Image of the City* that talks about orientating the visitor. Nodes along a path becomes a useful way to describe what these structures need to be in order to successfully guide people into and through spaces barely visible from the road. Pedestrian paths will provide the visitors access through the curtain and into the garden space, but will also serve as a network connecting all the pockets of green spaces.



## Practical Workings of the Scheme



Every pocket of space within the built fabric will be its own garden with a specific theme for example herbs or greens. Babylonstoren serves as precedent for the exact layout and compatibility of specific plant types next to each other when farming organically. Information was gathered with kind cooperation from Jaco Brand, garden layout designer. One of the space pockets have been drawn in detail to show an example layout and the practical workings of the scheme.

### Legalities

At the moment the open spaces consists of parts of privately owned plots. In order to use this space, cooperation of the owners as well as compensation for their property is required. Dividing up, buying and consolidating the plots will take too long and need a too much start-up capital. Thus I suggest a 100 year lease contract with each owner as well as the release of taxes, service costs and maintenance for the duration of the lease. Additionally the developer agrees to garden the property and keep it neat and tidy. The law states that any property built by a tenant on rented land is the owner, not the tenant's property (Isb, 2015). Thus all supporting infrastructure built on site needs to be of a lightweight nature that can be removed, disassembled or re-used. Where larger or more permanent infrastructure is needed, the plot will have to be purchased. Thus a separate site will be chosen and purchased for the main architectural intervention (for more detail see the site selection section). To gain access to the property a servitude from the road through to the back garden will also have to be registered.

### Privacy

Further the privacy of the residents need to be respected. At the moment knee high walls and transparent chicken wire fences are the only barriers between plots. A low level wall will be built on the perimeter of the garden space, using the Cape Dutch Werf wall as precedent. This will allow the residents to still keep pets and it will be a clear barrier for visitors to stay within and not trespass onto the residents' land. Along the servitude a pedestrian path will be laid out, lined with a low level wall or higher planted fence where it runs close to a house and some privacy is required. At the start of the servitude a timber gate will be placed which will be left open in the day but can be locked at night to keep stragglers and trouble makers out.

\* Strategy proposed after advised by property lawyer Callie Loyd (admitted attorney and conveyancer)

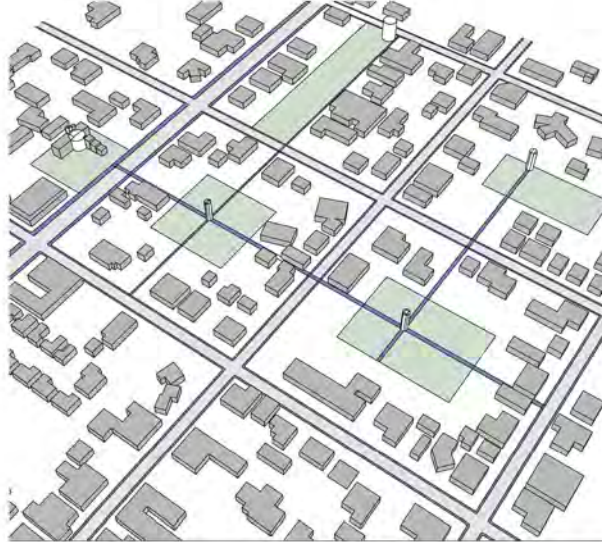

Path

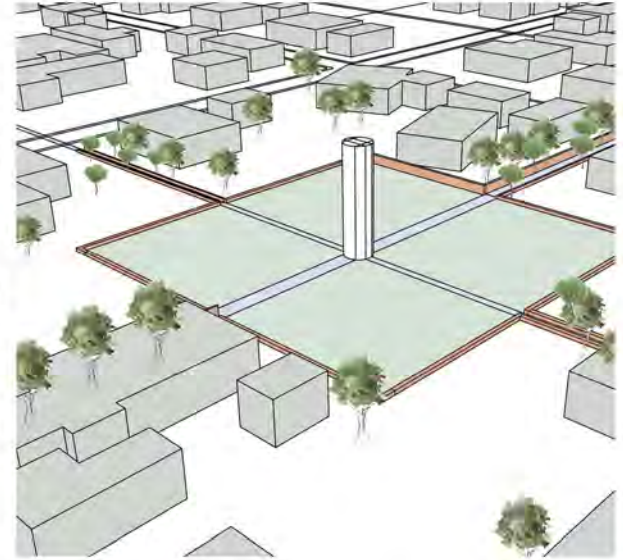

Boundary

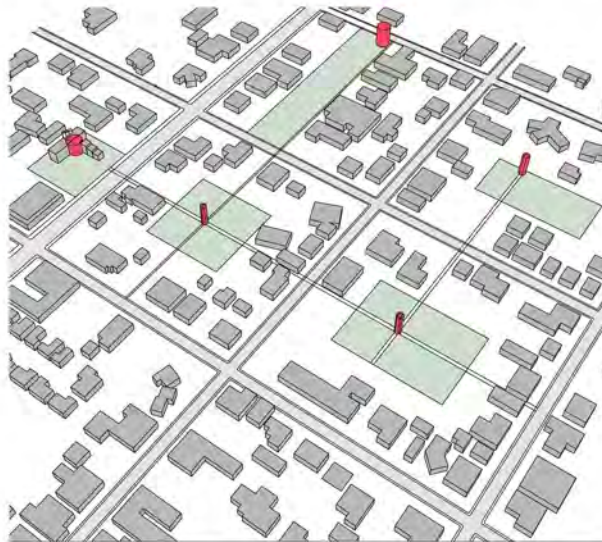

Nodes



Landmark

Making use of Path, Edge, District, Node, Landmark as tools to organize the space in Porterville

## Analysis of the Urban Scheme, using the 5 Elements of Kevin Lynch

Creating a town identity and a pedestrian navigatable green spatial system through the town cannot be discussed without mentioning Kevin Lynch's 5 elements in *The Image of the City*. His study concluded in 5 elements: paths, edges, districts, nodes and landmarks that help visitors observe and absorb information in a city. Since Porterville is not a large city, it can be discussed in terms of the five elements but should be regarded similar to a district within a city that distinguishes itself from the city by a specific identity or character. In order to draw together the entire urban scheme, zoomed out and in, the scheme has been broken up and analysed under Kevin Lynch's five elements.

### Paths, the Streets, Sidewalks, Trails, and other Channels in which People Travel

An extra network of pedestrian pathways that run through the street blocks and not only around them is added to increase the connectivity between the green pockets of space within the street blocks. All the roads are also lined with wide pedestrian sidewalks. The larger open spaces on the outskirts of town currently have desire lines that run through them. These will be made into formal pedestrian paths that still allow passing through the new green spaces. The desire lines cut across the formal grid of the streets.

### Edges, Perceived Boundaries such as Walls, Buildings, and Shorelines

The green belt of organic vegetable gardens will become the new, softer yet more definite edge to the town. On a smaller scale, knee height walls like the typical

Cape Dutch Werf wall will be used to clarify boundaries between private and public land within the town. This follows the current trend in Porterville. The werf wall will be heightened and trees will be planted where extra privacy is required.

### Districts, relatively large Sections of the City distinguished by some Identity or Character

Porterville is small enough to have only one identity or character. It can therefore not rely on different identities to attract visitors but have to ensure that everything in the urban scheme works together to really invest into one identity. In this case it is becoming the place where food production can be viewed and enjoyed from conception to completion and distribution.

### Nodes, Focal Points, Intersections or Loci

The supporting tool sheds and water towers are placed strategically in the urban scheme in order to organize the space. These are not always placed in very visible spots and therefore will be high enough and recognizable enough to serve as a focal point or point of recognition along a path. They are mainly placed on intersection points of two pedestrian pathways and should thus really assist navigation.

### Landmarks, readily Identifiable Objects which serve as External Reference Points

In Porterville the landmarks will be the main events on the skyline. All three are very recognizable forms, have a certain identity associated with them and stand tall on the sky line. These are the grain silo's, the church tower and the new supporting infrastructure building that draws together the urban scheme by being the point of collection, packaging, processing and distribution of the organic farming scheme.



## The Main Architectural Intervention

**This section sets out the aims of the main architectural intervention, the detailed program, selecting the site and placing the program on the site.**

### Program

Derived from social and resource particularity the main architectural intervention will be the largest piece of supporting infrastructure needed in order to operate and bring the urban scheme together. It will be a centre where all the vegetables from the organic gardening scheme can be collected, washed, packaged and in some cases processed and then distributed. Beyond that the building will serve as a built analogue that represents the values of organic farming and food production, thus helping build up the town identity. It will also be the last part of the food experience. In order to get a full experience of food production, visitors will first experience the sowing, growing and harvesting in the gardens and then the processing, sorting, packaging and preparing of food straight from the garden at the centre. The centre's functionality and management will also provide more employment opportunities. In addition there will also be three other programs all derived from the needs of the community, the available resources, need for job creation and the daily obstacles faced.

The first program will be a stone ground mill. This will allow the wheat to be harvested, milled, packaged and processed all in one place. This cuts out middle man costs and the unnecessary effects of additional transport on the environment. It is also in line with the organic farming approach and the ideals it associates with. The second, and supporting, program will be a bakery that doubles

up as a training centre for bakers. The third function is a restaurant that prepares food straight from the organic food scheme and provides an educational experience for the visitors by allowing them to experience the packing, milling and baking process while dining. The restaurant will be used as the glue to pull all the separate programs together. Tourists can be drawn from the cities to come and experience the entire "food manufacturing" process from growing to harvesting by walking through the network of gardens to processing, packaging and distribution by dining at the restaurant. In addition the existing dining options in Porterville has been mapped indicating a lack in dining options both from a local and tourist perspective.



Silos



Clean, wash, dry



Stone Grind



Packaging

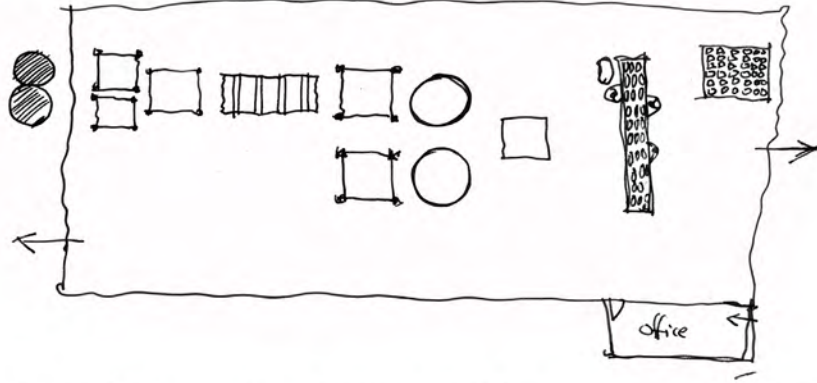

Silos Washing & Drying Rollers 10 layer Sieves Stone Grind Mixer Packaging Storage before distribution Office

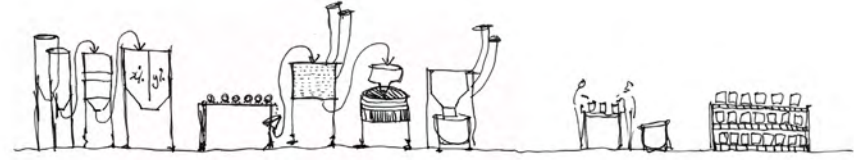

Silos Washing & Drying Rollers 10 layer Sieves Stone Grind Mixer Packaging Storage before distribution



Bagging seperated bran



Rollers



Sieve



Process and Spatial requirements of a stone ground Mill  
 Source: All information gathered through site visit to Fourie farm and interview with Heine Fourie

## Functional Precedent & Technical requirements

### Stone Ground Mill

The process, spatial and technical requirements of a stone ground mill was investigated through a site visit to the Bio Wheat mill on the Fourie farm in Caledon. An interview with owner Heine Fourie and a technical tour through the mill provided me with insight into the workings and operations of a stone ground mill.

A healthier "Bio wheat" product starts with a more natural way of ground preparation and caution about the content of compost and pesticides used. Although complete organic farming with wheat has not yet yielded very positive results, a few farmers have made the necessary move to a more sustainable approach to farming.

### Process

The first requirement of a mill is the required silos for wheat storage. At least two silos are needed to be able to have different grades of wheat containing a different percentage of protein so that it can be mixed to achieve the desired nutritional make up requires for wheat. Backers are strict about the specific nutritional make up since it influences the rising time of the flour.

The wheat is left to soak for at least 24 hours before the milling process starts. This softens the grain pip in preparation for milling and the outer shell absorbs water. Once again control is essential since wheat with moisture percentage of higher than 14% will go mouldy.

The wheat is then rinsed and left to dry for a minimum of 12 hours. From here the 2 types/grades of wheat is mixed in a tank that allows an equal amount of each to be funnelled in.

Next it is put through 6 rollers that crushes the wheat slightly to about twice as fine as it is. The coarse and fine brans are then split.

A ten layer sieve is used. It can be set finer or more coarse depending on the output required. A finer product is required for cake flour where as a more coarse flour is better for healthy bread.

Next it passes under the stone grinder that operates under much lower temperatures to roller mills and thus releases less glucose into the flour.

Depending on the product needed a mixer is used to mix some of the coarser brans back into the finer flour.

From there it is packaged, sealed and distributed.

### Staff requirements

4 persons on the floor, 1 for packaging, 2 managing the loading and driving of the truck for distribution, 2 office personnel and an accounts and marketing person is the sum total of staff for this mill that is a small scale mill processing an estimate of 50 tons of wheat a month. (other small scale competitors Eurika process about 200 tons per month and will require more people on the floor, especially for packaging.)

### Other observations

Ventilation is very important due to the powder that sits in the air and can be breathed in. This can however not be in the form of a strong draft. Extraction fans with filter

bags are attached to many of the machines to catch the excess flour that rises into the air with many of the processes.

Fire hazards is one of the only safety concerns for a mill. Flour is a highly flammable product and the necessary safety precautions must thus be taken.

The size of the building is 10m x 5m x 5m. With an increase in production, an increase in floor space will be needed.

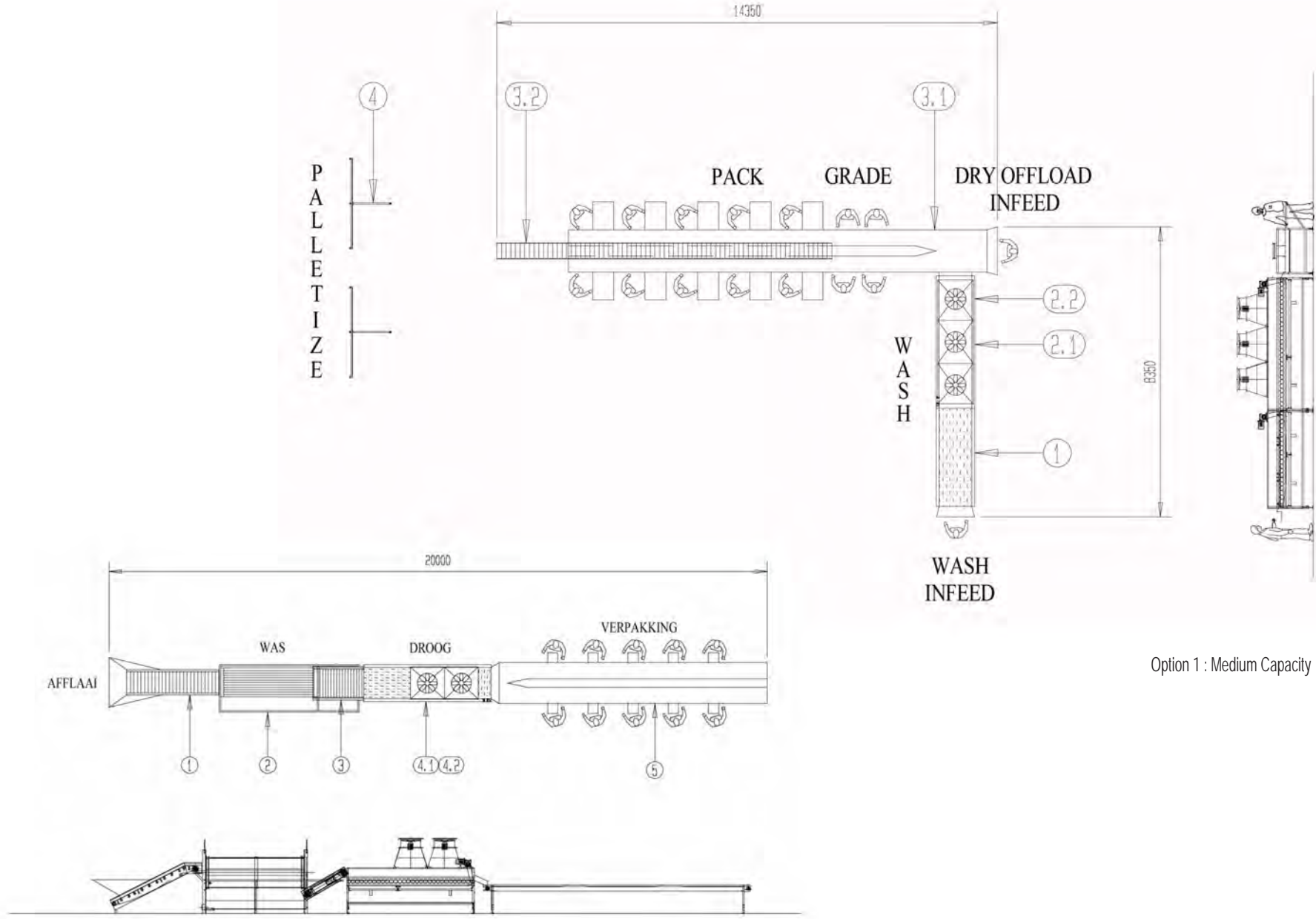

Option 1 : Medium Capacity

Option 2 : Small Capacity

## Fruit and Vegetable packaging and handling

An interview with the CEO of DORMAS Fruit and Vegetable handling specialists (Mr. A. Malan) gave me a better idea of the size and technology requirements that this organic farming scheme will require. Due to the smaller volumes and variety of products, a technically advanced pack line specialized according to the specific fruit or vegetable is unfeasible. A variety of products will help to spread the harvest and packaging periods over a longer time than having only one product. This allows for a smaller pack line and constant job creation rather than season workers. All things considered, a small soft handling automatic conveyor belt pack line was suggested with packing tables at a ninety degree angle, manned by two packers. This system will rinse and dry produce and speed up the manual packaging process. The following requirements need to be taken into account:

1. Enough space around the pack line is required for the collection of packed boxes either manually or by a small fork lift.
2. Tipping box at the start end of the pack line and a catch pit at the end.
3. Stacking space for boxes ready for distribution.
4. Cold room for storage of produce while in the queue to be packed or distributed.
5. Two entrances: one for deliveries and one for collections since it will happen at the same time.

6. Strictly marked circulation zones.
7. A wet floor since ripe fruit can get messy.
8. Strictly ordered systematic planning of the process. Crossovers can waste valuable time and cause safety hazards.
9. Natural ventilation or air-conditioning to ensure an acceptable temperature within the pack house. Extreme heats will affect the shelf life of the produce.  
Graphic: factory function diagram of all stations & size and dimension requirements of pack line.

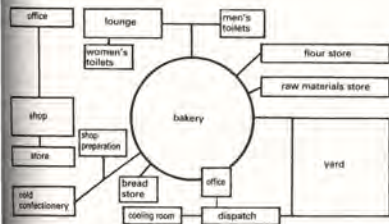

① Space relationship plan

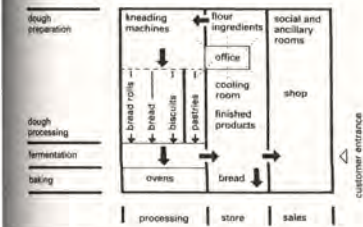

② Functional diagram

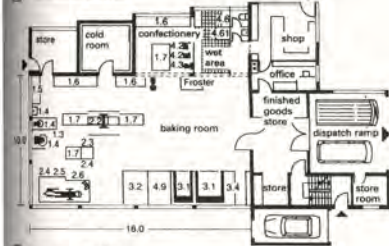

③ Example plan layout

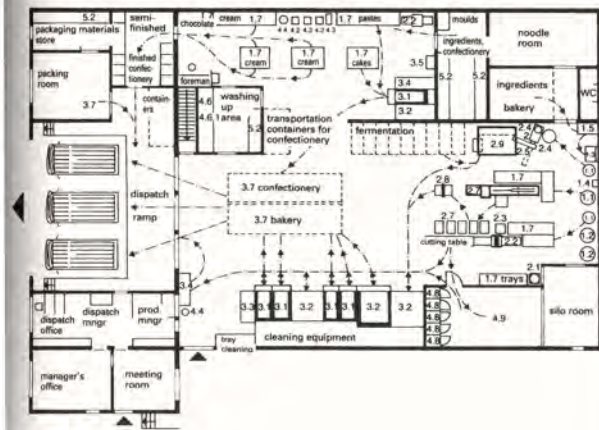

④ Example plan layout

### WORKSHOPS: BAKERY

Systematic planning must anticipate possible future developments in technology and operating procedures to which building elements will have to adapt. The planning procedure must also always include a review of the location.

**Schedule of accommodation and space requirements**  
There is a basic division into store areas, production areas, sales areas, building services areas, offices for administration and management, social rooms and ancillary rooms. → ①

Work processes in or between the individual areas → ②  
Distinction should be made between store rooms for raw materials (coarse meal, sugar, salt, baking powder, dry goods in sacks, flour in silos or sacks), ingredients (fruit, garnishings, dried fruit, fats, eggs) and packaging. Daily supplies are stored at the workstations. Establish space requirement for containers (shelving, racks, cupboards), stacks, counters and circulation (corridors). Minimum area for stores is 15m<sup>2</sup>; roughly 8-10m<sup>2</sup> per employee for all store rooms. Routes between stores and work areas should be short.

Work areas for bakery and pastry should be separate. The bakery needs a warm and humid environment; pastry making needs a rather cooler environment. The bakery includes the following areas: dough preparation, working of dough, baking, storage of finished products. Pastry making is split: cold area (butter cream, cream, chocolate, fruit) and warm area (pastes, cake, pastries and biscuits).

The space requirement can be determined using a layout plan. In a work area space is needed for equipment, for handling and working, for intermediate storage (trolleys) and counters, and for circulation (lost space).

WORKSHOPS AND INDUSTRIAL BUILDINGS

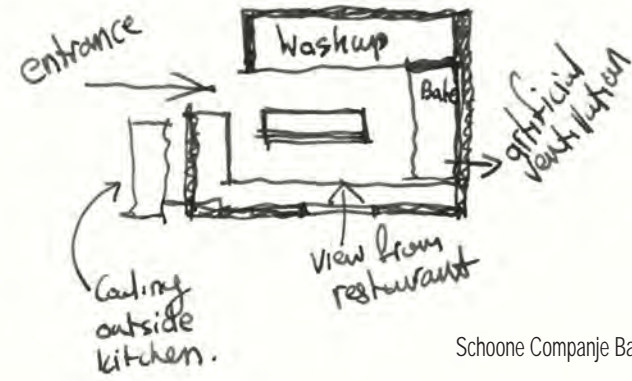

Schoone Comparje Bakery

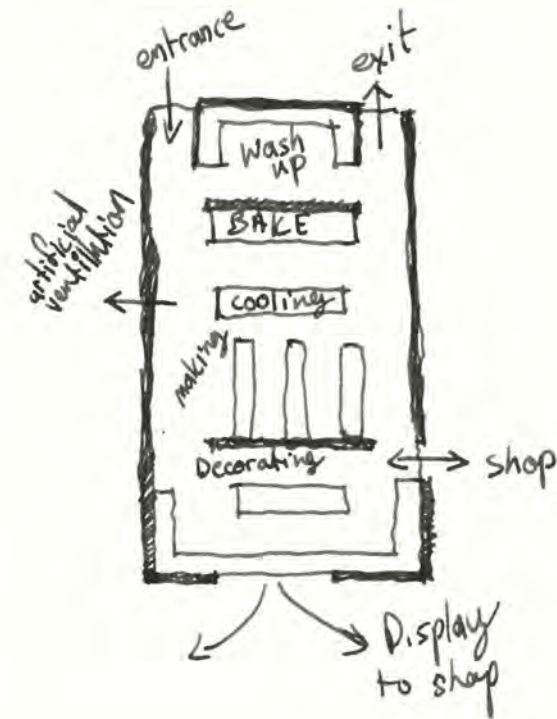

Schweet Eporium Bakery

## Operational bakery and training

I visited a Schoone Companje bakery as well as Schweet Eporium bakery. Schoone Companje bakes mainly bread and a select few sweet treats. They make use of a very small kitchen area and need optimal spatial use to manage a variety of baked goods. They work according to a strict time table and bake only one product at a time. They have one entrance for inflow and outflow of goods which is sufficient since deliveries only happens once a week and is scheduled after the last batch of baked goods has been dispatched.

Schweet Eporium bakery only bakes cakes and sweets but operates as a baking school as well and thus offered extra insight. Focusing on cakes can bring an entire extra discipline to your kitchen because professional cake decoration needs a lot of time and a clean, dedicated space or surface. From a training perspective, the bakery has additional working surfaces to accommodate more people and there is one central surface that can be viewed from all the other surfaces. The divisions between all the separate areas are also transparent to allow supervision from any point. The baking area needs good ventilation or thermal separation from the decorating area to ensure that the icing will not melt.

I could only visit the bakeries during operational hours, and thus couldn't take precise measurements without interference. The *Neufort Architect's Data's* guidelines for the spatial requirements of a bakery is therefore another useful consideration.

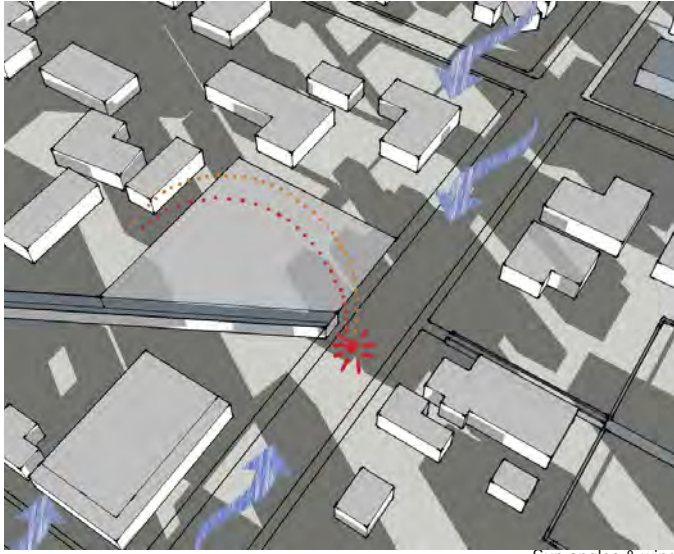

Sun angles & wind



Area, dimensions and set backs



East view from site

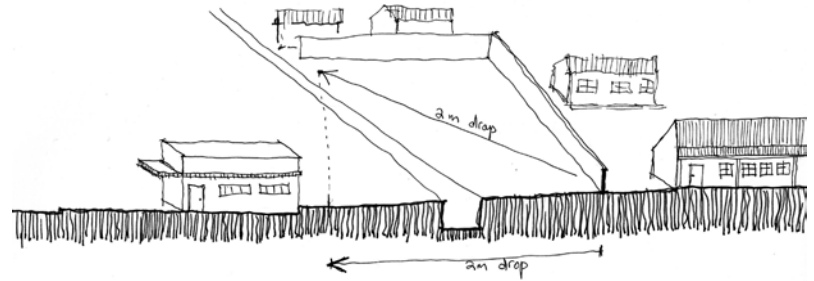

Slope/fall towards river

## Site Analysis

### Site Selection

The main architectural intervention needs to be easily accessible and visible in the community since it will have a constant traffic of employees moving through it on a daily basis and serve as a built analogue for the organic farming scheme. Thus an empty sites on the main road has been identified. From the network of open spaces in town the chosen site was selected as the main intervention site for having a large street front facing the main road, because it has possible access from two sides providing the possibility of a service entrance and because it is also situated next to the river and thus has potential to respond to the river rather than turn its back to the river as is the current situation(see mapping of water ways).

### Traffic Mapping and Diversion

Currently the main road has become a rush of large trucks moving through Porterville since it sits on a popular truck route. Then there is also the farmers' trucks that cut through town. The proposed scheme includes a widening of the pavements as well as the insertion of a middle man to slow traffic coming down the hill, and making it difficult for trucks to pass. The aim is to divert the truck routes to drive around instead of through Porterville. The dedicated space of the old railway line that is no longer operational can be used for this purpose.

## Site Analysis

The figures on the left show a summary of site analysis completed. The sun and wind angles, slopes, areas, setbacks, context and views are all represented here.



Site in context

Program diagram showing the necessary functional and thus spatial connections required

Production vs Public

Circulation

Thermal Comfort: Sun and Shade

Street Response

Restaurant: joint between the three production spaces

## Program on Site

### Functional flow of Program

Program diagram shows the relationship between the various programs and starts to dictate their physical position in relation to each other on site. The Restaurant has to be geographically connected to the bakery, mill and pack house in order to provide views into them. At the same time optimizing the view of the mountains for their customers will be ideal. The mill and bakery must be closely connected for direct flour deliveries. The mill and the pack house both need access to a truck delivery and pick up service zone. The bakery's volumes will be comparatively smaller and much lighter than the mill and pack house volumes and can thus be accommodated through a smaller entrance or transported a bit further to the truck service zone. Delivery and pick up times will also be pre-planned and at set times where as fruit and wheat might be delivered at whatever time the next load is full after the harvest.

### Precedent for arranging the building

The circulation within and around the building sets up a grid like framework which consists of the operational and the visitor circulation systems. From a functional perspective the public entrance and interface is facing onto the main road and pulls you off the pavement into the building. The truck delivery and pick up zone is created along the back end of the site and is accessed through a side road. The fruit handling pack house and mill is placed as a buffer between the public and the service zone, yet allowing glimpses through due to the transparent and educational approach to the operations.

The pack house is placed on the south side to prevent direct sun on the fruit. The court yard or public outside space is also on the south side, shaded by the bakery, since the Porterville summers are long and brutal. Shade is usually the biggest luxury. This way the open air public space can also respond to the river and interact with it.

The mill is next to the bakery and the bakery creates a face on the street as does the context in the town. This allows the bakery to have a window onto the pavement to sell fresh treats to pedestrians or people on lunch break.

The restaurant takes a circular form to overlap and protrude into a variety of spaces. This allows the restaurant guests to experience all the manufacturing processes from within the restaurant. Raising the restaurant provides a better visual over the operations, prevents interruption of the operations and optimizes the mountain views. It also allows for some North light to penetrate through the restaurant space.

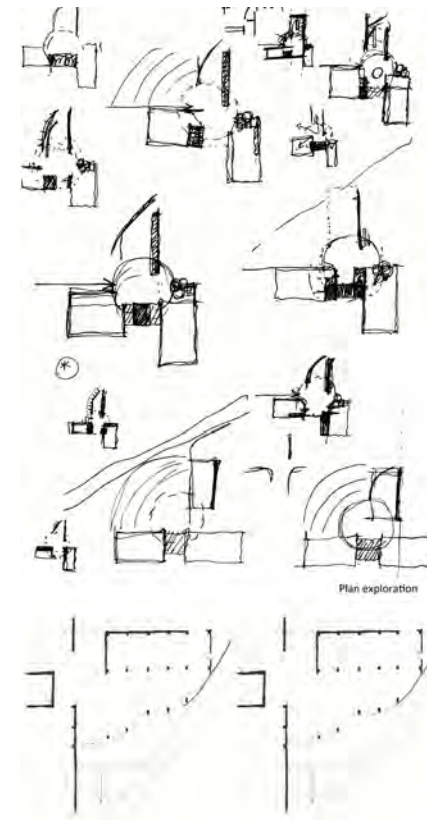

Process of Placement of Building on site

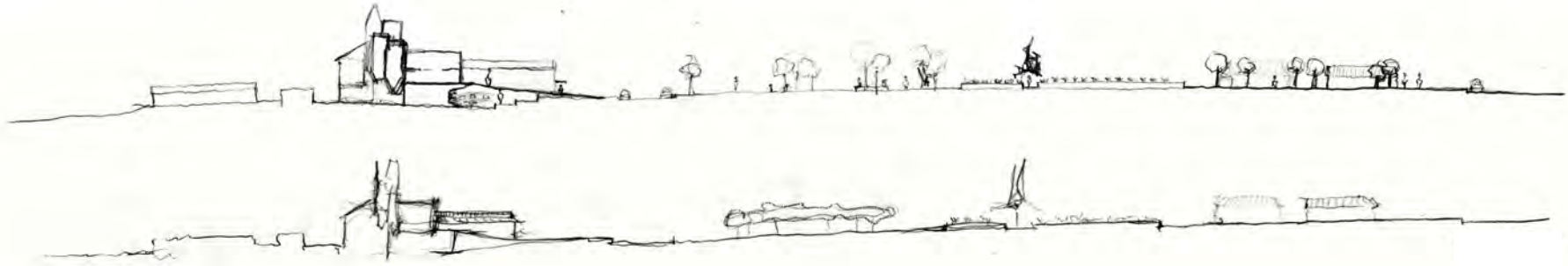

Points of height in landscape  
1:1000

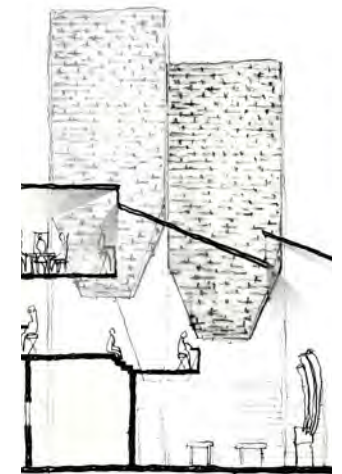
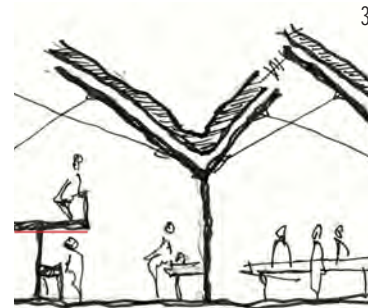
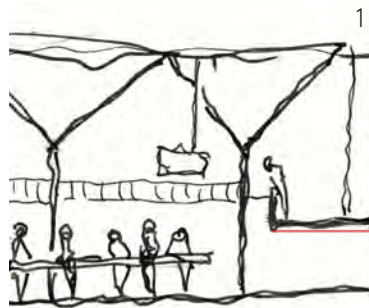
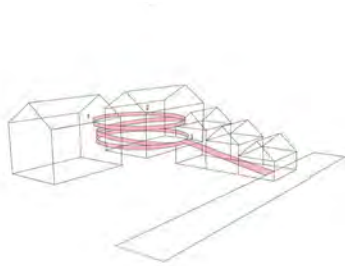

Circulation as experiential tool  
Used to bring visitors up close to the production in a safe and undistruptive way as well as close to the materiality of the "grown" building

Between the operational 1:200

## Sectional Concept



Silos:  
Functional & Economy

**This part of the dissertation shows the main concepts that developed from drawing sections through the scheme and the program placement. Sections were drawn keeping in mind the building as an experience for visitors as well as its part in creating a landmark as part of the new town identity.**

Porterville Skyline: Points of height in landscape

Although the idea of the supporting infrastructure as points of height and beacons in the landscape has already been covered in the urban scheme, the sectional exploration really shows how the two points of height will help the spaces relate to each other as part of a system and how it really pulls the pedestrian through the curtain, never losing touch with either point. This specific section also shows the potential of passing through under the canopy of trees next to the river as a type of an outdoor living room before reaching the next garden and point of height.



Church:  
Symbolic - Beliefs and Identity

Graphic (left hand section)

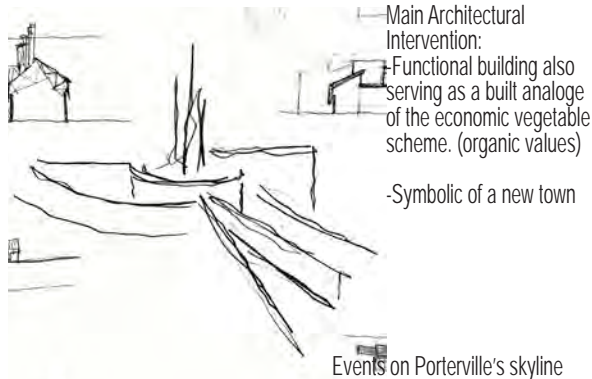

Between the operational

The spaces need to interact in a way that the visitors can occupy industrial spaces to experience them but without hampering the production or creating safety hazards. The tension between different elements invading unfamiliar spaces, like visitors having lunch under a grain silo, can create a new powerful tangible spatial experience. The aim is to see how closely you can integrate the visitors and the operations without losing affectivity (zoom in section under silos – initial sketch).

Precedent & Collages

# Conceptual 3D Exploration and form finding

Ideas & Concepts

Collage has been used as a technique for the initial conceptualizing of ideas. Vernacular precedent has been placed next to international precedent. In some instances the combinations are very strange next to each other, but the unusual combinations is what pushed the design explorations beyond the conventional. The figures on the left show the initial exploration s in collage form and the sketches show the main ideas that emerged from the collages.

Physical Modeling

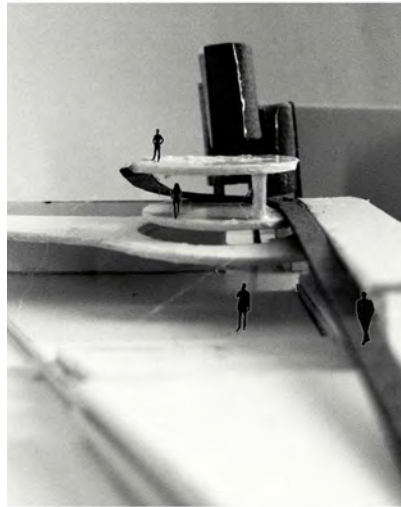

Digital Modeling

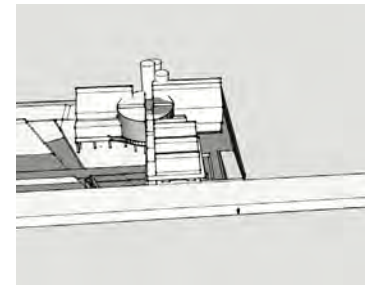
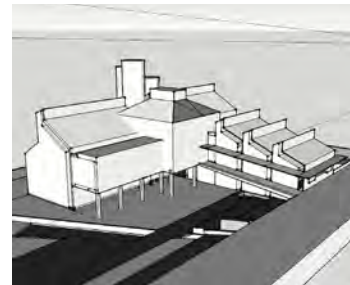
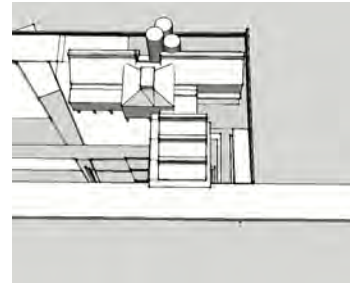
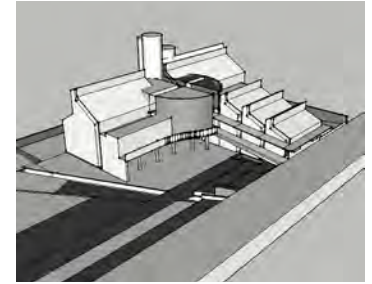
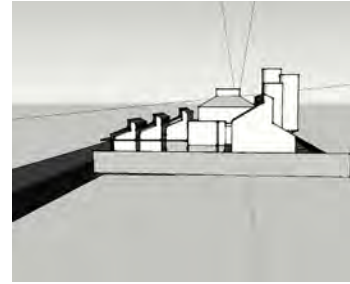
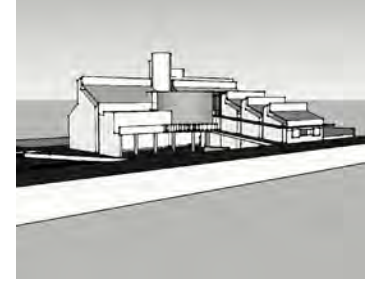
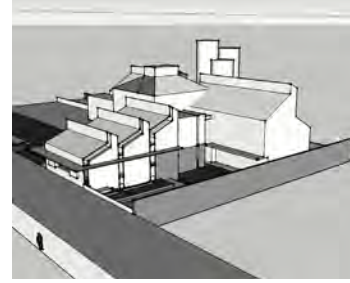

### 3D Sketches

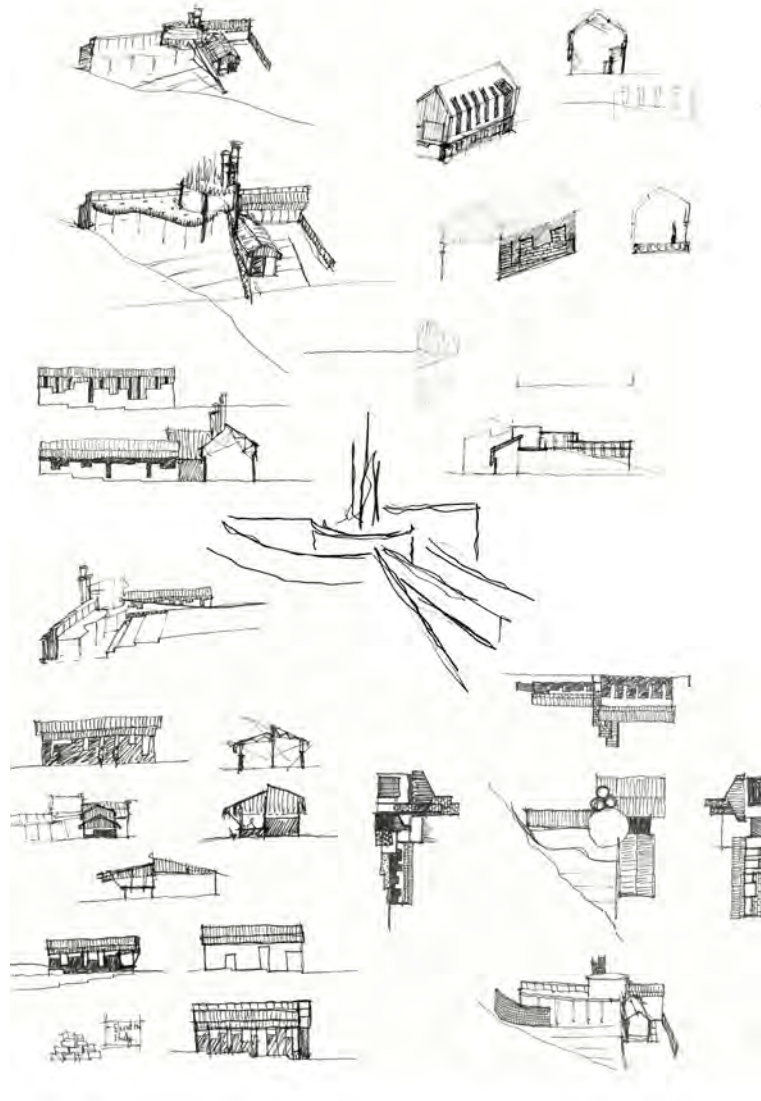

Both physical modeling, computer modeling and 3D sketches were used during a form finding exercise. The site placement and the idea of the building as a landmark has been taken into consideration. Furthermore local and global precedent has been thrown together in order to create a new particular yet globally relevant form. The material properties of the chosen material pallet also played a role in the form finding process.



# Theoretical Framing of the Architectural Strategy Continued

## Setting up a Pragmatic Methodology to achieve Particularity in the Design Process

**This section aims to compile a methodology that can be applied to the design process in order to have architecture serve as an interface between people (the local primitive) and advanced science (as a result of globalization) that will help architects to fully investigate a particularity approach. A particularity that stretches beyond imagery and form and includes materiality, composition, techniques and ways of thinking. The development of a methodology is a useful aid to ensure that good design principles are not compromised due to local material and technical unfamiliarity(Desner 2008). The aim is to achieve a particular architecture that is socially, environmentally and economically sustainable, by using local materials and techniques viewed through a global filter, hence establishing a tangible connection between the local primitive and advanced science for the benefit of society on a local and global scale(Bandy & Smith,2005). First the bridging opportunities between people(the local primitive) and advanced science (as a result of globalization) will be identified. There after a step by step framework will be drawn up off a precedent study and fleshed out by applying it to Porterville.**

### Introduction: Precedent for the Methodology

In order to compile a methodology for particular architecture, bridging opportunities between the local primitive, the environment and the technically advanced global first need to be identified through the analysis of

the development of people, advanced science and the environment over time. Following this analysis, a basic framework for the methodology will be drawn up using Burton Street Peace Garden's Learning Pavilion by the Asheville Design Centre, a small building that successfully bridges the gap, as a precedent study. Drawing from the precedent studies done earlier with regards to locality theories, a pragmatic approach will be followed, hence the framework will be fleshed out and clarified by applying it to Porterville. The objective is to implement this framework to test a methodology that investigates the architectural process with the intention of finding a technical groundwork process. The aim of finding this process is to give architects a tool that can be used to set up an appropriate material pallet, scope of techniques, and knowledge that will serve as the groundwork for creating a locally particular sustainable architecture.

### Defining "Local" within a Global Context

Advocating a local and thus particular focus can only be fully comprehended when the term "locality" has been defined in accordance with our current context and understood within the built environment. The Oxford Dictionary defines local as "relating or restricted to a particular area or an inhabitant of a particular area"(Oxford Dictionary,1995). This definition refers to an unspecific geographic limit and does not specify a time period that something needs to have been particular too. This leaves defining local skills, materials, cultures, services and vegetation open to a certain amount of interpretation. Frampton's interpretation of a region's culture is that "ancient and modern cultures are not the product of a single heritage, but rather hybrids of several cultures found in a region's past"(Orozco,2007). This suggests that in order

to be relevant today, historic consideration is equally important to current cultural trends for the picture to be complete. In the built environment material locality will have to be defined within a specific geographic boundary. One school of thought is the idea of a material radius. It is demonstrated by both the AFBC 100 mile house radius challenge and the 500 mile material radius requirement specified by LEED<sup>2</sup>(LEED,2012). Local is thus defined as what is currently present within the radius, irrelevant of its historic origin. Another view is that materials are local as long as it can be produced within the same climate/environment to where the site is situated. The emphasis is on "can be produced" and not necessarily "place of origin". This means imported materials that have been locally produced for years and flourishes in the natural conditions of the area, will classify as "local" materials(Diamond,1997). Similar to people, domestic farming crops have travelled the world to alike climates to increase the number of calories per hectare that can be produced(Diamond,1997). Urbanization as we know it was only possible because of domesticated crops and the ability to provide food for large groups of people living in the same region(Diamond,1997). Since then, many other refinement and process techniques have also been imported. Leather, for example, is locally abundant in South Africa but the technique to process it into a desirable product has been imported from Italy(Diamond,1997). This concept is described by Diamond as being "dependent on domestic from elsewhere."

Within an architecture context, climatic, landscape and topographical locality is easier to define since it directly relates to the building site and its immediate surroundings. Deciding who the local people and cultures are, is however more complex since long distance transport, moving homes and networking to find employment

Home development and lifestyle changes

Grass structure: Khoi-San moving around as hunter-gatherers



Matjieshuis: Reed mats on a timber structure moving around for new grazing fields (Khoi-San & temporary settlement for Dutch settlers)



Rondawels: Cob walls and thatch roof - settled farming communities with rotational farming

Cape Dutch Architecture (In degrees of wealth): cob walls painted in lime for water proofing - later fire bricks were used



Commercially Fired brick buildings built with materials and styles world wide (upper, middle and lower income classes)



Very poor communities: build out of waste (especially 2nd hand corrugated iron sheets)

10 000 - 5 000BC

1600s

1800s

2000s and on

opportunities worldwide, has become simple through globalization (Babb, Held and McGrew, 2003). Throughout history many places have also been colonized by foreign cultures and slave trade resulting in the importation of a variety of cultural groups (Diamond, 1997). Thus when building for the “local” people, the local cannot be exclusive to the very original hunter-gatherers only, but needs to include an historic understanding of cultures over time (Orozco). Referring back to Critical Regionalism in the light of locality discussions, Frampton emphasizes the “critical thinking” required in order to avoid copying the past and making an irrelevant architecture by using elements and ways from the past but adjusting it to suite modern life styles (Shumen, 1998). Curtiss’s approach of Authentic Regionalism could also offer a solution, resultantly providing a beautiful particular architecture (Orozco, 2007). The danger of copying vernacular architecture can be addressed by Curtiss’s approach to Authentic Regionalism. He proposes looking to history and the vernacular and understanding the reasoning behind decisions and moves made, thus drawing from the principles and not the actual object (Orozco, 2007). Using both Frampton and Curtis’s way of thinking about Critical Regionalism, figures 1-5 was compiled in order to analyze the primitive people’s process of habitation, as well as the development of modern science in order to find a bridging opportunity through an understanding of progression over time. The progression of modern science has been categorized into the evolution of lifestyles (fig 1), the development of materials (fig 2), development of knowledge and the spread thereof (fig 3), and the development/change in environment with the progress of modern science. Figure 5 concludes the analysis by synthesizing the information and demonstrating the bridging opportunities.

### Primitive Reasoning and the Evolution of Lifestyle and Habitation

Tracing human settlement back up to 10 000BC, the civilization of the time wandered around in search for food (Laksman). Shelter was primitive in the form of temporary settlement in caves or up in trees. Permanent settlement was not feasible since people constantly moved around after food (Laksman). The purpose of shelter was for protection against the weather elements and wild animals (Laksman).

Later the people today known as the Khoi-San started to build simple, temporary, light weight structures. This gave them the advantage of staying in a location of their choice (versus where they can find a cave) but still easily erect and disassemble their home structures so that they could continue to follow the hunter gatherer life style (Frescura). In the Western Cape this was referred to as “matjies huisies” which consisted of reed mats that could be rolled out onto a stick structure and rolled up again when moving on (Frescura).

With the later cultivation of land, followed by the domestication of animals, people were able to settle more permanently, since they could provide their own food (Diamond, 1998). This lifestyle also called for a more permanent form of settlement. A variety of clay/sand mix huts developed (Laksman). The South African version was the “rondawel” which had cob walls and a straw/grass roof (Laksman). At first these farming communities had to move every couple of years because the overplanted land became infertile (Frescura). Later with the new practice of rotational farming, permanent settlement was possible. Settlement was still built around the needs of protection against the elements, wild animals and later

in some parts against human enemies (Frescura).

The next step in the South African housing development was the Cape Dutch settlers’ homes. The homes became a lot larger and based on comfort beyond basic protection as well as on social standing (Laksman). The settlers also influenced this building process with preconceived ideas of comfort and aesthetics brought with them from an entirely different physical environment (Diamond, 1998). Local adaption of their preconceived ways of building was a given based on availability of materials. The resultant product was cob buildings with thatch roofs (Laksman). The gables was a combination of an imported aesthetic and a material limit namely the steep pitch requirement of a thatch roof (Frescura). Building gables also avoided another seam (waterproofing weak point) in the thatch that would be necessary if the roof had to close off the sides.

From there the modern habitation split into two groups: the wealthy and the poor. The wealthy build for comfort and social standing and used materials imported from all over the world (Frescura). The latest European fashionable styles and products are available and appeared in homes in South Africa. Hence South Africa has the potential to look like Europe and in effect like everywhere else in the world (Cato, 2008). The poor on the other hand approach building homes from a basic “roof-over-head” perspective. Their material choices are based on what is available, free and in proximity rather like the historic civilizations. Looking at the overview of history, the ancient civilization’s local proximity approach was a sustainable approach that was upheld from the cave dwellers to the more sophisticated “rondawels.” Yet their dwellings also adjusted according to their lifestyles (Frescura). We can apply that same approach today by building within a natural local proximity but

Materials Modern Science / Knowledge



Seperate and scattered with no connection

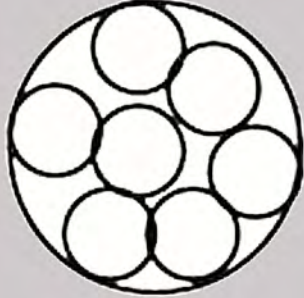

Growing and aware of other knowledge

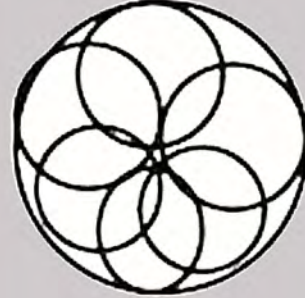

Overlapping knowledge and inventions

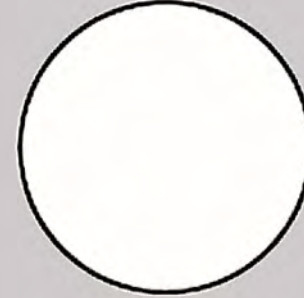

Globalization: all information available every where

Materials



Seperate natural materials in their natural habitat



Cultivation, mining, processing of resources



Trade & Barter expands, Transport systems, Technical advancement



Everywhere has the potential to look like everywhere else

Environment



10 000 - 5 000BC

1600s

1800s

2000s and on

providing for the modern need of comfort. The modern "poor" habitation approach does exactly that. In informal settlements where money is scarce, resources is defined as anything that is available. Thus waste as a local material has become a major resource. Although the waste materials may not be natural, re-using waste is a very sustainable way of disposing of waste(Desner,2008). It requires no transport or pollution due to burning. Shumen emphasizes waste as a resource in saying that every community has underground "mines" in the form of waste that they carelessly ignore(Shumen, 1998). The point is not to limit building materials to waste but to look at your immediate surroundings with new eyes and to analyse the unconventional materials as potential resources.

In today's informal settlements these waste materials are also processed into more than just basic shelter. Luxury furniture items, ornaments, frames, wall paper and many other decorative items are made from local waste materials. The people live in the same modern "consumerism" society as the rich yet have managed to fulfill their desires in a sustainable way.

### Development of Knowledge & Materials and the Spread there of

The development and spread of knowledge and technical innovation was hugely developed by the mobility of the global age(Shumen, 1998). The ancient civilizations put all their effort and energy into gathering food and surviving. With the cultivation of crops and domestication of animals, larger scale farming was possible. More kilojoules per hectare could be produced which meant communities could grow(Diamond, 1998). People's lives were freed up since a few could produce food for many. Hence labour

division happened. The barter system originated and grew rapidly(Diamond, 1998). Soon a new "profession" existed. Many of the traditional hunter-gatherers became traders(Frescura). Traders collected and spread knowledge along the way. Soon people started using commodities from all over(Frescura). The growth of communities also called for strong guidance and centralized rulers and kings. Centralized rule allowed for an increased production world(Frescura). Large mines, and huge expansion to large mines developed alongside of science and maths(Diamond,1998). New discoveries happened faster since knowledge from all over the world came into contact through travellers and traders(Frescura). Science started to overlap giving birth to some great discoveries and inventions. Scientific development brought about the improvement in the transport systems together with the machine age and the ability to reproduce many new material synthesis types(Diamond, 1998). These many types were transported across the world until the same materials were available everywhere. Places started to lose their distinct quality, cultures and cultural ways of living. We find ourselves today where people and materials mixed to a point where today everything and everywhere has the potential to look like everything and everywhere else(Frampton, 1992).

### Change in Environment

With technological development, and the advancement of transport and production systems, the CO<sub>2</sub> production and the use (or exploitation) of resources has drastically increased(Babb & Held & McGrew, 2003). At the same time the population is growing at an alarming rate and environmental specialists have predicted that the earth will not be able to sustain our way of living in the

near future(Cato, 2008). The damage to our planet that has already occurred cannot be erased yet some of the aspects like the amount of CO<sub>2</sub> in our atmosphere is reversible. Specifying local materials, for example, is a real way in which architects can contribute.

Bridging Opportunity

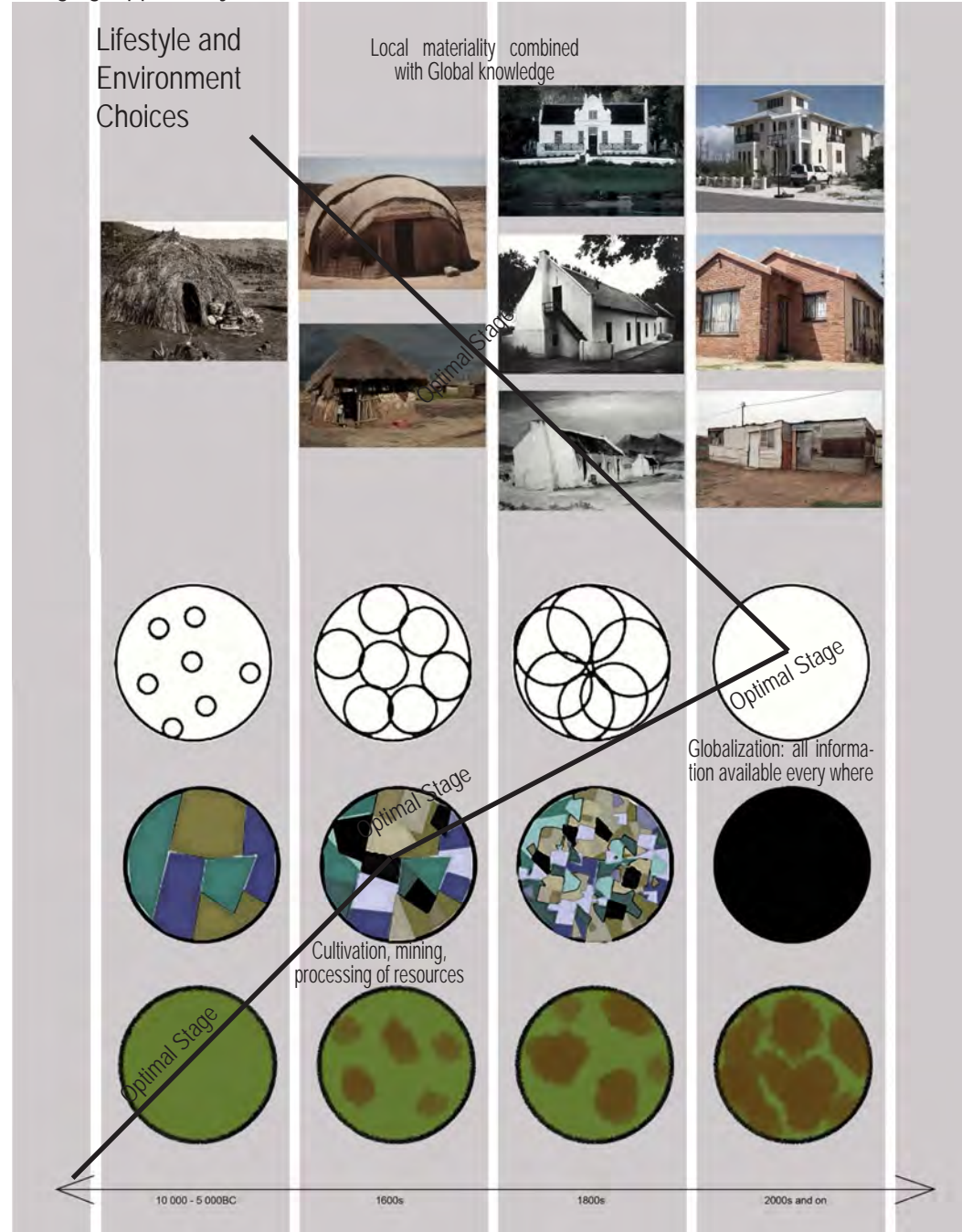

## Bridging Opportunity

By using the definition of sustainable development (as per Brutland Report 1983) and drawing from the reasoning of the primitive person (as suggested by Curtis in Authentic Regionalism) to select the optimum stage in the progression for each of the discussed categories<sup>3</sup>, the knowledge required to achieve a particular sustainable architecture surfaces (Moore, 2010). It is a matter of effectively combining these optimum stages (or what they represent) and bridging it through an architectural interface. Figure 5 demonstrates that the optimal stage in each category does not line up. We need architecture to shift the time line in order to line up all the desired stages with today and create a pivotal point in time for future generations to work from. A point where people and their needs, modern science and the environment is all lined up (Moore, 2010).

3. Discussed Categories: evolution of lifestyles, development of knowledge and the spread thereof, development of materials and the spread thereof and the development/change in environment with the progress of modern science

Material Radius Study

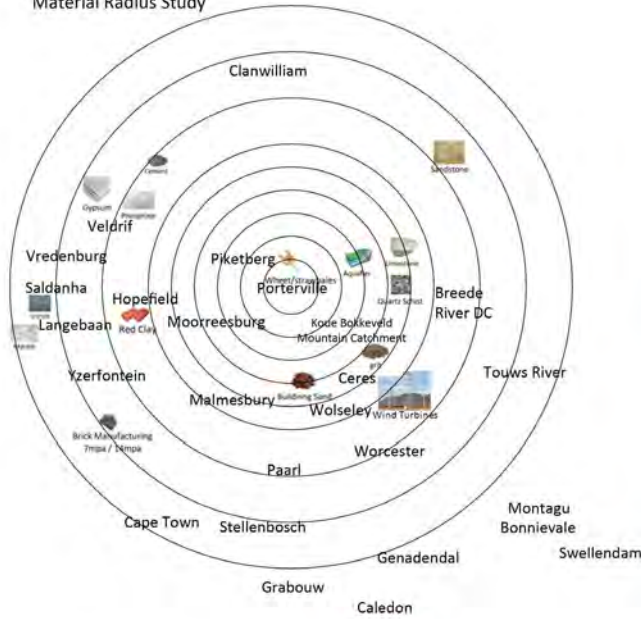

Defined by main transport routes

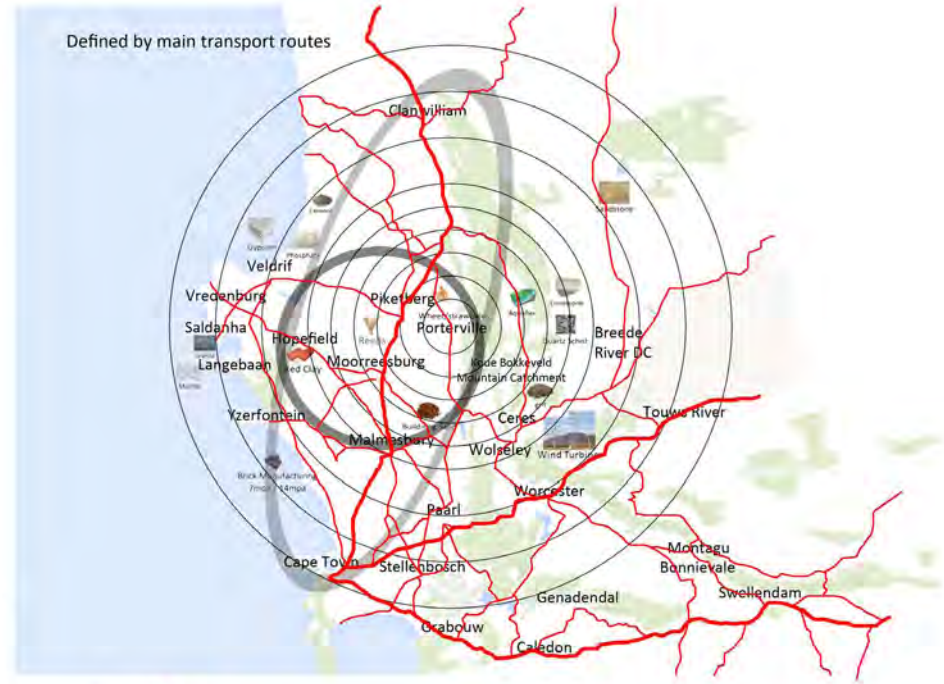

Natural Materials



Waste Materials

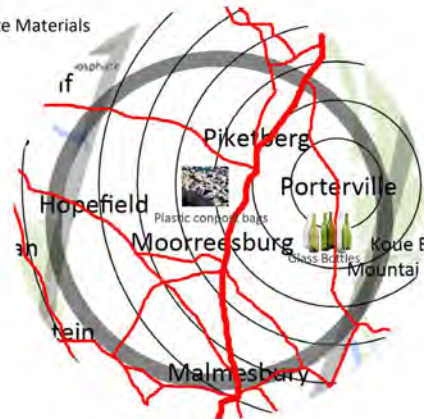

Radius Material Study  
process of determining a material pallet

## Compiling the Grocery List: Selecting a Local Kit of Parts through Mapping, Research and Defining the Local

### The Framework

Now that the river beds have been established, how do we go about bridging them? A precedent study of the Burton Street Peace Garden's Learning Pavilion, by the Asheville Design Centre, that has bridged the optimum stages of material, lifestyle, environment and knowledge was looked at in order to establish a framework for an architectural bridging process. The findings is a 5 step process. See appendix C for full precedent study and how the five steps were identified.

Step 1: Material pallet based on locality limits

Step 2: Investigating the local vernacular structures

Step 3: Investigating the vernacular use and techniques of the chosen materials (not region bound)

Step 4: Knowing the material limitations

Step 5: Beyond the conventional (international modern techniques)

For full precedent study please see appendix C. The methodology is tested through its application to Porterville.

### Application to Porterville

#### Step 1: Material pallet based on locality limits

For the purposes of this discussion local is considered to include everything that naturally occurs or is being cultivated/produced for years within the same climate/environment that the site is situated in (Diamond, 1998). That works out to a local radius of about 400km. The materials found within this region is plotted on the radial graph to investigate how much is lost when tightening the radius and thus needs to be restricted further according

to a sustainability filter. In finding a way to tighten the radius, the work of South African architect Vernon Collis needs to be considered. When looking at a material selection, he takes into account the distance by road/ship of transport for materials to get to site and the CO<sub>2</sub> emissions that is associated with it. Using transport routes to narrow down the radius would make the exercise more **energy efficient, and thus more sustainable** (Collis, 2013), hence demonstrating the narrowing down process. In the final selection of the material pallet, there is another environmental division to consider. The difference between natural local materials, manufactured local materials and existing resources of waste. The ideal would be to use natural materials as far as possible due to its abundance and ability to decompose and zero energy rating (Cato, 2008). Waste is also an efficient resource since it costs environmentally to dispose of it. We can however not ignore current life styles, thus if these needs cannot be met with the innovative use of natural local materials, the manufactured local materials needs to be considered (Babb & Held & McGrew, 2003). The focus of setting up the framework is to avoid drawing building materials from the manufactured local pool as far as possible. The final material pallet for Porterville is thus narrowed down to clay, straw, sand and reeds as natural local materials and glass bottles as a waste material.



## Step 2: Investigating the Local Vernacular Structures in and around Porterville

### Swartland Agriculture Vernacular

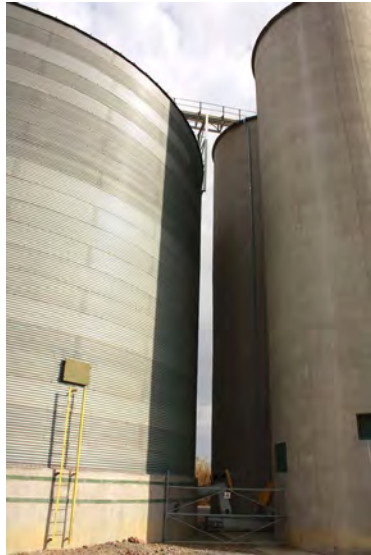

**A study of agriculture buildings in the Swartland was done and photographically recorded. These buildings have been looked at in terms of how they have been put together, their structure, their logic and the thinking that goes with it.**

A farm shed is built in the most efficient way of roofing a large open area without any supports in the middle of the floor space. It consists of a portal frame structure that is made of a light weight material. It is therefore quick to put up and simple enough that the local farm workers can put it together. The structure's ease of erection is paramount in the given context due to rapid changes in weather and logistical processes that can create a sudden need for additional storage. These structures are also simple to add to or alter. The Afrikaans saying "a boer maak 'n plan" (a farmer makes a plan) is very relevant. These structures are often edited on the spot in whatever way is needed. If a new implement is bought that sticks out beyond the roof, it is not uncommon to strip the roofing off one section of structure and build up only that part around where the new implement will stand. The roof covering is also a light weight material ensuring minimal structure needed to hold it up and easy adaption of the roof material.

In terms of covering, it is approached from an "only what is necessary" point of view. Many shed structures consists only of a roof. The roof often extends down to become the wall for an extra bit of covering but a wall is usually unnecessary. Where side covering is needed, a low level wall is often built. This is either just a three brick wall to mark the edges or end off the roof sheeting. Alternatively it is a person height wall so that it is high enough

to put shelving and other solid structures up against on the inside. This way it is also more weather proof when working inside.

Looking at the silos, these are usually round as a cylinder. It is a stable form that can gain height with little structure. Initially silos were made of timber, almost like large wine barrels. Later brick and concrete silos were built. Today smaller silos are also built with steel structures and corrugated sheeting.

Although the agriculture buildings are all very structure and space efficient and absolutely functionally orientated, there is a certain beauty to them in the Swartland landscape.



Roof as floating structure



Light weight perimeter structure



Landscaped groundplane

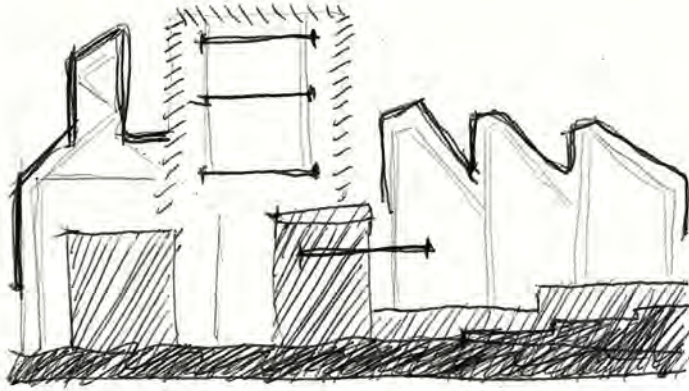

Structural Concept Drawing

### Spatial Organization Strategy

Other than the obvious influence of the Swartland vernacular structures on the structure of the building, the building's space is organized in the same way as the urban space. In both instances the spatial organization started with topography and landscaping. It moved to structure and organization through grid placements and the strategic structural placements. Once the space was organized, attention turned to the use and experience.

Topography & Landscaping

Structure & Organization

Landscape

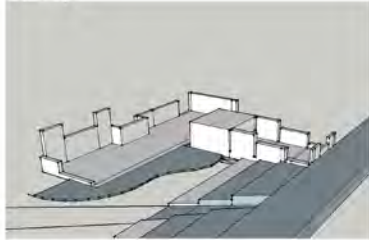

Primary Structure



Planes

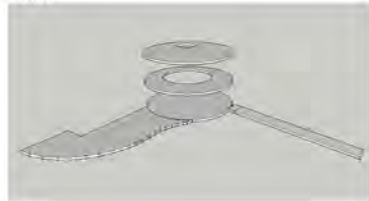

Cover

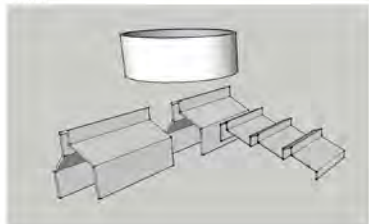

structure Exploded

## Overall Structural Strategy for Architectural Intervention

Drawing from the Swartland agricultural vernacular the following structural strategies have been put in place for the main architectural intervention in Porterville.

### Landscaping the Ground Plane

The ground will be landscaped to step down from the road. In strategic places the floor may rise to form a wall. The walls will be heavy and embedded as part of the landscape as opposed to sitting on top of it. It will be made from a similar material as the floor or ground plane.

### Primary Structure

The structure will be a light weight structure making use of the advantages of quick and easy erection by an unskilled labour force. Hereby large open spaces will be achieved, optimizing the working area, removing structural hindrances, allowing for large volumes and adaption of program as well as adaption of building structure.

### Cutting planes

The floor planes above ground floor cannot be part of the landscape. Instead they are viewed as floating planes cutting into or hanging from the building structure, retaining a light feel.

### Roof

The roof is one folded plane/surface that floats above the landscaped ground. Working together with the

protruding floor, the roof sometimes comes down to form a piece of wall. The roof's structure and materiality will be lightweight so that it can be supported on the light-weight structure and add to the "floating" feeling.

### The In-between: Doors and Windows

The floating roof and landscaped ground plane never touch. The in-between spaces become the openings of the building for windows and doors. Thus the doors and windows do not sit prominently in the facade but is rather left out panels of "wall" as seen in the Swartland agriculture vernacular.

### Service cores

Two service cores are inserted in strategic places for structural and functional support. The service cores will form part of the landscaped ground plane.

### The Restaurant

The restaurant is a separate element that serves as the connecting factor and lantern in the middle of the collection of "sheds". It follows the same cutting planes strategy but is wrapped in a lightweight transparent exterior. The structure is set back from the facade allowing a clear circulation zone all around the restaurant. Pushing the structure back also allows for the planes to have a floating appearance.



Sample of Typical Housing



Face & Body Identification

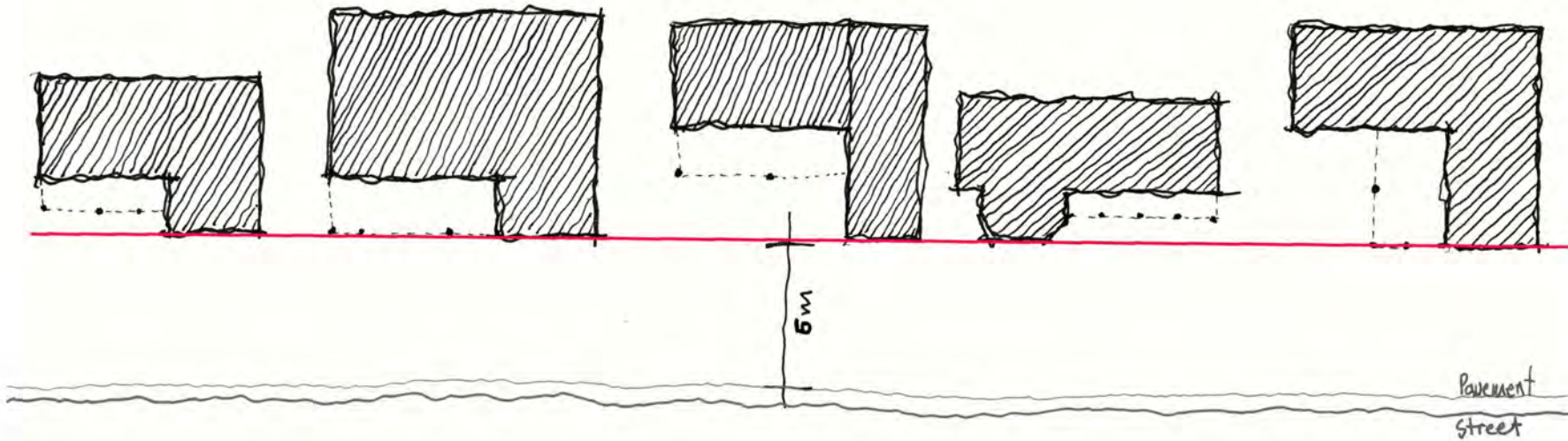
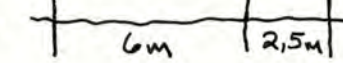
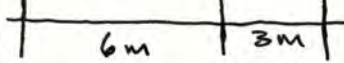
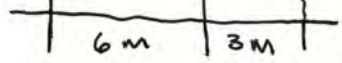



Example of a Cape Dutch "werf"  
 [Available at: <https://www.google.co.za/search?q=cape+dutch+werf&iz=1C1AR>]

## Housing Typologies in Porterville and more Vernacular Architecture

Most of the houses in Porterville are built according to the Cape Dutch style. The prominent features are the large white gables (often street facing and serving as the "face" of the house) and an L or H shaped house plan. The "voorstoop" or covered patio usually runs across the length, or in some cases all around the house. This keeps the homes cool in summer and provides an outdoor living room. The "outdoor living room" is usually street facing next to the gable or "face" of the building in order to provide a social interaction threshold between the private home and the public street. This way the streets are socially activated. The concept of the Cape Dutch "werf" is also visible. The traditional "werf" consisted of the farm buildings placed as a series of separate buildings and enclosed together with a garden area by a low level wall. The wall defines rather than encloses or cuts off the space. Most homes in Porterville are placed about a quarter into the property and have a low level wall or fence all along the perimeter. This way a front and back "enclosed garden" or "werf" is provided. Although the "body" of the house is placed further back, the "face" of the house still protrudes forward to create a defined street edge.

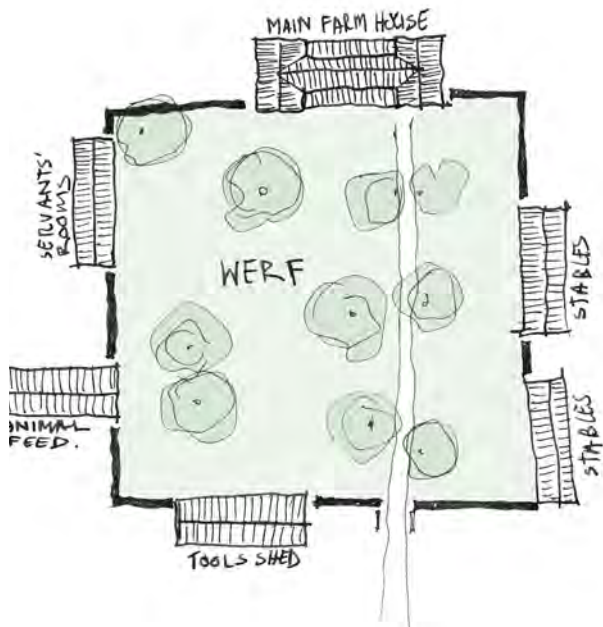

Spatial Organization of the Cape Dutch Home and "Werf"

## Building in Context - Locality considered

The design for the main architectural intervention considers the general Genius Loci of Porterville in terms of setbacks, shape of building, height on the street front, creating a "werf" and the familiar forms of the facade. All of these aspects were drawn from the housing typology study.



1

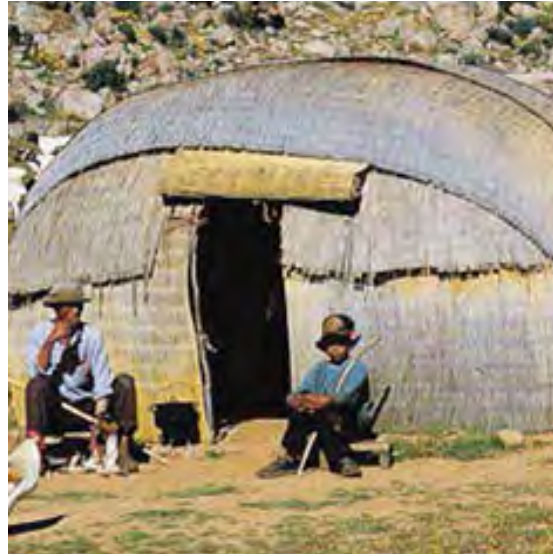

1



1



1



1

Figure: Flexible stick Framework of "Matjieshuis" tied together with natural fibers - [Available at: <https://www.google.co.za/search?q=building+with+reeds>]

Figure: Matjieshuis. The reed mats rolled out onto the framework [available at: <https://www.google.co.za/search?q=building+with+reeds>]

Figure: Cob Rondawel with thatch roof [Available at: <https://www.google.co.za/search?q=building+with+reeds>]

Figure: Making cob bricks with timber shutters [Available at: <https://www.google.co.za/search?q=building+with+reeds&biw=1391&bih>]

Figure : Timber framework that is eventually hidden in the cob walls. [Available at: <https://www.google.co.za/search?q=building+with+reeds&biw=1391&bih>]

### Step 3: Investigating the Vernacular Use and Techniques of the Chosen Materials

#### How to grow a building

The material aim for this project is to see how much of the building can be grown. This refers back to the initial idea of the building being a built analogue for the organic vegetable scheme. The same green, environmentally friendly, healthy, yet desirable and currently trendy aspects need to be visible in the building. Vernacular architecture was made from grow-able, local materials and the study there of can extend an architect's knowledge and thus design capabilities around "grow-able" materials.

Reeds, clay, sand and straw were used in vernacular ways within the Porterville region that could serve as precedent as how to use them within construction today. The best example of reed is the "matjieshuise" that has already been touched on briefly. These were used by both the Khoi-San (by the time that they have also begun to own cattle) and as temporary dwellings by the Cape Dutch settler (Frescura). It consisted of light-weight structures that can be packed up and moved a long easily according to the Khoi-San's life style. The structure consisted of a few bracing sticks or "latte" (supple sticks) that was bound together in a beehive like structure (Frescura). Reed mats were made and rolled out and tied to the structure with natural fibres (Frescura). The material selection was based on the lightness and availability (Frescura). These structures were however not water proof and were erected under trees or other natural structures to keep dry during the rainy season. Animal skins were also used as an inside lining at times.

Clay and straw was used in a combination with sand to build cob buildings (Frescura). In some regions where timber was available, a timber structure was hidden in

the walls which held up a thatch roof. The walls were not load bearing. In other areas structural timber was scarce and thus the cob mix had to be structural (Laksman). Bricks were made in timber formwork. They were "cemented" into place with more of the clay/sand mixture and plastered with it (Frescura). Straw was used in the bricks and acted as a binding agent. The roofs determined the size and shape of the homes (Frescura). The only way of making waterproof thatch roofs was by making them round. This explains the popularity of the "rondawel" in many areas. It consisted of bundles of grass or wild reeds opened up and sewn onto a timber framework. A wooden needle with tarred twine was used for the sewing (Frescura). The waterproofing of the eaves and apex was dealt with through an integrate grass detail of which there is no record today.

Furniture inside the homes were also sometimes sculpted from clay. A seat or ledge and sometimes little shelves out of the walls. This speaks to the malleability of clay (Frescura).

The Cape Dutch settlers brought knowledge of new ways of building with them and adapted their ways to suite the local materiality and conditions. They introduces a way to build rectangular buildings with thatch roofs that were a lot more space efficient than the "rondawels." A lime plaster and eventually fired clay bricks was an addition to building with clay techniques.

0084

Particularity  
Upliftment Strategy for struggling Agriculture Towns in South Africa

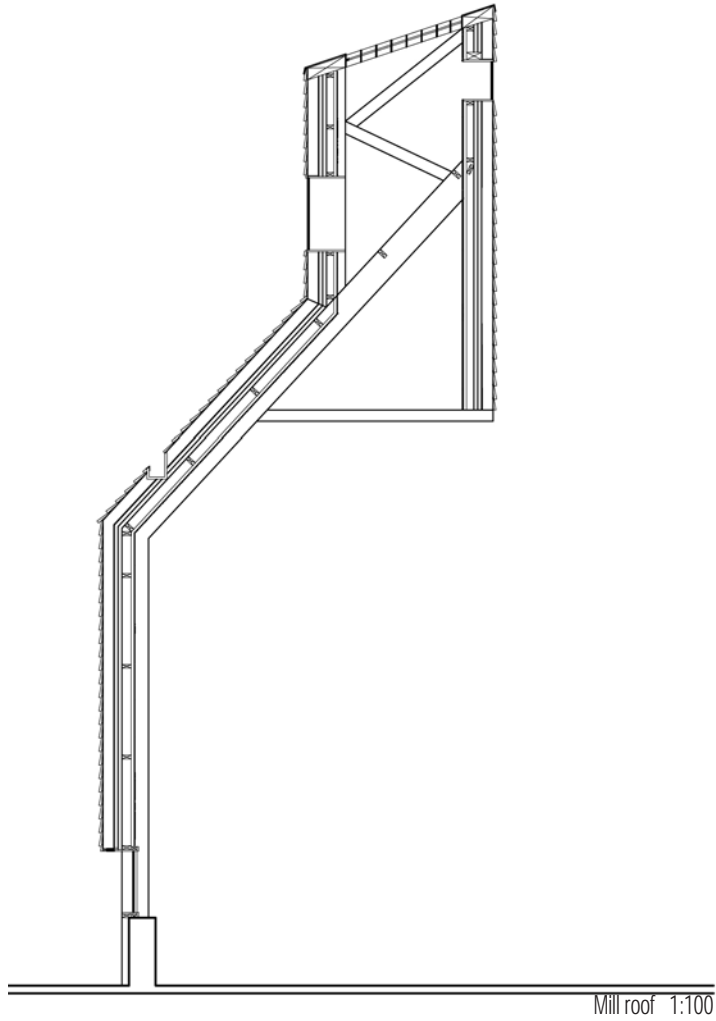

Option 1: Shingle roof covering  
works with original angular roof shape  
requires a lot of structure  
not a familiar technique in South Africa  
can cover vertical surfaces

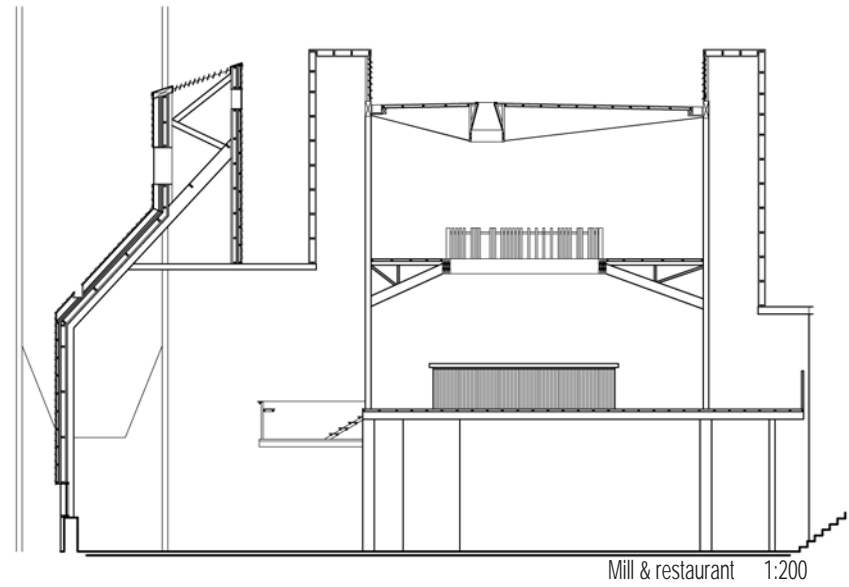

Material choices through design development

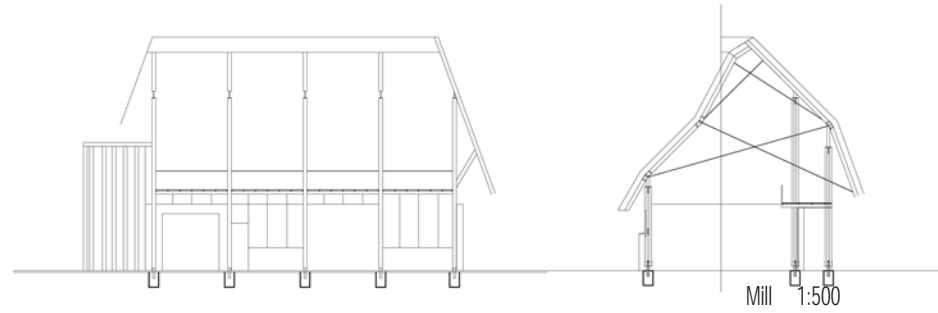

Option 2: Thatch roof covering (the chosen option)  
smoother edge finishing  
cannot cover vertical surfaces  
good thermal insulation  
fire risk needs to be considered

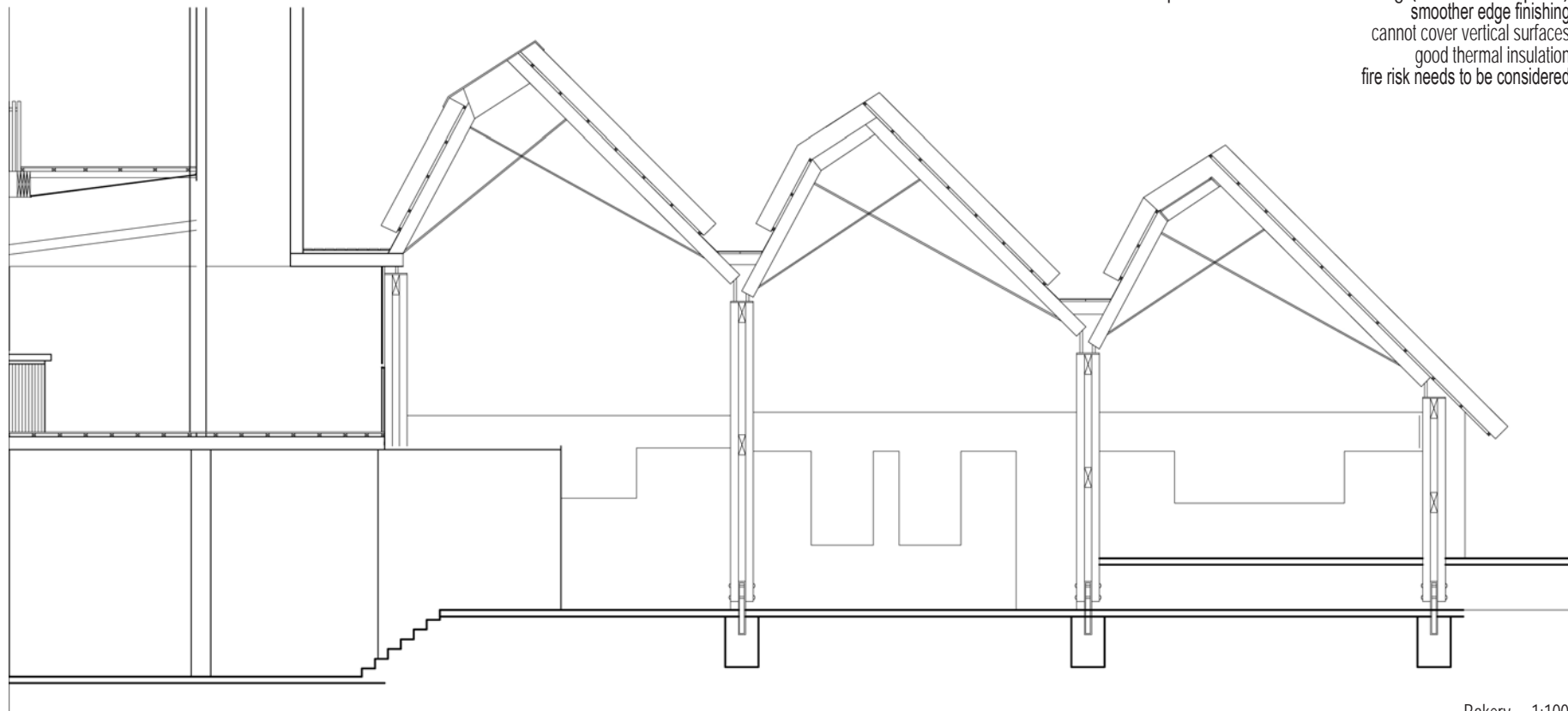

Bakery 1:100

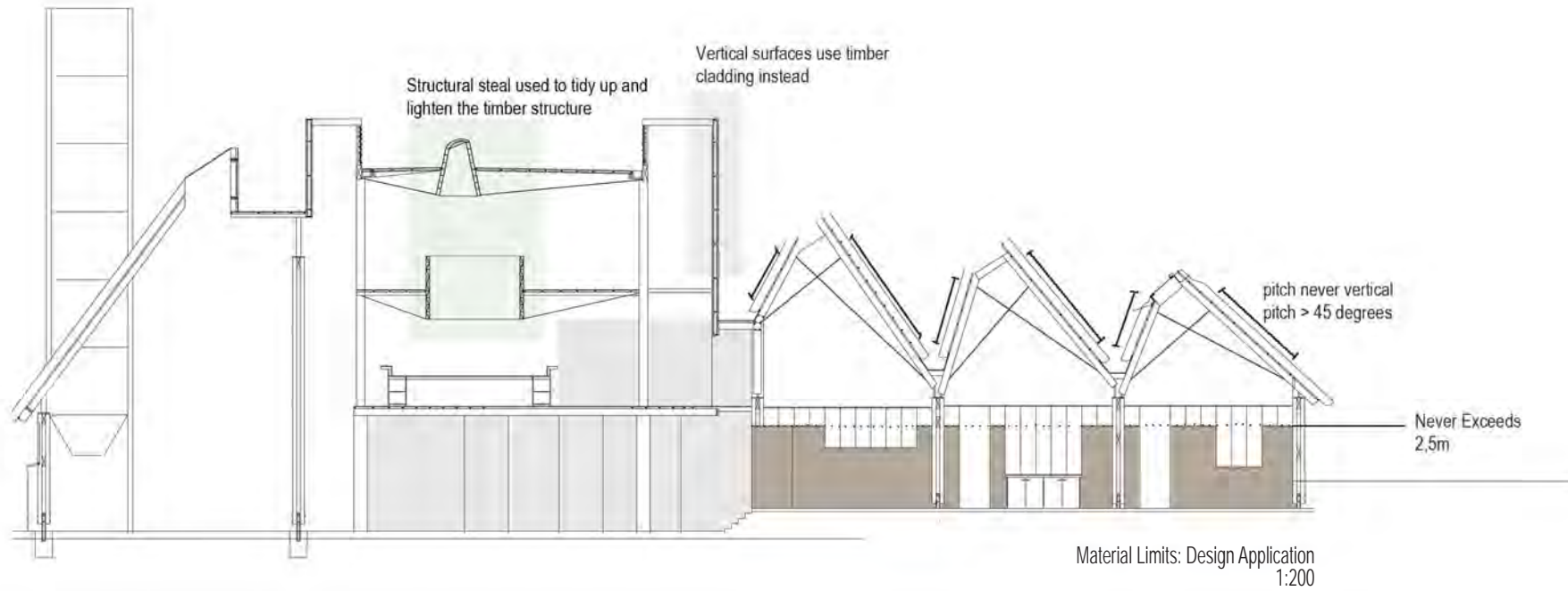

#### Step 4: Knowing the limitations of the materials

This is a summary of all the applicable information in appendix D(technical specification tables of materials). There are certain limitations to every material that needs to be taken into account. Knowing and understanding the limitations in advance can often assist the design process from the start by driving the design around it versus trying to solve the problems caused by limitations at the end. Looking at the walls, cob bricks needs a binding material else your bricks will not have the required strength(Upcyle 2009). Straw serves as a decent binder but must be avoided in termite rich areas. Else the termites will essentially "steel" you re-enforcement. An alternative, used by Francis Kere, is the correct mixture of sand into the clay with a tiny amount of modern cement(Kere, 2014). Cob bricks can support itself up to two storeys. Thus buildings that require more floors can look at building lightweight floors on top of the first two storeys(Upcyle 2009). The figures on the left show Heringer's DESI training centre demonstrates this. A bamboo floor was added ontop of the cob wall base. The lightweight addition is usually self supporting and does not rely on the cob walls. Alternatively load bearing floors made from a different structural material that can support the weight of cob walls need to be constructed. This way the walls in-between floors will be seperated, never exceeding one floor worth of enclosure ast a time(Anderson).

The wall thickness of a clay wall is more than that of a standard brick wall and is something to take into consideration when designing. Aesthetically it is important to remember that any form of clay building needs to be able to breathe and cannot be covered in any finish. There are however specified dyes and paints available. During construction, the clay bricks also need to be kept dry until they have been plastered and dried out. Thus building

out of the rainy season would be advised(Kere, 2014). Alternatively organizing waterproof covering while building would be necessary.

If you are building only out of natural local materials, the roof construction can be tricky. The traditional roofing material is thatch(Frescura). Thatch is quite malleable and can result in new, interesting forms but sharp corners need to be avoided to ensure better thatch work. Thatch roofs also need to be high in order to achieve the correct pitch to drain water properly. The downside to thatch is the regular maintenance it requires and that fire will destroy it in minutes. Thus alternative materials should be used or strict fire precautions should be taken where a building's program is susceptible to being a fire hazard.

Another way of making roofs in other areas was to make it out of cob. They were reinforced by thin stick rods which span wall to wall. Thus, area dependent, walls couldn't be further apart than what the rods could span(Frescura). These roofs did, however, require seasonal maintenance. Cob roofs are generally flat but not load bearing. Timber spans in general is a space planning factor if it is to be used as a main structure. Span tables are available from manufacturers.

Glass bottles by itself cannot be used as a structural material but can form part of structural walls if it is combined with a strong structural material like cement. The bottle's shape itself is also not the optimum shape for building with or stacking but can be overcome by stacking the bottles neck to back on top of each other. Alternatively it can be recycled to make new glass sheets which can be used for windows. The environmental impact of the recycling process must however be accounted for and

compared to the new production of glass. Coloured glass pieces are also a form of adding colour to cement as a purely decorative element. Lastly the concept of up cycling can also be applied to make furniture pieces or features inside the building.

In order to demonstrate the application of the material limits to the design process, please see figures on the left page.



Figure : Francis Kere's Library Roof being prepared for setting [Available at: <https://www.google.co.za/search?q=francis+kere+library+clay+roof>]



Figure : Local potters bringing their work to site to help set the roof [Available at: <https://www.google.co.za/search?q=francis+kere+library+clay+roof>]



Internal view - End result of Francis Kere's library [Available at: <https://www.google.co.za/search?q=francis+kere+making+clay+library>]

## STEP 5: Beyond the Conventional - International Model Diffusion

Sessions said that creativity is often fostered in the midst of sparse resources or time (Sessions, 2008). This last section of the framework is to explore out of the box ideas in order to open your mind to the extraordinary possibilities offered by filtering a world of knowledge through a locality lens with material restrictions. The process of researching global knowledge and techniques and diffusing it into a local context. The aim is not to take away from the local particularity but to enhance catering for a specific society's needs. This could be the difference between just another replica of vernacular architecture or just another Cape Dutch building and a new particular architecture that really speaks of relevance today. An example of this is Francis Kere's exceptionally creative and architecturally beautiful way to let light into his library in Burkina Faso (Kere, 2014). He used the local pottery tradition and asked the ladies to make pots and then used the pots as formwork while casting the roof. The pots created light -holes (or skylights) in the roof. A little bit of steel reinforcement was needed for the roof (Kere, 2014). This way he combined local materials and techniques with international knowledge to create something new and beautiful.

In my dissertation, technological advancement (the global) has been incorporated with the local in order to create a new form, relevant and modern, yet particular aesthetics and new spatial experiences in the following ways:

Although a timber structure is used, I have moved away from the round pole structure and "wooden cabin" image and used rectangular pieces. This way composite and laminate timber can be used giving longer spans. This also means that enormous trees are not needed to achieve efficient spans.

Connections to the floor have been done in steel to prevent the structure from getting moisture from the ground and thus rotting. It also gives a floating appearance to keep the structure visually light. In order to make the tree like rafter and beam connections less chunky and easier to erect, steel plate connections have also been used. For the importance of experiencing large, open roof volumes, not blocking out the light entering from the skylight and not to hamper visibility for visitors looking down on the production spaces, thin steel rods have been used for the centre bracing of the trusses.

A steel frame skylight also serves as a structural piece to form the top of the truss and give the roof its structural ability without having to connect the timber pieces coming up from both sides. This way the break in the roof where the skylight is, is continuous and the roof structure appears to disappear into the sky on both ends.

The roofing over the mill has also been replaced by a Rhine zinc roof. Rhine zinc can continue the form of the thatch roof but will perform better in the event of a fire. Since a flour mill has fire hazards, the Rhine Zinc as well as fire sprinklers is considered a necessary precaution.

### Structural development exploration using international materials and knowledge in combination with local

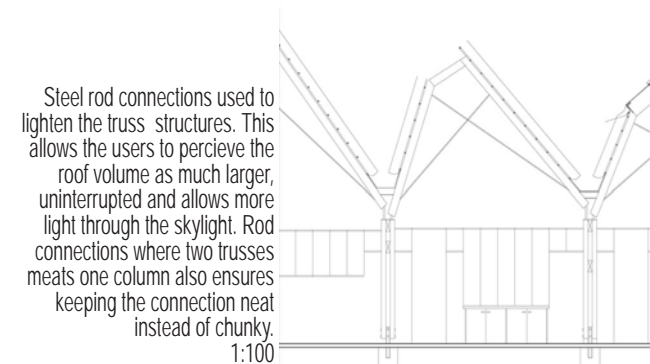
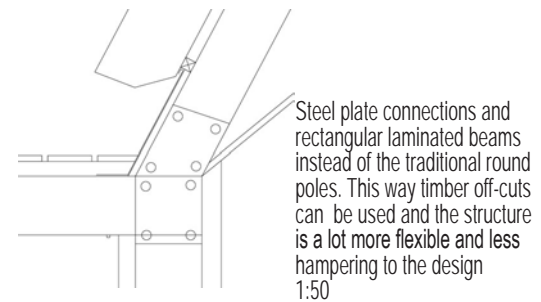
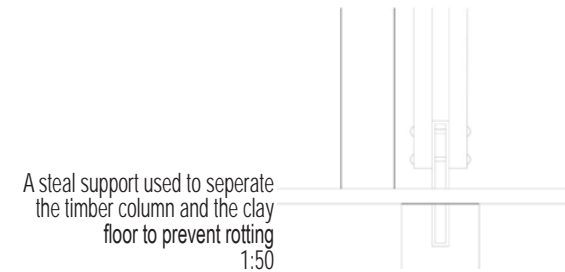

South Approach

Facade from the street

Restaurant

Plan indicating where views are taken from

# Final Visitor Experience: A Walk Through

A walk through of the building showing the full spatial experience of the visitor. Conceptual drawings of a variety of strategic views along the journey of the building have been made. These will be technically refined during the design development.

Mill Experience

Bakery Experience

Fruite and Vegetable Handling Experience

Connecting view to next point of height

North Approach

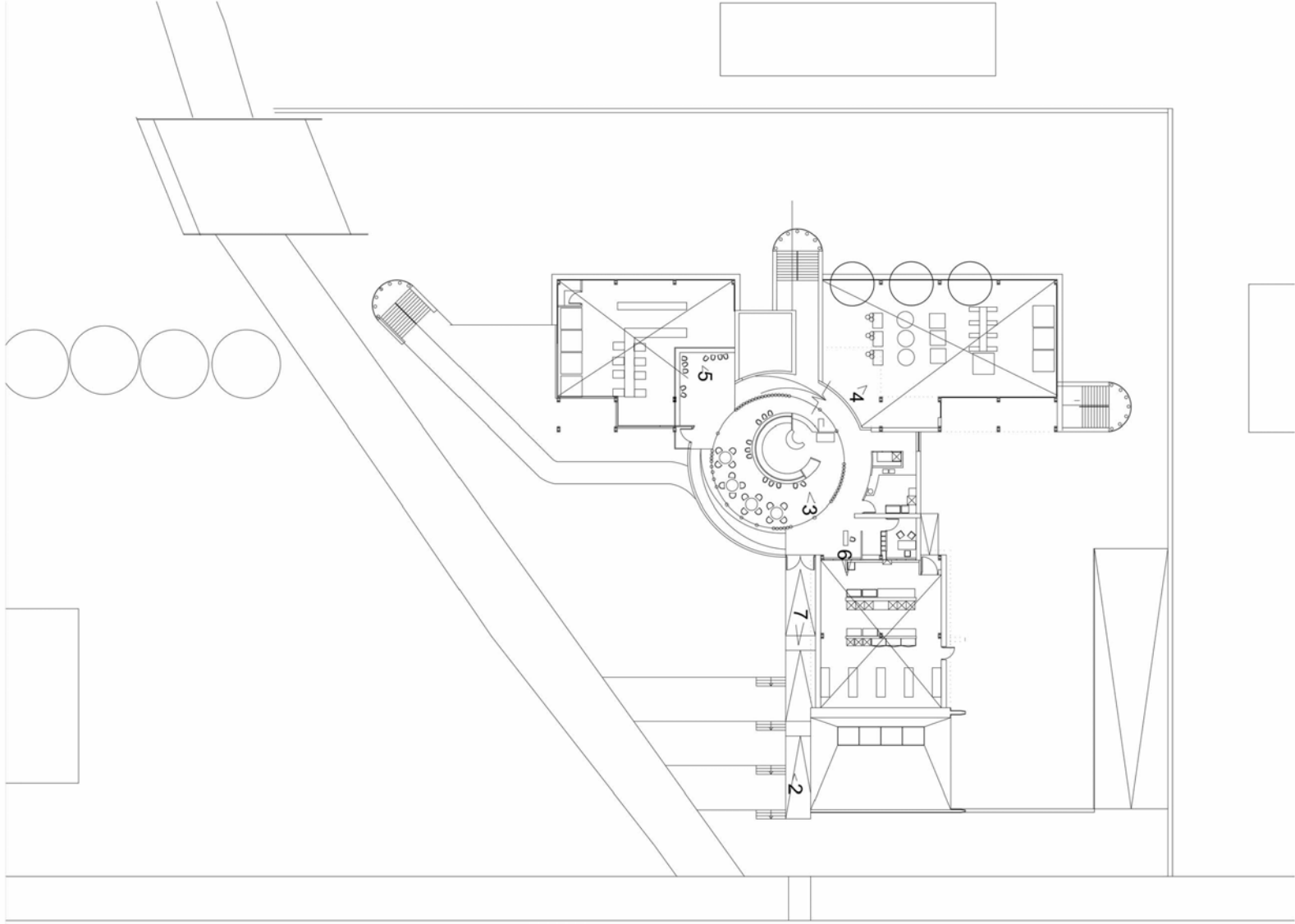

Firts Floor Plan  
1:500  
N

# Working Drawings

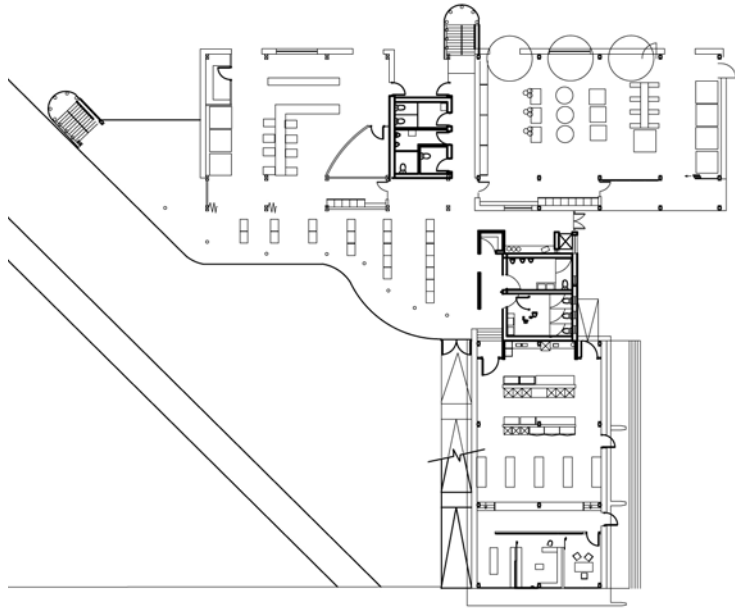

Ground Floor Plan 1:500

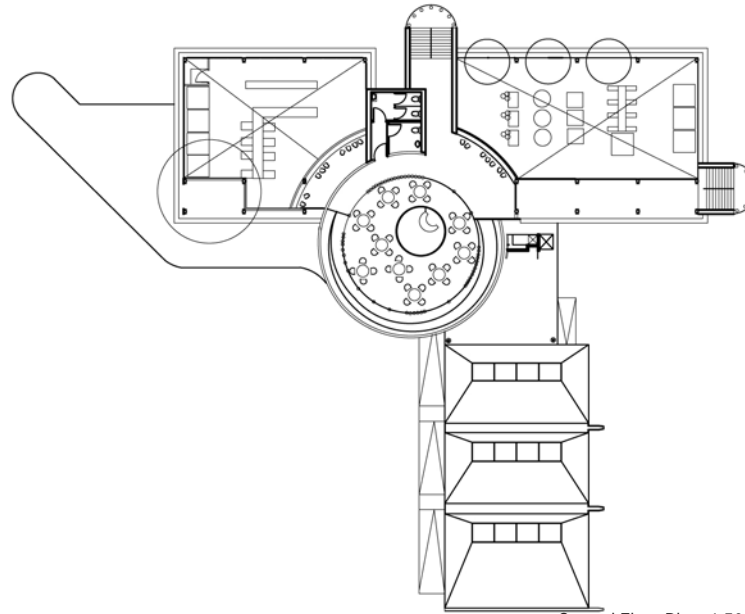

Ground Floor Plan 1:500

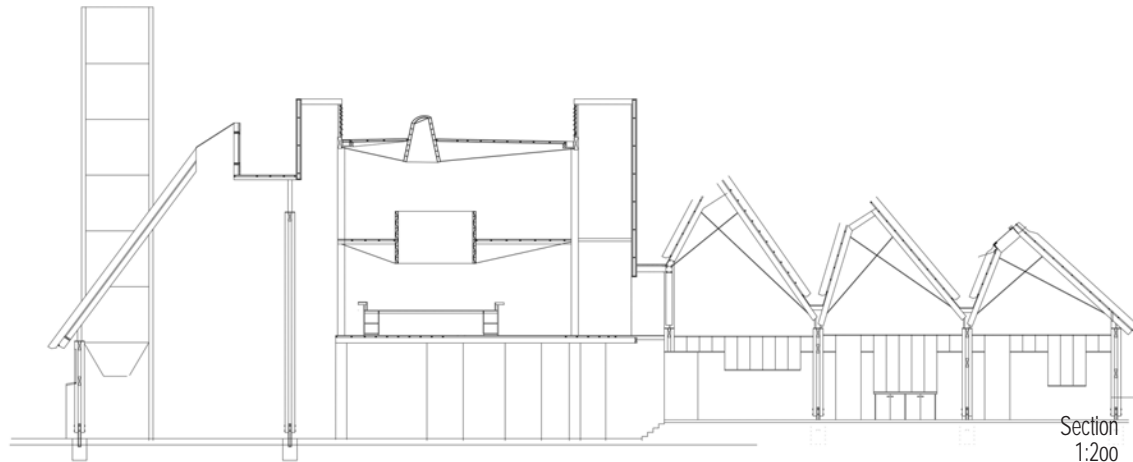

Section  
1:200

Intervention  
Opportunities

Vernacular and Global Precedent Combined

Local Kit of Parts

Siting / Placement / Program

Particularity Close Up

Particular Context

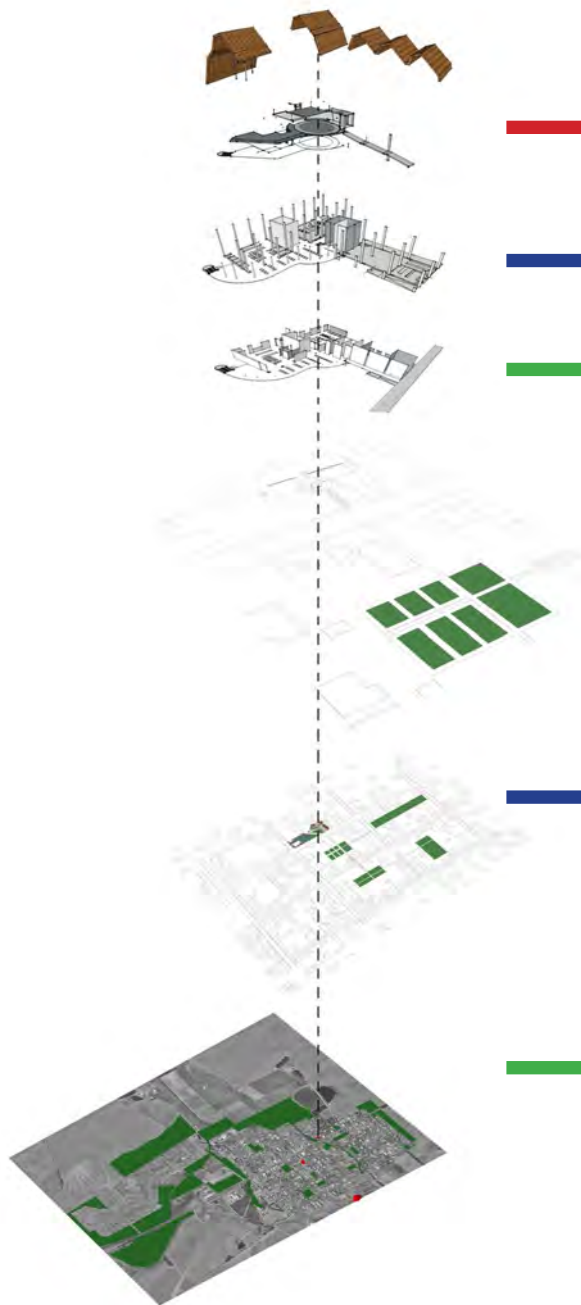

**Providing experience through Circulation**

Using circulation as a tool to bring the visitor up close to the farming, packaging and processing

**Structuring & Organization**

Grids, intersections, points of height

**Topography**

**Providing experience through Circulation**

Using circulation as a tool to bring the visitor up close to the farming, packaging and processing

**Structuring & Organization**

grids, intersections, points of height

**Topography**

## Scheme Summery

Concluding Thoughts: Relevance of this research and practical exploration

### The Urban:

Through this theoretical and practical research, a methodology that can be repeated in the upliftment process of other agriculture towns in the Western Cape Province is established. This methodology advocates that the solution has to be site (town) specific in order to create an own identity and economy, using local resources and precedent to solve local problems locally. This is achieved by means of an urban scheme that provides spatial connectivity through design and that utilizes the connected space through an economic scheme. Together the spatial and economic strategies promotes social connection within the community, by providing an economic drawing point as well as an image (through the spatial design) that installs civic pride.

### The Architecture: Particularity

The framework is an aid to make architecture the interface between people (the primitive) and modern science so that the interface can be new innovative design. It is offered to the architect profession as a pragmatic approach to overcome the challenges of building with local materials and ensure that good design principles are not compromised due to the unfamiliarity thereof. The interface between things is often where the most interesting happenings occur and will hopefully result in a particular architecture outcome establishing or re-enforcing the town's identity rather than just becoming another replica of a past culture.



## Bibliography

Anon 1. Farming Subsidies, Green Farming : International Journal of Applied Agricultural and Horticultural Sciences. Vol 5, No1 Jan-Feb 2014

Anon 2, (2015). [online] Available at: [http://www.incrediblethings.com/wp-content/uploads/resized/69cad395eed0e3611761cd56563d1981\\_1\\_c\\_595x0.jpg](http://www.incrediblethings.com/wp-content/uploads/resized/69cad395eed0e3611761cd56563d1981_1_c_595x0.jpg) (seat) [Accessed 28 Apr. 2015].

Babb, S., Held, D. and McGrew, A. (2003). Globalization/Anti-Globalization. Contemporary Sociology, 32(5), p.613.

Bandy, J. & Smith, J. 2005. Coalitions across borders: Transnational protest & the neoliberal order. Bowman & Littlefield: Boulder, CO.

Benyon, J. Dunkerleu, D. (eds.) 2000 Globalization: The reader. Routledge, New York.

Cato, M.S. (2008) Green Economics: An introduction to Theory, Policy and Practice. 1st Ed. Earthscan Ltd. pp 1-50

Cilliers, Paul. 1998. Complexity & Postmodernism. Routledge: New York. (Ch 7) pp.112-140

Cooke, J., (2014) Materials. Architecture SA, 68, pp.1-2

Decomagz.com, (2015). [online] Available at: <http://decomagz.com/wp-content/uploads/2013/11/Recycled-Home-Decor-Ideas-07.jpg> [Accessed 28 Apr. 2015].

Desner, S. (2008) The principals of sustainability. 2nd Rev Ed. Earthscan Ltd, pp 34-35 (chapter 3)

Diamond, J. (1998). Guns, germs, and steel. New York: W.W. Norton & Co.

du Bois, F.G., 2006, Land van die Disa, Personal Project for Porterville citizens (unpublished)

Goodman, D. (1995). Reviews : Zygmunt Bauman, Intimations of Postmodernity (Routledge, 1992); Steven

Hall, R & Cousins, B (2015) MOSAIC Research, Commercial farming and agribusiness in South Africa and their changing roles in Africa's, [online] Available at: [http://www.plaas.org.za/sites/default/files/publications-pdf/CMCP\\_D7\\_Hall\\_and\\_Cousins.pdf](http://www.plaas.org.za/sites/default/files/publications-pdf/CMCP_D7_Hall_and_Cousins.pdf) [Accessed in June 2015]

Holmgren, D. (2015). Permaculture Design Principles. [online] Permaculture Principles. Available at: <http://permacultureprinciples.com/principles/> [Accessed 28 Apr. 2015]. 26. Green Building Council Of South Africa. (2008) Technical Manual Green Star Sa, Office version 1.

Investopedia, (2003). Economics Definition | Investopedia. [online] Available at: <http://www.investopedia.com/terms/e/economics.asp> [Accessed 28 Apr. 2015].

JCT, 2011. The Joint Contracts Tribunal, Setting the Standard for construction contractors: Procurement process Available from: <http://www.jctltd.co.uk/procurement.aspx> [14 March 2014]

Louw, L., (2014) "Slow" architecture and its links with slow food. South African Journal of Art History, 29(2), pp.152-172

Madisonandcathedral.com, (2015). [online] Available at: [http://www.madisonandcathedral.com/wp-content/uploads/2012/03/Gary-Harvey-R-Main\\_1701871a.jpg](http://www.madisonandcathedral.com/wp-content/uploads/2012/03/Gary-Harvey-R-Main_1701871a.jpg) [Accessed 28 Apr. 2015].

Moore, S.A. (2010) Programatic Sustainability. 1st ed. Routledge. Chapter 9, Regionalism, Place, Specificity and Sustainable Design (Vincent B. Canizaro). pp.149-168.

Morin, E. (1992). From the concept of system to the paradigm of complexity. Journal of Social and Evolutionary Systems, 15(4), pp.371-385.

Nicolescu, Basarab. 2002. Manifesto of Transdisciplinary. State University of New York Press: New York. ch6

Pakulski and Malcolm Waters, Postmodernization: Change in Advanced Society (Sage Publications, 1992); Gianni

Rwelamila, PD & Talukhaba, AA & Ngowi, A Feb 2000, Sustainable Development: Project procurement systems in the attainment of sustainable construction. Volume 8. Issue 1. John Wiley & Sons, Ltd. pg 39-50

SA explorer, (2015) Porterville Climate, [online] Available at: [http://www.saexplorer.co.za/south-africa/climate/porterville\\_climate.asp](http://www.saexplorer.co.za/south-africa/climate/porterville_climate.asp) [Accessed in May 2015]

Seidman and David G. Wagner (eds), Postmodernism and Social Theory (Blackwell, 1992); Stephen Crook, Jan Sessions.edu, (2008). How Limitations Influence Creativity | Notes On Design. [online] Available at: <http://www.sessions.edu/notes-on-design/how-limitations-influence-creativity> [Accessed 28 Apr. 2015].

Shumen, M.H. (1998) Going local: creating self-reliant communities in a global age. Choice Reviews Online, 35(10), pp.35-5777-35-5777.

Snow, B. (2015). How Limitations Feed Creativity | Fuel Your Photography. [online] Fuelyourphotography.com. Available at: <http://www.fuelyourphotography.com/how-limitations-feed-creativity/> [Accessed 28 Apr. 2015].

Swartland, (2005) Swartland region economic profile, [online] Available at: <http://www.swartland.org.za/web-images/swartland/file/IDP/swartlandregioneconomicprofile.pdf> [Accessed in April 2015]

The longtail.com, (2015). [online] Available at: <http://www.thelongtail.com/conceptual.jpg> [Accessed 28 Apr. 2015]. 24. <http://www.investopedia.com/terms/l/long-tail.asp>

Tschumi, B. (1994) Architecture and Disjunction, The MIT Press, Cambridge  
 Vaitimo, The End of Modernity--Nihilism and Hermeneutics in Post-modern Culture (Polity Press, 1988). Thesis Eleven, 40(1), pp.138-146.



# Appendix A

Practical Framing of Architectural Interests - week one design work



Space Intervention



Effect on a Force Field



Moving through Space



Effect on a Force Field



Radius Research



Open Space System



Greenbelt/Urban Farming



Land use

This collection of artifacts explored the effect of strategically placing objects in space with the aim to order it in a new way that will influence people's behaviours in a possible way. Artifact one, two and four dealt with the physical change in space when objects are placed or shifted within it. Artifact three dealt with the experiential qualities rearranging space can have. These spatial ideas were explored in the form of mapping Porterville's spatial system and exploring spatial opportunities through design. Artifact five was a general investigation into the local materials available in and around Porterville. This speaks of a general interest in a more localized approach to architecture.



Figure 2.2: Mapungubwe Centre Interior - Using cob bricks and eucalyptus stalks to build the main shell [Available at: <http://www.architectureindevelopment.org>]



Figure 2.5: DESI centre Screen - The intricate bamboo screen inspired by local techniques but reinforced to use at large scale [Available at: [http://www.google.co.za/Heringer/DESI Trainingcenter](http://www.google.co.za/Heringer/DESI%20Trainingcenter)]



Figure 2.4: DESI centre Elevation - The building's ground floor is constructed mainly from clay with a lighter second floor made from bamboo. (Heringer, 2015) [Available at: [http://www.google.co.za/Heringer/DESI Trainingcenter](http://www.google.co.za/Heringer/DESI%20Trainingcenter)]



Figure 2.6: Local people building DESI centre [Available at: <http://archrecord.construction.com/features/humanitarianDesign/images/0810heringer2.jpg>]



Figure 2.3: Mapungubwe Centre Exterior - Using natural stone from the surrounding hills [Available at: <http://www.architectureindevelopment.org>]



Figure 2.7: Local people building Mapungubwe [Available at: <http://www.directoryofdesign.co.za/pics/news/world-build-1.jpg>]

## Appendix B

### Complete precedent studies of the application of locality theories

**The following precedent studies were done in order to investigate the concept of a Particular architecture in full.**

#### Application of Locality Theories

Mapungubwe followed the Green Economics approach of being locally reliant for the necessities but importing some luxuries. The main shell of the building was built from local materials. (Fagan, 2010) (figure 2.2 & 2.3) Some smaller/more specialized aspects like iron grilles for the baboons had to come from off site. (Fagan, 2010)

The DISA building followed a more absolute locality approach as suggested by permaculture. Only local, natural materials were used. (Heringer, 2015) (fig 2.4) Local solutions were found for materials that are usually imported. An example would be the sophisticated screens that developed from bamboo and local weaving techniques. (Heringer, 2015) (fig 2.5)

Both Architects had people at the center of the design process which also resulted in an environmentally sustainable approach since environmental sustainability is synonymous with good environments for people.

Time was spent to interact with people to realize their needs and preferences, as suggested by both sustainable theories, and thus investing in the social economy. (Fagan, 2010 & Heringer, 2015) The projects also focused on the local economy by training unskilled labour on site so that the locals gain more than just temporary employment. The challenge of the procurement process and unfamiliarity of materials was overcome by doing intense research, trial and error investigations and seeking for both local and international knowledge. (Fagan, 2010 &

Heringer, 2015) The DESI centre also applies the "Fair Share" principle, not from a material resource perspective, but by advocating good design and good architecture for all people without discrimination. (Heringer, 2015) Through the application of sustainable theory principles to particular projects with their particular context, the principles resulted in a more sustainable architecture.

#### Historical Roots: Vernacular and Cultural Influences

Vernacular architecture of the Venda people were the main influence for Mapungubwe. (Fagan, 2010) Rich's approach to using vernacular architecture associates with Curtis's authentic regionalism since Rich took a principled rather than direct approach. The shape of Mapungubwe was inspired by the Venda rondavel homes (fig 3.1) but reinterpreted to use at a much bigger scale appropriate to the modern function. (Fagan, 2010) (fig 3.2) It retained the round form in plan but found new ways of linking spaces and roof covering. The material selection was based on the principle of only using natural materials, but the selection was not exactly the same as the vernacular Venda selection. (Fagan, 2010) The archaeological influence from the findings of the merchants of Persia, India, Malaysia and China on the site influenced the choice of synthesis of 3 timber vaults as roofing, originating in the Mediterranean region 600 years ago. (Fagan, 2010) (Fig 3.3)

The connecting vault structure represents a system of caves which has vernacular and cultural significance. (Fagan, 2010) It refers to the original hunter gatherers who used caves for accommodation but also for spiritual activities like "rain making ceremonies". Giving Mapun-

gubwe a 'cave significance' which symbolise an important space in history, speaks to the value or importance attached to heritage. (Fagan, 2010) It is so important that it deserved its own 'cave' thus special place. (Fig 3.4 & 3.5)

The arrangement of buildings around an axis that connects important spaces on site with smaller 'back court yards' is a direct influence from the Venda homestead arrangements. (Fagan, 2010) (fig 3.6) This works well to connect the excavation site with the heritage centre. The 'court yard' spaces contribute to the embedded into the site experience. (Fig 3.7)

Lastly the shaded terraces made with horizontal slats creates a similar space to the Kgotla (traditional African gathering space). (Fagan, 2010) Once again understanding the purpose behind the Kgotla and not just cloning it for the sake of cultural reference. (Fig 3.8 & 3.9)

The material use of the DESI centre resonates more with Tzonis and Lefaivre's theories. The materials are selected and used in accordance with the materials and techniques used to build the vernacular Bangladeshi homesteads. (Heringer, 2015) Clay bricks were used for the ground floor. A second light weight bamboo floor was added above. (Heringer, 2015) (fig 3.10)

When it comes to the structuring of program and spaces, a contemporary approach to the current life styles of the locals were taken. The accommodation sections have been re-structured from revolving around architecture to a mixed-use contemporary yet rurally and culturally relevant structure. (Heringer, 2015) Thus senseless copying of old arrangements with only nostalgic purpose is avoided.



Figure 3.1: Venda Rondawel (Vernacular Venda housing) [Available at: [http://holyangelpalaceresort.co.za/data/images/four\\_rondavel\\_accommodation.jpg](http://holyangelpalaceresort.co.za/data/images/four_rondavel_accommodation.jpg)]



Figure 3.3: Ancient Vault in Mediterranean region [Available at: <https://www.google.co.za/search?q=mediterranean+ancient+vaults>]



Figure 3.4: Interior view of vault [Available at: [https://www.google.co.za/search?q=mapungubwe&rlz=1T4GGIE\\_enZA475ZA475&source=inms&tbm](https://www.google.co.za/search?q=mapungubwe&rlz=1T4GGIE_enZA475ZA475&source=inms&tbm)]



Figure 3.5: Cave like connections of vaults in elevation and section [Available at: [https://www.google.co.za/search?q=mapungubwe&rlz=1T4GGIE\\_enZA475ZA475&source=inms&tbm](https://www.google.co.za/search?q=mapungubwe&rlz=1T4GGIE_enZA475ZA475&source=inms&tbm)]



Fig 3.6: Three rondawels in a triangle to form a "private family courtyard" which is linked to a community gathering space on the other side [Available at: <http://www.timhaufphotography.com/South-Africa/Transkei/i-6SDCsqD/0/XL/5S7W2095-XL.jpg>]

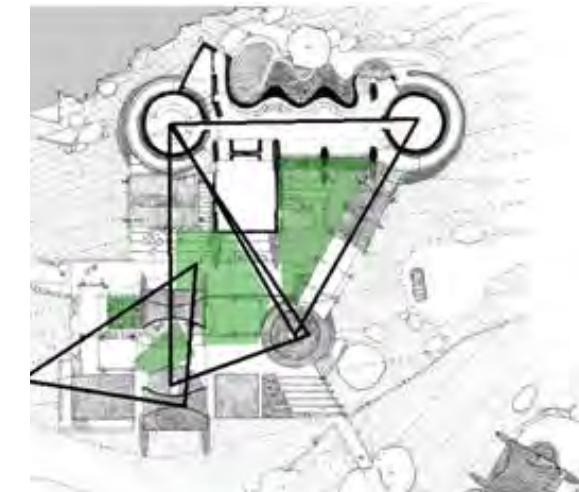

Fig 3.7: Courtyard spaces between buildings arranged in traditional triangle layout. [Photoshop edit of drawing available at: [http://www.e-architect.co.uk/images/jpgs/south\\_africa/mapungubwe-interpretation-centre-a010513-p1.jpg](http://www.e-architect.co.uk/images/jpgs/south_africa/mapungubwe-interpretation-centre-a010513-p1.jpg)]

## Physical Context

In terms of the physical context, Mapungubwe is really rooted in the landscape because the linked vaults read as part of the stone ledges and surrounding stony hill-ocks. (Fagan,2010) (Fig 3.11)

Furthermore the building is arranged around an axis that links the building's entrance with the archeological excavation. This axis also runs parallel with the hilltop ridge and rivulet. (Fagan,2010) Resultantly the buildings merge gradually into the slopes on the Sothern end. (Fagan,2010) Indigenous species of surrounding felt is planted between the structures which ties the building into the landscape, and creates the effect of large boulders sitting in a field,(Fagan,2010) (fig 3.11) hence altering not the character of this area but enhancing it along with the cultural identity. The natural landscape, archaeological discoveries and historic cultures are all emphasized. The DESI building on the other hand is not situated in as much of a natural landscape but rather the rural village Rudrapur in Bangladesh. (Heringer,2015) The context is one of small clay buildings with thatch roofs that sit on timber or bamboo structure. Thus the character of the DESI centre is right in line with the existing context of the town.(fig 3.12) It is grounded in the familiarity and associated character of the town since it is made from the same materials and used a similar building style. (Heringer,2015) Yet it is rooted in the modern way of living through spatial shifts.

## Social Context

Both precedent studies of particular architecture has a strong social component. (Heringer,2015 & Fagan,2010)

Without the social leg of sustainability, the environmental and economic legs will fail. (Desner,2008) These two projects ensured building according to their respective communities' needs and encouraged them to take ownership of the projects. (Heringer,2015 & Fagan,2010) Relationships were built by listening to, learning from and getting the community physically involved in the construction process. (Heringer,2015 & Fagan,2010) If the community can bring their own culture and skills to the process, the recognition thereof in the project will create a sense of pride, identity and belonging as advocated by Critical Regionalism. (Frampton,1992) This will also build ties and a strong sense of belonging within the community. A specific example is the bamboo work in the DESI project which was used of the local crafting skills as a basis to build a large bamboo screens, (Heringer,2015) revealing the opportunity to the community to use their local skills beyond the traditional borders. Both projects made use of simple construction techniques so that unskilled labour could be employed and trained on site. (Heringer,2015 & Fagan,2010) This gave them a temporary income and a set of skills to use in the future and provide a future income. The hope is that these skills will be used to build and uplift living standards and sustainable architecture within the region. (Heringer,2015) They also made use of local businesses and traders to ensure involving the entire community in a "mutual process of exchange," as expressed by Base Habitat, and build community ties by giving them a common goal.(Basehabitat) Giving them a sense and experience of space.

Both Mapungubwe and the DESI centre use natural resources like light and ventilation, the textures of natural materials together with a creative design of spaces and circulation to create a full body experience for the user. (Heringer,2015 & Fagan,2010) Frampton talks about enticing all the senses with architecture to get a full expe-

rience of place. (Frampton,1992) The particularity of that experience will be associated strongly with the place and its specific sense.

Rich achieves unconventional yet exceptional exhibition spaces by playing with a variety of structures, change of directions and orientations. (Fagan,2010) The composition of light and space serves as the connector between site, history and architecture. The spaces varies from large volumes in the vaulted restaurant space made from heavy textured materials to lightly covered, transparent walkways and darkened, curving narrow passages. (Fagan, 2010) The variety of spaces are pulled together by outside courtyards providing another layer of experience in terms of a textured landscape. (Fagan, 2010) The arrangement also visually links all the important moments in history on the site creating a sense of being connected. (Fagan, 2010) (fig 3.13)

Punctures in the form of sunlight through an oculus accentuated areas in the exhibition by creating a dramatic light effect. (fig 3.14) The vaults also have areas cut out to allow a softer "half-light" into the exhibition areas. (Fagan, 2010) A coloured light comes in through glass panels and falls on some of the artifact highlights. (Fagan, 2010) The light is used to generate appropriate emotion in every space.(fig 3.15)

The DESI Centre's program lends itself out less to a series of experiential settings since it is not an exhibition space aimed at proving an experience. Yet in its own simple way of using light, form and textures have a surprising sensual effect. The bamboo screens filter the light so that a softer, more ambient light exists in the circulation spaces. (Heringer,2015)(fig 3.16) Yet it still allows the cool breeze to blow through it. Thus a calm and comfortable setting is created. The heavy clay walls are used as an outer shell on ground floor and speak of a



Fig 3.8: Kgotla - shady meeting space under a tree [Available at: <http://www.dailynews.gov.bw/kgotla>]



Fig 3.9: shaded terraces made with horizontal slats [Available at: <https://www.google.co.za/search?q=mapungubwe>]



Fig 3.10: DESI centre under construction - Clay bricks for ground floor and bamboo for the first floor



Fig3.11: Mapungubwe Centre embedded in the landscape [Available at: [https://www.google.co.za/search?q=mapungubwe&rlz=1T4GGIE\\_enZA475ZA475&source](https://www.google.co.za/search?q=mapungubwe&rlz=1T4GGIE_enZA475ZA475&source)]



Fig 3.12: Photo of rudrapur, bangladesh [Available at: <https://www.google.co.za/search?q=bangladesh+village>]



Fig 3.13: variety of structures, change of directions and orientations [Available at: <https://www.google.co.za/search?q=mapungubwe>]



Fig 3.14: Oculus [Available at: <https://www.google.co.za/search?q=mapungubwe>]



Fig 3.15: Coloured light [Available at: <https://www.google.co.za/search?q=mapungubwe>]



Fig 3.16: Light filtering through the bamboo screen.

more private and enclosed space. (Heringer,2015)

These guidelines, together with a more urgently sustainable approach (using permaculture and green economics as a framework) with a more restrictive locality will help to realize a particular architecture. The more locally restricted, the more the architect will have to think “critically” about both the local and global in order to ensure a sustainable (socially, environmentally and economically), globally relevant and an identifiable particularity. Both projects indicate a bottom up pragmatic approach to ensure a thorough recording and understanding of the local. Overlaid with global thinking and the voice of the community, a sustainable particular architecture is achieved.



Figure : Burton Street Peace Garden's Learning Pavilion by the Asheville Design Center - Front Elevation

## Appendix C

### Precedent study for setting up the methodology framework

#### Precedent for Process

The Burton Street Peace Garden's Learning Pavilion by the Asheville Design Center was chosen as a simple precedent study of the process followed when bridging locality limits and modern science to achieve sustainable, yet innovative design. By tracing the steps followed to build this quick and small project, a basic guideline was set up as a starting point for a more in-depth framework required by more complex projects. The Learning Pavilion is built within a local (on site) materials only and synthesized with "imported" skills and techniques (Inhabitat, 2014). This project was used to experiment how much can be done with very strict limits within a short time frame and small budget. Resultantly the material radius was confined to site which also implied the use of waste at the lack of other materials. (Inhabitat, 2014) The available materials making up the material pallet was wood, metal, windows and a giant Texaco sign. (Inhabitat, 2014) Next, research into the available material pallet was done. This involved looking at the strengths, joining possibilities, treatments and precedent of the materials. Assessing the weaknesses and limitations as well as environmental response is also important. (Inhabitat, 2014) The south and east sides are made from windows and screens and are more transparent for the purposes of connecting to the garden as well as letting light in. The North and West sides were a lot more private and thus made from more solid pieces like discarded wood. (Inhabitat, 2014) Although the material pallet is rubble, the materiality of each object is still analyzed and used in an appropriate way to create a climatically and functionally appropriate place. Once materials were selected, the design evolved from the materials and not the materials from the design. (Frescura) From the available material pallet, design solutions for a floor, walls and roof was

made. (Inhabitat, 2014) Skills were imported in the form of students from North Carolina State, Appalachian State, and Virginia Tech with architecture, landscape architecture and construction management degrees. (Inhabitat, 2014) The limited resources forced innovative thinking around the design. Research into previous work with wooden pallets were done to serve as precedent. (Inhabitat, 2014) The four facades do not look identical which is a "variety condition" when materials are used that cannot be ordered in specific sizes or quantities. A Texaco sign was used as a type of a sliding door. (Inhabitat, 2014) Thus the creative use of unconventional materials resulted in a make-shift gutter made from an old vinyl sign to harvest rain water off the roof. Workstations are made from old ironing boards and street signs. (Inhabitat, 2014) Overall the building has a real American fast stop feel about it and managed to cleverly solve all the elements of the building with materials within a very tight radius.

Figure : Burton Street Peace Garden's Learning Pavilion by the Asheville Design Center - Front Elevation  
 The Learning Pavilion process thus consisted of six steps. Step one: Determining the radius/selecting materials, Step two: Investigating the vernacular use and techniques of the materials, Step 3: Investigating the modern use and technologies concerning the materials, Step 4: Knowing the limitations of the materials, step 5: taking the blinkers of vernacular research off and searching for creative possibilities and inspiration and step 6: using the knowledge gained through the framework to design innovative sustainable architecture. Step 1-5 of this framework will be applied and tested through a case study in preparation of the practical part of my dissertation where step 6 will be applied.  
 Vernon Collis also has a working philosophy that aims

towards architecture as an interface. His main philosophy is to reduce the impact and resource demand of any built intervention from the construction through to the commission and eventual deconstruction or reuse phase. (Collis, 20011) This will also be kept in mind when fleshing out the framework.

# Earth Construction

The cardinal earth construction principles are:

- sufficient structural stability and strength, obtained through design and reinforcement;
- interplay of the four elements, allowing movement of the natural 'liquid' elements of air and moisture through the built fabric, which if trapped and rendered static within in the hard, dry elements of earth and fibres, cause weakening and damage. Sufficient temperature change, mainly through exposure to the fourth element, warmth, enhances air/moisture movements, inducing curing;
- Longevity;
- Durability and strength are achieved in two ways:
  - appropriate consideration in the design stage;
  - careful detailing, allowing for movement (expansion/contraction), weather protection and waterproofing, integrity of junctions between adjacent elements (sizing components and placement of seams);
- Surface density and stability – in combination with movement a flexibility at the seams;
- Careful execution, allowing neither too much nor too little movement, avoid cracking and flaking, achieved essentially by overcoming stress. Failing to do so results in the entry/infiltration trapping of water. In turn this will cause softening, erosion or delamination. Seams and connections between elements of different densities are the ones requiring the most careful attention:
  - lintel to wall
  - sides(frame) to walls (stepped bonding)
  - window sill to wall
  - floor to wall
  - wall to foundation

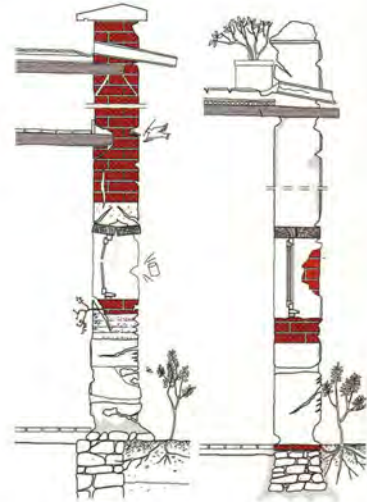

Fig 17 & 18 Vulnerable parts or elements in earthen walls

## 3.1 Structure

Earth construction can be load bearing or non-load bearing. The main challenges are:

- understanding crushing strength and vertical loads; the effect of wall height/weight;
- interpreting the effect of eccentric forces emanating from tensile sources (floor slabs, etc.);
- anticipating eccentric loads which may result from e.g. the pressure of a vault or dome onto walls;
- slenderness ratio, e.g. wall buckling if too thin/high/not tapering towards the top, etc.

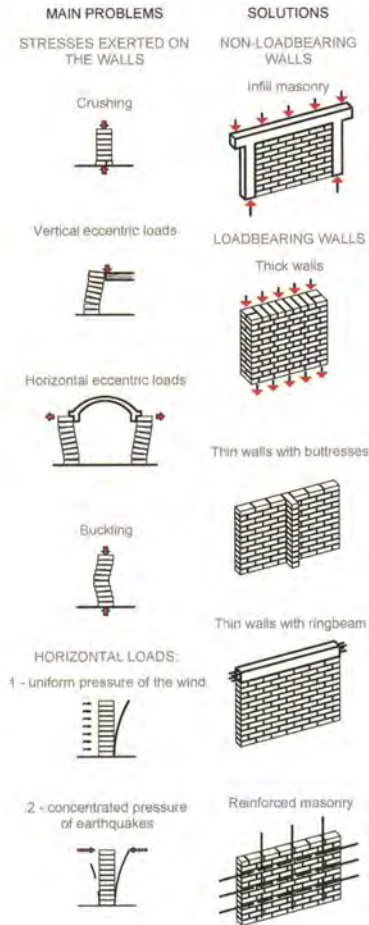

Fig 19 & 20 The five challenges and the solutions

The solutions:

- Use as in-fill; non-load bearing walls set into a tectonic frame in steel, timber or reinforced concrete. This will limit the risk of crushing.
- For load bearing walls:
  - enhance the thickness/taper of the wall
  - improve stability, e.g. by using a buttress and/ or ring beam,
  - add horizontal/vertical reinforcement.

## 3.2 Foundations

The challenges:

- Static surface storm water resulting in moisture infiltration;
- Static groundwater in the proximity of foundations preventing the soil from drying out.

The solutions:

The same basic rules as for other conventional materials and systems apply.

- Observe the main aim, which is to anchor the building in the soil;
- Keep the specific site and soil conditions in mind: slope, run-offs, weather orientation, and drip lines;
- In areas where clay is predominant, anticipate and make provision for more movement in the foundation of the building;
- Use a solid base-course material which is less sensitive to water, spreading weight bearing forces into the ground;
- Good drainage in all cases is cardinal.

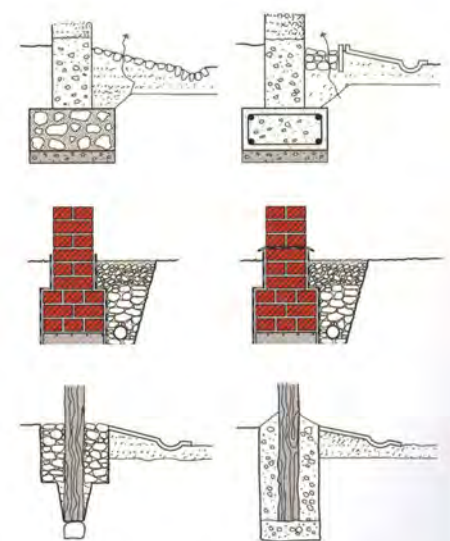
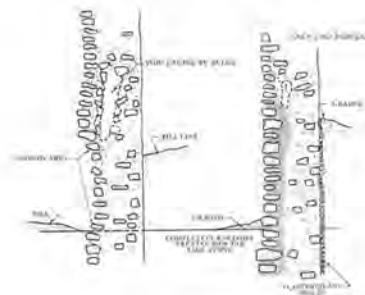
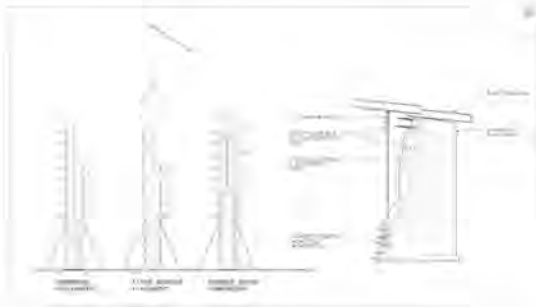
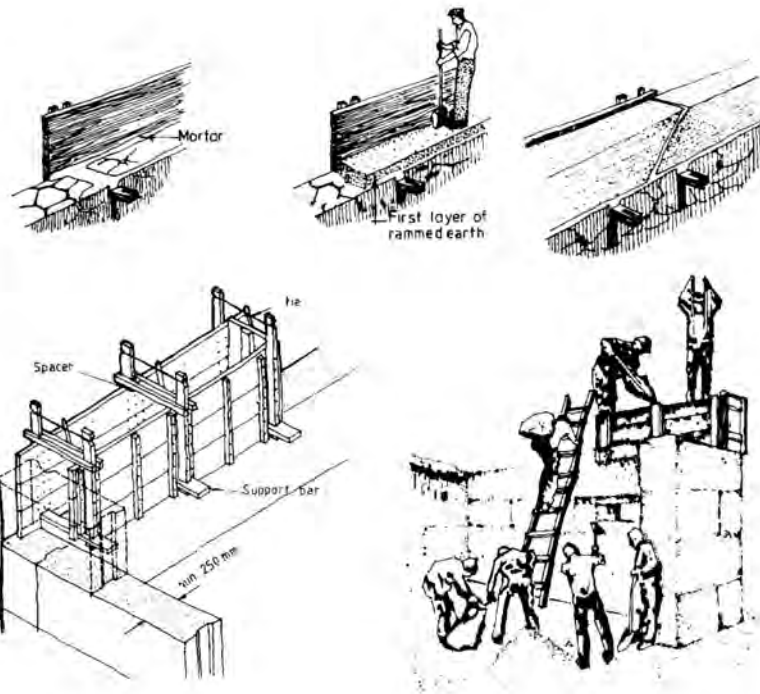
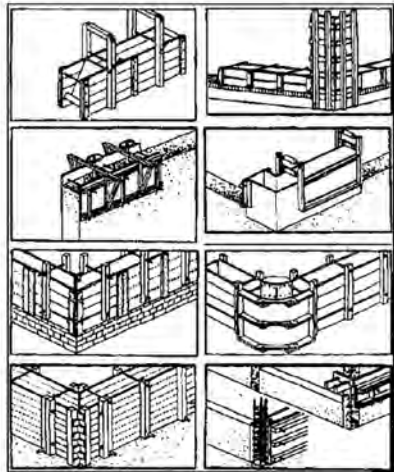

Fig 21, 22 & 23 Good drainage

# Appendix D





Technical data of material limits

## Earth Construction



## Timber Construction

### 5.3 Connections

| Connection   | Application   | Fixing   | Safe working loads   |
|--|---|--|--|
|  <p>Mini truss hangers</p>  | Lightly loaded trusses and timber joists  | 32mm galvanised clout nails and/or 2 x M6 bolts  | 2,2kN fully nailed   |
|  <p>900 Truss hangers</p>   | Designed to support truss-to-girder and girder-to-girder connections in prefabricated timber roof structures as well as truss or girder to concrete or masonry connections, timber joists and rafter supports   | Conventional galvanised clout nails or may be bolted using M12 bolts, structural timber washers or masonry connections   | 4,2kN fully nailed, 5,8kN nailed and bolted using M12 bolts and single sided shear connectors both sides with structural timber washers  |
|  <p>450 Truss hangers</p>  | Designed to provide adequate support for all 450 hip girder, hip truss and jack connections. Manufactured with a unique bottom cord 'fixing spike', which when fully nailed, provides additional restraint to the diagonal tension forces common to this type of application  | Conventional galvanised clout nails or M12 bolts and structural timber washers   | 3kN fully nailed, 4,5kN bolted using M12 bolts and structural timber washers. These values have been devalued to suit site conditions and tolerances   |
|  <p>'U'-type hanger</p>   | 50/80 'U'-type hangers are manufactured to cater for 48mm and 76mm widths of prefabricated timber roof trusses. The high supporting flanges significantly improve resistance to hanger rotation.  | 4 x M12 bolts or fully nailed with 32mm galvanised clout nails.  | 5,3 kN fully nailed and bolted with 4 x M12 bolts and structural timber washers  |
|  <p>Anti-split plates</p> | The anti-split plates for timber boards and poles are designed for easy insertion into end grain of timber. Anti-split plates will provide maximum protection against end splitting of timber. Anti-split plates (punched metal plates) are manufactured in a range of sizes to provide the most cost effective cover area. | Anti-split plates are either hydraulically pressed or hammered into the timber or pole ends. Anti-split plates provide an extremely high resistance to 'pull out'. | Steel Thickness: 1,2mm, Rolling Tolerance: ± 0,09mm<br>Weight used for calculation purpose: 9,7404 kg/m <sup>2</sup> .<br>Area of steel per 25 kg of product used for calculation: 2,5664 m <sup>2</sup> . |

**NOTE: SANS 457 and 1288** require coverage of 35% of cross sectional area on pole ends. All nails to be fully embedded into poles and timber boards and restricted to one plate per end.

Table 1 Common forms of timber

| Product   | Sizes   |                     |                              |    |     |     |
|---|---|---------------------|------------------------------|----|-----|-----|
|   | Lengths 1,8m up to 6,6m with increments of 300 mm or 600 mm                                   |                     |                              |    |     |     |
| Solid timber  | Depth of member, mm   | Width of member, mm |                              |    |     |     |
|   |   | 38                  | 50                           | 76 | 114 | 152 |
| Branding & Battens  | 38  | x                   | x                            |    |     |     |
|   | 50  |                     |                              | x  | x   | x   |
| Structural<br><small>(The lengths is limited by the quality of the logs and demand. The sawmill will manufacture the longest possible unit in compliance with the grade.)</small> | 38  |                     | x                            | x  | x   | x   |
|   | 50  |                     | x                            | x  | x   | x   |
| Finger joint timber   | As for solid timber   |                     |                              |    |     |     |
| Laminated beams<br><small>Limited up to 16 m. Determined by the manufacturer.</small>   | Depth of member, mm   |                     | Width of member, mm          |    |     |     |
|   | 67,89,111,133,156,178,192,216,240,264,288,312,336,360,384,408,432,456,480,504,528,552,576,600 |                     | 19,25,32,45,50,63,90,114,140 |    |     |     |
| Plywood   | 4,6,9,12,16,18,21,25,32   |                     | 1220                         |    |     |     |
|   | Lengths up to 2440 mm   |                     |                              |    |     |     |
| Blockboard  | Length: 2 440 mm  |                     |                              |    |     |     |
|   | Width: 1 220 mm   |                     |                              |    |     |     |
|   | Thickness: 18 and 21mm  |                     |                              |    |     |     |

Table 4 Basic load span tables

| Floor joist length between supports | Width | Thickness |
|-------------------------------------|-------|-----------|
| 2 500                               | 50    | 152       |
| 3 000                               | 38    | 228       |
| 4 000                               | 50    | 228       |
| 5 000                               | 76    | 228       |
| 6 000*                              | 70    | 297       |
| 7 000*                              | 70    | 363       |

Note: \* - these are laminated beam sizes

Table 5 Extracts from SANS 0163

| Nominal Bolt Diameter (mm) | Basic force (S.W.L) per bolt (kN) |             |             |             |
|----------------------------|-----------------------------------|-------------|-------------|-------------|
|                            | Grade of Timber                   |             |             |             |
|                            | 5                                 |             | 7           |             |
|                            | // to grain                       | // to grain | // to grain | // to grain |
| 8                          | -                                 | -           | -           | -           |
| 10                         | 1,9                               | 1,3         | 2,0         | 1,4         |
| 12                         | 2,7                               | 1,7         | 3,1         | 2,0         |

The above table extracted from SANS 0163 is given for reference and all structures with high risk factor should be checked by a Professional Engineer.

Thatch Construction

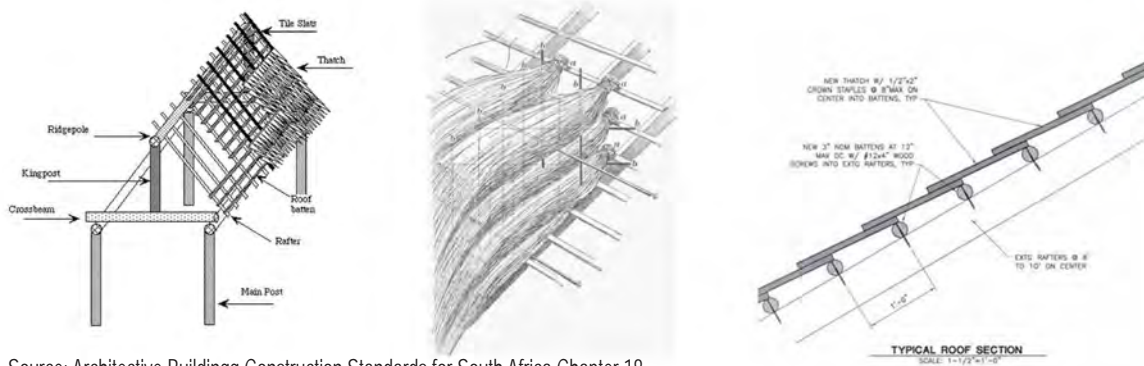
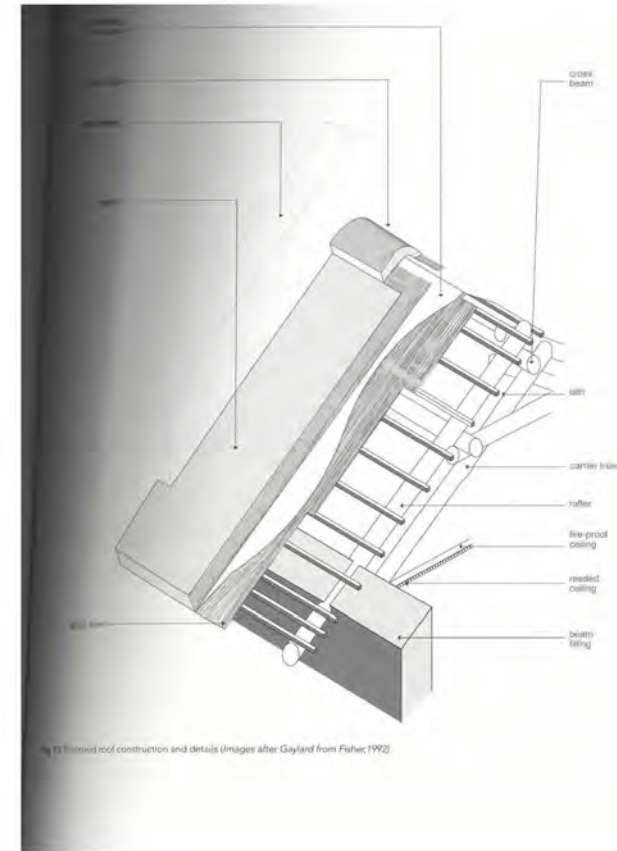
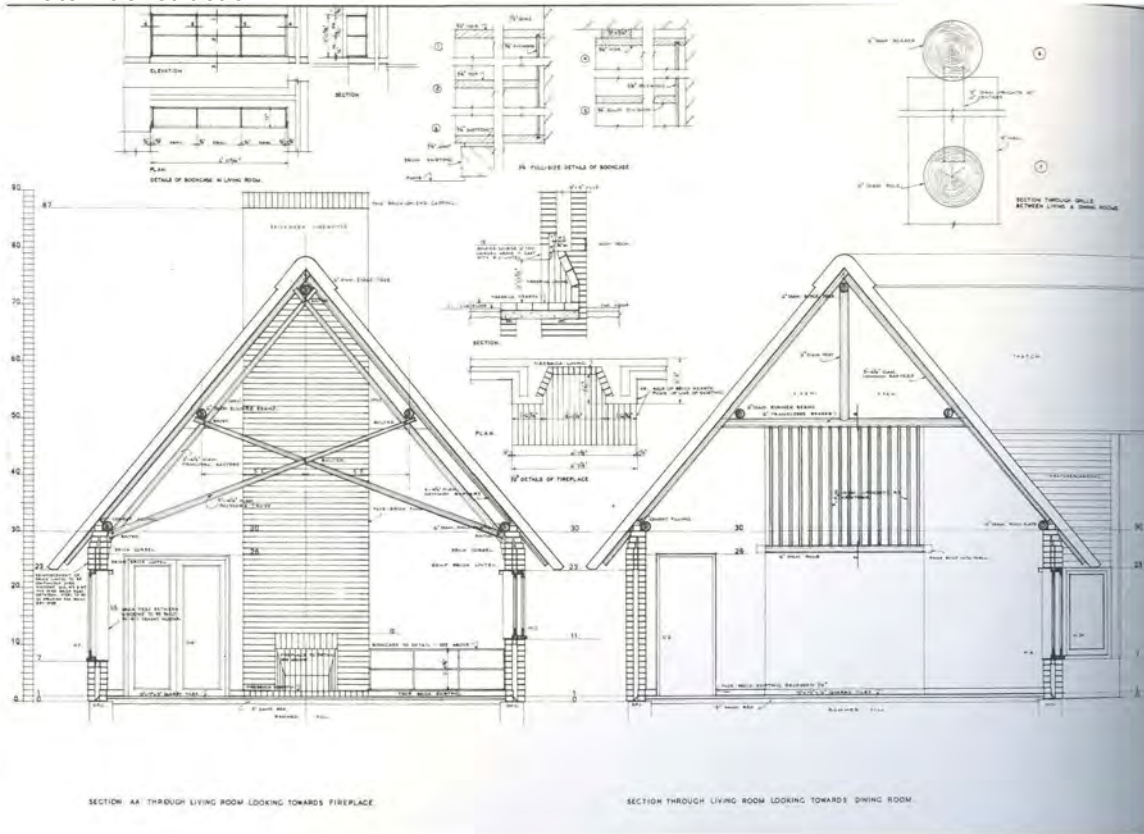

Source: Architectural Building Construction Standards for South Africa Chapter 18