

A Quantum Field Theory for the interaction of pions and rhos

Preshin Moodley

Thesis submitted for the degree of
Doctor of Philosophy in
Theoretical Physics

$\langle ct|mp\rangle$

CENTER FOR THEORETICAL
& MATHEMATICAL PHYSICS



Center for Theoretical & Mathematical Physics
Department of Physics
UNIVERSITY OF CAPE TOWN
Cape Town, South Africa 2017

The copyright of this thesis vests in the author. No quotation from it or information derived from it is to be published without full acknowledgement of the source. The thesis is to be used for private study or non-commercial research purposes only.

Published by the University of Cape Town (UCT) in terms of the non-exclusive license granted to UCT by the author.

© Preshin Moodley, 2017.

Supervisor: Prof. Cesareo Dominguez, UCT, Department of Physics

Co-Supervisor: Prof. Dr. Karl Schilcher, JGU Mainz, Institut für Physik (WA THEP)

Co-Supervisor: Dr. Gary Tupper, UCT, Department of Physics

Co-Supervisor: Prof. Dr. Hubert Spiesberger , JGU Mainz, Institut für Physik (WA THEP)

Ph.D. Thesis

Center for Theoretical & Mathematical Physics

Department of Physics

University of Cape Town

Cape Town

A Quantum Field Theory for the interaction of pions and rhos
Preshin Moodley
Department of Physics
University of Cape Town

Abstract

We extend the Kroll-Lee-Zumino model in its particle content to include the charged rho vector mesons and the neutral pion meson. This entailed using the larger $SU(2)$ gauge group. The masses for the vector mesons were generated via spontaneous symmetry breaking using the Higgs mechanism. The Lagrangian was then quantized and gauge fixed using the generalized class of R_ξ gauges. Tree scattering lengths were calculated for pion-pion scattering and the values for the a_0^0 and a_0^2 scattering lengths are found to be comparable with experiment. The one particle irreducible diagrams that contribute to the one loop corrections to the tree scattering lengths are renormalized.

Acknowledgements

I wish to thank my supervisors who have spurred me on into the field of particle physics:

Cesareo Dominguez, *The Boss*, has been patient for allowing me to learn new techniques and formalism for developing this model. His vision of the end result has chartered the path that I had to flesh out. Thank you Cesareo for letting me learn slowly so that I could understand all the intricate theory required for this project. We both didn't know how big this project would turn out to be at the start, but we made it to the end. You and Silva have invited me into your lives. We have shared many dinners discussing life and science over awesome steaks (and sometimes rabbit food) and great wines. I will fondly remember the lessons of cooking great steaks and living life.

Karl Schilcher taught me the elementary aspects of renormalization theory for non Abelian gauge theories and had generously typed up notes for me to read and learn from. Thank you Karl for suggesting alternative approaches to the loop calculations, providing the many references to articles when I needed help, and for insisting on my work being as *über sie gleich* as possible.

Hubert Spiesberger taught me the efficient way of extracting out the Feynman rules from the Lagrangian using functional methods and performing loop calculations with the Passarino-Veltman tensor reduction to scalar integrals. Thank you Hubert for patiently answering my questions even when they were terribly stupid and I was being very stubborn. If you had not shown me the Passarino-Veltman reduction, I would still be stuck doing loop calculations the old fashioned way. "*....I have done these calculations more then ten years ago,... and I've forgotten all the details, but what remains of that time is experience.*"—HS

Gary Tupper, *Lord of the Strings*, helped me through the journey of learning the non Abelian Higgs mechanism, using the 't Hooft-Fujikawa-Lee-Abers gauge fixing function to remove the mixing terms and the quantization process using the Faddeev-Popov ghosts. Thank you Dude for answering my constant bombardment of questions, and the helpful discussions on gauge theories. We have banished my ignorance to the deeper recesses of my mind...for now.

I have benefited from attending the discussions of gauge theories by Prof. Heribert Weigert for his students, and grateful for the invitation to his informal discussion sessions with Prof. Francois Gelis on unitarity cuts, the Slavnov-Taylor identities and renormalizability.

I thank Prof. Chris Clarkson and Dr. Obinna Umeh from the Department of Mathematics and Applied Mathematics for introducing me to the Mathematica packages used for tensor algebra and answering my endless questions on its usage.

I am grateful to Mawande Lushozi who has been a fellow explorer on this journey. We had many discussions, frustrating and rewarding about the workings of gauge theories and the complications of renormalization. My *mfethu* we have fought through the fog of mystery surrounding gauge theories, walked through the high halls of multi-loop calculations and breath in the rarefied air. My office mates Yingwen Zhang, Mirrete Fawzy and Luis Hernandez have kept me entertained and sober of thought. Thank you for the awesome experiences, memories and many sushi nights.

Dr. Mehdi Safari and Dr. Iniyan Natarajan read the initial draft chapters and suggested improvements and changes to the writing style.

I am grateful to the UCT Physics department which has been my academic home for these past years and has provided me with an academic environment.

I have been fortunate to meet people who have gone on from being friends to become family, Hari and Verosha, Justin and Hilda, Wesley and San, Umut, Martin, Yingwen and Summer, Mawande, Mirrete and Luiz. Thank you for being positive influences in my life and keeping me motivated.

And my dear family, who have instilled in me the value of an education. Thank you for letting me pursue my obsession, for the financial support which prevented me from starving and for letting me be me.

Preshin Moodley
Cape Town
June 2017

Declaration of authorship

I, Preshin Moodley, declare that this thesis titled: "A Quantum Field Theory for the interaction of pions and rhos", and the work presented in it are my own. I confirm that:

- This work was done wholly or mainly while in candidature for a research degree at this University.
- Where any part of this thesis has previously been submitted for a degree or any other qualification at this University or any other institution, this has been clearly stated.
- Where I have consulted the published work of others, this is always clearly attributed.
- Where I have quoted from the work of others, the source is always given. With the exception of such quotations, this thesis is entirely my own work.
- I have acknowledged all main sources of help.
- Where the thesis is based on work done by myself jointly with others, I have made clear exactly what was done by others and what I have contributed myself.

Signed: _____

Signed by candidate

Date: 06 June 2017

Contents

List of Figures	xii
List of Tables	xiii
1 Introduction	1
1.1 The Kroll-Lee-Zumino Model	2
I Generalizing the KLZ	6
2 Extending the KLZ	7
2.1 SU(2) Generalization	7
3 Spontaneous Symmetry Breaking	12
3.1 Higgs Mechanism	12
4 Quantization	19
4.1 Faddeev-Popov Ghosts	19
4.2 Gauge Fixing Term	27
4.3 Complete Lagrangian	29
5 Path to Calculations	30
5.1 Renormalization Transformation	30
5.2 Feynman Rules	33
II Quantum Corrections	42
6 Scattering Lengths at Tree Level	43
6.1 Useful Formulae	43
6.2 Tree Scattering Amplitudes	46
6.3 Isospin Amplitudes	52
6.4 Scattering Lengths	54
6.5 Tree Scattering Lengths Results	57
7 One Loop Corrections	61
7.1 One Loop Topologies	61
7.2 Dimensional Regularization	64
7.3 Passarino-Veltman Reduction	65
7.4 Summary of one loop self energies	68

7.4.1	Rho Self Energy	68
7.4.2	Higgs Self Energy	70
7.5	Summary of one loop vertices	72
7.5.1	Pion-Pion-Rho Vertex	73
7.5.2	Pion-Pion-Higgs Vertex	76
7.5.3	Pion-Pion-Pion-Pion Vertex	79
7.6	Renormalization	85
7.6.1	Rho Self Energy Renormalization	85
7.6.2	Higgs Self Energy Renormalization	88
7.6.3	Pion-Pion-Rho Vertex Renormalization	90
7.6.4	Pion-Pion-Higgs Vertex Renormalization	90
7.6.5	Pion-Pion-Pion-Pion Vertex Renormalization	91
8	Conclusion and Outlook	92
A	Scalar Functions	95
B	Self Energy	97
B.1	Vector Self Energy	97
B.1.1	ϕ bubble	97
B.1.2	ϕ tadpole	100
B.1.3	H- ρ bubble	100
B.1.4	H tadpole	101
B.1.5	H-Goldstone bubble	101
B.1.6	Goldstone bubble	104
B.1.7	Goldstone tadpole	106
B.1.8	Ghost bubble	106
B.1.9	ρ bubble	108
B.1.10	ρ tadpole	111
B.1.11	lollipops	112
B.1.11.1	ϕ	112
B.1.11.2	Goldstone	112
B.1.11.3	ghost	113
B.1.11.4	ρ	113
B.1.11.5	Higgs	114
B.1.11.6	Goldstone	114
B.1.11.7	ρ	114
B.1.11.8	ϕ	115
B.1.11.9	ghost	115
B.1.12	Summary	116
B.2	Higgs Self Energy	118
B.2.1	ϕ bubble	118
B.2.2	ϕ tadpole	119
B.2.3	ρ bubble	119
B.2.4	ρ tadpole	120
B.2.5	Goldstone bubble	120
B.2.6	Goldstone tadpole	121
B.2.7	Higgs bubble	121
B.2.8	Higgs tadpole	121

B.2.9	Goldstone- ρ bubble	122
B.2.10	Ghost bubble	123
B.2.11	Lollipops	124
B.2.12	Summary	124

Bibliography		126
---------------------	--	------------

List of Figures

1.1	Photon transforming into a Rho which decays into pions.	2
1.2	Pion form factor for $q^2 < 0$	3
1.3	Pion form factor for $s = q^2 > 0$	4
3.1	Rotationally symmetric symmetry breaking potential.	13
6.1	t channel scattering process	44
6.2	u channel scattering process	45
6.3	Predicted vs Experimental values	60

List of Tables

5.1	Feynman rules for this QFT. All momenta are incoming with $\sum_i p_i = 0$	35
6.1	Summary of predicted values and experimental data of the scattering length.	59
8.1	Summary of predicted values and experimental data of the scattering length.	92

1

Introduction

SOOON after the success of Quantum Electrodynamics (QED) as a description of the electromagnetic interaction, physicists turned to the investigation of the structure of nucleons and the strong force. Yukawa's conjecture [1] about the existence of a massive particle responsible for mediating the strong interaction was partially successful at explaining the low energy interactions of the nucleons. Numerous new particles were discovered during this period with seemingly no order among them. The quark model was developed by Gell-Man [2] and Zweig [3, 4] to tame and show some regularity in the particle zoo with hadronic multiplets. Further investigations lead to the development of the Parton model by Feynman [5, 6] which assumed the nucleons were made up of essentially free particles called partons. A nagging question at the time was where were these partons or quarks? The phenomenon of Bjorken scaling [7] incited a search for quantum field theories which exhibited this behaviour. This ended with the discovery of asymptotic freedom in non-Abelian gauge theories by Politzer [8], Wilczek and Gross [9] and leading to the formulation of Quantum Chromodynamics (QCD) which is a $SU(3)_c$ non-Abelian gauge with the new isospin degree of freedom identified as color charge. The partons were identified as the quarks and gluons of QCD and were forever bound in colorless unions.

The property of asymptotic freedom was fortunate since it allowed for the analysis of systems of high energy where the strong coupling has a relatively small value and conventional tools like perturbation theory were applicable. New tools needed to be forged to explore low energy systems. The direct approach taken in Lattice QCD has become feasible in recent years with the reduction in the costs of the massive computing power required and the steady increase in computing power. The alternate approach came with the development of models and effective field theories applicable in certain energy regimes. Chiral Perturbation Theory (χ PT) is the effective field theory for QCD and has been used for applications up to ~ 300 MeV with a failure beyond ~ 600 MeV [10]. The onset of Perturbative QCD has been pushed down to 1 GeV for some applications [11]. There exists this gap of ignorance in the interval $\sim (0.6, 1)$ GeV for which standard analytic tools can not explore. This energy region is dominated by the low energy scalar and vector mesons.

Nambu had suggested that the rho meson could explain the nucleon form factors [12]. Sakurai proposed the idea of Vector meson dominance (VMD) where the strong interaction would be mediated by vector mesons in a non-Abelian gauge theory [13, 14]. The idea of VMD is stated generally as: gauge bosons transform into the lowest energy vector mesons and interact with hadrons through effective vertices.

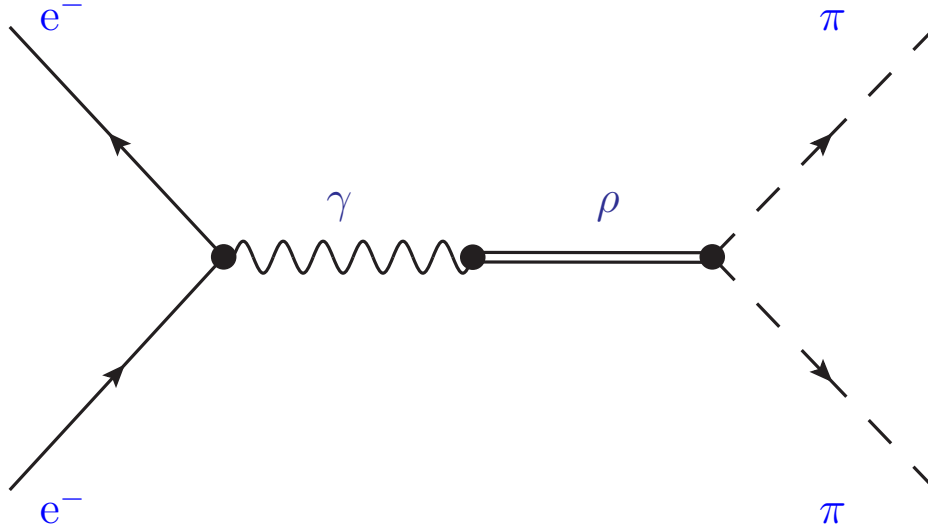

Figure 1.1: Photon transforming into a Rho which decays into pions.

The photon seems to interact with hadronic matter mainly through the rho vector meson [15, 16]. Sakurai had suggested interaction terms for VMD but this was not a field theory which could be used for higher order loop analysis. Kroll, Lee and Zumino suggested a model [17] involving the charged pions and neutral rho as a candidate for VMD.

1.1 The Kroll-Lee-Zumino Model

THE Kroll-Lee-Zumino Model (KLZ) is a quantum field theory developed to describe the interactions of charged pions and the neutral rho.

$$\mathcal{L} = (\partial_\mu \phi)^* \partial^\mu \phi - m^2 \phi^* \phi - \frac{1}{4} F_{\mu\nu} F^{\mu\nu} + \frac{1}{2} M^2 A_\mu A^\mu + ie A^\mu (\phi^* \partial_\mu \phi - \phi \partial_\mu \phi^*) + e^2 \phi^* \phi A_\mu A^\mu \quad (1.1.1)$$

with the field strength tensor $F_{\mu\nu}$ defined as

$$F_{\mu\nu} := \partial_\mu A_\nu - \partial_\nu A_\mu \quad (1.1.2)$$

Here the pions are represented by ϕ , with m the pion mass. The neutral rho is represented by A_μ , with M the rho mass and e represents the strength of the rho-pion coupling which has an approximate value of $e \approx 5.96$. The KLZ is a renormalizable quantum field theory despite the breaking of U(1) gauge symmetry with the presence of the explicit mass term for the vector rho. This is a result of the vector field coupling only to the conserved current [18, 19] i.e.

$$J_\mu := \phi^* \partial_\mu \phi - \phi \partial_\mu \phi^* \quad (1.1.3)$$

with

$$\partial^\mu J_\mu = 0 \quad (1.1.4)$$

This can be seen by looking at the propagator of a massive vector field

$$iD_{\mu\nu} = \frac{-i}{k^2 - M^2 + i\varepsilon} \left(g_{\mu\nu} - \frac{k_\mu k_\nu}{M^2} \right) \quad (1.1.5)$$

which due to the $k_\mu k_\nu$ term is usually logarithmically divergent. For the case of the KLZ, the above propagator would appear between conserved currents with

$$k^\mu J_\mu = 0 \quad (1.1.6)$$

using (1.1.4) in the momentum representation, thus allowing for renormalizability by removing the logarithmically divergent terms. The KLZ being renormalizable makes it an attractive model for analysis, since the renormalizability allows for a systematic calculation of higher order loop corrections without introducing additional parameters into the model. Since the perturbative series expansion parameter is of the form $\frac{e}{4\pi} \approx 0.47$, higher order analysis can be pursued seriously. This can be seen in the application of the KLZ in finite temperature calculations undertaken in [20]. The KLZ has also been used to analyse the pion form factor by [21], for space-like transferred momentum, the one loop correction to the form factor is in agreement with data with $\chi_F^2 \approx 1.1$ as shown in figure 1.2.

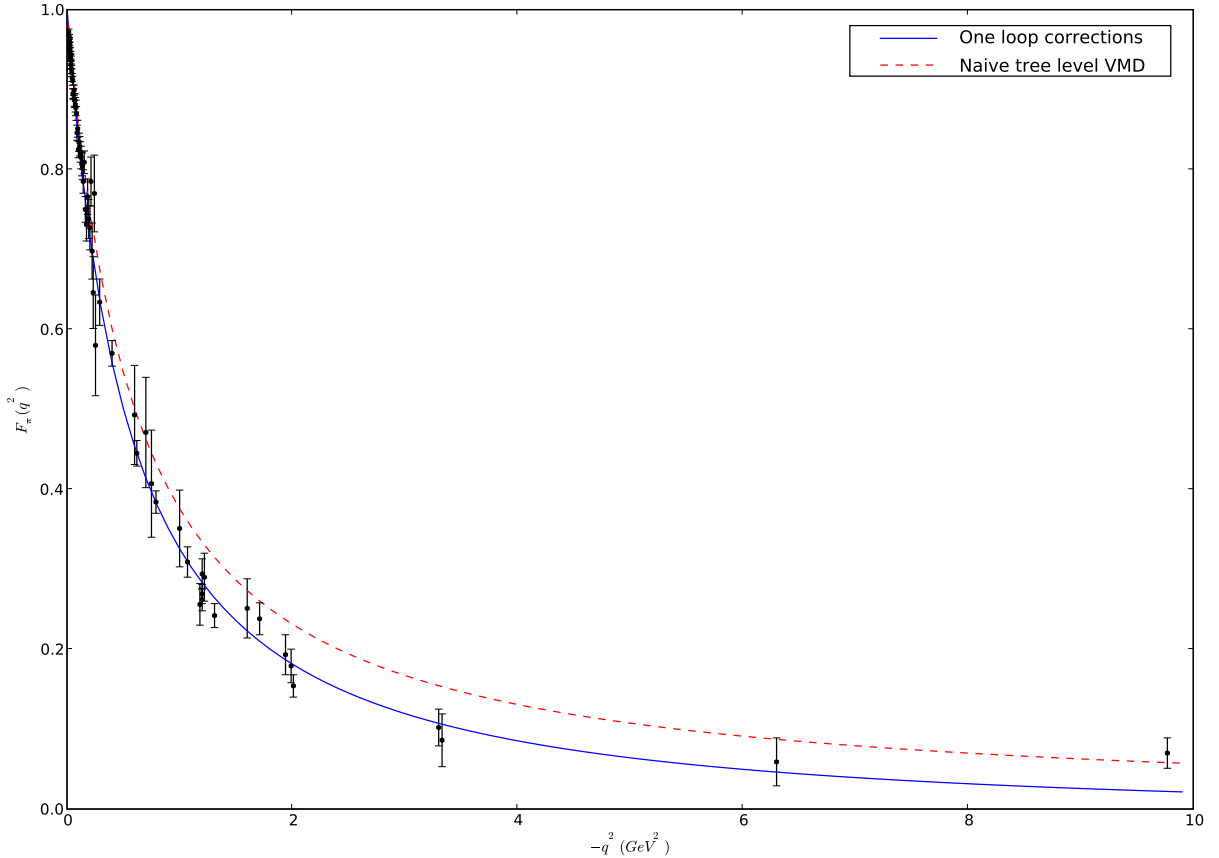

Figure 1.2: Pion form factor for $q^2 < 0$

For time-like transferred momentum the KLZ follows the data closely below the rho peak but starts to deviate from the data beyond the rho peak as can be seen in figure 1.3

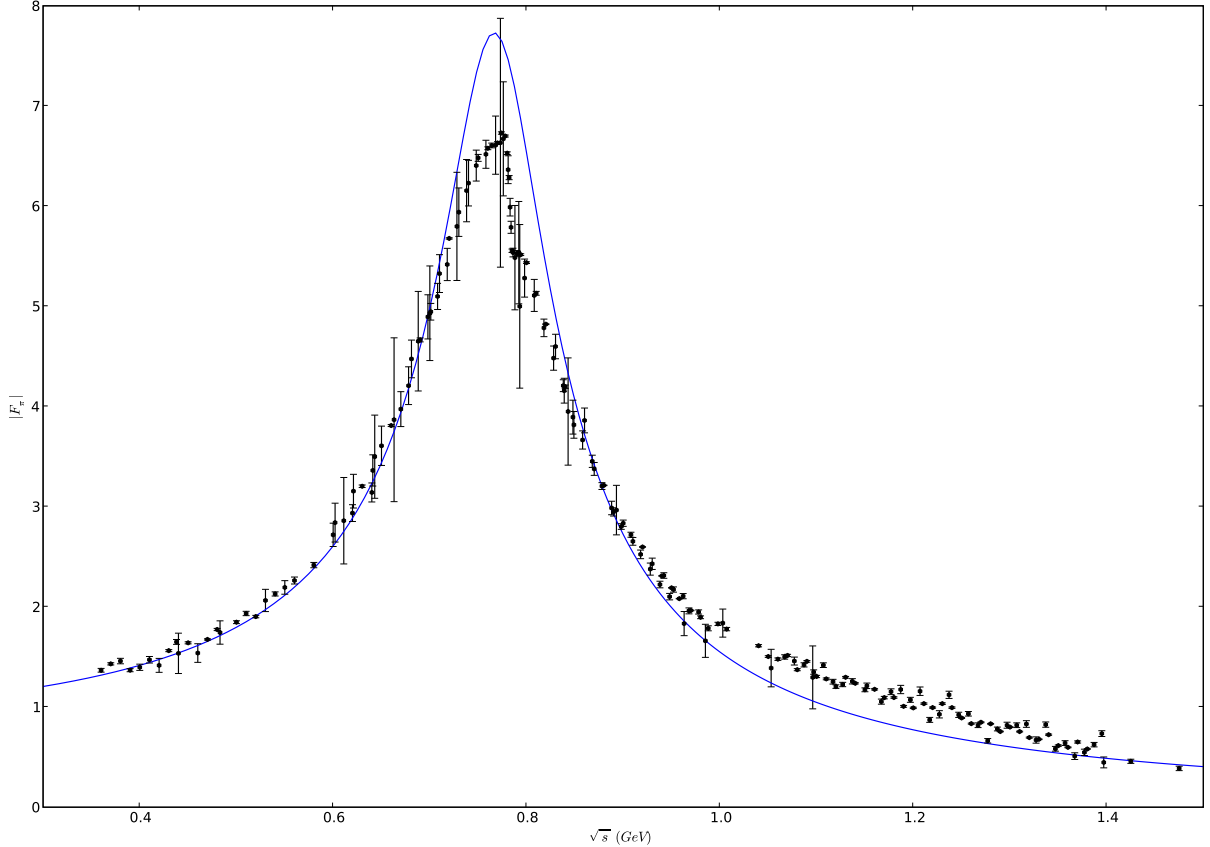

Figure 1.3: Pion form factor for $s = q^2 > 0$

This model has also been used to compute the electromagnetic radius of the pion with $\langle r_\pi^2 \rangle_S = 0.40 \text{ fm}^2$ in [22].

There are limitations to the KLZ model. The KLZ only provides a partial description of the pion-rho interactions. The particle content is only of the charged pions and neutral rho. There are more pion-rho interactions in nature than are captured by the KLZ, which ignores the neutral pion and charged rhos thus excluding a description of the decay of the charged rhos into pions. To address some of these limitations in the KLZ we shall have to chart a new path forward. The new model must use a larger gauge group to accommodate the full complement of the triplet of pions and rhos.

As an application of the new model we have chosen to calculate the pion-pion scattering lengths. The pion-pion scattering amplitude has been studied extensively through the Roy equations and Chiral Perturbation theory [23, 24, 25, 26]. Experimentally, NA48/2 [27] and DIRAC [28] have collected large data sets which allow for the precise extraction of the scattering lengths.

Outline

This document is organized in the following way. In part I, chapter 2, we develop the bare SU(2) model. Chapter 3 is dedicated to Spontaneous symmetry breaking to generate the rho mass. In

chapter 4, we quantize the new Lagrangian, introduce the Faddeev-Popov ghosts and fix the gauge. Chapter 5 contains the renormalization transformation and Feynman rules. In Part II, we apply the new model to evaluating the pion-pion scattering lengths. Chapter 6 has the calculations of the tree scattering lengths and results. In chapter 7, we start the program of finding the one loop corrections to the tree scattering lengths. Due to time constraints on a PhD project, the numerical evaluations have been excluded. Finally chapter 8 summarizes with a conclusion.

Part I

Generalizing the KLZ

2

Extending the KLZ

2.1 SU(2) Generalization

WE will now proceed in generalizing the U(1) KLZ model. What are some simple expectations could we have of such a model? We would like a model describing the interactions of pseudoscalar pions and vector rhos which includes the full triplet of pions $\{\pi^-, \pi^0, \pi^+\}$ and the triplet of rhos $\{\rho^-, \rho^0, \rho^+\}$. We would like it to be renormalizable since it would have some predictive power when considering higher order corrections. We shall make some simplifying assumptions. We shall assume all the particles are point like. We shall ignore the difference between the masses of the charged and neutral pion ($m_{\pi^\pm} - m_{\pi^0} = 4.5936 \pm 0.0005$ MeV) [29]. This small difference (small in comparison to their mass) in pion masses is due to the mass difference between the u and d quarks. This approximate flavour symmetry becomes exact in the chiral limit and we have the isospin SU(2) symmetry group. The pions are then in the adjoint representation of SU(2). We also ignore the difference in rho masses ($m_{\rho^\pm} - m_{\rho^0} = 0.7 \pm 0.8$ MeV) [29].

With these assumptions we can build an effective description of the interactions between the pions and rhos. The rhos will play the role of dynamical gauge bosons [30] mediating the interactions between the pions and the rhos themselves. We will let the principle of local gauge invariance guide our construction under which only terms invariant under SU(2) gauge transformations are to be admitted into our Lagrangian. We begin by writing down a SU(2) globally gauge invariant Lagrangian for scalars representing the pions $[\Phi(x) := \phi^a = \{\phi^1, \phi^2, \phi^3\}]$

$$\mathcal{L} = \frac{1}{2} [(\partial_\mu \Phi)^\dagger \partial^\mu \Phi - b^2 \Phi^\dagger \Phi] \quad (2.1.1)$$

where b has dimensions of mass. The Lagrangian (2.1.1) is invariant under the unitary transformation of

$$U = e^{iT^a \alpha^a} \in \text{SU}(2) \quad (2.1.2)$$

$$\Phi \rightarrow \Phi' = U\Phi \quad (2.1.3)$$

where T^a are the generators of the group and are elements of the Lie algebra $T^a \in \mathfrak{su}(2)$ and $\alpha^a \in \mathbb{R}$ are some constants. The repeated a 's imply a sum over $a = \{1, 2, 3\}$. When we promote the global gauge transformation to a local one with $\alpha^a \rightarrow \alpha^a(x)$, the derivatives in the Lagrangian produce extra terms which breaks the gauge invariance of the Lagrangian. The extra terms are proportional

to the generators T^a , so to remedy the problem we will introduce an extra field into the partial derivative as

$$\partial_\mu \rightarrow D_\mu := \partial_\mu + ieT^a A_\mu^a(x) \quad (2.1.4)$$

Here D_μ is the gauge covariant derivative, e the gauge coupling which is dimensionless, $[e] = 1$ and $A_\mu^a(x)$ are the gauge fields representing the rhos. The gauge fields are in the adjoint representation of $SU(2)$ so we expanded them using the generators as a basis. The covariant derivative is built to transform such that when we make a unitary transformation on the field Φ , the gauge fields A_μ^a must also transform to keep the Lagrangian invariant. This is done by insisting that

$$D'_\mu \Phi' = U D_\mu \Phi \quad (2.1.5)$$

which together with (2.1.3) gives us the transformation rule for the covariant derivative as

$$D_\mu \rightarrow D'_\mu = U D_\mu U^\dagger \quad (2.1.6)$$

We can infer the transformation rule for the gauge fields from the above condition as

$$\begin{aligned} D'_\mu f &= U D_\mu U^\dagger f \\ (\partial_\mu + ieA'_\mu) f &= U (\partial_\mu + ieA_\mu) U^\dagger f \\ \Rightarrow A'_\mu &= U A_\mu U^\dagger + \frac{1}{ie} U \partial_\mu U^\dagger \end{aligned} \quad (2.1.7)$$

with $A'_\mu = A_\mu^a T^a$ and f was some arbitrary function included to keep track of the derivatives. Now when we make a unitary transformation on the fields and noting that

$$\Phi \rightarrow \Phi' = U \Phi \quad (2.1.8)$$

$$D_\mu \rightarrow D'_\mu = U D_\mu U^\dagger \quad (2.1.9)$$

then the Lagrangian

$$\mathcal{L} = \frac{1}{2} [(D_\mu \Phi)^\dagger D^\mu \Phi - b^2 \Phi^\dagger \Phi] \quad (2.1.10)$$

remains invariant. Under the unitary transformation of the scalar field, the gauge field was required to maintain the gauge invariance of the Lagrangian. The gauge fields are just passive auxiliary fields at this stage. If the gauge fields are to represent the rhos then they must have some dynamic behaviour. So naturally we would like to make this a requirement for the gauge fields. Though since this is a nonabelian theory, we must take care when we construct the kinetic term for the gauge fields. For a kinetic term we require a scalar, which is Lorentz and gauge invariant, and quadratic in the first derivatives of the field. The commutator serves as natural product so we shall construct an operator from the commutator of the covariant derivatives,

$$\hat{O}_{\mu\nu} f = [D_\mu, D_\nu] f \quad (2.1.11)$$

where f is some arbitrary function we included to keep track of the derivatives. Under $SU(2)$ gauge transformations, the operator changes as $\hat{O}_{\mu\nu} \rightarrow \hat{O}'_{\mu\nu}$

$$\begin{aligned} \hat{O}'_{\mu\nu} f &= [D'_\mu, D'_\nu] f \\ &= [U D_\mu U^\dagger, U D_\nu U^\dagger] f \\ &= (U D_\mu D_\nu U^\dagger - U D_\nu D_\mu U^\dagger) f \\ &= U [D_\mu, D_\nu] U^\dagger f \\ &= U \hat{O}_{\mu\nu} U^\dagger f \end{aligned} \quad (2.1.12)$$

So we see that the transformed operator is,

$$\hat{O}'_{\mu\nu} = U\hat{O}_{\mu\nu}U^\dagger \quad (2.1.13)$$

We need to ensure that a kinetic term is Lorentz and gauge invariant. We can create a new operator by squaring $O^{\mu\nu}$:

$$\begin{aligned} \hat{O}'_{\mu\nu}\hat{O}'^{\mu\nu} &= U\hat{O}_{\mu\nu}U^\dagger U\hat{O}^{\mu\nu}U^\dagger \\ &= U\hat{O}_{\mu\nu}\hat{O}^{\mu\nu}U^\dagger \end{aligned} \quad (2.1.14)$$

Looking at (2.1.14) we can see that this operator is Lorentz invariant but still dependent on the SU(2) gauge transformation U . We also have to deal with (2.1.14) not being a scalar, since only scalar functions enter into the action. We have to transform (2.1.14) into a scalar while preserving its properties. We can remove the gauge dependence and create a scalar function by taking the trace of (2.1.14) as

$$\begin{aligned} \text{Tr} [\hat{O}'_{\mu\nu}\hat{O}'^{\mu\nu}] &= \text{Tr} [U\hat{O}_{\mu\nu}\hat{O}^{\mu\nu}U^\dagger] \\ &= \text{Tr} [\hat{O}_{\mu\nu}\hat{O}^{\mu\nu}UU^\dagger] \\ &= \text{Tr} [\hat{O}_{\mu\nu}\hat{O}^{\mu\nu}] \end{aligned} \quad (2.1.15)$$

which is independent of the gauge transformation. Now since this operator (2.1.15) is the square of the first derivatives of the fields and invariant under Lorentz and gauge transformations, it has the necessary behaviour of a kinetic term of the gauge fields. We will define the nonabelian field strength tensor as

$$G_{\mu\nu} := \frac{1}{ie}\hat{O}_{\mu\nu} = \frac{1}{ie}[D_\mu, D_\nu] \quad (2.1.16)$$

We can get the explicit form of the tensor by substituting in the covariant derivatives into (2.1.16), where f is included to keep track of the derivatives.

$$\begin{aligned} G_{\mu\nu}f &= \frac{1}{ie}[D_\mu, D_\nu]f \\ &= \frac{1}{ie}[\partial_\mu + ieA_\mu, \partial_\nu + ieA_\nu]f \\ &= \left(\partial_\mu A_\nu - \partial_\nu A_\mu + ie[A_\mu, A_\nu] \right) f \end{aligned} \quad (2.1.17)$$

So the field strength tensor is

$$G_{\mu\nu} = \partial_\mu A_\nu - \partial_\nu A_\mu + ie[A_\mu, A_\nu] \quad (2.1.18)$$

We can use the elements of $\mathfrak{su}(2)$ to write $G_{\mu\nu}$ as a sum over the generators. Using the Lie algebra

$$[T^b, T^c] = i\varepsilon_{abc}T^a \quad (2.1.19)$$

where ε_{abc} is the Levi-Civita symbol representing the structure constants of the algebra, and $A_\mu = A_\mu^a T^a$, we get the following expression

$$\begin{aligned} G_{\mu\nu}^a T^a &= \partial_\mu A_\nu^a T^a - \partial_\nu A_\mu^a T^a + ie[A_\mu^b T^b, A_\nu^c T^c] \\ &= [\partial_\mu A_\nu^a - \partial_\nu A_\mu^a - e\varepsilon_{abc}A_\mu^b A_\nu^c] T^a \end{aligned} \quad (2.1.20)$$

From (2.1.20) we can recognise the familiar abelian field strength tensor in the first two terms in (2.1.20). We will define

$$F_{\mu\nu}^a := \partial_\mu A_\nu^a - \partial_\nu A_\mu^a \quad (2.1.21)$$

then the nonabelian field strength becomes

$$G_{\mu\nu}^a = F_{\mu\nu}^a - e\varepsilon_{abc}A_\mu^b A_\nu^c \quad (2.1.22)$$

We can now define in analogy to (2.1.15) a kinetic term for the gauge fields as (the Yang-Mills term)

$$\begin{aligned} \mathcal{L}_{YM} &:= -\frac{1}{2}\text{Tr}[G_{\mu\nu}G^{\mu\nu}] \\ &= -\frac{1}{2}G_{\mu\nu}^a G^{b\mu\nu}\text{Tr}[T^a T^b] \\ &= -\frac{1}{4}G_{\mu\nu}^a G^{a\mu\nu} \\ &= -\frac{1}{4}F_{\mu\nu}^a F^{a\mu\nu} + \frac{1}{2}e\varepsilon_{abc}A^{b\mu}A^{c\nu}F_{\mu\nu}^a - \frac{1}{4}e^2\varepsilon_{abc}\varepsilon_{ade}A_\mu^b A_\nu^c A^{d\mu}A^{e\nu} \end{aligned} \quad (2.1.23)$$

where $-\frac{1}{2}$ is a factor by convention and we have used the normalization condition

$$\text{Tr}[T^a T^b] = \frac{1}{2}\delta^{ab} \quad (2.1.24)$$

We should pause at this stage and interpret what each term in (2.1.23) represents. After all we went in search for a kinetic term for the gauge field, but requiring Lorentz and local gauge invariance provided extra terms. So the first term in (2.1.23) is the pure kinetic term, the second and third terms represent three point and four point interactions among the gauge fields. So the full nonabelian Lagrangian is

$$\mathcal{L} = \frac{1}{2}[(D_\mu\Phi)^\dagger D^\mu\Phi - b^2\Phi^\dagger\Phi] - \frac{1}{4}G_{\mu\nu}^a G^{a\mu\nu} \quad (2.1.25)$$

Expanding out the covariant derivatives

$$\frac{1}{2}(D_\mu\Phi)^\dagger D^\mu\Phi = \frac{1}{2}\left\{(\partial_\mu\Phi)^\dagger\partial^\mu\Phi + ie\left[(\partial_\mu\Phi)^\dagger A^\mu\Phi - \Phi^\dagger A^\mu\partial_\mu\Phi\right] + e^2\Phi^\dagger A^\mu A_\mu\Phi\right\} \quad (2.1.26)$$

we can write out all the terms in components of the fields using the adjoint representation of the generators $(T^a)_{ij} = -i\varepsilon_{aij}$, so the terms become

$$\begin{aligned} (\partial^\mu\Phi)^\dagger A_\mu\Phi &= A_\mu^a(\partial^\mu\Phi)^\dagger T_a\Phi \\ &= A_\mu^a(\partial^\mu\phi_i)^\dagger(T^a)_{ij}\phi_j \\ &= -i\varepsilon_{aij}A_\mu^a(\partial^\mu\phi_i)\phi_j \\ \implies \Phi^\dagger A_\mu(\partial^\mu\Phi) &= \left[(\partial^\mu\Phi)^\dagger A_\mu\Phi\right]^\dagger \\ &= -i\varepsilon_{aij}A_\mu^a\phi_i(\partial^\mu\phi_j) \end{aligned}$$

with

$$(\partial^\mu\Phi)^\dagger A_\mu\Phi - \Phi^\dagger A_\mu(\partial^\mu\Phi) = -iA_\mu^a\varepsilon_{aij}[\phi_j(\partial^\mu\phi_i) - \phi_i(\partial^\mu\phi_j)] \quad (2.1.27)$$

and

$$\begin{aligned}\Phi^\dagger A^\mu A_\mu \Phi &= A_\mu^a A^{b\mu} \phi_i (T^a)_{ij} (T^b)_{jk} \phi_k \\ &= -\varepsilon_{aij} \varepsilon_{bjk} \phi_i \phi_k A_\mu^a A^{b\mu}\end{aligned}\quad (2.1.28)$$

So the Lagrangian in component form is

$$\begin{aligned}\mathcal{L} &= \frac{1}{2} \left(\partial_\mu \phi_a \partial^\mu \phi_a - b^2 \phi_a^2 \right) + \frac{1}{2} e \varepsilon_{aij} A_\mu^a (\phi_j \partial^\mu \phi_i - \phi_i \partial^\mu \phi_j) - \frac{1}{2} e^2 \varepsilon_{aij} \varepsilon_{bjk} \phi_i \phi_k A_\mu^a A^{b\mu} - \frac{1}{4} F_{\mu\nu}^a F^{a\mu\nu} + \\ &+ \frac{1}{2} e \varepsilon_{abc} A^{b\mu} A^{c\nu} F_{\mu\nu}^a - \frac{1}{4} e^2 \varepsilon_{abc} \varepsilon_{ade} A_\mu^b A_\nu^c A^{d\mu} A^{e\nu}\end{aligned}\quad (2.1.29)$$

Now there has been an omission from the start, we claimed that under the principle of local gauge invariance all terms which preserve the invariance of the Lagrangian are valid terms for inclusion into the Lagrangian. This allows for the inclusion of a polynomial with an infinite number of terms of the form

$$\begin{aligned}P(\Phi) &= \sum_{n=1}^{\infty} c_n (\Phi^\dagger \Phi)^n \\ &= b^2 \Phi^\dagger \Phi + \frac{\lambda_4}{8} (\Phi^\dagger \Phi)^2 + \sum_{n=3}^{\infty} c_n (\Phi^\dagger \Phi)^n\end{aligned}\quad (2.1.30)$$

The first term we included from the start with b having dimensions of mass, $[b] = M$, the second term represents a self coupling and λ_4 is dimensionless, $[\lambda_4] = 1$. This quartic coupling term for the pions was left out in the original U(1) KLZ formulation. There is no legitimate reason at this stage to exclude this term so we shall include it in the Lagrangian. For terms greater than $n = 3$, the coefficients c_n have dimensions of inverse mass, $[c_n] = M^{-n}$. This poses a problem to our requirement for a renormalizable theory [31]. We shall thus ignore all terms for $n \geq 3$. Then finally the Lagrangian is

$$\begin{aligned}\mathcal{L}_{\phi A} &= \frac{1}{2} \left(\partial_\mu \phi_a \partial^\mu \phi_a - b^2 \phi_a^2 \right) + \frac{1}{2} e \varepsilon_{aij} A_\mu^a (\phi_j \partial^\mu \phi_i - \phi_i \partial^\mu \phi_j) - \frac{1}{2} e^2 \varepsilon_{aij} \varepsilon_{bjk} \phi_i \phi_k A_\mu^a A^{b\mu} - \frac{\lambda_4}{8} (\phi_a^2 \phi_b^2) + \\ &- \frac{1}{4} F_{\mu\nu}^a F^{a\mu\nu} + \frac{1}{2} e \varepsilon_{abc} A^{b\mu} A^{c\nu} F_{\mu\nu}^a - \frac{1}{4} e^2 \varepsilon_{abc} \varepsilon_{ade} A_\mu^b A_\nu^c A^{d\mu} A^{e\nu}\end{aligned}\quad (2.1.31)$$

Let us provide an interpretation for the remaining terms in (2.1.31). The first two terms in the parenthesis behave like the kinetic and mass-like¹ terms of a scalar field. The third and fourth terms are the three and four point interaction terms between the scalar and vector fields. Note of course the lack of a mass-like term for the gauge field.

¹These are not the couplings nor physical mass identified from experiment. Since we have not renormalized and completed the definition of the theory as yet these terms only have the dimensions of a mass and appearance of couplings.

3

Spontaneous Symmetry Breaking

3.1 Higgs Mechanism

As noted in the last chapter the Lagrangian has a mass term for the pions but none for the rhos. For this quantum field theory to be a good description of reality, it would be wise to endow the particles with the appropriate masses. The term $b^2\Phi^\dagger\Phi$ for the pion was included by hand since the form of the term remained invariant under gauge transformations. We could attempt to do the same for the gauge field by including a term proportional to the form $A^\mu A_\mu$, but recalling the transformation rule for the gauge field in (2.1.7) shown here below

$$A'_\mu = UA_\mu U^\dagger + \frac{1}{ie}U\partial_\mu U^\dagger$$

We see that the product is

$$A'_\mu A'^\mu = UA_\mu A^\mu U^\dagger + \frac{1}{ie} [UA_\mu \partial^\mu U^\dagger + U(\partial^\mu U^\dagger)UA_\mu U^\dagger] - \frac{1}{e^2}U(\partial^\mu U^\dagger)U(\partial^\mu U^\dagger) \quad (3.1.1)$$

This does not look very appealing, we could use the identity $U^\dagger U = 1$

$$\partial^\mu (U^\dagger U) = 0 \Rightarrow U^\dagger (\partial^\mu U) = -(\partial^\mu U^\dagger)U \quad (3.1.2)$$

$$\partial^\mu (UU^\dagger) = 0 \Rightarrow U(\partial^\mu U^\dagger) = -(\partial^\mu U)U^\dagger \quad (3.1.3)$$

and write the product as

$$A'_\mu A'^\mu = UA_\mu A^\mu U^\dagger - \frac{1}{ie}U [A_\mu U^\dagger \partial^\mu U + U^\dagger (\partial^\mu U)A_\mu] U^\dagger + \frac{1}{e^2}\partial^\mu U \partial^\mu U^\dagger \quad (3.1.4)$$

We could argue that this expression is not a scalar, and for the case of the Yang-Mills kinetic term it was necessary to take the trace to yield a scalar which also removed the gauge dependence. Unfortunately this does not work for a mass term as

$$\text{Tr} [A'_\mu A'^\mu] = \text{Tr} [A_\mu A^\mu] - \frac{2}{ie}\text{Tr} [A_\mu U^\dagger \partial^\mu U] + \frac{1}{e^2}\text{Tr} [\partial^\mu U^\dagger \partial^\mu U] \quad (3.1.5)$$

and (3.1.5) still has remnants of the gauge transformation. So we cannot put in a mass term for the gauge field by hand without breaking gauge invariance. The mass term for the gauge field must

be generated dynamically [32]. This is done by introducing a new scalar field which has rotational symmetry with respect to some potential. A translation in the field is performed and the previous rotational symmetry becomes hidden. This process is referred to as the Higgs mechanism or spontaneous symmetry breaking. We note that this is not the Higgs mechanism used in the Standard Model to give all the elementary particles their masses. We use a Higgs-like mechanism here only to give mass to the rhos. Generating the vector mass using the Higgs mechanism preserves the renormalizability of the theory [33].

We introduce a new field X which is a complex doublet that has the gauge transformation

$$X \rightarrow X' = UX \quad (3.1.6)$$

We construct an $SU(2)$ gauge invariant Higgs Lagrangian, with the covariant derivatives acting on the complex doublets

$$\mathcal{L} = (D_\mu X)^\dagger (D^\mu X) - V(X, X^\dagger) - \kappa (X^\dagger X) (\Phi^\dagger \Phi) \quad (3.1.7)$$

where the potential $V(X, X^\dagger)$ is

$$V(X, X^\dagger) = \frac{\lambda}{8} (X^\dagger X)^2 - \frac{\mu^2}{2} (X^\dagger X) \quad (3.1.8)$$

which has been tuned for symmetry breaking. The term $\kappa (X^\dagger X) (\Phi^\dagger \Phi)$ is present since it is gauge invariant and thus allowed by the principle of local gauge invariance. κ is the coupling between the pions and complex doublet and is dimensionless, $[\kappa] = 1$. Plotting $V(X, X^\dagger)$ we can see the rotational symmetry present in the potential [under rotations about an axis through $(0, 0)$] by the contours which are circles.

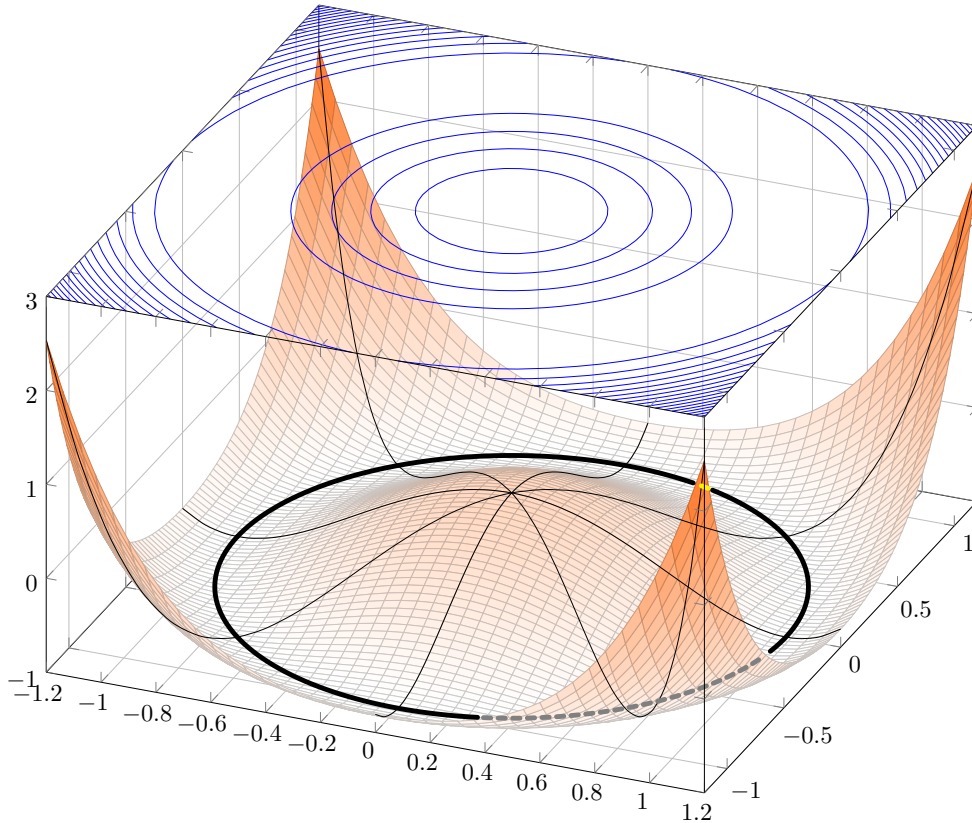

Figure 3.1: Rotationally symmetric symmetry breaking potential.

We can express the potential in terms of real fields by decomposing the complex double into a doublet of real valued fields.

$$X = \frac{1}{\sqrt{2}} \begin{pmatrix} x_2 + ix_1 \\ x_0 - ix_3 \end{pmatrix} \quad (3.1.9)$$

so

$$X^\dagger X = \frac{1}{2} x_\alpha x_\alpha \quad (3.1.10)$$

$$(X^\dagger X)^2 = \frac{1}{4} x_\alpha x_\alpha x_\beta x_\beta \quad (3.1.11)$$

We note the usage of the repeated Greek index in the above expressions. We only resort to using the Greek index since the sum is over $\{0, 1, 2, 3\}$. The potential in terms of the real fields is

$$V(x_\alpha) = \frac{\lambda}{32} x_\alpha x_\alpha x_\beta x_\beta - \frac{\mu^2}{4} x_\alpha x_\alpha \quad (3.1.12)$$

We now search for the minimum (the vacuum) of this potential.

$$\begin{aligned} \frac{\partial V}{\partial x_\kappa} &= \frac{\lambda}{32} (2x_\alpha \delta_{\alpha\kappa} x_\beta^2 + x_\alpha^2 \cdot 2x_\beta \delta_{\beta\kappa}) - \frac{\mu^2}{4} \cdot 2x_\alpha \delta_{\alpha\kappa} \\ &= \frac{\lambda}{32} (4x_\kappa x_\alpha^2) - \frac{\mu^2}{2} x_\kappa \\ &= x_\kappa \left(\frac{\lambda}{8} x_\alpha^2 - \frac{\mu^2}{2} \right) \\ &= 0 \end{aligned}$$

which has solutions

$$x_\kappa = 0 \quad \text{OR} \quad x_\alpha^2 = 4 \frac{\mu^2}{\lambda} \quad (3.1.13)$$

Computing the second derivative to test the above solutions

$$\frac{\partial^2 V}{\partial x_\pi \partial x_\kappa} = \delta_{\kappa\pi} \left(\frac{\lambda}{8} x_\alpha^2 - \frac{\mu^2}{2} \right) + \frac{\lambda}{8} x_\kappa x_\pi$$

with the results along the axes $\kappa = \pi$

$$\left. \frac{\partial^2 V}{\partial x_\pi \partial x_\kappa} \right|_{x_\alpha=0} = -\frac{\mu^2}{2} \leq 0, \quad \left. \frac{\partial^2 V}{\partial x_\pi \partial x_\kappa} \right|_{x_\alpha^2=4\frac{\mu^2}{\lambda}} = \mu^2 \geq 0$$

The $x_\kappa = 0$ yields a local maximum for the potential and the $x_\alpha^2 = 4 \frac{\mu^2}{\lambda}$ solution results in the local minimum. We can see these solutions from the plot in figure 3.1. There is a circle of solutions which are the minima of the potential. We define

$$\nu^2 := \frac{\mu^2}{\lambda} \quad \chi_\alpha^2 = 4\nu^2 \quad (3.1.14)$$

We shall pick one of the possible minima with

$$x_1 = x_2 = x_3 = 0 \quad \text{AND} \quad x_0 = 2\nu \quad (3.1.15)$$

The X field has acquired its vacuum expectation value with the above choice of a minimum. The vacuum is located at

$$X_M = \frac{1}{\sqrt{2}} \begin{pmatrix} 0 \\ 2\nu \end{pmatrix} \quad (3.1.16)$$

Defining a new field χ

$$\chi := \frac{1}{\sqrt{2}} \begin{pmatrix} \chi_2 + i\chi_1 \\ \chi_0 - i\chi_3 \end{pmatrix} \quad (3.1.17)$$

we now consider fluctuations about the minimum X_M by defining

$$X := \chi + X_M \quad (3.1.18)$$

This is just translating the vacuum to the origin. Now we rewrite the Lagrangian in terms of this new translated field. Starting with the potential

$$X^\dagger X = \frac{1}{2} (\chi_\alpha \chi_\alpha + 4\nu \chi_0 + 4\nu^2) \quad (3.1.19)$$

$$\begin{aligned} (X^\dagger X)^2 &= \frac{1}{4} [\chi_\alpha \chi_\alpha \chi_\beta \chi_\beta + 8\nu \chi_0 \chi_\alpha \chi_\alpha + 16\nu^2 \chi_0^2 + 8\nu^2 \chi_\alpha \chi_\alpha + 32\nu^3 \chi_0 + 16\nu^4] \\ &= \frac{1}{4} \chi_\alpha^2 \chi_\beta^2 + 2\nu \chi_0 \chi_\alpha^2 + 4\nu^2 \chi_0^2 + 2\nu^2 \chi_\alpha^2 + 8\nu^3 \chi_0 + 4\nu^4 \end{aligned} \quad (3.1.20)$$

So the potential is given by

$$\begin{aligned} V(\chi_\alpha) &= \frac{\lambda}{8} (X^\dagger X)^2 - \frac{\mu^2}{2} X^\dagger X \\ &= \frac{\lambda}{32} \chi_\alpha^2 \chi_\beta^2 + \frac{\nu\lambda}{4} \chi_0 \chi_\beta^2 + \frac{\mu^2}{2} \chi_0^2 - \frac{1}{2} \mu^2 \nu^2 \end{aligned} \quad (3.1.21)$$

The pion-chi interaction becomes

$$(X^\dagger X) (\Phi^\dagger \Phi) = 2\nu^2 \phi_a^2 + 2\nu \chi_0 \phi_a^2 + \frac{1}{2} \chi_\alpha^2 \phi_a^2$$

The covariant derivatives expanded out is

$$(D_\mu X)^\dagger D^\mu X = \partial_\mu X^\dagger \partial^\mu X + ie (\partial^\mu X^\dagger A_\mu X - X^\dagger A_\mu \partial^\mu X) + e^2 X^\dagger A^\mu A_\mu X \quad (3.1.22)$$

The kinetic term of the Lagrangian is then

$$\begin{aligned} \partial_\mu X^\dagger \partial^\mu X &= \partial_\mu \chi^\dagger \partial^\mu \chi \\ &= \frac{1}{\sqrt{2}} (\partial_\mu \chi_2 - i\partial_\mu \chi_1 \quad \partial_\mu \chi_0 + i\partial_\mu \chi_3) \frac{1}{\sqrt{2}} (\partial_\mu \chi_2 + i\partial_\mu \chi_1) \\ &= \frac{1}{2} \partial_\mu \chi_\alpha \partial^\mu \chi_\alpha \end{aligned} \quad (3.1.23)$$

We note that the gauge field expanded over the generators are

$$\begin{aligned} A_\mu &= A_\mu^a T^a \\ &= \frac{1}{2} \begin{pmatrix} A_\mu^3 & A_\mu^1 - iA_\mu^2 \\ A_\mu^1 + iA_\mu^2 & -A_\mu^3 \end{pmatrix} \end{aligned} \quad (3.1.24)$$

$$\begin{aligned} \implies A_\mu A^\mu &= \frac{1}{4} \begin{pmatrix} A_\mu^a A^{a\mu} & 0 \\ 0 & A_\mu^a A^{a\mu} \end{pmatrix} \\ &= \frac{1}{4} A_\mu^a A^{a\mu} \mathbb{1}_{2 \times 2} \end{aligned} \quad (3.1.25)$$

The four field coupling term of (3.1.22) can be expressed using the above expression as

$$\begin{aligned} X^\dagger A^\mu A_\mu X &= X^\dagger \frac{1}{4} A_\mu^a A^{a\mu} \mathbb{1}_{2 \times 2} X \\ &= \frac{1}{2} \nu^2 A_\mu^a A^{a\mu} + \frac{1}{2} \nu \chi_0 A_\mu^a A^{a\mu} + \frac{1}{8} \chi_\alpha^2 A_\mu^a A^{a\mu} \end{aligned} \quad (3.1.26)$$

The process of picking a vacuum and translating it to the origin, thus hiding the rotational symmetry has generated a mass. The first term in the above equation represents a mass for the gauge field. Lastly we have to deal with the three field coupling term of (3.1.22).

$$\begin{aligned} \partial^\mu X^\dagger A_\mu X &= \partial^\mu \chi^\dagger A_\mu X_M + \partial^\mu \chi^\dagger A_\mu \chi \\ &= -\chi^\dagger \partial^\mu A_\mu X_M + \partial^\mu \chi^\dagger A_\mu \chi \end{aligned} \quad (3.1.27)$$

We have integrated by parts (using the integral over the Lagrangian) and discarded the surface term for the first term of the above expression. Substituting the above expression into the three field coupling term

$$\begin{aligned} \partial^\mu X^\dagger A_\mu X - X^\dagger A_\mu \partial^\mu X &= X_M^\dagger \partial^\mu A_\mu \chi - \chi^\dagger \partial^\mu A_\mu X_M + \partial^\mu \chi^\dagger A_\mu \chi - \chi^\dagger A_\mu \partial^\mu \chi \\ &= \partial^\mu A_\mu^a \left[X_M^\dagger T^a \chi - \chi^\dagger T^a X_M \right] + \partial^\mu \chi^\dagger A_\mu \chi - \chi^\dagger A_\mu \partial^\mu \chi \end{aligned} \quad (3.1.28)$$

we see a separation into two types of interaction terms. The last two terms are three field interaction terms but the term in the square brackets seems to have two field interaction terms i.e. mixing terms. Let us check

$$\begin{aligned} \chi^\dagger \partial^\mu A_\mu X_M &= \frac{1}{\sqrt{2}} \begin{pmatrix} \chi_2 - i\chi_1 & \chi_0 + i\chi_3 \end{pmatrix} \frac{1}{2} \partial^\mu \begin{pmatrix} A_\mu^3 & A_\mu^1 - iA_\mu^2 \\ A_\mu^1 + iA_\mu^2 & -A_\mu^3 \end{pmatrix} \begin{pmatrix} 0 \\ 1 \end{pmatrix} \\ &= \frac{1}{2\sqrt{2}} \left[(\chi_2 \partial^\mu A_\mu^1 - \chi_1 \partial^\mu A_\mu^2 - \chi_0 \partial^\mu A_\mu^3) - i (\chi_2 \partial^\mu A_\mu^2 + \chi_1 \partial^\mu A_\mu^1 + \chi_3 \partial^\mu A_\mu^3) \right] \\ &= \frac{1}{2\sqrt{2}} \left[-i\chi_a \partial^\mu A_\mu^a + (\chi_2 \partial^\mu A_\mu^1 - \chi_1 \partial^\mu A_\mu^2 - \chi_0 \partial^\mu A_\mu^3) \right] \end{aligned} \quad (3.1.29)$$

Taking the hermitian conjugate of (3.1.29) and substituting into the two field interaction terms of (3.1.28) we get

$$X_M^\dagger \partial^\mu A_\mu \chi - \chi^\dagger \partial^\mu A_\mu X_M = \frac{i}{\sqrt{2}} \chi_a \partial^\mu A_\mu^a \quad (3.1.30)$$

which indeed has only two fields interacting a point. These pesky terms are hard to interpret so we will leave them alone for now and come back to them when we discuss gauge fixing. The remaining term to work on is the three field interaction terms of (3.1.28). First the $A_\mu \chi$ product

$$\begin{aligned} A_\mu \chi &= \frac{1}{2} \begin{pmatrix} A_\mu^3 & A_\mu^1 - iA_\mu^2 \\ A_\mu^1 + iA_\mu^2 & -A_\mu^3 \end{pmatrix} \frac{1}{\sqrt{2}} \begin{pmatrix} \chi_2 + i\chi_1 \\ \chi_0 - i\chi_3 \end{pmatrix} \\ &= \frac{1}{2\sqrt{2}} \begin{pmatrix} A_\mu^3 \chi_2 + A_\mu^1 \chi_0 - A_\mu^2 \chi_3 + i (A_\mu^3 \chi_1 - A_\mu^1 \chi_3 - A_\mu^2 \chi_0) \\ A_\mu^1 \chi_2 + A_\mu^2 \chi_1 - A_\mu^3 \chi_0 + i (A_\mu^1 \chi_1 + A_\mu^2 \chi_2 + A_\mu^3 \chi_3) \end{pmatrix} \end{aligned} \quad (3.1.31)$$

then the three field interaction term is

$$\begin{aligned}
 & \partial^\mu \chi^\dagger A_\mu \chi \\
 &= \frac{1}{\sqrt{2}} \left(\partial^\mu \chi_2 - i \partial^\mu \chi_1 \quad \partial^\mu \chi_0 + i \partial^\mu \chi_3 \right) \frac{1}{2\sqrt{2}} \left(\begin{aligned} & A_\mu^3 \chi_2 + A_\mu^1 \chi_0 - A_\mu^2 \chi_3 + i \left(A_\mu^3 \chi_1 - A_\mu^1 \chi_3 - A_\mu^2 \chi_0 \right) \\ & A_\mu^1 \chi_2 + A_\mu^2 \chi_1 - A_\mu^3 \chi_0 + i \left(A_\mu^1 \chi_1 + A_\mu^2 \chi_2 + A_\mu^3 \chi_3 \right) \end{aligned} \right) \\
 &= \frac{1}{4} \left\{ \begin{aligned} & \left(A_\mu^3 \chi_2 + A_\mu^1 \chi_0 - A_\mu^2 \chi_3 \right) \partial^\mu \chi_2 + \left(A_\mu^3 \chi_1 - A_\mu^1 \chi_3 - A_\mu^2 \chi_0 \right) \partial^\mu \chi_1 + \\ & + i \left[\partial^\mu \chi_2 \left(A_\mu^3 \chi_1 - A_\mu^1 \chi_3 - A_\mu^2 \chi_0 \right) - \left(A_\mu^3 \chi_2 + A_\mu^1 \chi_0 - A_\mu^2 \chi_3 \right) \partial^\mu \chi_1 \right] + \\ & + \left(A_\mu^1 \chi_2 + A_\mu^2 \chi_1 - A_\mu^3 \chi_0 \right) \partial^\mu \chi_0 - \left(A_\mu^1 \chi_1 + A_\mu^2 \chi_2 + A_\mu^3 \chi_3 \right) \partial^\mu \chi_3 + \\ & + i \left[\partial^\mu \chi_0 \left(A_\mu^1 \chi_1 + A_\mu^2 \chi_2 + A_\mu^3 \chi_3 \right) + \left(A_\mu^1 \chi_2 + A_\mu^2 \chi_1 - A_\mu^3 \chi_0 \right) \partial^\mu \chi_3 \right] \end{aligned} \right\} \quad (3.1.32)
 \end{aligned}$$

The appearance of the individual χ_α fields interacting differently is troubling. Taking the hermitian conjugate of the above and substituting into the three field interaction terms of (3.1.28)

$$\begin{aligned}
 \partial^\mu \chi^\dagger A_\mu \chi - \chi^\dagger A_\mu \partial^\mu \chi &= \frac{i}{2} \left[\begin{aligned} & \left(\chi_1 \partial^\mu \chi_2 - \chi_2 \partial^\mu \chi_1 \right) A_\mu^3 + \left(\chi_3 \partial^\mu \chi_0 - \chi_0 \partial^\mu \chi_3 \right) A_\mu^3 + \\ & + \left(\chi_2 \partial^\mu \chi_3 - \chi_3 \partial^\mu \chi_2 \right) A_\mu^1 + \left(\chi_1 \partial^\mu \chi_0 - \chi_0 \partial^\mu \chi_1 \right) A_\mu^1 + \\ & + \left(\chi_2 \partial^\mu \chi_0 - \chi_0 \partial^\mu \chi_2 \right) A_\mu^2 + \left(\chi_3 \partial^\mu \chi_1 - \chi_1 \partial^\mu \chi_3 \right) A_\mu^2 \end{aligned} \right] \quad (3.1.33)
 \end{aligned}$$

A pattern emerges in the way the individual χ_α fields interact with the gauge fields. To clarify we define the operator

$$A \overleftrightarrow{\partial}^\mu B := A \partial^\mu B - B \partial^\mu A \quad (3.1.34)$$

Rewriting (3.1.33) in terms of the above operator

$$\begin{aligned}
 \partial^\mu \chi^\dagger A_\mu \chi - \chi^\dagger A_\mu \partial^\mu \chi &= \frac{i}{2} \left[\begin{aligned} & \left(\chi_1 \overleftrightarrow{\partial}^\mu \chi_2 \right) A_\mu^3 + \left(\chi_3 \overleftrightarrow{\partial}^\mu \chi_0 \right) A_\mu^3 + \\ & + \left(\chi_2 \overleftrightarrow{\partial}^\mu \chi_3 \right) A_\mu^1 + \left(\chi_1 \overleftrightarrow{\partial}^\mu \chi_0 \right) A_\mu^1 + \\ & + \left(\chi_2 \overleftrightarrow{\partial}^\mu \chi_0 \right) A_\mu^2 + \left(\chi_3 \overleftrightarrow{\partial}^\mu \chi_1 \right) A_\mu^2 \end{aligned} \right] \\
 &= \frac{i}{2} \left[\frac{1}{2} \varepsilon_{abc} \left(\chi_a \overleftrightarrow{\partial}^\mu \chi_b \right) A_\mu^c + \left(\chi_a \overleftrightarrow{\partial}^\mu \chi_0 \right) A_\mu^a \right] \quad (3.1.35)
 \end{aligned}$$

The pattern for the χ_α fields interacting allowed us to write the three field interactions compactly in terms of the Levi-Civita symbol, with the χ_1, χ_2, χ_3 interacting among themselves with the gauge fields and the separate interaction term with the χ_0 field. We have all the needed pieces, substituting (3.1.30) and (3.1.35) into (3.1.28)

$$\begin{aligned}
 \partial^\mu X^\dagger A_\mu X - X^\dagger A_\mu \partial^\mu X &= \partial^\mu A_\mu^a \left[X_M^\dagger T^a \chi - \chi^\dagger T^a X_M \right] + \partial^\mu \chi^\dagger A_\mu \chi - \chi^\dagger A_\mu \partial^\mu \chi \\
 &= \partial^\mu A_\mu^a \left[X_M^\dagger T^a \chi - \chi^\dagger T^a X_M \right] + \frac{i}{2} \left[\frac{1}{2} \varepsilon_{abc} \left(\chi_a \overleftrightarrow{\partial}^\mu \chi_b \right) A_\mu^c + \left(\chi_a \overleftrightarrow{\partial}^\mu \chi_0 \right) A_\mu^a \right] \quad (3.1.36)
 \end{aligned}$$

The covariant derivative in terms of the real χ_α fields are

$$\begin{aligned}
 (D_\mu X)^\dagger D^\mu X &= \partial_\mu \chi^\dagger \partial^\mu \chi + ie \left(\partial^\mu \chi^\dagger A_\mu \chi - \chi^\dagger A_\mu \partial^\mu \chi \right) + e^2 \chi^\dagger A^\mu A_\mu \chi \\
 &= \frac{1}{2} \partial_\mu \chi_\alpha \partial^\mu \chi_\alpha + ie \partial^\mu A_\mu^a \left[X_M^\dagger T^a \chi - \chi^\dagger T^a X_M \right] - \frac{1}{4} e \varepsilon_{abc} \left(\chi_a \overleftrightarrow{\partial}^\mu \chi_b \right) A_\mu^c - \frac{1}{2} e \left(\chi_a \overleftrightarrow{\partial}^\mu \chi_0 \right) A_\mu^a + \\
 &+ \frac{1}{2} e^2 \nu^2 A_\mu^a A^{a\mu} + \frac{1}{2} e^2 \nu \chi_0 A_\mu^a A^{a\mu} + \frac{1}{8} e^2 \chi_\alpha^2 A_\mu^a A^{a\mu}
 \end{aligned} \tag{3.1.37}$$

Substituting in the covariant derivative, the potential and the $X^\dagger X \Phi^\dagger \Phi$ interaction terms into the Lagrangian after symmetry breaking

$$\begin{aligned}
 \mathcal{L}_H &= (D_\mu X)^\dagger D^\mu X - V(X, X^\dagger) - \kappa (X^\dagger X) (\Phi^\dagger \Phi) \\
 &= \frac{1}{2} \left(\partial_\mu \chi_0 \partial^\mu \chi_0 - \mu^2 \chi_0^2 \right) + \frac{1}{2} \partial_\mu \chi_a \partial^\mu \chi_a + ie \partial^\mu A_\mu^a \left[X_M^\dagger T^a \chi - \chi^\dagger T^a X_M \right] - \frac{1}{4} e \varepsilon_{abc} \left(\chi_a \overleftrightarrow{\partial}^\mu \chi_b \right) A_\mu^c + \\
 &- \frac{1}{2} e \left(\chi_a \overleftrightarrow{\partial}^\mu \chi_0 \right) A_\mu^a + \frac{1}{2} e^2 \nu^2 A_\mu^a A^{a\mu} + \frac{1}{2} e^2 \nu \chi_0 A_\mu^a A^{a\mu} + \frac{1}{8} e^2 \chi_\alpha^2 A_\mu^a A^{a\mu} - \frac{\lambda}{32} \chi_\alpha^2 \chi_\beta^2 - \frac{\nu \lambda}{4} \chi_0 \chi_\alpha^2 - \frac{1}{2} (4\kappa \nu^2) \phi_a^2 + \\
 &- 2\kappa \nu \chi_0 \phi_a^2 - \frac{1}{2} \kappa \chi_\alpha^2 \phi_a^2 + \frac{1}{2} \mu^2 \nu^2
 \end{aligned} \tag{3.1.38}$$

Due to our choice of the vacuum along the χ_0 direction, the χ_0 field behaves differently from the χ_1, χ_2, χ_3 terms. We will separate the χ_0 component out with

$$\begin{aligned}
 \chi_\alpha^2 &= \chi_0^2 + \chi_a^2 \\
 \chi_\alpha^2 \chi_\beta^2 &= \chi_0^4 + 2\chi_0^2 \chi_a^2 + \chi_a^2 \chi_b^2
 \end{aligned} \tag{3.1.39}$$

and make a cosmetic change in relabeling the χ_0 component with $\chi_0 := H$ which we shall refer to for convenience as the Higgs field. A reminder again, this is not the Standard Model Higgs field.

$$\begin{aligned}
 \mathcal{L}_H &= \frac{1}{2} \left(\partial_\mu H \partial^\mu H - \mu^2 H^2 \right) + \frac{1}{2} \partial_\mu \chi_a \partial^\mu \chi_a + ie \partial^\mu A_\mu^a \left[X_M^\dagger T^a \chi - \chi^\dagger T^a X_M \right] - \frac{1}{4} e \varepsilon_{abc} \left(\chi_a \overleftrightarrow{\partial}^\mu \chi_b \right) A_\mu^c + \\
 &- \frac{1}{2} e \left(\chi_a \overleftrightarrow{\partial}^\mu H \right) A_\mu^a + \frac{1}{2} e^2 \nu^2 A_\mu^a A^{a\mu} + \frac{1}{2} e^2 \nu H A_\mu^a A^{a\mu} + \frac{1}{8} e^2 H^2 A_\mu^a A^{a\mu} + \frac{1}{8} e^2 \chi_b^2 A_\mu^a A^{a\mu} - \frac{\lambda}{32} H^4 - \frac{\lambda}{16} H^2 \chi_a^2 + \\
 &- \frac{\lambda}{32} \chi_a^2 \chi_b^2 - \frac{\nu \lambda}{4} H^3 - \frac{\nu \lambda}{4} H \chi_a^2 - \frac{1}{2} (4\kappa \nu^2) \phi_a^2 - 2\kappa \nu H \phi_a^2 - \frac{1}{2} \kappa H^2 \phi_a^2 - \frac{1}{2} \kappa \chi_a^2 \phi_a^2 + \frac{1}{2} \mu^2 \nu^2
 \end{aligned} \tag{3.1.40}$$

Some terms of (3.1.40) require some special attention, we point out the entire process of spontaneous symmetry breaking was to generate a mass for the gauge field. This was achieved with the generation of the term $\frac{1}{2} e^2 \nu^2 A_\mu^a A^{a\mu}$. A contribution to the mass of the pion was generated during the symmetry breaking process, this depended on the coupling κ as $\frac{1}{2} (4\kappa \nu^2) \phi_a^2$. A mass term for the Higgs field was also generated during this process with the mass term being $\frac{1}{2} \mu^2 H^2$. The χ_a are massless and are the three Goldstone fields. The rotational symmetry is still present in the Lagrangian, it is hidden from casual inspection. We could reverse the process and translate the potential back to its original configuration. The rotational symmetry would be made explicit again. We noted the appearance of the pesky mixing terms which are present in the above Lagrangian.

4

Quantization

4.1 Faddeev-Popov Ghosts

THE classical Lagrangian is ready for quantization. There is an obvious problem at the start. Since this is a gauge theory, there are infinitely many field configurations which are related to each other via a gauge transformation which led to equivalent states. This leads to an over-counting of the physical states and must be dealt with as it leads to an overall multiplicative divergence. We can extract out the contribution from the physically distinct states via a suitable gauge fixing process. This means that the gauge transformation partitions the configuration space of gauge fields and sets up an equivalence class for sets of physically equivalent gauge fields. This leads to a problem when summing over all field contributions as there are infinitely many physically equivalent field configurations leading to a divergence. So we need to count only one member from each partition once and this is done with a gauge fixing function which is designed to traverse the configuration space and intersect the set of all physically equivalent gauge fields only once. This is the method pioneered by Feynman and formalized by Faddeev and Popov [34]. Consider a function $g(x)$ and some $w \in \mathbb{R}$ with

$$g(x) = w \tag{4.1.1}$$

which has roots at x_k which can be ordered as $x_1 < x_2 < \dots < x_N$ and $g'(x_i) \neq 0$, then

$$\int dx \delta [g(x) - w] = \sum_{k=1}^N \frac{1}{|g'(x_k)|} \tag{4.1.2}$$

we have the one dimensional identity

$$\left[\sum_{k=1}^N \frac{1}{|g'(x_k)|} \right]^{-1} \int dx \delta [g(x) - w] = 1 \tag{4.1.3}$$

We restrict the class of functions $g(x)$ to those which yield only a single root and this simplifies to

$$\left. \frac{d}{dx} g(x) \right|_{x=a} \int dx \delta [g(x) - w] = 1 \tag{4.1.4}$$

This can be generalized to the field theoretic version

$$\Delta[A] \int \mathcal{D}\mu[U] \delta[G^a(A^U) - w^a] = 1 \quad (4.1.5)$$

where $\Delta[A]$ is a generalization of the derivative of the function $g(x)$, and will later turn out to be a Jacobian matrix. A^U indicates the dependence of the gauge field on the transformation U . $\mathcal{D}\mu[U]$ is the Haar measure [31]. The condition placed on $g(x)$ earlier was to select injective mappings as candidates for gauge fixing functions $G^a(A^U)$. This is the problem of the Gribov Ambiguity [35, 36]. For perturbative considerations we will stay within one horizon.

Consider now the path integral for the gauge field

$$\begin{aligned} Z' &= \int \mathcal{D}A e^{iS[A]} \\ &= \int \mathcal{D}A^U e^{iS[A^U]} \cdot 1 \\ &= \int \mathcal{D}A^U e^{iS[A^U]} \Delta[A^U] \int \mathcal{D}\mu[U] \delta[G^a(A^U) - w^a] \end{aligned} \quad (4.1.6)$$

We have inserted a 1 using the identity (4.1.5). We can now make a gauge transformation where $A^U \rightarrow A$ and noting the Haar measure is invariant under gauge transformations

$$\begin{aligned} Z' &= \int \mathcal{D}A e^{iS[A]} \Delta[A] \int \mathcal{D}\mu[U] \delta[G^a(A) - w^a] \\ &= \int \mathcal{D}\mu[U] \int \mathcal{D}A e^{iS[A]} \Delta[A] \delta[G^a(A) - w^a(x)] \end{aligned}$$

We can insert a 1 in the form of a ratio of Gaussian functionals and absorb the denominator into the measure.

$$\begin{aligned} Z' &= \int \mathcal{D}A e^{iS[A]} \Delta[A] \int \mathcal{D}\mu[U] \delta[G^a(A) - w^a] \\ &= \int \mathcal{D}\mu[U] \frac{\int \mathcal{D}w e^{-\frac{i}{2\xi} \int d^4x w_a^2(x)}}{\int \mathcal{D}w e^{-\frac{i}{2\xi} \int d^4x w_a^2(x)}} \int \mathcal{D}A e^{iS[A]} \Delta[A] \delta[G^a(A) - w^a(x)] \\ &= \int \mathcal{D}\tilde{\mu}[U] \int \mathcal{D}w e^{-\frac{i}{2\xi} \int d^4x w_a^2(x)} \int \mathcal{D}A e^{iS[A]} \Delta[A] \delta[G^a(A) - w^a(x)] \end{aligned} \quad (4.1.7)$$

Since all the fields are independent of the gauge transformation we can factor out the integral over the measure which contributes an overall multiplicative divergence. Note also that Z' can not depend on the parameter ξ , since only a 1 was inserted.

$$\frac{Z'}{\int \mathcal{D}\tilde{\mu}[U]} = \int \mathcal{D}A \mathcal{D}w e^{iS[A]} e^{-\frac{i}{2\xi} \int d^4x w_a^2(x)} \Delta[A] \delta[G^a(A) - w^a(x)] \quad (4.1.8)$$

We can now define the path integral which does not suffer from the over-counting

$$\begin{aligned} \mathcal{Z} &:= \frac{Z'}{\int \mathcal{D}\tilde{\mu}[U]} \\ &= \int \mathcal{D}A \mathcal{D}w e^{iS[A]} e^{-\frac{i}{2\xi} \int d^4x w_a^2(x)} \Delta[A] \delta[G^a(A) - w^a(x)] \\ &= \int \mathcal{D}A e^{iS[A]} e^{-\frac{i}{2\xi} \int d^4x G_a^2(A)} \Delta[A] \end{aligned} \quad (4.1.9)$$

where we have integrated over the w using the delta functional. We are left with the task of evaluating $\Delta[A]$. Recall the identity in (4.1.5)

$$\Delta[A] \int \mathcal{D}\mu[U] \delta[G^a(A^U) - w^a] = 1$$

with the transformation $U = e^{i\alpha^a T^a}$, we see that the invariant Haar measure $\mathcal{D}\mu[U] \propto \mathcal{D}\alpha$. We can rewrite the identity as

$$\Delta[A] \int \mathcal{D}\alpha \delta[G^a({}^\alpha A) - w^a] = 1 \quad (4.1.10)$$

We note the change in notation from A^α (which looks like the components of a Lorentz vector) to ${}^\alpha A$ (which serves to indicate the dependence of the gauge field on the group parameters α). We can make a change of variables

$$\begin{aligned} \mathcal{D}G &= \det \left[\frac{\delta G^b[{}^\alpha A; x]}{\delta \alpha^c(y)} \right] \mathcal{D}\alpha \\ \implies \mathcal{D}\alpha &= \mathcal{D}G \cdot \frac{1}{\det \left[\frac{\delta G^b[{}^\alpha A; x]}{\delta \alpha^c(y)} \right]} \end{aligned} \quad (4.1.11)$$

Substituting in the new measure

$$\begin{aligned} \Delta[A] \int \mathcal{D}G \cdot \frac{1}{\det \left[\frac{\delta G^b[{}^\alpha A; x]}{\delta \alpha^c(y)} \right]} \delta[G^b({}^\alpha A) - w^b] &= 1 \\ \Delta[A] \frac{1}{\det \left[\frac{\delta G^b[{}^\alpha A; x]}{\delta \alpha^c(y)} \right]} \Bigg|_{G^b({}^\alpha A) = w^b} &= 1 \\ \Delta[A] &= \det \left[\frac{\delta G^b[{}^\alpha A; x]}{\delta \alpha^c(y)} \right] \Bigg|_{G^b({}^\alpha A) = w^b} \\ &= \det M^{bc}(x, y) \end{aligned} \quad (4.1.12)$$

We observe that $\Delta[A]$ is the determinant of a matrix of variational derivatives of the gauge fixing function with respect to the group parameters and we defined

$$M^{bc}(x, y) := \frac{\delta G^b[{}^\alpha A; x]}{\delta \alpha^c(y)} \quad (4.1.13)$$

We can choose a class of gauge fixing functions [37, 38]

$$G^b[{}^\alpha A; x] = \partial^\mu A_\mu^b + \xi i e \left(X_M^\dagger T^b \chi - \chi^\dagger T^b X_M \right) \quad (4.1.14)$$

We shall justify the choice of (4.1.14) in the next section. The derivative of the gauge fixing function with respect to the group parameters is

$$\begin{aligned} \frac{\delta G^b[{}^\alpha A; x]}{\delta \alpha^c(y)} &= \int d^4 z \left[\frac{\delta}{\delta A_\nu^d(z)} \partial^\mu A_\mu^b(x) \right] \frac{\delta A_\nu^d(z)}{\delta \alpha^c(y)} + \frac{\delta}{\delta \alpha^c(y)} \xi i e \left(X_M^\dagger T^b \chi - \chi^\dagger T^b X_M \right) \\ &= \int d^4 z \partial_x^\mu \delta_{bd} \delta(x - z) g_\mu^\nu \frac{\delta A_\nu^d(z)}{\delta \alpha^c(y)} + \frac{\delta}{\delta \alpha^c(y)} \xi i e \left(X_M^\dagger T^b \chi - \chi^\dagger T^b X_M \right) \end{aligned} \quad (4.1.15)$$

We now turn to finding the variation of the gauge field with respect to the group parameters. Recall that the gauge field transforms as

$$\begin{aligned} A'_\mu &= \frac{1}{ie} U \partial_\mu U^\dagger + U A_\mu U^\dagger \\ U &= e^{i\alpha^a T^a} \end{aligned} \quad (4.1.16)$$

Since we are looking for the variational derivative we need only concern ourselves with working with the infinitesimal transformation, so for $\delta\alpha_a \ll 1$

$$U \simeq 1 + i\delta\alpha^a T^a + \mathcal{O}(\delta\alpha_a^2) \quad (4.1.17)$$

The gauge field transforms as

$$\begin{aligned} A'_\mu &\simeq \frac{1}{ie} (1 + i\delta\alpha^a T^a) \partial_\mu (1 - i\delta\alpha^b T^b) + (1 + i\delta\alpha^a T^a) A_\mu (1 - i\delta\alpha^b T^b) + \mathcal{O}(\delta\alpha_a^2) \\ &= -\frac{1}{e} (1 + i\delta\alpha^a T^a) \partial_\mu \delta\alpha^b T^b + (1 + i\delta\alpha^a T^a) (A_\mu - i\delta\alpha^b A_\mu T^b) + \mathcal{O}(\delta\alpha_a^2) \\ &= A_\mu - \frac{1}{e} \partial_\mu \delta\alpha^a T^a - i\delta\alpha^a A_\mu^b T^b T^a + i\delta\alpha^a T^a A_\mu^b T^b + \mathcal{O}(\delta\alpha_a^2) \\ &= A_\mu - \frac{1}{e} \partial_\mu \delta\alpha^a \delta^{ac} T^c + i\delta\alpha^a A_\mu^b [T^a, T^b] + \mathcal{O}(\delta\alpha_a^2) \end{aligned} \quad (4.1.18)$$

Using the algebra of the group $[T^a, T^b] = i\varepsilon_{abc} T^c$.

$$\begin{aligned} A'_\mu &= A_\mu - \frac{1}{e} \partial_\mu \delta\alpha^a \delta^{ac} T^c - \varepsilon_{abc} T^c \delta\alpha^a A_\mu^b + \mathcal{O}(\delta\alpha_a^2) \\ &= A_\mu - \frac{1}{e} [\delta^{ac} \partial_\mu + e\varepsilon_{abc} A_\mu^b] \delta\alpha^a T^c + \mathcal{O}(\delta\alpha_a^2) \\ &= A_\mu - \frac{1}{e} D_\mu^{ac} \delta\alpha^a T^c + \mathcal{O}(\delta\alpha_a^2) \end{aligned} \quad (4.1.19)$$

We recognise the covariant derivative D_μ^{ac} in the adjoint representation. Expanding the gauge field over the generators

$$A_\mu^{ic} T^c = A_\mu^c T^c - \frac{1}{e} D_\mu^{ac} \delta\alpha^a T^c + \mathcal{O}(\delta\alpha_a^2) \quad (4.1.20)$$

Extracting only the components

$$A_\mu^{ic} = A_\mu^c - \frac{1}{e} D_\mu^{ac} \delta\alpha^a + \mathcal{O}(\delta\alpha_a^2) \quad (4.1.21)$$

$$\begin{aligned} \delta A_\nu^d(z) &:= A_\nu^{id}(z) - A_\nu^d(z) \\ &= -\frac{1}{e} D_\nu^{ad} \delta\alpha^a(z) + \mathcal{O}(\delta\alpha_\nu^2) \end{aligned} \quad (4.1.22)$$

We can now construct the variational derivative,

$$\begin{aligned} \frac{\delta A_\nu^d(z)}{\delta\alpha^c(y)} &= -\frac{1}{e} D_\nu^{ad} \frac{\delta\alpha^a(z)}{\delta\alpha^c(y)} \\ &= -\frac{1}{e} D_\nu^{ad} \delta^{ac} \delta(z-y) \\ &= -\frac{1}{e} D_\nu^{cd} \delta(z-y) \end{aligned} \quad (4.1.23)$$

Next is the variation of the Higgs and Goldstone fields. Recall the definition of the translated field in (3.1.18) from symmetry breaking shown below

$$X := \chi + X_M$$

Under a gauge transformation this transforms [39, 40] as

$$X' = \chi' + X_M \tag{4.1.24}$$

with $X' = UX$. So we can deduce the transformation rule for the translated field χ'

$$\begin{aligned} \chi' &= UX - X_M \\ &= U\chi + (U - 1)X_M \end{aligned} \tag{4.1.25}$$

For infinitesimal transformations

$$\begin{aligned} \delta\chi &:= \chi' - \chi \\ &= i\delta\alpha^c T^c (\chi + X_M) \end{aligned} \tag{4.1.26}$$

The variation of the Higgs and Goldstone fields are

$$\begin{aligned} \delta(X_M^\dagger T^b \chi - \chi^\dagger T^b X_M) &= X_M^\dagger T^b \delta\chi - \delta\chi^\dagger T^b X_M \\ &= i\delta\alpha^c [X_M^\dagger T^b T^c (\chi + X_M) + (\chi^\dagger + X_M^\dagger) T^c T^b X_M] \\ &= i\delta\alpha^c [X_M^\dagger T^b T^c X_M + X_M^\dagger T^c T^b X_M + X_M^\dagger T^b T^c \chi + \chi^\dagger T^c T^b X_M] \\ &= i\delta\alpha^c [X_M^\dagger \{T^b, T^c\} X_M + X_M^\dagger T^b T^c \chi + \chi^\dagger T^c T^b X_M] \end{aligned} \tag{4.1.27}$$

We can use $T^b = \frac{1}{2}\sigma^b$ and the anti-commutation relations

$$\begin{aligned} \{T^b, T^c\} &= \frac{1}{4} \{\sigma^b, \sigma^c\} \\ &= \frac{1}{2} \delta^{bc} \end{aligned} \tag{4.1.28}$$

and recalling the location of the vacuum from (3.1.16) shown below

$$X_M = \frac{1}{\sqrt{2}} \begin{pmatrix} 0 \\ 2\nu \end{pmatrix} \implies X_M^\dagger X_M = 2\nu^2$$

the first term of (4.1.27) can be simplified to

$$X_M^\dagger \{T^b, T^c\} X_M = \nu^2 \delta^{bc} \tag{4.1.29}$$

We now turn to evaluating the last two terms of (4.1.27). We show two ways to calculate this which serves also as an algebraic check. First, the brute force way is to note the sigma matrices can be parameterized as

$$\sigma^b = \begin{pmatrix} \delta_{b3} & \delta_{b1} - i\delta_{b2} \\ \delta_{b1} + i\delta_{b2} & -\delta_{b3} \end{pmatrix} \tag{4.1.30}$$

and the product of the sigma matrices is

$$\sigma^c \sigma^b = \begin{pmatrix} \delta_{ci} \delta_{bi} + i(\delta_{c1} \delta_{b2} - \delta_{c2} \delta_{b1}) & \delta_{c3} \delta_{b1} - \delta_{c1} \delta_{b3} + i(\delta_{c2} \delta_{b3} - \delta_{c3} \delta_{b2}) \\ \delta_{c1} \delta_{b3} - \delta_{c3} \delta_{b1} + i(\delta_{c2} \delta_{b3} - \delta_{c3} \delta_{b2}) & \delta_{ci} \delta_{bi} + i(\delta_{c2} \delta_{b1} - \delta_{c1} \delta_{b2}) \end{pmatrix} \quad (4.1.31)$$

This product of generators acting on the vacuum

$$\begin{aligned} T^c T^b X_M &= \frac{2\nu}{4\sqrt{2}} \sigma^c \sigma^b \begin{pmatrix} 0 \\ 1 \end{pmatrix} \\ &= \frac{\nu}{2\sqrt{2}} \begin{pmatrix} \delta_{ci} \delta_{bi} + i(\delta_{c1} \delta_{b2} - \delta_{c2} \delta_{b1}) & \delta_{c3} \delta_{b1} - \delta_{c1} \delta_{b3} + i(\delta_{c2} \delta_{b3} - \delta_{c3} \delta_{b2}) \\ \delta_{c1} \delta_{b3} - \delta_{c3} \delta_{b1} + i(\delta_{c2} \delta_{b3} - \delta_{c3} \delta_{b2}) & \delta_{ci} \delta_{bi} + i(\delta_{c2} \delta_{b1} - \delta_{c1} \delta_{b2}) \end{pmatrix} \begin{pmatrix} 0 \\ 1 \end{pmatrix} \\ &= \frac{\nu}{2\sqrt{2}} \begin{pmatrix} \delta_{c3} \delta_{b1} - \delta_{c1} \delta_{b3} + i(\delta_{c2} \delta_{b3} - \delta_{c3} \delta_{b2}) \\ \delta_{ci} \delta_{bi} + i(\delta_{c2} \delta_{b1} - \delta_{c1} \delta_{b2}) \end{pmatrix} \end{aligned} \quad (4.1.32)$$

Recalling the translated field χ

$$\chi = \frac{1}{\sqrt{2}} \begin{pmatrix} \chi_2 + i\chi_1 \\ \chi_0 - i\chi_3 \end{pmatrix}$$

then

$$\begin{aligned} \chi^\dagger T^c T^b X_M &= \frac{1}{\sqrt{2}} \begin{pmatrix} \chi_2 - i\chi_1 & \chi_0 + i\chi_3 \end{pmatrix} \frac{\nu}{2\sqrt{2}} \begin{pmatrix} \delta_{c3} \delta_{b1} - \delta_{c1} \delta_{b3} + i(\delta_{c2} \delta_{b3} - \delta_{c3} \delta_{b2}) \\ \delta_{ci} \delta_{bi} + i(\delta_{c2} \delta_{b1} - \delta_{c1} \delta_{b2}) \end{pmatrix} \\ &= \frac{\nu}{4} \left\{ \chi_2 (\delta_{c3} \delta_{b1} - \delta_{c1} \delta_{b3}) + \chi_1 (\delta_{c2} \delta_{b3} - \delta_{c3} \delta_{b2}) + i [\chi_2 (\delta_{c2} \delta_{b3} - \delta_{c3} \delta_{b2}) - \chi_1 (\delta_{c3} \delta_{b1} - \delta_{c1} \delta_{b3})] + \right. \\ &\quad \left. + \chi_0 (\delta_{ci} \delta_{bi}) - \chi_3 (\delta_{c2} \delta_{b1} - \delta_{c1} \delta_{b2}) + i [\chi_0 (\delta_{c2} \delta_{b1} - \delta_{c1} \delta_{b2}) + \chi_3 (\delta_{ci} \delta_{bi})] \right\} \end{aligned} \quad (4.1.33)$$

Taking the hermitian conjugate of the above expression and substituting into the last two terms of (4.1.27) we obtain

$$\chi^\dagger T^c T^b X_M + X_M^\dagger T^b T^c \chi = \frac{1}{2} \nu \left\{ \chi_2 (\delta_{c3} \delta_{b1} - \delta_{c1} \delta_{b3}) + \chi_1 (\delta_{c2} \delta_{b3} - \delta_{c3} \delta_{b2}) - \chi_3 (\delta_{c2} \delta_{b1} - \delta_{c1} \delta_{b2}) + \chi_0 (\delta_{ci} \delta_{bi}) \right\} \quad (4.1.34)$$

A closer observation of the above expression and we can see the anti-symmetric pattern present in the first three terms. This can be made clearer by using the Levi-Civita symbol

$$\begin{aligned} \chi^\dagger T^c T^b X_M + X_M^\dagger T^b T^c \chi &= \frac{1}{2} \nu (\chi_a \varepsilon_{abm} \delta_{cl} \delta_{bm} + \chi_0 \delta_{bc}) \\ &= \frac{1}{2} \nu (\chi_0 \delta_{bc} - \chi_a \varepsilon_{abc}) \end{aligned} \quad (4.1.35)$$

Secondly, a more elegant way to see this result is to make use of the commutation and anti-commutation relation between the sigma matrices,

$$[\sigma^b, \sigma^c] = 2i\varepsilon_{abc} \sigma^a, \quad \{\sigma^b, \sigma^c\} = 2\delta_{bc} \quad (4.1.36)$$

which when summed give an expression for the product of the sigma matrices in terms of the Levi-Civita symbol

$$\begin{aligned} \sigma^b \sigma^c &= \delta_{bc} + i\varepsilon_{abc} \sigma^a \\ \implies T^b T^c &= \frac{1}{4} \delta_{bc} + \frac{1}{4} i\varepsilon_{abc} \sigma^a \end{aligned} \quad (4.1.37)$$

So

$$X_M^\dagger T^b T^c \chi = \frac{1}{4} \delta^{bc} X_M^\dagger \chi + \frac{1}{4} i \varepsilon_{abc} X_M^\dagger \sigma^a \chi \quad (4.1.38)$$

and the pieces (can be obtain using parameterized sigma matrices), are given by

$$X_M^\dagger \chi = \frac{1}{\sqrt{2}} \begin{pmatrix} 0 & 2\nu \end{pmatrix} \frac{1}{\sqrt{2}} \begin{pmatrix} \chi_2 + i\chi_1 \\ \chi_0 - i\chi_3 \end{pmatrix} \quad (4.1.39)$$

$$= (\chi_0 - i\chi_3) \nu$$

$$X_M^\dagger \sigma^a \chi = \frac{1}{\sqrt{2}} \begin{pmatrix} 0 & 2\nu \end{pmatrix} \begin{pmatrix} \delta_{a3} & \delta_{a1} - i\delta_{a2} \\ \delta_{a1} + i\delta_{a2} & -\delta_{a3} \end{pmatrix} \frac{1}{\sqrt{2}} \begin{pmatrix} \chi_2 + i\chi_1 \\ \chi_0 - i\chi_3 \end{pmatrix} \quad (4.1.40)$$

$$= \nu [i(\chi_m \delta_{am}) + \chi_2 \delta_{a1} - \chi_1 \delta_{a2} - \chi_0 \delta_{a3}]$$

The result for the $X_M^\dagger T^b T^c \chi$ product is given by

$$X_M^\dagger T^b T^c \chi = \frac{1}{4} \delta^{bc} (\chi_0 - i\chi_3) \nu + \frac{1}{4} \nu [-\chi_a \varepsilon_{abc} + i(\chi_2 \varepsilon_{1bc} - \chi_1 \varepsilon_{2bc} - \chi_0 \varepsilon_{3bc})]$$

Summing the above with its hermitian conjugate yields

$$\chi^\dagger T^c T^b X_M + X_M^\dagger T^b T^c \chi = \frac{1}{2} \nu (\chi_0 \delta^{bc} - \chi_a \varepsilon_{abc}) \quad (4.1.41)$$

which is the same result from the brute force computations. Substituting (4.1.29) and (4.1.41) into (4.1.27)

$$\begin{aligned} \delta (X_M^\dagger T^b \chi - \chi^\dagger T^b X_M) &= i \delta \alpha^c [X_M^\dagger \{T^b, T^c\} X_M + X_M^\dagger T^b T^c \chi + \chi^\dagger T^c T^b X_M] \\ &= i \delta \alpha^c \left[\nu^2 \delta^{bc} + \frac{1}{2} \nu (\chi_0 \delta^{bc} - \chi_a \varepsilon_{abc}) \right] \end{aligned} \quad (4.1.42)$$

We have gathered all the ingredients to compute the matrix M^{bc} , substituting (4.1.23) and (4.1.42) into (4.1.15)

$$\begin{aligned} M^{bc} &= \frac{\delta G^b [\alpha A; x]}{\delta \alpha^c (y)} \\ &= \int d^4 z \left[\partial_x^\mu \delta_{bd} \delta(x-z) g_\mu^\nu \frac{\delta A_\nu^d(z)}{\delta \alpha^c(y)} \right] + \xi i e \frac{\delta}{\delta \alpha^c(y)} (X_M^\dagger T^b \chi - \chi^\dagger T^b X_M) \\ &= -\frac{1}{e} \partial_x^\mu \int d^4 z [\delta(x-z) D_\mu^{bc} \delta(z-y)] - \xi e \left[\nu^2 \delta^{bc} + \frac{1}{2} \nu (\chi_0 \delta^{bc} - \chi_a \varepsilon_{abc}) \right] \frac{\delta \alpha^c(x)}{\delta \alpha^c(y)} \\ &= -\frac{1}{e} \partial_x^\mu D_\mu^{bc} \delta(x-y) - \xi e \left[\nu^2 \delta^{bc} + \frac{1}{2} \nu (\chi_0 \delta^{bc} - \chi_a \varepsilon_{abc}) \right] \delta(x-y) \\ &= \frac{1}{e} \left[-\partial_x^\mu D_\mu^{bc} - \xi e^2 \nu^2 \delta^{bc} - \frac{1}{2} \xi e^2 \nu \chi_0 \delta^{bc} + \frac{1}{2} \xi e^2 \nu \chi_a \varepsilon_{abc} \right] \delta(x-y) \end{aligned} \quad (4.1.43)$$

Note that in the third line we have moved the ∂_x^μ out of the integral since it acts only on the $\delta(x-z)$. The derivative of the covariant derivative in the adjoint representation is

$$\partial_x^\mu D_\mu^{bc} = \partial_x^\mu [\delta^{bc} \partial_{x\mu} + e \varepsilon_{bac} A_\mu^a] \quad (4.1.44)$$

where the ∂_x^μ is understood to act on everything to its right. We are still left with the problem of constructing determinant of matrix M^{bc} . In its current form the usefulness of the path integral,

$$\mathcal{Z} = \int \mathcal{D}A e^{iS[A]} e^{-\frac{i}{2\xi} \int d^4x G_a^2(A)} \Delta[A] \quad (4.1.45)$$

is limited since functional techniques are limited to functionals of Gaussian form and the determinant spoils this form. This can be remedied by noting that Berezin-type functional integrals [41] over Grassmann variables results in a determinant in the numerator i.e.

$$\begin{aligned} \Delta[A] &= \det [M^{bc}] \\ &= \int \mathcal{D}\bar{u} \mathcal{D}u e^{-ie \int d^4x d^4y \bar{u}^b(x) M^{bc}(x,y) u^c(y)} \end{aligned} \quad (4.1.46)$$

Where \bar{u}^a, u^a are anti-commuting Grassmann fields with

$$\{u^a, u^b\} = \{\bar{u}^a, \bar{u}^b\} = \{\bar{u}^a, u^b\} = 0 \quad (4.1.47)$$

Since the expressions are long we shall write down the pieces separately

$$\begin{aligned} -ie \int d^4x d^4y \bar{u}^b(x) M^{bc}(x,y) u^c(y) &= -ie \int d^4x d^4y \bar{u}^b(x) \frac{1}{e} \left[-\partial_x^\mu D_\mu^{bc} - \xi e^2 \nu^2 \delta^{bc} - \frac{1}{2} \xi e^2 \nu \chi_0 \delta^{bc} + \right. \\ &\quad \left. + \frac{1}{2} \xi e^2 \nu \chi_a \varepsilon_{abc} \right] \delta(x-y) u^c(y) \\ &= i \int d^4x \bar{u}^b(x) \left[\partial_x^\mu D_\mu^{bc} + \xi e^2 \nu^2 \delta^{bc} + \frac{1}{2} \xi e^2 \nu \chi_0 \delta^{bc} - \frac{1}{2} \xi e^2 \nu \chi_a \varepsilon_{abc} \right] u^c(x) \end{aligned} \quad (4.1.48)$$

Substituting in the covariant derivative in the adjoint representation for

$$\begin{aligned} \bar{u}^b \left[\partial_x^\mu D_\mu^{bc} + \xi e^2 \nu^2 \delta^{bc} \right] u^c &= \bar{u}^b \left[\partial^\mu (\delta^{bc} \partial_\mu + e \varepsilon_{bac} A_\mu^a) + \xi e^2 \nu^2 \delta^{bc} \right] u^c \\ &= \bar{u}^a \left(\partial^\mu \partial_\mu + \xi e^2 \nu^2 \right) u^a + e \varepsilon_{bac} \bar{u}^b \partial^\mu (A_\mu^a u^c) \\ &= \bar{u}^a \left(\partial^\mu \partial_\mu + \xi e^2 \nu^2 \right) u^a + e \varepsilon_{abc} A_\mu^a \left(\partial^\mu \bar{u}^b \right) u^c \end{aligned} \quad (4.1.49)$$

Putting all the pieces together for the exponent

$$\begin{aligned} -ie \int d^4x d^4y \bar{u}^b(x) M^{bc}(x,y) u^c(y) &= i \int d^4x \left[\bar{u}^a \left(\partial^\mu \partial_\mu + \xi e^2 \nu^2 \right) u^a + e \varepsilon_{abc} A_\mu^a \left(\partial^\mu \bar{u}^b \right) u^c + \frac{1}{2} \xi e^2 \nu \chi_0 \bar{u}^a u^a + \right. \\ &\quad \left. - \frac{1}{2} \xi e^2 \nu \varepsilon_{abc} \chi_a \bar{u}^b u^c \right] \end{aligned} \quad (4.1.50)$$

The determinant can now be expressed as

$$\begin{aligned} \Delta[A] &= \int \mathcal{D}\bar{u} \mathcal{D}u e^{-ie \int d^4x d^4y \bar{u}^b(x) M^{bc}(x,y) u^c(y)} \\ &= \int \mathcal{D}\bar{u} \mathcal{D}u e^{i \int d^4x \left[\bar{u}^a \left(\partial^\mu \partial_\mu + \xi e^2 \nu^2 \right) u^a + e \varepsilon_{abc} A_\mu^a \left(\partial^\mu \bar{u}^b \right) u^c + \frac{1}{2} \xi e^2 \nu \chi_0 \bar{u}^a u^a - \frac{1}{2} \xi e^2 \nu \varepsilon_{abc} \chi_a \bar{u}^b u^c \right]} \end{aligned} \quad (4.1.51)$$

Substituting the determinant into the path integral

$$\begin{aligned}
 \mathcal{Z} &= \int \mathcal{D}A e^{iS[A]} e^{-\frac{i}{2\xi} \int d^4x G_a^2(A)} \Delta[A] \\
 &= \int \mathcal{D}\bar{u} \mathcal{D}u \mathcal{D}A e^{iS[A] - \frac{i}{2\xi} \int d^4x G_a^2(A) + i \int d^4x [\bar{u}^a (\partial^\mu \partial_\mu + \xi e^2 \nu^2) u^a + e \varepsilon_{abc} A_\mu^a (\partial^\mu \bar{u}^b) u^c + \frac{1}{2} \xi e^2 \nu \chi_0 \bar{u}^a u^a - \frac{1}{2} \xi e^2 \nu \varepsilon_{abc} \chi_a \bar{u}^b u^c]} \\
 &= \int \mathcal{D}\bar{u} \mathcal{D}u \mathcal{D}A e^{i \int d^4x [\mathcal{L} - \frac{1}{2\xi} G_a^2(A) + \bar{u}^a (\partial^\mu \partial_\mu + \xi e^2 \nu^2) u^a + e \varepsilon_{abc} A_\mu^a (\partial^\mu \bar{u}^b) u^c + \frac{1}{2} \xi e^2 \nu \chi_0 \bar{u}^a u^a - \frac{1}{2} \xi e^2 \nu \varepsilon_{abc} \chi_a \bar{u}^b u^c]} \\
 &= \int \mathcal{D}\bar{u} \mathcal{D}u \mathcal{D}A e^{i \int d^4x \mathcal{L}_{\text{eff}}}
 \end{aligned} \tag{4.1.52}$$

Where we have defined the effective Lagrangian

$$\mathcal{L}_{\text{eff}} := \mathcal{L} - \frac{1}{2\xi} G_a^2(A) + \bar{u}^a (\partial^\mu \partial_\mu + \xi e^2 \nu^2) u^a + e \varepsilon_{abc} A_\mu^a (\partial^\mu \bar{u}^b) u^c + \frac{1}{2} \xi e^2 \nu \chi_0 \bar{u}^a u^a - \frac{1}{2} \xi e^2 \nu \varepsilon_{abc} \chi_a \bar{u}^b u^c \tag{4.1.53}$$

4.2 Gauge Fixing Term



give a justification of the choice of the gauge fixing function in (4.1.14) shown here:

$$G^b[\alpha A; x] = \partial^\mu A_\mu^b + \xi i e (X_M^\dagger T^b \chi - \chi^\dagger T^b X_M)$$

After spontaneous symmetry breaking, some pesky two point mixing terms (3.1.30)

$$X_M^\dagger \partial^\mu A_\mu \chi - \chi^\dagger \partial^\mu A_\mu X_M = \frac{i}{\sqrt{2}} \chi_a \partial^\mu A_\mu^a$$

were generated which were hard to interpret. These terms survived and were present in the Higgs lagrangian shown below:

$$\begin{aligned}
 \mathcal{L}_H &= \frac{1}{2} (\partial_\mu H \partial^\mu H - \mu^2 H^2) + \frac{1}{2} \partial_\mu \chi_a \partial^\mu \chi_a + i e \partial^\mu A_\mu^a [X_M^\dagger T^a \chi - \chi^\dagger T^a X_M] - \frac{1}{4} e \varepsilon_{abc} (\chi_a \overleftrightarrow{\partial}^\mu \chi_b) A_\mu^c + \\
 &- \frac{1}{2} e (\chi_a \overleftrightarrow{\partial}^\mu H) A_\mu^a + \frac{1}{2} e^2 \nu^2 A_\mu^a A^{a\mu} + \frac{1}{2} e^2 \nu H A_\mu^a A^{a\mu} + \frac{1}{8} e^2 H^2 A_\mu^a A^{a\mu} + \frac{1}{8} e^2 \chi_b^2 A_\mu^a A^{a\mu} - \frac{\lambda}{32} H^4 - \frac{\lambda}{16} H^2 \chi_a^2 + \\
 &- \frac{\lambda}{32} \chi_a^2 \chi_b^2 - \frac{\nu \lambda}{4} H^3 - \frac{\nu \lambda}{4} H \chi_a^2 - \frac{1}{2} (4\kappa \nu^2) \phi_a^2 - 2\kappa \nu H \phi_a^2 - \frac{1}{2} \kappa H^2 \phi_a^2 - \frac{1}{2} \kappa \chi_a^2 \phi_a^2 + \frac{1}{2} \mu^2 \nu^2
 \end{aligned} \tag{4.2.1}$$

We see that the gauge fixing term,

$$\begin{aligned}
 \mathcal{L}_{\text{GF}} &= -\frac{1}{2\xi} G_a^2(A) \\
 &= -\frac{1}{2\xi} [\partial^\mu A_\mu^a + \xi i e (X_M^\dagger T^a \chi - \chi^\dagger T^a X_M)]^2 \\
 &= -\frac{1}{2\xi} (\partial^\mu A_\mu^a)^2 - i e \partial^\mu A_\mu^a [X_M^\dagger T^a \chi - \chi^\dagger T^a X_M] + \frac{1}{2} \xi e^2 (X_M^\dagger T^a \chi - \chi^\dagger T^a X_M)^2
 \end{aligned} \tag{4.2.2}$$

in the effective Lagrangian has been designed specifically to remove the pesky two point mixing terms from symmetry breaking. We now are left to the task of evaluating the last term of (4.2.2). Recall the earlier result of (4.1.40) of

$$X_M^\dagger \sigma^a \chi = \nu [i(\chi_m \delta_{am}) + \chi_2 \delta_{a1} - \chi_1 \delta_{a2} - \chi_0 \delta_{a3}]$$

Taking the hermitian conjugate and finding the difference

$$\begin{aligned} X_M^\dagger \sigma^a \chi - \chi \sigma^a X_M &= 2i\nu \chi_a \\ \implies X_M^\dagger T^a \chi - \chi T^a X_M &= i\nu \chi_a \end{aligned} \tag{4.2.3}$$

The gauge fixing terms final form is given by

$$\mathcal{L}_{\text{GF}} = -\frac{1}{2\xi} (\partial^\mu A_\mu^a)^2 - ie \partial^\mu A_\mu^a [X_M^\dagger T^a \chi - \chi^\dagger T^a X_M] - \frac{1}{2} \xi e^2 \nu^2 \chi_a^2 \tag{4.2.4}$$

4.3 Complete Lagrangian

UE make the cosmetic change of relabeling $\chi_0 \rightarrow H$ then list the complete Lagrangian

$$\mathcal{L}_{\text{eff}} := \mathcal{L} + \mathcal{L}_{\text{GF}} + \bar{u}^a \left(\partial^\mu \partial_\mu + \xi e^2 \nu^2 \right) u^a + e \varepsilon_{abc} A_\mu^a \left(\partial^\mu \bar{u}^b \right) u^c + \frac{1}{2} \xi e^2 \nu H \bar{u}^a u^a - \frac{1}{2} \xi e^2 \nu \varepsilon_{abc} \chi_a \bar{u}^b u^c \quad (4.3.1)$$

with

$$\mathcal{L} := \mathcal{L}_{\phi A} + \mathcal{L}_H \quad (4.3.2)$$

the pion-rho Lagrangian

$$\begin{aligned} \mathcal{L}_{\phi A} = & \frac{1}{2} \left(\partial_\mu \phi_a \partial^\mu \phi_a - b^2 \phi_a^2 \right) + \frac{1}{2} e \varepsilon_{aij} A_\mu^a \left(\phi_j \partial^\mu \phi_i - \phi_i \partial^\mu \phi_j \right) - \frac{1}{2} e^2 \varepsilon_{aij} \varepsilon_{bjk} \phi_i \phi_k A_\mu^a A^{b\mu} - \frac{\lambda_4}{8} \left(\phi_a^2 \phi_b^2 \right) + \\ & - \frac{1}{4} F_{\mu\nu}^a F^{a\mu\nu} + \frac{1}{2} e \varepsilon_{abc} A^{b\mu} A^{c\nu} F_{\mu\nu}^a - \frac{1}{4} e^2 \varepsilon_{abc} \varepsilon_{ade} A_\mu^b A_\nu^c A^{d\mu} A^{e\nu} \end{aligned} \quad (4.3.3)$$

the Higgs-rho-pion Lagrangian

$$\begin{aligned} \mathcal{L}_H = & \frac{1}{2} \left(\partial_\mu H \partial^\mu H - \mu^2 H^2 \right) + \frac{1}{2} \partial_\mu \chi_a \partial^\mu \chi_a + ie \partial^\mu A_\mu^a \left[X_M^\dagger T^a \chi - \chi^\dagger T^a X_M \right] - \frac{1}{4} e \varepsilon_{abc} \left(\chi_a \overleftrightarrow{\partial}^\mu \chi_b \right) A_\mu^c + \\ & - \frac{1}{2} e \left(\chi_a \overleftrightarrow{\partial}^\mu H \right) A_\mu^a + \frac{1}{2} e^2 \nu^2 A_\mu^a A^{a\mu} + \frac{1}{2} e^2 \nu H A_\mu^a A^{a\mu} + \frac{1}{8} e^2 H^2 A_\mu^a A^{a\mu} + \frac{1}{8} e^2 \chi_b^2 A_\mu^a A^{a\mu} - \frac{\lambda}{32} H^4 - \frac{\lambda}{16} H^2 \chi_a^2 + \\ & - \frac{\lambda}{32} \chi_a^2 \chi_b^2 - \frac{\nu \lambda}{4} H^3 - \frac{\nu \lambda}{4} H \chi_a^2 - \frac{1}{2} \left(4\kappa \nu^2 \right) \phi_a^2 - 2\kappa \nu H \phi_a^2 - \frac{1}{2} \kappa H^2 \phi_a^2 - \frac{1}{2} \kappa \chi_a^2 \phi_a^2 + \frac{1}{2} \mu^2 \nu^2 \end{aligned} \quad (4.3.4)$$

and the gauge fixing Lagrangian

$$\mathcal{L}_{\text{GF}} = -\frac{1}{2\xi} \left(\partial^\mu A_\mu^a \right)^2 - ie \partial^\mu A_\mu^a \left[X_M^\dagger T^a \chi - \chi^\dagger T^a X_M \right] - \frac{1}{2} \xi e^2 \nu^2 \chi_a^2 \quad (4.3.5)$$

5

Path to Calculations

5.1 Renormalization Transformation

THUS far we have constructed a Lagrangian which contains bare fields and couplings. Bare in the sense that they are not directly related to experiment. To complete the definition of the theory, we must show how these bare couplings and fields are related to the experimentally measured coupling and give meaning to the fields and couplings. This is done by renormalization [42, 43, 44]. Since the complete bare Lagrangian has many terms in it, we shall split up the calculation and deal with the self contained pieces. We begin with the bare pion-rho Lagrangian:

$$\begin{aligned}
 \mathcal{L}_{\phi_0 A_0} = & \frac{1}{2} \left(\partial_\mu \phi_{0a} \partial^\mu \phi_{0a} - m_0^2 \phi_{0a}^2 \right) + \frac{1}{2} e_0 \varepsilon_{aij} A_{0\mu}^a (\phi_{0j} \partial^\mu \phi_{0i} - \phi_{0i} \partial^\mu \phi_{0j}) - \frac{1}{2} e_0^2 \varepsilon_{aij} \varepsilon_{bjk} \phi_{0i} \phi_{0k} A_{0\mu}^a A_0^{b\mu} + \\
 & - \frac{\lambda_{4_0}}{8} (\phi_{0a}^2 \phi_{0b}^2) - \frac{1}{4} F_{0\mu\nu}^a F_0^{a\mu\nu} + \frac{1}{2} M_0^2 A_{0\mu}^a A_0^{a\mu} - \frac{1}{2\xi_0} (\partial^\mu A_{0\mu}^a)^2 + \frac{1}{2} e_0 \varepsilon_{abc} A_0^{b\mu} A_0^{c\nu} F_{0\mu\nu}^a + \\
 & - \frac{1}{4} e_0^2 \varepsilon_{abc} \varepsilon_{ade} A_{0\mu}^b A_{0\nu}^c A_0^{d\mu} A_0^{e\nu}
 \end{aligned} \tag{5.1.1}$$

The subscript 0 is used to indicate bare quantities. We make a redefinition of the fields and couplings in terms of the renormalized fields and couplings:

$$\begin{aligned}
 \phi_{0a} & := \phi_a \sqrt{Z_\phi} & m_0 & := m \sqrt{Z_m} & e_0 & := e \sqrt{Z_e} \\
 M_0 & := M \sqrt{Z_M} & \frac{1}{\xi_0} & := \frac{\sqrt{Z_\xi}}{\xi} & \lambda_{4_0} & := \lambda_4 \sqrt{Z_{\lambda_4}}
 \end{aligned} \tag{5.1.2}$$

Substituting (5.1.2) into (5.1.1)

$$\begin{aligned}
 \mathcal{L}_{\phi_0 A_0} = & \frac{1}{2} \left(Z_\phi \partial_\mu \phi_a \partial^\mu \phi_a - Z_\phi Z_m m^2 \phi_a^2 \right) + \frac{1}{2} e Z_\phi \sqrt{Z_e Z_A} \varepsilon_{aij} A_\mu^a (\phi_j \partial^\mu \phi_i - \phi_i \partial^\mu \phi_j) + \\
 & - \frac{1}{2} e^2 Z_e Z_\phi Z_A \varepsilon_{aij} \varepsilon_{bjk} \phi_i \phi_k A_\mu^a A^{b\mu} - \frac{Z_\phi^2 \sqrt{Z_{\lambda_4}} \lambda_4}{8} (\phi_a^2 \phi_b^2) - \frac{1}{4} Z_A F_{\mu\nu}^a F^{a\mu\nu} + \frac{1}{2} Z_M Z_A M^2 A_\mu^a A^{a\mu} + \\
 & - \frac{Z_A \sqrt{Z_\xi}}{2\xi} (\partial^\mu A_\mu^a)^2 + \frac{1}{2} e \sqrt{Z_e Z_A^3} \varepsilon_{abc} A^{b\mu} A^{c\nu} F_{\mu\nu}^a - \frac{1}{4} e^2 Z_e Z_A^2 \varepsilon_{abc} \varepsilon_{ade} A_\mu^b A_\nu^c A^{d\mu} A^{e\nu}
 \end{aligned} \tag{5.1.3}$$

The definition of the Z_i factors are given by:

$$\begin{aligned}
 Z_\phi &:= 1 + \delta Z_\phi & Z_\phi Z_m m^2 &:= m^2 + \delta m^2 & e Z_\phi \sqrt{Z_e Z_A} &:= e + \delta Z_{A\phi^2} \\
 e^2 Z_e Z_\phi Z_A &:= e^2 + \delta Z_{\phi^2 A^2} & Z_\phi^2 \sqrt{Z_{\lambda_4}} \lambda_4 &:= \lambda_4 + \delta Z_{\phi^4} & Z_A &:= 1 + \delta Z_A \\
 Z_M Z_A M^2 &:= M^2 + \delta M^2 & \frac{Z_A \sqrt{Z_\xi}}{\xi} &:= \frac{1}{\xi} + \delta \xi & e \sqrt{Z_e Z_A^3} &:= e + \delta Z_{A^2 \partial A} \\
 e^2 Z_e Z_A^2 &:= e^2 + \delta Z_{A^4}
 \end{aligned} \tag{5.1.4}$$

and substituting (5.1.4) into (5.1.3), the Lagrangian will split into two pieces

$$\mathcal{L}_{\phi_0 A_0} = \mathcal{L}_{\phi A} + \mathcal{L}_{\phi A}^{\text{CT}} \tag{5.1.5}$$

where $\mathcal{L}_{\phi A}$ is of a form that resembles the bare Lagrangian $\mathcal{L}_{\phi_0 A_0}$

$$\begin{aligned}
 \mathcal{L}_{\phi A} &= \frac{1}{2} \left(\partial_\mu \phi_a \partial^\mu \phi_a - m^2 \phi_a^2 \right) + \frac{1}{2} e \varepsilon_{aij} A_\mu^a (\phi_j \partial^\mu \phi_i - \phi_i \partial^\mu \phi_j) - \frac{1}{2} e^2 \varepsilon_{aij} \varepsilon_{bjk} \phi_i \phi_k A_\mu^a A^{b\mu} - \frac{\lambda_4}{8} (\phi_a^2 \phi_b^2) + \\
 &- \frac{1}{4} F_{\mu\nu}^a F^{a\mu\nu} + \frac{1}{2} M^2 A_\mu^a A^{a\mu} - \frac{1}{2\xi} (\partial^\mu A_\mu^a)^2 + \frac{1}{2} e \varepsilon_{abc} A^{b\mu} A^{c\nu} F_{\mu\nu}^a - \frac{1}{4} e^2 \varepsilon_{abc} \varepsilon_{ade} A_\mu^b A_\nu^c A^{d\mu} A^{e\nu}
 \end{aligned} \tag{5.1.6}$$

and the new piece $\mathcal{L}_{\text{CT}}^{\phi A}$ is the counter term Lagrangian

$$\begin{aligned}
 \mathcal{L}_{\phi A}^{\text{CT}} &= \frac{1}{2} \left(\delta Z_\phi \partial_\mu \phi_a \partial^\mu \phi_a - \delta m^2 \phi_a^2 \right) + \frac{1}{2} \delta Z_e \varepsilon_{aij} A_\mu^a (\phi_j \partial^\mu \phi_i - \phi_i \partial^\mu \phi_j) - \frac{1}{2} \delta Z_{A\phi^2} \varepsilon_{aij} \varepsilon_{bjk} \phi_i \phi_k A_\mu^a A^{b\mu} + \\
 &- \frac{\delta Z_{\phi^4}}{8} (\phi_a^2 \phi_b^2) - \frac{1}{4} \delta Z_A F_{\mu\nu}^a F^{a\mu\nu} + \frac{1}{2} \delta M^2 A_\mu^a A^{a\mu} - \frac{1}{2} \delta \xi (\partial^\mu A_\mu^a)^2 + \frac{1}{2} \delta Z_{A^2 \partial A} \varepsilon_{abc} A^{b\mu} A^{c\nu} F_{\mu\nu}^a + \\
 &- \frac{1}{4} \delta Z_{A^4} \varepsilon_{abc} \varepsilon_{ade} A_\mu^b A_\nu^c A^{d\mu} A^{e\nu}
 \end{aligned} \tag{5.1.7}$$

which contains all the δZ_i factors. The bare Lagrangian from symmetry breaking is

$$\begin{aligned}
 \mathcal{L}_{H_0} &= \frac{1}{2} \left(\partial_\mu H_0 \partial^\mu H_0 - m_{H_0}^2 H_0^2 \right) + \frac{1}{2} \left(\partial_\mu \chi_{0a} \partial^\mu \chi_{0a} - \xi_0 M_0^2 \chi_a^2 \right) - \frac{1}{4} e_0 \varepsilon_{abc} \left(\chi_{0a} \overleftrightarrow{\partial}^\mu \chi_{0b} \right) A_{0\mu}^c + \\
 &- \frac{1}{2} e_0 \left(\chi_{0a} \overleftrightarrow{\partial}^\mu H_0 \right) A_{0\mu}^a + \frac{1}{2} e_0^2 \nu_0 H_0 A_{0\mu}^a A_0^{a\mu} + \frac{1}{8} e_0^2 H_0^2 A_{0\mu}^a A_0^{a\mu} + \frac{1}{8} e_0^2 \chi_{0b}^2 A_{0\mu}^a A_0^{a\mu} - \frac{\lambda_0}{32} H_0^4 + \\
 &- \frac{\lambda_0}{16} H_0^2 \chi_{0a}^2 - \frac{\lambda_0}{32} \chi_{0a}^2 \chi_{0b}^2 - \frac{\nu_0 \lambda_0}{4} H_0^3 - \frac{\nu_0 \lambda_0}{4} H_0 \chi_{0a}^2 - 2\kappa_0 \nu_0 H_0 \phi_{0a}^2 - \frac{1}{2} \kappa_0 H_0^2 \phi_{0a}^2 - \frac{1}{2} \kappa_0 \chi_{0a}^2 \phi_{0b}^2
 \end{aligned} \tag{5.1.8}$$

Redefining the bare fields and couplings in term of the renormalized fields and couplings

$$\begin{aligned}
 H_0 &:= H \sqrt{Z_H} & m_{H_0} &:= m_H \sqrt{Z_{m_H}} & \chi_{0a} &:= \chi_a \sqrt{Z_\chi} \\
 M_0 &:= M \sqrt{Z_M} & \nu_0 &:= \nu \sqrt{Z_\nu} & \lambda_0 &:= \lambda \sqrt{Z_\lambda} \\
 \kappa_0 &:= \kappa \sqrt{Z_\kappa}
 \end{aligned} \tag{5.1.9}$$

Reusing some definitions in (5.1.2) and (5.1.9), and substituting into (5.1.10) gives us

$$\begin{aligned}
 \mathcal{L}_{H_0} &= \frac{1}{2} \left(Z_H \partial_\mu H \partial^\mu H - Z_H Z_{m_H} m_H^2 H^2 \right) + \frac{1}{2} \left(Z_\chi \partial_\mu \chi_a \partial^\mu \chi_a - \xi_0 Z_\chi Z_M M^2 \chi_a^2 \right) + \\
 &- \frac{1}{4} e Z_\chi \sqrt{Z_e Z_A} \varepsilon_{abc} \left(\chi_a \overleftrightarrow{\partial}^\mu \chi_b \right) A_\mu^c - \frac{1}{2} e \sqrt{Z_e Z_\chi Z_H Z_A} \left(\chi_a \overleftrightarrow{\partial}^\mu H \right) A_\mu^a + \frac{1}{2} e^2 \nu Z_A Z_e \sqrt{Z_H Z_\nu} H A_\mu^a A^{a\mu} + \\
 &+ \frac{1}{8} e^2 Z_e Z_H Z_A H^2 A_\mu^a A^{a\mu} + \frac{1}{8} e^2 Z_e Z_\chi Z_A \chi_b^2 A_\mu^a A^{a\mu} - \frac{\lambda}{32} Z_H^2 \sqrt{Z_\lambda} H^4 - \frac{\lambda}{16} Z_H Z_\chi \sqrt{Z_\lambda} H^2 \chi_a^2 + \\
 &- \frac{\lambda}{32} Z_\chi^2 \sqrt{Z_\lambda} \chi_a^2 \chi_b^2 - \frac{\nu \lambda}{4} \sqrt{Z_\nu Z_\lambda Z_H^3} H^3 - \frac{\nu \lambda}{4} Z_\chi \sqrt{Z_\nu Z_\lambda Z_H} H \chi_a^2 - 2\kappa \nu Z_\phi \sqrt{Z_\kappa Z_\nu Z_H} H \phi_a^2 + \\
 &- \frac{1}{2} \kappa Z_H Z_\phi \sqrt{Z_\kappa} H^2 \phi_a^2 - \frac{1}{2} \kappa Z_\chi Z_\phi \sqrt{Z_\kappa} \chi_a^2 \phi_b^2
 \end{aligned} \tag{5.1.10}$$

The definition for the Z_i factors are

$$\begin{aligned}
 Z_H &:= 1 + \delta Z_H & Z_H Z_{m_H} m_H^2 &:= m_H^2 + \delta m_H^2 & Z_\chi &:= 1 + \delta Z_\chi \\
 \xi_0 Z_\chi Z_M M^2 &:= \xi M^2 + \delta M_{\chi\xi}^2 & e Z_\chi \sqrt{Z_e Z_A} &:= e + \delta Z_{A\chi^2} & e \sqrt{Z_e Z_\chi Z_H Z_A} &:= e + \delta Z_{\chi H A} \\
 e^2 \nu Z_A Z_e \sqrt{Z_H Z_\nu} &:= e^2 \nu + \delta Z_{H A^2} & e^2 Z_e Z_H Z_A &:= e^2 + \delta Z_{H^2 A^2} & e^2 Z_e Z_\chi Z_A &:= e^2 + \delta Z_{\chi^2 A^2} \\
 \lambda Z_H^2 \sqrt{Z_\lambda} &:= \lambda + \delta Z_{H^4} & \lambda Z_H Z_\chi \sqrt{Z_\lambda} &:= \lambda + \delta Z_{H^2 \chi^2} & \lambda Z_\chi^2 \sqrt{Z_\lambda} &:= \lambda + \delta Z_{\chi^4} \\
 \nu \lambda \sqrt{Z_\nu Z_\lambda Z_H^3} &:= \nu \lambda + \delta Z_{H^3} & \nu \lambda Z_\chi \sqrt{Z_\nu Z_\lambda Z_H} &:= \nu \lambda + \delta Z_{H \chi^2} & \kappa \nu Z_\phi \sqrt{Z_\kappa Z_\nu Z_H} &:= \kappa \nu + \delta Z_{H \phi^2} \\
 \kappa Z_H Z_\phi \sqrt{Z_\kappa} &:= \kappa + \delta Z_{H^2 \phi^2} & \kappa Z_\chi Z_\phi \sqrt{Z_\kappa} &:= \kappa + \delta Z_{\chi^2 \phi^2} & &
 \end{aligned} \tag{5.1.11}$$

Substituting (5.1.11) into (5.1.10), the Lagrangian will split into two pieces

$$\mathcal{L}_{H0} = \mathcal{L}_H + \mathcal{L}_H^{\text{CT}} \tag{5.1.12}$$

where \mathcal{L}_H is

$$\begin{aligned}
 \mathcal{L}_H &= \frac{1}{2} (\partial_\mu H \partial^\mu H - m_H^2 H^2) + \frac{1}{2} (\partial_\mu \chi_a \partial^\mu \chi_a - \xi M^2 \chi_a^2) - \frac{1}{4} \varepsilon \varepsilon_{abc} (\chi_a \overleftrightarrow{\partial}^\mu \chi_b) A_\mu^c - \frac{1}{2} e (\chi_a \overleftrightarrow{\partial}^\mu H) A_\mu^a + \\
 &+ \frac{1}{2} e^2 \nu H A_\mu^a A^{a\mu} + \frac{1}{8} e^2 H^2 A_\mu^a A^{a\mu} + \frac{1}{8} e^2 \chi_b^2 A_\mu^a A^{a\mu} - \frac{\lambda}{32} H^4 - \frac{\lambda}{16} H^2 \chi_a^2 - \frac{\lambda}{32} \chi_a^2 \chi_b^2 - \frac{\nu \lambda}{4} H^3 + \\
 &- \frac{\nu \lambda}{4} H \chi_a^2 - 2 \kappa \nu H \phi_a^2 - \frac{1}{2} \kappa H^2 \phi_a^2 - \frac{1}{2} \kappa \chi_a^2 \phi_b^2
 \end{aligned} \tag{5.1.13}$$

and $\mathcal{L}_H^{\text{CT}}$ is the counter term Lagrangian:

$$\begin{aligned}
 \mathcal{L}_H^{\text{CT}} &= \frac{1}{2} (\delta Z_H \partial_\mu H \partial^\mu H - \delta m_H^2 H^2) + \frac{1}{2} (\delta Z_\chi \partial_\mu \chi_a \partial^\mu \chi_a - \delta M_{\chi\xi}^2 \chi_a^2) - \frac{1}{4} \delta Z_{A\chi^2} \varepsilon_{abc} (\chi_a \overleftrightarrow{\partial}^\mu \chi_b) A_\mu^c + \\
 &- \frac{1}{2} \delta Z_{\chi H A} (\chi_a \overleftrightarrow{\partial}^\mu H) A_\mu^a + \frac{1}{2} \delta Z_{H A^2} H A_\mu^a A^{a\mu} + \frac{1}{8} \delta Z_{H^2 A^2} H^2 A_\mu^a A^{a\mu} + \frac{1}{8} \delta Z_{\chi^2 A^2} \chi_b^2 A_\mu^a A^{a\mu} + \\
 &- \frac{1}{32} \delta Z_{H^4} H^4 - \frac{1}{16} \delta Z_{H^2 \chi^2} H^2 \chi_a^2 - \frac{1}{32} \delta Z_{\chi^4} \chi_a^2 \chi_b^2 - \frac{1}{4} \delta Z_{H^3} H^3 - \frac{1}{4} \delta Z_{H \chi^2} H \chi_a^2 - 2 \delta Z_{H \phi^2} H \phi_a^2 + \\
 &- \frac{1}{2} \delta Z_{H^2 \phi^2} H^2 \phi_a^2 - \frac{1}{2} \delta Z_{\chi^2 \phi^2} \chi_a^2 \phi_b^2
 \end{aligned} \tag{5.1.14}$$

Finally the bare Faddeev-Popov ghost Lagrangian is

$$\begin{aligned}
 L_{\text{FPG}} &= \bar{u}_0^a (\partial^\mu \partial_\mu + \xi_0 M_0^2) u_0^a + e_0 \varepsilon_{abc} A_{0\mu}^a (\partial^\mu \bar{u}_0^b) u_0^c + \frac{1}{2} \xi_0 e_0^2 \nu_0 H_0 \bar{u}_0^a u_0^a + \\
 &- \frac{1}{2} \xi_0 e_0^2 \nu_0 \varepsilon_{abc} \chi_{0a} \bar{u}_0^b u_0^c
 \end{aligned} \tag{5.1.15}$$

Only a single field redefinition is required for the bare ghost field:

$$u_0^a := u^a \sqrt{Z_u} \tag{5.1.16}$$

Substituting the appropriate definitions from (5.1.2) and (5.1.9), and (5.1.16) into (5.1.15)

$$\begin{aligned}
 L_{\text{FPG}} &= \bar{u}^a (Z_u \partial^\mu \partial_\mu + \xi_0 M^2 Z_u Z_M) u^a + e Z_u \sqrt{Z_e Z_A} \varepsilon_{abc} A_\mu^a (\partial^\mu \bar{u}^b) u^c + \frac{1}{2} \xi_0 e^2 \nu Z_e Z_u \sqrt{Z_\nu Z_\chi} H \bar{u}^a u^a + \\
 &- \frac{1}{2} \xi_0 e^2 \nu Z_e Z_u \sqrt{Z_\nu Z_\chi} \varepsilon_{abc} \chi_a \bar{u}^b u^c
 \end{aligned} \tag{5.1.17}$$

We define the Z_i factors as

$$\begin{aligned} Z_u &:= 1 + \delta Z_u & \xi_0 Z_u Z_M M^2 &:= \xi M^2 + \delta M_{u\xi}^2 & e Z_u \sqrt{Z_e Z_A} &:= e + \delta Z_{Au^2} \\ \xi_0 e^2 \nu Z_e Z_u \sqrt{Z_\nu Z_\chi} &:= \xi e^2 \nu + \delta Z_{Hu^2} & \xi_0 e^2 \nu Z_e Z_u \sqrt{Z_\nu Z_\chi} &:= \xi e^2 \nu + \delta Z_{\chi u^2} \end{aligned} \quad (5.1.18)$$

Substituting (5.1.18) into (5.1.17), the Lagrangian will split into two pieces

$$\mathcal{L}_{\text{0FPG}} = \mathcal{L}_{\text{FPG}} + \mathcal{L}_{\text{FPG}}^{\text{CT}} \quad (5.1.19)$$

where \mathcal{L}_{FPG} is

$$\mathcal{L}_{\text{FPG}} = \bar{u}^a \left(\partial^\mu \partial_\mu + \xi M^2 \right) u^a + e \varepsilon_{abc} A_\mu^a \left(\partial^\mu \bar{u}^b \right) u^c + \frac{1}{2} \xi e^2 \nu H \bar{u}^a u^a - \frac{1}{2} \xi e^2 \nu \varepsilon_{abc} \chi_a \bar{u}^b u^c \quad (5.1.20)$$

and $\mathcal{L}_{\text{FPG}}^{\text{CT}}$ is the counter term Lagrangian:

$$\mathcal{L}_{\text{FPG}}^{\text{CT}} = \bar{u}^a \left(\delta Z_u \partial^\mu \partial_\mu + \delta M_{u\xi}^2 \right) u^a + \delta Z_{Au^2} \varepsilon_{abc} A_\mu^a \left(\partial^\mu \bar{u}^b \right) u^c + \frac{1}{2} \delta Z_{Hu^2} H \bar{u}^a u^a - \frac{1}{2} \delta Z_{\chi u^2} \varepsilon_{abc} \chi_a \bar{u}^b u^c \quad (5.1.21)$$

The bare field and coupling redefinitions (5.1.2), (5.1.9), (5.1.16) together with the Z_i definitions in (5.1.4), (5.1.11) and (5.1.18) is the Renormalization Transformation.

5.2 Feynman Rules

THE Feynman rule will be computed for the specific example of the rho Green's function/propagator to demonstrate the ideas required to extract out the Feynman rules for this Lagrangian. The Lagrangian for the rho is

$$\mathcal{L}_A = -\frac{1}{4} F_{\alpha\beta}^c F^{\alpha\beta} + \frac{1}{2} M^2 A_\alpha^c A^{\alpha c} - \frac{1}{2\xi} (\partial^\alpha A_\alpha^c)^2 \quad (5.2.1)$$

with the anti-symmetric property of the field strength tensor

$$\begin{aligned} F_{\alpha\beta}^c &= \partial_\alpha A_\beta^c - \partial_\beta A_\alpha^c \\ &= -F_{\beta\alpha}^c \end{aligned} \quad (5.2.2)$$

We can manipulate the form of the Lagrangian as follows

$$\begin{aligned} \mathcal{L}_A &= -\frac{1}{4} \left(\partial_\alpha A_\beta^c - \partial_\beta A_\alpha^c \right) F^{\alpha\beta} + \frac{1}{2} M^2 A_\alpha^c A^{\alpha c} - \frac{1}{2\xi} (\partial^\alpha A_\alpha^c)^2 \\ &= -\frac{1}{4} \left(F^{\alpha\beta} \partial_\alpha A_\beta^c - F^{c\beta\alpha} \partial_\alpha A_\beta^c \right) + \frac{1}{2} M^2 A_\alpha^c A^{\alpha c} - \frac{1}{2\xi} (\partial^\alpha A_\alpha^c)^2 \\ &= -\frac{1}{2} F^{\alpha\beta} \partial_\alpha A_\beta^c + \frac{1}{2} M^2 A_\alpha^c A^{\alpha c} - \frac{1}{2\xi} (\partial^\alpha A_\alpha^c)^2 \\ &= -\frac{1}{2} \left[\partial^\alpha A^{c\beta} \partial_\alpha A_\beta^c - \partial^\beta A^{c\alpha} \partial_\alpha A_\beta^c - M^2 A_\alpha^c A^{\alpha c} + \frac{1}{\xi} \partial^\alpha A_\alpha^c \partial^\beta A_\beta^c \right] \end{aligned} \quad (5.2.3)$$

where we have used the anti-symmetric property of the field strength tensor. The action for this Lagrangian is:

$$\begin{aligned}
 S &= \int d^4z \mathcal{L}_A \\
 &= -\frac{1}{2} \int d^4z \left[\partial^\alpha A^{c\beta} \partial_\alpha A_\beta^c - \partial^\beta A^{c\alpha} \partial_\alpha A_\beta^c - M^2 A_\alpha^c A^{c\alpha} + \frac{1}{\xi} \partial^\alpha A_\alpha^c \partial^\beta A_\beta^c \right] \\
 &= -\frac{1}{2} \int d^4z \left[-A_\nu^a \left(\partial_z^2 + M^2 \right) A^{a\nu} + A_\nu^a \partial^\mu \partial^\nu A_\mu^a - \frac{1}{\xi} A_\nu^a \partial^\nu \partial^\mu A_\mu^a \right] \\
 &= \frac{1}{2} \int d^4z A_\alpha^c(z) \left[\left(\partial_z^2 + M^2 \right) g^{\alpha\beta} - \left(1 - \frac{1}{\xi} \right) \partial_z^\alpha \partial_z^\beta \right] A_\beta^c(z)
 \end{aligned} \tag{5.2.4}$$

where we have performed integration by parts with the surface terms contributing zero. The two-point function in configuration space is defined as

$$\begin{aligned}
 \Gamma^{(2)}(x, y) &:= \frac{\delta^2}{\delta A_\mu^a(x) \delta A_\nu^b(y)} iS \\
 &= i\delta^{ab} \left[\left(\partial_y^2 + M^2 \right) g^{\mu\nu} - \left(1 - \frac{1}{\xi} \right) \partial_y^\mu \partial_y^\nu \right] \delta(y - x)
 \end{aligned} \tag{5.2.5}$$

and the Fourier transform of the two-point function is

$$\begin{aligned}
 \tilde{\Gamma}^{(2)}(p, q) &= \int d^4x d^4y e^{-i(px+qy)} \Gamma^{(2)}(x, y) \\
 &= i\delta^{ab} \left[\left(-q^2 + M^2 \right) g^{\mu\nu} + \left(1 - \frac{1}{\xi} \right) q^\mu q^\nu \right] (2\pi)^4 \delta^4(p + q)
 \end{aligned} \tag{5.2.6}$$

We are now left to the task of finding the Green's function which is the reciprocal of

$$\bar{\Gamma}_{ab}^{\mu\nu}(k) = -i\delta^{ab} \left[\left(-k^2 + M^2 \right) g^{\mu\nu} + \left(1 - \frac{1}{\xi} \right) k^\mu k^\nu \right] \tag{5.2.7}$$

where

$$\bar{\Gamma}_{ab}^{\alpha\beta}(k) D_{\beta bc}^\mu(k) = \delta_{ac} g^{\alpha\mu} \tag{5.2.8}$$

and $D_{\beta bc}^\mu(k)$ the Green's function. We can extract out the isospin indices $D_{\beta bc}^\mu(k) = \delta_{bc} D_\beta^\mu(k)$ and substituting into (5.2.8)

$$\begin{aligned}
 -i\delta^{ab} \left[\left(-k^2 + M^2 \right) g^{\alpha\beta} + \left(1 - \frac{1}{\xi} \right) k^\alpha k^\beta \right] \cdot \delta_{bc} D_\beta^\mu(k) &= \delta_{ac} g^{\alpha\mu} \\
 \implies \left[\left(-k^2 + M^2 \right) g^{\alpha\beta} + \left(1 - \frac{1}{\xi} \right) k^\alpha k^\beta \right] D_\beta^\mu(k) &= ig^{\alpha\mu}
 \end{aligned} \tag{5.2.9}$$

We need to find a $D_\beta^\mu(k)$ which satisfies (5.2.9). The most general tensor we can construct is a linear combination of g_β^μ and $k^\mu k_\beta$ with

$$D_\beta^\mu(k) := Ag_\beta^\mu + Bk^\mu k_\beta \tag{5.2.10}$$

with $A, B \in \mathbb{C}$. Substituting (5.2.10) into (5.2.9)

$$\begin{aligned} & \left[(-k^2 + M^2) g^{\alpha\beta} + \left(1 - \frac{1}{\xi}\right) k^\alpha k^\beta \right] (A g_\beta^\mu + B k^\mu k_\beta) = i g^{\alpha\mu} \\ \implies & A (-k^2 + M^2) g^{\alpha\mu} + \left[B \left(M^2 - \frac{k^2}{\xi} \right) + A \left(1 - \frac{1}{\xi}\right) \right] k^\alpha k^\mu = i g^{\alpha\mu} \end{aligned} \quad (5.2.11)$$

Since g_β^μ and $k^\mu k_\beta$ are linearly independent we just have to match coefficients with

$$A (-k^2 + M^2) = i \quad \text{and} \quad B \left(M^2 - \frac{k^2}{\xi} \right) + A \left(1 - \frac{1}{\xi}\right) = 0 \quad (5.2.12)$$

which has solutions:

$$B = \frac{A(\xi - 1)}{k^2 - \xi M^2} \quad (5.2.13)$$

$$A = -\frac{i}{k^2 - M^2} \quad (5.2.14)$$

The rho Green's function/propagator is then given by

$$\begin{aligned} D_{ab}^{\mu\nu} &= \delta_{ab} D^{\mu\nu} \\ &= -\frac{i\delta_{ab}}{k^2 - M^2 + i\epsilon} \left[g^{\mu\nu} + \frac{\xi - 1}{k^2 - \xi M^2} k^\mu k^\nu \right] \end{aligned} \quad (5.2.15)$$

The counter term Lagrangian for the rho propagator is

$$\mathcal{L}_A^{\text{CT}} = -\frac{1}{4} \delta Z_A F_{\mu\nu}^a F^{a\mu\nu} + \frac{1}{2} \delta M^2 A_\mu^a A^{a\mu} - \frac{1}{2} \delta \xi (\partial^\mu A_\mu^a)^2 \quad (5.2.16)$$

Going through the above procedure again for the counter term Lagrangian but stopping at (5.2.7), we get the counter term for the rho two point function

$$\bar{\Gamma}_{ab\text{CT}}^{\mu\nu} = i\delta_{ab} \left[(-k^2 \delta Z_A + \delta M^2) g^{\mu\nu} - (\delta \xi - \delta Z_A) k^\mu k^\nu \right] \quad (5.2.17)$$

Table 5.1: Feynman rules for this QFT. All momenta are incoming with $\sum_i p_i = 0$



Kinetic(P)/Interaction(I)/Counter(C) term	Feynman Rule
P.1 $\mathcal{L} = \frac{1}{2} (\partial^\mu \phi_a \partial_\mu \phi_a - m^2 \phi_a^2)$	 $\bar{\Gamma}^{2ab} = \frac{i\delta^{ab}}{k^2 - m^2 + i\epsilon}$
P.2 $\mathcal{L} = -\frac{(F_{\mu\nu}^a)^2}{4} + \frac{M^2 (A_\mu^a)^2}{2} - \frac{(\partial^\mu A_\mu^a)^2}{2\xi}$	 $\Gamma_{ab}^{2\mu\nu} = \frac{-i\delta^{ab}}{k^2 - M^2 + i\epsilon} \left[g^{\mu\nu} + \frac{(\xi - 1) k^\mu k^\nu}{k^2 - \xi M^2} \right]$
P.3 $\mathcal{L} = \frac{1}{2} (\partial^\mu H \partial_\mu H - m_H^2 H^2)$	 $\bar{\Gamma}^2 = \frac{i}{k^2 - m_H^2 + i\epsilon}$

Table 5.1 – continued from previous page

Kinetic(P)/Interaction(I)/Counter(C) term	Feynman Rule
P.4 $\mathcal{L} = \frac{1}{2} (\partial^\mu \chi_a \partial_\mu \chi_a - \xi M^2 \chi_a \chi_a)$	$\frac{a \quad k \quad b}{\bar{\Gamma}^{2ab} = \frac{i\delta^{ab}}{k^2 - \xi M^2 + i\epsilon}}$
P.5 $\mathcal{L} = -\bar{u}^a (\partial^\mu \partial_\mu + \xi M^2) u^a$	$\frac{a \quad k \quad b}{\bar{\Gamma}^{2ab} = \frac{i\delta^{ab}}{k^2 - \xi M^2 + i\epsilon}}$
I.1. $\mathcal{L} = \frac{1}{2} e \varepsilon_{aij} A_\mu^a (\phi_i \partial^\mu \phi_j - \phi_j \partial^\mu \phi_i)$	 $\bar{\Gamma}_{bmn}^\nu = e \varepsilon_{bmn} (p_1 - p_2)^\nu$
I.2. $\mathcal{L} = -\frac{1}{2} e^2 \varepsilon_{aij} \varepsilon_{bjk} \phi_i \phi_k A_\mu^a A^{b\mu}$	 $\bar{\Gamma}_{cdmn}^{\alpha\nu} = ie^2 g^{\alpha\nu} (\varepsilon_{jdn} \varepsilon_{jcm} + \varepsilon_{jdm} \varepsilon_{jcn})$
I.3. $\mathcal{L} = -\frac{\lambda}{32} H^4$	 $\bar{\Gamma} = -\frac{3}{4} i \lambda$
I.4. $\mathcal{L} = -\frac{\lambda}{16} H^2 \chi_a^2$	 $\bar{\Gamma}^{bc} = -\frac{1}{4} i \lambda \delta^{bc}$

Table 5.1 – continued from previous page

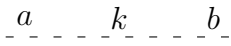
Kinetic(P)/Interaction(I)/Counter(C) term	Feynman Rule
I.5. $\mathcal{L} = -\frac{\lambda}{32}\chi_a^2\chi_b^2$	 $\bar{\Gamma}^{bcde} = -\frac{1}{4}i\lambda \left(\delta^{cd}\delta^{be} + \delta^{bd}\delta^{ce} + \delta^{bc}\delta^{de} \right)$
I.6. $\mathcal{L} = -\frac{1}{4}\lambda\nu H^3$	 $\bar{\Gamma} = -\frac{3}{2}i\lambda\nu$
I.7. $\mathcal{L} = -\frac{1}{4}\lambda\nu H\chi_a^2$	 $\bar{\Gamma}^{bc} = -\frac{1}{2}i\lambda\nu\delta^{bc}$
I.8. $\mathcal{L} = -\frac{1}{4}e\varepsilon_{abc}(\chi_a\partial^\mu\chi_b - \chi_b\partial^\mu\chi_a)A_\mu^c$	 $\bar{\Gamma}_{cab}^{c,\mu} = -\frac{1}{2}e\varepsilon_{cab}(p_1 - p_2)^\mu$
I.9. $\mathcal{L} = -\frac{1}{2}e(\chi_a\partial^\mu H - H\partial^\mu\chi_a)A_\mu^a$	 $\bar{\Gamma}_{bc}^{c,\nu} = \frac{1}{2}e\delta^{bc}(p_1 - p_2)^\nu$

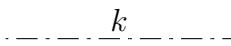
Table 5.1 – continued from previous page

Kinetic(P)/Interaction(I)/Counter(C) term Feynman Rule

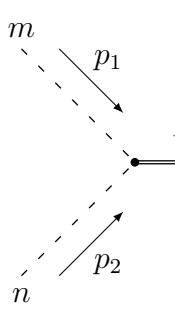
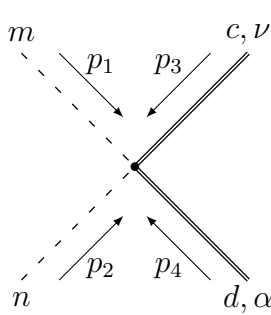
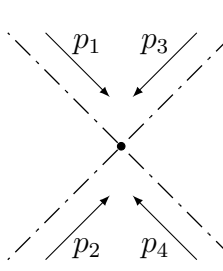
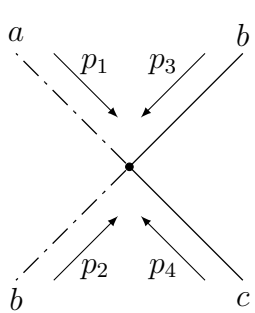
I.10. $\mathcal{L} = \frac{1}{2}e^2\nu HA_\mu^a A^{a\mu}$

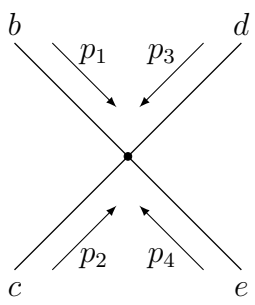
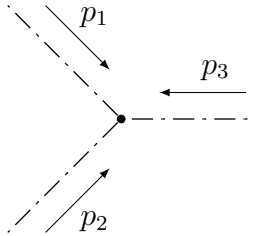
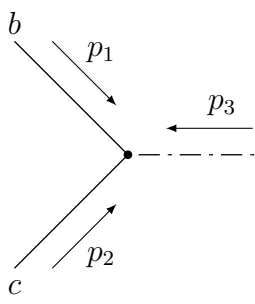
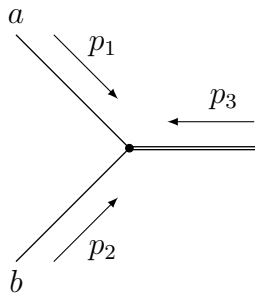
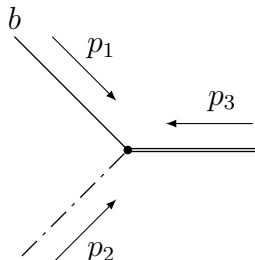
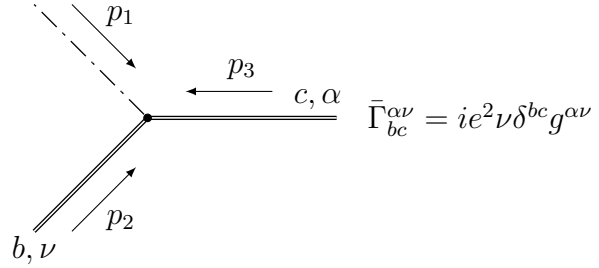

I.11. $\mathcal{L} = \frac{1}{8}e^2H^2 A_\mu^a A^{a\mu}$

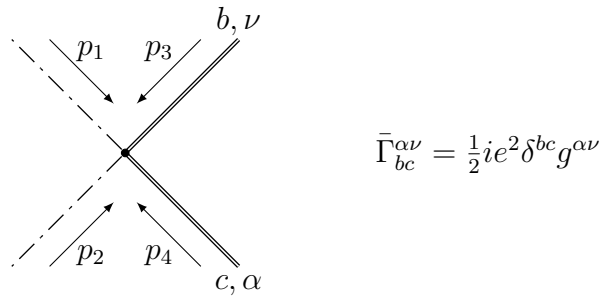

I.12. $\mathcal{L} = \frac{1}{8}e^2\chi_b^2 A_\mu^a A^{a\mu}$

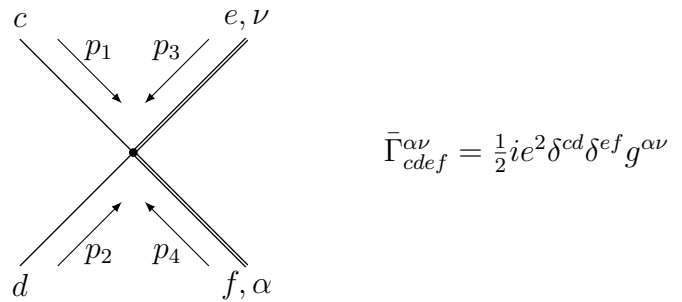

I.13. $\mathcal{L} = -\frac{1}{2}\kappa H^2\phi_n^2$

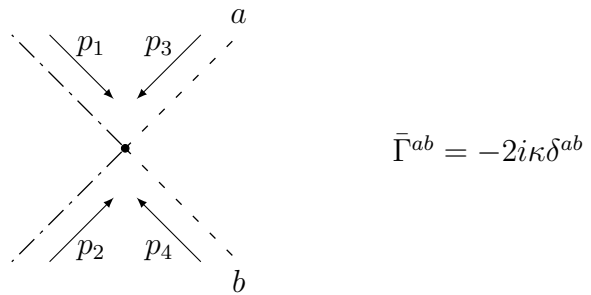

Table 5.1 – continued from previous page

Kinetic(P)/Interaction(I)/Counter(C) term	Feynman Rule
I.14. $\mathcal{L} = -\frac{1}{2}\kappa\chi_a^2\phi_n^2$	 $\bar{\Gamma}^{abef} = -2i\kappa\delta^{ab}\delta^{ef}$
I.15. $\mathcal{L} = -2\kappa\nu H\phi_n^2$	 $\bar{\Gamma}^{ab} = -4i\kappa\nu\delta^{ab}$
I.16. $\mathcal{L} = -e\varepsilon_{abc}(\partial^\mu\bar{u}_a)u_bA_\mu^c$	 $\bar{\Gamma}_{fgh}^\nu = -e\varepsilon_{fgh}(p_2 + p_3)^\nu$
I.17. $\mathcal{L} = \frac{1}{2}e\varepsilon_{abc}F_{\mu\nu}^aA^{b\mu}A^{c\nu}$	 $\bar{\Gamma}_{\alpha\beta\gamma}^{abc} = e\varepsilon_{abc}[(p_3 - p_2)_\alpha g_{\beta\gamma} + (p_1 - p_3)_\beta g_{\gamma\alpha} + (p_2 - p_1)_\gamma g_{\beta\alpha}]$

Table 5.1 – continued from previous page

Kinetic(P)/Interaction(I)/Counter(C) term	Feynman Rule	
I.18. $\mathcal{L} = \frac{1}{2}\xi e^2 \nu H \bar{u}^b u^b$		$\bar{\Gamma}_{ac} = \frac{1}{2}i\xi e^2 \nu \delta_{ac}$
I.19. $\mathcal{L} = -\frac{1}{2}\xi e^2 \nu \varepsilon_{abc} \chi_a \bar{u}^b u^c$		$\bar{\Gamma}_{fed} = -\frac{1}{2}i\xi e^2 \nu \varepsilon_{fed}$
I.20. $\mathcal{L} = -\frac{1}{8}\lambda_4 \phi_a^2 \phi_b^2$		$\bar{\Gamma}_{abcd} = -i\lambda_4 (\delta_{ab}\delta_{cd} + \delta_{bc}\delta_{da} + \delta_{bd}\delta_{ac})$
I.21. $\mathcal{L} = -\frac{1}{4}e^2 \varepsilon_{abc} \varepsilon_{aef} A_\mu^b A_\nu^c A^{e\mu} A^{f\nu}$		$\Gamma_{\mu\nu\pi\sigma}^{abcd} = -ie^2 [\varepsilon_{fab}\varepsilon_{fcd} (g_{\mu\rho}g_{\nu\sigma} - g_{\mu\sigma}g_{\nu\rho}) + \varepsilon_{fac}\varepsilon_{fdb} (g_{\mu\sigma}g_{\rho\nu} - g_{\mu\nu}g_{\rho\sigma}) + \varepsilon_{fad}\varepsilon_{fbc} (g_{\mu\nu}g_{\rho\sigma} - g_{\mu\rho}g_{\nu\sigma})]$
C.1. $\mathcal{L} = -\frac{1}{4}\delta Z_A F_{\mu\nu}^a F^{a\mu\nu} + \frac{1}{2}\delta M^2 A_\mu^a A^{a\mu} - \frac{1}{2}\delta\xi (\partial^\mu A_\mu^a)^2$		$\bar{\Gamma}_{abCT}^{\mu\nu} = i\delta^{ab} [(k^2 \delta Z_A - \delta M^2) g^{\mu\nu} + (\delta\xi - \delta Z_A) k^\mu k^\nu]$
C.2. $\mathcal{L} = \frac{1}{2} (\delta Z_H \partial_\mu H \partial^\mu H - Z_H Z_{m_H} m_H^2 H^2)$		$\bar{\Gamma}_{CT} = i (k^2 \delta Z_H - \delta m_H^2)$

Table 5.1 – continued from previous page

Kinetic(P)/Interaction(I)/Counter(C) term	Feynman Rule
C.3. $\mathcal{L} = \frac{1}{2}\delta Z_e \varepsilon_{aij} A_\mu^a (\phi_j \partial^\mu \phi_i - \phi_i \partial^\mu \phi_j)$	 $\bar{\Gamma}_{abCT}^\mu = \delta Z_e \varepsilon_{cab} (p_1 - p_2)^\mu$
C.4. $\mathcal{L} = -2\delta Z_{H\phi^2} H \phi_a^2$	 $\bar{\Gamma}_{abCT} = -4i\delta Z_{H\phi^2} \delta^{ab}$
C.5. $\mathcal{L} = -\frac{1}{8}\delta Z_{\phi^4} (\phi_a^2 \phi_b^2)$	 $\bar{\Gamma}_{abcdCT} = -i\delta Z_{\phi^4} (\delta_{ab}\delta_{cd} + \delta_{bc}\delta_{da} + \delta_{bd}\delta_{ac})$

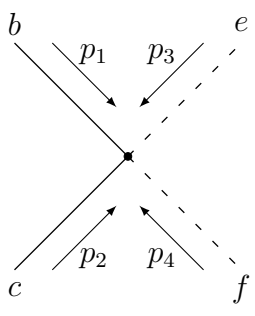
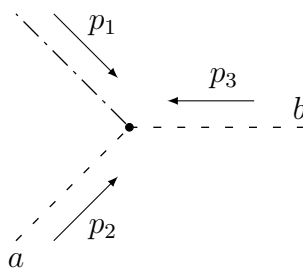
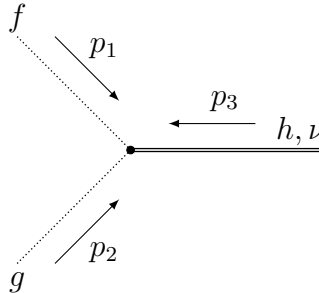
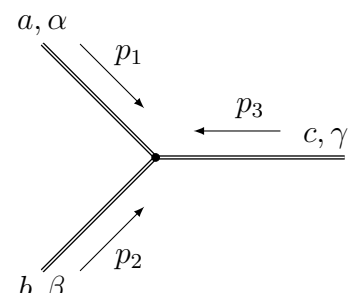
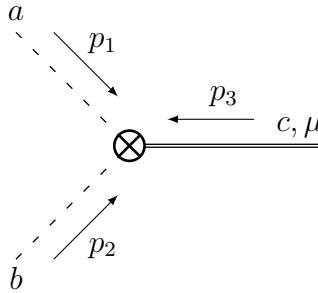
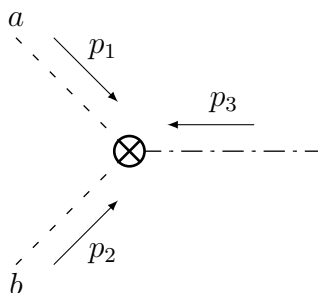
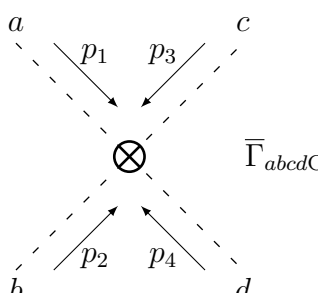
Part II

Quantum Corrections

6

Scattering Lengths at Tree Level

6.1 Useful Formulae



CONSIDER an on-shell scattering process of

$$\phi^a(p_1) + \phi^b(p_2) \rightarrow \phi^c(p_3) + \phi^d(p_4)$$

with the 4-momentum conservation equation

$$p_1^\mu + p_2^\mu = p_3^\mu + p_4^\mu$$

Since these particles are on-shell $p_i^2 = m^2$. We can define the Mandelstam invariants:

$$\begin{aligned} s &:= (p_1 + p_2)^2 = (p_3 + p_4)^2 \\ t &:= (p_1 - p_3)^2 = (p_4 - p_2)^2 \\ u &:= (p_1 - p_4)^2 = (p_3 - p_2)^2 \end{aligned} \tag{6.1.1}$$

We can rewrite the dot products $p_1 \cdot p_2$ and $p_3 \cdot p_4$ using the s Mandelstam variable,

$$\begin{aligned} s &= p_1^2 + 2p_1 \cdot p_2 + p_2^2 \\ &= 2m^2 + 2p_1 \cdot p_2 \\ \Rightarrow p_1 \cdot p_2 &= \frac{s - 2m^2}{2} \end{aligned} \tag{6.1.2}$$

$$\begin{aligned} s &= p_3^2 + 2p_3 \cdot p_4 + p_4^2 \\ \Rightarrow p_3 \cdot p_4 &= p_1 \cdot p_2 = \frac{s - 2m^2}{2} \end{aligned} \tag{6.1.3}$$

A summary of all the dot products are listed below

$$\begin{aligned} p_3 \cdot p_4 &= p_1 \cdot p_2 = \frac{s - 2m^2}{2} \\ p_2 \cdot p_4 &= p_1 \cdot p_3 = \frac{2m^2 - t}{2} \\ p_2 \cdot p_3 &= p_1 \cdot p_4 = \frac{2m^2 - u}{2} \end{aligned} \tag{6.1.4}$$

Consider now the case of the elastic pion scattering process in the center of mass frame, with the incoming three momentum \underline{q} and the outgoing three momentum \underline{q}' with

$$\underline{q} \neq \underline{q}' \quad (6.1.5)$$

$$q := |\underline{q}| = |\underline{q}'| \quad (6.1.6)$$

where q is defined as the magnitude q . For the t channel process,

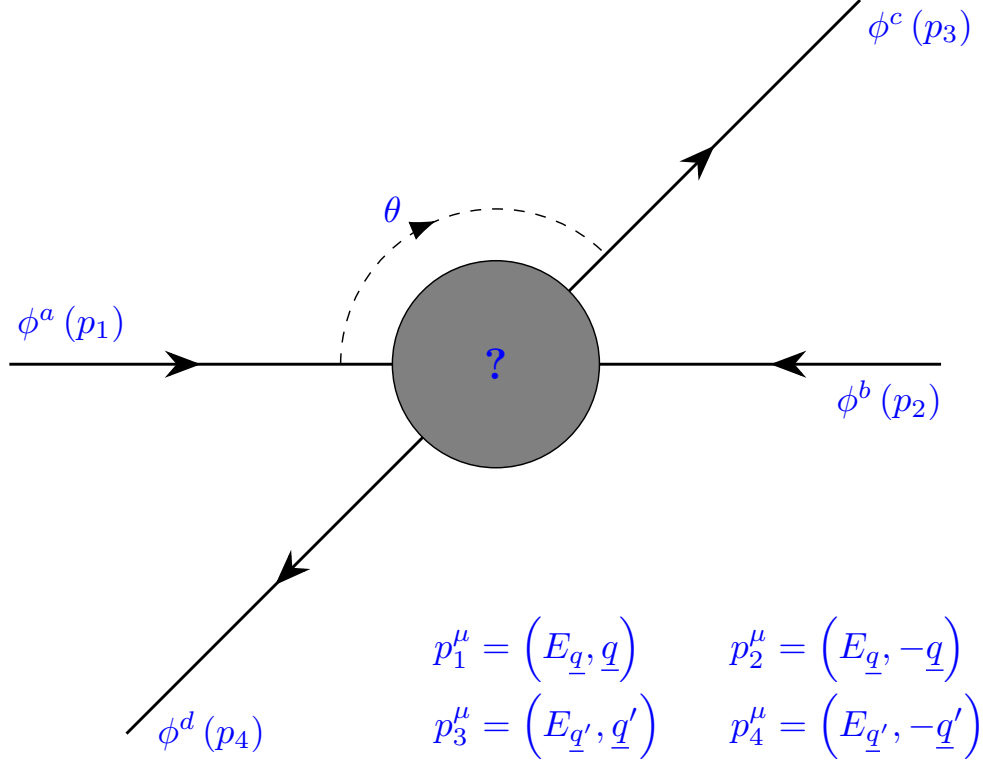

Figure 6.1: t channel scattering process

Let the 3-momenta for ϕ^a and ϕ^c be \underline{q} and \underline{q}' respectively, such that

$$p_1^\mu = (E_{\underline{q}}, \underline{q}) = (\sqrt{m^2 + |\underline{q}|^2}, \underline{q}) \quad (6.1.7)$$

$$p_3^\mu = (E_{\underline{q}'}, \underline{q}') = (\sqrt{m^2 + |\underline{q}'|^2}, \underline{q}') = (\sqrt{m^2 + |\underline{q}|^2}, \underline{q}') \quad (6.1.8)$$

The product of $p_1 \cdot p_3$ is

$$\begin{aligned} p_1 \cdot p_3 &= (\sqrt{m^2 + |\underline{q}|^2})^2 - \underline{q} \cdot \underline{q}' \\ &= m^2 + |\underline{q}|^2 - |\underline{q}| |\underline{q}'| \cos \theta \\ &= m^2 + q^2 (1 - \cos \theta) \end{aligned} \quad (6.1.9)$$

Substituting $p_1 \cdot p_3$ from (6.1.4) into (6.1.9) the t Mandelstam variable is now given by

$$\begin{aligned} t &= 2m^2 - 2p_1 \cdot p_3 \\ &= 2m^2 - 2 [m^2 + q^2 (1 - \cos \theta)] \\ &= -2q^2 (1 - \cos \theta) \end{aligned} \quad (6.1.10)$$

Consider the u channel scattering process.

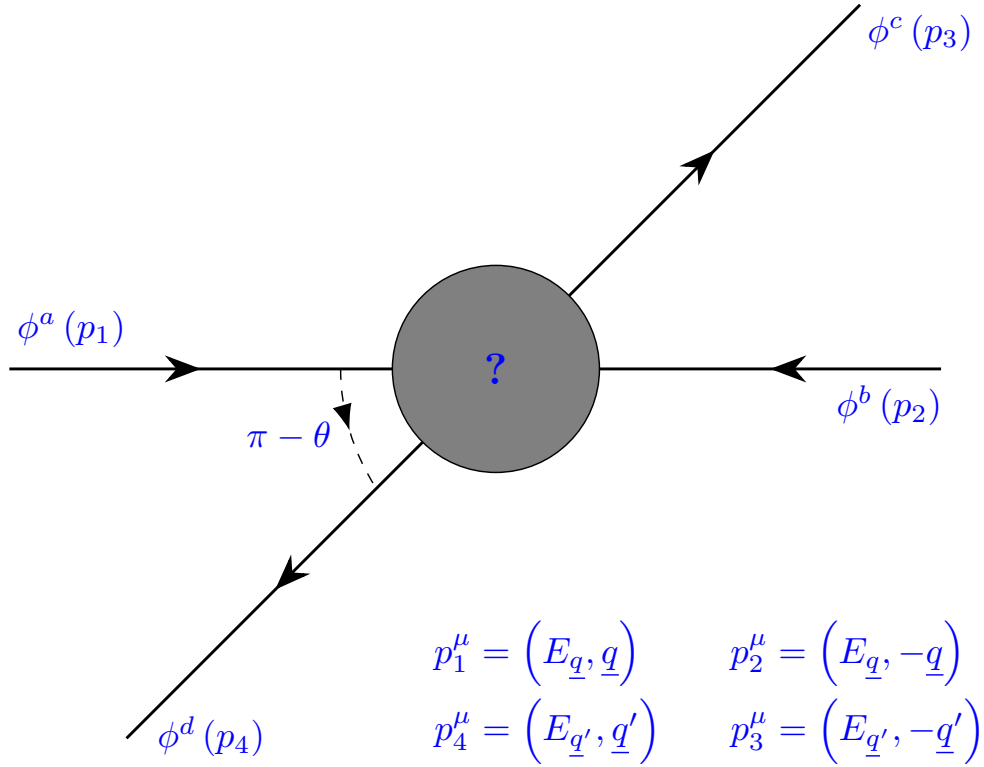

Figure 6.2: u channel scattering process

Let the 3-momenta for ϕ^a and ϕ^d be \underline{q} and \underline{q}' respectively, such that

$$p_1 = (E_{\underline{q}}, \underline{q}) = (\sqrt{m^2 + |\underline{q}|^2}, \underline{q}) \quad (6.1.11)$$

$$p_4 = (E_{\underline{q}'}, \underline{q}') = (\sqrt{m^2 + |\underline{q}'|^2}, \underline{q}') = (\sqrt{m^2 + |\underline{q}|^2}, \underline{q}') \quad (6.1.12)$$

The product of $p_1 \cdot p_4$ is

$$p_1 \cdot p_4 = m^2 + q^2 (1 + \cos \theta) \quad (6.1.13)$$

Substituting $p_1 \cdot p_4$ from (6.1.4) into (6.1.13) the u Mandlestam variable is now given by

$$u = -2q^2 (1 + \cos \theta) \quad (6.1.14)$$

The three Mandlestam variables are related to each with

$$s + t + u = \sum_{j=1}^4 p_j^2 = 4m^2 \quad (6.1.15)$$

We can use (6.1.15) to find the s Mandlestam variable from t and u .

$$\begin{aligned} s &= 4m^2 - t - u \\ &= 4m^2 + 2q^2 (1 - \cos \theta) + 2q^2 (1 + \cos \theta) \\ &= 4m^2 + 4q^2 \end{aligned} \quad (6.1.16)$$

We shall define the cosine of the scattering angle and the ratio R

$$z := \cos \theta \tag{6.1.17}$$

$$R := \frac{q^2}{m^2} \tag{6.1.18}$$

Then the necessary formulae for the following calculations in terms of z and R are

$$s = 4m^2 (1 + R) \tag{6.1.19}$$

$$t = -2m^2 (1 - z) R \tag{6.1.20}$$

$$u = -2m^2 (1 + z) R \tag{6.1.21}$$

$$s - t = 2m^2 [2 + (3 - z) R] \tag{6.1.22}$$

$$s - u = 2m^2 [2 + (3 + z) R] \tag{6.1.23}$$

$$t - u = 4m^2 R z \tag{6.1.24}$$

6.2 Tree Scattering Amplitudes

WE have now reached the stage to calculate the pion scattering lengths. A list of the required tree diagrams are generated from the Feynman rules for pion-pion scattering and are shown below.

6. Scattering Lengths at Tree Level

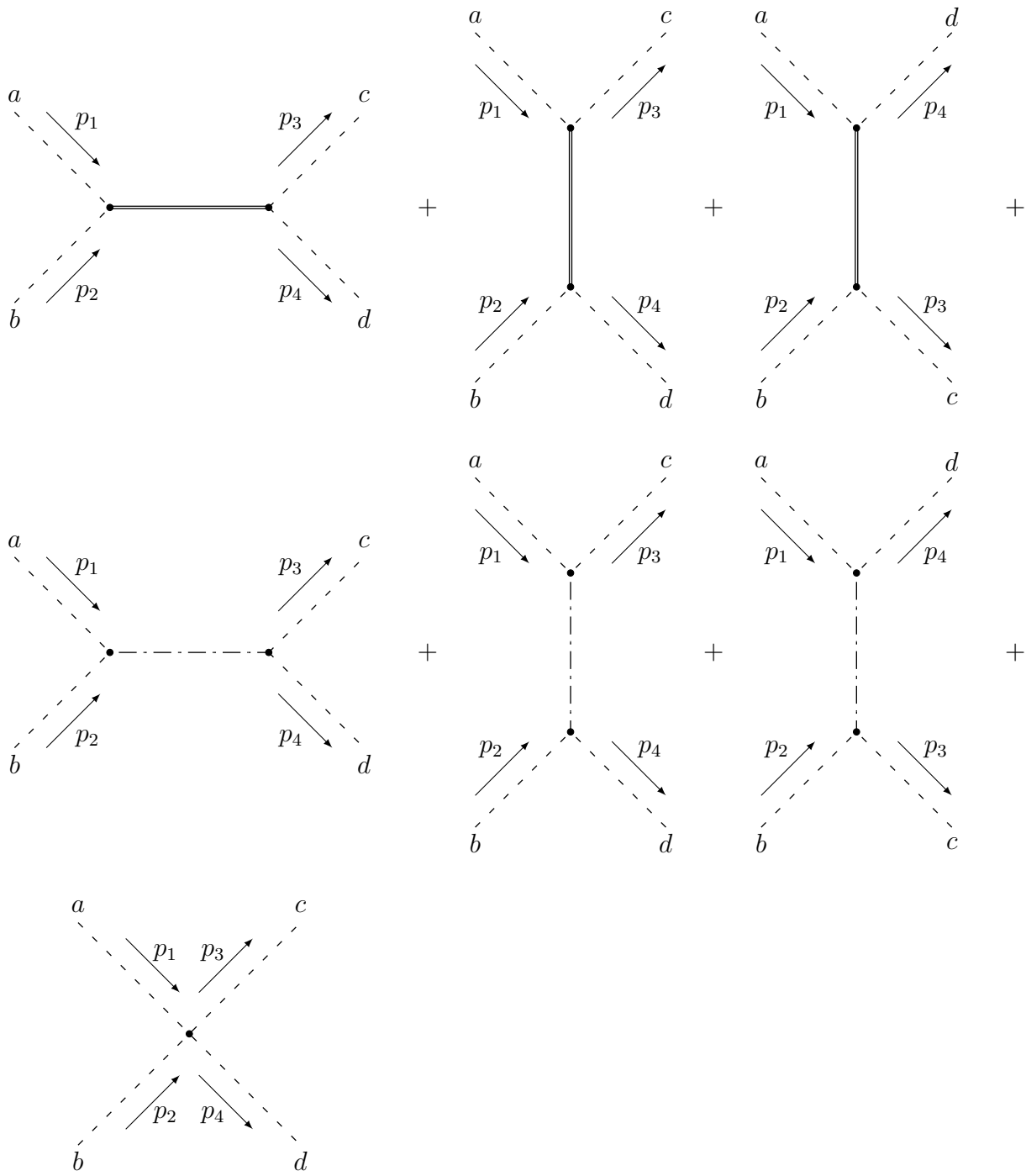

For the s channel scattering process mediated by the rho:

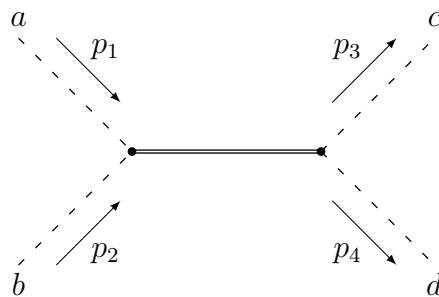

With the definitions for the vertices

$$\Gamma_1 = e\varepsilon_{fab}(p_1 - p_2)^\alpha \quad \Gamma_2 = e\varepsilon_{hdc}(p_3 - p_4)^\beta \quad D_{\alpha\beta}^{fh}(p) = -\frac{i\delta_{fh}g_{\alpha\beta}}{p^2 - M^2}$$

The amplitude is given by:

$$\begin{aligned} M_s^A &= \Gamma_2 \cdot D_{\alpha\beta}^{fh}(p) \cdot \Gamma_1 \\ &= -i\frac{e^2}{p^2 - M^2} \varepsilon_{fab}\varepsilon_{fdc} (p_1 - p_2) \cdot (p_3 - p_4) \\ &= S_A (\delta_{ad}\delta_{bc} - \delta_{ac}\delta_{bd}) \end{aligned} \quad (6.2.1)$$

with

$$\begin{aligned} S_A &:= -i\frac{e^2}{s - M^2} (p_1 - p_2) \cdot (p_3 - p_4) \\ &= -i\frac{e^2}{s - M^2} (t - u) \\ &= -4ie^2m^2 \frac{zR}{4m^2(1 + R) - M^2} \end{aligned} \quad (6.2.2)$$

For the t channel scattering process mediated by the rho:

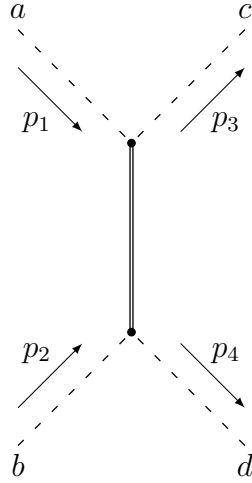

With the definitions for the vertices

$$\Gamma_1 = -e\varepsilon_{fca}(p_1 + p_3)^\alpha \quad \Gamma_2 = e\varepsilon_{hbd}(p_2 + p_4)^\beta \quad D_{\alpha\beta}^{fh}(p) = -\frac{i\delta_{fh}g_{\alpha\beta}}{p^2 - M^2}$$

The amplitude is given by:

$$\begin{aligned} M_t^A &= \Gamma_2 \cdot D_{\alpha\beta}^{fh}(p) \cdot \Gamma_1 \\ &= i\frac{e^2}{p^2 - M^2} (p_1 + p_3) \cdot (p_2 + p_4) (\delta_{bc}\delta_{ad} - \delta_{ab}\delta_{cd}) \\ &= T_A (\delta_{ab}\delta_{cd} - \delta_{bc}\delta_{ad}) \end{aligned} \quad (6.2.3)$$

with

$$\begin{aligned}
 T_A &:= -i \frac{e^2}{t - M^2} (p_1 + p_3) \cdot (p_2 + p_4) \\
 &= -i \frac{e^2}{t - M^2} (s - u) \\
 &= 2ie^2 m^2 \frac{2 + (3 + z) R}{2m^2 (1 - z) R + M^2}
 \end{aligned} \tag{6.2.4}$$

For the u channel scattering process mediated by the rho:

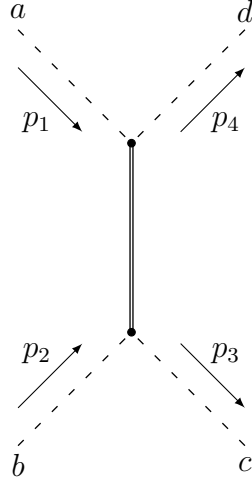

With the definitions for the vertices

$$\Gamma_1 = -e \varepsilon_{fda} (p_1 + p_4)^\alpha \quad \Gamma_2 = e \varepsilon_{hbc} (p_2 + p_3)^\beta \quad D_{\alpha\beta}^{fh}(p) = -\frac{i \delta_{fh} g_{\alpha\beta}}{p^2 - M^2}$$

The amplitude is given by:

$$\begin{aligned}
 M_u^A &= \Gamma_2 \cdot D_{\alpha\beta}^{fh}(p) \cdot \Gamma_1 \\
 &= i \frac{e^2}{p^2 - M^2} \varepsilon_{fda} \varepsilon_{hbc} (p_1 + p_4) \cdot (p_2 + p_3) \\
 &= i \frac{e^2}{p^2 - M^2} (p_1 + p_4) \cdot (p_2 + p_3) (\delta_{ac} \delta_{bd} - \delta_{ab} \delta_{cd}) \\
 &= U_A (\delta_{ab} \delta_{cd} - \delta_{ac} \delta_{bd})
 \end{aligned} \tag{6.2.5}$$

with

$$\begin{aligned}
 U_A &:= -i \frac{e^2}{u - M^2} (p_1 + p_4) \cdot (p_2 + p_3) \\
 &= -i \frac{e^2}{u - M^2} (s - t) \\
 &= 2ie^2 m^2 \frac{2 + (3 - z) R}{2m^2 (1 + z) R + M^2}
 \end{aligned} \tag{6.2.6}$$

The sum of the amplitudes due to the rho mediator

$$\begin{aligned} T_A^{ab,cd} &= S_A (\delta_{ad}\delta_{bc} - \delta_{ac}\delta_{bd}) + T_A (\delta_{ab}\delta_{cd} - \delta_{bc}\delta_{ad}) + U_A (\delta_{ab}\delta_{cd} - \delta_{ac}\delta_{bd}) \\ &= (T_A + U_A) \delta_{ab}\delta_{cd} - (S_A + U_A) \delta_{ac}\delta_{bd} + (S_A - T_A) \delta_{ad}\delta_{bc} \end{aligned} \quad (6.2.7)$$

For the s channel scattering process mediated by the Higgs:

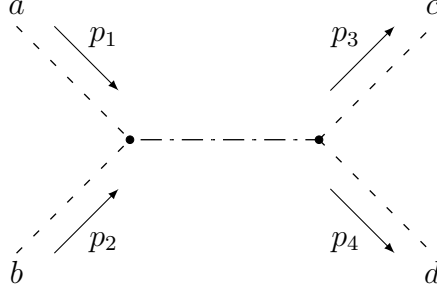

With the definitions for the vertices

$$\Gamma_1 = -4i\kappa\nu\delta_{ab}$$

$$\Gamma_2 = -4i\kappa\nu\delta_{cd}$$

$$D(p) = \frac{i}{p^2 - m_H^2}$$

The amplitude is given by:

$$\begin{aligned} M_s^H &= \Gamma_2 \cdot D(p) \cdot \Gamma_1 \\ &= -i \frac{16\kappa^2\nu^2}{p^2 - m_H^2} \delta_{ab}\delta_{cd} \\ &= S_H \delta_{ab}\delta_{cd} \end{aligned} \quad (6.2.8)$$

with

$$S_H := -i \frac{16\kappa^2\nu^2}{s - m_H^2} \quad (6.2.9)$$

For the t channel scattering process mediated by the Higgs:

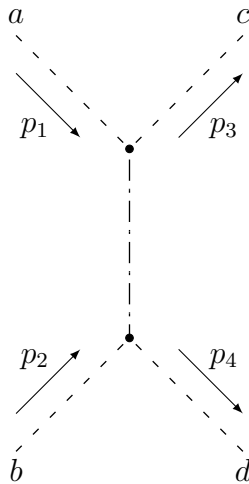

With the definitions for the vertices

$$\Gamma_1 = -4i\kappa\nu\delta_{ac}$$

$$\Gamma_2 = -4i\kappa\nu\delta_{bd}$$

$$D(p) = \frac{i}{p^2 - m_H^2}$$

The amplitude is given by:

$$\begin{aligned} M_t^H &= \Gamma_2 \cdot D(p) \cdot \Gamma_1 \\ &= -i \frac{16\kappa^2\nu^2}{p^2 - m_H^2} \delta_{ac}\delta_{bd} \\ &= T_H \delta_{ac}\delta_{bd} \end{aligned} \quad (6.2.10)$$

with

$$T_H := -i \frac{16\kappa^2\nu^2}{t - m_H^2} \quad (6.2.11)$$

For the u channel scattering process mediated by the Higgs:

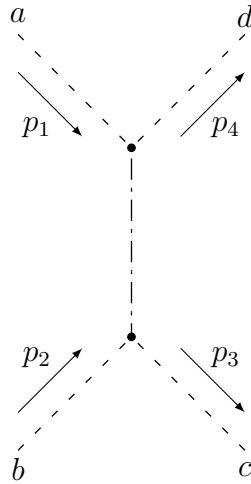

With the definitions for the vertices

$$\Gamma_1 = -4i\kappa\nu\delta_{ad}$$

$$\Gamma_2 = -4i\kappa\nu\delta_{bc}$$

$$D(p) = \frac{i}{p^2 - m_H^2}$$

The amplitude is given by:

$$\begin{aligned} M_u^H &= \Gamma_2 \cdot D(p) \cdot \Gamma_1 \\ &= -i \frac{16\kappa^2\nu^2}{p^2 - m_H^2} \delta_{ad}\delta_{bc} \\ &= U_H \delta_{ad}\delta_{bc} \end{aligned} \quad (6.2.12)$$

with

$$U_H := -i \frac{16\kappa^2\nu^2}{u - m_H^2} \quad (6.2.13)$$

The sum of the amplitudes due to the Higgs mediator

$$T_H^{ab,cd} = S_H \delta_{ab} \delta_{cd} + T_H \delta_{ac} \delta_{bd} + U_H \delta_{ad} \delta_{bc} \quad (6.2.14)$$

For the four pion scattering process:

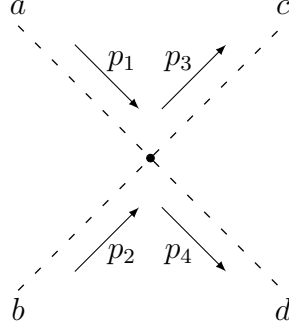

With the definitions for the vertices

$$\begin{aligned} S_\lambda &:= -i\lambda_4 & \Gamma &= S_\lambda (\delta_{ab}\delta_{cd} + \delta_{ad}\delta_{bc} + \delta_{ac}\delta_{bd}) \\ \implies M^\phi &= \Gamma \end{aligned}$$

$$T_\lambda^{ab,cd} = S_\lambda (\delta_{ab}\delta_{cd} + \delta_{ad}\delta_{bc} + \delta_{ac}\delta_{bd}) \quad (6.2.15)$$

6.3 Isospin Amplitudes



THE most general form of the scattering amplitude is

$$M^{ab,cd} = F(s, t, u) \delta_{ab} \delta_{cd} + G(s, t, u) \delta_{ac} \delta_{bd} + H(s, t, u) \delta_{ad} \delta_{bc} \quad (6.3.1)$$

The amplitude can be decomposed over an isospin invariant basis

$$M^{ab,cd} = \sum_{m=0}^2 T^m P_m^{abcd} \quad (6.3.2)$$

where T^m are the isospin amplitudes and the basis vectors [45] are

$$P_0^{abcd} := \frac{1}{3} \delta_{ab} \delta_{cd} \quad (6.3.3)$$

$$P_1^{abcd} := \frac{1}{2} (\delta_{ac} \delta_{bd} - \delta_{ad} \delta_{bc}) \quad (6.3.4)$$

$$P_2^{abcd} := \frac{1}{2} (\delta_{ac} \delta_{bd} + \delta_{ad} \delta_{bc}) - \frac{1}{3} \delta_{ab} \delta_{cd} \quad (6.3.5)$$

Expanding the amplitude (6.3.2)

$$M^{ab,cd} = \frac{1}{3} (T^0 - T^2) \delta_{ab} \delta_{cd} + \frac{1}{2} (T^1 + T^2) \delta_{ac} \delta_{bd} - \frac{1}{2} (T^1 - T^2) \delta_{ad} \delta_{bc} \quad (6.3.6)$$

and identifying coefficients between (6.3.1) and (6.3.6), we obtain a system of linear equations

$$\frac{1}{3} (T^0 - T^2) = F(s, t, u) \quad (6.3.7)$$

$$\frac{1}{2} (T^1 + T^2) = G(s, t, u) \quad (6.3.8)$$

$$-\frac{1}{2} (T^1 - T^2) = H(s, t, u) \quad (6.3.9)$$

which has the solution,

$$T^0 = 3F(s, t, u) + G(s, t, u) + H(s, t, u) \quad (6.3.10)$$

$$T_1 = G(s, t, u) - H(s, t, u) \quad (6.3.11)$$

$$T_2 = G(s, t, u) + H(s, t, u) \quad (6.3.12)$$

The isospin amplitudes for rho mediation are given by:

$$\begin{aligned} T_A^0 &:= 3(T_A + U_A) - (S_A + U_A) + (S_A - T_A) \\ &= 2(T_A + U_A) \\ &= 4ie^2 m^2 \left[\frac{2 + (3+z)R}{2m^2(1-z)R + M^2} + \frac{2 + (3-z)R}{2m^2(1+z)R + M^2} \right] \end{aligned} \quad (6.3.13)$$

$$\begin{aligned} T_A^1 &:= -(S_A + U_A) - (S_A - T_A) \\ &= -2S_A + T_A - U_A \\ &= 2ie^2 m^2 \left[\frac{4zR}{4m^2(1+R) - M^2} + \frac{2 + (3+z)R}{2m^2(1-z)R + M^2} - \frac{2 + (3-z)R}{2m^2(1+z)R + M^2} \right] \end{aligned} \quad (6.3.14)$$

$$\begin{aligned} T_A^2 &:= -(S_A + U_A) + (S_A - T_A) \\ &= -(T_A + U_A) \\ &= -\frac{1}{2} T_A^0 \end{aligned} \quad (6.3.15)$$

The isospin amplitudes for Higgs mediator are given by:

$$\begin{aligned} T_H^0 &:= 3S_H + T_H + U_H \\ &= -3i \frac{16\kappa^2 \nu^2}{s - m_H^2} - i \frac{16\kappa^2 \nu^2}{t - m_H^2} - i \frac{16\kappa^2 \nu^2}{u - m_H^2} \\ &= 16i\kappa^2 \nu^2 \left[-\frac{3}{4m^2(1+R) - m_H^2} + \frac{1}{2m^2(1-z)R + m_H^2} + \frac{1}{2m^2(1+z)R + m_H^2} \right] \end{aligned} \quad (6.3.16)$$

$$\begin{aligned} T_H^1 &:= T_H - U_H \\ &= -i \frac{16\kappa^2 \nu^2}{t - m_H^2} + i \frac{16\kappa^2 \nu^2}{u - m_H^2} \\ &= 16i\kappa^2 \nu^2 \left[\frac{1}{2m^2(1-z)R + m_H^2} - \frac{1}{2m^2(1+z)R + m_H^2} \right] \end{aligned} \quad (6.3.17)$$

$$\begin{aligned}
 T_H^2 &:= T_H + U_H \\
 &= -i \frac{16\kappa^2 \nu^2}{t - m_H^2} - i \frac{16\kappa^2 \nu^2}{u - m_H^2} \\
 &= 16i\kappa^2 \nu^2 \left[\frac{1}{2m^2(1-z)R + m_H^2} + \frac{1}{2m^2(1+z)R + m_H^2} \right]
 \end{aligned} \tag{6.3.18}$$

The isospin amplitudes for the four pion vertex are given by:

$$T_\lambda^0 := -5i\lambda_4 \qquad T_\lambda^1 := 0 \qquad T_\lambda^2 := -2i\lambda_4 \tag{6.3.19}$$

The sum of the amplitudes of the Higgs and 4 pion tree diagrams are:

$$\begin{aligned}
 T_{H\lambda}^0 &= T_H^0 + T_\lambda^0 \\
 &= 16i\kappa^2 \nu^2 \left[-\frac{3}{4m^2(1+R) - m_H^2} + \frac{1}{2m^2(1-z)R + m_H^2} + \frac{1}{2m^2(1+z)R + m_H^2} \right] - 5i\lambda_4
 \end{aligned} \tag{6.3.20}$$

$$\begin{aligned}
 T_{H\lambda}^1 &= T_H^1 + T_\lambda^1 \\
 &= 16i\kappa^2 \nu^2 \left[\frac{1}{2m^2(1-z)R + m_H^2} - \frac{1}{2m^2(1+z)R + m_H^2} \right]
 \end{aligned} \tag{6.3.21}$$

$$\begin{aligned}
 T_{H\lambda}^2 &= T_H^2 + T_\lambda^2 \\
 &= 16i\kappa^2 \nu^2 \left[\frac{1}{2m^2(1-z)R + m_H^2} + \frac{1}{2m^2(1+z)R + m_H^2} \right] - 2i\lambda_4
 \end{aligned} \tag{6.3.22}$$

6.4 Scattering Lengths



CATTERING lengths are computed from the coefficients of the partial wave scattering amplitude with the partial wave scattering amplitude obtained from the projection of the isospin amplitudes over the Legendre polynomials. We begin with the isospin amplitude $T^I(q^2, z)$ expressed as a sum over partial scattering amplitudes $T_m^I(q^2)$

$$T^I(q^2, z) = 32\pi \sum_{m=0}^{\infty} (2m+1) P_m(z) T_m^I(q^2) \tag{6.4.1}$$

where $P_m(z)$ is the Legendre polynomials indexed by m with $z = \cos\theta$ as defined in (6.1.17). Using the orthogonality of the Legendre polynomials on the inner product:

$$\int_{-1}^1 P_m(z) P_n(z) dz = \frac{2}{2m+1} \delta_{mn} \tag{6.4.2}$$

the partial scattering amplitudes can be extracted by multiplying $T^I(q^2, z)$ by the Legendre polynomials and integrating:

$$\begin{aligned}
 \int_{-1}^1 P_n(z) T^I(q^2, z) dz &= 32\pi \sum_{m=0}^{\infty} (2m+1) \int_{-1}^1 P_m(z) P_n(z) dz \cdot T_m^I(q^2) \\
 &= 32\pi \sum_{m=0}^{\infty} (2m+1) \frac{2}{2m+1} \delta_{mn} \cdot T_m^I(q^2) \\
 &= 64\pi T_n^I(q^2) \\
 \Rightarrow T_n^I(q^2) &= \frac{1}{64\pi} \int_{-1}^1 P_n(z) T^I(q^2, z) dz
 \end{aligned} \tag{6.4.3}$$

A Maclaurin series expansion can be made in terms of q^2 [46] as

$$\begin{aligned}
 T_n^I &= i \left(\frac{q^2}{m_\pi^2} \right)^n \left[a_n^I + b_n^I \left(\frac{q^2}{m_\pi^2} \right) + \dots \right] \\
 &= i R^n \left[a_n^I + b_n^I R + \dots \right]
 \end{aligned} \tag{6.4.4}$$

where $R = \frac{q^2}{m^2}$ which was defined in (6.1.18) and a_n^I and b_n^I are the scattering lengths. We shall project the isospin amplitudes using the first three Legendre polynomials which are

$$P_0(z) = 1 \qquad P_1(z) = z \qquad P_2(z) = \frac{1}{2} (3z^2 - 1) \tag{6.4.5}$$

The first two scattering lengths are calculated below. For T^0

$$\begin{aligned}
 T^0(R) &= T_A^0 + T_{H\lambda}^0 \\
 &= 4ie^2 m^2 \left[\frac{2 + (3+z)R}{2m^2(1-z)R + M^2} + \frac{2 + (3-z)R}{2m^2(1+z)R + M^2} \right] + \\
 &+ 16i\kappa^2 \nu^2 \left[-\frac{3}{4m^2(1+R) - m_H^2} + \frac{1}{2m^2(1-z)R + m_H^2} + \frac{1}{2m^2(1+z)R + m_H^2} \right]
 \end{aligned} \tag{6.4.6}$$

The partial wave amplitude T_0^0 is

$$\begin{aligned}
 T_0^0(R) &= \frac{1}{64\pi} \int_{-1}^1 P_0(z) T^0(R, z) dz \\
 &= a_0^0 + b_0^0 R
 \end{aligned} \tag{6.4.7}$$

Setting $R = 0$ gives us

$$\begin{aligned}
 a_0^0 &= T_0^0(R) \Big|_{R=0} \\
 &= \frac{e^2 m^2}{2\pi M^2} + \frac{\kappa^2 \nu^2}{\pi} \left[\frac{1}{m_H^2} - \frac{3}{2(4m^2 - m_H^2)} \right] - \frac{5\lambda_4}{32\pi}
 \end{aligned} \tag{6.4.8}$$

and differentiating with respect to R and then setting to zero

$$\begin{aligned}
 b_0^0 &= \left. \frac{dT_0^0(R)}{dR} \right|_{R=0} \\
 &= \frac{e^2}{4\pi} \frac{m^2}{M^2} \left(3 - 4 \frac{m^2}{M^2} \right) + \frac{2m^2 \kappa^2 \nu^2}{\pi} \left[\frac{3}{(4m^2 - m_H^2)^2} - \frac{1}{m_H^4} \right]
 \end{aligned} \tag{6.4.9}$$

The above calculations can be repeated for T^1, T^2 and the three Legendre polynomials $P_0(z), P_1(z)$ and $P_2(z)$.

6.5 Tree Scattering Lengths Results



summary of the results for the scattering lengths are listed below:

$$\begin{aligned}
 a_0^0 &= \frac{e^2 m^2}{2\pi M^2} + \frac{\kappa^2 \nu^2}{\pi} \left[\frac{1}{m_H^2} - \frac{3}{2(4m^2 - m_H^2)} \right] - \frac{5\lambda_4}{32\pi} \\
 b_0^0 &= \frac{e^2 m^2}{4\pi M^2} \left(3 - 4\frac{m^2}{M^2} \right) + \frac{2m^2 \kappa^2 \nu^2}{\pi} \left[\frac{3}{(4m^2 - m_H^2)^2} - \frac{1}{m_H^4} \right] \\
 a_1^0 &= 0 \\
 b_1^0 &= 0 \\
 a_2^0 &= \frac{2e^2 m^4}{15\pi M^4} \left(1 + 4\frac{m^2}{M^2} \right) + \frac{16 m^4 \kappa^2 \nu^2}{15\pi m_H^6} \\
 b_2^0 &= \frac{4e^2 m^6}{5\pi M^6} \left(1 - 12\frac{m^2}{M^2} \right) - \frac{96 m^8 \kappa^2 \nu^2}{5\pi m_H^8} \\
 \\
 a_0^1 &= 0 \\
 b_0^1 &= 0 \\
 a_1^1 &= \frac{e^2}{24\pi} \frac{16m^6 - 3m^2 M^4}{4m^2 M^4 - M^6} + \frac{2 m^2 \kappa^2 \nu^2}{3\pi m_H^4} \\
 b_1^1 &= \frac{e^2 m^4 \left(-\frac{64}{3} \frac{m^6}{M^6} + 16\frac{m^4}{M^4} - 4\frac{m^2}{M^2} + 1 \right)}{6\pi M^4 \left(1 - 4\frac{m^2}{M^2} \right)^2} - \frac{8 m^4 \kappa^2 \nu^2}{3\pi m_H^6} \\
 \\
 a_2^1 &= 0 \\
 b_2^1 &= 0 \\
 \\
 a_0^2 &= -\frac{e^2 m^2}{8\pi M^2} + \frac{\kappa^2 \nu^2}{2\pi m_H^2} - \frac{\lambda_4}{32\pi} \\
 b_0^2 &= -\frac{e^2 m^2}{48\pi M^2} \left(3 - 4\frac{m^2}{M^2} \right) - \frac{1 m^2 \kappa^2 \nu^2}{3\pi m_H^4} \\
 a_1^2 &= 0 \\
 b_1^2 &= 0 \\
 a_2^2 &= -\frac{e^2 m^4}{30\pi M^4} \left(1 + 4\frac{m^2}{M^2} \right) + \frac{8 m^4 \kappa^2 \nu^2}{15\pi m_H^6} \\
 b_2^2 &= -\frac{e^2 m^6}{15\pi M^6} \left(1 - 12\frac{m^2}{M^2} \right) - \frac{16 m^6 \kappa^2 \nu^2}{5\pi m_H^8}
 \end{aligned}$$

For the experimental input we shall use the average masses of the charged and uncharged pions and

rhos:

$$m = 0.1372734 \pm 0.0000007 \text{ GeV} \quad M = 0.77649 \pm 0.00034 \text{ GeV} \quad (6.5.1)$$

which are taken from [29]. The rho-pion-pion coupling,

$$e = 5.96 \pm 0.20 \quad (6.5.2)$$

is taken from [47]. The value of the vacuum expectation value can be inferred from the definition of the mass of the rho

$$\begin{aligned} M &:= e\nu \\ \implies \nu &= \frac{M}{e} = 0.130 \pm 0.004 \text{ GeV} \end{aligned} \quad (6.5.3)$$

The pion decay constant and its ratio in the chiral limit,

$$F_\pi \approx 0.093 \text{ GeV} \quad \frac{F_\pi}{F} = 1.0627 \pm 0.0028$$

is taken from [48]. The four pion coupling is taken from [49]:

$$\begin{aligned} \lambda_4 &:= \left(\frac{m}{F}\right)^2 \\ &= 2.45074 \pm 0.1568 \end{aligned} \quad (6.5.4)$$

The mass of the symmetry breaking field m_H is taken to be the mass of the $f_0(500)$:

$$m_H := m_{f_0} = 0.450 \pm 0.016 \text{ GeV} \quad (6.5.5)$$

This value is taken from [50]. Using the above values and a_0^0 and b_0^0 we can infer an average value for κ of:

$$\kappa = 1.31 \pm 0.03 \quad (6.5.6)$$

The values for the scattering lengths are tabulated below with NABKLZ referring to the model developed in this thesis.:

6. Scattering Lengths at Tree Level

Lengths	Weinberg ^d	χ PT(1 st \mathcal{O}) ^a	χ PT(2 nd \mathcal{O}) ^a	NABKLZ [†]	Colangelo ^b	Bijnens ^c	Exp ^{abc}
a_0^0	0.20	0.16	0.20	0.21	0.220	0.219	0.220 ± 0.005
b_0^0		0.18	0.26	0.30	0.276	0.279	0.25 ± 0.03
a_1^0				0			
b_1^0				0			
$a_2^0 \times 10^3$		0	2	2.06	1.75	2.2	1.7 ± 3
$b_2^0 \times 10^4$				-5.23	-3.55	-3.2	
a_0^1				0			
b_0^1				0			
a_1^1		0.030	0.036	0.0528	0.0379	0.0378	0.038 ± 0.002
b_1^1		0	0.043	0.0053	0.0057	0.0059	
a_2^1				0			
b_2^1				0			
a_0^2	-0.06	-0.045	-0.041	-0.0456	-0.0444	-0.0420	-0.044 ± 0.001
b_0^2				-0.0225	-0.0803	-0.0756	-0.082 ± 0.008
a_1^2				0			
b_1^2				0			
$a_2^2 \times 10^4$		0	3.5	-2.03	1.70	2.90	1.3 ± 3
$b_2^2 \times 10^4$		-8.9	-7	-0.53	-3.26	-3.60	-8.2

[†] Tree results

^a Results taken from [51]

^b Results taken from [46]

^c Results taken from [52]

^d Results taken from [53]

Table 6.1: Summary of predicted values and experimental data of the scattering length.

A parity plot can be made to show the predicted versus experimental values for the scattering lengths. The dashed line in figure 6.3 is the reference line of predicted values equal to experimental values.

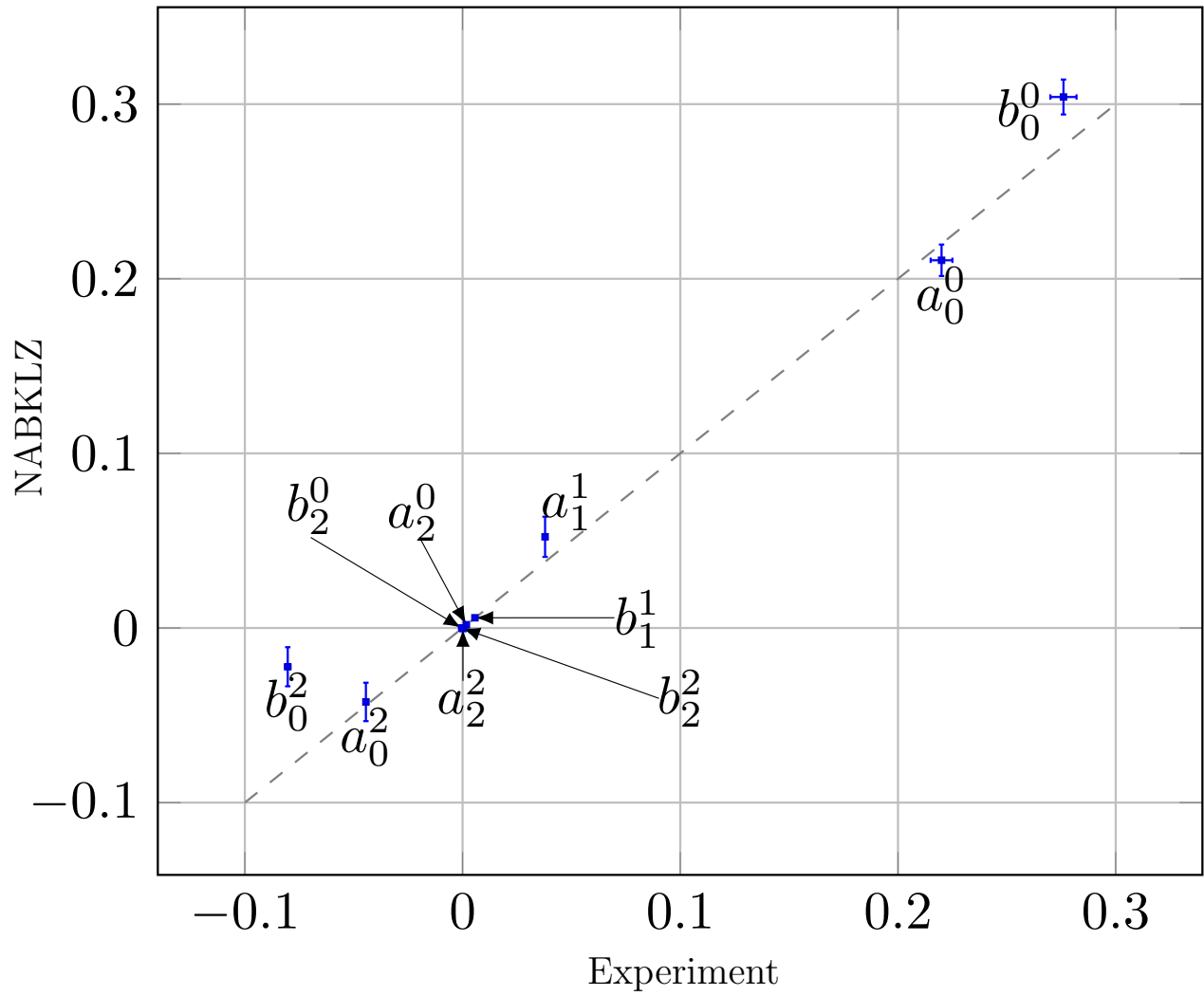

Figure 6.3: Predicted vs Experimental values

7

One Loop Corrections

THE tree results for the scattering lengths can be improved upon by including in the next order correction terms from the perturbative series. This can be done systematically by first computing the one particle irreducible (1PI) diagrams for the self energies and vertices. These 1PI diagrams then serve as the building blocks for the higher order analysis [54]. We shall list the topologies that contribute to the self energies and vertices. In total there are ~ 85 diagrams.

7.1 One Loop Topologies

DIAGRAMS that contribute to the self energy of the rho.

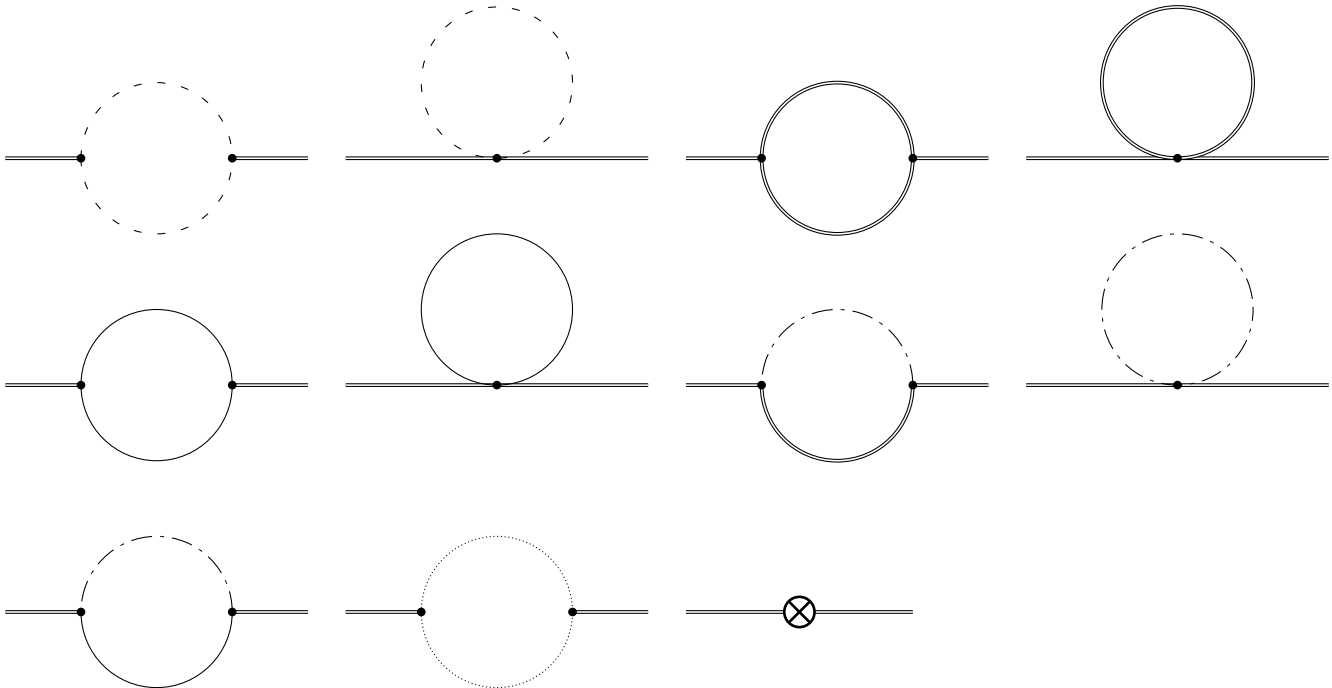

Diagrams that contribute to the self energy of the Higgs.

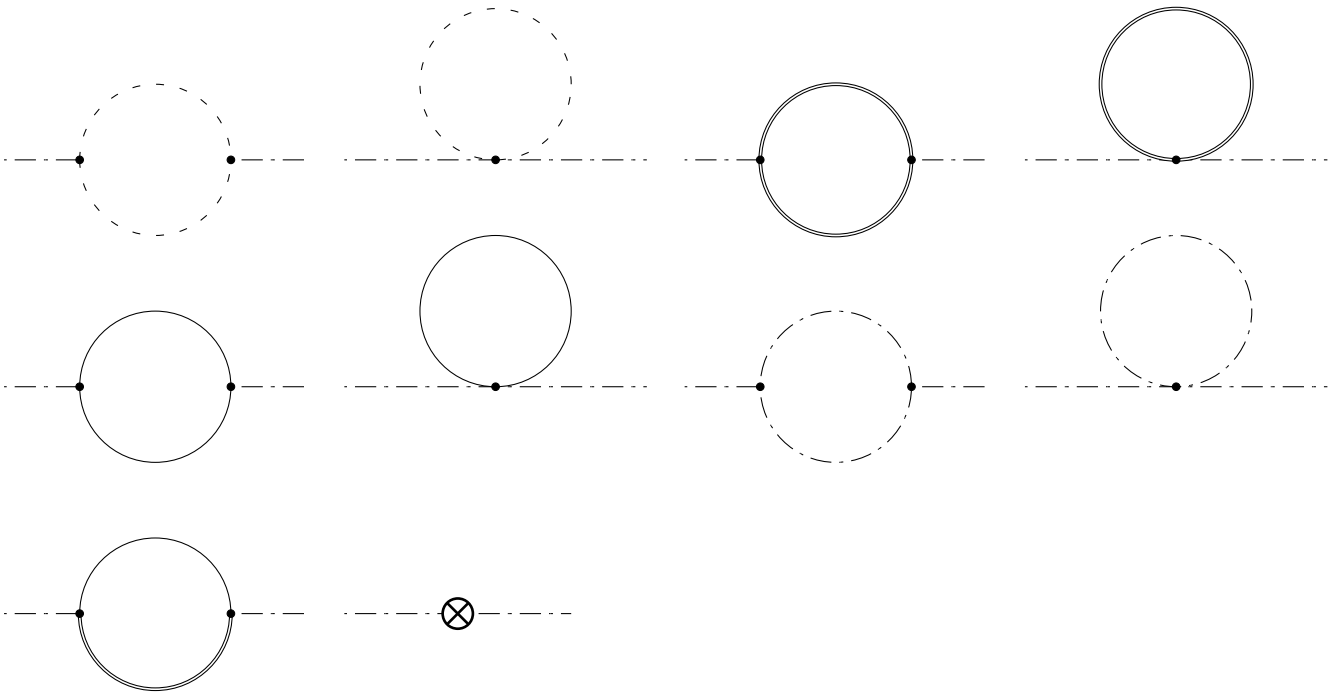

The lollipop diagrams for the rho and Higgs self energies will be included separately later during the analysis. Diagrams that contribute to the vertex of the $\phi\phi\rho$.

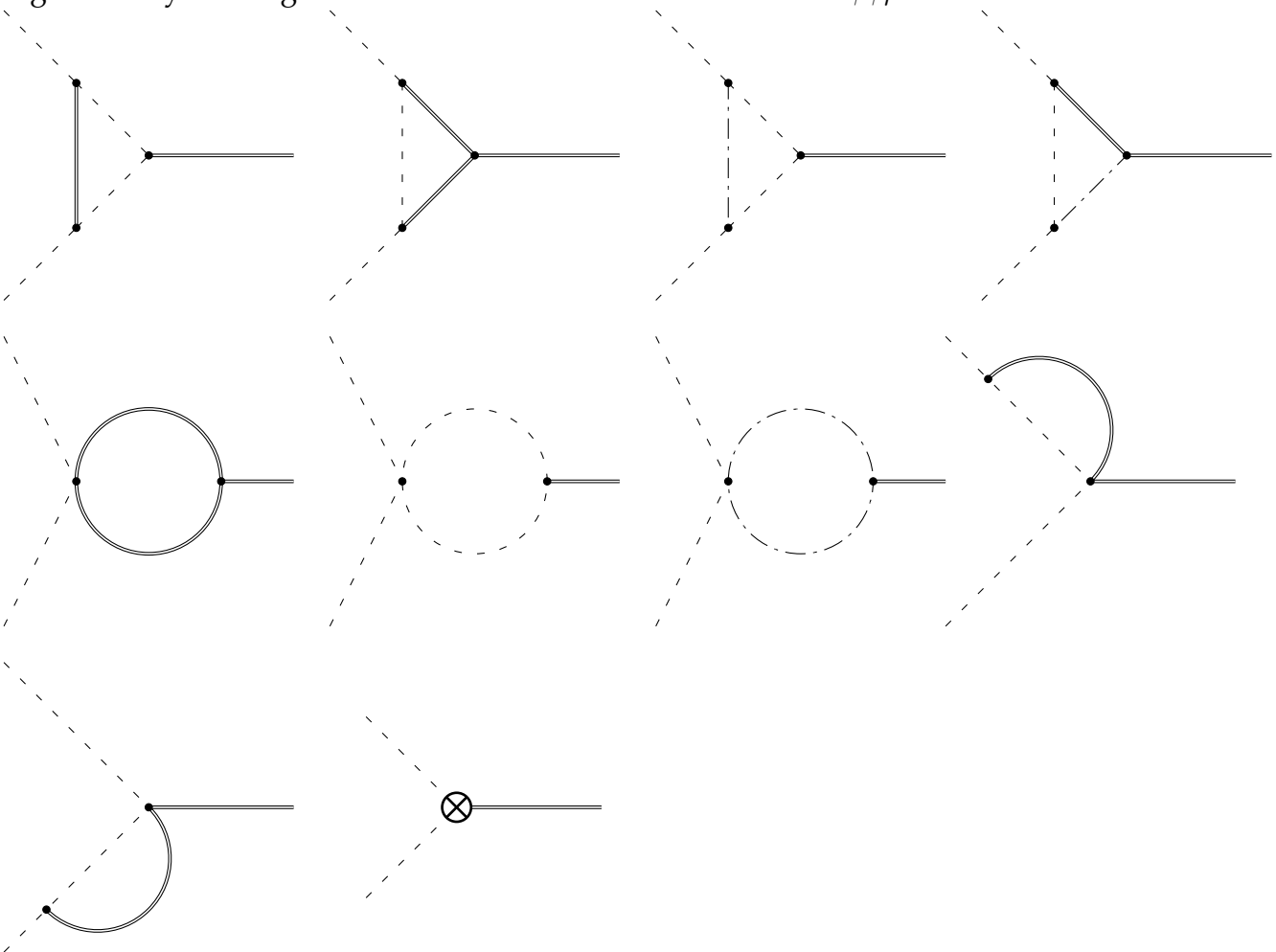

Diagrams that contribute to the vertex of the $\phi\phi H$.

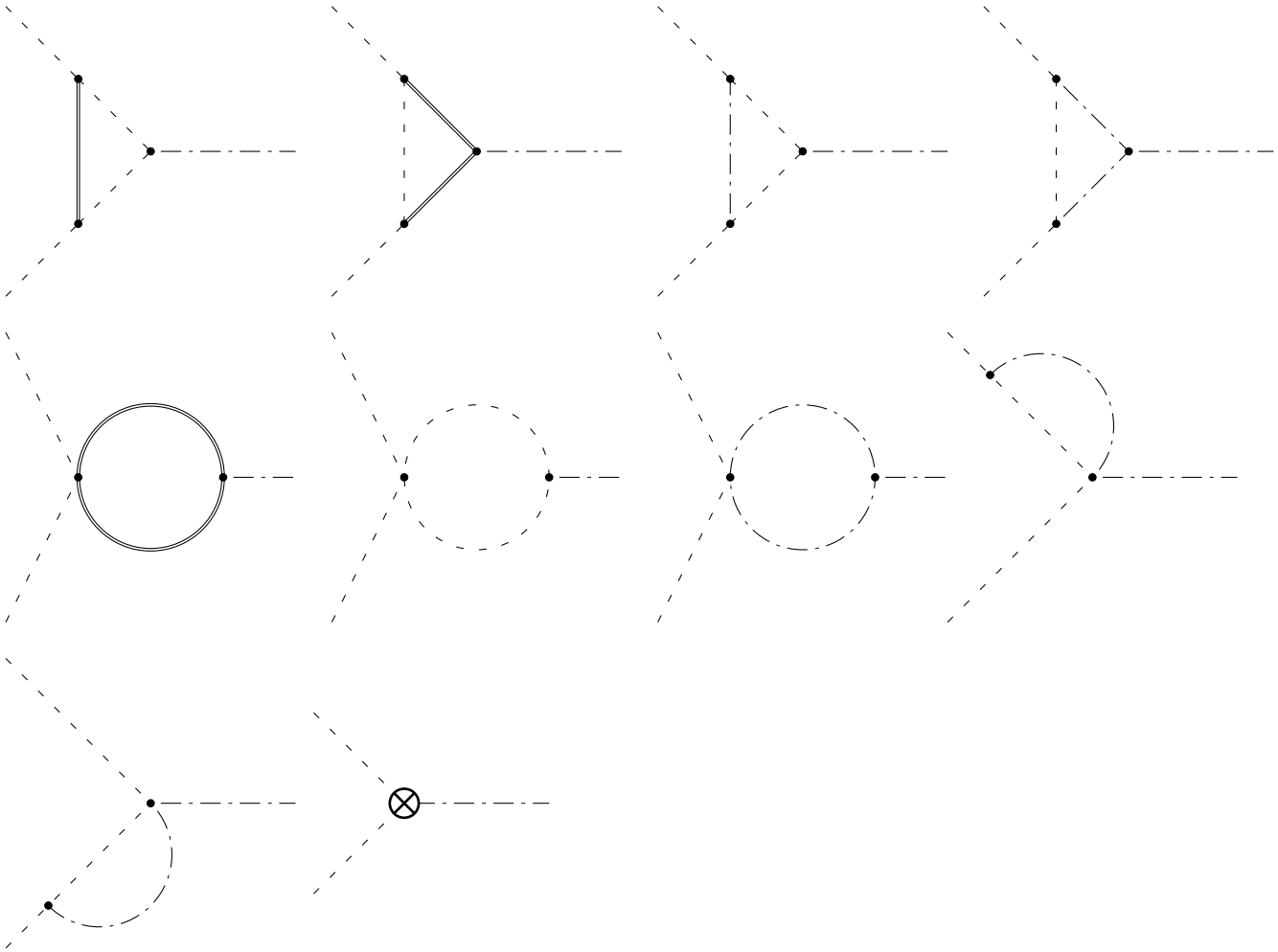

Diagrams that contribute to the $\phi\phi$ scattering via a loop.

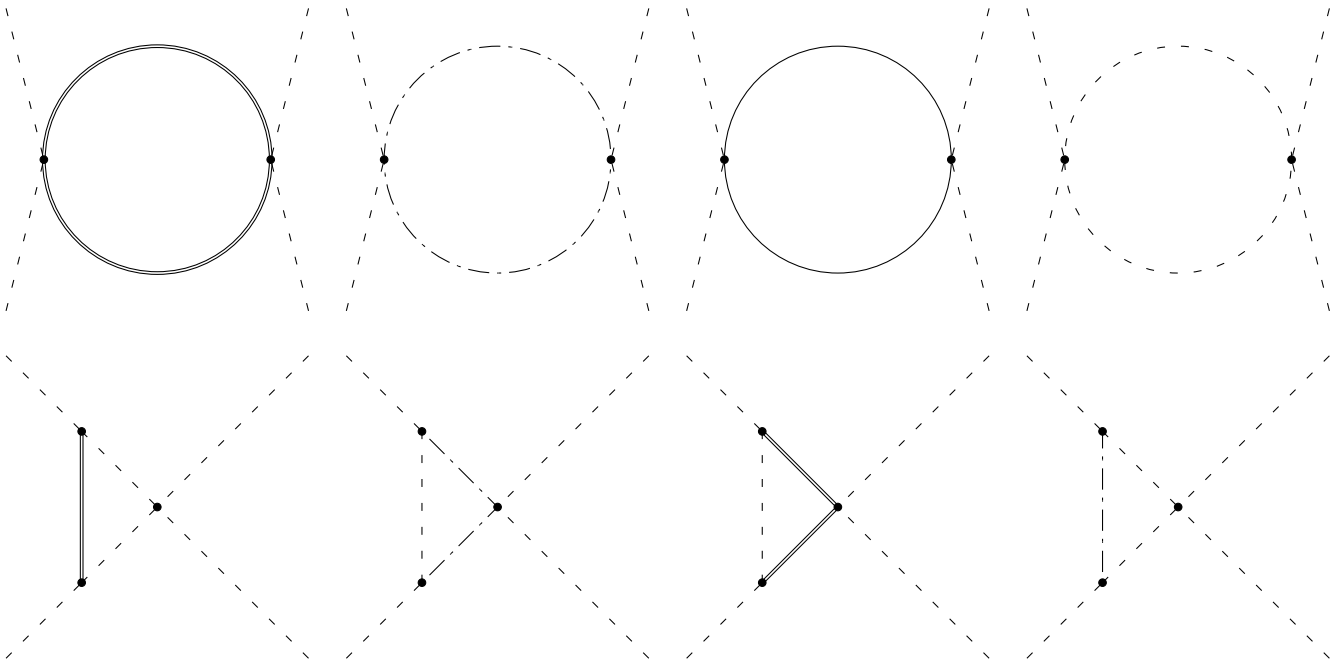

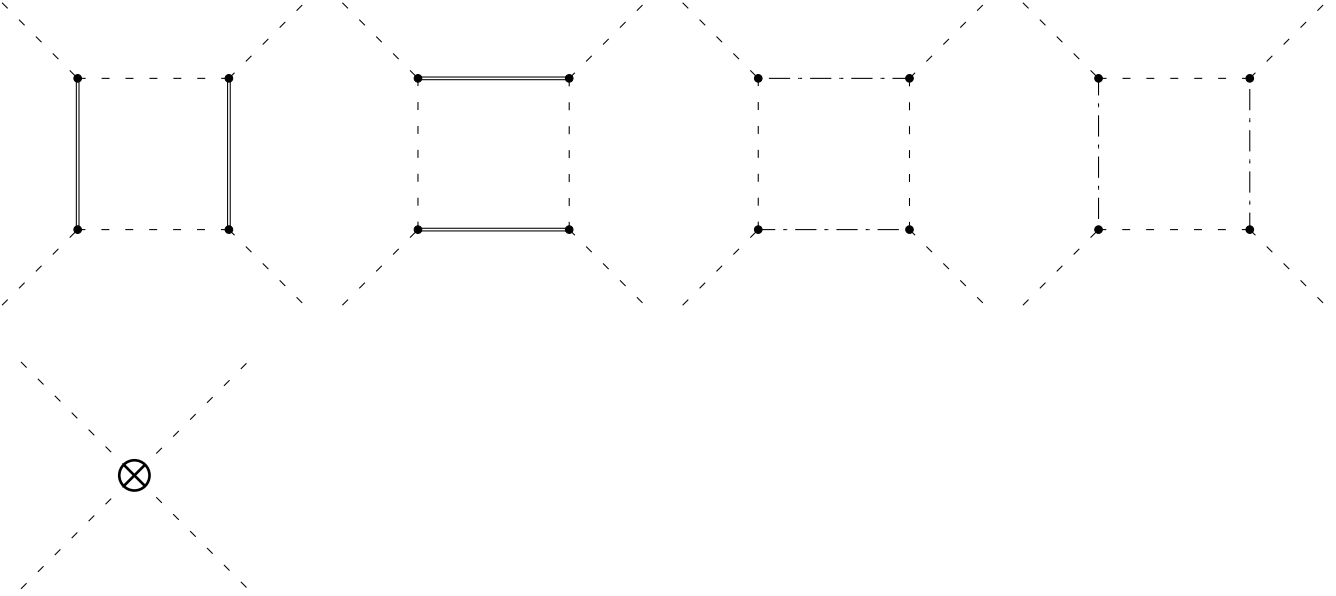

7.2 Dimensional Regularization

To parameterize the divergences that result in higher order loop calculations, we shall use dimensional regularization [55]. This is done by analytically continuing the spacetime dimension from $n = 4$ dimensions to $n = 4 - 2\varepsilon$ dimensions [56]. Making this change in the spacetime dimension will capture the divergences in terms of the form $\frac{1}{\varepsilon}$ and $\frac{p^2}{\varepsilon}$ which can be appropriately absorbed by the counter terms. A further consequence of changing the spacetime dimension to $n = 4 - 2\varepsilon$ is that the couplings are not dimensionless. This can be remedied by explicitly taking out the extra mass dimension. The action in n dimensions is

$$S = \int d^n x \mathcal{L} \quad (7.2.1)$$

Since the action is dimensionless

$$[S] = 1 \implies [d^n x] = [dx]^n = M^{-n} \text{ and } [\mathcal{L}] = M^n \quad (7.2.2)$$

Using the dimension of the Lagrangian we can determine the dimensions of the fields:

$$[A] = [\phi] = [\chi] = [H] = M^{\frac{n-2}{2}} \quad (7.2.3)$$

The dimensionful couplings can now be worked out to be

$$[e] = M^{\frac{4-n}{2}}, \quad [\lambda_4] = M^{4-n}, \quad [\nu] = M^{\frac{n-4}{2}}, \quad [\lambda] = M^{4-n}, \quad [\kappa] = M^{4-n} \quad (7.2.4)$$

We shall define a parameter μ which is referred to as the renormalization scale with dimensions of mass, $[\mu] = M$ and define dimensionless couplings in terms of the renormalization scale as

$$e \sim \mu^{\frac{4-n}{2}} e, \quad \lambda_4 \sim \mu^{4-n} \lambda_4, \quad \nu \sim \mu^{\frac{n-4}{2}} \nu, \quad \lambda \sim \mu^{4-n} \lambda, \quad \kappa \sim \mu^{4-n} \kappa \quad (7.2.5)$$

We will suppress the explicit appearance of the scale during the calculations but absorb it into the definition of the Passarino-Veltman scalar functions.

7.3 Passarino-Veltman Reduction

AN efficient way to compute the one loop diagrams is to use the Passarino-Veltman reduction technique [57]. This technique allows us to compute a Feynman diagram in terms of a few master scalar integrals [58, 59], which in principle only have to be computed once. The Passarino-Veltman reduction technique is implemented by using the denominators of the propagators to write all the scalar products between external momenta and the loop momentum. Practically this means expressing the numerators of the Feynman amplitude in terms of the denominator, leaving only scalar integrals to be evaluated. This is demonstrated below for the case of a vector self energy diagram.

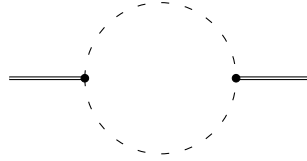

The Feynman vertices are:

$$\Gamma_1 = e\varepsilon_{adc}(2k + p)^\mu \quad \Gamma_2 = e\varepsilon_{bef}(2k + p)^\nu$$

with the self energy contribution due the pion bubble:

$$\begin{aligned}
 -i\pi_{ab1}^{\mu\nu} &= \int \frac{d^n k}{(2\pi)^n} \Gamma_1 \cdot D^{df}(k) \cdot \Gamma_2 \cdot D^{ce}(k + p) \\
 &= \int \frac{d^n k}{(2\pi)^n} \frac{e\varepsilon_{adc}(2k + p)^\mu \cdot \delta^{df} \cdot e\varepsilon_{bef}(2k + p)^\nu \delta^{ce}}{(k^2 - m^2) [(k + p)^2 - m^2]} \\
 &= e^2 \varepsilon_{cda} \varepsilon_{cdb} \int \frac{d^n k}{(2\pi)^n} \frac{(2k + p)^\mu (2k + p)^\nu}{(k^2 - m^2) [(k + p)^2 - m^2]} \\
 &= e^2 \varepsilon_{cda} \varepsilon_{cdb} I_1^{\mu\nu}
 \end{aligned} \tag{7.3.1}$$

Using $\varepsilon_{cda} \varepsilon_{cdb} = 2\delta_{ab}$

$$-i\pi_{ab1}^{\mu\nu} = 2e^2 \delta_{ab} I_1^{\mu\nu} \tag{7.3.2}$$

We can make some definitions for aiding in the calculation:

$$\begin{aligned}
 N_1^{\mu\nu} &:= (2k + p)^\mu (2k + p)^\nu \\
 &= 4k^\mu k^\nu + 2(k^\mu p^\nu + p^\mu k^\nu) + p^\mu p^\nu
 \end{aligned} \tag{7.3.3}$$

$$D_1 := k^2 - m^2 \tag{7.3.4}$$

$$\begin{aligned}
 D_2 &:= (k + p)^2 - m^2 \\
 &= k^2 + 2k \cdot p + p^2 - m^2 \\
 &= D_1 + 2k \cdot p + p^2
 \end{aligned} \tag{7.3.5}$$

So we have the relations

$$k^2 = D_1 + m^2 \tag{7.3.6}$$

$$2k \cdot p = D_2 - D_1 - p^2 \tag{7.3.7}$$

The scalar product have now been expressed in terms of the denominators. We can split the integral over the transverse and longitudinal parts

$$\begin{aligned} I_1^{\mu\nu} &:= \int \frac{d^n k}{(2\pi)^n} \frac{N_1^{\mu\nu}}{D_1 D_2} \\ &= f_{T1} P_T^{\mu\nu} + f_{L1} P_L^{\mu\nu} \end{aligned} \quad (7.3.8)$$

where the projectors are defined as

$$P_L^{\mu\nu} := \frac{p^\mu p^\nu}{p^2} \quad (7.3.9)$$

$$P_T^{\mu\nu} := g^{\mu\nu} - \frac{p^\mu p^\nu}{p^2} \quad (7.3.10)$$

The coefficients can be extracted using the transverse and longitudinal projectors.

$$P_{L\mu\nu} I_1^{\mu\nu} = f_{L1} \quad (7.3.11)$$

$$P_{T\mu\nu} I_1^{\mu\nu} = (n-1) f_{T1} \quad (7.3.12)$$

The projectors acting on the numerator $N_1^{\mu\nu}$ yield

$$\begin{aligned} P_{L\mu\nu} N_1^{\mu\nu} &= \frac{1}{p^2} (2k \cdot p + p^2)^2 \\ &= \frac{1}{p^2} (D_2^2 - 2D_1 D_2 + D_1^2) \end{aligned} \quad (7.3.13)$$

and

$$\begin{aligned} P_{T\mu\nu} N_1^{\mu\nu} &= g_{\mu\nu} N_1^{\mu\nu} - P_{L\mu\nu} N_1^{\mu\nu} \\ g_{\mu\nu} N_1^{\mu\nu} &= 4k^2 + 2k \cdot p + p^2 \\ &= 2D_1 + 2D_2 + 4m^2 - p^2 \end{aligned} \quad (7.3.14)$$

The necessary ingredients have been assembled to extract the longitudinal coefficient

$$\begin{aligned} f_{L1} &= \int \frac{d^n k}{(2\pi)^n} \frac{P_{L\mu\nu} N_1^{\mu\nu}}{D_1 D_2} \\ &= \frac{1}{p^2} \int \frac{d^n k}{(2\pi)^n} \frac{D_2^2 - 2D_1 D_2 + D_1^2}{D_1 D_2} \\ &= \frac{1}{p^2} \int \frac{d^n k}{(2\pi)^n} \left(\frac{D_2}{D_1} + \frac{D_1}{D_2} - 2 \right) \\ &= \frac{1}{p^2} \int \frac{d^n k}{(2\pi)^n} \left(\frac{D_2}{D_1} + \frac{D_1}{D_2} \right) \end{aligned} \quad (7.3.15)$$

Since there are no massless particles in this field theory, we can safely make use of the Veltman conjecture by setting all dimensionless integrals to zero i.e.

$$\int \frac{d^n k}{(2\pi)^n} k^{2\alpha} = 0 \quad (7.3.16)$$

for $\alpha \in \mathbb{C}$. We are left with the task of evaluating

$$\int \frac{d^n k}{(2\pi)^n} \frac{D_1}{D_2} = \int \frac{d^n k}{(2\pi)^n} \frac{k^2 - m^2}{(k+p)^2 - m^2} \quad (7.3.17)$$

Making a change of variables $l^\mu = -(k+p)^\mu \Rightarrow k^\mu = -(l+p)^\mu \Rightarrow \int \frac{d^n k}{(2\pi)^n} = \int \frac{d^n l}{(2\pi)^n}$. Substituting in the new measure

$$\begin{aligned} \int \frac{d^n k}{(2\pi)^n} \frac{D_1}{D_2} &= \int \frac{d^n l}{(2\pi)^n} \frac{(l+p)^2 - m^2}{l^2 - m^2} \\ &= \int \frac{d^n k}{(2\pi)^n} \frac{D_2}{D_1} \\ &= \int \frac{d^n k}{(2\pi)^n} \left(1 + \frac{2k \cdot p}{k^2 - m^2} + \frac{p^2}{k^2 - m^2} \right) \\ &= p^2 A_0(m) \end{aligned} \quad (7.3.18)$$

where we have used the Passarino-Veltman scalar function $A_0(m)$ (see Appendix A). So the longitudinal coefficient is

$$\begin{aligned} f_{L1} &= \frac{1}{p^2} \int \frac{d^n k}{(2\pi)^n} \left(\frac{D_2}{D_1} + \frac{D_1}{D_2} \right) \\ &= 2A_0(m) \end{aligned} \quad (7.3.19)$$

The transverse coefficient can be evaluated as

$$\begin{aligned} (n-1) f_{T1} &= P_{T\mu\nu} I_1^{\mu\nu} \\ &= \int \frac{d^n k}{(2\pi)^n} \frac{P_{T\mu\nu} N_1^{\mu\nu}}{D_1 D_2} \\ &= \int \frac{d^n k}{(2\pi)^n} \left(\frac{g_{\mu\nu} N_1^{\mu\nu}}{D_1 D_2} - \frac{P_{L\mu\nu} N_1^{\mu\nu}}{D_1 D_2} \right) \\ &= \int \frac{d^n k}{(2\pi)^n} \frac{2D_1 + 2D_2 + 4m^2 - p^2}{D_1 D_2} - \int \frac{d^n k}{(2\pi)^n} \frac{P_{L\mu\nu} N_1^{\mu\nu}}{D_1 D_2} \\ &= \int \frac{d^n k}{(2\pi)^n} \left[\frac{2}{D_1} + \frac{2}{D_2} + \frac{4m^2 - p^2}{D_1 D_2} \right] - f_{L1} \\ &= 4A_0(m) + (4m^2 - p^2) B_0(m; p, m) - 2A_0(m) \\ &= 2A_0(m) + (4m^2 - p^2) B_0(m; p, m) \\ \Rightarrow f_{T1} &= \frac{1}{n-1} \left[2A_0(m) + (4m^2 - p^2) B_0(m; p, m) \right] \end{aligned} \quad (7.3.20)$$

So the integral $I_1^{\mu\nu}$ is

$$I_1^{\mu\nu} = \frac{1}{n-1} \left[2A_0(m) + (4m^2 - p^2) B_0(m; p, m) \right] P_T^{\mu\nu} + 2A_0(m) P_L^{\mu\nu} \quad (7.3.21)$$

with the self energy due to a pion bubble.

$$\begin{aligned} -i\pi_{ab1}^{\mu\nu} &= 2e^2 \delta_{ab} I_1^{\mu\nu} \\ &= \frac{2e^2 \delta_{ab}}{n-1} \left[2A_0(m) + (4m^2 - p^2) B_0(m; p, m) \right] P_T^{\mu\nu} + 4e^2 \delta_{ab} A_0(m) P_L^{\mu\nu} \end{aligned} \quad (7.3.22)$$

7.4 Summary of one loop self energies

APPENDIX B contains the details for the complete one loop corrections for the self energies. We shall summarize the results below:

7.4.1 Rho Self Energy

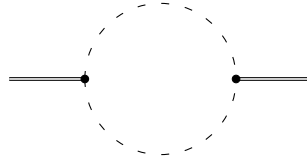

$$-i\pi_{ab1}^{\mu\nu} = \frac{2e^2\delta_{ab}}{n-1} \left[2A_0(m) + (4m^2 - p^2) B_0(m; p, m) \right] P_T^{\mu\nu} + 4e^2\delta_{ab}A_0(m) P_L^{\mu\nu} \quad (7.4.1)$$

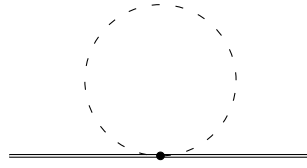

$$-i\pi_{ab2}^{\mu\nu} = -4e^2\delta_{ab}A_0(m) P_T^{\mu\nu} - 4e^2\delta_{ab}A_0(m) P_L^{\mu\nu} \quad (7.4.2)$$

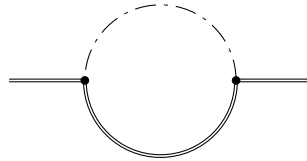

$$-i\pi_{ab3}^{\mu\nu} = -e^2M^2\delta_{ab}B_0(M; p, m_H) P_T^{\mu\nu} - e^2M^2\delta_{ab}B_0(M; p, m_H) P_L^{\mu\nu} \quad (7.4.3)$$

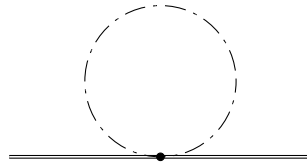

$$-i\pi_{ab4}^{\mu\nu} = -\frac{1}{2}e^2\delta_{ab}A_0(m_H) P_T^{\mu\nu} - \frac{1}{2}e^2\delta_{ab}A_0(m_H) P_L^{\mu\nu} \quad (7.4.4)$$

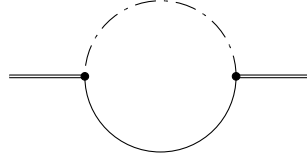

$$\begin{aligned}
 -i\pi_{ab5}^{\mu\nu} = & -\frac{e^2\delta_{ab}}{4(n-1)} \left\{ A_0(M) + A_0(m_H) + (2m_H^2 + 2M^2 - p^2) B_0(M; p, m_H) + \right. \\
 & \left. - \frac{m_H^2 - M^2}{p^2} [A_0(M) - A_0(m_H) + (m_H^2 - M^2) B_0(M; p, m_H)] \right\} P_T^{\mu\nu} + \\
 & -\frac{1}{4}e^2\delta_{ab} \left\{ A_0(M) + A_0(m_H) + \frac{m_H^2 - M^2}{p^2} [-A_0(m_H) + A_0(M) + (m_H^2 - M^2) B_0(M; p, m_H)] \right\} P_L^{\mu\nu}
 \end{aligned} \tag{7.4.5}$$

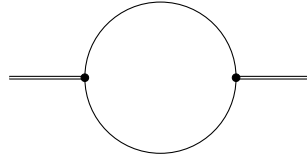

$$-i\pi_{ab8}^{\mu\nu} = \frac{e^2\delta_{ab}}{2(n-1)} [2A_0(M) + (4M^2 - p^2) B_0(M; p, M)] P_T^{\mu\nu} + e^2\delta_{ab} A_0(M) P_L^{\mu\nu} \tag{7.4.6}$$

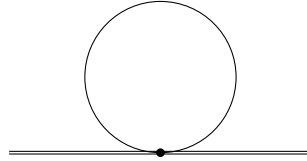

$$-i\pi_{ab6}^{\mu\nu} = -\frac{3}{2}e^2\delta^{ab} A_0(M) P_T^{\mu\nu} - \frac{3}{2}e^2\delta^{ab} A_0(M) P_L^{\mu\nu} \tag{7.4.7}$$

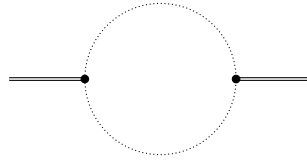

$$-i\pi_{ab7}^{\mu\nu} = \frac{2e^2\delta_{ab}}{n-1} \left[\frac{1}{2}A_0(M) + \left(M^2 - \frac{1}{4}p^2\right) B_0(M; p, M) \right] P_T^{\mu\nu} + 2e^2\delta_{ab} \left[\frac{1}{2}A_0(M) + \frac{1}{4}p^2 B_0(M; p, M) \right] P_L^{\mu\nu} \tag{7.4.8}$$

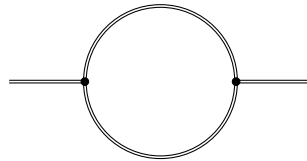

$$\begin{aligned}
 -i\pi_{ab9}^{\mu\nu} = & 2e^2\delta_{ab} \left\{ \frac{4n-5}{n-1} A_0(M) + \frac{1}{2(n-1)} [4(3n-4)M^2 + (6n-5)p^2] B(M; p, M) \right\} P_T^{\mu\nu} + \\
 & + 2e^2\delta_{ab} \left[(2n-1) A_0(M) + \frac{1}{2} (4M^2 - p^2) B(M; p, M) \right] P_L^{\mu\nu}
 \end{aligned} \tag{7.4.9}$$

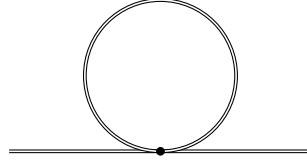

$$-i\pi_{ab10}^{\mu\nu} = -4e^2\delta_{ab}(n-1)A_0(M)P_T^{\mu\nu} - 4e^2\delta_{ab}(n-1)A_0(M)P_L^{\mu\nu} \quad (7.4.10)$$

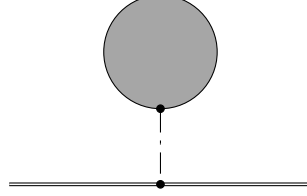

$$\begin{aligned} -i\pi_{ab11}^{\mu\nu} = & \frac{3}{2}M^2\delta_{ab} \left\{ \lambda \frac{A_0(m_H)}{m_H^2} + [\lambda + e^2(n-1)] \frac{A_0(M)}{m_H^2} + 8\kappa \frac{A_0(m)}{m_H^2} \right\} P_T^{\mu\nu} + \\ & + \frac{3}{2}M^2\delta_{ab} \left\{ \lambda \frac{A_0(m_H)}{m_H^2} + [\lambda + e^2(n-1)] \frac{A_0(M)}{m_H^2} + 8\kappa \frac{A_0(m)}{m_H^2} \right\} P_L^{\mu\nu} \end{aligned} \quad (7.4.11)$$

7.4.2 Higgs Self Energy

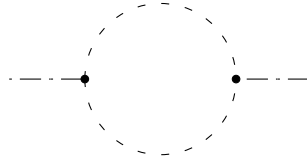

$$-i\pi_1^H = 48\kappa^2\nu^2 B_0(m; p, m) \quad (7.4.12)$$

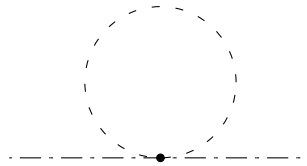

$$-i\pi_2^H = 6\kappa A_0(m) \quad (7.4.13)$$

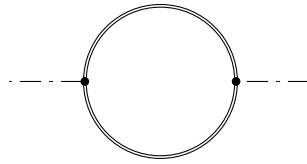

$$-i\pi_3^H = 3e^4\nu^2 n B_0(M; p, M) \quad (7.4.14)$$

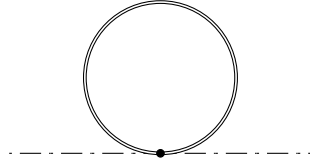

$$-i\pi_4^H = \frac{3}{2}e^2 n A_0(M) \quad (7.4.15)$$

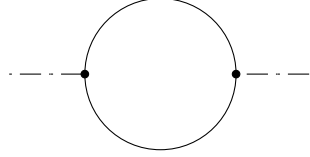

$$-i\pi_5^H = \frac{3}{4}\lambda^2\nu^2 B_0(M; p, M) \quad (7.4.16)$$

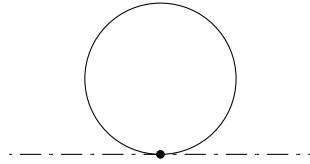

$$-i\pi_6^H = \frac{3}{4}\lambda A_0(M) \quad (7.4.17)$$

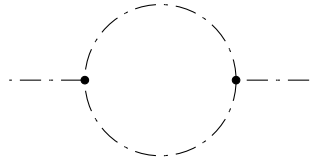

$$-i\pi_7^H = \frac{9}{4}\lambda^2\nu^2 B_0(m_H; p, m_H) \quad (7.4.18)$$

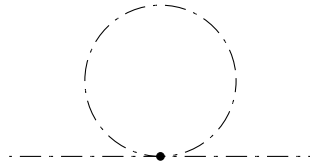

$$-i\pi_8^H = \frac{3}{2}\lambda A_0(m_H) \quad (7.4.19)$$

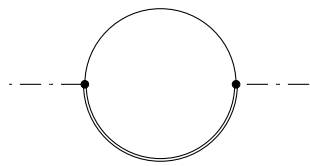

$$-i\pi_9^H = -\frac{3}{4}e^2 \left[A_0(M) + (M^2 + 2p^2) B_0(M; p, M) \right] \quad (7.4.20)$$

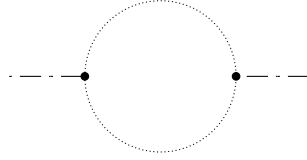

$$-i\pi_{10}^H = \frac{3}{4}e^2 M^2 B_0(M; p, M) \quad (7.4.21)$$

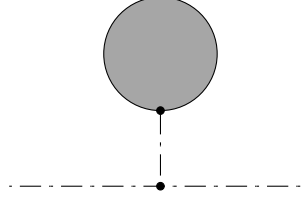

$$-i\pi_{11}^H = -\frac{9}{4}\lambda\nu^2 \left\{ \lambda \frac{A_0(m_H)}{m_H^2} + [\lambda + e^2(n-1)] \frac{A_0(M)}{m_H^2} + 8\kappa \frac{A_0(m)}{m_H^2} \right\} \quad (7.4.22)$$

7.5 Summary of one loop vertices

WE shall use these definitions for the calculations of the one loop corrections to the three point vertices:

$$\begin{aligned} p^\mu &= p_1^\mu + p_2^\mu \\ p \cdot (p_1 - p_2) &= (p_1 + p_2) \cdot (p_1 - p_2) \\ &= 0 \\ p_1 \cdot p_2 &= \frac{1}{2} [(p_1 + p_2)^2 - p_1^2 - p_2^2] \\ &= \frac{1}{2} p^2 - m^2 \\ p \cdot p_1 &= (p_1 + p_2) \cdot p_1 \\ &= \frac{1}{2} p^2 \\ p \cdot p_2 &= (p_1 + p_2) \cdot p_2 \\ &= \frac{1}{2} p^2 \end{aligned}$$

$$\begin{aligned} p \cdot p_1 &= (p_1 + p_2) \cdot p_1 & p \cdot p_2 &= (p_1 + p_2) \cdot p_2 \\ &= \frac{1}{2} p^2 & &= \frac{1}{2} p^2 \end{aligned}$$

where $\{a, p_1\}$, $\{b, p_2\}$ are incoming momenta of the pions and $\{c, p^\mu\}$ is the momentum of the outgoing rho.

7.5.1 Pion-Pion-Rho Vertex

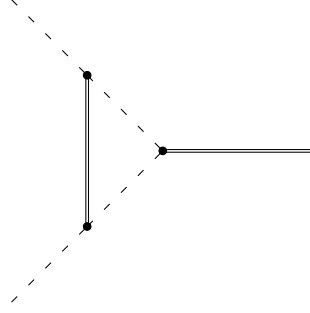

$$\begin{aligned}
 V_1^\mu = & -ie^3 \varepsilon_{cab} \frac{(p_1 - p_2)^\mu}{4m^2 - p^2} \left[\frac{1}{m^2} (4m^2 - p^2) [A_0(M) - A_0(m)] \right. \\
 & + \frac{1}{m^2} [16m^4 - 6m^2 (M^2 + p^2) + M^2 p^2] B_0(m, m, M) - 2(4m^2 - M^2 - 2p^2) B_0(m, p, m) + \\
 & \left. + (4m^2 - M^2 - 2p^2) (4m^2 - 2M^2 - p^2) C_0(m; p_2, M; p, m) \right] \quad (7.5.1)
 \end{aligned}$$

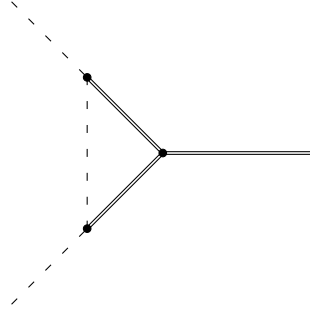

$$\begin{aligned}
 V_2^\mu = & 2ie^3 \varepsilon_{cab} \frac{(p_1 - p_2)^\mu}{4m^2 - p^2} \left[\left(1 - \frac{p^2}{4m^2}\right) [A_0(m) - A_0(M)] + \left(-4m^2 + 2M^2 + \frac{3p^2}{2} - \frac{M^2 p^2}{4m^2}\right) B_0(m; m, M) + \right. \\
 & \left. - \left(M^2 + \frac{p^2}{2}\right) B_0(M; p, M) + \left(-4m^2 M^2 + M^4 - 2m^2 p^2 + M^2 p^2 + \frac{1}{4} p^4\right) C_0(m; p_1, M; -p_2, M) \right] \quad (7.5.2)
 \end{aligned}$$

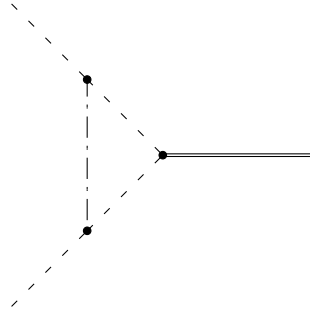

$$V_3^\mu = \frac{32i\kappa^2 \nu^2 e \varepsilon_{cab} (p_1 - p_2)^\mu}{4m^2 - p^2} \left[B_0(m; m, m_H) - B_0(m; p, m) + \frac{1}{2} (4m^2 - p^2 - 2m_H^2) C_0(m_H; p_1, m; -p_2, m) \right] \quad (7.5.3)$$

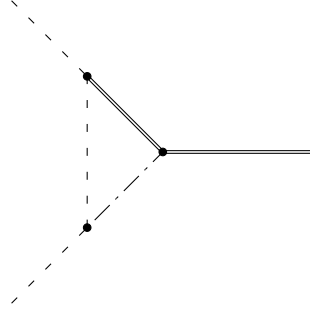

$$\begin{aligned}
 V_4^\mu = & -2i\kappa\nu^2 e^3 \varepsilon_{cab} \frac{(p_1 - p_2)^\mu}{4m^2 - p^2} \left[B_0(m, m, M) + B_0(m, m, m_H) - 2B_0(M, p, m_H) + \right. \\
 & \left. + (-8m^2 + M^2 + m_H^2 + p^2) C_0(m; p_1, M; -p_2, m_H) \right] + \\
 & -2i\kappa\nu^2 e^3 \varepsilon_{cab} \frac{(p_1 + p_2)^\mu}{p^2} \left[B_0(m, m, m_H) - B_0(m, m, M) + \right. \\
 & \left. + (M^2 - m_H^2 - p^2) C_0(m; p_1, M; -p_2, m_H) \right] \tag{7.5.4}
 \end{aligned}$$

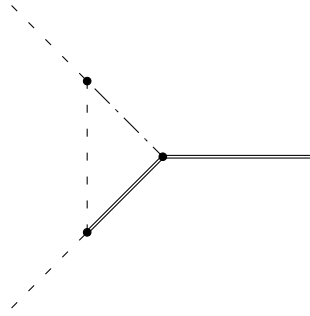

$$\begin{aligned}
 V_5^\mu = & -2i\kappa\nu^2 e^3 \varepsilon_{cab} \frac{(p_1 - p_2)^\mu}{4m^2 - p^2} \left[B_0(m, m, M) + B_0(m, m, m_H) - 2B_0(M, p, m_H) + \right. \\
 & \left. + (-8m^2 + M^2 + m_H^2 + p^2) C_0(m; p_1, M; -p_2, m_H) \right] + \\
 & -2i\kappa\nu^2 e^3 \varepsilon_{cab} \frac{(p_1 + p_2)^\mu}{p^2} \left[-B_0(m, m, m_H) + B_0(m, m, M) + \right. \\
 & \left. + (-M^2 + m_H^2 + p^2) C_0(m; p_1, M; -p_2, m_H) \right] \tag{7.5.5}
 \end{aligned}$$

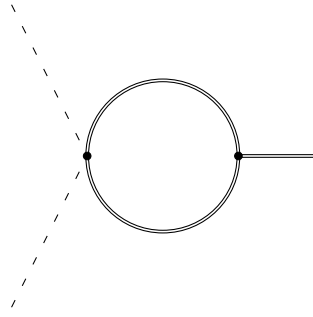

$$V_6 = 0$$

(7.5.6)

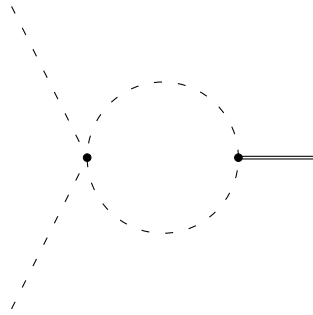

$$V_7 = 0$$

(7.5.7)

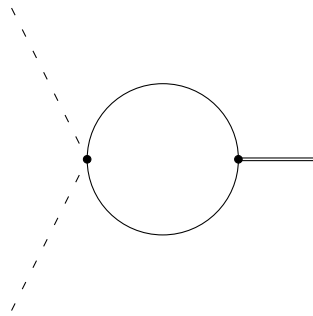

$$V_8 = 0$$

(7.5.8)

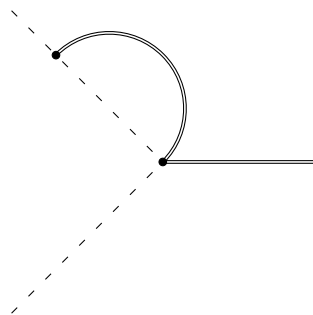

$$V_9 = -3ie^3 \varepsilon_{cab} \frac{p_1^\mu}{2m^2} [A_0(m) - A_0(M) + (M^2 - 3m^2) B_0(m; m, M)] \quad (7.5.9)$$

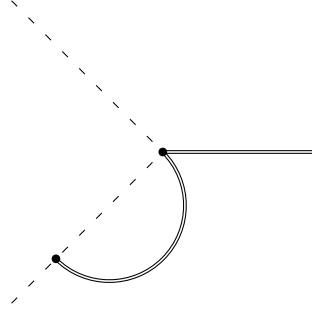

$$V_{10} = 3ie^3 \varepsilon_{cab} \frac{p_2^\mu}{2m^2} \left[A_0(m) - A_0(M) + (M^2 - 3m^2) B_0(m; m, M) \right] \quad (7.5.10)$$

$$V_9 + V_{10} = -3ie^3 \varepsilon_{cab} \frac{1}{2m^2} \left[A_0(m) - A_0(M) + (M^2 - 3m^2) B_0(m; m, M) \right] (p_1^\mu - p_2^\mu) \quad (7.5.11)$$

7.5.2 Pion-Pion-Higgs Vertex

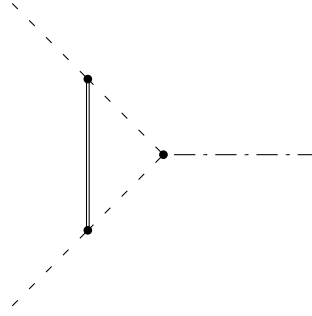

$$V_1^H = -8\kappa\nu e^2 \delta_{ab} \left[2B_0(m; m, M) - B_0(m; p, m) + (4m^2 - M^2 - 2p^2) C_0(M; p_1, m; -p_2, m) \right] \quad (7.5.12)$$

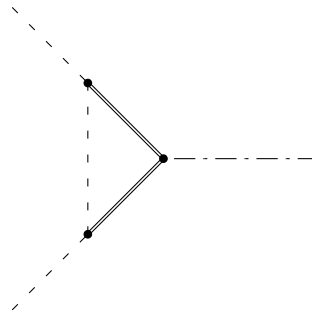

$$V_2^H = -2e^4 \nu \delta_{ab} \left[2B_0(M; p, M) - B_0(m; m, M) + \left(4m^2 - M^2 - \frac{1}{2}p^2 \right) C_0(m; p_1, M; -p_2, M) \right] \quad (7.5.13)$$

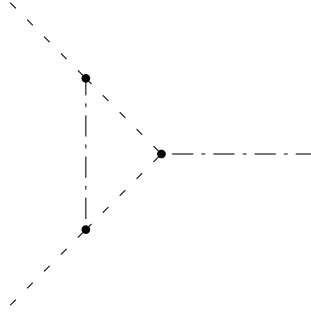

$$V_3^H = 64\kappa^3\nu^3\delta_{ab}C_0(m; p_2, m_H; p, m) \quad (7.5.14)$$

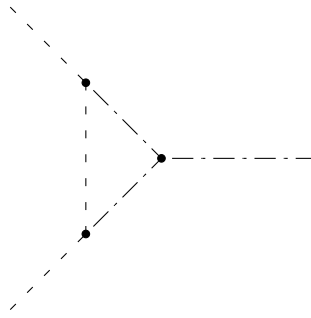

$$V_4^H = 24\kappa^2\nu^3\lambda\delta_{ab}C_0(m; p_1, m_H; -p_2, m_H) \quad (7.5.15)$$

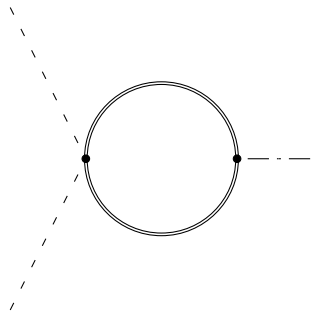

$$V_5^H = 4ne^4\nu\delta_{ab}B_0(M; p, M) \quad (7.5.16)$$

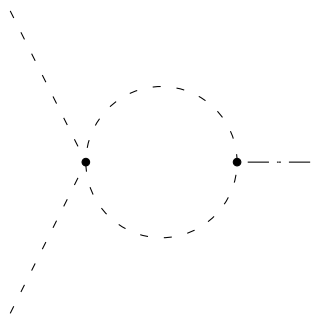

$$V_6^H = 20\kappa\nu\lambda_4\delta_{ab}B_0(m; p, m) \quad (7.5.17)$$

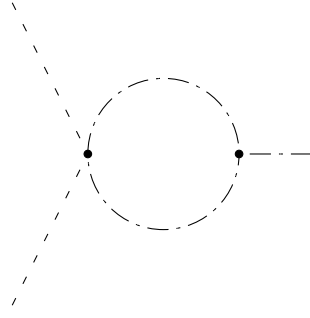

$$V_7^H = 3\kappa\lambda\nu\delta_{ab}B_0(m_H; p, m_H) \quad (7.5.18)$$

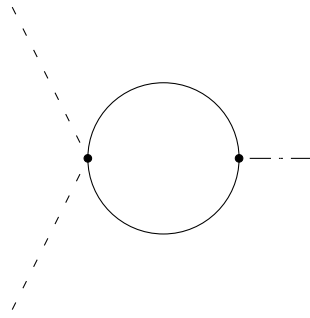

$$V_8^H = 3\kappa\lambda\nu\delta_{ab}B_0(M; p, M) \quad (7.5.19)$$

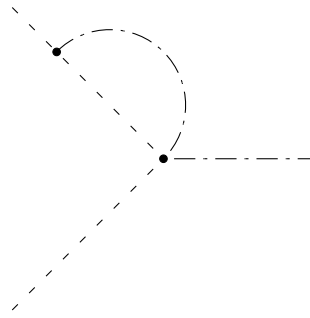

$$V_9^H = 8\kappa^2\nu\delta_{ab}B_0(m; m, m_H) \quad (7.5.20)$$

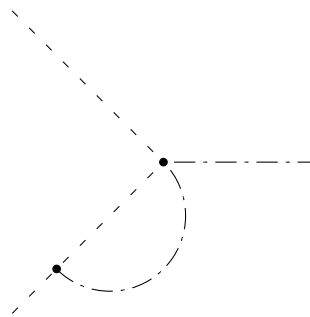

$$V_{10}^H = 8\kappa^2\nu\delta_{ab}B_0(m; m, m_H) \quad (7.5.21)$$

7.5.3 Pion-Pion-Pion-Pion Vertex

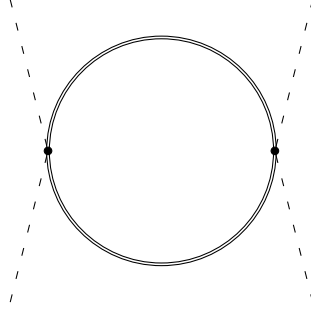

$$V_1^\phi(s) = 2ne^4 (2\delta_{ab}\delta_{cd} + \delta_{ac}\delta_{bd} + \delta_{ad}\delta_{bc}) B_0(M; \sqrt{s}, M)$$

Including the Mandelstam t and u channels

$$V_{abcd}^{1\phi}(s, t, u) = 2ne^4 \left[(2\delta_{ab}\delta_{cd} + \delta_{ac}\delta_{bd} + \delta_{ad}\delta_{bc}) B_0(M; \sqrt{s}, M) + \right. \\ \left. + (\delta_{ab}\delta_{cd} + 2\delta_{ac}\delta_{bd} + \delta_{ad}\delta_{bc}) B_0(M; \sqrt{t}, M) + (\delta_{ab}\delta_{cd} + \delta_{ac}\delta_{bd} + 2\delta_{ad}\delta_{bc}) B_0(M; \sqrt{u}, M) \right] \quad (7.5.22)$$

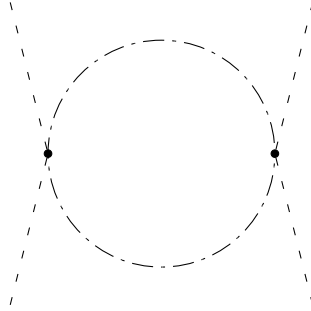

$$V_2^\phi(s) = 4\kappa^2 \delta_{ab}\delta_{cd} B_0(m_H; \sqrt{s}, m_H)$$

Including the t and u Mandelstam channels

$$V_{abcd}^{2\phi}(s, t, u) = 4\kappa^2 \left[\delta_{ab}\delta_{cd} B_0(m_H; \sqrt{s}, m_H) + \delta_{ac}\delta_{bd} B_0(m_H; \sqrt{t}, m_H) + \delta_{ad}\delta_{bc} B_0(m_H; \sqrt{u}, m_H) \right] \quad (7.5.23)$$

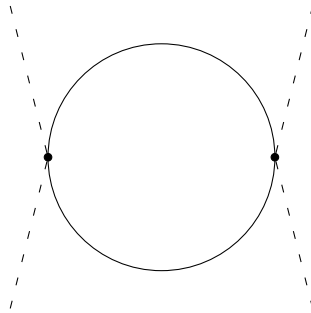

$$V_3^\phi(s) = 12\kappa^2 \delta_{ab}\delta_{cd} B_0(M; \sqrt{s}, M)$$

with

$$V_{abcd}^{3\phi}(s, t, u) = 12\kappa^2 \left[\delta_{ab}\delta_{cd}B_0(M; \sqrt{s}, M) + \delta_{ac}\delta_{bd}B_0(M; \sqrt{t}, M) + \delta_{ad}\delta_{bc}B_0(M; \sqrt{u}, M) \right] \quad (7.5.24)$$

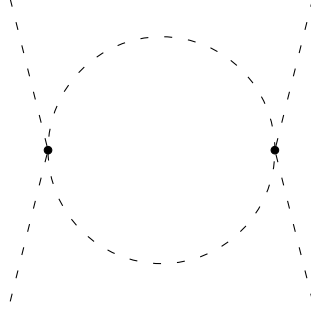

$$V_4^\phi(s) = \lambda_4^2 (7\delta_{ab}\delta_{cd} + 2\delta_{ac}\delta_{bd} + 2\delta_{ad}\delta_{bc}) B_0(m; \sqrt{s}, m)$$

with

$$V_{abcd}^{4\phi}(s, t, u) = \lambda_4^2 \left[(7\delta_{ab}\delta_{cd} + 2\delta_{ac}\delta_{bd} + 2\delta_{ad}\delta_{bc}) B_0(m; \sqrt{s}, m) + (2\delta_{ab}\delta_{cd} + 7\delta_{ac}\delta_{bd} + 2\delta_{ad}\delta_{bc}) B_0(m; \sqrt{t}, m) + (2\delta_{ab}\delta_{cd} + 2\delta_{ac}\delta_{bd} + 7\delta_{ad}\delta_{bc}) B_0(m; \sqrt{u}, m) \right] \quad (7.5.25)$$

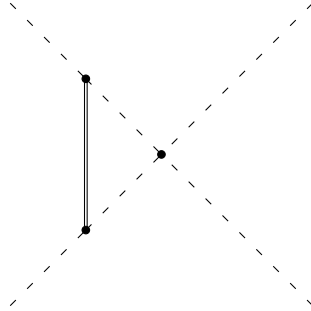

$$V_5^\phi(s) = -e^2\lambda_4 \left(-4\delta_{ab}\delta_{cd} + \delta_{ac}\delta_{bd} + \delta_{ad}\delta_{bc} \right) \left[2B_0(m; m, M) - B_0(m; \sqrt{s}, m) + (4m^2 - M^2 - 2s) C_0(m; p_2, M; \sqrt{s}, m) \right]$$

with

$$V_{abcd}^{5\phi}(s, t, u) = -e^2\lambda_4 \left\{ \begin{aligned} & (-4\delta_{ab}\delta_{cd} + \delta_{ac}\delta_{bd} + \delta_{ad}\delta_{bc}) \left[2B_0(m; m, M) - B_0(m; \sqrt{s}, m) + (4m^2 - M^2 - 2s) C_0(m; p_2, M; \sqrt{s}, m) \right] + \\ & (\delta_{ab}\delta_{cd} - 4\delta_{ac}\delta_{bd} + \delta_{ad}\delta_{bc}) \left[2B_0(m; m, M) - B_0(m; \sqrt{t}, m) + (4m^2 - M^2 - 2t) C_0(m; -p_3, M; \sqrt{t}, m) \right] + \\ & (\delta_{ab}\delta_{cd} + \delta_{ac}\delta_{bd} - 4\delta_{ad}\delta_{bc}) \left[2B_0(m; m, M) - B_0(m; \sqrt{u}, m) + (4m^2 - M^2 - 2u) C_0(m; -p_4, M; \sqrt{u}, m) \right] \end{aligned} \right\} \quad (7.5.26)$$

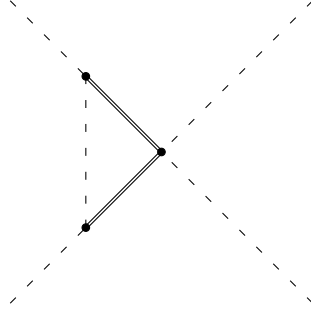

$$V_7^\phi(s) = e^4 (2\delta_{ab}\delta_{cd} + \delta_{ac}\delta_{bd} + \delta_{ad}\delta_{bc}) \left[2B_0(M; \sqrt{s}, M) - B_0(m, m, M) + \frac{1}{2} (8m^2 - 2M^2 - s) C_0(m, p_2, M, \sqrt{s}, M) \right]$$

with

$$\begin{aligned} \frac{1}{e^4} V_{abcd}^{7\phi}(s, t, u) &= (2\delta_{ab}\delta_{cd} + \delta_{ac}\delta_{bd} + \delta_{ad}\delta_{bc}) \left[2B_0(M; \sqrt{s}, M) - B_0(m, m, M) + \right. \\ &\quad \left. + \frac{1}{2} (8m^2 - 2M^2 - s) C_0(m, p_2, M, \sqrt{s}, M) \right] + \\ &\quad + (\delta_{ab}\delta_{cd} + 2\delta_{ac}\delta_{bd} + \delta_{ad}\delta_{bc}) \left[2B_0(M; \sqrt{t}, M) - B_0(m, m, M) + \right. \\ &\quad \left. + \frac{1}{2} (8m^2 - 2M^2 - t) C_0(m, -p_1, M, \sqrt{t}, M) \right] + \\ &\quad + (\delta_{ab}\delta_{cd} + \delta_{ac}\delta_{bd} + 2\delta_{ad}\delta_{bc}) \left[2B_0(M; \sqrt{u}, M) - B_0(m, m, M) + \right. \\ &\quad \left. + \frac{1}{2} (8m^2 - 2M^2 - u) C_0(m, -p_1, M, \sqrt{u}, M) \right] \end{aligned} \quad (7.5.27)$$

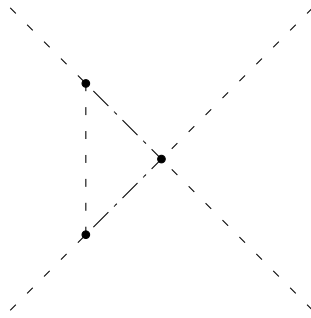

$$V_6^\phi(s) = 32\kappa^3 \nu^2 \delta_{ab}\delta_{cd} C_0(m_H; p_2, m; \sqrt{s}, m_H)$$

with

$$\begin{aligned} V_{abcd}^{6\phi}(s, t, u) &= 32\kappa^3 \nu^2 \left[\delta_{ab}\delta_{cd} C_0(m_H, p_2, m, \sqrt{s}, m_H) + \delta_{ac}\delta_{bd} C_0(m_H, -p_3, m, \sqrt{t}, m_H) + \right. \\ &\quad \left. + \delta_{ad}\delta_{bc} C_0(m_H, -p_4, m, \sqrt{u}, m_H) \right] \end{aligned} \quad (7.5.28)$$

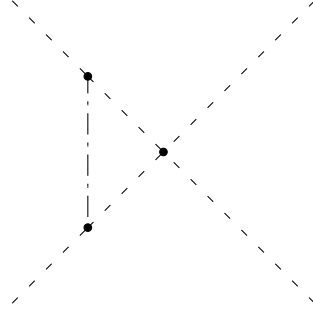

$$V_8^\phi(s) = 16\kappa^2\nu^2\lambda_4 (\delta_{ab}\delta_{cd} + \delta_{ac}\delta_{bd} + \delta_{ad}\delta_{bc}) C_0(m; p_2, m_H; \sqrt{s}, m)$$

with

$$V_{abcd}^{8\phi}(s, t, u) = 16\kappa^2\nu^2\lambda_4 (\delta_{ab}\delta_{cd} + \delta_{ac}\delta_{bd} + \delta_{ad}\delta_{bc}) \left[C_0(m; p_2, m_H; \sqrt{s}, m) + C_0(m; -p_3, m_H; \sqrt{t}, m) + C_0(m; -p_4, m_H; \sqrt{u}, m) \right] \quad (7.5.29)$$

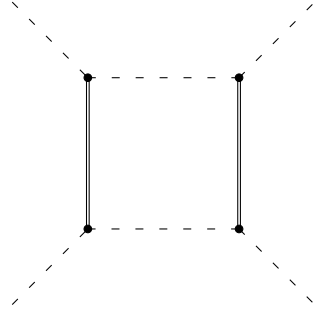

$$V_9^\phi = e^4 (\delta_{ab}\delta_{cd} + \delta_{ac}\delta_{bd}) \left[B_0(m, \sqrt{s}, m) + \frac{4(s+t-4m^2)}{t-4m^2} [B_0(M, t, M) - B_0(m, m, M)] + \frac{2}{4m^2-t} (32m^4 - 8m^2(M^2 + 2s+t) + 2M^2(s+t) + 3st) C_0(m, p_1, M, p_3, M) + 2(-4m^2 + M^2 + 2s) C_0(m^2, p_1, M, p_3, M) + (-4m^2 + M^2 + 2s)^2 D_0(m, p_2, M, \sqrt{s}, m, p_4, M) \right]$$

with

$$\begin{aligned}
 \frac{1}{e^4} V_{abcd}^{9\phi}(s, t, u) = & (\delta_{ab}\delta_{cd} + \delta_{ac}\delta_{bd}) \left[B_0(m, \sqrt{s}, m) + \frac{4(s+t-4m^2)}{t-4m^2} [B_0(M, \sqrt{t}, M) - B_0(m, m, M)] \right] + \\
 & + \frac{2}{4m^2-t} (32m^4 - 8m^2(M^2 + 2s+t) + 2M^2(s+t) + 3st) C_0(m, p_1, M, p_3, M) + \\
 & + 2(2s - 4m^2 + M^2) C_0(m^2, p_1, M, p_3, M) + (2s - 4m^2 + M^2)^2 D_0(m, p_2, M, \sqrt{s}, m, p_4, M) \Big] + \\
 & + (\delta_{ac}\delta_{bd} + \delta_{ad}\delta_{bc}) \left[B_0(m, \sqrt{u}, m) + \frac{4(u+t-4m^2)}{t-4m^2} [B_0(M, \sqrt{t}, M) - B_0(m, m, M)] \right] + \\
 & + \frac{2}{4m^2-t} (32m^4 - 8m^2(M^2 + 2u+t) + 2M^2(u+t) + 3ut) C_0(m, -p_3, M, -p_1, M) + \\
 & + 2(2u - 4m^2 + M^2) C_0(m^2, -p_3, M, -p_1, M) + (2u - 4m^2 + M^2)^2 D_0(m, p_2, M, \sqrt{u}, m, p_4, M) \Big] + \\
 & + (\delta_{ab}\delta_{cd} + \delta_{ad}\delta_{bc}) \left[B_0(m, \sqrt{u}, m) + \frac{4(u+s-4m^2)}{s-4m^2} [B_0(M, \sqrt{s}, M) - B_0(m, m, M)] \right] + \\
 & + \frac{2}{4m^2-s} (32m^4 - 8m^2(M^2 + 2u+s) + 2M^2(u+s) + 3us) C_0(m, p_2, M, -p_1, M) + \\
 & + 2(2u - 4m^2 + M^2) C_0(m^2, p_2, M, -p_1, M) + (2u - 4m^2 + M^2)^2 D_0(m, -p_3, M, \sqrt{u}, m, p_4, M) \Big]
 \end{aligned} \tag{7.5.30}$$

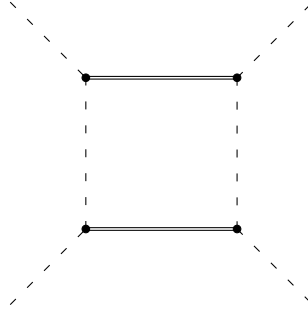

$$\begin{aligned}
 V_{10}^{\phi} = & e^4 (\delta_{ab}\delta_{cd} + \delta_{ac}\delta_{bd}) \left[B_0(m, \sqrt{s}, m) + \frac{4(s+t-4m^2)}{t-4m^2} [B_0(M, \sqrt{t}, M) - B_0(m, m, M)] \right] + \\
 & + \frac{2}{4m^2-t} (32m^4 - 8m^2(M^2 + 2s+t) + 2M^2(s+t) + 3st) C_0(m, p_1, M, p_3, M) + \\
 & + 2(-4m^2 + M^2 + 2s) C_0(m^2, p_1, M, p_3, M) + (-4m^2 + M^2 + 2s)^2 D_0(m, p_2, M, \sqrt{s}, m, p_4, M) \Big]
 \end{aligned}$$

with

$$\begin{aligned}
 \frac{1}{e^4} V_{abcd}^{10\phi}(s, t, u) = & (\delta_{ab}\delta_{cd} + \delta_{ac}\delta_{bd}) \left[B_0(m, \sqrt{t}, m) + \frac{4(s+t-4m^2)}{s-4m^2} [B_0(M, \sqrt{t}, M) - B_0(m, m, M)] + \right. \\
 & - 2(2t-4m^2+M^2) C_0(M, \sqrt{s}, M, p_2, m) + (2t-4m^2+M^2)^2 D(M, p_2, m, \sqrt{s}, M, p_4, m) + \\
 & \left. + \frac{2}{4m^2-s} (32m^4 - 8m^2(M^2+s+2t) + 2M^2(s+t) + 3st) C_0(M, \sqrt{s}, M, p_2, m) \right] + \\
 & + (\delta_{ac}\delta_{bd} + \delta_{ad}\delta_{bc}) \left[B_0(m, \sqrt{t}, m) + \frac{4(u+t-4m^2)}{u-4m^2} [B_0(M, \sqrt{t}, M) - B_0(m, m, M)] + \right. \\
 & - 2(2t-4m^2+M^2) C_0(M, \sqrt{u}, M, p_2, m) + (2t-4m^2+M^2)^2 D(M, p_2, m, \sqrt{u}, M, p_4, m) + \\
 & \left. + \frac{2}{4m^2-u} (32m^4 - 8m^2(M^2+u+2t) + 2M^2(u+t) + 3ut) C_0(M, \sqrt{t}, M, p_2, m) \right] + \\
 & + (\delta_{ab}\delta_{cd} + \delta_{ad}\delta_{bc}) \left[B_0(m, \sqrt{s}, m) + \frac{4(s+u-4m^2)}{u-4m^2} [B_0(M, \sqrt{s}, M) - B_0(m, m, M)] + \right. \\
 & - 2(2s-4m^2+M^2) C_0(M, \sqrt{u}, M, -p_3, m) + (2s-4m^2+M^2)^2 D(M, -p_3, m, \sqrt{u}, M, p_4, m) + \\
 & \left. + \frac{2}{4m^2-s} (32m^4 - 8m^2(M^2+u+2s) + 2M^2(u+s) + 3us) C_0(M, \sqrt{t}, M, -p_3, m) \right] \quad (7.5.31)
 \end{aligned}$$

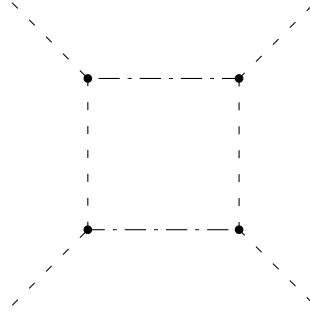

$$V_{11}^{\phi} = (4\kappa\nu)^4 \delta_{ab}\delta_{cd} D_0(m_H; p_2, m; p, m_H; p_4, m)$$

with

$$\begin{aligned}
 \frac{1}{(4\kappa\nu)^4} V_{abcd}^{11\phi}(s, t, u) = & \delta_{ab}\delta_{cd} D_0(m_H; p_2, m; \sqrt{s}, m_H; p_4, m) + \delta_{ac}\delta_{bd} D_0(m_H; -p_3, m; \sqrt{t}, m_H; p_4, m) + \\
 & + \delta_{ad}\delta_{bc} D_0(m_H; p_2, m; \sqrt{u}, m_H; p_4, m) \quad (7.5.32)
 \end{aligned}$$

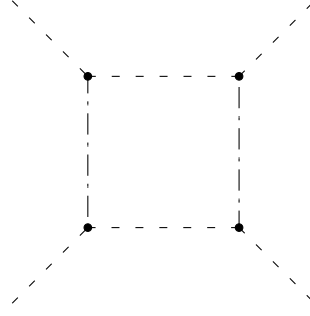

$$V_{12}^{\phi} = (4\kappa\nu)^4 \delta_{ac} \delta_{bd} D_0(m; p_2, m_H; \sqrt{s}, m; p_4, m_H)$$

with

$$\begin{aligned} \frac{1}{(4\kappa\nu)^4} V_{abcd}^{12\phi}(s, t, u) &= \delta_{ab} \delta_{cd} D_0(m; -p_3, m_H; \sqrt{t}, m; p_4, m_H) + \delta_{ac} \delta_{bd} D_0(m; p_2, m_H; \sqrt{s}, m; p_4, m_H) + \\ &+ \delta_{ad} \delta_{bc} D_0(m; -p_4, m_H; \sqrt{u}, m; -p_2, m_H) \end{aligned} \quad (7.5.33)$$

7.6 Renormalization

WE shall use the On Shell Renormalization conditions to define the mass and residue of the pole which will fix the renormalization constants. The conditions are

$$\Pi(p^2) \Big|_{p^2=m^2} = 0 \quad (7.6.1)$$

$$\frac{d}{dp^2} \Pi(p^2) \Big|_{p^2=m^2} = 0 \quad (7.6.2)$$

where $\Pi(p^2)$ represents the self energy, with the mass being set by condition (7.6.1) and the residue set with (7.6.2).

7.6.1 Rho Self Energy Renormalization

The counter term for the rho propagator can be written in terms of the projectors as

$$\begin{aligned} \bar{\Gamma}_{abCT}^{\mu\nu} &= i\delta^{ab} \left[(p^2 \delta \bar{Z}_A - \delta \bar{M}^2) g^{\mu\nu} + (\delta \bar{\xi} - \delta \bar{Z}_A) k^\mu k^\nu \right] \\ &= i\delta^{ab} \left[(p^2 \delta \bar{Z}_A - \delta \bar{M}^2) P_T^{\mu\nu} + (p^2 \delta \bar{\xi} - \delta \bar{M}^2) P_L^{\mu\nu} \right] \end{aligned} \quad (7.6.3)$$

The rho self energy is the sum of contributions including the symmetry factors from (7.4.1)-(7.4.11) and the counter term:

$$-i\pi_{ab}^{\mu\nu} = \sum_{j=1}^{11} [-i\pi_{abj}^{\mu\nu}] + i\delta^{ab} \left[(p^2 \delta \bar{Z}_A - \delta \bar{M}^2) P_T^{\mu\nu} + (p^2 \delta \bar{\xi} - \delta \bar{M}^2) P_L^{\mu\nu} \right]$$

7. One Loop Corrections

$$= \frac{i}{(4\pi)^2} \delta_{ab} \pi^{\mu\nu} + \frac{i}{(4\pi)^2} \delta^{ab} \left[(p^2 \delta Z_A - \delta M^2) P_T^{\mu\nu} + (p^2 \delta \xi - \delta M^2) P_L^{\mu\nu} \right] \quad (7.6.4)$$

$$:= \frac{i}{(4\pi)^2} \delta_{ab} (\pi_T P_T^{\mu\nu} + \pi_L P_L^{\mu\nu}) + \frac{i}{(4\pi)^2} \delta^{ab} \left[(p^2 \delta Z_A - \delta M^2) P_T^{\mu\nu} + (p^2 \delta \xi - \delta M^2) P_L^{\mu\nu} \right] \quad (7.6.5)$$

with

$$\begin{aligned} \pi_T := & \frac{65e^2 p^2}{12\varepsilon} + \frac{1}{\varepsilon} \left[e^2 \left(2m^2 + \frac{9M^4}{2m_H^2} + 11M^2 - \frac{m_H^2}{2} \right) + \frac{12\kappa m^2 M^2}{m_H^2} + \frac{3\lambda M^4}{2m_H^2} + \frac{3\lambda M^2}{2} \right] + \\ & + \left(-\frac{2e^2}{3} + \frac{12M^2 \kappa}{m_H^2} \right) A_F[m] + \left[e^2 \left(\frac{7}{6} + \frac{9M^2}{2m_H^2} \right) + \frac{3M^2 \lambda}{2m_H^2} \right] A_F[M] + \left(-\frac{e^2}{3} + \frac{3M^2 \lambda}{2m_H^2} \right) A_F[m_H] + \\ & + \frac{8}{3} e^2 m^2 B_F[m, p, m] + 12e^2 M^2 B_F[M, p, M] + e^2 \left(-\frac{13M^2}{6} - \frac{m_H^2}{6} \right) B_F[M, p, m_H] + \\ & + \frac{e^2}{p^2} \left(\frac{1}{12} (M^2 - m_H^2) (A_F[m_H] - A_F[M]) + \left(\frac{M^4}{12} - \frac{M^2 m_H^2}{6} + \frac{m_H^4}{12} \right) B_F[M, p, m_H] \right) + \\ & + \frac{12m^2 M^2 \kappa \gamma_e}{m_H^2} + \frac{3}{2} M^2 \lambda \gamma_e + \frac{3M^4 \lambda \gamma_e}{2m_H^2} + \\ & + e^2 \left(\frac{8m^2}{3} + \frac{23M^2}{6} - \frac{3M^4}{m_H^2} - \frac{m_H^2}{6} + 2m^2 \gamma_e + 11M^2 \gamma_e + \frac{9M^4 \gamma_e}{2m_H^2} - \frac{m_H^2 \gamma_e}{2} \right) + \\ & + e^2 p^2 \left(-\frac{2}{3} B_F[m, p, m] + 6B_F[M, p, M] + \frac{1}{12} B_F[M, p, m_H] - \frac{7}{18} + \frac{65\gamma_e}{12} \right) \end{aligned} \quad (7.6.6)$$

and

$$\begin{aligned} \pi_L := & -\frac{e^2 p^2}{2\varepsilon} + \frac{1}{\varepsilon} \left[e^2 \left(2m^2 + \frac{9M^4}{2m_H^2} + 11M^2 - \frac{m_H^2}{2} \right) + \frac{12\kappa m^2 M^2}{m_H^2} + \frac{3\lambda M^4}{2m_H^2} + \frac{3\lambda M^2}{2} \right] + \\ & + \left(2e^2 + \frac{12M^2 \kappa}{m_H^2} \right) A_F[m] + \left(e^2 \left(9 + \frac{9M^2}{2m_H^2} \right) + \frac{3M^2 \lambda}{2m_H^2} \right) A_F[M] + \left(-\frac{e^2}{2} + \frac{3M^2 \lambda}{2m_H^2} \right) A_F[m_H] + \\ & + 4e^2 M^2 B_F[M, p, M] - 2e^2 M^2 B_F[M, p, m_H] + \\ & + \frac{e^2}{p^2} \left(\frac{1}{4} (M^2 - m_H^2) (A_F[M] - A_F[m_H]) + \left(-\frac{M^4}{4} + \frac{M^2 m_H^2}{2} - \frac{m_H^4}{4} \right) B_F[M, p, m_H] \right) + \\ & + e^2 p^2 \left(-\frac{1}{2} B_F[M, p, M] - \frac{\gamma_e}{2} \right) + \frac{12m^2 M^2 \kappa \gamma_e}{m_H^2} + \frac{3}{2} M^2 \lambda \gamma_e + \frac{3M^4 \lambda \gamma_e}{2m_H^2} + \\ & + e^2 \left(-4M^2 - \frac{3M^4}{m_H^2} + 2m^2 \gamma_e + 11M^2 \gamma_e + \frac{9M^4 \gamma_e}{2m_H^2} - \frac{m_H^2 \gamma_e}{2} \right) \end{aligned} \quad (7.6.7)$$

where $\pi^{\mu\nu}$ will in general have the form

$$\pi^{\mu\nu} = i (A P_T^{\mu\nu} + B P_L^{\mu\nu}) \quad (7.6.8)$$

with

$$A := \frac{1}{(4\pi)^2} (\pi_T + p^2 \delta Z_A - \delta M^2) \quad (7.6.9)$$

$$B := \frac{1}{(4\pi)^2} (\pi_L + p^2 \delta \xi - \delta M^2) \quad (7.6.10)$$

Applying the On Shell Renormalization conditions (7.6.1) and (7.6.2) to (7.6.9) and (7.6.10) we obtain the renormalization constants:

$$-\delta Z_A = \frac{65e^2}{12\varepsilon} - \frac{2}{3} e^2 B_F[m, M, m] + 6e^2 B_F[M, M, M] + \frac{1}{12} e^2 B_F[M, M, m_H] +$$

$$\begin{aligned}
 & -\frac{e^2}{M^4} \left[\frac{1}{12} (M^2 - m_H^2) (A_F[m_H] - A_F[M]) + \left(\frac{M^4}{12} - \frac{M^2 m_H^2}{6} + \frac{m_H^4}{12} \right) B_F[M, M, m_H] \right] + \\
 & + \left(\frac{8e^2 m^2}{3} - \frac{2e^2 M^2}{3} \right) \frac{\partial}{\partial p} B_F[m, p, m] \Big|_{p=M} + 18e^2 M^2 \frac{\partial}{\partial p} B_F[M, p, M] \Big|_{p=M} + \\
 & + \left(\frac{e^2 M^2}{12} + e^2 \left(-\frac{13M^2}{6} - \frac{m_H^2}{6} \right) + \frac{e^2}{M^2} \left(\frac{M^4}{12} - \frac{M^2 m_H^2}{6} + \frac{m_H^4}{12} \right) \right) \frac{\partial}{\partial p} B_F[M, p, m_H] \Big|_{p=M} + \\
 & + e^2 \left(-\frac{7}{18} + \frac{65\gamma_e}{12} \right)
 \end{aligned} \tag{7.6.11}$$

$$\begin{aligned}
 \delta M^2 = & \frac{1}{\varepsilon} \left[e^2 \left(2m^2 + \frac{9M^4}{2m_H^2} + 11M^2 - \frac{m_H^2}{2} \right) + \frac{12\kappa m^2 M^2}{m_H^2} + \frac{3\lambda M^4}{2m_H^2} + \frac{3\lambda M^2}{2} \right] + \\
 & + \left(-\frac{2e^2}{3} + \frac{12M^2 \kappa}{m_H^2} \right) A_F[m] + \left(e^2 \left(\frac{7}{6} + \frac{9M^2}{2m_H^2} \right) + \frac{3M^2 \lambda}{2m_H^2} \right) A_F[M] + \\
 & + \left(-\frac{e^2}{3} + \frac{3M^2 \lambda_4}{2m_H^2} \right) A_F[m_H] + \frac{8}{3} e^2 m^2 B_F[m, M, m] + \frac{2}{3} e^2 M^2 B_F[m, M, m] + \\
 & + 6e^2 M^2 B_F[M, M, M] - \frac{1}{12} e^2 M^2 B_F[M, M, m_H] + e^2 \left(-\frac{13M^2}{6} - \frac{m_H^2}{6} \right) B_F[M, M, m_H] + \\
 & + \frac{2e^2}{M^2} \left[\frac{1}{12} (M^2 - m_H^2) (A_F[m_H] - A_F[M]) + \left(\frac{M^4}{12} - \frac{M^2 m_H^2}{6} + \frac{m_H^4}{12} \right) B_F[M, M^2, m_H] \right] + \\
 & + \left(-\frac{8}{3} e^2 m^2 M^2 + \frac{2e^2 M^4}{3} \right) \frac{\partial}{\partial p} B_F[m, p, m] \Big|_{p=M} - 18e^2 M^4 \frac{\partial}{\partial p} B_F[M, p, M] \Big|_{p=M} + \\
 & + \left(-\frac{1}{12} e^2 M^4 - e^2 M^2 \left(-\frac{13M^2}{6} - \frac{m_H^2}{6} \right) - e^2 \left(\frac{M^4}{12} - \frac{M^2 m_H^2}{6} + \frac{m_H^4}{12} \right) \right) \frac{\partial}{\partial p} B_F[M, p, m_H] \Big|_{p=M} + \\
 & + M^2 \left(-\frac{2}{3} e^2 B_F[m, M, m] + 6e^2 B_F[M, M, M] + \frac{1}{12} e^2 B_F[M, M, m_H] \right) \\
 & + e^2 M^2 \left(-\frac{7}{18} + \frac{65\gamma_e}{12} \right) + \frac{12m^2 M^2 \kappa \gamma_e}{m_H^2} + \frac{3}{2} M^2 \lambda \gamma_e + \frac{3M^4 \lambda \gamma_e}{2m_H^2} - e^2 M^2 \left(-\frac{7}{18} + \frac{65\gamma_e}{12} \right) + \\
 & + e^2 \left(\frac{8m^2}{3} + \frac{23M^2}{6} - \frac{3M^4}{m_H^2} - \frac{m_H^2}{6} + 2m^2 \gamma_e + 11M^2 \gamma_e + \frac{9M^4 \gamma_e}{2m_H^2} - \frac{m_H^2 \gamma_e}{2} \right)
 \end{aligned} \tag{7.6.12}$$

$$\begin{aligned}
 -\delta\xi = & -\frac{e^2}{2\varepsilon} - \frac{2}{3} e^2 B_F[m, M, m] + 6e^2 B_F[M, M, M] + \frac{1}{12} e^2 B_F[M, M, m_H] + \\
 & -\frac{e^2}{M^4} \left(\frac{1}{12} (M^2 - m_H^2) (A_F[m_H] - A_F[M]) + \left(\frac{M^4}{12} - \frac{M^2 m_H^2}{6} + \frac{m_H^4}{12} \right) B_F[M, M, m_H] \right) + \\
 & + \left(\frac{8e^2 m^2}{3} - \frac{2e^2 M^2}{3} \right) \frac{\partial}{\partial p} B_F[m, p, m] \Big|_{p=M} + 18e^2 M^2 \frac{\partial}{\partial p} B_F[M, p, M] \Big|_{p=M} + \\
 & + \left[\frac{e^2 M^2}{12} + e^2 \left(-\frac{13M^2}{6} - \frac{m_H^2}{6} \right) + \frac{e^2}{M^2} \left(\frac{M^4}{12} - \frac{M^2 m_H^2}{6} + \frac{m_H^4}{12} \right) \right] \frac{\partial}{\partial p} B_F[M, p, m_H] \Big|_{p=M} + \\
 & + e^2 \left(-\frac{7}{18} + \frac{65\gamma_e}{12} \right)
 \end{aligned} \tag{7.6.13}$$

The contributions from infinitely many self energy insertions leads to a geometric series which can

be summed with $D := p^2 - M^2 + i\varepsilon$,

$$\begin{aligned}
 iD_{ab}^{(1)\mu\nu} &= \frac{-i}{D} \delta_{ab} (P_T^{\mu\nu} + P_L^{\mu\nu}) \\
 &+ \sum_{n=1}^{\infty} \frac{-i}{D} \delta_{ab} (P_T^{\mu\alpha_1} + P_L^{\mu\alpha_1}) \prod_{k=1}^n \left[i\pi_{\alpha_{2k-1}}^{\alpha_{2k}} \frac{-i}{D} (P_{T\alpha_{2k}}^{\alpha_{2k+1}} + P_{L\alpha_{2k}}^{\alpha_{2k+1}}) \right] \left[i\pi_{\alpha_{2n+1}}^{\alpha_{2n+2}} \frac{-i}{D} (P_{T\alpha_{2n+2}}^{\nu} + P_{L\alpha_{2n+2}}^{\nu}) \right] \\
 &= \frac{-i}{D} \delta_{ab} (P_T^{\mu\nu} + P_L^{\mu\nu}) + \frac{-i}{D} \delta_{ab} (P_T^{\mu\alpha_1} + P_L^{\mu\alpha_1}) \cdot i (AP_{T\alpha_1}^{\alpha_2} + BP_{L\alpha_1}^{\alpha_2}) \cdot \frac{-i}{D} (P_{T\alpha_2}^{\nu} + P_{L\alpha_2}^{\nu}) + \dots \\
 &= \frac{-i}{D} \delta_{ab} (P_T^{\mu\nu} + P_L^{\mu\nu}) + \frac{-i}{D^2} \delta_{ab} (AP_T^{\mu\nu} + BP_L^{\mu\nu}) + \frac{-i}{D^3} \delta_{ab} (A^2 P_T^{\mu\nu} + B^2 P_L^{\mu\nu}) + \dots \\
 &= \frac{-i\delta_{ab}}{D} \left\{ \left[1 + \frac{A}{D} + \left(\frac{A}{D}\right)^2 + \dots \right] P_T^{\mu\nu} + \left[1 + \frac{B}{D} + \left(\frac{B}{D}\right)^2 + \dots \right] P_L^{\mu\nu} \right\} \\
 &= \frac{-i\delta_{ab}}{D} \left[\frac{1}{1 - \frac{A}{D}} P_T^{\mu\nu} + \frac{1}{1 - \frac{B}{D}} P_L^{\mu\nu} \right] \\
 &= \frac{-i\delta_{ab}}{D - A} \left[P_T^{\mu\nu} + \frac{D - A}{D - B} P_L^{\mu\nu} \right] \\
 &= \frac{-i\delta_{ab}}{D - A} \left[g^{\mu\nu} + \frac{B - A}{D - B} P_L^{\mu\nu} \right] \\
 &\cong \frac{-i\delta_{ab}}{D - A} g^{\mu\nu}
 \end{aligned} \tag{7.6.14}$$

Since the longitudinal projector is made up of on shell momenta which will always encounter the on shell momentum from the Feynman vertices, the longitudinal piece of the one loop propagator will not contribute to scattering amplitudes.

7.6.2 Higgs Self Energy Renormalization

The counter term for the Higgs propagator is

$$\bar{\Gamma}_{\text{CT}} = i (k^2 \delta \bar{Z}_H - \delta \bar{m}_H^2) \tag{7.6.15}$$

The of Higgs self energy diagrams from (7.4.12) to (7.4.22) including the symmetry factors and the counter term is

$$\begin{aligned}
 -i\Pi_H &= \sum_{j=1}^{11} [-i\pi_j^H] + i (p^2 \delta \bar{Z}_H - \delta \bar{m}_H^2) \\
 &= \frac{i}{(4\pi)^2} [\pi_H + k^2 \delta Z_H - \delta m_H^2]
 \end{aligned} \tag{7.6.16}$$

with

$$\begin{aligned}
 \pi_H &:= -\frac{3e^2 p^2}{4\varepsilon} + \frac{1}{\varepsilon} \left[\frac{27e^2 M^2}{2} + 3m^2 \kappa + \frac{3M^2 \lambda}{8} - \frac{27M^4 \lambda}{4m_H^2} + \frac{3m_H^2 \lambda}{4} + \right. \\
 &\quad \left. + \frac{M^2}{e^2} \left(48\kappa^2 - \frac{18m^2 \kappa \lambda}{m_H^2} + \frac{3\lambda^2}{4} - \frac{9M^2 \lambda^2}{4m_H^2} \right) \right] + \frac{9M^4 \lambda}{2m_H^2} + 3m^2 \kappa \gamma_e + \frac{3}{8} M^2 \lambda \gamma_e +
 \end{aligned}$$

$$\begin{aligned}
 & -\frac{27M^4\lambda\gamma_e}{4m_H^2} + \frac{3}{4}m_H^2\lambda\gamma_e + 3\kappa A_F[m] + \frac{3}{8}\lambda A_F[M] - \frac{27M^2\lambda A_F[M]}{4m_H^2} + \frac{3}{4}\lambda A_F[mh] + \\
 & + e^2 p^2 \left(-\frac{3\gamma_e}{4} - \frac{3}{4}B_F[M, p, M] \right) + \\
 & + e^2 \left(-\frac{15M^2}{2} + \frac{27M^2\gamma_e}{2} + \frac{21A_F[M]}{8} + \frac{87}{8}M^2 B_F[M, p, M] \right) + \\
 & + \frac{1}{e^2} \left[48M^2\kappa^2\gamma_e - \frac{18m^2M^2\kappa\lambda\gamma_e}{m_H^2} + \frac{3}{4}M^2\lambda^2\gamma_e - \frac{9M^4\lambda^2\gamma_e}{4m_H^2} - \frac{18M^2\kappa\lambda A_F[m]}{m_H^2} + \right. \\
 & - \frac{9M^2\lambda^2}{4m_H^2} (A_F[M] + A_F[m_H]) + 48M^2\kappa^2 B_F[m, p, m] + \frac{3}{4}M^2\lambda^2 B_F[M, p, M] + \\
 & \left. + \frac{9}{4}M^2\lambda^2 B_F[m_H, p, m_H] \right] \tag{7.6.17}
 \end{aligned}$$

Applying the On Shell Renormalization conditions (7.6.1) and (7.6.2) to (7.6.17) we obtain the renormalization constants:

$$\begin{aligned}
 -\delta Z_H &= -\frac{3e^2}{4\epsilon} + \frac{87}{8}e^2 M^2 \frac{\partial}{\partial p} B_F[M, p, M] \Big|_{p=m_H} - \frac{3}{4}e^2 m_H^2 \frac{\partial}{\partial p} B_F[M, p, M] \Big|_{p=m_H} + \\
 & + \frac{1}{e^2} \frac{\partial}{\partial p} \left[48M^2\kappa^2 B_F[m, p, m] + \frac{3}{4}M^2\lambda^2 B_F[M, p, M] + \frac{9}{4}M^2\lambda^2 B_F[m_H, p, m_H] \right] \Big|_{p=m_H} + \\
 & + e^2 \left(-\frac{3}{4}B_F[M, m_H, M] - \frac{3\gamma_e}{4} \right) \tag{7.6.18}
 \end{aligned}$$

$$\begin{aligned}
 \delta m_H^2 &= \left[\frac{27e^2 M^2}{2} + 3m^2\kappa + \frac{3M^2\lambda}{8} - \frac{27M^4\lambda}{4m_H^2} + \frac{3m_H^2\lambda}{4} + \right. \\
 & + \left. \frac{M^2}{e^2} \left(48\kappa^2 - \frac{18m^2\kappa\lambda}{m_H^2} + \frac{3\lambda^2}{4} - \frac{9M^2\lambda^2}{4m_H^2} \right) \right] \frac{1}{\epsilon} - \frac{15}{2}e^2 M^2 + \frac{9M^4\lambda}{2m_H^2} + \\
 & + \left(3\kappa - \frac{18M^2\kappa\lambda}{e^2 m_H^2} \right) A_F[m] + \left(\frac{21e^2}{8} + \frac{3\lambda}{8} - \frac{27M^2\lambda}{4m_H^2} - \frac{9M^2\lambda^2}{4e^2 m_H^2} \right) A_F[M] + \\
 & + \left(\frac{3\lambda}{4} - \frac{9M^2\lambda^2}{4e^2 m_H^2} \right) A_F[m_H] + \frac{48M^2\kappa^2}{e^2} B_F[m, m_H, m] + \\
 & + \left(\frac{87e^2 M^2}{8} + \frac{3M^2\lambda^2}{4e^2} \right) B_F[M, m_H, M] + \frac{9M^2\lambda^2}{4e^2} B_F[m_H, m_H, m_H] + \\
 & - \frac{48M^2 m_H \kappa^2}{e^2} \frac{\partial}{\partial p} B_F[m, p, m] \Big|_{p=m_H} + \\
 & + \left(-\frac{87}{8}e^2 M^2 m_H^2 + \frac{3e^2 m_H^4}{4} - \frac{3M^2 m_H^2 \lambda^2}{4e^2} \right) \frac{\partial}{\partial p} B_F[M, p, M] \Big|_{p=m_H} + \\
 & - \frac{9M^2 m_H^2 \lambda^2}{4e^2} \frac{\partial}{\partial p} B_F[m_H, p, m_H] \Big|_{p=m_H} + \frac{27}{2}e^2 M^2 \gamma_e + 3m^2 \kappa \gamma_e + \frac{48M^2 \kappa^2 \gamma_e}{e^2} + \frac{3}{8}M^2 \lambda \gamma_e + \\
 & - \frac{27M^4 \lambda \gamma_e}{4m_H^2} + \frac{3}{4}m_H^2 \lambda \gamma_e - \frac{18m^2 M^2 \kappa \lambda \gamma_e}{e^2 m_H^2} + \frac{3M^2 \lambda^2 \gamma_e}{4e^2} - \frac{9M^4 \lambda^2 \gamma_e}{4e^2 m_H^2} \tag{7.6.19}
 \end{aligned}$$

7.6.3 Pion-Pion-Rho Vertex Renormalization

For the vertex renormalization, we shall resort to using the Minimal Subtraction scheme. A conventional condition is to define the coupling at zero transferred three momentum. This is difficult to impose since the three point scalar function C_0 is difficult to manipulate. Summing up the vertex corrections (7.5.1) to (7.5.10)

$$\sum_{k=1}^{10} V_k^\mu = \frac{i}{(4\pi)^2} \varepsilon_{cab} (p_1 - p_2)^\mu (iV_e) \quad (7.6.20)$$

where V_e is defined as

$$\begin{aligned} V_e := & \frac{e^3}{2\varepsilon} + e^3 \left(-\frac{3A_F[m]}{2m^2} + \frac{3A_F[M]}{2m^2} + \left(\frac{9}{2} - \frac{3M^2}{2m^2} \right) B_F[m, m, M] + 3\gamma_e \right) + \frac{1}{4m^2 - p^2} \times \left\{ \right. \\ & e\kappa^2\nu^2 \left(32B_F[m, m, m_H] - 32B_F[m, p, m] + (64m^2 - 32m_H^2 - 16p^2) C_0[m_H, p_1, m, -p_2, m] \right) + \\ & + e^3 \left[\left(6 - \frac{3p^2}{2m^2} \right) (A_F[m] - A_F[M]) + \left(-24m^2 + 10M^2 + 9p^2 - \frac{3M^2p^2}{2m^2} \right) B_F[m, m, M] + \right. \\ & + (8m^2 - 2M^2 - 4p^2) B_F[m, p, m] + (-2M^2 - p^2) B_F[M, p, M] + \\ & + \left. \left(-8m^2M^2 + 2M^4 - 4m^2p^2 + 2M^2p^2 + \frac{p^4}{2} \right) C_0[m, p_1, M, -p_2, M] + \kappa\nu^2 \left(-4B_F[m, m, M] + \right. \right. \\ & \left. \left. - 4B_F[m, m, m_H] + 8B_F[M, p, m_H] + (32m^2 - 4M^2 - 4m_H^2 - 4p^2) C_0[m, p_1, M, -p_2, m_H] \right) \right] + \\ & \left. \left(-16m^4 + 12m^2M^2 - 2M^4 + 12m^2p^2 - 5M^2p^2 - 2p^4 \right) C_0[m, p_2, M, p, m] - 10m^2\gamma_e + \frac{5p^2\gamma_e}{2} \right\} \quad (7.6.21) \end{aligned}$$

The one loop vertex correction including the counter term for the pion-pion-rho vertex correction is

$$\begin{aligned} e^{(1)} \varepsilon_{cab} (p_1 - p_2)^\mu &= \sum_{k=1}^{10} V_k^\mu + \delta\bar{Z}_e \varepsilon_{cab} (p_1 - p_2)^\mu \\ &= \sum_{k=1}^{10} V_k^\mu + \frac{1}{(4\pi)^2} \delta Z_e \varepsilon_{cab} (p_1 - p_2)^\mu \\ \implies -(4\pi)^2 e^{(1)} &= V_e - \delta\bar{Z}_e \quad (7.6.22) \end{aligned}$$

with $e^{(1)}$ the finite one loop correction to the coupling. Comparing (7.6.22) with (7.6.21) we can read off the renormalization constant:

$$\delta Z_e := \frac{e^3}{2\varepsilon} \quad (7.6.23)$$

7.6.4 Pion-Pion-Higgs Vertex Renormalization

The one loop vertex corrections (7.5.12) to (7.5.21) to the pion-pion-Higgs vertex is summed to be

$$\sum_{k=1}^{10} V_k^H = \frac{i}{(4\pi)^2} \delta_{ab} V_H \quad (7.6.24)$$

where V_H is defined to be

$$\begin{aligned}
 V_H = & \frac{1}{\varepsilon} \left(16e^4\nu - 16e^2\kappa\nu + 16\kappa^2\nu + 6\kappa\lambda\nu + 20\kappa\nu\lambda_4 \right) - 8e^4\nu + 16\kappa^2\nu B_F [m, m, m_H] + \\
 & + \left(16e^4\nu + 3\kappa\lambda\nu \right) B_F [M, p, M] + 3\kappa\lambda\nu B_F [m_H, p, m_H] + 24\kappa^2\lambda\nu^3 C_0 [m, p_1, m_H, -p_2, m_H] \\
 & + 64\kappa^3\nu^3 C_0 [m, p_2, m_H, p, m] + 16e^4\nu\gamma_e + 16\kappa^2\nu\gamma_e + 6\kappa\lambda\nu\gamma_e + 20\kappa\nu B_F [m, p, m] \lambda_4 + 20\kappa\nu\gamma_e\lambda_4 + \\
 & e^2\kappa\nu \left[-16\gamma_e - 8B_F [m, m, M] + 8B_F [m, p, m] - 16B_F [M, p, M] + \right. \\
 & \left. \left(-32m^2 + 8M^2 + 4p^2 \right) C_0 [m, p_1, M, -p_2, M] + \left(-32m^2 + 8M^2 + 16p^2 \right) C_0 [M, p_1, m, -p_2, m] \right]
 \end{aligned} \tag{7.6.25}$$

The one loop correction to the pion-pion-Higgs vertex with the counter term is

$$\begin{aligned}
 iV_H^{(1)}\delta_{ab} &= \sum_{k=1}^{10} V_k^\mu - i\delta\bar{Z}_H\delta_{ab} \\
 &= \frac{i}{(4\pi)^2}\delta_{ab}V_H - \frac{i}{(4\pi)^2}\delta Z_H\delta_{ab} \\
 \Rightarrow (4\pi)^2 V_H^{(1)} &= V_H - \delta Z_H
 \end{aligned} \tag{7.6.26}$$

Comparing the expressions (7.6.25) with (7.6.26) we can read off the renormalization constant

$$\delta Z_H = \frac{1}{\varepsilon} \left(16e^4\nu - 16e^2\kappa\nu + 16\kappa^2\nu + 6\kappa\lambda\nu + 20\kappa\nu\lambda_4 \right) \tag{7.6.27}$$

where $V_H^{(1)}$ is the finite one loop correction to the pio-pion-Higgs coupling.

7.6.5 Pion-Pion-Pion-Pion Vertex Renormalization

The one loop vertex corrections (7.5.22) to (7.5.33) to the pion-pion-pion-pion vertex is summed to be

$$\begin{aligned}
 iV_{abcd}^\lambda &:= \sum_{k=1}^{12} V_{abcd}^{k,\phi} = \frac{i}{(4\pi)^2} V_{abcd}^\phi \\
 &= \frac{i}{(4\pi)^2} \left[\left(40e^4 + 16\kappa^2 + 2e^2\lambda_4 + 11\lambda_4^4 \right) (\delta_{ab}\delta_{cd} + \delta_{ac}\delta_{bd} + \delta_{ad}\delta_{bc}) \right] \frac{1}{\varepsilon} + \text{UV finite terms}
 \end{aligned} \tag{7.6.28}$$

The counter term for this vertex is

$$\begin{aligned}
 \bar{\Gamma}_{abcd\text{CT}} &= -i\delta\bar{Z}_{\phi^4} (\delta_{ab}\delta_{cd} + \delta_{bc}\delta_{da} + \delta_{bd}\delta_{ac}) \\
 &= -\frac{i}{(4\pi)^2}\delta Z_{\phi^4} (\delta_{ab}\delta_{cd} + \delta_{bc}\delta_{da} + \delta_{bd}\delta_{ac})
 \end{aligned} \tag{7.6.29}$$

Matching coefficients between (7.6.28) and (7.6.29), we see the value of the counter term is

$$\delta Z_{\phi^4} := \left(40e^4 + 16\kappa^2 + 2e^2\lambda_4 + 11\lambda_4^4 \right) \frac{1}{\varepsilon} \tag{7.6.30}$$

We have completed the renormalization of all the 1PI diagrams that can contribute to pion-pion scattering processes.

8

Conclusion and Outlook

WE set off on a journey to extend the Kroll-Lee-Zumino model which only had as its particle content the charged pions and neutral rho. This was done by using the larger gauge group SU(2). This group allowed for the inclusion of a larger particle content with the charged and neutral pions and rhos. Though there was a price to be paid in the form of simplicity. Whereas for the Kroll-Lee-Zumino model, the neutral rho mass could be included externally by hand without breaking the U(1) gauge invariance, such a procedure in the SU(2) extension was not possible as it breaks the gauge invariance of the theory. The predictive power of gauge theories were too alluring to sacrifice and this forced us to generate the mass for the rho via Spontaneous Symmetry breaking using the Higgs mechanism while preserving the gauge invariance.

We went on to calculate the pion-pion scattering amplitudes. The scattering lengths a and b were then computed with values summarized in the table 6.1, listed below for convenience:

Lengths	Weinberg ^d	χ PT(1 st \mathcal{O}) ^a	χ PT(2 nd \mathcal{O}) ^a	NABKLZ [†]	Colangelo ^b	Bijnens ^c	Exp ^{abc}
a_0^0	0.20	0.16	0.20	0.21	0.220	0.219	0.220 ± 0.005
b_0^0		0.18	0.26	0.30	0.276	0.279	0.25 ± 0.03
$a_2^0 \times 10^3$		0	2	2.06	1.75	2.2	1.7 ± 3
$b_2^0 \times 10^4$				-5.23	-3.55	-3.2	
a_1^1		0.030	0.036	0.0528	0.0379	0.0378	0.038 ± 0.002
b_1^1		0	0.043	0.0053	0.0057	0.0059	
a_0^2	-0.06	-0.045	-0.041	-0.0456	-0.0444	-0.0420	-0.044 ± 0.001
b_0^2				-0.0225	-0.0803	-0.0756	-0.082 ± 0.008
$a_2^2 \times 10^4$		0	3.5	-2.03	1.70	2.90	1.3 ± 3
$b_2^2 \times 10^4$		-8.9	-7	-0.53	-3.26	-3.60	-8.2

Table 8.1: Summary of predicted values and experimental data of the scattering length.

We sought to increase the precision with the inclusion of the one loop corrections to the tree scattering lengths. This entailed computing the ~ 85 one-particle-irreducible diagrams. The calculations were done using dimensional regularization to parameterize the divergences. These divergences were absorbed into the counter terms using the On Shell renormalization conditions for the self energies and Minimal Subtraction for the vertices. All the pieces required to compute the one loop correction to the tree scattering lengths have been calculated but due to time constraints we could not complete the program of computing the one loop correction to the scattering lengths.

For the future, one possible path lies ahead with:

- Completing the program with the inclusion of the one loop corrections to the scattering lengths. At this stage we cannot estimate the size of the corrections, since the expansion parameter for the perturbative series is of the form $\left(\frac{e}{4\pi}\right)^2 = 0.2 < 1$, this could lead to a reasonable perturbative series, though the size of the coefficients to the expansion parameter cannot be commented on without further analysis.
- Changing from the isospin basis to the physical basis gives direct access to the rho decay rates.
- Computing the pion form factor using this quantum field theory as this has been a fruitful path of investigation for the U(1) Kroll-Lee-Zumino model.

For further development of the model, one could consider if the $\omega(782)$ could be included to this model? One could follow the path taken in the standard electroweak model and introduce an additional vector field and mix one component of the rho triplet with the new vector field to give the ρ^0 and ω . This requires investigation whether this is possible.

Appendix

A

Scalar Functions

The scalar functions used in these calculations are defined below. In $n = 4 - 2\varepsilon$ dimensions

$$\Delta := \frac{1}{\varepsilon} + \gamma_e \quad (\text{A.1})$$

$$\gamma_e := -\gamma_E + \ln(4\pi) \quad (\text{A.2})$$

The one point scalar function:

$$\begin{aligned} A_0(m) &= \int \frac{d^n k}{(2\pi)^n} \frac{1}{k^2 - m^2} \\ &= \frac{i}{(4\pi)^2} \left[m^2 \Delta + A_F(m) + O(\varepsilon) \right] \end{aligned} \quad (\text{A.3})$$

with the finite part defined as

$$A_F(m) := m^2 \left(\ln \frac{m^2}{\mu^2} + 1 \right) \quad (\text{A.4})$$

The two point scalar function:

$$\begin{aligned} B_0(m_0; p, m_1) &:= \int \frac{d^n k}{(2\pi)^n} \frac{1}{(k^2 - m_0^2) [(k+p)^2 - m_1^2]} \\ &= \frac{i}{(4\pi)^2} \left[\Delta + B_F(m_0; p, m_1) + O(\varepsilon) \right] \end{aligned} \quad (\text{A.5})$$

with the finite part

$$B_F(m_0; p, m_1) := 2 - \ln \frac{m_0 m_1}{\mu^2} + \frac{m_0^2 - m_1^2}{p^2} \ln \frac{m_1}{m_0} - \frac{m_0 m_1}{p^2} \left(\frac{1}{r} - r \right) \ln(r) \quad (\text{A.6})$$

the value of r is found from the roots of the polynomial equation

$$x^2 + \frac{m_0^2 + m_1^2 - p^2 - i\varepsilon}{m_0 m_1} x + 1 = (x+r) \left(x + \frac{1}{r} \right) \quad (\text{A.7})$$

with

$$r = \frac{1}{2m_0m_1} \left(m_0^2 + m_1^2 - p^2 - i\varepsilon \pm \sqrt{(m_0^2 + m_1^2 - p^2 - i\varepsilon)^2 - 4m_0^2m_1^2} \right) \quad (\text{A.8})$$

$$\frac{1}{r} - r = \mp \frac{1}{m_0m_1} \sqrt{(m_0^2 + m_1^2 - p^2 - i\varepsilon)^2 - 4m_0^2m_1^2} \quad (\text{A.9})$$

The three and four point scalar functions are finite in 4 dimensions and are defined as

$$C_0(m_0, p_1, m_1, p_2, m_2) := \int \frac{d^n k}{(2\pi)^n} \frac{1}{(k^2 - m_0^2) [(k + p_1)^2 - m_1^2] [(k + p_2)^2 - m_2^2]} \quad (\text{A.10})$$

and

$$D_0(m_0, p_1, m_1, p_2, m_2, p_3, m_3) := \int \frac{d^n k}{(2\pi)^n} \frac{1}{(k^2 - m_0^2) [(k + p_1)^2 - m_1^2] [(k + p_2)^2 - m_2^2] [(k + p_3)^2 - m_3^2]} \quad (\text{A.11})$$

B

Self Energy

For completeness, the reduction for the self energies are presented below.

B.1 Vector Self Energy

B.1.1 ϕ bubble

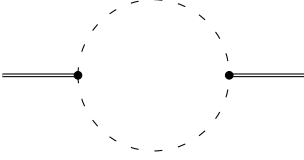

$$\Gamma_1 = e\varepsilon_{adc}(2k+p)^\mu \quad \Gamma_2 = e\varepsilon_{bef}(2k+p)^\nu$$

$$\begin{aligned} -i\pi_{ab1}^{\mu\nu} &= \int \frac{d^n k}{(2\pi)^n} \Gamma_1 \cdot D^{df}(k) \cdot \Gamma_2 \cdot D^{ce}(k+p) \\ &= \int \frac{d^n k}{(2\pi)^n} \frac{e\varepsilon_{adc}(2k+p)^\mu \cdot \delta^{df} \cdot e\varepsilon_{bef}(2k+p)^\nu \delta^{ce}}{(k^2 - m^2) [(k+p)^2 - m^2]} \\ &= e^2 \varepsilon_{cda} \varepsilon_{cdb} \int \frac{d^n k}{(2\pi)^n} \frac{(2k+p)^\mu (2k+p)^\nu}{(k^2 - m^2) [(k+p)^2 - m^2]} \\ &= e^2 \varepsilon_{cda} \varepsilon_{cdb} I_1^{\mu\nu} \end{aligned}$$

Using $\varepsilon_{cda} \varepsilon_{cdb} = 2\delta_{ab}$

$$-i\pi_{ab1}^{\mu\nu} = 2e^2 \delta_{ab} I_1^{\mu\nu}$$

Making some definitions

$$N_1^{\mu\nu} := (2k+p)^\mu (2k+p)^\nu$$

$$\begin{aligned}
 &= 4k^\mu k^\nu + 2(k^\mu p^\nu + p^\mu k^\nu) + p^\mu p^\nu \\
 D_1 &:= k^2 - m^2 \\
 D_2 &:= (k + p)^2 - m^2 \\
 &= k^2 + 2k \cdot p + p^2 - m^2 \\
 &= D_1 + 2k \cdot p + p^2
 \end{aligned}$$

So we have the relations

$$\begin{aligned}
 k^2 &= D_1 + m^2 \\
 2k \cdot p &= D_2 - D_1 - p^2
 \end{aligned}$$

Splitting the integral over the transverse and longitudinal parts

$$\begin{aligned}
 I_1^{\mu\nu} &:= \int \frac{d^n k}{(2\pi)^n} \frac{N_1^{\mu\nu}}{D_1 D_2} \\
 &= f_{T1} P_T^{\mu\nu} + f_{L1} P_L^{\mu\nu}
 \end{aligned}$$

and we can extract the coefficients using the transverse and longitudinal projectors.

$$\begin{aligned}
 P_{L\mu\nu} I_1^{\mu\nu} &= f_{L1} \\
 P_{T\mu\nu} I_1^{\mu\nu} &= (n - 1) f_{T1}
 \end{aligned}$$

$$\begin{aligned}
 P_{L\mu\nu} N_1^{\mu\nu} &= \frac{1}{p^2} (2k \cdot p + p^2)^2 \\
 &= \frac{1}{p^2} (D_2^2 - 2D_1 D_2 + D_1^2)
 \end{aligned}$$

$$\begin{aligned}
 P_{T\mu\nu} N_1^{\mu\nu} &= g_{\mu\nu} N_1^{\mu\nu} - P_{L\mu\nu} N_1^{\mu\nu} \\
 g_{\mu\nu} N_1^{\mu\nu} &= 4k^2 + 2k \cdot p + p^2 \\
 &= 2D_1 + 2D_2 + 4m^2 - p^2
 \end{aligned}$$

$$\begin{aligned}
 f_{L1} &= \int \frac{d^n k}{(2\pi)^n} \frac{P_{L\mu\nu} N_1^{\mu\nu}}{D_1 D_2} \\
 &= \frac{1}{p^2} \int \frac{d^n k}{(2\pi)^n} \frac{D_2^2 - 2D_1 D_2 + D_1^2}{D_1 D_2} \\
 &= \frac{1}{p^2} \int \frac{d^n k}{(2\pi)^n} \left(\frac{D_2}{D_1} + \frac{D_1}{D_2} - 2 \right) \\
 &= \frac{1}{p^2} \int \frac{d^n k}{(2\pi)^n} \left(\frac{D_2}{D_1} + \frac{D_1}{D_2} \right)
 \end{aligned}$$

$$\int \frac{d^n k}{(2\pi)^n} \frac{D_1}{D_2} = \int \frac{d^n k}{(2\pi)^n} \frac{k^2 - m^2}{(k + p)^2 - m^2}$$

B. Self Energy

Making a change of variables $l^\mu = -(k+p)^\mu \Rightarrow k^\mu = -(l+p)^\mu \Rightarrow \int \frac{d^n k}{(2\pi)^n} = \int \frac{d^n l}{(2\pi)^n}$

$$\begin{aligned}
 \int \frac{d^n k}{(2\pi)^n} \frac{D_1}{D_2} &= \int \frac{d^n l}{(2\pi)^n} \frac{(l+p)^2 - m^2}{l^2 - m^2} \\
 &= \int \frac{d^n k}{(2\pi)^n} \frac{D_2}{D_1} \\
 &= \int \frac{d^n k}{(2\pi)^n} \left(1 + \frac{2k \cdot p}{k^2 - m^2} + \frac{p^2}{k^2 - m^2} \right) \\
 &= p^2 A_0(m)
 \end{aligned}$$

$$\begin{aligned}
 f_{L1} &= \frac{1}{p^2} \int \frac{d^n k}{(2\pi)^n} \left(\frac{D_2}{D_1} + \frac{D_1}{D_2} \right) \\
 &= 2A_0(m)
 \end{aligned}$$

$$\begin{aligned}
 (n-1) f_{T1} &= P_{T\mu\nu} I_1^{\mu\nu} \\
 &= \int \frac{d^n k}{(2\pi)^n} \frac{P_{T\mu\nu} N_1^{\mu\nu}}{D_1 D_2} \\
 &= \int \frac{d^n k}{(2\pi)^n} \left(\frac{g_{\mu\nu} N_1^{\mu\nu}}{D_1 D_2} - \frac{P_{L\mu\nu} N_1^{\mu\nu}}{D_1 D_2} \right) \\
 &= \int \frac{d^n k}{(2\pi)^n} \frac{2D_1 + 2D_2 + 4m^2 - p^2}{D_1 D_2} - \int \frac{d^n k}{(2\pi)^n} \frac{P_{L\mu\nu} N_1^{\mu\nu}}{D_1 D_2} \\
 &= \int \frac{d^n k}{(2\pi)^n} \left[\frac{2}{D_1} + \frac{2}{D_2} + \frac{4m^2 - p^2}{D_1 D_2} \right] - f_{L1} \\
 &= 4A_0(m) + (4m^2 - p^2) B_0(m; p, m) - 2A_0(m) \\
 &= 2A_0(m) + (4m^2 - p^2) B_0(m; p, m)
 \end{aligned}$$

$$\Rightarrow f_{T1} = \frac{1}{n-1} \left[2A_0(m) + (4m^2 - p^2) B_0(m; p, m) \right]$$

$$I_1^{\mu\nu} = \frac{1}{n-1} \left[2A_0(m) + (4m^2 - p^2) B_0(m; p, m) \right] P_T^{\mu\nu} + 2A_0(m) P_L^{\mu\nu}$$

$$\begin{aligned}
 -i\pi_{ab1}^{\mu\nu} &= 2e^2 \delta_{ab} I_1^{\mu\nu} \\
 &= \frac{2e^2 \delta_{ab}}{n-1} \left[2A_0(m) + (4m^2 - p^2) B_0(m; p, m) \right] P_T^{\mu\nu} + 4e^2 \delta_{ab} A_0(m) P_L^{\mu\nu}
 \end{aligned}$$

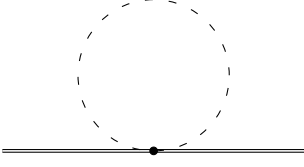
B.1.2 ϕ tadpole

$$\Gamma = ie^2 g^{\mu\nu} (\varepsilon_{jac} \varepsilon_{jbd} + \varepsilon_{jad} \varepsilon_{jbc})$$

$$\begin{aligned} -i\pi_{ab2}^{\mu\nu} &= \int \frac{d^n k}{(2\pi)^n} \Gamma \cdot D^{cd}(k) \\ &= \int \frac{d^n k}{(2\pi)^n} ie^2 g^{\mu\nu} (\varepsilon_{jac} \varepsilon_{jbd} + \varepsilon_{jad} \varepsilon_{jbc}) \cdot \frac{i\delta^{cd}}{k^2 - m^2} \\ &= -e^2 g^{\mu\nu} (\varepsilon_{jac} \varepsilon_{jbc} + \varepsilon_{jad} \varepsilon_{jbc}) \int \frac{d^n k}{(2\pi)^n} \frac{1}{k^2 - m^2} \\ &= -2e^2 g^{\mu\nu} \varepsilon_{jac} \varepsilon_{jbc} A_0(m) \\ &= -4e^2 \delta_{ab} g^{\mu\nu} A_0(m) \\ &= -4e^2 \delta_{ab} (P_T^{\mu\nu} + P_L^{\mu\nu}) A_0(m) \\ &= -4e^2 \delta_{ab} A_0(m) P_T^{\mu\nu} - 4e^2 \delta_{ab} A_0(m) P_L^{\mu\nu} \end{aligned}$$

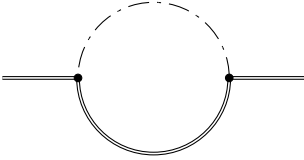
 B.1.3 H- ρ bubble

$$\begin{aligned} \Gamma_1 &= ie^2 \nu \delta^{ac} g^{\alpha\mu} & \Gamma_2 &= ie^2 \nu \delta^{bd} g^{\beta\nu} \\ D_{\alpha\beta}^{cd}(k) &= \frac{-i\delta_{cd} g_{\alpha\beta}}{k^2 - M^2} & D(k+p) &= \frac{i}{(k+p)^2 - m_H^2} \end{aligned}$$

$$\begin{aligned} -i\pi_{ab3}^{\mu\nu} &= \int \frac{d^n k}{(2\pi)^n} \Gamma_1 \cdot D_{\alpha\beta}^{cd}(k) \cdot \Gamma_2 \cdot D(k+p) \\ &= -(e^2 \nu)^2 \delta_{ab} g^{\mu\nu} \int \frac{d^n k}{(2\pi)^n} \frac{1}{(k^2 - M^2) [(k+p)^2 - m_H^2]} \\ &= -e^2 (e\nu)^2 \delta_{ab} (P_T^{\mu\nu} + P_L^{\mu\nu}) B_0(M; p, m_H) \\ &= -e^2 (e\nu)^2 \delta_{ab} B_0(M; p, m_H) P_T^{\mu\nu} - e^2 (e\nu)^2 \delta_{ab} B_0(M; p, m_H) P_L^{\mu\nu} \end{aligned}$$

Recall the definition $M := e\nu$

$$-i\pi_{ab3}^{\mu\nu} = -e^2 M^2 \delta_{ab} B_0(M; p, m_H) P_T^{\mu\nu} - e^2 M^2 \delta_{ab} B_0(M; p, m_H) P_L^{\mu\nu}$$

B.1.4 H tadpole

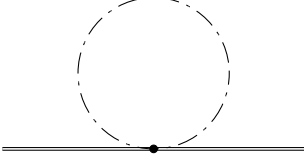

$$\Gamma = \frac{1}{2} i e^2 \delta_{ab} g^{\mu\nu} \quad D(k) = \frac{i}{k^2 - m_H^2}$$

$$\begin{aligned} -i\pi_{ab4}^{\mu\nu} &= \int \frac{d^n k}{(2\pi)^n} \Gamma \cdot D(k) \\ &= -\frac{1}{2} e^2 \delta_{ab} g^{\mu\nu} \int \frac{d^n k}{(2\pi)^n} \frac{1}{k^2 - m_H^2} \\ &= -\frac{1}{2} e^2 \delta_{ab} (P_T^{\mu\nu} + P_L^{\mu\nu}) A_0(m_H) \\ &= -\frac{1}{2} e^2 \delta_{ab} A_0(m_H) P_T^{\mu\nu} - \frac{1}{2} e^2 \delta_{ab} A_0(m_H) P_L^{\mu\nu} \end{aligned}$$

B.1.5 H-Goldstone bubble

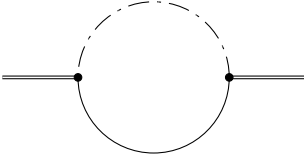

$$\begin{aligned} \Gamma_1 &= \frac{1}{2} e \delta_{ac} (2k+p)^\mu & \Gamma_2 &= \frac{1}{2} e \delta_{bd} (2k+p)^\nu \\ D^{cd}(k) &= \frac{i \delta^{cd}}{k^2 - M^2} & D(k+p) &= \frac{i}{(k+p)^2 - m_H^2} \end{aligned}$$

$$\begin{aligned} -i\pi_{ab5}^{\mu\nu} &= \int \frac{d^n k}{(2\pi)^n} \Gamma_1 \cdot D^{cd}(k) \cdot \Gamma_2 \cdot D(k+p) \\ &= -\frac{1}{4} e^2 \delta_{ab} \int \frac{d^n k}{(2\pi)^n} \frac{(2k+p)^\mu (2k+p)^\nu}{(k^2 - M^2) [(k+p)^2 - m_H^2]} \\ &= -\frac{1}{4} e^2 \delta_{ab} I_5^{\mu\nu} \end{aligned}$$

Some definitions

$$\begin{aligned} N_5^{\mu\nu} &:= (2k+p)^\mu (2k+p)^\nu \\ &= 4k^\mu k^\nu + 2(k^\mu p^\nu + p^\mu k^\nu) + p^\mu p^\nu \end{aligned}$$

$$D_1 := k^2 - M^2$$

$$\begin{aligned} D_2 &:= (k+p)^2 - m_H^2 \\ &= D_1 + 2k \cdot p + M^2 + p^2 - m_H^2 \end{aligned}$$

Now we have the relations

$$\begin{aligned} k^2 &= D_1 + M^2 \\ 2k \cdot p &= D_2 - D_1 + m_H^2 - M^2 - p^2 \end{aligned}$$

$$\begin{aligned} I_5^{\mu\nu} &:= \int \frac{d^n k}{(2\pi)^n} \frac{N_5^{\mu\nu}}{D_1 D_2} \\ &= f_{T5} P_T^{\mu\nu} + f_{L5} P_L^{\mu\nu} \end{aligned}$$

$$\begin{aligned} P_{L\mu\nu} N_5^{\mu\nu} &= \frac{1}{p^2} (2k \cdot p + p^2)^2 \\ &= \frac{1}{p^2} \left[D_2^2 - 2D_1 D_2 + D_1^2 + 2M^2 (D_1 - D_2) + 2m_H^2 (D_2 - D_1) + (m_H^2 - M^2)^2 \right] \\ &= \frac{1}{p^2} \left[D_2^2 - 2D_1 D_2 + D_1^2 + 2(m_H^2 - M^2) (D_2 - D_1) + (m_H^2 - M^2)^2 \right] \end{aligned}$$

$$P_{T\mu\nu} N_5^{\mu\nu} = g_{\mu\nu} N_5^{\mu\nu} - P_{L\mu\nu} N_5^{\mu\nu}$$

$$\begin{aligned} g_{\mu\nu} N_5^{\mu\nu} &= 4k^2 + 2k \cdot p + p^2 \\ &= 2D_1 + 2D_2 + 2m_H^2 + 2M^2 - p^2 \end{aligned}$$

$$\begin{aligned} f_{L5} &= \int \frac{d^n k}{(2\pi)^n} \frac{P_{L\mu\nu} N_5^{\mu\nu}}{D_1 D_2} \\ &= \frac{1}{p^2} \int \frac{d^n k}{(2\pi)^n} \frac{D_2^2 - 2D_1 D_2 + D_1^2 + 2(m_H^2 - M^2) (D_2 - D_1) + (m_H^2 - M^2)^2}{D_1 D_2} \\ &= \frac{1}{p^2} \int \frac{d^n k}{(2\pi)^n} \left[\frac{D_2}{D_1} + \frac{D_1}{D_2} - 2 + 2(m_H^2 - M^2) \left(\frac{1}{D_1} - \frac{1}{D_2} \right) + \frac{(m_H^2 - M^2)^2}{D_1 D_2} \right] \\ &= \frac{1}{p^2} \int \frac{d^n k}{(2\pi)^n} \left[\frac{D_2}{D_1} + \frac{D_1}{D_2} + 2(m_H^2 - M^2) \left(\frac{1}{D_1} - \frac{1}{D_2} \right) + \frac{(m_H^2 - M^2)^2}{D_1 D_2} \right] \end{aligned}$$

$$\int \frac{d^n k}{(2\pi)^n} \frac{D_1}{D_2} = \int \frac{d^n k}{(2\pi)^n} \frac{k^2 - M^2}{(k+p)^2 - m_H^2}$$

We make a change of variables $l^\mu = -(k+p)^\mu \Rightarrow k^\mu = -(l+p)^\mu \Rightarrow \int \frac{d^n k}{(2\pi)^n} = \int \frac{d^n l}{(2\pi)^n}$

$$\int \frac{d^n k}{(2\pi)^n} \frac{D_1}{D_2} = \int \frac{d^n l}{(2\pi)^n} \frac{(l+p)^2 - M^2}{l^2 - m_H^2}$$

$$\begin{aligned}
 &= \int \frac{d^n k}{(2\pi)^n} \frac{k^2 + 2k \cdot p + p^2 - M^2}{k^2 - m_H^2} \\
 &= \int \frac{d^n k}{(2\pi)^n} \frac{k^2 - m_H^2 + 2k \cdot p + m_H^2 - M^2 + p^2}{k^2 - m_H^2} \\
 &= \int \frac{d^n k}{(2\pi)^n} \left[1 + \frac{2k \cdot p}{k^2 - m_H^2} + \frac{m_H^2 - M^2 + p^2}{k^2 - m_H^2} \right] \\
 &= (m_H^2 - M^2 + p^2) A_0(m_H)
 \end{aligned}$$

$$\begin{aligned}
 \int \frac{d^n k}{(2\pi)^n} \frac{D_2}{D_1} &= \int \frac{d^n k}{(2\pi)^n} \frac{(k+p)^2 - m_H^2}{k^2 - M^2} \\
 &= \int \frac{d^n k}{(2\pi)^n} \frac{k^2 + 2k \cdot p + p^2 - m_H^2}{k^2 - M^2} \\
 &= \int \frac{d^n k}{(2\pi)^n} \frac{k^2 - M^2 + 2k \cdot p - m_H^2 + M^2 + p^2}{k^2 - M^2} \\
 &= \int \frac{d^n k}{(2\pi)^n} \left[1 + \frac{2k \cdot p}{k^2 - M^2} + \frac{-m_H^2 + M^2 + p^2}{k^2 - M^2} \right] \\
 &= (-m_H^2 + M^2 + p^2) A_0(M)
 \end{aligned}$$

$$\begin{aligned}
 f_{L5} &= \frac{1}{p^2} \int \frac{d^n k}{(2\pi)^n} \left[\frac{D_2}{D_1} + \frac{D_1}{D_2} + 2(m_H^2 - M^2) \left(\frac{1}{D_1} - \frac{1}{D_2} \right) + \frac{(m_H^2 - M^2)^2}{D_1 D_2} \right] \\
 &= \frac{1}{p^2} \left[(-m_H^2 + M^2 + p^2) A_0(M) + (m_H^2 - M^2 + p^2) A_0(m_H) + 2(m_H^2 - M^2) (A_0(M) - A_0(m_H)) + \right. \\
 &\quad \left. + (m_H^2 - M^2)^2 B_0(M; p, m_H) \right] \\
 &= \frac{1}{p^2} \left[(m_H^2 - M^2) (A_0(m_H) - A_0(M)) + p^2 (A_0(M) + A_0(m_H)) + 2(m_H^2 - M^2) (A_0(M) - A_0(m_H)) + \right. \\
 &\quad \left. + (m_H^2 - M^2)^2 B_0(M; p, m_H) \right] \\
 &= \frac{1}{p^2} \left[-(m_H^2 - M^2) (A_0(m_H) - A_0(M)) + p^2 (A_0(M) + A_0(m_H)) + (m_H^2 - M^2)^2 B_0(M; p, m_H) \right] \\
 &= A_0(M) + A_0(m_H) + \frac{m_H^2 - M^2}{p^2} \left[-A_0(m_H) + A_0(M) + (m_H^2 - M^2) B_0(M; p, m_H) \right]
 \end{aligned}$$

$$\begin{aligned}
 (n-1) f_{T5} &= P_{T\mu\nu} I_5^{\mu\nu} \\
 &= \int \frac{d^n k}{(2\pi)^n} \frac{P_{T\mu\nu} N_5^{\mu\nu}}{D_1 D_2}
 \end{aligned}$$

$$\begin{aligned}
 &= \int \frac{d^n k}{(2\pi)^n} \left(\frac{g_{\mu\nu} N_5^{\mu\nu}}{D_1 D_2} - \frac{P_{L\mu\nu} N_5^{\mu\nu}}{D_1 D_2} \right) \\
 &= \int \frac{d^n k}{(2\pi)^n} \frac{2D_1 + 2D_2 + 2m_H^2 + 2M^2 - p^2}{D_1 D_2} - \int \frac{d^n k}{(2\pi)^n} \frac{P_{L\mu\nu} N_5^{\mu\nu}}{D_1 D_2} \\
 &= \int \frac{d^n k}{(2\pi)^n} \left[\frac{2}{D_1} + \frac{2}{D_2} + \frac{2m_H^2 + 2M^2 - p^2}{D_1 D_2} \right] - f_{L5} \\
 &= 2A_0(M) + 2A_0(m_H) + (2m_H^2 + 2M^2 - p^2) B_0(M; p, m_H) - A_0(M) - A_0(m_H) + \\
 &\quad - \frac{m_H^2 - M^2}{p^2} \left[-A_0(m_H) + A_0(M) + (m_H^2 - M^2) B_0(M; p, m_H) \right] \\
 &= A_0(M) + A_0(m_H) + (2m_H^2 + 2M^2 - p^2) B_0(M; p, m_H) + \\
 &\quad - \frac{m_H^2 - M^2}{p^2} \left[-A_0(m_H) + A_0(M) + (m_H^2 - M^2) B_0(M; p, m_H) \right]
 \end{aligned}$$

$$\begin{aligned}
 I_5^{\mu\nu} &= f_{T5} P_T^{\mu\nu} + f_{L5} P_L^{\mu\nu} \\
 &= \frac{1}{n-1} \left\{ A_0(M) + A_0(m_H) + (2m_H^2 + 2M^2 - p^2) B_0(M; p, m_H) + \right. \\
 &\quad \left. - \frac{m_H^2 - M^2}{p^2} \left[-A_0(m_H) + A_0(M) + (m_H^2 - M^2) B_0(M; p, m_H) \right] \right\} P_T^{\mu\nu} + \\
 &\quad + \left\{ A_0(M) + A_0(m_H) + \frac{m_H^2 - M^2}{p^2} \left[-A_0(m_H) + A_0(M) + (m_H^2 - M^2) B_0(M; p, m_H) \right] \right\} P_L^{\mu\nu}
 \end{aligned}$$

$$\begin{aligned}
 -i\pi_{ab5}^{\mu\nu} &= -\frac{1}{4} e^2 \delta_{ab} I_5^{\mu\nu} \\
 &= -\frac{e^2 \delta_{ab}}{4(n-1)} \left\{ A_0(M) + A_0(m_H) + (2m_H^2 + 2M^2 - p^2) B_0(M; p, m_H) + \right. \\
 &\quad \left. - \frac{m_H^2 - M^2}{p^2} \left[A_0(M) - A_0(m_H) + (m_H^2 - M^2) B_0(M; p, m_H) \right] \right\} P_T^{\mu\nu} + \\
 &\quad - \frac{1}{4} e^2 \delta_{ab} \left\{ A_0(M) + A_0(m_H) + \frac{m_H^2 - M^2}{p^2} \left[-A_0(m_H) + A_0(M) + (m_H^2 - M^2) B_0(M; p, m_H) \right] \right\} P_L^{\mu\nu}
 \end{aligned}$$

B.1.6 Goldstone bubble

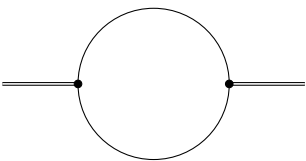

$$\Gamma_1 = \frac{1}{2} e \varepsilon_{adc} (2k + p)^\mu \quad \Gamma_2 = \frac{1}{2} e \varepsilon_{bfg} (2k + p)^\nu$$

B. Self Energy

$$D^{dg}(k) = \frac{i\delta^{dg}}{k^2 - M^2} \quad D^{cf}(k+p) = \frac{i\delta^{cf}}{(k+p)^2 - M^2}$$

$$\begin{aligned} -i\pi_{ab8}^{\mu\nu} &= \int \frac{d^n k}{(2\pi)^n} \Gamma_1 \cdot D^{dg}(k) \cdot \Gamma_2 \cdot D^{cf}(k+p) \\ &= -\frac{1}{4} e^2 \varepsilon_{adc} \varepsilon_{bcd} \int \frac{d^n k}{(2\pi)^n} \frac{(2k+p)^\mu (2k+p)^\nu}{(k^2 - M^2) [(k+p)^2 - M^2]} \\ &= \frac{1}{2} e^2 \delta_{ab} \int \frac{d^n k}{(2\pi)^n} \frac{(k+p)^\mu (k+p)^\nu}{(k^2 - M^2) [(k+p)^2 - M^2]} \\ &= \frac{1}{2} e^2 \delta_{ab} I_8^{\mu\nu} \end{aligned}$$

Making some definitions

$$\begin{aligned} N_8^{\mu\nu} &:= (2k+p)^\mu (2k+p)^\nu \\ &= 4k^\mu k^\nu + 2(k^\mu p^\nu + p^\mu k^\nu) + p^\mu p^\nu \\ D_1 &:= k^2 - M^2 \\ D_2 &:= (k+p)^2 - M^2 \\ &= k^2 + 2k \cdot p + p^2 - M^2 \\ &= D_1 + 2k \cdot p + p^2 \end{aligned}$$

We have the relations

$$\begin{aligned} k^2 &= D_1 + M^2 \\ 2k \cdot p &= D_2 - D_1 - p^2 \end{aligned}$$

$$\begin{aligned} I_8^{\mu\nu} &:= \int \frac{d^n k}{(2\pi)^n} \frac{N_8^{\mu\nu}}{D_1 D_2} \\ &= f_{T8} P_T^{\mu\nu} + f_{L8} P_L^{\mu\nu} \end{aligned}$$

Looking at $N_8^{\mu\nu}, D_1, D_2$ we see that this is the same integral as in the case of the $I_1^{\mu\nu}$ but with the replacement of $m \rightarrow M$.

$$\begin{aligned} f_{T8} &= f_{T1} \\ f_{L8} &= f_{L1} \\ I_8^{\mu\nu} &= \frac{1}{n-1} \left[2A_0(M) + (4M^2 - p^2) B_0(M; p, M) \right] P_T^{\mu\nu} + 2A_0(M) P_L^{\mu\nu} \end{aligned}$$

$$\begin{aligned} -i\pi_{ab8}^{\mu\nu} &= \frac{1}{2} e^2 \delta_{ab} I_8^{\mu\nu} \\ &= \frac{e^2 \delta_{ab}}{2(n-1)} \left[2A_0(M) + (4M^2 - p^2) B_0(M; p, M) \right] P_T^{\mu\nu} + e^2 \delta_{ab} A_0(M) P_L^{\mu\nu} \end{aligned}$$

B.1.7 Goldstone tadpole

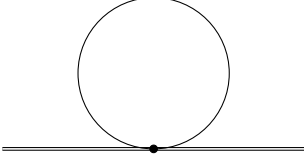

$$\Gamma = \frac{1}{2} i e^2 \delta^{ab} \delta^{cd} g^{\mu\nu} \quad D^{cd}(k) = \frac{i \delta^{cd}}{k^2 - M^2}$$

$$\begin{aligned} -i\pi_{ab6}^{\mu\nu} &= \int \frac{d^n k}{(2\pi)^n} \Gamma \cdot D^{cd}(k) \\ &= -\frac{1}{2} e^2 \delta^{ab} \delta^{cc} g^{\mu\nu} \int \frac{d^n k}{(2\pi)^n} \frac{1}{k^2 - M^2} \\ &= -\frac{3}{2} e^2 \delta^{ab} (P_T^{\mu\nu} + P_L^{\mu\nu}) A_0(M) \\ &= -\frac{3}{2} e^2 \delta^{ab} A_0(M) P_T^{\mu\nu} - \frac{3}{2} e^2 \delta^{ab} A_0(M) P_L^{\mu\nu} \end{aligned}$$

B.1.8 Ghost bubble

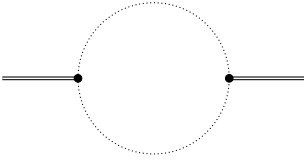

$$\begin{aligned} \Gamma_1 &= -e \varepsilon_{adc} (k+p)^\mu & \Gamma_2 &= e \varepsilon_{bfg} (k+p)^\nu \\ D^{dg}(k) &= \frac{i \delta^{dg}}{k^2 - M^2} & D^{cf}(k+p) &= \frac{i \delta^{cf}}{(k+p)^2 - M^2} \end{aligned}$$

$$\begin{aligned} -i\pi_{ab7}^{\mu\nu} &= (-1) \int \frac{d^n k}{(2\pi)^n} \Gamma_1 \cdot D^{dg}(k) \cdot \Gamma_2 \cdot D^{cf}(k+p) \\ &= -e^2 \varepsilon_{adc} \varepsilon_{bcd} \int \frac{d^n k}{(2\pi)^n} \frac{(k+p)^\mu (k+p)^\nu}{(k^2 - M^2) [(k+p)^2 - M^2]} \\ &= 2e^2 \delta_{ab} \int \frac{d^n k}{(2\pi)^n} \frac{(k+p)^\mu (k+p)^\nu}{(k^2 - M^2) [(k+p)^2 - M^2]} \\ &= 2e^2 \delta_{ab} I_7^{\mu\nu} \end{aligned}$$

Some definitions

$$N_7^{\mu\nu} := (k+p)^\mu (k+p)^\nu$$

$$\begin{aligned}
 &= k^\mu k^\nu + (k^\mu p^\nu + p^\mu k^\nu) + p^\mu p^\nu \\
 D_1 &:= k^2 - M^2 \\
 D_2 &:= (k + p)^2 - M^2 \\
 &= k^2 + 2k \cdot p + p^2 - M^2 \\
 &= D_1 + 2k \cdot p + p^2
 \end{aligned}$$

We have the relations

$$\begin{aligned}
 k^2 &= D_1 + M^2 \\
 2k \cdot p &= D_2 - D_1 - p^2
 \end{aligned}$$

$$\begin{aligned}
 I_7^{\mu\nu} &:= \int \frac{d^n k}{(2\pi)^n} \frac{N_7^{\mu\nu}}{D_1 D_2} \\
 &= f_{T7} P_T^{\mu\nu} + f_{L7} P_L^{\mu\nu}
 \end{aligned}$$

$$\begin{aligned}
 P_{L\mu\nu} N_7^{\mu\nu} &= \frac{1}{p^2} [(k \cdot p)^2 + p^2 (2k \cdot p) + p^4] \\
 &= \frac{1}{4p^2} [D_1^2 + D_2^2 - 2D_1 D_2 + 2p^2 (D_2 - D_1) + p^4]
 \end{aligned}$$

$$P_{T\mu\nu} N_7^{\mu\nu} = g_{\mu\nu} N_7^{\mu\nu} - P_{L\mu\nu} N_7^{\mu\nu}$$

$$\begin{aligned}
 g_{\mu\nu} N_7^{\mu\nu} &= k^2 + 2k \cdot p + p^2 \\
 &= D_2 + M^2
 \end{aligned}$$

$$\begin{aligned}
 f_{L7} &= \int \frac{d^n k}{(2\pi)^n} \frac{P_{L\mu\nu} N_7^{\mu\nu}}{D_1 D_2} \\
 &= \frac{1}{4p^2} \int \frac{d^n k}{(2\pi)^n} \frac{D_1^2 + D_2^2 - 2D_1 D_2 + 2p^2 (D_2 - D_1) + p^4}{D_1 D_2} \\
 &= \frac{1}{4p^2} \int \frac{d^n k}{(2\pi)^n} \left[\frac{D_1}{D_2} + \frac{D_2}{D_1} - 2 + 2p^2 \left(\frac{1}{D_1} - \frac{1}{D_2} \right) + \frac{p^4}{D_1 D_2} \right]
 \end{aligned}$$

$$\int \frac{d^n k}{(2\pi)^n} \frac{D_1}{D_2} = \int \frac{d^n k}{(2\pi)^n} \frac{k^2 - M^2}{(k + p)^2 - M^2}$$

Making a change of variables $l^\mu = -(k + p)^\mu \Rightarrow k^\mu = -(l + p)^\mu \Rightarrow \int \frac{d^n k}{(2\pi)^n} = \int \frac{d^n l}{(2\pi)^n}$

$$\int \frac{d^n k}{(2\pi)^n} \frac{D_1}{D_2} = \int \frac{d^n l}{(2\pi)^n} \frac{(l + p)^2 - M^2}{l^2 - M^2}$$

$$\begin{aligned}
 &= \int \frac{d^n k}{(2\pi)^n} \frac{D_2}{D_1} \\
 &= \int \frac{d^n k}{(2\pi)^n} \left(1 + \frac{2k \cdot p}{k^2 - M^2} + \frac{p^2}{k^2 - M^2} \right) \\
 &= p^2 A_0(M)
 \end{aligned}$$

$$\begin{aligned}
 f_{L7} &= \frac{1}{4p^2} \left[2p^2 A_0(M) + p^4 B_0(M; p, M) \right] \\
 &= \frac{1}{2} A_0(M) + \frac{1}{4} p^2 B_0(M; p, M)
 \end{aligned}$$

$$\begin{aligned}
 (n-1) f_{T7} &= P_{T\mu\nu} I_7^{\mu\nu} \\
 &= \int \frac{d^n k}{(2\pi)^n} \frac{P_{T\mu\nu} N_7^{\mu\nu}}{D_1 D_2} \\
 &= \int \frac{d^n k}{(2\pi)^n} \left(\frac{g_{\mu\nu} N_7^{\mu\nu}}{D_1 D_2} - \frac{P_{L\mu\nu} N_7^{\mu\nu}}{D_1 D_2} \right) \\
 &= \int \frac{d^n k}{(2\pi)^n} \frac{D_2 + M^2}{D_1 D_2} - \int \frac{d^n k}{(2\pi)^n} \frac{P_{L\mu\nu} N_7^{\mu\nu}}{D_1 D_2} \\
 &= A_0(M) + M^2 B_0(M; p, M) - f_{L7} \\
 &= A_0(M) + M^2 B_0(M; p, M) - \frac{1}{2} A_0(M) - \frac{1}{4} p^2 B_0(M; p, M) \\
 &= \frac{1}{2} A_0(M) + \left(M^2 - \frac{1}{4} p^2 \right) B_0(M; p, M)
 \end{aligned}$$

$$\begin{aligned}
 I_7^{\mu\nu} &= f_{T7} P_T^{\mu\nu} + f_{L7} P_L^{\mu\nu} \\
 &= \frac{1}{n-1} \left[\frac{1}{2} A_0(M) + \left(M^2 - \frac{1}{4} p^2 \right) B_0(M; p, M) \right] P_T^{\mu\nu} + \left[\frac{1}{2} A_0(M) + \frac{1}{4} p^2 B_0(M; p, M) \right] P_L^{\mu\nu}
 \end{aligned}$$

$$\begin{aligned}
 -i\pi_{ab7}^{\mu\nu} &= 2e^2 \delta_{ab} I_7^{\mu\nu} \\
 &= \frac{2e^2 \delta_{ab}}{n-1} \left[\frac{1}{2} A_0(M) + \left(M^2 - \frac{1}{4} p^2 \right) B_0(M; p, M) \right] P_T^{\mu\nu} + 2e^2 \delta_{ab} \left[\frac{1}{2} A_0(M) + \frac{1}{4} p^2 B_0(M; p, M) \right] P_L^{\mu\nu}
 \end{aligned}$$

B.1.9 ρ bubble

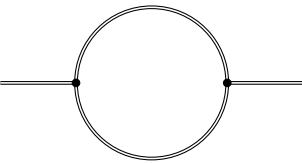

$$\Gamma_1 = e\varepsilon_{adc} \left[-(2k+p)^\mu g^{\alpha\beta} + (k+2p)^\beta g^{\mu\alpha} + (k-p)^\alpha g^{\mu\beta} \right]$$

$$\Gamma_2 = e\varepsilon_{fgb} \left[-(2k+p)^\nu g^{\kappa\lambda} + (k+2p)^\lambda g^{\kappa\nu} + (k-p)^\kappa g^{\lambda\nu} \right]$$

$$D_{\beta\lambda}^{dg}(k) = \frac{-i\delta_{dg}g_{\beta\lambda}}{k^2 - M^2} \quad D_{\alpha\kappa}^{cf}(k+p) = \frac{-i\delta_{cf}g_{\alpha\kappa}}{(k+p)^2 - M^2}$$

$$\begin{aligned} -i\pi_{ab9}^{\mu\nu} &= \int \frac{d^n k}{(2\pi)^n} \Gamma_1 \cdot D_{\beta\lambda}^{dg}(k) \cdot \Gamma_2 \cdot D_{\alpha\kappa}^{cf}(k+p) \\ &= -e^2 \varepsilon_{adc} \varepsilon_{bcd} \int \frac{d^n k}{(2\pi)^n} \times \\ &\times \frac{\left[-(2k+p)^\mu g^{\alpha\beta} + (k+2p)^\beta g^{\mu\alpha} + (k-p)^\alpha g^{\mu\beta} \right] \cdot g_{\beta\lambda} g_{\alpha\kappa} \cdot \left[-(2k+p)^\nu g^{\kappa\lambda} + (k+2p)^\lambda g^{\kappa\nu} + (k-p)^\kappa g^{\lambda\nu} \right]}{(k^2 - M^2) \left[(k+p)^2 - M^2 \right]} \\ &= 2e^2 \delta_{ab} \times \\ &\int \frac{d^n k}{(2\pi)^n} \frac{\left[-(2k+p)^\mu g^{\alpha\beta} + (k+2p)^\beta g^{\mu\alpha} + (k-p)^\alpha g^{\mu\beta} \right] \left[-(2k+p)^\nu g_{\alpha\beta} + (k+2p)_\beta g_\alpha^\nu + (k-p)_\alpha g_\beta^\nu \right]}{(k^2 - M^2) \left[(k+p)^2 - M^2 \right]} \\ &= 2e^2 \delta_{ab} I_9^{\mu\nu} \end{aligned}$$

Some definitions

$$\begin{aligned} N_9^{\mu\nu} &:= \left[-(2k+p)^\mu g^{\alpha\beta} + (k+2p)^\beta g^{\mu\alpha} + (k-p)^\alpha g^{\mu\beta} \right] \left[-(2k+p)^\nu g_{\alpha\beta} + (k+2p)_\beta g_\alpha^\nu + (k-p)_\alpha g_\beta^\nu \right] \\ &= (4n-6) k^\mu k^\nu + (2n-3) (k^\mu p^\nu + p^\mu k^\nu) + (n-6) p^\mu p^\nu + (2k^2 + 2k \cdot p + 5p^2) g^{\mu\nu} \\ D_1 &:= k^2 - M^2 \\ D_2 &:= (k+p)^2 - M^2 \\ &= k^2 + 2k \cdot p + p^2 - M^2 \\ &= D_1 + 2k \cdot p + p^2 \end{aligned}$$

We have the relations

$$\begin{aligned} k^2 &= D_1 + M^2 \\ 2k \cdot p &= D_2 - D_1 - p^2 \end{aligned}$$

We can simplify $N_9^{\mu\nu}$ with the above relations

$$N_9^{\mu\nu} = (4n-6) k^\mu k^\nu + (2n-3) (k^\mu p^\nu + p^\mu k^\nu) + (n-6) p^\mu p^\nu + (D_1 + D_2 + 2M^2 + 4p^2) g^{\mu\nu}$$

$$\begin{aligned} I_9^{\mu\nu} &:= \int \frac{d^n k}{(2\pi)^n} \frac{N_9^{\mu\nu}}{D_1 D_2} \\ &= f_{T9} P_T^{\mu\nu} + f_{L9} P_L^{\mu\nu} \end{aligned}$$

$$\begin{aligned} P_{L\mu\nu} N_9^{\mu\nu} &= \frac{1}{p^2} \left[(4n-6) (k \cdot p)^2 + (2n-3) p^2 (2k \cdot p) + (n-6) p^4 + (D_1 + D_2 + 2M^2 + 4p^2) p^2 \right] \\ &= \frac{1}{p^2} \left[\left(n - \frac{3}{2} \right) (D_1^2 + D_2^2) + (3-2n) D_1 D_2 + p^2 (D_1 + D_2) + \frac{1}{2} p^2 (4M^2 - p^2) \right] \end{aligned}$$

$$P_{T\mu\nu}N_9^{\mu\nu} = g_{\mu\nu}N_9^{\mu\nu} - P_{L\mu\nu}N_9^{\mu\nu}$$

$$\begin{aligned} g_{\mu\nu}N_9^{\mu\nu} &= (4n-6)k^2 + (2n-3)(2k \cdot p) + (n-6)p^2 + n(D_1 + D_2 + 2M^2 + 4p^2) \\ &= 3(n-1)(D_1 + D_2) + 2 \cdot 3(n-1)m^2 + 3(n-1)p^2 \\ &= 3(n-1) \left[(D_1 + D_2) + 2m^2 + p^2 \right] \end{aligned}$$

$$\begin{aligned} f_{L9} &= \int \frac{d^n k}{(2\pi)^n} \frac{P_{L\mu\nu}N_9^{\mu\nu}}{D_1 D_2} \\ &= \frac{1}{p^2} \int \frac{d^n k}{(2\pi)^n} \frac{1}{D_1 D_2} \left[\left(n - \frac{3}{2} \right) (D_1^2 + D_2^2) + (3-2n)D_1 D_2 + p^2(D_1 + D_2) + \frac{1}{2}p^2(4M^2 - p^2) \right] \\ &= \frac{1}{p^2} \int \frac{d^n k}{(2\pi)^n} \left[\left(n - \frac{3}{2} \right) \left(\frac{D_1}{D_2} + \frac{D_2}{D_1} \right) + (3-2n) + p^2 \left(\frac{1}{D_1} + \frac{1}{D_2} \right) + \frac{1}{2}p^2(4M^2 - p^2) \frac{1}{D_1 D_2} \right] \\ &= \frac{1}{p^2} \int \frac{d^n k}{(2\pi)^n} \left[\left(n - \frac{3}{2} \right) \left(\frac{D_1}{D_2} + \frac{D_2}{D_1} \right) + p^2 \left(\frac{1}{D_1} + \frac{1}{D_2} \right) + \frac{1}{2}p^2(4M^2 - p^2) \frac{1}{D_1 D_2} \right] \end{aligned}$$

$$\int \frac{d^n k}{(2\pi)^n} \frac{D_1}{D_2} = \int \frac{d^n k}{(2\pi)^n} \frac{k^2 - M^2}{(k+p)^2 - M^2}$$

Making a change of variables $l^\mu = -(k+p)^\mu \Rightarrow k^\mu = -(l+p)^\mu \Rightarrow \int \frac{d^n k}{(2\pi)^n} = \int \frac{d^n l}{(2\pi)^n}$

$$\begin{aligned} \int \frac{d^n k}{(2\pi)^n} \frac{D_1}{D_2} &= \int \frac{d^n l}{(2\pi)^n} \frac{(l+p)^2 - M^2}{l^2 - M^2} \\ &= \int \frac{d^n k}{(2\pi)^n} \frac{D_2}{D_1} \\ &= \int \frac{d^n k}{(2\pi)^n} \left(1 + \frac{2k \cdot p}{k^2 - M^2} + \frac{p^2}{k^2 - M^2} \right) \\ &= p^2 A_0(M) \end{aligned}$$

$$\begin{aligned} f_{L9} &= \frac{1}{p^2} \int \frac{d^n k}{(2\pi)^n} \left[\left(n - \frac{3}{2} \right) \left(\frac{D_1}{D_2} + \frac{D_2}{D_1} \right) + p^2 \left(\frac{1}{D_1} + \frac{1}{D_2} \right) + \frac{1}{2}p^2(4M^2 - p^2) \frac{1}{D_1 D_2} \right] \\ &= \frac{1}{p^2} \left[2 \left(n - \frac{3}{2} \right) p^2 A_0(M) + 2p^2 A_0(M) + \frac{1}{2}p^2(4M^2 - p^2) B(M; p, M) \right] \\ &= (2n-1) A_0(M) + \frac{1}{2} (4M^2 - p^2) B(M; p, M) \end{aligned}$$

$$(n-1) f_{T9} = P_{T\mu\nu} I_9^{\mu\nu}$$

$$\begin{aligned}
 &= \int \frac{d^n k}{(2\pi)^n} \frac{P_{T\mu\nu} N_9^{\mu\nu}}{D_1 D_2} \\
 &= \int \frac{d^n k}{(2\pi)^n} \left(\frac{g_{\mu\nu} N_9^{\mu\nu}}{D_1 D_2} - \frac{P_{L\mu\nu} N_9^{\mu\nu}}{D_1 D_2} \right) \\
 &= \int \frac{d^n k}{(2\pi)^n} \frac{3(n-1)[(D_1 + D_2) + 2M^2 + p^2]}{D_1 D_2} - \int \frac{d^n k}{(2\pi)^n} \frac{P_{L\mu\nu} N_9^{\mu\nu}}{D_1 D_2} \\
 &= 3(n-1) \int \frac{d^n k}{(2\pi)^n} \left[\frac{1}{D_1} + \frac{1}{D_2} + \frac{2M^2 + p^2}{D_1 D_2} \right] - f_{L9} \\
 &= 3(n-1) \left[2A_0(M) + (2M^2 + p^2) B(M; p, M) \right] - (2n-1) A_0(M) + \\
 &\quad - \frac{1}{2} (4M^2 - p^2) B(M; p, M) \\
 \implies (n-1) f_{T9} &= (4n-5) A_0(M) + \frac{1}{2} \left[4(3n-4) M^2 + (6n-5) p^2 \right] B(M; p, M)
 \end{aligned}$$

$$\begin{aligned}
 I_9^{\mu\nu} &= f_{T9} P_T^{\mu\nu} + f_{L9} P_L^{\mu\nu} \\
 &= \left\{ \frac{4n-5}{n-1} A_0(M) + \frac{1}{2(n-1)} \left[4(3n-4) M^2 + (6n-5) p^2 \right] B(M; p, M) \right\} P_T^{\mu\nu} + \\
 &\quad + \left[(2n-1) A_0(M) + \frac{1}{2} (4M^2 - p^2) B(M; p, M) \right] P_L^{\mu\nu}
 \end{aligned}$$

$$\begin{aligned}
 -i\pi_{ab9}^{\mu\nu} &= 2e^2 \delta_{ab} I_9^{\mu\nu} \\
 &= 2e^2 \delta_{ab} \left\{ \frac{4n-5}{n-1} A_0(M) + \frac{1}{2(n-1)} \left[4(3n-4) M^2 + (6n-5) p^2 \right] B(M; p, M) \right\} P_T^{\mu\nu} + \\
 &\quad + 2e^2 \delta_{ab} \left[(2n-1) A_0(M) + \frac{1}{2} (4M^2 - p^2) B(M; p, M) \right] P_L^{\mu\nu}
 \end{aligned}$$

B.1.10 ρ tadpole

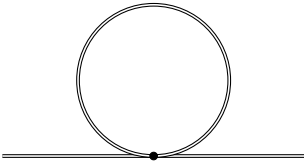

$$\begin{aligned}
 \Gamma &= -ie^2 \left[\varepsilon_{abe} \varepsilon_{cde} (g^{\mu\lambda} g^{\nu\sigma} - g^{\mu\sigma} g^{\nu\lambda}) + \varepsilon_{ace} \varepsilon_{bde} (g^{\mu\nu} g^{\sigma\lambda} - g^{\mu\sigma} g^{\nu\lambda}) + \varepsilon_{ade} \varepsilon_{bce} (g^{\mu\nu} g^{\sigma\lambda} - g^{\mu\lambda} g^{\nu\sigma}) \right] \\
 D_{\sigma\lambda}^{cd}(k) &= \frac{-i\delta_{cd} g_{\sigma\lambda}}{k^2 - M^2}
 \end{aligned}$$

$$-i\pi_{ab10}^{\mu\nu} = \int \frac{d^n k}{(2\pi)^n} \Gamma \cdot D_{\sigma\lambda}^{cd}(k)$$

$$\begin{aligned}
 &= -e^2 \left[\varepsilon_{abe} \varepsilon_{cde} (g^{\mu\lambda} g^{\nu\sigma} - g^{\mu\sigma} g^{\nu\lambda}) + \varepsilon_{ace} \varepsilon_{bde} (g^{\mu\nu} g^{\sigma\lambda} - g^{\mu\sigma} g^{\nu\lambda}) + \varepsilon_{ade} \varepsilon_{bce} (g^{\mu\nu} g^{\sigma\lambda} - g^{\mu\lambda} g^{\nu\sigma}) \right] \delta_{cd} g_{\sigma\lambda} \times \\
 &\times \int \frac{d^n k}{(2\pi)^n} \frac{1}{k^2 - M^2} \\
 &= -e^2 \left[\varepsilon_{abe} \varepsilon_{cce} (g^{\mu\lambda} g^{\nu\sigma} - g^{\mu\sigma} g^{\nu\lambda}) g_{\sigma\lambda} + \varepsilon_{ace} \varepsilon_{bce} (n g^{\mu\nu} - g^{\mu\nu}) + \varepsilon_{ace} \varepsilon_{bce} (n g^{\mu\nu} - g^{\mu\nu}) \right] A_0(M) \\
 &= -2e^2 (n-1) \varepsilon_{ace} \varepsilon_{bce} g^{\mu\nu} A_0(M) \\
 &= -4e^2 (n-1) \delta_{ab} (P_T^{\mu\nu} + P_L^{\mu\nu}) A_0(M) \\
 &= -4e^2 \delta_{ab} (n-1) A_0(M) P_T^{\mu\nu} - 4e^2 \delta_{ab} (n-1) A_0(M) P_L^{\mu\nu}
 \end{aligned}$$

B.1.11 lollipops

B.1.11.1 ϕ

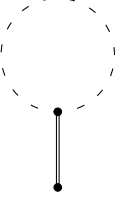

$$\Gamma_2 = 2e\varepsilon_{dab} k^\gamma \quad D^{ab}(k) = \frac{i\delta^{ab}}{k^2 - m^2}$$

$$\begin{aligned}
 t_{A1}^{d\gamma} &= \int \frac{d^n k}{(2\pi)^n} \Gamma_2 \cdot D^{ab}(k) \\
 &= 2ie\varepsilon_{daa} \int \frac{d^n k}{(2\pi)^n} \frac{k^\gamma}{k^2 - m^2} \\
 &= 0
 \end{aligned}$$

B.1.11.2 Goldstone

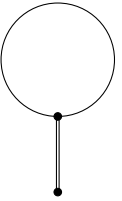

$$\Gamma_2 = -e\varepsilon_{dab} k^\gamma \quad D^{ab}(k) = \frac{i\delta^{ab}}{k^2 - M^2}$$

$$t_{A2}^{d\gamma} = \int \frac{d^n k}{(2\pi)^n} \Gamma_2 \cdot D^{ab}(k)$$

$$\begin{aligned}
 &= -ie\varepsilon_{daa} \int \frac{d^n k}{(2\pi)^n} \frac{k^\gamma}{k^2 - m^2} \\
 &= 0
 \end{aligned}$$

B.1.11.3 ghost

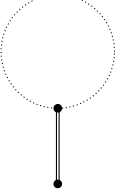

$$\Gamma_2 = e\varepsilon_{dab} k^\gamma \quad D^{ab}(k) = \frac{i\delta^{ab}}{k^2 - M^2}$$

$$\begin{aligned}
 t_{A3}^{d\gamma} &= \int \frac{d^n k}{(2\pi)^n} \Gamma_2 \cdot D^{ab}(k) \\
 &= ie\varepsilon_{daa} \int \frac{d^n k}{(2\pi)^n} \frac{k^\gamma}{k^2 - m^2} \\
 &= 0
 \end{aligned}$$

B.1.11.4 ρ

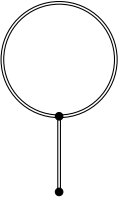

$$\Gamma_2 = e\varepsilon_{dab} [k^\alpha g^{\beta\gamma} + k^\beta g^{\alpha\gamma} - 2k^\gamma g^{\alpha\beta}] \quad D_{\alpha\beta}^{ab}(k) = \frac{-i\delta^{ab} g_{\alpha\beta}}{k^2 - M^2}$$

$$\begin{aligned}
 t_{A4}^{d\gamma} &= \int \frac{d^n k}{(2\pi)^n} \Gamma_2 \cdot D^{ab}(k) \\
 &= -ie\varepsilon_{daa} \int \frac{d^n k}{(2\pi)^n} \frac{k^\alpha g^{\beta\gamma} + k^\beta g^{\alpha\gamma} - 2k^\gamma g^{\alpha\beta}}{k^2 - m^2} \\
 &= 0
 \end{aligned}$$

B.1.11.5 Higgs

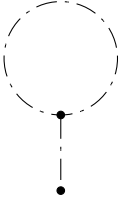

$$\Gamma_2 = -\frac{3}{2}i\lambda\nu \quad D(k) = \frac{i}{k^2 - m_H^2}$$

$$\begin{aligned} t_1^H &= \int \frac{d^n k}{(2\pi)^n} \Gamma_2 \cdot D(k) \\ &= \frac{3}{2}\lambda\nu \int \frac{d^n k}{(2\pi)^n} \frac{1}{k^2 - m_H^2} \\ &= \frac{3}{2}\lambda\nu A_0(m_H) \end{aligned}$$

B.1.11.6 Goldstone

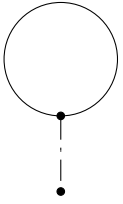

$$\Gamma_2 = -\frac{1}{2}i\lambda\nu\delta_{ab} \quad D^{ab}(k) = \frac{i\delta^{ab}}{k^2 - M^2}$$

$$\begin{aligned} t_2^H &= \int \frac{d^n k}{(2\pi)^n} \Gamma_2 \cdot D^{ab}(k) \\ &= \frac{1}{2}\lambda\nu\delta_{aa} \int \frac{d^n k}{(2\pi)^n} \frac{1}{k^2 - M^2} \\ &= \frac{3}{2}\lambda\nu A_0(M) \end{aligned}$$

B.1.11.7 ρ



$$\Gamma_2 = \frac{1}{2}ie^2\nu\delta_{ab}g^{\alpha\beta} \quad D_{\alpha\beta}^{ab}(k) = \frac{-i\delta^{ab}g_{\alpha\beta}}{k^2 - M^2}$$

$$\begin{aligned}
 t_3^H &= \int \frac{d^n k}{(2\pi)^n} \Gamma_2 \cdot D_{\alpha\beta}^{ab}(k) \\
 &= \frac{1}{2} e^2 \nu n \delta^{aa} \int \frac{d^n k}{(2\pi)^n} \frac{1}{k^2 - M^2} \\
 &= \frac{3}{2} e^2 \nu n A_0(M)
 \end{aligned}$$

B.1.11.8 ϕ

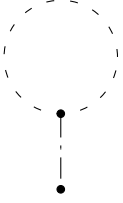

$$\Gamma_2 = -4i\kappa\nu\delta_{ab} \quad D^{ab}(k) = \frac{i\delta^{ab}}{k^2 - m^2}$$

$$\begin{aligned}
 t_4^H &= \int \frac{d^n k}{(2\pi)^n} \Gamma_2 \cdot D^{ab}(k) \\
 &= 4\kappa\nu\delta^{aa} \int \frac{d^n k}{(2\pi)^n} \frac{1}{k^2 - m^2} \\
 &= 12\kappa\nu A_0(m)
 \end{aligned}$$

B.1.11.9 ghost

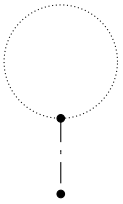

$$\Gamma_2 = \frac{1}{2} i e^2 \nu \delta_{ab} \quad D^{ab}(k) = \frac{i\delta^{ab}}{k^2 - M^2}$$

$$\begin{aligned}
 t_5^H &= \int \frac{d^n k}{(2\pi)^n} \Gamma_2 \cdot D^{ab}(k) \\
 &= -\frac{1}{2} e^2 \nu \delta^{aa} \int \frac{d^n k}{(2\pi)^n} \frac{1}{k^2 - M^2} \\
 &= -\frac{3}{2} e^2 \nu A_0(M)
 \end{aligned}$$

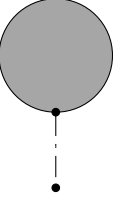

$$\begin{aligned} T_H &= \sum_{k=1}^5 t_k^H \\ &= \frac{3}{2} \nu \left\{ \lambda A_0(m_H) + [\lambda + e^2(n-1)] A_0(M) + 8\kappa A_0(m) \right\} \end{aligned}$$

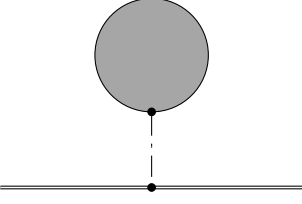

$$\begin{aligned} \Gamma &= ie^2 \nu \delta_{ab} g^{\mu\nu} \quad D(0) = \frac{-i}{m_H^2} \\ &= ie^2 \nu \delta_{ab} (P_T^{\mu\nu} + P_L^{\mu\nu}) \end{aligned}$$

$$\begin{aligned} -i\pi_{ab11}^{\mu\nu} &= \Gamma \cdot D(0) \cdot T_H \\ &= ie^2 \nu \delta_{ab} (P_T^{\mu\nu} + P_L^{\mu\nu}) \cdot \frac{-i}{m_H^2} \cdot \frac{3}{2} \nu \left\{ \lambda A_0(m_H) + [\lambda + e^2(n-1)] A_0(M) + 8\kappa A_0(m) \right\} \\ &= \frac{3}{2} e^2 \nu^2 \delta_{ab} (P_T^{\mu\nu} + P_L^{\mu\nu}) \left\{ \lambda \frac{A_0(m_H)}{m_H^2} + [\lambda + e^2(n-1)] \frac{A_0(M)}{m_H^2} + 8\kappa \frac{A_0(m)}{m_H^2} \right\} \\ &= \frac{3}{2} M^2 \delta_{ab} \left\{ \lambda \frac{A_0(m_H)}{m_H^2} + [\lambda + e^2(n-1)] \frac{A_0(M)}{m_H^2} + 8\kappa \frac{A_0(m)}{m_H^2} \right\} P_T^{\mu\nu} + \\ &+ \frac{3}{2} M^2 \delta_{ab} \left\{ \lambda \frac{A_0(m_H)}{m_H^2} + [\lambda + e^2(n-1)] \frac{A_0(M)}{m_H^2} + 8\kappa \frac{A_0(m)}{m_H^2} \right\} P_L^{\mu\nu} \end{aligned}$$

B.1.12 Summary

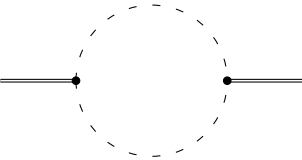

$$\begin{aligned} -i\pi_{ab1}^{\mu\nu} &= 2e^2 \delta_{ab} I_1^{\mu\nu} \\ &= \frac{2e^2 \delta_{ab}}{n-1} \left[2A_0(m) + (4m^2 - p^2) B_0(m; p, m) \right] P_T^{\mu\nu} + 4e^2 \delta_{ab} A_0(m) P_L^{\mu\nu} \end{aligned}$$

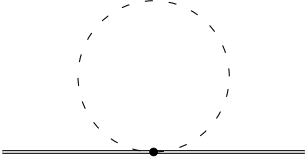

$$-i\pi_{ab2}^{\mu\nu} = -4e^2\delta_{ab}A_0(m)P_T^{\mu\nu} - 4e^2\delta_{ab}A_0(m)P_L^{\mu\nu}$$

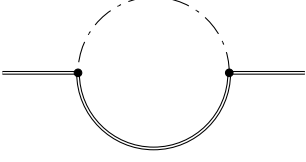

$$-i\pi_{ab3}^{\mu\nu} = -e^2M^2\delta_{ab}B_0(M;p,m_H)P_T^{\mu\nu} - e^2M^2\delta_{ab}B_0(M;p,m_H)P_L^{\mu\nu}$$

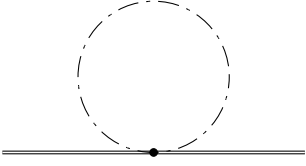

$$-i\pi_{ab4}^{\mu\nu} = -\frac{1}{2}e^2\delta_{ab}A_0(m_H)P_T^{\mu\nu} - \frac{1}{2}e^2\delta_{ab}A_0(m_H)P_L^{\mu\nu}$$

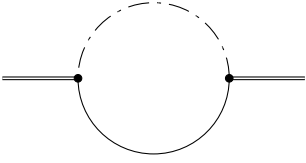

$$\begin{aligned} -i\pi_{ab5}^{\mu\nu} = & -\frac{e^2\delta_{ab}}{4(n-1)} \left\{ A_0(M) + A_0(m_H) + (2m_H^2 + 2M^2 - p^2) B_0(M;p,m_H) + \right. \\ & \left. - \frac{m_H^2 - M^2}{p^2} [A_0(M) - A_0(m_H) + (m_H^2 - M^2) B_0(M;p,m_H)] \right\} P_T^{\mu\nu} + \\ & -\frac{1}{4}e^2\delta_{ab} \left\{ A_0(M) + A_0(m_H) + \frac{m_H^2 - M^2}{p^2} [-A_0(m_H) + A_0(M) + (m_H^2 - M^2) B_0(M;p,m_H)] \right\} P_L^{\mu\nu} \end{aligned}$$

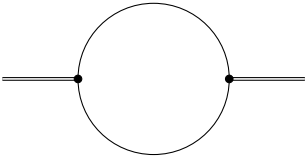

$$-i\pi_{ab6}^{\mu\nu} = \frac{e^2\delta_{ab}}{2(n-1)} [2A_0(M) + (4M^2 - p^2) B_0(M;p,M)] P_T^{\mu\nu} + e^2\delta_{ab}A_0(M) P_L^{\mu\nu}$$

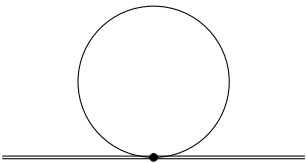

$$-i\pi_{ab7}^{\mu\nu} = -\frac{3}{2}e^2\delta^{ab}A_0(M)P_T^{\mu\nu} - \frac{3}{2}e^2\delta^{ab}A_0(M)P_L^{\mu\nu}$$

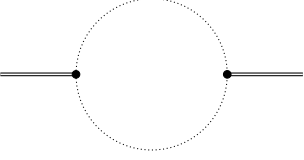

$$-i\pi_{ab7}^{\mu\nu} = \frac{2e^2\delta_{ab}}{n-1} \left[\frac{1}{2}A_0(M) + \left(M^2 - \frac{1}{4}p^2\right) B_0(M; p, M) \right] P_T^{\mu\nu} + 2e^2\delta_{ab} \left[\frac{1}{2}A_0(M) + \frac{1}{4}p^2 B_0(M; p, M) \right] P_L^{\mu\nu}$$

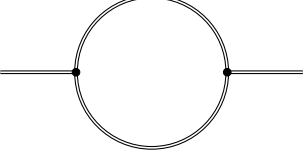

$$-i\pi_{ab9}^{\mu\nu} = 2e^2\delta_{ab} \left\{ \frac{4n-5}{n-1}A_0(M) + \frac{1}{2(n-1)} \left[4(3n-4)M^2 + (6n-5)p^2 \right] B(M; p, M) \right\} P_T^{\mu\nu} + 2e^2\delta_{ab} \left[(2n-1)A_0(M) + \frac{1}{2}(4M^2 - p^2) B(M; p, M) \right] P_L^{\mu\nu}$$

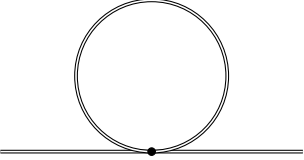

$$-i\pi_{ab10}^{\mu\nu} = -4e^2\delta_{ab}(n-1)A_0(M)P_T^{\mu\nu} - 4e^2\delta_{ab}(n-1)A_0(M)P_L^{\mu\nu}$$

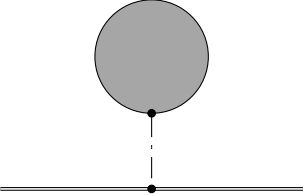

$$-i\pi_{ab11}^{\mu\nu} = \frac{3}{2}M^2\delta_{ab} \left\{ \lambda \frac{A_0(m_H)}{m_H^2} + [\lambda + e^2(n-1)] \frac{A_0(M)}{m_H^2} + 8\kappa \frac{A_0(m)}{m_H^2} \right\} P_T^{\mu\nu} + \frac{3}{2}M^2\delta_{ab} \left\{ \lambda \frac{A_0(m_H)}{m_H^2} + [\lambda + e^2(n-1)] \frac{A_0(M)}{m_H^2} + 8\kappa \frac{A_0(m)}{m_H^2} \right\} P_L^{\mu\nu}$$

B.2 Higgs Self Energy

B.2.1 ϕ bubble

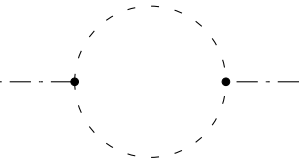

$$\Gamma_1 = -4i\kappa\nu\delta_{ab} \quad \Gamma_2 = -4i\kappa\nu\delta_{cd}$$

$$D^{bd}(k) = \frac{i\delta_{bd}}{k^2 - m^2} \quad D^{ac}(k+p) = \frac{i\delta_{ac}}{(k+p)^2 - m^2}$$

$$\begin{aligned} -i\pi_1^H &= \int \frac{d^n k}{(2\pi)^n} \Gamma_2 \cdot D^{bd}(k) \cdot \Gamma_1 \cdot D^{ac}(k+p) \\ &= (4\kappa\nu)^2 \delta_{aa} \int \frac{d^n k}{(2\pi)^n} \frac{1}{(k^2 - m^2) [(k+p)^2 - m^2]} \\ &= 3(4\kappa\nu)^2 B_0(m; p, m) \\ &= 48\kappa^2 \nu^2 B_0(m; p, m) \end{aligned}$$

B.2.2 ϕ tadpole

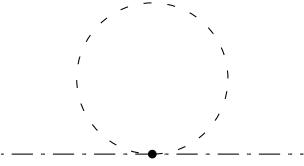

$$\Gamma = -2i\kappa\delta_{ab} \quad D^{ab}(k) = \frac{i\delta_{ab}}{k^2 - m^2}$$

$$\begin{aligned} -i\pi_2^H &= \int \frac{d^n k}{(2\pi)^n} \Gamma \cdot D^{ab}(k) \\ &= 2\kappa\delta_{aa} \int \frac{d^n k}{(2\pi)^n} \frac{1}{k^2 - m^2} \\ &= 6\kappa A_0(m) \end{aligned}$$

B.2.3 ρ bubble

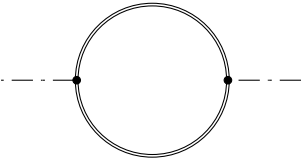

$$\Gamma_1 = ie^2\nu\delta_{ab}g^{\alpha\beta} \quad \Gamma_2 = ie^2\nu\delta_{cd}g^{\gamma\delta}$$

$$D_{\beta\delta}^{bd}(k) = \frac{-i\delta_{bd}g_{\beta\delta}}{k^2 - M^2} \quad D_{\alpha\gamma}^{ac}(k+p) = \frac{-i\delta_{ac}g_{\alpha\gamma}}{(k+p)^2 - M^2}$$

$$\begin{aligned}
 -i\pi_3^H &= \int \frac{d^n k}{(2\pi)^n} \Gamma_2 \cdot D^{bd}(k) \cdot \Gamma_1 \cdot D^{ac}(k+p) \\
 &= e^4 \nu^2 n \delta_{aa} \int \frac{d^n k}{(2\pi)^n} \frac{1}{(k^2 - M^2) [(k+p)^2 - M^2]} \\
 &= 3e^4 \nu^2 n B_0(M; p, M)
 \end{aligned}$$

B.2.4 ρ tadpole

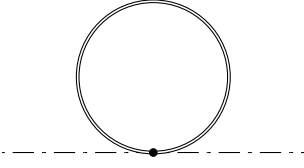

$$\Gamma = \frac{1}{2} i e^2 \delta_{ab} g^{\alpha\beta} \quad D_{\alpha\beta}^{ab}(k) = \frac{-i \delta_{ab} g_{\alpha\beta}}{k^2 - M^2}$$

$$\begin{aligned}
 -i\pi_4^H &= \int \frac{d^n k}{(2\pi)^n} \Gamma \cdot D_{\alpha\beta}^{ab}(k) \\
 &= \frac{1}{2} e^2 n \delta_{aa} \int \frac{d^n k}{(2\pi)^n} \frac{1}{k^2 - M^2} \\
 &= \frac{3}{2} e^2 n A_0(M)
 \end{aligned}$$

B.2.5 Goldstone bubble

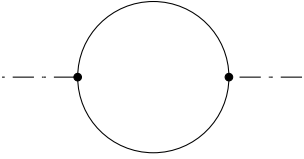

$$\begin{aligned}
 \Gamma_1 &= -\frac{1}{2} i \lambda \nu \delta_{ab} & \Gamma_2 &= -\frac{1}{2} i \lambda \nu \delta_{cd} \\
 D^{bd}(k) &= \frac{i \delta_{bd}}{k^2 - M^2} & D^{ac}(k+p) &= \frac{i \delta_{ac}}{(k+p)^2 - M^2}
 \end{aligned}$$

$$\begin{aligned}
 -i\pi_5^H &= \int \frac{d^n k}{(2\pi)^n} \Gamma_2 \cdot D^{bd}(k) \cdot \Gamma_1 \cdot D^{ac}(k+p) \\
 &= \left(\frac{1}{2} \lambda \nu\right)^2 \delta_{aa} \int \frac{d^n k}{(2\pi)^n} \frac{1}{(k^2 - M^2) [(k+p)^2 - M^2]} \\
 &= \frac{3}{4} \lambda^2 \nu^2 B_0(M; p, M)
 \end{aligned}$$

B.2.6 Goldstone tadpole

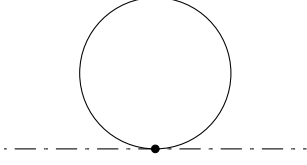

$$\Gamma = -\frac{1}{4}i\lambda\delta_{ab} \quad D^{ab}(k) = \frac{i\delta_{ab}}{k^2 - M^2}$$

$$\begin{aligned} -i\pi_6^H &= \int \frac{d^n k}{(2\pi)^n} \Gamma \cdot D^{ab}(k) \\ &= \frac{1}{4}\lambda\delta_{aa} \int \frac{d^n k}{(2\pi)^n} \frac{1}{k^2 - M^2} \\ &= \frac{3}{4}\lambda A_0(M) \end{aligned}$$

B.2.7 Higgs bubble

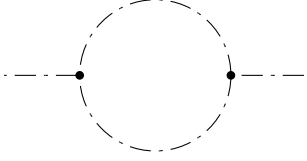

$$\begin{aligned} \Gamma_1 &= -\frac{3}{2}i\lambda\nu & \Gamma_2 &= -\frac{3}{2}i\lambda\nu \\ D(k) &= \frac{i}{k^2 - m_H^2} & D(k+p) &= \frac{i}{(k+p)^2 - m_H^2} \end{aligned}$$

$$\begin{aligned} -i\pi_7^H &= \int \frac{d^n k}{(2\pi)^n} \Gamma_2 \cdot D(k) \cdot \Gamma_1 \cdot D(k+p) \\ &= \left(\frac{3}{2}\lambda\nu\right)^2 \int \frac{d^n k}{(2\pi)^n} \frac{1}{(k^2 - m_H^2) [(k+p)^2 - m_H^2]} \\ &= \frac{9}{4}\lambda^2\nu^2 B_0(m_H; p, m_H) \end{aligned}$$

B.2.8 Higgs tadpole

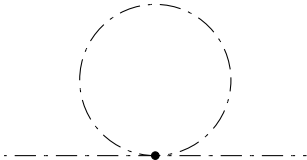

$$\Gamma = -\frac{3}{2}i\lambda \quad D(k) = \frac{i}{k^2 - m_H^2}$$

$$\begin{aligned} -i\pi_8^H &= \int \frac{d^n k}{(2\pi)^n} \Gamma \cdot D(k) \\ &= \frac{3}{2}\lambda \int \frac{d^n k}{(2\pi)^n} \frac{1}{k^2 - m_H^2} \\ &= \frac{3}{2}\lambda A_0(m_H) \end{aligned}$$

B.2.9 Goldstone- ρ bubble

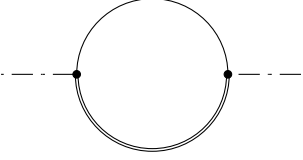

$$\begin{aligned} \Gamma_1 &= -\frac{1}{2}e\delta_{ac}(k+2p)^\alpha & \Gamma_2 &= \frac{1}{2}e\delta_{bd}(k+2p)^\beta \\ D_{\alpha\beta}^{ac}(k) &= \frac{-i\delta_{ac}g_{\alpha\beta}}{k^2 - M^2} & D^{cd}(k+p) &= \frac{i\delta_{cd}}{(k+p)^2 - M^2} \end{aligned}$$

$$\begin{aligned} -i\pi_9^H &= \int \frac{d^n k}{(2\pi)^n} \Gamma_2 \cdot D_{\alpha\beta}^{ac}(k) \cdot \Gamma_1 \cdot D^{cd}(k+p) \\ &= -\frac{1}{4}e^2\delta_{aa} \int \frac{d^n k}{(2\pi)^n} \frac{(k+2p)^2}{(k^2 - M^2) [(k+p)^2 - M^2]} \\ &= -\frac{3}{4}e^2 I_9 \end{aligned}$$

We make some definitions

$$\begin{aligned} D_1 &= k^2 - M^2 \\ D_2 &= (k+p)^2 - M^2 \\ &= k^2 + 2k \cdot p + p^2 - M^2 \\ &= D_1 + 2k \cdot p + p^2 \end{aligned}$$

Which gives us the relations

$$\begin{aligned} k^2 &= D_1 + M^2 \\ 2k \cdot p &= D_2 - D_1 - p^2 \end{aligned}$$

We can write the numerator as

$$\begin{aligned} N_9 &= (k + 2p)^2 \\ &= k^2 + 2(2k \cdot p) + 4p^2 \\ &= 2D_2 - D_1 + M^2 + 2p^2 \end{aligned}$$

$$\begin{aligned} I_9 &= \int \frac{d^n k}{(2\pi)^n} \frac{N_9}{D_1 D_2} \\ &= \int \frac{d^n k}{(2\pi)^n} \frac{2D_2 - D_1 + M^2 + 2p^2}{D_1 D_2} \\ &= 2A_0(M) - A_0(M) + (M^2 + 2p^2) B_0(M; p, M) \\ &= A_0(M) + (M^2 + 2p^2) B_0(M; p, M) \end{aligned}$$

$$\begin{aligned} -i\pi_9^H &= -\frac{3}{4}e^2 I_9 \\ &= -\frac{3}{4}e^2 [A_0(M) + (M^2 + 2p^2) B_0(M; p, M)] \end{aligned}$$

B.2.10 Ghost bubble

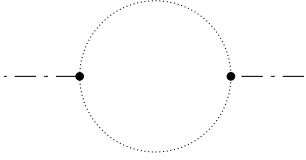

$$\begin{aligned} \Gamma_1 &= \frac{1}{2}ie^2\nu\delta_{ab}; \Gamma_2 = \frac{1}{2}ie^2\nu\delta_{cd} \\ D^{bd}(k) &= \frac{i\delta_{bd}}{k^2 - M^2} \quad D^{ac}(k+p) = \frac{i\delta_{ac}}{(k+p)^2 - M^2} \end{aligned}$$

$$\begin{aligned} -i\pi_{10}^H &= \int \frac{d^n k}{(2\pi)^n} \Gamma_2 \cdot D^{bd}(k) \cdot \Gamma_1 \cdot D^{ac}(k+p) \\ &= \left(\frac{1}{2}e^2\nu\right)^2 \delta_{aa} \int \frac{d^n k}{(2\pi)^n} \frac{1}{(k^2 - M^2) [(k+p)^2 - M^2]} \\ &= \frac{3}{4}e^4\nu^2 B_0(M; p, M) \\ &= \frac{3}{4}e^2 M^2 B_0(M; p, M) \end{aligned}$$

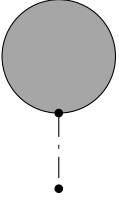
B.2.11 Lollipops

$$T_H = \frac{3}{2}\nu \left\{ \lambda A_0(m_H) + [\lambda + e^2(n-1)] A_0(M) + 8\kappa A_0(m) \right\}$$

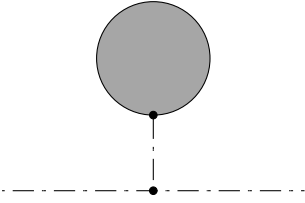

$$\Gamma = -\frac{3}{2}i\lambda\nu \quad D(0) = \frac{-i}{m_H^2}$$

$$\begin{aligned} -\pi_{11}^H &= \Gamma \cdot D(0) \cdot T_H \\ &= -\frac{3}{2}i\lambda\nu \cdot \frac{-i}{m_H^2} \cdot \frac{3}{2}\nu \left\{ \lambda A_0(m_H) + [\lambda + e^2(n-1)] A_0(M) + 8\kappa A_0(m) \right\} \\ &= -\frac{9}{4}\lambda\nu^2 \left\{ \lambda \frac{A_0(m_H)}{m_H^2} + [\lambda + e^2(n-1)] \frac{A_0(M)}{m_H^2} + 8\kappa \frac{A_0(m)}{m_H^2} \right\} \end{aligned}$$

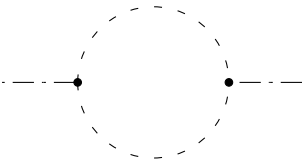
B.2.12 Summary

$$-i\pi_1^H = 48\kappa^2\nu^2 B_0(m; p, m)$$

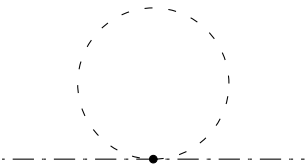

$$-i\pi_2^H = 6\kappa A_0(m)$$

B. Self Energy

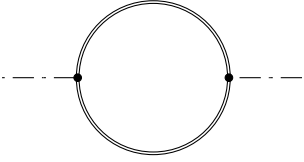

$$-i\pi_3^H = 3e^4\nu^2 nB_0(M; p, M)$$

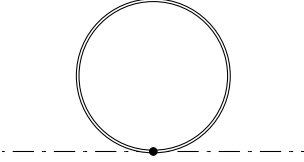

$$-i\pi_4^H = \frac{3}{2}e^2 nA_0(M)$$

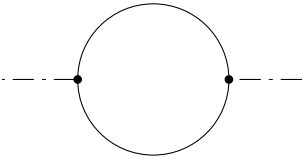

$$-i\pi_5^H = \frac{3}{4}\lambda^2\nu^2 B_0(M; p, M)$$

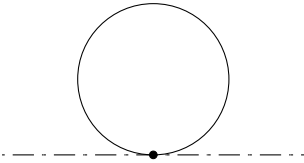

$$-i\pi_6^H = \frac{3}{4}\lambda A_0(M)$$

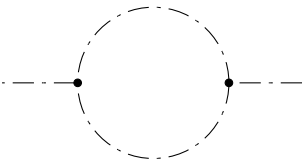

$$-i\pi_7^H = \frac{9}{4}\lambda^2\nu^2 B_0(m_H; p, m_H)$$

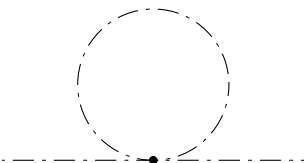

$$-i\pi_8^H = \frac{3}{2}\lambda A_0(m_H)$$

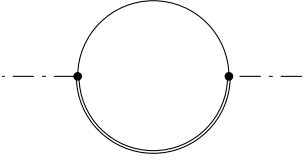

$$-i\pi_9^H = -\frac{3}{4}e^2 \left[A_0(M) + (M^2 + 2p^2) B_0(M; p, M) \right]$$

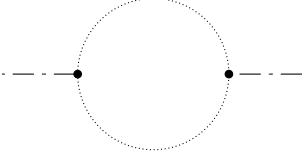

$$-i\pi_{10}^H = \frac{3}{4}e^2 M^2 B_0(M; p, M)$$

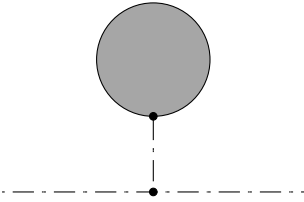

$$-i\pi_{11}^H = -\frac{9}{4}\lambda\nu^2 \left\{ \lambda \frac{A_0(m_H)}{m_H^2} + [\lambda + e^2(n-1)] \frac{A_0(M)}{m_H^2} + 8\kappa \frac{A_0(m)}{m_H^2} \right\}$$

Bibliography

- [1] Yukawa H. On the interaction of elementary particles. *Proc.Phys.Math.Soc.Jap.* 17 (1935) 48;, 1935.
- [2] M. Gell-Mann. A schematic model of baryons and mesons. *Physics Letters*, 8(3):214 – 215, 1964.
- [3] G. Zweig. An $su(3)$ model for strong interaction symmetry and its breaking. Technical Report CERN Report No.8182/TH.401, CERN, 1964.
- [4] G. Zweig. An $su(3)$ model for strong interaction symmetry and its breaking:II. Technical Report CERN Report No.8419/TH.412, CERN, 1964.
- [5] Feynman R. P. The behavior of hadron collisions at extreme energies. In *High Energy Collisions: Third International Conference at Stony Brook, N.Y.*, 1969.
- [6] Feynman R. P. Very high-energy collisions of hadrons. *Phys. Rev. Lett.*, 23:1415–1417, Dec 1969.
- [7] J. D. Bjorken and E. A. Paschos. Inelastic electron-proton and γ -proton scattering and the structure of the nucleon. *Phys. Rev.*, 185:1975–1982, Sep 1969.
- [8] H. David Politzer. Reliable perturbative results for strong interactions? *Phys. Rev. Lett.*, 30:1346–1349, Jun 1973.
- [9] David J. Gross and Frank Wilczek. Ultraviolet behavior of non-abelian gauge theories. *Phys. Rev. Lett.*, 30:1343–1346, Jun 1973.
- [10] Boyle P.A. Kaon physics from lattice. In *PoS(KAON09)002*, 2009.
- [11] Tsung-Wen Yeh. Applicability of perturbative qcd and nlo power corrections for the pion form factor. *Phys. Rev. D*, 65:074016, Mar 2002.
- [12] Yoichiro Nambu. Possible existence of a heavy neutral meson. *Phys. Rev.*, 106:1366–1367, Jun 1957.
- [13] J.J Sakurai. Theory of strong interactions. *Annals of Physics*, 11(1):1 – 48, 1960.

- [14] Jun John Sakurai. *Currents and mesons*. University of Chicago press, 1969.
- [15] T. H. Bauer, R. D. Spital, D. R. Yennie, and F. M. Pipkin. The hadronic properties of the photon in high-energy interactions. *Rev. Mod. Phys.*, 50:261–436, Apr 1978.
- [16] R. Engel and J. Ranft. Hadronic photon-photon interactions at high energies. *Phys. Rev. D*, 54:4244–4262, Oct 1996.
- [17] Norman M. Kroll, T. D. Lee, and Bruno Zumino. Neutral vector mesons and the hadronic electromagnetic current. *Phys. Rev.*, 157:1376–1399, May 1967.
- [18] Ling-Fong Li. Introduction to Renormalization in Field Theory. In *100 Years of Subatomic Physics*, pages 465–491. WORLD SCIENTIFIC, 2013.
- [19] P. Ghose and A. Das. A variant of the stuckelberg formalism for massive gauge fields and applications. *Nuclear Physics B*, 41(1):299 – 316, 1972.
- [20] Charles Gale and Joseph I. Kapusta. Vector dominance model at finite temperature. *Nuclear Physics B*, 357(1):65 – 89, 1991.
- [21] Cesareo A. Dominguez, Juan I. Jottar, Marcelo Loewe, and Bernard Willers. Pion form factor in the Kroll-Lee-Zumino model. *Phys. Rev. D*, 76:095002, Nov 2007.
- [22] C. A. Dominguez, M. Loewe, and B. Willers. Scalar radius of the pion in the Kroll-Lee-Zumino renormalizable theory. *Phys. Rev. D*, 78:057901, Sep 2008.
- [23] J. R. Peláez and F. J. Ynduráin. Pion-pion scattering amplitude. *Phys. Rev. D*, 71:074016, Apr 2005.
- [24] R. Kamiński, J. R. Peláez, and F. J. Ynduráin. Pion-pion scattering amplitude. II. Improved analysis above $\bar{K}k$ threshold. *Phys. Rev. D*, 74:014001, Jul 2006.
- [25] R. Kamiński, J. R. Peláez, and F. J. Ynduráin. Pion-pion scattering amplitude. III. Improving the analysis with forward dispersion relations and roy equations. *Phys. Rev. D*, 77:054015, Mar 2008.
- [26] R. García-Martín, R. Kamiński, J. R. Peláez, J. Ruiz de Elvira, and F. J. Ynduráin. Pion-pion scattering amplitude. IV. Improved analysis with once subtracted roy-like equations up to 1100 mev. *Phys. Rev. D*, 83:074004, Apr 2011.
- [27] J.R. Batley et al. Observation of a cusp like structure in the invariant mass distribution from decay and determination of the $\pi\pi$ scattering lengths. *Physics Letters B*, 633(2-3):173 – 182, 2006.
- [28] B. Adeva et al. Evidence for πK -atoms with DIRAC. *Physics Letters B*, 674(1):11 – 16, 2009.
- [29] C. et al. Patrignani. Review of Particle Physics. *Chin. Phys.*, C40(10):100001, 2016.

- [30] M. Bando, T. Kugo, S. Uehara, K. Yamawaki, and T. Yanagida. Is the ρ meson a dynamical gauge boson of hidden local symmetry? *Phys. Rev. Lett.*, 54:1215–1218, Mar 1985.
- [31] Ansgar Denner Manfred Böhm and Hans Joos. *Gauge Theories of the Strong and Electroweak Interaction*. Vieweg Teubner Verlag, Stuttgart, Leipzig, Wiesbaden, 3rd edition, 2001.
- [32] Chris Quigg. Spontaneous symmetry breaking as a basis of particle mass. *Reports on Progress in Physics*, 70(7):1019, 2007.
- [33] G. 't Hooft. Renormalizable lagrangians for massive Yang-Mills fields. *Nuclear Physics B*, 35(1):167 – 188, 1971.
- [34] L.D. Faddeev and V.N. Popov. Feynman diagrams for the yang-mills field. *Physics Letters B*, 25(1):29 – 30, 1967.
- [35] GIAMPIERO ESPOSITO, DIEGO N. PELLICCIA, and FRANCESCO ZACCARIA. Gribov problem for gauge theories: A pedagogical introduction. *International Journal of Geometric Methods in Modern Physics*, 01(04):423–441, 2004.
- [36] Marco Ghiotti. *Gauge fixing and BRST formalism in non-Abelian gauge theories*. PhD thesis, Adelaide U., 2007.
- [37] Kazuo Fujikawa, Benjamin W. Lee, and A. I. Sanda. Generalized renormalizable gauge formulation of spontaneously broken gauge theories. *Phys. Rev. D*, 6:2923–2943, Nov 1972.
- [38] Ernest S. Abers and Benjamin W. Lee. Gauge theories. *Physics Reports*, 9(1):1 – 2, 1973.
- [39] T.P. Cheng and L.F. Li. *Gauge Theory of Elementary Particle Physics*. Oxford science publications. Clarendon Press, 1984.
- [40] Steven Weinberg. *The quantum theory of fields. Vol. 2: Modern applications*. Cambridge University Press, 2013.
- [41] F.A. Berezin, A.A. Kirillov, J. Niederle, and R. Kotecký. *Introduction to Superanalysis*. Mathematical Physics and Applied Mathematics. Springer, 1987.
- [42] M. Bohm, H. Spiesberger, and W. Hollik. On the 1-loop renormalization of the electroweak standard model and its application to leptonic processes. *Fortschritte der Physik*, 34(11):687–751, 1986.
- [43] Zenro Hioki. Introduction to higher order analysis of the electroweak interaction. *Acta Physica Polonica, Series B*, 17(12):1037–1084, 1986.
- [44] D. Bardin and G. Passarino. *The Standard Model in the Making: Precision Study of the Electroweak Interactions*. International series of monographs on physics. Clarendon Press, 1999.
- [45] James D. Bjorken and Sidney D. Drell. *Relativistic quantum fields*. Dover Publications, Incorporated,

rated, 1965.

- [46] G. Colangelo, J. Gasser, and H. Leutwyler. $\pi\pi$ scattering. *Nuclear Physics B*, 603(1-2):125–179, 2001.
- [47] CA Dominguez, M Loewe, and M Lushozi. Scalar form factor of the pion in the kroll-lee-zumino field theory. *Advances in High Energy Physics*, 2015, 2015.
- [48] Szabolcs Borsányi, Stephan Dürr, Zoltán Fodor, Stefan Krieg, Andreas Schäfer, Enno E. Scholz, and Kálmán K. Szabó. $Su(2)$ chiral perturbation theory low-energy constants from 2+1 flavor staggered lattice simulations. *Phys. Rev. D*, 88:014513, Jul 2013.
- [49] Stefan Scherer. *Introduction to Chiral Perturbation Theory*, pages 277–538. Springer US, Boston, MA, 2003.
- [50] Jose R. Pelaez. From controversy to precision on the sigma meson: A review on the status of the non-ordinary resonance. *Physics Reports*, 658:1 – 111, 2016.
- [51] John F Donoghue, Eugene Golowich, and Barry R Holstein. *Dynamics of the standard model*, volume 35. Cambridge university press, 2014.
- [52] G. Amoros, J. Bijnens, and P. Talavera. K_{14} form-factors and $\pi - \pi$ scattering. *Nuclear Physics B*, 585(1):293 – 352, 2000.
- [53] Steven Weinberg. Pion scattering lengths. *Phys. Rev. Lett.*, 17:616–621, Sep 1966.
- [54] A. Das. *Lectures on Quantum Field Theory*. World Scientific, 2008.
- [55] G. 't Hooft and M. Veltman. Regularization and renormalization of gauge fields. *Nuclear Physics B*, 44(1):189 – 213, 1972.
- [56] J.C. Collins. *Renormalization: An Introduction to Renormalization, the Renormalization Group and the Operator-Product Expansion*. Cambridge University Press, 1984.
- [57] G. Passarino and M. Veltman. One-loop corrections for e^+e^- annihilation into $\mu^+\mu^-$ in the Weinberg model. *Nuclear Physics B*, 160(1):151 – 207, 1979.
- [58] G. 't Hooft and M. Veltman. Scalar one-loop integrals. *Nuclear Physics B*, 153:365 – 401, 1979.
- [59] Ansgar Denner. Techniques for calculation of electroweak radiative corrections at the one loop level and results for W physics at LEP-200. *Fortsch. Phys.*, 41:307–420, 1993.