

Suburban Metabolism:

A Project for a Suburb of the Future

Lloyd Pretorius



The copyright of this thesis vests in the author. No quotation from it or information derived from it is to be published without full acknowledgement of the source. The thesis is to be used for private study or non-commercial research purposes only.

Published by the University of Cape Town (UCT) in terms of the non-exclusive license granted to UCT by the author.

Declaration

I understand the terms of plagiarism and declare that all work in this document is my own work, unless stated otherwise.

The majority of the images and photos in this document are property of the author. In cases where images and photographs have been taken from other sources, these are acknowledged in the list of figures.

Suburban Metabolism: A Project for a Suburb of the Future

Design Research Project APG5079W

Submitted in partial fulfilment of the requirements for the degree

Master of Architecture (Professional)

University of Cape Town

by

Lloyd Pretorius

October 2012

Index

- 1 Preface
- 3 **A Manifesto for *Cyclic Architecture***
- 7 **Re-aligning the Natural - (Sub)urban Symbiosis:
A case for Metabolic Architecture**
- 8 Introduction
- 11 (Sub)urban Metabolism
- 17 The Architecture of Metabolism
- 27 • Metabolism as a Biological Metaphor
- 31 • Artificial Land
- 33 • Metabolic Change
- 34 • Master Form
- 37 • Symbiosis
- 41 Towards a Metabolic Architecture
- 43 **(Sub)urban Infrastructure:
An Analysis of Cape Town's Residential Metabolism**
- 44 Introduction
- 47 Infrastructural Metabolism
- 49 The Metabolism of Cape Town
- 43 Cape Town Residential Profile
- 55 Extractive Demands
- 57 • Existing Water System
- 61 • Existing Energy System
- 65 Excretive Demands
- 67 • Solid Waste
- 69 • Liquid Waste
- 71 • Gaseous Waste
- 73 Towards a Cyclic Metabolism for Cape Town
-

75 **Re-aligning the Symbiosis of Plumstead:
A Project for a Suburb of the Future**

76 Introduction

77 Plumstead

81 From Linear to Cyclic Metabolism

83 Strategies for a Cyclic Metabolism: Plumstead

85 The (Sub)urban Organism = A Kit of Wholes

87 (Sub)urbanism of Time

93 More is More

95 Complete Programme for the Suburb

97 Active context

101 Integrated Resource Reuse Strategy

103 Integrated Resource Reuse Strategy: Scale of Functionality

107 Humanity

109 Infrastructural Web

111 Hybrid Node

117 EcoBlock

111 Hybrid House

127 Hi_brid Spine

141 Conclusion

143 **List of Figures**

151 **References**

Preface

One of my initial research questions was to answer how informal settlements can pioneer the mitigation of greenhouse gas emissions in Cape Town. The objectives included understanding energy usage in informal settlements, investigating current energy technologies and innovating an architectural typology which can support multiple renewable fuel sources and create positive, urban space in these communities (fig. 1).

What was immediately apparent, in terms of energy usage, is that Cape Town's existing suburban environment holds a greater need than the informal settlements, for intervention due to its reliance on, primarily, a single source of energy - electricity derived from non-renewable fossil fuel sources. This realisation directed the development of *Cyclic Architecture* as a manifesto for an architecture enabled by the rhythms of the seasons and production, and an investigation into Cape Town's existing suburban environment.

In response to the ideas of *Cyclic Architecture* and the existing suburban condition, this design report has developed through research into the 1960's Japanese group, *The Metabolists*, as a theoretical investigation and Cape Town's (Sub)urban Infrastructure as a technological analysis. The conclusion being an architectural intervention that attempts to shift the metabolic relationship between one of Cape Town's existing suburbs and its natural environment.

(Sub)urban Metabolism: A Project for the Suburb of the Future, locates itself in Plumstead, a typical suburb approximately 20 kilometres(km) from Cape Town's Central Business District, and attempts to answer this series of questions.

How can the existing suburban environment support multiple renewable fuel sources?

How can the existing suburb progress from a state of linear to cyclic metabolism?

How can an architectural intervention initiate a shift from homogenous to heterogeneous (sub)urban environment?

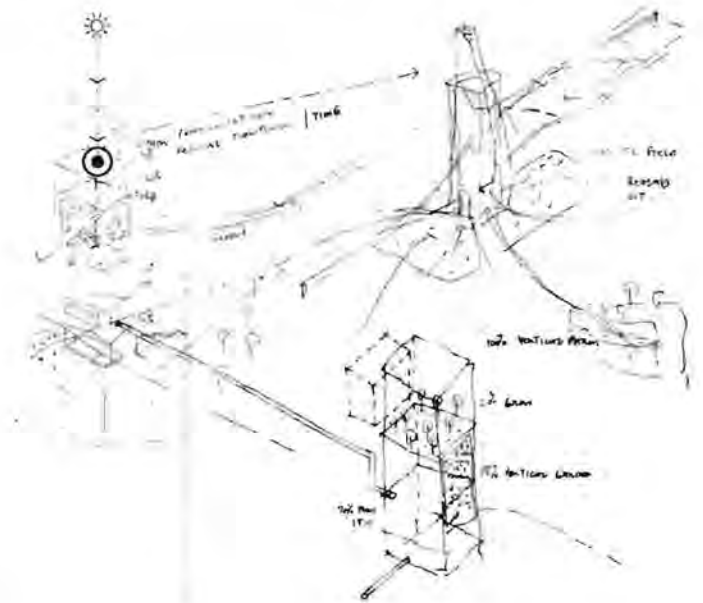

[1] Author, Energy Harvesting Nodes (2012)

A Manifesto for *Cyclic Architecture*

Cyclic Architecture demands fluid occupancies, not defined land uses. It vectors the frequencies of energy and matter enabling an architecture following the rhythm of the seasons and production. It realises an architecture shaped by its active context which becomes elastic bodies liable to continuous transformation. In this way -

FORM FOLLOWS FREQUENCY

Mobility has determined the structure of the city. But, for as long as the city excludes particular kinds of motion, it will remain incomplete. The city needs a compound of rhythms based on numerous different modes of movement.

Human + Natural + Mechanical

What if the arterial system that has previously driven the structure of the city sustained life?

The vitality of the city could be steered by self-sufficiency. The city could be defined by its ability to sustain its own life rather than a composition of functional zones. There could have been no modern architecture before there was a machine aesthetic; similarly *Cyclic Architecture* seeks its aesthetic. *Cyclic Architecture* is concerned with discovering an architectural language cultivated by the active context. It seeks to answer the tangible questions of architecture in providing for humanity using the immaterial structure of the environment as a point of departure; reconciling the symbiosis between humanity and nature. Humanity is an integral member of the environment and so their co-operation is essential to repair the centuries of division and the hope for the sustainability of life. Rather than regarding buildings as static objects the goal is to realise an architecture that will evolve through processes of exchange between building and its active context.

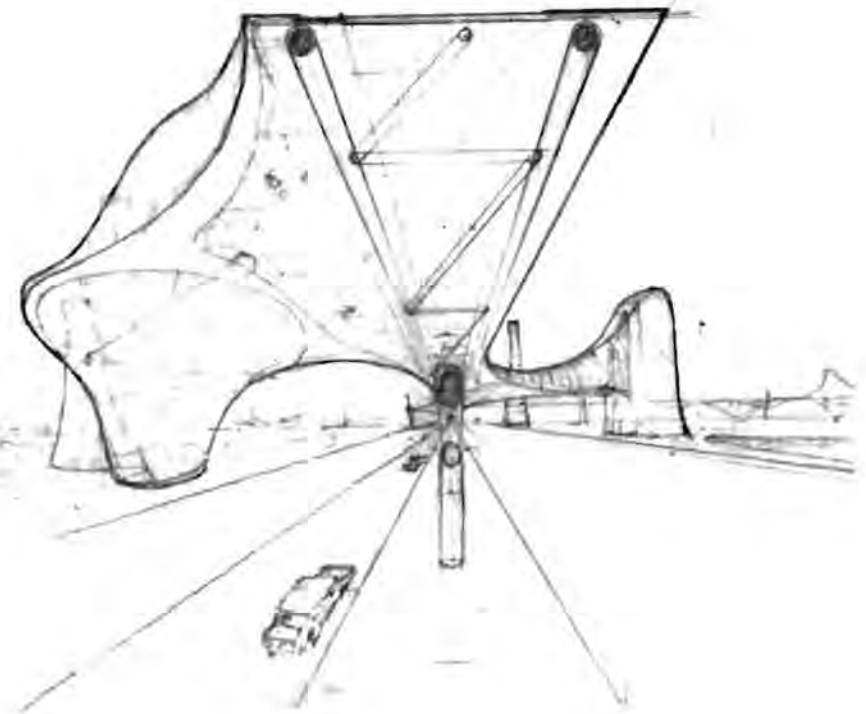

[2] Author. (2012) *Cyclic Architecture: Human + Nature + Mechanical*

human



+ natural

SOLAR = SURFACE [HORIZONTAL]

WIND = SURFACE [VERTICAL]

HYDRO = VECTOR [FLOW + DIRECTION]

GEO = POINT [VERTICAL]

BIO [VERTIC
[ORGANIC]
ANIMAL

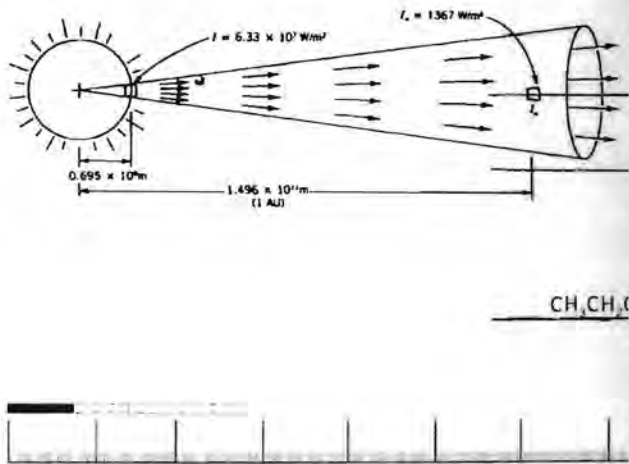

the unified city

+ mechanical

AL + HORIZONTAL ——— BIOMASS

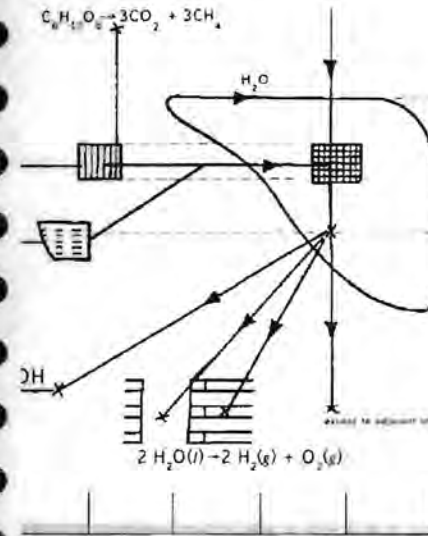

UNITY
LIBERTY
EQUALITY
FRATERNITY

The diagram for *The Unified City* is a response to the ideas expressed in the manifesto for *Cyclic Architecture*, and represents a unified relationship between humanity, nature and city, where the existing city begins to include renewable processes for energy generation enabled by its existing infrastructure.

[3] Author. The Unified City (2012)

Solar constant	1367W/m ²
Anaerobic Digestion	C ₆ H ₁₂ O ₆ – 3CO ₂ +3CH ₄ (Methane)
Biofuel	CH ₃ CH ₂ OH (Ethanol)
Hydrolysis	2H ₂ O(l) – 2H(g) + O ₂ (g) (Hydrogen fuel cell)
Wind	Power = 0.5 x Swept Area x Air Density x Velocity ³

Re-aligning the Natural - (Sub)urban Symbiosis:

A case for Metabolic Architecture

Introduction

Nothing is permanent. Everything is in constant flux and change. Through the day and night, through summer and winter, year after year, from birth to death, life flows in a timeless cycle – life in the soil, and on the ground, in water and air, life of man and animal and plant – always in change and transformation, in rise and fall, in growth and decline, so that in all nature nothing is the same at day's end as it was at day's beginning.¹

No period in history has seen such a drastic urban expansion as have the past 50 years. With the world urban population now exceeding the rural population there is an increasing need to answer the question of how we govern and use our resources to create a sustainable future.

We belong to a generation that is attempting to establish a new relationship with nature in the quest for sustainability. The symbiosis between city and nature is a vision for cities that wishes to transcend the reliance on fossil fuels and other forms of unsustainable energy sources, towards a renewable and sustainable power base for urban communities, cities, towns, and suburbs. Cities designed to respond to and benefit from their active context begin to function like organisms.

Traditionally, nature has always been in opposition to the artificial; the countryside as the opposite of the city. The suburban model presented the ideal to interweave country and town in response to The Industrial Revolution and a pursuit for a better standard of living. However, suburbia has failed in its attempt to provide a sustainable environment. While the compact city is not entirely sustainable with regard to its energy consumption, the suburbs, as they move further from the core of the city, continue to intensify the problem and are therefore not exempt from the need to respond to the current climatic crisis.

The Metabolists presented a radically different perspective on architecture and believed that future society should be represented as an assertion of human rationality over and above the sterility, homogeneity, and machine aesthetic brought about by modernism. Their objective was to fundamentally reconfigure the modern city, using biology as a point of departure. In this sense, The Metabolists proposed a view of both architecture and the city which were in a constant state of change; suggesting that the "metabolism" of a city could function in the same way as a living organism².

The need to re-align the natural and suburban environments is a reaction to the contemporary suburb and its failure to provide a sustainable living environment. Therefore, the challenge is to investigate how the balance between nature, culture and the suburban environment can be re-aligned in reference to The Metabolists and the idea of (Sub)urban Metabolism.

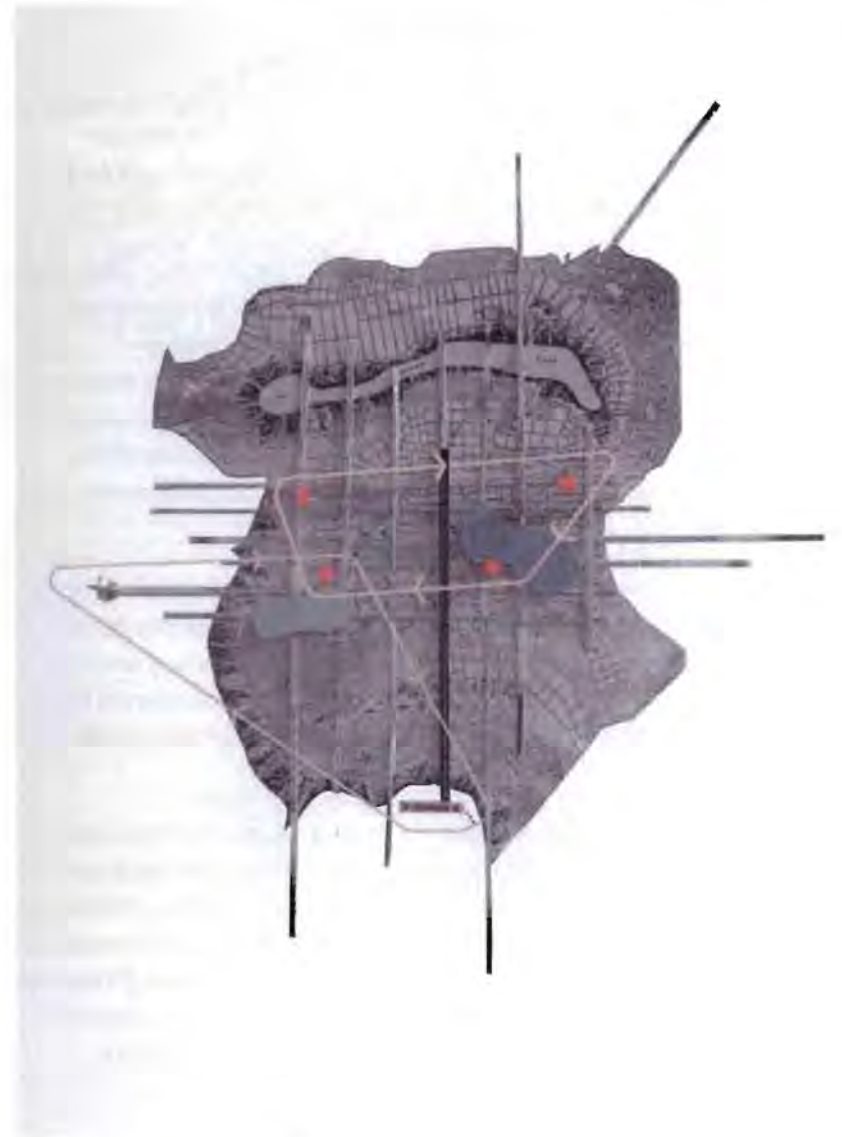

[4] Author. City of Process (2012)

(Sub)urban Metabolism

*Our suburban architecture ... reveals the spirit and character of modern civilisation, just as the temples in Egypt and Greece, the baths and amphitheatres of Rome, and the cathedrals and castles of the Middle Ages help us to comprehend and penetrate the spirit of previous civilisations.*³

The Suburb or "Suburbia" is an integral part of contemporary culture and an architecture that best "reveals the spirit and character of modern civilisation". The inadequate living standards during The Industrial Revolution and the outburst of middle-class activism heralded a change in the use of space and the conception of the suburban model, as a decentralised city, inclusive of idyllic landscapes, efficient services, responsive government, and a secluded life.

Derived from the Old French *suburbe*, and Latin *suburbium*, the term Suburb refers to any residential community at the periphery of a large city and is defined by its homogeneous low density, residential environment set in the greenery of an open park-like setting⁴. Suburbs are therefore separate from the urban core of the city but their relationship can be seen as symbiotic due to their cultural and economic dependence.

Ironically, 100 years after conception of the suburban model, as the solution to the industrial city, suburbia is now seen as the problem that needs to be repaired. The sprawling pattern of contemporary suburbs can be criticised for the loss of productive landscape, for air and water pollution, for the waste of natural resources and for exacerbating segregation. In *The Future of Suburbia* (2006) Nicolaidis and Wiese explain that the suburban model has failed to provide a successful or sustainable living environment but continues to dominate the development of metropolitan areas⁵.

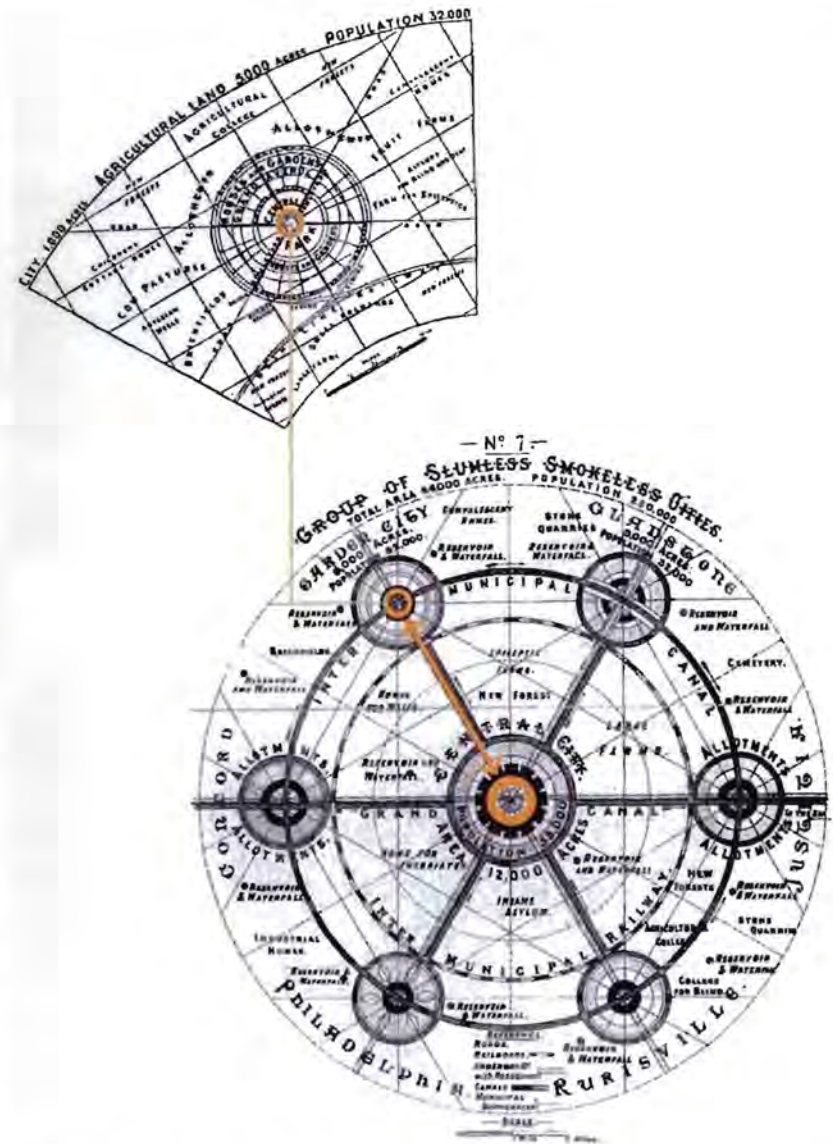

[5] Howard E., *Garden Cities of To-Morrow* (1902)

Two questions emerge: Can architecture bridge the divide between suburbia and sustainability? How can architecture catalyse the re-alignment of the symbiosis between the suburban and natural environment?

The notion of (sub)urban metabolism is an extension of the biological concept of metabolism as first stated by Abel Wolman in *The Metabolism of Cities* (1960), where he describes:

The metabolism of the city can be defined as all the materials and commodities needed to sustain the city's inhabitants at home, at work, and at play. Over a period of time these requirements include even the construction materials needed to build and rebuild the city itself. The metabolic cycle is not completed until the waste and residues have been removed and disposed of with minimum of nuisance and hazard. As man has come to appreciate that the earth is a closed ecological system, casual methods that once appeared satisfactory for the disposal of waste no longer seem acceptable. He has the daily evidence of his eyes and nose to tell him that his planet cannot assimilate without limit the untreated wastes of his civilisation.⁶

The emphasis on (sub)urban metabolism represents a belief that the city and nature are intimately bound together in reciprocity. Therefore it is argued that human activity, inclusive of architecture and urbanism, cannot be viewed as separate to the functioning of the ecosystem. Henri Lefebvre in *The Production of Space* (1971) describes the urban environment as a "second nature", where he explains that destroyed nature is reconstructed and transformed as a new material, synthesised at an urban scale; however the metabolism of the city requires a cyclic relationship to its "first nature" in order to maintain a state of ecological equilibrium⁷.



[6], [7] Author. Plumstead (2012)

The understanding of a reciprocal urban metabolism highlights the current imbalance between the (sub)urban and natural environments where resources demanded from nature's non-renewable and renewable sources are harvested at rates that exceed nature's regenerative capabilities. Current ecological capacity is accepted and described as the *Ecological Footprint* that was defined by Wackernagel and Rees in *Our Ecological Footprint – Reducing Human Impact on the Earth* (1996) as:

*The Ecological Footprint starts from the assumption that every category of energy and material consumption and waste discharge requires the productive or absorptive capacity of a finite land or water. If we sum land requirements for all categories of consumption and waste discharge by a defined population, the total area represents the Ecological Footprint of that population on the Earth whether or not this area coincides with the population's home region.*⁸

The condition for an ecologically, sustainable (sub)urban environment therefore implies a balance between resource extraction, waste generation and the spatial requirements of the city. The suburb of Plumstead was chosen to investigate how an architectural intervention could re-establish the balance between nature and an existing suburban context. Plumstead can be criticised for its regression from a natural heterogeneous to a largely homogenous suburban state that is dependent on Cape Town's vast infrastructural network for its continued existence.

The work of The Metabolists represented a belief in the reciprocal relationship between humanity and nature. The group declared that their proposals were explicitly created to accommodate change, in opposition to the widely held standpoint at the time that viewed the city as a static object. In this sense the work of The Metabolists bears relevance to the quest for a sustainable (sub)urban environment by defining an architecture in constant flux and a belief in a symbiotic relationship between the city and nature.



PLUMSTEAD

1796
96.1% natural land
3.8% productive land

1899
41% natural land
58% productive land

2012
5.5% natural land
8.4% productive land
91.8% built land
3% vegetation
11.7% informal land

[8] Author. Plumstead Productive and Natural Land Comparative Study (2012)

The Architecture of Metabolism

*We regard human society as a vital process, a continuous development from atom to nebula. The reason why we use the biological word metabolism is that we believe design and technology should denote human vitality. We do not believe that metabolism indicates only acceptance of a natural, historical process, but we are trying to encourage the active metabolic development of our society through our proposals.*⁹

In *Metabolism in Architecture* (1977), Kisho Kurokawa describes this passage as an important declaration as it reflects an understanding of human society as part of a continuous natural entity, inclusive of all animals and plant life, and a belief that technology is an extension of humanity. Inspired by biomorphic models of growth and transformation, the idea of organic expansion and replacement of elements had its roots in the traditional Japanese and Buddhist understanding of *samsara*, meaning the cyclic movement between death, decay and rebirth¹⁰. In this sense, The Metabolists endeavoured to create a city that utilised the model of biological urbanism that could regenerate its life through the constant renewal of its parts.

The following analysis evolves through two questions: first, what are the architectural principles of Metabolism and second, how are these principles replicable as a method to re-align the symbiosis between the suburban and natural environments? The architectural principles that will be researched include: (1) Metabolism as a Biological Metaphor, (2) Artificial Land, (3) Metabolic Change, (4) Master Form and (5) Symbiosis. These ideas form the fundamental principles as described by Reyner Banham in his book *Megastructure: Urban Futures of the Recent Past* (1976), where The Metabolists believed that different built elements of the city have natural rates of metabolic change and that artificial building land needs to be created to alleviate overcrowded cities¹¹.



[9] Awazu K., Book Design (1970)

Kenzo Tange

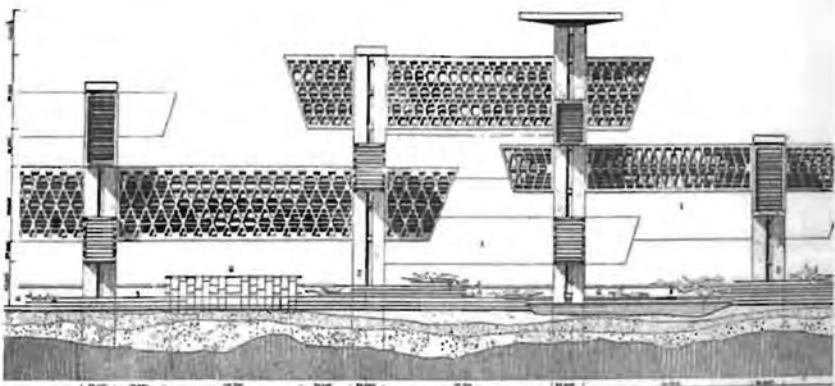

[10], [11] Tange K., Plan for Tokyo Bay (1960)

Kisho Kurokawa

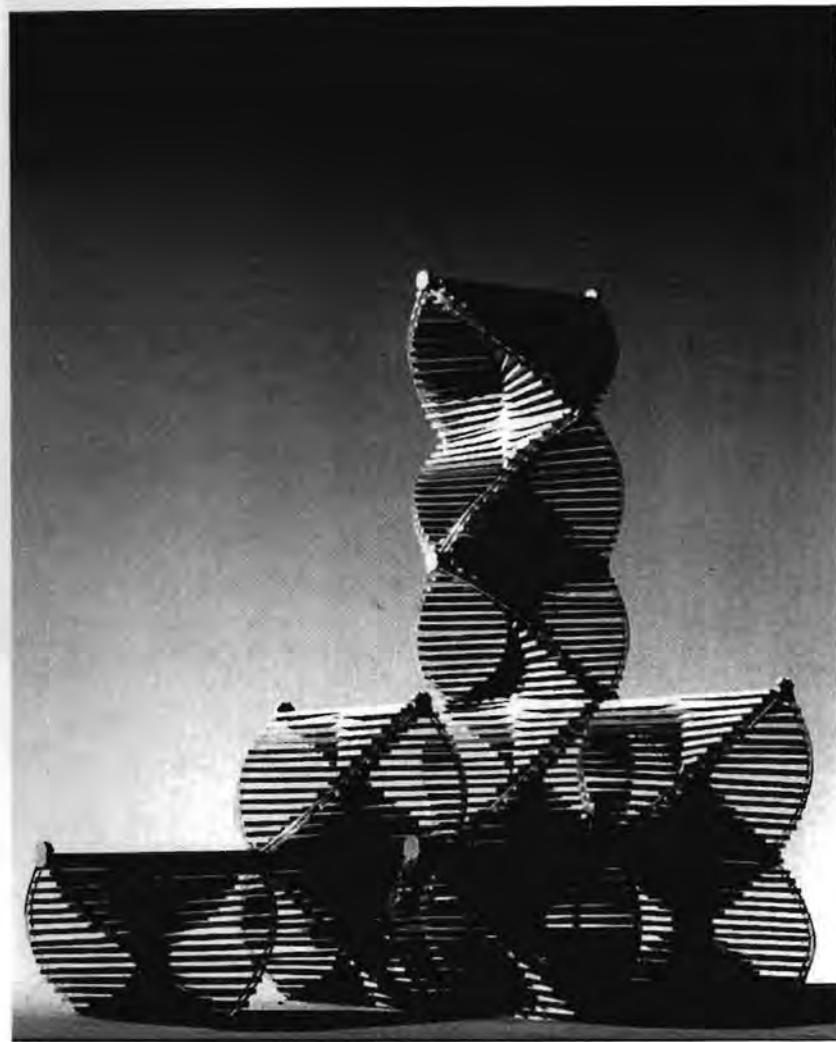

[12] Kurokawa K., Project for a Helix City (1961)

Kisho Kurokawa

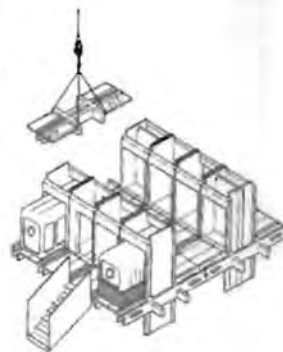
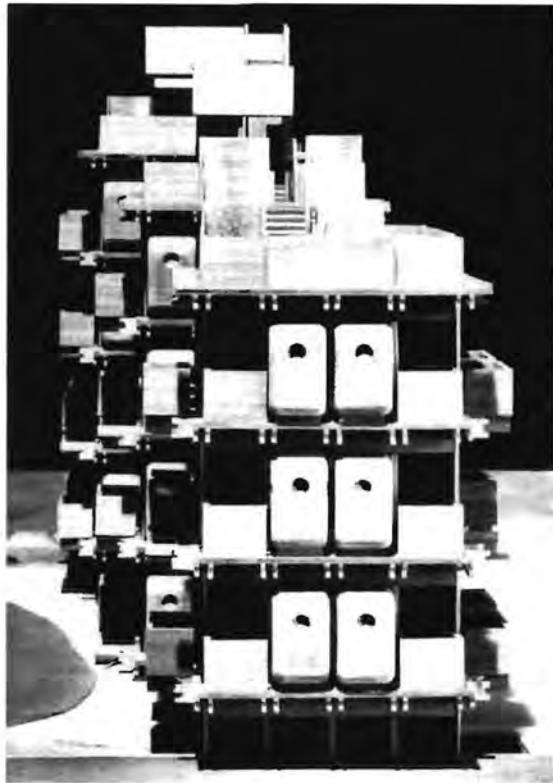

[13] Kurokawa K., Box-type Mass-produced Apartment Project (1962)

Kisho Kurokawa

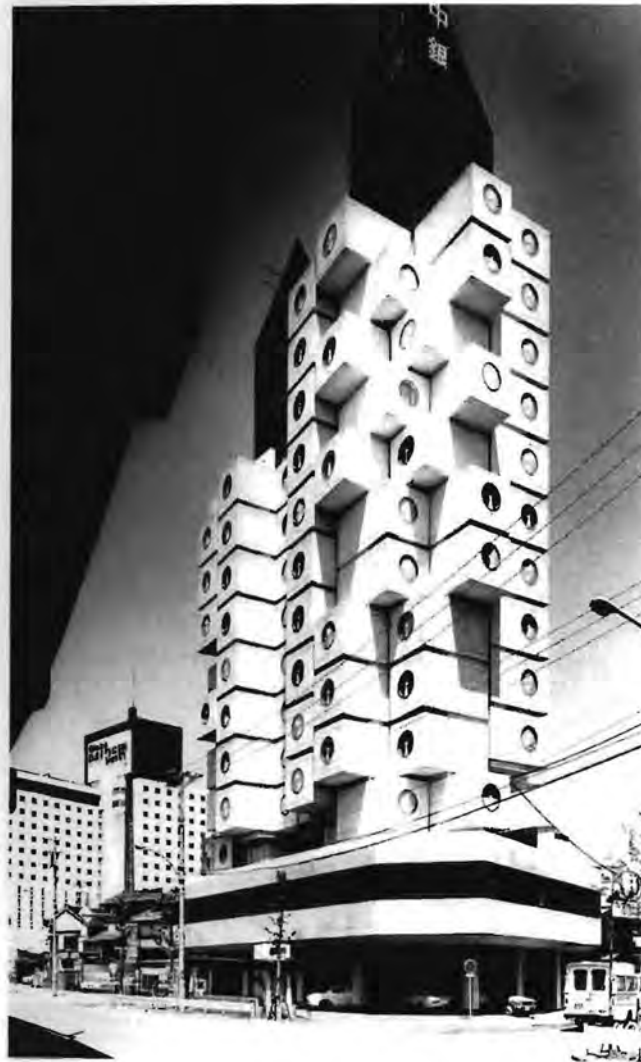

[14] Kurokawa K., Nakagin Capsule Tower (1970-2)

Arata Isozaki



[15] Isozaki A., Clusters in the Air (1991)

[16] Isozaki A., Qatar National Library (2002)

Kiyonori Kikutake



[17] Kikutake K., Marine City (1958)

Fumihiko Maki

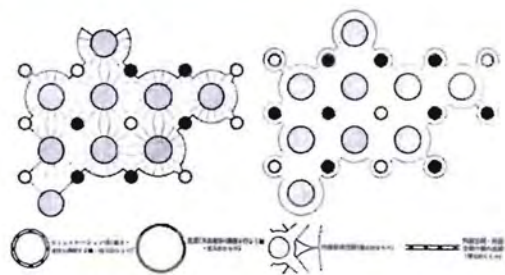
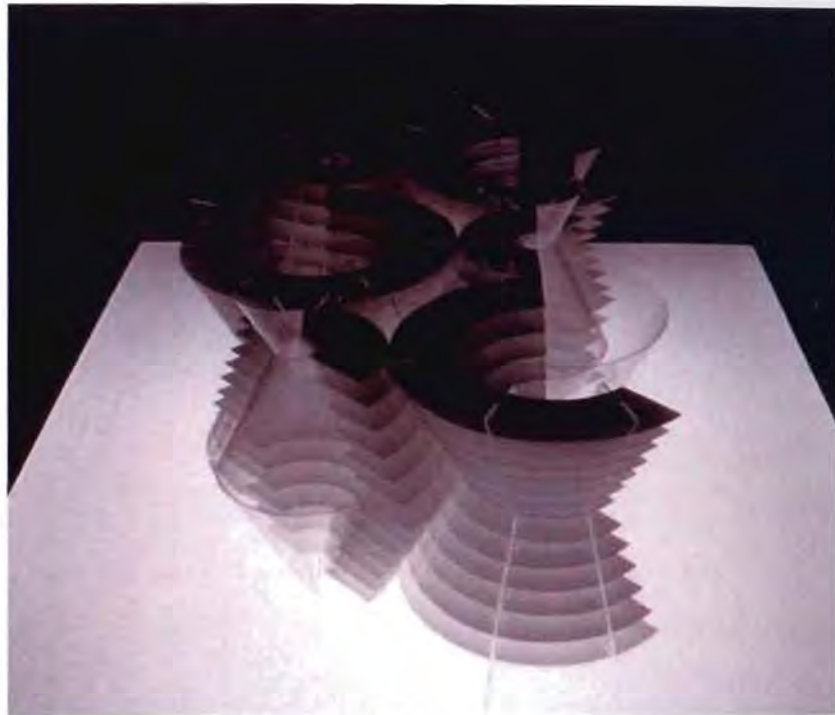

[18] Maki F., Golgi Structure (1968)

[19] Maki F., Golgi Structure (1968)

Kenji Ekuan



[20] Ekuan K., Dwelling City (1964)

Metabolism as a Biological Metaphor

Metabolism, in biological terms, is defined as the sum of the physical and chemical processes in an organism by which its material substance is produced (*anabolism*), maintained, and destroyed (*catabolism*), and by which energy is made available¹².

The concept of metabolism therefore refers to a process that can be followed continually from start to end. Kisho Kurokawa's *Project for a Helix City* (1961), embodies deoxyribonucleic acid (DNA) as a double-helix metamorphosing structure for a city, anticipating that the structure would perform similarly to DNA in the organic process of duplicating itself¹³.

In architecture, the biological metaphor invoked by The Metabolists was not without precedence. Scottish urban theorist Patrick Geddes articulated a city and organism analogy in his *Cities of Evolution* (1914). Geddes explained an organism's relationship to its environment as follows:

*The environment acts, through function, upon the organism and conversely the organism acts, through function, upon the environment*¹⁵

This is understood as interdependence between the environment and the organism, between the city and nature.

In his book *The City: Its Growth, Its Decay, Its Future* (1943), Eliel Saarinen makes the analogy of healthy tissue formation as "community planning", where he expresses architecture and urban planning as the existence of individual cells and the correlation of these cells into cellular tissue. Saarinen explains that although there are myriad of different cells, each cell is engaged in mutual co-operation to collectively form cellular tissue. He recognises that the underlying organic order of nature's architecture should be applied as a principle for humanity's architecture¹⁵.

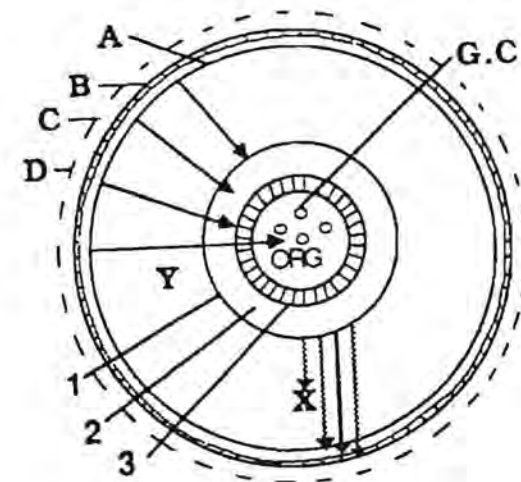

[21] Geddes P., *Action and Reaction between Organisms and Environment* (1931)

[22] Saarinen E., *Healthy Cell Tissue* (1943)

In response to the biological metaphor applied by The Metabolists, a pictorial exercise was undertaken to represent the idea of cellular growth as a concept to develop a polycentric city and its organic growth (fig. 23).

In figure 24, the different functional aspects of a chosen area, were represented as different cell types. The study area was between Wynberg and Tokai, and indicated their connection to the M3 highway.



[23] Author. Polycentric City (2012)

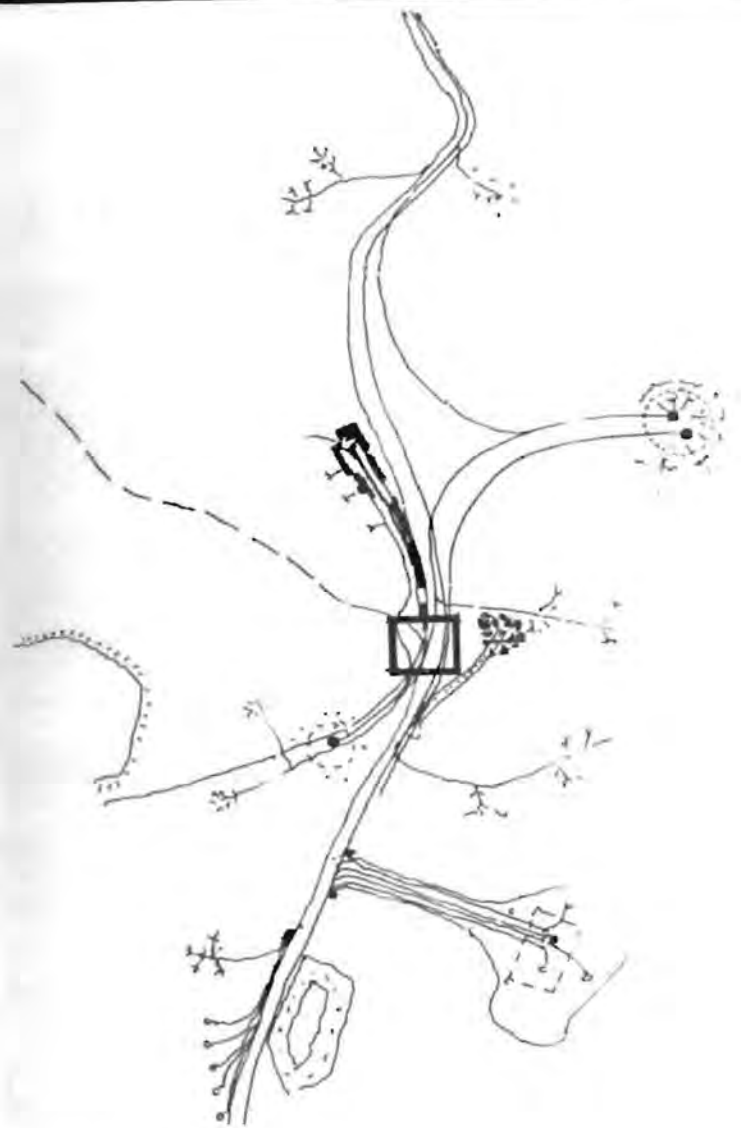

[24] Author. Function as Cell Types (2012)

Artificial Land

The concept of artificial land was an attempt by The Metabolists to define a new relationship between man and the ground, particularly in relation to Japanese ground, which is often too densely populated, expensive, mountainous, flood-prone and seismically unstable to build on.

Kiyonori Kikutake argued that poverty is attributed to the rapid increase in a population that creates an imbalance between agricultural productive land and human habitation¹⁶. In his project *Marine City* (1958), Kikutake proposed building floating cities as a means to accommodate the rise in population (fig. 17). Kikutake developed the idea of artificial land as a vertical wall plain in contrast to Kenzo Tange's predominantly horizontal *Plan for Tokyo Bay* (1960) (fig. 11).

Although the idea of artificial land was a fundamental concept of The Metabolists, the reality of finite land space available must dictate how cities respond to their ecological imbalances. To continue to create "new" on artificial land is merely idealistic rather than responding to the current (sub)urban condition. Therefore, in contemporary society the emphasis should be placed on establishing a relationship between humanity, nature and the city that can address this imbalance within its current form. In this sense, the *Project for the Suburb of the Future* is closer to the *Agricultural City Project* (1960) by Kisko Kurokawa, in which the architectural intervention is raised on *pilotis* in an attempt to liberate the land as public property and revert it back to its natural state. But, instead of developing a suburb on artificial land, *A Project for a Suburb of the Future* considers the use of the existing city fabric to restore the symbiosis with nature.



Plan for Tokyo Bay (1960)



Agricultural City Project (1960)



Plan for a Suburb of the Future (2012)

[25] Author. Artificial Land Comparative Study (2012)

100% artificial land

100% artificial land
100% restored land

5.4% artificial land

Metabolic Change

To paste new paper on the shoji, which sets the basic tone of the Japanese room, was enough to create a startling effect of freshness and light. In the same way, to have the tatami re-covered was to fill the room with the faint, clean smell of rice straw.¹⁷

Noboru Kawazoe's statement above, can be described as an interpretation of both The Metabolists and Japanese building traditional, where the periodic renewable of its parts are primarily based on natural cycles. Similarly, Rem Koolhaas in his book, *Project Japan: Metabolism Talks..* (2011), makes the point that there is a strong Japanese tradition of making buildings and cities as temporary structures, and uses the example of the Ise Shrine that has been rebuilt every 20 years over the past 1300 years¹⁸. This highlights the notion of metabolic change and impermanence as an archetypal ethos of The Metabolists.

This principle of impermanence was applied at an urban scale and manifested in projects such as Kikutake's *Marine City* (1963) and Kurokawa's *Nakagin Capsule Tower* (1970-2) where The Metabolists accepted that elements of the city and their buildings have natural rates of metabolic change.

In *A Project for a Suburb of the Future*, this duality between that which is permanent and replaceable is explored in the conception of the (sub)urban organism where infrastructure, existing and new, is re-imagined to accommodate change. In figure 26, a secondary infrastructural armature is envisaged to enable the occupation of a cluster type building in residual space that can support a combination of living, production and leisure units that can be replaced periodically.

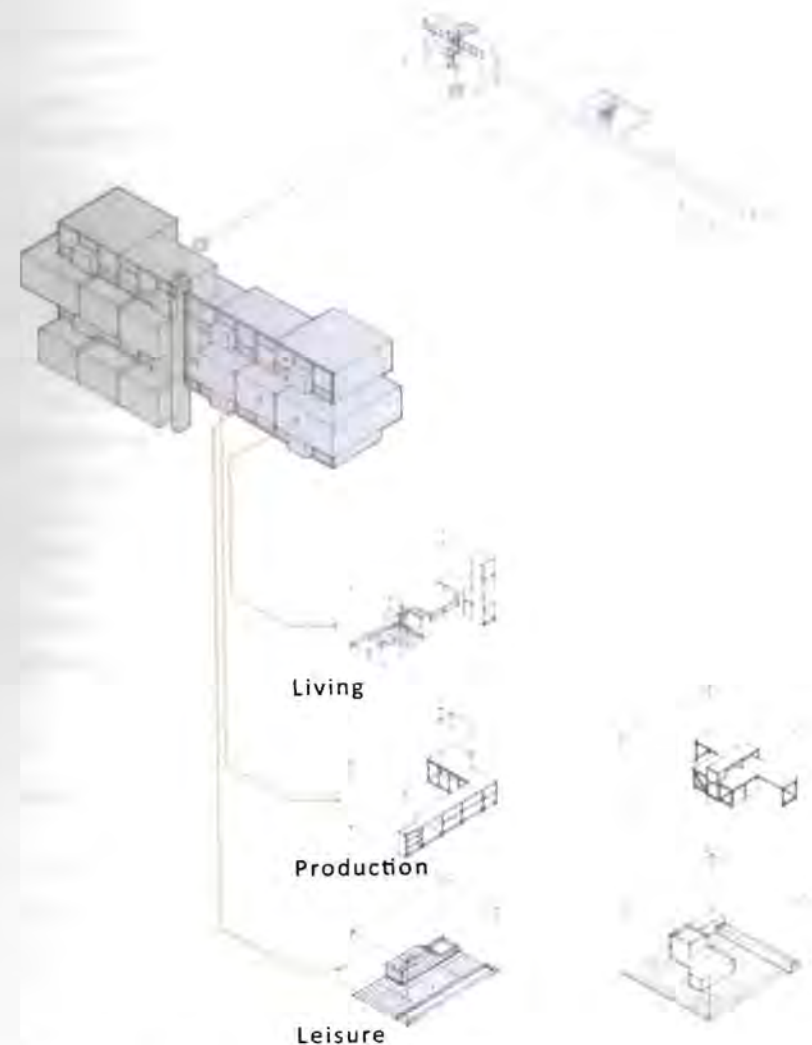

[26] Author. Cluster Unit Supported by Hi_brid Spine (2012)

Master Form

In city planning the concept of 'master planning' has been often criticised for the following shortcomings: First, the whole plan cannot be comprehended until it is completed. Second, when completed, it may as well become socially obsolete or at least obsolescent. Then, at the worst, the plan is never completed¹⁹.

In *Metabolism: The Proposals for New Urbanism* (1960), Masato Otaka and Fumihoki Maki argue for a shift from the conventional master planning methodology, which tends to envision a final stable state of the city, towards the idea of a master form as a method for dynamic urbanism.

Master form is understood as a system that can be followed consistently from the present into the distant future. This type of system planning refers to clusters or units as self-developing and self-generating that would be a complete form in each stage of their growth. In Kikutake's *Marine City* (1963) the main structures continue to grow as the population increases. In addition to the towers, the individual living cells were imagined to be replaceable, similar to Kurokawa's *Box-type Mass-produced Apartment Project* (1962) and *Nakagin Capsule Tower* (1970-2), where the capsule units were designed to be detachable and replaceable.

The notion of master form was explored to develop a proposal for a (sub)urban master form which utilises the logic of The Metabolists. In figure 27, the diagrammatic section of a Ctenophore (*Eucharis*) was used as a starting point in understanding the form, geometry and replication of an organism to produce an idea of a (sub)urban master form without a master plan.

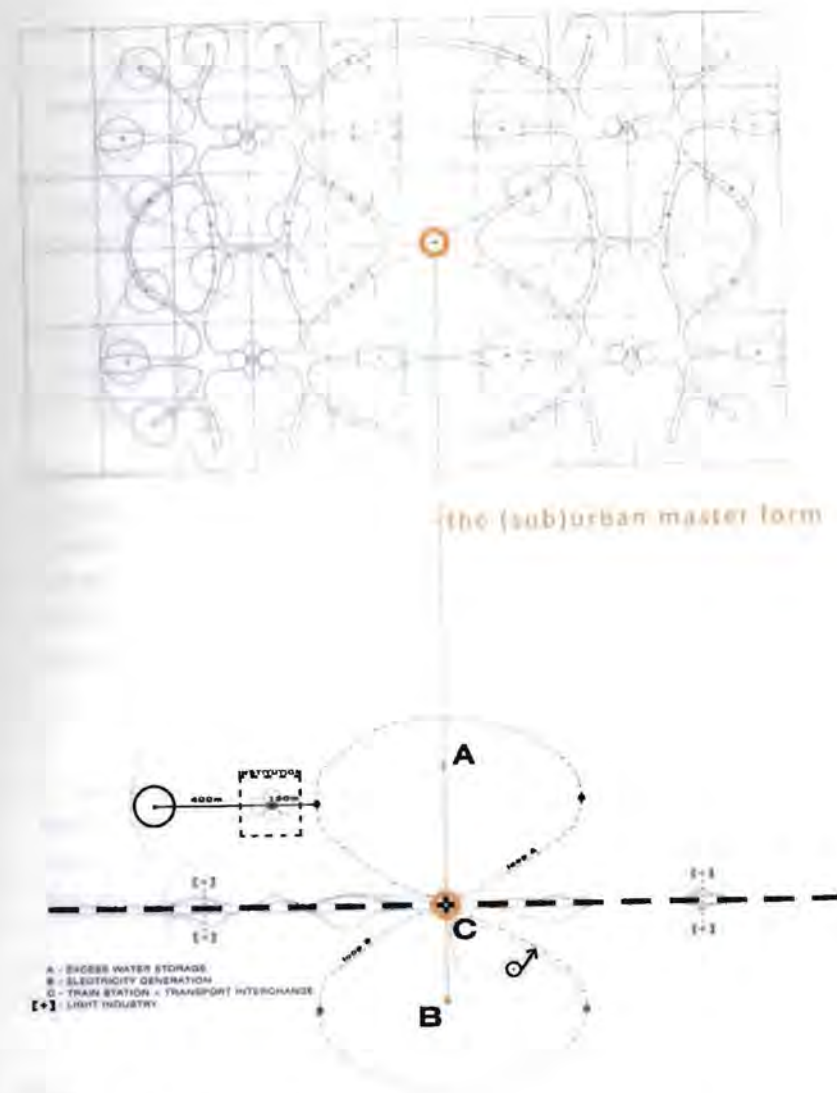

[27] Author. The (Sub)urban Master Form (2012)

Symbiosis

Symbiosis is a concept that by its very nature requires a relationship between organisms. In *The Architecture of the Life Principle* (1995) Kisho Kurokawa explains:

*Symbiosis is a tolerant order which allows the intrusion of heterogeneous elements or outside noise. Neither harmony nor compromise symbiosis represents a new and different order.*²⁰

This understanding of symbiosis means that architecture can no longer be regarded as an independent entity but derives its meaning from a plurality of relationships between culture, the environment and the city.

Figures 28 and 29 represent the concept of symbiosis as the autonomy of various forces within their own geometry and their relationship to a central geometric order. The central space in figure 28 is regarded as the "universal space" within which all geometry and forces interact, while in figure 29 the timeline represents the constant, within which force and their frequencies resonate. The intention was to represent the notion of symbiosis in terms of a spatial geometry and relationships in a two and three dimensional, diagrammatic form.

Symbiosis is therefore a shift from the homogeneous to heterogeneous. Architectural symbiosis is essentially a merging of different functions of the city which form, at its core, a hybrid. In the book, *This is Hybrid* (2011), it is described that the term hybrid is a celebration of complexity, diversity and variety of programme. Hybridity encourages coexistence and takes advantage of the unexpected and unpredictable²¹.

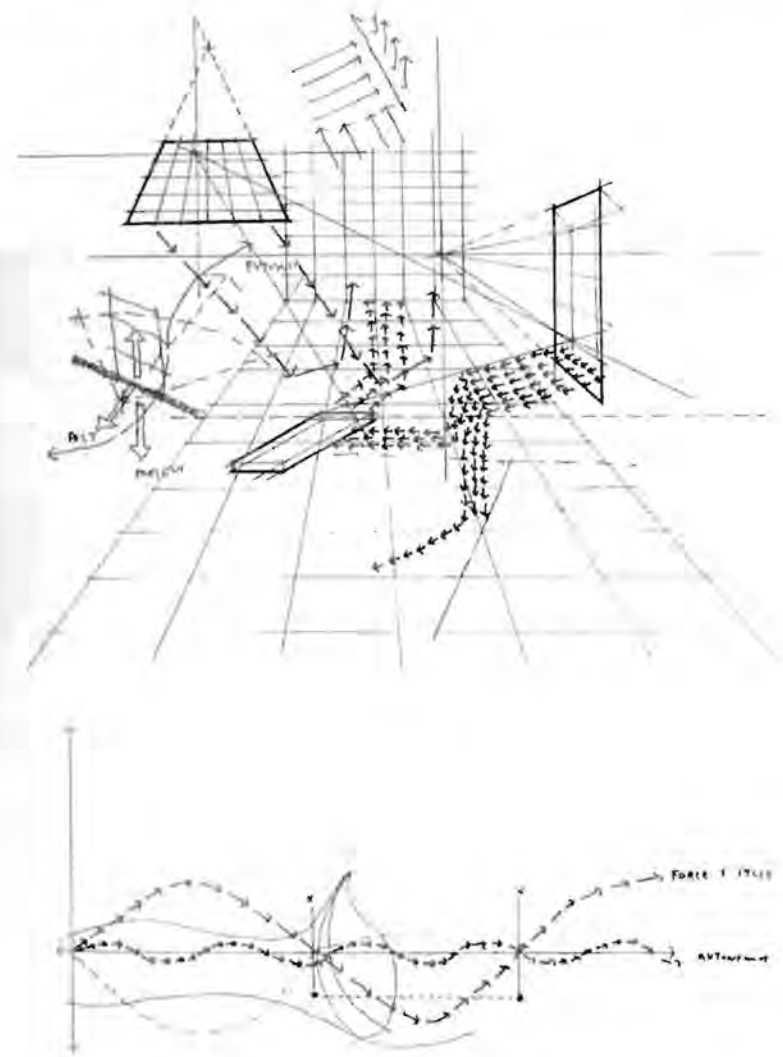

[28] Author. Symbiosis: Three-Dimensional Diagram (2012)

[29] Author. Symbiosis: Two-Dimensional Diagram (2012)

The model shown below attempts to unify the living, productive and leisure space of the city (fig. 30). The hybrid roof is imagined as a structure that unifies the different functions of the city, as well as harvests locally bound resources and facilitates the generation of renewable energy.



[30] Author. Model (2012)

In Section C of this document, *Re-aligning the Symbiosis of Plumstead: A Project for a Suburb of the Future*, the concept of symbiosis occurs essentially between the suburb and its active context (nature), where the intention is to allow for the autonomy of each part of the architectural intervention operating collectively, to form a (sub)urban organism. In this way the emphasis is not only of the whole but the existence and autonomy of parts, its sub-systems and sub-cultures.

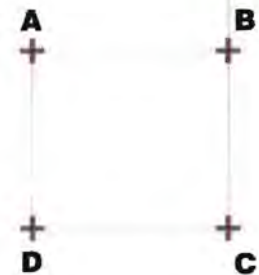
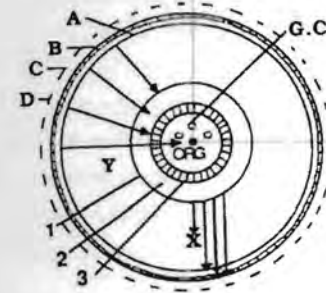

[31] Author. Plumstead (Sub)urban Organism(2012)

Towards a Metabolic Architecture

The symbiosis of the city and nature is ultimately the resolution that The Metabolists sought. Nature should be seen as an integral part of the city, and thereby intimately woven into the social life of cities. In the same way, Paul Klee in his book *The Thinking Eye* (1961), articulates that humans are both nature and a part of nature in natural space²². Therefore, cities, towns, and suburbs should be regarded not only in their formal physical structure but also in their symbiotic relationship with nature.

The concepts of The Metabolists presented a radically different perspective on architecture. The rejection of modernism advocated a belief in an architecture that is both dynamic and an expression of pluralism. The use of biology as a point of departure established an architectural language that reinforced the view of contemporary urban society in a continual flux. In this sense the analysis and pursuit of a Metabolic Architectural process speaks into the current architectural climate with emphasis on sustainability and the emergence of city and suburb design that draws from past theories, current climate and future ideals.

In section B of this document, the focus will shift to an analysis of Cape Town's residential infrastructure as an enabling device for (sub)urban reformation. The intention of the research is to understand how the extractive and excretive demands of Cape Town's residential sector impact the current city metabolism.

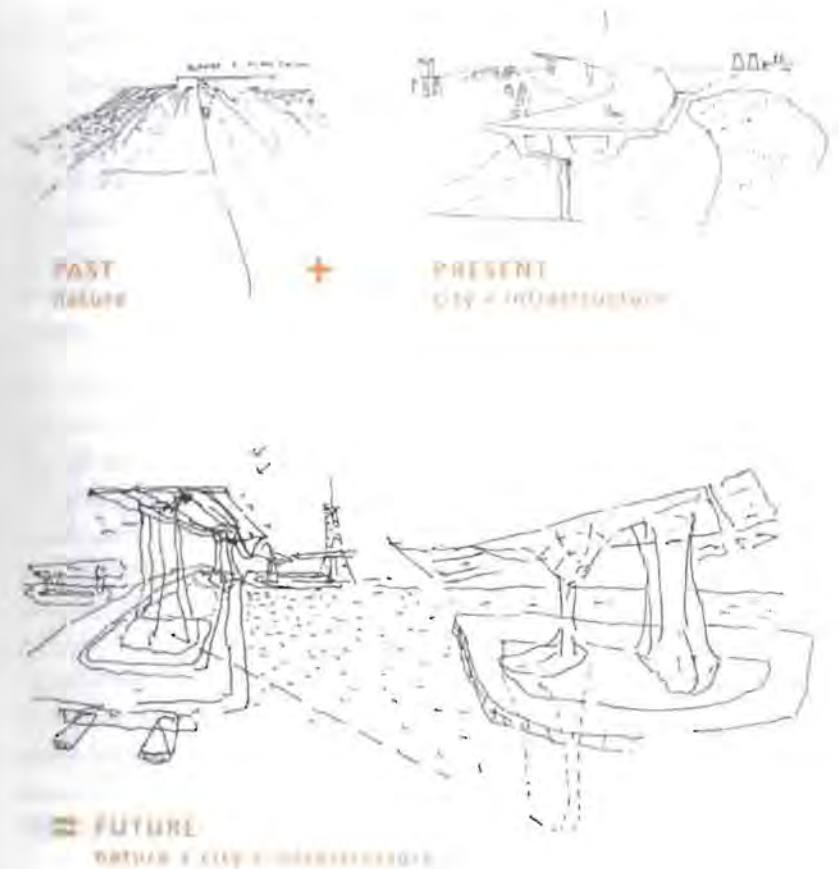

[32] Author. Past + Present = Future (2012)

(Sub)urban Infrastructure:

An Analysis of Cape Town's Residential Metabolism

Introduction

A city of 1 million, it has been calculated, takes in 9,500 tons of fossil fuel, 2,000 tons of food, 625,000 tons of water, and 31,599 tons of oxygen every day – and puts out 500,000 tons of sewerage, 28,500 tons of carbon dioxide, and great quantities of other solid, liquid, and gaseous wastes.¹

The city is comprised of dense networks of socio-ecological processes that are simultaneously human, physical, cultural, and organic. The circulatory conduits of water, food, vehicles, waste and labour, move in and out of the city, and transform the city's landscape. In this sense the city is realised as a product of this flux. The city therefore relies heavily on the infrastructure that enables the flow of material and information.

The City of Cape Town is the third largest city in South Africa with a population of 3.4 million. According to the *Cape Town Spatial Development Framework* (2011), the city is expanding at a rate of approximately 640 hectares per year, with a need for 15 000 to 18 000 new households each year to accommodate this growth². However, the current form of urban development is grossly unsustainable – low density suburbs are built on the principle of one family on one plot of land. This continuously sprawling pattern of urban development puts tremendous strain on the infrastructural needs of the city – water supply across the Cape is limited, huge amounts of energy are consumed, volumes of solid wastes are disposed of, and waste water treatment works located in the south east and north of the city are currently working at limited capacity. This highlights the imbalance between the (sub)urban and natural environments.

According to Professor Mark Swilling, Academic Director of the *Sustainability Institute*, Stellenbosch, the South African government has emphasised the investment in infrastructure as a key strategic objective of the country's economic growth and social development³. This acknowledges the need for a sustainable approach to (sub)urban infrastructure that avoids the erosion of non-renewable resources. Cape Town's future therefore hinges, in part, on better use of its (sub)urban infrastructure.

This section of the document introduces the concept of infrastructural metabolism, and follows with an analysis of Cape Town's residential metabolism with regard to its extractive and excretive demands.



[1] Author. City of Cape Town (2012)

Infrastructural Metabolism

Barrie Gasson, former University of Cape Town Professor, in *The Biophysical Environment of Metropolitan Cape Town* (1990) explains how human communities make three types of demands upon their natural environment to satisfy their needs⁴:

- (1) **Extractive demands** in the form of assured daily inputs of clean water, air, food and energy.
- (2) **Excretive demands** that require the collection, breakdown and recycling of waste (solid, liquid and gaseous) as a by-product of urban metabolic processes.
- (3) **Expansive demand** for vacant land, upon which to accommodate new housing, employment areas, transport routes and social and economic infrastructure.

In the city these demands are enabled by the network of infrastructural systems. The extractive and excretive demands of human communities are rooted in nature in two important ways⁵. Firstly, nature is the source of air, water, food, fibre, fossil fuels and minerals that are processed and consumed by humans. Secondly, nature is the sink that holds the solid, liquid and gaseous wastes that are discharged by urban production. These two demands therefore constitute a network of ecological dependence, inseparably linking the city to both local and peripheral environments, which are connected by their infrastructural system.

If the city can be regarded as a living system then its infrastructure is the enabling system that mediates flow of matter and energy through the environment. It is therefore understood that infrastructure is the life-supporting circulation system critical to the urban and, consequently, (sub)urban existence.



[2] Author. City of Cape Town: Infrastructural Network (2012)

The Metabolism of Cape Town

The rapidly expanding population of Cape Town and the finite resources of the environment highlight the need for sustainable infrastructure. Nisa Mammon, Principle Planner and Managing Director of NM & Associates, describes that the current sprawling form of urban development is unsustainable, where Cape Town's "Business As Usual" planning standards are based on quantity, not quality - promoting low density suburbs instead of urban environments⁶. This has been demonstrated as extremely inefficient from the perspective of managing infrastructural systems.

In *Counter Currents: Experiments in Sustainability in the Cape Town Region* (2010), Edgar Pieterse explains that Cape Town has a predominant linear metabolism, where environmental resources are consumed and a high proportion are disposed of as waste⁷. This perpetuates a one-way flow of materials and energy as a large proportion of the resources consumed is non-renewable. The concept of cyclic metabolism is explained in Justus von Liebig's *The Natural Laws of Husbandry* (1863), where:

If it were practicable to collect, with the least loss, all the solid and fluid excrements of the inhabitants of the town, and return to each farmer the portion arising from produce originally supplied by him to the town, the productiveness of the land might be maintained almost unimpaired for ages to come, and the existing store of mineral elements in every fertile field would be amply sufficient for the wants of increasing populations.⁸

The understanding of von Liebig's metabolic environment is similar to the concept of the Ecological Footprint, where the assumption is made that every material and energy consumed and discharged, occupies a finite quantity of land.

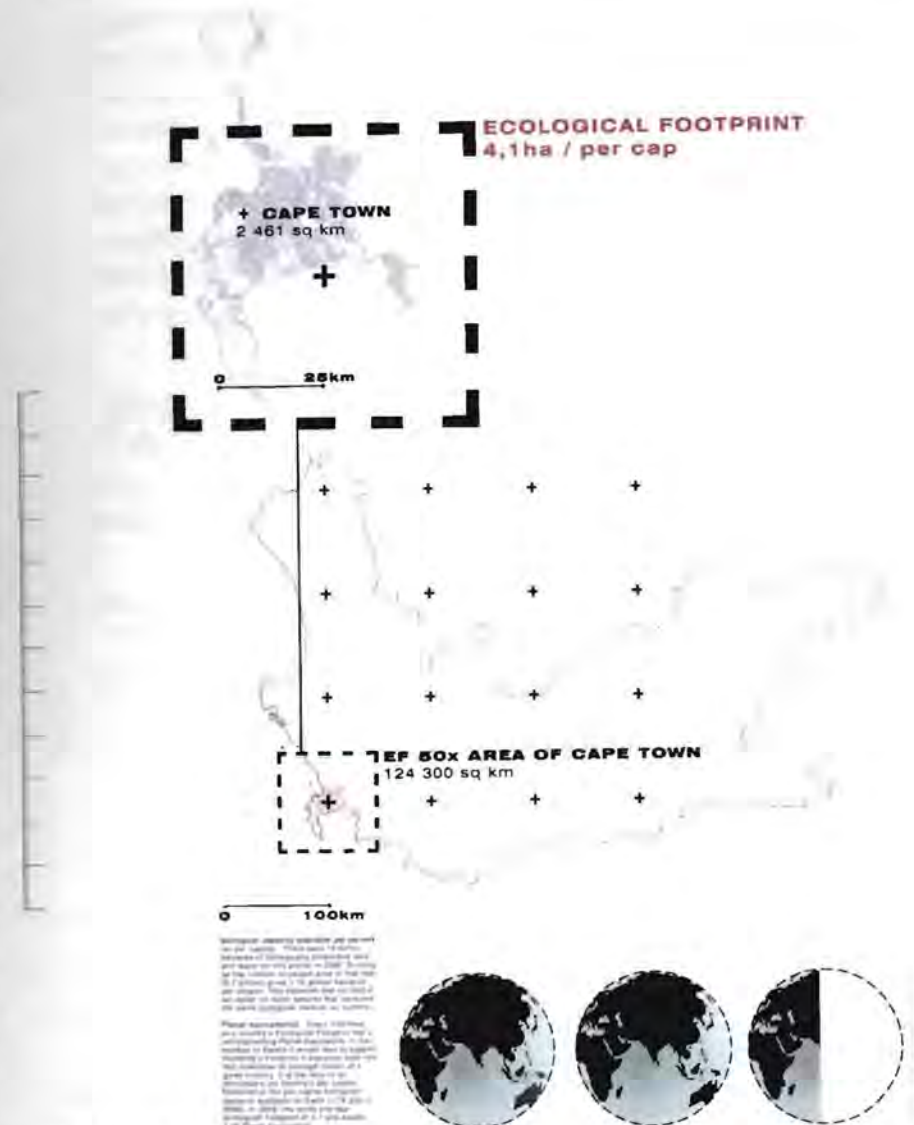

[3] Author. Cape Town Ecological Footprint (2012)

Cape Town Residential Profile

Cape Town occupies an area of 2 461 km² and is home to an estimated 3,5 million people¹¹. According to the *2007 Community Survey Analysis for Cape Town (2008)*, the city has approximately 904 000 households at an average household size of 3,9 persons. The city has 159 suburbs, with 83% of the total housing being formal, 15,6% informal housing and 1,4% being other (fig. 6). The city of Cape Town boasts a high percentage of access to basic services, compared to the national statistics; where 60% of the households in South Africa have access to flush toilets, 80% of households use electricity for lighting, 88,6% of the population have access to piped water, and 59% have their refuse removed at least once a week (fig. 7)¹².

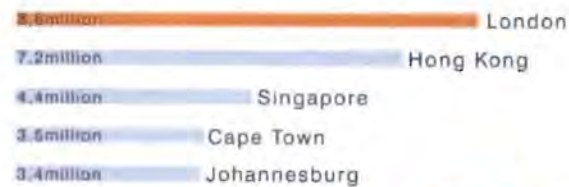

[5] Author. Cape Town Comparative Population Size (2012)



- 83% **Formal** include house of brick structure on a separate stand or yard, flat in block of flats, town/cluster/semi-detached house.
- 15,6% **Informal** include shacks not in back yards as well as those in back yards.
- 1,4% **Other** includes traditional dwellings, caravans, tents, private ships and workers' hostels.

[6] Author. Cape Town Housing Types (2012)

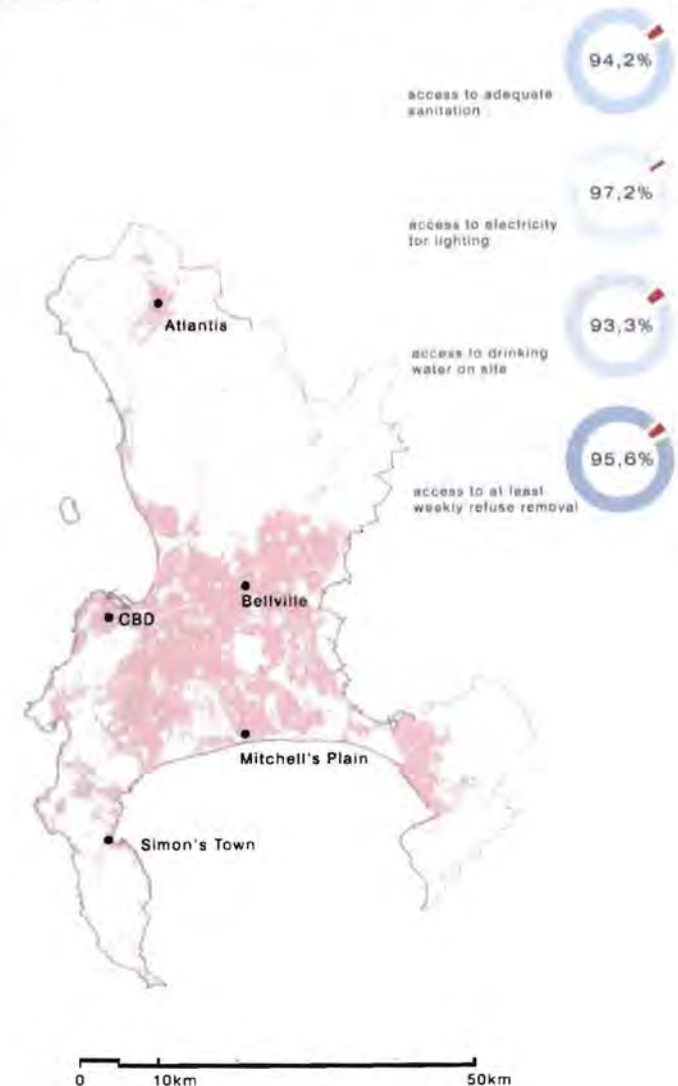

[7] Author. City of Cape Town: Access to Services (2012)

Extractive Demands

Extraction is the primary method of 'mining' raw material from the earth into valuable resources fit for human consumption. In *Landscapes of Energy* (2009), Gavin Bridge cites Lewis Mumford explaining that extractive landscapes represent:

*(A) Triumph of human ingenuity and fortitude over the fickle reluctance of nature.*¹³

This is understood as the exploitation of nature for the benefit of humanity and to the detriment of the natural environment. These extractive processes include the conversion of agricultural or forest land for urban uses and infrastructure, reclaiming of wetlands, quarrying and excavation of sand, gravel and building materials in large quantities, and deforestation to meet fuel demand.

The five main extractive demands of a metropolitan metabolism are freshwater, materials, oxygen, energy and food. Of these demands, materials, oxygen and food are difficult to quantify as they are drawn from a variety of sources both within and beyond the borders of Cape Town. As a result the analysis of Cape Town's extractive demands will only focus on the city's Water and Energy Systems.

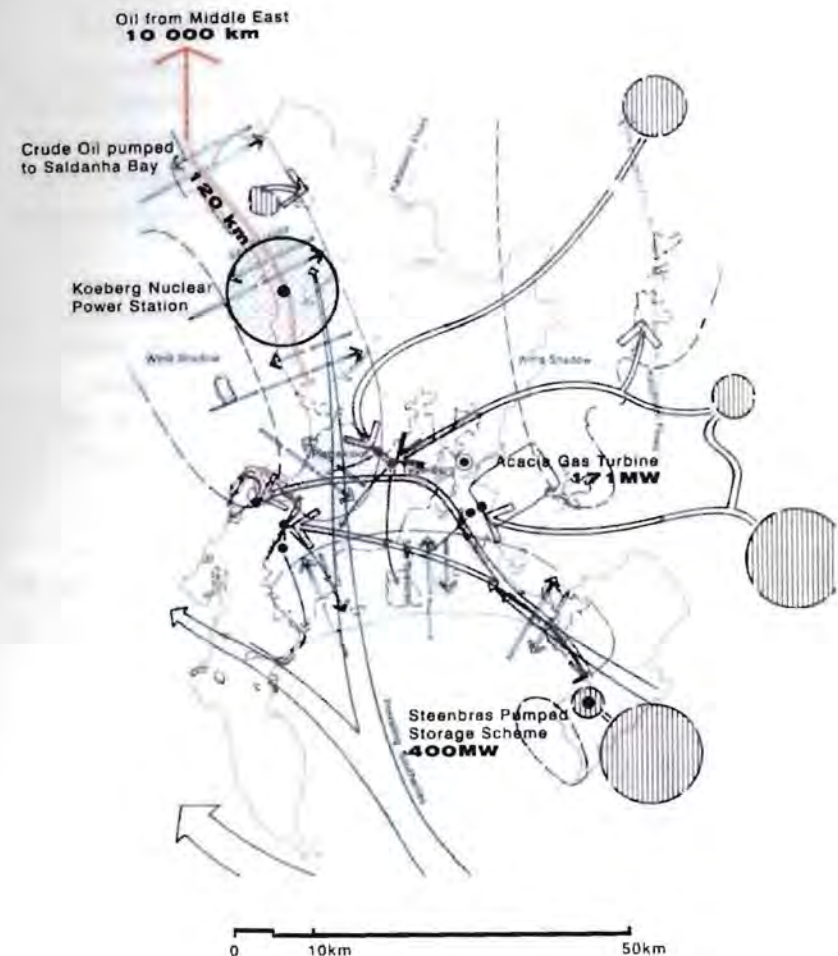

[8] Author. City of Cape Town: Extractive Demands' Synthesis (2012)

Existing Water System

Water is the most locally bound resource, and the one in most limited supply¹⁴. According to the City of Cape Town's *Water Balance, Resource Planning & Management Report* (2006), the available water resources and the shortage of storage capacity for untreated water have increased the risk of water shortages occurring in Cape Town. It is anticipated that the limit of potential water supplies will be reached by 2025. As a result one of the major tasks facing the city is reduction of the water demand to ensure a sustainable supply for the future.

Most of the water sources serving Cape Town are seasonally replenished, meaning that water is stored in dams during the winter months in order to supply water during the dry, summer months. Cape Town is therefore dependant on its infrastructure of pipelines (397km), tunnels (45km), canals (41km) and pumping stations to connect to the major water reservoirs¹⁵.

The city has 6 supply dams, the largest being the Theewaterskloof dam between Franschoek and Villiersdorp which has a capacity of 480,250MI (Million Litres) while the smallest is Steenbras Upper, which has a capacity of 31,767MI, with Cape Town having a total capacity of 898 million cubic metres per year. These dams supply Cape Town's 8 water treatment plants that distribute approximately 25 000 MI of potable water per month (1 628 MI/day)¹⁶.

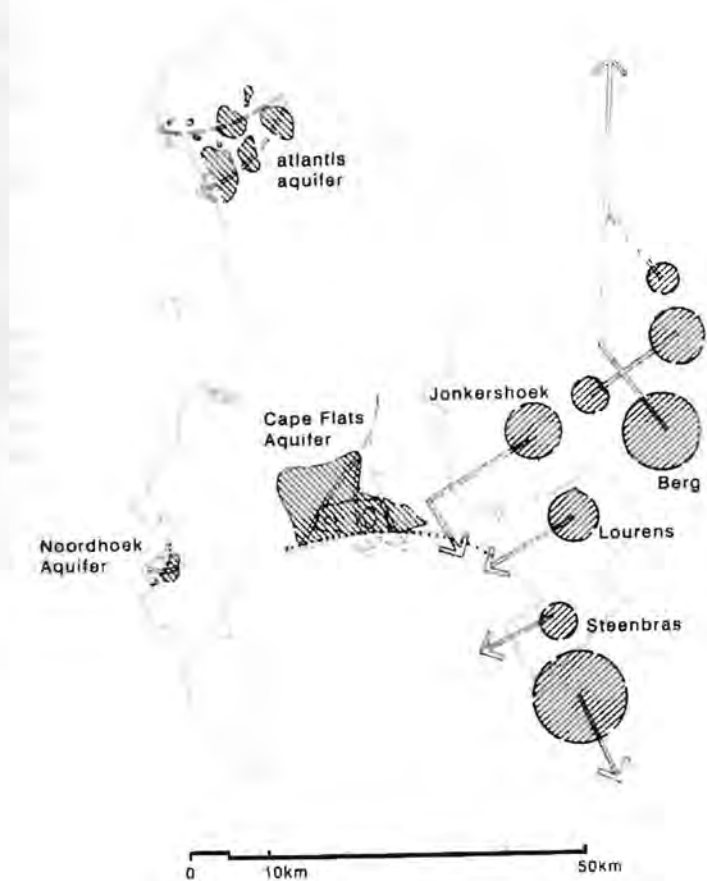

[9] Author. City of Cape Town: Water System (2012)

Cape Town's residential sector accounts for 59% of the total water consumption and is the largest, single consumer of water in the city. A significant proportion of this water usage is dedicated to the irrigation of private gardens (21,3% of total water consumption)¹⁷. In addition to the large residential sector water usage, 9,3% of water is unaccounted for and is assumed to be due to leakages in distribution infrastructure. This contributes to a significant amount of Cape Town's total water supply and therefore suggests that a considerable impact could be made with regard to water usage in Cape Town, if the emphasis were to shift towards sustainable infrastructure that can re-use water in an efficient way and improve in the areas where water is being lost.

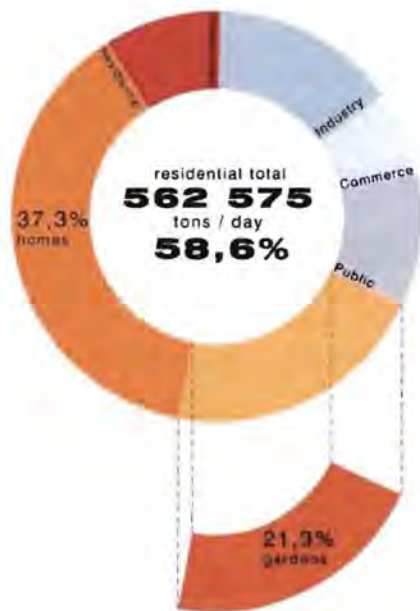

sector	million tons /yr	%
Residential:		
Homes	122,3	37,3%
Gardens	69,9	21,3%
Industry:	48,0	14,7%
Commerce:	21,8	6,7%
Public:	34,9	10,7%
Unaccounted:	30,6	9,3%

[10] Author. Cape Town Residential Water Consumption (2012)

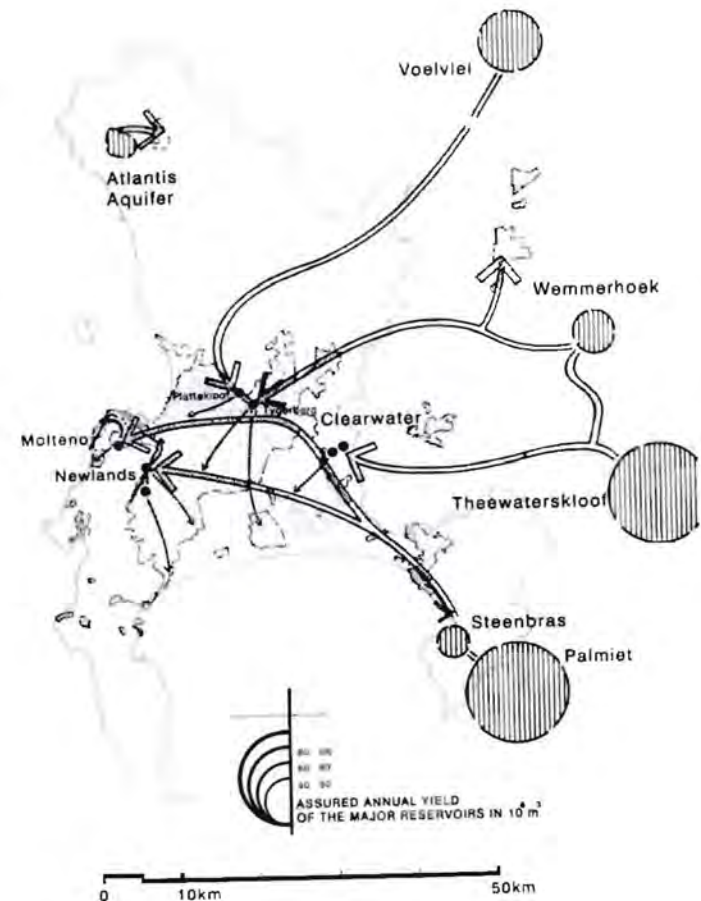

[11] Author. City of Cape Town: Fresh Water Infrastructure (2012)

Existing Energy System

Cape Town's metabolism is driven by flows of non-renewable fossil energy. The availability and affordability of coal as an energy source in South Africa has made electricity generation heavily dependent on coal, with 85% of electricity generated through burning low-grade coal, 6% through nuclear power, and a relatively small amount of energy is generated by renewable sources, of which only 2,3% is generated by hydroelectric stations and pumped storage stations¹⁸. In 2007, 247,7 million tons of coal were mined, and it is estimated that there are only a further 31 billion tons of recoverable coal resources remaining¹⁹. In addition, Cape Town's fuel supply infrastructure is exceptionally lengthy; crude oil is shipped from the Middle East (approximately 10 000km away) and is pumped ashore at Saldanha Bay (120km north of Cape Town), it is then piped to the Caltex refinery in Milnerton (15km from the Central Business District), where it is refined and distributed to depots and smaller suppliers²⁰.

The majority of Cape Town's electrical supply is a combination of coal power stations (2600 mega-Watt (MW) from power stations in Mpumalanga) and the nuclear power facility at Koeberg (1800MW net capacity). In addition to this, Cape Town has emergency gas turbines at Acacia (171MW capacity) and the Steenbras Pumped Storage Scheme located at Palmiet (400MW)^{21,22}.

According to the City of Cape Town's *State of the Energy Report* (2011), the transport sector consumes the highest amount of energy (50%), while the residential sector accounts for 18% of the total energy consumed (23 486 363 Giga-Joule), with a high proportion of this energy being electricity (83%). As a result the residential sector is the highest consumer of electricity in the city (43%), followed by the commercial and industrial sectors (fig. 14)²³.

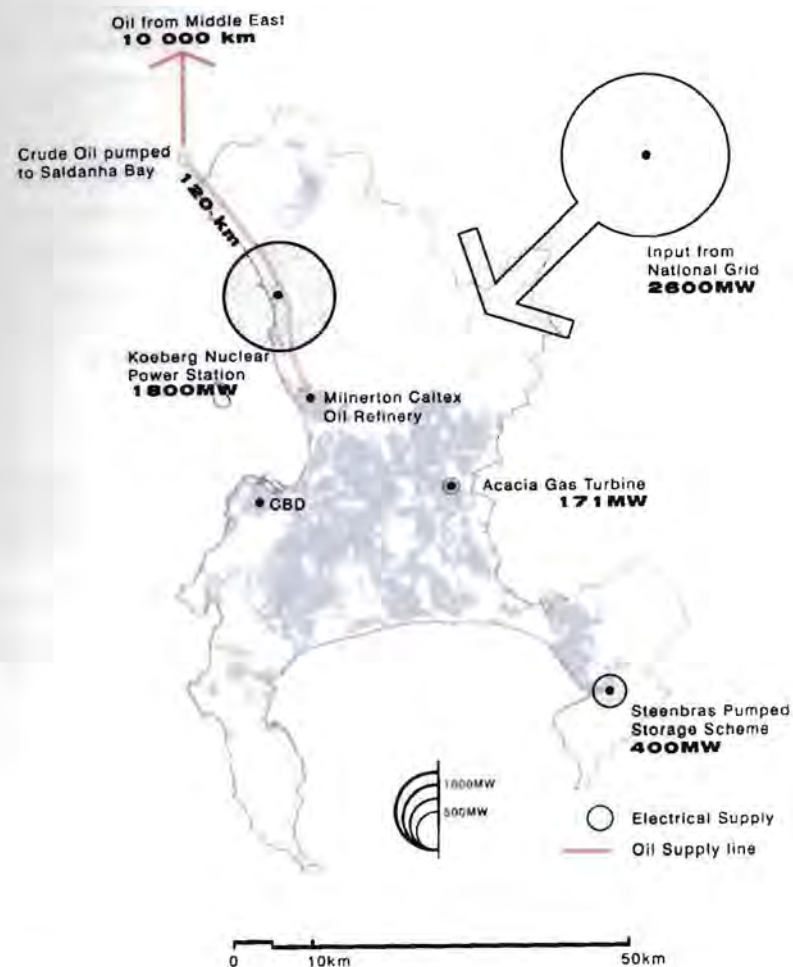

[12] Author. City of Cape Town: Energy Infrastructure (2012)

In *Cape Town energy futures: Policies and scenarios for sustainable city energy development* (2005), Harald Winkler explains that Cape Town's residential sector can be divided into 3 categories: medium-to-high-income households, low-income households: electrified, and low-income households: unelectrified. These categories are attributed to Cape Town's households being 40% medium-to-high income and 60% low-income²⁴.

Medium-to-high-income households almost exclusively use electricity for all energy needs (774 kWh/month). As a result, these households are high consumers of electricity and occupy a large carbon footprint, emitting 750kg of carbon dioxide per month. Comparatively, low-income households use much less electricity (274 kWh/month), and therefore occupy a smaller carbon footprint, emitting 230kg of carbon dioxide per month. This is primarily due to the use of multiple fuel sources to meet living requirements²⁴.

This disparity of electrical usage between household income groups and the negligible use of locally available and renewable sources of energy is a cause for concern.

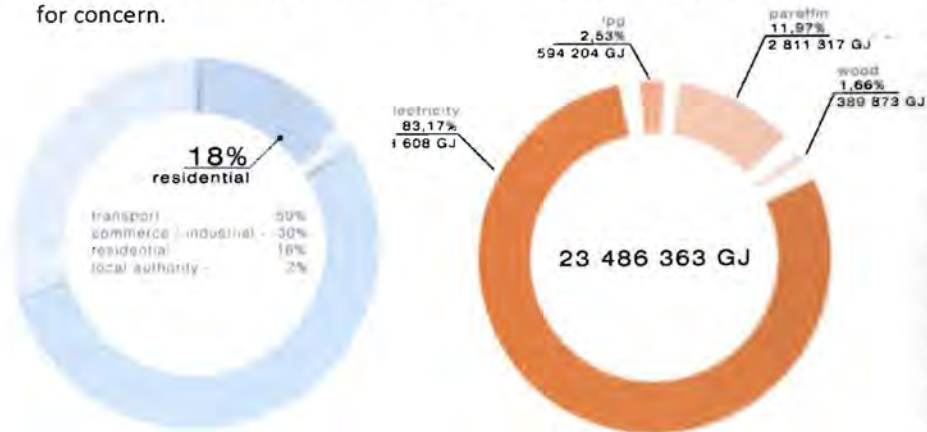

[13] Author. Cape Town Total Energy Consumption by Sector (2012)

[14] Author. Cape Town Electrical Consumption by Sector (2012)

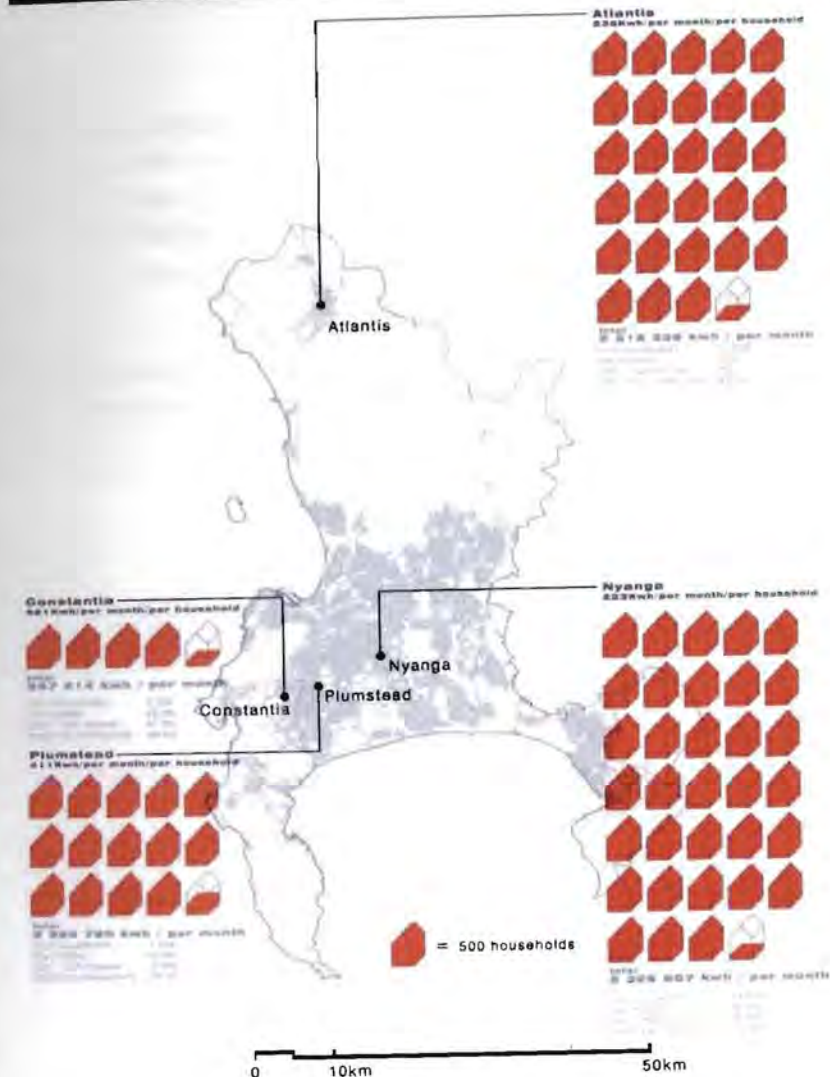

[15] Author. City of Cape Town: Suburban Energy Consumption Comparison (2012)

Excretive Demands

Excretive demands constitute the release of waste (solid, liquid and gaseous) and heat that arise as a by-product of (sub)urban metabolism. This waste is, by and large, a result of Cape Town's predominantly linear metabolism, where 62% of raw material consumed is excreted as waste, as well as the discharge of 236 million MJ (mega-joules) of heat into the sea and atmosphere²⁵.

This section will analyse the solid, liquid and gaseous waste of Cape Town in an attempt to quantify the city's waste and strengthen the case for cyclic metabolism.

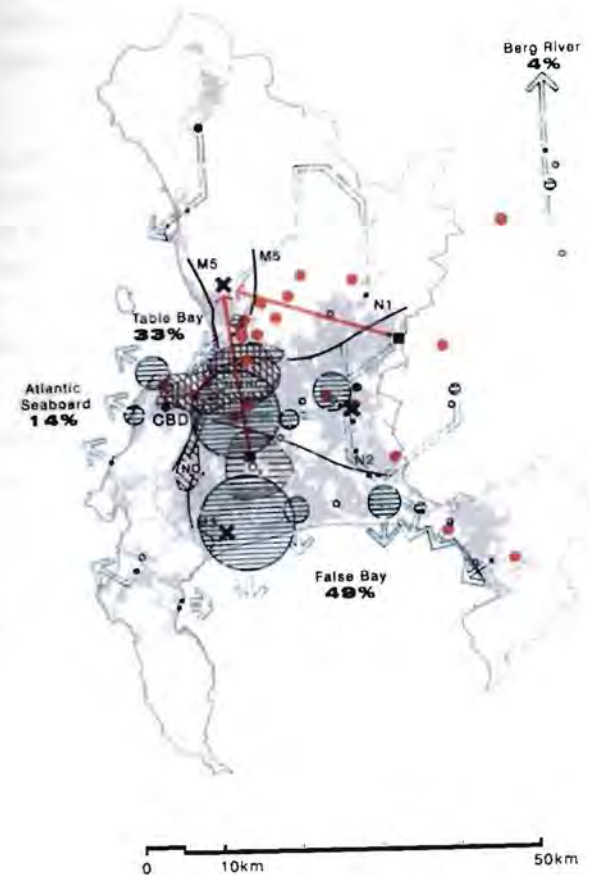

[16] Author. City of Cape Town: Excretive Demands Synthesis (2012)

Solid Waste

Households account for the largest source of solid waste in the city. In 2009-2010 the total extractive demands of material and food generated approximately 1 600 000 tons of solid waste; the equivalent of 4 383 tons per day. It is estimated that the residential sector accounts for 46% of the total waste generated in Cape Town, followed by the industrial and commercial sectors, 27% and 26% respectively²⁶.

From an infrastructural point of view, the city has 19 drop-off sites, 2 transfer sites and only 3 landfill sites in operation. This is of particular concern as the lifespan of the existing landfill sites range between 3 and 12 years. According to Wendy Crane, an independent sustainable development consultant, a new regional landfill site will be established in Kalbaskraal near Atlantis²⁷. This increase in distance from the city will inevitably increase the cost of the waste and transport infrastructure of Cape Town.

It is known that a substantial amount of waste materials can be recycled. Currently, waste recycling accounts for 24% of the total waste output; however, this figure is dominated by the industrial sector, generating approximately two-thirds of the recycled material²⁸. Recycling in the residential sector is relatively limited, where waste constitutes 46% of the total waste in the city and yet only 8% of this is currently being recycled. These figures suggest that the case for recycling should take precedence in shifting from a linear to cyclical metabolism.



Liquid Waste

The present water and sanitation systems are particularly inefficient. The city has 22 wastewater works and 2 sea outfalls that collectively process an estimated 20 000MI (Million litres) of sewage per month. According to the *Water Services Development Plan for City of Cape Town (2011)*, 60% of the potable water used in households is used to transport sewage. This waste water is treated and either re-used (10% used for irrigation of sports fields and golf courses) or discharged into the sea as treated effluent²⁹.

From a public health perspective the city's stormwater runoff is as important as sewerage effluent, as seasonal rivers and wetlands are becoming permanently flooded and contaminated due to urban stormwater flows³⁰. Cape Town's stormwater infrastructure comprises 180 000 gullies (predominantly road catch-pits), underground pipes and culverts (7 500 km), 800 detention ponds, and an extensive network of surface channels, canals and swales. According to the *State of the Environment Report (2009)*, 64% of rivers and 77% of vleis have a poor quality of water³¹. The deterioration in water quality is attributed to the rapid rate of urbanisation and the inefficiency of wastewater reticulation and treatment systems to cope with the demands of a growing city.

Therefore, the aim of wastewater treatment systems needs to be expanded from a purely sanitation perspective to embrace recycling as a means to reduce the load on Cape Town's limited freshwater supply, as well preserving the city's oceans, rivers and wetlands as public amenities.

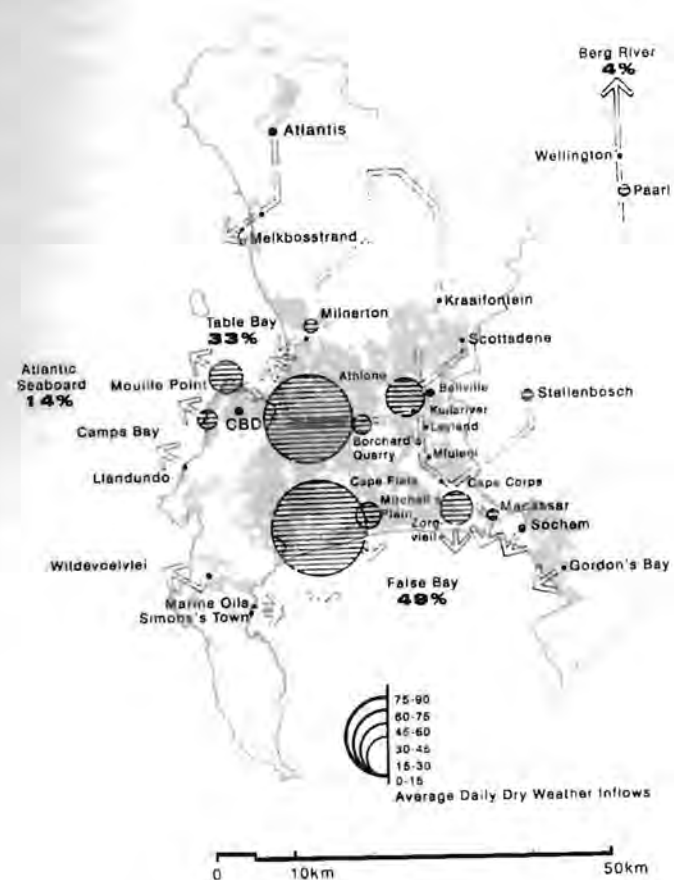

[18] Author. City of Cape Town: Liquid Waste Infrastructure (2012)

Gaseous Waste

The conversion of energy into heat for motion and electricity is accompanied by the release of gaseous by-products into the atmosphere. This release of gaseous waste has a direct relation to the air quality in the city, and has been identified as the leading cause of anthropogenic climate change. Cape Town releases 5 352 635 tons of gas into the atmosphere annually, with carbon dioxide accounting for an estimated 97,5% of the total emissions³².

Although the transport sector consumes the largest amount of energy (fig. 13), it is only responsible for 27% of the carbon emissions in the city³³. It is the residential sector, again, that contributes the greatest proportion of emissions to the atmosphere (29%), as a consequence of South Africa's largely coal-generated electricity infrastructure.

However, the transport sector emissions should be viewed in conjunction with the residential sector, as the extensive use of motor vehicles is, in part, a response to Cape Town's sprawling development patterns and inefficient public transport system. The low density suburbs essentially increase commuting distances to work resulting in higher fuel consumption and consequently, increased emissions.

The resultant problem is that of high carbon emissions and poor air quality. To improve upon Cape Town's gaseous waste, cleaner renewable fuel sources must be made available, the population density of the suburbs needs to increase and a radical overhaul of the public transport system must be considered.

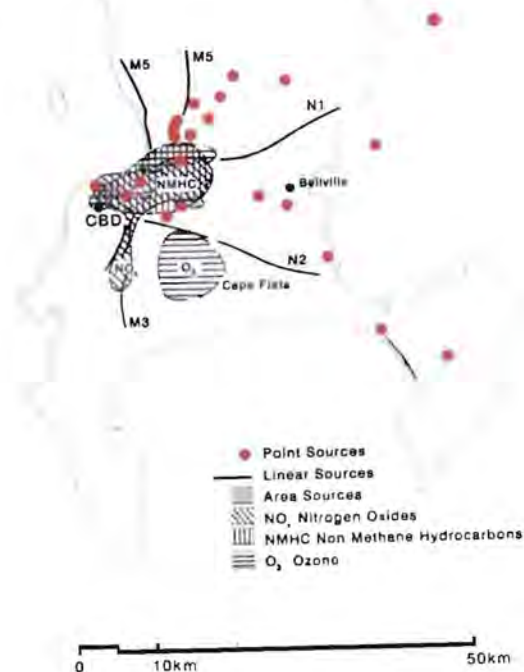

[19] Author. City of Cape Town: Gaseous Waste (2012)

Towards a Cyclic Metabolism for Cape Town

The preceding analysis has shown the ecological unsustainability of Cape Town's infrastructure. Cyclic metabolism in architecture encourages the city to ensure its extractive demands equal its excretive outputs. This shift would acknowledge the city's infrastructure to be a living organism. Cape Town's infrastructure is primarily linear to the effect that the city is wasting its non-renewable resources while the excretive outputs are destroying the natural environment.

It is therefore essential to reduce Cape Town's ecological footprint by shifting from a linear to cyclic metabolism in design thought. What is required is the re-imagining of infrastructure to closer replicate the processes of natural ecosystems by making greater use of renewable and locally available resources, reducing excessive resource consumption, and increasing the efficient reuse and recycling of waste.

The next section of this document introduces the architectural intervention which unifies Metabolic Architecture and Cape Town's Residential Infrastructure to form *A Project for a Suburb of the Future*.

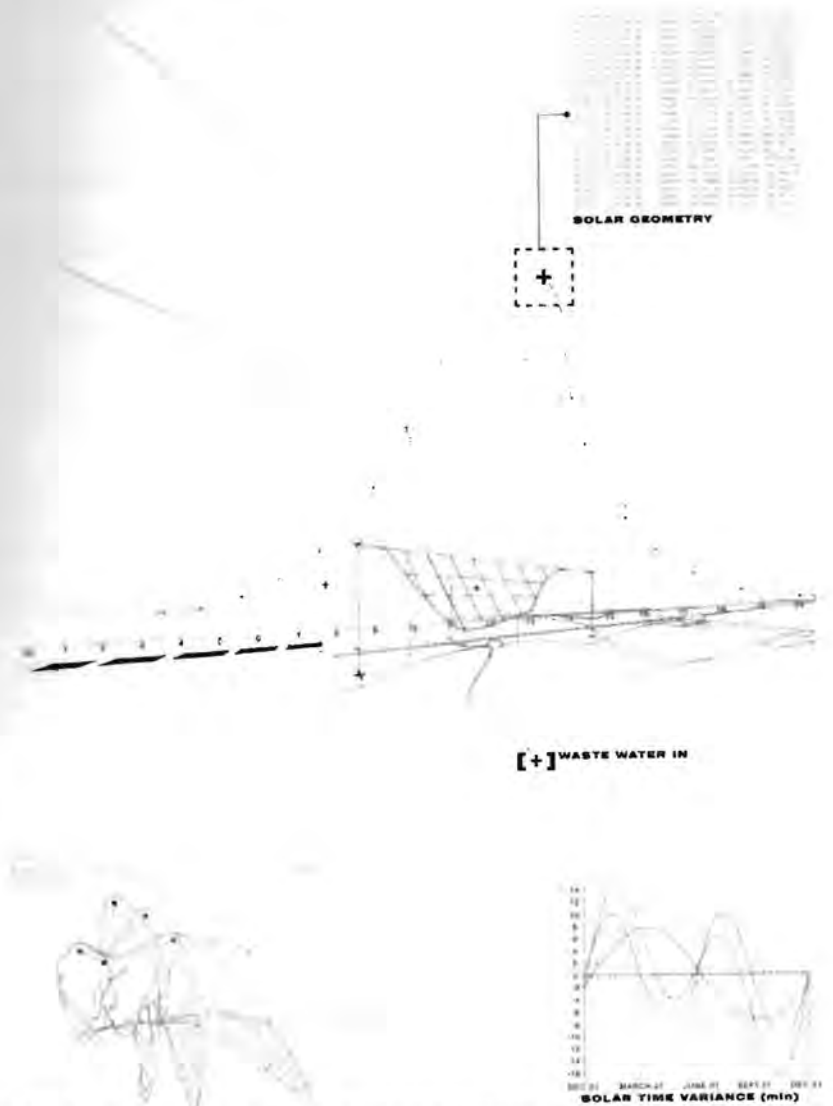

[20] Author. Suburban Boundary as Cyclic Metabolism (2012)

Re-aligning the Symbiosis of Plumstead:

A Project for a Suburb of the Future

Introduction

The suburb of Plumstead was first mentioned in 1762, when a portion of the land beyond Wynberg and Constantia Valley was granted to the free burghers Hendrik Jergens and Johan Barrens who named the land 'Rust' (Rest) and 'Werk' (Work). During the British occupation, an Englishman, Henry Batt arrived in 1807, bought 'Rust and Werk' and renamed it Plumstead, after a district in London¹. During these years the area of Plumstead was principally an agricultural productive landscape, until it was subdivided and bought by Higgs, Loubscher and Southey in 1896.

Today, Plumstead is a predominantly residential suburb, and is comparable to most of Cape Town's suburbs where productive land was appropriated for the homogeneity of the suburban condition.

This project hereby attempts to investigate how the concept of production can be re-introduced into the suburb, using Plumstead as a case study. Over and above the need for agricultural production, this project recognises that the harnessing of renewable energy is paramount to reduce the excessive use of non-renewable fossil fuel sources for generating energy in Plumstead as well as greater Cape Town.

This section documents the details of the suburb of Plumstead and progresses through key concepts that provide a framework for the architectural intervention. The suburb of Plumstead is investigated as an organism consisting of autonomous parts operating together to form a more viable suburb of the future. The latter part of this section will define the parts of the (sub)urban organism beginning with *Humanity, the Infrastructural Web, Hybrid Node, EcoBlock, Hybrid House* and concluding with the *Hi_brid Spine*.

Plumstead

Plumstead is located approximately 20 km from Cape Town's CBD and the area of study covers roughly 471 hectares. The initial research considered the suburb of Constantia (fig. 2), however Plumstead was chosen as its form, layout, and homogeneity bears more of a similarity to other suburbs in Cape Town.



[1] Author. Location of Plumstead (2012)

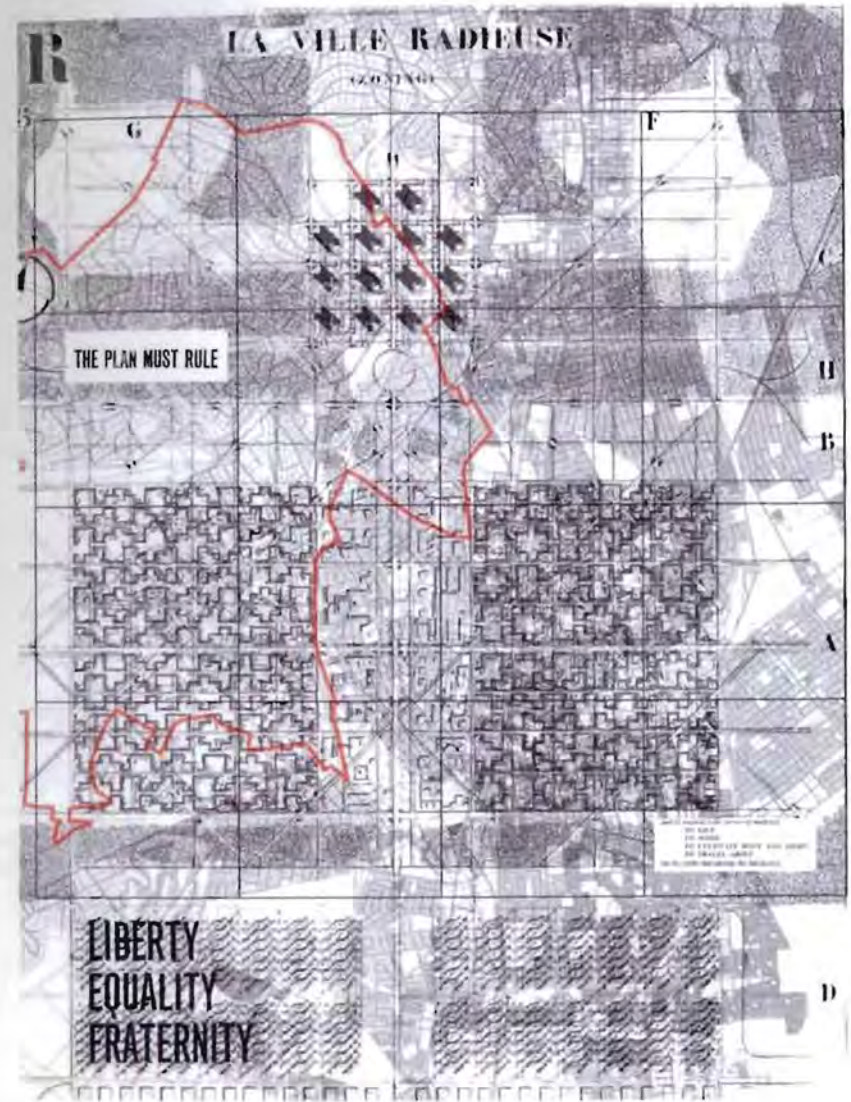

[2] Author. Overlay of Constantia and Le Corbusier's The Radiant City (2012)

Plumstead

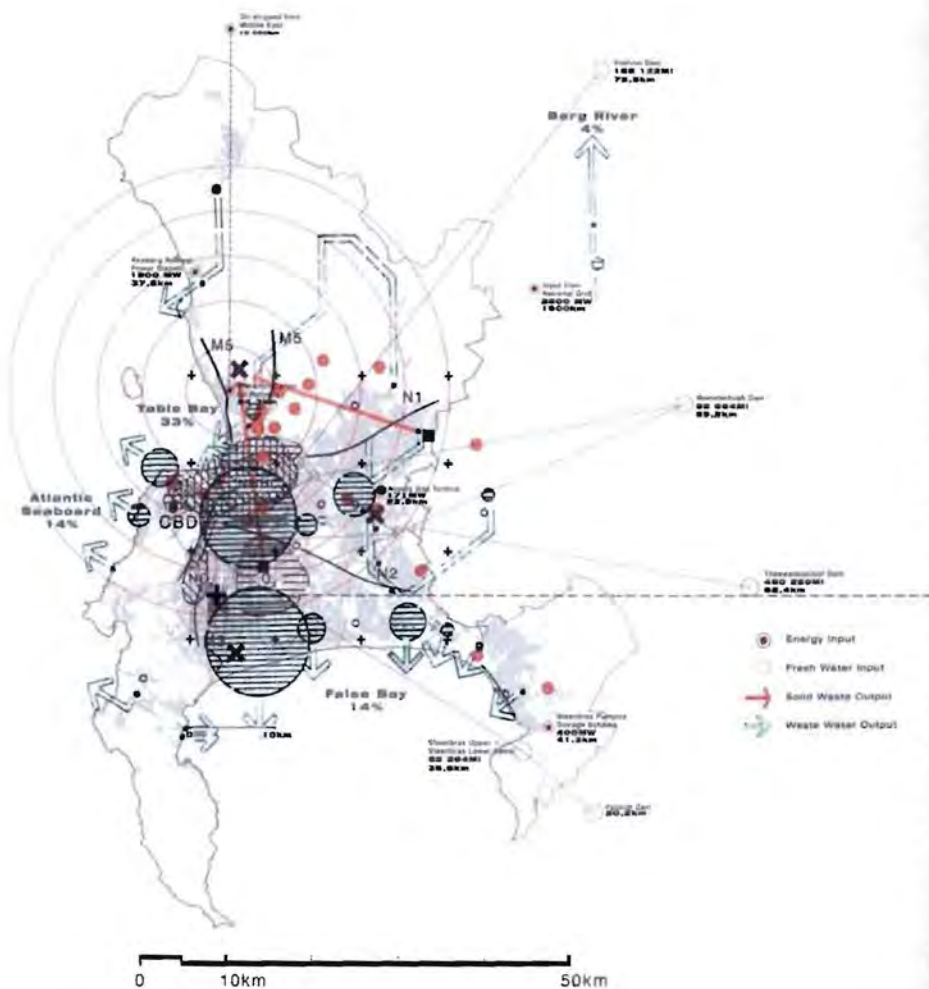

Plumstead, Cape Town

Area	4 719 870m ²
Population	18,886
Households	7,249 (2.6 persons per du)
Density	15.3 du/ha

OPEN SPACE	5,5%
SCHOOLS	2,5%
CEMETERY	3,8%
52,9%	built area

[3] Author. Synthesis of Cape Town's Infrastructural Network (2012)

[4] Author. The Suburb of Plumstead (2012)

From Linear to Cyclic Metabolism

The shift from linear to cyclic metabolism in the (sub)urban environment requires a shift from modernity to metabolism, from homogeneity to heterogeneity, from regression to evolution. This project attempts to establish a new symbiotic relationship between nature and the suburb of Plumstead in the hope for a more sustainable future.

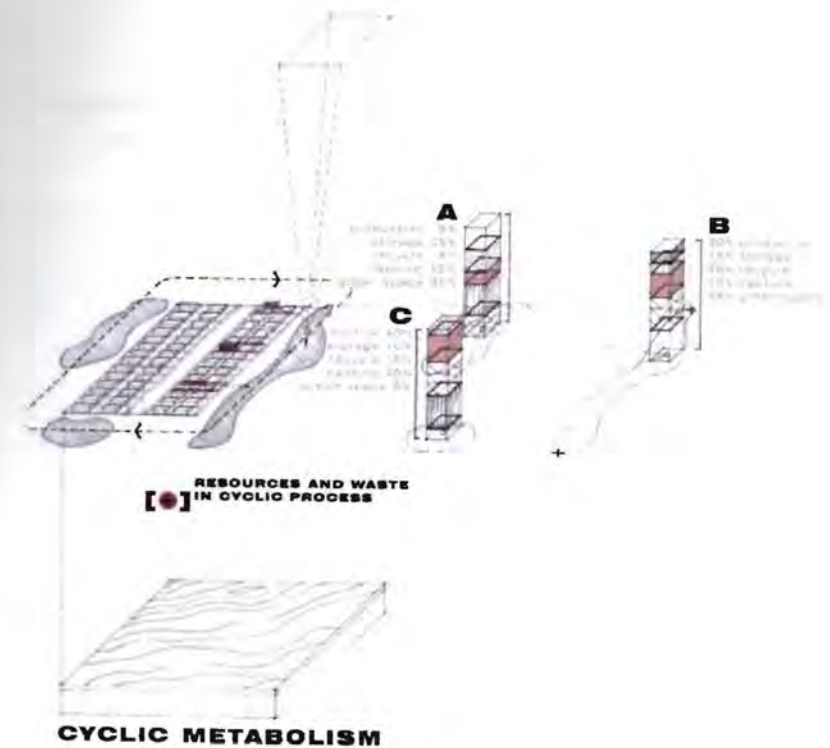
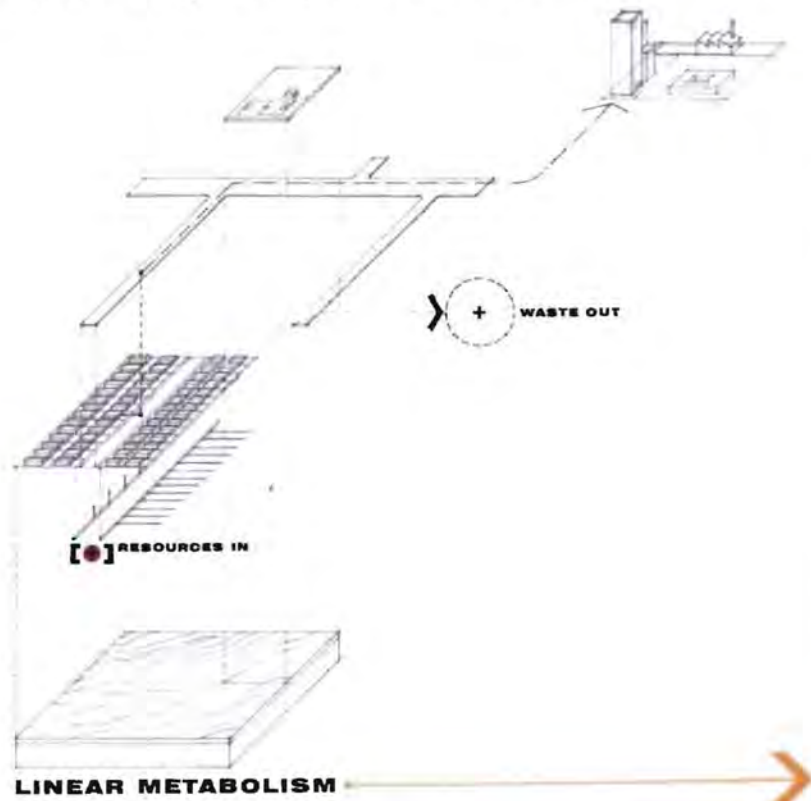

[5] Author. Suburban Linear Metabolism (2012)

[6] Author. Suburban Cyclic Metabolism (2012)

Strategies for a Cyclic Metabolism: Plumstead

In response to the need to shift from a linear to cyclic metabolism, 3 strategies were identified that could enable a heterogeneous suburban environment.

- 1 Densify Suburb
- 2 Establish Infrastructural Web
- 3 Create Hybrid Nodes

The next part of this section defines concepts that are regarded as important in relation to these strategies and the need to integrate locally bound resources and natural processes in the architectural intervention.



The (Sub)urban Organism = A Kit of Wholes

Like any organism [a city] has a circulatory system in its streets, railroads and rivers, a brain in its universities and planning offices, a digestive system in its food distribution and sewage lines, muscles in its industrial centres.⁵

The project seeks a methodology that involves both top-down and bottom-up logics operating in a feedback loop, as an organising principle that promotes communication across scales. In this way, the hierarchy of this project has less to do with power structures, rather, is characterised by its material organisation and deployment of whole parts within the entire (sub)urban organism. This categorisation means that the relationship to the whole is not reducible to its parts, rather, it is expressed as a whole-whole relationship within the (sub)urban organism. Therefore the project is divided into wholes that operate at different scales.

- 1 Humanity
- 2 Infrastructural Web
- 3 Hybrid Node
- 4 EcoBlock
- 5 Hybrid House
- 6 Hi_brid Spine

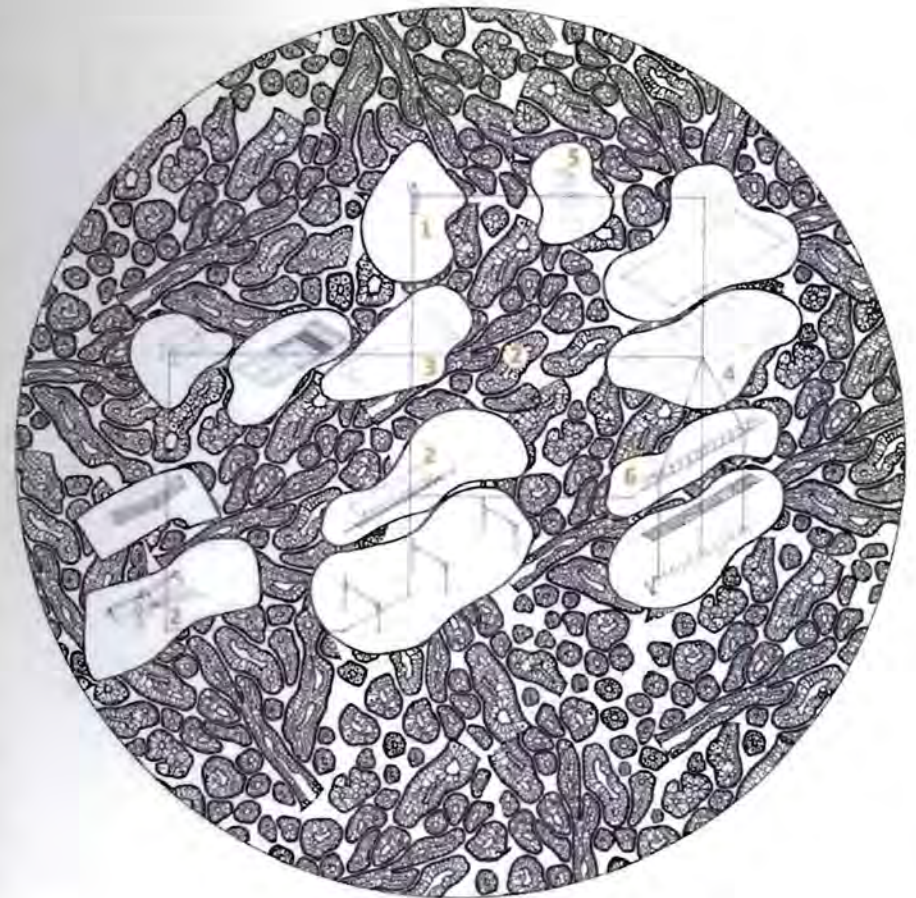

(Sub)urbanism of Time

It would be a mistake to regard the old and new as polar opposites. Rather, this project recognises that the constructed suburban form has a complex relationship with time, and anything that has survived up to today is current, contemporary and therefore useful. In the same way, it would be a further mistake to regard the *tabula rasa* as the only way to solve a problem. Rather, the project regards a strategy of *use and reuse*, as a concept for a healthy suburb. Therefore, the architectural intervention is placed on top, below, and between existing structures, progressing beyond the division: to live, to work, to cultivate body and spirit and to travel about.

1796

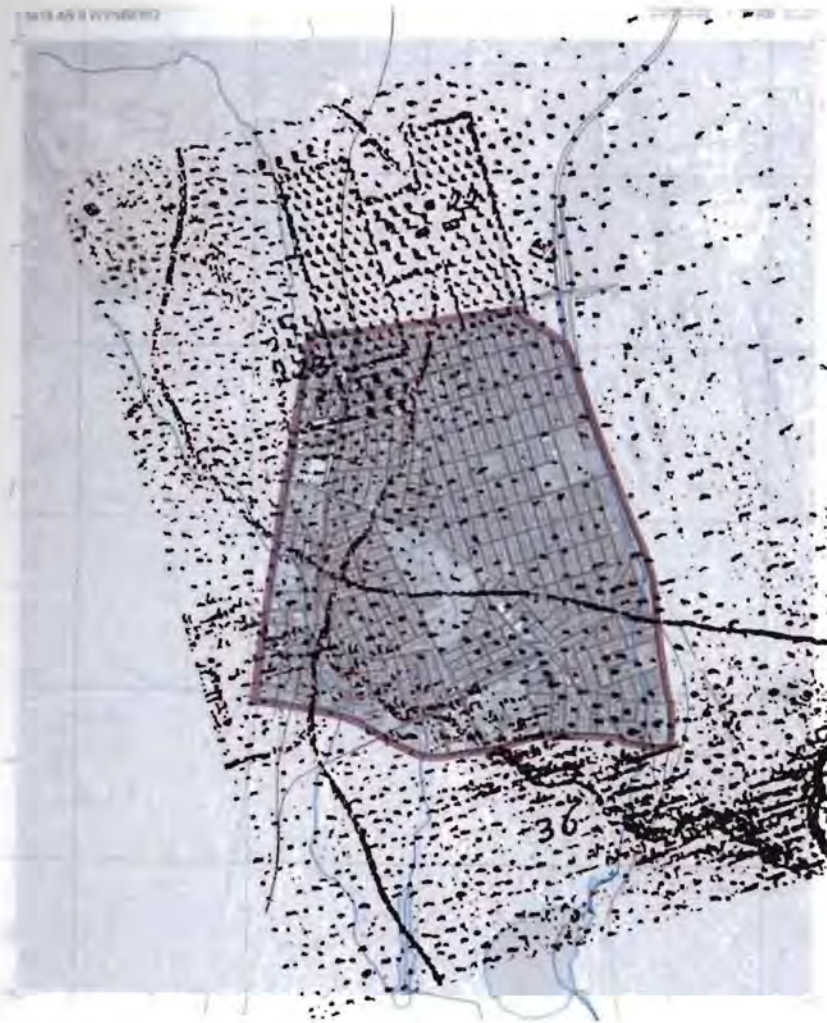

[9] Author. Plumstead Mapping Overlay: 1796 (2012)

1895

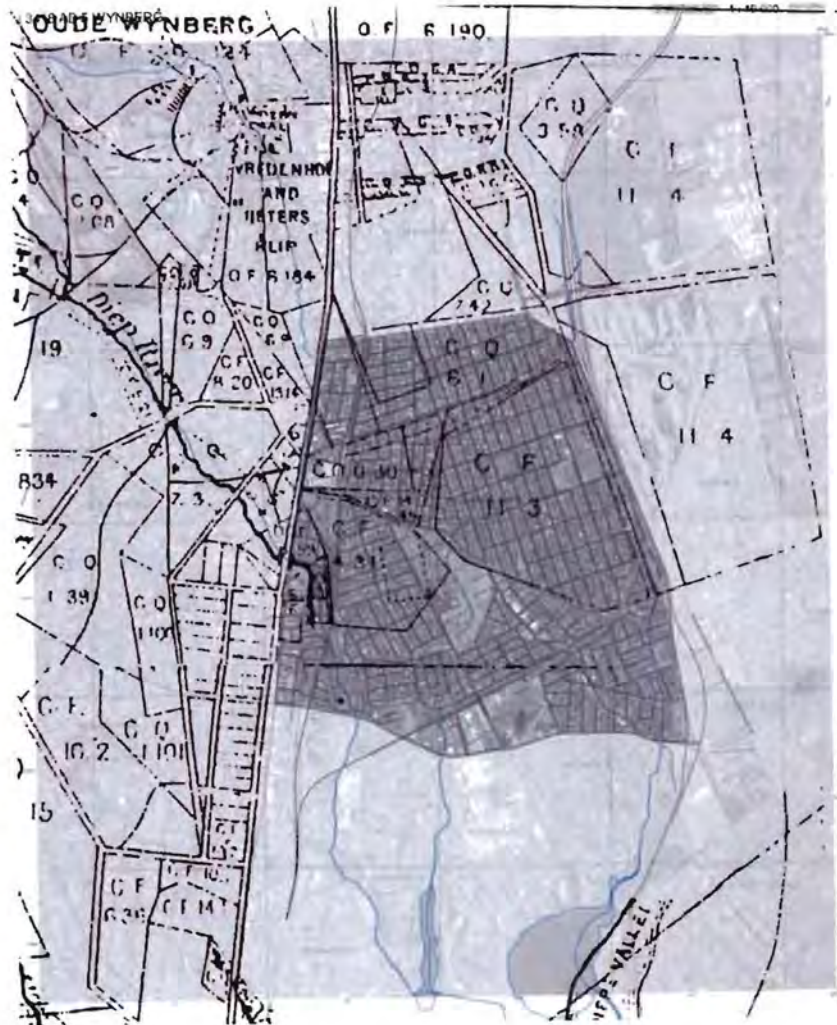

[10] Author. Plumstead Mapping Overlay: 1895 (2012)

1899



[11] Author. Plumstead Mapping Overlay: 1899 (2012)

1962



[12] Author. Plumstead Mapping Overlay:1962 (2012)

2012



[13] Author. Plumstead Mapping Overlay:2012 (2012)

More is More

In *Complexity and Contradiction in Architecture* (1966), Robert Venturi explains that Mies van der Rohe's doctrine of "less is more" justifies a reductionist view of architecture at the expense of complexity. Venturi recognises that complexity and contradiction are important component in architecture's progress beyond orthodox modern architect's idealisation of the primitive and elementary.

Hybrid rather than "pure," compromising rather than "clean," distorted rather than "straightforward,"...accommodating rather than excluding, redundant rather than simple, vestigial as well as innovating²

Similarly, in *The Death and Life of Great American Cities* (2000), Jane Jacobs explains falling into the trap of analysing and categorising the city by its uses one at a time, where this view of the city lacks the combination and mixture of uses that make up the city's essential defining phenomena. She makes the point that city diversity itself permits and stimulates more diversity³. Therefore, more is more.

William McDonough, in *Cradle to Cradle* (2002), uses the analogy of a blooming cherry tree that produces an overabundance of blossoms, as a description of nature's design framework. The "purpose" of the tree is to reproduce itself and yet the overabundance of blossoms supports a wide variety of animals and organisms, thereby extending the "purpose" of the tree. In this way the overabundance is not seen as waste, rather, as a concept of diversity and interdependence between the tree, animals and organisms to sustain their ecosystem.

A flowering of diversity, a flowering of abundance⁴

Therefore, as far as possible, the project aims to include complexity, diversity and variety of programme as a consideration in the creation of hybrid situations within the (sub)urban organism.

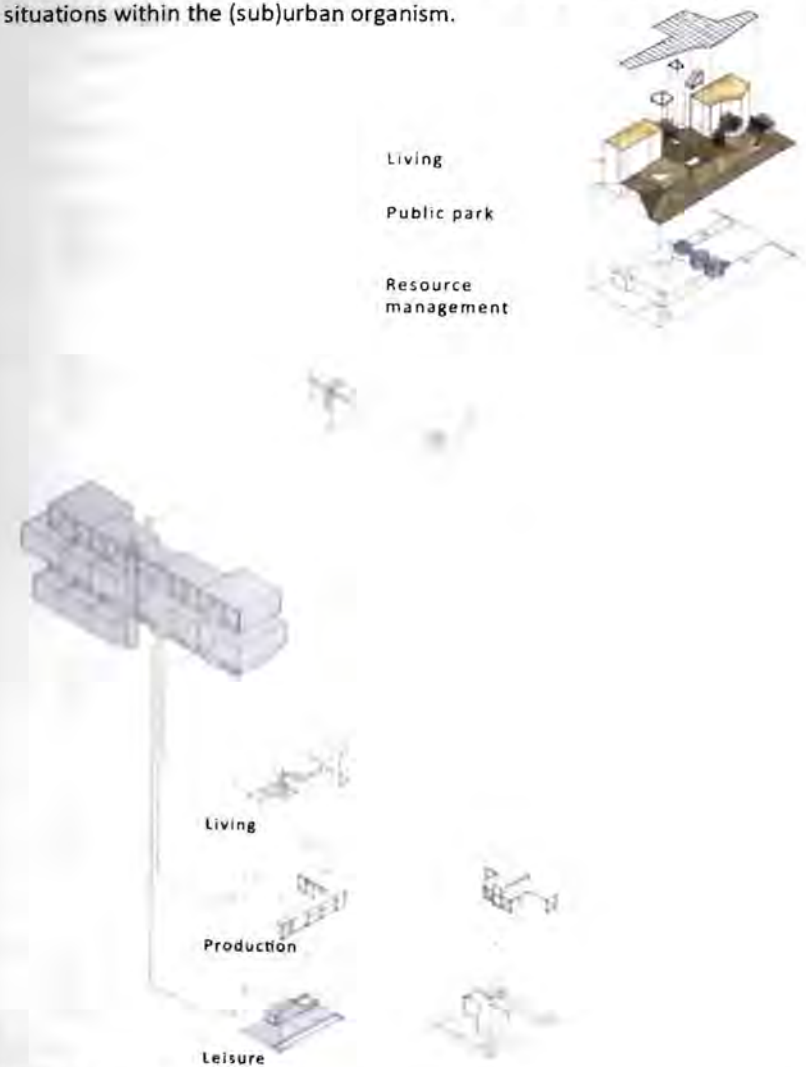

Complete Programme for the Suburb

Compared to the functionally fragmented city, the imagined suburb will have to be capable of accommodating all the functions of the city, including housing, social amenities, shopping spaces, workplaces, access to open spaces, and leisure spaces. The suburb will have to behave like a micro-city, able to recycle its own waste, purify its own water, generate its own energy, and connect to other suburbs and the city.

- 1 Housing
- 2 Workplaces + Shopping Spaces
- 3 Green Spaces + Production: Agricultural
- 4 Production: Renewable Energy
- 5 Institutional + Educational Places
- 6 Social Amenities + Leisure Spaces

the complete suburb—



[15] Author. The Complete Suburb (2012)

Active Context

The active context refers to the variable energies and material flows associated with spatial qualities (photo-electrolysis, light, air flows, moisture, and heat transfer) acting upon a particular region at a particular point in time. In figure 16, the active context for Cape Town was analysed in terms of locally bound resources and their respective annual frequency. In this way the architectural intervention can accommodate change in response to seasonal variations.

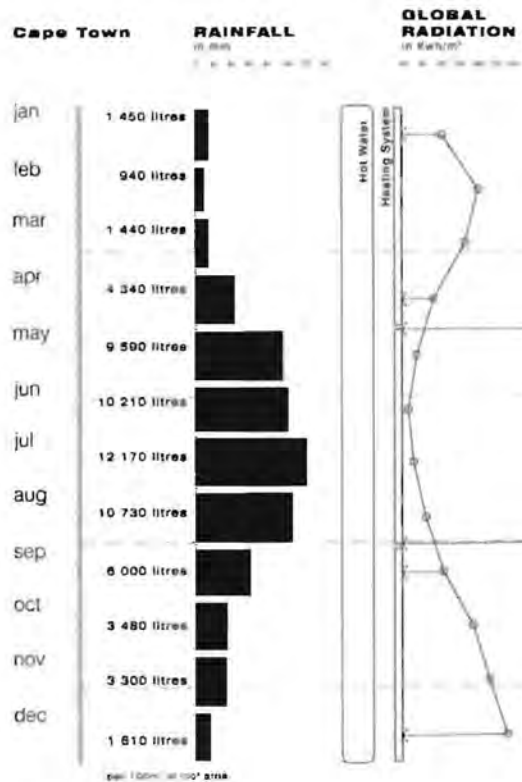

[16] Author. Cape Town Active Context (2012)

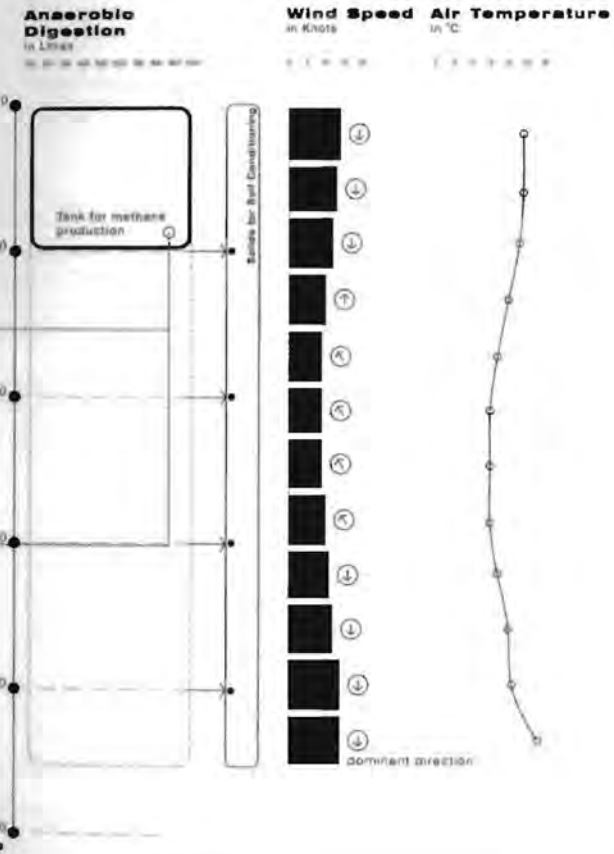

Plumstead Active Context : Rainwater Resources



[17] Author. Plumstead Active Context: Rainwater Resources (2012)

Plumstead Active Context : Solar Energy



[18] Author. Plumstead Active Context: Solar Energy (2012)

Integrated Resource Reuse Strategy

The Integrated Resource Reuse Strategy (IRRS) aims to take advantage of the active context and waste generated in the suburb as a strategy to increase the symbiotic relationship between the (sub)urban and natural environments. The strategy attempts to use natural processes for waste rehabilitation and reuse.

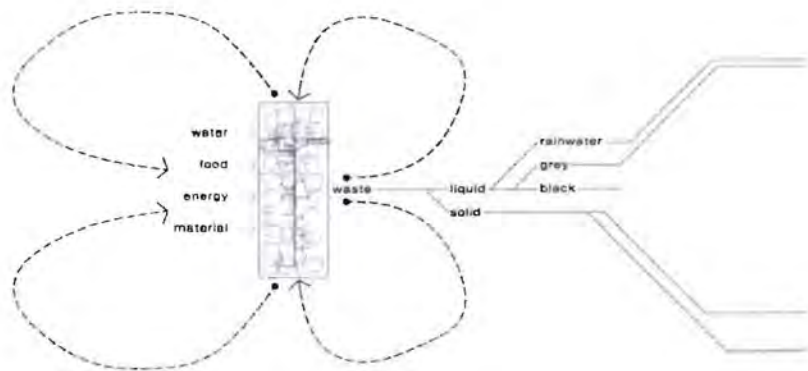

[19] Author. Integrated Resource Reuse Strategy (2012)

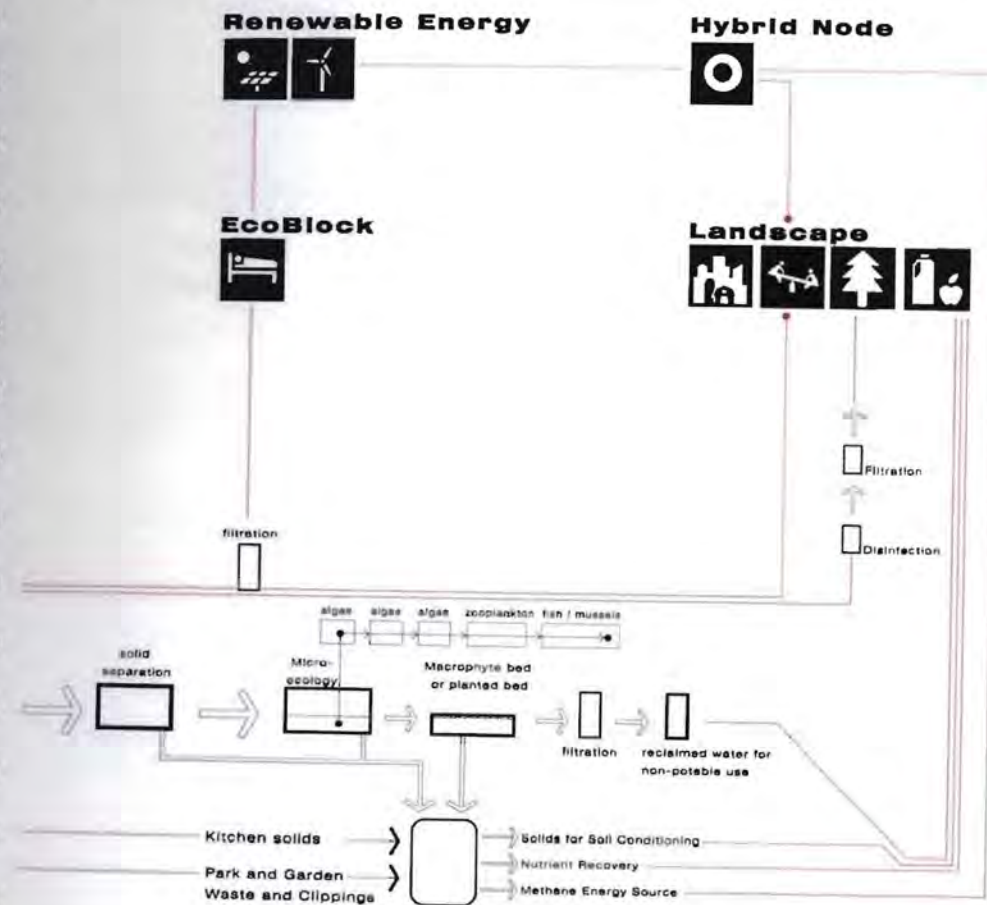

IRRS: Scales of Functionality

Each part of the (sub)urban organism has a responsibility to function as a part of the Integrated Resource Reuse Strategy (fig. 21). These functions include harvesting of renewable energy and, the collection and processing of locally available resources for reuse. These resources are circulated by the Infrastructural Web that connects the EcoBlocks and the Hybrid Nodes to Plumstead and greater Cape Town as well as the Hi_brid Spine linking the existing houses to the Hybrid House and the EcoBlock (fig. 20).



[20] Author. Integrated Resource Reuse Strategy: Connections (2012)

RENEWABLE ENERGY



-  solar energy
-  waste recycling
-  wind energy
-  renewable energy power plant
-  black water
-  grey water
-  rain water

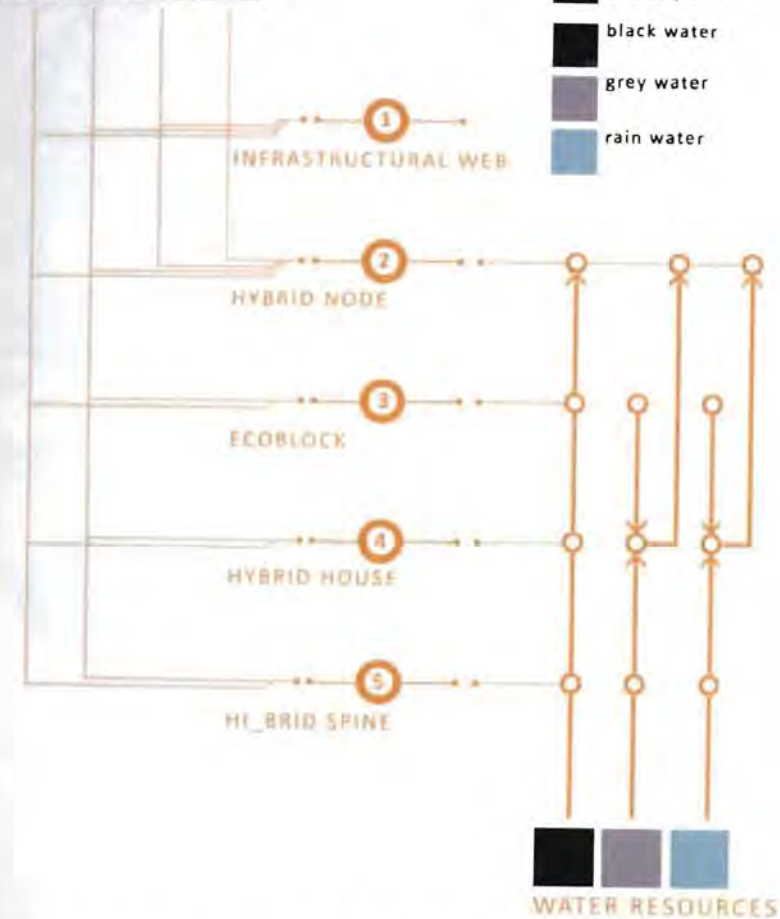

[21] Author. Integrated Resource Reuse Strategy: Scales of Functionality (2012)

The (Sub)urban Organism

The next section of this study will explain the 6 aspects of the suburban organism.

- 1 Humanity
- 2 Infrastructural Web
- 3 Hybrid Node
- 4 EcoBlock
- 5 Hybrid House
- 6 Hi_brid Spine

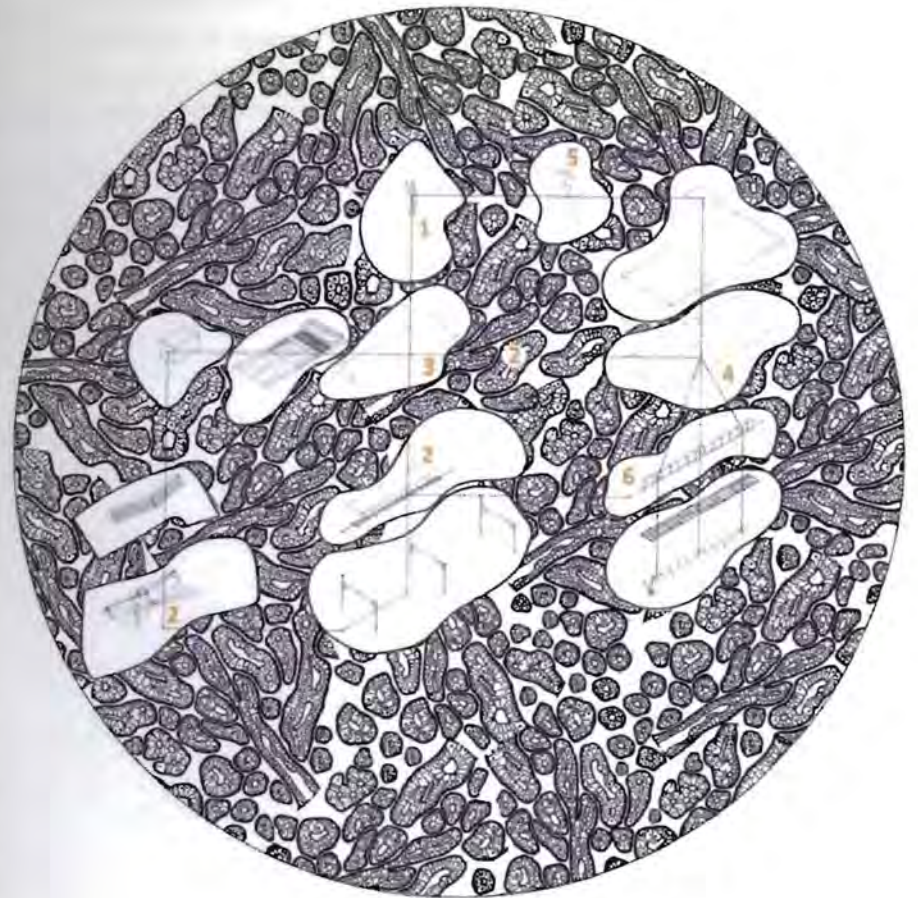

[22] Author, The (Sub)urban Organism (2012)

Humanity

It has been previously mentioned that humans are both nature and a part of nature in natural space. In this project the notion of humanity is regarded in two ways. Firstly, by establishing Cape Town's average daily metabolism per person, and second, the use of a proportion system related to the human figure. In this way humanity is intrinsically bound within every part of the entire (sub)urban organism.

Average Metabolism per Capita per day (Cape Town)

	Input	Output
Water ⁵	240 litres	144 litres
Energy ⁷	6,4 kW/h	8kg CO ₂
Material ⁸	5,3kg	2,05kg

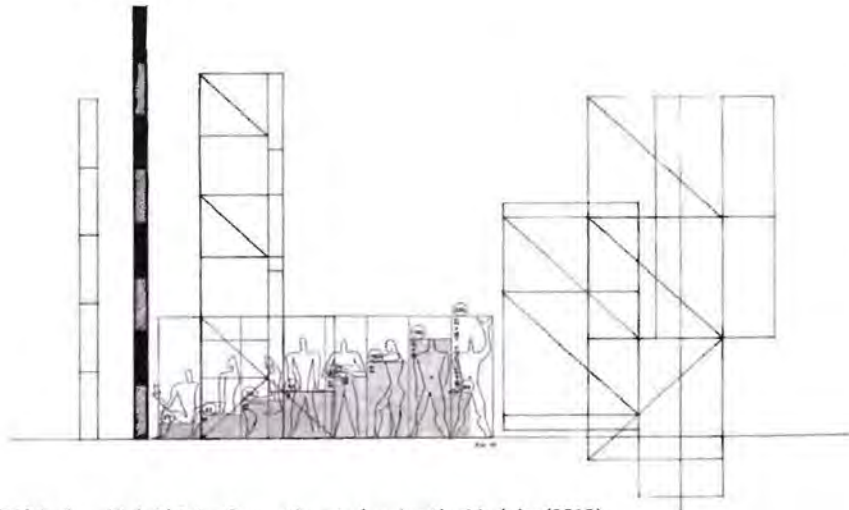

[23] Author. Hi_brid Spine Proportion study using the Modular (2012)

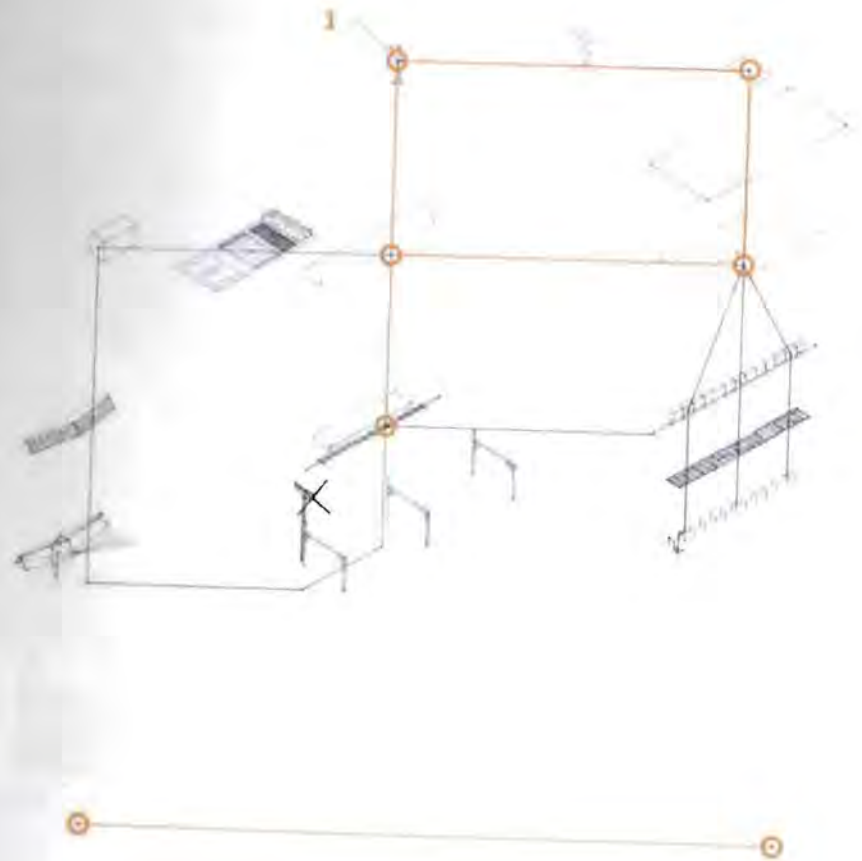

[24] Author. (Sub)urban Organism: Humanity (2012)

Infrastructural Web

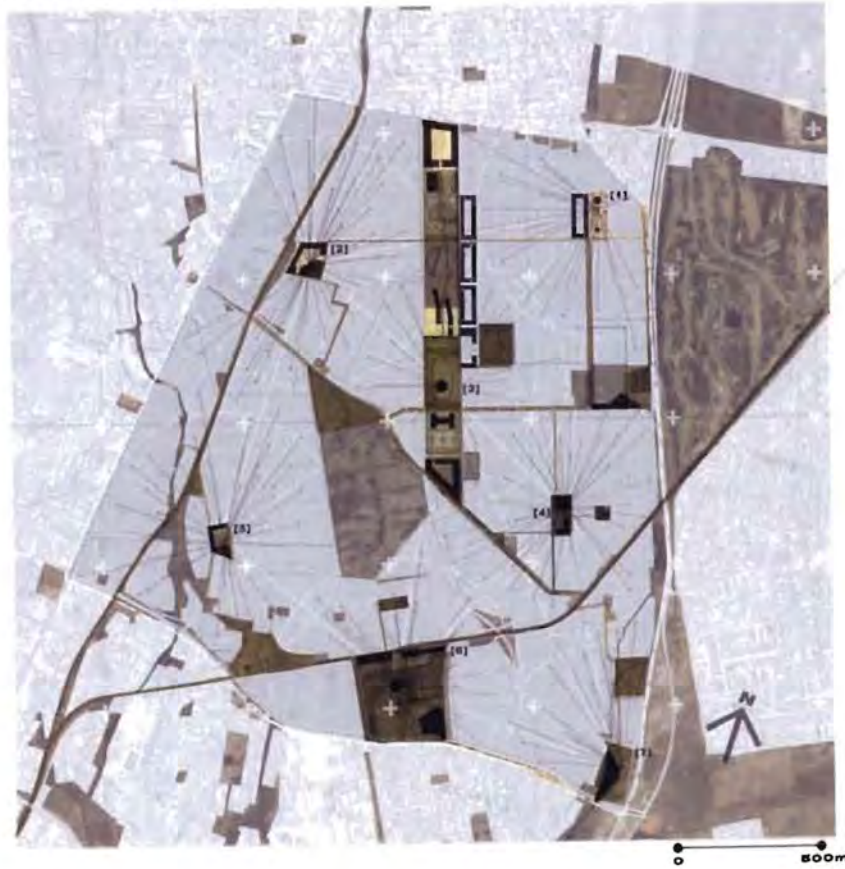

[25] Author. (Sub)urban Organism: Infrastructural Web (2012)

The role of the Infrastructural Web is to distribute resources, while connecting the Hybrid Nodes to the EcoBlocks, existing green spaces and public facilities. The aim of the Infrastructural Web is to make greater use of renewable and locally available resources and to reduce excessive resource consumption by enabling the reuse and recycling of waste.

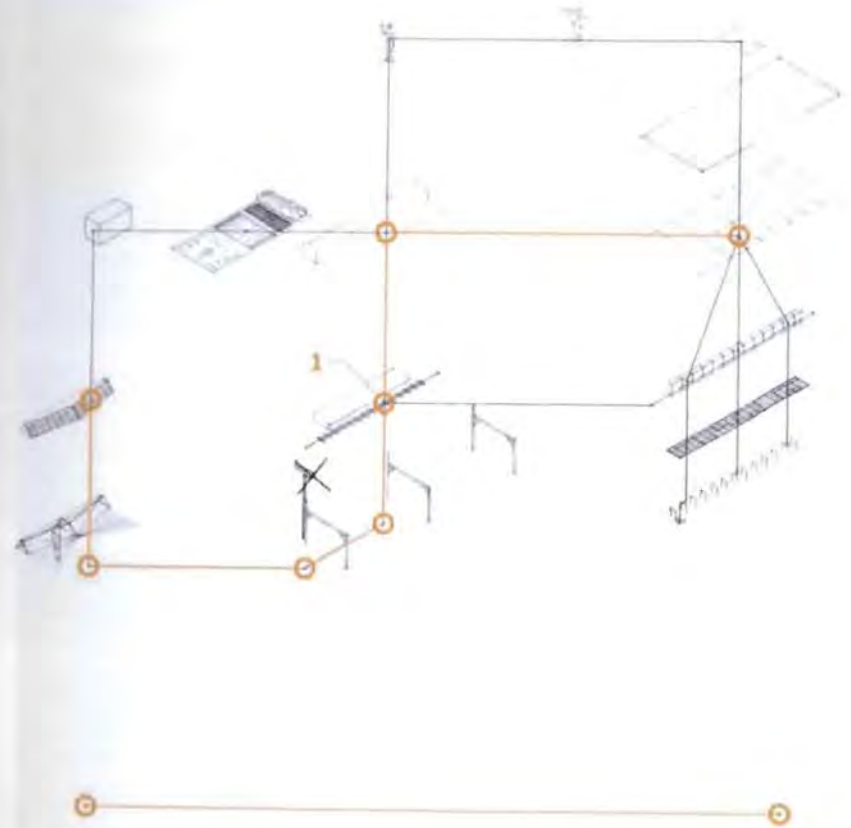

[26] Author. (Sub)urban Organism: Infrastructural Web (2012)

Infrastructural Web: Attaching to Existing Infrastructure



[27] Author. Plumstead Existing Infrastructure (2012)

By using the existing railway infrastructure as a resource harvester and distributor, connections can be made within the suburb and to adjacent suburbs

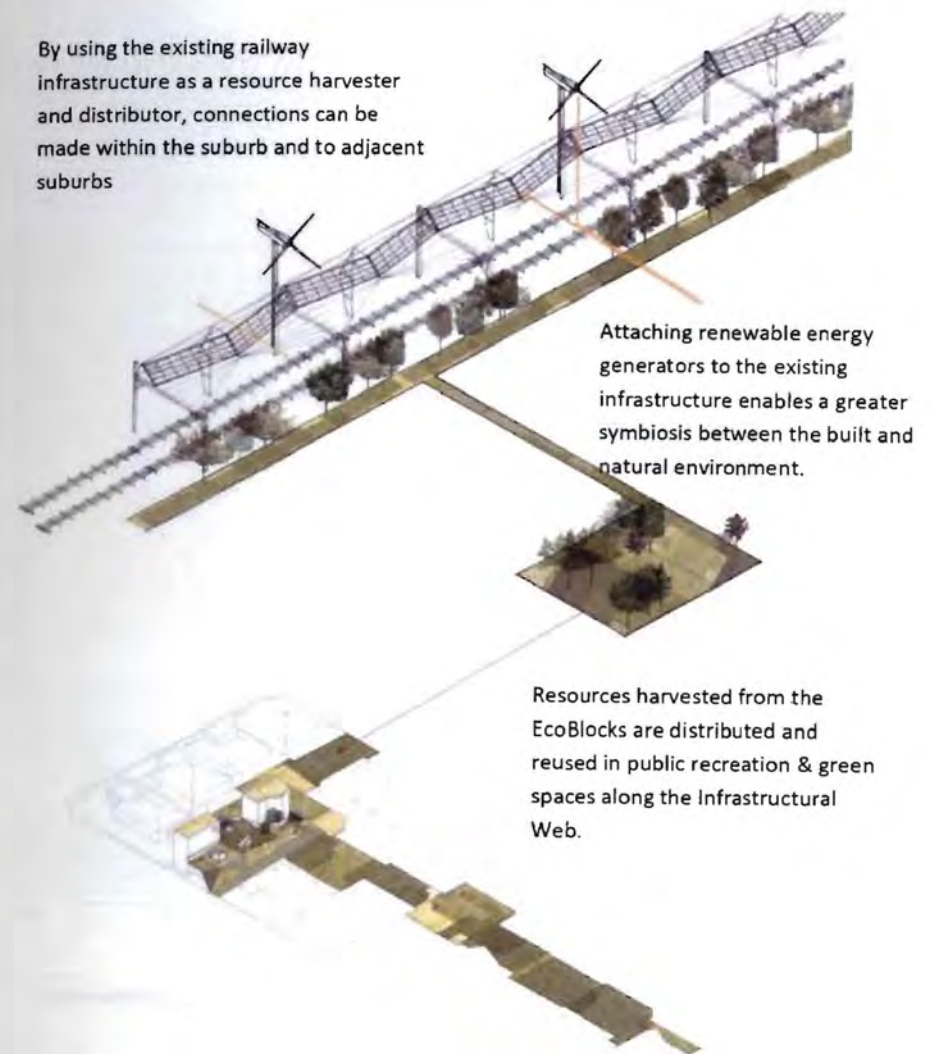

Attaching renewable energy generators to the existing infrastructure enables a greater symbiosis between the built and natural environment.

Resources harvested from the EcoBlocks are distributed and reused in public recreation & green spaces along the Infrastructural Web.

[28] Author. Infrastructural Web: Attaching onto Existing Infrastructure (2012)

Hybrid Node



[29] Author. (Sub)urban Organism: Hybrid Node (2012)

The Hybrid Nodes work in collaboration with the Ecoblocks to increase the density of Plumstead by providing a combination of residential accommodation, community facilities and green spaces. The nodes work within the Infrastructural Web and act as receptacles for excess waste for processing and conversion into usable energy.

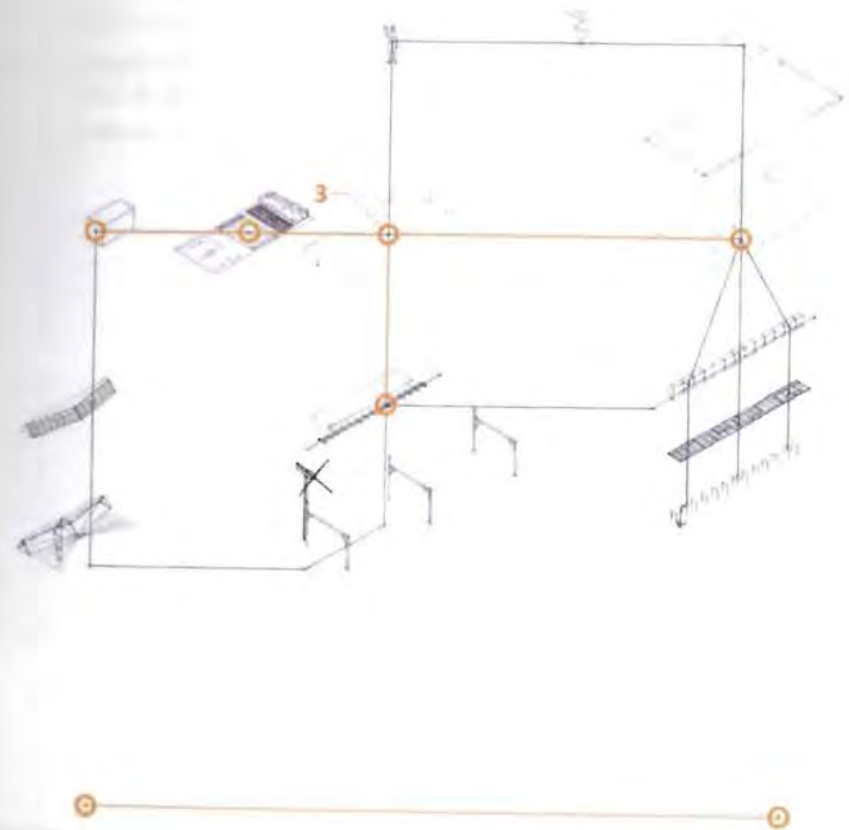

[30] Author. (Sub)urban Organism: Hybrid Node (2012)

Hybrid Node

Living + Community + Green Space

The idea of the Hybrid Node enforces a heterogeneous (sub)urban environment comprising of accommodation, community facilities and green spaces relevant to renewable resource harvesting. In this way the Hybrid Node reinforces the strategy of increasing the density of the suburb while providing the necessary social and recreation spaces equal to the facilities threshold.



[31] Author. Facility and Resource Threshold (2012)

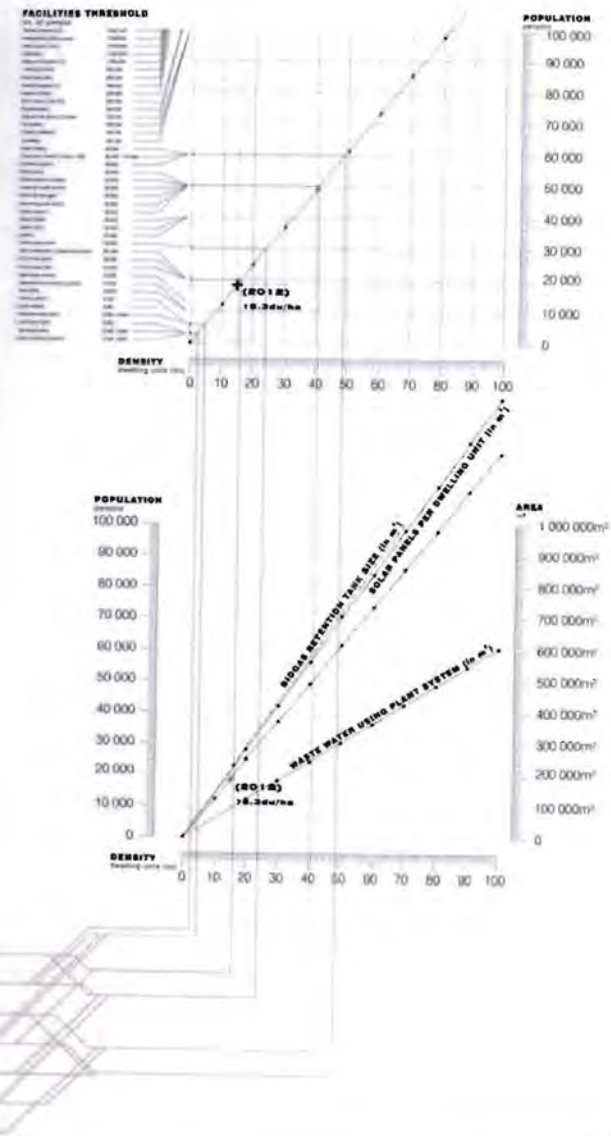

EcoBlock



[32] Author. (Sub)urban Organism: EcoBlock (2012)

Each suburban block is regarded as an organism within the Infrastructural Web, as an extension of the environment, inclusive of living, production and waste management systems.

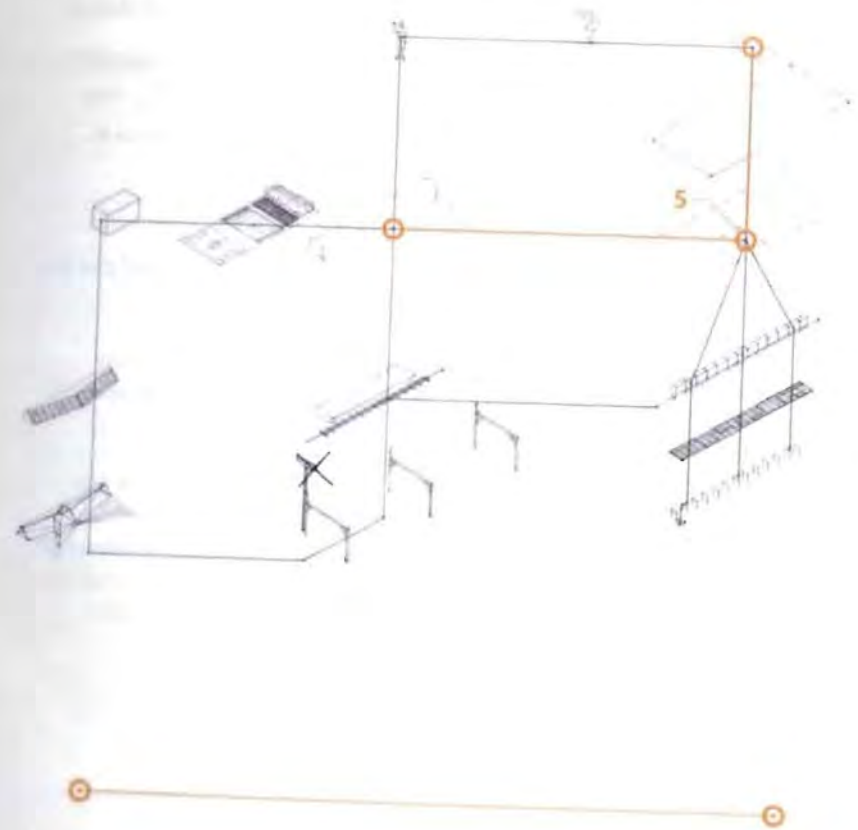

[33] Author. (Sub)urban Organism: EcoBlock (2012)

EcoBlock: Concepts

- 1 Insertion of Hi_brid Spine forming an elevated boundary between houses of the EcoBlock and establishing a link to the Hybrid House.
 - 2 Conversion of one house per block to contain waste management systems for the EcoBlock in addition to an increased density. The ground floor becomes a public space, while the roof becomes a public park.
- A* Annual Water Demand – 7008m³**
Based on Cape Town's average water use of 240l per capita/ per day.
- B* Annual Rainfall Collection – 1331m³**
Based on 100m² of roof area receiving an average 665,875mm rainfall annually (12 year average 2000-2011 taken at Zeekoei Vlei).
- C* Solar Panels – 900m²**
Based on an average household electrical usage of 770kW/h per month = 30m² of solar panels per household
Based on 12V, 60W photovoltaic panel (measuring 1100x500mm), that receives an average 8,42 hours of sunlight per day (2993 average sunshine hours per year), producing 505W/h of power per day.

* Refers to a suburban block that contains 30 households, and 80 persons per block using Plumstead's average of 2,6 persons per household

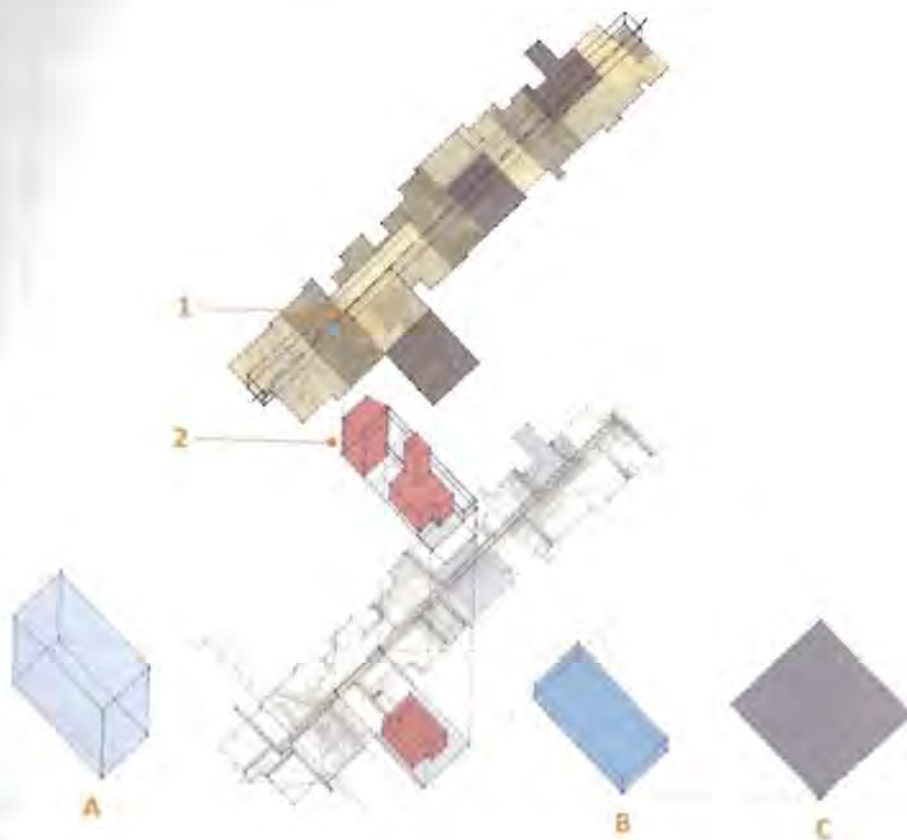

[34] Author. (Sub)urban Organism: EcoBlock (2012)

Hybrid House

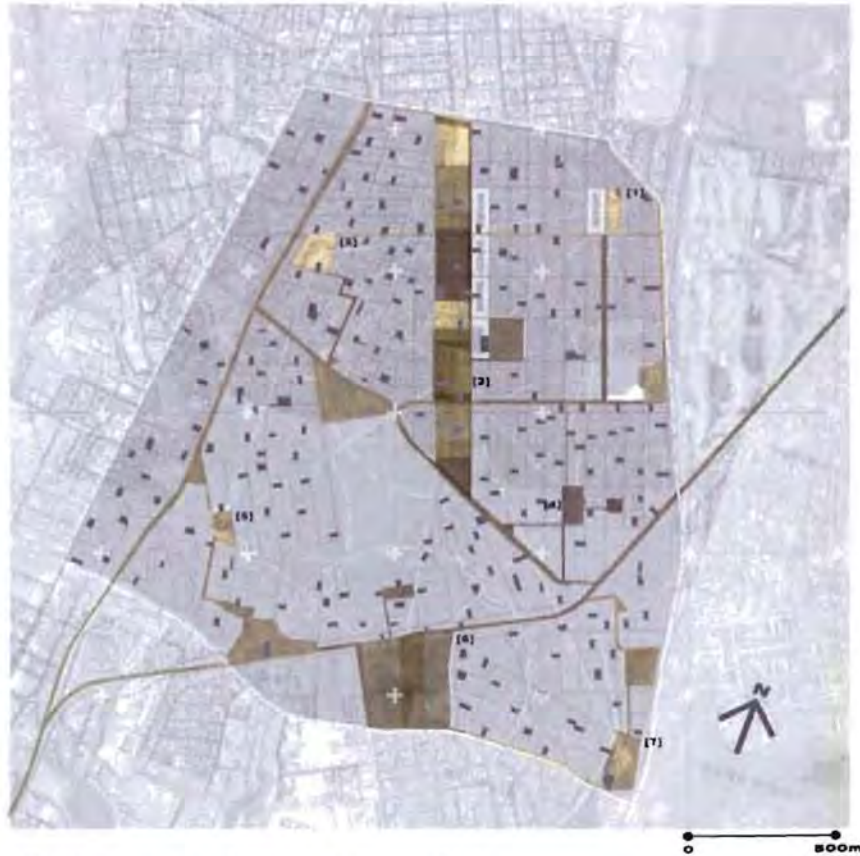

[35] Author. (Sub)urban Organism: Hybrid House (2012)

One house per block is converted to contain the waste management systems for the EcoBlock in addition to becoming a catalyst for increasing the density. The Hybrid House collects and distributes the block's resources while managing the resource systems. Following the rhythms of seasons and production these hybrid houses contribute to the biological equilibrium of the block, and collectively, to the suburb.

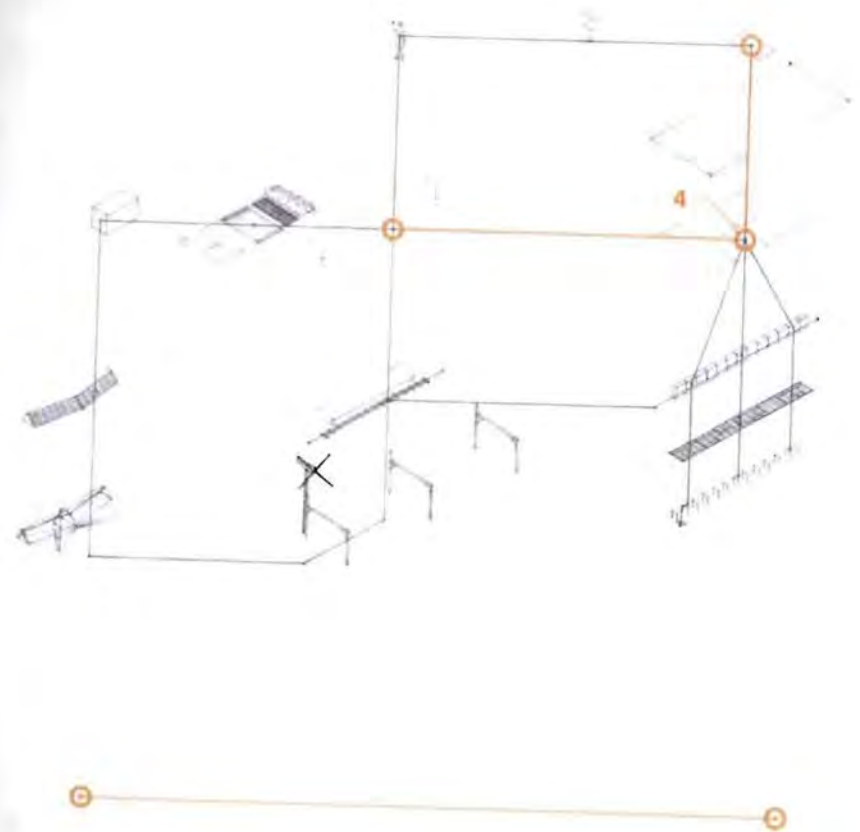

[36] Author. (Sub)urban Organism: Hybrid House (2012)

Hybrid House: Resource Systems

- 1 Greywater Collection – 0,081m³ per capita per day**
50,4% Laundry
39,7% Shower
6,7% Bath
3% Dishwasher
- 2 Rainwater Collection – 0,042m³ per capita per day for toilet flushing**
77% Rainwater - Other
23% Rainwater – Toilet Flushing
- 3 Productive Roof Space**
Utilise remaining space on site as a productive roofscape serviced by rain + greywater harvesting systems.
- 4 (Sub)urban Green System**
Integrated (Sub)urban green system serviced by a combination of grey + black + rainwater harvesting systems.
- 5 Anaerobic Biodigester – 0,824m³ methane per day**
Based on 80 persons per block at 20,6l/kg/day with an 80 day retention at 26-28° C, and 0,5kg excrement per person per day.

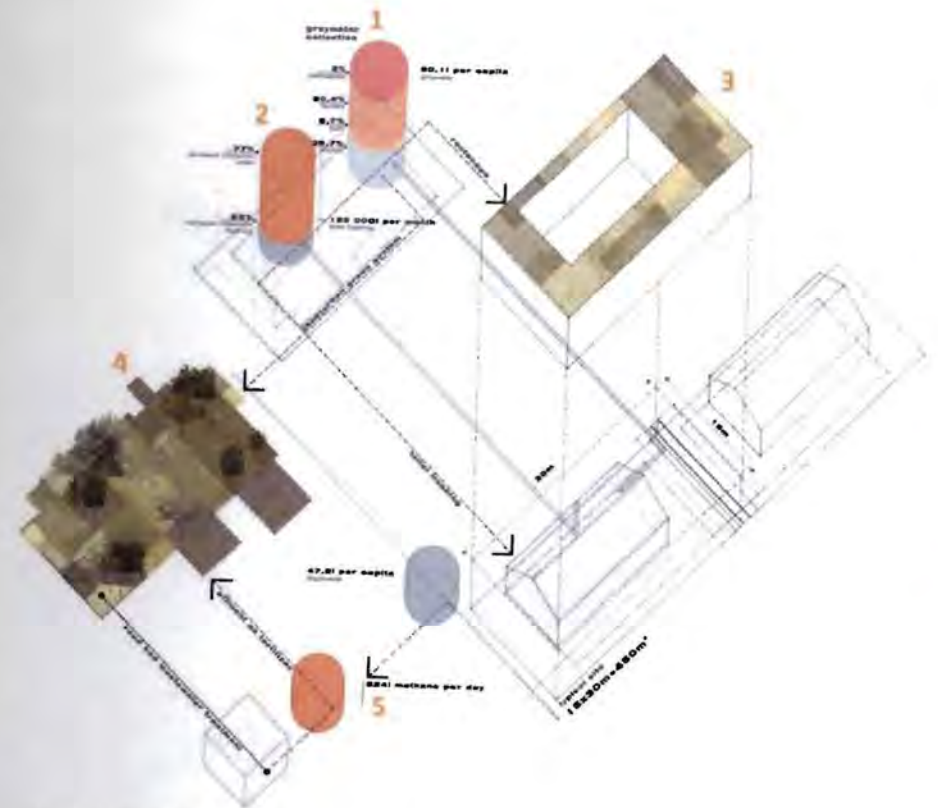

[37] Author. (Sub)urban Organism: Hybrid House: Resource Systems (2012)

Hybrid House: Public Function

Public Function

- Internet Cafe
- Pilates Studio
- Restaurant
- Laundry
- Gymnasium
- Public Kitchen
- Reading Room
- Book Club
- Bar
- Yoga Studio
- Games Room
- Art Studio
- Exhibition Space
- Billiards Room
- Coffee Shop
- Fabrication Workshop
- Creche
- Bowling Alley

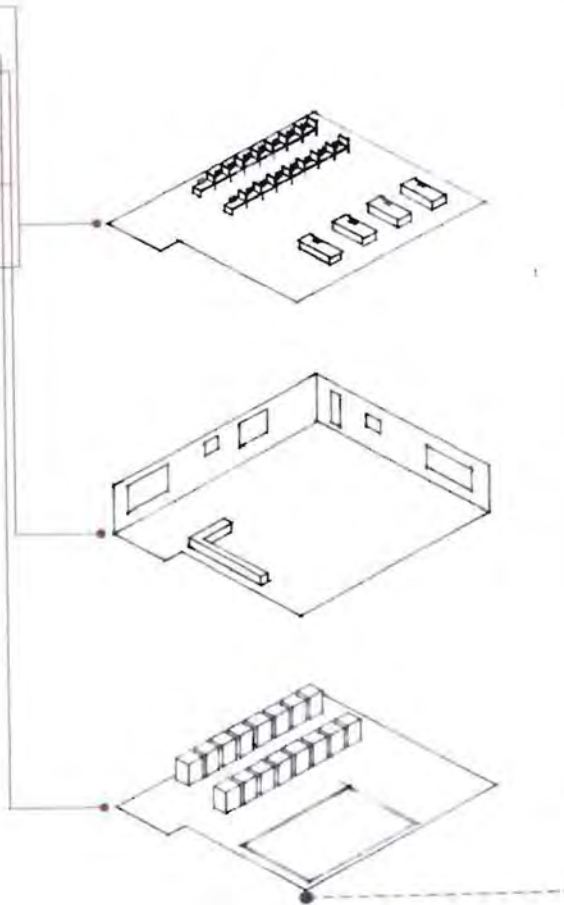

Over and above the need to process resources, the Hybrid House accommodates a hybrid of public function at different levels.

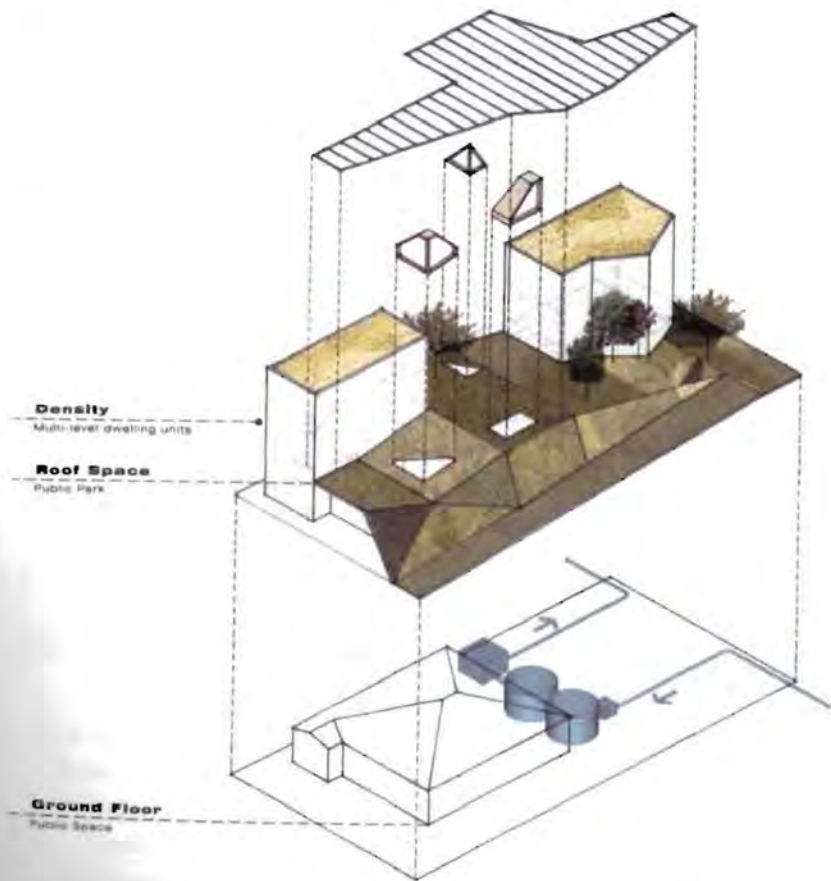

[38] Author. (Sub)urban Organism: Hybrid House: Public Function (2012)

Hi_brid Spine



[39] Author. (Sub)urban Organism: Hi_brid Spine (2012)

The Hi(gh)_brid Spine re-imagines the traditional (sub)urban boundary as an elevated infrastructural spine that links the Hybrid House to the houses of the established EcoBlock. Pre-fabricated modules distribute harvested and processed resources to and from the Hybrid House. The Hi_brid Spine establishes a secondary armature of occupation within the rear boundary regulatory and remainder spaces with a combination of living, productive and leisure spaces.

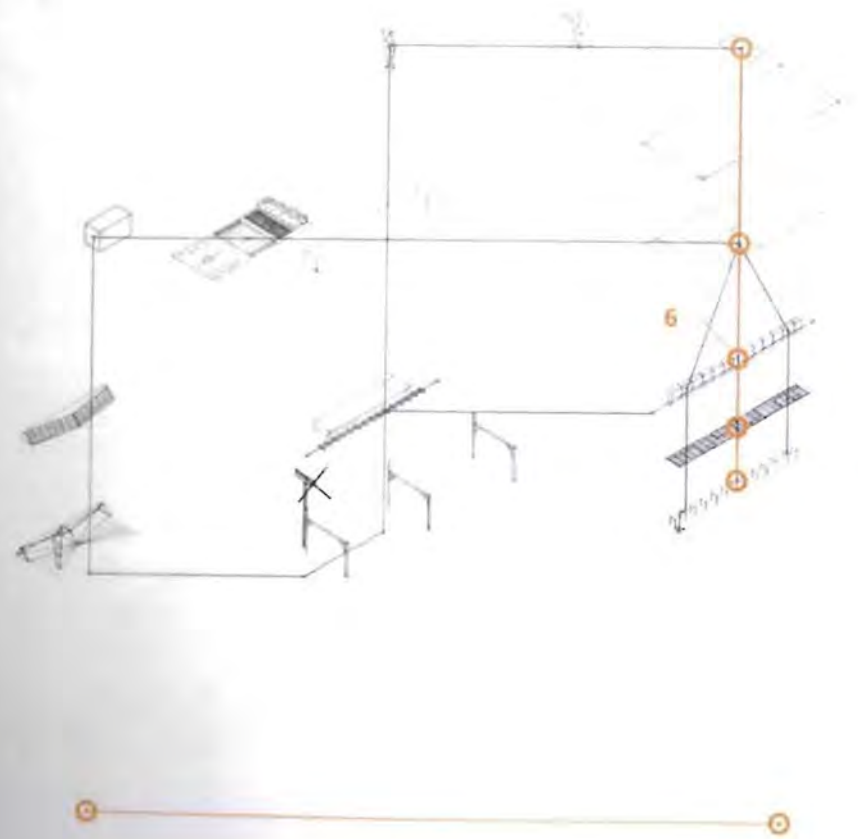

[40] Author. (Sub)urban Organism: Hi_brid Spine (2012)

Hi_brid Spine: Habitation

The Hi_brid Spine enables the habitation of the remainder of space in the EcoBlock in the form of a cluster of occupation, that includes living, working and leisure spaces.

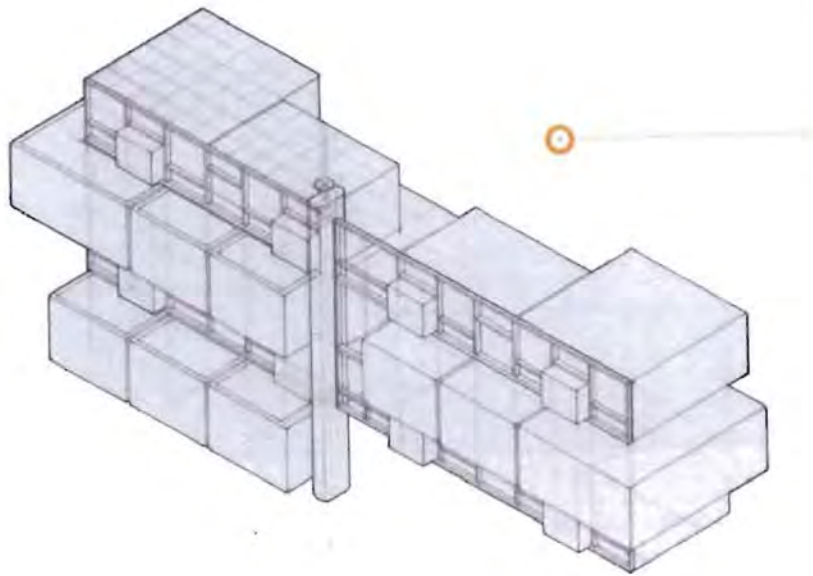

[41] Author. (Sub)urban Organism: Hi_brid Spine: Habitation (2012)



Hi_brid Spine: Habitation

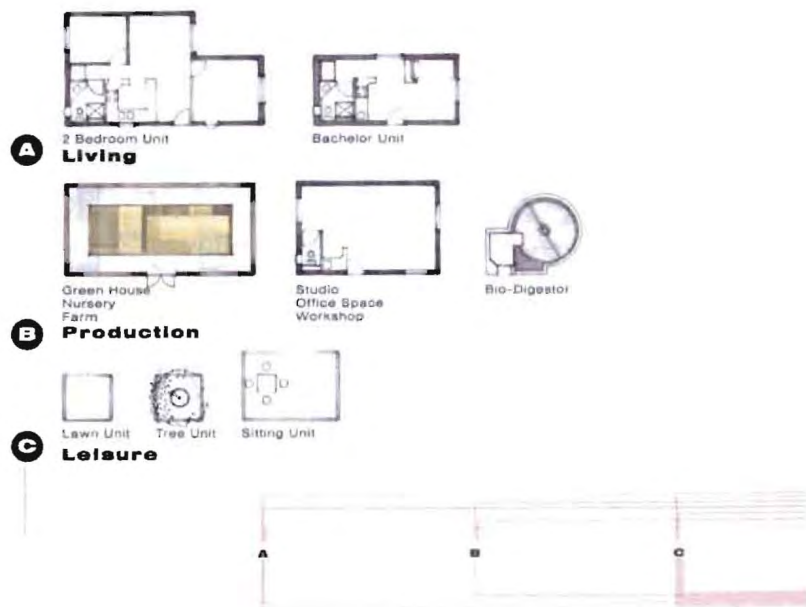

[42] Author. (Sub)urban Organism: Hi_brid Spine: Habitation (2012)

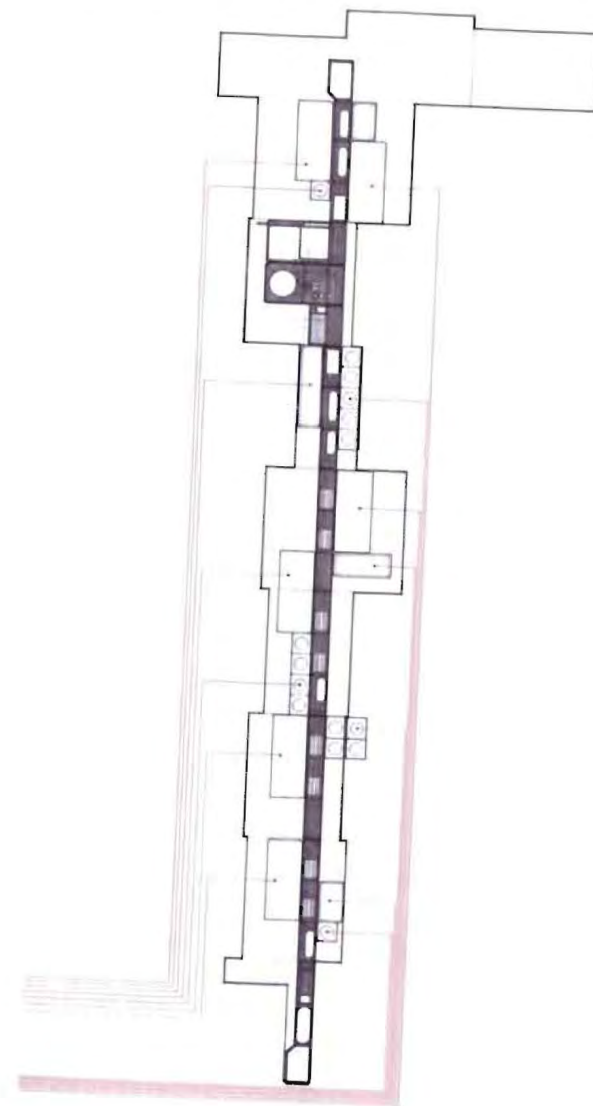

Hi_brid Spine: Habitation

The Hi_brid Spine is envisioned to facilitate metabolic change. It is therefore the intention that the cluster unit support structure and the Hi_brid Spine work in unison to enable living, working and leisure units to be periodically replaced.

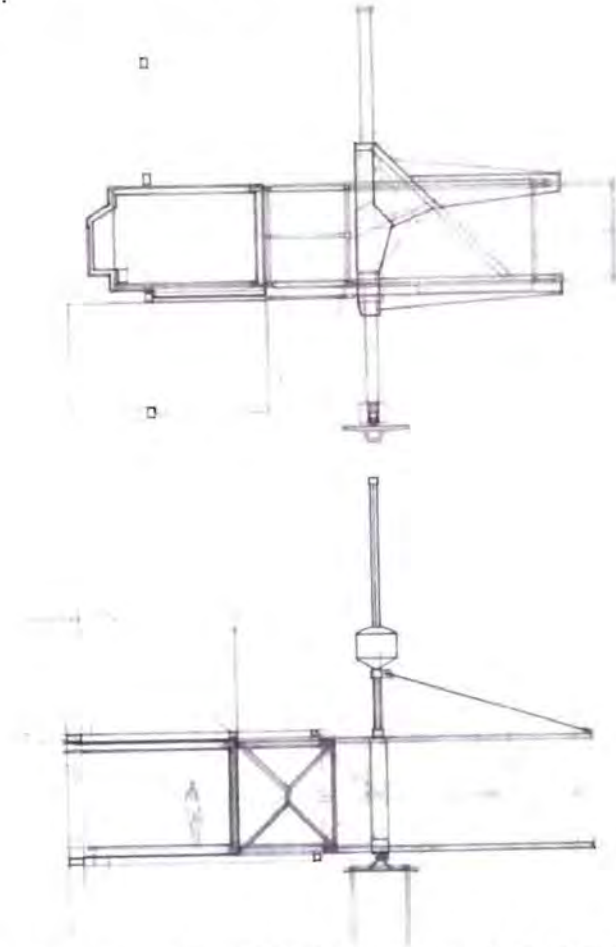

[43] Author. Process Section: Cluster Unit with gantry for adding/replacing units (2012)

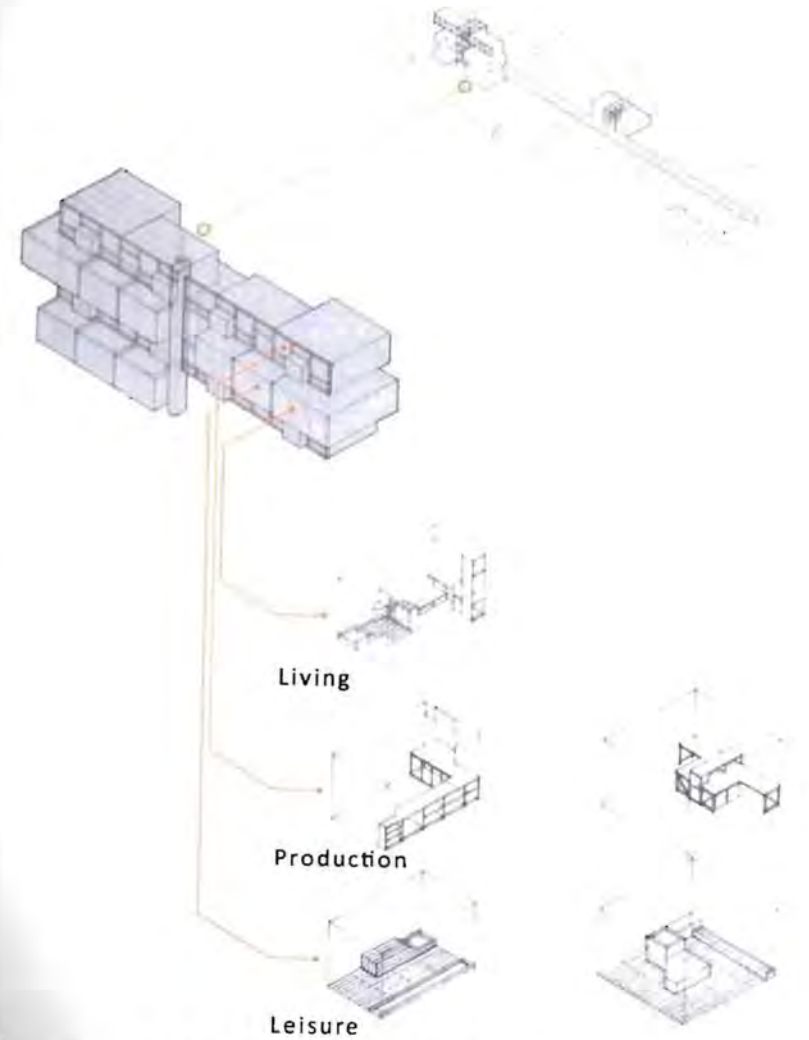

[44] Author. Cluster Unit Supported by Hi_brid Spine (2012)

Hi_brid Spine: Prefabricated Spine Module

- 1 **Photovoltaic Panel on steel frame**
1100x500mm 60W photovoltaic panel on adjustable steel frame
- 2 **Hybrid Handrail with seating rail**
- 3 **Vertical Planter Attachment**
- 4 **Rainwater Collection Tank**
Consists of a two tanks process with a two stage filter process in initial collection tank, and an overflow attached to main rainwater collection pipe
- 5 **Access door to adjacent Hi_Brid Spine Unit**
- 6 **Walkway**
- 7 **Solar Regulator and Power Invertor**
- 8 **Batteries**
Space for 48no deep cycle batteries per Hi_brid Spine Unit
- 9 **Three pipe collection and distribution system**
Black water, Grey water and water supply pipe

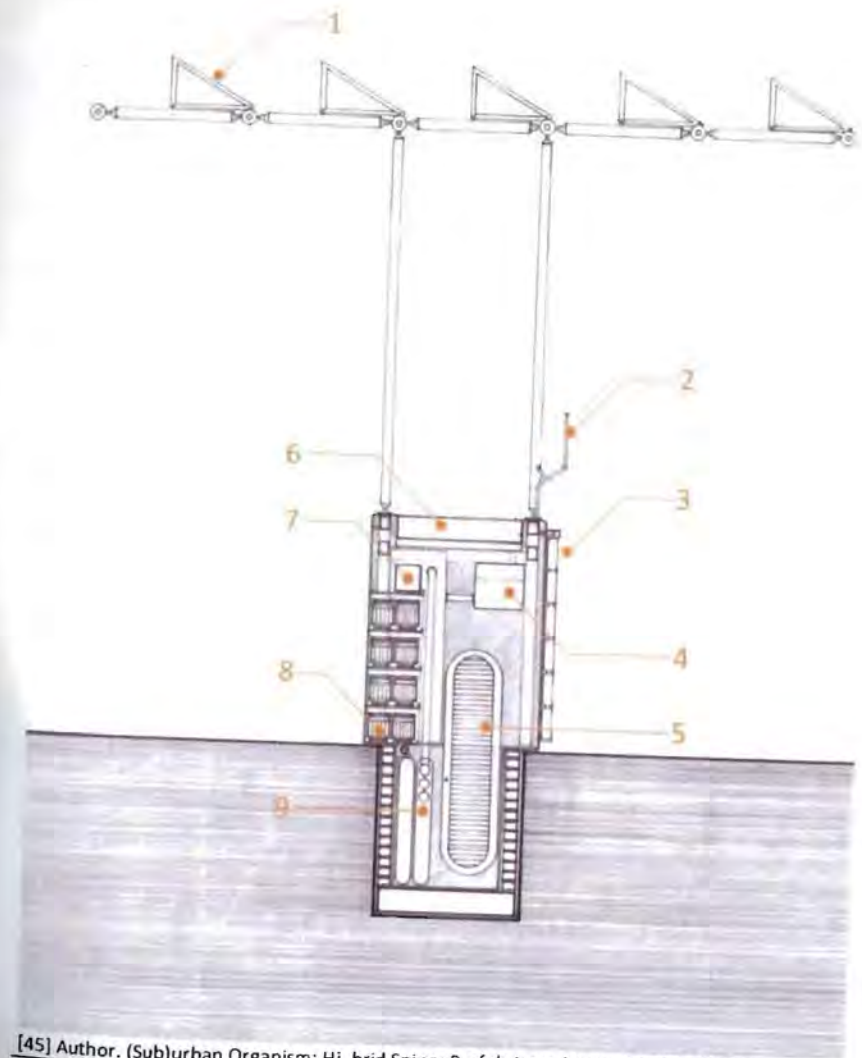

[45] Author. (Sub)urban Organism: Hi_brid Spine: Prefabricated Spine Module (2012)

Hi_brid Spine: Prefabricated Spine Module

- 1 Steel Structure**
Steel structure of modules connected in series to form a continuous structural support
- 2 Rainwater Collection Tank**
Consists of a two tanks process with a two stage filter process in initial collection tank, and an overflow attached to main rainwater collection pipe
- 3 Batteries**
Space for 48no deep cycle batteries per Hi_brid Spine Unit
- 4 Control Panel**
- 5 Concrete Foundation**

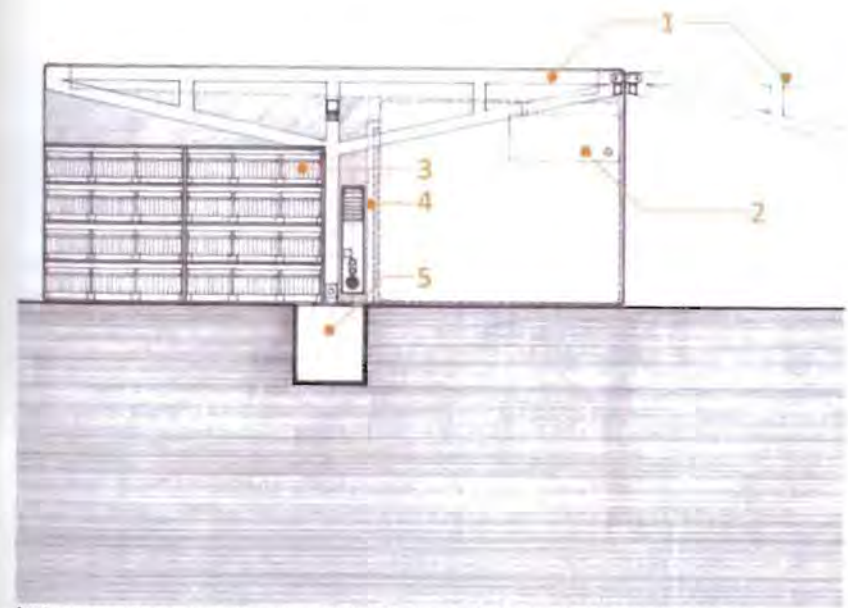

[46] Author. (Sub)urban Organism: Hi_brid Spine: Prefabricated Spine Module (2012)

Hi_brid Spine: Process of Occupation

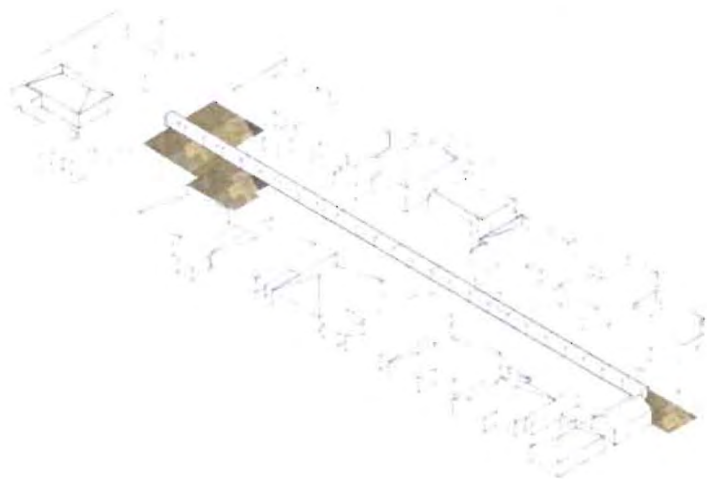

[47] Author. (Sub)urban Organism: Hi_brid Spine: Process of Occupation (2012)

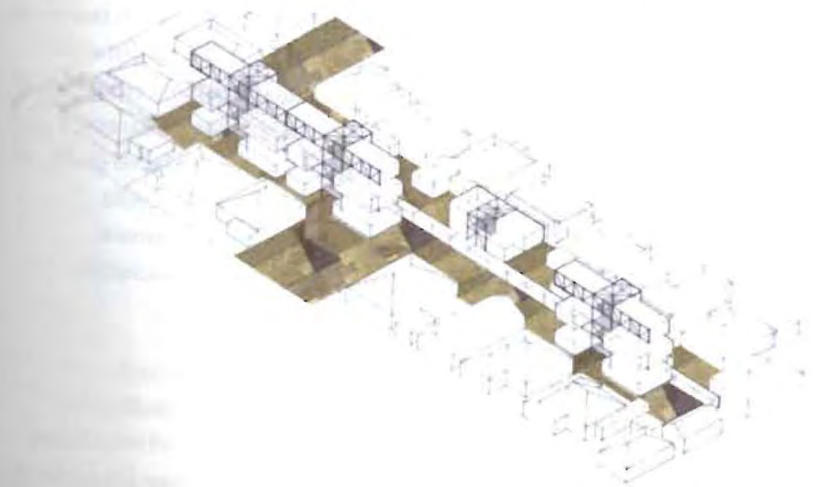
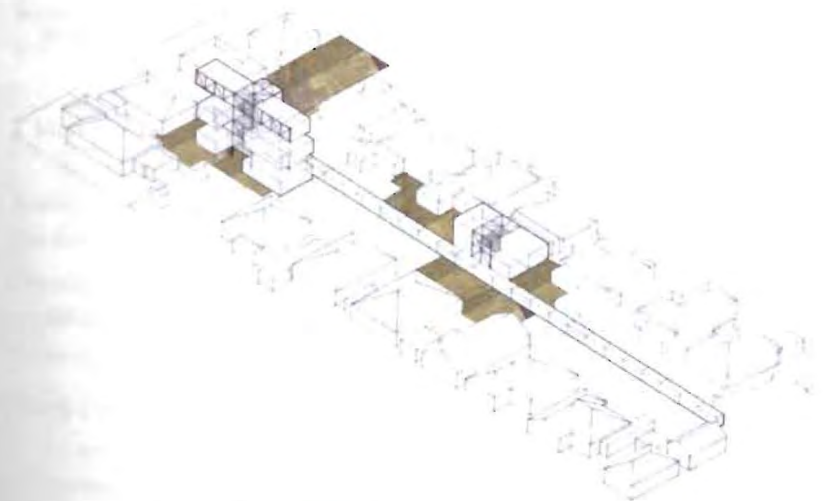

Conclusion

The preceding analysis of The Metabolists' principles and Cape Town's residential infrastructure has provided a platform to explore the re-imagining of the city's suburban environment.

The Metabolists advocated a belief in an architecture that was in a constant state of change. By considering the city as a living and mutable entity they suggested that the city could regenerate its life through the constant renewal of its parts. In this way, The Metabolists' principles provide a method that can explore the possibility of creating a 'symbiotic environment' that would encourage greater interaction within suburbia – between nature, cultures and its built form.

The analysis of Cape Town's extractive and excretive demands paints a dire picture of the city's current infrastructural network. Cape Town has an extremely limited supply of water, with the residential sector accounting for 59% of total water usage of which 60% of this fresh water is used to transport sewage. In addition, the city is dependent on an excessively long-distance energy supply line. The residential sector is currently the highest consumer of electricity in the city and contributes the greatest proportion of gaseous emissions into the atmosphere. Finally, only 8% of the 736 000 tons of waste being generated by the residential sector is recycled annually. Cyclic metabolism requires infrastructure to mimic the processes of natural ecosystems resulting in the extractive demands equalling the excretive outputs.

A Project for a Suburb of the Future seeks reconciliation of the suburb of Plumstead to its natural environment. The conception of the (sub)urban organism is regarded as a process to restore the severed link of nature and suburbia to a productive landscape. By coupling the (sub)urban organism to locally bound resources, which support multiple renewable fuel sources, the suburb and nature rediscover their balance. The inclusion of complexity,

diversity and variety became integral in initiating a shift from a largely homogenous to a more heterogeneous (sub)urban environment.

In the Architectural Digest, *The Work of Team 10* (1965), Kenzo Tange makes the statement

The true vitality in any creative activity must derive from the confrontations to reality – the reality which is a dilemma. There is no vitality where no dilemma exists or nobody sees the reality as a dilemma.⁹

The reality is that the suburban model has failed to create a successful and sustainable living environment. This project presents an approach to challenge the status quo with the hope of an improved (sub)urban environment and a more sustainable future.

List of Figures

Section A

Re-aligning the Natural - (Sub)urban Symbiosis:
A case for Metabolic Architecture

Fig. 1. Author. Energy Harvesting Nodes

Fig. 2. Author. Cyclic Architecture: Human + Nature + Mechanical

Fig. 3. Author. The Unified City

Fig. 4. Author. City of Process

Fig. 5. Source: Howard E., 1902, *Garden Cities of To-morrow*, Sonnenschein & Co., London

Fig. 6. Author. Plumstead

Fig. 7. Author. Plumstead

Fig. 8. Author. Plumstead Productive and Natural Land Comparative Study

Fig. 9. Source: Koolhaas R. & Obrist H., 2011, *Project Japan: Metabolism Talk...*, Taschen, Köln

Fig. 10. Source: Banham R., 1976, *Megastructure: Urban Futures of the Recent Past*, Thames & Hudson, London

Fig. 11. Source: <http://architecturalmoleskine.blogspot.com/2011/10/metabolism-movement/>, [Accessed 8 June 2012]

Fig. 12. Source: Kurokawa K., 1995, *The Architecture of the Age of Life Principles*, The Japan Architect, Vol 18

Fig. 13. Source: Kurokawa K., 1995, *The Architecture of the Age of Life Principles*, The Japan Architect, Vol 18

Fig. 14. Source: Kurokawa K., 1995, *The Architecture of the Age of Life Principles*, The Japan Architect, Vol 18

Fig. 15. Source: Brayer M. et al (eds), 2005, *Archilab's Urban Experiments: Radical Architecture, Art and the City*, Thames & Hudson, London

Fig. 16. Source: Brayer M. et al (eds), 2005, *Archilab's Urban Experiments: Radical Architecture, Art and the City*, Thames & Hudson, London

Fig. 17. Source: <http://www.domusweb.it/en/news/metabolism-the-city-of-the-future/>, [Accessed 23 May 2012]

Fig. 18. Source: Brayer M. et al (eds), 2005, *Archilab's Urban Experiments: Radical Architecture, Art and the City*, Thames & Hudson, London

Fig. 19. Source: Koolhaas R. & Obrist H., 2011, *Project Japan: Metabolism Talk...*, Taschen, Köln

Fig. 20. Source: Koolhaas R. & Obrist H., 2011, *Project Japan: Metabolism Talk...*, Taschen, Köln

Fig. 21. Source: Geddes P. & Thomas J. 1931, *Life: Outlines of General Biology*, Vol. 2, Williams & Norgate, London

Fig. 22. Source: Saarinen E., 1943, *The City: Its Growth, Its Decay, Its Future*, Reinhold Publishing Corporation, New York

Fig. 23. Author. Polycentric City

Fig. 24. Author. Function as Cell Types

Fig. 25. Author, Source: Banham R., 1976, *Megastructure: Urban Futures of the Recent Past*; Kurokawa K., 1995, *The Architecture of the Age of Life Principles*, The Japan Architect, Vol 18

Fig. 26. Author. Cluster Unit Supported by Hybrid Spine

Fig. 27. Author. The (Sub)urban Master Form

Fig. 28. Author. Symbiosis: Three-Dimensional Diagram

Fig. 29. Author. Symbiosis: Two-Dimensional Diagram

Fig. 30. Author. Model

Fig. 31. Author. Plumstead (Sub)urban Organism

Fig. 32. Author. Past + Present = Future

Section B:

(Sub)urban Infrastructure:

An Analysis of Cape Town's Residential Metabolism

Fig. 1. Author. Source: Adapted from GIS image

Fig. 2. Author. Source: Adapted from GIS image

Fig. 3. Author. Source: Adapted from Gasson B., The Ecological Footprint of Cape Town

Fig. 4. Author. Source: Adapted from Gasson B., The Ecological Footprint of Cape Town

Fig. 5. Author. Source: Statistics from, Pieterse E.(ed), Counter Currents: Experiments in Sustainability in the Cape Town Region

Fig. 6. Author. Source: Statistics from, Small K., 2007 Community Survey Analysis for Cape Town

Fig. 7. Author. Source: Statistics from, Small K., 2007 Community Survey Analysis for Cape Town

Fig. 8. Author. Source: Adapted from, Gasson B., The Biophysical Environment of Metropolitan Cape Town in An Overview of Development Problems in the Cape Town Metropolitan Area

Fig. 9. Author. Source: Adapted from, Gasson B., The Biophysical Environment of Metropolitan Cape Town in An Overview of Development Problems in the Cape Town Metropolitan Area

Fig. 10. Author. Source: Statistics from, Gasson B., The Ecological Footprint of Cape Town

Fig. 11. Author. Source: Adapted from, Gasson B., The Biophysical Environment of Metropolitan Cape Town in An Overview of Development Problems in the Cape Town Metropolitan Area

Fig. 12. Author. Source: Statistics from, City of Cape Town, State of Energy Report for the City of Cape Town 2007

Fig. 13. Author. Source: Adapted from, Gasson B., The Biophysical Environment of Metropolitan Cape Town in An Overview of Development Problems in the Cape Town Metropolitan Area

Fig. 14. Author. Source: Statistics from, City of Cape Town, State of Energy Report for the City of Cape Town 2007

Fig. 15. Author. Source: Adapted from, Gasson B., The Biophysical Environment of Metropolitan Cape Town in An Overview of Development Problems in the Cape Town Metropolitan Area

Fig. 16. Author. Source: Adapted from, Gasson B., The Biophysical Environment of Metropolitan Cape Town in An Overview of Development Problems in the Cape Town Metropolitan Area

Fig. 17. Author. Source: Adapted from, Gasson B., The Biophysical Environment of Metropolitan Cape Town in An Overview of Development Problems in the Cape Town Metropolitan Area; City of Cape Town, <http://www.capetown.gov.za/en/Solidwaste2/Wastedisposal>, [Accessed 4 June 2012]

Fig. 18. Author. Source: Adapted from, Gasson B., The Biophysical Environment of Metropolitan Cape Town in An Overview of Development Problems in the Cape Town Metropolitan Area

Fig. 19. Author. Source: Adapted from, Gasson B., The Biophysical Environment of Metropolitan Cape Town in An Overview of Development Problems in the Cape Town Metropolitan Area

Fig. 20. Author. Suburban Boundary as Cyclic Metabolism

Section C

Re-aligning the Symbiosis of Plumstead:
A Project for a Suburb of the Future

Fig. 1. Author. Source: Adapted from GIS image

Fig. 2. Author. Source: Adapted from GIS image and Corbusier the Radiant City

Fig 3. Author. Source: Adapted from Gasson B., The Ecological Footprint of Cape Town

Fig 4. Author. Source: Adapted from GIS image, Statistics from, City of Cape Town

Fig. 5. Author. Suburban Linear Metabolism

Fig. 6. Author. Suburban Cyclic Metabolism

Fig. 7. Author. (Sub)urban Re-alignment Strategies

Fig. 8. Author. (Sub)urban Organism

Fig. 9. Author. Source: Cape Archives M3/19

Fig. 10. Author. Source: Cape Archives M3/29 – M3/30

Fig. 11. Author. Source: Geography Department

Fig. 12. Author. Source: Geography Department

Fig. 13. Author. Source: Trigonometry Survey Office, Mowbray

Fig. 14. Author. Hybrid Buildings

Fig. 15. Author. The Complete Suburb

Fig. 16. Author. Source: Statistics from, Rainfall: South African Weather Bureau, Solar Radiation: www.crses.sun.ac.za, Wind and Air Temperature: www.windguru.cz [Accessed 12 August 2012]

Fig. 17. Author. Plumstead Active Context: Rainwater Resources

Fig. 18. Author. Plumstead Active Context: Solar Energy

Fig. 19. Author. Integrated Resource Reuse Strategy

Fig. 20. Author. Integrated Resource Reuse Strategy: Connections

Fig. 21. Author. Integrated Resource Reuse Strategy: Scales of Functionality

Fig. 22. Author. (Sub)urban Organism

Fig. 23. Author. Hi_brid Spine Proportion study using the Modular

Fig. 24. Author. (Sub)urban Organism: Humanity

Fig. 25. Author. (Sub)urban Organism: Infrastructural Web

Fig. 26. Author. (Sub)urban Organism: Infrastructural Web

Fig. 27. Author. Plumstead Existing Infrastructure

Fig. 28. Author. Infrastructural Web: Attaching onto Existing Infrastructure

Fig. 29. Author. (Sub)urban Organism: Hybrid Node

Fig. 30. Author. (Sub)urban Organism: Hybrid Node

Fig. 31. Author. Source: Statistics from, CSIR, Summary Guidelines and Standards for the Planning of Social Facilities and Recreational Spaces in Metropolitan Areas

Fig. 32. Author. (Sub)urban Organism: EcoBlock

Fig. 33. Author. (Sub)urban Organism: EcoBlock

Fig. 34. Author. (Sub)urban Organism: EcoBlock

Fig. 35. Author. (Sub)urban Organism: Hybrid House

Fig. 36. Author. (Sub)urban Organism: Hybrid House

Fig. 37. Author. (Sub)urban Organism: Hybrid House: Resource Systems

Fig. 38. Author. (Sub)urban Organism: Hybrid House: Public Function

Fig. 39. Author. (Sub)urban Organism: Hi_brid Spine

Fig. 40. Author. (Sub)urban Organism: Hi_brid Spine

Fig. 41. Author. (Sub)urban Organism: Hi_brid Spine: habitation

Fig. 42. Author. (Sub)urban Organism: Hi_brid Spine: habitation

Fig. 43. Author. Process Section: Cluster Unit with gantry for adding/replacing units

Fig. 44. Author. Cluster Unit Supported by Hi_brid Spine

Fig. 45. Author. (Sub)urban Organism: Hi_brid Spine: Prefabricated Spine Module

Fig. 46. Author. (Sub)urban Organism: Hi_brid Spine: Prefabricated Spine Module

Fig. 47. Author. (Sub)urban Organism: Hi_brid Spine: Process of Occupation

References

Section A

Re-aligning the Natural - (Sub)urban Symbiosis: A case for Metabolic Architecture

- 1 – Feininger A., 1966, *Forms of Nature and Life*, Viking Press, New York:,p. 19
- 2 – Kurokawa, K., 1977, *Metabolism in Architecture*, Studio Vista, London
- 3 – Daly C., 1864, *L'Architecture privée au XIX siècle sous Napoleon III*, Morel, Paris
- 4 – Fishman R., 1987, "Bourgeois Utopias: Visions of Suburbia" from *Bourgeois Utopias: The Rise and Fall of Suburbia*, Basic Books , New York
- 5 – Nicolaidis B. & Wiese A. (eds), 2006, *The Suburban Reader*, Routledge, London
- 6 – Wolman A., 1965, *The Metabolism of Cities*, Scientific America, Vol 213, Nr 3
- 7 – Lefebvre, H., 1971, *The Production of Space*, Blackwell, Oxford
- 8 – Wackernagel M. & Rees W., 1996, *Our Ecological Footprint – Reducing Human Impact on the Earth*, New Society Publishers, Canada
- 9 – Kurokawa, K., 1977, *Metabolism in Architecture*, Studio Vista, London
- 10 – Collins G., 1979, *Visionary Drawings of Architecture and Planning 20th Century through the 1960s*, MIT Press, Massachusetts, p48
- 11 – Banham R., 1976, *Megastructure: Urban Futures of the Recent Past*, Thames & Hudson, London

- 12 – This definition is derived from <http://www.merriam-webster.com/dictionary/metabolism> [Accessed 1 May 2012]
- 13 – Crick F. & Watson J.D., 1953, *Nature* 171, 737–738. The structure of deoxyribonucleic acid (DNA) in chromosomes was discovered by James D. Watson and Francis Crick
- 14 – Geddes P., 1915, *Cities of Evolution*, Williams & Norgate, London
- 15 – Saarinen E., 1943, *The City: Its Growth, Its Decay, Its Future*, Reinhold Publishing Corporation, New York
- 16 – Lin Z., 2010, *Kenzo Tange and The Metabolist Movement: Urban Utopias of Modern Japan*, Routeledge, London, p.98
- 17 – Lin Z., 2010, *Kenzo Tange and The Metabolist Movement*, p.54
- 18 – Koolhaas R. & Obrist H., 2011, *Project Japan: Metabolism Talk...*, Taschen, Köln
- 19 – Kawazoe N., et al., 1960, *Metabolism 1960: The Proposals for a New Urbanism*, Bitjutsu Shuppan Sha
- 20 – Kurokawa K., 1995, *The Architecture of the Age of Life Principles*, The Japan Architect, Vol 18
- 21 – Fernández Per et al, 2011, *This is Hybrid*, a+t Architecture Publishers, Spain
- 22 – Klee P., 1961, "Ways or Nature Study." In *Notebooks: Volume One: The Thinking Eye*, Lund Humphries, London

Section B

(Sub)urban Infrastructure:

An Analysis of Cape Town's Residential Metabolism

- 1 – Sale K., 1991, *Dwellers in the Land: the Bioregional Vision*, New Society Publishers, Philadelphia
- 2 – City of Cape Town, 2011, *Cape Town Spatial Development Framework*, City of Cape Town
- 3 – Swilling, M. 2005. *Sustainability and Infrastructure Planning in South Africa: A Cape Town case study*. Environment & Urbanization 2005. International Institute for Environment and Development (IIED) Vol 18(1): 23-50.
- 4 – Gasson B., 1990, *The Biophysical Environment of Metropolitan Cape Town in An Overview of Development Problems in the Cape Town Metropolitan Area*, The Urban Problems Research Unit, Cape Town, p.130
- 5 – Gasson B., 2002, *The ecological footprint of Cape Town: unsustainable resource use and planning implications*, Paper presented at the National Conference of the South African Planning Institution, p.4
- 6 – Mammon N., 2005, *Cape Town 2025: Urban Form and Infrastructure*, Paper prepared for ISANDLA Institute
- 7 – Pieterse E.(ed), 2010, *Counter Currents: Experiments in Sustainability in the Cape Town Region*, Jacana Media, Auckland Park
- 8 – von Liebig, J., 1863, *The Natural Laws of Husbandry*, D. Appleton, New York, p. 261
- 9 – Gasson B., 2002, *The ecological footprint of Cape Town: unsustainable resource use and planning implications*, Paper presented at the National Conference of the South African Planning Institution
- 10 – Glossary, www.footprintnetwork.org/en/index.php/GFN/page/glossary, [Accessed 16 May 2012]
- 11 – Small K., 2008, *2007 Community Survey Analysis for Cape Town*, Strategic Development Information and GIS Department, City of Cape Town

- 12 – Statistics South Africa, 2008, *Community Survey, 2007 Basic Results: Municipalities*, Statistics South Africa
- 13 – Ghosh R., 2009, *New Geographies 2: Landscapes of Energy*, Harvard University Press, Massachusetts
- 14 – City of Cape Town, 2006, *City of Cape Town's Water Balance, Resource Planning & Management Report*, City of Cape Town
- 15 – Gasson B., 2002, *The ecological footprint of Cape Town: unsustainable resource use and planning implications*, Paper presented at the National Conference of the South African Planning Institution, p.8
- 16 – City of Cape Town, <http://www.capetown.gov.za/en/Water/>, [Accessed 16 May 2012]
- 17 – Gasson B., 2002, *The ecological footprint of Cape Town: unsustainable resource use and planning implications*, Paper presented at the National Conference of the South African Planning Institution, p.10
- 18 – Harald W. et al, 2005, *Cape Town energy futures: Policies and scenarios for sustainable city energy development*, Energy Research Centre, University of Cape Town
- 19 – City of Cape Town, 2008, *State of Energy Report for the City of Cape Town 2007*, City of Cape Town
- 20 – *Clean vs Dirty Energy*: <http://www.capeowngreenmap.co.za/go-green/energy>, [Accessed 16 May 2012]
- 21 – Sustainable Energy Africa, 2007, *Energy: City of Cape Town Integrated Analysis Baseline Report*, Sustainability Institute, Stellenbosch
- 22 – Harald W. et al, 2005, *Cape Town energy futures: Policies and scenarios for sustainable city energy development*, Energy Research Centre, University of Cape Town
- 23 – City of Cape Town, 2011, *Cape Town 2011: State of Energy and Futures Report*, City of Cape Town, p.26

-
- 24 – Harald W. et al, 2005, *Cape Town energy futures: Policies and scenarios for sustainable city energy development*, Energy Research Centre, University of Cape Town, p.8
 - 25 – Gasson B., 2002, *The ecological footprint of Cape Town: unsustainable resource use and planning implications*, Paper presented at the National Conference of the South African Planning Institution, p.7
 - 26 – City of Cape Town, 2012, *2011/2012 Solid Waste Management Sector Plan for City of Cape Town*, City of Cape Town p.7
 - 27 – Pieterse E.(ed), 2010, *Counter Currents: Experiments in Sustainability in the Cape Town Region*, Jacana Media, Auckland Park, p.85
 - 28 – Gasson B., 2002, *The ecological footprint of Cape Town: unsustainable resource use and planning implications*, Paper presented at the National Conference of the South African Planning Institution, p.14
 - 29 – City of Cape Town, 2011, *Water Services Development Plan for City of Cape Town*, City of Cape Town
 - 30 – Haskins C., 2012, *Cape Town's sustainable approach to urban stormwater management*, City of Cape Town: Catchment, Stormwater and River Management Branch, p.3
 - 31 – City of Cape Town, 2010, *State of the Environment Report 2009*, City of Cape Town, p.41
 - 32 – Gasson B., 2002, *The ecological footprint of Cape Town: unsustainable resource use and planning implications*, Paper presented at the National Conference of the South African Planning Institution, p.12
 - 33 – City of Cape Town, 2011, *Cape Town 2011: State of Energy and Futures Report*, City of Cape Town, 27

Section C

Re-aligning the Symbiosis of Plumstead:

A Project for a Suburb of the Future

- 1 – *History of Plumstead*: <http://www.ancestry24.com/history-of-plumstead>, [Accessed 5 June 2012]
- 2 – Venturi R., 1977, *Complexity and Contradiction in Architecture*, The Museum of Modern Art, New York
- 3 – Jacobs J., 2000, *The Death and Life of Great American Cities*, Pimlico, London
- 4 – McDonough W. & Braungart M., 2002, *Cradle to Cradle: Remaking the Way We Make Things*, Farrar, Straus and Giroux, New York
- 5 – Mammon N., 2005, *Cape Town 2025: Urban Form and Infrastructure*, Paper prepared for ISANDLA Institute
- 6 – City of Cape Town, 2006, *City of Cape Town's Water Balance, Resource Planning & Management Report*, City of Cape Town
- 7 – City of Cape Town, 2011, *Cape Town 2011: State of Energy and Futures Report*, City of Cape Town
- 8 – City of Cape Town, 2010, *State of the Environment Report 2009*, City of Cape Town
- 9 – Tange K., 1960, *The Work of Team 10*, in *Architectural Digest*, May 1960