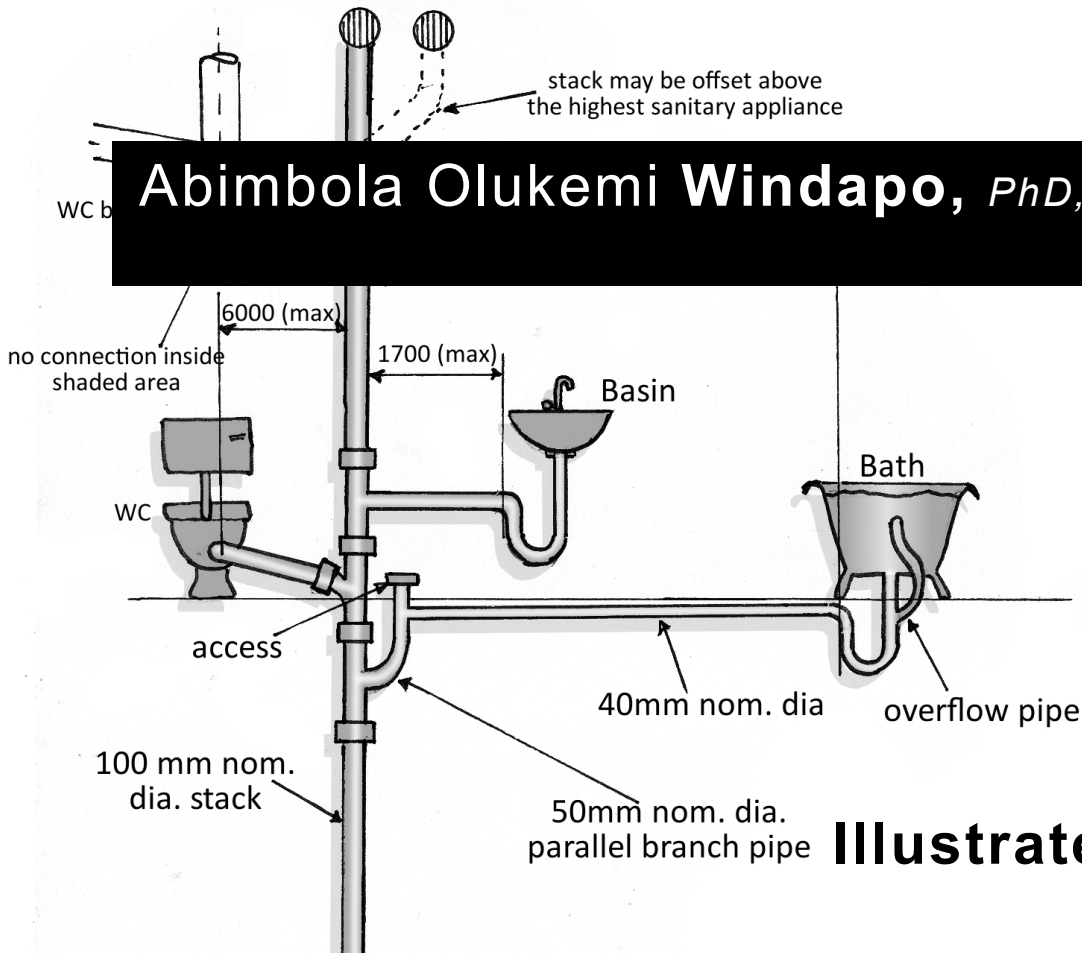


# BUILDING SERVICES STUDY GUIDE

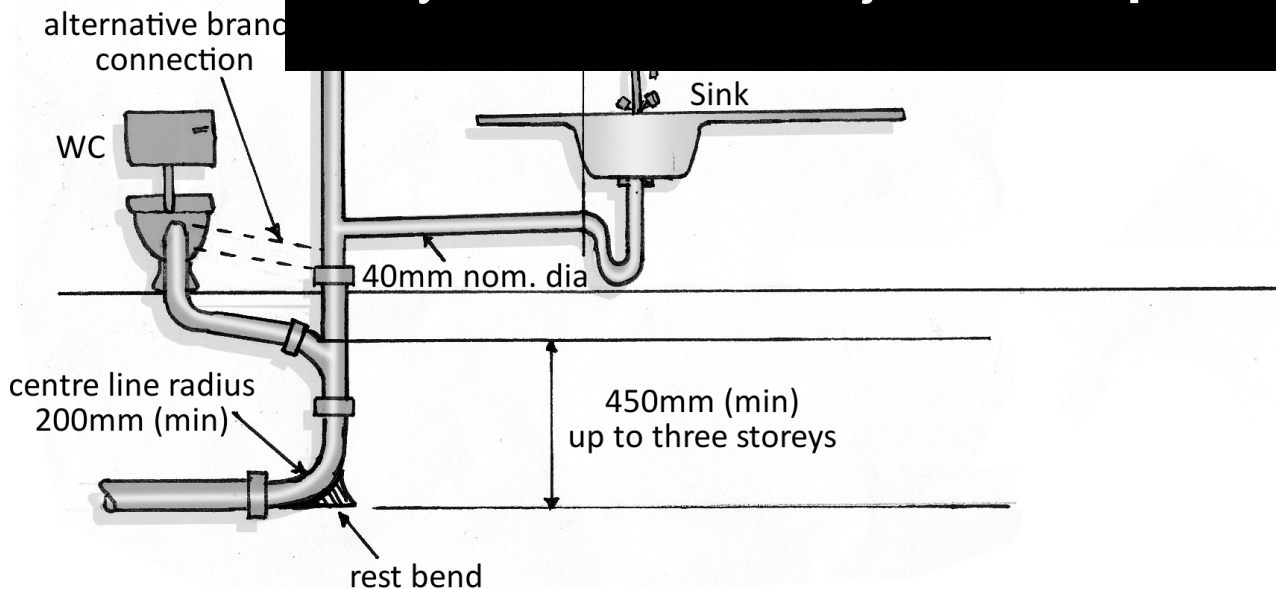
Compiled By

**Abimbola Olukemi Windapo, PhD, PrCM, FNIOB**



Illustrated By

**Bayonle Olanrewaju Windapo, BAS**



© Building Services Study Guide 1<sup>st</sup> Edition

Cover image: Bayonle Windapo

ISBN 978-0-7992-2492-4

This work is licensed under a Creative Commons Attribution-NonCommercial-No-Derivs 2.5 Generic license. You are free to copy, distribute and transmit the work on condition that the source is attributed. A copy of this license is viewable at: <http://creativecommons.org/licenses/by-nc-nd/2.5/>



# FOREWARD

This book is based on a series of lecture notes used by the author for teaching Construction and Building Technology at University of Lagos, Caleb University, Lagos, and University of Cape Town between 1996 and 2012. The book is also based on research undertaken, personal work experience of the author, and other contemporary construction and building technology literature.

Dr. Abimbola Windapo  
[Abimbola.windapo@uct.ac.za](mailto:Abimbola.windapo@uct.ac.za)  
Dept. of Construction Economics and Management  
University of Cape Town

## Acknowledgements

Heartfelt gratitude goes to the following individuals who have supported and contributed to this publication in various ways:

- Bayonle Windapo: Design, images and layout
- James Rotimi: Advice and Peer Review
- Glenda Cox: UCT OER support

# TABLE OF CONTENTS

<b>FOREWARD</b> .....	<b>3</b>
<b>Acknowledgements</b> .....	<b>3</b>
<b>DRAINAGE / PLUMBING INSTALLATION</b> .....	<b>10</b>
<b>DEFINITION</b> .....	<b>10</b>
<b>FUNCTION OF DRAINAGE INSTALLATION</b> .....	<b>10</b>
<b>DRAINAGE PROBLEMS</b> .....	<b>10</b>
<b>SANITARY PLUMBING SYSTEMS</b> .....	<b>11</b>
The Single Stack System: .....	12
The One-Pipe System:.....	13
The Two-Pipe System:.....	14
The 'Sovent' System: .....	15
<b>FACTORS THAT AFFECT THE CHOICE OF DRAINAGE SYSTEM</b> .....	<b>16</b>
<b>REGULATORY REQUIREMENTS FOR DRAINAGE INSTALLATION IN SOUTH AFRICA</b> .....	<b>16</b>
Pipes: .....	17
Sanitary Fixtures:.....	18
Single Stack System:.....	18
<b>NBRI Recommendations - Single Stack System:</b> .....	<b>25</b>
Two-Pipe System: .....	26
<b>Sizing of Discharge Pipes</b> .....	<b>28</b>
<b>Ventilating Pipes</b> .....	<b>29</b>
<b>Installation of Discharge and Ventilating Pipes</b> .....	<b>30</b>
<b>Traps and Water Seals</b> .....	<b>32</b>
<b>Foul Water Drains Below Ground</b> .....	<b>36</b>
<b>Parts of Foul Water Drain Below Ground Level</b> .....	<b>36</b>
Drain .....	36
Gullies .....	37
Rodding Eye .....	40
Inspection Eyes.....	41
Manholes and Inspection Chambers .....	41
Ventilation of Drains .....	43
<b>DRAIN PIPE MATERIALS</b> .....	<b>43</b>
Rigid Pipes: .....	43
Flexible Pipes:.....	44
<b>SEWAGE DISPOSAL</b> .....	<b>46</b>
Connection to Public Sewer:.....	46
Septic Tank and French Drain:.....	46
Conservancy Tank: .....	49
<b>COLD WATER SUPPLY</b> .....	<b>50</b>
<b>INTRODUCTION</b> .....	<b>50</b>
<b>THE SOURCE OF WATER</b> .....	<b>53</b>
Service Pipe: .....	53
<b>COLD WATER DISTRIBUTION SYSTEM</b> .....	<b>54</b>
Pipe Layout: .....	54
Pipe Location and Fixing: .....	54
Pipe Materials:.....	54
Pipe Cleaning: .....	55
Pipe Jointing: .....	55
Control and Isolating Valves: .....	55
<b>Cistern Feed Cold Water Distributing Pipe System</b> .....	<b>57</b>
<b>HOT WATER DISTRIBUTION SYSTEM</b> .....	<b>60</b>

Central Hot Water Supply .....	61
Local Hot Water Supply .....	64
<b>ELECTRICITY SUPPLY .....</b>	<b>68</b>
<b>INTRODUCTION .....</b>	<b>68</b>
<b>Entry and Intake of Electrical Service into a Building .....</b>	<b>71</b>
<b>ELECTRIC CABLES .....</b>	<b>73</b>
<b>ELECTRICAL INSTALLATION .....</b>	<b>74</b>
Conduits: .....	75
Trunking: .....	76
<b>POWER CIRCUITS .....</b>	<b>77</b>
Ring circuits: .....	77
Lighting Circuits: .....	78
<b>Electrical Accessories for Power and Lighting Circuits .....</b>	<b>79</b>
Cooker control units and fused connector units .....	79
Socket Outlets .....	79
Plugs .....	80
Switches .....	80
Lamp holders .....	81
<b>POWER DEMAND AND ENERGY CONSUMPTION OF DOMESTIC APPLIANCES .....</b>	<b>82</b>
Example: .....	83
<b>FUSE OR MINIATURE CIRCUIT BREAKER (MCB) PROTECTION .....</b>	<b>84</b>
Rewirable fuses (semi-enclosed fuses) .....	84
High breaking or rupturing capacity fuses (HBC or HRC) cartridge fuses .....	85
Miniature Circuit Breaker (MCB) .....	86
<b>HEATING, VENTILATING AND AIR-CONDITIONING (HVAC) SYSTEMS .....</b>	<b>88</b>
<b>INTRODUCTION .....</b>	<b>88</b>
<b>HEATING SYSTEMS .....</b>	<b>88</b>
General Concept: .....	88
<b>HEATING SYSTEMS AND APPLIANCES .....</b>	<b>89</b>
Electric Space Heating Systems .....	89
Direct heaters: .....	89
Indirect or Storage Heaters: .....	93
Hot Water Heating Systems .....	95
Low Temperature Hot Water Heating Systems: .....	95
High Temperature Pressurized Hot Water Heating Systems: .....	100
Solar Space Heating .....	106
District Heating System .....	106
Warm Air Heating Systems .....	110
<b>VENTILATION OF BUILDINGS .....</b>	<b>112</b>
Natural Ventilation .....	112
Stack Effect .....	113
Wind Effect .....	113
Ventilation & Heating for an Assembly Hall or Similar Building .....	114
Passive Stack Ventilation (PSV) .....	114
Mechanically Assisted Ventilation Systems (MAVS) .....	115
Mechanical Ventilation with Heat Recovery (MVHR) .....	116
Mechanical Ventilation Systems .....	117
Spot Ventilation .....	120
<b>Appliances used with the Ventilation Systems .....</b>	<b>120</b>
Ducts .....	120
Fans .....	120
Propeller fan .....	120
Axial flow fan .....	122
Bifurcated axial flow fan .....	122
Cross-flow or tangential fan .....	122
Centrifugal fan .....	122

<b>AIR CONDITIONING .....</b>	<b>125</b>
<b>Difference between Air conditioning and Ventilation:.....</b>	<b>125</b>
<b>COOLING SYSTEMS .....</b>	<b>125</b>
Compressive Refrigeration .....	125
Heat Pumps.....	126
<b>FACTORS TO CONSIDER IN THE PLACEMENT OF AIR-CONDITIONING EQUIPMENT AND DISTRIBUTION SYSTEM .....</b>	<b>127</b>
<b>TYPES OF HVAC SYSTEMS .....</b>	<b>128</b>
All-Air Systems .....	128
b. All-Water Systems.....	130
Air-Water Systems.....	131
Packaged Systems.....	132
Rooftop packaged units .....	132
Split-packaged systems .....	133
Small terminal units .....	134
<b>AIR-CONDITIONING SYSTEMS.....</b>	<b>134</b>
<b>AIR DISTRIBUTION OUTLETS .....</b>	<b>135</b>
1. Diffusers .....	135
2. Registers.....	135
<b>FIRE PROTECTION OF BUILDINGS .....</b>	<b>137</b>
<b>Characteristics of Materials Used for Fire Protection.....</b>	<b>137</b>
Materials commonly used to provide Fire Protection .....	137
Minimum Steps to be taken for Fire Protection in Buildings: .....	137
<b>Devices used for Fire Protection.....</b>	<b>139</b>
1. FIRE DETECTORS .....	139
Smoke Detectors: .....	139
Heat Detectors: .....	140
Light Obscuring Detector: .....	141
Laser beam: .....	142
Radiation Fire Detectors:.....	142
2. SPRINKLERS.....	143
The Wet Sprinkler System:.....	144
The Dry Sprinkler System: .....	144
The Alternative Wet and Dry System: .....	144
Types of Sprinkler Head: .....	144
Quartzoid Bulb-Type Head - .....	144
Fusible Soldered Strut-Type Head:.....	145
Duraspeed Soldered-Type Head:.....	146
3. DRENCHERS .....	146
4. HOSE REELS .....	148
5. GAS EXTINGUISHING SYTEMS .....	148
Halon and Halon Substitutes:.....	148
Carbon dioxide: .....	149
6. PRESSURIZATION OF ESCAPE ROUTES .....	149
7. SMOKE EXTRACTION AND VENTILATION .....	150

# LIST OF FIGURES

Figure 1 Water Seal Loss by Poor System Design and/or installation .....	11
Figure 2: Single Stack System in a Residential Building–Groups of Appliance ....	12
Figure 3: Fully Vented One-Pipe System .....	13
Figure 4: The Two-Pipe System .....	14
Figure 5: ‘Sovent’ System in a Residential Building .....	15
Figure 6: PVC Drainage Pipes .....	18
Figure 7: Sub rule PP15.1 (d): Supplementary vent stacks and cross-connections .....	20
Figure 8: Enlargement of Foot of Stack and Radius.....	21
Figure 9a: Sub rule PP15.1 (g): Single-stack system: Provision of vent pipe at offset in discharge stack .....	21
Figure 9b: Sub rule PP15.1 (g): Venting offsets in Discharge Stacks – Single Stack System.....	22
Figure 10: Sub rule PP15.1 (k): Single Stack System: Connection of waste and soil branches to discharge stack .....	22
Figure 11: Single Stack Drainage Systems – General Design Requirements .....	23
Figure 12: Single Stack Drainage Systems – Requirements for Residential Buildings (Groups of Appliances) – 25 Floors Maximum.....	24
Figure 13: Sub rule PP15.4: One-Pipe System.....	26
Figure 14: Sub rule PP15.5: Two Pipe System.....	27
Figure 15: Rule PP15: The Family of Discharge Pipes.....	28
Figure 16: Sub rule PP19.1 (d): Connection of Stack Vent to Discharge Stack ....	30
Figure 17: Sub rule PP20.4: Height of Ventilating Pipe .....	32
Figure 18: Types of ‘P’ Trap .....	33
Figure 19: Basin ‘S’ Trap Coupled to Waste Outlet .....	34
Figure 20: Bath ‘P’ Trap Coupled to Waste and Overflow Outlet .....	34
Figure 21: Double Trap Siphonic Pan with Close Coupled Cistern .....	35
Figure 22: Wash Down Pan – Cradle Hung with Flushing Valve .....	35
Figure 23: Drains Below Ground – General Requirements.....	37
Figure 24: Ground Floor Soil Appliance Connection to Drain.....	38
Figure 25: Ground Floor Waste Appliance Discharge to Trapped Gully.....	39
Figure 26: Stub Stack means of connecting a Waste Pipe directly to a Drain – without a Gully Trap .....	39
Figure 27: Sub rule PP21.1 (f): Rodding Eyes .....	40
Figure 28: Cut-away view of typical Manhole.....	42
Figure 29a: Typical Domestic Septic Tank.....	47
Figure 29b: Typical Domestic Septic Tank and French Drain.....	48
Figure 30: Typical Conservancy Tank – capacity to be prescribed by Local Authority .....	49
Figure 31: Traditional method of water supply to South African urban dwellings..	50
Figure 32: Method of water supply to South African urban dwellings due to higher mains supply pressure .....	51
Figure 33: Method of water supply to South African urban dwellings with the use of Pressure Reducing Valves.....	52
Figure 34: Hot and cold water supply – typical domestic installation; direct mains supply – balanced high pressure at fittings .....	56
Figure 35: Cold water storage cistern .....	57
Figure 36: Cold water distributing system for a two-floor residential building .....	59
Central hot water storage and supply                      Local hot water supply .....	60
Figure 37: Hot water supply systems .....	60
Figure 38: Hot water distributing pipe system .....	61
Figure 39: Galvanised Mild Steel and Copper Hot Water Storage Cylinders .....	63
Figure 40: Electrical Supply Intake Details with Meter Box inside the Building ....	70
Figure 41: Electrical Supply Intake Details with Meter Box located on the external wall .....	71

Figure 42: Layout of incoming service cable, meter boxes and consumer control unit.....	72
Figure 43: Electrical Cables .....	73
Figure 44: Cable Ratings .....	74
Figure 45: Rewire-able Systems housed in horizontal conduits.....	75
Figure 46: Typical Conduit Fittings.....	76
Figure 47: Typical Ring Main Wiring Diagram .....	77
Figure 48: Typical Lighting Circuit.....	78
Figure 49: Recommended Fixing Heights for Sockets .....	79
Figure 50: Internal section of a fused plug .....	80
Figure 51: A rewirable/semi-enclosed fuse .....	84
Figure 52: A cartridge fuse.....	85
Figure 53: A Typical Electromagnetic MCB.....	86
Figure 54: General Concepts of Heat Transfer.....	89
Figure 55: Infra-red Direct Heaters.....	90
Figure 56: Oil-filled Radiator .....	90
Figure 57: A Convector Heater.....	91
Figure 58: Parabolic Reflector Fire.....	91
Figure 59: A wall mounted panel heater.....	92
Figure 60: A wall mounted fan heater .....	92
Figure 61: Storage Radiator & Wiring to Consumer Control Unit .....	93
Figure 62: Storage Radiator .....	94
Figure 63: Section through Concrete Floor Slab to show installation of Heating Element.....	95
Figure 64: One-pipe ring low pressure hot water heating systems.....	96
Figure 65: One-pipe drop low pressure hot water heating systems.....	97
Figure 66: One-pipe ladder low pressure hot water heating systems .....	97
Figure 67: One-pipe parallel low pressure hot water heating systems .....	98
Figure 68: Two-pipe parallel low pressure hot water heating systems .....	98
Figure 69: Two-pipe return low pressure hot water heating systems .....	98
Figure 70: Two-pipe upfeed, Two-pipe drop and Two-pipe high level return low-pressure hot water heating systems respectively .....	99
Figure 71: Hospital and Column radiators .....	101
Figure 72: Panel and Pressed Profiled Steel Welded Panel Radiators .....	102
Figure 73: Convector heaters .....	102
Figure 74: Types of Radiant Panel Heaters .....	103
Figure 75: Convector Heater.....	103
Figure 76: Overhead Unit Heaters .....	104
Figure 77: Copper pipes used in the installation of the panel heating system....	105
Figure 78: Cross section of Floor slab showing Copper pipes used in heating...	105
Figure 79: Components of a Solar Space Heating System.....	106
Figure 80: Two-Pipe District Heating System.....	107
Figure 81: Two-Pipe District Heating System.....	108
Figure 82: Four-Pipe District Heating System .....	109
Figure 83: Return Air Duct .....	110
Figure 84: Warm Air Heating System .....	111
Figure 85: Air duct installation in concrete floor slab.....	111
Figure 86: Convected Air currents rising in tall building stack .....	113
Figure 87: Wind causing ventilation through windows .....	113
Figure 88: Ventilation for an assembly hall .....	114
Figure 89: PSV to a residential building.....	115
Figure 90: MAVS in a group of flats.....	115
Figure 91: Schematic of an MVHR system of ventilation .....	116
Figure 92: Mechanical Ventilation System in interior sanitary accommodation ..	117
Figure 93: Mechanical Ventilation System in Cafeteria kitchen .....	118
Figure 94: Mechanical Inlet and Mechanical Extract System .....	119
Figure 95: Air extraction through specially made light fittings .....	119
Figure 96: Rectangular Duct.....	121

Figure 97: Circular Duct.....	121
Figure 98: Propeller Fan .....	122
Figure 99: Bifurcated axial flow fan .....	123
Figure 100: Axial flow fan .....	123
Figure 101: Centrifugal Fan.....	124
Figure 102: Cross flow fan .....	124
Figure 103: Compressive Refrigeration .....	126
Figure 104: Method of operation of a Heat Pump .....	127
Figure 105: Single-duct, Constant-Air-Volume (CAV) system.....	129
Figure 106: Single-duct, Variable-Air-Volume (VAV) system.....	129
Figure 107: Dual-duct system .....	130
Figure 108: A Terminal Reheat system .....	130
Figure 109: A Two-Pipe All-Water System.....	131
Figure 110: A Four-Pipe All-Water System .....	131
Figure 111: Air-Water Systems .....	132
Figure 112: Rooftop packaged unit installed externally.....	133
Figure 113: Wall packaged unit installed externally.....	133
Figure 114: Split-packaged system.....	134
Figure 115: Small terminal air-conditioning systems units.....	134
Figure 116: Ceiling Diffusers .....	135
Figure 117: Register .....	135
Figure 118: Air grill, wall mounted and floor registers .....	136
Figure 119: Light Scattering or Optical Smoke Detector.....	139
Figure 120: Fusible Alloy Heat Detector.....	140
Figure 121: Bi-Metal Coil Heat Detector.....	141
Figure 122: Light Obscuring Detector .....	141
Figure 123: Laser Beam Detector.....	142
Figure 124: Components of an Infrared Detector.....	142
Figure 125: Infrared Detector for Large (Left) and Small Areas .....	143
Figure 126: Domestic Sprinkler Installation .....	143
Figure 127: Quartzoid Bulb-Type Head and Colour Coding.....	145
Figure 128: Fusible Soldered Strut-Type Head .....	145
Figure 129: Duraspeed Soldered Type Head .....	146
Figure 130: Drencher Installation .....	147
Figure 131: Window, Roof and Wall Drencher.....	147
Figure 132: Hose Reel Installation .....	148
Figure 133: Air Pressured Stairway .....	150
Figure 134: Fire in unvented building showing unrestricted spread of smoke ....	151
Figure 135: Fire in unvented building showing ultimate smoke logging.....	151
Figure 136: Fire in vented building showing restricted spread of smoke .....	152

# DRAINAGE / PLUMBING INSTALLATION

## DEFINITION

Drainage installation means an installation vested in the owner of a site and which is situated on such site and is intended for the reception, conveyance, storage or treatment of sewage, and may include sanitary fixtures, traps, discharge pipes, drains, ventilating pipes, septic tanks, conservancy tanks, sewage treatment works, or mechanical appliances associated therewith; (National Building Regulations, 1977).

## FUNCTION OF DRAINAGE INSTALLATION

The main requirement of drainage installation is that waste and soil water (solids and liquids) should be carried away quickly, quietly and effectively without blockage and without the escape of foul air into the building.

## DRAINAGE PROBLEMS

**Foul air** is prevented from escaping into the building by sealing off the drainage pipe system at the appliance with water seals contained in traps. **Water seals** are dips/traps in the pipe designed to retain water across the whole section of the pipe without restricting the passage of fluid or solid matter it is designed to take. However, these seals can be broken or become ineffective due to excessive air fluctuations in the pipe work.

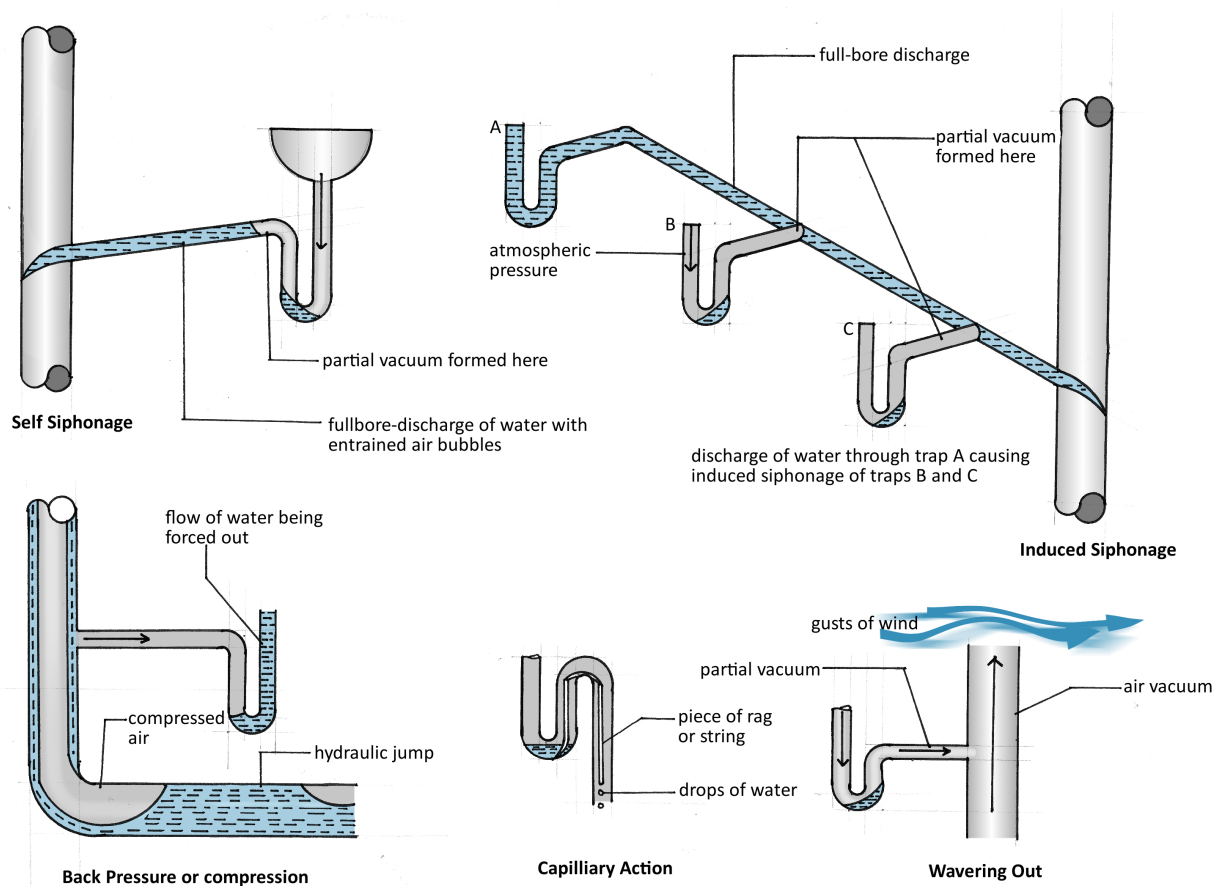
Water seal can be broken due to:

- i. Leakage due to defective fittings or poor workmanship;
- ii. Evaporation;
- iii. Poor system design and/or installation (see Figure 1 below):
  - **Self-siphonage**: as an appliance discharges, the water fills the waste pipe and creates a vacuum to draw out the seal. Causes are a waste pipe that is too long, too steep or too small in diameter.
  - **Induced siphonage**: the discharge from one appliance draws out the seal in the trap of an adjacent appliance by creating a vacuum in that appliance's branch pipe. Causes are the same as for self-siphonage, but most commonly a shared waste pipe that is undersized. Discharge into inadequately sized stacks can have the same effect on waste branch appliances.
  - **Back pressure** – compression occurs due to resistance to flow at the base of a stack. The positive pressure displaces water in the lowest trap. Causes are sharp bends being used where pipe stack converts to horizontal drain; too small radius bottom bend; an undersized stack; or the lowest branch fitting too close to the base of the stack.

- **Capillary action** – a piece of rag, string or hair caught on the trap outlet.
- **Wavering out** – gusts of wind blowing over the top of the stack can cause a partial vacuum to disturb water seals.

Due to the increase in size of installation and particularly the height of buildings, drainage problems including the following arose:

- How to ensure with economy of pipe work, that excessive pressure fluctuations do not occur which might affect the trap seals, thereby allowing air to escape through the traps of appliances; and
- How to estimate flows so that satisfactory but economical pipe sizes may be employed.



**Figure 1 Water Seal Loss by Poor System Design and/or Installation**

## SANITARY PLUMBING SYSTEMS

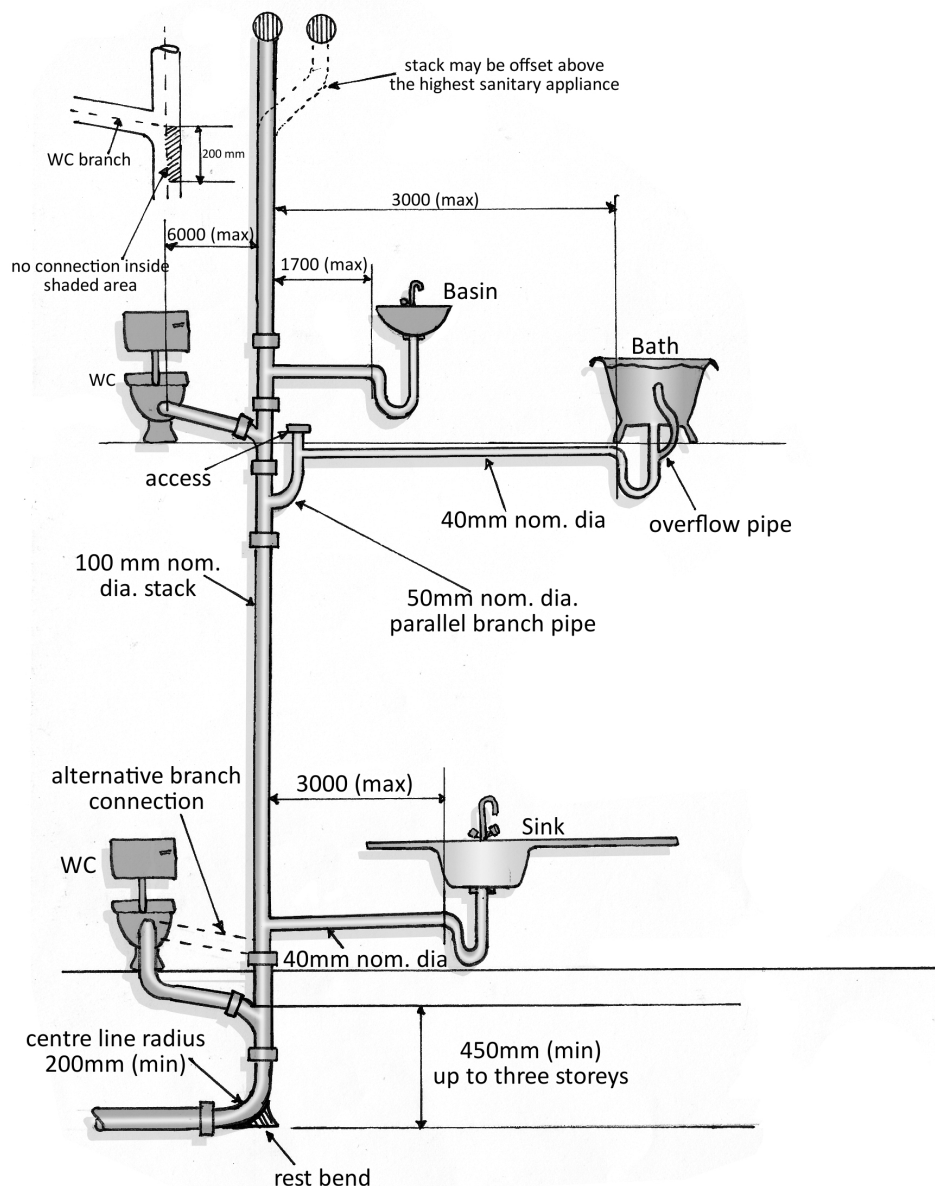
Except in the case of some ground floor appliances, sanitary appliances are connected to a vertical pipe or 'stack' having an open vent at its upper extremity. Single appliances may be connected directly to the stack, or groups, or batteries of appliances may discharge into horizontal branch pipes, which, in turn, connect to the stack.

To avoid the flow problems discussed earlier, various pipe systems have evolved. An understanding of the principles of these systems is a prerequisite to the understanding of regulations governing installations and the design of installations. Systems commonly used in South Africa are described below:

## The Single Stack System:

The British Research Establishment (BRE) developed the single stack system shown in Figure 2 during the 1960s, as a means of simplifying the extensive pipework previously associated with above ground drainage. According to Clark (1988) it is the simplest and most economical system

available for use in any environment. The concept is to group appliances around the stack with a separate branch pipe serving each. Individual traps are unvented and one stack serves as both the main discharge component and the ventilating component of an installation.



### Advantages:

- It is economical – there is savings in the length of pipework and duct space used; and
- Where pipework is exposed the appearance is less unsightly.

**Disadvantage** is that the branch pipe lengths and falls are constrained.

**Figure 2: Single Stack System in a Residential Building–Groups of Appliance**

The single stack system is not catered for in the outdated by-laws of many areas in South Africa, the system in a form slightly modified from the British

requirements, is permitted in terms of the National Building Regulations for use in residential and office buildings. According to Clark (1988), only when the design limits of the single stack system are exceeded should the one-pipe system be used.

### The One-Pipe System:

In this system, soil and waste discharge into one common stack. However, a common vent pipe serves all appliances, both soil and waste. The fully vented one-pipe system is used in buildings where there are a large number of sanitary appliances in ranges e.g. factories, schools, offices and hospitals.

The trap on each appliance is fitted with an anti-siphon or vent pipe. This must be connected within 300mm of the crown of the trap. Individual vent

pipes combine in a common vent for the range, which is inclined until it meets the vertical vent stack. This vent stack may be carried to outside air or it may connect to the discharge stack at a point above the spillover level of the highest appliance.

The base of the vent stack should be connected to the discharge stack close to the bottom rest bend to relieve any compression at this point. A typical One-Pipe system is shown in Figure 3.

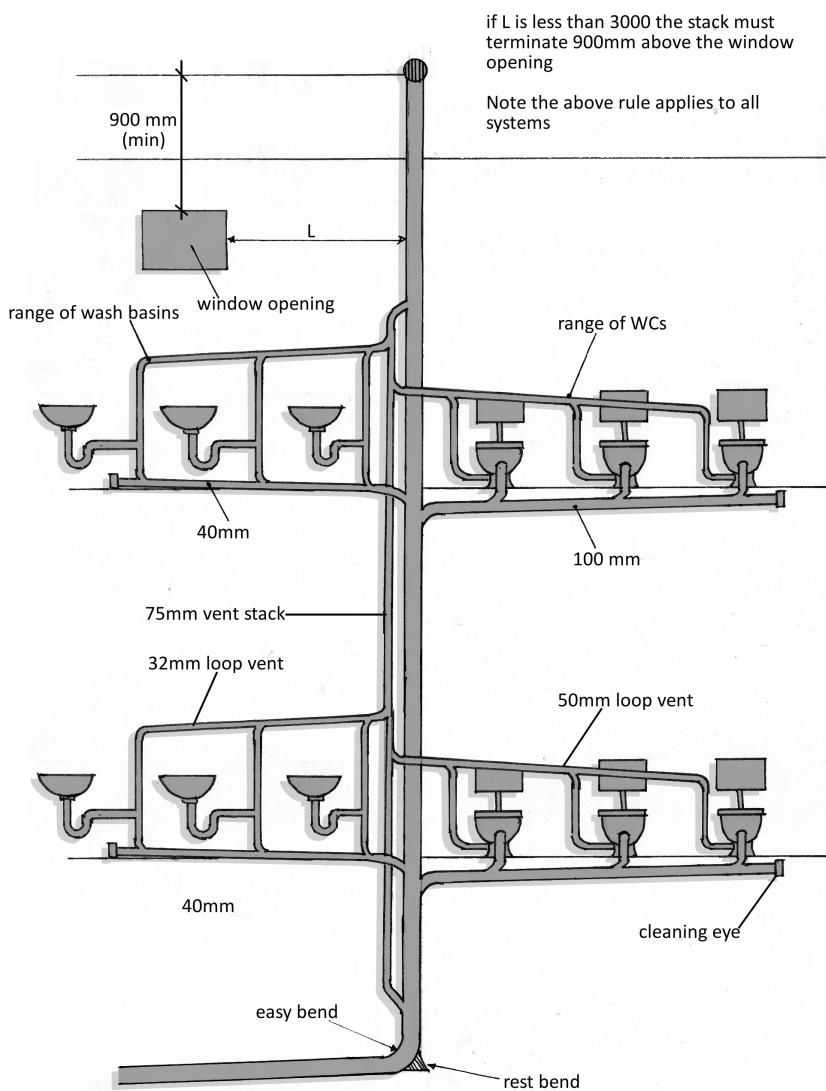


Figure 3: Fully Vented One-Pipe System

## The Two-Pipe System:

This system illustrated in Figure 4, was devised to comply with the demands for hygienic arrangements wherein, waste water from basin, bath, bidet and sink appliances and soil from WC and urinal were connected to separate stacks. For modern systems, the terms soil and waste pipes are generally replaced by the terminology, discharged pipes and discharge stacks.

Although relatively expensive to install, the Two-Pipe system due to the large outlay of pipework required, it is rarely used today and is being faced out of by-laws. However, it is still permissible and may be retained in existing buildings that are the subject of refurbishment. It may also be used where the sanitary appliances are widely spaced or remote and a separate waste stack is the only viable method for connecting these to the drain. A variation typical of 1930s dwellings has first floor bath and basin wastes discharging through the wall into a hopper. The waste stack from this and the ground floor sink waste discharge over a gully. A gully may be used as an alternative to a rest bend before the drain.

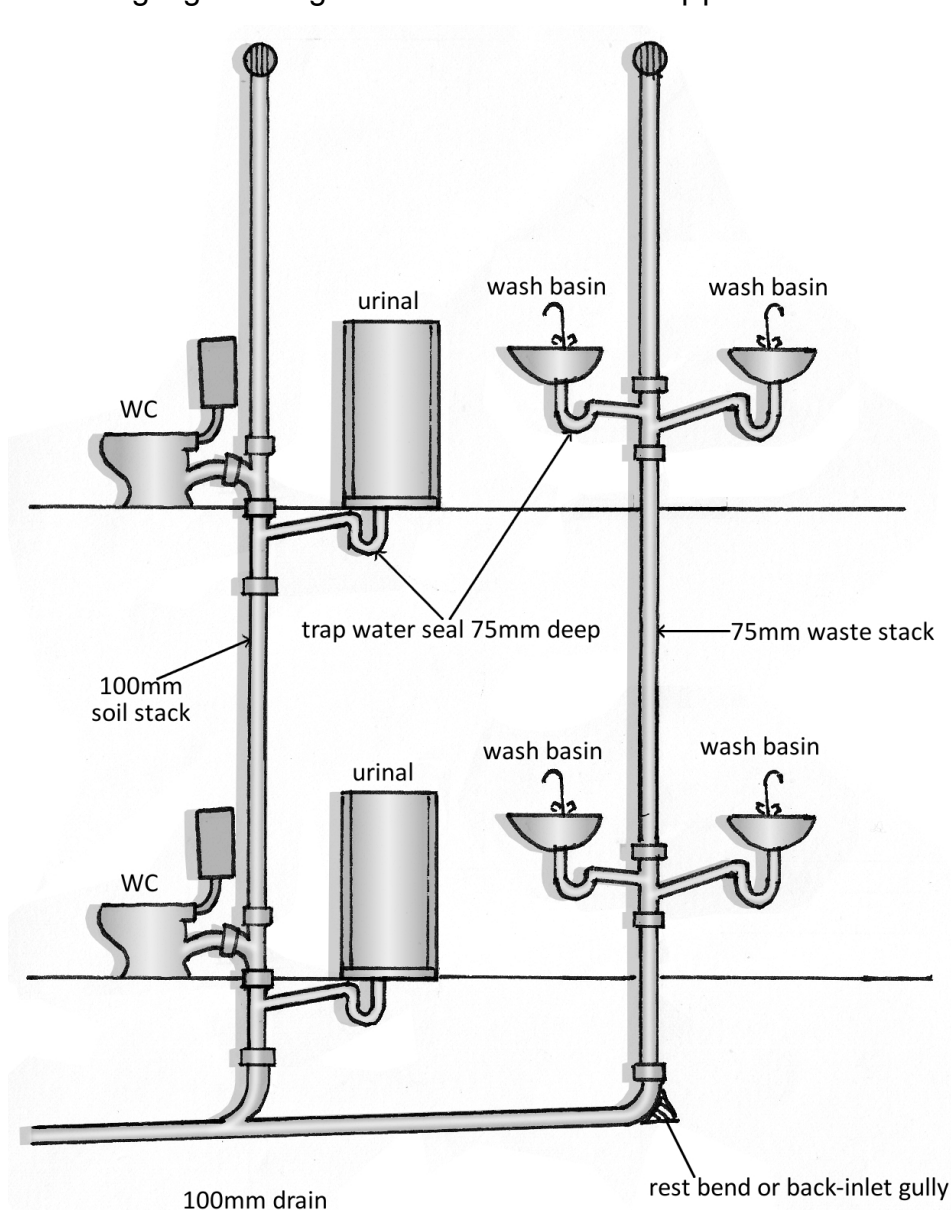


Figure 4: The Two-Pipe System

## The 'Sovent' System:

'Sovent' is an example of a patented system not covered by the regulations but permitted where designed by a professional engineer. Developed in Switzerland in 1959, the system is illustrated diagrammatically in Figure 5. Designed for use in residential buildings, it is basically a single stack system in which the flow capacity of the stack is increased by a special aerator fitting at the junction of the branches with the stack of particular floor.

### Advantages:

- Smaller stacks can be used;
- Eliminates the need for supplementary stack venting in high rise buildings; and
- Branches are designed to dispose effluent without the need for anti-siphon pipes.

Its major disadvantage is that it is expensive.

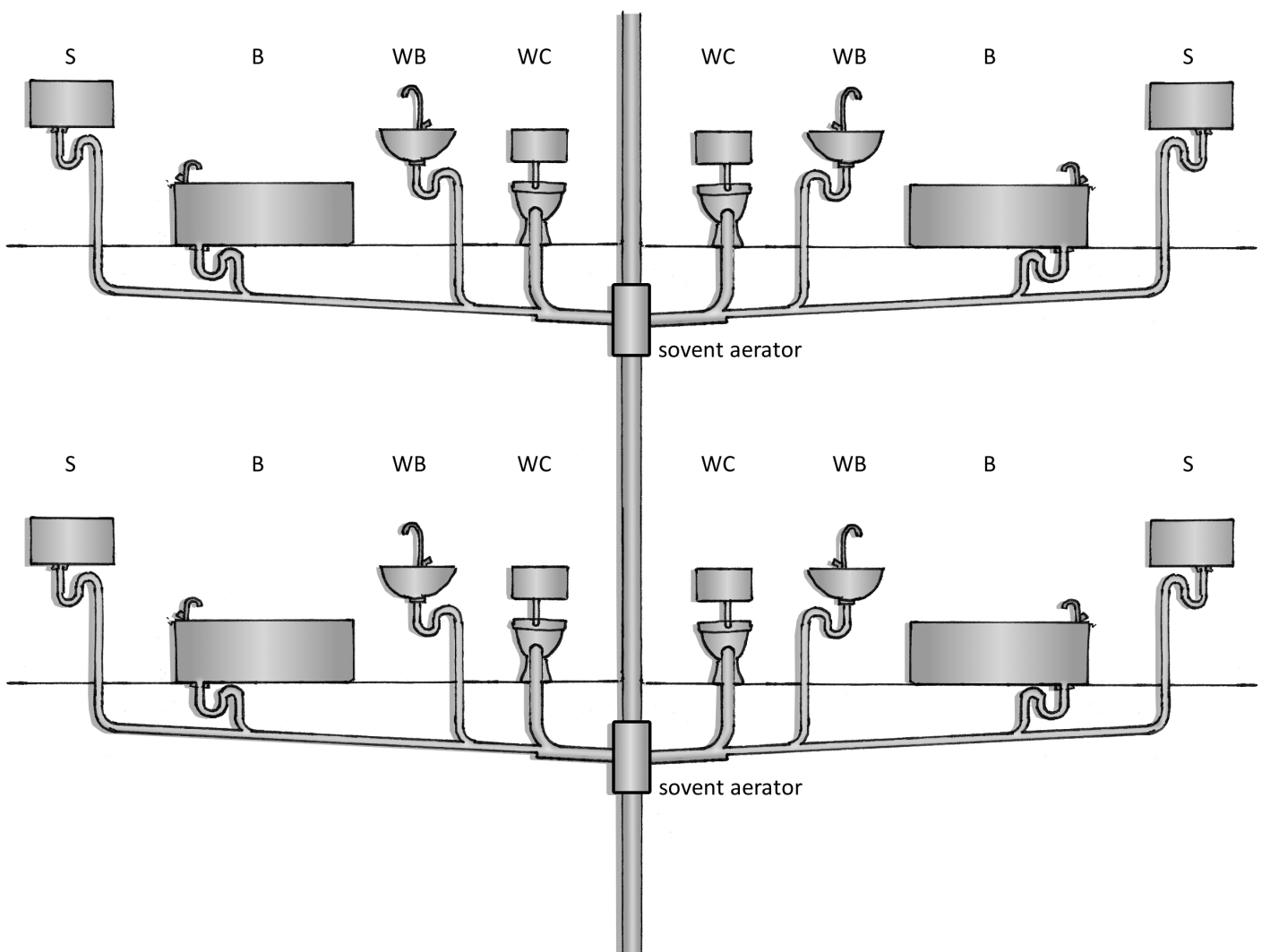


Figure 5: 'Sovent' System in a Residential Building

# **FACTORS THAT AFFECT THE CHOICE OF DRAINAGE SYSTEM**

According to Clark (1988), no system has all the answers and, although most systems can be used in most buildings, care should be taken to decide which system is the most suitable for a particular building. For an economical system, it can almost be given as a rule that anti-siphonage pipes should be avoided as far as possible.

When it is impossible to meet the requirements of the single stack system, the fully vented one-pipe system can be used. Generally, the single stack system is more economical up to about 10 floors. However, in planning an installation, the designer is required to work within the drainage regulations.

## **REGULATORY REQUIREMENTS FOR DRAINAGE INSTALLATION IN SOUTH AFRICA**

Part P of the National Building Regulations states the requirements for foul water drainage. It is important to note that the Regulations permit alternative rational design of installation (ref Clause P1 (1) (a) – which states that: “where in respect of any building a suitable means of disposal of waterborne sewage is available, the owner of such building shall provide a drainage installation) prepared by a ‘professional engineer’ or other approved competent person. Provision is made in the Regulations for compliance with one of three basic plumbing systems including ~

- Single Stack;
- One-Pipe; and
- Two-Pipe Systems.

Which are quite suitable for the more usual building types. It should be noted however that NBRI/CSIR recommend that the outdated two-pipe system should be avoided and that the one-pipe system should be used where the design limits of the single stack system are exceeded. Also, the two-pipe system application at ground floor installations, i.e. the use of gullies for all ground floor waste fixtures should be limited and regarded as the exception to the rule.

Areas dealt with by the Code of Practice include the following clauses:

PP2 Materials, Pipes, Fittings and Joints

PP3 Sanitary Fixture Standards

PP4 Standards for WC Pans

PP5 Standards for Urinals

PP6 Flexible Connectors for WC Pans

PP7 Electrical Sanitary Fixtures

PP8 Macerator Type Sanitary Towel-Disposers

PP9 Sewage Lifts

PP10 Conservancy Tanks, Septic Tanks and French Drains

PP11 Discharges from Washing Areas

PP12 Discharges from Swimming Baths, Swimming Pools, Fountains or Reservoirs  
PP13 Provision of Sanitary Fixtures  
PP14 Hydraulic Loading of Drainage Installations  
PP15 Drainage Systems  
PP16 Sizing of Discharge Pipes  
PP17 Sizing of Drains  
PP18 Protection of Water Seals  
PP 19 Sizing of Ventilating Pipes  
PP20 Installation of Discharge and Ventilating Pipes  
PP21 Access to Drainage Installation  
PP22 Provision of Traps  
PP23 Provision of Gullies  
PP24 Installation of Drains  
PP25 Common Drains  
PP26 Test for Drains  
PP27 Tests for Discharge Pipes and Ventilation Pipes  
PP28 In-situ Percolation Test for Soils

Please refer to: The National Building Regulations – An Explanatory Handbook by C. J. Freeman (1990) – for further explanation of these clauses. The definition section of the Code contains a large number of definitions relating to Part P. Some of which relate to specialized technical concepts, which are explained and illustrated where applicable below (other classifications should be looked up):

### **Pipes:**

Pipe means any number of pipes and fittings joined together to form a pipeline.

Clause PP2 Materials, Pipes, Fittings and Joints of the Code states that:

In any drainage installation any type of joint between pipes or between such pipes and fittings shall:

- (a) Be appropriate to the materials of which such pipes and fittings are made;
- (b) Remain watertight to the standard set in rule PP26 under normal working conditions or where there may be any differential movement between such pipes and any building or ground or other construction forming part of the drainage installation; and
- (c) Be able to withstand an internal water pressure of 50kPa and an external water pressure of 30kPa without leaking.

**Pipe Materials:** A thorough knowledge of the materials available for sanitary pipe-work, their particular characteristics and related costs is a necessary prerequisite to the selection of materials for a particular installation, and to ensure that the installation is carried out correctly. Full details are readily available from the manufacturers and suppliers of the various pipes and related fittings.

The traditional waste pipe materials are **lead** (now largely outdated) and **galvanized mild steel** (G.M.S) in conjunction with screwed fittings. Recently, **cast iron** screwed fittings have become available for use at low cost with G. M. S. pipes.

**Copper** used in conjunction with brass fittings is used in coastal areas.

**Stainless steel** often competes with copper and is used in coastal areas or where exposed in prestigious projects.

The new comers in this field have been the **plastic** pipes, polyvinylchloride



(PVC), polyethylene (PE), acrylonitrile-butadiene-styrene (ABS) and polypropylene (PP). According to Clark (1988) only PVC shown below, has made significant inroads into the South African market, where several UPVC soil, waste and vent pipe systems have been manufactured to SABS standards for a number of years.

**Figure 6: PVC Drainage Pipes**

### **Sanitary Fixtures:**

Means a receptacle to which water is permanently supplied, and from which wastewater or soil water is discharged.

Clause PP3 of the Code states that:

PP3.1 Any sanitary fixture shall be made of impermeable, non-corrosive material, shall have a smooth and readily cleanable surface and shall be so constructed and fitted as to discharge through a trap, into a soil pipe or waste pipe, as the case may be.

PP3.2 The water supply outlet to any waste fixture shall be situated not less than 20mm above the flood-level rim of such fixture: Provided that this requirement shall not apply to any bidet.

Types of sanitary fixtures include: Water Closets, Urinals, Bidets, Baths, Wash Hand Basins, Showers and Kitchen Sinks. Clause PP13 of the Code on Provision of Sanitary Fixtures states that: The number of sanitary fixtures to be provided in any building shall be based on the population for which such building is designed, and such population shall be calculated in terms of Regulation A21.

### **Single Stack System:**

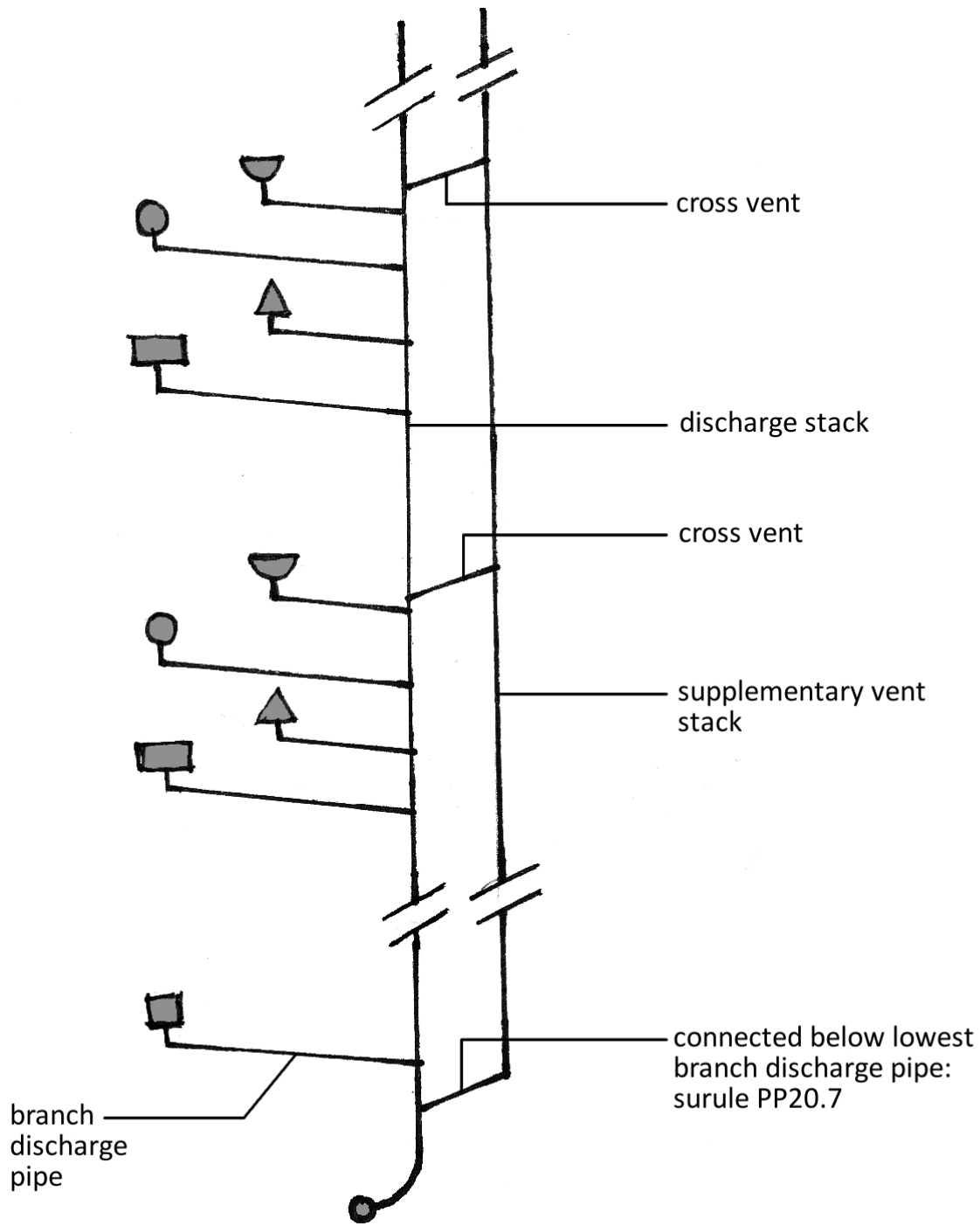
Means a particular one-pipe system in which trap vents are not required in terms of specific criteria set out in Part P of the NBR.

Clause PP15.1 of the Code states that the following **requirements** shall apply with regard to the single stack system:

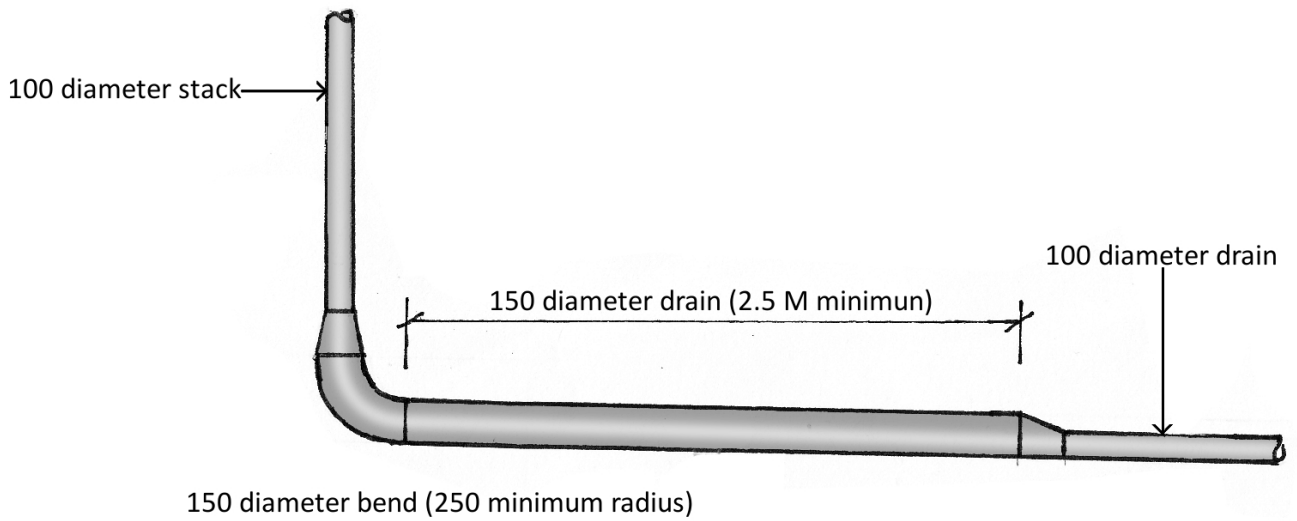
- (a) It shall only be installed where the building in question is of the office class, which has sanitary fixtures, installed in ranges or of the residential class, which has sanitary fixtures, installed in groups.

A 'group' comprises not more than one of each of a water closet, bath, shower and sink and either two washbasins or one washbasin and one bidet.

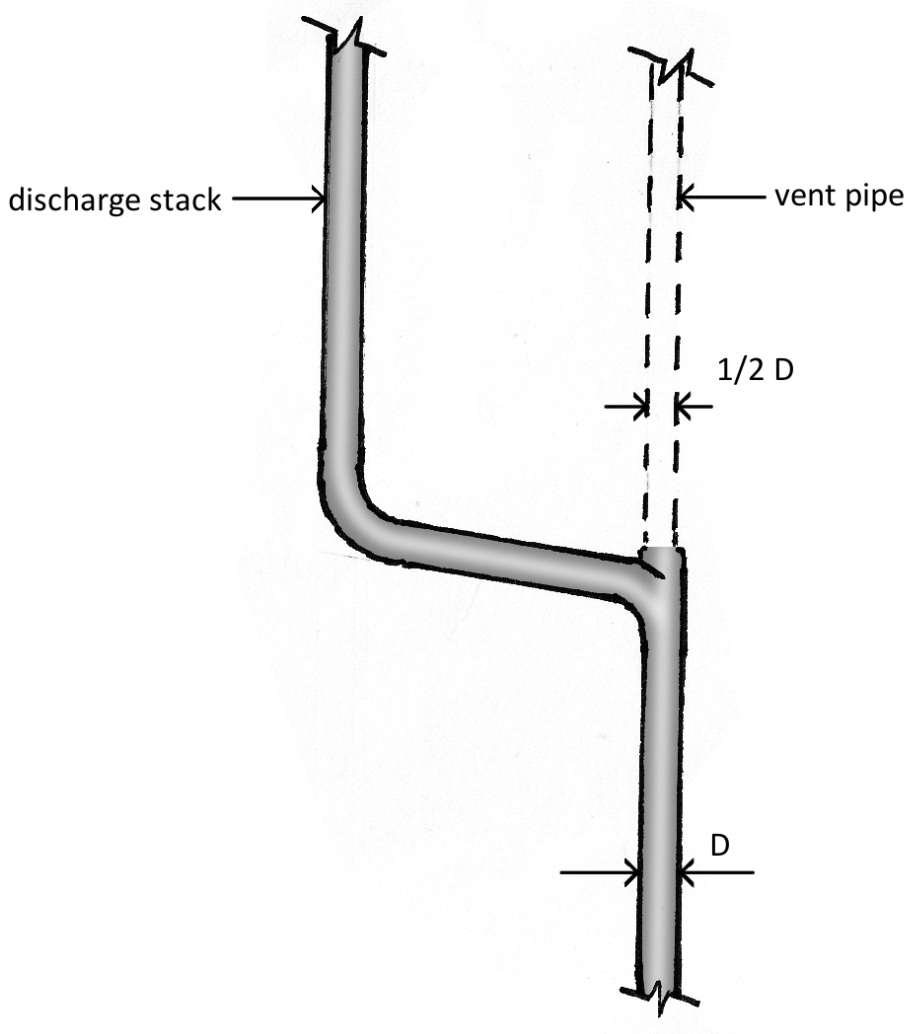
- (b) It shall not be installed in any residential building exceeding 30 floors in height or in any office building exceeding 25 floors in height above the lowest ground level.
- (c) No trap vents for the protection of any water seals shall be required in terms of this rule or in terms of sub rules PP15.2 or PP15.3.
- (d) Any supplementary vent stack contemplated in sub rules PP15.2 (additional requirements) or PP15.3 (office class buildings) shall be cross connected at each storey with the discharge stack above the level of the highest branch discharge pipe connection to the discharge stack (see Figure 7).
- (e) The discharge stack shall be continued upwards to form a stack vent.
- (f) The radius of the centre line of any bend at the foot of the discharge stack shall not be less than 300mm (see Figure 8).
- (g) No offset shall be made in any discharge stack unless a ventilating pipe is provided to reduce any pressure, which may be caused by the offset (see Figure 9a and 9b).
- (h) Every waste fixture trap shall be either a 'P' trap, which has a water seal of not less than 75mm in depth or shall be a resealing trap of the 'P' type.
- (j) The vertical distance between the invert of the lowest branch discharge pipe connected to any discharge stack and the invert of the bend at the foot of the stack shall not be less than –
- i. 450mm for stub stacks in single dwellings up to 3two storey's in height serving a maximum of two groups of sanitary fixtures;
  - ii. 750mm for stacks up to five storey's in height in other buildings; and
  - iii. One storey in height for stacks higher than five storeys.
- (k) Where any waste branch and any opposed soil branch from a WC pan are connected to any discharge stack, the centre line of such waste branch shall not intersect the centre line of such stack within 200mm below the intersection of the centre line of such soil branch with the centre line of such stack (see Figure 10).



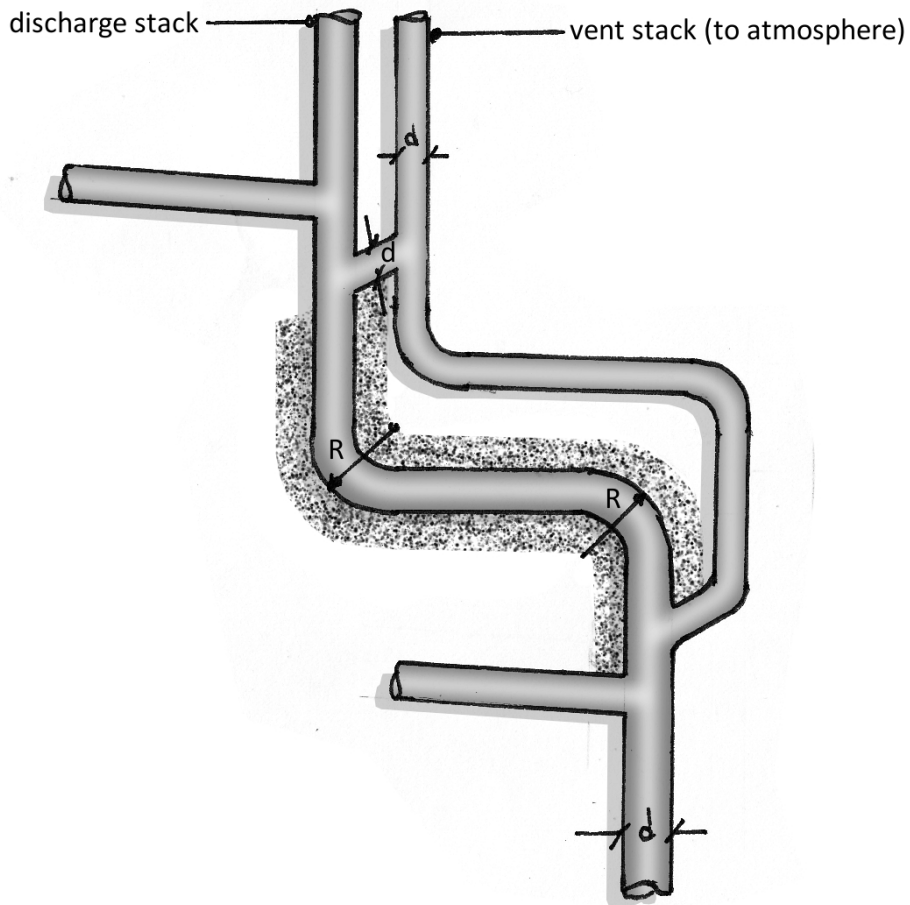
**Figure 7: Sub rule PP15.1 (d): Supplementary vent stacks and cross-connections**



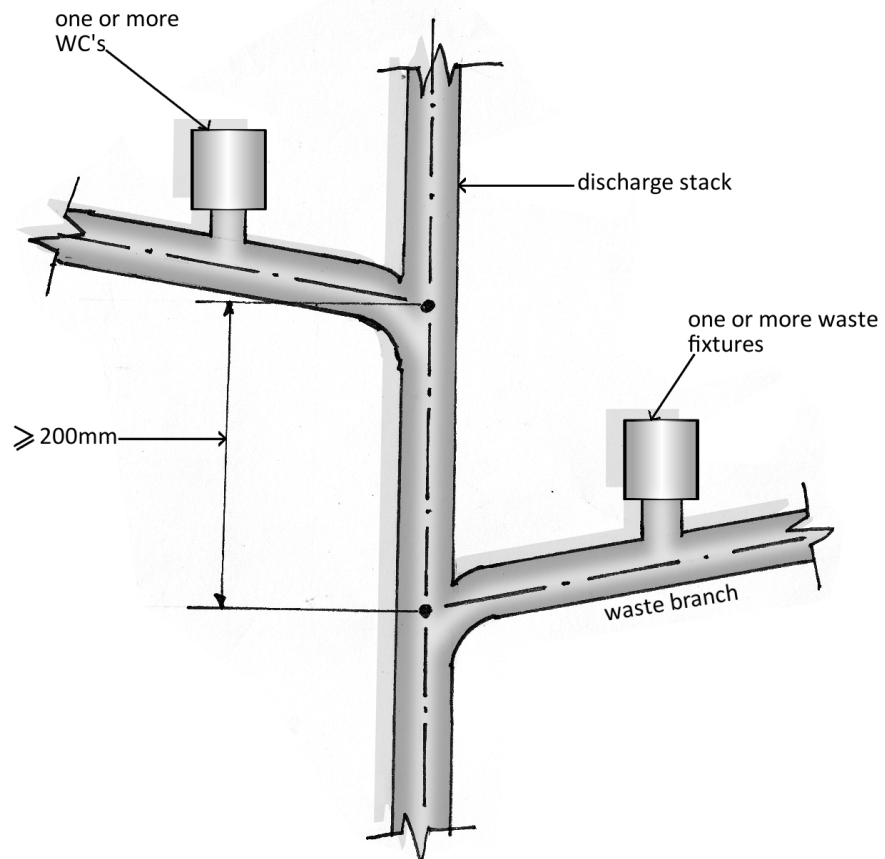
**Figure 8: Enlargement of Foot of Stack and Radius**



**Figure 9a: Sub rule PP15.1 (g): Single-stack system: Provision of vent pipe at offset in discharge stack**



**Figure 9b: Sub rule PP15.1 (g): Venting offsets in Discharge Stacks – Single Stack System**

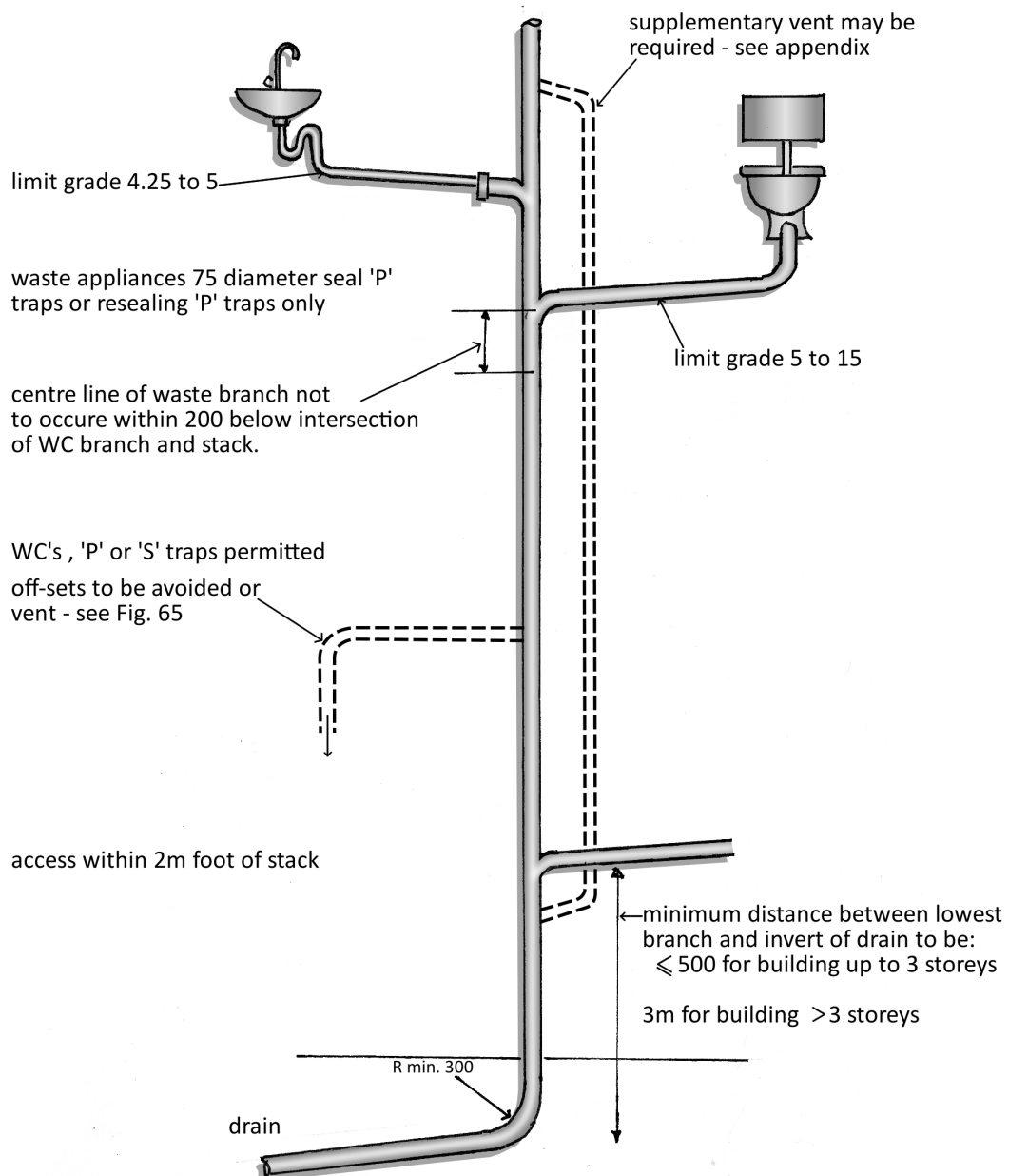


**Figure 10: Sub rule PP15.1 (k): Single Stack System: Connection of waste and soil branches to discharge stack**

PP15.2 the following **additional requirements** shall apply with regard to any single stack installation in any building where the occupancy is of residential class:

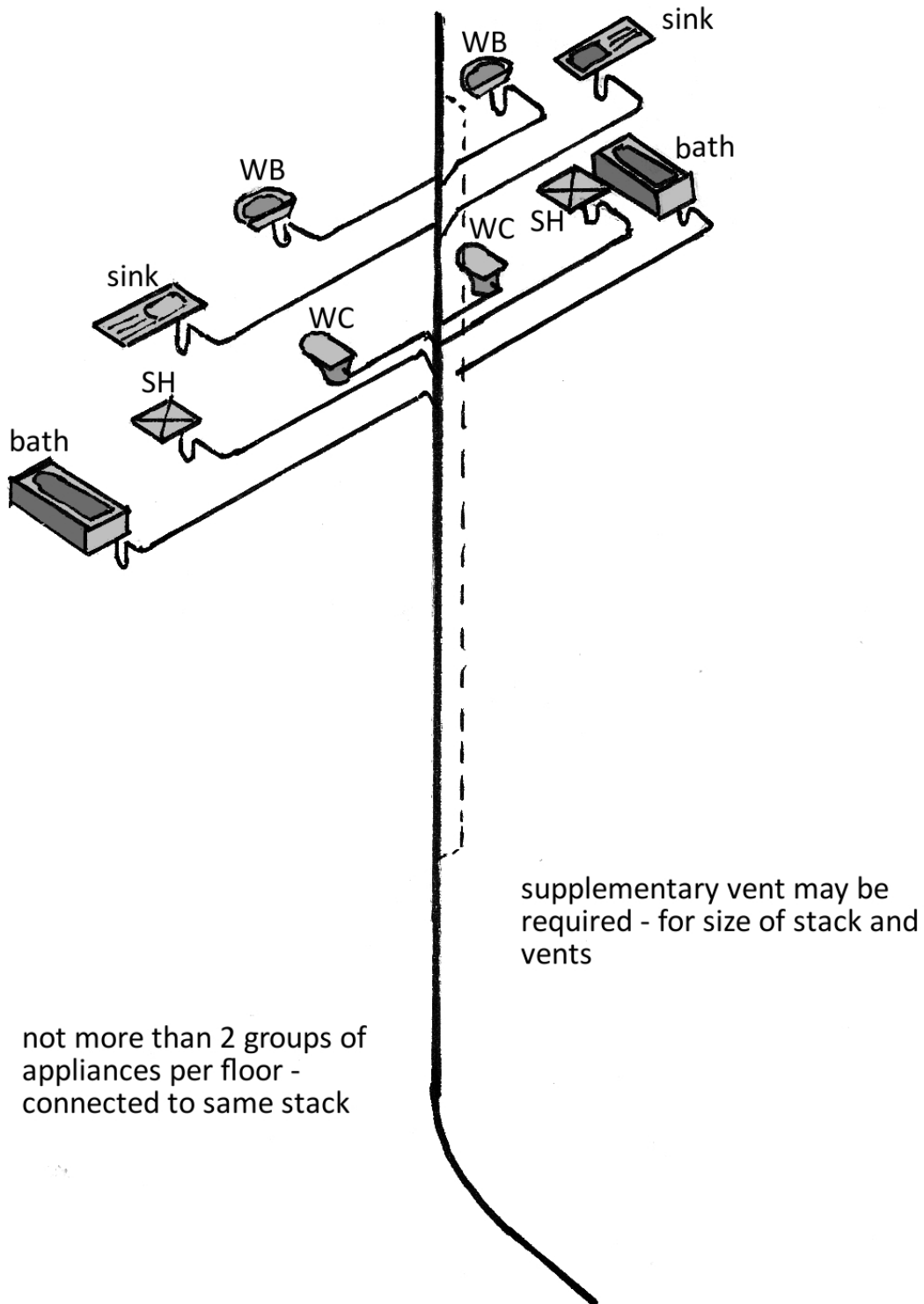
- (a) The fixture branch of any sanitary fixture in any sanitary group shall be separately connected to the discharge stack.
- (b) Where the trap fitted to any washbasin has a nominal diameter of 32mm, the internal diameter of the fixture branch serving such washbasin shall not be less than 40mm.
- (c) Not more than two sanitary groups installed in any one storey shall be connected to the same discharge stack.
- (d) A discharge stack of not more than two storeys in height serving a maximum of two groups of sanitary fixtures may discharge into a stub stack.
- (e) The minimum discharge stack size is 100mm for up to 10 floors and 150mm for 11 – 30 floors.

General design requirements for the single stack system are summarized in Figure 11.



**Figure 11: Single Stack Drainage Systems – General Design Requirements**

Additional requirements for residential buildings are summarized in Figure 12.



**Figure 12: Single Stack Drainage Systems – Requirements for Residential Buildings (Groups of Appliances) – 25 Floors Maximum**

## **NBRI Recommendations – Single Stack System:**

The following additional recommendations are made by NBRI, which are not specifically called for in the National Regulations:

- i. Offsets in the wet portion of a discharge stack should be avoided. When they have to be made, large-radius bends should be used and ventilation should be provided as shown in Figure 7.
- ii. WC branches should have entries at an angle of 45<sup>0</sup> into the stack.
- iii. Two 45<sup>0</sup> bends should preferably be used to form the radius of the bend at the foot of the stack.
- iv. Access for maintenance should be provided so that each internal part of the installation can be reached with cleaning equipment. It is preferable that traps, integral or separate, should be removable and that bends in branches be either long radius or provided with an access/rodding eye.

Access to the main stack should also be provided within 2m of the foot of the stack and at every third or fourth floor at a point immediately above the entry of the highest appliance branch on any particular floor.

It should be noted that most of these general requirements are not unique to the single stack system and are also applicable to vented systems.

## **One-Pipe System:**

Means a system of piping between sanitary fixtures and a drain in which both waste and soil water discharge down a common discharge stack and in which any trap venting or other venting that is required may be via a common vent stack;

PP15.4 the following requirements shall apply with regard to the one-pipe system (including the single stack system) as shown in Figure 13:

- (a) Any soil pipe shall be connected to another soil pipe, a stack or directly to a drain;
- (b) Any waste pipe shall be connected to another waste pipe, a soil pipe, a stack, directly to a drain or to a gully which shall be connected to a drain;
- (c) Any waste or any soil fixture trap may have a common ventilating pipe.

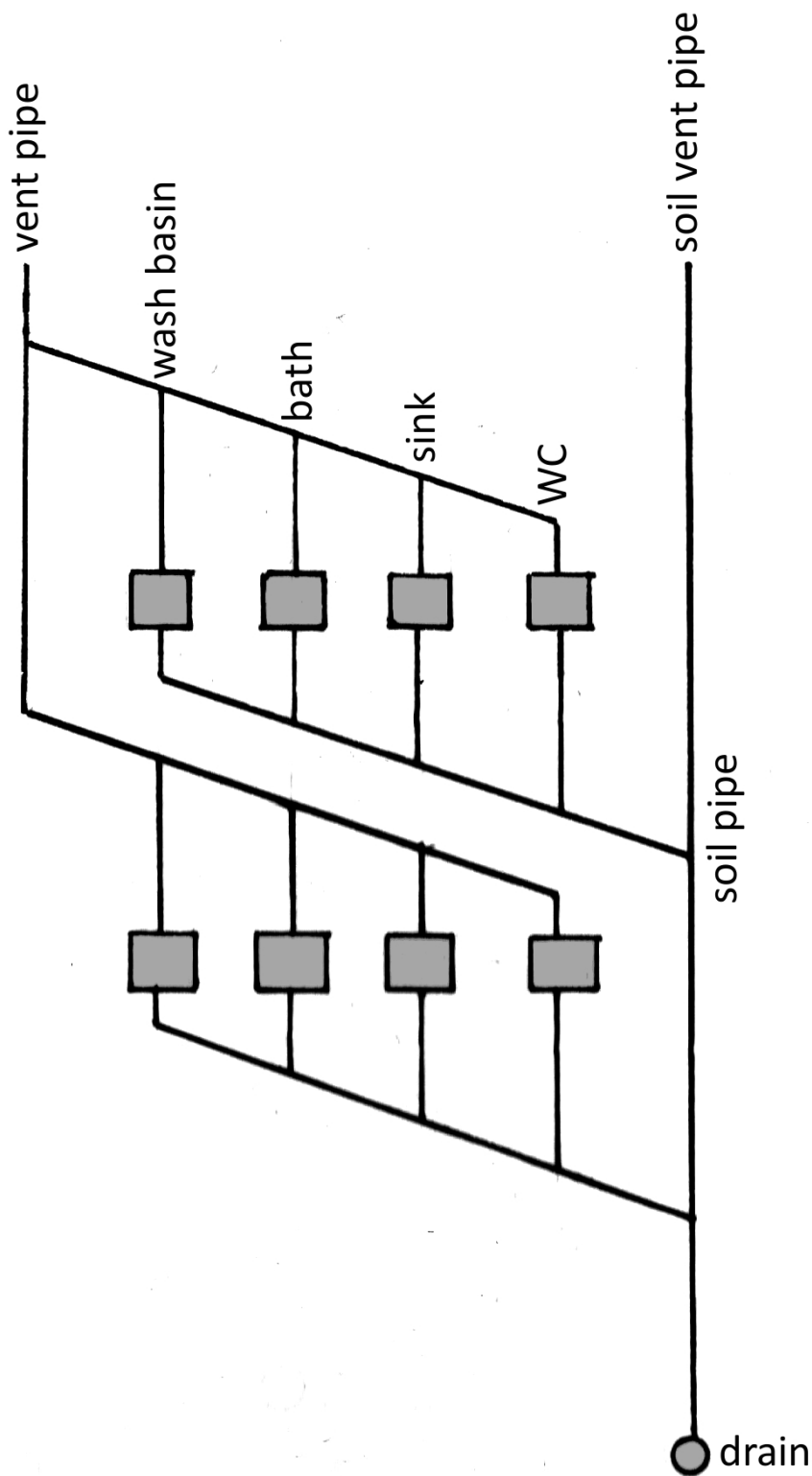


Figure 13: Sub rule PP15.4: One-Pipe System

### Two-Pipe System:

Means a system of piping between sanitary fixtures and a drain in which waste water and soil water discharge through separate discharge pipes and in which any trap venting or other venting that is required is via separate ventilating pipes for the waste and soil water systems.

PP15.5 the following requirements shall apply with regard to the two-pipe system shown in Figure 14:

- (a) Any soil pipe shall be connected to another soil pipe, a stack or directly to a drain;
- (b) Any waste pipe shall discharge into another waste pipe, a stack or to a gully which shall be connected to a drain;
- (c) Any waste and soil fixture traps shall be separately ventilated.

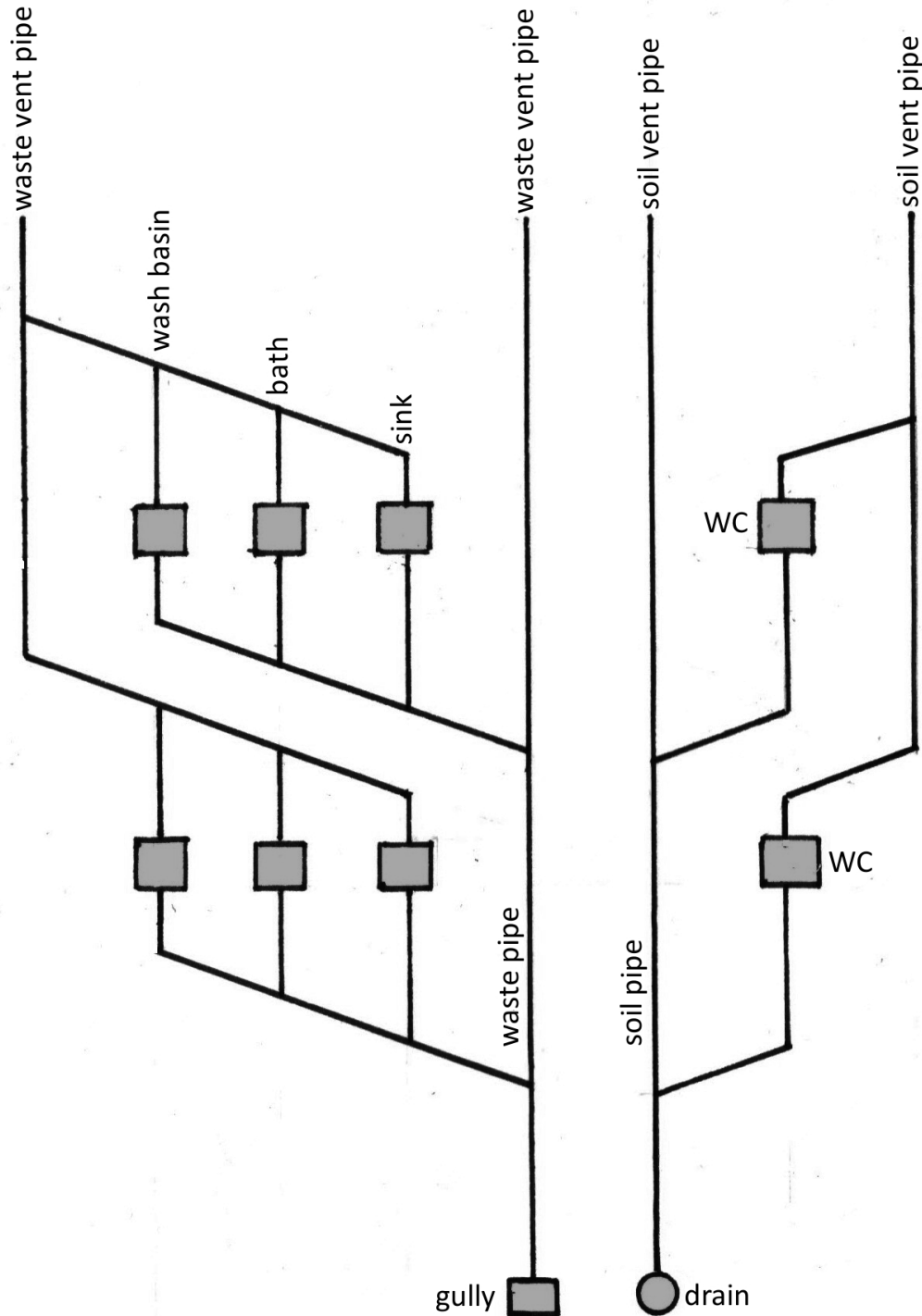


Figure 14: Sub rule PP15.5: Two Pipe System

## Sizing of Discharge Pipes

**Discharge pipe** means a pipe, which conveys the discharge from a sanitary fixture to a drain, and includes a soil pipe, a waste pipe, a discharge stack, a branch discharge pipe or a fixture discharge pipe;

**Soil pipe** means a discharge pipe, which conveys soil water;

**Waste pipe** means a discharge pipe, which conveys wastewater only;

**Discharge stack** means a vertical discharge pipe of any part of a drainage installation and includes a stub stack;

**Stub stack** means a straight 100mm diameter discharge stack not more than one storey high with a rodding eye at it top;

**Branch discharge pipe** means a horizontal discharge pipe conveying the discharge from one or more sanitary fixtures to a discharge stack;

**Fixture discharge pipe** means a discharge pipe, which conveys the discharge from a single sanitary fixture;

Figure 15 shows the family of discharge pipes.

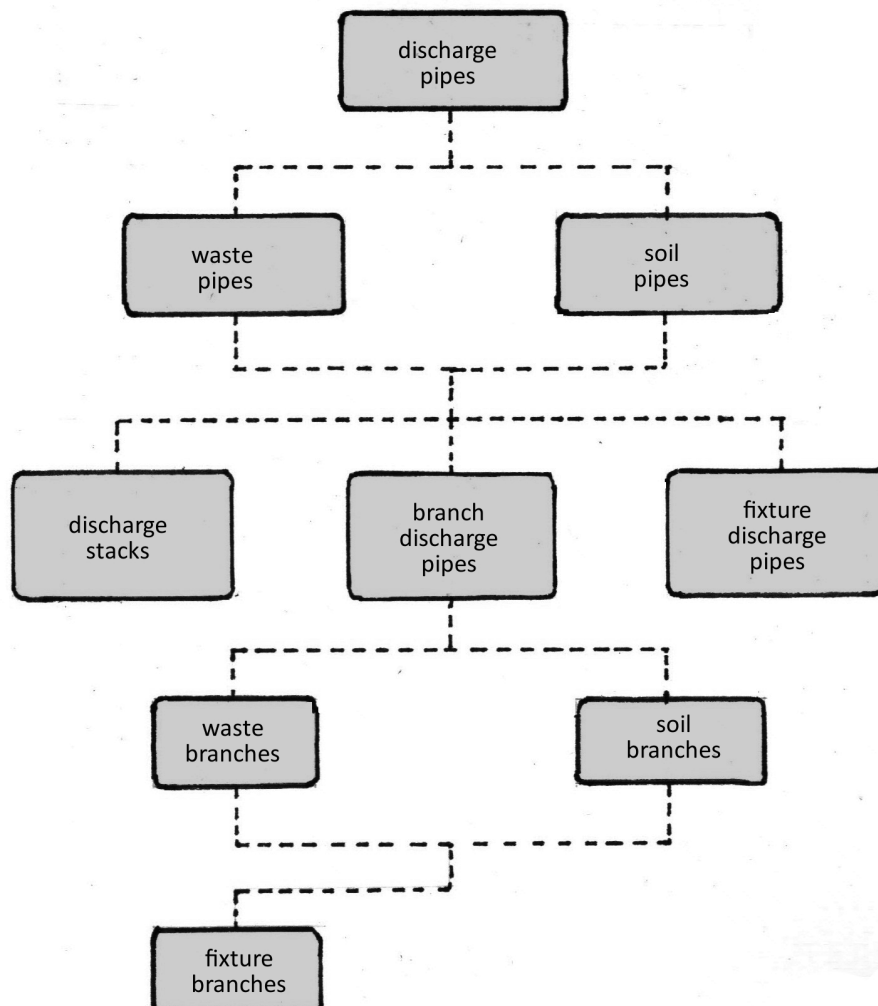


Figure 15: Rule PP15: The Family of Discharge Pipes

The following requirements shall apply with regard to the sizing of any discharge pipe:

- (a) The nominal diameter of any discharge pipe shall not be less than the internal diameter of any pipe or outlet of any sanitary fixture, which discharges into it: Provided that where the nominal diameter of any horizontal pipe in an offset is greater than that of the discharge stack which discharges into it, the nominal diameter of such stack downstream of such offset may be less than that of such horizontal pipe.
- (b) The internal diameter of any soil pipe other than a soil pipe from any urinal shall not be less than 100mm.
- (c) The internal diameter of any waste pipe shall not be less than 32mm if it serves a washbasin, bidet or drinking fountain and not less than 40mm if such pipe serves any other waste fixture.
- (d) In the single stack system, the internal diameter shall not be less than 40mm.
- (e) Etc. has to do with hydraulic loads and calculations.

According to Clark (1988), little difficulty in sizing of pipe work arises in small installations. The 100mm minimum diameter soil pipe is statutory regulations in South Africa. This minimum diameter was established so as to accept solids and will cater for considerable discharge. Except in the case of washbasins, pipe work from individual wastewater appliances is usually required to be the same diameter as the outlet of the appliance served.

In large installations such as high-rise buildings, shopping malls, airports, stadiums etc., it is essential that pipe sizes are determined correctly, so as to be large enough to accept the required flow but not oversized and hence uneconomical. This is clearly the preserve of the specialist sanitary engineer who determines sizes of pipes accurately using Tables 1 and 2 in Appendix 5 included in the National Building Regulations.

## **Ventilating Pipes**

Ventilating pipe means a pipe, which leads to the open air at its highest point and which provides ventilation throughout a drainage installation for the purpose of preventing the destruction of water seals against siphonage, but does not include a discharge pipe.

Clause PP19 of the National Building Regulations states the requirements that would apply with regard to the sizing of ventilating pipes to include:

- (a) Any drain or branch drain or any part thereof carrying a hydraulic load of not more than 50 discharge units shall have a ventilating pipe with a nominal diameter of not less than 40mm.
- (b) The size of pipe depends on the number of sanitary appliances ventilated either directly or indirectly, and is governed by Regulations.
- (c) Any stack vent shall have a nominal diameter, which is not less than that of the discharge stack to which it is connected.
- (d) Where a vent stack is connected to the top of any discharge stack, such connection should not be more than 150mm above the flood level of the highest positioned sanitary fixture (see Figure 16).

- (e) The diameter of the vent stack may not be less than the size contemplated in the Regulations
- (f) In tall buildings, the vent stack may increase in size as it is carried up as it serves more appliances.

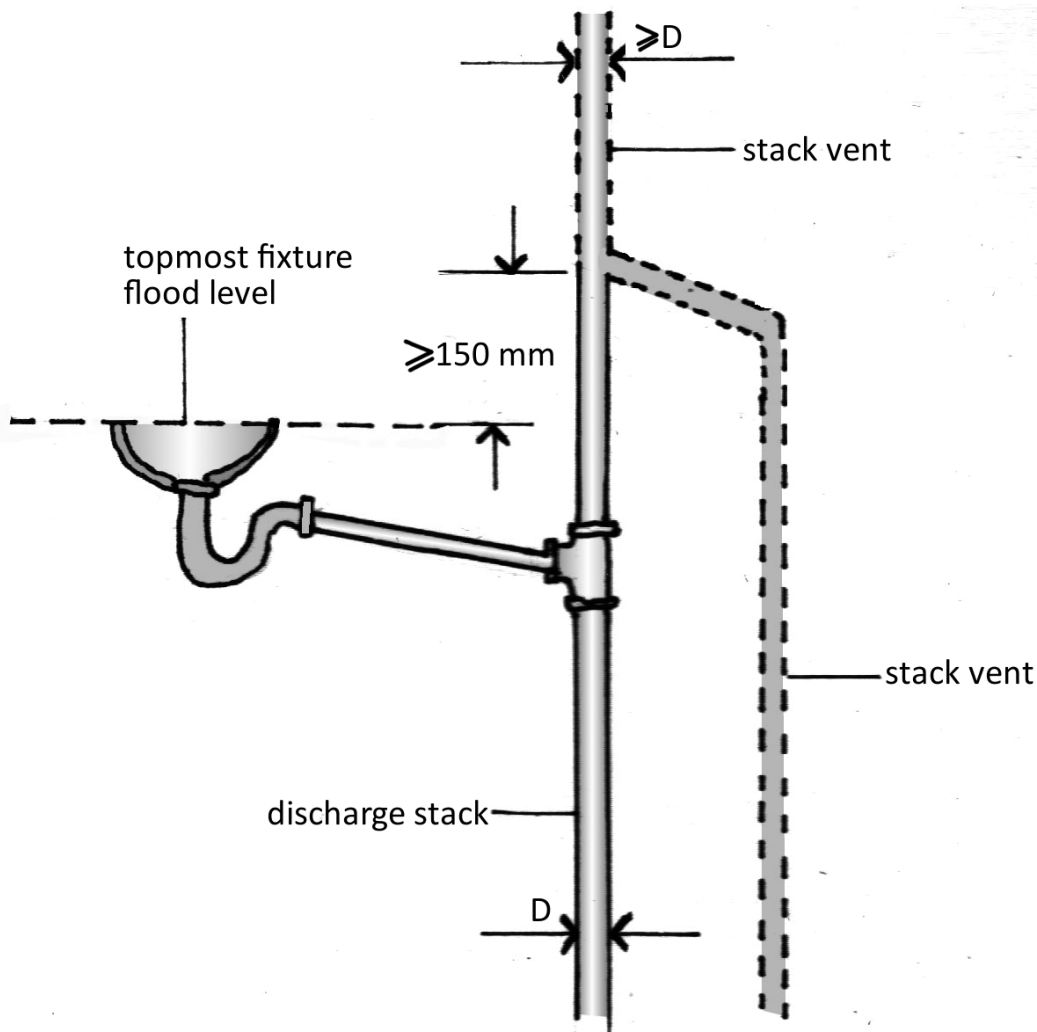


Figure 16: Sub rule PP19.1 (d): Connection of Stack Vent to Discharge Stack

## Installation of Discharge and Ventilating Pipes

'Horizontal' pipes require continuous fall. Thus, long pipe runs create difficulties, both at the design and construction stages of a project, so that careful consideration must be given to this aspect. Clause PP20 of the National Building Regulations states the requirements for the installation of discharge and ventilating pipes as follows: -

PP20.1 Any Discharge or ventilating pipe shall –

- (a) Not cause electrolytic corrosion due to any association of dissimilar metals;
- (b) Not form any obstruction in such pipe;
- (c) Be so installed that any bend does not form an acute angle and has the largest practicable radius of curvature with no change in the cross-section of the pipe throughout such bend;

- (d) Be safely supported along its length without restraining thermal movement;
- (e) Be so installed that the gradients, where applicable, are within the limits given by Regulations;
- (f) Be so installed as to be able to with stand the test stated in rule PP27 (Air test) and;
- (g) Have means of access for internal cleaning (**rodding/access eye**).

PP20.2

- (a)
  - i. Where any discharge pipe is located within any building and it is desired that such pipe be enclosed, it shall be enclosed within a duct; provided that any part of such pipe may be built into brickwork or concrete where the interior of such part is rendered readily accessible for cleaning.
  - ii. Such duct shall either be of a size and shape that any person can readily enter it and work therein or shall be provided with covers that can be readily removed to enable access to be gained to all junctions, bends and cleaning eyes.
  - iii. Where in any room contemplated in sub rule PP21.1 (c) (kitchen, pantry etc) that such duct is installed, there shall be provided inside such duct a means which in the event of any leak from any pipe therein will direct any released liquid or matter from the area of such room to a point of discharge where it shall be readily detectable.
- (b) Any pipe shall be so installed that the removal of any part of a building for the purpose of gaining access to such pipe will not endanger the structural stability of such building.

PP20.3

Any discharge pipe or any ventilating pipe shall be adequately protected against damage from vehicular impact.

PP20.4

Any ventilating pipe shall –

- a. Be carried upwards without reduction in diameter and shall throughout its length be horizontal or so graded as to provide a continuous fall from its open end back to the discharge pipe or drain to which it is connected.
- b. Be so installed that its open end is not less than:
  - i. 2.5m above ground level;
  - ii. 100mm above the closest part of the roof to which it is attached or through which it passes;
  - iii. 2m above the head of any window or other opening in any building (whether part of the same premises or not) – within a horizontal distance of 5m of the open end.
  - iv. 2.5m above the surface level of any roof slab covering the building, which it serves where the slab may at any time, be occupied by people.

See Figure 17 ~

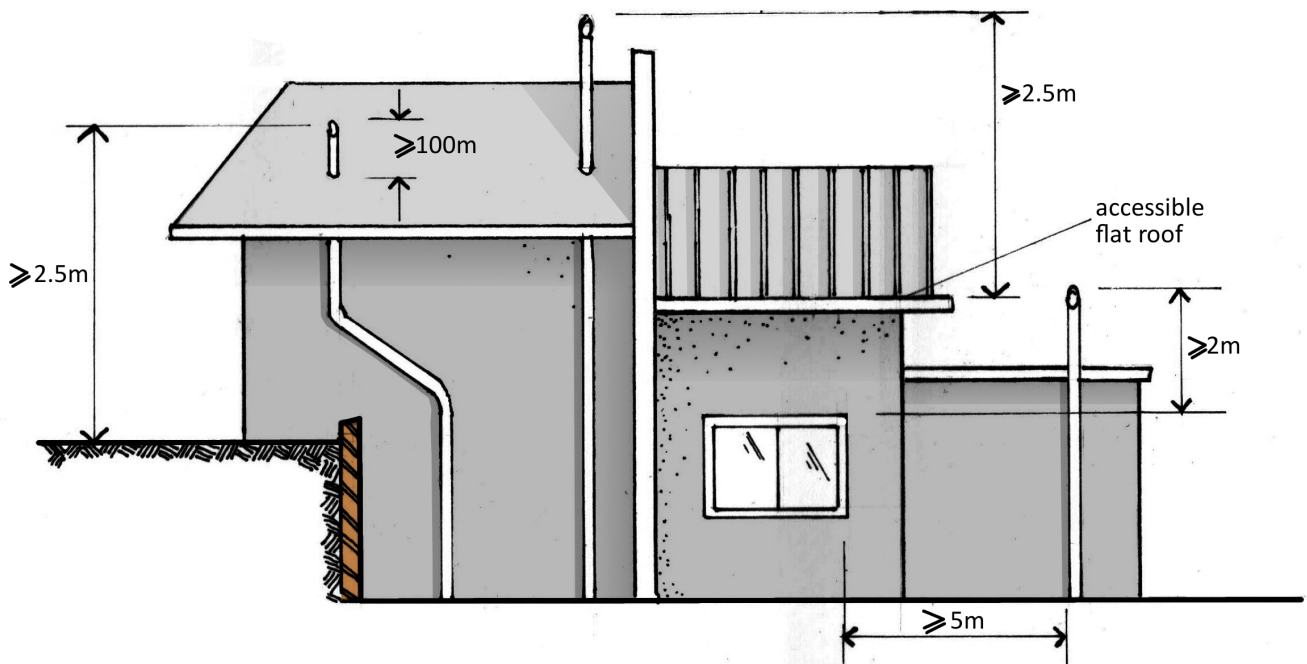


Figure 17: Sub rule PP20.4: Height of Ventilating Pipe

## Traps and Water Seals

**Trap** means a pipefitting or a part of a sanitary fixture, which is designed to retain a water seal.

**Water seal** means the water in a trap, which acts as a barrier against the flow of any foul air or gas.

The National Building Regulations makes it mandatory for the provision of traps in Clause PP22.

PP22.1 Any sanitary fixture shall be provided integrally or immediately at its outlet with an effective self-cleaning trap except where such fixture is a bath, washbasin or shower, which discharges into –

- (a) An open channel which shall –
  - i. Be made of an impervious material;
  - ii. Have a semi-circular cross-section of diameter not less than 100mm;
  - iii. Be accessible for cleaning throughout its length;
  - iv. Be fixed immediately beneath the point of discharge; and
  - v. Discharge into a gully; or
- (b) An open channel serving a urinal where such bath, washbasin or shower is installed in the same room as such urinal.

PP22.2 Any trap, which is integral with a sanitary fixture, shall –

- (a) Have a smooth waterway; and

- (b) Be so constructed that any change from one cross-section to another does not cause an obstruction to the passage of solids.

PP22.3 Any trap that is not integral with a sanitary fixture shall be made of non-absorbent and corrosion resistant material and shall be so constructed that –

- (a) It has a smooth waterway;
  - (b) There is no constriction;
  - (c) It has an outlet diameter which is not less than that of its inlet; and
  - (d) It has at its lowest point a means of access for cleaning;
- Provided that this requirement shall not apply where the trap is made of rubber or other similar material.

PP22.4 the minimum nominal diameter of a trap connected to any sanitary fixture, and the minimum depth of its water seal shall be in accordance with those values given for the relevant fixture and installation in Table 16 of the NBR: Provided that the maximum depth of the water seal contained in any trap shall be 100mm.

Traps associated with wastewater appliances are usually separate from and mounted immediately below the outlet of the appliance. Obtainable in either 'P' or 'S' forms, traps were formerly nearly all of lead, followed later by brass and more recently by plastic and rubber.

Resealing and bottle traps are sometimes required to overcome difficulties in providing anti-siphonage, especially for isolated appliances with long waste pipe runs. The diameter of the traps usually coincides with the size of the outlet of the appliance served, except where more than one appliance discharges to a common trap. Various traps are illustrated in Figures 18, 19, 20, 21 and 22.

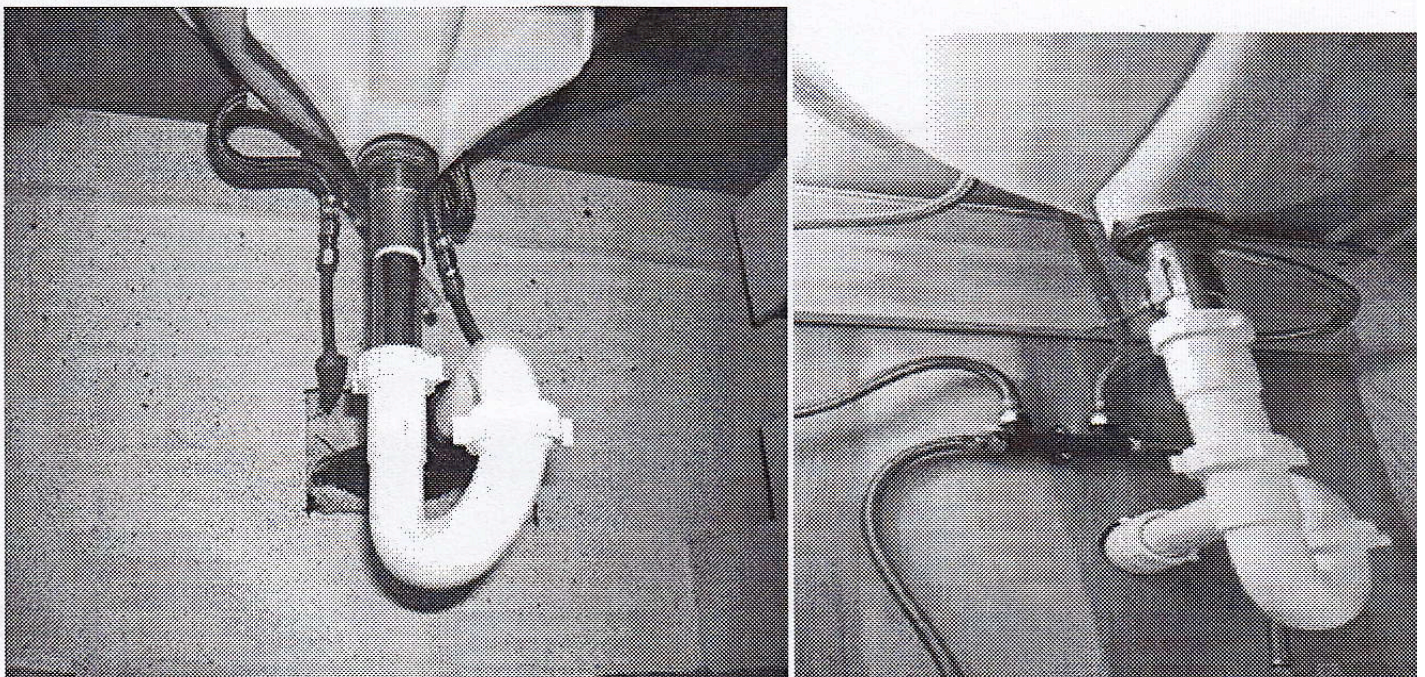
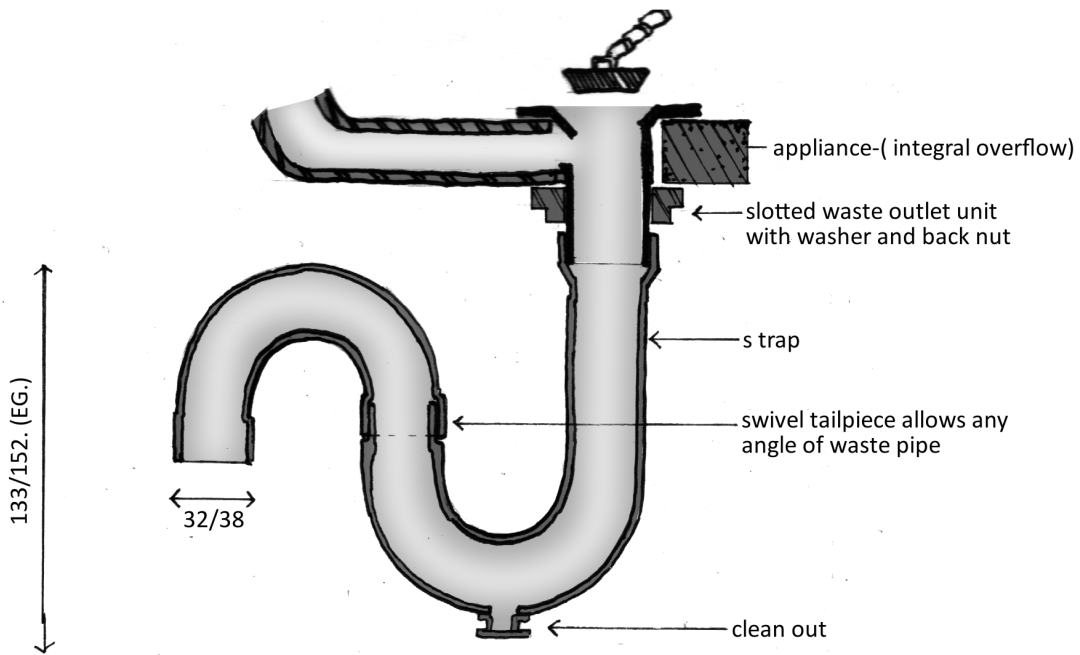
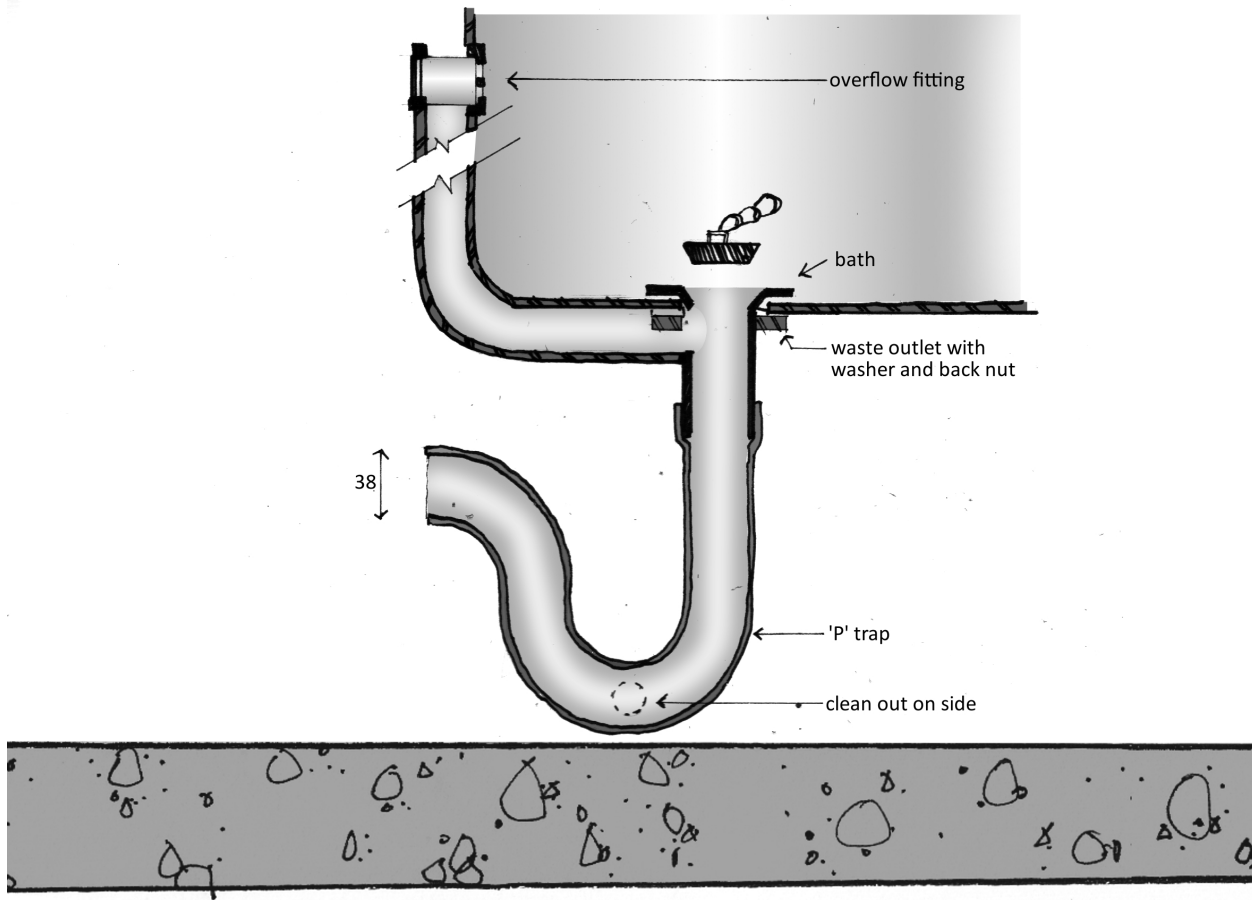


Figure 18: Types of 'P' Trap



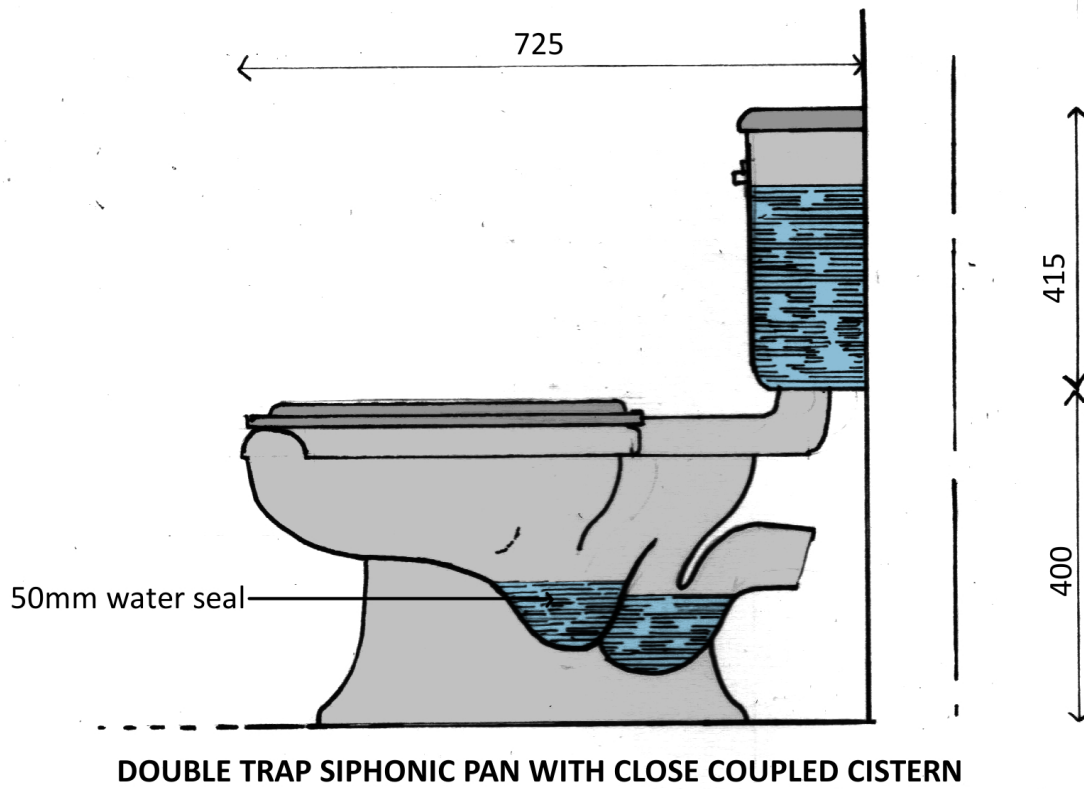
**BASIN 'S' TRAP COUPLED TO WASTE OUTLET**

**Figure 19: Basin 'S' Trap Coupled to Waste Outlet**

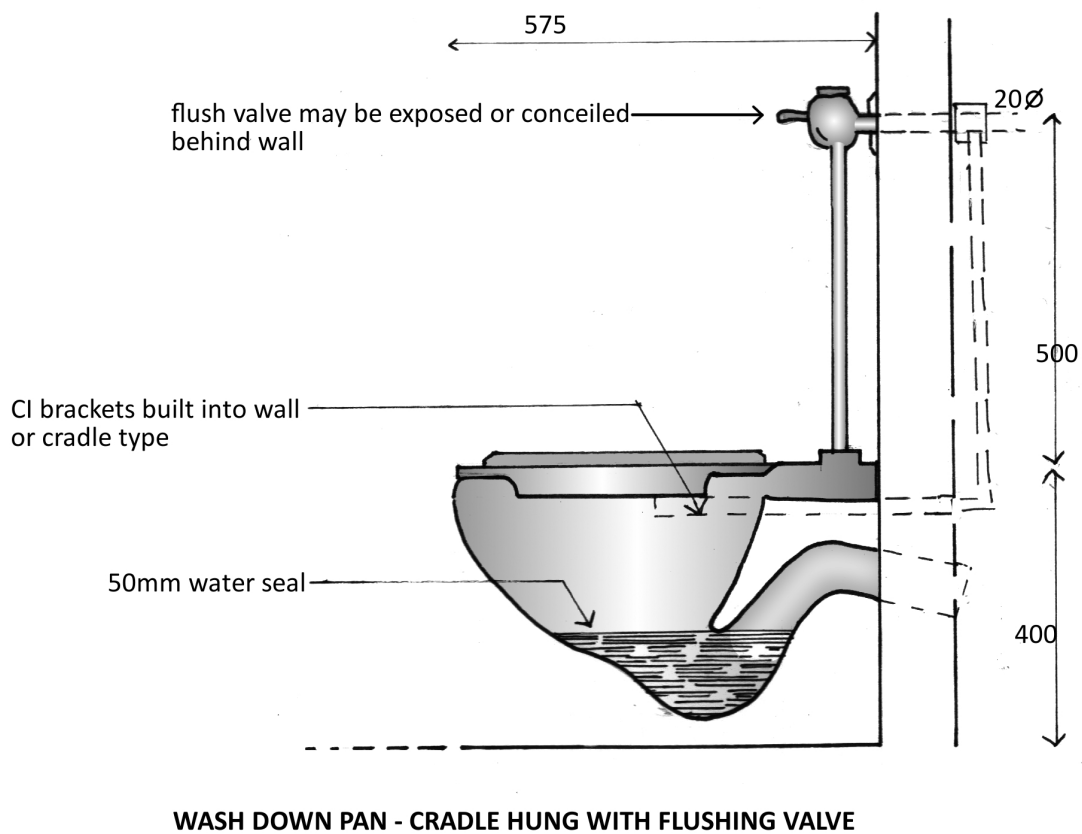


**BATH 'P' TRAP COUPLED TO WASTE AND OVERFLOW OUTLET**

**Figure 20: Bath 'P' Trap Coupled to Waste and Overflow Outlet**



**Figure 21: Double Trap Siphonic Pan with Close Coupled Cistern**



**Figure 22: Wash Down Pan – Cradle Hung with Flushing Valve**

Provision is made sometimes for waste appliances to discharge without an individual trap, to a trapped floor channel. This proviso being particularly applicable to ablution blocks, public washrooms and club change rooms. In public buildings, use is sometimes made of a system where batteries of wash-hand basins discharge un-trapped to a common waste pipe having a common trap.

The depth of **water seal** in traps is important when related to the particular pipe and ventilation system it is connected to. These depths of seal requirements are based on both long experience and experimental research findings, where a criterion has been adopted that minimum trap seal retention must always be maintained under all operating conditions. With the various soil, waste and vent pipe systems in use in South Africa, minimum depth of waste trap seals are specified in regulations. The National Building Regulations in **Clause PP18** also states requirements for the protection of any water seal under working conditions.

## **Foul Water Drains Below Ground**

The various parts of the foul water drains below ground are discussed and illustrated in this section. The requirements generally are summarized in Figure 23.

## **Parts of Foul Water Drain Below Ground Level**

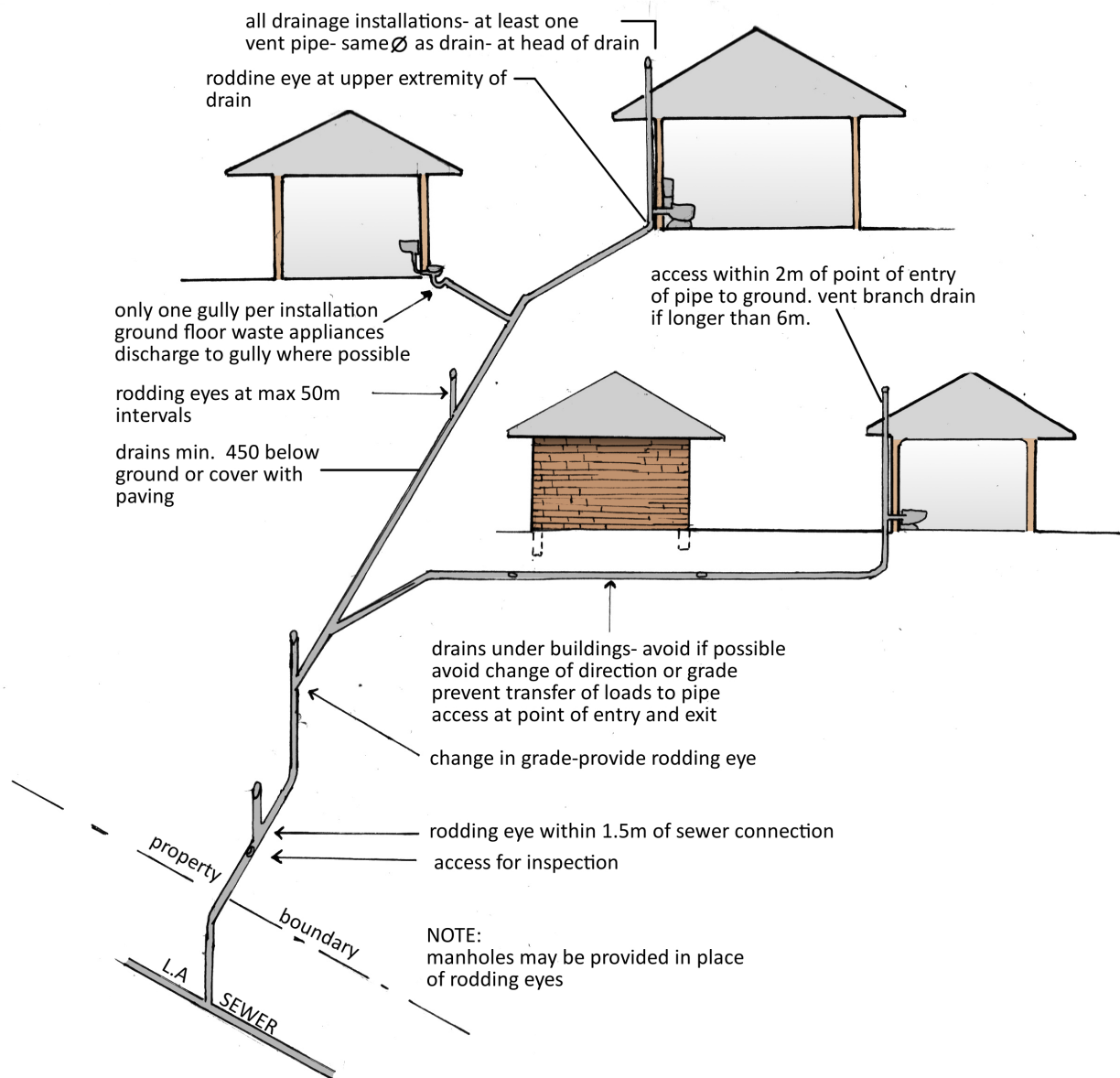
### **Drain**

This means that part of a drainage installation which conveys sewage from a building to a common drain or any other means of sewage disposal situated on the site concerned, or to a connecting sewer, but shall not include the following:

- (a) Any discharge pipe;
- (b) That portion of a discharge stack which is below ground level;
- (c) The bend at the foot of a discharge stack whether that bend is exposed or not.

The drain is the point of entry of the sewage into the drainage installation below ground level and flows from waste and soil pipes have to be introduced into the drain without any discharge of drain air into the building. Traditionally in a single building, soil water sanitary fixtures connect directly to the drain by means of a long radius bend (see Figure 24), while wastewater sanitary fixtures discharge over a trapped gully (see Figure 25).

In terms of the National Building Regulations, ground floor waste pipes may discharge to a soil pipe and hence to a drain or may discharge over a trapped gully or may connect directly to a drain. With advances in plumbing practice, sanitary fixtures on upper floors (both waste and soil) discharge into a combined stack (one-pipe system etc.), which in turn connects to the drain by means of a long radius bend.

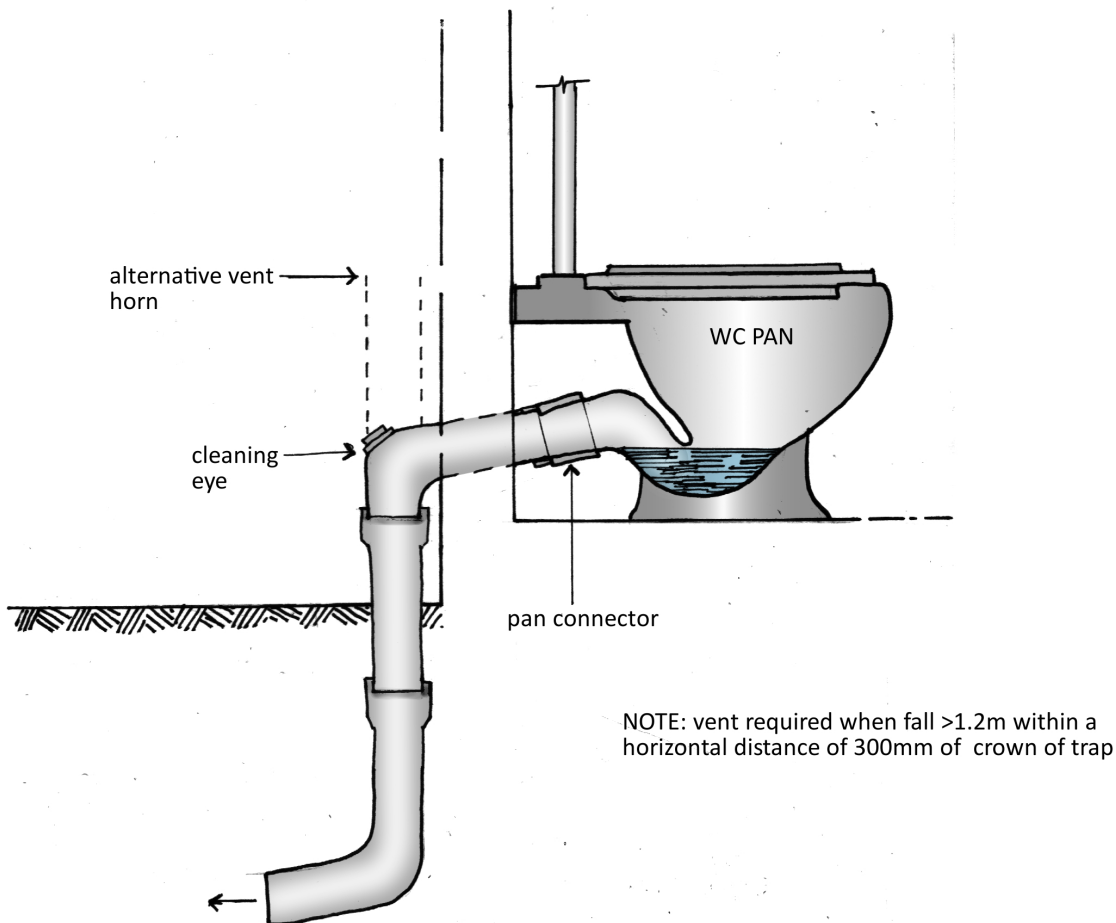


**Figure 23: Drains Below Ground – General Requirements**

**Entry points** into the drain are governed by the position of sanitary appliances. Where possible, entry points should be closely grouped to allow discharges from various sanitary fixtures to combine as soon as possible as this would assist the flow of sewage and effect economics in both supply and discharge pipe work etc.

## Gullies

Gully means a pipefitting incorporating a trap into which wastewater is discharged. The sole purpose of a gully is to prevent any possible flooding of sanitary fixtures by drain water.

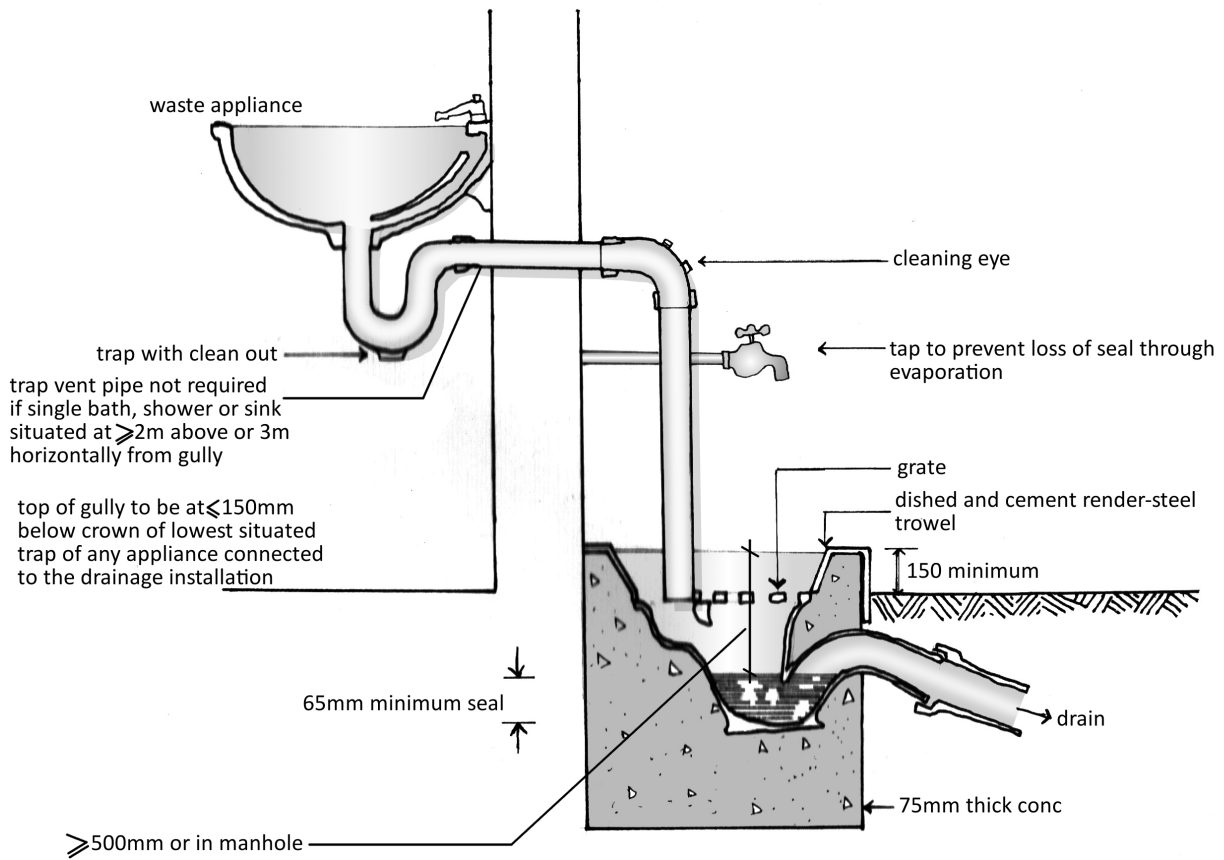


**Figure 24: Ground Floor Soil Appliance Connection to Drain**

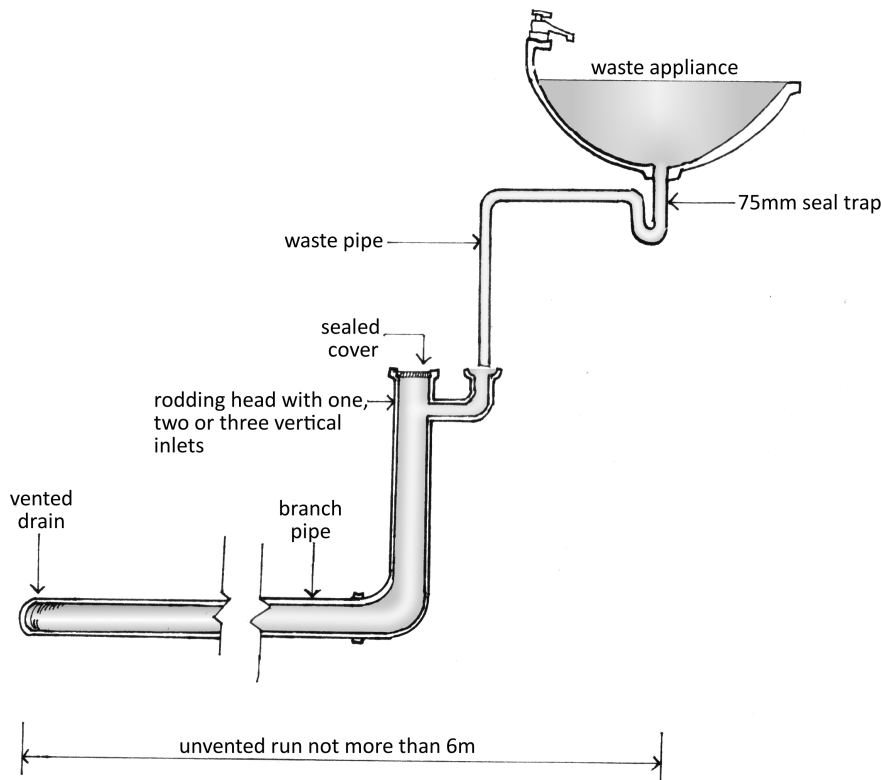
The National Building regulation in Clause PP23 requires that any drainage installation shall be provided with one gully and no limit is placed on the number of gullies provided in an installation. According to Clark (1988), some local authorities have in the past insisted that all ground floor waste appliances and the two-pipe waste water pipe discharge over a gully.

The gully should be provided with a tap located above it, to prevent loss of seal by evaporation. Gullies are potential sources of infection into which surface water; sand and other foreign matter can ingress. Waste pipes, which discharge into a gully, should discharge at a point below the grating but above the surface of the water seal. The National building Regulations states only that, waste pipes may not discharge more than 100mm above the grating.

Where practical, ground floor sanitary fixtures should discharge into the single gully trap. Where this is not practical, connection may be made directly to a drain or soil pipe. Alternatively, waste pipes may be connected by means of a stub stack as shown in Figure 26.



**Figure 25: Ground Floor Waste Appliance Discharge to Trapped Gully**



**Figure 26: Stub Stack means of connecting a Waste Pipe directly to a Drain – without a Gully Trap**

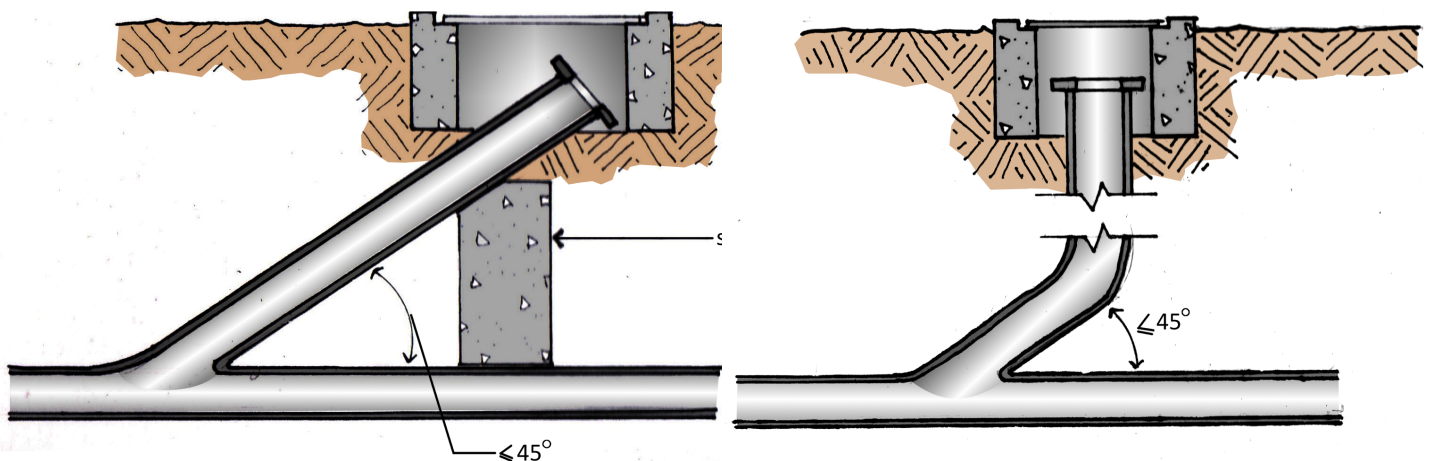
**Access to Interior of Drains:** The access to the interior of drains is necessary for clearing blockages, inspecting and testing. Access points are best located where blockages are most likely to occur and from which every part of the system can be reached by rodding equipment. Access for clearing (cleaning eye) is required to be provided within 2m above the point of entry of discharge pipe to the ground. Once underground, access is obtained by means of **rodding eyes** or more traditionally, **manholes** and **inspection chambers**.

Clause PP21 of the National Building Regulations gives the requirements for access to Drainage Installation.

## Rodding Eye

Rodding eye means an access opening in a drainage installation provided for the purpose of gaining full-bore access to the interior of a drain for internal cleaning, and which remains permanently accessible after completion of the installation, but does not include the inspection chamber or manhole. Rodding eyes provide a simple and inexpensive means of access at the head of a drain or on shallow drain runs for rodding in the direction of flow. The more modern concept of drainage installation makes use of rodding eyes to clear blockages.

The rodding eye consists of a  $45^{\circ}$  junction at the top of a drain with a vertical or sloping pipe extended to ground level and fitted with an airtight cap, situated in a small concrete chamber at ground level with cast iron cover plate (see Figures 23, 26 and 27).



**Figure 27: Sub rule PP21.1 (f): Rodding Eyes**

In terms of the National Building Regulations, Clause 21, a rodding eye is required to be provided:

- i. Where there is a change in direction of the drain that exceeds  $45^{\circ}$ ;

- ii. At any point within 1.5m of the connection of the drain to a connecting sewer, septic tank or conservancy tank: Provided that an inspection eye shall be installed immediately downstream of such point;
- iii. At the highest point of the drain; and
- iv. At such intervals along the drain that no rodding distance is more than 25m measured along the line of such drain from a rodding eye or other means of access to such drain;

The National Building Regulations also states that such rodding eye shall (as shown in Fig. 27) –

- i. Join the drain in the direction of flow at an angle of not more than  $45^{\circ}$ , be continued up to ground level and where inclined be adequately supported; and
- ii. Be adequately marked and protected.

## Inspection Eyes

This means any access or opening to the interior of any pipe or pipe fitting in a drainage installation provided solely for the purpose of inspection and testing, and to which permanent access after completion of the drainage installation need not be provided. Inspection eyes are simply removable covers on pipe not brought up to the surface. They were traditionally required by by-laws at drain junction points where rodding eyes or manholes are not required, at change of direction and at every point of junction with another drain.

With present day materials, the necessity of inspecting lengths of drains for true alignment is no longer required. A pressure test on the drainage installation is all that is required before commission. Therefore, only one inspection eye is considered necessary to test the effluent. In terms of the National Building Regulations, an access eye is to be installed immediately upstream of the rodding eye connection of drain and 'connecting sewer'. See Figure 23.

## Manholes and Inspection Chambers

**Manhole** means a chamber of a depth greater than 750mm and of such dimension that allows entry of a person into such chamber for the purpose of providing access to a drain.

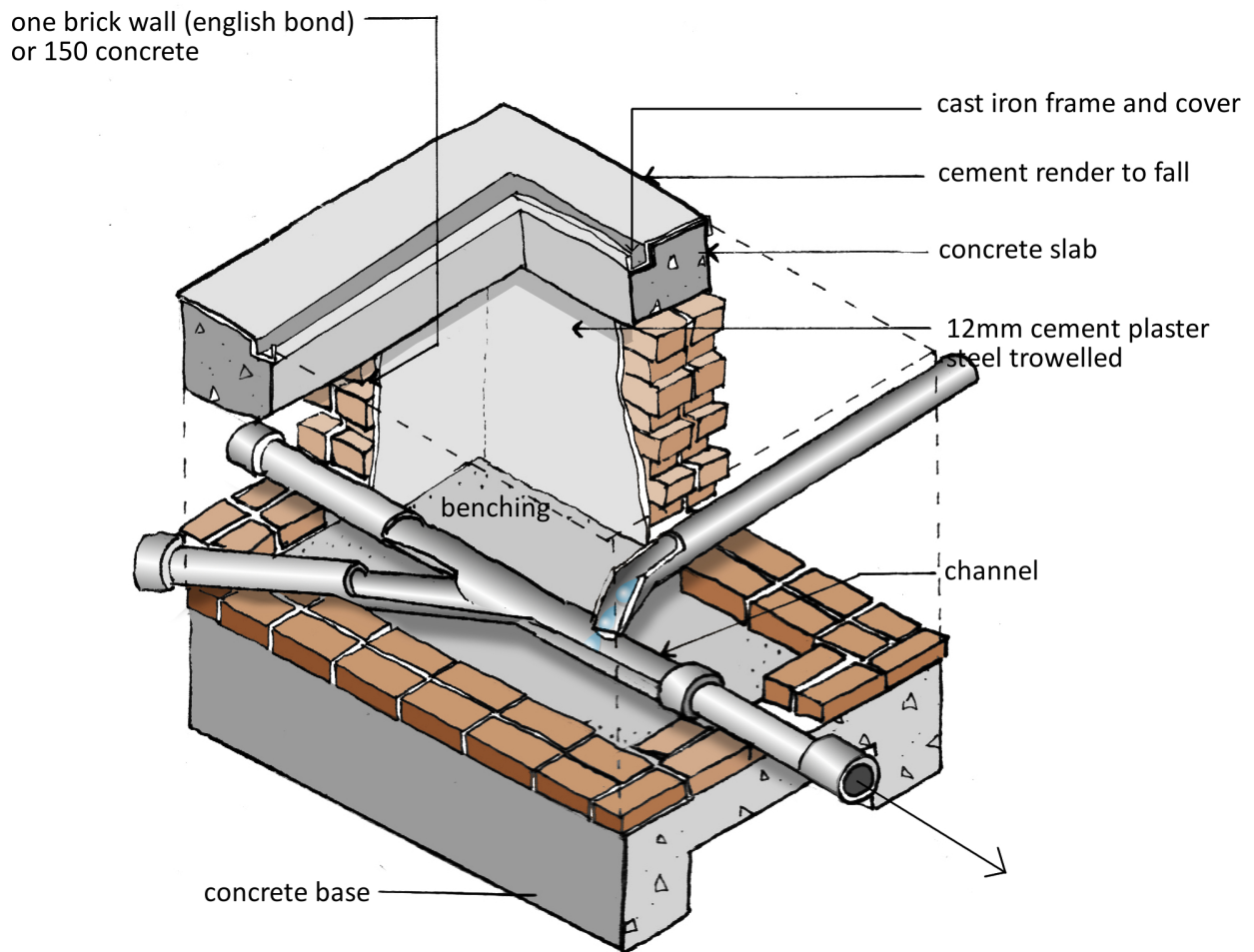
**Inspection Chamber** means a chamber not deeper than 750mm and of such dimension that access may be obtained to a drain without requiring a person to enter into such chamber.

The manholes or inspection chambers were provided traditionally to allow for inspecting, testing and clearing blockages in underground drains. The traditional earthenware drains which, were in short lengths were liable to blockage due to:

- Misalignment of the many joints; and
- To fracture of the rigid pipes and joints.

Manholes at frequent intervals were useful, but also caused many problems due to differential settlement, water and root intrusion etc.

Manholes may be constructed of brick or concrete as a rectangular compartment in different sizes – 600x450 to 750mm deep, 900x600 to 2000mm deep or 1000x750 over 2000mm deep - or with precast concrete sections placed one upon another depending on depth required as a circular compartment. Typical traditional manhole requirements are shown in Figure 28.



**Figure 28: Cut-away view of typical Manhole**

As an alternative to open channels in the bottom of the manhole, a recent innovation is to construct the manhole around a screwed cover on the drainpipe.

The disadvantages of manholes include ~

- High cost;
- Inconvenient and unsightly obstructions around buildings;
- Liable to house undesirable insects; and
- Can become unsealed through ill-fitting lids.

Because of these disadvantages, the NBRI recommended that rodding eyes, which accept clearing rods more easily should be, used in place of manholes and inspection chambers wherever possible.

## Ventilation of Drains

In terms of the National Building Regulations, every drainage installation requires at least one vent the same diameter as the drain. This vent must be situated at the head of the drain as far as practical from the local authority sewer connection. Any branch drain exceeding 6m developed length must be similarly vented, provided that where the branch drain carries the discharge from only one gully or other trap or from only one soil appliance, the diameter of the vent may be reduced to 50mm.

## DRAIN PIPE MATERIALS

In any sewer system, the house drains or house connections on private property usually account for greater footage than the public or street sewers. These drains are normally laid at relatively shallow depths of from 600mm to 2m, and are usually of 100mm diameter except in the case of large buildings or complexes of buildings where larger diameters may be necessary.

Pipes intended for underground use as sewers and drains can generally be classed in two main categories that is:

- Rigid pipes and
- Flexible pipes.

### Rigid Pipes:

Rigid pipes rely mainly on their inherent strength to resist backfill loads. The supporting strength of rigid pipes usually only come into consideration for larger diameters and at greater depths. Rigid pipes are usually weak in tension (or shear) and the impact of the forces acting on it such as the vertical loads imposed on it by the trench back fills can be reduced by the use of short length pipes with flexible joints which permit some freedom of movement to individual pipes both axially and transversely.

Types of rigid pipes include:

1. **Earthenware pipes:** The traditional pipe material in South Africa for home drainage was the earthenware pipe, jointed by means of cement/mortar-caulked joints. It is this traditional practice that resulted in the problems faced by local authorities with house connections (Clark, 1988). Problems faced include the fact that ground movements have cracked the pipelines allowing both:
  - Serious ground-water infiltration in high water table areas; and
  - Severe root penetration where lines traverse gardens filled with trees and shrubs.

## 2. **Vitrified Clay:**

Advantages:

- Inertness and resistance to all types of domestic and industrial effluent; and
- Life in sewer service is virtually indefinite.

Disadvantages:

- Brittle and require careful handling during transport, storage and installation;
- Manufactured in relatively short lengths (1.5m) therefore requiring a large number of joints which in turn reduces their hydraulic efficiency; and
- Relatively heavy per unit length and require substantial handling and transport facilities.

## 3. **Asbestos Cement:**

Advantages:

- Light weight;
- Ease of handling and laying; and
- Long laying lengths

Disadvantage: Health problems caused by cutting through asbestos fibres.

## 4. **Cast or Spun iron:**

A rigid heavy material unable to compete with other materials under usual conditions, cast iron is used in vulnerable positions, such as under buildings and roads or suspended under floors, where its **superior strength** and long proven **durability** is an asset.

Disadvantage: Brittle fracture caused by load or due to careless handling.

## **Flexible Pipes:**

Flexible pipes derive their ability to support load from their inherent strength plus the possible resistance pressure of the soil as they deflect and the sides of the pipe moves outward against the soil side-fills. Flexible pipes fail by excessive deflection and collapse or buckling rather than by rupture of the pipe walls as in the case of pipes made of brittle materials. Therefore, design of flexible pipes is directed towards determination of deflection under load.

Almost the entire performance of a flexible conduit in retaining its shape and integrity is dependent on the selection, placement and compaction of the envelope of earth surrounding the pipe. The backfill material selected should preferably be of a granular nature to provide good shear characteristics.

### **1. Pitch Fibre:**

Manufactured from coal tar pitch and wood cellulose fibres. Pitch fibre or bituminized fibre pipes have been used for underground drainage for over 50 years, but their use has remained fairly limited and restricted to the smaller diameters.

#### Advantages:

- Ability to withstand ground movement and other secondary forces without fracture;
- Good hydraulic characteristics due to long length between joints;
- Lightness for ease of transport and handling;
- Ease of laying due to simplicity of the joint and the ease of cutting and machining joint surfaces in the field; and
- Resistance to attack by acids and other chemicals.

#### Disadvantages:

- Very close supervision is required during back-filling and compaction of side fill material;
- The possibility of attack by solvents such as benzene, creosotes and naphtha;
- Relatively poor resistance to abrasion;
- The possibility of damage by cleaning tools and hot effluents;
- The possibility of deformation by tree roots; and
- Material cannot be protected from dynamic loads at shallow depths.

## 2. UPVC

UPVC sewer and drainpipes are available in sizes up to 300mm in diameter and are made in long lengths up to 9m.

#### Advantages:

- Lightness more so than pitch fibre;
- Long lengths with few joints;
- Ease of handling and laying;
- Tight joints;
- Good hydraulic characteristics;
- Resistance to most chemicals and effluents; and
- The ability to withstand ground movements without fracture.

#### Disadvantages:

- Susceptible to temperature changes and thus has to cater for expansion and contraction in the jointing system;
- Very close supervision is required during back-filling and compaction of side fill material around the pipe;
- Possibility of damage by maintenance and cleaning tools;
- Possible damage by dynamic loads at shallow depth; and
- The need for protection, during storage, from damage by ultraviolet rays and distortion by the heat of the sun.

Because PVC pipe is softened by heat, it cannot be used for the conveyance of continuously hot effluent.

### **Some common items used in Drainage Installation: -**

- Bend; Tee; Plug; Clip; Adaptor; Gum; Putty; Roll of Yarn
- Pipes and Traps have been defined and identified

## SEWAGE DISPOSAL

Sewage disposal may be by:

- Connection to public sewer.
- Septic tank and French drain/soak away pit. (Site treatment).
- Conservancy tank (storage and removal by Local Authority).

### Connection to Public Sewer:

Where a local authority sewer exists, it is obligatory to connect to it. The local authority carries out connection from boundary to sewer, costs being recovered from the building owner.

**Sewer** means a pipe or conduit, which is the property of or is vested in the local authority and which is used or intended for the conveyance of sewage.

### Septic Tank and French Drain:

Whilst **septic tank** means a tank designed to receive sewage and to retain it for such a time and in such a manner as to secure adequate decomposition – the tank is a watertight chamber in which the sewage is liquefied by anaerobic bacterial activity, a **French drain** means a trench filled with suitable material, which is used for the disposal of liquid effluent from a septic tank or wastewater.

Where no public sewers exist for example in remote/rural areas, the local authority may permit septic tanks; it is in effect a private sewage disposal plant. However, if ground porosity is suspect, the local authority should be notified at the earliest opportunity (before design drawings are prepared) in order to conduct permeability tests. The statutory requirements for septic tanks and French drains are given in Clause PP10 of the National Building Regulations.

If septic tank sewage is allowed to stand, sludge will settle to the bottom and scum form on top and a clear liquid will overflow as new flow comes in. A break down of the organic content by means of aerobic bacteria, which thrive in these conditions, takes place. From the septic tank the effluent is disposed off in a French drain.

Septic tanks must be designed to allow flows to enter and leave without being affected by scum and to allow gentle passage of liquid. The one-pipe system is recommended by NBRI; that is soil and waste through the septic tank. Traditionally built tanks are divided into two compartments with an overall length of three times the breadth. Capacity is determined by the simple formula:

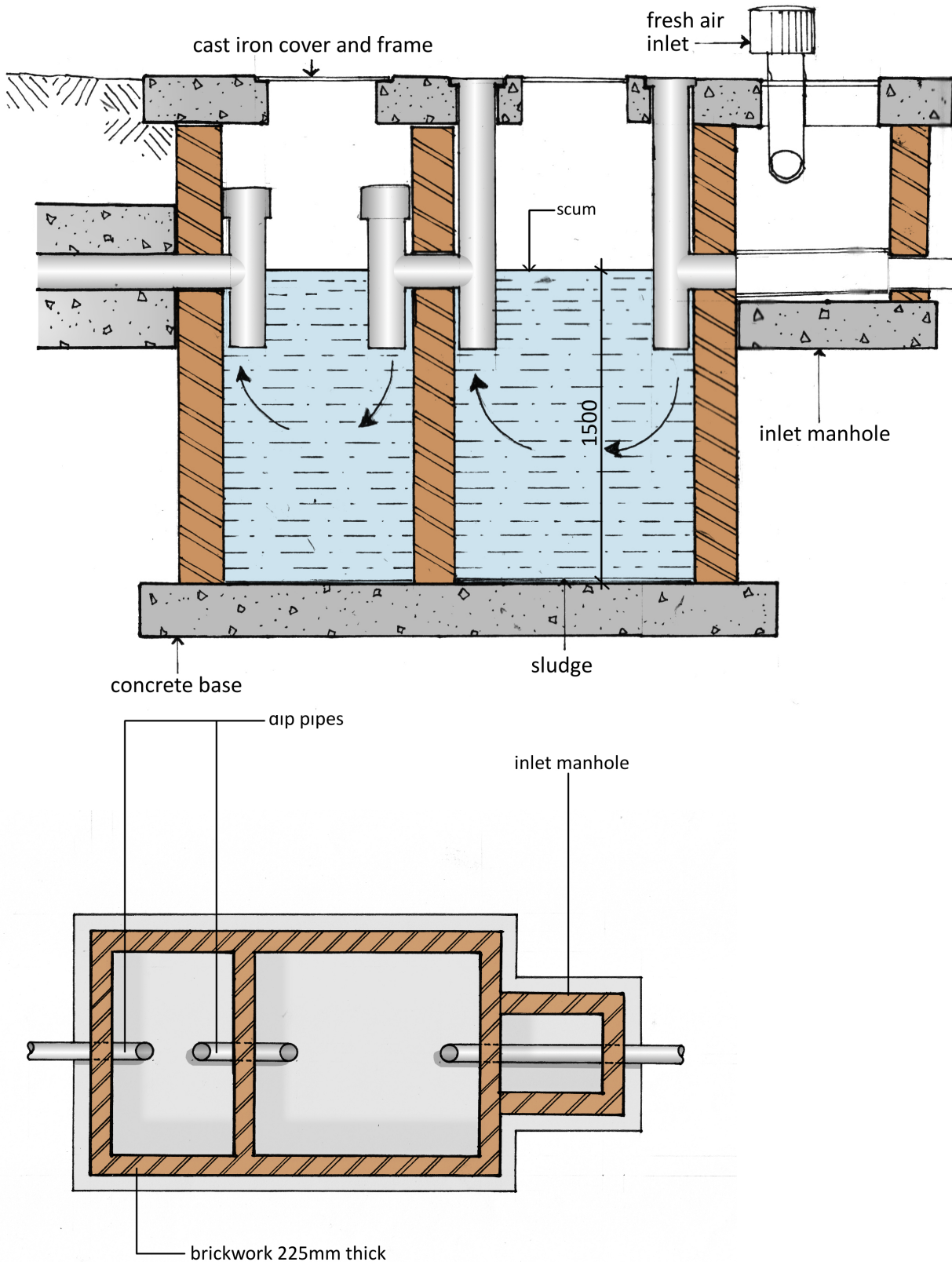
$$C = (180 \times P) + 2000$$

Where: C = capacity in litres; and

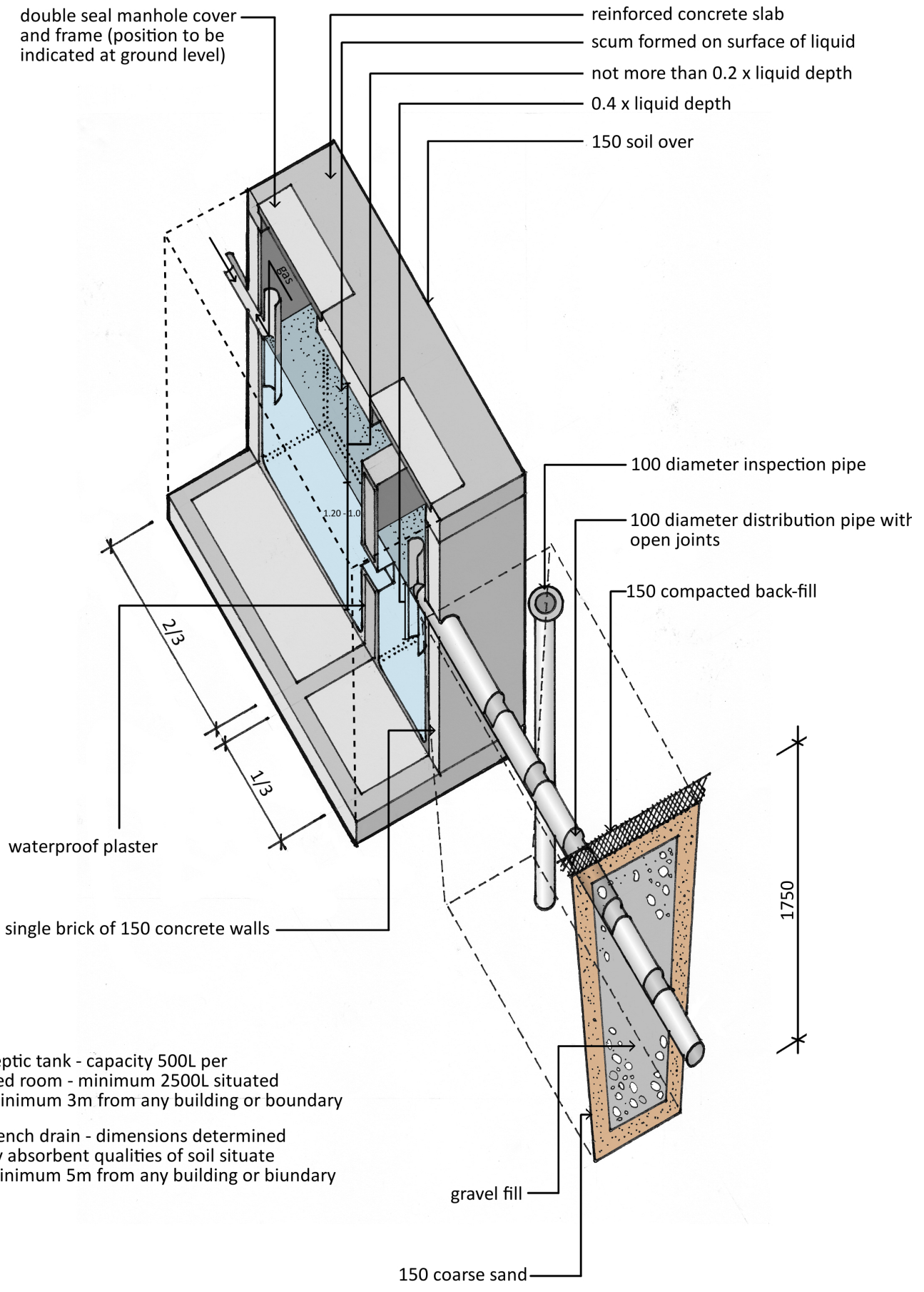
P = number of persons served

E.g. 10 persons:  $C = (180 \times 10) + 2000 = 3800$  litres ( $3.8\text{m}^3$ )

Domestic septic tanks are brick or precast concrete structures. A typical domestic septic tank and French drain are illustrated in Figures 29a and 29b. It should be noted here that a septic tank must be sited so as not to endanger the stability of any building or services on the site and the related French drain may not be closer than 3m to any building or property boundary.



**Figure 29a: Typical Domestic Septic Tank**

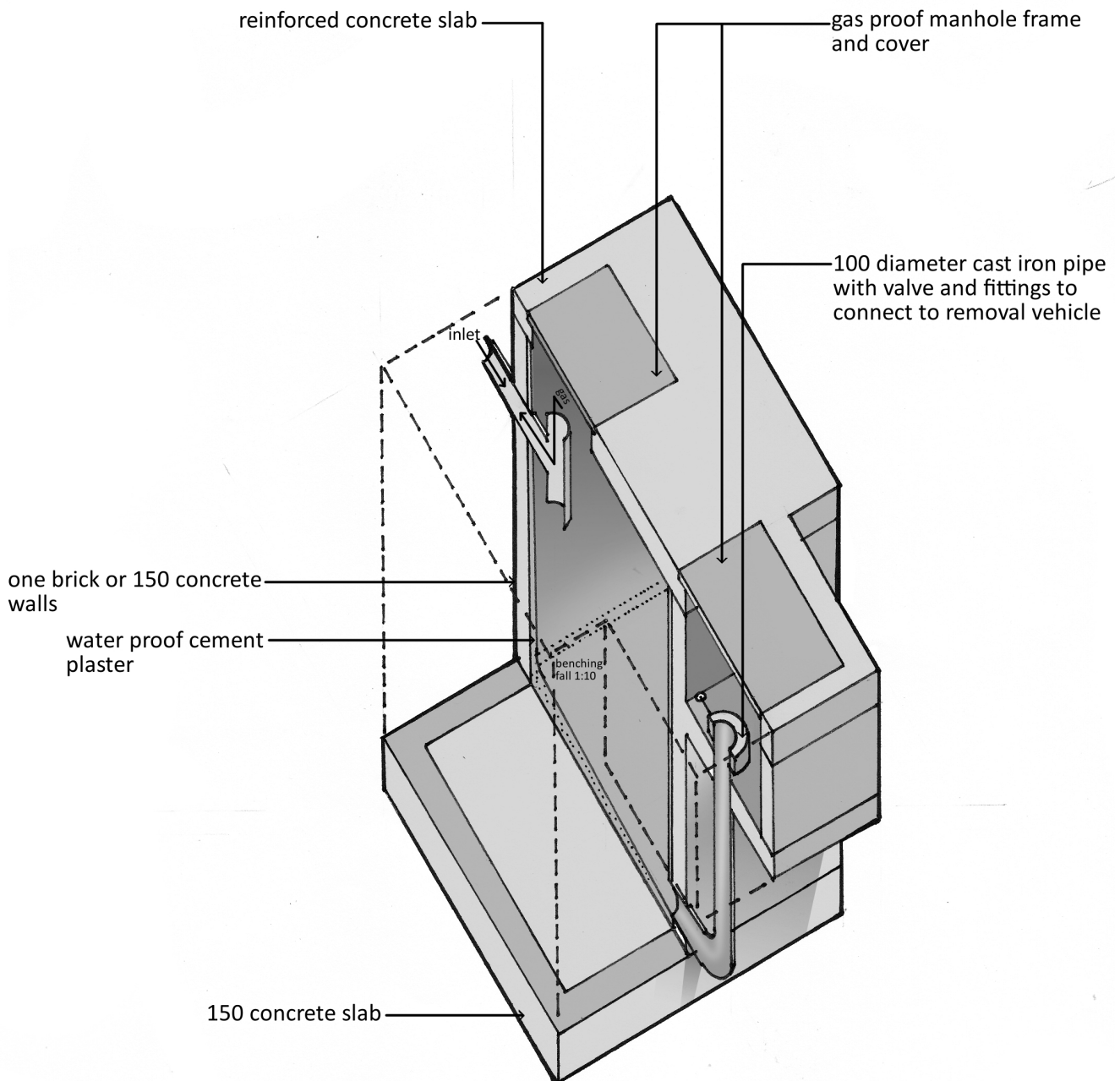


**Figure 29b: Typical Domestic Septic Tank and French Drain**

## Conservancy Tank:

This means a covered tank used for the reception and temporary retention of sewage and which requires emptying at intervals. In areas where sewers are not yet commissioned or in other special circumstances where the installation is of a temporary nature, conservancy tanks may be permitted.

The local authority should be consulted at an early stage. The frequency and cost of emptying the service should be ascertained and citing and access for removal vehicles must be considered in its location. The statutory requirements for conservancy tanks are given in Clause PP10 of the National Building Regulations. A typical conservancy tank is illustrated in Figure 30.



**Figure 30: Typical Conservancy Tank – capacity to be prescribed by Local Authority**

# COLD WATER SUPPLY

## INTRODUCTION

Historically in South African urban dwellings, water was supplied from the local authority connection to:

1. **A Roof Tank** and hence via large diameter pipe work and terminal fittings to various appliances at low pressure or
2. **A Water Heater Tank**, which in turn fed terminal fittings by gravity flow at low pressure (see Figure 31).

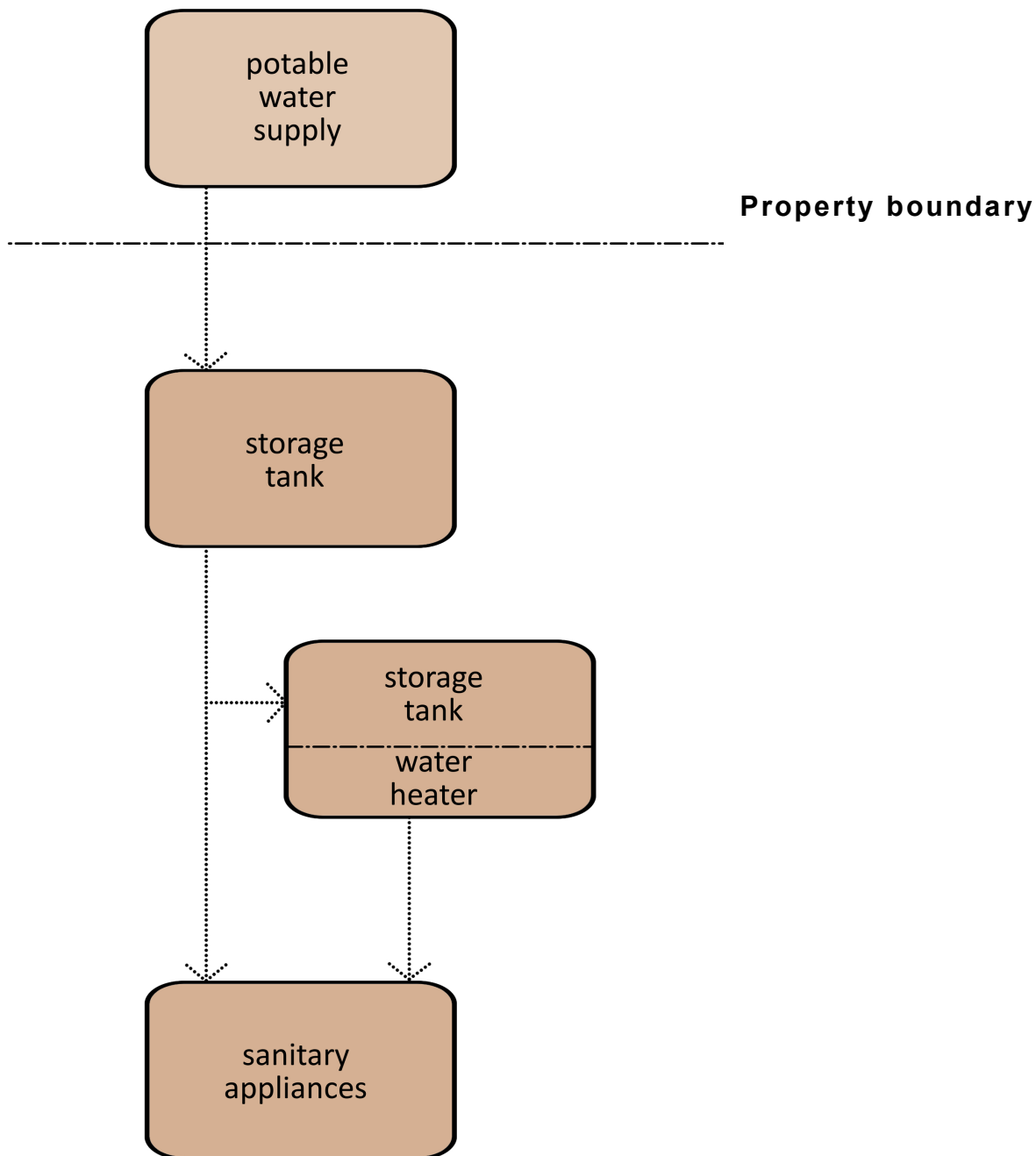
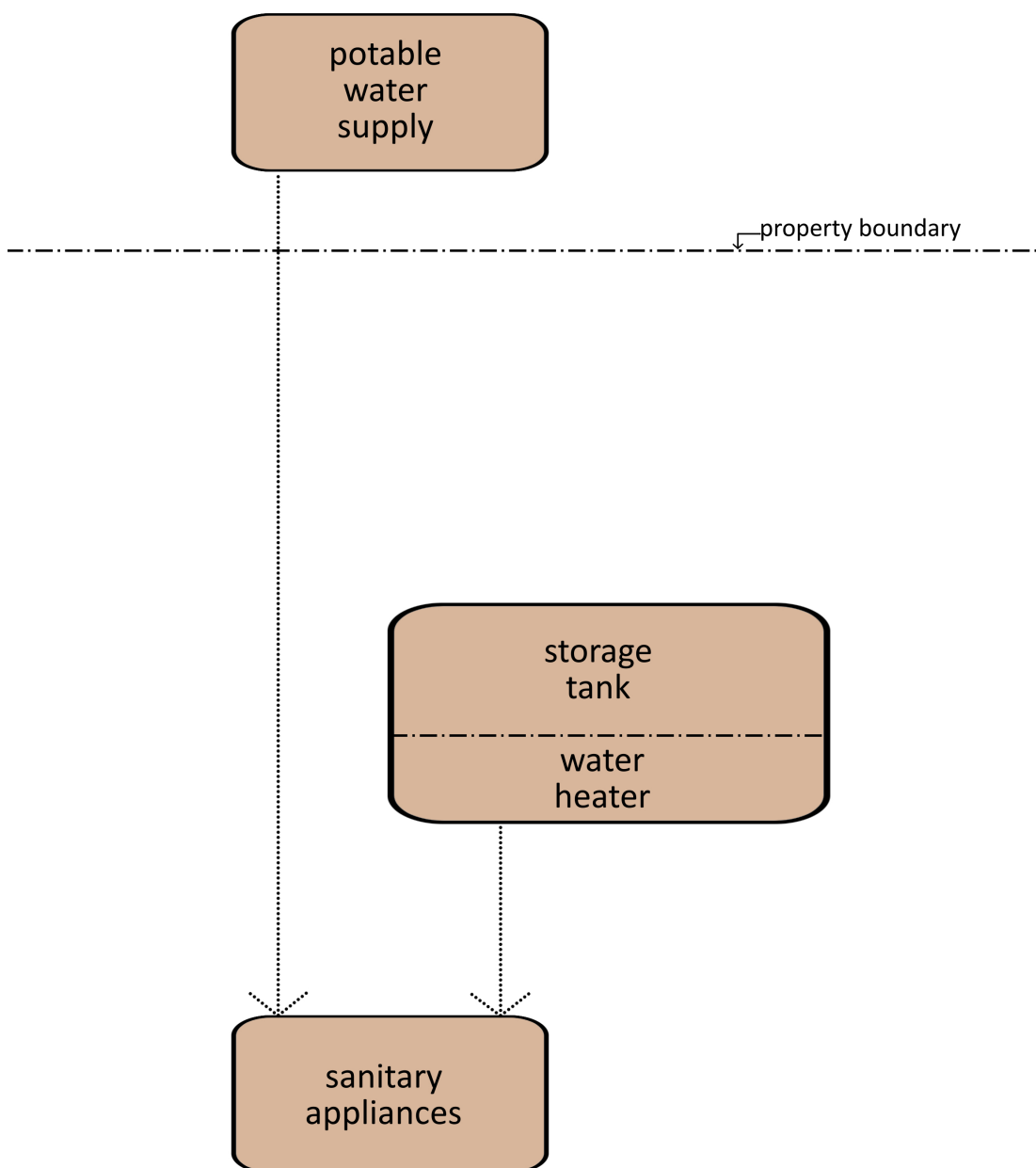


Figure 31: Traditional method of water supply to South African urban dwellings

With improvements to municipal water supplies, higher mains supply pressure can be expected. Hence, the cold water storage tank with the following attendant problems:

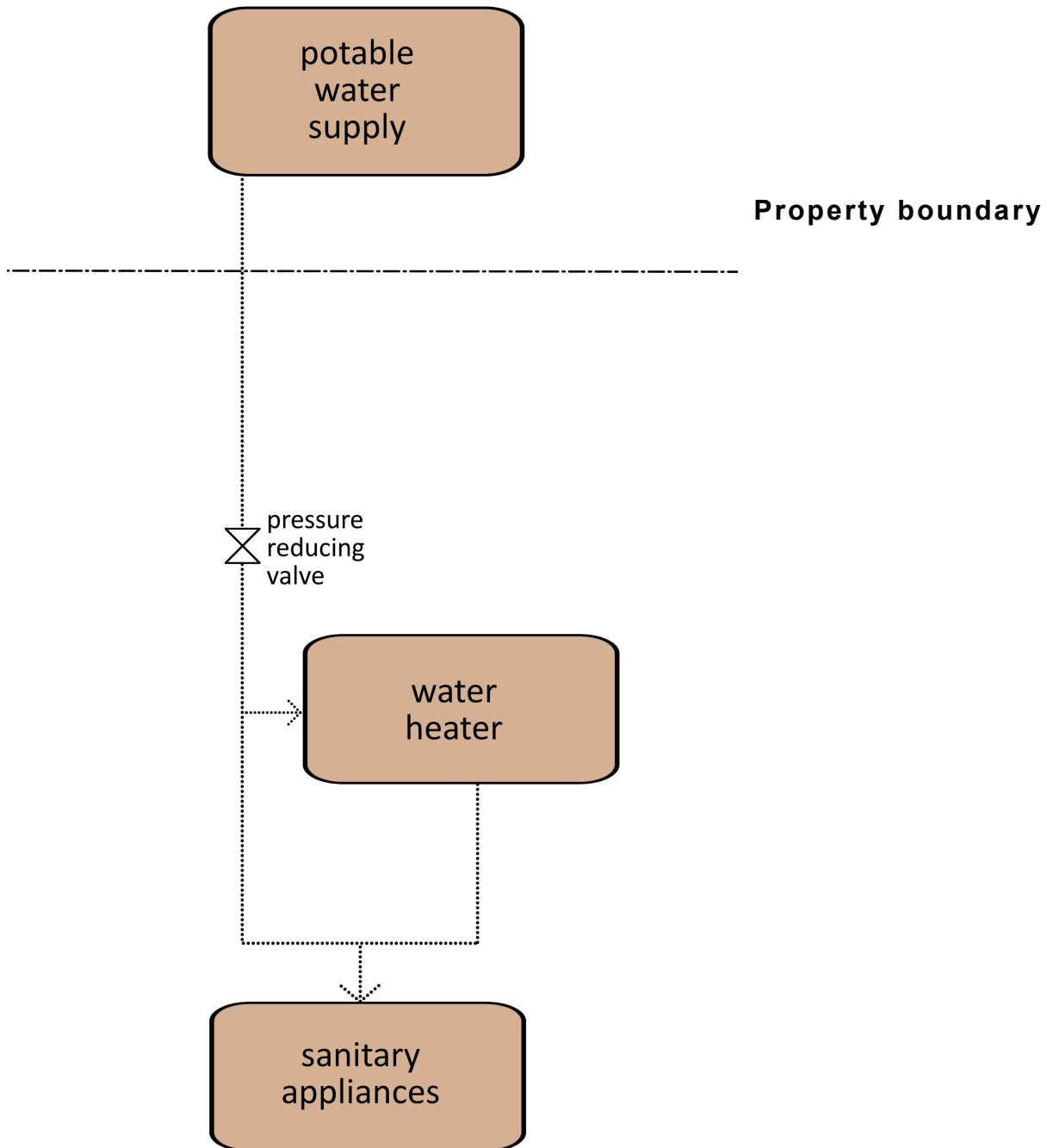
1. Possible pollution of supply due to ingress of dirt etc.
2. Its need for suitable roof space
3. Support structure
4. Leaking float valve
5. Drip tray and overflow

Is eliminated. Cold water could be fed to appliances by direct mains pressure. However, water was stored in a smaller quantity for the water heater, so that appliances were still fed with hot water by gravity flow (see Figure 32).



**Figure 32: Method of water supply to South African urban dwellings due to higher mains supply pressure**

With the development of the **pressure reducing valve** and the **multi-outlet pressure type domestic water heater**, the need for hot water storage is removed and the water both hot and cold can be fed at high and balanced pressure via single outlet mixing valves to appliances. Limiting pressure by means of the pressure reducing valves eliminates water noise and extends tap washer life.



**Figure 33: Method of water supply to South African urban dwellings with the use of Pressure Reducing Valves**

With these desirable advantages comes the need for much closer attention to all aspects of the installation if it is to function satisfactorily.

## THE SOURCE OF WATER

There are different sources of water available to man and these include:

1. Rainwater
2. Well water
3. Spring water
4. Streams, Rivers
5. Lakes
6. Recycled water

Whichever form of water that is available to man, this water has to undergo a form of treatment before it is fit to use/potable. Buildings within urban areas receive potable water under pressure from a **metered connection** provided by a local authority.

The usual connection for a house consists of a **20mm tapping** into the water main connected to a **15mm or 20mm water meter** on the boundary by a **20mm pipe**. This pipe is referred to as a **communication pipe**.

The water pressure at the connection point just after the meter is usually **250kPa** and **600kPa** under low demand conditions. (Note that  $1\text{kPa} = 1000\text{N/m}^2$ ). These standard connections provide enough water for a modest household where the flow and pressure requirements are not much.

### Service Pipe:

The service pipe refers to the supply pipe within the property boundary. A **Stop Valve** should be provided in the service pipe in an accessible position, as near as is practical to the point of entry of the pipe so that the supply may be readily shut off for repair or maintenance.

**Precautions** in laying underground pipe work should be noted as follows:

- As a precaution against **contamination**, water pipes running parallel to drains or sewers are to be kept 500mm away.
- As a precaution against **damage by impact**, pipes of 75mm diameter or less should have a minimum cover of 450mm, while pipes of larger diameter should have a minimum cover of 750mm.
- Pipes should not be more than **1m below** ground
- Pipes under buildings are to be **sleeved** to allow for removal, thus bends and junctions are to be avoided.
- Pipe material to be **corrosion resistant** and **joints sound**.
- A **filter** of adequate design and size should be fitted on the service pipe.

## COLD WATER DISTRIBUTION SYSTEM

**Traditionally**, water from the **municipal mains** is supplied to a cold-water storage tank from which cold water is fed to sanitary appliances and to a hot water supply cylinder.

In most areas of South Africa falling within municipal areas, it has become **usual practice** to supply cold water to appliances by direct mains pressure via the service pipe.

### Pipe Layout:

The pipe network should be laid out to **minimize pipe length** and **directional changes**. This would lead to savings in material and labour and reduction in pressure due to friction will be avoided.

### Pipe Location and Fixing:

- Pipes are usually installed where they are **unobtrusive**. Access for repair must be considered.
- Pipes, which are built in or buried, must be **carefully located** because of leaking joints and access for repairs.
- Exposed pipe work must be **firmly supported** so that it cannot sag under the weight of the pipe and its contents, nor bend due to misuse.
- Pipe work must be **isolated and secured** so as to eliminate water hammer shock waves, generated when taps or valves are closed suddenly.
- **Fixing systems** and recommended **support intervals** for different pipe materials are stipulated by regulations, manufacturers and textbooks.

### Pipe Materials:

1. **Galvanized Mild Steel** piping was **traditionally** used for most domestic water supply systems in South Africa. The primary reasons for this are that:
  - a. The material is inexpensive and robust
  - b. Local installers are used to working with it and
  - c. Clients accept it as the norm.

Due to the **deterioration of water quality**, galvanized mild steel pipe is not as widely used as before. Galvanized mild steel pipe should not be used in soft water coastal areas. Alternative materials are:

1. **Copper**
2. **Stainless Steel**
3. **Polypropylene**
4. **Polyethylene**
5. **U.P.V.C** and
6. **Plastic piping such as Chlorinated PVC and Polybutylene** can be considered for use for both hot and cold water piping.

**Disadvantages of Plastic pipes include:**

- a. Plastic pipes are more susceptible to damage
- b. Require more support
- c. Internal diameters are usually smaller than metal pipes and it may therefore be necessary to use larger sizes.

**Advantages of Plastic pipes include:**

- a. Plastic pipes have smooth bores and outside surfaces, which make for quiet operation and neat appearance.
- b. Easier to install – maneuverable
- c. Light in weight
- d. Do not corrode

However, for all the pipe materials, **cost** is also a factor that determines the choice of pipe material and with the fluctuating prices of raw materials; the choice will vary from time to time.

**Pipe Cleaning:**

After installation of pipes and before any valves are connected, the entire pipe-work must be thoroughly flushed. After flushing, pipe ends should be protected against entry of grit, plaster etc pending fitments of valves.

**Pipe Jointing:**

Typical methods of jointing pipes of different materials include:

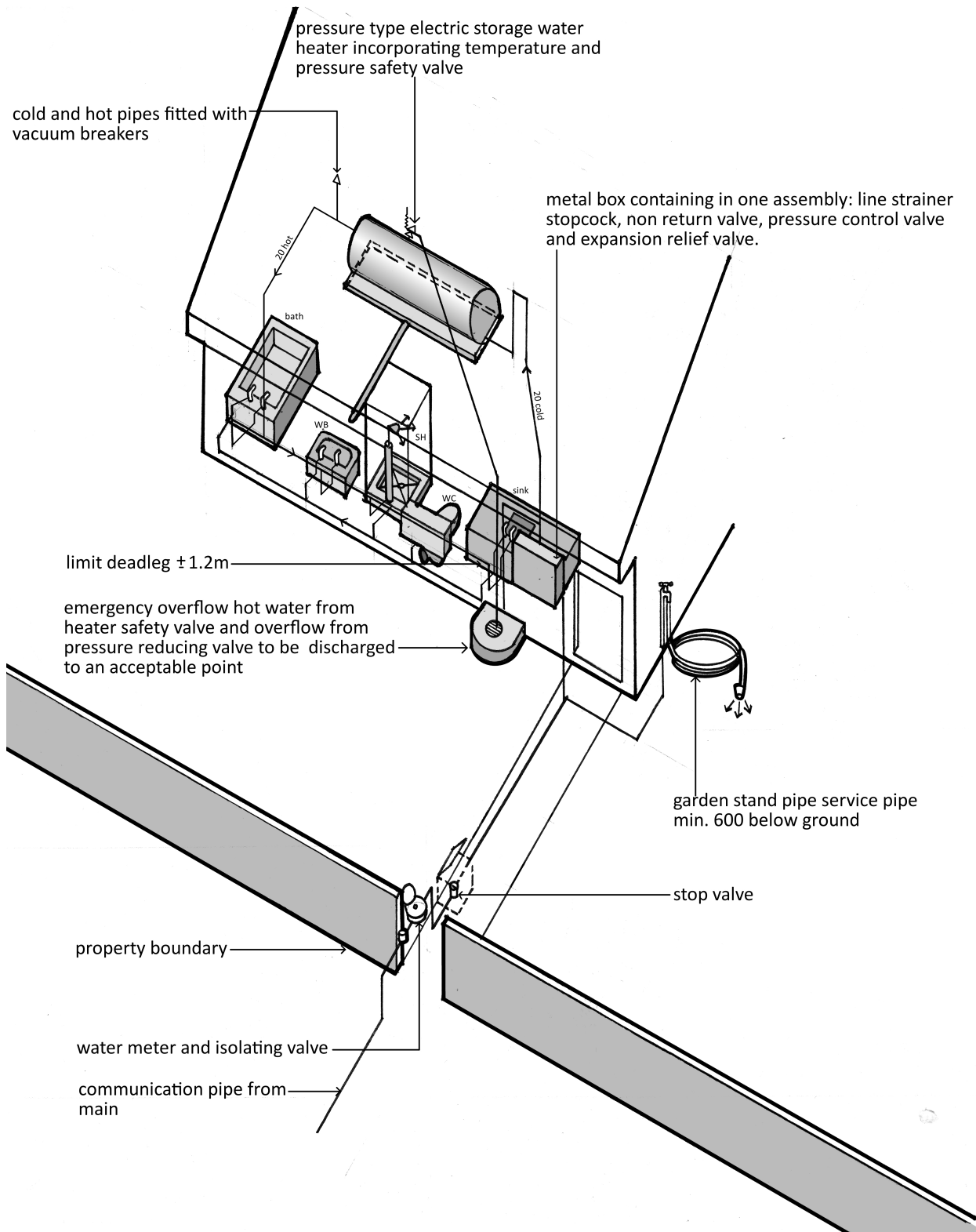
1. **Copper Tube** – Manipulative compression joint, Non-manipulative compression joint and capillary solder joint
2. **U.P.V.C** – Cold solvent welds
3. **Galvanized Mild Steel** – Screw Coupling

**Control and Isolating Valves:**

Control valves commonly used in a domestic water supply installation include:

1. Taps – both single and mixer variety
2. Ball valves in storage tanks and W. C. cisterns,
3. Pressure control valves and
4. Flushing valves

**Isolating valves** enable maintenance to be carried out on a portion of the system without disrupting the whole network. The local authority provides an isolating valve between the water main and the meter. This valve is reserved for their use when the meter requires attention. A second valve should be fitted directly after the meter, which is used to shut down the system for maintenance purposes inside the property. See Figure 34. **Ball valves** require regular maintenance and should be fitted with isolating valves.



**Figure 34: Hot and cold water supply – typical domestic installation; direct mains supply – balanced high pressure at fittings**

# Cistern Feed Cold Water Distributing Pipe System

Where mains pressures are inadequate, it may be necessary to install a storage cistern as depicted in Figure 35.

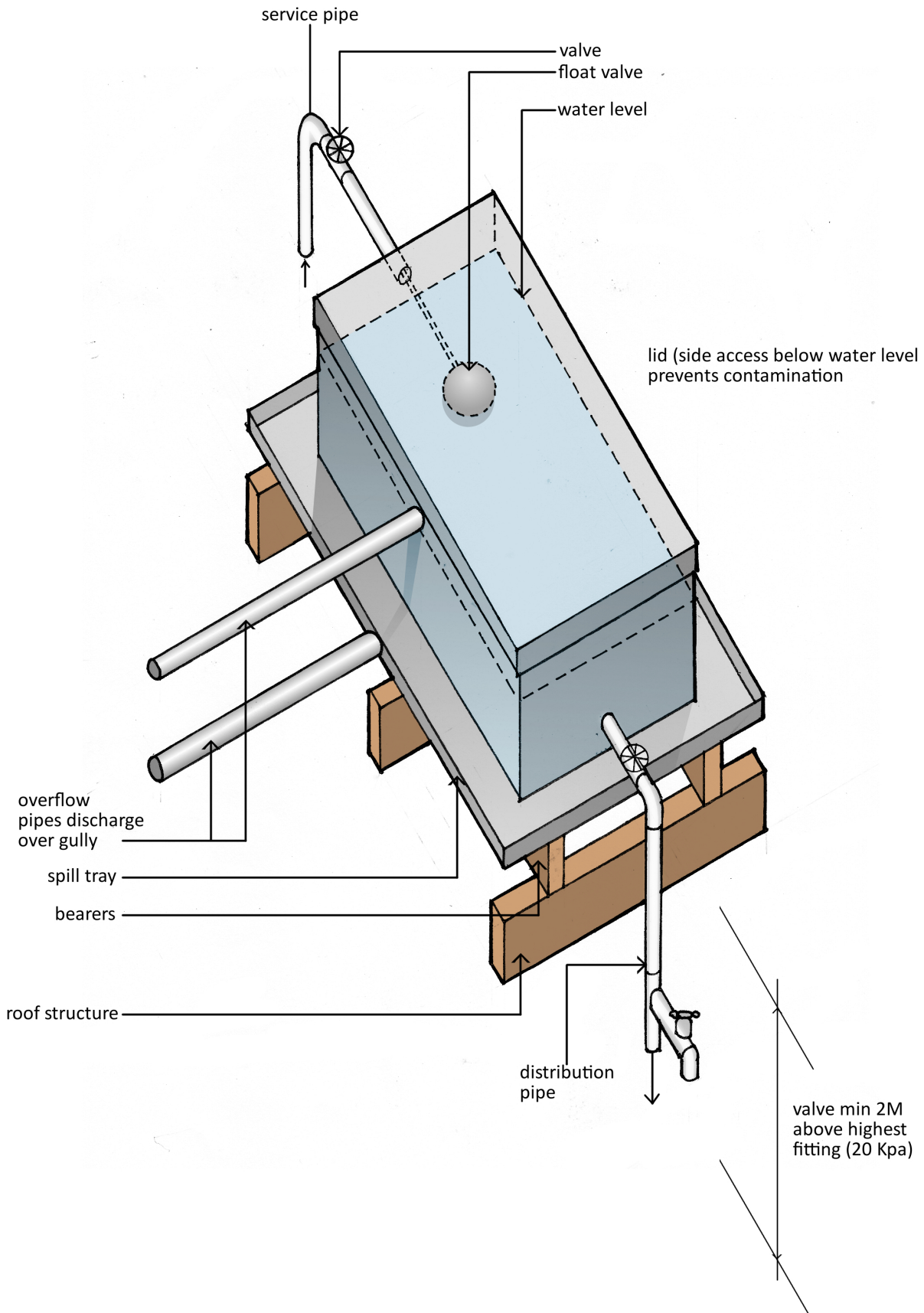


Figure 35: Cold water storage cistern

The **advantages of a storage cistern** are:

- Provides storage against interruption of supply during repair work on mains.
- Relieves demands on main during peak use periods.
- Provides a constant supply of water with limited pressure in distribution pipes and reduces noise and wear on fittings.
- Limits back siphonage of water from fittings into the mains.
- Assists in achieving a balanced hot and cold water supply.

The **disadvantages of a storage cistern** are:

- Possible contamination of water supply due to dust entry into cistern etc.
- Space and support required at high level to obtain head pressure and protect from corrosion and frost.
- Provision to be made for overflow and leaks.
- Water can become stagnant if the householder is away.
- Pipe-work more extensive than in a mains supply system.
- Limited pressure

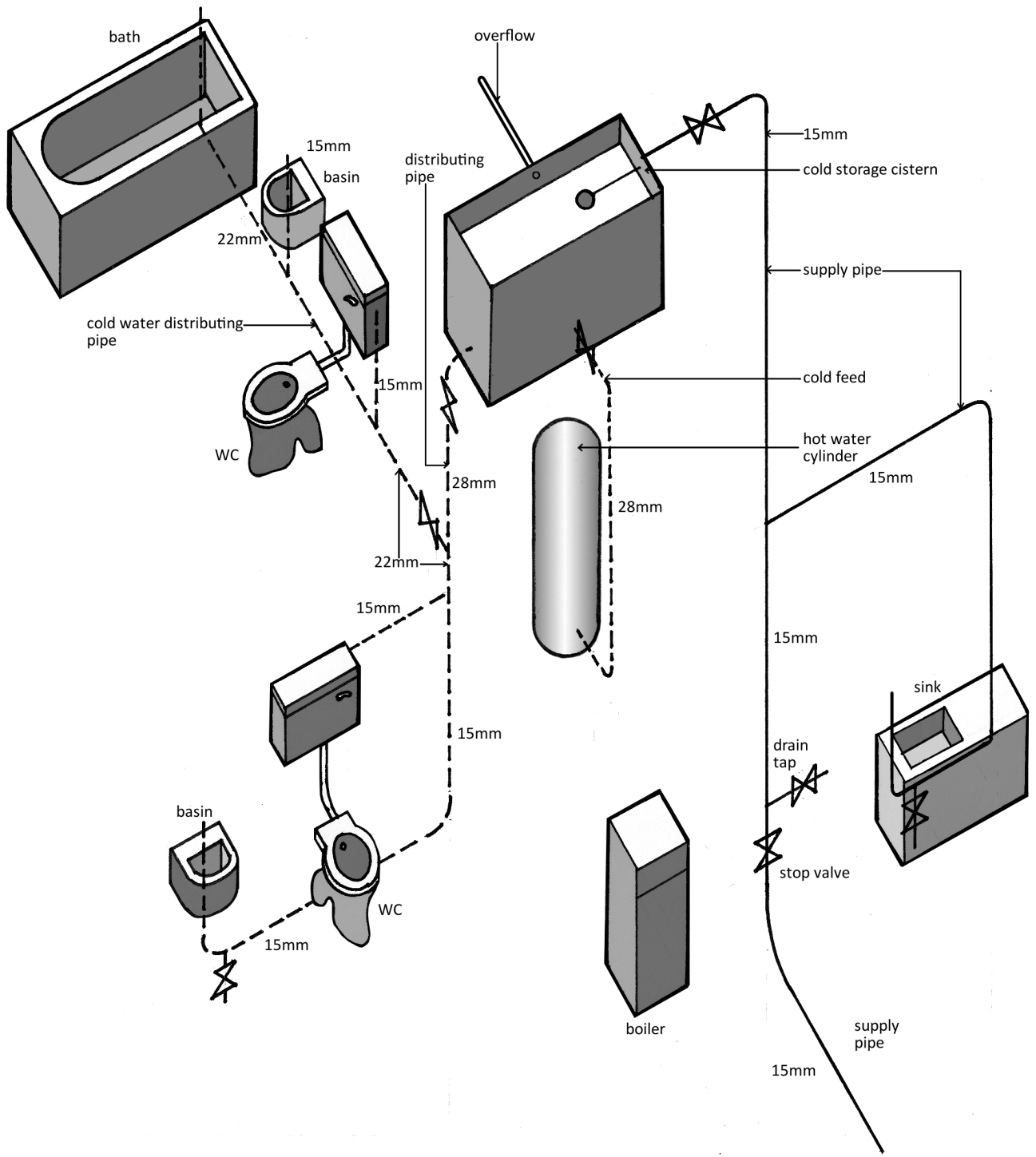
However the **capacity** of the cold-water cistern must be related to the occupancy of the dwelling. Various references give recommendations. Clark (1988) suggests **90 litres** per resident. Figure 36 illustrates the cold water distributing system for a two-floor house.

The distributing pipe is connected to the cistern at **50mm** above the bottom of the cistern to prevent any sediment that may have collected from entering the pipe. In addition, a **stop valve** is fitted to the pipe adjacent to the cistern, isolating the whole system from the cistern in the event of repairs and renewals. The **distributing pipe** is carried down inside the building with **horizontal branches** the first floor and ground floor fittings.

The **aim** in the layout of pipe-work is **economy** in the length of pipe runs, and on this depend a **sensible layout** of sanitary fittings. It can be seen from the figure above that one horizontal branch serves bath, basin and WC. Where one branch serves three fittings such as these, one stop valve will serve to isolate all three fittings.

**Drain or draw-off taps** should be provided where:

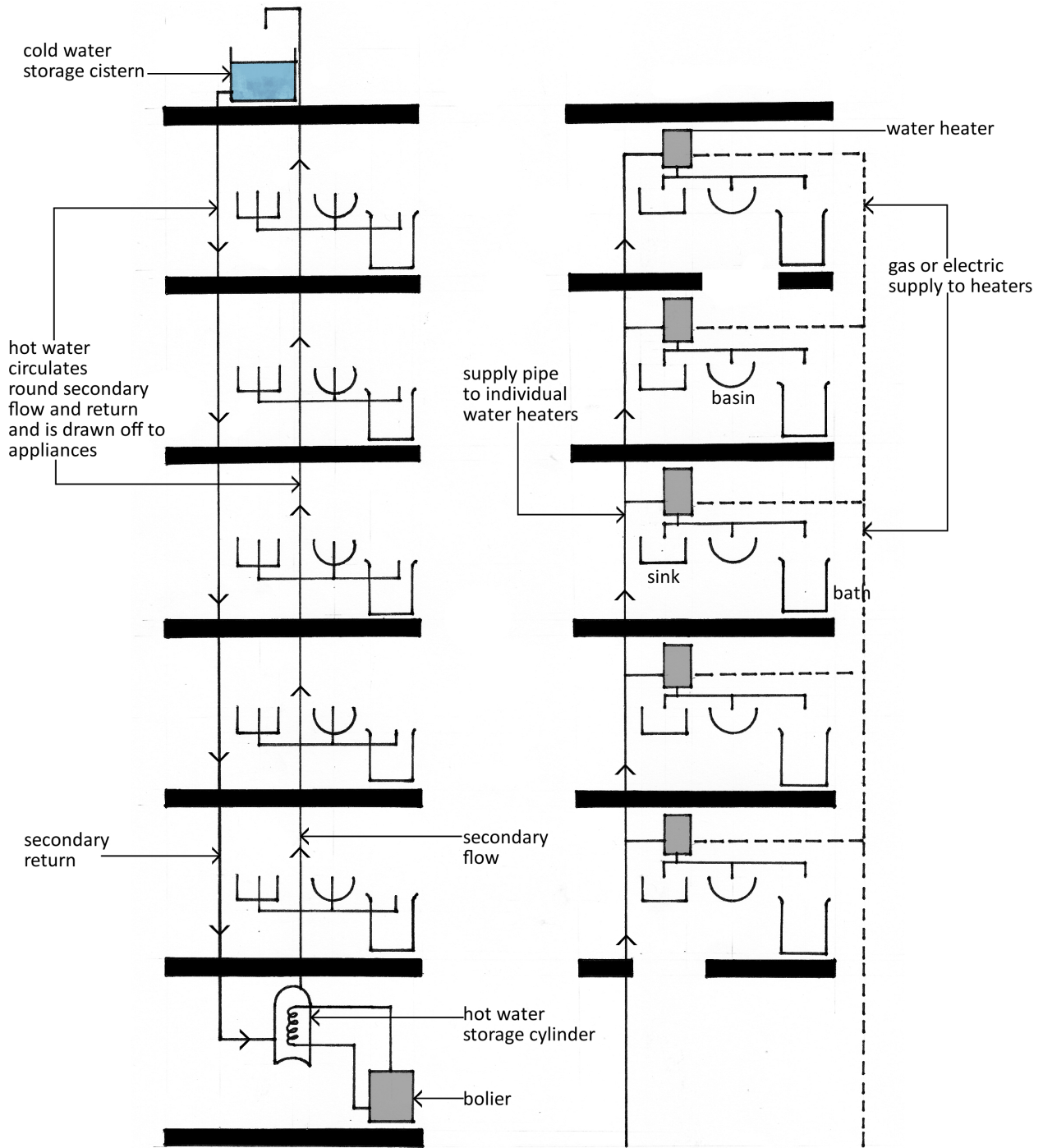
1. Pipe-work cannot be drained to taps so that the whole distributing system may be drained for renewal or repair of pipe-work or
2. When a building is left empty and water in the system might otherwise freeze and fracture pipe-work or joints.



**Figure 36: Cold water distributing system for a two-floor residential building**

# HOT WATER DISTRIBUTION SYSTEM

There are two hot water supply systems – the **Central** and the **Local**. The difference between these systems is that with the central system, hot water is run to the site of the sanitary appliances from a central heat source, and with the local system, the heat source, gas or electricity, is run to the local heater which is adjacent to the sanitary appliances. Figure 37 illustrates the two systems diagrammatically.



Central hot water storage and supply

Local hot water supply

Figure 37: Hot water supply systems

# Central Hot Water Supply

In this system, water is heated and stored centrally for general distribution. Water is heated and stored in a central cylinder from which a pump circulates it around a distributing pipe system and from which hot water is drawn. Figure 38 shows the hot water distributing system for a two-floor residential building. The hot water is drawn from a cylinder, which is fed, by cold water drawn from the cold-water storage cistern in the roof.

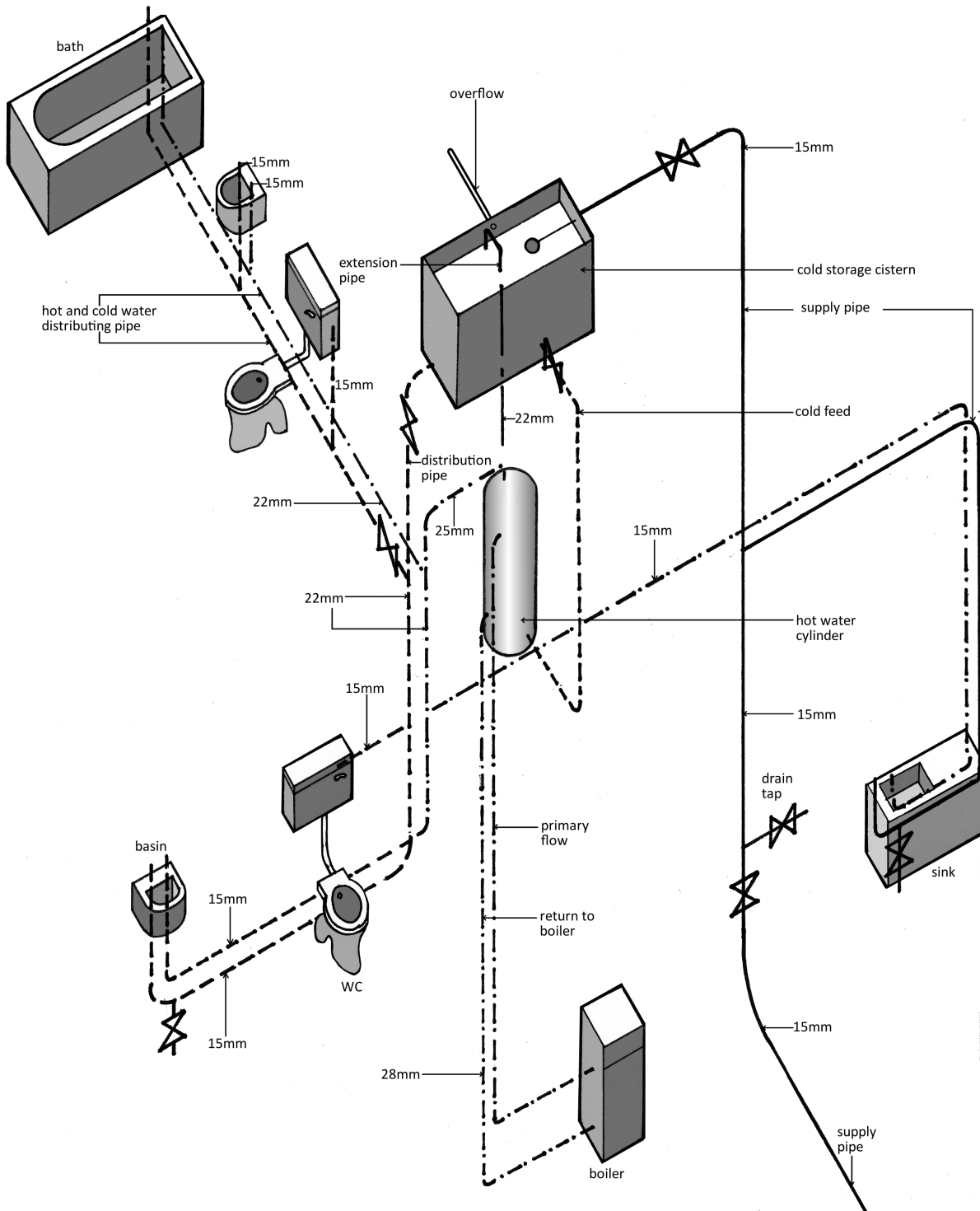


Figure 38: Hot water distributing pipe system

The cold water in the hot water cylinder is **heated by a heat exchanger** in the cylinder through which hot water circulates from the **boiler**. The **cold water feed** to the cylinder is run through a stop valve to the **bottom** of the cylinder. The hot water is then drawn directly from single branches.

In small buildings such as a house, where the sanitary fittings are compactly sited close to the cylinder, the slight inconvenience of funning off cooled water in the single branches before hot water is discharged is acceptable.

In larger multi-storey buildings, the inconvenience of running off cooled water from long single branches is unacceptable as it is also wasteful of both water and energy.

**Dead leg draw-off:** Because the water in single pipe branches to draw-off taps cools, these branches are termed dead leg branches or pipes, or dead-leg of pipe. To avoid too great an inconvenience and waste of water and energy, the length of these dead legs is limited to:

- 20m for 12mm pipes and
- 3m for pipes more than 28mm, unless the pipes are adequately **insulated** against loss of heat.

The storage cylinder contains hot water **sufficient** for both anticipated peak demands and demands during the recharge period. The system is therefore designed to supply hot water on demand at all times.

The **one disadvantage** of the system is that there is some loss of heat from the distributing pipes no matter how adequately they are insulated.

The **advantages** of the system include:

- Economy and convenience of one central heat source that can be fired by the cheapest fuel available and
- One hot water source to install, supply and maintain – hot water being at hand constantly by turning a tap.

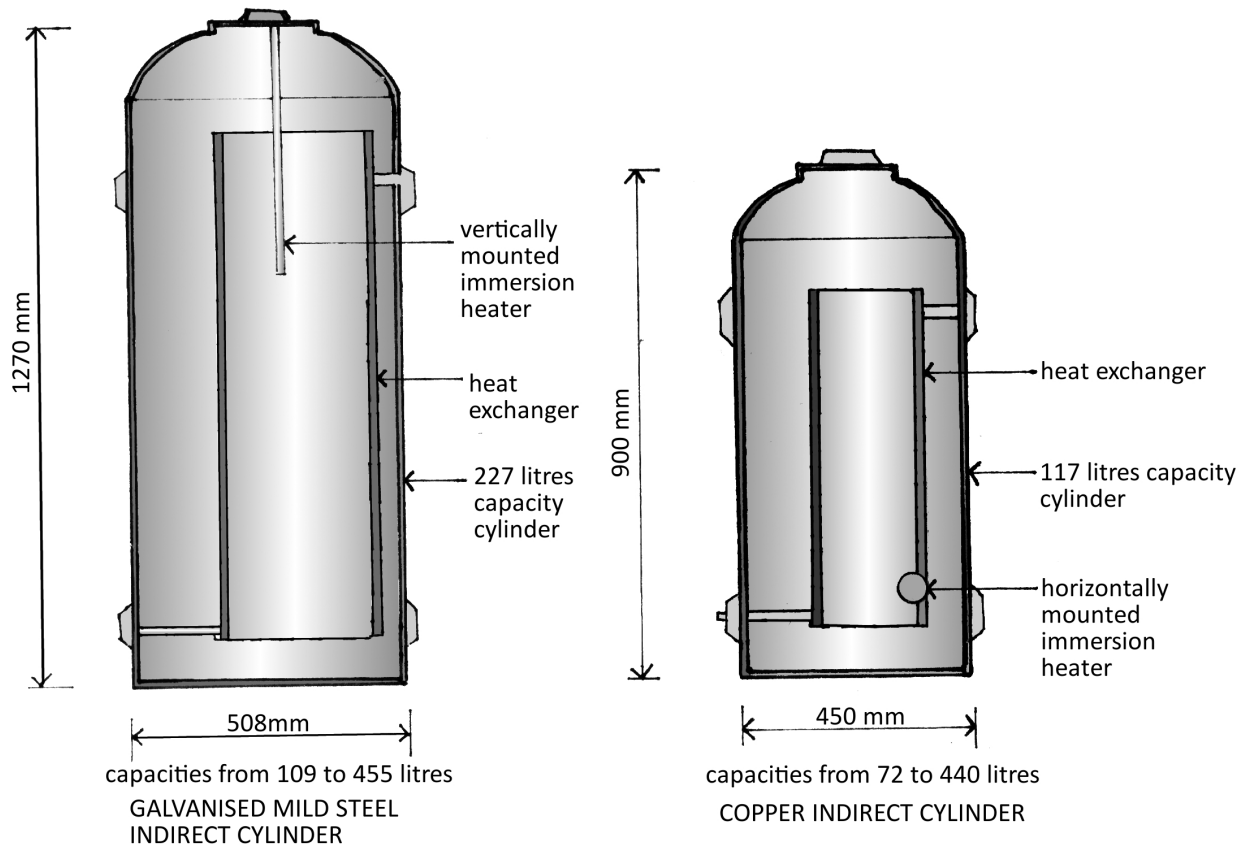
Where **mains pressure supply system** is used, the supply pipe connects to the **unvented hot water storage cylinder** from which supply pipes connect to fittings and there is no roof level storage system.

**Hot Water Storage Cylinder:** Hot water storage cylinders are designed to **contain water under pressure** of the head of water from the cold-water storage cistern. Most hot water storage containers are cylindrical and are fixed vertically to encourage **cold water fed into the lower part of the cylinder to rise**, as it is heated by the heat exchanger, to the top of the cylinder from which hot water is drawn, and so minimize mixing of cold and hot water.

The cold feed pipe to the cylinder is run from the cold-water storage cistern and connected through an isolating stop valve to the base of the cylinder. The **hot water distribution pipe** is run from the top of the cylinder to the

draw-off branches to sanitary appliances and is carried up to discharge over the cold cistern as an **expansion pipe**, in case of overheating.

Storage cylinders are made either of galvanized sheet steel or copper sheets welded or riveted. Figure 39 illustrates typical hot water storage cylinders.



**Figure 39: Galvanised Mild Steel and Copper Hot Water Storage Cylinders**

Whilst galvanized steel cylinders may rust and their average life is about 20 years, copper cylinders may have an unlimited life. Also, most steel cylinders can support greater water pressure than copper cylinders and are appreciably cheaper than copper cylinders.

The different types of **Hot water storage cylinder** include:

- **Vented or Open Vented Cylinders:** When the expansion pipe discharges through the open end of the pipe, over the cold water storage cistern, in case of overheating and expansion of the hot water.
- **Unvented Cylinders:** This is used with mains pressure distribution system
- **Indirect cylinder:** The hot water storage cylinders illustrated above are indirect cylinders. They are so called because the primary hot water from the boiler exchanges its heat indirectly through a **heat exchanger** to the hot water supply, there being no connection between

the water from the boiler and the hot water supply. The purpose of this indirect transfer of heat is to avoid drawing hot water directly from the water system of the boiler.

With an indirect cylinder there is no replacement of water to the boiler and its **primary pipes** and therefore no build up of **scale**. Indirect cylinders are in addition a protection against the possibility of drawing **scalding** water directly from the boiler.

- **Direct cylinder**

**Heat Exchanger:** The heat exchanger, which is fixed inside the cylinder and immersed in the water to be heated, takes the form of a coil of pipes to provide the maximum surface area for heat exchange.

**Primary Flow:** The system of pipes that carries hot water from the boiler through the heat exchanger and back to the boiler is described as a primary flow system.

**Hot water boiler or heater:** The boiler may be fired by solid fuel, gas, oil or electricity, in that order of current costs, solid fuel being the cheapest.

Water heated in the boiler rises in the in the **primary flow pipe** to the **heat exchange coil** or container inside the hot water storage cylinder and as it exchanges its heat through the exchanger to the water in the cylinder, **it cools and returns through** the primary return pipe back to the boiler for **reheating**. There is a **gravity circulation** of water in the primary pipe system.

**Immersion heater:** In urban areas, the most common method of heating water is by an immersion type electrical resistant element mounted in an insulated storage cylinder. This is commonly called a **geyser**.

An electric immersion heater is both an inefficient and an expensive means of heating water. The main **advantages** are that a geyser is quiet, clean, can be installed in a convenient position and requires little maintenance. The **disadvantage** is that a limited volume of water is available and when this is depleted, because of the comparatively small surface of the immersion heater, it requires about four hours to heat the water in the cylinder when compared to two hours for the heat exchange coil from the boiler. This slow recharge rate is can be inconvenient at peak user times added to the high cost of electricity.

## **Local Hot Water Supply**

In this system, water is either

- a. heated instantaneously as it flows through the heater, or
- b. Heated and stored locally for local use by a water heater.

A water heater adjacent to fittings to be supplied is fired by gas or electricity run to the site of the heater.

The **advantages** of this system are that:

- there is a minimum of distributing pipe work
- Initial outlay is comparatively low and
- Control and payment for fuel can be local which is of advantage to the landlord of residential flats.

The **disadvantage** is that local heaters are appreciably more expensive to run and maintain than one central system.

### **Hot Water Storage Heaters**

There are two types of local water heater:

#### **A. The Hot Water Storage Heater and**

#### **B. The Instantaneous Water Heater**

**The Local Hot Water Storage Heater:** This consists of a heat source and a storage cylinder and tank. These are used to supply hot water to ranges of fittings such as basins, showers and baths used in communal changing rooms of sports pavilions and washrooms of students' hostels.

The storage heater is **heavily insulated** to conserve energy. The size of the heater is determined by the anticipated use of hot water at times of peak use. The **different types** of local hot water storage heater include:

1. **Gas water storage heater**
2. **Electric water storage heater**
3. **Electric storage single point water heater** – designed to heat and store a small volume of water for the supply to single basins.
4. **Combined cold and hot water storage unit** - which is designed to fit into a confined space

**The Instantaneous Water Heater:** This consists of a heat source through or around which cold-water runs and is heated instantaneously as it is run off. The heat exchanger only operates when water is flowing, hence the name instantaneous water heater.

Because the temperature of the water at the outlet is dependent on the rate of flow of water, there is a limitation on the rate of flow from the outlet if the water is to be hot. Consequently the rate of flow from these heaters is limited. The different types of Instantaneous water heaters in use include:

**1. Instantaneous gas water heater:** Most instantaneous water heaters are fired by gas, which is ignited by a pilot light immediately water flows, to provide hot water instantaneously. **The cold water supply valve controls these heaters;** when the valve is opened, the flow of water opens a **gas valve** to ignite the burners that heat the water. The different types include:

- **Gas instantaneous single point water heater-** which is designed to supply hot water to single fittings such as basins or sink.
- **Multi-point instantaneous gas water heater-** these heaters can hot water to a sink, basin and bath through **dead-leg** draw-off pipes to fittings, hence the name multi-point. These heaters were commonly used to supply domestic hot water to small houses and flats before combined space heating and hot water boilers became common.

The **disadvantages** of these heaters include:

- a. The rate of flow of hot water from these heaters is limited by the need for sufficient time to allow an exchange of heat to the water coils in the heat exchanger. When more than one tap is opened there will be a restricted rate of flow of hot water.
- b. The comparatively large output from these heaters necessitates a flue to open air exhaust combustion gasses and also an adequate intake of air for efficient and safe combustion of gasses.
- c. The gas valves in these heaters will only operate when there is comparatively **high water pressure**, such as that from a main supply, or a good head of water from a cistern.

**2. Instantaneous Electric Water Heater:** Water is heated as it flows through coiled heating elements immersed in a compact, sealed tank. A flow switch in the cold water supply inlet operates the electric supply. These heaters are fixed over the single appliance to be supplied, with hot water delivered through a swivel outlet discharging over the appliance.

The **disadvantages** include:

- a. The output of hot water from these heaters is **limited** by the rate of exchange of heat from the heating elements to cold water.
- b. In hard water areas, **lime scale** will coat the heating element and appreciably reduce the efficiency of these heaters.
- c. The heat exchange tank has to be **heavily insulated**.

The **advantages** of these heaters are that:

- a. They are compact
- b. They require only one visible supply pipe
- c. They may be fixed in internal unventilated toilets because they have no need for air intake or a flue.

# ELECTRICITY SUPPLY

## INTRODUCTION

The high demand for electrical energy in virtually all-human endeavors has engendered the continuous rapid growth of electricity production, transmission and distribution worldwide. Modern technology prefers the use of electrical energy due to its numerous technical/economic benefits over other forms of energy. Every habitable building structure usually requires electrical appliances such that the cost of electrical installation in a building is usually between 2.5% to 5% of the total building cost.

Improper design and installation of the electrical networks in a building could render it useless justifying the adage that “Electricity is a good servant but a bad master”. Therefore, in order to avert impending danger to lives and properties in buildings, there is a need to be informed on the supply, design and installation of electrical networks.

**GENERATION:** Electrical energy is generated in power stations and supplied and distributed to cities, villages, industries, teaching hospitals, theatres, universities, homes etc through Area Electricity Boards. Power stations consist of different rating of generators and can be classified as follows:

1. **Hydro-power stations** – energy from water
  
2. **Thermal power stations** – energy from heat including:
  - i. Steam turbines
  - ii. Gas turbine
  - iii. Coal fired power station
  - iv. Diesel oil power station – standby private generators in factories and private residences
  - v. Petrol fuel power plant – for private residences only
  
3. **Nuclear power stations** – energy from nuclear reactors. This is also termed thermal source, because heat is generated from these Nuclear reactors to raise the heat energy of steam, which drive turbo-generators.
  
4. **Wind turbines** – energy from wind is used to drive wind power generators. Commonly used where abundant wind energy is available.

**SUPPLY AND DISTRIBUTION:** Electricity is usually transmitted and distributed using a **grid system**. This is a system of overhead cables (conductors) carried on pylon or steel towers linking all power stations and for distributing electrical energy over a large area.

The generating plants in power stations produce energy of 6.6 to 11KV; the voltage is stepped up to a maximum of 1500KV in the grid system. It is advisable to transmit electricity at high voltages in order to reduce the cost of energy supply.

Power  $P = IV$  (where  $I$  = current and  $V$  = voltage)

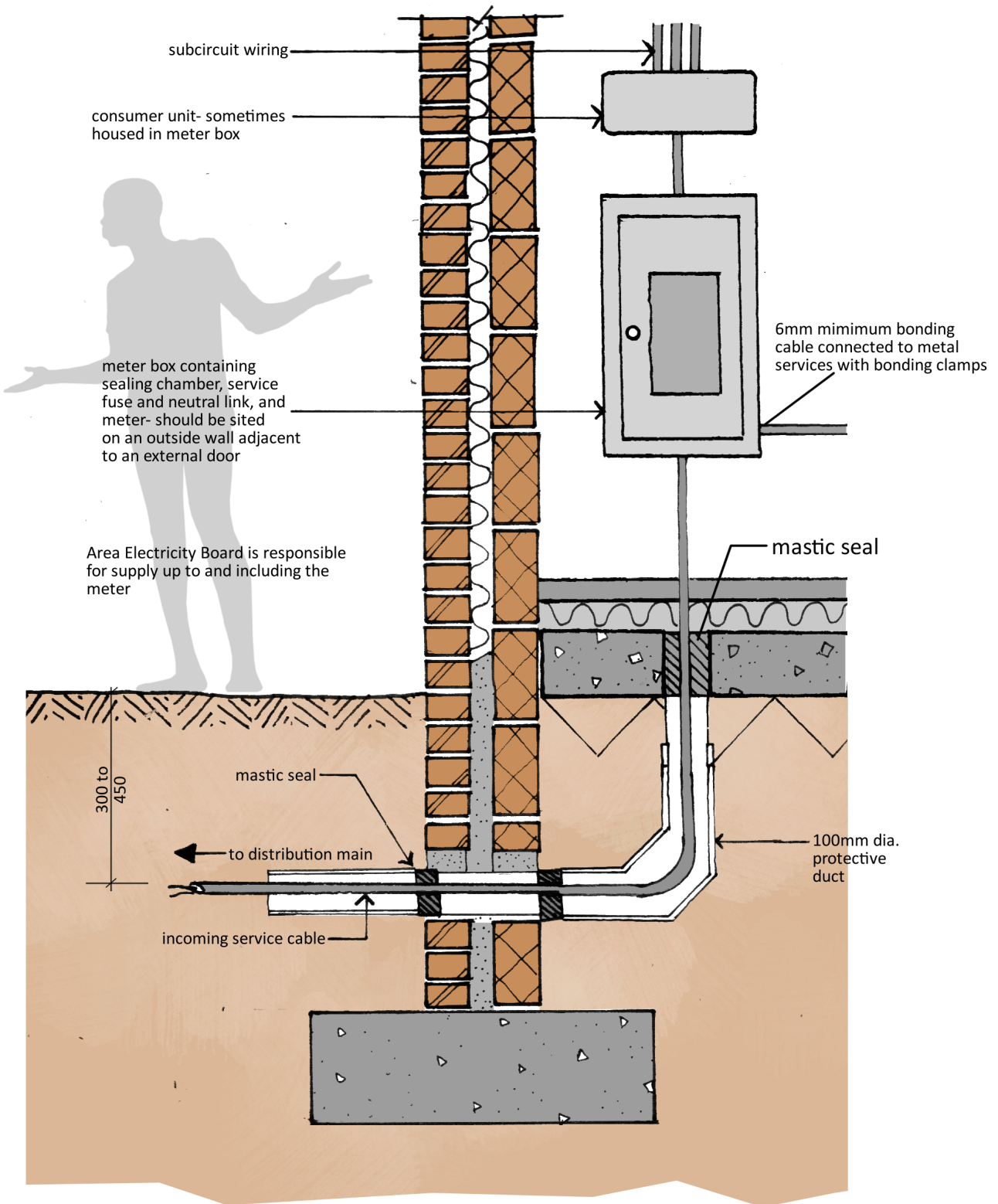
This means that for a given power, an increase in voltage causes a reduction in current and subsequently a reduction in cable and switchgear sizes.

The power in the grid system is stepped down to different voltages depending on needs to 33KV substations, 11KV substations that has to be sited at the consumer's premises for industries, factories, teaching hospitals, universities etc. and 400 to 230V for domestic consumers.

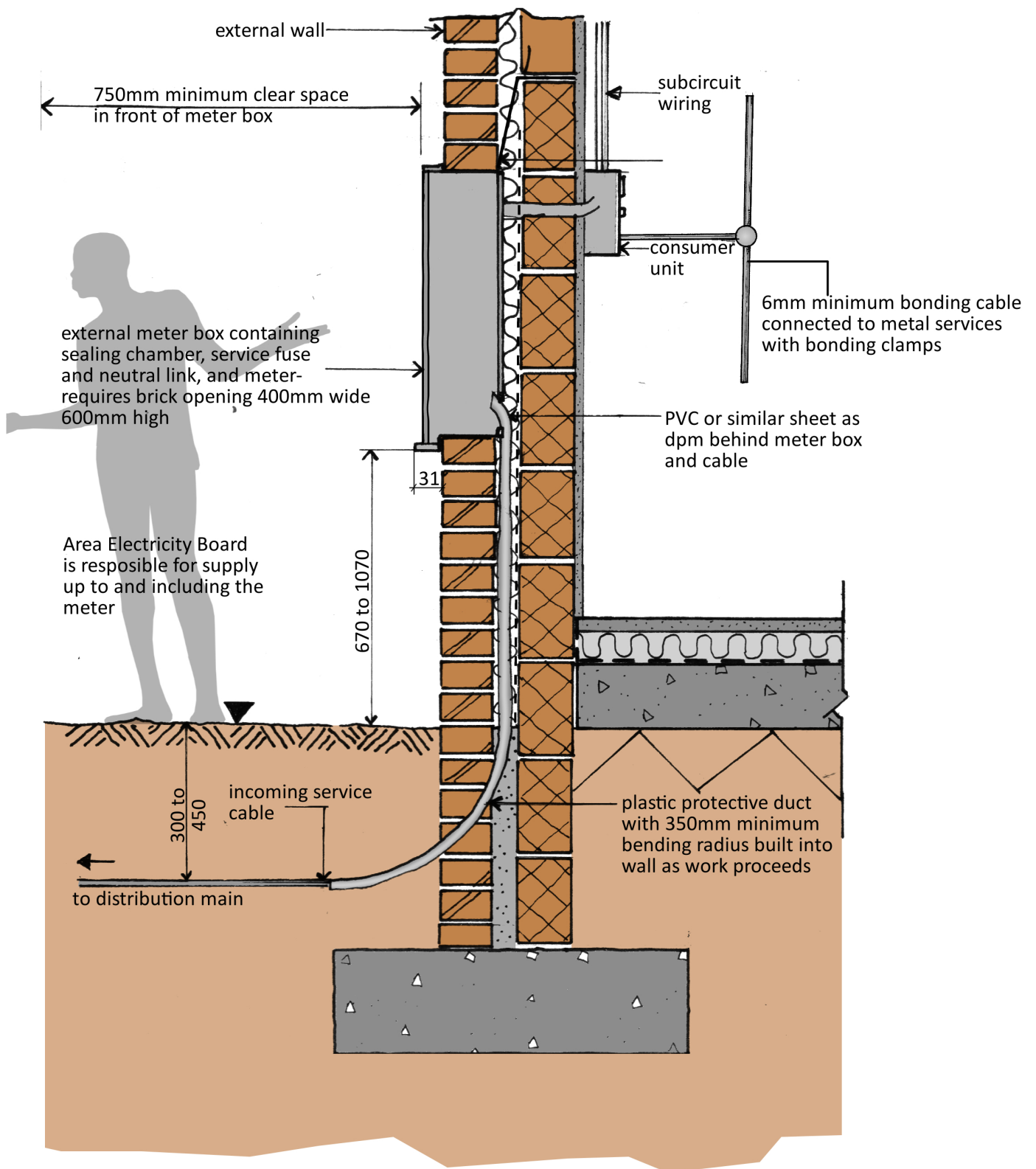
The electrical supply to a domestic installation is usually 230V single phase and it is designed with the following basic aims:

1. Proper earthing to avoid shocks to occupants
2. Prevention of current leakage
3. Prevention of fire outbreak.

Typical electrical supply intake details are shown in Figures 40 and 41. If the meter is a pre-paid meter, the electrical supply intake can be terminated in a meter box situated within the building. However, most Area Electricity Boards prefer to use the external meter box in the case of post-paid meters, which enables the meter to be read without the need to enter the premises.



**Figure 40: Electrical Supply Intake Details with Meter Box inside the Building**



**Figure 41: Electrical Supply Intake Details with Meter Box located on the external wall**

## **Entry and Intake of Electrical Service into a Building**

The Area Electricity Board is responsible for providing the electrical supply up to and including the **meter** but the consumer is responsible for safety and protection of the Board's equipment. The Area Electricity Board will install

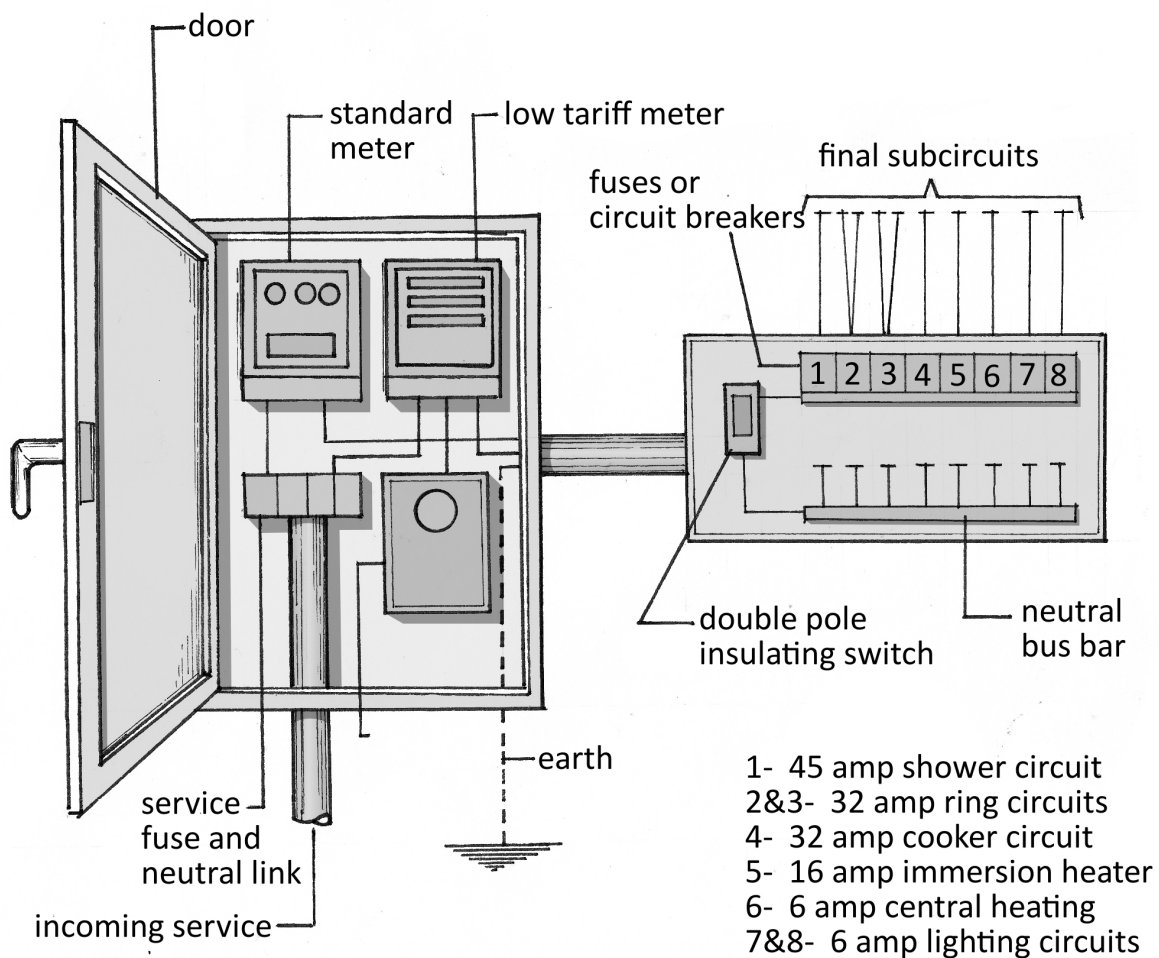
the **service cable** up to the meter position where their **termination equipment** is installed.

**Meter Boxes:** Generally, the Area Electricity Board's meters and termination equipment are housed in meter boxes which are available in fiberglass and steel ranging in size from 450mm wide x 638mm high to 585mm wide x 815mm high with an overall depth of 177mm.

**Consumer Control Unit/Distribution Board:** This provides a uniform, compact and effective means of efficiently controlling and distributing electrical energy within a dwelling. It contains:

- i. A **main double pole isolating switch** controlling the **live phase** and
- ii. **Solid metal conductors**, called the **bus bars**, for the **neutral phase**, which in turn is connected to the **fuses** or **miniature circuit breakers** protecting the **final sub circuits**.

A typical layout of the incoming service cable, the meter boxes and the consumer control unit is shown in Figure 42:



**Figure 42: Layout of incoming service cable, meter boxes and consumer control unit**

## ELECTRIC CABLES

These are made up of copper or aluminium wires called conductors surrounded by an insulating material such as densely packed pure magnesium oxide insulation, PVC or rubber. Typical examples of these are shown in Figure 43.

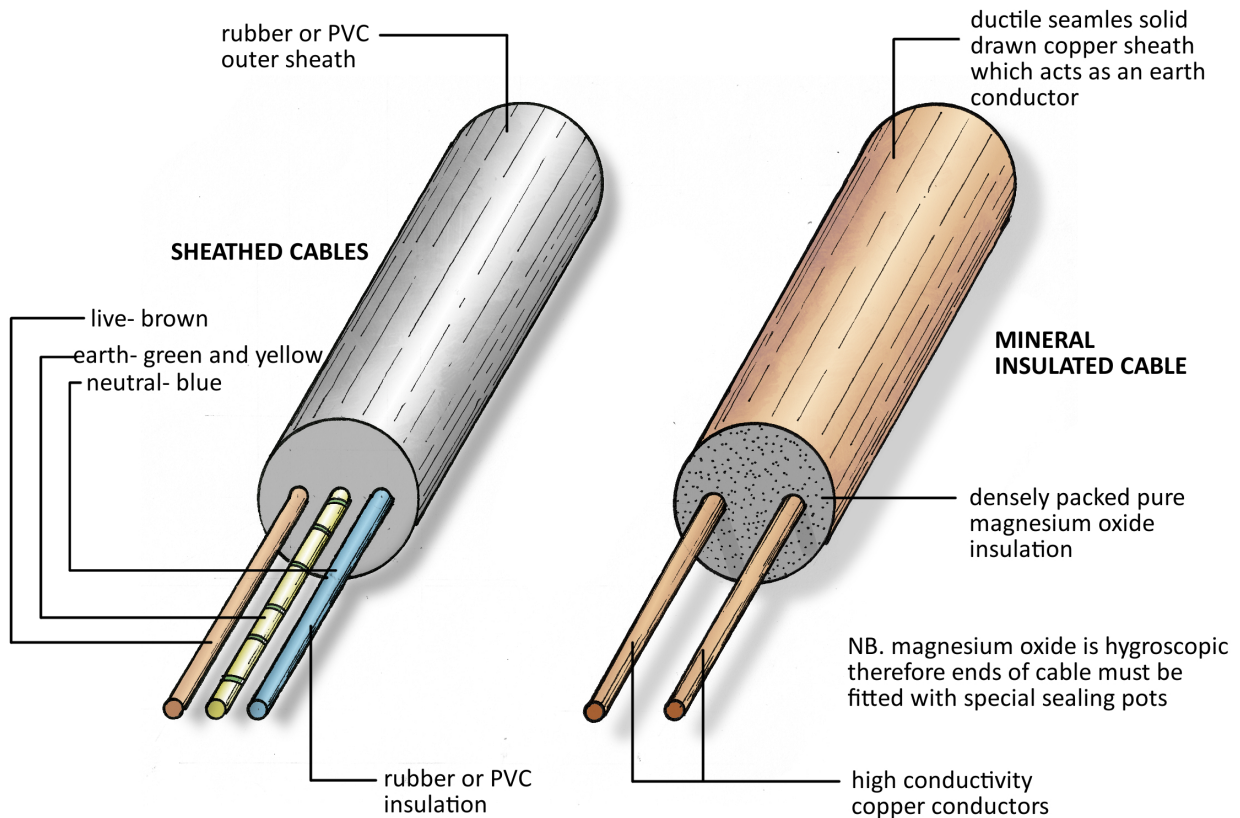


Figure 43: Electrical Cables

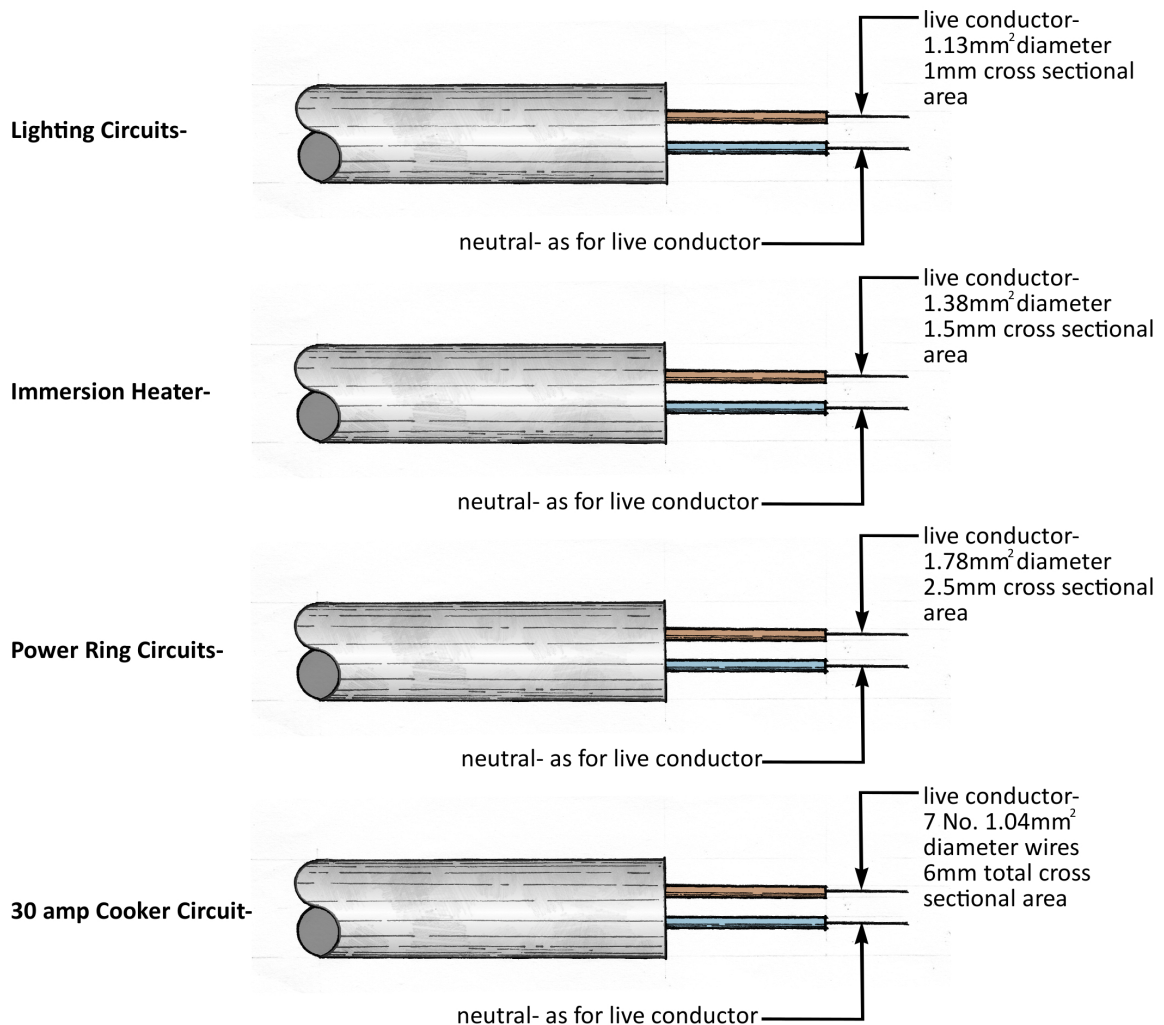
**Choice of Cables and Conductors:** The I.E.E Regulation stipulates that all cables carrying current must be so selected as to be able to carry their rated currents, without deterioration. This is why in choosing cables; the following **factors** have to be borne in mind:

1. The current carrying capacity of a cable
2. The voltage drop along the cable

This obeys Ohm's law ( $V = IR$ ). Where  $V$  = voltage,  $I$  = current and  $R$  = resistance. Every cable should possess very low resistance; therefore, for wiring purposes, **copper** and **aluminium** are chosen because of their **cheapness** and **low resistivity**.

**Cable Sizing:** The size of a conductor wire can be calculated taking into account the **maximum current** the conductor will have to carry (which is **limited by the heating effect caused by the resistance** to the flow of electricity through the conductor) and the **voltage drop** which will occur

when the current is carried. For **domestic electrical installations**, the following cable ratings shown in Figure 44 are usually suitable: -



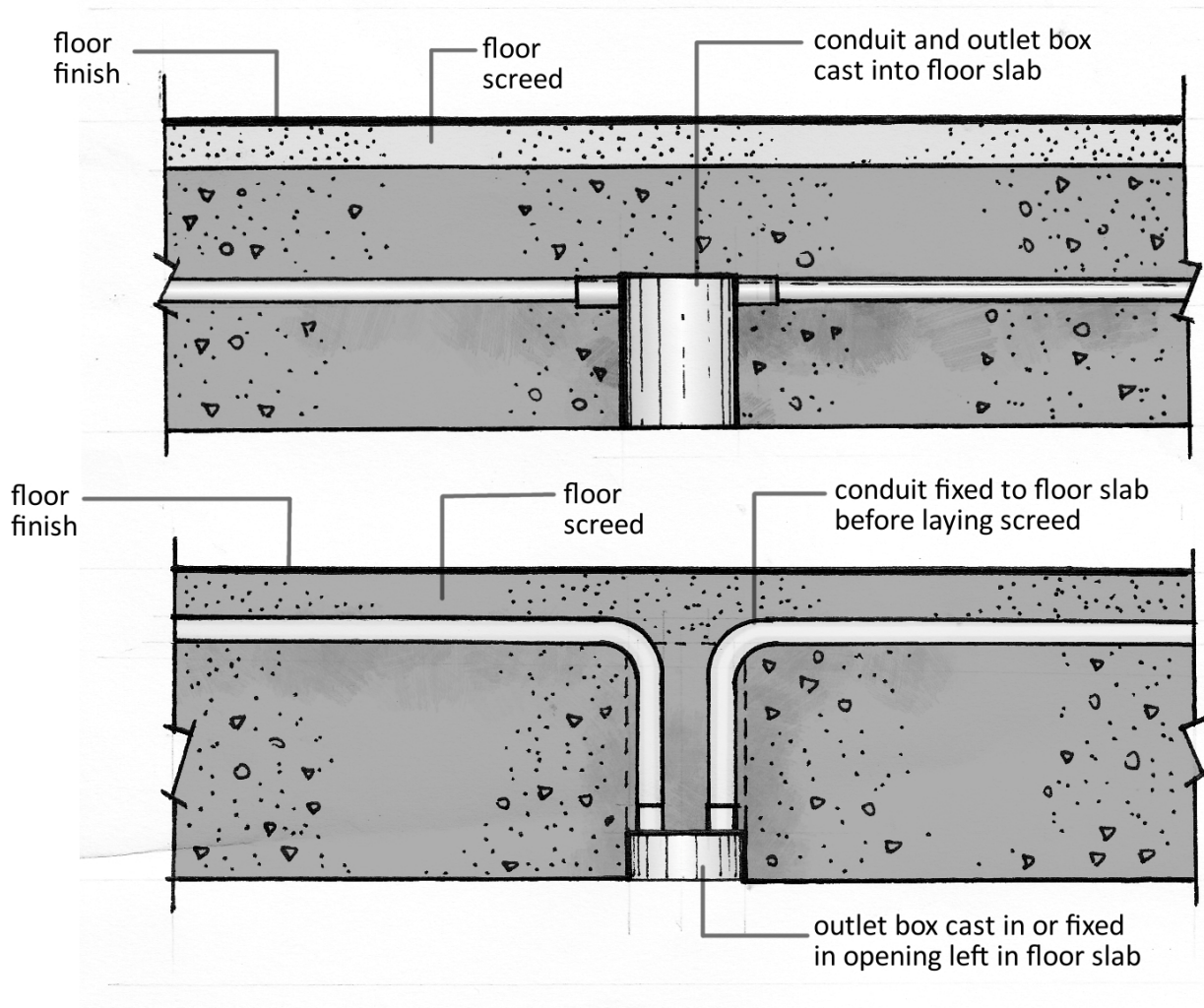
**Figure 44: Cable Ratings**

## ELECTRICAL INSTALLATION

Being relatively small, rewire-able systems housed in horizontal and vertical **conduits** can be easily accommodated in most construction systems. Rewire-able systems housed in horizontal conduits can be cast into the structural floor slab or sited within the depth of the floor screed and chased into vertical walls. Vertical conduits can be surface mounted or housed in a **chase** cut into a wall provided the depth of the chase is not more than one third of the wall thickness. To ensure that such a system is rewire-able, **draw-in boxes** must be incorporated at regular intervals.

Conduit should be **adequately supported** and **laid out as directly** as possible. **Co-ordination** with the building's mechanical and plumbing systems is required to avoid conflicting paths.

Typical examples of rewire-able systems housed in horizontal conduits are shown in Figure 45:



**Figure 45: Rewire-able Systems housed in horizontal conduits**

### **Conduits:**

These are **steel** or **plastic** tubes, which protect the cables. Steel conduits act as an earth conductor whereas plastic conduits will require a separate earth conductor drawn in.

### **Advantages of the Steel Conduit System include:**

- a. Good mechanical protection of conductors
- b. Permits easy rewiring when necessary
- c. Minimizes fire risks
- d. Provides efficient earth continuity
- e. Good pleasing appearance, when properly installed

## Disadvantages:

- a. Very expensive
- b. Difficulty of installation under wood floors in houses and flats
- c. Corrosion effect due to Acid, Alkali and other fumes
- d. Formation of condensed moisture, under certain condition.

Conduits enable a system to be rewired without damage or interference to the fabric of the building.

### Typical Conduit Fittings:

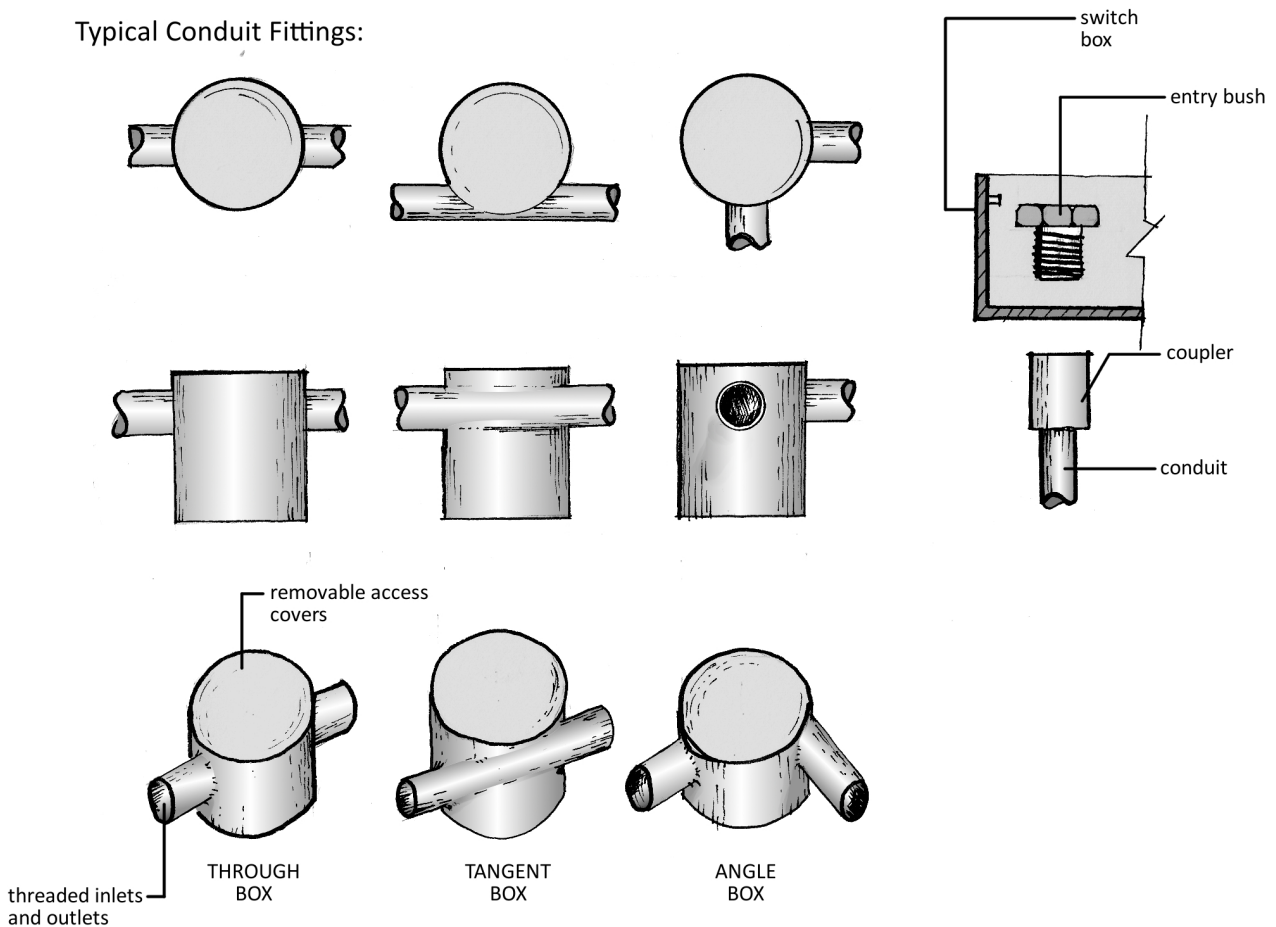


Figure 46: Typical Conduit Fittings

## Trunking:

This is an alternative to conduit and it consists of a **pre-formed cable carrier** which is **surface mounted** not concealed as that of conduit, because of its large surface area and is fitted **with a removable or 'snap on' cover** which can have the dual function of protection and trim or surface finish. In order to put cables in trunking, the lid is normally taken off, and after laying it is again replaced.

Where a large number of cables has to be run together, it is often convenient to put them in trunking. Trunking can be made of steel or plastic. A variety of bends, tees and junctions are available from all manufacturers of trunking. It could be installed vertically along the builder's vertical duct containing other utility pipes (heating, gas or water).

## POWER CIRCUITS

In new domestic electrical installations, the **ring main system** is usually employed instead of the older system of having each socket outlet on its own individual fused circuit with un-fused round pin plugs.

### Ring circuits:

A Typical Ring Main Wiring Diagram is shown in Figure 47.

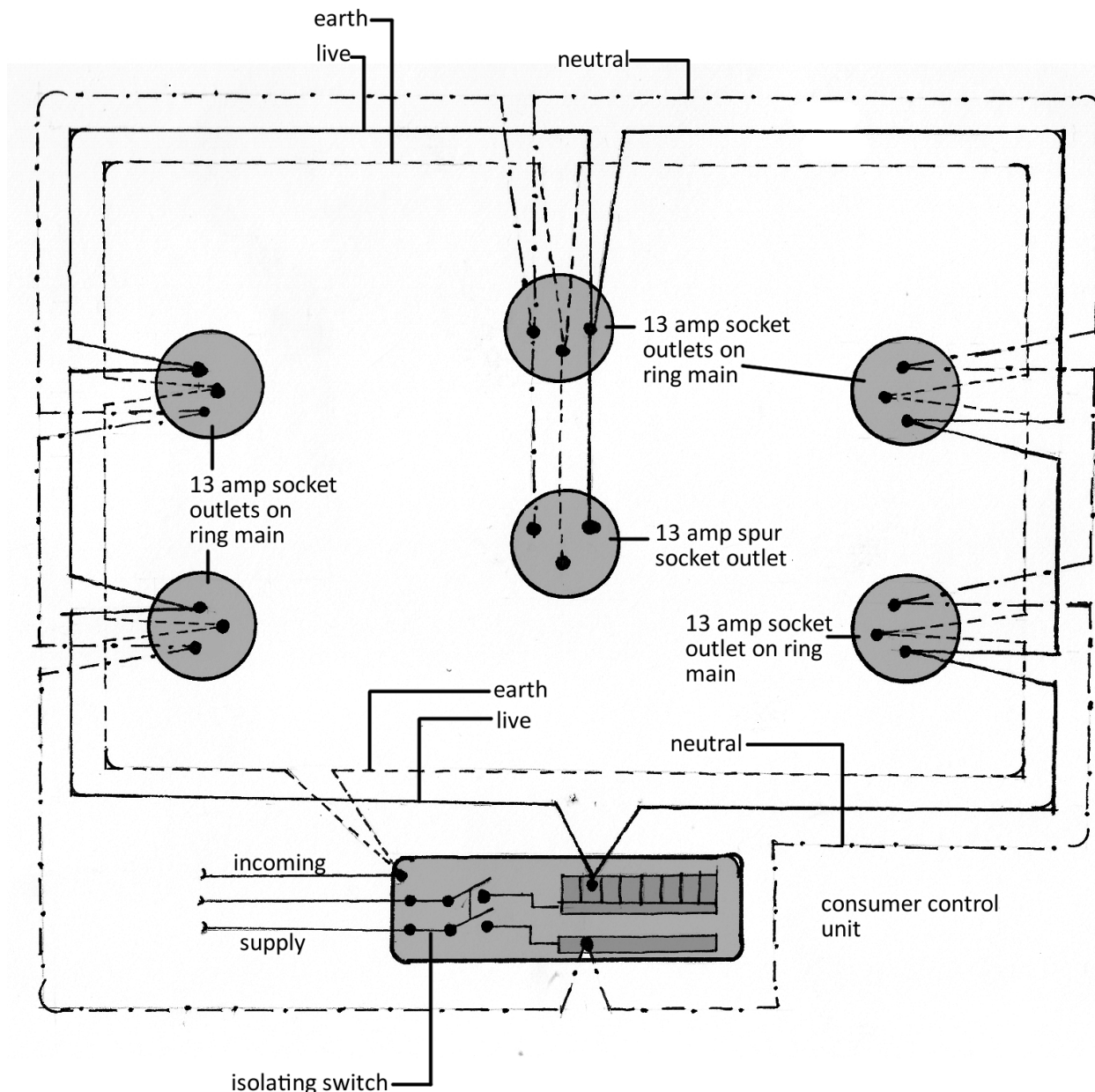
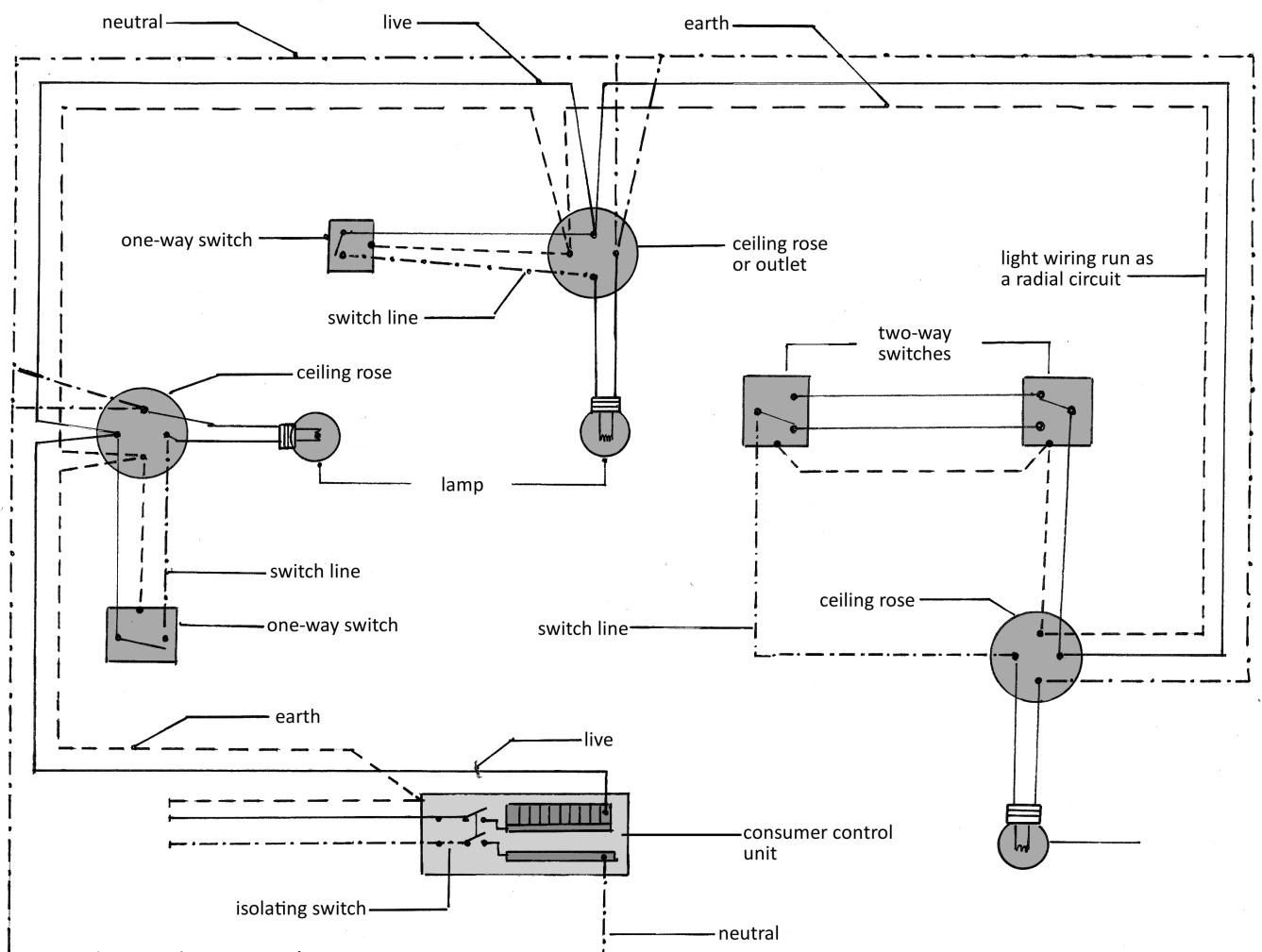


Figure 47: Typical Ring Main Wiring Diagram

Ring circuits consist of a **fuse or miniature circuit breaker** protected sub-circuit with a 32 amp rating of a **live** conductor, **neutral** conductor and an **earth** looped from socket outlet to socket outlet. Metal conduit systems do not require an earth wire providing the conduit is electrically sound and earthed. The number of socket outlets per ring main is unlimited but a separate circuit must be provided for every 100m<sup>2</sup> of floor area.

## Lighting Circuits:

These are usually wired by the loop-in method using an earthed twin cable with a 6-amp **fuse or miniature circuit breaker protection**. In calculating the rating of a lighting circuit, an allowance of 100 watts per outlet should be used. More than one lighting circuit should be used for each installation so that in the event of a circuit failure, some lighting will be in working order.



**Figure 48: Typical Lighting Circuit**

# Electrical Accessories for Power and Lighting Circuits

From the user's point of view, the electricity in a building consists of light switches, power points (switched socket outlets), cooker control units and similar outlets. Such fittings are collectively known as **accessories**; this name came about because they are accessory to the wiring, which is the main substance of the installation from the designer's and installer's point of view. To them, the way the outlets are served is the major interest, but it is quite secondary to the user who is concerned only with the appearance and function of the outlet.

In the complete electrical installation of a building, the wiring and accessories are **interdependent** and neither can be fully understood without the other.

These electrical accessories include:

## Cooker control units and fused connector units

for fixed appliances such as immersion heaters, water heaters, refrigerators and air-conditioners.

## Socket Outlets

these may be single or double outlets, switched or un-switched, surface or flush mounted and may be fitted with indicator lights.

A socket outlet is the correct name for what is popularly known as a **power point**. It is a **female socket** connected to the power wiring in the building and will accept the **male plug** attached to the end of the flexible wire of an appliance such as a vacuum cleaner, fan, television set, radio etc.

Majority of sockets are designed for **13A** maximum load in commercial and residential buildings. 13A plugs are used with these socket outlets. The 13A plugs are designed to have three rectangular pins, which enter into corresponding **rectangular slots** in the sockets.

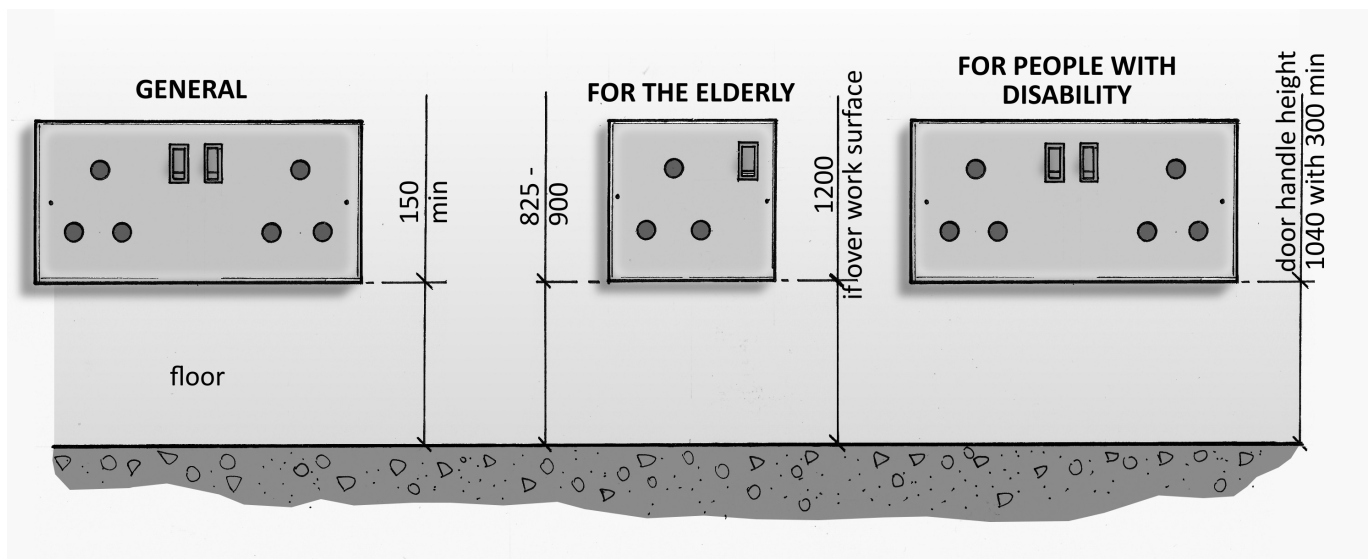
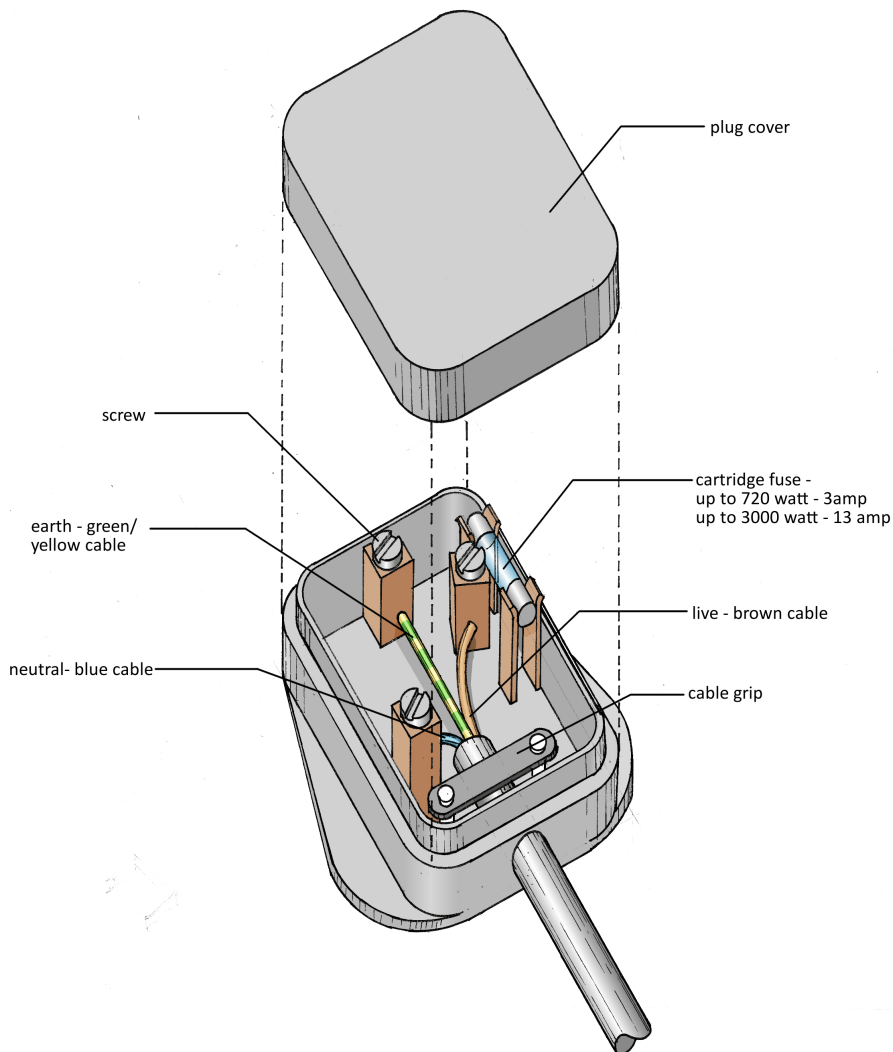


Figure 49: Recommended Fixing Heights for Sockets

There are also sockets and plugs of **2A, 5A and 15A**. Their plugs have **round pins**. Their sockets have **cylindrical holes** to accept corresponding pins from the plugs. The 2A and 5A plugs have only two pins, whereas the 15A plugs have three pins. The recommended fixing heights for sockets are shown in Figure 49.

## Plugs



**Figure 50: Internal section of a fused plug**

## Switches

A switch is used to make or interrupt a lighting circuit. A complete switch consists of **three parts**. There is **the mechanism itself, a box containing it and a front plate over it**.

The box is either fixed on the wall or recessed in it and the wires going to the switch are drawn into the box. After this the wires are connected to the mechanism.

Switches are rated 5A, 15A and 20A and are used to match the maximum anticipated load currents. Switches are available in a variety of types such as:

- Double or 2 gang
- Dimmer
- Pull or pendant switches

## **Lamp holders**

Lamp holders are used in buildings to house electric bulbs. They are meant for quick removal and replacement of lamps. They must hold the lamp firmly to prevent sparking which may lead to overheating of its surrounding.

Lamp holders can be wall mounted, ceiling mounted or pendant in format with one or more bulb or tube holders.

# POWER DEMAND AND ENERGY CONSUMPTION OF DOMESTIC APPLIANCES

**Power rating** of electrical appliances is usually measured in **Watts (W)** whilst the **rated demand** is measured in **Kilo Watts (KW)**. The unit of **electricity consumed** is measured in **Kilo Watts Hour (KWH)**.

Therefore, if the rated demand of an electrical appliance is known and the length of time for which it is used is also known, it is possible to calculate the cost of the energy supplied to the consumer in order to reduce expenses made on electricity. Table 1 shows the power demand and energy consumption of some domestic appliances.

**Table 1: Power Demand & Energy Consumption of Some Domestic Appliances**

S/No	APPLIANCE	TYPE	RATING	RATED DEMAND IN KW	RATED CURRENT IN AMPS	No OF HOURS FOR 1KWH
1	Lamp		40 Watts	0.04	0.2	25
2			60 Watts	0.06	0.25	17
3			100 Watts	0.10	0.4	10
4	Iron	Small	750 Watts	0.75	0.75	1.3
5		Medium	850 Watts	0.85	3.6	1.3
6	Toaster	Regular	1000 Watt	1.0	4.3	1
7	Kettle	Small	2000 Watt	2.0	8.6	0.5
8		Medium	3500 Watt	3.5	11	0.3
9	Water Heater	50 Litres	1200 Watt	1.2	5.2	0.8
10		100 Litres	2500 Watt	2.5	11	0.4
11	Cooker (4 plate)	Regular	8000 Watt	8	34	0.12
12		Large	10500Watt	10.5	45	0.1
13	Single Plate Cooker	Portable	1800 Watt	1.8	7.7	0.6
14	Fan	Table	0.08 HP	0.06	0.25	17
15		Ceiling	0.3 HP	0.22	0.9	4.5
16	Air-Conditioner	Small	1.5 HP	1.1	4.7	1
17		Medium	2 HP	1.5	5.6	0.7
18	Refrigerator	Small	0.2 HP	0.15	0.6	7
19		Medium	0.25 HP	0.19	0.8	5
20		Large	0.3 HP	0.22	0.9	4.5
21	Transistor Radio		5 Watts	0.005	0.02	200
22	Stereo System		100 Watts	0.1	0.4	10
23	TV (Black & Wt)		200 Watts	0.2	0.9	5
24	TV (Colour)		300 Watts	0.3	1.3	3
25	Vacuum Cleanr	Small	700 Watts	0.7	3.0	14
26		Medium	900 Watts	0.9	3.9	1
27	Water Pump	Small	745 Watts	0.745	3.2	1.3
28	Washing Mach	Automatic	600 Watts	0.6	2.5	2
29	Ditto + heater	Automatic	3000 Watt	3	13	0.3

Calculated from: Watts = Amps (current) x Voltage  
And 1HP = 0.75 Watts

### Example:

Table 2 shows the electrical appliances used daily by John and the time he spent using them. Calculate the cost of electricity to John if a unit of electricity cost 77.37cents.

**Table 2: Electricity consumption by John**

S/No	Appliance	Rating	Time Spent	
1	Lamp	40 Watts	4 hours	
2	Lamp	60 Watts	4 hours 30 mins	
3	Iron	850 Watts	30 mins	
4	Toaster	1000 Watts	10 mins	
5	Kettle	3500 Watts	25 mins	
6	Cooker (4 Plate)	8000 Watts	45 mins	
7	Refrigerator	0.25 HP	24 hours	
8	Colour T. V	300 Watts	6 hours	
9	Water Heater	1200 Watts	12 hours	

# FUSE OR MINIATURE CIRCUIT BREAKER (MCB) PROTECTION

**Protection** is defined as the process by which possible dangers arising from electrical installation works are being prevented.

The dangers are:

1. Overload current
2. Short circuit current
3. Earth leakage current

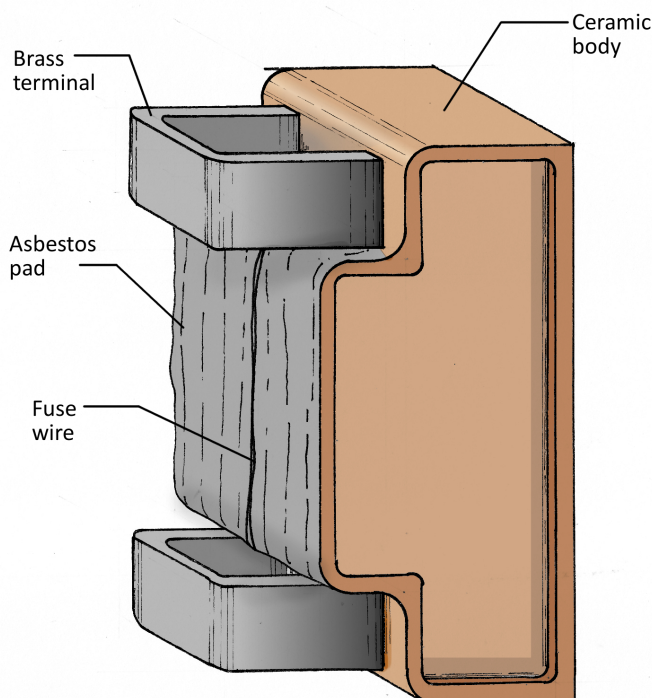
In an electrical wiring system, when the above dangers are not minimized or totally prevented, the consequences may be disastrous and costly and may involve fire outbreak, damage of costly equipment and loss of lives. The I.E.E. Regulation stipulates the necessary requirements to avert dangers arising from electrical installation works. Some of the available protective devices stipulated include:

1. Rewirable fuses (semi-enclosed fuses)
2. High breaking or rupturing capacity (HBC or HRC) fuses and cartridge fuses
3. Miniature Circuit Breaker (M.C.B)
4. Earth Leakage Circuit Breaker (E.L.C.B)
5. Isolating Transformer

None of these devices operate instantly. Their efficiency depends on the degree of overload.

## Rewirable fuses (semi-enclosed fuses)

Figure 51 below describes a semi-enclosed fuse. It consists of a **thin wire**, called a fuse held between **two terminals** in a **porcelain or Bakelite holder**.



**Figure 51: A rewirable/semi-enclosed fuse**

The fuse is inserted in a **circuit** being protected and the size of the fuse wire is such that it matches the **rating** of the protected circuit. The function of the fuse element is to melt, whenever a current in excess of the rated circuit current flows across the element, thereby disconnecting this very circuit from the supply power. When current twice the current rating of circuit flows, the wire melts or blows.

**Advantages:**

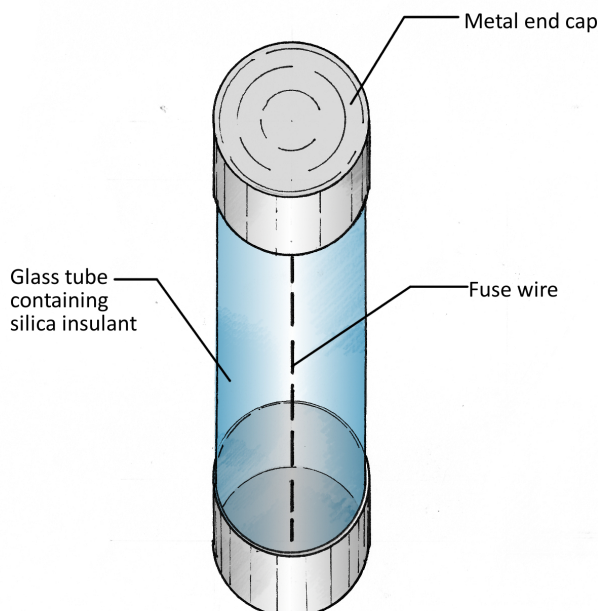
- Inexpensive
- Simple, i.e. no moving parts

**Disadvantages:**

- Prone to abuse (wrong wire could be used)
- Age deterioration
- Unreliable with temperature variations
- Cannot be tested

**High breaking or rupturing capacity fuses (HBC or HRC) cartridge fuses**

The rewirable fuse has limited breaking capacity. When a large current flows, the fuse element melts very quickly and a large amount of energy is released. This energy may be high enough to damage the fuse carrier and its surrounding elements. Because of these shortcomings and its other disadvantages, a different fuse variously known as High Breaking Capacity (HBC) fuses or High Rupturing Capacity (HRC) fuses or technically called Cartridge fuse (used in plugs) was developed.



**Figure 52: A cartridge fuse**

Figure 52 shows a Cartridge fuse. The **fuse wire** is mounted between **two end caps**, which form the **terminals** of the complete fuse link. Closely packed granular filler surrounds the wire and the whole is contained in a

**solid casing.** When the wire melts or blows, the granular filler absorbs the energy.

**Advantages:**

- Compact
- Fairly inexpensive but costs more than rewirable
- No moving parts

**Disadvantages:**

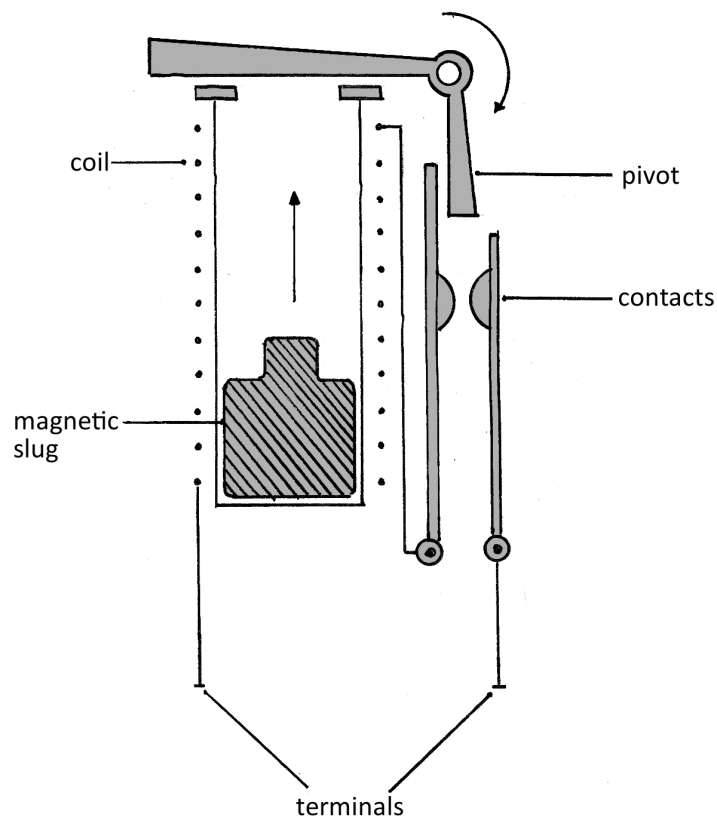
- Not repairable
- Could be abused

### Miniature Circuit Breaker (MCB)

A miniature circuit breaker is one, which has a rating similar to that of a cartridge fuse and is about the same physical size. It differs from the fuse in the sense that **it consists of no melting element**. The miniature circuit breakers are of two types:

- The Magnetic type and
- The Thermal type

A typical electromagnetic MCB is shown in Figure 53 below:



**Figure 53: A Typical Electromagnetic MCB**

The **magnetic type** is operated on the principle that the current passes through the coil and sets up an electromagnetic force, which attracts the **slug** in oil filled cylinder. The oil delays the movement of the slug except during short circuit periods where immediate response to trip is essential to disconnect the load from the supply. The on and off switching is effected by the lever which is being actuated by the slug.

The **thermal-magnetic type** is working with the principle of bimetallic action. When an overload current flows, the **bimetallic strip is heated**. The time delay here is established by the slow rate at which the bimetallic strip is heated, causing **deflection**. This deflection causes the make and break of electric contacts, which consequently disconnect and connects the appropriate control circuit of the system.

**Advantages:**

- Factory tested
- Instantaneous in high current flow
- Unlikely to be misused

**Disadvantages:**

- Relatively expensive

# HEATING, VENTILATING AND AIR-CONDITIONING (HVAC) SYSTEMS

## INTRODUCTION

One object of buildings is to provide comfortable internal conditions in an economic way. It is not only the building's inert mass of stone, brick and iron etc that provides the comfortable internal conditions by which heat is conducted in winter and fresh air in summer, there are other systems which also need to be incorporated with the building's fabric to bring about these comfort levels. These systems include:

1. The Heating System
2. The Ventilation System and
3. Air-Conditioning Systems

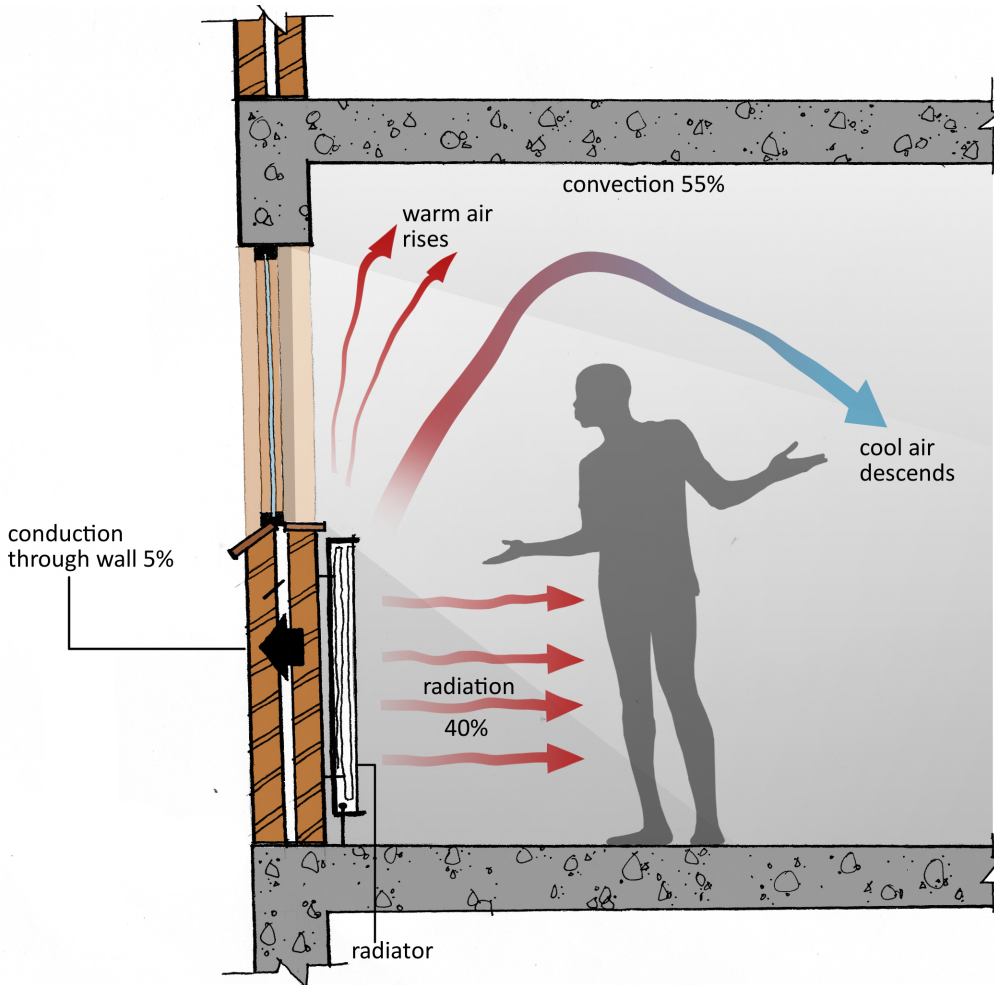
## HEATING SYSTEMS

### General Concept:

**HEAT:** This is the energy transferred from one place to another due to a temperature difference between them.

There are three main processes of heat transfer including:

- a. **Conduction:** heat travelling along or through a material without appreciable change in position of the material particles. **Copper** is a **good** heat and electrical **conductor** while **wood** is a good heat and electrical **insulator**.
- b. **Convection:** Heat travelling by **movement of particles** in air and liquid **as they expand or contract**. This method is commonly used for space and water heating. When air/liquid particle comes into contact with a heated element, it absorbs heat energy causing it to expand. The expansion causes the density of the air/liquid particle to be reduced; hence it becomes lighter and rises. The dense particle descends and goes in contact with the heating element and this in turn undergoes the same process of rising.
- c. **Radiation:** This is the process of heat transfer by **electromagnetic waves** from a heated body to a distant body through space without heating the ambient air or medium. The sun warms the earth by radiation.



**Figure 54: General Concepts of Heat Transfer**

## **HEATING SYSTEMS AND APPLIANCES**

The following are some of the heating systems and appliances in use:

### **Electric Space Heating Systems**

These can be divided into two types:

- a. Direct heaters
- b. Indirect or storage heaters

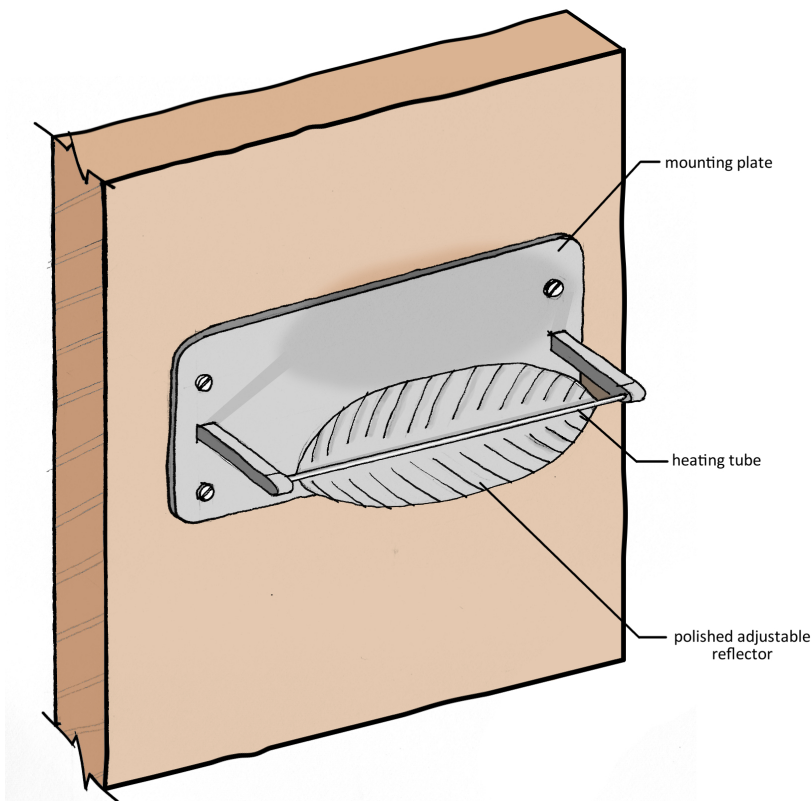
#### ***Direct heaters:***

The direct system consists of appliances that heat objects directly. The appliances may be stationary or portable, supplied by plugged flexible cords from socket outlets in a ring electrical power circuit. There are numerous types of independent heat emitters for use with 15 amp/13 amp sockets. These are available as:

##### **i. Infra-red Heaters**

This type of heaters consists of a nickel – chrome spiral element in a glass tube with terminals at each end, backed by a curved polished reflector. May be used at high level in a bathroom and controlled with a pull string. They

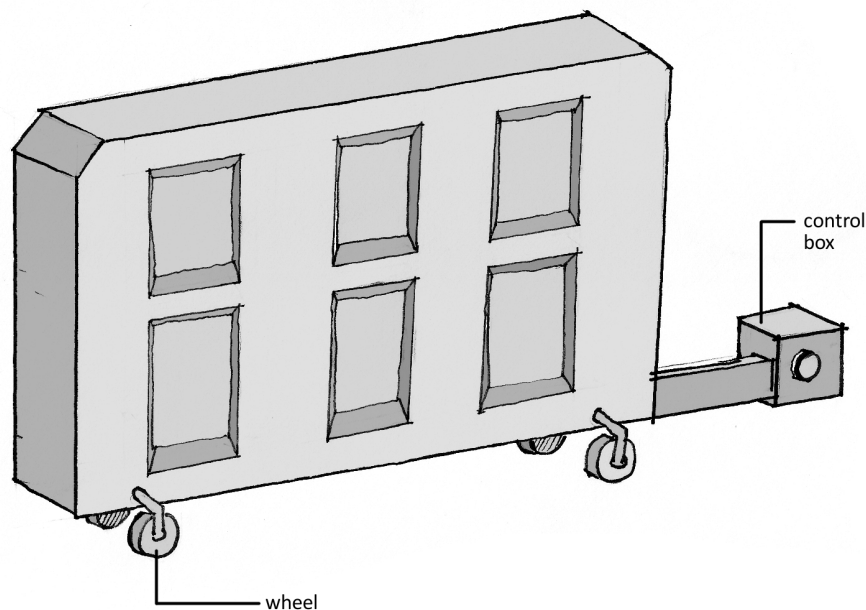
may also be used for local heating in large areas such as workshops, market halls and exhibition sites where there are limited internal partitions.



**Figure 55: Infra-red Direct Heaters**

## ii. Oil-filled Radiators

The radiator consists of an immersion heater enclosed in a pressed steel case filled with high-grade oil. It is similar in appearance to steel hot water radiators. It however uses oil as a heat-absorbing medium from one or two electrical elements. These appliances give out heat by radiation and convection. An integral thermostat allows for manual adjustment of output.



**Figure 56: Oil-filled Radiator**

### iii. Convector Heater

These consist of two low temperature electrical heating elements with independent control to vary the output, inside a metal cabinet. Cool air enters the lower inlet and the heated air at around 85°C is expelled by convection through the top outlet into the room. It may be used where a constant level of background warmth is required.

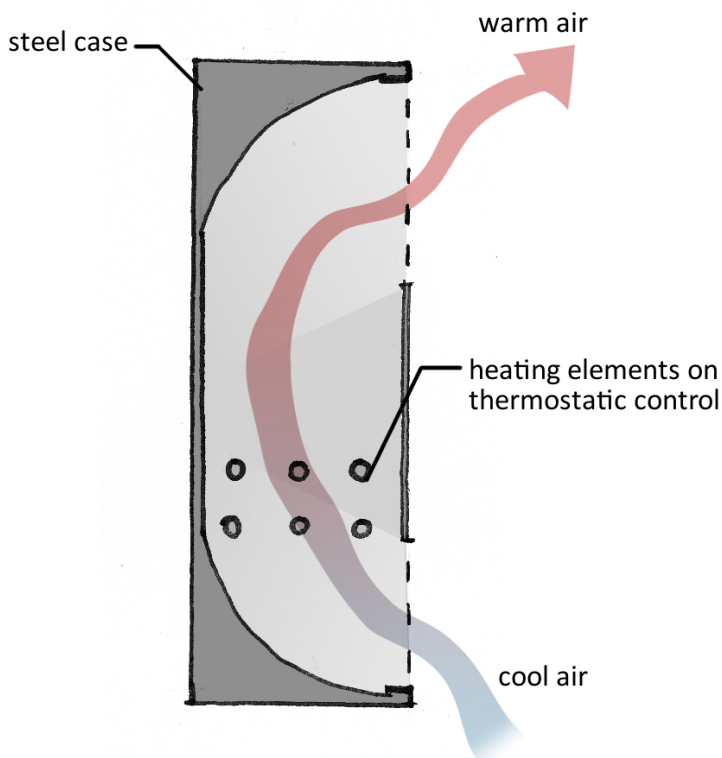


Figure 57: A Convector Heater

### iv. Parabolic Reflector Fire

They are manufactured in the range of 750 Watts to 3000 Watts. They consist of a heating element wound into various shapes as the focal point to create efficient radiant heat output. The heat is radiated and reflected in desired directions by a polished reflector. The heat rays emanating from the heating element heat the wall, furniture and human body without heating the ambient air and are therefore not suitable for thermostatic control.

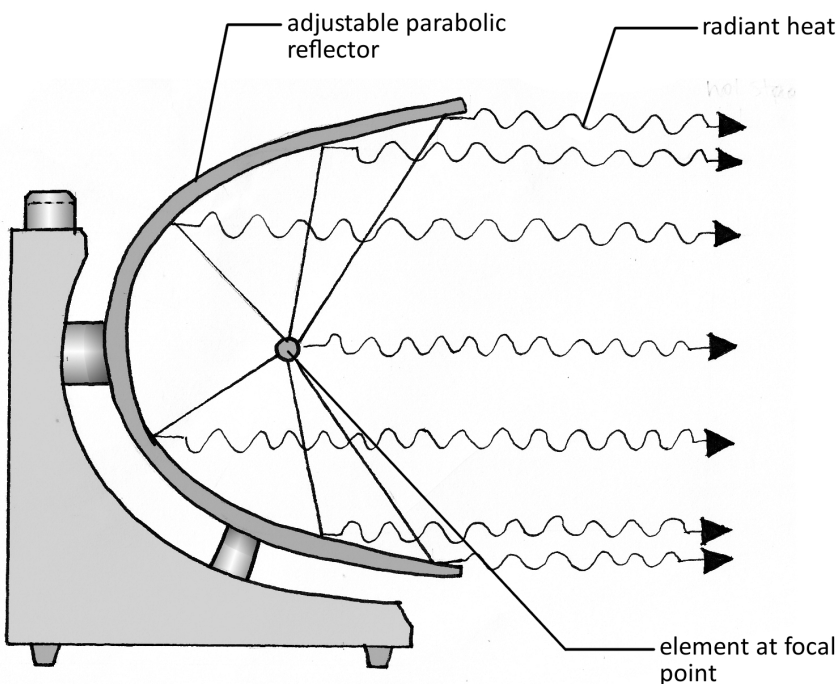


Figure 58: Parabolic Reflector Fire

## v. Panel Heaters

The heat output is mainly radiant from a surface operating temperature of between 204°C and 240°C. For safety reasons, it is mounted at high levels on a wall or suspended from ceilings and may be guarded with a mesh screen. The enclosed panels are usually 30cmx60cm.

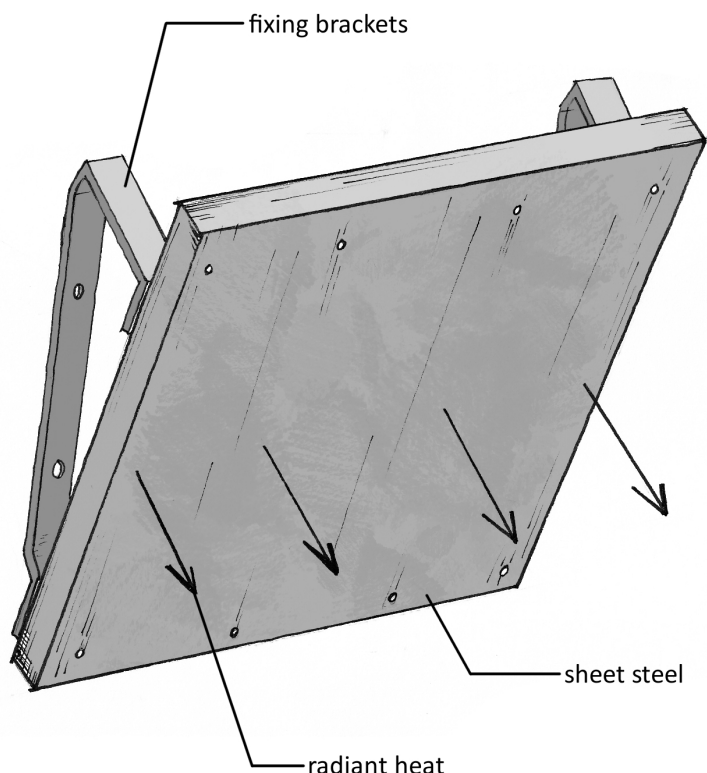


Figure 59: A wall mounted panel heater

## iv. Wall-Mounted Fan Heaters

These types of heaters use the principle of convector to work. It is usually provided with a two-speed fan to deliver air through a bank of electrical elements at varying velocities. Adjustable louvres determine direction. It is possible to use the in-built **thermostat** to switch from heat to cool air in warm weather. They are available in all sizes and rating from 750 Watts to 21 KW (industrial types).

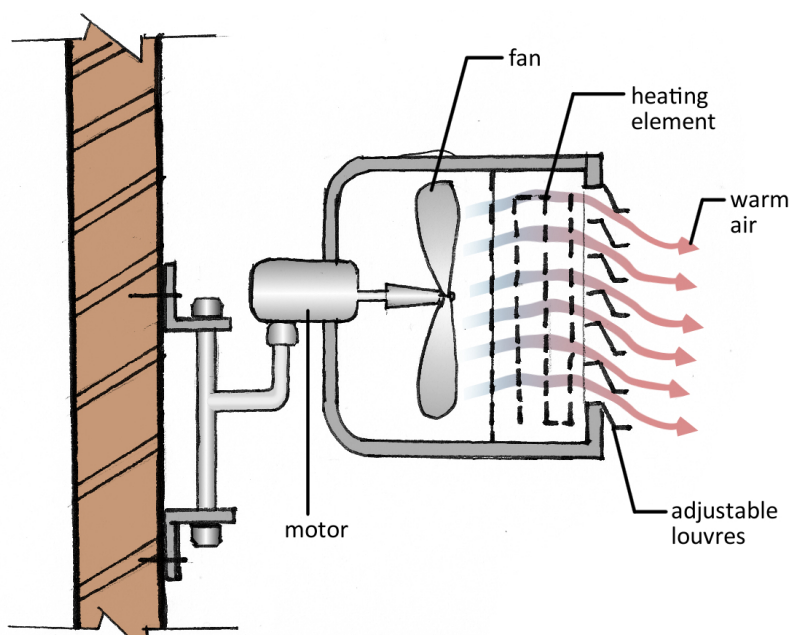


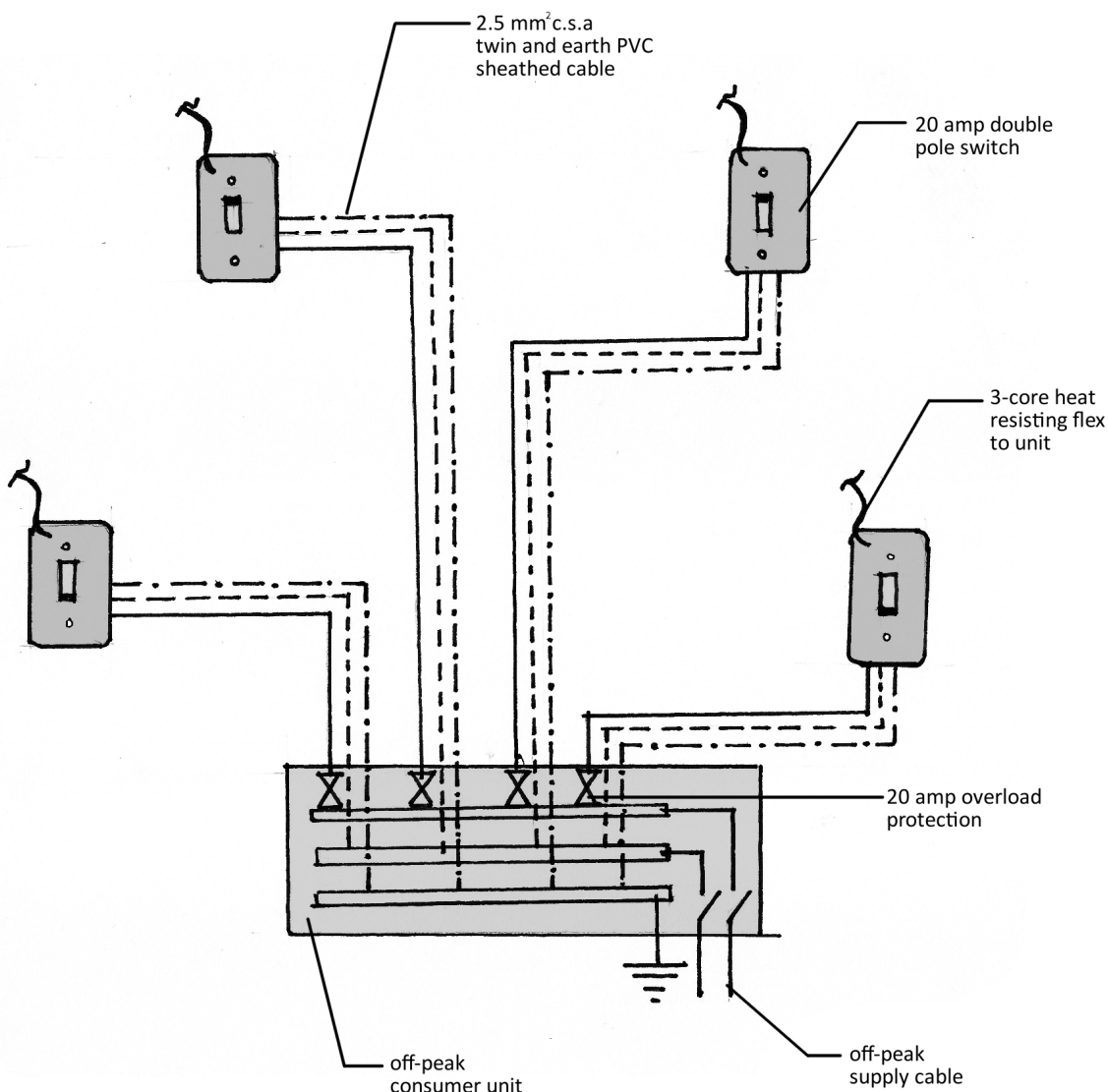
Figure 60: A wall mounted fan heater

### **Indirect or Storage Heaters:**

These are operated on the cheaper “off peak” supplies. This is because it is uneconomic to shut down electricity generating plant over night, even though there is considerably less demand. To encourage the use of off-peak energy, the electricity supply companies offer it at an inexpensive tariff. The “off peak” supplies can then be stored in the following energy storage heaters:

#### **i. Storage Radiator/Night Storage Heaters**

These have developed from very bulky cabinets containing concrete blocks, which effectively absorb the overnight electrical energy and dissipate it gradually during the next day. Improvements in storage block material have considerably reduced the size of these units to compare favourably with hot water radiators.

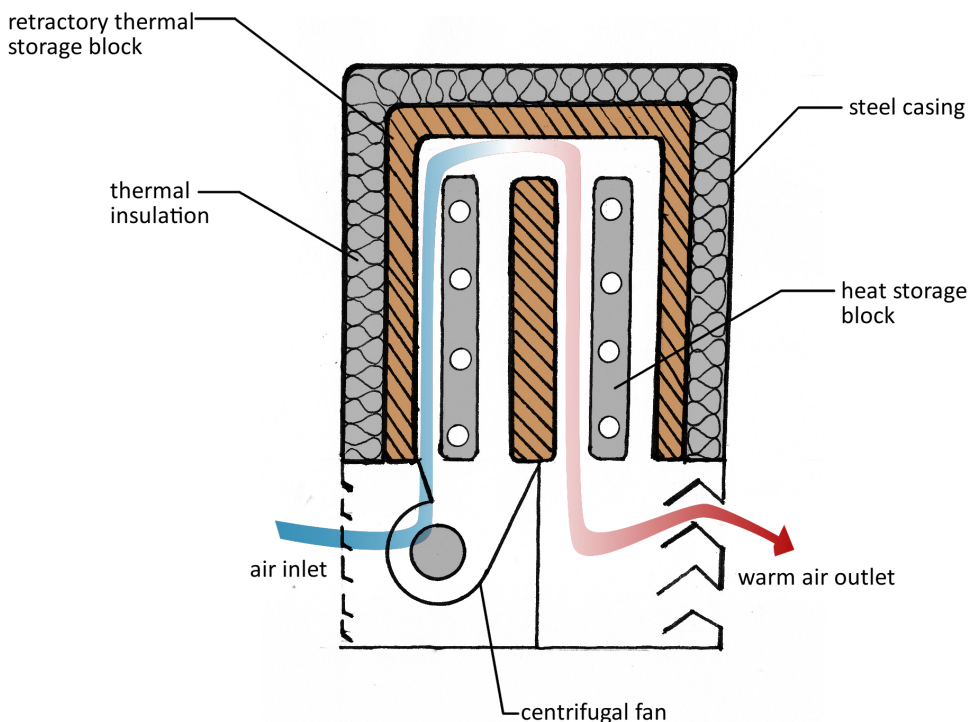


**Figure 61: Storage Radiator & Wiring to Consumer Control Unit**

It consists of **heating elements** mainly of nickel – chrome wire **embedded in a storage core**, usually of refractory bricks and then surrounded by a layer of fibre glass material and encased in a metal container with removable

covers. They contain a number of controls, including a manually set input **thermostat** on each heater, an internal thermostat, which is protected by a heat fuse to prevent overheating and a timed programmed fan. Manufacturers provide design tables to establish unit size. As a rough guide, a modern house will require about 200 W output per square meter of floor area.

They are available in the rating of 3 KW and when connected to a 240V power supply, it will take a current of 12.5A. Each heater is wired back to the off-peak time controlled consumer unit on its own radial sub-circuit of 20A rating. The cable size will normally be 2.5mm<sup>2</sup> terminated at the heater end with a double pole switch unit.



**Figure 62: Storage Radiator**

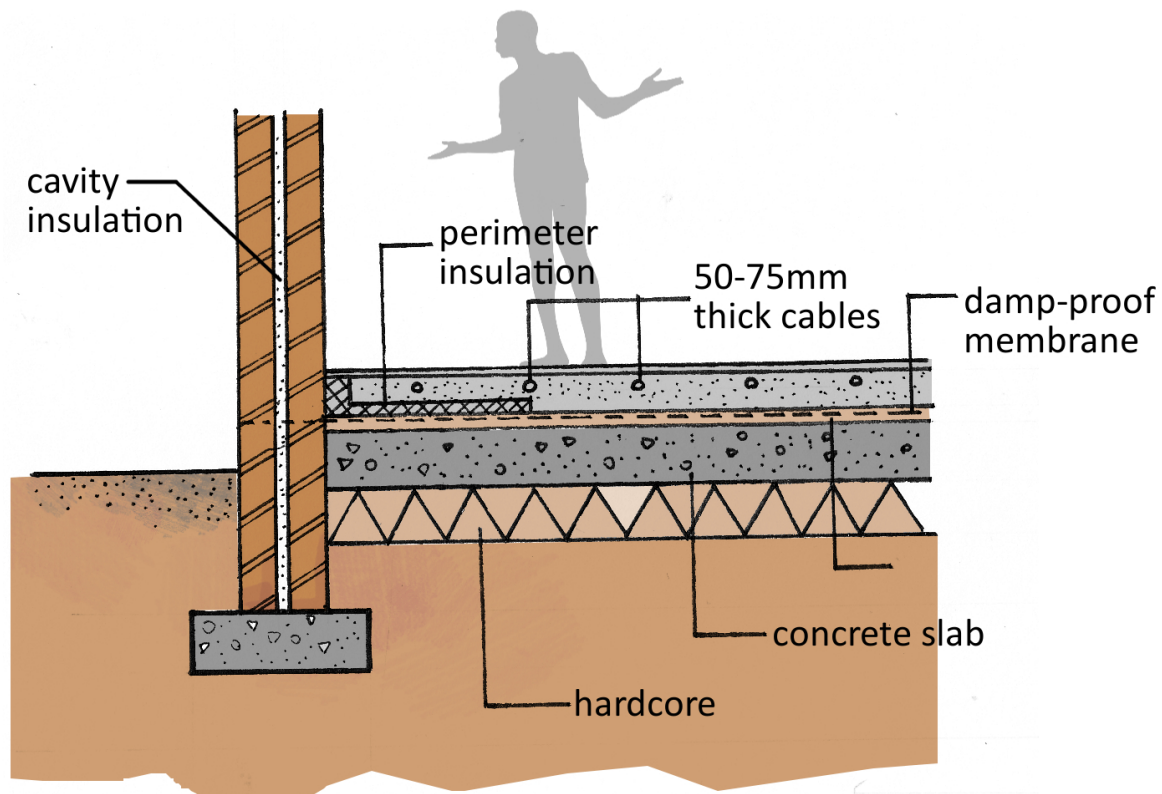
### ii. Centrally Sited Warm Air Unit

This is a development of the storage heater concept. A central unit rated from 6 kW to 12 kW absorbs electrical energy off-peak and during the day delivers this by a fan into ducts or pipe-work which leads to rooms which require heating. A room thermostat controls the fan to maintain the air temperature at the desired level.

### iii. Under Floor Warming

This system makes use of the thermal storage properties of a concrete floor. It consists of a heating element which is made of a high resistance wire/conductor insulated by refractory material and enclosed in an overall metallic sheath, arranged in parallel lines on top of a concrete floor slab at 100 to 200mm spacing, depending on the desired output, leaving the termination available for connection to power supply. It is then covered with

sand – cement mixture screed of 50 to 75mm thick, on top of which the floor finishing is placed. To be fully effective, the underside of the screed should be completely insulated.



**Figure 63: Section through Concrete Floor Slab to show installation of Heating Element**

## Hot Water Heating Systems

These can be divided into:

- a. Low Temperature Hot Water Heating Systems
  - Small bore hot water heating systems
  - Micro bore hot water heating systems
- b. High Temperature Pressurized Heating Systems
  - Steam
  - Nitrogen

### ***Low Temperature Hot Water Heating Systems:***

In low temperature, hot water heating systems, the boiler water temperature is thermostatically controlled to about 80°C. Systems may be 'open' with a small feed and expansion cistern or mains fed 'sealed' with an expansion vessel.

Low temperature hot water systems include:

- Traditional solid fuelled systems operate by **Old gravity/convection circulation systems**, which sometimes required pipes of over 50mm diameter to effect circulation. Contemporary practice is to install a **pump** for faster circulation and a more rapid and effective thermal response.
- **Pumped small bore hot water heating systems** with 28mm or 22mm diameter copper tube for the main heat flow and return pipe-work, with 15mm diameter branches to each radiator.
- **Pumped micro bore hot water heating systems**: in this system, hot water is also circulated through 28mm or 22mm copper tube for the main heat flow and the return pipe-work. The only difference between this system and small bore is the application of a centrally located manifold between boiler and emitters. Manifolds are produced with standard tube connections for the flow and return and several branches of 6, 8, 10 or 12mm diameter pipes.

The type of system and pipe layout will depend on the building purpose and space available for the pipe work. A **ring or loop circuit** is used for one-floor buildings while **drop and ladder systems** are used for buildings of several floors.

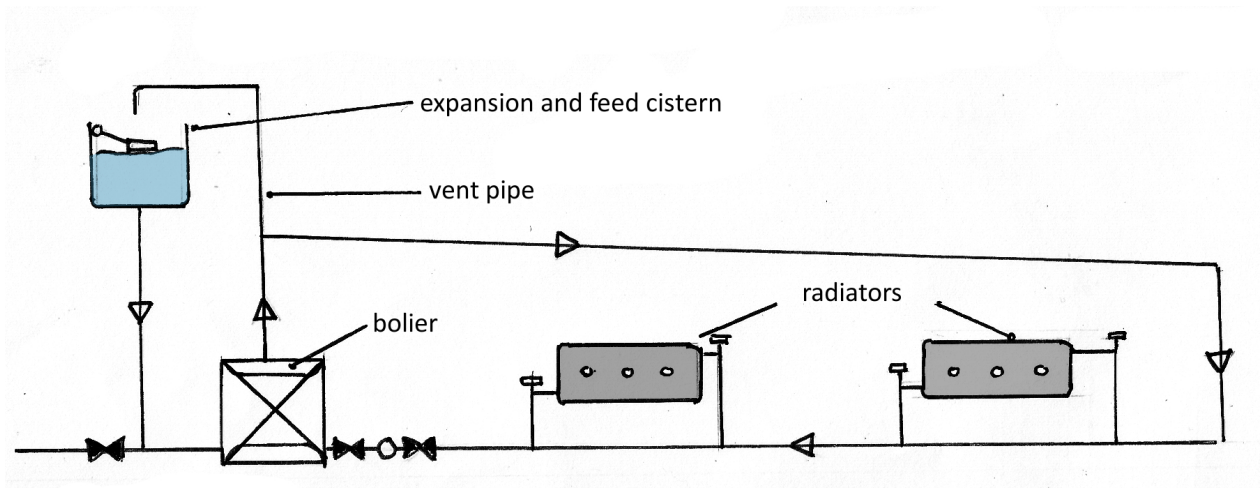


Figure 64: One-pipe ring low pressure hot water heating systems

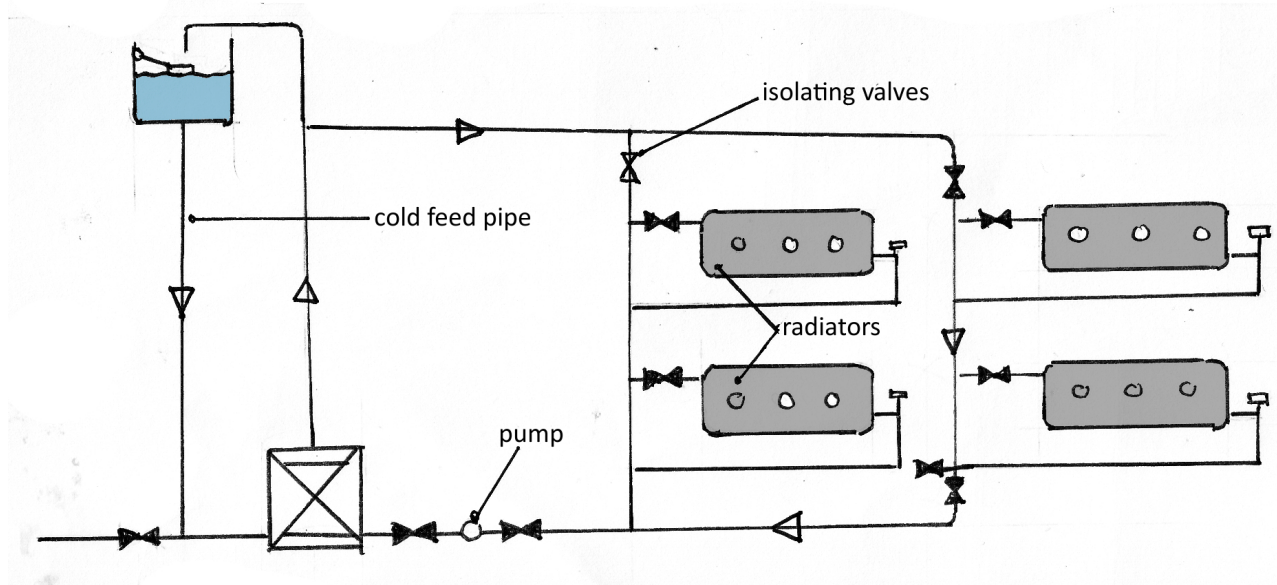


Figure 65: One-pipe drop low pressure hot water heating systems

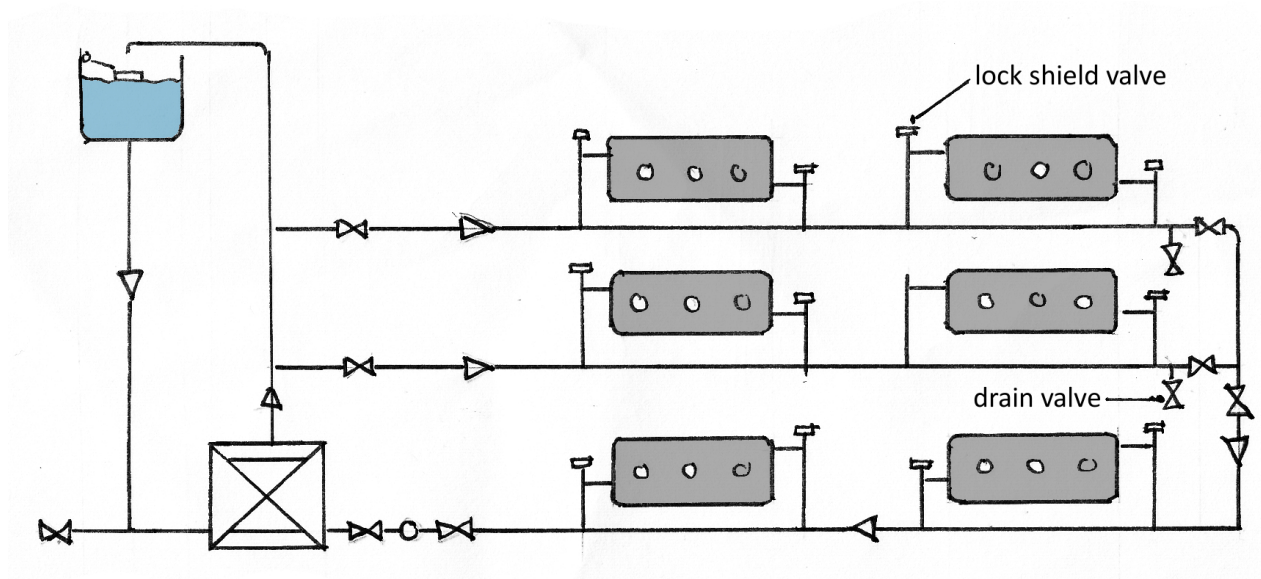
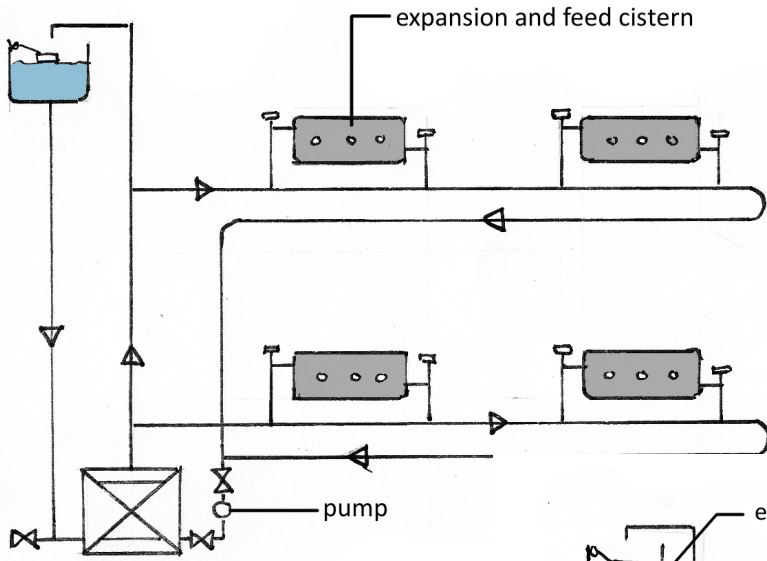


Figure 66: One-pipe ladder low pressure hot water heating systems

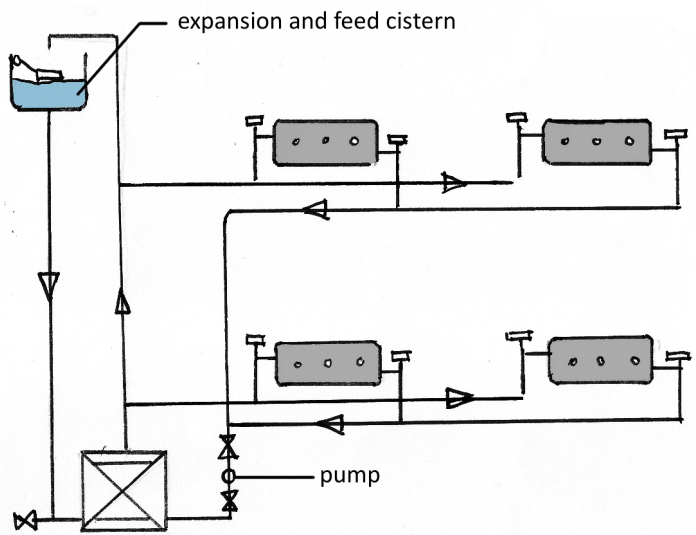
Other variations in one and two pipe systems include:

- The **one and two pipe parallel systems**, which are useful where pipe work can be accommodated within a floor structure, a raised floor or a suspended ceiling.
- The **reverse-return or equal travel system**. In this system, the length of pipework to and from each radiator at each floor level is equal

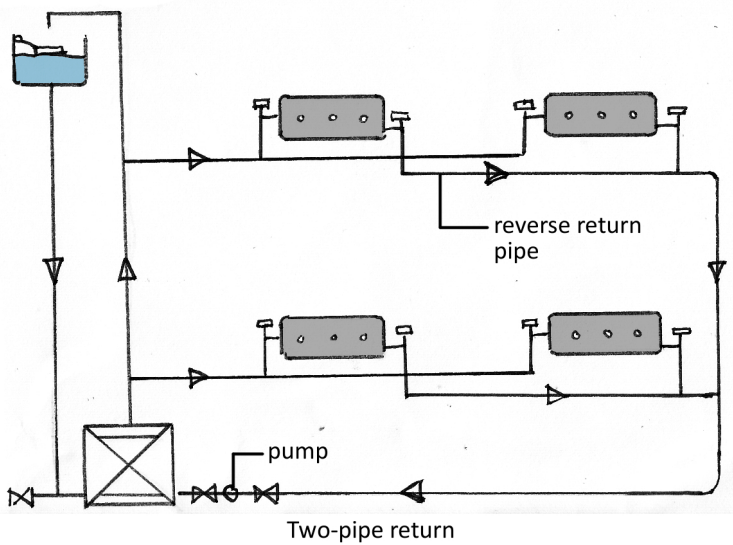
- The **two-pipe up-feed system** is used when it is impractical to locate pipe horizontally at high level



**Figure 67: One-pipe parallel low pressure hot water heating systems**

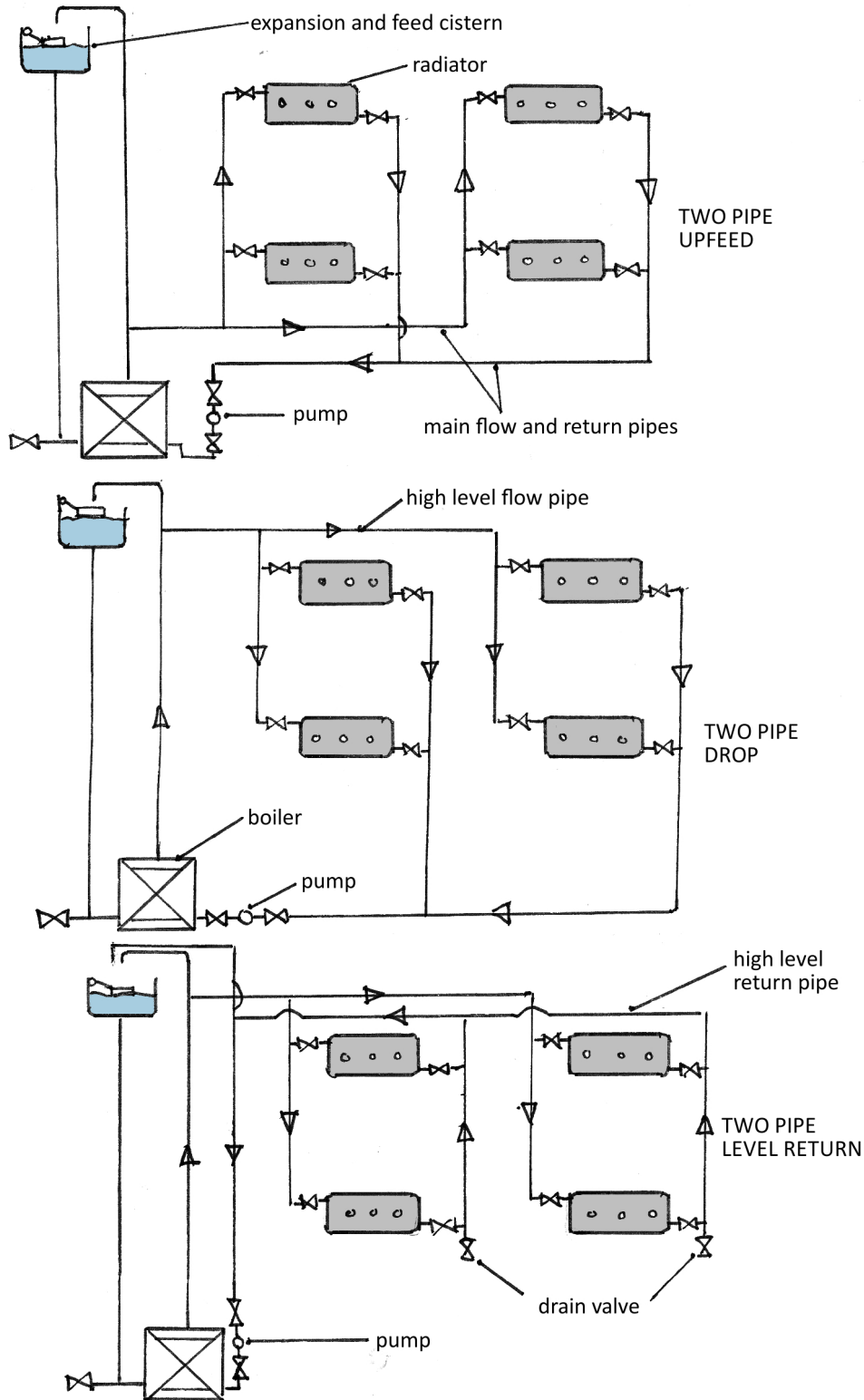


**Figure 68: Two-pipe parallel low pressure hot water heating systems**



**Figure 69: Two-pipe return low pressure hot water heating systems**

- The **two-pipe drop** is used where a high level horizontal flow pipe can be positioned in a roof space or in a suspended ceiling, and a low level return within a ground floor or basement ceiling.



**Figure 70: Two-pipe upfeed, Two-pipe drop and Two-pipe high level return low-pressure hot water heating systems respectively**

- The **two-pipe high-level return system** is particularly appropriate for installation in refurbishments to existing buildings with solid ground floors. In this situation, it is usually time consuming, impractical and possibly structurally damaging to cut a duct in the concrete.

### ***High Temperature Pressurized Hot Water Heating Systems:***

Pressurization allows water to be heated up to 200°C without the water changing state and converting to steam. This permits the use of relatively small diameter pipes and **heat emitters**, but for safety reasons these systems are only suitable in commercial and industrial situations. Even then **convectors** are the preferred emitters as there is less direct contact with the heating surface. Alternatively, **radiators** must be encased or provision made for **overhead unit heaters** and **suspended radiant panels**. Water can be pressurized by **steam** or **nitrogen**.

#### **a. Nitrogen Pressurization**

When pressurizing with nitrogen, it is important that the pressure increases in line with temperature. If it is allowed to deviate, the water may 'flash' i.e. convert to steam, causing system malfunction and possible damage to equipment.

#### **b. Steam Pressurization**

Traditionally, before the discovery of electricity and associated equipment that we now take for granted, steam was the energy source. Steam was generated in solid fuel boilers to power engines, drive machines and used as a medium for **heat emitters**. In this latter capacity it functioned well, travelling over long distances at high velocity (24 – 36 m/s) without the need for a pump.

By contemporary standards it is uneconomic to produce steam solely for heating purposes. However, it can be used for heating where steam is available from other processes such as laundering, manufacturing and electricity generation. Most of these processes require very high pressure; therefore **pressure-reducing valves** will be installed to regulate supply to the heating circuits.

Steam systems maximize the latent heat (this is heat which produces a change of state without a change in temperature, i.e. heat which converts water to steam) properties of water when evaporating. This is approximately 2260 kJ/kg. Because of this high heat property, the size of heat emitters and associated pipework can be considerably less than that used for hot water systems.

**Steam heating systems** can be categorized as gravity or mechanical. In the **gravity system**, the steam flows naturally from boiler to emitters without the need for a pump. In the **mechanical system**, a positive displacement pump is used to lift condensed steam (condensate) into the boiler.

#### **Heat Emitters/Appliances Used for the Hot Water Heating Systems**

**Radiators** and **convectors** are the principal means of heat emission in most buildings. Less popular alternatives include **exposed pipes** and **radiant panels** for use in warehousing, workshops and factories, where appearance is not important. **Embedded panels of pipework** in the floor screed can also be used to create 'invisible' heating, but these have a slow thermal response as heat energy is absorbed by the floor structure.

### i. Radiators

Despite the name radiator, no more than 40% of the heat transferred is by radiation. The remainder is convected, with a small amount conducted through the radiator brackets into the wall.

Originally, radiators were made from **cast iron** in three forms: **hospital**, **column** and **panel**. **Hospital radiators** were so called because of their smooth, easy to clean surface, an important specification in a hygienic environment. **Column radiators** vary in the number of columns. The more columns, the more heat is emitted.

Cast iron radiators are still produced to special order, but replicas in **cast aluminium** can be obtained. Cast iron panels have been superseded by **pressed profiled steel welded panels**, which are much slimmer and easier to accommodate than cast iron in the modern house. It also has a higher convected output because of finned backing.

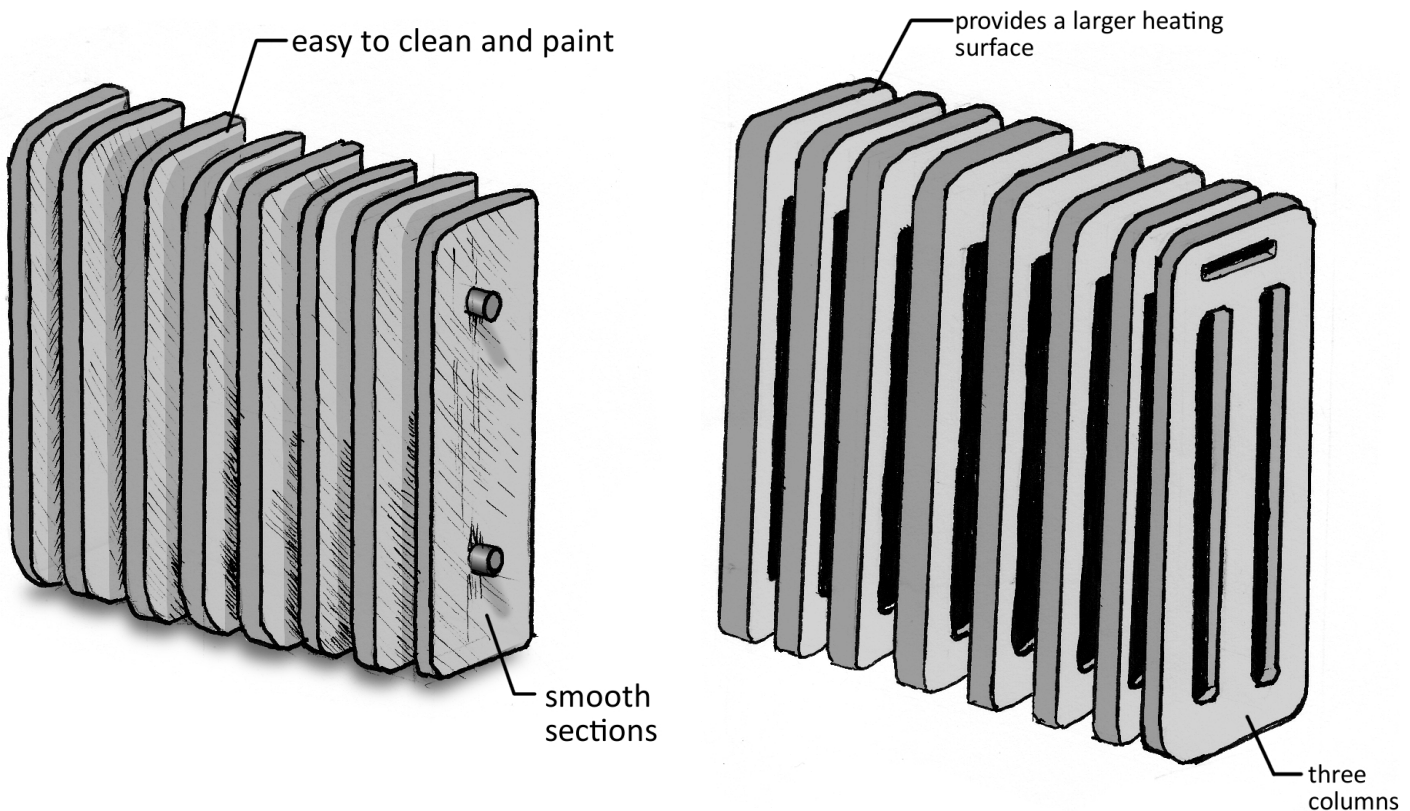
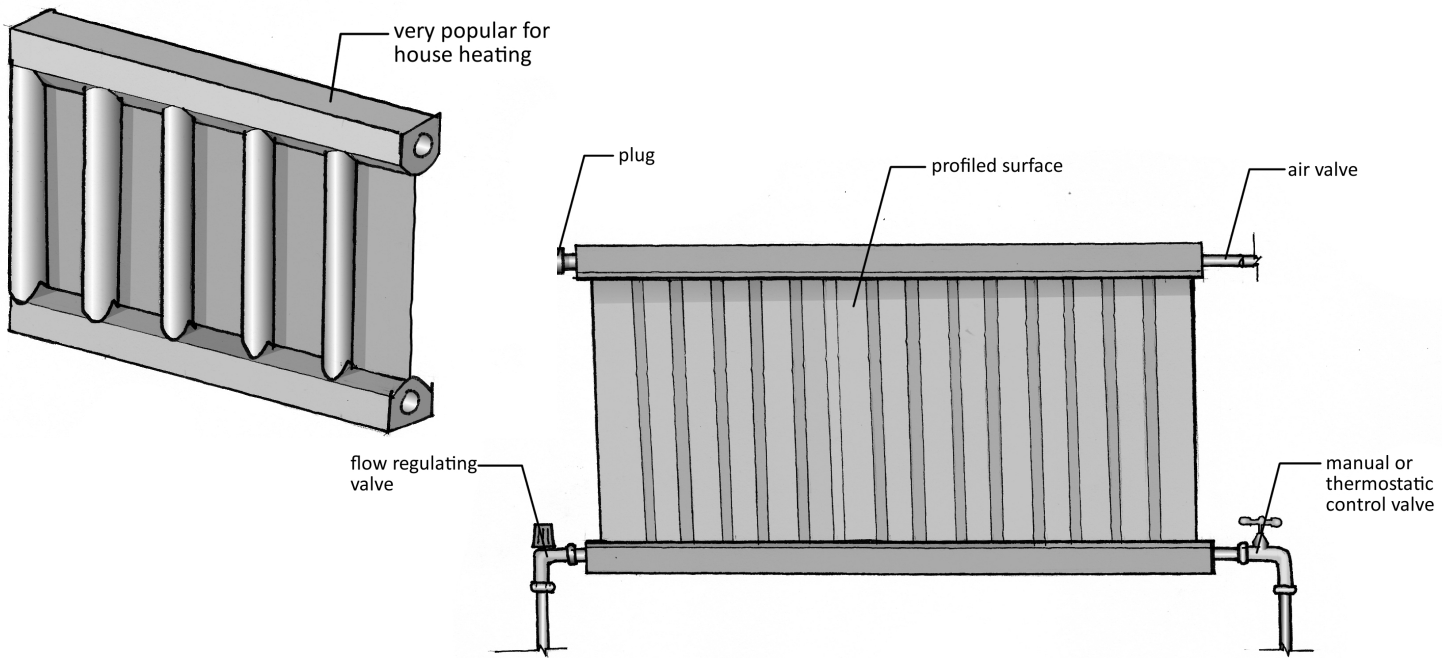


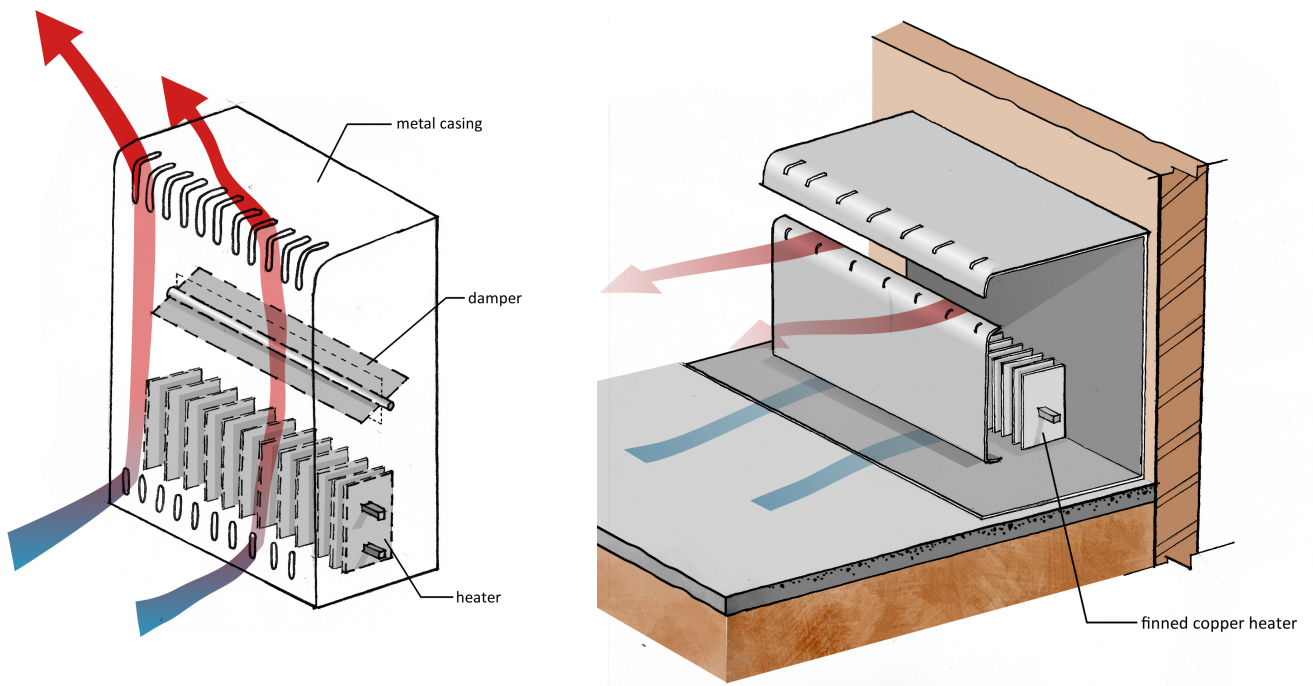
Figure 71: Hospital and Column radiators



**Figure 72: Panel and Pressed Profiled Steel Welded Panel Radiators**

## ii. Convectors

Convectors have a steel casing/metal cabinet containing a **heat exchanger/element** at a low level within the casing. About 90% of the heat emission is convected and this may be enhanced if a thermostatically controlled fan is also located in the casing. They are more effective than radiators for heating large rooms and because of this; their extra bulk can be accommodated.



**Figure 73: Convector heaters**

### iii. Radiant Panels

They consist of a heat exchanger wound into various shapes on a flat steel sheet. Radiant panels and strips suspend from the ceiling in industrial premises and other situations where wall space is unavailable.

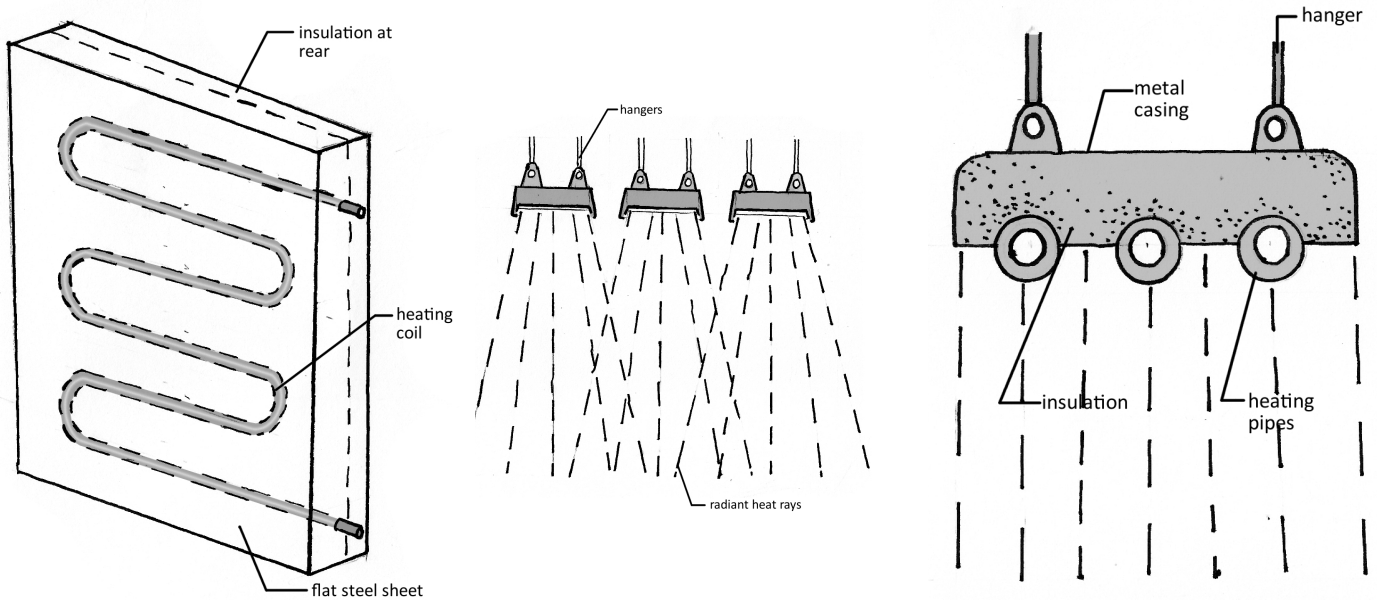


Figure 74: Types of Radiant Panel Heaters

### iv. Fan Convectors

These types of heaters use the principle of convector to work. They may have the heater at a high level with a variable speed fan, which circulates the warm air located below. It is possible to use the in-built **thermostat** to switch from heat to cool air in summer.

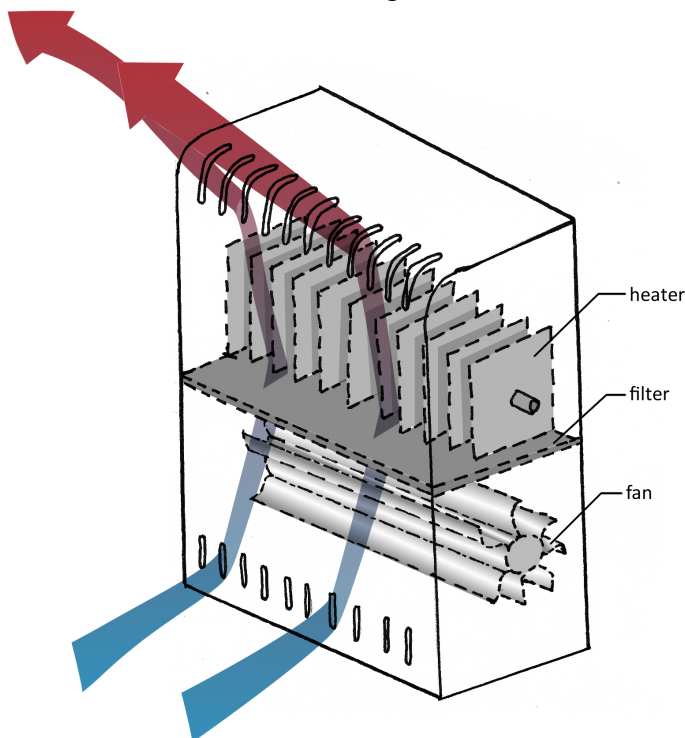
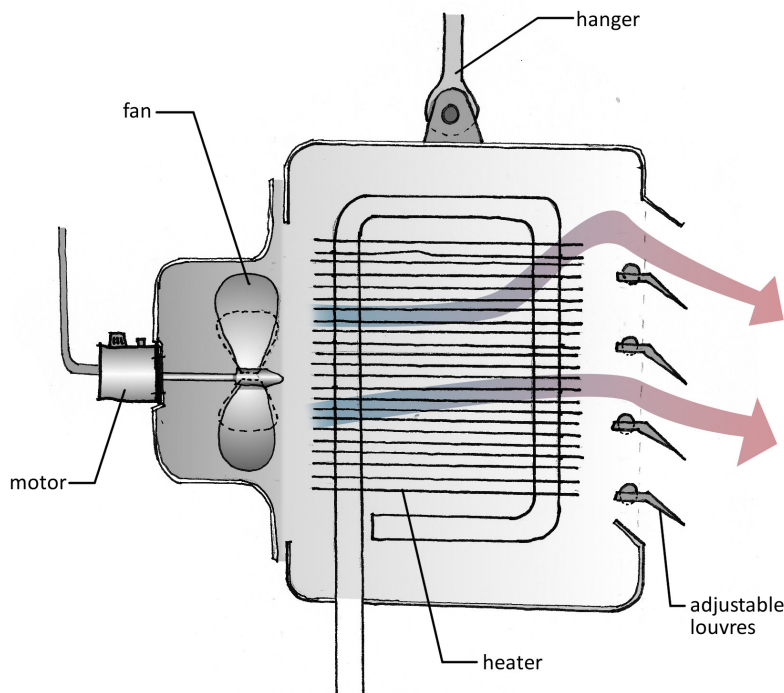


Figure 75: Convector Heater

## v. Overhead unit heaters

These types of heaters are used in workshops to free the wall space for benches, machinery, etc. A variation may be used as a warm air curtain across doorways and shop entrances.



Individual unit heaters may have a thermostatically controlled inlet valve or a bank of several units may be controlled with zoning and diverter valves to regulate output in variable occupancy situations.

Figure 76: Overhead Unit Heaters

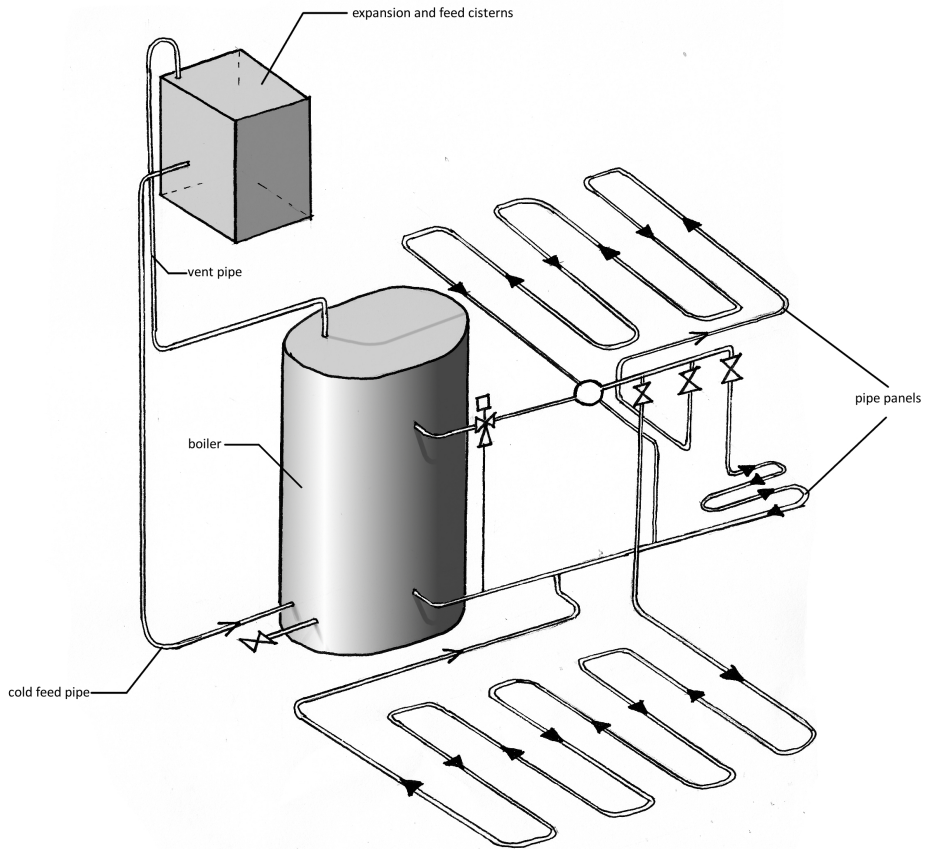
## vi. Panel Heating

The system consists of 15mm or 22mm o. d. **annealed copper pipes** embedded in the floor, ceiling or walls. This has the **benefit of avoiding unsightly pipes and radiators**. Heat distribution is uniform, providing a high standard of thermal comfort as heat is emitted from the building fabric. However, **thermal response is slow** as the fabric takes time to heat up and to lose its heat.

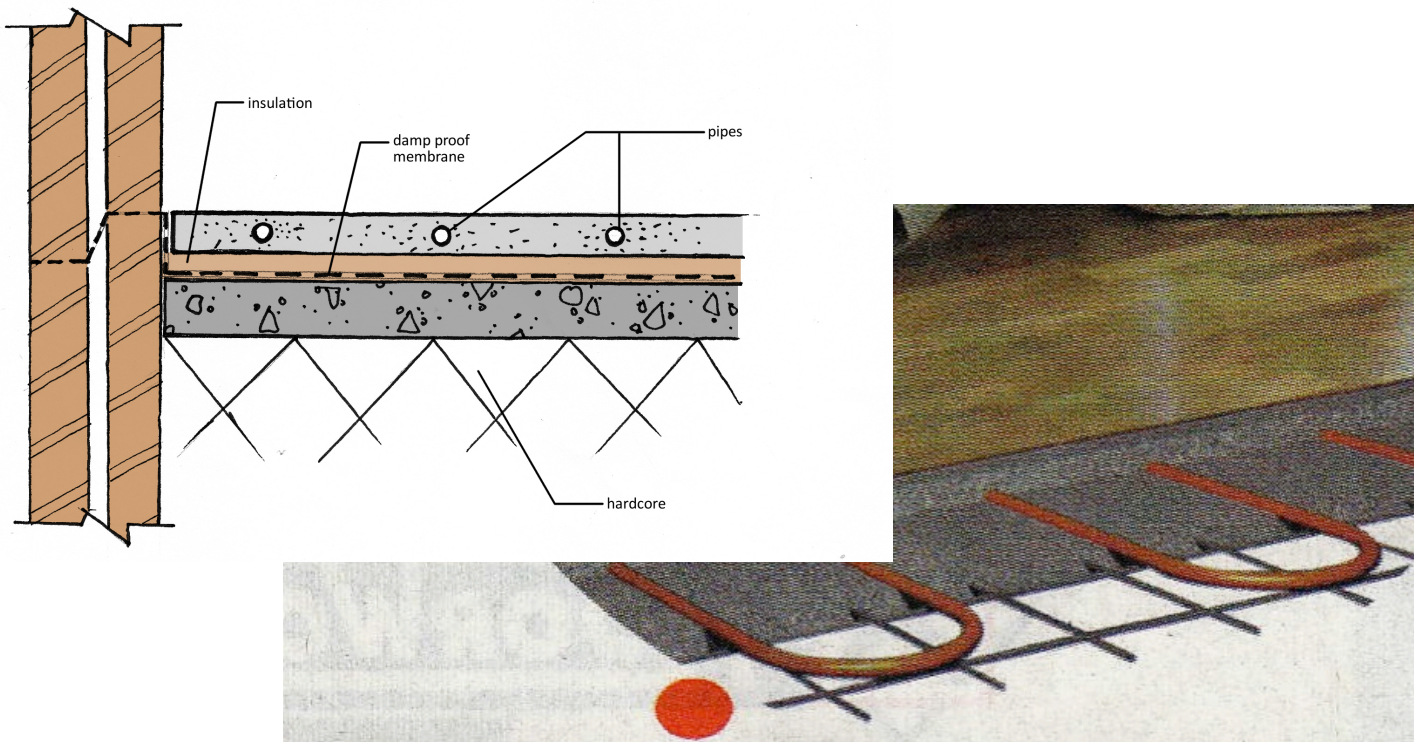
**Thermostatic control** is used to maintain the following surface temperatures:

Floors	- 27°C
Ceilings	- 49°C
Walls	- 43°C

Figures 55 and 56 show details of the installation of the panel heating system.



**Figure 77: Copper pipes used in the installation of the panel heating system**



**Figure 78: Cross section of Floor slab showing Copper pipes used in heating**

## Solar Space Heating

With diminishing fossil fuel resources and inevitable rising fuel prices, solar heating is encouraged as a supplement or even an alternative to conventionally fuelled systems.

Solar space heating should be complemented with a very high standard of thermal insulation to the building fabric. The solar panel size should typically be  $40\text{m}^2$  for a 3 to 4 bedroom house. A **solar tank heat exchanger** of about  $40\text{m}^3$  water capacity is located in the ground. **The solar panel and associated pipework are mains filled.**

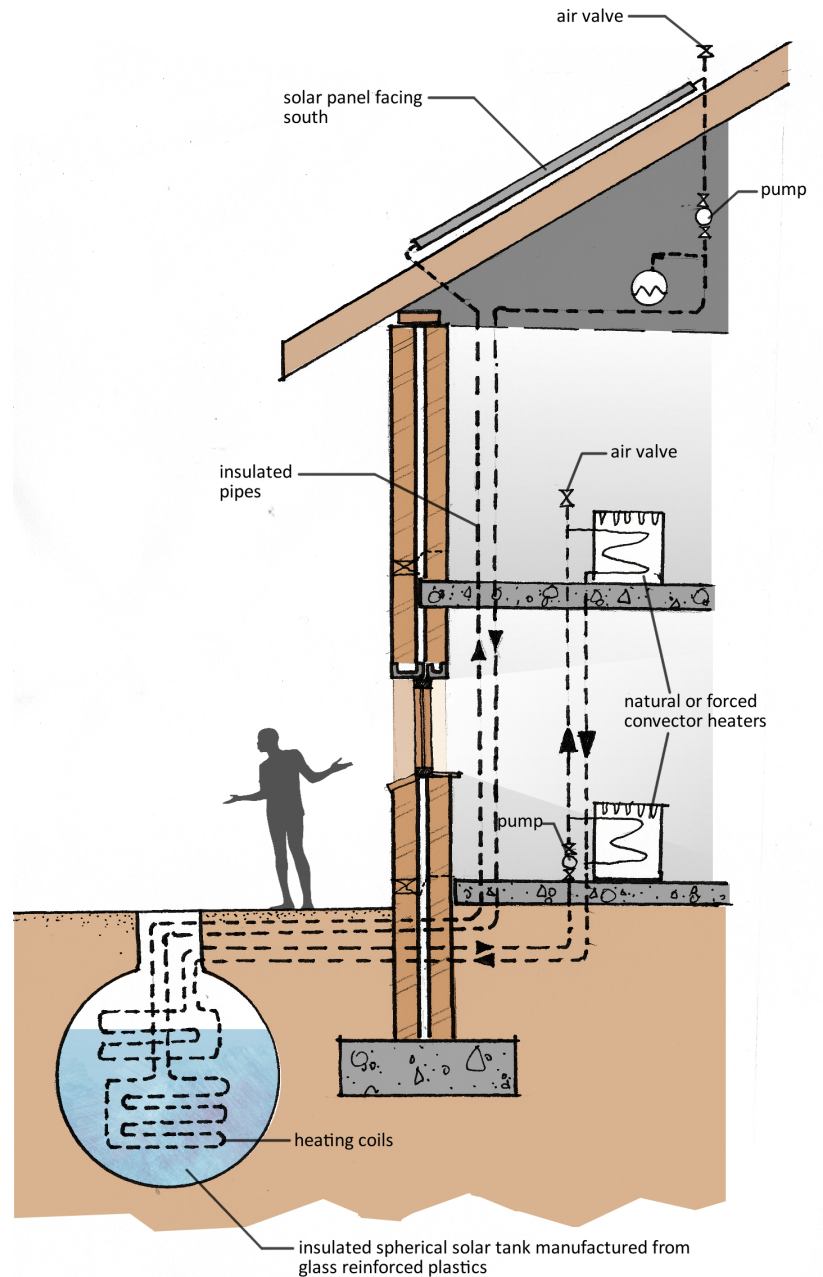


Figure 79: Components of a Solar Space Heating System

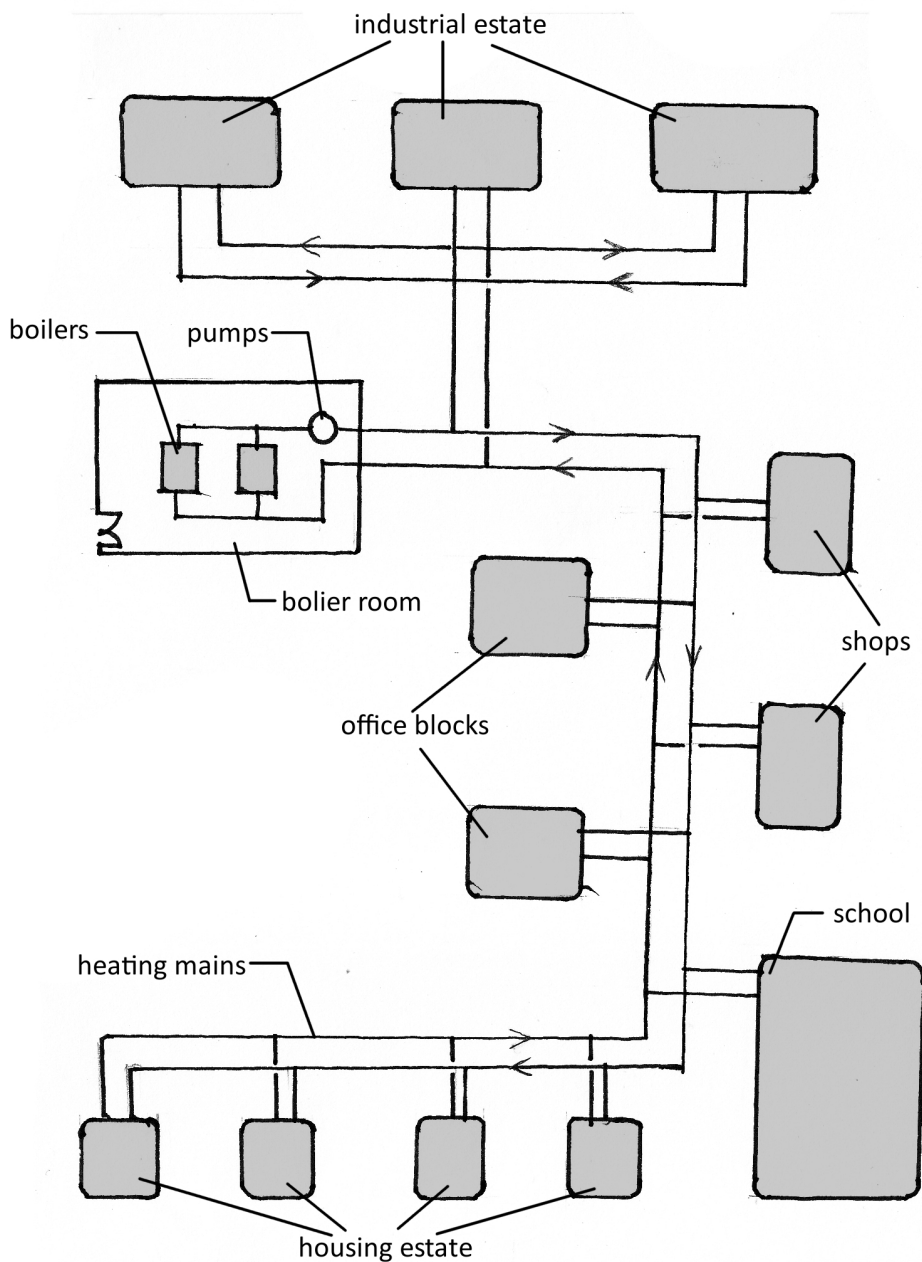
## District Heating System

A district heating system is in principle an enlarged system of heating one building, extended to heat several buildings. It can be sufficiently large enough to heat a whole community or even a small town from one **centralized boiler plant**. Centralizing plant and controls **saves space** in individual buildings. An effective plant management service will ensure that the equipment is functioning to peak efficiency.

Each building owner is required to pay a standing charge for the maintenance of plant and to subscribe for heat consumed through an **energy metered supply**, similar to other utilities. An energy meter monitors the heat energy in the water flow, as this will vary in temperature depending on the location of buildings. The boiler and associated plant should be located in close proximity to buildings requiring a high heat load e.g. an industrial estate. Long runs of heating pipes are required and these must be well **insulated** against heat loss and frost damage if water is not circulating. The pipes are normally located at least 450mm below ground as protection from vehicle loads but may be elevated around factories.

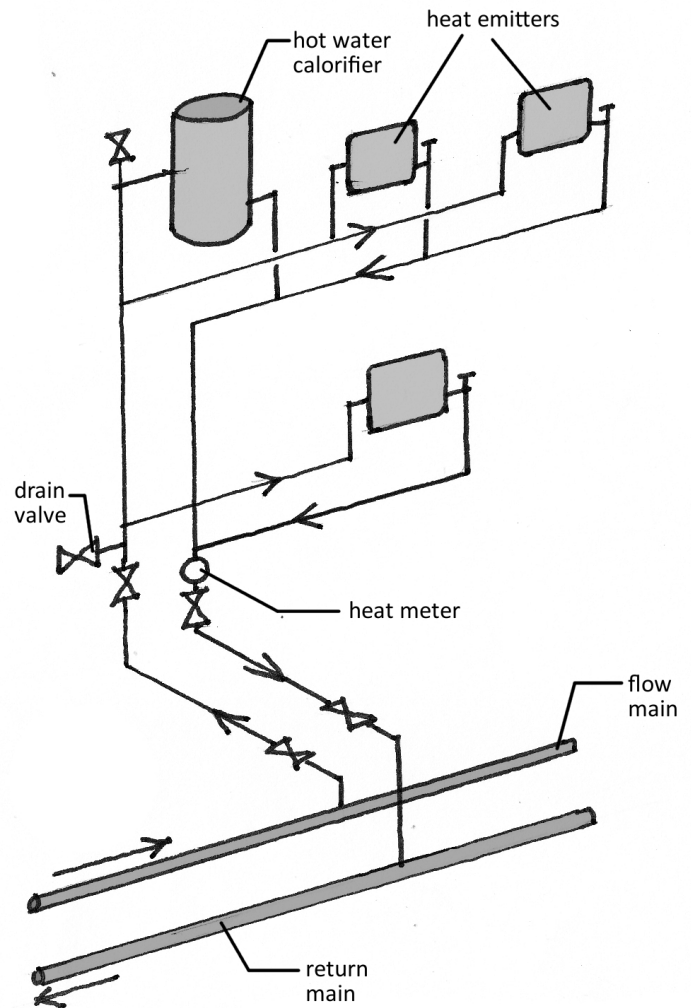
**Heating Methods:** District Systems can incorporate **industrial waste incinerators** operating in parallel with **conventional boilers** and may also use **surplus hot water from turbine cooling processes** in power stations or electricity generators. This is known as **Combined Heat and Power**.

Figures 80 and 81 illustrate the plan of a typical **two-pipe district heating system**.



**Figure 80: Two-Pipe District Heating System**

The **three-pipe system** is similar to the two-pipe system **except for an additional small diameter flow pipe** connected to the boilers. This is laid alongside the larger diameter flow pipe and has a separate circulation pump. This smaller flow pipe is **used during the summer months when space heating is not required**, although in the intermediate seasons it could supply both with limited application to heating.



**Figure 81: Two-Pipe District Heating System**

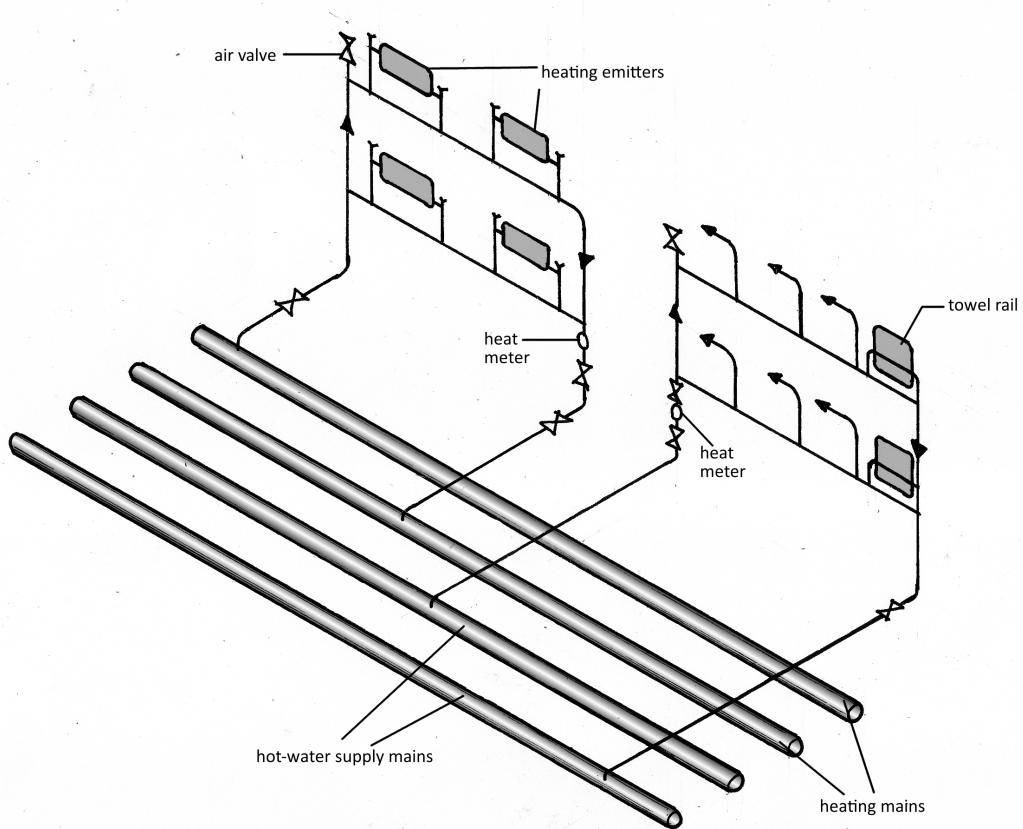
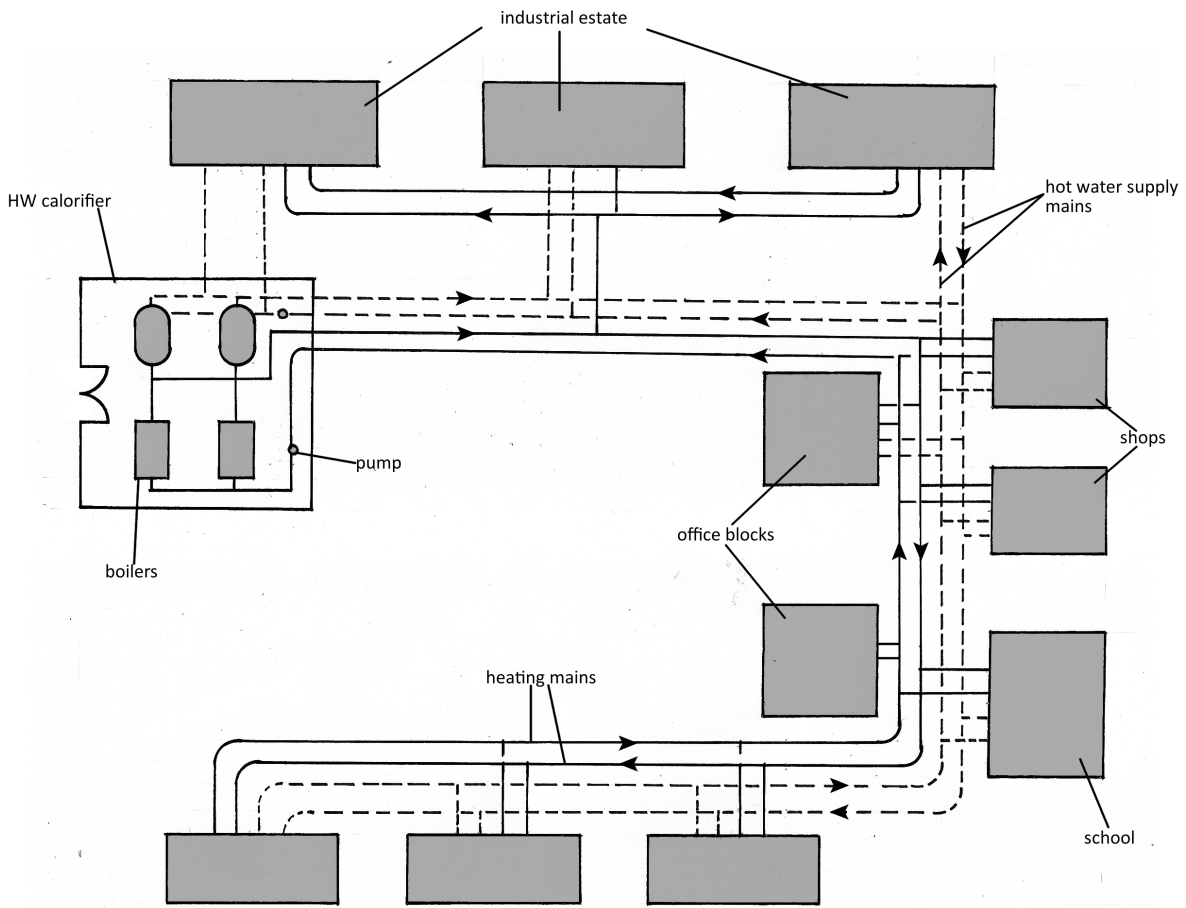
The **four-pipe system** supplies both hot water and space heating as two separate systems.

**Advantages:**

- **Individual hot water storage cylinders are not required**, as large capacity calorifiers are located in the boiler plant room and possibly at strategic locations around the district being served.
- The plumbing in each building is considerably simplified as **cold water cisterns are also unnecessary**, provided all cold water outlets can be supplied direct from the main.
- **There is economy in use** due to system flexibility and closure of the heating mains and associated boilers during the summer months.

**Disadvantages:**

- **The boiler plant room will be considerably larger** to accommodate the additional components and controls.
- Excavation and installation costs will also be relatively expensive.



**Figure 82: Four-Pipe District Heating System**

## Warm Air Heating Systems

If there is sufficient space within floors and ceilings to accommodate **ducting**, warm air can be used as an alternative to hot water in pipes. **Air diffusers or grilles** with adjustable louvers finish flush with the ceiling or floor. Control is simple, using a room **thermostat** to regulate the heat exchanger and fan.

**Fresh air** can be supplied to rooms through windows that can be opened or trickle ventilators in the window frames. If rooms are completely sealed, fresh air should be drawn into the heating unit. The minimum ratio of fresh to re-circulated air should be 1:3.

**Heat Source:** - This may be from:

- Gas
- Oil or
- Solid fuel boiler with a pumped supply of hot water to a heat exchanger within the air distribution unit
- Electricity

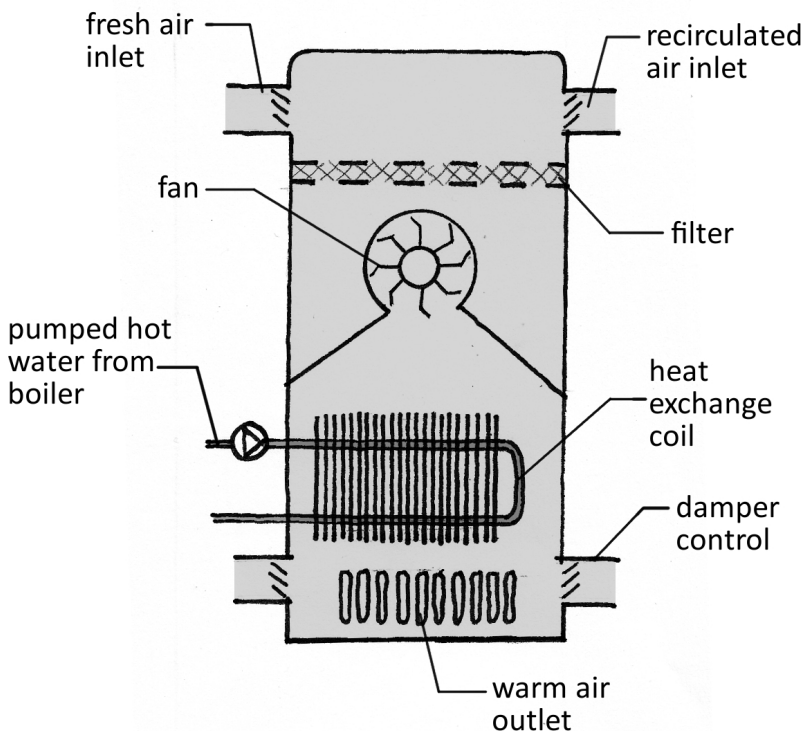
**Advantages:**

- There are no obtrusive emitters such as radiators.
- The risk of water leakage or freezing is minimal.

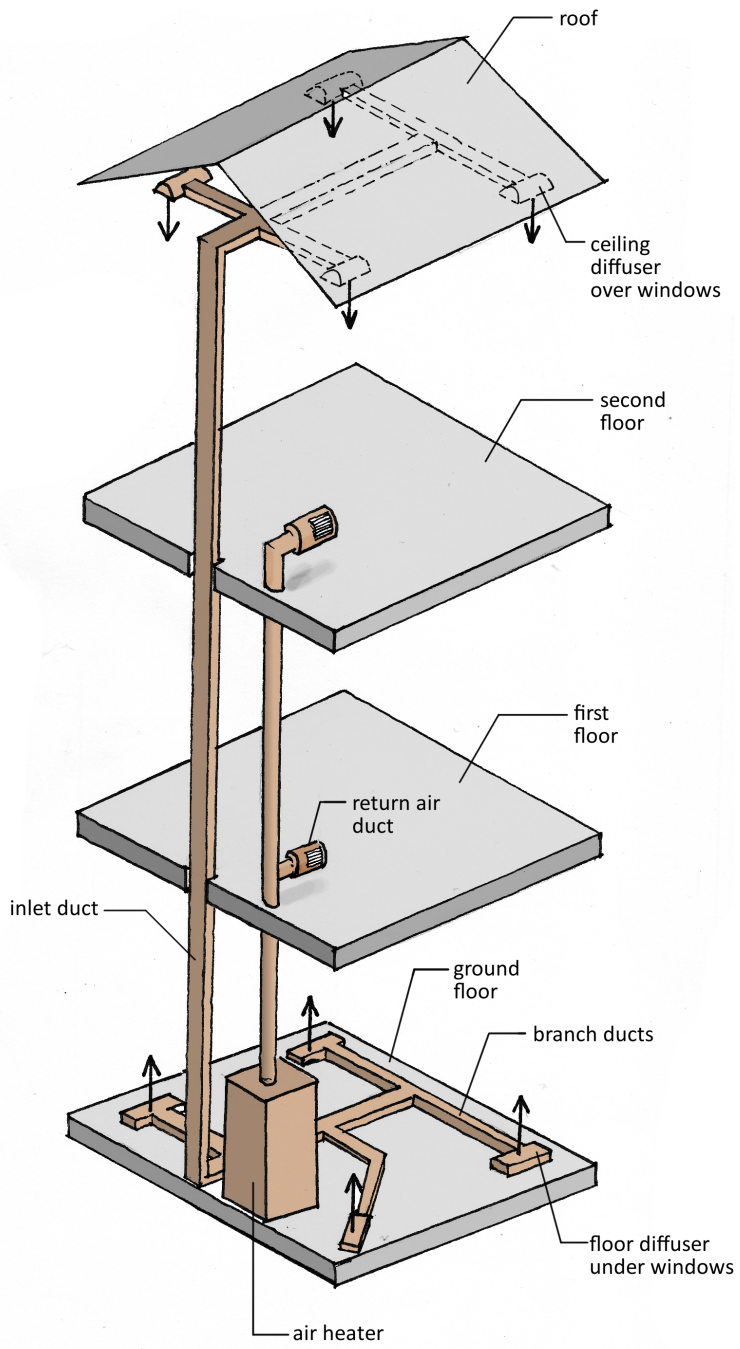
**Disadvantages:**

- Air ducts need to be well insulated to reduce heat losses.

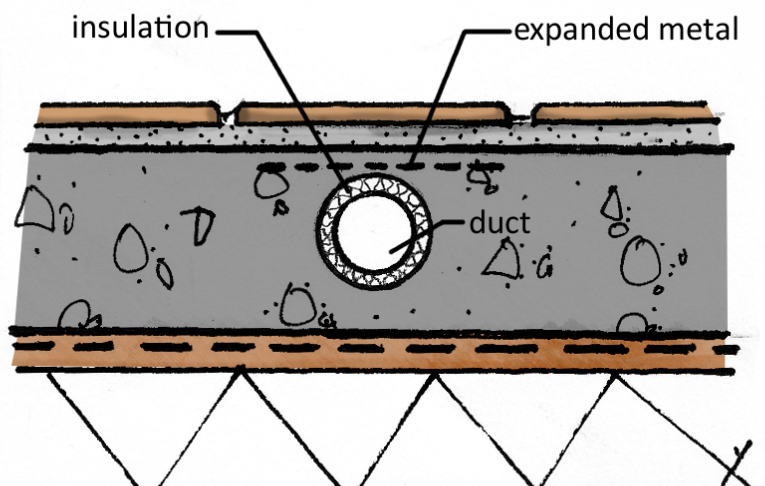
Figures 83, 84 and 85 illustrate the **return air duct**, the **warm air heating system** and section through a floor in which the air duct is installed.



**Figure 83: Return Air Duct**



**Figure 84: Warm Air Heating System**



**Figure 85: Air duct installation in concrete floor slab**

# VENTILATION OF BUILDINGS

**Ventilation** is a means of changing the air in an enclosed space with outdoor air to:

- Provide **fresh air** for respiration. Requirements for an acceptable amount of fresh air supply in buildings will vary depending on the nature of occupation and activity.
- Preserve the correct level of **oxygen** in the air – approx. 21%.
- Control **carbon dioxide** content to no more than 0.1%. Concentrations above 2% are unacceptable as carbon dioxide is poisonous to humans and can be fatal.
- Control **moisture**. Excess moisture generated within the home needs to be removed before high humidity levels lead to physical damage in the home or mold growth.
- Remove excess **heat** from people, machinery, lighting etc.
- Dispose of odours and other pollutants, smoke, dust and other **atmospheric contaminants**. Contaminants such as formaldehyde that may cause problems can accumulate in poorly ventilated homes. Inadequate ventilation prevents unpleasant odors from being removed
- Relieve **stagnation** and provide a sense of **freshness** – air movement of 0.15 to 0.5 m/s is adequate.

Ventilation of buildings can be provided by any of the following:

## Natural Ventilation

Natural ventilation is an economic means of providing air changes in a building. It is a form of **uncontrolled air movement** into a building through cracks and small holes (infiltration) and through vents such as windows and doors. It is the **traditional method** of allowing fresh outdoor air to replace indoor air.

It uses **components** integral with construction such as:

- Air bricks and Louvre's or
- Openable windows

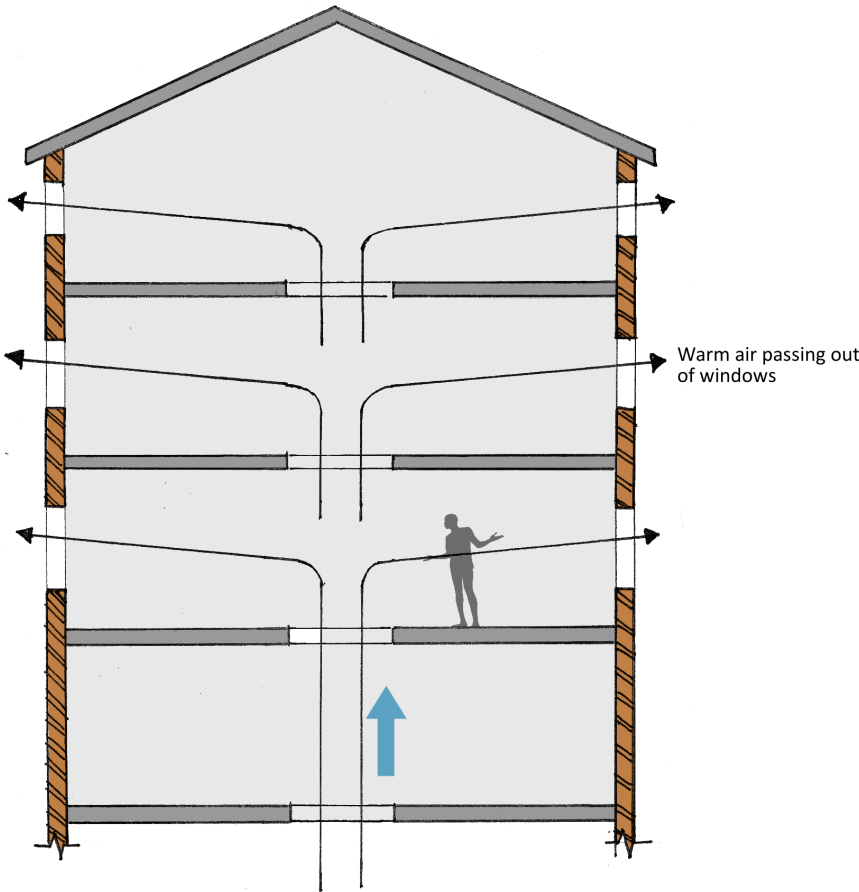
The sources for natural ventilation are:

- Wind effect/pressure and
- Stack effect/pressure

### Stack Effect

Stack effect is an application of **convected** air currents. Cool air is allowed to enter a building at low level. Here occupancy, lighting, machinery and or purposely-located heat emitters warm it.

A **column of warm air rises** within the building to discharge through vents at high level, as shown in the adjacent illustration. This should be regulated otherwise it can produce **draughts** at low levels and excessive warmth on the upper floors.



Stack effect method of ventilation can be very effective in tall office-type buildings and shopping malls, but has limited effect during the summer months due to warm external temperatures. A temperature differential of at least 10 K (degree Kelvin) is needed to effect movement of air, therefore a supplementary system of mechanical air movement should be considered during the warmer seasons.

Figure 86: Convected Air currents rising in tall building stack

### Wind Effect

Wind passing the walls of a building creates a slight vacuum. With provision of controlled openings this can be used to draw air from a room to effect air changes.

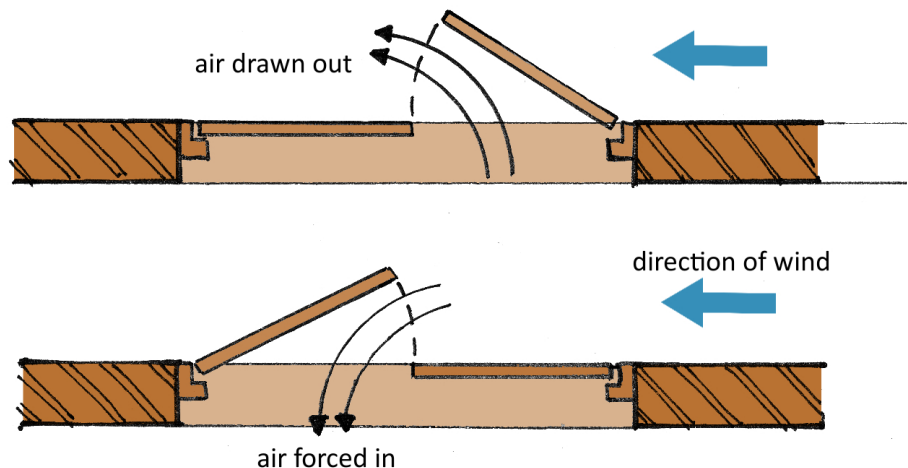


Figure 87: Wind causing ventilation through windows

## Ventilation & Heating for an Assembly Hall or Similar Building

This may be achieved by admitting cool external air through **low-level convectors**. The warmed air rises to high level **extract ducts**.

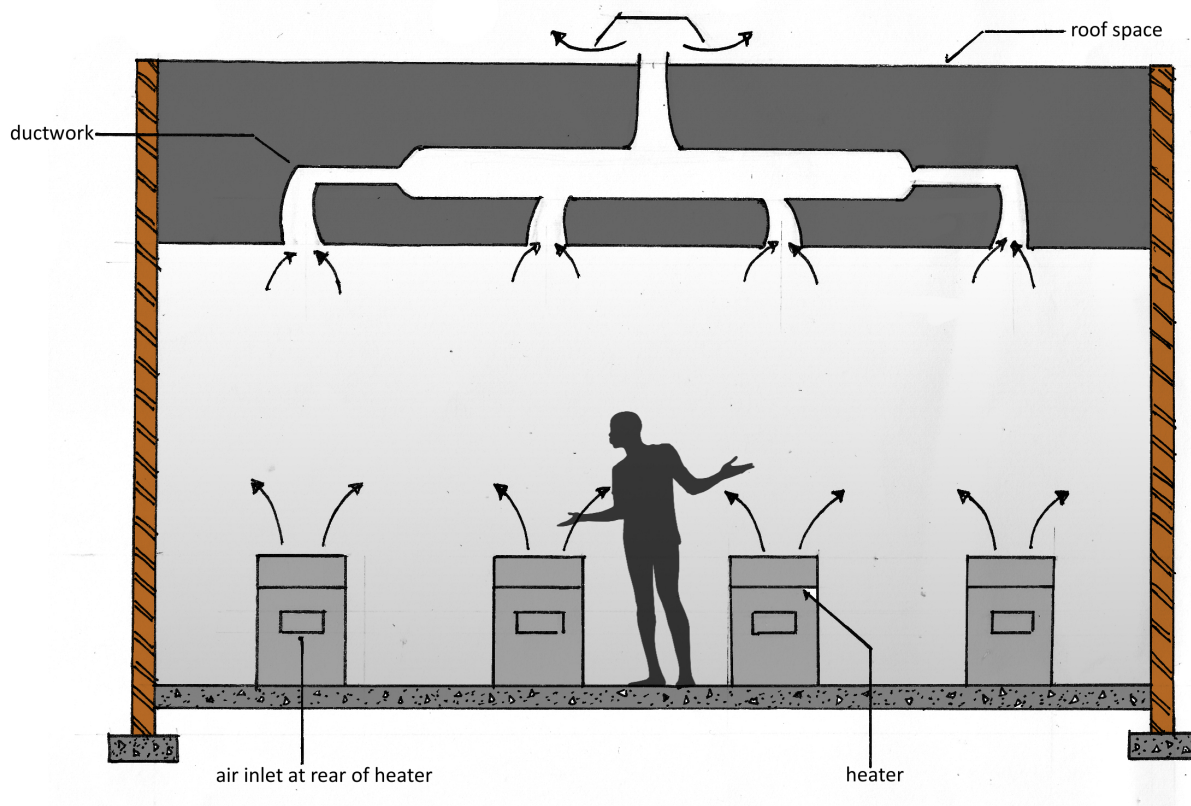


Figure 88: Ventilation for an assembly hall

### Passive Stack Ventilation (PSV)

PSV consists of vertical or near **vertical ducts** 100 to 150mm diameter, extending from grilles set at ceiling level to terminals above the ridge of a roof. It works by combining **stack effect** with air movement and wind passing over the roof (**wind effect**).

These systems can be used in kitchens and bathrooms, in buildings up to five floors requiring up to three stacks/ducts. PSV is energy efficient and environmentally friendly with no running costs. It is self-regulating, responding to a temperature differential when internal and external temperatures vary.

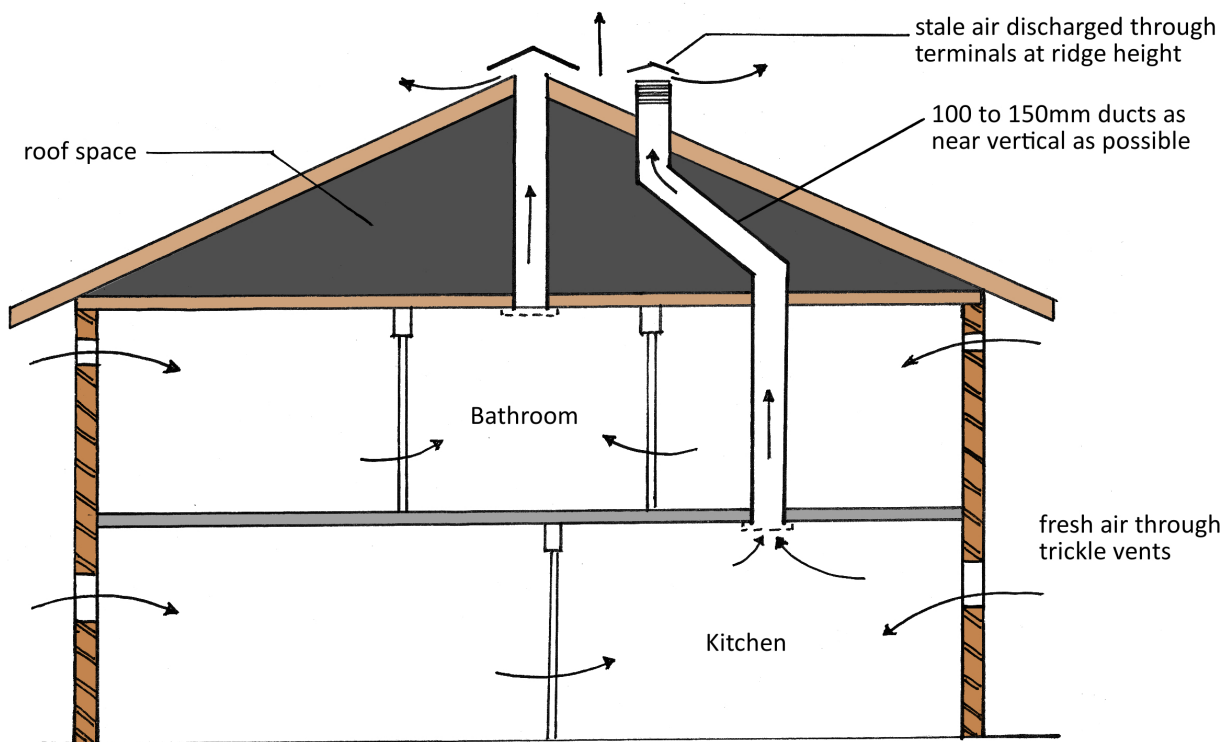


Figure 89: PSV to a residential building

## Mechanically Assisted Ventilation Systems (MAVS)

MAVS may be applied to dwellings and commercial premises where PSV is considered inadequate or impractical. This may be because the number of individual ducts would be **excessive**, i.e. too space consuming and obtrusive

with several roof terminals.

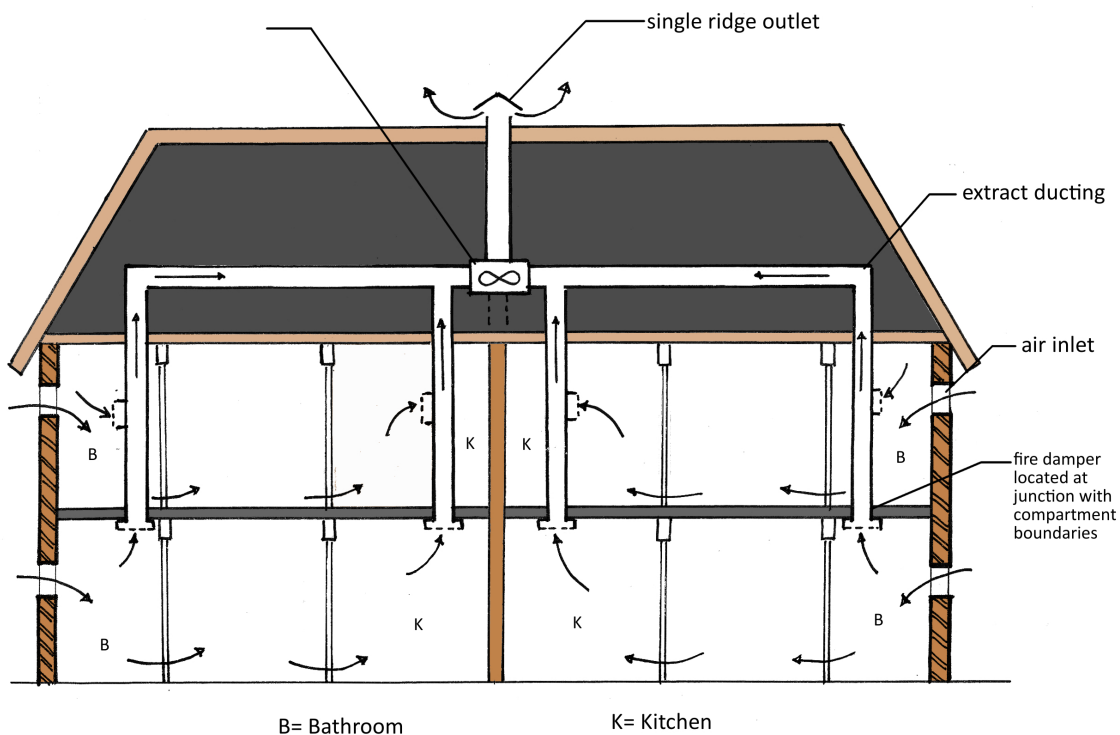


Figure 90: MAVS in a group of flats

MAVS are acceptable as an alternative to the use of mechanical fans in each room.

The MAVS may be in form of:

- **A low powered (40W) silent running fan.**

The fan is normally located within the roof structure and it runs continuously and **may be boosted** by manual control when the level of cooking or bathing activity increases.

- **Humidity Sensors**

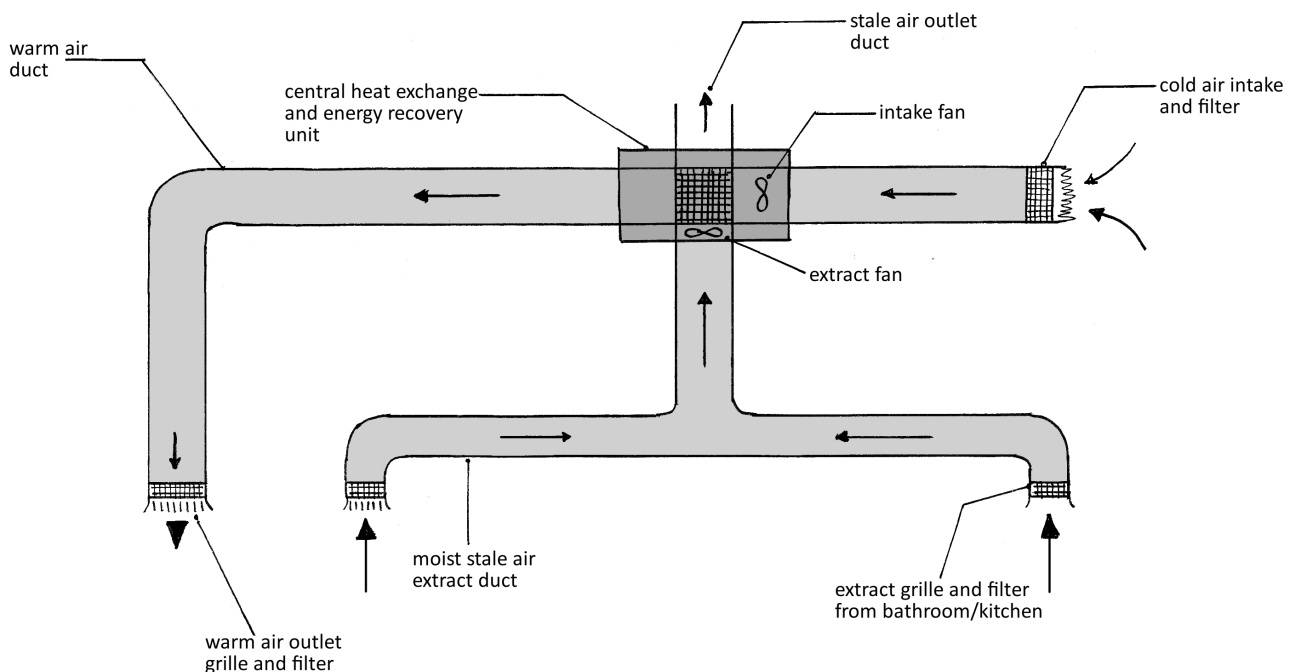
These are used to automatically increase airflow.

## Mechanical Ventilation with Heat Recovery (MVHR)

MVHR is a development of MAVS to include **energy recovery** from the **warmth** in fan extracted **moist air** from bathrooms and kitchens. The **heat recovery unit** contains:

- An extract fan for the stale air
- A fresh air supply fan and
- A heat exchanger

This provides a balanced continuous ventilation system and up to 70% of the heat energy in stale air can be recovered, but this system is not an alternative to central heating.



**Figure 91: Schematic of an MVHR system of ventilation**

## Mechanical Ventilation Systems

Mechanical Ventilation Systems are frequently applied to commercial buildings, workshops, and factories etc., where the air change requirements are defined for health and welfare provision. There are three categories of the system:

1. Natural inlet and mechanical extract
2. Mechanical inlet and natural extract
3. Mechanical inlet and mechanical extract

### Advantages:

- System design provides for more reliable air change and air movement than that of natural systems of air movement.

### Disadvantages

- The capital cost is greater than that of natural systems of air movement.
- Some noise will be apparent from the fan and air turbulence in the ducting.
- Smoke or smells can pass between rooms. This can be prevented with the use of a **shunt duct**.
- Duplicated fans with automatic changeover are required in public buildings in event of failure of the duty fan.

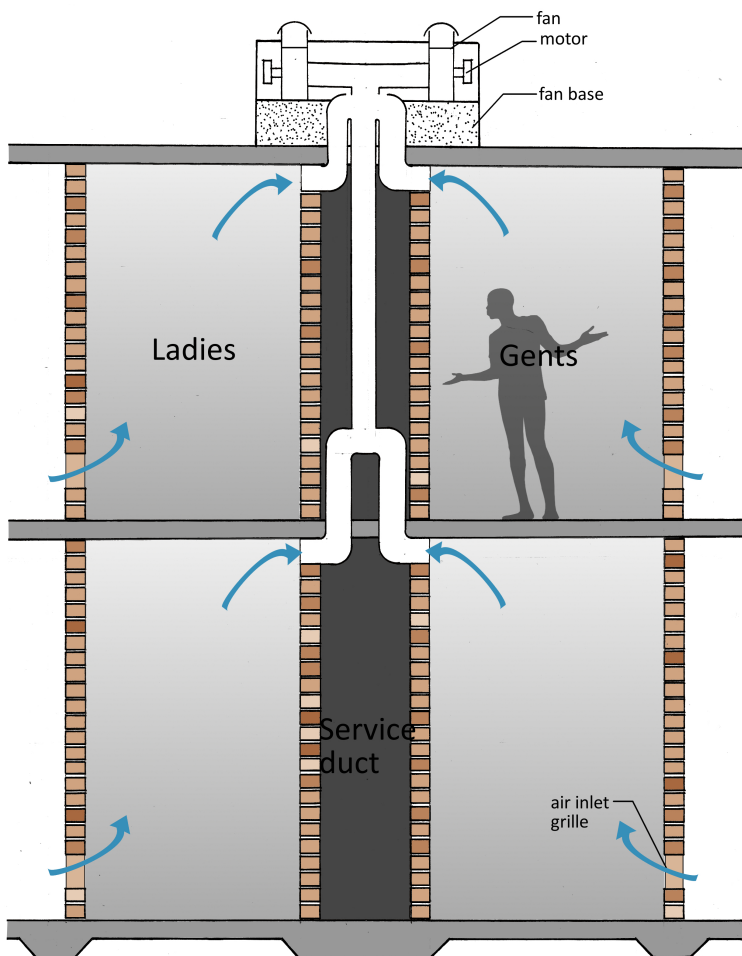
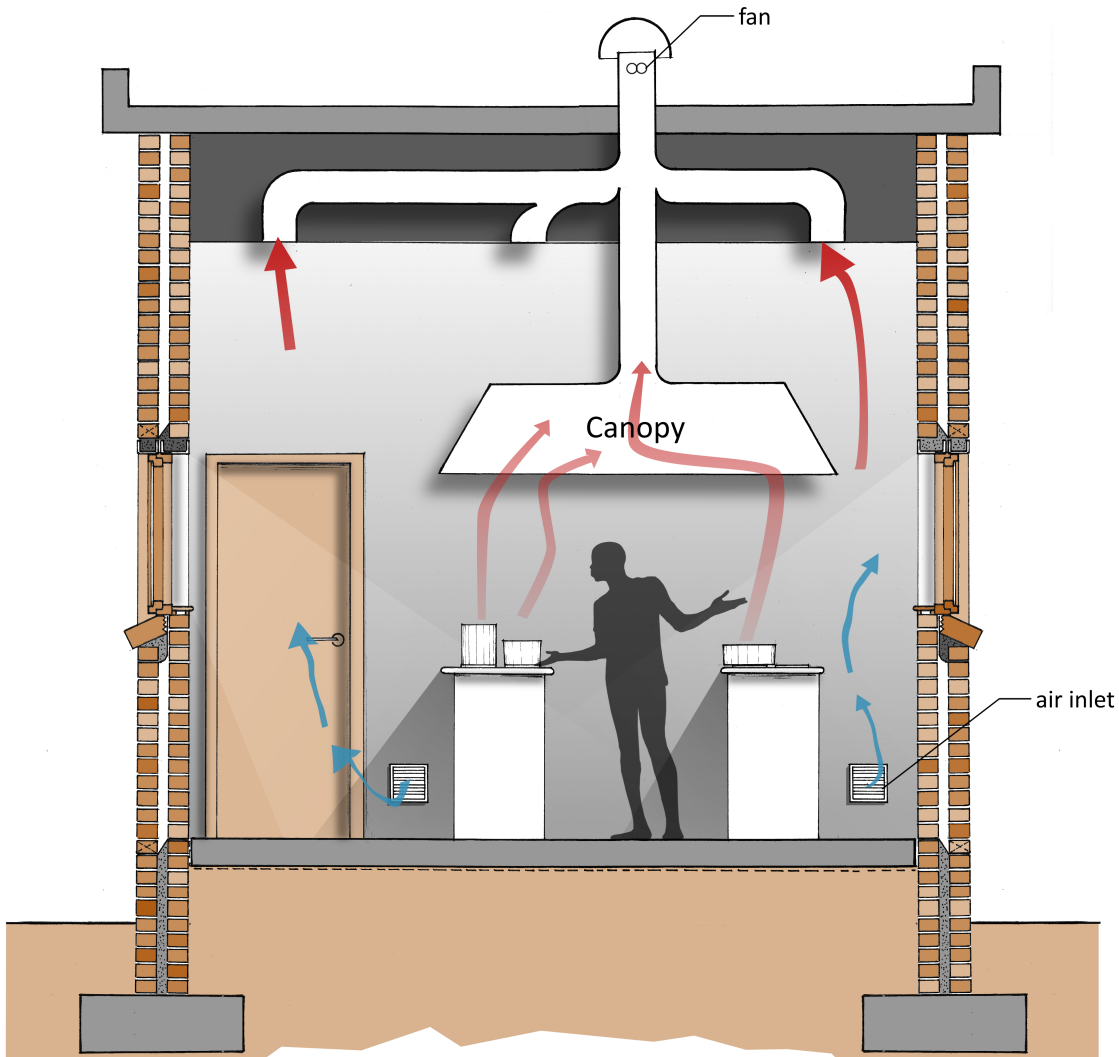


Figure 92: Mechanical Ventilation System in interior sanitary accommodation



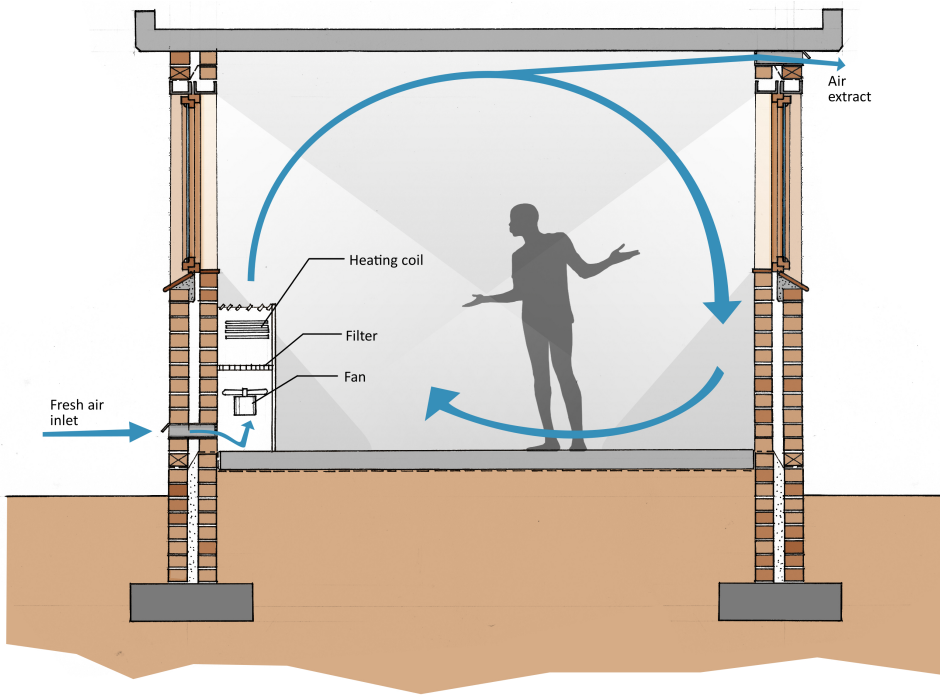
**Figure 93: Mechanical Ventilation System in Cafeteria kitchen**

A **mechanical inlet and mechanical extract system** can be used to **regulate and balance supply and emission of air** by designing the **duct size and fan rating** specifically for the situation.

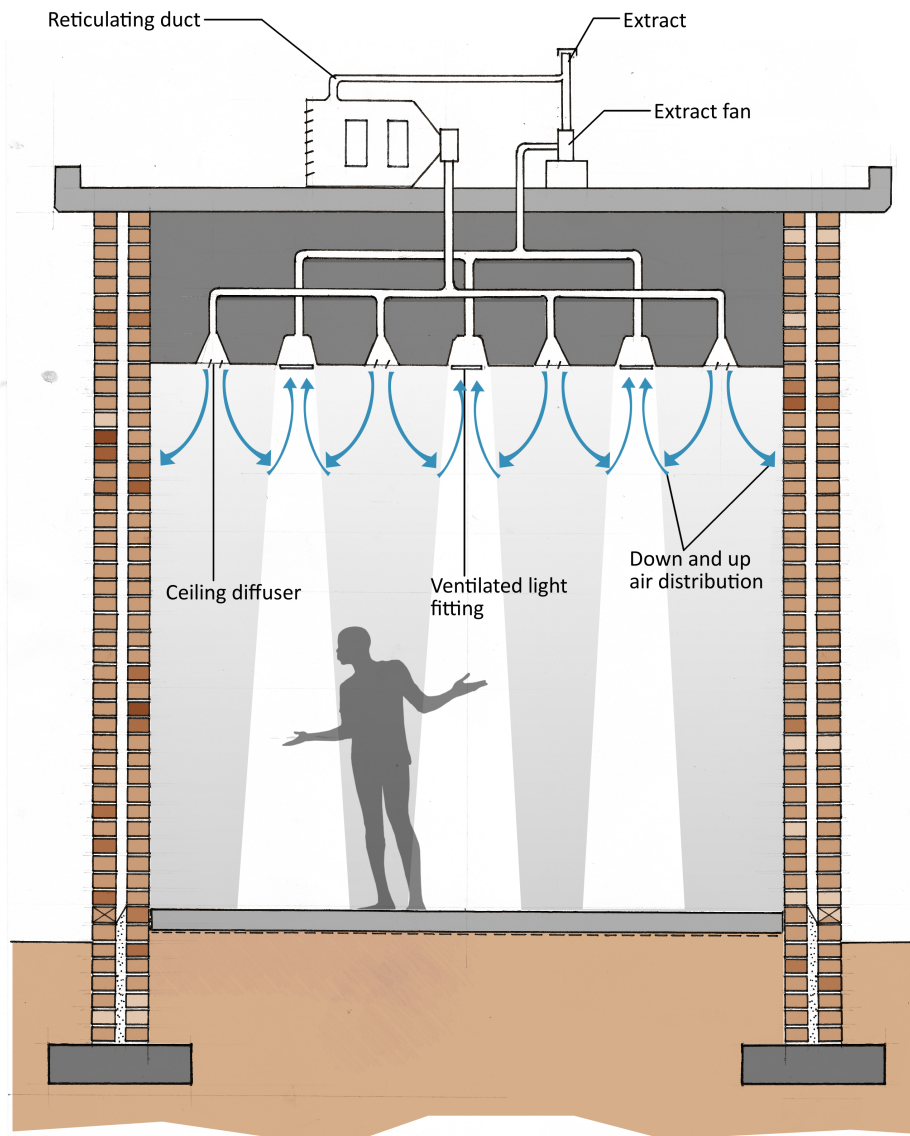
Therefore, fan assisted ventilation systems **supplying air** to habitable rooms must have a **facility to pre-heat the air**. They must also have **control over the amount of air extracted**; otherwise there will be excessive heat loss.

**Ductwork** in all ventilation systems should be **insulated to prevent heat losses** from processed air and to prevent **surface condensation**.

Figure 72 shows that **air may be extracted** through specially made **light fittings**. These permit the heat-enhanced air to be re-circulated back to the heating unit.



**Figure 94: Mechanical Inlet and Mechanical Extract System**



**Figure 95: Air extraction through specially made light fittings**

## Spot Ventilation

All the above ventilation systems can be classified as **centralized systems/whole building ventilation strategy**. Spot ventilation makes use of **localized exhaust/extractor fans** (e.g., kitchen and bath fans) to quickly remove pollutants at their source as they are generated.

## Appliances used with the Ventilation Systems

Some of the appliances used with the ventilation systems include:

### Ducts

**Profile** – Generally circular, square or rectangular but may be oval. **For efficient distribution** of air due to less opportunity for turbulence, less resistance to friction etc., **the uniformity of the circular ducting is preferred**.

Where **space is restricted** under floors or in suspended ceilings, rectangular ducting may be required. Also, **direction changes** are more easily formed with square or rectangular ducting than with circular sections.

**Galvanized sheet steel** is the most common material used for ventilation and air conditioning ducting. Factory prefabricated sections are **site jointed by bolted steel angle flanges** with a **rubber sealing gasket**; the rigid angles may also function as suspended bracket fixings.

In addition to galvanized steel, **aluminium** may be used in smaller profiles or externally in non-corrosive atmospheres. **Copper** or **stainless steel** is used where the ducting forms a feature, e.g. a cooker/stove hood. **Polypropylene** and **uPVC** piping is suitable in short lengths and small diameters, mainly for domestic applications such as extract fan extensions. **Plastic materials** have limitations where performance in fire is a consideration.

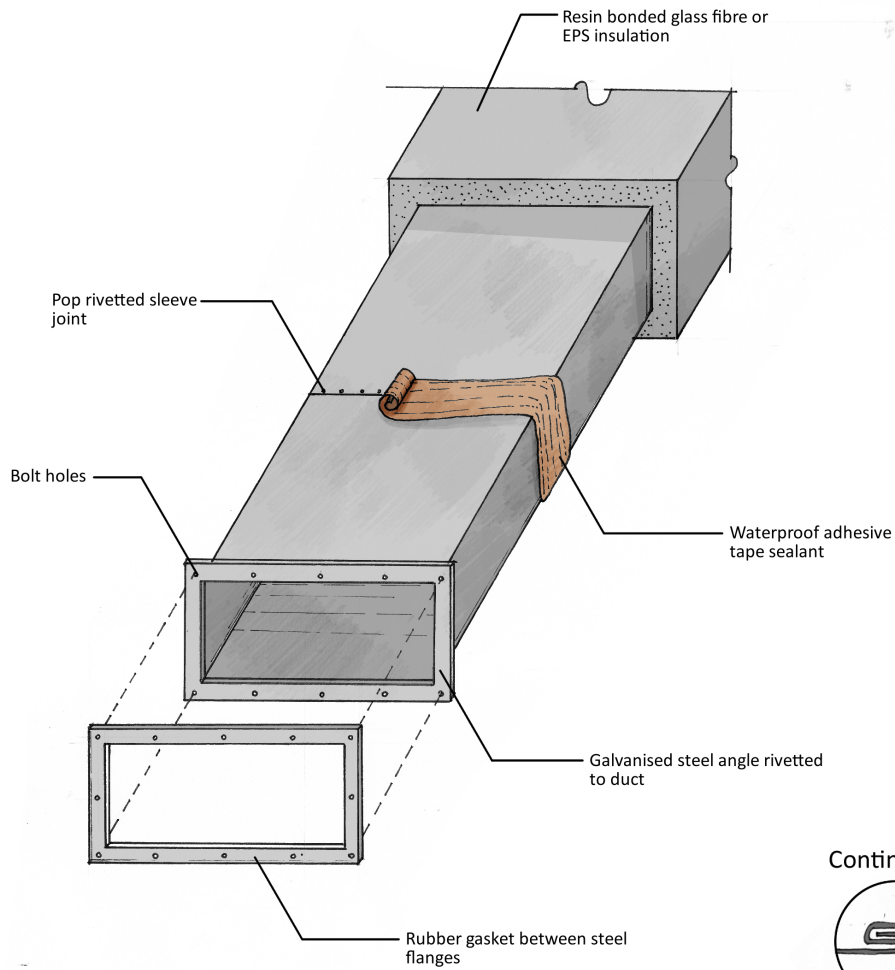
Apart from standard plastic pipe profiles (100 and 150mm nominal diameter drainage pipes), **most ducting is factory produced to the designer's specification**. It is unrealistic for sheet metal fabricators to produce standard section due to unknown demand and the space requirement for storage.

### Fans

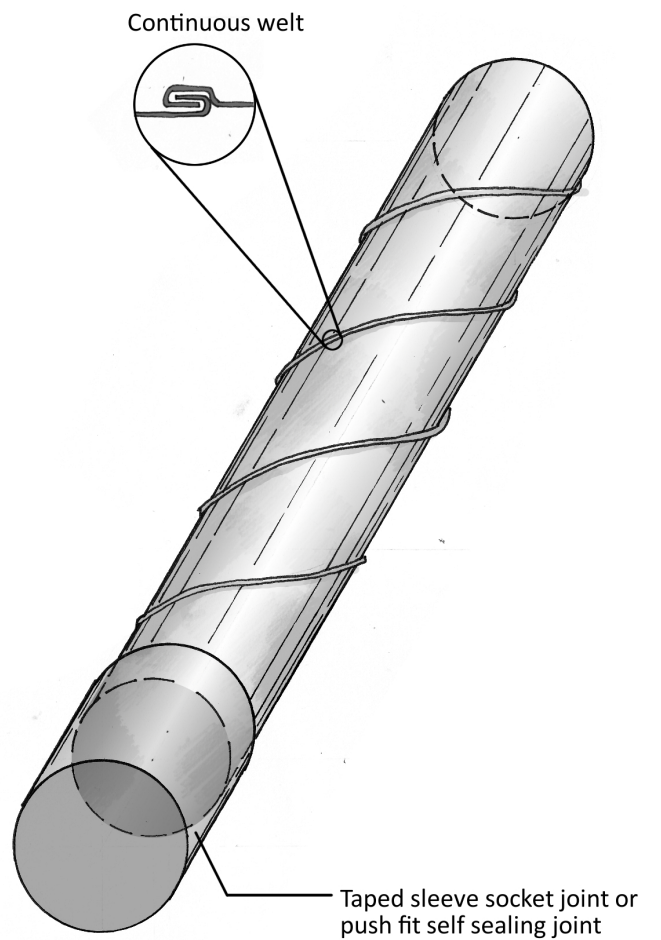
Fan performance depends very much on characteristics such as **type** and **configuration of components**. Types of fan include:

#### *Propeller fan*

does not create much air pressure and has limited effect in ductwork. Ideal for use at air openings in windows and walls.



**Figure 96: Rectangular Duct**



**Figure 97: Circular Duct**

***Axial flow fan***

Can develop high pressure and is used for moving air through long sections of ductwork. The fan is integral with the run of ducting and does not require a base.

***Bifurcated axial flow fan***

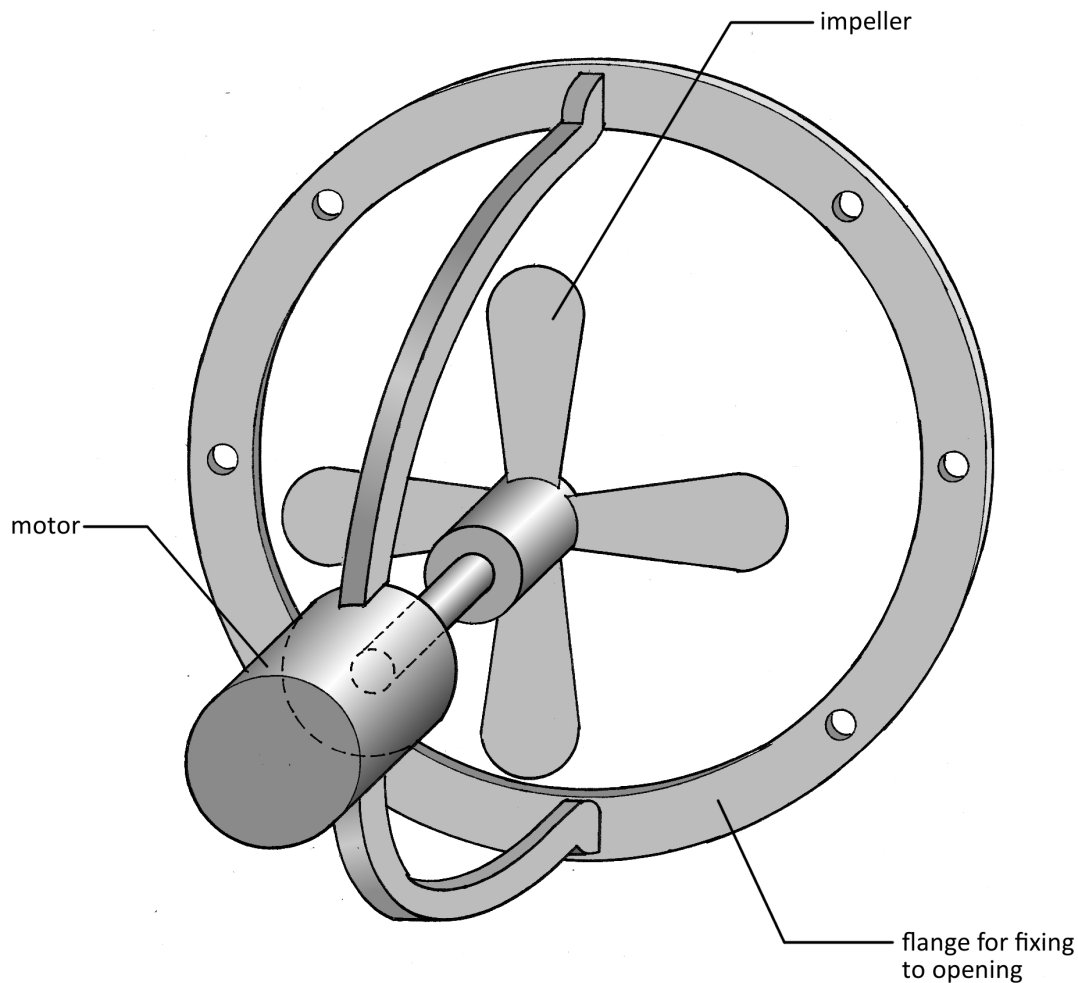
used for moving hot gasses e.g. flue gasses and greasy air from commercial cooker hoods.

***Cross-flow or tangential fan***

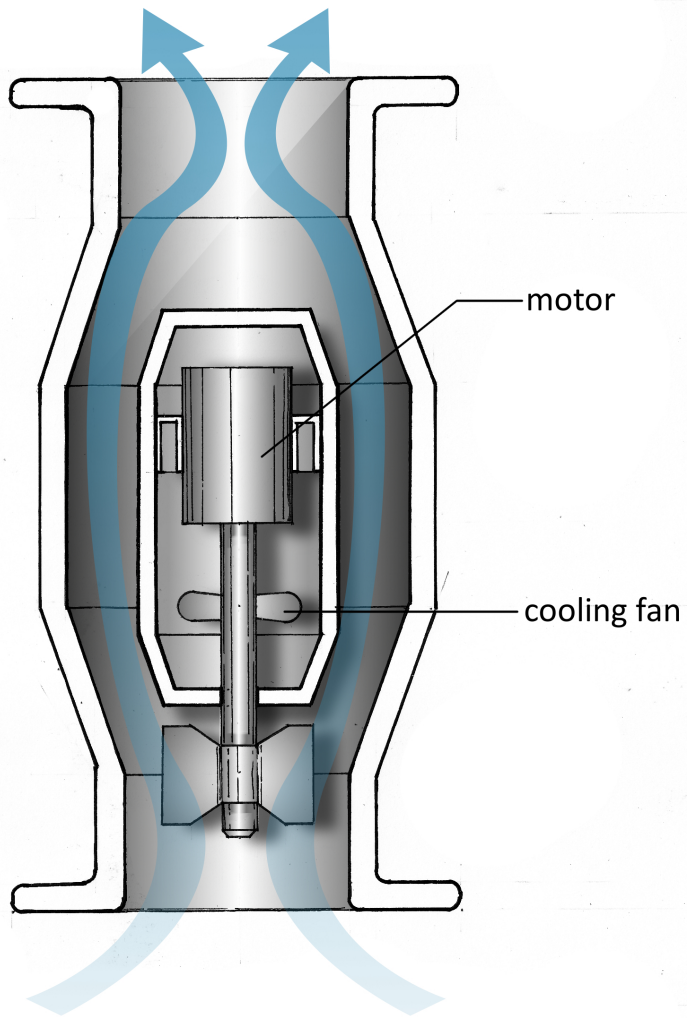
used in convector units

***Centrifugal fan***

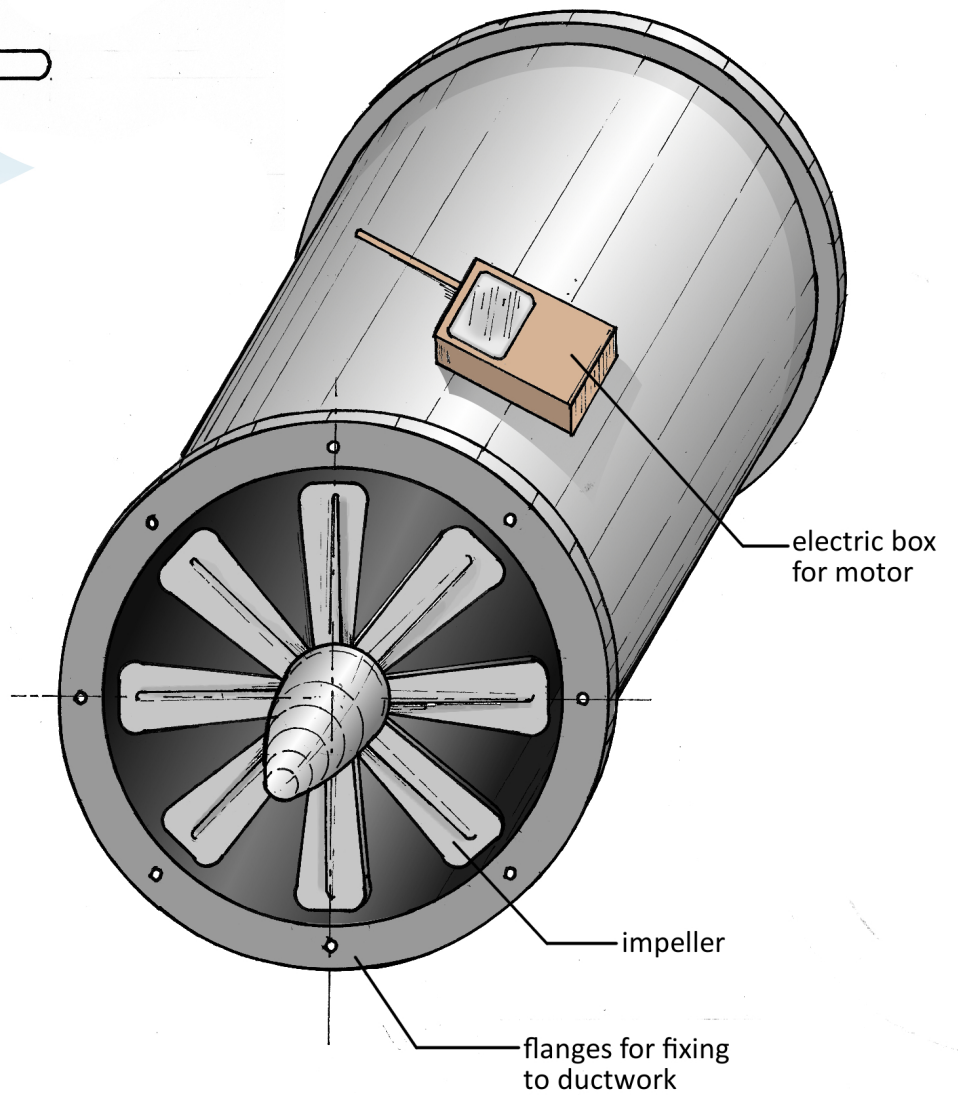
can produce high pressure and has the capacity for large volumes of air. Most suited to larger installations such as air-conditioning systems. It may have one or two inlets. Various forms of impeller can be selected depending on the air condition. Variable impellers and pulley ratios from the detached drive motor make this the most versatile of fans.



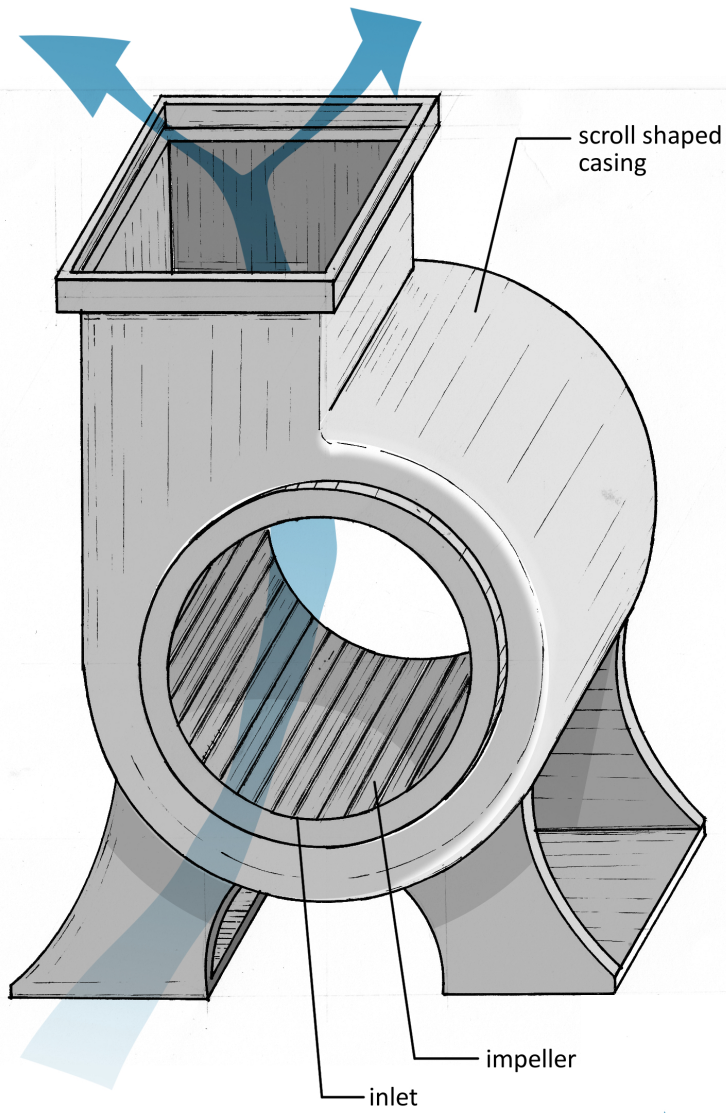
**Figure 98: Propeller Fan**



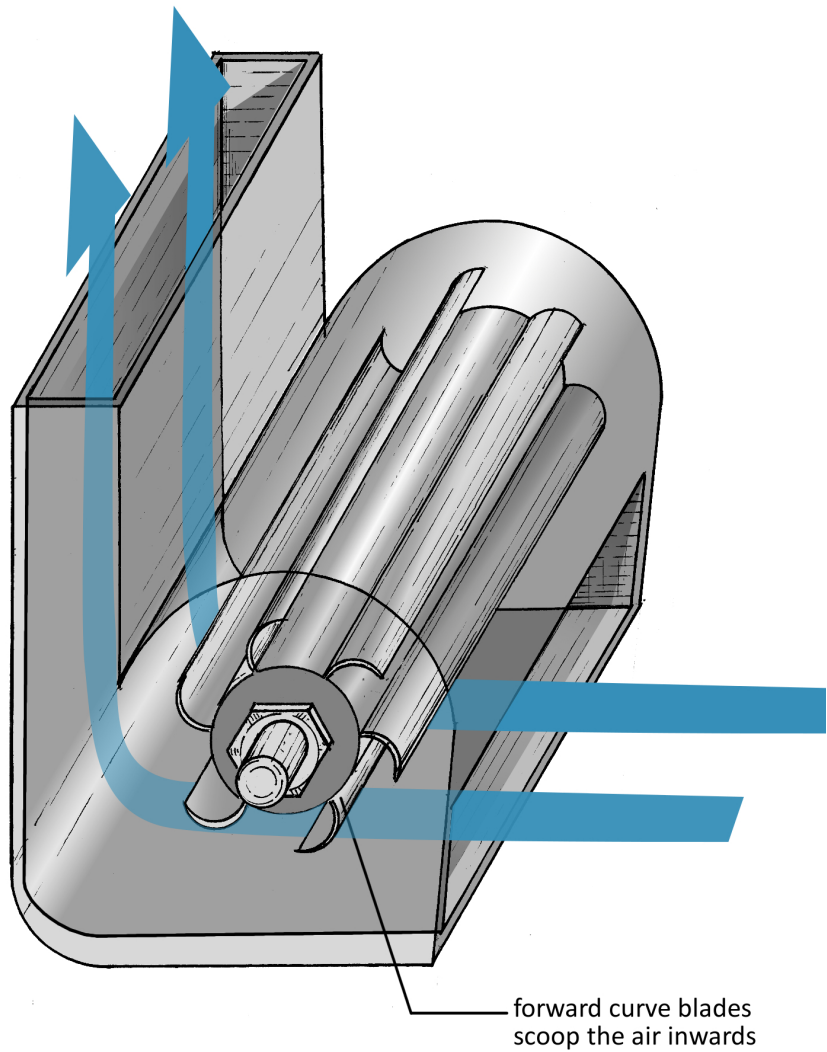
**Figure 99: Bifurcated axial flow fan**



**Figure 100: Axial flow fan**



**Figure 101: Centrifugal Fan**



**Figure 102: Cross flow fan**

# AIR CONDITIONING

## Difference between Air conditioning and Ventilation:

Whilst **ventilation** is the adequate provision of outdoor air to a space by natural or mechanical means,

**Air conditioning** is the process of providing a space/room with clean air at controlled temperature and humidity by **heating** or **cooling** and by **humidification** or **de-humidification** and to supply outdoor air for ventilation. The air conditioner therefore sometimes combines the work of a **heater**, a **refrigerator** and an **air filter**.

**Air conditioning** is achieved by developing the principles of moving air in ducted ventilation systems to include a number of physical and scientific processes, which **enhance the air quality**. The objective is to provide and maintain internal air conditions at a pre-determined state, regardless of the time of year, the season and the external atmospheric environment.

For buildings with human occupancy, the **design specification** is likely to include an internal air temperature of **19-23°C** and relative humidity between **40 and 60%**.

The **heating** and **ventilating** systems have been reviewed in details in preceding lectures. In order to understand air conditioning, the **cooling** systems also have to be reviewed.

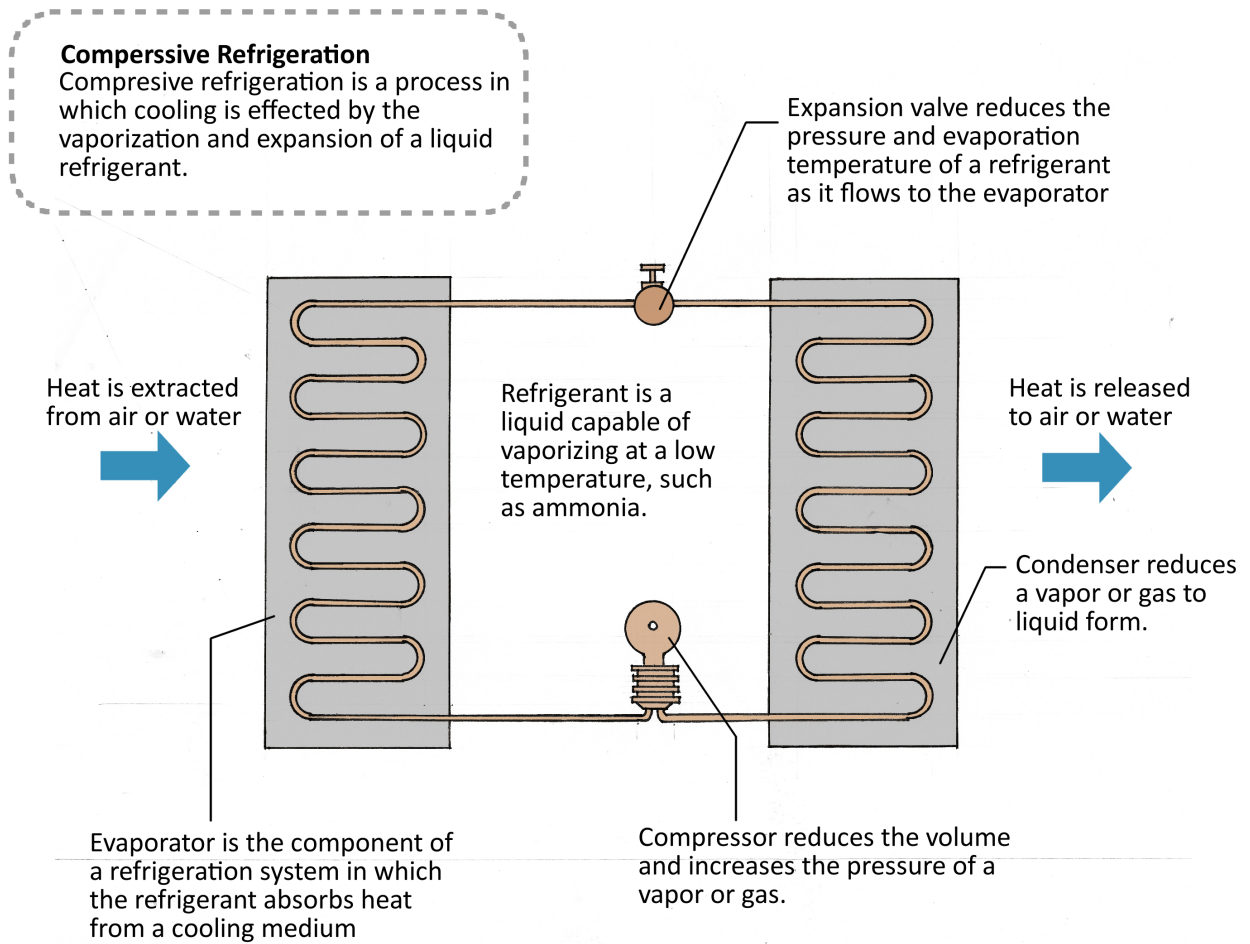
## COOLING SYSTEMS

These include:

### Compressive Refrigeration

Compressive refrigeration is a process in which cooling is effected by the **vaporization** and **expansion** of a liquid refrigerant. When the hydrocarbon refrigerant gas (FREON) is **pressurized** by the motor driven **compressor** to a point where it can be condensed to liquid form, it leaves the compressor at a high pressure and temperature it flows to the **condenser**. The refrigerant gas condenses on contact with the tube walls where **heat is released** to the air/atmosphere or water and the liquid refrigerant flows to the receiver tank for storage. The liquid tube carries the refrigerant from this tank still at high pressure, to the **expansion valve**, which regulates its flow to the **evaporator tubes** and maintains the pressure difference between the condenser and the evaporator.

**Heat is removed** from the air/atmosphere or water passing over the evaporator tubes causing it to fall in temperature. During this time, the liquid refrigerant evaporates or “boils off” and returns as a gas at low pressure back to the suction side of the compressor and the cycle is repeated.



**Figure 103: Compressive Refrigeration**

## Heat Pumps

Heat pumps are **electrically powered heating and cooling units**. For cooling the normal **compressive refrigeration** cycle is used to absorb and transfer excess heat to the outdoors. For heating, heat energy is drawn from the outdoor air by **reversing the cooling cycle** and switching the heat exchange functions of the condenser and evaporator. These pumps are efficient in temperate regions where heating and cooling loads are almost equal.

In cold climates, a heat pump would require an electric resistant heater to keep the outdoor coils from freezing.

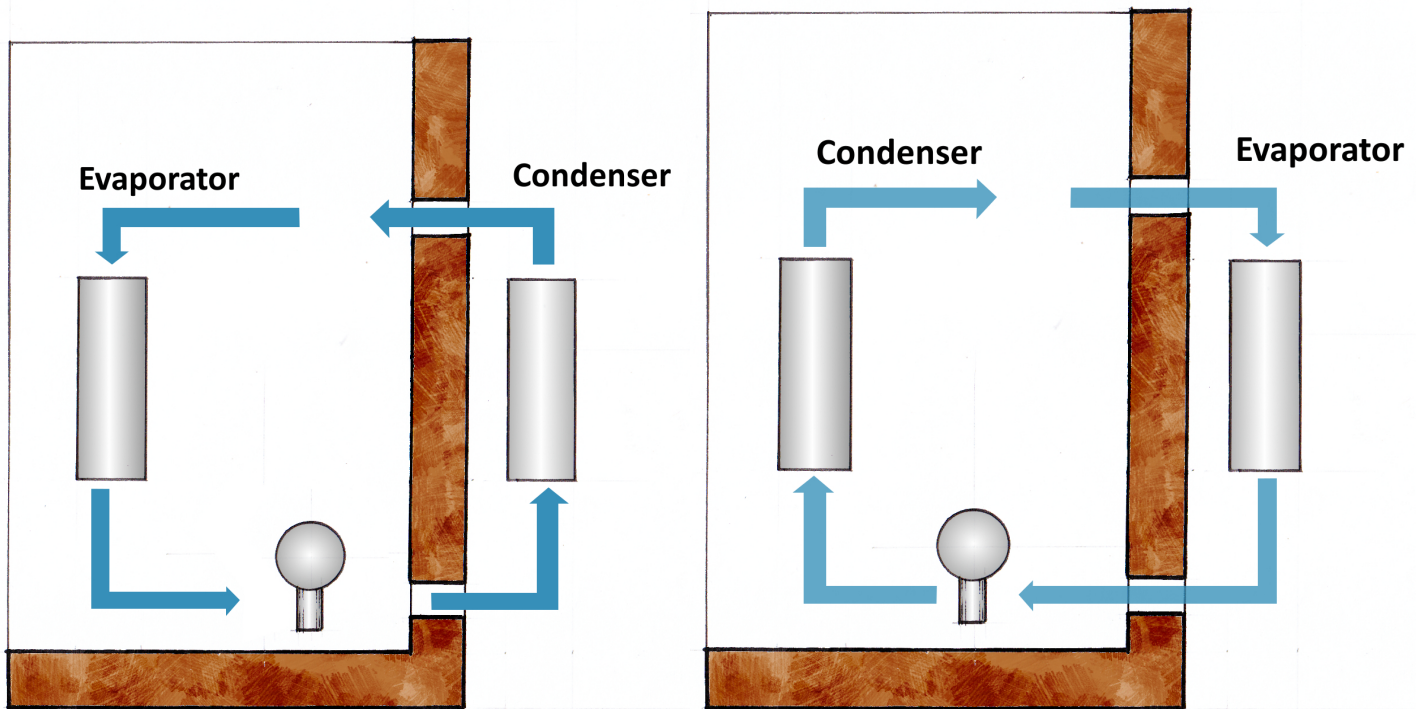


Figure 104: Method of operation of a Heat Pump

## FACTORS TO CONSIDER IN THE PLACEMENT OF AIR-CONDITIONING EQUIPMENT AND DISTRIBUTION SYSTEM

The efficiency of an air-conditioning system will depend on the accuracy of the engineering analysis and the successful integration of the system into the structure. Air-conditioning equipment occupies significant space within a building. It also requires space for access, service and maintenance.

Air duct systems require more installation space than either pipes for water and drainage or electrical systems. For this reason, ductwork must be **carefully laid** out such that it is properly integrated with a building's structure, form and spaces as well as with other systems (i.e. water, drainage and electrical).

If the ductwork is to be left **exposed**, it becomes even more important that the lay out has a **visually coherent** order and be coordinated with the physical element of the space (i.e. structural elements, surface pattern and light fixtures). **Concealed ductwork** usually has vertical components housed in **shaft** spaces whilst horizontal runs may be **underground**, in basements or **within floor and roof construction**.

Factors to consider in the placement of air-conditioning equipment and distribution system include:

- Location and method of supply of power, fuel, fresh air and water.

- Space, enclosure and construction requirements for the heating and cooling plant.
- Accessibility requirements for service and maintenance.
- Type and layout pattern of the distribution system used for the heating and cooling media.
- Type of installation: concealed within the building construction or exposed to view.

## TYPES OF HVAC SYSTEMS

The air-conditioning plant may be centralized in one location or dispersed throughout a building. Some plant require both indoors and outdoors components, others may be self-contained units which may be located on exterior walls or rooftops.

Heating, ventilating and air-conditioning (HVAC) simultaneously control the temperature, humidity, purity, distribution and motion of the air in the interior spaces of a building.

**Heating and cooling energy** can be distributed by air, water or a combination of both.

### All-Air Systems

These include:

- **A single – duct, constant-air-volume (CAV) system:** This delivers conditioned air at a constant temperature through a low velocity duct system to the served places.
  - **Single-zone system** – a master thermostat regulates the temperature for the entire building.
  - **Multi-zone system** – separate ducts from a central **air-handling unit** serve each of a number of zones.

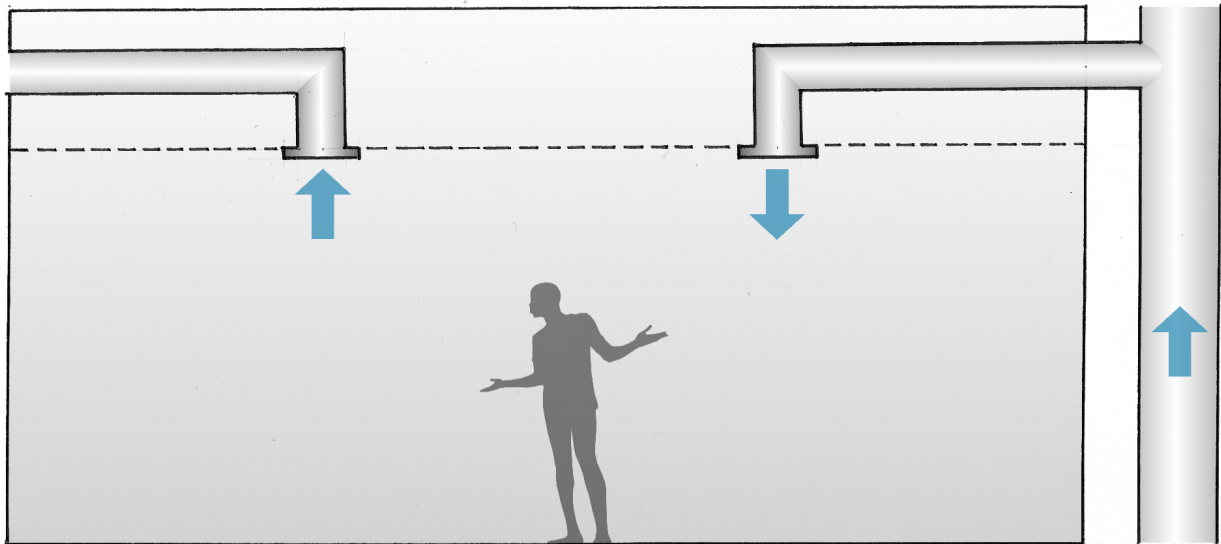


Figure 105: Single-duct, Constant-Air-Volume (CAV) system

- **A single-duct, variable-air-volume (VAV) system:** Uses dampers at the terminal outlets to control the flow of conditioned air according to the temperature requirements of each zone or space. This is illustrated in Figure 83.

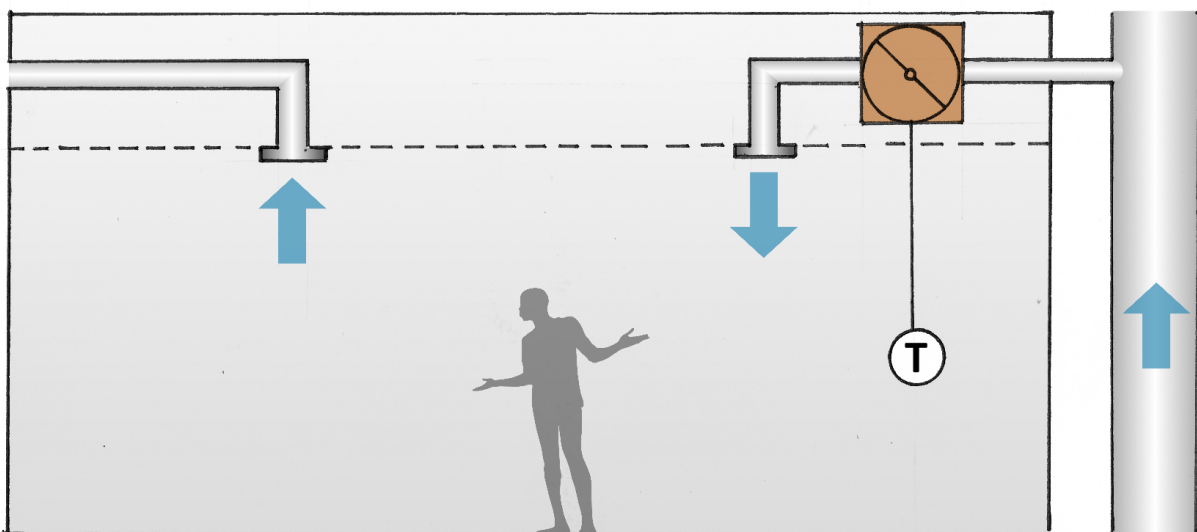


Figure 106: Single-duct, Variable-Air-Volume (VAV) system

- **A dual-duct system:** Uses separate ducts to deliver warm air and cool air to **mixing boxes**, which contain thermostatically controlled dampers.
  - The mixing boxes proportion and blend the warm and cold air to reach the desired temperature before distributing the blended air to each zone or space.
  - This is usually a high-velocity system intended to reduce duct sizes and installation space.

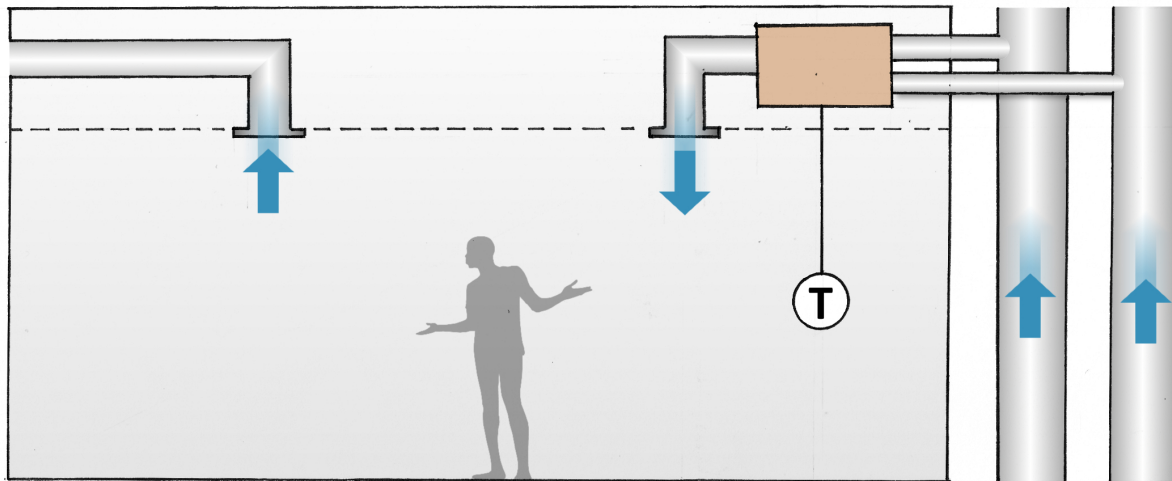


Figure 107: Dual-duct system

- **A terminal reheat system:** It offers more flexibility in meeting changing space requirements. It supplies air at about 12°C to terminals equipped with electric or hot-water reheat coils which regulate the temperature of the air being furnished to each individually controlled zone or space.

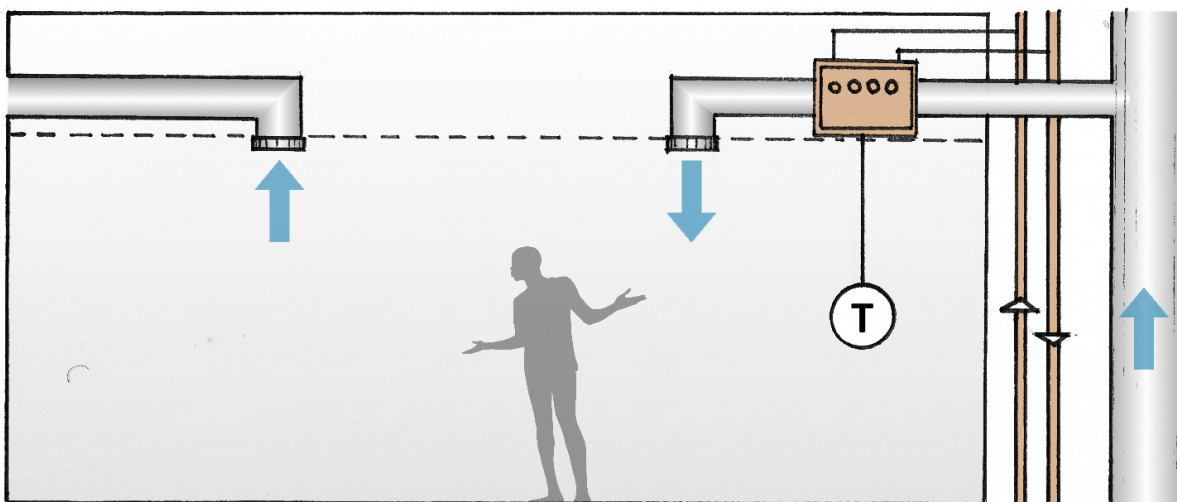


Figure 108: A Terminal Reheat system

## b. All-Water Systems

Pipes which require less installation space than air ducts, deliver hot or chilled water to fan-coil units in the served spaces.

- **A two-pipe system** uses one pipe to supply hot or chilled water to each fan-coil unit and another to return it to the boiler or chilled water plant. **Fan coil units** contain an **air filter** and a **centrifugal fan** for

drawing in a mixture of room air and outside air over coils of heated or chilled water and then blowing it back into the room space.

- **A four-pipe system** uses two separate piping circuits – one for hot water and one for chilled water – to provide simultaneous heating and cooling as needed to the various zones of a building.
- **Ventilation** is provided through wall openings, by infiltration, or by a separate duct system.

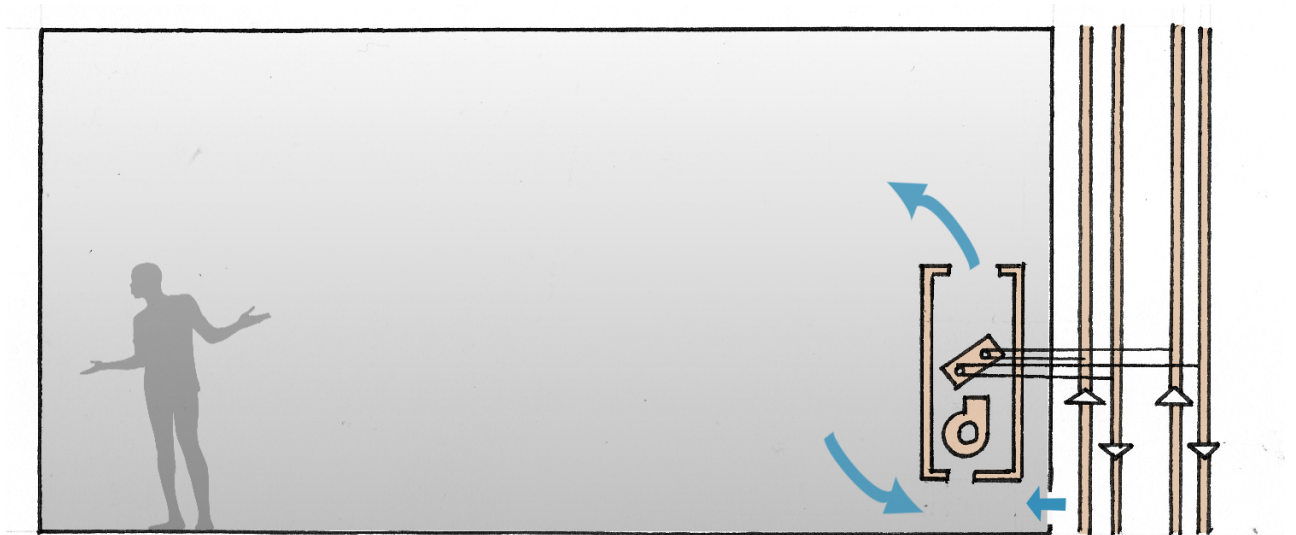


Figure 109: A Two-Pipe All-Water System



Figure 110: A Four-Pipe All-Water System

## Air-Water Systems

Air-water systems use high-velocity ducts to supply conditioned primary air from a central plant to each zone or space where it mixes with room air and is further heated or cooled in **induction units**.

- The primary air draws in room air through a filter and the mixture passes over coils that are heated or chilled by secondary water piped from a boiler or chilled water plant.
- Local thermostats control water flow over the coils to regulate air temperature.

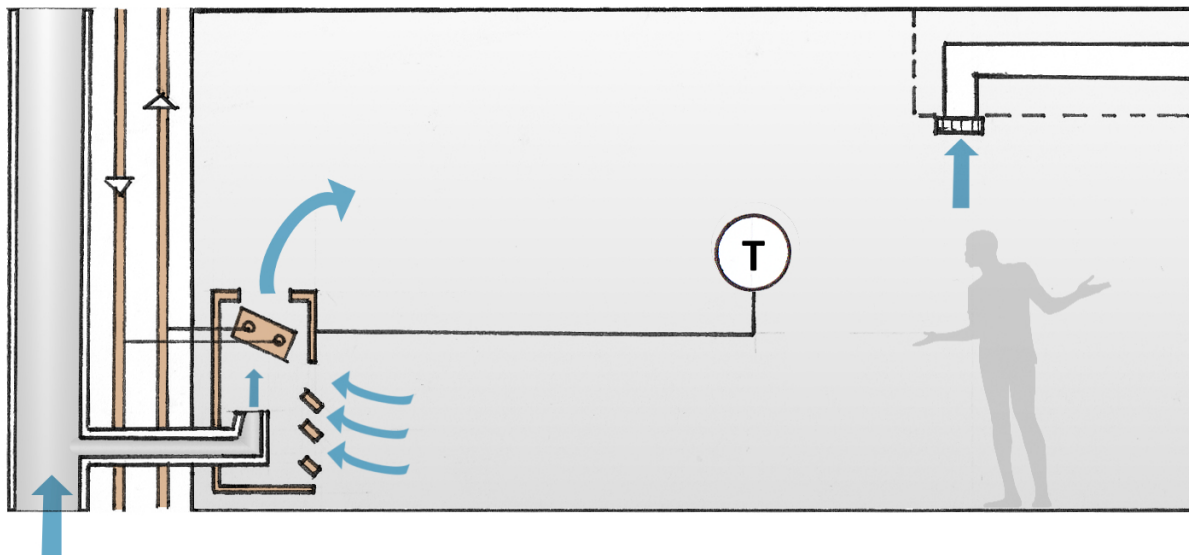


Figure 111: Air-Water Systems

## Packaged Systems

Factory assembled packaged systems can be obtained for installation in buildings and are **powered** by electricity, gas or by a combination of electricity and gas.

Packaged systems are **self-contained**, weatherproof units incorporating a **fan, filters, compressor, condenser and evaporator coils for cooling**. For **heating**, the unit may operate as a **heat pump** or contain **auxiliary heating elements**.

Packaged systems may be mounted as a single piece of equipment on the roof, on a concrete pad alongside an exterior wall of a building or cut into the exterior wall of each served space.

### ***Rooftop packaged units***

may be placed at intervals to serve long buildings. Packaged units with vertical shafts that connect to horizontal branch ducts can serve buildings up to four or five floors in height.

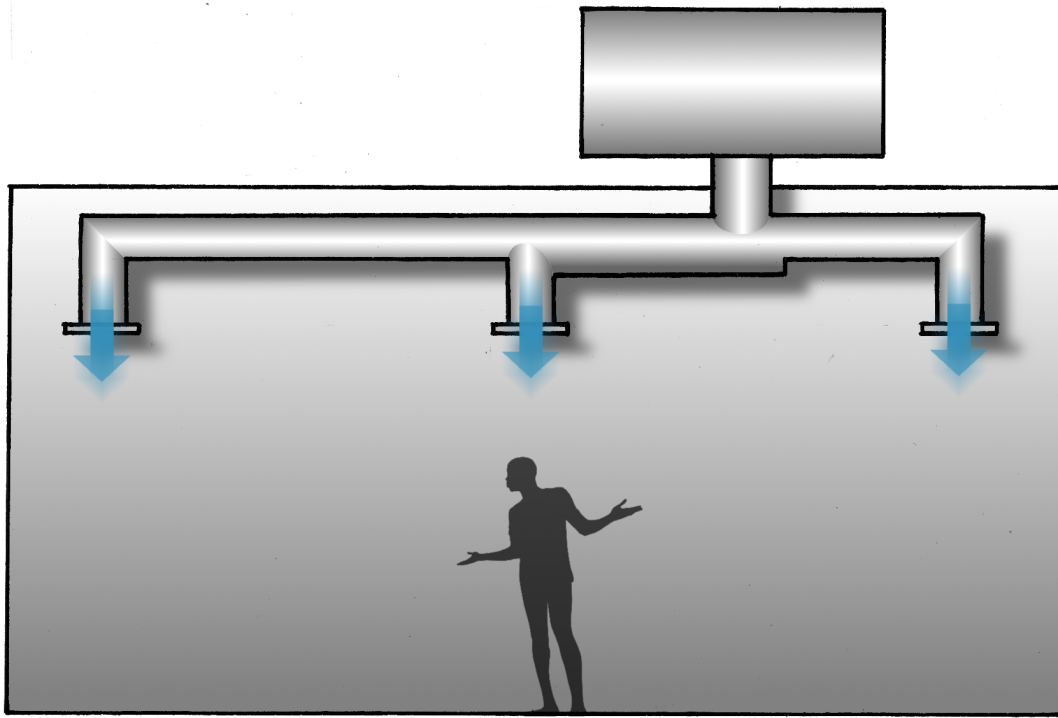


Figure 112: Rooftop packaged unit installed externally

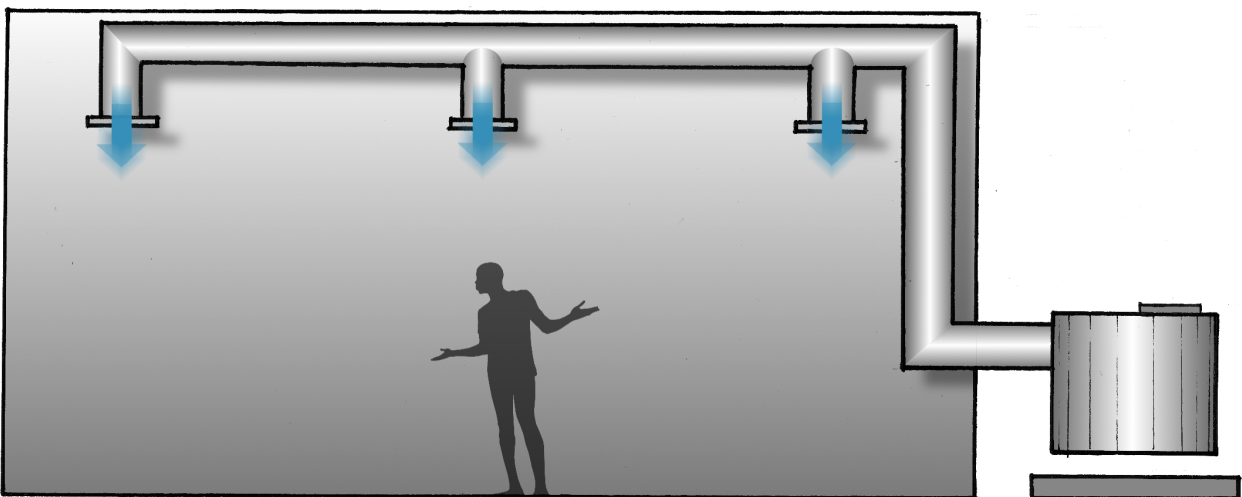
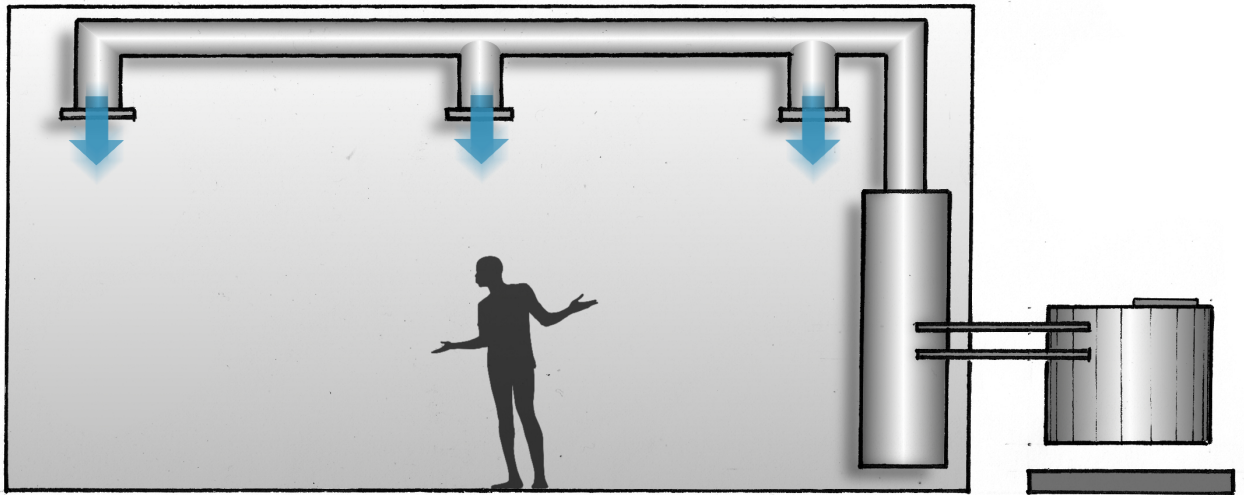


Figure 113: Wall packaged unit installed externally

### ***Split-packaged systems***

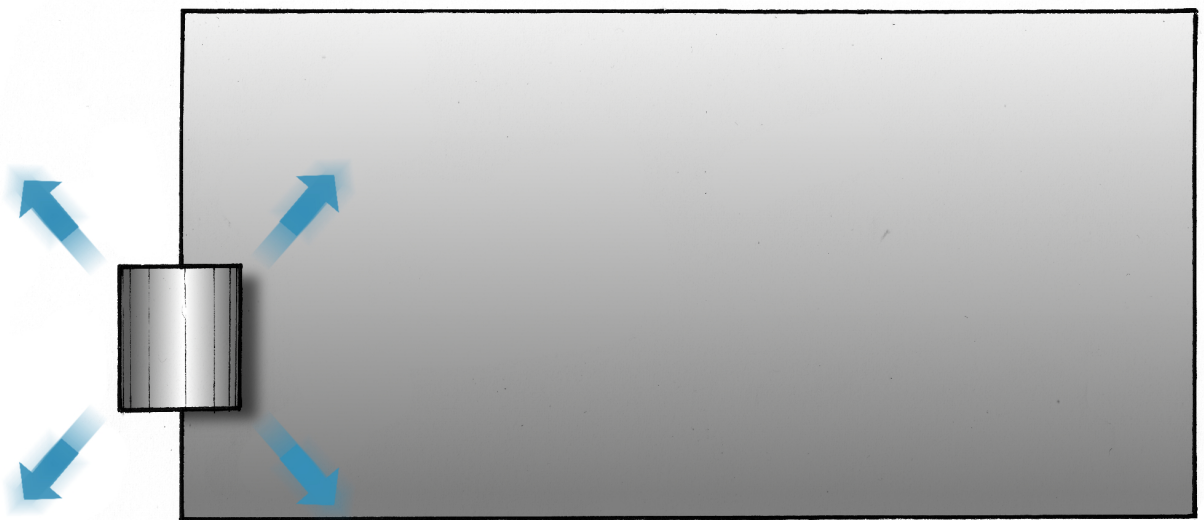
consist of an **outdoor unit** made up of the **compressor** and **condenser** and an **indoor unit** that incorporates the **cooling** and **heating coils** and the **circulating fan**. The outdoor and the indoor units are connected by **insulated refrigerant tubing** and **control wiring**.



**Figure 114: Split-packaged system**

***Small terminal units***

may be mounted directly below a window or in openings cut into the exterior wall of each served space. Window-mounted units are usually used for retrofitting existing buildings. These units are used for smaller spaces and are mounted at a high level in openings in the walls. It is usually sized 600mm wide x 450mm high with power ratings of between 1 – 2<sup>1</sup>/<sub>2</sub> HP. The usual arrangement is for all the component parts – compressor, condenser and evaporator to be mounted as a single unit.



**Figure 115: Small terminal air-conditioning systems units**

**AIR-CONDITIONING SYSTEMS**

In regions not requiring space heating such as tropical regions, the air-conditioning systems are usually only for cooling and ventilating spaces. It is usually in form of the central air-conditioning systems with extensive ductwork, split packaged systems and small terminal units.

# AIR DISTRIBUTION OUTLETS

The location of air distribution outlets depends on the size and proportion of the space, its areas of heat loss or gain, its wall, ceiling or floor construction and its finish. Air supply outlets should be located to distribute warm or cool air to the occupied spaces comfortably, without noticeable drafts and without stratification.

Air for heating, cooling and ventilating is supplied through:

## 1. Diffusers

Diffusers have slats at different angles for deflecting warm or conditioned air from an outlet in various directions. Diffusers may be round, square or linear or in form of perforated ceiling tiles.

**Ceiling diffusers** discharge low-velocity air in a spreading pattern.

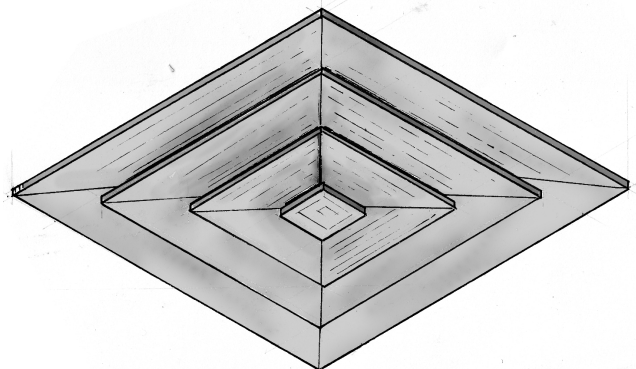
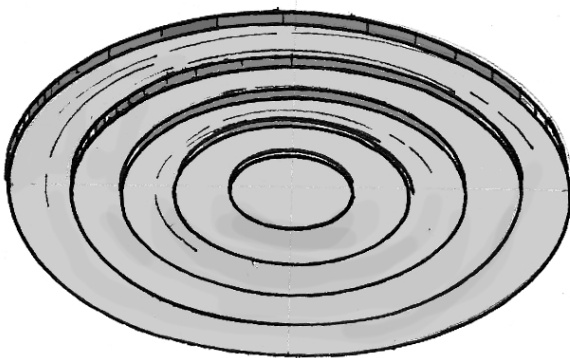


Figure 116: Ceiling Diffusers

## 2. Registers

Registers control the flow of warm or conditioned air from an outlet, composed of a grill with a number of parallel blades that may be adjusted so as to overlap and close the opening.

**Floor registers** are used to control heat loss and condensation along exterior windows and walls.

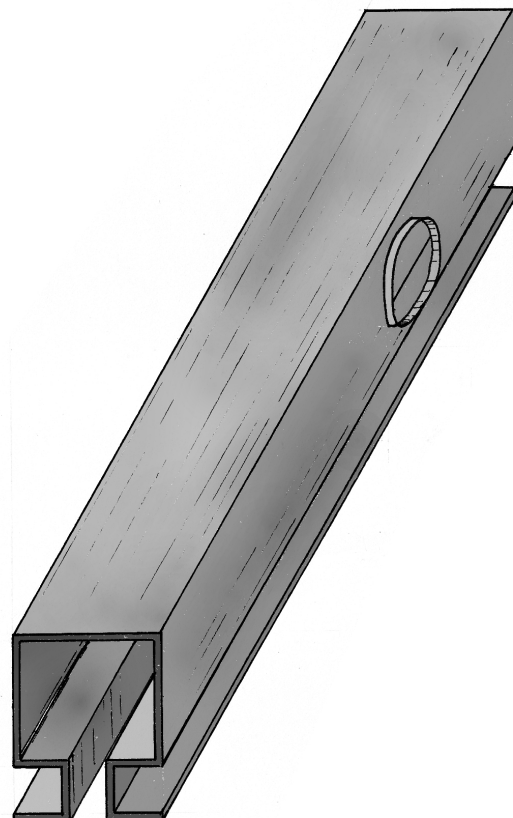
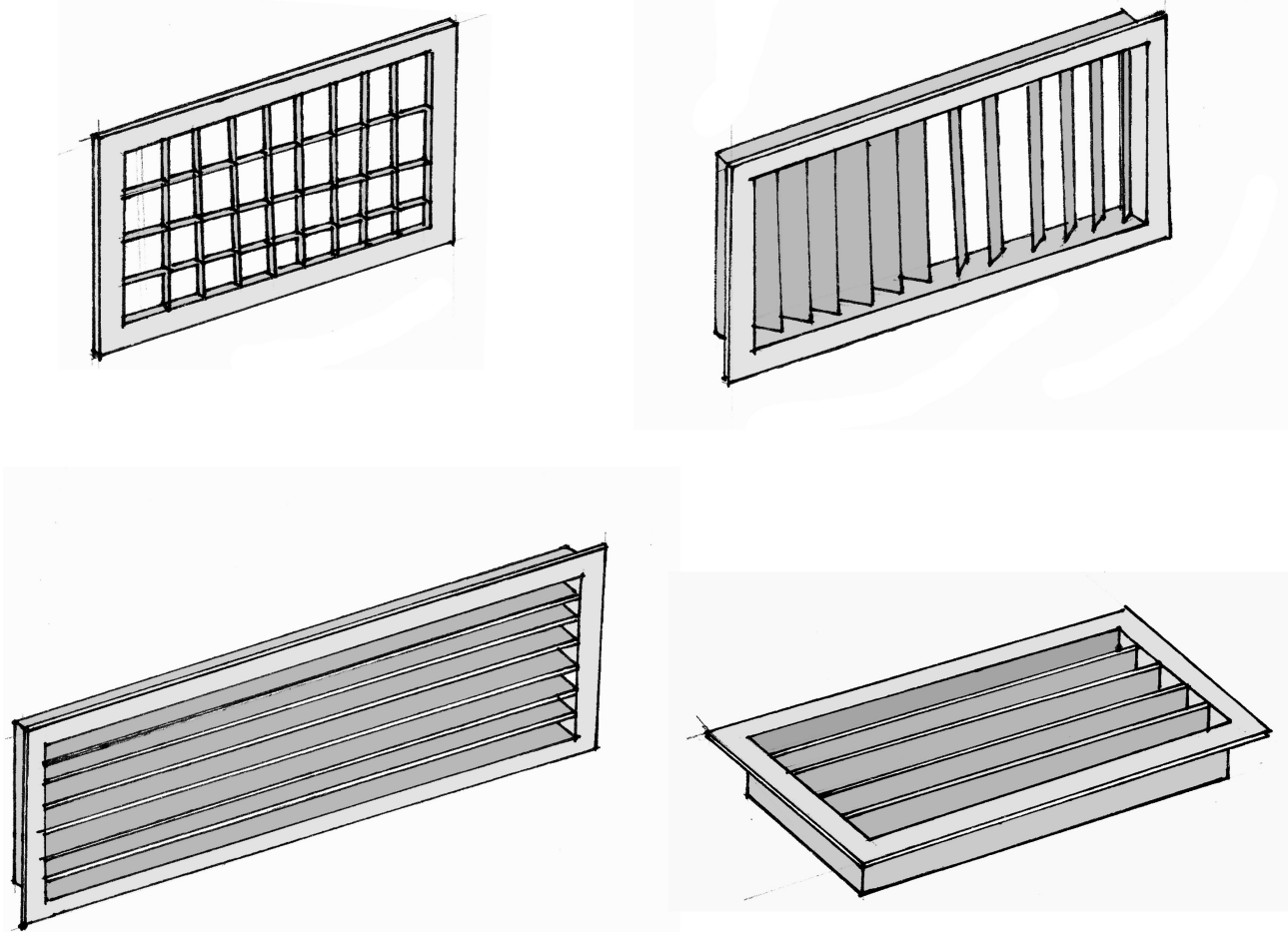


Figure 117: Register



**Figure 118: Air grill, wall mounted and floor registers**

**References:**

1. Ching, Francis D K & Adams, Cassandra  
**Building Construction Illustrated, 3rd Edition**  
Wiley: New York, 2001
2. Hall, F and Greeno, R  
Building Services Handbook, 5<sup>th</sup> Edition  
Butterworth-Heinemann: Oxford, 2009

# FIRE PROTECTION OF BUILDINGS

Although fire in buildings can be avoided, they nevertheless occur.

The following can cause fire:

- Human error
- Arson
- Faulty electrical equipment
- Poor maintenance of heating equipment and
- Natural causes such as lightning

## Characteristics of Materials Used for Fire Protection

Materials used to provide fire protection for a building's construction must:

- Be inflammable
- Withstand high temperatures without disintegrating.
- Be low conductors of heat.

In general, load bearing external walls of normal materials satisfying the conditions of strength, stability and weather resistance will usually provide sufficient **fire protection**.

## Materials commonly used to provide Fire Protection

Materials used include:

- Concrete
- Gypsum board and plaster
- Mineral fibre products
- Wood may be chemically treated to reduce its flammability.

## Minimum Steps to be taken for Fire Protection in Buildings:

These include:

1. **Limit potential fire loads** with respect to both combustibility and ability to generate smoke and toxic gasses.
2. Provide means for **prompt detection** of fire with warnings to occupants who may be affected and notification of the presence of fire to fire fighters.
3. **Communication of instructions** to occupants as to procedures to adopt for safety, such as staying place, proceeding to a designated refuge area, or evacuating the building.
4. Provide means for **early extinguishments** of any fire that may occur **primarily** by automatic **sprinklers** but also by trained fire fighters.

5. Make **available also for fire fighting** an adequate water supply, appropriate chemicals, adequate – sized piping, and conveniently located valves on the piping, hoses, pumps and other equipment necessary.
6. **Prevent spread of fire** from building to building either through adequate separation or by enclosure of the building with incombustible materials.
7. Partition the interior of the building with **fire barriers**, or division to confine the fire to a limited space.
8. Enclose with **protective materials** structural components that may be damaged by fire (Fire proofing).
9. Provide refuge areas for occupants and **safe evacuation** routes to outdoors. Fire codes specify the required means of exits for a building's occupants in case of fire. Fire exits must provide a protected means of evacuation from the building to safe discharge points externally. Typical fire-rating requirements for exits enclosures (floors, wall, ceiling and stair construction) are:-
  - One-hour fire rating for buildings up to 3 floors in height.
  - Two-hour fire rating for buildings 4 or more floors in height.
10. Provide means for **removal of heat** and smoke from the building as rapidly as possible without exposing occupants to these hazards, with the air-conditioning system, if one is present, assisting the removal by venting the building and by **pressuring smoke proof towers**, elevator shafts and other exits.
11. For large buildings, install standby **generating equipment** for operation in emergencies of electrical systems and elevators.

# Devices used for Fire Protection

These include:

## 1. FIRE DETECTORS

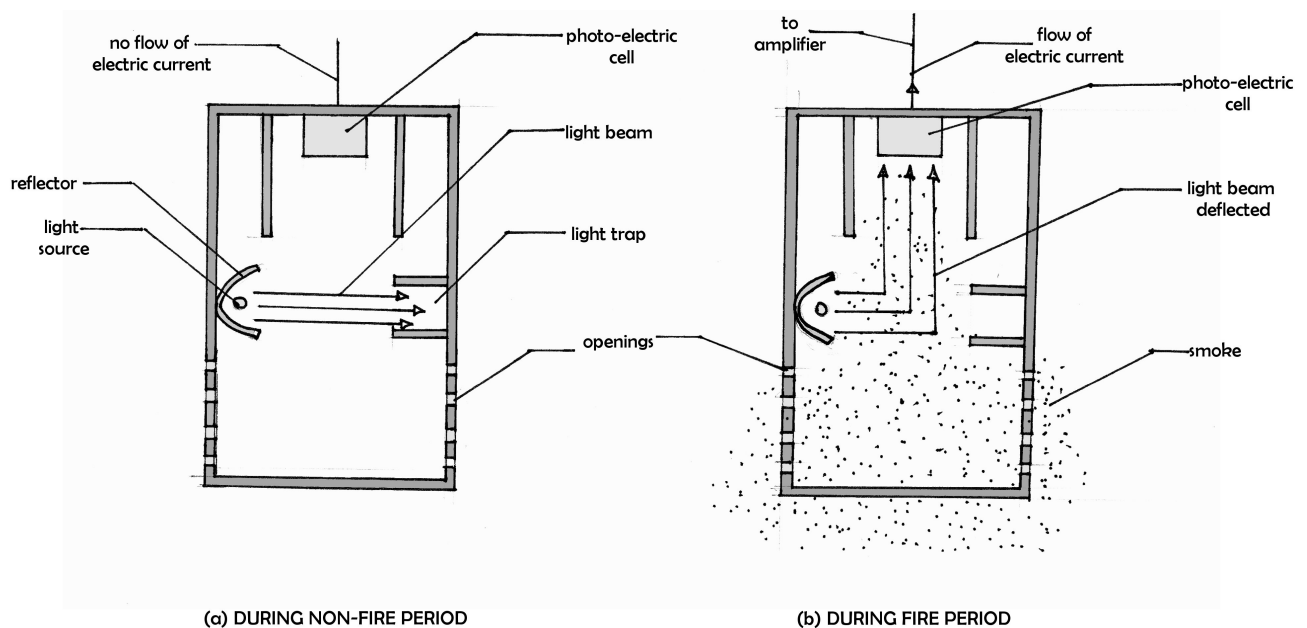
An early warning device that can detect smoke and fire could significantly reduce the number of human casualties. These can be by:

### **Smoke Detectors:**

Detectors are available in two basic types. Each can be powered by a simple battery cell or by mains electricity. The latter will normally have battery back up if the mains supply fails. Types of smoke detectors include:

**Ionization Smoke Detector:** This is an inexpensive device, sensitive to tiny smoke particles and fast burning fires. Positive and negative charged plate electrodes attract opposing charged ions such that a small electric current is produced. If smoke enters the unit, particles attach to the ions slowing their movement. The reduction in current flow activates an electronic relay circuit to operate an **alarm**.

**Light Scattering or Optical Smoke Detector:** More expensive but more sensitive in slow burning and smouldering fire produced by burning fabrics or upholstery and overheating PVC wiring. A light beam projects onto a light trap into which it is absorbed. When smoke enters the detector, some of the light beam is deflected upwards onto a photoelectric cell. This light energizes the cell to produce an electric current, which activates the **alarm relay**.



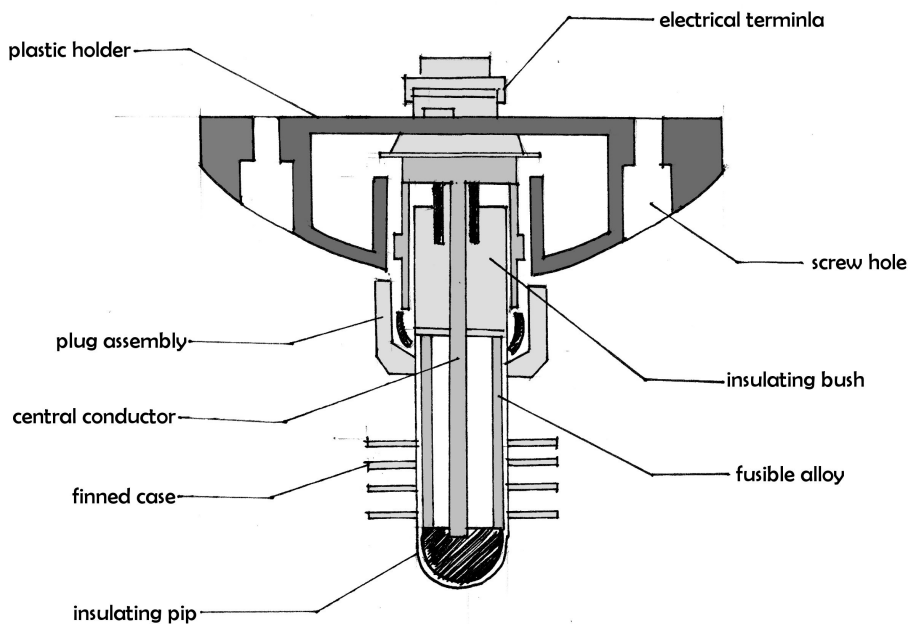
**Figure 119: Light Scattering or Optical Smoke Detector**

**Combined Smoke Detector:** This is a unit containing both ionization and optical detectors.

**Heat Detectors:**

These are used where smoking is permitted and in other situations where a smoke detector could be inadvertently activated by process work in the building, e.g. a factory. Detectors are to identify fire in an advanced stage, so their response time is longer than smoke detectors. These include:

**Fusible Heat Detector:** It has an alloy sensor with a thin walled casing fitted with heat collecting fins at its lower end. An electrical conductor passes through the centre. The casing has a fusible alloy lining and this functions as a second conductor. Heat melts the lining at a pre-determined temperature causing it to contact the central conductor and complete an alarm relay electrical circuit.



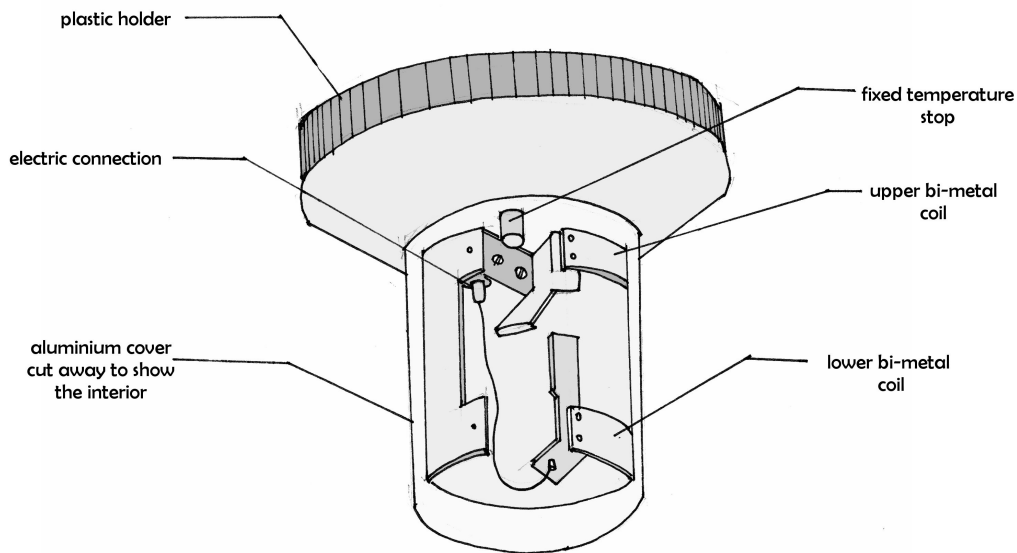
FUSIBLE ALLOY HEAT DETECTOR

Temperature ratings  
57 to 102 degree celcius

Protected area approximately  
36 m2

**Figure 120: Fusible Alloy Heat Detector**

**Bi-metallic coil type:** Heat passes through the cover to the bi-metal coils. Initially the lower coil receives greater heat than the upper coil. The lower coil responds by making contact with the upper coil to complete an electrical alarm circuit.



BI-METAL COIL HEAT DETECTOR

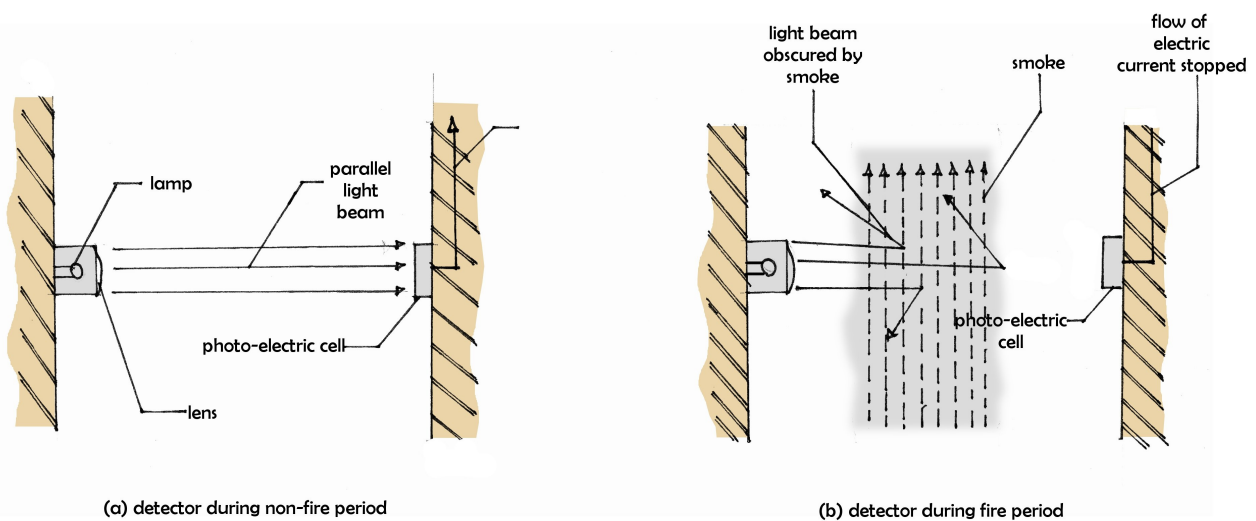
Temperature ratings  
57 to 100 degree celcius

Protected area  
approximately 50m<sup>2</sup>

Figure 121: Bi-Metal Coil Heat Detector

**Light Obscuring Detector:**

A beam of light is projected across the protected area close to the ceiling. The light falls onto a photoelectric cell, which produces a small electrical current for amplification and application to an alarm circuit. Smoke rising from a fire passes through the light beam to obscure and interrupt the amount of light falling on the photoelectric cell. The flow of electric current from the cell reduces sufficiently to activate an alarm relay. It is a variation of the light-scatter type detector.



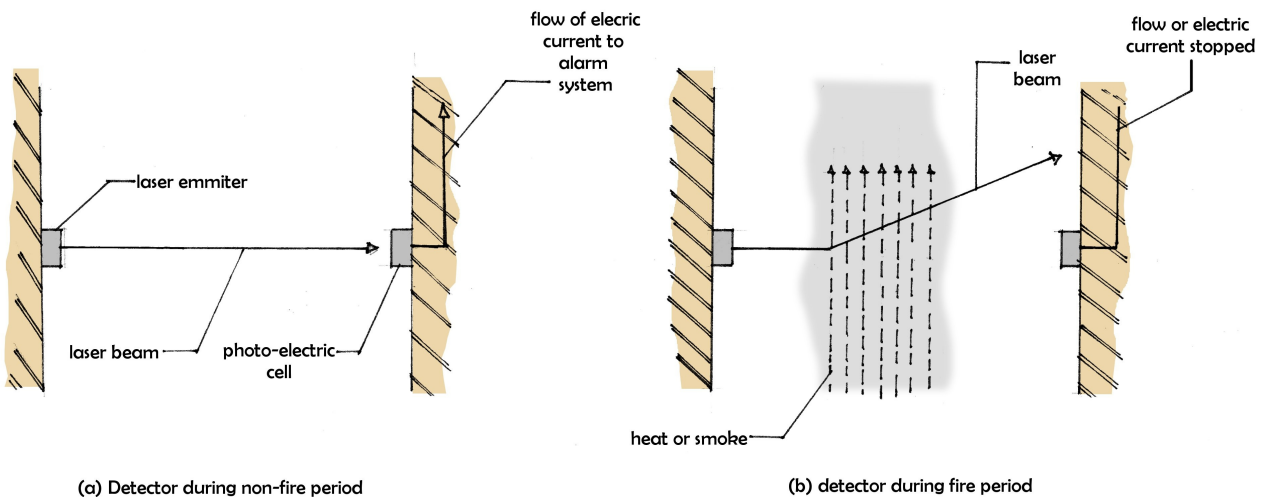
LIGHT OBSCURING DETECTOR

Note: The light beam will operate over a distance up to 15m.

Figure 122: Light Obscuring Detector

### **Laser beam:**

This is a band of light, which can be visible or infrared projected onto a photoelectric cell. It does not fan out or diffuse as it travels through an uninterrupted atmosphere. The beam can operate effectively at distances up to 100m. If fire occurs, smoke and heat rises and the pulsating beam is deflected away from the cell or reduced in intensity. As the cell is de-energised, this triggers off an alarm relay.

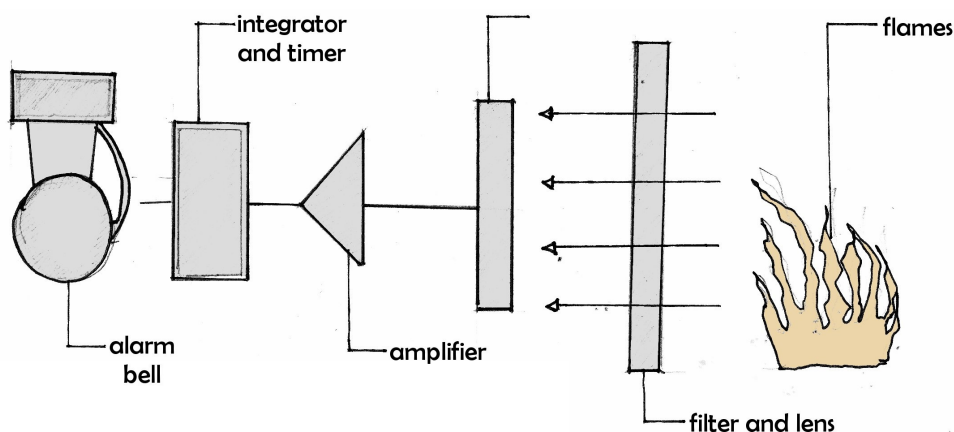


**Figure 123: Laser Beam Detector**

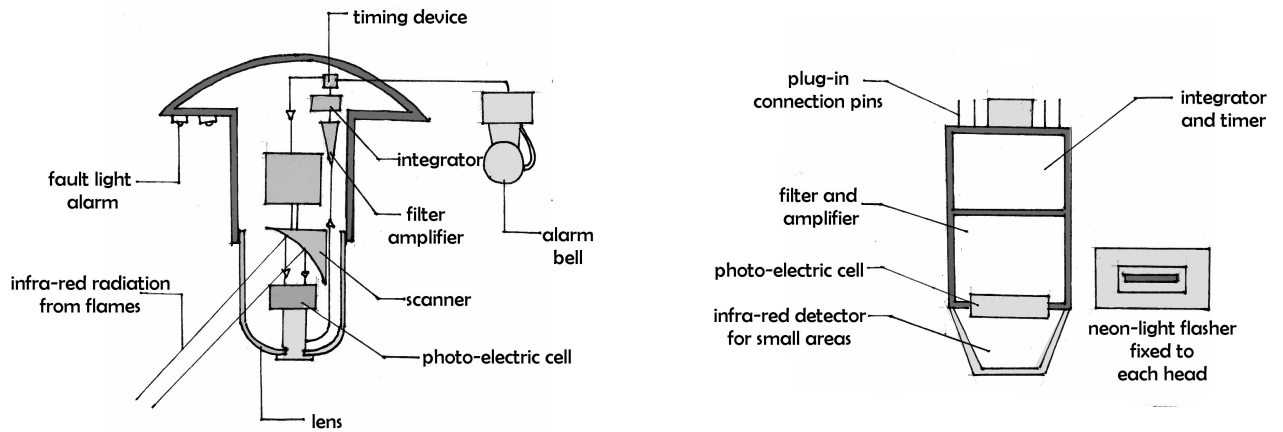
### **Radiation Fire Detectors:**

In addition to producing hot gasses, fire also releases **radiant energy**, which travels in waves from the fire in the form of visible light, infrared and ultra-violet radiation. Types of Radiation fire detectors include:

- i. **Infrared detector:** This has a sensitive **filter and lens** to only allow infrared radiation to fall on a **photoelectric cell**. The **amplifier** is used to increase the current from the photoelectric cell. To reduce false alarms, a **timing device** operates the **alarm** a few seconds after the outbreak of fire.



**Figure 124: Components of an Infrared Detector**



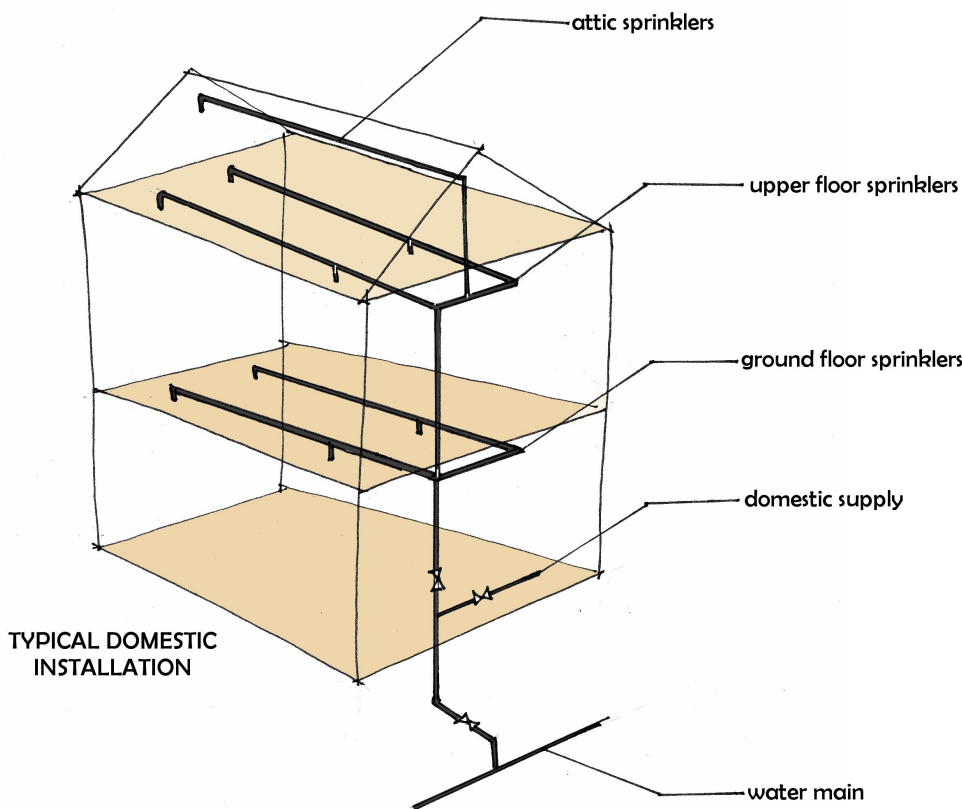
**Figure 125: Infrared Detector for Large (Left) and Small Areas**

- ii. **Ultra-violet detector:** These detectors have a gas filled bulb, which reacts with ultra-violet radiation. When the bulb receives radiant energy, the gas is ionized to produce an electric current. When this current exceeds the set limit of the amplifier the alarm circuit closes to operate the alarm system.

## 2. SPRINKLERS

Sprinklers provide an automatic spray dedicated to the area of fire outbreak. Sprinkler heads have temperature sensitive elements that respond

immediately to heat, discharging the contents of the water main to which they are attached. In addition to a rapid response, which reduces and isolates fire damage, sprinklers use less water to control a fire than the fire fighting service, therefore preventing further damage from excess water.



**Figure 126: Domestic Sprinkler Installation**

The simplest application is to attach and suspend sprinkler heads from a water main fixed at ceiling level. A typical domestic sprinkler installation is shown in Figure 103.

The specification of a sprinkler system will depend on the purpose intended for a building, its content, function, occupancy, size and disposition of rooms. Sprinkler systems in use include:

***The Wet Sprinkler System:***

It has the simplest and most widely used application. The pipe-work is permanently pressure charged with water. It is only suitable in premises where there is no risk of the water in the pipe-work freezing.

The sprinkler heads are usually attached to the underside of the range pipes. When a sprinkler head is fractured, water is immediately dispersed. The maximum number of sprinklers on one control valve is 1000.

***The Dry Sprinkler System:***

This is an installation pipe-work that is permanently charged with compressed air at about 200 kPa. A small compressor automatically replenishes any loss of pressure. It is applied to unheated premises such as warehousing, where winter temperatures could drop below zero.

The sprinkler heads are fitted above the range pipes, which are slightly inclined to allow the system to be fully drained. When a sprinkler head is fractured, the compressed air escapes to allow the retained water to flow to the broken sprinkler head. The maximum number of sprinklers on one control valve is 250, but this may increase to 500 if the air controls include an accelerator – an automatic booster pump –, which can be used to rapidly exhaust the air and improve water flow.

***The Alternative Wet and Dry System:***

This is essentially a wet system but due to the slightly slower response time as air precedes water on discharge, the pipe-work is charged with water for most of the year and only air-charged in winter. The maximum number of sprinklers is the same as a dry system.

**Types of Sprinkler Head:**

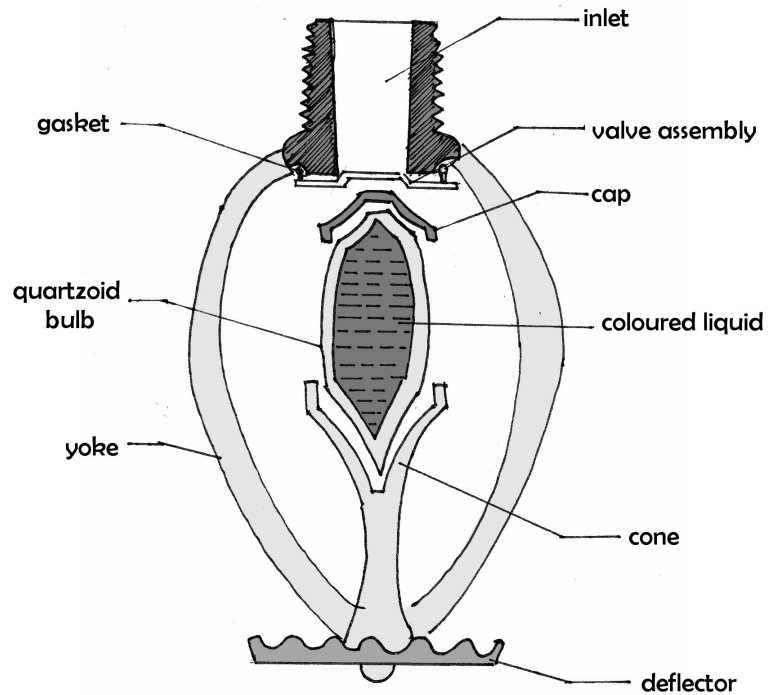
These include: -

***Quartzoid Bulb-Type Head –***

A glass tube is used to retain a water valve on its seating. The bulb or tube contains a coloured volatile fluid, which when heated to a specific temperature expands to shatter the glass and open the valve. Water

flows on to a deflector, dispersing as a spray over the source of fire. Operating temperature varies with a colour-coded liquid:

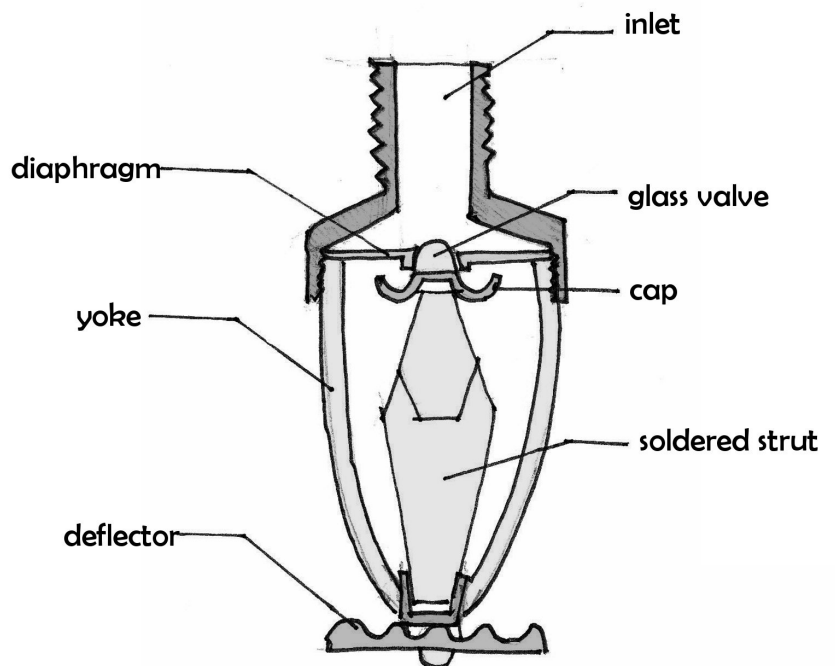
Colour	Operating Temperature
Orange	57°C
Red	68°C
Yellow	79°C
Green	93°C
Blue	141°C
Mauve	182°C
Black	204 or 260°C



**Figure 127: Quartzoid Bulb-Type Head and Colour Coding**

***Fusible Soldered Strut-Type Head:***

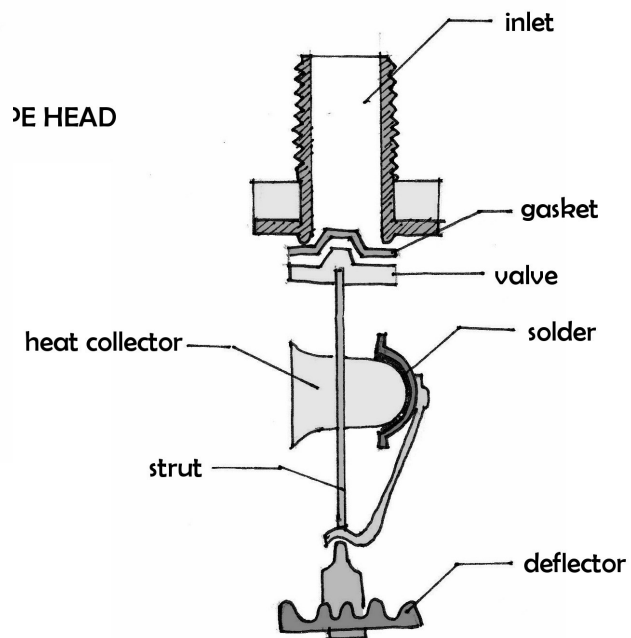
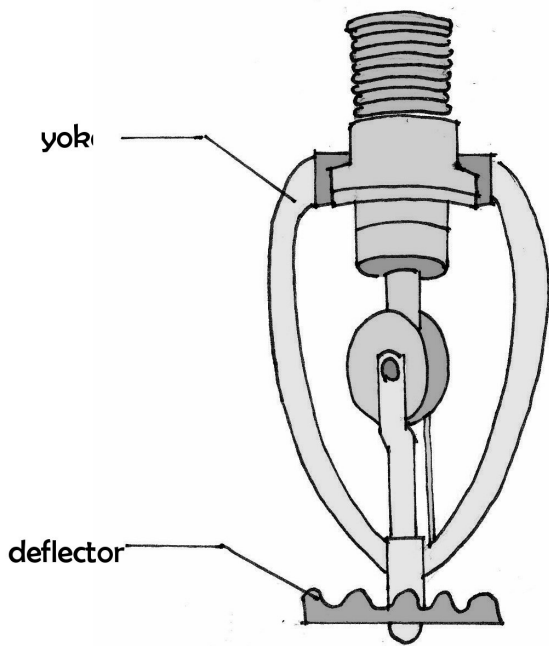
It has two metal struts soldered together to have a water valve in place. Ranges of solder melting temperatures are available to suit various applications. Under heat, the struts part to allow the valve part and discharge water on the fire.



**Figure 128: Fusible Soldered Strut-Type Head**

### **Duraspeed Soldered-Type Head:**

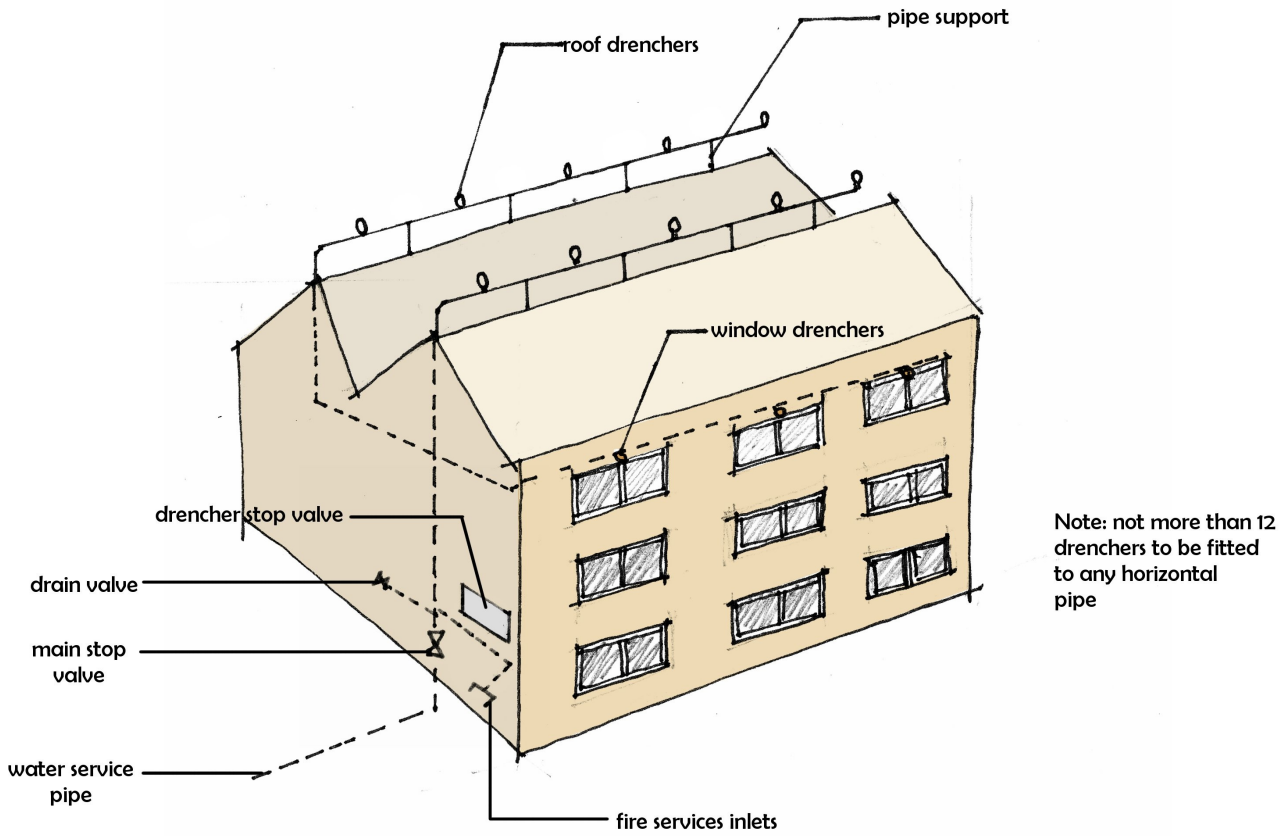
It contains a heat collector which has a soldered cap attached. When heat melts the solder, the cap falls away to displace a strut allowing the head to open. It is also produced in a range of temperatures.



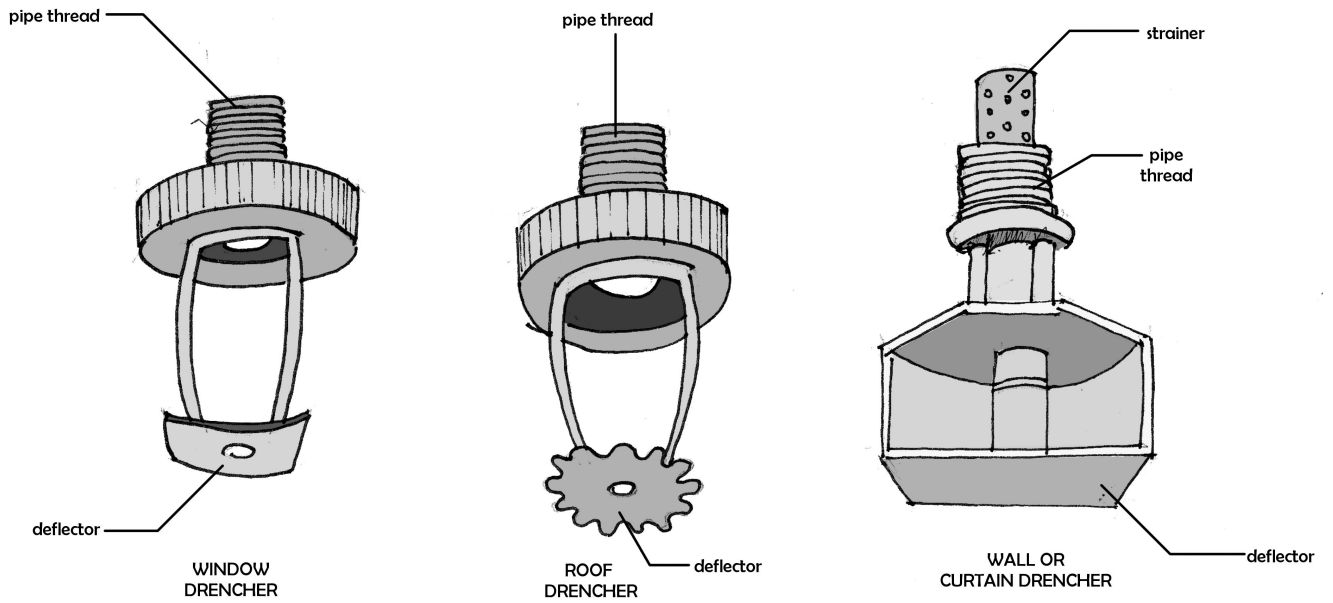
**Figure 129: Duraspeed Soldered Type Head**

## **3. DRENCHERS**

A drencher fire control system provides a discharge of water over roofs, walls and windows to prevent fire spreading from or to adjacent buildings. Automatic drenchers are similar in operating principle to individual quartzoid bulb sprinkler heads. The number of drencher nozzles per pipe is similar to the arrangements for conventional sprinkler installations. A 25mm i.d. pipe can normally supply two drenchers; a 50mm i.d. pipe can supply ten drenchers, a 75mm i.d. pipe 36 drenchers and a 150mm i.d. pipe over 100 drenchers. An example of its application is in theaters, where the drenchers may be fitted above the safety curtain.



**Figure 130: Drencher Installation**



**Figure 131: Window, Roof and Wall Drencher**

## 4. HOSE REELS

Hose reels are fire-fighting equipment for use as a first-aid measure by building occupants. Hose reels should be located where users are least likely to be endangered by the fire, i.e. the staircase landing. The hose most distant from the source of water should be capable of discharging 0.4l/s at a 6m distance from the nozzle.

Fixed or swinging hose reels are located in wall recesses at a height of about 1m above floor level. They are supplied by a 25mm i.d. pipe to 20 or 25mm i.d. reinforced non-kink rubber hose in lengths up to 45m to cover 800m<sup>2</sup> of floor area per installation.

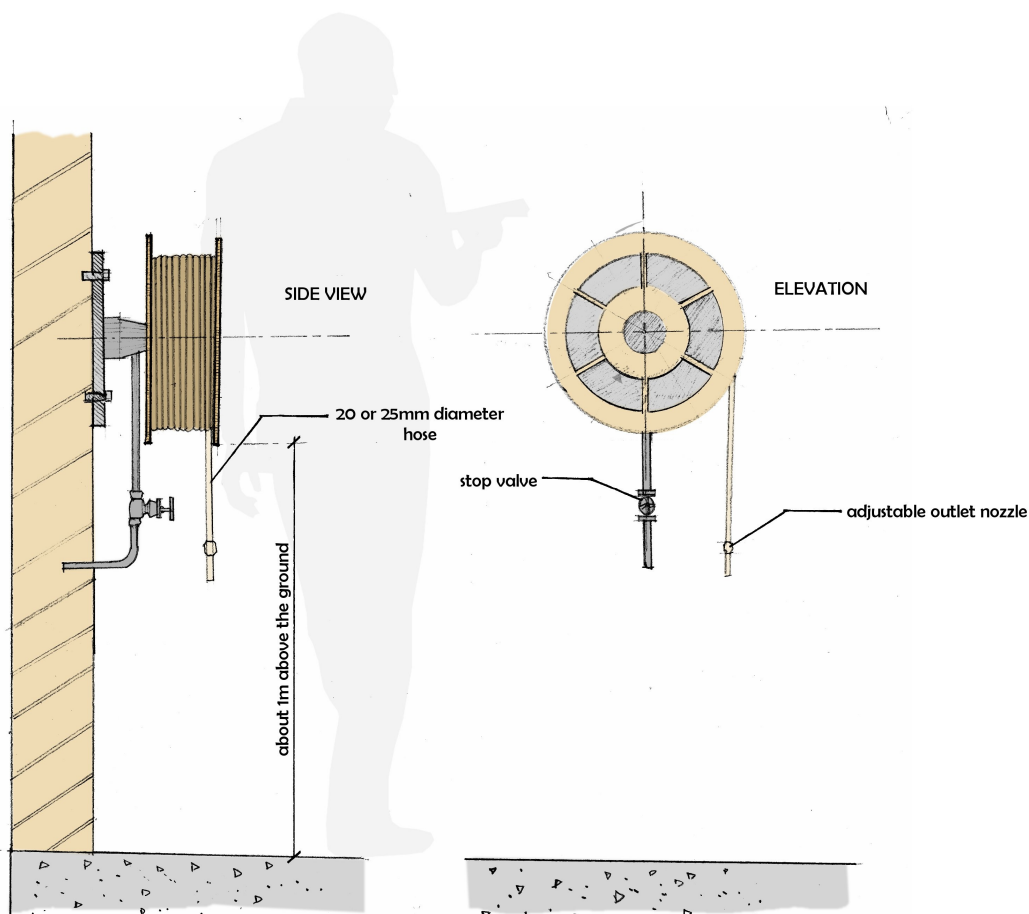


Figure 132: Hose Reel Installation

## 5. GAS EXTINGUISHING SYSTEMS

The majority of gas extinguishing systems are either halon 1301 or carbon dioxide.

### ***Halon and Halon Substitutes:***

These are electrically non-conductive and therefore safe to use where personnel remain in an area of gas discharge. They are also more

effective than carbon dioxide, being five times the density of air, whilst carbon-dioxide is only one-and-a-half times. Unfortunately, halon or BCF gases are a hazard to the environment, by contributing significantly to the depleting effect of the ozone layer. Therefore, new installations contain halon substitutes. These include inergen and argonite both mixtures of nitrogen and argon.

In principle the systems are suitable where there is a high density of equipment, e.g. tape libraries and computer suites where an alternative wet system would be considered too damaging. Gas is stored in spherical steel containers, which can be secured in a ceiling or floor void or against a wall. When activated by smoke or heat, detectors immediately open valves on the extinguishers to flood the protected area with a colourless and odourless gas.

### ***Carbon dioxide:***

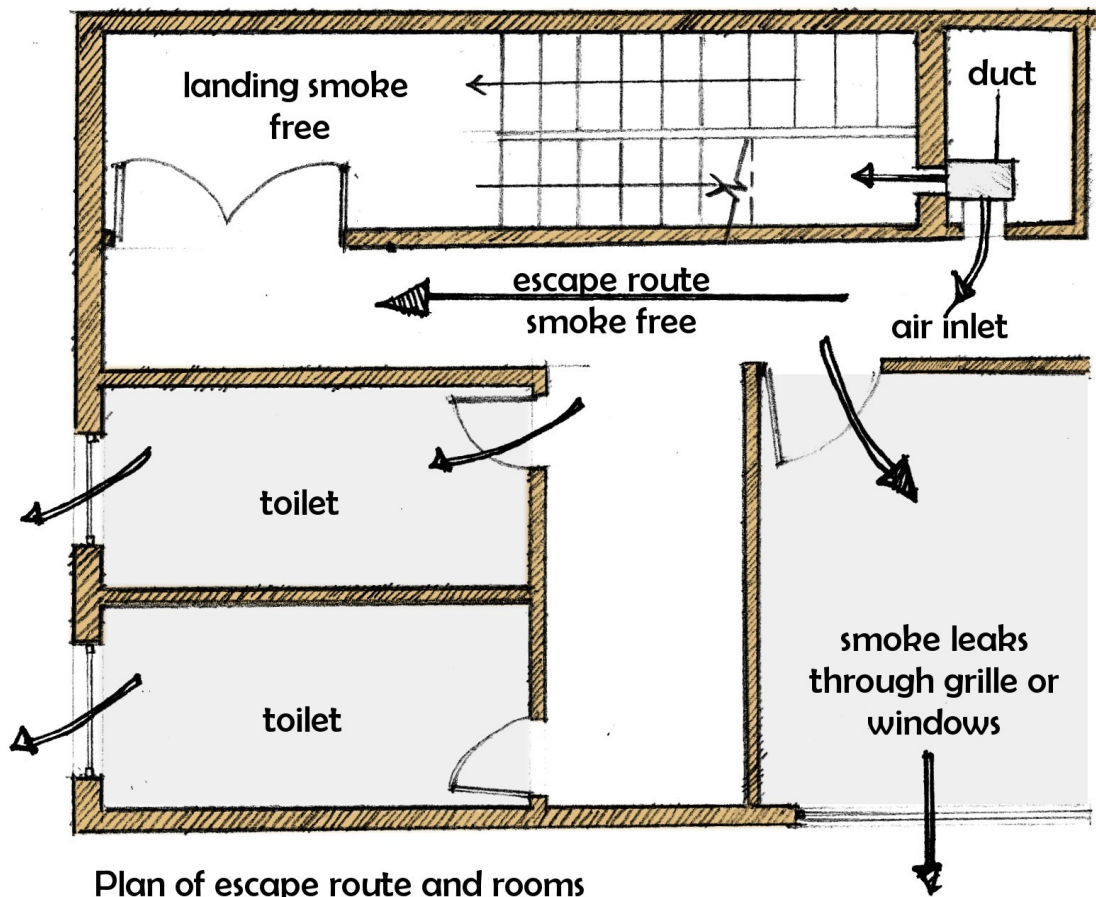
This is an alternative to halon as a dry gas extinguisher. It has been used as an extinguishing agent for a considerable time, particularly in **portable fire extinguishers**. As the gas is dry and non-conductive it is ideal for containing fires from electrical equipment, in addition to textiles, machinery, petroleum and oil fires. Carbon dioxide is heavier than air and can flow around obstacles to effectively reduce the oxygen content of air from its usual 21% to about 15%. This considerably reduces an important component of the combustion process.

Carbon dioxide is potentially **harzardous** to personnel; therefore it is important that the system is automatically locked off when the protected area is occupied. Air tightness of a protected room is essential for the success of this system as total flooding relies on gas containment by peripheral means.

## **6. PRESSURIZATION OF ESCAPE ROUTES**

In multi-storey buildings, stairways and lobbies may be air pressurized to clear smoke and provide an unimpeded escape route. The air pressurization is usually between 25 and 50Pa depending on the building height and degree of exposure. This pressure is insignificant for movement of people. Therefore, a pressurization plant can run fully during hours of occupancy as part of a building's ventilation system.

It is essential to provide openings so that smoke is displaced from the escape routes to the outside air. This can be through purpose made grilles or window vents. Pressurization would help to limit entry of rain and draughts at external openings.



Plan of escape route and rooms

Figure 133: Air Pressured Stairway

## 7. SMOKE EXTRACTION AND VENTILATION

Automatic fire ventilation is designed to remove heat, smoke and toxic gasses from buildings. Fire vents are fitted at the highest part of a roof section as is practical. Heat and smoke rise within the roof section above the fire outbreak. At a pre-determined temperature, usually 70°C, a fusible link breaks and opens the ventilator above the fire. Heat and smoke escape to reduce the amount of smoke logging within the building. This will aid people in their escape and assist the fire fighters to see and promptly tackle the source of fire. The heat removed prevents risk of an explosion, flashover and distortion to the structural steel frame.

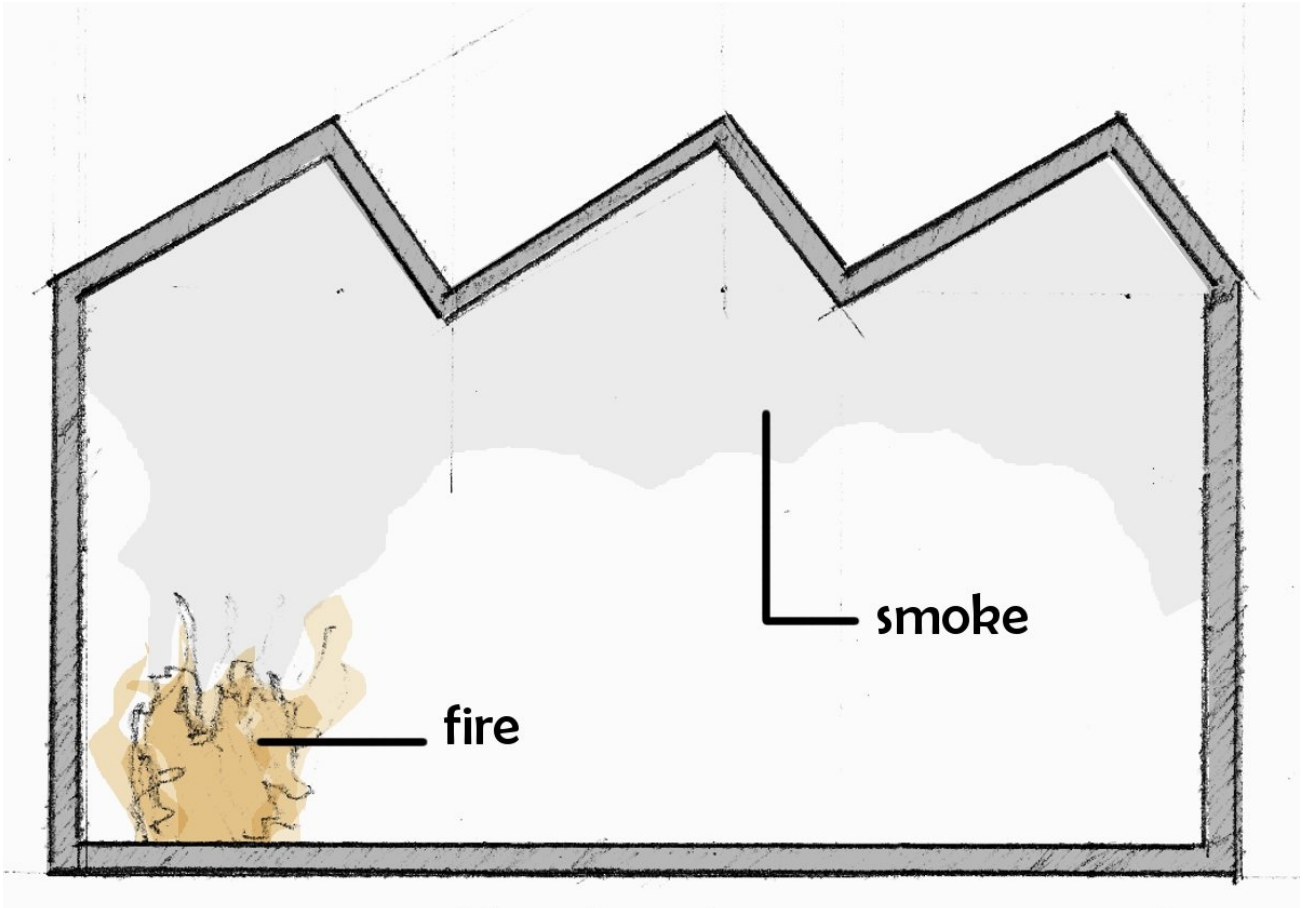


Figure 134: Fire in unvented building showing unrestricted spread of smoke

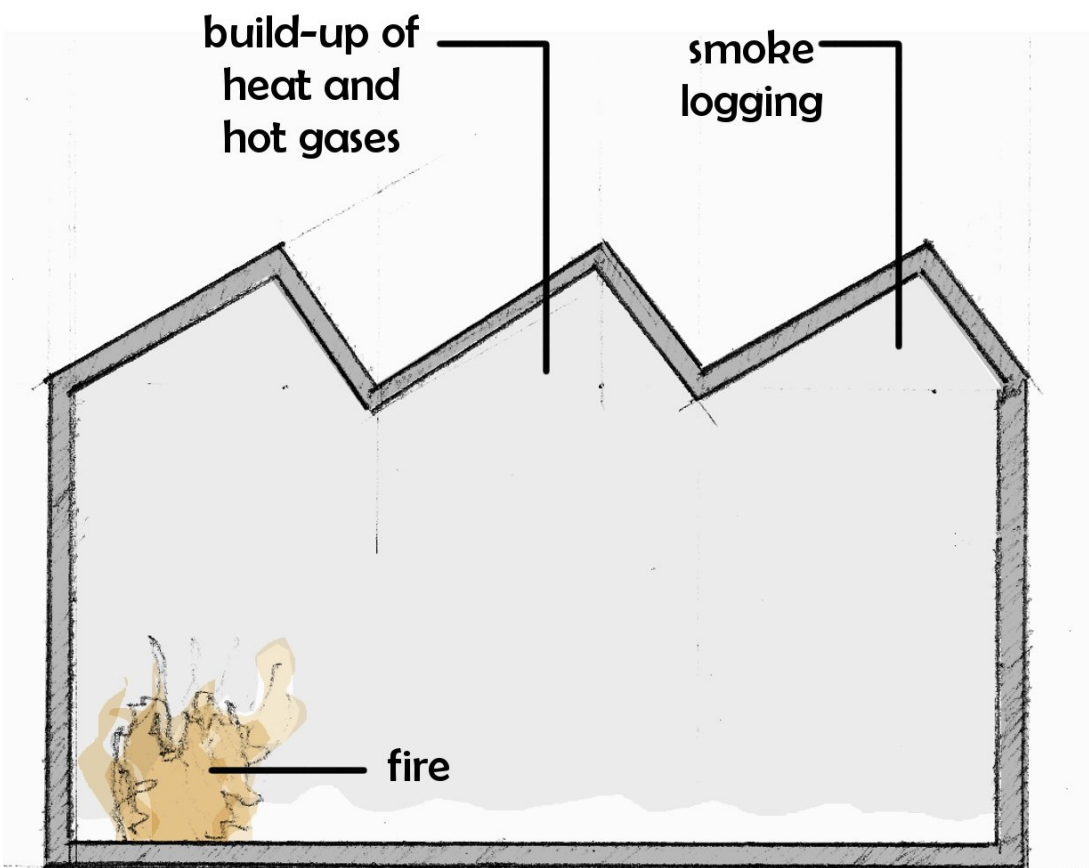


Figure 135: Fire in unvented building showing ultimate smoke logging

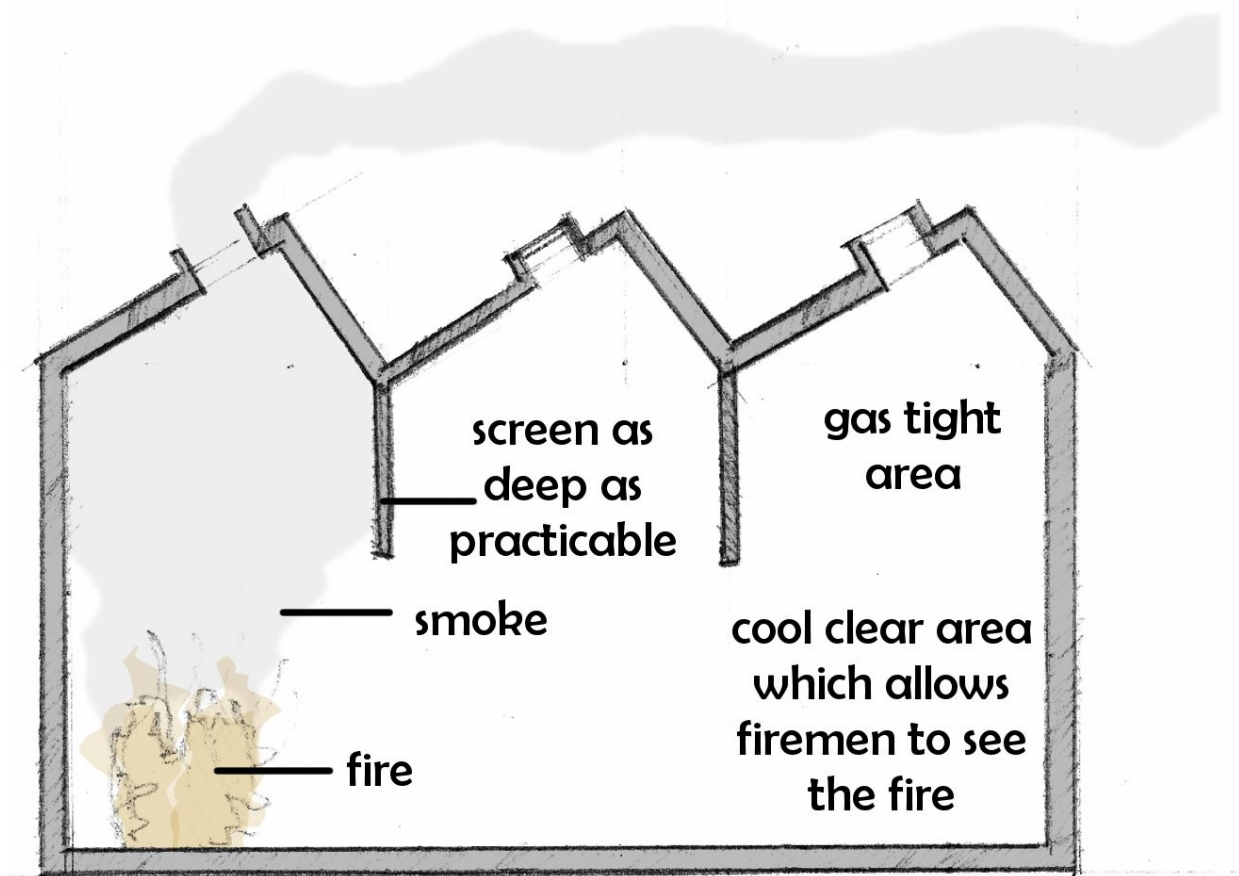


Figure 136: Fire in vented building showing restricted spread of smoke

## References

1. Hall, F and Greeno, R  
Building Services Handbook, 5<sup>th</sup> Edition  
Butterworth-Heinemann: Oxford, 2009
2. Merritt (1985)