

The copyright of this thesis vests in the author. No quotation from it or information derived from it is to be published without full acknowledgement of the source. The thesis is to be used for private study or non-commercial research purposes only.

Published by the University of Cape Town (UCT) in terms of the non-exclusive license granted to UCT by the author.

16

**The lateral load carrying capacity of wall ties used in cavity wall construction in the Western Cape: A comparison between the Butterfly-type wire tie and the Crimped-type wire tie.**

I. Ebrahim

30 August 2002

Thesis prepared in partial fulfilment of the requirements for the degree of Master of Science in Civil Engineering in the Department of Civil Engineering at the University of Cape Town

Supervisor: Professor A. Zingoni

## **ACKNOWLEDGMENTS**

I would like to thank the following people for their time and effort they have consumed in assisting me with this thesis:

Professor Zingoni of the University of Cape Town, for his guidance and advice. Salie Lodewyk who built the couplets. Nur and Eike, senior laboratory assistants at UCT who kindly helped to set up the Zwick Testing machine. Mogahmat Noor Khan for proof-reading.

Lastly, I would like to acknowledge contributions made by my colleagues in the structural engineering field. These contributions have been in the form of comments, (helpful) criticism and discussions.

## SYNOPSIS

The aim of the testing was to compare the relative positives and negatives of the Butterfly Tie and the Crimped Tie as regards to water transfer, tensile and compression strengths based on the Australian Code (AS 2699-1984) requirements as it is more comprehensive.

The reason was because the Butterfly Tie has been promoted in cavity wall construction in South Africa for a number of reasons, for example:

- NHBC (National Home Builders Registration Council) compels contractors to use the Butterfly Tie
- SABS 28:1986 and SABS 0164-1:1980 also compel the use of Butterfly Tie, even though there is an anomalous statement in the specifications

Another reason was because the use of the Crimped Tie was not being promoted in cavity wall construction in South Africa mainly because of a lack of information regarding characteristic strength and its resistance to water transfers. The following tests, based on the Australian Code, which is more stringent than the South African Codes were then carried out on the Butterfly Tie and the Crimped Tie:

- Tests for water transfer
- Tests for compression and tensile strengths using couplets
- Tests for compression and tensile strengths using ties only

Although the testing showed that the Butterfly Tie and the Crimped Tie fulfilled the requirements of the Australian Code, there were negative aspects relating to the Butterfly Tie.

It is recommended that serious considerations be given by the South African Bureau of Standards to include the Crimped Tie in its Code of Practice for Cavity Walls.

University of Cape Town

# **TABLE OF CONTENTS**

## **CHAPTER 1**

### INTRODUCTION

- 1.1 Historical Background
- 1.2 Application
- 1.3 Survey of Wall Ties used by Contractors
- 1.4 Tie Selection and Types of Wall Ties

## **CHAPTER 2**

### LITERATURE REVIEW

- 2.1 The South African Codes of Practice
- 2.2 The British Standard Institution
- 2.3 The Australian Standard
- 2.4 Characteristic Strength
- 2.5 Characteristic Stiffness
- 2.6 Resistance to Water Transfer
- 2.7 Resistance to Corrosion
- 2.8 Statement of Research
- 2.9 Specific Objectives
- 2.10 Methodology

## **CHAPTER 3**

### EXPERIMENTAL PROGRAMME

- 3.1 Method of Test for Resistance to Water Transfer
- 3.2 Method for Determination of Characteristic Strength
- 3.3 Method for Testing Tie only for Compression and Tension

## **CHAPTER 4**

### **RESULTS OF TESTS AND DISCUSSION**

- 4.1 Results of Tests for Resistance to Water Transfer
- 4.2 Results of Tensile and Compression Testing of Ties  
in Couplets
- 4.3 Results of Compression and Tensile Tests for the Tie  
on its own

## **CHAPTER 5**

### **CONCLUSIONS AND RECOMMENDATIONS**

- 5.1 Conclusions
- 5.2 Recommendations

## **REFERENCES**

## **APPENDICES**

# CHAPTER 1

## INTRODUCTION

### 1.1 HISTORICAL BACKGROUND

According to Ritchie (2000), the term cavity wall is applied to a type of masonry wall construction in which a continuous air space or cavity is provided inside the wall. A cavity wall therefore is actually two walls separated by an air space, but joined by means of metal ties for structural strength, see figure 1 below. They are extensively used in European countries, particularly the United Kingdom, where they have been developed as a means of obtaining protection from penetration of rain through masonry walls and improvement of thermal insulation.

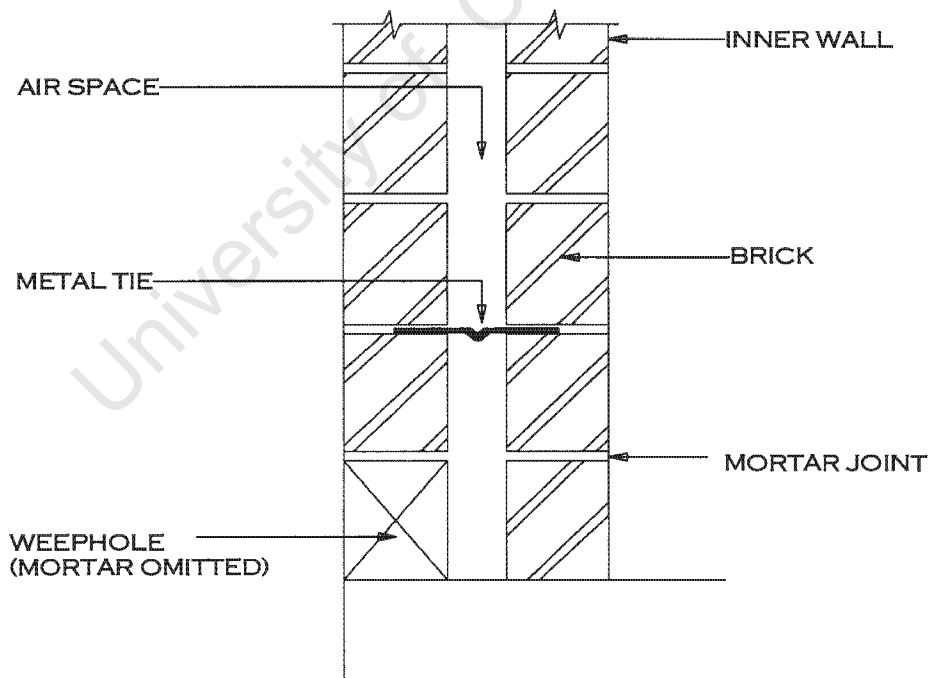

**Figure 1: Typical section through a Cavity Wall**

The use of wall ties in cavity walls is by no means a recent invention. A recent study by de Vekey (1988) showed that the general view is that cavity walls initially appeared in buildings near the coast of England as early as 1709 where the exposure to rain and damp conditions is particularly high. The reason for their introduction was clearly to improve the resistance of the buildings to ingress of rain, and doubtless to make the buildings warmer and drier in the process. The earliest forms of a cavity wall were achieved simply by the addition of either a full brick or a half brick rain shield to the outside of the structural wall.

Recent studies (BIA 1998) have shown that cavity walls, long common in Europe, were first built in the United States as early as 1850. However, it was not until 1937 that this type of construction gained official acceptance by any building code or construction agency in the United States. Since then, interest in and use of cavity walls in the United States have increased rapidly. Extensive testing and research and empirical data from previous cavity wall construction, has been used to formulate guide-lines on cavity wall properties and performance.

Cavity wall ties were introduced into the construction of the walls in order to connect the inner and outer leaves of the wall together, and to add additional strength and wind resistance to the property walls. On the older cavity walls with thicker internal walls, the wall ties were introduced during construction in order to give a higher wind resistance to the outer leaf as well as preventing the outer wall from buckling or failing under high wind loads.

With later cavity wall constructed buildings, the wall ties were designed and introduced so that they would mutually support and transfer the applied lateral and/ or vertical loads through to the foundation of a property. If cavity wall ties do not exist, then the outer leaf wall may fail under wind loads causing the inner leaf wall to become unstable under vertical loads.

When wall ties are provided at the spacing recommended in the building codes, this will ensure that the applied lateral loading is shared between the two leaves, as illustrated in Figure 2 and figure 3. Where the load is carried by one leaf only, the load-bearing capacity of the wall should be based on the horizontal cross-sectional area of that leaf alone, although the stiffening effect of the other leaf can be taken into account when calculating the slenderness ratio, (Curtin et al, 1995)

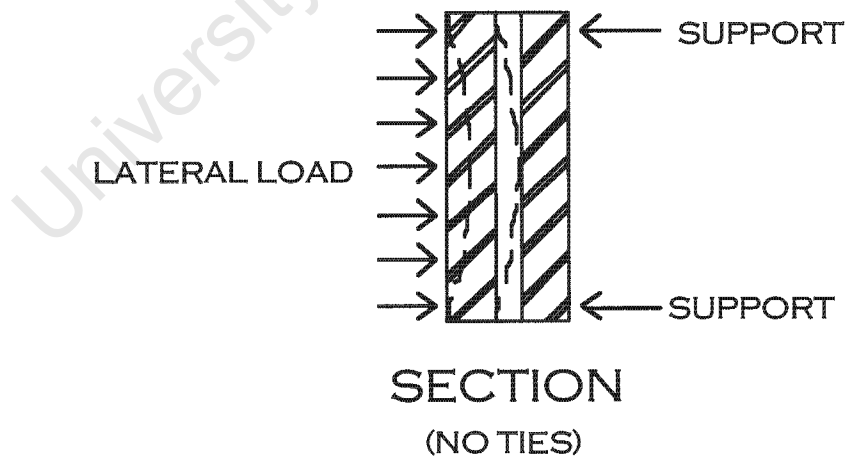

**Figure 2: Deflected shape outer leaf only loaded**

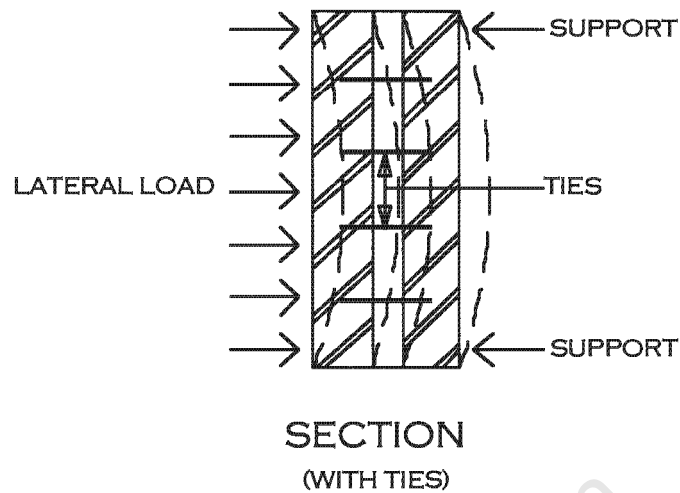

**Figure 3: Deflected shape: load transmitted to inner leaf via ties- both leaves loaded**

During the nineteenth century a range of shapes was used for metal ties, mostly broadly similar to the modern vertical twist ties in design. A number of special tie bricks were also developed, of which some were glazed to reduce water transmission and some had a one-course step down from inner to outer leaf. Jaggard and Drury as quoted by de Vekey (1988), illustrated the use of hollow stoneware ties and a range of metal ties including vertical-twist type and butterfly type. Fitzmaurice as quoted by de Vekey (1988), illustrates a large selection of metal tie forms in the 1938 edition of *Principles of modern building* (Figure 4). Although the function of all these ties is basically the same, the ties with their various shapes as designed and patented by their designers/inventors are being pushed and promoted by them for reasons other than basic need and use.

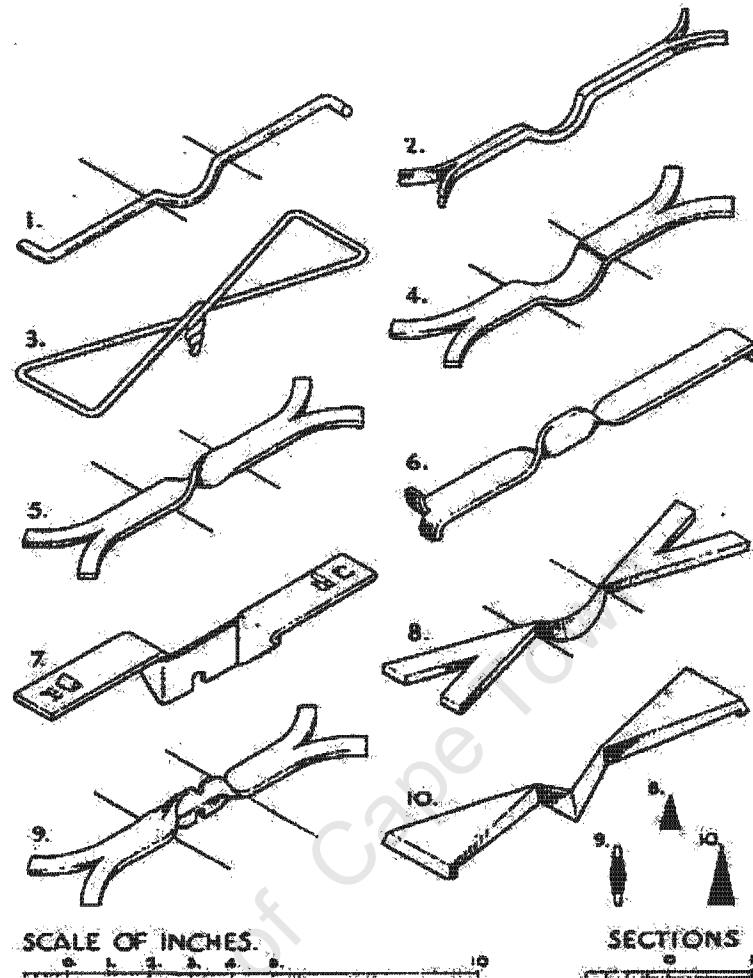

Figure 4: A large selection of metal tie forms

## 1.2 APPLICATION

DeVekey (2000) stated simply, "The job the tie has to do has determined its basic shape". It has to be thin enough to fit into a mortar bed at each end yet give a good grip to the mortar. It has to have a drip and allow some sideways movement yet be stiff enough to resist wind loads.

Originally, for many current types of building, the wall ties were merely there to hold the external rain shield wall on to the main

structure. In order to do this, they have to be firstly, for safety reasons, very good at stopping wind suction forces from pulling the wall off, therefore they must be strong in tension. They also need to be sufficiently stiff to stop the cavity from closing in strong face winds and damaging the walls; hence, they must have some resistance in compression. Ties must also allow sufficient sideways movement to let the two walls expand and contract independently owing to temperature and moisture changes without damaging ties or walls. To prevent rain entering the structure, they need a water bar, or "drip", to stop water leaking from the outside to the inside. They also function better if they catch as little mortar dropped down the cavity as is possible: they should ideally be fairly thin in plan. The reason for this is that any mortar on top of the tie will tend to short circuit the water bar. In the "traditional" brick/block cavity wall of the last 70 years, the ties also have a structural function of sharing any lateral (wind) loads between the two leaves.

The principal structural function of wall ties, according to Moore (1981), is to provide a degree of interaction between the two leaves of a cavity wall so that more load can be carried than by the two leaves acting separately. Therefore, wall ties in a cavity wall perform the function of making the leaves of a wall to act as a complete structural unit to resist compressive and flexural forces whilst in some cases, permitting some differential longitudinal and vertical movement between the leaves.

Typically, the structural selection (sizing and spacing) of wall ties has been based largely on empirical information and the designer's judgment (BIA, 1988). Recently, questions concerning strength,

stiffness, corrosion and the effects of these on the long-term performance of wall ties, have been posed. Selection of a tie system to function properly under these conditions is further complicated by the vast number of tie types available in the Western Cape and the variety of materials from which they are fabricated.

### **1.3 SURVEY OF WALL TIES USED BY CONTRACTORS**

The author conducted a recent survey amongst contractors in the Western Cape and the following questions were posed:

- 1.3.1 Which wall ties (tie wires) do you make use of?
- 1.3.1 What is your reason for the use thereof?
- 1.3.1 If you had a choice, which type of tie wire would you make use of?
- 1.3.1 What is the reason for your choice?

- The answer to the first question by the contractors was "Butterfly Tie wire". The response was 100%, in favour of this type of tie wire.
- In response to the second question, 66,7% of the contractors' said that they were compelled by the NHBRC to use the Butterfly type tie wire, 6,7% stated that it was a building regulation requirement, 13,3% said that it gives better grip, 6,7% responded that it was the only approved tie wire readily available at a hardware store" and 6,7% stated that it was the only one allowed to be used by company.
- 53,3% of the contractors agreed that if they had a choice, they would use the crimp tie wire, while 40,0% preferred the

butterfly type tie wire and 6.7% said: "Don't know of any other approved tie available".

- Additional comments to the fourth question made by contractors were: "Crimp Ties are more economical; less possibility of mortar falling on the tie wire; cheaper, was good enough for buildings built prior to 1997, (date when NHBC implemented the use of Butterfly Ties); far better than Butterfly Ties, because crimp ties are fool proof".

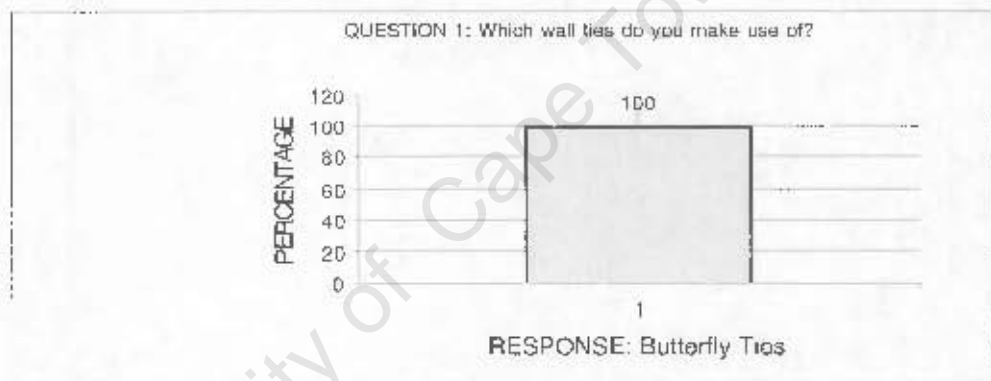

Figure 5: Response to Question 1 of Survey

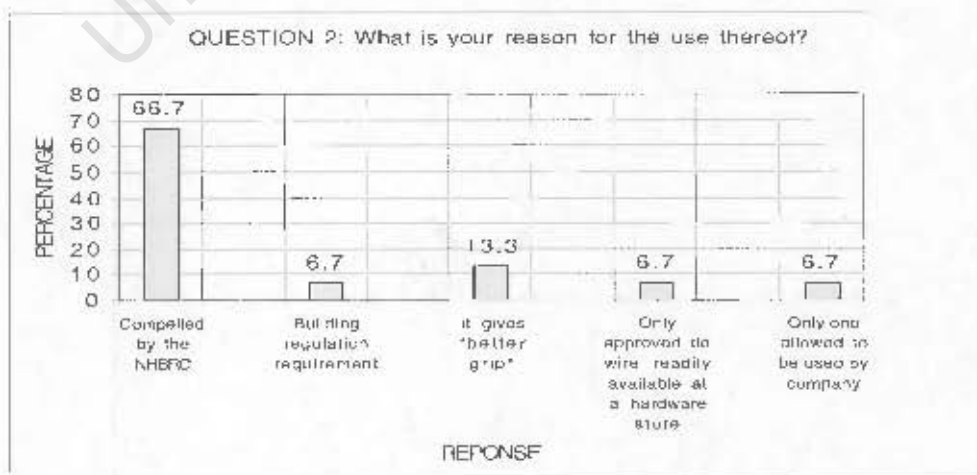

Figure 6: Response to Question 2 of Survey

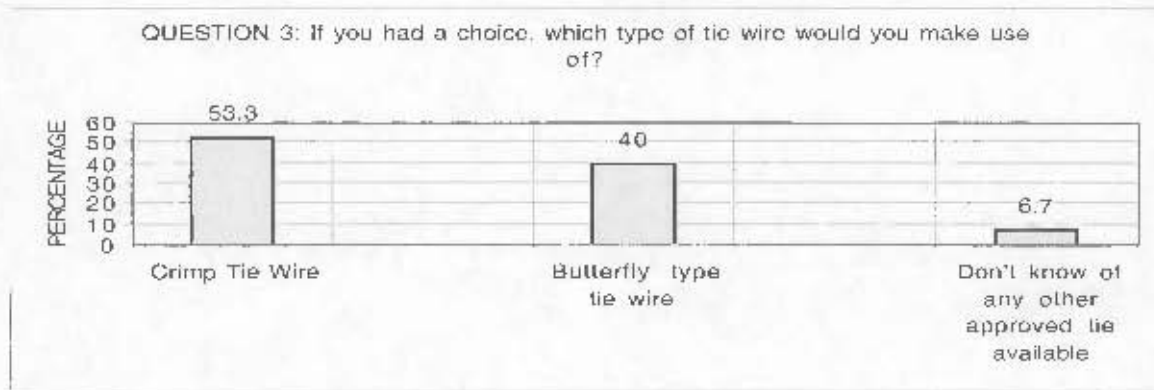

Figure 7: Response to Question 3 of Survey

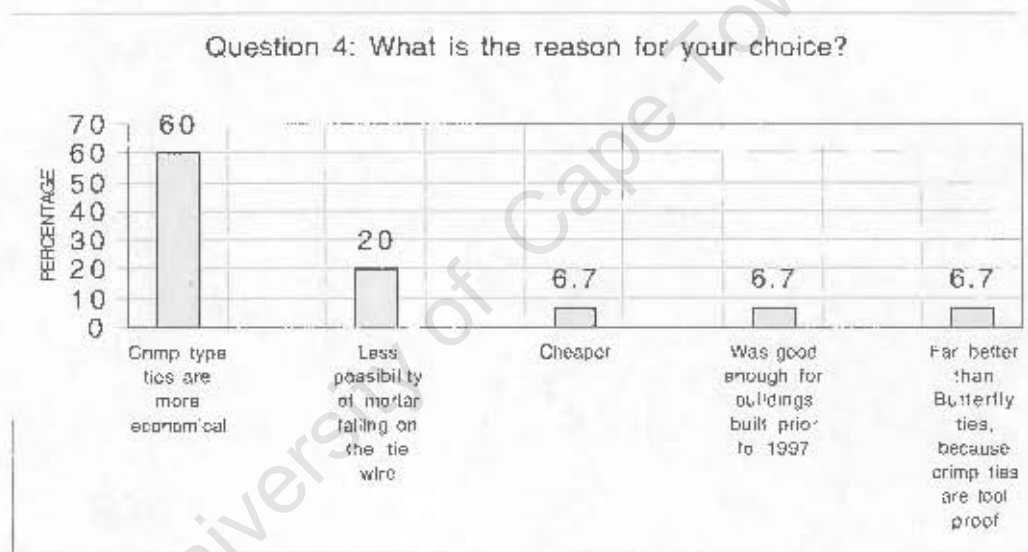

Figure 8: Response to Question 4 of Survey

In the light of the above, it is apparent that the Butterfly Tie wire is more commonly used, not because it is cost-effective, nor because it necessarily fulfils its principal function. There is therefore the need to know whether other wire ties could not also fulfil this main function.

#### 1.4 TIE SELECTION AND TYPES OF WALL TIES

The strength and deformation characteristics of the tie system are not generally analysed nor investigated during the project design or

specification phase (BIA, 1988). Building codes and standards have typically required minimum tie size (diameter and gauge) and maximum tie spacing limits to control tie loading and deformation. Present tie size spacing requirements have been derived from some testing and from the past performance of traditional tie systems.

There are a number of different wall tie systems available on the market. The two most common wall ties available from hardware stores are the butterfly type and the crimped type.

SABS 28: 1986 provides only a detailed specification, but no performance details on the six wall ties (as mentioned below), whereas SABS 0164-1:1980 gives detailed specifications and performance details, but for the vertical twist tie only. Although the following wall ties are all used in cavity wall construction, the vertical twist wall tie provides better interaction between leaves than do wire ties, except where large differential movements are likely to occur where the wire is more suitable:

- 1.4.1 Butterfly type tie (Figure 9)
- 1.4.2 Modified PWD tie (Figure 10)
- 1.4.3 Double triangle type tie (Figure 11)
- 1.4.4 Single wire tie (Crimp Type) (Figure 12)
- 1.4.5 Vertical Twist (Figure 13)
- 1.4.6 Flat Twisted (Figure 14)

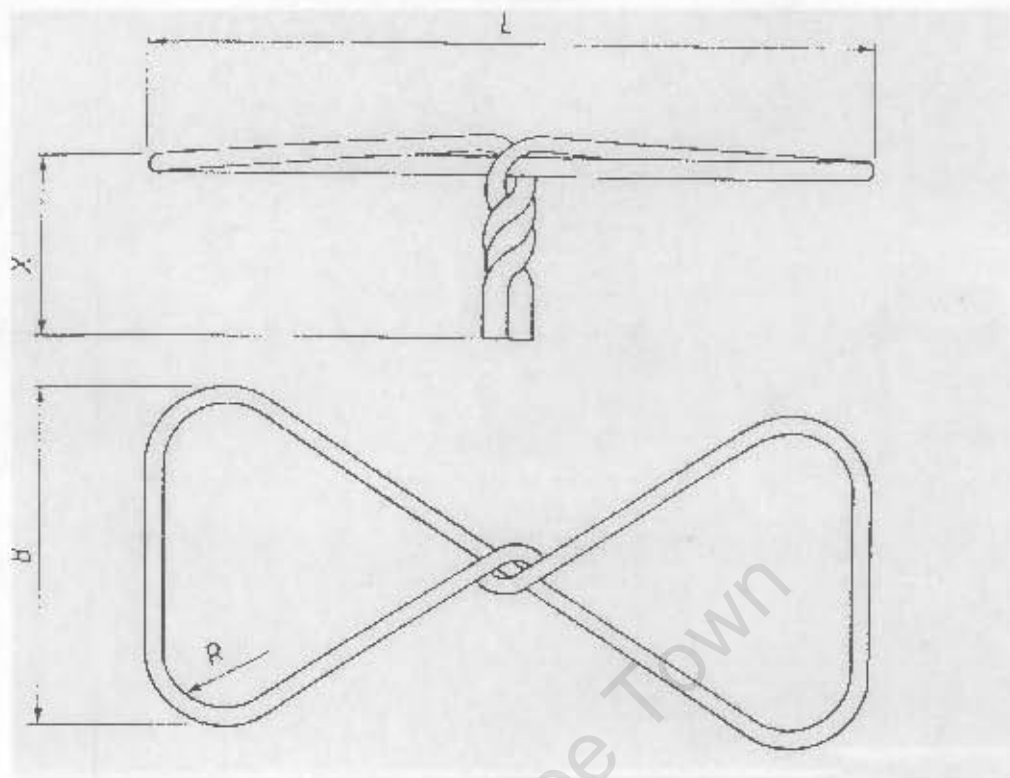

MATERIAL	SUBSECTION	WIRE DIA mm	L mm	B mm	R, min mm	X mm
Mild Steel (Galvanized)	2.3.2	3.15 +/- 0.1	150 +/- 5	75 +/- 5	13	25 +/- 5
Copper	2.3.3		or 200 +/- 5	or 100 +/- 5		
Copper-zinc alloy	2.3.4					
Stainless Steel	2.3.5					

Figure 9: Butterfly type tie (SABS 28 – 1986)

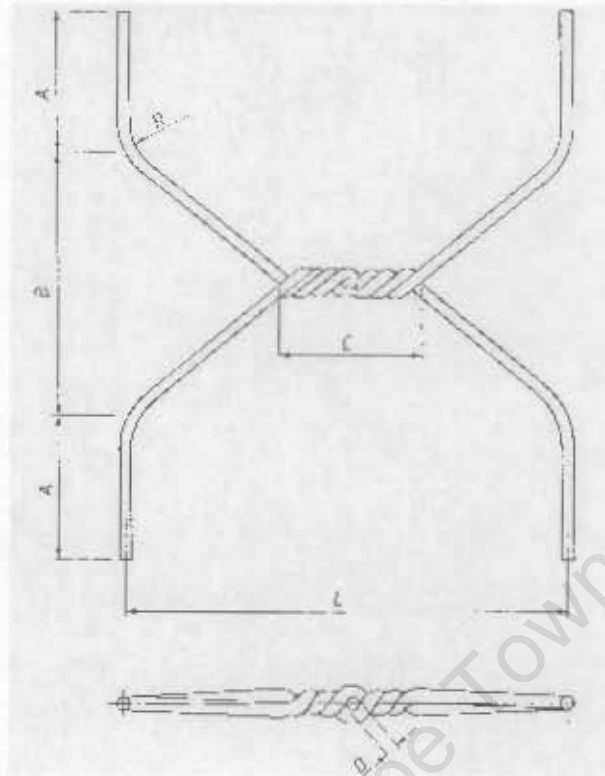

MATERIAL	SUBSECTION	WIRE DIA mm	L mm	A mm	B mm	C mm	R, min mm	X mm
Mild Steel (Galvanized)	2.3.2		150		75 +/-			
Copper	2.3.3	3.15 +/- 0.1	+/- 5 or 200		5 or 100		13	25 +/- 5
Copper-zinc alloy	2.3.4		+/- 5		+/- 5			
Stainless Steel	2.3.5							

Figure 10: Modified PWD Type Wall Tie (SABS 28 – 1986)

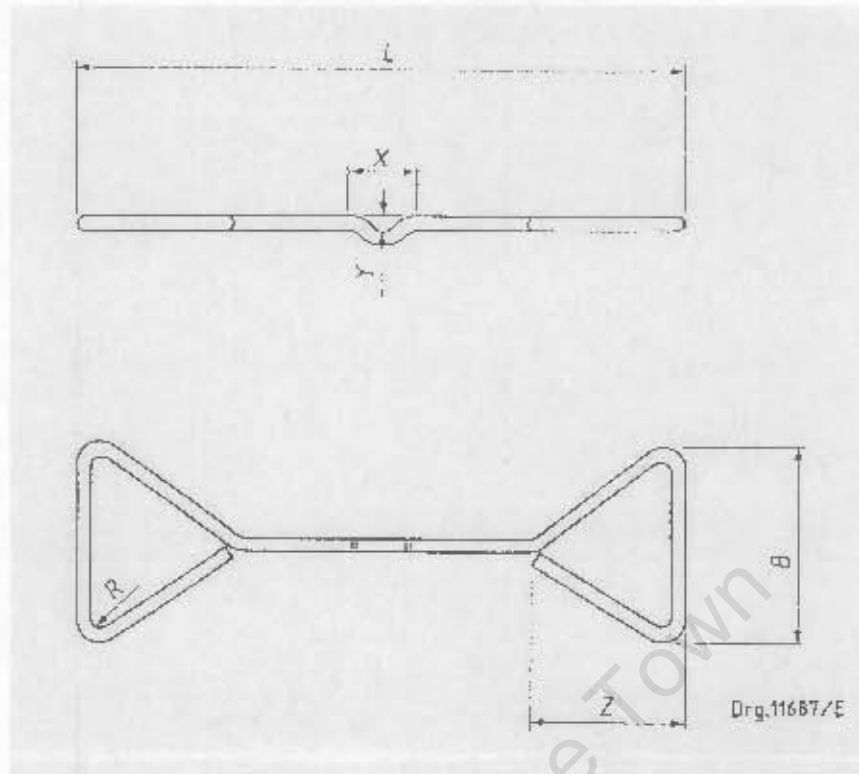

MATERIAL	SUBSECTION	WIRE DIA mm	L mm	B mm	R, min mm	X mm	Y mm	Z mm
Mild Steel (Galvanized)	2.3.2	4.3 +/-0.1	150 +/- 5					
Copper	2.3.3		or 200 +/- 5	65 +/- 5				
Copper-zinc alloy	2.3.4	4.0 +/-0.1			8	22 +/- 2	7 +/- 2	50 +/- 5
Stainless Steel	2.3.5							

Figure 11: Double Triangle Type Wall Tie (SABS 28 – 1986)

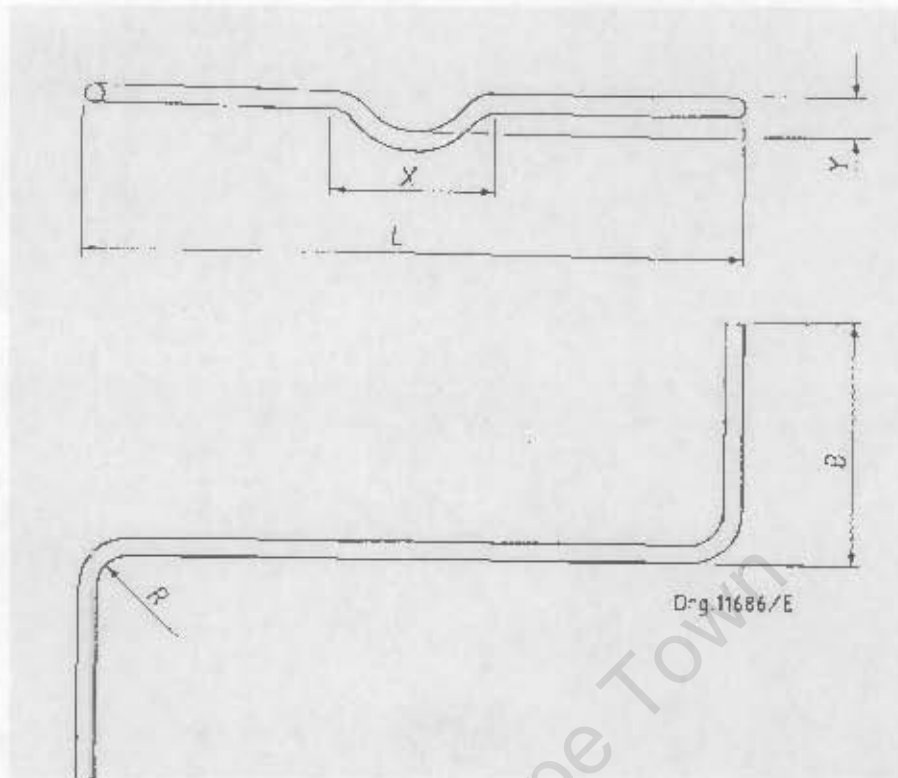

MATERIAL	SUBSECTION	WIRE DIA. mm	L mm	B mm	R, min mm	X mm	Y min mm
Mild Steel (Galvanized)	2.3.2	4.5 +/- 0.1	150 +/- 5 or 200 +/- 5	70 +/- 5	8	22 +/- 2	7 +/- 2
Copper	2.3.3						
Copper-zinc alloy	2.3.4	4.0 +/- 0.1					
Stainless Steel	2.3.5						

Figure 12: Single Wire Type Wall Tie (SABS 28 – 1986)

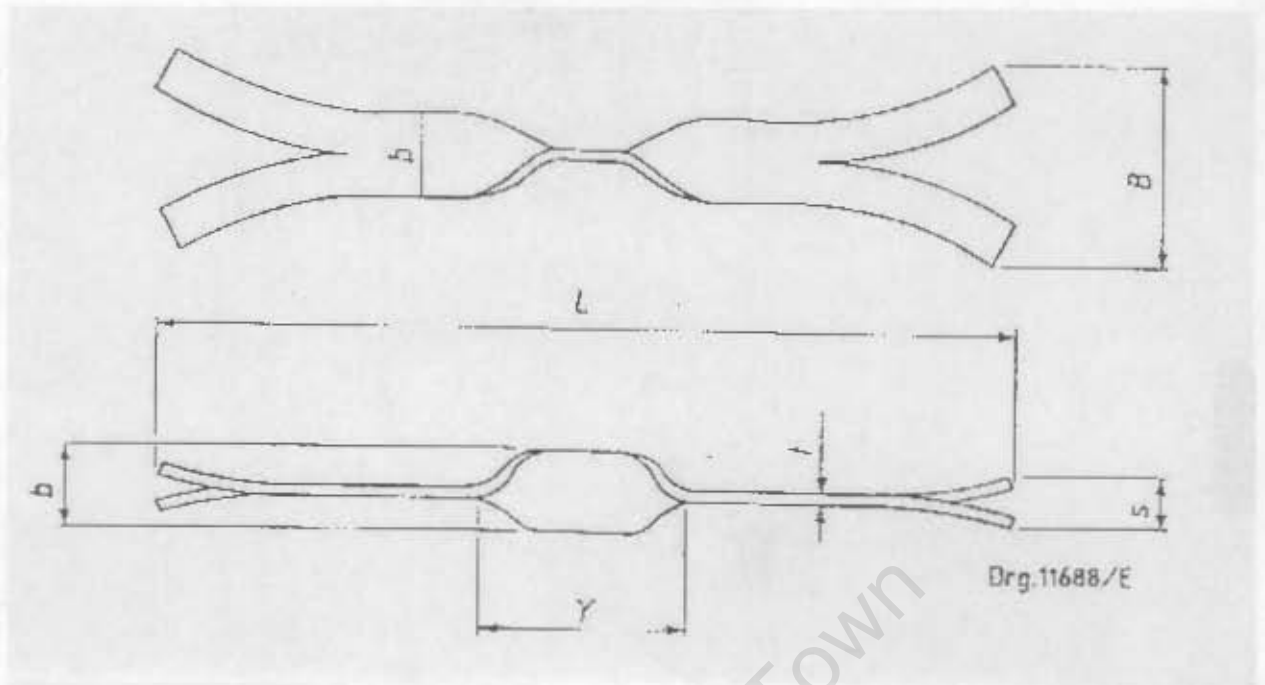

MATERIAL	SUBSECTION	WIRE DIA mm	L mm	b mm	B mm	S, max mm	t mm	Y mc mm
Mild Steel (Galvanized)	2.3.2	4.5 +/- 0.1	150 +/- 5 or 200 +/- 5					
Copper	2.3.3			20 +/- 1	40 +/- 10	22 +/- 2	4 +/- 1	50
Copper-zinc alloy	2.3.4		255 +/- 5					
Stainless Steel	2.3.5	4.0 +/- 0.1	or 305 +/- 5					

Figure 13: Vertical Twist Type Wall Tie (SABS 28 – 1986)

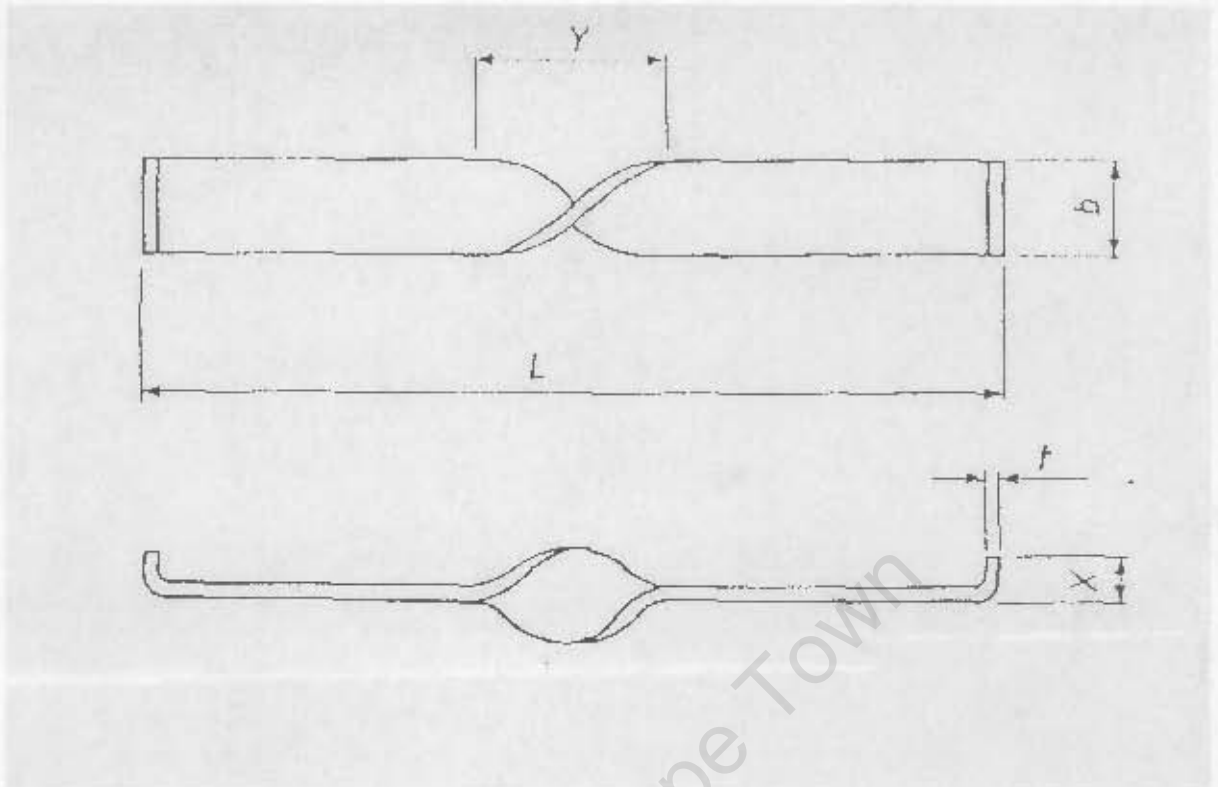

MATERIAL	SUBSECTION	L mm	b, min mm	t, min mm	X mm	Y, max mm
Stainless Steel	2.3.5	150 +/- 5	13	1.5	7 +/- 1	50

**Figure 14: Flat Twisted Type Wall Tie (SABS 28 – 1986)**

# CHAPTER 2

## LITERATURE REVIEW

### 2.1 THE SOUTH AFRICAN CODES OF PRACTICE

#### 2.1.1 SABS 28:1972

This code of practice covers metal ties suitable for cavity walls in which the width of the cavity does not exceed 75 mm

#### 2.1.2 SABS 28:1986

This code of practice covers the dimensional and material requirements of metal ties suitable for walls having cavity widths of up to the largest likely to be found in masonry walling constructed to dimensionally co-ordinated size.

#### 2.1.3 SABS 0164-1:1980

This code of practice covers recommendations and requirements for the design of unreinforced loadbearing masonry walling erected in areas other than those where earthquakes may be encountered.

SABS 28 – 1986 is a detail specification and not a performance specification. As such, it describes the physical dimensions of wall ties for a specific material type and the corrosion protection requirements relating thereto. It leaves no room for innovators to develop new wall ties, as it provides no means for their acceptance. The Code specifies that wall ties shall be made of galvanized mild steel wire, of galvanized mild steel strip, of copper, of copper-zinc alloy or austenitic stainless steel. Furthermore, it also provides guidance on the selection and use of metal wall ties.

When a wall is constructed of two separate leaves with a vertical joint not exceeding 25mm wide between them, i.e. a cavity wall with a very narrow cavity, in accordance with SABS 0164-1:1980, it may be designed as a cavity wall, or as a single leaf wall (effectively a solid wall ) with an effective thickness equal to actual overall thickness, provided the following conditions are satisfied:

- Each leaf shall be at least 90mm thick
- For concrete blockwork, the characteristic compressive strength obtained in accordance with 4.2.2 (SABS 0164-1:1980) shall be multiplied by 0,9
- The space between the two leaves shall be solidly filled with mortar or grout as the work proceeds, except that, if the width of the space exceeds 25mm, it is the responsibility of the designer to specify a suitable concrete
- If the two leaves of the wall are constructed of two different structural units, the wall shall be designed on the assumption that the wall is constructed entirely in the weaker unit; the possibility of differential movement shall be considered
- Except in the case of laterally loaded panels, the load shall be applied to the two leaves, and the eccentricity shall not exceed  $0,2t$ , where  $t$  is the overall thickness of the wall
- Flat metal wall ties of cross-sectional area 20mm x 3mm shall be placed at centre to centre distances not exceeding 450mm, both vertically and horizontally, or an equivalent mesh at the same vertical centres shall be provided
- The minimum depth of embedment of wall ties or equivalent mesh into each leaf shall be 50mm.

The above wall is referred to as a "double leaf wall", by SABS 0164-1:1980. SABS 28-1986, on the other hand refers to a "non-cavity" wall

and states: "In the particular case of a non-cavity wall of nominal thickness 230mm and that is constructed in two stretcher bond leaves with the vertical joint between the two leaves solidly filled with mortar, crimped wire ties may be used. Where such a wall is to be a structural wall, reference should be made to subsection 5.2.4 of SABS 0164-1:1980.

It is clear that SABS 0164-1:1980 and SABS 28-1986 refer to different types of wall ties.

It should be noted, and as mentioned by Dreyer (1998), that in Natal, particularly in the Durban area, cavity walls are not used in the specified manner. The inner leaf is built and bagged then coated with two coats of bituminous paint before building the outer leaf about 10 or 20mm away. This specification does not comply with the SABS codes of practice, NHBRC or the National Building Regulations (all of which require a minimum cavity of 50mm), but it provides homeowners with a satisfactory product, which resist weather and normal loading conditions.

SABS 28:1972 specifies a steel wire with a tensile strength of less than 540MN/m<sup>2</sup>, the test method in this specification only refers to wall ties of "any other type of construction" (Clause 3.2(e)). This Code therefore makes provision for the use of wall ties other than the "standard" butterfly and Modified PWD types. An interesting anomaly is that the Butterfly Tie does not meet the requirements of SABS 28:1972 Clause 3.2(e) which states, "will prevent, whichever side is used uppermost, the transmission of moisture from one leaf of a cavity wall to the other leaf:" The butterfly cannot be placed upside down, but the crimp wire tie is reversible.

Although the crimp wire tie complies with the requirements of SABS 28:1972, it does not comply however, with SABS 0164-1:1980 Clause 5.2.1.4(b), which expressly excludes it by stating, ".....comply with SABS 28 subject to the provision that ties of the single wire type shall not be used." No justification or explanation is given for this statement in SABS 0164-1:1980.

The required spacing of ties is given in clause 5.2.1.4 of SABS 0164-1:1980 and in table 7. The spacing may be varied, provided the number of ties per square metre on elevation is not less than the values given in the table. Additional ties may be necessary around the sides of openings. According to the Code, the minimum embedment of a tie in a mortar joint should be 50mm in each leaf. The width of the cavity may vary between 50mm and 150mm but, in accordance with the Code, may not be wider than 75mm where either of the leaves is less than 90mm in thickness. However, the Code does allow that in special circumstances, with appropriate supervision, the width of the cavity may be reduced below 50mm.

## **2.2 THE BRITISH STANDARD INSTITUTION**

### **2.2.1 DD 140:PART 1:1986**

This part of DD 140 describes methods for determining the strengths of wall ties intended for connecting two leaves of masonry or for connecting one leaf of masonry to a timber frame.

### **2.2.2 DD 140:PART 2:1987**

This part of DD 140 gives recommendations for the design of wall ties, including remedial ties, manufactured from materials listed in clause

4 and intended for use in masonry and timber frame construction anywhere in the UK.

### **2.2.3 BS 1243:1978**

The BS specifies requirements for metal wall ties manufactured from wire or strip and suitable for cavity walls. The types of wall ties specified are those considered most suitable for buildings generally, and the requirements provide a minimum specification suitable for such work. The lengths of the larger tie are adequate to tie together two leaves across the largest cavity likely to occur in walls constructed to dimensionally co-ordinated sizes.

The British wall tie specification (BS 1243:1978) is a detailed specification. There have been no developments of this standard since amendments in 1981 and 1982. It is still limited to 150-200mm - long wire ties and 150-300mm - long vertical twist ties made from zinc-coated steel, austenitic stainless steel, copper, phosphor bronze and aluminium bronze. Longer ties are made, which comply in all other respects with BS 1243, but these cannot at present be claimed to meet BS 1243.

Until 1987, there was no standard for ties for any purpose other than for linking the two leaves of a masonry/masonry cavity wall. Other ties, such as those used for supporting masonry cladding on to frame structures, were not covered by a British Standard.

Since 1987, proprietary designs for cavity wall ties and for timber frame ties have either been standardised in accordance with DD 140:Part 2:1987 or have been certified by the British Board of Agreement or WIMLAS etc. DD 140:Part 2:1987 contains a set of

Classifications of ties of Type 1,2,3 and 4 for masonry/masonry cavity walls and types 5 and 6 for attaching masonry cladding to timber frame structures.

Although the DD 140:PART 1:1986 allows for methods for determining the strengths of wall ties, it does not allow for testing of water transfer along the length of the tie.

### **2.3 THE AUSTRALIAN STANDARD AS 2699 – 1984**

This standard specifies the requirements for wall ties for use in tying together: (a) the leaves of cavity brick or cavity block walls; and (b) masonry veneer walls of brick or block and loadbearing frames.

The Australian Code on the other hand, provides a more detailed performance requirement. Clause 8.1 of this specification reads as follows: "Wall ties shall be manufactured so that they comply with the following performance requirements:

- 2.3.1 To provide stability to the outer leaf of masonry against lateral loads and, where the design requires it, cause the lateral loads to be shared between the leaves of a cavity wall, or between a load-bearing frame and a masonry veneer.
- 2.3.2 To prevent the transfer of water along their length.
- 2.3.3 To tolerate both horizontal and vertical differential movements of the leaves or of the leaf and the load bearing frame, so as to maintain compliance with the applicable requirements of Table 1 when subject to the applicable displacements of Table C1 of Appendix C (Table 3)
- 2.3.4 To resist corrosion in accordance with clause 6.1"

It is clear that this specification provides the following acceptance tests/requirements, viz:

- Characteristic Strength
- Characteristic Stiffness
- Resistance to Water transfer
- Resistance to Corrosion

#### **2.4 THE EFFECT OF WALL TIE SPACING ON THE STRENGTH OF CAVITY WALLS**

West et al (1982) tested a number of cavity walls for the resistance to lateral loading. These have had one leaf of brick and the other of either a different brick or concrete block; various types and distribution of ties were incorporated. The author then compared experimental strengths with predicted strengths, using yield -line theory, and strengths obtained from design in accordance with BS 5628:Part 1.

All walls were built within a steel frame and a uniformly distributed load was applied by means of an inflatable air-bag. Two types of brick and three types of concrete block have been used for the leaves of the cavity walls, together with two types of wall tie. The width of cavity and spacing of wall ties have also been varied in some of the wall tests.

Nine of the walls were analysed by Haseltine (1982) and co-workers, using a yield line approach to calculate predicted failure pressures for the individual leaves. These predicted pressures were then summed for comparison with the actual failure pressures of the cavity walls. No reference was made to the effect of the wall tie strength or behaviour under load upon the strength of the cavity walls.

According to BS 5628, the design moment of resistance of a cavity wall should be taken as the sum of the design moments of resistance of the two leaves, with the proviso that, where Butterfly or Double Triangle Ties are used, the ties must be capable of transmitting the necessary compressive force. The aim of the design was to ensure that laterally loaded cavity walls have an adequate factor of safety against ultimate failure. The method of analysis used must, before it can be used with confidence, be shown to be valid by experimentation.

West et al (1982) shows in his conclusions that when the predicted strengths of the single leaves of a cavity wall, obtained using yield-line analysis, and flexural strengths from wallette tests, allowing for partial edge restraint, are added together, a safe prediction of the lateral strength of the cavity wall, for the range of walls considered, is obtained. The author states further that the cavity walls having Vertical Twist Ties generally exhibited greater strengths than the simple addition of the strength of the two leaves. In the light of this, it suggests some composite action, which might permit the design strength of such walls to be enhanced.

The increase in the number of wall ties for 75-150mm cavity walls required by BS 5628 maybe unnecessary, according to the author, because the experimental results for 150mm cavity walls suggest that there may be an enhancement due to composite action over similar walls with narrower cavities.

West et al (1982) is of the opinion that design of laterally loaded cavity walls in accordance with BS 5628: Part 1 ensures an adequate

factor of safety against ultimate failure for the range of walls considered, when the wall strength is based on the sum of the individual leaf strengths or of one leaf and wall tie strengths when appropriate. The author concluded and states that the fact that even some of these walls with leaves of the same thickness suffered failure due to tie collapse, indicates that stiffer ties than Butterfly Ties are required for safe designs on walls with leaves of widely different stiffness.

The influence of the spacing of wall-ties in cavity walls on their compressive strength and resistance to lateral loading is important in both existing and new construction (Edgell, 1984). Therefore, in existing construction the importance of the structural implications of the corrosion or omission of wall-ties needs to be established. In new construction, on the other-hand, where wider cavities are specified in order to permit the fixing of thermal insulation, the Code of Practice requirement that the number of wall-ties be doubled affects the rate at which the insulation may be introduced.

In an experiment, Edgell, (1984), viewed the available results of tests on cavity walls made from a range of materials and with a range of cavity widths then subjected to axial, eccentric and lateral load. The author is of the opinion that there is insufficient evidence to recommend any change to the standard frequency of wall-ties of 2.5 ties/m<sup>2</sup> for those walls for which it is specified in the Code of Practice. However, according to Edgell, (1984), the Code should acknowledge that there is no need to increase the number of wall-ties for walls consisting of leaves at least 90mm thick, when the cavity width exceeds 75 mm but is less than or equal to 150 mm

(See Table 1). In addition the Code gives values for the strength characteristics of the various types of tie which are of importance in particular in relation to the lateral load resistance of cavity walls.

**Table 1: TIE SPACINGS RECOMMENDED IN BS 5628 : PART 1**

Leaf thickness (mm)	Cavity width (mm)	Spacing of ties		Ties /m <sup>2</sup>
		Horizontally (mm)	Vertically (mm)	
Less than 90	50 - 75	450	450	4.9
90 or more	50 - 75	900	450	2.5
90 or more	75 - 100	750	450	3.0
90 or more	100-150	450	450	4.9

In recent developments the importance of knowing the influence of the frequency of wall ties per square metre on the compressive and flexural strengths of cavity walls was highlighted. The durability of wall-ties has been investigated by the Building Research Establishment and as a result several things have happened: the strength and stability of walls in which the wall-ties have corroded is in question, a replacement wall-tie industry has developed, the British Standard requirement for the protection of wall-ties against corrosion has been increased and the cost of ties has risen by between 20% and 40%. These developments have far-reaching effects and their necessity must be judged against the structural requirements of the ties in the first instance. In addition the strength and stability of walls that have been constructed with some or all of the ties omitted is often a situation that is currently assessed against the Code provisions only.

Edgell, (1984) proposes to review the experimental data on the influence of the frequency of wall ties on the compressive and lateral strength of walls.

Davey & Thomas (1950) observed that the stiffness of the wall ties is important in ensuring that the deflected profiles of both leaves of an eccentrically loaded cavity wall are the same. In their work they examined the effect of using two different metal - gauge Butterfly Ties on the compressive strength of cavity walls; the results are given in Table 2

**Table 2: Results due to Davey & Thomas : eccentric loads**

Wall type	Mortar type	Eccentricity (mm)	Failure load (kN)
Single leaf	1 : 3	25	907
Cavity: 9 swg ties	1 : 3	25	857
Cavity: 9 swg ties	1 : 3	25*	827
Single leaf	1 : 1 : 6	25	309
Cavity: 12 swg ties	1 : 1 : 6	25	369
Cavity: 12 swg ties	1 : 1 : 6	25*	259

From the results of Davey & Thomas (1950), it seems that the reduction in strength of a wall due to the addition of a second leaf connected to it with Butterfly Ties is relatively low.

For Edgell, (1984), the influence of the frequency of wall-ties on the resistance of cavity walls to lateral loads is of interest in two main respects. Firstly in relation to existing walls where the cavities are likely to be in the range 50-75 mm and the ties originally placed at the frequency, originally specified in CP 111: Part 2: 1970, of 2.5 ties/m<sup>2</sup>. In this case it is the strength of the wall in the long term, when there is the possibility of some of the ties having corroded, that is of interest. Secondly in relation to the somewhat arbitrary requirement in BS 5628: Part 1 (Table 1) that the spacing of wall-ties be reduced as the width of the cavity is increased. Table 3 includes the results due to WEST, HODGKINSON & DE VEKEY from two walls each constructed of two brickwork leaves separated by a 50mm cavity and connected by butterfly wire - ties where in one case the standard tie spacing of 900 x 450 mm has been used leading to 25 ties being placed in the wall; in the other the spacing has been increased to 900 x 900 mm and consequently there were 15 ties in the wall.

**Table 3: RESULTS DUE TO WEST, HODGKINSON & de VEKEY REDUCED TIES IN 50mm CAVITY WALL**

Material †		Type of tie	Tie spacing(mm)	Number of ties	Failure pressure (kN / m <sup>2</sup> )
Inner	Outer				
Brick	Brick _	Butterfly	900 x 450	25	6.0
Brick	Brick _	Butterfly	900 x 900	15	5.9

Clearly the ultimate strengths are very close although in the case of the wall with the reduced number of ties the cavity began to close due to buckling of the ties at loads in excess to two thirds of the ultimate load.

Hence, according to Edgell, (1984), the overall conclusion which may be drawn is that there is insufficient evidence to recommend any change to the standard spacing of wall-ties of 2.5 ties/m<sup>2</sup> for those walls for which it is specified in the Code of Practice. The Code should acknowledge that there is no need to increase the number of wall-ties for walls consisting of leaves at least 90 mm thick, when the cavity width exceeds 75 mm but is less than or equal to 150 mm.

According to West et al (1979), a typical cavity wall in the UK consists of two leaves of masonry, usually either brick and brick or brick and lightweight concrete block, held together by ties. The authors are of the opinion that in the design of masonry walls to withstand lateral loading – that is uniformly distributed loading at right angles to the plane of the wall – it is necessary first of all to compute the resistance of the two separate leaves and then make an allowance for the interaction between the two leaves. Their view is that if the tie is so weak as to be incapable of acting as a stud, then a positive pressure acting on the outer leaf will not be transmitted to the inner leaf and the effective resistance of the two leaves will be little more than that of the outer leaf on its own. If, however, the tie is capable of transmitting thrust, then there will be load distribution between the two leaves. If in addition to transmitting thrust, the tie is also capable of transmitting some shear, then there will be a degree of interaction between the two leaves and an enhanced lateral resistance would be expected. The authors describe the results of lateral tests on cavity walls with variously vertical twist and Butterfly Ties (both in galvanized mild steel) polypropylene ties and a mild steel truss type reinforcement between the two leaves.

The authors built their test walls into steel frames representing one bay of a multi-bay framed structure and applied a uniformly distributed pressure to the face of the wall by a system of inflatable air-bags. The physical properties of the bricks and blocks are shown in Table 4.

**Table 4: Physical Properties of Bricks and Blocks**

Unit	Mean crushing strength (N/mm <sup>2</sup> )	Mean water absorption	Mean suction rate (kg/m <sup>2</sup> /min)	Density (kg/m <sup>3</sup> )
Brick A	63.1	6.4	0.35	n.a.
Brick B	27.9	22.2	2.35	n.a.
Block A.A.C.	4.1	n.a.	n.a.	700

Before the authors started with the programme, they considered that the lateral strength of cavity walls should be taken as 0.9 times the sum of the moments of resistance of the two leaves. However, subsequent tests with various combinations of brick and block with 1:1:6 mortar showed that the mean ratio of twenty-four walls built with vertical twist, Butterfly or polypropylene ties was 1.08.

The authors suggested that the less rigid ties (Butterfly and polypropylene) might transmit load less effectively from one leaf to the other. Some evidence for this is given by the fact that shorter, and thus stiffer, sections generally give lower values for the ratio of the failure load of the cavity wall to the sum of the leaves. However, in view of the fact that the ratio uses a mean value for the single leaves since it is not possible to determine the actual value of those in the cavity wall, this effect may not be serious.

West et al (1979), concluded that:

- The mean ratio of the lateral load resistance of the cavity wall to the sum of the moments of resistance of the two individual leaves for twenty-four walls using three types of ties is 1.08.
- There is some evidence that Butterfly Ties and polypropylene ties tend to give lower ratios at high lateral resistance, that is with the shorter walls.
- The use of truss type reinforcement as a tie gives enhanced strength as does quadrupling the number of twisted steel ties.
- In the experiments so far on reducing the number of ties, the results are inconclusive though no serious diminution in strength is suggested.
- There is no significant difference in the results whether the cavity walls are loaded from the outer or inner leaves.
- When walls with cavities of 150mm width were tested using the standard tie spacing, appropriate to narrower cavities, there was no weakening of the wall. Some advantage was gained, though not fully proportional to the ratio of the moduli of the two types of cavity wall.

## **2.5 CHARACTERISTIC STIFFNESS**

Wall ties are an essential component of cavity or veneer walls. The behaviour of these walls is complex and a function of the relative stiffness of the outer and inner leaves, the support conditions for each leaf, and the stiffness on the ties themselves (Page, 1996).

In veneer construction the outer leaf relies on the wall ties for support, and the magnitude and distribution of the forces in the ties is directly influenced by the flexibility of the backup. Consequently, the distribution of the forces in the wall ties is markedly different for the

flexible and stiff backup cases. For cavity construction with both leaves supported, the ties are less important, but their properties will still influence the degree of load sharing between the inner and outer leaf.

The authors describe an analytical study of the behaviour of veneer and cavity walls and presents simplified methods for the design of wall ties for wind loading in both veneer and cavity construction.

They have shown in this paper that the behaviour of the walls, and the loads induced in the wall ties, is critically influenced by the stiffness of the structural backup or load transmitting leaf. When the backup is flexible, as in a timber or steel stud wall, and the veneer is un-cracked, the deflection of the backup induces high tie forces in the top row of ties adjacent to the backup support, with tie forces in other areas being quite low. In multi-storey veneer construction, high tie forces may also be induced near the base of the wall at each storey in a similar manner. If the veneer cracks horizontally along a bed joint near mid-height, a likely scenario, the distribution of tie forces changes dramatically, with the rows of ties near mid-height now being critically loaded. This also increases the deflection of the backup system with a corresponding increase in the size of the crack in the masonry veneer.

According to the authors, the design procedures for the ties must therefore include ultimate strength checks of both the uncracked and cracked conditions, together with a serviceability check of crack size in the veneer to limit the possibility of water penetration. When the backup is stiff, as in masonry cavity or cavity veneer construction, the deflection of the masonry backup is much less, and

serviceability conditions are not critical. The distribution of force within the ties is also more uniformly distributed down the wall for both the cracked and uncracked condition. Therefore, according to the authors, design considerations in this case relate to the ultimate strength conditions only.

It has been shown by the authors in their designs that the behaviour of the walls, and the loads induced in the wall ties, is critically influenced by the stiffness of the structural backup or load transmitting leaf. When the backup is flexible, as in timber or steel stud wall, and the veneer is uncracked, the deflection of the backup induces high tie forces in the top row of ties adjacent to the backup support, with tie forces in other areas being quite low. In multiple storey veneer construction, high tie forces may also be induced near the base of the wall at each storey in a similar manner. If the veneer cracks horizontally along a bed joint near mid-height, a likely scenario, the distribution of tie forces changes dramatically, with the rows of ties near mid-height now being critically loaded. This also increases the deflection of the backup system with a corresponding increase in the size of the crack in the masonry veneer. Design procedures for the ties must therefore include ultimate strength checks of both the uncracked and cracked conditions, together with a serviceability check of crack size in the veneer to limit the possibility of water penetration.

However, when the backup is stiff, as in masonry cavity or cavity veneer construction, the deflection of the masonry backup is much less, and serviceability conditions are not critical. The distribution of forces within the ties is also more uniformly distributed down the wall for both the cracked and uncracked condition. Design

considerations in this case therefore relate to the ultimate strength conditions only.

For the design of the wall ties, a first principles analysis can be used to obtain the tie forces, or the simplified design procedures developed by the authors.

## **2.6 RESISTANCE TO WATER TRANSFER**

Rain penetration through walls can damage the building envelope. Corrosion of metal accessories in the exterior or cladding, efflorescence of the masonry and damage to interior finishes and staining, are just a few examples of problems related to moisture penetration, according to BIA (1994).

Over the years, many methods have been used to prevent moisture penetration of walls, some more successfully than others. Masonry barrier walls rely on the massive wall materials to deter water penetration. Drainage type walls, such as brick veneer and cavity walls, provide good moisture penetration resistance. However, it must be recognized that the exterior brick skin cannot be made watertight. Provision for internal drainage is necessary for these wall systems to function as intended. A brick masonry cavity wall, properly designed and built, is virtually resistant to water penetration through the entire wall assembly. The outside brick skin may permit some moisture penetration, but the overall design of the cavity wall assembly accommodates this expected infiltration. It should be assumed that wind driven rain would penetrate the exterior brick skin.

A cavity wall is designed as a drainage wall system, so that any moisture which does penetrate the exterior brick skin will run down

the back face of the exterior brick skin to the bottom of the cavity where it is diverted to the outside by flashing and weep holes. One of the functions of the wall tie is to prevent water transfer from the exterior wall to the interior wall by means of a water bar known as a "drip" to stop water leaking from the outside to the inside (de Vekey, 1988).

The Crimped Tie provides at least two drips across a 50mm cavity, whereas the Butterfly Tie has only one. The Crimped Tie can be inadvertently placed upside down without compromising performance. If the Butterfly Tie, however is placed upside down, its water transfer ability will be compromised. Whereas there is a risk with the Butterfly Tie of placing the drip too close to the inner leaf and thereby promoting the possible transmission of moisture from the outer leaf, there is no such risk with the Crimped Tie. See Figures 15 and 16 below.

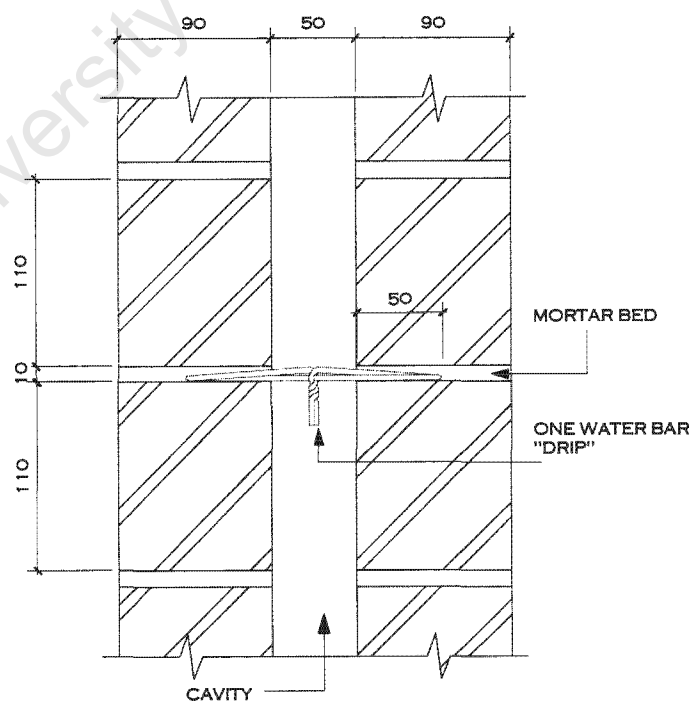

**Figure 15: Butterfly Tie placed in Cavity Wall**

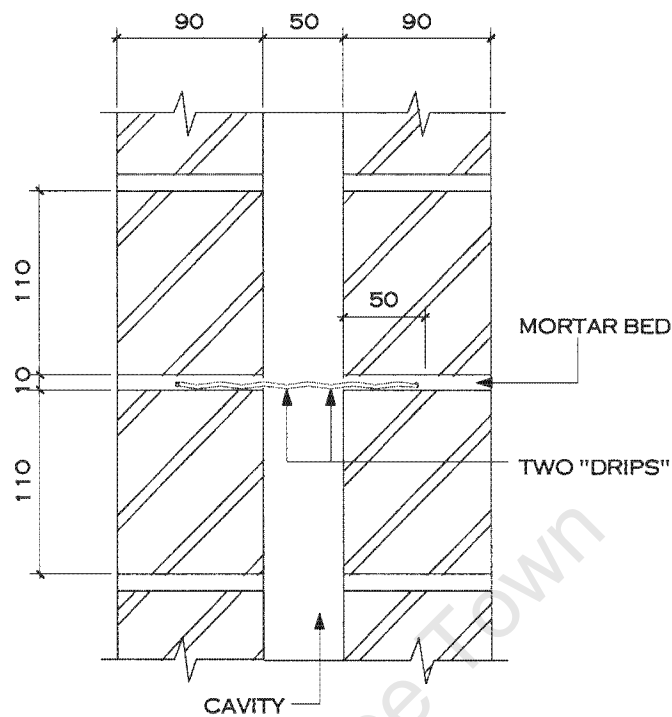

**Figure 16: Crimped Tie placed in Cavity Wall**

## 2.7 RESISTANCE TO CORROSION

Awareness of possible corrosion problems in metal-tied masonry walls has increased due to corrosion damage found on reinforcement in concrete bridge decks and marine environment structures (BIA, 1988). In the light of this, the potential for corrosion problems in masonry has increased as construction and design philosophies have changed and as environmental conditions have changed over the last decades. These changes include use of thinner masonry walls that are most susceptible to water penetration, increases in atmospheric pollutants, and use of accelerators containing calcium chloride. Rousseau (2000), hence states that new mortar provides a protective alkaline environment to the ties similar to that provided to steel reinforcement in concrete. This protection does not last long, however, because the higher porosity of mortar makes it vulnerable

to rain, carbon dioxide, and such pollutants as sulphur dioxide, which reduce the alkalinity (carbonation) This explains why corrosion usually occurs on the part of the tie within the mortar joint or under mortar droppings in the cavity areas likely to absorb and retain moisture. By the elimination of a platform on which a mortar bridge may form and reducing the area embedded in the mortar, the effects of corrosion is reduced when the Crimped Tie is used instead of the Butterfly Tie.

This list is not all-inclusive; corrosion potential can also be affected by the function of a structure, geographic location, compatibility of construction materials, detailing and workmanship.

Once corrosion of wall ties has been detected and established, deterioration is comparatively rapid. Moore (1981) states that the expansive forces generated by the volume of rust formed from ties cause progressive disruption of mortar beds, probably before the structural connection is impaired. It is for this reason that it is very important that all the original ties are isolated or removed from within the walls. Wire ties however, when rusting, are unlikely to cause any visible damage and therefore give no warning of corrosion.

Corrosion of all galvanised wall ties leads eventually to loss of structural connection between the two leaves of a cavity wall.

In order to provide corrosion protection, environmental factors must be controlled or metals used in construction must be protected. Conventional corrosion protection methods attempt to protect metals embedded in masonry by isolating them with impervious coatings (barrier protection), by using metals that are corrosion resistant. A consideration, especially marine environment structures, is

to provide cathodic protection in which one metal becomes sacrificial to another.

It is clear that, ties manufactured from copper and copper alloy, cadmium-coated steel, zinc-coated steel, stainless steel or polypropylene, according to SABS 28-1986, are deemed-to-satisfy the corrosion resistance requirement, provided the material itself complies with certain standards.

## **2.8 STATEMENT OF RESEARCH**

Cost is always a factor in product specifications. Since the cost of ties is typically a very small part of the total wall cost, wire tie cost should then not have a major influence on the selection of a wall tie system, since the cost of ties is typically a very small part of the total wall cost. However, given the fact that the Butterfly Type is approximately four times the price of a Crimp Type, and the fact that these two types are the most commonly used ties in the Western Cape, the price does play a significant role as any housing structure must be erected as economically as possible.

Therefore the need is there for the design of more economical shapes for ties.

## **2.9 SPECIFIC OBJECTIVES**

- 2.9.1 To evaluate the South African, Australian and British Codes on Wire Ties
- 2.9.2 To test the Butterfly and Crimp wire tie for strength and resistance to water transfer

2.9.3 To identify possible areas of further research

2.9.4 To make design recommendations where appropriate.

## **2.10 METHODOLOGY**

The research was carried out by means of a literature study and a survey amongst contractors regarding the use of the different wall tie systems available on the market as specified in SABS 28-1986, and a comparative set of tests on both Butterfly and Crimped wire wall ties.

University of Cape Town

## CHAPTER 3

### EXPERIMENTAL PROGRAMME

#### 3.1 METHOD OF TEST FOR RESISTANCE TO WATER TRANSFER

##### 3.1.1 Principle

Ties were cleaned and placed into a rig in which the outer end of the ties are clamped between rubber-faced jaws, see figure 17. The inner ends of the ties were placed in a level position and also with the inner leaf lower than the outer leaf end. The jaws of the test rig were subjected to a controlled flow of water to simulate free water flowing down the inside face of the external leaf of a cavity wall. The ties are observed to see whether water is transferred by them across the wall cavity.

##### 3.1.2 Apparatus.

The following apparatus was used:

- A testing apparatus of the Type illustrated in Figure 17
- A supply of clean tap water to which a wetting agent were added
- Blotting paper sufficient to wrap the specimens.

##### 3.1.3 Samples

A test sample consisted of five specimens, which were sampled at random

##### 3.1.4 Preparation of Test Specimens

Specimens were wiped clean of any grease, loose rust or dirt.

### 3.1.5 Procedure

- The ties were installed horizontally with a designated top face uppermost, into the testing apparatus with the rubber-faced jaws firmly clamped over it and the clamped section of the tie projecting 50mm inside, and at right angles to the face of, the jaws.
- A piece of blotting paper, 20mm wide, were wrapped around the exposed end of the tie with its nearest point at a distance from the jaws of the apparatus equal to the design cavity width. To secure the blotting paper, a piece of sticky tape were used, where 3mm length of the blotting paper were exposed towards the jaws.
- The header tank was filled with water so that it continuously overflowed without interruption. A continuous film of water was running across the distribution plate of the test rig.
- The rate of flow was adjusted to approximately 50ml/s per metre of distribution width. The flow was continued for one minute.
- At the conclusion of the test period, the blotting paper was removed and examined for signs of dampness. Fresh paper was used for subsequent tests.
- The above steps were repeated for each tie, except that the exposed end was lowered vertically by 10mm.



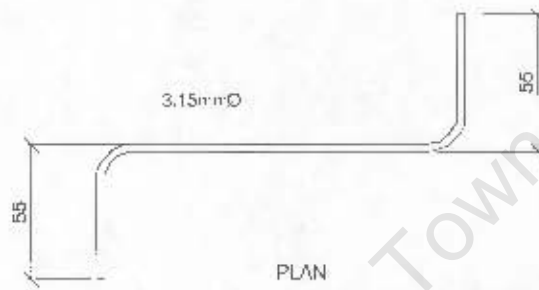
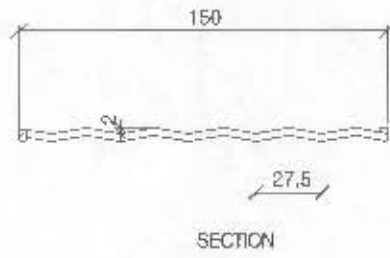

Figure 18: Crimped Wire Tie

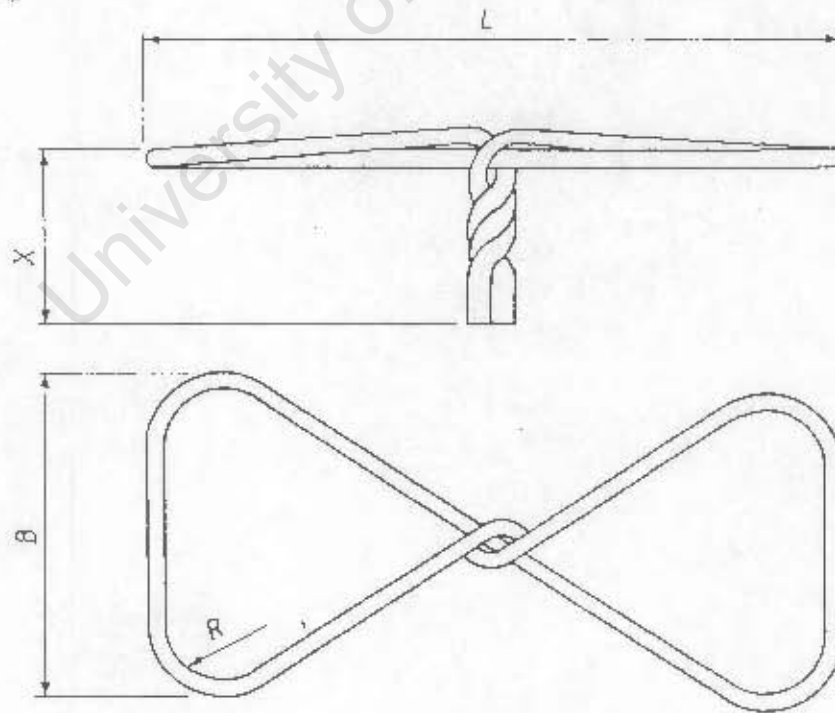

Figure 19 Butterfly Wire Tie

(Dimensions are given Figure 9)

### 3.2.3 Principle

Cavity ties were set at each end into a mortar-bonded couplet of bricks. The specimens were held in a "Zwick" (Figure 21) testing machine and a force was applied until the brick couplets failed.

### 3.2.4 Materials

- Bricks – 220mm x 110mm x 90mm
- Mortar – of type cement 1: lime 2: sand 9 parts by volume, was used for not less than 15 minutes and not more than 30 minutes after mixing.
- Vapour-proof sheet – sufficient to wrap specimens were used.

### 3.2.5 Construction.

Construction of the couplets were done as follows (figure 20):

- A timber batten was placed, cut with its horizontal width equal to the designated cavity, and vertical dimension of 50 mm, on a vapour-proof sheet on a horizontal surface.
- 6 bricks were set out along each side of the timber batten so that each brick was separated from the adjacent bricks in the same line by a perpendicular gap approximately 13 mm wide.
- A bed of mortar was placed on the bricks, using a normal bricklaying action and using as nearly as possible a single trowelful of mortar for each set of 6 bricks.
- The ties were firmly pressed into the mortar bed, one tie to each pair of couplets, with an embedment of 50 +/- 5 mm from each side of the cavity, in such a position so that they were in the middle of the line of bricks, at right angles to the inside faces of the bricks and fully embedded in the mortar.
- After not less than 1 minute nor more than 4 minutes from the commencement of spreading of the bed, the second course

of bricks, was placed in position ensuring a uniform 10 mm joint thickness. Any excess mortar, were struck including perpendicular joints.

- The above steps were repeated as required until the total number to be tested had been made.
- The specimens were wrapped in the vapour-proof sheet and they were left undisturbed.

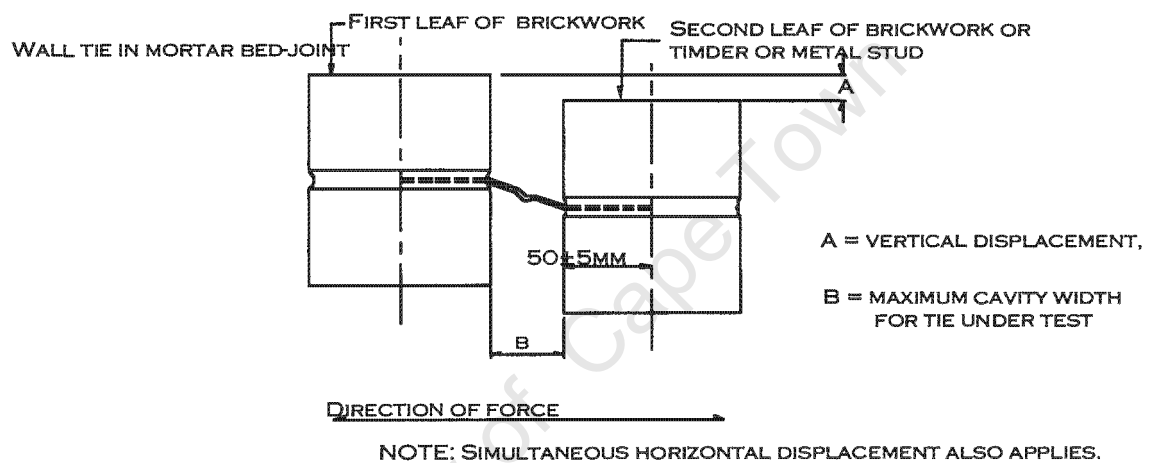

**Figure 20: Vertical displacement of wall ties under test conditions**

### 3.2.6 Test Procedure

Testing took place following the procedure set out in AS 2699 – 1984 for testing wall ties in brick couplets. All testing was carried out in a “Zwick” (Figure 21) testing machine. The generic set ups for the tension and compression tests are shown in Figure 21. A total of 12 specimens were made, comprising of 3 couplets with Crimp type ties for compression testing, 3 for tensile testing and with 3 couplets each repeated for the butterfly type tie.

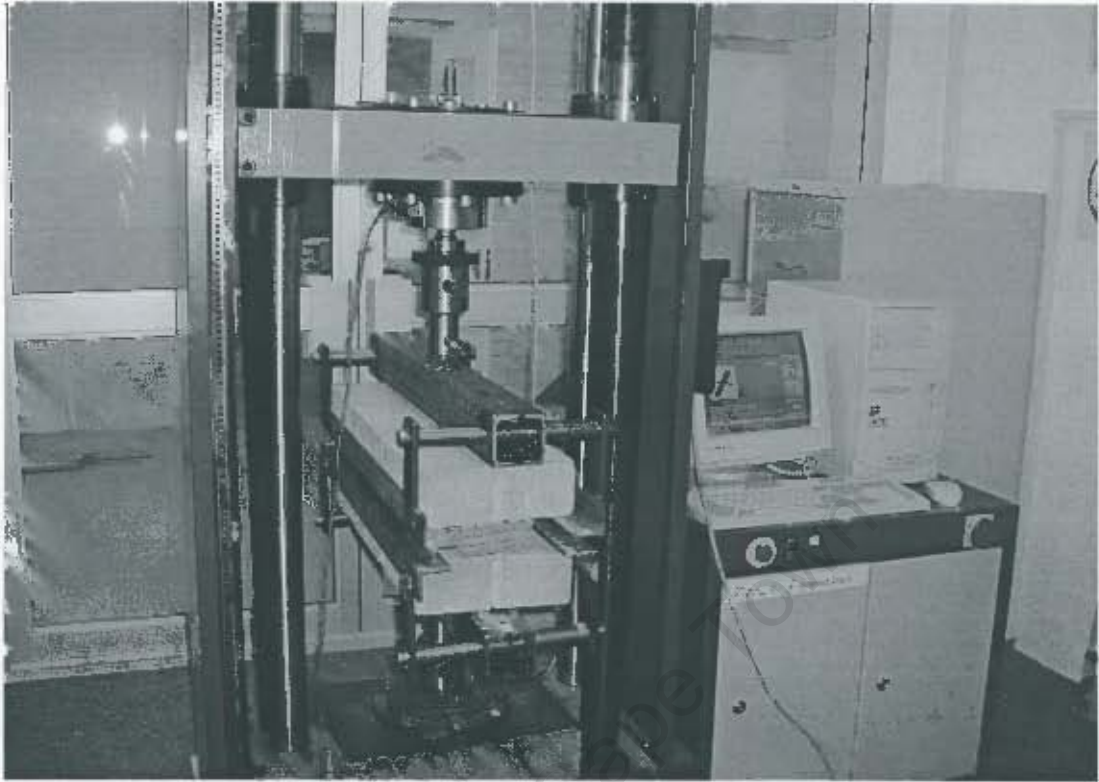

**Figure 21: Zwick Testing Machine**

### 3.2.7 Preparation and Sampling of Specimens

- The specimens were tested on the 7<sup>th</sup> day after the construction of the couplets was completed.
- The specimens were randomly divided into two equal groups, one of which was used in the compression test and the other in the tensile test.
- In the tensile test, each pair of couplets was firmly held by the machine in the relative positions they would occupy if no displacements occurred. The couplets were then displaced relative to each other by an amount dependent on the type of tie being tested.

### 3.2.8 Procedure

- The specimen was securely held in the displaced position.
- The tie was subjected to tension and compression force along the axis it held before displacement (normal to the inside of the couplet).
- In the compression test, the force was steadily increased, until the specimen failed.
- The force was recorded at failure.
- In the tensile test, the force was steadily increased, until the tie was "pull-out" of the mortar.

### 3.2.9 Calculation of Characteristic Values

- The characteristics value is that value above which 95 percent of results can be expected to lie.
- Any number of test results may be used with the appropriate formula, but it should be noted that the greater the number of test results, the more accurate and favourable the characteristics value is likely to be.
- The characteristic strength of the lot of wall ties shall be calculated upon a statistical analysis of 3 or more individual test results, in both compression and tension using the following formula:

$$X_c = X - 1.65 S_{(x)}$$

- $X_c$  = characteristics strength in either compression or tension, in kilonewtons
- $X$  = average strength of  $n$  results where  $n \geq 3$ , in kilonewtons
- $S_{(x)}$  = unbiased standard deviation of  $X$

### **3.3 METHOD FOR TESTING TIE ONLY FOR COMPRESSION AND TENSION**

#### **3.3.1 Procedure**

All testing was carried out in a "Zwick" testing machine. Six Crimped Ties were tested for compression and six for tension. These tests were repeated for Butterfly Ties.

#### **3.3.2 Preparation and Sampling of Specimens**

The specimens were randomly divided into two equal groups, one of which was used in the compression test and the other in the tensile test.

#### **3.3.3 Procedure**

- The specimen was securely held in the displaced position.
- The tie was subjected to tension and compression force along the axis it held before displacement
- In the compression test, the force was steadily increased, until the specimen reached a 10mm reduction
- The force was recorded at 10mm reduction
- In the tensile test, the force was steadily increased, until the 10 mm extension occurred.

## CHAPTER 4

### RESULTS OF TEST AND DISCUSSION

#### 4.1 RESULTS OF TESTS FOR RESISTANCE TO WATER TRANSFER

Butterfly Ties and Crimped Ties were tested for Water Transfer using different scenarios as indicated in the tables below:

Key: B – Butterfly Tie

W – Water Transfer

C – Crimped Tie

##### 4.1.1 Butterfly Tie

LABEL/NO	POSITION	OBSERVATION
BW - 1	Horizontal	Blotting Paper Dry
BW - 2	Vertically Lowered by 10 mm	Blotting Paper Dry
BW - 3	Drip upside down	Blotting Paper Dry
BW - 4	Mortar droppings on drip	Blotting Paper Dry

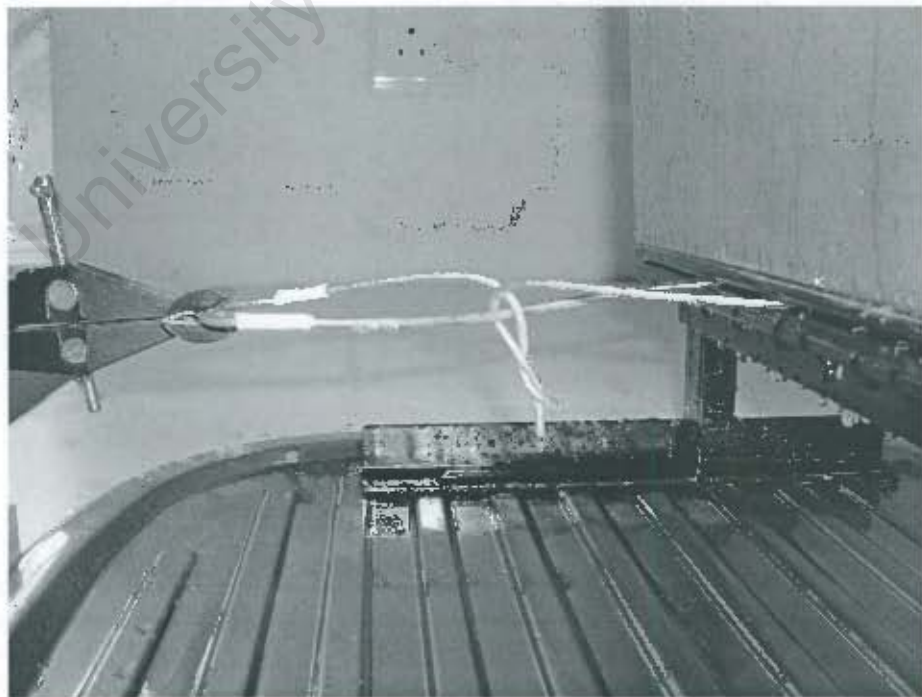

Figure 22: (BW-1)



Figure 23: (B'W-2)



Figure 24: (BV'-3)



**Figure 25: (BW-4)**

#### 4.1.1.1 Discussion on Butterfly Tie

The Butterfly Tie fulfilled its requirements for water transfer. It was observed that when the Butterfly Tie was placed in the horizontal position, then vertically lowered by 10mm, with the drip upside down and with mortar droppings on the drip, no water transfer had occurred.

At one stage water did transfer from the outer leaf towards the inner leaf, but fortunately the water dropped off before it reached the drip. However when the Butterfly Tie was placed under tension, the drip part was pulled closer to the inner leaf and therefore the possibility is there that if the Butterfly Tie is placed upside down, and this type of transfer did take place, then water could have transferred to the inner wall.

#### 4.1.2 Crimped Tie

LABEL/NO	POSITION	OBSERVATION
CW - 1	Horizontal	Blotting Paper Dry
CW - 2	Vertically Lowered by 10 mm	Blotting Paper Dry
CW - 3	Drip Flat on side Horizontal	Blotting Paper Dry
CW - 4	Drip Flat on side Lowered by 10 mm	Blotting Paper Dry
CW - 5	Water directly on tie	Blotting Paper Dry
CW - 6	Crimped Tie after tensile test. Hardly any drips- horizontal	Blotting Paper Dry
CW - 7	Crimped Tie after tensile test. Hardly any drips- Lowered by 10 mm	Blotting Paper Dry



Figure 26: (CW-1)

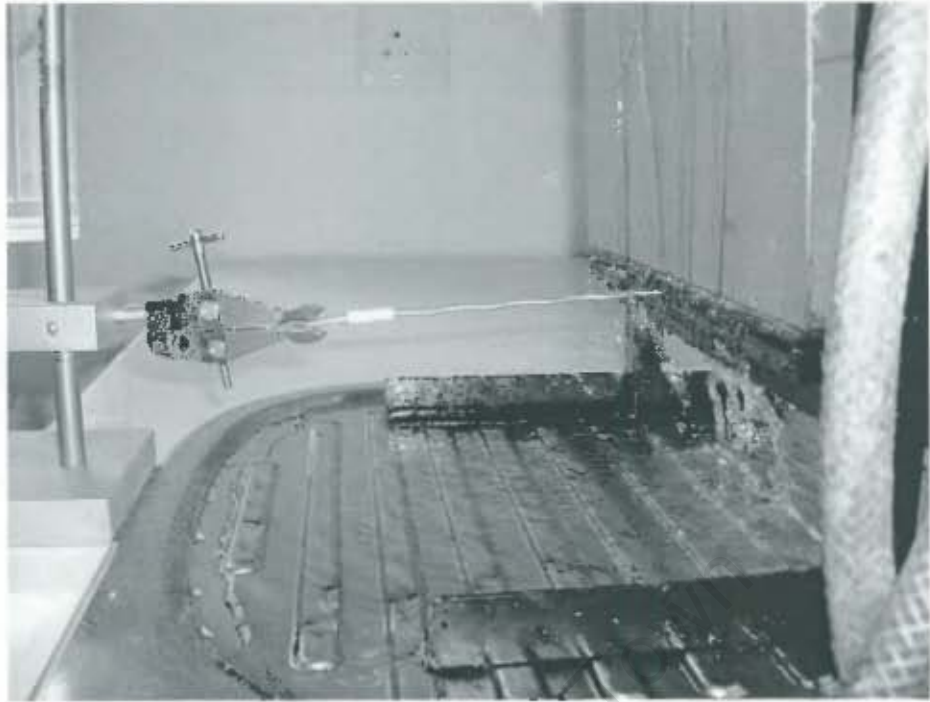

Figure 27: (CW-2)

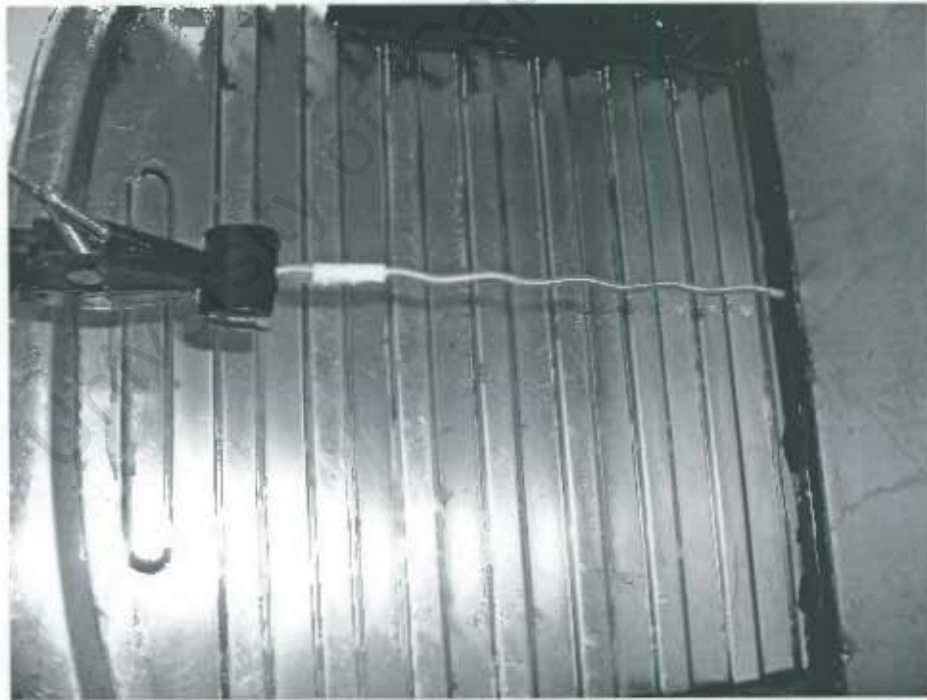

Figure 28: (CW-3)



Figure 29: (CW-4)



Figure 30: (CW-5)

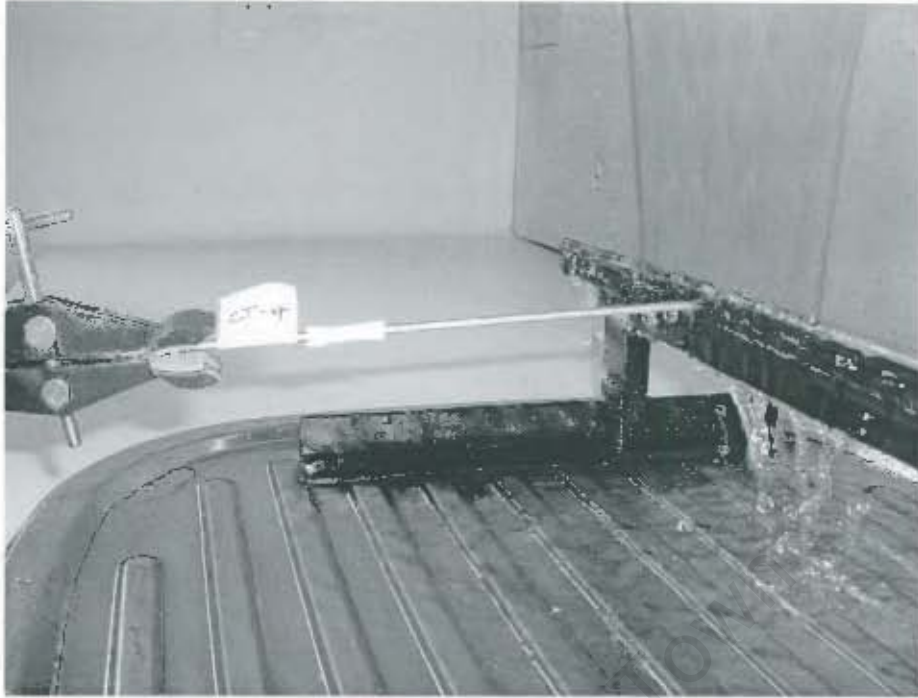

Figure 31: (CW-6)

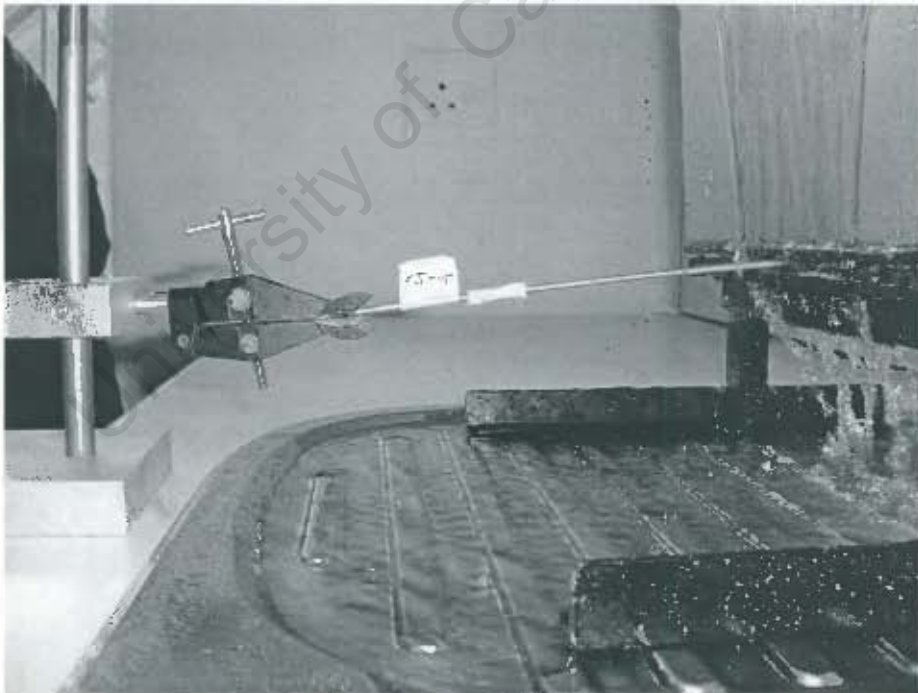

Figure 32: (CW-7)

#### 4.1.2.1 Discussion on Crimped Tie

The Crimped Tie also fulfilled all the requirements for water transfer. Even on a Crimped Tie that was previously used in a

tensile test and where there were hardly any drips left, the Crimped Tie still fulfilled its required function.

The Crimped Tie was tested for water transfer in a horizontally correct position with the drips facing down and then vertically lowered on the inner leaf side by 10mm. It was also tested with the drip horizontally flat on its side, then with the drip horizontally flat on its side but declined by 10mm towards the inner leaf. Afterwards it was tested with water dripping directly onto the tie.

After it was used in a tensile test, a Crimped Tie, with hardly any drips, was tested for water transfer and the same tie was also tested, declined by 10mm towards the inner leaf.

In all cases the blotting paper was found to be dry after the minimum test period required and also after an extended test period.

#### 4.2 RESULTS OF COMPRESSION AND TENSILE TESTING OF TIES IN COUPLETS

**Table 5: Butterfly Tie Compression Test Results**

LABEL/TEST NO	LOAD (N)	DIAMETER	FAILURE MODE OF TIE
BC-1	813	3.15 mm	Brick couplet collapse
BC-2	587	3.15 mm	Brick couplet collapse
BC-3	623	3.15 mm	Brick couplet collapse
<b>Mean</b>	674.33		
<b>Std Dev</b>	121.43		
<b>Characteristic</b>	473.97		

**Table 6: Crimped Tie Compression Test Results**

LABEL/TEST NO	LOAD (N)	CAVITY WIDTH	FAILURE MODE OF TIE
CC-1	986	50 mm	Buckling
CC-2	1123	50 mm	Buckling
CC-3	1235	50 mm	Buckling
<b>Mean</b>	<b>1114.67</b>		
<b>Std Dev</b>	124.71		
<b>Characteristic</b>	908.89		

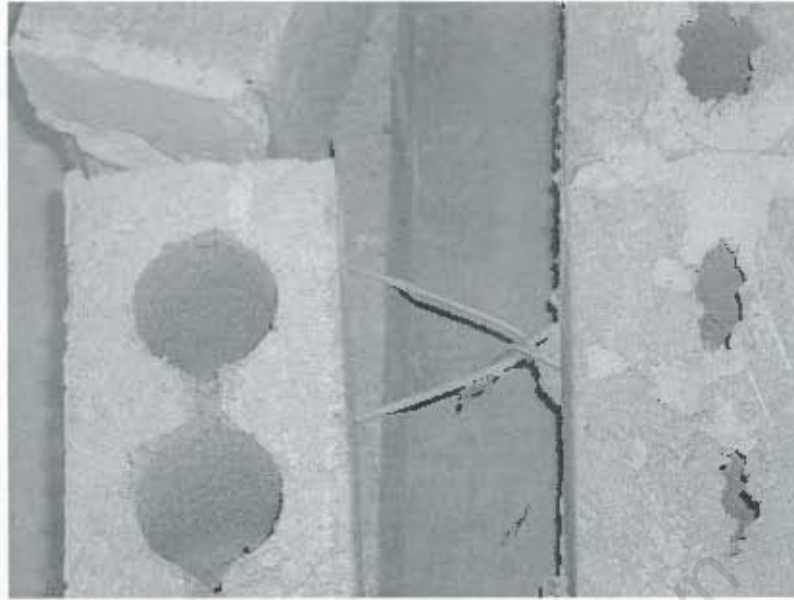

**Figure 33: Butterfly Tie Compression Test result in Couplet**



**Figure 34: Crimped Tie Compression Test result in Couplet**

#### 4.2.1 Discussion on Compression Testing

The results of the compression tests on the specimens are shown in Tables 5 and 6 and figures 33 and 34. In each case the load of the "compressed" force was recorded.

They show that the mean load for the Butterfly Tie was 674,3 N and the mean load for the Crimped Tie was 1114,67 N. The only visible sign of the Butterfly Tie having been tested was the brick couplets falling apart due to the excessive force applied.

The actual compressive failure strength of the specimen in a structure is actually even lower than the characteristic strength. For design purposes the Codes apply an additional material (safety) factor of 1.5 to material strength, but that is not applicable when actual failure capacities are being evaluated.

Therefore, according AS 2699-1984, (Table 1), Table 7 the min characteristic strength of wall ties is shown:

**Table 7:**  
**MINIMUM CHARACTERISTIC STRENGTH AND STIFFNESS OF WALL TIES**

1	2	3	4
Classification	Min. characteristic strength, kN		Min. characteristic stiffness, kN/mm
	Tension	Compression	
Light duty	0.25	0.3	Not applicable
Medium duty	0.5	0.6	1.0
Heavy duty	1.25	1.5	2.5
Extra-heavy duty	2.5	3.0	5.0

Watermeyer (1999) writes in a report to SABS that based on some work done in the SA Transport Services Track Laboratories in the mid-1980's, the Joint Structural Division recommends that the characteristic strengths of ties should be slightly higher than that for a medium duty tie, viz. Characteristic strength of 0,6 kN (Tension) and 0,7 kN (Compression).

In the opinion of the writer, the Butterfly Tie and the Crimped Tie are to be classified as medium duty. Therefore according to AS 2699-1984, Table 7, the minimum characteristic strength for compression is 0,6 kN.

According to Table 4 reflecting the characteristic strength applicable in the test performed, the characteristic value was 0,474 kN for the Butterfly Tie. Consequently, with a safety factor of 1,5 this will give a minimum characteristic strength of 0,32 kN which is NOT within the limit of table 7.

Table 6 shows the characteristic strength for the Crimped Tie as 0,909 kN and with a safety factor of 1,5 will give 0,61 kN, which is within the limit of table 7.

**Table 8: Butterfly Test in Tension Results**

LABEL/TEST NO	LOAD (N)	DIAMETER	FAILURE MODE OF TIE	OBSERVATION
BT-1	2605	3,15 mm	Tie did not break	Drip Extension
BT-2	2675	3,15 mm	Tie did not break	Drip Extension
BT-3	2847	3,15 mm	Tie did not break	Drip Extension
<b>Mean</b>	2709,00			
<b>Std Dev</b>	124,53			
<b>Characteristic</b>	2503,52			

**Table 9: Crimped Tie Test in Tension Results**

LABEL/TEST NO	LOAD (N)	DIAMETER	FAILURE MODE OF TIE	OBSERVATION
CT-1	1053	3,15 mm	Tie did not break	Tie Slippage
CT-2	948	3,15 mm	Tie did not break	Tie Slippage
CT-3	1248	3,15 mm	Tie did not break	Tie Slippage
<b>Mean</b>	1083			
<b>Std Dev</b>	152,23			
<b>Characteristic</b>	831,82			

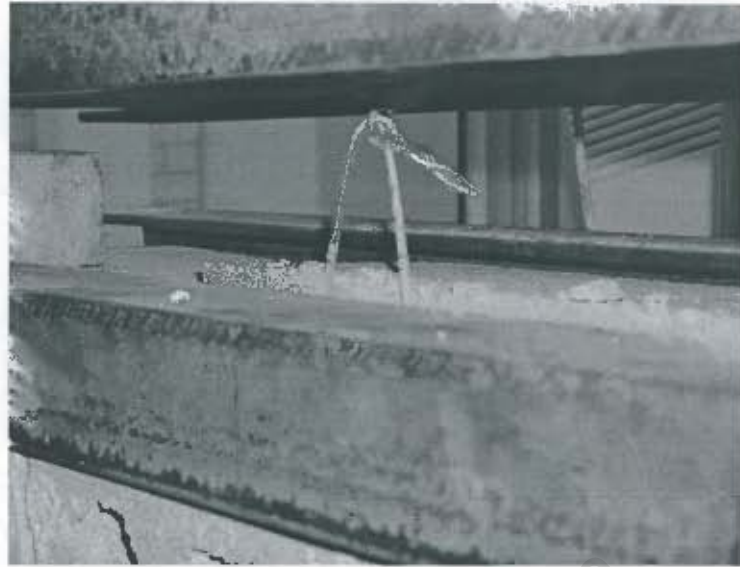

**Figure 35: Butterfly Tie Tensile Test result in Couplet**



**Figure 36: Crimped Tie Tensile Test result in Couplet**

#### 4.2.2 Discussion on Tensile Testing

The results of the tensile tests on the specimens are shown in Tables 8 and 9 and figures 35 and 36.

In each case the load of the "pull-out" force was recorded.

They show that the mean load for the Butterfly Tie was 2709 N and the mean load for the Crimped Tie was 1083 N. The "pull-out" force was greater in the case of the Butterfly Tie, because the Butterfly Tie has a greater area embedded in the mortar.

In none of the tests was there any indication of tie failure. The only visible sign of the Crimped Tie having been tested, was "slippage" and the visible sign of the Butterfly Tie having been tested was the central drip section of the ties, extending.

The minimum characteristic strength for tension is 0,5 kN according to AS 2699-1984, (Table 1), Table 7.

The tensile test for the Butterfly Tie according to table 8 produced a characteristic strength of 2,503 kN and with a safety factor of 1,5, will give 1,668 kN which is within well within the limit.

According to table 9, the tensile test for the Crimped Tie shows a characteristic strength of 0,832 kN. With a safety factor of 1,5, this will provide a value of 0,555 kN which is within the limit of table 7.

### **4.3 RESULTS OF COMPRESSION AND TENSILE TESTS FOR THE TIE ON ITS OWN**

#### **4.3.1 Introduction**

To be more comprehensive in the testing of the ties, the author decided that, in addition to the water transfer test and the tie in a couplet test (which included mortar), compression and tensile tests of the Butterfly Tie and the Crimped Tie, each on its own, be done.

**Table 10: Butterfly Tie (on its own) Compression Test Results**

LABEL/TEST NO	LOAD (N)	DIAMETER	EXTENSION	DURATION	OBSERVATION
BC-1	350	3.15 mm	10 mm	29.1 sec	"Drip untwisted"
BC-2	456	3.15 mm	10 mm	30 sec	"Drip untwisted"
BC-3	275.6	3.15 mm	10 mm	30.12 sec	"Drip untwisted"
BC-4	426.5	3.15 mm	10 mm	28.7 sec	"Drip untwisted"
BC-5	364	3.15 mm	10 mm	28.8 sec	"Drip untwisted"
BC-6	291.3	3.15 mm	10 mm	30.23 sec	"Drip untwisted"
<b>Mean</b>	390				
<b>Std Dev</b>	33.25				
<b>Characteristic</b>	335.14				

**Table 11: Crimped Tie (on its own) Compression Test Results**

LABEL/TEST NO	LOAD (N)	DIAMETER	EXTENSION	DURATION	OBSERVATION
CC-1	1681.38	3.15 mm	10 mm	6.77	Buckling
CC-2	1861.77	3.15 mm	10 mm	4.95	Buckling
CC-3	1667.97	3.15 mm	10 mm	4.76	Buckling
CC-4	1739.78	3.15 mm	10 mm	5.92	Buckling
CC-5	1752.34	3.15 mm	10 mm	5.17	Buckling
CC-6	1872.67	3.15 mm	10 mm	6.2	Buckling
<b>Mean</b>	1761.65				
<b>Std Dev</b>	80.93				
<b>Characteristic</b>	1628.12				

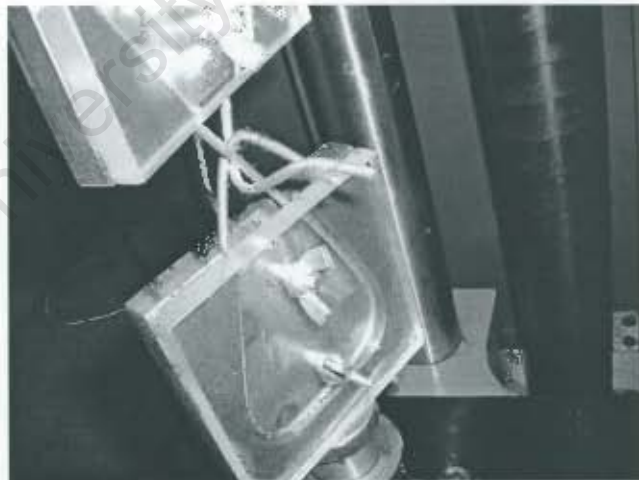
**Figure 37: Butterfly Tie (on its own) Compression Test result**

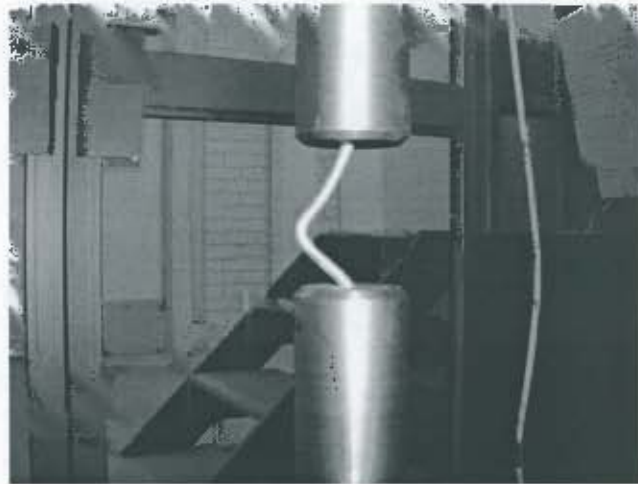

Figure 38: Crimped Tie (on its own) Compression Test result

#### 4.3.1 Discussion on Compression Tests results

The characteristic strength of the Butterfly Tie in the compression test, according to table 10 (figures 37) is 0,335 kN and for the Crimped Tie in table 11 (figure 38) is 1,628 kN. This test result proves very clearly that the Crimped Tie has a greater resistance to buckling under compressive loads, than the Butterfly Tie.

Table 12: Butterfly Tie (on its own) Tensile Test Result

LABEL/TEST NO	LOAD (N)	DIAMETER	EXTENSION	STRAIN	OBSERVATION
BT-1	635	3.15 mm	10 mm	9.43	Drip Extension
BT-2	664	3.15 mm	10 mm	9.52	Drip Extension
BT-3	560	3.15 mm	10 mm	9.98	Drip Extension
BT-4	600	3.15 mm	10 mm	9.10	Drip Extension
BT-5	574	3.15 mm	10 mm	9.41	Drip Extension
BT-6	604	3.15 mm	10 mm	9.94	Drip Extension
<b>Mean</b>	606.2				
<b>Std Dev</b>	35.08				
<b>Characteristic</b>	548.32				

Table 13: Crimped Tie (on its own) Tensile Test Result

LABEL/TEST NO	LOAD (N)	DIAMETER	EXTENSION	STRAIN	OBSERVATION
CT-1	3224	3.15 mm	10 mm	9.54	Straightening drip
CT-2	3237	3.15 mm	10 mm	9.98	Straightening drip
CT-3	3418	3.15 mm	10 mm	9.9	Straightening drip
CT-4	3435	3.15 mm	10 mm	9.93	Straightening drip
CT-5	3339	3.15 mm	10 mm	9.96	Straightening drip
CT-6	3487	3.15 mm	10 mm	9.84	Straightening drip
<b>Mean</b>	3356.67				
<b>Std Dev</b>	99.26				
<b>Characteristic</b>	3192.89				

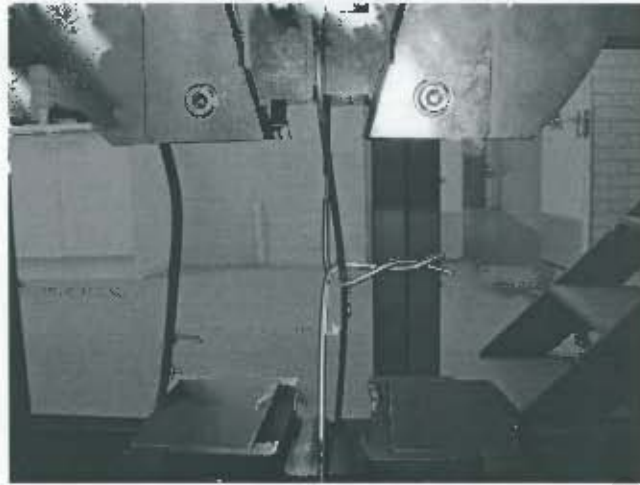

**Figure 39: Butterfly Tie (on its own) Tensile Test result**

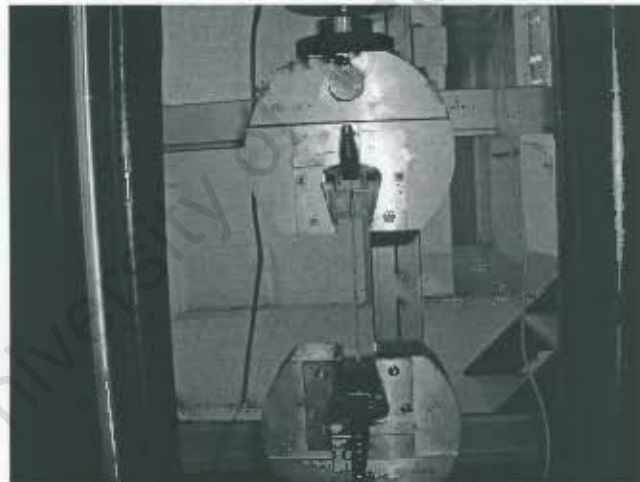

**Figure 40: Crimped Tie (on its own) Tensile Test result**

#### 4.3.2 Discussion on Tensile Tests results

In the tensile tests the characteristic strength of the Butterfly Tie, as shown in table 12 (figure 39), was 0,584 kN and in table 13 (Figure 40) for the Crimped Tie is 3,913 kN.

It is very clear that the Crimped Ties' characteristic strength in tension is more than six times greater than that of the Butterfly Tie.

## CHAPTER 5

# CONCLUSIONS AND RECOMMENDATIONS

### 5.1 CONCLUSIONS

- The Crimped Tie complies with SABS 28: 1986 with respect to composition, physical tests and dimensions.
- It also complies with SABS 0164-1:1980 Clause 3.2.1 (a), which allows for the use of alternative materials, subject to the designer ensuring that levels of performance and safety are equivalent to those in the relevant standards and codes of practice.
- The Crimped Tie provides at least two drips across a 50 mm cavity, while the Butterfly Tie has only one drip.
- The Crimped Tie can be placed upside down, inadvertently, without compromising performance, whereas the Butterfly Tie cannot be placed upside down.
- The Crimped Tie provides less of a platform on which mortar may form, than the Butterfly Tie. New mortar provides a protective alkaline cover over the tie. But the higher porosity of mortar allows the elements to reduce this alkalinity-carbonation. Hence, corrosion will occur on the tie embedded in the mortar joint or on mortar droppings on the tie wire.
- To comply with AS 2699-1984, there is no risk with the Crimped Tie of placing the drip too close to the inner leaf and thereby promoting the transmission of moisture from the outer to the inner leaf, but there is such a risk with the Butterfly Tie.
- The galvanised coating of Crimped Ties are practically never damaged in the manufacturing process, however Butterfly Ties routinely have nicks out of the coating near the drip.

- The tests have proved that Crimped Ties have a greater resistance to buckling under compressive loads than Butterfly Ties.
- There is the perception that the crimping effect of the Crimped Tie weakens its characteristic strength. A plain round wire was tested for compression and the result was that it could withstand a force of 2,092 kN before buckling, while the Crimped Tie's maximum strength was 1,861 kN. This is only a difference of 0,231 kN.
- It appears that the Crimped Tie has been excluded from cavity wall construction by SABS 0164-1:1980 without valid reasons.
- The actual twisted "drip" of the Butterfly Tie became "undone" in both the tensile and compression tests and this causes a drastic reduction in strength.
- Even though the Crimped Tie complies with the permissible tensile strength according AS 2699-1984, the "pull-out" force of the Butterfly Tie was comfortably higher. The reason being that the Butterfly Tie has a greater area embedded in the mortar.
- A negative aspect of the Butterfly Tie, considering the possibility of water transfer, is that the Butterfly Tie has 2 strands of wire extending from the one leaf to the other, which increases the possibility of water transfer by 200%.

## 5.2 RECOMMENDATIONS

- Because the Crimped Ties' characteristic strength in tension (in the couplet testing) is very close to the permissible requirements, an additional safety measure could be to increase the number of ties from 2.5/m<sup>2</sup> (as stipulated in SABS 28-1986) to 3.5/m<sup>2</sup>. This would be still more cost effective than the Butterfly Tie.

- It is strongly recommended, to avoid incorrect bending, by the artisans that the Crimped Tie be bent into the required Z – shape by the manufacturer. Furthermore, to increase the bearing area of the Crimped Tie, a 'return' to be added at the ends of the Crimped Tie to increase the resistance to the "pull-out" force, see figure 41 below. This would then still be more economical than the Butterfly Tie.

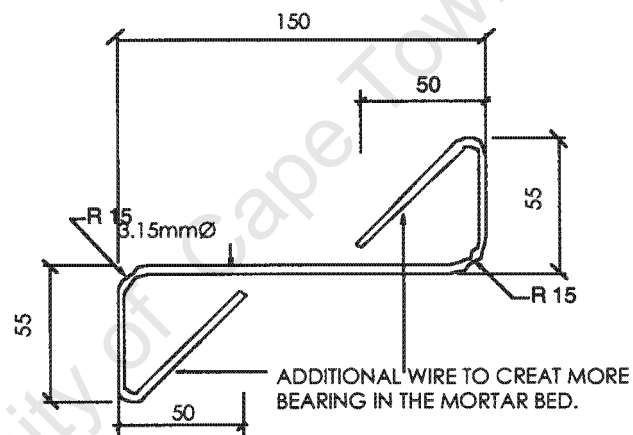

**Figure 41: Crimped Tie with a "Return"**

- Further research is needed and It is recommended that smaller diameter wire and different shapes Crimped wire be tested for compliance to the South African Codes. And if the smaller diameter wire were found to be in accordance with the South African Codes, then this would make the Crimped Tie even more cost effective.
- As the Butterfly Tie does not comply with the requirements in all aspects, it is strongly recommended that it be removed from the SABS 28 code.

- In order to increase the mortar cover to the Crimped Tie in the embedment, it is recommended that it is better not to have crimps on the parts embedded in the mortar.

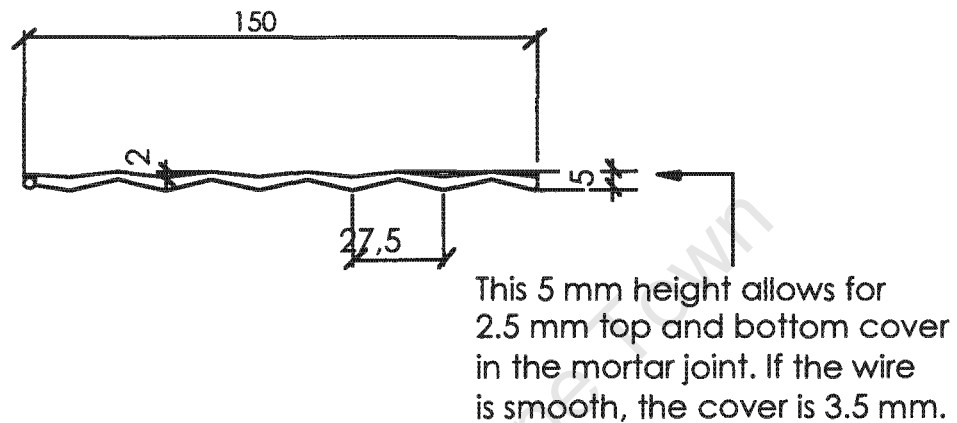

**Figure 42: Crimped Tie without "Crimps" at the ends**

- Another recommendation, and an area for further research would be to increase the resistance to the 'pull out' force would be to use an additive in the mortar mix/cement for extra grip.

## REFERENCES

1. Arora, S.K. 1986 The Spacing of Wall Ties in Cavity Walls. UK: Building Research Establishment. IP/86
2. BIA. 1998. Technical Notes on Brick Construction. Brick Industry Association: Virginia, USA.
3. BIA. 1988. Technical Notes on Brick Construction: Wall Ties for Brick Masonry. 44B Revised. Virginia USA.
4. BIA. 1994. Technical Notes on Brick Construction: Brick Masonry Rain Screen Walls. 27 Revised. Virginia USA.
5. BIA. 1998. Technical Notes on Brick Construction: Brick Masonry Cavity Walls Introduction. 21 Revised. Virginia USA.
6. BIA. 1999. Technical Notes on Brick Construction: Brick Masonry Walls Selection of Materials. 21A. Revised. Virginia USA.
7. British Standards Institution. 1986. Draft Development. Wall Ties. Part 1. Methods of Test for Mortar Joint and Timber Frame Connections. DD 140: Part 1. UK.
8. British Standards Institution. 1987. Draft Development. Wall Ties. Part 2. Recommendations for Design of Wall Ties. DD 140: Part 2. UK.
9. BS 5628 Part 1.1978. Code of Practice for Structural use of Masonry. Unreinforced Masonry. : Part 1. UK: British Standards Institution.
10. Cole, I.S., Bradbury, A. and Ganther, W. 1995. Controlled Humidity/Salt Dose Tests for the Estimation of the Durability of Masonry Ties. Australia: CSIRO. Division of Building, Construction and Engineering.
11. Croft F S and Lane J W. 2000. Structural Concrete Masonry. A Design Guide. Concrete Manufacturers Association: Midrand, South Africa.

12. Curtin.W.G., et al. 1995. Structural Masonry Designers' Manual.2nd Ed. Great Britain: Blackwell Science.
13. De Vekey R C. 1988. Ties for Cavity Walls: New Developments. BRE Information Paper IP16/88. Garston, UK: BRE.
14. De Vekey, R.C. and Hickson, C. 1999. Untied Cavity Party Walls. Structural Performance when using AAC Blockwork. CI/SfB(22) F. UK: BRE.
15. De Vekey. 2000. Ties for Masonry Walls: a Decade of Development.IP 11/00. UK: BRE.
16. Dyer, C.G. 1998. Appraisal of Crimped Wire Ties for use in Cavity Walls.
17. Edgell, G.J. The Effect of Wall-Tie Spacing on the Strength of Cavity Walls. Tech Note 355. UK: B Ceram R A
18. Hall, R. and Hopkins, C. 2001. Dynamic Stiffness of Wall Ties used in Masonry Cavity Walls: Measurement Procedure. UK: BRE. CI/SfB(21.1)(J4).
19. Hendry, A.W. 1993. The Structural Performance of Cavity Walls under Vertical Load. UK: British Masonry Society Proceedings No 5.
20. Maurenbrecher, A.H.P. and Rousseau, M.Z. 1992. Masonry Ties and Rust. Canadia: "The Canadian Architect" 37(6), p. 39, 41.
21. Moore J F A. 1981. The Performance of Cavity Wall Ties: New developments. BRE Information Paper IP4/81. Garston, UK: BRE.
22. Moore, J. F. A. 1981. The Performance of Cavity Wall Ties. Current Paper CP3/81. UK. BRE.
23. Newman, A.J. 1984. Rain Penetration through Masonry Walls: Diagnoses and Remedial Measures. UK: BRE.

24. Page, A.W., Kautto, J. & Kleeman, P.W. 1996. A Design Procedure for Cavity and Veneer Wall Ties. Australia: Masonry International Vol 10, No 2.
25. Ritchie, T. 2000. Cavity Walls. CBD-21. Canada: Canadian Building Digest.
26. SABS 0164: Part 1. 1980. Code of Practice for The Structural use of Masonry. Part 1: Unreinforced Masonry Walling. Pretoria, SA: The Council of the South African Bureau of Standards.
27. SABS 28. 1986. Standard Specification for Metal Ties for Cavity Walls. The Council of the South African Bureau of Standards. 3rd Ed. Pretoria, SA.
28. Standards Association of Australia. 1984. Wall Ties for Masonry Construction. AS 2699. Australia.
29. West, H.W., Hodgkinson, H.R. and de Vekey, R.C. 1979. The Lateral Resistance of Cavity Walls with Different Types of Wall Ties. Technical Note No. 298. UK: B.Ceram.
30. West, H.W.H. et al. 1982. The Lateral Resistance of Cavity Walls with Dissimilar Leaves. Technical Note No. 330 B. UK: Ceram R A.
31. West, H.W.H., Hodgkinson, H.R. & de Vekey, R.C. 1979. The Lateral Resistance of Cavity Walls with Different Types of Wall Ties. Tech Note 298 UK: B Ceram RA.

# **APPENDICES**

University of Cape Town

**APPENDIX A**  
**BRICK COUPLETS**



## APPENDIX B

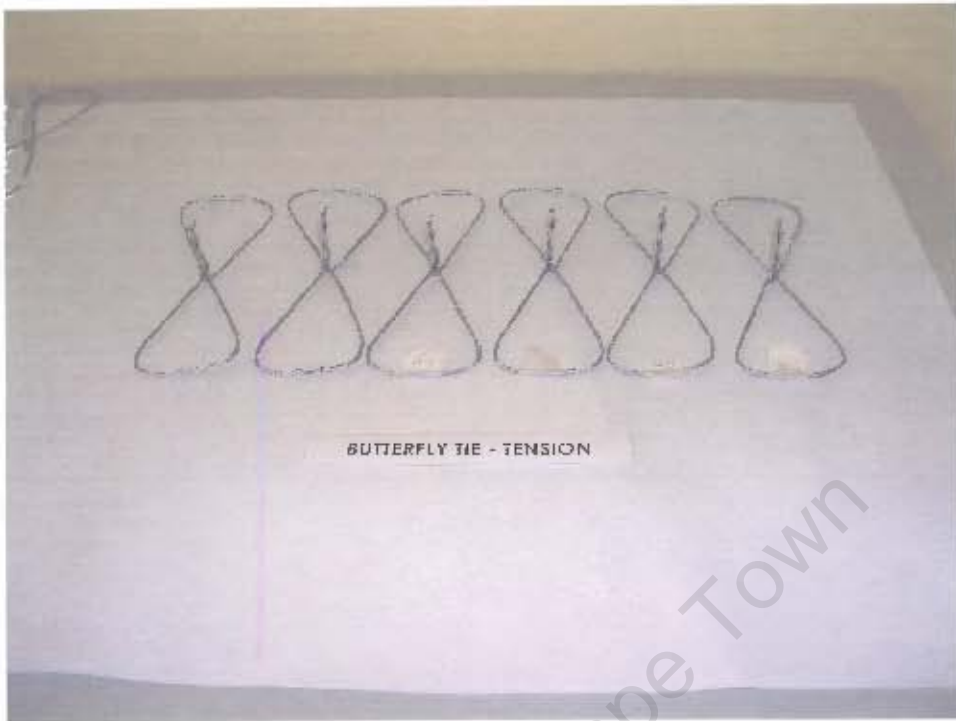

**BUTTERFLY TIE TESTING FOR TENSION**

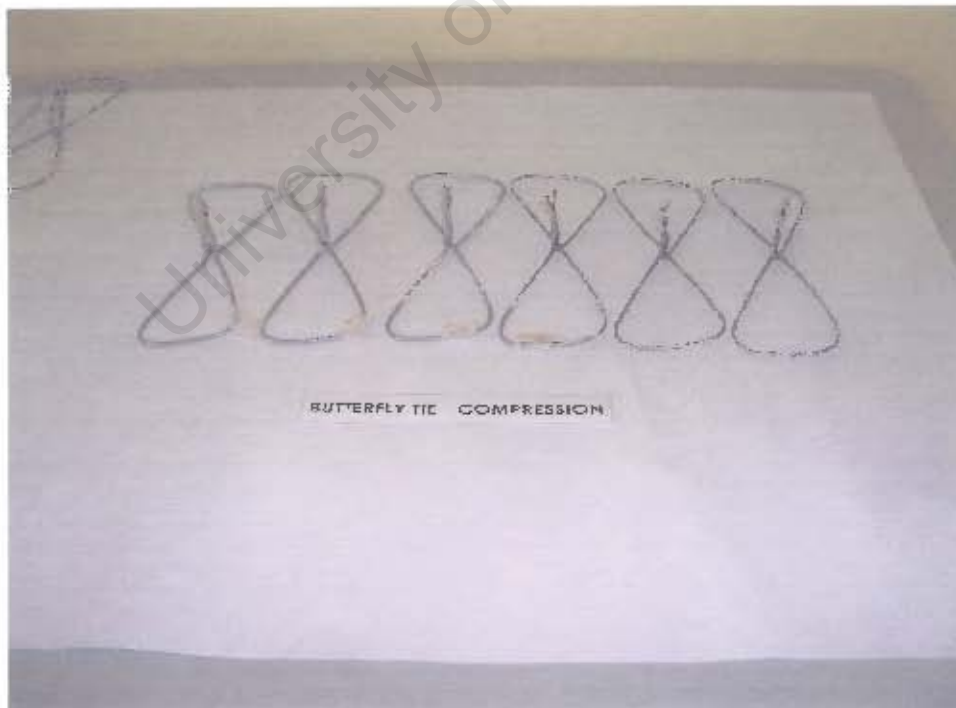

**BUTTERFLY TIE TESTING FOR COMPRESSION**

## APPENDIX C



**CRIMPED TIE TESTING FOR TENSION**



**CRIMPED TIE TESTING FOR COMPRESSION**

## APPENDIX D

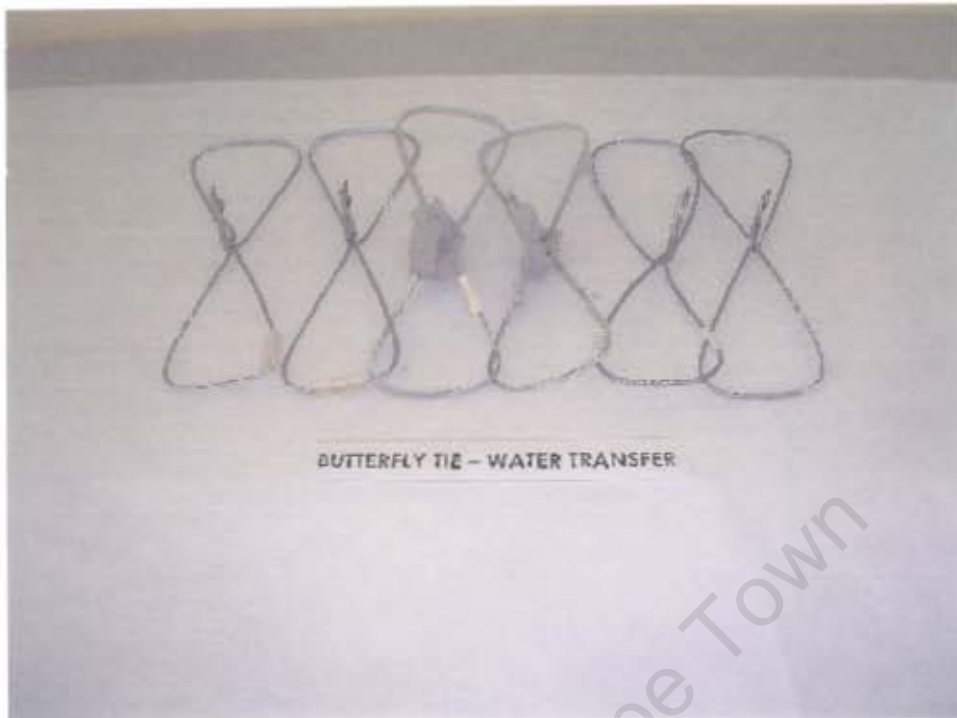

**BUTTERFLY TIE - WATER TRANSFER**

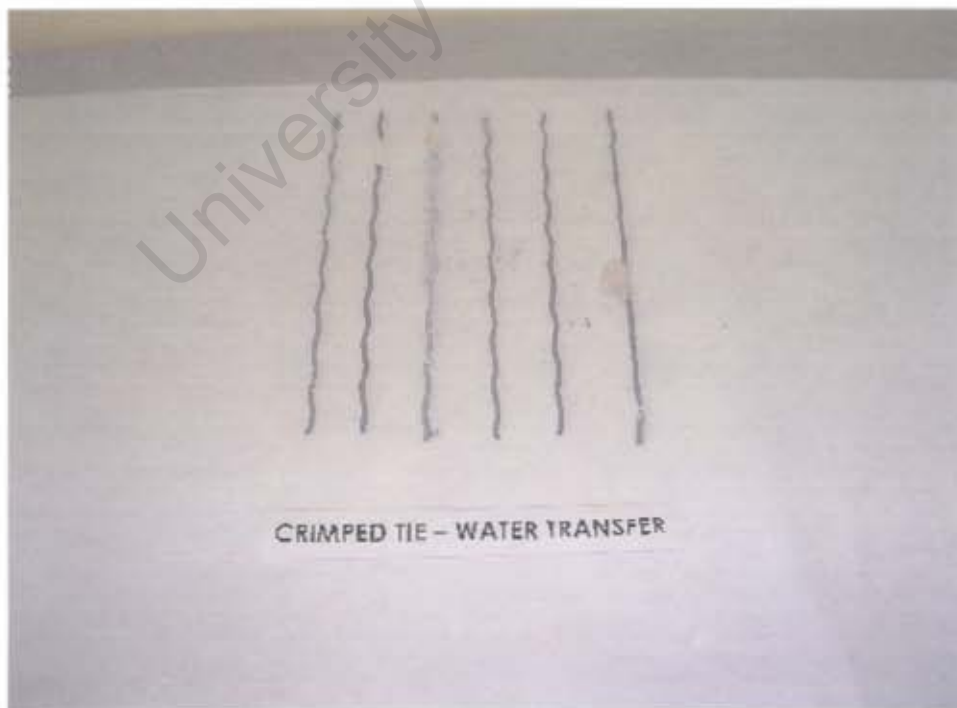

**CRIMPED TIE - WATER TRANSFER**

## APPENDIX E

### QUESTIONNAIRE ON WALL TIES FOR CONTRACTORS

NO	QUESTION	RESPONSE
1.	Which wall ties (tie wires ) do you make use of?	
2.	What is your reason for the use thereof?	
3.	If you had a choice, which type of tie wire would you make use of?	
4.	What is the reason for your choice?	

University of Cape Town

# APPENDIX F

## CRIMPED TIE: TENSION TESTING TYPICAL GRAPH

Protocol

1/10/02

### Parameters:

Order number :           Material :  
Charge :                 Extensometer (path) :  
Test standard :         Load cell :  
Tester :                 Specimen grips :  
Customer :             :

Pre-load : 2 N/mm<sup>2</sup>  
Pre-load speed: 50 mm/min  
Test speed : 100 mm/min

### Results:

Nr	Diameter d0 mm	Rm N/mm <sup>2</sup>	$\epsilon$ Rm %	RB N/mm <sup>2</sup>	$\epsilon$ Break %
1	3.15	122.52	1.05	30.39	8.13

### Series graphics:

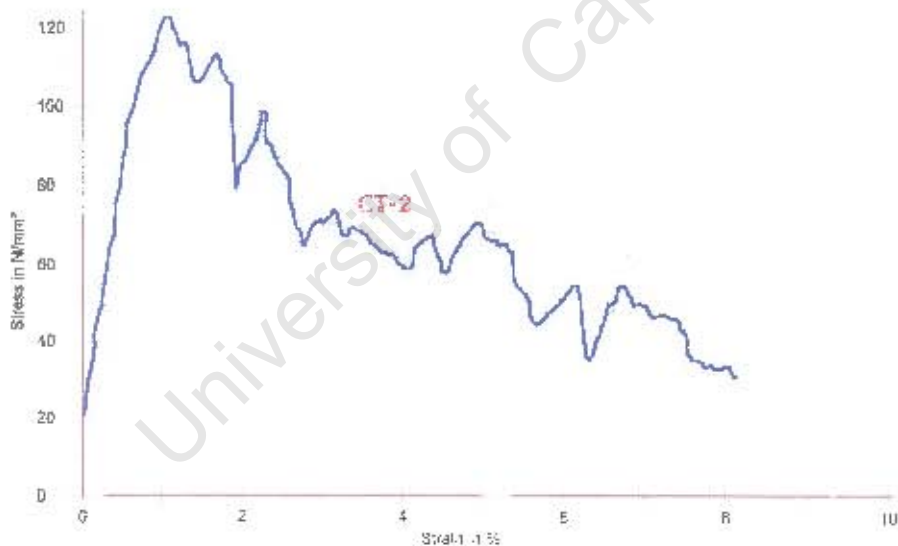

### Statistics:

Series	Diameter d0	Rm	$\epsilon$ Rm	RB	$\epsilon$ Break
n = 1	mm	N/mm <sup>2</sup>	%	N/mm <sup>2</sup>	%
x	3.15	122.52	1.05	30.39	8.13
s	-	-	-	-	-
v	-	-	-	-	-