

The copyright of this thesis vests in the author. No quotation from it or information derived from it is to be published without full acknowledgement of the source. The thesis is to be used for private study or non-commercial research purposes only.

Published by the University of Cape Town (UCT) in terms of the non-exclusive license granted to UCT by the author.



**Hydrometallurgical Extraction of Platinum
Group Metals from a Low-Grade Ore
Concentrate**

By

James Malumbo Mwase

Supervisor

Dr Jochen Petersen

Submitted in partial fulfillment of the requirements for the award of the
degree of Master of Science in Chemical Engineering

October 2009

Acknowledgements

Praises to my heavenly Father and Lord and saviour Jesus Christ, everything comes from you and all I do is for your honour.

Special thanks to my supervisor Dr Jochen Petersen not only for your supervision but for the opportunity to work on this project and all the other opportunities you have graciously given to me to expand my knowledge and skills in the areas of hydrometallurgy and general chemical engineering.

I would like to acknowledge Lonmin Plc for providing the funding for this project and the test material.

To my family, my parents Frank and Julie Mwase, my elder brother Frank, my elder sisters Patricia and Thoko, my nieces Sammy and Nandi and my nephews Nthato and Frank Jnr. Thank you for your support and love, I will always love you all.

My thanks to Frances Pocock, Emmanuel Ngoma and Sue Jobson for their technical and administrative support. I would also like to thank all the members of the Centre of Bioprocess Engineering Research for the challenging and pleasant working and social environment you have provided.

For their technical support, my thanks to Jenni Wiese and the CMR team, Helen Divey and the analytical team and Jeeten Natho and the CPU team.

Finally thanks to various individuals and groups in and outside the department who contributed to my project in ways big and small.

Declaration

I know that plagiarism is wrong, hence I declare that the work I am submitting is my own and I have duly acknowledged other people's work with an acceptable form of referencing.

James Malumbo Mwase

University of Cape Town

Symbols

Al: Aluminium

Ca: Calcium

Co: Cobalt

Cr: Chromium

Cu: Copper

Fe: Iron

g: Grams

L: Litres

m: Metres

M: Molar

Mg: Magnesium

mg: Milligrams

Ni: Nickel

Pd: Palladium

Pt: Platinum

Rh: Rhodium

Ru: Ruthenium

s: Seconds

Si: Silicon

µg: micrograms

ppm: parts per million

ppb: parts per billion

BSTR: Batch stirred tank reactor

PGMs: Platinum Group Metals

BMs: Base Metals

PMR: Precious Metals Refinery

BMR: Base Metals Refinery

PLS: Pregnant Leach Solution

Abstract

The aim of this study is to investigate the economic and technical feasibility of processing platinum group metals (PGMs) and base metals (BMs) from a low-grade ore concentrate produced in the concentrator plant at Lonmin Plc. The PGMs of particular interest are platinum, palladium, ruthenium and rhodium, while the BMs of interest are copper and nickel.

The ore concentrate, as a by-product, represents only 5 % of the total PGM value but as much as 70 % of the total tonnage of material processed in the concentrator plant. Further upgrading this material is not considered a viable route. However, even this low PGM content in the concentrate material accumulates to appreciable value on an annual basis motivating the need to develop alternative methods of extracting value from it. Initial estimates indicate that extraction levels of at least 50 % of the PGMs and 50 % of the BMs would need to be achieved, using low cost hydrometallurgical processes, to make the venture economically viable. These methods would exclude treatment via the smelter and pressure leaching: which are costly, energy intensive and result in leaching of large quantities of non-valuable elements.

Previous studies revealed that organic acids had the potential to economically extract the PGMs under alkaline conditions, and BMs under acidic conditions, from various ores and concentrate materials. A literature survey confirmed that certain organic acids can be used to leach metals from ores and concentrates via chemical complexation. It further revealed that other chemical agents, namely cyanide, thiosulphate and bisulphide, were similarly capable of strongly complexing PGMs under various conditions of pH and temperature. The survey also revealed industrially established methods for extracting BMs from low-grade ores and concentrates. Based on this material, this study experimentally evaluated these options with the intent to propose a flowsheet to treat the concentrate material. This was conducted in two phases of experimental work.

The preliminary test work was conducted on PtS₂ (75% platinum) which served as a proxy material for the platinum group minerals in the concentrate. The main reason for using this salt was that the economic viability of any process to treat the concentrate material was critically dependant on the levels of platinum extracted. Several small scale batch experiments were

conducted in which the PtS_2 was dissolved in solutions of organic acids, cyanide, thiosulphate and bisulphide in a batch stirred tank reactor varying conditions of reagent concentration, temperature, pH and chemical oxidisers. Cyanide solution and a combination of tartaric and malic acids were found to be the most effective methods of dissolving the platinum from the salt.

These options were tested on the ore concentrate in batch stirred tank, granular bed and packed bed reactors in a series of experiments. From the results it was concluded that:

- Cyanide was the most effective chemical treatment for leaching the PGMs: extracting 20 % Pt, 87 % Pd and 46 % Rh using a packed bed reactor in a space of 21 days.
- A bioleach process using thermophilic microorganisms in a packed bed reactor and at an operating temperature of $>65^{\circ}C$, was the best option for extracting copper (52 %) and nickel (95 %) from options including organic acids and ferric/sulphuric acid.
- Pre-treating the material to extract BMs was shown only to be beneficial to Pd extraction and this was conclusively linked to high nickel extractions.
- A packed bed reactor, which at industrial level would take the form of a heap, was the best reactor configuration for both the above processes.

A cost analysis, based on projected extractions of BMs and PGMs on longer leach times in heap reactors, revealed that a flowsheet combining the above processes was economically viable. It was therefore recommended that further bench scale test work be conducted on the above processes over longer operating times to confirm the projected extractions, and the inclusion of mineralogical analysis of the ore concentrate test samples before and after leach tests. The data can then be used to proceed to pilot scale test work if initial projections can be confirmed.

Contents

Acknowledgements	i
Declaration	ii
Symbols	iii
Abstract	iv
Chapter 1: Introduction	1
1.1 Overview of Project	1
1.2 Project Background	2
1.3 Key Questions	2
1.4 Objectives	3
1.5 Extractive Metallurgy of Platinum Group Metals	4
Chapter 2: Literature Review	8
2.1 Preliminary Selection Criteria	8
2.2 Characterisation of the Concentrate	9
2.3 Potential Routes of Extraction	11
2.3.1 Organic Acids	11
2.3.1.1 The Leaching Mechanism.....	13
2.3.1.2 Other Process Considerations	15
2.3.2 Cyanidation	17
2.3.2.1 Overview.....	17
2.3.2.2 Leaching Mechanism	18
2.3.2.3 PGM Cyanidation	19
2.3.2.4 Other Process Considerations	21
2.3.3 Copper-Ammoniacal Thiosulphate System	24
2.3.3.1 Overview.....	24
2.3.3.2 PGM Thiosulphate Leaching	25
2.3.3.3 Leaching Mechanism	27
2.3.3.4 Other Process Considerations	27
2.3.4 Sodium Bisulphide.....	28

2.3.4.1 Overview.....	28
2.3.4.2 PGM Leaching.....	28
2.3.4.3 Process Considerations.....	29
2.3.5 Ferrous-Ferric Cycle.....	30
2.3.5.1 Overview.....	30
2.3.5.2 Leaching Mechanism.....	30
2.3.5.2.1 Biologically Aided.....	31
2.3.5.2.2 Chemically Aided.....	32
2.3.5.3 Leaching of BMs from the Concentrate.....	33
2.3.5.4 Other Process Considerations.....	34
2.4 Methods of Recovery.....	34
2.4.1 Adsorption to carbon.....	34
2.4.2 Merrill-Crowe Process (Zinc Cementation).....	35
2.4.3 Recovery from Organic Acids.....	37
2.5 Reactor Configurations.....	37
2.5.1 Packed Bed.....	38
2.5.2 Granular Bed.....	40
2.6 Hypotheses.....	41
Chapter 3: Methodology.....	43
3.1 Phase 1: Preliminary Test Work on Proxy Material.....	43
3.1.1 Experimental Plan.....	43
3.1.1.1 Organic Acids.....	44
3.1.1.2 Cyanide.....	45
3.1.1.3 Thiosulphate.....	45
3.1.1.4 Bisulphide.....	45
3.1.2 Materials and Methods.....	45
3.2 Phase 2: Final Test Work on Low-Grade Ore Concentrate.....	48
3.2.1 Preparation of Concentrate Material.....	48
3.2.2 Material Sampling.....	48
3.2.3 Size Analysis.....	49
3.2.4 Ore Concentrate Split.....	49
3.2.5 Experimental Plan.....	50

3.2.6 Granular Bed-Operation Procedure	51
3.2.7 Packed Bed Reactor Operating Procedure for Chemical Leaching.....	54
3.2.7.1 Preparation of Sample.....	55
3.2.7.2 Packing of Column	56
3.2.7.3 Start-up Procedure	56
3.2.7.4 Sampling Procedure	57
3.2.7.5 Recovery of Concentrate Material	57
3.2.7.6 Pump Calibration Procedure	57
3.2.8 Packed Bed Reactor Operating Procedure for Bioleach Process.....	61
3.2.9 Batch Stirred Tank Reactor Operating Procedure	64
3.2.10 Analytical Methods.....	66
Chapter 4: Results, Discussion & Conclusions.....	68
4.1 Preliminary Test Work on a Proxy Material.....	68
4.1.1 Aims of Experimental Work.....	68
4.1.2 Observations and Results.....	68
4.1.3 Discussion.....	73
4.1.4 Conclusions.....	75
4.2 Final Test Work on the Low-Grade Ore Concentrate.....	75
4.2.1 Size Analysis.....	75
4.2.2 Ore Concentrate Split.....	75
4.2.3 Experiment 1: Direct leaching of PGMs using a combination of tartaric and malic acid in the presence of hydrogen peroxide at 50°C in a granular bed reactor	76
4.2.3.1 Aims.....	76
4.2.3.2 Theory	76
4.2.3.3. Materials and Methods.....	77
4.2.3.4 Results.....	78
4.2.3.5 Discussion.....	78
4.2.4 Experiment 2: Leaching of BMs using a combination of ferric sulphate and sulphuric acid at 65°C in a granular bed reactor.....	79
4.2.4.1 Aims.....	79
4.2.4.2. Theory	79

4.2.4.3. Materials and Methods.....	79
4.2.4.4. Results.....	80
4.2.4.5 Discussion.....	82
4.2.5 Experiment 3: Comparison of PGM extractions using a combination of tartaric and malic acid in the presence of hydrogen peroxide, and cyanide at 50°C in a granular bed reactor	82
4.2.5.1 Aim	82
4.2.5.2 Theory	82
4.2.5.3 Materials and Methods.....	83
4.2.5.4 Results.....	84
4.2.5.5 Discussion.....	85
4.2.6. Experiment 4: Leaching of PGMs using a combination of tartaric and malic acid, and cyanide at 50°C in batch stirred tank reactors (BSTRs)	86
4.2.6.1. Aim	86
4.2.6.2. Theory	86
4.2.6.3 Materials and Methods.....	87
4.2.6.4. Results.....	88
4.2.6.5 Discussion.....	88
4.2.7 Experiment 5: Cyanide leaching of PGMs from a pre-treated sample of concentrate material in a packed bed reactor	90
4.2.7.1 Aim	90
4.2.7.2 Theory	90
4.2.7.3. Materials and Methods.....	91
4.2.7.4 Results.....	91
4.2.7.5 Discussion.....	93
4.2.8 Experiment 6: Determining the influence of first extracting BMs on subsequent cyanide PGM leaching	95
4.2.8.1 Aim	95
4.2.8.2 Theory	95
4.2.8.3 Materials and Methods.....	96
4.2.8.4 Results.....	97
4.2.8.5 Discussion.....	100
4.2.9 Experiment 7: Organic acid leaching of BMs using BSTRs	103
4.2.9.1 Aim	103

4.2.9.2 Theory	103
4.2.9.3 Materials and Methods.....	103
4.2.9.4 Results and Discussion	104
4.2.10 Experiment 8: BM leaching from the concentrate material using tartaric-malic acid combination in a granular bed.....	107
4.2.10.1 Aim	107
4.2.10.3 Theory	107
4.2.10.4 Materials and Methods.....	107
4.2.10.5 Results.....	108
4.2.10.6 Discussion.....	109
4.2.11 Experiment 9: BM leaching using a combination of tartaric and malic acids in a packed bed reactor.....	109
4.2.11.1 Aims.....	109
4.2.11.2 Theory	109
4.2.11.3 Materials and Methods.....	109
4.2.11.4 Results.....	110
4.2.11.5 Discussion.....	110
4.2.11.6 Conclusion	112
4.2.12 Experiment 10: Bioleaching of BMs using a mixed culture of thermophiles at 65°C in a packed bed reactor	112
4.2.12.1 Aim	112
4.2.12.2 Theory	113
4.2.12.3 Materials and Methods.....	113
4.2.12.4 Results.....	114
4.2.12.5 Discussion.....	119
4.3 Chapter Conclusion	122
Chapter 5: Final Assessment.....	126
5.1 Flowsheet Generation	126
5.1.1 Flowsheet 1	126
5.1.2 Flowsheet 2	130
5.1.3 Flowsheet 3	132
5.1.4 Comparison of the flowsheets (advantages and disadvantages)	134

5.2 Environmental Remediation	135
5.2.1 Cyanide Regeneration.....	135
5.2.2 Effluent and Concentrate Treatment.....	135
5.2.3. Iron Precipitate Treatment	136
5.3. Cost Analysis of Flowsheet 1.....	136
5.4 Recommendations.....	141
6.0 References.....	143

University of Cape Town

List of Figures

Figure 1: Source of low-grade concentrate.....	2
Figure 2: General Lonmin flowsheet.....	6
Figure 3: Proposed modified Lonmin flowsheet.....	7
Figure 4: Organic acid bioleaching.....	13
Figure 5: The gold cyanidation-adsorption to carbon process.....	18
Figure 6: Various pre-treatment steps before gold cyanidation.....	22
Figure 7: Principle behind separation of ions using membrane technology.....	24
Figure 8: Ferrous-ferric cycle chemically and biologically aided.....	33
Figure 9: Merrill-Crowe process/Cementation.....	36
Figure 10: Typical heap leaching operation.....	40
Figure 11: Delkor Belt Filter developed by Delkor Industries.....	41
Figure 12: General overall experimental plan for phase 1.....	44
Figure 13: Phase 1 experiments.....	47
Figure 14: 50°C Temperature Experiments.....	47
Figure 15: General overall experimental plan for phase 2.....	50
Figure 16: Taping of support cloth for granular bed.....	51
Figure 17: Schematic drawing of equipment for granular bed leach.....	52
Figure 18: Granular bed leaching of PGMs and BMs.....	53
Figure 19: Granular bed leaching of PGMs with cyanide in fume hood.....	54
Figure 20: Schematic diagram for chemical heap leach experiment.....	59
Figure 21: Cyanide heap leaching of PGMs in fume hood.....	60
Figure 22: Organic acid heap leaching of BMs.....	61
Figure 23: Schematic drawing of bioleach process equipment.....	63
Figure 24: Bioleaching of concentrate in packed columns.....	64
Figure 25: BM batch stirred tank reactor leaching experiments.....	65
Figure 26: BM batch stirred tank reactor experiments at elevated temperatures.....	65
Figure 27: Dissolution of PtS ₂ using 0.5 M tartaric-malic acid in the presence of 2 M hydrogen peroxide at ambient and 50°C.....	72
Figure 28: Dissolution of PtS ₂ using 0.5 M sodium cyanide in the presence of 0.5 M hydrogen peroxide at ambient and 50°C.....	73

Figure 29: Overall process for direct PGM leaching	77
Figure 30: Copper extractions from ferric/sulphuric acid leach	80
Figure 31: Nickel extractions from ferric/sulphuric acid leach	81
Figure 32: Iron extractions from ferric/sulphuric acid leach	81
Figure 33: Overall process for leaching PGMs by first extracting BMs	83
Figure 34: PGM extractions via cyanidation from chemically treated concentrate.....	84
Figure 35: PGM extractions via organic acids from chemically treated concentrate	85
Figure 36: Secondary PGM extractions via cyanidation in BSTR	88
Figure 37: PGM extractions from cyanide heap leach.....	92
Figure 38: Indiscriminate leach process for PGMs and BMs.....	96
Figure 39: Platinum extractions from BSTR tests	97
Figure 40: Copper extractions in BSTR cyanide tests.....	102
Figure 41: Cu and Ni Extractions from tartaric-malic acid leach.....	105
Figure 42: BM leach using tartaric-malic acid over 5 days.....	106
Figure 43: Copper and nickel extractions	108
Figure 44: BM heap leaching using organic acids.....	110
Figure 45: pH profiles for experiments 7 and 9.....	112
Figure 46: Copper extractions from bioleach process	115
Figure 47: Nickel extractions from bioleach process	115
Figure 48: Iron extractions from bioleach process	116
Figure 49: Cobalt extractions from bioleach process	116
Figure 50: pH profile	121
Figure 51: Eh profile.....	121
Figure 52: Matrix of experiments on low-grade ore concentrate	125
Figure 53: Flowsheet 1.....	129
Figure 54: Flowsheet 2.....	131
Figure 55: Flowsheet 3.....	133
Figure 56: Platinum leach slope in cyanide heap leach test.....	137

List of Tables

Table 1: Suspected PGM and BM minerals present in the ore concentrate.....	10
Table 2: Relative content of precious metals in Merensky and UG2 ores.....	11
Table 3: Masses weighed.....	56
Table 4: Pump Calibration Procedure.....	58
Table 5: Percentage dissolution of platinum from PtS ₂ in sodium bisulphide tests.....	69
Table 6: Percentage dissolution of platinum from PtS ₂ in sodium thiosulphate tests.....	69
Table 7: Percentage dissolution of platinum from PtS ₂ in sodium thiosulphate tests.....	70
Table 8: Various organic acid combinations evaluated and results.....	71
Table 9: Ore concentrate split.....	76
Table 10: Tartaric-malic acid leaching of PGMs in the presence of hydrogen peroxide.....	78
Table 11: Tartaric-malic acid leaching of BMs in the presence of hydrogen peroxide.....	78
Table 12: Ferric/sulphuric acid leaching of BMs.....	80
Table 13: Tartaric-malic acid leaching of PGMs in the presence of hydrogen peroxide and cyanide.....	84
Table 14: Percentage extractions of PGMs from residual concentrate.....	88
Table 15: PGM, BM and gangue metal extractions from cyanide heap leach.....	91
Table 16: PGM material balance over cyanide heap leach test.....	92
Table 17: BM material balance over cyanide heap leach test.....	93
Table 18: Gangue element material balance over cyanide heap leach test.....	93
Table 19: PGM, BM and gangue element percentage extractions from cyanide BSTR tests.....	97
Table 20: PGM material balance over BSTR cyanide test with untreated material.....	98
Table 21: BM material balance over BSTR cyanide test with untreated material.....	98
Table 22: Gangue element material balance over BSTR cyanide test with untreated material....	98
Table 23: PGM material balance over BSTR cyanide test with bioleached material (pre-treatment).....	99
Table 24: BM material balance over BSTR cyanide test with bioleached material (pre-treatment).....	99
Table 25: Gangue element material balance over BSTR cyanide test with bioleached material (pre-treatment).....	100
Table 26: Cu and Ni extractions from organic acid leaching.....	104

Table 27: BM leach using tartaric-malic acid over 5 days	105
Table 28: Percentage extractions for various concentrations of tartaric-malic acid combination	107
Table 29: BM extractions from granular bed organic acid leaching	108
Table 30: BM heap leaching using organic acids	110
Table 31: Mixed Culture of Thermophiles	114
Table 32: BM Extractions from bioleach process in packed columns.....	114
Table 33: BM material balance for column 1	117
Table 34: PGM material balance for column 1.....	117
Table 35: Gangue element material balance for column 1	117
Table 36: BM material balance for column 2	118
Table 37: PGM material balance for column 2.....	118
Table 38: Gangue element material balance for column 2	118
Table 39: Percentage Extractions of PGMs and copper in Phase 2 cyanide tests on ore concentrate	122
Table 40: Percentage Extractions of BMs in Phase 2 tests on ore concentrate	123
Table 41: Flowsheet comparison	134
Table 42: Expected annual production	138
Table 43: Estimated annual production costs	138
Table 44: Estimated annual revenue	139
Table 45: Cash flow diagram for first year.....	140

Chapter 1: Introduction

1.1 Overview of Project

Current flowsheets prohibit the mining industry from economically recovering platinum group metals (PGMs) from low-grade materials such as tailings and intermediates. Due to the high production tonnage of these materials, the low concentrations of PGMs accumulate to appreciable value and a potentially high revenue stream is lost annually as they go unprocessed. Unlike the copper, uranium and gold industry where heap and dump leaching of waste and low-grade ores (with and without microbial assistance) have found widespread application in this regard, similar approaches have not been established in the PGM industry.

To that effect the aim of the study was to demonstrate the feasibility of developing a low cost hydrometallurgical process to directly leach the PGMs from a low-grade ore concentrate originating from Lonmin Plc. Any such process should eliminate the need for further concentration (milling and flotation), treatment via the smelter; aggressive chemical treatments and the use of acid pressure leaching. The reasons for this are that these methods of treatment are costly, energy intensive and result in the leaching of non-valuable metals; making them unsuitable for low-grade ore materials. The ore concentrate, reportedly containing 15 g/t PGMs, represents 70% of the total tonnage from the Lonmin concentrator plant but only 5% of the PGM value (see Figure 1).

The study experimentally evaluated various chemical reagents and reactor configurations for leaching the PGMs. The leaching of base metals (BMs) using commercially established techniques (chemical and microbially assisted), was also investigated to determine its influence on PGM leaching and to add additional value to the process by recovering the BMs in addition to the PGMs.

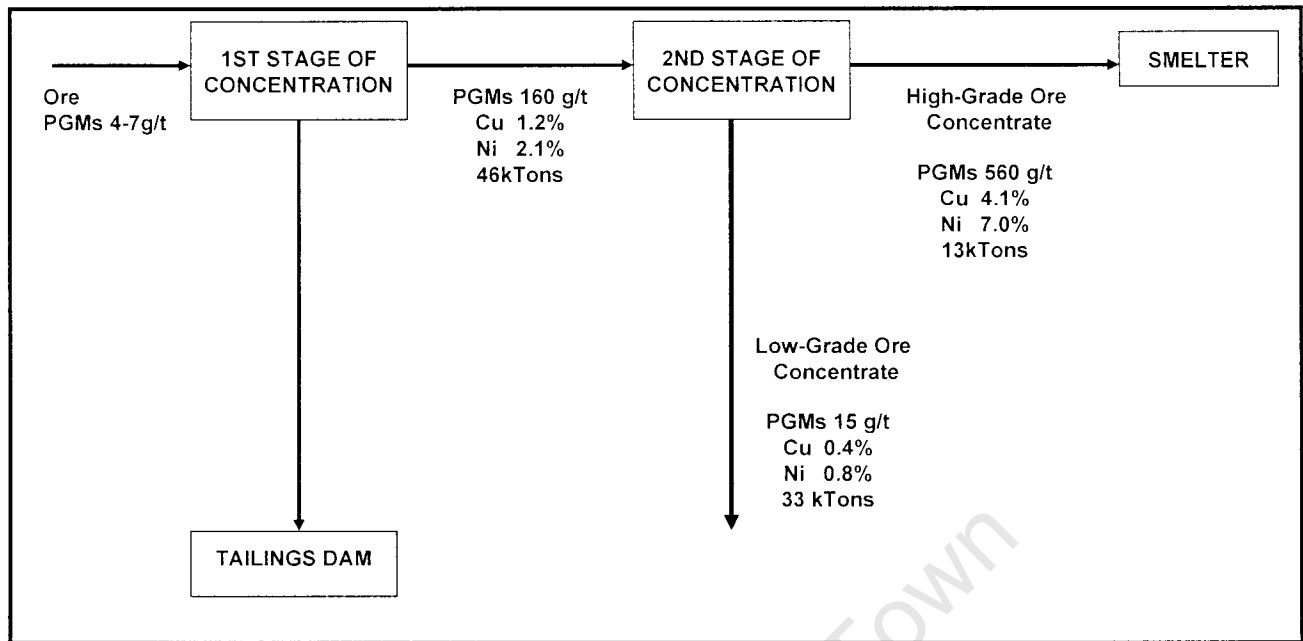

Figure 1: Source of low-grade concentrate

1.2 Project Background

Previous research conducted by Biomed Corporation of Russia and Mineral Solutions Ltd (MSL) in England revealed a potential route for directly leaching the metals from the concentrate (Evans 2007). It was discovered that an indigenous community of microorganisms found on various ores and concentrates from Lonmin mine sites are capable of producing solutions containing various organic acids. When applied to the Lonmin ores and concentrates these solutions were found to leach considerable amounts of PGMs and BMs through the process of complexation, at atmospheric temperature and pressure. When the microbes were cultured under anaerobic conditions an acidic solution was produced which leached BMs (maximums of 60% Cu, 62% Ni and 37% Co) and some PGMs, and when cultured under aerobic conditions they produced an alkaline solution which leached PGMs (maximums of 56% Pt, 79% Pd and 49% Ru) at an optimal pH of 8.

1.3 Key Questions

The key questions for this investigation that arose from the findings of this work were:

- Would maintaining the observed optimal pH for PGM leaching in the organic acids alone result in significant levels of extraction from the low-grade ore concentrate?

- Given that the ore concentrate is from the Bushveld Igneous Complex, in which case the PGMs may be occluded in base metal sulphide minerals: would a BM extraction stage be required to precede PGM leaching to increase exposure of the PGMs?
- Considering that the organic acids leached the PGMs by complexation: can other chemical complexing agents be as effective as the organic acids in leaching PGMs?
- Similarly can other commercially established methods for leaching BMs from low-grade ores and concentrates (chemically or biologically aided) be just as effective as the organic acids?

1.4 Objectives

It has been recognized that the previous work was not a focused attempt to optimize metal leaching but only served to prove the existence of an indigenous community of microorganisms on the Lonmin ores and concentrates, and identify their possible role in bioleaching metals from these various materials. This study was a more systematic effort which aimed to:

- Investigate PGM (specifically platinum, palladium, ruthenium and rhodium) and BM (copper and nickel,) leaching via organic acids from a low-grade ore concentrate originating from Lonmin's concentrator plant. Iron was also of some focus due to its effect on the processing of the other metals of interest and not for its value.
- Compare PGM leaching results using organic acids to other potentially effective chemical treatments.
- Benchmark BM leaching results using organic acids against commercially established techniques for leaching BMs from low-grade ores and concentrates.
- Assess the feasibility of taking any or a combination of the successful options to industrial scale.
- Produce a preliminary process flow-sheet including possible recovery methods and systems for environmental remediation.
- Use the above outputs to assess the potential of the process to proceed to demonstration plant level.

1.5 Extractive Metallurgy of Platinum Group Metals

A general and summarized version of the processing of PGMs and BMs from Merensky ores at Lonmin Plc is presented below (Figure 2): This is not a detailed account but briefly describes the major steps in the process and how the new proposed process for treating the low-grade ore concentrate contrasts with this standard procedure.

In the concentrator plant, mined ore containing 4-8 g/t of PGMs is crushed and milled followed by flotation. The flotation process produces a high grade stream (560 g/t PGMs) and a low-grade stream (1-15g/t PGMs) that is stored in ponds or dams.

The high grade flotation stream is put through thickeners, filtered, dried and charged with fluxes and sent to the smelters. This stage produces two streams: slag containing primarily oxides (silica and iron) and a matte consisting of copper, nickel, iron sulphides and PGMs (1000-2500 g/t). The matte is then treated in the base metal refinery (BMR) using the Sherrit-Gordon process, in a series of agitated leach tanks at atmospheric pressure and temperature range 85-95°C. Copper is precipitated out as a sulphate, leaving nickel in the leach liquor to be recovered as nickel sulphate crystals using crystallisers. From here the solid residue undergoes a two stage pressure leach at 60 kPa and temperature range 115-140°C. The leachate undergoes a selenium removal stage (via precipitation) and then an electrowinning process to produce copper cathodes. The solid residue from this stage undergoes a high-pressure oxidising caustic leach to upgrade the PGM concentration. The residue undergoes a further upgrade by means of an alkaline pressure leach to remove metalloids such as selenium, tellurium, arsenic and sulphur. This is followed by an atmospheric formic acid reduction leach to remove any nickel and iron. The product is a low volume extremely high-grade concentrate consisting of at least 65% PGMs as metallics and alloys. The solid residue (precipitates) from the selenium removal stage may contain some PGMs and hence they are subjected to a low-pressure oxidising leach to remove the selenium and tellurium. This residue is then put through a fourth stage leach under oxygen pressure and then sent to the high-pressure caustic leach.

Due to the high market value of PGMs and the fact that 70 % of the world's supply comes from South Africa (Seymour and O'Farrelly 2001), the exact processes in various PMRs are confidential. As a result the processes in Lonmin's PMR cannot be accurately reported and the

following description is general information based on literature (Seymour and O'Farrelly 2001). In the PMR the high-grade PGM concentrate undergoes a complex hydrometallurgical circuit consisting of various leaching and separation processes to selectively recover the six PGMs. The first stage is treatment by an extremely aggressive HCl/HNO₃ ("aqua regia" leach) to dissolve platinum and palladium, which are subsequently recovered by solvent extraction, stripping with concentrated HCl and then precipitation. The remaining solid residue is dissolved in hot nitric acid and rhodium is recovered using crystallisation. The rest of the solid residue is fused with sodium peroxide to dissolve, ruthenium, osmium and iridium which are then recovered by distillation, reduction and precipitation.

The refinery is more the size of a large laboratory because of the low volume feeds, usually with a monthly tonnage of 4-5 tons as compared to the 33 kilotons of the low-grade concentrate. Also in direct contrast is the PGM concentration of the feed which stands at 65% as compared to the 15 g/t in the concentrate. Therein lies the novelty of this project: the attempt to leach PGMs directly from the low-grade ore concentrate without further concentration or processing through the smelter and pressure leach circuit. It is envisaged that the new process can be incorporated into the current Lonmin flowsheet to treat the low-grade concentrate (See Figure 3). The process should produce soluble forms of the PGMs and BMs either in the form of leach liquors or low volume solid residues that can be sent to the PMR and BMR.

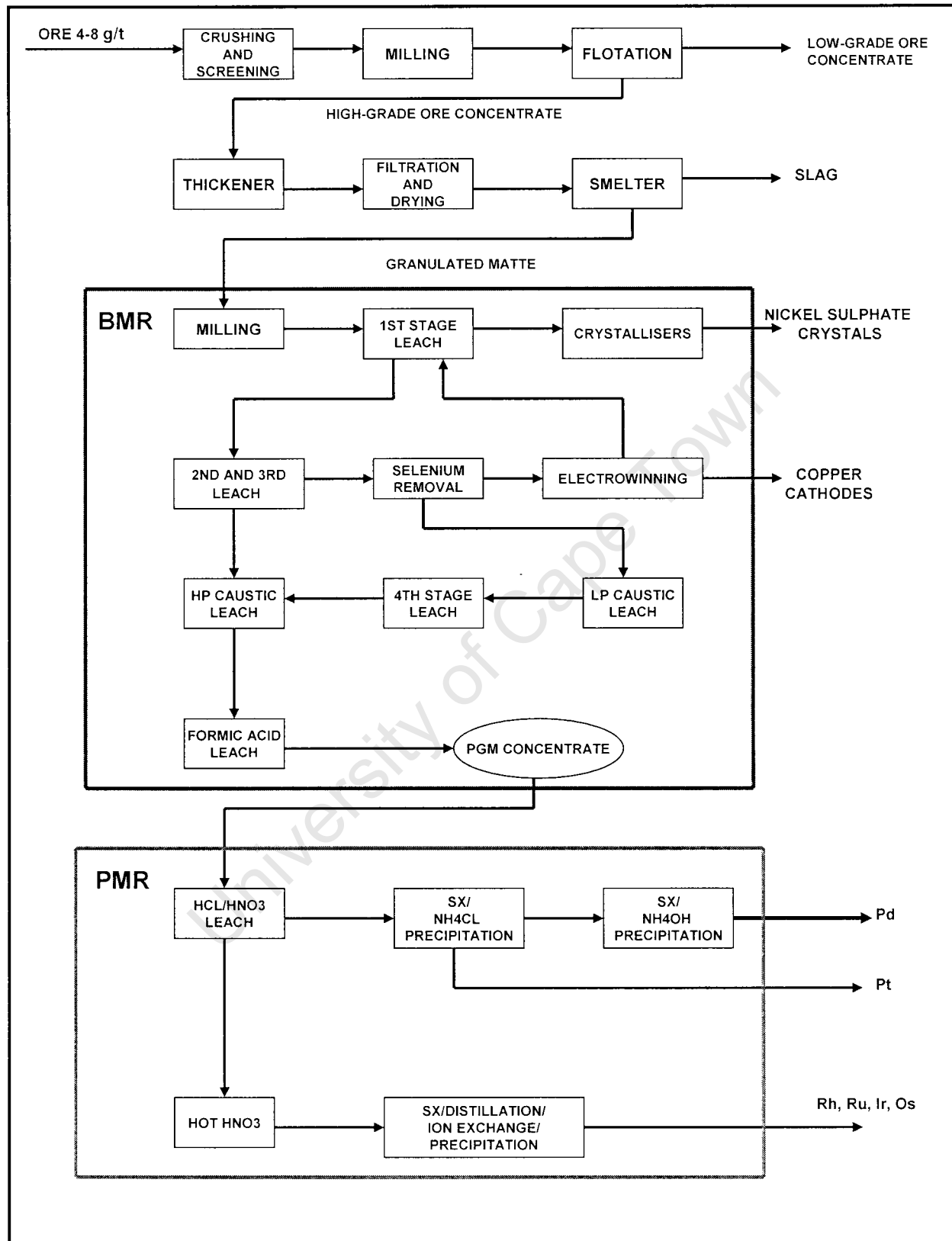

Figure 2: General Lonmin flowsheet

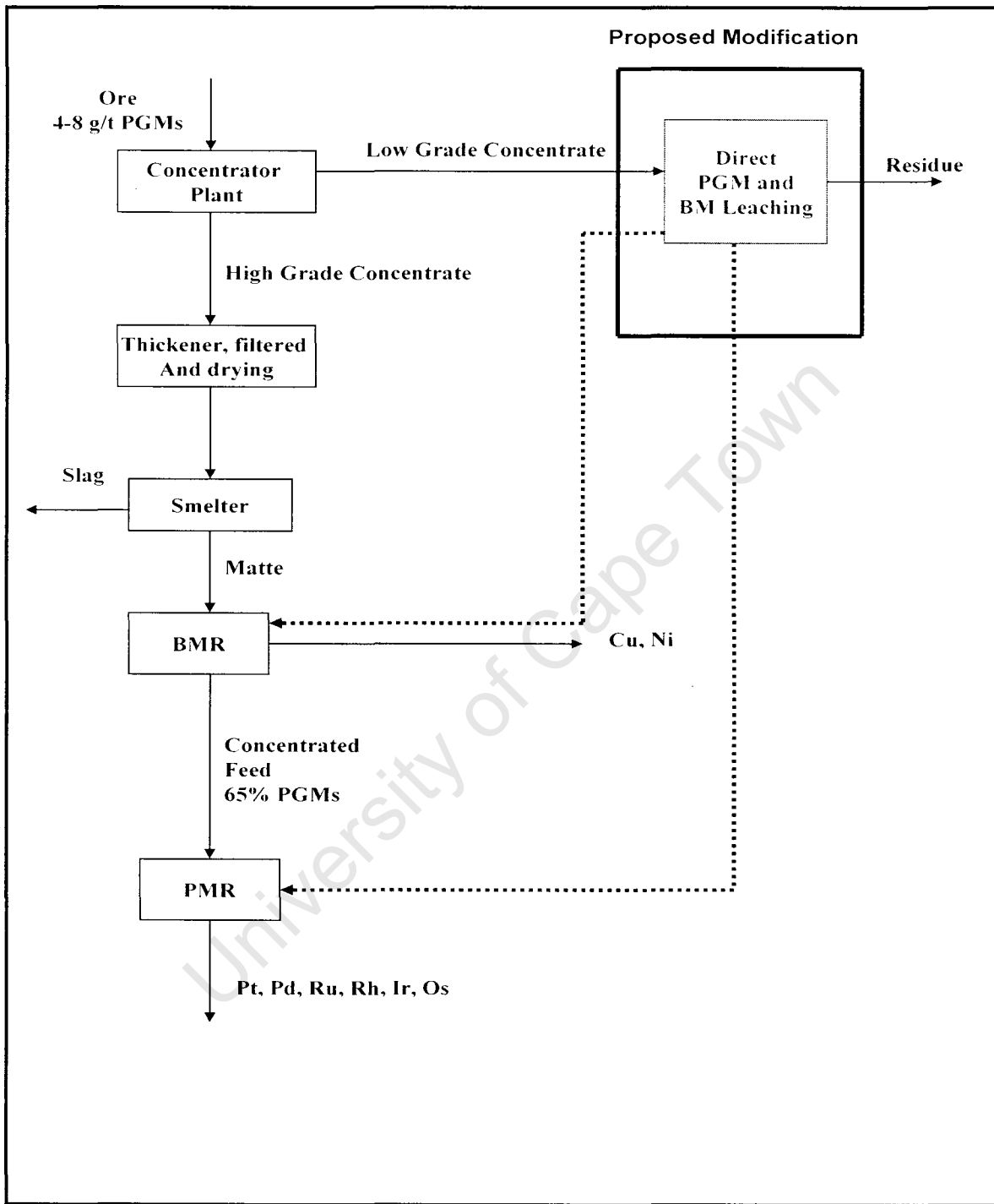

Figure 3: Proposed modified Lonmin flowsheet

Chapter 2: Literature Review

This chapter opens with a brief layout of boundaries that the process parameters must adhere to in order for the metals to be extracted economically. This was meant to guide the literature search for suitable methods of treating the low-grade ore concentrate. The rest of the chapter consists of a brief characterisation of the test material; an in-depth discussion on the mechanisms of potential leaching processes for evaluation; including empirical studies and data conducted from similar studies and any industrial applications similar to the proposed process, possible recovery methods and finally suitable reactor configurations for the process.

2.1 Preliminary Selection Criteria

It has been initially estimated that for the process to be economically feasible, it should hydrometallurgically extract and recover at least 50% of the PGMs and, if possible but not a priority, 50% of the BMs. Suitable processes for evaluation were selected based on the following preliminary selection criteria. These were established based on the nature of the material, low-grade and high throughput and also on current practices for metal leaching from low-grade ores in the copper and gold industry. The PGM industry currently does not have any commercial routes of extracting PGMs from low-grade sources hence the copper and gold routes were used as a reference and contrasted with current PGM processing methods. Selection of suitable options to evaluate was based on the following:

- Ideally, reagents must selectively and directly leach PGMs and BMs from the concentrate material, in contrast to the standard process which involves treatment via the smelter, a series of high temperature and high pressure acid leaches followed by the aggressive “aqua regia” (HNO_3/HCl) or (Cl_2/HCl) treatment. These methods are costly, energy intensive and result in the leaching of non-valuable metals, restricting them for use on high grade materials.
- Ideal operating conditions should be at atmospheric pressure, given the prohibitive capital and operating costs of high pressure and high temperature (above 100°C) leaching for this grade of material at high throughput.
- The leaching time should not exceed a space of two days at the most; and for this application it will be practical if the lixivants can be re-circulated amongst different batches accumulating an appreciable amount of metals over a longer time.

- Relatively easy recovery from solution, preferably using existing infrastructure within the PMR and BMR at Lonmin.
- A strong factor is the reagents' potential to allow for direct re-use or regeneration (for re-use) after the metals have been recovered from the solution.
- From an environmental perspective the process must yield by-products that are easily handled or disposed of so as not to incur extra costs. Alternatively these by-products should have some commercial value either directly or after processing.

2.2 Characterisation of the Concentrate

The mineralogy of an ore or concentrate undeniably affects the success of the type of hydrometallurgical treatment used (Castro et al 2000; Vegliò et al 1997; Bosecker 1997; Valix, Usai and Malik 2001; Evans 2007; McInnes, Sparrow and Woodcock, 1994). PGMs exist in a variety of minerals and these can be expected to have different responses to different lixivants. This may mean more than one form of treatment may be required to extract the target amount of PGMs from the various minerals in the ore concentrate. Other factors affecting the hydrometallurgical treatment are exposed surface area of the minerals in the particles and the pulp density.

The concentrate material under investigation consists of ore mined from the Bushveld Igneous Complex (BIC) in the Transvaal area; either from the Merensky Reef or the Upper Group 2 (UG2) or it may be a blend of both. The major difference between these two ores is that the UG2 has a higher chromite content and lower PGM content as compared to the lower chromite and higher PGM content of the Merensky Reef (Schouwstra and Kinloch 2000; Seymour and O'Farrelly 2001). The PGMs from these areas are found in the form of ferroplatinum alloy, sulphides, arsenides or tellurides. A brief summary of these forms is laid down in Table 1 (Schouwstra and Kinloch 2000; Seymour and O'Farrelly 2001).

Table 1: Suspected PGM and BM minerals present in the ore concentrate

Platinum Group Minerals	Base Metal Sulphides	Others
Cooperite (PtS)	Pyrrhotite (FeS)	Silicates (various primary and secondary)
Braggite [(Pt, Pd)NiS]	Pentlandite [(Fe, Ni) ₉ S ₈]	
Sperrylite (PtAsS ₂)	Chalcopyrite (CuFeS ₂)	Chromite
Laurite (RuS ₂)	Millerite (NiS)	
Ferropalladium (Pt ₃ Fe)	Troilite (FeS)	
Moncheite (PtTe ₂)	Pyrite (FeS ₂)	
Unnamed (PtRhCuS)	Cubanite (Cu ₅ FeS ₄)	
Laurite (RuOsIr sulphide)		

An important aspect that influences the success of a hydrometallurgical treatment in leaching a metal is the oxidation state of the metal in its mineral. Some states are more favourable than others to specific lixivants and hence a process may require an oxidizing agent to either:

- Change the oxidation state of the target metal:
- Or oxidise the element that is chemically bonded to the target metal in the compound, in order to release the target metal ion.

Further to this conditions such as pH and temperature also influence the success of the leaching process of the metals in specific oxidation states. One or a combination of the above must be considered for the success of the leaching process.

Of the PGMs of interest in this study: Platinum and palladium may occur in a variety of oxidation states, but +2 and +4 states are the most important for complexation in aqueous solutions and are reported to represent the most stability in a variety of compounds (Pourbaix 1966; Mountain and Wood 1987; Seymour and O'Farrelly 2001). Similarly ruthenium and rhodium are also multivalent, although stability is highest in the +2, +3 and +4 oxidation states (Pourbaix 1966; Mountain and Wood 1987; Seymour and O'Farrelly 2001; Bard et al 1985). The relative proportions of PGMs in a Merensky and UG2 ores can be viewed in Table 2 (Seymour and O'Farrelly 2001). Platinum constituting the most by content and being the second most valuable metal (second to rhodium) of the group, dictates the economic viability of any process

for treating the low-grade concentrate in the South African environment. South African mining companies are the only defined PGM producers in the world, other major PGM producers are primarily BM producers with PGMs being side or by-products.

Table 2: Relative content of precious metals in Merensky and UG2 ores

Precious Metal	% Content	
	Merensky Reef	UG2
Platinum	59	42
Palladium	25	35
Ruthenium	8	12
Rhodium	3	8
Iridium	1	2.3
Osmium	0.8	
Gold	3.2	0.7

2.3 Potential Routes of Extraction

This section outlines the basic mechanisms behind the selected routes of leaching the metals to be evaluated, along with any experimental work that has been conducted with similar objectives to this project. Additionally, current industrial practices for extracting BMs and gold from similar materials as the concentrate are discussed for their applicability to the project's aims.

2.3.1 Organic Acids

When microorganisms facilitate the dissolution of metals from ores and concentrates, the process is referred to as bioleaching. There are two known forms of bioleaching, one is described below and the other is discussed in section 2.3.5 of this chapter.

Previous research work commissioned by Lonmin Plc revealed the presence of an indigenous community of microorganisms on various ores and concentrates at Lonmin mine sites. It was found that the metabolic products of these microorganisms were capable of leaching considerable quantities of PGMs and BMs from various Lonmin ores and concentrates (Figure

4). Further inquiry revealed that this form of bioleaching has been researched for the past two decades for the extraction of nickel and zinc, and to some small extent other BMs from low-grade ores (Barathi et al 2004; Valix, Usai and Malik 2001; Tang and Valik 2006; Tang, Ryan and Valx 2006; Castro et al 2000; Tzeferis 1994; Alibhai et al 1993; Cameselle et al 2003; Golab and Orłowska 1988; Burgstaller and Schinner 1993) and more recently PGMs (Evans 2007).

The microorganisms involved in this process include fungi such as *Aspergillus Niger*, *Penicillium*, *Botrytis*, *Mucor* and *Trichoderma*; and bacteria from the genera *Bacillus*, *Pseudomonas*, *Erwinia*, *Bacterium* and *Sarcina ureae* genus. These organisms are called heterotrophs because they need to and are capable of fermenting saccharine materials (glucose, sucrose, and molasses), as a carbon source, into a wide range of metabolic products namely organic acids, amino acids, enzymes, proteins, peptides, hydrocarbons and vitamins. From the various metabolites produced, the bulk of mineral dissolution is caused specifically by the hydroxyl carboxylic and amino acids. Further to this Holgersen (2006), Wood (1996), Wood et al (1994), Wood (1990) and Wilkinson (1987), have all demonstrated that PGMs can be dissolved by simple carboxylic acids and more complex ones such as fulvic and humic acids (which also contain the carboxylic functional group).

The work done by Golab and Orłowska (1988) on zinc, copper and aluminium shows that overall, organic acids (citric, oxalic, lactic, malic, gluconic, acetic, butyric, tartaric and salicylic) are capable of leaching up to ten times more than amino acids. Although Golab and Orłowska (1988) have suggested that the other metabolites do play a part in the leaching process but are unable to identify exactly what role they play and prove it with experimental evidence. Given the high cost of producing amino acids, in comparison to their relatively much lower leaching capabilities, it is clear they are not an economic option. Given also that the other metabolic products appear to play no part in metal dissolution; this investigation thus focused only on the organic acids out of all the metabolites.

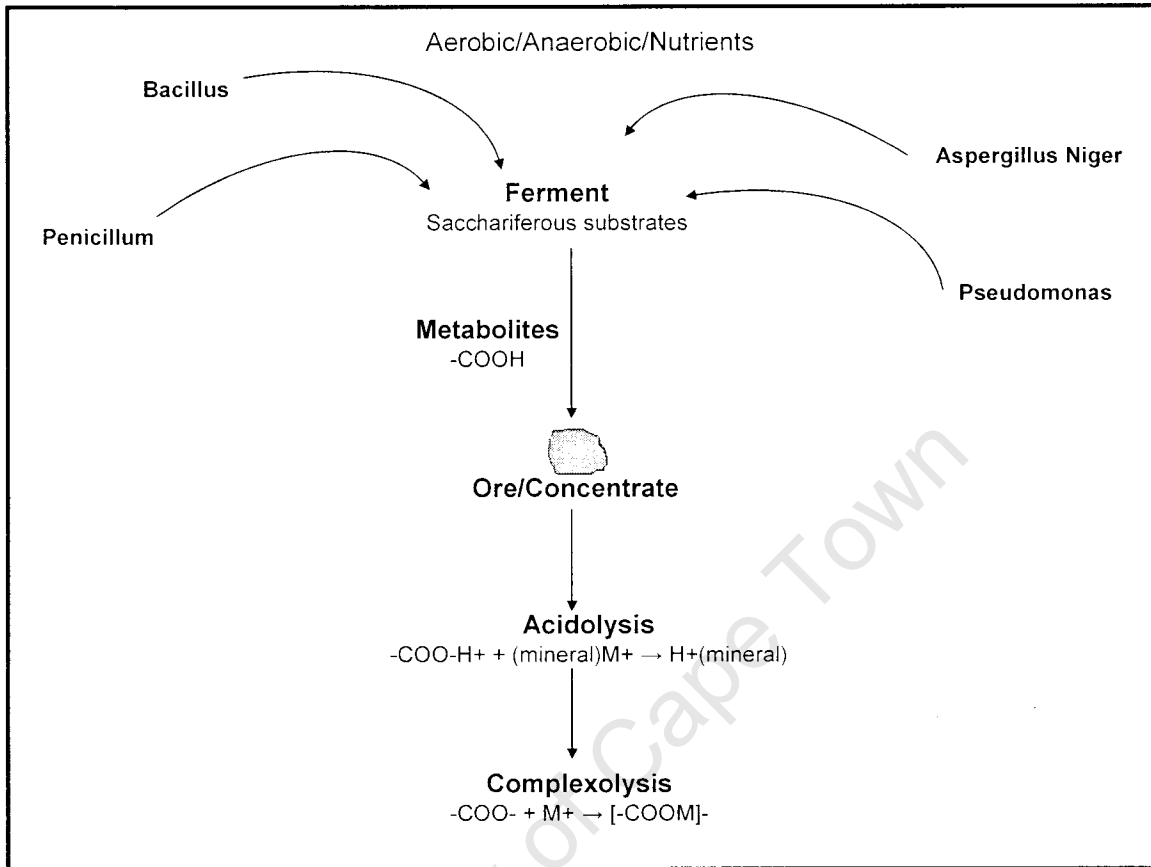
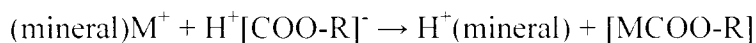

Figure 4: Organic acid bioleaching

2.3.1.1 The Leaching Mechanism

The leaching mechanism involves the processes of acidolysis, complexolysis and chelation, redoxolysis, and biosorption (Cameselle et al 2003; Tzeferis 1994; Alibhai et al 1993; Burgstaller and Schinner 1993; Evans 2007). Some researchers have concluded that of these, the acidolysis, complexolysis and chelation are the processes responsible for most of the metal dissolution. Acidolysis involves metal ions being directly displaced from the ore matrix by hydrogen ions from the acid, specifically the carboxyl group. This process is described by others as oxygen protonation, in which oxygen atoms covering the surface of the metal are protonated very fast. Protons and oxygen atoms covering the surface of the metal combine with water to detach the metal ion. The process can be summarised by the general reaction below (Rossi 1990):



The liberated metal ions then undergo the processes of complexolysis or chelation. Solubilisation of metal ions is enhanced due to the capacity of a molecule to form a complex or chelate. In aqueous media organic acids are known to form complexes and chelates, through coordinate covalent bonding, with many multivalent metal ions depending on pH and ionic strength (Lopez-Garcia 2002; Blair and Defraties 1995). The liberated metal ions are stabilised in solution by acidolysis (preventing them from re-precipitating into insoluble form), long enough for them to be recovered. The process can be represented as follows (Rossi 1990):

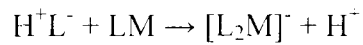
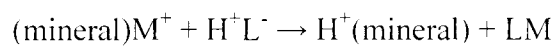

where L is an organic ligand

The organic (carboxylic and hydroxy carboxylic) acids have their characteristic chemical behaviour determined by the carboxyl functional group ($-\text{COOH}$). This group consists of the carbonyl group ($\text{C}=\text{O}$) and a hydroxyl group ($-\text{OH}$). It is the ($-\text{OH}$) group that virtually undergoes all reactions by loss of the H^+ and/or replacement by another group (Morrison and Boyd 1966). The number of carboxyl groups (electron donor atoms) will determine the type of reaction: if there is only one (monodentate) the metal is complexed whereas in the case of two or more (bidentate, tridentate or tetradentate) the metal ion will be chelated (Howard and Wilson 2003).

The exploratory work on the Lonmin ores and concentrates (Evans 2007) supports the above literature data on two counts:

It would appear that organic acid containing solutions effectively leached the PGMs and BMs from the ore materials because the PGMs were already in an oxidised state (typically as sulphides, selenides and tellurides) and the BMs as sulphides. Hence they only needed an effective complexing agent to stabilise them in aqueous solution. Leaching also occurred from ferroplatinum alloys possibly because the oxidative state of the platinum was favourable to organic acid complexation. Analysis of the material left over from the leach process revealed that the different platinum group minerals responded differently to the leach: some like the unnamed

PtRhS and possibly the Pt-Pd tellurides were significantly leached whereas others, namely PtS were unaffected. Possibly because the oxidative state of platinum in this mineral was not favourable for complexation with the organic acids or requires an oxidising agent to oxidise the sulphur thus releasing the platinum ions to be complexed. BM leaching occurred mainly from the minerals chalcopyrite and pentlandite which account for a large portion of the base metal sulphides in Merensky/UG2 ore (Schouwstra and Kinloch 2000).

Secondly, on the importance of pH to the process: under acidic conditions only 30% PGMs were leached and some BMs. In a near neutral to alkaline media (pH 8) the PGMs leached optimally, but no leaching of BMs occurred. As the leach progressed and the solution became more acidic, PGM leaching came to a stop. In terms of the PGMs there are several proposed theories for this (Evans 2007), but the ones that were investigated by this study were:

- The effects of pH, and other process conditions (temperature and concentration).
- The use of other leaching agents.
- The possibility that the platinum group minerals are locked within base metal sulphide matrices having insufficient exposure to the organic acids.
- The need for an oxidising agent to oxidise the sulphur and liberate the metal ions to be complexed in solution or to change the oxidative state of the PGMs to ones that are more favourable to the lixiviant.

2.3.1.2 Other Process Considerations

A major feature of this type of bioleach is that leaching of metals can be done either: "Directly" (one step process) in which case the ore, substrate and microorganisms are all contacted in the reactor. Or "indirectly" (two step process) in which case the microorganisms have no physical contact with the ore or concentrate but are cultured separately and then the metabolites are separated from the biomass and the filtrate applied to the ore or concentrate.

Opinions amongst authors differ over which is the best method for carrying out the process. Valix, Usai and Malik (2001) concluded that the direct method was more effective and postulated that this type of leaching was not just a chemical attack by the organic acid on the ore, but benefited from the presence of the fungi. This would certainly appear to be the case with

MSL and Biomed. Evans (2007) noted that in their experiments, the PGMs being positively charged, would be attracted to the negatively charged microbial cell walls, and then precipitate out on the biomass or some other mineral form. MSL, which did not employ a wash technique to recover the metals from the biomass like Biomed, may thus have reported lower recoveries. Tzeferis (1994) and Cameselle et al (2003) have on the other hand supported the viability of both techniques but finally lean towards the "indirect" method to counter problems of metal ion and microbial contamination (in heap, dump or in-situ scenarios). The work by Castro et al (2000, p41) on zinc and nickel showed the effectiveness of the two methods was dependent on the metal leached and the type of microorganism used. It must also be noted that the two-step process has the advantage that the reactor can be heated (up to 95°C) to improve reaction kinetics and does not suffer from the problem of losing and having to recover metals accumulated in mycelial biomass (Tzeferis 1994; Evans 2007).

No researchers have been able to show that biosorption results in increased metal recoveries. Possibly the biomass may simply compete with the organic ligands for the liberated metal ions and result in the need for an extra separation stage. This investigation did not focus on the aspect of which method is better. Whether used as a direct or indirect method, this route consists of two different processes: production of metabolites by the microorganisms and mineral dissolution by the organic acids. The study focused on the aspect of mineral dissolution by the organic acids as most of the literature has indicated that the bulk of the mineral dissolution is achieved by this mechanism. Making use of analytically reagent grade organic acids, the objectives entailed determining whether significant levels of extraction (>50%) could be achieved using the organic acids, identifying the most effective organic acids and the optimal conditions under which the organic acids leach metals from the concentrate.

Involving the microorganisms in the production of the organic acids will have to take into consideration a number of factors and hence before embarking on such a study, it must be shown that significant levels of extraction can be achieved using organic acids. Additionally the most effective acids have to be identified before a study into their production using microorganisms is conducted.

Although there is a general agreement that citric acid is the most effective in almost all cases; others dispute this, claiming that the choice of acid depends on a number of factors such as type

of metal being leached, the mineralogy of the ore material, pH (influencing amongst other things the acid activity of the organic acids), acid concentration, pulp density and metal concentration (Tang and Valix 2006; Castro et al 2000). This would imply that other organic acids can be as effective as or more effective than citric acid under their individual optimal conditions. This warranted the study to consider the different classes (one, two or more carboxyl groups) of organic acids and their effectiveness in leaching metals from the low-grade ore concentrate as no literature can conclusively identify one.

There are currently no full scale industrial applications for leaching any metals from ore through this form of bioleaching. Burgstaller and Schinner (1993) give the following as some reasons why it is so:

- The cost of the organic feed stocks required by heterotrophic microorganisms is considered uneconomical for low grade ores;
- widespread unfamiliarity in handling fungi amongst biohydrometallurgists;
- the production rate of the leach solutions (metabolites) is slow in comparison to sulphur reducing/ferric oxidising bacterial processes, naturally resulting in slower recovery of metals;
- limited experience regarding genetic approaches.

Counter to this Burgstaller and Schinner (1993) offer many arguments in favour of further investigation and development of this form of bioleaching, among which is the fact that this form can offer niche applications, as is currently being investigated for PGM and BM leaching in this study.

2.3.2 Cyanidation

2.3.2.1 Overview

The cyanidation process has proved to be an effective and economical option for successful gold extraction over the years. It works optimally at ambient conditions and depending on the grade of ore, cyanide leaching can be carried out in open vats or open dumps and heaps (Chamberlain and Pojar 1984). In conjunction with this, adsorption to carbon is an economic and efficient recovery

method. As a bonus it is possible to reclaim and regenerate the sodium cyanide in all the processes (Cohn et al 2001). Similarly, in the adsorption to carbon process, the stripped carbon can be used up to two to three times without regenerating or can be regenerated for re-use (Chamberlain and Pojar 1984).

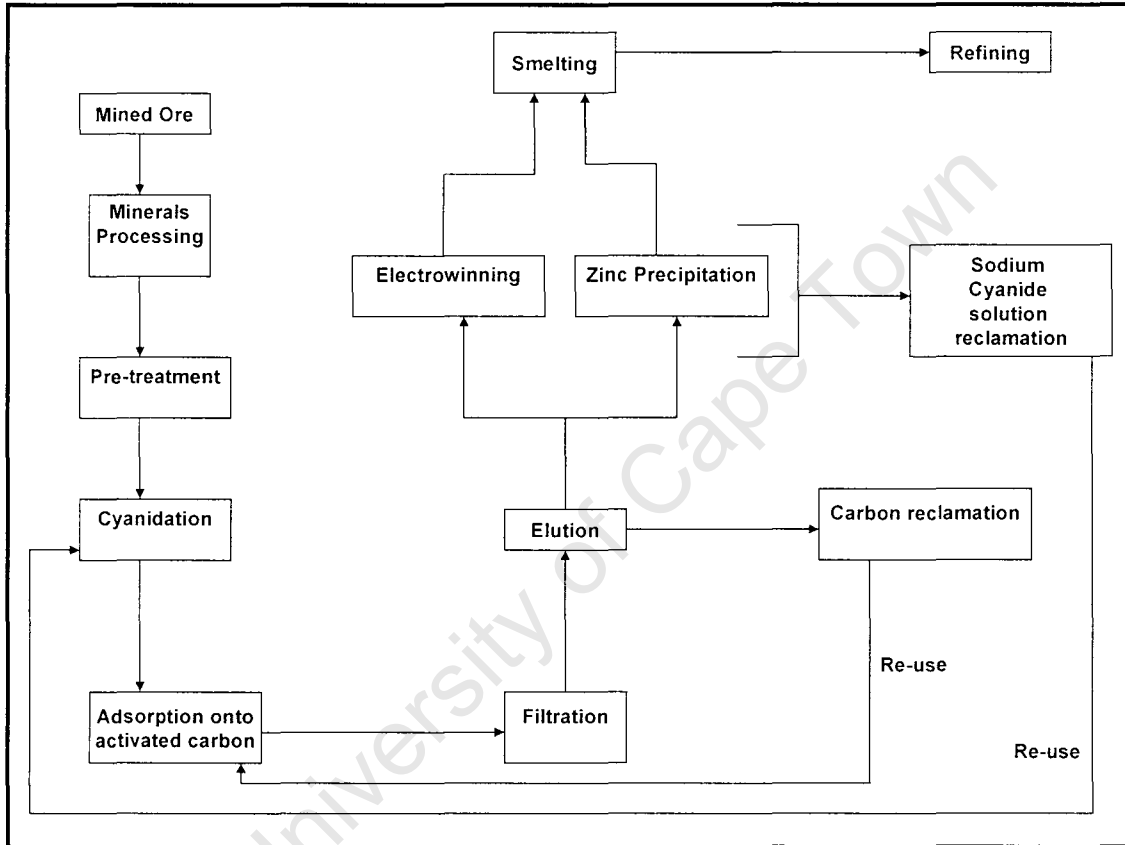

Figure 5: The gold cyanidation-adsorption to carbon process

2.3.2.2 Leaching Mechanism

Gold will be used to illustrate this mechanism as it is literally the only metal that currently extensively uses cyanidation for recovery from ores [silver only to some extent and the exception of the Coronation Hill process for PGMs (McInnes et al 1994; Bruckard et al 1992)]. O_2 is added by either adding hydrogen peroxide solution to pulp or bubbling pure oxygen or air through the pulp. The dissolved O_2 oxidises the metallic gold to form soluble Au^+ cations which are in turn strongly complexed by cyanide ligands (CN^- anions) forming the aurocyanide complex ion $[Au(CN)_2]^-$ (Grosse et al. 2003):



Alkali salts such as calcium hydroxide or sodium hydroxide are added to keep the pH of the reaction above 9.6 to ensure that the lethal hydrogen cyanide gas does not form:

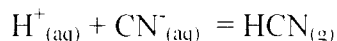

2.3.2.3 PGM Cyanidation

Experimentally it has been shown that PGM cyanidation occurs in the same manner as that of gold. Platinum(II) and palladium(II) form stable complexes with cyanide, namely $[\text{Pt}(\text{CN})_4]^{2-}$ and $[\text{Pd}(\text{CN})_4]^{2-}$ (McInnes et al 1994). As in the case of gold the reactions for PGMs can take place at ambient conditions (Torres and Costa 1997; McInnes, Sparrow and Woodcock 1994) and the reactions reported follow the Elsner equation (Chen and Huang 2006):

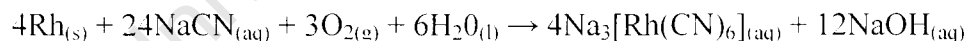
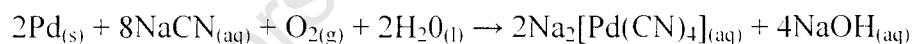
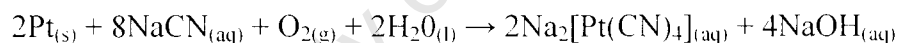

However cyanidation of PGMs at ambient temperature and pressure, specifically platinum, has always reported to result in relatively poor extractions averaging 15% for Pt and 44% for Pd (Torres and Costa 1997; McInnes et al 1994; Bruckard et al 1992). Chen and Huang (2006) contend that at ambient conditions the reaction does not even take place at all due to poor kinetics, and that it will only occur at elevated temperatures (100-125°C) and pressures (1.5-1.8Mpa). These conditions have reported excellent extractions in the order 60-96% for Pt, 70-98% for Pd, and 92% for Rh (Torres and Costa 1997; Chen and Huang 2006; Bruckard et al 1992). Based on a study conducted by Wadsworth et al (2000) on gold dissolution in cyanide, Cheng and Huang (2006) propose the following on the rate of PGM dissolution in cyanide. They propose that PGM dissolution in cyanide is controlled by aqueous boundary layer diffusion (external mass transfer) of cyanide and oxygen to the surface of the PGMs. The reaction rate is

controlled by a surface chemical reaction and the high metallic bonding strength of PGMs results in the formation of a surface oxide passivating layer. It is for this reason that cyanide leaching of PGMs can only occur at higher temperatures and pressure. The fact that Chen and Huang (2006) could not achieve a reaction at ambient conditions might be explained by the different mineralogy of the ore to the ones used by Torres and Costa (1997) and McInnes et al (1994) who achieved some noticeable dissolution of PGMs at ambient temperature. However, their assertions would explain the overall general poor recoveries of PGM cyanidation at ambient conditions.

It must be noted that both studies were conducted on platinum alloy bearing ores: hence the need to introduce oxidizing conditions to bring the platinum ions into solution. The concentrate material in this study contains PGMs largely in form of sulphide, telluride and selenide minerals: hence they are already in an oxidised state. This means that autoclave conditions may not be needed to achieve the desired extractions. However, some of the PGM minerals, such as the ferroplatinum alloys, may require the presence of an oxidizing agent to aid in the liberation of metal ions to be complexed by the cyanide or to change the oxidative state to one that is amiable to cyanide leaching.

McInnes et al (1994) systematically studied the effects of pH, time, particle size of ore, leach additives, and oxidative pre-treatment at ambient temperatures to an ore bearing a gold-platinum-palladium alloy. They reported the maximum dissolution rate for both PGMs was at around pH 10. The addition of thallium salts improved only the extraction of platinum (up to 30%) whereas other additives such as sodium sulphite, sodium thiosulphate, lead salts and hydrogen peroxide had little or no effect. No rationale was provided for the choice of the additives. Thallium on the other hand was chosen as a result of its' reported ability to improve gold extraction by preventing passivation of the surface of gold during cyanidation (McInnes et al 1994). However McInnes et al (1994) are quick to point out that due to associated health hazards, practical use of thallium salts is not possible. No explanation has been offered as to how thallium prevents passivation in gold or platinum ores, and considering the health risk relative to the small improvement in platinum extraction, this route was not further pursued in this investigation.

2.3.2.4 Other Process Considerations

There are challenges to processing gold, using cyanide, from BM bearing ores such as the concentrate material in this study and these may similarly impact the processing of PGMs from this material:

- Firstly it must be noted that cyanide is not selective to PGMs and will also readily complex with copper and the other BMs (which have a significantly greater presence in the concentrate than the PGMs). As much as 40% of the cyanide solution can be consumed by copper in these ores if they are not pre-treated first (Aylmore 2001) (See Figure 6 for various pre-treatment processes for gold cyanidation). The type of treatment used depends on the type of ore (high sulphide content, arsenopyrite, telluride) and the gold content in the ore (high or low). Similarly, for the present application, it is viewed that the cyanidation process can be used in combination with a BM removal process to first extract the BMs from the concentrate material, and then proceed with PGM extraction and recovery by the cyanidation and adsorption to carbon processes.
- Secondly BMs also readily adsorb to carbon, hence the use of activated carbon in purifying waste waters of BM ions (Marsden and House 2006). However BM cyanide complexes do not adsorb to carbon as well as gold (to commercial extraction levels), but they do adsorb to some extent, and this generally interferes with gold recovery (Marsden and House 2006).

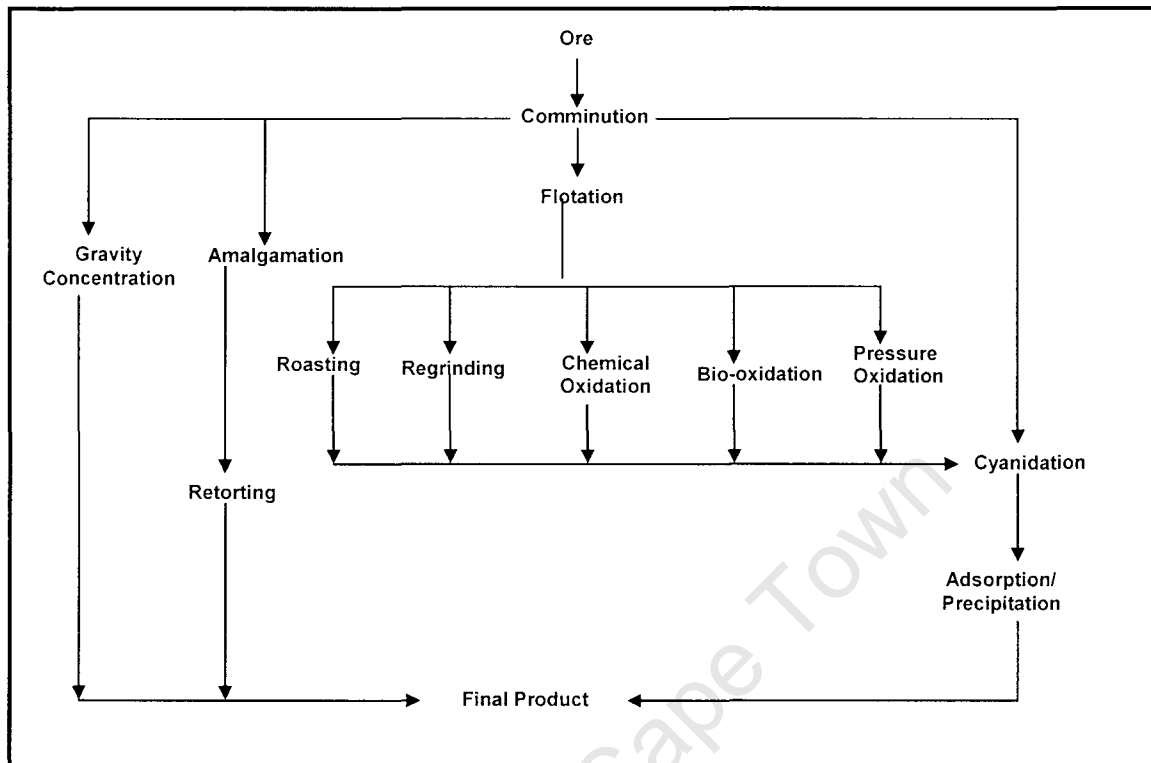

Figure 6: Various pre-treatment steps before gold cyanidation

However a BM removal step may not be necessary as the copper in the concentrate material occurs mainly as chalcopyrite and cubanite. These copper bearing minerals have been observed to leach very slowly in cyanide solution (Adams et al 2008; Gupta and Mukherjee 1990) and if their leaching rate is low, relative to the leaching rate of the PGMs. It means the solution consumption may not be significant enough to warrant a copper removal step first.

On the other hand even if consumption of cyanide by the copper is high, but the desired extractions of PGMs are still achieved; an indiscriminate leach to extract both the PGMs and copper can be employed. Cyanide being a relatively inexpensive and commercially available reagent, is a viable method to extract the copper. Focus can thus be shifted to exploring the following theoretical selective recovery methods for the PGMs and BMs:

- At high pH and free cyanide concentration copper in the form of $\text{Cu}(\text{CN})_4^{3-}$ adsorbs poorly to carbon and reportedly nickel and iron cyanide complexes have less adsorptive capacity than the copper cyanide complex (Marsden and House 2006). Under these conditions an evaluation can be conducted to determine if the PGMs will adsorb to carbon better than the BM cyanide complexes. The copper can then be recovered by acidification which leads to

sulphide precipitation (Cu_2S) according to the following reaction (Gupta and Mukherjee 1990):

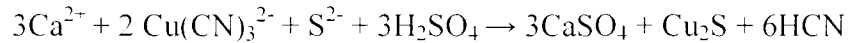

Subsequently the precipitate can be sent to a smelter matte or pressure leach operation. Alternatively copper can be recovered by electrolysis (Gupta and Mukherjee 1990; Lien 2008) to produce cathodes and the HCN-bearing liquor processed to regenerate cyanide. The order of metal recovery can be switched around if the copper interferes with PGM recovery.

- The second alternative is to explore whether cementation (Chen and Huang 2006) will preferentially recover the PGMs or not, and then recovery of the copper subsequently, using the methods suggested above.
- The final alternative can be exploration of membrane technology currently in use in the gold industry. The Engineered Membrane System (EMS[®]) developed by H W Process Technologies, uses a thin-film membrane, to separate ions based on absolute size, shape of specific non-charged molecules, the charge, charge density and degree of hydration of charged inorganic salts or organics (Lien 2008). It can additionally be used to recover the free cyanide. Membrane technology has found wide spread use in waste water treatment, but now lends itself to hydrometallurgical applications. One successful application is in the fractionation, concentration and purification of a gold-silver-copper pregnant leach solution (PLS) (Figure 7). The membrane fractionates the PLS into a large volume gold-silver PLS stream and a small volume "copper concentrate" stream for individual recovery of the metals. A similar approach can be evaluated for a PGM-BM PLS.

The obvious motivation for investigating a direct cyanide leach and selective recovery is faster recovery of PGMs to generate faster profits. This is dependent on one of the above theoretical selective recovery methods being successfully realised at an industrial scale and a profitable operation from the recovery of the PGMs and copper alone, due to the fact that the literature does not indicate any methods (at laboratory, pilot or industrial scale) for successfully recovering nickel and cobalt from cyanide solutions.

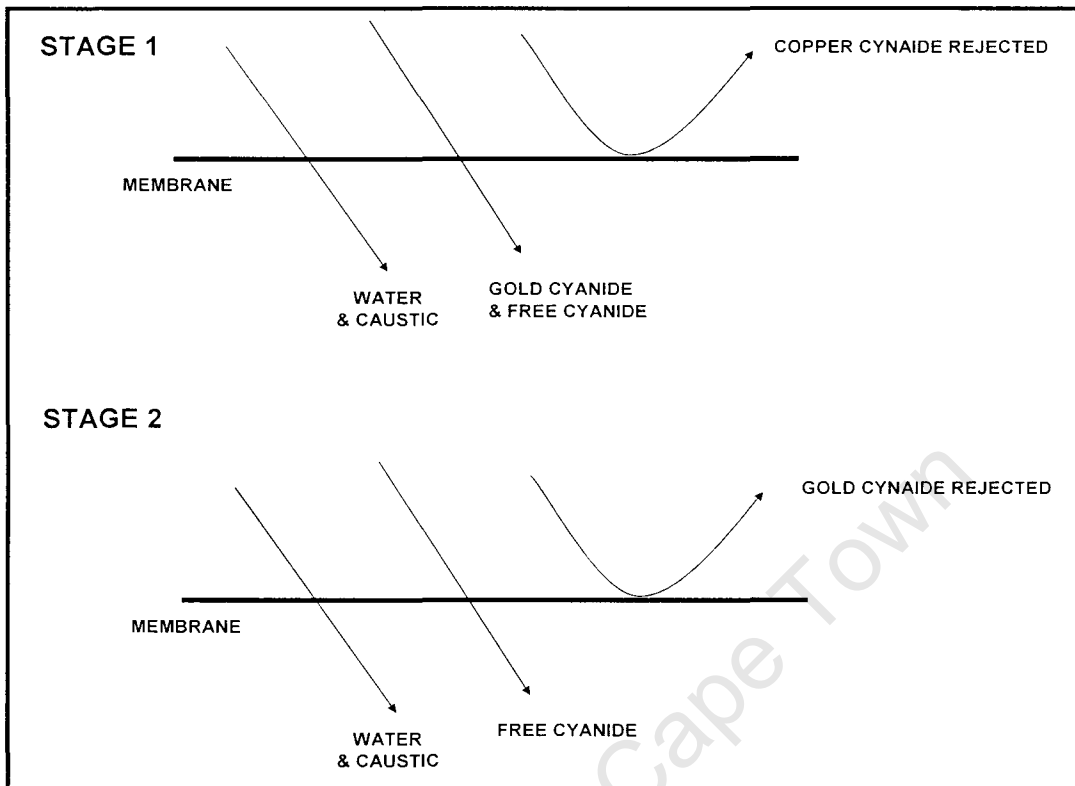

Figure 7: Principle behind separation of ions using membrane technology

2.3.3 Copper-Ammoniacal Thiosulphate System

2.3.3.1 Overview

Leaching via the copper-ammonia thiosulphate system has for sometime now been investigated as an economical and more environmentally friendly alternative to gold cyanidation (Grosse et al 2003; Abbruzzese et al 1995; Aylmore 2001). Other advantages of this system are that (Aylmore 2001; Abbruzzese et al 1995; Grosse et al 2003):

- It can be used without pre-treatment on auriferous sulphide ores containing copper and a wide array of refractory gold ores.
- The ammonia can easily be recycled after the precious metals have been recovered
- Ammoniacal thiosulphate is less vulnerable than cyanide solutions to contamination by unwanted cations as the presence of ammonia has the effect of hindering dissolution of undesirable ions like iron oxides, silicates and carbonates

- The copper sulphate consumption is virtually nil owing to the copper acting as a reversible redox couple.

These advantages make this a very attractive option for treating the low-grade ore concentrate which has appreciably higher amounts of copper, silica and iron than the PGMs.

However this system does have several problems associated with it. Amongst them; are that the leaching mechanism (solution chemistry and mineralogical factors) of thiosulphate solutions is not fully understood (Grosse et al 2003; Feng and Van Deventer 2002). This is partly due to the ease with which thiosulphate undergoes oxidation in aqueous solutions forming various other species including sulfite, sulfate, di-, tri- and higher polythionates, as a function of pH and Eh (Grosse et al 2003). In addition the metallo-thiosulphate complexes are susceptible to decomposition into metallic sulphides and other species (Grosse et al 2003). Apart from this, it is reported that gold leaching with thiosulphate solutions consumes large amounts of the solution, as a result of the relative instability of the thiosulphate ligand as compared to cyanide. This also limits leaching times. A severe drawback to thiosulphate leaching, is that metal recovery through adsorption to carbon, which is standard in the gold industry, is not possible as the $[\text{Au}(\text{S}_2\text{O}_3)_2]^{3-}$ reportedly cannot be adsorbed by carbon (Grosse et al 2003). This leaves options such as solvent extraction, cementation and ion exchange to be explored.

2.3.3.2 PGM Thiosulphate Leaching

At 25°C and pH 7 the reactions between thiosulphate solutions and platinum and palladium are known to yield the more stable $[\text{Pt}(\text{S}_2\text{O}_3)_2]^{2-}$ and $[\text{Pd}(\text{S}_2\text{O}_3)_2]^{2-}$ ions, and $[\text{Pt}(\text{S}_2\text{O}_3)_4]^{6-}$ and $[\text{Pd}(\text{S}_2\text{O}_3)_4]^{6-}$ which are thermodynamically less stable and slowly decompose to insoluble S-bridged oligomers (Grosse et al 2003; Mountain and Wood 1987). Mountain and Wood (1987) contend that thiosulphate ion stays stable longer at a more basic pH and lower temperatures having reported solubilities of Pt and Pd as $[\text{Pt}(\text{S}_2\text{O}_3)_4]^{6-}$ and $[\text{Pd}(\text{S}_2\text{O}_3)_4]^{6-}$ in the range 10ppb in near neutral to basic solutions at 25°C. Further to this, leaching experiments have shown the effectiveness of thiosulphate solutions in dissolving metallic platinum and palladium at 25°C and pH range 6-9 (Anthony and Williams 1992). The reported achieved solubilities were 111ppm after 75 days for palladium and 23ppm after 46 days for platinum. Anthony and Williams (1994) observed that PGM dissolution rates varied inversely with the concentration of thiosulphate, i.e.

the rates of dissolution increase with decreasing concentration and that in pH range 6-9 dissolution rates are independent of pH. The small quantities and long recovery times do not discount his method immediately as these experiments were in a geochemical context and not intended to optimise the leach process for hydrometallurgical application.

2.3.3.3 Leaching Mechanism

Given the extremely slow rates of dissolution of metallic PGMs in plain thiosulphate solutions, it is proposed that first the dissolution of PGMs from sulphide minerals be observed, and then copper-ammoniacal thiosulphate system be investigated, to ascertain its effectiveness in catalysing PGM thiosulphate leaching. Aside from catalysing what would be a slow dissolution process of metals in plain thiosulphate solution, it has been experimentally proven that the presence of ammonia and cupric ions greatly reduces solution consumption for gold and silver leaching by forming readily soluble ammine complexes (Grosse et al 2003; Feng and Van Deventer 2002).

Looking at this system for gold, the process proceeds via the catalytic oxidation of the zerovalent gold and silver by the copper(II) tetra-ammine complex acting as the primary oxidant. The reduction of the copper(II) ammine complex is believed to transfer two ammonia ligands, allowing the kinetically favoured diaminoaurate(I) complex to form. This exchanges ligands with the free thiosulphate ions to form the more thermodynamically stable aurothiosulphate complex. The reactions are described below (Grosse et al. 2003):

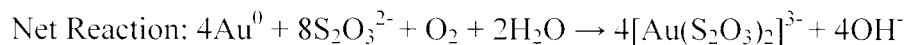
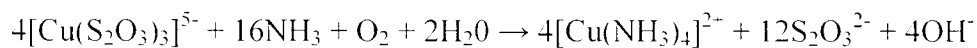
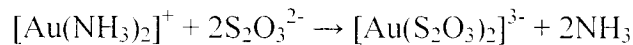
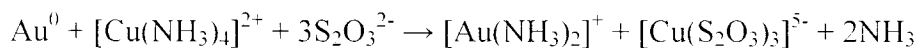

In the case of the concentrate material it is postulated that the copper and ammonia will take the role of oxidising the ferroplatinum alloy, sulphide, telluride and selenide minerals to liberate the

platinum metal ions to be complexed by the thiosulphate. Additionally it may change the oxidative state of the PGMs to ones that are more favourably complexed by the thiosulphate. It is unknown if, as in the case of gold, platinum metal ammine complexes will be formed as a transitional state before thiosulphate complexation and whether this will in fact speed up and/or increase PGM leaching.

2.3.3.4 Other Process Considerations

An important factor in maintaining the stability of thiosulphate is the pH of the solution, since thiosulphate rapidly decomposes in acidic media (Grosse et al 2003). In addition Abbruzzese et al (1995) experimentally observed that temperatures higher than 25°C retarded thiosulphate leaching of gold: postulating that this was due to a cupric sulphide passivating layer formed by the thermal reaction between Cu(II) ions and thiosulphate:



They also attributed this to the fact that at higher temperatures thiosulphate decomposes to sulphur compounds reducing the amount of thiosulphate ions available for gold complexation:

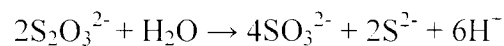
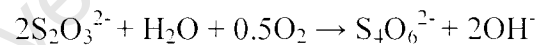

Additionally Mountain and Wood (1987) observed that thiosulphate is only an effective ligand to PGMs at lower temperatures in the area of 25°C. Certain metal ions and reagents have also been known to cause the breakdown of thiosulphate according to the reactions below (Grosse et al. 2003):

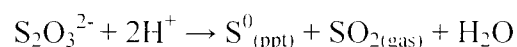
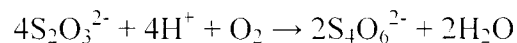

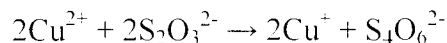
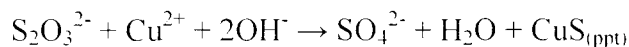

Grosse et al (2003) report further that thiosulphate is also consumed by peroxides, phosphines, polysulfides, permanganates, chromates, the halogens and their oxyanions: leaving copper ions as the logical choice for an oxidizing agent. Likewise many iron minerals like pyrite and haematite will catalyse the oxidative degradation of thiosulphate ions into tetrathionate (Grosse et al 2003). Grosse et al (2003) also recommend the allowance for natural degradation of thiosulphates by O_2 , H_3O^+ , trace Fe^{3+} and other oxidants.

The gradual but inevitable loss of thiosulphate from leaching solutions necessitates relatively speedy leaching and handling operations to optimise leaching and minimise precipitation (Grosse et al 2003). This would also suggest that recovery must be done promptly.

2.3.4 Sodium Bisulphide

2.3.4.1 Overview

Research has been conducted into the use of bisulphide solutions for applications in the extraction of gold from refractory ores as well as for recovery, by precipitation, of copper and zinc from waste waters. Geology/geochemical studies have experimentally proven that PGMs can dissolve in bisulphide solutions under acidic conditions forming complexes as stable as those formed with cyanide (Mountain and Wood 1994).

2.3.4.2 PGM Leaching

Wood et al (1994) have reported solubilities of 4-22 ppb for Pt and 0.5-14 ppb for Pd, over a temperature range of 25-90°C, a pH range of 3-5 and constant pressure of 1 bar in bisulphide solutions. In their experimental work Wood et al (1994) saturated distilled, deionised water with H_2S gas to produce the bisulphide ions:

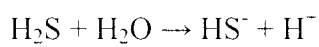

It is postulated that similar to an acidolysis process it is the hydrogen ions that displace the PGMs from the ore matrix to be complexed by bisulphide ions. The overall general reaction equation suggested by Wood et al (1994) was:

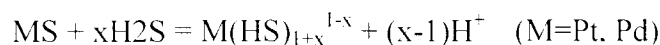

and the suspected complexes formed were $[\text{Pt}(\text{HS})_4]^{2-}$ and $[\text{Pd}(\text{HS})_4]^{2-}$; $[\text{Pt}(\text{HS})]^{+}$ and $[\text{Pd}(\text{HS})]^{+}$; $[\text{Pt}(\text{HS})_2]^0$ and $[\text{Pd}(\text{HS})_2]^0$; and $[\text{Pt}(\text{HS})_3]^{-}$ and $[\text{Pd}(\text{HS})_3]^{-}$. Wood et al (1994) suggest that at 25°C the dominant species were $[\text{Pt}(\text{HS})_3]^{-}$ and $[\text{Pd}(\text{HS})_3]^{-}$, and at much higher temperatures (200-300°C) this shifts to $[\text{Pt}(\text{HS})_2]^0$ and $[\text{Pd}(\text{HS})_2]^0$. However at basic to alkaline conditions it is highly probable that the species present are different from those present in acidic conditions over the same temperature ranges (Wood et al 1994).

However these experiments were not focused on optimising PGM dissolution. A more focused effort is presented by the patent of Hunter et al (1997), which incorporates the leaching of sulphide, oxidised or refractory ores containing PGMs using a lixiviant containing bisulphide ions and having a low fugacity of hydrogen gas. The operation would preferably take place at alkaline or neutral pH under anaerobic conditions. Anaerobic conditions are achieved by submerging the ore under water in a tank or vat. For this patent the source of the bisulphide solution is an anaerobic bioreactor that requires sulphur reducing bacteria and a number of expensive additives which are not economical for this investigation's application. It has been seen as more practical to evaluate the use of plain sodium bisulphide solution.

2.3.4.3 Process Considerations

It must however be noted that a bisulphide system has the disadvantage that the leach slurry needs to be fully contained due to the stench of the solution, and the danger of evolving H_2S gas which is toxic. This presents a dilemma because the tonnage of this material is more suited to open heap or vat leaching. However it is nevertheless an option worth considering, especially for leaching of precious metals from difficult ores, and taking into account the limited number of PGM leaching options available it is worth exploring.

2.3.5 Ferrous-Ferric Cycle

2.3.5.1 Overview

The ferrous-ferric cycle, biologically or chemically aided, is a well established technology in the economical recovery of copper, gold and uranium from low-grade ores, as well as in the pre-treatment of refractory gold ores (Dresher 2004; Gonzalez et al 2004). It is proposed that this process be investigated (biologically aided and as a pure chemical process) as an economical method for extracting the BMs from the low-grade ore concentrate. Furthermore, if a significant portion of the PGMs are occluded in BM sulphide matrices, a BM leach would better expose them for subsequent PGM leaching. Early experimental work on organic acid PGM leaching revealed that certain platinum group minerals were resistant to organic acid leaching (Evans 2007). It has been postulated that this may be that these minerals are occluded in the base metal sulphide matrices. PGMs are known to occur mostly in association with sulphides (Schouwstra and Kinloch 2000). Sulphur and BM removal is a critical pre-treatment step in PGM processing and has been observed in other studies by Torres and Costa (1997), Chen and Huang (2006) and Hunter et al (1997).

2.3.5.2 Leaching Mechanism

This process involves the oxidation of ferrous ion (Fe^{2+}) to ferric ion (Fe^{3+}):

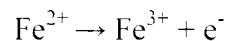

The ferric ion oxidises the sulphur in the sulphide minerals thus liberating the metal ions:

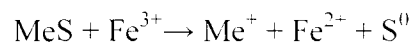

In so doing, Fe^{3+} is reduced back to Fe^{2+} to be re-oxidised and hence propagates the cycle.

This cycle can be achieved in two ways:

2.3.5.2.1 Biologically Aided

In this form of bioleaching the microorganisms obtain their carbon source from carbon dioxide in the atmosphere (as opposed to the one discussed in section 2.3.1) and their energy from the oxidation of sulphur compounds such as sulphates, sulphides, and elemental sulphur. Hence their role in catalyzing the oxidation of these compounds in a bioleach process. The commercially exploited iron oxidizing bacteria strains are *Acidithiobacillus ferrooxidans* and/or *Leptospirillum ferrooxidans*. Sulphur oxidizing bacteria are employed to catalyse oxidation of elemental sulphur to produce sulphuric acid. This provides the acidic media for the process to take place, and aids mineral dissolution as well. In this case the commercial choice is *Acidithiobacillus thiooxidans* or Archaea *Sulfolobus*. The process can be summarised by the equations below (Gonzalez et al 2004; Bosecker 1997):

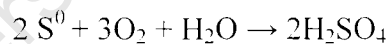
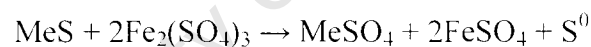
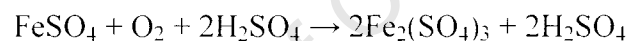

The microorganisms involved in this process can be categorised according to the optimal temperature range in which they operate: Mesophiles (25-40°C), thermophiles (40-75°C) and hyperthermophiles or extreme thermophiles (>75°C). Of particular interest to this study are the thermophiles which are reported to effectively facilitate the leaching of copper from chalcopyrite (Bosecker 1997; Petersen and Dixon 2002; Kelly et al 2008) at temperatures higher than 40°C. Normally chalcopyrite does not leach effectively at temperatures below 40°C due to the formation of a "passivating" layer on the surface of the unreacted material; coating it and preventing further leaching (Gupta and Mukherjee 1990). The layer restricts flow of bacteria, nutrients, oxidants and reaction products to and from the mineral surface (Stott et al 2000). This layer comes either in the form of jarosite ($\text{KFe}_3(\text{SO}_4)_2(\text{OH})_6$), iron-hydroxy precipitates (such as $\text{Fe}(\text{OH})_3$) or elemental sulphur formed in the reaction (Gupta and Mukherjee 1990; Leahy and Schwarz 2009). Additionally, jarosite formation can cause loss of ferric ions from solution, and clogging of pore spaces, preventing solution flow on both a micro and macro-scale (Leahy and

Schwarz 2009). However, elevated temperatures have been observed to destabilize the passivating layer and allow leaching from chalcopyrite (Gupta and Mukherjee 1990). Chalcopyrite is of special relevance as it is suspected to contain a significant portion of the copper in the concentrate material (Evans 2007; Schouwstra and Kinloch 2000).

Industrially, bioleaching can be carried out as (Bosecker 1997):

- Heap or dump leaching: A full description of this process is described in section 2.5.1 of this chapter.
- Underground/in situ leaching: This is done in abandoned mines or when ore deposits are too low-grade or too small to be mined. Solutions with the appropriate bacteria are flooded into galleries of the ore body or injected into boreholes in the fractured ore body. After sufficient time for reaction the pregnant liquor solution (PLS) is pumped to the surface.
- Agitated Tanks: Is more expensive to construct and operate than heap, dump or in situ methods; but the rate of extraction and the yields are much higher.

2.3.5.2.2 Chemically Aided

By using chemicals as direct oxidisers of ferrous ions, current industrial practice makes use of pyrolusite, which contains mainly manganese dioxide (MnO_2), sodium chlorate (NaClO_3) (Lottering and Lorenzen 2007; Ring 1980), as well as direct oxidation by oxygen at temperatures above 65°C .

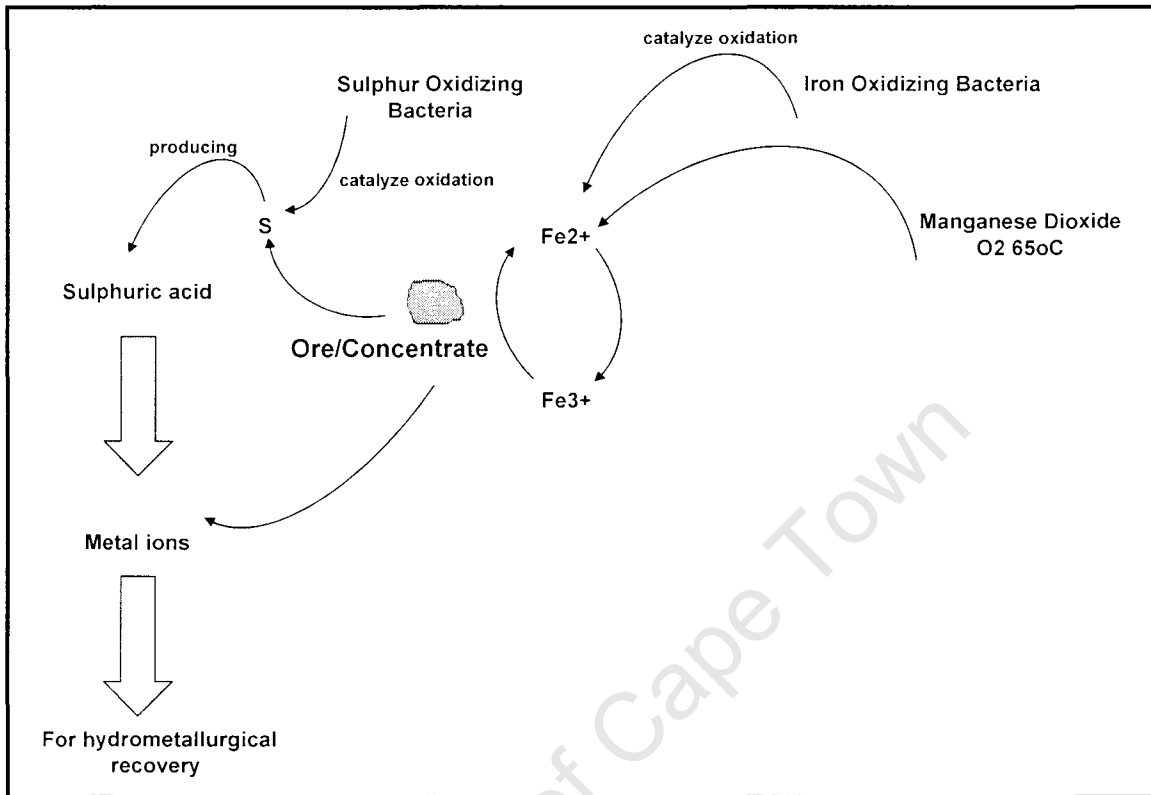
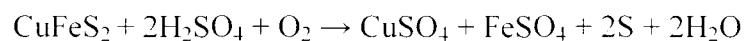
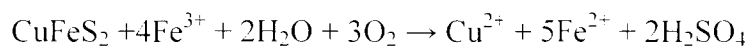
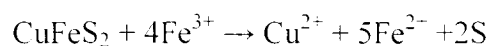
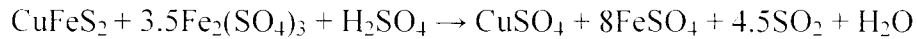

Figure 8: Ferrous-ferric cycle chemically and biologically aided

2.3.5.3 Leaching of BMs from the Concentrate

The major component of copper and nickel in the concentrate material is in the form of chalcopyrite (CuFeS_2) and pentlandite ($(\text{FeNi})_9\text{S}_8$) respectively. Chalcopyrite is not soluble in either dilute sulphuric acid or ferric sulphate solutions under conditions of ambient temperature and pressure (Gupta and Mukherjee 1990). For low grade ores commercial extraction rates are achieved under oxidising conditions; using bacteria or oxygen at temperatures above 40°C for ferric solutions, and using ferric ions as an oxidising agent in dilute sulphuric acid. The processes follow the reactions below:





Unlike copper, nickel sulphides (such as pentlandite) are known to be soluble in both ferric sulphate and dilute sulphuric acid solutions (Gupta and Mukherjee 1990):

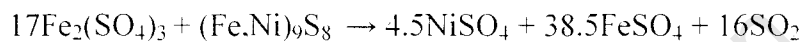

In practice, however the above two processes are carried out in the presence of oxygen normally at temperatures above 100°C. These conditions are not viable for the intermediate material hence it is suggested a system using dilute sulphuric acid in the presence of ferric ions as an oxidising agent be employed.

2.3.5.4 Other Process Considerations

This process must be run at a pH below 2 to ensure that ferric does not precipitate as the hydroxide and to favour formation of the most efficient ferric complex FeSO_4^+ (Ring 1980).

2.4 Methods of Recovery

2.4.1 Adsorption to carbon

This process can be carried out in two ways depending on the reactor configuration used for leaching:

- Carbon in pulp process (CIP): This form is used for agitated tank leaching of metals. In this case porous granules of carbon are added to the pulp in a flow counter-current to the pulp in a series of agitated tanks. The metal cyanide complex adsorbs onto the carbon and the pulp is then filtered through a mesh to remove ore particles. The adsorbed metals can then be recovered by desorption/elution in hot caustic solution (NaOH or NaOH-NaCN) often under pressure and high pH followed by electrolysis/electrowinning (Chamberlain and Pojar 1984).

- For heap leaching the leach solution is passed through a series of columns containing fixed or fluidised beds of carbon (Chamberlain and Pojar 1984). After which the pregnant carbon is removed from the columns to recover the metals in the same manner as detailed above.

Adsorption to carbon has proved successful for the recovery of PGMs from cyanide leach liquors at bench scale (Grosse et al 2003; Torres and Costa 1997; Bruckard et al 1992). The leach liquors did not contain BMs because of mineralogy of ore or they had been extracted from the ore before cyanide leaching via a pressure and atmospheric acid leach. The adsorption to carbon method is proposed for evaluation on PGM leach liquors of bisulphide (Hunter et al 2004) and thiosulphate.

Chamberlain and Pojar (1984) report that it is possible to regenerate the stripped carbon by washing with aqueous acid, and then heating in an oven, kiln or chamber at 700°C for several hours under a non oxidising atmosphere such as steam. While the life expectancy of carbon is not well documented some operators have reported 25% reduction in adsorptive capacity after eight to nine cycles of re-use while others have reported 33% reduction in adsorptive capacity after eight to nine years of continuous use (Chamberlain and Pojar 1984).

2.4.2 Merrill-Crowe Process (Zinc Cementation)

The process (Gupta and Mukherjee 1990) (see Figure 9) starts with the filtration of pregnant solution in media filters (pressure leaf filters, filter presses, and vacuum leaf filters) or countercurrent decantation (CCD). Generally, a precoat of diatomaceous earth is used to produce a sparkling clear solution. Clarified solution is then passed through a vacuum deaeration tower where oxygen is removed from the solution. The precipitation is a reduction process hence removal of an oxidant (O₂) improves the efficiency of the process. Zinc powder, or other metal powders such as copper, iron or aluminium (Grosse et al 2003) are then added to the solution with a dry chemical feeder and an emulsification cone. The reaction of the special fine metal powder with the solution is almost instantaneous. This technique involves a redox reaction between the zerovalent base metal grains and the target precious metal. The precipitant stoichiometrically displaces the precious metals in solution according to the following equation:

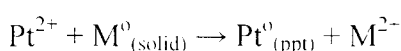

Precipitation occurs in the pipeline between the press feed pumps and the filter presses. The precipitated metal is then typically recovered in a recessed plate or plate and frame filter press. Chen and Huang (2006) used this procedure to successfully recover PGMs from a cyanide solution after pressure leaching. In this case the leach liquor did not contain BMs, they had been extracted from the ore using an acid pressure leach process. Considering that this method has had varying degrees of success with recovery of gold from thiosulphate solutions (Grosse et al 2003), it is proposed that it can be evaluated to recover PGMs from thiosulphate and bisulphide solutions.

The disadvantage of this process is that the separation step typically involves a series of expensive gravity separation thickeners or continuous filters arranged for countercurrent washing or filtration of the solids. For ores exhibiting slow settling or filtration rates, such as ores with high clay content, the countercurrent decantation (CCD) step can become cost prohibitive. Thus in many cases in industry, the adsorption to carbon method is preferred over the Merrill-Crowe process because it eliminates the need for the leached ore solids and liquid separation unit operations.

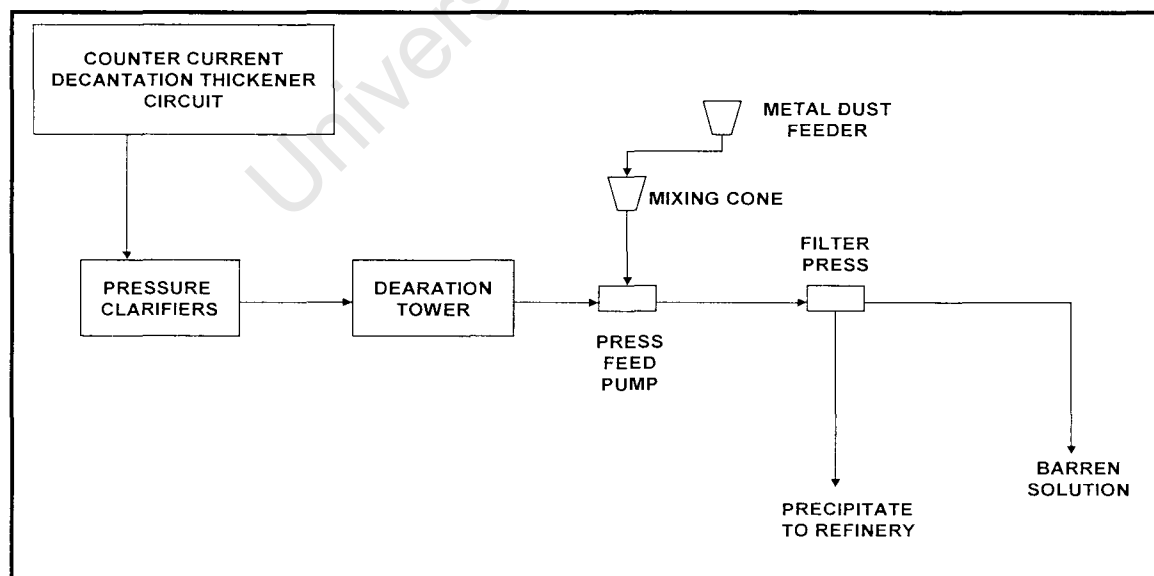

Figure 9: Merrill-Crowe process/Cementation

2.4.3 Recovery from Organic Acids

There are no recovery methods on record for this form of leaching: however since Evans (2007) suggests that PGMs do not complex very well in organic acids under highly acidic conditions the following theory of how to achieve recovery is proposed in the interim:

Similar to the stripping stage in a solvent extraction process a solution of HCl and Chloride could be used to lower the pH to acidic levels in which case the PGMs may preferentially complex with the chloride ions to form the standard PGM chloride complexes. A solution like this can then be sent to the PMR as it is similar in constitution to the standard treatments used in PGM recovery. Since the BMs are leached in acidic media it may be that only an acid such as HCl or H₂SO₄ would be required. For the latter acid, the solution can be sent to the BMR directly as it is the acid used in the pressure leach circuit of BMs. In the case of the ferrous-ferric cycle, it is also proposed that recovery may take place in the BMR (For methods of recovery used in the PMR and BMR see Chapter 1 section 1.5).

2.5 Reactor Configurations

Considering the grade and the tonnage of the material, the reactor choice was critical. Even at bench scale it was decided that the choice of reactor should be one that is viable on an industrial scale. Conventional reactors such as stirred tank, fluidised bed, plug-flow, were initially viewed as unsuitable for the following reasons:

- They require a high solid to liquid ratio, around 10 % (e.g. 10 tons of liquid to 1 ton material).
- They are energy intensive; requiring some form of mechanical agitation. Hence the need to keep the solid to liquid ratio in the area of 10 %.

For these reasons the following reactors were proposed for evaluation:

2.5.1 Packed Bed

A packed bed reactor (Sinnott 1999) is one in which special structured objects are used to improve the contact between liquid-solid (reactant), gas-liquid or gas-gas phases. The latter two are more common in the chemicals production industry where the packing may be a catalyst; while the first type is more common in the extractive metallurgy industry in the form of heap leaching. The packed bed configuration is such that the inter-spatial channels in the packing allow for easy flow of fluid allowing for improved contact between fluids or fluids and solid. The packing is contained in a vessel such as a tube, pipe, and column or stacked as an open heap.

Heap and dump leaching are perhaps the oldest method for recovering copper from low-grade oxide and sulphide ores. It has also found application in pre-treating of refractory gold ores before cyanidation as well as for the recovery of gold, silver and uranium from low grade ores (Figure 10). It provides a profitable route for treating copper, gold and uranium ores whose grades are considered too low for the usual methods of concentration before treatment (crushing→milling→flotation). Typically grades are copper <0.5 % (Gupta and Mukherjee 1990) and gold <1 g/t (Chamberlain and Pojar 1984). Operations can be purely chemical employing the use of dilute sulphuric acid or cyanide solutions; or they can be assisted by microbial agents in a ferric-ferrous system.

The site for constructing the heap is inclined and cleared of any growth before it is rolled and packed with clay or slimes to make it as waterproof as possible. The alternative to this is using plastic or rubber lining over the area. Culverts are built for ventilation and drainage towards a common collecting site. The ore, sometimes uncrushed, is piled into heaps and leaching solution is evenly sprayed on top of the heap to percolate through the heap; flowing through the drainage system for collection and metal recovery.

In this case the ore is in slurry form and hence a GEOCOAT® style procedure will be employed. The GEOCOAT®¹ process, developed by GeoBiotics LLC, uses iron and sulfur oxidising microorganisms to facilitate the oxidation and leaching of sulfide minerals in an engineered heap environment. It uses a combination of mesophiles and thermophiles. Unlike regular heap leaching it uses specially designed heap pads (made of high density polyethylene HDPE) and an

¹ <http://www.geobiotics.com/page.cfm/ID/27/Process-Description>

algorithmic computerised process control system to regulate air flow and solution irrigation rates in the heap to maintain desired operating temperatures (as part of the HotHeap™ control philosophy). It additionally differs from conventional heap leaching (which may only employ chemical reagents; without the aid of biological agents) in that it was designed to treat flotation or gravity concentrate as opposed to whole ore in regular heap leaching. The concentrate is coated onto a sterile support media which is usually barren or waste rock, or waste sulphide ore. The mass ratio of concentrate to media is typically in the range of 1:5 to 1:10 and the support media is carefully and uniformly sized (+25-6mm). This results in sufficient inter-spatial channels in the heap to provide low resistance to air and solution flow. The support media (rock) is reclaimed for re-use by using a front-loader to transfer the contents of the heap to a conveyor for delivery to a vibrating washing screen or trommel, where the coating is washed off using water sprayers.

A heap leach operation will typically result in slower recovery of metals and is most profitable for huge tonnages of ore or concentrate (Gupta and Mukherjee 1990).

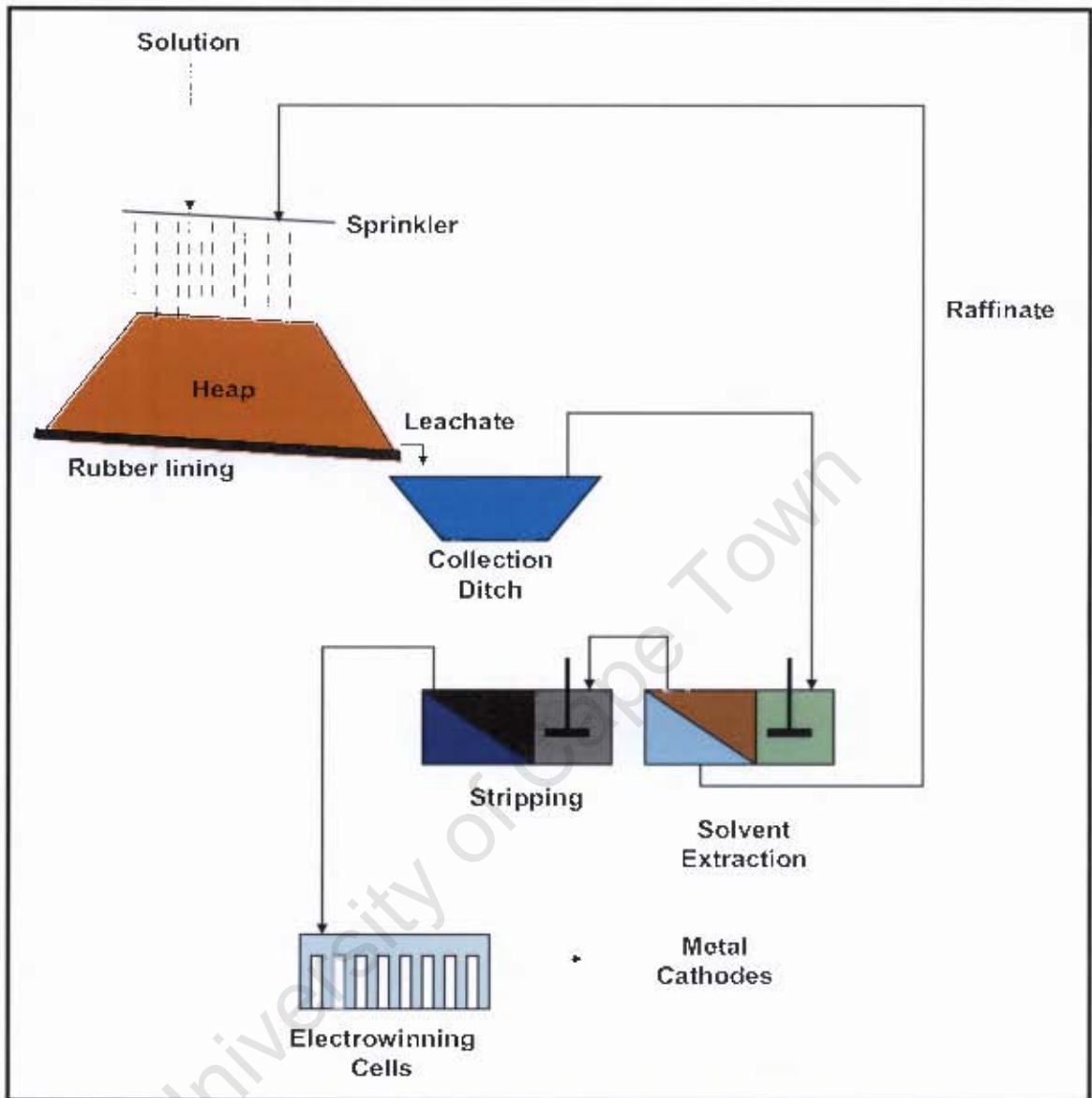

Figure 10: Typical heap leaching operation

2.5.2 Granular Bed

The granular bed (Richardson and Harker 2002) type reactor is a common occurrence in the chemical process industry; it takes the form of a bed of stationary granular particles through which a fluid flows for the purpose of filtration, drying a gas or catalytic reactions.

This idea originates from a belt filter operation to de-water tailings (Figure 11). A layer of slurry is spread on a conveyor belt made of filter cloth and water is extracted under vacuum. A typical operation handles 100 tons of slurry per hour. Tailings de-watering is very much a physical

process, but bench scale test work will show if a similar operation can be used to handle the tonnages of the low-grade ore concentrate produced while at the same time providing sufficient contact with the leaching reagent while on the belt. In this case leach solution will be sprayed on top of a layer of slurry and allowed to percolate under gravity and re-circulated as often as is needed to achieve the required leaching targets. Once a batch of concentrate material has been fully processed, it can be moved along the conveyor belt to make room for another batch. In this manner, the operation allows for contacting large amounts of material with a small amount of liquid and has the potential for operation at elevated temperatures to achieve quicker recoveries of metals.



Figure 11: Delkor Belt Filter developed by Delkor Industries²

2.6 Hypotheses

Based on the literature reviewed, the following were hypothesised:

² Photo taken from <http://www.batemanengineering.com/Globe72/Jpeg/GI%2072%20p7%20ft.jpg>

- Pure chemical treatments such as cyanide, thiosulphate and bisulphide can achieve comparable PGM extraction levels to those achieved by the organic acids.
- Established techniques for leaching BMs from low-grade sulphide ores, chemical and biologically aided, can achieve comparable BM extraction levels to those achieved by the organic acids.

University of Cape Town

Chapter 3: Methodology

The hypotheses were tested through experimental work and analysis of the generated data. This chapter discusses details of experimental procedures and analytical methods. The experimental work proceeded in two phases.

3.1 Phase 1: Preliminary Test Work on Proxy Material

This phase revolved around selection of the most suitable lixiviants for dissolving PGMs from a selection of organic acids and comparison of results against those from using cyanide, thiosulphate and bisulphide solutions. Additional process conditions explored included influence of pH, temperature, reagent concentration and use of chemical oxidisers. A series of small scale batch experiments using a high grade platinum sulphide material (74.8% Pt), were used as a preliminary screening process to identify the most promising routes before proceeding to bench scale evaluation using the concentrate material. PtS_2 was chosen as a proxy material because the economical feasibility of any potential process is critically dependant on the quantities of platinum extracted (the platinum constituents 60% of total PGM content in the low-grade ore concentrate) and PGMs occur largely as sulphide, telluride and selenide minerals in the concentrate. Also, because the work was conducted on a small scale it was doubtful that measurable quantities of PGMs in leach solutions would be achieved given that the concentration of PGMs in the ore concentrate is a mere 15 g/t. Finally, PtS_2 is readily available commercially, whereas any PGM selenide or telluride compounds are not.

3.1.1 Experimental Plan

This is a consolidation of the extensive literature review (chapter 2) and how it was applied to formulating an experimental plan for evaluating the various lixiviants identified in the literature survey. Figure 12 illustrates the general overall path followed to identify the best options.

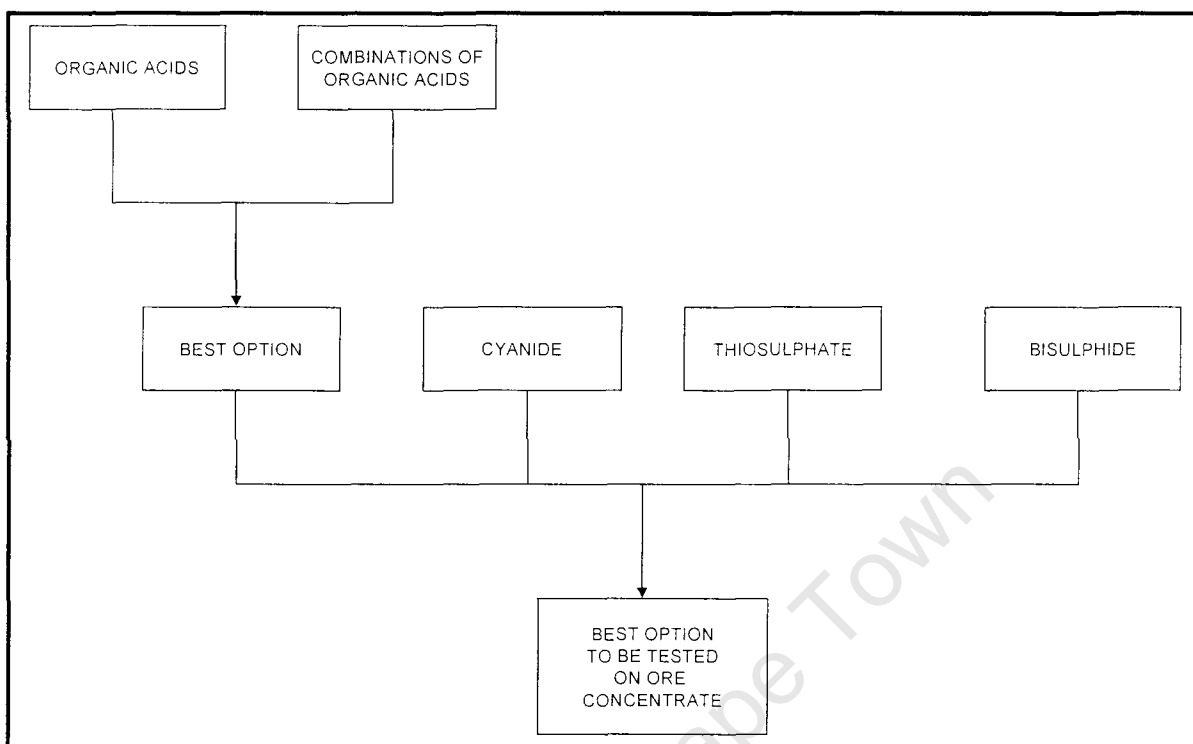

Figure 12: General overall experimental plan for phase 1

3.1.1.1 Organic Acids

The experiments would proceed using analytical reagent grade acids varying in the number of carboxylic groups (-COOH) present in the acids. Additionally various combinations of the acids will also be evaluated. As stated earlier, this avenue of research was originally started with the observation that microorganisms could be the source of the organic acids. It has therefore been postulated that with different organic feed stocks, the microorganisms are likely to produce mixtures of organic acids.

The use of analytical reagent grade acids was chosen over the route of biologically producing them because it was a convenient method to determine if they had the potential to leach the target amounts of platinum, and to identify the most effective acids or combination of acids before exploring their biological production.

Process conditions varied were pH, reagent concentration, temperature (up to 50oC) and introduction of chemical oxidisers.

3.1.1.2 Cyanide

It had been concluded that the only viable routes for exploration with cyanide solutions were to observe recoveries using plain solutions on platinum sulphide minerals, use of a chemical oxidising agent and the influence of heating to a maximum of 50°C. Reagent concentrations were varied but pH had to be above 9.6 to prevent evolution of the toxic HCN gas.

3.1.1.3 Thiosulphate

Dissolution of platinum would be explored using plain sodium thiosulphate solution, and in the presence of copper and ammonia, as oxidising agents. Additionally reagent concentration, pH and temperature were varied.

3.1.1.4 Bisulphide

Plain sodium bisulphide solution was explored with the bubbling of H₂S gas, as an additional source of (HS⁻) to increase platinum dissolution levels. Reagent concentration, pH and temperature were also varied.

Process conditions were generally varied as follows:

- Reagent concentration- from 0.1 to 1 M. There are no commercial operations that currently directly leach PGMs from low-grade ore materials and hence there is no comparative data to base these concentrations on. Considering the low concentration of PGMs in the concentrate, stoichiometrically, low reagent concentrations (>0.01 M) should be enough to leach the PGMs. But if higher concentrations are needed, it may still be economically feasible to use them considering the high market value of PGMs and the possibility of re-circulating the lixiviant and regenerating it after recovery of PGMs.
- Reagent pH- This varied according to the lixiviant, but was in all cases in the alkaline media range (7-12), based on the literature. Solutions were buffered to maintain pH using various combinations of potassium phosphate, sodium carbonate, sodium hydroxide and boric acid solutions:

- Temperature-was maintained with the aid of a water bath and up to a maximum of 50°C. For this process it has been predicted only mild operating temperatures would be economically justifiable given the tonnage and grade of the ore material.
- Chemical oxidisers-at this stage chemical oxidisers were used as a proxy to determine if an oxidising environment would aid PGM dissolution.

3.1.2 Materials and Methods

Small amounts of platinum(IV) sulphide salt (15-50mg) were weighed into a 500 mL Erlenmeyer flask/Beaker to which 250 ml of solution was added. The mixture was agitated using a magnetic or overhead stirrer (Figure 13). For the experiments running at 50oC, the desired temperature was achieved and maintained using a water bath (Figure 14). To minimise evaporation of solution and water from the water bath respectively, the top of the beaker was covered with parafilm and the top of the water bath was covered with bubble wrap. Samples withdrawn at various intervals were vacuum filtered using a 0.22 micron membrane filter paper, which was weighed before hand, and then analysed through Atomic Absorption Spectrometry (AAS) and Inductively Coupled Plasma-Optical Emission Spectrometry (ICP-OES). A sample of solution was withdrawn before commencing with the experiment (Sample Blank) to ensure the reading for a blank sample was zero for the desired elements. If it was not, this amount was subtracted from the AAS/ICP readings to account for this discrepancy. Solution was replaced with distilled water to maintain constant volume. At the end of each experiment the remaining solids were recovered via vacuum filtration through the same 0.22 micron membrane filter paper used during the experiment and then dried and digested using the Karbochem R and D laboratory method (see Appendix 3) to perform a material balance.

% Extraction= E_1

Sample Blank= SB

Concentration in leach sample (mg/L or $\mu\text{g/L}$) from AAS/ICP reading = C

% of Pt in PtS_2 = 0.748 (74.8 %)

Mass of PtS_2 used in test = M

Volume of solution = V

Conversion of μg to mg = $\times 10^{-3}$

$$E_1 = \frac{(CxV) SB}{0.748xM}$$



Figure 13: Phase 1 experiments



Figure 14: 50°C Temperature Experiments

Details of reagent preparation methods, standardisation procedures and risk management protocol can be found in the Appendices in the CD attachment.

3.2 Phase 2: Final Test Work on Low-Grade Ore Concentrate

This phase involved the test work on the actual concentrate material to explore the most promising routes identified in phase 1 for leaching of PGMs from the material and as a secondary objective, investigate BM leaching.

3.2.1 Preparation of Concentrate Material

The concentrate material was received in the form of a slurry in a 200L drum. To ensure homogeneity before attempting to sample from the container, the slurry was processed as follows:

It was dried in a 37°C incubation room to powder form: this caused some of it agglomerate. It was laid out on a 2 x 6 m plastic sheet and mixed with a shovel and rake. It was then put through an Osborn MMD cone crusher to reduce the lumps to fine dust. A Riffle splitter was then used to split the ore into 20 kg samples and then 10 kg samples. The 10 kg samples were then split, using a Dickie and Stockler (Pty) rotary splitter, into 1 kg samples. The samples were then packed into 2 kg samples in polyethylene bags.

3.2.2 Material Sampling

A Fritsch Rotary Sample divider and a Quantachrome Instruments' Rotary Micro Riffler were used to obtain samples:

- From the 2 kg samples for the leaching tests, size analysis and BM solid assays.
- From the above samples before tests were conducted to carry out solid assays for PGMs and BMs.
- From the solid residue after the leaching tests to conduct solid assays for PGMs and BMs.

3.2.3 Size Analysis

The ore concentrate was sized using a process known as wet screening. An analysis was conducted using a Malvern, to give an estimate of the size distribution of the particles before proceeding to the wet screening.

A sample of approximately 200 g was weighed and placed on a 75 µm screen. The screen was vibrated and water was poured onto the screen with the filtrate being collected in a 40 L bucket. When the bucket was full, another was used until the water appeared clear. The remaining residue on the screen was thoroughly washed off into a small dish. The filtrate in the buckets was passed through a 45 µm screen (vibrating) and the filtrate similarly collected in separate 40 L buckets. The residue on the screen was then washed off into a separate small dish. Filter papers were weighed and used to vacuum filter the samples in the small dishes and the filtrate in the 40 L buckets. The samples were then oven dried at 96°C overnight and weighed. The % passing 45 and 75 µm was calculated as follows:

$$\text{Passing 75 } \mu\text{m} = \frac{\text{Weight of Sample} - \text{residue collected from 75 } \mu\text{m screen}}{\text{Weight of Sample}} \times 100$$

$$\text{Passing 45 } \mu\text{m} = \frac{\text{Weight of Sample} - \text{residue collected from 45 + 75 } \mu\text{m screens}}{\text{Weight of Sample}} \times 100$$

3.2.4 Ore Concentrate Split

In addition to the data provided by Lonmin on the percentages of the various elements in the ore concentrate, it was decided that samples from the successful experiments (before and after tests) would be assayed externally for verification. However external assaying could not be conducted on the samples before testing due to logistical problems and sheer number of experiments conducted. Hence, for initial calculations, the data provided by Lonmin and from solid assays for copper, nickel, cobalt and iron conducted at UCT were used. This data would be used in initial calculations to determine the most successful experiments and from these, samples put aside before testing and samples obtained after testing would be sent off to Mintek for PGM and BM assays (see Appendix O).

For the BM solid assays conducted at UCT, 12 samples of 0.1 g were digested using the Karbochem R and D laboratory method and the percentage of the elements calculated using the formula for E₂ (see Appendix 3).

3.2.5 Experimental Plan

The series of experiments proceeded as laid out in Figure 15. The best options identified in phase 1 were used to leach the PGMs directly from the concentrate material to further narrow down the options. Parallel to this BM extraction leach experiments were conducted to add further value to the process and to test the theory that a BM extraction stage preceding a PGM leach would lead to increased extractions of PGMs. The residual concentrate material from the best BM leach tests were subjected to the best PGM leach processes and the extractions obtained were compared with those from testing on untreated material. The data would be used to generate the best flow sheet options.

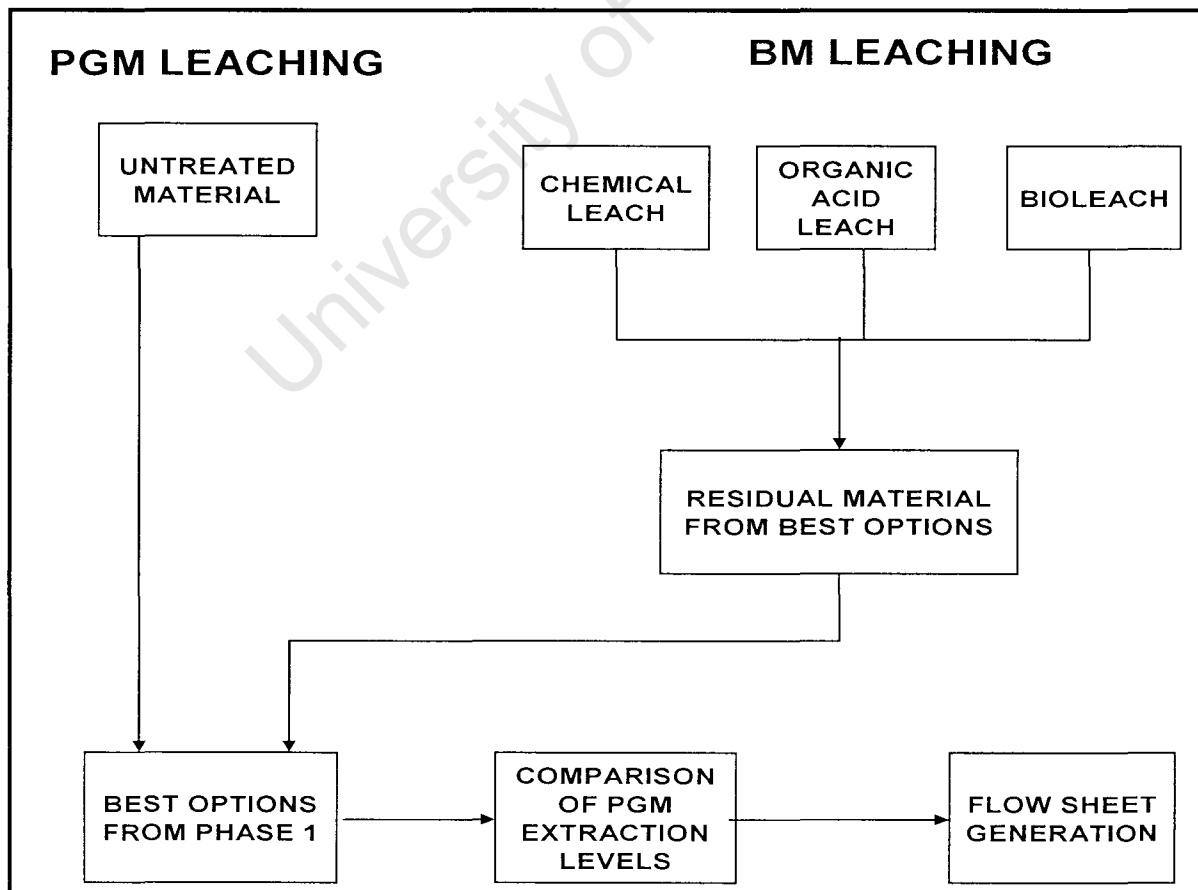

Figure 15: General overall experimental plan for phase 2

3.2.6 Granular Bed-Operation Procedure

Figure 17 shows a general schematic of the experimental set-up while actual equipment can be viewed in Figure 18 and Figure 19. Filter cloth was sewn on to the false bottom of the column and then placed on a larger piece of filter cloth to hold the false bottom. Strips of cloth were attached to the larger piece and held in place in the column using masking tape. This arrangement would fully contain the granular bed and leach solution preventing slurry from spilling over the sides of the false bottom into the collecting vessel (Figure 16).

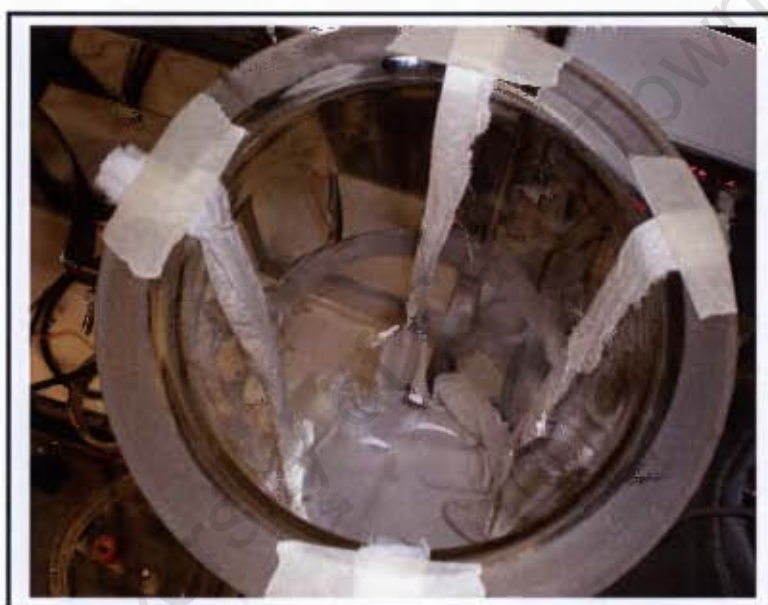

Figure 16: Taping of support cloth for granular bed

The column was heated to the desired temperature using a heating jacket and the solution was heated and maintained at the desired temperature using a water bath. The required amount of concentrate material was mixed to form a slurry using deionised water, to cause it to saturate and prevent consumption of lixiviant and maintain a constant volume as much as possible. The slurry was then placed on the false bottom in the column. In earlier trial runs it was observed that the rate at which the solution percolated through the bed only became uniform after the first cycle. This was because the particles in the bed shifted and only settled in their final place after the first cycle. For this reason in the first instance the solution was pumped from the Erlenmeyer flask into the column using a pump, and initially collected in a separate vessel. The solution was added back to the flask to give time zero.

The temperature of the granular bed was measured using a Major Tech MT 630 thermometer and MT 660 probe. In the first few hours temperature was measured and adjustments made to the heating jacket until the temperature of the granular bed was the desired one. Samples were withdrawn from the Erlenmeyer flask, using a syringe and tube for vacuum filtration using a 0.22 μm membrane filter paper and collected in macarthy bottles for appropriate analysis (see section 3.2.10). A sample of solution was withdrawn before commencing with the experiment (Sample Blank) to ensure the reading for a blank sample was zero for the desired elements. If it was not, this amount was subtracted from the AAS/ICP readings to account for this discrepancy. The temperature of the granular bed and the water bath were checked during sampling and regularly during the course of the experiment. Solution samples were replaced with distilled water to maintain a constant volume. On completion of the experiment, materials were collected via filtration and oven dried to obtain samples (section 3.2.2) for solid assays to perform full material balances.

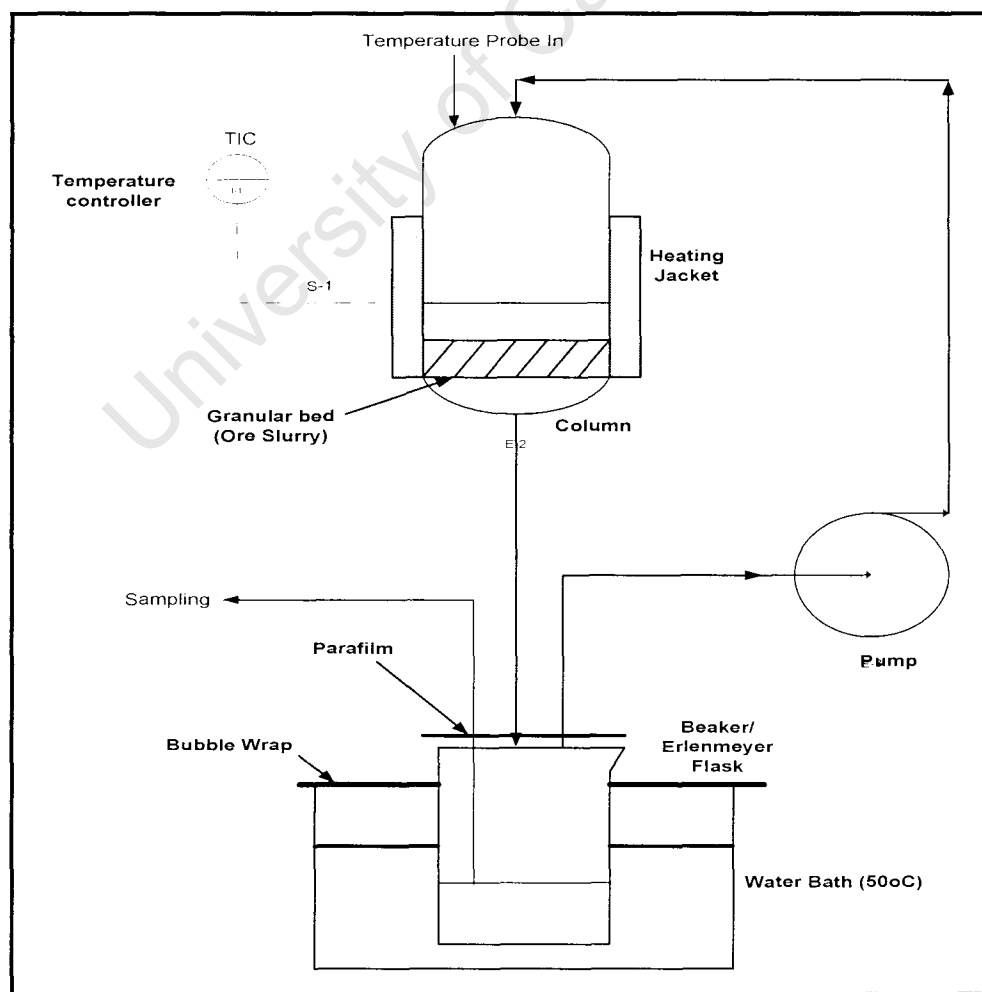

Figure 17: Schematic drawing of equipment for granular bed leach



Figure 18: Granular bed leaching of PGMs and BMs



Figure 19: Granular bed leaching of PGMs with cyanide in fume hood

3.2.7 Packed Bed Reactor Operating Procedure for Chemical Leaching

The conventional method of testing a heap leach process at bench scale is by using a packed column (Figure 20). For this study a PVC pipe was placed in the glass columns used previously for the granular bed experiments and supported upright with newspaper packed on the sides (Figures 21 and 22). The equipment was held in place using a metal frame. In the case of the cyanide, the experiment was conducted in a fume hood.

3.2.7.1 Preparation of Sample

The method of creating a packed bed by coating the concentrate material as slurry onto a support media results in significant loss of material (around 20 %). This is because in the process of preparing the slurry, coating it on to the support media and packing it, some of it is left on the different vessels used. To determine the exact amount of concentrate in the packed bed the following procedure (Table 3) was followed to carefully account for the concentrate lost on route to the packed bed:

- Enough plastic fillers were placed at the bottom of the column such that the bottom surface was completely covered.
- Granite pebbles were loaded until approximately 300ml volume short of the top, and then more plastic fillers were placed at the top. This is the amount of granite needed to coat the slurry. The extra volume would be occupied by the slurry.
- A plastic tray was weighed.
- The contents of the column were released into a plastic bucket and the fillers removed.
- The granite was weighed in the pre-weighed plastic tray.
- A sample of concentrate material was weighed.
- A dry 500 mL glass beaker was weighed.
- Using the weighed sample and deionised water, slurry of density representing solid to liquid ratio 5:3 was made in the glass beaker and weighed.
- The granite in the tray was coated; using a long rod to mix and the tray was weighed. After packing the column the empty tray would also be weighed

Table 3: Masses weighed

Vessel	Mass
Tray	M_1
Granite	M_2
Material	M_3
Dry Beaker	M_4
Slurry	M_5
Empty Beaker	M_6
Empty Tray	M_7

Water used to make slurry $M_8 = M_5 - M_3$

Liquid: Solid Ratio $X = \frac{M_8}{M_5}$

Actual mass of slurry coated onto media $M_9 = M_5 - [(M_7 - M_1) + (M_6 - M_4)]$

Actual mass of concentrate in packed column = $M_9 - (M_9 \times X)$

3.2.7.2 Packing of Column

- Two handfuls of plastic filler blocks were placed into column
- The column was then packed with the coated granite, slowly and carefully, using half a spade at a time to ensure none of the coating was lost. The tray was not scraped: the remaining slurry was weighed with the tray and accounted for in the above calculations.
- Another handful of filler blocks was placed on top of the packed bed

3.2.7.3 Start-up Procedure

- A collection vessel was filled with 1000 mL of the prepared feed solution and the exact volume noted. The feed tubing was immersed such that the solution intake was near the bottom of the container.
- The pump was switched on and was run at a rate of 1000 mL/24 hours (see section 3.2.7.6 for pump calibration procedure). Care was taken to ensure the solution was actually flowing

from the reservoir through the tubing and pump in the feed shaft on the correct pump (this was confirmed by the advancing meniscus through the clear tubing). The date and approximate time when solution flow *into* the column actually started was noted (about 20 minutes after switching on the pump) as the start-up point.

- Regular checks were made daily to ensure that solution was actually emerging at the bottom of the column and being pumped from the holding and collection vessel.

3.2.7.4 Sampling Procedure

- Before sampling the level of effluent collected was noted and samples were collected in the macarthy bottles for appropriate analysis. During the experiments pH was measured from samples using a Hanna pH211 Microprocessor pH meter.

3.2.7.5 Recovery of Concentrate Material

On completion of experiments the concentrate material was recovered as follows:

- Contents of the column were released into a 20 L bucket and any slurry that adhered to surfaces was washed off into the bucket with a small amount of water.
- Enough water was poured into the collection bucket for the fillers to float for collection. The contents were mixed by gloved hand to bring up all the fillers and any slurry adhering to them was washed off into the bucket with a small amount of water.
- The slurry was washed off the granite by placing it onto a 9 mm sieve and pouring water to remove slurry into the 20 L bucket.
- Some filter paper was weighed and used to filter contents of the bucket using a filter press.
- The filter cake was dried in an 80°C oven, weighed and sampled (see section 3.2.2) for PGM and BM solid assays.

3.2.7.6 Pump Calibration Procedure

The pump was set to feed the columns at a rate of 1 l/day. This slow feed rate ensures that a small quantity of feed solution is sent to the column to allow clear absorption to the coated

granite. The feed rate 40 ml/hour translates to 3.5 ml of feed solution every 5 min. Using distilled H₂O to calibrate the pump: density of distilled H₂O = 1g/ml therefore 1 ml of distilled H₂O = 1 g of distilled H₂O. Distilled H₂O from a small beaker was pumped into another small pre-weighed beaker for 5 min and final mass is noted. Adjustments to pump speed were made until the final reading is 3.5 ml of difference between the empty beaker and the beaker filled after 5 min. Table 4 illustrates the calibration method with the readings for the calibration of one of the pumps used.

Table 4: Pump calibration calculations

Pump No.	Beaker Initial Weight (g)	Beaker Final Weight (g)	Time Run (mins)	Pump Speed (rpm)	Difference In Weight (g)	Volume (ml)
	34.00	40.66	5	1.25	6.66	6.66
	34.00	39.43	5	1.15	5.43	5.43
	34.00	37.81	5	1.05	3.81	3.81
	34.00	37.68	5	1.02	3.68	3.68
	34.00	37.65	5	1.015	3.65	3.65
	34.00	37.50	5	1.010	3.50	3.50

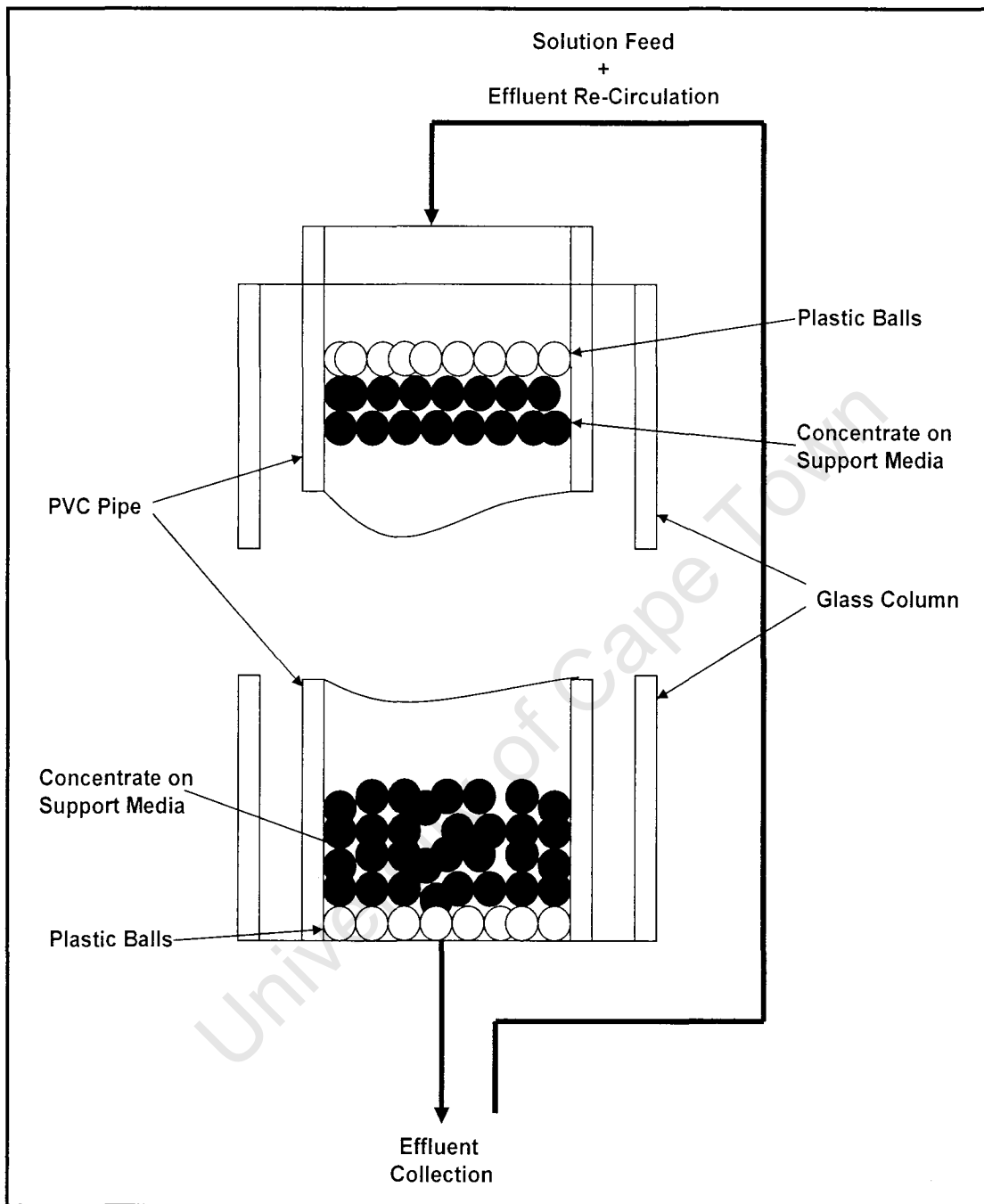

Figure 20: Schematic diagram for chemical heap leach experiment



Figure 21: Cyanide heap leaching of PGMs in fume hood



Figure 22: Organic acid heap leaching of BMs

3.2.8 Packed Bed Reactor Operating Procedure for Bioleach Process

The procedure for this was exactly the same as the chemical heap leach procedure (see section 3.2.7 above) with a few notable additions:

- During the “Preparation of Sample” (see 3.2.7.1) and “Packing of Column” (see 3.2.7.2) a temperature probe was fastened into the packed bed when it was packed about two-thirds of

the way. It was tilted so that the cable would run along the side of the column and then it was buried as the column was fully packed.

- The heating coil was switched on and the feed solution was allowed to flow into the bed but unlike the chemical heap leach it was not re-circulated but collected in a separate vessel from the vessel from which it was pumped from. Sampling was done from the collection vessel and the levels of solution in the feed and collection vessels were noted to account for evaporation.
- The mixed culture of thermophiles in a broth was only inoculated into the column when the bed temperature reached 65°C. Inoculation was done by removing the feed tube from the feed holding vessel and placing it in the vessel holding the broth.
- From the samples taken pH was measured using a Metrohm 713 pH meter and Eh using Crison redox meter.

A schematic diagram of the experimental set-up for the heap bioleach can be seen in Figure 23 while the actual equipment is pictured in Figure 24.

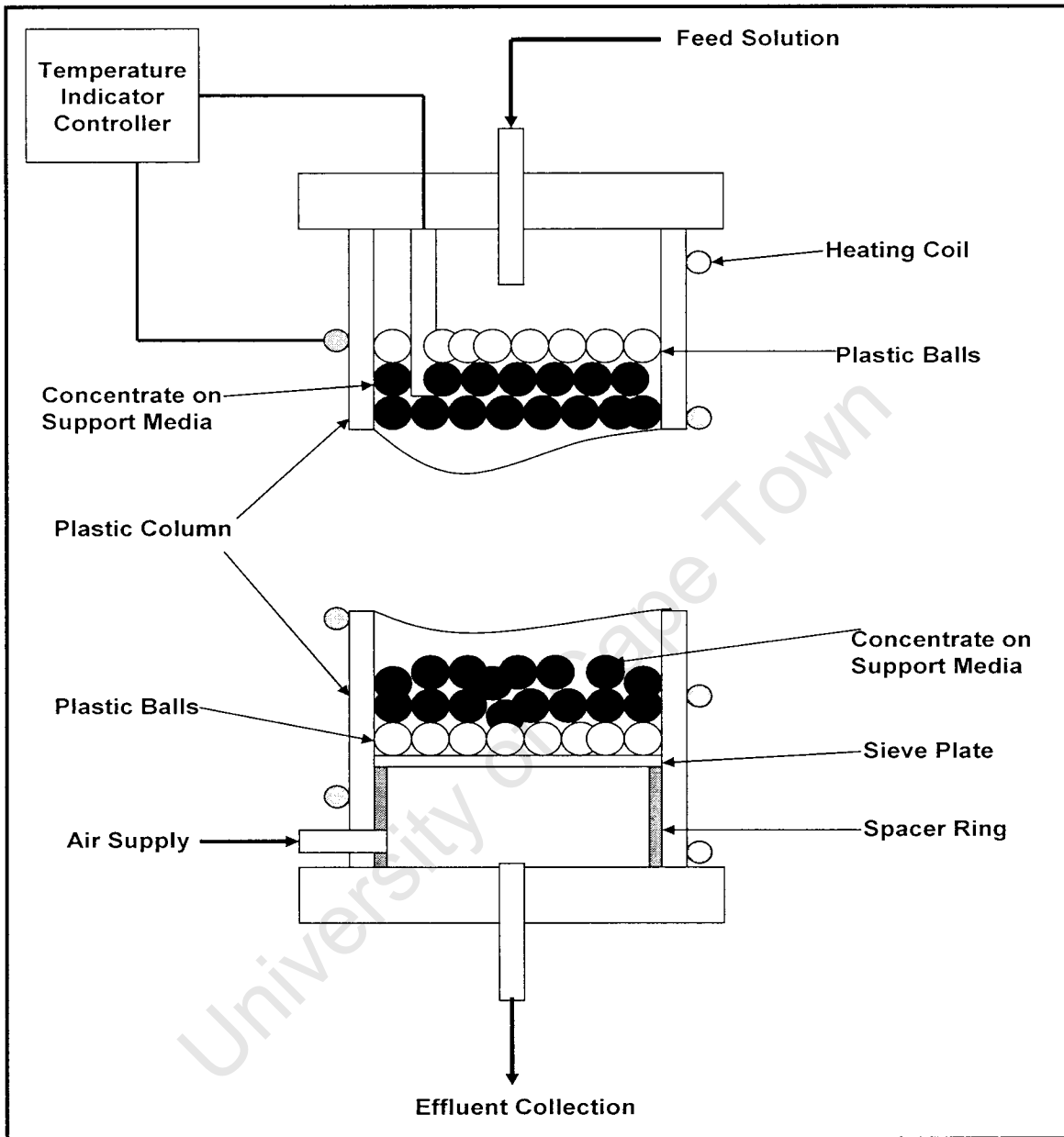

Figure 23: Schematic drawing of bioleach process equipment



Figure 24: Bioleaching of concentrate in packed columns

3.2.9 Batch Stirred Tank Reactor Operating Procedure

Figures 25 and 26 shows the general experimental set-up for the batch stirred tank reactor experiments and the procedure was identical to that which has been described in section 3.1.1.



Figure 25: BM batch stirred tank reactor leaching experiments

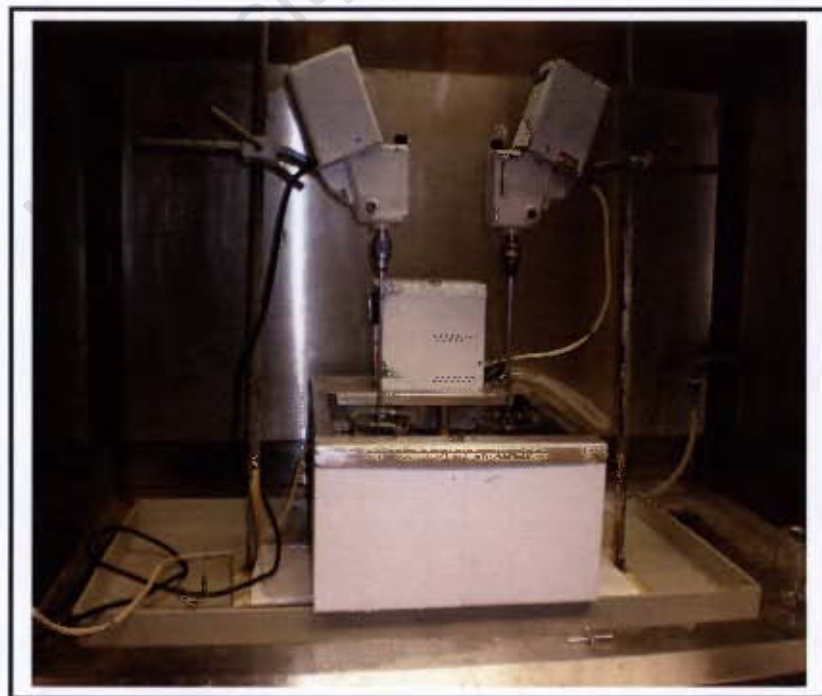

Figure 26: BM batch stirred tank reactor experiments at elevated temperatures

3.2.10 Analytical Methods

The amounts of metal extracted were determined by analysing all leach solution samples by Atomic Absorption Spectrometry (AAS) and Inductively Coupled Plasma Spectrometry (ICPS) at the University of Cape Town and solid assay of samples from remaining solid residue was conducted by Mintek. The PGM and BM solid assays were only conducted for a select few experiments, mainly those that according to the amounts of metals in solution were judged as the most successful.

Using this data the following calculations were made:

Amount of element leached (A_1) was calculated by:

$$A_1 = C_1 V_1$$

C_1 = concentration of element in solution (mg/L or $\mu\text{g/L}$)

V_1 = measured volume of solution in reactor/effluent collected (L)

Percentage leached (E_3) was thus calculated:

$$E_3 = \frac{A_1}{M_2 \times C_3} \times 100$$

M_2 = mass of ore concentrate used

C_3 = concentration of element in ore concentrate sample (% or ppm)

The data from the solid assays conducted by Mintek were reported as percentages (E_4) and these were used to calculate the amount of element left unleached (A_2):

$$A_2 = E_4 \times M_2$$

A mass balance over the system using IN-OUT = 0, was thus performed using:

$$M_2 C_3 = A_1 + A_2$$

McCartney bottles used to collect samples were rinsed in 10 % HCl solution to make them sterile to hold samples for ICP analysis.

Detailed calculations for the experiments can be found in the appendices in the CD attachment.

University of Cape Town

Chapter 4: Results, Discussion & Conclusions

4.1 Preliminary Test Work on a Proxy Material

4.1.1 Aims of Experimental Work

- To determine first hand the rate and extent of platinum dissolution in various organic acids from a sulphide proxy material.
- In so doing identify the most effective acid or combination of acids, along with the optimal conditions (concentration, temperature, pH, catalysts) within the project specifications.
- Using the results as a benchmark, evaluate the effectiveness of the chosen inorganic lixivants (thiosulphate, cyanide and bisulphide) in comparison to the organic acids.

To put the work in context: the experiments proceeded based on the reports in the literature (Evans 2007) that organic acids have the potential to leach significant amounts of PGMs from various ores and concentrates. There is no data (solubilities, reaction thermodynamics, complexes formed) in the literature concerning these reactions hence the solubilities observed from the experiments, will be presumed to have the potential to leach PGMs from the ores and these will be the bench mark against which the other treatments will be evaluated.

4.1.2 Observations and Results

The amounts of platinum dissolved by thiosulphate (optimal pH 7) and bisulphide (pH range 9-11) solutions were in the ppb range (μg of platinum), even when an elevated temperature of 50°C was used and concentration was varied. In the case of thiosulphate after the introduction of copper and ammonia, the extent of dissolution still remained in the ppb range. This was less than 1% of the total amount of salt used (Tables 5 and 6).

Table 5: Percentage dissolution of platinum from PtS₂ in sodium bisulphide tests

Reagent				% dissolution
Concentration (M)	pH	Temperature	Additive	of Platinum (x 10 ⁻³)
0.5	7-9	room	-	1.48
0.5	9-11	room	-	1.13
0.5	9-11	room	H ₂ S	1.15
0.5	9-11	50°C	-	3.55

Table 6: Percentage dissolution of platinum from PtS₂ in sodium thiosulphate tests

Reagent				% dissolution
Concentration (M)	pH	Temperature	Additive	of Platinum (x 10 ⁻³)
0.1	10	room	-	1.07
0.1	12	room	-	1.65
0.5	10	room	-	6.04
0.5	12	room	-	5.84
1	7	room	-	23.8
1	11	room	-	11.7
0.5	6	room	Copper & Ammonia	11.5
0.5	7	room	Copper & Ammonia	20.8
0.5	11	room	Copper & Ammonia	12.0
0.5	7	50°C	-	22.3
0.5	7	50°C	Copper & Ammonia	42.3

From an assortment representing acids with 1 to 3 carboxyl groups (Table 7), AAS analysis results identified citric acid as the most effective in dissolving platinum. Although the amounts were in the ppb range they were more than those achieved by thiosulphate and bisulphide solutions. The optimal concentration was observed to be 0.5 M; and an increase to 1 M had little impact on the amount of platinum dissolved relative to the increase in concentration. A dramatic increase was observed when an oxidising agent in the form of hydrogen peroxide (Eul et al 2001)

was introduced. Evaluation using concentrations of 0.2, 0.5, 1.5 and 2 M showed that 2 M of hydrogen peroxide in citric acid resulted in the dissolution of 27% of the platinum from the salt after 20 hours.

Table 7: Percentage dissolution of platinum from PtS₂ in sodium thiosulphate tests

Organic Acid	Reagent		Temperature	% dissolution of Platinum
	Concentration (M)	pH		
Gluconic	0.5	8	room	0.06
Gluconic	0.5	12	room	0.05
Acetic	0.5	8	room	0.03
Acetic	0.5	12	room	0.03
Formic	0.5	8	room	0.04
Formic	0.5	12	room	0.03
Malic	0.5	8	room	0.09
Malic	0.5	12	room	0.09
Tartaric	0.5	8	room	0.09
Tartaric	0.5	12	room	0.09
Citric	0.5	8	room	0.10
Citric	0.5	12	room	0.09
Citric	0.1	8	room	0.06
Citric	1	8	room	0.12

The investigation proceeded to observe the influence of using a combination of organic acids on the dissolution of platinum. The AAS analysis showed that the combination of tartaric and malic acid dissolved the most platinum (see Table 8 for a full list of combinations and results). Under identical operating conditions it performed better than citric acid. Further experiments were conducted with this combination to observe the influence of temperature in the presence of an oxidising agent.

Similar to the case of citric acid, the presence of 2 M hydrogen peroxide, had a dramatic influence resulting in the combination of tartaric and malic acid dissolving 44% of the platinum from the salt. A temperature increase of 50°C had the expected effect of speeding up the reaction.

It can be seen that at 50°C the reaction has dissolved about 43% after 5 hours whereas at ambient it takes 24 hours to dissolve 43% of the salt (Figure 27). Experimentally, hydrogen peroxide proved its ability to act as an effective agent in alkaline media as opposed to nitrate (Pokorny et al 2006) and chlorate (Bureau of Mines Information Circular 1981) which were observed to be ineffective oxidisers in alkaline pH.

Table 8: Various organic acid combinations evaluated and results

Acids	pH	Temperature	Additives	% Dissolution of Pt from PtS ₂
Citric, Malic, Gluconic	8	room	-	0.07
Malic, Formic, Gluconic	8	room	-	0.06
Citric, Tartaric, Malic	8	room	-	0.11
Citric, Tartaric	8	room	-	0.14
Malic, Tartaric	8	room	-	0.20
Citric, Malic	8	room	-	0.08
Gluconic, Formic	8	room	-	0.10

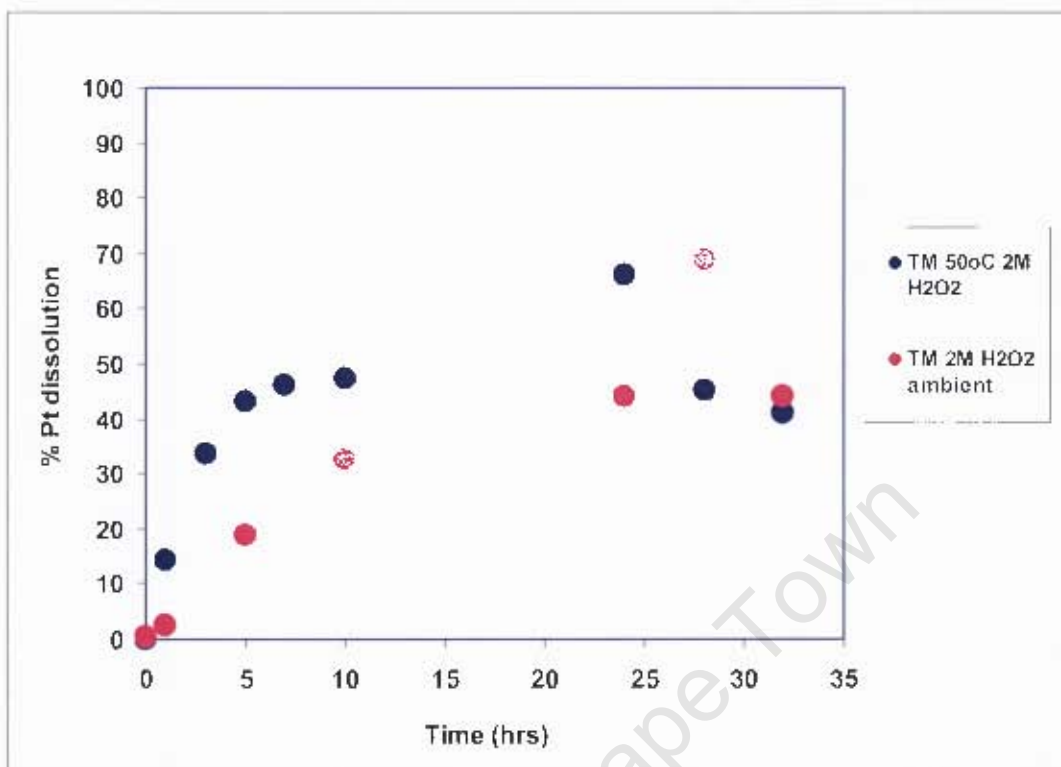

Figure 27: Dissolution of PtS₂ using 0.5 M tartaric-malic acid in the presence of 2 M hydrogen peroxide at ambient and 50°C

It can be seen from Figure 28 that a solution of cyanide performed remarkably well dissolving 91.5% of the platinum from the salt in a period of 29 hours. An increase in temperature to 50°C had the expected effect of increasing the rate while the presence of hydrogen peroxide as an oxidising agent resulted in decreased recoveries.

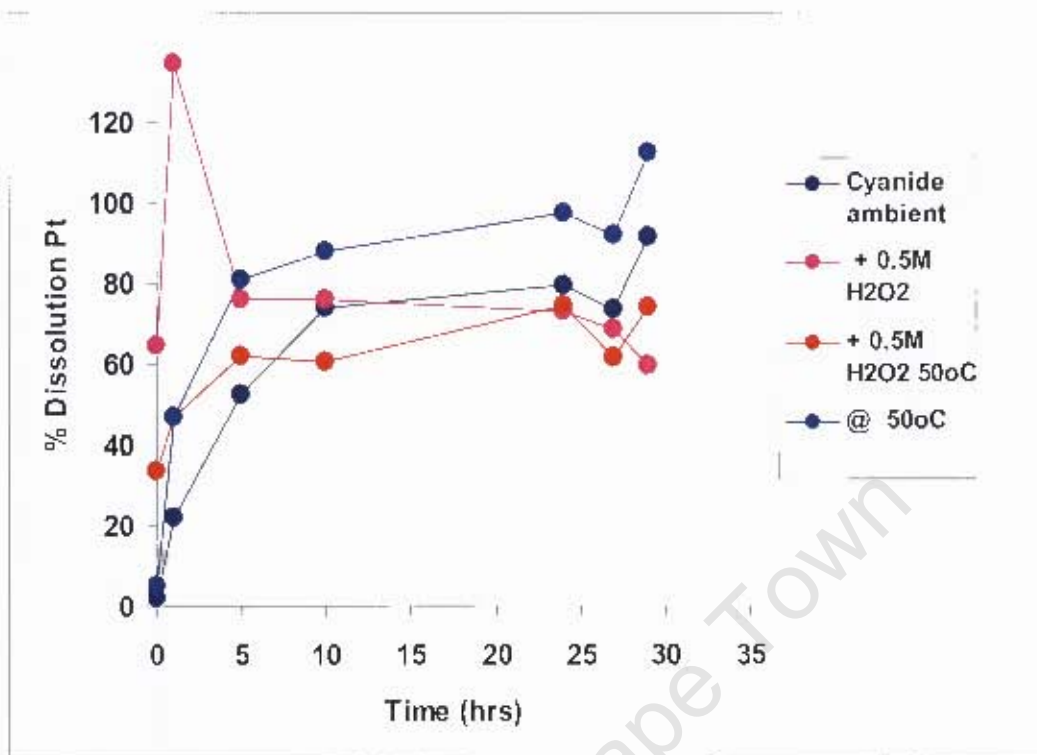

Figure 28: Dissolution of PtS₂ using 0.5 M sodium cyanide in the presence of 0.5 M hydrogen peroxide at ambient and 50°C

4.1.3 Discussion

In the case of the organic acids, the aspect that stands out most in this work was the appearance of lower solubilisation of platinum from the high grade salt (up to 44 %) relative to the reported extractions from the ore materials (58 %) (Evans 2007). Considering that the proxy material was 74.8 % Pt whereas the Pt content in the ores is typically 1-9 g/t, the percentages of Pt dissolved from the PtS₂ were expected to be higher especially considering that the previous work did not use an oxidising agent.

This can be explained by a combination of equilibrium constraint and the fact that the PGM content of the materials used in the exploratory work (Evans 2007) may have been less than in the concentrate being used in this study. Evans (2007) reports that 2 ppm of platinum was dissolved in the exploratory studies, which translated to an extraction of 50 %. In comparison the organic acid combination in this study dissolved as much as 4.91 ppm which translated to only 44 % dissolution. However if the comparison is made on the basis of actual amounts of platinum dissolved and not percentages dissolved, it is clear that the results in this study are in actual fact

4.1.4 Conclusions

- The two most promising routes to investigate on the material are sodium cyanide solution and a combination of tartaric and malic acids in the presence of excess hydrogen peroxide.
- The presence of an oxidising agent in this system of organic acids will help increase the platinum extractions from the low-grade ore concentrate, by oxidizing the sulphur in the minerals and aiding the ionization of the PGMs to be complexed by the organic acid ligands in solution.
- Sodium cyanide will sufficiently dissolve PGMs from the low-grade ore concentrate not only because they are in an oxidised form, but due to the stronger attraction of platinum ions to the (CN⁻) ligand than to the S⁻ ion in the sulphide minerals. Further the +4 oxidative state of the platinum appeared to be very favourable to cyanide dissolution.

4.2 Final Test Work on the Low-Grade Ore Concentrate

4.2.1 Size Analysis

The size analysis showed the ore concentrate size distribution was 97 % passing 75 µm and 88 % passing 45 µm.

4.2.2 Ore Concentrate Split

The individual concentrations for the PGMs platinum, palladium, ruthenium and rhodium were calculated using the percentage distribution from chapter 2 section 2.2 Table 2. PGM assays could not be conducted at UCT and the BM assay values were averages from 12 samples used. The full final assay reports from Mintek, containing the data used for the calculations of the selected experiments are presented in Appendix S. Table 9 presents data from Lonmin, the UCT assays and a random sample analyzed by Mintek after test work.

Table 9: Ore concentrate split

	Lonmin	UCT assays	Mintek
PGM g/t	15		
Pt g/t			11.9
Pd g/t			8.34
Ru g/t			4.38
Rh g/t			2.64
% Ni	0.2	0.744	0.81
% Cu	0.1	0.362	0.32
% Fe	10.5	6.75	10.8
% Co	0.007	0.018	<0.05
% Al	1.53		1.10
% Mg	13.7		15.1
% Ca	3		1.54
% Si	11.98		25
% Cr	1.02		0.44

4.2.3 Experiment 1: Direct leaching of PGMs using a combination of tartaric and malic acid in the presence of hydrogen peroxide at 50°C in a granular bed reactor

4.2.3.1 Aims

Evaluate the effectiveness of the combination of tartaric-malic acids, in the presence of hydrogen peroxide, in leaching PGMs from the concentrate material.

4.2.3.2 Theory

It is expected that the combination of tartaric-malic acids, identified by phase 1 experimental work as the optimal option amongst organic acids, will achieve comparable if not better extractions of PGMs than was achieved by previous exploratory work (Evans 2007). Combined with phosphate buffers to maintain the optimal pH and the presence of hydrogen peroxide to aid leaching from those platinum group minerals reported to be resistant to organic acid leaching, it is proposed that this system is the optimal option for organic acid leaching of PGMs from the concentrate material.

This experiment forms the basis of a process to directly and selectively leach the PGMs from the concentrate, as the priority metals, after which the BMs may be pursued (Figure 29).

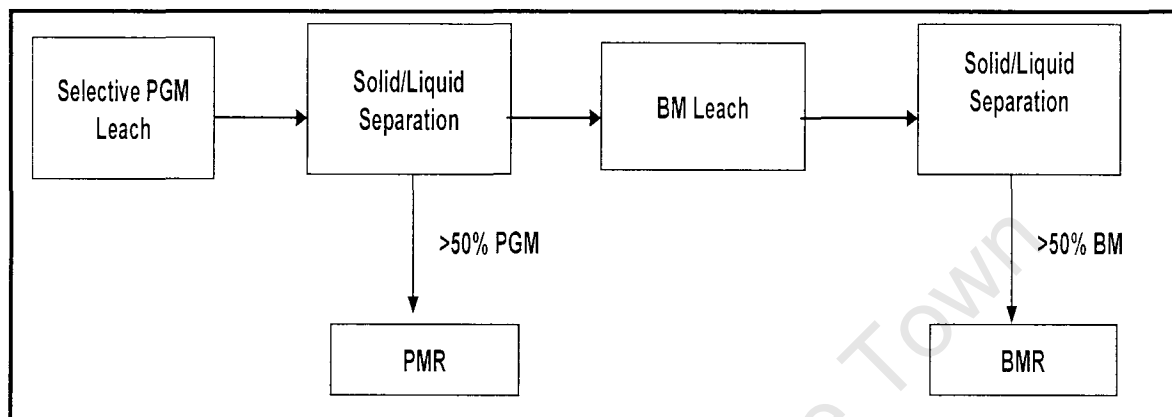

Figure 29: Overall process for direct PGM leaching

4.2.3.3. Materials and Methods

Solution of 0.5 M tartaric-malic acid was prepared by mixing 37.5225 g of L(+) Tartaric acid salt (0.25 M in 1 L) and 33.5225 g DL Malic acid (0.25 M). 500 ml of deionised water was added and the solution pH raised to 8 using 6 M NaOH solution. Buffer solutions of 1 M K_2HPO_4 (94 ml) and 1 M KH_2PO_4 (6 ml) were added after the pH was raised to prevent precipitation of these salts in acidic media. The solution was made up to 1 L in a standard volumetric flask.

Three solutions were prepared and to each the required amount of 50 % hydrogen peroxide solution was added to make concentrations of 0.2, 1 and 2 M in 1 L of solution.

The equipment used and full operating procedure of the granular bed reactor is detailed in chapter 3 section 3.2.6. For this experiment 500 g of untreated concentrate material was used in the column operating at 50°C. 1 L of the solution of organic acids combination was fed into the column at a rate of 0.44 mL/s using a pump, and was re-circulated for 5 days with sampling done daily and pH measured. The samples were analysed via ICP to determine the full range of elements (PGM, BM and gangue) dissolved in solution.

4.2.3.4 Results

Table 10: Tartaric-malic acid leaching of PGMs in the presence of hydrogen peroxide

Hydrogen Peroxide Concentration	Duration (Days)	Percentage Extractions (%)			
		Pt	Pd	Ru	Rh
0.2 M	5	0.01	-	0.52	1.55
1 M	5	0.02	0.11	0.34	0.95
2 M	5	0.06	0.09	0.37	0.87

Table 11: Tartaric-malic acid leaching of BMs in the presence of hydrogen peroxide

Hydrogen Peroxide Concentration	Duration (Days)	Percentage Extractions (%)		
		Cu	Ni	Fe
0.2 M	5	1.68	0.82	0.26
1 M	5	0.47	0.23	0.08
2 M	5	0.46	0.22	0.06

4.2.3.5 Discussion

The poor recoveries were attributed to any one or a combination of the following:

- The PGMs are heavily encapsulated in base metal sulphides or other matrices, making it impossible for the lixiviant to reach them.
- They are sufficiently exposed but are not responding to this treatment.
- The reactor configuration does not facilitate sufficient contact between the lixiviant and the PGMs.
- There may have been heavy consumption of lixiviant by the base metals. Referring to Table 11, the percentage extractions may seem low due to the fact the BMs are present in significantly greater quantities than the PGMs, in the concentrate material. However the

actual quantities are much higher ranging in the ppm range as compared to the PGMs which were present in the ppb range.

- Finally the presence of hydrogen peroxide in this system (concentrate as opposed to PtS_2) may be a hindrance to PGM dissolution. This is apparent from the reduction in Ru and Rh dissolution with increase in hydrogen peroxide. However this does not support the slight increases of Pt dissolution with increase in hydrogen peroxide concentration. To further investigate these theories a systematic approach was adapted beginning with the first theory:

4.2.4 Experiment 2: Leaching of BMs using a combination of ferric sulphate and sulphuric acid at 65°C in a granular bed reactor

4.2.4.1 Aims

Determine the effectiveness a system of ferric sulphate and sulphuric acid in extracting at least 50 % of the BMs from the concentrate.

4.2.4.2. Theory

Autoclave conditions (high temperatures and pressures) are required to extract copper and nickel rapidly from sulphide minerals to commercial levels. Considering the grade of this material and the aim being to extract a minimum of 50 %, it has been assumed that a temperature of 65°C will suffice.

4.2.4.3. Materials and Methods

10 L of solution containing 10 g/L Fe^{3+} from ferric sulphate and 80 g/L sulphuric acid from 98% solution was prepared. Using the same procedure and equipment as detailed in chapter 3 section 3.2.6. the experiment ran for 5 days at a temperature at 65°C. The experiment ran in two separate columns. The solution was fed into the column using a pump at a rate of 0.44 mL/s and was refreshed every 24 hours. Samples were withdrawn every 24 hours, vacuum filtered using 0.22 μm membrane filter paper for AAS analysis of BMs and for pH measurements using a standard meter. The temperature in the column and the water bath was checked during sampling and regularly during the course of the experiment. On completion of the experiment the columns

an improvement over those achieved in previous test work. Additionally Evans (2007) indicated that the exploratory work used a continuous solution flow system and in other cases solution was refreshed, whereas this study used a batch system of reactor with the same solution for the duration of all the experiments.

The higher amounts of platinum dissolved in this preliminary work therefore suggests that increased PGM extractions from the low-grade concentrate can be achieved by addition of an oxidising agent to aid in leaching. It is suggested that this technique may aid in leaching of those minerals that appeared unresponsive to organic acid leaching (Evans 2007). It is further suggested that the hydrogen peroxide acts as a catalyst by oxidising sulphur and liberating platinum ions to be complexed in solution:

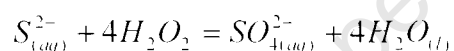

The reason why the combination of tartaric and malic acids dissolved more platinum than any of the single acids or other combinations is yet to be determined. Individually, tartaric and malic acids in the presence of 2 M hydrogen peroxide dissolved only 5% and 6% respectively. Combining the acids seems to enhance the complexation process that is reported to be responsible for metal leaching (Rossi 1990; Lopez-Garcia 2002; Blair and Defraties 1995) in a way that is not explained in the literature. If the combination proves successful in leaching from the concentrate, further fundamental research is required to fully understand the mechanism(s) involved.

The cyanide performed exceptionally well, probably because as a competing ligand (CN⁻) is able to overcome the (S²⁻) bond with the platinum ion. In the presence of hydrogen peroxide the graph (Figure 28) shows an initial increase in kinetics but then the hydrogen peroxide begins to attack the cyanide and platinum-cyanide complexes resulting in lower amounts of platinum dissolved:

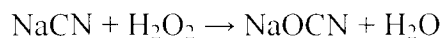

were allowed to cool, and distilled water followed by 1 g/L NaOH solution were pumped through the granular bed to wash away and neutralise acid residue in preparation for the alkaline cyanide and organic acid leaches. The concentrate material samples were removed from the columns, then oven dried for weighing and use in the next set of experiments.

4.2.4.4. Results

Table 12: Ferric/sulphuric acid leaching of BMs

	Duration (Days)	Percentage Extractions (%)		
		Cu	Ni	Fe
Column 1	5	38.96	10.79	55.87
Column 2	5	54.81	11.43	81.21

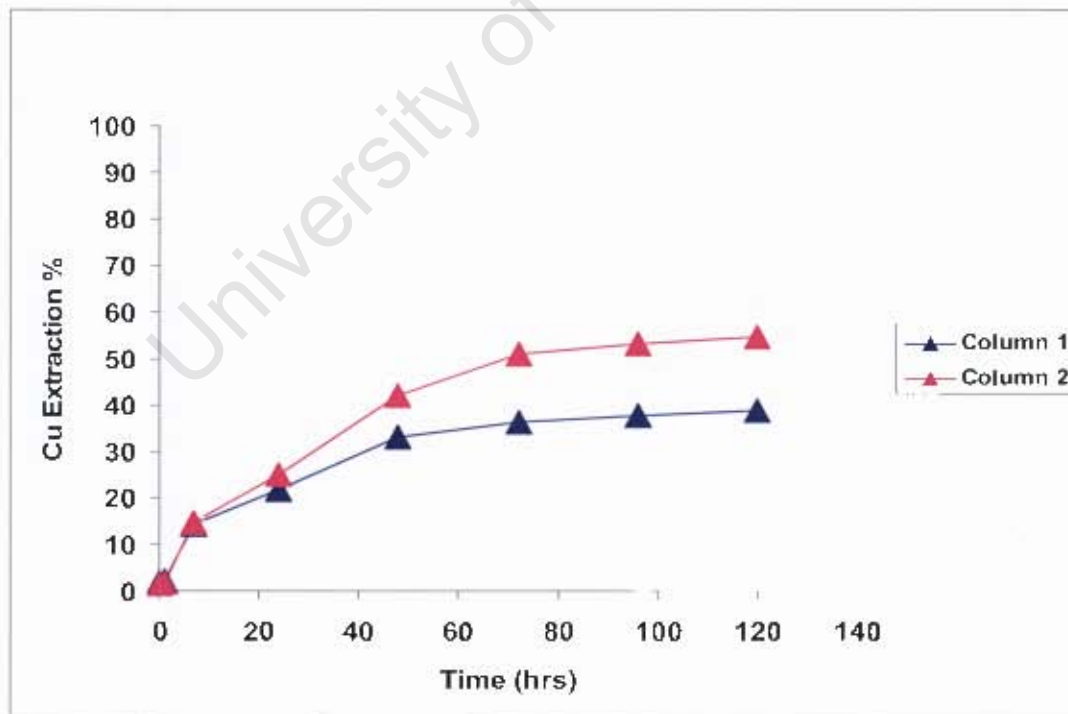

Figure 30: Copper extractions from ferric/sulphuric acid leach

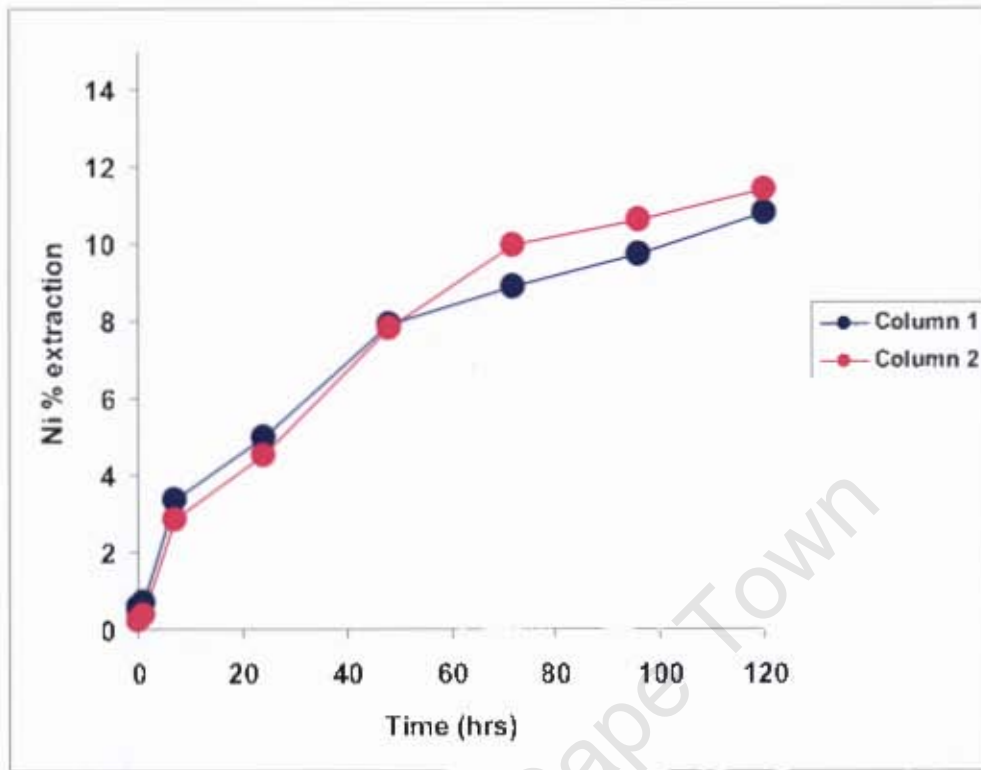

Figure 31: Nickel extractions from ferric/sulphuric acid leach

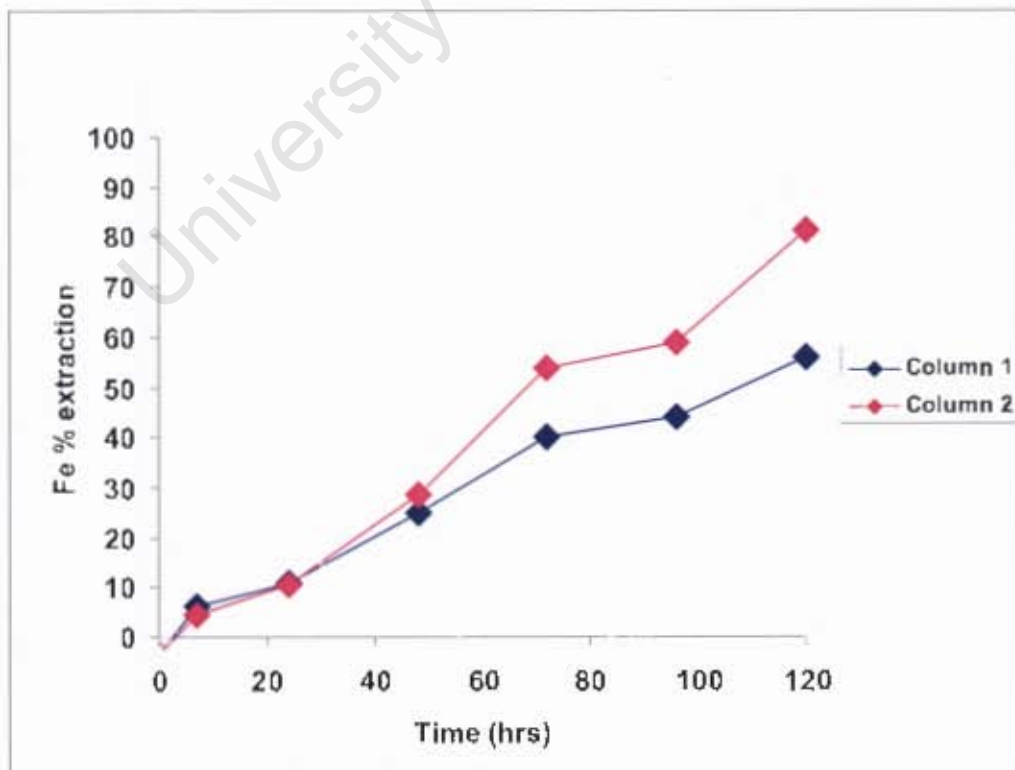

Figure 32: Iron extractions from ferric/sulphuric acid leach

4.2.4.5 Discussion

Only column 2 achieved an extraction of over 50 % Cu and performed noticeably better in terms of Fe extraction than column 1. This can only be explained by different flow regimes occurring in the beds as all other conditions were kept identical. The nickel extractions in comparison were poor. It is apparent that either more time or higher temperatures are required to reach complete extraction levels of the copper and iron. However such conditions are not considered in the context of this application. Considering that even though the copper extraction levels were to the desired level, the residence time was still long (5 days). It would thus appear that this chemical treatment and perhaps the reactor configuration are not a practical choice for this ore material.

4.2.5 Experiment 3: Comparison of PGM extractions using a combination of tartaric and malic acid in the presence of hydrogen peroxide, and cyanide at 50°C in a granular bed reactor

4.2.5.1 Aim

To observe the influence that the BM removal step from experiment 2, has on PGM extractions using samples of the material that have been pre-treated. A comparison will be made in the case of the organic acids whereas in the case of cyanide the investigation is moving a step ahead to simply observe the PGM extractions achievable when the concentrate has been pre-treated.

4.2.5.2 Theory

Platinum group minerals for this type of ore often occur in association and occluded in base metal sulphide matrices. Pre-treating the concentrate to remove some of the BMs should result in increased extractions of the PGMs using the organic acids (Figure 33). Similarly the cyanide treatment should produce comparable results.

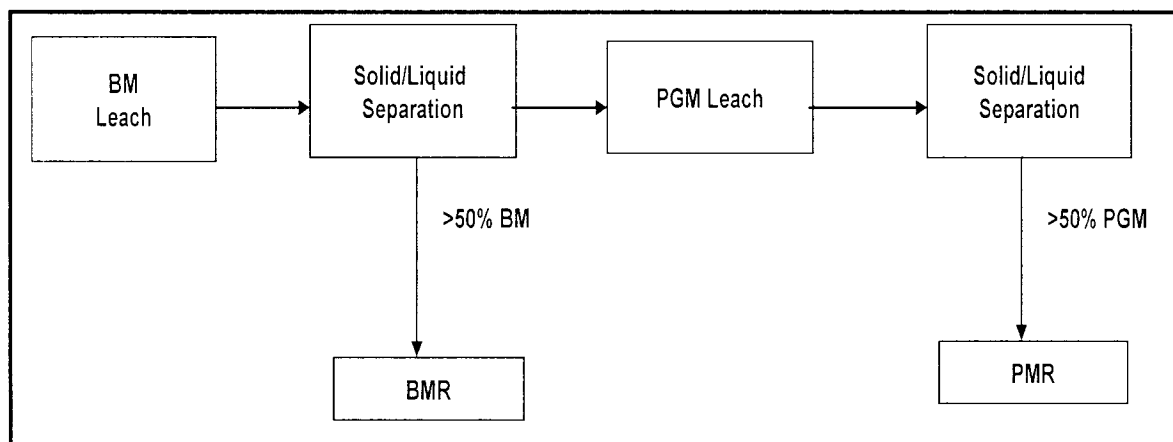

Figure 33: Overall process for leaching PGMs by first extracting BMs

4.2.5.3 Materials and Methods

The organic acid combination solution was prepared as detailed in experiment 1 above. The cyanide solution at 0.5 M was prepared by dissolving 24.505 g of salt in 1 L of buffered water containing 10.6 g of Na_2CO_3 and 8.4 g of NaHCO_3 salts.

The experimental set-up and procedure were as detailed in chapter 3 section 3.2.6 with the addition that the cyanide work was conducted in a fume hood for safety reasons and the concentrate material used was the pre-treated material from experiment 2. The organic acids were used on the sample from column 1 while the cyanide was used on the sample from column 2. Using this residual material, slurry granular beds were made in the columns and leached using 1 L of the above solutions. The columns were operated at 50°C and the solution was fed into the columns at a rate 0.44 mL/s. The experiment ran for 5 days during which sampling was done daily and pH measured from the samples using a pH meter. The samples were analyzed via ICP to determine the full range of elements (PGM, BM and gangue) dissolved in solution.

4.2.5.4 Results

Table 13: Tartaric-malic acid leaching of PGMs in the presence of hydrogen peroxide and cyanide

	Duration (Days)	Percentage Extractions (%)			
		Pt	Pd	Ru	Rh
Tartaric-Malic Acid 0.5 M + Hydrogen Peroxide 2 M	5	0.05	0.96	0.78	1.88
Sodium Cyanide 0.5 M	5	8.46	26.93	3.41	16.32

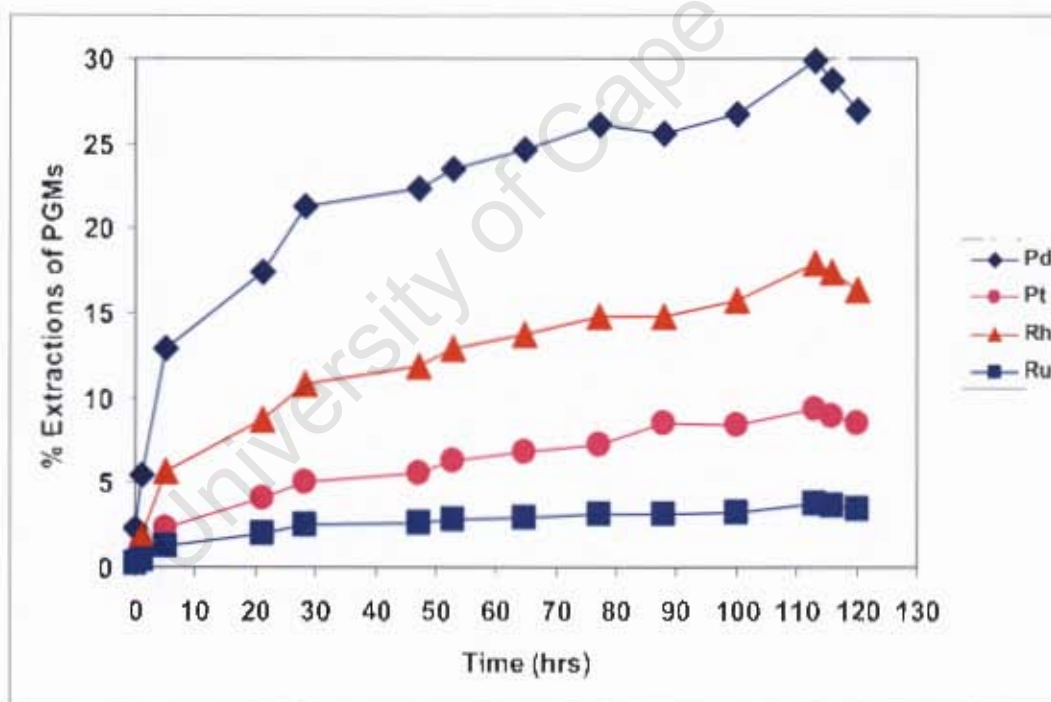

Figure 34: PGM extractions via cyanidation from chemically treated concentrate

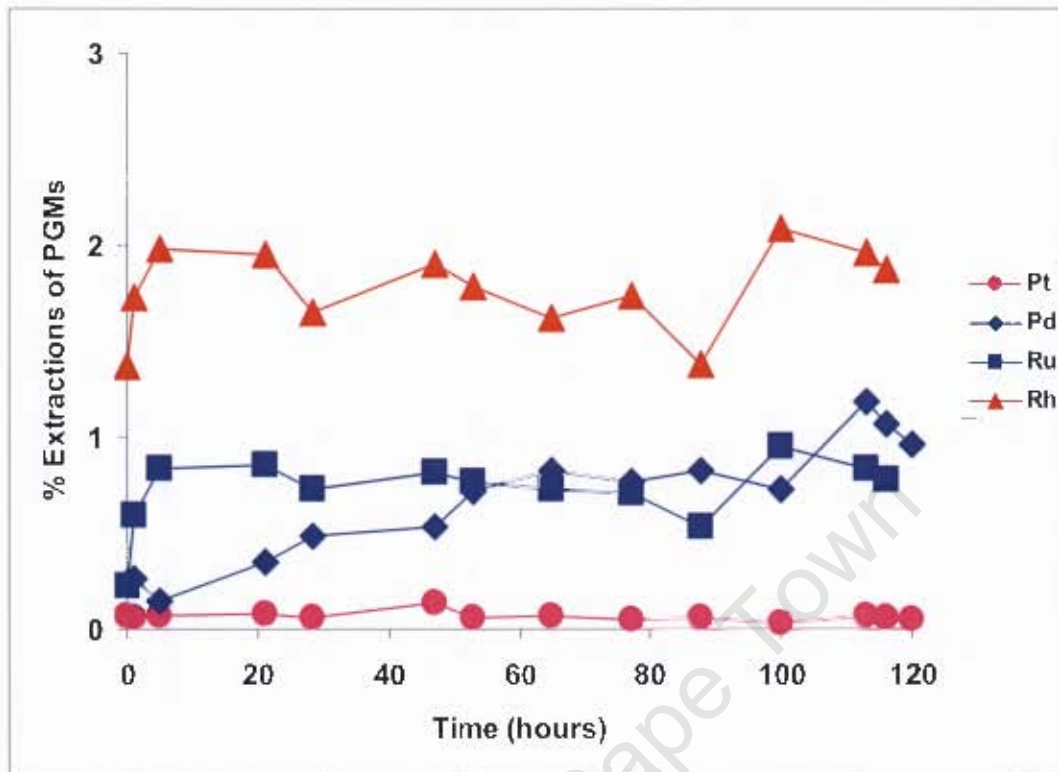

Figure 35: PGM extractions via organic acids from chemically treated concentrate

4.2.5.5 Discussion

The poor PGM extractions achieved by the organic acids means either they are not responding to this treatment or the hydrogen peroxide is preventing their dissolution. As stated earlier the concentrate material is a significantly different environment to the proxy material. It contains ions such Cu and Fe that may catalyse the oxidation and degradation of the organic acid ligands and ionic complexes formed. On the other hand cyanide performed significantly better although extractions, especially for ruthenium, were still low. The low PGM extractions for cyanide can be explained by one of or a combination of the following:

- The graphs in Figure 34 indicate that the metals have reached equilibrium; a theory supported by the fact that the Pt extraction achieved is in line with extractions achieved by other researchers (Torres and Costa 1997; McInnes, Sparrow and Woodcock 1994) who attempted to leach Pt from low grade concentrates using cyanide at ambient temperature and pressure. This would mean that the solution has to be refreshed to extract more; a technique that was employed in previous exploratory research (Evans 2007) in which Pt extractions of 60 % were achieved in a heap reactor where the solution was refreshed.

- The minerals housing the PGMs in the concentrate are not responding to either cyanide or organic acid treatment.
- The PGM bearing minerals are still encapsulated in the remaining BM sulphide matrices or other matrices such as silica or chromium based.
- Finally the minerals may be sufficiently liberated but the granular bed reactor configuration does not allow sufficient contact with the lixivants.

The following experiments were conducted to investigate all the above theories:

4.2.6. Experiment 4: Leaching of PGMs using a combination of tartaric and malic acid, and cyanide at 50°C in batch stirred tank reactors (BSTRs)

4.2.6.1. Aim

To determine whether the use of a different reactor configuration would result in increased extractions of PGMs, especially platinum, using the same chemical treatments from the previous experiments and identical operating conditions. A third system was investigated; plain organic acid combination to determine if hydrogen peroxide was in fact a hindrance in this system.

4.2.6.2. Theory

Although successful extractions of copper and iron, and to a lesser extent rhodium and palladium were achieved using the granular bed reactor in experiments 2 and 3, it is apparent that the leaching rates were far too slow for commercial applications. Considering that to achieve an operable percolation rate, the thickness of material has to be no greater than 1.5 cm, corresponding to a mass of 500 g. Using the Delkor Belt Filter unit (a survey of various models indicated it had the largest operating surface area) with available surface area of 134 m² for a scale up model: direct portion calculations show that a unit like this can handle at most 550-600 kg of material at a time. Due to the fact that extractions starting from 60 % took at least 48 hours to attain in the granular bed: the result is that a surface area of 2.6×10^5 m² or 2200 Delkor Belt filter units would be needed to handle the tonnages of the concentrate produced. Alternatively one filter unit can be used but the reaction would have to proceed at a rate that would handle each batch in 1.44 minutes at a time. Neither of these is feasible, denying the possibility of the

quick recovery process envisaged and creating the need to explore a different reactor configuration. The BSTR was chosen to determine whether more platinum can be extracted with a different reactor configuration before the more laborious GEOCOAT-ed heap reactor is explored. The reason for this is that heap leaching produced successful results (59 % Pt extraction) in early exploratory work (Evans 2007).

4.2.6.3 Materials and Methods

The solutions were prepared as before with the exception that the concentration of cyanide was reduced based on the amounts consumed in the previous experiments and in accordance to concentrations used in the literature for similar experiments (Torres and Costa 1997; Chen and Huang 2006). Sodium cyanide concentration was at 4.901 g/L (0.1 M; prepared as before with buffered water) and the organic acid combination remained unchanged for the moment. Considering that they still had appreciable amounts of PGMs, the residual concentrate material samples from experiment 3 were used with the same chemical treatments. That is the material from the cyanide granular bed was used for the cyanide BSTR and the residual concentrate from the organic acid experiment was used in the organic acid BSTR experiments. Approximately 120 g of material was agitated with an overhead stirrer in an Erlenmeyer flask in 1 L of solution maintained at 50°C in a water bath. Samples were withdrawn every 24 hours for 72 hours and vacuum filtered using 0.22 µm membrane filter paper for ICP analysis and measured for pH using a standard meter. Previous PGM dissolution profiles (Figures 34, 35 and 36) indicated that the bulk of the PGMs were dissolved in the first 24 hours in the granular bed reactors. The experiment was allowed to go an extra 48 hours to see if the batch stirred tank reactor had a similar pattern.

4.2.6.4. Results

Table 14: Percentage extractions of PGMs from residual concentrate

	Duration (Days)	Percentage Extractions (%)			
		Pt	Pd	Ru	Rh
Cyanide	3	23.46	24.29	2.87	13.13
Tartaric-Malic Acid	3	0.32	5.33	4.12	9.34
Tartaric-Malic Acid + 2 M H ₂ O ₂	3	0.28	3.76	3.09	10.44

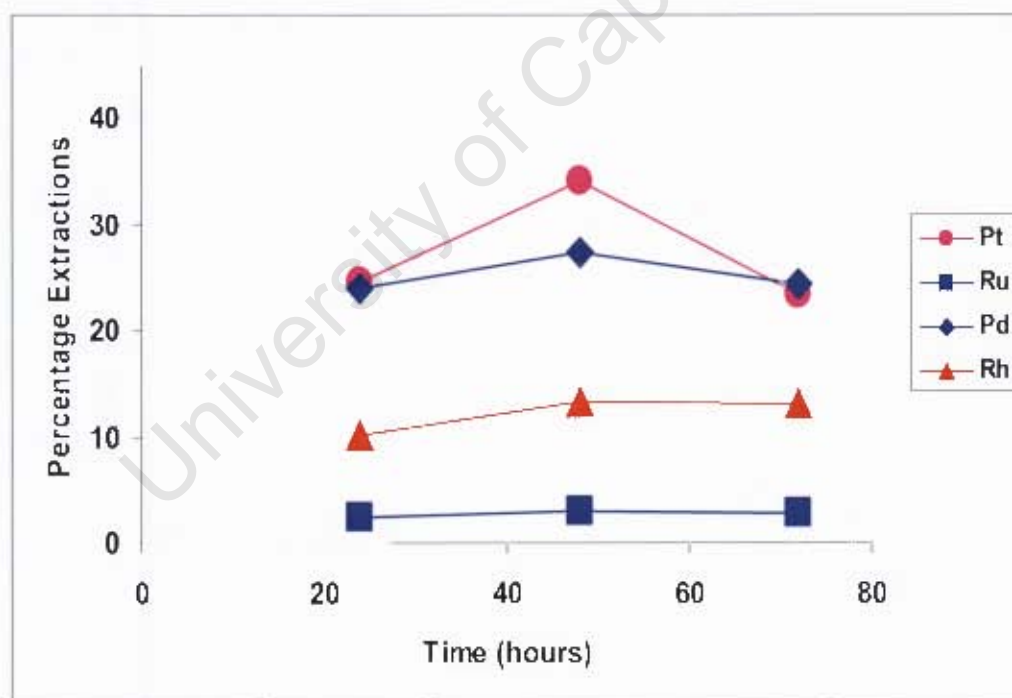

Figure 36: Secondary PGM extractions via cyanidation in BSTR

4.2.6.5 Discussion

The results show conclusively that the PGMs are not being extracted to levels that have potential for commercial application, by this particular combination of organic acids even in the absence

of hydrogen peroxide. The results are a far contrast to those achieved in the early exploratory work (Evans 2007), and the following explanations have been put forward for this:

It may be a combination of equilibrium constraint and the fact that the PGM content of the materials used in the exploratory work (Evans 2007) may have been less than in the concentrate being used in this study. Evans (2007) reports that the PGM analysis in the leachates was in ppb, but does not give the actual amounts. Similarly he reports that solid assay analysis was in ppm, but again does not mention the grades of the concentrates. He reports on the PGM levels in ppb translating to amounts in the range of 2-3 g/t in the concentrate and extractions of up to 60 %, but not how these calculations were made. For this reason, the actual quantities of PGMs dissolved in this study (also in ppb for leachates) may be comparable to those dissolved in the reports, whereas the percentage extractions would then differ if the grades of the concentrates used in the previous studies was lower. Additionally Evans (2007) indicated that in the exploratory work, a continuous solution flow system was used and in another case the solution was refreshed. As a result the cumulative amounts in these cases would be comparably more than in this study where only 1 L. was used for the duration of the experiments.

However it may be that the exact organic acid or combination of acids that were used in the original exploratory work (Evans 2007) are critical to PGM leaching, unlike BM leaching which is successfully executed with a variety of acids. Even if the acid(s) were identified, analytical reagent grade acids could be used for bench scale work but they may not be available commercially at the large scale for the proposed operation or may be relatively expensive. In addition it must be kept in mind that the exploratory work on the PGMs was conducted in sterile conditions with heterotrophic microorganisms. This is not feasible on an industrial scale for ore concentrate of this grade and tonnage, and providing feed stocks for the microorganisms to produce the acids is not likely to be economical.

Examining the results through Figure 36 and Table 14 proves that in general, higher PGM extractions can be achieved by using fresh solution once equilibrium has been achieved. Comparing the maximum 34 % extraction of Pt achieved (Figure 36) in the BSTR with the 8.46 % of the granular bed reactor: shows that the granular bed reactor did not facilitate sufficient contact between the PGMs and the lixiviant which lead to lower extractions and long leach times. Ruthenium on the other hand, did not show an improvement and was in fact slightly less

possibly because its parent minerals are heavily occluded in the remaining BM minerals or it is in an oxidative state not susceptible to cyanide leaching.

In comparison to the extraction levels achieved by the organic acids above, cyanidation, being a more established technique, is the better option to explore from this point on.

Considering all factors thus far, the most appropriate reactor configuration for this operation is a heap bed reactor. It is postulated that a heap reactor (GEOCOAT[®] style) may allow for the same mineral exposure that led to the high extraction levels achieved in the BSTR with the difference that the process will be slower. However at industrial level, the facility to handle large tonnages at a time may still ensure profitability, as it has been in the case of gold heap leaching.

It must be noted that even though the BSTR produced the best results thus far, it was only used for the convenience of producing measurable results in a short period of time. At industrial scale it is unlikely to be an economical option if the grade and tonnage of this material are weighed against the operating costs and conditions of this reactor (solid to liquid ratio, energy for mechanical agitation and external heat source required to produce high extraction rates).

4.2.7 Experiment 5: Cyanide leaching of PGMs from a pre-treated sample of concentrate material in a packed bed reactor

4.2.7.1 Aim

To evaluate the extractions of PGMs that can be achieved using cyanide solution in a heap bed reactor on a sample that has been bioleached to first extract BMs.

4.2.7.2 Theory

Cyanidation in a heap bed reactor is potentially an industrially feasible process for extracting the PGMs from the concentrate. Cyanide, as a chemical treatment, has thus far shown high potential for leaching the PGMs from the concentrate material. A heap reactor configuration (GEOCOAT[®] style) has the advantage of low capital and operating costs while promoting mineral exposure and avoiding the long leaching times associated with the granular bed leaching.

relative to the lower Pt extractions achieved. Based on the times required to reach equilibrium in the granular bed reactor it is postulated that a heap reactor will similarly require no less than 4 days before the re-circulating solution is refreshed.

4.2.7.3. Materials and Methods

A feed solution containing 4.901 g/L of cyanide solution was prepared as before with buffered water. The equipment was set up and operated as detailed in chapter 3 section 3.2.7. The ore concentrate sample leached was residual material from a heap bioleach (Experiment 10) weighing approximately 350 g. The heap bioleach resulted in extractions of 43.77 % copper and 87.15 % nickel. The slurry made from the low-grade ore material was coated onto 2.2 kg of granite pebbles and carefully packed into a PVC pipe acting as a column. The solution was fed at a rate of 1 L/day and the experiment was run at room temperature. Considering the amount of time taken to reach maximum leaching limit in the BSTR and granular bed reactor, the solution of 1 L was re-circulated for 7 days and refreshed every 7 days thereafter for 21 days. Samples were withdrawn at regular intervals for ICP analysis and at the end of the experiment the material was rinsed with a 3 g/L ferrous sulphate solution to decontaminate the cyanide, oven dried and sampling of the material (see chapter 3 section 3.2.2) was done to conduct solid assays for PGMs and BMs.

4.2.7.4 Results

Table 15: PGM, BM and gangue metal extractions from cyanide heap leach

PGMs	Pt	Pd	Ru	Rh	
% of Residual	20.34	87.17	3.35	46.03	
% of Total	20.00	82.78	2.63	31.04	
BMs	Cu	Ni	Fe		
% of Residual	33.78	40.86	0.84		
% of Total	8.40	10.43	1.20		
Gangue	Mg	Ca	Cr	Al	Si
% of Residual	0.004	0.38	0.0019	-0.004	0.86
% of Total	0.004	0.26	0	0	0.88

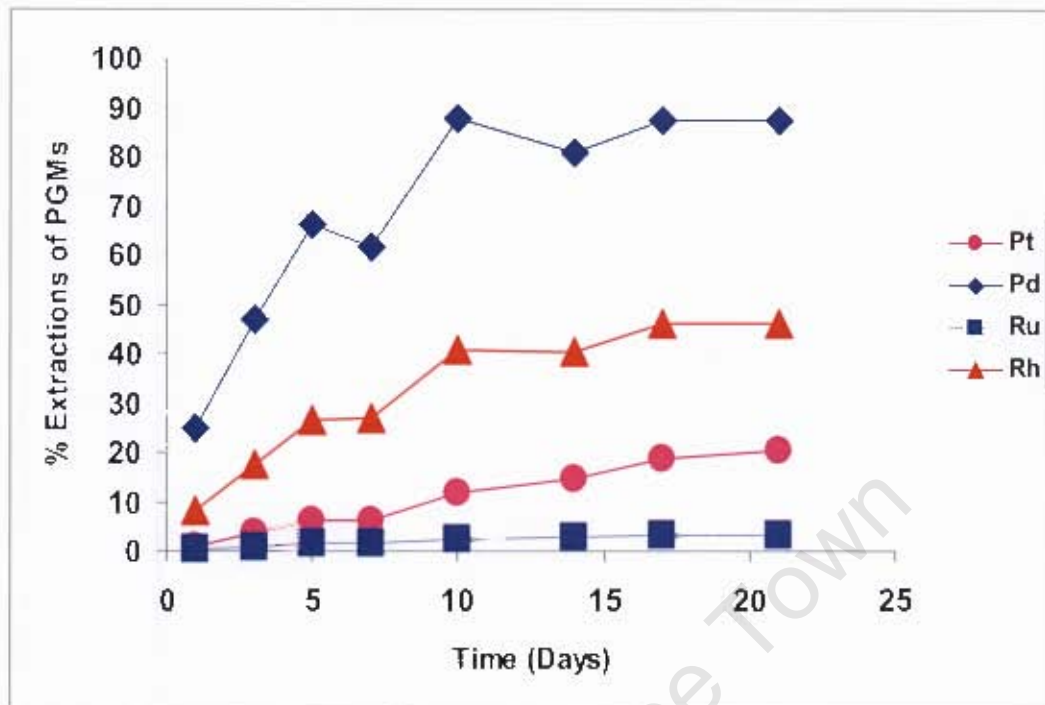

Figure 37: PGM extractions from cyanide heap leach

Table 16: PGM material balance over cyanide heap leach test

IN (before leach test)	Pt	Pd	Ru	Rh
ppm	11.7	7.92	3.44	1.78
Amount (mg)	3.63	2.46	1.07	0.553
OUT (after leach test)	Pt	Pd	Ru	Rh
% in leachate	20.34	87.17	3.35	46.03
Amount in leachate (mg)	0.74	2.14	0.04	0.25
Solid assay (ppm)	10.6	1.65	3.04	0.86
Amount in concentrate (mg)	3.29	0.51	0.94	0.27
BALANCE (mg)	-0.40	-0.20	0.09	0.03
BALANCE (%)	-10.94	-8.00	8.28	5.66

Table 17: BM material balance over cyanide heap leach test

IN (before leach test)	Cu	Ni	Fe	Co*
%	0.09	0.19	9.47	<0.05
Amount (g)	0.28	0.59	29.41	
OUT (after leach test)	Cu	Ni	Fe	Co
% in leachate	33.78	40.86	0.84	69.94
Amount in leachate (g)	0.09	0.24	0.25	
% from solid assay	0.076	0.11	9.29	<0.05
Amount in concentrate (g)	0.24	0.34	28.85	
BALANCE (g)	-0.05	0.01	0.31	
BALANCE (%)	-18.22	1.25	1.06	

It must be noted that the detection limit for BMs in the Mintek solid assays is 0.05 %, anything less is not readable. Although a solid assay conducted at UCT was able to read the initial amount of cobalt as 0.018 % in the ore concentrate before leach tests, the data was poor after leach tests, when a considerable amount was leached. This was possibly because the amounts were too small and as a result no calculations were conducted for cobalt in the material balances.

Table 18: Gangue element material balance over cyanide heap leach test

IN (before leach test)	Mg	Al	Si	Ca	Cr
%	14.50	0.68	25.60	1.04	0.43
Amount (g)	45.02	2.11	79.49	3.23	1.34
OUT (after leach test)	Mg	Al	Si	Ca	Cr
% in leachate	0.004	0.0042	0.86	0.38	0.0019
Amount in leachate (g)	0.00	0.00	0.68	0.01	0.00
% from solid assay	14.8	0.72	25.9	1.18	0.42
Amount in concentrate (g)	45.96	2.24	80.42	3.66	1.30
BALANCE (g)	-0.93	-0.12	-1.62	-0.45	0.03
BALANCE (%)	-2.07	-5.88	-2.03	-13.84	2.32

4.2.7.5 Discussion

The metals rhodium and palladium as in previous cases, have responded well to the cyanide leach, compared to the platinum and ruthenium. Ruthenium showed lower extraction levels than

both the granular bed and BSTR. The slope of the ruthenium extraction graph appears to be horizontal, indicating a maximum has been or will be reached soon. Additionally the granular bed and BSTR experiments were carried out at a higher temperature which no doubt accelerated the ruthenium leaching in those cases, resulting in slightly better extraction levels. Platinum on the other hand, although on the low side showed potential. The platinum leach graph in Figure 37 appears to be a linear increasing slope, and based on the combined platinum extraction from the granular bed and BSTR (proportionally about 30 %), it appears that there is still a chance that the desired target of >50% extraction of platinum can be achieved over a longer time period. The material balance over the PGMs (Table 16) shows some discrepancies particularly, in the case of platinum, but these were never excessive. This is because the significant portion of the concentrate material (which was extremely fine) was lost during the recovery and filtration of the residual material. It is clear that the material recovered were the larger particles which contained the unleached PGMs hence a negative balance and in the case of the positive balance, the particles mostly contained the leached PGMs. This was observed for the other PGM material balances in subsequent experiments.

Table 18 shows that the extraction of gangue elements was miniscule. The only exception was calcium which was in the ppm range. This can be considered as an advantage for the cyanide treatment owing to the fact that it will not consume large amounts of unwanted elements.

The percentages of BM extractions although appearing high, must be scrutinised carefully considering a number of factors. The actual amounts solubilised ranged from 100-250 ppm for copper, nickel and iron, whereas for cobalt the amount was in the ppb range. It must be kept in mind that considerable quantities of copper, nickel and cobalt had already been bioleached, hence supporting the advantage of a pre-treatment step to reduce cyanide consumption by the BMs. However given the amounts of PGMs extracted, and the potential to extract more, combined with the high market value of the PGMs, the cost of operating with this relatively high cyanide concentration may still be economically viable. The cyanide concentration used in this leach (0.15 M) is relatively high compared with gold hydrometallurgy which operates in the range 0.003 to 0.05 M.

Further to this, there are the technical implications of leaching the concentrate with high BM content. Copper concentrations in the area of 100 ppm have been known to have a detrimental

effect on the carbon adsorption of gold from cyanide leachate (Marsden and House 2006) and this may also be the case in recovering PGMs from the cyanide solution using the adsorption to carbon method. The presence of iron in the concentrate may result in co-complexation with the PGM cyanide ions, an occurrence observed in copper leaching with cyanide (Gupta and Mukherjee 1990). This would result in PGM losses or the need for additional stages (processes) to recover the PGMs. A further evaluation is required to determine the influence of these levels of BMs in the leachate to PGM recovery.

4.2.8 Experiment 6: Determining the influence of first extracting BMs on subsequent cyanide PGM leaching

4.2.8.1 Aim

To investigate whether extracting substantial amounts ($\geq 50\%$) of BMs first, will lead to increased extractions of PGMs (especially platinum) in a subsequent leach. A comparison will be made to an untreated sample of concentrate material leached under identical conditions.

4.2.8.2 Theory

Previous efforts to directly leach PGMs from the Lonmin concentrate materials using organic acids resulted in a maximum of 56 % Pt, 79 % Pd and 49 % Ru being leached. One explanation proposed is that the remaining amounts could have been locked up in BM sulphide matrices, hence first extracting substantial amounts of BMs should lead to increased exposure of PGMs and increased amounts leached. Furthermore, copper complexes will form with cyanide and large consumptions by this reaction may lead to decreased amounts of cyanide available for PGM leaching. However because the copper is present largely as chalcopyrite and cubanite, two minerals known to leach slowly in cyanide (Adams et al 2008; Gupta and Mukherjee 1990): this may not necessarily be the case.

If on the other hand the copper and other BM extractions are still high, but PGM extractions are equal to or close to the desired target levels, then the possibility of a direct leach still exists (Figure 38). In this case the process would be an indiscriminate leach to extract both PGMs and BMs, followed by selective recovery of the PGMs and BMs. Cyanide is a relatively inexpensive

and widely commercially available leaching reagent and hence is a viable method of leaching the BMs as well as the PGMs. The proposed selective recovery methods are discussed in chapter 2 section 2.3.2.4.

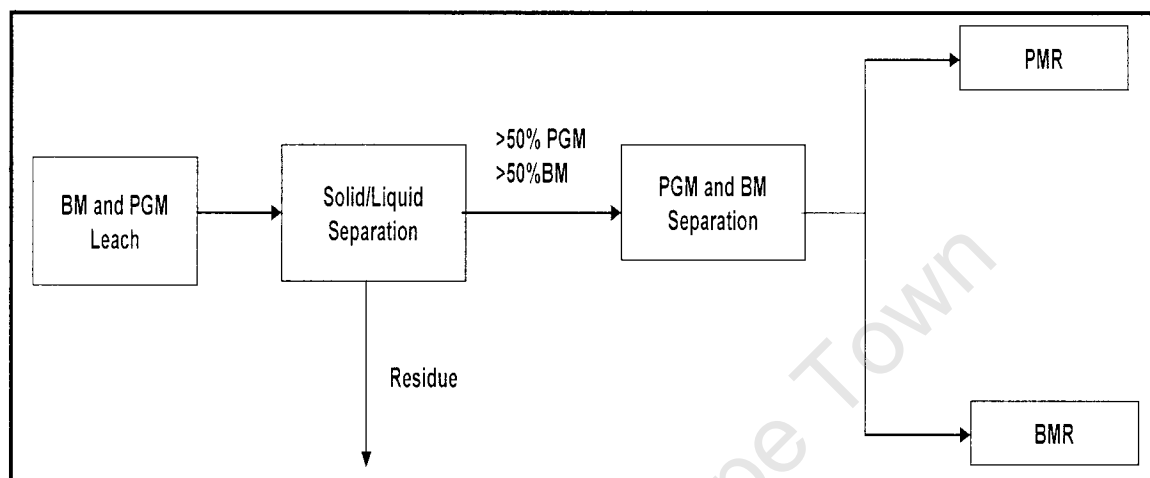

Figure 38: Indiscriminate leach process for PGMs and BMs

4.2.8.3 Materials and Methods

Two samples of concentrate material, one treated via a bioleach process (experiment 10) and another untreated were leached with 0.15 M of cyanide solution (prepared with buffered water as before) in BSTRs at room temperature. The bioleach process achieved extractions of 51.89 % Cu and 94.99 % Ni. The slurry was agitated with an overhead stirrer rotating at 550 rpm and the solution was refreshed every 48 hours for 6 days. This interval was based on the 34 % Pt extraction achieved in experiment 4 (See Figure 36). Samples were withdrawn daily and vacuum filtered using a 0.22 μm membrane filter for ICP analysis. The materials were recovered after the experiment to perform solid assays for PGMs and BMs.

4.2.8.4 Results

Table 19: PGM, BM and gangue element percentage extractions from cyanide BSTR tests

PGMs	Percentage Extractions				
	Pt	Pd	Ru	Rh	
Untreated	9.56	40.98	4.29	23.81	
Bioleached (Residual)	8.97	72.23	2.26	31.76	
Bioleached (Total)	8.67	67.56	1.83	19.61	
BMs	Cu	Ni	Co	Fe	
Untreated	40.26	23.89	26.55	5.83	
Bioleached (Residual)	21.39	35.51	-	0.63	
Bioleached (Total)	3.39	4.17	10.17	10.07	
Gangue	Mg	Ca	Cr	Al	Si
Untreated	0.04	0.29	0.042	0.00159	-0.44
Bioleached (Residual)	-0.01	0.64	-8.91	-0.10	3.68
Bioleached (Total)	-0.07	0.63	-8.71	-0.10	3.66

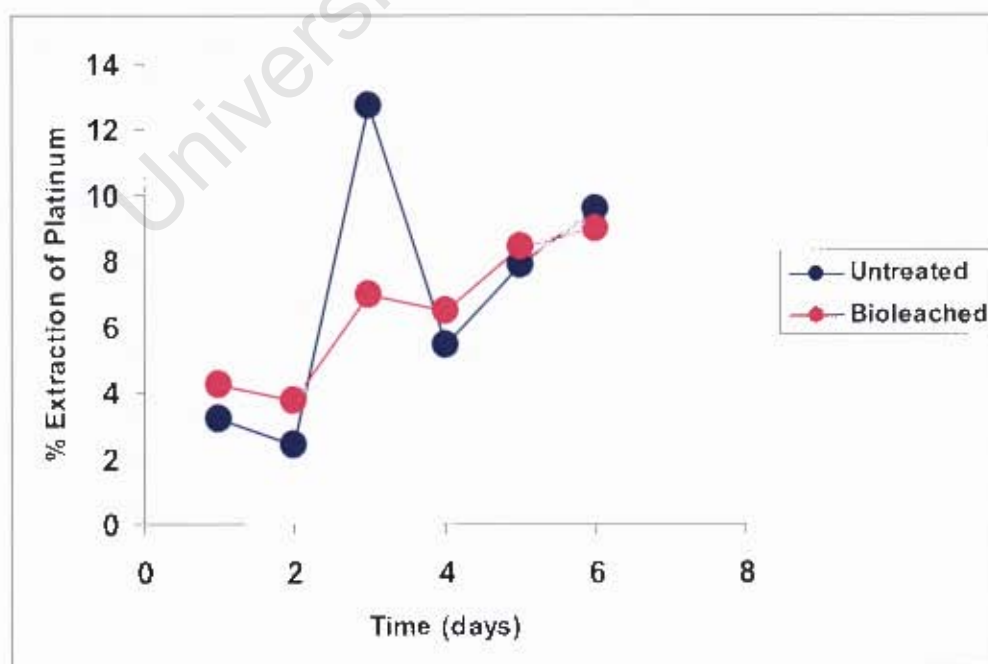

Figure 39: Platinum extractions from BSTR tests

Table 20: PGM material balance over BSTR cyanide test with untreated material

IN (before leach test)	Pt	Pd	Ru	Rh
ppm	11.8	8.02	4.13	2.57
Amount (mg)	1.18	0.80	0.41	0.26
OUT (after leach test)	Pt	Pd	Ru	Rh
% in leachate	9.56	40.98	4.29	23.81
Amount in leachate (mg)	0.11	0.33	0.02	0.06
ppm from solid assay	11.7	4.94	4.32	2.10
Amount in concentrate (mg)	1.17	0.49	0.43	0.21
BALANCE (mg)	-0.10	-0.02	-0.04	-0.01
BALANCE (%)	-8.71	-2.58	-8.89	-5.52

Table 21: BM material balance over BSTR cyanide test with untreated material

IN (before leach test)	Cu	Ni	Fe	Co
%	0.31	0.79	10.80	0.018
Amount (g)	0.31	0.79	10.82	0.02
OUT (after leach test)	Cu	Ni	Fe	Co
% in leachate	40.26	23.89	5.83	26.65
Amount in leachate (g)	0.125	0.189	0.631	0.005
% from solid assay	0.15	0.56	10.3	<0.05
Amount in concentrate (g)	0.15	0.56	10.32	
BALANCE (g)	0.04	0.04	-0.13	
BALANCE (%)	11.35	5.22	-1.20	0.00

Table 22: Gangue element material balance over BSTR cyanide test with untreated material

IN (before leach test)	Mg	Al	Si	Ca	Cr
%	15.00	1.07	24.90	1.50	0.43
Amount (g)	15.03	1.07	24.95	1.50	0.43
OUT (after leach test)	Mg	Al	Si	Ca	Cr
% in leachate	0.04	0.02	-0.44	0.29	0.04
Amount in leachate (g)	0.01	0	-0.110	0.004	0
% from solid assay	15.6	1.13	25.3	1.56	0.43
Amount in concentrate (g)	15.63	1.13	25.35	1.56	0.43
BALANCE (g)	-0.61	-0.06	-0.29	-0.06	0.00
BALANCE (%)	-4.04	-5.62	-1.17	-4.29	-0.04

Table 23: PGM material balance over BSTR cyanide test with bioleached material (pre-treatment)

IN (before leach test)	Pt	Pd	Ru	Rh
ppm	11.5	7.57	3.53	1.63
Amount (mg)	1.22	0.80	0.37	0.17
OUT (after leach test)	Pt	Pd	Ru	Rh
% in leachate	8.97	72.23	2.26	31.76
Amount in leachate (mg)	0.11	0.58	0.01	0.05
ppm from solid assay	11	1.58	3.48	0.99
Amount in concentrate (mg)	1.16	0.17	0.37	0.10
BALANCE (mg)	-0.06	0.06	0.00	0.01
BALANCE (%)	-4.62	6.90	-0.84	7.50

Table 24: BM material balance over BSTR cyanide test with bioleached material (pre-treatment)

IN (before leach test)	Cu	Ni	Fe	Co
%	0.06	0.09	11.20	0.02
Amount (g)	0.06	0.09	11.86	0.02
OUT (after leach test)	Cu	Ni	Fe	Co
% in leachate	21.39	35.51	0.63	10.17
Amount in leachate (g)	0.013	0.033	0.075	0.002
% from solid assay	0.05	0.064	11.4	<0.05
Amount in concentrate (g)	0.05	0.07	12.07	
BALANCE (g)	-0.01	-0.01	-0.29	
BALANCE (%)	-9.11	-9.07	-2.42	0.00

Table 25: Gangue element material balance over BSTR cyanide test with bioleached material (pre-treatment)

IN (before leach test)	Mg	Al	Si	Ca	Cr
%	13.90	0.73	25.20	1.03	0.41
Amount (g)	14.72	0.77	26.68	1.09	0.43
OUT (after leach test)	Mg	Al	Si	Ca	Cr
% in leachate	-0.01	-0.1	3.68	0.64	-8.91
Amount in leachate (g)	-0.001	-0.001	0.982	0.01	-0.04
% from solid assay	14.1	0.75	24.4	1.05	0.41
Amount in concentrate (g)	14.93	0.79	25.84	1.11	0.43
BALANCE (g)	-0.21	-0.02	-0.13	-0.03	0.04
BALANCE (%)	-1.43	-2.64	-0.51	-2.58	8.91

4.2.8.5 Discussion

The rhodium and palladium extractions in both cases were the highest amongst the PGMs, particularly palladium for the test on the bioleached sample (pre-treatment). In comparison with the test on the untreated material, this points to the fact that a significant amount of palladium was occluded in the nickel bearing minerals. Supporting this fact is the observation that the palladium extractions on the sample pre-treated with ferric/sulphuric acid with a nickel extraction of only 11.43 % produced a palladium extraction of only 24.29 % in the cyanide BSTR test at 50°C. Ruthenium showed a slight improvement to 4.29 % for the untreated material, as compared to 2.26 % extracted from sample pre-treated via the bioleach process. Once again a sample pre-treated via a bioleach process has resulted in less ruthenium being extracted in the subsequent PGM leach and hence temperature can now be ruled out as the contributing factor (see section 4.2.5.5). Considering that the leach on the untreated concentrate sample resulted in 4.29 % Ru extraction and the concentrate pre-treated by the ferric/sulphuric acid leach resulted in 3.41 % Ru extraction for the granular bed and 2.87 % in the BSTR, it seems more likely that the contributing factor is method of pre-treatment and perhaps surface chemistry and mineralogy. The acidic pre-treatments, especially the bioleach process, are possibly causing a precipitation reaction on the ruthenium minerals resulting in a coating or passivation layer, which reduces the amount of ruthenium mineral exposed to succeeding PGM leaches. This can be noted from the pattern of decreasing amount of ruthenium extracted from untreated concentrate (4.29 %) to chemically treated concentrate for 5 days (3.41 and 2.87 %) to

the bioleached sample for 30 days (2.08 and 2.26 %). The sample pre-treated in acidic media for the longest period had the least amount of ruthenium extracted.

The lower extractions of platinum in both cases can be attributed to the fact that these experiments ran at room temperature, instead of 50°C as with experiment 4 (section 4.2.4). The system of refreshing the solution after two days, generally did not have the same positive influence that it was postulated to have according to experiment 4. Examining the leach slope for platinum from Figure 39, it appears that with the exception of the last two days for each experiment, the platinum concentration tends to drop slightly after the first 24 hours. From the low extractions of platinum in the both cases, no concrete determination can be made as to whether the BM extraction stage had an impact on the platinum extraction levels or not. However it must be said that both slopes still appear to be on a linear increasing path to higher extraction levels. Final analysis of the results indicates that the low platinum and ruthenium extractions may be attributed to:

- The two metals being less soluble in cyanide than rhodium and palladium or
- That they are occluded in the copper or iron bearing minerals considering that the extractions from both concentrate samples were similar and the bioleached sample still had considerable amounts of copper and iron, but + 90 % of nickel and cobalt had been extracted.

The extraction of copper in the untreated material (in terms of percentage extraction and amount leached) was significantly higher than in the test on the pre-treated sample. It must be kept in mind that although the other sample was pre-treated, there was still an appreciable amount of copper, in the order of around 43 %. With Reference to Figure 40, this can be explained by mineralogy. Comparing the two slopes, the bioleach test appears to have leached copper from minerals that seem to leach rapidly in cyanide. This would count as an advantage for the bioleach pre-treatment only if it can be shown that:

- The high copper consumption is uneconomical
- The copper cannot be recovered
- The copper interferes with PGM leaching and/or recovery from leachate
- Significant platinum bearing minerals are occluded in these copper bearing minerals

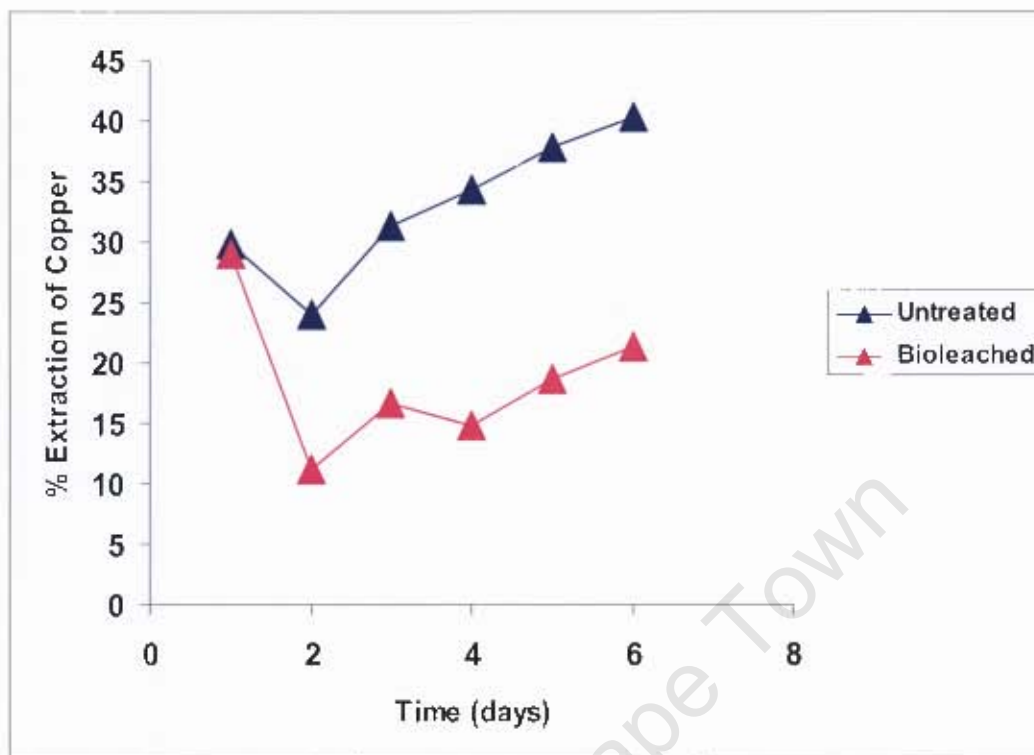

Figure 40: Copper extractions in BSTR cyanide tests

The nickel extractions in the untreated material are quite high (23.89 %) whereas the ones in the bioleached sample appear to be high, but are in fact low when the actual amount is taken into account. It must be considered that 95 % of the nickel in this sample had already been extracted. The advantage of this step can be scrutinised under the same points used above for the copper.

Even considering that 85 % of the cobalt had been removed in the bioleached sample, the actual amounts dissolved for the untreated and the bioleached sample were 4 and 0.29 ppb respectively, showing that this particular metal does not threaten to consume much cyanide.

Iron although appearing low in percentage extraction, was present in relatively large amounts of samples taken from the tests on the untreated material. Up to 640 ppm. The test on the bioleached sample dissolved only 75 ppm, which was even lower than the amount dissolved in the cyanide heap leach test (experiment 5). This seems peculiar because only 6 % of the iron appeared to have leached in the bioleach test (see section 4.2.12 experiment 10). As discussed in section 4.2.12, there is a possibility that a large quantity of the iron was solubilised but then immediately precipitated into a form not soluble in cyanide.

4.2.9 Experiment 7: Organic acid leaching of BMs using BSTRs

4.2.9.1 Aim

To investigate the extraction of BMs from the low-grade ore concentrate using organic acids as a means of aiding PGM extraction and gaining additional value from the overall process. A BSTR will be used to identify the best route from a number of proposed options before testing proceeds to granular and heap bed reactors.

4.2.9.2 Theory

Organic acids, in acidic pH range, have been shown to leach copper and nickel from chalcopyrite and pentlandite without the aid of an oxidizing agent or the use of high temperature and pressure (Evans 2007). In Phase 1 of the test work on the platinum proxy material, citric acid and the combination of tartaric and malic acids proved to be the most effective in dissolving platinum. Additionally citric acid has been reported by a number of researchers as being the most efficient organic acid for leaching a variety of BMs. It is for these reasons that these two routes were explored in this experiment.

4.2.9.3 Materials and Methods

Two sets of solutions: 0.5 M citric acid and a combination of 0.25 M tartaric and 0.25 M malic acid were prepared by dissolving their salts in deionised water. One set was kept at the natural pH of the solutions which was around 2 and the other set was alkalisied to pH 4 using the combination³ of 25 mL 0.1 M potassium hydrogen phthalate solution and 0.65 mL 0.1 M sodium hydroxide solution. Where necessary a solution of 6 M sodium hydroxide was added drop by drop to raise the pH to the required level.

In the first instant a comparison between citric acid and the combination of tartaric and malic acids was conducted, and the best option tested at an elevated temperature of 50°C. Approximately 20g of the concentrate was weighed into a 500 ml Erlenmeyer flask to which 200

³ Analytical Chemistry Solutions. "Preparation of pH buffer solutions." Retrieved from <http://delloyd.50megs.com/moreinfo/buffers2.html>

mL of solution of was added. The solution was agitated using a magnetic stirrer and samples were withdrawn at various intervals over a 28 hour period for vacuum filtered using a 0.22 μ m membrane filter for AAS analysis for copper and nickel. The pH was measured using a standard pH meter and at the end of all experiments the material was recovered using vacuum filtration and oven dried at 80°C to obtain samples (see chapter 3 section 3.2.2) for a solid assay.

4.2.9.4 Results and Discussion

Table 26: Cu and Ni extractions from organic acid leaching

	Duration (hours)	pH	Percentage Extractions (%)	
			Cu	Ni
Tartaric-Malic Acid 0.5 M	28	2	27.5	10.5
Citric Acid 0.5 M	28	2	15.2	9.3
Tartaric-Malic Acid 0.5 M	28	4	27.1	4.8
Citric Acid 0.5 M	28	4	20.9	7.2
Tartaric-Malic Acid 0.5 M at 50°C	28	2	36.11	11.46

The combination of tartaric and malic acids in the pH range around 2 proved the most successful option for leaching copper and nickel. At the start of the experiment the pH was 2.27 and over the 28 hour period it dropped to 1.95. It is clear that pH only plays an important role for the nickel leaching and has minimal impact on copper leaching. The graphs for this system show that both copper and nickel reach their limit before the 24 hour mark (Figure 41). There are three possible reasons for this: firstly both reactions may have reached equilibrium and hence the solution must be refreshed to leach more metal, or the organic acids only leach from specific copper and nickel minerals (based on the literature chalcopyrite and pentlandite (Evans 2007)) and as a result have leached all or most of the metals from these minerals. The third possibility is a combination of the two: equilibrium was reached and the organic acids only leach from specific minerals. Finally it was observed that an increase in temperature had a significant influence on the copper extraction, but not the nickel extraction.

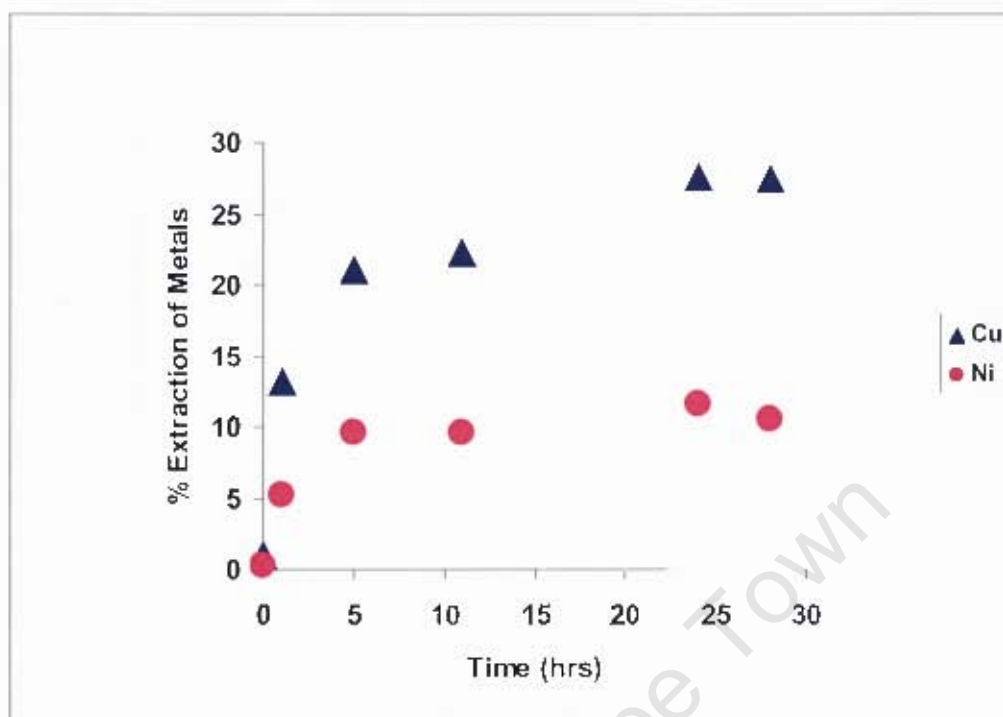

Figure 41: Cu and Ni Extractions from tartaric-malic acid leach

To investigate the above theories a fresh sample of concentrate was leached for 5 days, and the solution refreshed every 24 hours:

Table 27: BM leach using tartaric-malic acid over 5 days

Cumulative Percentage Extraction	Day 1	Day 2	Day 3	Day 4	Day 5
Cu	17.42	20.37	21.26	21.58	21.79
Ni	5.81	6.72	6.98	7.13	7.25

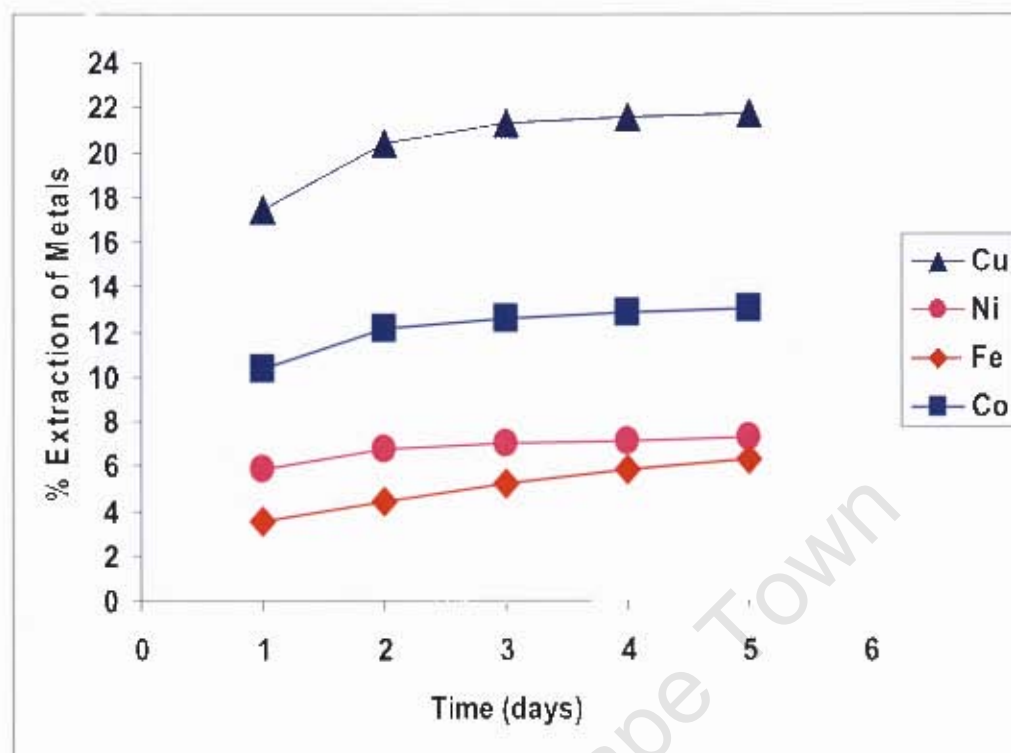

Figure 42: BM leach using tartaric-malic acid over 5 days

The much lower extractions of copper and nickel achieved were noticeable and for this reason the experiment was repeated a second time with two different samples and the same conditions. In this instance it was only for the duration of 24 hours and the extractions achieved were copper 19 % and 20.27 %, and nickel 6.56 % and 5.01 %. The high percentages achieved in the first experiments were likely due to the fact that the extraction was calculated from average values obtained when the entire sample of the material (200 L) was homogenised; whereas the sub sample used for the experiment might have had slightly lower content of copper and nickel (see chapter 3 section 3.2.1).

The investigation proceeded to determine the influence of using different concentrations of acid, ranging from 0.2-1 M a period of 24 hours per test.

Table 28: Percentage extractions for various concentrations of tartaric-malic acid combination

	0.5 M (pH 2)	0.5 M (pH 1.71-1.91)	0.5 M (pH 2.27-2.35)	0.2 M (pH 1.85-2.23)	1 M (pH 1.46-1.67)
Cu	27.5	19	20.27	18.36	20.05
Ni	10.5	6.56	5.01	7.94	8.86
Fe	-	5.68	5.10	5.12	7.12
Co	-	9.58	9.42	7.67	9.14

A comparison of the results across the different concentrations reveals no marked increase in BM extraction with the increase in concentration from 0.2 to 1 M. It was therefore decided that the concentrate would be tested through leaching in a granular bed and heap with a tartaric-malic acid combination of strength 0.2 M.

4.2.10 Experiment 8: BM leaching from the concentrate material using tartaric-malic acid combination in a granular bed

4.2.10.1 Aim

Evaluate the BM extractions that can be achieved using a tartaric-malic acid combination in a granular bed reactor as a means of pre-treating the concentrate before PGM extraction and a way to gain additional value from the BMs extracted.

4.2.10.3 Theory

Organic acids have been reported to effectively leach copper and nickel from sulphide minerals such as chalcopyrite and pentlandite without the aid of autoclave conditions. Used in a granular bed reactor they may provide an economical option to extract the BMs from the concentrate.

4.2.10.4 Materials and Methods

The equipment was set up and the procedure ran as detailed chapter 3 section 3.2.3. A sample of the low-grade concentrate weighing 500 g was made into a slurry using deionised water and

leached with 1 l. of a combination of tartaric and malic acid of solution strength 0.2 M. The experiment was conducted room temperature for 24 hours, during which samples were withdrawn for pH measurement and AAS analysis of BMs.

4.2.10.5 Results

Table 29: BM extractions from granular bed organic acid leaching

	Duration (hours)	Percentage Extractions (%)			
		Cu	Ni	Fe	Co
Reactor 1	24	16.91	8.00	0.39	5.78
Reactor 2	24	16.33	7.30	0.40	5.47

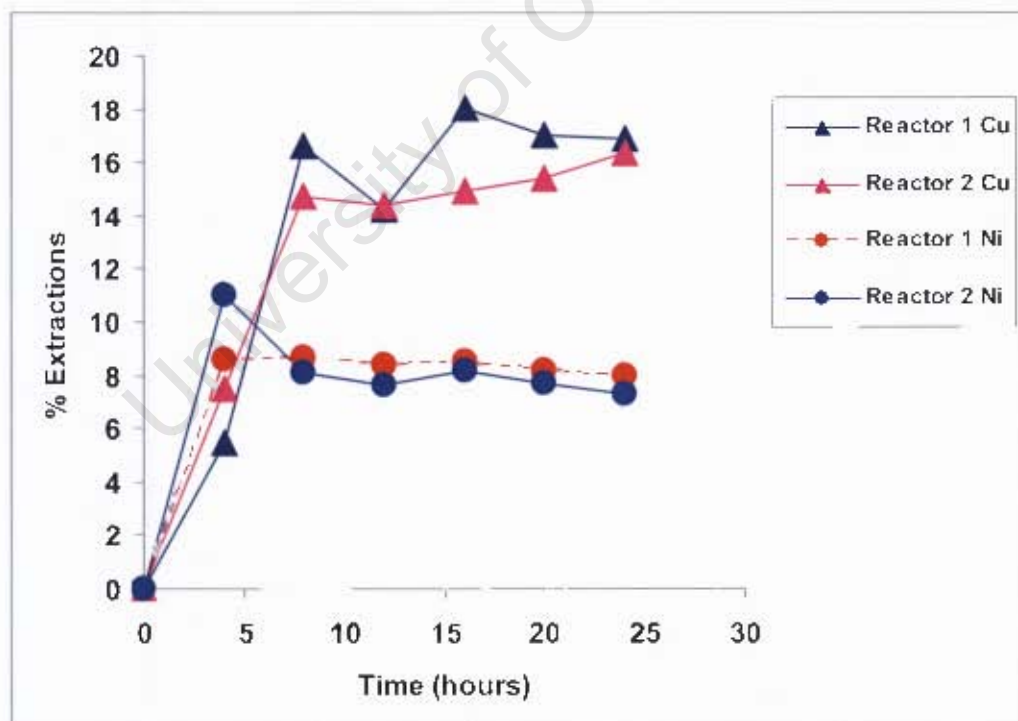

Figure 43: Copper and nickel extractions

4.2.10.6 Discussion

Comparing the results with those achieved using a BSTR: all the BMs except for iron are comparable in terms of amounts leached and time taken to extract those amounts. This can be explained by the following: The BM minerals are generally very well liberated and exposed to leaching, the BMs are present in significantly larger quantities and they are generally more soluble than the PGMs. As a result the reactor configuration did not have as much of an impact on the amounts leached as it did with the PGMs. However, as established earlier: because the granular bed reactor can only handle small amounts of material at a time relative to the total output, it is unlikely to be a commercially viable option.

4.2.11 Experiment 9: BM leaching using a combination of tartaric and malic acids in a packed bed reactor

4.2.11.1 Aims

Evaluate the BM extractions achievable using a combination of tartaric and malic acids in a heap leach reactor configuration and determine their potential for commercialisation.

4.2.11.2 Theory

Organic acids have been reported and have thus far shown to have potential for commercial extraction of BMs from the concentrate. Applied in a heap reactor they present a possible low cost option for recovering BMs from the concentrate.

4.2.11.3 Materials and Methods

The procedure followed and equipment used is detailed in chapter 3 section 3.2.7. Approximately 600 g of concentrate was made into slurry using deionised water in a ratio of 5:3 (solid to liquid) and coated onto 3.5 kg of granite. The charge was packed into a PVC pipe acting as a column. The solution was fed at a rate of 1 L/day and the experiment was run at room temperature. Considering the times taken to reach maximum leaching in the BSTR and the granular bed reactor, the solution of 1 L was re-circulated for 3 days and refreshed every 3 days

thereafter. This was done for 30 days and samples were withdrawn, for AAS analysis, every 24 hours for the first 3 days and then at intervals of 3 days thereafter.

4.2.11.4 Results

Table 30: BM heap leaching using organic acids

	Duration (Days)	Percentage Extractions (%)			
		Cu	Ni	Fe	Co
Column 1	30	25.18	11.53	14.46	13.29

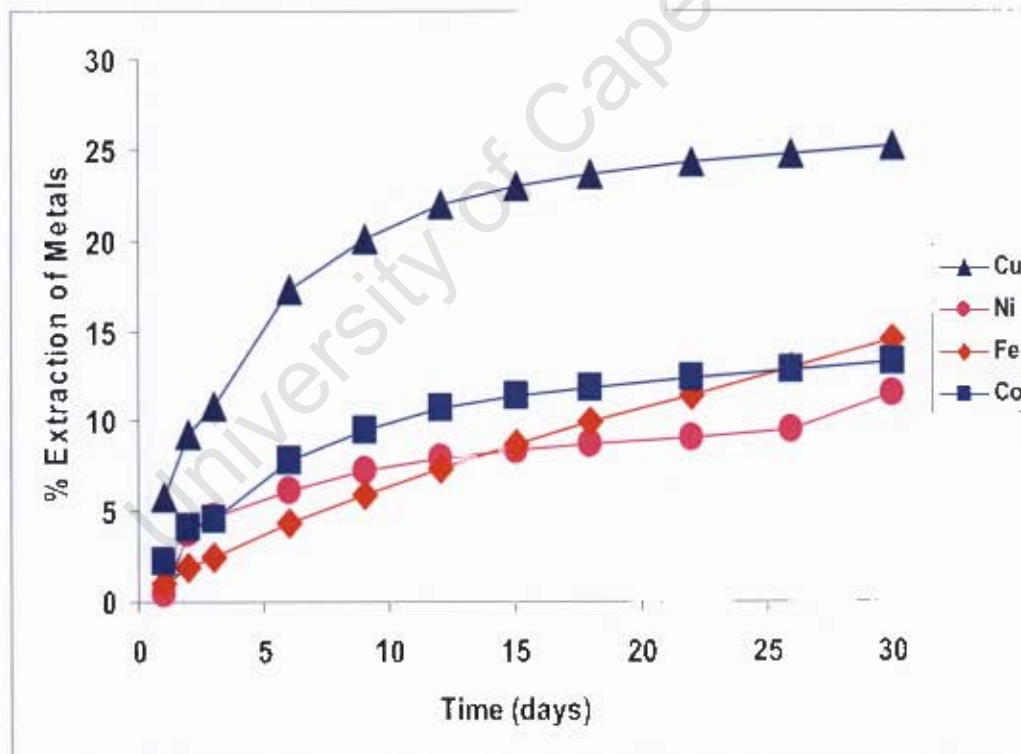

Figure 44: BM heap leaching using organic acids

4.2.11.5 Discussion

The results appear to be a sharp contrast to those achieved in the exploratory work (Evans 2007) by Biomed (Ni 62 %, Cu 60 %, 37 %; see chapter section 1.2) but closer to those achieved by

MSL (38 % Ni, Cu 26 %, 34 %; see chapter section 1.2). It must be noted that Evans (2007) only provides a summary of main facts in the report and not critical information to conduct a proper comparison between the results achieved in the different studies. One of the omitted pieces of information would be the grades of the materials used in the previous studies. A clear case in point of the importance of this information is with nickel. Evans (2007) reports previous studies extracting amounts of 420 ppm and 610 ppm, which converted to reported percentages of 62, 30 and 38. The amount leached in this experiment was 447.2 ppm (Appendix Q) which against the grade of this material translates to only 11.53 %.

Explaining the poor BM extractions; attention is drawn to the graphs of copper, nickel and cobalt in Figure 44. The shapes would indicate the approach to equilibrium, but this is discounted due to the fact the solution was refreshed periodically in both cases. The other alternative would be that leaching occurs from specific minerals which constitute small amounts of the aforementioned metals. The leveling would thus indicate the depletion of the metals from these minerals. However, Evans (2007) reports on the susceptibility of the copper and nickel bearing minerals, chalcopyrite and pentlandite, to organic acid leaching. These generally represent a substantial amount of the metals in the ore material (Schouwstra and Kinloch 2000). However, this theory may still be plausible if the low-grade concentrate does indeed have copper and nickel in only small amounts of chalcopyrite and pentlandite, while the bulk are in other sulphide minerals or other forms not susceptible to organic acid leaching.

The final possibility is the formation of sulphur or iron precipitate layers on the mineral surfaces, restricting further leaching with the progress of time. Figure 45 shows the pH profiles of the two experiments: both circle in the region of 2 which combined with other factors may have been conducive for the formation of iron oxyhydroxide precipitates (also reported by Evans (2007) in the exploratory work) and sulphur precipitate layers (Pourbaix 1966).

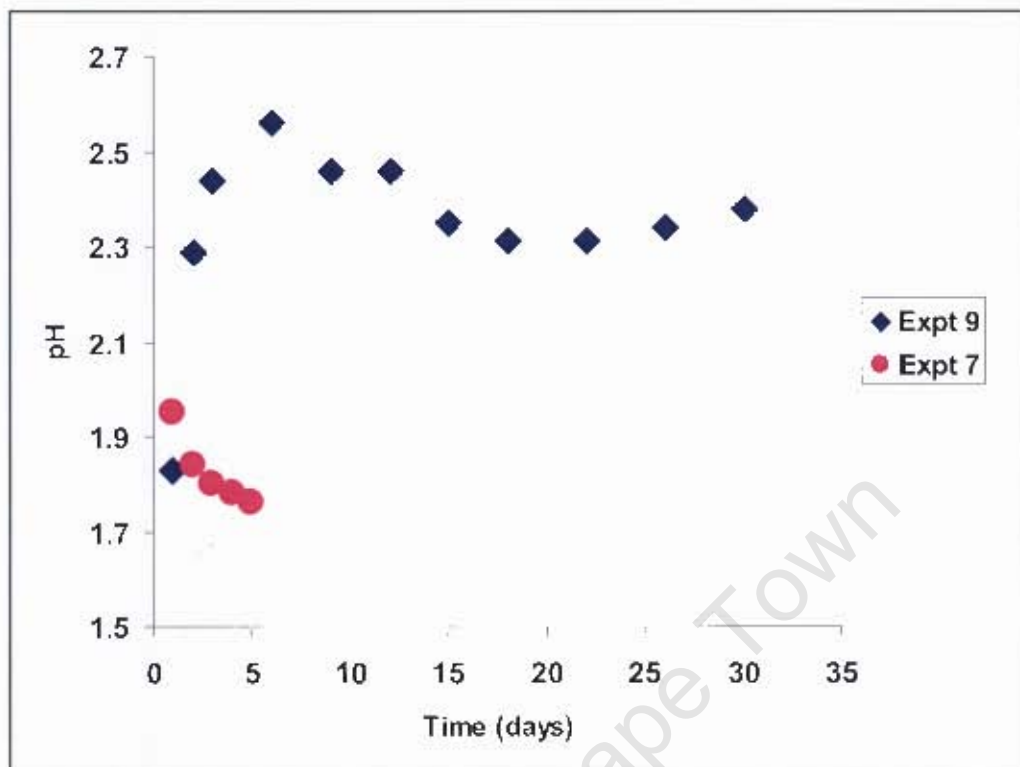

Figure 45: pH profiles for experiments 7 and 9

4.2.11.6 Conclusion

The experiments 7 through to 9 have shown that organic acids are not a viable method of extracting BMs from the low-grade ore concentrate. The most likely explanation would be the formation of a passivation layer which may be overcome by applying an elevated temperature. This may not be economically feasible for large heaps that would be required to handle the tonnages of this concentrate material.

4.2.12 Experiment 10: Bioleaching of BMs using a mixed culture of thermophiles at 65°C in a packed bed reactor

4.2.12.1 Aim

Determine the effectiveness of a bioleach process in extracting BMs from the concentrate. As an established technology use the results from the bioleach process for benchmarking the performance of organic acids for the same application thereby assessing their potential for commercialisation.

4.2.12.2 Theory

Thermophilic microorganisms have been shown to successfully leach copper from chalcopyrite (and other sulphide minerals in general) to commercial levels in the temperature range of 65-75°C. This leaching process is an exothermic reaction which produces heat that can be used to maintain the temperature level for optimal leaching rates by controlling leach solution irrigation and aeration rates in a heap bioleach scenario (Petersen and Dixon 2002). This was demonstrated by Dixon and Petersen (2002) in a heap heat conservation model and realized on a commercial scale by GeoBiotics LLC in their trademark GEOLEACH™ process (Kelly et al 2008). This forms the basis of this experiment: to determine if a similar process can be used to extract copper from the low-grade ore concentrate on a commercial scale. In the experiment the temperature was kept constant using a heating jacket and not by control of solution irrigation and aeration rates.

4.2.12.3 Materials and Methods

A feed solution containing 2 g/L Fe (1 g Fe³⁺ and 1 g Fe²⁺) and 20 g/L sulphuric acid was prepared. The experimental procedure is detailed in chapter 3 section 3.2.8 and was run in two columns starting with a sample of approximately 600 g of concentrate for each column. The concentrate was made into a slurry using deionised water in a ratio of 5:3 (solid to liquid) by mass and coated onto approximately 3.5 kg of granite pebbles. The charge was then carefully packed into the columns after which the feed solution was fed at a rate of 1 L/day and air at a flow rate of 130 mm/min. The column was operated at a temperature of 65°C and a mixed culture of thermophiles (Table 31) was inoculated into the columns only when the temperature reached 65°C. Samples of 15 mL were withdrawn from the effluent every 24 hours for the first 4 days and every 4 days after for 30 days for AAS analysis of Cu, Ni and Fe. The pH and Eh were measured using standard meters and along with these samples of 5 mL were withdrawn for a cell count to ensure the culture community was thriving. The material was recovered, oven dried and samples obtained (see chapter section 3.2.2) for solid assays for PGMs and BMs.

Table 31: Mixed Culture of Thermophiles

Archaea 2
Acidithiobacillus ferrooxidans
Ferropasma cupricumulans
Sulfolobus metallicus
Metallosphaera sedula
Sulfobacillus thermosulfidooxidans
Acidithiobacillus thiooxidans
Leptospirillum ferriphilum
Leptospirillum ferrooxidans

4.2.12.4 Results

Table 32: BM Extractions from bioleach process in packed columns

	Duration (Days)	Percentage Extractions (%)			
		Cu	Ni	Fe	Co
Column 1	30	43.77	87.15	46.76	77.01
Column 2	30	51.89	94.99	6.68	85.25

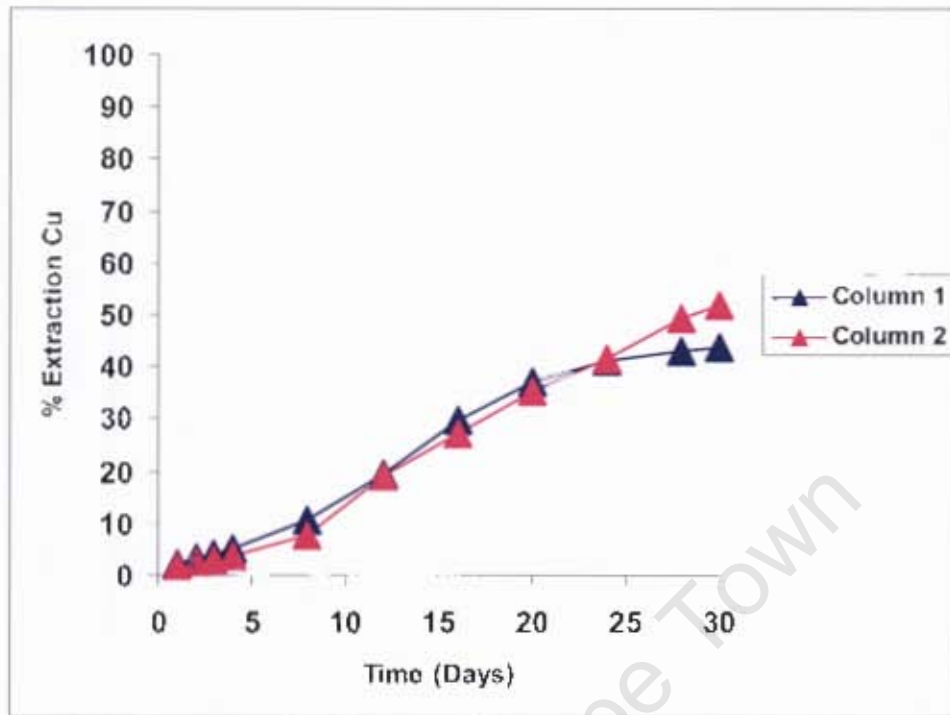

Figure 46: Copper extractions from bioleach process

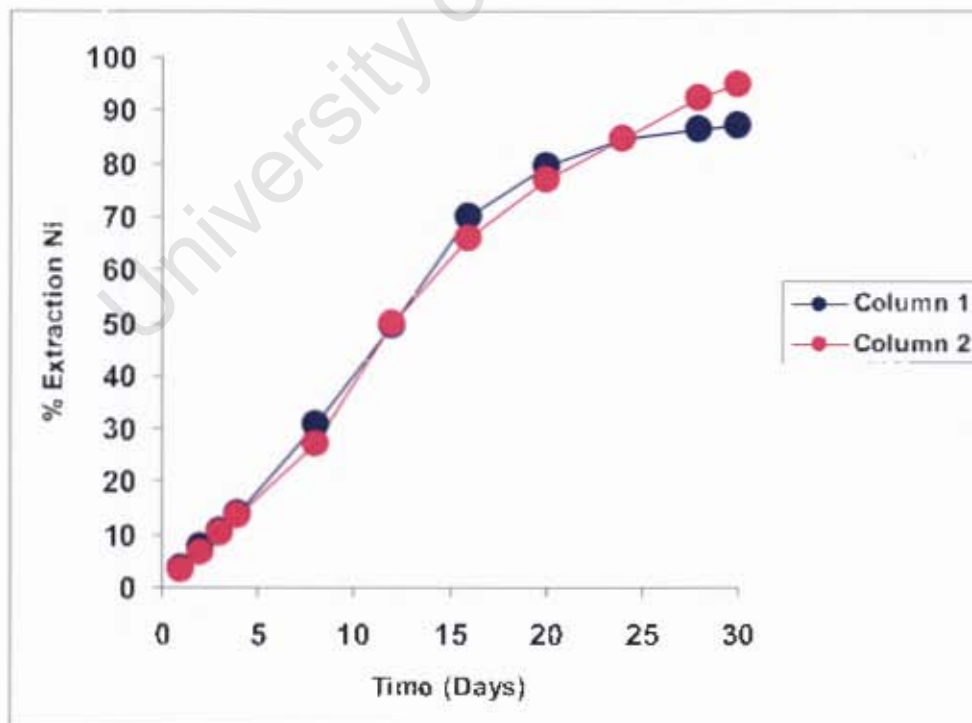

Figure 47: Nickel extractions from bioleach process

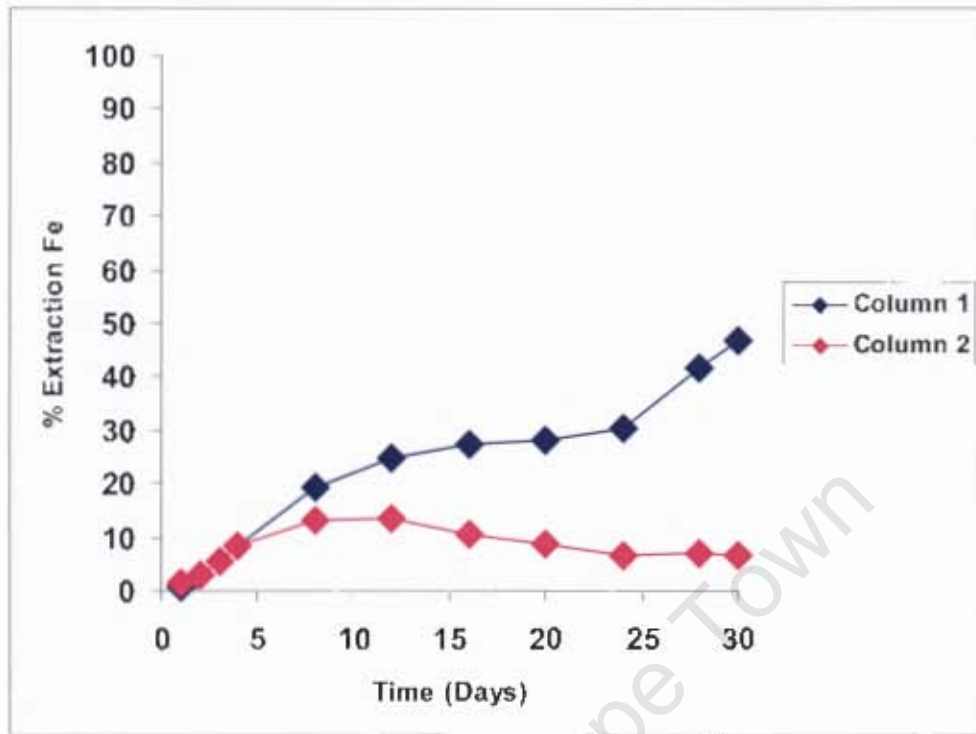

Figure 48: Iron extractions from bioleach process

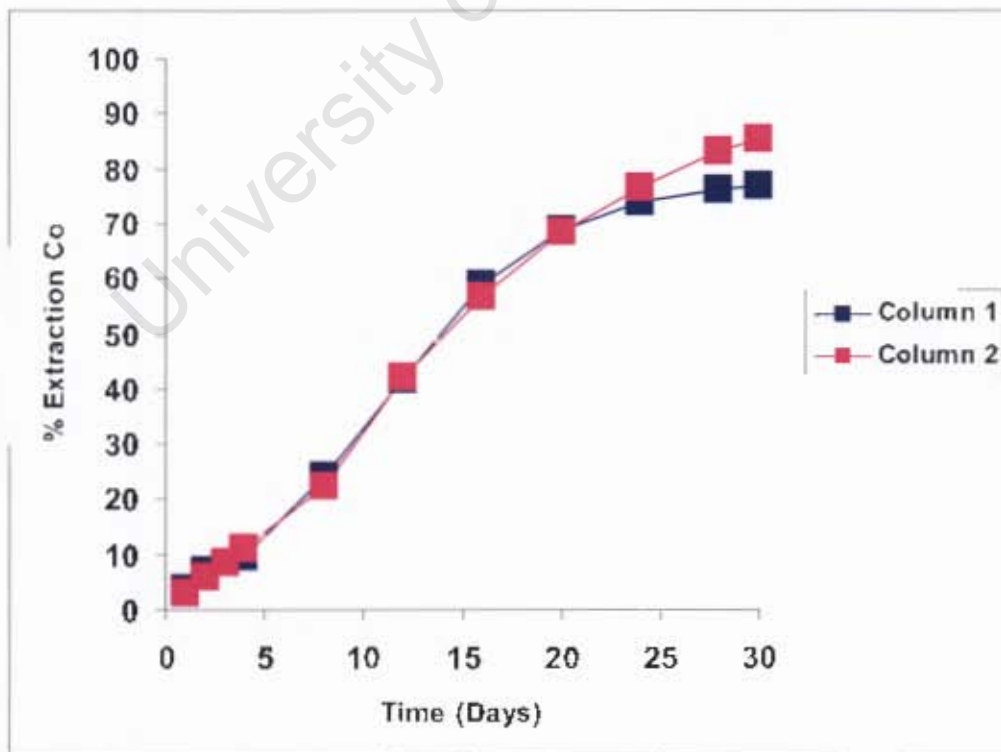

Figure 49: Cobalt extractions from bioleach process

Table 33: BM material balance for column 1

IN (before leach test)	Cu	Ni	Fe	Co
%	0.36	0.74	6.75	0.02
Amount (g)	1.90	3.91	35.44	0.10
OUT (after leach test)	Cu	Ni	Fe	Co
% in leachate	43.77	87.15	46.76	77.01
Amount in leachate (g)	0.83	3.40	16.57	0.07
% from solid assay	0.09	0.19	6.1	<0.02
Amount in concentrate (g)	0.47	1.00	32.04	
BALANCE (g)	0.59	-0.50	-13.17	

Table 34: PGM material balance for column 1

IN (before leach test)	Pt	Pd	Ru	Rh
ppm	11.9	8.34	4.38	2.64
Amount (mg)	6.250	4.380	2.300	1.386
OUT (after leach test)	Pt	Pd	Ru	Rh
ppm	11.7	7.92	3.44	1.78
Amount (mg)	6.14	4.16	1.81	0.93
BALANCE (mg)	0.11	0.22	0.49	0.45
PERCENTAGE LOSS	1.68	5.04	21.46	32.58

Table 35: Gangue element material balance for column 1

IN (before leach test)	Mg	Al	Si	Ca	Cr
%	15.1	1.10	25.0	1.54	0.44
Amount (g)	79.30	5.78	131.29	8.09	2.31
OUT (after leach test)	Mg	Al	Si	Ca	Cr
%	14.5	0.68	25.6	1.04	0.43
Amount (g)	76.15	3.57	134.44	5.46	2.26
BALANCE	3.15	2.21	-3.15	2.63	0.05
% DISSOLVED	3.97	38.18	-2.40	32.47	2.27

Table 36: BM material balance for column 2

IN (before leach test)	Cu	Ni	Fe	Co
%	0.36	0.74	6.75	0.02
Amount (g)	1.84	3.78	34.30	0.09
OUT (after leach test)	Cu	Ni	Fe	Co
% in leachate	51.89	94.99	6.68	85.25
Amount in leachate (g)	0.95	3.59	2.29	0.08
% from solid assay	0.057	0.087	8.15	<0.02
Amount in concentrate (g)	0.29	0.44	41.43	
BALANCE (g)	0.59	-0.25	-9.42	

Table 37: PGM material balance for column 2

IN (before leach test)	Pt	Pd	Ru	Rh
ppm	11.9	8.34	4.38	2.64
Amount (mg)	6.05	4.24	2.23	1.34
OUT (after leach test)	Pt	Pd	Ru	Rh
ppm	1.15	7.57	3.53	1.63
Amount (mg)	5.85	3.85	1.79	0.83
BALANCE (mg)	0.20	0.39	0.43	0.51
PERCENTAGE LOSS	3.36	9.23	19.41	38.26

Table 38: Gangue element material balance for column 2

IN (before leach test)	Mg	Al	Si	Ca	Cr
%	15.3	1.08	24.8	1.52	0.44
Amount (g)	80.35	5.67	130.24	7.98	2.31
OUT (after leach test)	Mg	Al	Si	Ca	Cr
%	13.9	0.73	25.2	1.03	0.41
Amount (g)	73.00	3.83	132.34	5.41	2.15
BALANCE	7.35	1.84	-2.10	2.57	0.16
% DISSOLVED	9.15	32.41	-1.61	32.24	6.82

4.2.12.5 Discussion

This system has shown great potential for extracting value from the BM component of the concentrate at a commercial level. The success of this process can be attributed to the fact that the BMs (more specifically nickel and cobalt) are mostly, if not entirely, contained in sulphide minerals (Schouwstra and Kinloch 2000). Although the copper and iron extractions are not at the level of the nickel and cobalt extractions, it must be kept in mind that the experiment only ran for 30 days at the minimum temperature of 65°C (from a range of 65-75°C). It is reasonable to postulate that if the rest of the copper and iron are contained in sulphide minerals, and if the experiment was allowed to run for 90-120 days at the maximum achievable temperature of 75°C, extractions for copper in particular could reach 90 % plus as achieved by other researchers (Petersen and Dixon 2002; Kelly et al 2008) who have run similar experiments. These experiments were conducted on ore concentrates where the bulk of the copper (>90 %) was in the form of sulphide minerals. Further to this, the copper extraction graphs (Figure 46) for both columns, shows that they are still on a linear slope and likely to continue increasing to as much as 90 % extraction.

The large amount of copper unaccounted for in the material balance of both columns can be explained by the fact that about 150-170 g of material had been lost during filtration. The acid leach process must have reduced that quantity of material into extremely fine particles that passed through the filter paper. Assuming that this lost quantity of material contained the bulk of unleached copper, a quick calculation ($170 \times 0.36 \% = 0.612 \text{ g}$) shows it is close to the unaccounted for 0.59 g for both columns.

The big difference in the amounts of iron present in solution between the two columns can be explained by the much higher Eh in column 2. Comparing Figure 48 and Figure 51, shows the decreasing amount of iron in solution with the increasing Eh after around day 8. This suggests that under these conditions the iron precipitated out. This may work as an advantage for this process, motivating the possibility of operating the process under the pH and Eh conditions of column 2 to reduce the amount of iron in the solution. Lonmin's BMR takes in a feed with no or low iron content and this is achieved by smelting of the high-grade ore concentrate before sending it to the leach circuit (see chapter 1 section 1.5). Precipitation of iron during the bioleach process is unlikely to drop the iron in solution to an acceptable level for the BMR, possibly

<0.05 g/L (Gupta and Mukherjee 1990), but it can reduce the load and subsequently the operating cost of an iron removal step needed after the bioleach process. The level of iron in solution in column 2 was about 2.3 g/L as compared to 16.5 g/L in column 1. These amounts are over and above the initial 2 g/L Fe added in solution and needed to keep the bioleach process going. Further motivation for operating under the conditions in column 2 comes from the fact that column 2 outperformed column 1 in extractions of copper, nickel and cobalt (Table 32).

The material balances over the PGMs for both columns show some losses in the processes specifically for ruthenium and rhodium. This may require a rhodium recovery stage before the leachate is sent to the BMR. However the losses for the more valuable platinum do not appear to be very significant. An analysis was not conducted on the leach liquors to determine if any PGMs had been solubilised, it cannot be determined conclusively if this loss is due to solubilisation or loss of the concentrate material during the processes of recovering it from the support media and filtration.

With the exception of Silicon there is a considerable amount of gangue element dissolution in the bioleach process (Table 38). But this is to be expected in an acid leach of ore containing these elements.

Even with extraction levels of 85.25 % of cobalt and the high tonnage production of the ore concentrate, the production potential for cobalt is still very low (around 65 tons). Hence cobalt will not be considered further in the economic viability of this process.

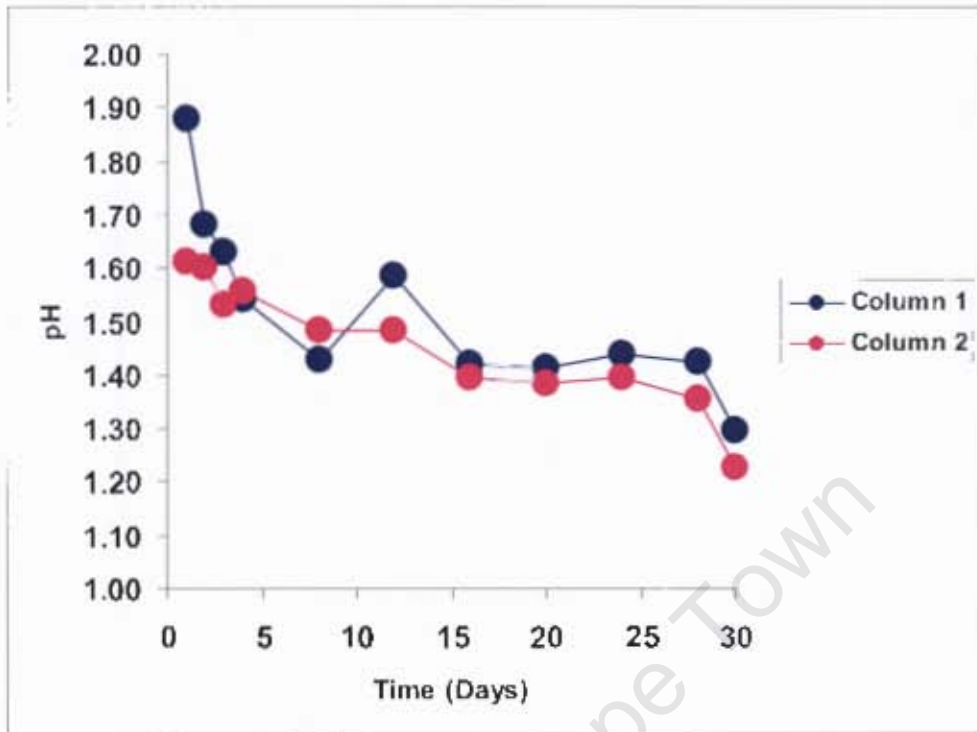

Figure 50: pH profile

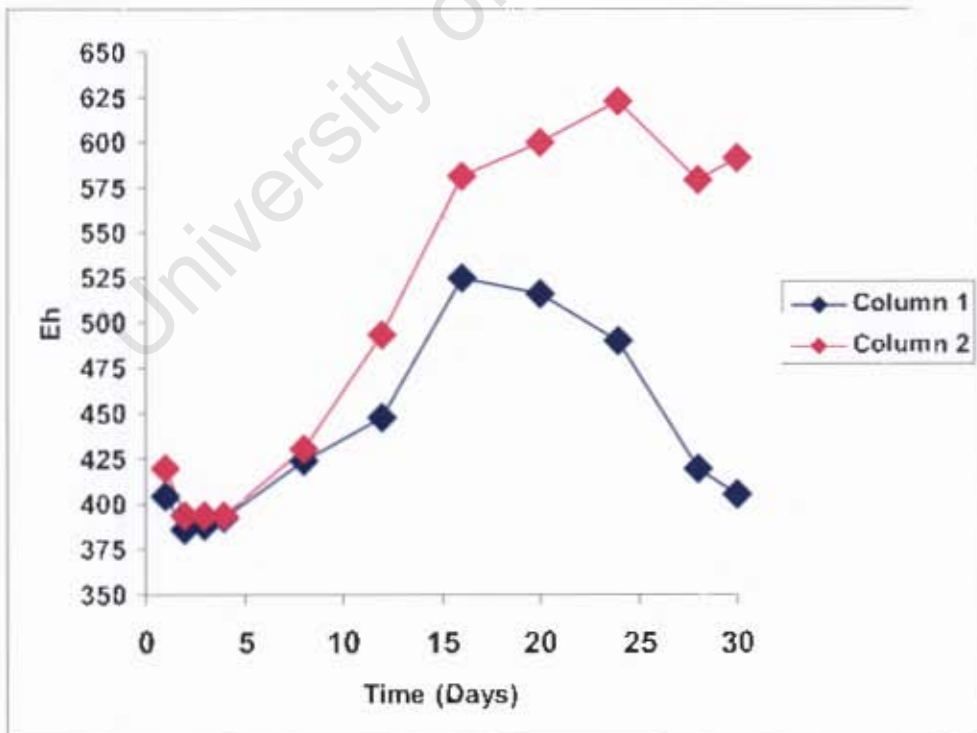

Figure 51: Eh profile

4.3 Chapter Conclusion

From a variety of lixivants identified in the literature survey for this study, phase 1 of the experimental work on the proxy sulphide material (PtS₂) identified cyanide solution and the combination of tartaric and malic acid as the most promising routes to pursue on the ore concentrate.

Based on a rigorous experimental matrix (Figure 52) and thorough analysis of data generated, the hypotheses (chapter 2 section 2.6) have been sufficiently tested, the key questions answered and the following have been concluded with absolute certainty and confidence:

- Cyanidation as a chemical treatment has proven to be the option with most potential for developing a commercial process to extract value from the low-grade ore concentrate via extraction of the PGMs (Table 39). Additionally it does not consume large amounts of gangue elements and it has the potential for regeneration of lixiviant after recovery of metals. It is a superior option than the earlier reported organic acids (Evans 2007). Although the BSTR experiment at 50°C achieved the highest Pt extraction, it is unlikely to be feasible at industrial level considering that even under these conditions the residence time was still long (48 hours) in relation to the small amount of material handled and the large amount of solution needed (solid to liquid ratio 10 %). Given the tonnage and grade of concentrate material, this is not likely to be economically justifiable.

Table 39: Percentage Extractions of PGMs and copper in Phase 2 cyanide tests on ore concentrate

Reactor Type	Operating Temp	Pre-treatment method	% Extractions			
			Pt	Pd	Ru	Rh
Granular Bed	50°C	Ferric/H ₂ SO ₄	8.46	26.93	3.41	16.32
BSTR	50°C	Ferric/H ₂ SO ₄	23.46	24.29	2.87	13.13
Packed Bed	Room	Biobleach	20.34	87.17	3.35	46.03
BSTR	Room	Untreated	9.56	40.98	4.29	23.81
BSTR	Room	Biobleach	8.97	72.23	2.26	31.76

- A bioleach process using thermophilic microorganisms at an operating temperature above 65°C is the optimal option for extracting the BMs. Amongst the three processes explored (Table 40) it extracted the most copper, nickel and cobalt. This process produced the test with the least amount of iron in solution, making it a feed that would require the least amount of processing before entering the BMR at Lonmin. Additionally it is capable of producing its own heat to work optimally at industrial scale. Contrary to this, the organic acid and ferric/sulphuric acid options did not leach commercial levels of nickel and would require elevated temperatures from external heat sources in order to leach substantial amounts of copper. This is not considered practical for any of the reactor configurations explored in this study.

Table 40: Percentage Extractions of BMs in Phase 2 tests on ore concentrate

Process	Reactor Type	% Extractions			
		Cu	Ni	Co	Fe
Ferric/H ₂ SO ₄	Granular Bed	54.81	11.43	-	81.21
Bioleach	Packed Bed	51.89	94.99	85.25	6.68
Organic Acids	Packed Bed	25.18	11.53	13.29	14.46

- Pre-treating the material to extract BMs was shown only to be beneficial to Pd extraction and this was conclusively linked to high nickel extractions.
- A packed bed reactor in the form of a heap, wherein the low-grade ore concentrate, in its original form of a slurry is coated onto a support medium, has proven to be the most suitable reactor for processing the low-grade ore concentrate. The reasons for this are as follows:
 - The cyanidation and bioleach process although successful in extracting PGMs and BMs, are slow and with these kinetics and the tonnage of concentrate material produced, it is unlikely that the ore concentrate can be economically processed in a reactor requiring mechanical agitation.
 - Experimentally it has proven to provide sufficient contact between the leaching lixiviant and the various PGM and BM minerals.

- On an industrial scale this reactor is associated with low capital and operating costs, and the ability to handle large tonnages of ore concentrate.

University of Cape Town

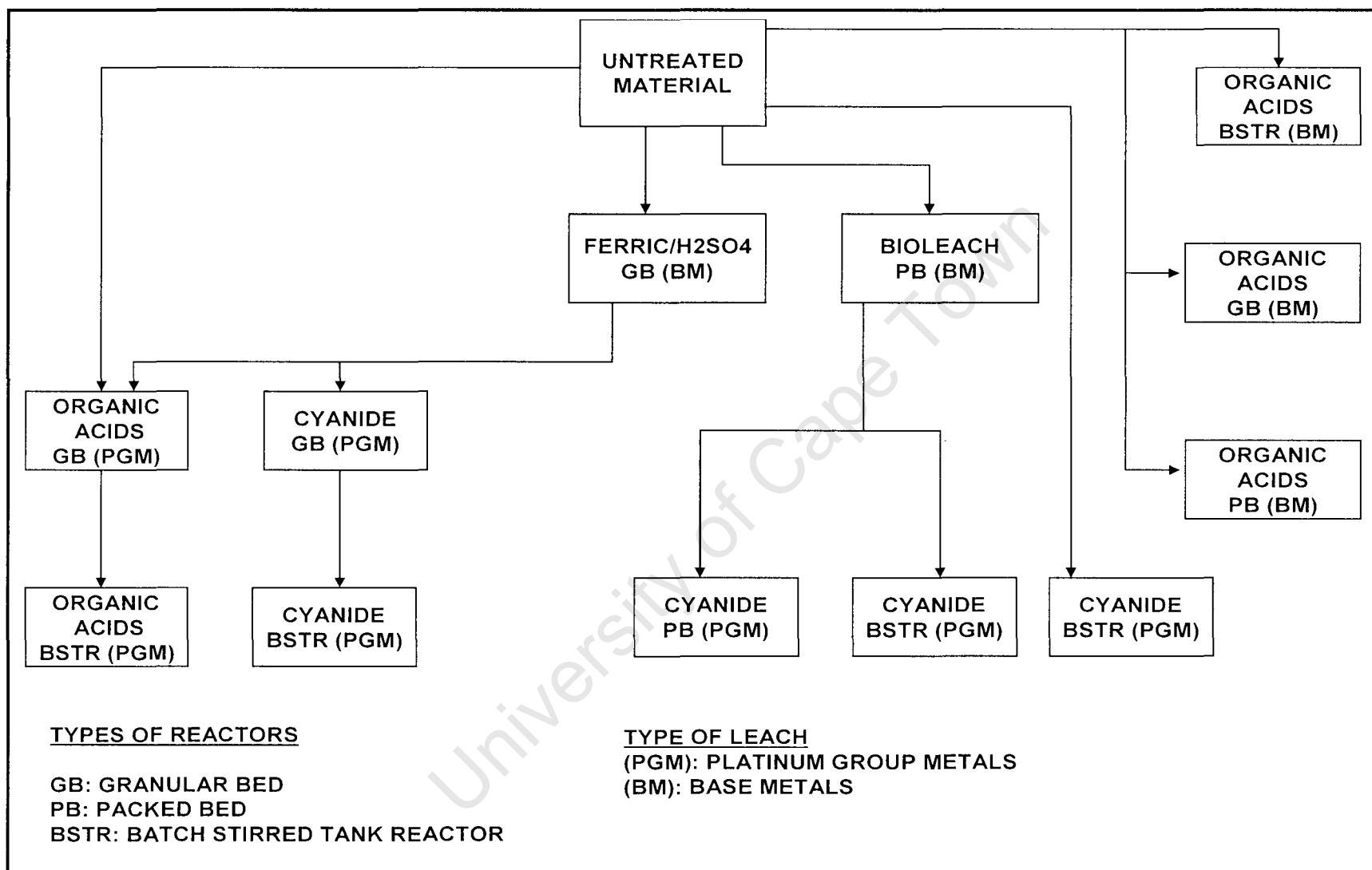

Figure 52: Matrix of experiments on low-grade ore concentrate

Chapter 5: Final Assessment

The concluding chapter of this study consolidates the data generated from the literature review and the experimental work to construct flow sheet options based on experiments 5, 6 and 10 from phase 2 of the experimental work. For the best option chosen, environmental remediation steps are suggested and a cost analysis is conducted to determine the financial viability of the process. The chapter closes with some recommendations as to what direction the project should take after this study.

5.1 Flowsheet Generation

Based on the literature review and the experimental work, three flowsheets are proposed:

5.1.1 Flowsheet 1

This process (Figure 53) will begin with a heap bioleach run to completion (60 plus days) to extract the bulk of the BMs. The resulting copper-nickel-iron leach liquor would require the iron to be removed as an impurity. The current Lonmin flowsheet achieves this by smelting of the high-grade ore concentrate before leaching it (see chapter 1 section 1.5). In this case it is recommended that further investigation can be conducted into running the heap under conditions in which the iron would precipitate out during the bioleach process (see chapter 4 section 4.2.10.5: results in column 2) and the use of an additional iron removal step using one of the following two processes (Gupta and Mukherjee 1990):

- Jarosite Process: In this process iron is precipitated in the form of $(\text{NH}_4/\text{Na})\text{Fe}_3(\text{SO}_4)_2(\text{OH})_6$ from acidic solutions ($\text{pH} < 1.5$) at a temperature of $90\text{-}100^\circ\text{C}$ in the presence of cations like NH_4^+ or Na^+ . The equation representing this reaction is as follows:

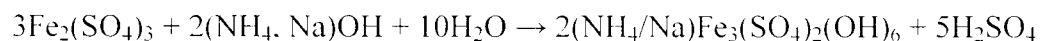

- Goethite Process: Two variations of this process exist, namely the Electrolyte Zinc Industry process (EZ) and the Vieille Montagne process (VM). Goethite (FeO.OH) precipitates at pH 2-3.5 and a temperature range of 70-90°C, according to the following reaction:

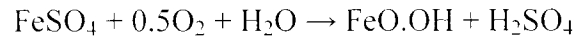

The two processes differ in that, in the EZ, the concentration of ferric ions in solution must be maintained at no more than 1 g/L by adding ferric ion solutions to the precipitation vessel at such a rate that the soluble ferric iron does not exceed this limit. In the VM process, the leach liquor should contain iron in the ferrous state and it should be oxidised with air at a controlled rate. If the leachate contains significant quantities of ferric, it should first be reduced to ferrous in a separate step.

A third option called the Hematite process exists. This process was discounted due to its need to operate at 200°C which is contrary to the operating conditions deemed viable for treating this material (see chapter 2 section 2.1). Additionally, this process is reportedly the least efficient process among the three (Gupta and Mukherjee 1990). Unless a profitable outlet for the hematite can be sourced to justify operating under autoclave conditions, this process has been excluded.

Although this stage will require starting capital investment, it is likely to be less costly than resorting to a solvent extraction and stripping circuit to selectively remove the nickel and copper (Gupta and Mukherjee 1990). An additional advantage of this iron removal step is that it produces a leach liquor which can be directly processed using the current infrastructure in Lonmin's BMR, as explained below.

The solution, free of or low in iron, can then be sent to Lonmin's BMR where it will undergo copper precipitation to separate the copper from the nickel, after which nickel can be recovered by crystallisation and the copper by electrowinning (see chapter 1 section 1.5)

The concentrate while still on the heap can then be washed with caustic water to raise the pH before being washed off and coated onto separate support media, for a different heap, for the leaching the PGMs with cyanide. The reason for this is that the bioleach process requires airflow and irrigation systems controlled by a patented process control system, and heap pads not

required for the cyanide leach (see chapter 2 section 2.5.2 and chapter 4 section 4.2.10.2). Assuming that the bioleach extracts +95 % of all the BMs, recovery of PGMs can be done using either the Merrill-Crowe (chapter 2 section 2.4.2) process, after which the precipitate can be sent to the "aqua regia" leach (chapter 1 section 1.5) in the Lonmin PMR. Alternatively, adsorption to carbon (chapter 2 section 2.4.1) can be used, after which the carbon can be burnt to ash to produce a low volume solid residue for the PMR, or the PGMs can undergo the full process with the advantage of recovering the cyanide and carbon.

University of Cape Town

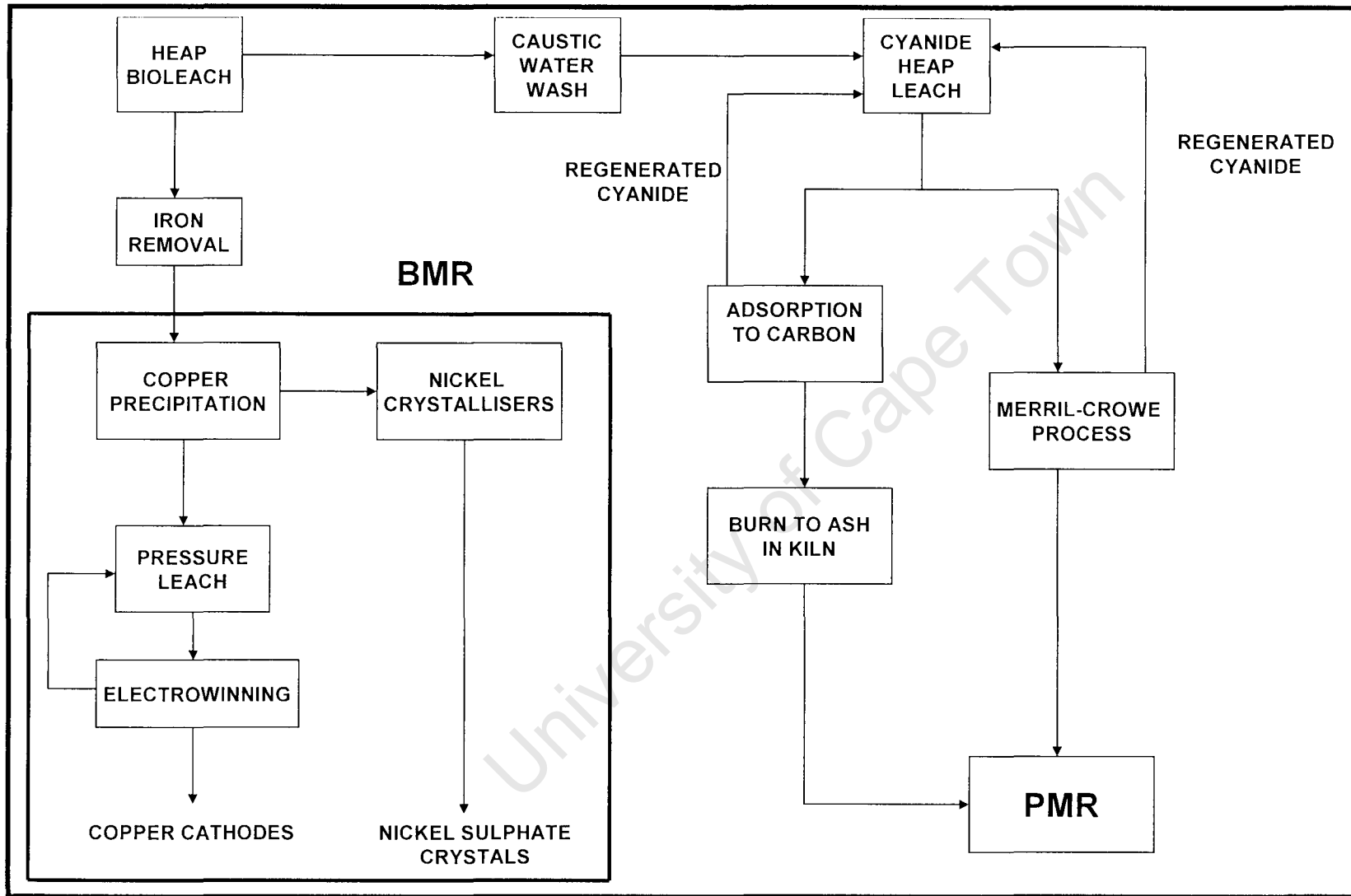

Figure 53: Flowsheet 1

5.1.2 Flowsheet 2

This flowsheet involves an indiscriminant cyanide heap leach, excluding any pre-treatment, which proposes to leach both the PGMs and BMs, followed by a bioleach to extract the remaining BMs. This process can use one of three selective recovery methods discussed under chapter 2 section 2.3.2.4 and illustrated in Figure 54. Flowsheet 2 would be advantageous for faster PGM recovery than flowsheet 1, if the proposed recovery methods can be realized at an industrial scale and if the revenue from the PGMs and copper alone is profitable enough, as these metals (according to literature) seem to be the only ones with established technology for recovery from cyanide solutions.

University of Cape Town

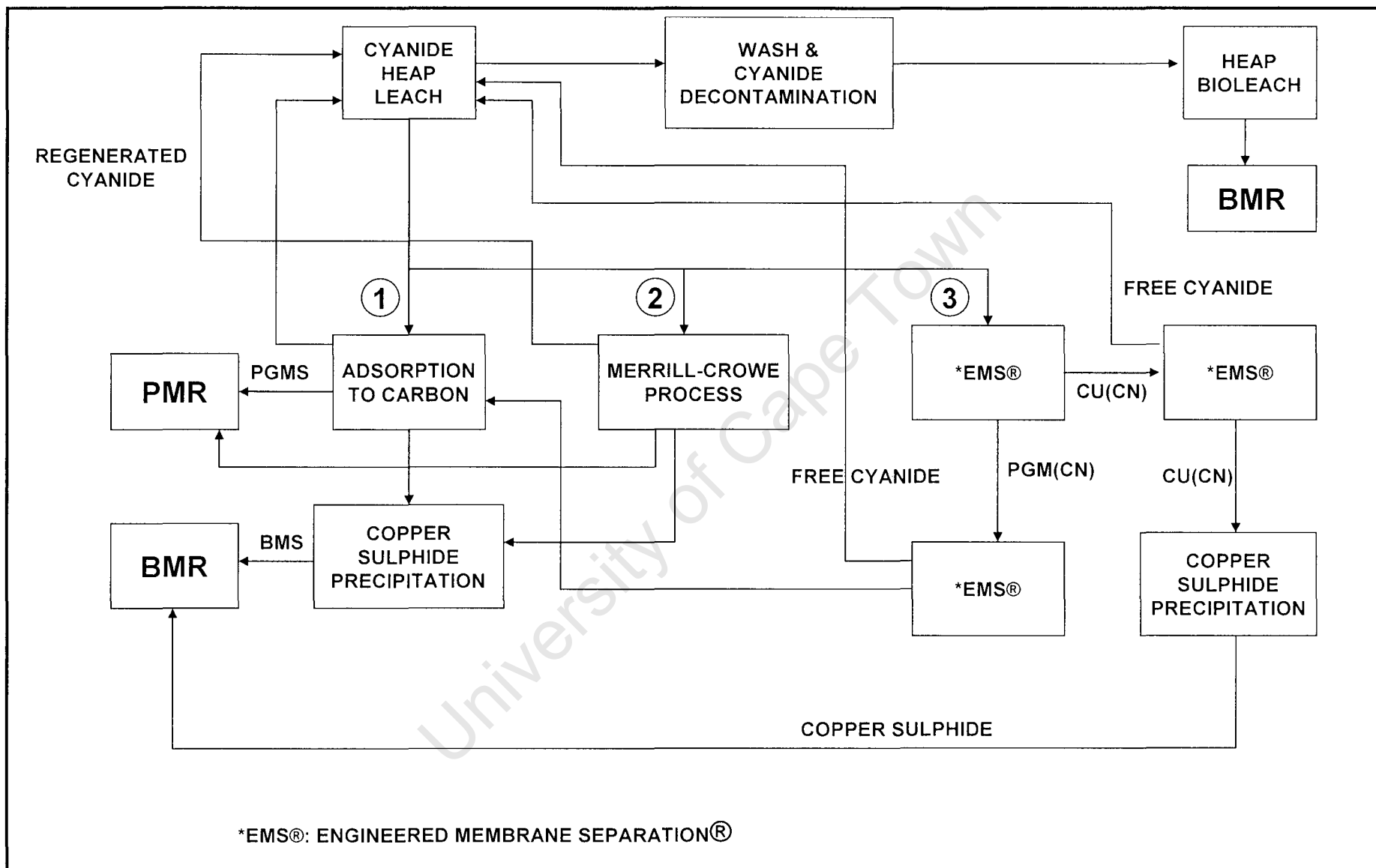

Figure 54: Flowsheet 2

5.1.3 Flowsheet 3

The third option is a combination of the flowsheets 1 and 2, and is aimed at reducing the amount of time for the bioleach process while still extracting the bulk of the nickel and copper.

It is proposed that the heap bioleach process should operate for 30 days, which according to the benchscale test work (see chapter 4 section 4.2.12.4, Table 32) is adequate to extract up to 95 % nickel and 52 % copper. These metals will be recovered using the methods detailed in flowsheet 1. The residue containing the remaining half of the copper will undergo an indiscriminant PGM-BM leach to extract the PGMs and the remaining amount of copper. These metals can then be extracted via one of the selective recovery methods of flowsheet 2.

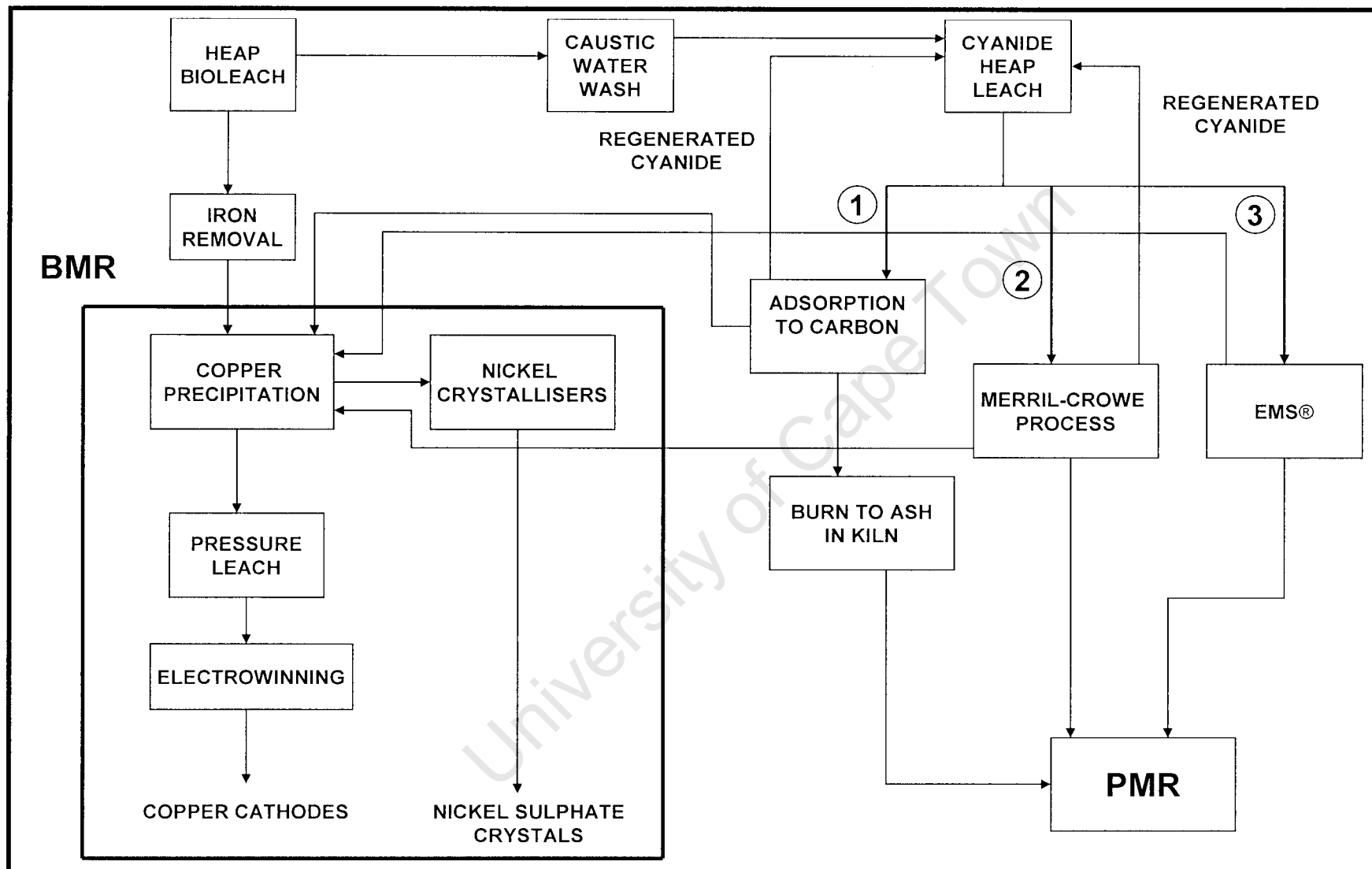

Figure 55: Flowsheet 3

5.1.4 Comparison of the flowsheets (advantages and disadvantages)

Table 41: Flowsheet comparison

Flowsheet 1	Flowsheet 2	Flowsheet 3
<ul style="list-style-type: none"> • The technology to leach and recover both PGMs and BMs is available on an industrial scale or has been achieved at bench scale, convincingly enough to show industrial application. • Full recovery of the BMs may liberate any platinum and ruthenium minerals occluded in the copper and iron bearing minerals • A long period (60 plus days) to conduct the bioleach before leaching the PGMs. • Bioleach pre-treatment appears to reduce ruthenium extraction levels 	<ul style="list-style-type: none"> • The selective recovery methods proposed are theoretical, and have not been tested for PGM recovery from cyanide leach liquors heavy with BMs. • Possible loss of PGMs through co-complexation with BMs. • Possible loss of nickel, which the literature has not provided for in terms of recovery methods from cyanide solution. • There is no waiting period for leaching the PGMs, it is done at the same time as the BMs. • Achieves higher ruthenium extractions 	<ul style="list-style-type: none"> • The selective recovery methods proposed are theoretical, and have not been tested for PGM recovery from cyanide leach liquors heavy with BMs. • Possible loss of PGMs through co-complexation with BMs. • Full recovery of all the BMs. • Shorter operating time for the bioleach process as compared with flowsheet 1. • Bioleach pre-treatment appears to reduce ruthenium extraction levels

Based on the comparison in Table 40, it has been decided that flowsheet 1 is currently the more viable method to use for treating the low-grade concentrate. This is based on the fact that the technology in flowsheet 1 is either available at an industrial scale or has been convincingly demonstrated at bench scale. The due diligence in terms of environmental remediation, financial analysis and recommendations, was thus conducted on flowsheet 1 setting aside flowsheet 2 and 3 temporarily.

5.2 Environmental Remediation

The following remediation methods are proposed for flowsheet 1:

5.2.1 Cyanide Regeneration

The cyanide that can be regenerated from the leach solutions, exist either as free cyanide which can be recovered using membrane technology (see chapter 2 section 2.3.2.4), or as cyanicides of BM sulphide minerals, from which the bound cyanide can be recovered using the process detailed by Gupta and Mukherjee (1990):

The first step is to acidify the solution with SO₂ to neutralize lime and convert cyanides to HCN:

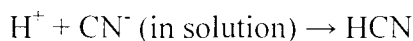

The HCN is then vaporized from the solution by heating and purging it with a large volume of air, and then adsorbing the HCN gas in the regular alkaline mill solution:

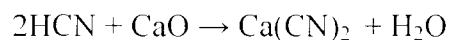

5.2.2 Effluent and Concentrate Treatment

There are currently a number of commercially available processes to treat cyanide solution effluents and decontaminate concentrates from cyanide leaching operations, using oxidising agents such as O₂, O₃, Cl₂, H₂O₂, permanganate and cupric ions (Gupta and Mukherjee 1990).

The oxidation reaction proceeds in stages and eventually converts all cyanide ions to CO₂ and N₂.

5.2.3. Iron Precipitate Treatment

If the Jarosite process (section 5.1.1) is used as the iron removal step, Gupta and Mukherjee (1990) report that the precipitate may be treated by thorough washing to remove all environmentally hazardous metals. A provision must be made for storage under controlled conditions to prevent decomposition, otherwise the jarosite can be thermally/hydrothermally decomposed to hematite, for iron production and sodium/ammonium sulfate recycle to the jarosite precipitation step in the Jarosite process.

If goethite is the precipitate, Ismael and Carvalho (2003) report that it is generally of lower volume than jarosite, and it can subsequently be treated via inertisation and solidification, or smelting and slag fuming. In both cases the result is an inert material that is used in the construction industry.

5.3. Cost Analysis of Flowsheet 1

The following cost analysis on flowsheet 1 is based on close estimates to generate “ball park figures” on the financial viability of this flowsheet. It must be emphasised the data is mainly composed of estimates, due to the fact that a number of accurate data required is proprietary information. However, much effort was put into using data that closely matched the proposed processes as much as possible. In some cases the costs may be over or understated. Typically the figures generated in this form of analysis at this stage in a process evaluation can deviate by as much as 20-30% (Sinott 1999; Vancas 2003).

This analysis is based on the heap bioleach operation running for 60 days (see chapter 4 section 4.2.10.5) at temperatures >65°C wherein it is postulated that it would achieve 90 % copper and 100 % nickel extraction. The cyanide leach would be operated for 50 days wherein it is postulated that it would achieve 50 % platinum assuming a linear trend continues for the heap cyanide leach process in experiment 5 (Figure 56). Based on the same experiment, taking into

consideration the losses that are likely to occur in the bioleach process, extractions of 75 % palladium and 50 % extraction for rhodium are projected.

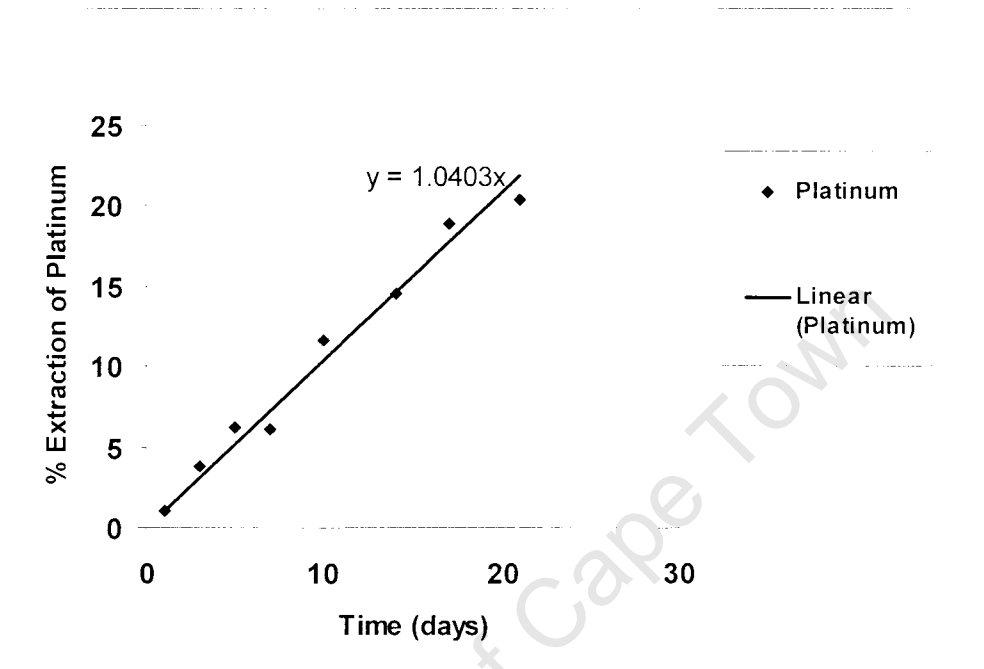

Figure 56: Platinum leach slope in cyanide heap leach test

The total operating time required will be 110 days, allowing for 5 full bioleach operations to extract the BMs and 4 full cyanide leach operations to extract the PGMs in the space of a year. Each full operation will process 33 000 tons of ore concentrate for a total of 165 000 tons per annum. The remaining days in the year can be for down time between washing off concentrate, re-coating, re-stacking of heaps. Iron precipitation and BM recovery can run parallel to PGM heap construction and operation and by the same token PGM recovery can run parallel to the bioleach heap construction and operation.

Working with a ratio of 1:7 for concentrate to support media, the operation will require 231 000 tons of support rock (33 000 x 7). This can be stacked into two heaps, handling 16, 500 tons of concentrate on 115, 500 tons of support rock. Each heap would have approximate dimensions (length x width x height) of 84 x 64 x 6 m. These dimensions were interpolated from the Gold Acres operation which handles 170 000 tons of ore (Rossi 1990) and the now decommissioned Agnes Mine operation which handled 12 000 tons of concentrate (Rawlings and Johnson 2007). At the concentrate to support media ratio of 1:7, this would be 84 000 tons of support rock.

The prescribed tonnage of 165 000 is the production from 5 months and can successfully be processed in the space of one year by the heaps described above. To process the subsequently produced ore concentrate more such heaps can be constructed. This cost analysis is conducted on an annual basis and only takes into account this tonnage and capital investment to process it.

Table 42: Expected annual production

	Annual tonnage processed (tons)	Metal content in concentrate (ppm)	Expected extraction (%)	Annual production (oz)⁴
Platinum	132000	12	50	25464
Palladium	132000	8.45	75	26896
Rhodium	132000	2.64	50	5602
		% of metal in concentrate		(tons)
Copper	165000	0.364	90	541
Nickel	165000	0.744	100	1228
Iron	165000	6.75	6.68	744

Table 43: Estimated annual production costs

	Cost of production (US\$/oz)	Annual production (oz)	Annual Cost of Production \$ 000
Platinum	238	25464	6.060
Palladium	238	26896	6.401
Rhodium	238	5602	1.333
	(US\$/ton)	(tons)	
Copper	2172	541	1.174
Nickel	2172	1228	2.667
Iron	4344	744	3.232
Total			20,868

⁴ Conversion factor of grams to oz: 1: 0.032151 from <http://www.digitaldutch.com/unitconverter/mass.htm>

To estimate the cost of production of the PGMs by cyanidation, the cost of production of gold from an operation producing 100 000 oz of gold per annum was used considering that there are no commercial operations producing PGMs from low-grade ores and concentrates. This cost includes crushing, screening, bio-oxidation of sulphides, water treatment, cyanide heap leaching of ores, adsorption to carbon process, carbon stripping and refining (U.S. Gold Corporation, News Release 2004).

An estimate for the cost of production of copper was derived from Dresher (2004). This is the cost of producing copper from 0.4 % grade ore in a heap/dump bioleach operation. The cost includes mining, leaching, solvent extraction/electrowinning, maintenance and sales. Price was doubled to account for inflation since 2004 and the fact that a GEOLEACH™ process is likely to cost more than a regular heap leach process due to the patented algorithmic computerized process control system and special heap pads made from high density polyethylene (HDPE). The same cost of production was used for nickel and doubled for iron considering the iron precipitation processes operate in the range of 70-100°C.

Table 44: Estimated annual revenue

	Price (US\$/oz)⁵	Annual Production (oz)	Annual Revenue \$ 000
Platinum	1309	25464	33.331
Palladium	292	26896	7.854
Rhodium	1600	5602	8.963
	(US\$/ton)⁶	(tons)	
Copper	6145	541	3.321
Nickel	16650	1228	20.440
Iron			
Total			73,910

⁵ Prices as of 14 09 2009 from Tax Free Gold <http://www.taxfreegold.co.uk/preciousmetalpricesusdollars.html>

⁶ Prices as of 14 09 2009 from London Metal Exchange-<http://www.lme.co.uk/home.asp>

Table 45: Cash flow diagram for first year

	Year 1
	US\$ 000
Capital Costs	
Bioleach heap	1,297
Cyanide heap	15,560
Iron precipitation process	2,595
Crushing extra support rock	4,668
Total Capital Costs	19,452
Total Production Costs	20,868
Total Revenue	73,910
Profit	33,590

The capital cost for the bioleach heap was extracted from the relationship between copper production by bioleaching in tons and capital cost, developed by the Organisation of Economic Co-operation Development (2001). It was doubled for the same reasons used for doubling cost of production of copper. It was further doubled for the iron precipitation process.

The capital cost for the cyanide heap was taken from the SME Mining Engineering Handbook volume 1 for a gold cyanide heap leaching operation with a similar output of gold in ozs.

The extra support rock is required to run the PGM and BM leaching processes side by side. Considering that the cost of production of the PGMs included crushing, and based on the estimate that mining accounts for 65-75 % of the production costs of PGMs (Cabri 2002), 30 % of that cost was taken for the cost of crushing the support rock.

This cash flow analysis indicates that the operation will pay back and go into profit within the first year. However it must be kept in mind that the figures used were estimates and do not include costs such as taxes, labour, administrative costs, etc.

Nevertheless, given that the proposed process is in the category that is widely known to have relatively low capital and operating costs and that even if the figures are off by 30 %, there is a chance it can become profitable within the first or second year of operation but perhaps with not such a high a profit margin.

5.4 Recommendations

It is recommended to conduct further bench scale test work on the ore concentrate in accordance with Flowsheet 1, which has now be shown to be technically and economically viable. In this context experiments 5 (cyanide heap leach) and 10 (heap bioleach) should be repeated, running them until completion. Based on the results obtained in these experiments, it is projected that:

- Experiment 10 will need to be run for a minimum of 60 days at 70-75°C to achieve the maximum copper extraction, considering that 52 % copper extraction was achieved in 30 days at 65°C. Additionally the possibility of precipitating out as much iron as possible during this process, by operating under the pH and Eh conditions of column 2, must be investigated. Running this experiment to completion will reveal whether further copper extractions will be beneficial to subsequent PGM leaching.
- Experiment 5 will need to be run for 84 days refreshing the solution every 7 days, considering that 20 % platinum extraction was achieved in 21 days.

For each of these experiments, in addition to the solid assays conducted before and after leach tests, it is recommended that mineralogical analysis be conducted on the concentrate samples as well. This is for the purpose of determining which minerals are present, possibly what portions of a particular metal they contain and which minerals respond to the treatments. Some attention should be paid to the microscopic analysis of ore concentrate residue after the bioleach process to determine its effect on the ruthenium bearing minerals.

Additional bench-scale test work should be conducted for the iron removal step and for the PGM recovery stage, possibly comparing the adsorption to carbon method with the Merrill-Crowe process.

With the generated data the process can then be re-evaluated and should proceed to pilot scale if prospects remain favourable.

As a final commentary it must be said that this study has built up considerably on the previous exploratory work (Evans 2007) by taking into account a number of concerns associated with evaluating a process for commercial application. Some of the critical ones were:

- Exploring and comparing alternative methods to the organic acids for extracting the PGMs and BMs.
- Consideration of the grade and throughput of the ore material when choosing the treatments and reactor configuration.
- Tailoring the solutions to the current infrastructure at Lonmin to reduce capital costs as much as possible.

6.0 References

Abbruzzese, C., Fornari P., Massidda, R., Vegliò, F., Ubaldini, S. 1995. "*Thiosulphate leaching for gold hydrometallurgy*". Hydrometallurgy, vol. 39, pp265-276.

Adams, M., Lawrence, R., Bratty, M. 2008. "*Biogenic sulphide for cyanide recycle and copper recovery gold-copper ore processing*". Minerals Engineering, vol. 21, pp509-517. Retrieved: 16 February, 2009, from http://www.sciencedirect.com/science?_ob=ArticleURL&_udi=B6VDR4S3G9N51&_user=635696&_coverDate=05%2F31%2F2008&_aliid=895653583&_rdoc=1&_fmt=high&_orig=search&_cdi=5989&_sort=d&_docanchor=&view=c&_ct=1&_acct=C000033878&_version=1&_urlVersion=0&_userid=635696&md5=bc91d4fad9753c3ff657e1308aad8a1b.

Alibhai, K.A.K., Dudeney, A.W.L., Leak, D.J., Agatzini, S., Tzeferis, P. 1993. "*Biobleaching and bioprecipitation of nickel and iron from laterites*". FEMS Microbiology Reviews, vol. 11, Issues 1-3, pp87-95.

Alymore, M.G. 2001. "*Treatment of a refractory gold-copper sulfide concentrate by copper ammoniacal thiosulphate leaching*". Minerals Engineering, vol. 14, No. 6, pp615-637.

Anthony, E.Y., Williams, P.A. 1994, "*Thiosulphate complexing of platinum group elements: implications for supergene geochemistry*", Symposium of the Environmental Geochemistry of Sulphide Oxidation. American Chemical Society, Washington DC.

Bard, J.A., Parsons, R., Jordan, J. (editors). 1985. "*Standard potentials in aqueous solutions*". International Union of Pure and Applied Chemistry.

Bharathi, K., Bhagvanth R.M., Lakshmi N.M., Ravindra P. 2004. "*Effect of biochemical reactions in enhancement of rate of leaching*". Chemical Engineering Science, vol. 59, Issues 22-23, pp5069-5073.

Blair, G.T., Defratis, J.J. 1995. "*Hydroxy Dicarboxylic Acids*". Haarmann and Reimer Corporation. Kirk-Othmer Encyclopedia of Chemical Technology. Retrieved: 9 August, 2007. from <http://www.mrw.interscience.wiley.com/emrw/9780471238966/kirk/article/hydrblai.a01/current/pdf>.

Bosecker, K. 1997. "*Bioleaching: metal solubilization by microorganisms*". FEMS Microbiology Reviews 20. pp591-604.

Bruckard, W.J., McDonald, K.J., McInnes, C.M., Sparrow, G.J., Woodcock, J.T. 1992. "*Platinum, palladium, and gold extraction from Coronation Hill ore by cyanidation at elevated temperatures*". Hydrometallurgy. vol. 30. pp 211-227.

Bureau of Mines Information Circular. 1981. "*In Situ Mining Research*". Proceedings: Bureau of Mines Technology Transfer Seminar, Denver, Colo., 5 August, 1981. Compiled by staff-Bureau of Mines.

Burgstaller, W., Schinner, F. 1993. "*Leaching of metals with fungi*". Journal of Biotechnology. vol. 27. pp91-116.

Cabri, L.J. (Editor). 2002. "*The Geology, Geochemistry, Mineralogy and Mineral Beneficiation of Platinum-Group Elements*". CIM Special Volume 54. Canadian Institute of Mining, Metallurgy and Petroleum. Quebec, Canada.

Cameselle, C., Ricart, M.T., Núñez, M. J., Lema, J.M. 2003. "*Iron removal from kaolin. Comparison between "in situ" and "two-stage" bioleaching processes*". Hydrometallurgy. vol. 68. pp97-105.

Castro, I. M., Fietto, J.L.R., Vieira, R.X., Trópia, M.J.M., Campos, L.M.M., Panaiago E.B., Brandão, R.L. 2000. "*Bioleaching of zinc and nickel from silicates using *Aspergillus niger* cultures*". Hydrometallurgy. vol. 57. pp39-49.

Chamberlain, P.G., Pojar, M.G. 1984. "*Gold and Silver leaching practices in the United States*". Bureau of Mines Information Circular/1984. United States Department of the Interior IC 8969.

Chen, J., Huang, K. 2006. "*A new technique for extraction of platinum group metals by pressure cyanidation*". Hydrometallurgy in China Journal, vol. 82, Issues 3-4, pp 164-171. Retrieved: 3 July, 2007, from <http://www.sciencedirect.com/science/journal/0304386X>.

Cohn, J.G., Stern E.W., Etris S. F. 2001. "*Gold and Gold Compounds*". Kirk-Othmer Encyclopedia of Chemical Technology-Online. Published online: 16 April, 2001. Retrieved: 8 October, 2007, from <http://www.mrw.interscience.wiley.com/emrw/9780471238966/kirk/article/goldcohn.a01/current/pdf.com/emrw/9780471238966/kirk/article/platgian.a01/current/pdf>.

Denver Mineral. "*The basic processes of gold recovery*". Retrieved: 3 September, 2007, from <http://www.denvermineral.com/basicp~1.html>.

Dresher, W.H. 2004. "*Producing copper nature's way: bioleaching*". Retrieved: 3 September, 2007, from http://www.copper.org/innovations/2004/05/producing_copper_natures_way_bioleaching.html.

Eul, W., Moeller, A., Steiner, N. 2001. "*Hydrogen Peroxide*". Kirk-Othmer Encyclopedia of Chemical Technology-Online. Published online: 17 August, 2001. Retrieved: 22 September, 2007, from <http://www.mrw.interscience.wiley.com/emrw/9780471238966/kirk/article/hydrhess.a01/current/html>.

Evans, T. 2007. "*Comments on Bioleaching of PGMs to accompany Report Nos. 102 CON MS0006 SB and 111/MS030/SB*". Lonmin Plc.

Feng, D., Van Deventer, J.S.J. 2002. "*Leaching behaviour of sulphides in ammoniacal thiosulphate systems*". Hydrometallurgy, vol. 63, pp189-200.

Giandomenico, C. M. 2000. "*Platinum Group Metals. Compounds*". Kirk-Othmer Encyclopedia of Chemical Technology-Online. Published online: 4 December, 2000. Retrieved: 22 September, 2007. from <http://www.mrw.interscience.wiley>.

Golab, Z. and Orlowska, B. 1988. "*The effect of amino and organic acids produced by selected microorganisms on metal leaching*". Acta Microbiologica Polonica. vol. 37. No. 1. 83-93.

Gonzalez, R., Gentina, J.C., Acevedo, F. 2004. "*Biooxidation of a gold concentrate in a continuous stirred tank reactor: mathematical model and optimal configuration*". Biochemical Engineering Journal. vol. 19. pp33-42.

Green, F. H. 2004. "*Leaching with caustic silica solution for improved recovery of metal values from ores and wastes*". SciFinder online database. Retrieved: 29 June, 2007, from <http://appft1.uspto.gov/netacgi/nph-Parser?Sect1=PTO1&Sect2= =PALL&p=1&u=%2Fmetahtml%2FPTO%2Fsrchnum.htm&r=1&f=G&l=50&s1='20040083856'.PGR.&OS=DN/20040083856&RS=DN/20040083856.50&s1=7166145.PN.&OS=PN/7166145&RS=PN/7166145>.

Grosse, A.C., Dicoski, G.W., Shaw, M.J., Haddad, P.R. 2003. "*Leaching and recovery of gold using ammoniacal thiosulfate leach liquors (a review)*". Hydrometallurgy. vol. 69. pp1-21.

Gupta, C.K., Mukherjee, T.K. 1990. "*Hydrometallurgy in Extraction Processes Volume II*". CRC Press. Boston.

Han, K. N., Meng, X. 1996. "*Redox leaching of ores and spent catalysts using halide-containing solutions for recovery of platinum-group metals and rhenium*". Braindex online database. Retrieved: 10 July, 2007. from http://www.braindex.com/patent_pdf/patents/US5542957.pdf.

Han, K.N. 2007. "*Recovery of gold, rhenium and other precious metals from sulfide ores*". SciFinder online database. Retrieved: 2 July, 2007. from http://patft.uspto.gov/netacgi/nph-Parser?Sect1=PTO1&Sect2=HITOFF&d leaching+operation&source=bl&ots=2Nx_sWcFPk&sig=Kr5r9MkTmTvElluZyB-lipcqngA&hl=en&ei

=cWSvSv3aA5Od4ga3rKj6Bw&sa=X&oi=book

Hartman, H.L. (Senior Editor). SME Mining Engineering Handbook, vol. 1. 2nd Edition. Society for mining, metallurgy and exploration (U.S.). Retrieved: 15 September, 2009, from <http://books.google.co.za/books?id=DsSmPKEOWDcC>
HITOFF&d=PG01&p=1&u=/netahtml/PTO/srchnum.html&r=1&f=G&l=&pg=PA1490&lpq=PA1490&dq=Capital+cost+gold+cyanide+heap+_result&ct=result&resnum=1#v=onepage&q=Capital%20cost%20gold%20cyanide%20heap%20leaching%20operation&f=false.

Holgersen, J.D. 2006. "*Process for extraction of noble metals from ores or industrial materials using NaOH*". SciFinder online database. Retrieved: 30 June, 2007, from <http://appft1.uspto.gov/netacgi/nph-Parser?Sect1=PTO1&Sect2=HITOFF&d=PG01&p=1&u=/netahtml/PTO/srchnum.html&r=1&f=G&l=50&s1='20060037438'.PGNR.&OS=DN/20060037438&RS=DN/20060037438>.

Howard, W.L., Wilson, D. 2003. "*Chelating Agents*": Kirk-Othmer Encyclopedia of Chemical Technology, vol. 5, pp708-739. Retrieved: 9 August, 2007, from <http://www.mrw.interscience.wiley.com/emrw/9780471238966/kirk/article/chelhowa.a01/current/pdf>.

Hunter, R. M., Stewart, F. M., Darsow, T. 1997. "*Recovery of precious metals from oxidized ores and scrap by cyanide-free leaching and bioprocessing stages with complexing by bisulfide ions*". SciFinder online database. Retrieved: 29 June, 2007, from <http://patft.uspto.gov/netacgi/nph-Parser?Sect1=PTO1&Sect2=HITOFF&d=PALL&p=1&u=%2Fmetahtml%2FPTO%2Fschnum.htm&r=1&f=G&l=50&s1=5672194.PN.&OS=PN/5672194&RS=PN/5672194>.

Ismael, M.R.C., Carvalho, J.M.R. 2003. "*Iron recovery from sulphate leach liquors in zinc hydrometallurgy*". Minerals Engineering, vol. 16, pp31-39.

Kelly, G., Ahlborn, G., Carretero, E., Gunn, M., Harvey, P. 2008. "*Laboratory and Demonstration Scale Optimization of the Quebrada Blanca Heap Leach Bacterial Regime Using Geoleach™*". II taller Internacional de Procesos Hidrometalurgicos-HydroProcess 2008, Mayo 14-16, 2008. Hotel Sheraton, Santiago, Chile.

Kodali, B., Rao, M.B., Narasu, L.M., Pogaku, R. 2004. "*Effect of biochemical reactions in enhancement of rate of leaching*". *Chemical Engineering Science*, vol. 59, pp5069-5073. Retrieved: 4 July, 2008. from http://www.sciencedirect.com/science?_ob=ArticleURL&_udi=B6TFK-4DN9R04-2&_user=635696&_coverDate=11%2F01%2F2004&_alid=755571970&_rdoc=1&_fmt=high&_orig=search&_cdi=5229&_sort=d&_st=4&_docanchor=&_ct=1&_acct=C000033878&_version=1&_urlVersion=0&_userid=635696&md5=8aa0d63b22df9d28bd90d85b2eb22836.

Lawrence D. Pesce . 2000. "*Cyanides*". Retrieved: 16 February, 2008. from <http://www.mrw.interscience.wiley.com/emrw/9780471238966/kirk/article/cyanpesc.a01/current/pdf>.

Le, L., Tang, J., Ryan, D., Valix, M. 2006. "*Bioleaching nickel laterite ores using multi-metal tolerant *Aspergillus foetidus* organism*". *Minerals Engineering*, vol. 19, pp1259-1265.

Leahy, M.J., Schwarz, P.M. 2009. "*Modelling jarosite precipitation in isothermal chalcopyrite bioleach columns*". *Hydrometallurgy*, vol. 98, Issues 1-2, pp181-191.

Lien, L. 2008. "*H W Process technologies' Engineered Membrane Separation[®] (EMS[®]) systems for hydrometallurgical applications*". Proceedings for Hydrometallurgy 2008-6th International Symposium. Society of Mining, Metallurgy and Exploration . 17-20 August 2008. J W Marriot Desert Ridge Resort, Phoenix, Arizona.

Lopez-Garcia, R. 2002. "*Citric Acid*". *Kirk-Othmer Encyclopedia of Chemical Technology*, vol. 6, pp631-657. Retrieved: 9 August, 2007 <http://www.mrw.interscience.wiley.com/emrw/9780471238966/kirk/article/citrblai.a01/current/pdf>.

Lottering, M.J., Lorenzen, L. 2007. "*Development of a diagnostic leaching method for low grade uranium ores*". 25th Annual Mineral Processing Conference, Cape Town, South African Institute of Mining and Metallurgy, Western Cape Branch.

Marsden, J., House, I. 2006. *"The Chemistry of Gold Extraction"*. Society of Mining, Metallurgy and Exploration. Retrieved: 18 August, 2009, from http://books.google.co.za/books?id=OuoV-o_Xf-EC&pg=PA312&dq=copper+adsorption+carbon+cyanide&ei=XvWISvLjElvyyATj2O3ZDQ#v=onepage&q=copper%20adsorption%20carbon%20cyanide&f=false.

McInnes, C., M., Sparrow, G., J., Woodcock, J., T. 1994. *"Extraction of Platinum, palladium, and gold by cyanidation of Coronation Hill ore"*, *Hydrometallurgy*, vol. 35, pp141-159.

Miltzarek G.L., Sampaio C.H., Cortina J.L. 2002 *"Cyanide recovery in hydrometallurgical plants: use of synthetic solutions constituted by metallic cyanide complexes"*, *Minerals Engineering*, vol. 15, pp75-82. Retrieved: 16 February, 2009, from http://www.sciencedirect.com/science?_ob=ArticleURL&_udi=B6VDR-44P6T9S-5&_user=635696&_rdoc=1&_fmt=&_orig=search&_sort=d&view=c&_acct=C000033878&_version=1&_urlVersion=0&_userid=635696&md5=e2c8d84016e6bfda5728bd5586e6a038.

Morrison, R.T., Boyd, R. N. 1966. *"Organic Chemistry"*, Second Edition, Allyn and Bacon, Inc., Boston.

Mountain, B. W., Wood, S. A. 1987. *"Solubility and transport of platinum-group elements in hydrothermal solutions: thermodynamic and physical chemical constants"*, Prichard, H. M. *Geoplatinum 87*, Open University, pp57-82.

Organisation of Economic Co-operation Development. 2001. *"The application of biotechnology to Industrial sustainability"*. Retrieved: 15 September, 2009, from http://books.google.co.za/books?id=Wa6uoPDOOPYC&pg=PA128&lpq=PA128&dq=Capital+cost+copper+heap+bioleaching+operation&source=bl&ots=UIYM3Mvab6&sig=n2n_Tp2xUtYajCX6ZeYzSWZEKk&hl=en&ei=smCvSvq9DMqj4gax45CtCg&sa=X&oi=book_result&ct=result&resnum=8#v=onepage&q=Capital%20cost%20copper%20heap%20bioleaching%20operation&f=false.

Pan, P., Wood, S.A. 1994. "The solubility of Pt and Pd sulfides and Au in bisulfide solutions-II. Results at 200°C-350°C and saturated vapor pressure". *Mineralium Deposita*, vol. 29, No. 5, pp373-390.

Petersen, J. and Dixon, D.G. 2002. "Thermophilic Heap Leaching of A Chalcopyrite Concentrate". *Minerals Engineering*, Vol. 15 (11), pp 777-785.

Pokorny, L., Maturana, I., Bortle, W.H. 2006. "Sodium Nitrate and Nitrite". *Kirk-Othmer Encyclopedia of Chemical Technology-Online*. Published online: 27 January, 2006. Retrieved: 22 September, 2007, from <http://www.mrw.interscience.wiley.com/emrw/9780471238966/kirk/article/sodipoko.a01/current/abstract>.

Pourbaix, M. 1966. "Atlas of electrochemical equilibria in aqueous solutions", Pergamon Press, Cebelcor Brussels.

Rao, S.R., Finch, J.A., Kuyucak, N. 1995. "Ferrous-ferric oxidation in acidic mineral process effluents: comparison of methods". *Minerals Engineering*, vol. 8, No. 8, pp905-911.

Rawlings, D.E., Johnson, D.B. 2007. "Biomining", Springer-Verlag, Heidelberg, Germany.

Richardson, J.F., Harker, J.H. 2002. "Coulson & Richardson's Chemical Engineering volume 2: Particle technology and separation processes". Fifth Edition. Butterworth-Heinemann, Woburn, Great Britain.

Ring, R.J. 1980. "Ferric sulphate leaching of some Australian Uranium Ores". *Hydrometallurgy*, vol. 6, pp89-101.

Rossi, G. 1990. "Biohydrometallurgy", McGraw Hill: Hamburg.

Schouwstra, R., P.; Kinloch, E., D. 2000. "A short geological review of the Bushveld Complex". *Platinum Metals Review*, vol. 44, Issue 1, pp33-39.

Seymour, R.J., O'Farrelly, J.I. 2001. "*Platinum Group Metals*". Kirk-Othmer Encyclopedia of Chemical Technology-Online. Published online: 13 July, 2001. Retrieved: 22 September, 2007, from <http://www.mrw.interscience.wiley.com/emrw/9780471238966/kirk/article/platseym.a01/current/pdf>.

Sinnott, R.K. 1999. "*Coulson & Richardson's Chemical Engineering volume 6: Chemical Engineering Design*". Third Edition. Butterworth-Heinemann. Woburn. Great Britain.

Sridhar, R., Lakshmanan, V.I., Puvvada, G., Harris, G. B. 2005. "*A process for the recovery of value metals from base metal sulfide ores*", Braindex online database. Retrieved: 2 July, 2007, from http://www.braindex.com/patent_pdf/patents/CA2204424.pdf. [patents/CA2478516.pdf](http://www.braindex.com/patent_pdf/patents/CA2478516.pdf).

Stott, M.B., Watling, H.R., Franzmann, P.D., Sutton, D. 2000. "*The role of iron-hydroxy precipitates in the passivation of chalcopyrite during bioleaching*", Minerals Engineering, vol 13, No 10-1, pp1117-1127.

Tang, L., Le, L., Ryan, D., Valix, M. 2006. "*Bioleaching nickel laterite ores using multi-metal tolerant *Aspergillus foetidus* organism*", Minerals Engineering, vol 19, pp1259-1265.

Tang, L., Valix, M. 2006. "*Leaching of low grade limonite and nontronite ores by fungi metabolic acids*". Minerals Engineering, vol. 19, pp1274-1279.

Torres, V. M., Costa, R. S. 1997. "*Recovery and production of gold and platinum-group metals by using cyanidation under pressure*", Braindex online database. Retrieved: 2 July, 2007 from http://www.braindex.com/patent_pdf

Tzeferis, P.G. 1994. "*Leaching of low grade hematitic laterite ore using fungi and biologically produced acid metabolites*", International Journal of Mineral Processing, vol. 42, Issues 3-4, pp267-283.

U.S. Gold Corporation, News Release. "U.S. Gold Reports Positive Feasibility Study for Tonkin Springs Gold Mine Project". Retrieved: 15 September, 2009, from

http://books.google.co.za/books?id=DsSmpKKEOWDcC&pg=PA1490&lpg=PA1490&dq=Capital+cost+gold+cyanide+heap+leaching+operation&source=bl&ots=2Nx_sWcFPk&sig=Kr5r9MkTmTvElluZyB-lipcqngA&hl=en&ei=cWSvSv3aA5Od4ga3rKj6Bw&sa=X&oi=book_result&ct=result&resnum=1#v=onepage&q=Capital%20cost%20gold%20cyanide%20heap%20leaching%20operation&f=false.

Valix, M., Usai, F., Malik, R. 2001. "*Fungal Bio-leaching of low grade laterite ores*". *Minerals Engineering*, vol. 14. pp197-203.

Vancas, M.F. 2003. "*Feasibility studies: Just how good are they?*". *Hydrometallurgy 2003 – Fifth International Conference in Honor of Professor Ian Ritchie –Volume 2: Electrometallurgy and Environmental Hydrometallurgy*. Edited by C.A. Young, A.M. Alfantazi, C.G. Anderson, D.B. Dreisinger, B. Harris and A. James
TMS (The Minerals, Metals & Materials Society). 2003

Veglió, F., Beolchini, F., Gasbarro, A., Toro, L., Ubaldini, S., Abbruzzese, C. 1997. "*Batch and semi-continuous tests in the bioleaching of manganese minerals by heterotrophic mixed microorganisms*". *International Journal Mineral Processing*, vol. 50. Issue 4. pp255-273.

Wadsworth, M.E., Zhu, X., Thompson, J.S., Pereira, C.J. 2000. "*Gold dissolution and activation in cyanide solution: kinetics and mechanism*". *Hydrometallurgy*, vol. 57 pp1-11.

Wassink, B., Dreisinger, D., West-Sells, P., Fisher, N. 2005. "*Leaching of a gold ore using the hydrogen sulfide-bisulfide-sulfur system*". *Proceedings of the International Symposium on the Treatment of Gold Ore*. Publisher: Canadian Institute of Mining, Metallurgy and Petroleum.
Retrieved: 24 September. 2007. from
http://www.mmat.ubc.ca/hydrometallurgy/papers/Wassink__West-Sells__Dreisinger_and_Fisher__2005__COM_2005_Au_HS-_Leach.pdf.

Wilkinson, G.W., Gilard R.D., McCleverty, J.A. 1987. "*Comprehensive coordination chemistry, Vol. 5*". First Edition. New York Pergamon Press. Oxford. p466.

Wood, S. A. 1990. "*The interaction of dissolved platinum with fulvic acid and simple organic acid analogues in aqueous solutions*". Canadian Mineralogist, vol. 28, pp665-673.

Wood, S. A. 1996. "*The role of humic substances in the transport and fixation of metals of economic interest (Au, Pt, Pd, U, V)*". Ore Geology Reviews, vol. 11, pp1-31.

Wood, S. A., Pan P., Zhang, Y., Mucci, A. 1994. "*The solubility of Pt and Pd sulfides and Au in bisulfide solutions-I: Results at 25°C-90°C and 1 bar pressure*". Mineralium Deposita, vol. 29, No. 4, pp309-317.

Wood, S. A., Tait, D. C., Vlassopoulos, D., Janecky, D. R. 1994. "*Solubility and spectroscopic studies of the interaction of palladium with simple carboxylic acids and fulvic acid at low temperature*". Geochimica et Cosmochimica Acta, vol. 58, Issue 2, pp625-637