

The copyright of this thesis vests in the author. No quotation from it or information derived from it is to be published without full acknowledgement of the source. The thesis is to be used for private study or non-commercial research purposes only.

Published by the University of Cape Town (UCT) in terms of the non-exclusive license granted to UCT by the author.

Greenhouse gas mitigation cost of energy from biogas: A techno-economic analysis of co-digestion of three types of waste in Cape Town

By

Lesego Malla

BSc (Eng) Chemical

Thesis submitted to the University of Cape Town

In partial fulfilment of the requirements for the degree of Master of Science in
Sustainable Energy Engineering

2011

ENERGY RESEARCH CENTRE

University of Cape Town



Declaration

I know the meaning of plagiarism and declare that all the work in the document, save for that which is properly acknowledged, is my own.

Date: 31 August 2011

Acknowledgements

This thesis is actually a contribution of a lot of people, some I know on a professional level and others are more personal. But this contribution would not have been possible without God Almighty placing them within my reach. So, first and foremost I would like to express my deepest gratitude to my Saviour and Redeemer, the Lord Jesus Christ for placing all the relevant people in my life and also humbling me with this MSc.

My supervisors, Alison Hughes and Prof Harro von Blottnitz I'm really appreciative of your unwavering efforts, patience, understanding and guidance right from the beginning. Alison, you've shown exceptional commitment through our weekly Friday meetings. You've really kept me on my toes and I'm eternally grateful for this. Harro, thanks for coming on board and putting an interesting twist to this work as well as arranging funding from the 'Technology for Human Resources in Industry Programme (Thrip)', ERC Energy Modelling group and Centre for Renewable and Sustainable Energy Studies. From the City of Cape Town, I'd like to thank Mr Melumzi Nontangana for providing me with all relevant information which made this work possible. Lastly, on the professional side I'd like to extend my gratitude further to the Biogas Team (Harro, Linus, Thabi, Gracia and 'the Leo Marquard digester') for allowing me to sit and absorb issues surrounding biogas.

Now on the personal side, I'd really like to thank Mama le Papa, Maemo Malla and Ishmael Malla for their lives-really. I can't thank both of you enough for simply just being faithful parents to me. To my little rascals, Refiloe, Baki and Malebo I hope this work will inspire you to dream big and pursue standing above the rest. To Mama, Mamotsei, Mamogolo, Ausi Mmatlou, Lerato, Boitumelo, Malome Tlami, Malome Jali and Lucky thank you for your prayers, support and best wishes for me.

To my fellow theses-writing-friends in the Cape; Tapiwa, Porogo, Nozonke and Caitlin you guys are the best. And outside varsity, Kudzai and Ryan thanks for being faithful and committed friends through prayer and regular check-ups. Last but certainly not least to Modise. You've really been a great support!!! I hope I'll see more of you in the future...

Abstract

This paper investigates, in the context of Cape Town the emission reduction potential (ERP) of energy from biogas and related cost. Two project-scale models and a city-scale model were developed. Substrates for project model 1 were organic fraction of municipal solid waste (OFMSW) and primary sludge (PS) from sewage works. Project model 2 considered waste paper sludge (WPS) and PS. For the city-scale model, substrates for project model 1 were extended to include total amounts of OFMSW and PS generated in Cape Town. Financial results show that at the REFIT tariff model 1 would have a higher internal rate of return (20.5%) than model 2 (5.6%). The landfill ERP of the project-scale models is 98 600 CO₂ equivalent tons per year, corresponding to a weighted average capital investment of R372 per CO₂ equivalent ton saved in year 1. The results for the city-scale model indicate that a landfill ERP of 458 000 CO₂ equivalent tons per year can be expected at an investment cost of R287 per CO₂ equivalent ton saved in year 1. Energy emissions from fossil fuels at city-scale are most effectively mitigated if coal rather than other fossil fuel based power and heat generation are replaced.

Synopsis

The increased atmospheric concentrations of greenhouse gas emissions (GHG) result in global climate change. Some of the impacts of climate change in South Africa include the increased frequency of fires during extremely high temperatures and a rise in sea-level along the coastal areas (DEA, 2010). It is also predicted that climate change impacts would exacerbate the issue of water scarcity in the country (Pegels, 2009). The adverse impacts of climate change have led to growing interests in developing and implementing mitigation options. Experts in the energy sector have emphasized the importance of mitigating GHG emissions at a sectoral level (ERC, 2011). In South Africa, the sector which contributes the most to the country's high GHG emissions is the energy sector. This sector is responsible for approximately 79% of the country's total GHG emissions (DEA, 2009). The dominance of the energy sector to the total emissions is due to the country's dependence on fossil fuels.

In addition to South Africa's climate change concerns, there is a waste management challenge. The environmental challenge of employing landfill disposal as a waste management technique is the release of landfill gas to the atmosphere. Landfill gas contains methane as its majority component which is a greenhouse gas. Although the waste sector only contributes approximately 2% to the total GHG emissions, it represents an opportunity for energy recovery and improved waste management practice (DEA, 2010). This indicates that a two-fold advantage for GHG reduction could potentially be realized. Waste is also an abundant resource. The rate of waste landfilled is as high as 2 kg per person per day in the country's six metros (Von Blotnitz et al., 2006).

There are alternative (energy-from-waste) technologies that can be employed to divert waste from the landfill sites to energy recovery facilities. One of these technologies is the anaerobic digestion technology. This technology produces biogas from organic waste and has the following advantages; saving on landfill space, avoiding landfill emissions, reducing energy emissions and stabilization of wastes and the production of a fertilizer which is a by-product of the process.

Although the production and use of biogas could avoid landfill and energy emissions, previous studies have not estimated the emission reduction potential of biogas. The cost of reducing these emissions via the production and utilization of biogas is also currently unknown. Therefore, the objectives of this study were to estimate the emission reduction potential of energy from biogas and the corresponding

cost. These were estimated in the context of Cape Town as it is the only South African city that is integrating sustainable energy in its energy plans. This is evident from the energy research work undertaken by the city (Winkler et al., 2005; SEA & ERC, 2010).

This dissertation focuses on the opportunity of using food waste (OFMSW), waste paper sludge (WPS) and primary sewage sludge (PS) to produce biogas. The study focused on these wastes because they are available in the city in large quantities and are disposed of at landfill sites. OFMSW constitutes the largest proportion of the total amount of waste landfilled. WPS is a by-product from paper manufacturing and is produced in significant quantities (Baloyi, 2011). The waste management challenge with WPS is that it may be prohibited from being disposed of at landfill sites in the near future (Nontangana, 2011). PS is also produced in large quantities from the wastewater treatment plants (WWTPs) and is already being stabilized in anaerobic digesters at some of the city's WWTPs such as the Athlone WWTP. The abundance, availability and landfill disposal challenges of these wastes make them attractive for this study.

The study estimated the landfill gas potential of OFMSW, WPS and PS using based on the degradable organic carbon content of the waste (IPCC, 2006). The calculations were performed at model scale and city-scale. At model scale, WPS had the highest amount of landfill emissions relative to OFMSW and PS. This was due to its high degradable organic carbon content and high methane composition in landfill gas. The high carbon content could possibly explain the strict environmental regulations which promote the prohibition of landfilling WPS. At city-scale, landfill emissions as a result of the deposition of the total amount of OFMSW and PS available in Cape Town were estimated. OFMSW generated higher emissions than PS. This was expected due to the large generation rate of OFMSW.

Studies on anaerobic digestion show that the rate of biogas production can be improved by co-digesting waste types that are compatible. Therefore, the dissertation calculated the potential biogas output from co-digestion of OFMSW with PS from the Athlone WWTP (termed Model 1) and WPS with PS from the Bellville WWTP (termed Model 2). In each model, the results from co-digestion showed biogas output to be a sum of the individual biogas yields of the wastes. This was expected due to the conservative method used to estimate the combined biogas production for both Models 1 and 2. The effect of co-digestion was accounted for by assuming a shorter hydraulic retention time of 21 days.

The energy potential from co-digestion in both models was also calculated. The purpose was to determine the amount of energy (electricity and heat) that could be available for sale in order to generate revenue. Model 1 had a higher energy generation capacity than Model 2. This was expected due to the larger total waste quantity and therefore higher biogas potential calculated in Model 1. For both models, a scrubber unit was incorporated in the calculations due to the poor methane composition in the biogas (less than 60%). The methane composition in Models 1 and 2 was 51.6% and 53.8% respectively. Upgrading the composition of methane increased the electricity consumption of the biogas plant as the scrubber unit had the largest parasitic electricity demand of over 70%. This revealed the importance of achieving a satisfactory methane composition without utilizing a scrubber.

The emission reduction potential (ERP) of energy from biogas was computed firstly with respect to mitigating landfill emissions from OFMSW, WPS and PS. As expected, Model 2 had the largest ERP compared to Model 1. Secondly, Model 1 was extended to include the total amount of OFMSW and PS wastes available in Cape Town for a city-wide energy modeling on LEAP and also for estimating the total landfill emissions at city-scale. The landfill emissions of OFMSW and PS at city-scale indicated that biogas can mitigate significant amount of CO₂ equivalent emissions. LEAP modeling was undertaken in order to estimate the potential of biogas to mitigate emissions associated with energy supply from fossil fuels. The simulation was performed over a 38 year modeling period (2012-2050). The results from the LEAP model showed that energy from biogas can contribute 49 GWh per modeling year (electricity and heat) to Cape Town's energy supply. Furthermore, the results indicated that emissions from energy generation using biogas are ~7 times less than emissions generated from using fossil fuels to satisfy the same energy supply. A key highlight from this analysis is that using coal as an electricity source and also as a thermal fuel generated the highest amount of emissions compared to using diesel, LPG, HFO and paraffin. This confirms the adverse impact of coal on the environment.

A financial analysis was conducted for both models in order to evaluate the profitability of energy generation from biogas. The costs included in the analysis were; investment costs and fixed and variable operating and maintenance costs. Electricity, heat and fertilizer sales were considered as revenue streams. The analysis indicated that at the same selling price of electricity of 96 c/kWh, Model 1 was more profitable (internal rate of return > discount rate) than Model 2. Furthermore, the cost of reducing landfill emissions was calculated for each model and also at city-scale in terms of *investment costs* per

ton of carbon dioxide (CO₂) equivalent emissions. The results showed that the costs of mitigating landfill emissions for Model 1 and Model 2 were R442 per ton CO₂-equivalent and R307 per ton CO₂-equivalent respectively. At city-scale the cost was lower (R287 per ton) compared to Model 1 and 2. The cost of mitigating emissions associated with energy supply from fossil fuels was also estimated assuming that total quantities of OFMSW and PS are used for biogas production.

The findings from the study indicate that energy from biogas has the potential to mitigate landfill and energy related GHG emissions. This can be profitable depending on the quantity of organic wastes diverted from the landfill sites as this corresponds to the amount of biogas produced and ultimately energy available for sale as a source of revenue. A conservative method for estimating the biogas production from co-digestion was used.

The key recommendations for future work are that the accuracy of estimating the combined biogas potential for co-digestion can be improved by incorporating and modeling the reaction kinetics of anaerobic digestion. The high electricity consumption of the scrubber revealed the importance of biogas quality (methane content > 60%). Thus future work should investigate combining different feedstocks with the purpose of achieving high methane content in order to avoid the added consumption cost of a scrubber.

Table of Contents

Acknowledgements.....	ii
Abstract.....	iii
Synopsis.....	iv
List of Figures.....	xii
List of Tables.....	xiii
Acronyms.....	xv
Symbols.....	xvi
1 Introduction.....	1
1.1 Background.....	1
1.2 Problem Statement.....	3
1.3 Objective.....	4
1.4 Key Questions.....	4
1.5 Research Approach and Scope.....	4
1.6 Thesis Outline.....	5
2 Literature Review.....	6
2.1 Cape Town’s Status quo: waste, energy and emissions.....	6
2.1.1 Municipal Waste generation and Waste management.....	6
2.1.2 Non-energy and energy emissions of greenhouse gases.....	10
2.2 Energy from Biomass and Energy-from-Waste technologies.....	11
2.3 Anaerobic Digestion: Brief Overview.....	14
2.3.1 Review of Process Parameters.....	15
2.4 Anaerobic co-digestion.....	23
2.4.1 Co-digestion of OFMSW with nitrogen-rich wastes.....	23
2.4.2 Co-digestion of Waste Paper Sludge with N-rich wastes.....	27

2.4.3	Estimating biogas production and composition	28
2.5	Batch and Continuous digesters for Biogas production	29
2.6	Biogas to Energy	29
2.6.1	Biogas Applications	29
2.6.2	Technologies for upgrading biogas.....	31
2.7	Baseline and Project GHG emissions.....	32
2.7.1	Baseline: Estimating GHG emissions from LFS	32
2.7.2	Baseline: Estimating GHG emissions from energy use.....	34
2.7.3	Project activity: Estimating GHG emissions from biogas production.....	35
2.8	Financial Analysis of energy generation from biogas.....	36
2.8.1	Estimation of Costs and revenue streams	36
2.8.2	Evaluation of profitability.....	38
2.9	Modeling energy from biogas	41
3	Research Methodology	43
3.1	Overview	43
3.2	Site selection	44
3.3	Gathering Waste Data	46
3.3.1	C-rich sources (OFMSW & waste paper sludge)	46
3.3.2	N-rich sources (Primary Sludge)	49
3.3.3	Calculating biogas potential, C/N ratio, chemical formulae and CH ₄ compositions	51
3.3.4	Limitations of data sources	54
3.4	Estimating GHG emissions for baseline and biogas production.....	55
3.4.1	Methodology for estimating landfill emissions from OFMSW and WPS.....	55
3.4.2	Landfill disposal and land application of primary sludge.....	56
3.4.3	Emissions due to biogas production	57

3.5	Sizing of units.....	57
3.6	Plant’s energy supply and consumption.....	58
3.7	Methodology for Financial Analysis.....	60
3.8	City-scale modeling on LEAP.....	65
3.8.1	Accounting for GHG emissions related to energy supply	65
3.8.2	Estimating Landfill emissions from OFMSW and PS at city-scale.....	67
4	Results and Discussions.....	68
4.1	Influence of co-digestion on C/N ratio.....	68
4.2	Influence of co-digestion on estimated biogas production.....	70
4.3	Sizes of units, Energy supply and consumption.....	74
4.3.1	Sizes of digester tanks and CHP units	74
4.3.2	Calculated energy supply and consumption	75
4.4	Financial analysis	78
4.4.1	Profitability assessment	78
4.4.2	Sensitivity Analysis	81
4.5	GHG emissions for baseline and biogas production	83
4.5.1	GHG emissions from landfill disposal of OFMSW, WPS and PS from Athlone WWTP .	84
4.5.2	GHG emissions from biogas production and the emission reduction potential.....	85
4.6	Results for city-scale modeling on LEAP	86
4.6.1	Estimating emissions from energy generated from fossil fuels	87
4.6.2	GHG emissions from landfill disposal of total quantities of OFMSW and PS	90
5	Conclusions and Recommendations	92
5.1	Conclusions to key questions	92
5.1.1	Key Question 1	92
5.1.2	Key Question 2	93

5.1.3	Key Question 3	93
5.1.4	Key Question 4	93
5.1.5	Key Question 5	94
5.2	Recommendations for future work.....	95
6	References	97
7	Appendices	106
7.1	Waste generation data	106
7.2	Estimating avoided emissions from landfill disposal.....	111
7.2.1	Estimating CH ₄ generated from landfill disposal of OFMSW and WPS	111
7.2.2	Estimating CH ₄ generated from landfill disposal of primary sludge	113
7.3	Plant's own energy consumption	114
7.4	Estimating costs for Model 1 and Model 2	115
7.5	Interviews: Email correspondence	115
7.6	C/N ratio for co-digestion	116
7.7	Influence of co-digestion on biogas production.....	117
7.7.1	Calculating biogas production from SBP's.....	117
7.7.2	Estimating biogas composition from Buswell's formula.....	117
7.7.3	Estimating enriched CH ₄ content in the biogas stream.....	118
7.8	Calculating digester sizes and CHP capacities.....	119
7.8.1	Estimating the digester sizes	119
7.8.2	Estimating the electricity and heat from a CHP unit and its nominal capacity	119
7.9	Profitability Assessment: Payback Period.....	121
7.10	Determining energy associated emissions.....	123
7.11	Estimating input parameters for LEAP modeling	124
7.12	Accounting for total landfill gas emissions from OFMSW and PS	126

List of Figures

Figure 2-1: Categorization of waste generated in Cape Town (2003).....	8
Figure 2-2: General household waste characteristics for 2003.....	9
Figure 2-3: Energy consumption by energy source for 2007, Cape Town.....	11
Figure 2-4: Energy-from-Waste technologies	12
Figure 2-5: Classification and examples of types of waste suitable for AD.....	16
Figure 2-6: Wastewater treatment plants in Cape Town	26
Figure 2-7: Investment costs of a water scrubber (TUS\$=1000US\$)	37
Figure 2-8: Estimating operational costs of a scrubber unit (TUS\$=1000US\$).....	38
Figure 2-9: Generic project cash-flow diagram	39
Figure 3-1: Graphical representation illustrating sections corresponding to each key question	43
Figure 3-2: Geo-referencing of compatible organic waste types.....	45
Figure 3-3: Waste streams entering ARTS from the Integrated Solid Waste Management Study.....	47
Figure 3-4: A simplified mass balance approach on a total solids/dry matter basis.....	52
Figure 3-5: Investment costs of a scrubber unit (TUS\$=1000US\$)	61
Figure 3-6: Operational costs of a scrubber unit (TUS\$=1000US\$)	63
Figure 4-1: C/N ratio for mono-digestion of substrates.....	68
Figure 4-2: Individual and combined C/N ratio in Model 1 and Model 2.....	69
Figure 4-3: Specific biogas production from each waste type under Laboratory conditions	70
Figure 4-4: Effect of co-digestion on the potential biogas output (large-scale)	71
Figure 4-5: Influence of upgrading biogas on electricity consumption.....	77
Figure 4-6: Effect of co-digestion on energy potential (scrubber included).....	78
Figure 4-7: Graphical representation of the payback period for Model 1 and 2.....	81
Figure 4-8: Effect of varying the selling price of electricity on Model 1	82
Figure 4-9: Effect of varying electricity price on Model 2.....	83

List of Tables

Table 2-1: Classification of households by annual income (2003).....	8
Table 2-2: Typical biogas composition.....	15
Table 2-3: C/N ratio of a few organic wastes	20
Table 3-1: Chemical formula for OFMSW.....	48
Table 3-2: Characteristics and biogas potential of OFMSW from ARTS	48
Table 3-3: Chemical formula and characteristics of WPS.....	49
Table 3-4: Quantities of primary sludge produced (PS) from the two WWTPs.....	50
Table 3-5: Elemental analysis of PS	51
Table 3-6: Chemical formulae and characteristics of PS.....	51
Table 3-7: Molar masses of elements contained in the substrates	53
Table 3-8: Input parameters for estimating DOC and methane generation for OFMSW and WPS.....	55
Table 3-9: Input parameters for estimating DOC and methane generation for PS	56
Table 3-10: Summary of cost parameters for the models	62
Table 3-11: Financial variables for financial assessment	64
Table 3-12: Summary of input parameters used for city-scale modeling of biogas cogeneration in LEAP	66
Table 4-1: Mass Balance (MB) results for Model 1 and Model 2 on a total solids basis.....	72
Table 4-2: Estimated biogas production after upgrade	73
Table 4-3: Calculated sizes of main plant units for each model	74
Table 4-4: Estimated energy obtainable and consumed by Model 1 and 2	75
Table 4-5: Cost comparison between Model 1 and 2	79
Table 4-6: Results for the financial analysis of Model 1	80
Table 4-7: Results for the financial analysis of Model 2	81
Table 4-8: Influence of electricity on the profitability assessment of Model 1	82
Table 4-9: Degradable organic carbon and methane generation for OFMSW, WPS and PS.....	84
Table 4-10: Estimating CH ₄ emissions from disposal of OFMSW and WPS	85
Table 4-11: Estimated GHG emissions from biogas production	85
Table 4-12: The cost of mitigating GHG emissions	86
Table 4-13: Input parameters for LEAP	87
Table 4-14: Emissions from fossil fuel-derived <i>thermal</i> energy	89

Table 4-15: Estimated total emissions from coal-derived power and thermal fuels.....	89
Table 4-16: The <i>total</i> ERP of biogas energy and cost <i>over the model period for city-wide modeling (2012-2050)</i>	90
Table 4-17: The quantities of methane generated and emitted from landfill disposal.....	91
Table 7-1: Waste generation rates per income group in Cape Town (2003)	106
Table 7-2: Composition of waste from households in Cape Town (2003).....	106
Table 7-3: Waste stream entering ARTS (2003)	106
Table 7-4: Elemental analysis of OFMSW in ARTS.....	106
Table 7-5: Characteristics of OFMSW from ARTS	107
Table 7-6: OFMSW formula.....	107
Table 7-7: Elemental analysis of WPS	109
Table 7-8: Capacities of Wastewater plants in Cape Town	109
Table 7-9: Densities of the feedstocks used.....	110
Table 7-10: Climatic conditions for Western Cape	111
Table 7-11: Profitability assessment for Model 1	121
Table 7-12: Profitability assessment for Model 2.....	122
Table 7-13: Effect of varying of electricity selling price (Model 1).....	122
Table 7-14: Emission factors of energy fuels 1	123
Table 7-15: Emission factors of energy fuels 2	123

Acronyms

Notation	Definition
AD	Anaerobic Digestion
ARTS	Athlone Refuse Transfer Station
ASD	Alternative Service Delivery
A_WWTP	Athlone Wastewater treatment plant
B_WWTP	Bellville Wastewater treatment plant
BMP	Bio-methane potential
BOD	Biological Oxygen Demand
CoCT	City of Cape Town
COD	Chemical Oxygen Demand
DCF	Discounted Cash Flow
EA	Energy Activity
EF	Emission Factor
ESRI	Environmental Systems Research Institute
FOD	First Order Decay
Gg	Gigagram
GGP	Gross Geographic Product
GIS	Geographic Information System
GJ	Gigajoule
GWP	Global Warming Potential
HRT	Hydraulic Retention Time
HS	High Solids
ISWM	Integrated Solid Waste Management
LPG	Liquefied Petroleum Gas
MAP	Mean Annual Precipitation
MAT	Mean Annual Temperature
MS	Medium Solids
MSW	Municipal Solid Waste
NCCRGP	National Climate Change Response Green Paper
NCF	Net Cash-Flow

OFMSW	Organic Fraction of MSW
PBP	Payback period
PET	Potential Evapotranspiration
PS	Primary sludge
RE	Renewable Energy
REFIT	Renewable-Energy-Feed-In-Tariff
SBP	Specific Biogas Potential
SRT	Solids Retention Time
TJ	Terajoule
TS	Total Solids
VS	Volatile Solids
WPS	Waste Paper Sludge
WWTP	Waste Water Treatment Plant

Symbols

Notation	Definition	Units
A	Plant availability	%
F	Fraction of CH ₄ in landfill gas	%
t_{yr}	Number of hours in a year	hours
Q_s	Thermal energy demand	kW
C_p	Heat capacity	kJ/kg°C
E_{el}	Potential electricity generated	kW
E_{th}	Potential heat generated	kW
E_{consumed}	Electricity consumed by auxiliary equipment	kW
E_{scrubber}	Electricity consumed by the water scrubber	kW

1 Introduction

This chapter contextualizes the subject of the thesis and sets a scene by presenting the background, problem statement and objectives of the project.

1.1 Background

Global climate change, also known as global warming is one of this century's most challenging problems, predicted to have disastrous consequences if its causes are not aggressively contained. Africa is one of the continents that are most vulnerable to the impacts of global climate change which vary from country to country (Pegels, 2009). South Africa is a country that is already water-stressed and the impacts of climate change are projected to intensify water scarcity and increase the demand of water supply which could decline the quality of water (Pegels, 2009). In addition to water challenges, sea-level rise and increased fire frequency are also predicted to occur. In fact, the rise in sea-level is already evident along the west and east coast of the country (DEA, 2010).

The impacts of climate change occur as a result of increased greenhouse gas (GHG) concentrations in the atmosphere, themselves reported to be a result of anthropogenic activities, particularly the large and still increasing emissions of GHGs on the one hand, and of land use changes on the other (IPCC, 2007). Sources of GHG emissions have been categorised to include emissions from the energy sector, industrial processes, agriculture, forestry and other land use as well as emissions from the waste sector (DEA, 2009). The DEA (2009) estimated that in 2000, 78.9% of GHG emissions were from the energy sector. This high contribution reveals the country's dependence on fossil fuels (coal, oil and gas) (DME, 2003).

Regardless of South Africa's dependence on conventional fuels, the government has re-emphasized their commitment to mitigate climate change. This is evident in the 2010 National Climate Change Response Green Paper (NCCRGP) (DEA, 2010). However, experts in the energy sector have commented on the lack of well-defined emission reduction targets at a sectoral level (ERC, 2011).

The NCCRGP stated that the government's medium-term (10 years) target which is to incorporate 10 000 GWh of energy from renewable energy (RE) technologies to the final energy consumption by 2013, needs to be reviewed and scaled-up (DME, 2003). The RE technologies considered in this target are biomass, wind, solar and hydro-electric. This is to be harnessed for electricity generation and non-

electric technologies such as solar water heating and biofuels. Of all the RE technologies mentioned, biomass can address the additional challenge of municipal waste management that South Africa faces as it involves the utilization of organic matter for energy generation instead of landfill disposal. The landfill disposal of waste was responsible for approximately 2% of South Africa's GHG emissions (DEA, 2010). Although this is a small contribution relative to the energy sector there is potential for energy recovery (and thus a "double dividend" for mitigation) and improved waste management practice.

The challenge is to reduce and manage the quantities of municipal solid waste (MSW) that arrive at the country's landfill sites (LFS). The disposal rate of MSW landfilled at South Africa's six metros¹ is equivalent to 2 kg per person per day. This figure is reported to be larger than European cities and also indicates that there is a significant amount of MSW generated at South African cities (Von Blottnitz et al., 2006).

In the City of Cape Town, it was estimated that 87% of the total waste generated was disposed of at LFS (Jeffares&Green & IngeropAfrica, 2004). This figure indicates that waste management is highly reliant on landfill disposal. The large quantity of MSW increases pressure on the only three remaining LFS (Coastal Park, Bellville South and Vissershok) which are approaching the end of their lifespan (CoCT, 2007). It is clear that waste minimization and recovery methods to divert waste from the LFS are essential.

Waste can be diverted from LFS and converted through various technologies and some of it used as a source of energy, usually referred to as *energy-from-waste* or *waste-to-energy* technologies (Luxresearch, 2007). These technologies can address three environmental issues: limited space for landfilling waste and emissions from LFS, they can also reduce emissions associated with dependency on fossil fuels (Luxresearch, 2007).

A 2011 assessment of alternate service delivery (ASD) mechanisms for solid waste management for Cape Town includes energy-from-waste projects (CoCT, 2011). Separately, energy modeling studies have been completed which include an assessment of the impact of energy-from-waste on Cape Town's

¹ City of Cape Town, City of Johannesburg, Ekurhuleni Metropolitan, eThekweni Municipality, Nelson Mandela Metropolitan and City of Tshwane Municipality

energy sector. Two notable studies are *Optimum Energy Futures for Cape Town* and *Energy Scenarios for Cape Town* (Winkler et al., 2005; SEA & ERC, 2010). Both these studies have included energy-from-waste under the renewable electricity generation mix for Cape Town as part of the city's energy and climate change objectives.

Of the two studies, *Energy Scenarios for Cape Town* is more recent and it included modeling the contribution of electricity from biomass and municipal waste. It is unclear from that study whether this contribution includes a biogas option. When organic waste is placed under anaerobic environment it generates biogas which can be used to produce thermal and/or electric energy. The advantages of using biogas technology to divert organic waste from landfill disposal include energy production, avoided emissions from the LFS and generation of a sludge which is a by-product of biogas production. It is reported that the sludge can be used as a fertilizer, potentially adding a 3rd GHG mitigation benefit as both the production and use of mineral fertilisers release significant amounts of GHG (especially nitrous oxide) (AgamaBiogas, 2009).

The amount of biogas produced can sometimes be enhanced by combining organic wastes with different characteristics to create a more favourable environment for the microorganisms responsible for biogas production.

1.2 Problem Statement

Energy-from-waste has been considered by SEA and ERC (2010) in the *Energy Scenarios for Cape Town*, but the biogas option was not included in that study. Biogas production from the organic fraction of municipal solid waste could reduce dependency on waste disposal by landfill. Furthermore, it could be an attractive option as it relies on available waste sources and currently existing technology at some of the city's wastewater treatment plants (WWTPs). Although energy-from-waste has been considered in Cape Town studies, the quantity and cost of energy from biogas was not considered. The quantity of GHG emissions that can be avoided by diverting organic waste from LFS for biogas production and ultimately energy generation is also unknown.

1.3 Objective

The objectives of this dissertation are to make a contribution to a better integration of municipal responses to issues of energy and climate change with waste management planning, specifically by estimating, in the context of Cape Town, firstly the emission reduction potential associated with energy from biogas, and secondly the corresponding cost.

1.4 Key Questions

1. What are the waste sources of landfill gas and therefore of potential biogas in Cape Town?
2. Which sources are compatible and suitable for co-digestion?
3. What are their individual and combined biogas potentials?
4. What would the impact be on Cape Town's energy and climate change plans (energy supply and emissions reduced)?
5. What would be the cost of reducing GHG emissions via biogas production?

1.5 Research Approach and Scope

This dissertation focuses on Cape Town as the region of study due to the available energy and waste management work that has been completed for the city. The study relies on data from previous feasibility studies for Cape Town and from academic literature. This is the case for estimating waste data, individual biogas potential and individual chemical formulae of organic wastes. The study used a mass balance approach to calculate the biogas potential for co-digestion of wastes. Avoided emissions resulting from organic waste diversion from LFS were estimated. Furthermore, avoided energy emissions due to the replacement of fossil fuel energy by energy from biogas were also estimated. To complete the analysis the digester tanks and CHP units were sized as their sizes were necessary to estimate their capital costs. The thesis developed its own financial analysis for energy generation from biogas. This analysis serves as an order of magnitude estimate for biogas production. The project also adapted a LEAP software model that was developed for the *Energy Scenarios for Cape Town* study. The model was extended to include electric and thermal energy from biogas.

1.6 Thesis Outline

This project is composed of various chapters as outlined below:

- *Chapter 2:* Synthesizes literature on Cape Town's status quo, suitable waste types for biogas production, technologies useful for converting biogas to energy, estimating mitigation options and methods used for performing financial analysis on biogas projects. This chapter informs the theory and methodology for the project.
- *Chapter 3:* This chapter extracts lessons learned from literature and provides a detailed research methodology that was used to reach the set objectives and key questions.
- *Chapter 4:* In this chapter, the results are formulated from the research methodology and the discussions compare the study's findings with literature synthesized in Chapter 2.
- *Chapter 5:* The thesis ends with a chapter on Conclusions and Recommendations. The conclusions are presented specifically for the set objectives and key questions while the recommendations are presented for future work and thus show the identified research gaps from this work.

2 Literature Review

This chapter firstly presents a synthesis of literature in the context of Cape Town, then technical parameters and considerations for the modelling.

2.1 Cape Town's Status quo: waste, energy and emissions

This section presents a synthesis of recent studies on the status of Cape Town with respect to municipal waste generation and management, energy supply and consumption, emissions from landfill disposal of waste as well as emissions from energy supply.

2.1.1 Municipal Waste generation and Waste management

Municipal waste can be classified into municipal sewage sludge and municipal solid waste (MSW). Municipal sewage sludge is produced from municipal wastewater treatment works which receive wastewaters from residential areas, industry, groundwater infiltration and stormwater runoff (Klass, 1998). Wastewater from these sources contains a wide range of suspended and dissolved compounds and oxygen demanding substances of which many are toxic. Certain pathogenic compounds such as organic compounds, heavy metals, bacteria, inorganic nutrients and viruses are present (Klass, 1998). The objective of wastewater treatment plants is to remove or minimize these components, pollutants and biological oxygen demand (BOD) before disposal (Klass, 1998; Mamabolo, 2006). This is achieved through various processes.

Processes in a WWTP typically consist of preliminary, primary and secondary treatments (Tesfai, 2004). Preliminary treatment or screening removes larger floating materials such as rags and litter. Following the preliminary treatment, the process continues to the primary treatment unit where suspended solids settle out and are concentrated into primary sludge (Mamabolo, 2006). The secondary process usually consists of a percolating filter or activated sludge treatment for further settling of sludge. The sludge from this process is termed secondary sludge (Mamabolo, 2006). A mixture of primary and secondary sludge is referred to as sewage sludge (Sosnowski et al., 2003). It is reported that the primary sludge constitutes the majority of sewage sludge produced from the treatment plant (Mamabolo, 2006). In certain WWTPs the primary sludge is stabilised via anaerobic digestion prior to ultimate disposal.

In 1997, it was reported that approximately 245 200 tons of wet sewage sludge was produced at Cape Town's 21 WWTPs (Wright-Pierce, 1999). Alcock (2009) reported that the city utilizes four methods

for sewage sludge disposal. These include direct agricultural use, composting and thermal drying. The fourth method is the disposal of sewage sludge at LFS which is regarded as an emergency option. However, in Cape Town this emergency option accounts for the majority of disposed sludge (Alcock, 2009). City officials recognise that from an environmental perspective, alternative plans are necessary to reduce heavy reliance of sewage sludge disposal by landfill (Alcock, 2009).

MSW represents a relatively more diverse and complex type of municipal waste. The amount of MSW generated in Cape Town in 2002/2003 was estimated to be 2,158,500 tons (Jeffares&Green & IngeropAfrica, 2004). This corresponded to a daily generation amount of approximately 5900 tons. A slight increase in this amount was recorded in 2007 as the daily amount of waste generated in Cape Town reached 6000 tons (SEA & AMATHEMBA, 2007). The general challenge in the Cape Town studies on waste is the difficulty to accurately quantify the amount of waste generated. Often assumptions about economic and population activities are required.

Jeffares & Green and IngeropAfrica (2004) compared the rate of waste generation with population growth. This 2003 study, reported that the rate at which waste increased in Cape Town was approximately 3.8% per year whereas the population growth increased at a lower rate of 1.57%. Another study, a 2011 assessment study for the City of Cape Town revealed the percentage change of MSW landfilled as a function of both economic and population dynamics. Akhile Consortium (2011) indicated that for every 1% annual increase in the City's gross geographic product² (GGP) the amount of MSW disposed at LFS increases by 0.6%. On the other hand a 1% increase in population results in a 0.9% increase in the MSW quantities sent to LFS.

The correlation between economic activity and waste growth, and population and waste growth was evident in 2008 when Cape Town's economy was in a boom phase and waste generation outstripped population growth by 5% (CoCT, 2011). Post 2008, when the economic recession hit waste generation decreased. These figures indicate that MSW generation is a function of economic activity and population growth.

² GGP reflects the market value of all final goods and services produced and sold within a local municipality

MSW is a broad term and can be characterized further into sectors. In Cape Town, it can be categorized as Household, Commercial, Industrial, Green waste and Builder's Rubble (Jeffares&Green & IngeropAfrica, 2004). Household waste contributed the largest percentage compared to all other categories (Jeffares&Green & IngeropAfrica, 2004). In 2003, household waste accounted for 38% of the waste stream in Cape Town but in 2011 it accounted for 46% (Jeffares&Green & IngeropAfrica, 2004; CoCT, 2011). Figure 2-1 represents the categorization of waste generated in Cape Town in 2003. As shown household waste contributes the largest percentage of waste generated:

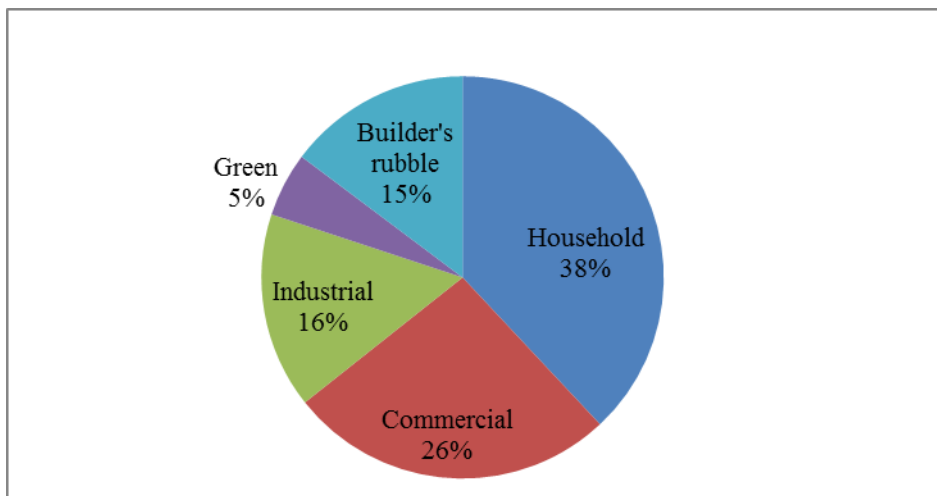

Figure 2-1: Categorization of waste generated in Cape Town (2003)

Source: (Jeffares&Green & IngeropAfrica, 2004)

Households can be classified into income groups. Jeffares&Green and IngeropAfrica (2004) classified households as high, middle or low income according to the following criteria:

Table 2-1: Classification of households by annual income (2003)

Low income	0-R41,999
Middle income	R42,000- R71,999
High income	R72,000+

Source: (Jeffares&Green & IngeropAfrica, 2004)

High income households have the highest waste generation rate per capita of 2 kg per capita per day relative to middle and low income households which have generation rates of 1.1 and 0.5 kg per capita

per day respectively (SEA & AMATHEMBA, 2007; Jeffares&Green & IngeropAfrica, 2004). These generation rates exclude garden waste. Figure 2-2 illustrates the general characteristics of household waste.

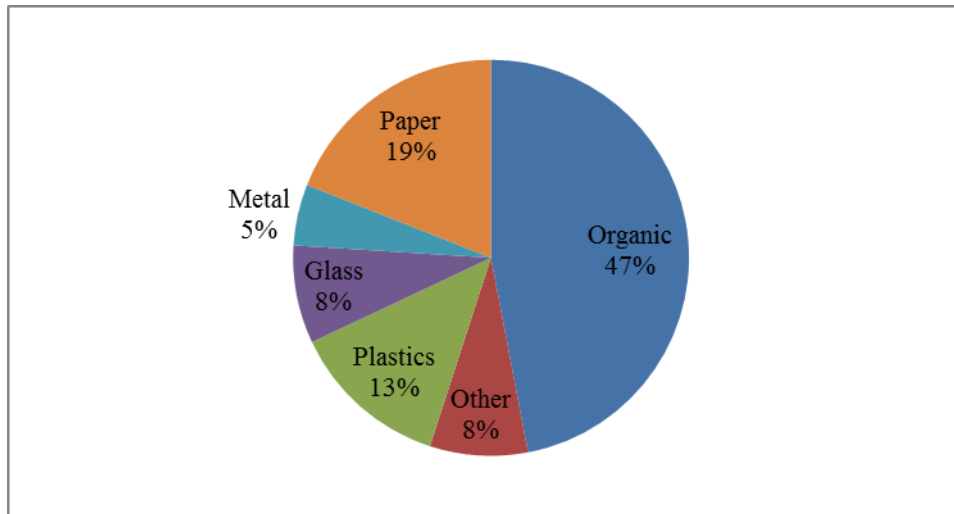

Figure 2-2: General household waste characteristics for 2003

Source: (Jeffares&Green & IngeropAfrica, 2004)

It is evident that waste generation in Cape Town is generally increasing and that waste from households is the significant contributor. Some of the household waste collected by the city is transported to the Refuse Transfer Stations (RTS) where separation of recyclable and non-recyclable materials may occur (clean material recovery facility at Oostenberg, dirty material recovery facility at Athlone, none at Swartklip). The non-recyclable material is disposed of at the Vissershok Landfill site (LFS) (SEA & AMATHEMBA, 2007).

It is recorded that in 2007/8 2.1 million tons of waste were disposed of in the three landfill sites, Bellville, Vissershok and Coastal Park (CoCT, 2011). Waste management by landfill disposal reduces available space for landfill. Furthermore, these three landfill sites are soon to reach the end of their operational life span and finding geologically suitable and socially acceptable sites for landfill disposal is difficult in Cape Town. New LFS outside Cape Town would need to be utilized. This means waste would need to be transported long distances to sites suitable for landfill disposal (SEA & AMATHEMBA, 2007).

2.1.2 Non-energy and energy emissions of greenhouse gases

Landfill disposal of organic waste (organic fraction of MSW and sewage sludge) also adds to the global problem of climate change as organic wastes decompose within the landfill site and generate landfill gas which is dominantly rich in methane (CH₄) and carbon dioxide (CO₂) (DEA, 2009). These greenhouse gases (GHG) diffuse into the atmosphere from the landfill sites. For Cape Town, the exact amount of landfill gas emitted to the atmosphere is currently unknown (Ward & Walsh, 2010). However, for South Africa at large, it is estimated that 2% of GHG emissions come from the country's landfill sites (DEA, 2009).

The adverse effects of landfill disposal of organic waste on the environment have led to increasing interest in technologies that could either harvest the landfill gas, or divert waste from the city's LFS. Diverting organic wastes from the LFS would avoid GHG emissions associated with waste disposal.

GHG emissions from LFS are not the only ones the city is responsible for. Other sources of GHG emissions are electricity, petrol, diesel, jet fuel, heavy fuel oil (HFO), coal, natural gas and paraffin (Ward & Walsh, 2010). It has been estimated that in 2006, Cape Town was responsible through electricity purchases for emissions of 6.21 tons of CO₂-equivalent per capita (Ward & Walsh, 2010). This translates to approximately 21.1 million tons of CO₂-equivalent, from an estimated population of 3.4 million (Ward & Walsh, 2010). The majority of these emissions are attributed to the consumption of energy.

Figure 2-3 shows the various energy sources and their percentage contribution to energy consumption for Cape Town. As indicated electricity is the dominant energy source consumed followed by petrol and diesel. This figure proves that Cape Town relies heavily on fossil fuels to satisfy her energy requirements (Ward & Walsh, 2010). This heavy dependence on fossil fuels contributes to the increased levels of GHG emissions (DEA, 2009).

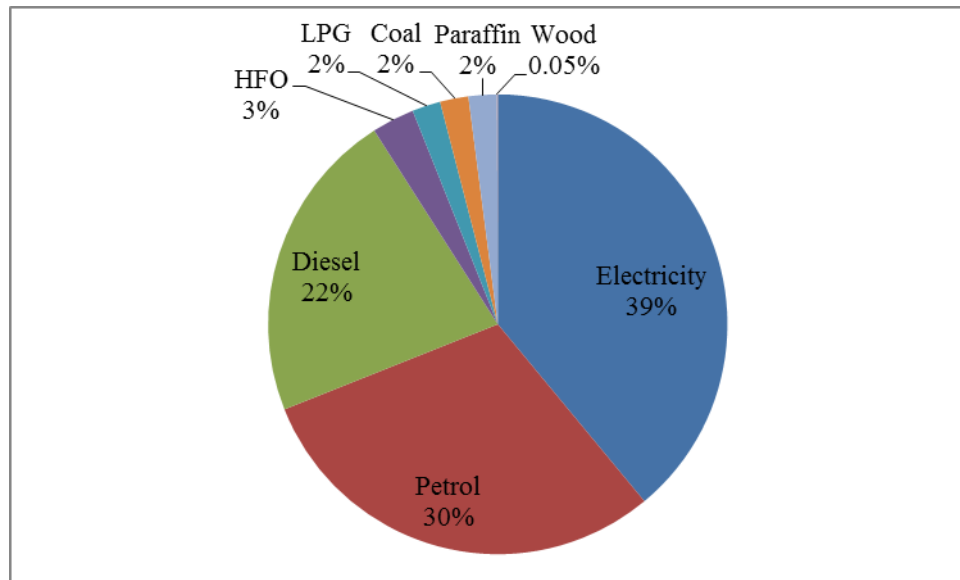

Figure 2-3: Energy consumption by energy source for 2007, Cape Town

Source: (SEA & ERC, 2010)

In summary lessons learnt from this section are that the organic waste stream of municipal solid waste (MSW) contributes the largest portion to the total quantity of waste disposed of at the LFS. This is due to a lack of alternative diversion technologies or methods that could reduce the amount of organic waste disposed of in LFS. Reducing the amount of waste disposed in LFS would also reduce the GHG emissions from LFS. The following section reviews and synthesises available studies that could inform the City's waste management, energy and GHG emissions issues, particularly as they relate to the organic fraction of solid waste.

2.2 Energy from Biomass and Energy-from-Waste technologies

Biomass is regarded as energy-containing materials that are not fossil fuels such as dedicated energy crops, agricultural crop residues, animal manures and industrial and municipal organic wastes (Deublein & Steinhauser, 2008). Globally the contribution of dedicated energy crops to energy generation has been realized on a commercial scale. Klass (1998) stated that up to the mid-1990s there were few operational biomass energy systems in which dedicated energy crops were grown as sources of energy in industrialized countries. Industrial trends indicate that in the 1990s, most of the contribution of biomass to primary energy demand was attributed to waste biomass.

The global development of biomass energy systems based on waste is receiving much deserved political attention in Cape Town. This is evidenced in the report issued by the executive mayor of the City of Cape Town regarding alternate service delivery mechanisms for solid waste management in Cape Town (CoCT, 2011). In this report it is recommended that energy-from-waste projects be investigated in support of the Council’s Energy policy and targets.

Energy-from-waste is a broad term and includes numerous technologies that can convert waste materials to energy. Examples of these technologies include thermal processing, physical, chemical and biological processing (Wagner, 2007; Luxresearch, 2007). Figure 2-4 illustrates the categorization of different technologies.

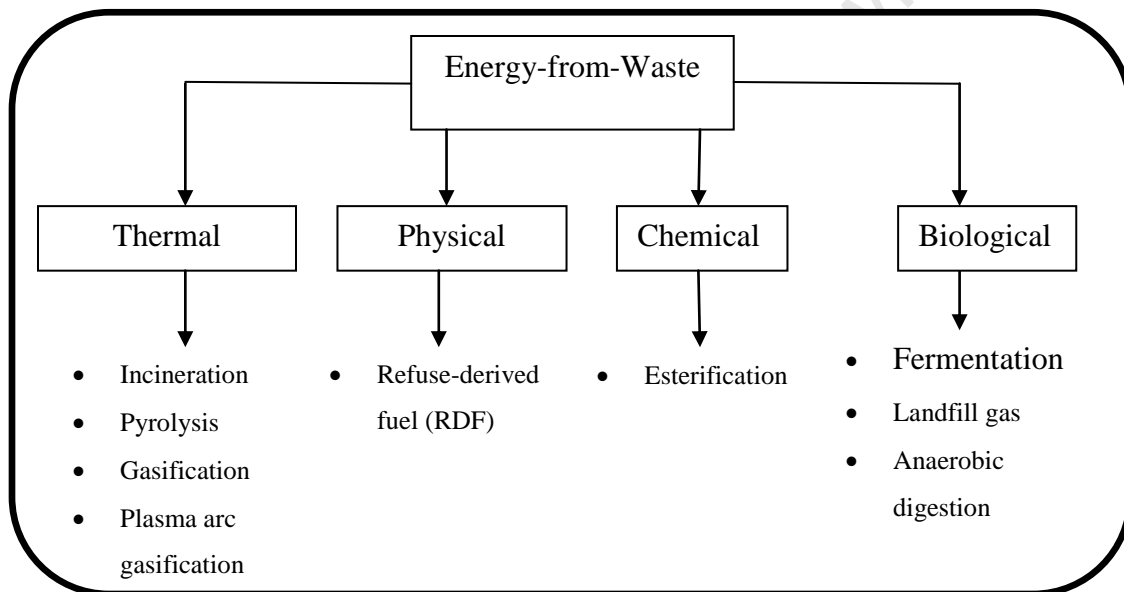

Figure 2-4: Energy-from-Waste technologies

Sources: (Luxresearch, 2007; Wagner, 2007)

Although these technologies divert waste from LFS they have certain disadvantages. The disadvantages of incineration include the production of toxic fumes and very hazardous ash which necessitate further costly pollution control installations. These installations would make incineration uneconomical relative to the currently utilized waste management technique (SEA & AMATHEMBA, 2007).

The second method shown in the figure is the physical method of preparing waste for use in thermal energy generation. It involves the mechanical processing of municipal solid waste (MSW) into a combustible fuel called “Refuse-Derived Fuel” (RDF) which is of a higher combustible quality than raw

MSW (Luxresearch, 2007). The disadvantage of this technology is that the presence of small particles and glass fines in RDF cause problems during the combustion of RDF. The exclusion of these particles is difficult which characterizes this technology with high costs due to the required separation of MSW (UNEP, 2005).

Vegetable oil regarded as waste from food industries such as restaurants and hotels can be chemically treated by a process called esterification to produce a valuable fuel, biodiesel (Wagner, 2007). Esterification is limited to waste oil and excludes all other types of waste such as municipal and industrial solid wastes.

The biological methods include fermentation, landfill gas capture and anaerobic digestion. Bacterial fermentation converts simple sugars available in the organic feedstock such as glucose and fructose to ethanol (Wagner, 2007). Ethanol is a transport fuel and can be used as it is to substitute petrol or blended with petrol to enhance the combustion process.

Landfill gas capture and anaerobic digestion technologies are directly aligned with Cape Town's initiative to investigate the utilization of waste-to-energy projects as this initiative focuses on organic wastes. Landfill gas is formed by the anaerobic digestion of organic waste. The major constituents of landfill gas are methane (CH_4) and carbon dioxide (CO_2) both of which are greenhouse gases (GHG). Landfill gas capture involves the extraction of landfill gas from landfill sites (LFS), thus reducing the amount of greenhouse gases released to the atmosphere. Landfill gas to electricity technologies has reached African soil. South Africa's City of Durban has launched a Landfill gas-to-electricity project (CoD, 2009). Utilizing landfill gas for energy generation is attractive as it provides solutions for energy and climate change. However, it fails to address the limited space left to landfill wastes, and also extracts only a fraction of the landfill gases.

Anaerobic digestion, unlike the energy-from-waste technologies mentioned above provides solutions to energy supply, climate change, waste management and agriculture. Anaerobic digestion produces biogas which is regarded to be much like landfill gas. Similar to landfill gas, biogas can be used to generate energy. However, unlike landfill gas the generation of biogas could divert organic waste from disposal at LFS.

2.3 Anaerobic Digestion: Brief Overview

Anaerobic digestion (AD) is a complex process in which organic matter is decomposed by the action of bacteria into biogas (Deublein & Steinhauser, 2008; Wilkie, 2008). The AD process takes place in reactor vessels, called digesters (Wilkie, 2008). There are four stages responsible for the biogas formation and each stage is performed by a group of microbes. The four stages involved are hydrolysis, acidogenesis, acetogenesis and methanogenesis (Deublein & Steinhauser, 2008; Wilkie, 2008).

In the first stage, the biomass components such as carbohydrates, proteins and fats are hydrolyzed into short chained sugar, amino acids, fatty acids and glycerin. The hydrolysis of carbohydrates is shorter relative to proteins, fats, lignocellulose and lignin. Hydrolysis of carbohydrates is a process that only requires few hours. On the other hand hydrolysis of proteins and fats takes place within few days. Lignocellulose and lignin hydrolyze slowly and incompletely (Deublein & Steinhauser, 2008). The second stage of anaerobic digestion, acidogenesis relies on the products formed from the hydrolysis stage. The short chained sugar, amino acids, fatty acids and glycerin products are converted into short chained acids, alcohols, CO₂ and hydrogen (H₂) (Deublein & Steinhauser, 2008).

The products from acidogenesis act as substrates for bacteria involved in the third stage, acetogenesis. Additional CO₂ and H₂ are formed from this stage together with carbonic acids, alcohols and acetate. Methanogenic microorganisms, that is, methanogens are responsible for the formation of methane in the fourth stage of methanogenesis. In this stage, the microorganisms are selective about the substrates they degrade. The CO₂-type of products from the third phase are degraded into CH₄ and H₂O while the acetate-type of substrates degrade to CH₄ and CO₂. (Deublein & Steinhauser, 2008). It is stated that approximately 70% of CH₄ produced during methanation is accredited to the degradation of acetate (Chynoweth & Isaacson, 1987). The typical products of AD are biogas and liquid slurry. A typical biogas composition following the success of the above-mentioned stages is presented in Table 2-2 (Deublein & Steinhauser, 2008):

Table 2-2: Typical biogas composition

Biogas constituent	Volume %
Methane (CH ₄)	55-75
Carbon Dioxide (CO ₂)	25-50
Water (H ₂ O)	1-5
Hydrogen Sulphide (H ₂ S)	0-0.5
Nitrogen (N ₂)	<2
NH ₃	0-0.05

Source: (Deublein & Steinhauser, 2008)

As shown, the primary constituents of biogas are CH₄ and CO₂ with negligible amounts water, hydrogen sulphide, nitrogen, oxygen and hydrogen. CH₄ is insoluble in water thus it readily separates from the sludge and leaves the system.

The stages of AD indicate that they are dependent upon each other as each stage use products from the previous stage as a starting point. The success of these stages depends on several parameters which include digester temperature, hydraulic and solids retention times, degree of decomposition, type of waste being digested and C/N ratio (Dennis & Burke, 2001).

2.3.1 Review of Process Parameters

Reasons for focusing on AD have been outlined in Section 2.2. This section addresses process parameters essential for AD. Parameters included are waste types, total solids content, degree of volatile solids decomposition, C/N ratio, temperature and hydraulic and solids retention times. These parameters control the biogas output from AD and ultimately the corresponding energy obtainable, therefore they are worth reviewing.

2.3.1.1 Parameter: Waste types

The various types of waste suitable for AD can be classified into municipal wastes, agricultural solid wastes and industrial wastes and wastewater (Klass, 1998). As shown in Figure 2-5 these categories can be further broken down into specific waste types:

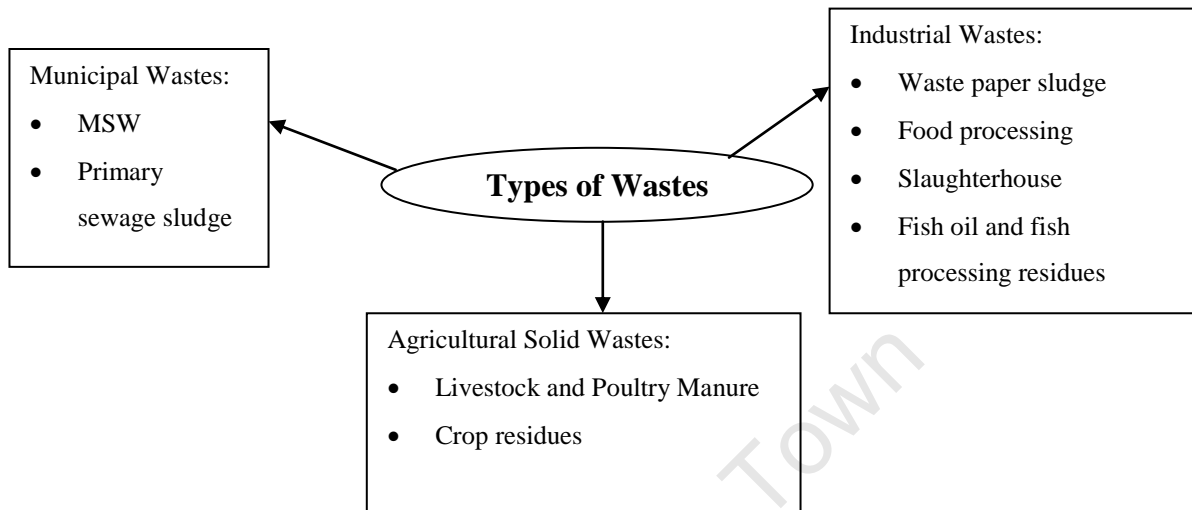

Figure 2-5: Classification and examples of types of waste suitable for AD

Source: (Klass, 1998)

2.3.1.1.1 Livestock and Poultry Manure and Crop Residues

AD has been used for the treatment of animal manure (cattle, pig and poultry) since the 1970s (Monnet, 2003). Globally animal manure represents the largest material used for AD. In Denmark, 75% of the biomass treated in the Centralised Anaerobic Digester (CAD) plants is manure. The advantage of using AD for manure is the odourless digestate that can be applied on agricultural land after the digestion process. Although AD of animal manure is advantageous, it is economical to use for AD at animal farms in order to minimise transportation costs associated with collecting and delivering wastes. Manure collection for AD is a challenge that farmers face with as cows often spend long periods of time grazing on pastures (Monnet, 2003).

Crop residues are also suitable wastes for farm digesters (Steffen et al., 1998). Crop residues are often co-fermented with animal manure to enhance the gas yield (Deublein & Steinhauser, 2008)

2.3.1.1.2 Municipal Solid Waste

Municipal solid waste (MSW) refers to household waste such as yard trimmings, food wastes, paper, glass, metals and more (EPA, 2010). Food wastes contained in MSW represent the biodegradable fraction of MSW (OFMSW) which is usually 30-45% of household waste depending on household income (Deublein & Steinhauser, 2008).

According to Klass (1998) as populations of urban areas grow, the generation of MSW also increases. In the United States, the production of MSW increased from 80 million tons in 1960 to 180 million tons in 1990 with no signs of reaching a constant level. In support of this, studies show that during the same period, the amount of MSW generated per person per day was 1.23 kg per person per day in 1960 and increased to 1.97 kg per person per day in 1990 (Klass, 1998). This observation is consistent with the growth trends of MSW in Cape Town described above (CoCT, 2011; Jeffares & Green & Ingerop Africa, 2004).

Cuetos et al (2008) state that OFMSW is facing challenges from environmental legislation concerning its landfill disposal due to its large generation quantities and potential to generate landfill gas. In the context of Cape Town, the large quantities of OFMSW exert pressure on landfilling space (Nontangana, 2011). Legislations against disposal of OFMSW enhance the uptake of technologies such as AD.

2.3.1.1.3 Sewage Sludge (Primary)

The production of sewage sludge from WWTPs has already been discussed in Section 2.1.1 above. As mentioned primary sludge (PS) is the major contributor to the total amount of sewage sludge produced from a WWTP (Mamabolo, 2006). Due to the dominant quantity of PS this study focuses on PS instead of secondary sludge. As discussed AD is the standard technology for stabilizing PS at WWTPs (Monnet, 2003). In relation to Cape Town, only a few WWTPs use AD for sludge treatment. Athlone WWTP is an example of a Cape Town plant that utilizes this technology to stabilize sludge (CoCT, 2008). The use of AD in the Athlone WWTP generates biogas that could potentially be used to generate 6.9 GWhe per year (AgamaEnergy, 2008). However the gas is simply released to the atmosphere thus contributing to the City's GHG emissions. This implies that AD is viewed solely as a sludge stabilization technology: a much earlier attempt to generate energy ended in failure after the expensive gas engine had stood idle for over a decade (von Blottnitz, 2005). In a recent change of practice, raw sewage sludge from Athlone will in future be transported to the refurbished digesters at the Cape Flats WWTP where the produced

gas is to be used in the thermal drying process for stabilised sludge from both works (von Blottnitz, 2011). The contribution to GHG emissions and untapped potential of energy from PS makes this waste an important source of biogas for the current study.

2.3.1.1.4 Organic Industrial Wastes

Organic industrial wastes include a very wide range of waste materials as Figure 2-5 illustrates. Studies have documented the effect that these have on AD. For instance, slaughterhouse waste (SHW) is an ideal substrate for AD as it contains lipids (that is, fat) which represent an important fraction of the organic charge in the SHW (Cuetos et al., 2008). Although this waste type is suitable for AD, digesting it may cause inhibition problems in the process due to the high content of nitrogen (Cuetos et al., 2008). Fish waste is also suitable for AD and it is reported that its biogas yield is slightly higher compared to SHW (Munganga et al., 2010). However, the biogas yields of SHW and fish waste have been reported to be lower compared to the yield achievable with waste paper sludge (WPS) (Munganga et al., 2010).

WPS is generated in large quantities from the Pulp and Paper industry. Scott and Smith (1995) reported that on average 35% of the feed material used for paper manufacturing become residues or rejects. Currently WPS is disposed of in LFS and this has raised concerns due to the quantity of WPS produced from the Pulp and Paper industry (Scott & Smith, 1995). The ultimate disposal of WPS by landfill is no longer an attractive solution for the Pulp and Paper industry as disposal charges are increasing (Scott & Smith, 1995).

Cape Town has three paper companies namely Nampak, Mondi and Sappi. During a site visit to Nampak, it was observed that large quantities of WPS are collected for landfill disposal at Vissershok. The exact quantity of WPS disposed varies but on average, it was estimated that 800 tons of WPS per month are landfilled (Baloyi, 2011). This figure indicates that WPS in the city is in abundance and landfilling it is costly due to the high disposal charge of R264 per ton which is destined to increase (Nontangana, 2011). Special wastes such as WPS might be banned from disposal at LFS in the near future (Nontangana, 2011). The challenges surrounding WPS makes it an interesting waste source for the current project. Furthermore, WPS has a relatively high biogas yield which makes it a good waste source for biogas generation.

2.3.1.1.5 Parameter: Total Solids content

Total Solids (TS) content is defined as the total amount of solids contained in a given waste material (Rohlich et al., 1977). The quantity of TS content in a feedstock affects the digestion process and ultimately gas production. Monnet (2003) states that there are three levels of TS that AD can operate with. These are Low Solid (LS), Medium Solid (MS) and High Solid (HS) systems. LS, MS and HS refer to solid content of less than 10%, 15-20% and 22-40% respectively (Monnet, 2003). AD with a TS content above 25% are called dry digesters and those with a TS content less than 15% are called wet digesters (AgamaBiogas, 2009). The advantages of a higher TS content is that the required digester size is smaller because no additional amount of water needs to be added for digestion unlike in the case of LS and MS where water needs to be added, thus requiring a larger digester size to accommodate this addition. Dry digestion is well suited for water stressed regions such as South Africa as water dilution of the feedstock is not required.

2.3.1.1.6 Parameter: Degree of decomposition

The degree of decomposition (X) also known as the destruction rate refers to the percentage of volatile solids (VS) that is decomposed by bacteria. VS is the amount of organic matter content present in the total solids (TS) of an organic waste feed. That is (Deublein & Steinhauser, 2008):

$$VS(\%) = \frac{VS_{in}(ton)}{TS_{in}(ton)} * 100\%$$

Equation 1

X (%) is the degree at which VS (%) degrades to form biogas. According to Zamudio Canas (2010) Equation 2 can be used to estimate X(%):

$$X(\%) = \left(\frac{VS_{in} - VS_{decomposed}}{VS_{in}} \right) * 100\%$$

Equation 2

VS_{in} refers to the VS content in the feedstock as it enters the digester and $VS_{decomposed}$ refers to the amount of VS that actually decomposes to form biogas. Thus $VS_{decomposed}$ equals the quantity of biogas produced on a mass basis. This method is based on fundamentals of mass balances on reactive systems (Felder & Rousseau, 2000). Karellas et al (2010) also used the same method for estimating $VS_{decomposed}$ and digestate produced from the digestion of three feedstocks. This approach will be used in this project as it is based on fundamentals and also is consistent with other literature.

Deublein and Steinhauser (2008) state that the normal degree of VS decomposition varies between 27-76% and is usually 43.5%. X(%) depends on the type of waste considered and operating conditions for AD. As a result X(%) has been used as one of the criteria for digestion (Mata-Alvarez et al., 2000).

2.3.1.1.7 Parameter: Carbon/Nitrogen (C/N) ratio

The C/N ratio measures the relative amounts (on a mass basis) of carbon and nitrogen contained in the feedstock. When operating the digestion process, it is important to have the right ratio as a high C/N ratio will lead to a rapid consumption of nitrogen by the methanogens and lower gas production (Deublein & Steinhauser, 2008). A low ratio implies that there is too much nitrogen in the system and that ammonia is accumulating, this is not desired as it will inhibit the digestion process (Deublein & Steinhauser, 2008). Therefore, literature suggests that the optimal C/N ratio is in the range of 20-30, that is 20-30 Carbon to a unit of Nitrogen on a mass basis (Parkin & Owen, 1986). It is important to note that these figures are not percentages but mass ratios.

Table 2-3 presents the C/N ratios of a few organic wastes and as shown the values in the table are outside the suggested range from literature. However waste from households is quite close to the optimal range indicating that it will positively contribute to digestion. Paper and straw have C/N ratios that are too high indicating that digesting them would result in low gas yields. The low C/N ratios for primary sludge (PS) and slaughterhouse waste indicate that they are nitrogen-rich waste sources and digesting them would result in inhibition of methane production due to an accumulation of ammonia.

Table 2-3: C/N ratio of a few organic wastes

Waste	C/N ratio
Waste from households	18-28
Primary sludge (PS)	6-9
Paper	125.5 [#] , 201 ^{**}
Straw	90
Slaughterhouse waste	3.7*

(*Cuetos et al., 2008; Deublein & Steinhauser, 2008; [#]Myréen et al., 2010; ^{**}Munganga et al., 2010)

2.3.1.1.8 Parameter: Temperature

Studies indicate that there are two optimal temperature ranges involved in AD namely mesophilic and thermophilic temperatures. The mesophilic range is more commonly used and is at a lower range of 32-42 °C compared to the thermophilic temperature range which occurs at 48-55 °C (Deublein & Steinhauser, 2008; Vindis et al., 2009). Most of the methanogens belong to the mesophilic temperature range and only a few are thermophilic (Vindis et al., 2009).

Vindis et al (2009) compared the biogas production under thermophilic and mesophilic conditions. The results indicated that the degradation under thermophilic conditions was eight times faster and more efficient than under mesophilic conditions. Although thermophilic digestion yields more biogas and has a higher removal efficiency of volatile suspended solids (VSS) its utilization is not popular as a significant amount of energy is required to maintain the high temperature range, this is the disadvantage of thermophilic digestion. Furthermore, thermophilic methanogens are relatively more temperature sensitive than mesophilics. Small variations in temperature decrease the activity of the microorganisms, resulting in biogas losses. Deublein and Steinhauser (2008) found that when operating at thermophilic conditions the temperature should be kept within a range of 2 °C otherwise biogas losses can be as high as 30%.

Mesophilic temperature ranges are more common and have some advantages over thermophilic conditions. Mesophilic conditions are relatively less energy intensive as they require lower temperature ranges for operation. For thermophilic operation, more energy is required to heat the digesters. Therefore for this study mesophilic temperature ranges are considered.

2.3.1.2 Parameter: Hydraulic and Solids Retention Times

Hydraulic Retention Time (HRT) refers to the number of days that the influent liquid phase stays in the digester while the solids retention time is the ratio of the amount of solids in the digester per amount of solids that are washed out (wasted) per day in the effluent (Dennis & Burke, 2001).

A mathematical definition of HRT is illustrated in Equation 3. As shown it is a ratio between the digester volume (V) and the volumetric flowrate (Q) of the feed (Dennis & Burke, 2001; Zamudio Canas, 2010):

$$HRT = \frac{V}{Q}$$

Equation 3

For certain digester technologies such as complete mixing or plug-flow digesters (follows in Section 2.5), the HRT and Solids Retention Time (SRT) are equal (Zamudio Canas, 2010). However for batch digesters the conversion of organic material to biogas is closely related to SRT rather than HRT. A shorter retention time produces a larger amount of biogas per digester volume but results in less organic matter digested. Therefore, the retention time should be selected according to the primary aim of AD. Optimum retention times for large-scale ADs are between 14 and 30 days.

2.3.1.3 Remarks

Anaerobic digestion is a proven and suitable technology for treating organic wastes while simultaneously producing biogas and possibly a treated fertilizer. As mentioned, there are several types of wastes suitable for AD. However, in relation to AD within the Cape Town city setting some wastes are more feasible than others. MSW constitutes the largest proportion of waste landfilled in Cape Town (Jeffares&Green & IngeropAfrica, 2004). Studies show that MSW is quite dependent on economic and population dynamics (Akhile-Consortium, 2011). The landfill disposal of MSW increases pressure on the available LFS and the organic fraction of MSW (OFMSW) results in the generation and emission of landfill gas (which contributes to global warming). AD could potentially address these problems associated with MSW hence it is one of the waste types worth including in this study.

Primary sludge is included in this project as it is available in significant quantities in Cape Town and it is already stabilized via AD in some of Cape Town's WWTPs (CoCT, 2008). The Athlone WWTP illustrates the feasibility of biogas production from primary sludge.

WPS is generated in large quantities in Cape Town and is currently facing disposal problems in terms of the increasing disposal charges and the possibility of disposal prohibition in the near future (Nontangana, 2011). Diverting WPS for biogas production could address these challenges with added benefits of energy generation and mitigation of landfill gas emission. Therefore this dissertation will also include WPS as one of the waste types.

Although the diversion of OFMSW, primary sludge and WPS from landfill disposal avoids the emission of landfill gas, larger quantities of waste can be diverted from LFS by co-digestion instead of individual AD of wastes. Synergies between different waste types might also imply more productive use of expensive capital equipment. The next section covers anaerobic co-digestion of organic wastes.

2.4 Anaerobic co-digestion

Anaerobic co-digestion or simply co-digestion is the simultaneous digestion of carbon-rich and nitrogen-rich organic material (Zamudio Canas, 2010). Examples of these materials are shown in Table 2-3. The primary advantage of co-digestion is the improvement of the rate of biogas yield. This means that shorter HRT (~21 days) in the case of co-digestion can be expected compared to a HRT of 30 days used for mono-digestion (Luste & Luostarinen, 2010). This is achieved as co-digestion offers an improved C/N ratio, increased load of biodegradable organic matter, dilution of potential toxic compounds such as ammonia and synergistic effects resulting from complementary microbial consortia coming from different wastes (Sosnowski et al., 2003; Zamudio Canas, 2010). From an economical perspective the benefit of co-digestion results from sharing of equipment (Zamudio Canas, 2010).

2.4.1 Co-digestion of OFMSW with nitrogen-rich wastes

OFMSW is evidently the largest quantity of municipal waste available in Cape Town (Greiben & Oelofse, 2009; Jeffares & Green & IngeropAfrica, 2004). Its availability, biodegradability and current method of disposal make it an attractive waste for this study. As has been indicated already, OFMSW represents a carbon-rich waste source relative to primary sludge, slaughterhouse and other wastes with high nitrogen content. Pure AD of OFMSW has already been documented (Juanga, 2005; Chaudhary, 2008). Although pure digestion of OFMSW is economical, this can be improved upon by co-digesting OFMSW with nitrogen-rich (n-rich) waste types such as SHW, animal manure and primary sludge (Chaudhary, 2008; Cuetos et al., 2008; Sosnowski et al., 2003).

Cuetos et al (2008) investigated the effect of co-digesting SHW with OFMSW on the treatment of lipid and protein waste. OFMSW and SHW are compatible wastes; OFMSW is rich in carbon while SHW is a good nitrogen source. The study was conducted at laboratory scale using semi-continuous reactors which were operated at a HRT of 25 days and mesophilic conditions (34 °C). The co-digestion mixture of SHW:OFMSW was prepared at 1:5 in weight. SHW has a high fat content, it was observed that

during the pure digestion of SHW the fat removal was only 61% but with the addition of OFMSW values as high as 83% were reached. The other observation was an increase in biogas yield during co-digestion. In fact, the biogas yield for co-digestion of SHW with OFMSW doubled that of pure digestion of SHW. The study illustrated the advantages of co-digestion of SHW with OFMSW. However, not much additional research is available on co-digestion of SHW with OFMSW. On the other hand co-digestion of OFMSW with municipal sewage sludge or animal manure is mature and well established as it dates back to the seventies (Mata-Álvarez et al., 2009).

Co-digestion of OFMSW with animal manure also improves the C/N ratio, alkalinity, buffering capacity (ability to resist pH change upon formation of acid during digestion) and biogas production (Zaher et al., 2007). The advantages of interest to this project are the co-digestion effects on C/N ratio and biogas production which can be easily calculated. Macias-Corral et al (2008) investigated co-digestion of cow manure with OFMSW. The co-digestion mixture was at a ratio of 10:1 (OFMSW:cow manure). As expected the biogas production increased relative to the pure digestion of each of these waste types. Pure digestion of OFMSW and cow manure had poor yields of 37 m³ CH₄ per dry ton of waste and 62 m³ per dry ton of waste respectively. However, the amount of methane produced from co-digesting OFMSW with cow manure was 172 m³CH₄ per dry ton of waste. This increase in production was attributed to the synergistic effects of complementary nutrients contained in the wastes. The results from the study indicate that co-digestion of OFMSW and cow manure is technically feasible. Zaher et al (2007) state that co-digestion of these waste types is a popular method in existing biogas plants. However, there are some disadvantages such as transportation costs associated with collection and delivery of one waste to the other. This issue is quite relevant to Cape Town as agricultural wastes are not commonly found within a city setting.

However, co-digestion of OFMSW with primary sludge instead of cow manure may provide a solution to the transport problem. This is because WWTPs are widely distributed in cities and may be closer to OFMSW relative to cow manure. The proximity of compatible waste sources is essential as it can enhance the economic viability of co-digestion (Rohlich et al., 1977). The current study used a geographic information system (GIS) to locate WWTPs in Cape Town that are nearest to OFMSW sources. Figure 2-6 shows a map of Cape Town illustrating the distribution of WWTPs within the city.

A significant amount of research has investigated co-digestion of OFMSW with municipal sludge. Mata-Álvarez et al (2009) stated that over 50% of research on co-digestion of OFMSW is credited to using sewage sludge as a substrate. A large-scale illustration of co-digestion of OFMSW with sewage sludge can be found at the WWTP in Treviso. OFMSW and sewage sludge were fed into the digester at a ratio of 60:40 on a VS basis. It is reported that the gas production increased by a factor of 3.4 due to the co-digestion of sewage sludge with OFMSW. A WWTP in Velenje (Slovenia) was used to co-digest OFMSW and sewage sludge at an HRT of 20 days. It was reported that the biogas production increased by 80% (Mata-Álvarez et al., 2009).

In summary, research shows that co-digestion of OFMSW with nitrogen-rich wastes such as SHW, animal manure and sewage sludge improves the performance of the process. This is due to the balance of nutrients which ultimately results in higher biogas production. The large-scale co-digestion of manure with OFMSW is popular but it has draw backs due to the location of manure sources. The wide distribution of WWTPs in Cape Town is shown in Figure 2-6. This figure was constructed for the current thesis. As the figure illustrates, the WWTPs are within the boundaries of the city and are therefore likely to be closer to OFMSW sources than animal manure which is an agricultural waste.

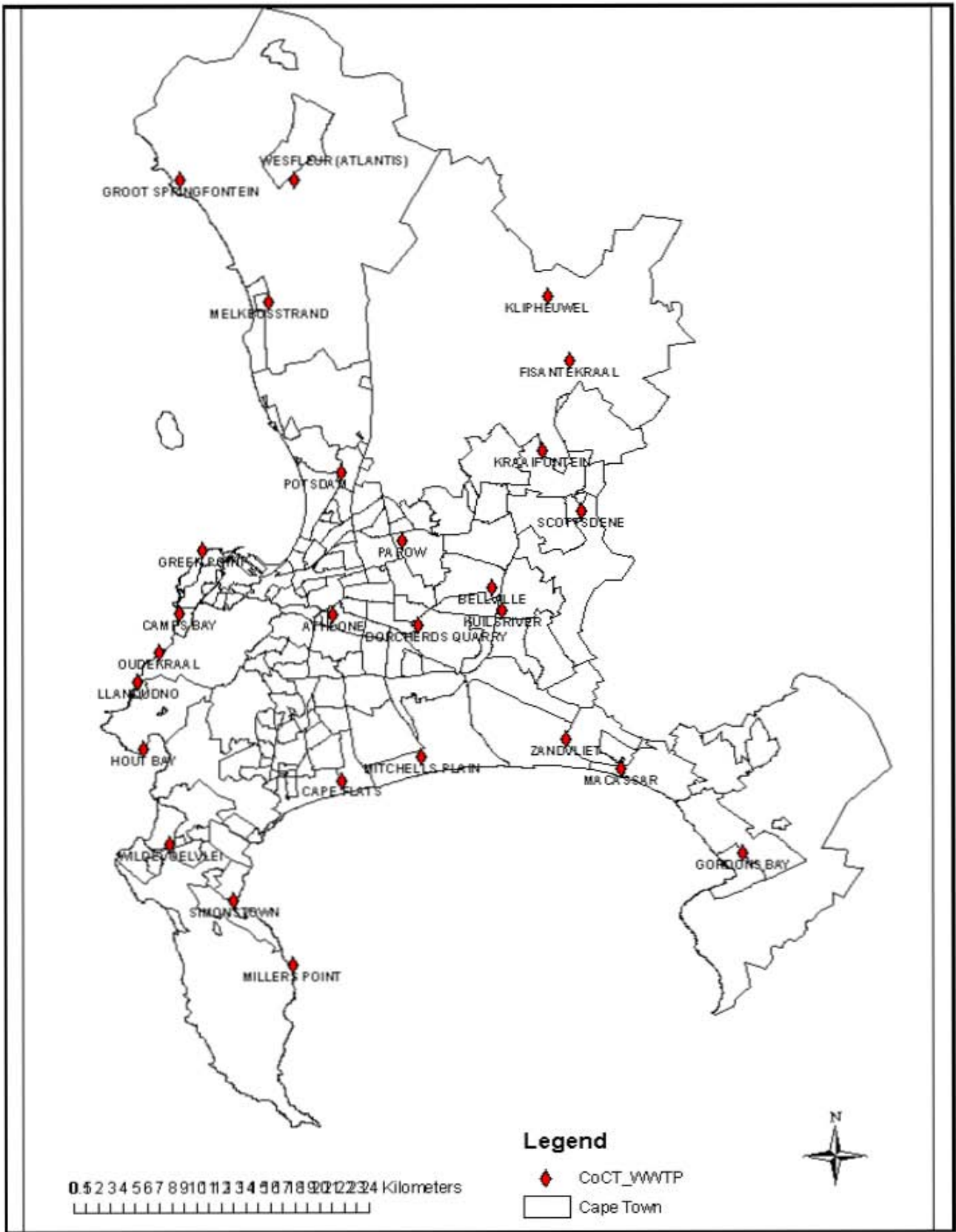

Figure 2-6: Wastewater treatment plants in Cape Town

2.4.2 Co-digestion of Waste Paper Sludge with N-rich wastes

Waste Paper Sludge (WPS) is an example of a carbon-rich industrial organic waste. A few studies have investigated the use of WPS for co-digestion with nitrogen-rich materials.

Hagelqvist (2009) studied the possibility of enhancing biogas production by co-digesting WPS with municipal sewage sludge. The study revealed that WPS was harder to degrade relative to municipal sewage sludge and the digestion process had a very long retention time of 76 days. After 76 days the individual VS degradation of WPS was 6% and that of sewage sludge was 37%. This prolonged retention time and low VS degradation might render co-digestion with WPS unattractive. Hagelqvist (2009) states that the process could be improved by adding 'enough' quantities of municipal sewage sludge. However, the exact definition of 'enough' was not made clear.

Munganga et al (2010) investigated the biomethane potential (BMP) of seventeen organic waste types available in the City of Cape Town. WPS from Nampak, abattoir and animal blood waste were included among the waste types in the BMP study. The C/N ratio of WPS, abattoir and blood wastes were 201, 11.1 and 3.6 respectively. These ratios show that WPS has the highest C/N ratio which makes it a carbon-rich waste type whereas abattoir and blood wastes are nitrogen-rich waste sources due to their low C/N ratios. The differences in C/N ratios imply that WPS is compatible to be co-digested with the nitrogen-rich waste sources. Pure digestion of abattoir, animal blood and WPS resulted in biogas yields of 77.7, 79 and 140.9 ml biogas per gram VS respectively. The results from co-digestion were 72.9 ml per gram VS (for WPS and abattoir) and 60.3 ml per gram VS (for WPS and blood). These are lower than biogas yields from pure digestion of each waste. It could be due to the different retention times as co-digestion was 4 weeks long and pure digestion, ~8 weeks.

Lessons from Hagelqvist (2009) and Munganga et al (2010) reveal that digestion of WPS is difficult. This is illustrated by the low VS reduction rate of WPS from Hagelqvist (2009) of 6% and also Munganga et al (2010) who obtained a VS reduction rate of ~10%. To solve the low VS reduction of WPS, Poggi-Varaldo et al (1997) investigated the use of non-anaerobic inocula for the digestion of a mixture of WPS, sewage sludge and municipal solid waste. This improved the VS reduction efficiency to 60% and the benefit of co-digestion was realised with the increase in biogas yield. This thesis will investigate a large-scale co-digestion of WPS with municipal primary sludge with the aim of diverting

WPS from LFS. Municipal primary sludge is an interesting waste source as it is generated from the widely distributed WWTPs located in Cape Town (Figure 2-6). The aim of using the primary sludge is to minimize transportation costs associated with collection and delivery.

2.4.3 Estimating biogas production and composition

The theoretical biogas production and composition can be determined based on the chemical formula for the feedstock and Buswell's stoichiometric equation (Sosnowski et al., 2003):

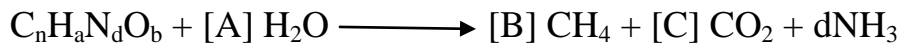

Where A, B and C are coefficients in the chemical reaction equation and are defined as:

$$A = n - \frac{a}{4} - \frac{b}{2} + \frac{3d}{4}$$

$$B = \frac{n}{2} + \frac{a}{8} - \frac{b}{4} - \frac{3d}{8}$$

$$C = \frac{n}{2} - \frac{a}{8} + \frac{b}{4} + \frac{3d}{8}$$

And n , a , b and d are subscripts in the chemical formula of the substrates. e.g. for carbohydrates $n=6$, $a=12$, $d=0$, $b=6$.

According to Van Lier et al (2008), Buswell's equation assumes that the feedstock ($C_nH_aN_dO_b$) is completely biodegradable and that it would be completely converted to CH_4 , CO_2 and NH_3 without any sludge produced from the digestion process (Van Lier et al., 2008). However in reality a fertilizer is an inevitable by-product of biogas formation (AgamaBiogas, 2009). A mass balance (MB) approach can be used to estimate the amount of biogas obtainable from co-digestion of wastes. Karellas et al (2010) used a MB approach to estimate biogas produced from three feedstocks. Although the study only focused on mono-digestion of these feedstocks the approach can be applied to co-digestion. The calculations were based on the predetermined VS (g VS per kg feedstock) and potential biogas yield (Nm^3 per ton VS) values of each feedstock.

According to Sosnowski et al (2003), the composition of CH_4 in the biogas can be estimated as follows:

$$\%CH_4 = \left(4 + \frac{a}{n} - \frac{2b}{n} - \frac{3d}{n}\right)$$

Equation 4

This approach can be utilized in the current study to estimate the CH₄ composition in the biogas under co-digestion.

2.5 Batch and Continuous digesters for Biogas production

Anaerobic digesters can be classified as batch or continuous (Karellas et al., 2010). The type and characteristics of feedstocks determine the type of digester technology. Batch digesters are the simplest and most common types of digester technology (Klass, 1998). Batch digesters work similar to landfill disposal of waste. That is, feed is added to the digester and digestion is allowed to proceed until gas production stops (Deublein & Steinhauser, 2008). A major disadvantage of batch digestion is that it is relatively unstable and difficult to control due to changes in the bacterial population during the digestion process. These changes can lead to digester failure and variations in the quantity and quality of the biogas (Klass, 1998).

A continuous digester receives feed on one end and on the other end an equivalent volume of the product is removed. The Continuously Stirred Tank Reactor (CSTR) is an example of a continuous digester and it is typically used in WWTPs (Klass, 1998). A CSTR is suitable for feedstock with high TS content (Karellas et al., 2010). It has already been established from Section 2.3.1.1.5 that a high content of TS is suitable for the current study. This shows that a continuous type of digestion is applicable.

In the following section, options for converting biogas to energy are reviewed as well as the suitable technologies.

2.6 Biogas to Energy

The section looks at various applications of biogas, technologies for converting biogas to energy, the energy content of biogas and technologies used to upgrade the biogas to a methane-rich biogas stream.

2.6.1 Biogas Applications

Biogas produced from co-digestion represents a renewable energy source with various applications. It can be used for domestic heating, cooking or lighting, in a fuel cell for direct conversion into power, fed

into a natural gas pipeline, used in a transport vehicle or burnt in a co-generation plant to simultaneously generate both heat and power (Deublein & Steinhauser, 2008).

The use of biogas in a co-generation plant or Combined Heat and Power (CHP) unit is especially attractive as it optimises the quality and quantity of energy obtained. The biogas is collected via a pipeline from the top of a digester tank through a removal unit (hydrogen sulphide or carbon dioxide) to a CHP unit in which the biogas is burned in a combustion chamber (Deublein & Steinhauser, 2008; IEA, 2008). This produces a flow of hot gas that drives a turbine which is coupled to a generator producing electricity. The hot gas is then captured using a heat recovery boiler (IES, 2008).

CHP produces power and heat from a fuel source and ideally it should be situated at or near the point of consumption (IEA, 2008). An optimized CHP system is designed to meet the heat demand of a building, industry or other energy users. Any excess amount of power from the CHP unit can be sold to the grid or supplied to another customer via a distribution system (IEA, 2008). The advantage of feeding electricity from a CHP unit to the grid is the potential reduction in transmission and distribution losses that occur when generation takes place far from the point of use. This is particularly relevant to Cape Town's energy picture.

Statistics on Cape Town's electricity supply indicate that the city is reliant on the country's dominant electricity generator, Eskom (SEA, 2007). Energy statistics reveal that 95% of the city's electricity is supplied from the national coal-fired power stations and ~5% from the Koeberg Nuclear Power Stations (SEA & AMATHEMBA, 2007). Approximately 12% of electricity generated from the power stations is lost in transmission and distribution (Winkler et al., 2005). This enormous inefficiency can be reduced by the use of a CHP unit as it is sited near the end user (IEA, 2008). Furthermore, the overall efficiency, that is, the sum of electrical and thermal efficiencies of a CHP unit range from 75-80% depending on the technology and the type of fuel source used (IEA, 2008).

Deublein and Steinhauser (2008) report that the maximum electrical efficiency of a CHP is 40% and that from 1m³ of biogas, only 6 kWh electricity can be produced. This was used to estimate the electricity that could be generated from biogas.

The volume composition of biogas as it leaves the digester is indicated in Table 2-2 (Section 2.3). As the desirable gas is CH₄, all other gases are actually impurities and must be reduced before the gas can be used in a CHP unit. Deublein and Steinhauser (2008) suggest that for the use of biogas for power generation the *minimum* composition of CH₄ should be approximately 60% by volume. Equation 4 can be used to provide an indication of the CH₄ content in the biogas. Technologies that can be used to upgrade biogas to a CH₄-enriched biogas stream are well documented and are discussed in the following section (Deublein & Steinhauser, 2008; IEABionergy, 2001; de Hullu et al., 2008).

2.6.2 Technologies for upgrading biogas

This section discusses available technologies required to remove unwanted gases from the raw biogas that exits the digester. CH₄ and CO₂ represent the majority of the gases contained in the raw biogas. All other gases are present in relatively small amounts (Table 2-2, Section 2.3). Therefore the study has focused on the technologies that remove CO₂ from the biogas. These technologies are cryogenic separation, membrane separation, chemical absorption, high pressure swing adsorption (PSA) and water scrubbing (Deublein & Steinhauser, 2008; IEABionergy, 2001; de Hullu et al., 2008).

Cryogenic separation operates at a cryogenic temperature of -170°C and also at a high pressure of 80 bar (de Hullu et al., 2008). The separation process takes place by cooling and compressing biogas with the aim of liquefying CO₂. The CO₂ is then easily separated from the remaining gas. There is a large capital cost associated with this technology due to the quantity of equipment required and it is this large investment cost that makes cryogenic separation undesirable (de Hullu et al., 2008).

Membrane separation uses the difference in the particle sizes of CH₄ and CO₂. Molecules of certain sizes pass through a membrane while others do not (de Hullu et al., 2008). The disadvantages of this technology are; membranes are expensive and the associated energy costs are relatively high (de Hullu et al., 2008). In chemical absorption, hydrogen sulphide contained in the biogas stream is removed and converted to elementary sulphur (S) which can be sold to other companies. de Hullu et al (2008) reported that a disadvantage of this process is that an additional scrubber unit is required to effectively remove CO₂. The poor performance of this technology in removing CO₂ makes it unattractive.

PSA adsorbs CO₂ under pressure using its molecular characteristics and affinity for an adsorption material (Deublein & Steinhauser, 2008). Adsorption takes place at high pressure and then the process

swings to low pressure to de-adsorb the adsorbent material (de Hullu et al., 2008). The disadvantage of this technology is the high investment costs required relative to the water scrubber (Deublein & Steinhauser, 2008).

The removal of CO₂ with water scrubbing is reported to be the simplest technology (de Hullu et al., 2008). The process is operated at high pressures and separates CO₂ from biogas based on the high solubility of CO₂ in water relative to CH₄. A high water scrubber also has the advantage of removing H₂S from the biogas stream. The disadvantage of this technology is the large amounts of water required, however, this can be minimized by recycling the water (IEABionergy, 2001). The biogas exits the scrubber unit as a CH₄-enriched biogas stream with a CH₄ composition of 95% (Deublein & Steinhauser, 2008). Although CH₄ compositions as high as 98% can be achieved, this is at the expense of water and energy. Murphy and Power (2009) stated that in a biogas plant, the scrubber unit consumes the largest amount of electricity. The electricity consumed by the scrubber is approximately 0.75 kWh_{el} per m³ CH₄-enriched biogas stream (Murphy et al., 2004).

2.7 Baseline and Project GHG emissions

Baseline GHG emissions refer to emissions produced in the absence of a mitigation intervention such as generating energy from a renewable energy intervention, such as biogas produced via anaerobic co-digestion. However, the diversion of organic waste from the LFS to a biogas-producing facility has GHG emissions associated with it (IPCC, 2006). These emissions must be quantified in order to compute the emission reduction potential of generating energy from biogas (NTE, 2006). This section presents and discusses the theory and methods underpinning the estimation of baseline and project related GHG emissions.

2.7.1 Baseline: Estimating GHG emissions from LFS

Currently, OFMSW, WPS and a significant portion of Cape Town's primary sludge waste are disposed of at LFS (Jeffares&Green & IngeropAfrica, 2004; Alcock, 2009). The landfill disposal of organic wastes produces significant amounts of methane (CH₄), a GHG with a global warming potential (GWP) that is 21 times that of carbon dioxide (CO₂) (NCASI, 2005). In addition to the quantities of CH₄

generated, other substances are also produced: biogenic CO₂, non-methane volatile organic compounds (NMVOC's), nitrous oxide (N₂O) (IPCC, 2006).

IPCC (2006) reports that in 2001, CH₄ generated from LFS contributed approximately 3 to 4% of the annual global anthropogenic GHG emissions. There are alternative waste management techniques such as co-digestion that can be used to reduce the amount of waste disposed of at LFS thereby avoiding GHG emissions associated with waste disposal. It is in the interest of this project to estimate amounts of avoided GHG emissions as a result of diverting OFMSW, WPS and primary sludge from the LFS.

The potential amount of methane emissions can be estimated depending on the carbon content of each waste. Equation 5 estimates the amount of degradable organic carbon (DOC) contained in waste *i* (IPCC, 2006):

$$DOC = \sum_i(DOC_i * W_i) \quad \text{Equation 5}$$

Where;

DOC: Fraction of degradable organic carbon (ton of Carbon/ton of waste).

DOC_i: Fraction of degradable organic carbon in waste type *i*.

W_i: fraction of waste type *i* by waste category.

DOC is that organic carbon in the waste that is accessible to biochemical decomposition. Bhattacharya et al (1996) estimated the CO₂ emissions from animal waste by assuming that the carbon content can be used to approximate the emissions. A similar approach can be followed by the current study. However, as mentioned above, organic wastes decompose in LFS to generate CH₄ emissions. Therefore the DOC value from Equation 5 can be used in Equation 6 to determine the CH₄ emissions (IPCC, 2006):

$$CH_{4_{generated}} = DOC * F * 16/12 \quad \text{Equation 6}$$

Where;

CH_{4_{generated}}: the amount of CH₄ emissions generated within the landfill (ton of methane/ton of waste).

DOC: as explained in Equation 5

F: composition of CH₄ in landfill gas.

16/12: molecular ratio of CH₄ to CO₂

Equation 6 estimates the amount of CH₄ generated in a particular LFS but not all CH₄ generated is released to the atmosphere. A certain portion of CH₄ generated may be oxidized in the soil or other material covering the waste. An oxidation factor (OX) is used to estimate the amount of CH₄ oxidized in the soil or material covering the waste. It is reported that sanitary, well managed LFS tend to have higher OX rates than unmanaged dump sites (IPCC, 2006). IPCC (2006) suggests two OX values that can be used depending on the type of LFS. Landfill sites which are not covered with soil, that is, unmanaged sites have an OX value of 0. This means that as CH₄ is generated by unmanaged LFS, it is released to the atmosphere and not oxidized. Managed LFS are those that have a soil or compost covering the waste and the suggested OX value is 0.1 (IPCC, 2006).

In Cape Town, OFMSW and WPS are currently disposed of at the largest LFS, Vissershok (CoCT, 2011). On a site visit to Vissershok waste was being covered with soil thus by IPCC's definition this is a managed LFS. Therefore the study will use an OX value of 0.1 for the site. Alcock (2009) stated that sewage sludge (mixture of primary sludge and secondary sludge) generated in Cape Town is either stockpiled on site, used for agricultural purposes or disposed of at dedicated landfill sites. The sludge produced from Bellville WWTP in Cape Town is applied on agricultural land whereas the Athlone WWTP disposes its sludge at a dedicated LFS. Therefore different OX values are applicable depending on whether the sludge is landfilled or stockpiled.

In the case of sewage sludge applied on agricultural land, CO₂ is formed instead of CH₄. However, this CO₂ is of biogenic origin and thus generally not included under landfill emissions (IPCC, 2006).

2.7.2 Baseline: Estimating GHG emissions from energy use

As mentioned previously, a significant proportion of Cape Town's *electricity* supply is generated by coal-fired stations (95%) (SEA & AMATHEMBA, 2007). Letete et al (2009) presents an average emission factor (EF) specific to South Africa's coal-generated electricity which was calculated by Eskom. This EF enables the estimation of carbon emissions associated with electricity generation from coal using (NTE, 2006):

$$CO_{2emissions} = EA * EF \quad \text{Equation 7}$$

Where;

EA: Energy activity (kW)

EF: Emission factor (kg CO₂ per kW) of a fuel source (diesel, coal, LPG, etc)

Fossil fuels such as diesel, heavy fuel oil (HFO), coal, LPG and paraffin are often used to meet industrial *thermal energy* demand (Winkler et al., 2005; SEA & ERC, 2010). The use of fossil fuels for thermal energy also contributes to Cape Town's GHG emissions. These emissions can be mitigated by replacing fossil fuels with the thermal component of energy derived from biogas (Junfeng et al., 1997; Bhattacharya et al., 1996). In order to determine the emission reduction potential of biogas energy it is important to estimate the amount of GHG emissions generated from using fossil fuels to meet industrial demand for heat. For this, IPCC (2007) lists EF (kg CO₂-equivalent/GJ) associated with diesel, heavy fuel oil (HFO), coal, LPG and paraffin. The thermal energy component produced from the CHP unit would replace these fuels and their associated CO₂-equivalent emissions.

2.7.3 Project activity: Estimating GHG emissions from biogas production

When estimating GHG emissions generated from the co-digestion process of organic wastes, CO₂ and N₂O are often excluded due to the biogenic origin of CO₂ and the negligible quantities of N₂O, thus only CH₄ is included in the estimations (IPCC, 2006).

Biogas facilities have unintentional CH₄ leakages due to process disturbances. IPCC (2006) suggested that the amount of CH₄ leaking from the facility is generally 0 to 10% of the amount of CH₄ generated. A default value of 5% can be used in the absence of further information (IPCC, 2006). This dissertation used this default figure as a ball-park estimate of CH₄ emissions generated from biogas production.

In summary, to compute the quantities of GHG emissions associated with project activity one has to estimate the amount of CH₄ leakages and add them to the amount of CO₂ generated as a result of combusting biogas via CHP for energy generation. The CO₂ generated from combustion should be included in the GHG emissions for the project. Emissions associated with energy generation via CHP can be estimated from either Equation 7 or from energy modeling software programs. The emissions reduced will then be the difference between project emissions and baseline emissions (NTE, 2006).

Although, biogas derived energy can be expected to reduce GHG emissions, the cost of emission reduction is worth investigating. The following section discusses methods relevant to perform a financial analysis of energy from biogas production.

2.8 Financial Analysis of energy generation from biogas

It is in the interest of this project to estimate the cost of mitigating GHG emissions via biogas production as well as investigating possible sources of revenue to improve the economics of emission reduction via biogas.

2.8.1 Estimation of Costs and revenue streams

The cost of a biogas project can be divided into investment costs, operating and maintenance (O&M) costs and other costs such as insurance (Deublein & Steinhauser, 2008). Investment costs refer to the amount of money required to completely construct a biogas plant and bring it to the point of start-up. This includes purchasing of land, excavation-work, construction of the biogas digester and gasholder, piping work and storage tanks for feedstocks (Amigun & von Blottnitz, 2010). O&M costs, as the name suggests are costs necessary for the general running of the plant. They are divided into fixed and variable O&M costs. Fixed costs refer to depreciation, insurance costs, rent, property tax, employee benefits and so on. Variable costs refer to costs to acquire waste feedstocks and costs associated with the plant's energy consumption.

The method used for estimating investment costs is largely dependent on the level of accuracy required (Amigun & von Blottnitz, 2010). The capital cost of a project is not always linearly proportional to the plant capacity. The *order of magnitude* accounts for economies of scale and provides an approximate estimate of the capital cost of a project and it is based on knowledge of a historical project (Amigun & von Blottnitz, 2010). This method can be used prior to the preparation of a process flow diagram and suffices as a quick estimate of the investment cost (Sinnott, 1999). Equation 8 is used to estimate the investment cost (Peters & Timmerhaus, 1991):

$$C_{-1} := \left(\frac{Q_{-1}}{Q_{-2}} \right)^n \cdot C_{-2} \quad \text{Equation 8}$$

Where;

C_1 : cost of item (or project) at capacity Q_1

C_2 : cost of reference item (or reference project) at capacity Q_2

n : cost capacity factor

The cost capacity factor, n is usually taken to be 0.6 and referred to as the *six-tenths rule*. This value can be used in the absence of sufficient data available for the project (Sinnott, 1999). However, Amigun and von Blottnitz (2010) have determined that for large-scale biogas plants that are greater than 20 m³ in size, the cost capacity factor of 0.8 applies. This value is slightly larger than the *six-tenths rule* that is usually used for chemical processes. However, the n factor of 0.8 is more suitable for use in this project as it is specific to biogas plants. Studies have estimated the distribution of this investment cost for a digester to be 63-65% for construction costs and 35-37% for technical equipment (AgamaBiogas, 2009; Deublein & Steinhauser, 2008).

The investment costs of a CHP and water scrubbing unit must be added to the investment cost of Equation 8. This is because the investment costs of a CHP unit are specific to its nominal capacity and include electrical installations. The investment costs of a CHP unit are approximated to be 650 US\$ per kW_{el} (Deublein & Steinhauser, 2008). Similarly the investment costs of a scrubber are based on the nominal capacity of the CHP engine. Figure 2-7 is a graphical representation of the investment costs of a water scrubber and a pressure swing adsorption (PSA) (Deublein & Steinhauser, 2008). The curve at the bottom in Figure 2-7 is the investment cost for a *scrubber unit* as a function of the estimated nominal capacity of a CHP unit (kW_{el}).

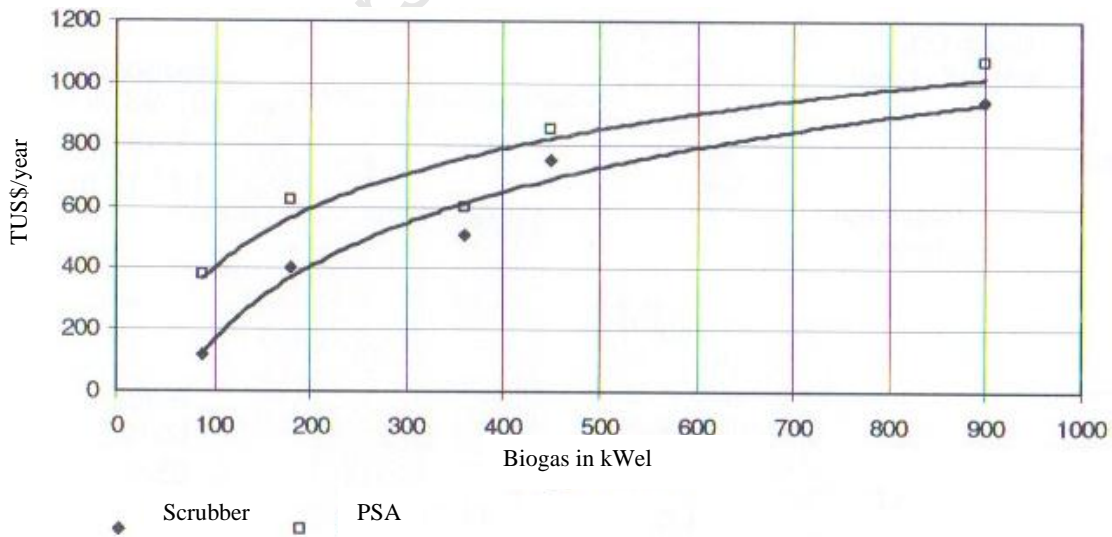

Figure 2-7: Investment costs of a water scrubber (TUS\$=1000US\$)

Source: (Deublein & Steinhauser, 2008)

For O&M costs, Deublein and Steinhauser (2008) report that maintenance costs for construction/concrete works are 0.5% of the investment cost required for construction and 3% of the investment for technical equipment (piping and installation). The estimated O&M cost for a CHP is regarded to be 4% of the of the investment costs of the CHP. The following Figure 2-8 is a schematic representation of the operational cost of a scrubber unit (top curve) (Deublein & Steinhauser, 2008). This curve will be used in this study to estimate the operating costs of a water scrubber based on the nominal capacity of the CHP engine.

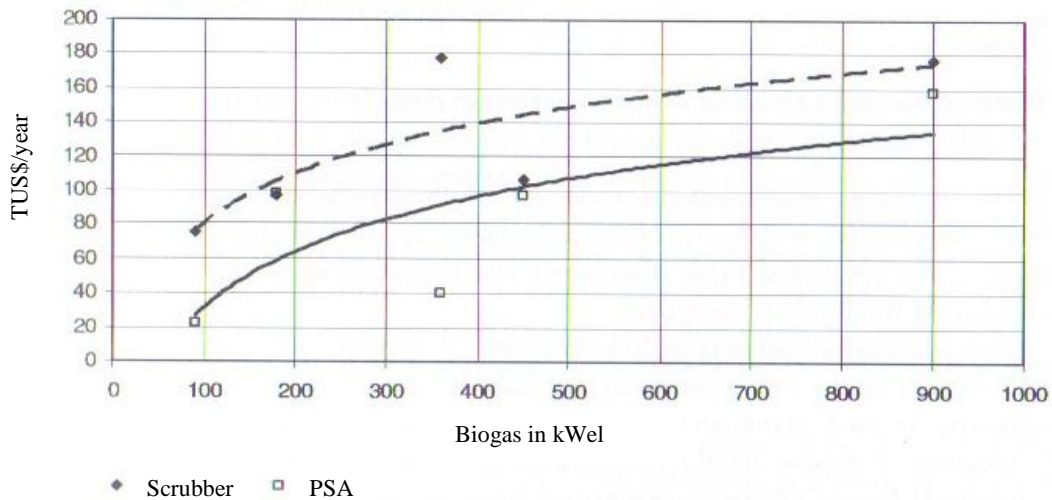

Figure 2-8: Estimating operational costs of a scrubber unit (TUS\$=1000US\$)

Source: (Deublein & Steinhauser, 2008)

The costs mentioned above should be balanced by a revenue stream in order for the biogas plant to be economically viable. Typical sources of income for biogas plants are electricity sales, heat sales and fertilizer sales (Deublein & Steinhauser, 2008).

2.8.2 Evaluation of profitability

The ultimate incentive of investing money into any project apart from environmental and energy supply issues, is the ability of that project to remain economically feasible. Methods for evaluating the economic performance of a biogas project can be divided into methods that are value based, time based or rate based (Cohen, 2009). Value based methods include cash-flow/cumulative cash flow analysis and net present value (NPV). Figure 2-9 represents a general cash-flow diagram (Sinnott, 1999):

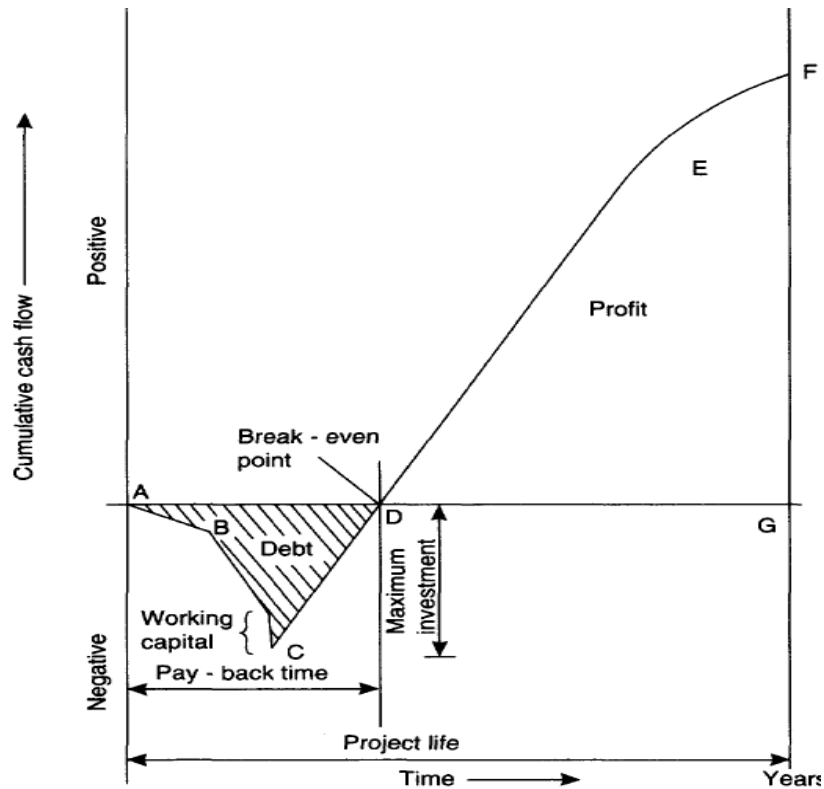

Figure 2-9: Generic project cash-flow diagram

Source: (Sinnott, 1999)

The flow of cash is essential for any project to be kept operational. Figure 2-9 illustrates the forecast cumulative cash-flow over the project life. The cash-flows are calculated based on the investment costs, operational costs and revenue streams (Sinnott, 1999). As shown in the figure, the project life can be divided into five regions. These are:

A-B: The investment required to design a plant

B-C: Investment required for constructing the plant and bringing it to the point of start-up

C-D: From point C, income is generated from sales and as a result the curve turns. Although at this point the *net cash-flow* is positive, the cumulative cash-flow remains negative until point D where the project *breaks even* and the investment is paid off. The time required to reach point D is referred to as *pay-back period (PBP)*.

D-E: Cumulative cash-flow is positive in this area and the project is earning a return on investment (ROI)

E-F: The slope of the curve may fall off in this region due to increased operating costs and falling revenues. Point F shows the end of project life.

The advantage of a net cash-flow analysis is that it serves as a basis of calculating other profitability assessment criteria such as the NPV, IRR, ROI and PBP.

NPV is also a value based profitability criterion which takes into account the time-value of money (Karellas et al., 2010; Sinnott, 1999). NPV is the sum of discounted cash-flows after tax over the life of the project. The NPV is defined as (Karellas et al., 2010):

$$NPV = \sum_{t=0}^n \frac{(NCF)_t}{(1+r)^t} \quad \text{Equation 9}$$

Where;

NPV: net present value

NCF_t : net cash-flow at time period *t*

t: time period from 0 to *n* years

r: discount rate (%)

Evaluating the profitability of a project using the NPV is fairly simple, if the NPV is positive then the project is attractive and the higher the NPV the more profitable the project. Karellas et al (2010) argues that NPV being an absolute variable, does not accurately express the profitability of a project. This is much like the PBP, which is a time based profitability criterion.

Payback period (PBP) refers to the length of time required to recoup the initial investment as indicated in Figure 2-9. Sinnott (1999) and Perry et al (1997), state that the PBP does not reflect of the economic performance of the project after the break-even point. The PBP is based on the grounds that the earlier the initial investment costs are recovered, the better the project. However this is misleading as a project can take longer to recoup investments but would have a larger cumulative cash-flow relative to a project that has a shorter PBP with a smaller cumulative cash-flow.

The rate based methods refer to the internal rate of return (IRR) and the return on investment (ROI). IRR is defined as the discount rate, (*r* (%)) at which the NPV defined in Equation 9 is zero. This means that the present value of investment funds equals the net present revenues (Karellas et al., 2010). IRR is defined as:

$$0 = \sum_{t=0}^n \frac{(NCF)_t}{(1+IRR)^t}$$

Equation 10

Where; IRR is the internal rate of return (%).

The advantage of using the IRR is that projects of vastly different sizes can be compared. Using the IRR as an investment criterion is fairly simple, if the IRR of a project is higher than the discount rate the project is accepted and deemed to be profitable otherwise it is rejected. The higher the IRR the more profitable the project is (Karellas et al., 2010).

There is also the ROI which is defined as the ratio of the annual net profit to the initial investment (Sinnott, 1999). ROI represents a method of measuring the performance of the funds invested. The ROI is defined as (Cohen, 2009):

$$ROI = \frac{\text{Average annual net profit}}{\text{initial investment}}$$

Equation 11

The above profitability assessment methods will be used in this study so that the viability of energy generation from biogas can be fully checked and verified.

According to Sinnott (1999) and Perry et al (1997) a sensitivity analysis can be performed to examine the effects of uncertainties in the profitability of the biogas project. Sensitivity analysis was used in this project to assess the sensitivity of electricity sales to economic viability of energy generated from biogas.

In the following section, energy modeling studies are discussed within the context of investigating the impact biogas could have on Cape Town's energy supply and emissions.

2.9 Modeling energy from biogas

The impact of energy from biogas on a region's energy supply can be analysed by use of an energy model. The adoption of a particular energy model depends on the objectives and nature of a study. MARKAL and LEAP have been commonly used for regional and national energy planning in South Africa. The national Long-Term Mitigation Scenarios (LTMS) used the MARKAL (Market Allocation)

model which is an optimization model that provides a least cost solution subject to constraints (Winker, 2007). LEAP (Long-Range Energy Alternatives Planning) is an accounting framework or simulation model which has been used on a regional level for modeling Cape Town's energy systems (Winkler et al., 2005). The purpose of the model was to simulate scenarios for Cape Town's energy future over a twenty year period (2000-2020).

Energy Scenarios for Cape Town is a more recent study undertaken by Sustainable Energy Africa (SEA) and the Energy Research Centre (ERC) (SEA & ERC, 2010). The study developed a LEAP model to simulate the implications of using different energy supply mixes and energy efficiency interventions. Various generation technologies and fuels were considered to meet electricity consumption by the city. The sources considered were municipal waste, solar thermal electricity, coal, nuclear, hydro and natural gas for Gas turbines (SEA & ERC, 2010). The list of energy sources considered excluded energy from biogas. It is the intent of the current study to use the same model including energy generated biogas to analyze the impact biogas could have on Cape Town's optimum energy future.

3 Research Methodology

The objectives of the thesis are to estimate the emission reduction potential of energy generation from biogas and the associated cost. Highlights from literature indicate that the organic fraction of MSW (OFMSW), primary sludge and waste paper sludge (WPS) are interesting waste types to include in this work due to their abundance and unattractive disposal methods. Biogas production via AD could be a worthwhile alternative option of disposal with the added advantage of energy recovery. From the literature, it is evident that biogas production via anaerobic co-digestion of carbon-rich waste with nitrogen-rich waste types results in higher biogas yields than mono-digestion. This implies that a relatively higher energy output can be expected from anaerobic co-digestion, thus reducing the unit cost of producing an alternative energy product. This chapter presents the methodology that was followed to reach the research objectives and provide answers to the key questions.

3.1 Overview

Figure 3-1 shows the sections in this chapter where each key question is answered.

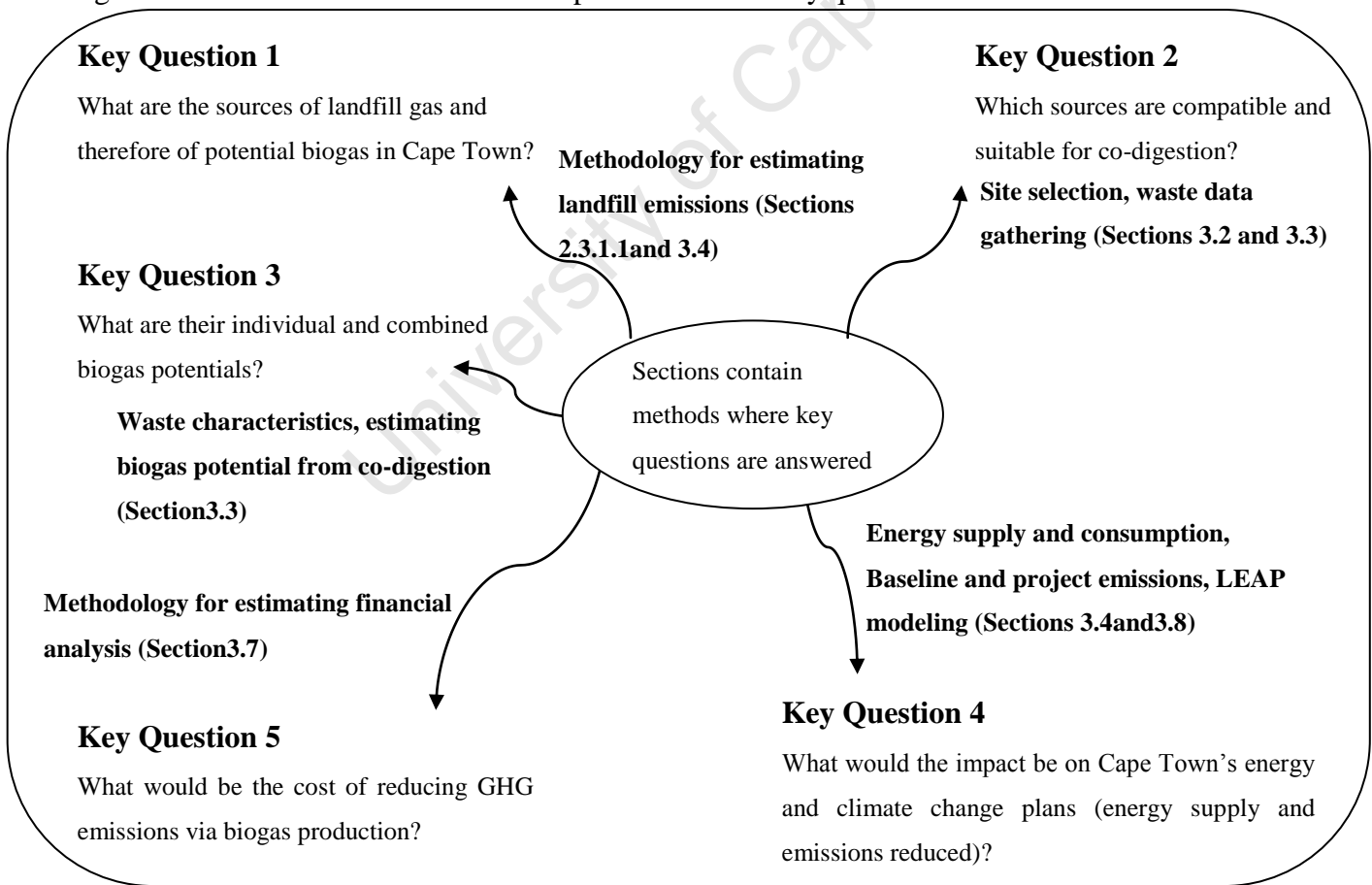

Figure 3-1: Graphical representation illustrating sections corresponding to each key question

Chapter 2 (Section 2.3.1.1) has already answered *key question 1*. The answer is further solidified by determining the landfill gas potential of wastes (Section 3.3). To answer *key question 2*, information beyond waste composition (C/N ratios) is needed, especially in terms of waste quantities and places of origin: the methods adopted for this are presented in the sections on waste data gathering (Section 3.2) and site selection (Section 3.3) as these contain characteristics of carbon-rich and nitrogen-rich wastes as well. The characteristics of the waste sources revealed their compatibility. However, Section 3.2 provides a map that shows which wastes should be co-digested in order to minimise transportation costs. Sections on waste characteristics contain biogas yields and volatile solids content from previous literature studies, illustrate how to estimate the combined biogas potential from co-digestion thus answering *key question 3*. Section 3.6 answers *key question 4*. The financial results provide the costs of avoiding landfill emissions by diverting wastes from landfill disposal. Answers to *key questions 2* and *4* (waste quantities and cost of biogas production) are extended to provide a city-wide energy modeling using LEAP, this answers *key question 5*.

3.2 Site selection

Figure 3-2 shows only a portion of the Cape Town map which was constructed using ArcGIS software. ArcGIS is a geographic information system (GIS) mapping software developed by Esri (Esri, 2011). This software was useful in this project as it could be used to identify the locations of carbon-rich (OFMSW and WSP) and nitrogen-rich (primary sludge, PS) waste sources. This served as a justification for co-digesting wastes available from these locations. In the figure, waste types for Model 1 are OFMSW available from the Athlone Refuse Transfer Station (ARTS) which could be co-digested with PS from the nearby A_WWTP. Furthermore, the figure shows that Model 2 includes co-digestion of WPS from Nampak and PS from B_WWTP as the waste sources are in close proximity. Due to the closeness of the compatible waste generators, transportation costs were assumed to be negligible. The purpose of developing Model 1 and Model 2 is to investigate the feasibility of obtaining energy from decentralised biogas plants in Cape Town.

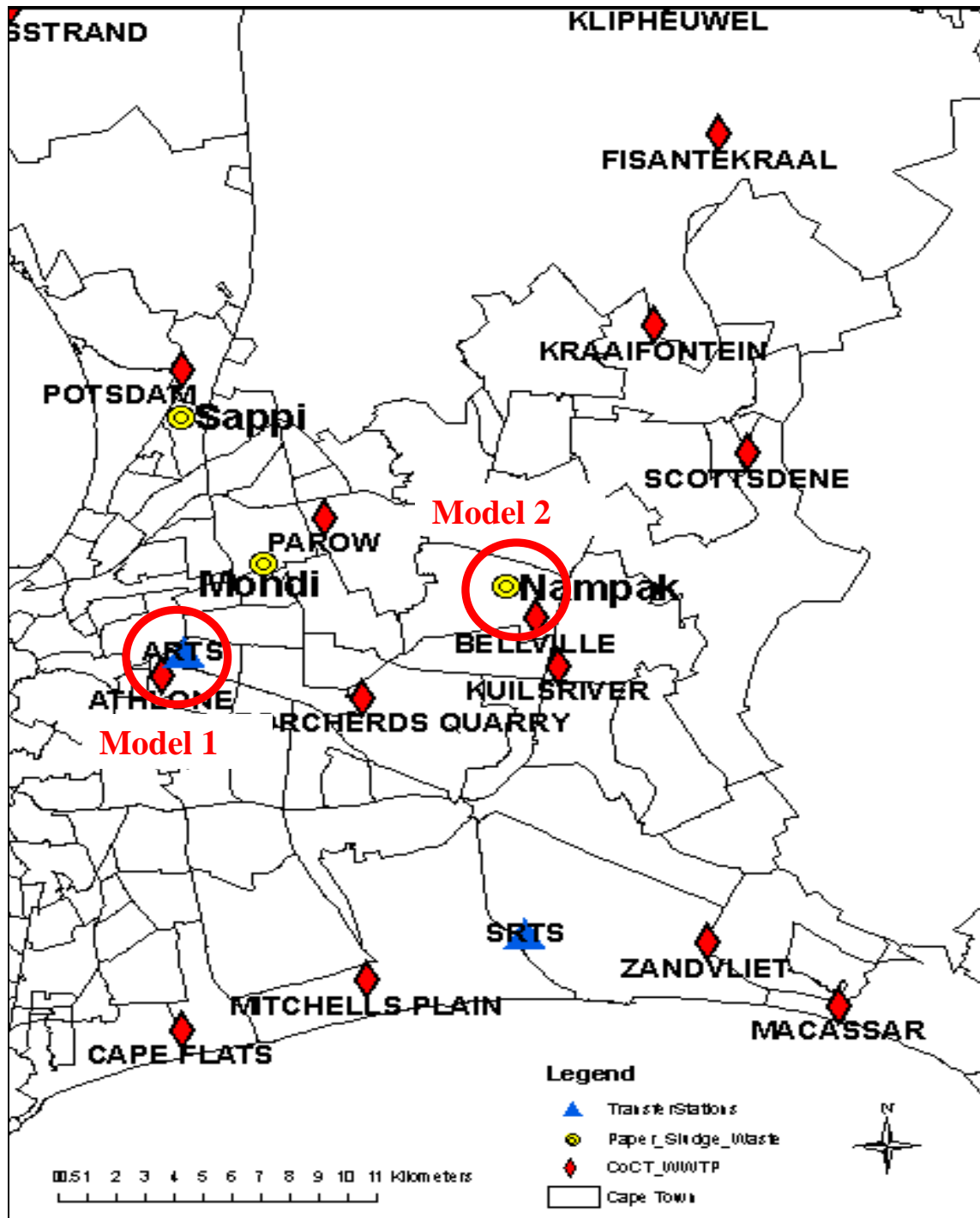

Figure 3-2: Geo-referencing of compatible organic waste types

In the following section, the parameters (tonnages, chemical analysis and biogas yields) of both Model 1 (OFMSW and Athlone PS) and Model 2 (WPS and Bellville PS) are quantified prior to the estimation of biogas production and associated energy output from the two models.

3.3 Gathering Waste Data

This section estimates the quantities of wastes generated from the sites shown in Figure 3-2. The chemical formulae, individual characteristics of wastes and biogas yields are presented from other literature sources. The carbon-rich sources are discussed first, followed by the nitrogen-rich sources.

3.3.1 C-rich sources (OFMSW & waste paper sludge)

3.3.1.1 OFMSW

Waste generation data for OFMSW used in the current study was obtained from the Integrated Solid Waste Management (ISWM) consultancy study conducted in 2004 (Jeffares&Green & IngeropAfrica, 2004). The study was conducted for the City of Cape Town (CoCT) by Jeffares & Green (Pty) Ltd in joint venture with Ingerop Africa (Pty) Ltd.

Research shows that waste generation is dependent on income levels and population density (Ojeda-Benitez et al., 2008; Engledow, 2008; Mazzanti et al., 2008). Table 3-1 (Appendix 7.1) shows that the consultancy study for CoCT disaggregated waste data according to different income levels (high, middle and low), population and waste characteristics. The consultancy study aligns well with the current study as it provided bulk waste data and waste characterised data for the greater Cape Town and for the Athlone Refuse Transfer Station (ARTS) which is one of the areas of interest for the current study.

Figure 3-3 below shows the type and quantities of waste streams that enter ARTS. It was assumed that the household waste is from high income households as the transfer station services the Cape Town Central Business District (CBD) area (Jeffares&Green & IngeropAfrica, 2004).

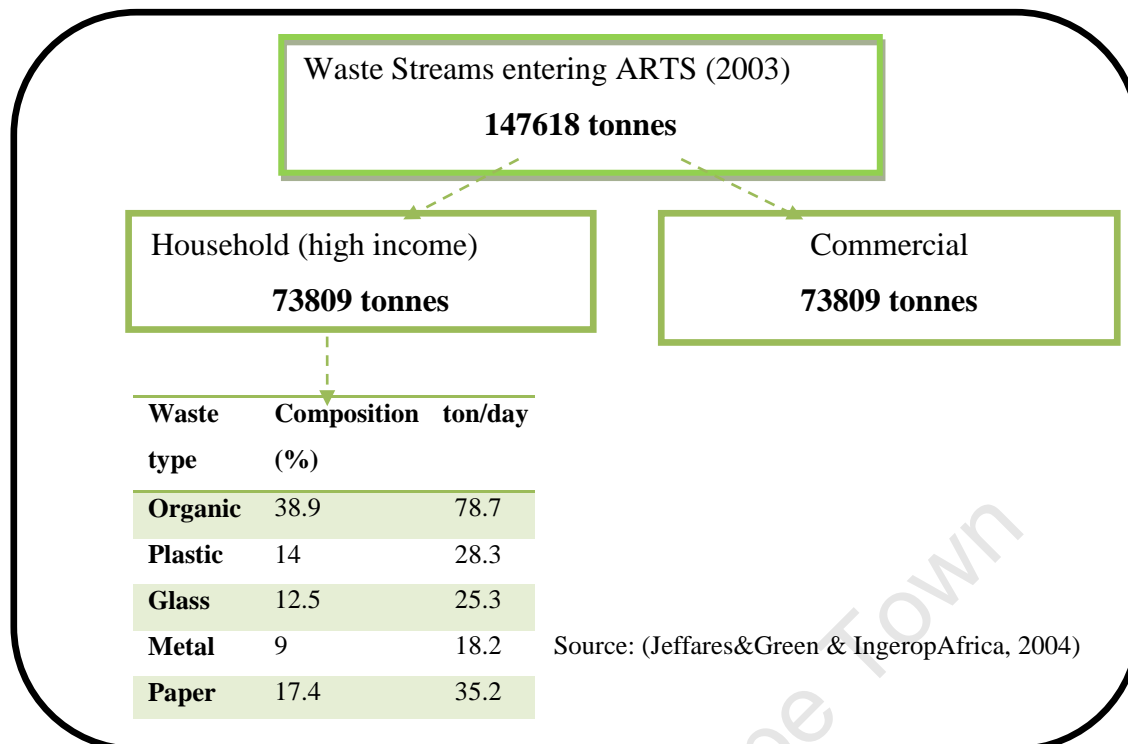

Figure 3-3: Waste streams entering ARTS from the Integrated Solid Waste Management Study
Source: (Jeffares&Green & IngeropAfrica, 2004)

Table 7-2 (Appendix 7.1) contains household composition of wastes according to high, middle and low income groups in Cape Town. An analysis of the household waste data indicates that waste from low income households has the highest organic fraction relative to the other two income groups. Intuitively, this is expected as low income households would tend to spend their income on staple food and not purchasing printing paper, for instance. It is essential to note that the organic composition referred to in Figure 3-3 and Table 7-2 excludes garden waste, and thus includes only food waste and is referred to as OFMSW in the present study.

More recent research Munganga et al (2010) assessed the bio-methane potential (BMP) of OFMSW in Cape Town. The study was carried out in a laboratory, and was thus experimental in nature. An elemental analysis of four samples of OFMSW from ARTS was also included in the research and the results from the analysis are shown in Table 7-4 (Appendix). These results are on a mass basis and are important to the study as they enable computation of the carbon to nitrogen ratio (C/N). The elemental analysis from Munganga et al (2010) did not include the composition of oxygen, it was calculated in the

current project by subtracting the sum of *mass* percentages of other elements (C, H and N) from 100%. That is:

$$O(\%) = 100\% - (C(\%) + H(\%) + N(\%))$$

Calculating O(%) enabled the current study to determine formulae for each OFMSW sample as shown in Table 7-6 (Section 7.1, Appendix). However, only average numbers of the subscripts for each element were used and the overall chemical formula of OFMSW is shown in Table 3-1. Section 7.1 (Appendix) contains a sample calculation showing how the mass percentages of each element were used to determine the chemical formula.

Table 3-1: Chemical formula for OFMSW

Waste type	Chemical formula
OFMSW	C ₂₅ H ₄₁ N ₁ O ₂₁

The BMP study for CoCT also included a characterization of four food samples. These are shown in Table 3-2, this project uses the average amounts of the four OFMSW samples throughout.

Table 3-2: Characteristics and biogas potential of OFMSW from ARTS

Sample number	1	2	3	4	Average	Std. deviation
Biogas yield (ml /g VS)	250.1	191.6	171.5	261.4	218.65	43.86
Moisture Content (MC, %)	83	84	83	78	82	2.6
Total Solids (TS, %)	17	16	17	22	18	2.6
Volatile Solids (VS, %)	82	90	88	68	82	9.83
pH	5.6	5.6	5.4	5	5.4	0.28

Source: (Munganga et al., 2010)

3.3.1.2 Waste Paper Sludge

There are three paper manufacturers in Cape Town namely; Sappi, Mondi and Nampak. The current study only includes the amount of waste paper sludge (WPS) from Nampak as it is closest to the Bellville WWTP (Figure 3-2). It was reported that Nampak disposes 800 ton/month (25.81 ton per day) of their WPS at the Vissershok landfill site (Baloyi, 2011). This amount is considered credible as it was

obtained from Nampak. Therefore, all the computations in the current study associated with WPS were based on this amount.

Table 7-7 (Appendix 7-1) contains the elemental analysis of WPS which has a C/N ratio of 126 (Myréen et al., 2010). This indicates that WPS is a highly carbon rich waste source. Munganga et al (2010) also measured a significantly high C/N ratio of 201 for WPS.

The chemical formula for WPS was determined from the elemental analysis (Table 7-7) and is shown in Table 3-3.

Table 3-3: Chemical formula and characteristics of WPS

Waste type	Chemical Formula	TS(%)	MC (%)	VS (%)	pH	Biogas yield (ml/g VS)
WPS	$C_{0.021}H_{0.03}N_{0.0001}O_{0.012}$	32	68	98.5	6.7	140.9

Source: (Munganga et al., 2010)

Table 3-3 also shows the total solids, moisture content and volatile solids of WPS and shows the biogas yield of 140.9 ml/g VS was obtained in the BMP study for CoCT by Munganga et al (2010). This biogas yield and that of OFMSW represent the biogas potential for mono-digestion. This study estimated the increase in biogas potential as a result of co-digesting the wastes in Model 1 and 2. Data collection and analysis associated with the nitrogen-rich sources is analysed in the following section.

3.3.2 N-rich sources (Primary Sludge)

3.3.2.1 Athlone and Bellville

At the time of writing the current work, the exact amount of primary sludge (PS) produced from the city's WWTPs was unknown as site visits during the present study could not provide useful quantities. However, a feasibility study prepared in 1999 for the Water and Waste Directorate for the CoCT reported that in 1997, approximately 245 200 wet tons of sludge per year was produced from the WWTPs serving the city (Wright-Pierce, 1999). Detailed amounts of sludge generated per plant were not available from this feasibility study. Mamabolo (2006) stated that the majority of sewage sludge

generated at the WWTPs is PS, thus it was assumed in this study that the 245 200 wet tons mentioned above is PS. The project used the total capacity of WWTPs in Cape Town and the total amount of wet PS produced to estimate the quantities of PS produced from Athlone and Bellville. This is explained further below.

Table 7-8 (Appendix) shows the capacities of each WWTP in Cape Town (CoCT, 2008). As shown, the total capacity of all the WWTPs is 590ML/day. It was assumed that this capacity corresponds to 245 200 wet tons per year, as mentioned above. Thus, based on this assumption and capacities of the Athlone and Bellville plants, it was possible to estimate the quantities of PS produced, these are shown in Table 3-4

Table 3-4: Quantities of primary sludge produced (PS) from the two WWTPs

	Capacity (ML/day)	PS (ton/day) ³
Athlone WWTP	*98.25	111.8
Bellville WWTP	*59.37	67.57

Source: *(CoCT, 2008)

The quantities of PS generated from Athlone and Bellville may be underestimated due to the population increase since 1998 (~3million) to 2007 (3.4million) and also the increase in sanitary services (CoCT, 2008). This implies that the overall results of the current study only serve as an indication.

Table 3-5 presents an elemental analysis of PS from the Mitchell's Plain WWTP from Brint (2008). The present study used the same values for Athlone and Bellville due to the lack of data for these plants. During a site visit to Athlone, the plant manager indicated that there are variations in wastewater received by treatment plants, thus the elemental analysis would vary depending on the activities in serviced areas. That is, variations in the characteristics of wastewater received at the treatment works are inevitable. Therefore, the elemental analysis and chemical formulae used for Athlone and Bellville are considered to be sufficiently accurate to meet the objectives of this dissertation. Moreover, the C/N ratio shown in the table is approximately the same as the C/N ratio found in other literature sources (Iranzo et al., 2004).

³ See below Table 7-8 (Appendix)

Table 3-5: Elemental analysis of PS

	C (%)	H (%)	N (%)	O (%)	C/N
Mitchell's Plain	48.64	7	7.005	34.08	6.94

Source: (Brint, 2008)

The above elemental analysis translates to $C_{4.05}H_7N_{0.5}O_{2.13}$ shown in Table 3-6. Luste and Luostarinen (2010) estimated that the methane potential from primary sludge is $300 \text{ m}^3/\text{tVS}$ (volatile solids). The characteristics of PS (TS, MC and VS) are also shown in the table. These were adopted for PS from both Athlone and Bellville.

Table 3-6: Chemical formulae and characteristics of PS

Primary sludge	Chemical Formula	TS(%)	MC(%)	VS(%)	pH	CH ₄ (m ³ /tVS)
PS	$C_{4.05}H_7N_{0.5}O_{2.13}$	4.5	95.5	66.7	7.2	300

Source: (Luste & Luostarinen, 2010)

3.3.3 Calculating biogas potential, C/N ratio, chemical formulae and CH₄ compositions

This section presents the methodology used to estimate the combined biogas potential for each model using individual biogas yields and VS content from Table 3-2, Table 3-3 and Table 3-6. The approaches used to estimate the C/N ratios, chemical formulae and CH₄ compositions are also outlined.

3.3.3.1 Estimating biogas potential from co-digestion

In order to estimate the biogas potential for each model, it was assumed that:

- The substrates for Model 1 (OFMSW and PS) and Model 2 (WPS and PS) would be “fed” at their available quantities as the aim of the project is to divert wastes from landfill disposal.
- Section 7.7.1 (Appendix) shows the method used to estimate biogas potential from individual biogas yields and volatile solids content. Linearity was assumed as the individual yields were summed to make up the total.
- The combined biogas potential is given as $v_{totbiogas}$. This is in volumetric terms, the density of biogas (ρ_{biogas}) was used to calculate biogas produced on a mass basis (Figure 3-4)
- Figure 3-4 shows a simplified mass balance approach used to estimate X(%), digested biomass and $VS_{decomposed}$. The mass balance calculations for both models were based on a dry basis, that is, total

solids. As it has already been established from literature, $VS_{\text{decomposed}}$ equates to m_{biogas} . This was a key assumption that assisted the calculations.

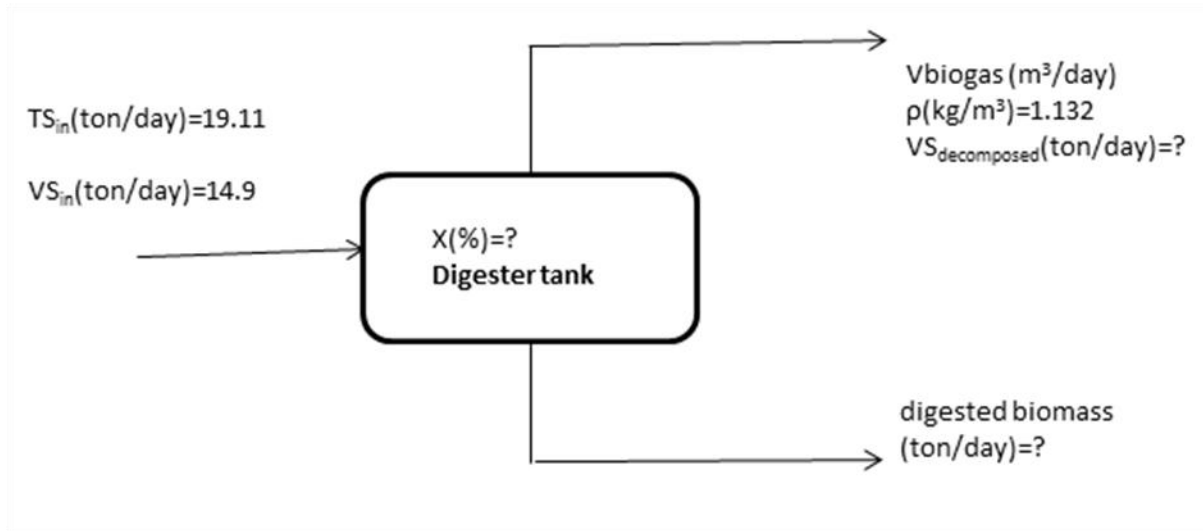

Figure 3-4: A simplified mass balance approach on a total solids/dry matter basis

- m_{biogas} (ton/day) was calculated from the density and volume of the biogas ($\rho * v_{\text{totbiogas}}$).
- The study performed a small iteration in MS Excel to solve for $X(\%)$ at which $VS_{\text{decomposed}} = m_{\text{biogas}}$

3.3.3.2 Estimating C/N ratio for co-digestion

The elemental content of carbon and nitrogen in each waste was used to estimate the C/N ratio for model 1 and 2. The procedure used for both models is outlined below:

$$C(\%) = x_n; N(\%) = y_n$$

Where subscript n indicates that $C(\%)$ and $N(\%)$ are from a **nitrogen-rich waste source** (PS) and x and y are mass percentages of C and N respectively.

$$C(\%) = x_c; N(\%) = y_c$$

Subscript c indicates that $C(\%)$ and $N(\%)$ are from a **carbon-rich waste source** (OFMSW and/or WPS) and x and y are mass percentages of C and N respectively.

$$C_{\text{tot}} = M_c * x_c + M_n * x_n$$

$$N_{\text{tot}} = M_c * y_c + M_n * y_n$$

M_n and M_c are the total mass of the nitrogen and carbon-rich sources respectively. For instance, in Model 1, this was 111.8 ton/day and 78.7 ton/day respectively. The C/N ratio for each model was calculated as:

$$C/N = C_{tot}/N_{tot}$$

Equation 12

3.3.3.3 Determining the chemical formulae and CH₄ compositions

This section outlines how the chemical formulae for combined substrates in Model 1 and 2 were determined. Determining the chemical formula was important as it enabled the theoretical CH₄ composition to be computed. For each model, the elemental analysis of each substrate was used to obtain the chemical formula.

The following are elements (C, H, N and O) and their corresponding mass compositions (x , y , z and w) for a nitrogen-rich waste type, indicated by subscript n :

$$C(\%) = x_n ; N(\%) = y_n ; H(\%) = z_n ; O(\%) = w_n$$

Similarly, for carbon-rich waste type indicated by subscript c :

$$C(\%) = x_c ; N(\%) = y_c ; H(\%) = z_c ; O(\%) = w_c$$

M_n and M_c values are as defined in Section 3.3.3.2

Molar masses shown in Table 3-7 were obtained from Felder and Rousseau (2000):

Table 3-7: Molar masses of elements contained in the substrates

	C	H	N	O
$M_{m,i}$ (kg/kmol)	12.01	1.01	14.01	16

Source: (Felder & Rousseau, 2000)

From Table 3-7 $M_{m,i}$ is the molar mass of element i (carbon, nitrogen, hydrogen or oxygen) which was used to obtain the total number of moles of i :

$$N_{m,i} = \frac{x_n * M_n}{M_{m,i}} + \frac{x_c * M_c}{M_{m,i}}$$

Equation 13

$N_{m,i}$ refers to the total number of moles of element i . Equation 13 was used to estimate the number of moles of each element using the appropriate mass percentages and molar mass values from Table 3-7. $N_{m,i}$ are the subscripts used to complete Buswell's chemical equation below:

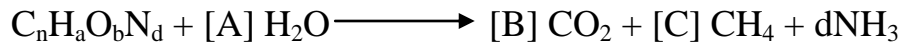

Source: (Sosnowski et al., 2003)

A, B and C were defined in Section 2.4.3

$N_{m, carbon}$, $N_{m, hydrogen}$, $N_{m, oxygen}$ and $N_{m, nitrogen}$ from Equation 13 correspond to n , a , b and d respectively. According to Sosnowski et al (2003) the CH_4 composition is:

$$\%CH_4 = \left(\frac{4 + \frac{a}{n} - \frac{2b}{n} - \frac{3d}{n}}{8} \right) * 100$$

Equation 14

The subscripts n , a , b and d were then substituted into Equation 14 to calculate the methane composition in biogas.

3.3.4 Limitations of data sources

- Biogas yields from Munganga et al (2010) are specific to the type of OFMSW and WPS available in Cape Town, this is an advantage for the present study. However, they were obtained under batch conditions and had hydraulic retention times (HRT) of approximately 60 days. These conditions are laboratory based and thus significantly different from the large-scale, continuous flow and relatively short HRT (i.e 14-30days) conditions which are considered in this study as mentioned in Section 2.5. It is essential to note that the batch tests if correctly done, (which Munganga et al (2010) admit was not the case) show the maximum potential of biogas production for OFMSW and WPS, thus actual yields for continuous processes will be lower and might have trace elements that were not included in the elemental analyses (i.e sulphur)(Karellas et al., 2009).
- Data concerning primary sludge such as production, elemental analyses and characteristics were not available. Thus the study relied on published literature and a previous feasibility study for the CoCT

(Brint, 2008;Wright-Pierce, 1997). This reveals that detailed experimental work needs to be conducted prior to a large-scale project implementation of biogas facilities with energy recovery units.

3.4 Estimating GHG emissions for baseline and biogas production

In this section, methodologies for estimating baseline GHG emissions are presented, followed by methods for calculating GHG emissions as a result of generating electricity and heat from biogas for Model 1 and 2.

3.4.1 Methodology for estimating landfill emissions from OFMSW and WPS

The study used the 2006 IPCC Guidelines for National Greenhouse Gas (GHG) Inventories to estimate emissions due to the landfill disposal of OFMSW and WPS. This section addresses CH₄ emissions only as CO₂ from LFS is composed of biomass carbon and N₂O emissions can be assumed to be negligible (NCASI, 2005; IPCC, 2006).

Equation 5 and Equation 6 (Section 2.7.1) were used to estimate the degradable organic carbon and the amount of methane generated inside a landfill site. In Table 3-8, the values for w_i and DOC_i were taken from IPCC (2006). The values for F are the theoretical methane composition in the landfill gas.

Table 3-8: Input parameters for estimating DOC and methane generation for OFMSW and WPS

Input Parameters	OFMSW	WPS
M_{waste} , ton/day	78.7	25.8
Parameters for Equation 5:		
w_i	0.4	1
DOC_i	15%	40%
Parameters for Equation 6		
F, CH ₄ composition in landfill gas%	48.6	54.7

Source: (Munganga et al., 2010; Baloyi, 2011; IPCC, 2006)

As stated in Section 2.7.1, the methane generated gets oxidized by the soil covering the LFS and thus the actual methane released needs to be accounted for (IPCC, 2006):

$$CH_4\text{-emissions} = CH_4\text{-generated} * (1 - OX) * M_{waste}$$

Equation 15

Where;

CH_4 -emissions: the actual amount of methane emitted to the atmosphere (ton of methane/ton of waste)

CH_4 -generated: from Equation 6 (Section 2.7.1)

OX: 10% of oxidation as discussed in Section 2.7.1

M_{waste} : quantity of waste deposited at landfill (ton of waste)

In the following section, a method of estimating CH_4 emissions due to the landfill disposal of primary sludge is presented.

3.4.2 Landfill disposal and land application of primary sludge

Primary sludge (PS) produced from the Bellville WWTP is used for agricultural land application whereas the sludge from the Athlone plant is disposed of at a dedicated LFS (CCT, 2008). Therefore, emissions associated with the landfill disposal of PS from the Athlone WWTP were calculated. A similar methodology for estimating landfill emissions from OFMSW and WPS was used here.

Table 3-9: Input parameters for estimating DOC and methane generation for PS

Input parameters	Athlone PS
M_{waste} (ton of waste/day)	111.8 ⁴
Parameter for Equation 5:	
w_i	1
DOC_i	0.05
Parameters for Equation 6	
F, %	53.8

Source: (IPCC, 2006)

The exact amount of PS disposed of at a dedicated LFS was unavailable at the time of writing, thus it is assumed that the entire quantity of PS generated (112 ton/day) at the Athlone WWTP is dumped at a LFS.

The CO_2 emissions released as a result of agricultural land application of primary sludge were not calculated because the CO_2 is of biogenic origin and should not be included under landfill emissions (IPCC, 2006).

⁴ See below Table 7-8 (Appendix)

3.4.3 Emissions due to biogas production

Sources of GHG emissions from Model 1 and 2 are leaks and CO₂ emissions from energy generation. The recommended figure of 5% of the quantity of CH₄ produced from each model was used to estimate the amount of CH₄ emissions that leak (IPCC, 2006). This can be written in a mathematical format as:

$$CH_{4-leak} = 5\% * CH_{4-produced}$$

Equation 16

The CO₂ emissions produced via biogas combustion can be estimated from Equation 7 (Section 2.7.2).

The emission reduction potential (ERP) of energy generation via biogas production is then:

$$ERP = |Baseline\ emissions - Project\ emissions|$$

Equation 17

Where, *Project related emissions* are the sum of Equation 16 and Equation 17

3.5 Sizing of units

The present study focused on sizing the digester tanks and CHP engine which are the main units in the biogas models. The method of sizing is the same for both Model 1 and Model 2.

Digester tanks

To estimate the sizes of the digester tanks, it was assumed that the Hydraulic Retention Time (HRT) was 21 days (Luste & Luostarinen, 2010). This HRT is shorter than the normal HRT used for mono-digestion but the advantage of co-digestion as discussed in Section 2.3 is the high rate of biogas production. The residence time ($t_{residence}$) has a direct effect on the volume size of the digester, that is, the longer the residence time the larger the digester and vice versa. The volumes of the digesters were calculated using Equation 18, this equation also illustrates the link between the volume sizes of the digesters and residence time (Deublein & Steinhauser, 2008):

$$Volume = \frac{(t_{residence} * M_{waste} * freeboard)}{density_{feedstock}}$$

Equation 18

A *freeboard* quantity of 1.1 (that is, 10%) was used for design consideration (Deublein & Steinhauser, 2008). *Freeboard* refers to extra volume allowance.

CHP Capacity

The capacities of the CHP units were calculated the same way for both models. It was assumed that the biogas energy content is 6 kWh/m^3 ($E_{content}$) and that the CHP unit performs at 30% (η_{el}) and 50% (η_{th}) electrical and thermal efficiencies respectively (Deublein & Steinhauser, 2008). The following equations adopted from Deublein and Steinhauser (2008) were used to estimate the total energy output (E_{total}), electrical energy (E_{el}), thermal energy (E_{th}) and the nominal capacity ($E_{capacity}$) of the engine for each model. v_{biogas} refers to the volumetric amount of biogas produced for each co-digestion model.

$$E_{total} = \frac{(E_{content} * v_{biogas})}{24}$$

Equation 19

Divide by 24 hour/day to obtain the answer in kW.

$$E_{el} = E_{total} * \eta_{el}$$

Equation 20

$$E_{th} = E_{total} * \eta_{th}$$

Equation 21

$$E_{capacity} = E_{el}(1 + \eta_{el})$$

Equation 22

3.6 Plant's energy supply and consumption

Equation 20 and Equation 21 actually indicate the potential electrical and thermal energy that can be generated from each model. However, literature indicates that biogas plants consume a portion of the energy they produce (Deublein & Steinhauser, 2008; Murphy & Power, 2009; Karellas et al., 2009). This energy is consumed in two forms; as electrical and thermal energy.

It was assumed that both Model 1 and Model 2 consumed 15% of the electricity they produced (Karellas et al., 2009). This is electricity required to drive machinery such as agitators, compressors and pumps (Deublein & Steinhauser, 2008). The electrical energy demand was then calculated as follows:

$$E_{consumed} = F_{consumed} * E_{el}$$

Equation 23

$F_{consumed}$ is the fraction (15%) of electricity consumed ($E_{consumed}$) by the plant. This project also considered the electricity demand of a high pressure scrubbing unit required to increase the composition of CH₄ contained in the biogas. The inclusion of a scrubber unit was dependent upon the theoretical gas composition calculated from Equation 14. Literature suggests that for biogas utilization in a CHP unit, the minimum CH₄ volumetric composition in the biogas is 60% (Deublein & Steinhauser, 2008). For CH₄ composition that is less than 60%, the parasitic electricity demand of the scrubbing unit was assumed to be 0.75 kWh_{el}/m³ of the CH₄-enriched biogas stream (Murphy et al., 2004). The following is the equation used:

$$E_{scrubber} = \frac{0.75 * v_{CH_4-enriched_{biogas}}}{24}$$

Equation 24

Divide by 24 hour/day to obtain the answer in kW. $E_{scrubber}$ refers to the electric capacity of the scrubber and $v_{CH_4-enriched_{biogas}}$ refers to the biogas stream with 60% CH₄ on a volumetric basis.

Finally, the surplus electricity that can be fed to the national grid network was calculated as:

$$E_{surplus} = E_{el} - E_{consumed} - E_{scrubber}$$

Equation 25

The thermal energy demand was calculated based only on the amount of energy required to heat the substrates. The following assumptions were used:

- A constant specific heat capacity of water (4.18 kJ/kg °C) was assumed for each substrate. This would not be applicable if there was phase change encountered (Perry & Green, 1997).
- T_1 was assumed to be 16.5 °C, this is the mean annual temperature of Cape Town (Schulze, 1997). T_2 was assumed to be 35 °C as both the digesters of Model 1 and 2 operate at mesophilic conditions (Deublein & Steinhauser, 2008). Thus the study estimated the amount of energy required to heat the feedstocks from 16.5 °C to 35 °C, this is the thermal energy consumption of

the biogas process. Equation 26 was used to perform the calculation for both Model 1 and 2 (Deublein & Steinhauser, 2008):

$$Q_s = M_{waste} * C_{pwaste} * (T_2 - T_1) \quad \text{Equation 26}$$

Where C_{pwaste} is (Felder & Rousseau, 2000):

$$C_{pfeed} = x_{bs} * C_{pbs} + x_{wps} C_{pwps}$$

Q_s : energy required to heat the substrate (kW)

M_{waste} : Total amount of feedstock for each model

C_{pbs} , C_{pwps} and C_{pfeed} : specific heat capacities of Bellville primary sludge and waste paper sludge.

x_{bs} and x_{wps} refer to mass fractions of the waste (for instance Bellville sludge and waste paper sludge) in the feedstock.

The complete calculation is included in Section 7.3 (Appendix). The surplus heat was calculated as follows:

$$H_{surplus} = E_{th} - Q_s \quad \text{Equation 27}$$

3.7 Methodology for Financial Analysis

The financial analysis performed used the discounted cash flow (DCF) approach to assess the profitability of using energy from biogas to mitigate against GHG emissions. The current study used Equation 8 (defined in Section 2.8.1) to estimate the Fixed Capital Investment of biogas plants for each model ($FCI_{digester}$) (Amigun & von Blottnitz, 2009).

Amigun and von Blottnitz (2009) suggest that for biogas plants with digesters larger than 20 m³, a cost capacity factor of 0.8 is applicable. Since the digester sizes for Model 1 and 2 are greater than this value, this capacity factor was used to estimate $FCI_{digester}$ for both models. This approach is reasonable as it takes into account economies of scale and the cost capacity factor was developed based on biogas installations in Africa. An existing South African plant of 4500 m³ capacity and capital cost of 1.6

million US\$ was used as the capital cost of the reference project (C_2 as defined in Equation 8 and C_1 is the capital cost of either Model 1 or 2). A sample calculation is included in Section 7.4 (Appendix). The capital cost of the reference project is in 2007 values, therefore cost indices were used to convert to 2010 values by using this ratio:

$$\frac{C_{2010}}{C_{2007}}(\text{CEPI}, 2010)$$

C_{2010} and C_{2007} represent the capital costs of the reference project.

The fixed capital investment cost estimated from Equation 8 excludes the cost of the CHP unit and the scrubber unit. Deublein and Steinhauser (2008) suggest that the cost of a CHP unit can be estimated to be 650 US\$/kW_{el} (4424 R/kW_{el}), where kW_{el} indicates the nominal capacity of the CHP engine. Figure 3-5 shows the relationship between the electrical capacity of the CHP engine and the capital cost of a scrubber, this was adapted from Deublein and Steinhauser (2008). The figure was used to estimate the capital cost of the scrubber unit for both models. The nominal capacities estimated from Equation 22 for Model 1 and 2 were used to approximate the capital cost of the scrubber units as shown:

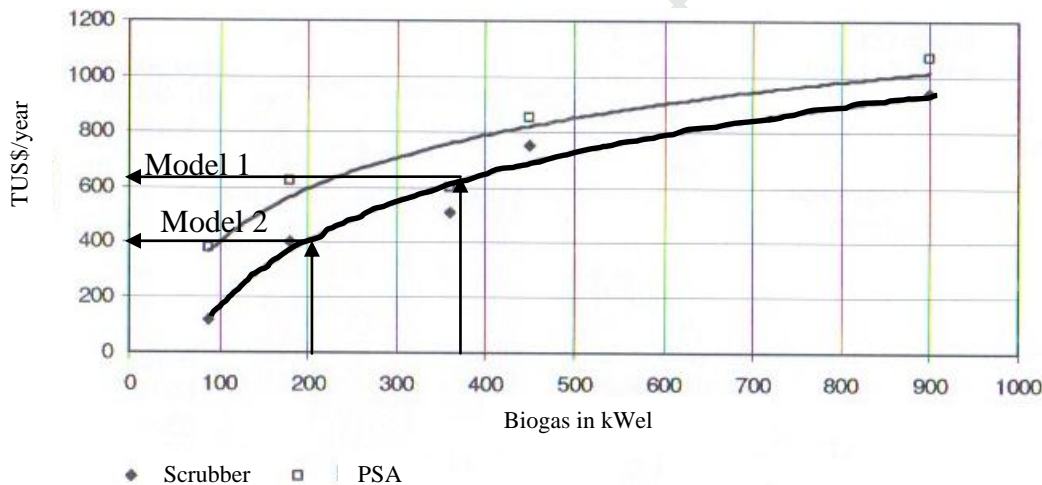

Figure 3-5: Investment costs of a scrubber unit (TUS\$=1000US\$)

Source: (Deublein & Steinhauser, 2008)

The capital costs of the CHP and scrubber were added to Equation 8 to estimate the total initial investment required for each model. Table 3-10 presents the cost parameters and their corresponding values used in this project. The following provides an overview of these parameters:

- The FCI_{digester} of the project (excluding the cost of the CHP and scrubber) is distributed between concrete works (63% of FCI_{digester}) and technical equipment (37% of FCI_{digester}), shown in the table by symbol x_B and x_T respectively (Deublein & Steinhauser, 2008).
- The two costs of electricity (Service and electricity charges) were obtained from Cape Town's Tariff Development Department through personal communication. The interview question is included in Section 7.5 (Appendix).
- It was assumed that the maintenance costs for concrete works is 0.5% of its fraction of investment cost (that is, of $x_B \cdot FCI_{\text{digester}}$), and for the technical equipment it is 3% of its investment cost ($x_T \cdot FCI_{\text{digester}}$) (Deublein & Steinhauser, 2008). Furthermore, the maintenance for the CHP unit was assumed to be 4% of its investment cost (Deublein & Steinhauser, 2008)
- The cost of labour was obtained from the City of Cape Town's job vacancy advertisement for a senior wastewater plant operator (CoCT, 2011).

Table 3-10: Summary of cost parameters for the models

Type of cost	Parameter	Reference
FCI_{digester} distribution:		
Concrete works (x_B)	63%	Deublein & Steinhauser (2008)
Technical equipment (x_T)	37%	Deublein & Steinhauser (2008)
FCI_{CHP}:	4424 R/kWel	Deublein & Steinhauser (2008)
FCI_{scrubber}:	See Figure 3-5	Deublein & Steinhauser (2008)
Consumption-bound costs/year:		
Cost of electricity:		
Service Charge	14.35 R/day	Ross (2011)
Electricity Charge	0.7766 R/kWh	Ross (2011)
Cost of heat	0.05 R/kWh	AgamaBiogas (2009)
Maintenance for concrete works (y_B)	0.5% of $x_B \cdot FCI_{\text{digester}}$ R/year	Deublein & Steinhauser (2008)
Maintenance for technical equipment (y_T)	3% of $x_T \cdot FCI_{\text{digester}}$ R/year	Deublein & Steinhauser (2008)
Maintenance for CHP	4% of FCI_{CHP} R/year	Deublein & Steinhauser (2008)
Operational cost: scrubber	See Figure 3-6	Deublein & Steinhauser (2008)
Avoided cost of waste disposal	264 R/ton	Nontangana (2011)

Labour cost (single personnel per model)	80316 R/year	CCT (2011)
Other costs/year:		
Insurance per model	0.5% of FCI _{digester} /year	Deublein & Steinhauser (2008)
Revenue:		
Sales of electricity	0.96 R/ kWh	REFIT II ⁵ (2011)
Sales of heat	0.05 R/kWh	AgamaBiogas (2009)
Sales of fertilizer:	7019 R/year	Deublein & Steinhauser (2008)

Source: (Deublein & Steinhauser, 2008; AgamaBiogas, 2009; Ross, 2011; CoCT, 2011)

Figure 3-6 shows how the operational costs of the scrubber unit was estimated. The dashed line indicates that the curve was extrapolated to approximate the cost for Model 1. This figure was obtained from (Deublein & Steinhauser, 2008). The operational costs are shown in Table 3-10.

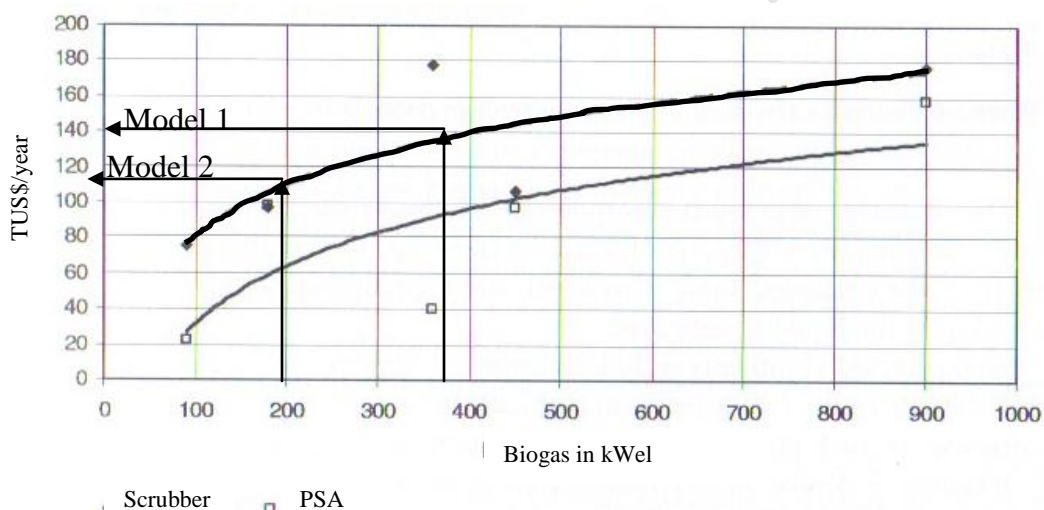

Figure 3-6: Operational costs of a scrubber unit (TUS\$=1000US\$)

Source: (Deublein & Steinhauser, 2008)

- For the 2010/2011 financial year, the Solid Waste Department of the City of Cape Town charged approximately 264 R/ton for the disposal of OFMSW and WPS (Nontangana, 2011). The same cost was assumed for PS from Athlone WWTP as the sludge from here is sent to a dedicated private LFS whose disposal cost is unknown. PS from Bellville is applied on agricultural land at no costs.

⁵ REFIT (Renewable Energy Feed-In-Tariff) is the policy instrument introduced by the South African government in support of Renewable Energy technologies. This price indicates the price at which the single buyer office (SBO) will purchase biogas-generated electricity.

Therefore the disposal charge only applies to OFMSW, WPS and PS from Athlone. This was included in the current study as an avoided cost of disposal.

- The revenue streams considered in this study are also shown in Table 3-10. The price of electricity from the Renewable Energy Feed-In Tariff (REFIT) scheme for South Africa was used as a basis of calculation. The biogas feasibility model prepared by AgamaBiogas for the South African Cities Network suggested the selling price of heat to be 0.05 R/kWh. The cost of transporting the heat to industrial hest users was not included as it was assumed that the users would incur this cost.
- Another revenue stream considered is the selling price of the fertilizer. For Model 2 the fertilizer will be sold directly without any subsequent treatment. This is because both inputs (WPS and PS from Bellville WWTP) used in this model are suitable for agriculture. However for Model 1, in practice the PS from the Athlone WWTP contains metal contamination. At the time of conducting the present study exact figures on the value of this type of fertilizer were not available for South Africa. Therefore, the study used the price suggested by Deublein and Steinhauser (2008) of 1000 US\$/year (7019 R/year) which was converted to Rand per year using the exchange rate (Table 3-10).

Table 3-11 below contains the financial variables used in this project to perform a financial analysis. The interest rate (i) and exchange rate were obtained from the South African Reserve Bank (SARB). The discount rate (r) used is the same as the discount rate used in the Integrated Resource Plan (IRP) 2010 document:

Table 3-11: Financial variables for financial assessment

Interest rate, i	9%
Discount rate, r	8%
R/US\$	6.8066

Source: (SARB, 2011; IRP, 2010)

A financial analysis was performed for each model. The Net present value (NPV), Return on investment (ROI) and Internal rate of return (IRR) were the primary figures used to check the financial viability of each model. The IRR was used as a criterion for the acceptance or rejection of the project. If the IRR values calculated for Model 1 and 2 were greater than the discount rate indicated in Table 3-11, the

project was considered financially viable. The profitability assessment was performed over a life-time of 20 years as this is a typical life-time of biogas plants (Deublein & Steinhauser, 2008).

The following section presents the methodology and input parameters used for modeling energy supply in the LEAP software. The landfill emissions are also accounted for at city-scale.

3.8 City-scale modeling on LEAP

Up until this point, the dissertation has developed two hypothetical models and has also established technical, financial and environmental approaches for the models. These models illustrate the biogas potential from co-digesting different wastes. In this section, a city-scale model is developed in order to assess the impact of energy from biogas at a larger city setting. For this a LEAP simulation tool is used to assess the impact of biogas over a specific time period. The LEAP modeling software is a simulation software developed by the Stockholm Environment Institute (SEI). It was used in this study as it is an integrated modeling tool that helps analyse energy supply and consumption. LEAP was also used to assess the impact of the energy sectors on climate change (Section 3.8.1). This was achieved through developing five base case scenarios for each thermal energy fuel mentioned in Section 2.7.2. A corresponding scenario which uses energy from biogas was also developed in order to estimate the emission reduction potential of biogas. In addition to quantifying the energy emissions, landfill emissions at a city-scale were also accounted for.

3.8.1 Accounting for GHG emissions related to energy supply

As already reported in chapters 1 and 2, a LEAP model was developed for the study: *Energy Scenarios for Cape Town* which analysed the city's energy sector (SEA & ERC, 2010). On the energy supply side of the model, technologies that were included are nuclear, wind, hydro, coal, biomass, municipal waste, solar thermal electricity, solar photovoltaic connected to the grid and biomass cogeneration (SEA & ERC, 2010). As energy from biogas was excluded from this modeling, the present study adapted this model and included cogeneration from biogas. This was done by assuming that in Cape Town, all the OFMSW generated was co-digested with primary sludge from all the wastewater plants, that is, the city-scale model is an extension of Model 1. A list of assumptions is given below:

- *Waste generation:* It was assumed that the amount of primary sludge generated from the 21 WWTPs in Cape Town is 245 200 ton/year (Wright-Pierce, 1999). For the carbon-rich waste, OFMSW, it was

assumed that OFMSW generated from *households* is 398 074 ton/year (Jeffares&Green & IngeropAfrica, 2004). These values were useful in estimating the amount of biogas produced.

- *Biogas yields:* As the city-scale model is an extension of Model 1, the biogas yields and volatile solids content for OFMSW and primary sludge from Table 3-2 and Table 3-6 were used. These were used to estimate the combined biogas production in m³ per year.
- *Energy output:* Similar to Model 1 and 2, the energy content of biogas was assumed to be 6 kWh per m³ of biogas produced. The electrical and thermal energy efficiencies for a CHP were assumed to be 30% and 50% respectively (Deublein & Steinhauser, 2008). These were useful to estimate the capacity of the biogas plant in megawatt (MW). This capacity was inserted into LEAP directly and results are shown in Chapter 4 (Section 4.6.1).

See Section 7.11 (Appendix) on the procedure used to estimate the capacity of the plant.

- *Capital Cost:* Equation 8 was used to estimate the capital cost of the biogas plant with Model 1 used as the reference project.
- *Variable O&M costs:* These costs refer to consumption-bound costs of electricity, heat and avoided disposal costs.
- *Fixed O&M costs:* Labour and insurance costs were included under fixed O&M costs.
- *Economic indicators:* It was assumed that the GDP (Cape Town) and population was 3.4% and 3.5 million respectively.

The above assumptions were used to set up the LEAP model. Table 3-12 contains a summary of input parameters that were entered in the LEAP model:

Table 3-12: Summary of input parameters used for city-scale modeling of biogas cogeneration in LEAP

Variables		Comments
Output fuels:		
Electricity		Electricity from the CHP was modelled as a co-product fuel
Heat		Heat from the CHP was modelled as a co-product fuel
Variables:		
Co-product efficiency	30%	Electrical conversion efficiency
Lifetime	20 years	
Dispatch rule	Run to full capacity	

Losses	20%	CHP is only 80% efficient
Model period	2012-2050	This is the simulation period.
First simulation year	2012	1 st year in which LEAP uses process dispatch rule
Capacity (MW)	See Section 7.11	Total Capacity of all the biogas cogeneration plants in Cape Town
Availability per year	75%	
Capital cost	Equation 8	Model 1 was taken as the reference project C_2
Fixed O&M Cost	Table 3-10(Units required: R/MW)	Salaries and insurance.
Variable O&M Cost	Table 3-10 (Units required: R/MWh)	Electricity and heat consumption

LEAP was used to analyse the impact of energy from biogas on Cape Town's energy sector in terms of the amount of energy in the form of electricity and heat as well as emissions associated with energy generation from biogas.

3.8.2 Estimating Landfill emissions from OFMSW and PS at city-scale

The city's landfill emissions as a result of disposal of OFMSW and PS were estimated similar to the calculations and input parameters for Model 1. As mentioned in Section 3.8.1, Cape Town generates approximately 398 074 ton/year and 245 2000 ton/year of OFMSW and PS respectively (Jeffares&Green & IngeropAfrica, 2004; Wright-Pierce, 1999). These quantities were used to calculate the landfill emissions. The same w_i , DOC_i and F values in Table 3-8 and Table 3-9 for OFMSW and PS were used here.

In the following chapter, results corresponding to the methodology and assumptions developed in this chapter are presented.

4 Results and Discussions

The results obtained from the research methodology are presented in this section. The advantages of co-digestion on C/N ratios and biogas production are shown for each model. Results from the mass balance calculations are also presented. The potential energy that could be generated from the models was estimated. On the financial side, a financial analysis of generating energy from biogas is included for each model. Finally, results from the LEAP software are presented, showing the potential of biogas from waste and its cost at the scale of the city.

4.1 Influence of co-digestion on C/N ratio

Figure 4-1 and Figure 4-2 illustrate the effect that co-digesting primary sludge (PS) with carbon-rich OFMSW and WPS would have on the C/N ratio. Figure 4-1 presents the C/N ratio for mono-digestion of each waste determined from elemental analyses in Chapter 3.

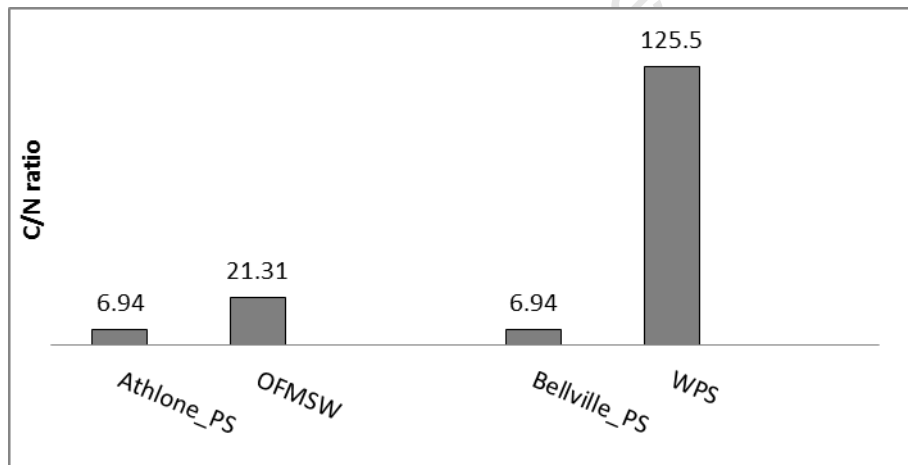

Figure 4-1: C/N ratio for mono-digestion of substrates

The same elemental analysis was used for PS from Athlone and Bellville WWTPs hence they have the same C/N ratio Brint (2008), although in reality the C/N ratio may be different and varying with time. Nonetheless, it is generally expected that PS would have low ratios indicating that they are high in nitrogen (Sosnowski et al., 2003; Iranzo et al., 2004). Sosnowski et al (2003) and Iranzo et al (2004) determined a C/N ratio of 9.26 and 7.3 respectively. Figure 4-1 indicates that OFMSW is relatively carbon rich compared to PS. As shown in the figure WPS has the highest C/N ratio of 125.5 (Myréen et al., 2010). Scott and Smith (1995) also reported a C/N ratio of WPS of 243.5. This observation indicates that this waste is a good carbon source.

For OFMSW, the indicated ratio is an average value as four OFMSW samples were taken by Munganga et al (2010). Sosnowski et al (2003) analysed that in their study the C/N ratio for mono-digestion of OFMSW was 24.46, which is not significantly different from the ratio of 21.31 used in the present study (Munganga et al., 2010). The variations are possibly due to the different compositions of food waste used as that research had potato peels, fruits and vegetable, bread, paper and rice and spaghetti. The OFMSW samples from ARTS by Munganga et al (2010) did not specify the composition to enable a thorough comparison.

A highlight from Figure 4-1 is that individual C/N ratios for PS (Athlone and Bellville WWTPs) and WPS are outside the desired range (20-30) (Parkin & Owen, 1986). As per co-digestion discussions from Chapter 2 co-digestion can offer an improved C/N ratio.

The C/N ratio for co-digestion was calculated using the individual elemental analyses of the substrates. The calculation, as per Section 3.3.3.2 is included in Section 7.6 (Appendix). The results illustrating the effect that co-digestion has on C/N ratio are shown in Figure 4-2 below:

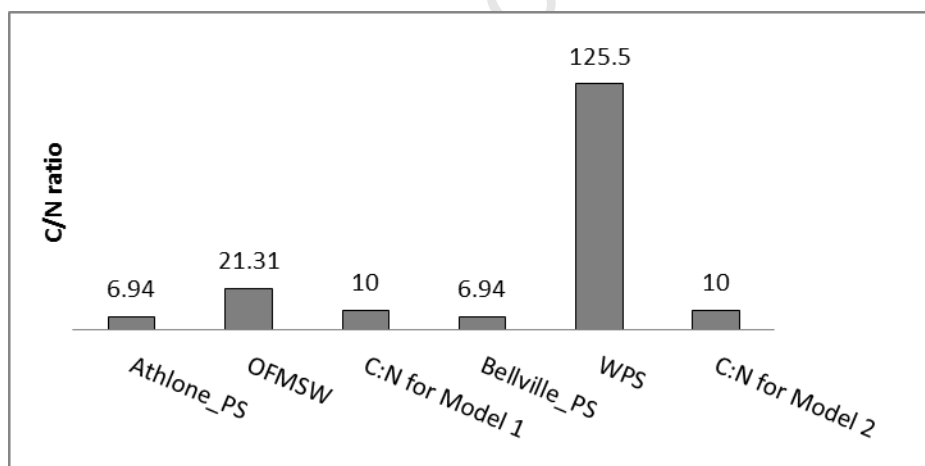

Figure 4-2: Individual and combined C/N ratio in Model 1 and Model 2

Co-digestion changed the C/N ratios significantly and as indicated they are below the optimal C/N ratio range. This indicates that additional quantities of carbon rich wastes are required in order to improve the C/N ratio for the co-digestion models. Nonetheless it is noted that the addition of OFMSW and WPS to Athlone_PS and Bellville_PS respectively improved their C/N ratio. Sosnowski et al (2003) found that co-digestion of sewage sludge (primary sludge mixed with waste activated sludge) with OFMSW

increased the C/N ratio of sewage sludge from 9.26 to 14.19. Furthermore, in a study by Yen and Brune (2007) the paper waste improved the C/N ratio of algae from 6.7 to 11.8, 18 and 36.4 at feed ratios of 25%, 50% and 75% of waste paper respectively.

A high C/N ratio justifies co-digestion over mono-digestion as it implies an increase in biogas production (Munganga et al., 2010). Although co-digestion increased the calculated C/N ratios for PS in Model 1 and Model 2, they are still below the optimal and acceptable range. Munganga et al (2010) state that they noticed a two-fold increase in biogas yields from co-digestion of N-rich sources with C-rich sources. The following section presents the biogas production results estimated from co-digesting both OFMSW and WPS with PS.

4.2 Influence of co-digestion on estimated biogas production

Figure 4-3 below illustrates the specific biogas potential (SBP) of each waste type from experimental laboratory work conducted by other studies. The SBP values for OFMSW and WPS were adopted from Munganga et al (2010). For the PS values, they were taken from Luste and Luostarinen (2010) who stated that the specific biogas potential of their PS was 558 ml biogas/g VS as outlined in Section 3.3.2.1

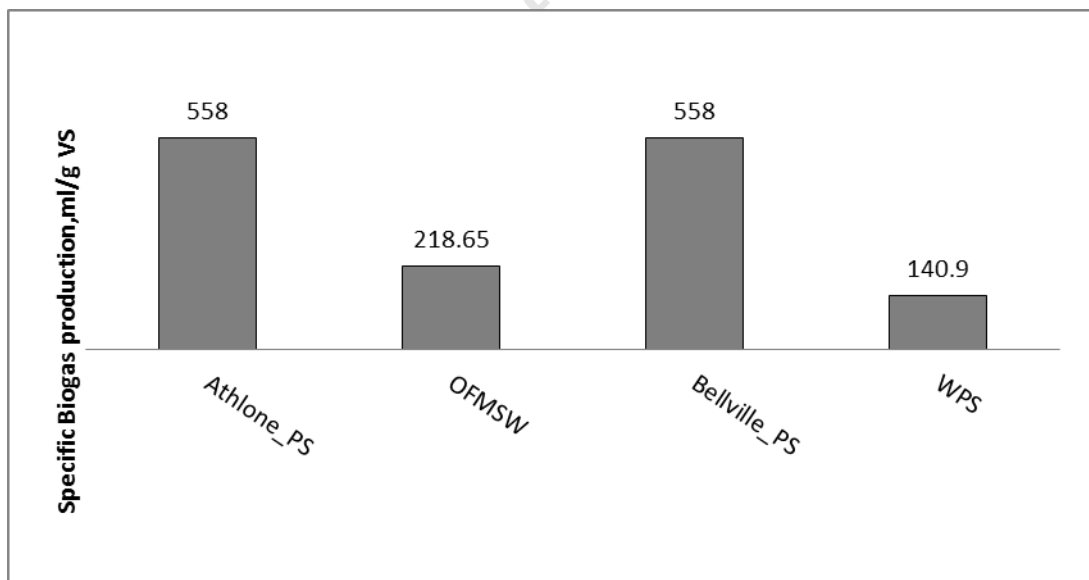

Figure 4-3: Specific biogas production from each waste type under Laboratory conditions

Source: (Munganga et al, 2010; Luste & Luostarinen, 2010)

The SBP of OFMSW was expected to be higher or equal to that of PS especially since its C/N ratio falls between the optimal range mentioned above (Sosnowski et al., 2003; Fernandez et al., 2005). The SBP

value for WPS is low compared to the values obtained for different batches from (Dalwai, 2011). These inconsistencies in results were expected because the SBP values were obtained from different laboratory conditions. However, they are suitable for determining the biogas potential from co-digestion.

Figure 4-4 below illustrates the effect of co-digestion on biogas production for each model. The method used for the calculation is outlined in Section 7.7 (Appendix). Figure 4-4 shows that the volume of biogas from co-digestion is the sum of the individual amounts from mono-digestion. This is as a result of the assumptions made in the calculation (Section 3.3.3.1). Literature reports that for co-digestion, there is less ammonia inhibition and therefore a faster rate of digestion. This means a higher biogas yield per unit reactor volume. Demirekler and Anderson (1998) observed an increase in the rate of biogas production as a result of co-digesting OFMSW with primary sludge (PS) at the same mesophilic conditions, this observation was for the feed ratio of 80:20 (OFMSW:PS) on a total solids (TS) basis. The biogas production rate for mono-digestion of OFMSW only was 32% lower than the co-digestion of OFMSW with PS at the ratio mentioned above.

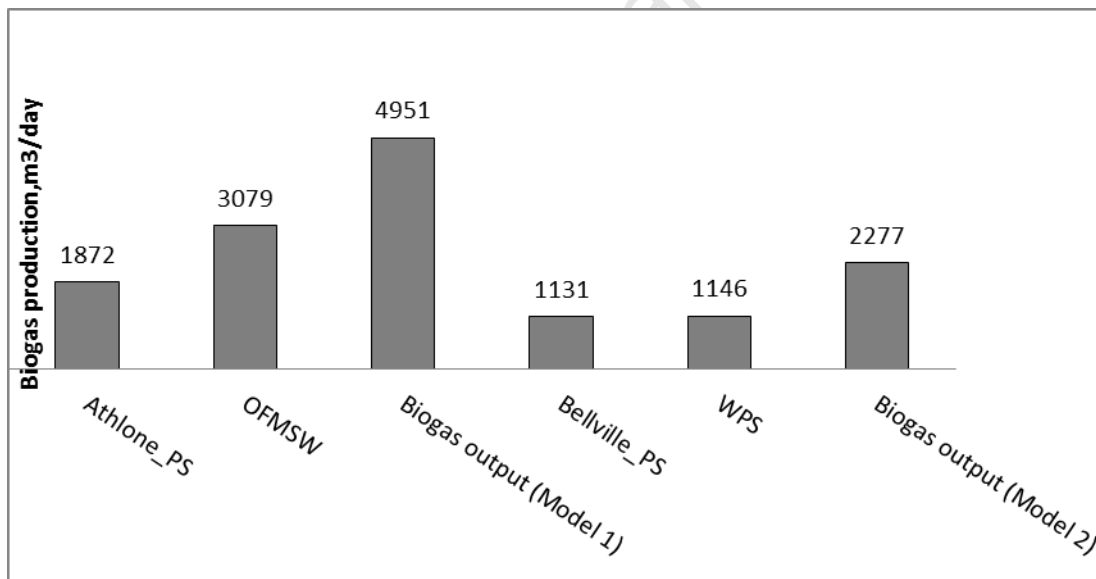

Figure 4-4: Effect of co-digestion on the potential biogas output (large-scale)

Further interpretation of Figure 4-4 indicates that the estimated biogas potential of Model 1 is higher than that of Model 2. This could be due to the low biogas yield of WPS obtained from Munganga et al (2010) and also due to the differences in quantities of total solids (TS) contained in the substrates. As Table 4-1 illustrates, Model 1 had more TS and subsequently more volatile solids (VS) relative to Model 2. This meant that in Model 1, there was more VS available for degradation thus estimated biogas

production was higher. Murphy and Power (2009) reports a similar observation with substrates rich in VS.

The conversions [X (%)] of VS that correspond to this estimation of biogas potential in Model 1 and 2 are approximately 32.12% and 25.4% respectively. These were estimated by performing a Mass Balance (MB) calculation on the models separately as shown in Figure 3-4. The results are shown in Table 4-1. The higher X (%) rate for Model 1 relative to Model 2 explains their differences in the estimated biogas potential shown in Figure 4-4.

Table 4-1 contains the mass balance calculations which were calculated on a dry matter/total solids basis. TS and VS refer to the total and volatile solids contained in the substrates for Model 1 and 2. X (%) is the degree of VS degradation and VS_{decomposed} equals the amount of biogas produced (Deublein & Steinhauser, 2008). This definition of VS further explains the higher biogas production estimate for Model 1 relative to Model 2. The undigested biomass shown in Table 4-1, also known as the fertilizer refers to that portion of the substrates that did not biodegrade in each model.

Table 4-1: Mass Balance (MB) results for Model 1 and Model 2 on a total solids basis

Model:	TS	VS	X	VS _{decomposed}	undigested biomass	m _{biogas}	V _{biogas}
	(t/day)	(t/day)	%	(t/day)	(t/day)	(t/day)	m ³ /day
1	19.1	14.9	32.12	5.60	13.51	5.60	4951
2	11.3	10.2	25.40	2.58	9	2.58	2277

Equation 28 and Equation 29 below present Buswell's chemical formulae for substrates in Model 1 and 2 respectively. The sample calculation is included in Section 7.7.2. The calculation also illustrates how the theoretical gas composition was determined for both models. Although these are theoretical calculations, they were useful in deciding whether this project should incorporate a biogas scrubbing unit prior to utilization. The *theoretical* CH₄ compositions are shown below the chemical formulae:

Model 1:

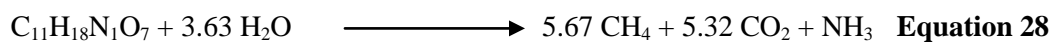

$$\%CH_4 = 51.6\%$$

Model 2:

$$\% CH_4 = 53.8\%$$

The compositions are lower than expected as other studies have recorded biogas with methane compositions as high as 70% (Sosnowski et al., 2003). The low compositions suggest that the wastes are rich in carbohydrates (Section 2.3). From literature, the use of biogas in a CHP unit requires the composition of CH₄ to be 60% (at *minimum*) on a volume basis. As the compositions calculated from the current study are less than 60%, calculations for upgrading the biogas in a scrubbing unit were performed using the estimated biogas output from Table 4-1. It was assumed that the biogas quantity after the scrubber unit would have 60% of CH₄ content as this is sufficient for biogas utilization in a CHP unit (Deublein & Steinhauser, 2008). Higher CH₄ content can be achieved but scrubbers are energy intensive, as illustrated in Sections 4.3.2. A simplified MB calculation to estimate the volumetric amount of CH₄-enriched biogas stream was performed, it is shown in Section 7.7.3 (Appendix) and also presented in Table 4-2 below. This simplified approach assumes that all the volumetric amount of CH₄ contained in the biogas stream prior to the scrubber is recovered in the desired CH₄-enriched biogas stream.

Table 4-2: Estimated biogas production after upgrade

Model	CH ₄ composition	CH ₄ -enriched biogas
	%	m ³ /day
1	60	3785
2	60	2042

This approach is consistent with other literature sources, Murphy et al (2004) used a similar approach when estimating the volumetric quantity of the biogas stream that was enriched with CH₄ after a scrubber unit. As Table 4-2 shows, the estimated biogas production decreases when calculations associated with a scrubber unit are included. This is acceptable as the calculations assume that unwanted gases are removed from the biogas stream while enriching it with CH₄. Murphy and Power (2009) also determined that biogas production before the scrubbing unit was higher than the CH₄-enriched biogas.

Although, the scope of this project excludes detailed design work, it is important to include the calculations associated with a scrubbing unit as without it, the CH₄ content in the biogas is too low.

4.3 Sizes of units, Energy supply and consumption

This section presents the results from calculating the sizes and nominal capacities of digester tanks and CHP units respectively. The estimated energy supply and consumption in each model is also presented.

4.3.1 Sizes of digester tanks and CHP units

Table 4-3 presents the results from estimating the sizes of the digester (from Equation 18) and CHP for each co-digestion model. The energy values in Table 4-3 were calculated from Equations 20 to 22. A sample calculation is illustrated in Section 7.8.1. The currently existing anaerobic digesters at the Athlone WWTP were used as a benchmark to check the correctness of the digester sizes estimated in this study. During a site visit at the Athlone WWTP, it was revealed that the digesters had a total volume of 4800 m³ and this project estimated that 112 tons of primary sludge (PS) is produced per day from this plant. The HRT for this plant is approximately 30 days. But the HRT of 21 days was used in this study as discussed in Section 3.5. The digester volumes for both models were lower than the current volume of the Athlone digesters due to the shorter HRT for these models. Estimating the digester volumes was paramount in this project as they were used to estimate the capital cost for each model.

Table 4-3: Calculated sizes of main plant units for each model

	Model 1	Model 2	Reference
Digester:			
Volume, m ³	4710	2178	Equation 18
CHP:			
E _{el} , kW	284	153	Equation 20
E _{th} , kW	473	255	Equation 21
Nominal capacity, kW	369	199	Equation 22

Table 4-3 also shows the calculated CHP nominal capacities for each model. As shown, the thermal component of the CHP unit constitutes a higher fuel share than the electrical component; this is the case for both models. This is due to the differences in the electrical and thermal efficiencies which are 30% and 50% respectively. The results also show that, overall Model 1 offers a larger amount of energy than

Model 2. This is due to the higher biogas output estimated for Model 1. The assumed biogas yield of WPS (140.9 ml/gVS) was relatively low and has resulted in low biogas output for Model 2 as well as low energy obtainable from this model. Section 7.8.2 in the Appendix contains a sample calculation for Model 1 which illustrates that the energy output from a CHP unit is a function of the estimated amount of biogas output hence the energy output from Model 1 is higher than that obtainable from Model 2.

4.3.2 Calculated energy supply and consumption

Table 4-4 contains the parasitic energy demand and the surplus energy potential for each model. Parasitic energy demand refers to energy that the biogas production process would consume. For each model, surplus energy is the difference between the estimated energy generated and the parasitic energy demand.

Table 4-4: Estimated energy obtainable and consumed by Model 1 and 2

	Model 1	Model 2	Reference
Energy obtained, kW	757	408	
E_{el} , kW	284	153	Equation 20
E_{th} , kW	473	255	Equation 21
Heat consumed:			
Q_s , kW	171	84	Equation 26
C_p , kJ/kg °C	4.18	4.18	Equation 26
Surplus Heat, kW	303	172	Equation 27
Electricity consumed:	161	87	
$E_{consumed}$, kW	43	23	Equation 23
$E_{scrubber}$, kW	118	64	Equation 24
Surplus Electricity, kW	123	66	Equation 25
Total surplus energy, kW	426	238	
Energy consumed, %	44%	42%	

For each model, the energy generated is the sum of E_{el} and E_{th} . It has already been discussed that Model 1 provides a larger quantity of energy relative to Model 2 due to its higher amount of biogas potential. Section 7.3 (Appendix) contains the calculations for determining thermal energy consumption for each model, Q_s . As the calculation shows, the values for C_p , T_2 and T_1 are the same for Model 1 and 2 except for the amount of feedstock available for each model. Thus mentioned, Table 4-4 illustrates that Model 1 requires more thermal energy to heat up its substrates as it has a larger amount of feedstock to heat.

Q_s is also a function of C_p , thus it will vary according to the amount of specific heat capacity utilized. For both models, this study assumed a *specific heat capacity of water* for the substrates due to unavailability of their C_p values. This assumption seems to be the general trend for non-experimental based studies similar to this project. Murphy and Power (2009) also assumed the C_p value of water for their study which focused on biogas production from crops.

It was assumed that for each model thermal energy was required to heat the substrates from a temperature T_1 (16.5 °C) to T_2 (35 °C). T_2 is the operating temperature of the digesters referred to as the mesophilic temperature. Due to the proportionality of the temperature *difference* to Q_s as defined in Equation 26, higher operating temperatures would increase the thermal energy required to heat the substrates while the amount of surplus heat available would decline.

The scrubber unit consumes a significant amount of the electricity generated in each model. In Model 1, it was calculated that 161 kW of electrical energy is consumed by the biogas production process and approximately 118 kW of this consumption was attributed to the scrubber unit (assuming 0.75 kWhel/m³), in percentage terms this is 73%. This result suggests that upgrading biogas is an energy intensive process. Murphy and Power (2009) also indicate that scrubbing the biogas generated the largest electricity consumption. These results suggest that biogas might be more efficient for thermal application, although this was not investigated in this study. It was also observed that the importance of biogas quality is highly dependent on the composition of the feedstock. This observation is supported by other studies (Sosnowski et al., 2003). The biogas quality could be improved by using highly carbon-rich material such as waste paper sludge (C/N ratio is high ~126). Figure 3-2 indicates that Cape Town has abundant resources of this waste type as it has at least three paper manufacturers which are a source of paper sludge.

Table 4-4 indicates that the energy consumption for Model 1 and 2 was roughly the same. Model 1 consumed 44% of its total energy (electrical and thermal) output whereas Model 2 consumed approximately 42%. These figures are within the range found in literature sources. Karellas et al (2009) estimated that the biogas production process consumed about 39% of the energy produced. Deublein and Steinhauser (2008) calculated that for an agricultural biogas plant, 18% of the total energy produced

was required by the plant. This figure is much lower than those for model 1 and 2 in this study, the difference could be in the assumptions used to estimate the parasitic energy demand of the processes.

Figure 4-5 illustrates the effect of upgrading the biogas to a CH₄-rich stream via a scrubber on the amount of electricity consumed and surplus amount for Model 1 and 2. This figure emphasizes further that scrubbing the biogas is highly energy intensive, although necessary.

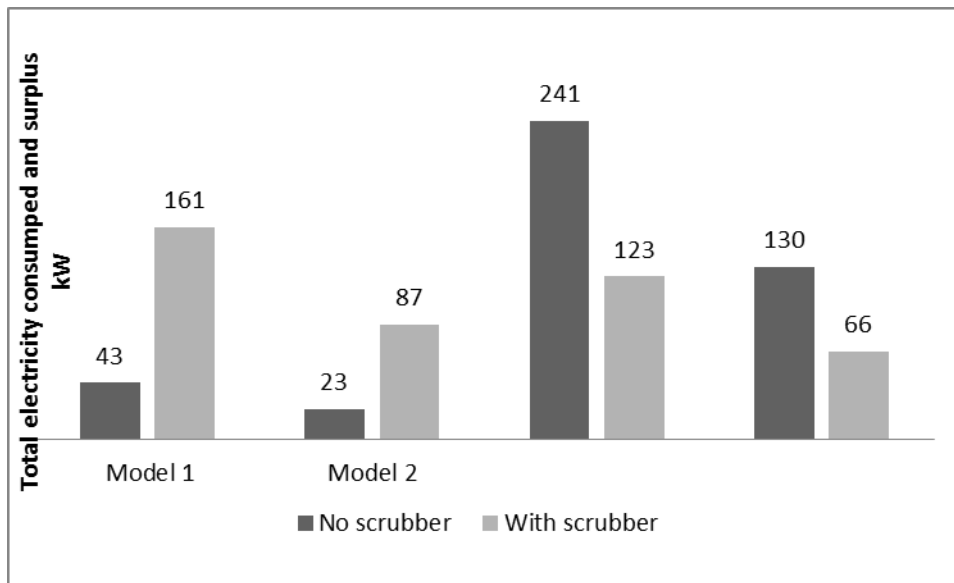

Figure 4-5: Influence of upgrading biogas on electricity consumption

This analysis shows that including the scrubbing unit in the calculations decreases the amount of surplus electricity available from the models. Thus it reduces the amount of electricity that can potentially be sold. Although this is the case, the excess amount would be much lower with mono-digestion. This has been shown by mono-digestion achieving lower biogas potential amounts and also the calculated electrical and thermal energy are dependent on the volume of biogas obtainable from the substrates. Figure 4-6 presents the total energy supply for mono-digestion of the substrates as well as co-digestion. The trend shown in this figure is very similar to Figure 4-4 which compared biogas potential from mono-digestion and co-digestion.

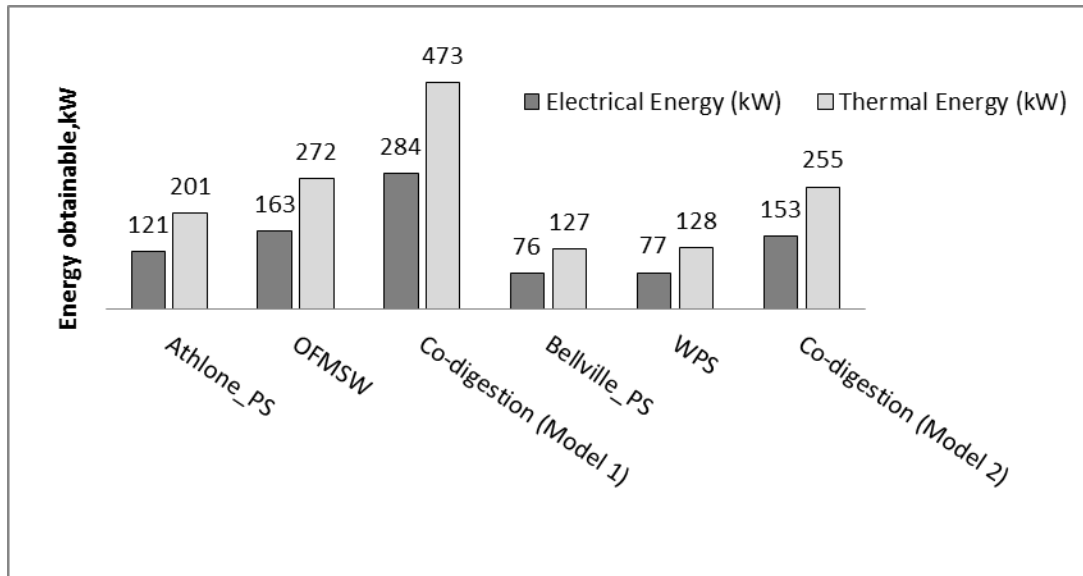

Figure 4-6: Effect of co-digestion on energy potential (scrubber included)

The total energy potential from Model 2 is lower than that from Model 1 due to the differences in quantities of substrates available and also biogas yields. Figure 4-6 implies that energy from co-digestion of the waste types included in Model 1 and 2 can potentially produce approximately 1.3 MW of power; this is the combined energy potential from the two models.

The following section presents the associated cost of biogas production as well as the financial analysis of energy from biogas from Model 1 and 2.

4.4 Financial analysis

This section presents the financial evaluation results for Model 1 and Model 2. At first, the cost values of the two models are presented followed by their NPV, ROI and IRR. Results from the sensitivity analysis of the electricity price are presented thereafter.

4.4.1 Profitability assessment

This section presents the financial analysis results based on the cost figures and financial variables in Table 3-10 and Table 3-11 respectively. Table 4-5 below contains the calculated investment costs, consumption and operational-bound costs for Model 1 and 2.

Table 4-5: Cost comparison between Model 1 and 2

	Model 1	Model 2
Digester volumes, m³	4710	2178
Investment Costs per unit R/m³	4 456	7 244
Investment Costs(R):	20 989 226	15 776 360
Digester (R)	14 392 138	10 328 294
CHP (R)	1 683 743	908 358
Scrubber (R)	4 913 344	2 807 625
Consumption-bound costs	-6 421 606	-1 863 048
Electricity (R/year)	1 084 629	587 556
Heat (R/year)	73 655	36 106
Avoided Disposal tariff (R/year)	-7 579 889	-2 486 710
Operational-bound costs	1 634 059	1 160 531
Concrete works (R/year)	71 961	38 826
Technical equipment (R/year)	431 764	232 957
CHP (R/year)	67 350	36 334
Labour costs (R/year)	80 316	80 316
Scrubber (R/year)	982 669	772 097
Other Costs (R/year)	104 946	57 406
Total Costs	16 306 626	15 131 249

The total investment cost for each model is the sum of the investment cost for the digester, CHP and scrubber. The investment costs for the digester were calculated from Equation 8 as outlined in Section 3.7. The investment cost for CHP was calculated assuming that the CHP costs are typically 650 US\$/kW_{el} for both models. For the scrubber unit, its investment cost values were obtained from Figure 3-5 using the nominal capacity of the CHP engine. In Model 1 and 2, the digester is the most capital intensive. This observation is consistent with literature sources as according to literature, the most expensive part of the biogas system is the digester (Rohlich et al., 1977). According to Murphy and Power (2009), the larger the facility the lower the capital cost per unit. This is evidenced in the table as Model 1 has a lower capital cost per unit than Model 2, indicating economies of scale.

For each model, the avoided disposal cost under the consumption-bound cost is shown as a negative cost to indicate a cost saving. This is due to the diversion of OFMSW and WPS from LFS to a biogas-

producing facility. This significant cost saving makes the economics of biogas production from the wastes considered in this study very attractive as it avoids the municipality's disposal charge of R264 per ton which applies only to OFMSW and WPS (Section 3.7). The PS produced from the Athlone WWTP is sent to a dedicated LFS and the cost of disposal at this site is unknown (Alcock, 2009). Therefore for the purpose of this study, the disposal charge was set to R264/ton. This charge excludes PS from the Bellville WWTP as it is applied to agricultural land at no cost.

The cost values in Table 4-5 were annualised and calculated over the project-lifetime to determine evaluate the profitability of each model. The annualised cost values are shown in Table 7-11 and Table 7-12 (Section 7.9, Appendix).

Table 4-6 and Table 4-7 present the financial feasibility results for Model 1 and 2 using the cost figures indicated in Table 4-5. Equations 9, 10 and 11 were used to calculate the NPV, IRR and ROI respectively. The electricity, heat and fertilizer (fertilizer sales applies to Model 2 only) values indicate their selling prices (Section 3.7, Table 3-10). The criterion used in this project to assess feasibility was primarily the IRR (discussed in Section 3.7). That is, for IRR values that are greater than the discount rate [r (%) set in Table 3-11] the models are financially feasible. As r (8%) is less than the IRR for Model 1 given the values of the revenue stream it can be stated that Model 1 is financially feasible and the REFIT Phase 2 biogas value of 96 cents/kWh is sufficient based on the assumptions considered in this study.

Table 4-6: Results for the financial analysis of Model 1

Electricity, R	Heat, R	NPV,R	ROI,%	IRR,%
0.96	0.05	70 190 892	50%	21%

However, at the same selling price of electricity and heat the NPV, ROI and IRR values for Model 2 are comparatively smaller than Model 1 values although the selling price of the fertilizer is included here. This difference in profitability was expected given the variations in the calculated biogas output and energy associated with this output. According to the profitability criterion used in this project, the IRR value (Table 4-7) is less than r (%) indicating that although the NPV is positive, Model 2 is relatively less profitable than Model 1. This is further shown in Figure 4-7.

Table 4-7: Results for the financial analysis of Model 2

Electricity, R	Heat, R	Fertilizer, R/ton	NPV,R	ROI,%	IRR,%
0.96	0.05	2.206	79 815 65	16%	5.6%

Figure 4-7 is a graphical representation of the payback period (PBP) for Model 1 and 2. The PBP for Model 1 (5years) is shorter than for Model 2 (10 years). This means that a longer length of time is required to recoup the initial investment (FCI) in Model 2 compared to Model 1 (Karellas et al., 2009). It is worth noting that the PBP is not used as a measure of profitability in this study as this can be misleading but it is used to indicate the different lengths of time required by each model to recoup the initial investment costs (Perry & Green, 1997).

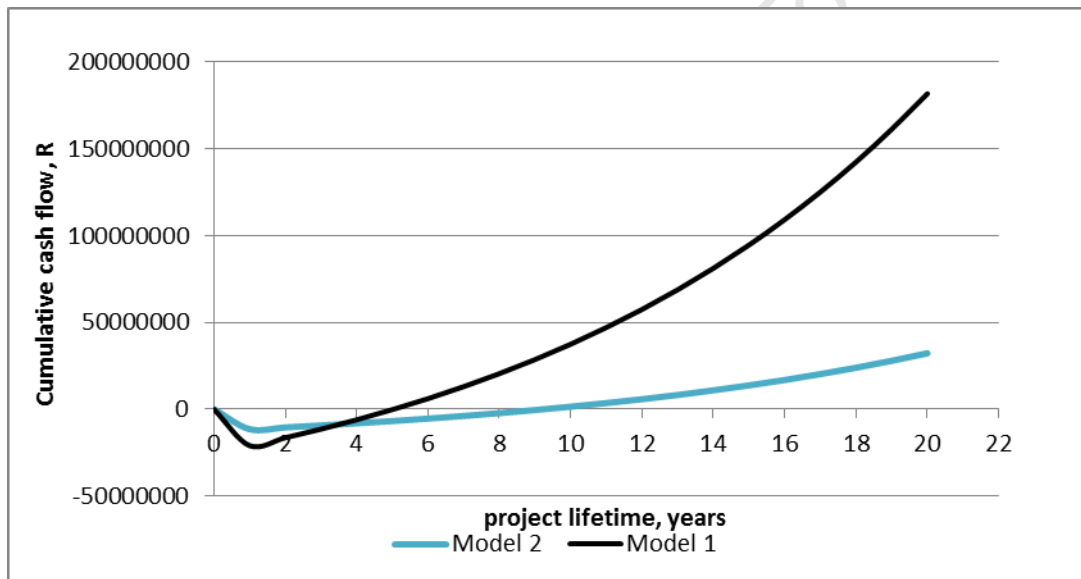

Figure 4-7: Graphical representation of the payback period for Model 1 and 2

4.4.2 Sensitivity Analysis

The results shown in Table 4-6 and Table 4-7 were based on a number of assumptions including the selling price of electricity. This assumption has a great effect on the economics of each model. Therefore, a sensitivity analysis was carried out to determine the extent to which the selling price of electricity affects the financial feasibility of each project.

4.4.2.1 Selling price of electricity

A sensitivity analysis was carried out for a variation in the selling price of electricity. Currently, the REFIT Phase 2 value of electricity from biogas is 96 cents/kWh (NERSA, 2011). This price indicates the price at which the single buyer office (SBO) will purchase biogas-generated electricity. For Model 1, the study agrees that this selling price is sufficient as the profitability criterion is satisfied. It could be argued that this may be due to the fact that the financial calculations performed for Model 1 also incorporated revenue from selling heat but the study investigated that for Model 1 excluding the price of heat still gives an IRR value that is higher than r (%) (Table 4-8), and thus not influencing the profitability of this model.

Table 4-8: Influence of electricity on the profitability assessment of Model 1

Electricity price, R/kWh	Heat price, R/kWh	NPV,R	ROI	IRR
0.96	0	68 633 208	48%	20%

It was expected that varying the selling price of electricity in Model 1 would significantly enhance the model's profitability as it is already financially viable. **Figure 4-8: Effect of varying the selling price of electricity on Model 1** Figure 4-8 illustrates the effect of varying the selling price of electricity on Model 1's profitability.

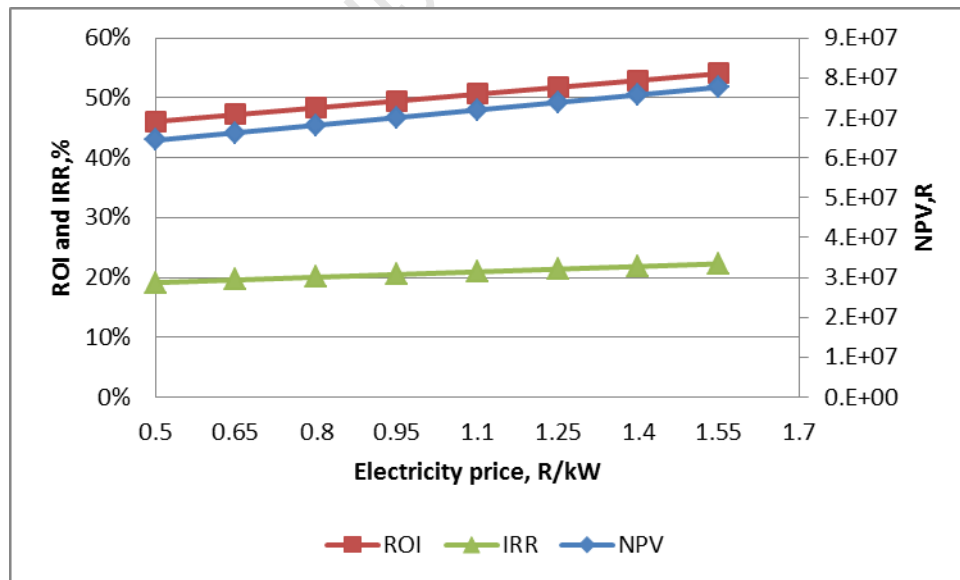

Figure 4-8: Effect of varying the selling price of electricity on Model 1

The electricity price was varied from R0.5/kWh to R1.55/kWh. The results indicate that for electricity prices less than R0.96/kWh the model is still profitable based on the IRR values that are greater than the discount rate. The changes in NPV, ROI and IRR values are fairly small over the wide range of electricity price. This is due to the large saving realised by avoiding the cost of disposal of OFMSW.

Figure 4-9 shows the effect of varying the selling price of electricity on Model 2’s profitability:

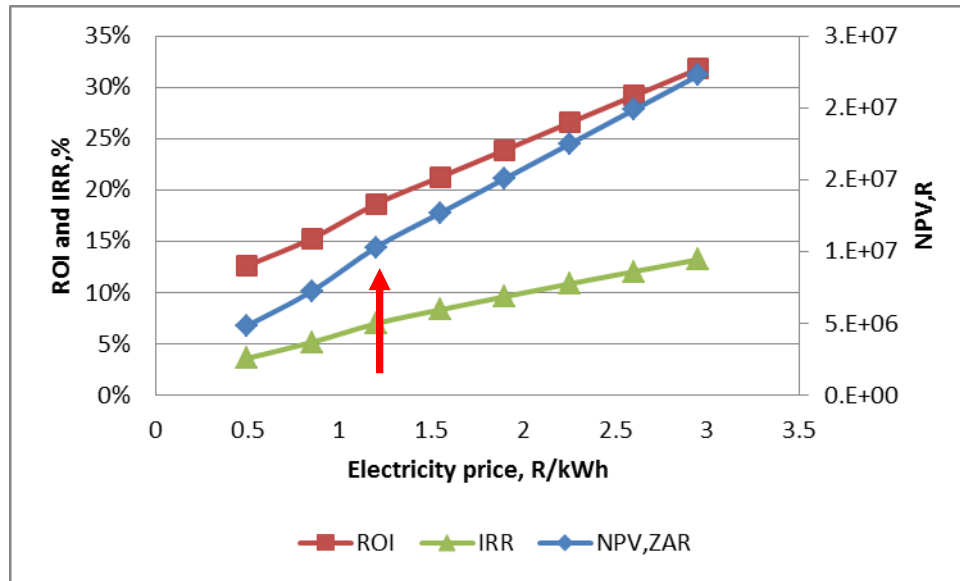

Figure 4-9: Effect of varying electricity price on Model 2

As expected the NPV, ROI and IRR increase with increasing electricity price. The electricity price was varied from R0.5/kWh to R2.95/kWh. For this model the IRR is less than the discount rate at prices below R2.25/kWh indicated by the arrow. However, the IRR is greater than the discount rate (8%) from R2.50/kWh onwards. This means that from R0.5/kWh to R2.50/kWh the model is financially infeasible. However for selling prices of R2.50/kWh to R2.95/kWh the model becomes financially feasible. Model 1 is relatively more profitable than Model 2. The reason may be due to the differences in biogas production and ultimately the amount of electricity available for sale. Model 2 has less feedstock available for biogas production relative to Model 1 indicating that a lesser amount of electricity was available for sale.

4.5 GHG emissions for baseline and biogas production

This section presents GHG emissions for baseline followed by emissions due to biogas production. Baseline emissions refer to CO₂-equivalent emissions in the absence of diverting OFMSW, WPS and

primary sludge (PS) from landfill sites to a biogas producing facility. The section concludes with the calculation of the emission reduction potential of biogas.

4.5.1 GHG emissions from landfill disposal of OFMSW, WPS and PS from Athlone

WWTP

Section 7.2.1 (Appendix) provides a sample calculation that illustrates the methodology used to estimate the parameters in Table 4-9.

Table 4-9: Degradable organic carbon and methane generation for OFMSW, WPS and PS

	OFMSW	WPS	Athlone PS
DOC, ton of carbon/ton of waste	0.06**	0.4**	0.05**
M_{waste} (ton/day)	78.7 [#]	26*	111.8 ⁶
CH₄-generated (ton of CH₄/year)	1 117	2 753	1 464

Source: (**IPCC, 2006; *Baloyi, 2011; [#]Jeffares & Green & IngeropAfrica, 2004)

Table 4-9 shows that WPS has a higher DOC than OFMSW and PS. This was expected given its high C/N ratio (Figure 4-1) and methane fraction in the landfill gas (Table 3-8). As a result of having the highest DOC, WPS also generates the highest amount of methane in the landfill. Although the DOC for OFMSW is higher than that for PS, it has a lower methane composition of 48.6% (Table 3-8). Hence the amount of methane generated within the landfill is lower.

In order to estimate the amount of CH₄ released to the atmosphere, it is important to note that the CH₄ generated in the landfill is less than the CH₄ released (NCASI, 2005). Thus, the study used the oxidation factor (OX) as it reflects the fraction of CH₄ that is oxidised by the soil. For managed LFS covered with soil such as Vissershok, OX is 0.1 (IPCC, 2006). This means that 10% of the CH₄ generated from OFMSW, WPS and PS is oxidised by the soil, therefore the remaining 90% escapes to the atmosphere. Assuming a Global Warming Potential (GWP) of 21 for CH₄, the amount of CO₂ equivalent was computed (IPCC, 2007). Table 4-10 presents the methane emissions computed:

⁶ See below Table 7-8 (Appendix)

Table 4-10: Estimating CH₄ emissions from disposal of OFMSW and WPS

	OFMSW	WPS	Athlone PS	Total
CH₄-emitted (ton/year)	1 005	2 478	1 318	4 801
CH₄-emitted (tons of CO₂-equivalent/year)	21 110	52 040	27 670	100 820

The results indicate the impact that the continual disposal of OFMSW, WPS and PS at the LFS will have on the environment. It is worth noting that the emissions from the disposal of WPS is higher than the sum of emissions for OFMSW and PS although WPS has a lower waste quantity (M_{waste} , 25.8 ton/day). This shows that WPS has a greater adverse impact on the environment when landfilled relative to OFMSW and PS. This may explain why the environmental regulations are banning the disposal of WPS by landfill.

The total amount of GHG emissions is *100 820 ton of CO₂-equivalent per year* (Table 4-10). The significance of this figure is that 100 000 ton of CO₂-equivalent per year is released to the atmosphere due to the landfill disposal of OFMSW, WPS and PS. This is based on quantities used for Models 1 and 2.

The following section presents results on emissions from the biogas process as well as the emission reduction potential.

4.5.2 GHG emissions from biogas production and the emission reduction potential

The GHG emissions due to the production of biogas and the associated energy are shown in Table 4-11. The procedure used for calculation is explained in Section 3.3.3.

Table 4-11: Estimated GHG emissions from biogas production

	Model 1	Model 2	Total
CH₄-leak (m³/year)	77 720	37 271	114 990
CO₂-equivalent_{CH4-leak} (ton/year)	1 175	564	1 739
CO₂-emissions (ton/year)	296	142	438
Total CO₂ (ton/year)	1 471	706	2 177

As shown in Table 4-11, the potential amount of GHG emissions from biogas production is significantly lower than the calculated amount of GHG emissions generated as a result of landfilling wastes (OFMSW, WPS, and PS). The emissions resulting from the land application of PS (from the Bellville

WWTP) were not included because the carbon dioxide emitted is of biogenic origin. Thus the emission reduction potential (ERP) of biogas from Models 1 and 2 is:

$$ERP = 100\ 820 - 2177$$

$$ERP = 98\ 643 \text{ ton of CO}_2 \text{ equivalent per year}$$

This value indicates that 98 643 tons of CO₂ equivalent per year could be mitigated by obtaining energy via biogas production in Model 1 and Model 2. Table 4-12 reports the baseline and project activity emissions for each model. The ERP is also shown per model. In Table 4-12, the cost below the ERP value is the *total investment cost* obtained from Table 4-5 for Model 1 and 2. As shown, the investment cost of mitigation for Model 2 is slightly lower than for Model 1. This was expected given the larger ERP for Model 2. That is, since Model 2 mitigates larger emissions than Model 1 its investment cost of mitigation is lower. This is not linked to the profitability of the two Models as the cost of mitigation was calculated as the investment cost over the ERP. The results from Table 4-12 indicate that it is cost-effective to divert waste from the LFS in order to mitigate emissions. The weighted average of the cost of mitigation of Model 1 and 2 is R372 per CO₂ equivalent ton saved in year 1 [R37million/98807ton].

Table 4-12: The cost of mitigating GHG emissions

	Model 1	Model 2	Total
Baseline emissions (tons of CO₂ equivalent/year)	48 780	52 040	100 820
Project activity (tons of CO₂ equivalent/year)⁷	1 308	705	2 013
ERP (tons of CO₂ equivalent/year)	47 472	51 335	98 807
Cost (R)	20 989 226	15 776 360	36 765 586
R/ton CO₂	442	307	

This section presented the emission reduction potential and associated cost of diverting OFMSW, WPS and PS from landfill sites. The following section presents the results for a *city-wide modeling* of biogas energy from the *total* amount of OFMSW and PS available in the city.

4.6 Results for city-scale modeling on LEAP

This section firstly presents the energy analysis results from LEAP and secondly the landfill emissions as a result of disposal of total quantities of OFMSW and PS. The energy which can be supplied from biogas and the associated energy emissions are presented. The carbon emissions from biogas are

⁷ Project activity refers to emissions as a result of biogas production (See Chapter 2 and 3)

compared with emissions from other electricity and thermal energy fuels in a form of a scenario analysis as mentioned in Section 2.9.

4.6.1 Estimating emissions from energy generated from fossil fuels

LEAP was set up to include the energy from biogas (both heat and electricity) from 2012 to 2050. The assumptions and summary of input parameters are included in Section 3.8. Table 4-13 contains the parameters that were calculated prior to setting up the LEAP model as outlined and calculated in Section 3.8 and Section 7.11 respectively. The 7.51 MW capacity is the annual generation capacity for each model year. Comparing this capacity to other technologies indicates that it is larger than the generation capacity of the wind farm (5.2 MW) but significantly smaller than the smallest coal-based power plant (Komati, 202MW) (Ward & Walsh, 2010; IRP, 2010).

Table 4-13: Input parameters for LEAP

Model Period	2012-2050
Capacity, MW	7.51
Capital cost, R/MW	1.32E+08
Fixed O&M, R/MW	2.49E+05
Variable O&M, R/MWh	828

The results from the model show that the *total* amount of energy (thermal and electrical) that can be derived from biogas via anaerobic co-digestion from the *total* amount of OFMSW and primary sludge (PS) available in Cape Town is 49 GWh per model year and the emissions associated with this are 416.2 tons of CO₂-equivalent per model year.

The study estimated the emissions associated with energy use that could be avoided by using energy from biogas. This was achieved by determining the amount of electricity and heat that could be produced with biogas. According to the electrical (30%) and thermal efficiency (50%) of CHP, the *output energy share*⁸ of electricity and heat from the CHP unit are 37.5% and 62.5% respectively. Thus the amount of electricity and heat from the biogas would be:

$$E_{\text{cape town}} = 37.5\% * 49\text{GWh per model year}$$

⁸ Total efficiency of CHP is 80%. Therefore the output energy share as required by LEAP is 30/80 for electricity and 50/80 for heat.

$$E_{\text{cape town}} = 18.375 \text{ GWh per model year}$$

$$\text{Heat}_{\text{cape town}} = 62.5\% * 49 \text{ GWh per model year}$$

$$\text{Heat}_{\text{cape town}} = 30.625 \text{ GWh per model year}$$

That is, 18.4 GWh/year and 30.6 GWh/year of electricity and heat respectively are potentially available via the anaerobic co-digestion of OFMSW with PS using their *total* amounts available in Cape Town. It was assumed that the electricity component (18.4GWh) of energy from biogas would replace 18.4 GWh/year of coal-derived electricity. As coal accounts for 95% of the city's electricity supply (SEA, 2007; SEA & AMATHEMBA, 2007).

For thermal energy, 30.6 GWh/year of heat from biogas can replace fuels that are usually used to meet industrial heat demand. These fuels are diesel, LPG, paraffin, coal and heavy fuel oil (SEA & ERC, 2010). It is not clear the percentage split ratio of the industrial consumption of these fuels for thermal energy demand.

Section 7.10 (Appendix) contains the emission factors for electricity generated from coal by Eskom, diesel, LPG paraffin, coal and Heavy fuel oil. The results are presented in Table 4-14. The table shows that if Eskom's coal fired power stations are used to deliver the same amount of electricity as biogas (18.7 GWh/year), the amount of CO₂-equivalent produced was approximately 1900 tons. Furthermore, if diesel, LPG, Paraffin, coal or heavy fuel oil (HFO) was used to meet the thermal energy requirement of 30.6 GWh/year the amount of CO₂-equivalent emissions corresponding to each of these fuels is shown in the table.

Table 4-14: Emissions from fossil fuel-derived *thermal* energy

Fuel Type	Tons of CO₂-equivalent per model year
Electricity source:	
For Eskom-generated electricity (coal)	1 898
Thermal energy sources:	
Diesel	2 225
LPG	1 894
Paraffin	2 203
Coal	2 864
Heavy Fuel Oil	2 324
Total	13 410

As mentioned previously, the contribution of each fuel (diesel, LPG, paraffin, coal and HFO) to industrial heat in Cape Town is unknown because the sale and use of fuels within Cape Town is not well monitored. The study developed a scenario analysis to estimate the quantity of CO₂-equivalent emissions from coal-derived electricity and each industrial thermal energy fuel. Table 4-15 contains a list of scenarios (1 to 5) with each corresponding CO₂-equivalent emissions.

Table 4-15: Estimated total emissions from coal-derived power and thermal fuels

Scenario number	Scenario description	Ton CO₂-equivalent per model year
1	Coal-derived power and diesel	4 123
2	Coal-derived power and LPG	3 793
3	Coal-derived power and paraffin	4 101
4	Coal-derived power and coal	4 762
5	Coal-derived power and HFO	4 222

For scenario 1 in which industrial electricity (18.7 GWh/year) and thermal (30.6 GWh/year) energy demands are met from coal (Eskom) and diesel respectively, the total amount of CO₂-equivalent emissions is approximately 4123 tons per year. Similarly for scenario 2 to 5 their emissions in tons of CO₂-equivqlent are 3793, 4101, 4762 and 4222 as presented in the table. These quantities of emissions are significantly higher than the emissions produced (416.2 tons CO₂-equivalent per year) with energy from biogas. Table 4-16 contains the total amount of emissions for each scenario over the entire modeling period. The corresponding emission reduction potential (ERP) of biogas and % of emissions

reduced [ERP over fossil fuel emissions] are also shown. The results show that obtaining energy (49 GWh) from biogas via co-digestion of OFMSW and PS in Cape Town could result in ~90% of emissions reduced.

Table 4-16: The *total* ERP of biogas energy and cost *over the model period for city-wide modeling (2012-2050)*

Scenario	Emissions (tons of CO ₂ -equivalent)	ERP (tons of CO ₂ -equivalent)	Cost, R/ton	%Emissions reduced
1	157000	140 900	934	90%
2	144 200	128 400	1026	89%
3	155 900	140 000	940	90%
4	181 000	165 150	797	91%
5	160 500	144 700	910	90%

Table 4-16 also contains the cost associated with reducing energy emissions for each scenario over the model period at city-scale (2012-2050). The investment cost given in Table 4-13 was used to estimate the cost in Rand per ton basis for scenarios 1 to 5. The study expected larger ERP values. However, these results show that energy from biogas production has the potential to mitigate GHG emissions associated with energy utilization from fossil fuels. The potential of biogas to mitigate emissions was expected as biogas is a renewable energy source.

The results from the landfill disposal of *total quantities* of OFMSW and PS generated at city-scale (that is extension of Model 1) are discussed in the following section. The section uses the same types of waste as Model 1 but larger quantities to illustrate the effect of diverting waste from LFS to a biogas facility.

4.6.2 GHG emissions from landfill disposal of total quantities of OFMSW and PS

Table 4-17 contains the quantities of methane emissions generated and emitted from the LFS as a result of depositing the total quantities of OFMSW and PS generated in Cape Town. Section 7.12 (Appendix) shows the method of calculation for both OFMSW and PS.

Table 4-17: The quantities of methane generated and emitted from landfill disposal

	OFMSW	PS	Total
CH₄-generated (ton of CH₄/year)	15 480	8 795	24 275
CH₄-emitted(ton/year)	139 30	7 915	21 845
CH₄-emitted (tons of CO₂-equivalent/year)	292 500	166 000	458 500

The results in Table 4-17 show the total potential of methane released over a long time period due to the annual landfill deposit of OFMSW and PS. The ERP of biogas [458500-416.2] is then 458 084 ton of CO₂ equivalent per year. The total cost of mitigation is R287/ton CO₂-equivalent based on the investment cost from Table 4-13 [R1.32E+08/458 084]. This mitigation cost is lower than the mitigation costs for the two small-scale models. This is an expected outcome as the city-scale model avoids higher quantities of landfill emissions. Although city scale requires larger plants, these can benefit from economies of scale as is the case for large-scale biogas plants > 20m³ (Amigun & von Blottnitz, 2010).

5 Conclusions and Recommendations

The objectives of this dissertation were to make a contribution to a better integration of municipal responses to issues of energy and climate change with waste management planning. Specifically the dissertation set out to estimate, in the context of Cape Town, firstly the *emission reduction potential associated with energy from biogas*, and secondly *the corresponding cost*.

5.1 Conclusions to key questions

In line with the above objectives, five key questions were formulated as a way of providing a platform to meet them. The following conclusions are reported with respect to each key question.

5.1.1 Key Question 1

What are the sources of landfill gas and therefore of potential biogas in Cape Town?

Organic wastes generate landfill gas at the landfill sites. This indicates that they are suitable for biogas production. Types of wastes suitable for biogas production include fish wastes, animal manure, primary sludge, food wastes and industrial wastes. The study focused on the organic fraction of municipal solid waste (OFMSW), waste paper sludge (WPS) and primary sludge (PS) from sewage treatment. Chapter 3 outlined a method for estimating the landfill gas potential from these waste types at a small scale level. The results are presented in Chapter 4 and they show that OFMSW, WPS and PS generate significant quantities of landfill gas. The WPS generates more landfill gas than OFMSW and PS. This is due to the higher degradable organic carbon content in the WPS and also the percentage composition of methane in landfill gas was higher for WPS relative to OFMSW and PS. The high carbon content could possibly explain the strict environmental regulations which promote the prohibition of landfilling WPS. OFMSW generated the least landfill emissions as its methane composition in landfill gas was the lowest (48.6%) although it had slightly higher organic carbon content than PS.

The study then estimated the landfill emissions at city-scale by including the total amount of OFMSW and PS available in Cape Town. The results show that OFMSW and PS have the combined potential to release 500 000 tons of CO₂ equivalent/year from the city's landfill sites. OFMSW contributes the highest amount to the total landfill emissions compared to PS at city-scale. The landfill gas potential of these wastes shows that they can be used for biogas production.

5.1.2 Key Question 2

Which sources are compatible and suitable for co-digestion?

Literature studies show that wastes are compatible when one type is rich in carbon and the other in nitrogen. The carbon-rich waste has a high carbon-to-nitrogen ratio (C/N) whereas the nitrogen-rich waste has a low C/N ratio. The elemental analyses of OFMSW, WPS and PS presented in Chapter 3 indicate that WPS (125.5) is an extremely carbon-rich waste, OFMSW is well balanced with a C/N ratio between 20 and 30 whilst PS is nitrogen-rich and therefore usually inhibited in mono-digestion. Therefore two hypothetical biogas models were developed. Model 1 investigated the co-digestion of OFMSW with PS (from the Athlone WWTP) whilst Model 2 focused on WPS and PS (from the Bellville WWTP). These were also deemed compatible due to the close location of the sources, as identified with ArcGIS which is a geographic information system (GIS). Chapter 4 shows that the combined C/N ratio in each model was lower than the optimal range found in literature, indicating the need for more carbon-rich waste types.

5.1.3 Key Question 3

What are their individual and combined biogas potentials?

Chapter 3 reports the individual biogas yields for each waste. The biogas production for the two hypothetical models was also estimated, as the weighted sum of the individual yields. The results are presented in Chapter 4 and the calculations indicate that Model 1 would have a larger biogas potential than Model 2. This is due to the larger quantity of waste available for Model 1 than for Model 2 and also due to Model 1 having a higher decomposition efficiency than the second model, as a result of the higher fraction of easily degradable volatile solids in OFMSW compared to WPS. It should be noted that there were significant uncertainties associated with the specific biomethane potential (SBP) of these waste types.

5.1.4 Key Question 4

What would the impact be on Cape Town's energy and climate change plans (energy supply and emissions reduced)?

The impact of utilising energy from biogas was answered by quantifying the energy output from Model 1 and Model 2. The energy output from Model 1 was higher than that of Model 2 due to its higher biogas production. The study observed that for both models, the most energy intensive component of the biogas plant was the scrubber needed to upgrade the biogas by removing carbon dioxide. The scrubber

was responsible for over 70% of the total electricity consumption. The results showed that the inclusion of a water scrubber would consume a significant portion of the energy generated and thereby making less energy available for sale. The scrubber was needed because the methane content in the biogas was below acceptable levels (60% on a volume basis). This confirms that the composition of the feedstock affects the biogas quality. The analysis also indicates that biogas may be more efficient for thermal application, although this was not investigated in this study.

The study determined that biogas production processes also have their associated GHG emissions but are significantly lower than the emissions from the landfill disposal of OFMSW, WPS and PS. This strongly suggests that landfill emissions can be reduced by diverting wastes to a biogas facility.

The impact that energy from biogas could have on the city's energy supply was determined by extending Model 1 to include the total amount of OFMSW and PS available in Cape Town. The analysis on the LEAP model was conducted from 2012 to 2050. The results showed that approximately 49 GWh (thermal and electrical energy) per model year could be available from biogas. This translates to an annual generation capacity of 7.5 MW which is smaller than any of the currently existing power stations except for the wind farm. The study estimated the potential of energy from biogas to mitigate emissions associated with energy (electricity and heat) supply from conventional fuels. Obtaining energy (49 GWh) from biogas via co-digestion of *total generated quantities* of OFMSW and PS in Cape Town (that is beyond Model 1) could result in ~90% of emissions reduced. Coal was assumed to be the dominant electricity generator. The thermal fuels used were paraffin, heavy fuel oil (HFO), diesel, coal and liquefied petroleum gas (LPG). The results showed that, supplying electricity and heat from coal generates the highest amount of energy related emissions. On the other hand, supplying electricity and heat from coal and LPG respectively generates the lowest amount of emissions. The results show that energy generated from biogas can mitigate GHG emissions without compromising energy supply.

5.1.5 Key Question 5

What would be the cost of reducing GHG emissions via biogas production?

A profitability assessment was carried out for Model 1 and 2. Model 1 had a lower investment cost per digester unit compared to Model 2, indicating economies of scale. The avoided cost of disposal was

large and significant in the financial analysis for both models. The financial results show that Model 1 was more profitable than Model 2. This is because Model 1 satisfied the investment criterion (internal rate of return > discount rate) at the same selling price of electricity as Model 2. The IRR values for Models 1 and 2 were 20% and 6% respectively. This significant difference was due to the low biogas yield used for WPS (Model 2 substrate) and the avoided cost of disposal only applies to WPS in Model 2. Therefore Model 2 only realises a comparatively smaller saving than Model 1. Both models relied on selling the surplus electricity and heat as well as the fertilizer from the digestion process for income generation. The payback period for the first model was also shorter (5 years) compared to the second model (~10 years).

The study concludes that the cost [investment] of mitigating landfill emissions is dependent on the amount of landfill emissions avoided. For instance between Models 1 and 2, Model 2 avoided higher emissions than Model 1. Therefore Model 2 had a lower cost of mitigation. At city-scale, the cost of mitigating landfill emissions from disposal of total quantities of OFMSW and PS available in Cape Town was lower compared to the two models. This is because at city-scale larger quantities of emissions are saved. Large scale biogas plants (> 20m³) also benefit from economies of scale.

The costs of mitigating GHG emissions associated with energy supply from conventional fuels were also estimated by extending Model 1. The results showed that biogas has the potential to mitigate energy emissions associated with using fossil fuels.

5.2 Recommendations for future work

The study has demonstrated that biogas is a worthwhile mitigation option and should be integrated in the city's energy, waste management and climate change plans. This study has provided a useful structure that can be followed by future work. The research gaps that have been identified are:

- The accuracy of estimating the combined biogas potential for co-digestion can be improved by incorporating and modeling the reaction kinetics of anaerobic digestion. This would assist with mimicking the behaviour of the microorganisms involved in the digestion process. Then a detailed design of a biogas plant should be completed in order to develop a financial analysis of the plant.

- The biogas output calculated from Model 1 and 2 had a poor methane composition and this necessitated the inclusion of a scrubber unit to upgrade the methane content. This unit was the largest energy consumer in both models; this indicates the need to pre-determine the quality of biogas from a given feedstock (using elemental analysis of the waste and the Buswell's equation). Therefore future work should investigate which waste types would not require biogas upgrading if they were to be digested. For waste types that would result in poor methane content, they should be combined with wastes that could improve the biogas quality.
- The study observed that the assumed biogas yield of WPS (140.9 ml/gVS) was relatively low and resulted in low biogas output for Model 2 as well as low energy obtainable from this model. It is recommended that Model 2 be re-calculated with new biogas yields from more recent studies.
- Sludge from the WWTPs are rich in nitrogen and thus have very low carbon to nitrogen (C/N) ratios. Additional and highly carbon rich sources available in the city should be investigated in order to improve the C/N ratios of the substrates used for co-digestion.
- Further research should also investigate the emission reduction potential per energy generation capacity of other renewable energy technologies and the associated costs. This will be useful in assisting South African cities at large in their sustainable energy plans.
- The use of biogas for thermal application should be investigated further as an observation from this study might indicate that biogas is more suitable for thermal application. However this is not certain hence a further study is required.
- Future work should investigate the practicality and technicality of linking up anaerobic digesters to CHP units in existing WWTP in Cape Town. This would provide valuable insight to the implications of the City of Cape Town pursuing the waste-to-energy option.

6 References

- AgamaBiogas, 2009. *Biogas Services: Introduction to Biogas*. [Online] Agama Biogas Available at: HYPERLINK "<http://agama.co.za/home/biogas-services/biogas-services>" <http://agama.co.za/home/biogas-services/biogas-services> [Accessed 06 July 2011].
- AgamaBiogas, 2009. *Knowledge and Resource: Waste to energy publication toolkit*. [Online] SACN Available at: HYPERLINK "<http://www.sacities.net/component/content/article/32-workshops/411-waste-to-energy>" <http://www.sacities.net/component/content/article/32-workshops/411-waste-to-energy> [Accessed 3 June 2011].
- AgamaBiogas, 2009. *SUSTAINABLE CITIES: BIOGAS ENERGY FROM WASTE, A FEASIBILITY STUDY AND GUIDELINES FOR IMPLEMENTING BIOGAS FROM WASTE PROJECTS IN MUNICIPALITIES*. Technical Report. Cape Town: AGAMA Biogas (Pty) Ltd South African Cities Network.
- AgamaEnergy, 2008. *High Level Assessment of AWWTW Gas Use - N2 Gateway*. Cape Town.
- Akhile-Consortium, 2011. *MSA Section 78(3) to Assess Alternative Service Delivery Options RFP No:554C/2008/09*. Executive Summary. Cape Town: City of Cape Town.
- Alcock, N., 2009. *APPROPRIATE TECHNOLOGY FOR REUSE OF SLUDGE EMANATING FROM SOUTH AFRICAN CITIES*. Master's Thesis. Cape Town: University of Cape Town.
- Amigun, B. & von Blottnitz, H., 2009. Capital Cost prediction for Biogas Installations in Africa: Lang Factor Approach. *Environmental Progress & Sustainable Energy*, 28(1), pp.134-42.
- Amigun, B. & von Blottnitz, H., 2010. Capacity-cost and location-cost analyses for biogas plants in Africa. *Resources, Conservation and Recycling*, 55, pp.63-73.
- Baloyi, M.O., 2011. *Personal Communication*. Cape Town: Nampak Tissue.
- Bhattacharya, S.C., Thomas, J.M. & ABDUL SALAM, P., 1996. GREENHOUSE GAS EMISSIONS AND THE MITIGATION POTENTIAL OF USING ANIMAL WASTES IN ASIA. *Energy*, 22(11), pp.1079-85.
- Brint, I., 2008. *Measurement of composition of organic constituents of municipal wastewater for plant-wide modelling*. Master's Thesis. Cape Town: University of Cape Town.
- Burton, S. et al., 2009. *Energy from wastewater : A feasibility study*. Technical Report. Cape Town: Water Research Commissioner University of Cape Town.
- CCT, 2008. *Details of the Wastewater Treatment Works*. [Online] Available at: HYPERLINK "<http://www.capetown.gov.za/en/Pages/Results.aspx?k=athlone%20treatment%20process%20used>"

<http://www.capetown.gov.za/en/Pages/Results.aspx?k=athlone%20treatment%20process%20used>

[Accessed 1 June 2011].

CEPI, 2010. *Economic Indicators*. [Online] Available at: HYPERLINK

"<http://www.scribd.com/doc/39035256/CEPCI-2010>" <http://www.scribd.com/doc/39035256/CEPCI-2010> [Accessed 11 May 2011].

Chynoweth, D. & Isaacson, R., 1987. *Anaerobic Digestion of Biomass*. England: Elsevier Applied Science Publishers LTD.

CoCT, 2007. *Smart Living Handbook*. Cape Town: AMATHEMBA Management Consulting, Sustainable Energy Africa City of Cape Town.

CoCT, 2008. *City Statistics*. [Online] Available at: HYPERLINK

"<http://www.capetown.gov.za/en/stats/Documents/City%20Statistics%202009.htm>"

<http://www.capetown.gov.za/en/stats/Documents/City%20Statistics%202009.htm> [Accessed 28 May 2011].

CoCT, 2008. *Wastewater Treatment Works List*. [Online] Available at: HYPERLINK

"<http://www.capetown.gov.za/en/Pages/Results.aspx?k=wastewater%20treatment>"

<http://www.capetown.gov.za/en/Pages/Results.aspx?k=wastewater%20treatment> [Accessed 28 May 2010].

CoCT, 2008. *Wastewater Treatment Works List*. [Online] Available at: HYPERLINK

"<http://www.capetown.gov.za/en/Pages/Results.aspx?k=wastewater%20treatment>"

<http://www.capetown.gov.za/en/Pages/Results.aspx?k=wastewater%20treatment> [Accessed 28 May 2011].

CoCT, 2011. *Consultant's Final draft Report regarding municipal system's Act, Section 78(3)*

Assessment of alternate service delivery mechanisms for solid waste management in Cape Town. Cape Town: City of Cape Town.

CoCT, 2011. *Personnel Vacancies*. [Online] Utility Services: Water and Sanitation Available at: HYPERLINK

"<http://web1.capetown.gov.za/web1/employmentnet/OpenDocument.aspx?JobID=3913&DisplayMedium=Internet>"

<http://web1.capetown.gov.za/web1/employmentnet/OpenDocument.aspx?JobID=3913&DisplayMedium=Internet> [Accessed 3 June 2011].

CoCT, 2011. *Solid Waste Department*. [Online] Available at: HYPERLINK "http://www.capetown.gov.za/en/Solidwaste2/Pages/default.aspx" <http://www.capetown.gov.za/en/Solidwaste2/Pages/default.aspx> [Accessed 8 July 2011].

CoD, 2009. *City of Durban: Landfill gas to electricity project*. [Online] Available at: HYPERLINK "http://www.durban.gov.za/durban/services/cleansing/gastoelec/landfill" <http://www.durban.gov.za/durban/services/cleansing/gastoelec/landfill> [Accessed 06 July 2011].

Cohen, B., 2009. *CHE4048 Finance notes*. Cape Town: Department of Chemical Engineering University of Cape Town.

Cuetos, M.J., Gomez, X., Otero, M. & Moran, A., 2008. Anaerobic digestion of solid slaughterhouse waste (SHW) at laboratory scale: Influence of co-digestion with the organic fraction of municipal solid waste (OFMSW). *Biochemical Engineering Journal*, 40, pp.99-106.

Dalwai, I., 2011. *Results for BMP assays of co-digestion of paper sludge with nitrogen-rich waste substrates*. Unpublished. Cape Town: Environment and Process Engineering.

de Hullu, J. et al., 2008. *Comparing different biogas upgrading techniques*. Interim Report. Technical University of Eindhoven.

DEA, 2009. *Greenhouse gas inventory for South Africa:2000*. National Inventory Report. Pretoria: Department of Environmental Affairs Department of Environmental Affairs.

DEA, 2010. *National Climate Change Response Green Paper 2010*. Pretoria: Department of Environmental Affairs.

Dennis, A. & Burke, P.E., 2001. *Dairy Waste Anaerobic Digestion Handbook:Options for Recovering Beneficial Products From Dairy Manure*. Handbook. Olympia: Environmental Energy Company Environmental Energy Company.

Deublein, D. & Steinhauser, A., 2008. *Biogas from Waste and Renewable Resources: An Introduction*. Deggendorf: WILEY-VCH Verlag GmbH & Co. KGaA.

DME, 2003. *White Paper on Renewable Energy*. Pretoria: Department of Minerals and Energy.

Ecoplexity, 2009. *Measuring Soil Respiration*. [Online] Portland State University Available at: HYPERLINK "http://www.ecoplexity.org/node/551" <http://www.ecoplexity.org/node/551> [Accessed 3 August 2011].

EPA, 2010. *Greening EPA Glossary*. [Online] Available at: HYPERLINK "http://www.epa.gov/oaintrnt/glossary.htm" <http://www.epa.gov/oaintrnt/glossary.htm> [Accessed 22 December 2010].

ERC, 2011. *Comments on the National Climate Change Response Green Paper 2010*. Energy Research Centre, University of Cape Town.

Esri, 2011. *ArcGIS for Desktop*. [Online] Available at: HYPERLINK

"<http://www.esri.com/software/arcgis/arcgis-for-desktop/index.html>"

<http://www.esri.com/software/arcgis/arcgis-for-desktop/index.html> [Accessed 21 August 2011].

Felder, R.M. & Rousseau, R.W., 2000. Fundamentals of Material Balances on Reactive Systems. In *Elementary Principles of Chemical Processes*. 3rd ed. New Jersey: John Wiley & Sons, Inc. pp.125-42.

Fernandez, A., Sanchez, A. & X, F., 2005. Anaerobic co-digestion of a simulated organic fraction of municipal solid wastes and fats of animal and vegetable origin. *Biochemical Engineering Journal*, 26, pp.22-28.

Greben, H.A. & Oelofse, S.H.H., 2009. Unlocking the resource potential of organic waste: a South African perspective. *Waste Management and Research*, pp.1-9.

Green, J.& & IngeropAfrica, 2004. *Development of an Intergrated Solid Waste Management Plan for the City of Cape Town: Final Assessment Report*. Consultant Service Report. Cape Town: Mega-Tech Inc (MTI).

IEA, 2008. *Combined Heat and Power: Evaluating the benefits of greater global investment*. France: OECD/IEA International Energy Agency.

IEABionergy, 2001. *Biogas and More: Systems and Markets Overview of Anaerobic digestion*. United Kingdom: AEA Technology Environment International Energy Agency.

IPCC, 1996. *Revised 1996 IPCC Guidelines for National Greenhouse Gas Inventories : Reference Manual, Chapter 6: Waste*. [Online] Available at: HYPERLINK "<http://www.ipcc-nggip.iges.or.jp/public/gl/guidelin/ch6ref1.pdf>" <http://www.ipcc-nggip.iges.or.jp/public/gl/guidelin/ch6ref1.pdf> [Accessed 30 May 2011].

IPCC, 2000. *Good Practice Guidance and Uncertainty Management in National Greenhouse Gas Inventories*. [Online] IPCC Available at: HYPERLINK "http://www.ipcc-nggip.iges.or.jp/public/gp/english/5_Waste.pdf" http://www.ipcc-nggip.iges.or.jp/public/gp/english/5_Waste.pdf [Accessed 30 May 2011].

IPCC, 2006. *2006 IPCC Guidelines for National Greenhouse Gas Inventories*. Japan: IGES National Greenhouse Gas Inventories Programme.

IPCC, 2007. *2006 IPCC Guidelines for National Greenhouse Gas Inventories Volume 2 energy*. Intergovernmental Panel on Climate Change.

IPCC, 2007. *Climate Change 2007: The Physical Science basis. Contribution of working group I to the fourth assessment report of the Intergovernmental Panel on Climate Change*. Cambridge, United Kingdom and New York: Cambridge University Press.

IPCC, 2007. *Intergovernmental Panel on Climate Change*. [Online] Available at: HYPERLINK "http://www.ipcc.ch/publications_and_data/ar4/wg1/en/ch2s2-10-2.html" http://www.ipcc.ch/publications_and_data/ar4/wg1/en/ch2s2-10-2.html [Accessed 31 May 2011].

Iranzo, M. et al., 2004. Characteristics of rice straw and sewage sludge as composting materials in Valencia(Spain). *Bioresource Technology*, 95, pp.107-12.

IRP, 2010. *Integrated Resource Plan for Electricity*. DRAFT version 8. Department of Energy.

Jeffares&Green & IngeropAfrica, 2004. *Development of an Intergrated Solid Waste Management Plan for the City of Cape Town: Final Assessment Report*. Consultant Service Report. Cape Town: Mega-Tech Inc (MTI).

Karellas, S., Boukis, I. & Kontopoulos, G., 2010. Development of an investment decision tool for biogas production from agricultural waste. *Renewable and Sustainable Energy Reviews*, 14, pp.1273-82.

Klass, D.L., 1998. Waste Biomass Resource Abundance, energy potential, and Availability. In *Biomass for Renewable Energy, Fuels, and Chemicals*. California: Academic Press. pp.137-57.

Letete, T., Guma, M. & Marquard, A., 2009. *Topic 3 Information on Climate Change in South Africa: greenhouse gas emissions and mitigation options*. Energy Research Centre, University of Cape Town.

Lund, H., 2010. *Renewable Energy Systems: The Choice and Modeling of 100% Renewable Solutions*. California: Elsevier.

Luste, S., & Luostarinen, S. 2010. Anaerobic co-digestion of meat-processing by-products and sewage sludge: Effect of hygienization and organic loading rate. *Bioresource Technology*. 101:2657-2664.

Luxresearch, 2007. *Waste to Energy*. Technical. Lux Research Inc.

Macias-Corral, M. et al., 2008. Anaerobic digestion of municipal solid waste and agricultural waste and the effect of co-digestion with dairy cow manure. *Bioresource Technology*, 99(17), pp.8288-93. Available at: HYPERLINK "http://www.ncbi.nlm.nih.gov/pubmed/18482835" <http://www.ncbi.nlm.nih.gov/pubmed/18482835> [Accessed 15 July 2011].

Mamabolo, M.M., 2006. *A survey of Organic Pollutants in the South African Sewage Sludges*. Master's Thesis. Pietermaritzburg: University of Kwazulu-Natal.

Map, C.T.G., 2009. *Cape Town Green Map*. [Online] Available at: HYPERLINK "http://www.capetowngreenmap.co.za/go-green/energy" <http://www.capetowngreenmap.co.za/go-green/energy> [Accessed 21 August 2011].

Mata-Álvarez, J., Mace, S. & Astals, S., 2009. *Co-digestion of Solid Wastes-Principles and Challenges*. [Online] Available at: HYPERLINK "http://www.ite-narbonne.com/pdf/14-joan-mata-alvarez.pdf" <http://www.ite-narbonne.com/pdf/14-joan-mata-alvarez.pdf> [Accessed 15 July 2011].

Mata-Alvarez, J., Mace, S. & Llabres, P., 2000. Anaerobic digestion of organic solid wastes. An overview of research achievements and perspective. *Bioresource Technology*, 74, pp.3-16.

Monnet, F., 2003. *An Introduction Anaerobic Digestion of Organic Wastes*. [Online] Remade Scotland Available at: HYPERLINK "http://www.biogasmax.co.uk/media/introanaerobicdigestion__073323000_1011_24042007.pdf" http://www.biogasmax.co.uk/media/introanaerobicdigestion__073323000_1011_24042007.pdf [Accessed 10 July 2011].

Munganga, G., Melamu, R., von Blottnitz, H. & Haider, S., 2010. *An assessment of the bio-methane potential of seventeen types of organic fraction of the municipal solid waste (OFMSW) in Cape Town*. Cape Town: University of Cape Town.

Murphy, J.D., McKeogh, E. & Kiely, G., 2004. Technical, economic and environmental analysis of biogas utilisation. *Applied Energy*, 77, pp.407-27.

Murphy, J.D. & Power, N., 2009. Technical and economic analysis of biogas production in Ireland utilising three different crop rotations. *Applied Energy*, 86, pp.25-26.

Myréen, L. et al., 2010. *Waste to energy by industrially integrated SCWG – Effect of process parameters on gasification of industrial biomass*. Chemical Engineering Transactions.

NCASI, 2005. *Calculation Tools for Estimating Greenhouse Gas Emissions from Pulp and Paper Mills*. NC, USA: National Council for Air and Stream Improvement, Inc.

NERSA, 2011. *Documents*. [Online] Department of Energy Available at: HYPERLINK "http://www.google.co.za/url?sa=t&source=web&cd=2&ved=0CCIQFjAB&url=http%3A%2F%2Fwww.remtproject.org%2FFileDownload.aspx%3FFileID%3D56&rct=j&q=south%20africa%20renewable%20energy%20feed-in%20tariff%20march%202011%20&ei=CjgKTp7sK865hAeN2Y3IDw&usg=AFQjCNFuIj" <http://www.google.co.za/url?sa=t&source=web&cd=2&ved=0CCIQFjAB&url=http%3A%2F%2Fwww.remtproject.org%2FFileDownload.aspx%3FFileID%3D56&rct=j&q=south%20africa%20renewable%20energy%20feed-in%20tariff%20march%202011%20&ei=CjgKTp7sK865hAeN2Y3IDw&usg=AFQjCNFuIj>

[Oenergy%20feed-](#)

[in%20tariff%20march%202011%20&ei=CjgKTp7sK865hAeN2Y3IDw&usg=AFQjCNFuIj](#) [Accessed 28 June 2011].

Nontangana, M., 2011. *Personal Communication*. Solid Waste Department, Cape Town.

NTE, 2006. *PROMOTION OF RENEWABLE ENERGY ENERGY EFFICIENCY AND GREENHOUSE GAS ABATEMENT (PREGA)*. Pre-feasibility Study Report. Philippines: National Technical Experts from Geosphere Technologies, Inc.

Parkin, G.F. & Owen, W.F., 1986. Fundamental of anaerobic-digestion of wastewater sludge. *Journal of Environmental Engineering*, 112, pp.867-920.

Pegels, A., 2009. *Prospects for Renewable Energy in South Africa: Mobilizing the private sector*. Discussion Paper. Bonn: German Development Institute.

Perry, R.H. & Green, D.W., 1997. In *Perry's Chemical Engineer's Handbook*. 7th ed. McGraw Hill.

Peters, M.S. & Timmerhaus, K.D., 1991. *Plant Design and Economics for Chemical Engineers*. 4th ed. Singapore: McGraw-Hill International.

Rohlich, G. et al., 1977. Research and Development Needs: Technical R&D Issues. In *Methane generation from Human, Animal, and Agricultural Wastes*. Washington D.C: National Academy of Sciences. pp.108-09.

SARB, 2011. *South African Reserve Bank*. [Online] Available at: HYPERLINK

"<http://www.resbank.co.za/pages/default.aspx>" <http://www.resbank.co.za/pages/default.aspx> [Accessed 23 June 2011].

Schulze, R.E., 1997. *South African Atlas of Agrohydrology and Climatology*. Report TT82/96. Pretoria: Water Research Commission.

Scott, A., Ball, B.C., Crichton, I.J. & Aitken, M.N., 2000. Nitrous oxide and carbon dioxide emissions from grassland amended with sewage sludge. *Soil Use and Management*, 16, pp.36-41.

Scott, G.M. & Smith, A., 1995. SLUDGE CHARACTERISTICS AND DISPOSAL ALTERNATIVES FOR THE PULP AND PAPER INDUSTRY. In: *Proceedings of the 1995 International environmental conference*, pp.269-79.

SEA, 2007. *Energy: City of Cape Town Integrated Analysis Baseline Report*. Stellenbosch: Sustainability Institute.

SEA & AMATHEMBA, 2007. *Smart Living Handbook*. Cape Town: City of Cape Town Sustainable Energy Africa and AMATHEMBA Environmental Management Consulting.

- SEA & ERC, 2010. *Energy Scenarios for Cape Town*. Draft Report. Cape Town: Sustainable Energy Africa and Energy Research Centre.
- SEA & ERC, 2010. *ENERGY SCENARIOS FOR CAPE TOWN: EXPLORING THE IMPLICATIONS OF DIFFERENT ENERGY FUTURES FOR THE CITY UP TO 2050*. Draft Report. Cape Town: Sustainable Energy Africa and Energy Research Centre.
- SEA & ERC, 2010. *ENERGY SCENARIOS FOR CAPE TOWN: EXPLORING THE IMPLICATIONS OF DIFFERENT ENERGY FUTURES FOR THE CITY UP TO 2050*. Draft Report. Cape Town: Sustainable Energy Africa and Energy Research Centre (University of Cape Town).
- Sinnott, R.K., 1999. *Coulson and Richardson's Chemical Engineering Design*. 3rd ed. Manchester: Butterworth-Heinemann.
- Sosnowski, P., Wiczorek, A. & Ledakowicz, S., 2003. Anaerobic Co-digestion of sewage sludge and Organic Fraction of Municipal Solid Waste. *Advances in Environmental Research*, 7, pp.609-16.
- Sosnowski, P., Wiczorek, A. & Ledakowicz, S., 2003. Anaerobic co-digestion of sewage sludge and organic fraction of municipal wastes. *Advances in Environmental Research*, 7, pp.609-16.
- Steffen, R., Szolar, O. & Braun, R., 1998. *Feedstocks for Anaerobic Digestion*. Vienna: Institute for Agrobiotechnology Tulln.
- Suriyanarayanan, S. et al., 2010. Studies on the Characterization and Possibilities of Reutilization of Solid Wastes from a Waste Paper Based Paper Industry. *Global Journal of Environmental Research*, 4(1), pp.18-22.
- Tesfai, F.K., 2004. *Determination of the Inorganic Pollutants in South African Sewage Sludges*. Master's thesis. Pietermaritzburg: University of Kwazulu-Natal.
- Tesfai, F.K., 2004. *Determination of the Inorganic Pollutants in South African Sewage Sludges*. MSc Thesis. Pietermaritzburg: University of KwaZulu-Natal.
- UNEP, 2005. *Solid Waste Management*. [Online] Available at: [HYPERLINK "http://www.unep.or.jp/ietc/Publications/spc/Solid_Waste_Management/Vol_I/18-Chapter12.pdf"](http://www.unep.or.jp/ietc/Publications/spc/Solid_Waste_Management/Vol_I/18-Chapter12.pdf)
http://www.unep.or.jp/ietc/Publications/spc/Solid_Waste_Management/Vol_I/18-Chapter12.pdf
 [Accessed 06 July 2011].
- Van Lier, J.B., Mahmoud, N. & Zeeman, G., 2008. Anaerobic Wastewater Treatment. In M. Henze, M.C.M. Van Loosdrecht, G.A. Ekama & D. Brdjanovic, eds. *Biological Wastewater Treatment*. 1st ed. London: IWA Publishing. p.425.

Vindis, P., Mursec, B., Janzekovic, M. & Cus, F., 2009. The impact of mesophilic and thermophilic anaerobic digestion on biogas production. *Journal of Achievements in Materials and Manufacturing Engineering*, 2(36), pp.192-98.

von Blottnitz, H., 2005. Personal Communication of von Blottnitz with Mazeema.

von Blottnitz, H., 2011. Personal communication of von Blottnitz with Ballard.

Von Blottnitz, H. et al., 2006. *Burn, Gasify, Pyrolyse or Ferment? Making sense of the many possibilities for energy from waste in South Africa*. Cape Town.

Wagner, L., 2007. *Waste-to-Energy technology*. Research. MORA Associates.

Ward, S. & Walsh, V., 2010. *Cape Town Energy Case Study*. Cape Town: City of Cape Town: Environment Resource Management Department.

Ward, S. & Walsh, V., 2010. *Cape Town Energy Study*. Case Study. Cape Town: Environmental Resource Management Department and World Energy Congress City of Cape Town.

Wilkie, A.C., 2008. Biomethane from Biomass, Biowaste, and Biofuels. In J. Wall, ed. *Bioenergy*. 1st ed. Florida: ASM Press. pp.195-205.

Winker, H., 2007. *Long Term Mitigation Scenarios*. Technical Report. Pretoria: Department of Environmental Affairs Prepared by Energy Research Centre.

Winkler, H. et al., 2005. *Cape Town Energy Futures: Policies and scenarios for sustainable city energy development*. Cape Town: Energy Research Centre.

Wright-Pierce, 1999. *Cape Metropolitan Council Feasibility Study Towards An Integrated Solid Waste Management Plan*. Maine, USA: Prepared for Cape Metropolitan Area.

Zaher, U., Cheong, D.-Y., Wu, B. & Chen, S., 2007. *Producing Energy and Fertilizer From Organic Municipal Solid Waste*. Washington: Ecology Publication Department of Biological Systems Engineering Washington State University.

Zamudio Canas, E.M., 2010. *Technical Feasibility of Anaerobic Co-digestion of Dairy Manure with Chicken Litter and other wastes*. Master's Thesis. Tennessee: University of Tennessee.

7 Appendices

7.1 Waste generation data

Table 7-1: Waste generation rates per income group in Cape Town (2003)

Income group	Population by income group	Household (kg/capita/day)	Garden (kg/capita/day)	Total (kg/capita/day)
Low	2046144	0.5	0	0.5
Middle	600008	1.1	0.35	1.45
High	247099	2	0.35	2.35

Source: (Jeffares&Green & IngeropAfrica, 2004)

Table 7-2: Composition of waste from households in Cape Town (2003)

	High	Middle	Low
Organic	38.9%	38.80%	57.8%
Other	8.2%	11.20%	6.3%
Plastics	14%	15.50%	9.9%
Glass	12.5%	7%	6.1%
Metal	9%	4.70%	3.5%
Paper	17.4%	22.70%	16.4%

Source: (Jeffares&Green & IngeropAfrica, 2004)

Table 7-3: Waste stream entering ARTS (2003)

Category	Quantity (tonnes)
Household	73809
Commercial	73809
Industrial	-
Green	-
Builder's rubble	-
Total waste entering ARTS (2003) (tonnes)	147618

Source: (Jeffares&Green & IngeropAfrica, 2004)

Table 7-4: Elemental analysis of OFMSW in ARTS

Sample number	C (%)	H (%)	N (%)	O (%)	C:N
1	43.94	6.27	2.2	47.59	19.97
2	46.15	6.07	2.15	45.63	21.47
3	47.48	6.12	1.7	44.7	27.93

4	39.08	5.63	2.24	53.05	17.44
Average	44.16	6.02	2.07	47.74	21.31
Std. deviation	3.69	0.275	0.251	3.74	4.47

Source: (Munganga et al., 2010)

Table 7-5: Characteristics of OFMSW from ARTS

Sample number	1	2	3	4	Average	Std. deviation
Biogas yield (ml /g VS)	250.1	191.6	171.5	261.4	218.65	43.86
Moisture Content (MC,%)	83	84	83	78	82	2.6
TS (%)	17	16	17	22	18	2.6
VS (%)	82	90	88	68	82	9.83

Source: (Munganga et al., 2010)

Table 7-6: OFMSW formula

Sample	Chemical Formula
1	$C_{23}H_{40}N_1O_{19}$
2	$C_{25}H_{40}N_1O_{19}$
3	$C_{33}H_{50}N_1O_{23}$
4	$C_{20}H_{35}N_1O_{21}$

A sample calculation for determining a chemical formula:

Food Waste from Athlone Refuse Station

For OFMSW Sample #1:

$$C_{-1} := \frac{43.94}{100} \quad H_{-1} := \frac{6.27}{100} \quad N_{-1} := \frac{2.2}{100}$$

$$Mm_C := 12.0 \quad Mm_H := 1$$

$$Mm_O := 16 \quad Mm_N := 14.0$$

$$O_{-1} := 1 - (C_{-1} + H_{-1} + N_{-1})$$

$$O_{-1} = 0.476$$

moles of elements contained in 1gram of a sample:

$$nC1 := \frac{C_{-1}}{Mm_C} \quad nH1 := \frac{H_{-1}}{Mm_H} \quad nN1 := \frac{N_{-1}}{Mm_N} \quad nO1 := \frac{O_{-1}}{Mm_O}$$

$$nC1 = 0.037 \quad nH1 = 0.063 \quad nN1 = 1.57 \times 10^{-3} \quad nO1 = 0.03$$

mole for each element equals the subscript, thus:

$$n1 := nC1 \quad a1 := nH1 \quad d1 := nN1 \quad b1 := nO1$$

For OFMSW Sample#2:

$$C_2 := \frac{46.15}{100} \quad H_2 := \frac{6.07}{100} \quad N_2 := \frac{2.15}{100}$$

$$O_2 := 1 - (C_2 + H_2 + N_2)$$

$$O_2 = 0.456$$

$$nC2 := \frac{C_2}{Mm_C} \quad nH2 := \frac{H_2}{Mm_H} \quad nN2 := \frac{N_2}{Mm_N} \quad nO2 := \frac{O_2}{Mm_O}$$

$$nC2 = 0.038 \quad nH2 = 0.061 \quad nN2 = 1.535 \times 10^{-3} \quad nO2 = 0.029$$

$$n2 := nC2 \quad a2 := nH2 \quad d2 := nN2 \quad b2 := nO2$$

For OFMSW Sample#3:

$$C_3 := \frac{47.48}{100} \quad H_3 := \frac{6.12}{100} \quad N_3 := \frac{1.7}{100}$$

$$O_3 := 1 - (C_3 + H_3 + N_3)$$

$$O_3 = 0.447$$

$$nC3 := \frac{C_3}{Mm_C} \quad nH3 := \frac{H_3}{Mm_H} \quad nN3 := \frac{N_3}{Mm_N} \quad nO3 := \frac{O_3}{Mm_O}$$

$$nC3 = 0.04 \quad nH3 = 0.061 \quad nN3 = 1.213 \times 10^{-3} \quad nO3 = 0.028$$

$$n3 := nC3 \quad a3 := nH3 \quad d3 := nN3 \quad b3 := nO3$$

For OFMSW Sample#4:

$$C_4 := \frac{39.08}{100} \quad H_4 := \frac{5.63}{100} \quad N_4 := \frac{2.24}{100}$$

$$O_4 := 1 - (C_4 + H_4 + N_4)$$

$$O_4 = 0.53$$

$$nC4 := \frac{C_4}{Mm_C} \quad nH4 := \frac{H_4}{Mm_H} \quad nN4 := \frac{N_4}{Mm_N} \quad nO4 := \frac{O_4}{Mm_O}$$

$$nC4 = 0.033 \quad nH4 = 0.056 \quad nN4 = 1.599 \times 10^{-3} \quad nO4 = 0.033$$

$$n4 := nC4 \quad a4 := nH4 \quad d4 := nN4 \quad b4 := nO4$$

$$n_{ave} := \frac{(n1 + n2 + n3 + n4)}{4} \quad a_{ave} := \frac{(a1 + a2 + a3 + a4)}{4} \quad b_{ave} := \frac{(b1 + b2 + b3 + b4)}{4}$$

$$d_{ave} := \frac{(d1 + d2 + d3 + d4)}{4}$$

b_{ave} and d_{ave} are subscripts in

$$n_{ave} = 0.037 \quad a_{ave} = 0.06 \quad b_{ave} = 0.03 \quad d_{ave} = 1.479 \times 10^{-3}$$

$C_nH_aN_dO_b$. These can be converted to whole numbers as follows:

$$x_n := \frac{n_{ave}}{d_{ave}} \quad x_a := \frac{a_{ave}}{d_{ave}} \quad x_b := \frac{b_{ave}}{d_{ave}} \quad x_d := \frac{d_{ave}}{d_{ave}}$$

$$x_n = 24.857 \quad x_a = 40.712 \quad x_b = 20.171 \quad x_d = 1$$

$$A_{fw} := x_n - \left(\frac{x_a}{4}\right) - \left(\frac{x_b}{2}\right) + \left(3 \cdot \frac{x_d}{4}\right) \quad B_{fw} := \left(\frac{x_n}{2}\right) + \left(\frac{x_a}{8}\right) - \left(\frac{x_b}{4}\right) - \left(3 \cdot \frac{x_d}{8}\right)$$

$$C_{fw} := \left(\frac{x_n}{2}\right) - \left(\frac{x_a}{8}\right) + \left(\frac{x_b}{4}\right) + \left(3 \cdot \frac{x_d}{8}\right)$$

Substituting the variables gives:

$$A_{fw} = 5.344 \quad B_{fw} = 12.1 \quad C_{fw} = 12.757$$

A_{fw} , B_{fw} and C_{fw} are coefficients

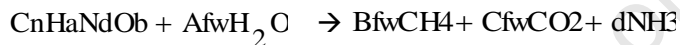

The same procedure is applied for the other feedstocks.

Table 7-7: Elemental analysis of WPS

	C (%)	H (%)	N (%)	O (%)	C/N
WPS	25.1	3.3	0.2	19.4	125.5

Source: (Myréen et al., 2010)

Table 7-8: Capacities of Wastewater plants in Cape Town

Wastewater Plant	ML/day
Athlone	98.25
Bellville – DA	59.37
Borcherds Quarry	32.76
Camps Bay	2.28
Cape Flats	157.85
Gordons Bay	2.88

Green Point	28.68
Hout Bay	4.34
Klipheuwel	0.03
Kraaifontein	10.91
Llandudno	0.24
Macassar	34.44
Melkbosstrand	10.37
Mitchel ls Pl ain	27.82
Parow	8.33
Potsdam	29.65
Scottsdene	14.79
Simons Town	3.29
Wesfleur Domestic	5.55
Wesfleur Industri al	5.46
Wildevleivlei	9.29
Zandvliet	43.56
Millers Point	0.03
Oudekraal	0.03
Total	590

Source:(CoCT, 2008)

The quantities of Primary Sludge (PS) for Athlone and Bellville (in Table 3-4) were estimated by current study. Given the total volume capacity of all 21 WWTPs (590ML/day) from Table 7-8 and the corresponding total primary sludge of 245 300 tons per year (equivalent to 671.8 ton/day) from the 21 WWTPs the individual PS quantities of Athlone and Bellville are calculated as:

$$\text{Athlone PS} = (671.8/590) * 98.25 = 111.8 \text{ ton/day}$$

$$\text{Bellville PS} = (671.8/590) * 59.37 = 67.6 \text{ ton/day}$$

Table 7-9: Densities of the feedstocks used

	Density (kg/m ³)
Primary sludge (dry basis)	721
primary sludge (wet basis)	1000
OFMSW* (wet basis)	790
OFMSW** (wet basis)	896
OFMSW_average	843

WPS	1000
-----	------

Source: (Walker, 2011; Rhee & Park, 2010; Chaudhary, 2008)

7.2 Estimating avoided emissions from landfill disposal

The climatic conditions specific to the Western Cape, these are shown in the table below (Schulze, 1997):

Table 7-10: Climatic conditions for Western Cape

	MAP (mm)	MAT (°C)	PET (mm)	MAP/PET
Western Province	348	16.5	2230	0.156

(Schulze, 1997)

7.2.1 Estimating CH₄ generated from landfill disposal of OFMSW and WPS

Estimating emissions from landfill disposal of OFMSW:

$w_i := 1$ $w := 0.4$ the composition of OFMSW in MSW

The following DOC_i is a default value

DOC₁ := 0.15 this is the fraction of organic degradable carbon in OFMSW

$$\text{DOC}_{\text{calculated}} := (\text{DOC} \cdot w)_i \cdot \frac{\text{Gg}_C}{\text{Gg}_{\text{OFMSW}}}$$

The units of DOC_{calculated} are Gg C/Gg OFMSW

$$\text{OFMSW} := \frac{78.7}{1000} \cdot \frac{\text{Gg}}{\text{day}} \quad \text{divide by a 1000 ton because 1Gg=1000tons}$$

OX := 0.7 oxidation factor frac_{ch4} := 0.48 percentage fraction of methane in the landfill gas

GWP := 21 global warming potential

$$\text{CH}_4_{\text{gen}} := \left(\text{DOC}_{\text{calculated}} \cdot \text{OFMSW} \cdot \text{frac}_{\text{ch4}} \cdot \frac{16}{12} \right) \cdot 100036$$

$$\text{CH}_4_{\text{emitted}} := \text{CH}_4_{\text{gen}} \cdot (1 - \text{OX})$$

$$\text{CH}_4_{\text{emitted}} = 1.005 \times 10^3 \quad \frac{\text{ton}}{\text{year}}$$

$$\text{CO}_2_{\text{equi}} := \text{CH}_4_{\text{emitted}} \cdot \text{GWI}$$

$$\text{CO}_2_{\text{equi}} = 2.111 \times 10^4 \quad \text{ton of CO}_2 \text{ equivalent per year}$$

GWP := 21 global warming potential

$$\text{CH4_gen} := \left(\text{DOC_calculated} \cdot \text{OFMSW} \cdot \text{frac_ch4} \cdot \frac{16}{12} \right) \cdot 1000365$$

$$\text{CH4_emitted} := \text{CH4_gen} \cdot (1 - \text{OX})$$

$$\text{CH4_emitted} = 1.005 \times 10^3 \quad \frac{\text{ton}}{\text{year}}$$

$$\text{CO2_equi} := \text{CH4_emitted} \cdot \text{GWF}$$

$$\text{CO2_equi} = 2.111 \times 10^4 \quad \text{ton of CO2 equivalent per year}$$

Estimating emissions from landfill disposal of WPS:

The carbon content of the waste paper sludge determine CO2 emissions

$$i := 1 \quad w := 1$$

$$\text{DOC}_i := 0.4$$

$$\text{DOC_calculated} := (\text{DOC} \cdot w)_i \quad \frac{\text{Gg_C}}{\text{Gg_PS}}$$

The units of DOC_calculated are Gg C/Gg WPS sludge

$$\text{WPS} := \frac{25.81}{1000} \quad \frac{\text{Gg}}{\text{day}} \quad \text{divide by a 1000 ton because 1Gg=1000tons}$$

$$\text{OX} := 0. \text{oxidation factor} \quad \text{frac_ch4} := 0.54 \quad \text{percentage fraction of methane in the landfill gas}$$

GWP := 21 global warming potential

$$\text{CH4_gen} := \left(\text{DOC_calculated} \cdot \text{WPS} \cdot \text{frac_ch4} \cdot \frac{16}{12} \right) \cdot 1000365$$

$$\text{CH4_emitted} := \text{CH4_gen} \cdot (1 - \text{OX})$$

$$\text{CH4_emitted} = 2.478 \times 10^3 \quad \frac{\text{ton}}{\text{year}}$$

$$\text{CO2_equi} := \text{CH4_emitted} \cdot \text{GWF}$$

$$\text{CO2_equi} = 5.204 \times 10^4 \quad \text{ton of CO2 equivalent per year}$$

7.2.2 Estimating CH₄ generated from landfill disposal of primary sludge

Estimating emissions from landfill disposal of primary sludge from Athlone WWTP:

The carbon content of sewage sludge determine CO₂ emissions

$$i := 1 \quad w := 1$$

$$DOC_1 := 0.0\%$$

$$DOC_{\text{calculated}} := (DOC_w)_1 \cdot \frac{Gg_C}{Gg_PS}$$

The units of DOC_{calculated} are Gg C/Gg primary sludge

$$A_{\text{sludge}} := \frac{111.8\%}{1000} \cdot \frac{Gg}{\text{day}} \quad \text{divide by a 1000 ton because } 1Gg=1000\text{tons}$$

$$OX := 0.1 \quad \text{oxidation factor} \quad \text{frac_ch4} := 0.53\% \quad \text{percentage fraction of methane in the landfill gas}$$

$$GWP := 21 \quad \text{global warming potential}$$

$$CH4_{\text{gen}} := \left(DOC_{\text{calculated}} \cdot A_{\text{sludge}} \cdot \text{frac_ch4} \cdot \frac{16}{12} \right) \cdot 1000 \cdot 365$$

$$CH4_{\text{emitted}} := CH4_{\text{gen}} \cdot (1 - OX)$$

$$CH4_{\text{emitted}} = 1.318 \times 10^3 \quad \frac{\text{ton}}{\text{year}}$$

$$CO2_{\text{equi}} := CH4_{\text{emitted}} \cdot GWP$$

$$CO2_{\text{equi}} = 2.767 \times 10^4 \quad \text{ton of CO}_2 \text{ equivalent per year}$$

7.3 Plant's own energy consumption

Energy Balance for Model 1: Athlone primary sludge and OFMSW

heat for heating the feedstocks

$$Cp_{fw} := 4.18 \frac{\text{kJ}}{\text{kg}\cdot\text{C}} \quad Cp_{AS} := 4.18 \frac{\text{kJ}}{\text{kg}\cdot\text{C}}$$

$$Cp_{feed} := x_{was} \cdot Cp_{AS} + x_{fw} \cdot Cp_{fw}$$

$$T_{1} := 16.4 \text{ degC} \quad T_{2} := 35 \text{ degC}$$

$$M_{AD} = 1.907 \times 10^5 \frac{\text{kg}}{\text{day}}$$

$$Q_s := M_{AD} \cdot Cp_{feed} \cdot (T_2 - T_1)$$

$$Q_s = 1.475 \times 10^7 \frac{\text{kJ}}{\text{day}}$$

$$Q := \frac{Q_s}{243600} \text{ kW}$$

$$Q = 170.681 \text{ kW}$$

Energy Balance for Model 2: Bellville primary sludge and WPS

heat for heating the feedstocks

$$Cp_{pw} := 4.18 \frac{\text{kJ}}{\text{kg}\cdot\text{C}} \quad Cp_{BS} := 4.18 \frac{\text{kJ}}{\text{kg}\cdot\text{C}}$$

$$T_{1} := 16.4 \text{ degC} \quad T_{2} := 35 \text{ degC}$$

$$M_{AD} = 9.427 \times 10^4 \frac{\text{kg}}{\text{day}}$$

$$Cp_{feed} := x_{bs} \cdot Cp_{BS} + x_{pw} \cdot Cp_{pw}$$

$$Q_s := M_{AD} \cdot Cp_{feed} \cdot (T_2 - T_1)$$

$$Q_s = 7.29 \times 10^6 \frac{\text{kJ}}{\text{day}}$$

$$Q := \frac{Q_s}{243600} \text{ kW}$$

$$Q = 84.378 \text{ kW}$$

7.4 Estimating costs for Model 1 and Model 2

Estimating Capital cost of Model 1

$$V_{AD} = 4.71 \times 10^3 \text{ m}^3 \quad X_{rate} := 6.806 \quad \text{exchange rate} \quad (23\text{June}2011)$$

$$C_2 := 167142 \text{ R} \quad n := 0.8 \quad Q_1 := V_{AD} \quad Q_2 := 4500$$

$$i_{2010} := 541.1 \text{ \%} \quad i_{2004} := 444.1 \text{ \%} \quad i_{2007} := 525.4 \text{ \%}$$

$$C_1 := \left(\frac{Q_1}{Q_2} \right)^n \cdot C_2 \cdot X_{rate} \cdot \frac{i_{2010}}{i_{2004}}$$

$$C_1 = 1.439 \times 10^7 \quad 2010 \text{ Rand}$$

Estimating Capital cost of Model 2

$$V_{AD} = 2.178 \times 10^3 \text{ m}^3 \quad X_{rate} := 6.806 \quad \text{exchange rate} \quad (23\text{June}2011)$$

$$C_2 := 167142 \text{ R} \quad n := 0.8 \quad Q_1 := V_{AD} \quad Q_2 := 4500$$

$$i_{2010} := 541.1 \text{ \%} \quad i_{2004} := 444.1 \text{ \%} \quad i_{2007} := 525.4 \text{ \%}$$

$$C_1 := \left(\frac{Q_1}{Q_2} \right)^n \cdot C_2 \cdot X_{rate} \cdot \frac{i_{2010}}{i_{2004}}$$

$$C_1 = 7.765 \times 10^6 \quad 2010 \text{ Rand}$$

7.5 Interviews: Email correspondence

Solid waste Personnel: Mr Melumzi Nontangana, Head of Research and Development, Solid Waste Department, City of Cape Town

Q: Currently what are the City's disposal tariffs? For organic household waste, sewage sludge (from the wastewater plants) and waste paper sludge?

A: For the 2010/2011 financial year ending 30th June, the general household waste has a tariff of R264 per ton. This figure applies for organic household waste and paper sludge. In the case of sewerage sludge, we don't allow the disposal of sewerage sludge onto our landfill sites

Utility Services Personnel: Mr Gary Ross, Tariff Development Department, Cape Town

Electricity

Q: What is the tariff for the Athlone and Bellville wastewater plants in Cape Town?

A: I would imagine the majority (if not all) the wastewater treatment plants would be on our Small Power User 1 tariff. This tariff currently has a daily service charge of R14.35 and an energy charge of 77.66c/kWh. Please note that from 1 July 2011 these values will be increasing to R17.21 per day and 93.15c/kWh. All values exclude VAT

7.6 C/N ratio for co-digestion

For Model 1: Athlone PS and OFMSW

$$M_{\text{primarysludge}} := 111.8 \frac{\text{ton}}{\text{day}} \quad M_{\text{ofmsw}} := 78.7$$

$$M_{\text{total}} := M_{\text{primarysludge}} + M_{\text{ofmsw}}$$

$$M_{\text{total}} = 190.53 \frac{\text{ton}}{\text{day}}$$

$$C_{\text{ps}} := 0.486 \quad C_{\text{ofmsw}} := 0.44162$$

$$C_{\text{tot}} := C_{\text{ps}} \cdot M_{\text{total}} + C_{\text{ofmsw}} \cdot M_{\text{total}}$$

$$C_{\text{tot}} = 176.817$$

$$N_{\text{ss}} := 0.0700 \quad N_{\text{ofmsw}} := 0.02072$$

$$N_{\text{tot}} := N_{\text{ss}} \cdot M_{\text{total}} + N_{\text{ofmsw}} \cdot M_{\text{total}}$$

$$CN := \frac{C_{\text{tot}}}{N_{\text{tot}}}$$

$$CN = 10.223$$

Following similar procedure for Bellville PS and WPS:

C/N is 10.235

7.7 Influence of co-digestion on biogas production

7.7.1 Calculating biogas production from SBP's

The following is a sample procedure (for Model 1: OFMSW and Athlone PS) for estimating biogas production from the given Specific Biogas Potential values from Mungaga et al (2010) and Luste & Luostarinen (2010)

$$M_{\text{OFMSW}} := 78.7 \frac{\text{ton}}{\text{day}} \quad \text{from Jeffares and Green \& ingerop Africa (2004)}$$

$$M_{\text{PS}} := 111.8 \frac{\text{ton}}{\text{day}} \quad \text{from Wright-Pierce (1996)}$$

$$TS_{\text{OFMSW}} := 0.18 \quad \text{based on the average TS(\%)} \text{ from Mungaga et al (2010)}$$

$$VS_{\text{OFMSW}} := 0.82 \quad \text{based on the average VS(\%)} \text{ from Mungaga et al (2010)}$$

$$\text{ton_VSOFMSW} := VS_{\text{OFMSW}} \cdot TS_{\text{OFMSW}} \cdot M_{\text{OFMSW}}$$

$$TS_{\text{PS}} := 0.04 \quad \text{based on TS(\%)} \text{ from Luste \& Luostarinen (2010)}$$

$$VS_{\text{PS}} := 0.66 \quad \text{based on VS(\%)} \text{ from Luste \& Luostarinen (2010)}$$

using these TS and VS values for OFMSW and PS assumes that they are the same across the City.

$$\text{ton_VSPS} := VS_{\text{PS}} \cdot TS_{\text{PS}} \cdot M_{\text{PS}}$$

$$v_{\text{OFMSW}} := 218.6 \text{ ml biogas/g VS} \quad \text{from Mungaga et al (2010)}$$

$$v_{\text{PS}} := 558 \text{ ml biogas/g VS} \quad \text{from Luste \& Luostarinen (2010)}$$

$$V_{\text{totbiogas}} := v_{\text{OFMSW}} \cdot \text{ton_VSOFMSW} + v_{\text{PS}} \cdot \text{ton_VSPS} \quad \text{no need for unit conversion here as } 1000000\text{gram}/1000000\text{m}^3$$

7.7.2 Estimating biogas composition from Buswell's formula

For Model 1 which is a co-digestion model of primary sludge with OFMSW, the chemical formula of these combined substrates is:

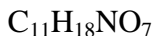

Where n, a, b and d is 11, 18, 7 and 1 respectively. These are substituted in the following equation:

$$\%CH_4 = \left(4 + \frac{a}{n} - \frac{2b}{n} - \frac{3d}{n}\right)$$

Thus, %CH₄ is 51.6% for Model 1. The similar approach is used for Model 2(%CH₄ is 53.8%)

7.7.3 Estimating enriched CH₄ content in the biogas stream

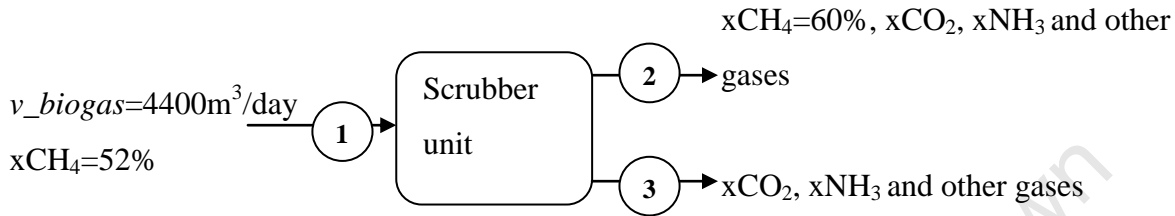

x_A is a volume composition of gas A contained in the biogas. 1, 2 and 3 are stream numbers.

This is a simplified schematic of a high pressure scrubber unit that this study used to estimate the quantity of the enriched biogas stream. This calculation assumes that all the CH₄ contained in stream 1 is recovered in stream 2 on a volumetric basis:

Estimating the CH₄- enriched stream

$$x_d := \frac{60}{100} \quad \text{desired CH}_4 \text{ content in the biogas post-scrubbing}$$

$$x_c := \frac{51.6105}{100} \quad \text{CH}_4 \text{ content in the biogas before scrubbing for substrates used in Model 1}$$

$$v_{\text{enriched}} := \frac{(v_{\text{biogas}} \cdot x_c)}{x_d} \quad \mathbf{v_{biogas}}$$
 is the estimated biogas production from **Model 1** at 52% CH₄ content

This assumes that all the volumetric flow of CH₄ contained in stream 1 is recovered in stream 2 thus to obtain the total volumetric flow of stream 2, CH₄ flow in stream 1 is divided by the composition of CH₄ in stream 2.

$$v_{\text{enriched}} := 3785 \text{ m}^3/\text{day}$$

A similar procedure was followed for Model 2

7.8 Calculating digester sizes and CHP capacities

7.8.1 Estimating the digester sizes

The following is a sample calculation illustrating the procedure followed to determine the volume sizes of the digesters.

For Model 2:

2. Digester design

$t := 21$ days residence time

$f_{AD} := 0.1$

$H_{D_AD} := \frac{1}{2}$ ratio of digester height to digester diameter

$M_{AD} := m_{PW} + m_{BS}$ $\frac{\text{kg}}{\text{day}}$ total amount of waste entering the reactor

$x_{pw} := \frac{m_{PW}}{M_{AD}}$ $x_{bs} := \frac{m_{BS}}{M_{AD}}$

$v_{AD} := \frac{M_{AD}}{\text{raw_water}}$

$v_{AD} = 94.275$

$V_{AD} := t \cdot v_{AD} \cdot (1 + f_{AD})$

$V_{AD} = 2.178 \times 10^3 \text{ m}^3$ volume of the digester for Model 2

The same procedure was followed for Model 1 and the following digester volume was obtained:

$V_{AD} = 4.71 \times 10^3 \text{ m}^3$ volume of the digester

7.8.2 Estimating the electricity and heat from a CHP unit and its nominal capacity

Sample calculation for Model 1: Athlone primary sludge and OFMSW

$\eta_{el} := \frac{30}{100}$ $\eta_{th} := \frac{50}{100}$ (Deublein & Steinhauser, 2008)

After upgrade, the estimated biogas production with a CH_4 content of 60% gives the following volumetric production:

$$v_{\text{biogas}} := 4259 \frac{\text{m}^3}{\text{day}}$$

The following energy content of 6kWh/m^3 of biogas from Deublein & Steinhauser (2008) was used:

$$E_{\text{content}} := 6 \frac{\text{kWh}}{\text{m}^3}$$

$$E_{\text{total}} := \frac{(E_{\text{content}} \cdot v_{\text{biogas}})}{24}$$

$$E_{\text{el}} := E_{\text{total}} \cdot \eta_{\text{el}}$$

$$E_{\text{el}} = 319.425 \quad \text{kW}$$

$$E_{\text{th}} := E_{\text{total}} \cdot \eta_{\text{th}}$$

$$E_{\text{th}} = 532.375 \quad \text{kW}$$

$$E_{\text{capacity}} := E_{\text{el}} \cdot (1 + \eta_{\text{el}}) \quad (\text{Deublein \& Steinhauser, 2008})$$

$$E_{\text{capacity}} = 415.253 \text{ kW}$$

The same procedure was followed for Model 2. The results are presented in chapter 4.

7.9 Profitability Assessment: Payback Period

Table 7-11 and Table 7-12 show the capital costs, total expenses, total income and cash flows calculated in this project. The IRR which shows the profitability in each model is presented. The NPV, ROI and PBP are also indicated.

Table 7-11: Profitability assessment for Model 1

Profitability Assessment:		Expenses			Income	Gross Profit	Depreciation	Net Profit	Net C.Flow	DCF	Cum.CashFlow
time,years	Capital Cost	Consumptio	Operatio	Other cos	ZAR/yr	ZAR/yr	ZAR/yr	ZAR/yr	ZAR/yr	ZAR/yr	ZAR/yr
0	-2.10E+07	0	0	0	0	0			-2.10E+07	-2.10E+07	0
1	0	-7.01E+06	1.78E+06	1.14E+05	8.42E+05	5.95E+06	1.05E+06	3.53E+06	4.58E+06	4.24E+06	-2.10E+07
2	0	-7.64E+06	1.94E+06	1.25E+05	9.18E+05	6.49E+06	1.05E+06	3.92E+06	4.96E+06	4.26E+06	-1.64E+07
3	0	-8.32E+06	2.12E+06	1.36E+05	1.00E+06	7.07E+06	1.05E+06	4.34E+06	5.38E+06	4.27E+06	-1.14E+07
4	0	-9.07E+06	2.31E+06	1.48E+05	1.09E+06	7.71E+06	1.05E+06	4.79E+06	5.84E+06	4.29E+06	-6.06E+06
5	0	-9.89E+06	2.51E+06	1.61E+05	1.19E+06	8.40E+06	1.05E+06	5.29E+06	6.34E+06	4.32E+06	-2.18E+05
6	0	-1.08E+07	2.74E+06	1.76E+05	1.30E+06	9.16E+06	1.05E+06	5.84E+06	6.89E+06	4.34E+06	6.13E+06
7	0	-1.17E+07	2.99E+06	1.92E+05	1.41E+06	9.98E+06	1.05E+06	6.43E+06	7.48E+06	4.36E+06	1.30E+07
8	0	-1.28E+07	3.26E+06	2.09E+05	1.54E+06	1.09E+07	1.05E+06	7.08E+06	8.13E+06	4.39E+06	2.05E+07
9	0	-1.40E+07	3.55E+06	2.28E+05	1.68E+06	1.19E+07	1.05E+06	7.78E+06	8.83E+06	4.42E+06	2.86E+07
10	0	-1.52E+07	3.87E+06	2.48E+05	1.83E+06	1.29E+07	1.05E+06	8.55E+06	9.60E+06	4.45E+06	3.75E+07
11	0	-1.66E+07	4.22E+06	2.71E+05	1.99E+06	1.41E+07	1.05E+06	9.39E+06	1.04E+07	4.48E+06	4.71E+07
12	0	-1.81E+07	4.60E+06	2.95E+05	2.17E+06	1.54E+07	1.05E+06	1.03E+07	1.14E+07	4.51E+06	5.75E+07
13	0	-1.97E+07	5.01E+06	3.22E+05	2.37E+06	1.67E+07	1.05E+06	1.13E+07	1.23E+07	4.54E+06	6.88E+07
14	0	-2.15E+07	5.46E+06	3.51E+05	2.58E+06	1.82E+07	1.05E+06	1.24E+07	1.34E+07	4.57E+06	8.12E+07
15	0	-2.34E+07	5.95E+06	3.82E+05	2.81E+06	1.99E+07	1.05E+06	1.36E+07	1.46E+07	4.61E+06	9.46E+07
16	0	-2.55E+07	6.49E+06	4.17E+05	3.07E+06	2.17E+07	1.05E+06	1.49E+07	1.59E+07	4.64E+06	1.09E+08
17	0	-2.78E+07	7.07E+06	4.54E+05	3.34E+06	2.36E+07	1.05E+06	1.63E+07	1.73E+07	4.68E+06	1.25E+08
18	0	-3.03E+07	7.71E+06	4.95E+05	3.64E+06	2.58E+07	1.05E+06	1.78E+07	1.88E+07	4.71E+06	1.42E+08
19	0	-3.30E+07	8.40E+06	5.40E+05	3.97E+06	2.81E+07	1.05E+06	1.95E+07	2.05E+07	4.75E+06	1.61E+08
20	0	-3.60E+07	9.16E+06	5.88E+05	4.33E+06	3.06E+07	1.05E+06	2.13E+07	2.23E+07	4.79E+06	1.82E+08
									NPV,ZAR	6.86E+07	
									ROI	48.62%	
									IRR	20%	

Table 7-12: Profitability assessment for Model 2

Profitability Assessment:		Expenses			Income	Gross Pro	Depreciat	Net Profit	Net C.Flov	DCF	Cum.CashFlow
time,years	Capital Cost	(Consumpti	Operatio	Other cos	ZAR/yr	ZAR/yr	ZAR/yr	ZAR/yr	ZAR/yr	ZAR/yr	ZAR/yr
0	-1.15E+07	0	0	0	0	0			-1.15E+07	-1.15E+07	0
1	0	-2.04E+06	1.26E+06	6.26E+04	5.18E+05	1.23E+06	5.74E+05	4.70E+05	1.04E+06	9.67E+05	-1.15E+07
2	0	-2.22E+06	1.38E+06	6.82E+04	5.65E+05	1.34E+06	5.74E+05	5.50E+05	1.12E+06	9.63E+05	-1.04E+07
3	0	-2.42E+06	1.50E+06	7.43E+04	6.16E+05	1.46E+06	5.74E+05	6.36E+05	1.21E+06	9.61E+05	-9.31E+06
4	0	-2.64E+06	1.64E+06	8.10E+04	6.71E+05	1.59E+06	5.74E+05	7.31E+05	1.30E+06	9.59E+05	-8.10E+06
5	0	-2.87E+06	1.79E+06	8.83E+04	7.32E+05	1.73E+06	5.74E+05	8.34E+05	1.41E+06	9.58E+05	-6.80E+06
6	0	-3.13E+06	1.95E+06	9.63E+04	7.97E+05	1.89E+06	5.74E+05	9.46E+05	1.52E+06	9.58E+05	-5.39E+06
7	0	-3.42E+06	2.12E+06	1.05E+05	8.69E+05	2.06E+06	5.74E+05	1.07E+06	1.64E+06	9.58E+05	-3.87E+06
8	0	-3.72E+06	2.31E+06	1.14E+05	9.47E+05	2.24E+06	5.74E+05	1.20E+06	1.78E+06	9.59E+05	-2.23E+06
9	0	-4.06E+06	2.52E+06	1.25E+05	1.03E+06	2.45E+06	5.74E+05	1.35E+06	1.92E+06	9.61E+05	-4.51E+05
10	0	-4.42E+06	2.75E+06	1.36E+05	1.13E+06	2.67E+06	5.74E+05	1.51E+06	2.08E+06	9.63E+05	1.47E+06
11	0	-4.82E+06	2.99E+06	1.48E+05	1.23E+06	2.91E+06	5.74E+05	1.68E+06	2.25E+06	9.66E+05	3.55E+06
12	0	-5.25E+06	3.26E+06	1.61E+05	1.34E+06	3.17E+06	5.74E+05	1.87E+06	2.44E+06	9.69E+05	5.80E+06
13	0	-5.73E+06	3.56E+06	1.76E+05	1.46E+06	3.45E+06	5.74E+05	2.07E+06	2.65E+06	9.73E+05	8.24E+06
14	0	-6.24E+06	3.88E+06	1.92E+05	1.59E+06	3.76E+06	5.74E+05	2.30E+06	2.87E+06	9.77E+05	1.09E+07
15	0	-6.81E+06	4.23E+06	2.09E+05	1.73E+06	4.10E+06	5.74E+05	2.54E+06	3.11E+06	9.81E+05	1.38E+07
16	0	-7.42E+06	4.61E+06	2.28E+05	1.89E+06	4.47E+06	5.74E+05	2.81E+06	3.38E+06	9.86E+05	1.69E+07
17	0	-8.09E+06	5.02E+06	2.48E+05	2.06E+06	4.87E+06	5.74E+05	3.09E+06	3.67E+06	9.92E+05	2.03E+07
18	0	-8.81E+06	5.47E+06	2.71E+05	2.24E+06	5.31E+06	5.74E+05	3.41E+06	3.98E+06	9.97E+05	2.39E+07
19	0	-9.61E+06	5.97E+06	2.95E+05	2.44E+06	5.79E+06	5.74E+05	3.75E+06	4.33E+06	1.00E+06	2.79E+07
20	0	-1.05E+07	6.50E+06	3.22E+05	2.66E+06	6.31E+06	5.74E+05	4.17E+06	4.70E+06	1.01E+06	3.22E+07
									NPV,ZAR	7.98E+06	
									ROI	16.09%	
									IRR	5.606%	

The following table was used to graphically represent the effect of the selling price of electricity on the financial viability of Model 1.

Table 7-13: Effect of varying of electricity selling price (Model 1)

Electricity price,R/kWh	NPV	ROI	IRR
0.5	6.44E+07	46.05%	19%
0.65	6.63E+07	47.20%	20%
0.8	6.82E+07	48.34%	20%
0.95	7.01E+07	49.49%	20%
1.1	7.20E+07	50.63%	21%
1.25	7.39E+07	51.77%	21%
1.4	7.58E+07	52.92%	22%
1.55	7.77E+07	54.06%	22%

7.10 Determining energy associated emissions

The following table contains a list of fuels used for industrial energy demand. The corresponding emission factor for each fuel is also shown.

Table 7-14: Emission factors of energy fuels 1

	Emission factor	Reference
For Eskom-generated electricity (coal)	1.015 kgCO ₂ -eqt/kWh	(Letete et al., 2009)
Default Carbon content		
Diesel	20.2 (kg/GJ)	(IPCC, 2007)
LPG	17.2 (kg/GJ)	(IPCC, 2007)
Paraffin	20 (kg/GJ)	(IPCC, 2007)
Coal	26 (kg/GJ)	(IPCC, 2007)
Heavy Fuel Oil	21.1 (kg/GJ)	(IPCC, 2007)

The emission factors for diesel, LPG, paraffin, coal and heavy fuel oil are in kg/GJ units. However, for the comparison necessary for this study they were converted to kg/GWh using the following conversion:

$$1 \text{ GJ} = 0.000277777778 \text{ GWh}$$

For Eskom-generated electricity from bituminous coal:

$$1 \times 10^6 \text{ kWh} = \text{GWh}$$

Table 7-15: Emission factors of energy fuels 2

Fuel type	Emission factor	Units
For Eskom-generated electricity (coal)	1015	tonCO ₂ /GWh
Diesel	72.72	tonCO ₂ /GWh
LPG	61.92	tonCO ₂ /GWh
Paraffin	72.00	tonCO ₂ /GWh
Coal	93.60	tonCO ₂ /GWh
Heavy Fuel Oil	75.96	tonCO ₂ /GWh

The emission factor for Eskom's electricity generated coal is significantly larger than that of other fuels shown in Table 7-15. This may be due to the fact that its value includes CO₂-equivalent emissions from electricity generation, transmission and distribution. Whereas emission factors of diesel, LPG, Paraffin,

Coal and heavy fuel oil are default values from the 2006 IPCC and not specific to the possible processes that these fuels may undergo. For this study, it was assumed that these fuels are combusted for industrial *thermal energy* demand. Coal for Eskom-generated electricity was assumed that industry utilizes it for *electricity* requirements.

7.11 Estimating input parameters for LEAP modeling

Calculating energy input for the LEAP model

$$M_{\text{OFMSW}} := 39807 \frac{\text{ton}}{\text{day}} \quad \text{from Jeffares and Green \& ingerop Africa (2004)}$$

$$M_{\text{PS}} := 24520 \frac{\text{ton}}{\text{day}} \quad \text{from Wright-Pierce (1996)}$$

$$TS_{\text{OFMSW}} := 0.18 \quad \text{based on the average TS(\%)} \text{ from Munganga et al (2010)}$$

$$VS_{\text{OFMSW}} := 0.82 \quad \text{based on the average VS(\%)} \text{ from Munganga et al (2010)}$$

$$\text{ton_VSOFMSW} := VS_{\text{OFMSW}} \cdot TS_{\text{OFMSW}} \cdot M_{\text{OFMSW}}$$

$$TS_{\text{PS}} := 0.04 \quad \text{based on TS(\%)} \text{ from Luste \& Luostarinen (2010)}$$

$$VS_{\text{PS}} := 0.66 \quad \text{based on VS(\%)} \text{ from Luste \& Luostarinen (2010)}$$

using these TS and VS values for OFMSW and PS assumes that they are the same across the City.

$$\text{ton_VSPS} := VS_{\text{PS}} \cdot TS_{\text{PS}} \cdot M_{\text{PS}}$$

$$v_{\text{OFMSW}} := 218.6 \text{ ml biogas/g VS} \quad \text{from Munganga et al (2010)}$$

$$v_{\text{PS}} := 558 \text{ ml biogas/g VS} \quad \text{from Luste \& Luostarinen (2010)}$$

$$x_{\text{ch4}} := 0.6$$

$$V_{\text{totbiogas}} := v_{\text{OFMSW}} \cdot \text{ton_VSOFMSW} + v_{\text{PS}} \cdot \text{ton_VSPS} \quad \text{no need for unit conversion here as } 1000000\text{gram}/1000000\text{m}^3$$

assuming that the raw biogas stream is enriched to 60% methane

$$V_{\text{tot_ch4}} := V_{\text{totbiogas}} \cdot x_{\text{ch4}}$$

$$E_{\text{content}} := 6 \frac{\text{kWh}}{\text{m}^3} \quad \text{from Deublein and Steinhauser (2008)}$$

$$E_{\text{total}} := \frac{(E_{\text{content}} \cdot V_{\text{tot_ch4}})}{1000} \quad \text{divide by a 1000 to convert to MWhr}$$

$$E_{\text{total}} = 6.103 \times 10^4 \frac{\text{MWhr}}{\text{year}}$$

$$\text{tyr} := 8640 \frac{\text{hours}}{\text{year}}$$

$$a := 0.75 \cdot \text{tyr} \quad \text{assuming 75\% annual availability}$$

$$E_{\text{el}} := 0.3 \cdot E_{\text{total}} \quad \text{at 30\% electrical efficiency}$$

$$E_{\text{th}} := 0.5 \cdot E_{\text{total}} \quad \text{at 50\% thermal efficiency}$$

$$E_{\text{capacity}} := \frac{(E_{\text{el}} + E_{\text{th}})}{a}$$

$$E_{\text{capacity}} = 7.535 \text{ MW}$$

University of Cape Town

7.12 Accounting for total landfill gas emissions from OFMSW and PS

Estimating emissions from landfill disposal of **primary sludge from the 21 WWTPs**:

The carbon content of sewage sludge determine CO2 emissions

$$i := 1 \quad w := 1$$

$$\text{DOC}_i := 0.0\%$$

$$\text{DOC}_{\text{calculated}} := (\text{DOC}_w)_i \cdot \frac{\text{Gg}_C}{\text{Gg}_{\text{PS}}}$$

The units of DOC_{calculated} are Gg C/Gg primary sludge

$$A_{\text{sludge}} := \frac{245200}{1000} \frac{\text{Gg}}{\text{year}} \quad \text{divide by a 1000 ton because } 1\text{Gg}=1000\text{tons}$$

$$\text{OX} := 0.1 \quad \text{oxidation factor} \quad \text{frac}_{\text{ch4}} := 0.53\% \quad \text{percentage fraction of methane in the landfill gas}$$

$$\text{GWP} := 21 \quad \text{global warming potential}$$

$$\text{CH4}_{\text{gen}} := \left(\text{DOC}_{\text{calculated}} \cdot A_{\text{sludge}} \cdot \text{frac}_{\text{ch4}} \cdot \frac{16}{12} \right) \cdot 1000$$

$$\text{CH4}_{\text{emitted}} := \text{CH4}_{\text{gen}} \cdot (1 - \text{OX})$$

$$\text{CH4}_{\text{emitted}} = 7.915 \times 10^3 \frac{\text{ton}}{\text{year}}$$

$$\text{CH4}_{\text{gen}} = 8.795 \times 10^3$$

$$\text{CO2}_{\text{equi}} := \text{CH4}_{\text{emitted}} \cdot \text{GWF}$$

$$\text{CO2}_{\text{equi}} = 1.662 \times 10^5 \quad \text{ton of CO2 equivalent per year}$$

For total OFMSW:

Estimating emissions from landfill disposal of OFMSW:

The carbon content of OFMSW determine CO2 emissions

$i := 1$ $w := 0.4$ the composition of OFMSW in MSW

The following DOC_i is a default value

$DOC_1 := 0.15$ this is the fraction of organic degradable carbon in OFMSW

$$DOC_calculated := (DOC \cdot w)_i \cdot \frac{Gg_C}{Gg_OFMSW}$$

The units of $DOC_calculated$ are Gg C/Gg OFMSW

$$OFMSW := \frac{398074}{1000} \frac{Gg}{day}$$

divide by a 1000 ton because 1Gg=1000tons

$OX := 0.1$ oxidation factor $frac_ch4 := 0.48$ percentage fraction of methane in the landfill gas

$GWP := 21$ global warming potential

$$CH4_gen := \left(DOC_calculated \cdot OFMSW \cdot frac_ch4 \cdot \frac{16}{12} \right) \cdot 100036 \quad REF_Ref2$$

$$CH4_emitted := CH4_gen \cdot (1 - OX) \quad CH4_gen = 5.649 \times 10^6$$

$$CH4_emitted = 5.084 \times 10^6 \frac{ton}{year}$$

$$CO2_equi := CH4_emitted \cdot GWP$$

$$CO2_equi = 1.068 \times 10^8 \text{ ton of CO2 equivalent per year}$$