

**FACULTY OF ENGINEERING AND THE  
BUILT ENVIRONMENT**

**DEPARTMENT OF CONSTRUCTION ECONOMICS  
AND MANAGEMENT**

**CONSTRUCTION TECHNOLOGY I  
COURSE READER  
PART B – BUILDING COMPONENTS**

**Compiled By:** Abimbola Olukemi Windapo *PhD, PrCM, FNIOB*

**Illustrated By:** Bayonle Windapo

January 2012

# CONTENTS

1. Foundation
2. Floor
3. Walls
4. Roof Systems
5. Stairs and Ramps

# FOUNDATION

## DEFINITION

- Broadly, anything that supports something else;
- In construction it is generally used to describe the lowest artificial work placed in contact with the natural ground to support a structure (Chappell, Cowlin and Dunn, 2009);
- Any part of the structure that serves to transmit load to the earth or rock, usually below ground level (Harris, 2001);
- The part of a structure that transfers the dead and imposed loads safely onto the ground (Brett, 1997);
- That part of a building which is in direct contact with and is intended to transmit loads to the ground;

## Importance of the Foundation to the Building Structure

- It serves as a critical link in the **transmission of building** loads down to the ground. It must distribute vertical loads so that settlement of the building is either negligible or uniform under all parts of the building; and
- It has to **anchor** the superstructure of the building against uplift and racking forces.

## Factors that affect the choice of Foundation

Often the foundation is considered as a separate entity from the structure. This approach leads to the belief that the foundation should be designed on its own to provide a stable base for the structure. However, the foundation is only one element in the overall picture of soil - structure interaction.

This means that:

1. The type of building structure and how it transmits the load to the ground places demands on the foundation; and
2. The type of soil and soil behaviour, which is likely to occur, also influences the foundation design.

The influence of structure type can be seen simply in the case of a three-storey block of flats where load bearing walls will have a bearing pressure that can be carried on relatively shallow strip footings, whereas a framed building of the same size will concentrate the loads on the columns, possibly necessitating much deeper foundations or even piles.

Similarly a flexible structure on a soil likely to settle a little will need only a light foundation as it can tolerate the movement, whereas, a design using rigid brittle finishes will require a much more complicated foundation to prevent any movement reaching the structure.

Therefore, in choosing a suitable foundation, the factors to be considered are the type of building structure and the soil type. While the structural design may be altered, the soil exists on the site and can only be changed at great cost. It must therefore be accepted as it is and its probable long-term behaviour assessed.

## **Types of Soils & Suitable Foundation**

Before deciding on the type of foundation to use, it is essential to examine the subsoil material below the level of the proposed foundation. Sub-soil samples are obtained by hand or power auger and subjected to tests to ascertain its characteristics such as: bearing capacity, expansiveness, cohesiveness etc. Soil survey reports by soil engineering specialists determine whether the ground is good for conventional foundations or not.

According to Kohler (1984), the bearing capacity of Southern African soils is quite adequate for domestic housing and even for three storey buildings. He noted that the materials that are most likely to cause problems are loose sandy soils, such as that found on the coast, on the Cape Flats, the wind-blown deposits in the north-western part of the country and soft clays, which exist along river banks and on mountain slopes.

Soils can be classified broadly into:

- Rocks
- Cohesive soils
- Non-cohesive soils
- Peat
- Made ground or fill (Man made)
- Water logged soils

### **Rocks**

Igneous Rocks which include granite are massively bedded soils and therefore not subject to cracking and shrinkage

**Suitable Foundation:** Simple Strip Foundation

### **Cohesive Soils Such as Clay**

**Characteristics:**

- Soil Particles stick together
- Subject to shrinkage & cracking in dry weather & expansion in wet weather.

**Soil problems:**

- Relatively low shear strength
- Small safe load bearing capacity
- Consolidation settlement - depending on the density of packing, the soil may either heave or settle or even collapse.

It is important that the foundations are deep as the soil movement decreases with depth below ground level.

**Suitable Foundation:** Rafts and Deep Strip or Pad foundations

## **Non Cohesive Soils - Gravel & Sands**

### **Characteristics/Soil problems:**

- Bearing Capacity depends on the grading, packing and average size of the particles
- Consolidation settlement problems - the better the grading, the tighter the packing, and the larger the grains, the higher will be the capacity for carrying loads
- Quicksand

**Suitable foundation:** Raft or wide strip foundation

## **Peat**

- Decayed Vegetable matter Black or dark brown in colour
- Highly compressible and unsuitable to receive foundations

**Suitable Foundation:** Piles driven down to underlying firm stratum

## **Made Ground or Fill**

- Excavated Soil, House or industrial refuse deposited in a depression
- Unequal settlements
- Injurious chemicals may be present

If site must be used, the best foundation to use is pile foundations

## **Water logged soils**

### **Characteristics:**

These are soils where there is a shallow water table or where there is the possibility of water flowing through the soil. Water tends to improve soil-bearing capacity especially in non-cohesive soils such as sand. The water fills the voids in the soil therefore giving it more strength.

### **Soil problems:**

- Relatively low shear strength
- Poor load bearing capacity
- Quicksand

It is important that the ground is dewatered to improve the density, shear strength and bearing capacity of the soil after which Rafts and Wide Strip foundations can be used.

## **Soil Behaviour/Problems, its Effect on Buildings & Solution**

As a first step in choosing the right type of foundation, it is also essential to understand the various causes of foundation problems. All the problems in foundation, which can arise, causes differential **movement** or distortion of the building, which causes excessive stresses and strains, which in turn cause cracking.

Foundation movement in buildings can be divided into two main categories:

1. Those as a direct result of the application of load and

2. Those resulting from changes in soil behaviour, usually as a result of moisture change.

The application of load can lead to bearing capacity failure or consolidation settlement, while moisture changes bring heaving in expansive soils and the collapse of certain clayey sands.

## **Inadequate Bearing Capacity**

The bearing capacity or strength of a soil is derived from its shear strength. The denser it is, the stronger it is, and also, the wetter it is, the weaker it is. Usually, soil strength improves with depth. However, surface appearances only must not be used to judge the strength of the soil because, a hard-baked surface crust may conceal soft wet clay underneath. Hence the need for a trial hole of at least 1.5m depth on site for houses.

However, according to Kohler (1984) surface soils in South Africa have more than adequate bearing capacity for single and double-storey houses. Problems may however arise in coastal areas or loose sands near dunes or in old vleis or alluvial areas where soft clays occur. Bearing capacity failure is characterized by the foundation punching down into the soil, either forcing soil out in wedges or squeezing soft clay from underneath it.

There are several points to note even where the general conditions are good. These include:

1. There may be local weak spots where foundations cross filled-in trenches or even more hazardous, where part of the building rests on a made ground or fill.
2. The fact that the bearing capacity is not only derived from the soil directly under the foundation but from the adjacent soil as well. If a trench is cut too close to a foundation, it can remove sufficient of this adjacent soil to cause the foundation to fail.
3. In areas of fine sand, wind erosion can remove enough soil from outside the foundations to cause bearing capacity failure.

## **Methods used to solve the problem of inadequate bearing capacity:**

The first requirement of a foundation is that it should transmit the load to the soil without overstressing it. The foundation design is largely a matter of economics once the bearing capacity of the soil is known and the magnitude of the loads. Usually, the soil strength increases with depth and the choice has to be made between large footings at shallow depth and smaller footing at greater depth. Where the upper layers of the soil are very poor, very deep foundations such as piles are used to transmit the load to good material at some depth.

The foundation pressure of an average house (with typical strip footings) is about 35 - 40 K Pa (35 - 40 KN/mm<sup>2</sup>) and 60 - 65 K Pa (60 - 65 KN/mm<sup>2</sup>) for a three-floor house (Kohler, 1984). All rock (except decomposed rock) and all sandy soils with the exception of loose sands are capable of supporting such loads. With clayey soils, only the soft and very soft varieties of these are unable to support a normal sized house without an increased footing width.

## **Consolidation Settlement**

The soil mass consists of an arrangement of soil grains which may be rounded or angular in sands and plate-like in clays. Starting with a newly deposited soil layer, these grains are relatively openly packed but as load is applied they are compressed and become more tightly packed. This process is known as consolidation.

In sands and silts, there is good drainage between the particles and as load is applied the water between the grains is squeezed out rapidly and settlement, if it takes place, occurs almost instantaneously, whereas in clays, the drainage is poor and any settlement occurring may continue for a long while after the application of load. Loose sands, silts, gravels and soft clays will show marked settlements under load.

It is important to note that while bearing capacity failure involves the physical displacement of soil from beneath the foundation, consolidation settlement is the compression in situ of soil beneath the foundation.

Serious consolidation problems may arise where buildings cover two different soil conditions, which have very different settlement characteristics, e.g. half on rock outcrop and half on deep fills. This commonly occurs where a building on a slope has foundations in a cut and on fill and breaks its back near the changeover. All fills are highly suspect unless there is proof of adequate compaction. Rubbish tips are worse because they contain compressible vegetable matter, which will rot, and metal, which will corrode over time. Normal consolidation settlement is generally not a major problem in house construction; however, care must be exercised in dune areas at the coast, in windblown sand areas in the interior and where fill has been placed.

## **Methods used to solve the problem of consolidation settlement:**

While the soil may be able to carry the load without failing, there may still be undue consolidation settlement under the load. As the settlement is load dependent, the solutions include:

- Reducing the amount of movement by reducing the foundation pressure. This is done by enlarging the foundations - if necessary to the point where there is a raft foundation (where the whole base of the building acts as a foundation).
- Founding at a slightly greater depth in better material. In extreme cases it may be necessary to drive piles to some considerable depth.

Apart from the foundation design, it is possible in some cases to adapt the structure. This can be made more flexible to tolerate the expected differential movements, or it may be designed as a single rigid unit with its foundation, so that it will settle as a unit without distortion.

## **Heaving of Expansive Soil**

According to Kohler (1984) one of the commonest problems associated with foundation failure in South Africa is that of expansive soils, which swell when they get wet and lift up a house built on them. It would not constitute a problem if every part were lifted to the same height, but because of uneven wetting or drying; the middle of the house is usually raised more than the corners. This differential produces cracks. With the realization that the heave under a house often reaches 70mm, it is not surprising that the differential heave can cause a crack into which a hand can be put into.

When the dry season comes the soil will shrink and in some cases the building may even subside. This settlement may create new cracks and when the rains come again the situation can deteriorate further. There are different terms used in explaining heaving of expansive soils including:

- a. **Mechanism of heaving:** For heaving to occur, a potentially expansive soil must be subjected to a change in moisture content within the critical moisture content range for that soil.

Potential expansiveness is determined by the amount of expansive clay minerals the soil contains, which can be ascertained by means of various laboratory tests; and the thickness of the potentially expansive layers.

- b. **Effect of climate:** The higher the initial moisture content of the soil, the smaller the amount of heave likely. Therefore in the relatively **dry inland regions** of South Africa, this change in moisture content usually occurs in whole or in part within the critical range, and swelling will occur causing the structure to heave.

In **wet regions**, the initial moisture content may be above the upper limit of the critical range and consequently no swelling will occur. In this case however, drying out as a result of drought or of higher than usual evaporation by vegetation will cause shrinkage settlement if the moisture content drops to within the critical range.

In the **very dry semi-desert regions** the rainfall is so sparse and the water-table so deep that building causes no natural change in the moisture content of the soil and, even if the soil is potentially expansive and the initial moisture content is within the critical range, no heaving will occur.

- c. **Rate of heave:** This depends on the availability of moisture and the permeability of the soil, which controls the ingress of moisture into the soil. During years of low rainfall there would be less movement than during wet years.

Where there is a high permeability due to fissures and cracks in the soil, the moisture can enter rapidly and most of the movement will occur during the first wet season. In deep less permeable soil on the other hand, the movement is more gradual.

- d. **Crack patterns:** The cracking of buildings is due to differential movement and there is no specific pattern, which distinguishes cracks due to heaving from those resulting from other causes.

The construction of a building involves removal of vegetation, thus cutting off evaporation losses as well as the direct ingress of moisture. When it rains, the soil outside the building gets wet and moisture moves inwards under the building. The soil under the outer walls therefore becomes moister and heaves, causing a 'dishing' pattern with the centre of the building lower than the corners. This leads to vertical and diagonal cracks, which are wider lower down than they are at the top. In addition, walls often tend to be pushed over the foundation at the level of the damp-proof course.

As more moisture moves under the building, the centre will rise too. During the dry season, the outer walls will settle slightly as the soil under them dries out a little, but

the centre will be unaffected. This means that after a period, the centre will be higher than the sides of the building and will remain so, resulting in the doming - or 'corners down' - pattern of cracking as shown below in Figure 1.

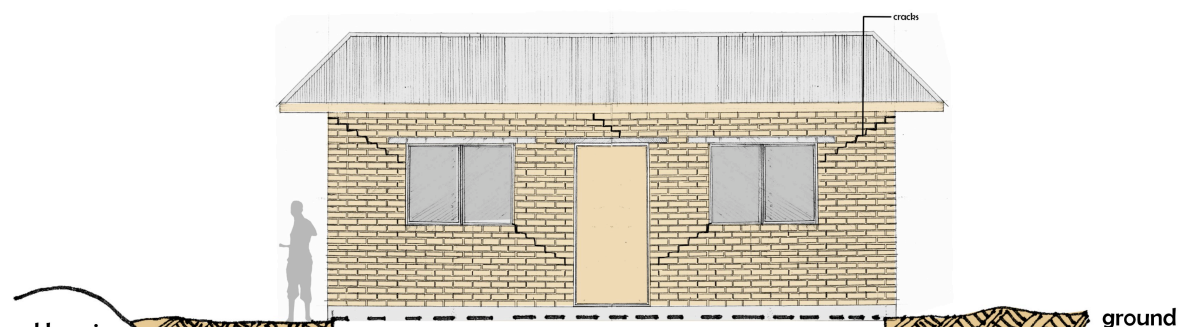

**Fig. 1 Typical doming crack pattern**

Here the cracks are widest at the top and the cracking of brickwork over internal doors and above windows is particularly noticeable.

**Methods used to solve the problem of heaving soil:** Since movements on expansive soils are as a result of changes in moisture content of the soil, the solutions to this problem include:

- **Modification of the soil properties by some form of stabilization (Soil treatment):** While it is possible to modify the expansive properties of clay soil by **chemical treatment**, this has so far been found to be economically impractical.

The only successful method of soil treatment is the **removal** of the expansive material. In certain areas such as Brits in the Transvaal, it may be possible to excavate the heaving soil to better founding below and replace the material excavated with non-expansive fill. For houses, a depth of about 1.3m is considered adequate.

A second solution is to excavate beneath the foundations only and to carry these foundations down to a good founding. However, provisions must be made for suspending the floors and for preventing lateral pressure against the foundation walls.

Both these methods of founding aim at ensuring the heaving soil will not affect the structure.

- **Maintaining constant moisture conditions (Moisture control):** If no moisture changes occur, no movement will occur. However, there are seasonal rainfalls and climatic cycles of evaporation, trees and shrubs (which have a rapid desiccating influence on soil in dry periods), gardens are watered and water pipes leak all of which contribute to changes in soil moisture content. Two solutions are possible:
  - a. **Controlling all moisture ingress** into the soil so that the change takes place gradually from a relatively dry to a wet condition and differential movement is thus controlled to some extent.

- b. **Pre-wetting:** anticipating later conditions by wetting the soil before building construction begins. It has been found that by pre-wetting a site, up to 80% of the movement can take place before building construction begins. The aim is to thoroughly soak the site and begin building as soon as the site has dried sufficiently to allow the foundations and slabs to be cast. The moisture is thus sealed into the subsoil.

Pre-wetting is done by digging trenches and drilling auger holes in the bottom of the trenches right across the foundation area. These trenches and auger holes are filled with water and kept full for 2 to 3 months.

If both of these are unsuccessful, then movement must be accepted and;

- **Structural treatment** must be applied so that the building can either withstand or tolerate the movement. Structural treatment can be divided into three categories:
  - a. **Isolation of the structure from the soil movements:** anchor piles can be used or deep strip foundations.  
**Anchor piles:** To isolate the building structure from the soil movements, piles taken down below the layer of potentially expansive soil, or below the permanent water table or below 10m whichever is the shallowest are used. The building is carried on grade-beams, which span between the piles at least 300mm above ground level in order to prevent any surface movements of the soil from being transmitted to the grade-beams.
  - b. **Rigid construction to withstand the soil movement:** The building and its foundation are designed as a rigid base, which will ride out the movement like a ship at sea. This may be done by designing the foundation as a rigid raft and sitting the building on it, or the rigidity may be achieved by using the walls as deep beams. This requires engineering design and high standards of workmanship.
  - c. **Flexible construction to tolerate the differential movements:** There are few building systems available today that will tolerate differential movement however small. Certain industrialized building systems involving panel construction and some lightweight framed construction may more readily accommodate movement than traditional masonry construction.

The method that has found wide application in South Africa has been to make single storey structures **semi-flexible** by providing vertical open joints/gaps approximately 12mm wide in the brickwork at selected positions in the masonry walls and reinforcing the individual units so formed to prevent them from cracking or floors separated from the walls as shown in the figure below or constructing internal doorways so that they act as open joints. This is known as split construction.

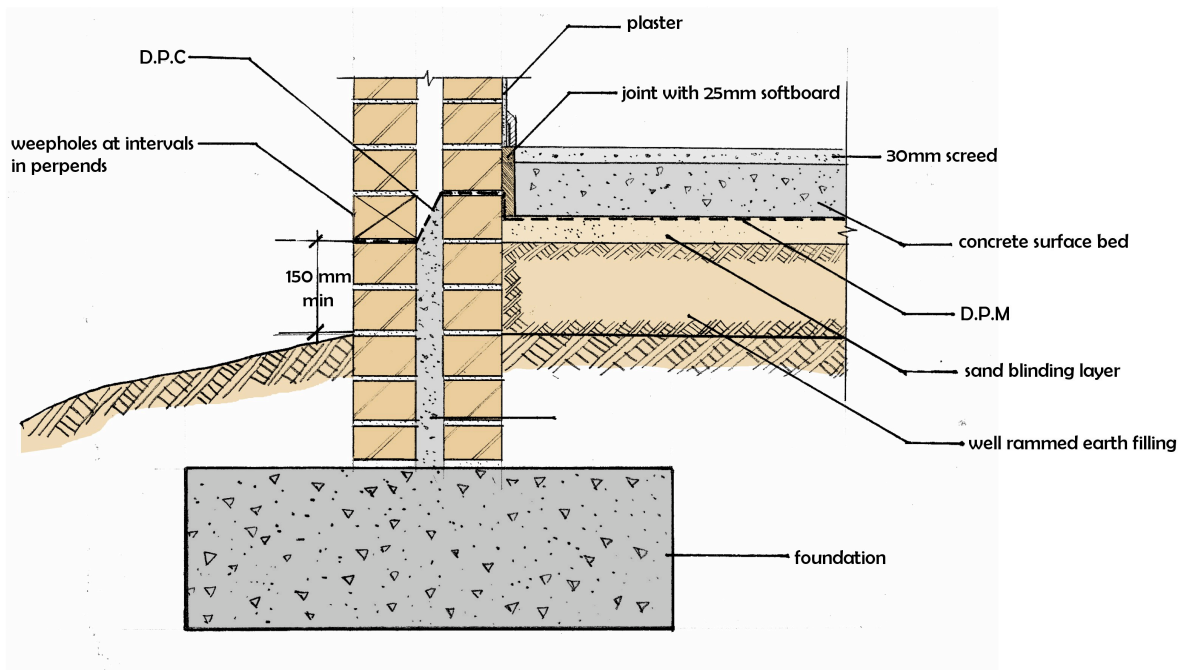

**Fig. 2 Detail of a joint between floor slab and wall of a house**

According to Kohler (1984) a combination of soil, moisture and structural treatment is often the best result and the final choice depends on cost.

## **Collapsing Sands or Soils**

These are fine-grained sands that contain a small percentage of clay or salts, or both. The sand grains are open packed, usually as a result either of deposition in a loose state by wind or water or as the skeleton of grains left behind during decomposition of a rock. The dry clay or salt particles act as cement, which gives the open lattice structure an apparent stability.

Thus, in the dry state these soils appear strong and will sustain quite heavy loads. It is also possible to cut vertical trenches to considerable depths in them. However, when they become thoroughly wet, the clay and salts are softened and the cementing action ceases, with the result that the open-grain structure can no longer sustain load and will collapse.

If the soil is very moist when a building is erected, the cementing agent will have no strength and normal consolidation settlement will occur. However, where the soil is dry and appears strong and the house is built in the conventional way, it may stand for a long time without showing any signs of damage. The problem will however occur when the soil under the foundation becomes wet due either to a leaking drain or to an accumulation of surface water. The result would be a sudden loss of strength and very rapid settlement or collapse.

If this failure were restricted to one part of the building, the differential movement would be severe and cause bad cracking.

**Methods used to solve the problem of collapsing soil:** In many instances the collapsing soils are of relatively shallow depth and foundations can be taken through them to better material below. Where the collapsing soil is slightly deeper, it should be excavated in wide foundation trenches to good material and then moistened and compacted in layers in

the trenches until the desired founding depth is reached.

A heavy compacting roller or 'vibro-floatation' (a vibratory compaction method) can also be used, which will hasten the sand's collapse to the point that one can build on it in reasonable confidence that it will not sink again. The ground should be thoroughly soaked during this operation. Pile foundations are recommended for large buildings on deep collapsing sand profiles.

## **Calcrete and Limestone**

While limestone is a sedimentary rock, which has resulted from the consolidation of deposited material on a sound base with very high calcium content, calcretes have the same chemical composition as limestone but are formed in situ by the upward leaching of lime solutions. The water evaporates leaving a residue at that level. This material can be powdery, nodular, boulders or a compact hard layer – which are often called limestone.

The danger is that as the calcrete is formed in the soil, the material below it may be weak or expansive. The tendency is for builders to stop excavation as soon as they hit the limestone and found on it, but if the layer is thin or broken, movement from below may be transmitted to the building.

## **Ferricrete: 'Laterite' or 'Ouklip'**

Ferricrete, often-called laterite and known colloquially as oukclip (Kohler, 1984), are formed in situ in much the same way as calcrete except that the material contains iron salts. The true ferricrete is a hard cement rocklike material but in its formative stages as ferruginous gravel. The material can form a sound foundation but the danger also lies in a thin layer covering weaker or expansive soils.

**Methods used to solve problems involving Calcretes and Ferricretes:** Because these materials are formed in the soil, the surface may be very irregular or pocketed and there is even the possibility of gaps in the layer. If the foundation is to be placed on this material, it is essential that all pockets of loose soil be cleaned out before foundations are cast. Where gaps occur between patches of these materials or boulders, they should be filled with concrete.

## **Sinkholes and subsidence caused by subsurface erosion**

Sinkholes occur because material is removed at some depth below the surface by erosion. This results in the formation of caves and tunnels, which are gradually enlarged until the surface soil either collapses into them, causing a sinkhole, or runs into them more slowly, causing a severe subsidence. The erosion may be chemical or physical, such as the erosion of fine material by sub-surface flow in weathered granites.

For the formation of a sinkhole, there must be voids into which the eroded material can be washed; in this case they are the open fissures and cavities in the dolomite. Secondly, there must be a flow of water sufficient to erode the material and the soil must be of such permeability as to allow sufficient flow to cause erosion. The third factor, which is closely

related to the second, is that the soil must be capable of being eroded by the flow of water passing through it.

**Methods used to solve the problem of sinkholes & subsidence:** There is no method of construction suitable to withstand the severe subsidence that occurs. The formation of a sinkhole could have catastrophic consequences. The obvious solution therefore would be site selection – steps should be taken to prevent buildings being subjected to these types of movement.

If the site must be used for whatever reason, the only factor over which control can be exercised is the source of water that may cause erosion. Therefore, all water retaining structures, pipelines, canals and drains should be watertight and checked frequently to see that they remain so.

## Quicksand

Contrary to popular belief, quicksand is not a type of sand but a condition, which in special circumstances can occur, in any granular material from fine sand to gravel. It is characterized, in the extreme case by the inability of the material to support a load; while in the partial condition, where the material is likely to become quick, a great reduction in the expected load-carrying capacity of the material results.

A common practical observation of quicksand conditions may be found on many beaches where at low tide the damp sand is firm enough to support motor vehicles, but once the tide starts coming in, the upward flow of water through these sands causes them to lose stability, and hence bearing capacity, until the extreme case arises where all stability is lost and the sand can support no load.

Quicksand conditions are also frequently encountered at the bottom of excavations below the water table where these conditions are produced by seepage pressure. According to Kohler (1984), the 'running sands' of the Table Bay area are typical of these conditions. It is therefore evident that quicksand conditions are intimately associated with the flow of water through the soil. This flow tends to float the grains in the water, gradually reducing the inter-granular pressure as the rate of flow is increased until, in the extreme case, the material becomes liquid and all the particles are in suspension.

However, in building practice, such extreme cases are very rare. The more common cases occur where a flow of water, either still existing, or present in some past history of the deposit, is holding or has left a layer of material in a very loose state. The soil profile as a whole is usually able to support a fair load without failure, but if the load is increased to the point where the shearing force transferred to the weak layer becomes greater than the available shear strength of that layer, a sudden and spectacular collapse of the whole profile occurs, usually with disastrous results. This increase in shearing force may also be brought about by sudden shock, such as occurs with pile driving, and is a frequent cause of damage to buildings on sites adjacent to new constructions founded on piles.

Trenches dug in sands where the water table is virtually at the surface can produce similar conditions due to the effect of water flowing into the trench. This is not only a danger to the trench, but can affect foundations if the trench is close to them.

## Sloping Ground

Soil cover results from the action of wind and rain, frost and plants, which break down the surface of rocks. The dangerous zone in sloping grounds is midway because as we go up the hillside, the soil cover is less, the soil collects at the base, while midway, the soil can slide down the slope. Soils have a natural angle of repose. Gravel and soil particles always tend to settle at an angle, which is fixed by the natural characteristics of the soil itself. If a spade full of sand is taken from the side of a heap, the grains above this point will slide down to fill the space. This is because an unstable slope was created. Therefore, cutting out a site for a house in a slope will make the system unstable and may create landslip problems (see Fig. 3 below).

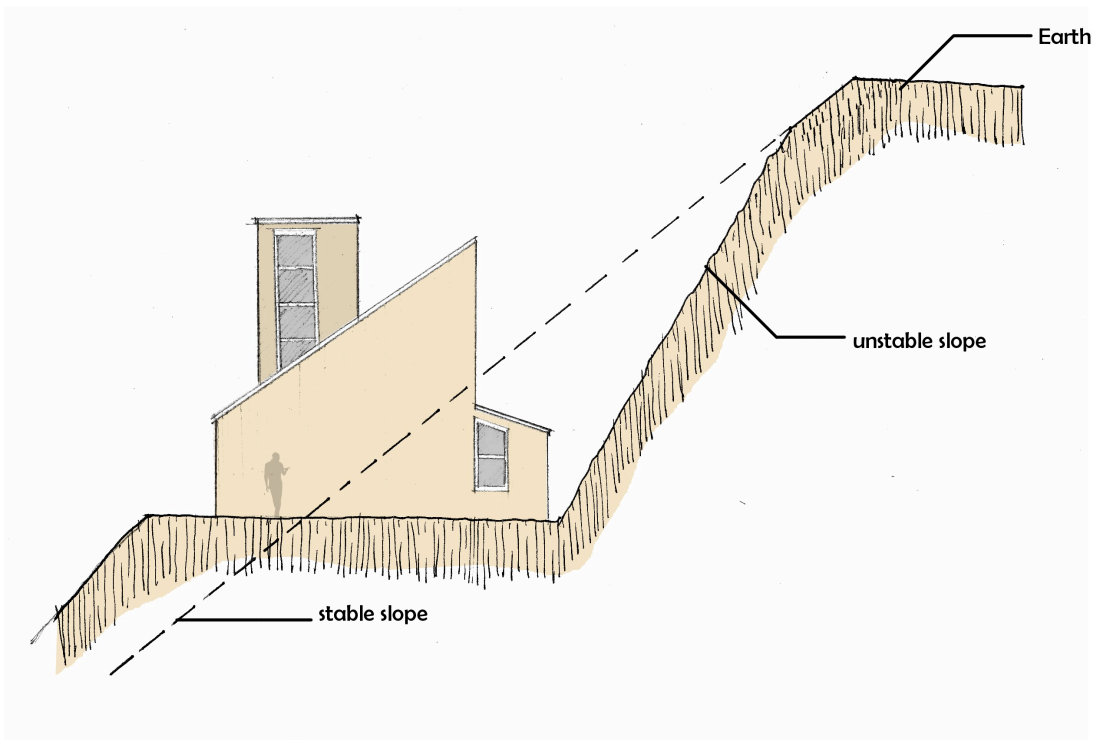

**Figure 3 Instability due to building in cut**

If on the other hand the building is placed on the outer edge of the cut or too close to the top of a slope, the additional weight may cause the loose material to slide.

**Methods used to solve the problem posed by sloping grounds:** When any building on a sloping site is considered, a competent engineer's opinion should be obtained on the overall stability of the project. Where there are inherent signs of instability in the surface material, the project should be abandoned or approached with the utmost care.

Where cuts are made into hillsides, it should be ensured that one is not cutting across dip planes or in any other way undermining the stability of the portion left behind. If it is necessary to maintain material at slopes greater than the natural angle of repose, properly retaining walls should be used.

## Made Ground or Fills

Made grounds or fills as suggested earlier in this document should be avoided. However, if a trench is required to pass for only a limited distance over this type of soil – say less than 1m – normal foundations and wall construction should safely span over this weak area.

# Requirements for a Good Foundation

Part H: Foundations of the National Building Regulations states as follows:

1. The foundations of any buildings shall be designed to safely transmit all the load of such building to the ground.
2. The requirement of sub regulation (1) shall be deemed to be satisfied where the design and construction of such foundation complies with Part H of section 3 of SABS 0400.

SABS 0400 Code of Practice for the application of the National Building Regulations, Part H, states as follows:

## HH1 General

The regulation contained in Part H of the National Building Regulations shall be deemed to be satisfied where –

- (a) Any foundation is the subject of rational design in accordance with the requirements contained in Part B (structural design); or
- (b) The construction of any foundation complies with deemed-to-satisfy rules contained in the following provisions of this Part. **Some of which include:** -

## HH2 Empirical Rules for Foundations

HH2.1 Any foundation constructed in accordance with sub rules HH2.2 to HH2.8 inclusive shall not be used to support any wall forming part of the structural system of any building except where –

- (a) Such wall is placed centrally on such foundation;
- (b) Such wall is the wall of any building contemplated in rule KK2 (for structural wall) of this Code; and
- (c) The soil supporting such foundation is not a heaving soil or shrinkable clay or a soil with a collapsible fabric.

HH2.2 Any such foundation shall be constructed in concrete having a compressive strength not less than 10 MPa at 28 days or concrete mixed in proportions (by volume) not weaker than 1 part of cement to 4 parts of sand to 5 parts of coarse aggregate.

HH2.3 Any continuous strip foundation shall a thickness of not less than 200mm; Provided that where the foundation is laid on solid rock such thickness shall not apply.

HH2.4 The width of any continuous strip foundation shall be not less than –

- (a) 600mm in the case of foundation to a masonry wall or to a timber framed wall supporting a roof with Class B covering (concrete tiles, clay tiles of similar materials and thatch); or
- (b) 400mm in the case of a foundation to a masonry wall or to a timber framed wall supporting a roof with Class A or Class C covering (metal roof tiles/sheets and fibre-cement sheets).

HH2.5 (a) Where any strip foundation is laid at more than one level, the higher portion of the foundation shall extend over the lower portion for a distance at least equal to the thickness of the foundation (see Figure below).

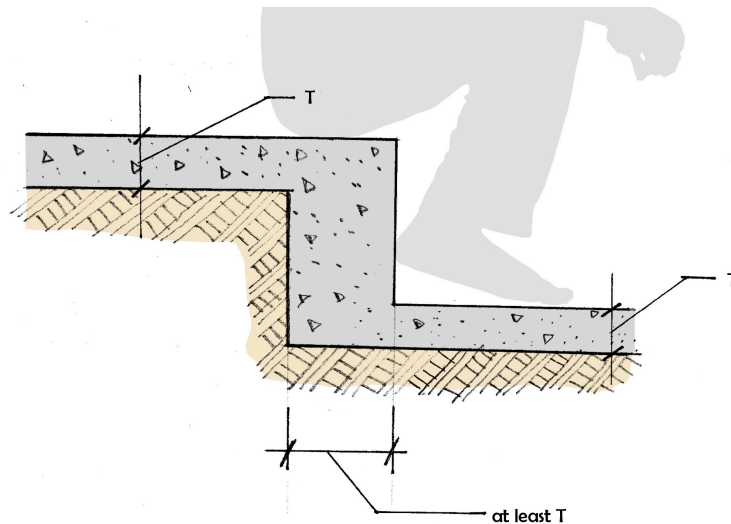

**Figure. Showing Stepped Foundations**

(b) Any void between the top of the lower portion of such foundation and the underside of the higher portion shall be completely filled with concrete of the same strength as that required for such foundation

It is also important to note the requirement of Part G: Excavations Clause GG2.5 that states that: Except where the foundation for any external masonry wall is placed on solid rock, the bottom of the excavation for such a foundation shall not be less than 300 mm below the level of the adjoining finished ground.

## Terms, Common Types of Foundation and Selection

Apart from simple domestic foundations, most foundation types are constructed in reinforced concrete and may be considered as being shallow or deep. Foundations for low-rise construction are usually classified as:

1. Strip – Traditional shallow; wide and deep;
2. Raft;
3. Pad; and
4. Short-bored pile – Cast in-situ and precast.

Foundations can also be classified as:

1. Shallow foundations
  - Pad or column footings (isolated or combined)
  - Cantilever or strap footings
  - Continuous footings
  - Wall footings
  - Mat (raft) footings (thickened slabs)
2. Deep Foundations
  - Pile
  - Piers
  - Caissons

A **Footing** can be defined simply as the foundation to a wall, beam or column.

## Strip Foundations (or Wall footings)

This type of foundation is a continuous longitudinal inverted T-shape support for load-bearing walls. A footing is placed below the floor line and then the walls are added on top. The footing is wider than the walls in this way, giving extra support at the base of the foundation. These foundations are usually suitable for most subsoil's and light structural loadings such as those encountered in light to medium rise domestic dwellings where mass concrete can be used. It is produced from concrete of minimum strength of 15N/mm<sup>2</sup> (1: 3: 6 – batching by weight) and may be reinforced for poor subsoil's or high loading. Strip foundations include:

**a) Traditional Shallow Strip Foundations:** is commonly adopted for two or three-floored domestic buildings on good firm non-shrinkable sub-soils such as gravel (See Figure 4).

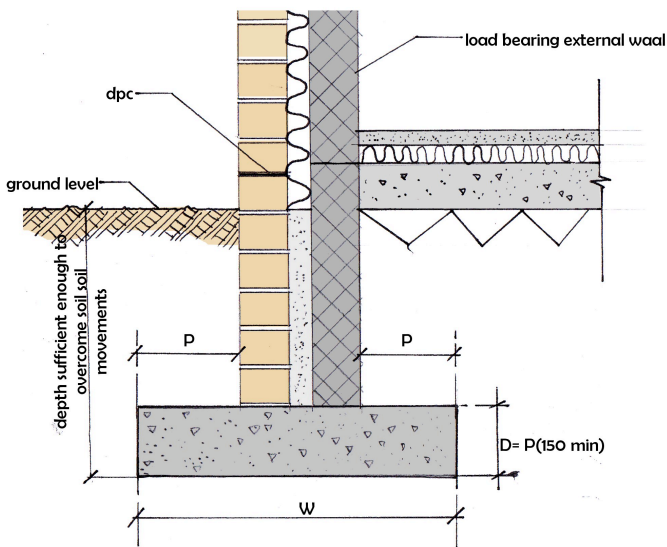

Figure 4 Traditional Shallow Strip

is commonly adopted for two or three-floored domestic buildings on good firm non-shrinkable sub-soils such as gravel (See Figure 4).

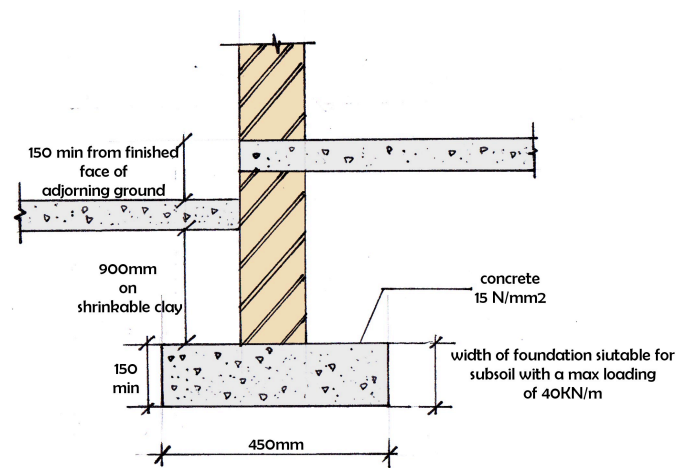
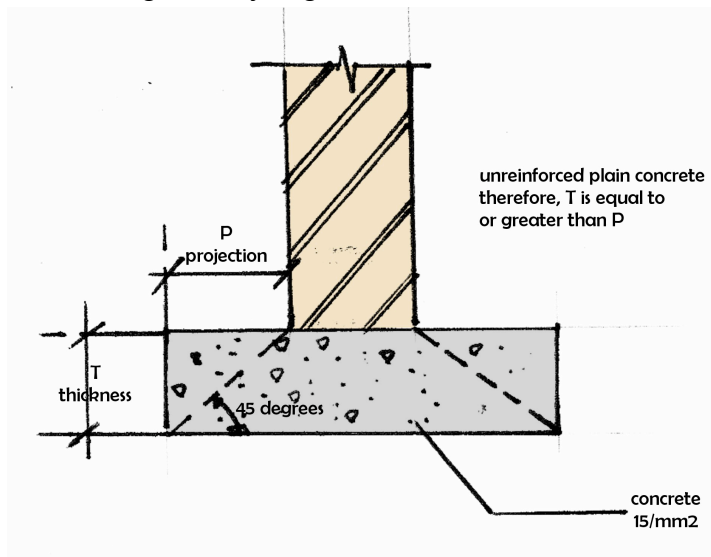

Figure 5 Strip Foundation

The section at Figure 5 is adopted for dwelling houses of three-floors on compact and stiff sub-soils. For shrinkable sub-soils, the depth should be 915mm minimum.

**b) Wide Strip Foundations:** This type of foundation is used where the structural loading is very high relative to the sub-soil bearing capacity. Figures 6 and 7 show the two possible forms of construction, one is unreinforced with the thickness at least equivalent to the projection, whilst the second is reinforced in the area of greatest tensile stress to economize in concrete.



one is unreinforced with the thickness at least equivalent to the projection, whilst the second is reinforced in the area of greatest tensile stress to economize in concrete.

Figure 6 Wide Strip Foundation (Mass Concrete)

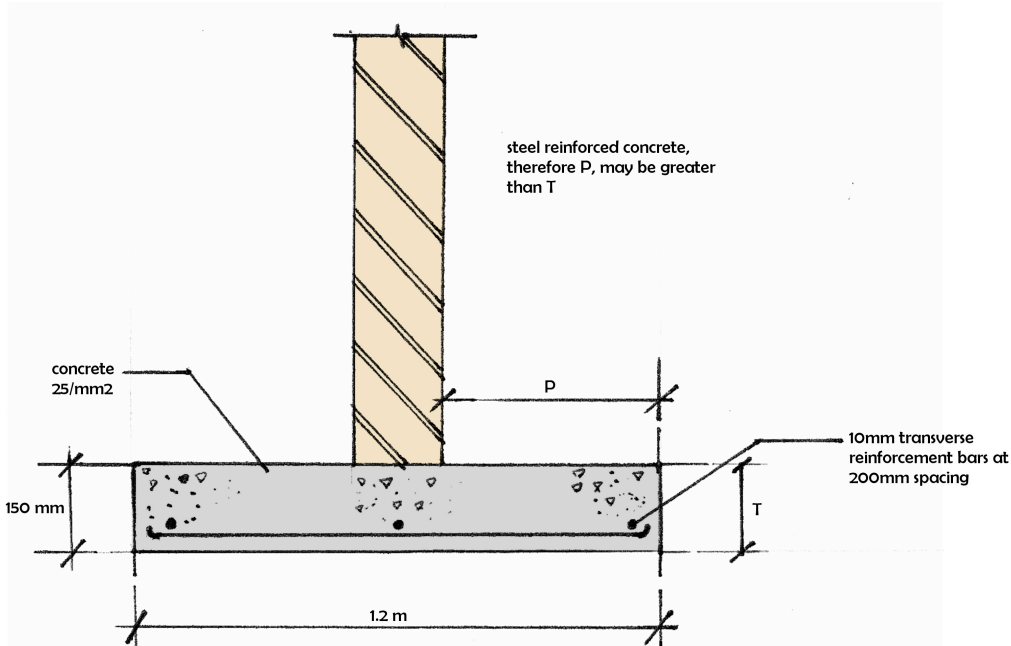
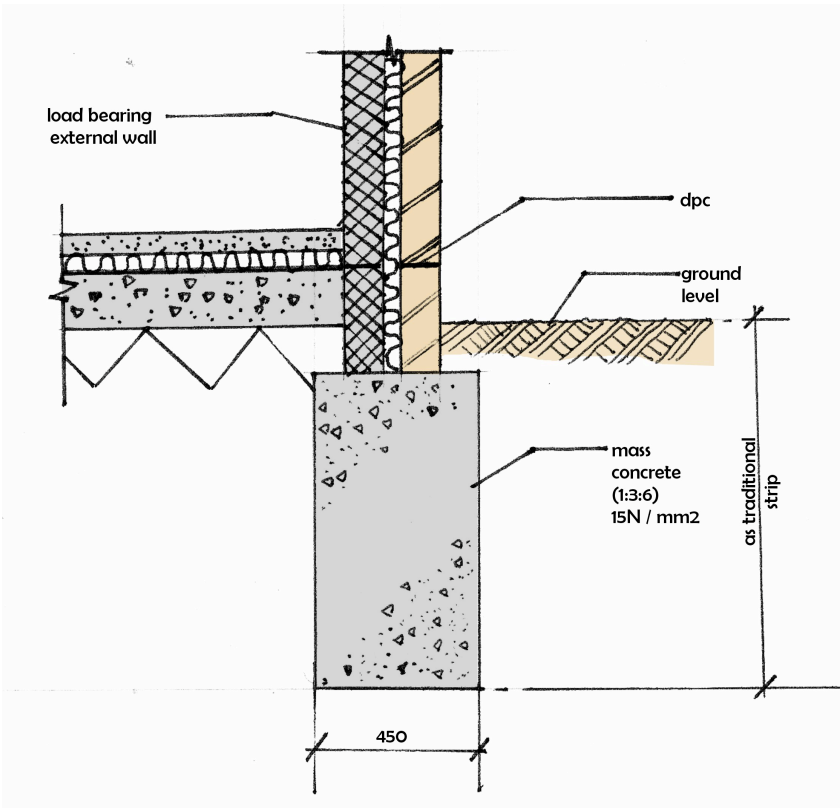

**Figure 7 Reinforced Concrete Wide Strip Foundation**

**c) Deep Strip Foundations:** These are either constructed as:

- Trench fill; and
- Reinforced concrete

**Trench fill** is a very simple form of construction designed to save considerable sub-structural construction time. After trench excavation to the required width and depth, concrete is placed to within 450mm of the finished ground level.



**Figure 8 Deep Strip Foundation (Trench Fill)**

**Reinforced concrete deep strip** foundation is an acceptable alternative to wide strip foundations for soft clay sub-soil conditions. The depth should be at least 900mm to avoid the effects of shrinkage and swelling and about 400mm wide to provide sufficient support for the wall. A narrow strip is adequate, as resistance to settlement is achieved by frictional resistance between the sides of the foundation and surrounding subsoil and by longitudinal bearing. Reinforcement is required as subsoil prone to volume change may develop voids in long periods of dry weather. Figure 8 illustrates possible construction for use on shrinkable clay subsoil.

## Raft Foundations (or Slab Footings)

A raft foundation covers an area at least equal to the base structural area of a building (planar). In its simplest form, this is a 150mm layer of concrete on hardcore. As foundations on soft compressible subsoil, concrete rafts are used in dwellings, provided they are well reinforced to resist the effect of ground movement as shown in Figure 9.

Note that ground beams can be designed as up-stand beams with a concrete suspended floor at ground level therefore creating a void space between the raft and the ground floor.

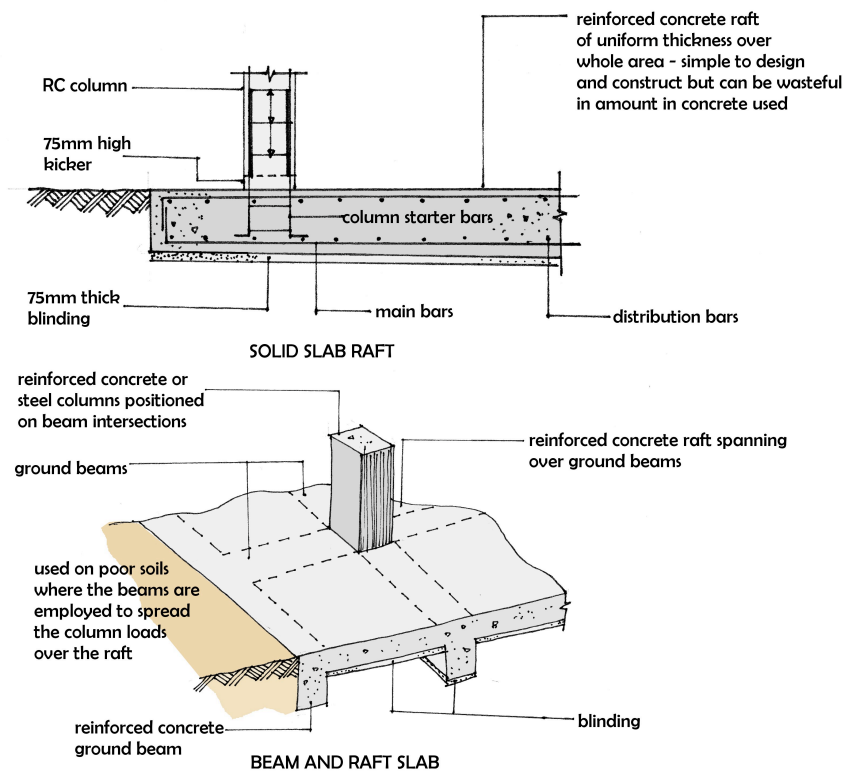

**Figure 9 Solid raft and; beam and raft slab**

## Pad Foundations (Column Footings)

Pad foundations are used in houses where isolated or combined brick or concrete columns are required, for example in a framed or skeletal structure as shown in Figure 10.

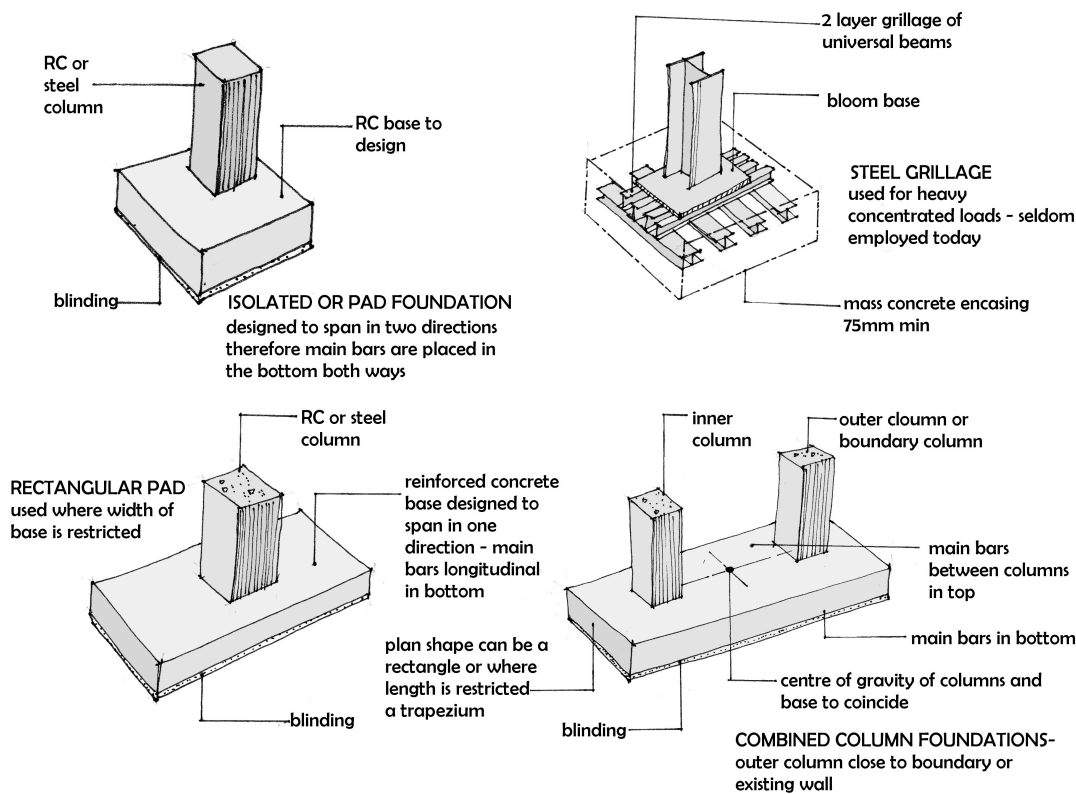

**Figure 10 Typical Pad Foundation Types**

Pad foundations are suitable for most subsoil's except loose sands, loose gravel and filled areas. Pad foundations are usually constructed of reinforced concrete and where possible are square in plan.

## Pile Foundations

Pile foundations are used where conventional foundations would be very deep and uneconomical. It is uneconomical to consider normal excavation beyond 2m. The lack of suitable foundation conditions may be caused by:

1. Natural low bearing capacity of subsoil such as shrinkable clays, in-fill or waste tips and peat;
2. High water table in poorly drained areas – giving rise to permanent dewatering costs;
3. Subsoil(s) which may be subject to moisture movement; and
4. Steep slopes

Pile foundations can be defined as a series of columns constructed or inserted in the ground to transmit the load(s) of a structure to a lower level of subsoil. This system resembles building on stilts or columns, with the base of the support resting on a load-bearing stratum up to about 4m below the surface. Piles may be classified by their basic design functions into - end bearing piles, friction or floating piles, replacement piles or displacement piles – or by their method of construction into cast in-situ or precast piles.

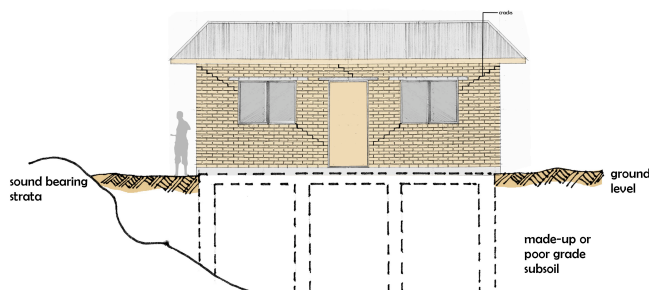

Figure 11 shows the principle, which is the same for cast in situ or precast driven piles.

**Figure 11 Piled Foundations**

**Cast In-situ Piles:** These piles are generally end bearing, but may have an enlarged diameter for frictional resistance to settlement where quality subsoil is impossible to locate. Boring is by powered auger to a depth rarely exceeding 4m. (Beyond this is expensive for simple dwellings). A steel tube lining is required where the boring is liable to collapse, and this should be extracted after reinforcement and concrete are placed. Figure 12 below shows the construction of a typical cast in-situ end bearing pile with longitudinal reinforcement to resist the effect of ground movement.

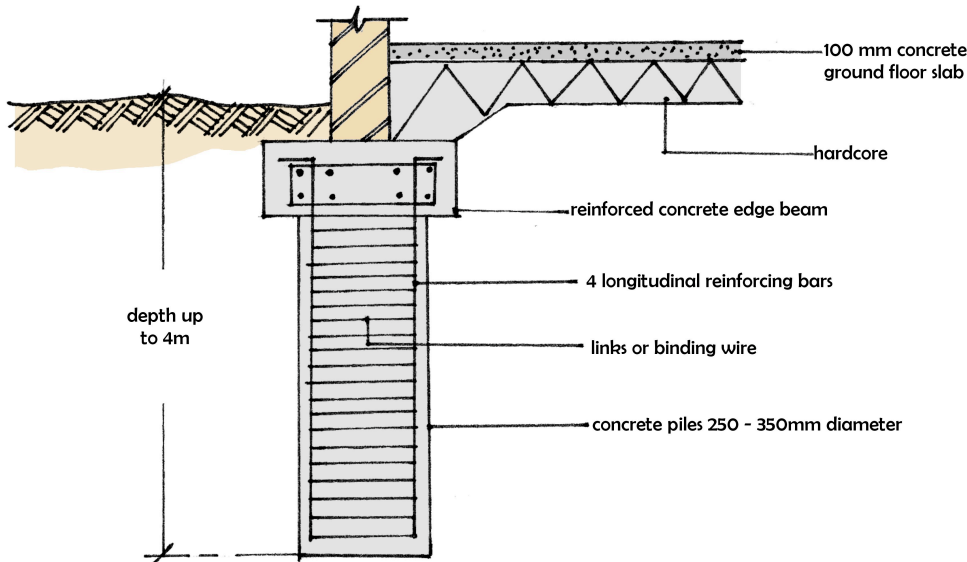
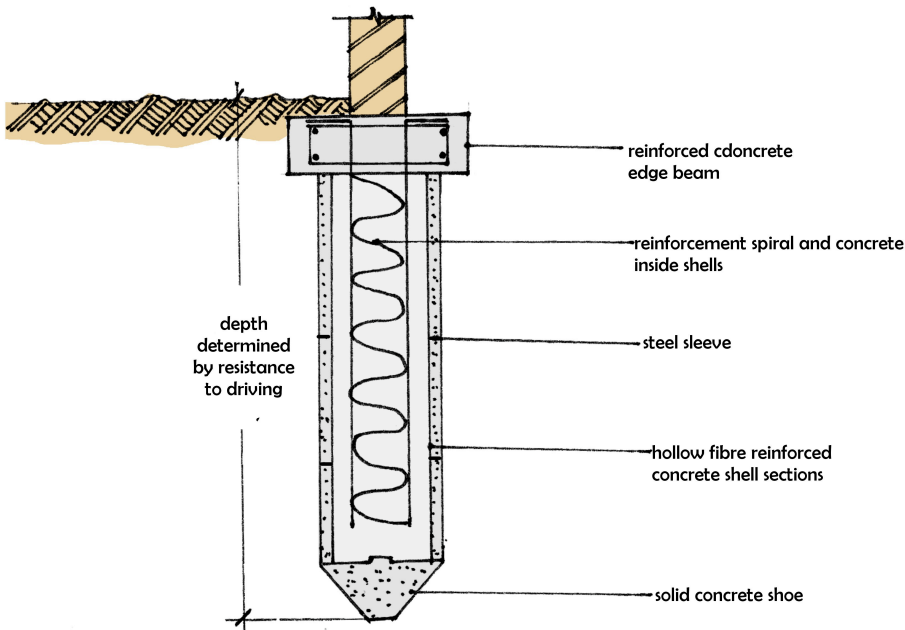

Figure 12 Cast In situ Piles

**Precast Concrete Piles:** These are fibre reinforced concrete hollow shells of approximately 300mm diameter and 1 m length linked with a steel sleeve. Placing is by driving each section with a vertical drop hammer until sufficient resistance is achieved. The hollow core receives reinforcement and in-situ concrete, which ties in with an in-situ concrete edge beam. The potential in poor subsoil is considerable, as boring equipment is not required and depth of ground penetrations is less critical.



# Simple Foundation Design Calculations - Strip Foundations

**Foundation design principle** ~ the main objectives of foundation design are to ensure that the structural loads are transmitted to the subsoil(s) safely, economically and without any unacceptable movement during the construction period and throughout the anticipated life of the building.

**Basic Design Procedure** ~ this according to Chudley and Greeno (2006) can be considered as a series of steps or stages including ~

1. Assessment of site conditions in the context of the site and soil investigation report.
2. Calculation of anticipated structural loading(s).
3. Choosing the foundation type taking into consideration –
  - a. Soil conditions;
  - b. Type of structure;
  - c. Structural loadings;
  - d. Economic factors;
  - e. Time factors relative to the proposed contract period; and
  - f. Construction problems.
4. Sizing the chosen foundation in the context of loading(s), ground bearing capacity and any likely future movements of the building or structure.

Figure 14 shows a cross-section through a house with the roof resting on the walls and the walls supported on concrete strip footing bearing on firm ground. The function of the footing is to spread the load from the wall over a sufficiently large area to ensure that the safe bearing capacity of the supporting ground is not exceeded. If the soil has a high bearing capacity it should be possible to build the brick wall directly onto the bottom of a level foundation trench.

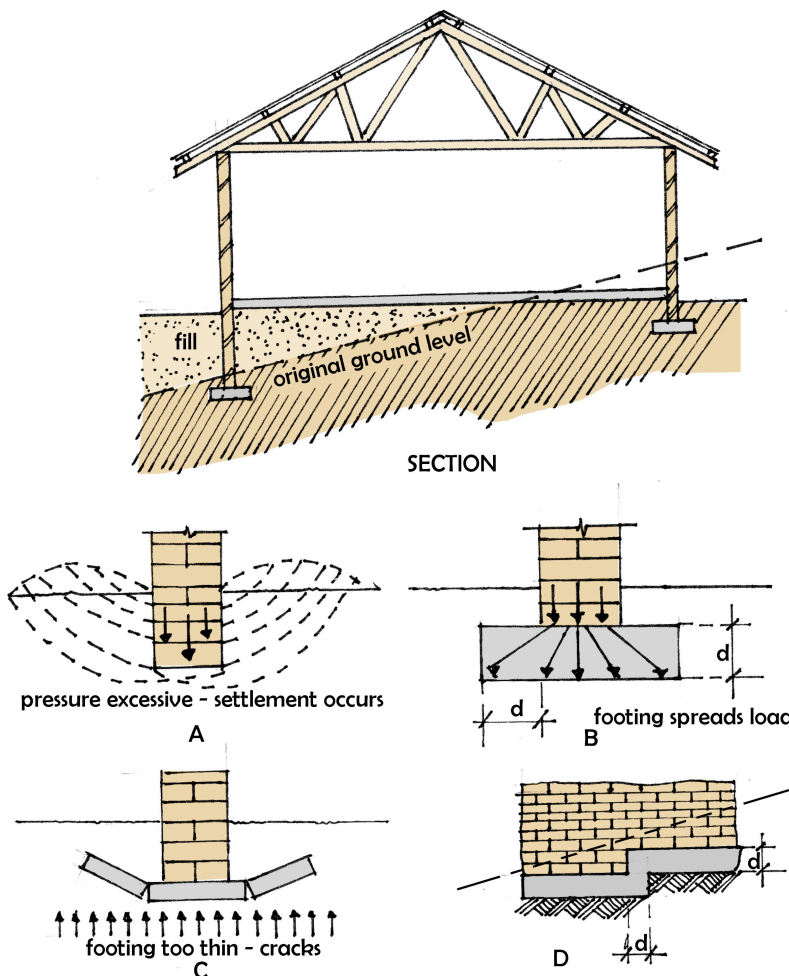

**Figure 14** Foundation Requirements

Generally, it would be found out however that the safe bearing capacity is likely to be exceeded if a foundation footing is not provided and the wall will be subjected to excessive settlement as shown in Figure 14 A. A further practical reason for having a footing is that the bricklayer needs a level surface on which to start his first course of brickwork. For both these reasons therefore, a concrete footing as shown in Figure 14 B is employed.

### **Width of Footing Required:**

The width of footing necessary to reduce the bearing pressure to a safe value for the given soil depends on the following factors:

1. The load per unit length of the wall, which in turn is determined by the size of the building (roof and floor spans), number of storey's and whether the roof is heavy or light construction;
2. The bearing capacity of the soil in question, which varies over a very wide range from one site to another.

To avoid taking these factors into account for every house, a set of simple rules for footing dimensions, which will be conservative for all normal situations, is usually adopted. The following requirements would be conservative for all soils except very poor unstable soils such as loose sands, very soft clays including silts and made-up ground:

- (a) In a large single-storey house with a heavy roof, the load per unit length of exterior bearing wall is unlikely to exceed about 22 KN/m and in a double-storey house about 45 KN/m. It is worth noting here that the bulk of the above specified loads arise from the weight of the masonry wall itself. Safe bearing pressure for all soils except very poor unstable soils would be in the range of 50 - 100 KN/mm<sup>2</sup>.

This means that for a single-storey house a safe width of foundation for a 215mm wall would be 500mm and for an interior 110mm wall, this could be reduced to 400mm.

- (b) In double-storey building construction, a safe width would be 700 - 750mm for 215mm walls with a possible reduction to 600mm if the roof is of lightweight (corrugated or troughed steel or aluminium) construction. For 110mm walls, the footing width may be reduced to 500mm, or 600mm if there is a concrete slab roof.

See examples shown in Figure 15

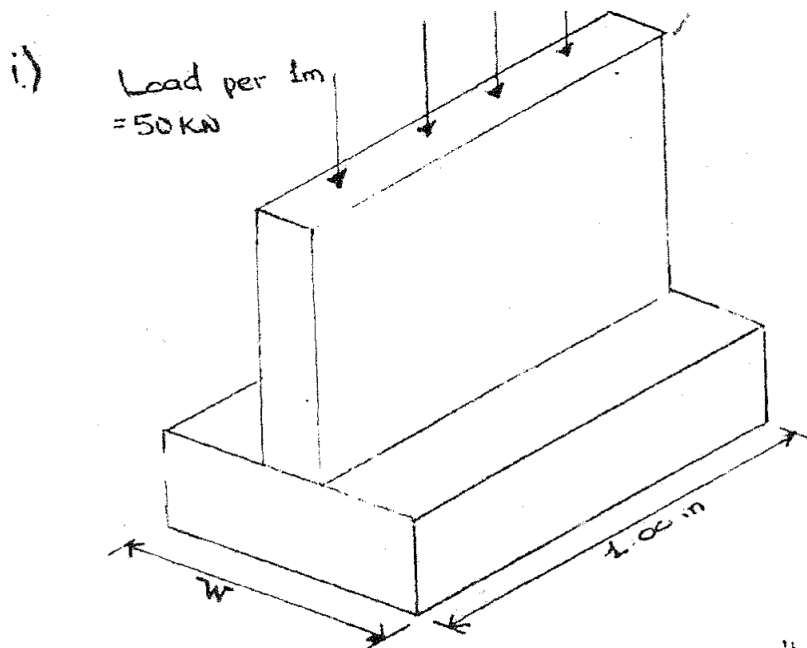

Assume subsoil of safe bearing capacity = 80 kN/m<sup>2</sup>

$$w = \frac{50}{80} = \underline{625 \text{ mm}}$$

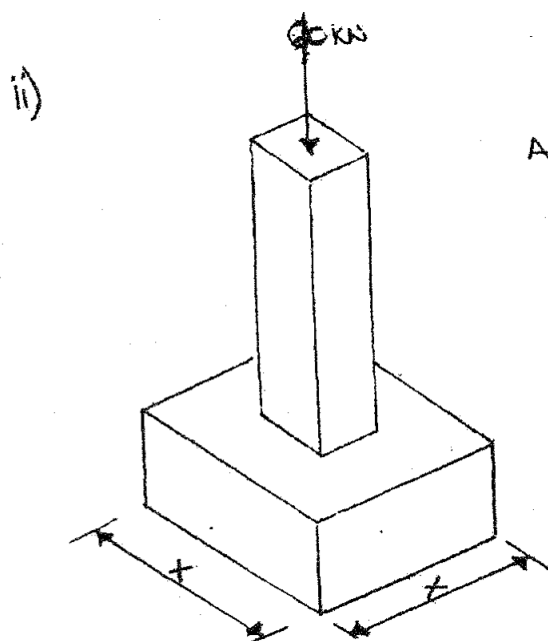

Assume subsoil of safe bearing capacity = 80 kN/m<sup>2</sup>

$$\begin{aligned} x &= \sqrt{\frac{60}{80}} \\ &= \sqrt{0.75} \\ &= \underline{866 \text{ mm}} \end{aligned}$$

Figure 15 Foundation Design Calculations

### Thickness of Footing Required:

The thickness of the footing must be sufficient to ensure that it does not break off or crack under the upward pressure of the soil on the projecting portions as illustrated in Figure 14 C and the downward pressure by the wall.

The subsoil beneath the foundation is compressed and reacts by exerting an upward pressure to resist foundation loading. If foundation load exceeds maximum passive pressure of ground (i.e. bearing capacity) a downward movement of the foundation could occur.

Remedy is to increase plan size of foundation, to reduce the load per unit area or alternatively reduce the loads being carried by the foundation.

Whatever solution that is adopted, the thickness of the concrete footing should not be less than the projection of the strip each side of the wall because if there were a failure by shear, the  $45^\circ$  angle of shear would not reduce the bearing of the base on the subsoil as shown in Figure 16. If  $T$  is not less than  $P$ , then the bearing area is not reduced.

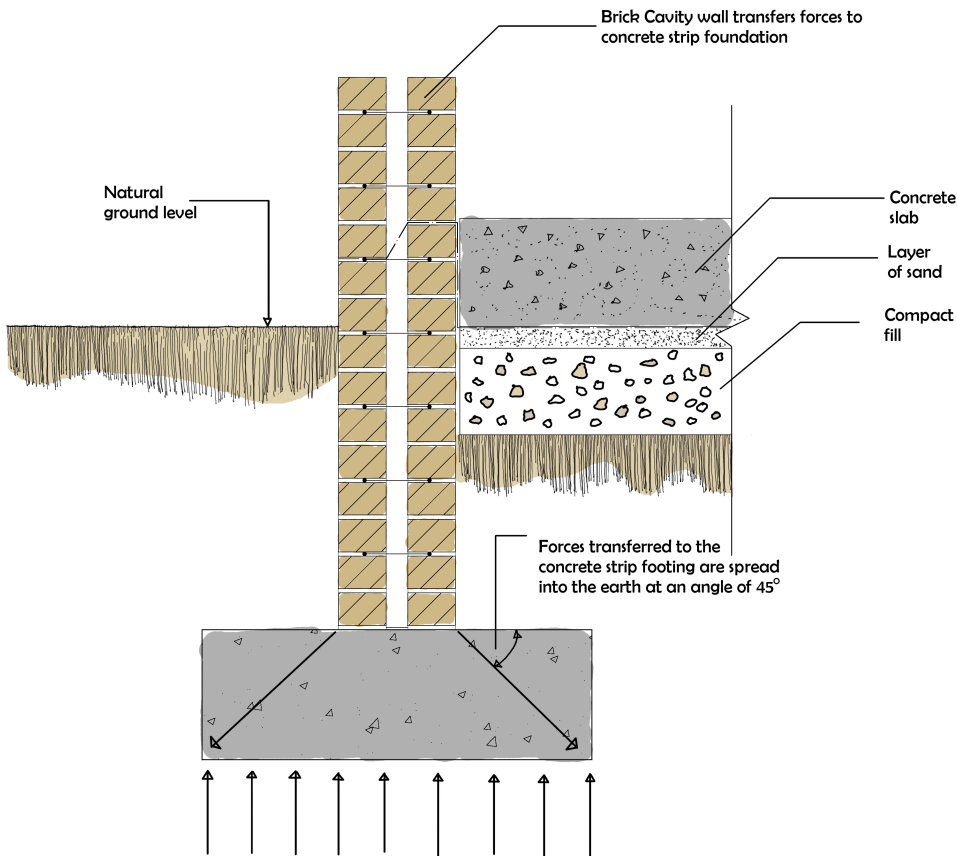

Figure 16 Shear Failure of Concrete Strip footing at an angle of  $45^\circ$

### Depth of Strip Foundation:

The practical minimum depth of a strip foundation is usually 450mm to allow for removal of topsoil, variation in ground level and anchorage. It is obviously undesirable for footings to be placed on the surface of the ground, since apart from appearance considerations there is a risk of erosion of the soil by rainwater. However, where solid rock is encountered in foundation trenches at a depth less than 300mm, it is not necessary to excavate to this depth.

### Stepped Foundations due to Changes in Site levels:

Generally, houses are not built on perfectly flat sites and it is therefore necessary to step the trenches and footings. At such step in the footings, the higher portion should overlap the

lower but there are no structural reasons for making the thickness 'd' of the footing the same with the overlap as shown in Figure 14 D.

On steeply sloping sites as shown in Figure 14, it is common to employ a bulldozer to create a level area on which to build the house. This often means that the house is sited partly on cut and partly on fill as in the section shown in Figure 14. In such cases, it is imperative to take the foundation excavations through the fill into undisturbed ground if settlement and cracking are to be avoided.

### Support for Internal Walls:

Where a continuous surface bed or slab is used, it is possible for lightweight non-load bearing internal walls such as gypsum drywall partitions to be located on the surface bed with the foundations being omitted. If such surface bed is on filling, as is usually the case, care must be taken to ensure that the filling is properly consolidated.

Where conventional brick internal walls are to be built directly on the concrete surface bed, it is essential that:

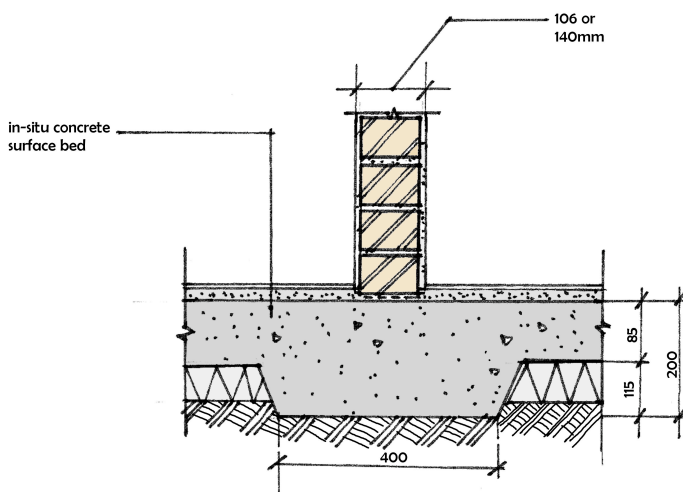

- The surface bed is of sufficient thickness and that it is properly reinforced; or,

- Footings are formed for the internal wall by thickening out the underside of the surface bed by about an extra 110mm and for a width of about 500mm. If this solution is adopted, the surface bed need only be of about one course of brickwork thick (say, 90mm) resulting in a 200mm total thickness along the thickened out portions. Strips of standard welded steel mesh reinforcement should also be cast into the surface bed in all thickened out portions.

As mentioned above, thorough compaction of the fill under the surface bed is particularly important with this form of foundation construction.

## Materials Used in Foundation Construction

Foundations must be constructed of durable materials of adequate strength in order for it to be able to function properly. Which is principally to spread the load imposed on it evenly over the ground on which it rests. The most suitable material used is **concrete**.

**Concrete** is a mixture of cement, aggregates and water in controlled proportions.

**Cement** is manufactured from kaolin clay and limestone and is the binder of the concrete mix. Cement powder can be supplied in bags or in bulk.

**Aggregates** are of two types:

- i. **Coarse aggregate:** which is a material, which is retained on a 5mm sieve, e.g. it can be either natural rock which has disintegrated, crushed stone or gravel; and
- ii. **Fine aggregates:** such as sand are materials, which passes a 5mm sieve.

Concrete is a material, which is strong in compression but weak in tension. If its tensile strength is exceeded, cracks will occur resulting in a weak and unsuitable foundation (see Figures 14 C and 17).



**Concrete Materials**

Source: Group 11 CON1018W 2010

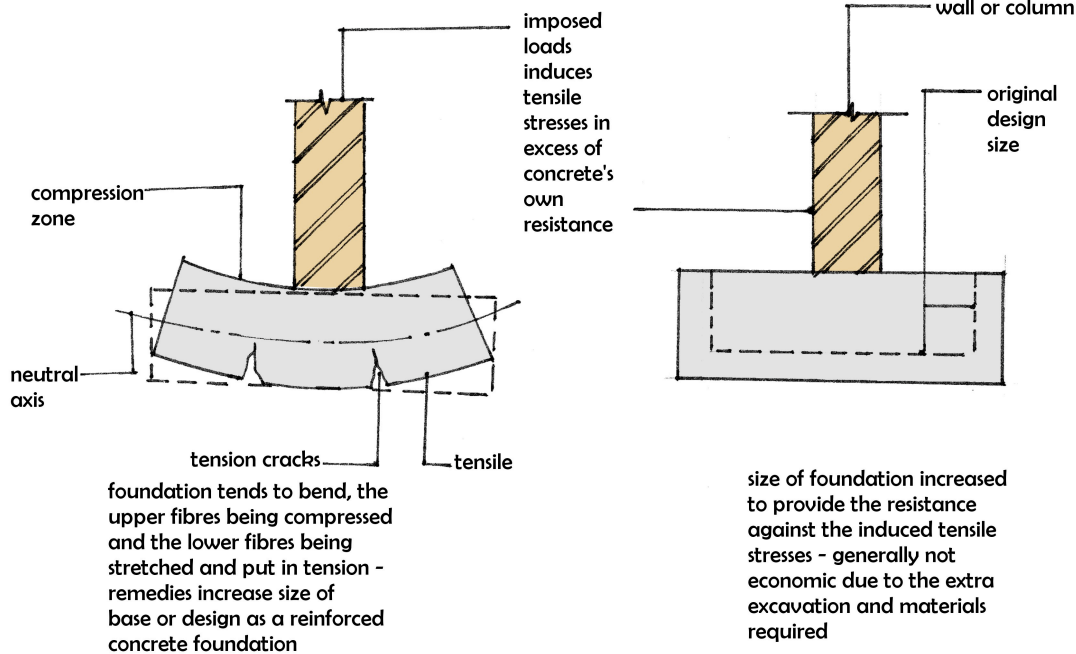

**Figure 17** Concrete Foundation Footing behaviors when loaded

One method of providing tensile resistance is to include in the concrete foundation, bars of steel as a form of reinforcement to resist all the tensile forces induced into the foundation (see Figure 18).

**Steel** a material that has high tensile strength is available as rolled bars.



**Steel Reinforcement**  
Source: Group 11 CON1018W 2010)

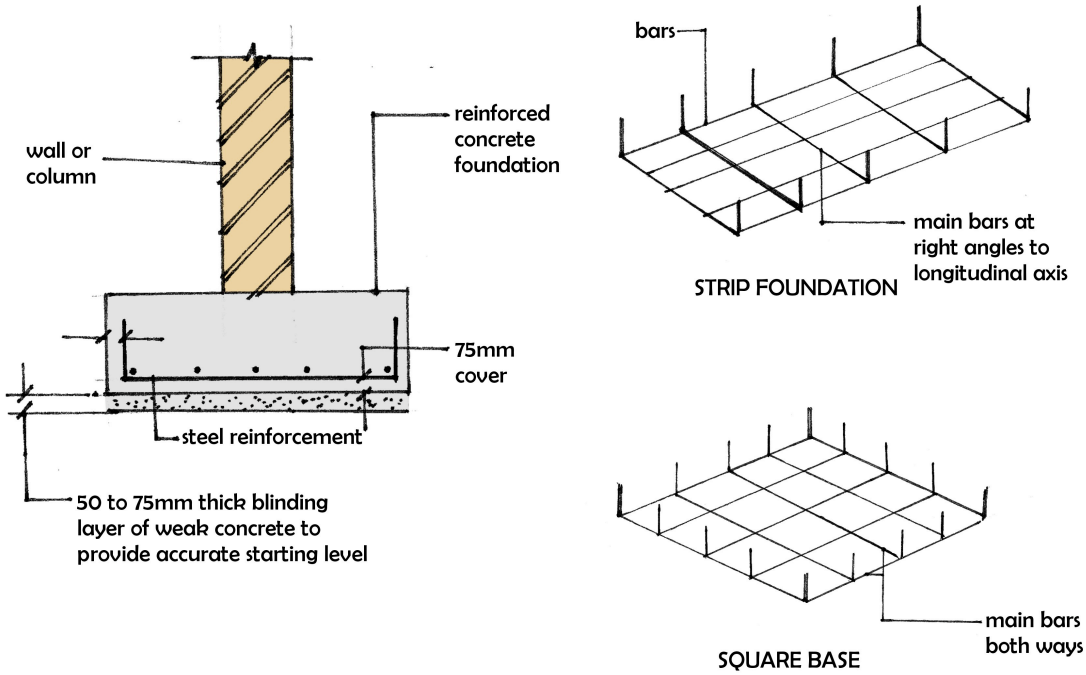

**Figure 18** Typical RC Foundation Reinforcement Patterns

## **Method of Strip Foundation Construction**

The strip foundation is produced by first of all, excavating a trench to the required design depth and width as shown in Figure 19(a-e). The bottom of the trench is leveled and compacted and then blinding with concrete 50mm thick (also known as concrete blinding). A concrete bed not less than 150mm thick is then placed on the blinding and leveled. Brick/block wall is then set till the designed height of the foundation is achieved (Figure 20(a-c)). The side of the trench is then backfilled with selected excavated materials. There are two possible forms of construction of the strip foundation:

- Un-reinforced with the thickness of the concrete at least equivalent to the projection of the footing on both sides of the foundation wall, which is un-economical; or
- Reinforced in the area of greatest tensile stress to economize the amount of concrete used.



Figure 19a. Trench Excavation  
**Source:** CON1004W  
2010 Group 2



**Figure 19b.** Trench Excavation  
**Source:** CON1018W 2010 Group 11



**Figure 19 c.** Trench Excavation  
**Source:** CON1004W 2010 Group 2



**Figure 19d.** Placing Reinforcement  
**Source:** CON1018 2010 Group 11



**Figure 19 e.** Earthwork support  
**Source:** CON1004W 2010 Group 2



**Figure 20a.** Foundation wall construction  
**Source:** CON1018W 2010 Group 11



**Figure 20b.** Foundation construction  
**Source:** CON1018W 2010 Group 11



**Figure 20c.** Foundation construction  
**Source:** CON1018W 2010 Group 11

On completion of the foundation walls, the foundation cavity is filled with sand and compressed. Also, the gap between the two external layers of bricks is filled with concrete.



**Figure 21:** Concrete Fabrication  
**Source:** CON1018W 2010 Group 11

# FLOORS

A floor is the ground or upper levels in a building, which provides an acceptable surface for walking, living and working (Brett, P. (1997) An Illustrated Dictionary of Building).

## General Requirements of Floors (Clause J1 of the Building Regulations)

1. Any floor of any building shall –
  - a. be strong enough to support its own weight and any loads imposed upon such floor; and
  - b. have a fire resistance appropriate for its use and where required be non-combustible.
2. The floor of any laundry, kitchen, shower-room, bathroom or room containing a WC pan or urinal shall be water-resistant
3. Any suspended timber floor in a building shall be provided with adequate under-floor ventilation
4. Where required by the local authority, the entire area within the foundation walls shall be covered by a suitable damp-proof membrane
5. The requirements of sub-regulations 1 – 4 shall be deemed to be satisfied where the design and construction of any floor and under-floor membrane, comply with Part J of section 3 of SABS 0400

## Types of Floors

- Ground Floors
  - In-situ Concrete (Solid or Suspended)
  - Suspended Timber
- Suspended Floors
  - Timber
  - Steel Joist
  - Concrete (Filler Joist; Reinforced Concrete; Hollow Pot; and Pre-cast concrete floors)

## Compliance Requirements stated in Part J of Section 3 of SABS 0400

### JJ1 General

The regulations contained in Part J of the NBR shall be deemed to be satisfied where ~

- a. any floor is the subject of a rational design
- b. the construction of any floor complies with the deemed-to-satisfy rules contained in the following provisions: -

### JJ2 Concrete Floors

1. Any floor of any building shall comply with the fire requirements
2. Any floor supported on ground or on filling shall be constructed of-
  - a. impervious floor units not less than 40mm thick and consisting of slate, bricks, natural stone or other approved material; or

- b. a concrete slab which shall have a compressive strength of not less than 10 MPa at 28 days, or be mixed in the proportions by volume of one part cement, four parts sand and five parts coarse aggregate, and the thickness of such slab shall not be less than 75mm.

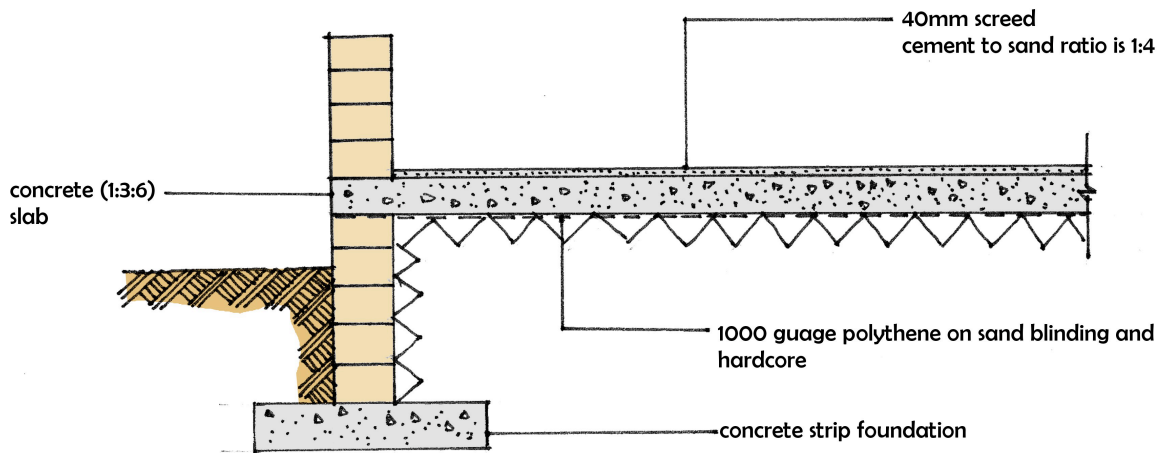

3. Such filling material shall –
- consist of suitable material; and
  - be applied in well compacted layers not exceeding 150mm in thickness



#### Filling Material

Source: CON1018W 2010 Group 11

4. Any concrete floor slab passing over or supported on foundation walls shall be designed as a suspended floor slab.

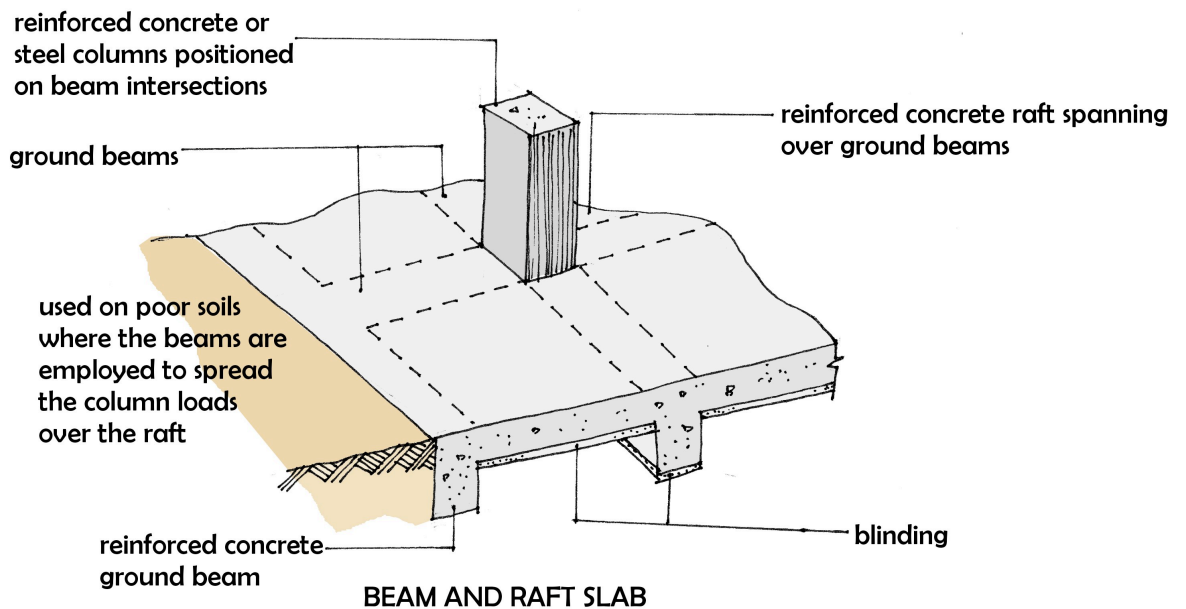

- Any water-resistant floor shall be constructed of concrete or other approved material.

## Timber Floors

- Any suspended timber floor shall be constructed in accordance with SABS 082.
- The underside of any floorboards other than those laid on a concrete slab shall not be less than 550mm above the surface of the ground immediately below such floorboards.

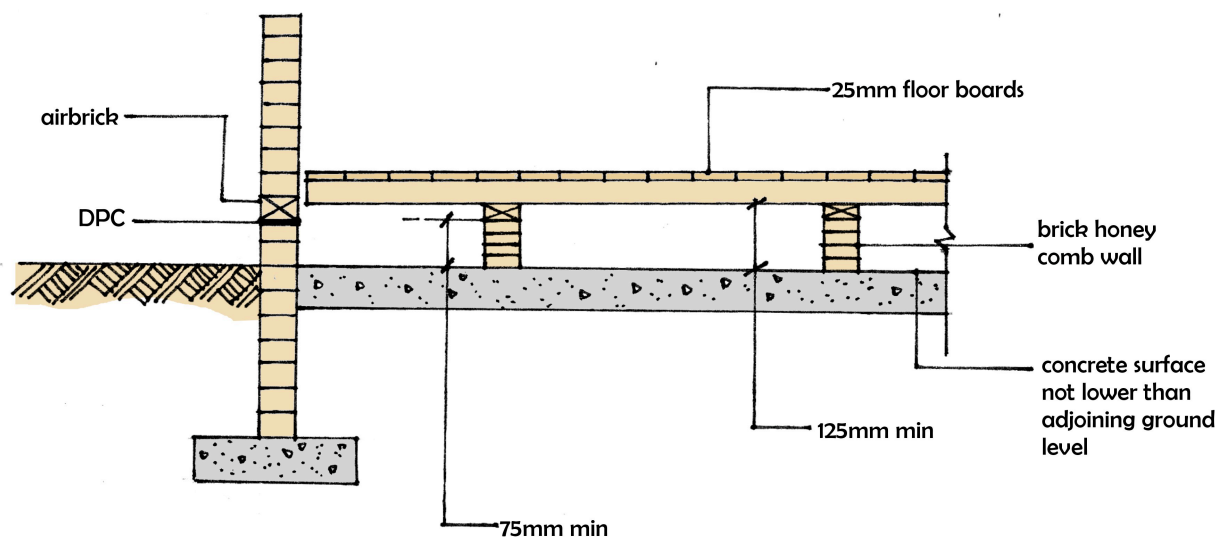

- Provision for ventilation under suspended timber floors and the protection of ventilation openings shall be in accordance with SABS 082 (Code of Practice for timber buildings).

9. The materials used in any suspended timber floor shall be in accordance with SABS 082.

### JJ3 3 Under-Floor Membrane

1. Any under-floor membrane shall not be less than 0.25 mm thick and shall be laid on a surface, which shall not contain any sharp object, which may perforate such membrane.
2. Such membrane shall be turned up around the perimeter of and at least for the full thickness of any slab.
3. Any joint in such membrane shall overlap by not less than 150mm and shall be effectively sealed.



**Floor Fabrication**

**Source:** CON1018W 2010 Group 11

### Insitu Concrete Ground Floor Construction

#### **Components:**

Solid concrete ground floors have three main components:

- **Hardcore:**  
Materials with fairly large particles that are hard and durable such as rock wastes, brick rejects, demolition rubble or any other broken rubble

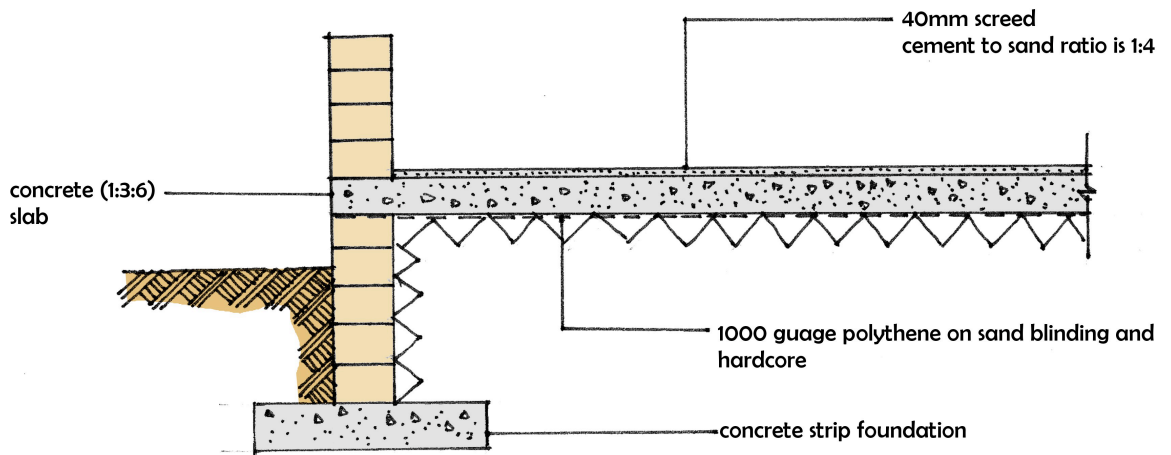

**Solid Concrete Ground Floor Construction**

- **Damp Proof Membrane (DPM):**  
An impervious layer such as Polythene sheet of at least 500 gauge (0.25mm) incorporated into solid ground floors in order to prevent the rise of moisture by **capillarity** (the tendency of a liquid in a narrow tube to rise or fall as a result of surface tension).
  
- **A layer of Dense Concrete:**  
Composed of cement, sand and granite stones mixed at a ratio of 1: 3: 6 to provide a minimum strength specification not less than 10 M Pa (N/mm<sup>2</sup>) at 28 days

## Suspended Timber Ground Floor Construction

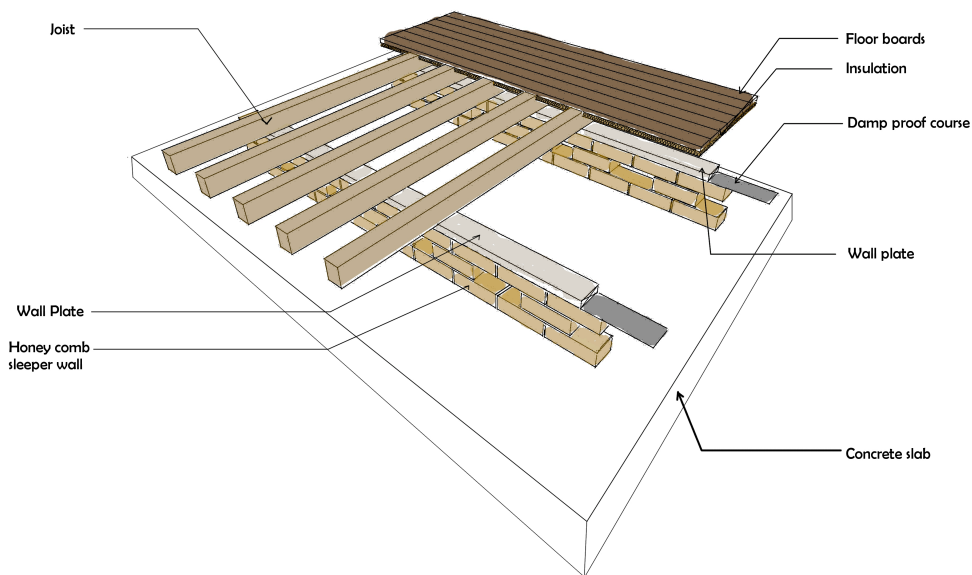

**Suspended Timber Ground Floor Construction**

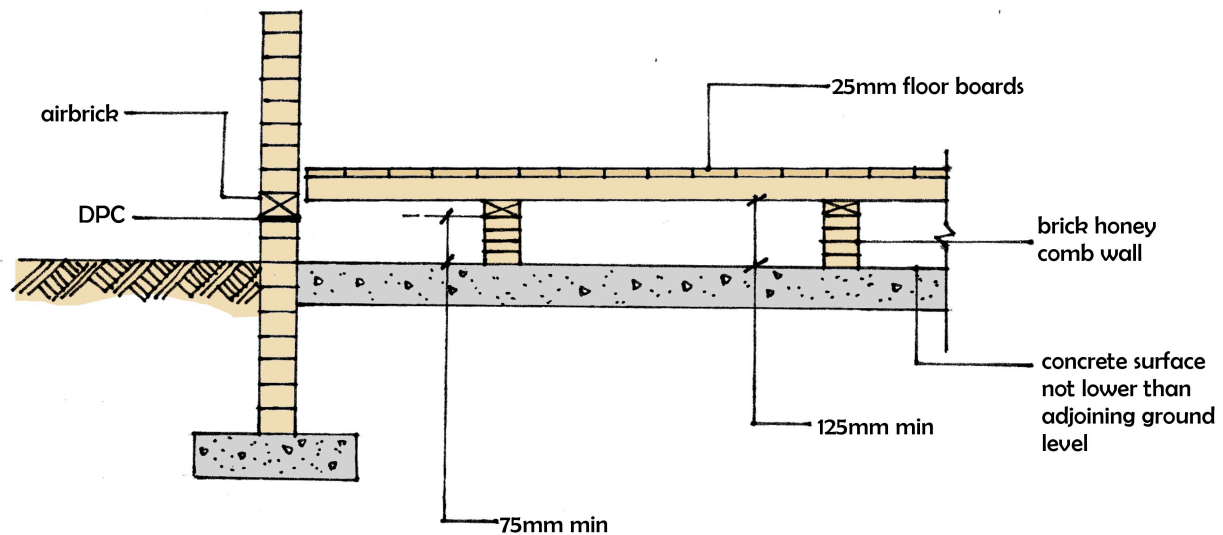

**Suspended Timber Ground Floor Construction**

**Components Used in Suspended Timber Ground Floor Construction: -**  
These are as follows:

- **Air Brick/Air Void:**  
Placed at least 125mm beneath the wooden floor joists. The air brick/air void provides air circulation to prevent **condensation** (water from humid air collecting as droplets on a cold surface. It can also refer to the conversion of a vapour or gas to a liquid).
- **Perforated/Honeycomb Dwarf Sleeper Wall:**  
Provided in the form of 100mm thick walls @ a maximum spacing of 1800mm on a concrete surface not lower than the adjacent ground
- **DPC (Damp Proof Course):**  
An impervious layer paced on the full length and width of the Honeycomb sleeper wall at least 150mm above the Natural Ground Level (NGL) to prevent the rise of moisture by **capillarity**
- **Wall Plate:**  
A horizontal piece of timber 75mm x 100mm in cross section bedded level on the DPC in order to distribute load, ensure a level surface and provide a bearing and fixing point for the joists.
- **Joists:**  
One of a series of parallel timber beams 75mm x 100mm in cross section that directly supports the floorboards. It is nailed to the wall plates across the shortest span @ 300 – 400mm centres.
- **Floor Boards:**  
100 x 25mm wide x 25 – 38mm thick timber boards nailed to joists. (The narrower the floor boards the better to avoid **warping** (become bent or twisted out of shape) caused by shrinkage.

The timber floorboards are planed to a level and smooth surface, either by hand or machine. Scraped, rubbed smooth with sandpaper and finally oiled or waxed and polished.

## **Differences b/w Ground Floors and Suspended Floors**

### **Ground Floor Slabs: -**

- Rest on stable compacted soil
- Does not carry superstructure loads
- Reinforced with steel mesh fabric to control thermal stresses, shrinkage, cracking and any slight differential movement in the soil bed if concrete.

### **Suspended Floor Slabs: -**

- Requires engineering analysis for each specific situation
- Structurally reinforced to act as a unit if concrete

## **Materials Used in Flooring**

### **1. Timber**

This material is used in wood joist floors and as floor finishing. There are two major classes of wood: softwood and hardwood. Hardwood includes: Mahogany, Iroko, Cedar etc and are used for flooring, finishing, stairway construction, paneling, furniture and interior décor.

### **2. Steel**

Steel is used in steel joist floors. It is a structural material that combines high strength and stiffness with elasticity. Measured in terms of weight to volume, it is probably the strongest low-cost material available.

### **3. Concrete**

It is used in concrete floor construction. It is a composite material made from a mixture of cement, aggregate and water. It is classified as plain, reinforced, pre stressed, cast in situ, precast or lightweight.

#### **Advantages of concrete: -**

- It can encase and bond with steel reinforcement
- It is capable of being formed into almost any shape with a variety of surface finishes, textures and patterns.

#### **Disadvantages: -**

- It is heavy
- It requires a forming or molding process before it is placed to set and harden if insitu.

# FLOOR FINISHING

## Factors to consider ~

When selecting a floor finish, many factors deserve consideration but not all are of equal importance as requirements vary from one room to another. For example:

- **Resistance to moisture**  
This is important in a bathroom but not a bedroom
- **Appearance**  
Maybe relevant in the sitting room, but is of little consequence in a store

Functional requirements considered in choice of floor finish ~

- **Durability**  
Against traffic wear
- **Resistance**  
To wear, oil, grease, chemical and moisture
- **Safety**  
That is the finishes should be non-slip, particularly in bathrooms and kitchens where floors may become damp

## Types of Floor Finishes in Use

These include:

### 1. Ceramic Floor Tiles

These are small surfacing units made of fired clay and other ceramic materials. The tiles are available in a variety of colours and provide a permanent, durable, waterproof and easily cleaned surface.

The tiles are first soaked in clean water and then laid on a cement and sand (1:6) bed. The thickness of this bed is dependent on the thickness of the tile deducted from the level of the finished floor surface required.

### 2. Wood Flooring

Durable, hard, close-grained species of hardwood such as mahogany, masonia and cedar are mostly used. The three basic types of wood flooring include ~

Strip, Plank and Block Flooring, examples of its different design format are shown below ~

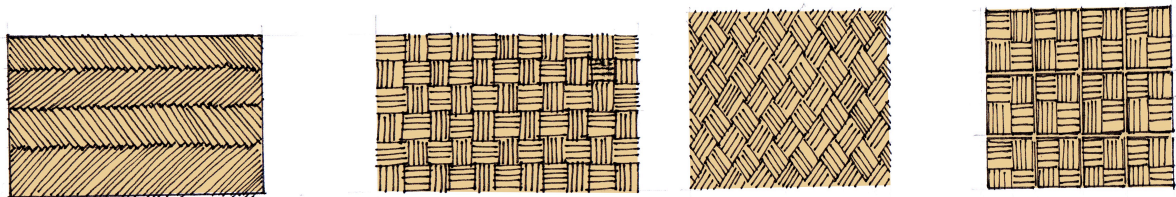

Examples of Wood flooring designs

### **3. Resilient Flooring**

This provides an economical, dense, non-absorbent flooring surface with good durability and ease of maintenance. Because of its **resilience** (able to recoil or spring back into shape, after bending, stretching or being compressed), it is able to withstand permanent indentation, whilst contributing to its quietness. Types include ~

- Flexible PVC tiles
- Cork tiles
- Rubber tiles
- Linoleum
- Asphalt

### **4. Terrazzo Flooring**

This is a decorative form of concrete usually made in situ or precast, from marble chips and white or coloured cement to a mix of 2:1

### **5. Carpets**

Made from synthetic fibres placed on jute backing, it provides warmth, comfort, additional texture and acoustically absorbent floors

### **6. Granite and Marble Floors**

These are naturally occurring stones, which are processed and cut into smaller square or rectangular tiles laid on a cement and sand backing.

# WALLS

A **wall** is the vertical enclosing and dividing elements of a building. The wall may be classified as load bearing or non-load bearing, structural or non-structural. It may also be classified as either solid, framed or cavity. External walls form part of the external envelope of buildings.

A **structural** wall is one, which is provided to resist the loads acting on a building and to transfer these loads to the ground.

A **non-structural** wall is defined as one which does not form part of a structural system but which may from time to time be subject to forces other than its own weight. Examples of which are panel walls in framed structures, partition walls, balustrade walls and parapet walls, all of which may from time to time have to resist horizontal forces due to wind or use by occupants of the building. The strength of non-structural walls is thus just as important as that of structural walls.

The National Building Regulations (NBR) in Part K states the requirements for wall based on its functions as follows:

## **K1 Structural Strength and Stability**

Any wall shall be capable of safely sustaining any loads to which it is likely to be subjected and in the case of any structural wall, such wall shall be capable of safely transferring such loads to the foundation supporting such wall.

## **K2 Water Penetration**

Any wall shall be so constructed that it will adequately resist the penetration of water into any part of the building where it would be detrimental to the health of occupants or to the durability of such building.

## **K3 Roof Fixing**

Where any roof truss, rafter or beam is supported by any wall, provision shall be made to fix such truss, rafter or beam to such wall in a secure manner that will ensure that any forces to which the roof may normally be subjected will be transmitted to such wall.

## **K4 Behaviour in Fire**

Any wall shall have combustibility and fire resistance characteristics appropriate to the location and use of such wall.

## **K5 Deemed-to-Satisfy Requirements**

The requirements of regulations K1, K2, K3 and K4 shall be deemed to be satisfied where the structural strength and stability of any wall, the prevention of water penetration into or through such wall, the fixing of any roof to such wall and the behaviour in a fire of such wall, as the case may be, comply with Part K of section 3 of SABS 0400 (the 'How' part).

## **Part K Section 3 of SABS 0400: Walls**

### **KK1 General**

The regulations contained in Part K of the NBR shall be deemed to be satisfied where any wall:

- (a) (i) is the subject of a rational design indicating that the strength and stability of such wall comply with the requirements of Part B; or
  - (ii) forms part of the structural system in any building contemplated in provision KK2 (Building Limitations for Empirical Design) and complies with deemed-to-satisfy rules contained in provisions KK3 to KK11 inclusive;
    - KK3 – Empirical Rules for Walls
    - KK4 – Materials
    - KK5 – Wall Dimensions
    - KK6 – External masonry Cladding or Infilling Panels in Framed Buildings
    - KK7 – Column and Piers in Walls
    - KK8 – Cavity Walls
    - KK9 – Foundation Walls
    - KK10 – Balustrade Walls
    - KK11 – Free-Standing Walls

This clause is concerned only with the **structural design** of walls. Two options are given – rational design in accordance with Part B of the NBR, or empirical design in agreement with Rules KK3 to KK11

- (b) Complies with deemed-to-satisfy rules contained in –
  - (i) provisions KK15(Damp-proof course) and KK17 (Rain Penetration Test for Walls); or
  - (ii) provisions KK14 (Water Penetration) and KK15

This section deals with resistance to rising damp and rain penetration.

- (c) Complies with requirements contained in provision KK13 (Roof Anchoring)  
This part is concerned with the anchorage of roofs to the top of walls.
- (d) Complies with requirements contained in provision KK16 (Behaviour in Fire)  
This section provides a cross-reference to various fire requirements in Part T.

## **KK2 Building Limitations for Empirical Design**

KK2.1 Where any structural wall is to be erected in terms of rules KK3 (Empirical Rules for Walls) to KK15 inclusive, and without detailed structural design calculations, the building of which such wall forms a part shall be subject to the limitations contained in sub rule KK2.2

KK2.2 The building referred to in sub-rule KK2.1 shall not exceed two storey's in height and shall be subject to the following limitations.

- (a) The building plan-form and the layout of the intersecting mutually stabilizing walls that form part of such building shall be such as to provide a structure which is stable against the action of horizontal forces from any direction and shall consist of a rectangular, polygonal or circular cell or series of contiguous or intersecting cells.
- (b) The span between supporting walls of a timber or metal roof truss, roof rafter or roof beam shall not exceed 10m and the span between supporting walls of any first floor or roof slab shall not exceed 6m.
- (c) (i) The dead load of the roof covering material shall not exceed 800N/mm<sup>2</sup> of slope area for roofs other than concrete slabs.

- (ii) Concrete roof slabs shall not exceed 175mm in thickness if of solid construction or the equivalent mass if of voided construction.
- (d) Concrete first-floor slabs shall not exceed 175mm in thickness if of solid construction or the equivalent mass if of voided construction.
- (e) In order to limit floor loading on first-floor space or on suspended ground-floor slabs, the use of such floors shall be restricted to –
  - (i) detached dwelling houses and dwelling units;
  - (ii) bedrooms, wards, dormitories, bathrooms, rooms containing soil fixtures, kitchens, dining-rooms, lounges and corridors in educational buildings, hospitals, hotels and other institutional occupancies;
  - (iii) classrooms;
  - (iv) offices; and
  - (v) cafes and restaurants.
 This list exclude areas where heavy floor loading (e.g. in store rooms) or impact loading (e.g. dance halls) can occur.

### KK3 Empirical Rules for Walls

KK3.1 Any wall used as a structural, external or internal wall, non-structural internal wall, non-structural external wall panel, parapet wall, balustrade wall, freestanding wall or retaining wall (where such retaining wall is not part of a basement) shall comply with KK3 to KK17, as the case may be.

KK3.2 States the requirements for when such wall is a structural wall either – masonry or timber framed wall

KK3.3 Gives the requirements for a non-structural wall – a masonry external cladding or external infilling panel, a masonry parapet wall or a timber-framed wall.

### KK4 Materials

KK4.1 Masonry units used in the erection of walling shall comply with the requirements for compressive strength contained in Table 1.

KK4.2 Mortar used in the erection of a building shall comply with Table 1.

KK4.3 Materials used in any wall of timber framed construction shall be in accordance with SABS 082.

**TABLE 1 – STRENGTH REQUIREMENTS FOR MASONRY UNITS AND MORTAR**

1 Wall Type	2 Position		3 Minimum average compressive strength, MPa		5 Class* of mortar required
			Solid units	Hollow units	
Structural other than foundation and retaining walls	Single storey building	External or Internal	7.0	3.5	II
	Double storey building	External or Internal	10.5 or **14.0	7.0	II
Non-structural other than parapet, balustrade and free-standing walls	External		7.0	3.5	II
	Internal		7.0	3.5	III

Free-standing	External or internal	10.5	7.0	II
Foundation	Supporting single storey	7.0	3.5	II
Foundation	Supporting double storey	10.5 or 14.0	7.0	II
Parapet	-	7.0	3.5	II
Balustrade	-	7.0	3.5	II
Retaining	-	10.5	7.0	II

\* Lime may be added to the mortar mix

SABS 0164 specifies the method of test for the compressive strength of mortar and gives details of the compressive strength required of the various classes of mortar and appropriate mix proportions used to attain the required strength.

\*\* See Table 2 – Permissible Dimension of masonry Walls in Buildings

## KK5 Wall Dimensions

KK5.1 (a) Where any wall is a masonry wall contemplated in Table 2, the height and unsupported length of such wall shall not exceed the relevant values given in Table 2.

**TABLE 2 – PERMISSIBLE DIMENSIONS OF MASONRY WALLS IN BUILDING (ABRIDGED VERSION)**

Use of wall in a building	Max. storey height m <sup>(1)(5)</sup>	Nominal wall thickness, mm
Non-structural internal wall in any storey	3.0	90
External infilling and cladding to framed building to height of 25m	3.3	
Wall providing lateral support in single storey building but carrying no gravity load other than its own weight	3.0	
Non-structural internal wall in any storey	3.3	110
External infilling and cladding to framed building to height of 25m	3.3	
Structural wall in single storey building	2.6	
Wall providing lateral support in single or double storey building but carrying no gravity load other than its own weight	3.3	
Non-structural internal wall in any storey	3.0	140
External infilling and cladding to framed building to height of 25m	3.0	
Structural wall in single storey building	3.3	
Structural wall in double storey	3.0	
Non-structural internal wall in any storey	3.5	190
External infilling and cladding to framed building to height of 25m	3.3	
Structural wall in single storey building	3.5	
Structural wall in double storey	3.3	
Non-structural internal wall in any storey	4.0	230
External infilling and cladding to framed building to height of 25m	3.3	
Structural wall in single storey building	4.0	
Structural wall in double storey	3.3	
External infilling and cladding to framed building to height of 25m	3.3	90-50-90 to 90-110-90 cavity wall
Structural wall in single storey building	3.0	
Structural wall in double storey dwelling unit without concrete slab roof	2.8	
External infilling and cladding to framed building to height of 25m	3.3	110-110-110 cavity wall
Structural wall in single storey building	3.0	
Structural wall in double storey building	3.0	

(1) Measured from floor level to floor level or from floor level to eaves in case of topmost storey

(5) A parapet wall of 500mm in height added to storey height is permitted

(b) Where any wall is of timber framed construction, the height and unsupported length shall not exceed the values given in Table 3.

**TABLE 3 - PERMISSIBLE DIMENSIONS FOR TIMBER-FRAMED WALLS**

1 Wall Type	2 Stud size, mm	3 Stud spacing, mm	4 Maximum panel length, m		6 *Max. height, m	7 Max. storey height, m
			Supported both ends	Supported one end		
Structural	114 x 38	400	4.8	2.4	6.0	4.0
	114 x 38	600	4.0	2.0	6.0	3.0
	76 x 38	450	3.6	1.8	3.0	3.0
Non- Structural	114 x 38	600	4.8	3.0	-	4.0
	76 x 38	600	4.2	2.4	-	3.0

\*Maximum height means height to wall plate of highest storey or height to top of gable, if there is a gable.

(c) All gable walls shall be adequately laterally supported.

**KK5.2** Where effective lateral support is to be provided to any masonry wall by means of an intersecting masonry wall, such intersecting wall shall –

- (a) be constructed of masonry units and mortar of strengths not less than those of the units and mortar used in the wall it supports;
- (b) intersect the supported wall at an included angle of between 60° and 120°

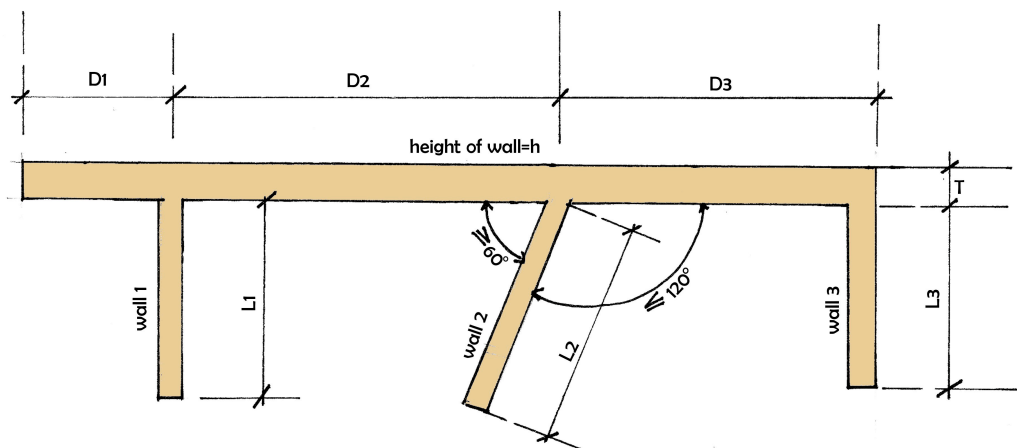

**Figure showing form of Lateral Support to Masonry Wall prescribed in KK5.2**

- (c) have a height of not less than 80% of the height of the supported wall
- (d) have a thickness of not less than 45% of the thickness of the supported wall or 90mm, whichever is greater, such thickness in the case of a cavity wall being deemed to be the sum of the thickness of the leaves of the wall, and
- (e) have a length of not less than one-fifth of the height of the wall panel to be supported or one-eighth of the greatest distance between such intersecting wall and any other intersecting wall providing lateral support, whichever is the greater, and such length shall not include the thickness of the supported wall.

**KK5.3** Where effective lateral support is to be provided to any wall by means of an integral masonry pier, such pier shall –

- (a) have a depth perpendicular to the length of any such wall, of three times the thickness of such wall where such depth includes the thickness of such wall

- (b) have a width along the length of any such wall of twice the thickness of such wall
- (c) be effective only if the height of such pier is at least 80% of the height of any such wall.

## **KK6 External Masonry Cladding or Infilling Panels in Framed Buildings**

KK6.1 Any external masonry cladding or infilling panel in a framed building shall be securely anchored to the structure

KK6.2 Where the area of window openings in such panel exceeds 20% of the face area of the panel calculated as the storey height multiplied by the unsupported length, the top of the panel shall be anchored to the structure in a manner that will permit relative vertical movement but restrain the wall against lateral movement

KK6.3 Such cladding shall be supported on suitable beams, slabs or nibs at each storey and adequate provision shall be made for relative vertical movement between the masonry and the structure frame at the underside of such supports

KK6.4 Movement joints shall be provided in such cladding at intervals not exceeding 10m to allow for relative horizontal movement

The walls referred to in this rule are categorized as 'non structural' since the only loads they have to resist, apart from their own weight are wind forces and accidental impact. In high-rise buildings, these walls are often referred to as 'curtain walls'.

Where an infilling panel in a framed structure takes the form of a cavity wall, the provisions of Rule 8 will also be applicable.

In large buildings, it is common practice to fix brick, stone, precast concrete or metal cladding to external walls. The failure of these fixing to the cladding sometimes have very serious consequences and therefore, taking the safety of cladding into consideration is of utmost importance.

## **KK7 Columns and Piers in Walls**

Masonry columns and piers between openings in walls shall have a height not exceeding 12 times their least lateral dimension; Provided that the local authority may require the strength and stability of such column or pier to be substantiated by calculation or other acceptable means.

## **KK8 Cavity Walls**

KK8.1 Any cavity formed in an external masonry wall shall not be less than 50mm wide and not more than 110mm wide



**Cavity wall construction**

KK8.2 Wall ties shall be installed in any cavity wall in an evenly distributed pattern, at a rate of 2.5 ties per square metre of the face area of such wall where the cavity does not exceed 75mm and at a rate of 3 ties per square metre of face area where the cavity is greater than 75mm in width.

KK8.3 Such wall ties shall comply with the requirements contained in SABS 28.

It should be noted that the wall thicknesses, heights etc for the leaves of structural (load bearing) cavity walls presented in Table 2 of Rule KK5 are based on the assumption that the entire load at first floor or roof level may be borne by the inner leaf only. This enables the cavity to remain open at the level of the first floor slab.

## KK9 Foundation Walls

- (a) The height of any foundation wall not acting as a retaining wall shall not exceed 1.5m
- (b) Where a difference in ground level including backfill exists between the two sides of any foundation wall, such difference shall not exceed 1.0m
- (c) No foundation wall shall have a thickness less than the relevant value given in Table 4: Provided that such thickness shall not be less than –

**TABLE 4 – MINIMUM THICKNESS OF FOUNDATION WALLS**

1	2	3	4	5	6	7	8	9
Type of Foundation Wall		Minimum Thickness of the wall, mm						
		Acting as a retaining wall			Not acting as a retaining wall			
		*Difference in ground level, mm			Height, mm			
		Less than 500	500 to 750	750 to 1000	Less than 300	300 to 500	500 to 1000	1000 to 1500
Single leaf brick	External	140	190	230	140	140	140	190
	Internal	-	190	230	90	140	140	190
Single leaf hollow block (cavities filled with concrete)	External	140	190	230	140	140	140	190
	Internal	140	190	230	90	140	140	190
Cavity walls (cavity filled to 150mm below damp-proof course level)	External	190	190	230	190	190	190	190

- (i) the thickness of the wall carried by such foundation wall; or
- (ii) where the wall carried by such foundation wall is a cavity wall, the sum of the thicknesses of such cavity wall.

### **KK10 Balustrade Walls**

The provision for balustrade walls is stated in this clause.

Badly designed balustrade walls especially to balconies, can be extremely dangerous and have been the cause of many serious and even fatal accidents. Balustrade walls have to resist horizontal impact, and must be designed by professional engineers or other competent persons.

### **KK11 Freestanding Walls**

The provision for freestanding walls is given under this rule.

A freestanding wall is structurally a cantilever

### **KK12 Retaining Walls of Masonry**

A retaining wall, which is a wall of a basement, should be designed by calculation.

The provision for retaining walls of masonry is provided in this section.

### **KK13 Roof Anchoring**

KK13.1 In the case of a wall erected of masonry units or of concrete, a galvanized steel strap or wires shall be embedded in the wall at positions suitable for anchoring any timber roof truss, rafter or beam to such wall.

KK13.2 Such strap of wire shall extend into the wall to a depth of at least 300mm in the case of a heavy roof (concrete or clay tiles or slate) or at least 600mm in the case of a sheeted roof except that in the case where the depth of the masonry or in-situ concrete is less than 300mm or 600mm, respectively, such strap or wire shall extend as far as possible into such masonry or concrete.

KK13.3 (a) Galvanized steel strap anchors shall be taken up over the top of the rafter or tie beam, bent down on the other side and nailed down from both sides, or galvanized roof ties shall be made of two strands of wire which shall be taken up on either side of the rafter or tie beam, twisted together so as to have no slack, but so as not to overstrain the wire, and the free ends then nailed down to prevent untwisting.



Figure shows roof anchoring

**Source:** CON1018W 2010 Group 11 Project

(b) Any roof truss, rafter or beam shall be fixed to any wall by using one of the following types of anchors:

- (i) Type A: two strands of 4 mm galvanized steel wire
- (ii) Type B: 30 mm x 1.2mm galvanized steel strap
- (iii) Type C: 30 mm x 1.6 mm galvanized steel strap

(c) For any roof truss, rafter or beam the type of anchor to be used shall be in accordance with Table 7.

**TABLE 7 – TYPES OF ANCHOR**

1	2	3		4
Roof slope, degrees	Max. roof truss, rafter or beam spacing, mm	Type of anchor required		
		Light roof	Heavy roof	
Less than 15	760 1050 1 350	A, B or C B or C C		Type A for all applications
15 to 30	760 1050 1 350	A, B or C B or C C		
Greater than 30	Any	A, B or C		

**KK13.4** In the case of a building of timber-framed construction, provision for the anchoring of any timber roof truss, rafter or beam to the wall shall be made in the manner described in SABS 082.

Note that this regulation gives details of acceptable methods of anchoring roofs to walls in order to resist upward forces caused by means.

## **KK14 Water Penetration**

- KK14.1 Any external wall of any building shall be –
- (a) capable of satisfying the relevant requirements of the rain penetration test contained in rule KK17; or
  - (b) a single leaf externally plastered block wall not less than 140mm thick or a single leaf brick wall not less than 190mm thick; or
  - (c) a cavity wall built of masonry; or
  - (d) a precast concrete wall forming part of a garage or garden store and having a nominal thickness not less than 40mm providing that any joints in such wall are sealed; or
  - (e) a timber framed wall built in accordance with SABS 082

KK14.2 Notwithstanding the requirements of subrule KK14.1(b), any local authority may, in areas of prolonged heavy wind-driven rain, require that any masonry external wall shall be a cavity wall, or a double leaf wall with the inner skin of the outer leaf bagged and painted with two coats of approved sealer.

## **KK15 Damp-proof Course (DPC)**

KK15.1 Any wall or sleeper pier of a building shall be provided with a DPC in such position and to an extent that will protect the wall against rising damp and the interior of the building against ingress of moisture from abutting ground.

- KK15.2
- (a) Any material used as a DPC shall conform to the relevant requirements contained in SABS 248, SABS 952 or SABS 298;
  - (b) In any masonry wall a DPC shall be installed –

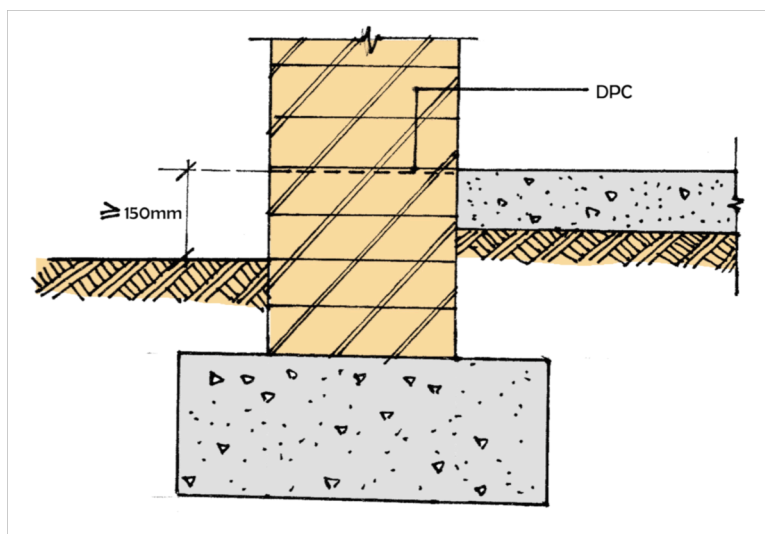

- (i) at the level of a top of a concrete floor slab resting on the ground; or,

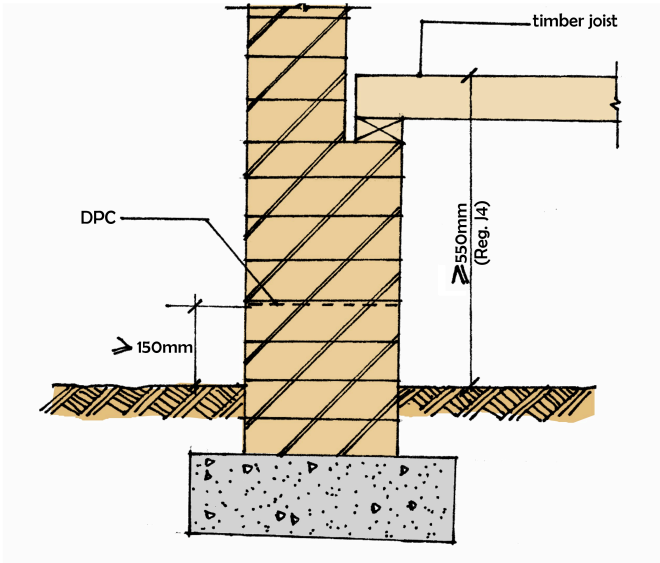

(ii) where applicable, below any ground floor timber beam or joist.

(c) In any timber framed wall a DPC shall be installed between the bottom plate of the wall and any foundation wall or concrete floor slab.

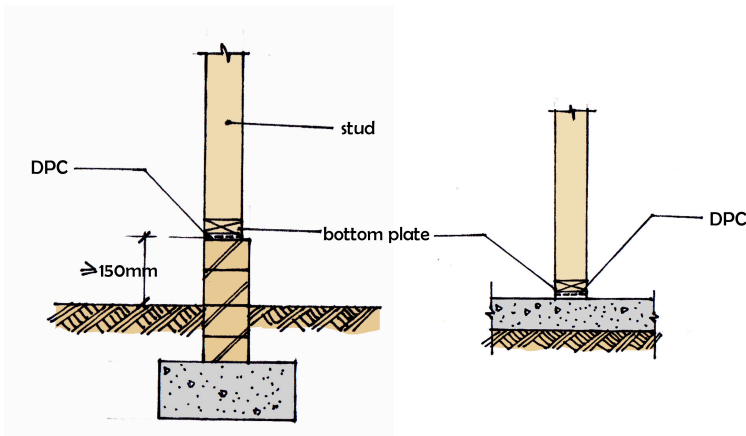

(d) In the case of any solid masonry wall or timber-framed wall, any DPC shall extend over the full thickness of such wall.

(e) In the case of any masonry cavity wall –

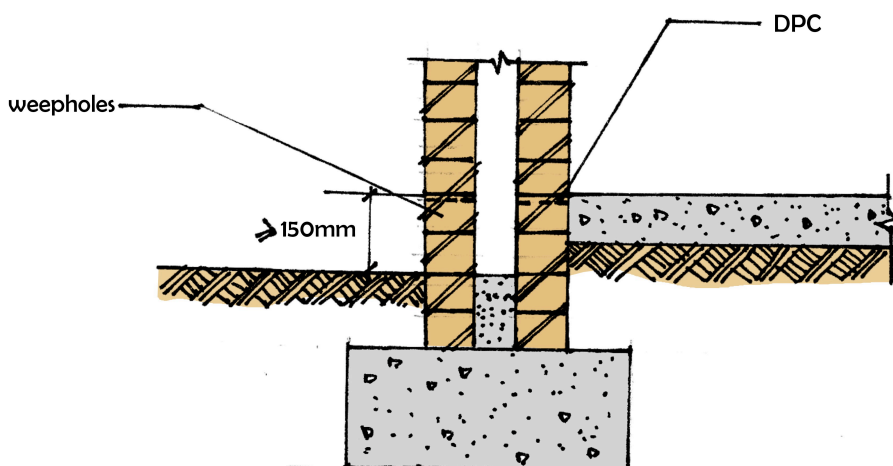

(i) each leaf of such wall shall be provided with its own DPC which shall extend over the full thickness of such leaf, in which case the cavity must extend 150mm below the DPC; or

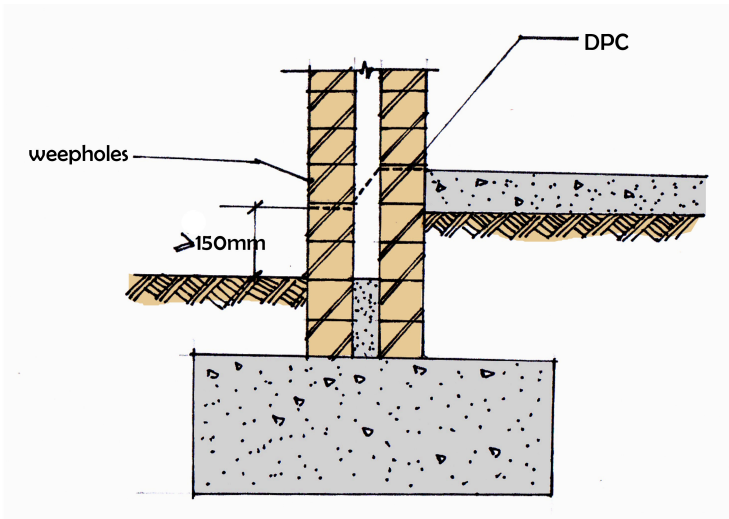

(ii) each leaf of such wall shall be covered by a membrane which extends across the cavity provided that the position of the membrane at the inner leaf is higher than its position at the outer leaf; and

(iii) where necessary, weep holes to prevent build-up of water in the cavity wall shall be provided in the external leaf of every cavity wall, spaced not more than 1m apart, in the masonry unit course immediately below the DPC contemplated in paragraph (i) or in the masonry unit course immediately above the membrane contemplated in paragraph (ii).



Picture showing weep holes  
**Source:** CON1004W Group 8 Project Report

- (f) No horizontal DPC shall be installed less than 150mm above the level of the adjacent finished ground
- (g) Transverse joints in the DPC shall be overlapped to a minimum distance of 150mm and at junctions and corners to a distance equal to the full thickness of the wall or the leaf; as the case may be.
- (h) (i) Where any part of any wall of a room is so situated that the ground will be in contact therewith, it shall be protected by a vertical waterproof membrane or by a drained cavity which shall extend below the level of the floor of such room;  
  
(ii) drainage shall be provided at the base of such wall to prevent water accumulating there.

It should be noted that Clause KK15 deals mainly with the movement of moisture through walls which are in contact with the ground or retained earth as a result of capillary action and does not deal with water entering the tops of parapet walls or penetrating window sills or reveals or similar situations.

## **KK16 Behaviour in Fire**

Any wall shall comply with the relevant requirements for fire resistance, non-combustibility and, where appropriate, wall lining index set out in rules (fire requirements) TT2, TT5, TT6, TT7, TT8, TT9, TT10, TT39, TT40, TT41, TT45, TT49, TT52 and subrules TT18.1 and TT19.1, as the case may be.

## **KK17 Rain Penetration Test for Walls**

### **KK17.1 Test Method**

The wall shall be thoroughly air-dry before being tested. In the case of a masonry or similar wall, the inner surface may be lime washed or other means may be adopted to facilitate the detection of moisture, which has penetrated through the wall. The portion of the outer surface under test shall then be continuously sprayed with water in the form of a finely divided spray distributed over the whole area under test at the rate of 40 – 50mm depth of water per hour.

### **KK17.2 Test Criteria**

The test wall shall, in regard to rain penetration, be considered to comply with the requirements of regulation K2 where –

- (a) no moisture has penetrated to the inner surface of the wall within the relevant minimum test period given
- (b) in the case of a timber framed wall, there is no evidence of water having been retained within the cavity in the wall.

## TYPES OF WALLS

Walls can be classified as:

- Walls to Framed Buildings ~
  1. Wood Stud Walls
  2. Metal Stud Walls
  3. Wood Post and Beam Framing Walls
  4. Steel and Reinforced Concrete Framing Walls
  
- Walls to both Solid Structures and Framed Buildings ~  
Masonry Walls

## WOOD STUD WALL CONSTRUCTION

These are lightweight wall systems which are generally non-load bearing.

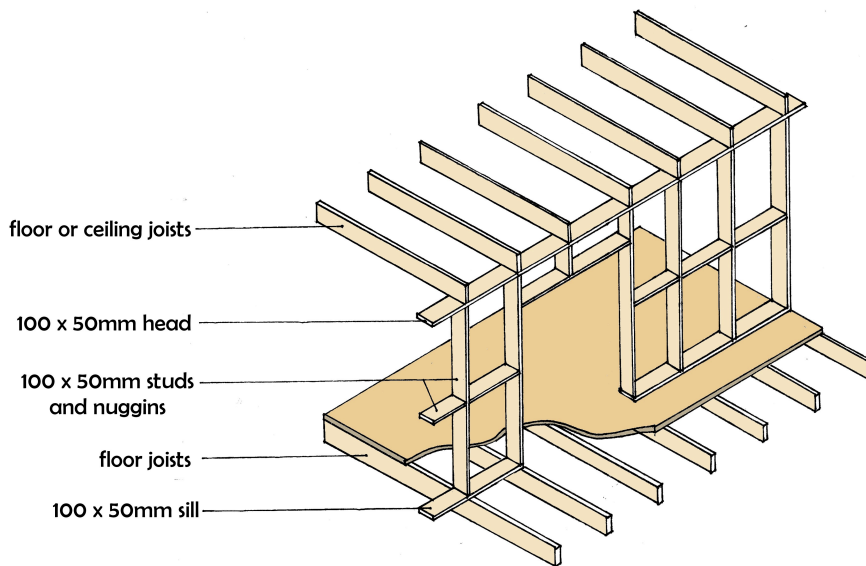

Wood Stud Wall

## Elements used in wood stud wall construction

1. 100 mm x 75 mm Timber Head and Sill
2. 75 mm x 38 mm to 100 mm x 50 mm Vertical studs and noggins framed between the head and sill @ 400 mm to 600 mm spacing. Noggin pieces are inserted between the studs @ 1 m spacing to restrain movement.
3. 100 mm x 75 mm Door head and Jamb posts
4. Framework cladding of ~
  - Plywood siding
  - Wood shingles
  - Plasterboard or
  - Wood/aluminium siding

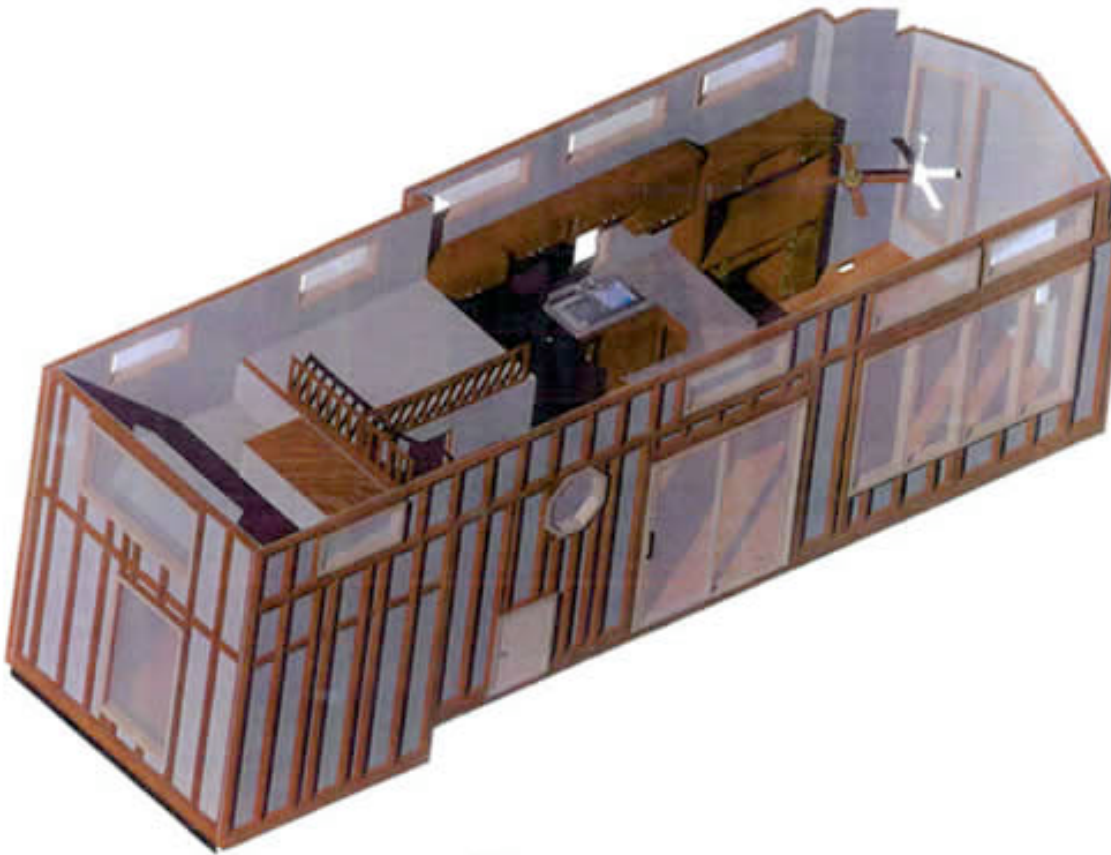

### **METAL STUD WALL CONSTRUCTION**

This is similar in construction to the wood stud wall. The only difference being in that the studs, noggins, posts and headers used are metal and the connections have to be welded, screwed or bolted.

### **BEAM AND POST WALL CONSTRUCTION**

These walls have larger but fewer structural members than in stud framing.

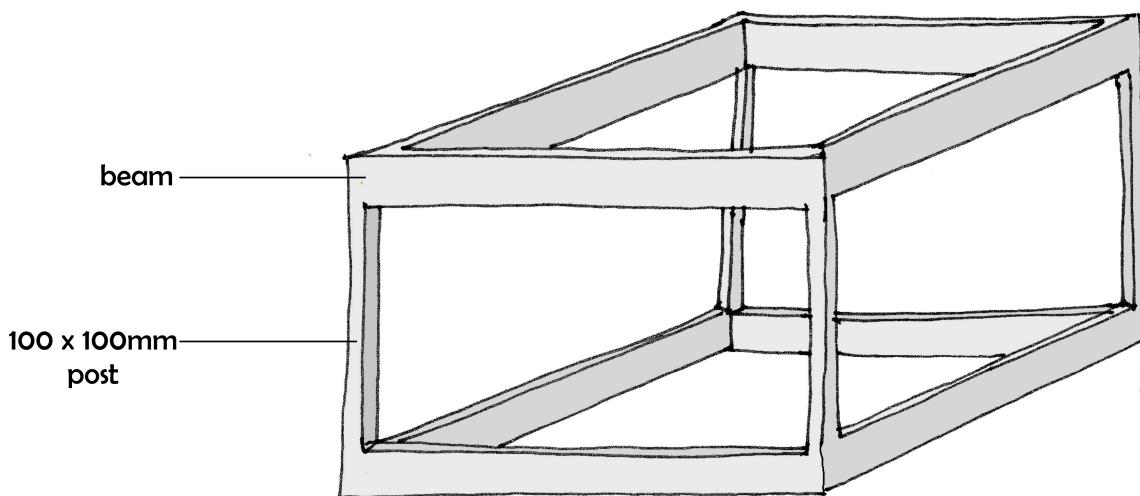

Beam and Post Wall

## Elements used in Beam and Post Wall Construction

1. **100 mm x 150 mm Beams** which support the floor and the roof system
2. **100 mm x 100 mm Posts or Columns**, which support the beam and transfer the loads down to the foundation.
3. **Non-load bearing infill wall panels** such as transparent glass or solid in-fill panels used in wood stud walls serve to ~
  - enclose and further define space;
  - act as weather barrier; and
  - impart lateral stability

## STEEL & REINFORCED CONCRETE FRAMING WALL CONSTRUCTION

This is similar in construction to the wood post and beam framing wall system. The only difference being in the materials used.

This system makes use of concrete and steel, which are stronger materials that can span greater distances and also carry larger loads.

## MASONRY WALL CONSTRUCTION

These are dependent on mass for load carrying capability and are structurally efficient in compression. Masonry walls are made up of **modular building blocks**, **bonded** together with **mortar** to form load bearing walls or non-load bearing walls.

The units employed for its construction are either ~

- brick,
- clay,
- block, or
- stone



Masonry Wall Under Construction

**Source:** CON 1018W 2010 Group 11 Project Report

## CAVITY WALL CONSTRUCTION

This consists of an outer **brick** or **block** leaf or skin separated from an inner brick or block leaf or skin by an air space called **cavity**. These walls have better **thermal insulation** (movement of heat) and **weather resistance** (sun and rain) properties than a comparable solid brick or block wall. The two leaves of a cavity wall are tied together with **wall ties**. The width of the cavity should be between 50 mm and 75 mm.



Cavity Wall Under Construction

Source: CON1004W 2010 Group 8 Project Report

## Elements used in Masonry Wall Construction ~

### 1. Clay Bricks

Bricks are manufactured from burnt clay, autoclaved sand and lime or coloured concrete. The standard brick sizes are shown in the adjacent Figure:

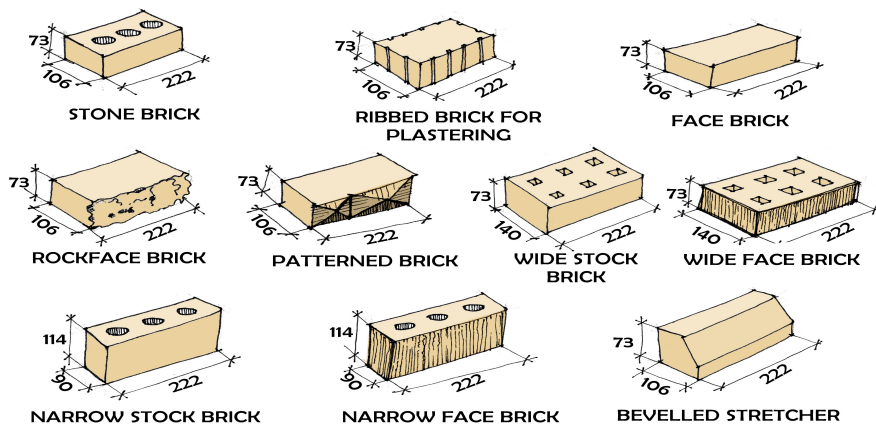

Standard Brick Sizes

## 2. Concrete Blocks

These are made from Portland cement and aggregates. They are either, dense and used for sub-structural works etc. or hollow blocks for load bearing and non-load bearing walls.

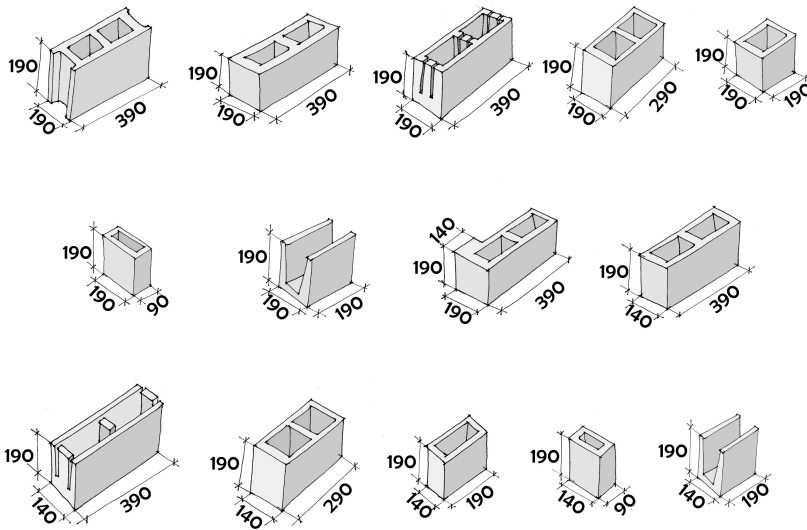

140mm WIDTHS - FOR EXTERNAL FOR SINGLE OR DOUBLE STOREY BUILDINGS

### Standard Concrete Blocks

## 3. Stone Masonry

This is usually generally limited to its availability in the construction area. Building stones include igneous rock such as granite, sedimentary rocks like sandstone and limestone and metamorphic rocks like marble. Stonework may be coursed by dressing the stones to an agreeable size of about 200 or 300 mm square, alternatively, walls may be constructed from stones as they arrive from the quarry.

## 4. Wall Ties

These are manufactured from galvanized or plastic coated mild steel, copper, zinc, stainless steel or polypropylene. The two leaves of a cavity wall are tied together with 3 wall ties for every  $m^2$  of wall face.

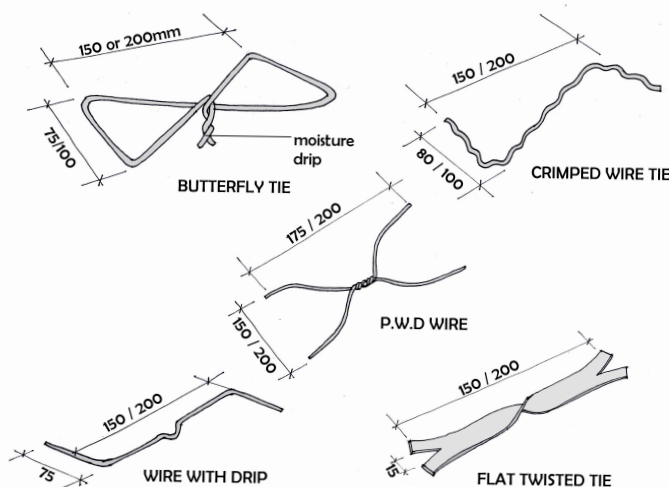

### Cavity Wall Ties

## MASONRY WALL CONSTRUCTION METHODS

The course or rows of bricks/blocks in a row are laid to ensure that each brick/block overlaps a portion of the brick/block immediately below. The amount of overlap and part of the brick/block used determines the pattern or **bond** of brickwork.

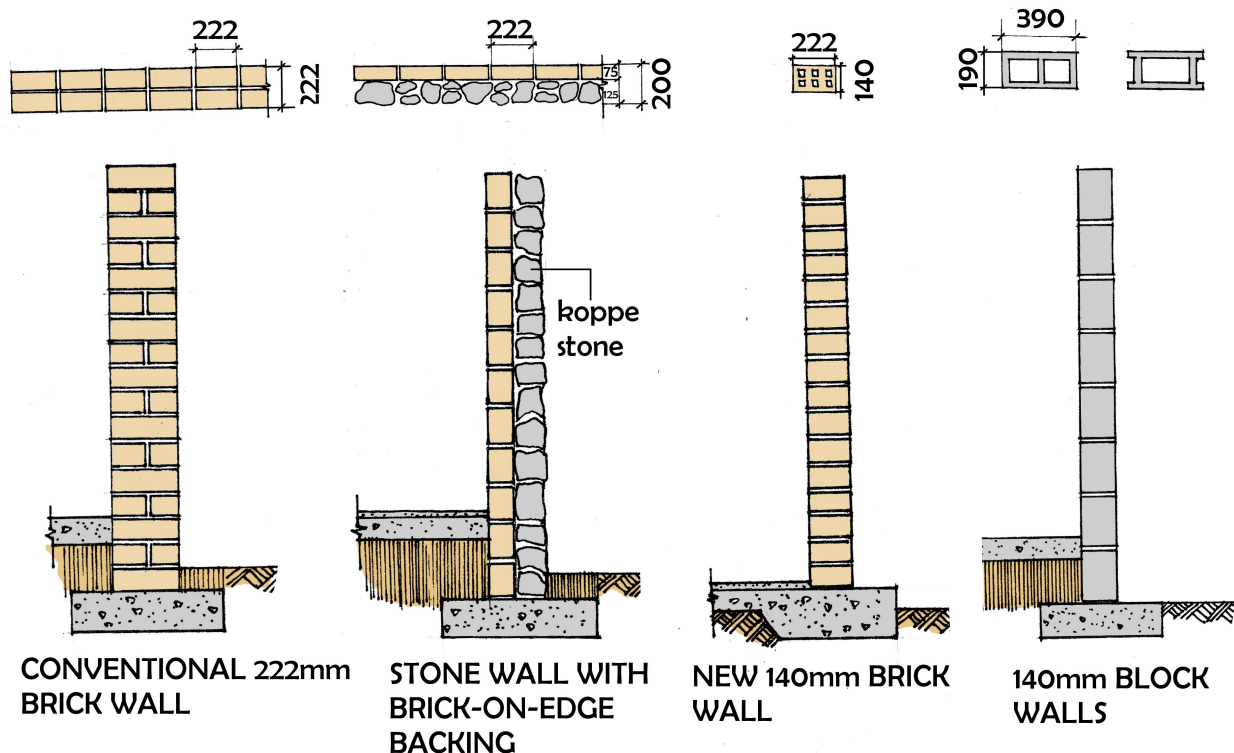

### Types of Masonry Wall

## TYPES OF BONDS

Bricks and blocks are bonded together to ~

1. Make them strong and also provide adequate distribution of vertical and horizontal loads over the wall. Un-bonded walls have continuous vertical walls which is prone to failure due to possible transverse settlement and collapse
2. Minimize movement between bricks – by providing lateral stability and resistance to side thrust, and
3. For appearance/aesthetics.

Bonds are influenced by the ~ situation, function and thickness of the wall. For example, external walls to buildings usually require a good appearance whilst for walls in inspection chambers/manholes, strength is of utmost importance.

**Brick bond types** include ~

- a. Stretcher
- b. English, and
- c. Flemish bonds

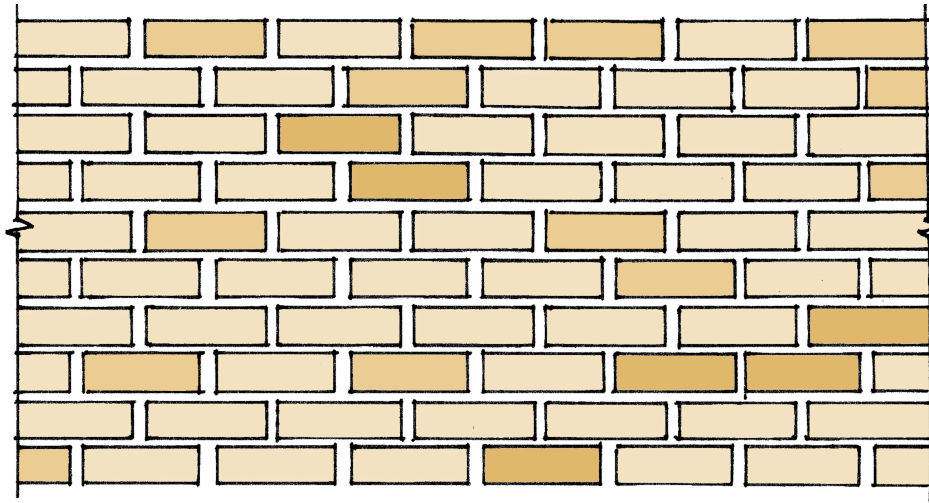

**STRETCHER BOND**

Stretcher bond for 280mm cavity walls and single walls

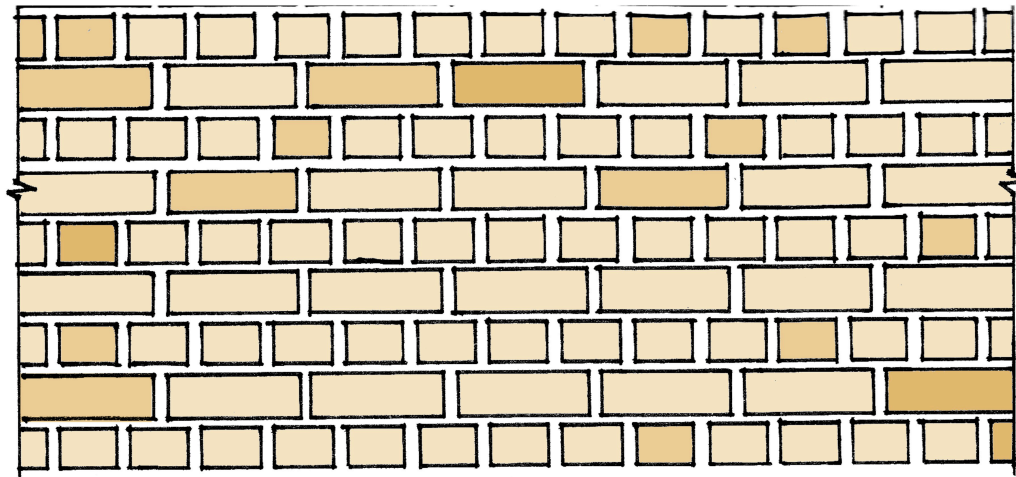

**ENGLISH**

One stretcher course followed by one header course, and repeat

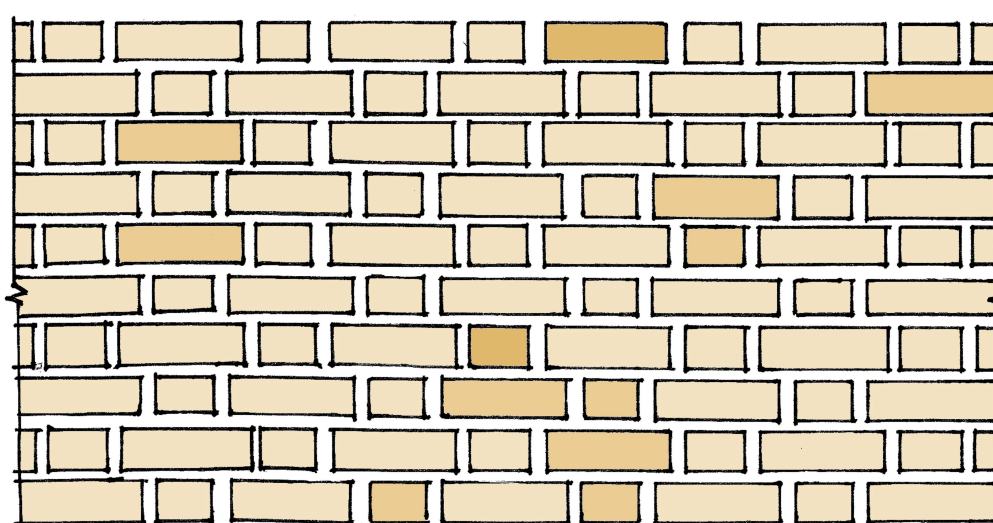

**FLEMISH BOND**

A course consists of one stretcher followed by one header which is repeated

**Brick Bond Types**

**Bonds used to join two walls** comprise of ~

- a. Tooth bonding and
- b. Block bonding



**TOOTH  
BONDING**

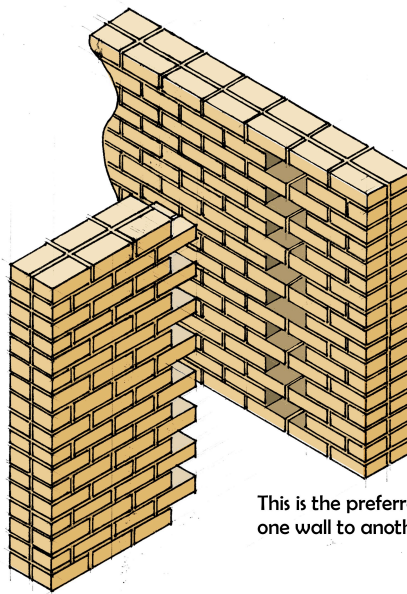

This is the preferred method for bonding one wall to another

### **Tooth Bonding**

**BLOCK  
BONDING**

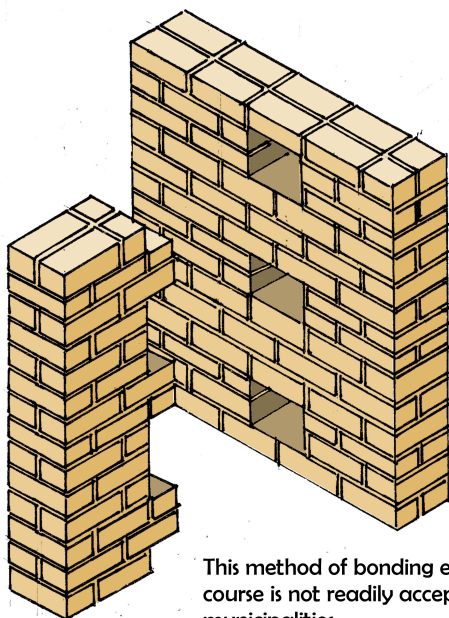

This method of bonding every 4th or 5th course is not readily accepted by all municipalities

## MORTAR

Mortars are used in bedding and joining of bricks and blocks. A good mortar should spread readily and retain its plasticity whilst being laid so as to provide a good bond between bricks and mortar. The mortars in use include:

1. **Lime Mortar:** - It was used in the past before the advent of cement. It is mixed at a ratio of one part of lime to three of sand. Its characteristic is that it develops its strength slowly. With the discovery of cement, it is hardly ever used in construction.
2. **Cement Mortar:** - It is mixed at a ratio of 1: 6 (cement and sand) except in extremely wet situations where a ratio 1: 4 is workable but too strong.
3. **Cement-Lime Mortar:** - It is the most useful general-purpose mortar because it combines the best properties of both lime and cement to produce a mortar, which has good working, water-retention and bonding qualities, and also develops early strength without an excessively high mature strength.
4. **Air-entrained (plasticized) Mortar:** - It has the ability to trap air in the mix and is used as an alternative to lime in improving the working qualities of lean cement and sand mixes.
5. **Mortars containing special cements:** - High alumina cement and sulphate resisting cement are special cements, which may be used where high early strength or resistance to chemical/sulphate attack is possible.

## POINTING & JOINTING

After the bricks are laid, the mortar joints can be finished in a number of ways – the most common being the struck flush or the curved recessed. The others are the struck or weathered, overhung struck and the square recessed.

**Jointing** is the process where the finish is carried out while the mortar is still fresh while **pointing** is when the mortar is allowed to harden and then some is removed and replaced with fresh mortar.

Pointing is slower and more expensive than jointing and as the surface finish is usually not part of the bedding mortar, there is the risk of the face of the joints falling off through improper adhesion. On the other hand, it is more attractive than jointing and the work is usually clean and of uniform colour.

## ARCHES & LINTELS

Arches, lintels or a combination of both usually spans wall openings.

An **arch** is an arrangement of wedge-shaped blocks, which give support to one another, whilst a **lintel** is a solid horizontal beam that spans an opening. Both members carry the super-imposed load and transmit it to the supports on either side.

### Types of Arches ~

Simple brick arches can be classified into three ~

- a. Flat gauged;
- b. Axed; and
- c. Rough

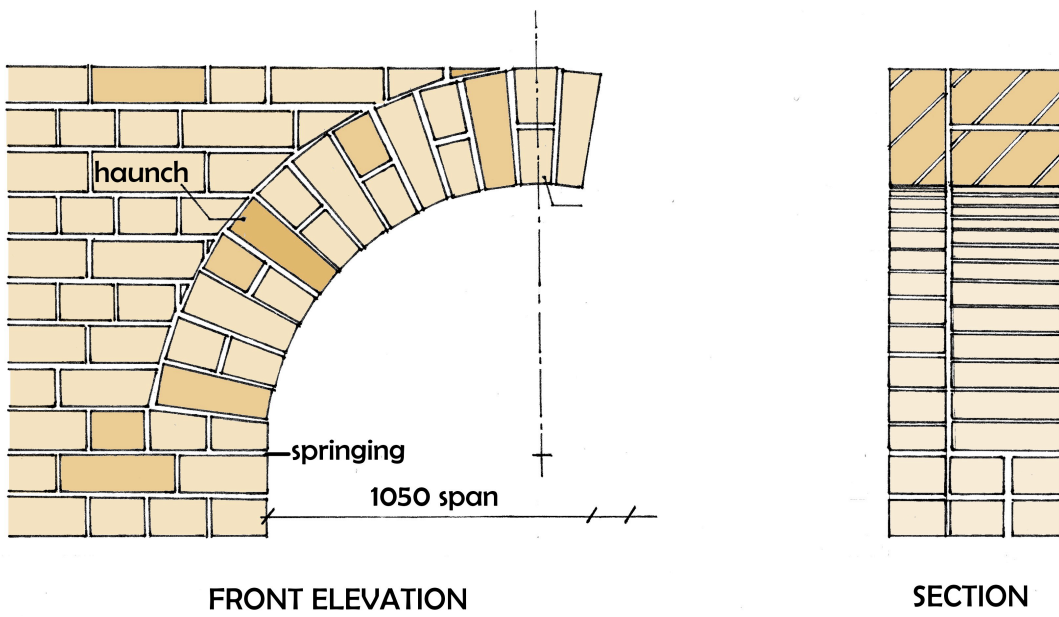
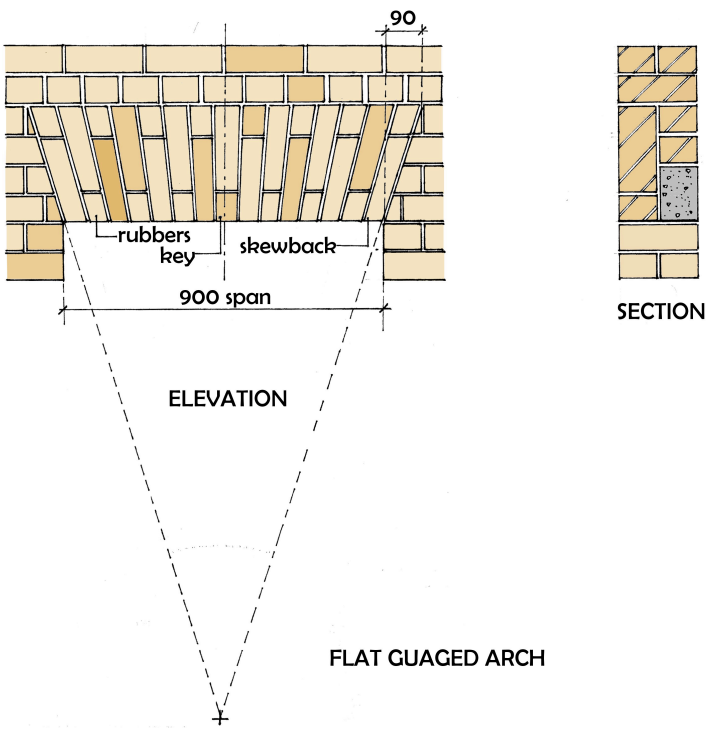

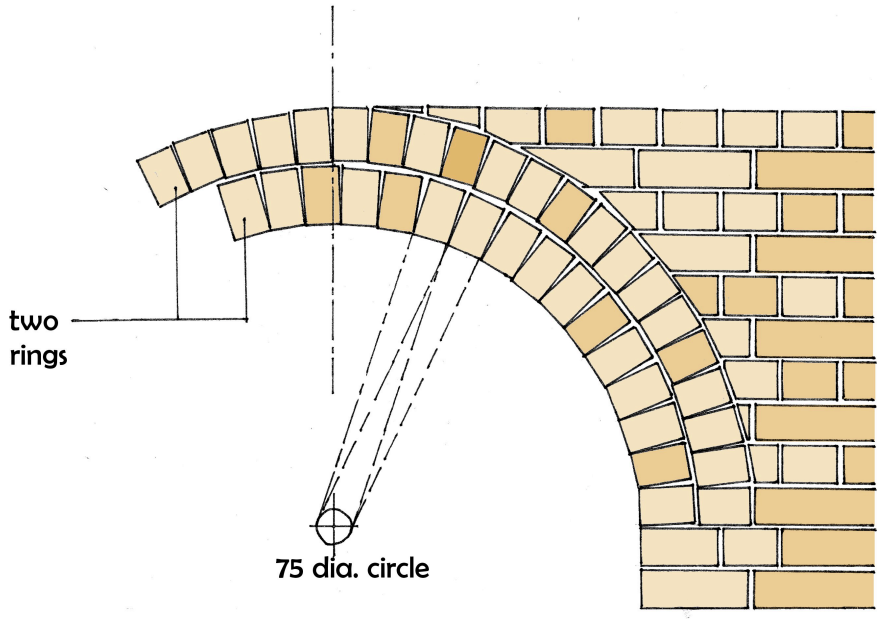

BACK ELEVATION

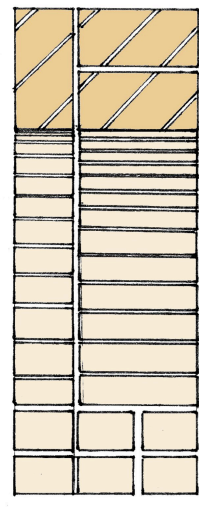

SECTION

ROUGH ARCH

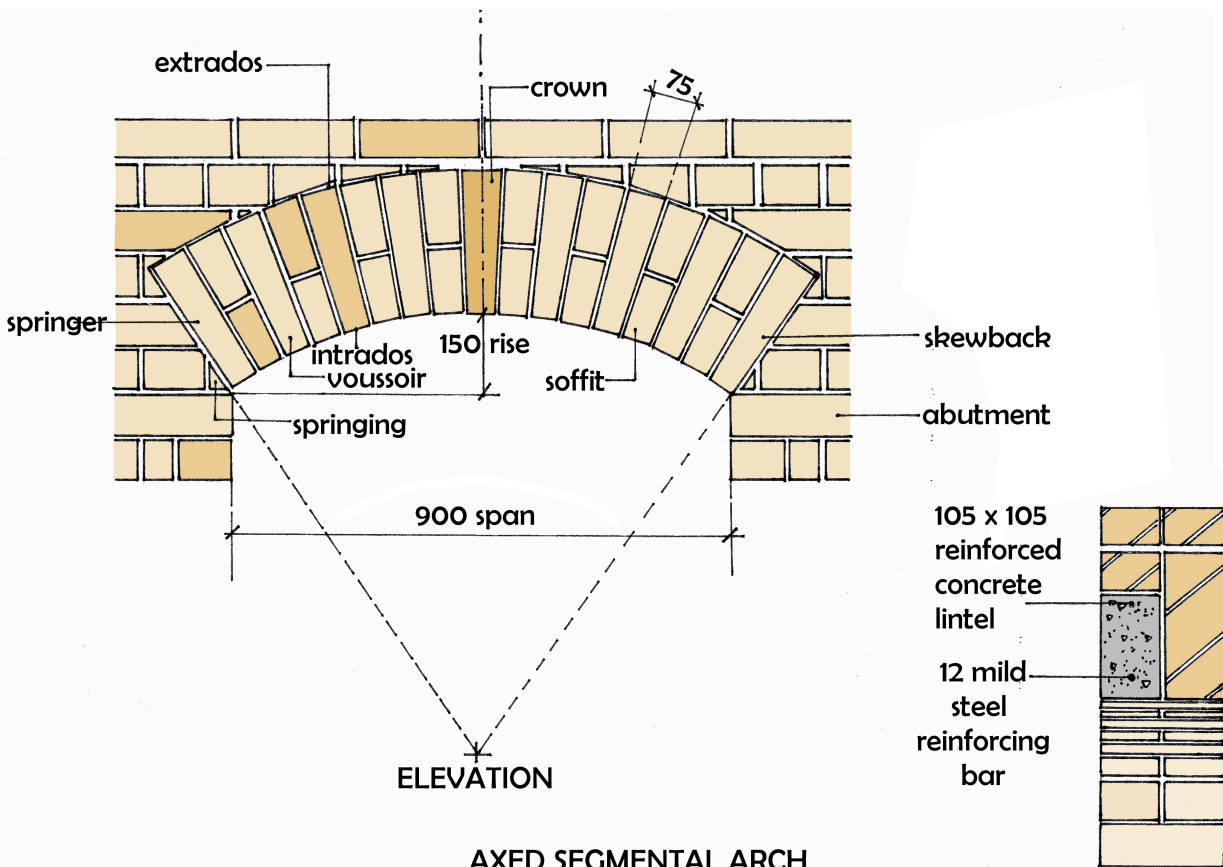

AXED SEGMENTAL ARCH

SECTION

## Types of Lintels ~

Lintels can also be classified into two main types:

- a. **Brick Lintels or Soldier Arches:** These are superior to wood lintels, which tend to decay and concrete lintels, which are not aesthetically pleasing.
- b. **Concrete Lintels:** These are subject to forces, which tend to cause bending, inducing compression at the top and tension at the bottom. Since concrete is strong in compression and weak in tension, steel reinforcement is introduced to resist the tensile stresses.

The mix of concrete is normally 1:2:4. When forming the lintels in-situ, timber or steel formwork depending on the span, is assembled over the opening, reinforcement is fixed into the formwork and concrete poured. The formwork is struck after the concrete has hardened sufficiently to take the super-imposed loads and this is usually after 28 days.



**Door opening showing brick and concrete lintel**  
Source: CON 1004W 2010 Group 8 Project Report



**Block and Concrete Lintel under construction**  
Source: CON 1018W 2010 Group 11 Project Report

# PARTITION WALLING

## Definition

Partition walls can be defined as a wall between rooms, non-load bearing and generally one floor high. Partitions can be built in a variety of ways, the commonest permanent ones being of plastered brick or block work but dry construction is possible.

## Functions of Partition Walls

The functions of partition walls are as follows ~

- Dividers and defining elements of space, visually and acoustically
- Accommodating vertical and horizontal travel of mechanical and electrical lines as well as their outlets
- May transmit floor and or roof loads.

## Types of Partition Walls

- Brick/Block wall partition
- Timber Frame or Stud partition
- Demountable Frame partition

## Methods of Constructing Partition Walls

- **Brick/Block wall Partition**

For load bearing walls in single and two-storey buildings, the minimum thickness of partition block wall is 100 mm, for three storeys, 150 mm.

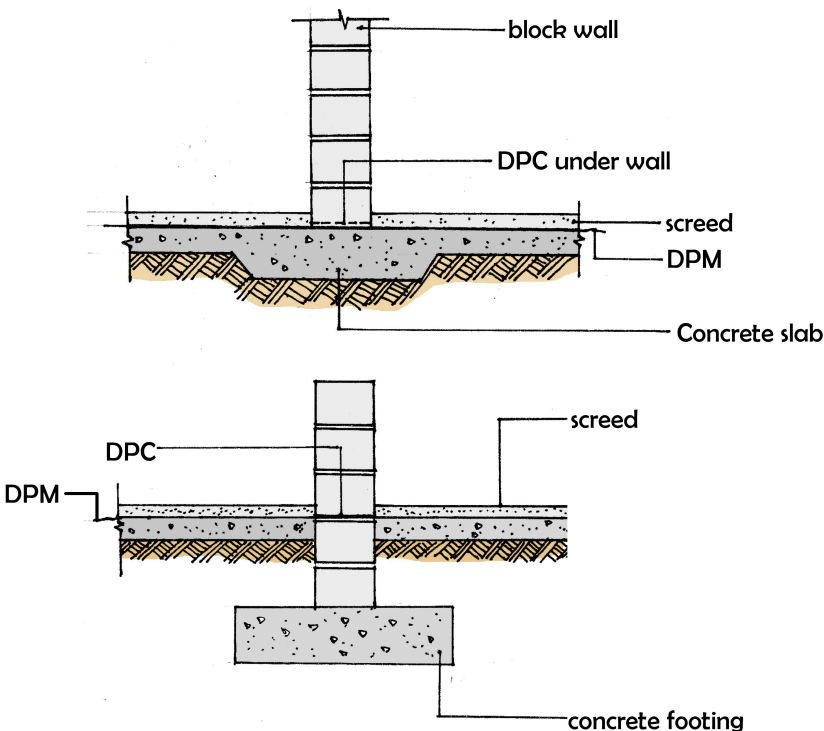

**Stability** is achieved at the base by an independent strip foundation or a thickened area of ground floor slab with reinforcement as shown in the adjacent diagram.

## Ground Floor Support to Block Wall Partition

Joists running square to the wall with at least 100mm thickness as shown below provide **restraints** at floor and ceiling ~

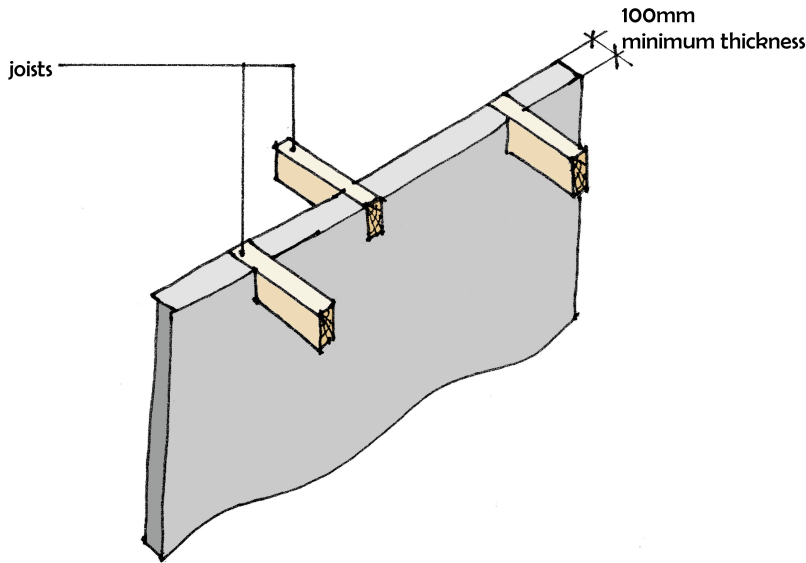

**Partition wall restraint at ceiling / wood joist floor**

Stability at the ends of the block wall is achieved with metal ties or alternate courses bonded into the inner leaf as tooth or block bonds shown in the following diagrams ~

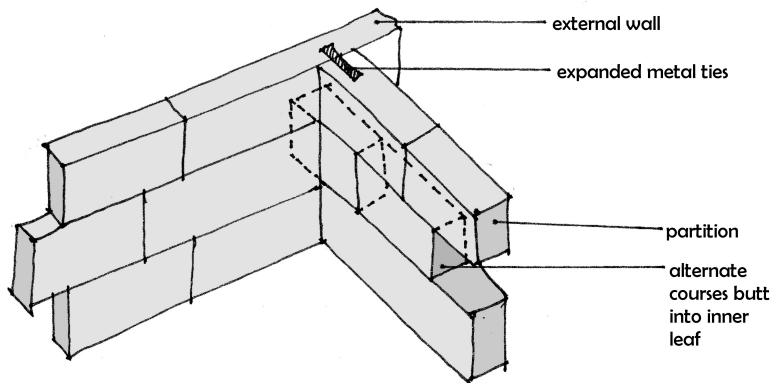

**BLOCK BONDING**

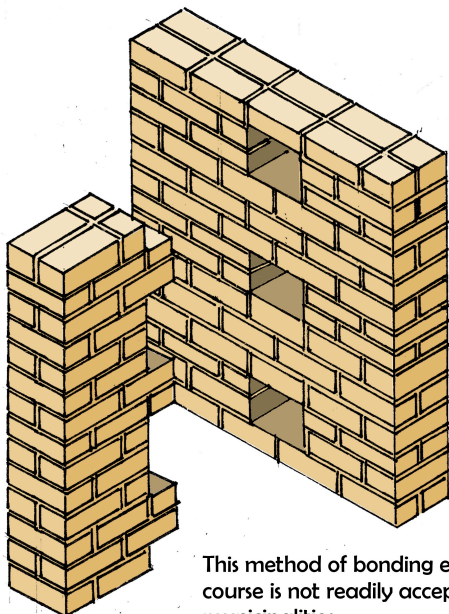

This method of bonding every 4th or 5th course is not readily accepted by all municipalities

**TOOTH BONDING**

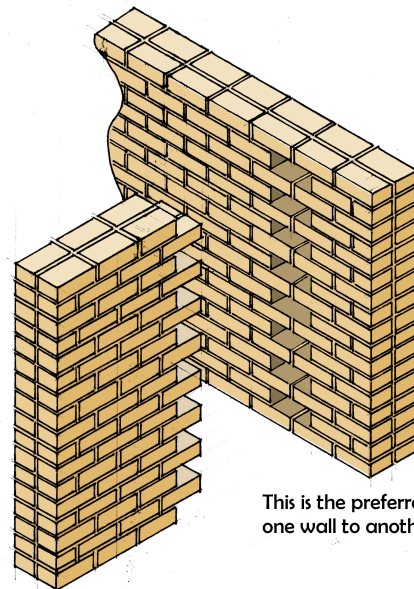

This is the preferred method for bonding one wall to another

Non-load bearing block partitions are ~

- less strictly controlled and may be of 60mm minimum thickness.
- the maximum height with regard to stability should not exceed 40 times the thickness inclusive of render and plaster finish.
- it does not require a foundation in excess of the ground floor slab if the bricks/blocks are light in weight

Provision is made for door openings with continuity of jambs from floor to ceiling to improve stability. However, openings in load bearing or dense concrete block partitions will require a lintel at the door head.

- ***Timber Frame or Stud Partitions***

~ See Wood Stud Walls

- ***Demountable Frame Partitions***

These are non-load bearing patented systems suitable for use in offices and other commercial buildings. They suit this type of buildings as changes in office layout or structural disruption. Many patented systems exist but most are based on a framework of lightweight galvanized steel or aluminium channel, fixed to the wall, ceiling and floor with plugs and screws.

It is clad with plasterboard, chipboard, plywood or glass, secured by self-tapping screws at approximately 1 m vertical spacing. Joints between boards are closed with a steel cover strip secured every 250mm and a plastic capping trim.

## **Advantages/Disadvantages of partition walls ~**

### ***Brick/Block wall Partitions***

Merits ~

- Ability to transmit floor and or roof loads
- High fire resistance
- Greater resistance to sound transmission

Demerits ~

- It is structurally heavy
- It is built on site
- It requires stability at the base, ends and restraints at the ceiling
- It can't be easily moved

### ***Timber Frame or Stud Partition***

Merits ~

- Lightweight construction
- Requires no special structural support unless designed to carry some roof loading
- It can be prefabricated

Demerits ~

- Poor resistance to fire

- Poor sound/thermal insulation
- It requires highly skilled workmanship

### **Demountable Frame Partition**

Merits ~

- Lightweight construction
- Requires no structural support at the base
- Changes in occupancy can easily be achieved without structural disruption

Demerits ~

- Poor resistance to fire
- Inability to carry roof/structural loading
- Poor sound/thermal insulation
- It requires skilled workmanship

## **WALL FINISHES**

A finish is the final surface, which can be ~

- Self finished e.g. facing bricks; or
- An applied finish such as rendering or wall tiles.

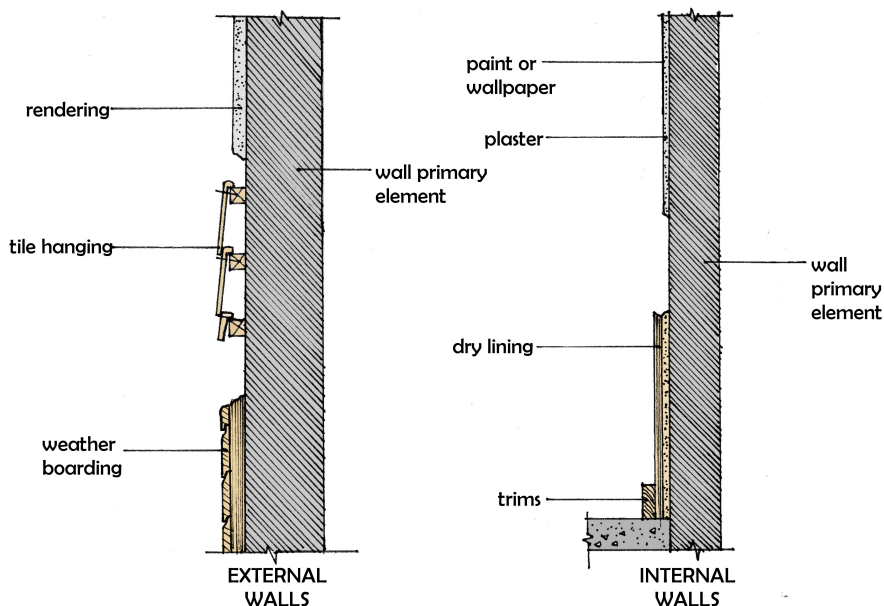

### **Types of External and Internal Wall Finishes**

#### **Internal Wall Finishes**

Internal wall finishes can be classified as ~

- Wet – plaster/rendering
- Dry – lining such as plasterboard, insulating fibreboard, hardboard, timber boards and plywood.

#### **Wet Plaster/Rendering Process ~**

1. Prepare the wall surface

2. Apply the undercoat plaster – 12mm thick; and
3. Finishing coat – 2mm thick

Materials used in mortar – cement and sand (1:4)

## **Wall Tiling**

Materials used ~

- Ceramic or mosaic tiles; and
- Adhesives ~
  - Ready mixed patented (thin bedding) and
  - Cement based (thick backing – 10mm thick)

## **ROOFS**

The roof is the uppermost external envelope of a building that spans the walls. It is a critical element in the visual image of a building and it can be classified as either being flat or pitch or according to its structure, or its shape.

**Part L of the NBR** states the requirements for roof ~

### **L1 General Requirements**

The roof of any building shall be so constructed that it will ~

- a. resist any forces to which it is likely to be subjected
- b. be durable and waterproof
- c. not allow the accumulation of any rain-water upon its surface; and
- d. as part of a roof and ceiling assembly provide adequate height in any room immediately such assembly.

### **L2 Fire Resistance and Combustibility**

The fire resistance of any roof or roof and ceiling assembly complete with light fittings or any other component, which penetrates the ceiling, shall be appropriate to its use and where necessary such roof or roof and ceiling assembly shall be non-combustible.

### **L3 Deemed-to-Satisfy Requirements**

The requirements of regulations L1 and L2 shall be deemed to be satisfied where any roof or roof and ceiling assembly, as the case may be complies with Part L of section 3 of SABS 0400.

**Part L of Section 3 of SABS 0400** stipulates as follows ~

#### **LL1 General**

The regulations contained in Part L of the NBR shall be deemed to be satisfied where ~

- (a) any roof or roof/ceiling assembly is the subject of a rational design in accordance with the requirements contained in Parts B and C and such roof or roof/ceiling assembly complies with deemed-to-satisfy rules contained in provisions LL4 (Fire Resistance and Combustibility) and LL5 (Waterproofing) of this part; or
- (b) the construction of any roof contemplated in provision LL2 complies with the requirements contained in that rule.

#### **LL2 Empirical Rules for the Construction of Roofs**

Where any roof is supported on the walls of any building, contemplated in rule KK2 of this code, such roof shall be constructed in accordance with rules LL3 (Construction and Fixing of Structural Roof Components), LL4 and LL5.

**The following should however be noted ~**

- The structural design of roofs may be carried out either by calculation or by the application of empirical rules.
- The empirical rules for structural design of roofs stated in LL3 may, however be used only where the building conforms to the limitations set out in sub rule KK2.2. Which means that the span of trusses or rafters may not exceed 10 m and the roof covering

may not weigh more than 800 N/m<sup>2</sup> measured on the slope. However, most common roof coverings (sheeting, boarding, slates and tiles) fall within this limit.

### LL3 Construction and Fixing of Structural Roof Components

LL3.1 The location and dimensions of any part of any roof shall be such that the minimum height requirements contained in Part C are satisfied.

LL3.2 Roof timbers shall comply with the requirements of the relevant – SABS 563, SABS 653, SABS 876, SABS 1089, or SABS 1245

LL3.3 The requirements of sub rules LL3.4 and LL3.4 shall apply only to single or double pitched **Howe-type trusses**, with a span not exceeding 10m, supported at heel joints only and having bays of equal lengths not greater than 1.5 m.

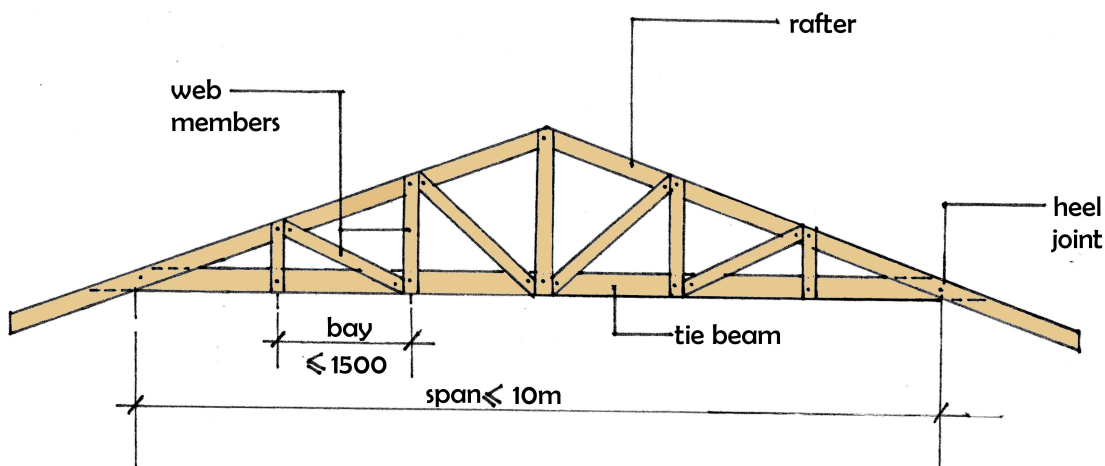

6-Bay Howe Truss

### LL4 Fire Resistance and Combustibility

The fire resistance of any roof/ceiling assembly complete with light fittings or any other component which penetrates the ceiling and the degree of non-combustibility of such assembly shall comply with the requirements contained in rule TT5, TT12, TT49 and VV3, as the case may be.

### LL5 Waterproofing

LL5.1 For the purpose of runoff of water any roof with a covering of one of the materials referred to in column 2 of Table 3 shall, subject to the limitations on roof slope contained in subrule LL3.4, be constructed to a slope not less than the relevant figure given in column 3 and such covering shall, where applicable, be provided with end laps not less than the relevant figure given in column 4 or 5 as the case may be.

**TABLE 3 – MINIMUM ROOF SLOPES AND SHEET END LAPS**

1	2	3	4	5
Class	Roof Covering	Minimum angle of slope, degrees	Minimum end lap, mm	
	Description		End laps sealed	End laps not sealed
A	Corrugated metal, plastic or glass reinforced plastic sheets (including box rib)	5	250	Not permitted
		11	150	250
		15	150	225
		17	150	200
		22	150	150
	Corrugated fibre-cement sheets	11	200	300
		15	175	275
		17	150	250
		22	150	200
		26	150	150
Long span specialized metal sheets	5	As required by the local authority		
Single length long span and specialized sheets	3			
B	Fibre-cement slates (i) with an approved underlay (ii) without an approved underlay	10		
		17		
	Single-lap concrete or clay interlocking tiles; concrete, clay, plain tiles or shingles (i) with an approved underlay (ii) without an approved underlay	17		
		26		
	Natural slate on open battens (i) with an approved underlay (ii) without an approved underlay	20		
		30		
	Thatch: Thickness of 150 mm Thickness of 300 mm	45		
35				
C	Metal tiles (i) with an approved underlay (ii) without an approved underlay	10		
		15		

NOTE: When metal roof tiles are used over an existing roof, the existing roof slope may be required.

### LL5.2 Flashing

Flashing shall be used where a roof abuts against a wall or around any projection through a roof covering and at any other place where it is deemed necessary by the local authority

### LL5.3 Flat Roofs

- (a) Where a nominally flat roof of boarded or concrete construction is used, it shall be provided with an impervious surface and laid to a fall of not less than 1 in 50.
- (b) Where a parapet wall abuts a covered flat roof the edges of the waterproofing material shall be turned up underneath corrosion proof metal cover flashing which is tucked into the horizontal joint of the brick work at least two courses above the roof level.
- (c) Where any nominally flat roofs to be subjected to pedestrian or vehicular traffic, any waterproofing membrane applied to it shall be protected against damage.

## TYPES OF ROOF STRUCTURES

Roof structures can be classified according to the interrelationship of components which make up their framework ~

- **Single Roofs**
  - Flat roofs
  - Shed roofs and
  - Pitched/Gable Roofs – Couple Roof, Close Couple Roof and Collar Roof
- **Purlin or Double Roofs**
- **Trussed or Framed Roofs**

### A. Single Roofs ~

Rafters are supported at their ends only. These include:

- a. **Flat Roofs:** inclined to a slope of  $10^0$

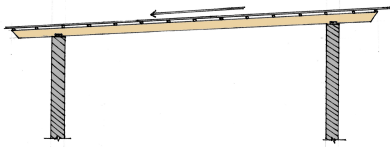
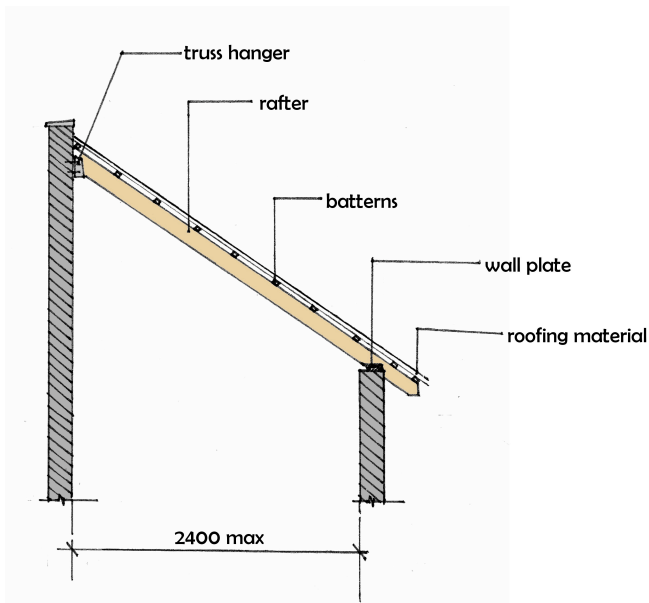

Figure showing flat roof with sloping ceiling at 6m span

- b. **Shed Roofs/Lean-To Roofs ~**

These are simple means of covering a small extension in preference to a flat roof, where a traditional pitched feature is required. Here, rafters are either built into a wall or nailed to wall plates plugged and screwed to the walls for easier leveling and fixing.



- c. **Gable Roofs ~**

It is built from pairs of opposing rafters with central rigidity provided by a ridge board. They are relatively weak and are limited to small garages, sheds etc. The weakness

caused as a result of the deflection of the rafters may be resolved by using ceiling ties, which also provide support for a ceiling finish.

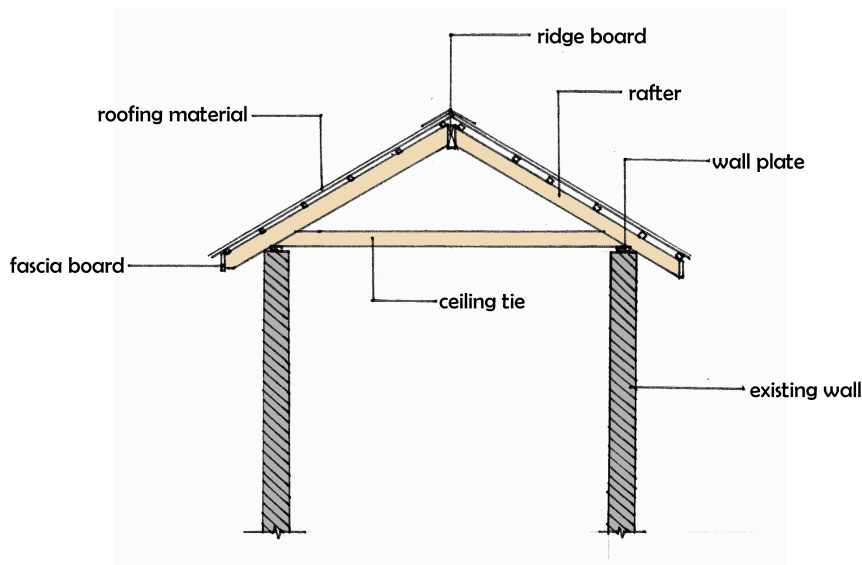

## Gable Roof

Gable Roofs can therefore be classified into the following ~

i. **Couple roofs** – when the pairs of opposing rafters are pitched up from supporting walls to a central ridge/ridge board.

- Maximum span  $\leq 3.5$  m
- 100 mm x 50 mm Rafters are spaced 400 mm – 600 mm apart

ii. **Close Couple Roofs** – the weakness of the deflection of the rafters in the couple roof is resolved by using the ceiling joists as ties.

- Maximum span  $\leq 5.5$  m
- Ceiling joists are usually 50 mm x 100 – 220mm thick

**Advantages** – provides insulation, space for water storage cisterns and storage space

**Disadvantage** – the need for lots of timber

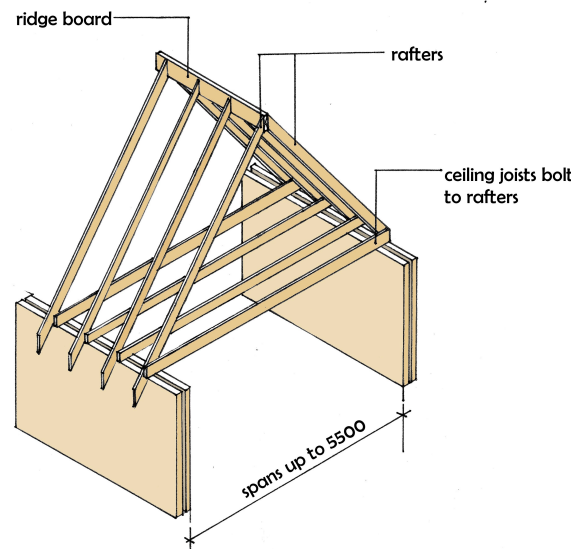

iii. **Collar Roofs** – this is another form of tied couple roof but, framed with collars joined across pairs of rafters  $\leq 1/3^{\text{rd}}$  up the height of the roof. It extends 1<sup>st</sup> floor rooms into the unused roof space.

### Disadvantages :

- Not as effective in tying the pairs of rafters together at the foot
- Gives less penetration of light due to high room height.

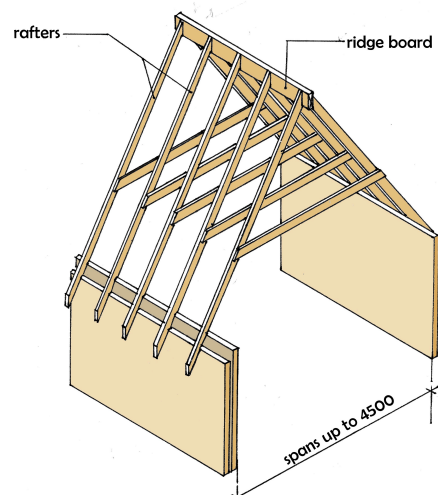

## B. Double Roofs ~

175 mm x 175 mm **Purlins** are used at 3 m centres to give intermediate support to 125 mm x 50 mm **rafters** in two ways ~

- i. Purlins are built into separating or gable end walls or on metal joist hangers built into the wall.

125 mm x 50 mm **ceiling joists** serve as ties and ceiling support

- ii. Purlins are supported by 75 mm x 75 mm **struts** which are in turn supported by

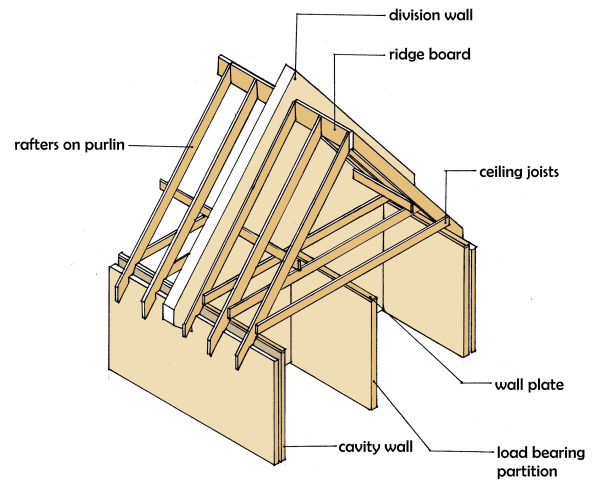

internal load bearing walls

125 mm x 50 mm ceiling joists also serve as ties and ceiling support

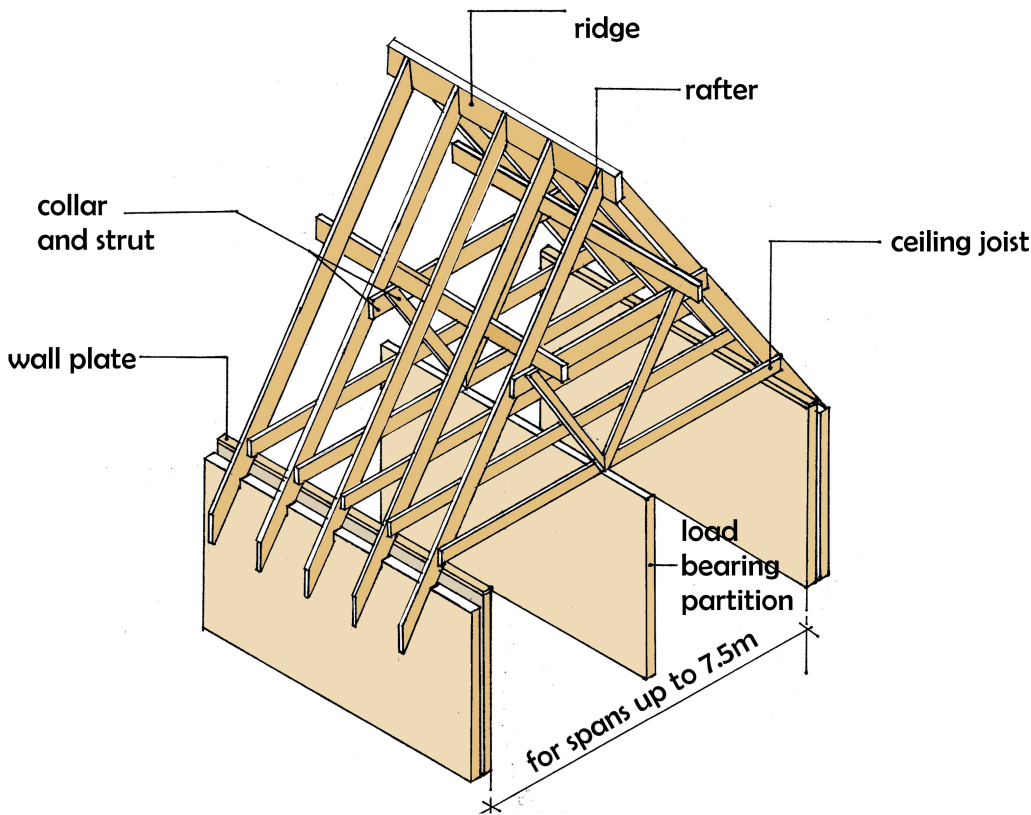

## C. Trussed or Framed Roofs ~

A traditional method of constructing pitched roofs, that do not need intermediate support from internal walls thereby allowing greater flexibility in internal planning was to form **timber trusses**. **Truss** means tied together.

A roof truss is a triangular frame of timbers securely tied/joined together with **double sided toothed plate timber connectors**. Designed for spans up to 8m unsupported, timber trusses are spaced at 1.8 m centres.

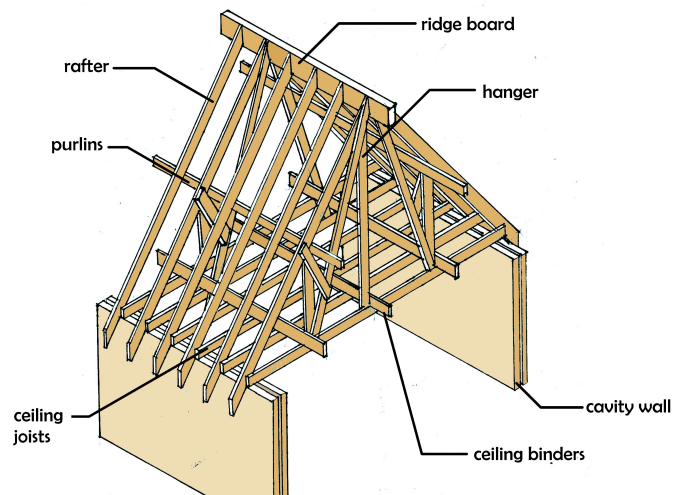

The earlier trusses include King Post Truss which was used for spans of 6m – 9m and Queen Post Truss which was used for spans of 9 m – 12.75 m (when supported).

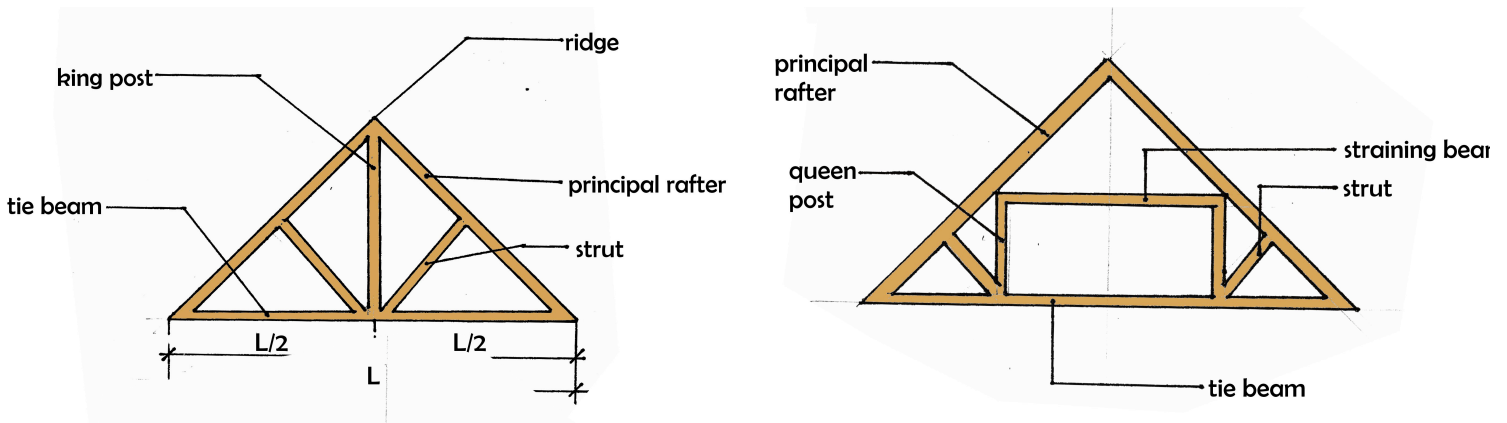

Figure showing the King and Queen Post Truss

### Pre-fabricated Trussed Rafters ~

These are standard roof trusses used extensively for housing and smaller developments. Much of the preparation and fabrication of these trussed rafter is mechanized, resulting in accurately cut and finished rafters that are delivered to site ready to be installed as a roof frame with minimum site labour.

The members of the truss are joined rigidly together with steel connector plates with protruding teeth.

### TERMINOLOGY USED IN ROOF CONSTRUCTION

The terms used to describe the parts of a roof are illustrated below:

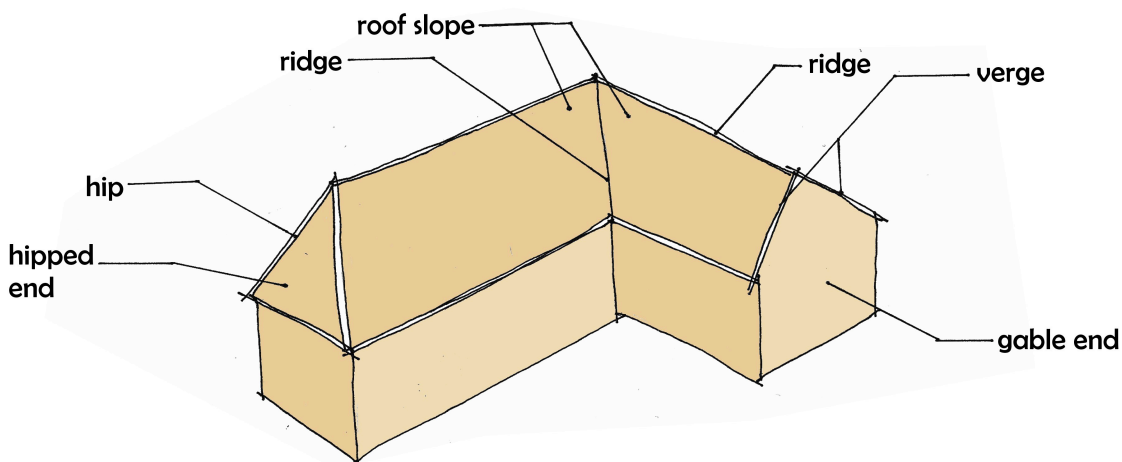
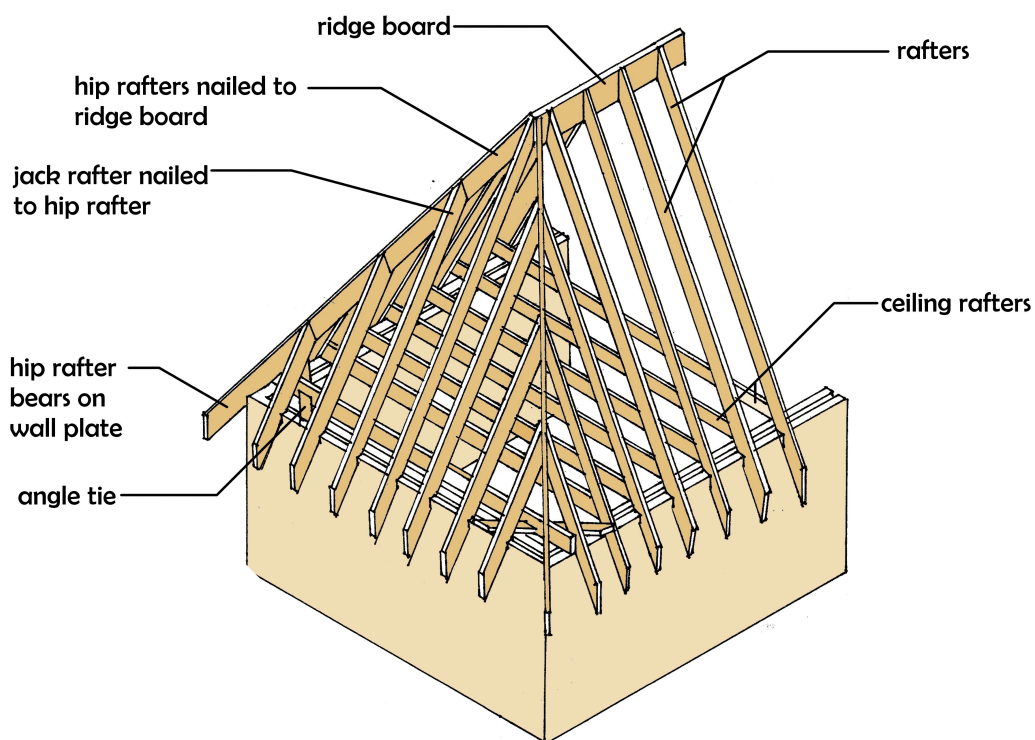

Figure showing the terms used in roof construction

1. **Ridge:** is the highest horizontal part of a pitched roof
2. **Eaves** is the general term for the lowest portion of the roof overhanging the wall from which rain water drains to a gutter or to the ground
3. **Gable end** is the triangular part of a wall that is built up to the underside of roof slopes
4. **Verge** is where the roof covering overhangs the gable wall/end
5. **Valley** is the internal intersection of two slopes at right angles
6. **Hipped end** is the external intersection formed by two, generally similar slopes at right angles

## TERMINOLOGY USED IN ROOF FRAMEWORK CONSTRUCTION

The terms used to describe some of the parts of a roof framework construction are illustrated below:



**Figure showing Terms used in roof framework construction**

1. **Rafters:** - These are sloping roof members in a pitched roof, spanning from wall plate to ridge and which gives the roof its triangular shape. Variously named according to their position as jack, hip, valley, crown or principle.
  - **Jack Rafter** are the short lengths of rafters, that spans from the wall plate to the hipped rafter
  - **Hip Rafter** is the pitched roof rafter used where two sloping roof surfaces meet at an external angle, providing a fixing point for the jack rafter and transferring their load to the wall plate.

- **Valley Rafter** is the rafter used where two pitched roofs meet at an internal angle. It provides fixing for the Jack rafters, supports the valley gutter and transfer loads to the wall.
- **Crown or Principle Rafter** is the central common rafter of a hipped end roof.

2. **Wall Plate** is a horizontal piece of timber fixed to the top of walls in order to distribute load from and to provide a bearing and fixing point for joists and rafters.

The sawn softwood wall plate, usually 100 mm x 75 mm in section is laid on its 100 mm face.

A 'birdsmouth' cut is made in the top of each rafter to fit closely round the wall plate.

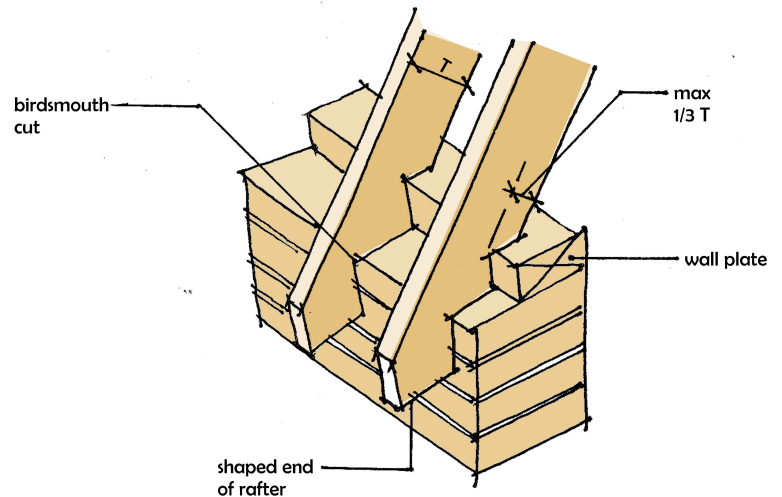

3. **Ridge Board**: This is a horizontal piece of timber at the apex of a pitched roof, which provides a bearing and fixing points for the top of rafters.

The ridge board is one continuous length of hardwood, usually 32 mm thick.

The depth of the ridge board is determined by the depth of the splay cut ends of rafters that must bear fully on each side of the board.

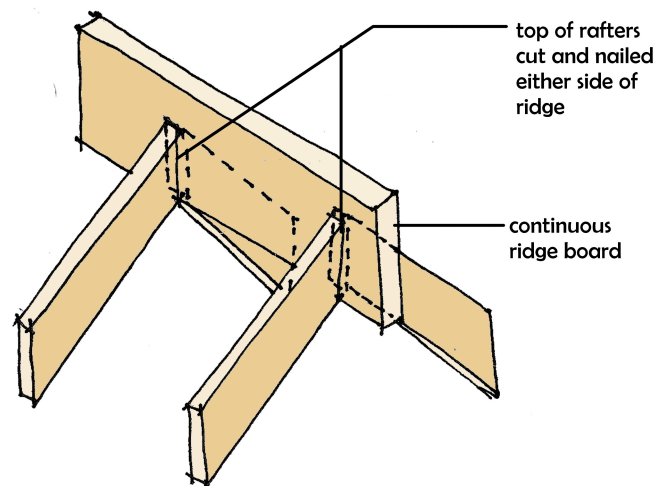

4. **Eaves**: - This is a general term used to describe the lowest courses or slates or tiles of a pitched roof slope or the edge of a flat roof. Both usually overhang the wall and are finished with a **fascia board**

The eaves of post pitched roofs are made to project by 150 mm – 300 mm beyond the external face of the wall. Types include open, flush and closed eaves.

A Fascia board 25 mm thick is nailed to the ends of the rafters and ceiling joists/tie beam.

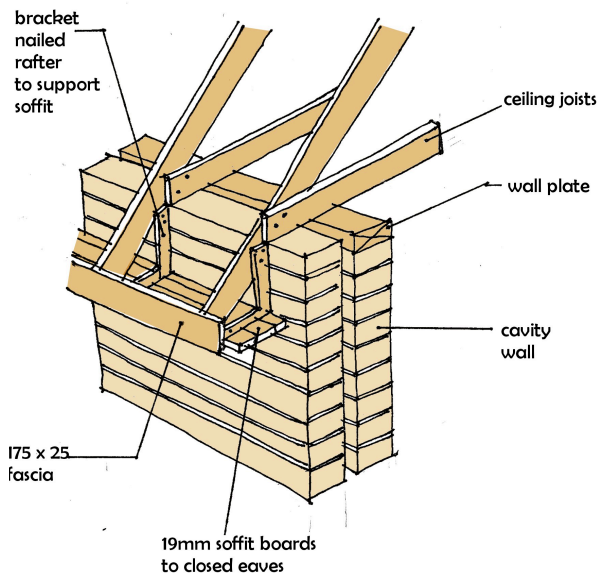
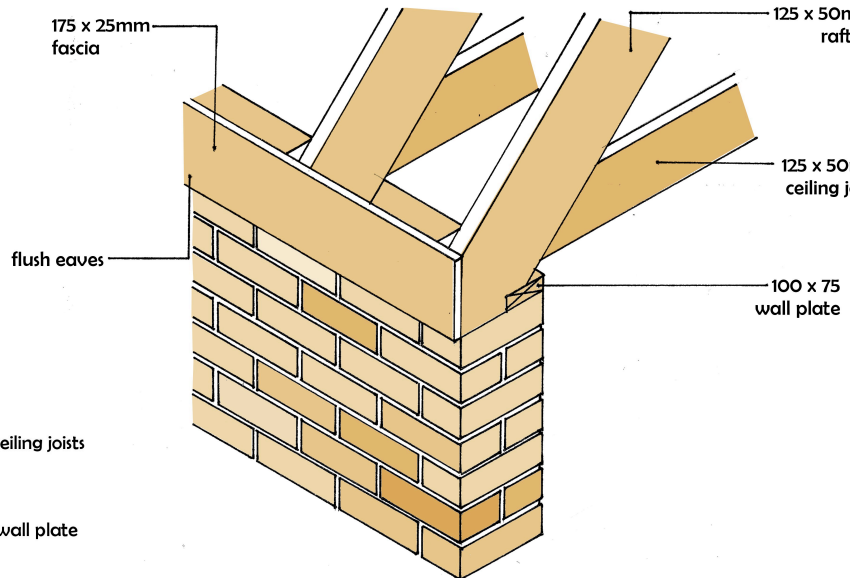
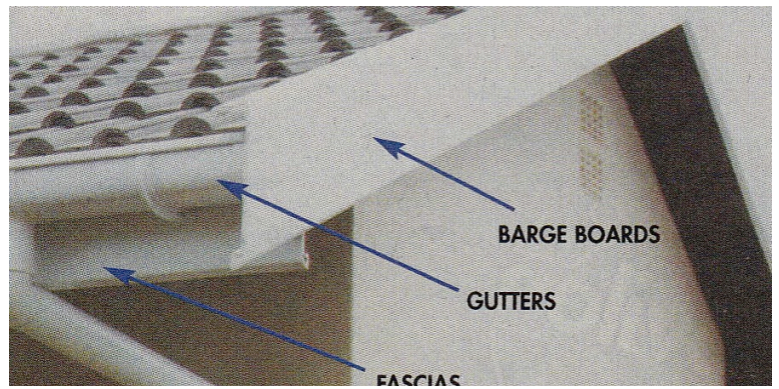
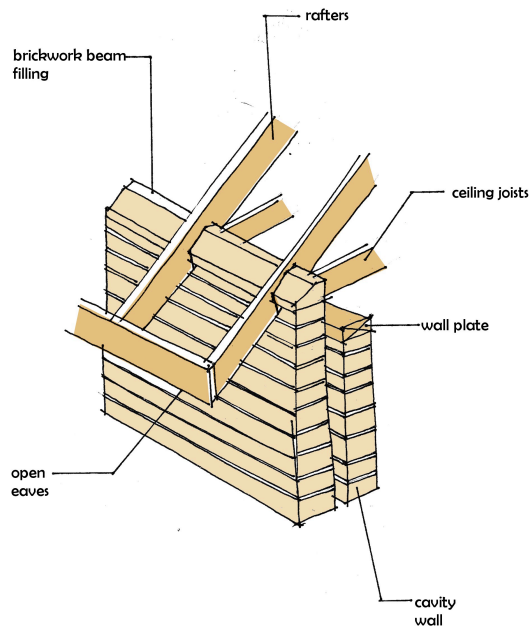

Figures showing types of open, flushed and closed eaves

5. **Fascia Board:** This is a deep board fixed to the end of rafters at the eaves of a roof.

6. **A Vergé** is where the roof covering overhangs the gable end. It is the termination of a pitched roof at the gable end

7. **A Barge Board** is the continuation of the fascia board around the sloping verge of a pitched roof

8. **Purlin** is a beam/horizontal roof member used in a double roof to provide

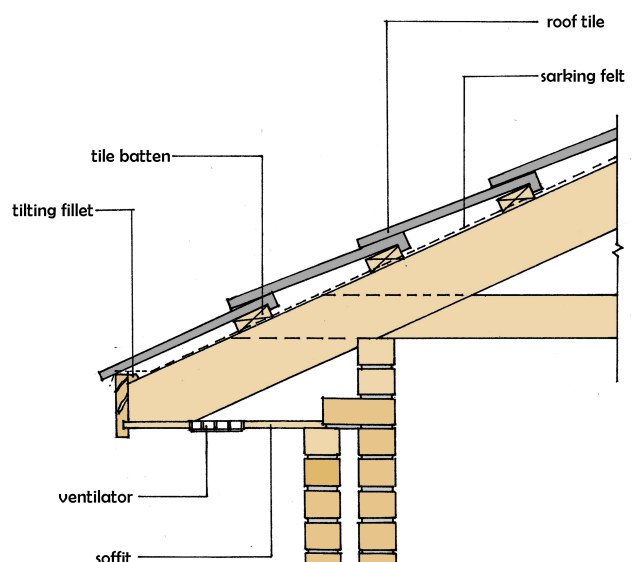

intermediate support to the rafters at their mid span

9. A **Tie beam** is a joist that ties the feet of rafters together

## MATERIALS USED IN ROOF CONSTRUCTION

These are as follows ~

### A. Timber

Timber is the most common material used in roof construction and can be used in the construction of single, double, trussed or framed roofs. Timber used must be of **structural quality** (see NBR) and must be **planed on all faces** to ensure accuracy and efficiency of location. Pitched roofs can also be constructed from **pre-fabricated timber trusses**.

#### Timber Joints ~

The wall plates should be **butt jointed** together and at intersections – **lap jointed** as shown below ~



Lap joint

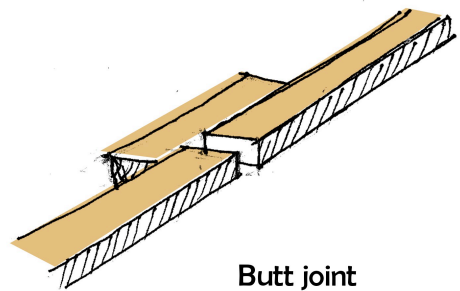

Butt joint

Tie beams and rafters should be joined together with a **scarf joint**, nailed and clenched. In addition, the scarf joint is **battened** at the side as shown below ~



Scarf joint

Purlins could also butt jointed and battened at the sides one to the other, the joint can also be mitred and kept in position with a cleat/wedge as shown below ~

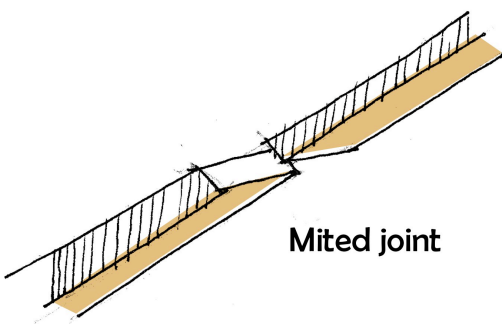

Mited joint

## B. Concrete

Reinforced concrete roofs are constructed in a similar manner to reinforced concrete floors and may be solid, hollow pot or self-centering. Concrete roof slabs are often reinforced with steel bars in both directions, with larger bars following the span. It should also bear on walls of at least 100 mm thick (NBR).

Pre-cast concrete is widely used in the construction of single roofs either flat or shed roofs. Pre-cast concrete planks are placed on top of solid block or continuous bond beams or steel or concrete beam support as shown below ~

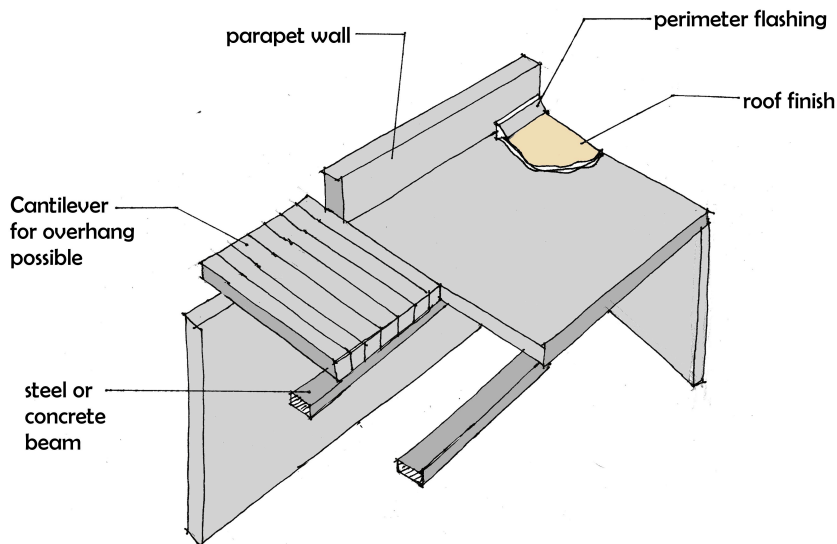

Figure showing Concrete Roof Construction

Lightweight pre-cast concrete which may be used for sloping roofs is supported by light steel framing or trusses. Steel angle stops are required to absorb the downward thrust of planks and prevent the pre-cast concrete planks from slipping, especially for slopes above 4 in 12. The slab is generally finished level and the fall obtained with a screed. It is also required that the slab is waterproofed (NBR).

## C. Steel

The general principles of design for Steel Roof Structures are similar to those adopted for timber trusses, with members given direct support at specific points and those in **compression** kept as short as possible. Steel roof trusses are very important for use in industrial, commercial (warehouses) and agricultural buildings.

Steel roof trusses are made up of members of **small section**, can be used for spans which would be beyond the economic capacity of timber in character and quality.

## ROOF COVERING MATERIALS (Properties and Fixing Details)

Types of roof covering materials are as follows ~

## 1. Slates

Slates are hard, fine-grained naturally occurring material. Clayey stone slate is as a result of tremendous lateral pressure and heat on clay. The slates may be nailed to ~

- Battens fixed direct to rafters,
- Boarding fixed to rafters or
- Battens on boarding

The slates are arranged to bond so that side joints in one course are over the centre of slates in the course below.

Good slates are hard, tough and durable, of rough texture, would not split when holed or dressed, practically non-absorbent and of a satisfactory colour.

## 2. Single Lap or Interlocking Tiles

These are machine made of concrete in various sizes and sections. Typical size being 380 mm x 230 mm.

### Advantages ~

- a. These are the lightest form of roof tiling. Hence, the roof structure of rafters and purlins can be lighter
- b. It permits a flatter slope of roof because it can be obtained in larger sizes

### Disadvantages ~

- a. It is difficult to replace
- b. It is not adaptable to complicated designs.

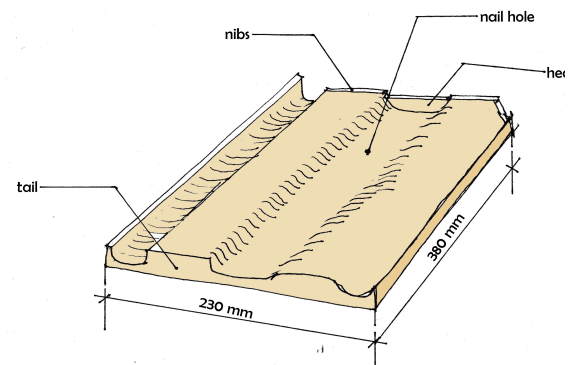

## 3. Plain Clay or Concrete Tiles

- These can be made of clay or concrete in a wide range of colours, although clay tiles retain their colour better
- The size is usually 265 mm x 165 mm and 12 mm thick
- Plain tiles are laid in regular bond
- Unlike slating, every tile is not secured with nails except for tiles in exposed positions.

Tiles nailed are ~

- every tile in each fourth course
- the double eaves course tiles
- the ridge course tiles, and
- all verge, hip and valley tiles.

## 4. Felt and lead Covering

Bituminous felt and lead are the most common covering materials employed to waterproof flat roofs. They act as a continuous impervious membrane for flat and low slope roofs.

Three layers of **felt** bonded with hot bitumen are essential for all except temporary buildings. Vapour barriers which include asphalt saturated felt is first placed on the roof deck. Roofing felts applied with asphalt or tar pitch surface bitumen is then placed on top of the vapour barrier. Finally, white granite stones are used to finish the surface of the felt for appearance also, the stones may aid in stiffening the membrane and resisting wind blow off.

**Lead** is ductile and flexible, easily cut and shaped, highly resistant to corrosion and has a long life. It is however of low strength, high cost, very heavy in weight, creeps on all but the flattest slopes, can be attacked by damp cement mortar, and is supplied in smallish sheets entailing many expensive joints. A lead flat is laid on roof boarding which are laid on roof joists which bridge the shortest span.

## 5. Metal Roof Covering

Sheet metal roofing may be of aluminium, copper, galvanized and stainless steels. Other alloys may also be used. Factors to consider in the use of metal roofing are as follows ~

- Corrosion resistance
- Low rate of expansion and contraction desirable
- Finish, colour and weathering properties
- Compatibility with other building materials when in direct contact
- Maintenance characteristics
- Also important are weight, workability and cost

**Characteristics:** A sheet metal roof is characterized by a pattern of strong vertical lines and articulated ridges and edges created by interlocking seams and cleats. A nailable deck is required for fastening of cleats; if a non-nailable deck is used, nailing strips must be provided.

### Types of Metal Roofing include ~

#### ○ **Copper Roofing Sheet**

Copper sheet and strip for flat roofs has a common thickness of 0.61mm. A thin stable insoluble film (patina) forms on copper on exposure to air, consisting of a combination of copper oxide, sulphate, carbonate and chloride. The coating is green in colour and improves the appearance in addition to giving protection.

**Advantage:** - Copper sheet is very tough and durable, easy to cut and bend, light in weight, does not creep and resists corrosion reasonably well.

**Disadvantage:** - It is comparatively expensive, the smallish sheets involve many joints, and electrolytic corrosion may take place if it comes into contact with metals other than lead.

A minimum fall for a copper roof is 1 in 60. A copper roof covering consists of a number of sheets joined along the edges, and held by clips inserted in the folds.

#### ○ **Aluminium Roofing Sheet**

A common size of sheet is 1800 mm x 610 mm and the thickness is often 0.90 mm. The method of fixing aluminium sheets is similar to that of copper. The strength of aluminium is increased by the addition of alloys, although alloys reduce its ductility.

#### ○ **Zinc Roofing Sheet**

The sheets are normally about 2400 mm x 900 mm and should have a minimum thickness of 14 zinc guage.

**Advantage:** It may be used as a cheaper alternative to other metal roof covering, it does not creep, it is light weight and reasonably ductile.

**Disadvantage:** It corrodes in coastal and heavy industrialized areas and has a shorter life span.

## 6. Asbestos Sheet

It is made of fiberised asbestos and Portland cement; the natural colour is Grey but, it is obtainable in other colours. Sheets are normally corrugated about 50 mm deep in various lengths up to 4.60 m. They are generally laid with an end lap of 150 mm and the side lap varies with the design (see NBR). Asbestos cement sheets are fixed to wood purlins with galvanized drive screws or to steel angle purlins with hook bolts.

**Advantages:** It is incombustible, light weight and corrosion resistant.

**Disadvantages:** Unattractive in appearance, the surface softens with weathering, the materials become brittle with age and is unlikely to have a life span exceeding 30 years.

Asbestos sheet is hardly used nowadays due to the health conditions such as cancer that results from its prolonged use.

## 7. Thatch Roofs

It is a roof covering of reed, straw or palm fronds laced with flexible willow sticks such as those used for basket weaving. It provides a most attractive finish to steep roofs of at least 45° and preferably 55° inclination. Several are twisted into a cable for tying reeds onto rafters in thatching.

Reed is the most durable thatching material with a life of 50 to 75 years, while the life of a good straw or palm frond roof is not more than 20 years. However, about every seven years, thatch must be cleaned to lengthen its life.

Reed is laid about 300mm thick and it is best confined to simple roofs. Rafters spaced at about 400 mm centres support battens (25 mm x 19 mm at 225 mm centres) which carry the reed.

**Advantage:** An attractive finish to steep roofs and high thermal insulation

**Disadvantage:** It requires regular maintenance; short life; unpleasantness of thatching; the difficulty of finding experienced thatchers; high cost; liable to attack from birds and vermins; and prone to fire damage than other types of roof covering materials. Its susceptibility to fire can now be reduced by soaking the reed or straw in a fire – resisting solution instead of in water before laying it.



## STAIRWAY

This is defined as a set of steps or flight leading from one floor to another, giving floor-to-floor access including any landing, balustrade or handrail. Each continuous set of steps in between floors or landings is termed a flight of stairs. The space in which a flight of stairs was built now used to mean the flight itself was formally called a staircase. Internal stairways are now often of reinforced concrete or timber; escape stairs are fabricated with steel, cast iron or reinforced concrete.

A stairway must be designed to provide a safe, serviceable and commodious means of access from one floor to another of a building. The National Building Regulations prescribe certain minimum requirements for stairs design and construction.

**The National Building Regulations in Part M: Stairways** stipulates the requirements for stairway construction as follows ~

### **M1 General requirements**

1. Any stairway, including any wall, screen, railing or balustrade to such stairway, shall be capable of safely sustaining any loads to which it is likely to be subjected and shall permit safe movement of persons from floor to floor.
2. Any such stairway shall have dimensions appropriate to its use.

### **M2 Fire Requirements**

A stairway contemplated in regulations M1 shall comply with the relevant requirements in Part T of these regulations.

### **M3 Deemed-to-Satisfy Requirements**

The requirements of regulations M1 and M2 shall be deemed to be satisfied where the design of any stairway complies with Part M of section 3 of SABS 0400.

## **Part M of Section 3 of SABS 0400 ~ Deemed-to-Satisfy Requirements**

### **MM1 General**

The regulations contained in Part M of the National Building Regulations shall be deemed to be satisfied where –

- (a) any stairway, including any wall, screen, railing or balustrade to such stairway, is the subject of a rational design in accordance with the requirements contained in Part B; and
- (b) the construction of any stairway, including any handrail to such stairway, complies with deemed-to-satisfy rules contained in the following provisions of this Part.

### **MM2 Dimensional Requirements**

MM2.1 The clear **headroom** at any point of any stairway shall not be less than 2.1m measured vertically from the **pitch line**, and the clear width of any stairway not forming part of any emergency route shall not be less than 750mm.

## MM2.2

- (a) Any **landing** serving two flights in the same straight line shall ~
  - (i) have a length of not less than 900 mm; and
  - (ii) have a width of not less than that of such **flights**
- (b) No flight of stairs shall have a vertical **rise** greater than 3 m between landings
- (c) No door shall open onto a stairway unless such door opens onto a landing and the width of such landing shall not be less than that of such door.

## MM2.3

The rise of any step shall not exceed 200 mm.

## MM2.4

The **going** and width of any **tread** shall not be less than 250 mm: Provided that where the stairway does not have solid risers, each tread shall overlap the next lower **tread** by not less than 25 mm

## MM2.5

The variation in the dimension of the risers and the going of the treads in any one flight shall not be more than 6mm: Provided that this requirement shall not be construed as prohibiting the use of tapered treads in the same flight as treads that are not tapered.

## MM2.6

Any **tapered tread** not being a **winder** shall –

- (a) be so designed that the going –
  - (i) complies with the requirement contained in sub rule MM2.4; or
  - (ii) is equal, in the case of a flight containing both tapered and non-tapered treads, to the going of the non-tapered treads; in respect of that part of the tread which is 400 mm from the narrower end of such tread;
- (b) have a minimum going of 125 mm;
- (c) be so constructed that the angle between the successive risers, measured in the horizontal plane, shall be constant; and
- (d) comply with the requirement for variation in going contained in sub rule MM2.5, where such variation is in each case measured at the same distance from the narrower end of each tread.

## MM2.7

Stairways incorporating winders shall be permitted only in dwelling houses and within individual dwelling units, and at any point on such stairway –

- (a) there shall be not more than three successive winders; and
- (b) such winders shall not turn through more than 90<sup>0</sup>.

## MM3 Prevention Against Falling

### MM3.1

- (a) Any **flight of steps** which contains more than three risers shall have protection on each side provided by a secure wall, screen, **railing** or **balustrade** which shall not be more than 1 m high and so erected that any such wall, screen, railing or balustrade in any occupancy classified E2, E3, H1, H2 or H3 shall not have any opening that permits the passage of a 100 mm diameter ball: Provided that such protection in any occupancy not being classified E2, E3, H1, H2, H3 or H4, shall consist of at least a **handrail**, one rail not more than 150 mm above the

stair nosing, and one other rail or other form of protection in between such rail and handrail.

- (b) (i) Any flight of steps which contains more than 5 risers shall be provided with at least one continuous handrail extending the full length of such flight: Provided that this requirement shall not apply to any building classified H4, or within individual dwelling units in an occupancy classified H3.
- (ii) Such handrail shall be securely fixed to such wall, screen, railing or balustrade at a height of not less than 850 mm and not more than 1 m measured vertically from the pitch line to the upper surface of the handrail.
- (iii) Such handrail shall be of such design and be so fixed that there shall be no obstructions on, above or near to it, which may obstruct the movement of any hand moving along it.
- (c) (i) Subject to paragraph b (i), any flight which is less than 1.1 m wide shall have a handrail on at least one side and where the width of any flight is greater than 1.1 m, handrails shall be provided on both sides of such flight.
- (ii) such handrails shall comply with the requirements contained in paragraphs b (ii) and b (iii).

It can be inferred from the rules stated in Sub rule MM3.1 (b) that ~

- a. If the flight has fewer than four risers, no balustrade, screen etc and handrail are required.
- b. If it has four or five risers, a balustrade, screen etc is required but no handrail is required.
- c. If it has six or more risers, both a balustrade, screen etc and a handrail are required.

#### MM4 Fire Requirements

Any stairway shall comply with the requirements contained in rules TT5, TT7, TT19, TT20, TT21, TT22, TT23, TT24, TT25, TT26 and TT27, as the case may be.

#### TERMINOLOGIES USED IN STAIRWAY CONSTRUCTION

1. **Riser:** The upright face of a step
2. **Treads:** The level part of a step or its length
3. **Going:** The distance (measured on plan) between the nosing of a tread and the nosing of a tread or landing next above it
4. **String:** A sloping board at each end of the treads housed or cut to carry the treads and risers of a stair
5. **Nosing:** A half-round, over hanging edge of a stair tread in concrete, stone or timber

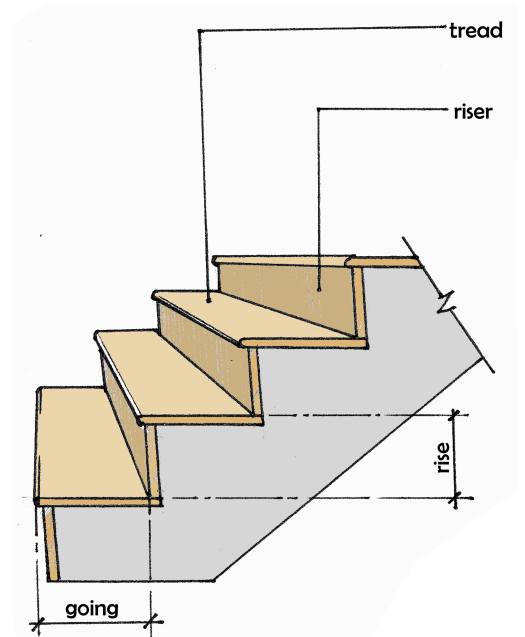

Figure showing Staircase Treads and Risers

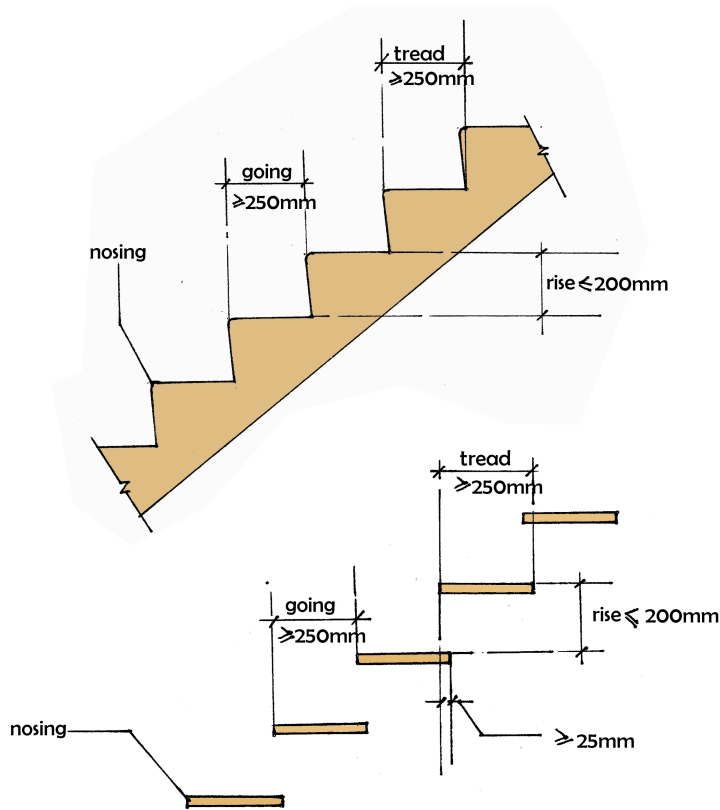
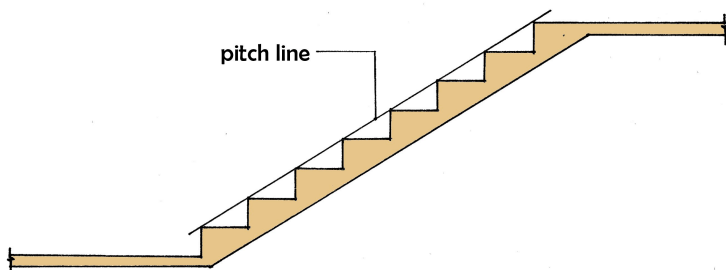

Figure showing the nosing, going, tread, rise

6. **Landing:** A platform between two flights of a stairway. It can be either a half-landing or quarter-space landing
7. **Balusters:** A post in a balustrade of a flight of stairs
8. **Handrails or Guardrails:** A rail forming the top of a balustrade on a stairs, balcony, bridge etc.



9. **Newel Post:** A post in a flight of stairs carrying the ends of the outer string and handrail and supporting these at a corner

10. **Balustrade:** Collective name to the whole in-filling from handrail down to the floor level at the edge of a stairway

11. **Flight:** A series of steps which joins one floor or landing to the next floor or landing

12. **Pitch line:** A notional line which connects the nosing's of all the treads in a flight or stairs

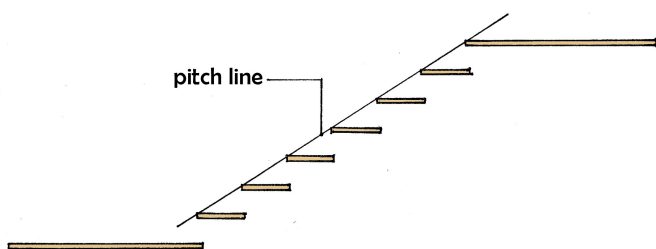

Figure Showing a Pitch Line

13. **Tapered Tread:** A tread, which has a greater width at one side than at the other and a going, which changes at a constant rate throughout its length. Tapered treads may not taper to a point.

14. **Winder:** A tread, which tapers to a point.

## TYPES OF STAIRWAYS

There are various types of stairways depending on the layout. However, the most common are the following ~

### A. The Straight Flight/Run Stairs

#### 3 TO 5 STEPS

This layout shows the regulation standards.

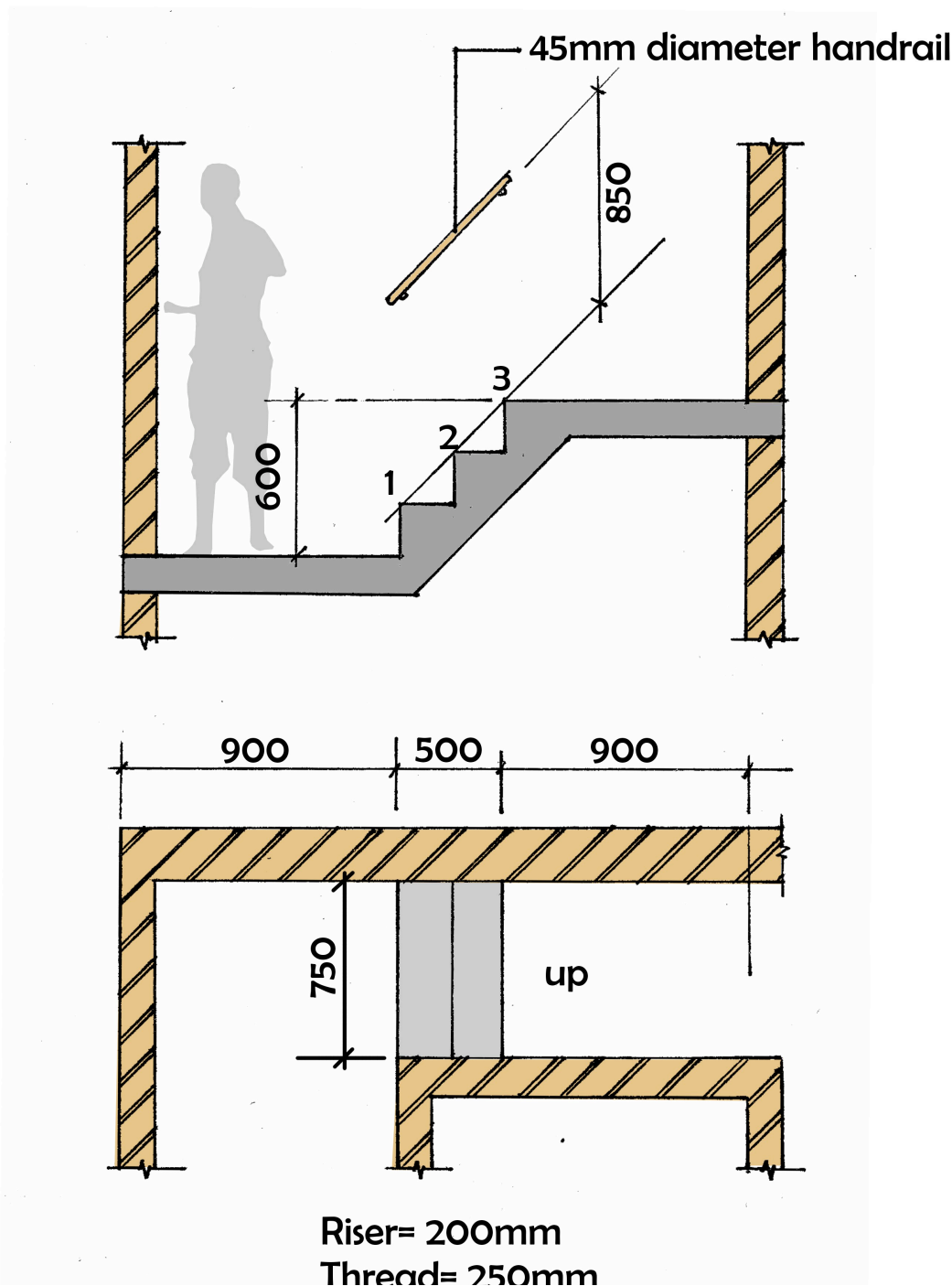

# STRAIGHT FLIGHT (13 steps)

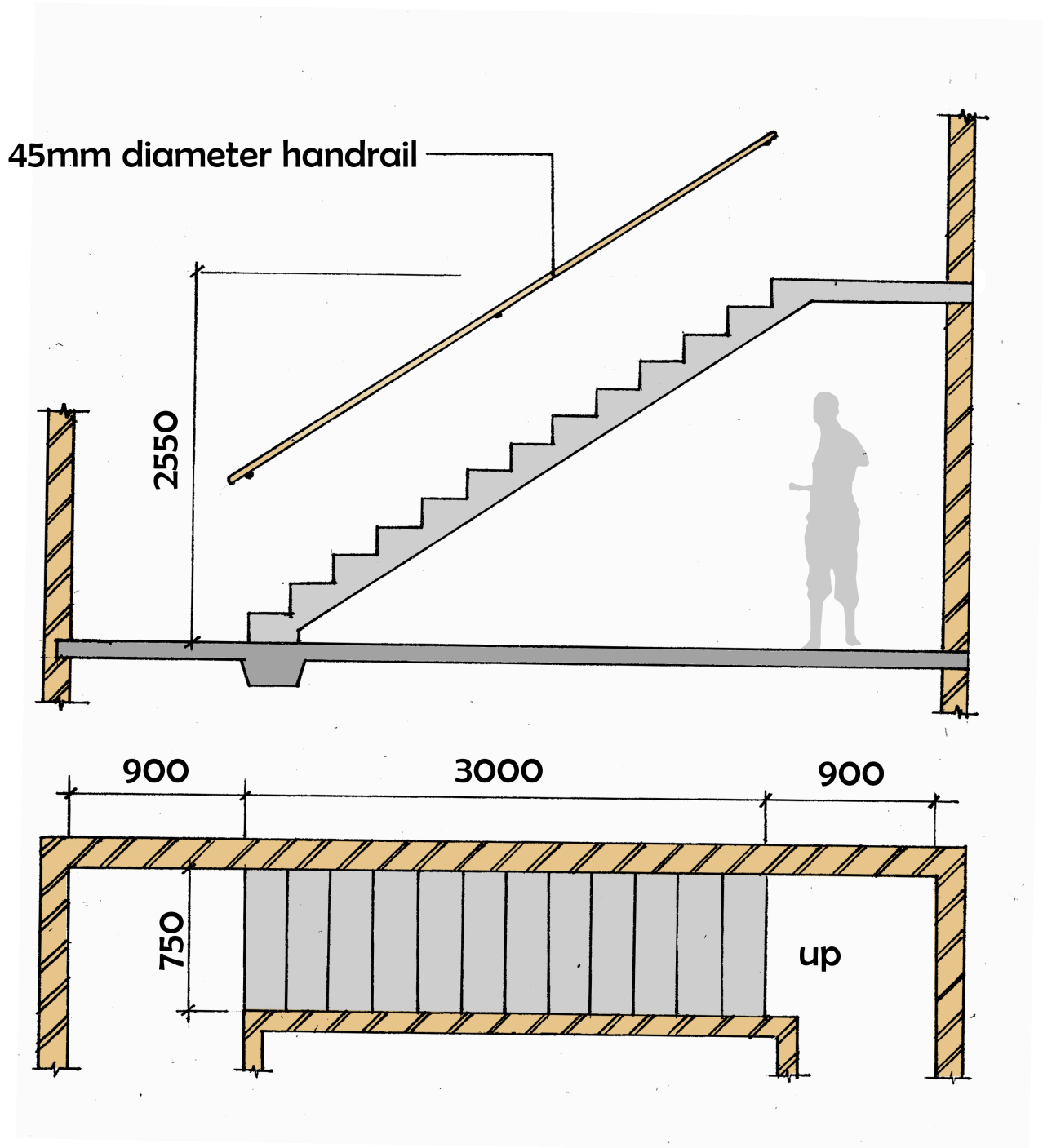

Riser= 196mm  
Tread= 250mm

# STRAIGHT FLIGHT (15 steps)

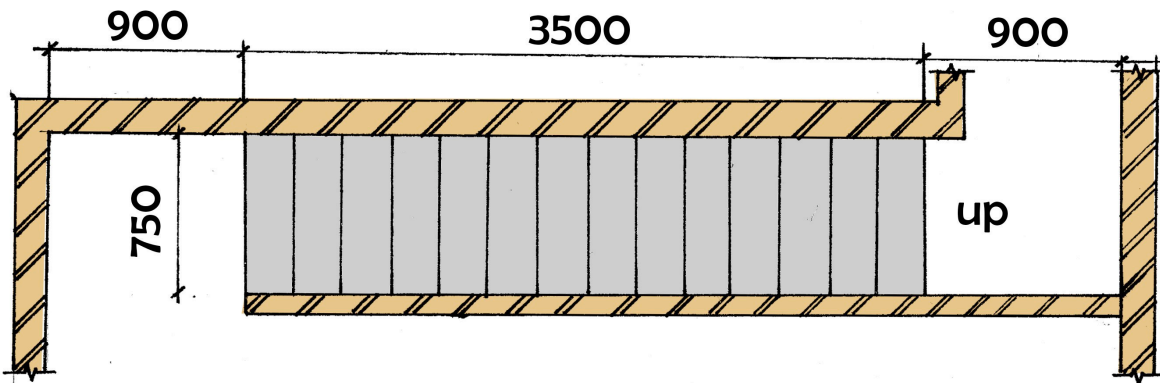
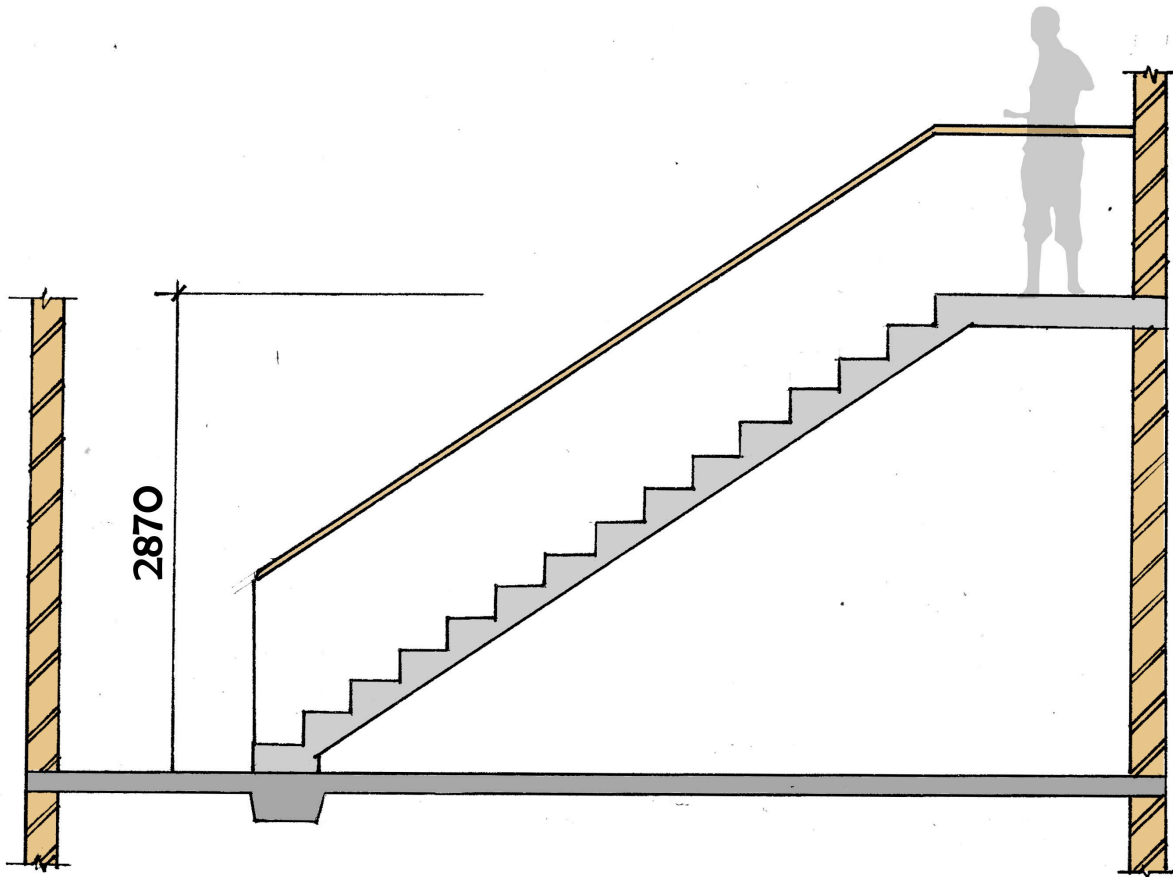

Riser= 191mm  
Tread= 250mm

## B. Dog-Leg/ "U" Return Stairs

DOG-LEG STAIR (15 steps)

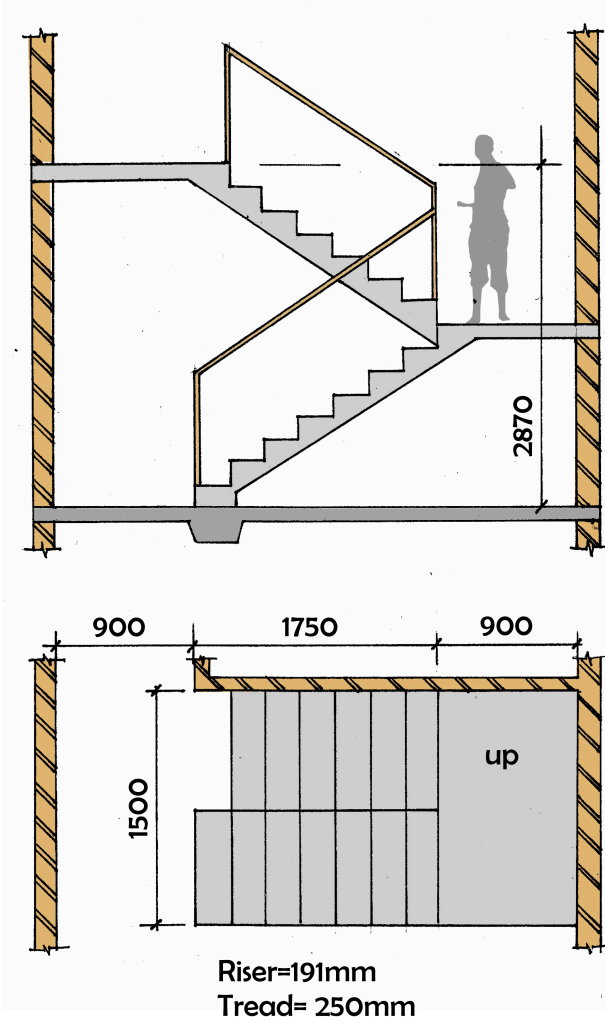

DOG-LEG & FLOWER BOX (18 steps)

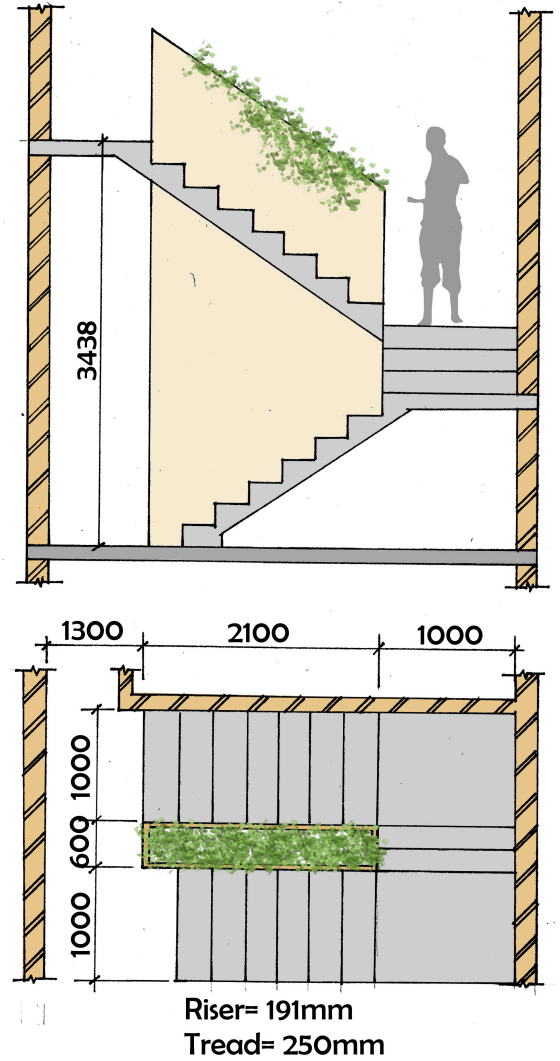

### C. Quarter Turn/L - Stairs

QUARTER-TURN STAIRS (15 steps)

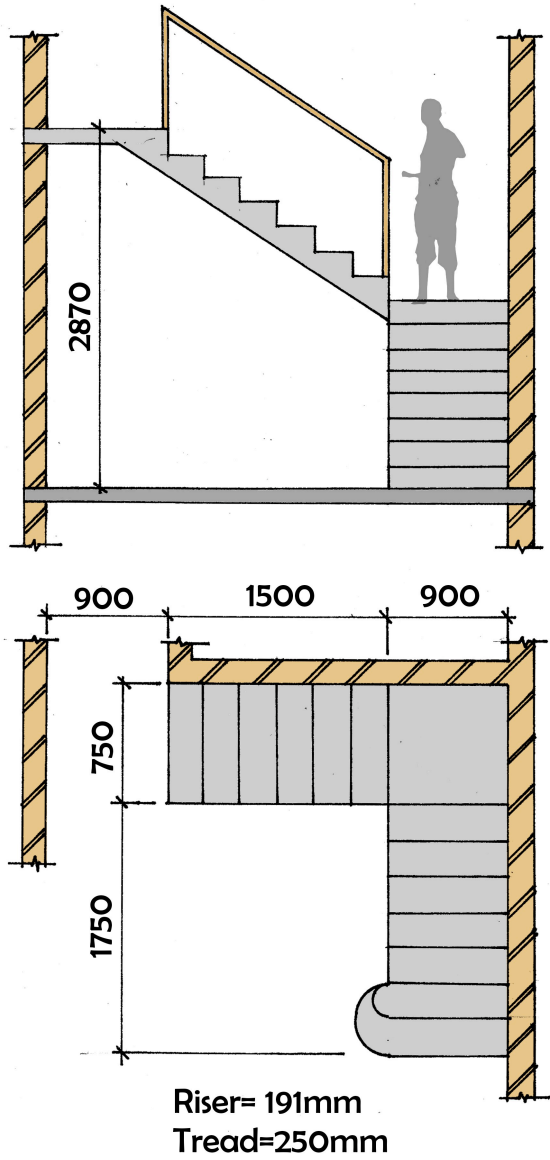

### D. Quarter Turn and Winder Stairs

QUARTER-TURN & WINDERS (15 steps)

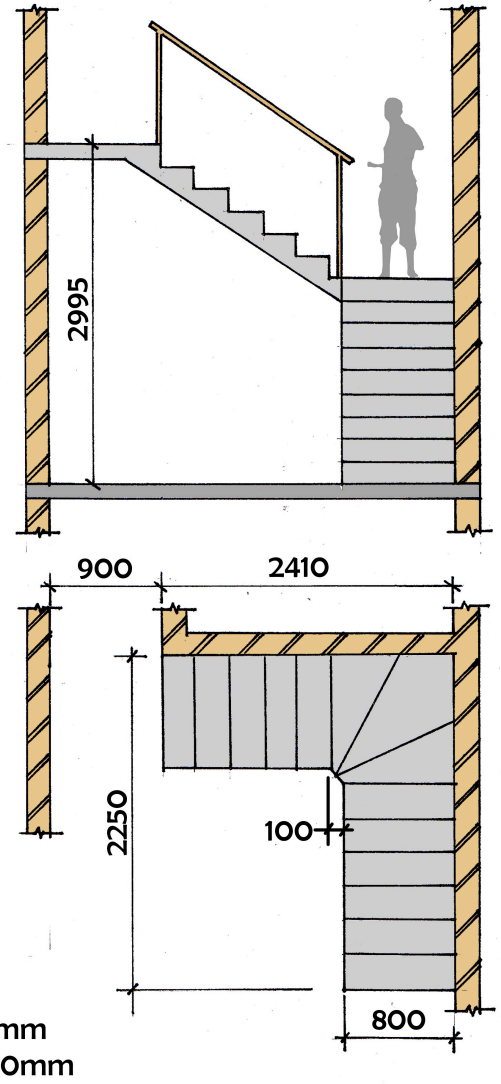

## E. Spiral Stairs

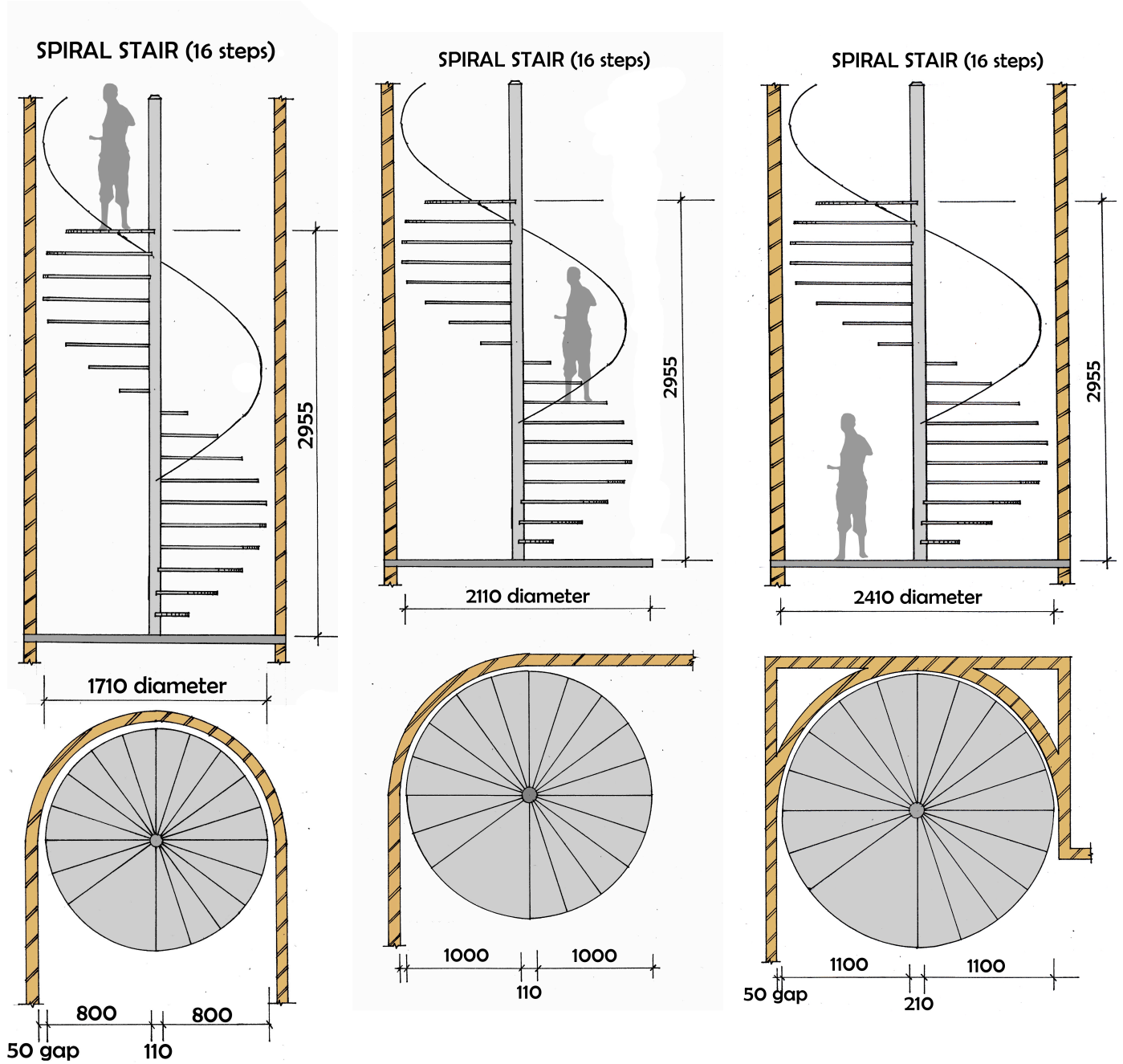

Steps: metal with wood or glass treads

## References

- Barry (2001) Construction of Buildings, Vol. 1-4, Wiley: New York
- Brett, P. (1997) An Illustrated Dictionary of Building: A Reference Guide for Practitioners and Students, 2<sup>nd</sup> Ed., Elsevier Butterworth Heinemann, Oxford
- Chappell, D., Cowlin, M., and Dunn, M. (2009) Building Law Encyclopaedia, Wiley-Blackwell, Chichester
- Chudley, R., and Greeno, R. (2006) Building Construction Handbook, 6<sup>th</sup> Ed., Elsevier Butterworth-Heinemann, Oxford
- Freeman, C. J. (1990) The National Building Regulations: An Explanatory Handbook; Juta & Co Ltd

Grobellar, A. (1992) Building Construction Graphics Standards, Anglo-Rand Publications, South Africa

Kohler, T. H. (1984) A Technical Guide to Good House Construction, National building Research Institute of the CSIR in collaboration with the Association of Building Societies of South Africa