

**Testing the use of port biological baseline surveys to support relevant  
marine alien species management applications in Africa**

**Alexander Adnan Awad**

**Thesis Presented for the Degree of**

**DOCTOR OF PHILOSOPHY**

**in the Department of Biological Sciences**

**UNIVERSITY OF CAPE TOWN**

**September 2018**

The copyright of this thesis vests in the author. No quotation from it or information derived from it is to be published without full acknowledgement of the source. The thesis is to be used for private study or non-commercial research purposes only.

Published by the University of Cape Town (UCT) in terms of the non-exclusive license granted to UCT by the author.

## Abstract

The prevention of non-native marine species introductions is the first line of defense in the management of alien invasive species problems occurring on coastlines around the world. Ports and the shipping industry have been targeted as a sector requiring increased attention and regulation to reduce the significance of the ballast water and biofouling pathways. Ballast water management (BWM) processes have matured significantly at international levels over recent decades, with the support of the International Maritime Organization (IMO) and its BWM Convention. The development of baseline species and environmental data for port areas is increasingly recognized as a foundational step in managing ports and ships with respect to potentially harmful species transfers. Several countries have been conducting port biological baseline surveys using protocols developed at the Centre for Research on Introduced Marine Pests (CRIMP) in Australia, which has become the recommended approach at the IMO for developing countries tackling this issue. This study applies the CRIMP methodology for conducting comprehensive baseline surveys in three key African ports to examine the relevance for practical and effective management outcomes. Lessons learned through survey implementation were consolidated into a set of guidelines for conducting port surveys in developing regions. The generation of species and environmental data allowed for investigation of methodologies for shipping-focused risk assessment for new species introductions. Furthermore, the ability of risk assessment processes to support decisions for Port State Control measures related to BWM was tested through the development of a ship-specific decision support system. Where the presence of a potentially problematic species has been recorded, the role of species-specific risk assessment was also considered. The European Green Crab *Carcinus maenas*, presently found in isolated bays of South Africa was assessed with respect to the validation of management concerns related to the likelihood for further spread and impact, especially to the valuable aquaculture sector.

## Table of Contents

<b>Introduction and acknowledgements</b> .....	1
<b>Chapter I - Port biological baseline surveys in key African ports</b> .....	7
1.1 Aims and objectives .....	7
1.2 Port survey protocols .....	8
1.3 Port of Saldanha, South Africa .....	10
1.3.1 Background .....	10
1.3.2 Description of the port.....	11
1.3.3 Survey methods .....	13
1.3.4 Survey results.....	18
1.3.5 Discussion.....	20
1.4 Port of Mombasa, Kenya.....	24
1.4.1 Background .....	24
1.4.2 Description of the port.....	24
1.4.3 Survey methods .....	25
1.4.4 Survey results.....	32
1.4.5 Discussion.....	36
1.5 Port Louis, Mauritius.....	39
1.5.1 Background .....	39
1.5.2 Description of the port.....	40
1.5.3 Survey methods .....	41
1.5.4 Survey results.....	45
1.5.5 Discussion.....	49
1.6 General considerations .....	50
<b>Chapter II - Guidance on port biological baseline surveys</b> .....	58
2.1 Introduction and background.....	58
2.1.1 The need for biological data .....	58
2.1.2 The purpose of PBBS.....	59
2.2 Types of surveys .....	61
2.2.1 Protocols for PBBS.....	61
2.2.2 Adapting protocols to local circumstances.....	62
2.3 Planning and design.....	63

2.3.1	Initial steps .....	64
2.3.2	Survey design .....	66
2.3.3	The survey team.....	72
2.3.4	Planning for contingencies.....	74
2.4	Field operations: sampling and sample processing .....	75
2.4.1	Communications .....	75
2.4.2	Safety .....	75
2.4.3	Field base and laboratory .....	76
2.4.4	Boats and transportation.....	78
2.4.5	Collecting samples .....	79
2.4.6	Sample handling.....	80
2.5	Biological recording.....	85
2.5.1	Categories of output .....	85
2.5.2	Facilities.....	86
2.5.3	Taxonomic analysis .....	87
2.5.4	The survey report.....	89
2.6	Optimizing the benefits of PBBS.....	90
2.6.1	PBBS in a wider context .....	90
2.6.2	The role of the port authority .....	91
2.6.3	Data storage and access.....	93
2.6.4	Improving capacity for PBBS .....	93
<b>Chapter III - Risk assessment to support management of the shipping vector .....</b>		<b>95</b>
3.1	Achieving ship-specific risk assessment for alien species transfer .....	95
3.2	Approach taken for the Port of Saldanha .....	96
3.2.1	Aims and objectives .....	96
3.2.2	Methods.....	98
3.2.3	Results.....	109
3.2.4	Conclusions and recommendations.....	114
3.3	Approach taken for Port Louis.....	117
3.3.1	Aims and objectives .....	117
3.3.2	Methods.....	119
3.3.3	Results.....	124
3.3.4	Conclusions and recommendations.....	128

3.4 Discussion.....	130
<b>Chapter IV - Assessing the risk posed by the extant populations of <i>Carcinus maenas</i> in South Africa</b>	<b>133</b>
4.1 Introduction.....	133
4.2 Objectives and approach.....	134
4.3 Overview of marine IAS impacts.....	135
4.4 Socio-economic and environmental risk assessments .....	136
4.5 The European Green Crab <i>Carcinus maenas</i> .....	137
4.5.1 Ecology and biology .....	137
4.5.2 Commercial impacts.....	139
4.5.3 Environmental impacts .....	142
4.5.4 Establishment and potential spread .....	143
4.5.5 Assessing the risk of further spread.....	145
4.5.6 A bio-economic model for <i>C. maenas</i> .....	146
4.6 Conclusions .....	149
4.7 Recommendations .....	151
<b>Conclusions</b> .....	<b>153</b>
<b>Literature cited</b> .....	<b>158</b>
Appendix 1 .....	170
Appendix 2 .....	171
Appendix 3 .....	174

## Introduction and acknowledgements

The human-facilitated transfer of marine organisms has become one of the major factors impacting the health of oceanic coastlines. Invasive species tend to have their greatest impacts on those areas already stressed by anthropogenic disturbance, causing irreversible changes, often with significant ecological, economic and social impacts (Pimentel, 2002). Hundreds of marine species have migrated between oceans and seas following the opening of major canals around the world (Carlton, 1999). Furthermore, numerous species have been introduced, either intentionally or unintentionally, from fisheries, aquaculture practices and the aquarium trade. However, international shipping has come into focus as the primary vector responsible for most of the recorded marine species invasions globally (Hilliard, 2005).

Commercial ships can be effective at transferring living organisms across large distances, through two equally-significant mechanisms: as plankton carried in ballast water (water taken on board to stabilize the vessel at sea, an essential process for the safety of modern vessels), and as biofouling, or the species attached to the immersed parts of the vessel. Each of these vectors presents an interesting set of management challenges. Ballast water management (BWM) emerged as a critical area of focus for national administrations, regional bodies and international organizations, including the International Maritime Organization (IMO), following the outcome of the 1992 UN Conference on Environment and Development in Rio de Janeiro, where member states agreed to work through the IMO to consider “the adoption of appropriate rules on ballast water discharge to prevent the spread of non-indigenous organisms” (UNSD, 1992).

Following decades of research and development, the IMO International Convention for the Control and Management of Ships’ Ballast Water and Sediments (BWM Convention), which was first adopted by Member States in 2004, entered into force internationally on 8 September 2017. This international regulatory regime stipulates that all ballast water must be treated to remove or deactivate the organisms contained therein (according to a set of water quality standards), before it can be discharged into the marine environment of recipient ports. The costs of installation of expensive on-board treatment technologies is to be borne by the shipping companies. The burden for inspection for compliance with the regulations falls on the Port State Control authority for all vessels arriving in ports, including the costs for such procedures. It is then the duty of the Flag State Control authority to ensure all nationally registered vessels are operating in compliance with the international regime.

Over recent years, and in response to heightened international awareness of threats from marine invasive species, the biofouling vector has also been receiving regulatory attention at various levels. Governments such as Australia, New Zealand and the USA have robust national programmes in place to regulate and manage hull inspections and cleaning procedures, in order to minimize threats of species transfer. South Africa and Mauritius have recently been exploring options for regulating in-water hull cleaning, and other possible approaches to biofouling management. At the international level, the IMO has developed voluntary guidelines for Member States to adopt, containing best international management practices for vessel hull maintenance, including considerations for hull coatings. It is likely that this will evolve into a mandatory instrument over coming years.

The IMO recommends the use of port biological baseline surveys as an initial stepping stone in the development of a port's ballast water management regime. Such surveys of species already present within the major ports are an important mechanism for establishing the extent of existing invasive alien species (IAS) concerns. This not only helps raise the awareness of such concerns, but more importantly provides baseline data of existing species, both native and introduced. This baseline provides an essential reference point for ongoing monitoring and management in the port area, and can help catalyze inter-departmental (maritime and environment) collaboration around the issue. Properly conducted surveys and monitoring will also allow managers to track any existing introductions, and facilitate the early detection of any new species arrivals. Functional collaboration between environment and maritime sectors, in consideration of the respective national obligations under the CBD and IMO, is essential in ensuring that robust scientific methodologies are applied in challenging circumstances related to shipping and ports.

In 2000, the IMO partnered with the UNDP and the Global Environment Facility (GEF) to launch the GloBallast Programme, designed to support developing countries in preparing for implementation of the BWM convention. Countries such as Australia and the USA, where national concerns regarding species invasions had already prompted significant research and experimental regulations, were quick to collaborate and contribute lessons-learned through the growing nexus of ballast water related activity at the IMO. The IMO-based programme emerged over subsequent years as a hub for technical and capacity support, and a center for consolidation and dissemination of international best practices. Although port biological baseline surveys were not regarded by the IMO as being essential for BWM, the programme committed significant resources over many years to support pilot surveys in developing regions, as a mechanism to catalyze further cross-sectoral engagement and BWM activity.

Beyond conducting biological surveys in ports, it was also recognized that capacity limitations throughout ports of the developing world limited the potential to apply regulatory measures for IAS. Inspections of vessels, in terms of ensuring compliance with ballast water or biofouling regulations, are critical to support legal enforcement processes. The application of risk assessment methodologies can assist with the identification of higher risk vessels, which may subsequently be targeted for increased regulatory attention. The IMO Convention encourages the use of risk assessment to support compliance monitoring and enforcement, as well as being a mechanism that can be used to justify exemptions from the regulations for vessels operating on low-risk routes. For a port authority to effectively apply risk-based management procedures, the data (environmental and biological) must be available and complete from the local port, as well as from all source ports for the ballast water being received. The GloBallast programme developed a risk assessment methodology that was then tested in pilot countries, including South Africa, on the basis that the proposed system may be replicated at other local and regional ports.

Risk analysis is a useful decision support tool for management, when applied at the right level for a specified purpose. The vector-specific approaches being applied for ballast water and biofouling aim to prevent new species introductions, recognizing that prevention is the strongest form of management available for alien species threats. However, once a species incursion has been detected, it can be helpful to develop and apply a risk assessment model to better understand the realities of the apparent threat. Target species risk assessments are being used in South Africa to evaluate applications for proposed species importation (e.g. for aquaculture, pet trade etc.). However, there has been no methodological

approach to evaluating the risk posed by alien species detected in local waters, in terms of possible further spread and impact (including economic, environmental and social). In the case of the European Shore Crab, *Carcinus maenas*, significant resources were allocated to a trial extirpation project, in order to assess if a national-level eradication would be feasible, based on the perceived risk that the species might spread and impact the local mariculture industry. The project demonstrated that an eradication would not be feasible, and the threat persists that this species may not yet have realized its full potential to spread and impact coastal South African waters.

Although South African coastal waters have been relatively well studied, in terms of documenting the numbers and ranges of extant alien species (Robinson et al., 2005), biological information from port environments has been comparatively less available. For other African countries, the quality of marine species data is patchy, and IAS information is relatively non-existent. Considering that most African ports have never been surveyed, and that these are the environments where new species are most likely to settle, achieving biological baseline surveys in key ports was seen as a first step in linking knowledge to action towards preventing new IAS from arriving.

Given that the methodologies recommended by the IMO were developed in other countries, under different circumstances, it was not clear that they could be successfully applied in African ports, considering capacity constraints and other challenges. It was even less clear if any continuity with IAS management applications would be feasible or effective. This study therefore aimed to test and demonstrate the various benefits and values of conducting port biological baseline surveys, and the role that the survey outputs, including baseline data and highlighted management concerns, could play in supporting ongoing regulatory practices. Given that these direct linkages had not previously been developed, it was necessary to design approaches for risk-based management frameworks that fit the needs and circumstances of the authorities involved.

Therefore, the over-arching question being addressed in this study is:

***Can port surveys generate meaningful baseline data and lead to more targeted management for IAS, and if so, can the questions coming out of the surveys be addressed through these management approaches?***

Each chapter tackles a different aspect of the question, as follows:

**Chapter 1** - Are large-scale, once-off baseline surveys able to generate adequate and useful data to support management needs, in an African context?

**Chapter 2** - Can lessons learned from port survey experiences in Africa be synthesized into a guidance document that helps facilitate further implementation and capacity for such surveys?

**Chapter 3** - How can risk assessment methodologies be developed and applied to support Port State Control practices in managing the risk posed by alien species introductions?

**Chapter 4** - Does the risk of further spread and impact posed by the European Shore Crab warrant further consideration, especially as regards the growing mariculture industry?

This thesis is not the usual or ‘normal’ approach to a PhD project, offered and funded by a university department and conducted full-time over a period of 3-4 years. The study was initiated in 2001, following the completion by the author, of a Master’s degree in 2000, at the University of Cape Town (UCT). The study was initiated as a two-year survey project, which was subsequently followed by a progression of related projects, each with specific time frames and conditions, but all tied directly to the core questions of the study, as well as to the professional work of the author. In fact, one of the major challenges for the author was to secure institutional and funding support for each project iteration, while maintaining the professional flexibility to comprehensively manage and coordinate the projects in their entirety. Additionally, some of the realities of working full-time, including managing non-related projects throughout the course of the PhD study, factored into the extended timeframe. Nonetheless, the long project duration has allowed for the real-world scenarios supporting and intimately tied to this work, to play out, with relevant implications for the project.

As mentioned above, the management implications of the study were real-world ones, in that the projects were supported by the relevant management authorities themselves, explicitly to produce applicable and viable outcomes within and for their departments. Therefore, some aspects of the project design were constrained by the needs or circumstances of the authorities or policies involved, as well as their funding priorities. The author did not necessarily have the flexibility to steer project components in different directions than those mandated by the agreements with the various funding bodies. However, in all cases, the author secured the appropriate permission for the projects to be integrated with the ongoing PhD study.

There are several references throughout the text of the thesis to institutions involved in various components of this study. It is helpful to understand the job and role that was being played by the author within these institutions at the relevant time over the project period, as summarized below.

Relevant period	Position, employer	Role in components of the PhD study
2001-2004	Coordinator for the GloBallast programme in Africa, International Maritime Organization (IMO)	Project leader for the Port of Saldanha survey, SA team leader for the Port of Saldanha risk assessment, Project leader for the Port of Mombasa survey
2005-2006	Marine Programme Director, Global Invasive Species Programme (GISP)	Project leader for the taxonomic phase of the Port of Mombasa survey
2007-present	Director, International Ocean Institute - Southern Africa (IOI-SA)	Project leader for the Port Louis survey, Project leader for the Port Louis risk assessment, Project leader for the <i>Carcinus maenas</i> risk assessment

Each project component, as listed below, had a unique set of institutional, funding and stakeholder arrangements. The contributions made by all parties involved are simply too many to list, however acknowledgment of these is made at broad institutional level. Members of project teams are detailed in the subsequent chapters, and most substantive contributions are also noted, as many of these were integral in guiding the outputs of the study.

#### **Port biological baseline survey for the Port of Saldanha (2001-2003)**

This project was funded by the GEF/UNDP/IMO Global Ballast Water Management Programme (GloBallast), with support from the Government of South Africa (Department of Environmental Affairs). Further support was provided through the University of Cape Town, the University of the Western Cape and the Transnet National Ports Authority (TNPA). Access to restricted areas was granted by the South African Navy and National Parks Board.

#### **Port biological baseline survey for the Port of Mombasa, Kenya (2004-2007)**

The field work phase of this project was funded by the GloBallast programme. The IMO Technical Cooperation Division provided funding support via GISP for the coordination of the taxonomy phase. Further in-kind support was given by the government of Kenya, through the Kenya Marine and Fisheries Research Institute, the Kenya Ports Authority and the National Museum of Kenya. Additional contributions were made from the IUCN, the University of Cape Town, the University of the Western Cape, and the IOI-SA.

#### **Port biological baseline survey for Port Louis, Mauritius (2010-2014)**

The survey project for Port Louis was entirely funded by the government of Mauritius, via the Shipping Division and the Mauritius Oceanography Institute (MOI). The work was undertaken by the IOI-SA, with the contracted assistance of Anchor Environmental Consultants. Additional support was provided from the University of Cape Town, the University of the Western Cape. Invaluable in-kind assistance was given by the National Coast Guard in Mauritius, and the Mauritius Ports Authority in facilitating port access and approvals.

#### **Guidance on port biological baseline surveys (2011-2012)**

This publication was developed as a joint initiative between the IOI-SA and the GloBallast Programme. The document content was developed by the author, with technical contributions from experts in the IMO, the National Institute of Oceanography in India and the IUCN. The publication was funded by the GloBallast programme, as a printed manual that was distributed to administrations of Member States, and made available for free download via the websites of the IMO and IOI-SA. The guidance document was published under the GloBallast Monograph Series (No, 22), with the author of this study as the lead author.

### **Port of Saldanha risk assessment (2002-2004)**

The project was funded and coordinated by the GloBallast programme, with the contracted assistance of URS Australia. In-kind support was provided by the TNPA, CSIR, and the Department of Environmental Affairs. The risk assessment project document was published under the GloBallast Monograph Series (No, 13), with the author of this study as the lead author.

### **Port Louis risk assessment (2013-2014)**

This project followed the Port Louis survey project, as an ongoing extension, and was also funded by the government of Mauritius, via the Shipping Division and MOI. The work was undertaken by the IOI-SA, with the contracted assistance of Reuben Roberts to programme the software used in the risk assessment. Assistance was provided by the Mauritius Ports Authority in gaining ship access and work space in the port.

### **Risk assessment of *Carcinus maenas* (2015)**

This project was funded by the Department of Environmental Affairs via the South African National Biodiversity Institute, as part of a contribution to a national marine monitoring programme, also being developed by the author for the Department of Environmental Affairs. The work was conducted through the IOI-SA, with contracted assistance from Andrea Angel who helped compile a literature review.

The sincere gratitude of the author is hereby expressed to all the institutions and individuals listed above, and others who made this study possible.

### **Further expressions of appreciation and gratitude:**

Additional gratitude is expressed to the Supervisor of this PhD study, Emer. Prof. Charles Griffiths of UCT, for his guidance, patience and support over the significant duration and through the various complexities of this project.

At a personal level, the author wishes to thank all family members that kept the pressure on to see this through, while accepting the sacrifice at home and providing all the love necessary.

## Chapter I - Port biological baseline surveys in key African ports

### 1.1 Aims and objectives

The three projects described herein essentially each had the same core aim of conducting a port biological baseline survey at a priority port within the African region. Although the same guiding protocols were consistently applied as a methodological guide for all three surveys, the context and conditions under which each project was conducted differed significantly, along with some of the peripheral areas of focus. Also, the sequential approach to the surveys, which took place over several years, allowed for lessons-learned in the earlier surveys to be applied in later ones, and hence for a progressive maturation and refinement of the port survey process. This culminated in the production of the 'Guidelines for Conducting Port Biological Baseline Surveys', which was applied during the design and implementation of the Port Louis survey (section 1.5), and which is presented as Chapter 2 of this thesis.

Each of the three surveys is therefore presented separately in sections 1.3-1.5 below, with each description demonstrating both the core outcomes in terms of species information, and the more unique supplemental aspects or values derived from the broad projects as implemented. Some of the cross-cutting considerations are discussed further in the final section of the chapter.

The objectives of the conducted port biological baseline surveys were to:

- Develop baseline data on the species composition/biodiversity, distribution and abundance in all marine habitats of the port.
- Identify the presence/absence of alien and invasive species (IAS) in the port.
- Provide training and capacity building to local personnel in all aspects of IAS surveys and monitoring.
- Provide updated information for the relevant regional and international IAS databases and information management systems.
- Build the foundation for long-term, ongoing IAS monitoring at the port, and replication of IAS surveys and monitoring at other relevant ports.
- Develop the foundation for an eventual IAS detection, early warning and reporting system.
- Establish national specimen collections (including reference and voucher collections of marine species) for all species collected during the survey, which can be further enhanced through subsequent monitoring efforts.
- Catalyze IAS management (e.g. ballast water, biofouling etc.) efforts, including cross-sectoral collaboration with all key stakeholders associated with the port.
- Provide the essential port-specific data (biological and environmental) to support risk-based management approaches related to limiting species translocation.
- Highlight any particular species of concern, and related questions, which may require further investigation and/or management.

## 1.2 Port survey protocols

The Australian Centre for Research on Introduced Marine Pests (CRIMP) has developed technical protocols for carrying out port baseline surveys (Hewitt and Martin, 2001). This has been used successfully in a number of locations worldwide, including most ports in Australia, all ports in New Zealand and, in a modified format, in the six GloBallast pilot countries (Brazil, China, India, Iran, South Africa and Ukraine), with the result that there is now good knowledge of application and adaptation of this protocol. The CRIMP protocols were selected to guide the methodologies for the surveys presented here.

The protocol provides design criteria and methodologies for the collection of baseline data from port areas. It also allows for the inclusion of a targeted approach that gives extra priority to habitats associated with introduced species. The protocol recommends the use of a dive team for the majority of sample collections, and aims to sample all accessible habitats in a port area, irrespective of available taxonomic capacity. Considerations for alternative methodological approaches and the adaptation of the CRIMP protocols are presented in Chapter 2 of this study.

Sampling site locations were selected for each port based on available maps (including habitats), charts, aerial photographs and circulation models, as well as detailed inspections conducted during reconnaissance visits. Sites were chosen to give adequate representation to all habitat types, and to focus sampling on areas of each port where organisms are likely to settle and establish populations. Areas of disturbance and ballast water discharge were emphasized due to the likelihood of detection of introduced species. All sites were prioritized according to the CRIMP protocols, and designated as quantitative, semi-quantitative or qualitative, to guide the rigor and methods to be applied.

Standard sampling methods (by habitat type) are described below, as recommended in the CRIMP protocols, and applied during each of the surveys reported here. More extensive descriptions of sampling and preservation methods are detailed in Chapter 2. Any significant deviations from the sampling methods or equipment described here is noted within the relevant sections for each of the surveys.

### **Benthic infauna - large hand corers**

Divers using a tubular 0.025m<sup>2</sup> (18cm diameter) hand corer sampled the benthic infauna. The corer was forced into the sediment to a depth of 200-250mm. The sediment core samples were sieved through a 1mm mesh sieve. The organisms were preserved in 5-10% buffered formalin and later transferred to 70% ethanol for holding. At each wharf, a maximum of 3 core samples (aggregated) were taken 1m away from the pile base, to ensure that debris from piling samples were not included in the core sample. In some cases, additional core samples were taken 50m away from the pile base as this area is considered the area that is most likely to be affected by ballast water discharge from ships.

### **Fouling communities - quadrat scrapes**

Biological samples were collected from wharf piles, jetties and other appropriate surfaces from a number of sites around each port. At each site three replicate 0.10m<sup>2</sup> quadrats were fixed to piles or facings. The divers photographed the full quadrat area (to assist with identification of specimens), then scraped the contents of the quadrats into 1mm mesh bags. Triplicate samples were aggregated and collected at three depth intervals (i.e. 0.5m, 3m and 7m below MLW). Samples were rough sorted as soon as they were brought on shore. Buffered formalin (10%) was used as a fixative for most organisms. Ethanol was used in 70% diluted solution for preserving bryozoans, sponges, and cnidarians. Representative specimens of certain species were narcotized with magnesium chloride before they were preserved, in order to ensure proper relaxation for subsequent identification purposes.

### **Epibenthos - traps**

Crab, shrimp and fish traps were laid overnight at various sites in and around the ports to investigate the presence of any highly mobile epifaunal alien species. The traps were fabricated according to either the CRIMP protocols or local specifications and set according to the recommended procedures. In some cases, the divers were able to manoeuvre the traps into favourable positions, and also help recover them afterwards. In normal situations the traps were deployed from the surface, with fixed lines.

### **Fish - rotenone sampling**

Poison stations were used to sample fish species during the survey of the Port of Saldanha, but not for the other ports surveys, as this method is considered unnecessarily impactful to reef communities in some areas. Where possible, the area to be sampled was enclosed within a plastic sheet measuring 3 x 3m, and weighted on the edge with chain. The ichthyocide rotenone, mixed with seawater, was then pumped under the sheet and left for at least 30 min to give it time to take effect. The sheet was then rolled back and anaesthetised fish collected with small hand nets. The function of the plastic sheet was to reduce dilution of the rotenone before it has had its full effect on the fish, and to reduce the chance of fishes escaping from the sample area.

### **Fish - beach seine sampling**

Beach seine netting was used to assess juvenile fish populations at appropriate sandy beach stations in and around the port area. The net used was approximately 30m long by 3m deep with 15mm mesh. The nets deployed in the field varied in length from 30 to 50m, and in mesh size from 15 to 20mm. Nets were laid by hand, enclosing an area of approximately 500 to 1000m<sup>2</sup> at each site. Small boats were used to assist with deployment in some cases.

### **Zooplankton and phytoplankton - plankton tows**

Samples were taken in the port channels and outside the ports in open areas by means of net tows. These were conducted during daylight and evening/dark hours in order to collect the plankton that rise to the surface in the evening. Where possible, an appropriate boat was fitted with a boom to facilitate net deployment. Phytoplankton was sampled using a 20µm mesh plankton net, towed behind a boat for a distance of 100m. Zooplankton samples were collected using a net sampler with 100µm mesh. The net was hauled vertically from a depth of 10m. Samples of both types were preserved in 5% buffered formalin.

### **Dinoflagellate cysts – small hand cores**

Divers using hand-held plastic core tubes, 30cm long with a 3.5cm internal diameter, collected samples for assessment of dinoflagellate resting cyst stages at the Ports of Saldanha and Mombasa. The cores were forced 20 - 25cm into the soft sediment at locations where large core samples were also collected. The core tubes were capped with bungs and kept in cool, dark conditions until further examination. Duplicate cores were taken at each site.

### **Environmental parameters and sediment**

At each sampling location environmental parameters such as pH, temperature, salinity and conductivity were measured using a calibrated multi-parameter field meter, and water clarity was measured using a Secchi disk. Sediment samples were opportunistically collected in jars by divers, and particle size analyses were carried out in some cases, in order to assist with habitat characterisation.

## **1.3 Port of Saldanha, South Africa**

### **1.3.1 Background**

As part of its objective of assisting developing countries to implement the IMO Guidelines, the GloBallast Programme supported each of its six Pilot Countries to conduct port biological baseline surveys at selected demonstration sites (ports), with specific emphasis on the detection of IAS. These were Dalian (China), Khark Island (Iran), Mumbai (India), Odessa (Ukraine), Saldanha (South Africa) and Sepetiba (Brazil). The intention was that activities carried out at the demonstration sites would then be replicated at additional sites within each region.

In South Africa, the demonstration port for the GloBallast Programme was selected to be the Port Saldanha, located in Saldanha Bay on the west coast. This site was selected over other ports in the country due to it being one of two deep-water ports in existence at the time (Richard's Bay being the other), the large volumes of ballast water received at the port from all over the world, and the extensive natural resources associated with the port, as described in the section below.

The field survey of the Port of Saldana was conducted over two weeks in April 2001. It was the first survey conducted under this global project. It was therefore used as an opportunity to convene project leaders from the other demonstration sites at Saldanha Bay to learn from the exercise. This section presents details of the design, implementation and results of the port biological baseline survey carried out at the Port of Saldanha in South Africa.

### 1.3.2 Description of the port

The Port of Saldanha is situated on the west coast of Africa, 60 nautical miles northwest of Cape Town, (Lat 33 ° 02' S; Long 17 ° 58' E) and is the deepest and largest natural port in Southern Africa. The Transnet National Ports Authority (TNPA) has jurisdiction over the land and sea within the port boundaries, which totals 18,300 hectares. The Port is located immediately north of Langebaan Lagoon, a large shallow natural lagoon which is the dominant feature within the West Coast National Park, and which has been a Ramsar-listed site since 1988. Small inshore islands in the Langebaan area support large breeding colonies of seabirds.

Located within the greater port area are the SA Navy Base, SAS Saldanha, and a major fishing harbour, which is administered by the Department of Agriculture Forestry and Fisheries (DAFF). The port of Saldanha is the only iron ore handling port in South Africa, and is supplied by a dedicated rail connection to the mines some 860km north-east of Saldanha. The port also receives base metals from mines situated in the Northern Cape. The port's oil terminal allows for imported crude to service the refinery near Cape Town, as well as for storage in a strategic facility near the port.

A 2km Spending Beach Breakwater protects the harbour entrance, anchorage and shore area against the south westerly swells, which are most severe during winter storms. Port facilities consist of a 990m long jetty with two iron ore berths and one crude oil berth joined to the north shore of the harbour by a 3,100m causeway. Additionally, the multipurpose terminal quay spans 874m to handle break-bulk cargo.

The Port of Saldanha operates under a broad range of conditions influenced by the strong local winds and open sea swells. Tidal ranges are from 0.6m (mean neap) to 1.4m (mean spring).

**Table 1.1** Selected environmental parameters for Saldanha Bay.

Water Temperatures (°C)				Summer Air Temp (°C)		Winter Air Temp (°C)		Total Rainfall (mm)	
Mean Summer	Max Summer	Mean Winter	Lowest winter	Mean day-time	Max day-time	Mean night-time	Lowest night-time	Driest 6 Months	Wettest 6 Months
18.5	22.6	14.0	9.0	26.0	35.0	10.0	4.0	69	274

Saldanha Bay is linked to the Benguela upwelling system to the west and to Langebaan Lagoon to the south. The Bay comprises three main bodies of water, namely Outer Bay (of predominantly coastal character), Big Bay, and Small Bay (a relatively enclosed area bounded by the iron-ore jetty and the breakwater). There are no significant river inputs into either Saldanha Bay or Langebaan Lagoon and consequently the system is fully marine in character. In winter, however, there is some seepage of freshwater into the bay due to rainfall (Day, 1981).

The currents in the Bay are forced by the wind and the tide, the relative importance of the two processes changing with depth and location in the bay. In general, wind-forcing is the dominant physical mechanism determining the surface current speed and direction, although this varies seasonally (Figure 1.1). Tidal forcing is stronger at depth, in the vicinity of the mouth of Saldanha Bay and with increasing proximity to Langebaan Lagoon.

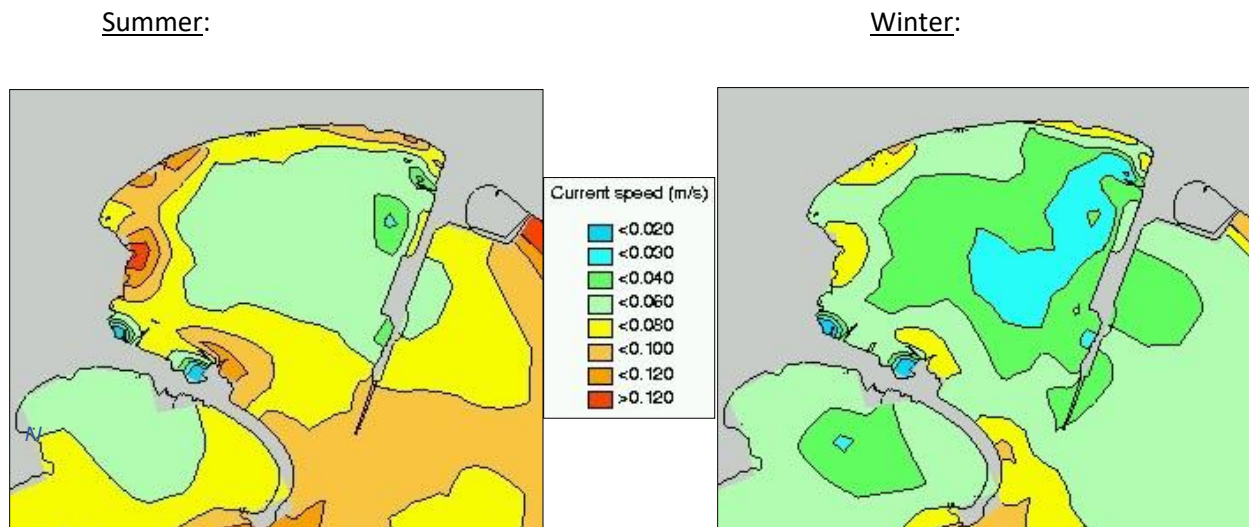

**Figure 1.1** Median current speeds of the surface waters in Saldanha Bay during summer and winter seasons (provided by TNPA).

A long history of shipping records maintained by TNPA demonstrates trade partners and source ports for imported ballast water spread all around the globe. The highest volumes of ballast water being discharged in the Port of Saldanha originate from the Far East and Europe (Top five source nations in order of importance: China, Japan, Netherlands, Singapore, Turkey and United Kingdom). As no specific location is demarcated as the discharge site for ballast water in Saldanha, ships are free to discharge wherever they berth. However, 90% of ballast water discharges, by volume, occur at the Ore Loading Jetty, with the Tanker and Fishing berths accounting almost equally for the remaining 10% of discharges (Awad et al., 2004).

### 1.3.3 Survey methods

#### Plan and approach

This survey represented the first attempt to comprehensively sample a port system in South Africa for introduced marine species. By working with the TNPA, it was ensured that the survey would be included as part of their ongoing ballast water management practices, and further monitoring would be encouraged as part of a long-term biological monitoring program for the port. This would allow any existing introductions to be tracked and managed, and any new introductions to be detected.

The team that was assembled (Table 1.2) comprised representatives from the GloBallast Programme, the University of the Western Cape (UWC), the University of Cape Town (UCT) and independent consultants, and was responsible for all aspects of the field survey, from initial planning to final reporting. Marine science graduate students associated with the above academic institutions assisted with the physical sampling and sorting of samples collected from benthic and intertidal habitats. Plankton and fish sampling was conducted on contract by local independent consultants. A combination of local and international taxonomists handled the identification of specimens from these the samples.

**Table 1.2** The Port of Saldanha field survey team members.

Name	Role	Affiliation (at time of survey)
Adnan Awad	Project leader, survey coordinator	IMO - GloBallast
Marnie Campbell	Technical Advisor	IMO - GloBallast (consultant)
Andre Kleynhans	Dive Supervisor	Independent (Paternoster)
Toufiek Samaai	Diver	University of the Western Cape
Wayne Florence	Diver	University of the Western Cape
Goosain Isaacs	Diver	University of the Western Cape
Gordon Harkins	Diver	University of the Western Cape
Mark Rothman	Diver	Marine and Coastal Management
Allison Dainty	Diver	University of Cape Town
Martin Hendricks	Sampling Supervisor	University of the Western Cape
William Snyman	Subtidal sampling (hard substrata), Diver	University of the Western Cape
Natasha Kruger	Subtidal sampling (soft substrata)	University of Cape Town
Tamara Robinson	Intertidal sampling	University of Cape Town
Barry Clark	Fish sampling	Anchor Environmental Consultants
Jimmy Norman	Port Liaison	TNPA

Three Master's-level students were recruited to help oversee the field sampling and post-field stages of the survey that were related to major habitat types. Each student carried out a thesis project based on work related to this survey. The first project focused on the changes in the intertidal community composition over time, comparing the new sampling data with data gathered in the early 1970's, before the harbour was constructed. This student designed an extensive and comprehensive intertidal sampling

plan, which greatly exceeded the recommendations of the CRIMP Protocols. The other two projects focused on changes in the sub-tidal community. One compared soft sediment habitat data with similar historical data, while the other focused on alien species presence on hard substrates and areas associated with shipping activities.

The South African Museum in Cape Town (now the Iziko South African Museum) agreed to curate all samples from the survey as part of its own collection. Following final taxonomic analysis, all samples were placed in appropriate containers for long-term storage at the museum, and labeled accordingly. The reference and voucher collections of all specimens have therefore been lodged with the museum.

### Survey design

A total of 39 sites (including 24 quantitative/semi-quantitative sites, and 15 qualitative sites) were selected during the planning stages of the survey. Justification for site selection was based on likelihood for species detection (with emphasis on IAS), and maximizing the diversity of available habitats to be sampled. Priority rankings were allocated to each site (Table 1.3), as per the CRIMP protocol and appropriate sampling methods were designated (Table 1.4). While the site selection ensured that the operational port areas were well covered, it was also important that several sampling sites were located in non-shipping areas outside the Port that were expected to be more pristine, and throughout Langebaan Lagoon.

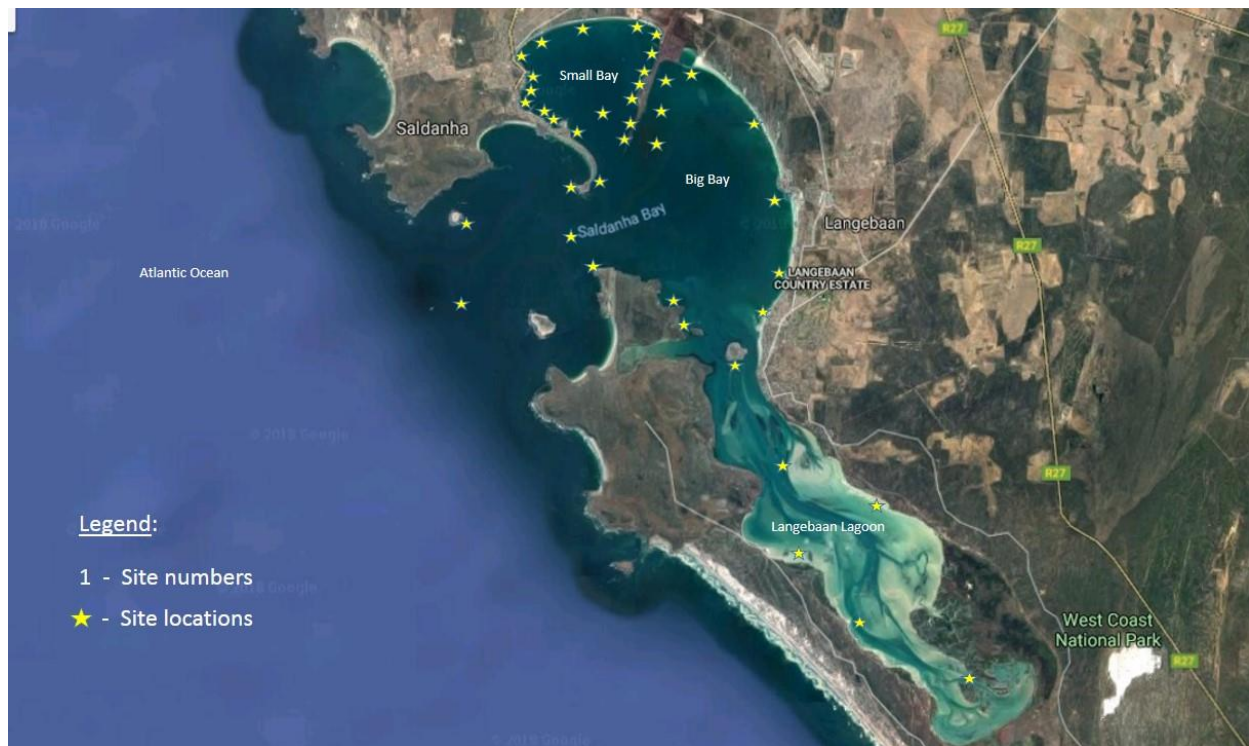

**Figure 1.2** Map of Saldanha Bay and Langebaan Lagoon showing primary sampling locations.

**Table 1.3** Port of Saldanha sampling sites, allocated site number, site code, priority and designation.

Name	Site No.	Site Code	Priority	Sampling Designation
<b>Small Bay</b>				
Ore Jetty West	1	SAWCSBIHOJW	1	Quantitative
End of the Ore Jetty	2	SAWCSBIHEOR	1	Qualitative
Pollution Boatshed	3	SAWCSBIHPB	1	Qualitative
Multipurpose Berth 1	4	SAWCSBIHMB1	1	Quantitative
Multipurpose Berth 2	5	SAWCSBIHMB2	1	Qualitative
Multipurpose Berth 3	6	SAWCSBIHMB3	1	Quantitative
Multipurpose Berth 4	7	SAWCSBIHMB4	1	Quantitative
Oil Rig Wall	8	SAWCSBIHORW	3	Qualitative
Private Jetty	9	SAWCSBIHPJ	3	Qualitative
Disused Fish Wharf	10	SAWCSBIHDFW	2	Quantitative
Fish Wharf 1	11	SAWCSBIHFW1	1	Qualitative
Fish Wharf 2	12	SAWCSBIHFW2	1	Quantitative
Moorings	13	SAWCSBIHM	1	Semi-quantitative
Yacht Club	14	SAWCSBIHYC	2	Semi-quantitative
Slipways	15	SAWCSBIHS	1	Quantitative
Presidents Jetty	16	SAWCSBIHPJ1	3	Qualitative
Fish Wharf 3	17	SAWCSBIHFW3	2	Qualitative
Fish Wharf 4	18	SAWCSBIHFW4	2	Quantitative
Tug Berth	19	SAWCSBIHTB	1	Quantitative
Anchorage West	20	SAWCSBIHAW	2	Semi-quantitative
Mussel Culture West	21	SAWCSBIHMCW	2	Semi-quantitative
<b>Big Bay</b>				
Channel Buoy 1	22	SAWCSBOHCB1	1	Semi-quantitative
Channel Buoy 2	23	SAWCSBOHCB2	1	Semi-quantitative
Mussel Culture East	24	SAWCSBOHMCE	2	Semi-quantitative
Anchorage East	25	SAWCSBOHAE	2	Semi-quantitative
Ore Jetty East	26	SAWCSBOHOJE	1	Quantitative
Oyster Dam Outer	27	SAWCSBOHODO	3	Qualitative
Oyster Dam Inner	28	SAWCSBOHODI	2	Semi-quantitative
Club Mykonos Marina	29	SAWCSBOHCM	1	Quantitative
Club Mykonos Breakwall	30	SAWCSBOHCMB	3	Qualitative
<b>Langebaan Lagoon</b>				
Navy Jetty	31	SAWCSBLLNJ	1	Quantitative
Navy Slipways	32	SAWCSBLLNS	1	Quantitative
Langebaan Jetty	33	SAWCSBLLJ	1	Quantitative
Langebaan Yacht Club	34	SAWCSBLLYC	1	Qualitative
Mytilus Beds	35	SAWCSBLLM	2	Qualitative
Skaapeiland South	36	SAWCSBLLSS	3	Qualitative
<b>Offshore deballasting areas</b>				
Marcus Island	37	SAWCSBOMI	2	Semi-quantitative
Wasserfall Bank	38	SAWCSBOWB	2	Qualitative
Malgas Island	39	SAWCSBOMI1	2	Qualitative

**Table 1.4** Sample methods used at each site during the survey of the Port of Saldanha.

SITE	Small core (dinoflagellate cysts)	Large core (benthic infauna)	20um plankton net	100um plankton net	Traps (crab/ shrimp)	Qualitative visual surveys	Quadrat scraping	Photo stills	Poison stations (fish)	Beach seines (fish)
<b>Inner Harbour</b>										
Ore Jetty West										
End of the Ore Jetty										
Pollution Boatshed										
Multipurpose Berth 1										
Multipurpose Berth 2										
Multipurpose Berth 3										
Multipurpose Berth 4										
Oil Rig Wall										
Private Jetty										
Disused Fish Wharf										
Fish Wharf 1										
Fish Wharf 2										
Moorings										
Yacht Club										
Slipways										
Presidents Jetty										
Fish Wharf 3										
Fish Wharf 4										
Tug Berth										
Anchorage West										
Mussel Culture West										
<b>Outer Harbour</b>										
Channel Buoy 1										
Channel Buoy 2										
Mussel Culture East										
Anchorage East										
Ore Jetty East										
Oyster Dam Outer										

SITE	Small core (dinoflagellate cysts)	Large core (benthic infauna)	20um plankton net	100um plankton net	Traps (crab/ shrimp)	Qualitative visual surveys	Quadrat scraping	Photo stills	Poison stations (fish)	Beach seines (fish)
Oyster Dam Inner										
Club Mykonos Marina										
Club Mykonos Breakwall										
<b>Langebaan Lagoon</b>										
Navy Jetty										
Navy Slipways										
Langebaan Jetty										
Langebaan Yacht Club										
Mytilus Beds										
Skaapeiland South										
<b>Offshore deballasting areas</b>										
Marcus Island										
Wasserfall Bank										
Malgas Island										

Intertidal zone sampling was added to the Port of Saldanha survey as a discrete student (M.Sc.) project, in addition to the sampling methods prescribed in the CRIMP protocol, and consistent with those described by Day (1959). As such, the following methodologies were incorporated into the overall survey design:

- **Rocky shore intertidal transects**

The shoreline of Saldanha Bay and Langebaan Lagoon was divided into 28 areas measuring 2.5km each. Three rocky shore sites were sampled within each area, and at each site triplicate transects were taken. Three quadrats (one in the high, one in the mid and one in the low shore zone) measuring 0.016m<sup>2</sup> were taken within areas of 100% mussel cover within 0.5m of each transect. The various mussel species were separated out and individuals of each species weighed separately. The biomass per linear meter of rocky shore was also calculated.

- **Sandy shore intertidal transects**

Transects were taken at five sites around Saldanha Bay and Langebaan Lagoon, running from MHWS to MLWS, and each were surveyed using the methods from Day (1959). Quadrats measuring 33 x 33cm were taken at 20cm height intervals along the transect lines. Two random samples were taken in each vertical zone. Epifauna was sampled by hand. Burrowing forms were sampled by removing all sediment within the quadrat to a depth of 30cm and passing it through a 1mm sieve. All species collected were identified and counted. The results from the duplicate quadrats were pooled to obtain an average number of individuals per m<sup>2</sup> for each station.

- **Visual intertidal transects**

Triplicate surveyed transects were taken at three sites. A 0.5m<sup>2</sup> quadrat was rolled up the transect line, from MHWS to MLWS, and the number of individuals of each visually dominant species in each quadrat was counted.

#### 1.3.4 Survey results

A total of 546 species were found, preserved and recorded from the survey of the Port of Saldanha, with 404 of these having confirmed species identifications. Eight alien species were recorded from the samples, as well as two species of phytoplankton that are being considered as cryptogenic, and one new fish species that was previously undescribed, and is likely endemic to the region. Table 1.5 shows the distribution of species findings, including aliens, by general habitat type. Numbers of species found within each broad taxonomic group are listed in Table 1.6, and compared against historical records of species from Saldanha Bay and Langebaan Lagoon.

**Table 1.5** Results from the Port of Saldanha survey, presented by habitat type.

Habitat sampled	Number of species found	Alien species found
benthic soft substratum	194 species, representing 10 families from 19 classes	<i>Mytilus galloprovincialis</i> (mussel) <i>Ciona robusta</i> (ascidian) Both tend to occur on hard substrata, so presence likely due to sampling close to wharf piles
Benthic hard substratum and fouling communities	214 species, representing 11 families from 24 classes	<i>Mytilus galloprovincialis</i> (mussel) <i>Ciona robusta</i> (ascidian) <i>Diplosoma listerianum</i> (ascidian) <i>Botrylloides leachi</i> (ascidian)* <i>Bugula neritina</i> (bryozoan)*
Benthic fish (rotenone)	19 species from 10 families	none
Fish (seine net)	14 species from 11 families	One previously undescribed spp.
Intertidal zone	115 species from 11 families	<i>Mytilus galloprovincialis</i> (mussel) <i>Littorina saxatilis</i> (periwinkle) <i>Pateriella regularis</i> (starfish)* <i>Carcinus maenas</i> (crab) - carapace only
Phytoplankton	54 species	<i>Spatulodinium</i> sp. (cryptogenic) <i>Protoperidinium</i> sp. (cryptogenic)
Zooplankton	10 Species, 34 genera from 18 families	none
Dinoflagellate cysts	14 species from 4 genera	none

\* New records for South Africa

The introduced species recorded during this survey were thus:

- ***Mytilus galloprovincialis*** (Mediterranean Mussel)
- ***Carcinus maenas*** (European Shore/Green Crab - no live specimens found)
- ***Ciona robusta*** (Ascidian - previously *C. intestinalis*)
- ***Diplosoma listerianum*** (Ascidian)
- ***Botrylloides leachi*** (Ascidian)
- ***Bugula neritina*** (Bryozoan)
- ***Littorina saxatilis*** (Atlantic Snail)
- ***Pateriella regularis*** (Starfish)

Of these, *Mytilus galloprovincialis*, *Carcinus maenas*, *Ciona robusta* and *Littorina saxatilis* have been well established and documented invaders for several decades in South Africa (Robinson et al, 2005).

The first record of *Diplosoma listerianum* was from 2001, the same year this port baseline survey was conducted. The other three introductions are the first records of these species in South Africa.

Species-level identifications were achieved for most of the sampled fauna and flora. The specimen collection was lodged at the Iziko South African Museum, such that follow-up analyses could be conducted as possible. A new species was recorded from the fish specimens. The sand-dwelling clinid, from the family Clinidae, has characteristic features that indicate it to be an indigenous but undescribed species, rather than an alien species. Only six other sand dwelling clinid species have been described previously, and all are endemic to southern Africa.

### 1.3.5 Discussion

Before this survey, no comprehensive, targeted alien species survey had been completed in Saldanha Bay. Some alien species were already recorded from this area, and research was increasingly focused on their ecological impacts. For instance, the invasive Mediterranean mussel (*Mytilus galloprovincialis*) established itself in Langebaan Lagoon in 1992 (Griffiths *et al.* 1992), and studies have shown that it has negative impacts on the natural community (Stenton-Dozey *et al.* 2001, Robinson & Griffiths 2002). It has also been suspected that *Carcinus maenas* may be present in the Bay due to its abundance in nearby Port of Cape Town, and a recent single record of a mating pair in the Saldanha intertidal zone (Pers. Comm. C. Griffiths). Although it was not considered introduced to South Africa at the time of the survey, *Aureococcus anophagefferis*, which causes brown tide, was first found in Saldanha Bay in 1997, and has had severe impacts on the oyster farm there (Pitcher & Calder 2000, Probyn *et al.* 2001). This species was not detected in the survey.

Saldanha Bay has been well sampled and studied for over 50 years with good species records and publications generated from the local universities and government agencies. Extensive species lists of marine organisms identified during research studies at Saldanha Bay and Langebaan Lagoon exist, as described in Table 1.6. The table also presents the numbers of species found within these groups during the port baseline survey, indicating that this once-off intensive survey was effective in detecting a significant proportion of the extant flora and fauna in the area.

**Table 1.6** Historical records of marine organisms identified at Saldanha Bay (SB) and Langebaan Lagoon (LL) compared against those recorded during this study.

Marine groups surveyed	Number of species/forms previously identified	Time period	Locality	Author	Number of species/forms identified in the present study
Total species (algae and fauna)	473	~12 years up to 1957	SB, LL	Day 1959	404 confirmed species identifications from 546 species found

Fauna and flora	66	~2000	LL	Robinson & Griffiths 2002	
Benthic macrofauna	131	1956 - 1975	LL	Christie & Moldan 1977	227
	60	1960-1963	SB	Moldan 1978	
	66	1975	SB	Moldan 1978	
Fish	24	1994	SB, LL	Clark 1997	39
Algae	130	1997	SB, LL	Schils <i>et al.</i> 2001	91
	71, 47	1960, 1976	SB	Simons 1977	
Zooplankton	98	1946 - 1976	SB, LL	Grindley 1977	10 (18 Families identified)
Phytoplankton	173	1996-1997	SB	Marangoni <i>et al.</i> 2001	54
Inter-tidal fauna	~40	1974 - 1975	LL	Puttick 1977	115

At the time of the survey, only five alien species had been recorded for the area of Saldanha Bay and Langebaan Lagoon. All of these were detected again during the survey, and three new alien species were added to the local list (Table 1.7).

**Table 1.7** Comparison of introduced species found in the port survey with previous records from the area.

Species name	Species type	Previously recorded in Saldanha Bay or Langebaan Lagoon?*	Recorded in the baseline survey of the Port of Saldanha?
<i>Ciona robusta</i>	Ascidian	Yes	Yes
<i>Diplosoma listerianum</i>	Ascidian	Yes	Yes
<i>Botrylloides leachi</i>	Ascidian	No	Yes
<i>Bugula neritina</i>	Bryozoan	No	Yes
<i>Carcinus maenas</i>	Crab	Yes	Yes
<i>Mytilus galloprovincialis</i>	Mussel	Yes	Yes
<i>Littorina saxatilis</i>	Periwinkle	Yes	Yes
<i>Pateriella regularis</i>	Starfish	No	Yes

\* According to Robinson et al. (2005)

## **Alien species**

The Mediterranean Mussel, *Mytilus galloprovincialis*, was recorded on most rocky shores around the bay, as well as in many of the quadrat scrapes within the port structures. This species invasion has been well documented and studied. The presence of the Atlantic snail, *Littorina saxatilis*, in the salt marshes of Langebaan Lagoon was similarly unsurprising. The more interesting finding was the carapace of the European shore crab, *Carcinus maenas*, which was found on the rocky shore in front of the town of Saldanha Bay. Even though this indicated that the species had successfully reached the Saldanha area, no live specimens were recorded during the survey, suggesting that a local population had not yet established. The discovery of the alien starfish *Pateriella regularis*, which was recorded on the sandy shores of Langebaan Lagoon, presented a further opportunity for further study. Few specimens of the starfish were found, implying that the incursion was likely recent. Further studies would be needed to target these areas to monitor species presence and allow delineate the extent of the invasion.

## **Zooplankton**

In general, the zooplankton specimens were difficult to identify to species level, as many suffered damage from the sampling process, or from preservation methods. Also, many specimens were not adequately mature for further analysis. A total of 18 families, including 34 genera, were identified from the zooplankton samples, with positive species-level identifications only achieved within the family Medusae. A total of 10 species of Medusae were recorded, and six copepod species and three cladocerans were distinguished. While some of the records for the Medusae are the first for Saldanha, all species found are indigenous and already recorded from the west coast of South Africa. Had there been more taxonomic capacity and interest in these samples, there would potentially have been hundreds of species that could have been identified. Insofar as the larval forms of extant fauna may be distinguished from the zooplankton samples, this may be valuable in the context of the objectives of the port baseline survey. For this study, however, in consideration of the lack of local expertise to identify most of the zooplanktonic species, this method of sampling did not contribute the anticipated value.

## **Phytoplankton**

In contrast to the zooplankton sampling, the decision to sample phytoplankton throughout the port area was made on the basis of the involvement of a local phytoplankton expert. As a result, a catalogue showing various phytoplankton species found in Saldanha Bay, during the survey period, was developed by Dr. Lizeth Botes, who analyzed these samples. The catalogue was published through the GloBallast Monograph Series. Photographs, as well as taxonomic characteristics for identification, were given for each species in the catalogue. A list of diatom, dinoflagellate and flagellate species present/absent at each site was listed in the catalogue. A total of 54 phytoplankton species were recorded from this study. All species were typical for the area, except for a *Spatulodinium* sp. and a *Protoperidinium* sp., which were temporarily classified as cryptogenic, pending further investigation.

## **Dinoflagellate cysts**

As for the phytoplankton sampling. The decision to include sampling for dinoflagellate cysts was made following the involvement of a foreign specialist that happened to be working temporarily on cyst assemblages in Cape Town. Cysts were observed in 23 of the 24 samples taken at the Port. A total of 14 distinctive cyst types, belonging to four genera, were observed. All but two cyst types were identified to species level. Overall, cyst abundances at each of the sites were very low, one site having no cysts present at all. The bottom sediment types at the sites sampled were predominantly composed of sand (fine and coarse) and gravel, not especially favourable for cyst accumulation.

Information about the occurrence of cysts in South African sediments is very scarce, therefore, due to a lack of any comparable data, it is impossible to say which species, if any, are indigenous to Saldanha Bay, or have possibly been introduced. All species recorded for the Bay have been observed to occur elsewhere around the world. What can be said about the cyst assemblage in Saldanha Bay is that it is characteristic of a coastal upwelling association. The analysis of recent and subfossil sediment layers (e.g. deep cores) may be able to help determine if any species of cyst have been introduced into the Bay. Through this method an attempt could be made to identify any long-term trends in the frequency and distribution of cyst forming dinoflagellate species.

## **General observations**

Survey results will function as baseline data to be updated and amended as appropriate. Specimen collections from this survey have been lodged with the South African Museum (now Iziko South African Museum) in Cape Town, to allow for their availability for further reference or analysis. While no repeat surveys of this scope have been conducted in Saldanha Bay to assess changes in species composition, annual IAS monitoring was put in place, based on the methods demonstrated in the baseline survey.

The port survey involved several stakeholders from Saldanha Bay that were included in the Saldanha Bay Water Quality Forum, which had established a trust to assist with monitoring of the Bay. Following a presentation to the Forum of the survey and its results, it was decided to include IAS monitoring in the annual 'State of the Bay' reports, which are commissioned by the Forum, with significant funding and endorsement from TNPA. Also, attention continues to be focused on Saldanha Bay and Langebaan Lagoon through regular academic field trips and projects that serve to further investigate the impacts and implications of species introduced to the port area. Several new invasions have been detected since the time of the survey, however a population of *Carcinus maenas* has still not positively established in Saldanha Bay, with ongoing concern regarding its potential impacts (see Chapter 4).

Based on their involvement with this survey and the developing national ballast water management regime, the TNPA also commissioned replicate surveys, using the same methodologies, at the other major ports in South Africa. Biological baseline surveys have since been completed at the ports of Coega, Port Elizabeth, Durban and Richard's Bay. The survey at the developing port of Coega was achieved immediately before construction began, in order to establish a baseline for future comparisons following port development. The results and data from these additional surveys have, however, not been released by the TNPA in public reports.

## 1.4 Port of Mombasa, Kenya

### 1.4.1 Background

The GloBallast Programme in South Africa established a Regional Task Force (RTF) to advise on ballast water management issues affecting the region of Southern and Eastern Africa. The RTF developed a Regional Strategic Action Plan that aimed to conduct a series of activities throughout the region, including building capacity and laying the groundwork for effective ballast water management. One of the first activities conducted was the biological baseline survey for the Port of Mombasa, Kenya.

The port survey in Mombasa was coordinated in 2004 through the GloBallast Programme in South Africa. The Kenya Marine and Fisheries Research Institute (KMFRI) functioned as the local host institution throughout the various project stages. Cooperation and support from KMFRI, the Kenya Ports Authority (KPA), the National Museum of Kenya (NMK), the National Environment Management Authority (NEMA), the IUCN and the CSIR has also been an integral part of this port survey initiative. The field survey incorporated a regional training workshop which included two representatives from each of the countries within the region, to learn the methodologies of port survey planning and implementation. Participation in the training workshop by the representatives from Mauritius ultimately led to the support being put in place by the government of Mauritius for the survey in Port Louis, described in section 1.5.

Following the completion of the GloBallast Programme in December 2004, funding was no longer available to support the post-field analysis of specimens collected. The IMO Integrated Technical Cooperation Division was approached for assistance in this regard, and ultimately provided financial support via the Global Invasive Species Programme (GISP) for the taxonomic phase to be undertaken. This also included a regional capacity building workshop, focused on the taxonomic process and methods. The timeframe for the taxonomy phase of the project was limited, which created some constraints in reaching species-level identifications for some of the groups sampled.

### 1.4.2 Description of the port

The Port of Mombasa is the oldest major port in Southeast Africa, located on an extensive seasonal estuarine system on the south-eastern coast of Kenya (Lat 04° 03' S; Long 39° 38' E). The city of Mombasa supports a number of industries, importing and exporting goods through the Port, which also serves as a regional hub with rail and road services to inland destinations including the capital Nairobi, and the neighbouring states of Uganda, Rwanda, Burundi, the eastern DRC, and South Sudan. The Port is managed by the Kenya Ports Authority (KPA).

The port has a total of 19 deep-water berths. Significant focus has been placed on containerized goods, with six berths catering for panamax and post-panamax class vessels. Other capacities include dry bulk such as grain, fertilizers, cement, soda ash and liquid bulk such as crude oil and oil products. The oil terminal services the East Africa Oil Refinery. Additionally, the Port handles bagged products (e.g. coffee, tea, sugar), general break-bulk (e.g. iron, steel, timber), motor vehicles and machinery. The Port averages just over 1800 vessel visits annually, with 1,077,644 TEU in container throughput in 2015 and a total of 27.36 million tons of cargo processed in 2016.

The extensive area of the Port of Mombasa is subdivided into a number of smaller ports and related zones: Port Reitz, Port Kilindini, Port Tudor, Mombasa Harbour, including the Old Port area, and the many adjacent marine habitats used by shipping (Figure 1.3). The Port is surrounded by areas of natural beauty and high natural resource value. The extensive mangroves in the delta around the port are a bird sanctuary, providing essential habitat for fish, and are shrimp breeding grounds. Extensive seagrass meadows in the region also provide important fish habitats and may act as nursery grounds for many recreationally and commercially important species.

The Port of Mombasa trades with ports from Western Europe, Asia, the Far East, the Americas and the rest of Africa, thereby receiving ballast water from ports around the world. There has been no documentation of ballast water volumes discharged at the Port of Mombasa, or the frequency of discharges from the various source ports. No survey of the port area had previously been conducted for alien species presence, nor had any baseline survey been conducted to establish existing native biodiversity in the port areas.

### 1.4.3 Survey methods

#### Plan and approach

Although KMFRI is based in Mombasa, with a sizable compliment of marine scientists, no biological studies had been previously conducted in the Port, and little baseline information was available in terms of species lists. The institute was also in need of some support for field survey capacity, in terms of equipment and training for personnel. The project was therefore developed as an opportunity to acquire baseline data, while simultaneously developing the necessary capacity at KMFRI for ongoing field studies and monitoring in the port area. Project management focus was put onto associated training workshops and activities, as well as the procurement of equipment, materials and necessary laboratory and functional spaces (e.g. sample collection storage).

The field team that was assembled (Table 1.8) comprised representatives from the GloBallast Programme, KMFRI, KPA and the National Institute of Oceanography (NIO) in India. The project leader was responsible for all aspects of the field survey, from initial planning to final reporting. Fish sampling was conducted with the assistance of local fishermen, who provided the seine nets and advised on locations. A combination of local and international taxonomists handled the identification of specimens from these the samples.

**Table 1.8** The Port of Mombasa field survey team.

Name	Role	Affiliation (at time of survey)
Adnan Awad	Project leader, survey coordinator	IMO - GloBallast
Steve Raaymakers	Project advisor	IMO - GloBallast
Marnie Campbell	Technical advisor	IMO - GloBallast (consultant)
Melckzedeck Osore	Local team manager	KMFRI
Patrick Gwada	Boat team leader	KMFRI
Esther Fondo	Sampling supervisor	KMFRI
Steve Mwangi	Local team leader	KMFRI

Shailesh Sawant	Technical advisor	India National Inst. Oceanography
Johnson Kitheka	Local logistics coordinator	KMFRI
Masudi Juma Zamo	Dive supervisor	KMFRI
Samuel Ndirangu	Diver	Kenya Ports Authority
Charles Muthama	Diver	Kenya Ports Authority
Joseph Kilonzo	Diver	Kenya Ports Authority
Joseph Kamau	Diver	KMFRI
Edward Kimani	Diver	KMFRI
Peter Mbiriri	Port Authority Liaison	Kenya Ports Authority

The survey also provided the opportunity to test diver deployed sampling methods against alternative surface-based sampling methods. A marine scientist from NIO was brought in to join the project team, and to demonstrate the use of a scraper attached to a pole which is used in Indian ports in lieu of diver-based quadrat scrapes. Also, a Van Veen grab sampler was fabricated and deployed during the survey to enable direct comparison with diver-based sediment cores. These experiments were integrated with the survey to allow for a qualitative cost-benefit assessment regarding diver-based sampling (See Table 1.12). In Mombasa, the use of divers had been called into question due to a fatal shark attack on a diver from the KPA a couple years prior to the survey. For this reason, Shark Pods, which deter sharks using an electric field, were purchased and deployed on each diver during the course of the survey.

### **Design and sampling**

All phases of the survey (design, field work, taxonomic analysis and reporting) were guided by the methodologies outlined in the CRIMP port survey protocols. A total of 31 sampling sites were selected within the areas of the Port of Mombasa and associated habitats (Figure 1.3). The selection of each site to be sampled was approached by initially ensuring comprehensive coverage of all available habitat types, so as to maximize species richness obtained in the sample suite. Following this, prioritization rankings were decided on the basis of maximising likelihood of finding alien species introduced through discharged ballast water and other vectors (e.g. biofouling). Accordingly, each site is described below (Table 1.9) in terms of its proximity or relationship to ballast water discharge areas, or areas affected by historical shipping. Areas specifically targeted include shipping berths, anchorage areas, the shipping approach channel, and other potential sink areas where alien species may be deposited due to currents and geographic position.



**Figure 1.3** Map of the Port of Mombasa showing primary sampling locations.

**Table 1.9** Port of Mombasa sampling sites, allocated site number, site code, priority and designation.

Name	Site No.	Site Code	Priority	Sampling Designation
<b>Port Reitz</b>				
Tsunza Leading Marks	1	KEMOMPRTLM	2	Semi-Quantitative
Western Tsunza Island Seagrass Beds	2	KEMOMPRWTISB	2	Semi-Quantitative
Kipevu Oil Terminal (KOT)	3	KEMOMPRKOT	1	Quantitative
KOT Dolphins	4	KEMOMPRKOTD	3	Qualitative
Kenya Navy Base Quay	5	KEMOMPRKNBQ	2	Quantitative
Container Berth 17	6	KEMOMPRCB17	2	Quantitative
Kenya Navy Bay	7	KEMOMPRKNB	3	Semi-Quantitative
Kenya Navy Bay Beach	8	KEMOMPRKNBB	3	Qualitative
Cargo Berth 13	9	KEMOMPRCB13	2	Quantitative
<b>Port Kilindini</b>				
Shimanzi Oil Terminal (SOT)	10	KEMOMPKSOT	1	Quantitative
Makupa Creek West	11	KEMOMPKMCW	2	Qualitative
Makupa Creek East	12	KEMOMPKMCE	3	Qualitative
Bulk Berth 8	13	KEMOMPKBB8	1	Quantitative
Bulk Berth 3	14	KEMOMPKBB3	2	Quantitative
Mooring Buoy 4	15	KEMOMPKMB4	2	Qualitative
Mooring Buoy 2	16	KEMOMPKMB2	2	Qualitative
Kenya Navy Jetty	17	KEMOMPKKNJ	1	Quantitative
Liwatoni Creek	18	KEMOMPKLC	3	Qualitative
Mbaraki Creek Dry Dock	19	KEMOMPKMCDD	1	Semi-Quantitative
Mbaraki Creek North	20	KEMOMPKMCN	2	Qualitative
Mueza Creek	21	KEMOMPKMC	2	Qualitative

Mbaraki Wharf Center Berth (Cement Berth)	22	KEMOMPKMWCB	1	Quantitative
<b>Harbour Mouth</b>				
Florida Reef	23	KEMOMHMFR	1	Qualitative
Channel Buoy 3	24	KEMOMHMCB3	1	Semi-Quantitative
Nyali Reef	25	KEMOMHMNR	2	Qualitative
<b>Mombasa Harbour</b>				
Old Port	26	KEMOMMHOP	1	Quantitative
Ras Kidomoni (English Point, Cement Silo)	27	KEMOMMHRK	1	Quantitative
KMFRI	28	KEMOMMHKMFRI	2	Qualitative
Madhubaha	29	KEMOMMHHM	3	Qualitative
Nyali Bridge	30	KEMOMMHNHNB	3	Qualitative
<b>Port Tudor</b>				
Kenya Meat Commission (KMC) Jetty	31	KEMOMPTKMCJ	2	Semi-Quantitative

The type of sampling conducted at each site varied depending on the priority of the location, and the nature of the habitat found there. Table 1.10 summarises the sampling methods conducted at each site.

**Table 1.10** Sample methods deployed during the survey of the Port of Mombasa, shown by site name.

SITE	Small core (dinoflagellate cysts)	Large core (benthic infauna)	20um plankton net	100um plankton net	Traps (crab/ shrimp)	Qualitative visual surveys	Quadrat scraping	Photo stills	Poison stations (fish)	Beach seines (fish)
<b>Port Reitz</b>										
Tsunza Leading Marks										
Western Tsunza Island Seagrass Beds										
Kipevu Oil Terminal (KOT)										
KOT Dolphins										
Kenya Navy Base Quay										
Container Berth 17										
Kenya Navy Bay										
Kenya Navy Bay Beach										
Cargo Berth 13										
<b>Port Kilindini</b>										
Shimanzi Oil Terminal (SOT)										
Makupa Creek West										
Makupa Creek East										
Bulk Berth 8										
Bulk Berth 3										
Mooring Buoy 4										
Mooring Buoy 2										
Kenya Navy Jetty										
Liwatoni Creek										
Mbaraki Creek Dry Dock										
Mbaraki Creek North										

SITE	Small core (dinoflagellate cysts)	Large core (benthic infauna)	20um plankton net	100um plankton net	Traps (crab/ shrimp)	Qualitative visual surveys	Quadrat scraping	Photo stills	Poison stations (fish)	Beach seines (fish)
Mueza Creek										
Mbaraki Wharf Center Berth (Cement Berth)										
<b>Harbour Mouth</b>										
Florida Reef										
Channel Buoy 3										
Nyali Reef										
<b>Mombasa Harbour</b>										
Old Port										
Ras Kidomoni (English Point, Cement Silo)										
KMFRI										
Madhubaha										
Nyali Bridge										
<b>Port Tudor</b>										
Kenya Meat Commission (KMC) Jetty										

All samples collected during the field survey underwent a rough sort at the field station to break each sample into component taxonomic groups to allow for appropriate preservation. These samples were maintained in preservative and transported by road to the KMFRI laboratory facility to allow for further sorting and taxonomic analysis. This marked the conclusion of the GloBallast supported phase of the project, which had focused on the field work, and also the development of capacity in Kenya and the region.

### **Taxonomic identifications**

In 2005 the IMO-funded taxonomy phase of this project was coordinated through the Global Invasive Species Programme (GISP), based in Cape Town. The project aimed to complete the outstanding taxonomic analyses from the field survey, previously conducted under the GloBallast project. This involved the rough sorting of specimens at laboratories in Kenya, subsequent transport of samples to Cape Town, fine sorting of specimens in Cape Town, and the taxonomic analyses by specialists in South Africa. The project had limitations in terms of budget and time, however it was regarded as the best opportunity to extract valuable information and data from the samples and survey effort.

The rough sorting of all the samples was accomplished at KMFRI. Some local experts were able to identify certain taxonomic groups down to species level, leaving only some verification work to be completed for those groups. Some taxonomic capacity was built within Kenya through a taxonomy training workshop coordinated under the same project, and focusing on the samples taken during the survey. Experts from South Africa, Kenya and Australia were brought to Mombasa to assist with the workshop.

An assessment of the sample collection was conducted, which showed that the majority of the samples could be processed by experts within Kenya, or from South Africa. The available budget was adequate to cover this effort, leaving some groups to be completed in future (pending further funding arrangements) when international taxonomists would be sourced to analyze them. The samples were further sorted by taxonomic group and distributed to the relevant experts. Two batches of samples were sent to South Africa, where they were processed at the laboratory of Prof. Charles Griffiths in the University of Cape Town.

The International Ocean Institute - Southern Africa (IOI-SA) took responsibility for coordinating several of the South African experts involved. Others were contracted directly through GISP, while KMFRI coordinated all taxonomic efforts in Kenya. Specimens were identified to species level where possible, and generally to the degree achievable given the regional limitations of taxonomy. In many cases the relevant records or literature were not available for comparison from this region. In other cases, the time allowed for the taxonomic analyses was not adequate for comprehensive species-level identifications to be made, leaving some of the results incomplete and pending further investigation. The National Museum of Kenya in Nairobi provided some taxonomists to assist with the analyses, and the final specimen collection was ultimately housed at the Museum for ongoing reference.

#### 1.4.4 Survey results

A total of 345 species were identified from the samples taken during the survey at the Port of Mombasa. Table 1.11 shows how these species were distributed across the major taxonomic groups, as well as any alien species detected within each group.

Although historical species lists and relevant data on many taxonomic groups were generally lacking for the area around Mombasa, and no biological data existed for the port areas, the majority of these species are reported by the taxonomists as typical of the species known from coastal waters of eastern Africa. Of these species, two are confirmed introductions of alien species known from other areas of the world, and five others are considered possibly new or introduced. The number of alien species reported is likely artificially low, due to the constraints experienced during the taxonomic process. Some groups (e.g. molluscs, crustaceans) were inadequately assessed, and it is likely that some non-native species would be found within these groups should more rigorous taxonomic analyses be possible. In the case of the ascidians, there were no taxonomists available to analyze the samples over the duration of the project. The lack of data for this important group leaves a gap in the possible conclusions to be drawn from the survey, especially as concerns likely introduced species. Furthermore, data are missing for the fishes, which were all identified within KMFRI at the time of the field survey. The fish species list was not released during the taxonomic phase of the project, as this fell under separate funding and management authority, highlighting a serious challenge in streamlining support for completion of lengthy taxonomic processes within project funding and contractual cycles.

Although the polychaetes were categorized and well documented by a specialist in Cape Town, it is surprising to not have found more species, or any aliens within this group. It was, however, noted by some taxonomists that the species richness found in the samples was lower than what might be found outside the port areas, and that this is likely due to the impact of urban and port activity, especially with respect to pollutants in the water and sediments. This effect seems to have been well documented for seaweed communities, where it was noted by the taxonomist involved that the murky, polluted waters around Mombasa tend to consist of an upper layer of *Ulva* (mostly *U. reticulata*), which may only be up to 10cm thick, with animals below, and few other algal species.

**Table 1.11** Numbers of species recorded from the Port of Mombasa within major taxonomic groups.

Taxonomic group	Number of species	Introduced species found	Comment
Molluscs	92	none	Further taxonomy required
Polychaetes	24	none	Well documented
Algae (seaweeds)	12	none	Well documented
Bryozoans	7	<i>Bugula neritina</i> <i>Tricellaria occidentalis</i>	Confirmed identifications

Crustaceans - Crabs - Shrimps - Isopods - Amphipods	16 7 3 3	none	Further taxonomy required
Echinoderms	1	none	
Ascidians	1	none	Further taxonomy required, most samples not assessed
Cnidarians - Siphonophores - Hydroids  - Corals	4 12  1	<i>Diphasia sp. A</i> <i>Diphasia sp. B</i> <i>Salacia sp. A</i> <i>Eudendrium sp. A</i> <i>Halopteris sp. A</i>	Possible new or introduced species
Phytoplankton	76	none	Well documented
Zooplankton	90	none	Well documented
Cyanobacteria	1	none	

The two species that are confirmed alien species are both bryozoans (*Bugula neritina* and *Tricellaria occidentalis*). In global distribution, *Bugula neritina* is nearly cosmopolitan, probably through anthropogenic introduction (likely biofouling), but is not found in cold polar and subarctic/sub-antarctic regions. In South Africa, it is prevalent in all areas that contain a harbour, from Port Nolloth in the west to Durban in the east, and is a common fouling organism found on the hulls of ships. The likely vector of its introduction to the Port of Mombasa is therefore hull-fouling, and it is not a surprising discovery, given the maritime history of the Port. However, it was not found in high abundance during the survey, suggesting either this is a recent introduction, or that the sampling effort simply was not adequate for greater detection.

*Tricellaria occidentalis* is also notorious for being introduced to ports through shipping (specifically hull/biofouling). It is native to the northern hemisphere, where it has been recorded from British Columbia to southern California, Baja California, China, Japan and Europe. It is also found in New Zealand, where it is classified as having been introduced via shipping, and is also likely to be introduced in Australia. In Victoria, *T. occidentalis* is regarded as probably the most successful invader of the known introduced bryozoans.

There are also several hydroid species that were flagged for further research, and which may be either introduced or new to science. The data and specimens were returned to KMFRI, such that further analyses may be coordinated.

## Reference and Voucher Collections

An important product of the Port Survey was the development of a complete reference collection of all species found during the survey. The KMFRI taxonomists responsible for sorting and undertaking taxonomic analysis of the samples were also responsible for assembling the preserved specimens to make up the collection. The collection included at least one specimen, but where possible multiple specimens, of each species sampled. For phytoplankton and dinoflagellate species, a collection of photographs, complete with species identifications, accompanied the original samples. The specimen collection, consisting of multiple specimens of each of the species sampled, was eventually delivered to NMK in Nairobi, where it is to be permanently housed. The cost associated with the curation of the samples has been assumed by the museum.

A voucher collection was also assembled for the species sampled in the port survey. This is a collection of preserved specimens, from which selected groups or individuals can be sent to outside taxonomists for verification of identifications. The voucher collection is comprised only of species for which more than one specimen is available. In a case where only one specimen is available, that specimen will remain in the reference collection, and photos may be used to confirm identifications, should this be required. This collection is being maintained within KMFRI. Where samples are sent to international taxonomists for identification, the international taxonomists may be requested to return the identified samples to KMFRI.

In the time that has passed since the taxonomic phase was completed, no large scale formal analyses have been planned or conducted to update the identifications of the samples. As discussed in the next section, the ongoing communication, regarding any further assessments or updates of the data, has not been forthcoming.

## Comparative sampling

Comparisons made between sampling techniques for both benthic and fouling communities revealed that diver-based sampling was more effective at achieving consistency in sample quality, whereas the surface-deployed methods offered advantages in terms of time, cost and safety.

Three quay-side sites were sampled using the following surface-based methods, in addition to the diver-based methods already described.

- Extendable pole with attached scraper blade and mesh bag, designed to remove fouling organisms from vertical hard surfaces.
- Van Veen Grab sampler deployed by rope, designed to sample soft sediment from the benthic environment.

Replicate samples were collected from each site according to the CRIMP protocol (i.e. 9 scrapes and 3 grabs from each site). Comparisons of sample quality were made between scrapes collected by divers using quadrats and those collected using the pole scraper. Similarly, the diver-collected benthic core samples were compared with samples collected using the Van Veen grab. Qualitative assessment of sample quality was noted, based on magnitude, uniformity and consistency. Also, time spent per sample was noted in order to give an indication of efficiency. The results presented in Table 1.12 indicated that

overall sample quality was higher when collected by divers. This was mostly due to the amount of debris encountered on the bottom, as divers could work around it, but the Van Veen grab struggled to function properly in such conditions. A difference in specimen quality was also noted for the scrapes, as divers were less destructive in their approach to species removal. Divers also noted that mobile species found within quadrats may be captured in manual scrapes, whereas these may escape from the sample when using the pole scraper.

**Table 1.12** Qualitative results of comparative sampling showing the advantages of diver-based methods for sample quality, and the advantages of surface deployed methods for time, cost and safety.

Sample method	Sample quality	Approx. time per sample (mins)	Comment on cost and safety
<b>Benthos</b>			
Sediment core (divers)	Site 1: High Site 2: High Site 3: High	Average: 10  Range: 8 - 20	High cost of dive operations, including extra logistics. High risk due to safety considerations.
Van Veen grab (surface)	Site 1: Low Site 2: Med-low Site 3: Low	Average: 5  Range: 3 - 8	Low cost for Van Veen, other grabs may be more expensive. Medium risk in boat and quay-side operations.
<b>Vertical structures</b>			
Quadrat scrapes (divers)	Site 1: High Site 2: High Site 3: High	Average: 7  Range: 5 - 15	High cost of dive operations, including extra logistics. High risk due to safety considerations.
Pole scraper (surface)	Site 1: Med-low Site 2: Med Site 3: Med	Average: 4  Range: 3 - 6	Low cost and easy to fabricate and deploy. Medium risk in boat and quay-side operations.

#### 1.4.5 Discussion

##### **Field work**

The survey of the Port of Mombasa was the first attempt to conduct a full-scale port baseline survey outside of South Africa, and within the African region. The level of sampling intensity, both planned and implemented, was similar that which was conducted for the Port of Saldanha. It was therefore a considerably complex undertaking, in terms of coordination with all stakeholders involved, and especially in consideration of the lack of contingency options available in Mombasa. The required capacity development activities (training for KMFRI staff, regional training workshops) also increased the challenges of accomplishing an efficient and smooth field work phase. There were significant differences in the philosophical approaches taken by international (GloBallast) team members, and the local counterparts (e.g. necessity to pay a daily stipend to all salaried field researchers involved; the inability to access some data, such as the fish species list, that was developed within KMFRI), which increased the day to day challenges, stretched the limitations of the budget and time frame, and somewhat compromised the ability to draw conclusions from the final results (where data were missing). In retrospect, it may have been more effective to plan and execute a less rigorous and ambitious survey, to reduce the demands on the local team members. Nonetheless, the field work did produce the intended results in terms of capacity development (see below), as well as sampling intensity and comprehensiveness. The most significant short-fall was the timing of the survey near the end of the GloBallast funding cycle, which meant that the taxonomy could not be completed within the same project. Because this had been anticipated, the thrust of the project had been to instigate further support from the national government (Kenya) to take on and complete the taxonomic work, as well as continuing with ongoing monitoring. Unfortunately, there is a significant difference in perspective, as regards large international investment projects like this, and the local Kenyan institutions were unable to support the completion of the work.

There were, however, several unique aspects to the field work phase that warrant consideration.

- The use of the Shark Pods by the divers was highly successful at overcoming the residual anxieties related to prospective shark attacks in the port area. No sharks were spotted during the survey activities, and no other dangerous encounters or accidents manifested. The attention to safety, and the extra investment in the shark-specific devices, helped maintain a careful focus on the sampling activities of all involved during the diving operations.
- The involvement of local fishermen in the fish sampling (beach seines) proved to be useful, and the compensation provided to them to account for their time was minimal in the context of the overall budget. Their guidance was useful in terms of highlighting areas where more diverse catches could be obtained, and also in terms of deployment of the nets. This helped ensure that fish specimens sampled were representative of the community found in the port areas.
- The qualitative comparative sampling conducted for quadrat scrapes and sediment cores demonstrated that diver-based sampling was more efficient and consistent in terms of generating samples of useful size and quality. The obvious trade-off is that diver-based sampling is more expensive, lengthy, risky and requires available scientific diving capacity. The exercise also allowed

for the development of a twinning relationship with NIO in India, which led to their involvement in contributions of lessons on port surveys towards the guidelines presented here in Chapter 2.

- The government of Kenya had ratified the IMO BWM Convention, although no domestication of its provisions had yet manifested in terms of regulations at port or shipping levels. The collaboration during the survey with the KPA helped catalyse involvement of maritime authorities in Kenya towards further progress and inter-departmental approaches for BWM preparations. A national meeting was convened to discuss BWM during the field work phase, and a presentation on the survey and the related management implications was given.

### **The taxonomic process**

As mentioned above, the main constraint in achieving species-level information for all groups sampled was the scheduling and duration of project cycles. The taxonomic work was completed with funding provided by the IMO, following a motivation (proposal) developed by GISP to demonstrate the unique circumstance, and potential value in attaining identifications for the samples sitting at the KMFRI laboratory. The funded project had a one-year timeframe, as this reflected the nature of funding from the Integrated Technical Cooperation Division of the IMO. A final report on the outcomes of the investment was required for consideration by IMO Member States within that time frame. This therefore left less than one year available for the taxonomic work to be finalized, including fine sorting and specialist analyses. The constraints in the availability of taxonomists, and the need to return samples to Kenya before completion of the project, further confounded the process. As detailed in section 1.4.4, more comprehensive results may have been obtained had the luxury of more time been possible.

The concern with the fish species data that were not released by the associated researcher at KMFRI reflected another area for consideration in international survey project, such as this. The intellectual property and publication rights must be worked out in advance agreements. It is not uncommon for this situation to have arisen, especially considering that the project and related institutional arrangements that supported the first (field) phase of the survey (which is when the fish were identified) was not the same as that which supported the subsequent taxonomic phase. The fish list was therefore a casualty of this circumstance, and only the implicit goodwill of those involved would have allowed for it to be shared internationally and integrated with the overall species list. This evidently reflects a difference in perception between those involved, which should be anticipated in future engagements.

Some of the concerns with the taxonomic shortcomings could be overcome through more consulting style contracts with taxonomists, based on detailed terms of reference and legal agreements. Many of the issues encountered stem from the fact that many of the taxonomic specialists are based in academic institutions, which operate under different rules, norms and priorities. It would therefore be preferential to seek and encourage the development of taxonomic capacity within consulting and professional institutions.

There was no implication from the survey results for a direct or urgent management response. There were, however, some interesting questions that emerged, related to the baseline information generated and provided to KMFRI, as to possible follow-up studies. No such studies seem to have materialized from

KMFRI or institutions within Kenya or the region. This lack of follow-up raises further questions as to where the baseline data should be housed, managed and communicated. The design and objectives of international projects, such as this, should evolve to ensure that appropriate transparency, data sharing, communication and cooperation are better entrained in the project activities and deliverables.

### **Capacity development**

Capacity building was an important and integral aspect of this survey, as stipulated by the funding bodies, for both the field and taxonomic phases. Through training of personnel and improvement of facilities, capacity building should also form an essential part of any ballast water management regime. Port biological baseline surveys, although essential, are merely a snapshot in time and are designed to lay the groundwork for ongoing monitoring. They are also designed to be catalytic, leading to increased collaboration between stakeholders at port level, towards effective biosecurity measures. This project aimed to ensure that the capacity was improved within institutions in Kenya and the surrounding region to conduct port surveys. The institutional capacity of KMFRI has certainly been elevated to include broader marine sampling capabilities, as well as strong operational relations with the port management authorities. This conclusion is founded through qualitative assessment of the staff trained through hands-on field practices and taxonomic workshops, equipment provided and deployed, institutional reporting and direct expert feedback. However, KMFRI has not continued to monitor the Port for IAS, as there has been no international funding provided to support this. The unfortunate reality is that the government of Kenya has not prioritized or allocated funding to support broad protection of marine environments and resources. There has been some involvement of the Indian Ocean Commission, based in Mauritius, through its EU funded project on marine biodiversity, to consider sampling, monitoring and management of IAS in the region, including Kenya. To date this project has not conducted any field investigations.

Although highly experienced in sampling and marine sciences, KMFRI was lacking in terms of adequate equipment to carry out a comprehensive survey of this nature and the associated ongoing monitoring. As part of the survey, necessary diving, sampling and laboratory equipment were purchased. This equipment was used during the course of the survey, and subsequently remained as KMFRI property for future use. During the planning stages of this survey, KMFRI personnel underwent training sessions in survey methods, conducted by the international technical experts. Some personnel were also present during the regional training workshop. The lead scientist from KMFRI, Dr. Esther Fondo, was also sent, by the GloBallast project, to Australia to participate in a port survey at Thursday Island with Dr. Kerry Neil. This provided an overview of the survey process including logistics and real-world scenarios.

The 1<sup>st</sup> Southern and Eastern African Regional Port Biological Baseline Survey Training Workshop was held in conjunction with the port survey, in order to capitalise on the presence of materials and expertise for regional capacity building purposes. This three-day workshop was co-sponsored by the IUCN East Africa Office and held immediately prior to the field survey. The workshop consisted of two days of theory training and background presentations, including hands-on training with sampling equipment, and one day of field sampling activities. It covered all aspects of port surveys, from planning and funding to taxonomy, collection housing and final reporting. It also gave the participants an opportunity to initiate

planning for a port survey in their home port. This provided the first opportunity for delivery of a new GloBallast Port Survey Training Course, based on a Power Point format, and designed by the project leader from this survey.

Trainees consisted of two nominated representatives from each country in the GloBallast Southern and Eastern African Region, including Mozambique, Tanzania, Madagascar, Mauritius, Seychelles, Namibia and Angola. It was recommended that a lead scientist and manager be appointed to take responsibility for future replication of such surveys in each country.

To initiate the taxonomic phase of the project another regional workshop was organized to focus on the taxonomy of key groups, as discussed in Section 1.4.3.

## 1.5 Port Louis, Mauritius

### 1.5.1 Background

As a maritime nation, the Government of Mauritius, through its Shipping Division, has been seeking to implement ballast water management (BWM) practices in-line with the IMO BWM Convention of 2004. The Shipping Division is considering taking the necessary steps to ratify the IMO BWM Convention and thereby domesticate its provisions. In anticipation of this, a comprehensive programme was developed to better understand the implications of the international law, to verify the need for it and its benefits, and to build the relevant capacity to ensure that the ratification is meaningful.

Support for the survey of Port Louis was seen as an initial step in this regard, and was initiated and developed in the years following the Mombasa regional training workshop (Section 1.4.1), through contact with the representative from the Mauritius Oceanographic Institute (MOI) that attended the workshop. In 2012, the survey was designed, along with other ballast water management related project components, to set the foundation for a long-term and comprehensive approach to managing the risks associated with invasive species. It is well understood that the prevention of species introductions is the first and most important line of defence, considering that most marine invasions are irreversible. The IOI-SA was contracted to design and implement the survey in-line with international best practices (specifically the IMO recommended approach), and to ensure that the local team members received adequate training to be able to continue ongoing survey and monitoring work. By working with the MOI and the Shipping Division it was ensured that the survey methods would be included as part of the ongoing ballast water management practices of the Port.

The port survey and the related risk assessment (see Chapter 3) were hence integrated into this study as a logical progression to take forward the approaches initiated in Saldanha Bay, with an opportunity to catalyse meaningful and customized regulatory and management action. A participatory approach was taken for Port Louis, involving local team members from various government departments and related institutions, requiring extensive inter-agency coordination and cooperation.

### 1.5.2 Description of the port

Port Louis is strategically located on the west side of the island of Mauritius in the Western Indian Ocean region (Lat 20° 08' S; Long 57° 29' E), as a first port of call in the region for many vessels travelling from the East. As the only commercial port in Mauritius, it handles all of the country's seaborne trade. The Mauritius Ports Authority (MPA) has jurisdiction over the port area, with responsibility for ship movements, port activities and environmental controls. The port has been undergoing significant changes over recent years related to trade dynamics, mostly due to the decrease in sugar exportation, and concurrent expansion of containerized throughput, including transshipment. The container berth was recently extended by 150m, a dedicated oil terminal was constructed and the shipping channel was dredged to 14.5m depth to allow for larger vessels (including Post-Panamax) and faster ship processing.

Besides containers, the Port caters for general cargo including dry bulk and liquid bulk, a dedicated bulk sugar berth and fishing vessels. There are three terminals comprised of 16 berths, and a dedicated fishing port. In 2016 Port Louis processed a total of 7.273 million tons of cargo, including 6.007mt of imports and 1.266mt of exports, indicating that the Port is exporting far more ballast water than it is importing. The oil terminal handles around 1.1 million tons of petroleum products annually, and the container traffic for 2016 amounted to 388,514 TEUs, of which approximately 30% was transshipments (inwards).

A total of 2,934 vessels called at the port in 2016, including 567 container ships, 56 dry bulk carriers, 141 tankers, 101 general cargo ships, 977 fishing vessels, 28 cruise ship calls, and 1,064 unspecified. Although ballast water discharges at the Port (e.g. origin, volume and frequency) have not been tracked historically, the data available on last ports of call over recent years give some indication of likely sources for ballast water. The Port of Singapore featured as the most significant last port of call (over 13% of vessels), with vessels arriving from other African ports (including other islands of the Western Indian Ocean) accounting for over half of those reporting, and the remainder being distributed globally across the Middle East, the Americas, Asia, the Far East, Europe (including Eastern Europe), and Australia. In terms of major trade partners for Mauritius, China and India each account for approximately 30% of imports, with South Africa and France each accounting for approximately 15%, and Japan, Germany, Spain, Vietnam and Australia making up the rest. Exported goods are predominantly shipped to the UK, France and the USA, with South Africa, Madagascar, Italy, Spain and the Netherlands also featuring significantly.

Though the marine environment of Mauritius is relatively well studied, there has been no major biodiversity survey conducted within Port Louis, where species assemblages may differ from other parts of the island. The greater port area contains a variety of habitats including wharfs, pilings, rock walls, artificial reefs, sand banks, mud flats, mangroves and sandy beaches. Although the highest biodiversity is present on the natural coral reefs outside the port area, the habitats contained within the port are relatively diverse and support some marine life, despite being affected by port activities and conditions.

### 1.5.3 Survey methods

#### Plan and approach

A desktop review was conducted of the Port Louis conditions, history and physical situation. This was complemented by a field reconnaissance visit of the Port, and the data provided by the various stakeholders. Through this process, an appropriate approach to the survey was designed that would maximise the sampling capacity available and provide scientifically sound results. The port biological baseline survey protocols developed by CRIMP were used as a general guideline, and the new international guidelines for conducting port biological baseline surveys (Chapter 2), as developed by the IOI-SA and published by the IMO-GloBallast programme, were effective in guiding the technical aspects of the survey design. Due to the contractual nature of this project, time constraints were placed on various project components, which proved to be consequential as regards the taxonomic process (see section 1.5.4 and 1.5.5).

A five-member team was established from the IOI-SA, and each member was designated with a specific role and responsibility in the survey (Table 1.13). The MOI staff provided local counterparts for each role to be trained through a hands-on approach. The physical sampling and sorting of samples for benthic and subtidal habitats was handled by the core survey team. Beach seines for fish were conducted in cooperation with the Department of Fisheries, which also provided the seine nets. The diving was supported by the National Coast Guard (NCG) through the provision of boats, tanks and divers for assistance with sampling and safety. A field base was established in a mobile laboratory, built into a shipping container, and positioned on the bulk sugar export terminal.

**Table 1.13** The Port Louis field survey team members.

Name	Role	Affiliation (at time of survey)
Adnan Awad	Project leader, survey coordinator	International Ocean Institute
Prakash Mussai	Local team leader, marine scientist	Mauritius Oceanography Institute
Vimal Ramchandur	Oceanographer	Mauritius Oceanography Institute
Kamlesh Ramdhony	Marine scientist	Mauritius Oceanography Institute
Ragni Sooroojebally	Assistant sample supervisor	Mauritius Oceanography Institute
Samyan Chettanand	Diver supervisor	Mauritius Oceanography Institute
Shibloll Doorgaswarsing	Diver	National Coast Guard
Jacquete Dominique	Diver	National Coast Guard
Genave Delaitre	Diver	National Coast Guard
Begue Joseph Arly	Diver	National Coast Guard
Barry Clarke	Dive sampling supervisor and trainer	Anchor Environmental Consultants
Ken Hutchings	Diving and sampling assistant	Anchor Environmental Consultants
Clova Jurk	Technical assistant, diver	Anchor Environmental Consultants
Martin Hendricks	Sample supervisor	University of the Western Cape
Alan Donat	Port and shipping liaison	Shipping Division

## **Survey design**

A total of 18 locations were originally selected for the various sampling methods to be employed over a 7-day field schedule. Sampling sites were differentiated by sample method (see Figure 1.4), which was a minor departure from the CRIMP methodology, as well as that which was employed for the two previous port surveys reported. This simplified the format for site numbers and codes, and helped streamline the field work. Due to efficient progress in the field, new sites were added opportunistically and the survey plan was amended accordingly. As a result, a total of 27 locations (23 quantitative and four qualitative sites) were sampled. Site names, designations and the methods employed are further detailed in Table 1.14.

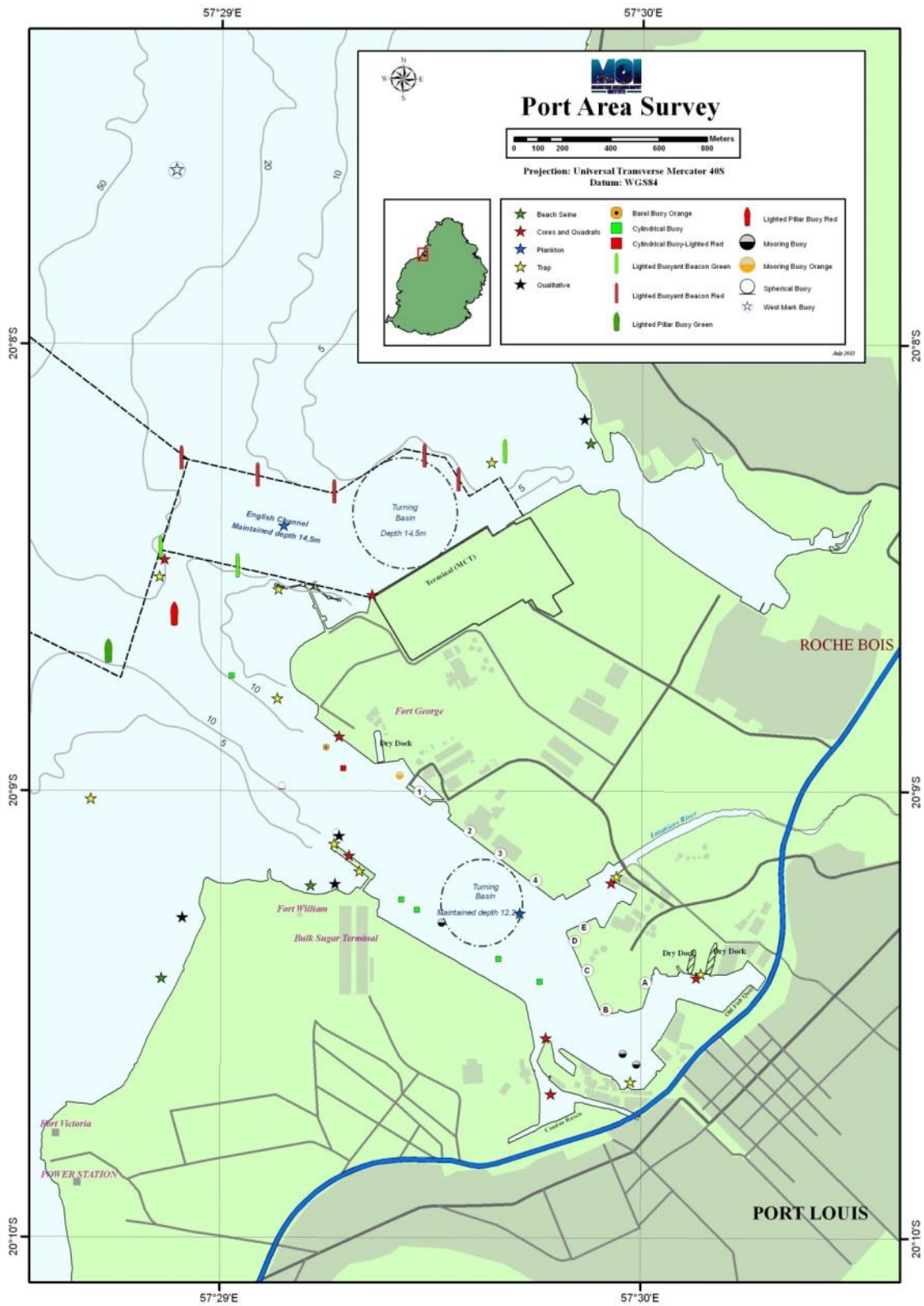

Figure 1.4 Actual sampling locations for Port Louis Harbour as undertaken in the field.

**Table 1.14** Port Louis sampling sites, allocated site number, site code, priority and designation.

Name	Site No.	Site code	Priority	Sampling designation
<b>Cores and quadrats</b>				
Quay A	C1	MRUPLC1	1	Quantitative
Quay E, Letenier river mouth	C2	MRUPLC2	1	Qualitative
Sugar terminal	C3	MRUPLC3	1	Qualitative
North inner harbour mouth	C4	MRUPLC4	1	Quantitative
MCT	C5	MRUPLC5	1	Qualitative
Red lighted pillar buoy	C6	MRUPLC6	1	Quantitative
<b>Beach seines</b>				
South harbour mouth	B1	MRUPLB1	1	Quantitative
North harbour sand bank	B2	MRUPLB2	3	Qualitative
<b>Traps - fish and crabs</b>				
Granary Quay	T1	MRUPLT1	3	Qualitative
Sugar terminal	T2	MRUPLT2	2	Quantitative
South harbour mouth	T3	MRUPLT3	1	Qualitative
Oil terminal	T4	MRUPLT4	1	Quantitative
Red channel marker	T5	MRUPLT5	1	Semi-quantitative
<b>Plankton tows</b>				
Inner turning basin	P1	MRUPLP1	2	Semi-quantitative
South harbour mouth	P2	MRUPLP2	1	Quantitative
Outer turning basin	P3	MRUPLP3	3	Qualitative
<b>Qualitative swims</b>				
Outer harbour south	Q1	MRUPLQ1	2	Qualitative
North wetland reserve	Q2	MRUPLQ2	2	Quantitative

Crab and fish traps were fabricated according to local specifications in lieu of using the crab and shrimp trap designs prescribed in the CRIMP protocol, and to avoid using poison stations for fish sampling. Traps were laid overnight at various sites around the port, and in some cases the divers were able to manoeuvre the traps into favourable positions, and also helped recover them afterwards.

### **Taxonomic process**

During the course of the field survey it was possible to classify some of the well documented organisms, such as reef fishes, to species level. The majority of the specimens were preserved following the rough sorting in field stations, and in some cases, due to time constraints in the field, entire samples (including sand, mud and debris) were preserved in containers for subsequent processing in the laboratory. All sample containers, with the exception of the fishes identified in the field, were packaged and shipped to Cape Town, South Africa where they were received by the IOI-SA at the University of the Western Cape.

The samples were further sorted (fine sorting) in the laboratory by seven marine researchers over a period of two months. This time-consuming process involved the separation of individual specimens into general

taxonomic groupings (e.g. polychaetes, algae) and while not requiring advanced taxonomic expertise, there was a need for these researchers to have a good understanding of marine invertebrate biology and systematics. The resulting groupings were each sent to different taxonomic specialists for identification.

The identification of the specimens from the samples can itself be a lengthy and complex process. Due to the contractual nature of this project, as dictated by the Government of Mauritius, the final taxonomy phase was limited to 6 months, after which all the specimens had to be sent back to MOI.

The taxonomists first completed an assessment stage to better understand the nature of the samples (i.e. physical condition, abundance, diversity). Following this, the detailed identification process was initiated for many of the groups. For some groups there were very few, if any, experts remaining within the region, and those that were working were usually significantly backlogged with samples from other projects. This taxonomic crisis is well recognized within the region, and is a challenge for future surveys to help overcome. However, port survey projects must also anticipate and allow for the flexibility for the taxonomic information to be updated and strengthened over time. The time-frame and budget of this project did not allow for comprehensive taxonomic assessment to be completed, therefore the results reported below should be regarded as preliminary, with a view to further updates as and when possible. All samples were ultimately returned to MOI, and have since been maintained as a collection for further study and reference. It is intended that another round of support will be allocated by the Government of Mauritius, which will allow for the time and costs of more detailed taxonomy to ascertain species-level identifications for all specimens sampled.

#### 1.5.4 Survey results

A total of 445 morphologically distinct specimens were isolated from the samples, of which 122 species have been identified with some confidence. A few of the groups were entirely assessed, with confirmed species lists produced. These included the vertebrates, barnacles, urchins and bryozoans. For the gastropods, bivalves and polychaetes, several species identifications were made, however many of the specimens remained unclassified, pending further analysis. For the remaining groups, the taxonomists involved indicated that they were unable to progress beyond the initial assessment stage, and that with significantly more time, they may have been able to identify most of the specimens. It should, however be noted that, in some of these cases, the samples had not been worked on for most or all of the six months allowed, despite prior agreement and commitment to the time-frame. This indicated that the taxonomists were simply too backlogged and overcommitted to achieve the project objectives within the time-frames given. Unfortunately, for most groups, there were not alternative taxonomic experts available. Furthermore, some of the groups for which final species-level identifications were not made, are relatively important in terms of likelihood for detection of introduced species (e.g. ascidians, crustaceans).

**Table 1.15** Species recorded from Port Louis within the major taxonomic groups.

Taxonomic group	Number of species or forms*	Introduced species found	Comment
Vertebrates - Fish - Eels	37 2	none	Confirmed indigenous
Molluscs - Gastropods - Bivalves	63 39	<i>Calyptraeid</i> (limpet) <i>Mytilopsis adamsi</i> <i>Musculista senhousia</i>	Further taxonomy required
Echinoderms - Urchins - Starfish	4 8	none	Confirmed indigenous Further taxonomy required
Worms - Polychaetes - Sipunculids - Platyhelminthes	83 15 1	<i>Marphysa sp.</i> <i>Spirobranchus sp.</i>	Further taxonomy required
Crustaceans - Crabs - Shrimps - Isopods/amphipods - Barnacles	24 29 14 9	<i>Amphibalanus reticulatus</i> <i>Amphibalanus amphitrite</i> <i>Megabalanus coccopoma</i> <i>Amphibalanus sp.</i> Balanidae (white balanid sp.)	Further taxonomy required
Sponges	39	none	Further taxonomy required
Algae	50	none	Further taxonomy required
Ascidians	10	none	Further taxonomy required
Bryozoans	3	none	Confirmed indigenous
Corals	15	none	Further taxonomy required

\* Including morpho-species distinguished by taxonomists, but not yet allocated a confirmed species name

The taxonomic analyses conducted on the specimens from the Port Louis survey have indicated the presence of some previously unrecorded introduced species amongst the samples. These are listed in Table 1.16. Descriptions of these and other interesting findings amongst the samples can be found in below.

**Table 1.16** List of introduced species recorded during the survey, compared with alien species previously recorded in Mauritius, showing that all alien species found in the survey were not previously recorded in Mauritius, and that those previously recorded were either mariculture species or planktonic, and not detected in the survey.

Species name	Organism type	History in Mauritius	Comment
<b>Recorded from the port baseline survey</b>			
<i>Mytilopsis adamsi</i>	Mussel	Possible first record	
<i>Musculista senhousia</i>	Mussel	First record	
<i>Amphibalanus reticulatus</i>	Barnacle	First record	
<i>Amphibalanus amphitrite</i>	Barnacle	First record	
<i>Amphibalanus</i> sp.	Barnacle	First record	
<i>Megabalanus coccopoma</i>	Barnacle	First record	Single specimen
White Balanid sp.	Barnacle	First record	
Calyptraeidae sp.	Limpet	First record	Single specimen
<i>Spirobranchus</i> sp.	Fanworm	First record	
<i>Marphysa</i> sp.	Polychaete worm	First record	
<b>Previously recorded</b>			
<i>Crassostrea commercialis</i>	Oyster	Not detected in survey	Mariculture species
<i>Crassostrea gigas</i>	Oyster	Not detected in survey	Mariculture species
<i>Crassostrea virginica</i>	Oyster	Not detected in survey	Mariculture species
<i>Ostrea edulis</i>	Oyster	Not detected in survey	Mariculture species
<i>Metapenaeus monoceros</i>	Prawn	Not detected in survey	Mariculture species
<i>Melicertus latisulcatus</i> <sup>1</sup>	Prawn	Not detected in survey	Mariculture species
<i>Penaeus monodon</i>	Prawn	Not detected in survey	Mariculture species
<i>Chlorella</i> sp.	Phytoplankton	Not detected in survey	
<i>Treselmis</i> sp.	Phytoplankton	Not detected in survey	
<i>Brachionus plicatilis</i>	Rotifer	Not detected in survey	

<sup>1</sup> Originally recorded as *Penaeus latisulcatus*

It is not surprising that the species listed as previously recorded in Mauritius were not detected in the survey because these are mostly cultured populations that have likely not established wild populations, and a few planktonic organisms that are difficult to detect. What is surprising is that all the non-native species found in the survey appear to be new records for Mauritius, suggesting a general deficit in coastal surveys or monitoring. Of the species listed above there are some concerning findings that require further assessment and research. The mussels *Mytilopsis adamsi* and *Musculista senhousia* are both well-known invaders, with potential to cause significant impact. The Asian Mussel (Asian Date Mussel) *Musculista senhousia* is native to East Asia, and known to have invaded New Zealand, Australia, the Mediterranean and the Pacific Coast of the USA, as well as Madagascar and Tanzania. Known for its rapid growth and the formation of dense mats on the surface of soft sediments, it is capable of causing significant habitat alteration. The mussel uses its byssal threads and the soft sediment to construct a cocoon to protect its soft shell. It burrows down in sand and muddy bottoms, and may exclude other native species (macroinvertebrates), and alter the habitat. It can be found from intertidal to subtidal habitats at a depth up to 20m on soft or hard substrata. Only juveniles were found in the survey, so further confirmation of adult specimens would be beneficial.

The mussel *Mytilopsis adamsi* is an invasive brackish water bivalve, native to the tropical West Pacific coast of America. It has spread westward to south-east Asia, Australasia and India, where it is considered a mass fouling agent in ports, wharves and marinas. There have been no prior records of its occurrence in Mauritius, but this does not mean that it has not been found by some authorities or researchers. Nearly all the material was dead, which would be expected considering that the habitat sampled was fully marine. The specimens were likely washed down from brackish habitats nearby where the animal is living, and where populations may be growing.

An interesting Calyptraeid limpet was found in one of the samples. This single specimen does not look like any species normally found in the south-west Indian Ocean. These limpets are known to be travellers, therefore this species was likely introduced. More samples would be needed to gain clarity on the identification.

A field identification of the collected fanworm was made as *Ficopomatus enigmaticus*, an invasive polychaete in many parts of the world, including South Africa. However, further taxonomic assessment showed that these specimens are of the genus *Spirobranchus*, which also is not native to Mauritius. More detailed studies will be required to confirm the extent of the invasion, and associated biogeography.

A total of nine barnacle morphospecies were identified from the samples, and of these five were considered as introduced species. The most common barnacle found throughout the port is *Amphibalanus reticulatus* which is alien to Mauritius, and was recorded at 20 of the stations in relatively high abundance. The next most common is *Amphibalanus* sp. found at eight of the sampling stations. All five of the introduced barnacle species identifications carry a high degree of confidence, and have not been recorded in the literature previously.

### 1.5.5 Discussion

It is notable that the port survey in Mauritius was the first African example of a country supporting a port baseline survey, and associated BWM development process, with its own financing and resources. This included a long-term vision for protection of natural resources and investment in national institutions with respect to expertise and capacity. The driving factor behind support for the survey was the development of ballast water and biofouling management frameworks, which has also led to strong cooperation between the Shipping Division and MOI. This is in part due to the Blue Economy focus taken by the government of Mauritius, recognizing the economic potential of marine resources, especially as regards marine based tourism. In addition, it is partly in anticipation of developing a monitoring programme for Port Louis and Port Mathurin (Rodrigues) that will allow for a risk assessment-based approach to reach exemption from ballast water treatment obligations for the vessels that travel between the two ports on dedicated runs. Since the baseline survey of Port Louis, the field work phase of the Port Mathurin baseline survey has also been completed. The Mauritian institutions involved are in the process of designing the biological monitoring frameworks for these ports.

Besides the ongoing monitoring work being supported by Mauritius, there remains a significant need to coordinate and streamline supporting taxonomic processing of samples. The specimens that remained unidentified from the Port Louis survey will be re-assessed during the upcoming taxonomic phase of the Port Mathurin survey. It was also recommended that the future engagement of taxonomists should include strict Terms of Reference to ensure consistency between the management needs and the data to be generated. Through this ongoing process, the baseline information presented here will be further updated and strengthened.

As described in the sections above, the Port Louis survey design made some deviations from the CRIMP protocols that were planned following lessons from the previous two surveys. These proved to allow more efficiency in the approach to the field work, even though specific sampling methods were applied as recommended. The fabrication of a field base within a 20-foot container, which was placed on the quay-side for the duration of the project, was a highly effective advancement that consolidated laboratory and field necessities. The support from the National Coast Guard, in terms of boats and divers, also allowed for sub-teams to sample simultaneously, which expedited progress in the field.

The results recorded from the survey effectively provided a baseline of known species in the area. Although some groups are well studied in Mauritian waters, the alien species list for Mauritius was lacking records for alien species with established wild populations. The species previously recorded were mainly related to mariculture operations, indicating that they were recorded due to having been imported for commercial use. This does not necessarily mean that those species had escaped and were growing in the wild. The baseline information provided several new records for Mauritius, with some concerning results. Population delineation surveys should be carried out for the recorded introduced species with special emphasis on known global invaders such as *Mytilopsis adamsi* and *Musculista senhousia*. Such projects may also be expanded to include impact assessment and potential threat scenarios for detected species.

The taxonomic process was, as for the Port of Mombasa, the most concerning aspect of the survey. In this case however, the shortcomings are being addressed by the funding body (government of Mauritius), which is aware of the challenges in the taxonomy sector. The MOI is currently developing terms of reference for taxonomists that anticipate and aim to overcome the difficulties experienced during the Port Louis survey. This will encourage the consulting side of taxonomy, where more rigorous contracts are put in place, with strict delivery timeframes and conditions for payment. The approach is also anticipating greater technical delivery from taxonomists, including photography of specimens, DNA analysis where appropriate, and comprehensive species descriptions.

## 1.6 General considerations

Besides the location-specific considerations presented in the above sections, some cross-cutting conclusions can be drawn from the experiences gained through implementing the three port survey projects. These are generically relevant in consideration of achieving the over-arching objectives for port biological baseline surveys.

1. **Goal** – The over-arching question guiding this chapter (“Are large-scale, once-off baseline surveys able to generate adequate and useful data to support management needs, in an African context?”) should be subdivided to allow for a more focused assessment of the answer. Certainly, the ability of the surveys to generate large amounts of useful species occurrence data is not in question, but rather the question is whether the resulting data are “adequate” to substantiate conclusions regarding local biodiversity, and “useful” towards a particular management application. Although many of the particular constraints encountered in the “African context” were highlighted in the previous sections, this should not be discounted as a factor in the scope of this question. The recognition that each of the surveys conducted was the first of its kind for the location, and that a range of unique and extenuating circumstances had to be overcome, renders significant value to the demonstration aspect, initiating the scientific process inherent through the port surveys. Therefore, the minimum standards necessary to produce scientifically justified and meaningful data, may be considered the minimum criteria for success of such surveys. Maintaining consistency with protocols in terms of sample integrity, replicates, chain of custody etc., is particularly challenging in port environments, especially those in Africa. Therefore a significant component of a positive answer to this core question is the navigation of the hurdles and challenges that were presented in each location and project situation.

Each of the surveys developed a significant species list, a profile of introduced non-native species, and a characterization of environmental parameters associated with the port. The data presented above demonstrate the potential of once-off surveys to detect a significant portion of the extant marine biodiversity. This is clearly demonstrated in Table 1.6 for Saldanha Bay, where there has been a long history of marine surveys. Such a comparison was not possible for either Mombasa or Port Louis harbours, due to the lack of comparable historical information. However, the

number of first records of alien species reported for Port Louis (see Table 1.15) demonstrates the adequacy of the survey methods in detecting introduced species.

In each case, the survey results proved consequential to management authorities. Permanent annual IAS monitoring, based on the same methods, was put in place for Saldanha Bay, and replications of the baseline survey were conducted at other South African ports, all at the cost of local authorities. Kenya has continued to curate the established collections of marine organisms, both at the National Museum and at a purpose-built laboratory at KMFRI in Mombasa. Also, a replicate survey for the developing Port of Lamu in Kenya has been planned. In Mauritius, the baseline survey at Port Louis marked the start of a national programme, which has continued to expand, including extensive actions towards ballast water and biofouling management, as well as a replicate survey in Port Mathurin, with ongoing monitoring mechanisms and a novel approach to taxonomy under development. The ongoing collaborative relationship forged between the Oceanographic Institute and the Shipping Division has demonstrated a less tangible, yet highly important outcome of the survey. The uptake of the species and environmental data into management processes has also served to indicate the usefulness of the survey outputs. Besides reporting for national obligations, such as biodiversity assessments, the data have been instrumental in supporting the risk assessment applications that are further discussed in Chapter 3.

2. **Data** – For each of the port surveys, a final report was generated for the responsible authorities, which included all summary data generated from the field work and taxonomic phases. Additional raw data included on field sheets, sample logs and taxonomists' reports were also left under the custody of the local responsible authorities. While there is potential value to be derived from each of these data sources, it was the environmental parameters, species lists and associated abundance and distribution data for particular IAS that were taken up by management authorities for further consideration and application. In all three cases the collection of a broad set of environmental parameters proved valuable to local researchers and managers outside of the context of IAS management. For Saldanha Bay the information was essential in laying the foundation for the risk assessment exercise that followed (see Chapter 3), whereas in Port Louis the local oceanography institute used the opportunity to initiate a long term data collection programme. The collection of such background data is standard practice for field surveys, as reference and in order to assist in habitat characterization.

The quality of the species lists generated varied greatly between the three ports surveyed, with ongoing work to be completed for Port Louis and acknowledged gaps in the lists for Mombasa. Further to this, the taxonomic groups that were adequately identified also varied in each case, as a function of which specialists were available to assist in species determinations. It is therefore clear that not only were more species sampled than were ultimately reported, but that there were likely more introduced species sampled as well, given that some of the groups not adequately identified are likely candidates, based on their life histories (e.g. polychaetes, ascidians). These

conclusions from the data produced may be interpreted as a recommendation to save cost and effort, by targeting the sampling at groups for which taxonomic expertise is available.

Other conclusions may be drawn from the resultant data regarding possibilities for more cost-effective approaches to surveys, based on the introduced species recorded from the three surveys. Table 1.17 below summarises the IAS records from all three surveys, and compares these with the sampling methods used for their detection. The quadrat scrapes used to sample the fouling communities evidently produced the most results in terms of non-native species detections, with benthic cores and intertidal sampling showing some value as well. Other methods, such as plankton sampling, traps and fish seines are essential in developing a comprehensive baseline of species richness, but may be less consequential in terms of detecting introduced species. Therefore, the prioritization of sampling locations that is introduced during the survey design, might be reconsidered to rather increase focus on sampling methods that have demonstrated higher efficiency for IAS detection. This may of course be location sensitive, and as a conclusion should be further tested and strengthened.

Table 1.17 also lists the likely vectors associated with the introduced species found in the three surveys. As discussed above, the bulk of the species detected are from the fouling community, and are more likely to have been introduced through biofouling than by ballast water. This also is an area that requires further verification to be conclusive, however the inference for management purposes is one that stresses the need to focus on prevention of biofouling introductions, as well as ballast water introductions. This study has largely focused on the role of the surveys in supporting ballast water management applications. The Mauritian authorities have, however, taken the outcomes and recommendations from the survey and instituted a broad maritime biosecurity approach, which, at the level of Port State Control, includes tackling biofouling management in parallel with ballast water.

**Table 1.17** Introduced species recorded during the three surveys, showing sampling method used for detection and likely vector of introduction.

Species name	Organism type	Sample method used for detection	Likely vector of introduction
<b>Saldanha Bay</b>			
<i>Ciona robusta</i>	Ascidian	Quadrat scrapes	Biofouling
<i>Diplosoma listerianum</i>	Ascidian	Quadrat scrapes	Biofouling
<i>Botrylloides leachi</i>	Ascidian	Quadrat scrapes	Biofouling
<i>Bugula neritina</i>	Bryozoan	Quadrat scrapes	Biofouling
<i>Carcinus maenas</i>	Crab	Intertidal transects	Ballast water
<i>Mytilus galloprovincialis</i>	Mussel	Quadrat scrapes and intertidal transects	Biofouling or ballast water

<i>Littorina saxatilis</i>	Periwinkle	Intertidal transects	Biofouling or ballast water
<i>Pateriella regularis</i>	Starfish	Intertidal transects	Biofouling or ballast water
<b>Mombasa</b>			
<i>Bugula neritina</i>	Bryozoan	Quadrat scrapes	Biofouling
<i>Tricellaria occidentalis</i>	Bryozoan	Quadrat scrapes	Biofouling
<i>Diphasia sp. A</i>	Hydroid	Quadrat scrapes	Biofouling or ballast water
<i>Diphasia sp. B</i>	Hydroid	Quadrat scrapes	Biofouling or ballast water
<i>Salacia sp. A</i>	Hydroid	Quadrat scrapes	Biofouling or ballast water
<i>Eudendrium sp. A</i>	Hydroid	Quadrat scrapes	Biofouling or ballast water
<i>Halopteris sp. A</i>	Hydroid	Quadrat scrapes	Biofouling or ballast water
<b>Port Louis</b>			
<i>Mytilopsis adamsi</i>	Mussel	Benthic cores and quadrat scrapes	Biofouling or ballast water
<i>Musculista senhousia</i>	Mussel	Benthic cores	Ballast water
<i>Amphibalanus reticulatus</i>	Barnacle	Quadrat scrapes	Biofouling
<i>Amphibalanus amphitrite</i>	Barnacle	Quadrat scrapes	Biofouling
<i>Amphibalanus sp.</i>	Barnacle	Quadrat scrapes	Biofouling
<i>Megabalanus coccopoma</i>	Barnacle	Quadrat scrapes	Biofouling
White Balanid sp.	Barnacle	Quadrat scrapes	Biofouling
Calyptraeidae sp.	Limpet	Quadrat scrapes	Biofouling
<i>Spirobranchus sp.</i>	Fanworm	Quadrat scrapes	Biofouling
<i>Marphysa sp.</i>	Polychaete worm	Quadrat scrapes	Biofouling or ballast water

3. **CRIMP Protocol** – The considerations mentioned above may bring into question the merits of adhering to the CRIMP protocol, which includes intensive sampling (e.g. high replicates) in all available habitats. For the fouling communities alone, the protocol calls for nine quadrat scrapes over three depth intervals at each location. Thus, while the above section provides possible reasoning for focusing on particular methods, it may also be interesting to consider the necessity of, and ideal number of, replicates. The rationale for the use of high replicate numbers is redundancy (largely to aid in the assessment of abundance) and increased detection power. The

trade-off for the high replicate sampling approach would be increased geographic coverage, and potentially broader detection capability, while compromising density/abundance estimates. For native species, the experiences presented here suggest that the local authorities and scientific communities have not placed high priority or value on the issue of abundance. This has only been a concern as regards certain potentially threatening introduced species (e.g. *Musculista senhousia* in Mauritius). Therefore, should non-native species detection be the primary aim of the survey, as opposed to the baseline of overall biodiversity, then less site-intensive approaches that maximize geographic coverage, might be more effective, especially considering that a follow-up species specific delineation and abundance survey may be added once a concerning introduced species is detected.

The CRIMP protocol is nonetheless comprehensive and effective in terms of its intended use. The deviations from the protocol that were reported here (some of which are further discussed in Chapter 2) were relatively minor, not compromising the scientific rigor required. Adaptations for local circumstances are certainly acceptable, as long as they are adopted in a consistent manner, and with the understanding that these may limit comparisons with other surveys. Therefore, adaptations should be considered comprehensively for all surveys being managed under a common authority (e.g. national), such that all resulting data are standardized and directly comparable.

4. **Sampling** – The sampling methods that were conducted at each port location differed to some extent. Dinoflagellate cysts were only sampled in Saldanha Bay, because a specialist was available to analyze them. Unlike other specimens that can be preserved, the cysts need to be grown out for the identification process to be effective. For this reason, it was not appropriate to sample for cysts in the other locations, given that no specialist was available for the analyses.

Throughout the three surveys, there were some concerns reported by taxonomists regarding specimen integrity. The sampling methods can be quite destructive to the tissues of the specimens, and this may compromise the ability of specialists to reach confident identifications. Even though divers were trained in scientific methods, this situation persisted. It would perhaps aid the situation if the divers were brought into the laboratories with the taxonomists, to better understand how the sampling methods might be adjusted to minimize specimen damage.

5. **Capacity** – The successful implementation and outcome of a port survey is largely dependent on significant capacity being put in place through effective collaborations. This includes extensive human resources (with relevant expertise), institutional back-stopping for legal, administrative and operational concerns, and availability of appropriate equipment and resources. Although the capacity circumstances will vary in each location, it is essential that an assessment be conducted to determine that all necessary aspects are in place prior to moving ahead with a port survey project.

As previously described in this chapter, significant focus was placed on capacity development mechanisms during each of the port surveys. In each case these included workshops with local marine scientists to be trained in the specific sampling methods. Technical workshops were also conducted for scientists from other countries in the region to gain experience in the field and to initiate planning for surveys in their home ports. Taxonomic approaches were also supported by bringing experts from other countries to work with local and regional marine taxonomists to transfer skills and tools accordingly.

The effectiveness of these approaches may be difficult to measure, however direct outcomes were evident, as described throughout the study. Regional workshops in South Africa and Mombasa lead directly to replicate surveys in other areas. In the case of Mauritius significant national funding was set aside to further compliment the development of capacity for local institutions and individuals. The method employed for the Mauritius survey team, using one-on-one expert-trainee counterparts throughout the survey, proved to be an efficient way to empower the local scientists to take on responsibilities and activities in their own right. This has led to the same local team planning and implementing the follow-up monitoring and surveys in Mauritius. Ultimately, the qualitative generation of momentum and progress towards the desired management goals is the best indicator of success for the port surveys, as they are designed explicitly with a broad set of objectives.

6. **Expense** – The costs associated with each survey are significant (Overall budgets: Saldanha Bay – USD \$90,000; Mombasa – USD\$ 80,000; Port Louis – USD \$50,000). It is important to note that direct cost comparisons between locations would be difficult and misleading, in that there were significant differences in the types and amount of in-kind support, which can go a long way in reducing costs, as well as local capacity. Nonetheless, proper allocation of funds to each survey component is essential (e.g. taxonomy may cost up to 30% of the total project budget). Although initial funding is often provided by external international sources, the experiences reported here demonstrate that national support and investment will ultimately lead to the most comprehensive and useful outcome. Chapter 2 provides further guidance on steps to be taken to achieve greater local suitability and customisation.
7. **Ongoing monitoring** – The initial port biological baseline survey is effectively a once-off snapshot of the local situation that does not capture all the extant species information. Follow-up or repeat surveys may be used to expand the local species data, either in a targeted approach (e.g. species or area specific), or as a comparison to the initial survey. It is, however, recommended that the survey project is used to catalyze and put in place ongoing local monitoring, to build on the baseline data and information, as well as providing ongoing detection capability for any new species arrivals. As presented above, the ongoing monitoring has manifested in the Port of Saldanha and is underway for Port Louis. Only international intervention is likely to lead to a similar approach for monitoring in the Port of Mombasa. In the absence of ongoing IAS monitoring, the early detection of any new species arrivals is not likely. Once the baseline data

are established, their value for management is largely in supporting ongoing sampling efforts to generate complimentary and comparative insights.

8. **Taxonomic process** – As demonstrated in the descriptions above, the taxonomic process is a distinct phase of the survey project that should itself be considered as open-ended. The survey of the Port of Saldanha was the only case where the taxonomic process was relatively complete. This was due to largely to the time available, and the fact that most taxonomists operate from academic institutions with heavy schedules and different priorities than those presented during the taxonomic phase of survey projects. All three survey projects presented here had sizable funding support, and allocated significant amounts (approximately 25% of the overall budget in each case) for the compensation of taxonomists, including some costs for fine sorting and preservation of specimens, international postage and temporary sample storage. The difficulties encountered proved not to be related to funding, and only somewhat related to the existence of taxonomic expertise, although ideally there would be several experts in the region for each of the taxonomic groups. It was, however, the closure of the projects and associated time limitations for the taxonomists (including the necessity to send samples back to both Kenya and Mauritius) that caused the most complications in terms of obtaining meaningful results. Realistic time frames for complete taxonomy would therefore be two to three years, as opposed to the 6-12 months allowed in these surveys. Open-ended contracts, where specimens can remain with the taxonomists until they finish, may also be considered.

There is nonetheless an apparent problematic lack of taxonomic experts within the African region, and where expertise does exist, it may not always be available to assist with large-scale projects like these. It is suggested that available taxonomic expertise be assessed and quantified prior to development of survey plans, such that the survey may be tailored toward groups for which specialist expertise is appropriately engaged. The approach being taken by the MOI is also likely to yield positive results in both obtaining species-level results, and developing a core of professional taxonomists available to support regional survey projects.

9. **Biosecurity framework** – The activities associated with a port survey rely heavily on cross-sectoral collaboration between port-related stakeholders and the scientific community. The incentives, and indeed mandate, for buy-in, participation and in-kind contributions by some of the stakeholders can be facilitated by integrating the port survey within a maritime biosecurity framework. This may also serve to avail support for ongoing monitoring efforts and repeat surveys. This was the case in both Saldanha Bay and Port Louis, where the core drive for stakeholder involvement was not from the survey or IAS management alone, but rather from national decisions to move towards port-based biosecurity measures. The IMO recommends port surveys as an early step in this process, as they can be facilitative and catalytic, especially in terms of cross-sectoral stakeholder collaboration. This was indeed observed in these two locations, and could help account for the observed lack of over-arching stakeholder drive in Mombasa.

10. **Outcomes** – The sequential progression of the three surveys allowed for a gradual maturation of the design and implementation process. The lessons learned through these experiences are largely captured and presented as guidance in Chapter 2 of this thesis. Each survey also produced results and questions that require follow-up by local authorities. This interface with the management repercussions of the surveys is critical, and indeed the intended purpose or justification for conducting the surveys in the first place. This thesis aims to draw the linkages between the baseline surveys and examples of key management actions that served to address questions arising from the surveys.

## Chapter II - Guidance on port biological baseline surveys

### 2.1 Introduction and background

#### 2.1.1 The need for biological data

Under Article 6 of the Ballast Water Management (BWM) Convention, States are encouraged to undertake scientific and technical research and monitoring including “*observation, measurement, sampling, evaluation and analysis of the effectiveness and adverse impacts of any technology or methodology, as well as adverse impacts caused by such organisms that have been identified to have been transferred through ships’ ballast water*”.

This clearly recognizes the need for biological information on coastal and inland waters frequented by shipping in order to assess historical exposure to non-indigenous species introductions, to detect impacts on native species and communities exposed to such introductions and to monitor change over time. Where large areas are lacking biological records, it would clearly be appropriate to record the most commonly-occurring plants and animals present in a manner that allows for updating of these records and the detection of changes following future monitoring activities.

Whereas few countries have established long-term monitoring programmes specifically to identify alien species and species that may be invasive, such information is a crucial component of risk assessment for ballast water and alien species management. Although port surveys are not a specific requirement under the BWM Convention, risk-based approaches are central to ballast water management (Hilliard et al., 2005). It is therefore appropriate that countries take steps to improve their information base on alien species, and where possible carry out port biological baseline surveys (PBBS) in their major commercial ports.

For those countries that may be undecided about the benefits of ratifying and implementing the BWM Convention, conducting PBBS can:

- a) Reveal the existing state of alien and invasive species infestation,
- b) Reinforce arguments for preserving the areas’ natural biodiversity, and
- c) Support granting exemptions under regulation A-4 of the BWM Convention, based on the IMO guidelines for risk assessment (G7).

The introduction of alien species is a global problem that can be mitigated only through coordinated international action (McNeely et al., 2001). Inventories of introduced species in different regions may form an important part of this international effort, particularly when the datasets are obtained by comparable methodologies. Accordingly, a uniform application of PBBS procedures would help to harmonize approaches to port surveys in different countries and regions, for example by encouraging similar levels of sampling intensity and thereby facilitating comparisons of alien species occurrence and abundance.

The aim of this chapter is, therefore, to provide general guidance on the design, planning and execution of PBBS, covering major ports and surrounding areas, as well as to harmonize the data generated by such surveys. It will have particular relevance for those countries with limited experience in conducting port surveys.

### 2.1.2 The purpose of PBBS

As conceived in this guidance document, a PBBS is a scientific survey of the port's biological communities and ecology, focusing on the identity, distribution and abundance of alien, or non-indigenous species, some of which may prove invasive and ecologically damaging. Ideally, the survey will provide an inventory of the more readily-observed plants and animals occurring in the various habitats and substrates of the port environment, as well as some of the more cryptic species. This may involve a number of surveys to cover the various taxonomic groups, locations and seasonal conditions. If possible, PBBS should be repeated at intervals of 3 - 5 years (Hewitt & Martin, 2001), although these follow-up surveys may be reduced in scope and scale, to form part of on-going environmental monitoring programmes.

Biological and ecological information for port areas is generally scarce and is seldom updated (Hewitt & Martin, 2001; Awad et al., 2004). This is due in part to the difficulties associated with scientific sampling in maritime and port areas, especially in light of security measures operating within most major ports. Ports, however, are the most likely places for new marine species to arrive and settle, and therefore a logical place to initiate biological surveys. The type, abundance and distribution of organisms may change considerably due to new species introductions, so even where surveys have previously been carried out, it is important to re-survey periodically.

Environments within port areas are generally distinct from the natural coastal systems surrounding them, due to the large number of artificial structures present and the nature of the activities taking place within ports, including, but not limited to, shipping. However, because ports have connectivity to the open coast, any biological changes occurring within the port may have effects on adjacent coastal ecosystems. There is, therefore, an overlap between the areas generally managed by maritime and port authorities with those managed by environmental administrations. This provides an opportunity, as well as a justification, for collaboration and resource-sharing between these sectors, which is important to the effectiveness of a PBBS.

In the context of BWM, a PBBS has four specific purposes, namely to:

- a) Inform port authorities and lead agencies responsible for BWM about the current position with respect to alien and cryptogenic species within the port and surrounding areas, including those that may have been introduced by shipping;
- b) Prepare an inventory of aquatic plants and animals inhabiting the port and adjacent areas, including their distribution and relative abundance;
- c) Guide the development of BWM strategies and measures applicable to the port and visiting ships; and
- d) Provide a baseline of biological data against which future changes in aquatic communities, including introduced species, can be measured.

There are, of course, other reasons for conducting biological surveys, such as assessments of environmental quality and harvestable marine resources, or studies of the effects of climate change. Whereas it is possible to investigate all these properties simultaneously, it is likely that for many countries this would prove far too demanding in terms of time, and of both human and financial resources. Furthermore, commercial ports are probably not the best areas for the kinds of biological surveys that require stable and/or pristine conditions. Ports have numerous man-made structures, are frequently subject to dredging and their water quality is often impaired to some degree; there is also much turbulence and redistribution of sediments. Although biological monitoring programmes are routinely carried out in many countries, these rarely include sampling sites in ports.

***An important message from this guidance document is that a PBBS does not need to be excessively complex or costly and should always be undertaken according to the resources available. It is better to conduct a simple, selective PBBS for a port frequented by ballasted vessels than to avoid the task because it cannot be done comprehensively. On the other hand, a comprehensive survey of the port most at risk from species introductions could demonstrate the likely extent of the problem within the region.***

The essentials of a PBBS for the management of port and coastal environments may include:

- a) A survey design that can detect introduced species, paying particular attention to a cross section of marine habitats representative of the region;
- b) A survey team trained in the recognition of introduced species and related laboratory techniques;
- c) Experience in the collection, verification and archiving of taxonomic information essential to the investigation and management of alien species within the region.

Biological information is not only important for protecting the local port and associated environments, but also to prevent, avoid, or reduce the potential for local species to be exported when ships load ballast water prior to departure. It may also help to reduce the spread of introduced species from the port to adjacent coastal areas. In a broader context, information from port surveys is essential in building regional and global databases on alien species, and ensuring that these databases provide sufficient information for risk assessment. As stated in Article 13(3) of the BWM Convention (IMO, 2009):

***“In order to further the objectives of this Convention, Parties with common interests to protect the environment, human health, property and resources in a given geographical area, in particular, those Parties bordering enclosed and semi-enclosed seas, shall endeavour, taking into account characteristic regional features, to enhance regional co-operation, including through the conclusion of regional agreements consistent with this Convention. Parties shall seek to co-operate with the Parties to regional agreements to develop harmonized procedures.”***

It is preferable that PBBS be repeated from time to time, so that changes in the biological and ecological conditions of the port can be kept under review. In some cases, it may be decided to establish an ongoing monitoring programme, rather than a comprehensive once-off survey; both options will provide data useful in risk assessments and alien species management. A PBBS may prove to be an effective catalyst in building support for ratification and implementation of the BWM Convention and is essential for risk assessment and mitigation measures. In accordance with the Convention, risk assessments based on reliable biological data

and on-going monitoring may be used to provide exemptions under Regulation A-4 for specific ships operating between specified ports and locations (e.g. those operating on low-risk routes).

## 2.2 Types of surveys

### 2.2.1 Protocols for PBBS

In 1997, the IMO released guidelines for BWM (Resolution A.868 (20)) encouraging countries to undertake biological surveys of port environments for potentially harmful non-indigenous aquatic species. In the BWM Convention, PBBS is implicitly encouraged in the requirement for risk assessments (see Guidelines G7 in IMO, 2009).

Several port sampling programmes have developed different sampling protocols, e.g. in the USA, Australia/New Zealand (CRIMP protocol) and Europe. Before launching a PBBS programme, it is recommended that the chosen design is compared to existing sampling protocols to ensure that it is appropriate for the area and jurisdiction concerned.

The majority of PBBS conducted around the world to date were designed around the protocol developed by CRIMP (Hewitt & Martin, 2001). Very few, however, followed this protocol precisely, as there are always adaptations and compromises that need to be made, depending on local circumstances, priorities and resources. Although the CRIMP protocol is very comprehensive, it was designed for application in Australian waters and, in most circumstances, it will need some adaptation. One of the more significant adaptations for areas with capacity limitations, is the use of non-diving based sampling methods. Another is a reduction in sampling intensity within particular sites or habitats.

Taking into account the above considerations, a range of examples covering different levels of PBBS, in terms of scope and scale, are shown in Figure 1. These options are categorized into different levels, based on the scope of work, manpower, funding and infrastructure requirements. They are by no means exclusive, but it is clear from the examples that cost and logistics become greater with increasing scope and complexity. Survey designs are flexible, and even the simpler examples (Levels 1 and 2), especially when aided by carefully compiled and locally relevant check lists of high-risk species, will yield information of considerable value to the management of species introduced by shipping.

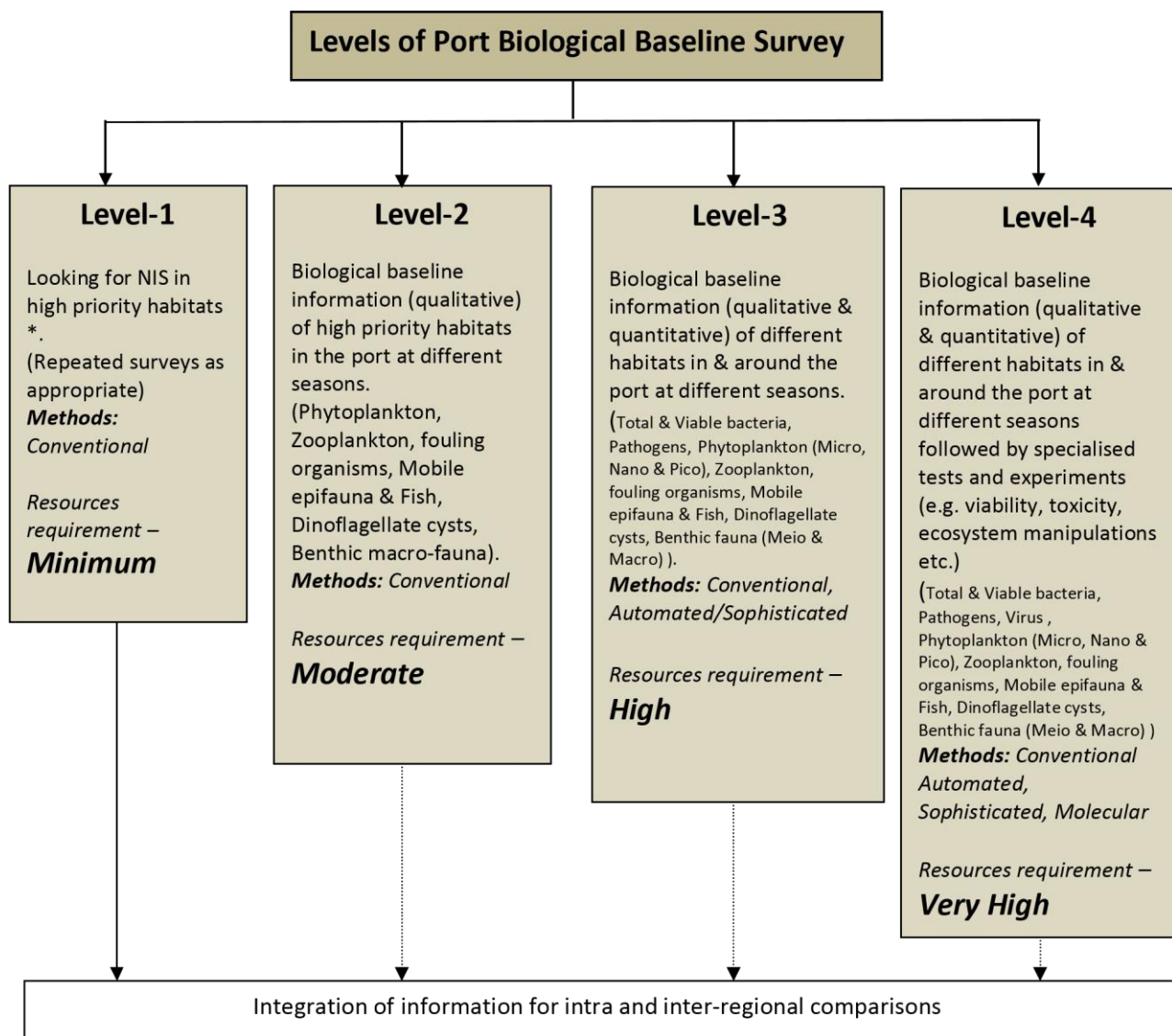

\* Areas targeted for maximum species richness, and with increased likelihood of finding alien species

**Figure 2.1** Examples of approaches to PBBS differing in scope, scale and complexity.

### 2.2.2 Adapting protocols to local circumstances

In the case of surveys specifically intended to investigate aquatic biodiversity, the focus is on the variety of organisms at different taxonomic levels and the communities of which they are part. In principle, there is no limit to the taxonomic groups that may be sampled, ranging from viruses to the largest marine mammals. However, where highly specialised equipment is required for sampling, sorting and identification (e.g. micro-benthos), the time, taxonomic expertise and costs involved may increase substantially. For this reason, most biological surveys will be restricted to organisms within a practically manageable size range, for example >10µm or >50µm, or species identifiable with a good quality binocular microscope (x10-40 magnification), such as benthic (infauna, epifauna and encrusting) organisms (Hewitt et al. 2004). A significant proportion of the

more problematic alien species (i.e. invasive species) so far identified are macro-invertebrates (Hayes et al., 2002). Comprehensive inventories of smaller forms, such as ciliates, bacteria and viruses, may be unrealistic as part of broad-scale surveys; such taxa can be the subject of specialised surveys, should they be warranted and affordable.

***The scope of a marine biological survey needs to be defined either in terms of taxa, size-ranges, target species and/or the procedures to be used in sampling, sorting and identification; decisions on scope should take into account the expressed purpose of the survey, the available financial and technical resources, including the requisite taxonomic expertise and capacity for sample throughput.***

PBBS in support of BWM may adopt a design strategy that is broad in scope, but should also give particular attention to species and taxonomic groups known to be spread by shipping, as well as their abundance and distribution. Illustrated check-lists of the most likely and problematic species transferred between different regions of the world are available from a number of sources (e.g. Fofonoff et al., 2013; NOAA, 2013; IUCN, 2012; Government of Australia, 2012; AquaNIS 2013). Although existing, up-to-date lists of target species are valuable, whenever possible they should be checked against records of potentially high-risk species in other bioregions frequented by incoming vessels. The preparation of target species lists, preferably illustrated, should be considered a preparatory task for the PBBS team. Ideally, the survey should encompass all habitats within and around the port, but it is sometimes more practical and cost-effective to concentrate on the substrates most suitable for the species of concern.

Lists of target species have enabled the use of so-called 'Rapid Assessments' of alien and invasive species (Ashton et al. 2006; Minchin 2007; Minchin 2012) whereby ports, harbours and marinas can be examined for the presence of listed species by smaller survey teams requiring far less time, so that large sections of coastline can be covered with minimum cost. For purposes of BWM, and alien species management generally, such methods are both useful and cost-effective. The implications of selecting a rapid assessment approach should be weighed against a more comprehensive PBBS approach, taking into account the objectives of the survey, and the types of information and data required. Due to the substantial differences in approach, rapid assessment surveys are not covered in this guideline.

## 2.3 Planning and design

The preceding section outlined various reasons for conducting PBBS and clarified the important relationship between *survey purpose* and the various *types of surveys*. The information generated by a PBBS is equally applicable to the management of ballast water as it is to other vectors, such as biofouling on ships' hulls. At the start of any new survey, it is important to clarify the questions to be answered and how the findings will be used for management purposes.

A typical PBBS is designed to detect introduced species, as well as providing an inventory of species within selected taxonomic groups, and/or of specified size-ranges, to serve as a baseline for future assessments. No single survey will be 100% effective with respect to these aims (Hayes et al., 2005), and results must therefore be treated accordingly e.g. by supplementing them with data from subsequent surveys or monitoring, or by focusing on different seasons or taxonomic groups.

### 2.3.1 Initial steps

#### Assessment of resources

At the outset, it is essential to fully assess the available resources, so that the survey design is realistic, accurately reflecting capacity in terms of manpower, expertise, equipment, facilities and financing. The assessment should also consider the time requirement (including seasonality), access to the survey area and any practical support available from port authorities and other relevant agencies. For each of these factors, the design team should consider possible limitations, the degree of flexibility and potential contingencies.

#### Stakeholder involvement

Apart from the principal agency responsible for conducting the surveys, other relevant stakeholders should be invited to participate in PBBS activities, starting at the design stage. Table 2.1 indicates some of the more likely stakeholders that may be involved, or have interest in PBBS, as well as their possible roles and contributions.

**Table 2.1:** Potential stakeholders that should be targeted for involvement in PBBS activities.

Stakeholder	Involvement
Maritime authority	Coordination, authorizations, access, vessel communications
Environmental administration	Permits, data, equipment
Port authority	Details of shipping activities, Access to port areas, field laboratory facilities, vessel coordination & communications
Research Institutes in the relevant field	Expertise, equipment, data
Fisheries department/Institute	Expertise, equipment, data
Coast Guard and/or Navy	Boats, divers, safety equipment
Academic institutions	Expertise, equipment, data processing, taxonomic specialists
Tourism board/Department	Awareness raising, community cooperation
Diving and recreation clubs	Assistance with passive monitoring, cooperation
Health department	Bacteria and pathogen analysis, data
Museums	Taxonomic specialists, sample curation
Terminal operators and port users	Cooperation for access and assistance with space, logistics, etc.
Parks or reserves	Access to controlled areas, data, collaboration
Community forum (e.g. water quality)	Awareness, cooperation, data
Regional bodies and organizations	Awareness, cooperation, data

Creating awareness and developing collaborative arrangements in advance of the survey can reduce cost and time. It is, however, important to communicate clearly, to define the expectations and roles of all parties involved, and even to use contracts and/or Memoranda of Understanding (MoU) to ensure that involvements are clearly understood. Site visits with key stakeholders can be helpful in survey preparation and design.

One of the principal stakeholders will, of course, be the port authority and it is essential to secure their cooperation and assistance at the earliest stage in PBBS planning. Direct contacts with port officials (e.g. harbour master) are essential for making pre-survey arrangements such as:

- Port familiarization visit
- Obtaining necessary permissions
- Entry passes for personnel and vehicles/ mobile laboratory
- Shipping information
- Port resources map
- Electricity and water requirements
- Survey vessel/ boat
- A room or shade for setting up of shore laboratory

### Establishing the scope of PBBS

The importance of decisions regarding the type of PBBS was highlighted in Section 2.2. The key considerations regarding the scope of PBBS are illustrated in Figure 2.2 below:

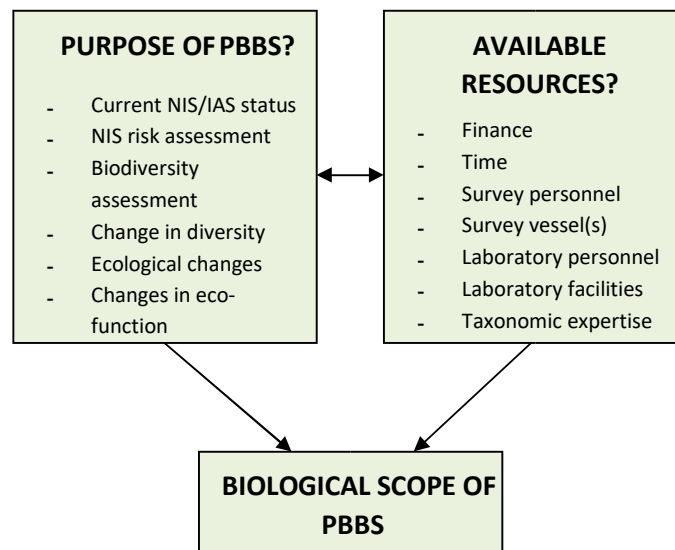

**Figure 2.2** Key considerations in establishing the scope of PBBS.

In certain areas it may be appropriate to consider seasonal variation when deciding on the scope and timing of the PBBS. Some organisms may be influenced by the seasonal changes in habitat conditions (Oluokolajo & Oluwaseun, 2008), which may also affect the likelihood of their detection. In cases where seasonal variation is considered to be a significant factor, the PBBS effort may in fact best be split into two distinct field surveys, separated by six months, in order to account for such variability and strengthen confidence in the results.

### **Survey Implementation Plan**

The Survey Implementation Plan for PBBS should be clearly documented and sub-divided into two phases: a) field survey (sample collection and sorting) and b) sample analysis. For each phase, the plan should include listings of:

- Schedules of daily activities,
- Roles and responsibilities,
- Contingencies or alternatives,
- Health and safety procedures and concerns,
- Materials, equipment and consumables required.

The plan should be flexible enough to account for any changes in weather, port and shipping operations or personnel availability. It should be realistic with respect to daily work load for individuals, allowing for adequate rest (e.g. for divers operating in strenuous conditions) and sufficient time each day for sample handling (sorting, labelling, preserving, etc.).

### **2.3.2 Survey design**

#### **Demarcating the survey area**

Ports vary greatly in terms of traffic type, position, size, complexity and the numbers and types of habitats found in and around them. The survey should maximize the range of habitats sampled and, as far as practical, should include sites representative of areas affected by each of the different port activities. It is also a good idea to include areas outside of the port for comparison. An initial site visit (Figure 2.3), including a tour of the port by boat, is indispensable for gaining familiarity with the lay-out of the port and to check the suitability of sites for sampling. Photographs of candidate sites can also be taken for future reference.



**Figure 2.3** Site visits with local stakeholders are helpful in survey preparation and design. Photo credit: Author.

Factors and features to consider in determining the appropriate survey area, and thus the survey limits, include:

- Operational shipping areas most commonly exposed to introduced species, such as cargo (bulk, container and multi-purpose) berths, anchorage areas, navigation buoys, approach channels (where de-ballasting often occurs), dry docks and cleaning areas, marinas and small craft harbours;
- Locations with hard vertical surfaces and areas of relatively undisturbed sediments;
- Areas where dredge spoils are dumped and that might provide opportunity for invaders to settle and colonize;
- Nearby aquaculture facilities as aquaculture structures provide good substrates for sessile organisms;
- Aerial photographs and water circulation maps providing information on the dynamics of the port and associated areas;
- Accessibility (administrative permissions, security requirements) and ease of sampling, especially in areas of high traffic.

### **Selecting the sampling sites**

Having demarcated the survey area, and having consulted the available charts, maps and photographs, the survey team will already have a good understanding of the potential sampling sites in each of the target habitat/substrate categories. In evaluating sampling sites, accessibility and the safety of survey crews are of high priority.

To get the best results, organisms should ideally be sampled from all port habitats and substrates, including the water column and soft sediments, as well as from hard substrates such as coastal defences, dock structures (harbour walls, jetties), navigation buoys, ship wrecks, bridge abutments etc. The surfaces of drainage culverts, cooling water inlets and power plant outlets should also be examined, as they may provide opportunities for some introduced species to become established.

In summary, the site selection process should ensure:

- A wide range of geographic and habitat coverage
- Optimal opportunity to document species diversity within the scope of the survey
- Maximum likelihood of introduced species detection

A sampling plan should be drawn up detailing the exact number and location of samples to be taken at each of the chosen sites. This will allow for an initial assessment of the scheduling and time requirements to complete the sampling and associated activities. The sampling plan and schedule should be entered into the PBBS implementation plan.

### **Selecting sampling methods**

For each site selected, sampling methods will be dictated largely by the habitat types present. Protocols, such as those developed by CRIMP, can be very specific about the sampling methods to be employed, as well as the numbers of samples to be taken. However, in many instances it would be appropriate to consider alternatives or variations to suit local conditions and capabilities. For example, where diving is hazardous due to the prevalence of predators (e.g. sharks, crocodiles), pollution or venomous jellyfish etc., surface-operated samplers might be used instead. Also, where the capacity for sample processing is limited, the number of replicate samples taken at each site should not preclude sampling all priority areas and habitats.

While the types of habitats found in the port area will determine, to some degree, the types of sampling device required, an array of options is available for each organism type, habitat and substrate. The choice of method should be based on likely effectiveness (including local experience), equipment availability, cost and practicality. Table 2.2 lists some of the more common substrates and a selection of devices used internationally in marine environmental surveys, as well as examples of different categories of marine organism associated with particular substrates.

The choice of sampling device will depend on the types of organism intended to be sampled, as well as the habitats/substrates in which they live. However, it is essential to take account of species abundance in selecting the number of samples collected at each site; if a species is not abundant it may not appear in a single sample. Information on abundances obtained from previous surveys or research will help to determine the appropriate number of replicate samples (typically 0-5) needed to represent the biota on or within a particular substrate type. Figures 2.4 to 2.9 show different kind of sampling gear that are routinely used for port biological surveys.

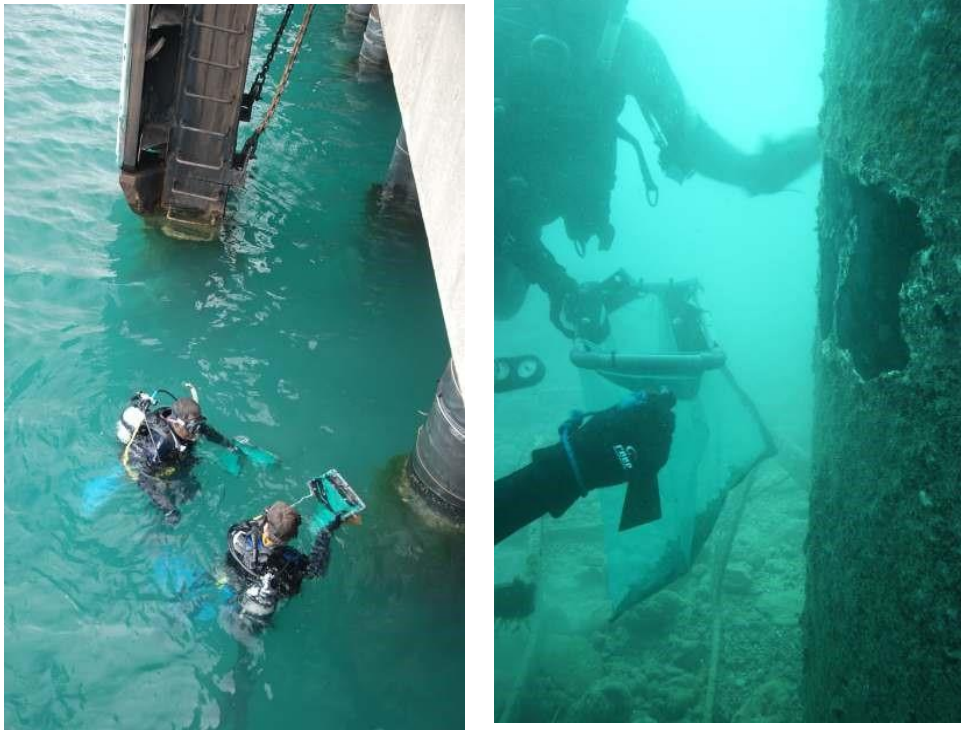

**Figure 2.4** Field demonstration of quadrat scraping methods.



**Figure 2.5** Pole scraper used in India to replace diver-based methods.



**Figure 2.6** Van Veen grab sampler, showing obstruction.



**Figure 2.7** Qualitative sampling along the buoy chain.



**Figure 2.8** Deploying plankton nets.



**Figure 2.9** Beach seines being deployed.

Photo credit for Fig. 2.4 to 2.9: Author. Further advice on sampling techniques is given in Appendix 2.

**Table 2.2** Sampling devices that are appropriate for use for different marine substrates.

Substrate types	Relevant sampling methods	Associated marine organisms
<b>Water column</b>	Niskin/Kemmerer Water Sampler Pump Plankton nets (20 µm/100 µm) - vertical or horizontal haul Sterile microbiological sampler/syringe/corer/filter	Zooplankton Phytoplankton/cysts Viruses/bacteria
<b>Hard substrates:</b> Concrete walls and facings Pilings – concrete and wood Breakwaters and rocky barriers Buoys and channel markers Wrecks and abandoned hulls Hulls of vessels including yachts Rocky/pebble beaches (intertidal) Rocky/pebble beaches (sub-tidal) Rock pools Reefs – rocky and coral	Scraper and quadrat Scraper and quadrat Scraper and quadrat/traps Scraper and quadrat/visual Scraper and quadrat/visual Scraper and quadrat/visual Transect/quadrat and scraper/hand-net Transect/quadrat and scraper/traps Scraper, hand-net Transect/quadrat/traps	Fouling organisms Mobile invertebrates and small fish Macroalgae
<b>Soft substrates:</b> Non-vegetated sand/mud bottom Low-tide mud flat Sub-tidal mud to sands Sandy beaches Seagrass meadow/algae bed Mangroves Saltmarshes Cyanobacterial algal mats	Grabs/cores/trawl/benthic sled Grabs/cores/benthic sled Grabs/cores/trawl/benthic sled/fine-mesh dredge Beach seine/transect Transect/traps Grabs/cores/traps/nets Transect/traps Transect/traps	Mobile and sessile epifauna Infauna, meiofauna Dinoflagellate cysts
<b>Animal and plant hosts</b>	Selected tissues and organs	Endo-ecto-parasites, diseases

### 2.3.3 The survey team

A PBBS is a significant undertaking, with logistical and technical complexities, and demands meticulous organisation and management. The human resources available, and the manner in which these are organized, are integral to the success of the survey. A team approach is essential; there could be one small team of experts, or several sub-teams working together in a coordinated manner and with a common goal. As a rough guide, a team comprising 8-10 individuals and divided into two sub-teams in most cases should be sufficient to sample a moderately-sized commercial port in less than a week. A small commercial port may require only 3 - 5 days, whereas a large commercial port, such as Mombasa, can require up to two weeks. The field time necessary is of course dictated by the level of detail of survey conducted, as well as the numbers and levels of experience of the skilled personnel on hand, and the overall size of the project team. There is no rule in this regard, and survey planning should carefully consider realistic time implications of activities, based on the experiences of the senior members of the project team. The roles of certain key individuals are described below and summarised in Table 2.3.

#### **Project leader**

The project leader should be a senior-level person with a scientific or technical background and should have adequate experience in managing inter-disciplinary environmental projects. He/she will have a major role in designing the survey, as well as selecting the project team and assigning tasks and responsibilities, according to the scope and scale of the project. The project leader will also select one or more suitably experienced person(s) as survey team leader(s) who can help in selecting other team members.

#### **Survey team leader(s)**

Leadership of the field survey will include the supervision of sampling activities, as well as making necessary arrangements with the port authorities. Survey team leaders should be well versed in both existing and potential alien species of the region, as well as with various sampling techniques, and be capable of managing unforeseen difficulties quickly and efficiently. They should list, and ensure the provision of necessary equipment and organise the survey in accordance with the implementation plan, instructing and assigning tasks to team members, as appropriate. For example, one member of each survey group should be assigned the task of keeping written records of samples, sample locations and all observations regarding species occurrence, abundance and distribution. Survey team leaders should also maintain contact with port officials to ensure the team is well informed of port traffic while the survey is in progress.

#### **Other team members**

A survey team may vary in size from only a few individuals, each taking on multiple roles and responsibilities, to 15 or more members forming sampling and sorting sub-teams (see Table 2.3 below for summary of common survey team roles). The members of the field survey team may be drawn from a variety of sources, such as state agencies, port authorities, hydrographic survey units, private companies, diving clubs and university science departments. Ideally, all team members will have experience with some form of sampling and measurement in the aquatic environment, familiarity with small boats and an ability to swim. It is preferable that several members have an appropriate scientific background, be trained in recognizing target alien species,

in operating devices for sampling, and in sample labelling and storage. Such individuals can assist the survey leader in instructing less experienced staff in the procedures to be used in the field and to allocate tasks accordingly.

Some of the team members may take on additional roles and responsibilities. For example, the survey team should include an appropriately trained person to act as safety officer. The safety officer has sole responsibility for all aspects of personnel safety, both on land and at sea, covering all field activities for the duration of the project. The brief of the Safety Officer embraces items such as clothing, footwear, life jackets, medical kits, emergency communications, rescue procedures, ensuring equipment operators are properly trained and that survey boats are adequately equipped and seaworthy. In some cases, diving teams may provide their own safety officer and adopt their own safety procedures; this should always be with the knowledge and approval of the team safety officer.

**Table 2.3** Summary of common survey team roles.

<b>Team member/role</b>	<b>Note</b>
Project leader	Overall responsibility for and management of the project.
Field logistics coordinator	This can be a distinct role, or may be performed by the Project Leader. If separate from project leader then this role may be combined with Laboratory Manager.
Field team leader(s)	Communicate(s) with project leader to implement the survey plan and coordinate the field team members and activities.
Dive supervisor	Plans and oversees all diving activity. Does not participate as a diver.
Boat captain	Responsible for boat safety and operations. Should be separate from Dive Supervisor.
Divers/samplers	In many locations a scientific dive certification may be required. Divers may also take on other sampling activities or team responsibilities.
Sampling supervisor	Maintains coordination, integrity and logs of all samples as they are generated in the field. Ensures safe transfer of samples to field laboratory.

Laboratory manager	Establishes and coordinates a safe and efficient field laboratory for sample processing (concurrent to field sampling activities).
--------------------	--

#### 2.3.4 Planning for contingencies

During the implementation of a PBBS, it is possible that not everything will go according to plan. Contingency planning, with a view to having back-ups and alternatives in place or on-call, is thus advisable. Circumstances in which advance planning is helpful include:

- **Field operations**

It is possible that weather and other field conditions may not allow for the survey implementation plan to unfold as envisioned. For example, port operations may change, sites may prove harder to access than anticipated and boats and other field equipment may malfunction, requiring servicing or replacement. It is a good idea to design a fall-back plan of strategy that allows for such eventualities, including “worst-case-scenarios”.

- **Finances**

It is possible that the survey expenses will be lower than anticipated and a decision is made to increase the survey intensity along the way. It is also possible, and unfortunately more likely, that the survey budget will not stretch as far as originally planned and some aspects of the PBBS will need to be foreshortened or abandoned, without compromising the main objective. Provisional decisions on where and how to exercise such cuts will make for smoother transitions in the field, although these may be updated in consideration of data collected along the way.

- **Safety/emergencies**

Comprehensive health and safety procedures should be part of the implementation plan, including daily briefings from the Safety Officer, inspection and documentation of safety equipment provided and emergency procedures to be followed. Extra support (e.g. phone numbers for emergency services, harbour police, insurance for divers) should be readily available, if and when needed.

- **Schedule and timing**

Any of the above contingencies may lead to a delay in the survey schedule, with consequences for the implementation plan, possibly requiring it to be changed or rescheduled. Advance planning for such contingencies may not be easy, but having available alternative dates for the survey, suitable for both port authorities and team members, may help to reduce pressure on survey leaders should serious difficulties or delays be encountered.

## 2.4 Field operations: sampling and sample processing

Efficient fieldwork is the key to successful biological surveys. This section gives guidance on the conduct and management of the field component of PBBS projects. It includes considerations relevant to communications and safety, as well as describing the main functions of the survey team and the collection and processing of samples.

A PBBS will typically involve one to two weeks of field activities, depending on the size and nature of the port, to collect and process the samples. Several operations will be underway at the same time, so good organization and coordination will be needed to ensure the success of the survey.

Although PBBS can and should include measurements of environmental (e.g. chemical, physical) variables, in addition to biological sampling, these guidelines do not address these non-biological measurements, whether or not these are made directly in the field or involve laboratory testing. In cases where biological and environmental surveys are carried out simultaneously, it is advisable to use separate teams and cruises for these activities. Basic water quality parameters, such as temperature ranges, salinity profiles and oxygen saturation levels, may be captured by the biological field team at each station, and are often the most influential in determining the aquatic communities present within the habitat concerned. Laboratories designed for analysis of other water quality parameters (e.g. nutrients, persistent organic pollutants) require very different facilities to those of biological laboratories.

### 2.4.1 Communications

A team approach to field work will help establish a hierarchy of authority and communication. All team members must know who they should report to (e.g. Project Leader, Survey Team Leaders), as well as how communications will be handled. It is advisable to hold daily briefings both at the start and the end of each day. Both expectations and progress should be discussed in light of any feedback from team members or other stakeholders. All personnel should have direct access to a comprehensive list of contact details, so that anyone can be reached at any time. The most appropriate and sensible means of communication should be used (i.e. mobile phones, VHF radio etc.).

In addition to internal communications within the project team, it will be necessary for the Project Leader, and occasionally Survey Team Leaders, to be in regular contact with port authorities/officials, and perhaps also with relevant state agencies, sponsors and others, to exchange pertinent information and updates.

### 2.4.2 Safety

Safety during PBBS is a most important and on-going consideration. The instructions of the Safety Officer should be observed at all times. Sampling procedures should not put any survey team member at risk. While working on the decks of survey boats, crowding at one place should be avoided. Cleanliness should be maintained on the deck, with no spillage of water/sediments or oil which could make the surface slippery. The deck also should be cleared of ropes attached to sampling gears and other equipment, as well as plastic ware. Any person operating sampling devices must wear a life jacket or safety belt. In addition, safety shoes, gloves,

masks, eye protectors, first-aid kits and clothing appropriate to weather and sea conditions should be available to all field team members.

Diver safety must be assured through the development of a dive plan by the dive supervisor. All appropriate considerations and protocols related to the diving demands of the particular survey should be included. For example, this includes some fundamental practices, such as always using the buddy system (Figure 2.10), attention to the dive tables for repeat dives, location of nearest hyperbaric chamber, and always having stand-by divers available.

The complexity and relevance of safety measures to be implemented will be determined by the sample design and implementation plan. Sampling protocols will ideally contain stringent and comprehensive checks and measures for ensuring safety at all stages of PBBS. Attention to these during the planning stages and in the field will ensure a more relaxed and effective survey operation.



**Figure 2.10** The buddy system being employed by divers taking benthic cores. Photo credit: Author.

### 2.4.3 Field base and laboratory

An integral component of the field operation is a fixed or mobile facility that can be used as a base and field laboratory. Having a centralized base for staging and coordination is essential, and if the same location can be used for storage of equipment, consumables and samples, as well as functioning as a sample sorting laboratory, this will make the field work much more efficient. Many types of samples must be processed and preserved within a few hours of their collection and therefore need to be taken to a shore-based laboratory or facility immediately after collection. Some attributes of a suitable field base include:

- Adequate space for tables for sorting, storage of equipment, wet/dry areas, etc.
- Connection to water supply, preferably with washing basins (including drains)
- Electricity supply
- Ventilation
- Storage and refrigeration facilities
- Locking doors and site security
- Easy access to waterside and moorings, and/or sample drop-off location

- Waste disposal facilities
- Access to toilets and showers (if possible)

Alternatively, a containerized mobile laboratory (Figures 2.11 and 2.12), especially designed and equipped for the purpose, and with all the necessary services (electricity, water, drainage, internet connections etc.) can greatly assist with this kind of work. Such a facility provides a clean space for sample processing that is not normally available on port premises.

The field base should be adequately equipped for sorting samples (rough sorting) and storing them in the appropriate preservatives. Attention to relevant details, such as electricity, water and ventilation (e.g. fans) will help maximise the efficiency of the survey. It should also be stressed that appropriate safety and quality assurance protocols are followed when designing and using a field laboratory.



**Figure 2.11** External and internal view of a containerized mobile laboratory being used in India for PBBS. Photo credit: NIO.



**Figure 2.12** The mobile lab used by the Mauritius Oceanographic Institute in collaboration with the IOI-SA for the PBBS in Port Louis is built into a container that can be moved to the quay-side during a survey. It has all the electrical and plumbing adaptations needed and contains adequate storage, microscope, computing and sorting facilities. Photo credit: Author.

In most cases there will be a need to further sort the samples (fine sorting) before final taxonomic analysis can be performed, requiring additional laboratory facilities away from the port area (e.g. associated university or research institute). The extent of fine sorting will depend on the scope of the survey (e.g. sample types, analysis required), as well as the capacities and facilities of the field station. In principle, a well-equipped and reasonably spacious field facility (i.e. serviced building, mobile laboratory) could be used for the fine sorting process, however in reality there may be time constraints on the survey team presence in the port area and/or facilities. By ensuring that all samples are preserved in sealed containers before leaving the field location, the team can transport the collected samples to more appropriate locations for subsequent fine sorting and analysis.

#### 2.4.4 Boats and transportation

Every port and every PBBS will differ in terms of the arrangements for access and transportation. In most cases the survey team will be staying in accommodation close to the port area, and arriving by car or boat at the field base each day. Access into and out of the port is likely to be controlled, so permits for individuals, as well as all vehicles, may be required. As such trips are likely to be frequent e.g. for supplies and other purposes (ice, bait, food, etc.), a good relationship with port authorities/officials is essential.

An efficient way to collect a majority of samples is to use a small to medium-sized boat (5-15m) as the main sampling platform. If divers are to be used, a suitable dive boat will be essential. The boat should be reasonably stable in choppy water, have enough deck or open space for one or two team members to deploy samplers over the side, a dry area for sample labelling and sufficient space for sample and equipment stowage. In deep water, a small, securely-mounted hoist or derrick is useful for deploying heavier devices, such as sediment grabs or large plankton nets. In many cases a medium-size boat is used as the main dive boat, and a smaller inflatable craft is used for other sampling at the same time (e.g. plankton tows, beach seines). It is, however, possible to conduct a PBBS without the use of boats. This may save costs, but it also limits the areas sampled and may involve more complex logistics.

Some sampling sites do not require the use of boats or divers. Most port areas will contain structures such as quaysides, pontoons and stationary barges that afford ideal substrates for a wide variety of marine invertebrates, including various types of alien species. Such substrates can frequently be accessed by land and may usually be sampled by means of long-handled scrapers fitted with nets. Similarly, benthic grab samples may be deployed from the quayside as an alternative to cores taken by divers. In general, however, in-water methods result in better and more consistent quantitative samples than their surface-deployed alternatives.



**Figure 2.13** Examples of boats used in PBBS. Photo credit: Author.

#### 2.4.5 Collecting samples

The benefits derived from PBBS will be heavily dependent on the skills of the sampling team, both in sample collection and the recording of information about the different organisms and communities sampled. The team will be guided by the Survey Implementation Plan, but should always be prepared to adapt planned sampling strategies, where conditions are found to differ significantly from those that prevailed during the initial port inspection. Sufficient samples should be taken at each site, and from each of the selected substrates, to represent the communities concerned. Ideally, the number of replicate samples (which may or may not be composited) taken from each site/substrate should be sufficient to represent the communities concerned. Observations (especially those of divers) concerning the abundance and distribution of particular species, groups of species and communities, should be recorded continually while sampling. Waterproof note-books, slates, boards and pencils are most useful in this regard. Such records will help in describing the nature, extent and biodiversity of the communities within the survey area.

The Survey Team Leader will be expected to provide detailed instructions for the collection of samples in different media. A PBBS will generate a mixture of sample types, depending on how the samples were taken and brought to shore. For example, some larger attached and free-living organisms may be hand-picked by divers or removed from tow-nets, whereas samples of plankton will be concentrated by filters into small volumes of water, sediments from grabs or cores will be kept intact until wet-filtered and scrapings of sessile communities will typically comprise a wet mass of hard-shelled and soft species.

It is good practice to place all samples into clean and secure containers as soon as possible after collection to protect them against de-hydration and from significant changes in temperature. Should samples be taken for bacteriological analysis, they will require the use of pre-sterilized tubes or vials (*see Appendix 3*). For other samples, there are a variety of suitable containers available, including plastic and glass screw-top jars, food containers with sealed clip-on lids and various sizes of lockable plastic bags. When stored in cooler boxes, these will adequately protect the samples until they can be sorted and preserved.

#### 2.4.6 Sample handling

The survey team leader should be responsible for all facets of sample handling. Areas used for sample storage should be separate from busy working areas to avoid any damage to samples or their containers. Procedures to be used for sample identification and tracking are discussed in-depth in the various available protocols. In essence, the process involves recording and keeping the samples in good condition from the time they are collected until they can be properly sorted and preserved (Figure 2.14).



**Figure 2.14** Maintenance of consistent field logs and labels is essential for sample tracking. Photo credit: Author.

#### Labelling

A labelling system is essential for the organization and archiving of samples and preserved specimens. It will help significantly with the PBBS organization and efficiency. Any established system can be used, or even a customized label designed to conform to other data management systems. One team member should be appointed as the keeper of field records; this individual might also help to supervise and document the labelling of samples at the shore station and/or laboratory.

Some points of information commonly included on sample labels are:

- Location codes - may include country and state, and should certainly include the port code
- Site codes - should reflect the site numeration used in the survey design
- Sample type - an abbreviation should be used for each sampling method being employed
- Replicate number
- Sample detail – indication of depth, distance, substrate, etc.
- Labelling of sample with Alpha-numerical code

Ensuring that adequate supplies of labels and log sheets (preferably waterproof) are prepared in advance will make the field operations more efficient and help avoid interruptions or mistakes. Labels should be completed by the designated field/laboratory record keepers and attached to each container. The lids of containers should also be marked with sample codes for ease of viewing when stacked or stored. It is advisable to have a plentiful supply of labels and sample tracking sheets (field log sheets, rough sorting log sheets, fine sorting log sheets, taxonomy log sheets etc.) as they will be used and replaced throughout the survey. The sorting of samples may involve replacing these labels with new ones both inside the preservation containers (written in pencil to avoid bleeding of ink) and attached to the outside.

### **Sample sorting**

When samples arrive at the field laboratory/facility, they should be checked for proper labelling and recorded appropriately (e.g. in a sample log book), along with details of preservation. Any deficiencies should be referred to the individuals who collected the samples and if they cannot be resolved, the samples should be discarded.

Biological samples that cannot be immediately identified will require preservation and may be arranged either according to taxonomic group or, in the case of mixed samples (e.g. vertical scrapes), by substrate type. Prior to preservation, some larger specimens (e.g. fish) may be photographed along with the scale bar and sample code and later preserved with appropriate labelling, both outside and inside the container.

The extent of sample sorting conducted in the field will vary considerably. It is preferable to complete as much of the sorting as possible in the field, both to save space in transporting samples and to expedite delivery to the relevant taxonomists. Actual sorting requirements will depend on the nature of the samples which could either be individual (larger) specimens, clumps of sessile organisms (single or multiple species), tubes containing microorganisms or mixed plankton in water, or lumps of muddy or sandy sediment. In the case of larger surveys, it would be useful to have a dedicated team to sort and process samples as they come ashore. Otherwise sampling crews may need to pause periodically to sort and preserve samples quickly after collection.

Clearly, samples that require most effort in sorting will be sediments (to extract the organisms) and mixed samples that need to be divided into taxa appropriate to the experts who will examine them. Subject to the facilities, personnel and time available, sorting may be done in one or two phases (rough and fine sorting). The extent of rough sorting to be conducted in the field (Figure 2.15) will depend on the variety and abundance of organisms present. For example, soft sediments can be wet-sieved to expedite removal of macro-fauna using

a variety of mesh sizes; this can sometimes be done at the quayside, where water is plentiful and the bulk of the inorganic component can be safely discarded, rendering the rough sorting process more manageable. The remaining organisms may then be separated into general categories or taxonomic groups and preserved accordingly. Similarly, clumps of sessile organisms obtained by surface scrapes can be cleaned-up by carefully removing detritus from the living material.



**Figure 2.15** Examples of areas and materials used for rough sorting of samples in the field. Photo credit: Author.

Should it be necessary, further sorting to facilitate expert identification may be postponed to a later date, following sample preservation. Most taxonomic experts will analyse the specimens of a particular taxonomic group and may discard or leave aside any specimens that fall outside that category. For this reason, the fine sorting of the samples must be conducted in accordance with the instructions of the relevant experts involved, so that all samples can be examined and identified efficiently.

Mixtures of small organisms are generally sorted and separated with the aid of binocular microscopes. This is often a tedious and lengthy procedure, and may require considerable skill and effort by several individuals. Students training in the biological sciences can be most helpful in this regard. In some cases, specimens may be sent to taxonomists experienced in identifying a wide range of taxa from the region concerned, and in such cases complete sorting may not be necessary.

Short descriptions of fine sorting procedures, applicable to three of the common faunal size-groups, are given below:

*Zooplankton:*

The biomass of the sample (preserved in 5% formaldehyde) is estimated as wet weight by using standard protocols. It is then split equally into appropriate parts, for example using a Folsom plankton splitter. One part is taken for the analysis and identification of various taxonomic groups. Numerical abundance is expressed as number per cubic meter.

*Macrobenthic fauna:*

Preserved samples should be prewashed through 500µm mesh and sorted under a binocular microscope. When samples are obtained by surface scrapes, numerical abundance of each species can be estimated as numbers per square meter.

*Meiobenthic fauna:*

Initial treatment and preservation: Samples collected by Van Veen grab are subsampled by means of a 3cm diameter corer (on site) and then the core is sliced into two equal halves, each being preserved separately. Seven percent magnesium chloride is added to the sediment sample to relax the organisms and soften the tissue. Five percent buffered formalin (with Rose Bengal) is added to the sample for preservation and colouration. Buffered formalin is used for preservation to avoid the decalcification of external hard parts of the organisms. Rose Bengal is added to stain the organisms so they may be removed easily while sorting.

Sorting: The preserved sediment samples are washed in water to remove formalin and passed through a 45µm sieve to remove sediment and detritus. Then they are sorted using a light microscope and preserved in 5% buffered formalin.

### **Sample preservation and storage**

To avoid the decay of specimens, it is imperative that samples are preserved as quickly as possible, preferably on the same day as collection. Ideally, samples should be kept on ice following collection, until they are sorted and preserved. Three steps are involved in the preservation of biological specimens; narcotisation, fixation and storage. It is recommended that specimens be grouped according to fixing requirements. Storage of hard and soft organisms together is not recommended, as some fragile specimens may be damaged or destroyed.

Narcotizing agents are used to prevent contraction or flexion of the body and antennae of some types of organism. Some, such as anemones and ascidians must be allowed to expand (tentacles out, siphons open) and then be gradually narcotized, otherwise they are very hard to subsequently identify.

Either 3-5 % buffered formalin or ethyl alcohol (70 - 90%) is normally used for fixation purposes. Within a week or two, specimens fixed in formalin should be transferred to ethanol or other long-term storage medium as prolonged storage in formalin, even buffered, will affect morphological features. As molecular archiving

techniques, such as DNA barcoding, are becoming more available, it is important to ensure that formalin is not used for any specimens for which DNA analysis might be required. It is also important to ensure that the links between the morphological samples and the molecular samples are maintained.

Further details of sample preservation for particular groups of organisms are provided in Appendix 1.

All samples must be stored under appropriate conditions and their preservatives checked periodically until identification has been completed. Samples for microbiological examination (bacteria, viruses), and those for analysis of phytoplankton, should be refrigerated or frozen and those to be examined for dinoflagellate cysts should be kept cool and in the dark. Following initial identification, samples and/or specimens should whenever possible be lodged with a museum or appropriate institution that can maintain and catalogue the specimens for future reference. It is in the national interest for the specimen collections to remain in-country within national institutions, perhaps with duplicate voucher specimens lodged at alternative international locations.

To summarize the processing of samples from collection to identification, a flow diagram is shown in Figure 2.16.

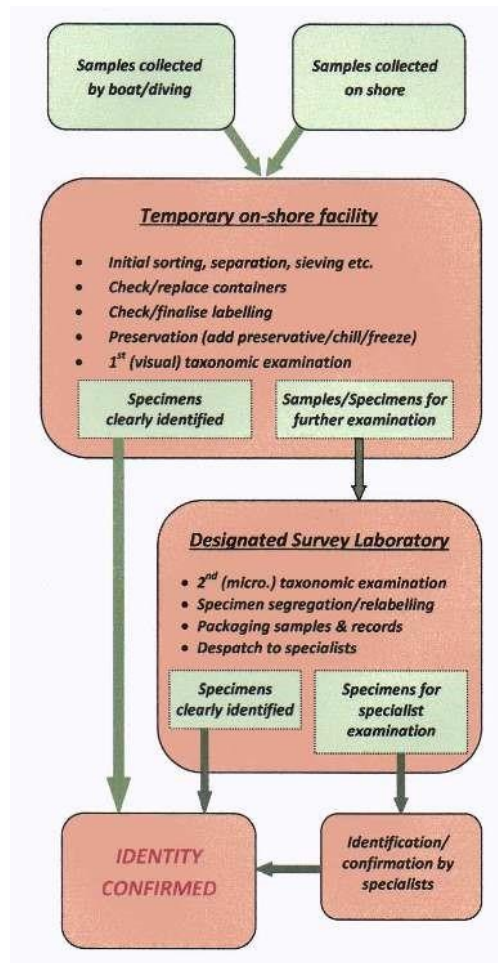

**Figure 2.16** Overview of the process of sample handling, from field collection to identification.

## 2.5 Biological recording

This section gives an overview of biological information derived from PBBS that is relevant to BWM and the control of alien species generally. It identifies the principal data required and the means of obtaining them.

### 2.5.1 Categories of output

Section 2.1 listed the various aims of PBBS and their implications for survey design. In general terms, the surveys can generate three principal categories of biological information regarding the port and adjacent coasts:

- |                  |  |
|------------------|--|
| a) Basic:        | Updates of alien species lists,                                    |
| b) Intermediate: | Alien species abundance and distribution,                          |
| c) Complex:      | Overall biodiversity to provide a baseline for future comparisons. |

Each of these has specific data requirements. Taking into account all three categories, there is an increasing amount of data required from a) to c), and concomitant increases in sampling approach (see Fig. 2.1), time and cost.

#### **a) Basic - Current status of alien species**

The simplest and quickest form of alien species survey, often referred to as a 'rapid assessment' (CBD, 2003), involves the use of a pre-prepared list of target species, selected on the basis of one or more of the following criteria:

- Known to have been introduced into this (or an adjacent) region;
- Considered likely to be introduced by human activities and potentially invasive;
- Could possibly be introduced, known to be invasive and ecologically damaging.

Several coastal states have already compiled short-lists of species that meet one or other of these criteria. A significant proportion of candidate species may be macro-invertebrates that can easily be photographed and described so as to assist surveyors in recognizing them. Ideally, observers trained to recognise target species would be included in port survey teams.

Lists of target species, including species that are either too small, or too difficult, to locate and recognize, will nevertheless be useful to biologists and taxonomists examining samples in the laboratory.

## **b) Intermediate - alien species abundance and distribution**

The occurrence of an alien species that is new to the area, when confirmed, is clearly important to those responsible for their prevention and management. However, it is equally important to establish its abundance and distribution. Key questions to be answered are whether or not the species has become established, has developed a breeding population and is gradually extending its range.

The need for information on abundance and distribution enforces the value of field identification of target species. For example, if a single specimen or isolated colony of a target species is identified during the sampling phase, the Survey Team Leader may decide to increase the number and density of sampling at comparable sites in order to further explore its distribution. This will greatly increase the value of the survey results and could save time, as otherwise it may be necessary to revisit the site at a later date.

## **c) Complex - Overall biodiversity**

An obvious limitation of surveys focusing on target species is that they do not describe the indigenous fauna and flora and therefore cannot be used to detect impacts on native biodiversity, or future changes in communities or species associations. A full-scale PBBS, aiming to provide a baseline account of aquatic life in the area, might be used to detect such impacts and changes over time.

The analysis and reporting of full-scale surveys can be a time-consuming and costly exercise. Thus, as part of such surveys, it is important to identify and immediately report any suspected or identified alien species, so that managers can consider options for mitigation and prevention without waiting for the final survey report. To this end, the survey team should include members who can recognize the species concerned; any such observations should be reported promptly to the Project Leader.

### **2.5.2 Facilities**

The previous section recommended the use of a temporary field laboratory, close to the port, for use as a survey team headquarters, as well as for labelling, sorting and preserving samples and for storage of samples and equipment. This could be either a mobile laboratory unit, or a fixed facility modified for the purpose. Depending on the survey design, and the range of biological material collected, some species may be identified either in the field or at the field laboratory, whereas others would be sent to one or more centres of taxonomic expertise. Such facilities often exist in university science departments, museums, agencies responsible for agriculture, water management, geology and health, and in most institutions engaged in environmental research.

In practice, the range of activities to be undertaken in either a temporary or permanent laboratory will be dictated by the scope and duration of the survey, the expertise within the survey team, the availability of specialists and where they are located. If a survey focuses on a list of high-risk species, easily visible and readily identified by trained field surveyors (e.g. sessile macro-invertebrates), much of the identification work will be done either at the point of sampling, or at the field laboratory. For more general and full-scale collections, not all of the expertise required to identify organisms to species level is likely to be available locally and it is normal

for samples to be sent to specialised taxonomists, sometimes overseas, by prior arrangement. For more comprehensive surveys, such as those covering micro-flora and -fauna in water and sediments, tasks including separation, sorting and culture will require more specialised facilities.

There may be further considerations in choosing the location for PBBS activities. It would certainly be convenient if a single facility were to be designated as the project headquarters, and especially if individuals engaged in reporting were housed on the same premises.

### 2.5.3 Taxonomic analysis

Taxonomy is the formal classification of organisms. There are different methods for identifying aquatic organisms ranging from simple visual examination through basic light microscopy, scanning electron microscopy, allozyme electrophoresis, DNA sequencing and, recently, genomics. Identification keys for particular groups of organisms are available in the scientific literature and there are also web-based interactive identification keys and global biodiversity mapping techniques (Godfray 2002). A recent innovation is the development of a web-based inventory of alien species and related data, structured by region and aimed at global coverage (AquaNIS 2013).

Identification of specimens contained in the samples collected during a PBBS should be done by biologists with experience of the biota of the area and/or with recognised taxonomic specialists. The taxonomists required for the identification of survey specimens should be contacted and engaged well before the survey is implemented. Apart from the specimens to be identified, each taxonomist should receive:

- Information on how the samples are to be labelled, coded and preserved; and
- Excel templates within which to enter and report results.

In addition, taxonomists may also require:

- Herbarium sheets for macro-algae; and
- Prepared slides for bacteria, phytoplankton, zooplankton etc.

The taxonomists should be requested to report results to the Project Leader and, where applicable, to the person responsible for preparing the survey report. They should also provide archive specimens (e.g. voucher specimens for museums or biological data centres), whenever possible. These are necessary for reference purposes, and may be used in the future for confirmation of the original identification.

#### *Determining if a species is native or non-indigenous*

The species collected during a PBBS may be native to the region or non-indigenous i.e. the port area is located outside the species' native biogeographical range. Where the origin of a species is unknown or uncertain, it is termed *cryptogenic* (Carlton 1996). A list of categories used for biogeographic designation is shown in Table 2.4.

In cases where survey team members have been involved in preparatory work to develop a list of target species relevant to the area, and have been trained to recognise them, the team itself will identify many of the more visible, listed species (e.g. invasive macro-invertebrates) that appear in the samples collected. Other foreign organisms may be identified by the specialists (i.e. consultant taxonomists) engaged for the project and familiar with the biota of the region. In cases of doubt, the identification of a suspected alien species should be confirmed by taxonomic experts in its native region.

**Table 2.4:** Common terminology used in categorization of species/specimens.

<p><b>Native species</b> Native species are those that occurred within the biogeographical region historically and have not been introduced by human mediated transport.</p> <p><b>Non-indigenous species</b> Non-indigenous species (NIS) are those known or suspected to have been introduced as a result of human activities.</p> <p>A series of questions posed by Chapman and Carlton (1991) can be used to guide decisions about whether a species is non-indigenous; as exemplified by Cranfield et al. (1998). These are as follows:</p> <ul style="list-style-type: none"> <li>i. Has the species suddenly appeared locally where it has not been found before?</li> <li>ii. Has the species spread subsequently?</li> <li>iii. Is the species' distribution associated with human mechanisms of dispersal?</li> <li>iv. Is the species associated with, or dependent on, other non-indigenous species?</li> <li>v. Is the species prevalent in, or restricted to, new or artificial environments?</li> <li>vi. Is the species' distribution restricted compared to natives?</li> <li>vii. Does the species have a disjunctive worldwide distribution?</li> <li>viii. Are dispersal mechanisms of the species inadequate to reach the region, and is passive dispersal in ocean currents unlikely to bridge ocean gaps to reach the region?</li> <li>ix. Is the species isolated from the genetically and morphologically most similar species elsewhere in the world?</li> </ul> <p><b>Cryptogenic species</b> Cryptogenic species are those whose identity (native or non-indigenous) is unclear. In certain cases they may have been spread around the world in the era of sailing vessels prior to scientific survey (Carlton 1992; Chapman and Carlton, 1991), such that it is no longer possible to determine their original native distribution.</p> <p><b>Species new to science</b> This category includes species previously undescribed in the scientific literature.</p> <p><b>Indeterminate species</b> Specimens that cannot be identified to species level cannot usually be ascribed a specific biogeographic origin. This group includes:</p> <ul style="list-style-type: none"> <li>(1) Organisms that are damaged or juvenile and lack morphological characteristics necessary for identification, and</li> <li>(2) Taxa for which there is not sufficient taxonomic or systematic information available.</li> </ul>
--

The above table includes nine questions (Chapman and Carlton, 1991) that will help in differentiating any species suspected not to be native to a region. To ensure consistency in reporting, it is important that the

taxonomists categorize alien species in accordance with these criteria when they return their identifications. The list of information on alien species to be provided by taxonomists is as follows:

- The authority and location of type specimen;
- Whether the identification represents a new record for the region (i.e., whether the species is already known to be present in the region or whether it has not previously been recorded in the region);
- If the species is known to be present in the region, whether its collection from the surveyed port indicates a regional range extension;
- The native and non-indigenous global distribution of the species (if known); and
- Materials (e.g. literature, museum collections) consulted for the purpose of the identification.

#### 2.5.4 The survey report

When preparing a PBBS report, it is important to keep in mind the various audiences for the report e.g. government agency, national task force, various stakeholders, etc. Comprehensive PBBS reports can be extremely detailed and lengthy. However, for many purposes, reports can be selective and therefore more concise.

In some cases, several different versions may be required. In addition to a report that meets the needs of the principal sponsors, shorter versions can be prepared in which the scope, presentation, and in particular the scientific content, have been adapted to the needs of particular audiences. In order to be read and understood by those with little technical knowledge, reports should be written in a clear, narrative style, making full use of carefully selected pictures and graphics.

Where a series of surveys and reports is anticipated, standardization of the reporting format will facilitate the comparison of findings from different areas.

The suggested structure and content for a PBBS report is as follows:

##### ***Executive summary***

##### ***Glossary***

##### **Introduction**

Description of ports in the region/area

Description of the port to be studied

Port operation and shipping movements

Physical environment

Existing biological information

### **Survey methods**

Physical and chemical measurements (as appropriate)

Sample collection

Survey of fouling and benthic organisms

Underwater camera surveys

Sediment sampling for cyst-forming species

Plankton sampling and identification

Survey of fish species

Laboratory sorting and identification of organisms

### **Results**

Water and sediment characteristics

Fouling and benthic organisms

Plankton sampling and identification

Phytoplankton

Zooplankton

Survey of fish species

Assessment of risk of new introductions to the port

### **Management of existing non-indigenous species**

#### **Prevention of new introductions**

#### ***Conclusions***

#### ***Recommendations***

#### ***References***

#### ***Appendices***

## 2.6 Optimizing the benefits of PBBS

### 2.6.1 PBBS in a wider context

As stressed in this document, PBBS may involve substantial investments in terms of time, human resources and funding, depending on their scope. However, the benefits can be optimized by ensuring that the results are utilized as much, and as widely as possible, both within national management strategies and also by contributing to scientific knowledge of the marine environment. In many countries, a shortage of information on biological communities is a weakness that is hampering management of the marine environment. The data gained from a PBBS can help to reverse this situation.

Within the IMO GloBallast Programme, a series of guidance documents has been produced to assist countries in their implementation of the BWM Convention, not least through the development and enforcement of a

National BWM Strategy (see GloBallast Monograph No. 18). The PBBS is also linked to the other tools and guidance suggested by the IMO: the development of a national ballast water status assessment, GloBallast Monograph Series No. 17 (GEF-UNDP-IMO, 2009); the development of an economic assessment for BWM, - GloBallast Monograph Series No. 19 (GEF-UNDP-IMO, 2010); and the identification and management of risks from organisms carried in ships' ballast water, GloBallast Monograph Series No. 21 (GEF-UNDP-IMO, 2013).

Following publication of survey results, it is important to ensure that the port authority and other stakeholders remain involved in addressing any concerns identified and opportunities for their mitigation. Although port authorities remain an important catalyst and potential coordinator for these initiatives, there is often a need for strategic and policy-level developments to encourage more proactive management of species of concern. Integrated management across the entire logistics chain is the only way to ensure a comprehensive, participatory and standardized approach to the reduction of alien species introduced through shipping vectors. Accordingly, the BWM Convention encourages scientific baseline assessments, such as PBBS, as a component of BWM activities, and as a means of catalysing multi-sectorial engagement.

PBBS are effective catalysts for the development or implementation of comprehensive ballast water or marine invasive species management frameworks. They assist ports in preparing their management plans and facilitate collaboration between the scientific and maritime communities.

Data from PBBS are necessary for risk assessments, either in the context of Compliance Monitoring and Enforcement (CME, i.e. understanding what routes/vessels may pose a high risk to the local marine environment), or for the assessment of possible exemptions granted to some ships under the BWM Convention (Regulation A-4). The results are also useful for identifying target or risk species that require on-going monitoring, or any further management or control measures.

## 2.6.2 The role of the port authority

From a port management perspective, a PBBS may form part of the port's overall environmental management programme and is consistent with best practices for the sustainable development of trade facilities, transport chains and the local economy. PBBS can assist in identifying marine environmental problems and opportunities for management intervention. In particular, they can help to catalyze buy-in and engagement of agencies and other stakeholders having diverse roles in alien species management.

In summary, from the standpoint of managers within port authorities, a PBBS can yield the following benefits:

- Provide baseline data on species and habitats to support environmental monitoring programmes;
- Detect introduced/alien species as a basis for targeted monitoring or control programmes;
- Facilitate risk assessment regarding the potential for further introductions, the spread of existing introduced species or the exportation of particular threat species to other areas;
- Provide information on ballast water operations of ships;

- Improve the reputation of the port authority (and other decision-makers and role players) as proactive and progressive in terms of best practices and sustainable development. This may provide opportunities to secure external support (i.e. funding, volunteers, public involvement, government support, corporate funding, etc.) for the management and control of alien species;
- Safeguard port and related infrastructure from the damage and costs associated with alien species impacts (this has implications for port development/construction, as well as maintenance requirements);
- Help to achieve alignment with international best practices for shipping;
- Inform the development and implementation of port environmental and ballast water/biofouling management plans; and
- Provide a focal point for collaborative engagement of port community stakeholders and the various relevant management sectors.

Ports may adopt a number of practices that will help to improve their programmes in environmental management, including BWM:

*a) Policy statement*

Port authorities may develop and display a policy statement relating to the port's mission, responsibilities and strategic objectives regarding sustainable practices, including biodiversity management. Another supporting policy document could outline the problems, trends, challenges and opportunities in relation to particular issues (in this case, alien species management); this could include specific activities and initiatives aimed at collecting data, managing and mitigating impacts and sharing information with stakeholders. The policy statement and supporting document would constitute a commitment that informs business planning, port and infrastructure development. Ideally, these documents would be updated at regular intervals to ensure they remain relevant and effective.

*b) Environmental Management Systems (EMS)*

Various Environmental Management Systems and tools exist to assist organizations in managing their environmental risks and opportunities, and to streamline management initiatives from a business planning perspective. The international ISO 14001 standard, however, is widely recognised across the globe and is popular with a variety of organisations within the marine transport industry (i.e. port and logistics chain). This standard outlines requirements associated with the development and implementation of policy, objectives and plans for environmental compliance and best practice management.

*c) Training and skills development*

Any successful PBBS and accompanying management initiatives cannot work in isolation of training and capacity building activities. Training and awareness raising should not just be limited to practitioners in port surveys and alien species management, but should also include port management, port stakeholders and port

users. Tailor-made training and awareness sessions can be developed for specific groups.

### 2.6.3 Data storage and access

An integral part of a PBBS is the systematic archiving of biological records, particularly of non-native species, not only for future reference, but also for the benefit of the international community engaged in preventative alien species programmes. Such programmes are heavily dependent on reliable, up-to-date information on the status of alien species in different regions, in order to assess the risks associated with different routes and vectors, to develop suitable management measures and to identify priorities for risk mitigation.

Suitable data archives should be created at national level and it is strongly recommended that national databases be made available for inclusion in archives at regional and international levels. One archive system presently under development that aims to record data on alien species by region, and ultimately worldwide, is the AquaNIS system at the Klaipeda University, Lithuania. This is already a valuable source of information for those engaged in alien species risk assessment and, if adequately supported, will continue to grow in importance.

### 2.6.4 Improving capacity for PBBS

Despite recent efforts by several countries to increase their support for PBBS and alien species surveys generally, there is still a fundamental lack of information regarding marine alien species in most areas of the world.

Until recently, most PBBS initiatives had been carried out either in more developed parts of the world, or were funded by external resources (GloBallast, NGOs/IGOs, etc.). However, there has been a recent and very encouraging shift towards funding being allocated locally (e.g. Ghana, Mauritius, India), which could be seen as an enhanced appreciation of the crucial need for improving the information base, as well as building capacity locally, rather than bringing in outside experts.

This capacity building element of port surveys is most important, and should be seen in the context of regional and national management strategies being developed around the world. Targeted regional capacity development workshops (Figure 2.17) have played an important role in unlocking further support for PBBS. A continuing capacity (locally, nationally, regionally) for biological monitoring and risk assessment will be required to support targeted management measures, including implementation of the BWM Convention.



**Figure 2.17 (a)** Participants gaining field experience and initiating home-port survey designs at a regional PBBS training workshop in Mombasa, Kenya Photo credits: Author



**Figure 2.17 (b)** Training workshops may focus on regional capacity and approaches, as was done for the Black Sea PBBS training workshop in Batumi, Georgia Photo credits: Author



**Figure 2.17 (c)** Regional taxonomy workshops with field and laboratory demonstrations may be associated with a PBBS and specimen identifications. Photo credits: Author

## Chapter III - Risk assessment to support management of the shipping vector

### 3.1 Achieving ship-specific risk assessment for alien species transfer

As part of its approach to biosecurity, a Port State may wish to apply ballast water management regulations uniformly to all vessels that call at its ports, or it may wish to assess the relative risk of these vessels to its coastal marine resources, and apply its regime selectively. Uniform application, or the 'blanket' approach, offers the advantages of simplified administration and there is no requirement for technical assessments or judgments to be made. This approach also requires substantially less information management effort. If applied strictly, the uniform approach offers greater protection from unanticipated bio-invaders, as it does not depend on the reliability of a decision support system. However, the key disadvantage of the strict blanket approach is the management cost imposed on vessels which otherwise might not be forced to take action. It also requires a substantial vessel monitoring (including port-based inspections) capacity and crew education effort to ensure that all foreign and domestic flagged ships are properly complying with the required management actions.

Several countries have therefore started to develop and test systems that allow for more selective application of ballast water management requirements, based on voyage-specific risk assessments. The advantage of this 'selective' approach is that it reduces the numbers of vessels subject to ballast water controls and monitoring, and is amenable to administrations that wish to reduce the introduction and/or domestic spread of targeted marine species. Also, more rigorous measures can be justified on those ships deemed to be of high risk, if fewer restrictions are placed on low risk vessels. For Port States with limited port-based inspection capacity, this option is particularly valuable, as it allows inspectors to focus their efforts on the higher risk vessels.

For countries or ports that choose the selective approach, it is essential to establish an organized means of evaluating the potential risk posed by each arriving vessel, through a decision support system (DSS). However, this approach places significant demand on the administration of the Port State, in terms of management of information technologies, and its effectiveness depends on the quality of the data that supports it. A selective approach that is based on a group of targeted species may also leave the port vulnerable to unknown risks from non-targeted species. Ultimately, the design of the risk assessment and DSS must balance the roles being played by shipping activities, environmental conditions and threat species distributions, to produce a synthesized output that addresses the specific management needs and circumstances of the Port State.

While differing approaches may be considered for implementing a risk assessment of this kind, they generally fall within one of the following three categories:

1. **Qualitative risk identification:** this is the simplest approach, and is based on subjective parameters drawn from previous experience, established principals and relationships and expert opinion, resulting in simple allocations of 'low', 'medium' and 'high' risk. However, it is often the

case that subjective assessments tend to overestimate low probability/high consequence events and underestimate higher probability/lower consequence events (Haugom *et al.*, 2002).

2. **Semi-quantitative ranking of risk:** this ‘middle’ approach seeks to increase objectivity and minimise the need for subjective opinions by using quantitative data and ranking of proportional results wherever possible. The aim is to improve clarity of process and results, thereby avoiding the subjective risk-perception issues that can arise in qualitative approaches.
3. **Quantitative risk assessment:** this is the most comprehensive approach and aims to achieve a full probabilistic analysis of the risk of alien species introductions, including measures of confidence. It requires significant collation and analysis of physico-chemical, biological and voyage-specific data, including key lifecycle and tolerance data for every pre-designated species of risk (‘target species’), port environmental conditions, ship/voyage characteristics, the ballast water management measures applied, and input and evaluation of all uncertainties. The approach requires a high level of resourcing, computer networking and relatively sophisticated techniques.

This study sought to conduct a first-pass risk assessment for the Port of Saldanha in South Africa, allowing for a static demonstration of alien species transfer risk associated with ports that have been functioning as sources and destinations for ballast water. Any management implications from the outputs would therefore be based on risk profiles for past shipping patterns of the port. It also provided the local authorities the opportunity to apply the system as the basis for a functional DSS for ongoing port management applications. Following on and applying the lessons learned from the risk assessment of the Port of Saldanha, a more simple and progressive approach was developed and applied for Port Louis in Mauritius. In this case, the decision was taken to focus less on the initial first-pass port risk assessment component (based on historical trade routes), and more on the risk associated with individual vessels visiting the port, in order to overcome many of the practical concerns related to the Saldanha system. It was therefore designed to function as a voyage or ship-specific DSS, for evaluation of new ships entering the port, with additional guidance to assist with management-related outcomes.

To maximise certainty while seeking cost-effectiveness and a relatively simple, widely applicable system, the middle (semi-quantitative) approach was selected in both the Saldanha and Port Louis cases, although the systems themselves differ markedly in terms of design and applicability.

## 3.2 Approach taken for the Port of Saldanha

### 3.2.1 Aims and objectives

The risk assessment for the Port of Saldanha was developed within the Marine and Coastal Management department (now Oceans and Coasts) of the national Department of Environmental Affairs, and with participation from the Transnet National Ports Authority. It was coordinated under the auspices of the IMO GloBallast project, in collaboration with URS Australia Pty Ltd, for the benefit of the South African national authorities responsible for ballast water management. The methodology was designed specifically for this application in support of South Africa’s developing ballast water management regime.

Source port and discharge port environmental comparisons were carried out and combined with other risk factors, including voyage duration and risk species profiles, to give a preliminary indication of overall risk posed by each source port. The analysis took a 'whole-of-port' approach, which compared the Port of Saldanha with all of its ballast water source and destination ports. The outputs include an integrated database and information system to manage and display the following:

- Ballast water data from arriving ships and port shipping records
- Data on the Port of Saldanha's physical and environmental conditions and aquatic resources
- Port-to-port environmental matching data
- Risk species data
- Ballast water discharge risk coefficients

The results provide the relevant information to evaluate the general risks currently posed by ballast water introductions, to identify high priority areas for action, and ultimately to decide whether to apply a blanket, or selective, ballast water management regime. If a selective regime is adopted, vessel and voyage-specific risk assessments can then be developed and applied. If a uniform approach is adopted, the results help identify which routes and vessel types warrant the most vigilance in terms of management compliance checking and verification monitoring, including ship inspections and ballast tank sampling.

The general aims of the risk assessment for the Port of Saldanha were to:

1. Assess and describe as far as possible from available data, the risk profile of marine species being both introduced to, and exported from, Saldanha Bay in ships' ballast water, and to identify the source ports and destination ports posing the highest risk for such introductions.
2. Help determine the types of management responses that are required, and provide the foundation blocks for implementing a more sophisticated ballast water management system for the Port of Saldanha.
3. Provide a fully operational risk assessment system for ongoing use by the port authority, with possibility for replication at additional South African ports.

The specific objectives of the risk assessment for the Port of Saldanha were to:

1. Identify, describe and map on a Geographic Information System (GIS) all coastal and marine resources (biological, social/cultural and commercial) in and around the port that might be impacted by introduced marine species.
2. Characterize, describe and map (on GIS) de-ballasting and ballasting patterns in and around the port including locations, times, frequencies and volumes of ballast water discharges and uptakes.
3. Identify all ports/locations from which ballast water is imported (source ports).
4. Identify all ports/locations to which ballast water is exported (destination ports).
5. Establish a database at the port authority for the efficient ongoing collection, management and analysis of the data collected at the Port of Saldanha via standard IMO reporting forms.

6. Characterize, as far as possible from existing data, the physical, chemical and biological environments for the Port of Saldanha and each of its source and destination ports.
7. Develop environmental similarity matrices and indices to compare the Port of Saldanha with each of its source ports and destination ports, as a key basis of the risk assessment.
8. Identify, as far as possible from existing data, any high-risk species present at the source ports that might pose a threat of introduction to the Port of Saldanha, and any high-risk species present at the Port of Saldanha that might be exported to a destination port.
9. Identify any information gaps that limit the ability to undertake the aims and objectives and recommend management actions to address these gaps.

### 3.2.2 Methods

#### **Project team**

The semi-quantitative risk assessment method aims to use as much quantitative data as possible, to identify the riskiest ballast discharges with respect to the port's current pattern of trade. Unlike a fully quantitative approach, it does not attempt to predict the specific risk posed by each intended tank discharge of individual vessels, nor the level of certainty attached to such predictions. This provides a coherent method for identifying which ballast water sources deserve more vessel monitoring and management efforts than others, which is appropriate for application to decision support in the context of Port State Control efforts.

The approach developed through the GloBallast project required contributions from a large project team, as it was considered demanding in terms of data gathering, management and synthesis. The project team was divided into three groups as follows:

#### Group A - GIS mapping

Ashleigh Schoultz	National Ports Authority of South Africa, Durban
Chris Clarke	Meridian GIS Pty Ltd (URS team)
Gail Nxumalo	Marine and Coastal Management Department, Cape Town

#### Group B - database ballast water records

Nokuthula Buthelezi	National Ports Authority of South Africa, Port of Richards Bay
John Polglaze	URS Australia Pty Ltd
Lerato Liphoto	CSIR Environmentek, Stellenbosch

### Group C - port environment and risk species data

Leticia Greyling	National Ports Authority of South Africa, Johannesburg
Robert Hilliard	URS Australia Pty Ltd
Saras Mundree	CSIR Environmentek, Durban
Adnan Awad	GloBallast Programme Office, South Africa

Group A was responsible for developing the port map and graphically displaying results via the GIS. All coastal and marine resources (biological, social/cultural and commercial) in and around the port that might be impacted by marine bio-invasions were mapped using the ArcView GIS, using specific layers to show the bathymetry, navigation aids, port infrastructure and tables of the port's de-ballasting/ballasting patterns (including frequencies and volumes of discharges and uptakes for the berth locations).

Group B was responsible for managing the customised Access database, and for entering, checking and managing the shipping and ballast water data, as collated from the IMO forms submitted by arriving ships (and/or derived from shipping records for periods or arrivals when forms were not obtained or were incomplete). This database was used to identify source and destination ports, and was designed for ongoing input of information from future arrival forms.

Group C was responsible for collating the port environmental and risk species data, and undertaking port-to-port environmental similarity analyses. Thirty-four environmental variables were collated for Saldanha Bay, and the majority of its source and destination ports, including sea water and air temperatures, salinities, seasonal rainfall, tidal regimes and proximity to a standardised set of intertidal and subtidal habitats. Where water temperature data or salinity data could not be found for a source or destination port, values were derived for the riverine, estuarine or coastal location of the port with respect to the temperature and salinity data ranges of its IUCN marine bioregion, plus ocean maps depicting sea surface temperature/salinity contours at quarter degree and degree scales.

URS Australia Pty Ltd (URS) was contracted by the GloBallast project to install the necessary software and provide 'hands-on' instruction and guidance for the local project team.

### **Data collection and mapping**

The initial steps in the process involved the sourcing and collation of data related to port activities and ship movements. The IMO Ballast Water Reporting Forms have been collected at the port since 1992 and were instrumental in helping to identify the source ports from which ballast water is imported to the Port of Saldanha. For periods or vessel arrivals where the forms were not collected, or were incomplete, gap-filling data were extracted from port shipping records. These records also helped identify which next ports of call may have been a destination port for any ballast water taken up at Saldanha Bay.

Extensive data on environmental conditions were also collected, including the essential baseline information on species present in the port waters. A total of 34 environmental parameters (Table 3.1) were collected for comparison between Saldanha Bay and all ballast water source and destination ports.

**Table 3.1** Port environmental parameters used in the environmental similarity analysis.

	<b>Name</b>	<b>Variable Type</b>
1.	Port type <sup>2</sup>	Categorical (1-6)
2.	Mean water temperature during warmest season (°C)	Scalable
3.	Maximum water temperature at warmest time of year (°C)	"
4.	Mean water temperature during coolest season (°C)	"
5.	Minimum water temperature at coolest time of year (°C)	"
6.	Mean day-time air temperature recorded in warmest season (°C)	"
7.	Maximum day-time air temperature recorded in warmest season (°C)	"
8.	Mean night-time air temperature recorded in coolest season(°C)	"
9.	Minimum night-time air temperature recorded in coolest season (°C)	"
10.	Mean water salinity during wettest period of the year (ppt)	"
11.	Lowest water salinity at wettest time of the year (ppt)	"
12.	Mean water salinity during driest period of year (ppt).	"
13.	Maximum water salinity at driest time of year (ppt).	"
14.	Mean spring tidal range (metres)	"
15.	Mean neap tidal Range (metres)	"
16.	Total rainfall during driest 6 months (millimetres)	"
17.	Total rainfall during wettest 6 months (millimetres)	"
18.	Fewest months accounting for 75% of total annual rainfall	Integer
19.	Distance to nearest river mouth (kilometres; negative value if upstream)	Scalable
20.	Catchment size of nearest river with significant flow (square kilometres)	"
<b>Logarithmic distance categories (0-5):</b> From the closest ballast water discharge location to nearest:		
21.	Smooth artificial wall	Categorical
22.	Rocky artificial wall	"
23.	Wooden pilings	"
24.	High tide salt marsh/lagoon, saline flats or sabkah	"
25.	Sandy beach	"
26.	Shingle, stony or cobble beach	"
27.	Low tide mud flat	"
28.	Mangrove fringe/mangrove forest	"
29.	Natural rocky shore or cliff	"
30.	Subtidal firm sandy sediments	"
31.	Subtidal soft muddy sediments	"
32.	Seagrass meadow <sup>3</sup>	"
33.	Rocky reef or pavement	"
34.	Coral reef (with carbonate framework)	"

<sup>2</sup> Offshore terminal or mooring / natural bay / breakwater harbour / tidal creek / estuary / river port.

<sup>3</sup> Kelp forest/macroalgae bank was not included but could be considered for future analysis.

The 34 parameters were taken or derived from data and information culled from a wide range of government, port and scientific publications, internet web sites, port survey reports and sampling records, sea surface temperature and salinity charts, climate databases, atlases, national tide-tables, nautical charts, coastal sensitivity and oil spill habitat maps, oil spill contingency plans, aerial photographs, national habitat databases and local expert advice.

The identification of 'high-risk' species that may be transferred to and/or from the Port of Saldanha was critical to the analyses performed. Information on species' distributions relative to ports of the world was collated, including taxonomic details, bioregional distribution, native/introduced status and level of threat. For the purposes of the risk assessment, a risk species was considered to be any introduced, cryptogenic or native species that might pose a threat to marine ecological, social and/or commercial resources and values if successfully transferred to or from the Port of Saldanha.

The database manages the bioregional locations and status of each entered species using the same bioregions displayed on the GIS world map. This map is used as a backdrop for displaying the source and destination ports and associated risk assessment results, and was compiled from a bioregion map provided by the Australian Centre for Research on Introduced Marine Pests (CRIMP). The boundaries of some bioregions were subsequently modified, adding new bioregions for several large river systems to accommodate some important river ports. No change was required for the Saldanha Bay bioregion (WA-IV; Figure 3.1).

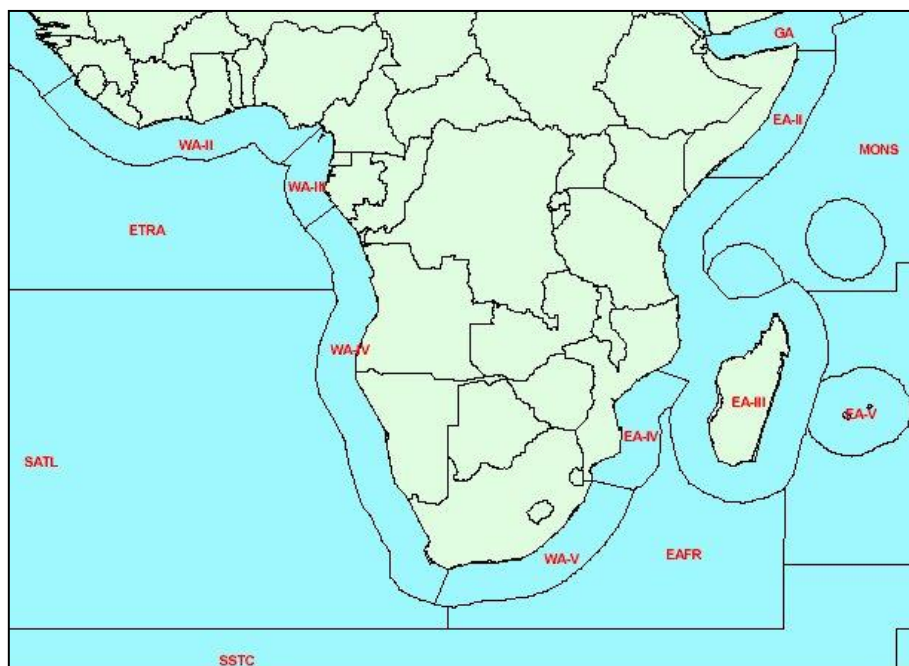

**Figure 3.1** Part of the GIS world map of marine bioregions, showing the code names of bioregions in the southern African region

The global bioregion map presently displays 204 discrete bioregions, which are coded in similar fashion as those in the IUCN scheme of marine bioregions, from which they were derived (Kelleher *et al.*, 1995). Bioregions serve multiple purposes and are required for several reasons. Many marine regions of the world remain poorly surveyed and have a limited marine taxonomy literature. This causes a patchy and essentially artificial distribution of recorded marine species distributions. Few marine species surveys have been undertaken in port environments and there are very few bioregions that contain more than one port that has undertaken a port biological baseline survey.

Bioregions represent environmentally similar geographic areas. Thus, if a species is found established in one part of a bioregion, there is a good chance it can spread via natural or human-mediated processes to other sites in the same bioregion. A conservative approach was therefore adopted for the purposes of this risk assessment, whereby a risk species, if recorded in at least one location of a bioregion, was assumed to be potentially present at all source ports within the same bioregion. This type of approach will remain necessary until many more port biological baseline surveys have been conducted and published. Since this project was completed, centralised global databases, such as the World Register of Marine Species (WoRMS) have evolved as useful tools for consolidated species biogeographic data. At the time of the project, information was gleaned from several resources available, such as those listed below, as these resources were less complete and reliable in terms of non-native species records.

The corresponding set of bioregions stored in the database each had particular sets of risk species assigned to them. The species and associated data added to the database over the course of the activity were collated from a wide range of sources. These included preliminary lists of organisms found by the port biological baseline survey of Saldanha Bay, plus two literature reviews listing marine introduced species in southern Africa available at the time (Awad and Jackson, 2001; Gollasch and Griffiths, 2001). Sources used for developing the risk species database also included a range of literature, plus international and regional internet databases, including those being developed by the Smithsonian Environmental Research Center's (SERC) National Estuarine and Marine Invasive Species Information System (NEMISIS), CSIRO's National Introduced Marine Pests Information System (NIMPIS), the Global Invasive Species Programme's (GISP) Global Invasive Species Database, and the Baltic, Nordic and Gulf of Mexico web sites. The database used for the risk assessment contains 421 species, but these do not represent a complete or definitive global list. Thus, the database tables and their associated Excel reference file represent a working source and convenient utility of risk species information that can be readily updated and improved.

The port resources were mapped using ArcView GIS to display the bathymetric, navigational and infrastructure features, including habitats and social-cultural features. The scope of the Saldanha Bay port map extends from the coastal waters beyond its mouth to the northern limit of the 15km long Langebaan Lagoon, which extends from the south side of Saldanha Bay. The map also extends north-westward to encompass all edges of the bay, the town of Saldanha and nearby rocky headlands (Figure 3.2).

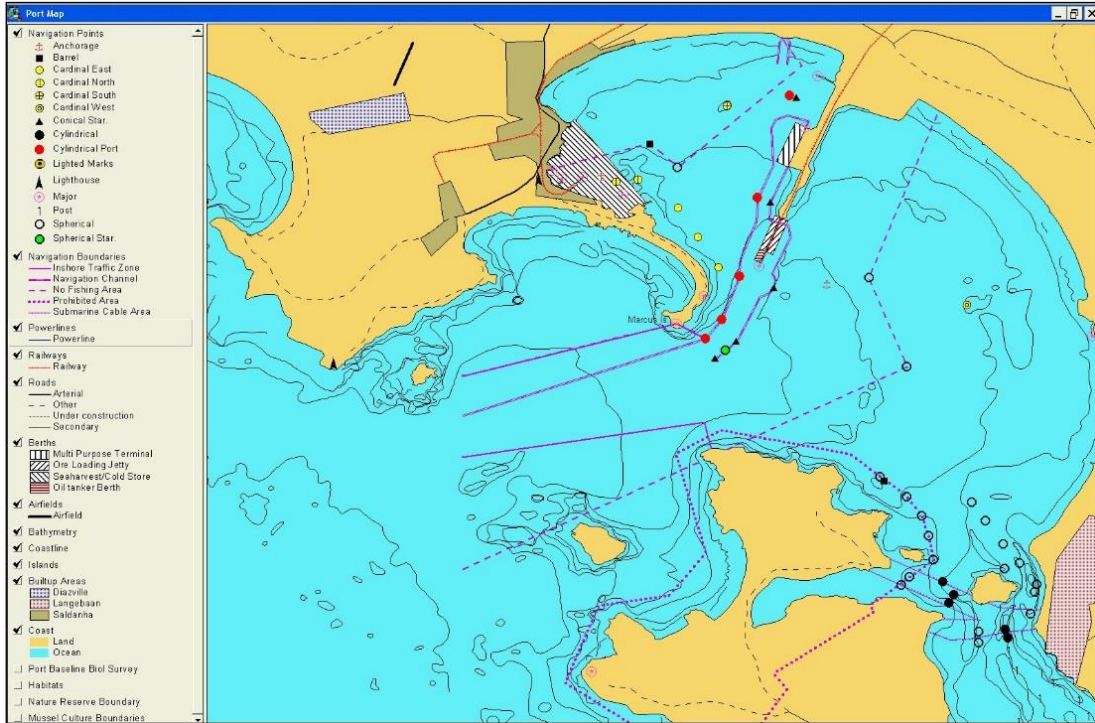

**Figure 3.2** The GIS Port Map of Saldanha Bay, generated for the purposes of this study, showing the navigation, infrastructure and active berth layers.

Vector-based electronic nautical charts were not available for Saldanha Bay, or for Langebaan Lagoon, so Group B generated the coastline/bathymetry and navigation layers by capturing salient details from 600 dpi scanned colour images of nautical hydrographic charts covering the Saldanha Bay and Langebaan Lagoon areas (i.e. charts SAN-C2, SAN-C2052, and SAN-1011).

Shipping channels, anchorage areas and other navigational features were added and digitized. Infrastructure and social cultural information was also captured from these charts, with other items and reserve boundaries added from maps and tourist guides. Mariculture site data were obtained during two port tours conducted by the project team. Group C assisted Group A to assemble the marine habitat layer using results from the port biological baseline survey, as well as information from local marine biologists. Gap-filling was required for some of the subtidal habitat boundaries through interpretation of the seafloor substrate symbols and bathymetric contours of the three nautical charts. For clarity and convenience of GIS data management and display, each 'theme' of information was added as a separate layer that followed the scheme shown below (Figure 3.3).

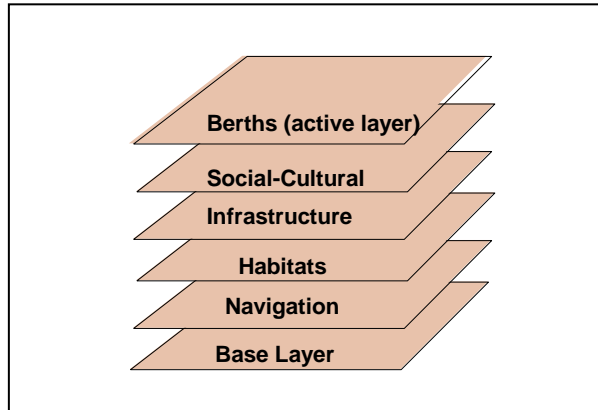

**Figure 3.3** Thematic layers used for the Port Map GIS.

**Base Layer:** The base layer included important planimetric features, such as depth contours, jetties, important channels and other permanent, or at least semi-permanent, ‘reference’ features that were unlikely to change or move. The key features of the base layer for the Port of Saldanha Bay comprised:

- Coastlines of the mainland and various islands within and beyond Saldanha Bay and Langebaan Lagoon (as depicted by the high tide mark on the nautical charts).
- The low tide mark (i.e. the 0-meter bathymetric contour of hydrographic charts).
- The 5 m isobath (often the first continuous contour below the low tide mark).
- The 10 m, 20 m and 30 m isobaths.
- Edges of the main shipping channels (often blue or purple lines showing the boundary of depths maintained by port dredging programs).

The colour scheme of the base layer followed that of standard nautical charts to maintain the familiar land/sea depth effect.

**Navigational Layer:** The standard navigational symbols of the IHO/IALA system were followed as closely as possible. ArcView’s symbol libraries do not contain these international navigation symbols, and convenient third-party symbology could not be found, despite extensive searches of public domain web resources. Closest-match point and pattern symbols were therefore developed for this purpose, using the UK Hydrographic Office Chart No. 5011 (= IHO INT 1) as the source.

**Habitat Layer:** This layer used a standardised, logical colour scheme to facilitate recognition of the main intertidal and subtidal habitat types in and near the port. These included the intertidal mud flats, sandy beaches, rocky shorelines and artificial walls, plus subtidal sand, mud and rocky seafloor areas, as obtained from the department of Environmental Affairs and the port biological baseline survey subtidal seafloor information. Some of the natural and artificial habitat boundaries were based on the notes and chart annotations made by team members during their inspection tours of the port facilities and of Langebaan Lagoon.

**Infrastructure Layer:** This showed the urban and developed land areas around the bay, plus the major and minor roads, railway lines, power lines and airstrips. The urbanised residential areas at Diazville, Langebaan and Saldanha were also shown, as was the main fishing jetty and vessel repair and maintenance wharf beside the town.

**Social-Cultural Layer:** Social-cultural features added included the boundaries of the three designated mariculture areas in Saldanha Bay, prohibited fishing areas and those of the West Coast National Park that encapsulates the Langebaan Lagoon.

**Berth Layer:** An 'active' berth layer was added to show the principal berthing and anchorage areas at the Port of Saldanha Bay. Their names and numbers were supplied by the NPA officer at Saldanha Bay (Mr. Jim Norman). This nomenclature was also used for the berthing area information stored in the Access database, to allow display of statistical summaries of the ballast water source and discharge data on the correct locations of the GIS port map.

As shown by the habitat layer of the GIS port map (Figure 3.4), the subtidal seafloor habitats in Saldanha Bay were dominated by sand sheets and rocky substrates which were covered in macroalgae that develop rapidly each spring. The connecting Langebaan Lagoon was shallow (6-7 m maximum depth) and completely sheltered from wave action, and it contained sandy beaches and salt marshes without significant freshwater inflows, plus well-developed seagrass meadows near its mouth. It was likely there were also some significant areas of seagrass in parts of Saldanha Bay, but no information could be found to delineate where these were located. The intertidal habitats of Saldanha Bay are also shown in Figure 3.4 and comprised the following:

- Narrow natural rocky shores and cliffs
- Sandy beaches along the Marcus Island causeway, around the bay and in Langebaan Lagoon
- High tidal marshes and low intertidal mud flats in Langebaan Lagoon

Artificial smooth and rocky wall substrates were restricted to the main pier and the Sea Harvest/Cold Store wharf and government jetty facilities beside the town of Saldanha. There were no coral reefs or mangroves in this temperate region of South Africa (the nearest being located along the north-east coast in KwaZulu-Natal, which was under the influence of the warm, southward-flowing Agulhas Current). There were three designated mariculture areas in Saldanha Bay, while the boundaries of the West Coast National Park encapsulate most of Langebaan Lagoon and part of the open coastline south of the entrance to Saldanha Bay (Figure 3.4).

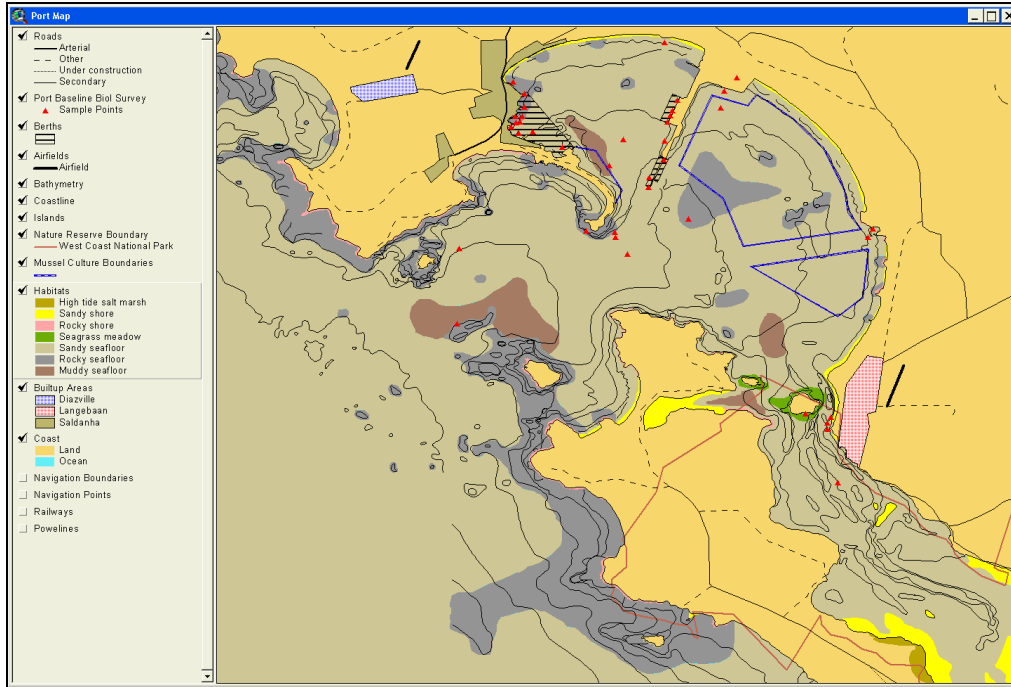

**Figure 3.4** The GIS Port Map, generated for the purposes of this study, showing the marine habitats and reserve layers.

The GIS port map also contained the locations of the 39 sampling sites from the port biological baseline survey. These were provided such that the results of the survey could be linked to the port map for convenient display. Because of the scale of the map and the extent of the urban and other developed areas, individual features, such as post offices, churches and radio masts, were not added. No historical wrecks of archaeological or cultural-heritage value could be precisely located in the area covered by the GIS port map. Saldanha Bay's protection from wave action and close linkage to the highly productive Benguela upwelling system provided optimal habitats, nutrients and temperatures for mussel farming and other aquaculture ventures (Pitcher *et al.*, 1999).

### System design

The database employed the ballast discharge, environmental matching and species distribution/threat data to calculate, as objectively as possible, the relative risk of a harmful species introduction to the Port of Saldanha, as posed by the discharges of water and associated organisms that have been ballasted at the port. A Graphic User Interface (GUI) was developed enabling further data input, alteration of the risk calculations and weighting values, and linkage to ArcView for geographically display of results. The GUI employed a modular approach that integrated three widely used computer software packages to provide a user-friendly tool for conducting, exploring and demonstrating semi-quantitative analyses. As shown in Figure 3.5, the software used included:

- Microsoft Access - for the main database;
- PRIMER 5 [*Plymouth Routines In Marine Environmental Research*] - a versatile multivariate analysis package from the United Kingdom enabling convenient multivariate analysis of the port environmental data; and
- ESRI ArcView 3.2 Geographic Information System (GIS) - to graphically display the results in a convenient, readily interpretable format using port and world maps.

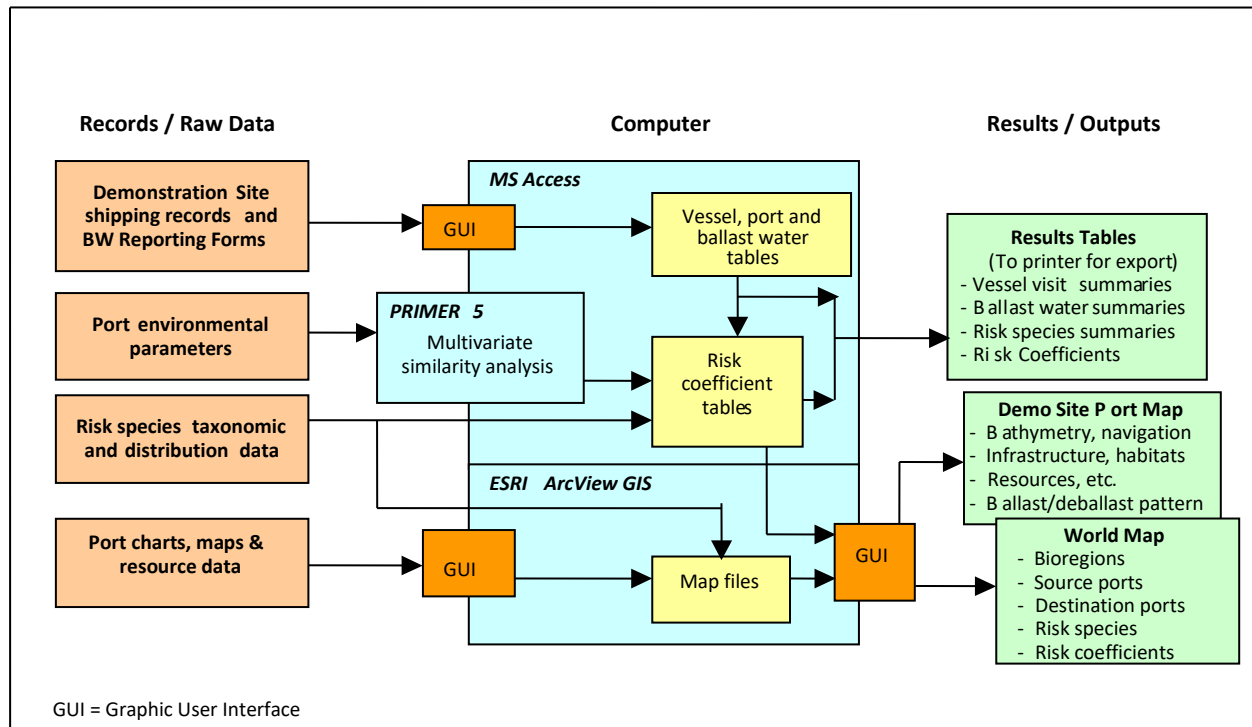

**Figure 3.5** Schematic showing the components of the risk assessment system.

For each source port, the database used four coefficients of risk (C1-C4) and two risk reduction factors (R1, R2) to produce a relative overall measure of the risk of a harmful species introduction. The database GUI shown above can be used to remove one or more of these components, or alter the way they are treated, from the default formula used for the first-pass risk assessment. The four risk coefficients calculated for each source port by the database were:

- C1** – Proportion from source port of the total number of ballast tank discharges made at the port
- C2** – Proportion from source port of the total volume of ballast water discharged at the port
- C3** – Port-to-port environmental similarity, as expressed by the matching coefficient
- C4** – Source port’s contribution to the total risk species threat to the port

In biological terms, C1 and C2 represented the frequency and size of potential organism inoculations, respectively. C3 provided a measure of the likely survivability of introduced organisms, and C4 indicated the relative threat posed by the organisms that comprise each inoculation. Each coefficient had values

between 0-1 except C3, where the lowest value was set to 0.01 (as it is unsafe to assume a port environment can be sufficiently hostile to prevent survival/establishment of every transferred introduced species).

The two risk reduction factors calculated by the database were R1 (effect of ballast tank size on C2) and R2 (effect of tank storage time on C4). R1 represented the effect of tank size on the number and viability of organisms that survive the voyage, since water quality typically deteriorates more rapidly in small tanks than in large tanks (owing to the volume/tank wall ratio and other effects, such as more rapid temperature change, with mortality rates generally higher in small tanks). No risk reduction was applied to any source port dispatching vessels with tank volumes greater than 1000 tonnes.

R2 represented the effect of tank storage time on the range and viability of discharged organisms. Survival of most phytoplankton and aerobic biota inside any tank decreases with time, with relatively high survival rates reported for voyages less than five days (as shown below, this was adopted as the cut-off point for any risk reduction due to in-tank mortality). If the focus was only on long-lived anaerobes, dinoflagellate cysts or pathogens (all of which have long tank survival rates), then R2 could be deleted from the risk calculation, using the GUI.

The database calculates the tank storage time by subtracting the reported tank discharge date from the ballast uptake date. For incomplete BWRFs with missing discharge or uptake dates, the vessel arrival date plus a standard voyage duration at 14 knots were used to estimate the BW uptake date for adding to the database. The database automatically provides values for R1 and R2, with the default (adjustable) R1 and R2 risk-reduction weightings to C2 and C4 shown in Table 3.2 below.

**Table 3.2** Default risk reduction weightings used in the database and applied to the calculation of risk associated with donor ports.

<b>R1</b>	Maximum tank volume discharged (tonnes) in the database record for each source port	<b>&lt;100</b>	<b>100-500</b>	<b>500-1000</b>	<b>&gt;1000</b>
<b>W4</b>	Default risk-reduction weighting applied to C2	0.4	0.6	0.8	1

<b>R2</b>	Minimum tank storage time (days) in the database record for each source port	<b>&lt;5</b>	<b>5-10</b>	<b>10-20</b>	<b>20-50</b>	<b>&gt;50</b>
<b>W5</b>	Default risk-reduction weighting applied to C4	1	0.8	0.6	0.4	0.2

The formula used for calculating the relative overall risk (ROR) posed by a source port was:

$$\text{ROR} = ( C1 + [C2 \times R1_{W4}] + C3 + [C4 \times R2_{W5}] ) / 4$$

In this case, ROR was the combined measure of the proportional 'inoculation' frequency (C1) and size (C2), the relative similarity of the source port/Demonstration Site environmental conditions (C3), and the relative level threat posed by the status of species assigned to the source port's bioregion (C4). The division by four kept the result in the 0-1 range to allow the convenient expression of the ROR as a ratio (or percentage if multiplied by 100) of the total risk posed by all the source ports.

The risk assessment calculation assigned each source port with one of five risk categories, labelled 'highest', 'high', 'moderate', 'low' or 'lowest'. The category boundaries were set at equal linear intervals along the 0-100% scale of cumulative percentage risk (i.e. at 80%, 60%, 40% and 20% intervals).

The database GUI allows the six components of the risk assessment calculation and the weighting factors to be altered from the default setting. The GUI could therefore be used to explore how particular risk components and their treatment influence the final result. It also allowed the user to shift one or more of the boundaries for the risk output categories to any point on the scale.

In summary, the risk assessment system for the Port of Saldanha stores, displayed and made available the following:

- Ballast water data obtained from arriving ship reporting forms and port shipping records
- Information on the port's navigational, physical and environmental conditions and aquatic resources
- Port-to-port environmental matching data
- Risk species data
- Risk coefficients and graphical categories of risk for (historic) ballast discharges

### 3.2.3 Results

A total of 1315 vessel visits were entered into the Saldanha Bay database, the large majority being extracted and expanded from ballast water records collected by the port's pollution control officer between January 1999 and June 2002. This database contained 82 vessel visits to the oil terminal berth (most laden VLCCs arriving at rates of 1-4 per month from the Persian Gulf and Nigerian oil export terminals). Reported ballast water discharges for the oil terminal totalled 1,269,137 tonnes (most occurring during a period of crude oil re-exports from South Africa's strategic reserve, which ceased in October 1999). The database also contained 593 visits to the iron ore export terminal (most Cape Class bulk carriers) which reported ballast water discharges totalling 26,802,325 tonnes, plus a further 607 visits by bulk carriers and general cargo ships to the nearby multi-purpose terminal. Ballast water discharges reported for the latter totalled 1,576,292 tonnes. On the southwest side of Saldanha Bay, 33 visits were also made to the Sea Harvest/Cold Store terminal by small reefers (<4,200 DWT), with only one of these reporting a discharge (200 tonnes of ballasted trim water).

Ballast water source ports identified from 1307 ballast water discharge records in the Saldanha database totaled 131. Those ‘supplying’ the highest frequency of ballast water discharges to Saldanha Bay (Figure 3.6) were Durban (9.2%) closely followed by Richards Bay (9.1%), then Rotterdam (5.1%) and Port Talbot (United Kingdom; 4.1%). The top 13 ballast water source ports provided 50% of all source-identified discharges, while the next 23 ports contributed a further 25%. Thus 36 of the source ports (27.3%) accounted for 75% of the total number of source-identified discharges.

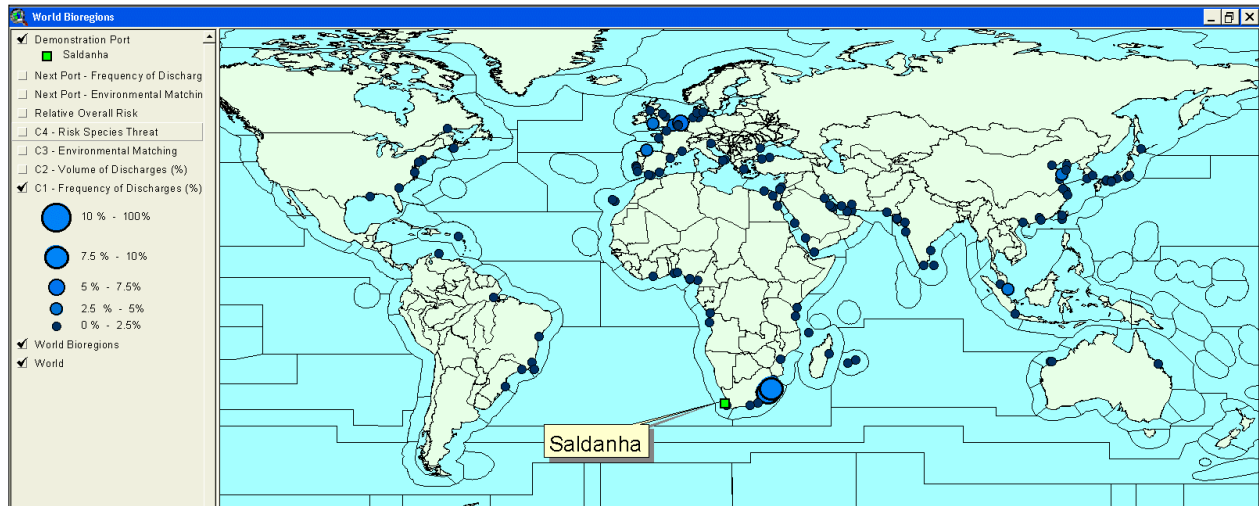

**Figure 3.6** GIS output showing location and relative importance of ballast water source ports with respect to frequency of tank discharges (C1) at Port of Saldanha Bay.

The total volume of source-identified discharged ballast water at Saldanha Bay between January 1999 and June 2002 was 29,647,954 tonnes. The source ports providing the largest volumes (Figure 3.7) were Rotterdam (7.3% of the total volume), Port Talbot (6.5%), Singapore (5.0%) and Immingham (4.2%). Only 30 of all identified source ports (22.7%) accounted for 75% of the total volume of source-identified ballast water discharged at Saldanha Bay. The port rankings for C2 (volume) were similar, but not the same as, those for C1. The top 13 of identified source ports provided 50% of the total discharged volume, and the next 17 ports a further 25%. Thus only 30 (22.7%) of all identified source ports accounted for 75% of the source-identified ballast water discharged at Saldanha Bay. Of the top 20 ports in terms of total discharge volume (64% of C2), three were in the Netherlands and three in China, two were in France, Japan, United Kingdom, and one each in Australia, Belgium, Germany, Israel, Italy, South Africa and Spain.

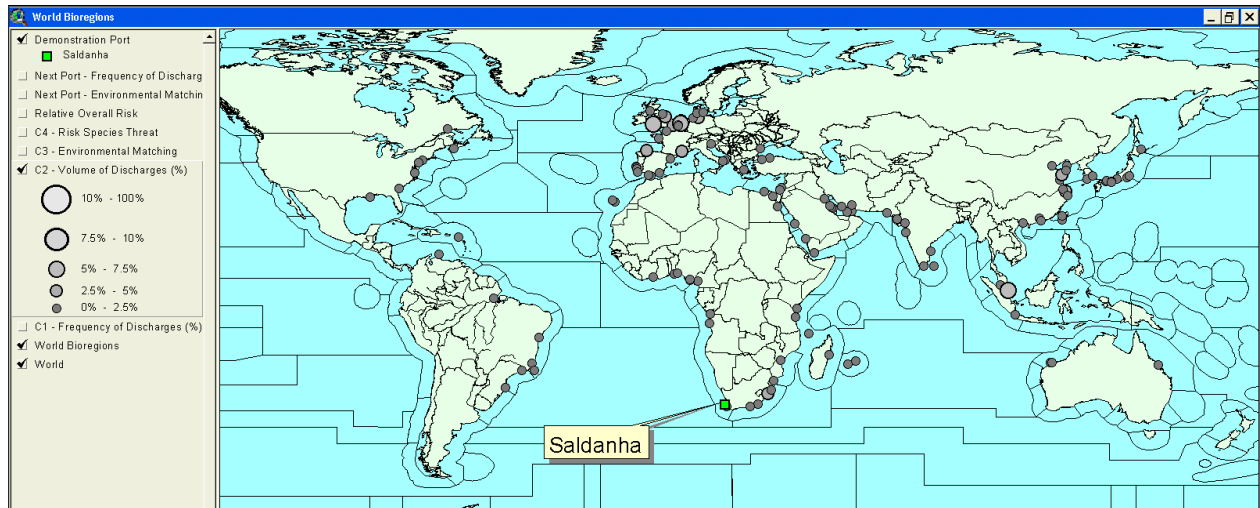

**Figure 3.7** GIS output showing location and relative importance of the source ports with respect to the volume of tank discharges (C2) at Port of Saldanha Bay.

Of the identified source and destination ports, sufficient port environmental data were obtained to include 71% of the former and 51% of the latter in the multivariate similarity analysis by PRIMER. These ports accounted for 90% of all recorded ballast water discharges and 84.5% of all recorded departures, respectively.

The most environmentally similar port to Saldanha Bay (Figure 3.8) was Piraeus in Greece (its matching coefficient was 0.78), with 11 other widely distributed ports also having matching coefficients above 0.7. Another widely dispersed group of ports (37) had relatively high matching coefficients in the 0.6-0.7 range. The most environmentally dissimilar ports trading with Saldanha Bay in 1999-2002 were a mixture of cool water and brackish ports, Persian Gulf ports and ports in the humid tropics. The most frequent recorded next ports of call (Durban and Beilun) had relatively high (0.64) and moderate (0.58) environmental matching coefficients, respectively.

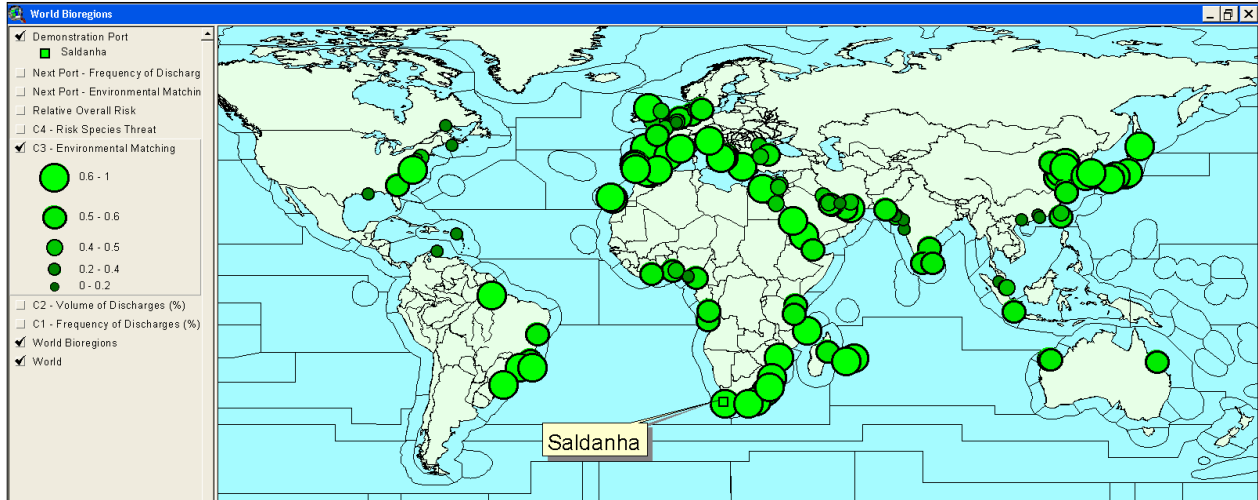

**Figure 3.8** GIS output showing the location and environmental matching coefficients (C3) of ballast water source ports identified for the Port of Saldanha Bay.

Many of the most frequent ballast water source ports were also frequent 'Next ports of call' (i.e. potential destination ports for ballast water uptaken at Saldanha Bay), with Durban, Beilun, Singapore, Rotterdam and Richards Bay accounting for over 33% of those reported by departing vessels (Figure 3.9). Of the 183 next ports of call recorded, the top 33 were recorded by 75% of the 1315 vessel departures. The most frequent recorded next port of call was Durban (8.9% of all departures) and Beilun (Ningbo) in north-east China (8.5%), and these had relatively high (0.643) and moderate (0.580) environmental matching coefficients, respectively.

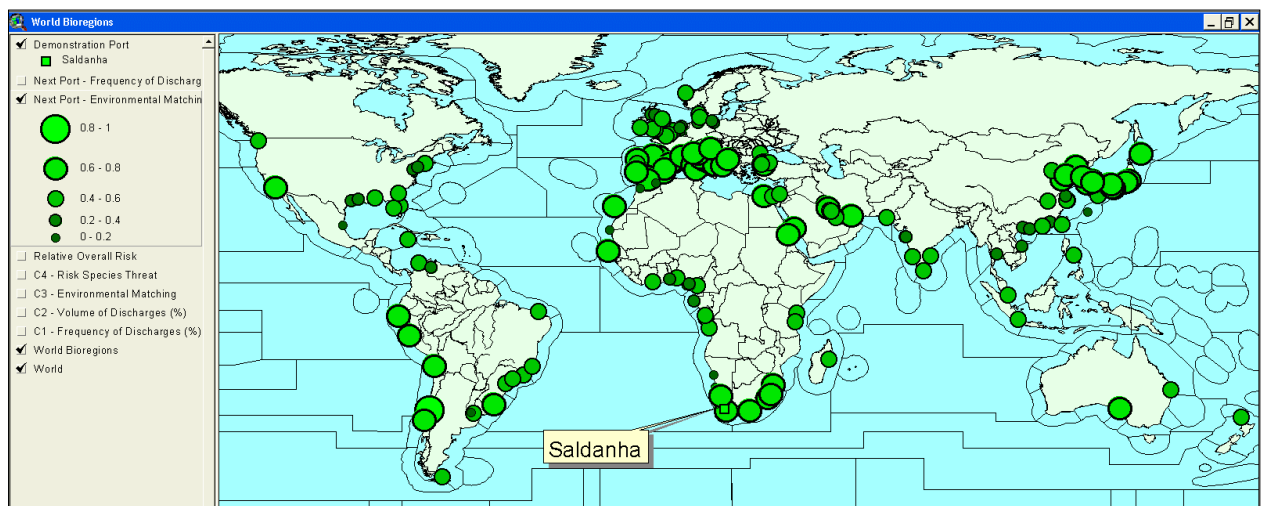

**Figure 3.9** GIS output showing the location and environmental matching coefficients (C3) of the destination ports identified for the Port of Saldanha Bay.

The risk species threat from a source port depended on the number of introduced and native species in its bioregion, and their categorisations as unlikely, suspected or known harmful species. The risk species threat coefficient (C4) of each ballast water source port that was identified for Saldanha Bay is mapped on Figure 3.10.

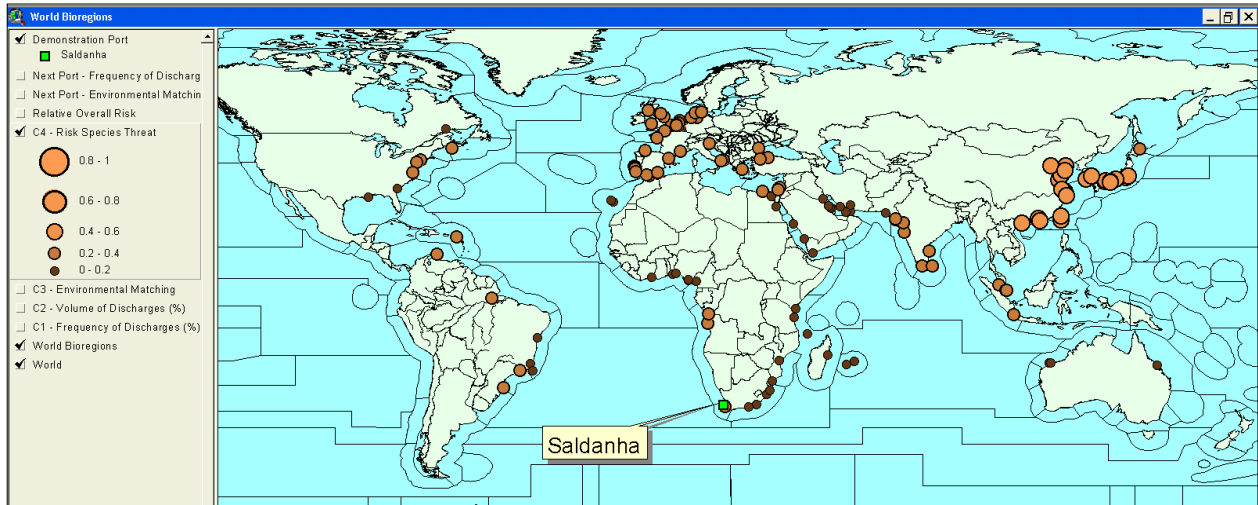

**Figure 3.10** GIS output showing the location and risk species threat coefficients (C4) of the ballast water source ports identified for the Port of Saldanha Bay.

The calculation of the relative overall risk (ROR) identified that 19 of the 131 source ports (14.5%) provided 20% of the total ROR to Saldanha Bay (Figure 3.11), and therefore formed the highest risk group (in terms of their ballast water source frequency, volume, environmental similarity and risk species threat). The highest risk group were predominantly Mediterranean, South African and North Asian ports, led by Piraeus in Greece (ROR = 0.250), Taranto in Italy (0.247) and Gijon in Spain (0.245). The group of source ports accounting for the next 20% of the ROR (i.e. 'high risk' ports) was 22, and these were predominantly north Asian, Brazilian and European ports. The number of ballast water source ports in the low risk (28) and lowest risk (38) categories were a mixture of cool, warm and/or brackish water ports and comprised 50% of the total. The wet tropics port of Onne on the Nigerian coast had the lowest ROR value (0.07).

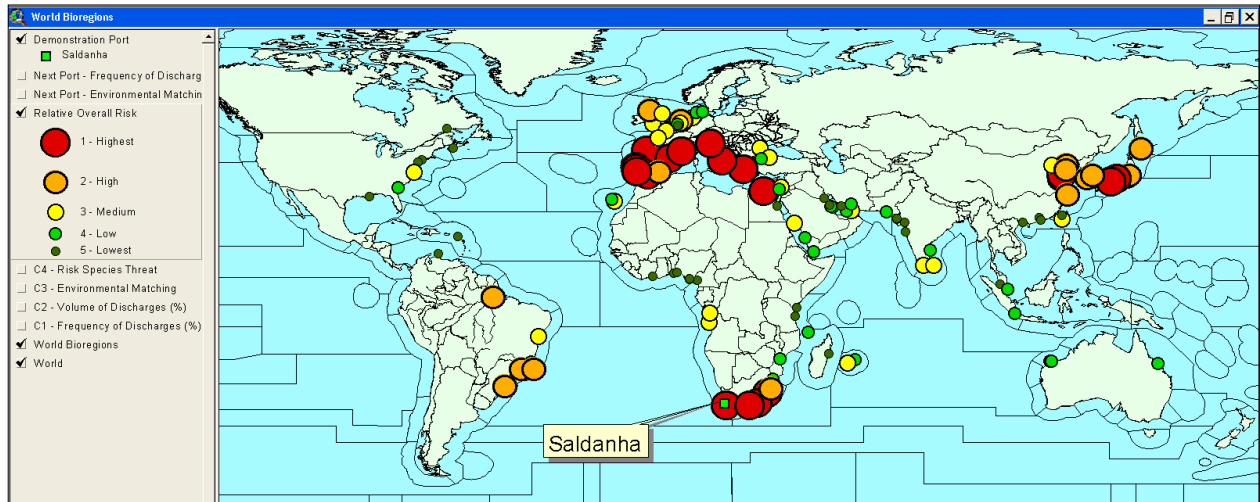

**Figure 3.11** GIS output showing the location and categories of relative overall risk (ROR-cat) of source ports identified for the Port of Saldanha Bay

Based on the 1999-2002 pattern of shipping trade, the ROR results showed that ballast water discharged from vessels arriving from the temperate and warm temperate open coastal ports in the Mediterranean and north Asian regions posed considerably more threat than those in the wet tropics and north American seaboard.

The assessment of relative overall risk to ballast water destination ports from ballast water taken from the Port of Saldanha was inconclusive. The reliable identification of destination ports that may receive ballast water from the Saldanha Bay was confounded by the lack of specific questions on the IMO reporting forms, and the uncertainty of knowing if the “Next of Port Call” recorded on the form was where Ballast Water was actually discharged. Furthermore, C4 values could not be assigned for destination ports (i.e. measures of the relative threat posed by any ballast water exported from Saldanha Bay). This would require knowing the sources of all the other ballast water discharged at each destination port. Thus, there was no mechanism enabling a ‘reverse risk assessment’ to be undertaken reliably.

### 3.2.4 Conclusions and recommendations

The ROR results were considered logical, given Saldanha’s biogeographic location, current pattern of trade and port type (a natural bay port). They also fitted with the origins of the introduced species already present in Saldanha Bay (i.e. mostly European and Asian species). The results therefore indicated that the ‘first-pass’ risk assessment, including treatment of the risk coefficients, provides a useful benchmark for management considerations, as well as potential further investigative manipulation of the risk calculations and database.

The following conclusions and recommendations were drawn from the process and related outcomes:

- A. It is worth considering how the environmental matching coefficient (C3) is treated by the risk calculation. The assumption was that C3 should be treated as an independent coefficient of risk. It may however, in some cases, be appropriate to redesign the calculation, such that the proportional risk species threat (C4) provides the focal point of the risk calculation, and to treat C3 as a risk reduction factor for influencing the size of C4, rather than using it as an independent 'surrogate' coefficient to help cover unidentified or unknown species. The GUI allowed the formula to be changed to reflect this approach, in which case C3 could be applied as follows:

$$\text{ROR} = ( \text{C1} + [\text{C2} \times \text{R1}_{\text{W4}}] + [\text{C3} \times \text{C4} \times \text{R2}_{\text{W5}}] ) / 3$$

For a source port in a bioregion with a large number of risk species (i.e. at relatively high C4 such as 0.2), but with an environment very dissimilar to Saldanha Bay (e.g. C3 = 0.2), then this adapted equation would reduce C4 by 0.04 (i.e. an 80% reduction). If the minimum tank storage time was relatively long (e.g. R2 was between 10-20 days for the quickest voyages, so W5 = 0.6), then C4 would be further reduced to 0.024 (i.e. an 88% reduction to its initial value).

The adapted equation was logical, provided the database contained an accurate distribution of appropriately weighted risk species in the various bioregions (including native species considered potentially harmful if they established in other areas). However, it was less conservative than the default equation, particularly if there were doubts that C4 provided a true picture of potential risk species threat. The default equation produced higher ROR values, unless a single source port accounted for over 50% of the frequency (C1) and volume (C2) of the total discharges at a Demonstration Site (which was highly unlikely).

Many of the species listed in the database could be related to their history of species transfers for aquaculture, plus hull fouling on sailing vessels and the canal-caused invasions of the east Mediterranean (Suez), north-east Europe (Ponto-Caspian river canal links) and Great Lakes (St Lawrence River seaway). The regional and often patchy sampling bias needs to be remembered when comparing C4 values between different bioregions, and was a further reason why the independent treatment of C3 for calculating the ROR values was a safer approach.

- B. In the case of risk species distribution and status data, many national and regional data sets remain incomplete and/or unpublished, and there were none for South Africa at the time of this study. Many web sites that list introduced species for North American, Caribbean, European, Asian or Australasian regions did not clearly separate or identify which species were historical introductions (e.g. by the aquaculture, fisheries, aquarium industry, sailing ship hulls, etc.) and which were recent (e.g. by ballast water and/or modern hull fouling vectors). Many lists do not identify the most likely vector(s) of their listed species, which was concerning in terms of application to vector-specific risk assessment, such as this one. It did, however, support the argument that risk assessment and management for species introductions should be conducted

at a broader scale to include a range or set of vectors (e.g. shipping-related), if not all known and relevant vectors in their totality.

Because of the different historical vectors (e.g. hull fouling, canals, aquaculture, dry ballast, water ballast, etc.), a future or alternative version of the risk assessment system could provide more accurate C4 values for ballast water-mediated introduction threats if vector weightings were added to the database for the C4 calculation.

- C. The threat species database did not give a complete global list, but provided a working resource enabling further update and improvement for each bioregion. Similarly, the 204 bioregions on the GIS world map should not be considered unalterable. Regional resolution of species-presence records is steadily improving in several areas, and this will allow many bioregions to become divided into increasingly smaller units (ultimately approaching the scale of local port waters). It should also be recognised that the distribution of risk species in the database contained a regional bias due to the level of aquatic sampling and taxonomic effort in Australia/New Zealand, Europe and North America.
- D. It was difficult to obtain reliable environmental information for many source port's waters, particularly for the seasonal water temperature and salinity averages and extremes. This was true for ports in developed regions (e.g. North America, Europe and Japan), as well as for less developed areas, including where considerable marine research has been undertaken. The reliance of the system on such rigorous environmental data (34 parameters), and the ongoing need for these data to be updated and maintained, may be seen as a handicap of the system. While incomplete or insufficient data may directly compromise the multivariate analysis, the effort and expertise required for its compilation and verification, as well as the development of valid surrogate data where necessary, may not realistically be anticipated from national management authorities. The establishment and maintenance of an international centralized database for this purpose may be the only logical mechanism to support risk assessments of this nature in ports around the world and in perpetuity.
- E. The risk assessment system placed high reliance on information provided in ballast water reporting forms. While these were standard IMO forms available in ports and on vessels the world over, it was not uncommon for ships to disregard their use, or to curtail the amount of information provided. Incomplete fields, errors and misleading information were common, providing hurdles for those capturing and interpreting the data. Furthermore, the standard forms could be altered to allow for greater detail, such as the last three ports of call, instead of last port of call, and greater resolution in terms of histories provided for each ballast tank on board. As ballast water management matures internationally in-line with the IMO BWM Convention, it is recommended that the next generation of reporting forms gravitate to a mandatory reporting format at port entry that also addresses the data shortcomings.
- F. At the conclusion of the risk assessment project, the Department of Environmental Affairs and the Transnet National Ports Authority were committed to the ongoing use of the system within the context of the emerging Port of Saldanha ballast water management framework. Ultimately,

the system was not integrated with other management processes, so it has remained isolated in terms of the usefulness of the database and associated applications. The lack of progress at national level in terms of domestication of the IMO BWM Convention and translation of this into port regulations has meant that the demand for the system has not yet been as anticipated. Now that the BWM Convention has come into force internationally (Sept. 2017), South Africa is again making progress towards detailed national regulations. The outputs from the system, though dated, may prove valuable in assessing management options at port level. However, it may be more interesting to consider the potential for revitalization of the system.

It was perhaps unrealistic to anticipate ongoing management and updating of the risk assessment database by local authorities, given the complexity and demand for technical content, and also premature to anticipate decisive and focused management outcomes or actions. While the output had value for supporting and guiding decisions in terms of focusing management effort on high risk areas, it must be noted that vessels are changing in terms of ballast capacity and on-board treatment options, and new shipping patterns are emerging due to shifting global markets. Therefore, a decision support system based on the foundation already developed, and focused on ship-specific risk assessment for new arrivals at the port may be needed to compliment and shape the implementation of the IMO's regulatory approach.

If South Africa can develop a more strategic integration of its agencies which have expertise and complimenting roles in the various maritime, port, ecological and environmental health aspects of ballast water and invasive species management, then the technical capacity and management support for such a system can be put in place. A system designed for and operating in the Port of Saldanha may then be more easily replicated at other South African ports, and potentially other key ports within the African region. Improved government coordination will allow South Africa to provide effective assistance, technical advice, guidance and encouragement to other port states in southern Africa, so that a clearer and more reliable picture can be formed on the role of shipping in the introduction of unwanted and potentially harmful aquatic species into and within the region.

### 3.3 Approach taken for Port Louis

#### 3.3.1 Aims and objectives

The Ministry of Public Infrastructure, National Development Unit, Land Transport and Shipping of Mauritius is actively pursuing the development of a ballast water management regime for Port Louis in order to increase adherence to international regulations and the corresponding protection of national marine resources. The Shipping Division and the Mauritius Oceanography Institute (MOI) are supporting this initiative and working directly with the International Ocean Institute - Southern Africa (IOI-SA) to build the foundation and put in place the relevant management approaches and capacity to support such a focused regulatory regime. In addition to the port biological baseline survey discussed in Chapter 1, the

Mauritian administration specifically requested the development of a risk assessment system for ships' ballast water, similar to what had been done for the Port of Saldanha. However, in discussion with the administration, as to the intended use of the system, it became clear that what was needed was not an analysis based on historical shipping routes, but rather a mechanism for assessing the relative risk posed by each new vessel entering the port, with a view to guiding the consequential management decisions and actions. As a small island developing state, the Port State Control inspection capacity is limited, and therefore should be focused on those ships that are in the highest risk category.

The approach taken for the risk assessment system in Port Louis was therefore considerably different in terms of its goals and intended outputs than the Saldanha study. The basic principles of combining an assessment of shipping activity, environmental similarity and threat species would nonetheless remain consistent, as these are the core pillars of this type of analysis. It also became clear that a backlog of shipping and broad environmental data, upon which a system could be based, did not exist for Port Louis, as it had for the Port of Saldanha. The decision was then made to take the lessons from the Saldanha system and apply these in the context of the constraints and demands for the Port Louis situation. A new system would be designed based on information that is internationally centralized and maintained, and is freely available. Simplicity and reduced user-demand were also to be emphasized in the design of the system.

The general aims of the risk assessment and decision support system for Port Louis were to:

1. Develop a computer-based ballast water risk assessment and decision support system customised to the conditions of Port Louis, Mauritius, that generates a semi-quantitative indication of risk associated with the intended discharge of ballast water on-board arriving vessels.
2. Incorporate into the system a mechanism to provide guidance for high risk vessels, whereby the system provides decision support related to the inspection procedures for ballast water, including the possibility of ballast tank sampling.
3. Advance the ballast water management capabilities of the Mauritian Port State Control authorities, by increasing the effectiveness of procedures related to the assessment of visiting international ships' ballast water and associated alien species transfer, in a manner that is consistent with the approach and requirements of the IMO BWM Convention.
4. Design and develop a system that is easily interpreted and manageable by the Port Authority, taking into consideration the technical limitations of the intended users.

The specific objectives of the risk assessment for Port Louis were to:

1. Collate and synthesize the appropriate baseline and background data and information relevant to the comprehensive risk assessment process.
2. Design and develop an application to streamline the collection of relevant ship and ballast water/tank-specific information, based on the reporting forms submitted by visiting vessels, as required by the Port Authority.

3. Develop a system, based on relevant and open-source software, to generate an indication of risk associated with each vessel and ballast tank that intends to discharge ballast water into Port Louis.
4. Generate a graphic (GIS-based) utility and display format for system outputs.
5. Provide automated guidance on when and how to undertake ship ballast tank sampling procedures, as may be necessary as an outcome of the decision support process, consistent with requirements and guidelines under the IMO BWM Convention.
6. Help ensure the sustainability of the system in Mauritius for ongoing risk assessment and decision support related to the developing ballast water management regime.

### 3.3.2 Methods

#### Project team

The risk assessment system was conceived, designed and developed by the IOI-SA team in Cape Town, based on information gathered during visits to Port Louis for general reconnaissance and meetings with the local project counterparts. The Mauritius-based team members assisted with fact-finding, data sourcing, local customization and integration of the system with port management systems. Representation on the project team from both the Mauritius oceanographic and shipping sectors was instrumental in ensuring the system was developed in a manner consistent with local operational needs and capacity for ongoing management.

Members of the overall project team included:

<u>Name</u>	<u>Role</u>	<u>Affiliation</u>
Adnan Awad	Project leader, designer	International Ocean Institute (IOI-SA)
Leticia Greyling	Technical assistant	International Ocean Institute (IOI-SA)
Reuben Roberts	Software developer	International Ocean Institute (IOI-SA)
Prakash Mussai	Mauritius team leader	Mauritius Oceanography Institute (MOI)
Vimal Ramchandur	Technical assistant	Mauritius Oceanography Institute (MOI)
Hemanaden Runghen	IT specialist	Mauritius Oceanography Institute (MOI)
Eric Martial	IT specialist	Mauritius Oceanography Institute (MOI)
Meenaksi Bhirugnath	Shipping liaison	Mauritius Shipping Division
Veganaden Maunikum	Port inspections	Mauritius Shipping Division

#### Information gathering and management

The initial preparatory work began in Cape Town with the project team discussions and research on the most appropriate mechanisms and applications for satisfying the project needs, the needs of MOI, the needs of the Shipping Division, and the general best interests of Mauritius with respect to supporting

effective ballast water management. A comprehensive review was conducted of the IMO BWM Convention, supporting guidelines and other international approaches to conducting risk assessment as part of a national or port ballast water management regime. The research focused on assessing the most logical and appropriate level and protocol to pursue in designing a system for Port Louis.

The process also aimed to answer key questions about the environmental conditions and resources in Mauritius, as well as the availability and quality of data describing them. The port biological baseline survey had already revealed that aggregate environmental and resource data were lacking for the area.

In order to address this concern, a questionnaire and data template were developed and circulated to the various stakeholders in Mauritius for solicitation of information related to key information requirements. These included environmental, management and shipping data previously deemed essential for conducting robust analyses of ballast water discharge risk. The information attained from the questionnaires and data templates was limited and inconsistent, confirming the data gap and challenge for risk assessment design. This perceived obstacle proved instrumental in the subsequent design of the system, such that it necessitated a new approach to addressing the components of the system that focus on shipping information and multivariate environmental matching processes.

### **System design**

Generally, the data available with respect to the various environmental parameters and the shipping (ballast water specifically) records were insufficient to take the same approach towards the ballast water risk assessment conducted for the Port of Saldanha in South Africa. It was also concluded that the approach applied in Saldanha was overly data intensive, to the point of being dysfunctional, should such data not be readily updated. A more simple, practical and effective approach was designed for the risk assessment system in Port Louis.

The basic principles of the methodology did not change from the previous more intensive approach, with environmental similarity, voyage conditions and threat species forming the three base pillars upon which the conclusions are based. The significant design differences between the system used for the Port of Saldanha and the system designed for Port Louis can be summarised as follows:

- The Port Louis system has no background shipping traffic data included, and does not assess risk associated with the patterns of trade. It depends entirely on input data for a visiting ship, which are then used to produce a risk profile specific to that ship and its ballast water on board.
- Environmental similarity analyses were conducted on an eco-region to eco-region basis (described later in this section) in the Port Louis system, as opposed to the port to port comparisons used for Saldanha.
- Decision support capability was integrated into the system to provide practical guidance for management outcomes, specific to each ship or case.

The graphic below (Figure 3.12) illustrates the relationship between the input data, the three cylinder ‘engine’ of the system that processes these data, and the output components that have targeted management applications.

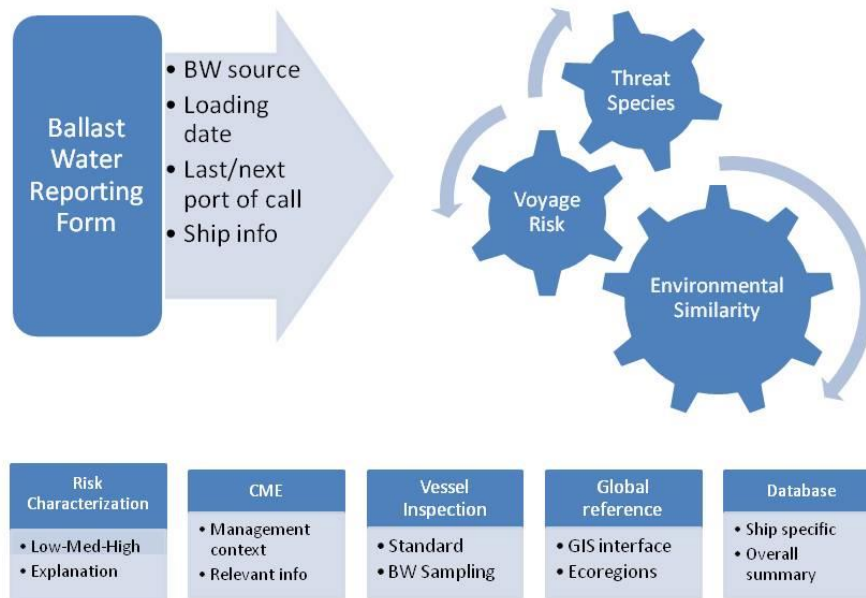

**Figure 3.12** Conceptual schematic of the risk assessment and decision support system to support compliance monitoring and enforcement (CME) efforts related to ballast water management.

In order to give life to this conceptual model, various layers of standardized and vetted data were needed. Some basic assumptions had to be made from the body of scientific research that has been conducted in this field, and experts were needed to programme the findings into an expert system format in a manner that is both user friendly and meaningful for the intended management application.

The system is designed to provide a qualified assessment of vessel or ballast tank-specific risk invasive species introduction in order to help target compliance control efforts (e.g. ship inspection) towards the highest risk vessels entering the port. It then provides guidance for the type of inspection to be conducted, and protocols to be used, while archiving the data provided. The system works on the basic information supplied by a vessel in the standard IMO Ballast Water Reporting Form. When the key information is entered by the user, an assessment of the relative risk for invasive species introduction is produced, along with interpretation of the risk and subsequent decisions to be made.

The risk assessment component of the system includes:

- A user interface and data input mechanism.

- A rule-based '3-cylinder engine' incorporating the world ecoregions with an environmental similarity cylinder, a ship voyage cylinder and a risk species cylinder, each with potential to be upgraded or revised in the future, should it be necessary.
- A graphical (GIS based) output including the risk categorization and options for entry into the decision support component.

The decision support component of the system includes:

- A decision tree or if/then approach to assessing ship inspections as part of the compliance monitoring and enforcement management.
- Support in selecting whether or not to board a vessel and procedures for compliance monitoring.
- A 'how-to' section on tank sampling for a range of possible scenarios, including guidance and protocols based on the IMO BWM Convention and associated guidelines.

Vessel visit risk assessment is computed using the '3-cylinder' model to aggregate the risks contributed by each of the following:

- Environmental similarity with source of ballast water (based on marine ecoregion similarity).
- Vector or voyage-specific risk (volume, duration, frequency).
- Invasive species (presence/absence in ecoregion associated with ballast water source ports).

Environmental similarity was assessed on a regional basis, due to the lack of information to support port-specific comparisons between Port Louis and its source ports. This was achieved by using available international oceanographic and coastal ecosystem information to produce a digital map of "ecoregions", whereby the environmental conditions of a port are assumed, for the purposes of the assessment, to be consistent with the ecoregion within which it is found. The ecoregion map was compiled using the Marine Ecosystems of the World (Spalding *et al.*, 2007) as a starting point, which provide the digital files for a biogeographic classification of the world's coasts and shelves, designed as a tool for use in planning and conservation applications across a range of scales. Next, global sea-surface temperatures were overlaid, using GIS, to ultimately create five categories of ecoregions (polar, cold-temperate, warm-temperate, sub-tropical, tropical), as opposed to the three categories used in the publication.

The ballast water source port was then compared to the intended port of discharge. Global records of invasive species presence and distribution were taken from The Nature Conservancy Database of Global Marine Invasive Species Threats (Molnar *et al.*, 2008), and strengthened by incorporating species records from other sources, including the port biological baseline surveys conducted. These data were incorporated into the system, whereby the assessed risk increases if the ballast water is sourced from ecoregions known to contain invasive species not already present in Port Louis.

All the major ports of the world and their corresponding data were entered into the system, along with the basic Port Louis shipping data that were provided from the Mauritius Ports Authority (MPA) and the

Shipping Division. The risk assessment system was therefore based on internationally recognized and vetted data which had been collated and processed uniquely for this application.

The system user interface was designed to look like and match the fields of the IMO Ballast Water Reporting Form, so as to reduce errors associated with data input. If the correct information is provided by the vessel, the risk is then calculated for each tank on board, recognising that some vessels may charge ballast from different source ports. This is conducted by assessing the volume of ballast water on board, the overall time since it was loaded and the number of recent discharges originating from the same source waters (to account for inoculation pressure).

Overall risk is presented as a simple five-level hierarchy, where the final risk coefficients correspond as follows:

**5 = Very high      4 = High      3 = Medium      2 = Low      1 = Negligible**

The overall risk is calculated as a sum of the three cylinders or components, with each being processed as described in Table 3.3.

**Table 3.3 (a)** The environmental similarity component of the risk assessment system.

<b>Ecoregion difference</b>	<b>Environmental similarity risk index</b>	<b>Contribution to overall risk index</b>
Same (e.g. tropical vs. tropical)	Very high	Starting coefficient = 4
1 away (e.g. tropical vs. subtropical)	High/medium	Starting coefficient = 3
2 away (e.g. tropical vs. warm temperate)	Medium/low	Starting coefficient = 2
3 away (e.g. tropical vs. cold temperate)	Low/negligible	Starting coefficient = 1
4 away (tropical vs. polar)	Negligible	Starting coefficient = 1

**Table 3.3 (b)** The vector or voyage risk component of the risk assessment system.

<b>Ballast water discharges from source ecoregion</b>	<b>Vector frequency risk index</b>	<b>Contribution to overall risk index</b>
<b>Frequency:</b> >10 in previous 90 days	High frequency	Increase risk coefficient by 1
<b>Duration:</b> Voyage duration < 30 days	Short duration	Increase risk coefficient by 1
<b>Volume:</b> >100 000 m <sup>3</sup> discharged	Large volume	Increase risk coefficient by 1
		<b>Total: max. 2 step increase in risk</b>

**Table 3.3 (c)** The invasive species risk component of the risk assessment system.

<b>No. of invasive species present in source ecoregion</b>	<b>Invasive species risk index</b>	<b>Contribution to overall risk index</b>
>0	High	Increase risk coefficient by 1
0	Low	Leave risk coefficient as-is

The system was implemented on a Windows platform as a Visual Basic for Application (VBA) software using a VBA-scripted database compatible with MS Access 2003 onwards. It has the following installation requirements:

- Desktop PC running MS Windows XP or later versions of Windows Operating System.
- 2GHz Processor, 2GB RAM, 1GB free Hard disk space, 1024x768 16-bit colour display.
- MS Office 2003 / 2007 / 2010 (Standard or Professional Edition) with latest service packs.
- If MS Office Standard Edition is selected, then MS Access 2007 / 2010 Runtime Edition.
- Appropriate free / open-source GIS package (the system may incorporate functionality from the MapWindow GIS open-source ActiveX component).
- Adobe Acrobat Reader or equivalent PDF reader.
- No internet/network access is required, since the system is installed stand-alone (internet access and 'Remote Desktop'-type software such as TeamViewer can be used for remote support, but is not required).

A Comprehensive User Manual was developed and provided to MOI during the training session. The training session included participants from MOI and Shipping Division, and provided hands-on instruction in system operations. The risk assessment system was installed on three computers at MOI, with the intention that one will serve as the main terminal at MOI, the second will serve as the main terminal at Shipping Division, and the third will be a 'test' terminal at MOI for providing feedback for possible future updates.

### 3.3.3 Results

#### **Overview of the functional system**

The risk assessment system supports decision-making when assessing the environmental risk of ballast water discharge from vessels. The system draws from global data, with specific reference and application to Port Louis, Mauritius. The 2011 shipping statistics indicate that approximately 700 vessels with the potential to exchange ballast water visited Port Louis in that year, and more recent trends indicate that multiple vessels arrive each day with intent to discharge.

The completed system was trialed in Port Louis using both live and dummy ship reporting information. A range of default setting were explored to demonstrate potential biases of the system. The system functionality was tested by the technicians from the port authority to confirm relevance to their day-to-day activities and needs. The outputs of ship-specific risk were available graphically for the user, and recorded and archived in the database.

It is important to note that the risk assessment system is intended to support the allocation of limited inspection resources, not to provide a legally-binding or exhaustive assessment of vessel visit risk. For example, this system is not intended to be used for the exemption of low-risk vessels from ballast water regulations. The system can, however, help identify vessels for which there may be a biofouling concern,

as the biofouling issue with respect to species transfers is now becoming as serious a management concern as ballast water.

The following images (Figures 3.13 - 3.18) have been taken directly from the risk assessment system to demonstrate the functionality and user interface as described in the sections above.



Figure 3.13 Front page of the system with user interface options.

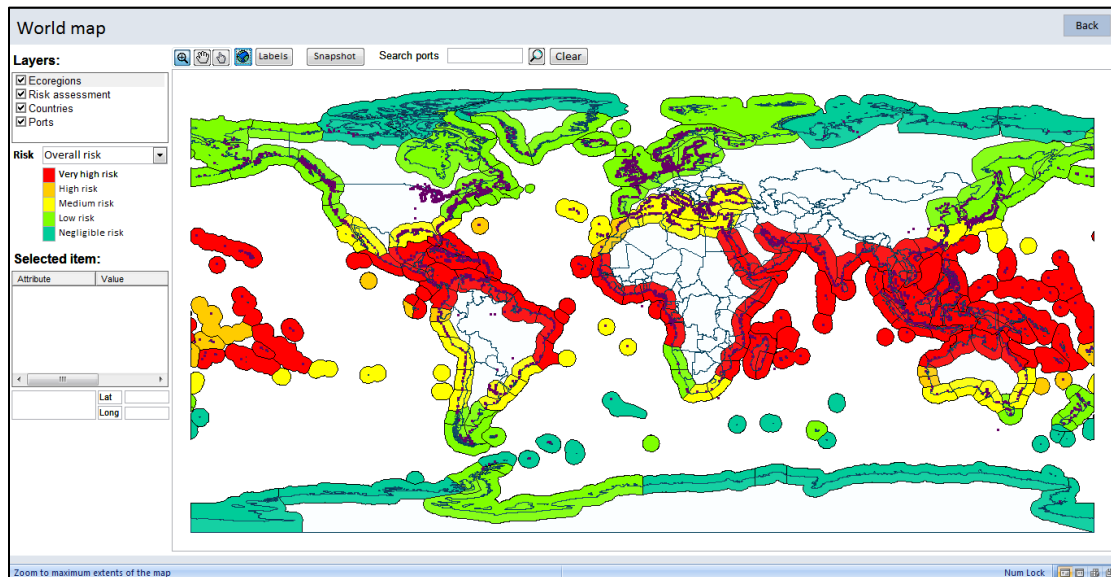

Figure 3.14 Global view of the environmental similarity component, displayed as ecoregions.

Overall Tanks

**1. VESSEL INFORMATION** Add new vessel

Vessel:  Type:  IMO no.:  BW units:

Owner:  GT:  Call sign:

Flag:  Arrival date:  Agent:  Total BW on board:

Last port of call:  Port of call:

Next port of call:

**2. BALLAST WATER**

Ballast water management plan on board?  Yes  No  Unknown No. ballast tanks:  Tanks in ballast:

Management plan implemented?  Yes  No  Unknown Tanks exchanged:  Tanks not exchanged:

Ballast water treatment system on board?  Yes  No  Unknown

**4. BALLAST WATER HISTORY:** RECORD ALL TANKS THAT WILL BE DEBALLASTED IN PORT STATE OF ARRIVAL; IF NONE GO TO NO. 5  
See next page

IF EXCHANGES WERE NOT CONDUCTED, STATE OTHER CONTROL ACTION(S) TAKEN

IF NONE, STATE REASON WHY NOT

**5. IMO BALLAST WATER GUIDELINES ON BOARD (RES. 868(20))?**  Yes  No  Unknown

Responsible officer's name and title:

Figure 3.15 The user interface for data entry into the system from the ballast water reporting form.

BWRADS: Dashboard

DASHBOARD Back

Search  Reset Risk assessment:  Simple  Detailed

Vessel name:	Arrival date:	Last port:	Overall:	Assessed?	Action required:	Legal compliance:	View:
Model Vessel 1	14-Mar-12	PORT EST (REU)	5	<input checked="" type="checkbox"/>	Yes	Yes	
Model Vessel 2	14-Mar-12	(Unknown)	5	<input type="checkbox"/>	Unknown	Unknown	
Model Vessel 3	12-Mar-12	PORT OUEST (REU)	2	<input type="checkbox"/>	Unknown	Unknown	
Model Vessel 4	12-Mar-12	(Unknown)	5	<input type="checkbox"/>	Unknown	Unknown	
Model Vessel 5	12-Mar-12	PORT LOUIS (MUS)	2	<input checked="" type="checkbox"/>	No	No	
Model Vessel 6	11-Mar-12	RAS TANNURAH (SAU)	5	<input checked="" type="checkbox"/>	No	Yes	
Model Vessel 7	10-Mar-12	TANJUNG PELEPAS (MYS)	5	<input type="checkbox"/>	Unknown	Unknown	
Model Vessel 8	10-Mar-12	PUNTA EUROPA TERMIN	3	<input type="checkbox"/>	Unknown	Unknown	

Add new vessel visit:    Add Export all

Record: 1 of 8 No Filter Search

Figure 3.16 Summary provided of recent visits in the risk assessment system, showing assessment, action and compliance status.

<b>Visit risk assessment:</b>		Environmental similarity	4	Amount of traffic	0
<input type="button" value="Update"/>	Overall	Invasive species	1	Voyage duration	0
	<b>5</b>	Vessel traffic	0	Discharge volume	0
Has this vessel visit assessment been reviewed and acted on?					<input type="radio"/> Yes <input checked="" type="radio"/> No
					<input type="button" value="Inspect"/>

**Figure 3.17** Vessel visit risk assessment is calculated automatically, and the breakdown of risk components is displayed.

### INSPECTION GUIDE

[What is risk?](#)  
[Compliance monitoring and enforcement](#)

**Inspection:** [How to](#)

Action necessary  Yes  No  Unknown

Notes

Legally compliant  Yes  No  Unknown

Notes

Vessel **Model Vessel 1**

Type CONTAINER SHIP

Visit risk assessment:

Overall **5**

Environmental similarity 4  
Invasive species 1  
Vessel traffic 0

---

### BALLAST TANKS

**Inspection:**

Information verification required [How to](#)  
 Yes  No  Unknown

Ballast water sampling required [How to](#)  
 Yes  No  Unknown

Inspection notes:

Code All

BW SOURCE DATE 18-Feb-12

ECOREGION Mascarene Islands

VOLUME 20000 m3

Tank risk assessment:

Overall **5**

Environmental similarity 4  
Invasive species 1  
Vessel traffic 0

Is this assessment complete?  Yes  No

**Figure 3.18** Entry page for the inspection guide component of the decision support tool, showing guideline support options.

### Decision support for shipboard sampling

Detailed guidelines for ship sampling were provided to the team members during the training session and are contained in the risk assessment system. These guidelines cover a range of methods for taking, preparing and analysing ballast tank samples. Two sampling methods were selected as the most practical and also the methods being employed by experts in South Africa and several other countries involved with ballast water management. The methods provide sampling approaches for different shipboard scenarios and tank arrangements. These should be adequate to cover sampling needs for most, if not all, vessels arriving in Port Louis.

The primary and most involved method relies on a submersible pump lowered into the ballast tank. Water is pumped out of the tank and into a large bin passing through a fine screen and then siphoned back into the ballast tank. This allows for organisms to be screened from a large quantity of water at the desired mesh size (depending on target organism). This method involves equipment that requires a minimum of two persons to carry and operate, and is somewhat restricted by the size (for tanks access) and immobility (in the tank) of the submersible pump. However, if conditions allow for its use, this method yields robust and scientifically valid results in terms of tank representation and sample size.

The second method employed is a grab sample taken using a Niskin Bottle sampler. This sampler is relatively small and very portable, and can be deployed by one person. The sampler is lowered to the desired depth and the trigger mechanism is released closing the seals. The water is captured at that depth and retrieved at the surface. The shortcoming of this method is that only small volumes (1-2 litres) can be sampled at a time. It is useful for limited access areas and for sampling water quality where tank representativeness is not as much of a concern.

Samples were analysed using two methods. The traditional approach using a standard stereomicroscope and counting chambers was compared with the modern and technologically advanced FlowCAM® system. The FlowCAM® uses a blue laser technology to assess particulates of 1 µm or larger in fluids. It provides a count of all organisms in the sample, and, following staining of the sample, it gives a live/dead analysis for both phytoplankton and zooplankton.

It is understood that the FlowCAM® is an expensive piece of equipment and highly specific in its applications, and it is therefore more likely that administrations will be using the traditional methods for sample analysis if needed. It is also understood that these analyses will be carried out by technicians with scientific backgrounds. For this reason, the team members from MOI and Shipping Division will likely be working together should any ballast tank sampling be required in the near future.

#### 3.3.4 Conclusions and recommendations

This project has allowed for a next generation of risk assessment methodology to be tested at Port Louis in Mauritius. The approach taken significantly reduced the complexity from that which was employed in Saldanha Bay, South Africa, and increased the relevance of the outputs in-line with the needs and capacity of the Administration (user). Ongoing application of the system within the context of the Port State Control responsibilities will increase compliance with international standards and allow Mauritius to develop more specific regulations to domesticate the provisions of the IMO BWM Convention. The following conclusions and recommendations were derived from the project implementation and outcomes:

- A. A significant factor in the decision by Mauritius to support active ballast water management, as well as other marine resource protections, was the transition the country has been undergoing, away from sugar exportation and towards a broader ocean economy, including marine-based tourism. The nature of shipping trade passing through Port Louis has therefore been evolving

rapidly. A risk assessment system that uses past voyages to produce a port risk profile, would not have had the same relevance for forward-looking regulatory approaches at the port. The ability of the system to capture the ship and voyage-specific details while providing the risk assessment, and to therefore populate the database over time with the details of arriving ships, will allow the system to be used in the future to answer broader questions about predominant shipping patterns, as needed.

B. Several assumptions were made in the design of the risk assessment system. Some of these were unalterable by the user as a function of the system design, such as the assumed homogeneity of ecoregions with respect to environmental and threat species conditions. However, other assumptions were explicitly made in order to be tested and altered to meet the preferred situation. The voyage-related risk components (duration, volume, frequency) each had a biologically justifiable rationale for the parameter settings used in the risk calculation. However, each of these could be revisited either experimentally, or as a reflection of differing circumstances. For example:

- High risk discharge volume was set at 100,000 m<sup>3</sup> to indicate heightened survivability in larger volumes (Dissolved oxygen content). Importantly, discharges of this volume and greater were not infrequent in Port Louis, although this represents the high end of discharges actually received. In many ports, discharges of this magnitude may never occur, in which case a different (lower) threshold of biological significance should be established.
- Inoculation (propagule) pressure was indicated through discharge frequency from the same source ecoregion. This was set at greater than 10 discharges in 90 days, having been originally established at greater than five discharges in 30 days.
- The duration of ballast water retention in a tank (which may be longer than voyage duration) will affect the survivability of the organisms contained in the water. The threshold of 30 days was used in the calculation, as an indication of the period after which most organism types would not survive. However, if dinoflagellate cysts, bacteria or other robust micro-organisms were of particular concern, then a longer duration would be appropriate. Similarly, a shorter duration could be justified if certain target organism types were defined.

C. The system relied completely on the input data from the ships' reporting forms. As these forms were required in Port Louis, and usually provided several days in advance of a ship's arrival at the port, it was seen as the best mechanism to generate the information needed in the assessment. It did, however, leave the system vulnerable to any errors or misinterpretations on the part of the ships or users. As these forms are already available electronically, it is foreseeable that future upgrades to the system could include more automated data capture, to streamline the collection of the forms by the port authority and the data entry.

- D. The management of ballast water varies considerably throughout the Western Indian Ocean region. Within the region, only Mauritius and South Africa have developed formal management programmes on this issue. The ecoregional approach employed in this system, implied vulnerability for any port to introductions of harmful species within the same ecoregion. While the scale of the ecoregions is relatively fine, there were still many ecoregions that contained several large ports and straddled national borders. Therefore, consistency of approaches between ports and neighbouring countries should be regarded as an essential line of protection for port states seeking to manage ballast water.

The risk assessment and decision support system has been presented at several workshops and meetings within the region. The output from a workshop held by the Indian Ocean Commission produced a series of recommendations for regional approaches to marine ballast water and IAS management, including through relevant protocols at the level of the Nairobi Convention. Though no framework for marine ballast water or IAS management currently exists for cooperation between countries of the Western Indian Ocean region, this remains an issue of ongoing development and activity. Efforts are underway through the Indian Ocean Commission to replicate the port survey efforts in other ports of the region, with a longer-term view to enhancing such regional management capacity.

- E. It is notable that the risk assessment system has been operational in Port Louis since it was developed and installed. The port administration and the MOI have developed various suggestions for operational improvements and upgrades, which will in many cases require a new project cycle. Ship ballast tank sampling is an area of ongoing research in the global community, and the International Maritime Organization is still working on the development of international guidelines, hence it is unlikely that ballast tank sampling will form an active part of the Port State Control inspection process until the international protocols are adopted.

### 3.4 Discussion

The experiences presented here, spanning over 10 years of risk assessment applications, starting with the Port of Saldanha and extending to Port Louis, demonstrated a progression in approach from experimental and developmental to applied and practical. The initial, complex, first-pass risk assessment conducted at the Port of Saldanha tested the core principles and allowed for a once-off demonstration of ballast water risk assessment as a visually mapped and databased process. Despite the progress in GIS technologies since the time of that project, it remains a complex model with significant maintenance implications (e.g. ongoing updates for shifts in shipping patterns).

The much-anticipated global ballast water management regulatory regime (IMO Convention) only came into force in 2017, and South Africa is yet to fully domesticate its provisions (i.e. develop national and port-specific regulations). This process is what is required to catalyze the decision of applying a risk-based

approach to ballast water management at the port level. Thus, effectively the risk assessment system has been sitting 'on ice' for over a decade, waiting for the policy-level impetus to force its further utility. It is likely the system will require significant updating and reconsideration, should the local authorities decide to apply this approach in the near future. It is, however, more likely that South Africa will opt to develop a system for decision support more along the lines of the one developed in Mauritius. The lessons learned through the development of the Port Louis system, will also most certainly influence the way forward for risk assessment at South African ports, as the Port Louis model provides an alternative with more targeted and amenable management considerations.

The system developed for Port Louis through this project is currently being employed by the Mauritius authorities, and is effectively a platform that has ongoing and broad utility based on vetted and publicly available information. The decision to use the ecoregion map as a surrogate for the environmental comparisons was necessitated by lack of data available for the area. It is understood that this compromise places significant weight on sea surface temperatures, which remains a weakness of the system and one that could be further improved. This constraint, as well as the lack of historical ship ballast water records, likely reflects the situation for many developing regions of the world, however the Saldanha experience did demonstrate that more robust environmental comparisons are possible if adequate effort is made.

It would be interesting to investigate whether the significant effort put into the environmental matching (using 34 parameters) component of the Saldanha Bay system produced results that would be inconsistent with the output from the Port Louis system, should it be applied at Saldanha Bay. Of course, the Port Louis system was designed as a ship-specific assessment, whereas the Saldanha Bay system looked at the pathways that had been established over time through the shipping routes. Nonetheless, a comparison could be achieved by configuring the more simple system to Saldanha Bay, and selecting ships from routes that were previously assessed in the original application for comparison of the results. In practice this was not possible, as there were significant implications for time and cost that fall outside of the scope of this project. In theory, it would be likely that the results would be aligned in terms of qualitative risk categories, given that both systems operate on an assessment of the same three core pillars (environmental matching, voyage characteristics, threat species presence).

Effectively the system designed for Port Louis was intended as a more appropriate alternative to the original complex system used for Saldanha Bay. The ballast water management demand for such a system lies within the context of the Port State Control inspections. The user input functionality, and the output from the Port Louis system were custom tailored to this need. The more robust assessment generated through the Saldanha Bay model would not add value to the decisions being made in this current regulatory framework. However, other applications for the Saldanha Bay model could be envisaged, including value for other management entities outside of the ballast water context. For example, a marine spatial planning (MSP) process for a large bay would benefit significantly from the incorporation of the information generated and consolidated into the existing GIS layers. In fact, the developing MSP process in South Africa may ultimately offer the most logical opportunity for uptake of the currently dormant system. Such an approach would also help facilitate cross-sectoral collaboration with respect to the use and necessary maintenance of the more complex system.

In the newer model, Port Louis is captured in the system as the point of reference for the analyses. This can be reconfigured to include any other port as the reference or focal point, and thereby to adapt the system for global application. Although this process would require the participation of the local authorities, as well as some degree of customization, it would ideally be employed by all the ports within the region, in order to allow for further integration and functionality. Furthermore, it would strengthen the overall assessment to expand the analyses to include other important vectors, such as biofouling (for both commercial vessels and recreational crafts). This could be achieved by integrating hull service/cleaning records into the required reporting, and expanding the voyage risk component to include this vector. For decision support, the IMO biofouling Guidelines could form the basis for management decisions and inspection protocols.

The experiences in each of these port environments have demonstrated that there is a role to be played for risk assessment in terms of assisting management processes. In both cases, clear and justifiable outputs were generated in a manner that was relevant to the operational concerns of the Port State Control authorities. Slow regulatory progress hindered the uptake of this for Saldanha Bay, whereas the authorities in Mauritius have been applying the system for Port Louis. However, the applications themselves need to be designed in a manner that takes into account the day-to-day constraints of the responsible authorities. It is therefore logical that the next iterations of risk assessment design should focus on centralization of information and processing, as well as user access and interface via remote nodes and devices. It is not a far leap to imagine that such a system would be housed and maintained by a responsible global authority (e.g. IMO), and that Port State Control officers could have access to ship-specific assessments in real time through a cell phone or tablet. Indeed, an expert workshop was convened at the IMO in 2017 to explore options for the evolution of port-based risk assessment for ballast water and biofouling. The outcomes included recognition of the practical limitations of the approach taken for Saldanha under the IMO GloBallast programme, similar to those discussed here. It also highlighted and explored the potential for the Port Louis system model to be expanded and strengthened, and for a more centralized model for risk assessment to emerge. A follow-up to this workshop is being discussed, whereby this issue should continue to evolve.

## Chapter IV - Assessing the risk posed by the extant populations of *Carcinus maenas* in South Africa

### 4.1 Introduction

Management authorities responsible for coastal environments are often faced with a range of threats to already stressed systems, and rely on limited capacity and resources. Therefore, management strategies need to support development of processes to prioritize interventions and investment. Despite the knowledge that there are ecological and economic impacts related to alien and invasive species (IAS), there is an apparent lack of rigorous analyses of their impacts in coastal systems (Grosholz et al. 2011). As marine species invasions continue to accelerate, closer alignment and integration of IAS research and on-the-ground management is becoming more urgent. Research and management institutions need to work closely to address questions around the potential spread of already established IAS and to propose clear management strategies. This includes potential socio-economic implications of such spread and the associated environmental impacts. Finally, the establishment of monitoring programs and management actions need to be accessible to coastal resource managers on the ground, to mitigate the threats associated with further spread of established marine IAS.

The application of risk assessment models to supplement IAS management has been growing and proving effective in supporting decision making processes, as well as advancing necessary response and control initiatives. In South Africa, species-specific risk assessment for marine IAS has been limited to qualitative analyses of risk posed for targeted species not yet introduced to South African waters. There is, however, a need to develop a model for analysing the risk associated with marine species once they have established in local waters. The risks to be assessed are therefore related to secondary spread and the resulting threats of impacts to resources, ecosystems and biodiversity. The case of *Carcinus maenas*, the European Shore Crab, presents the ideal opportunity to conduct such an assessment and thereby initiate the development of a national model for potential management and decision support use in similar cases.

Management interventions have already been supported to research and attempt eradication and/or control of *C. maenas* populations in Cape Town. While demonstrating the appropriate use of the precautionary principle, these efforts are aimed at reducing the probability of further spread of the crab on the presumption that it A) is likely to eventually broaden its range within the region, and B) this would then likely have significant impacts on aquaculture species/operations and natural resources along the coast. The study summarized in this report aimed to synthesize available information in a manner that allows for a qualitative categorization and assessment of these risks to support ongoing management efforts. This effort also provides a structural risk assessment, or bio-economic model, that can be further strengthened as and when relevant data and research are made available to produce more quantitative and rigorous output.

## 4.2 Objectives and approach

The first objective of this study is to explore socio-economic assessments or protocols, if available, on the impacts of marine IAS, focusing on invasion potential of particular species. The second objective is to use the European Green Crab *Carcinus maenas* as a case study, and provide qualitative and semi-quantitative data for the development of a model that explores the potential and implications of further spread from the established populations in South Africa. The final objective is to quantify, to some degree, the risks at socio-economic and environmental levels to ascertain a species-specific risk indicator with relevant value to current and developing management frameworks.

The outline below summarizes the overall process and management context of this exercise:

1. Review existing literature and case studies to answer the following general questions:
  - a. What socio-economic assessments or protocols already exist which assess the impacts and invasion potential of marine IAS?
  - b. What is the potential that *C. maenas* will disperse to other coastal locations in South Africa?
    - i. What is its ability to disperse and invade?
    - ii. What prevents or facilitates its spread?
  - c. What other locations within South Africa, or the region, could support populations of *C. maenas*?
    - i. What are the most important habitat features that would facilitate invasion by this species?
  - d. What specific transport vectors exist, or are potentially available, for the spread of the crab to these areas?
    - i. Can the vector strength be further quantified through available data?
  - e. What are the existing socio-economic impacts to industry and the environment from presently established *C. maenas* populations in South Africa, and what are the potential impacts, should it spread to other suitable locations?
2. Generate a bio-economic model for *C. maenas* in South Africa based on the information generated under point 1 above, and using known biological and ecological parameters and the socio-economic impact estimates.
3. Develop a monitoring strategy to deal with established marine IAS in South Africa, including targeted methods for *C. maenas*.
4. Feedback monitoring and other relevant data to update and strengthen the bio-economic model as possible.

Note - points 3 and 4 above fall outside of the scope of the study presented here, although it is recognized that these related components were addressed concurrently.

### 4.3 Overview of marine IAS impacts

In order to initiate an assessment of risk, the particular outcomes or scenarios that are of management concern must be clarified in advance. The impacts or risks of impacts from marine IAS can be broadly categorized as follows:

#### I. Ecological and evolutionary impacts

Genetic effects such as hybridization.

Direct and indirect competition with native species (e.g. predation, parasitism or niche monopolization), which may include:

- Change in population dynamics of native species, such as reduced or increased abundance, range and/or biomass of native species, or change in their size range, fecundity, etc.
- Change in community structure, such as increase or decrease in species diversity and in community composition.
- Changes at ecosystem level by altering process such as trophic structure, energy flow and nutrient cycling, or habitat changes (e.g. sediment accumulation, change in habitat type, light regime, etc; reduced oxygen tension or increased toxicity).

#### II. Economic and social impacts

Direct impacts:

- Loss of ecosystem function (including direct costs and values)
- Reduction in environmental quality
- Human health
- Possible positive impacts (e.g. new food resource)

Indirect impacts

- Governmental and non-governmental management programmes and costs
- Costs of associated research
- Support for eradication and control programmes
- Awareness and monitoring campaign costs
- Possible positive impacts (e.g. habitat protection)

#### 4.4 Socio-economic and environmental risk assessments

Almost all ecosystem types, whether terrestrial, freshwater, or marine, have to some extent been affected by biological invasions (Williamson 1998, Parker et al. 1999). The costs of control, or of preventing the invasion of alien species are high and often not well understood or documented. Despite the seriousness of non-native species invasions, that have been shown to cause extinction, as well as significant costs to the environment, economy, and public health (Pimentel 2002), studies are lacking that focus on estimating the economic costs and/or environmental impacts of aquatic invasive species (Perrings 2002, Lovell and Stone 2005, Grosholz et al. 2011). A review of the economic impacts of aquatic invasive species was conducted by the U.S. Environmental Protection Agency (Lovell and Stone 2005). The report gives examples of overall costs and benefit estimates of control of IAS in the United States. Some examples of species-specific estimates mentioned include:

- The comb jelly *Mnemiopsis leidyi* which has affected the recruitment of anchovy in the Black Sea, impacting commercial fisheries. Knowler (2005) uses a bio-economic model to demonstrate that, while significant, the economic losses were likely an order of magnitude lower than the hundreds of millions of dollars estimated annually by others. The subsequent introduction of another comb jelly, *Beroe ovata*, a predator of *Mnemiopsis*, has resulted in a major decline of *Mnemiopsis* there, and a substantial recovery of the ecosystem (Shiganova et al. 2004).
- There are various estimates of the costs for the control or economic impacts of the Zebra Mussel *Dreissena polymorpha* on power plants, water treatment plants, survey facilities, etc. adding up to an estimated US\$500 million per annum in the U.S. However, in spite of this species being the best studied and well-known aquatic invasive species, in most of these studies ecosystem impacts or services are not considered (Lovell and Stone 2005).

In another review Schaffelke and Hewitt (2007) analysed 69 publications on the environmental impacts of introduced seaweeds in the U.S.A., Australia, New Zealand and Europe. Of the total estimated number of macroalgae species introduced globally (over 260) the authors found relevant information for only 17 of those, of which only six provided estimates of the economic costs associated with control or eradication, highlighting the paucity of existing information for these algal species.

Generally, the main environmental impacts demonstrated were altered competitive relationships, which resulted in space monopolization due to the high abundance of the invasive species, and which in turn reduced native species abundance. Other effects identified included changes in community composition and biodiversity, direct effects on other marine (vertebrate and invertebrate) fauna, toxicity impacts on other species, and shifts in habitat (Schaffelke and Hewitt 2007). However, the low number of impact studies available implied that the mechanisms underlying these changes were poorly understood.

Species-specific bio-economic models have been developed to assess the risks associated with IAS, by incorporating both economic and ecological parameters. These have become increasingly popular by moving away from looking at impacts as either socio-economic or environmental, allowing the

development of better management tools (Finnoff et al. 2005, Cook et al. 2007). For example, Cook et al. (2007) quantified the potential impact of the bee mite *Varroa destructor*, should it invade Australia, and the negative effects it would subsequently have by reducing honey bee populations. Using a stochastic bio-economic model to assess the decrease in pollination services, reduced crop yields, and additional production costs to Australia, they estimated the potential economic impact at US\$16.4-38.8 million per year.

In another example, an integrated bio-economic model is used to assess the influence of invasive Lake Trout on native Cutthroat Trout in Yellowstone Lake under different scenarios of control (Finnoff et al. 2005). Their results show how integration of economic variables (such as recreational fishing pressure) and population responses lead to different native trout population numbers, compared to treating the problem from a purely economic point of view and applying management actions accordingly.

Dealing with the secondary spread of aquatic invasive species adds another dimension to the problem of dealing with alien species. The spread and establishment of aquatic alien species is often facilitated by changes in environmental condition and human behaviour, such as pollution, fishing practices, or changing patterns of land-use which alter existing flood-regimes and stream-flow (Perrings 2002). Forecasting the spread and further threat of established IAS therefore requires assessment of risks associated with three distinct aspects of biological invasions: colonization, site suitability, and adverse impact (Vander Zanden and Olden 2008). The effective translation of such an assessment into management tools is subsequently required for successful application to on-the-ground management.

## 4.5 The European Green Crab *Carcinus maenas*

### 4.5.1 Ecology and biology

The European Green Crab *Carcinus maenas* is one of the most successful and consequential invasive species in the coastal marine ecosystems of the world. It has established invasive populations on five continents, including North and South America (United States and Argentina), Africa (South Africa), Asia (Japan), and Australia. Its native range extends from Norway, Northern Europe to Mauritania in Northern Africa (Lovell et al. 2007, Compton et al. 2010). The species is well studied and a management plan produced by the Aquatic Nuisance Species Task Force provides detailed information on its biology, ecology, life history traits, population characteristics, and distribution (Grosholz and Ruiz 2002).

*Carcinus maenas* is a medium-sized crab ranging from 30 - 90mm carapace width. It has been described as a voracious predator with a wide range of preferred prey species (molluscs, polychaetes and crustaceans, preferring clams, bivalves and mussels). Echinoderms are, however, conspicuously absent from its diet (Grosholz and Ruiz 1996). The crab occupies a variety of substrates such as mud, sand, rock, and eelgrass, from intertidal habitats to depths of six meters or more (Breen and Metaxas 2008). Evidence from the United States and Australia suggests they tend to avoid exposed coasts and rocky habitats

(Grosholz and Ruiz 1996), which was further demonstrated in South Africa by Hampton and Griffiths (2007). There is also evidence that the crab avoids habitats occupied by potential predators, such as the Dungeness crab *Metacarcinus magister* in the U.S. (McDonald et al. 2006).

Adults can tolerate a wide range of temperatures (0 - 33°C), however, larvae have narrower temperature tolerance which seems to limit their ability to spread and establish. The larvae only develop successfully into adult stages in water ranging from 10 - 23°C, which has presumably prevented the establishment of populations in tropical regions (Yamada 2001, Carlton and Cohen 2003, deRivera et al. 2007). Cold winters and strong offshore wind-driven currents have been linked to high mortality of adults and poor recruitment (Yamada and Kosro 2009).

#### **Box 4.1: *Carcinus maenas* - Biology and ecology notes**

##### **Adults crabs:**

Salinity - Tolerant of low salinities, estuarine to marine environment, can survive from 1.4 -54 ppt. Usually found in waters from 10-33 ppt.

Temperature: adults can survive at extremes of: -1 - 30°C

Reproduction is reported from 3 - 26 °C

Longevity - at least 6 years

##### **Larvae and eggs:**

Exclusively marine with - Eggs develop normally at 10°C only in salinities greater than 26‰ (Crothers 1967).

##### **Juveniles:**

Recruit to mussel beds and other complex habitats such as macroalgae, eelgrass in Europe (Klein Breteler 1976).

##### **Life history:**

Sexual maturity is typically reached after 2 years in northern Europe. Introduced crabs, however, appear to mature earlier, grow more rapidly and reach a larger size along both coasts of North America and Australia when compared to crabs in the native range (Grosholz and Ruiz 2002).

##### **Habitat:**

The green crab is able to utilize a broad range of habitat types in its native environment and Eastern North America, such as sandy and muddy bottoms, salt marshes and seagrass beds and rocky substrate. They also occur in a wide range of exposure gradients, from protected embayments to exposed outer coasts. The utilization of rocky habitats appears to be relatively limited in crabs introduced to western North America,

Tasmania and South Africa, it is also absent from exposed shores (Grosholz and Ruiz 2002).

#### 4.5.2 Commercial impacts

##### **International**

The impacts of European Green Crabs have been the subject to several studies (Grosholz and Ruiz 1996, 2002, Lovell et al. 2007, Grosholz et al. 2011). In its native range it impacts several commercially important species, such as Blue mussel *Mytilus edulis*, the Quahog *Mercenaria mercenaria*, the Pacific Oyster *Ostrea edulis*, and the Palourde Clam *Tapes decussatus* (Grosholz and Ruiz 2002). There has been documented evidence of economic impacts on the fisheries or mariculture industries in Australia (Aquenal 2008). However, anecdotal reports of juvenile oyster losses by the Australian mariculture industry have been attributed to the crab. Subsequent changes in aquaculture practices – such as growing juveniles in closed, rather than the previously open, baskets - has prevented further losses (Aquenal 2008). The lack of direct economic impacts to the aquaculture industry in Australia may be attributed to the practice of farming oyster and mussels in cages and using lines, which are suspended above the bottom and not directly on the seabed (Aquenal 2008).

The best documented information available is from the United States, where the impact to the soft-shell clam fishery has been documented since the mid 1950's, as well as impacts to Blue Mussel, Manila Clams *Venerupis philippinarum*, Soft Shell Clam *Mya arenaria* and Bay Scallops *Argopecten irradians* (Grosholz et al. 2011, and references therein). The economic costs attributed to the Green Crab have been estimated at US\$44 million, however, it is unclear exactly what those costs include (Lovell and Stone 2005).

Grosholz et al. (2011) modelled the impacts of the crab on shellfisheries in the West coast of the U.S using a bio-economic model. Temperature was shown to be the only significant physiological variable limiting the spread of the crab. Other physical and hydrological variables, such as salinity, eutrophication or oxygen levels were not significant (Grosholz et al. 2011). Surprisingly, the economic losses attributed to the crab were found to be small in aquaculture systems due to existing predator reduction measures, such as bags, cages, and netting, and losses ranged from 770 kg/year to 1,450 kg/year. However, if the crab were to invade new areas these losses would increase due to the predation of wild and potentially harvestable populations of the same species. Grosholz et al. (2011) then estimated the losses could be as high as 147,100 kg/year.

## South Africa

There have been no qualitative assessments of the socio-economic impacts of the crab in South Africa (Le Roux et al. 1990). The sectors of the aquaculture industry potentially at risk in South Africa are abalone, oyster and mussel farms, of which mussel farming is the best established (DAFF 2012).

There is no literature to support claims of impact on abalone, other than as a general threat to intertidal biota, or general mention of potential concerns, e.g. the Australian government (Aquenal 2008) states “Potential impacts on abalone species” with concern due to reports stating “Although shellfish appear to be immune to Green Crab predation, when they reach a certain size (60mm for oysters and 45mm for mussels) it is the smaller-sized shellfish and seed stocks that will suffer” (Aquenal 2008).

Abalone farming facilities in South Africa are all onshore and therefore easily monitored for pests. The risk presented by the Green Crab, in this case, is likely negligible. The same may apply to the wild abalone populations that also settle on exposed rocky shores where Green Crabs are, with rare exception, absent. Furthermore, the juveniles (0.3 – 2 cm) of the South African abalone species (*Haliotis midae*) are significantly associated with the Cape Urchin populations (*Parechinus angulosus*), sheltering under them and concentrated in crevices rather than on exposed rock (flat or vertical). Only larger individuals (2.1 – 3.5cm) may be found alone, but usually in crevices (Day and Branch 2000). The Green Crab has been shown to not consume urchins (Le Roux et al. 1990, Klassen and Locke 2007), a fact which may provide further protection for abalone from the Green Crab.

### Box 4.2: Value of the aquaculture industry in South Africa

The most recently published information is by DAFF (2011) – the report does not mention concern over IAS being a threat to the industry, only that the industry is itself seen as a threat by being a potential vector for IAS.

#### **Main species cultured:**

Abalone (*Haliotis midae*), oysters (*Crassostrea gigas*), mussels (*Mytilus galloprovincialis* and *Choromytilus meridionalis*), finfish species and seaweed species.

#### **Location of farms:**

The Western Cape had the highest number of operating farms (20) located in Jacobsbaai (Ab. & Oy.), Saldanha (Mu., Oy. & Ab.), Hermanus (Ab.), Gansbaai (Ab.), Knysna (Oy.); Eastern Cape (6) located in Port Elizabeth (Oy.), Coega (Oy.), Hamburg (Finfish), East London (Finfish), Komga (Ab.); Northern Cape (3) located in Alexander Bay (Ab.), Port Nolloth (Ab.ranching), Kleinzee (Oy.), and KwaZulu-Natal (1) located in Mtunzini (Finfish).

**Production (excluding seaweeds):**

1 883 tons. The Western Cape was the dominant province with a total production of 1 624 tons. The abalone sub-sector contributes 55% of total production output, followed by mussels 35.1%, oysters 14.3% and finfish at 0.4% (7.99 tons).

**Total value of the marine aquaculture sector:**

Estimated at R378 million (increased by 11% from 2009). The abalone sub-sector represents 94% of the entire sector (sales of R355 million), followed by the Oyster sub-sector representing 3.8% (sales of R14 million), and the Mussel sub-sector representing 2.5% (sales of R9 million). Marine aquaculture contributed 0.02% towards South Africa's Gross Domestic Product (GDP) in 2011.

It is also worth noting the methodologies predominantly being used in the relevant aquaculture facilities, as they relate to availability of individuals to predation by the European Shore Crab.

***Abalone farming method:***

The largest farms in Hermanus (Abgold and HIK) are entirely land-based, with abalone being held in tanks and grown under strictly controlled conditions. The abalone farms generally consist of a hatchery and separate grow-out facility. In the hatchery, the broodstock are held and conditioned for spawning, which is followed by larval rearing and settlement, and also weaning to prepare the juveniles for the grow-out phase. During the grow-out phase, the juvenile abalone are kept in baskets arranged in land-based tanks, or raceways, until they reach market size. Abalone ranching at Port Nolloth allows the grow-out phase to be reached by placing juveniles at sea in suspended baskets.

***Mussel farming method:***

Stocking-mesh bags, with juveniles seeded from the wild, are hung off floating wooden/plastic rafts, or from longlines. In summer, when the mussels spawn, the larvae settle by attaching themselves to the ropes on the rafts. They are naturally fed by nutrient-rich currents that supply constant flow of plankton. It is interesting to note that a mating pair of Green Crab found in Saldanha in 1990 was amongst the cultured mussels (Le Roux et al. 1990).

***Oyster farming method:***

The oyster spat are imported from Guernsey, Chile and Namibia. A system of long-line, raft and rack culture is used in South Africa. The long-line system employs supporting ropes that are floated by buoys or plastic barrels. Lines are suspended from the supporting ropes, and plastic mesh cages, in which oysters are grown, are attached to these. The raft system is similar to the long-line system, except that it uses a

wooden raft, to which ropes with suspended mesh bags are attached. The systems employed on the West coast of South Africa tend to be in deeper waters than many of the shallow-water operations on the South or East coasts, where the oysters may be exposed at low tide and covered during high tide.



**Figure 4.1** Mbasa Sea Farm (oysters), Hamburg, South Africa

Aquaculture has been identified in the National Aquaculture Strategic Framework (NASF) as a sector being promoted for further expansion and diversification of its operations. Key components of the strategy include 1) development of aquaculture technology, especially for new species (e.g. scallops, urchins, seaweeds), and 2) continued enhancement and growth of existing aquaculture activities, including cage culture in freshwater lakes and reservoirs, land-based systems, bottom and cage culture in the intertidal and sub-tidal zones (DTI & DAFF 2011).

#### 4.5.3 Environmental impacts

##### **International**

In the United States, the European Green Crab has been implicated in the decline of a number of native aquatic species (e.g. clams, shore crabs) resulting from competition or direct predation (Lovell et al. 2007). Predation impacts are also associated with measurable changes in the morphology of intertidal snails on the east coast of North America (Trussell 2000, Trussell and Smith 2000). Indirect impacts on benthic communities have also been noted, such as the increase of polychaetes and tube-building crustaceans, due to declines of their natural predators as a result of *C. maenas* predation. No effects at higher trophic levels have been documented (Grosholz et al. 2000, Aquenal 2008).

## South Africa

Diet studies show the crab feeding on a wide range of prey, in particular isopods, limpets and polychaetes. It rejects urchin species, as shown in other diet studies (Klassen and Locke 2007, Le Roux et al. 1990). There are, however, no qualitative assessments of the environmental impacts of the crab on native populations, something that is generally lacking for all introduced marine IAS (Mead et al. 2011) in South Africa. Peters (2013) suggested that the low biomass of the invasive mussel *M. galloprovincialis* found in Table Bay and Hout Bay could be related to predation by *C. maenas*, thereby potentially controlling the density of the mussel population in these two harbours. Robinson (2005) reported high numbers of *C. maenas* in both Table Bay and Hout Bay harbours. Currently the established populations of the invasive crab seem contained to these two sites, with small populations having been recorded in nearby Seapoint (Mabin et al. 2017). The prevailing implication has been that should the invasion extend along the coast, the impacts to local biota could potentially be disastrous (le Roux et al. 1990).

### 4.5.4 Establishment and potential spread

#### International

Established populations have been present in the U.S. since the early 1800's and in Australia since the 1890's. During the 1980's and 1990's populations established in Argentina, Japan, Tasmania and South Africa, as well as western North America (Compton et al. 2010). In the nineteenth century, introductions were facilitated by ships as fouling on the hulls or as part of solid ballast (e.g. coral rock, sand). During the twentieth century, however, a variety of dispersal mechanisms may have contributed, including ballast water, transport with fisheries products, and new types of biofouling (Carlton and Cohen 2003).

Predicting the further spread of the species has been the focus of several publications (Carlton and Cohen 2003, deRivera et al. 2007, Darling 2011, Peters 2013). For instance, since its initial invasion during the 1980's in the Western U.S. the crab expanded rapidly, and now has the potential to inhabit coastal areas from the Gulf of Alaska to Baja California. The uniformity of the spread, and similarity to what has occurred in Australia, strongly suggests planktonic dispersal of the larval stages of the crab, aided by currents and other favourable physical conditions (Grosholz and Ruiz 2002).

Compton et al. (2010), using a combination of environmental and physiological parameters for the species from its native and invasive ranges, predicted the potential spread of *C. maenas* to extend along many currently-invaded coastlines, with potential for further invasion into countries like Chile, China, Russia, Namibia and New Zealand. Limits to its spread, however, are examples of biotic resistance, in this case of native and introduced predator crabs limiting the use and extent of habitats occupied by the European Green Crab (deRivera et al. 2005, McDonald et al. 2006, Jensen et al. 2007). On the East coast of North America the native Blue Crab *Callinectes sapidus* was shown to have restricted abundance and geographic range of *C. maenas*. Similarly other large native crabs, such as *Cancer productus*, Dungeness crab, and *Cancer antennarius*, all have the potential to limit the effects of the European Green Crab (deRivera et al.

2005, Jensen et al. 2007). Along the North American Atlantic coast, the recently introduced Japanese Shore Crab *Hemigrapsus sanguineus* appears to be displacing Green Crabs in many areas (Jensen et al. 2007).

## South Africa

In South Africa the most likely vectors of introduction appear to have been ballast water and/or as fouling on equipment (Robinson et al. 2005, Darling 2011). The crab was first detected in Table Bay in 1983. Since then, it was recorded at seven intertidal sites along the West Coast, six of which were between Table Bay and Hout Bay, the two known established populations. Vagrant individuals have twice been recorded in Saldanha Bay (Robinson et al. 2005, Hampton and Griffiths 2007), demonstrating potential for dispersal up the west coast. Subsequent reassessment of the intertidal sites between Table Bay harbour and Hout Bay by Mabin et al. (2017), showed the crab to be absent in all except for Seapoint, indicating the crab may experience difficulties in establishing a population in the more exposed areas.

The secondary spread of the species from Table Bay to other sites, including Hout Bay, was most probably facilitated by the movement of smaller vessels, such as yachts or small fishing and rock lobster vessels, which often move between these harbours (Robinson et al. 2005, Peters 2013). The populations established in South Africa have also been found to exhibit high genetic diversity, comparable to native populations (Darling 2011), a trait associated with ballast water transport, and which may directly contribute to invasiveness (Facon et al. 2008, Kolbe et al. 2007). Furthermore, the South African and Australian populations appear to be relatively free of parasites, which has been implicated as a factor in their invasion success (Zetlmeisl 2011).

However, contrary to expectations, this high genetic diversity has not meant increased invasiveness. The question as to why this is the case in South Africa is still being explored. It seems that oceanographic factors, such as wave action along exposed rocky shores and strong upwelling currents (driving larvae offshore), could explain the absence of planktonic larval dispersal similar to that which occurs along the west coast of the U.S (Grosholz and Ruiz 1995, Grosholz et al. 2000).

Hampton and Griffiths (2007) compared the ability of the native Cape Rock Crab *Plagusia chabrus* (now *Guinusia chabrus*) with that of the invasive crab to actively grip to a rock face, against vertical force and water flow. They also looked at the morphology of the legs and adaptations for gripping. They conclude that *C. meanas* is poorly adapted to grip and hold onto rocky substrata and hence unlikely to disperse along the open wave-exposed coastline of South Africa.

Dispersal seems to be limited at the larval stage by offshore wave action and temperature and at the adult stage by an inability to grip onto rocks on exposed shorelines. There are no available studies that look at potential native predators of the invasive crab in South Africa, which could potentially further limit its spread. Currently the risk of the crab spreading to other locations is limited to sheltered locations,

particularly Saldanha Bay and False Bay, although, the reasons behind it not having become established in Saldanha are still unexplored.

#### 4.5.5 Assessing the risk of further spread

There are several mechanisms that pose a risk for transferring IAS intra-regionally, namely aquaculture, recreational fishing, yachts, regional shipping and commercial fishing (Sink et al. 2012). For instance, Peters (2013) looked at the potential for the transfer of *C. maenas* in the oyster operation in Knysna, where the juveniles are purchased in Jeffreys Bay, and grown in Knysna for four months. After this they are trans-located to an oyster farm in Algoa Bay, where they grow to market size, before being returned to Knysna. The risk of transfer of crab larvae either with the produce or as fouling on transporting vessels in this case is high, because although manually cleaned, the consignments are not inspected for associated species (Haupt et al. 2010, 2012).

Harbours are by nature shallow, sheltered habitats with a high flux of boat traffic and associated activities, such as aquaculture facilities. All of these factors could aid in the spread and establishment of *C. maenas*. Peters (2013) looked at the number of IAS, including *C. maenas*, sampled from six South African harbours against various harbour related activities, such as shipping, mariculture, hull cleaning and repair etc. and found that Hout Bay harbour had the highest number of IAS and diversity per m<sup>2</sup>, followed by Table Bay. The result was surprising, given the relatively small size of the harbour in Hout Bay, and Peters (2013) discusses two possible reasons for this. The first was the enclosed nature of Hout Bay's water flow, which in other regions has been shown to limit dispersal and promote higher recruitment of organisms. Secondly, the movement of regional shipping traffic, such as yachts and fishing vessels, and vessels associated with oil and gas activities between the two harbours (Peters 2013). Furthermore, the proximity of both harbours would mean a similarity in environmental conditions, further aiding the spread and establishment of new arrivals to either harbour.

#### Box 4.3: The shipping vector and *C. maenas* survivability

The following experimental evidence sheds some light on the possible shipping vectors available for translocation of European Shore Crabs.

- Larvae were sampled from ballast water and correctly identified as *C. maenas* and *C. aestuarii* (see below) using PCR gels (Darling and Tepolt 2008).
- First-stage Zoea *C. maenas* larvae survival was tested under low oxygen and normal air saturated, experimental and control conditions, respectively. Simulating ballast water tanks being treated with oxygen purging nitrogen or control conditions. After two days of exposure to oxygen levels continuously below 0.8 mg/l, 97% of *C. maenas* larvae had died. In

contrast 85% of larvae left in containers open to air at oxygen levels >6.8 mg/l survived (Tamburri et al. 2002).

- Survival of *C. maenas* was assessed simulating adults being transported in ropes or seaweed on boats. Various stocking densities were tested, with or without water and at ambient temperatures of 24°C and 29°C. Results showed 50% of crabs fully exposed to air survived 60h, and if in seawater with seaweed or rope available, 60% of crabs survived to seven days. (Darbyson et al. 2009).
- In a study that looked at the taxonomic composition from Japanese ballast water release, the crab is not mentioned (despite 367 other taxa being documented)(Carlton and Jonathan 1993).
- *C. maenas* was not included in the taxonomic list of zooplankton recorded in Canadian Ballast water, although other decapods, including the invasive *Hemigrapsus* sp. are listed (Dibacco et al. 2012).

**Note:** There is no firm documented evidence of the crab having been introduced to the U.S or to other locations through ballast water. However, it is cited in all literature on the subject as the first vector of introduction - e.g. (Grosholz and Ruiz 2002). Secondary spread is divided between passive sea current transport or human facilitated, e.g “accidental release with discarded algae used in shellfish packaging” or “fouling” (Carlton et al. 1995).

#### 4.5.6 A bio-economic model for *C. maenas*

Traditional approaches to risk assessment for marine IAS have generally sought to assess potential for initial species incursion, and therefore incorporated various parameters falling within the categories of environmental similarity, vector strength and source population (Awad et al. 2004). However, as previously described, the analysis of the potential spread and risk of impact for established IAS may be separated into the following categories, each representing distinct aspects of biological invasions:

- Colonization - dispersal potential, vector strength
- Site suitability - habitat similarity, predation pressure
- Adverse impact - resource valuation, threat correlation

The assessment of risks relative to each category, as discussed in the sections above, may be translated into qualitative variables in a bio-economic model. The design of such a model must reflect the needs and intention of the management purpose that it is serving. In other words, a fundamental question, or set of questions, the answer(s) to which hold particular management value, should be driving design and

structure of the model. The ability to synthesize either qualitative or quantitative measurements of the parameters within each category will further define the effectiveness of the model to be developed.

An example of an initial rudimentary, but indicative qualitative bio-economic model structure was developed and is described in Table 4.1 below. The assigned values detailed therein are interpreted from the information presented in the relevant sections above, distilled from the available literature. Increased incorporation of, and confidence in, expanded and relevant data to support the model will allow for the components and sub-components to be further dissected, and therefore strengthened. Weightings may also be applied to categories, components or sub-components, further increasing the complexity of the model. The resulting risk indicator will only provide value relative to the initial question at the core of the model's design. Should a qualitative scale from 1 - 5 not be adequate to support management decisions, then the model must be designed in a manner to produce finer scale quantitative analysis.

**Table 4.1** A qualitative bio-economic model for overall risk of *C. maenas* spread and impact.

Category	Component	Component value*	Category average*
<b>Colonization ability</b>	Dispersal potential	3	3
	– Long range	2	
	– Short range	4	
	Vector strength	3	
	– Shipping	2	
	– other	4	
<b>Site suitability</b>	Habitat similarity	4	4
	Lack of predation/ competition	4	
<b>Adverse impact</b>	Resource valuation	3	2
	Threat correlation	1	
<b>Overall average threat risk</b>			<b>3</b>

\* 1 = v. low 2 = low 3 = med 4 = high 5 = v. high

The model indicates medium (3 out of 5) overall risk related to *C. maenas*, based on assessments of high potential site suitability, medium colonization ability, and low potential for adverse impact. The assessment integrates considerations for potential colonization sites across the country. It may also be useful to generate site specific assessments, which may help focus management efforts on vectors traveling between extant populations and those sites. Tables 4.2 and 4.3 demonstrate the application of the bio-economic model to Saldanha Bay and the Knysna Lagoon, respectively.

**Table 4.2** Application of the bio-economic model for *C. maenas* to Saldanha Bay.

Category	Component	Component value*	Category average*
<b>Colonization ability</b>	Dispersal potential	3	3.25
	– Long range	2	
	– Short range	4	
	Vector strength	3.5	
	– Shipping	3	
	– other	4	
<b>Site suitability</b>	Habitat similarity	4	4
	Lack of predation/ competition	4	
<b>Adverse impact</b>	Resource valuation	4	3.5
	Threat correlation	3	
<b>Overall average threat risk</b>			<b>3.58</b>

\* 1 = v. low 2 = low 3 = med 4 = high 5 = v. high

**Table 4.3** Application of the bio-economic model for *C. maenas* to the Knysna Lagoon.

Category	Component	Component value*	Category average*
<b>Colonization ability</b>	Dispersal potential	2	2
	– Long range	1	
	– Short range	3	

	Vector strength – Shipping – other	2 1 3	
<b>Site suitability</b>	Habitat similarity  Lack of predation/ competition	4  4	4
<b>Adverse impact</b>	Resource valuation  Threat correlation	3  1	2
<b>Overall average threat risk</b>			<b>2.67</b>

\* 1 = v. low 2 = low 3 = med 4 = high 5 = v. high

A significant difference is noted between Saldanha Bay and Knysna Lagoon, in terms of the assessed threat posed by *C. maenas*. The general biogeographic situation of each site accounts for some of the difference, as well as what is known qualitatively about the boating (including yachting and fishing vessels) and shipping traffic from Cape Town. The presence of the mussel farming industry in Saldanha Bay is another distinct factor, considering that, of the mariculture practices assessed, the mussel ropes remain the most vulnerable to potential predation. The previous record of *C. maenas* in Saldanha Bay, within the mussel farm infrastructure, lends further support to this conclusion. Considering that the mussel farming industry is also the best established, there is, based upon these findings, some economic reason for concern regarding *C. maenas* spread up the west coast. This may, however, be easily mitigated through minor adjustments in operational practices.

#### 4.6 Conclusions

This study represents the first pass at bringing together the ecological, transport and socio-economic components of the very complex issue related to the extant populations of *Carcinus maenas* in South Africa, with a view to generating a realistic indication of the risk of further spread and meaningful impact by the crab. The analysis has demonstrated that the risk may be broken into components, which may not be equal with respect to management implications. A mechanism for integrating the available information into a bio-economic model is proposed as an initial structure to be further developed, as possible, to support targeted management needs. Based on the initial findings presented here, the overall risk associated with *C. maenas* is perhaps not as severe as previously considered. While the risk of further

spread is very real, and should be considered from biodiversity and ecological perspectives, the risk of significant impact to commercially valuable marine resources is low. These initial conclusions should be taken in consideration of the context and explanations offered in the relevant sections of this report. More specific targeted conclusions are offered below, further summarizing the outcomes of this exercise.

1. The research suggests that the European Shore Crab *Carcinus maenas* is unlikely to have a significant impact on the major commercial aquaculture operations (mussels, oysters and abalone) in South Africa, due in large part to the farming methods and practices which render the farmed animals less available to predation. There may be some need to monitor and possibly adapt the mussel farming practices in Saldanha Bay, although further experimental investigation would be useful to strengthen this conclusion.
2. There may be significant ecological impact by the crab resulting from direct predation on wild populations of prey species (including mussels). Also, the crab may provide a new food resource to a local predatory species. Further research is needed to substantiate possible ecological impact scenarios.
3. The available information on vessel traffic along the coast and between key South African harbours is insufficient to support a robust analysis of vector strength. Further investigation is required to consolidate information from shipping, yachting and fishing communities, as well as incorporating other common vessel operations (e.g. rig movements).
4. Long-range spread from source populations in Cape Town is possible, but not highly likely based on the points below. This conclusion is supported by the fact that the crab has failed to spread from its founder populations over the course of the 32-year invasion period.
  - Recognising nonetheless that two distinct populations of *C. maenas* have established in South Africa, possibly from separate introductions, demonstrating long-range translocation success of this species.
  - Larval survivability in ballast tanks is not adequate to sustain long journeys.
  - Dominant strong offshore SE winds ensure that larval dispersal remains ineffective within the region.
  - Adult crab migration is restricted by exposed high energy rocky coastlines.
5. Spread of the species is more likely to occur into estuaries in close proximity of the source population.
  - Into estuaries with abundant prey species, but without predator species with whom they would compete for shelter and food.

- At present no predator or potential competitors have been identified and research into this area should be considered.
  - Estuaries that fall within suitable ranges of temperature (10 - 23°C) for larvae to develop into adults.
    - In South Africa these conditions exist along the entire West Coast, with potential for the species to spread into Namibia. Along the South and East coast the potential for spread is as far east as Port Elizabeth.
  - Enclosed harbours tend to accumulate a higher propagule pressure concentrating IAS with the potential to spread elsewhere.
    - This requires further investigation in the Western Cape and the rest of South Africa as an important indicator for the management of marine IAS.
6. The bio-economic model may be useful in providing a comprehensive and synthesized indicator of risk associated with the overall invasion, as well as the component parts. This process, however, relied on relevant and reliable data and information, and remains subject to the manipulation and interpretation of the user as regards management implications.
7. The bio-economic model structure developed in this study provided a starting point for risk-based management approaches to be developed. The model was intended to function as a platform upon which further structure and research could be built to increase the detail of the output and its power in terms of decision support.

#### 4.7 Recommendations

The following recommendations stem from the discussions and conclusions detailed above. Although these are by no means exhaustive, they are intended to provide some initial guidance for actions and considerations aimed at navigating the issues surrounding the *C. maenas* invasion.

- A targeted monitoring programme for *C. maenas* is needed along the coastal areas identified as being within its potential range. The developing national monitoring strategy and programme under the Department of Environmental Affairs should integrate this as a model for species-specific targeted monitoring. Coastal community based stakeholders, such as mariculture operators, NGO's and port and marina management authorities may contribute substantially to the monitoring programme if adequate sensitisation and training are conducted.
- Feedback and reporting mechanisms need to be developed to provide relevant input to researchers and managers.
  - It is important to include dissemination of the outcomes from any management interventions, such as the *C. maenas* control effort in Hout Bay.

- The model could be further strengthened and validated, in terms of relevant and available input data, and the possible application of weightings, for example through an expert workshop. Such an open stakeholder process may be useful in achieving consensus on the values derived for each parameter in the model, as well as implications for management outcomes.
- Further research is needed to support the various components and sub-components of this species-specific risk assessment. These areas have been highlighted throughout the text and should be supported in ongoing programmes including focus on ensuring connectivity and communication between academic and management interests.
- Guidance should be provided for new and developing aquaculture facilities to implement relevant methods of reducing possible impacts from predation.
- Given the current lack of spread outside of sheltered bays in South Africa, priority should be given to controlling and monitoring vessels (commercial, yachts and other recreational boats) that move between enclosed bays and harbours, such as Hout Bay, Knysna, Saldanha Bay, etc.
- Given that local spread of the crab is likely as a result of equipment and species movements for aquaculture purposes, increased controls should be implemented to avoid transfer of hitchhiking crabs during aquaculture operations.

## Conclusions

In order to draw general conclusions regarding this study, it may be useful to revisit the questions that lay at the core of each of the chapters.

### **1. *Are large-scale, once-off baseline surveys able to generate adequate and useful data to support management needs, in an African context?***

There certainly were difficulties that hindered the implementation and outputs from the surveys, as previously discussed. While these differed somewhat at each location, it was clear that the taxonomic process has been the weakest link in these projects. Better alignment between the timeframes and priorities of funders, and those of the academic experts involved in taxonomy, is required to better match project intentions with meaningful outcomes. Technical capacity limitations, such as those discussed here, are not unique to Africa, and as demonstrated in Chapter 2, the sharing of lessons between regions (e.g. Asia, South America) can continue to provide opportunities for overcoming these challenges. Also, by adjusting the methodology as necessary, and customizing the survey design around available expertise (for example by focusing sampling around those taxa for which taxonomic expertise is indeed available), more efficient use of resources might be realized.

The three surveys reported here were largely consistent, in terms of design and execution, despite being conducted by different field teams (with the exception of all having the same project leader). Some updates in terms of design, equipment, and approach were made as the methodologies matured through the course of the project. In all three cases, useful data on baseline conditions and introduced species were generated to better arm the relevant local authorities and scientific institutions. It should also be noted that all three surveys captured valuable environmental (e.g. temperature, salinity, dissolved oxygen etc.) and habitat specific (e.g. sediment grain size, turbidity) parameters which are useful outside of the context of IAS management specifically.

Furthermore, the Port of Saldanha survey recorded a considerably high proportion of the extant flora and fauna in the area, demonstrating the overall effectiveness of the methodology. The experiences in Kenya and Mauritius did not reveal the same results in terms of high species numbers, due largely to the unfortunate shortcomings of the taxonomic process. This is also likely due to differences in species richness between the tropical and temperate ecosystems, as well as the significant impacts within less regulated port areas from pollutants and disturbance. However, these two survey projects did develop a specimen catalogue that continues to be available as a taxonomic resource within each country. In the case of Mauritius, it is already understood that there are plans to continue the taxonomic examination of these specimens, in order to complete the species databases, thereby demonstrating that some of the value may be deferred until long after completion of the initial project.

It may be interesting to consider the cost effectiveness of the broad-scale surveys, with respect to effort, time and resources. While the overall cost and commitment may be hard to justify from a purely scientific

perspective, when considered in the management context, the benefits proved to be significant. Nonetheless, it is also worth asking if many African administrations will be in a position to fund such surveys and associated ongoing monitoring, or if indeed they would be in a position to even recognize and prioritize the long-term benefits of marine biodiversity protection. Mauritius has committed significant investment towards natural and human resources, and as a “large ocean state”<sup>4</sup> recognizing the perceived long-term benefits. There has, however, been little indication of similar progress within coastal African states.

It can be concluded that port biological baseline surveys are perhaps not the best way to develop IAS data alone, given that more targeted and efficient methods may be considered, especially for specific groups. New genetic rapid assessment tools and methods are also emerging that will likely reshape the methodologies for IAS monitoring in years to come. However, the approach of targeting IAS as part of a comprehensive once-off baseline survey does have merits in terms of the full body of scientific baseline data generated. The IAS-specific design components did not detract from the ability of the survey to sample representatively across all habitats. Furthermore, this study sought to justify the survey undertakings in a broad management context that integrates stakeholders and generates capacity for ongoing regulatory intervention. In this context, it is clear that such large-scale projects are highly useful as catalytic activities. Hence through the effective generation of baseline information and relevant support for management, it is recommended that national governments, regional bodies and international organizations seek to support port survey projects in other major ports in Africa.

## ***2. Can lessons learned from port survey experiences in Africa be synthesized into a guidance document that helps facilitate further implementation and capacity for such surveys?***

The detailed technical protocols (CRIMP) that have been available to guide the implementation of port baseline surveys, were not intended to function as general implementation guidelines, but rather to assist in standardization of methodologies. The application of the protocols to a port environment requires scientific, technical, administrative and logistical considerations. Many deviations from initial plans may be necessary, and options for contingency planning are not always obvious. The need that was recognized by the IOI-SA and the GloBallast Programme in developing these guidelines, was to overcome the daunting impression, within administrations that were considering the merits of implementing port biological baseline surveys, that the surveys involved technical capacity beyond that which was available locally. There was a need to present a range of options and scenarios that could assist them to reach realistic and valuable conclusions, based on differing local circumstances and support levels.

The guideline document was therefore specifically designed to draw from experiences in developing regions, in a manner to supplement the CRIMP protocol and to render it more achievable in a broad range of locations. Although the original intention was to base the document on the experiences in African ports,

---

<sup>4</sup> A term coined at the 2017 UN SDG 14 Oceans Conference to replace “small island developing state” in recognition of the significance of the high proportion of EEZ to land mass, and inferred socio-economic dependence on marine resources, in order to allocate more political influence in ocean-related matters.

it was valuable to have included some contributions from NIO in India, given that they have surveyed most of their national ports using the same methodology, and facing some serious challenges. For instance, extreme pollution concerns prevented any diving in the port of Mumbai, and other ports in India, that have nonetheless been well surveyed. Experiences of the author in extending training on port biological baseline surveys, into other developing regions (e.g. Black Sea) were also integrated into the guideline document.

The document was also structured in a manner that was less scientific, and aimed at managers and lead scientists that would be responsible for instigating, preparing and coordinating port biological baseline surveys. It was important for the document to be published through and circulated by the IMO, as technical guidance for regulatory compliance within the port and shipping sector is generally top-down, with high domestic uptake of IMO-endorsed methodologies and procedures. Considerable progress had been reported by Member States to the IMO in terms of application of the various tools and guidelines produced under the GloBallast Monograph Series, therefore inclusion of port survey guidance in the series was deemed to be the most appropriate mechanism to reach the appropriate countries and authorities.

The document titled *Guidance on Port Biological Baseline Surveys* was published as GloBallast Monograph No. 22 in 2014, and subsequently translated into Spanish and Arabic at the request of Member States and their responsible authorities. Hard copies were disseminated to port and environment authorities around the world, and because it was published and disseminated by the IMO, it brought with it the endorsement that was necessary to convince many national administrations that port surveys should form a foundational component of their IAS and biosecurity management regimes. There have been indications from the IMO GloBallast Programme that the guidelines have been applied in several ports around the world already (GEF-UNDP-IMO, 2017), suggesting that national governments are increasingly recognizing the potential benefits in providing support to conduct port biological baseline surveys. Ultimately, the primary mechanism for evaluation of the guideline document will be through an assessment of successfully completed surveys in ports where the guidelines have been applied. An interesting way to achieve this, in due course, may be through the development of an updated edition of the document that includes experiences from ports that have applied it.

### ***3. How can risk assessment methodologies be developed and applied to support Port State Control practices in managing the risk posed by alien species introductions?***

It was clear from the Port of Saldanha risk assessment experience that, even though the system was intricately designed and provided a complex analysis based on robust data sets, the output that it provided did not match the needs of the management authority at the time. One could point to the fact that the BWM Convention had not yet been adopted at the time of the project, and South Africa had no national regulation governing ballast water to necessitate the need for the management tool. Since then, however, South Africa has ratified the BWM Convention, and several national workshops have been conducted on the implications for national and port-level practices. To date, there remains a dearth of commitment and activity to support further implementation of the risk assessment tool, or any of the recommended port-level management

practices. It has been suggested that the Department of Transport plans to undergo a review of procedures necessary for domestication of the BWM Convention provisions, and it is hoped that this will lead to increased on-the-ground engagement.

It was likely premature to have developed the risk assessment system with the intention of facilitation for a compliance monitoring and enforcement framework, before the national regulations were in place. However, there was good engagement at the time with the port authority (TNPA), as well as with the Department of Environment, which was taking the lead in terms of IAS issues, including ballast water management. As discussed in Chapter 3, the system may have been over-designed, in terms of allowing for ownership, ongoing use and maintenance by the agencies involved. However, it is also notable that the ballast water portfolio was subsequently passed to the Department of Transport, and the scientific director involved at the TNPA moved to a different job. Though understandable, these coinciding shifts were consequential in diminishing the momentum that had been gained around this project.

The relative success of the risk assessment experience in Port Louis stemmed largely from working directly with the local authorities, who were well briefed on the risk assessment experiences from Saldanha Bay. Also, the fact that large amounts of data, over historic periods, were not available, serendipitously forced the project to develop a surrogate mechanism. This greatly simplified the demands on the user, thereby ensuring better comprehension and engagement by personnel. The cooperation between the Shipping division, Mauritius Ports Authority, and the Mauritius Oceanography Institute that was forged over years leading up to and including the port survey project, was ultimately the ingredient in the risk assessment project that ensured its success.

As part of the ongoing relationship between IOI-SA and the Mauritian agencies, the lessons learned in applying the risk assessment and decision support tool to support port inspections, are going to be integrated into a system update in the near future. Furthermore, the system was presented at an “expert workshop” hosted by the IMO in London, along with other international risk assessment approaches, in order to focus communal effort on realizing a system that could be centralized and applied to ports all over the world. Some aspects of the system developed for Port Louis were recognized as having broad applicability, such that they might feature in a global system to be further discussed in a follow-up workshop.

The simplified conclusion that can be extracted from these risk assessment projects, is that a system that helps someone do their job, and also explains the basics of what to do under a range of scenarios, is a system that will be used and effective. The technical output of the system must be digestible by the user, and must be based on scientifically sound assumptions and data. The technical rigor of the risk assessment system may be strengthened over time. Simplicity and functionality should guide the pilot model, such that it may first be vetted and proven in a real-world context.

**4. Does the risk of further spread and impact posed by the European Shore Crab warrant further consideration, especially as regards the growing mariculture industry?**

When a species incursion is detected, either through a port survey or other means, it is not always clear what an appropriate management response should be. Certainly, some cases may warrant immediate and urgent responses, but others may simply require further research or monitoring. The case of *C. maenas* is a little different, in that this alien species has been known to exist in South Africa for decades. What was discovered during the port survey in Saldanha Bay, was that isolated individuals of the crab had managed to reach the Bay, but that a founder population had seemingly not yet been established. Given the well-known reputation of this species, and the presence of growing mariculture industries in Saldanha, and also in Knysna, there was an opportunity to explore new methods for supporting decisions towards possible management intervention. With national authorities considering targeted monitoring programmes, expensive eradication attempts, and allocation of funds to conduct further research on the crab, there was a clear need for decision support. Consideration of the risk assessment methodologies discussed in Chapter 3, allowed for adaptation from a vector-specific approach to a species-specific model that incorporated biological and economic concerns.

The outcome of the risk assessment not only gives an indication of whether or not further action may be warranted, but also where further research is needed. The bio-economic model was developed as a pilot to help answer some key questions, but also as a starting point that may be strengthened through further research and investigation.

The project showed that some manner of exaggeration may be a factor, even within scientific communities (and publications), related to the perceived threats of this species to the economy. The risk assessment did not involve any novel experimentation, but rather extensive literature review on the subject species, which when consolidated and synthesized, seemingly demonstrated a different picture than the one projected more publicly (e.g. in local newspapers, broadcasts etc.). While there may be minimal risk to existing mariculture operators, this is a growing industry with new practices and operators emerging, that are being encouraged through national policy. On the basis of this assessment, mariculture practices may be modified to avoid practices that would render the product susceptible to predation by the crab, should it arrive in those areas, a circumstance that may not have been anticipated by the operator.

It is also worth noting that the thrust of this assessment was on potential impacts to socio-economic interests, which tend to be the driving forces of policy. Range expansion of any invasive species, especially one as significant as *C. maenas*, should be considered ecologically significant in terms of the potential permanent threat posed. Unfortunately, the coastlines of South Africa have been so transformed by other IAS, that preventing further departure from the indigenous ecological state does not currently rank as a high societal priority.

## Literature cited

- Abdulla, A., Floerl, O., Richmond, M., Johnston, O., Bertzky, M., Birch, S. and Walsh, A. 2007. Enhanced Detection and Management of Marine Introduced Species in the Seychelles. Final Project Report. IUCN Global Marine Program. [www.iucn.org](http://www.iucn.org). 125 pp.
- AMOG Consulting 2002. Hull fouling as a vector for transferring marine organisms. Phase 1 Study - Hull Fouling Research. Report by AMOG Consulting and MSE to Department of Agriculture, Fisheries and Forestry, Australia. Published by AQIS. Ballast Water Research Series Report No. 14.
- Anil, A. C., Venkat, K., Sawant, S. S., Dileepkumar, M., Dhargalkar, V.K., Ramaiah, N., Harkantra, S.N. and Ansari, Z.A. 2001. Marine bioinvasion: Concern for ecology and shipping. *Current Science* 83(3): 214-218.
- AquaNIS, 2013. Information system on Aquatic non-Indigenous Species. Version: 2.0. [www.corpi.ku.lt/databases/aquanis](http://www.corpi.ku.lt/databases/aquanis)
- Aquenal. 2008. National control plan for the European Green Shore Crab *Carcinus maenas*. Northern Territory Australian Government. Aquenal PTY, LTD. 44pp.
- Ashton, G., Boos, K., Shucksmith, R. and Cook, E. 2006. Rapid assessment of the distribution of marine non-native species in marinas in Scotland. *Aquatic Invasions* 1(4): 209-213.
- Awad, A., Clarke, C., Greyling, L., Hilliard, R., Polglaze and Raaymakers, S. 2004. Ballast water risk assessment, Port of Saldanha Bay, Republic of South Africa, November 2003: final report. GEF-UNDP-IMO GloBallast Monograph Series No. 13. IMO London, UK.
- Awad, A., Haag, F., Anil, A.C., Abdulla, A. 2014. GEF-UNDP-IMO GloBallast Partnerships Programme, IOI, CSIR-NIO and IUCN. Guidance on Port Biological Baseline Surveys. GEF-UNDP-IMO GloBallast Monograph Series No. 22. IMO. London, UK
- Awad, A., Greyling, L., Kirkman, S., Botes, L., Clark, B., Prochazka, K., Robinson, T., Kruger N. and Joyce, L. 2003. Port Biological Baseline Survey Report, Port of Saldanha, South Africa. Report for the Global Ballast Water Management Programme, IMO/UNDP/GEF. London, UK.
- Awad, A. and Jackson, L. 2001. Prevention and Management of Invasive Alien Species: Forging Cooperation throughout southern Africa. Unpublished report for the Global Invasive Species Programme. Regional Resource Directory. Cape Town, South Africa.
- Beckley, L.E. 1981. Marine benthos near the Saldanha Bay iron-ore loading terminal. *South African Journal of Zoology*. 16: 269-271.

- Breen, E., and Metaxas, A. 2008. A comparison of predation rates by non-indigenous and indigenous crabs (juvenile *Carcinus maenas*, juvenile *Cancer irroratus*, and adult *Dyspanopeus sayi*) in laboratory and field experiments. *Estuaries and Coasts* 31:728-737.
- Carlton, J.T. 1985. Transoceanic and interoceanic dispersal of coastal marine organisms: the biology of ballast water. *Oceanography and Marine Biology, an Annual Review* 23: 313-371.
- Carlton, J.T. 1996. Biological invasions and cryptogenic species. *Ecology* 77: 1653-1655.
- Carlton, J.T. 1999. Molluscan invasions in marine and estuarine communities. *Malacologia* 41: 439-454.
- Carlton, J. T., 1999. The scale and ecological consequences of biological invasions in the world's oceans. In, *Invasive Species and Biodiversity Management*, Sandlund, O. T., Schei, P. J. and Viken, Å (eds), pp. 195-212. Kluwer, Dordrecht, Netherlands.
- Carlton, J. T., and Cohen, A. N. 2003. Episodic global dispersal in shallow water marine organisms: the case history of the European Shore Crabs *Carcinus maenas* and *C. aestuarii*. *Journal of Biogeography* 30:1809-1820.
- Carlton, J. T., Donald, R. M., and Van Leeuwen, H. 1995. The role of shipping in the introduction of nonindigenous aquatic organisms to the coastal waters of the United States (other than the Great Lakes) and an analysis of control options. Report No. CG-D-11-95. National Sea Grant Programme. 373pp.
- Carlton, J. T. and Geller, J. B. 1993. Ecological roulette: the global transport of nonindigenous marine organisms. *Science* 261: 78-82.
- Carlton, J. T., and Jonathan, G. B. 1993. Ecological roulette: the global transport of non-indigenous marine organisms. *Science* 261:78-82.
- Carlton, J.T. and Ruiz, G.M. 2005. The magnitude and consequences of bioinvasions in marine ecosystems: implications for conservation biology. In *Marine Conservation Biology: The Science of Maintaining the Sea's Biodiversity*, EA. Norse and LB. Crowder (eds.). pp 123-148. Island Press, Washington
- CBD. 2003. Methods for rapid assessment of marine and coastal biodiversity. UNEP/CBD/SBSTTA/9/INF/25. Montreal, Canada.
- Chapman, J.W. and Carlton, J.T. 1991. A test of criteria for introduced species: the global invasion by the isopod *Synidotea laevidorsalis* (Miers, 1881). *Journal of Crustacean Biology* 11: 386:400.
- Christie, N.D. & Moldan, A. 1977. Distribution of benthic macrofauna in Langebaan Lagoon. *Transactions of the Royal Society of South Africa*. 42: 273-284.

- Clark, B.M. 1997. Variation in surf-zone fish community structure across a wave-exposure gradient. *Estuarine, Coastal and Shelf Science* 44: 659-674.
- Cohen, A.N. and Carlton, J.T. 1995. Non-indigenous aquatic species in a United States estuary: a case study of the biological invasions of the San Francisco Bay and delta. Report to the US Fish and Wildlife Service (Washington) and the National Sea Grant College Program, Connecticut Sea Grant, December, 1995. 211 pp. <http://nas.nfreg.gov/sfinvade.html>.
- Colnar, A. M., and Landis, W. G. 2007. Conceptual model development for invasive species and a regional risk assessment case study: the European Green Crab, *Carcinus maenas*, at Cherry Point, Washington, USA. *Human and Ecological Risk Assessment: An International Journal* 13:120-155.
- Compton, T. J., Leathwick, J. R. and Inglis, G. J. 2010. Thermogeography predicts the potential global range of the invasive European Green Crab (*Carcinus maenas* ). *Diversity and Distributions* 16:243-255.
- Cook, D. C., Thomas, M. B., Cunningham, S. A., Anderson, D. L. and De Barro, P. J.. 2007. Predicting the economic impact of an invasive species on an ecosystem service. *Ecological Applications* 17:1832-1840.
- Coutts, A.D.M., Moore, K.M. and Hewitt, C.L. 2003. Ships sea-chests: an overlooked transfer mechanism for non-indigenous species? *Marine Pollution Bulletin* 46: 1504-1515.
- Cranfield, H.J., Gordon, D.P., William, R.C., Marshal, B.A., Battershill, C.N., Francis, M.P., Nelson, W.A., Glasby, C.J. and Read, G.B. 1998. Adventive marine species in New Zealand. NIWA Technical Report 34. 48pp.
- Crothers, J. H. 1967. The biology of the Shore Crab *Carcinus maenas* (L.). *Field Studies* 2:407-434.
- CSIR Environmentek. 1999. Medium Term Expansion of the Port of Saldanha into Small Bay: A modeling-based predictive study of hydrodynamic, water quality, sediment transport & wave resonance consideration of four alternative port layouts. Council for Scientific and Industrial Research. Stellenbosch, South Africa.
- DAFF. 2012. A profile of the South African aquaculture market value chain. Department of Agriculture, Forestry and Fisheries, South Africa. Pages 1-41.
- DAFF. 2011. South Africa's aquaculture: annual report 2011. Department of Agriculture, Forestry and Fisheries, South Africa. 40pp.
- Daley, R.J. and Hobbie, J.E. 1975. Direct counts of aquatic bacteria by a modified epifluorescence technique. *Limnology and Oceanography* 20: 875-882.

- Darbyson, E. A., Hanson, J. M., Locke, A. and Willison, J. H. M. 2009. Survival of European Green Crab (*Carcinus maenas*) exposed to simulated overland and boating-vector transport conditions. *Journal of Shellfish Research* 28:377-382.
- Darling, J. A. 2011. More than one way to invade: lessons from genetic studies of *Carcinus* Shore Crabs. Pages 661-685 in B. S. Galil, P. F. Clark, and J. T. Carlton, editors. *In the Wrong Place-Alien Marine Crustaceans: Distribution, Biology and Impacts*. Springer Netherlands, Dordrecht.
- Darling, J., and Tepolt, C. 2008. Highly sensitive detection of invasive Shore Crab (*Carcinus maenas* and *Carcinus aestuarii*) larvae in mixed plankton samples using polymerase chain reaction and restriction fragment length polymorphisms (PCR-RFLP). *Aquatic Invasions* 3:141-152.
- Day, E., and Branch, G. M. 2000. Evidence for a positive relationship between juvenile abalone *Haliotis midae* and the sea urchin *Parechinus angulosus* in the South-Western Cape, South Africa. *South African Journal of Marine Science* 22:145-156.
- Day, J.H. 1959. The biology of Langebaan Lagoon: A study of the effect of shelter from wave action. *Transactions of the Royal Society of South Africa*.26: 475-545.
- Day, J.H. 1981 Summaries and current knowledge of 43 estuaries in southern Africa. In: *Estuarine ecology with particular reference to southern Africa*. Day, J.H. (ed), A. A. Balkema, Cape Town, pp. 251 – 329.
- De Rivera, C. E., Hitchcock, N. G., Teck, S. J., Steves, B. P., Hines, A. H. and Ruiz, G. M. 2007. Larval development rate predicts range expansion of an introduced crab. *Marine Biology* 150:1275-1288.
- De Rivera, C. E., Ruiz, G. M., Hines, A. H. and Jivoff, P. 2005. Biotic resistance to invasion: native predator limits abundance and distribution of an introduced crab. *Ecology* 86:3364-3376.
- Dibacco, C., Humphrey, D. B., Nasmith, L. E. and Levings, C. D. 2012. Supplementary material: ICES Journal of Marine Science, 69 Ballast water transport of non-indigenous zooplankton to Canadian ports. *Journal of Marine Science* 69:1–13.
- DTI and DAFF. 2011. Draft - national aquaculture strategic framework (NASF). Department of Trade and Industry, and Department of Agriculture, Forestry and Fisheries, South Africa. Pages 1-27.
- Du Plessis, A.J. 1977. Larval development, settlement and growth of the black mussel *Choromytilus meridionalis* in the Saldanha Bay region. *Transactions of the Royal Society of South Africa*. 42: 303-316.
- Eldredge, L.G. and Carlton, J.T. 2002. Hawaiian marine bioinvasions: a preliminary assessment. *Pacific Science* 56: 211-212.
- Facon, B. Pointier, J.P. Jarne, P. Sarda, V. David, P. 2008. High genetic variance in life-history strategies within invasive populations by way of multiple introductions. *Current Biology* 18:363–367

- Finnoff, D., Shogren, J. F., Leung, B. and Lodge, D. 2005. The importance of bioeconomic feedback in invasive species management. *Ecological Economics* 52:367-381.
- Fofonoff, P.W., Ruiz, G.M., Steves, B. and Carlton, J.T. 2013. National Exotic Marine and Estuarine Species Information System. <http://invasions.si.edu/nemesis>.
- GEF-UNDP-IMO GloBallast Partnerships Programme & IOI. 2009. Guidelines for National Ballast Water Status Assessments. GloBallast Monographs No. 17.
- GEF-UNDP-IMO GloBallast Partnerships Programme & IUCN. 2010. Economic Assessment for Ballast Water Management: a Guideline. GEF-UNDP-IMO GloBallast Partnerships, London, UK and IUCN, Gland, Switzerland. GloBallast Monographs No. 19.
- GEF-UNDP-IMO GloBallast Partnerships Programme & GESAMP. 2011. Establishing equivalency in the performance testing and compliance monitoring of emerging alternative ballast water management systems: a technical review. GEF-UNDP-IMO GloBallast Partnerships, London, UK and GESAMP, GloBallast Monographs No. 20, GESAMP Reports and Studies No. 82.
- GEF-UNDP-IMO GloBallast Partnerships Programme and WMU. 2013. Identifying and Managing Risks from Organisms Carried in Ships' Ballast Water. GEF-UNDP-IMO GloBallast Partnerships, London, UK and WMU, Malmö, Sweden. GloBallast Monograph No. 21.
- Geller, J. B., Walton, E. D., Grosholz, E. D. and Ruiz, G. M. 1997. Cryptic invasions of the crab *Carcinus* detected by molecular phylogeography. *Molecular Ecology* 6:901-906.
- Godfray, H.C.J. 2002. Challenges for taxonomy. *Nature* 417: 17-19.
- Gollasch S and Griffiths, C. 2001. Case studies of introduced species in South African waters prepared for the GloBallast project. Unpublished report to Globallast Program. Cape Town, South Africa.
- Government of Australia. 2012. National System for the Prevention and Management of Marine Pest Incursions (NIMPIS). <http://www.marinepests.gov.au/home>.
- Griffiths, C.L., Hockey, P. A. R., Van Erkom Schurink, C. and Le Roux, P.J. 1992. Marine invasive aliens on south African shores: implications for community structure and trophic functioning. *South African Journal of Marine Science*. 12: 713-722.
- Grindley, J.R. 1977. The zooplankton of Langebaan lagoon and Saldanha Bay. *Transactions of the Royal Society of South Africa*. 42: 341-370.
- Grosholz, E. 2002. Ecological and evolutionary consequences of coastal invasions. *Trends in Ecology and Evolution* 17: 22-27.

- Grosholz, E. D., and Ruiz, G. M. 1995. Spread and potential impact of the recently introduced European green crab, *Carcinus maenas*, in central California. *Marine Biology* 122:239-247.
- Grosholz, E. D., and Ruiz, G. M. 1996. Predicting the impact of introduced marine species: lessons from the multiple invasions of the European Green Crab *Carcinus maenas*. *Biological Conservation* 78: 59-66.
- Grosholz, E. D., Ruiz, G. M., Dean, C. A., Shirley, K. A., John, L. and Connors, P. G. 2000. The impacts of a nonindigenous marine predator in a California bay. *Ecology* 81:1206-1224.
- Grosholz, E., Lovell, S., Besedin, E. and Katz, M. 2011. Modeling the impacts of the European Green Crab on commercial shellfisheries. *Ecological Applications* 21:915-924.
- Grosholz, E., and Ruiz, G. 2002. Management plan for the European Green Crab. Report prepared for the Green Crab control committee. Aquatic nuisance species task force. 55pp.
- Hampton, S., and Griffiths, C. 2007. Why *Carcinus maenas* cannot get a grip on South Africa's wave-exposed coastline. *African Journal of Marine Science* 29:123-126.
- Haugom, G. P., Behrens, H. L., and Andersen, A. B. 2002. Risk based methodology to assess invasive aquatic species in ballast water. In *Invasive Aquatic Species of Europe Distribution, Impact and Management*, pp. 467-476. Ed. by E. Leppäkoski, S. Gollasch, and S. Olenin. Kluwer Academic, Dordrecht.
- Haupt, T., Griffiths, C. and Robinson, T. 2012. Intra-regional translocations of epifaunal and infaunal species associated with cultured Pacific Oysters *Crassostrea gigas*. *African Journal of Marine Science* 34:187-194.
- Haupt, T. M., C. L. Griffiths, T. B. Robinson, and A. F. G. Tonin. 2010. Oysters as vectors of marine aliens, with notes on four introduced species associated with oyster farming in South Africa. *African Zoology* 45:52-62.
- Hayes, K.R., McEnnulty, F.R. and Sliwa, C. 2002. Identifying potential marine pests – an inductive approach. Final report for Environment Australia, National Priority Pests Project, CSIRO Marine Research, Hobart, Tasmania, Australia, 42pp.
- Hayes, K. R., Cannon, R., Neil, K., Inglis, G. 2005. Sensitivity and cost considerations for the detection and eradication of marine pests in ports. *Marine Pollution Bulletin*. 50(8):823-834.
- Heemstra, P.C. and Wright, J.E. 1986. Two new species of clinid fishes (Perciformes: Clinidae) from South Africa. *Special Publications of the J.L.B. Smith Institute of Ichthyology*. No. 40.
- Herbet, D.G. 1999. *Siphonaria compressa*, South Africa's most endangered marine mollusc. *South African Journal of Science*. 95: 77-79.

- Hewitt, C. L., Campbell, M.L., Thresher, R.E., Martin, R.B., Boyd, S., Cohen, B.F., Currie, D.R., Gomon, M.F., Keogh, M.J., Lewis, J.A., Lockett, M.M., Mays, N., McArthur, M.A., O'Hara, T.D., Poore, G.C.B., Ross, D.J., Storey, M.J., Watson, J.E., and Wilson, R.S. 2004. Introduced and cryptogenic species in Port Phillip Bay, Victoria, Australia. *Marine Biology*, 144: 183-202.
- Hewitt, C.L. and Martin, R.B. 2001. Revised protocols for baseline port surveys for introduced marine species: Survey design, Sampling protocols and specimen handling. Centre for Research on Introduced Marine Pests. Technical Report No. 22. CSIRO Marine Research, Hobart. 46 pp.
- Hewitt, C.L., Campbell, M.L., Thresher, R.E. and Martin, J.B. 1999. Marine biological invasions of Port Phillip Bay, Victoria. CSIRO. Centre for Research on Introduced Marine Pests, Tech. Rep. No. 20, 344pp.
- Hilliard R. 2005. Best Practice for the Management of Introduced Marine Pests - A Review. Publisher: Global Invasive Species Programme. Cape Town, South Africa.
- Hyeon Ho Shin, Dhongil Lim, Soung-Yun Park, Seung Heo and So-Young Kim 2013. Distribution of dinoflagellate cysts in Yellow Sea sediments. *Acta Oceanologica Sinica* 32(9):91-98
- IMO. 2009. Ballast water management convention and the guidelines for its implementation. International Maritime Organization. London, UK. 234pp.
- Isaac, W.E. 1937. Studies of South African seaweed vegetation I - West coast from Lamberts Bay to the Cape of Good Hope. *Transactions of the Royal Society of South Africa*. 25: 115-151.
- Isaac, W.E. 1956. The ecology of *Gracilaria confervoides* (L.) Grev. In South Africa with special reference to its ecology in the Saldanha-Langebaan Lagoon. *Proceedings of the Second International Seaweed Symposium*. Trondheim, Norway, 1955: 173-185.
- IUCN. 2012. Marine Alien Invasive Species Strategy for the MEDPAN Network: Draft Strategy. International Union for the Conservation of Nature. Gland, Switzerland. 24pp.
- Jensen, G. C., McDonald, P. S., and Armstrong, D. A. 2007. Biotic resistance to green crab, *Carcinus maenas*, in California bays. *Marine Biology* 15:2231-2243.
- Kelleher, G., Bleakley, C. and Wells, S. 1995. A global representative system of marine protected areas. The World Bank, Washington DC, USA.
- Klassen, G., and Locke, A. 2007. A biological synopsis of the European Green Crab, *Carcinus maenas*. Canadian manuscript report of fisheries and aquatic sciences 2818. Fisheries and Oceans Canada. 75pp.
- Klein Breteler, W. C. M. 1976. Settlement, growth and production of the shore crab, *Carcinus maenas*, on tidal flats in the Dutch Wadden Sea. *Netherlands Journal of Sea Research* 10:354-376.

- Knowler, D. 2005. Reassessing the costs of biological invasion: *Mnemiopsis leidyi* in the Black sea. *Ecological Economics* 52:187-199.
- Kolbe, J.J. Larson, A. Losos, J.B. 2007. Differential admixture shapes morphological variation among invasive populations of the lizard *Anolis sagrei*. *Molecular Ecology* 16:1579–1591
- Le Roux, P. J., Branch, G. M. and Joska, M. A. P. 1990. On the distribution, diet and possible impact of the invasive European shore crab *Carcinus maenas* (L.) along the South African coast. *South African Journal of Marine Science* 9:85-93.
- Lebaron, P., Parthuisot, N. and Catala, P. 1998. Comparison of blue nucleic acid dyes for the flow cytometric enumeration of bacteria in aquatic systems. *Applied and Environmental Microbiology* 64, 1724-1730.
- Leppäkoski, E., Gollasch, S., Olenin, S. 2002. Introduction: alien species in European waters, in Leppäkoski, E. et al (Eds.) 2002. *Invasive aquatic species of Europe: distribution, impacts and management*. pp. 1-6.
- Leppäkoski, E.; Gollasch, S.; Olenin, S. (Ed.) 2002. *Invasive aquatic species of Europe: distribution, impacts and management*. Kluwer/Kluwer Academic: Dordrecht. ISBN 1-4020-0837-6. IX, 583pp.
- Lovell, S., Besedin, E. and Grosholz, E. D. 2007. Modeling economic impacts of the European Green Crab. Page 40 *American Agricultural Economics Association Annual Meeting*. Portland, Oregon.
- Lovell, S. J., and Stone, S. F. 2005. The economic impacts of aquatic invasive species: a review of the literature. Working paper series, National Center for Environmental Economics. Washington, DC. 66pp.
- Mabin, C. A., Wilson, J. R., Le Roux, J. J., Robinson, T. B. 2017. Reassessing the invasion of South African waters by the European Shore-Crab *Carcinus maenas*. *African Journal of Marine Science* 39: 259-288
- Mack R.N., Simberloff, D., Lonsdale, W.M., Evans H., Clout, M. and Bazzaz, F.A. 2000. Issues in Ecology. Biotic invasions: causes, epidemiology, global consequences, and control. *Ecological Applications* 10(3): 689-710.
- Marangoni, C., Pienaar, R. N. and Sym, S. D. 2001. Possible introduction of alien phytoplankton via shipping ballast water: A South African perspective. *South African Journal of Botany*. 67: 465-474.
- Marie, D., Partensky, F., Jacquet, S. and Vaulot, D. 1997. Enumeration and cell cycle analysis of natural populations of marine picoplankton by flow cytometry using the nucleic acid stain SYBR Green I. *Applied and Environmental Microbiology* 63: 186-93.

- Matsuoka, K. and Fukuyo, Y. 1995. Taxonomy of cysts. In: Manual on harmful marine microalgae (Hallegraeff, G.M., Anderson, D.M. and Cembella, A.D. eds.). IOC Manuals and Guides, no. 33, UNESCO
- Matsuoka, K., Fukuyo, Y. 2000. Technical guide for modern dinoflagellate cyst study. WESTPAC-HAB/WESTPAC/IOC.
- McDonald, S. P., Holsman, K. K., Beuchamp, D. A., Dumbauld, B. R. and Armstrong, D. A. 2006. Bioenergetics modeling to investigate habitat use by the nonindigenous crab, *Carcinus maenas*, in Willapa Bay, Washington. *Estuaries and Coasts* 29:1132–1149.
- McNeely, J.A., Mooney, H.A., Neville, L.E. Schei, P. and Waage, J.K. (eds.) 2001. A Global Strategy on Invasive Alien Species. IUCN Gland, Switzerland, and Cambridge, UK. x + 50 pp.
- Mead, A., Carlton, J. T., Griffiths, C. L. and Rius, M. 2011. Introduced and cryptogenic marine and estuarine species of South Africa. *Journal of Natural History* 45:2463-2524.
- Minchin, D. 2007. Rapid coastal survey for targeted alien species associated with floating pontoons in Ireland. *Aquatic Invasions* 2(1): 63-70.
- Minchin, D. 2012. Rapid assessment of the bryozoan, *Zoobotryon verticillatum* (Delle Chiaje, 1822) in marinas, Canary Islands. *Marine Pollution Bulletin* 64(10): 2146-2150.
- Moldan, A. 1978. A study of the effects of dredging on the benthic macrofauna in Saldanha Bay. *South African Journal of Science*. 74: 106-108.
- Molnar, J. L., Gamboa, R. L., Revenga, C., Spalding, M. D. 2008. Assessing the global threat of invasive species to marine biodiversity. *Frontiers in Ecology and the Environment*. Vol. 6, No. 9, pp. 485-492.
- Nelson, G. and Hutchings, L. 1983. The Benguala upwelling area. *Progress in Oceanography*, 12, pp. 333-356.
- NOAA. 2013. Great Lakes Non-Indigenous Species Information System (GLANSIS). National Oceanographic and Atmospheric Administration (NOAA). <http://nas.er.usgs.gov/queries/greatlakes/Search.aspx>.
- Olukolajo, S.O., & Oluwaseun, K.A. 2008. Seasonal Variation in the Distribution and Fish Species Diversity of a Tropical Lagoon in South-West Nigeria. *Journal of Fisheries and Aquatic Science*, 3: 375-383.
- Parker, I.M., Simberloff, D., Lonsdale, W.M., Goodell, K., Wonham, M., Kareiva, P.M., Williamson, M.H., Von Holle, B., Moyle, B.P.B, Byers, J.E. and Goldwasser, L. 1999. Impact: toward a framework for understanding the ecological effects of invaders. *Biological Invasions* 1(1): 3-19.

- Penrith, M. L. 1969. The systematics of the fishes of the family Clinidae in South Africa. *Annals of the South African Museum*. 55(1): 1-121.
- Perrings, C. 2002. Biological invasions in aquatic systems: the economic problem. *Bulletin of Marine Science* 70:541–552.
- Peters, K. 2013. Marine alien species in Western Cape harbours, South Africa: a tool for strategically focusing monitoring efforts. MSc dissertation, Department of Biological Sciences, University of Cape Town.
- Pimentel, D. (Ed). 2002. Biological invasions: economic and environmental costs of alien plant, animal, and microbe species. CRC Press. Boca Raton, FL. 384pp.
- Pitcher, G.C., Bernard, S. and Pienaar, R.N. 1999. Brown tides on the west coast. *Harmful Algal News*, 18, 8-10 pp.
- Pitcher, G.C. & Calder, D. 2000. Harmful algal blooms of the southern Benguela Current: a review and appraisal of monitoring from 1989 to 1997. *South African Journal of Marine Science*. Sci. 22: 255-271.
- Probyn, T., Pitcher, G., Pienaar, R. & Nuzzi, R. 2001. Brown tides and mariculture in Saldanha Bay, South African Marine Pollution Bulletin 42: 405-408.
- Puttick, G.M. 1977. Spatial and temporal variations in inter-tidal animal distribution at Langebaan Lagoon, South Africa. *Transactions of the Royal Society of South Africa* 42: 403-440.
- Robinson, T.B. & Griffiths, C.L. 2002. Invasion of Langebaan Lagoon, South Africa, by *Mytilus Galloprovincialis* – effects on natural communities. *African Zoology* 37: 151-158.
- Robinson, T., C. Griffiths, C. McQuaid, and M. Rius. 2005. Marine alien species of South Africa - status and impacts. *African Journal of Marine Science* 27:297-306.
- Ruiz, G.M., Fofonoff, P.W., Carlton, J.T., Wonham, M.J. and Hines, A.H. 2000. Invasion of coastal communities in North America: apparent patterns, processes, and biases. *Annual Reviews in Ecology and Systematics* 31: 481-531.
- Schils, T., De Clerck, O., Leliaert, F., Bolton, J.J. & Coppejans, E. 2001. The Change in macroalgal assemblages through the Saldanha Bay/Langebaan Lagoon Ecosystem (South Africa). *Botanica Marina* 44: 295-305.
- Simons, R.H. 1977. The algal flora of Saldanha Bay. *Transactions of the Royal Society of South Africa* 42: 461-482.

- Schaffelke, B., and C. L. Hewitt. 2007. Impacts of introduced seaweeds. *Botanica Marina* 50:397-417.
- Shiganova, T.A., Dumont, H.J., Sokolsky, A.F., Kamakin, A.M., Tinenkova, D. and Kurasheva, E.K. 2004. Population dynamics of *Mnemiopsis leidyi* in the Caspian Sea and effects on the Caspian ecosystem. In Dumont, et al. (Eds) *Aquatic Invasions in the Black, Caspian and Mediterranean Sea*. 2004, Kluwer Academic Publishers, Netherlands. Pages 71-111.
- Sink, K., S. Holness, L. Harris, P. Majiedt, L. Atkinson, T. Robinson, S. Kirkman, L. Hutchings, Leslie R, S. Lamberth, S. Kerwath, S. von der Heyden, A. Lombard, C. Attwood, G. Branch, T. Fairweather, S. Taljaard, S. Weerts, P. Cowley, A. Awad, B. Halpern, H. Grantham, and T. Wolf. 2012. National biodiversity assessment: technical report volume 4: marine and coastal component. South Africa. 325pp.
- Smith, M.M. & Heemstra, P.C. 1986. *Smiths' Sea Fishes*. Macmillan, Johannesburg.
- Spalding, M. D., Fox, H. E., Allen, G. R., Davidson, N., Ferdaña, Z. A., Finlayson, M., Halpern, B.S., Jorge, M. A., Lombana, A., Lourie, S. A., Martin, K. D., McManus, E., Molnar, J., Recchia, C. A., Robertson, J. 2007. Marine Ecoregions of the World: A Bioregionalization of Coastal and Shelf Areas. *Bioscience* Vol. 57 No. 7, July 2007, pp. 573-583.
- Stenton-Dozey, J., Probyn, T. & Busby, A. 2001. Impact of mussel (*Mytilus galloprovincialis*) raftculture on benthic macrofauna, in situ oxygen uptake, and nutrient fluxes in Saldanha Bay, South Africa. *Canadian Journal of Fisheries and Aquatic Science*. 58: 1021-1031.
- Tamburri, M. N., K. Wasson, and M. Matsuda. 2002. Ballast water deoxygenation can prevent aquatic introductions while reducing ship corrosion. *Biological Conservation* 103:331-341.
- Thresher R.E. and A.M. Kuris. 2004. Options for managing invasive marine species. *Biological Invasions*. 6: 295-300.
- Trussell, G. C. 2000. Predator-induced plasticity and morphological trade-offs in latitudinally separated populations of *Littorina obtusata*. *Evolutionary Ecology Research* 2:803-822.
- Trussell, G. C., and L. D. Smith. 2000. Induced defenses in response to an invading crab predator: an explanation of historical and geographic phenotypic change. *Proceedings of the National Academy of Sciences of the United States of America* 97:2123-7.
- UNSD. 1992. United Nations Sustainable Development, Agenda 21. Division for Sustainable Development, Department of Economic and Social Affairs, United Nations. Last accessed 7 October 2017. <https://sustainabledevelopment.un.org/content/documents/Agenda21.pdf>
- Vander Zanden, M. J., and J. D. Olden. 2008. A management framework for preventing the secondary spread of aquatic invasive species. *Canadian Journal of Fisheries and Aquatic Sciences* 65:1512-1522.

- Wilcove, D., Rothstein D., Dubow J., Phillips A. and Losos E. 1998. Quantifying threats to imperilled species in the United States. *BioScience*. 48(8): 607-615.
- Williamson, M. 1998. Measuring the impact of plant invaders in Britain. *Plant invasions: ecological mechanisms and human responses*. in: Starfinger, U. (Ed.) *Plant Invasions: Ecological Mechanisms and Human Responses*. Backhuys Publishers;1998: 57-68.
- Yamada, S. B. 2001. *Global invader: the European Green Crab*. Oregon Sea Grant, Oregon State University. i-xiii. 123 pp
- Yamada, S. B., and G. E. Gillespie. 2008. Will the European Green Crab (*Carcinus maenas*) persist in the Pacific Northwest? *Journal of Marine Science* 65:725-729.
- Yamada, S. B., and P. M. Kosro. 2009. Linking ocean conditions to year class strength of the invasive European green crab, *Carcinus maenas*. *Biological Invasions* 12:1791-1804.
- Zetlmeisl, C. 2011. Parasites of the Shore Crab *Carcinus maenas* (L.): implications for reproductive potential and invasion success. *Parasitology* 138, 394-401.

## Appendix 1

### Recommended preservation methods for different taxonomic groups

<b>Anemones</b>	Initially transfer the specimens to seawater to allow expansion of body/organs and then freeze or add menthol or magnesium chloride and leave overnight. Fix in formalin by adding the appropriate amount of formalin to the specimen and then store in formalin.
<b>Aplacophora</b>	Relax specimen using menthol, magnesium chloride or iced water and then fix in formalin. Rinse in water and store in 70% alcohol.
<b>Asteroids</b>	Fix in concentrated formalin with seawater (1:5) overnight. Remove the specimen from fixative and dry under the sun to remove moisture. Store dry. Alternatively, fix in formalin for 24-48hrs and transfer to 70% alcohol for long-term storage.
<b>Brachiopods</b>	Fix in formalin and store in formalin.
<b>Cephalopods</b>	Anaesthetize the specimen. Thaw and then fix in formalin. Finally, store in formalin or 70% alcohol.
<b>Corals (Soft)</b>	Allow the specimen to fully expand in seawater and then narcotise by freezing or adding menthol or magnesium chloride. Fix in formalin for 2-4 hrs. Remove formalin by rinsing with water and then store in 70% alcohol.
<b>Crinoids</b>	Fix in formalin for 2-3 days. Store in 70% alcohol.
<b>Crustaceans</b>	Specimen to be fixed in formalin and finally stored in formalin or 70% alcohol.
<b>Ctenophores (comb jellies)</b>	Fix in formalin and store in formalin or 70% alcohol.
<b>Ectoprocts</b>	<b>Hard species:</b> Fix in formalin and then dry. Store in dried condition. <b>Soft and lightly calcified species:</b> Fix in formalin for 4-12hrs and then store in 70% alcohol.
<b>Holothurians</b>	Fix in formalin overnight and rinse thoroughly in water, or fix in 100% alcohol. Store in 70% alcohol.
<b>Hydroids and hard corals</b>	First narcotise in menthol or magnesium chloride overnight then fix in formalin. Finally, store in formalin or 70% alcohol.
<b>Leeches</b>	Narcotize specimen using menthol or iced seawater. Fix in formalin and store in formalin.
<b>Molluscs (general)</b>	Fix in formalin and store in formalin. Small specimens may be stored in 70% alcohol.
<b>Oligochaete worms</b>	Relax in menthol or magnesium chloride, fix in formalin and store in formalin or 70% alcohol.
<b>Ophiuroids and Echinoids</b>	Large and solid specimens may be treated as for asteroids above. Others may be fixed in formalin and store in 70% alcohol.
<b>Opisthobranchs</b>	Should be relaxed before fixing. Allow specimens to crawl in seawater and then freeze overnight. Add formalin to frozen container or use menthol, magnesium chloride in seawater or iced seawater for relaxing purpose. Fix in formalin and finally store in 70% alcohol.
<b>Platyhelminths</b>	Use menthol or magnesium chloride for relaxation of specimens. Alternatively, place the specimen directly on the frozen formalin in a container to relax and then fix in formalin on ice.
<b>Polychaete worms</b>	Large specimens should be narcotized using menthol or magnesium chloride prior to fixing. Fix in formalin and finally store in formalin or 70% alcohol.
<b>Polyplacophora</b>	Flatten, fix in formalin and then store in formalin. Small specimens may be stored in 70% alcohol.
<b>Sipunculan, Nemertean and Echiuran worms</b>	Relax overnight using menthol or magnesium chloride in seawater followed by fixing in formalin and finally store in formalin.
<b>Sponges</b>	Fix overnight in 100% alcohol or in well-buffered formalin. Specimens can be preserved either in formalin or 70% alcohol (after thorough rinsing in water to remove the formalin).
<b>Urochordates</b>	For large solitary ascidians, narcotisation overnight is recommended prior to fixing. Use menthol or magnesium chloride in seawater for narcotising. Fix in formalin and finally store in formalin or 70% alcohol.

## Appendix 2

### **Some common procedures used in sampling marine communities**

Section 2.3.2 of these guidelines listed various devices used in sampling different marine substrates. Sampling methods, including the number of replicates and depths at which samples are collected, can vary widely depending on the target biota (i.e. survey objectives) and the characteristics of the site, as well as available time, funds and resources in terms of taxonomy, equipment and facilities. Descriptions of some of the more common methods are given below.

#### **Hard substratum organisms:**

Hard substratum organisms can be collected by active or passive sampling methods.

Active sampling involves scraping within a quadrat an area of 0.1m<sup>2</sup> whereby the detached material is captured in a mesh or plastic bag. The scraper generally consists of a sharp blade mounted on either a long or short handle. Scrapers can be operated either by divers, or deployed on a pole from the surface. Where the total depth exceeds 6m, samples are typically collected from three depth intervals: below high water mark (inter-tidal), mid-depth and near bottom. Where the water depth is less than 6m., one or two samples may suffice. As soon as possible after collection, samples should be rough-sorted and preserved as appropriate (see Annex 1).

Passive sampling methods involve the use of artificial substrates (e.g. settlement plates, panels, stone-filled wire-mesh baskets etc. of known area/volume) suspended under water for different exposure periods and collection of settled assemblages by scraping or rinsing, as appropriate.

#### **Mobile epifauna and fish:**

Beach seines may be used to sample near shore juvenile fishes over sandy or muddy substrates. A 25m seine with 15mm mesh can be used. Gill nets and casting nets may also be effective in the collection of fishes within the confines of the port. Baited fish traps may also prove effective, as well as traps designed for shrimp and crabs. Locally-used trap designs and methods are recommended. Some specific trap designs are detailed in the CRIMP protocol.

#### **Benthic infauna:**

Benthic infauna can be sampled either by divers (e.g. corer) or using an appropriate grab (e.g. Van Veen) operated from a boat or quayside.

Divers may insert a tubular hand corer (0.025m<sup>2</sup>) into the sediment (approx. 250mm deep) and seal the upper hole with a rubber bung or screw cap before withdrawing the corer from the sediment. On surfacing, it is emptied into a 0.5mm mesh bag and washed underwater by agitation.

Samples collected using box corer or a Van Veen grab with known grabbing area (0.04m<sup>2</sup>) may be transferred into a 0.5mm mesh bag with a drawstring mouth and a tapering bottom and washed underwater by agitation to remove fine sediment. The retained material can then be washed into a plastic bag and preserved in a 10% Rose Bengal and sea water formalin mixture. Subsequently, the sample is preserved in

5% formalin. Numerical abundance may be estimated using a stereo zoom microscope. Population density is expressed as numbers/m<sup>2</sup> and biomass as wet weight mg/m<sup>2</sup> (after removing the hard parts).

#### **Benthic Meiofauna:**

Benthic meiofauna can be sampled by means of sediment cores either taken by divers using Acrylic or PVC tube of 10-15cm length (2.5cm dia.), or collected from a Van Veen grab with a window. The sediment cores are transferred into plastic containers and preserved in 10% Rose Bengal and sea water formalin mixture. On shore, samples are washed gently through a 63-500 micron mesh. The retained material is preserved in 5% formalin in MgCl<sub>2</sub>.

#### **Sampling in rocky inter-tidal pools:**

Samples of sedentary fauna and flora are collected from a known area (0.1m<sup>2</sup>). Scraped material should be rough-sorted and preserved. The rough-sorted samples should then be subjected to fine sorting and photographed where appropriate. Macro-algae should be photographed and dry-pressed for future reference.

#### **Zooplankton:**

Zooplankton may be collected either with a suitable plankton tow-net (e.g. Heron-Tranter) or by pumping water through an appropriately-sized (e.g. 100µm) plankton mesh attached to the outside of the boat. Towed hauls may be vertical or oblique, as deemed appropriate, and at a low speed. The net is rinsed with water and the zooplankton collected in a plastic bottle, preserved with 5% formalin in seawater. In the laboratory, the sample may be split appropriately, if required, using a Folsom plankton splitter.

#### **Phytoplankton:**

There are 3 size-classes of marine phytoplankton: 1) Pico-phytoplankton (0.2 - 2.0µm); 2) Nano-phytoplankton (2.0 - 20µm) and 3) Micro-phytoplankton (20 - 200µm). To sample the entire range, several different methods may be required. As noted in the introduction to this Annex, the number of replicate samples, and the depths at which they are taken, will depend on the objectives of the survey, the characteristics of the site and the overall resources available.

For the investigation of pico-phytoplankton (0.2-2.0µm), small quantities of seawater (e.g. 1.8ml), collected from the surface and bottom using a Niskin or Van Dorn sampler, are placed in cryovials (2ml) and preserved with 0.2% paraformaldehyde (see CRIMP protocol). Subsequently, these vials should be transferred to liquid nitrogen for storage and transportation.

For nano-phytoplankton (2-20µm) and dominant micro-phytoplankton a known quantity of seawater (1 litre) may be collected from surface and bottom, using a Niskin or Van Dorn sampler, and preserved with a few drops of Lugol's iodine solution in plastic bottles. After transportation to the shore laboratory, the phytoplankton cells are concentrated by allowing the sample to settle for 48hrs and subsequently removing the supernatant and making it up to a known volume.

Supernatant water may be removed by siphoning with a plastic tube with a piece of 10µm mesh covering the dipped end.

For the larger micro-phytoplankton (20-200µm), vertical or horizontal hauls can be made with a fine-meshed plankton net (20µm). With horizontal hauls, the net should be maintained approximately 2m below the surface and towed at a speed of 0.3m s<sup>-1</sup>. Subsequently, the collected plankton cells should be washed off the net using seawater and transferred into appropriately labelled containers. Samples for incubation and culturing purposes should be kept in cool conditions; otherwise they can be preserved with a few drops of Lugol's iodine solution.

As an alternative to the above, large volume (10-20 litres) of water may be passed through 20µm mesh and the retained cells re-suspended with a known volume of seawater from the same depth.

The sample is then preserved as above.

**Dinoflagellate cysts:**

Sediment cores (acrylic or PVC tube of 10-15cm length) can be collected either with the help of divers or using a Van Veen grab with windows, as appropriate. A Van Veen grab has many advantages; it is efficient, easy and safe to operate, quick and, most importantly, cost effective. The cores should be kept on ice and transported to a shore laboratory for analysis or culture studies as appropriate. If culturing of cysts is not desired, the raw sample should be fixed as soon as possible. For long term preservation, neutralized formalin or glutaraldehyde can be used as fixing agent. There are two different processing methods for cleaning and concentrating cysts from sediment: sieving without chemicals and a palynological technique using several chemicals (see flowchart below on Figure 5 and Matsuoka and Fukuyo, 2000; Hyeon Ho Shin, et. al., 2013). The choice of method is dependent on the purpose of the study. For cyst assemblage analysis, the palynological method is recommended. For culturing (establishing clone culture and cyst-motile form relationship and toxin production), sieving is the method of choice.

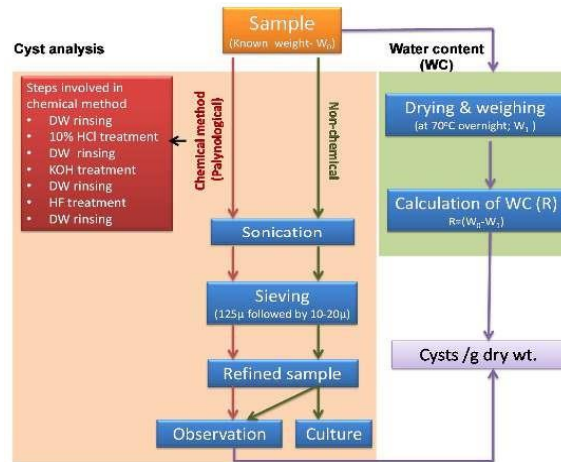

Techniques used to prepare sediment samples for cyst studies

DW – Distilled water, HCl – Hydrochloric acid, KOH – Potassium hydroxide, HF – Hydrofluoric acid

## Common Techniques for bacteriological investigations

Bacteria can be classified using 3 different methodologies:

1. Phenotypic Classification

Microscopic morphology

Macroscopic morphology

Biotyping

Serotyping

Antibiogram patterns

Phage typing

2. Analytic Classification

Whole cell lipid analysis

Whole cell protein analysis

Multifocus locus enzyme electrophoresis

Cell wall fatty acid analysis

3. Genotypic Classification

Guanine and cytosine ratio

DNA hybridization

Nucleic acid sequence analysis

Plasmid analysis

Ribotyping

Chromosomal DNA fragment

### Standard spread-plating method used for viable bacteria quantification

Culturable bacteria may be quantified using Zobell Marine Agar 2216. Pathogenic forms are quantified using specific media (Hi-media) following the manufacturer's instructions. For this, the sample is diluted and spread plated on Thiosulphate- Citrate-Bile Salts (TCBS) for Vibrios, MacConkey agar for coliforms, Enterococcus Confirmatory agar for Streptococcus and HiCrome EC0157:H7 Selective Agar Base to which HiCrome EC0157:H7 Selective Supplement (FD187) is added aseptically for *E. coli*. All the plates of specific media are incubated at 37°C for 24hr and colonies are counted.

To reduce uncertainties associated with counting of the pathogenic bacteria, *V. cholerae*, *S. faecalis* and *E. coli* are randomly picked from the selective agar and are confirmed by using a series of appropriate biochemical tests like gram staining, string test, oxidase, catalase, motility, indole, gas from glucose, Methyl Red, Voges Proskauer and citrate utilization.

The culturable bacterial abundance (Viable Bacterial Count, VC) is expressed as Colony Forming Units (CFU)  $\text{ml}^{-1}$  for water samples or  $\text{CFU g}^{-1}$  for sediment and fouling samples. The sample to be analyzed for Total Bacterial Count (TBC), that includes culturable and non-culturable bacteria, is fixed with formaldehyde (final concentration 1 to 2%; v/v).

#### **Total Bacterial Count (TBC) using epifluorescence microscopy**

The quantification of bacteria is done through the use of acridine orange and epifluorescence microscopy (Daley and Hobbie, 1975) and the values are expressed as  $\text{CFU ml}^{-1}$  for water samples or  $\text{CFU g}^{-1}$  for sediment and fouling samples.

Other dyes such as SYBR Greens I and II, SYTOX Green, and the SYTO family are less dependent on medium composition and can be used for enumerating bacteria in marine environments (Marie et al., 1997; Lebaron et al., 1998). Because SYBR Green I (SYBR-I) has a very high fluorescence yield, it is strongly recommended to use this dye to enumerate bacteria in marine samples.

#### **Flow cytometry (FCM) and enumeration of bacteria**

Flow cytometry (FCM) is a useful tool for enumerating and characterizing microorganisms. It is used extensively for assessing the viability of micro-organisms. It also offers the ability to physically separate the selected cells of interest by cell sorting for further molecular and physiological analysis. Bacterial samples stored in liquid nitrogen are stained or labelled with fluorescent tags that enable them to be identified electronically when passing through a beam of laser light. The advantage of associating FCM with the fluorescent molecular probes for differentiating viable and active or dead cells is noteworthy. Conventional methods for bacteriological tests of seawater quality take a long time to complete and the same can be achieved quickly and accurately using FCM which is capable of counting more than  $1000 \text{ cells s}^{-1}$ . This is particularly useful for assessing compliance with ballast water discharge standards.

Flow cytometry combined with Fluorescence In Situ Hybridisation (FISH) is an increasingly popular method of enumerating cells in environmental samples. The advantages of FCM over conventional microbiological techniques are the speed and accuracy of analysis. When compared to conventional culturing techniques there is also the advantage of being able to detect viable but non-culturable cells in seawater sample which represent a major fraction of marine bacterial species. The main concern is whether or not harmful organisms are being discharged into port waters and, if so, in what quantities. Flow cytometry analysis of ballast water may be important for control and optimization of different technologies used in ballast water treatment.

#### **Micro-organism Identification and Classification based on MALDI-TOF MS**

MALDI-TOF MS is a reliable, high throughput method for the classification and identification of micro-organisms. Starting from a single colony or other biological material, sample deposition and preparation with MALDI matrix is performed within a few minutes. After sample drying and loading the instrument spectra acquisition is completed rapidly. A prerequisite is the establishment of high-quality spectra libraries for the area under investigation.