

# SPACE + CULTURE + IDENTITY

CHINESE CULTURAL CENTER IN SEA POINT

(15)

The copyright of this thesis vests in the author. No quotation from it or information derived from it is to be published without full acknowledgement of the source. The thesis is to be used for private study or non-commercial research purposes only.

Published by the University of Cape Town (UCT) in terms of the non-exclusive license granted to UCT by the author.

# SPACE + CULTURE + IDENTITY

CHINESE CULTURAL CENTER IN SEA POINT

Design Report Submitted to the School of Architecture  
in Partial Fulfillment of the Requirements for the Degree of  
Master of Architecture (Professional) at  
University of Cape Town

by

**Jun Ren**

[RNXJUN001]

October 2010

# **\_CONTENTS 内容简介**

<b>INTRODUCTION .....</b>	<b>5</b>
<b>1 CULTURE, IDENTITY and ARCHITECTURE .....</b>	<b>7</b>
1.1 Chinese Culture.....	7
1.2 Traditional Chinese Architecture .....	8
1.3 Contemporary Chinese Architecture .....	19
1.4 Inspirations and Precedents .....	26
<b>2 SPATIAL AND URBAN MANIFESTATION OF CHINESE LIFE.....</b>	<b>33</b>
2.1 Urban life in China .....	33
2.2 Chinatown and Chinese community in South Africa .....	34
2.2.1 Cyrildene, Johannesburg .....	37
2.2.2 Chinese community in Cape Town.....	38
<b>3 MY THESIS .....</b>	<b>39</b>
3.1 Thesis Proposal .....	39
3.2 Site .....	40
3.4 Programme .....	47
3.5 Design Development .....	48
<b>REFLECTIONS .....</b>	<b>59</b>
<b>BIBLIOGRAPHY .....</b>	<b>60</b>



SOUTH AFRICA + CHINA [Jun's collection of images]

# INTRODUCTION 导言

---

On the African continent, South Africa has the largest population of Chinese people, who are the descendants of traders and settlers who came to the country four generations ago. According to Center for Chinese studies in Stellenbosch University, the last and ongoing wave of Chinese immigrants began arriving in South Africa in the year of 2000. The economic result from this migration trend will be more pronounced trading links between China and South Africa. In fact, Africa's growing consumer product trade ties with China is being driven by Chinese migration to the continent. This emerging trend will re-direct Africa's traditional trade networks away from Europe and toward China (Martyn J. Davies 2007).

My family moved here 10 years ago under this migration influence, and as a teenage at that time, I started living my life in a completely different environment and lifestyle. This thesis is inspired by the experience of living in two places that both have distinctive cultures. Architecture being a form of culture motivated me to enter the school of architecture. After 6 years of study, this paper attempts to answer my initial concerns on architecture and culture. For me it is very important to understand what the relationship between architecture and culture and how they influence each other.

How does one present culture and tradition in the design of architecture?  
How can architecture represent cultural identity in a foreign context, in a

more respectful way? Can architecture become the platform to connect people with distinct cultural backgrounds? Last but not least, in the contemporary city of Cape Town, what is the multi-cultural intervention that one can create for immigrants, in this case, the Chinese community in South Africa? These are the essential questions that I want to discuss and investigate in my thesis.

There are three sections in this paper. The first is an introduction to Chinese culture and its national identity, looking at traditional Chinese architecture and philosophies behind their making. The courtyard house will be studied as an example. Furthermore, contemporary Chinese architecture that looks at new approaches to representing the modern Chinese identity will be discussed. The second part explores spatial and urban manifestation in Chinese cities – how urban space affects one's cultural behavior. I will look at typical conditions of Chinatown and its architectural characteristic in the foreign context, including the new Chinatown in Johannesburg. In the last chapter, the paper will bring forward my thoughts through design development on site selection, programme and concept. I explored the subject of architecture and identity of nation and the way that cultural identity can be represented through architecture. I questioned how this can be translated into architecture when making its national image into a foreign country.

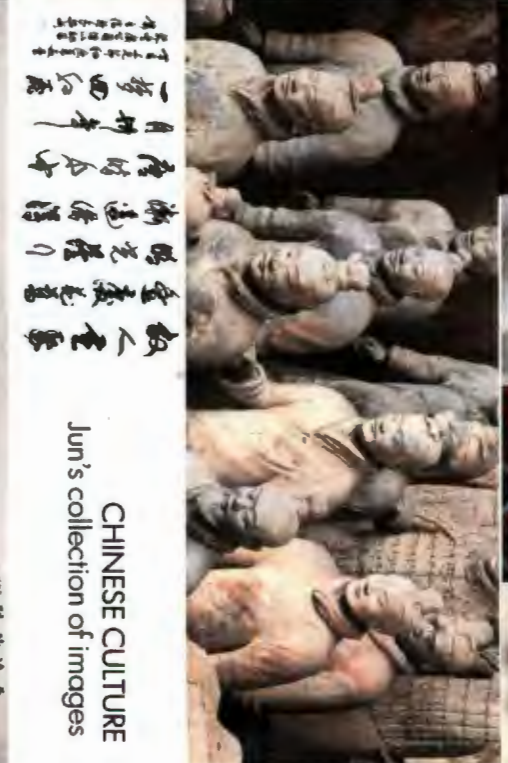

人生如夢  
 一轉回春  
 唐詩宋詞  
 漸遠傳揚  
 鳴冤怒聲  
 奴人冤家

中国书画  
 书画

CHINESE CULTURE  
 Jun's collection of images



Timeline of Dynasties in Chinese History

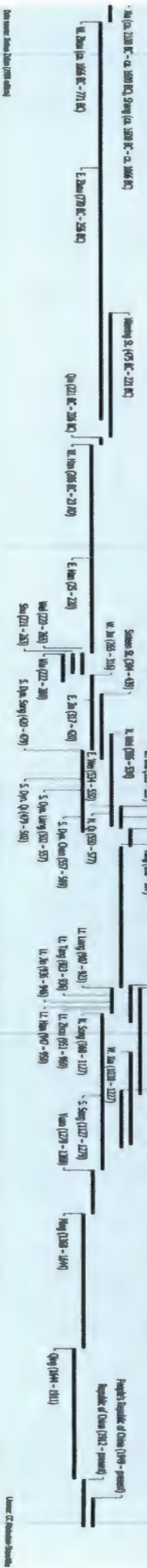

## Chapter 1

# CHINESE CULTURE, IDENTITY and ARCHITECTURE 文化与建筑

Throughout its 5000 year history, Chinese architecture, arts, music and culture has flourished. With centuries of trade and cultural exchange, some of this intangible heritage has been known to the West whilst many still remain mysterious. As the globe is merging, China is continuing to unfold its cultural identity. To begin to understand this project I will introduce China as a nation, along with my insight into its people and cultural richness. I will make an attempt to define two of the most difficult words of the present time: culture and identity and search their relationship within architecture. This chapter seeks to understand the essence and characteristic and cultural philosophy placed on Chinese architecture. It serves as a valuable background and design context for my thesis.

## 1.1 HISTORY + CULTURE 历史与文化

China is a nation with diversified nationalities, languages, and characters. It has 56 ethnic groups, over 80 languages, and about 30 kinds of character. Mandarin is the most widely used language in China and the world at large. Geographically, it locates in Southeast Asia along the coastline of the Pacific Ocean. With an area of 9.6 million square kilometers and a coastline of 18,000 kilometers, China is the world's third largest country, after Russia and Canada. Its shape on the map is like a rooster.

China is one of the Four Ancient Civilizations of the world (alongside Babylon, India and Egypt), according to Chinese scholar Liang Qichao (1900). It boasts a vast geographic expanse, 3,600 years of written history, as well as a rich and complex culture. Much of the traditional cultural identity within the society has to do with its social structure. Conceptually each imperial period are similar, with the government and military officials ranking high in the hierarchy, and the rest of the

population under regular Chinese law. From the late Zhou Dynasty (1046–256 BCE) onwards till the end of Qing Dynasty (1644–1912 AD), traditional Chinese society was organized into a hierarchic system of socio-economic classes known as the four occupations. And most of Chinese social values are derived from Confucianism and Taoism. The subject of which school was the most influential is always debated as many concepts such as Neo-Confucianism and Buddhism.

Many aspects of Chinese culture such as Chinese art, architecture, calligraphy, food, music, medicine, Kungfu, festivals and so many more can be traced back many centuries ago. The area in which the culture is dominant covers a large geographical region in eastern Asia with customs and traditions varying greatly between towns, cities and provinces.



TRADITIONAL  
CHINESE  
ARCHITECTURE  
IN SUMMERAY  
Jun's Collection

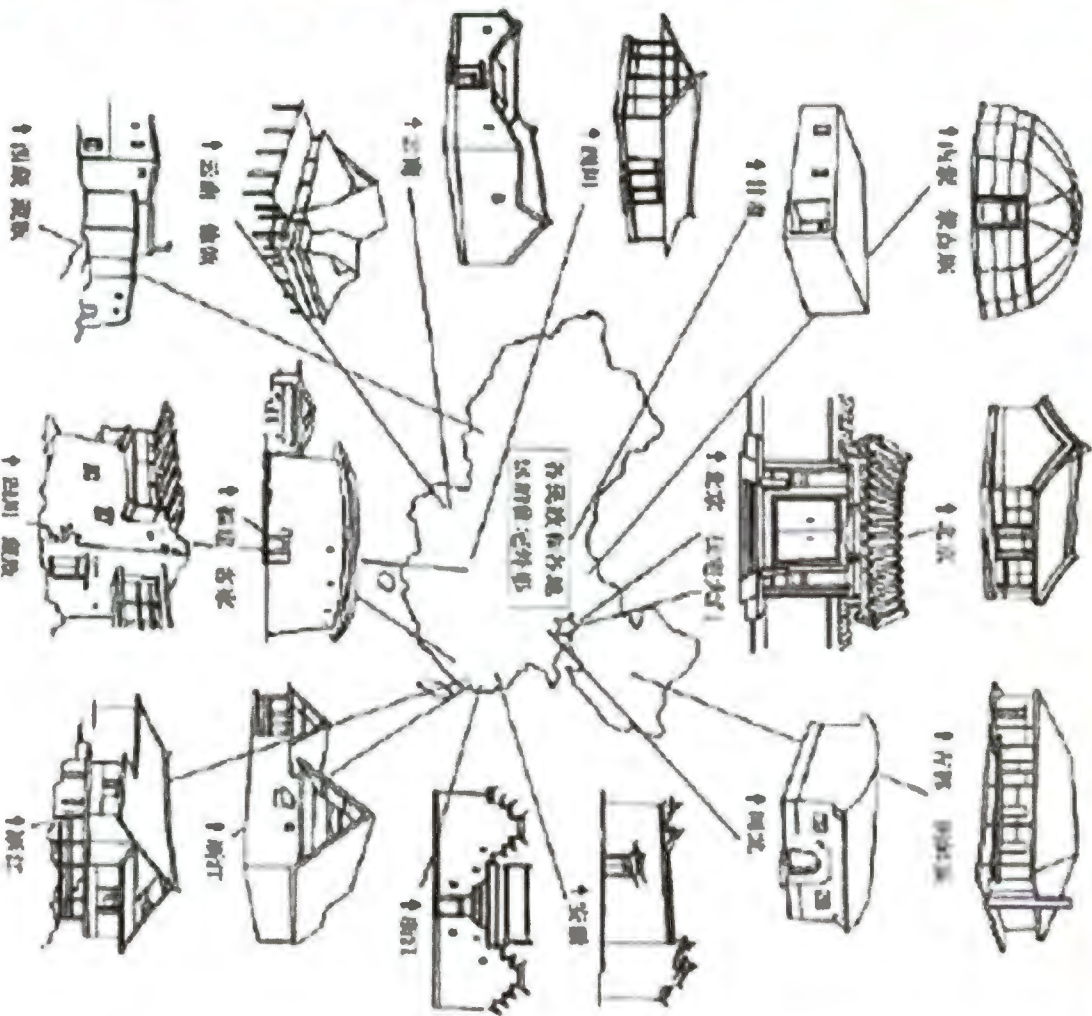

## 1.2 CHINESE ARCHITECTURE 中国式建筑

### 1.2.1 TRADITIONAL CHINESE ARCHITECTURE 中国古建筑

Much of Chinese traditional architecture is composed of small courtyards. Instead of pursuing the over-scaled architecture of for example western cathedrals, Chinese ancient people designed buildings to fit the human scale so that they may feel intimate and safe, and this idea reflects the practical thinking in Chinese culture. The styles of Chinese architecture are rich and varied, such as temples, imperial palaces, altars, pavilions, official residencies and folk houses, which greatly reveal Chinese ancient thought - the harmonious unity of human beings with nature. There is however certain common features regardless of specific region or use. The most important of the emphasis on width, as the wide halls of the Forbidden City serve as an example. In contrast, Western ancient architecture emphasizes height and its multi-volume space. Another important feature is symmetry, which connotes a sense of grandeur and majesty. One notable exception is in the design of gardens, which tends to be as asymmetrical as possible. Like Chinese scroll paintings, the principle underlying the garden's composition is to create enduring flow, to let the visitors wander and enjoy the garden without prescription, as in nature itself.

Confucianism and Taoism placed great values on the ancient Chinese society. Chinese people practice moderation in all things and they don't lay emphasis on strong self-expression but seek modesty and gentleness. The influence of this spirit on architecture is characterized by pursuing sense and connotation.

Concepts from Feng Shui and mythic concepts of Daoism are usually present in the construction and layout of Chinese architecture, from common residences to imperial and religious structures. This includes the use of: screen walls to face the main entrance of the house, which stems from the belief that evil things travel on straight lines. Talismans or images of door gods displayed on doorways to ward off evil and encourage the flow of good fortune.

Another principle is to orientate the structure with its back towards elevated landscapes, and ensuring that there is water in the front. Considerations are also made such that the generally windowless back of the structure faces the north, where the wind is coldest in the winter. Ponds, pools, wells, and other water sources are usually built into the design. Using water devices in the structure not only reflects the spirit of respecting nature, but also creates recycled and eco-friendly living environments.

The use of certain colors, numbers and the cardinal directions in traditional Chinese architecture reflected the belief in a type of immanence, where the nature of a thing could be wholly contained in its own form. The most common colors we see now are the red and gold, which imply happiness, prosperity and good fortune. The combination of white plastered walls and grey roof tiles is the material representation of Southern Chinese architecture.



TRADITIONAL CHINESE ARCHITECTURE:

- WATER DEVICES FOR RAIN COLLECTION IN COURTYARD
  - HANDCRAFTED WOODEN DETAILS
- Jun's collection of images

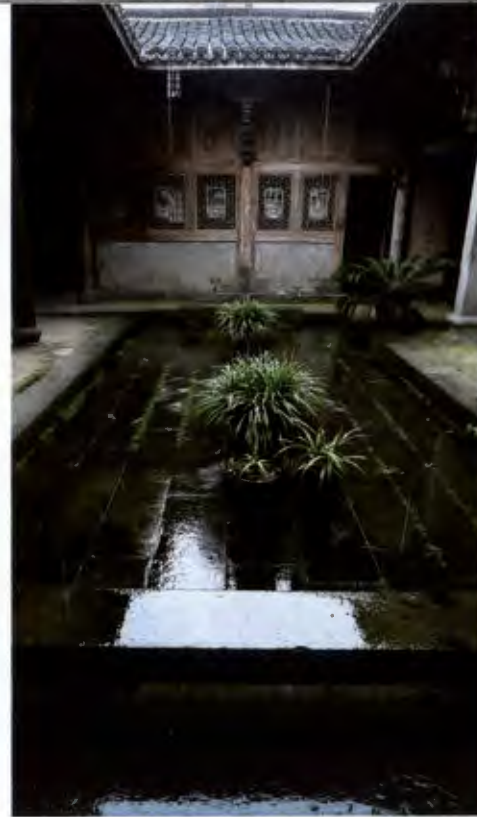

## 1.2.2 BUILDING TECHNOLOGIES

### ON TRADITIONAL CHINESE ARCHITECTURE 中国古建筑的技术与工艺

***"Architecture is a form of expressing the technological and cultural ideals and aspirations of each society"***

\_\_\_\_ **Homa Farjadi**, *Architecture Revisited* 2007. In *Aga Khan Award for Architecture: Intervention Architecture - Building for Change*, New York: I.B Tauris & Co Ltd, 2007.

There is strong evidence in literature, art, craftwork and so on testifying to the fact that the Chinese have always employed an indigenous system of construction that has retained its principal characteristics from prehistoric times to the present day (Liang, 1984). The intention of this subsection is to prepare my thesis with an understanding on material and form that can represent Chinese architectural identity. The technological investigation focuses on a more material approach to the subject. It is done through an investigation on traditional building materials such as timber, which has been used extensively in Chinese architecture and has become a modern material for Chinese cultural expression.



#### TIMBER / WOOD / 木

Chinese have used timber as a main construction material for thousands of years; wood to the Chinese represents life, and "life" is the main idea that Chinese culture strives to communicate. This feature has been preserved up to the present (Cheng, 1991). One of the main characteristics of traditional Chinese architecture is its use of a timber structural frame with pillars, beams, and earthen walls surrounding the building on three sides. The main door and windows are in front.

Guanyin Hall, dule-monastery, Tianjin (Liao dynasty, 916-1125)

Right: Woodblock print from the Ming dynasty *Carpenter's Manual*, showing a carpenter at work

Image courtesy Chinese academy of Cultural Heritage, Beijing



Left: Chunyang hall, Yongle palace, Ruicheng, shanxi province, (Yuan dynasty 1271-1368) Image courtesy architekturmuseum der tu münchen.



Middle : Bracketing cluster ('dougong'), interlocking wooden, often used in clusters to support roofs and add ornamentation. (Song dynasty 960-1279) Image courtesy architekturmuseum der tu münchen



Right: Diagram of three different wooden joints, from the architectural treatise *Yingzao Fashi* (1103 AD) Image from Wikipedia on Chinese Architecture.

According to Mies van der Rohe, "God is in the detail". In Chinese traditional architecture, details of woodworking go beyond pure decoration. Traditional wood joints make use of tenons, and reflect a successful combination of aesthetics and mechanics. The architecture and space created by employing this craftsmanship reflects Chinese people's understanding of the nature and the universe. Chinese timber architecture is the embodiment of wisdom of ancient technology and culmination of craftsmanship of Chinese craftsmen.

Study on traditional Chinese roof systems could take years of work. In the following pages, I would like to briefly look at structural orders, spatial organization and constructional process of the Foguangsi's roof system. Modern ways to create understandings of such structural system can be observed in an interactive tool, which provides calculations as well as drawing program.

Cross section of the Foguangsi main hall, drawn by Liang Sicheng (Liang Ssu-ch'eng). Note the zones created by the different roof levels, the rows of pillars, and the overhanging eaves. For scale, a person is drawn in at the lower right. Source: Fairbank, figure 2.

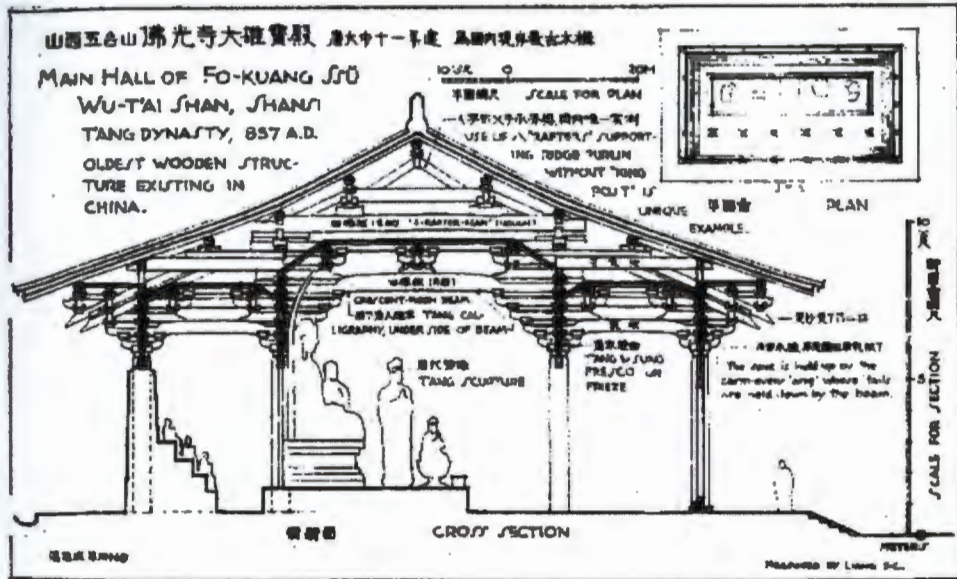

**Hierarchy, History, Politics, and Popularity in the Foguangsi Main Hall Roof's Design**

by John C. Klopff 1996

Front elevation of the Foguangsi main hall. Note modularity, square bays, and dominance of roof and overhanging eaves.

Source: Liu, Chinese Architecture, p. 92.

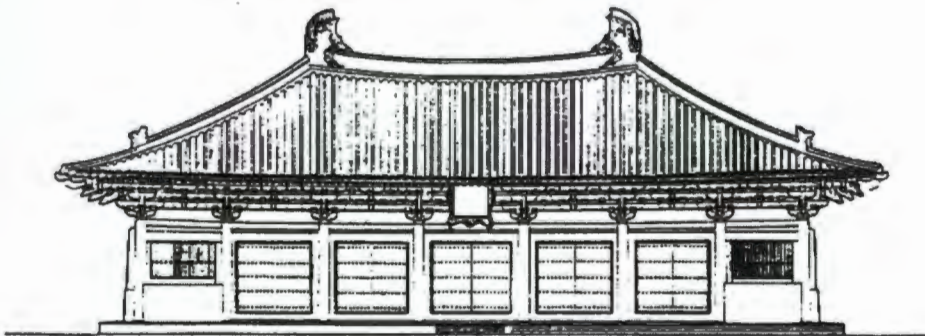
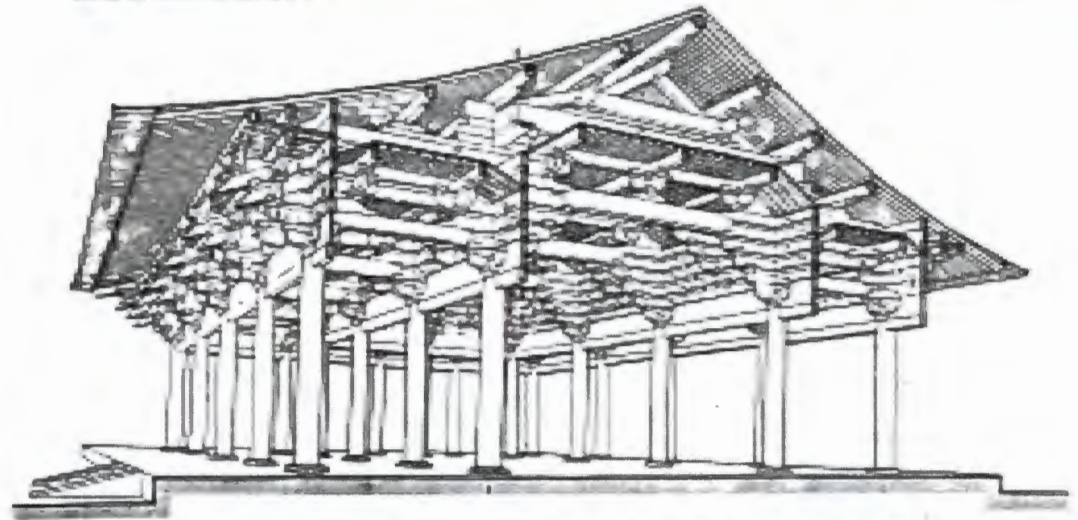
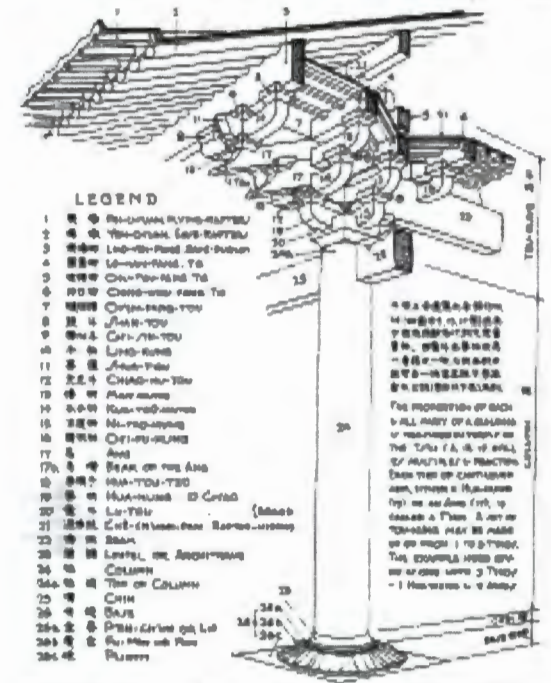

Diagram of the dougong system and its associated pillars and roof beams. Given that the dougong has four tiers, one can conclude that this diagram is based on the Foguangsi main hall. Because it only has five longitudinal bays, it cannot be a representation of it.

Source: Liu, Chinese Architecture, p. 93.



Detail diagram of the dougong system. Source: Liang; Coedrake, p. 84.



中國建築之「ORDER」 中國建築之「ORDER」 THE CHINESE 'ORDER'

# EXPLORING CHINESE TRADITIONAL ARCHITECTURE Interactive Realization of a Traditional Construction Process

by YINGDAN HUANG, IPEK OZKAYA, RAMESH KRISHNAMURTI  
School of Architecture, Carnegie Mellon University, USA.

This page describes an interactive tool for visually exploring the spatial organization and construction process of Chinese traditional dwellings.

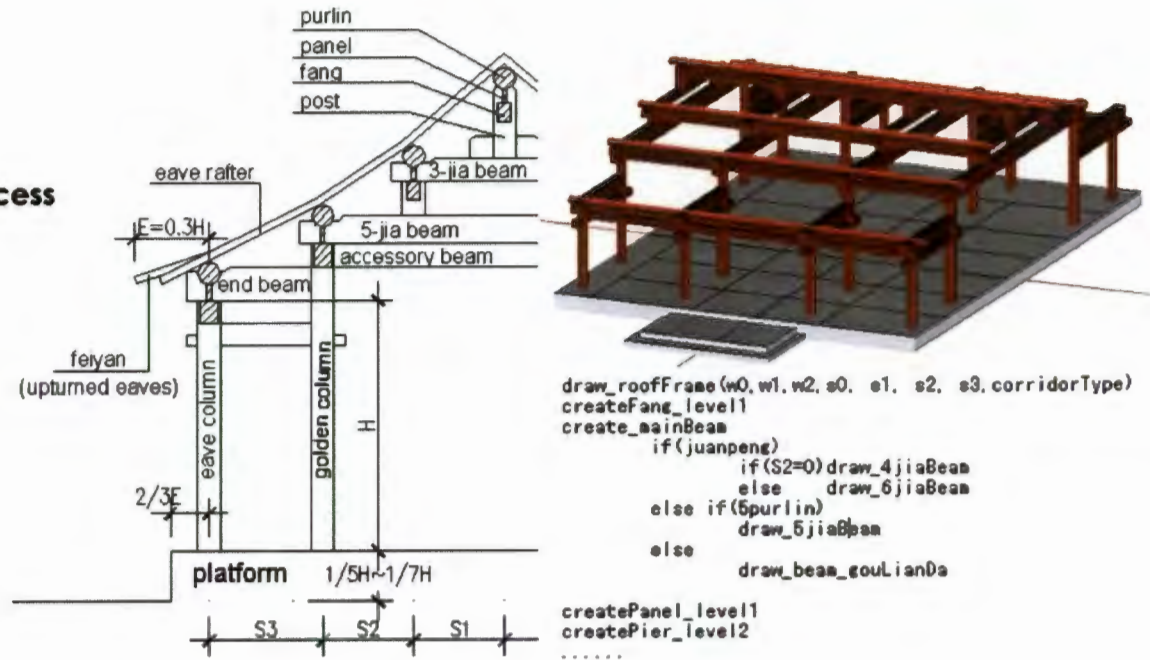

Figure 3. Wood framing of 4 bu-jia 5 lin with double corridors (in section and in 3D), code snip for roof rules

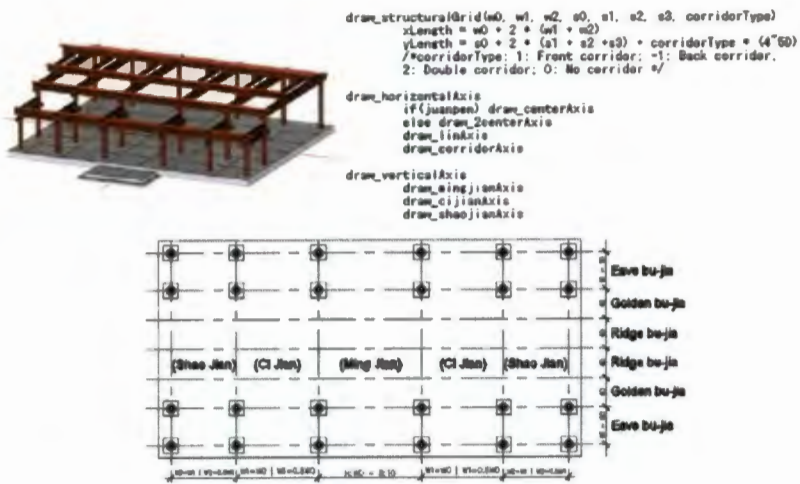
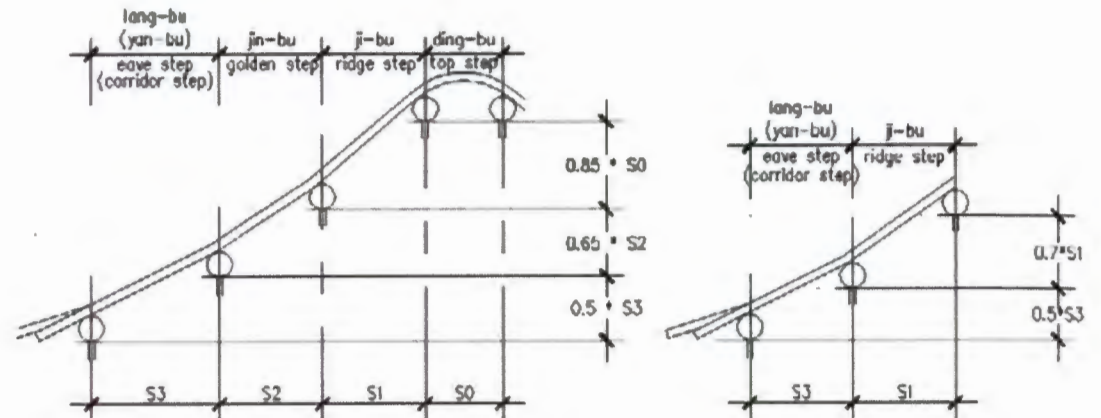
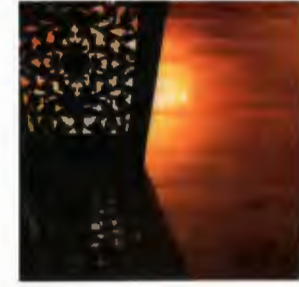
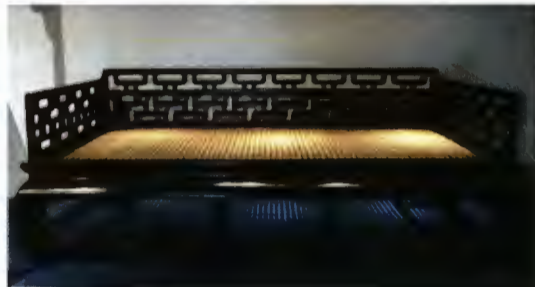

Figure 1. Snap shot from the tool representing a 5 jian, 4 bu-jia 5 lin front corridor style, code snip for axis rules and the columnar grid (comprising 5 purlins + double corridors)





Images of elaborate design variations of Chinese wooden door panels and screens. Photo of my own collection.

## DESIGN OF PATTERNS IN WOOD

In Chinese culture, or in most Asian culture, patterns are part of people's daily life experience. There is a strong sense of geometric forms that can be witnessed in the decoration of artifacts such as painting, sculpture, furniture design and architecture.

The design of patterns for wooden doors, windows and screens in Chinese traditional architecture has been a distinctive cultural expression. It not only served as shading device, but also decorative partitions for creating semi-private spaces. Woodwork reflects people's social status in traditional Chinese society. The more elaborate the pattern is, the higher one's status is on the hierarchy system. It is widely used as one of China's cultural expression in contemporary design.



SPACE CONFIGURATION OF TYPICAL COURTYARD HOUSE  
Jun's collection of images

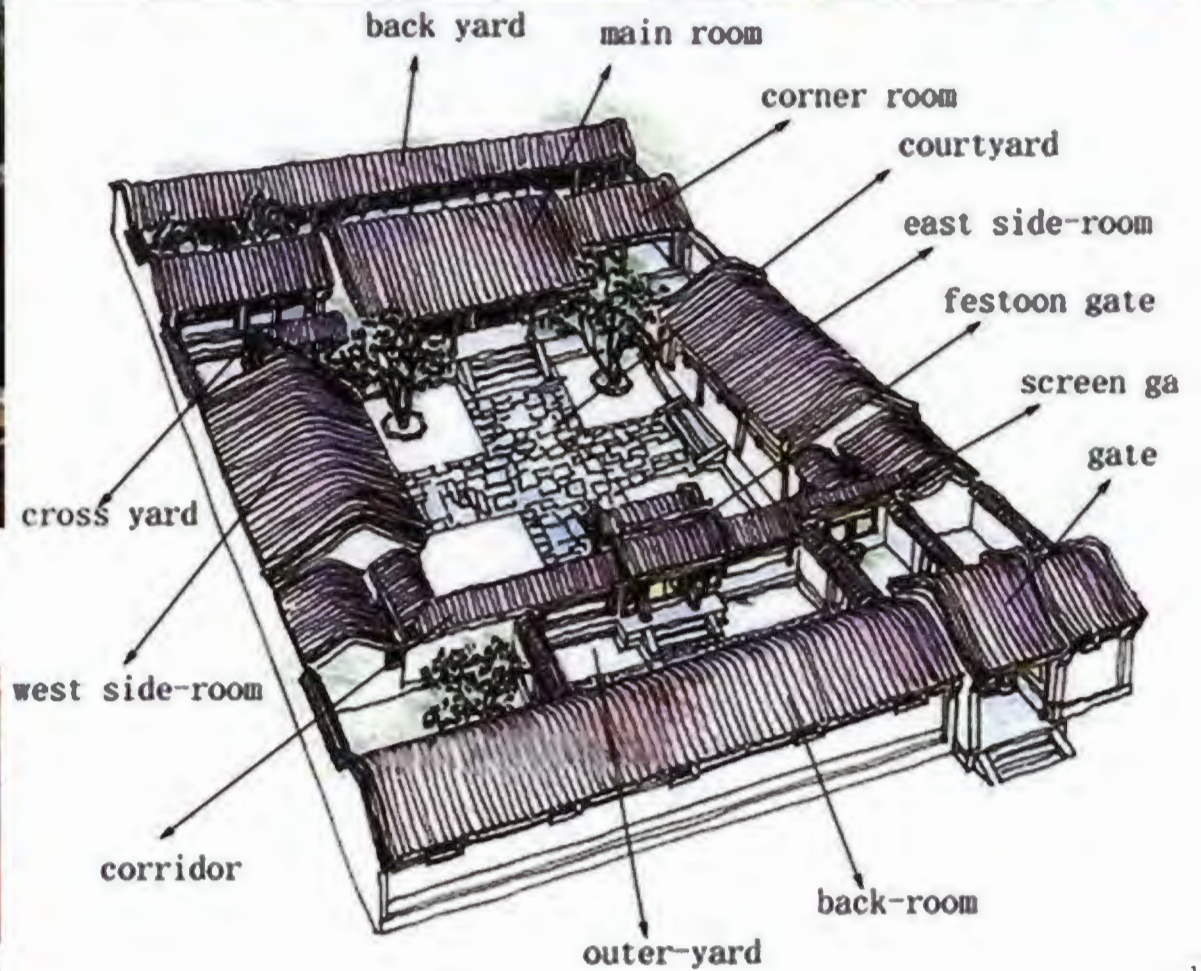

### 1.2.3 COURTYARD HOUSE – *Siheyuan* 四合院

For me and for many other people, courtyard house epitomize traditional Chinese architecture. It reflects Chinese social and ethical values and rootedness of family philosophy based on Confucianism. The courtyard house, also known in Chinese as '*Siheyuan*', is a rectangular unit of space joined together into a whole. The main structure is the axis, and the secondary structures are positioned as two wings on each side to form the main rooms and yard. The courtyard itself, even if very small, could contain potted plants and serve as a small garden as well as workspace. The main building would be at the back facing the courtyard. Children would live in the side rooms. The room beside the entrance was used for sundry and small agricultural purposes.

The main building faces south to avoid northerly winds and gain the most possible sunshine during winter. Overhanging eaves keep the building cool when the summer sun is high in the sky, and also keep off rain. There is often a screen just inside the entrance so that passes by cannot see directly into the courtyard - and to protect from evil spirits in the old times (who are said to travel in straight lines and deterred by curved paths and screens). (Zong Hui Chen, 1986)

These courtyard houses were constructed next to each other in rows to form a *hutong* - an alley less than 9m wide (the narrowest are less than 1m wide). During the rapid constructional developments in the recent decade, these lively communities are disappearing fast in Beijing, and elsewhere, although some such areas are now protected from redevelopment. (Pei Zhu, 2009)

In the interview with architect Pei Zhu with his Caiguo Qiang Courtyard House Renovation, he said, 'the attitude we developed for this project was one of sensitive regeneration, where contemporary buildings and modern building materials such as glass and steel can symbiotically co-exist with traditional structures'. The traditional courtyard houses were restored to its original condition, using both traditional and modern materials, construction technologies, and local skilled craftsmen and builders.

China is now modernized and westernised. Old buildings are swept out of the new Chinese urban landscape because of the difficulty in engaging traditional forms so steeped in history. Their modern uses are formalistically at odds with traditional contexts. Many cities in the China now look very similar to cities like New York, Hong Kong, or Tokyo, but still people miss the life in the courtyard house of the past. For me, it is a blurry but enjoyable memory of lifestyle that I had in my early childhood - a memory of being with the whole family in my own protected sunny playground.

In the contemporary design of Chinese architecture, there are many examples of work that are inspired by the axial planning and formal hierarchy of family dwellings such as courtyard house. The issues of solid and void, heavy and light, closed verse open, plain and textured – frequently inspire architects in their effort to find authenticity. (Miao, 1995) Courtyard houses represent incomparable modern significance both culturally and architecturally.



Caiguo Qiang Courtyard House Renovation. Architect Pei Zhu.

Local builder and craftsmen working on restoration of one of Beijing's Courtyard house, 2009. Image at [www.chinaarchitecture.com](http://www.chinaarchitecture.com)



### 1.3 CONTEMPORARY CHINESE ARCHITECTURE 中国当代建筑

The origins of modern Chinese architecture can be traced back to little more than a quarter of a century ago. The development of this modern Chinese Architecture has paralleled the country's growing role in the world's political and economic arenas. At the beginning of the twentieth century, the building methods of traditional Chinese architecture largely followed the standards and guidelines laid down by manual such as *Ying Tsao Fashi*, written in 1103. Even after that time, Chinese architecture continued to be influenced by the axial and hierarchical layout of Beijing's Forbidden City. After the return of China's first generation of overseas-trained architects in 1920s, the principles of Neo-classicism and the Modernist debate in Germany led them to search for typologies appropriate to China, both culturally and climatically. They endeavored to create a language that reflected the local context, while also showing the influence of the West. (Edward Kogel, 2004)

In his seminal text, 'In the Absence of Authenticity – An Interpretation of Contemporary Chinese Architecture' (Nordic Journal of Architectural Research, vol.8, no.3, 1995.), architectural critic Pu Miao maintains that the roots of Chinese contemporary architecture can be linked to the events of 1949, when the Communist Party took Power. A future milestone in its evolution came in the wake of the large-scale economic reforms of 1978 onwards from then.

Miao, like many others, believed that 'contemporary Chinese architecture, as an art, had yet to develop a language specific to its own unique conditions. During the 1950s China increasingly looked to the Soviet Union as its architectural role model. The significance of architecture in capturing

the essence of the nation, its traditions, culture and aesthetic value was never underestimated. (Bernard Chan, 2005)

After the dark and decade-long Cultural Revolution, and with the implementation of China's open-door policy in the 1980s, Western influence in the form of architectural exchange began to take root rapidly. (Bernard Chan, 2005) Miao used Martin Heidegger's theory of authenticity to help understand China's approach to architecture. He provided a simplified definition: "Authentic architecture must actively seek forms which plainly express the true conditions of its users' social, cultural and economic life." (Pu Miao, 1995) He described how Chinese architects adopt stylistic cues when confronted with different building typologies. 'Russian Classical' is applied to government buildings; cultural institutions and gardens are endowed with a 'Chinese Classical' language; Chinese vernacular is reserved for tourist facilities; and 'Western fashions' are borrowed for commercial and corporate developments. 'Modern' and 'Western' are often defined purely in terms of materials, hence the dominance of reflective glass curtain walls and exposed metal structures.

Reading through 'The Chronicle of Chinese Architecture: 1983-2003' compiled by architectural professor and critic Charlie Xue, it is clear where and how China's urban development accelerated. With China welcoming the world with open arms, the tourism industry grew rapidly. An increasing number of business travelers from overseas came to China, tapping into its economy. Xue points out the relationship between China's changing political scene and major architecture achievements such as I.M.Pei's Fragrant Hill Hotel in Beijing. Completed in 1982, the hotel was one

of several early examples of the type, setting a benchmark in contemporary hospitality. (Charlie Xue, 2003)

Pei returned to China in 1974 as part of a delegation from the American Institute of Architects. Four years later he was offered the commission of Fragrant Hill Hotel, when he said: 'This is not only a hotel; this is a way to explore the new Chinese architectural form.' (Carter Wiseman, 1990) He created an encapsulated, asymmetrical building with various inner courtyards. The structure that is integrated into the landscape, symbolizes a modern reinterpretation of traditional Chinese spatial principles and ornamentation. The construction borrowed artistic features of the Southern Chinese Garden and also worked with a courtyard house layout from the

Northern part of China, according to UIF Meyer in Beijing, Shanghai, Shenzhen – Cities of the 21<sup>st</sup> Century (Frankfurt 2000).

In many of Pei's works he often uses traditional Chinese architectural elements such as simple geometric shapes. Interior space links continuously with the exterior spaces and preserves tradition yet nonetheless introduces a contemporary style. His selection of materials such as steel structure, glass and detailed wooden work and so on shows a careful combination of western and eastern architectural quality.



Images of Hotel at Fragrant Hill, Beijing. (Carter Wiseman 1990)

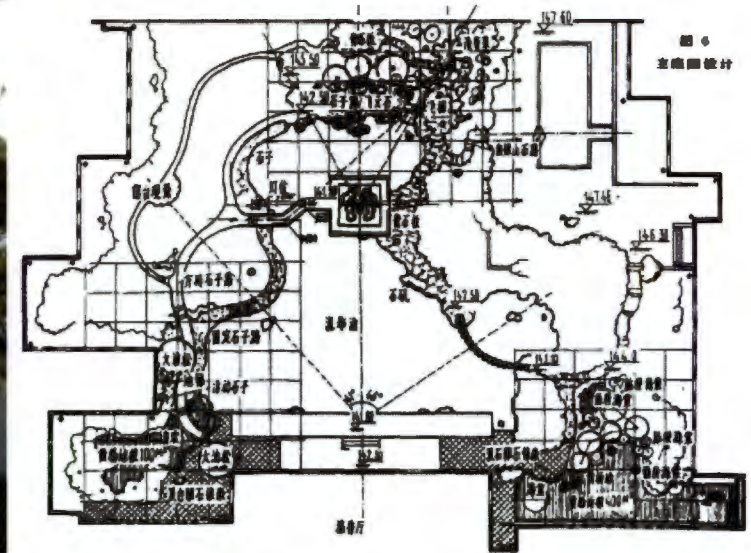



Chinese architectural elements are used with Suzhou Garden Landscape.

Images from Carter Wiseman, *I.M. Pei: a profile in American architecture*, the University of Michigan, H.N. Abrams, 1990.



Left: Interior of the central court acting. Middle: Steel tube structure of the roof. Right: Skylight. Key feature in Pei's Design.

Images from Carter Wiseman, *I.M. Pei: a profile in American architecture*, the University of Michigan, H.N. Abrams, 1990.

The **New Suzhou Museum** also designed by I.M.Pei was completed in 2006. The whitewashed plaster walls with dark gray clay tiles reflect the materials and constructional methods characteristic of Suzhou. The new museum adopts white and grey as its primary colors. Instead of using traditional clay tiles, the roof is made of gray granites with uniform colors. A modern steel structure is applied to the new museum to replace the traditional roof beam structure. The interior is decorated with wooden frames and white ceilings. In addition, metal sunscreens with wooden panels instead of the traditional carved lattice windows are introduced to make the new museum more sophisticated.

Under the design concept of "Chinese style with innovation, Suzhou style with creativity" and the idea of "not too high, not too large and not too

abrupt", through bold and meaningful site selection and high-quality construction, the new museum becomes a modern comprehensive museum with a humanist connotation (Zhang Xin, 2008). It not only has the character of the Suzhou style garden, but also contains the simple geometric form of modern art as well as the structural layout. The construction of the new museum makes good use of its space to advocate the culture, and to disclose the elegance of Chinese modern architecture and technical development. The new museum is adjacent to classical gardens such as the Humble Administrator's Garden, Zhong Wang Fu and the Lion Forest Garden. By enriching each other, they all become a historical and cultural gallery.



Left: Garden view of the Suzhou Museum in Suzhou.

Middle: Steel structured canopy at the main entrance, representing the traditional Chinese roof.

Right: Model of museum showing the surrounding context of the traditional architecture.



Left: Grey color outlines the building edges, contrasting with white walls.

Right: Architect's drawing. It's more like a Chinese painting.



Left: Interior, showing I.M.Pei's typical skylight for the passage. Middle: Typical architectural element of wooden screen window. Right: Waterside Pavilion in the modern look.

All images of Suzhou Museum are from Zhang Xin, *Suzhou Museum*, the University of California, Great Wall Publishing House, 2008.

The rich architectural and cultural heritage of China has been appropriated by politicians and property developers, whose ambitions to create something unique that can be critically evaluated as Chinese-ness have resulted in a wave of superficial styles. Many of Beijing and Shanghai's modern commercial buildings were required to incorporate Chinese features. Traditional motifs like pitched 'hat' roof tops were usually added to glossy, curtain-walled towers. The resultant mix of styles changed the landscape of China's urban development during the 90s. Professor Pu-peng Ho from the Chinese University of Hong Kong, quoted in *hinge* (vol.23, January 1996), emphasized the importance of culture and the spirit of the age when designing in China, and the place for traditional architecture:

'There is a context for its form, for its decorations etc., and that whole set of contexts cannot be transplanted without analyzing what it means in the broader scale. Architecture has to be holistic, it has to be in unity, or in coherence with itself, therefore if you just pull elements of the traditional vocabulary then you are going to misrepresent that element, you are just going to have a 'hat' without any function.'

New buildings whose architecture borrowed from traditional Chinese symbols, motifs or symmetry in planning continued to win favour with Chinese developers and government authorities. Approaching the end of the century, China had already fully embraced modernization. To the extent that large tracts of traditional urban fabric in cities such Beijing and Shanghai had been razed to make way to modern, international-style skyscrapers.

Many critics have been horrified by the indiscriminate demolition to the traditional *hutong* alleyways and courtyard houses. However, it was not long before one developer saw the economic benefits of preserving these neighborhoods (Bernard Chan, 2005). *Xiantiandi* in Shanghai, designed by Wood and Zapata Architects in 2001, was the first example restoring about fifteen the city's traditional *shikumen* houses and a former French colonial mansion. It has transformed the neighborhood into a buzzing commercial and residential district. The network of pedestrianized streets, public plazas and alleyways has spawned high-class restaurants, art galleries, book stores and alfresco café.

China's rapid urbanization also spawned a new species of architecture – the multiuse development. In *Beijing, Shanghai, Shenzhen – Cities of the 21<sup>st</sup> Century*, Dutch architect Rem Koolhaas claims the activity of shopping as a key common feature defining the Asian city. It is rare to find an urban architectural programme in China with no retail component. Multiuse commercial and residential complex hence become a fertile architectural model for China. These buildings, including office towers, apartments, entertainment and retail space, are favoured by the developers and their users. They have changed the once-human scale and proportion of China's cityscape.

In order to expand my understandings on contemporary Chinese architecture, a range of precedent studies have been carefully chosen to discuss the material and cultural expression, as well as the relationship between materiality and national identity for modern China.



Left: New look of the Hutong space. Middle: Public Plaza filled with restaurants and café. Right: Café culture in *Xintiandi* attracts many foreign inhabitants.

Images are from site: <http://sogou.com/xintiandi>, 2010-05-06

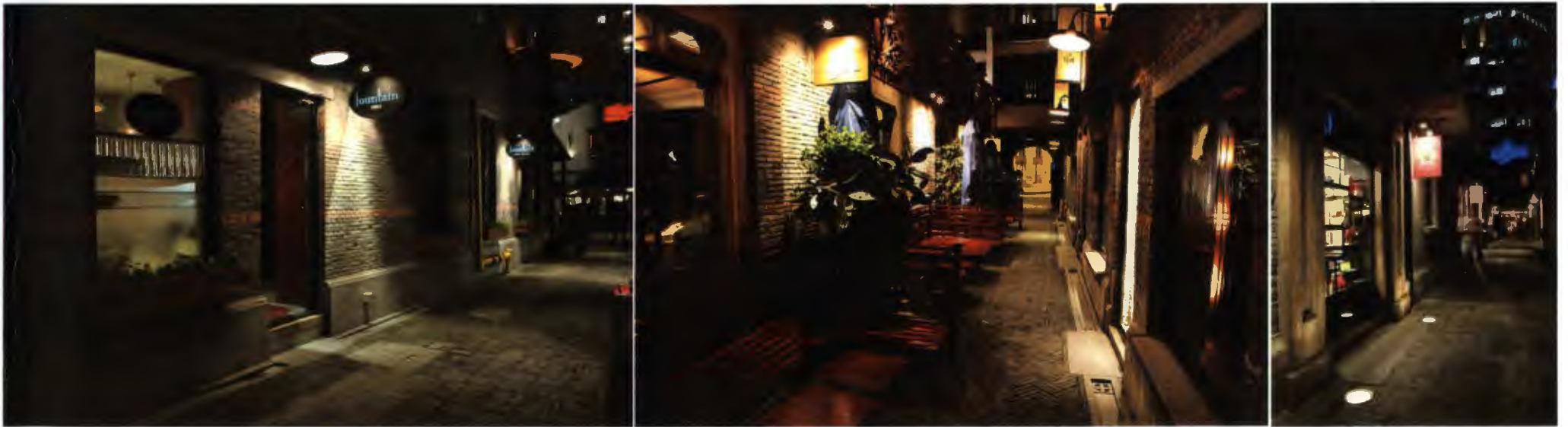

Views of restored retail space in alleyway, *Xintiandi* at night, Shanghai. Images are from site :<http://sogou.com/xintiandi>, 2010-05-06

# PRECEDENT STUDIES

on Contemporary Chinese Architecture



Wang Shu, is one of a few Chinese architects in china who really considerate its history and culture of the country in the design process. He uses traditional materials or recovers the materials freed from their structures by the passing of the bulldozers.

In a more spiritual mode, he takes up classical structures: that of the central courtyard, that of the great wood roofs, and that, of a dialogue with the landscape. But just he makes use of the materials according to the innovative directives of his intelligence (e.g. roof tiles can become sun-screens), he takes up the spatial traditions of China according to codes compatible with the demands of the most outright modernity.

Wang Shu shows how recycled and familiar materials (tiles and bricks) can be used in very contemporary architectural projects. He is referring to large scale demolition so common everywhere nowadays in China and how to keep up traditional modes of living in a rapidly changing context.

There are two of his recent works that I want to look at.



## Ningbo Historical Museum, Ningbo city, China

To make a mountain out of a museum, architect Wang Shu adopted a kind of geological will. At first glance, the stone-hewn Ningbo Historic Museum can be hard to distinguish from a natural form - or a force of nature. For Shu, the demolition of entire historical urban districts to make space for new high-rise housing developments was a painful experience to which he has given expression in his art works and architecture.

Exterior of the museum.

Iwan Bean's Photograph @ <http://www.iwan.com/>



In spite of its imposing scale, the building encourages intimacy with its intriguing facade. Here, Shu again borrowed from Chinese tradition - literally. The museum is clad in an armadillo shell of 20 different types of grey-and-red bricks and tiles, scavenged from the remains of farmers' homes on the site's now fallow fields. To cover the museum's 24m-high walls, which are made of concrete on a wood-and-bamboo frame, Shu guided craftsmen and builders on small mock-up experiments, and remained open to imperfections.

The walls are constructed with colored patchwork while respecting the old building techniques. By collecting history on the museum's facade, Shu highlights the impermanence of that culture, especially under the wrecking ball of China's urbanization. After all, it was partly because "Ningbo has demolished all of its history," he says, and then the officials commissioned the museum, because they were looking for something more modern, reflecting advanced technology.

The result is a stunning attempt to turn the museum inside out and encourage visitors to touch the past in the same way that they might scale a mountain. The public response has been resoundingly positive. "Rather than only using interiors or exhibitions, or some new and strange materials, I think it's the more physical and material culture, the remnants of the ruins, that can give us a more physical feeling," says Shu. "That can have a much stronger effect."

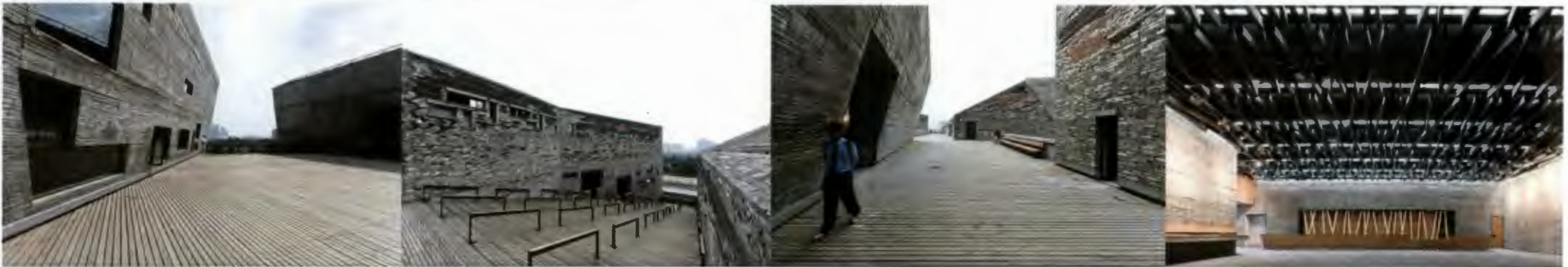

Above: three different views showing the spatial quality of the main courtyard.  
Iwan Baan's Photograph @ <http://www.iwan.com/>

Right: Interior exhibition space.  
Iwan Baan's Photograph @ <http://www.iwan.com/>

# Campus of China Academy of Art Hangzhou, China 2007

My eyes was immediately attracted to the richness of the texture when I first saw this project. I am very interested in Shu's use of materials such as timber, stone, recycled tiles and bricks in this project. They tied to that of traditional building elements and they appeal very 'Chinese'.

The campus is formed by about twenty main buildings. Although some of the structures differ among each other, the use of materials is similar in their common writing. The architect has designed a large square courtyard where one rediscovers the spirit of the Chinese tradition fortified by the use of large panels of wood. The wooden panels also allow the modulation of the irrupting light while providing a reassuring solidity on each level.

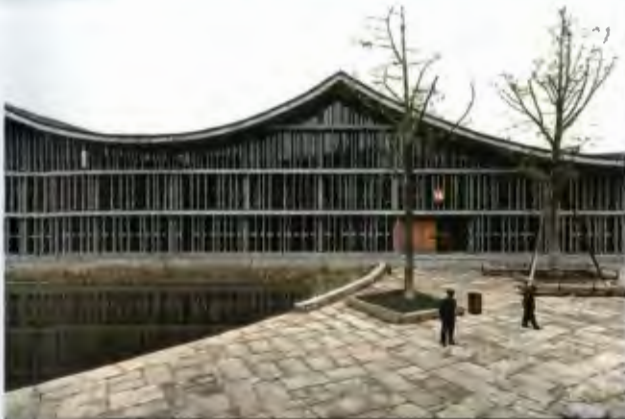



## Jade Valley Hotel Village, Xi'an, 2003

This project by architect Ma qingyun developed a renewed utilization of brick, the spaced meshing of which gives the illusion that the building is breathing, because there is only a small number of hexagonal openings on the exterior, a classical arrangement in Chinese houses. The elaborate woodwork also belongs to tradition and has been used extensively as sunscreens and decorative window devices in contemporary Chinese architecture.

It is built with local construction workers, based on a native knowledge and designed on-site brick by brick through a series of sketches and discussion. The project slightly changes the traditional typology with modified conventional elements found in the new Lantian courtyard house.

This design is to reflect a strong Chinese living philosophy: a piece of the sky is sufficient for an otherwise isolated, protected, introverted family.

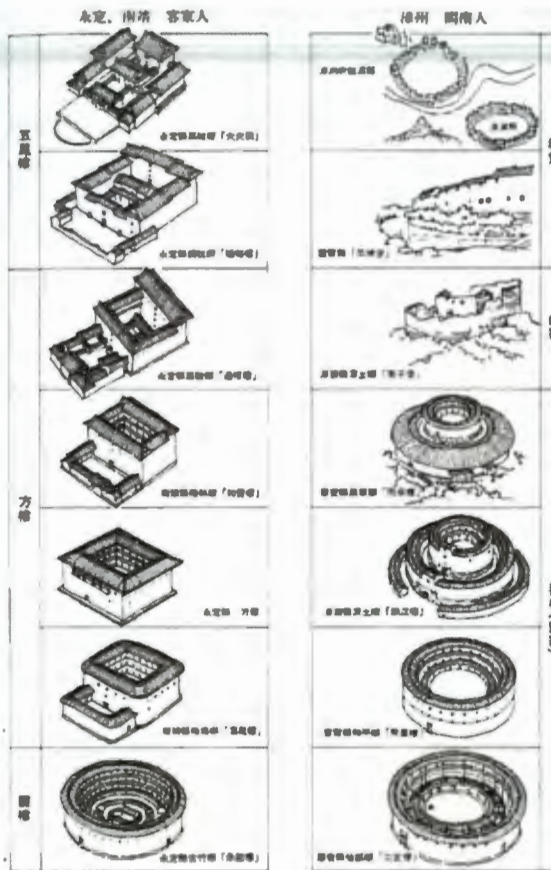

### Traditional Tulou Housing

A Tulou is a traditional communal residence in the Fujian province of Southern China, usually a large, enclosed and fortified earth building, rectangular or circular in configuration, with very thick load-bearing rammed earth walls between three and five stories high and housing up to 80 families. The term "tulou" first appeared in a 1573 Zhangzhou county record of the Ming dynasty. Many villagers built walled strongholds and tulous as a means of defense.

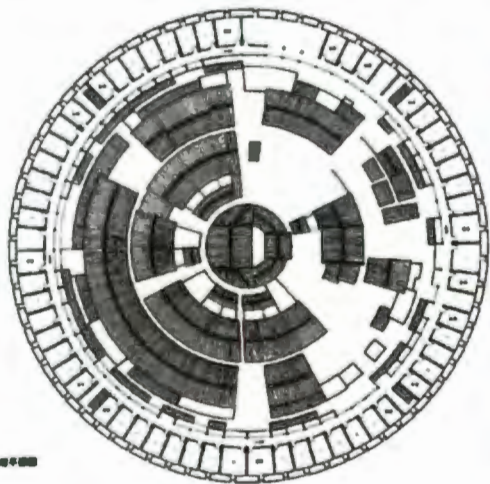



## VANKE Tulou Housing

### Affordable Housing Complex

Urbanus Architects, Guangzhou, China 2008

The Tulou is a dwelling type unique to the Hakka people in China. It is a communal residence between the city and the countryside, integrating living, storage, shopping, spiritual aspects, and public entertainment into a single building entity. Units in a traditional Tulou are laid out evenly along its perimeter, like a modern slab-style dormitory building, but with greater opportunities for social interaction. Although this type of dwelling is very suitable for low-income housing, simply copying the external form and style of the Tulou would not be a good solution for the design of contemporary low-income housing. However, by learning from the Tulou, one can help preserve community spirit among low-income families.

By introducing a 'new Tulou' for modern cities and by careful experimentation in form and economy, one can transcend conventional urban design. The close proximity of each Tulou building helps insulate the users from the chaos and noise of the outside environment, while creating an intimate and comfortable environment inside.

I have looked at this project because it is trying to integrate the communal living culture from the traditional Tulou housing, and both the form and materiality of this project speak vernacular architectural language.





## Chapter 2

# SPATIAL + URBAN MANIFESTATION of Chinese Life

## 中国人的都市空间与生活

### 2.1 URBAN LIFE IN CHINA 中国都市生活

Urban life in Chinese cities is always busy, fast-paced and vibrant. Architecture of Chinese urban nature is the production of urban culture, subject to all kinds of dynamics that many consider to be distanced from the real human and urban issues. Vernacular architecture and urban landscape in general are more fertile in human terms than architecture that is strictly controlled by politics and corporations.

Taking a look into the cultural behaviors of the inhabitants of Modern Chinese cities is very revealing, as it shows how Chinese use space in the urban context. One of the most exciting parts for me has been the lively street culture. The street is a public space. In fact, almost every street can be seen as public space due to the large population. The street life is crowded but vibrant. In my memory, it felt free, colourful and enjoyable throughout my childhood. The streets facilitate a range of Chinese functions and celebrations. It also stimulates people's senses such as viewing, hearing and feeling towards different spaces. The street serves as a natural playground for Chinese daily life.

Life in *Hutong* is one great example to show Chinese Cultural behaviors. *Hutong* are comprised mostly of alleys with no names that often twist and turn with no apparent rhyme or reason. During the day old men sell vegetables; children study on desks outside their homes; small time cobblers and fruit vendors go about their business. In the evening many residents gather in the alleys to eat dinner or play... The public Chinese cultural traditions have a direct relationship to the form of public spaces. Streets around the world are activated engaging spaces when they are filled with Chinese celebrations. Chinese culture makes a direct contribution to public life.





Left: Entrance gate at Chinatown Sydney.

Middle: Chinatown in London.

Right: Dragon Dance – typical Chinese New Year's Celebration.

[http://architecture.about.com/od/ Chinatown](http://architecture.about.com/od/Chinatown) 2010-04-26

## 2.2 CHINATOWN + CHINESE COMMUNITY IN SOUTH AFRICA

Chinatown is a place to experience and enjoy the Chinese style of living. In this subsection, I would like to talk about the spatial qualities that define a Chinatown and how I experience it in South Africa. A short history of South African Chinese community will be briefly presented as they will form the user group for my thesis design.

China has a long and rich history of exploration and migration around the world. A Chinatown is an urban region containing a large population of Chinese people within a non-Chinese society. The Chinatowns were created to bring a sense of home and community to strangers in a new land. The early Chinese immigrants created small Chinatowns in which they

opened their own stores and restaurants, set up temples, and formed different community support groups. Whatever their origins, you can find a Chinatown in almost every major city in the world. They vary in size – from a couple of streets to large, thriving cities within a city. Chinatowns are now generally viewed and valued as tourist attractions. Visit any Chinatown in the world, you will find large pagoda-style arches, red paper lanterns, Chinese dragons, gift shops, east medicine, groceries, various Chinese and other Asian restaurants and small businesses. The streets of Chinatown are usually well paved to create a pedestrian-friendly shopping environment. Restaurants serve many Chinatowns both as a major economic component and social gathering places.

### **2.2.1 CYRILDENE, Johannesburg**

Cyrildene is situated in the Johannesburg region of the Gauteng province in South Africa. This new Chinatown is now considered as the main Chinatown in Johannesburg, replacing the declining Chinatown on Commissioner Street in the inner-city of Johannesburg. The old Chinatown used to be in the middle of the city centre, although some spots still remain. But it is presently in Cyrildene, where you will find the largest collection of Chinese people. Although it is not as fully established as other Chinatowns in major global cities, this one certainly caught my eye when I visited it last year.

Technically, it is more like "Chinese Street". As soon as I got there, it was unbelievable for me how similar it was to an ordinary street in China. It instantly brought up my memory of living in my home city. I got surprised and excited. Indeed, it felt like I went home. While it did not necessarily look like a typical Chinese street, it felt like it. The smells of Chinese food, the sound of Mandarin being spoken, the ease with which couples walked lazily through the street, people eating meals outside in the courtyard spaces or on the pavement, all of these contributed to a very warm and comforting feeling of familiarity for a Chinese national in South Africa, like me.

The second time I visited Cyrildene was on this year's Chinese New Year during a festival celebration. I was lucky enough to take part with the whole Chinese community, this occurs rarely in Cape Town. Thousands of visitors coming from all parts of Johannesburg witnessed the true spirit of Chinese people as they honor their history and culture. Tables with New Year feast were set up on the street, which is one of Chinese traditional custom. Celebrations include lion dances, fireworks, parades, music and laughter. As I remember what Louis Kahn said, the street is the institution of society; the street is the theatre of life. It becomes a stage of event and a positive public place for gathering (Louis I. Kahn, Robert C. Twombly, 2003).



CHINESE NEW YEAR CELEBRATION  
CYRILDENE CHINATOWN, JOHANNESBURG, FEB 2010  
Jun's Collection



### **2.2.2 CHINESE COMMUNITY IN SOUTH AFRICA**

The South African Chinese community is, and has almost always been, one of the country's smallest minorities. Their earliest settlement in South Africa began from the first decades in the mid seventeenth century. The settlers established themselves in a variety of small-scale trades and crafts dealing in commodities such as tea, chinaware and fabrics or sold fish, fresh vegetables or small cakes. The second wave of Chinese immigration took place in the first decade of twentieth century after the discovery of gold on the Witwatersrand. The third and more recent wave of immigration comprises a very diverse range of Chinese immigrants, both in terms of origin and purpose. The nature of this third wave is also made more diverse by the political developments within South Africa, as well as those in Taiwan and the People's Republic of China (PRC) over the past half century. Although the current numbers of Chinese nationals in Cape Town are difficult to pin down, the total Chinese population in South Africa is about 120 000 and this is ever increasing in the recent years (Park, Y., 2007).

The Chinese community in South Africa range from SABCs, i.e. South African Born Chinese, students, businessmen, workers, tourists and professionals. They are divided by time, geography, national and regional-cultural affiliations and by the ways one speaks Chinese. Since people in the community have different intents and purposes in this country, it does not form a homogenous community, nor are there strong inter-community connections. One of the reasons that I discovered through thesis research and interviews is that there is no proper place in Cape Town for Chinese community to gather for functions and festival celebrations. CITCC is often hired for important functions and events but according to Cape Town Chinese embassy, it is inconvenient to hire it every time and the cost is expensive. Therefore, my thesis is to propose a Chinese Cultural center in Sea Point, where accommodates cultural events and cultural exchange with the locals.

## Chapter 3

# MY THESIS: CHINESE CULTURAL CENTER IN SEA POINT 南非开普敦 中国文化交流中心



### 3.1 THESIS PROPOSAL

The intention of my thesis is to build upon my experiences as a Chinese person living, working, and studying in South Africa. I propose to explore a better understanding of relationship between space, culture and identity, and how these things can help to bring comfort to people. I am interested in providing a space which can allow for better living and working relationships between South Africans and Chinese communities in Cape Town. I also intend to seek the way that cultural identity of a nation can be represented through the making of architecture.

Jun's Presentation on Thesis Ideas, March 2010

### 3.2 SITE: CONTEXTUAL ANALYSIS OF SEA POINT AREA



Map of Western Cape



Map of Central Cape Town

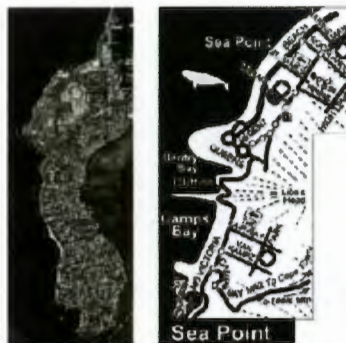

Map of Sea Point, Green Point

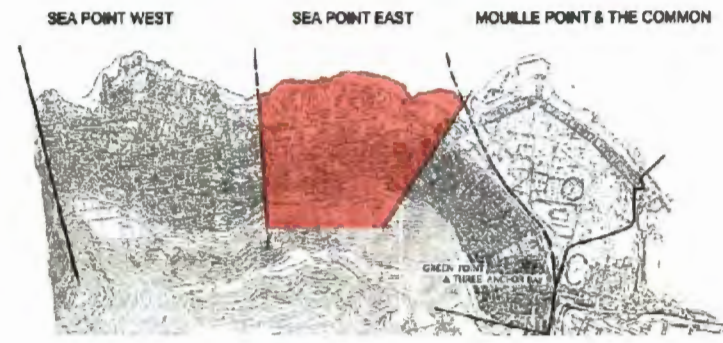

Study Area - SEA POINT EAST

Jun's Presentation on Contextual Analysis of Sea Point East, April 2010

Sea Point Main Road is an interesting piece of the urban landscape for many reasons. It is a multi-use mixed density commercial strip. It is edged by housing, shops, offices, public facilities and so on. In other words, it is one of the most 'urban' places in Cape Town. The richness of its urbanity is in no small measure affected by people who inhabit it. It is a cosmopolitan area, with people of all ethnic, racial, religious and social backgrounds living and working together. Geographically, Sea Point is located in the natural landscape between Signal Hill and Atlantic Ocean. It is close to Sea Point Promenade and the beach. These place together act as an urban social hub that is quite densely populated. It is a part of Cape Town that has for years been a destination for holiday makers as well as other Capetonians. Moreover, with the revitalizing plan of Green Point and Sea Point, the area is transforming into a more safe and vibrant urban strip. Sea Point's busyness, pedestrian-friendly streets, fast-paced lifestyle, and its rich cultural heritage have attracted the growing Chinese business and other organizations.

The location is very important because a good location that allows for the community to access it will increase its functionality and make it all the more successful space. In finding the site, I started to locate the major Chinese institutions and business organizations on the map. Observations, contacts, interviews and questionnaires contributed to an identification of the problems and issues from Chinese inhabitants in the city. The site is studied from a metropolitan scale which is Sea Point East, down to micro scale of streetscape – Sea Point Main Road, and lastly to site scale.

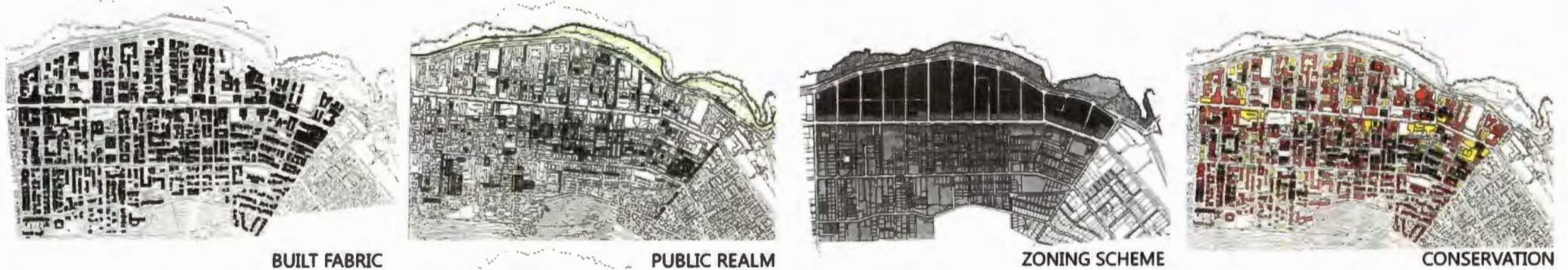
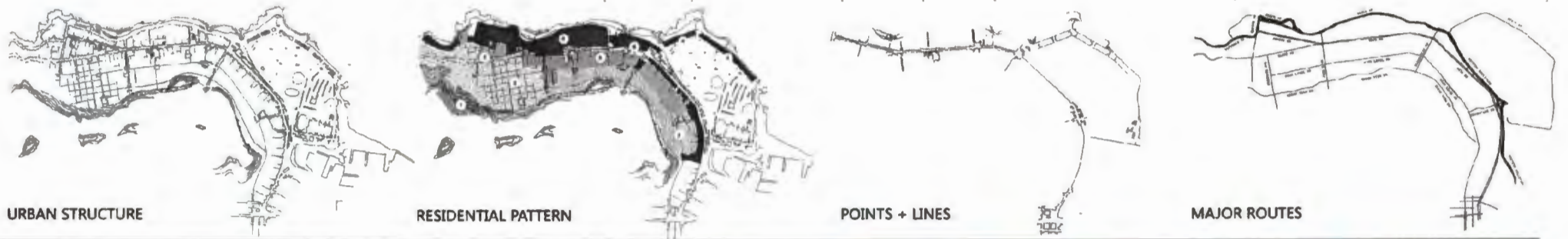

Jun's Presentation on Place and People of Sea Point, April 2010

## AT METROPOLITAN SCALE:

### **Movements**

Sea Point is structured in a way that is highly convenient and accessible to a large number of people. The urban structure of Sea Point East is developed along four major routes, which have distinctive characteristics: recreational, commercial, residential and high way. These roads accommodate the requirement of pedestrian and vehicular traffic.

### **Residential Pattern**

There are three homogenous dwelling types in the study area. The land between Main Road and Beach Road is characterized by high land values for its beach front view and recreational facilities. Consequently, high rise, high density apartment blocks development is the norm. This area is flanked by the Main Road strip, which forms the boundary of the second residential band above the Main Road. The third residential band enjoys higher land value as a result of the views on the slopes of Signal Hills. The residential fabric is arranged on a broad grid network between the major routes. Block size tends to decrease with distance from the Beach Front.

### **Recreational Space**

The public recreation facilities are clustered along the beach road. The Promenade stretches for approximately four kilometers and is edged by a grassed area of variable width for much of its length (the old railway reserve). Recreation and tourism play a fundamental role in the economy of Sea Point area. This area has historically been regarded as an area of outstanding natural beauty and has centuries been utilized for recreation. People making

use of the area's recreational potential are drawn from local, national and international sources. The natural site is generally linear and is very clearly confined between the coastline and the steep slopes of Signal Hill and Lion's Head.

### **Commercial Patterns**

Commercial land use patterns are structure about the movement system, in particularly Main Road. The structure attracts heavy traffic loads to the major routes, releasing pressure from other parts of the fabric. The major routes also tend to protect the more sensitive residential fabric. This dominance of the major routes attracts the location of commercial facilities which exploit the high thresholds generated by the movement. The relationship between commercial activity and the movement system is mutually beneficial, as the high traffic loads attract activities, and in turn the activities attract increased traffic loads.

### **Conservation**

In Sea Point, most of the historic buildings along the Main Road have either been replaced or else altered beyond recognition, but the present environment, both as an urban space and a social amenity is unique in Cape Town.

## AT STREET SCALE:

A large number of restaurants, cafes and night pubs are concentrated on the Main Road and Beach Road. Sea Point accommodates the highest density of restaurants per hectare in the metropolitan area, according to the Green Point and Sea Point Urban Policy Plan (Fabio, 1991). These facilities encourage pedestrian movement along the length of Main Road, particularly at night, and contribute significantly towards the amenable atmosphere of the place. The figure above is my presentation of analysis on Sea Point Main Road. It shows the greater context of the Sea Point East and buildings along the Main Road. All the Chinese shops are dotted in red colour along the Main Road. (Jun's Presentation on Sea Point Main Road Analysis, April 2010)



## AT SITE SCALE - MY SITE



rockland road elevation



main road elevation



surrounding + condition

1. Pre 1902 building, now use for small businesses. 2.SABC car garage. 3 Parking lot. 4 Pre 1935 residential building  
5. New residential+retail complex. 6. Pre-1935. 7. Pre-1920. 8. Pre-1935. 9. New residential+retail complex.

Jun's Presentation on SITE, April 2010

The site I choose is located at the intersection of Sea Point Main Road and Rocklands Road as shown in the red lines above. Building 1 is one storey high colonnade shopfront. It houses internet café, restaurants and other small retail business. Building 2 is occupied as storage place for SABC vehicles and number 3 is parking lot. Building 1 and 4 on site are significant buildings under national heritage protection. Therefore, both building façades will be considered with no future alteration in the design stage.

Corner condition of the site is very exciting for me as it give people a direction, a landmark, a place to meet each other, a beautiful signage to enjoy, a paved walkway to go down to the Rocklands beach and many other possibilities. The Rocklands Road has two traffic lanes and one off street parking at each direction. The road is planned as a 'mobility route' in Sea Point Urban Planning Policy (Fabio1991). After BRT system complete, there will be bus stop locate exactly at Rocklands Beach, thus pedestrian movement will be promoted and this will aid to decrease the heavy traffic load in Sea Point.

In summary, I have chosen this site because there is a great potential of for future development under Sea Point revitalizing influence. It serves as a gateway to the Sea Point strip. Its location is highly accessible to all inhabitants in the area and will be directly linked to BRT system in the future. It is close to Rocklands Beach and Sea Point Promenade for a positive public space. Most importantly, the corner condition of the site will provide direct visuals for meeting and interactions. Its architectural heritage, which will be preserved in the design, will give a rich historical and cultural background of the area. By keeping the existing building on site, it is very exciting for me to create an intervention that combines different architectural logics and philosophies.

The images below are similar projects that have been constructed in the recent years along Sea Point Main Road. All 7 storey, mix-use developments that provide of retail space, offices and residential apartments. Though my design process, these buildings have been looked at for their similar consideration of climate, sun orientation, accessibility as well as feasibility study.



Local Precedents on Sea Point Main

N 1: 1500

- Buildings of National/Local Significance
- Pre-1940 Buildings of historical interest
- Edges that contribute to urban streetscape
- Usable outdoor space
- Chinese business / commerce
- Significant avenue and trees

Atlantic Ocean

Rocklands Beach

PUBLIC REALM  
+ RECREATION

Pedestrian Movement

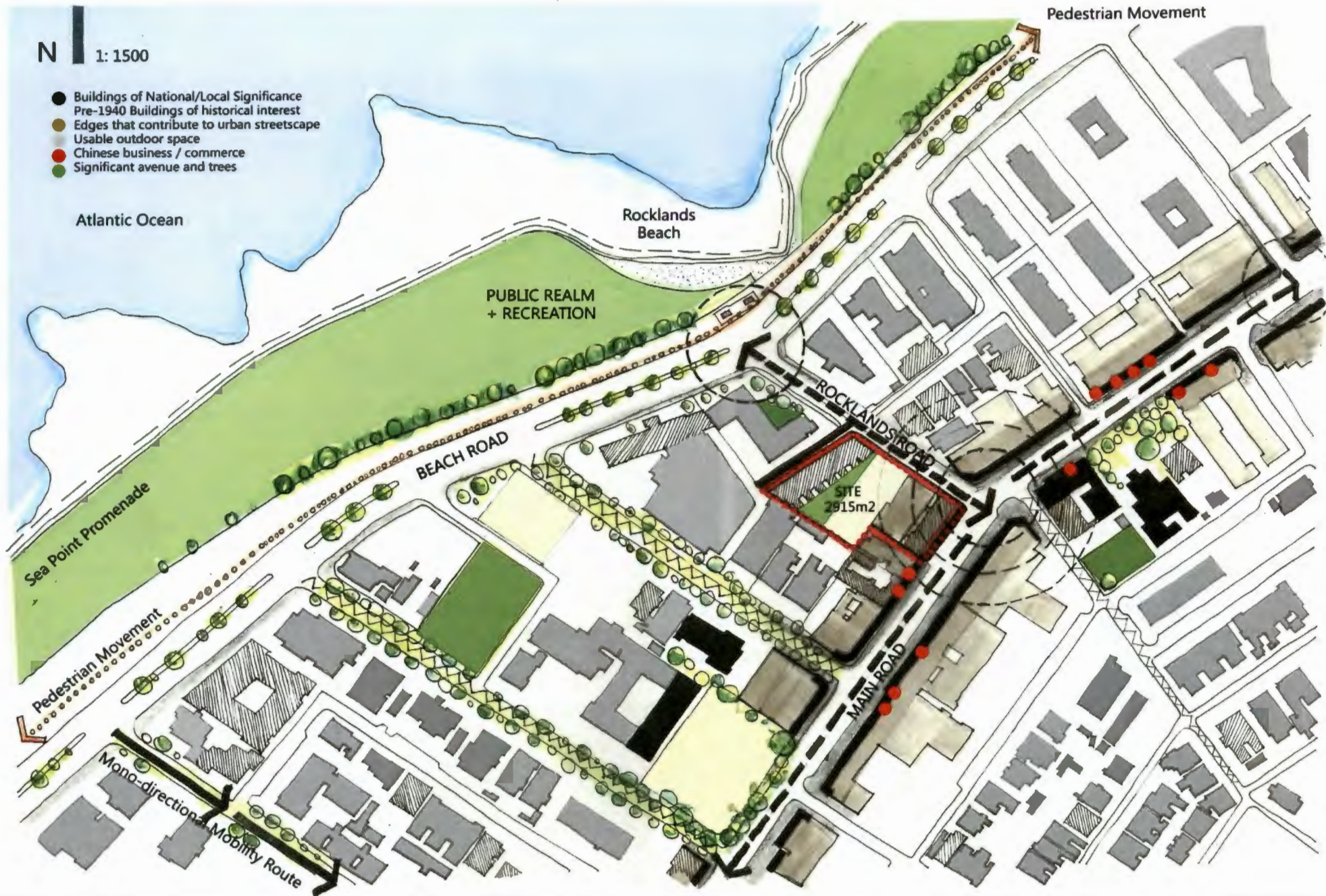

### 3.3 PROGRAMME

Culture is created and learned through communication, but the issue I experienced in this country is that there is tremendous lack of communication between Chinese and the local community. Although people of two nations have increasing desire for cultural exchange, there is no such place to accommodate the need. The architecture plays important role as a communication media to display culture, thus, the design of a Chinese Cultural Center must serve this purpose.

The Center offers a variety of educational and cultural programs. These programs range from lectures, workshops, and classes to art exhibitions, dance, Chinese cooking, martial art and musical performances, and cultural exchanges—all of which enable members of the Chinese community and the general public alike to gain a deeper knowledge of historical as well as contemporary Chinese culture.



### 3.4 DESIGN DEVELOPMENT

## early ideas + sketches

Design must show respect to **local heritage** and context.  
 Design must provide **full accessibility** to the Beach Road.  
 Design must reduce parking units on site and  
**Promotes pedestrian** or non-motorized movements  
**Main Road as a shopping street.**

**Good Public Space** on mountain side.

Design must have some improvement of the streetscape through tree planting, paving, street furniture etc.  
 Incorporating **Chinese architectural philosophies** and the users' lifestyle.

**A courtyard house idea**

+ consideration of Cape Town weather.

Commercial space at the shopfront must create a welcoming relationship with the street.

Issue of fire must take into consideration.

Consideration of slope, **Views** and rain water collection.

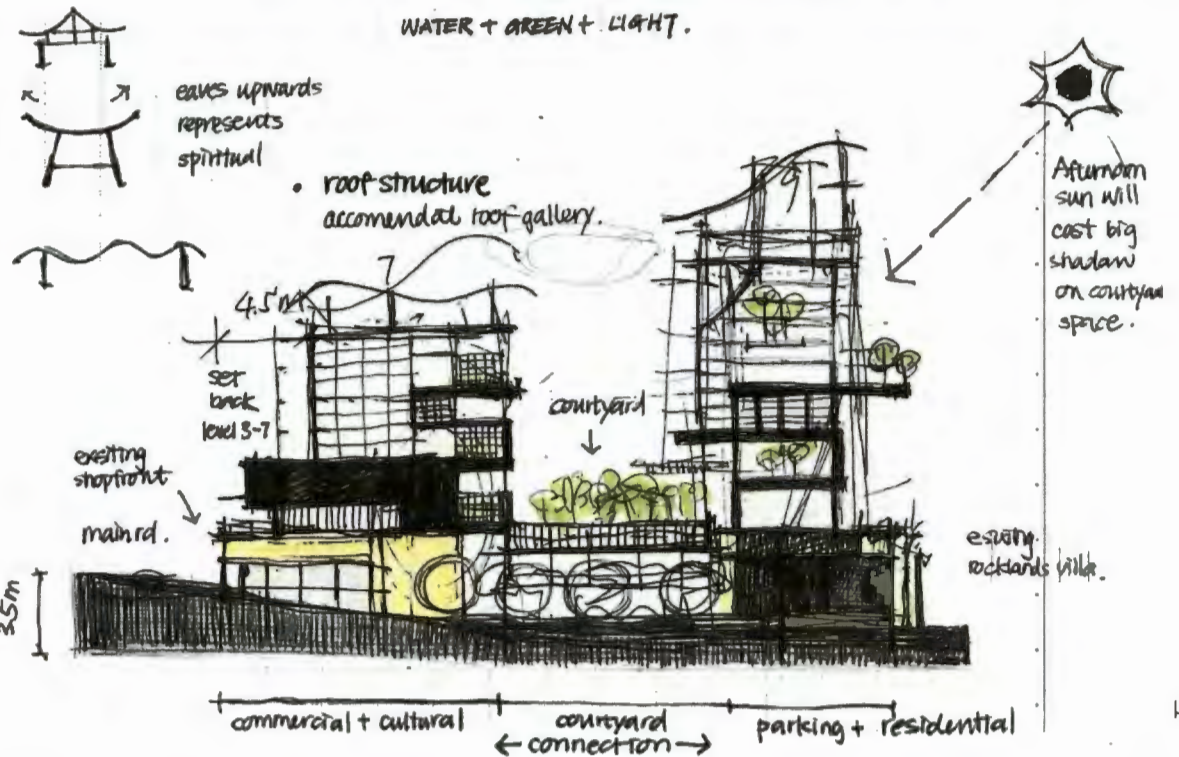
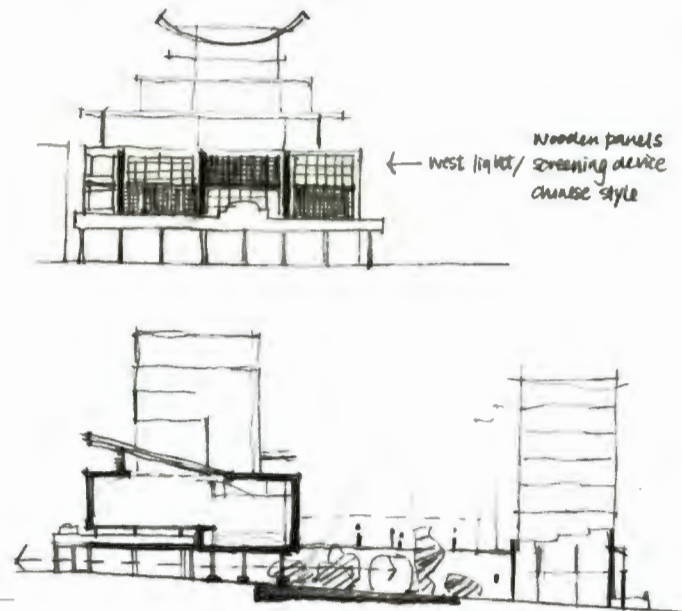
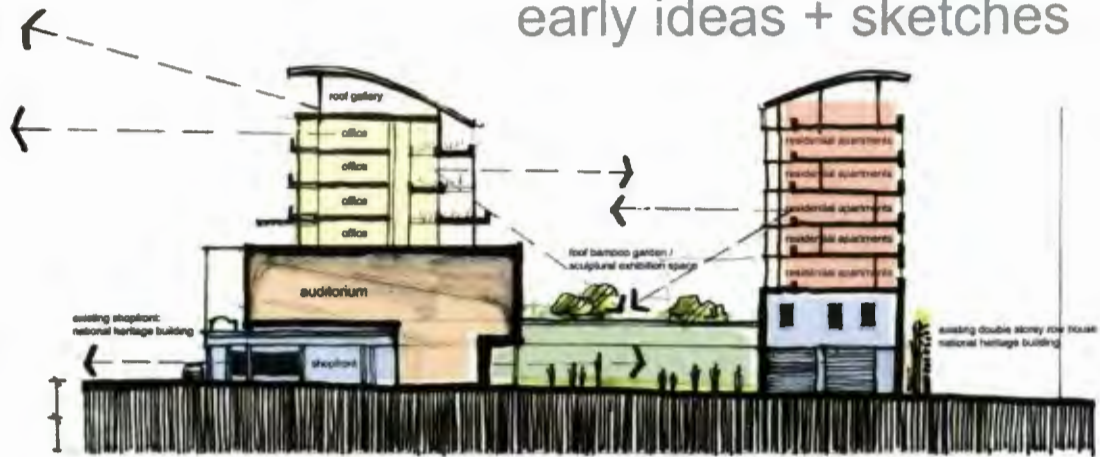

# MAIN ROAD PERSPECTIVE

Views to Promenade + Sea  
Views to Main Road

Roof garden :  
Social space + Views



Retail shopfront  
Keeping the existing structure as a Paifang.

Restaurant+Cafe - Sea Point lifestyle  
Office  
Residential

Corner condition:  
Announcement to pedestrians + traffic

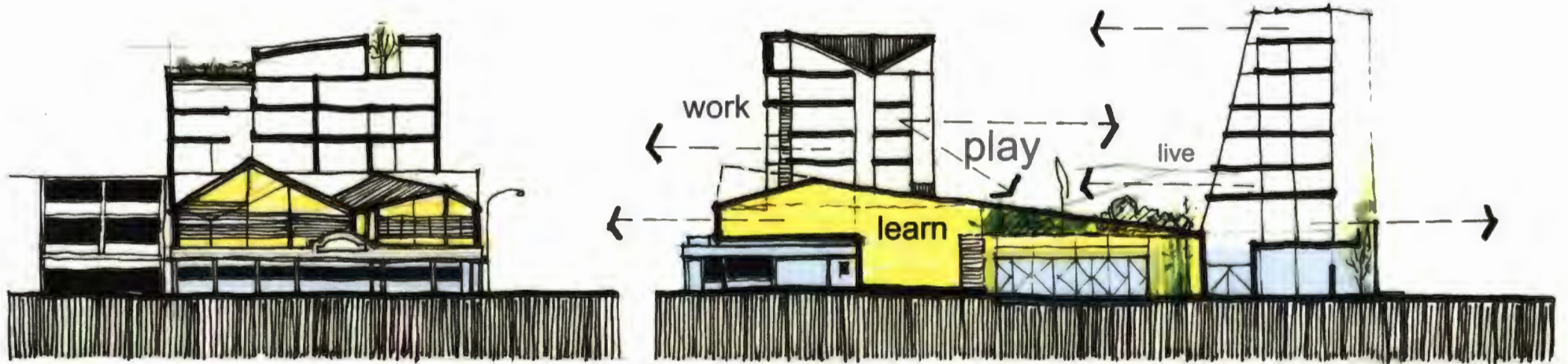

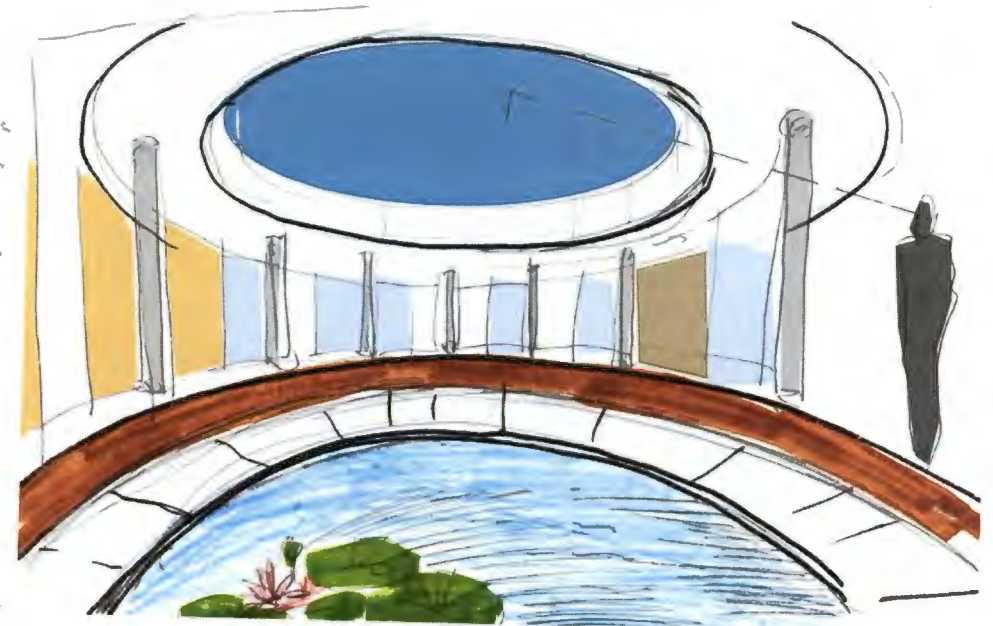
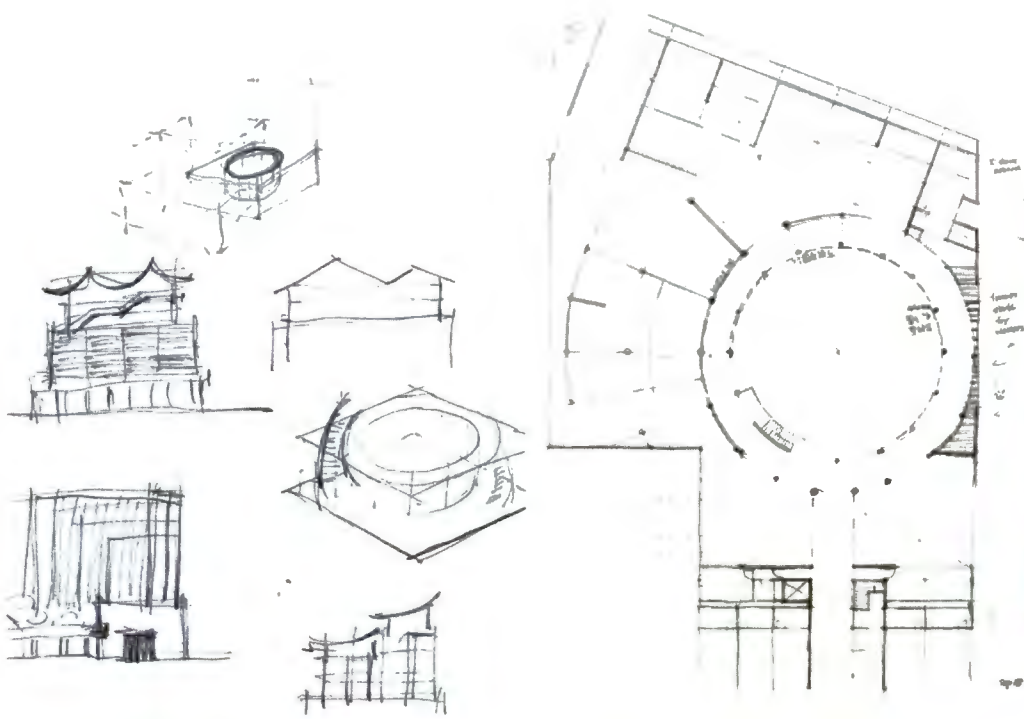

early sktech -  
courtyard space with water devices

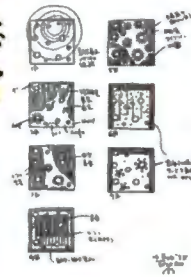
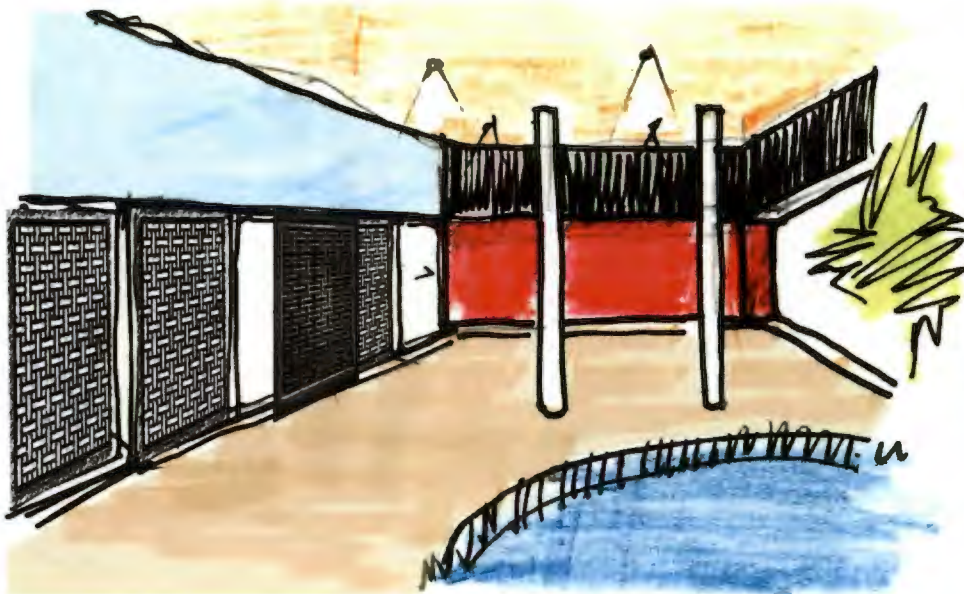

Other precedents on circular building: Tadao Ando, Sanna, Toyo Ito and James Stirling

## DESIGN INTENTION

The project seeks to represent Chinese cultural identity in an architectural language. The main idea of the design is to create a peaceful, meditative, Chinese garden, interlinking the Cultural Center on the Main Road side and the residential building at the back. The project deals with conservation of two national heritage buildings. The intention is to retain as much of the original structure, keeping both of the heritage facades and existing grid systems. The building was designed with natural light and panoramic views in mind.

On ground floor, retail space is kept to maintain a Sea Point Shopping Street style. It presents an interactive face to the public. On the edge of Rocklands Street, full width and height glazing of the Chinese restaurant will open up the corner and maximize the visibility to the street. The main entrance is located on the Rocklands Street to provide direct views of the courtyard space and circulations for the visitors. The courtyard is surrounded by gallery space and a south-facing library / bookstore. Level 1 and level 2 accommodate an auditorium, a multi-purpose space for festival events, a gym that is for both residence and general public. Offices and a Chinese language school are located from level 3 upwards to level 6. Residential unit types were explored in a variety of ways. The apartment building is occupied by a series of duplex apartments. There are two level units accessed only from the lower floor and include an internal staircase to the bedroom level. The living area enjoys a south view to the central courtyard of the cultural center. All occupants enjoy benefits such as a communal swimming pool and gym within the complex.

The form of the building is strongly influenced by feasibility studies for the site analysis. Consideration of sun orientation, climate, accessibility, setbacks, slope, allowable bulk, habitable room factors all shape and mould the envelope of the physical building. Externally, the building responds to the existing structural grid from ground floor and the roofline of the neighbour.

The structure of the building is standard: RC structural column with brick infill. The building will adopt white and grey as its primary colour since it represents a traditional architectural colour in Southern China. Metal sunscreens with wooden panels as well as wooden lattice pattern shutters are introduced to make the Cultural Center contemporary but Chinese.



Working Model of Chinese Cultural Center in Sea Point.

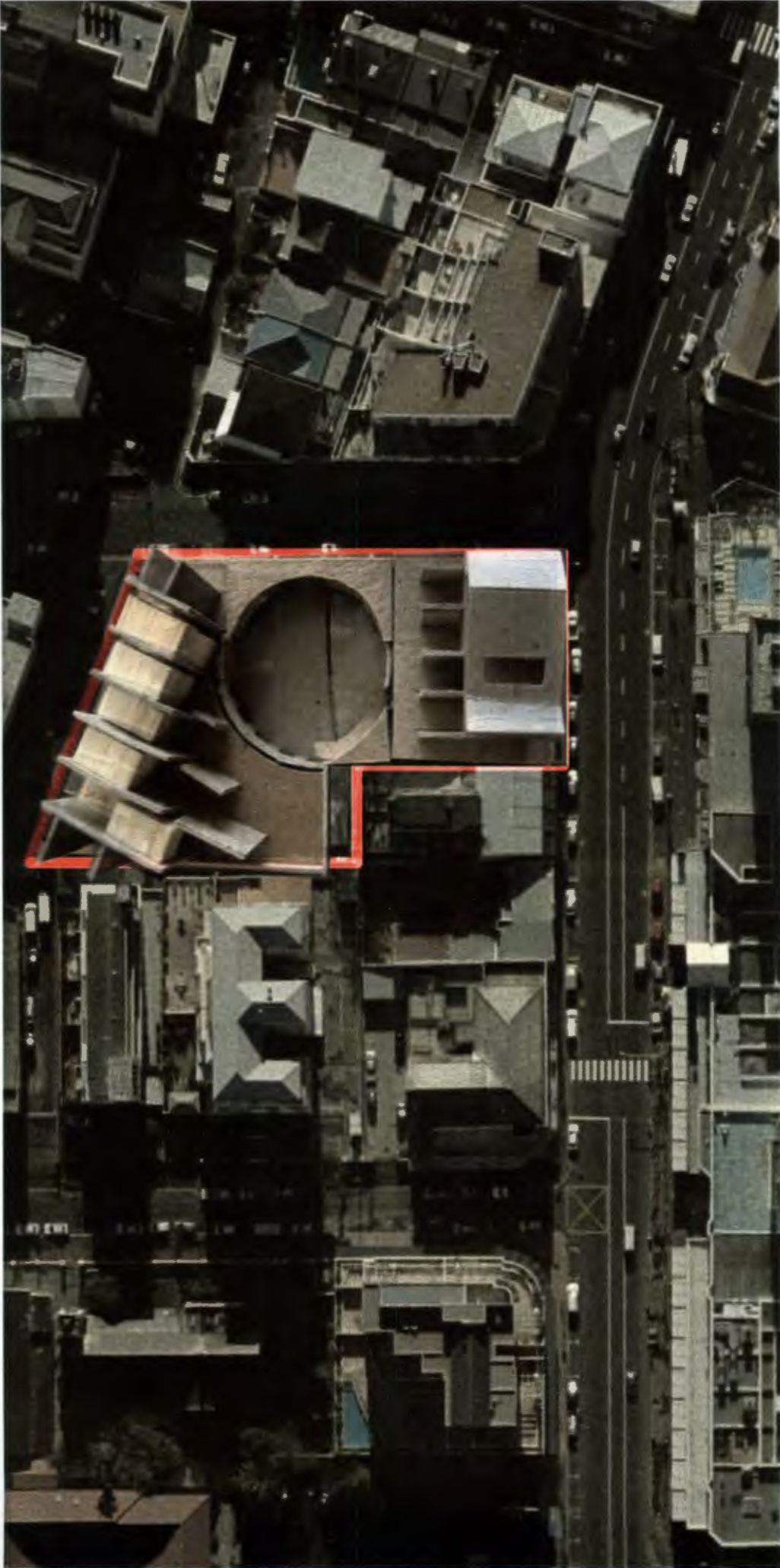

Working Model, on Sea Point Main Road.



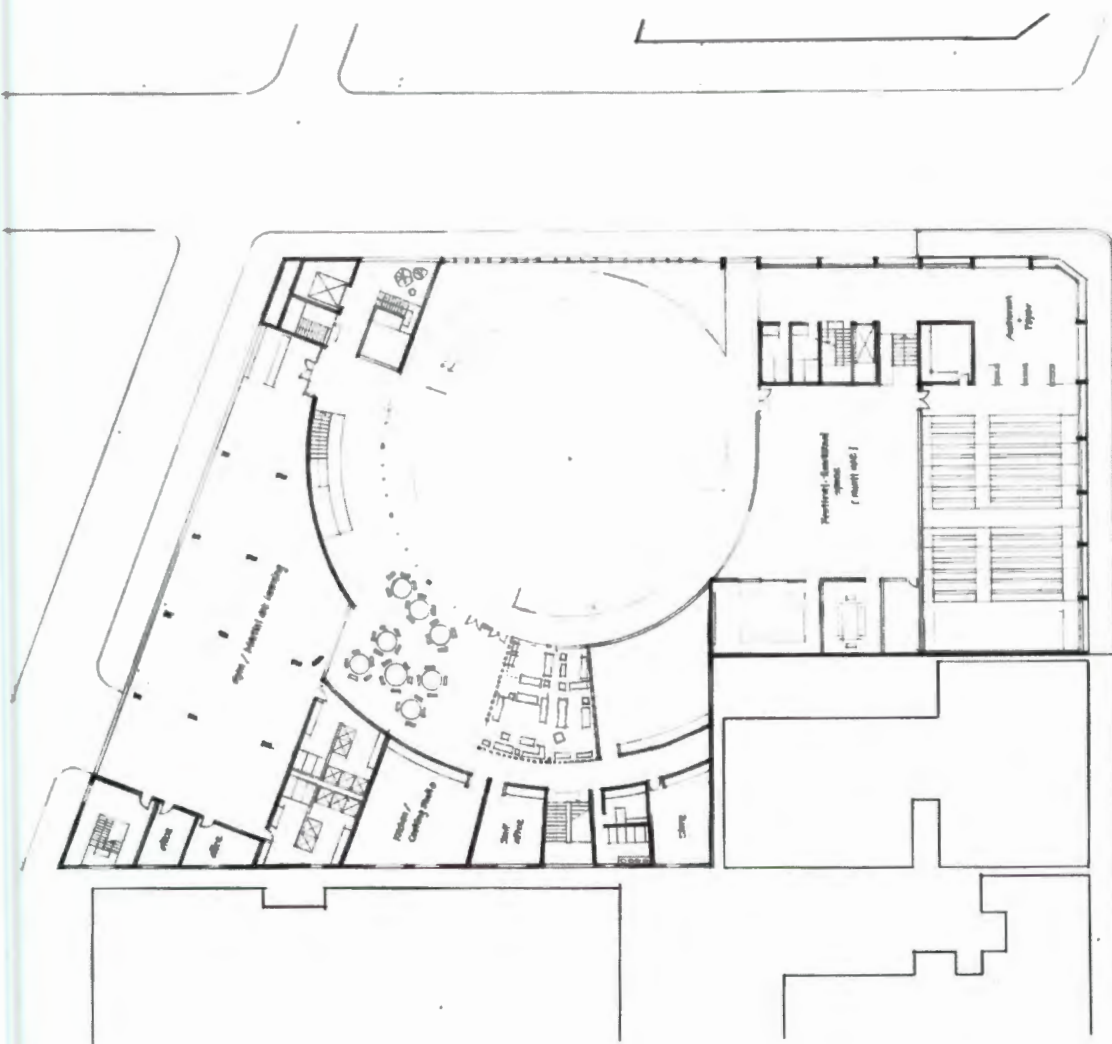

level 1

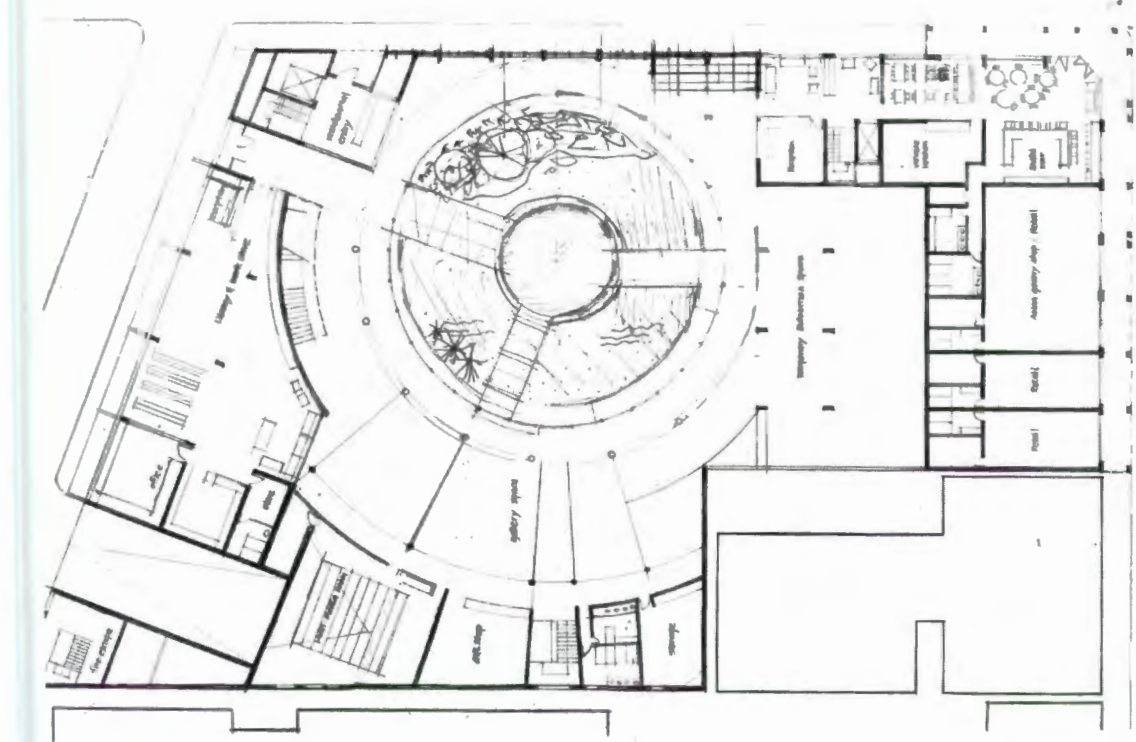

ground level

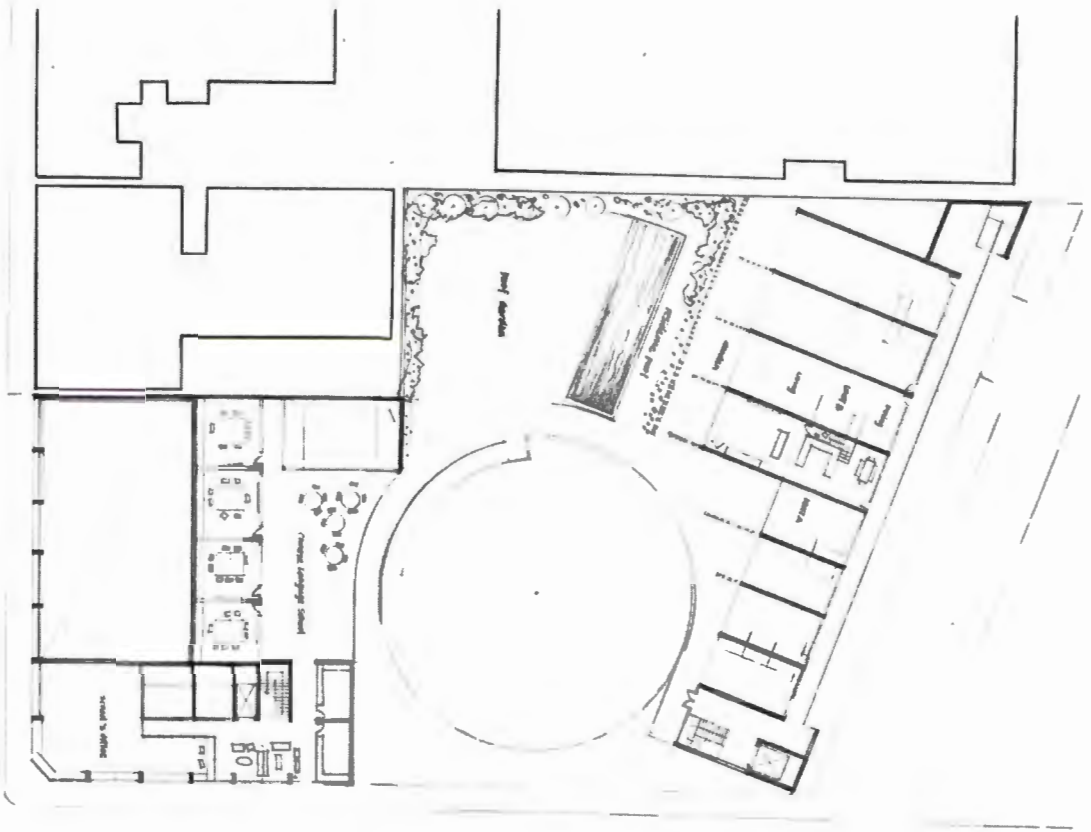

level 2

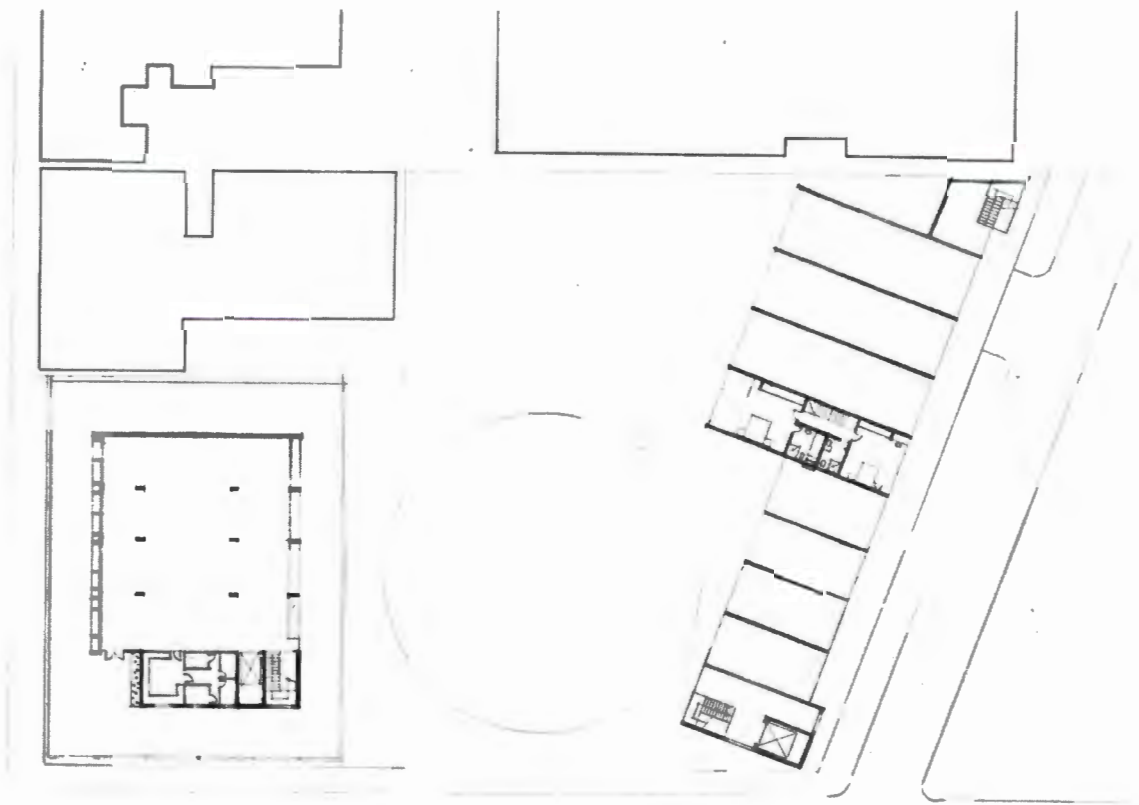

level 3, 4, 6

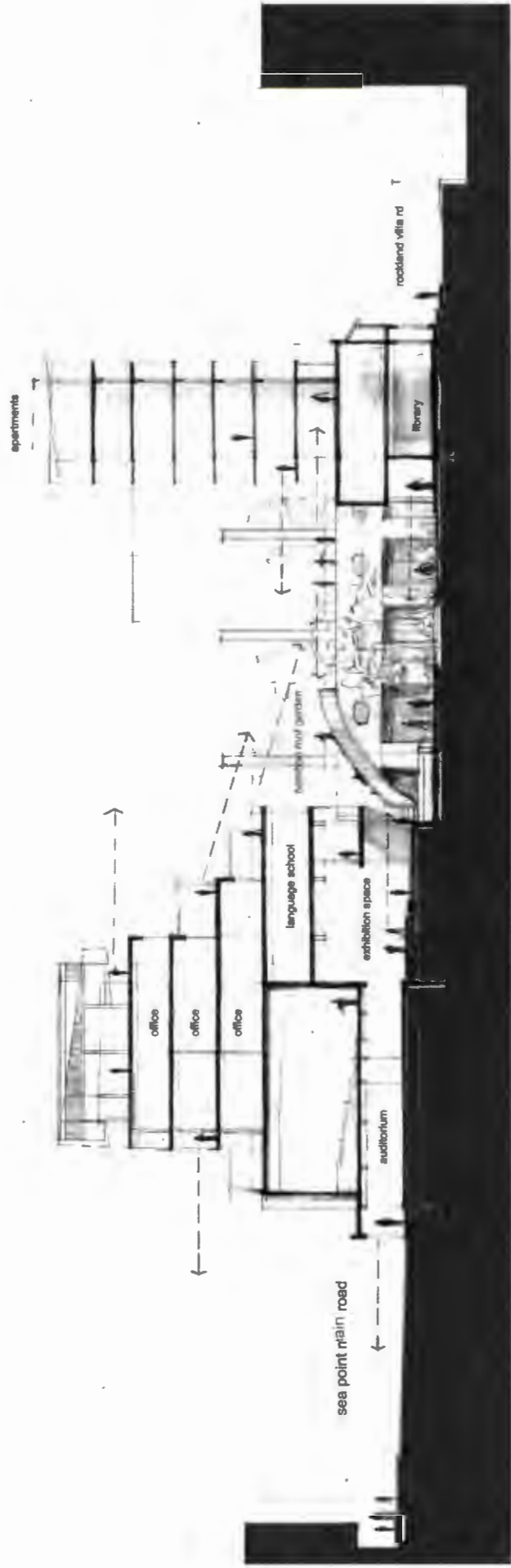

longitudinal section  
WORKING DRAWING

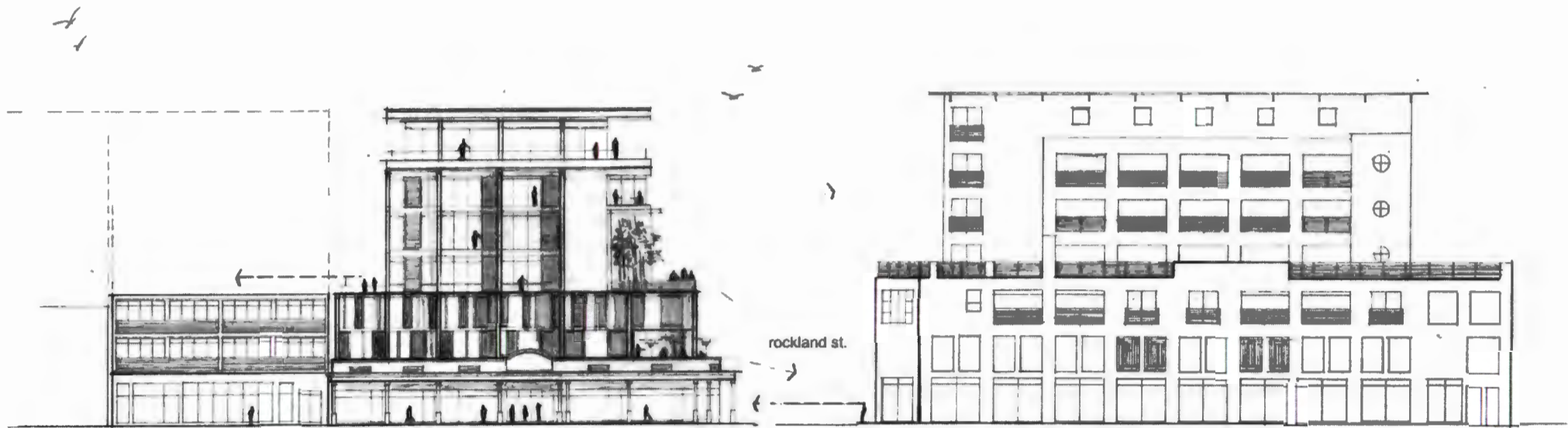

existing shopfront

main road elevation  
WORKING DRAWING

existing residential complex

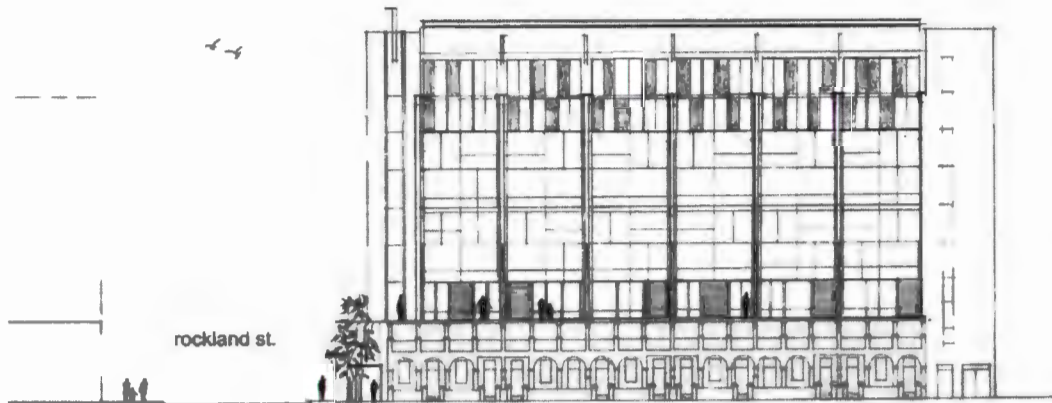

rockland st.

existing 2 storey row houses  
rear elevation

WORKING DRAWING



WORKING MODEL.

sea point main road

rockland street

## **REFLECTIONS** 结论。反思。

---

It is indeed a complex issue of representing a national identity on architecture in a foreign land. Through my thesis, I intended to explore the relationship between space, culture and identity and their implications on architecture. I questioned how this can be translated into architecture when making its national form and image for the inhabitants. I have attempted to put forward a study that has become a journey of seeking Chinese authenticity and a discovery of my own identity. As an oversea-trained architectural student, this thesis paper certainly expands my understanding on how space affects people's cultural behaviors. And it also provides me a valuable background on traditional and contemporary Chinese Architecture as well as the philosophies behind it. I find it is fascinating in the way that space is used in Chinese Culture once I came across 'another way' of making architecture that responded to a totally different environment.

For technology, my interest in Chinese traditional materials can be summarized as being a search for the relationship between materiality and identity for China. A cultural center must represent its cultural identity and creative spirit through architecture. It should also incorporate contemporary technologies into their structure and materials while finding innovative intersections with local techniques. By translating traditional structural and material logics into contemporary means of construction, the design will find new meanings that define its cultural expression.

It is necessary to be critical about the way we see nations and what we assume to be a valid representation of cultural identity. Just like any other forms of art, which have different styles, techniques and expressions to represent its social and cultural value, it is no right way of asserting the validity of such representation. However, the quality and validity is accepted as a good, beautiful, user-friendly building, which helps to bring comfort to people allow for better living and working relationships between South Africans and Chinese communities in Cape Town.

## BIBLIOGRAPHY. 参考书目。

---

- Todeschini and Japha Associated Architects and Town Planners, *Green Point and Sea Point Policy Plan – Phase 1 Report*, Cape Town City Council, March 1989.
- Todeschini and Japha Architects and Planners, *The Green and Sea Point Local Area Draft Town Planning Policy Plan for the Cape Town City Council, Phase 2: Final Report*. March 1991.
- Frederic Edelmann and Jeremie Descamps, *Positions – Portrait of a New Generation of Chinese Architects*, Actar-D, New York, 2009.
- Bernard Chan, *New Architecture in China*, Hugh Merrell, London and New York, 2005.
- Mohamad Tajuddin Haji Mohamad Rasdi, *Malaysian architecture: crisis within*, Utusan Publications & Distributors Sdn Bhd, 2005
- Farshid Moussavi, 'Hybrid Identities', In *Aga Khan Award for Architecture: Intervention Architecture - Building for Change*, New York: I.B Tauris & Co Ltd, 2007.
- Homa Farjadi, 'Architecture Retimed', In *Aga Khan Award for Architecture: Intervention Architecture - Building for Change*, New York: I.B Tauris & Co Ltd, 2007.
- Christine Manzano Visita, *Japanese Cultural Transition: Meiji Architecture and the Effect of Cross-Cultural Exchange with the West*, publisher and date unknown.
- Charlie Xue, 'The Chronicle of Chinese Architecture: 1983-2003', *Architecture and Urbanism*, Tokyo, No.399, December 2003.
- Martyn J. Davies, *The China Monitor*, © Centre for Chinese Studies, University of Stellenbosch, 2007.
- Chun Lin, Hans Hendrichske, *The Territories of the People's Republic of China*. Europa Publications, First edition, 2002, London.
- Karl-Heinz Pohl, *Identity and Hybridity – Chinese Culture and Aesthetics in the Age of Globalization*, publisher unknown, Germany, 2003.
- Zong Hui Chen, *Chinese Traditional Architecture*, Beijing, Béique Chevalier, 1986

- Edward Kogel, *Search for Identity in Contemporary Architecture in China*, delivered at Architecture and Identity conference in Berlin, 2004
- Pu Miao, *In the Absence of Authenticity – An Interpretation of Contemporary Chinese Architecture*, Nordic Journal of Architectural Research, vol.8, no.3, 1995.
- Cheng, Wanli, *Chinese Traditional Architecture*, China Architecture and Building Press, Hong Kong, Wanli Bookstore 1991.
- Liu, Dunzhen, *Chinese Ancient Architectural History*, China Architecture and Building Press, 1978.
- Carter Wiseman, *I.M. Pei: a profile in American architecture*, the University of Michigan, H.N. Abrams, 1990
- Zhang Xin, *Suzhou Museum*, the University of California, Great Wall Publishing House, New York, 2009
- Frederic Edelmann and Jeremie Descamps, *Positions – Portrait of a New Generation of Chinese Architects*, Actar-D, New York, 2009.
- Bernard Chan, *New Architecture in China*, Hugh Merrell, London and New York, 2005
- Farshid Moussavi, 'Hybrid Identities', In *Aga Khan Award for Architecture: Intervention Architecture - Building for Change*, New York: I.B Tauris & Co Ltd, 2007.
- Homa Farjadi, 'Architecture Retimed', In *Aga Khan Award for Architecture: Intervention Architecture - Building for Change*, New York: I.B Tauris & Co Ltd, 2007.
- Christine Manzano Visita, *Japanese Cultural Transition: Meiji Architecture and the Effect of Cross-Cultural Exchange with the West*, publisher and date unknown.
- Richard Weston, *Materials, Form and Architecture*, Laurence King Publishing, UK.2003.
- Xinian Fu, Nancy Shatzman Steinhardt, *Culture and Civilization of China*, Yale University Press, US., 2002
- Liu, Dunzhen, *Chinese Ancient Architectural History*, China Architecture and Building Press, 1978.
- Cheng, Wanli: 1991, *Chinese Traditional Architecture*, China Architecture and Building Press, Hong Kong Wanli Bookstore. Chiou, S-C. and Krishnamurti, 1995,
- Chen Mingda, *Ancient Chinese Timber-framed Structures and Craftsmanship*, Cultural Relics Publishing House, 1990.
- Liang, Ssu-ch'eng, *A pictorial history of Chinese architecture : a study of the development of its structural system and the evolution of its types*, ed. by Wilma Fairbank, Cambridge (Mass.): MIT Press, 1984.

## INTERNET RESOURCES:

<http://www.urbanus.com.cn/> accessed on March 16, 2010

<http://www.iwan.com/> accessed on March 16, 2010

<http://www.tsxian.com> accessed on April 23, 2010

<http://architecture.about.com/od/greatbuildings/ig/Museum-Architecture/Suzhou-Museum.htm>, April 11, 2010

<http://www.liveinsuzhou.com/article.asp>, accessed on April 11, 2010

[http://www.sahistory.org.za/pages/library-resources/articles\\_papers/kleios/xxvi-1994-chinese-in-SA.htm](http://www.sahistory.org.za/pages/library-resources/articles_papers/kleios/xxvi-1994-chinese-in-SA.htm), March 02 2010

[http://en.wikipedia.org/wiki/Asian\\_South\\_African](http://en.wikipedia.org/wiki/Asian_South_African) 2010-02-22.

[http://en.wikipedia.org/wiki/Culture\\_of\\_China](http://en.wikipedia.org/wiki/Culture_of_China), accessed on May 04 2010.

<http://www.chinatownconnection.com/chinatowns.htm>, accessed on 2010-05-05

<http://www.jobusy.com/index.php/tag/chinatown/>, accessed on 12 May 2010.

<http://www.sanfranciscochinatown.com/>, accessed on 12 May 2010.

<http://homeboynet.wordpress.com/2007/07/24/chinas-museum-of-art-architecture/> 12 May 2010.

Wikipedia: 2010, Category: Chinese Architecture, <http://en.wikipedia.org/wiki/Category:Architecture>. April 23, 2010.

<http://www.urbanus.com.cn/> accessed on March 16, 2010

<http://www.iwan.com/> accessed on March 16, 2010

[www.thinkbrick.com.au/brick-history.cfm](http://www.thinkbrick.com.au/brick-history.cfm) 2010-05-23